

When Should You 'Fight' a Speeding Ticket? Page 81

POPULAR MECHANICS

SEPT. 1969
50 CENTS

**New Tougher-to-Pick
Door Locks** Page 134

**ABCs of Chassis and
Suspension
Systems**

**Better
Sound
From
Your TV** Page 148

*New Fly-It-Home
Ejection Seat*

**IDEAS FOR YOUR
HOME:** Prepainted
Aluminum Fencing

Come-With-Color Shutters

A Work Center for Your Garden

Installing Gutters and Downspouts

Buying a Good Old House • Laying a Brick Driveway

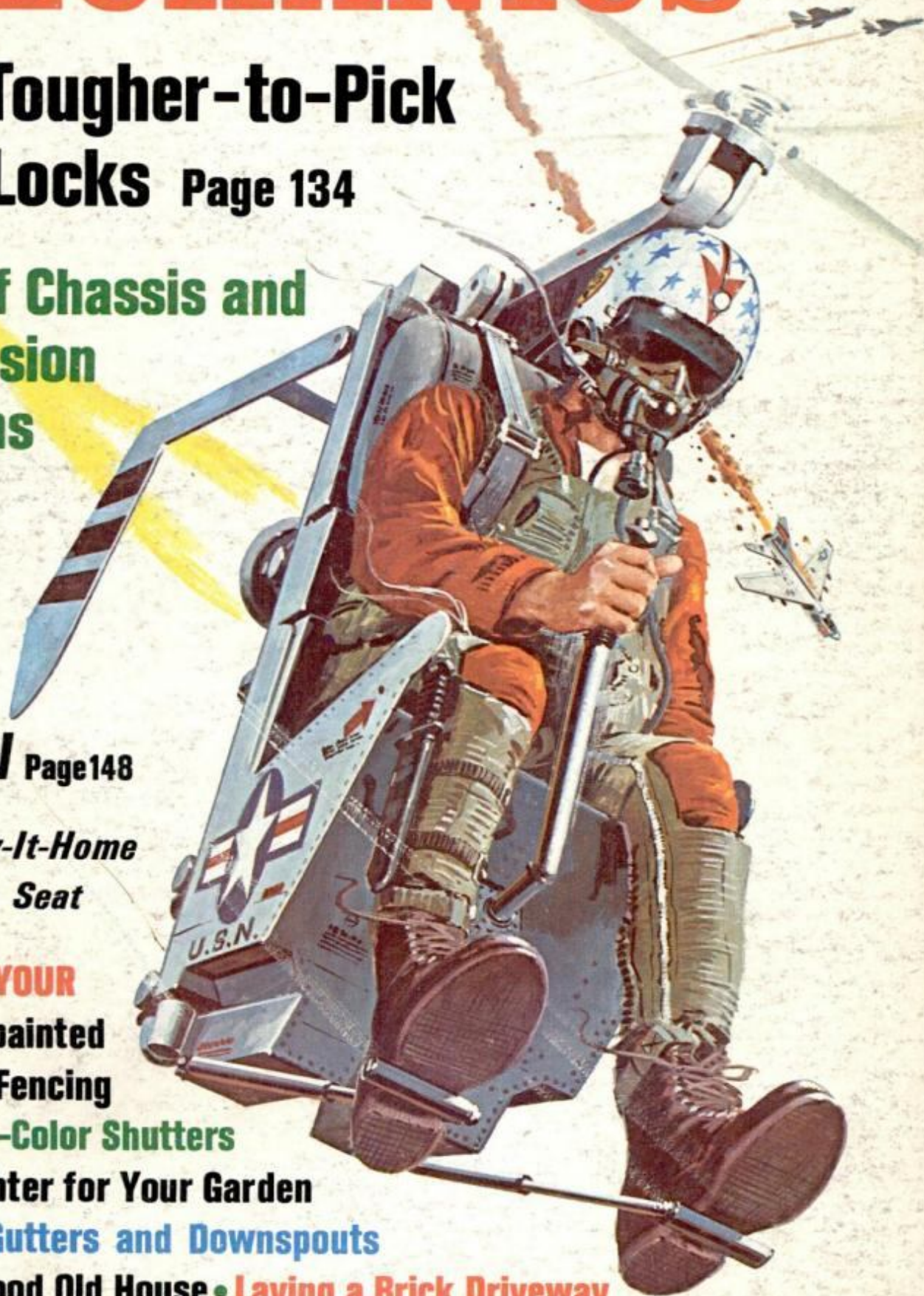

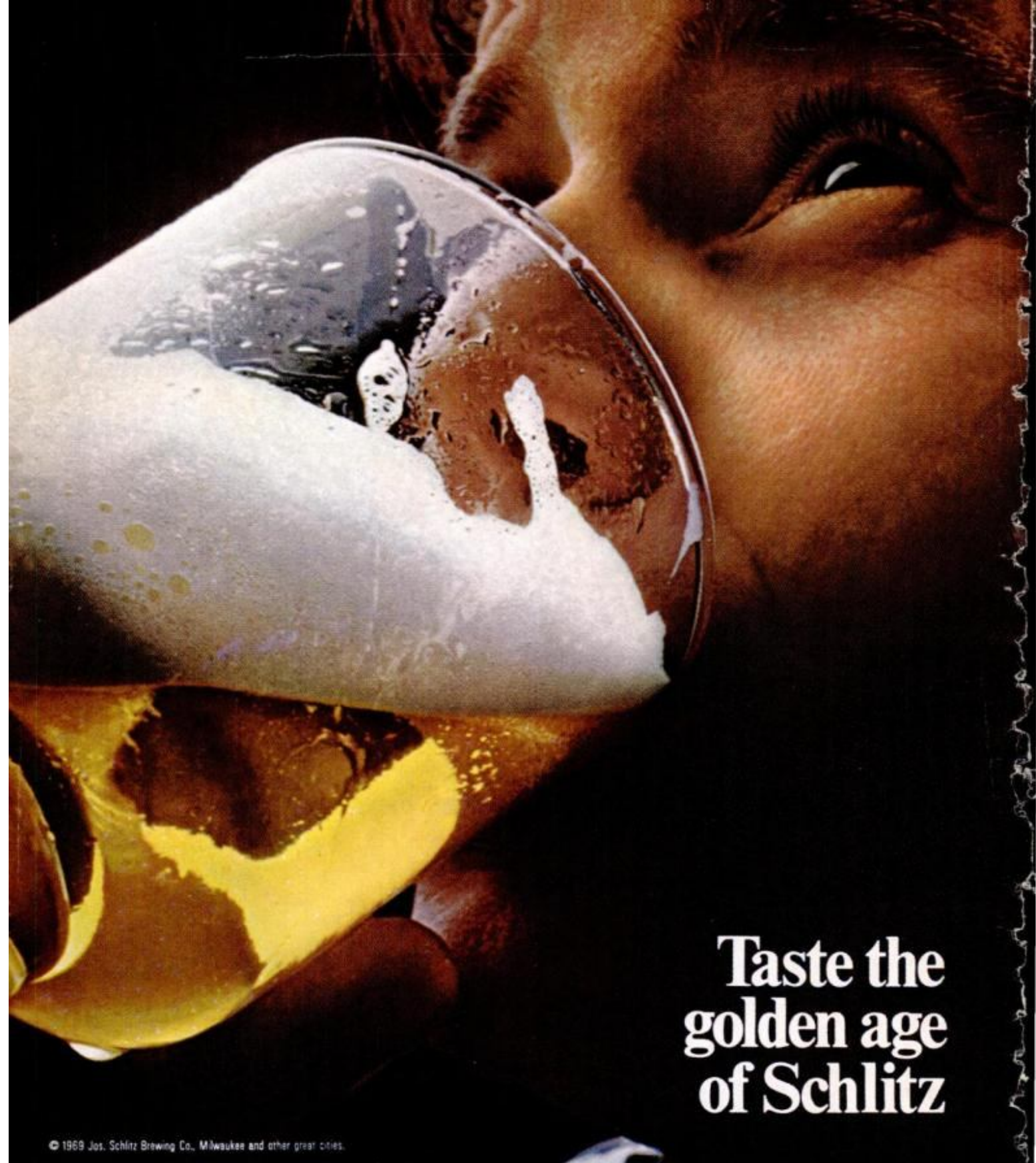

Taste the golden age of Schlitz

© 1969 Jos. Schlitz Brewing Co., Milwaukee and other great cities.

120 years ago, Joseph Schlitz took plenty of time to age his golden mellow beer. We still do. It's the golden age that makes Schlitz America's choicest premium beer.



“When you're out of Schlitz, you're out of beer.”

Материал, защищенный авторским правом

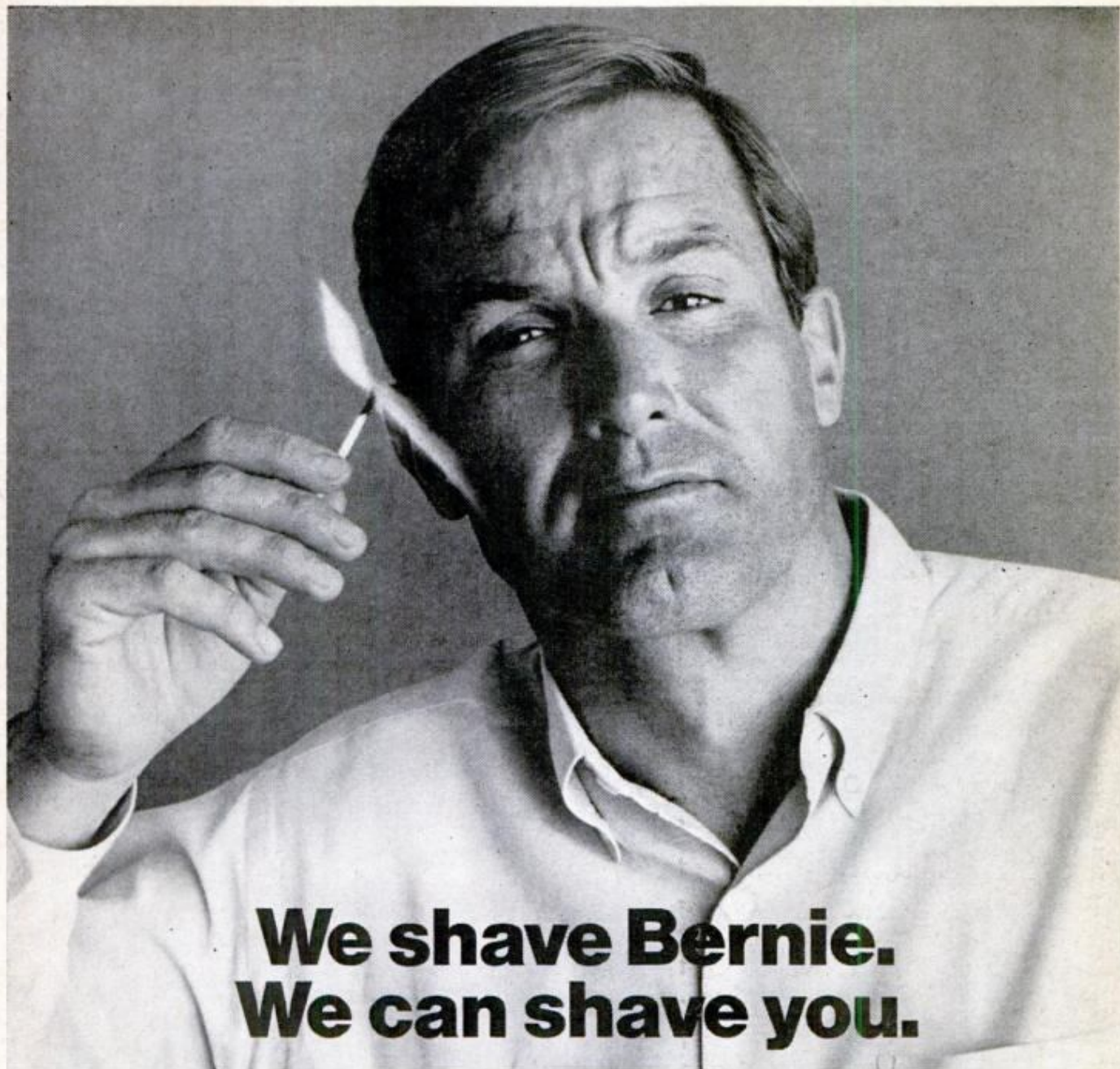

We shave Bernie. We can shave you.

The Norelco Tripleheader is for guys like Bernie who are proud of their beards. Who think their beards are as tough as they come.

Of course, Bernie had some pretty stiff arguments against electric shaving at first.

He'd tell you there was obviously only one way to shave a beard like his. With a blade.

You could tell him that an independent lab proved the Norelco shaves as close as a leading stainless blade in 2 out of 3 shaves. But he'd say: "Sure, maybe...but not on a really tough beard like mine."

Well, we finally got Bernie to face up to the Norelco Tripleheader.

When it was over, Bernie was man enough to admit that the Tripleheader could match shaves

with a blade on any beard—even a beard like his.

You see, the Norelco Tripleheader's got floating heads that fit the curves of a man's face. And inside those floating heads are 18 self-sharpening blades that shave close and smooth every day. Norelco's unique rotary action keeps blades sharp while it strokes off whiskers. Every time you shave.

And besides that, the Tripleheader has a popout trimmer. Plus flip-top cleaning.

Bernie's beard was tough. As tough as they come. But so's Norelco. It's even tough enough for a beard like yours.



Norelco®
Even on a beard like yours.

© 1969 North American Philips Corporation, 100 East 42nd Street, New York, N.Y. 10017.

Life insurance
for you, your wife,
all the kids...
\$20,000 worth
for \$17³⁰ a month.



When he was 25, Gene Taylor wanted life insurance a young father could build on. So he covered the whole family with a single policy. \$10,000 permanent insurance on himself, \$4,000 term on his wife, and \$2,000 term on each of the 3 children. Talk to the "good hands" people about the Family Plan.

Allstate—
the company that
makes life a lot easier
for the young
family man.

You're in good hands with Allstate®
Allstate Life Insurance Company, Northbrook, Illinois



**“Dragster?
No. It’s my getaway car
if I splash on too much
after shave.”**



This One



N484-61E-TT8G

You might be safer with a tank than a hot rod if you're not careful with your Hai Karate® After Shave and Cologne. (We're not kidding. Girls have been known to set up roadblocks.) So play it safe. Splash carefully. And read the instructions on self-defense which we include in every package. Or you'll look like a loser in the demolition derby.

Hai Karate-be careful how you use it.



POPULAR MECHANICS®

INTERNATIONAL EDITIONS: AUSTRALIA, BRAZIL, CARIBBEAN, DENMARK, FRANCE, MEXICO, SOUTHERN HEMISPHERE, SWEDEN

AUTOMOBILES AND DRIVING

- 24 Drivin' With Dan
- 36 Detroit Listening Post
- 74 Automobile Clinic
- 81 Our Crazy, Mixed-Up Speed Laws
- 98 PM Owners Report: Plymouth Valiant
- 106 PM Owners Report: Jeep Wagoneer
- 128 The ABCs of Chassis Frames and Suspensions
- 182 Saturday Mechanic: Ten Clues to Hidden Ignition Troubles

SHOP AND CRAFTS

- 16 Two Shockproof Drills
- 152 Stackable Shelf Modules Go Together Like 1-2-3
- 172 Weekend Projects
- 176 Mini-Pump Powers Two New Hydraulic Workholding Tools
- 180 Hints From Readers
- 181 New Tools You Should Know About
- 187 Hints From Readers
- 188 What's New for Polishing and Buffing
- 192 Hints From Readers
- 222 All-Purpose Cutting Tool

SPACE, AVIATION, MILITARY

- 10 Send Willy Ley's Ashes to the Moon
- 90 A Hot Seat to Bring 'Em Back Alive
- 114 Antisubmarine Warfare
- 124 Big Ambulance for Big Birds

SCIENCE AND INVENTIONS

- 20 Science Worldwide
- 84 Secrets of the Animal World
- 100 The World's Sharpest Tool
- 104 Just Patented: PM's Pick of the New Inventions

HOME AND YARD

- 78 Homeowners' Clinic
- 134 Those New Tough-to-Pick Door Locks
- 139 How to Buy a Good Old House
- 152 Stackable Shelf Modules Go Together Like 1-2-3
- 154 I Built This Driveway for a Mere \$100
- 156 Packaged Fence Panels Offer Both Beauty and Privacy
- 159 New Shutters You Don't Have to Paint
- 161 Enhance Your Yard with a Garden Work Center
- 163 Save by Making Your Own Colonial Door Frame
- 164 How to Install Gutters and Downspouts
- 170 New Building Products You Should Know About
- 172 Weekend Projects
- 178 Solving Home Problems
- 186 Build This Fish and Meat Smoker

BOATING, OUTDOOR RECREATION

- 14 On-the-Go Camping
- 42 New Super-Duper Snowmobiles
- 52 What's New Outdoors
- 110 Starcraft's Hefty Half-Pint
- 120 Look What's Happened to Bows and Arrows
- 144 Outboard-Motor Service Guide No. 3: How to Check Out Your Fuel System

ELECTRONICS, RADIO AND TV

- 148 How to Get Better Sound From Your TV Set

REGULAR FEATURES

- 6 Letters

Cover Illustration by Ed Valigursky
New Fly-It-Home Ejection Seat

NEXT MONTH IN POPULAR MECHANICS

In Color: The 1970 Cars. What's really new about them? How do they compare? Twenty-four pages of exclusive *PM* photos and first-hand reporting by *PM* editors.

Amazing New Instantaneous Fire Extinguisher. For your car, boat or home.

Great Ideas and Gadgets From World's Biggest Inventors Show. The best of Patexpo 69.

What's New in Snowmobiles and Outboards. Exciting developments in recreation.

ROBERT P. CROSSLEY

Editor

JAMES M. LISTON
Executive Editor

JOHN A. LINKLETTER
Managing Editor

WAYNE C. LECKEY
Home and Shop
Editor

SHELDON M. GALLAGER
Assistant Executive
Editor

THOMAS G. DAUER

Art Director

Published by The Hearst Corporation
RICHARD E. BERLIN, PRESIDENT

RICHARD E. DEEMS
President, Magazines Division

JOSEPH F. KERN
Publisher

WILLIAM KILPATRICK _____ Automotive
DANIEL C. FALES _____ Boating and Outdoors
SHELDON GALLAGER _____ Electronics and Photography
JOHN F. PEARSON _____ Science
BILL HARTFORD _____ Technical Automotive
HARRY WICKS _____ Home Workshop
GARRY WINTER _____ Copy and Production
RICHARD H. FUNK _____ Associate Copy and Production
JOHN ADKINS _____ Assistant Copy and Production
ALVIN KIETZ _____ Assistant Art Director
DON EVANS _____ Assistant Art Director
FRED A. LEERS _____ Assistant Art Director
GEORGE W. BLOW _____ Technical Art Director
CLIFFORD B. HICKS _____ Special Projects
SOPHIE GRONOWICZ _____ Director, Bureau of Information
EVERETT JOHNSON _____ Cabinetmaker

ADDRESS ALL EDITORIAL COMMUNICATIONS TO: 575 Lexington Ave., New York, N.Y. 10022. For additional sources of information on the articles and products in this issue, write to Bureau of Information, Popular Mechanics, for free "Where-to-Find-It" list.

DANIEL J. COLEMAN
Director of Advertising

ADVERTISING OFFICES: New York: 575 Lexington Ave., Murray Hill 8-8500; Chicago: 520 N. Michigan Ave., 527-2400; Detroit: General Motors Bldg., TRinity 5-8711; Cleveland: Hanna Bldg., 1422 Euclid Ave., Prospect 1-0456; Los Angeles: 601 North Vermont Ave., 666-6263; San Francisco: 1101 Hearst Bldg., YUkon 2-0823.

SUBSCRIPTION SERVICE: Mail all subscription orders, changes of address, correspondence concerning subscriptions, and Postmaster notices of undeliverable copies to Popular Mechanics, Box 646, New York, N.Y. 10019. Please enclose your latest address label for quickest service when writing about your subscription.

POPULAR MECHANICS IS PUBLISHED MONTHLY by The Hearst Corporation, 57th St. at 8th Ave., New York, N.Y. 10019, U.S.A. Richard E. Berlin, President; George Hearst, V-Pres.; Richard E. Deems, President of Magazines; John R. Miller, Executive V-Pres. of Magazines; Raymond J. Peterson, Senior V-Pres. of Magazines; William S. Campbell, V-Pres. of Magazines; Albert A. Rachol, V-Pres. and Director of Circulation; Joseph F. Kern, V-Pres. for Popular Mechanics; Frank Massi, Executive V-Pres. and Treasurer; Harvey L. Lipton, Secy. Single copy in the United States and Canada, 50 cents. Subscription prices: United States and Possessions, \$4.00 for one year; \$7.00 for two years; \$10.00 for three years. Canada, add \$0.75 for each year. Pan American Postal Union countries, add \$1.00 for each year. All other countries, add \$2.00 for each year. When changing address, give old address as well as the new, with postal-zone number, if any, and allow six weeks for change to become effective. Second-class postage paid at New York, N.Y., and at additional mailing offices. Authorized as second-class mail by the Post Office Department, Ottawa, and for payment of postage in cash. Registered as second-class matter at the Post Office at Mexico D.F., Mexico, June 20, 1950. © 1969 by The Hearst Corporation. All rights reserved. Printed in U.S.A.

SEPTEMBER 1969

86 Proof Early Times Distillery Co., Louisville, Ky. ©1968



portable bar

Make yourself the greatest home bartender in town. Just send \$3.50 to Early Times Glass Offer*—P. O. Box 1080, Louisville, Kentucky 40201. We'll send you a set of 6 Giant 15 oz. Early Times Jiggers. Or send \$3.00, for a set of 8 Early Times 10½ oz. Highball Glasses. They're beautiful, so get both sets while they last. Do it now.

*offer valid only where legal

THE TRUE OLD-STYLE KENTUCKY BOURBON

LETTERS

TO THE EDITOR

Not the largest

In *The Death of World Glory* (page 106, July PM) you state that in 1956 the *World Glory* was the largest ship of any kind to appear in San Francisco.

Not true. During World War II both the *Queen Mary* and the *Ile de France* visited San Francisco while used as troop ships.
SAN FRANCISCO SAMUEL H. KLINE

Underwater photography

Your article, *Now: Shoot Underwater Photos for Under \$20* (page 107, June PM), is excellent. I think it has made a significant contribution to the general understanding of the industry and equipment we produce.

I note that you pictured the Upsi underwater housing. I think it would be a service to your readers to let them know that about eight months ago our firm purchased from Upsi of Marathon, Fla., the manufacturing rights to the Upsi line of underwater camera housings. Thus, the Upsi housings are now made by Sea Research & Development, Inc., 390 East Davidson St., Box 589, Bartow, Fla. 33830.
BARTOW, FLA. W. H. STUART JR.
PRESIDENT

Pop goes the wheelie

You mention that high-riser bikes let riders perform antics like wheelstands (*Those Wild New Bikes*, page 150, July PM). I hope you don't think that you *have* to have a high riser to pull a wheelie. I can pull a wheelie on anything but a 26-inch derailleur and 26-inch balloon tire.

I had a 20-inch Schwinn *without* a banana seat, and I popped a wheelstand about 80 yards. (I stand up to pop wheelies.) On the same bike, I pop wheelies around in a complete circle.

TRAFFORD, PA.

EUGENE LINK

There's trouble in River City, all right. How come you kids aren't doing something worthwhile, like trying to give an ironclad leave to yourself from a three-rail billiard shot?

Up and away with Jeanie

Bud Gush of Fort Lauderdale, Fla., just finished building his Jeanie's Teenie (*Build This 'Flying Volkswagen' for Less Than \$600*, page 120, May '68 PM), and I

[\(Please turn to page 8\)](#)

The Lazy Pipe Tobacco

This gentle-tasting tobacco has just the right combination of plugs and flakes for smooth and steady burning. Think of it this way: on a single pipeful of Bond Street you can travel a couple of relaxing miles in a canoe, without even lifting a paddle. (Provided your mate does.) We think you'll find the Bond Street taste to your liking (and don't be surprised if a passing sportsman has some glowing compliments for the aroma).



Lights easy —
takes its own good
time about burning.



LA SALLE EXTENSION UNIVERSITY

A Correspondence Institution • 417 S. Dearborn Street, Dept. 93-133, Chicago, Illinois 60605

Please send me, without cost or obligation, FREE booklet and full information on the field I have checked below:

ACCOUNTING

- Complete Accounting
- Income Tax
- Accounting Fundamentals
- CPA Training
- Modern Bookkeeping

BUSINESS MANAGEMENT

- Complete Business Management
- Credit and Collections
- Office Management
- Personnel Management
- Sales Management

REAL ESTATE

- Complete Real Estate
- Real Estate Brokerage
- Real Estate Management

COMPUTER PROGRAMMING

- Complete Training

LAW COURSES

- Bachelor of Laws Degree
- Business Law
- Insurance Law
- Claim Adjusting Law
- Law for Police Officers

STENOTYPE

- Machine Shorthand

TECHNICAL COURSES

- Air Conditioning, Refrigeration, Heating
- Diesel

TRAFFIC & TRANSPORTATION

- Complete Traffic Mgt. Truck, Air, Rail, Sea

DRAFTING

- Complete Drafting

INTERIOR DECORATION

- Professional Training

ART TRAINING

- Commercial Art
- Oil, Water Color Painting
- Complete Training

Mr.

Mrs.

Miss Age.....

HIGH SCHOOL

- High School Diploma

LANGUAGE INSTRUCTION

- French
- Spanish

HOTEL/MOTEL MANAGEMENT

- Executive Training

CAREERS FOR WOMEN

- Accounting
- Bookkeeping
- Commercial Art
- Computer Programming
- Dental Assistant
- Hotel/Motel Mgmt.
- Interior Decorator
- Real Estate
- Secretarial
- Stenotype

Interested in a career not listed? Write here: _____

Address..... Apt.No.....

City & State..... Zip No.....

922

If you had mailed this coupon a year ago, your salary could be way up too!



WHY NOT MAIL IT TODAY?

Look at these enthusiastic letters. Have you ever seen anything like them? There are hundreds and hundreds more that pour in from LaSalle students week after week, month after month, year after year.

Do you know that many graduates attribute their increases in income largely to their LaSalle training?

All LaSalle students have one ambition in common—to get out of the ranks of the untrained and earn big money, prestige and security in a key job. Isn't that your goal too?

Without interfering with your present work—and by devoting only a little of your spare time—you too can prepare rapidly for advancement in the field of your choice through LaSalle home study. The cost is surprisingly low.

LaSalle has been an acknowledged leader in home education for more than sixty years. It has provided training in business, high school, and technical subjects to over 1,500,000 ambitious men and women. Its distinguished faculty includes some of the country's most outstanding authorities. That is why your LaSalle diploma is a credential recognized and respected everywhere.

Check the subject you are interested in—then send the coupon above for FREE booklet. No obligation.

"My salary has increased 400% as a direct result of my LaSalle studies"

Rudolph Urbatis,
Port Chester, N.Y.



"Salary more than doubled since enrolling"

William T. Black,
Canoga Park, Calif.



"Income has increased 100 per cent since graduation"

James L. Yonning,
Manhattan, Kansas



"I now earn three and a half times my former pay"

Robert Fisher,
Holbrook, Ariz.



LA SALLE EXTENSION UNIVERSITY

A Correspondence Institution • 417 S. Dearborn Street, Chicago, Illinois 60605

Winegard announces everything you need to make color tv sharp and clear!

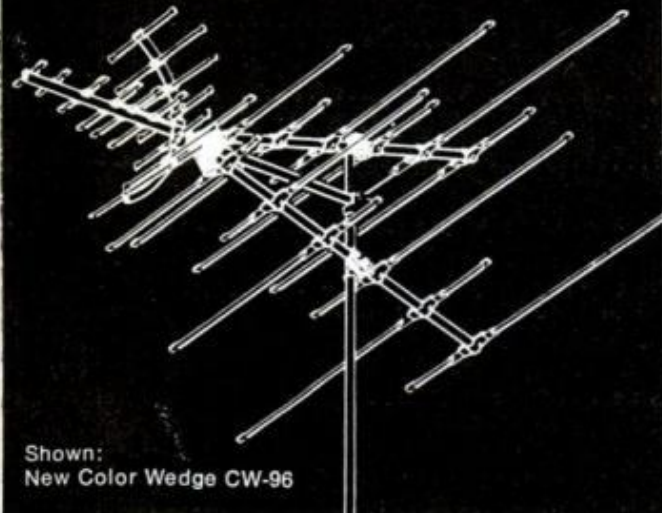

Shown:
New Color Wedge CW-96

Maybe all you need is a special made-for-color Winegard antenna. Like, say, one of our totally new Color Wedge models.

As you can see, the Color Wedge looks different than other antennas. It has a new electronic design that makes it work better on all channels. And it has a new mechanical design that makes it last years longer regardless of rain, ice, high winds and the like.

The unique "wedge" design provides greatly increased vertical capture area in a much shorter, more compact antenna. This means your TV set receives increased signal for sharper, clearer color reception. Even on those weak, hard-to-get channels. And it means that ghosts, snow and other TV interferences are drastically reduced or eliminated.

New truss construction makes Winegard Color Wedge the strongest antenna around. It's permanently weather-protected by the genuine gold anodized finish. Just like the TV wire connections are protected by the exclusive built-in cartridge housing.

In addition, Winegard supplies fine quality antenna mounts, TV cable, and everything you need for a convenient, plug-in home TV antenna system.

For sharpest, clearest TV—no matter what kind of set you own—see your Winegard dealer. Or write for our giant new catalog. It's free!

Solid state
home TV
system
amplifier.



Winegard

ANTENNA SYSTEMS

WINEGARD COMPANY • 3020-3 KIRKWOOD STREET
BURLINGTON, IOWA 52601

LETTERS

(continued from page 6)

was invited down to fly it and check it.

I pushed open the throttle and the acceleration was terrific! With a 36-hp engine, it took the plane only 300 feet to be off and climbing.

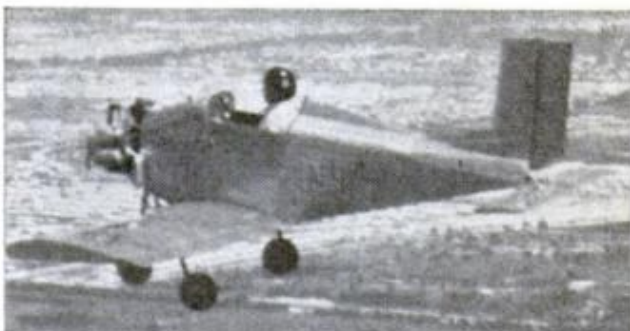

I was unable to get a complete stall. At 2000 feet, with the stick back and power on, it slowly sank at the landing speed (40 mph); without power it sinks at a faster rate with no tendency to fall out.

My original plane was built for \$600. Mr. Gush spent over \$800, but bought a lot of new parts and paid higher prices.

DAPHNE, ALA.

CALVIN Y. PARKER

Mr. Parker is the designer of Jeanie's Teenie, for which plans are still available. Send \$15 with your name and address to Service Bureau, Popular Mechanics, 575 Lexington Ave., New York, N.Y. 10022.

Where there's a will . . .

I decided to try my hand at making the *Oriental Wall Shelf* (page 162, April PM).

Not having a bandsaw, I used molding and trimmed off the corners. Instead of tassels, I used clear plastic tubing and gold-colored yarn. I looked in Oriental stores in Seattle and Tacoma and found no mandarin figures, so I used Japanese dolls. I made two for my wife and used $\frac{3}{8}$ -inch dowels instead of $\frac{1}{2}$ -inch, and I like these better. Thank you for the plans. PORT TOWNSEND, WASH. E.D. BROADSWORD

You're welcome. but somehow we feel you could almost get along without 'em.

Keep 'im guessing

Thanks to the information in your good magazine (I'm an avid reader), I have often been able to fool my husband into believing I'm quite clever. When he complains that I'm making him "magazine subscription poor," I defy him to drop my subscription. It's really great.

PONCE, P.R. MRS. WILLIAM H. DAVIES JR.

Hold that line, Mrs. Davies!

★★★

POPULAR MECHANICS

Tools you should get your hands on.

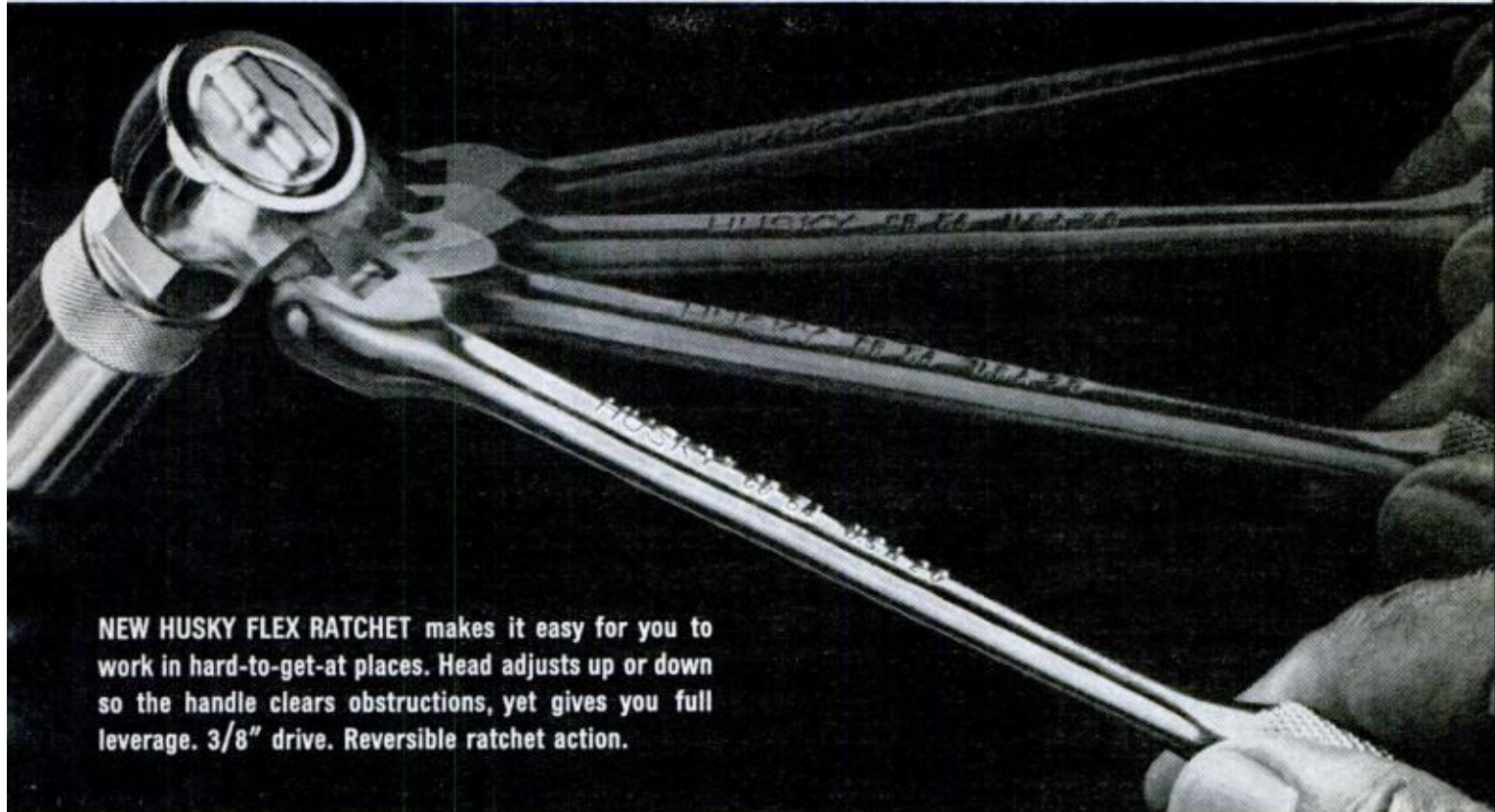

NEW HUSKY FLEX RATCHET makes it easy for you to work in hard-to-get-at places. Head adjusts up or down so the handle clears obstructions, yet gives you full leverage. 3/8" drive. Reversible ratchet action.

Get your hands on a Husky Tool and you'll never settle for the ordinary. Husky is professional mechanic quality. Made of special steel... forged, heat treated, precision machined. The 45-tooth ratchet action gives you remarkable smoothness and power. Four-way ball grooved sockets attach quickly, fit like a glove. Husky Tools are built to give you a

lifetime of satisfaction. And priced to give you a lifetime of value. Get your hands on them. You'll like what you get! Husky Tools, New Britain, Conn.

Husky



WHY FUMBLE? When you choose from Husky's Matched Socket Wrench Sets, you're sure to have the right tool to work on anything — car, truck, plane, boat, lawnmower, garden tractor or snowmobile. Choice of 1/4", 3/8", 1/2" and 3/4" drives... in sets ranging from 9 to 104 pieces.



Send Willy Ley's Ashes to the Moon!

In 1930 a group of engineers assembled on the outskirts of Berlin to examine a funny-looking piece of pipe, five feet long and light enough to lift with one hand. It was the first liquid-fuel rocket they had ever seen. They watched warily as a bushy-haired young man set off the rocket and with awe as it shot 1500 feet into the air, then floated back to earth by parachute.

"What good is it?" they asked.

"Someday," the young man replied, "rockets of this type will carry men to the moon."

Thirty-nine years later the prediction came true. But the man who made it and persuaded the world, Americans in particular, that man *could* go to the moon missed seeing his prophecy come true by three and one-half weeks.

Willy Ley was born in Berlin in 1906. He wrote his first book on space travel in 1926. He helped form the German Rocket Society and in 1927 brought a young student named Wernher von Braun to a meeting of the German Society for Space Travel. He fled Hitler's Germany in 1935 and became a U. S. citizen in 1944. When he died of a heart attack on June 25 *The New York Times* called him "the chief popularizer of the age of rocketry."

It would have been less important to him, of course, but he also missed, by about three days, the chance to see the July issue of *Popular Mechanics*, in which we dug back into the prophetic articles he and Dr. von Braun and Fred L. Whipple wrote for *Collier's* 17 years ago. We think he would have enjoyed seeing once again *Collier's* fantastic paintings by Chesley Bonestell and Rolf Klep, which *Popular Mechanics* reproduced to show how accurately the three "space cadets" had foretold the future. It will be forever one of our great regrets that we didn't send Willy Ley an advance copy of the July *PM*.

Willy Ley's last article for *Popular Mechanics* was in February, 1967: *The Next Five Years in Space*. We expect to see all of the predictions he made in it come true.

Willy Ley should have been at Cape Kennedy on July 16. He should have had the thrill of watching on TV as Neil Armstrong, Buzz Aldrin and Mike Collins fulfilled the dream that he, almost alone, was dreaming 40 years ago.

He didn't get to. For Willy Ley, man's greatest triumph came a month too late.

It's not too late, however, for America to honor this kindly, self-effacing scientist who convinced us the moon was within our reach. *Popular Mechanics* thinks it would be fitting and proper to honor this great man by scattering his ashes on the moon, and we urge NASA to take them there on Apollo 12.



Editor

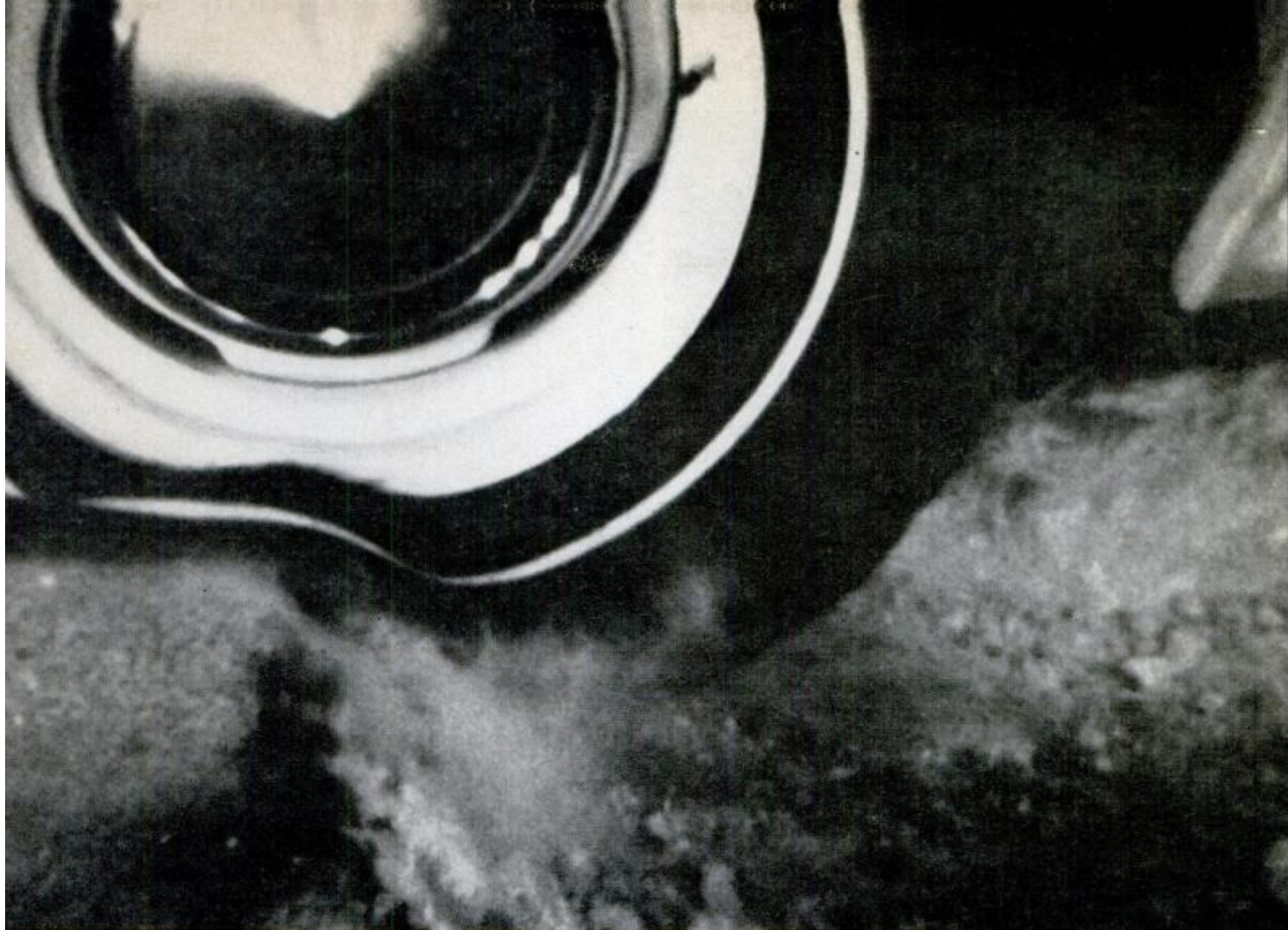

Photograph made by a special high-speed camera during a 40-mph impact demonstration.

This tire has 40,000 test miles on it.

But it can still take this kind of punishment.

The new Super Shell HP-40.

It can still take it when it's an old Super Shell HP-40.



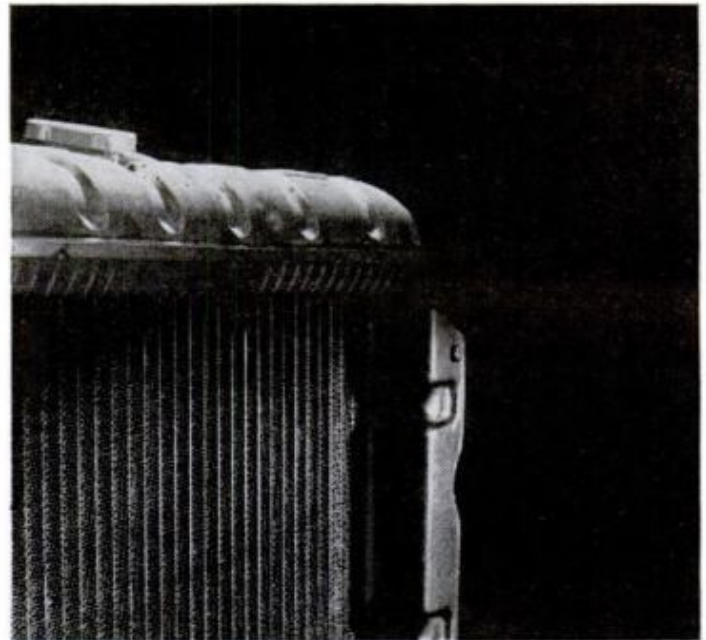

STOPS LEAKS IN SECONDS. We stabbed a hole into a radiator protected by the new Anti-leak "Zerex" Anti-freeze (left)... and in less than a minute the leak stopped (right).

Can an anti-freeze really stop leaks?

Here's why DuPont guarantees that new "Zerex" will give you radiator leak protection for a full year.

When a car radiator starts leaking, you stand to lose a lot more than your anti-freeze. You'd be surprised at how rapidly the pressure in a modern cooling system will squirt the coolant through even a pinhole leak. In a matter of minutes your engine overheats—an invitation to all kinds of trouble. And repair bills.

That's why for years many car owners have poured a sealer into their car cooling systems when they put in their anti-freeze. These sealers could do a pretty good job of stopping existing leaks. There has been just one catch: ordinary sealers quickly lose effectiveness and give little protection against future leaks.

A new kind of sealer.

The sealing ingredient usually used settles out of the cooling liquid. To achieve any sort of

preventive maintenance with these sealers would mean dosing the cooling system every month or so.

So engineers and chemists looked for a leak stopper that wouldn't separate out. It was Du Pont who found it: tiny balls of plastic polymer which "float" and circulate with the cooling liquid. When a hole or crack opens in the radiator or other parts in the cooling system, in a matter of seconds the plastic polymer balls collect, jam together and form an effective plug. And, because the plastic balls are smaller than the smallest passages in the cooling system, they can never cause clogging.

Why not add the new plastic sealer to anti-freeze so the car owner would be protected against radiator leaks without ever thinking

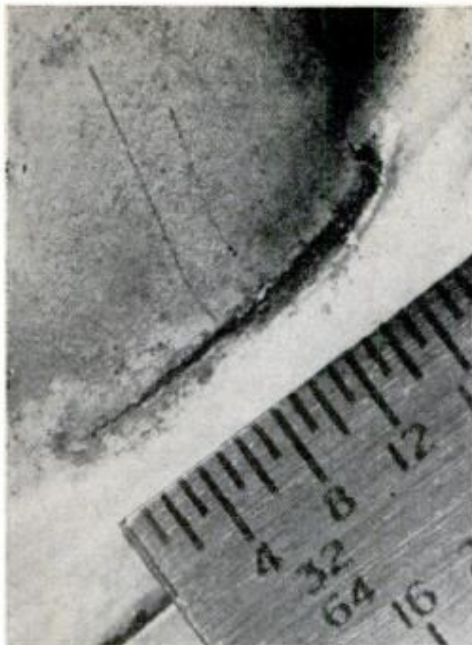

GIVES LASTING "REPAIRS". Here's a close-up of a radiator crack that was sealed by Anti-leak "Zerex" Anti-freeze. It's sealed tight after driving 7,713 miles and is still going strong.



SEALS FUTURE LEAKS WHILE YOU DRIVE. New "Zerex" keeps its leak-sealing ability month after month. In fact, it's *guaranteed* to stop any radiator leak for twelve months.

about it? That's just what Du Pont did.

The sealer was added to "Zerex" Anti-freeze, making "Zerex" the first anti-leak anti-freeze... the ideal coolant for year-round driving.

Proved in road tests.

New Anti-leak "Zerex" Anti-freeze already has a remarkable track record—in the lab and *on the road*. During its extensive road tests last winter, Anti-leak "Zerex" was bought and proved by tens of thousands of motorists—and tested by a fleet of big-city cabs. After 15,000 tough miles, the "Zerex" was drained from these cabs and installed in taxis with leaking radiators. The leaks were stopped immediately!

There may be other anti-freezes on the market this year with some kind of leak-stopping ingredient added, but the only anti-freeze that has a full year of

consumer testing behind it is Du Pont "Zerex".
Guaranteed for a year.

Du Pont obviously feels that the new Anti-leak "Zerex" Anti-freeze is a unique product and an effective one. That's why it's guaranteed to stop—and keep stopping—radiator leaks for a full year. If a "Zerex" user develops a radiator leak that "Zerex" doesn't stop, Du Pont will refund the purchase price of his anti-freeze.

Du Pont is the *only* anti-freeze manufacturer making this guarantee.

P.S. Of course, Anti-leak "Zerex" Anti-freeze is guaranteed against freeze-ups and corrosion, too. Available in cans or handy new plastic jugs.

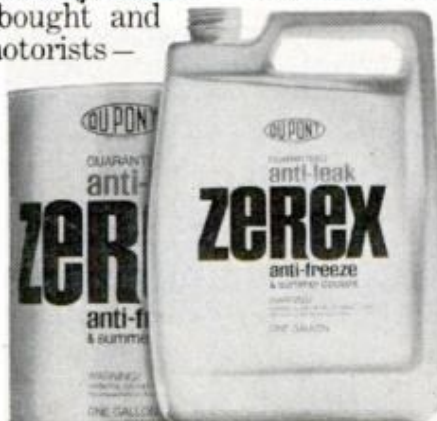

Better things for better living...through chemistry

ON-THE-GO

CAMPING

BY WADE MITCHELL

PRIVATE CAMPGROUNDS FOR EMPLOYEES are being considered by corporate giants. One plan is for winter campgrounds in Florida and Arizona, and summer camps in Minnesota, Wisconsin and Michigan. Crowding of state and national campgrounds, probably sired this imaginative approach to recreation. Private campgrounds, company-owned and operated, may be the answer.

NEW SUPERPLANT FOR ALL-RV PRODUCTION is planned by Starcraft. This well-known company has purchased a site near Banning, Calif., to build all these recreation vehicles: motor homes, pickup campers, travel trailers, tent trailers, all-terrain vehicles and mini-bikes. Undoubtedly, this is the most ambitious, all-embracing recreational manufacturing idea in years. It illustrates the strength and drive of this industry.

\$2 BILLION-A-YEAR RV SALES BY 1980 is a prediction from the Ford Motor Co. That's what Robert C. Honke expects and the Ford spokesman also predicts an increase in recreational vehicles from about 2½ million to 7½ million units by 1980. Honke points out that within 10 years, most American families will have 120 days of vacation periods a year. He says that recreational vehicles are a sort of "sociological safety valve" for a restless population. If predictions come true, we'll need millions more campsites within the next decade.

NEW MAGIC CABIN WILL HAVE COLLAPSIBLE WALLS, can be built on a rugged mobile chassis and be towed to any site. Made by Cal McClure, famed inventor of the "collapsible parallelogram" design, the new Magic Cabin will feature ideas never before exploited. Basic dimensions will be 25-foot overall length, 8-foot width for travel, and 11-foot width when opened. Inside height is 7 feet. The unit will be priced somewhere between \$6000 and \$7000, and should reach the retail market by late 1969.

DID YOU KNOW THAT . . . *nonprofit* groups can apply for large parcels of public land for *group recreation* sites? The Bureau of Land Management has not publicized this fact, but when certain qualifications are met, BLM lands may be leased, then purchased by nonprofit groups for recreational purposes. Contact your local office of BLM for details.

GIGANTIC PLANES MAY CARRY RV COACHES. Cross-country transportation charges still prohibit some companies from competing in states more than 1000 miles distant from the manufacturing plant. New jumbo jets will haul up to 55 new automobiles in one load! One could as easily carry 100 camper coaches, or 50 large travel trailers, or 25 luxury motor homes—chassis and all. Result will be better distribution of brands and overnight delivery of whole fleets of rental RVs wherever needed, thus bypassing bottlenecks that have held back segments of the industry.

FRANCHISING OF PRIVATE CAMPGROUND OPERATORS is under way by Flag Stop Camp Inns. Franchisees are given intensive training in campground management, and offered engineering-construction assistance and other professional counseling. Each Flag Stop Inn must have a minimum of 10 acres, with a master building, coin-operated laundries, restrooms, hot showers and a lounge area. Twenty-foot modules may be added as needed. Each franchised campground will have hookups for 40 to 60 units. Headquarters are in Belleville, Kans. ★★★

LEARN SURVEYING AT HOME!



YOU NEED NO TECHNICAL ABILITY... NO DRAWING SKILL!

North American's "Learn-by-Doing" home-study plan has trained thousands of men to step into good paying outdoor-technician positions in every state of the Union. Our staff of Professional Surveyors and Instructors guide you step by step... give you (without extra cost or deposit) all the surveying equipment and help you'll need to use the transit, stretch the tapes and work at practical field problems in all phases of Surveying.

This valuable equipment is yours to keep and use—not only during your training, but also throughout your Career as a Professional Surveyor. Your training is fun—exciting new lessons reveal the secrets of aerial, underground and underwater surveying and even the surveying of outer space! Your training is thorough, 100—in fact, so much so that many North American students report good earnings part time while still learning! You can too! Rush coupon for FREE "SURVEYING CAREER KIT."



Put Yourself on this HIGH PAY SURVEYING TEAM!

Prepare now at home for a rewarding Career in Surveying. Excitement! Fun! Prestige! Imagine yourself as part of a Surveying Team—in on planning of highways, bridges, dams, air-fields, subdivisions, etc. Wonderful Outdoor Career... ideal for men who like to work with their hands.

We'll Give You This Famous 2X SURVEYOR'S TRANSIT When You Train With Us For a HIGH PAY CAREER IN SURVEYING!

... lets you make Surveying measurements the way professionals do! PLUS 3 Big Surveying Kits you use during training... you keep throughout your Surveying Career..



A 3-WAY BIG PAY OPPORTUNITY FOR YOU!



1 SURVEYING
Work with a Surveying Team measuring and locating land boundaries, elevations, points, contours, etc.



2 MAP MAKING
Prepare map drawings from the information your Surveying Team has gathered in the field.



3 PHOTOGRAMMETRY
Prepare maps from Stereo 3-Dimensional photographs taken by your Aerial Surveying Team.

HOME-STUDY HAS TRAINED THOUSANDS OF SURVEYORS
America's leading national Surveying Magazine recently reported thousands of men who are Surveyors today got their initial training through home-study. And the number is growing through leaps and bounds every day. Now, thanks to North American, you can follow in the footsteps of these successful men. A few hours a week of home-study may change your whole future... may lead you to the lifetime of happiness and security... and "feeling of belonging" every ambitious man wants for himself and his family. Rush coupon today for FREE "SURVEYING CAREER KIT."

Take your pick of **4 EXCITING SURVEYING CAREER Opportunities!**

- career with **GOVERNMENT** (half of all U. S. Surveyors are employed by Government)
- career with **CONSTRUCTION CO.** (or engineering or architectural firm as member of Surveying Crew)
- career with **SURVEYING CO.** (that conducts surveys for others on fee or contract basis)
- **SURVEYING BUSINESS OF YOUR OWN** (as "free lance" Surveyor. Or, start your own Surveying Co.)

NO TECHNICAL ABILITY OR DRAWING SKILL NEEDED! We show you everything... furnish three big kits! Rush coupon for FREE "SURVEYING CAREER KIT"

RUSH COUPON TODAY! ALL 3 FREE!

- 1 20-PAGE SURVEYING CAREER FACT BOOK**—Packed with exciting information on Career Opportunities, qualifications, salaries, advancement, etc.
- 2 SELF-SCORING APTITUDE TEST**—Lets you decide for yourself in advance if you are suited for a top pay Career in Surveying.
- 3 SAMPLE LESSON**—A revealing "Sneak Preview" of things to come!

Accredited Member, National Home Study Council



SAMPLE LESSON YOUR FUTURE IN SURVEYING APTITUDE TEST

Rush Coupon for FREE "SURVEYING CAREER KIT"

... including 20-Page Book, "Your Future in Surveying, Sample Lesson and Self-Scoring Surveying Aptitude Test which will let you determine for yourself—in advance—whether you can qualify for a rewarding Career in Surveying. No cost or obligation, now or ever. No salesman will call. Rush coupon today.



North American School of Surveying, Dept. 4179
4500 Campus Drive, University Plaza, Newport, Calif. 92660
Rush "SURVEYING CAREER KIT" including Book, Sample Lesson, Aptitude Test & Surveying Instrument — ALL FREE!

NAME _____ AGE _____
ADDRESS _____
CITY _____
STATE _____ ZIP _____

A pruner
without a
Nicholson
blade



is like
a wrench
without
a jaw.



Tree pruning is free-and easy when you use any Nicholson pruning saw with Dupont Teflon-S® coating on the blade.

You nip through the greenest branches without binding. You zip through years of pruning without rust problems. Also available in bright silver-steel finish.

There's never a dull moment with

Nicholson

Nicholson File Co., Providence, R.I.



POWER-TOOL NEWS

Two Shockproof Drills

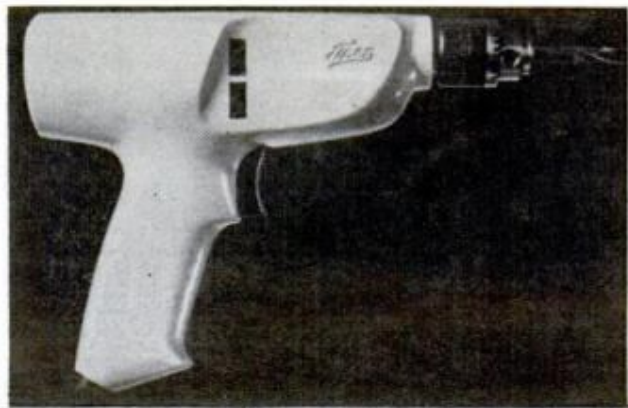

DESIGNED TO REDUCE wrist and arm fatigue, the Fast Back drill recently introduced by Thor delivers 30 percent more power, according to the maker. Lighter than similar-type drills, (the model shown weighs 1¾ lbs.), the double-insulated tool boasts a permanent-magnet motor with a solid-state field; its full-wave diode converts incoming alternating current into direct current with all the efficiencies of the latter type. The drill is manufactured in five models, ¼ and ⅜-in. capacity, with speed ranges from 0-1200 to 0-2000 rpm. The ¼-in. drill shown is \$25; a ⅜-incher with variable speed and reverse, \$43. Thor Power Tool Co., 175 N. State St., Aurora, Ill. 60507.



THE FIRST DOUBLE-INSULATED ¼-in. drill selling for less than \$10 will be unveiled by Rockwell Manufacturing Co., Rockwell Building, Pittsburgh, Pa. 15208, at the National Hardware Show late this month. Model 70 (above) features oil-impregnated bronze bearings and built-in cord and strain relief protector. As in all double-insulated tools, electric current is isolated from the user at all points and the conventional two-prong plug eliminates the need for an adapter plug. Additionally, Rockwell will lower the price on ⅜-inch drill models 73 and 74, the latter featuring variable speed. ★★★

Cast your ballot for a successful future!

266 ICS COURSES



You get the widest choice from ICS — oldest, largest home study school. Check the list. (Also available, programs tailored to your special needs.) You receive individual instruction, plus success-proved facts

and theory you can apply immediately. Mastery of subject is assured. No skimping. You earn your diploma. Why mark time when you can mark the coupon and get a fast, sure fix on your best course to success.

ACCOUNTING
Accounting (U.S.A.)
Accounting (Canadian)
Accounting for Business Programmers
Accounting for Man'g'm't Decisions
Auditing
Business Law (U.S.A.)
Canadian Business Courses
Cost Accounting
CPA Review (U.S.A.)
General Accounting
Income Tax (U.S.A.)
Industrial Accounting
Junior Accounting
Office Accounting
Practical Accounting
Public Accounting
Small Business Accounting (U.S.A.)
Starting and Managing a Small Bookkeeping Service (U.S.A.)

ARCHITECTURE AND BUILDING
Architectural Drawing and Designing
Architecture
Building Contractor
Building Estimator
Building Inspector
Building Maintenance
Carpenter-Building
Carpentry and Millwork
Fundamentals of Urban Planning
House Planning and Interior Design
Mason
Painting Contractor
Reading Arch. Blueprints
Review in Architectural Design and Practice
Review of Mechanical Systems in Buildings

ART
Amateur Artist
Commercial Art
Commercial Cartooning
Illustrating with Options: —Magazine —Advertising Layout and Illustration
Interior Decorating
Oil Painting for Pleasure
Show Card and Sign Prod.
Show Card Writing
Sign Painting & Designing
Sketching and Painting

AUTOMOTIVE
Automatic Trans. Spec.

Automobile Air Conditioning Specialist
Automobile Body Rebuilding & Refinishing
Automobile Engine Tune-Up
Automobile Mechanic
Automobile Technician
Diesel-Gas Motor Vehicle Engines

BUSINESS
Advertising
Business Administration
Business Practice (Cond.)
Canadian Business Course
Condensed Marketing
Direct Mail and Mail Order Advertising
Industrial Psychology
Inventory Control
Magazine & Newspaper Advertising
Managing a Retail Business
Managing a Small Store
Marketing Management
Marketing Research
Modern Exec. Management
Office Automation
Office Management
Production Management
Purchasing Agent
Retail & Local Advertising
Retail Bus. Management
Retail Merchandising
Retail Selling
Systems and Procedures Analysis

BUSINESS: SALES
Creative Salesmanship
Real Estate Salesmanship
Salesmanship
Sales Management

BUSINESS: SUPERVISION
Basic Supervision
Industrial Foremanship
Industrial Supervision
Management, Salesmanship and Sales
Modern Woman as a Supervisor
Personality Development
Personnel-Labor Relations (U.S.A.)
Supervision

CHEMICAL
Analytical Chemistry
Chemical Engineering
Chemical Laboratory Techn.
Chemical Process Equip. Design & Operation

Chemical Process Operator
Elements of Nuclear Energy
General Chemistry
Instrumental Laboratory Analysis

CIVIL ENGINEERING
Civil Engineering
Construction Eng'g Tech.
Highway Engineering Tech.
Principles of Surveying
Reading Highway Bl'pr'ts
Reading Structural Blueprints
Sanitary Engineering Tech.
Sewage Plant Operator
Structural Eng'g Tech.
Surveying and Mapping
Water Works Operator

COLLEGE COURSES
American History Economics
Calculus

COMPUTERS
COBOL Programming
Fortran Programming for Engineers
Programming for Digital Computers
Programming the IBM 1401 Computer
Programming the IBM System/360 Computer, Introduction

DRAFTING
Aircraft Drafting
Architectural Drafting
Design Drafting
Drafting Technology
Electrical Drafting
Electrical Eng'g Drafting
Electronic Drafting
Introductory Mech. Draft.
Mechanical Drafting
Pressure-Vessel and Tank Print Reading
Sheet Metal Layout for Air Conditioning
Structural Drafting

ELECTRICAL
Electrical Engineering —Electronics Option —Power Option
Electrical Appliance Ser. with Equipment Training
Electrical Contractor
Electrical Engineering Tech.
Electrical Home Maint.
Electrical Home Maint. with Equipment Training

APPROVED FOR VETERANS

Accredited member, National Home Study Council.
Convenient payment plan.
Special rates to members U.S. Armed Forces

Electrical Instrument Tech.
Electric Motor Repairman
Industrial Electrical Tech.
Power-Line Design and Construction
Power Plant Operator —Hydro Option —Steam Option
Practical Electrician
Practical Electrician with Equipment Training
Practical Lineman
Reading Elec. Blueprints

ENGINEERING (Refresher Courses for Graduate Engineers)
Chemical Civil Electrical
Industrial Mechanical
Sanitary Structural

ENGLISH AND WRITING
Better Business Writing
English for Spanish (U.S.A.)
Free Lance Writing for Fun and Profit
Introductory Tech. Writing
Modern Letter Writing
Practical English
Short Story Writing

HIGH SCHOOL
High School Business
High School (Canadian)
High School General
High School Mathematics
High School Secretarial
High School Vocational
High School College Preparatory—Arts
High School College Prep—Engineering and Science
Preparatory Course for High School Equivalency Test

MACHINE SHOP PRACTICE
Grinder Operator
Industrial Metallurgy
Lathe Operator

Machine Shop Inspection
Machine Shop Practice
Metallurgical Eng'g Tech.
Multicraft Maintenance Mechanic
Practical Millwrighting
Reading Shop Prints
Rigging
Tool & Die Making
Tool Engineering Tech.
Welding Engineering Tech.
Welding Process

MATHEMATICS
Advanced Mathematics
Math and Mechanics for Engineering Technicians
Math and Physics for Engineering Technicians

MECHANICAL
Mechanical Engineering
Aircraft and Power Plant Mechanic
Hydraulic and Pneumatic Power
Industrial Engineering
Industrial Eng'g Tech.
Industrial Instrumentation
Machine Design
Quality Control
Safety Engineering Tech.
Tool Design
Vibration Analysis and Control

PETROLEUM
Natural Gas Production and Transmission
Oil Well Technology
Petroleum Production
Petroleum Production Engineering Technology
Petroleum Refinery Oper.

PLASTICS
Design of Plastic Products
Plastics Technician

PLUMBING, HEATING AND AIR CONDITIONING
Air Conditioning
Air Conditioning Maint.
Domestic Heating with Gas and Oil
Heating
Heating & Air Conditioning with Drawing
Industrial Air Conditioning
Pipe Fitting Plumbing
Plumbing and Heating
Plumbing & Heating Est.
Practical Plumbing
Refrigeration and Air Conditioning Servicing

PULP AND PAPER
Paper Machine Operator
Paper Making Pulp Making
Pulp & Paper Eng'g Tech.

SECRETARIAL
Clerk-Typist Commercial Secretary, Engineering Sec'y, Legal Sec'y, Medical Secretary, Professional Shorthand Stenographic Typewriting

STEAM AND DIESEL POWER
Boiler Inspector
Industrial Building Eng'r
Power Plant Engineering
Stationary Diesel Engines
Stationary Fireman
Stationary Steam Eng'r'g

TEXTILES
Carding
Carding and Spinning
Dyeing and Finishing
Loom Fixing Spinning
Textile Mill Supervision
Textile Technology
Warping and Weaving

TRAFFIC
Motor Traffic Management
Traffic Management

TV-RADIO-ELECTRONICS
Color Television Principles and Servicing
Electronics Instrumentation and Servo Fundamentals
Electronics Technician
First Class Radio Telephone License

Fundamentals of Electronic Computers
General Electronics
General Electronics with Equipment Training
Hi-Fi Stereo and Sound System Servicing
Industrial Electronics Tech.
Numerical Control Electronics & Maint.
Practical Telephony
Principles of Semiconductor Radio & TV Servicing
Radio & TV Servicing with Equipment Training
Second Class Radio Telephone License
Sound Systems Specialist
Telephony, Electronics, and Radio Communications

ICS[®]
International
Correspondence
Schools
Division of Intext

ICS, Scranton, Pa. 18515
Canadian residents use this address for service from ICS Canadian, Ltd.
In Hawaii: P.O. Box 418, Honolulu.

TAKE YOUR FIRST STEP. . . MAIL THIS COUPON TODAY—ICS, SCRANTON, PA. 18515. R0569H

I'm interested in a program of independent study. Send me, without cost, your booklet on the principles of success, sample text demonstrating famous ICS method, and your catalog for _____ (Print name of course. See list.)

Miss _____ Age _____
Mrs. _____
Mr. _____
Address _____
City _____ State _____ Zip Code _____
Occupation _____ Employed by _____ Working Hours _____ A.M. to _____ P.M.

Science Worldwide BY JOHN F. PEARSON

The moon could become a source of power if huge arrays of solar cells were placed on it, according to a scientist at England's Manchester University. The electrical energy produced could be sent to Earth by laser beam. The scientist estimates that sunlight falling on a crater the size of Tycho—54 miles across—could produce from 10,000 to 100,000 megawatts of power. By comparison, a large dam on Earth produces about 100 megawatts. Solar cells would be more efficient on the moon than on Earth because of the absence of dimming clouds.

Stale bread may become a thing of the past if research at Cornell University pans out. Prof. Thomas J. Schoch hopes to make a longer-lasting loaf using a synthetic flour containing starch that is chemically modified to resist staling. Staleness, according to Prof. Schoch, is caused by the "interlocking" of starch molecules, resulting in hardness, dryness and loss of flavor. The researcher's immediate objective is to develop a bread that will remain fresh for a week or longer. "But with the right combination of ingredients," he says, "it's possible that we can produce bread that will stay fresh indefinitely."

"Old-fashioned" optical telescopes have not been pushed to the sidelines by their radio cousins and other space-age hardware. That's why a clutch of distinguished astronomers were on hand recently when a 25-ton chunk of glass was cast at a Toledo, Ohio, facility of Owens-Illinois, Inc. After it's ground and polished, the 158-inch disc will be installed as the mirror of a telescope now being assembled in the Andes Mountains of Chile. The scope will permit astronomers to explore the Southern Hemisphere sky, which has been neglected to some extent. The center of our galaxy can be seen only from sites below the equator.

New method to study the thyroid gland has been developed by the Atomic Energy Commission's Cancer Research Hospital at Argonne, Ill. The technique employs an external radiation source—americium-241—to excite iodine naturally present in the gland. The excited iodine gives off its own radiation, which can be detected. In the most common method currently in use, the patient swallows an "atomic cocktail" of diluted radioactive iodine-131, which winds up in the thyroid, where it can be scanned. Scientists say the new technique provides extremely accurate readings, yet exposes the gland to less radiation than is dealt out by iodine-131.

In a new type of hospital bed the patient "floats" in a fiberglass tub containing billions of tiny ceramic beads. An upward flow of forced air causes the mass of beads to assume the properties of a liquid. In tests at the Medical College of South Carolina, the bed was said to be especially beneficial for patients suffering from burns and those with insomnia. Patients who might have needed a drug in order to sleep snoozed for as long as 20 hours on the bed. The beads are contained by a polyester fabric to prevent a patient's breathing them in.

The design of future ice-breaking ships may be changed as a result of a recent investigation of sea-ice pressure ridging (ice mountains) conducted in the ice pack off Point Barrow, Alaska. That report comes from the Coast Guard, which is cooperating with private industry in probing the possibility of year-round shipping operations through this continent's Northwest Passage (*Beefed-Up Tanker For Alaskan Oil*, page 30, Aug. PM). Objectives of the study were to make detailed measurements of surface and subsurface structure and to determine mechanical strengths of individual ice ridges. Underwater photography and sonar techniques were used in addition to measurements obtained optically. Ice experts are now studying the data. ★★★



WILL YOUR CHILD MAKE IT BY 4?

"How to Raise a Brighter Child" by Joan Beck adds much to the latest theory that 80% of a child's intelligence is determined by 4 years of age. This must book for every parent outlines theories, facts, verifying case histories. Gives guidelines for stimulating intellectual growth, perception, language, reading and creativity, all predicated upon a child's insatiable drive to learn. Includes health tips, home atmosphere hints, and Montessori ideas. Covers learning in 3 age groups: 0-1 1/2 yrs; 1 1/2 to 3; 3 to 6.

Stock No. 9395H.. Hardbound.. \$5.95 Ppd.



'BRIGHT IDEAS' in UNIQUE LIGHTING

Big, new 100-page handbook packed with facts, loaded with illustrations. All latest developments, applications, equipment. Covers strobos, sources, back light, projectors, crystal and organic slides, color organs, mirrors, polarized color, screens, light boxes, MusicVision, etc. Rare find for business, home, hobby. Ideal for display houses, combos, experimenters, hobbyists. 8 1/2" x 11" looseleaf paper punched to fit 3 ring binder... add new devel.

Stock No. 9100H \$3.00 Ppd.

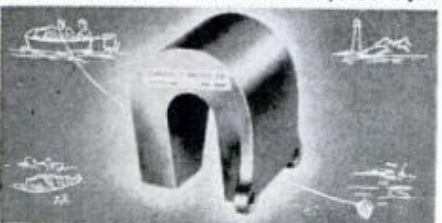

"FISH" WITH A MAGNET

Now go treasure hunting on the bottom! Great idea! Fascinating fun and sometimes tremendously profitable! Tie a line to our 5-lb. Magnet—drop it overboard in bay, river, lake or ocean. Troll it along the bottom—your "treasure" haul can be out-board motors, anchors, fishing tackle, all kinds of metal valuables. 5-lb. Magnet is war surplus—Alnico V Type—Gov't cost \$50. Lifts over 150 lbs. on land—much greater weights under water.

Stock No. 70,571H... 5 lb... \$12.50 Ppd.

Stock No. 70,570H... 3 1/2 lb... \$8.75 Ppd.

Stock No. 60,572H... 7 1/2 lb... \$18.75 Ppd.

Stock No. 85,152H... 15 3/4 lb... \$33.50 FOB



AMER. MADE OPAQUE PROJECTOR

Projects illustrations up to 3" x 3 1/2"—enlarges them to 35" x 30" if screen is 6 1/2 ft. from projector, larger if screen farther away. No film or negatives needed. Projects charts, diagrams, color, black-and-white. 115 V A.C. Operates on 60 W bulb, not incl. 12" x 8" x 4 1/2". 1 lb. 2 ozs.

Stock No. 70,199H \$7.95 Ppd.



SUPER 6" SPACE CONQUEROR

Share the wonders of space exploration. Features aluminized & overcoated 6" f/8 ground and polished pyrex parabolic mirror accurate to 1/4 wave. 48 F.L. 6X achromatic finder scope. 4 eyepieces—48X Kellner, 1/2" 96X & 1/4" 192X Ramsdens, Barlow to double or triple power—rack & pinion focusing mount. 47 3/4" aluminum tube. Electric clock drive w/manual slow-motion control. Setting circles. Heavy-duty equatorial mount. Pedestal base. Compares to \$295—\$350 models.

Stock No. 85,086H \$199.50 FOB

4 1/4" REFLECTOR TELESCOPE

Stock No. 85,105H \$84.50 FOB

Stock No. 85,050H ... 3" \$29.95 Ppd.

KEEP PACE WITH THE SPACE AGE!

AMAZING BARGAINS

for Fun • Study • Profit

from

EDMUND SCIENTIFIC CO.

300 Edscorp Building
Barrington, N. J. 08007

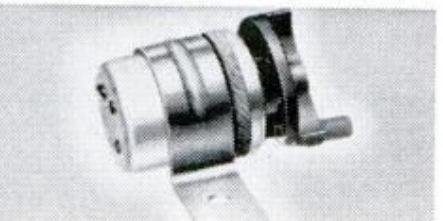

WAR SURPLUS ELECTRIC GENERATOR

Brand new Signal Corps Electric Generator. Generates up to 90 volts by turning crank. Use in high impedance relays. Charge ground and bring up night crawlers for bait or study. 2 Alnico Magnets alone worth more than original gov't cost of \$15. Wt. 2 lbs.

Stock No. 50,225H \$6.95 Ppd.

MOUNTED WITH LIGHT

TO DEMONSTRATE ELECTRICITY

Stock No. 50,365H \$11.95 Ppd.



PLASTIC MODEL V-8 ENGINE

Hours of fun! Get thrill of building your own easily assembled engine from over 350 parts. Then push starter and watch it run. Crankshaft revolves, pistons move, valves open and close in sequence with spark plugs. Does everything but burn oil. 1/4 scale molded in 4 colors. Same motor used in many auto-mechanic courses. Excellent, easy-to-understand "tech manual".

Stock No. 70,448H \$12.95 Ppd.



INSTANT ELECTRONIC PROJECTS!

Build 56 electronic marvels in minutes—that actually work! Simply match symbols of amazing new solid state building blocks with those in easy-to-follow diagrams. Presto—instant radios, organs, alarms, etc. No soldering, wiring, tools. Magnetic connectors hold see-thru blocks containing proper components in place. Safe. Easy. New fun-way to learn electronics. Requires 9V transistor battery (not included).

No. 71,178H \$33.50 Ppd.

No. 71,177H ... 20 PROJECT... \$12.00 Ppd.



GIANT WEATHER BALLOONS

"Balls of fun" for kids, traffic stoppers for stores, terrific for amateur meteorologists. Create a neighborhood sensation. Great backyard fun. Exciting beach attraction. Amateur meteorologists use to measure cloud heights, wind speed and temp. Heavy duty neoprene. Inflate with vacuum cleaner or auto air hose; or locally available helium for high rise.

Stock No. 60,568H... 8' \$2.00 Ppd.

Stock No. 60,632H... 16' \$7.00 Ppd.

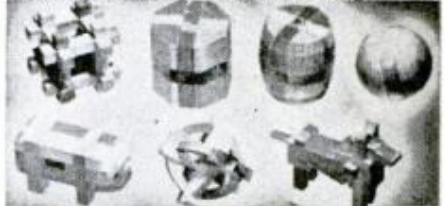

WOODEN SOLID PUZZLES

Here's a fascinating assortment of 12 different puzzles to provide hours of pleasure and stimulate ability to think and reason. Animals and geometric forms. Take them apart and reassemble them. Lots of fun for the whole family—young and old. Will test skill, patience and ability to solve problems. Order yours now.

Stock No. 70,205H \$4.00 Ppd.

MONEY-BACK GUARANTEE

Order by Stock No.—Send Check or M.O.

GIANT FREE CATALOG

148 Pages! More than 4,000

UNUSUAL BARGAINS

Completely new Catalog. Packed with huge selection of telescopes, microscopes, binoculars, magnets, magnifiers, prisms, photo components, parts, kits, accessories—many hard-to-get surplus bargains. 100's of charts, illustrations. For hobbyists, experimenters, schools, industry. Mail coupon for FREE Catalog "H".

EDMUND SCIENTIFIC CO., 300 Edscorp Building, Barrington, N. J. 08007.

NAME _____
 ADDRESS _____
 CITY _____
 STATE _____ ZIP _____

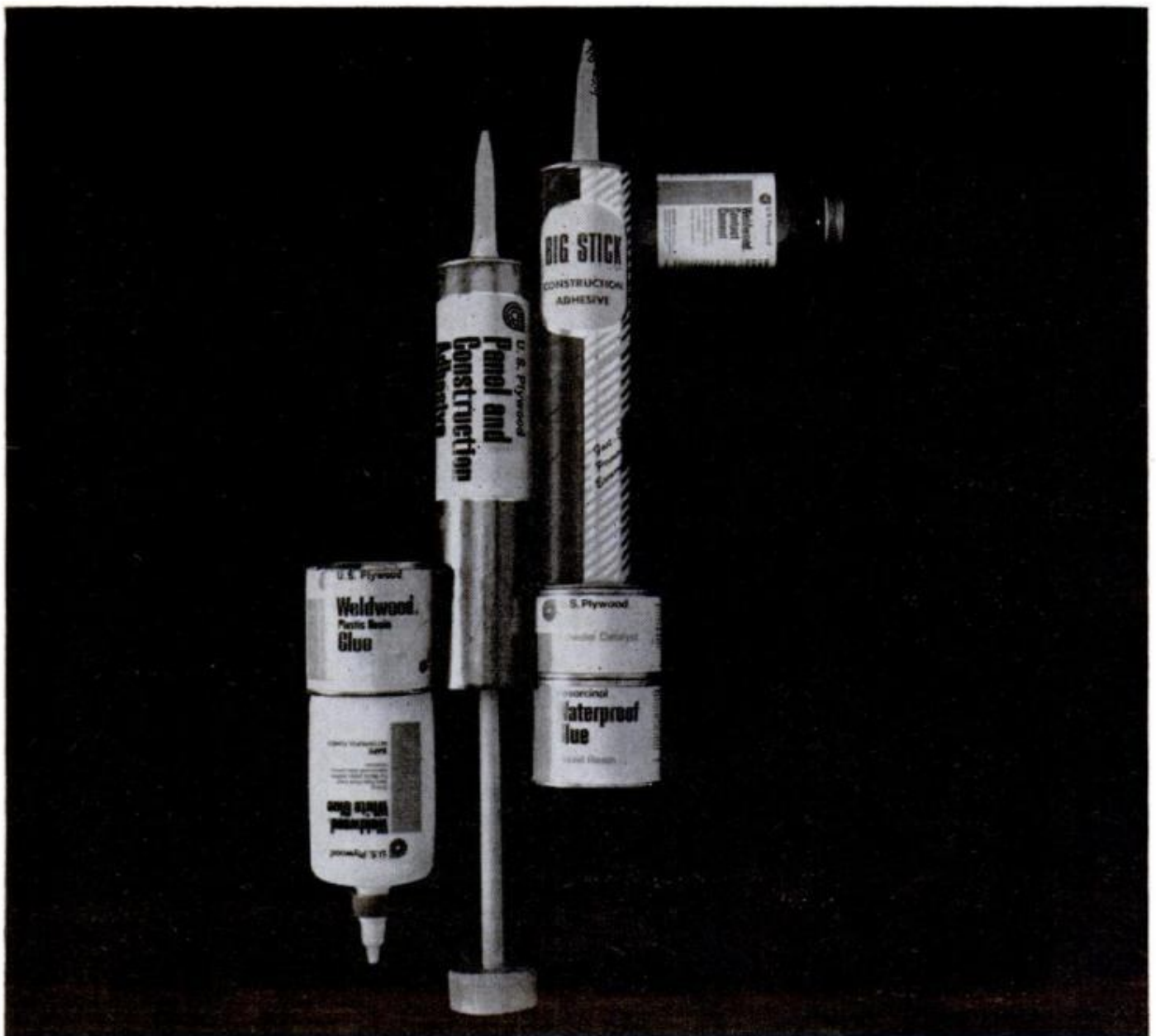

What Weldwood[®] hath joined together, let no man put asunder.

When you glue something to something else with a Weldwood glue, you can be sure it'll stay stuck.

For example, Weldwood White Glue keeps things around the house and shop glued together. Weldwood Contact Cement is for mending belts and luggage. If you're building cabinets, our Plastic-Resin Glue will make wood joints stronger than the wood itself.

Then there's Weldwood Water-resistant Exterior Resorcinol Glue. It's so strong it holds boats together. Heavy-duty glue?

Sure. Weldwood Panel and Construction Adhesive for bonding panels. Or our Big Stick Construction Adhesive that sticks big jobs together like dry walls and styrofoam.

So whatever kind of job you've got to do, stick with Weldwood Adhesives. You'll never get stuck. (If you'll pardon the pun.)



U.S. Plywood

A Division of U.S. Plywood-Champion Papers Inc.
777 Third Avenue, New York, N.Y. 10017



Weather...

or not.

'Jeep'
4-wheel drive
**The 2-Car
Cars.**

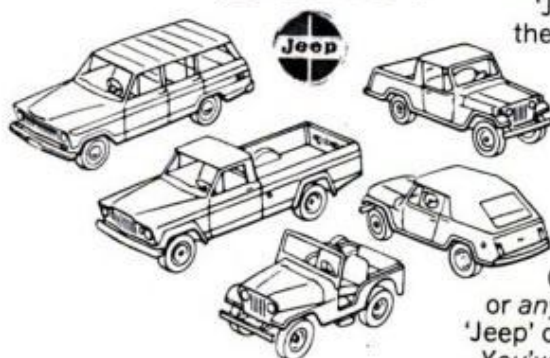

This 'Jeepster Commando' Station Wagon is more than a fair weather friend. When the other guy's weathered-in, you're not. Snow? Plow through snow to the hubcaps. Wet roads? You've got the safety and extra traction of 'Jeep' 4-wheel drive as standard equipment! Out in the boonies, it's a wildcat. Who needs roads? 'Jeep' 4-wheel drive eats up the rough country. But you're sure not roughing it with padded bucket seats. And options like V-6, console, air conditioning. Resale value? Terrific. 'Jeep' ruggedness is a lasting investment. Test drive the 'Jeepster Commando' Station Wagon, or any of the 2-Car Cars, at your 'Jeep' dealer. 'Jeep' 4-wheel drive. You've got to drive it to believe it.

KAISER Jeep CORPORATION TOLEDO OHIO 43601

See your 'Jeep' dealer for authorized 'Jeep' parts, equipment and service.

Drivin' with Dan

How much does it cost to build an average NASCAR stocker? Do any of the 'Big Three' make an overdrive? What is top rpm of 429 Fords at major tracks? Dan Gurney answers these and other automotive questions



A DETERMINED DAN GURNEY takes a hard look at the competition along pit row prior to the start of this year's Indy 500. Like last year, he finished second

Q. What is the difference between a turbine engine and a turbocharged engine?—Mike Maravich, Crete, Ill.

A. A turbocharged engine is a normal piston engine plus an exhaust-driven turbosupercharger. A turbocharger consists of a small exhaust-driven fan, much the same as an old-fashioned waterwheel, but instead of being driven by water it is driven at much higher rpm by the exhaust gases of the normal piston engine. This fan, or impeller, in turn drives a centrifugal impeller that compresses the air into the inlet ports of the engine. It's just another form of supercharging. A turbine engine has no pistons, valves or reciprocating parts, just fans or turbine wheels with blades on them to compress air into a combustion chamber.

Q. I have my heart set on a '69 Jaguar coupe

but the driver room would better fit a monkey. How can I best increase the legroom (seat to pedals is the problem). I'm only 6-1. Do the European manufacturers need educating on this subject?—James J. Graham, Norristown, Pa.

A. I don't know what they have in mind over there, but it's a very pretty car, anyway. Seriously, first I would try to adjust the seat rails so the seat can slide back farther. Then I would try to tilt the seatback itself back at more of an angle. Then I would attempt to lower the whole setup. If that doesn't work, take the seat out completely to see just how much room you have. Then you can start building a custom-made seat. I'm certain there's enough room in there for a big gorilla if you try hard enough.

Q. Approximately how much does it cost to build the average NASCAR stocker, and what is the final drive ratio in most cars of its type?—Kevin Hoepfner, Dunmore, Pa.

A. My guess is about \$30,000 without spares. Final drive at Daytona must be around 3-to-1. Even though such cars are essentially stock (at least in parts and general configuration), a lot of extra man-hours are spent in preparing them before they are ready to race.

Q. I've been looking all over New York for a new American-made car with overdrive. Only American Motors seems to have it, if I can believe the Ford, Chevy and Plymouth salesmen, all of whom tried to sell me an automatic transmission. Can you tell me whether any of the "Big Three" still make an overdrive, and what rear end is best for it?—M. Manfredi, Brooklyn.

A. To the best of my knowledge, the "Big Three" no longer make overdrive. About 4-to-1 is a good ratio for a rear end with

(Please turn to page 26)

100%

more mileage on this new Atlas tire.

**Proven against complete sets
of two-ply tires that came on most '69 cars**

Results of these tests against two-ply original equipment tires for most 1969 cars showed that you'll get twice the mileage with the new Atlas Plycron 2 plus 2*

Polyester/Fiberglass construction

We put fiberglass belts on a rugged Vicron polyester cord body. This tough "tread-saver" construction helps reduce tire scuff and squirm. So the tread lasts twice as long—for 100% more mileage.

Our safety pluses!

Our combination of fiberglass belts and blended chlorobutyl liner gives you extra resistance to cuts and punctures. Roll into your Atlas dealer. And roll out equipped for 100% more mileage.

ATLAS PLYCRON 2 plus 2

Atlas Tires • Batteries • Accessories
Sold at over 50,000 leading service stations.



Trademarks "Atlas," "Plycron,"
"Vicron" Reg. U.S. Pat. Off.
*Trademark
© 1969 Atlas Supply Company

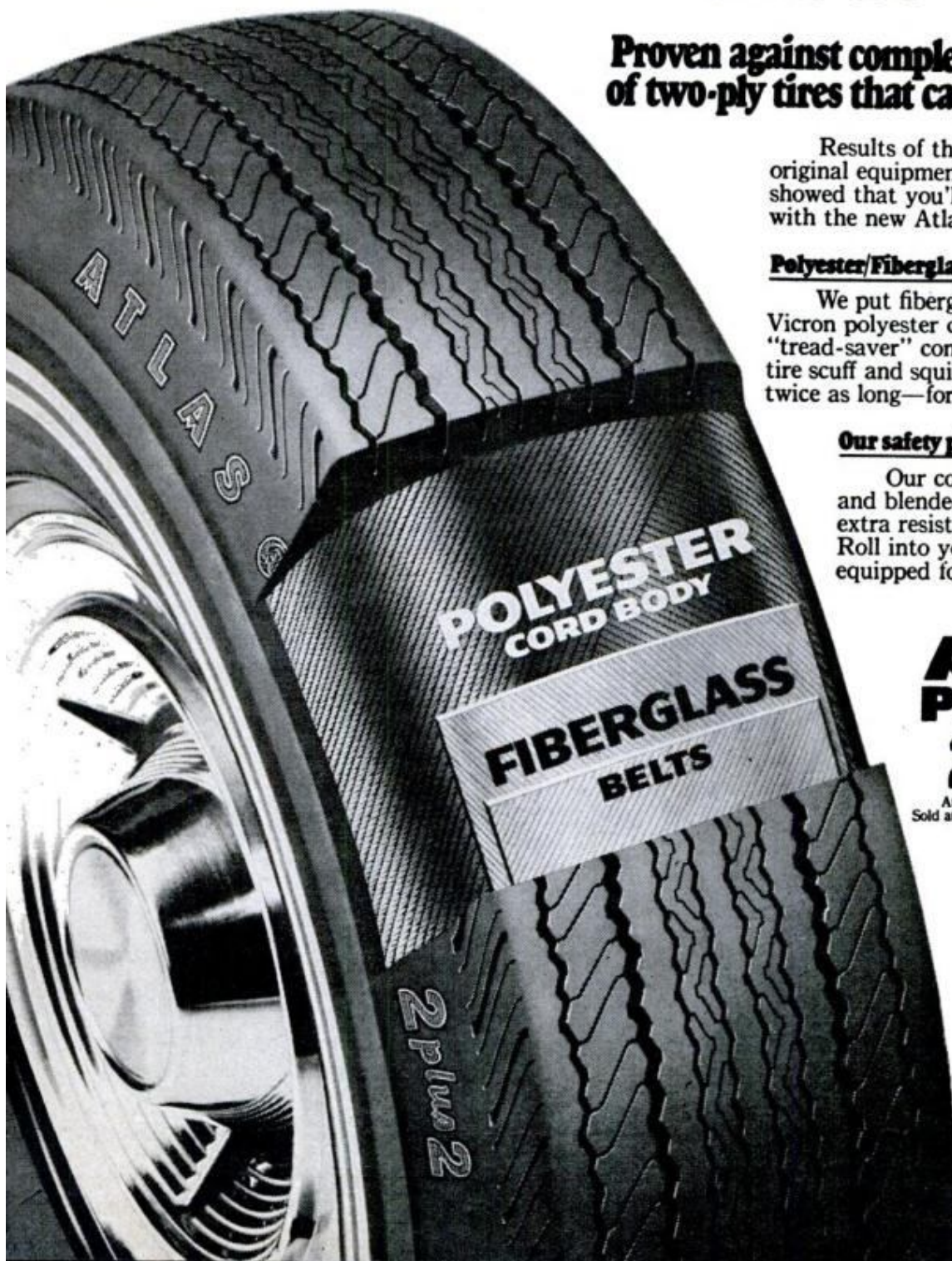

Toughest oil in the block

Any engine worth its power is tough on oil. Change to the 100% Pure Pennsylvania that's extra-refined to take the rough stuff.

Buy your oil the way you bought your car. Carefully. Wolf's Head Oil Refining Co., Oil City, Pa. 16301

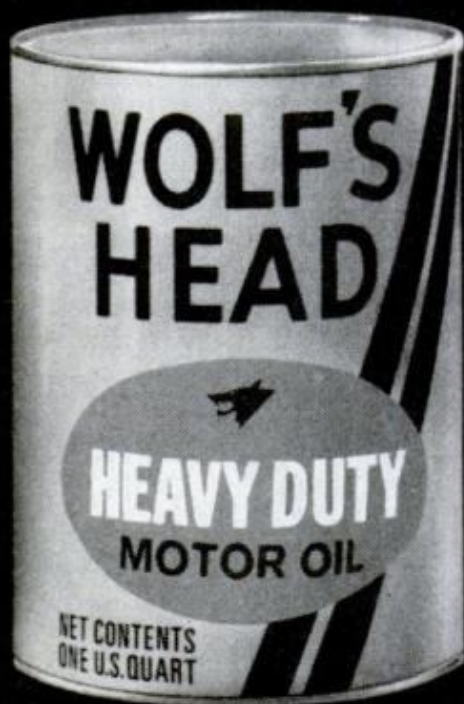

the uncommon motor oil
Exceeds car makers'
warranty requirements.

DRIVIN' WITH DAN

(Continued from page 24)

overdrive. Ford was the last to offer such a setup, as I remember. I had a Ford Six pickup with OD in 1955 and I loved it.

Q. How are classes determined in drag racing?—Neil Gerdes, Park Ridge, N.J.

A. Ask the National Hot Rod Assn. There are many classes, and I can't begin to list them myself. Most have to do with engine displacement, car weight and fuel. There are stock classes of various bodies. Then there is supercharging, and on and on. Even the rule book takes a lot of study before it begins to become clear. But I think it's great racing.

Q. What is the maximum rpm turned in the 429 Fords at major circuits like Riverside or Daytona? And are all the parts made by Ford? If so, are they "stock" (like the cam being the same in a 429 street version)? This will help me settle a shipboard argument.—Thomas P. Howard, USS Bennington, FPO San Francisco.

A. Approximately 7600 rpm, plus or minus about 200. All the parts are made by Ford. No, the cam isn't the same as in the street version. They don't idle nearly as nicely, being designed to do a different job.

Q. Could you explain what "elapsed time" means in drag racing? And why are slicks instead of regular tires used on the rear wheels?—Gerald Owens, China, Tex.

A. "Elapsed time" is the time spent in getting from the start of the quarter-mile to the end of the run; that is, how much time elapses from the moment the car moves enough to trip the electric eye at the start until it breaks the electric-eye light beam at the finish. Slicks get the best bite—or the most forward traction—on a dry surface, assuming they have a suitable rubber compound. They are very bad news in the rain, however.

Q. How can I get racing decals for my sports car like the ones you pros use on your cars?—William Jirik, Country Club Hills, Ill.

A. Write the racing department of each outfit and request free ones, or prices thereof.

Q. Can you tell if a driver has racing ability
(Please turn to page 32)

How to get rich

How can you get rich some day? Make a hit record . . . a killing on the stock market . . . or invent a gadget like the hula hoop?

For most of us, these are just dreams. But have you ever stopped to think that there is a way to get rich—possibly only one sure way? Most fortunes, as you know, are made by people who own their own business.

Perhaps you've thought of starting a small business of your own . . . a franchised drive-in, or maybe a service business. Trouble is, you need \$10,000 to \$15,000 to get started and even then it's a gamble—with slim chances of ever making really big money.

But there is *one* business which could make you rich—almost overnight! And the beauty of it is, you can start on a shoestring during your spare time, even while holding your regular job.

Cash by Mail

The business is Mail Order—and it's fabulous! Come up with a 'hot' new item . . . and WHAM!

It strikes like a bolt of lightning! Suddenly, you are deluged with cash orders from all over the country . . . MORE MONEY than you could ever make in a lifetime!

Like the Vermont dealer who ran one ad in Sports Afield Magazine. His ad pulled 22,000 orders—over A HALF MILLION DOLLARS IN CASH!

There is no other business where you can make a fortune so quickly!

● A beginner from Newark, N.J., ran his first small ad in House Beautiful—offering an auto clothes rack. Business Week reported that his ad brought in \$5,000 in orders. By the end of his first year in Mail Order, he had grossed over \$100,000!

● Another beginner—a lawyer from the midwest, sold an idea by mail to fishermen. Specialty Salesman Magazine reveals, he made \$70,000 the first three months!

Proof

It's a fascinating business! Running ads in newspapers and magazines . . . mailing gift catalogs . . . getting cash orders in your daily mail—steady as clockwork.

There is no other business where you can start on a shoestring and pyramid your profits—without investing in merchandise! One husband and wife mail order team took in \$40,000 selling one item. They obtained FREE ads in national magazines . . . didn't invest a cent in merchandise, and even got the supplier to ship all orders for them!

These exceptional cases are absolute proof that you can get rich in your own Mail Order business. Very rich. Even a U.S. Gov. Report stated: "A number of

one-man Mail Order enterprises make up to \$50,000!"

Pick up any magazine. Notice how the same mail order ads are repeated . . . month after month? That's concrete proof! You know those ads wouldn't be repeated over and over again—unless they were bringing in big cash profits to their owners.

The Secret

The secret of getting rich in Mail Order lies in *financial leverage*. It's a little-known, almost secret method—using other people's capital to make money for you!

You can get thousands of dollars worth of advertising in big national magazines—without investing your own money! And you don't have to write a single ad. Tested and proven ads are prepared for you by experts. Reinvest the profits from your first successful ad—to get more, larger ads, and the profits begin to snowball! It's like building a chain of stores . . . each new store puts more money in your pocket.

You mail out beautiful catalogs which offer hundreds of dollars worth of fine, quality gifts—yet you don't invest one



The thrill of receiving money in your mail is one you'll never tire of!

cent of *your* own money in merchandise! Your catalogs are printed with your name and address, so all orders come to you. Everything is "drop-shipped" for you, and there's up to 100% mark-up! You pocket the cash profits immediately—even before the orders are shipped to your customers!

Repeat orders alone, just from mailing catalogs, could bring you a steady income for the rest of your life!

Yes, Mail Order is the fastest-growing, most profitable business in America! And now, with more people moving to the suburbs . . . the population explosion . . . and the expanding teenage market . . . we are on the verge of the BIGGEST BOOM in Mail Order history!

Now, with the help and backing of Mail Order Associates, Inc., of Montvale, N.J., you can follow the same proven steps to Mail Order success—using the 'secret' of financial leverage!

Start Now

We supply you with beautiful gift catalogs throughout the year. All products are dropshipped for you, with up to 100% mark-up! You get free samples of top-selling mail order items, plus monthly trade reports on 'hot' new products . . . tested, successful ads are sent to you monthly. You get advertising directories, postal laws, complete courses, expert guidance—EVERYTHING you need to practically guarantee YOUR SUCCESS. Why? Because *our* business depends upon your success. It's mutually profitable!

A recent feature article in Income Opportunities Magazine stated, "Mail Order Associates Inc., offers the most comprehensive Mail Order program ever offered to beginners." They go on to say, "This could be the opportunity you've been looking for. A chance to get in on the ground floor in a little-known business which we believe is on the verge of a new boom."

Free

We are now accepting a limited number of charter members in our new Mail Order Program. No previous experience is required but you must be over 21.

If you are sincerely interested in starting a profitable business of your own . . . if you can see the tremendous advantages which Mail Order offers . . . then ACT NOW!

Mail the coupon today, or simply send your name and address on a postcard. No salesman will call. We will send you a free book—gift catalog, reprints of feature articles, plus complete facts about our program. Write to:

Mail Order Associates, Inc., Dept. 195
Montvale, New Jersey 07645

Rush Coupon for
FREE BOOK!

plus reprints of
Mail Order
articles

Mail Order Associates, Inc., Dept. 195
Montvale, New Jersey 07645

Please rush complete details on your Mail Order Program. I understand everything is free and there is absolutely no obligation. I am over 21.

Name

Address

City State Zip

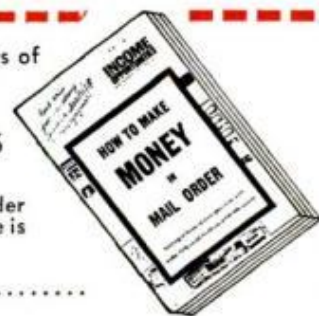

START A MONEY-MAKING BUSINESS FOR LESS THAN \$50!



You can have your own lifetime business right at home . . . work in spare time . . . and make up to \$200 a month CASH! My FREE PLAN gives you all the facts: How to start, how to grow. You don't need previous experience. You don't have to sell. I'll even finance you. People bring you the work and pay cash. Over 90¢ of every dollar you collect is clear cash profit. And you work when you want to. Let me prove you can't find a more certain, lower cost, higher paying business of your own.

Just Mail Coupon—No Salesman Will Call
BELSAW SHARP-ALL CO., Stan Field, Pres.
710S Field Bldg., Kansas City, Mo. 64111

FREE BOOK

Name _____
Address _____
City _____ State _____ Zip _____

enjoy a real wood-burning fireplace without expensive masonry



So Easy To Install You Can Do It Yourself



Save time, labor and money. No masonry or footings needed. Use ordinary tools. Complete Package, base to chimney top. Choice of contemporary or simulated brick chimney top — single or double.

Any room location. It's as easy to locate in an old or new house as a sofa. Finished with any mantel materials or trims. Corner or front styles. Choice of size. Listed by U/L. Built-in clearances permit butting against wood studs, floors, or walls. Thousands in use — nationwide.

For 1, 2, or 3 STORY HOUSES

Majestic® thulman®
FACTORY-BUILT WOOD-BURNING FIREPLACES

Write Today for Details — also other Majestic Fireplaces

The Majestic Co., Inc., 724 Erie St., Huntington, Ind. 46750

RADIAL ARM SAW KIT... for under \$100



Buy direct from factory, assemble yourself. Incl. 1/2 h.p. G.E. motor, easy to follow instructions, all parts, nuts and bolts. Guar. for life pat. pend. radial arm track; twice the usual bearings for extra rigidity, greater precision. Rips 24", crosscuts 12"; belt brake. \$99. complete, freight col. Kit less motor (any stand. 1/2 h.p. or larger will do) \$84.85. With optional G.E. motor developing 1 h.p. \$108.65. Money back guaranteed by one of world's largest manufacturers of bench power tools. Write for brochure. Terms if desired or check or M.O. to American Machine & Tool Co., Dept. PM9R, Royersford, Pa. 19468

BE YOUR OWN BOSS!

A SPACE AS SMALL AS 10" X 13" CAN MAKE YOU INDEPENDENT in the high profit (low investment) rubber stamp field. Increase your income; full or part time basis. Deal direct with manufacturer offering lowest prices on professional SIMPLE-X presses & supplies, plus valuable aid. For FREE full facts write



CUSTOM MFRS.

406PM E. Elm, Springfield, Mo. 65801

locksmithing and key making

PRACTICAL UP-TO-DATE COURSE — ONLY \$6.95

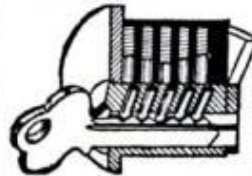

Teaches you how to pick locks, de-code, make master keys, repair, install, service, etc. New self-instruction lessons for every handyman, homeowner, carpenter, mechanic, service station operator, fix-it shop, hardware dealer, gunsmith. 53 easy illustrated lessons. Full price only \$6.95, postpaid. Satisfaction or refund guaranteed. Mail order today!

NELSON-HALL CO., Dept. JR-2
325 W. Jackson Blvd., Chicago 60606

Be a RECREATION DIRECTOR



SPORTS • CRAFTS • CAMP • NATURE LEADER
1000's positions open now for qualified men, women in Recreation. Supervise indoor-outdoor leisure activities for playgrounds, hospitals, camps, senior citizen centers, etc. Big demand! U.S. Labor Department predicts "750,000 new jobs by 1980!" Easy home-study plan. Send for FREE "RECREATION CAREER KIT." State your age.

Tom Harmon, NORTH AMERICAN SCHOOL OF RECREATION
4500 Campus Dr., Dept. 4179, Newport, Calif. 92660



BLAST CARBON
from every engine with
Fuel Mix Tune-Up Concentrate
New! from **GUMOUT**

REAL ESTATE BE A BROKER

PAYS BIG! SEND FOR BIG FREE CATALOG NOW! Graduates report making substantial incomes. Operate your own business quickly. Men, Women, all ages, learn easily. Course covers Sales, Appraising, Loans, Mortgages, & related subjects. **STUDY AT HOME** or in classrooms in leading cities. **Diploma Awarded. Write Today for FREE Book!** Accredited Member National Home Study Council. (Est. 1936) G. I. Approved.

FREE BOOK TELLS HOW

WEAVER SCHOOL OF REAL ESTATE
3521-P Broadway Kansas City, Mo. 64111



It's no picnic. Never has been.

**Valley Forge, Meuse-Argonne, Monte Cassino,
Pork Chop Hill—they were dirty jobs.
And not without sacrifice. But freedom lived.**

**American soldiers have never ducked
the dirty job. And free men everywhere are
grateful. But it's never been done for thanks.
Or gain. Or even glory.**

**When freedom cries help, men who have
known freedom hear the call. And they go.
It's no fun. But they go. Every time.**

Your future, your decision...choose ARMY.

Army Opportunities
Department 200
Hampton, Va. 23369

2PM9-69

Tell me about soldiering and service
to my Country.

Name _____ Age _____

Address _____

City _____ County _____

State _____ Zip _____

Материал, защищенный авторским правом

DISSTON

Ask your dad about Disston handsaws. Better yet, ask your granddad!

We're selling the fifth generation of American homeowners—and homebuilders. Since 1840, the Disston name has meant unexcelled craftsmanship, unmatched performance. Ask your granddad. Ask carpenters. Ask for the best—Disston—at your hardware store. Disston. H. K. Porter Company, Inc.

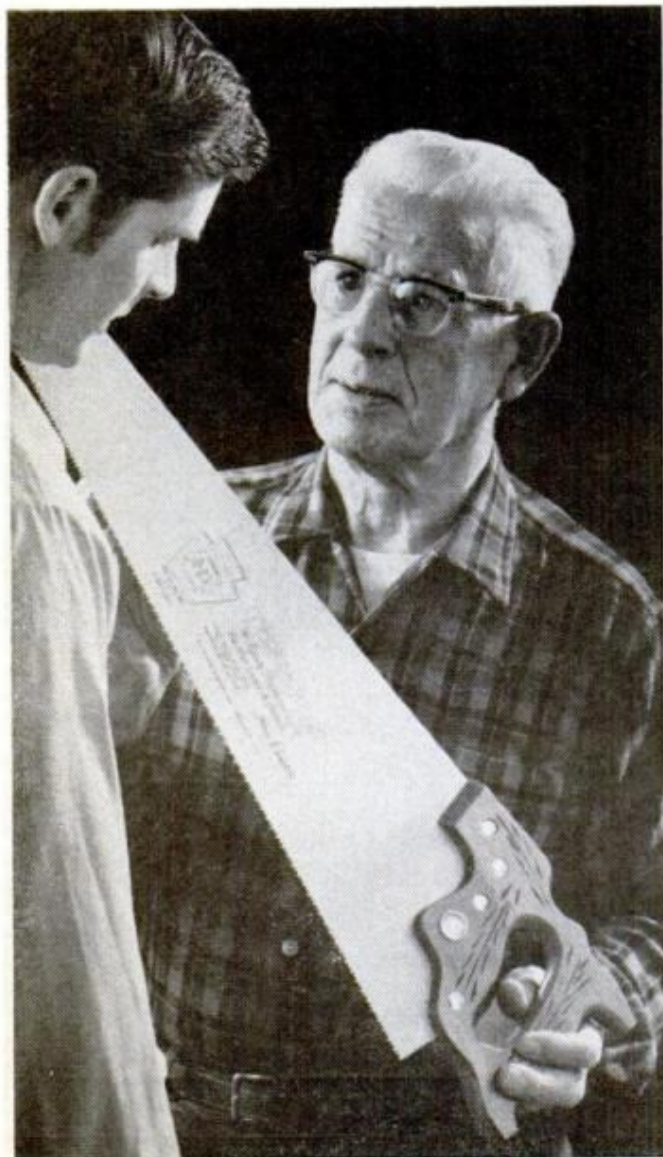

DRIVIN' WITH DAN

(Continued from page 26)

by watching him drive on the street, not breaking any laws? What would you look for in an outstanding "street driver?"—Ray Barnes, Atlanta.

A. I doubt if you could tell about his racing ability altogether, but you could learn a lot. An outstanding street driver is probably just as rare as an outstanding racing driver. It's difficult to be either; many of the same attributes are needed. Basically, I feel that judgment, anticipation, concentration, plus a seat-of-the-pants feel are the four most important things for any driving. A good street driver should be driving—or thinking—far enough ahead—so that another car can do something wrong and the good driver will still be able to avoid getting involved. Panic stops or abrupt lane changes, and so on, indicate that a driver is not thinking ahead far enough. Anticipation and good judgment will beat quick reactions any time. The latter are good when it's necessary to save a situation that's due to poor judgment.

Q. Are Trans-Am cars built like stock cars? Where do they race?—Frank Colvin, Castle Hayne, N.C.

A. Yes. They race strictly on road circuits as opposed to ovals. (NASCAR races similar cars on ovals in the South.) Trans-Am races are sanctioned by the Sports Car Club of America (SCCA). It's great racing with plenty of "hell-for-leather" driving. The Detroit manufacturers are very interested in having their products win, so most cars are first class. Pit action is important, just as in any car racing.

Q. Do you get a drink on each of your three pit stops at Indy, and what is it you drink?—Barbara Harrison, Seattle.

A. I didn't drink anything this year. I just wanted to get going. Water is great. Gatorade is fine. Things that become sticky if spilled aren't so good. I've eaten candy bars during the Riverside 500 stock-car race. ★ ★ ★

If you have questions on racing, high-performance and everyday driving techniques, send them to "Drivin' with Dan," c/o Popular Mechanics, 575 Lexington Ave., New York, N.Y. 10022. Questions cannot be answered by individual letters. Questions on maintenance and repair should be addressed to the Auto Clinic (see page 74).

spred.®

the word.



Homeowners everywhere spred the years with Spred House Paint



6 YEARS, NORTH CAROLINA. "Spred House Paint gets a real test in this mountain area—cold nights, hot days, and fumes from a nearby textile plant. There's no discoloration." J. B. Smith.



6 YEARS, CANADA. "Cold winters and strong sun are hard on paint. But our house has come through beautifully. Several neighbors switched to Spred House Paint." S. K. McBirnie.



8 YEARS, OHIO. "Spred House Paint solved a terrific blistering problem. I did repaint one side, south, after six years, but other three sides still don't need repainting." T. S. Trippett.



Victor Borge says, "spred the word." Look for him at your Glidden Paint dealer's.



GLIDDEN COATINGS & RESINS · CLEVELAND, OHIO 44115
GLIDDEN COMPANY DIVISION SCM (CANADA) LIMITED

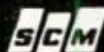

SCM CORPORATION

SWINGS EASY

PLUMB. FA57

**Advertised
Price
\$6.95**

**A "Proven Performer"
for more than 14 years**
Fiber-Glass handle
guaranteed not to break,
bend or collapse in normal use.
Dura-Cushion grip absorbs shock.

FAYETTE R. PLUMB, INC. • PHILADELPHIA, PA. 19137

HITS HARD

PUBLICATIONS **WORTH WRITING FOR**

BY CATHERINE BILSKI

HERE'S a 48-page booklet on how-to-do-it for people who don't know how to do it. Entitled *Skil Makes It Easy*, it includes descriptions, instructions and simplified plans for building patio tables, sewing centers, laundry centers and other projects. It sells for 50 cents and can be obtained from Skil Corp., Dept. K., Box 5309, Chicago, Ill. 60607.

YOU'LL GET MORE out of barbecues when you send for the booklet *Barbecue Fun*. It's loaded with more than 50 recipes for beef, lamb, fowl, fish and pork, also

has ideas on everything from selecting charcoal to improving flavor. Available for 25 cents from A.W. Petrey, Georgia-Pacific, Box 311, Portland, Ore. 97202.

"COMMON SENSE About Kitchen Floor Coverings" is "must" reading for all who plan to buy new kitchen flooring. This brochure contains tips on selecting a resilient flooring material, plus color illustrations of the latest flooring designs. Free from Armstrong Cork Co., Dept. P.I., Lancaster, Pa. 17604.

"HINTS ON THE CARE and Feeding of Small Engines" is the title of the 18-page booklet sent free on request to AC Spark Plug Div., General Motors Corp., Catalog Dept. 35-24, Flint, Mich. 48556. It contains 50 hints and 24 illustrations on operation and maintenance of small engines used on mowers, snowblowers, outboard boats, sprayers and power saws. ★★ ★

START YOUR NEW CAREER NOW! WITHOUT OVERHEAD! ANY PLACE! ANY AGE!

UPHOLSTERING JUST ONE CHAIR

can pay you as much — or more — than your present weekly paycheck!

you don't even have to quit your present job!!!



START LEARNING NOW, AT HOME, OR IN THE GARAGE, IN SPARE TIME.

If you can tie a knot and drive a tack, you can learn this business... **FAST!** Through the proven, M.U.I. Home Training Plan, you start doing the simple upholstering jobs... chairs, cushions, seats, footstools... right away! And even before you finish your training, people will start bringing their work to you! And remember the world is full of furniture that needs fixing & more wears out every day!

AS YOU LEARN, YOU JUST SLIP INTO THE IMMENSE FLOW OF UPHOLSTERY WORK!

Sofas, lounging chairs, bedroom chairs finished in beautiful fabrics, which M.U.I. shows you how to get at the right price! Built-ins, breakfast nooks, boats, trailers, millions of automobiles. You learn all this and more! When we finish teaching you (in your spare time, in your own home) and when you get our California State Approved diploma, you can be sure you **KNOW** upholstery... as a real professional. You will then have one of the most fantastic, most reliable, moneymaking skills in America, built into your head and hands (and it's automation proof — you'll never be replaced by a machine!) No one can ever take this skill away from you, because you're the boss of a business you can take with you wherever you go... city, country, farm... anyplace you want to hang out your shingle! Upholstering is needed everywhere!

"WHAT STARTED AS A PART-TIME HOBBY NOW PAYS ME BETTER THAN \$10 AN HOUR."



WORK THE HOURS YOU LIKE TO WORK!

If you favor a 35 hour work week, upholstery lets you do it and make a fine living. If you're really ambitious, and want to work 60 or 70 hours a week, you are starting to talk about some big, big money! The important thing is that you choose your own working hours!... you're the boss! Some students just do a few pieces now and then, just to have an extra income!

TO GET STARTED, JUST GET THE COUPON IN THE MAIL... TODAY!
The information is free... no salesman will call you... send the coupon in today!

AIRMAIL REACHES M.U.I. IN ONE DAY

FREE UPHOLSTERY BOOK! SEND TODAY



YOU'LL GET A BIG ILLUSTRATED 32 PAGE BOOK ON UPHOLSTERY and the upholstery business, and an actual free sample lesson showing how the fabulously successful M.U.I. system is taught. For your future's sake, fill in and mail the coupon NOW!

MODERN UPHOLSTERY INSTITUTE, Box 899-CBV Orange, Calif. 92669

"TOOLS OF THE TRADE" FREE!



YOU GET SIX BIG FURNITURE KITS FREE

AUTHORIZED DIPLOMA WHEN YOU GRADUATE



MODERN UPHOLSTERY INSTITUTE, Box 899-CBV Orange, Calif. 92669
Please send the **FREE UPHOLSTERY CAREER BOOK**, the **FREE SAMPLE LESSON**. I am under no obligation whatever and am just sending for the free facts on job and career opportunities in Upholstering and the M.U.I. home training program. No salesman will call.

Name _____ Age _____
Address _____
City _____
State _____ Zip _____

APPROVED FOR VETERANS

Still using the same type athlete's foot ointment you used in 1945?

You remember the type—greasy... didn't smell so good. Chances are, the ointment you've been using since then feels and smells just about the same.

But now Mennen introduces Quinsana Medicated Ointment. With the most effective ingredients you can buy to relieve Athlete's Foot and help prevent re-infection.

And at last! It smells fresher than what you've probably been using. And absorbs fast... no squishy, greasy feeling between toes.

Quinsana Medicated Ointment.

You've been waiting for this since you started wearing civvies.

For everyday foot care, try Mennen Quinsana: Aerosol Powder, Squeeze Powder, or Deodorant Spray.



Mennen Quinsana®
A tramp, tramp, tramp ahead in foot care.

PRODUCT OF THE MENNEN COMPANY



LISTENING POST

BY BILL KILPATRICK

THE NEW CARS bow this month amid industry-wide optimism (What else?) that the decade of the '70s will open with record production and sales. Automakers, as a breed rarely known to view the world through a glass darkly, see the spurt stemming primarily from still greater consumer interest in performance-type cars, greater general affluence, favorable public reaction to the new subcompacts.

Quietly and privately, however, a few industry executives admit they're worried about tighter credit, labor's opposition to increased automation, the public's disenchantment with indifferent workmanship and bad service, and, the biggest worry of all—a bigger role by Uncle Sam in industry affairs. Dropping for a moment Detroit's customary small-town booster pose, these perceptive few fear Washington will react even more strongly to such car-abetted ills as air pollution, ever-rising accidents, urban glut, the plundering of the countryside for roads, more parking lots, more camper facilities, and so on.

Biggest bludgeon hanging over the industry's head at the moment is a possible federal crackdown on warranty procedures. Bitter buyers complain to the government, claiming manufacturers are evading or minimizing obligations under their warranties. There could be so much government steam on the industry in the next decade that the entire economy could be affected.

SPEAKING OF STEAM, the most serious challenge to the internal combustion engine—the well-publicized effort by wizard Bill Lear and his Lear Motors Corp. (see *Bill Lear's Steam Car*, page 128, April *PM*)—seems to have evaporated. Lear himself is no longer president of the company, and the rosy plans announced over the past year—a fleet of steam-powered buses, a steam-powered Indianapolis racecar, steam-powered cars, a replica on the Nevada desert of the Indy racetrack, to mention just a few—have either been abandoned or “postponed indefinitely.” Just one rock over which the effort stumbled was the design and building of a suitable boiler. The one evolved by Lear worked okay, but its 850 feet of stainless-steel tubing alone cost \$1200! Consensus here seems to be that Lear mounted a bold, noble effort, but that he bit off more than even he could chew.

ALL STOPS ARE OUT in Detroit's effort to standardize components on all car lines produced by a given manufacturer. Both GM and Ford are heavily committed to such a scheme, the thought being to hold production costs down, keep retail prices stable. In theory, if it all works out, components and units on, say, the most menial Chevy will be used all along the line up to and including Cadillac. A likely side benefit will be simplified parts inventories and procedures, to say nothing of simplified service. The rub? Keeping the various lines truly distinctive.

FORD'S ELECTRIC-CAR PROJECT has been “realigned,” a polite way of saying the ship has been pretty much abandoned. There's still interest in the concept, and the company has every intention of staying plugged in on new electric-car developments and technology, but budget and personnel have been cut back sharply. Action by Ford is consistent with a recent GM announcement that it, too, was soft-pedaling electric-car research and development. Why? Too many seemingly insurmountable problems involved in evolving an all-round, producible car.

MID-ENGINE SPORTS CARS, tabbed in this space as a Detroit trend in the '70s, will see light sooner than expected. Due in '71 is an all-new Corvette that will feature a new engine mounted amidships. Other rumored touches on the new car include four-wheel drive and an entirely new type of automatic transmission. The car's projected

price tag is said to be in the \$10,000 category.

VENT WINDOWS, sadly missed by most motorists, are rumored to be on the way back, possibly as early as the '72s, maybe the '73s. Industry chatter has it, however, that if and when they do reappear, they'll be much smaller than those fondly remembered. But this column is skeptical; vents disappeared because of costs, not necessarily design. When it comes to saving on production, automakers count costs in fractions of pennies, and regardless of how it's sliced, vents cost a bit more per unit. The great hue and cry throughout the industry is to cut costs at all costs, so we can't really see vents making a strong comeback.

DISC BRAKES, gaining favor with both auto engineers and car buyers, will be pretty much standard in another couple of years, particularly front discs. Right now, such units are standard on most of the out-and-out luxury jobs. But look for 'em on full-sized cars next year, on the smaller intermediates and compacts a year or so later. Principal advantages of disc brakes are longer life, comparatively fade-free performance, greater directional stability in panic stops.

PONTIAC'S OVERHEAD-CAM SIX, heralded just a few short years ago as something only slightly shy of divinity, has gone by the board. The division won't offer the engine beginning with the '70 models. Why? Sales were too slow to justify using an entire line for its production.

MERCEDES-BENZ's new rotary-piston powered sports car will debut this month at the Frankfurt Auto Show. No specifications on the three-chamber Wankel engine have been released as yet, but it is reported that it will take the Mercedes coupe up to 60 mph in less than 6 seconds. "No immediate plans to import the car" is the official word from the company, even though *Popular Mechanics* has been invited to test the car in Germany this month.

FIRE ENGINES are always red, right? Wrong. Mack Trucks, Inc. reports that while most of the firefighting apparatus it makes is ordered painted red, a lot of it leaves company plants painted green, white, even broadly striped in red and white. Mack says it has delivered at least one job painted black and canary yellow—an odd combination that *really* flies in the face of tradition. The company assured us it will deliver fire apparatus in just about any color a customer might want. ★★ ★

If you change your oil every 3,000 miles, we have bad news for you.

At three or four thousand miles, if you drive like most people, your engine has made more sludge than the detergent in the oil can handle.

So instead of going into the oil filter, the stuff starts to settle inside your engine. You could change your oil sooner.

Or you could put in a can of CD-2 for low mileage cars. Add it when the oil's changed. Or at 2,000 miles, if you'd rather.

This CD-2 is a concentrated detergent, not a thick "additive." It'll keep your engine clean, like a new one.

So it'll act like a new one longer.

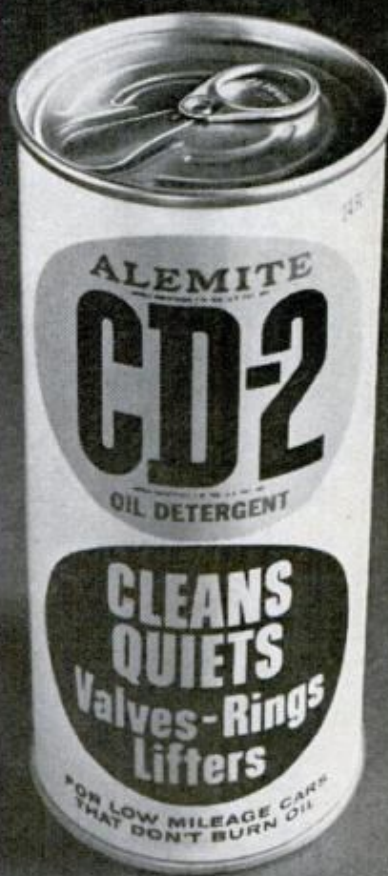

The other CD-2. We also make a CD-2 that stops oil burning in older cars. So be sure and get the right one. It may be confusing, but one kind couldn't do both jobs.

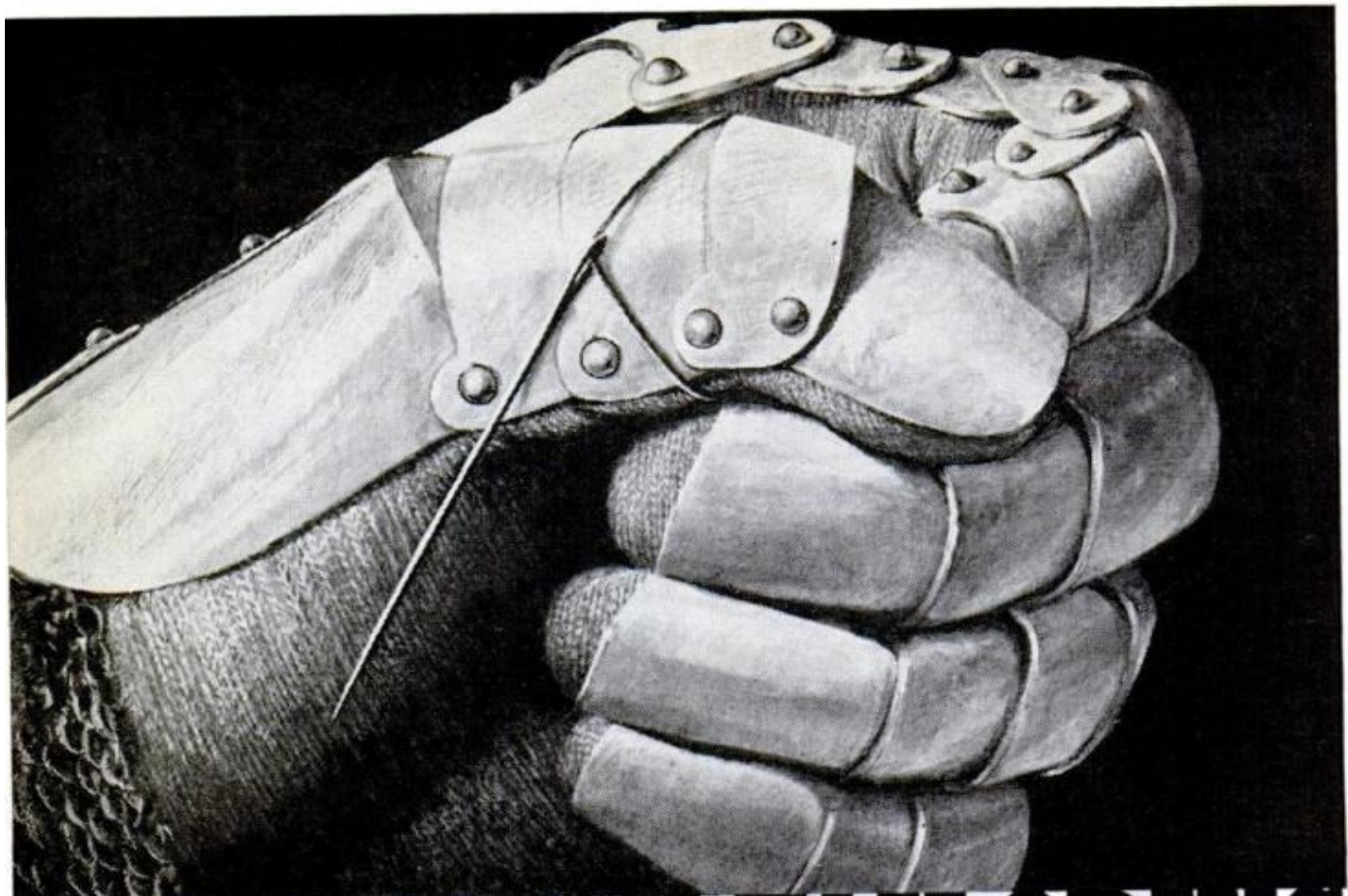

Lee[®] TOUGH TAILORING



LEE-PREST[®] CHETOPA TWILLS: TOUGH-TAILORED WITH DACRON[®]

A rugged blend of 50% Dacron* polyester and 50% cotton makes the fabric long wearing and great looking. Main seams won't shrink or pucker. Permanently pressed so they never need ironing, with tailored sizes to fit any shape. And if you think a pair isn't doing the job for you, we'll give you a new pair free. No questions asked. You have to have tough tailoring to make a guarantee like that.

H. D. Lee Company, Inc., Dept. A, P.O. Box 440,
Shawnee Mission, Kansas 66201.

World's Largest Manufacturer of Union-Made
Work Clothes. Also available in Canada.

*DuPont reg. T.M.



© VOLKSWAGEN OF AMERICA, INC.

Beware of the dog.

It may bite.

Into your wallet. For a new engine, perhaps. Or maybe a new transmission.

From such grief, we'd like to spare you. By suggesting you seek out a Volkswagen dealer.

His selected used VWs and domestic cars have much better manners.

Before they go on the lot for sale, they go in the shop for inspection. Where everything you'd want to have checked out gets checked out.

(Things like cylinder compression. Clutch play. Brake system.)

If anything at all needs to be repaired or replaced, it gets repaired or replaced.

And only those thoroughbreds strong enough to pass this tough going-over get the VW dealer's 100% guarantee sign.*

Which tells you the one thing you need to know about a used car:

It won't bite.



*The dealer guarantees 100% to repair or replace the engine, transmission, rear axle, front axle assemblies, brake system and electrical system, for 30 days or 1000 miles, whichever comes first.

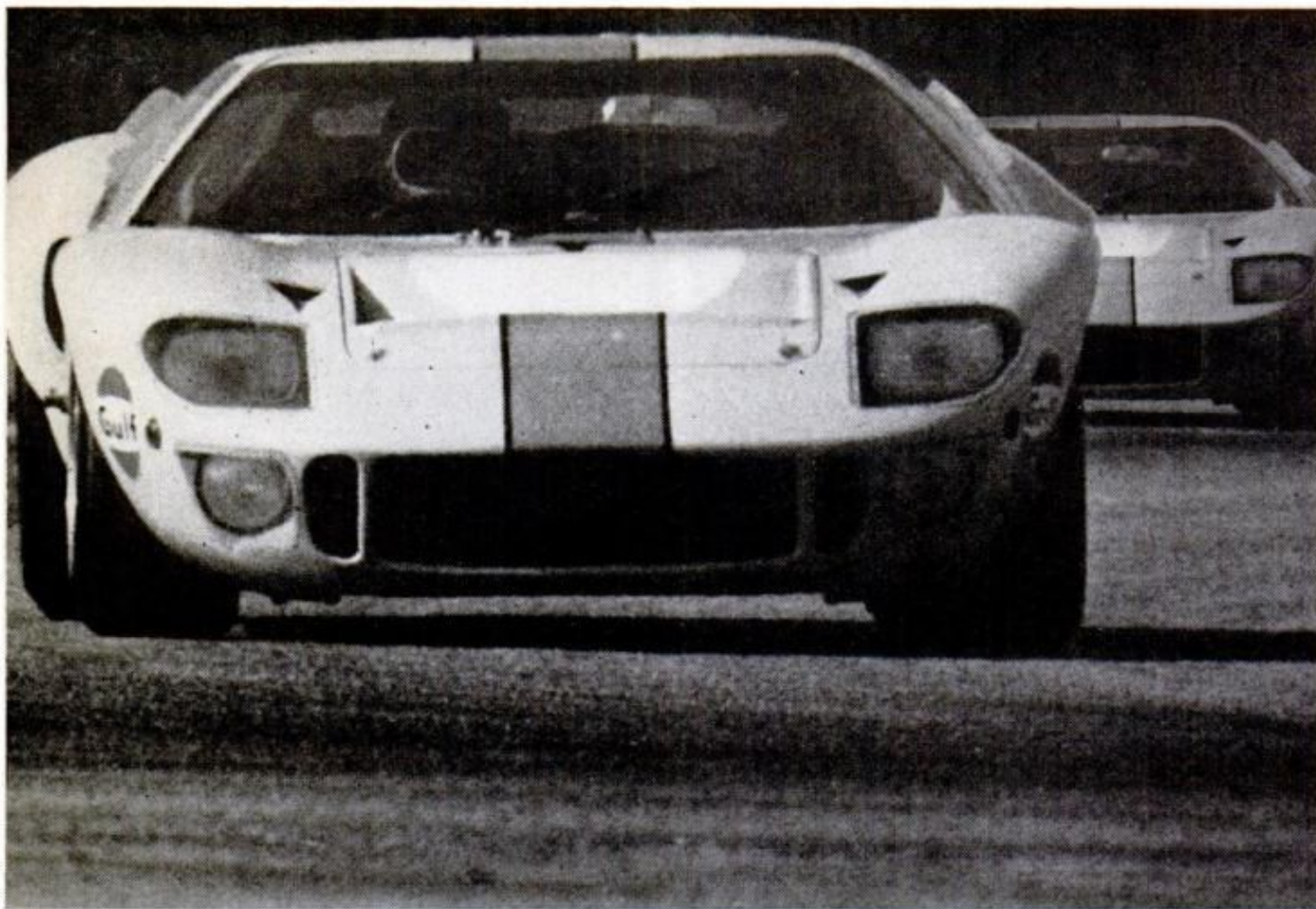

Gulf only ran two cars at Le Mans. They finished first and third.

45 cars started the 24 hours of Le Mans. Only 14 finished. But the two Gulf-sponsored Ford GT40s did a lot more than just keep running. They both broke last year's record by more than 300 miles. Jackie Ickx and Jackie Oliver won at an average speed of 129.923 m.p.h. David Hobbs and Mike Hailwood finished third at 128.685. Only one competitive car could stay with them—and it had to be content with second place.

But this wasn't the usual en-

durance contest, where you just wait for everyone else to break and then stroke it home. The last three hours were as close as a stock car race, with the lead changing hands many times and the cars being pushed to their limits.

To stand up to that, after more than 3,000 miles of racing, everything has to be right. Design, preparation, driving, pit work...and lubrication.

Both Gulf cars used Gulfpride® Formula G—the motor

oil that won Le Mans, the World Manufacturers Championship and the Can-Am series last year. Formula G has come through more than two years of the toughest kind of road racing without a single lubrication problem. But it isn't just made for racing. You can get it at any Gulf station.

If you drive a car with a high-performance engine, Formula G is the best protection against wear and overheating you can buy. Switch to it now.



Gulf Oil Corporation.

Be a LOCKSMITH



EARN'S BACK TUITION, PLUS

Joe E. Warren, Overland Park, Kansas, says,

"The lessons were so arranged that I could start earning almost at once. Before completing the course I earned enough money to pay for the entire course and purchase some \$800 worth of equipment and supplies."

**"I EARNED
\$1138.75
DURING
TRAINING!"**



Says Joel Daigle, Fort Kent, Me.,

"I wanted a complete change in work. Something more enjoyable and less tiring. Now that I've learned Locksmithing I average \$20 a week more. During my training period I earned \$1138.75 from Locksmithing. I have an established lock opener position in our town."

**"\$642
WHILE
LEARNING**



and used the money to outfit a complete shop. Now I'm able to average \$3.25 an hour in spare-time. With the help of your fine instructors, anyone can master the course with ease."

*R. Ted Gifford
506 East Main St.
Robinson, Ill.*

TRAIN AT HOME — EARN WHILE YOU LEARN

Add to YOUR INCOME—even double it with easy spare time earnings. Cash in on the nation-wide shortage that demands hundreds more trained locksmiths. Quickly step into a big pay opportunity, full- or part-time job, or start a high-profit shop of your own!

EARN EXTRA MONEY RIGHT AWAY!

You can quickly qualify as a skilled locksmith. Age, education, even minor physical handicaps don't matter in this ever-growing trade. So easy to learn—it's easy, it's fun, it's just like a fascinating new hobby!

Study at home as little as one hour a week. All special professional tools, supplies, including files, calipers, tweezers, cylinders, door handles, assemblies, gages, pins, springs, extractors, picks wrenches, and different kinds of locks and keys—supplied FREE! Gain practical experience by doing real jobs on car locks, house locks, padlocks, safe locks, etc. Just follow well-illustrated lessons under the guidance of experts.

For a future as your own boss or in a high-pay job, get all the facts, complete details.

Write today for FREE Illustrated Book, FREE Sample Lesson Pages Give Exciting Facts.

No cost, no obligation, no salesman will call.

*Only school of its kind: Licensed by State of New Jersey,
Accredited Member National Home Study Council.*

LOCKSMITHING INSTITUTE Dept. 1110-099

A Division of Technical Home Study Schools • Little Falls, New Jersey 07424

APPROVED FOR VETERANS

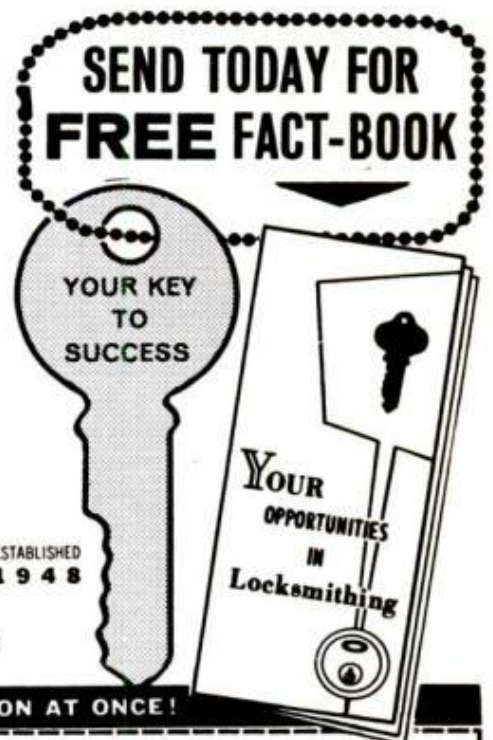

MAIL THE COUPON AT ONCE!

LOCKSMITHING INSTITUTE,
A Division of Technical Home Study Schools
Dept. 1110-099 Little Falls, New Jersey 07424

Please send without obligation the FREE illustrated book, "Your Opportunities in Locksmithing." I understand no salesman will call.

NAME _____

ADDRESS _____

CITY _____ STATE _____ ZIP _____

Check here if eligible for Vet Benefits.

New Super-Duper

'Exotic,' 'exciting,' 'expensive' all describe some of the way-out machines for 1970

ROARING OVER THE SNOW this winter, you'll see some of the strangest contraptions ever conceived for winter fun. These advanced designs and hand-built prototypes are examples of things to come in snowmobiles and all-terrain vehicles. Snowmobiling started years ago when crude variations of motorized sleds were built in garages and back yards. Today the snowmobile industry is a highly sophisticated, competitive multimillion-dollar business. And the same is predicted for all-terrain vehicles. Right now, the research and development boys are fooling around with new types of transmissions, new types of drive mechanisms, new principles in machine balance. One experimental Allouette snowmobile is equipped as a racing machine with engine in the rear.

As you can see on these pages, the idea of enclosing the driver in a bubble on a snowmobile is starting to catch on. The two-passenger machine has long been with us in the snowmobile world, but not with two passengers sitting side by side.

Also growing in popularity are machines that convert from snowmobiles to all-terrain vehicles just by adding wheels. The dual-purpose machine is not as ridiculous as it may sound. Sno Jet is introducing a new front-end wheel suspension system that has been popular out on the West Coast in the sand dunes.

But it takes a lot of doing to make a machine that will be at home on snow as well as on dirt, or vice versa. The regular snowmobile designs, like the Boatel pictured here, are great for all kinds of snow—hard-pack, powder, deep or thin. The all-terrain vehicles generally will go in snow only when the covering is no more



TRACKER by Alsport, Inc. of Norwalk, Ohio, comes with wheels and/or skis. The machine sells for \$1695



ATV-600 by American Eagle Co. is a new design for snowmobiles and ATVs. Price of twin-track is \$1350

Snowmobiles

SUPER SNO-SPORT by Rupp is a 525-hp experimental dragster that will do better than 100 mph. Many parts are from standard machines



than six inches or so. The new wide belts of the ATVs might conquer that problem. This winter will tell.

The side-by-side, two-passenger machines look great for flat going. But what is the advantage of a highly designed, expensive snowmobile that might cause problems when you need to side-hill on a rugged mountain?

The Super Sno-Sport looks like a drag machine. It will

actually do over 100 mph.

Amazingly, many standard production parts are used in this special machine. These include skis, springs, chassis, track and suspension system.

All the other machines shown on these pages are prototypes. The various designers plan limited production this year. The popularity of these models depends on the machine's ability to perform, the customer's desire for distinctive styling, and the customer's willingness to pay out the top dollar. ★★★



SNOCOUP (left) by Innovar of Dunnell, Minn., is a side-by-side-seating snowmobile. Priced from \$1695



RIDGE RUNNER, INC. of Minneapolis has this two-track, two-seater with canopy for about \$2100

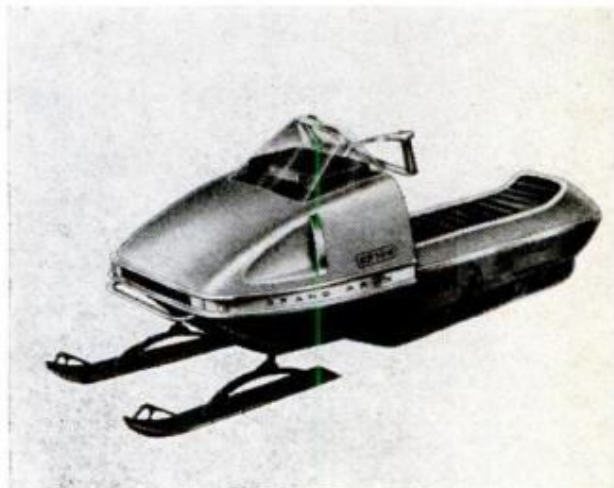

GRAND PRIX by Boatel of Mora, Minn., is a sophisticated, sleek snowmobile starting at \$1695

New Homelite® E-Z™

Easy to start

Easy to run

Easy to own

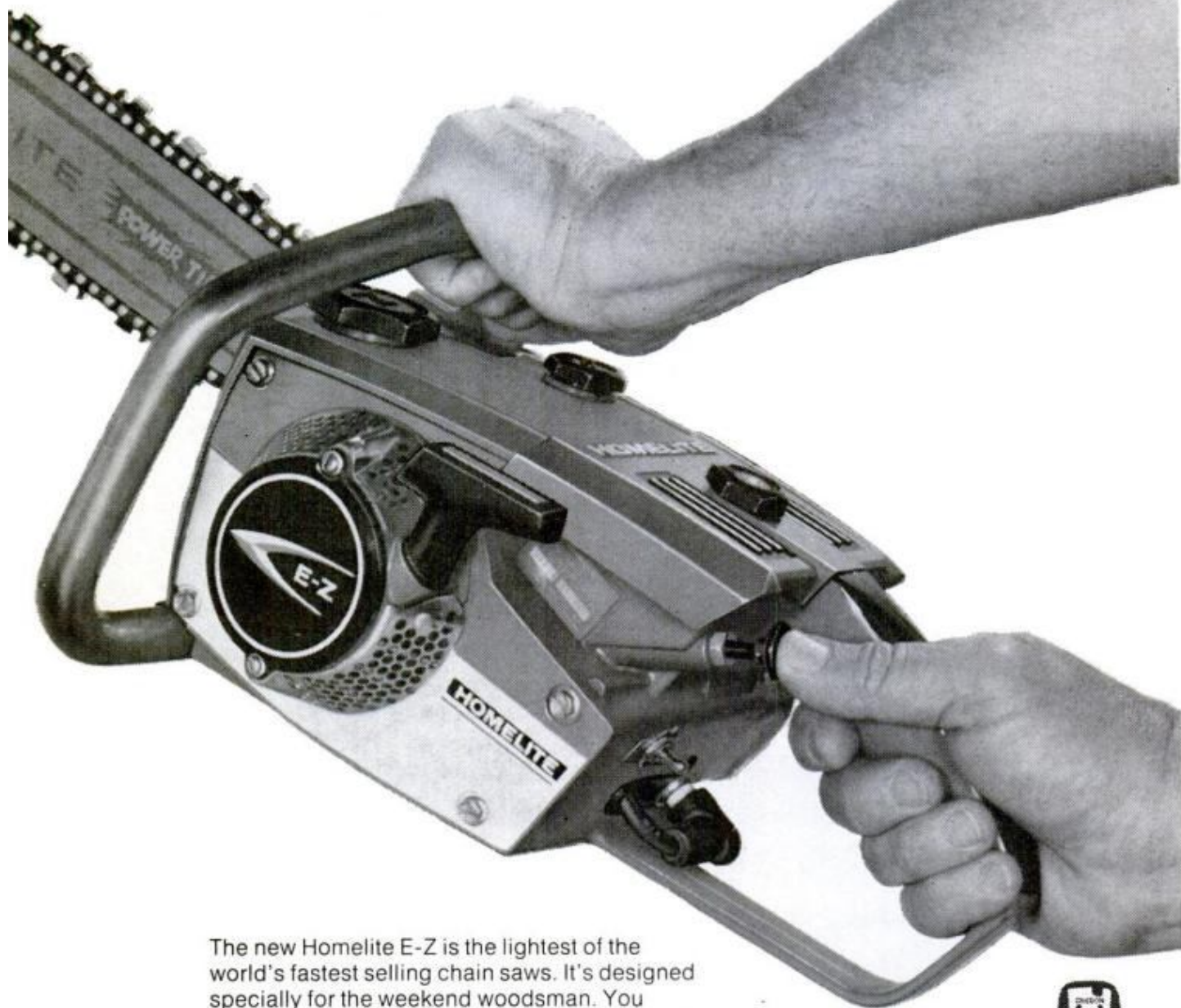

The new Homelite E-Z is the lightest of the world's fastest selling chain saws. It's designed specially for the weekend woodsman. You can start it with a gentle two-finger pull. You will like the natural feel and firm control of this super lightweight with its non-slip vinyl coated handle bar and grouped on/off switch, choke, throttle and manual oiler controls. Contact your local Homelite dealer (he's listed in the Yellow Pages) for a demonstration and see why we named it the E-Z.



HOMELITE®

10209 RIVERDALE AVE., PORT CHESTER, N.Y.

A **Textron**
DIVISION

POPULAR MECHANICS



TUNE UP ELECTRONICALLY ANY CAR EVER MADE!

- ✓ COMPACT or LIMOUSINE
- ✓ DOMESTIC or FOREIGN
- ✓ 4, 6 or 8 CYLINDER
- ✓ 6 VOLT or 12 VOLT
- ✓ POSITIVE or NEGATIVE GROUND

With New Improved Model BT-162

DWELL TACHOMETER

ASSURE - EASY STARTS, OPTIMUM PERFORMANCE and
MAXIMUM GAS ECONOMY with MODEL BT-162

MADE ORIGINALLY FOR THE PROFESSIONAL AUTOMOTIVE TECHNICIAN, MODEL BT-162 WILL
PAY FOR ITSELF MANY TIMES OVER FOR THE AUTOMOTIVE HOBBYIST AND EXPERIMENTER.

*The Model BT-162 will perform the services specified below
in addition to many other tasks too numerous to mention:*

- ✓ Assure precise adjustment of points that are slightly worn or pitted.
- ✓ Indicate the most effective point setting without removing the distributor cap.
- ✓ Read the average dwell of dual breaker points as well as individual dwell of each individual set of points.
- ✓ Indicate the correct settings for external adjustment type distributors.
- ✓ Car manufacturers' dwell angle recommendations are included in the manual provided with the Model BT-162 for all cars including the external adjustment type distributors specified above.
- ✓ It is no longer necessary to file points to smoothness when using the Model BT-162. The instrument will automatically make allowance for any existing "pitting" or "wear."
- ✓ To adjust for mathematically correct carburetor adjustment and thus insure maximum gas economy and quiet engine running, simply use the Tachometer section of the Model BT-162. Read the exact RPM while the engine is in neutral position. Then adjust the carburetor in conformity with the car manufacturer's recommendations as specified in the manual provided with the Model BT-162.
- ✓ To locate a "miss" you need only disconnect or "short" the spark plugs one at a time with the Model BT-162 switched to the Tachometer position. You will be able to instantly identify which particular plug (or frequently its wire lead) is responsible for the malfunction.
- ✓ Cars with automatic transmissions function efficiently only if the fluid pressures are correctly maintained and since manufacturer's instructions always refer to RPM the Model BT-162 (or an equivalent tachometer) is required to properly service automatic transmissions. Incidentally, the 5,000 RPM maximum range of the Model BT-162 is adequate for all car engines without any exceptions.

Comes complete, ready to use. Operating manual includes manufacturer's dwell angle recommendations for all cars. The manual is yours to keep even if you decide to return the instrument.

\$29⁹⁵

SEND NO MONEY WITH ORDER
PAY POSTMAN NOTHING ON DELIVERY

Try it for 10 days before you buy. If completely satisfied remit \$29.95 plus postage and handling charges. (If you prefer you may use our **EASY PAYMENT PLAN.**) If not completely satisfied, return to us, no explanation necessary.

ACCURATE INSTRUMENT CO., INC. Dept. 687
2435 White Plains Road, Bronx, N. Y. 10467

Please rush me one Model BT-162. If satisfactory I agree to pay at the terms specified at left. If not satisfactory, I may return for cancellation of account.

Name _____

Address _____

City _____ Zone _____ State _____

Save Money! Check here and enclose \$29.95 with coupon and we will pay all shipping and handling charges. You still retain privilege of returning after 10 day trial for full refund.

The bargain hunter



Today let these
**AMAZING
SHOES
ADD INCHES TO
YOUR HEIGHT!**

Nothing like a pair of "ELEVATORS" to help you get up in the world! In seconds, these miraculous height-increasing shoes make you almost 2 inches taller! And no one will suspect that you're wearing them because "ELEVATORS" look just as smart and feel just as comfortable as any other fine shoes.



Write for FREE CATALOG today.



ELEVATORS® HEIGHT-INCREASING SHOES

Brockton Footwear, Inc.
Dept. 5109K, Brockton, Mass. 02403
Please send free catalog

Name _____
Street _____
City _____ State _____

CLIP AND MAIL COUPON NOW



HOW MANY HANDY DANDYS CAN YOU USE?

Handy Dandys are plastic caps that hook onto pegboard and hold quarter-twist glass jars, such as used for baby food. Suggestions for getting FREE JARS in every package. Nothing better for storing supplies, parts and small tools. Keeps workshop neat. Sample pack 10 for \$1 ** 36 for \$3.50 ** 72 for \$6 ** 144 for \$11.50. Caps only. No jars. Postpaid U.S.A. No C.O.D.'s. WICKLIFFE INDUSTRIES, Box 286-PM-9, Wickliffe, Ohio 44092

MOMENTOS of the infamous 3rd REICH. 10"x12"x11 1/2" Cast HEER Wall plaque. Bronze finish with wood grain frame. While they last \$6.00 Postpaid.

Our fully illustrated relic collectors CATALOG of ... Helmets, Hats, Medals, Pins, Badges, Books, Photos, Posters, Manuals, Stamps, Flags, Decals, Arm Bands & other hard-to-find items. CATALOG free with order or Air Mailed to you for \$1.00. W.W. #2-M Ltd., Box 2063, St. Louis, Mo. 63188

YOUR NAME IN DIE CAST LETTERS

Everyone has a good reason to identify something they own, something they've made, something they like—with a name, a phrase, a greeting; and nothing identifies better than Die Cast Letters. Now you can individualize your home, your car, your prize possessions with distinction that befits a King. Die Cast Letters offer a NEW mode in home decoration by personalizing unique ideas at a remarkably low cost. **FREE BOOKLET.** Tells how Wellman Die Cast Letters can be used to identify, beautify and boost your ego. Available in a variety of styles from 1/2" to 3". **WELLMAN PRODUCTS COMPANY, 1445 East 49th Street, Cleveland, Ohio 44103.**



FREE!!! POWERFUL MUSCLES FAST!
Fantastic New Discoveries in the science of bodybuilding. Now, in the privacy of your bedroom, our method will add inches of powerful muscles to arms, chest, shoulders & legs. Learn secrets on trimming the waist with ultra-modern methods—fast! Results Guaranteed! Send for free brochure, Universal Bodybuilding, Box 5327, M-19, Northeastern, Dearborn, Mich. 48126.

TREASURE & COIN DETECTOR

10-DAY FREE TRIAL

New electronic circuit guarantees at least **TWICE THE DETECTION ABILITY** of any detector in this price range or your money back. Find gold, silver, coins, old weapons, etc. Works through earth, beach sand, water, wood, rock, etc. New circuit gives more power, more depth. Not a "probe" type but a fully electronic, 1969 model detector never offered before and available only from **VIKING**. Only detector in this price range sold on unconditional **MONEY BACK GUARANTEE!** You must



29⁹⁵
POST PAID

agree it will outperform any detector costing **TWICE** this low price or return in 10 days for refund of cost. Only **VIKING** dares make this offer. Fully transistorized, uses ordinary 9V battery, weighs 2 pounds. Gives loud, clear signal when object is detected. **NOTHING ELSE TO BUY.** Complete, ready to operate. Send \$29.95, check, cash or M.O. for postpaid shipment or \$3.00 and pay postman \$26.95 plus small C.O.D. when delivered.

VIKING DETECTORS
Dept. V-2, Box 10880
Houston, Texas 77018



AIR LIFT AUTO LEVELERS

These tough, inflatable butyl cylinders raise the rear of your vacation-loaded car to safe, normal riding level. Air Lift Auto Levelers literally lift excess weight from overworked springs... also minimize sway on turns and absorb impact of bumps. Simple to install—no parts to remove from car. Ideal for camping, a "must" for trailering. Low as \$33.95 per set—tell us model of car. Free literature.

AIR LIFT COMPANY
Dept. PM, 2710 Snow Road, Lansing, Mich.

IMPORTED STILETTO POCKET KNIFE

9" Overall Length
5" When Closed

- Opens instantly
- Sharp and Tough
- Stainless Steel Blade



ONLY
\$1⁷⁵

Opens instantly — folding finger guard snaps into position automatically. Razor sharp tough stainless steel blade holds its edge for years of long hard service. A knife you will be proud to own. Guaranteed. Money back in five days if not satisfied. Send \$1.75 plus 25c to cover postage and handling. **NOT SOLD TO MINORS.** Please state age.

WESTBURY SALES CO., DEPT. S1C
P. O. BOX 415, WESTBURY, N. Y.

MARKETING & PROMOTING

New Ideas & Products
IS OUR BUSINESS

Get Your Ideas Off of the Shelves and Write to

**MIDWEST
MARKETING**

114-80 WARNEN, HAZELWOOD, MD. 53042

314
PHONE **291-2160**

WHEN
ANSWERING ADS
GIVE YOUR
ZIP CODE

The bargain hunter



ONLY \$4.95

FRONTIER DOUBLE DERRINGER

SOLID METAL NOT A PLASTIC IMITATION
• EUROPEAN MADE
• FIRES POWERFUL 22 CAL. CRIMPED BLANKS

Looks and feels like the original Remington Derringer —The Hide-Out Gun of Wild Bill Hickock.

Now this beauty can be yours at this amazing low price. Positive reliable European Made—it fires two quick shots from its double barrels. Perfect for dog training, stage use, sporting events, personal defense. No bulky cylinder, it lays flat in the pocket ready for instant action. Purchaser must be over 21. Just send \$4.95 plus 30 cents postage and handling. State age when ordering. Not sold in New York City or California. Money back guarantee if not satisfied.

**WESTBURY SALES CO., DEPT. DR-53-B
P.O. BOX 434, WESTBURY, N.Y. 11590**



FREE MUSCLE COURSE!
Want a new Jet-Charged body? In 15 minutes I'll prove you can slap on 4" of muscles to your chest—3" to each arm—give you life-guard shoulders, trim your waist to athletic size—give you speedy athletic legs. I don't care if you're short or tall (skinny or fat) young or not so young, expect a muscle building miracle when you send for my free course. Send only 25¢ to cover postage and handling to Joe Weider, Dept. 38-99D2, 531 32nd St., Union City, N.J.

One Sharpening Machine Does All This—



Start your sharpening business with Treyco 6-in-1 grinder. No need to buy separate machines for every job. You can hollow-grind scissors, pinking shears, knives, tools, garden tools, rotary mower blades, hand and circular saws—all with ONE SIX-IN-ONE Treyco Sharpener at low price of one machine. Safeguard your future—build your own spare or full time sharpening business. Take in as much as \$6.00 an hour—no lay-offs, no cut-backs, no forced retirement—enjoy independence and security! **ACT NOW—write for FREE CATALOG and LOW FACTORY-TO-YOU 6-in-1 prices.**

TREYCO Products, Inc. 332-A Niagara St. N. Tonawanda, N.Y. 14120

AMERICA'S NO. 1 CLASSIFIED SECTION CAN BE FOUND ON PAGE 55 IN THIS ISSUE



SILVO (BRAND NAME) TOOL CATALOG

Thousands of Exciting Tool Values! Stanley, Millers Falls, Skil, Thor, Wen, Disston, Wiss, Wellisaw, Dremel, Speedy Sprayers, Plumb, Huot, Kennedy, Channellock, Porter-Cable, Rockwell, Helios, Vise-Grip, Crescent, Ridgid, Pony Clamps, Unimat, Foredom and many other Nationally Advertised brands of Tools & Supplies. We ship Coast to Coast at prices Hard to Beat. Send 25¢ for our big 132-page tool catalog, today. Silvo Hardware Co., PM-9, 107 Walnut St., Philadelphia, Pa. 19106.

RAZOSHARP
Pat. Pend.

\$1.89
P.P.



PRECISION TOOL HANDLE FOR INJECTOR TYPE RAZOR BLADES

IDEAL POCKET KNIFE—EXCELLENT HOUSEHOLD UTILITY TOOL—Only holder to use standard injector type razor blades. Only holder allowing for varying blade length exposure. Only holder allowing blade to be completely protected. Only razor blade holder to give precision tool feel.

ALWAYS RAZOR SHARP—When blade dulls—pop in new blade. Re-use injector type razor blades. **SHAVE and SAVE.** Inexpensive injector type razor blades always available. Expose new sharp edge—reverse blade or clip dull edge. Excellent for cutting clippings, cardboard, trimming, etc. Excellent for opening packages, cartons, etc. Use for carving, whittling, sharpening, erasing, etc. Shape blade to suit use—snip edge or break with pliers. Nothing to break or wear out.

RAZOSHARP 421 Stockholm Street, Brooklyn, New York 11237

When you see this mark



you've seen the product in Popular Mechanics



The original SNO-KASTLE

SNOWMOBILE CAMPER KIT

Everything you need to assemble your own fold-down snowmobile camper including heavy duck tent with 6 foot head room, two 3" foam rubber mattresses, table and heavy duty ski runners. Attaches readily to any make snowmobile. Adapts easily for summer use on a snowmobile trailer as a wheel camper, on a pick-up truck or pontoon raft. Complete with simple assembly instructions \$297.50 F.O.B. factory.

DOLPHIN-KAMPER, INC.
P.O. Box 2807, Fort Wayne, Ind. 46809
Enclosed \$297.50 for Sno-Kastle Snowmobile Camper Kit.

Name _____
Address _____
City _____ State _____ Zip _____

Now! Easy, do-it-yourself FOAM-IN-PLACE insulation for home, boat, hobbies!

LOW-COST SPACE AGE BREAKTHRU IDEAL FOR INSULATING REPAIRING PACKAGING HOBBIES—DISPLAYS—SOUND—DAMP-SEALING—CAULKING



New, self-contained, hand-held aerosol spray pack dispenser instantly dispenses the same rigid urethane foam miracle plastic used in construction, insulation and packaging. No skill required to operate. Lightweight, rigid, buoyant, versatile, you'll discover hundreds of uses around the home. No mixing, clean easy-to-use—froth foam forms a rigid product in 50 seconds. Unit can be used, stored, reused. Makes approximately 9.5 board feet of foam. Money back-guarantee. \$7.95 postpaid. **ORDER TODAY. INSTA-FOAM MIDWEST, Dept. 10, PO Box 287, Waukegan, Illinois 60085**

Gentlemen:

Send _____ Insta-Foam Froth-Pak units at \$7.95 postpaid each. I enclose \$ _____

Name _____
Address _____
City _____ State & Zip _____

The bargain hunter

WHEEL AWAY THAT STOMACH BULGE! EXERCISE WHEEL

Is the Fast Way to Look Better . . . Feel Better!

Scientifically designed to help you win your battle of the bulge, the ingenious EXERCISE WHEEL trims inches off your waistline the fast easy way without strenuous exercise. In just 2 weeks you'll have a flatter stomach and more erect posture. Please note that EXERCISE WHEEL is not an all around exerciser. It's made specifically for your bulge problem. The heavy duty, easy gliding wheel with steel reinforced grip handles weighs only 2 lbs., so you can keep it handy to use every day wherever you are. Try it, you'll be amazed!

Write for Free Catalog

Send check or M.O. No COD's • 21-day Money Back Guarantee

BARCLAY Dept. 59-K, 170-30 Jamaica Ave.
Jamaica, N.Y. 11432

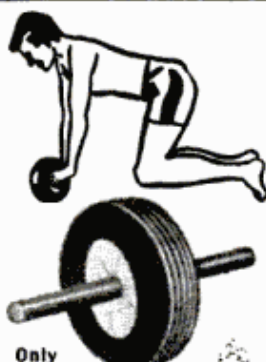

Only
\$3.95

plus 55¢ postage
2 for \$7.50
plus 75¢ postage

NEW Fantastic Swiss Measuring Tool



CALIPER

MODEL 60P

3 vernier scales.001"-1/10 mm 1/128" on each caliper. Depth and step, inside & outside measuring ability - parallax - free, unbreakable Cyclocac® precision construction.

ONLY **2.89** + 25¢ POSTAGE 3 for \$ 8.50
12 for \$33.00 p.p.

Send 25¢ for Money Saving Catalog of hundreds of tools

SCHLESINGERS FOR TOOLS LTD.
1020 East 54th Street, Brooklyn, N.Y.
TEL.: (212) 241-7482

Stamp Your Name PERMANENTLY



\$4.50
ppd.

EVERSTAMP

DIE TOOL

Hardened tool steel. Lasts a lifetime. Comparable to a \$10 die tool, still available at this special price. Stamps almost anything you own with a single blow. Made only by the Henry A. Evers Co., Inc., makers of quality marking devices since 1898.

HENRY A. EVERS CO., INC.

Dept. PM, 72 Oxford St., Prov., R. I. 02905

Enclosed is payment for die tool:

Reg. size 1/16". 15 letters max.

@ \$4.50 ppd.

Large size 3/32". 10 letters max.

@ \$5.75 ppd.

NAME.....

Please Print

STREET.....

CITY..... STATE..... ZIP.....



LAST COMPLETE SILVER SET \$2.95 + 25c p.p.

Brilliant uncirculated 1964 Phila. or Denver mint with scarce J.F.K. Silver 1/2 dollars \$2.95 + .25 p.p. Free 50c gift case. Both mints 10 coins \$5.50 + .25 p.p. Free luxurious \$1 Velvet lined, gold embossed presentation case (as illust.). Save, 10 sets \$49.50—twenty sets \$95. Fifty sets \$225. Collectors rare 80 yr. old uncirculated silver dollars \$4. each in gift case + .25 p.p. Five ass't'd dates in luxurious velvet lined presentation case \$19 + .50 p.p. 5 sets (25 coins) \$90 + 1.00 p.p. Roll of 20 silver dollars \$70. Five rolls (100) coins \$340. Ten rolls \$660. Add .50 per roll p.p. Money back guarantee. A valuable gift or investment rapidly growing in value. Write for free catalog. Member Retail Coin Dealers Assn., Amer. Numismatics Ass'n. Est. 1941. Novel Numismatics, 31 - 2nd Ave. Dept. 125, New York, N. Y. 10003.

ROUNDUP of the '70s . . .

- All the New Cars
- All the New Outboards
- All the New Snowmobiles
- Best New Ideas From World's Biggest Inventors Show

See them in the October issue of

POPULAR MECHANICS

On sale at your newsstand Sept. 30



APPROVED FOR VETERANS
G.I. Bill

THESE 3 BIG DRAFTING KITS* GIVEN TO YOU!

Coast-to-Coast Shortage of Trained Draftsmen Opens Thousands Big Salary Jobs for Beginners!

Now you can take your pick of thousands of big salary jobs open to Draftsmen (see "help wanted" sections of metropolitan newspapers). Huge nationwide demand... U.S. Dept. of Labor reports "42% more Draftsmen needed in next 10 years—not enough applicants to fill drafting jobs available now!" Our easy "Quick-Learn" Method has helped hundreds toward good income, security and prestige as Draftsmen. Why not you?

YOU NEED NO DRAWING SKILL... NO TECHNICAL ABILITY

NASD's staff of Professional Draftsmen guide you step-by-step. With our spare time home-study plan you work on actual projects. Makes learning fun—easy to remember, too. Many graduates have succeeded with only grade school training. Others report good earnings drafting part time while still learning!

...when you train at home with NASD for a

HIGH PAY JOB IN DRAFTING!

RUSH COUPON FOR FREE KIT...

Mail coupon today for FREE "DRAFTING CAREER KIT," Sample Lesson, Drafting Aptitude Test including intriguing new 5-Way Drafting Instrument & 20-page Book "Your Future in Drafting" — jam-packed with revealing facts on your opportunities to win top pay and job security in Drafting. No salesman will call. Everything sent FREE and WITHOUT OBLIGATION. Write today!

North American School of Drafting, Dept. 4179
4500 Campus Dr., University Plaza, Newport, Calif. 92660
Rush "DRAFTING CAREER KIT", including Book, Sample Lesson, Aptitude Test & Drafting Instrument — ALL FREE! No salesman will call. G.I. Approved.

NAME _____ AGE _____
ADDRESS _____
CITY _____ STATE _____ ZIP _____

A home study program in association with Cleveland Engineering Inst.

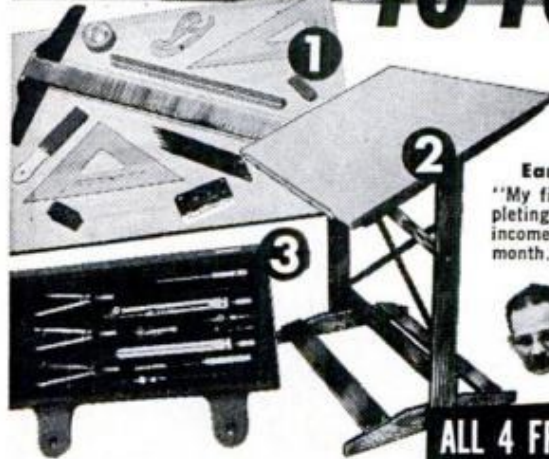

Earns \$820 Month!
"My first position after completing your course jumped my income from \$350 to \$820 per month." — G. W., Tenn.



Big Promotion!
I was promoted from the production line ahead of 4 others and got a good pay raise." — W. A., Wisc.

ALL 4 FREE!
Rush Coupon today!



*Precision Drawing Instrument Set, Professional Drafting Board Outfit & Fingertip Tilting Drafting Table are given to you with your complete North American Course in Drafting.

ARROW

HEAVY DUTY T-50

STAPLE GUN

Uses 6 staple sizes from 1/4" to 9/16" including CEILTILE

A HANDY CHECKLIST OF HOUSEHOLD FASTENING USES

- Install ceiling tile
- Apply insulation
- Fasten weatherstripping
- Reupholster chairs
- Fasten fence wire to posts
- Repair window screens
- Secure antenna wiring
- Tack down stair treads
- Replace worn window shades
- Attach vines to trellises
- Tack carpet underpadding
- Apply polyethylene vapor barriers
- Make window boxes
- Trim kitchen shelves
- Line closets
- Fasten burlap around tree trunks
- Cover valances
- Hang drapes
- Affix wall decorations
- Install plastic wall brick

SHOOT A STAPLE WHEREVER YOU'D DRIVE A NAIL!
FASTER .. BETTER .. CHEAPER ..

At Hardware, Lumber and Building Supply, Stationery and other retail outlets
ARROW FASTENER COMPANY, INC., Saddle Brook, N. J. 07663

Decorating possibilities as big as all outdoors

Outdoor floor

SEAMLESS

NEW GRANULAR TEXTURED SURFACE



The new E-Z do-it-yourself floor system designed to beautifully coat and decorate any outdoor surface: PORCH ... PATIO ... WALK ... STEPS ... POOL AREAS ... WALLS. Now a new way to decorate — and protect — outdoor surfaces quickly, easily. Colorful, durable Top Line 1-2-3 Outdoor Floor offers endless decorating effects, provides slip-proof, weather-resistant uniform coating on any rigid outdoor surface: Concrete, Stone, Metal, etc.

Available in Hardware Depts. & Spiegel Catalog or write:
TOP LINE DIV. OF OATEY CO., Cleveland, Ohio 44135

Not everyone does as well,
but C. E. Nevin, who started a
business of his own, reports...

for 12 months
I've averaged
\$1000⁰⁰
per
month



—most of it Clear Profit for Me!

• Mr. Nevin expressed his grateful thanks for the opportunity to have a fine business of his own. Many men have discovered how to be independent, to be freed of bosses and layoffs—to build their own future on a steady, dependable foundation. G. Mundt made more than \$400 one week. A father-son combination grossed \$33,000 first year. H. Lemon says, "I netted \$133 in one 8-hour day."

How much you make depends largely on you. You need no special skill, no large investment. Start part-time if you wish. We will help you get started and work with you for your success. Training and consulting with experts is available at no additional cost.

No shop necessary • Our **ELECTRIC RUG WASHER** cleans rugs and carpets like new right on the floor... removes dirt and grime and helps to show their natural color and beauty. So efficient and safe for carpets, it is used by largest hotels and railroads.

Don't delay. Mail coupon today for complete information including how to start making big profits in **YOUR OWN** business. **BIG** opportunity.

Ours is Not A Lease Arrangement • You are free to operate independently. You sign no contract. You own the detergent and are *your own boss*... every dollar you take in is *yours*. You pay no fees, or dues, or royalties, and enough supplies come with it to return far more than your investment. Many earn the cost of the detergent in a week or two. It costs nothing to get details... write **TODAY**.

Mail coupon today for interesting

↓ FREE BOOK

VON SCHRADER MFG. CO.
D910 "R" PL., Racine, Wisconsin 53403

Send at once (no obligation) your **FREE** booklet containing information about your **ELECTRIC RUG WASHER** and how I can start *my own* permanent, profitable business.

Name _____

Address _____

City _____ State _____ Zip _____

VON SCHRADER MFG. CO.

WHAT'S NEW OUTDOORS

BY DAN FALES

A **BRAND-NEW** all-terrain vehicle is now available from American Machine & Foundry. Called Sur-Trek, this articulated, two-unit machine is powered by a 295-cc JLO two-cycle engine that can develop 20 hp.

Unique among ATVs is Sur-Trek's eight-wheel drive system. A push-pull design is used, with the front four wheels pulling the machine and the back four pushing it. The motor is located in the front of the second unit. An articulated driveshaft transfers power from motor to front wheels. All eight wheels are fitted with low-pressure, high-flotation tires.

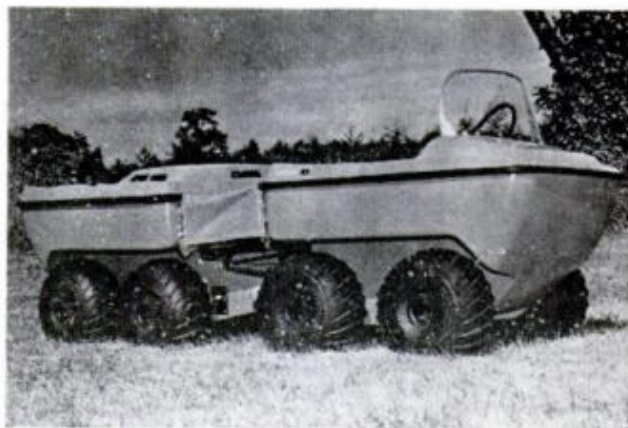

The 10½-foot-long ATV is 50 inches wide and 37 inches high. It can turn in a circle with a 13-foot radius.

Sur-Trek can travel on dirt and paved roads, in sand, snow, swamp, woods and on ice. It is amphibious—able to travel about 2 mph in water without the aid of an outboard motor. A low-power outboard can be attached to the Sur-Trek. On land, the ATV can do 30 mph.

Sur-Trek will take a 45° uphill grade and can easily handle a side slope of 20°.

The 600-pound machine can carry a load of four people, including the driver, or 750 pounds (also including the driver). Each hull of the two-unit body is made of fiberglass.

The transmission is an automatic variable-speed type with hand gearshift control for two speeds forward, one reverse and a neutral.

You steer Sur-Trek by shifting the position of the rear unit. This acts like the tiller on a boat—the rear unit moves right to turn the entire ATV left.

AMF is pricing its Sur-Trek at about \$1700.

★★★

TOM McCaHILL SAYS:

"The appliance repair field is so uncrowded it's almost lonely!"

Someone once said that if you build a better mousetrap, the world will beat a path to your door. In the home appliance business, a lot of enterprising companies have gotten rich peddling a list of handy electrical gadgets for the home longer than Wilt Chamberlain's arm. The trouble is, the dozen or more appliances in the average American home can go on the fritz, and men with the proper training to do repairs are as scarce as knee-length skirts on teen-agers.

Good Appliance Repairmen are a rare breed these days. Those with a little ambition are booked so solidly you can wait days to get somebody to fix a balky refrigerator or cantankerous toaster. Sometimes, you have to settle for a bum job from a guy who had no business calling himself an Appliance Repairman in the first place.

This brings me to my point. If you want to make money in a field that's begging for trained technicians, there's a fine, low-cost home-study plan available that teaches you how to handle every type of Appliance repair in detail—including refrigeration, air conditioners, and even small gas engines. The course was prepared by the instructors at National Radio Institute. This is the oldest and largest home-study school in the Electronics/Electrical fields with more than fifty years' experience training men like yourself for new careers or spare-time or full-time businesses of their own.

A few years ago, NRI recognized the increasing demand for trained Appliance Repairmen. They set about preparing well-illustrated, easy-to-understand lessons that teach you how to repair home, commercial and farm Appliances. NRI even added a professional Appliance Tester that's included in their low tuition. With the Tester and a few basic tools you probably already have,

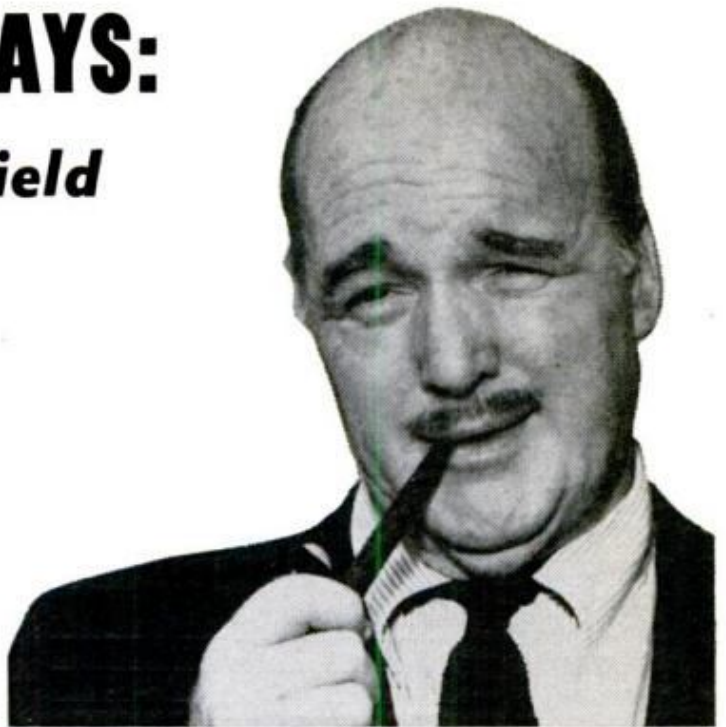

you're equipped to service most Electrical Appliances. If you aren't making as much as \$4 to \$6 an hour in spare time fixing Appliances for friends and neighbors within a few months after enrolling, my name isn't McCaHill.

The reason I'm no doubting Thomas, is because the staff at NRI is composed of experienced instructors who guide you through the course with more personal attention than you'd get in many classrooms. With the kind of help they give a student and the kind of course they have, you can be the man in demand in this field—even if you've never tried to rewire a plug, or got fed up with school at the 9th grade.

The best advice I can give you is to clip the coupon below and send for the NRI Appliance Training Catalog. It's free, and there's no obligation. NRI doesn't employ salesmen, so nobody will be knocking at your door. All it will cost you is a postage stamp. Take it from Uncle Tom, the Appliance Repair field needs good men. Now.

TOM McCA Hill

APPLIANCE DIVISION, NATIONAL RADIO INSTITUTE
3939 Wisconsin Avenue, Washington, D.C. 20016

APPROVED UNDER NEW GI BILL.
If you served since January 31, 1955, or
are in service, check GI line below.

600-099

OK—I want to see for myself. Send me the free book on Professional Appliance Servicing. No salesman will call.

Name..... Age.....

Address.....

City..... State..... Zip Code.....

Accredited Member National Home Study Council.

Check for facts on new GI Bill.



ACCORDIONS and AMPLIFIERS

BIG SAVINGS up to 1/2 or more on famous make accordions. Over 40 models. Standard and new electronic models. Buy direct at low discount prices. Get five-day home trial. Small down payment, easy terms. Free gifts. Trade in allowance. Money back guarantee. Rush coupon for color catalogs, discount price list. **Accordion Corp. of America, Dept. R-99, 5535 W. Belmont Ave., Chicago, Illinois 60641**

COUPON BRINGS FREE COLOR CATALOG & DISCOUNT PRICES	ACCORDION CORP. of AMERICA—Dept. R-99 5535 W. Belmont Ave., Chicago, Illinois 60641 Send FREE Color catalogs and discount prices. Include special information checked:
	<input type="checkbox"/> Amplifiers <input type="checkbox"/> Button Type Accordions
	Name _____
	Address _____ City _____ State _____ Zip _____

HOLD IT!

the glue that never lets go!

write for FREE glue and caulk selector guides

WILHOLD GLUES, INC.
8707 Miller Grove Dr., Santa Fe Springs, Cal. 90670



to get more work out of a power drill...

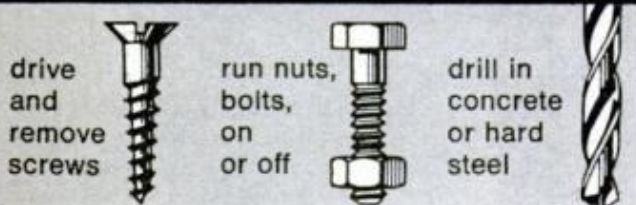

drive and remove screws

run nuts, bolts, on or off

drill in concrete or hard steel

get a Versamatic® Reversible Speed Reducer

A portable drill can be seven times more powerful when you add the ultimate accessory... the RIDGID/Supreme Versamatic. Use this extra power to drive or remove screws, drill in steel or concrete. A free folder tells the whole story: Request "How to double the value of your power drill." The Ridge Tool Company, 400 Clark Street, Elyria, Ohio 44035, U.S.A.

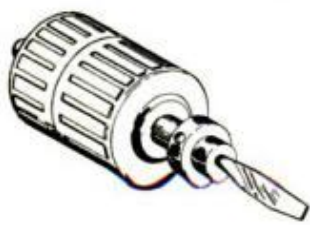

RIDGID Supreme

Ridge Tool Subsidiary
Emerson Electric Co.
EMERSON

BIG NEED FOR SYSTEMS MEN

... LEARN AT HOME IN SPARE TIME



Every company, large & small, needs a Systems Man. As a Systems Man, you'll work with management... help them make vital decisions... make a prestige salary... and enjoy your work, too! You'll supervise **CHARTING, PROCEDURE PLANNING, FORMS DESIGN, OFFICE LAYOUT, COMPUTER PROGRAMMING, DATA PROCESSING**, etc. Big demand — see high salary positions in "help wanted" sections of your newspaper. You need no previous experience or special training... easy home-study plan guides you toward success, prestige, good salary in exciting, respected field. High school education required. Send for Free Booklet, "OPPORTUNITIES IN SYSTEMS."



North American Institute of Systems & Procedures
4401 BIRCH ST., DEPT. 4179, NEWPORT, CALIF. 92660

EVERLITE*

World's THRIFTIEST Light Plants

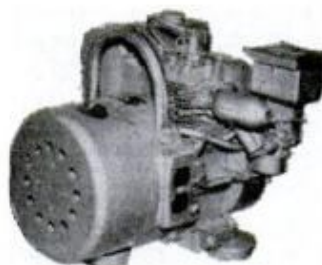

The Champion—1200 watts 115 volts AC for only \$149.50

Unbelievable but true—Brand new production methods now make possible world's finest design in a service free alternator light plant at this unprecedented price. Plant puts out a steady 1200 watts of 115 volt AC power to run power tools, oil burners, pumps, TV, or anything that requires up to 1200 watts. Powered by a rugged 3 HP, 4 cycle, easy start gas engine with 1 year factory warranty. Complete with carry handle and shock mounts. Why fool with short life 2 cycle plants when you can buy this rugged top quality machine at our factory price.

Item #1265
wt. 65 lbs. \$149.50

MASTER MECHANIC MFG. CO., Dept. A-99, Burlington, Wis.
Southern Customers write Dept. A-99, Box 65, Sarasota, Florida

Unimat

Convertible precision lathe is vertical miller, drill press, surface grinder, polisher too! \$139.50, incl. motor & parts. Request free catalog, or send \$1 for 40 pg. detailed handbook.

AMERICAN EDELSTAAL, INC.
B19 / 350 Broadway / NYC 10013



REPOWER with a 6 or V-8. H.D. ADAPTORS for using Car, Compact and some Truck engines. "State year & model, Jeep or Scout." Want fast action? Give us **FULL INFORMATION**. Send \$25.00 Dep. and we will ship correct kit, bal. COD. Send full amount for prepaid shipment. Wire, phone or write today. Details FREE

HOOSIER MACHINE PRODUCTS CO.
312 S. E. 6th St., Phone 276-3442, Pendleton, Oregon 97801

POLICE - FIRE - EMERGENCY - CAR RADIO \$9.99

Works with regular CAR RADIO and ANTENNA! NO special wiring or installation. Mounts UNDER DASH in 5 minutes in ANY CAR OR TRUCK. Panel switches INSTANTLY from REGULAR to POLICE-FIRE-EMERGENCY radio CALLS—Receives ALL stations in your AREA within range. Size only 2"x3 1/2"—Two tone steel cabinet. (Cash, Ck., M.O.) and pay **SEND ONLY \$2.00** postman \$7.99 plus COD post or send \$9.99 for ppd Del in USA. COMPLETE ready to clip in your CAR with all parts and instructions. One year parts and service Warranty—10 day money back trial (if retrnd). AMAZING OFFER good only by mail and from:



WESTERN RADIO Dept. BPM-9 Kearney, Nebr. 68847

CLASSIFIED ADVERTISEMENTS

Rate: \$1.85 per word payable in advance each insertion. Capitalized words—75¢ per word additional. Minimum insertion ten words. To be inserted under the proper classification, copy must be in our office by the 15th of the second month preceding date of issue. The next available issue to place an advertisement in America's No. 1 Classified Section is November. The closing date is September 15th. Send remittance and order to C. A. Martin, Popular Mechanics, 575 Lexington Avenue, New York, New York 10022. Please make remittance payable to Popular Mechanics.

POPULAR MECHANICS

AUTOMOBILES

SELL Your car for more money send \$1.00 for information E. J. Vaillancourt, 1817 Ferry Street, Easton, Pa. 18042.

KNOW YOUR EXACT SPEED Send \$1.00 to IRA, for Speed Calculator, P.O. Box 6, Crystal Lake, Ill. 60014.

AUTOMOBILE BUYING? SAVE MONEY. Know actual dealer cost. Get 1970 Price Book, listing 565 American models, accessories. \$2.00. Market Square, Box 22493, Houston, Texas 77027.

MIDGET CARS

OUR First 19 In Space. This limited edition lithograph has been created as a tribute to Americas Gallant Astronauts. 12 X 18 inch chart ready for framing. Only 75 cents. Popular Mechanics, Dept. GWP, 575 Lexington Avenue, New York, New York 10022.

AUTO SUPPLIES AND EQUIPMENT

BUGGIE-BIN, under-seat drawer for V-W "Beetle". \$4.50 pair; \$2.65 single. Mini-Max. 748 So. Trenton, Seattle, Wash. 98108.

PARTS: Army jeep and truck parts. Spare Parts & Equipment Co., P. O. Box 751, Lexington, Ky. 40502.

NEW heavy duty CD ignition system. Details free. Kits \$28.95, Assembled \$39.95. Dealers invited. Delta International Ltd., Box 1946PM, Grand Junction, Colo. 81501.

AUTO Parts for old and new Cars. All makes. Catalogue \$1.10. Antique Auto, Milwaukee, Wisconsin 53204.

VOLKSWAGEN Replacement parts at 20% to 50% discounts. Free Catalog. Western Distributors, Box 316 D, Cedar Crest, New Mexico 87008.

TRANSMISSION OVERHEATING—90% of automatic transmission failures are due to excessive heat buildup. \$1.00 (refundable) brings heat range chart and info. Bill Tugend, P.O. Box 4293, Panorama City, Ca. 91412.

GAS-OIL HOG??? . . . Smoking?? . . . No Pep?? . . . Hard Starting?? (Save \$150-\$250) with Motaloy Ring-Valve Job While driving (\$6.50 postpaid) Advertised here every month for years! Continues saving money on repairs, gas, oil for 100,000 miles! Absolutely true! (new engines too) Nothing compares! . . . Money-back guarantee. You can't lose! Motaloy, Grantham, Penna. 17027.

CROSLEY. Foreign. American. Parts. Discounts. Accessory Catalog. 616 Burnside, Inwood, New York 11696.

JEEP Owners—V8 conversions. Read Jeep Owners, ad, page 54.

HYDRAULIC Jack repair kits, parts and supplies. Catalog 50¢ (in coin). Hydraulic Jack Packing & Tool Co., Inc., General, P.O. Box 3, Staten Island, N.Y. 10314.

AUTO DRI-KLEENER. Waterless. Auto sparkles in minutes. Easy to use. \$2.25 Postpaid. Post House, 721 Hall Blvd., Mason, Michigan 48854.

POWER Booster—Delivers five times normal spark while starting. Automatically disconnects when engine starts. Great for winter starting problems. \$6.95 Postpaid. Automotive Specialties, 1401 Western Hills, Sherman, Texas 75090.

AIR CONDITIONERS — Wholesale — Terms — Complete Instructions, Training — Free Information — Technical Center. Box 59P, Buena Park, California 90620.

SOLID-STATE Electronic ignition \$9.95 postpaid! Built-in trouble-shooter. 10 min. installation to any negative grounded engines. Free literature! Bunda Specialty Co. Dept. M-1, Box 29, Cedar Grove, N.J. 07009.

AUTO DRI-KLEENER Washes Without Water Leaving Auto Sparkling Clean In Minutes. Simple. Easy To Use Anywhere. \$2.25 Postpaid. Hillsdale Gifts, Dept. A-1, Box 8052, Union City, New Jersey 07087.

BE Your own ignition expert. Free details. Q-arc, Box 47876, Los Angeles, Calif. 90047.

SNOWMOBILES

SNOWMOBILES—Factory Direct Prices. Save 20%. 7 latest 1970 models. 18-30 HP. Free inspection. Money back guarantee. Easy terms. Free catalog. Luger, Dept. SB-69, 1300 East Cliff Road, Burnsville, Minnesota 55378.

AUTO TRAILERS

PICKUP Camper, Trailer or Pickup—Cover . . . Build yourself. Save! Complete plans \$3.95 each, Cover plans \$2.00. Conversion Plans—econoline type van \$2.95; passenger bus or delivery van \$2.95. Satisfaction Guaranteed. Equipment catalog \$1.00 (refundable). Details 10¢. Viking Camper Supply, 99-F Glenwood, Minneapolis, Minn. 55403

BUILD Your Pickup Camper. Precut Kits, Blueprints, Supplies, Literature 25¢. Comstock Trailers, Dept. 664, Parsons, Kansas 67357.

CAMPER Plans. Compact buses, Vans—Volkswagens, Econoline, Dodges. Build yourself—Save! Details—Dot Campers, Box 2115M, Culver City, California 90230.

MOTORCYCLES, BICYCLES, MOTORSCOOTERS AND SUPPLIES

MOTORCYCLE TURN SIGNALS, Accessories. Catalog 25¢. Houston, PM Lockport, Illinois 60441.

HONDA 50-90-160 Speed Equipment, Cams—Big-Bore-Stroker. Columbia Engineering, 2105 E. 37 St., Los Angeles, Calif. 90058.

BUILD "Popular Mechanics" MINI-BIKE featured June 1967 issue. Detail plans, photographs \$2.50 refundable. Kits, parts, engines; factory discount prices. Catalog 25¢. Gilliom Mfg.; PMC; St. Charles, Missouri 63301.

BUILD Motorbike From Bicycle! Plans . . . \$2; Go-Cart Plans . . . \$2; Snowmobile Plans . . . \$3; Go-Byk Industries, Rothsay, Minn. 56579.

SNOW VEHICLE & KART Hop up accessory CATALOG. Speed and performance equipment—manifolds, engine mounts, exhaust systems. Send 25¢. G.E.M. PRODUCTS, Box 845, Carol Stream, Ill. 60187.

HARLEY-Davidsons—bargains. New, used, parts, accessories, all models. Bulletin 50¢. (Factory-Dealer). Milwaukee Harley Davidson, Inc., 6312 W. Fondulac, Milwaukee, Wis. 53218.

MINI-BIKES. Wheels, Chain Saws. Catalog 25¢. Loren Products, Danville, Illinois 61832.



AVIATION

BE A Government licensed aviation mechanic. Practical training. Free information. Aero Mechanics School, Municipal Airport, Kansas City, Missouri 64116.

TREMENDOUS OPPORTUNITIES IN AVIATION. Learn Aerosciences at home: Navigation, Aerodynamics, Communications, Weather. Free information: United Aerosciences, P.O. Box 4106, Torrance California 90503.

BARTLETT FLYING SAUCER. Amazing machine hovers 200 lb. man over land/water, powered by ordinary lawn mower engine. Easy to build. Fun to fly. Complete Plans, Kit Brochure and Photo Review \$3.00. Write: Herb Bartlett, Box 3234-C, Scottsdale, Arizona 85257.

AIRBOAT, Propellers, Engines, Plans, Kits, Supplies. Complete Airboats, Outboard Airdrives. Catalog \$1.00. Banks-Maxwell, Box 3301E, Ft. Worth, Texas 76105.

HELICOPTER, One-Man, Portable, Kits, Plans, Information 10¢. Photos and three-view drawings \$1.00 Compeop, Box 1267, Redwood City, California 94064.

AERO-CAR. Amazing Hovercraft built easily with ordinary tools. Lawnmower engine power. Carries one man plus. Hovers, flies forward, backward, sideways over land/snow/water. Complete construction plans and brochure, \$5.25. Aero-Projects, Box 5118PM, Clinton, N.J. 08809.

HOMEBUILT. Real enclosed helicopter, 24 pages ideas, information, \$2.50. Build "executive" helicopter, drawings, specifications, \$2.00. Helicopter Development, Box PM147, Washington, New Jersey 07882.

ANYONE Can build and fly amazing Bat-Glider. Plans, photos, flying instructions, \$5.00. Photos, information 50¢. Bat-Glider, Box 7115, Amarillo, Texas 79109.

HOME Built Lightplanes. Blueprints, Manuals, Plans, list 25¢. Kamcraft, Box 1153, Milwaukee 1, Wisconsin 53201.



BOATS

CANOE! Kayaks! Factory-direct quality kits, from \$25.00. Many different models. Canvas hulls. Strongest construction materials. Free literature. Sportscraft, Box 8393-PM, Columbus, Ohio 43201.

BOAT PLANS, FRAME KITS, BOAT KITS. World's largest catalog—Over 200 top design for the amateur builders. New catalog includes Cruisers, Runabouts, Deep vee's, Catamarans, Trimarans, Houseboats, Sailboats from small sail fish to 34 ft. motor sailers, large selection of inboard and outboard Hydroplanes. Send \$1.00 for large new plan & kit catalog or \$2.00 for catalog plus Boat Builder's Guide. Clark Craft Boat Company, 16-P Aqua Lane, Tonawanda, New York 14150.

BUILD Your own boat from our large-scale blueprints. Books of plans give how-to-build help. Hundreds of professional designs—motor, sail or auxiliary—for amateur builders. Free catalog. MoToR Boating, 959 Eight Ave., Dept. PM-RS, New York, N.Y. 10019.

FIBERGLASS Cloth and resin. World's finest cloth and non-run resin, at direct mill prices. Flotation foam. Complete line of plastics, silicon bronze and brass screws, save 60%. No Sales tax. Boat Plans, Catalog 25¢. Freight prepaid. Stiles Boat Supply, Box 11P, Linden Ave., Mantua Hts., N.J. 08051.

PLANS, FULL-SIZE PATTERNS, FRAME KITS with step-by-step instructions specially for amateurs. Send \$1.00 for new 96 page catalog of over 80 designs. 8' to 36' Sail, Jets, Inboards, Outboards, Cruisers, Houseboats, Hot Boats, Catamarans, Hydros "plus" boat trailers. New "How To Build Boat Trailers" book \$4.00 ppd. Glen Designs, 9152 Rosecrans, Bellflower, Calif. 90706.

KAYAKS—One-man \$21.00; two-man \$26.00; Sailboats \$45.50. Exciting Sitka Kayak Kits known world wide for speed and safety. Assemble in one afternoon. Free pictorial literature. Box 582-P, Willoughby, Ohio 44094.

FIBERGLASS CANOES. Four Exciting Models. Easily Assembled Kits. \$39.95 up. Factory Direct. Free Literature. Riverside Canoes, Box 5595-B, Riverside, California 92507.

BOAT maintenance information. LIFE-CALK, "GIT"-ROT, RUB-R-COTE, Finishes & Cleaners. Send for "How to do Where to do" literature. FREE. Boatlife, 5-45 49th Av., L.I.C., N.Y. 11101.

FREE CATALOG from manufacturer of nylon and Dacron rope. Direct to you at dealer cost. Other important accessories. Write: West Products, Dept. 20, Box 707, Newark, New Jersey 07101.

SUPER Or simple: Canoe, Kayak, Sailing Rig, Accessory plans. Free catalogue. Quicksilver, 115 McGavock, Nashville, Tenn. 37214.

BOAT Kits. Molded Fiberglass. Save money—assemble yourself. Factory molded sections bond into one-piece craft. 30 models—14' to 33'. Cruisers, Runabouts, Houseboats, Sailboats. Big line accessories, motors, trailers. Easy terms. Free 88 page catalog. Luger, Dept. BC-69, 9200 Interstate 35 W. South, Minneapolis, Minnesota 55431.

NEW 1969 McCulloch And Other Outboards. 4 H.P. \$112 . . . 9 Electric \$288 . . . 18 \$338 . . . 25 \$378 . . . 40 Electric \$548 . . . 55 Electric \$748 . . . All Sizes. Literature 50¢ Electra Marine, 1427 Broadway, Brooklyn, N.Y. 11221.

AMATEUR Boat Building Magazine—instructions, plans, kits, discounts, books. Sample 50¢. 111-B Woodcrest, White Plains, N.Y. 10604.

MARINE EQUIPMENT AND SERVICES

CONVERT Auto engines to marine. 68 Page Catalog. 50¢. Lehman Manufacturing Company, 800 Elizabeth Avenue, Linden 4, New Jersey 07036.

NEW. Used, rebuilt marine motors. Marine conversions, fittings. Free catalog. Stokes Marine Supply, Dept. 24, Coldwater, Michigan 49036.

BIG Discounts—Conversion Kits—Marine Engines—Manifolds—Transmissions—Outdrives—Free Brochure. Star Marine, Berkeley, California 94710.

FREE Catalog—Gray inboard, inboard-outboard marine engines—gasoline, diesel. Graymarine Corporation, Coldwater, Michigan 49036 or Berkeley, California 94710.

FREE Pontoon Boat Catalog. Dock Brackets, Float Brackets, Mooring Bars, Dock Ladders. Perma-D Marine Products, Dept. 35, 2308 Central Ave., Minneapolis, Minn. 55418.

EMERGENCY Marine Case-Cylindrical (4" dia. x 22") screw top case, perfect for carrying flares, flashlights, tools, first-aid, etc. Tough break proof plastic. Water tight. Government surplus. \$3.00 ppd. Sports Craft Co., Box 144, Muskegon, Mich. 49443.

COMPETITION Marine Equipment. Over 300 items for complete auto conversions and installations in high performance SK and ski boats. Mail \$1.00 for new 72 page catalog complete with photos, specifications and prices. Glenwood Marine, Dept. PM. 1627 W. El Segundo Blvd., Gardena, Calif. 90249.

ATHLETIC AND BODY BUILDING COURSES

"GIANT Arms." Dr. Young's, D.C. revolutionary discovery. \$2. Satisfaction or refund. Gaucho, Box 9309-S7, Chicago 60690.

POWERFUL Muscles fast! Free brochure! Universal Bodybuilding. Box 4327-C, Dearborn, Michigan 48126.

BIG Muscles fast, complete course \$5.00. Olympus Bodybuilding, Box 431, Garden City, Michigan 48135.

BEAUTIFUL MUSCLES FOREVER. ORDER TODAY—COMPLETE COURSE RUSHED WITHIN ONE WEEK—APPLY ENTHUSIASTICALLY FOR 150 DAYS—HAVE FAITH, NEVER GIVE UP. IT'S EASY, FABULOUS BUILD MUST RESULT, FAILURE IMPOSSIBLE. SUCCESS A99, BOX 1434, MUSKOGEE, OKLAHOMA 74401.

FEAR No bully! Master Authentic Chinese Kungfu Unbeatable Techniques! Defeat Within Seconds Any Attacker Including Giant Judo-Karate Experts. Free Details By Air Write Asia's Greatest Master, Leongfu (MI/42) 119 Anderson Road, Ipoh, Malaysia.

SPORTING GOODS AND EQUIPMENT

FREE . . . Wholesale Catalog, Arrow Shafts, Broadheads, Fletchings, Fisharrow Parts, Tools, Bows, Finnyports, (22G). Toledo, Ohio 43614.

IF YOU Fish or Hunt 9 Tools In One makes your trip complete. Finest Rust Resistant Drop Forged Steel. Details Free. F. McBride, 480 Pepper Street, Pasadena, California 91103.

FREE 1969 Catalog. Guaranteed Lowest Prices! Rods Reels, Lures, Accessories—Thousands of Items. Cabela's Inc., Dept S, Sidney, Nebraska 69162.



FISHING, TACKLE, LURES

SEND for FREE Wholesale Catalog. The most complete and fully illustrated catalog of reels, rods, beads, spinners, jigs, bodies and parts, sinker molds, feathers, tools, hooks, rod blanks, rod parts, swivels, wire, etc. FINNYSPOITS, ME Sports Bldg., Toledo, Ohio 43614.

MOLDS—For casting your own fishing sinkers. Free illustrated booklet. Reading Instrument Co., Box P78, Reading, Pa. 19603.

MOLDS For fisherman's sinkers, jigs, squids, casting and spinning lures. Free catalog. Sweets Molds, Tonawanda 1, New York 14150.

EARTHWORMS, LIVE BAIT

EARN Money raising fishworms for us! Exciting details free! Oakhaven—56, Cedar Hill, Texas 75104.

MAKE Money growing Fishworms. Outstanding new breed. Large size, tough, hardy. Plenty of action. They sell on sight. Free information. Pain's Hatchery-31, Edinburg, Georgia 31746.

BLACK Widow Spider Ranchers wanted!! Tremendous profits! Complete program \$1 (refundable). NBWC, Box 260-PM2A, Brigham City, Utah 84302.

FROGS, FISH, REPTILES

PROFITS FROM CLASSIFIED ADVERTISING!! Booklet shows you how to start your own business with Classified Advertising. Only \$1.00 (Refundable with first order.) C. A. Martin, Popular Mechanics, Dept. PM, 575 Lexington Avenue, New York 10022.



HUNTING, GUNS, DECOYS

IMPORTED Hunter's knife, famous Solingen 5" stainless blade simulated stag handle. Gift boxed with guarantee certificate. \$8.95 Postpaid. Marianca, Box 176, Bergenfield, N.J. 07621.



DOGS AND KENNELS

PROFITS FROM CLASSIFIED ADVERTISING!! Booklet shows you how to start your own business with Classified Advertising. Only \$1.00 (Refundable with first order.) C. A. Martin, Popular Mechanics, Dept. PM, 575 Lexington Avenue, New York 10022.



GAME BIRDS

QUAILS, Incubators, cages, supplies catalog. Marsh, 14216 Brookhurst, Garden Grove, Calif. 92640.

RABBITS—FUR BEARING ANIMALS

RAISE Rabbits for us on \$500 month plan. Free details. White's Rabbitry, Mt. Vernon, Ohio 43050.

RAISE Rabbits successfully by knowing facts. 48 page illustrated book describing 25 breeds. Housing, breeding, feeding, markets, marketing etc. 25 cents. American Rabbit Association, 36 Arba Building, Pittsburgh, Penn. 15217.

MAKE Big Money raising chinchillas, rabbits, guinea pigs for us, Catalog—25¢. Keeney Brothers, New Freedom, Pa. 17349.

EARN \$10,000 Yearly raising angora rabbit wool, and breeding stock for us. Information 25¢ coin. American Angora Company, Malta 12, Montana 59538.

\$500 - \$800 MONTHLY Raise small laboratory-breeding stock for us. We supply equipment, breeders, and instructions. Illinois Research Farms, Dept. MPB-9, McHenry, Illinois 60050.

TAXIDERMY

PROFITS FROM CLASSIFIED ADVERTISING!! Booklet shows you how to start your own business with Classified Advertising. Only \$1.00 (Refundable with first order.) C. A. Martin, Popular Mechanics, Dept. P.M., 575 Lexington Avenue, New York 10022.

PETS—BIRDS, CATS, HAMSTERS, ETC.

LIVE Traps, all sizes, mouse to dog. Collapsible or rigid. Carrying Cages. Free literature. National Live Traps, Tomahawk, Wisconsin 54487.

HAWKS, Reptiles, raccoons, skunks, squirrels. Catalogue 25¢. Trails End Zoo, St. Stephens, S.C. 29479.

CHICK-U-BATOR, see eggs hatch before your eyes, complete with instructions \$6.95. Collectors Wonderland, Box 1170, New York 10008.

MINIATURE Parrots that can learn to talk, \$24.95. Many others. Catalog 10¢. International, Box 2424, Mesa, Arizona 85201.

LIVE SEAHORSES, Marine Specimens, aquarium supplies. Illustrated catalog 20¢. Marine, Box 248-310 Dania, Florida 33004.

HORSES, LIVESTOCK

"HOW To Train Horses"—Everyone who likes horses or ponies should have this book; Free. Write Berry School, 1109, Pleasant Hill, Ohio 45359.

CAMPING EQUIPMENT AND TENTS

SAVINGS Plus dividends! Campers-fishermen-outdoorsmen cooperative. Free 68-page catalog. Recreational Equipment, Inc., 1525-P 11th, Seattle, Washington 98122.

FREE Catalog! Camping, Boating, Sailing Supplies; Gadgets, Hardware and Gifts, Laacke and Joy, 1439 N. Water St., Milwaukee, Wisconsin 53202.

CAMPING

YOUR Ad in Popular Mechanics will be seen by more than 5,000,000 active buyers for your products and services. It costs only \$1.85 per word. And, if you wish to run all or part of your ad in capital letters—you can do so for as little as 75¢ per word additional. Act now! Place your classified ad in Popular Mechanics today.

TRAVEL AND RESORTS

WILDERNESS CANOE TRIPS. Free brochure. Bill Rom's Outfitting, Ely, Minnesota 55731.

ELECTRICAL SUPPLIES

I MADE Over \$100,000.00 year selling by mail. IRS proof available. Success story, book form \$2.00. Wayne Johnson, 880 SW 60th Avenue, Ft. Lauderdale, Florida 33314.

METERS—Surplus, new, used, panel and portable. Send for list. Hanchett, Box 5577, Riverside, Calif. 92507.

LAMP Parts. Catalog, prices, wiring instructions. 50¢. Refunded first order. Gyro, 5218P N.W. 35 Ave., Miami 42, Fla. 33133.

RUN Your Three-Phase Motors from Single-Phase with T-P Phase Converter. Prices and Literature. T-P Electric Corp., Odin, Illinois 62870.

LAMP Parts for building, repairing converting. Catalog 40 cents. Refunded first order. Brown Lamp Co., Box 12511, Creve Coeur, Mo. 63141.

LAMP-APPLIANCE Parts. Wholesale catalogue 25¢. Seco 109 South 20th Street, Birmingham, Alabama 35233.

BATTERIES, GENERATORS

BATTERY Reconditioning Kit, includes molds, material, instructions. Battery Shop, Route 1-188D, Blythe, Calif. 92225.

ENGINES, MOTORS, MAGNETS

WINDING Data, 275 motors, \$1.20. Data Company, 512 Kensington, Kansas City, Mo. 64124.

LIVE Steam powered backyard railroads! All sizes. Complete "bolt-together-kits," and rough castings. Excellent drawings. 100 page catalog \$1.00. Little Engines, Lomita, Calif. 90717.

ELECTRICAL Projects! Motors! Generators! Batteries! Electroplaters! Modequip. Box 10025, Kansas City, Mo. 64111.

STEAM Engine Kits—automotive, Marine. Catalog 50¢. Reliable Industries, New Baltimore, Michigan 48047.

MACHINERY, TOOLS AND SUPPLIES

I MADE Over \$100,000.00 year selling by mail. IRS proof available. Success story, book form \$2.00. Wayne Johnson, 880 SW 60th Avenue, Ft. Lauderdale, Florida 33314.

SMALL Foundry furnaces, Supplies. Free literature. Pyramid Products, 3736 South 7th Avenue, Phoenix, Arizona 85041.

MICROMETERS—Indicators—Rods—Lathes—Accessories. Campbell, 1424 Barclay, Springfield, Ohio 45505.

BENCH MILLING MACHINE, Little Jewel, large 17"X11" understandable blueprints \$2.00. Microm, Box 2313-H, Santa Ana, Calif. 92707.

TOOL catalog, over 200 pages of discount bargains. Send 50¢ refundable with first order. Schlessingers for Tools Ltd., 1020 East 54th St. Brooklyn, N.Y. 11234.

WELDING, SOLDERING, PLATING

CHROME Plating equipment, supplies. All other finishes. Home workshop and production sizes. Send \$2.00 (refundable) for formulas, operating data, equipment guide and catalog. HBS Equipment Division L50, 3543 East 16th, Los Angeles, Calif. 90023.

WELDERS—110 220, 150 Amperes, \$53.50. Morris, 1070 Inner, Schenectady, New York, 12303.

WELDOR'S TEST GUIDE. Free information. Everett Smith, Box 191PM, New Castle, Delaware 19720.

GOVERNMENT SURPLUS

I MADE Over \$100,000.00 year selling by mail. IRS proof available. Success story, book form \$2.00. Wayne Johnson, 880 SW 60th Avenue, Ft. Lauderdale, Florida 33314.

GOV'T Surplus. How and where to buy in your area. Send \$1.00, Surplus information. Headquarters Building, P.M., Washington, D.C. 20036.

1969 SURPLUS Army, Navy store illustrated catalog. Send 25¢ (refundable with first \$5.00 order). Ruvel, 707 Junior Terrace, Dept. 9-J, Chicago, Illinois 60613.

JEEPS Typically From \$53.90 . . . Trucks From \$78.40 . . . Airplanes, Typewriters, Boats, Clothing, Camping, Sporting, Photographic, Electronics Equipment. Wide Variety. Condition. 100,000 Bid Bargains Direct From Government Nationwide. Complete Sales Directory and Surplus Catalog \$1.00 (Deductible First \$10.00 Order). Surplus Service, Box 820-A, Holland, Michigan 49423.

JEEPS From—\$52.50! Typewriters from \$4.15; Cars from—\$31.50. Walkie-talkies, motorcycles, airplanes, boats. Typical "As Is" bid bargains from Uncle Sam. Tremendous variety. Exciting free list. Write: Enterprises, Box 402X50, Jamaica, New York 11430.

JEEP and Gov't. Surplus Buying Manual (Jeeps Pictured) 50¢. Surplus Bargain Catalogue 50¢. Both \$1. Bargain Surplus, Box 789PM, York, Penna. 17405.

JEEPS \$60.00, Typewriters \$4.00. Government Surplus bargains, Booklet #MO-59S \$1.00. Troutman House, 39-410 Marietta Circle, Cathedral City, California 92234.

CASH IN ON GOVERNMENT SURPLUSES. Eliminate middle men. Complete new Government Agency Directory, 187 addresses, zipcodes, and telephone numbers. Over 2000 free publications. \$3.00. Cover Box, 283-B, Kent, Ohio 44240.

GOVERNMENT SURPLUS Direct. Jeeps to Battleships low as 2¢ on Dollar. Information, Application, \$1.00. Surplus Bureau, Box 80-JM, Las Vegas, Nevada 89101.

HOBBIES AND COLLECTIONS

OUR FIRST 19 IN SPACE. This limited edition lithograph has been created as a tribute to Americas Gallant Astronauts. 12 X 18 inch chart ready for framing. Only 75 cents. Popular Mechanics, Dept. GWP, 575 Lexington Avenue, New York, New York 10022.

PRESIDENTIAL Campaign buttons. Free list. Bristow, Box 1460-P, Los Gatos, Calif. 95030.

50 GORGEOUS Jungle butterflies \$2.50. Collectors Wonderland, Box 1170, New York, 10008.

SHOULDER PATCHES—Official U.S. Army and Air Corps. Special patches made to order. 10 assorted patches, price list and catalog, \$2.00. Catalog only, 25¢. SPRINGER'S, Box 577, El Paso, Texas 79944.

COLLECT COINS For Profit! How To Start, Where To Sell. Lists of valuable coins. Check your change! Send \$1.00 Graylines Express, 4465A Janice Lee Dr., Okemos, Mich. 48864.

EMBLEMS, BRASSARDS, PATCHES

EMBROIDERED—Skull Devil, all sports, industrial, automotive, civic, fraternal, professional, fireman, \$1.00 each. Refundable. Staydry PM—Whitestone, New York 11357.



STAMP COLLECTING

PENNY! Approvals! Regardless catalogue! Kloster, 4164 52nd St., San Diego 5, Calif. 92105.

500 DIFFERENT Stamps, \$1.00. Smith, 508-A Brooks, College Station, Texas 77840.

50 YEARS Old, fifteen different United States, over fifty years old—10¢ with approvals. Jaxon, Box 145-P, Brooklyn, New York 11230.

50 DIFFERENT United States, only 10¢, with Approvals. Shelton, Box 547C, North Miami, Florida 33161.

"AFRICA" 25 beauties, 10¢. Approvals, Gorriz, Box 1915PM, Naples, Florida 33940.

MILLIONS Foreign Stamps! 2¢ each! Send for gigantic approvals! ABC, Box 6000-MB, San Francisco, California 94101.

FREE Surprise collection sent with approvals. Gould, 1784 Union, San Francisco 94123.

50 DIFFERENT Old U.S. Revenue stamps 50¢. Winchester Stamps, Box 1592, Mansfield, Ohio 44907.

FREE!! Two Beautiful Multi-Colored Complete Mint Sets. Approvals, Hamilton, 1246 Pratt, Chicago OE-9, Illinois 60626.

FREE 50 Worldwide. Approvals, University Stamps, P.O. Box 1471, Lake Worth, Florida 33460.

"RUSSIAN Bear in Berlin Set. Only 10¢. Approvals, Ken Zielski, Box 364-M, Morton Grove, Illinois 60053."

WORLDWIDE Approvals, Humphrey, 805 24th Ave., Santa Cruz, Calif. 95060.

UNITED States commemorative collection containing 33 different—10¢. Approvals, White, 516-A Avenue L, Brooklyn 30, New York.

GIANT Stamp Collection including: Astronauts, Satellites, Moonrockets, Boy Scout issue, Complete U.N. Set, recent Olympic and Sport issues from many countries, etc., Plus Big Stamp Dictionary and approvals. Everything, 10¢! Stampex, Box 47-RM, White Plains, N.Y.

ABSOLUTELY Free 25 different United States Commemoratives when requesting United States Approvals, K & B, Box 70, Brooklyn, N.Y. 11223.

PENNY Stamps! 1000 Mounted in book at 1¢ each. Trust Stamp Company, P.O.B. 132-P, Jamaica, N.Y. 11435.

1500 FOREIGN \$1.00; 5000 \$3.00; 9000 \$5.00. 5000 USA \$3.00, contains airm. dues, 19th Century, presidentials, revenues, high values, etc. 200 large size only (your choice of USA or foreign) pictorials and commemoratives \$1.00; 700 \$3.00; 3000 \$12.00. No approvals. Meyers, 5321 Fleming, Richmond, Calif.

VATICAN Xmas Set 60¢ Approvals, Baricks, POB 7154, Detroit, Mich. 48202.

EXCHANGE, Send 100-200 Different stamps with 25¢. Receive different. Paterson, Lancaster, New York 14086.

100 OLD United States between 1861 and 1935, \$1.00. Roush Stamps, 51 Chestnut, Mansfield, Ohio 44903.

FREE! Big Bargain Catalog—New Edition listing thousands of bargains including U.S. & B.N.A. stamps, packets, albums, accessories and supplies. Also, fine stamps from our approval service which you may return without purchases and cancel service at any time. Jamestown Stamp, Dept. E99PM, Jamestown, N.Y. 14701.

WOW! 110 All Different Germany 10¢. Commemoratives, Airmails, High Values, Big catalog, bargain lists. Also, fine stamps from our approval service, which you may return without purchases and cancel service at any time. Jamestown Stamp, Dept. A99PM, Jamestown, N.Y. 14701.

PICTORIALS Galore—Large Beauties! Terrific Collection includes exciting Outer Space, colorful sports, animals, unusual triangles, diamonds plus many others. Only 10¢. Approvals accompany. Send Today! Shaw, Drawer E-44, Montevallo, Alabama 35115.

COUNTRY Collections: Free List. High Value Packet \$2. Persile, 436 New York Ave., Brooklyn, N.Y. 11225.

U.S. Mint specials! Flag set, complete \$1.00, 1¢, 2¢, 3¢ famous Americans (21 different) \$1.00. Free list, Brooks, 2601 Avenue "U," Brooklyn, N.Y. 11229.

ONE Pound value Geo. VI Bermuda, plus 100 worldwide 10¢. approvals. Stevens, Box 105A, Homecrest Sta., Brooklyn, N.Y. 11229.

U.S. Bargain, 50 different 10¢, with beautiful worldwide approvals. Stamp Center, Kennebunk, Maine 04043.

FREE! Triangles, Scout, 25 others. Approvals, Cambridge, Box 411, Cambridge, Ohio 43725.

50 DIFFERENT U.S. Commemoratives, 10¢. Approvals, Cambridge, Box 411, Cambridge, Ohio 43725.

"INVERTED ERROR" Dag Hammarak-jold, 6¢ with approvals. Belmont Stamps, Washington, D. C. 20015.

NEW Countries, New Issues, Free gift with approvals. Ernest, 1784 Union, San Francisco 94123.

14,000 DIFFERENT! AMAZING new plan builds your collection systematically, country by country. Only 50¢ weekly. Ware, Monroe, Conn. 06468.

RUSSIAN Space set 10¢. Russian approvals. Snedco, Box 68-P, Waldwick, N.J.

TOPICALS—Three Colorful Sets, 10¢! Approvals, COLE, Box 223-A, Buffalo, N.Y. 14221.

U.S. Approvals Low prices. Eagle, 2221 Romine Ave., Pittsburgh, Pa. 15226.

2,000,000 STAMPS, 150 Countries, 2¢ each. Beiden, Box 4175, Dearborn, Mich. 48126.

NUDE Goya (1930), Scott value \$1.00, superb sparkling mint, only 50¢. Approvals, George Bell, Barnes, Milton, Florida 32570.

225 STAMPS for only 10¢! Airmails, Pictorials; stamps from strange countries cataloging up to 25¢ each! Plus unusual stamps to examine. Buy any or none return balance, cancel service anytime. Mystic Stamp Co., Camden 80, New York 13316.

RUSSIA High-Value Collection. 32 different Russia—some over 50 years old! Commemoratives, Czarist Issues, Airmails, Catalog price \$2.50. Special Get-Acquainted Offer—all for only 10¢! H. E. Harris, Dept. GG-49, Boston, Mass. 02117.

AFRICAN TRIANGLES! Plus Van Dyck Art, Kennedy Memorial, Sport Championships, Colorful Insects, Plus big bonus collection of 25 exotic Persia. All only 10¢! Approvals included, Yukon, Dept. K, Box 834, Church Station, New York, N.Y. 10008.

500 COLORFUL Stamps 25¢ with approvals. Eric's, Box 1444, Kitchener, Ont., Canada.

FREE! \$1.00 GIFT CERTIFICATE! Plus Stamp Bulletin—Bonus Offers. No Approvals! Richley Stamps, P.O. Box 444, Dunellen, N.J. 08812.

BEAUTIFUL Topical Collection—includes Olympic sports stamps, wild animals, bicolor triangles, colorful birds, outer space stamps, Poland kitten stamp, and others. 10¢ with approvals. Clark Stamps, Dept. 57A, Muskegon, Mich. 49444.

RARE Stamp Free! Also new packet Aden to Urundi, with Kennedy, Triangles, Space, Sports, Ships, Dogs, Cats, Reptiles, Plus others. All Free. Send 10¢ for mailing. Empire Stamp Co., Dept. 1, Toronto, Canada.

POLAND 25 Different Pictorials 5¢. Approvals. Hijop Box 505, Norristown, Pa. 19404.

EISENHOWER airmail (mint) from Brazil plus mystery collection containing thirty fascinating and interesting "oldies," all for 10¢ with Worldwide approvals. Henry Smith, 31 Garland, Willingboro, N.J. 08046.

2¢, 3¢ APPROVALS. Other Bargains. Pam, Box 22092, Memphis, Tenn. 38122.

FREE Collection with approvals. Merlo, 1527 Anderson Ave., Fort Lee, New Jersey 07024.

EXOTIC ORIENTALS—200 Different only \$1.00 with bargain approvals. Edward Moore, Box 664, Smyrna, Georgia 30080.

50 PAINTINGS \$1.00! No approvals. Ross, Box 152, Wayne, Pa. 19087.

TWENTY Large Stamps, only 10¢! Colorful recent issues, older pictorials. Fascinating Foreign approvals accompany. Sundal, 1803-P Southwest Sixth Avenue, Austin, Minnesota 55912.

FREE! 55 Triangles, Space, Others, Nice, Low-Cost Approvals, L. Baird, PM-23, Box 8128, Portland, Oregon 97207.

50 GREAT BRITAIN from 1881 to date. Catalog price \$2.60—Introductory offer—only 10¢ with approvals. Roger Williams Stamp Co., Box 1281-P2 Pawtucket, R.I. 02862.

FREE Large Colorful Pictorials with Approvals W. Lamkin, Farmington, Maine 04938.

210 DIFFERENT U.S. Commemoratives \$1.00. Stamps, 7607 Larchview Drive, Dallas, Texas 75240.

125 - WONDERLAND Collection, Paintings, Rockets, Triangles, 10¢ With Approvals, Dealing, Box 185, Long Lake, Minnesota 55356.

FREE Stamp Wallet with approvals. Wide choice collections by Countries. Clark, Box 428, Northbrook, Illinois 60062.

5,000 GRAB Bags dollar each! Stamp Service, 1498/22, Huntsville, Ontario, Canada.

VIETNAM 25 Different 10¢ approval. Sam Chazen, Box 95, Ozone Park, N.Y. 11417.

POLAND—25 different beauties, 10¢. approvals. Tarheel Philatelics, Siler City, North Carolina 27344.

RUSSIAN Colorful Topical Set Free! Approvals. Iannuzzi, Box 76241-PM, Los Angeles 90005.

LAST CHANCE! My summer sale of Europe, British Empire, packets, sets, singles, U.S. ends September 30th! Write for free lists today! Faville, Box 4164 Brookwood, Madison, Wis. 53711.

SWAZILAND Latest African Animals—Crocodiles, Elephants, Deers,—Free! Approvals plus 101 Bonus Sets, William Deems, 226 Race, Ravenswood, West Virginia 26164.

AUSTRALIA, 100 Different, only 25¢. Farrell, Box 231 Plainview, New York 11803.

DWIGHT EISENHOWER Memorial stamp on special cacheted envelope addressed to you. Will have official Oct. 14 First day postal marking from Abilene, Kansas. 35¢ each or 3 for \$1. K. M. Walsh, Box 308, Tuckahoe, N.Y. 10707.

FREE Surprise Bonus with Approvals. Collier, Box 755, Folkston, Ga. 31537.

TEN Different Nudes: 20¢. Approvals, Stamp Farm, 2M10, Oxford, Wis. 53952.

WORLDWIDE Packet Free. Penny approvals. Froehlich, Box 7, Waukegan, Illinois 60085.

COINS, TOKENS, CURRENCY

PRICE List. Send 10¢. Village Coin Shop, Dept. P, Plaistow, N.H. 03865.

UNITED STATES Specials: Half Dime before 1873, \$3.00; Large Cent before 1857, \$3.00; 1893 Columbian World's Fair Half Dollar, \$3.00; Old style Large \$5.00 bill, \$12.00; All four offers \$20.00. Moneyback Guarantee. Raroca, 31-A, North Clark, Chicago 60602.

UNCIRCULATED Dollars, 1880-81-82 S, 1883-84-85-1899-1900 01-02 O mint, \$3.50 ea. Catalogue 50¢. Shultz, Salt Lake City, Utah 84110.

5,000 PENNIES GUARANTEED unpicked from our vending machines, 55.00 First Vending Company, Box PM, 5322 Belmont, Chicago, Illinois 60641.

FREE Bargain Lists—35 Different brilliant uncirculated Lincolns plus 2 Free Albums (\$6.95 Value) Special \$3.50; Ten Indianheads \$2.75; Five V-Nickels \$1.50; Silver Dollars \$2.25 Each. Pacificoin, Box 274-M, Downey, California 90240.

SCARCE Date Jefferson nickels. All V.G. Satisfaction Guaranteed. 1942-D—1949S—1950—50¢ each. 1943D—1951S—1955—75¢ each. 1939S—\$1.25. 1938D—\$1.65. 1938S—\$3.25. 1938D—\$5.00. 1950D—\$14.50. Dates not listed 20¢ each. Bryson Inc., 612A White, Toledo, Ohio 43605.

50 MIXED "S" cents, includes uncirculated 1955S, new 1968S, 1969S. Only \$1.95. BONANZA, Box 820F, Cupertino, Calif. 95014.

LINCOLNS: 22 "S" including 1955S, \$1.60, 26 1909-1939, \$1.60, 10 "S" Jeffersons, \$1.60, 10 "S" Roosevelts (1946S-1955S complete), \$3.25. All different. All four \$7.75. Silver Dollars \$2.45 each. Pricelist 10¢. Robert HARRIS, 2373P Pruneridge, Santa Clara, California 95050.

40-PAGE Illustrated United States and Canadian coin list 10¢. Stoney, 260 Washington, Boston 8, Mass.

SIX Different Mercury Dimes \$1.00. Bargain Lists Free. Sayers, 1000 Unaka, Johnson City, Tennessee 37601.

MAKE Money with coins. Full details \$2.00. Thomas, Box 158F, Staten Island, NY 10309.

GOLD! Nine California Souvenir Coins! \$4.95 Fairway 121-P Rye, New York 10580.

FLYING Eagle Cent \$3.25 Terrific List! Nelson 346-P Rye, New York 10580.

LINCOLN'S: 1927, 1928, 1929 only 10¢. Stevens, Box 546F, North Miami, Florida 33161.

SPACE Metal 1000 mintage bronze \$2.75. Silver \$12.75. Noah, Box 466, Camarillo, California 93010.

BARGAIN Coin list 10¢. Merlo, 1527 Anderson Avenue, Fort Lee, N.J. 07024.

BRILLIANT Proof Sets: 1957—\$7.35, 1958—\$14.95, 1959—\$8.45, 1960—\$6.95, 1961—1962—1963—each \$5.15, 1964—\$8.45, 1968—\$10.95, 1969—\$8.75. Bargain Lists 25¢. Bebee's Incorp. Omaha, Nebraska 68111.

HARD To find "S" mint cents 1940-S thru 1969-S \$1.50. Kennedy-Lincoln strange but true set in holder \$1.75. Sonner, Box 5049C, Sherman Oaks, Calif. 91413.

1852-1858 "50¢ CALIFORNIA Gold Pieces". All seven different, mounted in gift box presentation. With framable parchment map of old California. \$4.50. Heritage Society of America, 422 Washington Building, Washington, D.C. 20005. Souvenirs Guaranteed!

ANTIQUES, RELICS, INDIAN GOODS AND CURIOS

TONS Of antique gun parts and supplies. All reproduction muzzle loading guns. Send \$1.00 for enlarged illustrated catalog No. 118-A. Dixie Gun Works, Union City 12, Tennessee.

LIST Indian relics, 10 Arrowheads \$3.00. Hyde's, Box 2304, Santa Fe, New Mexico 87501.

10 BEAUTIFUL Arrowheads Two Dollars. Guajardo's, 8713 Shaver, El Paso, Texas 79925.

SWORDS—Send 75¢ For Brochure. Toledo Imports, Box 504, Winston-Salem, North Carolina 27102.

MODELS—SHIPS, TRAINS, PLANES, ETC.

ROCKETS: Real flying models—flights up to 2500 ft. New illustrated catalog 25¢. Single and multistage kits, cones, engines, launchers, trackers, rocket aerial cameras, technical information. Fast service. Estes Industries, Penrose 2, Colorado 81240.

SHIP And yacht model fittings; Pine construction hull kits; blueprints. Send 50¢ for illustrated catalog. A. J. Fisher, Inc., 1002 Etowah Avenue, Royal Oak, Michigan 48067.

SHIP Model kits and fittings: clippers, frigates, etc. Catalog paint-tool list, 1969 catalog 50¢. Models Shipways, Box 65, Bogota, N.J. 07603.

SHIP Models, Kits, fittings, plans, books, tools, engines, motors. Big illustrated catalog 50¢. Mass. residents add 3% tax. James Bliss & Co., Dept. SM, Route 128, Dedham, Mass. 02026.

SHIP Models catalog 25¢. Scientific, Inc., 100 Monroe, Newark, N.J. 07105.

MODEL Airplanes—Big 220 Page Catalog 50¢. Sig Company, Montezuma, Iowa 50171.

LIVE Steam Engine Kits. Fascinating Hobby for Model Mechanics. Boilers, Fittings, Accessories. Pictured Catalog \$1.00. H.P.K. Models, Centuck 34, Yonkers P, New York 10710.

GAMES, TOYS, PUZZLES, NOVELTIES

"ROULETTE DICE" . . . a number, color, column, dozen, Hi-Lo, odd or even, etc., turns up on each roll. Only \$2.00. DETAILS FREE. D.E. Products & CO. Box 488, Worcester, Mass. 01601.

FOR A gentle mental massage, try TACKLE—\$1 from WFF 'N PROOF Publishers, Box 71-EZ, New Haven Ct. 06501.

FASCINATING New game. All ages. Unbreakable. Money promptly returned if not satisfied. \$2.00—VanElk Enterprises, Box 783, Buffalo NY 14240.

BLAST Off! Toy rocket soars 600'. No chemicals, batteries, explosives. Nose cone separates from body. Both parachute back for relaunch. \$3.98. Pier House, Room 8, Commonwealth Pier 5, Boston, Mass. 02210.

MAGIC TRICKS, JOKES, VENTRILOQUISM

HOUDINI'S Original Magic Shop. Established 1856. Send 25 cents for Illustrated Catalog containing 5000 Tricks, Mindreading, Puzzles, Hypnotism and Jokes. Flossie-Hornmann, 304 West 34th St., N.Y. 10001.

HOUDINI Magic Catalog!! Giant Professional Deluxe Edition!! 1000 World's Greatest Tricks!! 25¢ with Free Gift Certificate!! House of 1000 Mysteries. Dept. PM9C, Northeast Fifth Ave., Ft. Lauderdale, Florida 33308.

500 TRICKS Catalog. 1969 Edition, showing latest magic for pocket, parlor, stage. Only 10¢. Fastest mail service for 45 years. Douglas Magicland, Dept. 11, Dallas, Texas 75221.

BE A Magician! Two booklets explaining sixty-eight tricks plus large professional catalog. \$1.00. Magic, Inc., 5082 Lincoln, Chicago, Illinois 60625.

VENTRILOQUISM! Information free! Dummy catalog, 25¢. State age. Maher, Studio 1, Box 8356, Kensington Station, Detroit, Michigan 48224.

COMPLETELY Illustrated catalog. 84 pages, 25¢. Manhattan Magic, Box 334-M, N.Y.C. 10011.

WORLD'S Finest professional magic tricks. Joker's Novelties. Giant illustrated catalog 10¢. Top Hat, Evanston, Illinois.

MAGIC MAGAZINE—Monthly since 1936. 44 pages. All phases. 3 month trial \$1.00. Genil, P.O. Box 36068, Los Angeles, CA 90036.

CATALOG \$26, 175 pages, 25¢ (1,500.-399 tricks, jokes, novelties). Elbee, 7408-P, San Antonio, Texas 78207.

MAGIC Catalog. World's finest 3000 tricks. (340) pages \$2.50. Beginners, amateurs, professionals. Kanter's, A-200 South 13th St., Philadelphia, Pa. 19107.

AMATEUR and PROFESSIONAL MAGICIANS all new magic tricks and gags catalog 25¢. Our specialty same day service. Fabulous Trick and Magic, 3319 E. Charleston, Las Vegas, Nevada 89104.

FREE! World's Leading Catalog 2000 Novelties, Jokes, Tricks, Scientific Gadgets, Hobbies. Johnson-Smith, D-191, Detroit, Michigan 48224.

FREE Ventriloquism Information on Dummy's — Books — Records — Mouthpiece 25¢—STAVDRY - Whitestone, New York.

VENTRILOQUISM! Unique "listen-and-learn" method. Write. Show-Biz, 1735-P East 26th Street, Brooklyn, N.Y. 11229.

CARD Tricks—Get 10 of the world's easiest and most amazing card tricks for party or parlor. \$1.00. Trix, Box 2929, Milwaukee, Wisconsin 53218.

MINDREADING Trick Cards Plus Catalog. Send 25¢. Ace Magic, Box 329, Evanston, Illinois 60204.

BOOKS, CATALOGS, NEWSPAPERS

NATIONAL Geographic Magazines, 1888-1967, any issue. Buxbaum, Box 465-PM, Wilmington, Delaware 19899.

PROPHET Elijah coming before Christ. Wonderful book free. E. Megiddo Mission, 481 Thurston Rd., Rochester, New York 14619.

BACK Date Magazines! Send needs. Midtown, Box 917-PM, Maywood, N.J. 07607.

SEND for a FASCINATING List of OCCULT Books to The Aquarian Age, Dept. 7-74 Winthrop Street, Cambridge, Massachusetts 02138.

SECRET Of Bowling Strikes \$2. Gene Chiasson, 507 West 8th Street, Dept. 695, Thibodaux, Louisiana 70301.

PAPERBACK Catalogue. 270 pages, 15,000 titles, subject indexed. \$1.00, credited toward order. New York Book, 4 P West 43 Street, N.Y.C. 10036.

FREE Brochure, Interesting Books, True Value Products. Box 903, Salt Lake City, Utah 84110.

LEARN to relax booklet tells all. \$1.00 postpaid. Pinetree Enterprises, 7 Pinetree Road, Old Bridge, New Jersey 08857.

BOOKS. Free catalog, on every subject. Courtesy Service, Box 15307, Las Vegas, Nevada 89114.

NOW Available! Low cost editions of 73 famous self improvement books. Folder free. Merchandise Enterprises, 6063 N. Piedra Rd., Piedra, Calif. 93649.

"GOOD NEWS For Modern Man." Today's English New Testament \$1.00. Crusade, 1014-A Woodhaven, Lynchburg, Virginia 24502.

PUBLISH Your book! Join our successful authors: All subjects invited. Send for free appraisal and detailed booklet. Carlton Press, Dept. PM-U, 84 Fifth Avenue, New York 10011.

HOW to get Success, Wealth, Happiness, Health. How to solve personal problems. Free list low cost books. M. Wyatt, 7713R Laramore, Sacramento, Calif. 95832.

PLANT MANAGERS: The ABC'S of Lubrication booklet for training personnel. \$2.00. Jess Carpenter, 1001 Usher St., Ft. Worth, Texas 76126.

FREE List of low cost interesting practical books. McAllister Sales, PM9, Box 13128, St. Louis, Mo. 63119.

READ Suggested books, for Self-Improvement. Free list, including Gifts Catalog. Distributors, 2574 North Cornelia, Fresno, Calif. 93705.

BOOK Sale. Write Modern Gift House, Dept PMA, 177 Granite Street, Mexico, Maine 04257.

FREE List! Personal Self Improvement Books. L. Cricket, Box 527, Ardmore, Penna 19003.

WHERE TO RETIRE OR VACATION. Norman Ford's 100,000 Word Book, covers hundreds of World Paradises. Only \$2.00. James House, 1714 Que St. N. W. Washington, D. C. 20009.

PLAYS, STORIES, MANUSCRIPTS

WANT Your book published? Learn how we publish, advertise, promote, distribute. Many successes. Free booklet PM, Vantage, 120 West 31, New York City.

FREE: HOW TO GET YOUR BOOK PUBLISHED right away, at low cost. For valuable, fact-filled book, FREE, write: Pageant Press International, Dept. N-2, 101 Fifth Avenue, New York, N.Y. 10003.

BUSINESS OPPORTUNITIES

I MADE Over \$100,000.00 year selling by mail. IRS proof available. Success story, book form \$2.00. Wayne Johnson, 880 SW 60th Avenue, Ft. Lauderdale, Florida 33314.

HUGE Profits! Mail order importing. Free information. ITIS, PM-9, Box 454, Hollywood, Calif. 90028.

WANT To make big money at home! \$10.00 profit in an hour possible with invisible mending. Make tears, holes disappear from clothing, fabrics. Steady year-round demand from cleaners, laundries, homes. Details free. Fabricon, 1585 Howard, Chicago 60626.

CONCRETE FACTS: Highly profitable home business. Experience unnecessary. Unlimited unique pottery designs easily made without moulds. Birdbaths, fountains, wishing-wells, benches, etc. Chemical coloring formulas, marbling. **FREE** illustrated brochure. Hollywood Cementcraft, 602 Athens Street, Altadena, California 91001.

WORLD'S Largest supply. Merchandise 25% to 40% under wholesale. Bankrupts, closeouts 10¢ under dollar. Imports. Hong-kong clothes. Automobile discounts. Free details. International Buyers, Box 4633-MM, Colorado Springs, Colo. 80909.

RAISE Rabbits for us on \$500 month plan. Free details. White's Rabbitry, Mt. Vernon, Ohio 43050.

FREE "Franchise Profit Letter" tells how unique NFR service is helping thousands seeking profitable businesses. Write today. National Franchise Reports, W-528, 333 North Michigan, Chicago 60601.

\$400.00 MONTHLY Raising giant fishworms. Soilless method. Charlie Morgan, Bushnell, Florida 33513.

EARN Money raising fishworms for us! Write: Oakhaven-38, Cedar Hill, Texas 75104.

400,000 BARGAINS Below wholesale! Many free. Liquidations . . . closeouts . . . job lots . . . single samples. Free details. Bargainhunters Opportunities, Box 730A, Holland, Michigan 49423.

BUILD Custom Cases at home for profit. Get orders by mail. We supply materials, instruction—everything. Free home business details. Custom Case Supply Co., 7630-CPI, Gloria Ave., Van Nuys, Calif. 91496.

VENDING Machines. No selling. Operate a route of coin machines and earn amazing profits. 32-page catalogue free. Parkway Machine Corporation, 715 PMB Ensor Street, Baltimore, Maryland 21202.

ADDRESSERS And mailers needed. Send stamp for information. Lindbloom, 3636 West Peterson, Chicago 60645.

FREE Book "990 Successful, Little-Known Businesses." Work Home! Plymouth-372-J, Brooklyn, New York 11218.

MAKE \$75.00 daily distributing tools to service stations. Free Plan. INKA, 2401 Crocker, Houston, Texas 77006.

ESTABLISH Profitable Catalog Mailorder Business! Vikari's, Box 1312PM-I, Salt Lake City, Utah 84110.

STOP Throwing Away Those Bostops! They're worth money, some 25¢ each! Write: Bostops—BO, Cedar Hill, Texas 75104.

ADVERTISING BUSINESS—YOU own it. \$350 First Week or Money Back. Electric Neon Action Ad Clock, 229 W. Illinois, Chicago 60610.

JOIN "MONEY GETTER'S GUILD". Receive hundreds money-making. Business Building Propositions. Year's membership only 25¢. Write: Fourstars, Box 839, Long Beach, New York 11561.

\$21.00 HOUR Profit—From Home Picture Framing Business. (Clampless Assembly Method) Write: Japs, 126-PM Seventh North, Hopkins, Minnesota 55343.

UNLOCK Your Future. Become professional Locksmith by spare time home-study. Make up to \$6 per hour. All tools, equipment incl. Facts free. Send name. Locksmithing Inst., Dept. 1310-099, Little Falls, New Jersey 07424.

I MADE \$40,000.00 Year by Mailorder! Helped others make money! Start with \$10.00—Free proof! Torrey, Box 318-Y, Ypsilanti, Michigan 48197.

MAIL Baby Catalogs imprinted with your address to New Mothers for Big Profits! Details 25¢. Volz-PM, Ypsilanti, Michigan 48197.

\$112,000.00 YEAR. Mailorder. Can make you money. **PROOF.** Write Williams, 44646 H, Los Angeles 90044.

MAKE big money growing ginseng! \$3,000-\$30,000 annually. We buy your crop. Send \$2 for seed sample and information. Glass' Ginseng Exchange, Box 1969, Springfield, Mass. 01101.

READ Progressive Mailtrade, the magazine that tells how to make money by mail. Quarter brings sample and special offer. Mailtrade, P.O. Box 357, Sheboygan, Wis. 53082.

FREE Catalogs. Repair air conditioning refrigeration. Tools, supplies, full instructions. Doolin, 2016 Canton, Dallas, Texas 75201.

VENDING Machine big catalog. Rake, 523 A Spring Garden, Philadelphia, Pa. 19123.

56 ACTIVE Franchise opportunities available all over USA. Brochure details 56 franchise chances for you to have your own business tied with successful national companies. Send name, address to P. Stewart, 1085 Walnut, Des Plaines, Illinois 60016.

CLIP Newspaper items. \$1.60-\$5.00 each. Details free. Walter, Box 1360-PA, Erie, Pa. 16512.

SELL Lifetime. Metal. Social Security Plates. Big Profits! Sample and Sales Kit Free. Russell, Box 286-PM, Pulaski, Tennessee 38478.

SPARE Time Cash—Sell Advertising Book Matches—every business a prospect—no investment—no experience needed to build steady repeat business. Daily Cash commission in advance. Write today—We'll send your sure-fire selling kit by return mail. Dept. MX 969, Superior Match Co., 7530 S. Greenwood, Chicago, Illinois 60619.

COPUBLISH "Mail Sale Advertiser," leading mailorder paper. Copy and details 25¢. U.S.A. only. Vanroy Shirk, Lebanon, Pa. 17042.

MAILORDER Records help get Increased Business! Complete 32 page Record Book shows your inquiries, orders, advertising expense, etc. Only \$1.00. Martin, Popular Mechanics, Dept. PM, 575 Lexington, New York 10022.

I MAKE \$1,200 MONTH IN ACCOUNTING. You start, train fast. Only 10 lessons. Certificate awarded. Work from home or office. Mail \$2. first lesson. Jenkins, Box 571, Taft, California, 93268.

START BIG-PAY Business at home in spare time. No experience needed to operate little table-top machine for bronzing baby shoes. Make \$7.32 profit on every pair. Full particulars free. Send postcard to: Mason, 1512 Jarvis, Room CM-2-C, Chicago, Illinois 60626.

SUPPLY Fried Chicken Dinners on \$500 week home plan. Free information. White's Chicken Dinners-PM, Mt. Vernon, Ohio 43050.

MAILORDER Beginner's catalog. 10¢. Guaranteed. Sullins, Box 2069-M, Forsyth, Georgia 31029.

MORE Sales, Profits! 88 Ways to Promote. Build Your Business. Free details. Write today. Graybow, Box 141, Brampton, Ontario, Canada.

LIQUID Molding rubber also liquid plastic. Free information. Chaney's, 5415-A San Jose Blvd., Jacksonville, Fla. 32207.

MAIL Baby Catalogs, Imprint, to new Mothers. Big Profits! Details \$1.00. Krefski, 609 Lee, Plymouth, Pa. 18651.

\$200.00 DAILY in your mailbox! Your opportunity to do what mailorder experts do. Free details. Associates, Box 136-A, Holland, Michigan 49423.

VACUUM Plastic Molding & Liquid Plastic Casting—At Home! Make hundreds of full 3-D plastic products. Big profit in spare time. Free facts, samples. Nationwide Plastics, Dept. HG, 4140 Eagle Rock Blvd., L.A., Calif. 90065.

CASH for magazine clippings. Up to \$2.00 each. Details free! Bowden Enterprises Box 585-B9, Rahway, New Jersey 07065.

TAKE Catalog orders. We drop-ship 1001 best selling specialty products. Guaranteed lowest below wholesale prices. Fantastic spare-full time home business. Free book shows you how. SMC 7630 SPI, Gloria Avenue, Van Nuys, California 91406.

BOOKKEEPERS Earn \$1000.00 month. Operate simplified Bookkeeping tax service. Universal, Box 664-M, Springfield, Missouri 65801.

MAKE Money mailing catalogs. Free Details. Newton, P.O. Box—F-PM Detroit, Mich. 48208.

\$70.00 WEEKLY—home, spare time. Simplified mail bookkeeping. Immediate income easy. Auditax, 34741A, Los Angeles 90034.

UP To \$5.00 each for newspaper clippings! Free details. Philip, Box 368-S, Southfield, Michigan 48075.

DRAFTSMEN! Operate own DRAFTING SERVICE! Full, Part Time; Experience unnecessary; Details: Roberts Drafting, 1741 Circle Road, Baltimore, Maryland 21204.

SELL Books by mail. 400% profit. Royal, Box 450-X, Cleveland, Ohio 44127.

MAKE Money Operating Home Mailorder Business. No Inventory. Write Purple Enterprises, Box 16291-AJ, Jacksonville, Fla. 32216.

MAKE Money from old tires. Operators clearing \$800, weekly. Equipment costs \$1500. Get facts, S & S Patents, Inc., 3752 N. Damen, Chicago 60618.

CALIFORNIA MANUFACTURER NEEDS man to assemble our product and be local agent, experience unnecessary. May start while presently employed. Five-figure income for responsible applicant. S.K.R.M. Manufacturers, 2540 Olive Avenue, Long Beach, California 90806.

MAKE \$46 from square foot plywood: jigsaw or bandsaw necessary. Free details. Woodar, Bridgewater, Mass. 02324.

INSTANT Mail Order Business—All you need is a mailbox. Details \$1 (Refundable). Mail Marketing Services, Benton, Illinois 62812.

\$60.00 DAY. Manufacturing concrete Posts, Blocks, Mold Equipment Catalog \$1.00 refundable. Carlayne, Route One, Box 106-T, Rapid City, South Dakota 57701.

MAKE. Sell magnetic car signs. Write PM-1834 Edgeland, Louisville, Ky. 40204.

JEWELRYCRAFT—It's easy! Big profits! Catalog, 25¢. Modern Craft, 12790 US 19, Clearwater, Florida 33516.

\$6 CAN START YOU IN BUSINESS. Investigate 100 business opportunities in every monthly issue of Franchise Journal. Get the facts, figures, company histories, profit potential, investment requirements, etc. Send \$6 for 12 exciting copies to Franchise Journal, 892-G W. 16 St., Newport Beach, Calif. 92660.

IMPORT Export opportunity, profitable world-wide, mail-order business from home, without capital; or travel abroad. We ship proven plan, for no risk examination. Experience unnecessary. Free details. Mellinger, Dept. C2709, Los Angeles, 90025.

BIG money-making new greaseless donuts in kitchen. Everything furnished. Sell stores. Free recipes. Montgomery Ray, Waseca, Minnesota 56093.

NEW Plan! Pays up to \$25.00 an hour! Little as 4 hours weekly. Place Thrifted self-service displays in stores. No cost to merchants. No experience needed. Free details. Lux Company Incorporated, Dept. 1226, Elkhart, Indiana 46514.

REPAIR WATCHES. Step up income. Unique home course. Watchmaking. YWB. Fox River Grove, Illinois 60021.

OPERATE Restaurant or diner. Free booklet reveals profitable plan. Write Restaurant Business School, Dept. EC-99, 1920 Sunnyside, Chicago, Illinois 60640.

250,000 NEW Mothers Every Month! Bonanza for Bronzed Baby Shoes! \$50.00 a day profit. No investment, no inventory. Full or spare time. Exciting details Free. Sentimental, 1919 Memory Lane, Dept. 8-G Columbus, Ohio 43209.

TO WOULD-BE OWNER-MANAGERS! Ready to work and grow as an independent businessman in your own right? It's time you investigated ServiceMaster, the world-wide system that specializes in setting up qualified men in profitable businesses of their own. ServiceMaster offers you comprehensive basic training to start an advanced managerial education from then on. Write today for a free booklet that tells you all about this opportunity, at no obligation. Write now. ServiceMaster Serv-Opp Int'l Corp. Dept. 147, 2300 Warrenville Road Downers Grove, Illinois 60515.

SECRETS! Mail Order Success Internationally famous expert reveals how to make home business fortunes. Beginners: Get free copy "Make Money By Mail." Discloses free advertising, profitable products. Mailco, 1554 Sepulveda, Dept. C2709, Los Angeles 90025.

MAKE Durable building plastic easily, waterproof, fireproof, economical. Bays Laboratory, Cedaredge, Colorado 81413.

MAKE Gorgeous original candles for all holidays and special occasions. Learn expert Candle decorating, candlemaking, use of professional molds. Free details on home instruction method. Candle Institute, Dept. WO, 1600 Cabrillo, Torrance, Calif. 90501.

SELL Gifts, Household Items—Make extra money. Toys, Jewelry, Stationery, Greeting Cards, 600 items. Experience unnecessary. Salable Samples on approval. Free—Catalog. Personalized Christmas Card Album. Hedenkamp, 361 Broadway, Dept. PM-101, New York 10013.

HOW To Get Capital. Case histories, testimonials, proof, \$500 to \$200,000, 1000 sources. Counselor-17, Kerrville, Texas 78028.

DEVELOP THAT HUNCH—convert that occasional intuitive impression into a Real Business Opportunity. Your secret partner is your unused mental potential. Write today for a free copy of "The Mastery Of Life." It explains how thousands have learned to use this undeveloped power as you can! Address: Scribe D.M.C. The Rosierucians, AMORC, San Jose, California 95114. Please include zip code if part of your address.

\$500 - \$800 MONTHLY Raise small laboratory-breeding stock for us. We supply equipment, breeders, and instructions. Illinois Research Farms, Dept. MPD-9, McHenry, Illinois 60050.

PRIVATE PARTY TO SELL POOL TABLES. Chief Products Inc., 6810 S. Flying Cloud Drive, Hopkins, Minn. 55343.

INSTALL Burglar Alarm Systems. Big profit home business. Beginners start spare time, without mechanical experience or costly equipment. Free starter plan. Nasco, Dept. C2709, 11071 Massachusetts, Los Angeles 90025.

FREE Book "999 Little-Known, Successful Businesses". Work home. Small Business Institute, Dept. A, Kerrville, Texas 78028.

PIANO TUNING learned quickly at home. Tremendous field! Musical knowledge unnecessary. GI approved. Information Free. Empire School, Box 327, Miami, Florida 33145.

EXTRA \$83.83 DAILY manufacturing Concrete Fence Posts. Practically no investment. Free information. Send stamp American, Excelsior Springs, Mo. 64024.

MAILORDER Book publisher wants dealers. Wonderful "drop-ship" proposition. Sample imprint circulars free. Neil H. Tasker, Shamokin, Pennsylvania 17872.

MONEY Writing short fillers. 10 Lesson course reveals all professional guidance, Market directories, and "Inside Secrets" to start those checks pouring in. Order course now; begin making money by mail. MO-711 Ten lesson writing course \$4.95. IMPORTS by Leonard, 2903 Sunset, Waukegan, Illinois 60085.

MAILORDER Program for Beginners. Write to Winco, 3905-M Mannerdale, Louisville, Kentucky 40220.

AMAZING Profits! Start your own successful business. Details free. Musgrove, 1404-A Camp Gifford Road, Bellevue, Nebraska 68005.

MAGNETIC SIGN BUSINESS. Plastic forming machine, supplies for complete Business \$1995. Will finance. Codaco, Post Office Box 411, Bessemer, Ala. 35020.

\$2.00 PER Dozen Cash Profits. Assemble New Art Foam Products. All Supplies Furnished. Showcase, Box 55392D, Indianapolis, Indiana 46205.

PROFIT With Popular Mechanics' subscription plan. No investment, no experience needed. Earnings begin immediately when you obtain subscription for Popular Mechanics, Good Housekeeping and others. High commissions, bonus. No experience needed. Deal directly with the publisher. Write Popular Mechanics, Room 9B, 250 West 55th St., New York 19, N.Y.

PREPARE TAX Returns—Policeman Albert Myers made \$2000 his very first season. Train at home. VA Approved. National Tax School, Monsey, 2JB, N.Y. 10952.

MAILORDER — Profitable products; dropshipped. No merchandise investment. Everything supplied—catalogs, ads, mailing lists. Gif-Guide, 1127 Crenshaw, Dept. 161, Los Angeles 90019.

MAILORDER! HOW TO PREPARE YOUR OWN CATALOG for pennies including popular products . . . without merchandise investment! Free Catalog-Proof! OBIE, 5711-MS—14th, Brooklyn, N. Y. 11219.

ESTABLISH profitable CONCERT MANAGEMENT. Your community. Details free. CONCERTS, 905 Fox Bldg., Detroit, Mich. 48201.

MAKE Money: Oil leases: \$4.00 acre: Others have. Free proof. Northern, Box 560-F Westmount, Montreal 215, Canada.

MAILORDER . . . No merchandise investment. Profitable! Tested! Dynamics, 1430P Wells, Milwaukee, Wisconsin 53233.

HOME Mailorder! 50 years proven method reveals how to turn mail box into "moneybox" anywhere US or Canada. Free details. Crescent Industries, Box 652 E, Windsor, Nova Scotia, Canada.

TREMENDOUS Mailorder Profits! Free Literature. George, Box 2188, Cypress, California 90630.

FREE REPORT. 609 Unusually successful businesses, work home, evenings. Write!! Associated, Box 238-B99, Lafayette, California.

FRANCHISED DISTRIBUTORSHIPS Decorative cabinet hardware. Start part-time or full-time. Write now: Hickman Manufacturing, 43-66PM Bowne Street, Flushing, New York 11355.

DAVELIA Cosmetics. Dealer Details. Samples, 35¢. Box 2902, Lubbock, Texas 79408.

\$10 DAILY Writing short articles at home. Begin immediately. How and Where revealed in booklet =MO-51F. \$1.00. Friendship Quality Gifts, 510 N. Catherine, Bay City, Mich. 48706.

FREE Selling Outfit Office Supplies, Furniture & Equipment. Oseco, 15-PM North Jefferson, Chicago 60606.

BECOME PROFESSIONAL DRIVING INSTRUCTOR. Earn \$10.00 hour. \$300 week. Part time. Full time. Business for yourself. Free details. Howard David, 1818 Evarts St., Phila., Pa. 19152.

INCREASE mailorder profits! Tested proven methods. Details free. Barry, 89-22B 218 Place, Queens Village, New York, 11427.

FREE Catalog: Showing moneymaking opportunities, Self Improvement, Selected Gifts. Davis Co., 11510 Rockcraft, Dallas, Texas 75218.

CATALOG of Opportunity. Unlimited, Opportunities. Write Mavis Associates, 2205-P So. Troost, Tulsa, Oklahoma 74114.

EMBOSSD Business Cards \$3.75—1000 postpaid! Dealers wanted. Mailreco, Box 22173J, Indianapolis, Indiana 46222.

FREE Wholesale Restaurant Equipment Catalog. SDC, G-4402 Calkins Rd., Flint, Mich. 48504.

STEADY Income Daily! Address, mail our commission circulars. Details, Stamp, Box 953-PM, Newark, N.J. 07101.

START Profitable Home Business. No Investment. Write: Cumberland, Monticello, Ky. 42633.

YOU CAN Make \$75.00—\$200.00 a day as Dur-A-Flex seamless floor dealer-installer. Revolutionary new floor covering rated tops by leading Consumer Report Magazine. Requires no skill only enthusiasm. Will even get you jobs. Dur-A-Flex, Inc., 100 Meadow St., Dept. PM7, Hartford, Conn. 06114.

QUICK Income with Mail Order Collection Agency. \$1000 monthly and more. We show you how. Continental, Box 2023-A, Des Moines, Iowa 50310.

MAILORDER Selling has made others successful, why not you. Free information about my plan. Millor, Box 185-PM Tonasket, 98855.

FANTASTIC Profits—Your Own Advertising Specialty Business. Buy direct and have hundreds of salesmen working for you. Dynamic, 509-P Fifth, New York 10017.

PROFITS FROM CLASSIFIED ADVERTISING!! Booklet shows you how to start your own business with Classified Advertising. Only \$1.00 (Refundable with first order.) C. A. Martin, Popular Mechanics, Dept. PM, 575 Lexington Avenue, New York 10022.

2000% PROFIT Bronzing shoes—Free Literature. NBC-Box 11069—Kansas City 64119.

MAILORDER Business. Free circulars. Andrews, P. O. Box 485, New York, New York 10013.

SAW SHARPENER. Build your own Saw Grinder. Own your own Business. Plans and instructions. Free information. Grind Rite, Box 2115 Dept. K, Montclair, Calif. 91763.

FREE Advertising? 500 Publications. Write: Dee, 10639-PM Riverside, North Hollywood, Calif. 91602.

\$75.00 THOUSAND. Home Addressing! Longhand, Typewriter. Information, send stamped self-addressed envelope. Brewster, Box 1348-TF, Clearwater, Florida 33517.

MONEYMAKING OPPORTUNITIES

I MADE Over \$100,000.00 year selling by mail. IRS proof available. Success story, book form \$2.00. Wayne Johnson, 880 SW 60th Avenue, Ft. Lauderdale, Florida 33314.

\$200.00 FROM Sheet 1/4" plywood (scrap). Details 25¢. Novelties, 610 So. 24th, Elwood, Indiana 46036.

EARN \$240.00 a month at home, spare time, doing only two \$5.00 invisible mending jobs a day. Big money paid for service that makes cuts, tears disappear from fabrics. Steady demand. Details free. Fabricon, 1532 Howard, Chicago 60626.

MAKE Statuettes, novelties, imitation marble. Sell to stores or start gift shop. Free details. Marbleizing, 41 Waverton, St. Louis, Mo. 63124.

HOW To Make money writing short paragraphs. Information free. Barrett, Dept. C-27-U1, 6216 N. Clark, Chicago 60626.

VENDING Machines. No selling. Operate a route of coin machines and earn amazing profits 32-page catalogue, free. Parkway Machine Corporation, 715 PMM Ensor Street, Baltimore, Maryland 21202.

FREE Copy of world's leading contest magazine! Write Prizewinner, Box 11569, St. Petersburg, Fla. 33733.

HOMEWORK. Mailing circulars. Free details! Cam Company, Dept. 155-KP, Verona, N.J. 07044.

FREE. 206 Easy Ways to make money taking orders for exciting new products—spare time. Send name, age for 5 months free subscription. Opportunity Magazine, 1460 Hancock Center, Dept. 17-JM Chicago 60611.

SCIENTIFIC Massage: Big Earnings uncrowded profession. Learn spare time at home. Diploma awarded. Free catalog. Write Anderson School, Dept. J-1C, Princeton, Illinois 61356.

CLIP Newspaper items. \$1.00-\$5.00 each. Details free. Walter, Box 1360-P, Erie, Pa. 16512.

SPARE Time Cash—Sell Advertising Book Matches—every business a prospect—no investment—no experience needed to build steady repeat business. Daily Cash commission in advance. Write today—We'll send your sure-fire selling kit by return mail. Dept. MA-969, Superior Match Co., 7530 S. Greenwood, Chicago, Illinois 60619.

MAKE: \$12.00 Profit each dozen assembling Belts. Details Free. (Stamp appreciated.) Redikut's-40, Richland Center, Wis.

HOW MUCH does being your own boss or making \$25,000.00 per year interest you? The Warner breakthrough in the Engraving field could be your future. Write: Warner, Room CE-2-C, 1512 Jarvis, Chicago, Ill. 60626.

SELL What You Write. Instantly! Beginners Market List tells where, how, and what to write. Send stamped, self-addressed envelope, free proof. Economy Box 1348G, Clearwater, Florida 33517.

HOW TO GET RICH!! Free "Money-making Brochure"! Success International, Box 2447-C, Livonia, Mich. 48151.

MONEY—SPARETIME OPPORTUNITY PANELISTS AT HOME WANTED BY NEW YORK RESEARCHER. Leading research firm seeking people to furnish honest opinions by mail from home. Pays cash for all opinions rendered. Clients' products supplied at no cost. For information write: Research 669 Mineola, N.Y. 11501, Dept. PM-24.

POWERFUL shortcuts to lucrative mail-order enterprises. Proof. Literature. Eddie's, 4809-MG North Montclare, Chicago, Illinois 60656.

MAKE Big Easy Profits making costume jewelry at home. Spare time. Quick, easy to make: easier to sell! Details Free! Donbar, 2934 Fullerton, Dept. J-209, Chicago, Illinois 60647.

HIGHLY Profitable spare-time business. Bronzing & PearlKoting baby shoes. Complete set-up on credit available. 31 year old company. Send 25¢ for brochure. Kik-tavi, Box 4187PM, Compton, Calif. 90224.

HOMEWORKERS! 200 companies—48 page Directory. FREE details. Quest, Box 6029, Dept. 19, San Jose, California 95150.

LEARN The secrets of repairing junk batteries "Fabulous Profits" at home. Batteryman, Route 1-188D, Blythe, Calif. 92225.

LYRIC WRITERS write songs with writers who write hits for top Nashville artists. Glcbe, 420 Broad, Dept. PM, Nashville, Tenn. 37203.

WATCH REPAIRING multiplies earnings. Free information and sample lesson. Watchmaking, YWA, Fox River Grove, Illinois 60021.

TEAR OUT THIS AD AND MAIL WITH NAME, address for big box of home needs and cosmetics for Free Trial, to test in your home. Tell your friends, make money. Rush name, Blair, Dept. 31HP, Lynchburg, Va. 24505.

\$500 - \$800 MONTHLY Raise small laboratory-breeding stock for us. We supply equipment, breeders, and instructions. Illinois Research Farms, Dept. MP-9, McHenry, Illinois 60050.

SELL Greeting Cards—Make extra money. Show friends Gifts, Toys, Jewelry, Stationery, 600 items. Experience unnecessary. Salable Samples on approval. Free—Catalog, Personalized Christmas Card Album. Hedenkamp, 361 Broadway, Dept. PM-102, New York 10013.

SELL Your Photos. Report Tells How, Where. Only \$1.00. KAY Company, 922 East Line, Kirksville, Mo. 63501.

SECRETS! Inside facts to get rich! 256 page booklet. Hurry! Only \$2.00 while they last! plus 30¢ handling. Fantastics! Dept. 16, 1900 Baxter Ave., Orlando, Fla. 32806.

MAKE Money Mailing our postcards! Work home, full, sparetime. Particulars 10¢. Westley, Dept 1, Western Springs, Illinois.

NEW Money-making Mail Order Catalog. 25¢. To Fitz, Freeville, New York 13068.

LEARN The "HIGH INCOME GROUP" way of making money. Details 25¢. C. Astling Associates, 61 N.W. 38 St. Dept. PM 99, Miami, Florida 33127.

BUILD YOUR FORTUNE. Monthly publication shows you how. You can participate in fortune ventures. \$30.00 year. GLOBE FORTUNE BUILDERS, Box 2152, Tallahassee, Florida 32304.

FREE Details. Many profit items. Heal, 7132 Colwyn, Highland, California 92346.

INVEST IN STAMPS! Free details. Needleman, 2367P East 18th, Brooklyn, N.Y. 11229.

BIG money with PROPERLY PLANNED school band concerts. Proven effective! Details FREE. CONCERTS, 905 Fox Bldg., Detroit, Mich. 48201.

100's MONEYMAKING Opportunities. Exciting details free. Opportunities, Box 722, Springfield, Illinois 62705.

MAILORDER Magazines. \$1.00 Per Package. Hale, Box 395PM, McDonald, Ohio 44437.

MAKE MONEY Sharpening saws on easy to use ZAPART Sawfile. Free details—Write Zapart, Dept. PM 360 So. 7 St. Lindenhurst, N.Y. 11757.

WEALTH Newsletter: wealth secrets revealed. Write: J. Henderzahs, 217 Williams Dr. Clarksville, Ind. 47130.

MAKE Money clipping newspaper items. Book reveals many ways. \$1.00 postpaid. LEUNG'S 38-48 Rutgers 5P, New York City 10002.

STOCK MARKET Interest you? How to control stock worth \$1,000's for only a few \$100.. Limited loss; Unlimited profit. Revealing report \$2.00. JAS-PM, RD=2, Box-260-D, Andover, N.J., 07821.

MIMEOGRAPH Machine and ruler can make you financially independent for life. Further details 25¢. H. Kania, 1916 'R' St., N.W. #808, Washington, D. C. 20009.

\$2.40 HOURLY Making simple wood novelties. Free details! Gene's, 55 Box-wood, Falmouth, Mass. 02540.

SELL Your Photos. Report tells How, Where. Color Slide Markets. Only \$1.00. Milton House, 329 Marlboro Road, North Charleston, 29406 S.C.

BLACK Widow Spider Ranchers wanted!! Tremendous profits! Complete program \$1 (refundable). NBWC, Box 260-PM2 Brigham City, Utah 84302.

MAKE Money—Win Prestige writing short poems, songs, etc. Poet's Handbook tells how to protect—Publish-sell your works. Lists 900 markets and rates paid. \$3.00 postpaid. Satisfaction guaranteed. Rufco, Box 308, Big Stone Gap, Virginia 24219.

SPARE Time cash. Sell Famous Hanover Shoes. Actual samples and sales kit Free. No experience needed. No age limit. Lowest prices for high quality makes selling easy. Every man a prospect. Big daily commissions. For full details, Write Hanover Shoe, 492 Carlisle, Hanover, Penna. 17331.

UNUSUAL RACING PROFITS from simplified handicapping methods. Gil Howard, Box 507, P. Carroll, Iowa, 51401.

OPPORTUNITIES. Bargains Galore. Free Information. Write Bargains, 10024 Oxborough, Minneapolis, Minnesota 55431.

MAKE Money operating home mailorder business. No inventory. Write Purple Enterprises, Box 16291-AJ9, Jacksonville, Fla. 32216.

SELL Your Photos. Report tells How, Where. Color Slide Markets. \$1.00. Temple House, Dept. PM99, 1125 Templeton Gap Road, Colorado Springs, Colorado 80907.

PROVEN Money-makers. Professional instruction booklets. "Writing Fillers", "Sell Your Photos", "Govt. Surplus", "Mailorder Imports", "Sell Coins" \$1.00 each. Mountain Mart, 230 So. Sierra Madre, Colorado Springs, Colo. 80903.

BIG Profits mailing letters featuring real merchandise. Everything furnished. Details 25¢. Robert's, Box 252, Garfield, Wash. 99130.

SELL Your photos! Over one million photos, slides bought by newspapers, and magazines every year! Learn what photos, how to submit them, laws, regulations. Includes directory of where to sell pictures. Booklet =MO-54P. Send \$1.00, name, address to: Oceanview House, 4382 Hill Street, San Diego, Calif. 92107.

\$350.00 MONTH ADDRESSING! EVERYTHING furnished. Details, mail stamped self-addressed envelope and 25¢. Happy, Box 1161-CC, Battle Creek, Michigan 49016.

OVER \$2,500.00 Weekly average income in mailorder by originator of guaranteed program. Free details. Enterprise Books, (PM8) Box 188, Seabrook, Texas 77586.

PROFITS FROM CLASSIFIED ADVERTISING!! Booklet shows you how to start your own business with Classified Advertising. Only \$1.00 (Refundable with first order.) C. A. Martin, Popular Mechanics, Dept. PM, 575 Lexington Avenue, New York 10022.

\$80.00 DAY selling Information Manuals by Mail. Write: Beach House, 3716 Gresham, Virginia Beach, Virginia 23452.

FREE INFORMATION 990 Little-known business opportunities for all write Devore, 824-C North Street, Iola, Kansas 66749.

\$100 WEEKLY "HOME TELEPHONING!" Valuable Instructions—\$3 Airmailed! Guaranteed! Fortune Cottage, Box 1177-A, Midland, Texas 79701.

PROFITABLE OCCUPATIONS

I MADE Over \$100,000.00 year selling by mail. IRS proof available. Success story, book form \$2.00. Wayne Johnson, 880 SW 60th Avenue, Ft. Lauderdale, Florida 33314.

BECOME A mortgage broker, earn \$10,000 to \$50,000 a year. Details free. United, Box 6284A, Marietta, Georgia 30060.

HOW To Make Money Writing Short Paragraphs. Information Free. Barrett, Dept. C-27-U2, 6216 N. Clark, Chicago 60626.

CHROME Plating. Instructions, equipment and supplies. Platers' Supply, P.O. Box 565, Lugo Station, Los Angeles, Calif. 90023.

FT. SMITH Auction School, Ft. Smith, Ark. Residents & Home study. Veteran approved.

FREE Book "990 Successful, Little-Known Businesses." Work Home! Plymouth-37-J, Brooklyn, New York 11218.

SHARPEN Scissors, Pinkers, Inexpensive equipment, tools, supplies. Blackhawk's, Sheldahl, Iowa 50243.

YOUR Own Sign shop, Signs, 410-S So. Western, Springfield, Ohio 45506.

EARN \$240.00 A month at home, spare time, doing only two \$5.00 invisible mending jobs a day. Big money paid for service that makes cuts, tears disappear from fabrics. Steady demand. Details free. Fabricon, 1586 Howard, Chicago 60026.

\$500 - \$800 MONTHLY Raise small laboratory-breeding stock for us. We supply equipment, breeders, and instructions. Illinois Research Farms, Dept. MPA-9, McHenry, Illinois 60050.

BAKE new greaseless doughnuts in kitchen. Sell stores. Free recipes. Michael Ray, Waseca, Minnesota 56093.

"RESEARCH AS A PROFESSION": Informative Manuscript reveals Home earning methods, without experience; write now; free details. Merkle, Forestville, Pennsylvania 16035.

SELL Your photos. Report Tells How. Where. Color Slide Market. Send \$1.00. July Gifts, P.M. 10, 132 Arlington Ave., Cliffwood, New Jersey 07721.

LEARN GUN REPAIR, GUNSMITHING in spare time. Book, details 25¢. Modern Gun Repair School, Dept. 108, 225 E. Fairmount, Milwaukee, Wis. 53217.

LEARN to sell Books by Mail for fun and Profit \$3. Owen, 715 G St NW, Washington, DC 20001.

SALESMEN—DISTRIBUTORS

I MADE Over \$100,000.00 year selling by mail. IRS proof available. Success story, book form \$2.00. Wayne Johnson, 880 SW 60th Avenue, Ft. Lauderdale, Florida 33314.

EARN Big Commission Full or Part Time. Show America's largest line Low Priced Business Printing and Advertising Specialties Plus calendars in season. No experience. No investment. No collections or deliveries. On-the-spot commissions. Big Free Sales Kit samples hundred items used daily by businessmen. Merchandise bonuses for you. Build profitable repeat business. Start now. National Press, Dept. 91F, North Chicago, Ill. 60064.

FREE. 206 Easy Ways to make money taking orders for exciting new products—spare time. Send name, age for 5 months free subscription. Opportunity Magazine, 1460 Hancock Center, Dept. 17-JS, Chicago 60611.

100% PROFIT—Sweet Georgia Brown Cosmetics sell fast. Write for Sample Case offer. Valmor, Dept. H, 2411 Prairie, Chicago 60616.

SELL Advertising book matches. Write us today. We put you in business by return mail, handling complete line ad book matches in demand by every business right in your town! No investment; everything furnished free! Top commissions daily: Superior Match. Dept. M969, 7530 S. Greenwood, Chicago, Illinois 60619.

FREE! Money Making Opportunities! Your Own Business! Write name, address, zip, today. Bradley, Box 509-D, Mt. Kisco, New York 10549.

GET New shirt outfit free! \$90 weekly on 5 average orders a day. Famous quality made-to-measure dress and sport shirts at \$4.95 up, sell to all men. No experience needed. Full or part time. Write: Packard Shirt Co., Dept. 217, Terre Haute, Indiana 47808.

HOUSEHOLD And food products route. \$25.00 or more daily profit. Larger repeat orders. Man, woman. Full, part time. McNess, Freeport 2699, Illinois 61032.

MAKE extra \$25 to \$75 spare time! Take orders for double air cushion Bronson Shoes. Amazing comfort. Terrific men's, women's line for dress, work, play. Highest commissions. Shoes for yourself. Big outfit Free. Write Bronson, Dept. 168, Minneapolis, Minnesota 55408.

PERSONAL Protective Devices Now in Big Demand due to increased crime rate. Proven. Sell easy to Drive-Ins, Stores, Nurses, Night Workers, Motorists. Sales experience unnecessary. Get profit details now. Hagen Supply, Dept. CLA-9, St. Paul, Minn. 55107.

\$100 A week spare time opportunity. Man Contact Service Stations. Cyclo Mfg., Dept. 183, Denver, Colorado.

SELL Hertel Bibles—Part Time. Finest reference Bible available. Demonstrator and supplies furnished. Excellent commissions. Write International Book, Dept. PM, Box 118, Wichita, Kansas 67201.

SPACE Energizer Fantastic Window attraction drives wheels suspended in space. Free information. Adult Toys, 800 Borrite Circle, Reno, Nevada 89502.

SELL Amazing New Action Signs, Walker Co., Cornell, Wis. 54732.

EARN big money calling on business-professional men. Send us their delinquent accounts for collection. General Finance, Dept. PM-11 Columbia Bank Bldg, Kansas City, Mo. 64106.

WANTED: Man contact newsdealers and photoshops. State distributorship available. Sample copy 25¢ Film Journal Advertiser, 391 Hoboken Avenue, Jersey City, N.J. 07306.

FREE Selling Outfit Office Supplies. Furniture & Equipment. Osco, 15-PM North Jefferson, Chicago 60606.

AGENTS WANTED

I MADE Over \$100,000.00 year selling by mail. IRS proof available. Success story, book form \$2.00. Wayne Johnson, 880 SW 60th Avenue, Ft. Lauderdale, Florida 33314.

YOUR Own business—Used suits \$1.50; overcoats 65¢; mackinaws 35¢; shoes 12½¢; ladies coats 30¢; dresses 15¢. Enormous profits. Catalog free. Nathan Portnoy Associates, 2109-AA Roosevelt Road, Chicago Ill. 60608.

LIFETIME Income. Business Loan Representative Write: Financial 28 E. Jackson, Suite 1204-X3, Chicago 60604.

EVERY Man a prospect. Refundable sales kit offer showing line belt buckles, tie clasps, money clips, cuff links, lapels, identification badges, individualized with customer's name and emblems. Cap badges for trucking, bus, taxi, police, firemen, also postal, letter carriers and heavy construction emblems. Choice 3000 emblems. Hook-Fast, Box 1088PM, Providence, R.I. 02901.

PRINTING. Advertising Salesmen—Excellent moneymaking sideline selling Decalcomania Name Plates, small quantities. Advertising Specialties, sign letters. Free Samples. Ralco XL, Boston, Mass. 02119.

CHRISTMAS CARDS—Business and Personal. Customer's name imprinted. Earn unusually high commissions from this medium—and high-priced line. No investment. No inventory. Free Sample Album. Process Corp. (our 48th year), 3436 S. 54th Ave., Chicago, Ill. 60650.

WANT TO MAKE UP TO \$100 A WEEK Spare time, and get free shoes for life, too? No investment. Rush card for free details. Mason Shoes, K-623, Chippewa Falls, Wisconsin 54729.

ESTABLISH Your own business. Low prices on used clothing, shoes, household goods. Unlimited profits. Free catalog. Northwestern Distributors, 2129 No. Western Avenue, Chicago, Illinois 60647.

WILL You test new items in your home? Surprisingly big pay. Latest conveniences for home, car. Send no money. Just your name. Kristee, 133, Akron, Ohio 44308.

MAKE Extra Money—Show friends, neighbors—Gifts, Stationery, Teys, Jewelry, Greeting Cards. 600 items. Experience unnecessary. Salable Samples on approval. Free Catalog, Personalized Christmas Card Album. Hedenkamp, 361 Broadway, Dept. PM-100, New York 10013.

EMPLOYMENT INFORMATION

FOREIGN And USA job opportunities available now. Construction, all trades. Earnings to \$3,000.00 monthly. Paid overtime, travel, bonuses. Write: Universal Employment, Woodbridge, Conn. 06525.

AUSTRALIA WANTS YOU! Government Assisted Passage. 50,000 Jobs. Latest Government Information and Forms \$1.00. Special Reports on Employment, Business, Taxes, Housing, Education, Ranching, Farming, Teaching, Maps, Etc. AUSTCO, Box 3623-E, Long Beach, California 90803.

COMING TO CALIFORNIA. Check Jobs. Rentals First Complete Los Angeles Classified Section \$1.00. Box 2546, Anaheim, Calif. 92804 Free Map.

HIGH Paying overseas jobs. Construction, other projects. Bonuses, Travel Expenses, Extras. International Information, 124, Cortez, Florida 33522.

"HOW To Get Overseas Jobs"—Worldwide—Lists Hiring Organizations—143 pages—\$3.98—Refundable. STAYDRYP—Whitestone, New York.

CANADA. Employment guide to Montreal, Toronto, Vancouver. Send \$1.00. Personnel Publications, Suite 101, 30 Bloor Street, West, Toronto 189.

WORLD-WIDE . . . U.S.A. jobs. Many benefits, allowances. Free Details!! Write: Global Employment, Box 706-C99, Orinda, California.

AUSTRALIA!! AUSTRALIA!! Jobs Galore. Government assisted transportation. 1969 Handbook \$1.00 Guaranteed!! Associated Box 17-B99, Lafayette, California.

BOOMING Australia wants You! Good jobs, Adventure. Forms and Australian Handbook (1969) describing Australian assisted passage, passport-visa, advantages, opportunities \$1.00. Buckeye, Box 1032MR, Fairborn, Ohio 45324.

HELP WANTED

OVERSEAS Jobs—Europe, South America, Australia, Far East, etc. 2000 openings all trades. Construction, Office, Engineering Sales, etc. \$400 to \$2,500 month. Expenses paid. Free Information. Write Overseas Jobs, International Airport, Box 536-M, Miami, Florida 33148.

OVERSEAS Jobs—Australia, Europe, South America, Far East, etc. Openings in all trades and professions. \$400. to \$2,500 monthly, free information write Foreign Employment Mart, Box 2235 A.M.F. Miami, Florida, 33159.

REAL ESTATE & FARMS

CANADIAN Vacation lands: Full price \$385.00. 40 acres, \$10 month. Suitable cottage sites, hunting, fishing, investment. Free information. Land Corporation, 3768-C Bathurst, Downsview, Ontario, Canada.

\$1 ACRE—Canadian Border—hundreds campsites, islands, farmlands, directly from tax authorities. (Non-profit). Lists, photographs mailed. Register, Room 10, 110 Church Street, Toronto 1, Canada.

CENTRAL Ontario—Choice 640 acre Sportsmen's paradises still available—\$20.00 plus \$6.50 taxes yearly. Maps, pictures. \$2.00 (Refundable). Information Bureau, Norval 4, Ontario, Canada.

GOVERNMENT LANDS . . . Low, as \$1.00 acre. Millions acres. For exclusive copyrighted report . . . plus "Land Opportunity Digest" listing lands available throughout U.S., send \$1.00. Satisfaction guaranteed. Land Disposal, Box 9091-PI, Washington, D.C. 20003.

CANADA'S Finest lands. \$4.00 an acre and up. Acquired through Estate liquidations. Suitable for hunting, fishing, camps, cottages, farming, timber, minerals, investment. Small monthly payments. Free descriptive booklet. Canadian Estate Land, Dept. PMC, 194 Wilson Ave. Suite 101, Toronto, 12, Canada.

NORTHWEST TIMBERED ACREAGES AS LOW AS \$950. TOTAL PRICE \$50 DOWN \$25 MONTH. 5-10-20-40 acres for people who love the land—A tract of Recreation Land to have for YOUR own! In Northern Idaho, Northeastern Washington, and Western Montana. In the heart of lakes and big game country. All covered with growing timber. Access, Title insurance with each tract. This is select land with natural beauty, recreational and investment values. We have tracts of many types and sizes from which to choose, including beautiful Northwest Waterfront property on the Pend Oreille, Priest and Kettle Rivers; and property on Pend Oreille Lake. Your inspection welcomed. Write us for free list, maps and complete information. Write to: Dept. PI, Reforestation, Inc., P.O. Box 8146, Spokane, Wash. 99203.

10 to 40 ACRE Tracts. Lake Superior, Marquette, Michigan area. \$99.00 acre, \$2.00 month. Write Hiawatha Lake Acres, 17129 Chrysler Drive, Detroit, Michigan 48203.

BUY with confidence for Retirement, Vacation, or Investment—under America's only "No-Risk Land Purchase Plan"—in Carolina Coast multi-million dollar, 14,000-acre development. 10-year money-back guarantee. 1/2-acre homesites as low as \$700.00 cash price; \$8.00 down, \$7.70 monthly for 120 months, including interest at an annual percentage rate of 6%. Motel, hunting, fishing, golf, country club, right on property. Private ocean beach, 50 fresh water lakes. Write for free literature. Dept. 1-N, Boiling Spring Lakes, North Carolina 28461. (Not offered to residents of California, Florida, New York.)

FREE! Real Estate Catalog! Farms, Ranches, Business, Recreational and Investment Property, 18 States, Pictures Galore. Note State desired. BANNER Adv., Box 3333, 19-A, Springfield, Mo. 65804. "Real Estate Our Specialty."

FREE CATALOG! Giant Fall-Holidays edition! Over 4,000 properties described, pictured—Land, Farms, Homes, Businesses—Recreation, Retirement. Selected Best throughout the U.S.! 69 Years' service, 515 Offices, 40 states Coast to Coast. Mailed FREE from the World's Largest! STROUT REALTY, 60-RX E. 42nd St. NY, NY 10017; 7-RX S. Dearborn, Chicago, Ill. 60603; 521-RX E. Green, Pasadena, Cal. 90013.

TOP BARGAINS! FREE Journal! Arkansas properties! Statewide Realty Co., 507-AE Pyramid Bldg., Little Rock, Ark. 72201.

ARIZONA: Secluded mountain retreat acreage near Prescott National Forest, 2 1/2 acres, \$995. Low terms. Mrs. Young, Glenarm Co., 2233 North 7th St., Phoenix, 85006.

VACATION Lands: Canada: \$4.00 acre. Free information. Tax Corp., Box 560-F Westmount, Montreal 215.

LESS Than 1 mile to Disney property. Lake living, 1/4 acre. Private ramp, beach, 11 mi. to Orlando. \$24 mo., \$50 down. BLOCH BROS., 1 North Rosalind, Orlando 26, Florida. AD65LS169-L

BUY CANADA \$10.00—10 ACRES. Thousands of Tax Sale properties direct from govt. authorities. Atlantic to Pacific. Easy driving distance. Lakeshore cottages. Hunting, Fishing, Investing. Researched lists published every few weeks. Particulars mailed. Write: BUREAU, 16 Quinby Court, Thistletown, Ontario, Canada.

OPPORTUNITY to make money in Florida Real Estate. Information booklet only \$2. SK Enterprises, 102 Washburn Avenue, Freeport, New York 11520.

FREE. . . NEW FALL-WINTER real estate catalog. All types property, coast to coast! UNITED FARM AGENCY, 612-PM West 47th St., Kansas City, Mo. 64112.

GOVERNMENT LANDS—450,000,000 Acres, U.S.A.—Alaska. Low as \$1.00 acre. Copyrighted guide covers sales, Homesteading, Vacation Sites, etc. Only \$1.00. Surplus Land Bureau, Box 80-JM, Las Vegas, Nevada 89101.

TAX Savings Through Real Estate. For opportunities checklist on Real Estate tax savings send \$1.00 to Stephanie Enterprises Inc., Post Office Box 101B, Wadsworth, Ohio 44281.

FARM & GARDEN EQUIPMENT

WATER!! Drill your own well the easy, economical way with Amazing New Invention. Save 75%. Free information. Deep-Rock Drilling Company, Opelika, Alabama 36801.



FLOWERS, PLANTS & NURSERY SUPPLIES

LEARN Landscaping and the growing of plants. Start a profitable business part or full time. Free information without obligation. Lifetime Career Schools, Dept. A-648, 2251 Barry Avenue, Los Angeles, California 90064.

GINSENG Bringing \$18 Pound. Have Seeds Roots. Goldenseal. Full Information. K. Collins, Viola, Iowa. 52350.



DRINKING WATER—PURIFIER

PROFITS FROM CLASSIFIED ADVERTISING!! Booklet shows you how to start your own business with Classified Advertising. Only \$1.00 (Refundable with first order.) C. A. Martin, Popular Mechanics, Dept. PM, 575 Lexington Avenue, New York 10022.

HOME CRAFTSMEN

CABINETMAKING MADE EASY and "How to Make Formica Counter Tops," two excellent guides let you build kitchen cabinets and counter tops like professionals. Extraordinary guides bring master craftsmen's shortcut methods. Satisfaction guaranteed. Write: Japs, 126-P Seventh North, Hopkins, Minn. 55343.

SPANISH FURNITURE PLANS. Send stamped, addressed envelope for circular. R. S. Plans, Box 12091, Parkville, Mo. 64152.

FREE Popular Mechanics 16 page illustrated catalog of publications, plans and projects. Booklet covers an extremely wide variety of do-it-yourself data on home remodeling, shop tools and machines, car repair, hobbies, crafts, boating, games, lawn and garden and hundreds of others. For your free copy write to Service Bureau, Dept. PE, Popular Mechanics, 575 Lexington Ave., New York, N.Y. 10022.

PLANS For pool table with extra two-face top for table tennis and model railroad. Blueprints B1209 and building instructions \$3.50. Popular Mechanics Service Bureau, 575-M Lexington Ave., New York, N.Y. 10022.

WOODWORKING Catalog and Manual 25¢. Plus free "101 Project Ideas." World's most beautiful veneers, lumber, plywood! Wood finishing, upholstery supplies. Cane Lamp parts. Furniture hardware. Animal whittling blocks, 2,000 workshop products. Constantine, 2051N, Eastchester Road, Bronx 10461.

FOUNDRYETTE 2400 F. 1 1/2 to 48 lb. capacity. Circular 10¢. Kansas City Specialties, Box 193-P-9, Middleton, Wisconsin 53562.

GOLDEN 5 Way Handyman's Knife. \$1.00 Prepaid, Elmo, 2136A 71 Street, Brooklyn, New York 11204.

"GETTING Started In Stained Glass". 25¢ Whittemore, Box 2065Y, Hanover, Mass. 02339.

FULL SIZE FURNITURE PLANS. Traditional, Early American, Danish Modern. Catalog 50¢. Furniture Designs, Dept. P-99, 1425 Sherman, Evanston, Illinois 60201.

WALNUT And Cherry tapered legs, lumber, gunstock blanks, picture frame moulding. Midland Lumber Company, Box 262, Savannah, Missouri 64485.

101 PATTERNS of smart Gifts, Novelties, Shelves, Action Windmills, plus "Make Money Jig Sawing", \$1.00. Mastercraft, 95M, 7041 Olcott, Chicago 60631.

BATHROOM Vanities. Assemble yourself, save 50%. Provincial style plastic laminated, complete details. \$1.00. Refundable. Vanities, Box 234, Babbitt, Minnesota 55706.

UPHOLSTERY

MAILORDER Records help get Increased Business! Complete 32 Page Record Book shows your inquiries, orders, advertising, expense, etc. Only \$1.00. C. A. Martin, Popular Mechanics, Dept. PM, 575 Lexington Ave., New York 10022.

DO-IT-YOURSELF

EXERCISE At home on build-it-yourself physical fitness equipment, including bicycle exerciser, rowing machine, belt massager, and abdominal board. Send \$2.50 for blueprints B1208 and instructions. Popular Mechanics Service Bureau, 575-K Lexington Ave., New York, N.Y. 10022.

14 WEATHER Instrument Plans \$2.00. Saco, Box 2513A, South Bend, Ind. 46614.

WHISKEY MAKING—Bourbon in small quantities on kitchen stove. New manual explains how and gives recipes. \$3.00 to Paterson, Box 1044, Silver Spring, Md. 20910.

BURGLAR-FIRE ALARM Systems and Supplies. Free Catalog. Informer Alarm Mfg., 715B Ensor Street, Baltimore, Maryland 21202.

REFRIGERATOR Door gaskets—Electric Range and Washer Parts. Send Make and model for cost. Box 5465, Hamden, Conn. 06518.

AIR Compressors made from Mower Engines. Write: Showalter, Box 409, Abilene, Kansas 67410.

BURGLAR-Fire Alarm Supplies and information. Free Catalog. Protecto Alarm Sales, Box 357, Birch Run, Michigan 48415.

MAKE Your own wall plaques for fun or profit. Easy to do. Catalog 10¢. Arts Magic, Box 6232, West Palm Beach, Fla. 33405.

GASOLINE Savings up to 15% plus decreasing smog for \$2.50 worth of material, only \$1.00 Instructions; 447 East Van Buren, Phoenix, Arizona 85004.

BURGLAR-Fire Alarms, Automatic Police Telephoning, Gas, Bells, Supplies. Free Catalog, Specify; business-residence. Alarm Supply, 7294 Glenview, Fort Worth, Texas 76118.

ARTS AND CRAFTS

FREE: New 136 page handicraft catalog. Supreme Handicrafts, Box 395-PM Sioux Falls, South Dakota 57101

MAKE Figurines, plaques, lawn ornaments, Molds, plastercraft kits, liquid rubber. Sample and catalogue 10¢. Woolley Company, Box 29-B, Peoria, Illinois 61601.

BINOCULARS, TELESCOPES, MICROSCOPES, MAGNIFIERS

BINOCULARS Direct from manufacturer. Finest quality, tremendous savings! Request catalog. Koyu, 3860 Crenshaw Blvd., Los Angeles, Calif. 90008.

SCIENCE Bargains! Lenses, telescopes, binoculars, microscopes, kits, parts, war surplus. Send \$1.50 for beginner's 10-lens kit with instruction booklet. Order Stock 2-CH. Request free 148 page Catalog CH. Edmund Scientific Co., 300 Edscorp Bldg., Barrington, New Jersey 08007.

BINOCULAR Sale! Free color catalog 100 models \$9.95-\$250.00. Write, United, 9043 So. Western, BC-AT-308, Chicago 60620.

WORLD Famous "DynaScope" Telescope Build your own reflector telescope, mirrors, eyepieces, tripods, accessories. Request free brochures. Criterion Manufacturing, Dept. PP35 Hartford, Connecticut 06101.



CAMERAS AND EQUIPMENT

WORLD'S Largest Buying Guide—800 Illustrations—50¢—Deductible With Your Order—Olden Camera—1265 Broadway, New York, N.Y. 10001.

48 PAGE ILLUSTRATED CATALOG with the low Central Discount price. Send 50¢. 75¢ CREDIT on order of \$7.50 or more. Central Camera Co., Headquarters for the amateur and professional since 1899. Central Camera, Dept. IAS, 230 S. Wabash Ave., Chicago, Ill. 60604.

FREE! FREE!—Photographic and optical bargain book. Jimsco, Dept. 1AF, 9006 Waukegan Road, Morton Grove, Ill. 60053.

PHOTO SUPPLIES

YOUR Ad in Popular Mechanics will be seen by more than 5,000,000 active buyers for your products and services. It costs only \$1.85 per word. And, if you wish to run all or part of your ad in capital letters—you can do so for as little as 75¢ per word additional. Act now! Place your classified ad in Popular Mechanics today.

ANSCOCHROME—DYNACHROME—FILM—save by mail-free price list. Hillis Products, Dept. M Box 1182, Kokomo, Indiana, 46901.

PHOTO FINISHING

A FREE Kodak roll returned with each black and white or Kodacolor developed and printed, fast service, lowest prices, guaranteed quality send for free mailers. Economy Photo Service, Dept. P.M., Box 1111, Albany, N.Y. 12201.

SPECIAL WITH THIS AD—Kodacolor developed 12 prints \$2.25. Black & White developed 2 prints each Jumbo size—12 exposure 70¢. LENS PHOTOS, Dept. J-4, Janesville, Wis. 53545.

CAMERA FANS! Expert photofinishing by one of Country's largest labs at lowest prices. Fast service and free "Foto-Fan" Stamps you quickly redeem for valuable Photo Supplies. 8MM Kodachrome \$1.29; 8 Exp. Kodacolor \$1.79; 35MM Kodachrome, 20 Slides \$1.39; 8 Exp. Black White 69¢. Satisfaction guaranteed. Send exposed film or request free mailers, complete Price List and Gift Catalog. Direct Mail Photo, Box 8352-PM, Pittsburgh, Pa. 15218.

LOOK—Save Money on Pictures! Jumbo Size Prints from your Kodacolor Rolls, \$1.98. Black & White, 69¢. Huge Discounts on Supplies. Enclose Advertisement. Wisconsin Film Service, Dept. 33, La Crosse, Wisconsin 54601.

50% DISCOUNT "get-acquainted" offer to 126 Instamatic Camera owners for one month only \$1.50 for 12 exposure (regular \$3.00). We develop, print ONLY 126 Instamatic film. no black and white. Send \$1.50 today. I/T/K CO., Dept. B, Ishpeming, Mich. 49849.

SPECIAL: BLACK-White, 8-45¢; 12-55¢. Kodacolor, 8-\$1.89; 12-\$2.09. Astro Photo Service, Box 530, Waterloo, New York 13165.

KODACOLOR, 20¢/Print, Free Develop- ing. Keaton's, 3540 N. 6th, Abilene, Texas 79603.

INTRODUCTORY Special—12-Exposure Kodacolor Developed For \$2.00 With This Ad. **FREE GIFT.** Expires March 1, 1970. Paul Bunyan Photo, Box 309P30, Brainerd, Minnesota 56401.

COLOR SLIDES

OUR FIRST 19 IN SPACE. This limited edition lithograph has been created as a tribute to Americas Gallant Astronauts. 12 X 18 inch chart ready for framing. Only 75 cents. Popular Mechanics, Dept. GWP, 575 Lexington Avenue, New York, New York 10022.

MOTION PICTURES AND SOUND EQUIPMENT

16MM Sound Features, Shorts, New, used for Sale. Free Catalog. National Cinema, 333 W. 57th, St.-N.Y.C., N.Y. 10019.

FREE! 64-page catalog, 8-16mm film, supplies, processing equipment. Superior, 448 N. Wells, Chicago 60610.

UNUSUAL Movie supplies. Free circular. Esor, 47th Holly, Kansas City, Missouri 64112.

5,000 8-16MM MOVIE Films. Free catalogues. International, Greenvale, L.I., N.Y. 11548.

16MM CLASSICS. Illustrated Catalog 25¢. Manbeck Pictures, 3621-PM Wakonda Drive, Des Moines, Iowa 50321.

FREE LISTS 8mm 16mm movies, FILM CLASSIC, 1926 SOUTH VERMONT AVENUE, LOS ANGELES, CAL. 90007.

8-16 MM, Used! Listings, 6¢ stamp, Hilton, 52 Columbia, Albany, New York 12207.

RADIO, TELEVISION AND HAM EQUIPMENT

33¢ RADIO & TV tubes. Free list. Cornell, 4213-17 University, San Diego, California 92105.

TUBES—Lowest prices in the world. Hard to get British, German, Foreign and American obsolete and present day special purpose transmitting tubes. Send for giant tube and parts catalog. United Radio Company, Dept. Z-56 Ferry St., Newark, N.J. 07105.

GOVERNMENT Surplus receivers, trans- mitters, snooper scopes, parts. Catalog. 25¢. Meshna, Nahant, Mass. 09108.

FREE Brochure MONITOR Fire, Police RADIOS with MINIVERTER II, full SQUELCH easy installation. Scientific Associates, Box 276(MX), South Glastonbury, Conn. 06073.

HEAR POLICE & Fire Radio Dispatch- ers! Stamp brings catalog: Receivers, exclusive "Confidential" Directories of Dispatcher Stations! Communications, Box 56-PM, Commack, N.Y. 11725.

ELECTRONIC Modules made easily. Now encapsulate your own electronic circuits in tough epoxy! Kits: 1 pound-\$2.25, 2 pounds-\$4.35, 3 pounds-\$6.30. ABSCO, Box 45275M, Chicago, Illinois 60645.

MAKE Money. Your songpoems set to my music, 50-50. Betty's music (PM 99) 3545 3rd Ave. So., St. Petersburg, Fla. 33711.

HIFI, RECORDS AND ELECTRONICS

FREE Catalogues, 2000 hard to find un- usual records. Rose's, 300 Chelsea, Louisville, Ky. 40207.

TAPE Recorders, hi-fi components. Sleep learning equipment, tapes. Unusual values. Free catalog. Dressner, 1523C Jericho Tpke., New Hyde Park, N.Y. 11040.

RECORDS! Discounts on all LP's. Free details. Citadel Record Club, Symphonette Sq., Dept. 2, Larchmont, N.Y. 10538.

CASSETTES AT HONG KONG PRICES! Lifetime Moneyback Guarantee! Three C-60s-\$4.75, Three C-90s-\$7.25, Three C-120s-\$8.75, Custom Record Development, Box 3, Mamaroneck, N.Y. 10543.

TAPES . . . Blank recording . . . pre- recorded music. Catalog 10¢. Tower, Lafayette Hills, Pa. 19444.

HOME Radio-Television Course. Free brochure. Progressive Edu., Department 717B, Hewlett, New York 11557.

MAGNETIC Tape slitting. Your 1/2", slit to 1/4". Write: Waltzman, Box 54, Palisade, Colo. 81526.

CASSETTE, 8-track cartridge-blanks, language, classical, special accessories, recorders. Quality, low prices. Box 13119M, Pittsburgh, Penna. 15243.



MUSIC AND MUSICAL INSTRUMENTS

PLAYER Piano Rebuilding—get details from: Vestal Press, Vestal 11, N.Y. 13850.

ACCORDION Manufacturing, 6846-P North Avenue, Chicago, Illinois 60635. Concertinas, Hohners, Chromatics, Guitars, Drums, New, Used, Tuning, Repairing. Wholesale Catalogs Free.

POEMS, Songs wanted for new song hits and recordings by America's most popular studio. Tin Pan Alley, 1650-PM Broadway, New York 10019.

VIOLIN and Guitar makers—send for latest Free Catalogue of woods & accessories. International Violin, PM8, 414 East Baltimore St., Baltimore, Md. 21202.

POEMS Wanted for new songs and records by America's largest song studio. Send poems. Free examination. Five Star Music, 6M Beacon, Boston, Mass. 02108.

GUITARS, MANDOLINS, BANJOS. Complete stock of Gibson Martin guitars. Free 100 page catalog, parts and accessories. Big Savings. New York discount prices. Send 50¢ postage handling. Eddie Bell Guitar, 201 West 49, New York 10019.

GUITAR, Banjo Making books Plans, woods, necks, tools. List 25¢. Satinwood, 510 East 11th Street, New York, N.Y. 10009.

30% DISCOUNT Any Name Brand musical instruments. Write for low price. Freeport Music, 127 W. Sunrise Highway, Freeport, New York 11520.

SONG Writers—Send Poems, Songs to: Weiss Music Company, 1472 Broadway, New York, New York 10036.

GUITAR Chord system most modern ever devised. Send \$3.50. Johnny Carlton, Canton Plaza, Marietta, Georgia 30060.

ELECTRIFY Player Pianos, Pump Or- gans quickly, inexpensively with Lee Silent Suction Units. Write Lee Music, 525 Venezia Avenue, Venice, California 90291.

ACCORDION Top brands. Buy direct. Tremendous discounts. Trade accepted. Free brochure PM. Accordion-O-Rama, 874 Broadway, N.Y.C. 10003.

DRUMS, Electric guitars, amps, organs. Free catalog M: A.L.A.S. Import Company, 31 East 18th Street, NYC. 10003.

SONGS, Poems wanted! Accepted songs published, recorded at our expense! Talent .17-PM, Longwood Road, Quincy, Mass. 02169.

GUITAR MAKING Books, Imported Woods, Supplies, Accessories, Catalog 25¢. Guitar Center, Box 15444, Tulsa, Okla. 74115.

SWISS Musical Movements. Mechanical-Electrical. Spielman, 131 West 42nd, New York 10036.

WRITERS—Make money. See my ad under Money-making Opportunities. Rufco.

CLASSICAL, Flamenco guitars. Finest Spanish makers. Gibson, Martin, Wood, tools, books. The Guitar, 4668 Hollywood Blvd. Hollywood 90027.

EXCELSIOR Accordions and Amplifiers. Save 50%. Buy Direct, Factory Distributor. Terms, Trades, Free Catalog. Excelsior 3147 North Luna, Chicago. 60641.

ACCORDIONS and Amplifiers! Save to 50%. Famous makes. Easiest terms. Trades accepted. Free home trial. Free discount catalog. Accordion Corporation, 5535-R West Belmont, Chicago 60641.

PLAY Organ easily. Amazing Method. Free Information. Kegley, 1016 Kelly, Joliet, Illinois 60435.

EDUCATION AND INSTRUCTION

LEARN Auctioneering. Term soon. Free catalog. Reisch Auction College, Box 850, Mason City, Iowa 50401.

PIANO Tuning quickly learned with home study course. Diploma granted. American Tuning School, Gilroy, Calif. 95020.

BOOKKEEPERS. Operate your own "Dollar-A-Week" system. Ellis, Box 200, Cedar Grove, North Carolina.

OWN Collection agency. "Little Gold Mine!" Franklin Credit, Roanoke, Virginia 24004.

EARN \$125 A week and up. Learn a trade with a future. Learn auto diesel mechanics in our shops. You learn with tools on real equipment. Earn while you learn. Many of our graduates earn \$125 a week and up. Write for free bulletin: Dept. 256, Auto Diesel College, Nashville, Tennessee 37219.

SWEDISH Massage and physical culture pays big profits. Learn at home. Diploma. Free catalog. National Institute, Dept. E-99, 307 North Michigan, Chicago 60601.

USED CORRESPONDENCE Courses and Books sold and rented. Money back guarantee. Catalog free. (Courses bought). Lee Mountain, Pisgah, Alabama 35765.

MISSOURI Auction School. GI Approved. Free Catalog! 424-03 Nichols Road, Kansas City, Mo. 64112.

SUPERIOR Auction School. Nation's top Auctioneers own and instruct. 120 East Cerrogorido, Decatur, Ill. 62523.

BE A POLICEMAN. Complete Course and Diploma, only \$10.00 Southern Police Academy, P.O. Box 306 Fairfield, Alabama 35064.

FCC First Class License in six weeks—Nations highest success rate—Approved for Veteran's Training. Schools in Dallas, Atlanta, Chicago, New Orleans, Minneapolis and Houston. Write Elkins Institute, 2603D Inwood Road, Dallas, Texas 75235.

HIGHLY effective home study courses in Electronics Engineering Technology and Electronics Engineering Mathematics. Earn your Degree. Write for Free Descriptive Literature. Cook's Institute of Electronics Engineering. (Dept. 10), P.O. Box 10634, Jackson, Miss. 39209. (Established 1945).

EARN College degree at home. All subjects. Ohio Christian College, 1156 Striebel Road, Columbus, Ohio 43227.

PROFITABLE National Camera Repair School training at home! PM-9, Englewood, Colorado.

DETECTIVE Course. Free information. Universal Detectives, Box 8180-F, Universal City, California 91608.

HIGH School diploma at home. Licensed teachers. Send age, highest grade completed for free details. No salesman will call. Southern States Academy, Westbury Square Professional Bldg., Dept. 16, Houston, Texas 77035.

USED Courses! Books! List 10¢. Smith's, 124 Marlborough, Salem, Mass. 01970.

COMPLETE YOUR HIGH SCHOOL At home in spare time with 72-year-old school. Texts furnished. No classes. Diploma. Information brochure free. American School, Dept. X645, Drexel at 58th, Chicago, Illinois 60637.

ORDAINED? Free credentials! Request information! NSU, 708 South Bragg, Monroe, North Carolina 28110.

AUCTIONEERING Resident or Home Study Course Free Catalog. Nashville Auction School, 2004 West End, Nashville, Tennessee 37203.

BARTENDING—Home Study course. Box 3191-P, North Las Vegas, Nevada 89030.

PIANO Technology—Electronic organ servicing, learned easily at home. G.I. Approved. Free booklet. Niles Bryant School, Dept. P, 3631 Stockton, Sacramento, California 95820.

BE A REAL Estate Broker. Big earnings. Prepare quickly, easily. GI approved. Free Catalog. Weaver School, 3519-P Broadway, Kansas City, Missouri 64111.

PHOTO RETOUCHING. Interesting, profitable career at home; full or part-time. Easily learned. Hamilton Studios, Dept. PR-39, Claymont, Del. 19703.

GET A British Degree. Divinity, Philosophy, Radionics, 35 Courses, Prospectus free. Brantridge Forest School, Highfield, Dane Hill, Sussex, England.

COLLEGE Degree at home. Includes law. Easy tuition plan. Williams College, 111-PM West College, Covina, California 91722.

PENMANSHIP Corrector. Improve poor penmanship quickly. Details free. Ozment, Box 665-34, St. Louis, Mo. 63188.

LEARN Asleep or awake! Records, tapes, equipment! Free catalog! Drawer, PM-400, Ruidoso, New Mexico 88345.

AUTOSUGGESTION. Sleep-learning headquarters! Tapes, records, books. Gigantic catalog free. Research Association, Box 24-PM, Olympia, Washington.

PIANO Tuning pays. Big money in spare time. Learn at home. No musical knowledge necessary. Phonograph, records, tools and instructions furnished. Electronic tuning also taught. Free catalog. Capital Tuning School, 3160 S.W. 16th Court, Ft. Lauderdale, Fla.

LEARN ACCIDENT INVESTIGATION. Train at home to earn \$750 to \$1,000 monthly. Car furnished. Expenses paid. No selling. No college needed. Full or spare time. Men urgently needed. Free placement service. Write for FREE information. No obligation. Universal Schools, CPM-9, 6801 Hillcrest, Dallas, Texas 75205.

WATCH REPAIRING. Learn to repair American and Swiss watches in spare time at home. Diploma awarded. Free sample lesson. No obligation. Chicago School, Dept. YW, Fox River Grove, Illinois 60021.

LEARN Civil and criminal investigation at home. Earn steady good pay. State age. Institute Applied Science, 1920 Sunny-side, Department 169, Chicago, Illinois 60640.

INSTANT Spanish. Free lesson. Mayco, Dept. J-1, 257 Chloride Star, Kingman, Ariz. 86401.

REAL ESTATE BROKER TRAINING Simplified course, train at home Write: RETA, Box 713, Ekhart, Ind. 46514.

FAMOUS HOME FIX-IT GUIDE. Other Self-Improvement books. Free list. Harry Haines, R. 1, Box 151, Mill Hall, Pennsylvania 17751.

LEARN Handwriting analysis. International, Dept. 700, 11749 Eldridge, Lake View Terrace, Calif. 91342.

PENMANSHIP Improver: Correct poor penmanship, plus ornamental. Tevis, Chillicothe, Mo. 64601.

MINISTERIAL Bible College. Christian Education, Ordination, and Degree Courses. Write: Soms, 887 West Spruce, Ravenna, Ohio 44266.

LEARN Bartending. Bartenders Correspondence School, 426C East Seventh Street, Tucson, Arizona 85705.

FOR INVENTORS

PATENT Searches complete and thorough. Related copies Air Mailed with maximum speed \$6.00. Free "Protection Forms" and "Patent Information." Write American Patent Search Company, Dept. 27, 711 14th St., N.W., Washington, D.C. 20008.

PATENT Application Financing. Free patent search plan. Global Patent Division, 2420 77th, Oakland, Calif. 94605.

PATENT And invention development by licensed professional patent engineer and U.S. Patent Office former examiner, and engineering specialists. Your inventions and ideas engineered for patent protection and commercial value. Inventions developed by us negotiated for cash or royalties with our nationwide contacts. Send for free protection "Invention Certificates" and further interesting, valuable patent information. George Spector, Licensed Professional Patent Engineer, Woolworth Building, New York.

U.S. Patent Office Searches, 234 Broadway, Room 3615, New York. Free invention certificates.

NEEDING ASSISTANCE? INVENTION DEVELOPMENT FOUNDATION, 1823 Jefferson Place, N.W., Washington, D.C. 20036. CANADIAN OFFICE: 155 Kent, Ottawa 4, Ontario.

INVENTORS—IF you have an invention for sale, patented or unpatented, write for free brochure outlining manufacturer's requirements. Royalty rates. Kessler Corporation, C-59-F1, Fremont, Ohio.

SEND \$1.00 for New publication, "Straightforward advice for Inventors". Wenzel, P.O. Box 397, Upland, California, 91786.

MANUFACTURERS NEED New Products! FREE Literature explains "How To Submit Your Invention." Congruss Invention Company, 911-C Warner Building, Washington, D.C. 20004.

INVENTORS! Free Promotion Analysis helps you sell for highest royalty value. Extensive Manufacturer's lists. Complete Invention Service. 10 years proven performance. Free information: International Invention Institute, Dept. M, 160 Broadway, New York, New York 10038. Financing available.

PATENT Searches, including copies of related U.S. patents. Inventors attorneys, manufacturers use our "worldwide" airmail service! "Invention Record" form and "Information Every Inventor Needs," sent free! Hayward Company, 1029P Vermont, Washington 5, D.C.

INVENTORS! Why deal with 2-3 invention firms and risk information leaks? We offer complete, rapid invention servicing. Searches, Copyrights, Promotion. Applications prepared (Mechanical, Chemical, Design, Foreign). Financing. Free Information, protection forms: New York Invention Service, Dept. M, 160 Broadway, New York, New York 10038.

INVENTORS: Your ideas and inventions (patented; unpatented) expertly searched, developed for commercial appeal and cash/royalty sales to manufacturers by professional Invention Developer with excellent record of experience. B.S., Industrial Engineering; United States Patent Office former Patent Examiner, United States Government former Patent Advisor. Second decade reliable service! Member: United States Chamber Commerce. Free "Invention Record" and "Recommended Protection Procedure." Airmailed! Write: Raymond Lee, Invention Developer, 230-P Park Ave., New York City 10017.

IMMEDIATE Cash, for patent applications. Free patent searches. Write for details. Universal Patents, 184-D, Marion, Ohio.

FREE PAMPHLET: "Tips on Safeguarding Your Invention." Write: United States Inventors Service Company, 501P Thirteenth Street N.W., Washington, D.C. 20004.

SELL Your Invention Now! Inventor's Guide for Marketing Inventions only \$1.00. Invention Marketing Research, 3138R Wilson, Chicago, Ill. 60625.

INVENTIONS WANTED

INVENTIONS Wanted. Patented: unpatented. Tremendous manufacturers lists. Global Marketing Service, 2420G 77th, Oakland, California 94605.

INVENTORS! Sell your invention for cash or royalties! Our client manufacturers eagerly seek new items. Patented. Unpatented. Financial assistance if needed. 25 Years proven performance. For free information, write Dept. 15, Gilbert Adams, Invention Broker, 80 Wall St., New York, N.Y. 10005.

INVENTORS! We will develop, sell your idea or invention patented or unpatented. Our national manufacturer-clients are urgently seeking new items for highest outright cash sale or royalties. Financial assistance available. 10 years proven performance. For free information write Dept. 47, Wall Street Invention Brokerage, 79 Wall Street, New York, N.Y. 10005.

INVENTORS! Don't sell your invention, patented or unpatented, until you receive our offer. Eagle Development Company, Dept. H, 79 Wall Street, New York 5, N.Y.

INVENTIONS Needed immediately for manufacturers. For additional information write Kessler Corporation, C-59-1W, Fremont, Ohio.

INVENTORS Needing help with any problem, financial, securing manufacturer, obtaining patent. Write the organization that delivers action and results—not promises. Pioneer Invention Service, Dept. 2, 150 Broadway, New York, New York 10038.

WE Either sell your invention or pay cash bonus. Write for details. Universal Inventions, 298-E, Marion, Ohio.

INVENTORS! Protect your ideas! Free "Recommended Procedures." Washington Inventors Service, 422F, Washington Building, District of Columbia 5.

INVENTORS! Don't sell or license your invention for cash or royalty until you receive our offer. Financial assistance available. For free information write: Dept. M-1, Wall Street Promotions, Inc., 99 Wall Street, New York, New York, 10005.

FREE "Directory of 500 Corporations Seeking new Products." For information regarding development, sale, licensing of your patented/unpatented invention. Write: Raymond Lee Organization, 230-N Park Avenue, New York City 10017.

PATENTS FOR SALE

WANTED Broker or Brokerage firm to sell patents on Royalty basis only. Sukala, Box 75, Natrona Heights, Penna. 15065.

MANUFACTURING

INVENTORS Ideas developed. Research. Models. Manufacturing. Sales. Free brochure. William Parker, 32 Westminster, Worcester, Mass. 01605.

MANUFACTURE AND INSTALL Brick Veneer Wall Covering. Start in your Garage. No capital investment. Send For free Prospectus. Masonry Specialists, 806 S. Knickerbocker, Sunnyvale, Calif. 94087.

BUY IT WHOLESALE

I MADE Over \$100,000.00 year selling by mail. IRS proof available. Success story, book form \$2.00. Wayne Johnson, 880 SW 60th Avenue, Ft. Lauderdale, Florida 33314.

500,000 BARGAINS BELOW WHOLESALE. New, name brand merchandise. Buy at 10¢ on the dollar. Closeouts, surplus, bankrupts, liquidations, imports. Free details. International Buyers, Box 4633-M, Colorado Springs, Colo. 80909.

BARGAINS! Buy wholesale and below. Name brands. Appliances, furniture, sports equipment, televisions, cameras, watches, jewelry, thousands more. Huge discounts to \$1,000.00 on new automobiles. All makes. Free details. Write today: Worldwide Bargainhunters, Box 730-A, Holland, Michigan 49423.

800,000 PRODUCTS Wholesale! Terrific Bargains! Wholesalers, 1265-M, Broadway, New York, N.Y. 10001.

NOVELTY Items, toys and other merchandise for promotion or fund raising. Send \$2.00 for catalog to handle shipping. Free Booklet sent with catalog tells many games for party and fun. Kaylin Wholesale Co., 707 Hill Road, Caseyville, Illinois, 62232.

WHOLESALE SOURCES DIRECTORY LISTS over 150,000 items. \$3.00 postpaid **SKI ENTERPRISES, 88 CARROLL STREET, CHELSEA, MASS. 02150.**

DRAFTING Equipment Slide Rules Catalog 30¢/Stamps. Amtech, Inc., Box M-122, Mt. Holly, N.J. 08060.

EXPORT-IMPORT

I MADE Over \$100,000.00 year selling by mail. IRS proof available. Success story, book form \$2.00. Wayne Johnson, 880 SW 60th Avenue, Ft. Lauderdale, Florida 33314.

JAPAN: 1200 Products Directory, Illustrated Manufacturers' names, addresses, \$3.00. Send cash. Yamagata Office, 814 Togin Bldg., Marunouchi, Tokyo.

FOR THE HOME

BURGLARY-FIRE Protection. Everyone can afford. No wiring, installation. Free details. Watchdog Alarms, P492M, Williamsburg, Ohio 45176.

COMBINATION Extension cord timer automatically turns off electrical appliances, including televisions, radios, lights, etc. \$7.95 plus 40¢ handling. Elayne Sales Co., 219 Jacoby Street, Maplewood, N.J. 07040.

SAVE \$\$\$\$ Sensational new Device prevents Theft or use of Electrical Appliances; Workshop Tools, easily attached. \$2.50 Postpaid. Guaranteed. Details 25¢ refundable with order. Home Aids, Post Office Box 2216, Naranja, Florida 33030.

TWO-WAY Intercom identify caller. Battery-operated. Easy kit install. \$16.95. 31-4101 E. Nichols, 1135 Delaware, Berkeley, California 94702.

FOR PARENTS

PROFITS FROM CLASSIFIED ADVERTISING!! Booklet shows you how to start your own business with Classified Advertising. Only \$1.00 (Refundable with first order.) C. A. Martin, Popular Mechanics, Dept. PM, 575 Lexington Avenue, New York 10022.

OF INTEREST TO WOMEN

WOMEN! Make big money at home. \$10.00 profit in an hour possible with invisible mending. Make holes, tears disappear from clothing, fabrics. Steady year-round demand from cleaners, laundries, homes. Details free. Fabricon, 1533 Howard, Chicago 60626.

HOW To make money writing short paragraphs. Information free. Barrett, Dept. C-27-U3, 6216 N. Clark, Chicago 60626.

DRIVE New car, wear new clothes, buy color TV. Get daily cash income. Put spare hours to work. Write for 5 months free subscription Opportunity Magazine, see hundreds easy ways to make money. Opportunity, 1460 Hancock Center, Dept. 17-JO, Chicago 60611.

WANTED! Addressers—Commission Mailers. Stamp required. Ooton Distributors, 4120P Duke Drive, Portsmouth, Virginia 23703.

EARN \$100.00 Fast Lacing Beautiful Products! Write: Cowboy, Warsaw 9, Indiana 46580.

\$75.00 THOUSAND. Home addressing! Longhand, typewriter. Information, send stamped self-addressed envelope. Brewster, Box 1348-YL Clearwater, Florida 33517.

WOMEN: Big Money! Studio Girl Cosmetics needs women in all States including Hawaii, Alaska, Puerto Rico and American Samoa. Full or part time. No experience required. No territory restrictions. Take orders anywhere. Highest profits. 500 Good Housekeeping approved cosmetics. Everything furnished. Credit extended. No stock to carry. No franchise fees. No stock investment. For full information by mail, plus 3 free samples, write Harry Taylor, Chairman, Studio Girl Cosmetics, Dept. BC-381, 11461 Hart Street, No. Hollywood, Calif. 91605. Also immediate big profit earnings for experienced City and State managers and former party plan operators.

\$100 WEEKLY Possible—Home Typing. Immediate earnings! Employers list, complete instructions. Details 25 cents. Typing, Box 593, PM-9, Bettendorf, Iowa 52722.

HOMEWORKERS! \$85 weekly addressing mail for firms. Start immediately! Details, send stamped self addressed envelope. Enterprises, Box 16143-PM, Phoenix, Arizona 85011.

HOME Workers Mailers wanted. Stamped self-addressed envelope. Bapps, Rosholt, South Dakota 57260.

SELL Gifts, Household Items—Make extra money. Toys, Jewelry, Stationery, Greeting Cards, 600 items. Experience unnecessary. Salable Samples on approval. Free - Catalog, Personalized Christmas Card Album. Hedenkamp, 361 Broadway, Dept. PM-100, New York 10013.

\$100 WEEKLY Possible! Homework, mailing circulars. Information, send stamped, self-addressed envelope. Martin's, Box 445-DN, Sonoma, Calif. 95476.

UNIQUE Full Length Mirror \$1.00! Ross, Box 152, Wayne, Pa. 19087.

\$500 MONTHLY POSSIBLE—clipping news at home. No experience. Free information—send stamp. American, Excelsior Springs, Mo. 64024.

PRINT, TYPE, handwriting. Addressers needed. Details 25¢ for handling and a self addressed stamped envelope. Hilltop, Box 882, Council Bluffs, Iowa 51501.

HOUSEWIVES, Teachers, students, office workers. If you need extra cash each week but household or other duties prevent you from taking a part-time job, learn how you can earn by accepting orders to Popular Mechanics. Good Housekeeping and all other magazines. No experience needed. Write Popular Mechanics, Room 9W, 250 West 55th St., New York 19, New York.

HOMEWORKERS PROFITS! Write if looking for homework, typing or mailorder. Send Stamped Addressed envelope. Rightway, Box 885—PM 9, Moorhead, Minn. 56560.

GIFT SHOPPING

GET FREE GIFTS Send for new catalog. Harry Haines, Route 1, Mill Hill, Pennsylvania 17751.

FREE Distinctive Gifts Catalog. Send Name Address, Elmo, 2136A 71 Street, Brooklyn, New York, 11204.

DISTINCTIVE Catalog Free! Chen, PM-919, 244 West 99, Rm-302, New York 10025.

SCRIMSHAW, Genuine Etched Whale teeth, Free Folder. Dealers Invited. F. E. Wallace, 1018 North 1st St., New Hyde Park, N.Y. 11040.

FREE Gift Catalogs. Holidays are coming, get a Head Start. Specify Domestic or Import. R. J. Renn Co., 16 Wellington Rd., Elmont, N.Y. 11003.

ATTRACTIVE Gifts for all occasions. Free Catalog. Harvard House, 1691 Davidson, Bronx, New York 10453.

QUALITY Gifts never out of season. Birthdays, anniversaries, Christmas. Send 10¢ coin for value packed catalogue. Woodland House, 2437 Tortugas Lane, Ft. Lauderdale, Fla. 33312.

AFRICAN Curics, jewelry, Exotic Swazi, N'debele, Zulu selection \$6.95 postpaid. Giant Christmas gift selection \$15. Abadora, Dept. PM1, P.O. Box 149, Rondebosch, Cape, South Africa.

FREE Catalog—Unusual items for Christmas. Supply Limited, Mardi Gras Gifts, 2657 Mardi Gras, Anaheim, California 92806.

NATIVE Made ALASKAN Yoyos and directions. Ideal for Christmas. \$2.95 Postpaid. Lee's Jewelry, 851 East Loop Rd., Anchorage, Alaska 99501.

WATCHES, OLD GOLD, JEWELRY

WATCH And clock repairing books. Free catalog, North American, Box-77-AK, Fox River Grove, Illinois 60021.

USED Wrist, pocket watches—\$3.00 up. Free list, Southern Watches, 5-PM South Wabash, Chicago 60603.

CASH Immediately for old gold, jewelry, gold teeth, watches, diamonds, silverware, spectacles, platinum, mercury. Free information, Rose Industries, 29-A East Madison, Chicago 60602.

WANTED—gold, silver, platinum (any form), mercury, information free. Wilmot's, 1069 Bridge Street, Grand Rapids, Michigan 49504.

HIGHEST CASH for Gold, Jewelry, Gold Teeth, Rings, Diamonds, Watches, Silver, Platinum, Mail Articles Today. Free gift with information, Chicago Gold & Precious Metals, 6 E. Monroe, Dept. 158, Chicago, 60603.

WATCHMAKERS'—Jewelers' Catalog: Surprise: \$1.00. Watchmaking Course; Tools; \$35.00. Bengal's, 17942 Ventura, Encino, California 91316.

WEARING APPAREL

MEN—Buy your Outerwear Coats and Jackets WHOLESALE directly from manufacturer. Write now for free illustrated booklet showing styles for Fall 1969. Sharob Corp., Carbondale, Penna. 18407.

HEARING AIDS

HEARING Aids below wholesale. Regular, eyeglass, completely hidden models. Smallest, most powerful. Free home trial. No Salesman will call. Free details. Write Prestige-C6, Box 10880, Houston, Texas 77018.

HEARING AIDS—Batteries Wholesale! Brochures—Hearing Center, Box 211, St. Petersburg, Florida.



SCIENCE AND CHEMISTRY

ROCKETS: Real flying models—flights up to 2500 ft. New illustrated catalog 25¢. Single and multistage kit, cones, engines, launchers, trackers, rocket aerial cameras, technical information. Fast service. Estes Industries, Penrose 7, Colorado 81240.

CHEMICALS, Apparatus, Microscopes, Biological Supplies. 1969 Catalog 35¢. Sheard Science Supplies, Inc., Columbus, Wisconsin 53925.

FREE Periodic classification of elements and conversion tables with catalog 35¢. Chemicals, apparatus, biology. Mid-States Scientific, 7053 N. Clark, Chicago, Ill. 60626.

35,000 VOLT CONTINUOUS Spark Generator, cheaply made in minutes. Plans, \$1.00 and self-addressed, stamped envelope. Lawrence Engineering, Box 18366, Phila., Pa. 19120.

ROCKETS! Flying models, engines, igniters. Send 25¢ for News-A-Log. Rocket Development Corporation, Route 3-M, Seymour, Ind. 47274.

ROCKETS!! Real flying models—2500 feet altitude with powerful motors. Terrific Science Projects. Tubes—Cones—Parachutes—Launchers—Igniters. Gigantic catalog—rocket data—diagrams—25¢. Fast Delivery. Centuri Rockets, Box 1988, Phoenix, Arizona 55001.

CHEMICALS And apparatus for industrial, analytical, and private laboratories. Catalog 50¢. Dept. M-50, Biological Supply Co., 1176 Mt. Hope Ave., Rochester, N.Y. 14620.

SEARCHING For economically priced Laboratory Supplies? Gifts with catalogue—25¢. Hagenow Laboratories; Manitowoc, Wisconsin 54220.

SEARCHING For Economically Priced Chemicals And Apparatus? Gifts with Catalogue—35¢. Starr Scientific, Manitowoc, Wisconsin 54220.

LABORATORY Supplies At Discount Prices. Catalog—35¢. Deluxe Scientific; Manitowoc, Wisconsin 54220.

ROCKETS, Launching Materials, Flying Saucers, Hot Air Balloons, Cannons, etc. Free Catalog. Zeller, Box 70, Hudson, Mich. 49247.

GET Smart, Science, Chemistry, Technology Books. Many fields. Catalog 45¢. See our interesting ads in back issues of PM. Bilton, Box 28, River Edge, N.J. 07661.

SCIENTIFIC Supplies Catalog. 35¢. Electric Motor Kit \$1.00. Xercon. 8542 Oglesby, Chicago, Illinois 60617.

FREE, Rocket Sent with Catalog 25¢. Scientific, 8886 Melvin, Livonia, Michigan, 48154.

SAVE! Quality Scientific Supplies — Chemistry, Physics, Biology, Mineralogy (Money Back Guaranteed)—Catalog 35¢ (Refundable)—Dale Hawkins, 24146 Naranjas, South Laguna, California 92677.

SATURN V Apollo Flight Configuration, cutaway rocket 13 inches. 25¢. Astro, Box 234, Merritt Island, Florida 32952.

CATALOG Of Ver-ry Interesting Products—25¢ (Free with any purchase—see our other Kenrus ad) Kenrus, Box 158M, Staten Island, New York 10309.

100 ONE Minute time delay fuses! \$1.00. 240—\$2.00. 700—\$5.00. Use with rockets, experiments, etc. Kenrus, Box 158M, Staten Island, New York 10309.

LASER PISTOL—\$1.00. How to build. PHASER PISTOL—\$1.00. (Add 25¢ postage.) New catalogue—25¢. Roy Davis Laboratories, Dept. PM, 118 West Adams St., Jacksonville, Florida 32202.

FORMULAS, PLANS, ETC.

ANY Formula \$3.00. Catalog—Treatise 10¢. Belfort, 192 N. Clark, Chicago 60601.

PERFUME Oils—Formulas—Ready made perfumes and cosmetics for private label. Edouard, P.O. #229, Covina, Calif. 91722.

PLASTICS

CASTOLITE Liquid Plastic pours like water and hardens like glass without heat. Clear, Colors. Embed real flowers, butterflies, photos, coins. Also new molding formulas for perfect reproductions. Illustrated booklet shows HOW. Send 25¢—Dept. 9/101K, CASTOLITE, Woodstock, Ill. 60098.

TREASURE FINDERS

TREASURE Hunters! Prospectors! Relco's new instruments detect buried gold, silver, coins, minerals, historical relics. Transistorized. Weighs 3 pounds. \$19.95 up. Free catalog. Relco-A40, Box 10839, Houston, Texas 77018.

TREASURE LOCATORS. MOST COMPLETE LINE. FREE INFORMATION. TESOROS, APARTADO 7-948, MEXICO 7, MEXICO.

FREE 128 Page detector catalog. General Electronic Detection Co., Box 67, Bellflower, California 90706.

FISHER DETECTORS! Treasure fun and profit with new professional quality solid-state models. Unsurpassed sensitivity, reliability. Guaranteed. Free literature. FISHER RESEARCH, Dept. PM-9, Palo Alto, California 94303.

POWERFUL Metrotech locators detect gold, silver, coins, relics. Moneyback guarantee. terms. Free information. Underground Explorations, Dept. A, Box 793, Menlo Park, California 94025.

ULTRA-SENSITIVE AND POWERFUL METAL DETECTORS—join the many who are finding buried coins, minerals, relics and artifacts. Don't buy till you see our FREE catalog of new models. Write Jetco—Box 132, PM-7, Huntsville, Texas 77340.

TREASURE BOOKLET. Excellent information on treasure hunting and metal detectors. Send 25¢. BOOKLET, Dept. 9-PM, Box 243, San Gabriel, California 91778.

FIND Buried treasure with new revolutionary analytical metal detector. Features push button tuning, automatic tuning, loudspeaker, negligible ground pickup, greatest range. Free catalog. Gardiner Electronics, Dept. 9, 4729 N. 7th Ave., Phoenix, Ariz. 85013.

TREASURE, Gold, silver, relics. New 1969 detectors now available. Free information. Rayscope, Box 715, North Hollywood, California 91603.

"METAL Locators—Accessories. Write: Detectors, Inc., Box 101-D, Springfield, Va. 22150."

GOLDAK Treasure Locators—New for '69! A hobby you'll enjoy for fun and profit. Find coins, gold, silver. Goldak, Dept. PMC, 1101A Airway, Glendale, California 91201.

NEW-Do-It-Yourself treasure finder kit—Locate buried gold, jewelry. Save money—Rush \$6.95—Refundable. Staydry PM—Whitestone, New York 11357.

PRECIOUS STONES AND MINERALS

EARTH Science Rockhound Magazine. Subscription \$2.50. Sample 35¢. Box-550-PM, Downers Grove, Ill. 60515.

100 COLORFUL, Polished gemstones, \$1.00. Tumblecraft, 5401 James North, Minneapolis, Minnesota 55431.

SEMI-Precious uncut gems. Ten different for \$1.00. Request list = 35. Prospectors Shop, 201 San Francisco, Santa Fe, New Mexico 87501.

GET Free catalog no serious rockhound, gem cutter, jewelry maker, hobbyist or craftsman can be without. Full of bargains, exclusive items, low prices from largest suppliers and authorities in the field. Free new catalog just off the press, yours for the asking. Write Grieger's, Dept. C-12, 1633 E. Walnut, Pasadena, California 91106.

LARGE, POLISHED, GEMSTONES. 15 different \$1.00. Colorful crystal specimens, 3 different \$1.00. Lists with order. Sering 1705 E. Michigan, Indianapolis, Indiana.

GOLD—10 Small Nuggets Panned from Oregon Streams, \$1.00. Robert Brandt, Sweet Home, Oregon 97386.

CARTOONING, COMMERCIAL ARTS, SHOWCARD & SIGN PAINTING

COMPACT 23 lesson Cartoon Course and Cartoonist's Magazine, \$2.00. Hartman, Box 30367, Lincoln, Nebraska 68510.

LEARN Sign painting at home. Free talent test. Ben Kerns, Box 812-PM, Greenville, S.C. 29601.

"HOW TO MAKE MONEY WITH SIMPLE CARTOONS"—Everyone who likes to draw should have this book; FREE. Write Cartoonists' Exchange, 99, Pleasant Hill, Ohio 45359.

SIGN Painting, Fascinating System—Straley, 410 So. Western, Springfield, Ohio 45506.

SIGN Painting - Free Catalogue, Instructions, Equipment, Kaufmann Signs, Centertown, Missouri, 65023.

LEARN Profitable tattooing. Illustrated information and instruction \$3.00. Zeis, 2220-P Delcy Dr., Rockford, Illinois 61107.

LEARN CARTOONING at home. Free book "Key To A Cartoon Career". Write: Cartooning, Box O3176, Colorado Springs, Colorado 80907.

ART Instruction, Moneymaking Opportunities, supply bargain offers, Year \$1. Midwest Arts, Box 95, Hamilton, Michigan 49419.

MODERN Cartooning taught by mail. Write for free brochure. Cartoonorama—Box 263-F Branford, Conn. 06405.

EASIEST, Fastest, Most Profitable Lettering System—Letter Patterns, Paulow, 1935 Stardust, Waukesha, Wis. 53186.

ADVERTISING AGENCIES, ADV. SERVICE, MAILING LISTS

MAILING Lists most all kinds 1000 \$5.00. Free folder. Your circulars mailed \$4.00 1000. Dixie Mailers, King, N.C. 27021.

ADVERTISING Ratebook leading newspapers, magazines, 25¢. Chicago Advertising Agency, 28-E Jackson, Chicago 60604.

TYPEWRITERS, DUPLICATORS, OFFICE EQUIPMENT

FREE Plan. Start printing, lettershop. Offset Presses, Mimeograph Copy machines, DixieGraph, King, N. Car. 27021.

RUBBER STAMPS AND OFFICE SUPPLIES

FREE 40 Page catalog. Rubber stamps, office supplies. Youngers Stamp Shop, Princeton, Iowa 52768.

CATALOG. Address Stamp \$1.50. Signature \$2.80. Carol's, McLoud, Okla. 74851.

RUBBER Stamps. Any copy, 4 lines \$1.00. Phillips, Box 164A, Staten Island, New York 10314.

NAMEPLATES, Doorplates \$1.00. Rubber Stamps, Social Stationery, Brochure, Morris, 410 West Oaklane, Lake Charles, Louisiana 70601.

4 LINE Stamp \$1.00. Script style 3 lines \$1.50. Pads 75¢ H. Henton, 95 3rd Street, Brooklyn, N.Y. 11231.

PRINTING PRESSES, RUBBER STAMP OUTFITS

PRINTING Presses, type, supplies. Lists, 5¢. Turnbaugh Service, Mechanicsburg, Pennsylvania 17055.

PRINTING-Rubber Stamps. Prompt service, reasonable prices, catalog 10¢, refundable. Lamkin Printing, Box (M) 623, Independence, Mo. 64052.

TYPE Catalog No. 12, 120 pages. Send One Dollar, Deductible First Order. Acme Type, 732 Federal, Chicago, Illinois 60605.

SAME Day shipment on rubber stamp supplies. Revised wholesale price list No. 6 free. Star Stamp Supply, 732 Federal, Chicago, Ill. 60605.

MAKE your own self-molding rubber stamps and printing cuts. Plexirubber, Argyle-1-, Wisconsin.

RUBBER Stamp Manufacturers Supplies, Presses, starting outfits, Best Prices. Service, Catalog, Jackson Supply, Box 443-A Franklin Park, Ill. 60131.

PRINTING AND SUPPLIES

DO Your own printing. Save money. Simple rules. We supply everything. Print for others; good profit. Raised printing like engraving too. Have home shop. Details free. Kelsey Presses, V-11, Meriden, Connecticut 06450.

8 HOUR PRINTING-Free Booklet "Secrets of Cutting Printing Cost" Nationwide Printing, Atlanta, Ill. 61723.

BUSINESS CARDS, \$7.95, 1000. Offering complete printing services. Box 322, North Dayton Station, Dayton, Ohio 45404.

FREE Literature, Address Labels, Business Cards, Printing, Rubber Stamps. Jordan's, 552 West O'Connor, Lima, Ohio 45801.

AMAZING business printing values. Quotations, Print Shop. Box 576, Greenville, R.I. 02828.

FREE Information: Business Cards, Beautifully Embossed, 3 Colors, Spartan. 8210 170th Ave., Stanwood, Mich. 49346.

BUSINESS CARDS, \$5.00 per thousand, Send for FREE samples. GRAHAM ENTERPRISES, Box 2304, Falls Church, Virginia 22042.

PERSONALIZED Memo pads—your three line imprint 100 sheets—\$1.25. Ski Enterprises, 88 Carroll, Chelsea, Mass. 02150.

FREE Samples, Business Cards \$4.95 thousand. Maxwell's, 7359—24th N.W. Seattle, Washington 98107.

TYPE For Printing, Multigraphing, Specimen Sheets Available. Monotype, Brentwood, Maryland 20722.

BEAUTIFUL EMBOSSED BUSINESS CARDS. 1-color \$5.50 Per 1000. 2-color \$6.50 Per 1000. Free Samples. Postage Prepaid, Westwood House, 4819 Beloit Avenue, Culver City, California 90230.

1000 LABELS, 4 Lines \$1.00. Pocket Stamp, \$1.00. Catalog 25¢. Refunded. Seal, Box 505P Elgin, Ill. 60120.

MULTIGRAPH, MIMEOGRAPH

GOOD Business Cards. Write: Goodall Printing, 68-N Joost, San Francisco, Calif. 94131.

GUMMED LABELS

1,000 GUMMED Address labels \$1.00. Walt's, Box 966A, South Bend, Indiana 46624.

1,000 GUMMED Address labels \$1.00. Robert Stephens, 180 Rancho Circle, Auburn, Cal. 95603.

GUARANTEED Gummed Address Labels. \$1.00/1000. ECway, 415 Hedding, San Jose, California 95110.

1,000 DELUXE, Gold trim, address labels. Satisfaction guaranteed. \$1.00. Cureton House, 11117 Herrick, Pacoima, California 91331.

REMAILING SERVICE

CONVENTION City Remails 25¢. Colorful Postcards, Schoen, Box 1963-P, Chicago, Illinois 60690.

MIAMI Remails 25¢. Monthly rates. Marle, Box 1266, Coral Gables, Fla. 33134.

KANSAS CITY Remails 25¢. Receiving—Forwarding, Midway 3115-F South 45th, Kansas City, Kansas 66106.

RECEIVING—Forwarding, \$4 Monthly. Hedgpath, 406-M South Second, Alhambra, Calif. 91802.

ASTRODOME City Confidential Re-mailing Service, 25¢. Dept-102, Box 14621, Houston, Texas 77021.

TIMES Square Mail Address, \$3.00 Month, Remails 25¢. Details Free, Birnhan, 152 West 42 St., New York 10036.

PHOENIX, Receiving, forwarding, re-mailing. Confidential. Troen, Box 2386, Phoenix, Arizona 85002.

ENTERSULL, Your secret address. Prompt, Reliable. Box 1889M, Forsyth, Ga. 31029.

CALIFORNIA Remails 25¢. Receiving, Forwarding, \$3.00 monthly. Colorful Postcards 10 for \$1.00. Confidential, prompt, Mickens, Box 94-C, Pasadena, Calif. 91104.

SECRET Receiving and remailing. Discreet and confidential. Remail 25¢. Pine Park, 8080 Main, Houston, Texas 77025.

NEW YORK 25¢, \$3.00 monthly. Reliable, Snow, 458 Vermont Street, Brooklyn 11207.

ST. LOUIS Remails 25¢; monthly \$3. Foley, Box 746, St. Louis, Mo. 63188.

NATION Capital Remails 25¢ \$3.00 monthly. BROWN, P.O. Box 3177-M, Washington, D.C. 20010.

HARTFORD—Confidential 25¢ each, \$3 monthly. Marshall Balfe, P.O. Box 14117, Hartford, Conn. 06114.

BOSTON—Singles—25¢—Monthly \$3.00 unlimited. P-Dad, Box 651, Waltham, Massachusetts 02154.

FROM Fabulous Las Vegas. Unexcelled, fast, dependable, confidential service. Remails 25¢. Monthly rates. Colorful cards. Ruthie, 558 Oakey Boulevard, Las Vegas, Nevada 89105.

DETROIT—Grosse Pointe; 25¢—\$3.00 Monthly. Lemke's, 3476SM Balfour, Detroit, Michigan 48224.

MICHIGAN, 35¢ Singles Individual and Commercial Rates: Information. Motor City Remails, Box 890, Dearborn, Mich. 48120.

GLAMOROUS, CENTRAL FLORIDA, Remails 25¢. Monthly \$3. Order 9 souvenir postcards \$1. JACKSON, Drawer 1535-PM, Bartow, Florida 33830.

JAY'S Remails 25¢, \$3.00 Monthly. Box 28574, Atlanta, Ga., 30328.

CANADA 35¢, Airmail \$1.00. Rix, 1028 Bridgeport, Richmond, British Columbia.

HOLLYWOOD Remails 25¢. Receiving, Forwarding, George, Box 38698, Hollywood, California 90038.

NORTHWEST REMAILS 25¢ each. Box 3365TA, Spokane, Washington 99230.

REPAIRS AND SERVICING

PROFITS FROM CLASSIFIED ADVERTISING!! Booklet shows you how to start your own business with Classified Advertising. Only \$1.00 (Refundable with first order.) C. A. Martin, Popular Mechanics, Dept. PM, 575 Lexington Avenue, New York 10022.

SPECIAL SERVICES

INFORMATION On anything. Ferguson Research Specialists, 83-45 Vieter Ave., Elmhurst, N.Y. 11373.

CANCER! You May be Next! Stop Smoking! New Book reveals medical and psychological method. Money Back Guarantee. Only \$1.00. Merritt House, 126 Bergen Terrace, Cresskill, N.J. 07626.

RETAIL Appliance Dealers. Want Increased Sales? Proven Copy-righted System, \$5.00. Speaver's, Drawer C, New Sarpy, Louisiana 70078.

LOCATING Service. Any Item, Product. Jake Barraco, 478 Gardner, South Beloit, Illinois 61080.

EARN 25% On your savings. Fool-proof. P.O. Box 11, Staten Island, New York 10301.

AUTHORITATIVE INFORMATION On Anything! \$2.00 (deductible). Metzler Research, P. O. Box 2206PG, Long Island City, New York 11102.

TOBACCO

LARGE Samples Smoking—Chewing 10¢. Jolley Farms, Dresden, Tenn. 38225.

PIPE SMOKING KIT Complete Instruction—tobacco—pipe. Send \$5.00 to IRA, P.O. Box 6, Crystal Lake, Illinois 60014.

RAZORS

PROFITS FROM CLASSIFIED ADVERTISING!! Booklet shows you how to start your own business with Classified Advertising. Only \$1.00 (Refundable with first order.) C. A. Martin, Popular Mechanics, Dept. PM, 575 Lexington Avenue, New York 10022.

PERSONAL

INVESTIGATORS. Latest Electronic Aids. Free Literature. Clifton, 11500-P NW 7th Ave. Miami Florida 33168.

RUPTURED. Relief and comfort. No understraps, elastic or steel. Write Hand-Lock Products, Preston 4, Ont., Canada.

MAKE YOUR WILL. Get 4 Will Forms and attorney's informative book, \$1.00. Legal Forms Company, Department 124, 1967 Guardian Building, Detroit, Michigan 48226.

MAKE NEW FRIENDS Worldwide. Meet Marriage minded Girls through our illustrated Catalog, 1200 Ladies's Fotos and Descriptions \$2.00. I. C. B., Box 12, Toronto, 16, Canada.

UNUSUAL domestic, foreign items. Free catalog series. Bohey Sales, Dept. 3710P, Santa Monica, Calif. 90403.

BIBLE Questions answered. Stamped envelope. Bylon, 17167 Bentler, Detroit, Michigan 48219.

GET OUT OF DEBT in 90 minutes, legally without borrowing or bankruptcy. Anderson, 8873E Kenwood, Cincinnati, Ohio 45242.

SUBCONSCIOUS Conditioning remakes personality while you sleep. Free details. Sleep-Learning, Box 24N, Olympia, Washington 98551.

SUB-MINIATURE LISTENING DEVICES. Low Priced, High performance, direct from Manufacturer. Dealers Welcome. Audiometrics, P-9, 156 5th Avenue, New York, New York 10010.

BORROW \$1,205 AIRMAIL! Repay \$47 for 36 months. State Licensed. Postal Finance, Dept. 17-N, 200 Keeline Building, Omaha, Nebraska 68102.

BORROW Up to \$1,000 By Mail. Money on your signature for any purpose. Write: Budget Finance Company, Dept. MB-0135, 317 South 20th Street, Omaha, Nebraska 68102.

SMALL Loans. Helped many others. Free details. \$500 to \$200,000. 1000 sources. Counselor-7, Kerrville, Texas 78028.

SECRET LOANS BY MAIL. Borrow \$100 to \$1500 for any good reason in absolute privacy. No interviews, no endorsers, no co-signers. Fast service. Write Dial Finance Co., Dept. J-214, 410 Kilpatrick Bldg., Omaha, Nebraska 68102.

LIFE DULL, UNINTERESTING?? Send \$1.00 to Sanada Enterprises, 15728 Pintura Drive, Hacienda Heights, Calif. 91745, and receive ten sizzling sure ways to add "New Life"!!

FREE Course—"What The Bible Teaches." Crusade, 1014 Woodhaven, Lynchburg, Virginia 24502.

IMPROVE Your Personality! 110 Page Book reveals technique to use—Subconscious to make new Personality for yourself. Be one of the Lively Ones. Begin to Live! Read How in this Fascinating Book. Stoneman Studios, 104 Idlewood Terrace, Danville, Virginia 24541.

ADVERTISING-Individuals! Direct mail your photo, art, printing, or pasteup on miniature, gummed glossies for pennies. Four sizes. Chapman-Photos, Box 631, Hurst, Texas 76053.

ESCAPE—daily grind. Retire without money. Details free. McAllister's International, 1111 Las Vegas Blvd. So., Suite 317-M, Las Vegas, Nevada 89104.

TATTOO Removing. Do-It-Yourself Kit \$14.00. Information Free: Atlanta Co., 907 Lakecrest, Fairport Beach, Ontario.

ARE YOU REALLY SINCERE about wanting to find a marriage partner? SOCIAL INTRODUCTION SERVICE, 1760 Willamette, Eugene, Oregon 97401.

RETIRE without money! Exciting book tells how. For free folder. Write Richard Miles, 104-P East Hilton Ave., Redlands, California 92373.

WANTED—MISCELLANEOUS

MERCURY. Gold, Silver, Platinum; Ores assayed. Wholesale Terminal, Norwood, Mass. 02062.

YOUR Ad in Popular Mechanics will be seen by more than 5,000,000 active buyers for your products and services. It costs only \$1.85 per word. And, if you wish to run all or part of your ad in capital letters—you can do so for as little as 75¢ per word additional. Act now! Place your classified ad in Popular Mechanics today.

MISCELLANEOUS

I MADE Over \$100,000.00 year selling by mail. IRS proof available. Success story, book form \$2.00. Wayne Johnson, 880 SW 60th Avenue, Ft. Lauderdale, Florida 33314.

ORNAMENTAL Iron designs. Book of 1600 beautiful, practical designs for railings, columns, etc. Free literature. Cunningham, 3881 South 3200 West, Salt Lake City, Utah 84119.

SILENCERS For pistols and rifles. Complete details for construction and operation. \$1.00. Gunsmith, Box 185, Fairfield, Alabama 35064.

YOUR Name sent to 1000 importers, publishers, mailers, wholesalers, etc. on our mailing list. Year \$1.00. Dixie Mailers, King, N. Car. 27021.

WINEMAKERS—Free catalog and recipes. Kraus, Box 451-L, Nevada, Missouri 64772.

CIGARETTES 12¢ a pack. Improved roller makes 20 filtertip, plain, king or regular for 12¢. Facts Free. Moberly, Box 954, Owensboro, Kentucky 42301.

BIRTH Certificates, Marriage Certificates, Diplomas! 2 blank forms \$1.00. Sample 10¢. Standard Forms, Box 482-M, Washington, D.C. 20044.

WANT Greatest Cash Crop working for you? Write, Ginseng, Asheville 53, N.C.

WINEMAKING . . . Grape, Elderberry, Dandelion, Frozen Juices, etc. Brewmasters' secrets revealed! Powerful Methods! Instructions, Recipes, and Supplies Catalog. \$1.00. Continental, Box 11071-PI, Indianapolis, Indiana 46201.

BOOKS On antiques and their prices. Free circular! P. Warman Publishers, Uniontown, Penna. 15401.

WINEMAKERS. Free illustrated catalog of yeasts, equipment, Semplex, Box 12276, Minneapolis, Minn. 55412.

PSYCHEDELIC Catalog send 25¢. Hole, 6055 Lankershim, North Hollywood, Calif. 91606.

KILL Mosquitoes, Insects, electrically. Free information. Insect Control, Box P374, Royal Oak, Michigan 48068.

PROTECTO-CARRY! Magic Seal Plastic Pouch, 6x10, For Hand Tools, Etc. 25¢ 3 for 50¢. Postage 10¢. Belwood's, Box 4494, Glendale, California 91202.

WINEMAKERS! New Illustrated Supplies Catalog . . . Free! Write Today! Winemakers, Box 11211-RW, Indianapolis, Indiana 46201.

OREGON HOPS (Quart Bag) with 101 recipes: Winemaking, Sourdoughs, Hop-breads, \$1. Nichols Hops, 1190 North, Albany, Oregon 97321.

SLOT & PINBALL machines, etc. Catalog 35¢, refunded with order. COFFCO, Dept. B, P.O. Box 522, Lake Zurich, Ill. 60047.

WINEMAKING Kit—\$4.95 Postpaid. Free Catalog—Jim Dandy Wine Supplies, Box 30230M, Cincinnati, Ohio 45230.

HEARING Aid batteries wholesale. Free list. Habs, Box 51, York, Penna. 17405.

AMAZING Books, jewelry-sweaters-watches. Lynn's, Box 1573, Waco, Texas 76703.

RADIO SUNGLASSES Catalog 25¢ (refundable) Carlton, P.O. Box 12005H, Houston, Texas 77017.

UP To \$151 Daily Track Wins With Scientific Computer. \$2 Stakes. Proof Supplied. Free Details: RH-P10, 5715, Carmel, Calif. 93921.

VIETNAM Color photos 10 in album \$1.00 . . . Makins Photos, P. O. Box 669, Bremerton, Wash. 98310.

PEACH BRANDY, WINES, ETC. Strongest Formulas, \$2.25. (hydrometers list and supplies catalog included)—Research Enterprises, 29-SN35 Samoset, Woburn, Mass. 01801.

BUY—SELL—TRADE. Need something? Want to sell? Trade? Tell us about it! Your listing 25¢. Mailers' Exchange Agency, Box 132-PM, Chicago Heights, Illinois 60411.

"STEEL All types cut to your size for home repairs, small manufacturing, barred windows, hobbies, etc. Send Specifications. Leonard Steel Company, 30 Howard Street, New York, N.Y. 10013."

MEN'S Handcrafted Wallets only \$5.95 send check or money order to R. Young, 116 Crystal Avenue, Staten Island, N.Y. 10302.

BUY DIRECT from Importer. \$1.00 (Refunded with order). Catalog of outstanding imports. Example: Cordless electric carving knife \$4.95. DON'T delay, ACT now. SAVE on Christmas buying. The Stewart Company, Dept. 119, Box 7237, Sacramento, Calif. 95826.

FREE List: Uncirculated coins, stamps embedded in sparkling lucite. Alstein, Box 467PM, Plano, Texas 57074.

HOW TO HAVE CONFIDENCE and Power with other People. Get what you want. Control Attitudes of others. Good first impressions. 164 Page Book reveals ways. \$2.00. Fernwood Studios, Dept. 3A, Ellsworth, Maine 04605.

AT LAST! The real McCoy! Send for Grandpa's old mountain dew and home brew recipes. All for \$1.00. Phil Harris, Route 1, Wartrace, Tennessee. 37183.

SANDPAPER For every job. All sizes sheets discs and Belts. Garnet Aluminum Oxide Waterproof. Leading National Brand. Free Catalogue. DIRECT SUPPLY, Box 237, Irmo, S.C. 29063.

WINEMAKING, Free catalogue. R. Mar-kins, Box 3636, Milwaukee, Wisconsin 53217.

MAGNETS. All types. Specials—20 disc magnets, or 2 stick magnets, or 10 small bar magnets, or 8 assorted magnets, \$1.00. Maryland Magnet Company, 5412-A Gist, Baltimore, Maryland 21215.

HOW to Sell your Way to Financial Freedom. A Salesmen's Treasury of Selling Secrets \$1.50. Includes postage—Brighten Sales, P.O. Box 09193, Chicago, Ill. 60609.

ARTHRITIS, stop pain with simple home remedy, write, Al Sappenfied, Lawtey, Fla. 32058.

You get more for your money from NRI

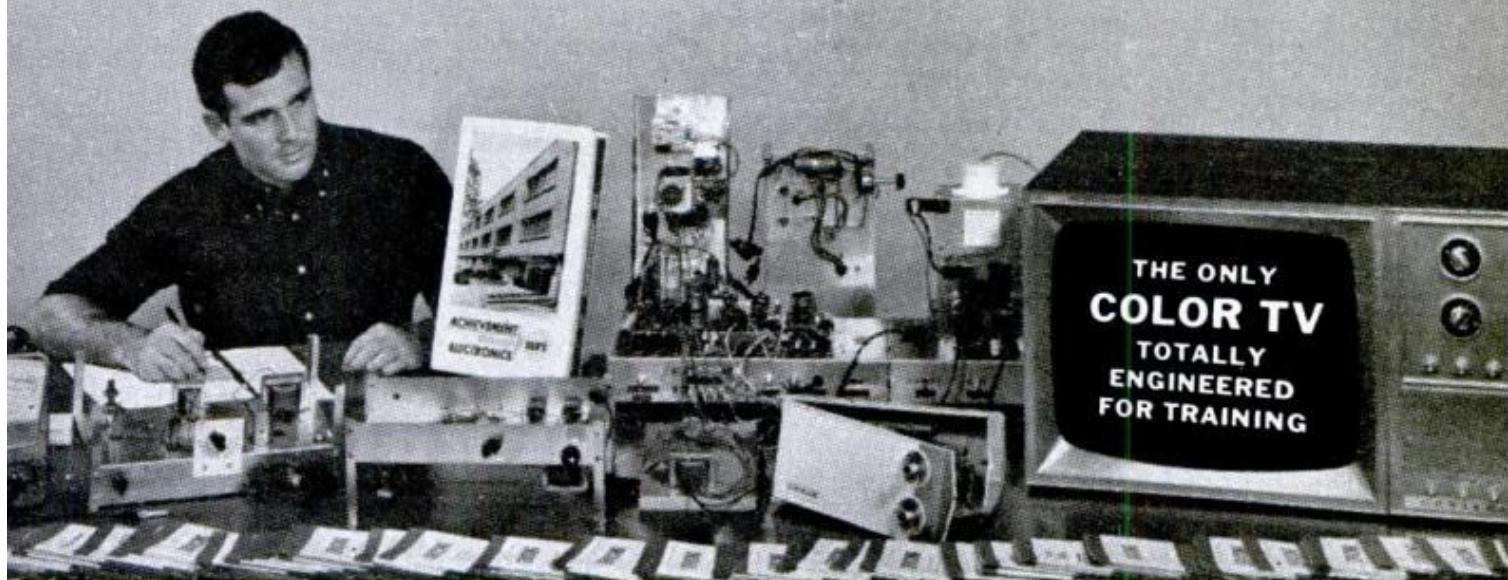

BUILD • TEST • EXPLORE All this is yours — from Achievement Kit, to solid state Radio, to training-engineered Color TV set—when you enroll for NRI's TV-Radio Servicing course. Other courses equally complete. Unique training methods, "bite-size" texts, many personal services have made NRI the leader in its field for over 50 years.

NRI Programmed Equipment Gives You Priceless Confidence, Makes Learning TV-Radio, Electronics Fast and Fascinating

NRI pioneered the idea of supplying home-study students with custom designed training kits to give practical on-the-job experience as you learn. Today, NRI's "3-Dimensional" training can't be equalled. You get more value—from the exclusive Achievement Kit sent the day you enroll, to "bite-size" texts and custom training equipment. Learning TV-Radio, Electronics or Communications at home is easy, exciting, the NRI simplified, dramatized way.

BE A SKILLED TECHNICIAN IN AMERICA'S FASTEST GROWING INDUSTRY

Regardless of your educational background, you can learn the Electronics field of your choice the practical NRI way. The NRI color catalog, sent to you free and without obligation, tells you how you can qualify quickly to be a part of the fast growing Electronic Age; about engineering jobs in business, industry, broadcasting, government, now offered to men without college degrees. It will open your eyes to the great number of success opportunities available right now in the high-pay world of TV-Radio Servicing, Broadcasting-Communications and Industrial-Military Electronics. With NRI technical training, you can take your choice of a wide variety of career

openings or have a business of your own. And if you choose one of five NRI courses that include FCC License preparation, you must earn your FCC License or NRI refunds your tuition!

MAKE \$5 TO \$7 AN HOUR EXTRA IN SPARE TIME STARTING SOON

Tens of thousands of NRI graduates are proof it is practical to train at home in your spare time. Keep your present job while preparing for a better one, and earn \$5 to \$7 an hour extra in spare time while you train, fixing sets for friends and neighbors. NRI shows you how. Equipment you build and keep becomes useful in your work.

STEP UP TO BETTER PAY, A BRIGHTER FUTURE

NRI can help you, but the decision to act must come from you. Decide now to move ahead . . . mail the postage-free card today for your FREE NRI color catalog. No obligation. No salesman will call. NATIONAL RADIO INSTITUTE, Electronics Division, Washington, D.C. 20016.

APPROVED UNDER GI BILL

If you served since January 31, 1955, or are in service, check GI line on postage-free card or in coupon.

CASH IN ON THE BOOM IN COLOR TELEVISION



The NRI TV-Radio Servicing course includes your choice of black and white or color TV training equipment. Color TV needs thousands of trained men to keep pace with millions of sets being sold every year. NRI prepares you quickly. Cash in on the boom.

Mail insert card for your **FREE NRI color CATALOG**

No salesman will call



SOLUTIONS FOR MECHANICAL HEADACHES

AUTOMOBILE CLINIC

BY MORT SCHULTZ

'Synched' out

The 3-speed manual transmission of my 1967 Camaro is supposed to be fully synchronized, but I have a heck of a time getting it into low gear. Two replacement synchronizers helped for about four weeks; then the same old trouble. What can I do?—D.K. Joder, Cheyenne, Wyo.

I hope that the man who's doing your transmission work is checking those parts in the transmission which, if damaged, can damage new synchronizers, making shifting tough. He should examine the synchronizer clutch sleeve, synchronizer spring and the synchronizer stop ring. He will have to disassemble the transmission and inspect each part individually.

Choked to death

My 1967 Thunderbird is very difficult to start, smokes and idles very rough. Unless I let the engine run for five minutes, it stalls and it then becomes necessary to hold the choke butterfly open to get the car started. The carburetor has been adjusted many times. I would appreciate your suggestions.—Nicholas E. Martin, River Edge, N.J.

This is obviously a case of an automatic choke that isn't releasing. No amount of carburetor adjustment is going to solve this condition. Instead, clean out the choke housing, make sure the thermostatic spring and choke piston work properly, and make sure the heat tube hasn't developed holes. If need be, install a new automatic choke kit and adjust to specs.

Rust problem

Rust keeps returning to the rear area beneath the rear bumper of my 1962 Oldsmobile. The area has been painted twice by professional body-shop men, but the rust returns. This year my husband sanded the spot and sprayed on an undercoating, but again rust has worked through. What can we do?—Mrs. Mae Pasko, Palatine, Ill.

Make doubly sure the rusted area is being properly prepared before spraying anything over it. Rust may have formed under the bumper, so the first thing to do is remove the bumper and any other

molding from the vicinity of the damage. If you don't, rust beneath these areas will spread. Now, sand the whole area down to bare metal, and spray on a sealer, primer and color coat in that order.

Critique on chrome

In the March '69 Auto Clinic, under the heading "Too much beauty treatment," Jim Round of Madison, Wis., advises that the use of auto polish completely rubbed away the chrome finish on an armrest. You answered, "The trim pieces in today's cars are chrome-finished plastic." I wish to advise that any so-called "chrome-finish" which rubs off with even a heavily abrasive auto polish is, in reality, not chrome. It is actually a vacuum-deposited coating of aluminum of the order of six millionths of an inch thick covered by a baked or air-dry clear or tinted lacquer coating. The thin soft lacquer and the very thin aluminum film are readily removed by abrasives.

A true chrome finish would be an electroplated series of metal deposits about one-thousandth of an inch thick and quite impervious to abrasive cleaners, just as is the chrome plate on a bumper or wheel cover. Many internal knobs and other small parts on today's cars are made of chrome-plated plastic and, if properly plated, they stand up even better than their chrome-plated metal counterparts.—H.M. Goldman, American Society of Electroplated Plastics, Washington, D.C.

I'll not make that mistake again. Thanks for the good information, Mr. Goldman.

Baffling slosh

The gas tank of my 1969 Impala has a nerve-racking slosh when I start and stop. The dealer told me the tank has one baffle near the top, and it's not enough to stop the trouble. Is it possible this is a problem only with my car? What can I do? Why did the manufacturer let this happen?—Mrs. Earl A. Ard, Greenville, S.C.

If it's any consolation, Mrs. Ard, your car isn't the only one that sloshes. All Chevys of this model have an almost bafflesless gas tank. Why? Well, the only reason I can deduce is that it's less expensive

(Please turn to page 76)

Special Invitation to Inventors

If you have an invention or an idea for an invention, whether patented or unpatented, that you wish to sell outright or on a royalty basis, the booklet we offer free in the coupon below may be very valuable in saving you both time and money.

We are specialists in representing inventors and submitting their inventions and ideas to manufacturers. We work continuously with scores of manufacturers seeking new products, and we have connections from coast to coast and in foreign countries. We are well informed which manufacturers may be especially interested in your particular kind of invention. Hundreds of these manufacturers have written us descriptions of the types of inventions they want.

Our service is designed to do all the many things the average inventor does not have the time or facilities for doing, or who lacks knowledge of the proper markets. When you appoint us to represent you, we prepare sales material that points up your invention, its advantages, its construction, its market potential and profit possibilities.

For presenting your invention to selected manufacturers we charge a modest fee (which is refunded if we handle the sale of the invention for you) and the customary commission. We are a Nationally known concern, with an impeccable reputation for ethics and integrity. We believe ours is the finest service offered inventors.

We are not patent attorneys. However, if you have need for a patent attorney and do not know one, write us and we'll tell you how to obtain the names of all U. S. Patent Attorneys in your area, and you can make your own choice.

To encourage inventors, whether their inventions are patented or unpatented we have prepared a booklet entitled "How to Go About Selling Your Invention." This booklet contains such information as current royalty rates being paid by manufacturers, discusses various types of inventions and the markets for them, and tells the most effective methods you can use in presenting your invention for sale, whether you employ us or do it yourself.

You can obtain a copy of this booklet merely by mailing the coupon below. It will be sent to you with our compliments, free, without any obligation whatever. If you wish to write us for comments about your invention, please do so. We make no charge for consultation. But please do NOT send blueprints or models. Just describe your invention briefly, its nature and purpose.

REFERENCES: Your own bank attorney, or Chamber of Commerce.

K. O. Kessler, President
KESSLER SALES CORPORATION
FREMONT, OHIO 43420

Accredited as a Corporation
Under the Laws of Ohio

MAIL THIS COUPON FOR FREE BOOKLET

Mr. K. O. Kessler, President

Kessler Sales Corporation, Dept. D-59, Fremont, Ohio 43420

Please mail me a copy of your FREE Booklet, "How to Go About Selling Your Invention," which reveals many points about selling inventions and explains your service. It is understood that there is no charge for this booklet now or at any other time and I am not obligated in any way.

MY NAME.....

STREET ADDRESS.....

CITY.....STATE.....ZIP.....

AUTOMOBILE CLINIC

(Continued from page 74)

putting one baffle into a gas tank than the number needed to stop sloshing. I'm afraid you'll have to live with it.

Whistling in Dixie

Maybe you can tell me why I get a whistling noise at 30 mph on up. The car's a 1968 Dart.—Justin C. Earl, Atlanta.

Check the outer edges of the front hood molding. Whistles have occurred as the air stream passes over and between the molding and hood, near the molding attaching clips. It can be fixed by removing the molding and filling the molding cavity and the small gap between molding and hood with a body sealer.

Fireless Firebird

It's been happening for the past two winters. My 1967 Pontiac Firebird won't start if the temperature dips to 10°F. and below. It seems as if the battery suddenly dies, but still, a booster does no good. However, let the temperature go to 35° or 40°, and the engine starts right up. The head mechanic at Pontiac, who is very capable, simply shakes his head in amazement. Do you have any ideas?—Morris Frankenstein, Kew Gardens, N.Y.

Yes. Tell the head mechanic to replace the condenser in the distributor. This sounds like a typical "cold weather" condenser problem. The cold causes the laminations in the condenser to contract, and the condenser is "open." When it warms up, the laminations expand to normal.

Ventless, but not noiseless

What can I do about all that wind noise from the ventless windows of my 1968 Grand Prix? It's so bad I can hardly hear the radio.—Roy Griffith, Union City, Tenn.

According to Pontiac, wind noise can be eliminated in the 1968 Grand Prix by adjusting the glass and shimming the weather stripping to assure proper seal. You'll have to remove the door panel for access to the window-glass adjustment.

Beating a buzz

I'm getting a heck of a lot of ignition

noise from the radio of my 1968 Cougar. I've checked for tight antenna connections. What else is there to do before I have the radio stripped down?—Harry Beauchamp, Louisville, Ky.

There's a suppression adapter (part No. C8AZ—18812-B) that you get from a Mercury dealer which plugs into the radio chassis lead-in socket. If it doesn't dampen the noise, another one should be added to the antenna cable. If there's noise after that, the trouble is inside the radio.

Service Tips

● Chevrolet says you can use chassis lubricant (part No. 1050020) for greasing front-wheel bearings. This grease has a high melting point and is water-resistant—characteristics a good front-wheel-bearing lubricant must have.

● 1969 Dodge Polaras and Monacos that develop chassis vibration should be checked for loose rear-engine support-stud nuts. These come loose when the washers (1 1/8") are too large in diameter. Have them replaced with 7/8" diameter washers (part No. 6023050) torqued to 50 ft.-lbs. Tell the dealer his authorization is service bulletin D69-9-1 (1/22/69).

● Oldsmobile urges that you watch it if you have to replace the radiator pressure cap of any model from 1964 to the present. Caps for 1964-1967 cars are different from those used in 1968 and 1969. Each has its relief valve open up at a different pressure. Switching a cap can lead to overheating. Use cap part No. 3886273 on 1964-1967 models (it's silver in color). Use cap part No. 6410390 on 1968-1969 models (it's gold).

● 1968 Corvair owners may be finding water in their luggage compartment. The trouble is a side-light lamp-bracket design that doesn't allow the gasket to seal tightly. The stop-gap measure is to use two gaskets—not one—at each side-light frame. The gaskets carry part No. 7765668.

● 1969 Camaros with optional urethane bumpers, can be repaired if they become cut or gouged. Your serviceman won't find the procedure in his service manual, however. Tell him to check Chevrolet Service News No. 10 (11/68), page 3. ★★

GOT A PROBLEM WITH YOUR CAR? Ask Mort about it. Send your question to Auto Clinic, Popular Mechanics, 575 Lexington Ave., New York, N.Y. 10022. Letters cannot be answered individually, but problems of general interest will be published in the column.

It's Like Having Auto Factory Experts Right Beside You...

when you use this famous illustrated step-by-step guide that shows you

HOW TO FIX ALMOST ANY PART OF ANY CAR

Now—Whether You're a Beginner or Pro Mechanic—You Can "Breeze Through" Almost ANY Repair Job on Any Popular-Make Car—1963-1969!

MOTOR'S AUTO REPAIR MANUAL shows you in step-by-step words and pictures all the factory-approved repair procedures you'll ever need for fixing practically ANY part of ANY car listed here—1963-1969.

**1,000 BIG PAGES—
3,000 PICTURES!**

This **GIANT NEW, 1969** Edition covers everything you need to know to fix almost any car model from 1963 thru 1969. 1,000 giant pages. 3,000 pictures. 365 "Quick-Check" charts. 55,000 essential repair specifications. Over 225,000 service and repair facts.

PLUS Adjustment Tables, Tune-Up Charts, Tables of Measurements and Clearances, Overhauling and Replacement Facts, Carburetor Adjustment, etc. Special Trouble-Shooter Section and detailed trouble-shooting information thruout help pinpoint the cause of any of 4,200 car troubles in a jiffy.

Same Offer on MOTOR'S AUTO ENGINES & ELECTRICAL SYSTEMS

1,300 big pictures. Clear text explains how parts work; principles involved; design; construction; maintenance. Covers all parts of engines & entire electrical system. For **FREE** trial, check coupon.



No guess-work! Even a green beginner mechanic can do a good job with this giant manual before him. And if you're a top-notch mechanic, you'll profit from the time-saving and work-cutting procedures you'll find. **MOTOR'S MANUAL** makes almost every operation on any car—from Volkswagen to Cadillac—as easy as A-B-C! Eliminates trial and error — saves you time, work and money.

**OVER 5
MILLION
COPIES SOLD**

**SEND NO MONEY
Try Manual at OUR
Risk — FREE**

See for yourself why U.S. Armed Forces, Schools, and garages everywhere "swear" by **MOTOR**. Just mail the coupon. **TRY Manual** for 10 full days—**FREE!** If it doesn't pay for itself in those 10 days, just return it and pay nothing, owe nothing. Mail the coupon **AT ONCE** to **MOTOR Book Dept.**, 250 West 55th Street, New York, N.Y. 10019 (**SCHOOLS, BOOKSTORES**: Write for Discounts.)

**TRY BOOK
FOR TEN DAYS
FREE**

FIX ALL THESE CARS

Volkswagen	Ford Bronco
Mustang	Buick
Barracuda	Special
Jeep	Comet
Chevy II	Corvair
Pontiac	American
Thunderbird	Olds F-85
Buick	Falcon
Imperial	Fairlane
Cadillac	Lancer
Continental	Tempest
Dart	Corvette
Mercury	Valiant
Ford	Cougar
Chevelle	Toronado
Chevrolet	Lincoln
Camaro	Front Drive
Scout	Cadillac
Chrysler	Mark III-
Plymouth	AMX
Rambler	Javelin
Dodge	Montego
Oldsmobile	Torino



MOTOR'S

**AUTO
REPAIR
MANUAL**

**TROUBLE-SHOOTER Section
Helps Spot 4,200 Car Troubles**
Trouble-Shooter section & detailed trouble-shooting info thruout help pinpoint 4,200 causes of car trouble: transmissions, brakes, engines, electrical systems, much more!

MAIL COUPON NOW FOR 10-DAY FREE TRIAL

**MOTOR BOOK DEPT., Desk 919
250 W. 55th St., New York, N. Y. 10019**

Rush to me at once **MOTOR'S New AUTO REPAIR MANUAL**. If O.K., I will remit \$2 in 10 days, \$3 monthly for 2 months and a final payment of \$1.95 (plus delivery charges and sales tax, if any) one month after that. Otherwise I will return the book postpaid in 10 days.

Print Name.....Age.....

Address.....

City & State.....

ZIP CODE ZONE NO.
[] [] [] [] [] [] [] [] [] []

Also send me for 10-day Free Trial **MOTOR'S AUTO ENGINES and ELECTRICAL SYSTEMS**. If O.K., I will remit \$8.95, plus delivery charges and sales tax, if any, in 10 days. Otherwise I will return book postpaid in 10 days.

Check box and save shipping charge by enclosing **WITH** coupon in envelope entire payment of \$9.95 for **AUTO REPAIR MANUAL** (or \$8.95 for **AUTO ENGINES and ELECTRICAL SYSTEMS**) plus sales tax, if any. Same 10-day return-for-refund privilege applies.

HOMEOWNERS' CLINIC

BY W. CLYDE LAMMEY

Waterproof 'shoes'

When we have an unusually heavy rain of 1½ to 2 in., I get about the same amount of water in my basement. I'm new here and don't know the reason for the seepage, but something must be done. I have furniture stored in the basement—no place else to put it—and most of these pieces have legs with casters. Is there some way to prevent water damage to the legs?—A. O., Tex.

You're probably thinking of rusty casters rather than legs if you get only 1½ to 2 in. of water, although some legs may absorb water at the higher level. I know of one homeowner with a similar problem who keeps the legs "shod" with plastic sacks and those large fruit-juice cans (the 46-oz. size). He simply raises the pieces and slips the cans or sacks over the legs. This stunt offers protection unless the water should rise above the tops of the sacks or cans. Probably the sacks are best as they are obtainable in various lengths.

Appliances such as a wringer-type washer or the legs on workshop power tools or a workbench can be protected in the same manner.

Those sweating windows

Windows in my home sweat and the water runs down over the sills to give the wood a dark, moldy color and streak the plaster below. The house is quite new and has wood casement sash. I'm told wood windows don't sweat, but mine do. And my bathroom is literally swampy wet. What causes this and is there a simple, inexpensive cure?—S.T., Ga.

The cause is the relatively high moisture level in the air. Everyone in your home contributes to this by bathing, showering, food preparation and simply by breathing. For example, if yours is a family of four and you are all at home for a weekend, the four of you will add about three gallons of moisture during that time just by breathing. All other normal activities—meal preparation, tub bathing or showering, laundering and washing dishes by hand—can add 4 to 10 gallons more.

In present-day homes with insulation and tight construction throughout, this moisture cannot escape at the same rate as it does in older structures. Window

sash, particularly the glass panes, are at a lower temperature than room air, so the moisture condenses on these surfaces.

Some homeowners with this problem operate an automatic (humidistat-controlled) dehumidifier to keep moisture at lower levels. In some cases tight-fitting storm sash will prevent, or at least minimize, condensation on casements. On warmer days open windows and doors and allow air to circulate for short periods. If your heating equipment is gas-fired (a gas kitchen range will contribute to the moisture level) make sure it is properly vented to the outside.

Calcimined ceiling

I've tried to wash off what I suppose is calcimine from the living-room ceiling in my older home. Some of it comes off, but some won't loosen with any amount of scrubbing. It's unpaintable and looks like a shedding camel. I've given up. I'm about to tear it all out and have an all-new ceiling. Do you have a suggestion before I start throwing things?—G.L., Wyo.

I like your description. I've seen such a ceiling, but have not thought of the "shedding camel." Somehow the term fits. But let's not give up yet.

If the old ceiling is still solid and dependable, leave it and think how nice it would be to have an all-new dropped ceiling with fancy translucent panels, indirect lighting, shiny moldings—all the trimmings. Nobody but you will ever know there's an old ceiling above the new. Ask your local building-materials dealer to show you how it's done. He'll have worksheets, pictures and how-to-do-its to help you. I venture to guess you'll be surprised how inexpensive the job can be.

Repairing old barometer

I have an old barometer heirloom and need to replace the mercury tube which evidently has been discarded. Are replacements available?—R.F., Md.

Your local antiques dealer should be able to help you. He'll know who supplies the tubes, and may even have them on hand. I assume you are referring to the mercury column that actuates the barometer and not the thermometer. But why go to all this trouble? You can replace, at small cost, the old instrument with a new one of the aneroid type. These are available in various sizes and, unless your barometer is unusually large, you should be able to locate a dial that fits. Dealers in clock movements usually carry aneroid barometers. ★ ★ ★



NEW PREVAL* SPRAYMAKER

**SPRAYS ANY COLOR,
ANY FINISH!**

With this disposable power sprayer you can spray paint, varnish, stain, lacquer—custom-mixed or right-off-the-shelf. Use the same paint you use with brush or roller. No mess, no bother. It even sprays itself clean! Then fill with lubricant or rust-protecter and protect tools and equipment. Sprays any household liquid. Better buy several. You'll find dozens of uses for them. Available at paint, hardware and hobby counters—wherever quality do-it-yourself products are sold.

ONLY \$149

Complete Suggested retail price

One Power Unit Sprays up to 16 oz.
Extra Power Units available

*Reg. Trademark of Precision Valve Corp., Yonkers, N.Y.

REMINGTON ROD SAW...THE TOOTHLESS WONDER.



Our new Rod Saw has no teeth. Instead, it has thousands of permanently bonded tungsten carbide cutting edges.

The rod itself fits any standard 10" hack saw frame. But the similarity ends there. Because the Rod Saw cuts through things a regular hack saw blade won't even scratch.

It cuts through spring steel, hardened bolts, welds and cast iron with ease. And because of the tool design, the cutting edges go all the way around the rod. So it not only cuts straight, but also cuts in any direction on brick, glass, flagstone, ceramics, fiber glass, laminates and other hard-to-cut materials. (And does it faster, because it cuts on both forward and backward strokes).

Originally developed for industry, now packaged for home use, the Remington Rod Saw is available at most hardware stores.

You should not have any trouble recognizing it. Just look for the saw without any teeth.

Remington DU PONT

Made in U. S. A. U. S. Patent 3,023,490. Applications pending. Remington is a trademark of Remington Arms Company, Inc., and DU PONT is a trademark of E. I. du Pont de Nemours & Co. (Inc.)



3 1/2" x 9 1/4"



Let's Do LEATHERCRAFT!

HERE'S A GENUINE LEATHER BILLFOLD KIT AS A STARTER

WORTH \$5.00 AFTER YOU ASSEMBLE AND LACE!

ONLY 50¢ with coupon below

ONLY 50¢ IF YOU ACT NOW!

Tandy
LEATHER COMPANY
A TANDY CORPORATION COMPANY

1001 Foch, Dept. GM, Fort Worth, Texas, 76107

Yes, send me your embossed billfold kit and 112-page catalog. I'm sending 50¢ as full payment. (Limit one per family.)

NAME _____

ADDRESS _____

CITY _____ STATE _____ ZIP _____

ONLY 50¢ IF YOU ACT NOW!

Get all the features of expensive billfolds...hidden money pocket, four-unit card case and two side pockets. Handsome design already embossed. Kit complete. Easy 'n fun to assemble and lace. You'll also receive a 112-page Leathercraft catalog and easy-to-follow instructional manual. **Order yours today!**



We hardly ever get to make two Scouts alike.

But with the biggest option list in the business people get 'em the way they want 'em.

One man lives halfway up a mountain. He wants his SCOUT® with all-wheel drive, V-8 engine and four-on-the-floor. It's his.

Another drives his to work, on nice flat blacktop. He'll take a 4 or maybe a 6 cylinder engine with a simple stick shift or an automatic...and only two-wheel drive. OK!

One uses his SCOUT like a pickup. He gets a cab top. Another SCOUT is somebody's second car. Full-length Traveltop with rear

seats for him and the whole family.

How much SCOUT do you need? How many seats do you want? Bucket or benches? What color? Flotation tires? Hubcaps or full discs? We have 'em all. And a lot more.

Get with your INTERNATIONAL SCOUT dealer and see how much fun a do-it-yourself SCOUT can be.

 **INTERNATIONAL HARVESTER COMPANY**
CHICAGO, ILLINOIS 60611

The do-it-yourself Scout®

Next Month in Popular Mechanics

Amazing New Instantaneous Fire Extinguisher

For the first time, you can equip your car, boat or home with an automatic fire-extinguishing system that "sees" and extinguishes a fire even before you're aware there is one. Infrared sensors spot the blaze and trigger the release of nontoxic Freon, which immediately squelches the fire. The new firefighting system is already being used by top race drivers in Can-Am and Indianapolis cars.

The 1970 Cars

PM gives you a first-hand, in-depth report on the 1970 models: What's really new about them? How do they compare? What are the industry trends? Twenty-four pages, seven in full color, of exclusive *PM* photos and reporting.

Build This Beautiful Hall Clock

Standing some six feet tall, this stately chime clock is a project the advanced craftsman will find challenging and rewarding. A two-part article begins next month.

PATEXPO '69: Exclusive Preview of World's Biggest Inventors Show

PM brings you a behind-the-scenes look at some of the more than 10,000 exciting new ideas to be unveiled in October at the Patexpo Inventors Show in the huge New York Coliseum.

How to Install a Wall Vault

Important to a homeowner is the fire protection of insurance policies, wills, deeds, birth certificates, bonds and other vital records. They can be preserved in a safe. It's a simple, do-it-yourself job to install one.

For Tops in Hi-Fi Listening, It's Back to Earphones!

They went out with cat-whisker radios only to return as one of today's biggest-selling hi-fi accessories. Next month's article tells why earphones are back in style.

Which Insulation Should You Use?

The wide variety of insulation materials available can cause confusion. To clear the air, *PM* tells the insulation story in simple do-it-yourself language: What's available, where to use it and how to install it. Vapor barriers and venting—and their important relationship to insulating—are all part of next month's article.

Five-Ton Press for Your Shop

Powered by a hand-operated hydraulic pump, this powerful little press is ideal for benchwork. It's a simple affair that's assembled from stock pieces of steel angle, channel and threaded rod. The small machine shop will have lots of use for it.



**Before you buy
any snowmobile...**

back up a moment!

You can with the new Skee-Horse Wide-Trac snowmobile. Back up, that is.

Off your trailer.

Away from a tree.

Out of any trouble spot. This new Wide-Trac has reverse. Most other snowmobiles don't. They don't have neutral either. The Wide-Trac does. You can warm up the engine without having to tip over or prop up the snowmobile. And you can start up without lurching.

If reverse and neutral don't turn you on, forward gear will. Powered by a brawny 25-horse engine, this Skee-Horse really flies. It accelerates quickly and cruises effortlessly. And the wide stance contributes good stability and over-

the-snow flotation at any speeds. All Skee-Horse models feature the rugged reliability of two cylinder engines. Our engines are American made, so parts and service are close and fast. The engine on the Wide-Trac is completely enclosed. Very quiet and very clean. And it has a compression relief valve to assure easy cold weather starts. As easy as turning a key if you like.

The new Skee-Horse Wide-Trac makes snowmobiling a sport instead of an ordeal. It's the one you can back up. One we can back up, too, with a 90-day warranty*. Get the full story from your Johnson dealer. Or write for a free catalog. Johnson Motors, Waukegan, Illinois 60085, Dept. PM-S99

*For 90 days after purchase, Johnson Motors will replace or repair without cost to the original purchaser any part of its manufacture which upon inspection proves to have failed in normal use due to faulty material or workmanship.

 **Johnson** FIRST IN DEPENDABILITY *is the way to go!*
Division Outboard Marine Corporation

Our Crazy, Mixed-Up Speed Laws

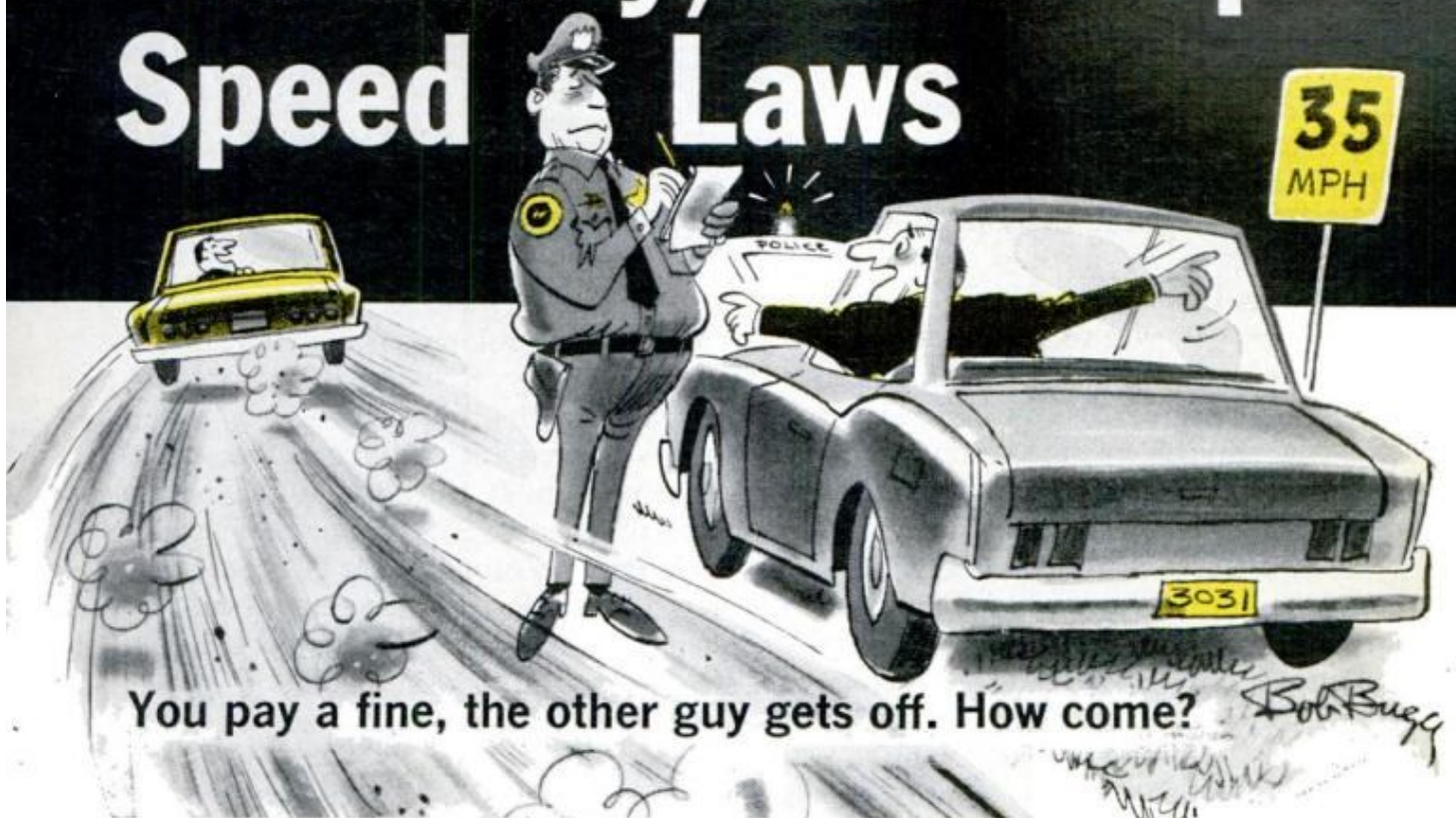

You pay a fine, the other guy gets off. How come?

By MARV HALL

HERE YOU ARE on an open highway, driving at the speed limit, and some clown roars past you on the right, cuts in, feeds you his exhaust and zooms ahead in and out of traffic like a fleeing bandit. There's not a traffic cop in sight.

The next day, you go 40 in a 35-mph zone, and a blinking red light appears in your mirror. What gives? Well, if you've ever had a run-in with the speed laws in this country, you know they're complicated, confusing and contradictory—so much so that many drivers conclude patrolmen play with loaded dice.

You're two or three times more likely to be cited for speeding than any other "moving" violation. And if you're a teen-ager, or drive a sports car, you may think traffic cops devote their lives to persecuting you. You may be right.

"Yeah, I admit I pick on teen-age

drivers," says one California traffic officer. "As a group, their driving record isn't the best, so I suppose I just naturally pay more attention to them."

The police say they just enforce the law. But are the laws fair laws?

Prima facie speed limits, maximum and minimum limits, speed zones, radar evidence, speed traps . . . it takes a legal eagle to tell you what they really mean. Even so, learning a few basic speed-law facts may keep a speeding violation off your record. It pays to know when you have a chance to plead "not guilty" and win your case. For openers, you ought to be familiar with the kinds of speed limits enforced.

Maximum speed limit—also called an *absolute*, or *fixed maximum* limit, is a posted speed that it is illegal to exceed, no matter what. If caught violating a maximum limit, you've had it—fine, points on your license, the works.

Basic speed rule—This rule says *you*

must judge what is a "reasonable and prudent" speed for given conditions—rain, snow, heavy traffic and so on—and for existing actual or potential hazards (hills, curves, blind intersections and so on).

Prima facie limit—Usually combined with the basic speed rule, this limit is posted and based on engineering studies of a given area. They are designed to help you judge a "reasonable and prudent" speed under the *normal daytime* conditions. Here, *prima facie* means "at first view." If you're stopped for violating this limit, it means the officer thinks you were driving too fast for existing conditions. This one you can fight in court. We'll cite some examples of *prima facie* speed limits later on.

Even with these definitions the situation is admittedly muddy. Lawmakers have battled for years over the best way to regulate speed. They seem to agree only that no really satisfactory speed law has as yet been invented.

The controversy goes 'way back to the days when an automobile was considered little more than a gadget that frightened horses. But today, the need for workable speed laws and fair enforcement has become crucial. Consider these two blunt facts:

1. Excessive speed is the most frequent violation noted on fatal-accident reports.

2. If you're killed on the highway this year it's almost a certainty that someone—maybe even you—will have been driving too fast for conditions.

It's no wonder traffic cops often seem hard-nosed. Most are conscientious public servants trying to prevent highway carnage by enforcing often-ambiguous speed laws as well as they can.

So how does the man in the patrol car know when you're speeding?

One of the newest ways—called VASCAR (*Watch It, Speeders*, page 61, Aug. '67 *PM*)—allows him to clock your speed no matter which way you're moving in relation to his patrol car. VASCAR can register your speed

If you're a teen-ager, you may think traffic cops are persecuting you. You may be right

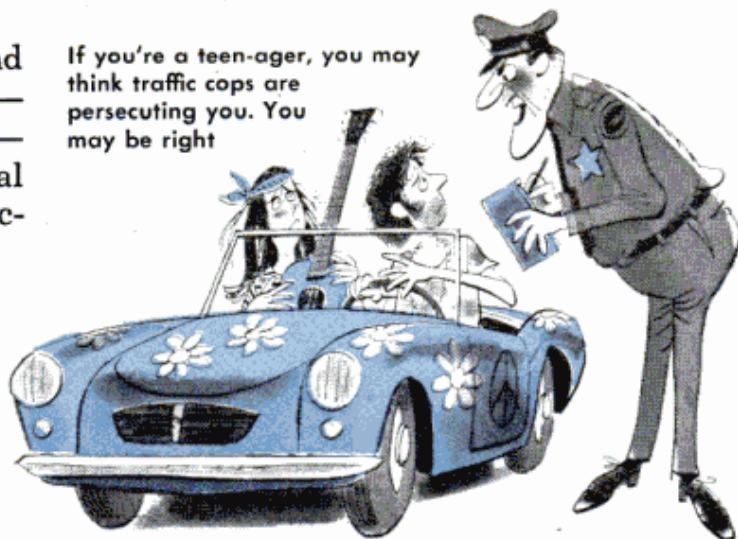

when the patrol car is parked, when you're passing it, when it's approaching you from the rear—even when you're approaching it from the opposite direction. It works at night, in the rain, whenever. Right now, 36 states have one or more units in operation.

In a number of states you can be tagged by a sky-cop. He clocks you, notes your violation, radios a patrol car below, which then moves in for the pinch.

The most common methods of registering your speed, however, are speedometer clocking and radar. Let a traffic officer tell the procedure he follows:

"First, I observe the vehicle. If it seems to be going too fast I can clock it—that is, try to follow the car for at least a block to get an accurate reading on my own speedometer that tells me how fast it's going—or, if I'm equipped with radar, I can check a car's speed even if I'm parked. An antenna on top of my car sends out an electronic beam 1500 feet in front and in back of me. As soon as the car breaks the beam, its speed is recorded on a graph. It's instantaneous.

"When I stop a driver, I ask him if he knows how fast he was going. And right here some guys admit they were breaking the law. Say, he was doing 35 in a 25-mph zone. If he's cooperative and polite, I may just give him a warning and let him go. But if he's uncooperative . . . well, it doesn't help much."

This officer stressed that a traffic ci-

tation is *not* an admission of guilt, merely a promise to appear in court.

Let's assume this officer pinched you for speeding. Seemingly, he holds all the cards and you haven't a prayer. But don't quit yet. You're innocent until *proven* guilty, and the courts don't always rubber-stamp a cop's word.

Know The Law, published by the Traffic Institute of Northwestern University, cites a case in which a state supreme court let a driver off, saying, "Traveling in excess of a designated speed is not necessarily a violation of the law. It becomes so only when . . . the basic rule as to speed is violated. Traveling in excess of a designated speed is merely *prima facie* evidence of a violation of the basic rule."

Back to those definitions. You can see why it helps to know and understand speed law terminology. But even if you *do* you'll soon realize there's lots of room for controversy.

Opponents of an absolute speed limit, for example, say that posting a maximum (or absolute) speed is an invitation to *drive* at that speed no matter what the conditions—rain, snow, ice, whatever. But, if the posted limit is too low it'll be generally ignored.

Those opposed to the basic speed rule say it leaves too much to driver judgment. Some people have funny ideas as to what speed is safe for *them*. Allowing them to judge "reasonable and prudent" speed is like having no law at all.

To solve this problem of judgment, *prima facie* speed limits were added to the basic rule. It would be pointless to post signs reading "Drive Prudent," or "Be Reasonable on This Curve." So in order to help patrolmen enforce the basic rule, traffic engineers make a study of conditions in various areas and post speed limits that are supposed to be a guide to a reasonable and prudent speed for that area.

Some typical examples of these limits: 25 mph, business and residential areas; 35 mph, roads with no controlled access; 50 mph, controlled-access roads;

60 mph day and 50 mph night, roads outside city limits.

Too low? Maybe. Unfair? Possibly. Again, it depends upon conditions, and conditions change constantly.

Some states follow a uniform vehicle code that uses the basic speed rule with *prima facie* limits in most areas, but posts maximum limits on open highways and expressways.

Unfortunately, you can't tell by looking at a speed-limit sign whether it's

(Please turn to page 198)

SPEED QUIZ

How much do you know about speed laws? The following questions were taken from the drivers' licensing examinations of various states. See if you can get a perfect score. Answers are on page 198.

1. The basic speed law limits speed to:
A. Maximum speed allowed by law.
B. Road, weather and vehicle conditions.
C. Posted speed limit.
D. 70 mph in daytime, 60 mph at night.
2. Can you be cited for driving 40 mph in a 45 mph zone?
A. Yes B. No
3. A posted speed limit of 60 mph means:
A. You can always lawfully drive 60 mph on that road.
B. You may drive 65 mph, because officers allow an extra 5 mph.
C. You may drive 60 mph day or night on that road.
D. You may drive 60 mph only under favorable driving conditions.
4. If you are driving at the speed limit and another driver sounds his horn and starts to pass, you should:
A. Refuse to give way as he is already driving at the speed limit.
B. Speed up to get out of his way.
C. Slow down and give way to him.
D. Sound your horn and warn him.
5. The approximate distance required to stop a passenger car from a speed of 60 mph is:
A. 150 ft. B. 200 ft. C. 260 ft. D. 350 ft.
6. At night, you should never drive at a speed which would prevent you from coming to a stop within the distance:
A. Of four car lengths.
B. You can see in your headlights.
C. Of 170 ft.
7. The speed limit as you enter most towns is:
A. 25 mph B. 35 mph C. 45 mph
8. If you drive faster than a *prima facie* speed limit:
A. You can be cited unless conditions are good.
B. You'll be convicted of speeding, no matter what.
C. You're assumed to be going too fast for conditions.
9. What is the best way to tell when you are driving at a safe speed?
A. By the speed limit signs.
B. By the speed of other traffic.
C. By existing driving conditions.
D. By the condition of your car.

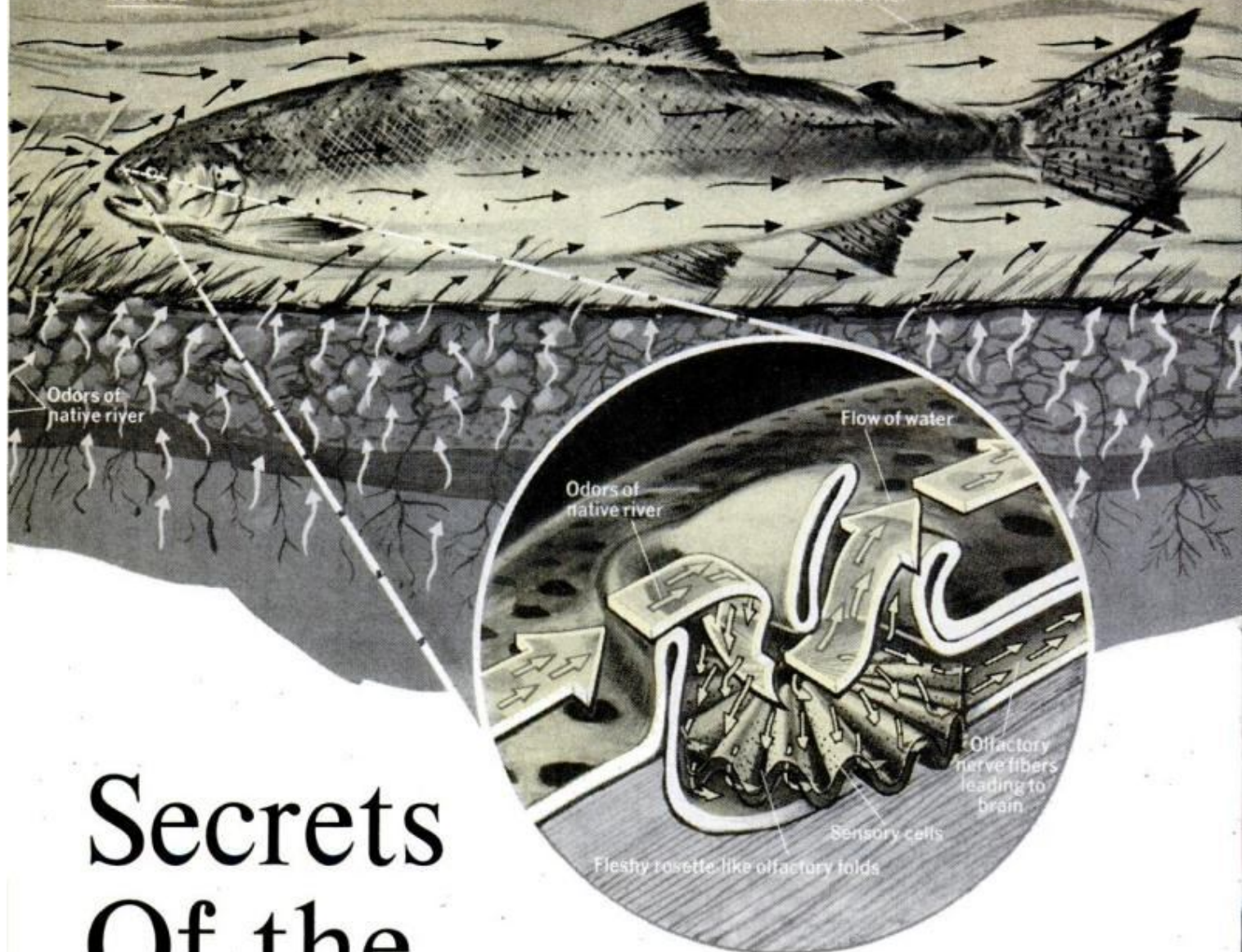

Secrets Of the Animal World

SALMON TROUT'S NASAL CAVITY

Bees and badgers have signals all their own. Salmon are unerring navigators and groupers go to the cleaner. Scientists have finally figured out why.

By RICHARD PETROW

THE ANIMAL WORLD, as scientists are discovering, is filled with hitherto unsuspected signals between animals and strange relationships between animals and their environment.

Prof. Wolfgang Schleidt, chairman of the University of Maryland's Div. of Animal Behavior, has detailed many of the more unusual discoveries in a fascinating book, *Signals in the Animal World* (McGraw-Hill Book Co., \$10), which he helped compile and edit.

Some puzzlers that have been solved:
 ● *How does a salmon find his home river?* The salmon's life cycle is well documented. Adult fish spawn in the upper reaches of rivers. Young salmon grow up there and then migrate downstream to the sea. Years later, the young fish—by now fully grown—return unerringly to their home river, bypassing without deviation the mouths of all other rivers along the way.

Is it a "miracle" of nature? Or is there a more practical answer?

For transoceanic travel, a salmon navigates by the sun and the stars, like a human navigator. This brings him back to the general area where his river is located. To find his particular river, however, the salmon relies on an organ that no one previously suspected—his nose.

Fish, incidentally, have two nasal cavities in front of the eyes. They are covered with a layer of skin and, unlike higher vertebrates, these nasal cavities are not connected to the mouth.

Scientists are convinced that young salmon become impregnated with the smell of their home river and that this odor code is fixed in their brain. On their return migration, the salmon recognize their home river by comparing the fresh smells with those they have memorized.

To prove the theory, a school of migrating salmon was netted. The noses of the fish were plugged. Then they were let free again.

What happened was dramatic. The salmon which previously had been swimming purposely in the same direction, now scattered in random fashion among all nearby rivers.

● *How does a bee point to a food find?* Don't ever sell insect languages short. The bee, for instance, not only has a language by which he can tell other bees that he has found a supply of nectar, he can also tell them how far away it is and in which direction to look.

Let's take a closer look inside a hive just as an excited worker enters. He has discovered a source of nectar and is eager to transmit knowledge of his find to his fellow bees. He does this by a "recruitment dance," a formalized routine which sees him running around on the vertical honeycomb in small circles, first to the left, then right.

Other bees join in. As they dance, the whole hive gets to know the smell of the nectar brought in by the "discov-

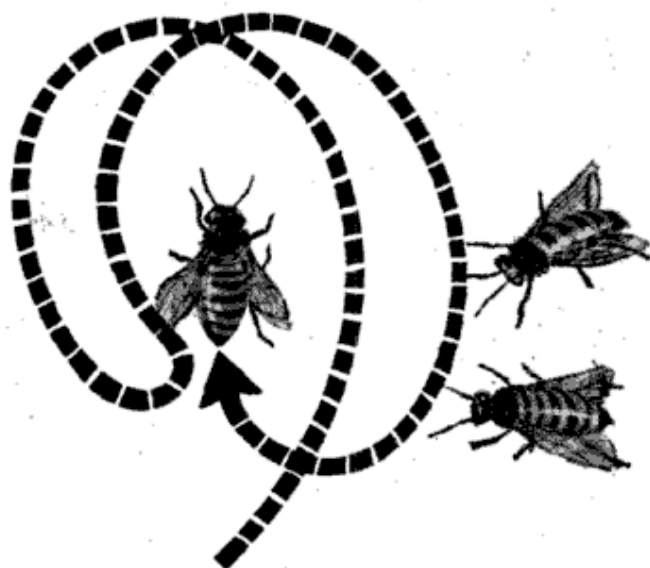

DISCOVERER BEE'S 'WAGGLE DANCE'

erer bee." Finally, they fly out to discover the source of food themselves.

What the bee's dance has said in effect is: "Fly out and search in the vicinity of the hive for flowers which smell like me. When you find them, gather the nectar or pollen while you can."

For distant finds, however, the discoverer bee must also indicate the distance and direction. He does this by a "waggle dance,"—a semicircle to the left, followed by a semicircle to the right, then by a straight run in which the bee wags his tail energetically.

The amazing aspect of this dance is that its speed is inversely related to the distance of the food. The slower the dance, the farther away the food. If the food supply is 100 meters from the hive, the discoverer bee makes 38 waggle runs per minute. If the food is 500 meters away, the number of waggle runs is 24 per minute. For a food supply 1000 meters away, it is 16, and for 5000 meters, the number of runs is only 6.

The direction of the food supply is indicated by the direction of the straight waggle runs. If the discoverer bee had flown to the south at noon, he runs straight up the vertical honeycomb. The rest of the bees know that they have to fly due south when they leave the hive in search of food.

Three hours later, when the sun has

SPOTTED GROUPE

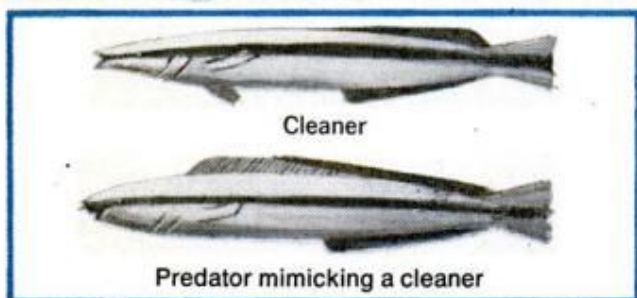

moved to the southwest 45° , the discoverer bee will make a waggle run that is 45° to the left of the perpendicular. The other bees, when they leave the hive, fly off in a direction 45° to the left of the sun, still due south. In this way, a bee can use the sun to indicate the direction of the food he has found.

● *How does a fish find a cleaner?* Place yourself 20 feet under the surface of the Caribbean Sea. Slowly, a large grouper swims into view. His breast fins are torn and covered with tiny parasites. Simultaneously, two small blue neon gobies appear. One searches along the grouper's body. The second enters its huge open mouth. Both peck continuously at the larger fish.

After several minutes, the grouper indicates he is finished by tensing his body and closing his mouth slightly. Both gobies swim away.

What we have witnessed is one of the strange symbioses, or "partnerships of mutual aid," that exist among marine animals. The gobies were cleaning the grouper of parasites and other unwanted

growths and were, in return, having their food brought to them.

How do cleaners and the host fish recognize each other? First, cleaners are striking in appearance. Second, they perform a distinctive dance to attract the host, swimming rapidly up and down while wiggling their bodies in a seesaw motion. The host fish indicates its desire to be cleaned by opening its mouth and presenting portions of its body to the cleaner fish.

If you observe cleaners at work long enough, however, you will occasionally see the host fish jerk away and flee from a cleaner. One curious oceanographer caught the cleaner after just such an incident and discovered that he was not holding a regular cleaner, but a small sabre-toothed predator fish which was interested not in cleaning the larger fish but in ripping out small chunks of his flesh.

Both cleaner and predator were blue, with horizontal black stripes running the length of their bodies. Not only did the predator mimic the appearance of

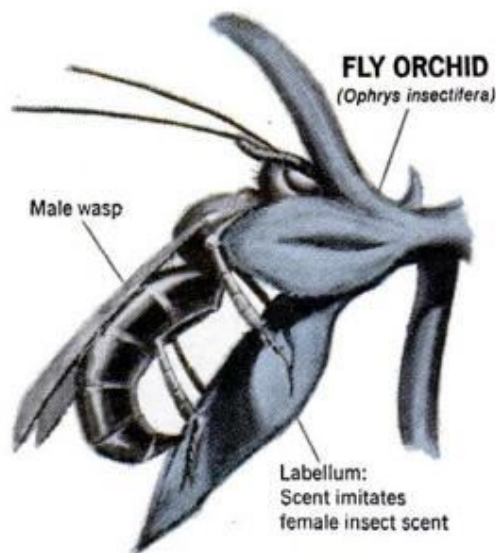

the cleaner, but he had also learned the cleaner's welcoming dance. The signals that pass between legitimate cleaner and host have been so sharply defined over the centuries that the imitator has been able to duplicate them to perfection—for his own advantage.

● *Why would a wasp try to copulate with an orchid?*

In the earliest days, plants depended

on the wind and water to distribute their pollen for them, about as efficient a system of fertilization as putting a message into a bottle, setting it adrift, and hoping it will reach the right addressee.

With the arrival on earth of insects and birds, the plant world was presented with an army of potential postmen who could deliver their pollen to the right address. To get these postmen to work, the plants had to develop a series of lures and attractions, and offer the postmen some rewards for a job well done.

Scents and colors serve to attract insects and birds. Most plants also offer nectar to visitors. Some even have special stamens which contain food for insects. All this serves to attract birds

and insects. But once attracted, how can the plants be sure that their pollen is delivered to a flower of the same species?

Some flowers bloom only at certain times of the year. Others, like the four-o'clock, bloom only at certain times of the day. And the reason why there is such a wealth of different color patterns in flowers is that insects and birds learn the color pattern of the flower which rewards them with nectar, and thereafter visit only flowers with the same pattern.

But the plant world has still more tricks to play. Some Brazilian orchids offer no nectar at all, but an oil that male bees collect in special pockets on

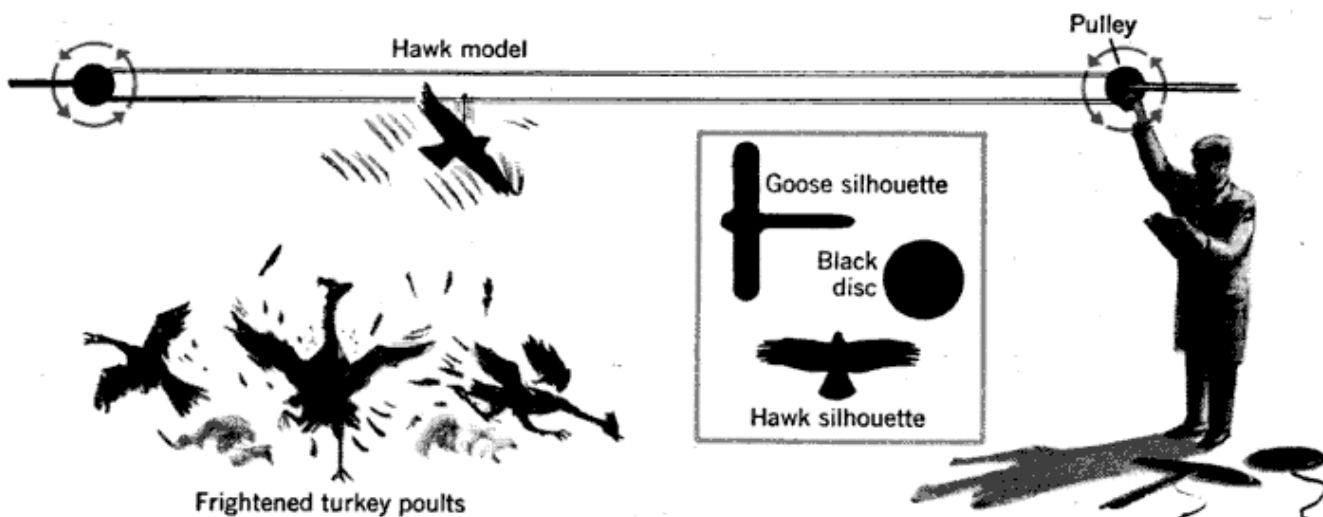

When he discovers his mistake, the wasp leaves the flower in a huff, but he carries pollen from the orchid.

Later, when he spies another orchid that looks like a female wasp, he descends upon her (or it) and goes through the same frustrating procedure. The pollen is accurately delivered from one flower to another.

As for the poor wasp, he does in fact play a key role in an act of reproduction, although it was not exactly the kind of reproduction he had in mind.

● How does a turkey poult know that a hawk means danger? One obvious theory has the turkey poult learning this crucial fact from adult turkeys, who

(Please turn to page 200)

SEPTEMBER 1969

87

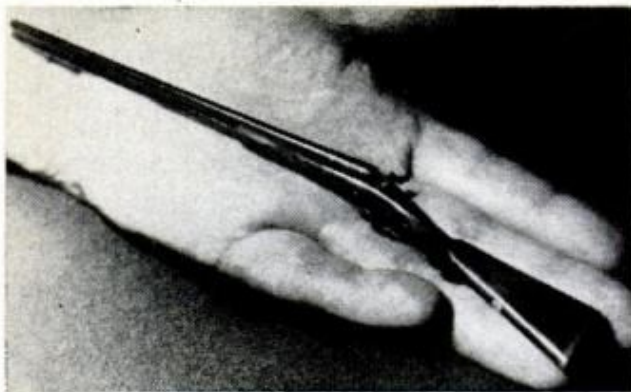

Tiny shotgun

On display at Purdeys, famed London gunsmiths, is a miniature shotgun that weighs just under an ounce, breaks down like a full-size gun—and fires tiny shells. The firm made three of these shotguns and gave two of them to King George V on his Silver Jubilee. The barrels are slightly more than 4½ inches long; bore of the gun is 0.1 inch, and each cartridge holds 0.162 grains of powder and 2.02 grains of shot.

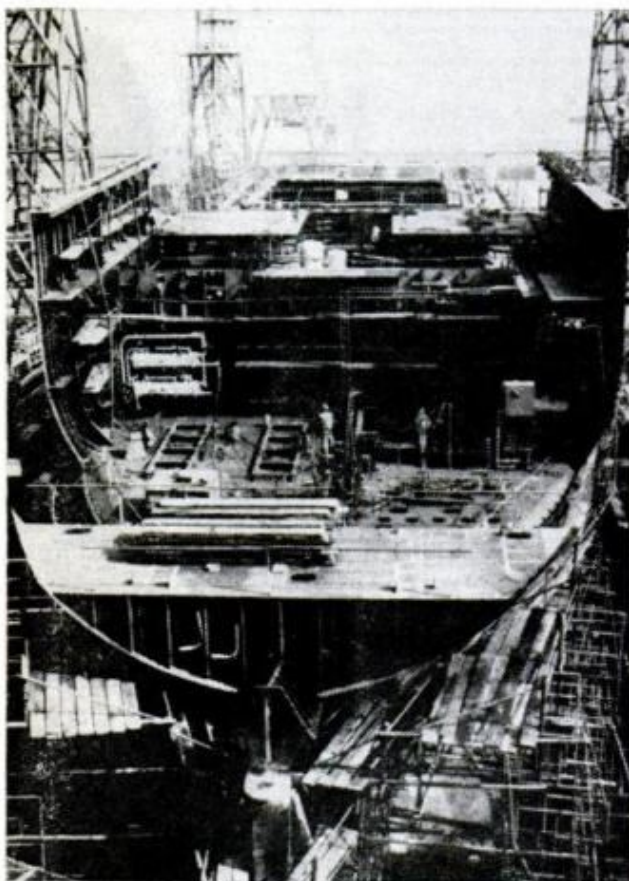

Japan's first nuclear ship

Shown during construction is Japan's first nuclear ship. Built for the Nuclear-Powered Ship Development Agency, the 8350-ton craft is to be used to train crews for future vessels. The square compartment on the upper deck houses the reactor. Builder is Ishikawajima-Harima Heavy Industries Co.

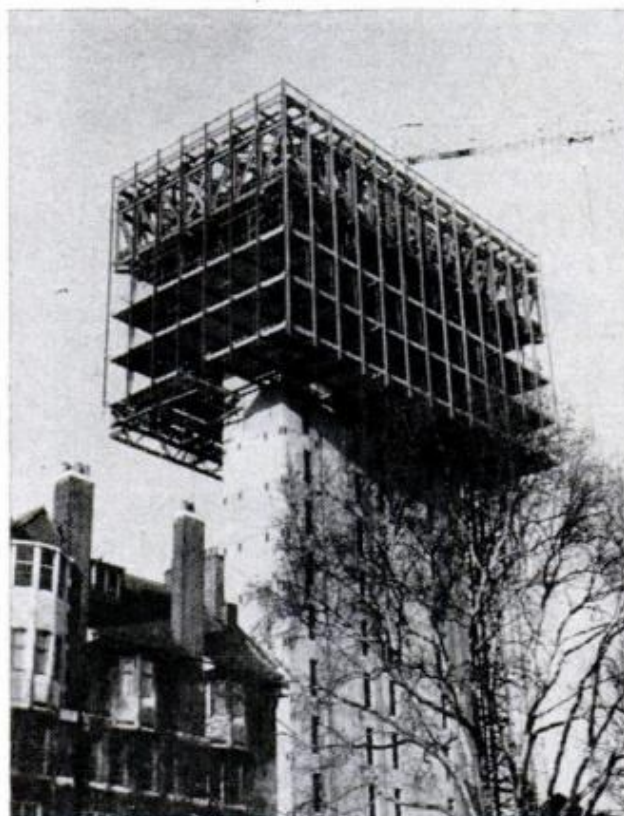

Comes down going up

Part of this building was erected from the ground up—and the rest is being built from the top down. First part of the structure to rise was the central utility core—for elevators and services—which is made of concrete. Then, suspended from the top floor and the core, the other floors are added. It's the Hearts of Oak Building Society headquarters in London.

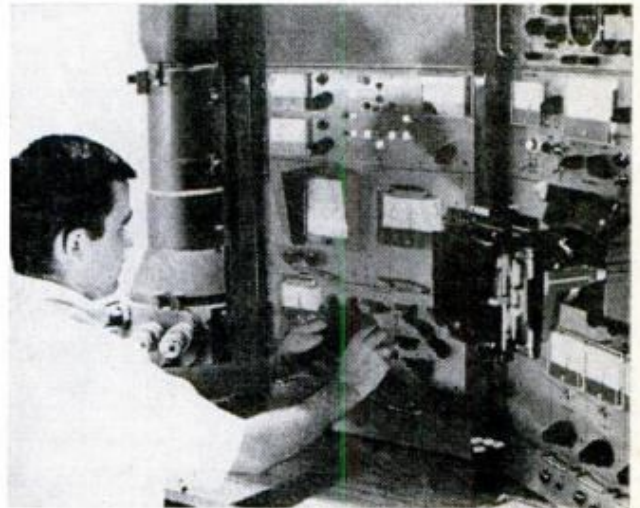
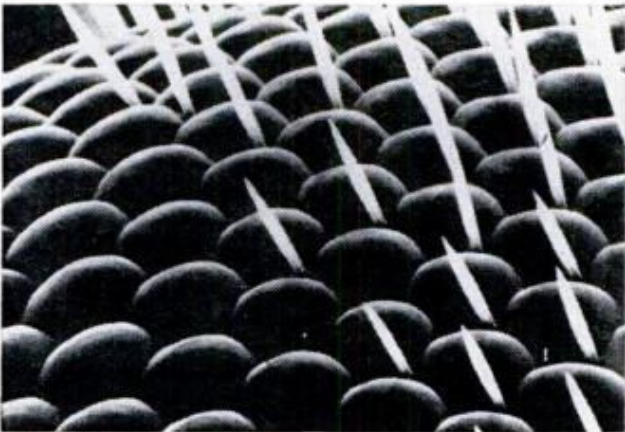
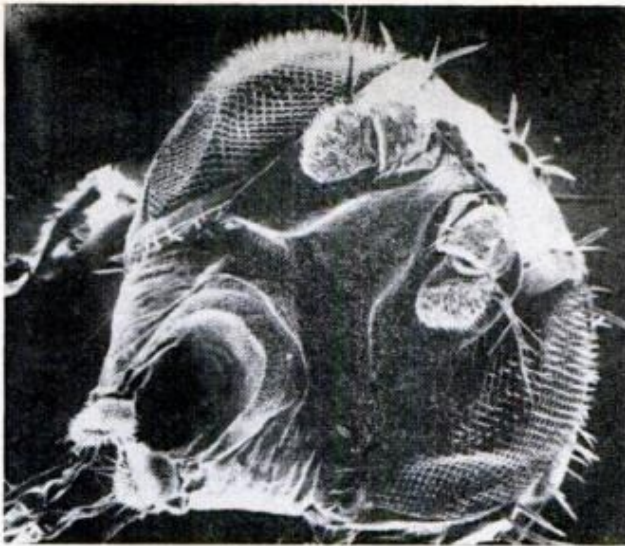

3-D microscope produces remarkable close-ups

A microscope that works somewhat like a television set magnifies objects in three dimensions from 30 to 50,000 times for study by biologists. These remarkable photos demonstrate the clarity of the image produced by the scanning electron microscope at Florida State University. At upper left is the head of a fruit fly magnified 300 times; zooming in at lower left, the microscope enlarges the eye 3450 times life size. At upper right is a 5400-times magnification of guppy skin. At lower right, a scientist works the controls.

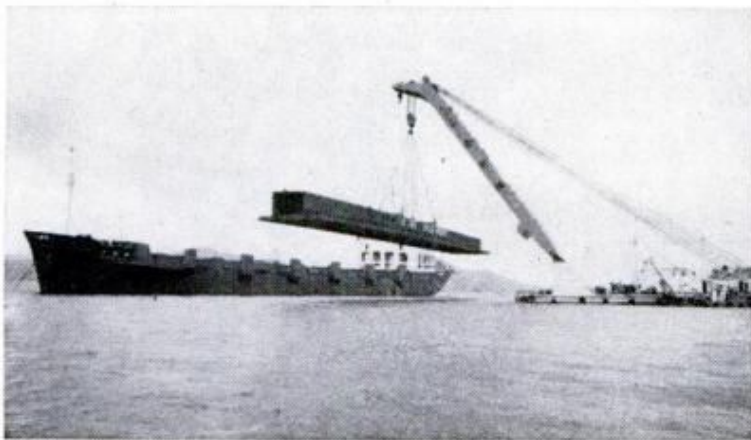

Prefab sections for Auckland bridge

Huge steel bridge sections prefabricated in Japan were carried by ship (above) to Auckland, New Zealand, and lifted by floating crane (right) to widen the harbor bridge from its original four lanes to eight. The prefab sections, over 360 feet long, weighed 400 tons apiece.

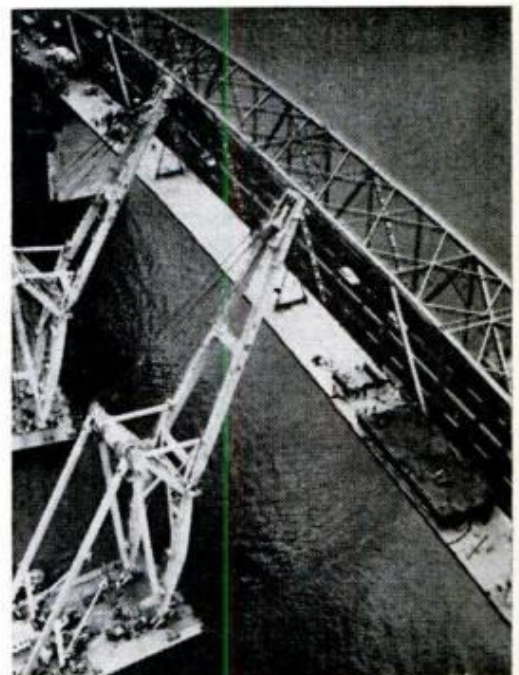

① PILOT ROCKETS FREE OF PLANE

DROGUE CHUTE DEPLOYS

②

ROTOR BLADES DEPLOY

ENGINE DROPS FROM NESTED POSITION

TAIL ASSEMBLY UNFOLDS

③

④

ENGINE STARTS

AUTOROTATING BLADES

⑤

PARACHUTE

CONTROL STICK

TURBOFAN ENGINE

STABILIZERS IN EXTENDED POSITION

EJECTION GUIDE ROLLERS

EJECTION POWER UNIT

JET FUEL

A Hot Seat

'Punching out' over enemy territory too often means capture for our pilots. Now the Air Force and Navy are working on a jet-powered ejection seat that really flies

GYROCOPTER CONCEPT
(Kaman)

ENEMY TERRITORY

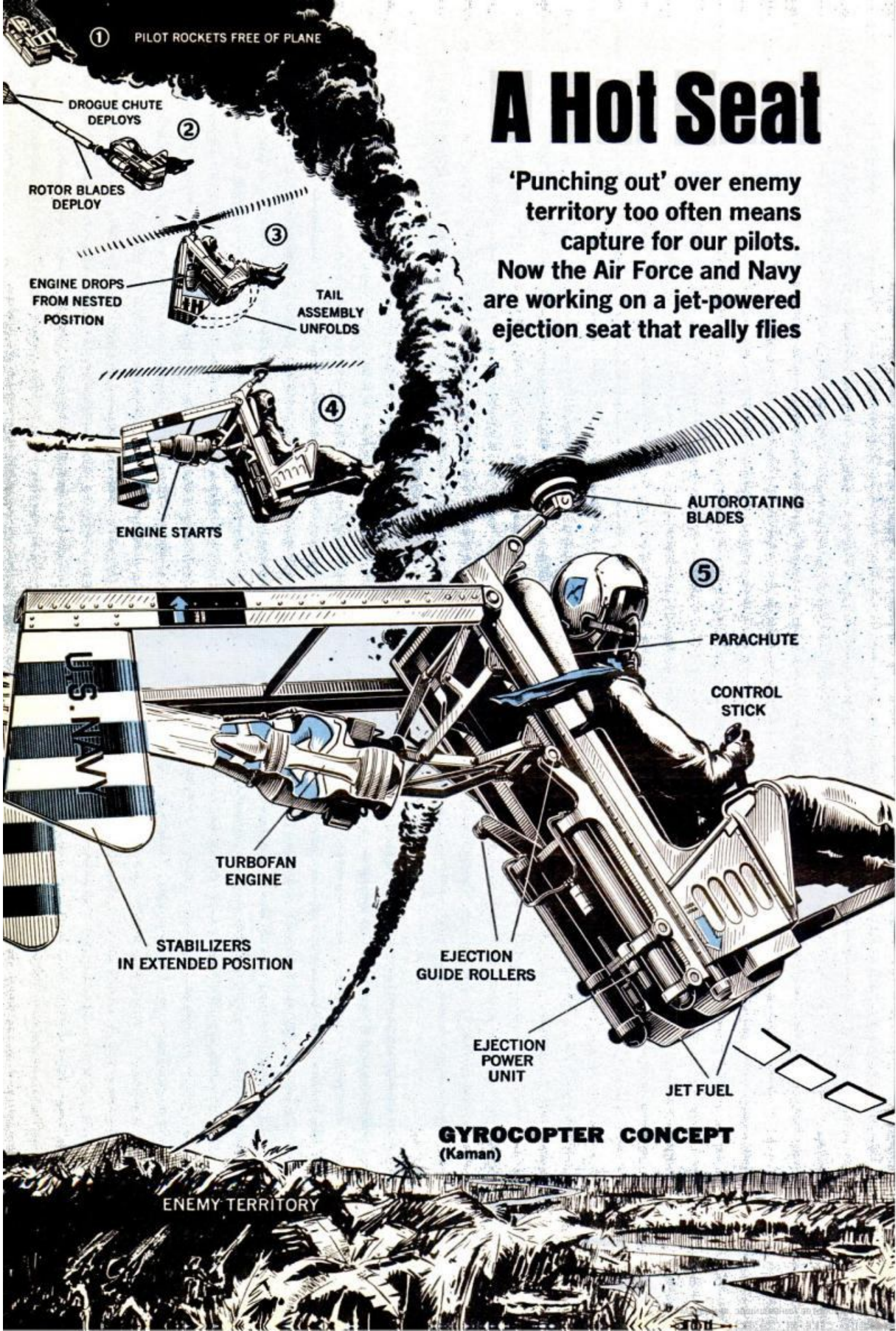

to Bring 'Em Back Alive

By KEVIN V. BROWN

Technical Art Concepts by Fred L. Wolff

THE PILOT LINED UP his jet, nursing the sight onto the designated target. Then he dived in low and fired his missiles, watching them streak out before him. It was a good run and a good hit.

Before he could congratulate himself he heard a *thunk*. Red lights flashed on his instrument panel.

He pushed the mike button. "I've been hit."

The flight leader called back: "I see it. You've got smoke."

"I'm losing fuel pressure. I may have to punch out."

"Try to make it to the coast."

"I can't. My engine just quit."

"Roger," said the flight leader. "We'll try to get a chopper in for you. Good luck."

The other pilots watched as the canopy peeled off the crippled plane. Then the seat, with the pilot in it, rocketed out. When well clear, pilot and seat separated. A parachute billowed, and the pilot floated to the dense jungle—in the heart of Vietcong territory.

His chances of being picked up by helicopter were reasonably good. Air

rescue has become a fine art in Vietnam.

But his chances of falling into enemy hands were even better.

The problem has prompted Navy and Air Force brains to seek a solution. What if a pilot could "fly" his seat to friendly territory, or to an

area that would make rescue more certain?

The Air Force and the Navy are working together to develop a "flying ejection seat" that can be stowed on a standard cockpit seat, deployed after the seat ejects, and, with a small jet engine, keep the pilot airborne until he can select his landing site.

Three versions of the AERCAB (Aircrew Escape/Rescue Capability) are now under study. One is based on the Rogallo wing, a triangular-shaped cloth supported by three keels. The Air Force's Wright-Patterson Flight Dynamics Laboratory is testing it with Bell Aerosystems Co., of Buffalo.

The second version is a two-bladed, free-swinging rotor that, with a jet en-

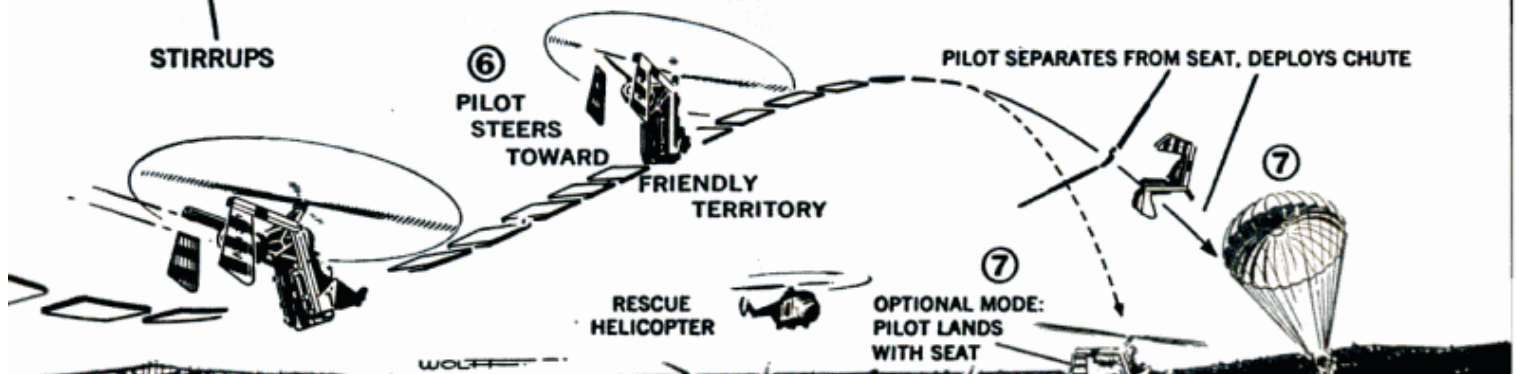
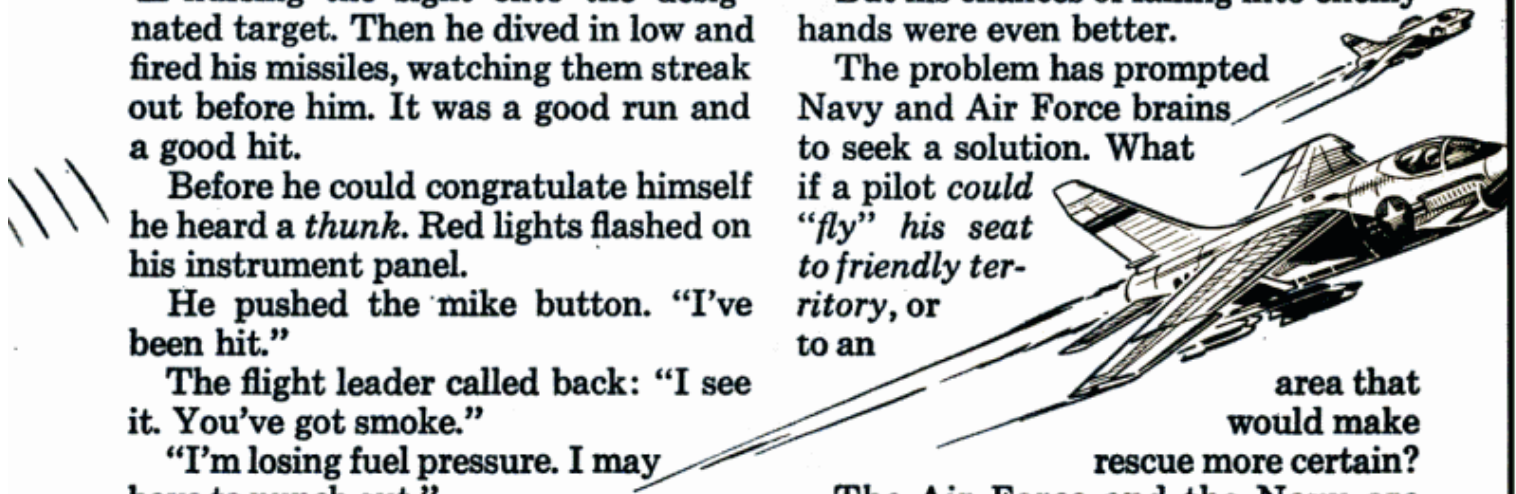

gine, converts the seat into a gyrocopter. The Navy Air Development Center, Johnsville, Pa., is studying this version. Contractor is Kaman Corp., Bloomfield, Conn.

The third version is based on the Princeton sailwing, which features cloth-covered wings and tail surfaces held taut by spring-loaded metal bars and cables. The Navy Air Development Center is studying this version with Stratos Western Div. of Fairchild Hiller Corp., Manhattan Beach, Calif.

Whichever system is picked must meet these specifications:

- Pilot has option of using the system—or his own parachute if he *knows* he's over friendly territory.
- After punch-out, the system will be automatic, but pilot will have option of overriding it at any time. The automatic feature insures that a wounded (or semiconscious) pilot can

use it, with the seat flying a predetermined heading and altitude.

- A barometric sensor will keep the system from deploying until it descends to 10,000 feet. If it deployed above that altitude, the pilot could suffer from exposure and use up his oxygen too quickly. If the pilot punches out below 10,000 feet, deployment sequence begins immediately.

- Seat must be capable of a speed of 100 knots, a rate of climb of 1000 feet per minute and a range of about 50 miles.

- System will include survival equipment and a locator beacon to aid air rescue.

- The automatic feature will include separation from the seat and deployment of pilot's own chute above 200 feet at the end of 30-minute flight. Though the gyrocopter and the Princeton wing would seem capable of taking the pilot all the way to the ground, the services have not made this mandatory. But they have asked for some glide capability when seat is unpowered.

Feasibility tests, including actual flights of models and wind-tunnel tests, will determine which of the three versions is the most stowable, the most easily deployable, and the most stable in flight. After that the services will select the power of the engine (they're

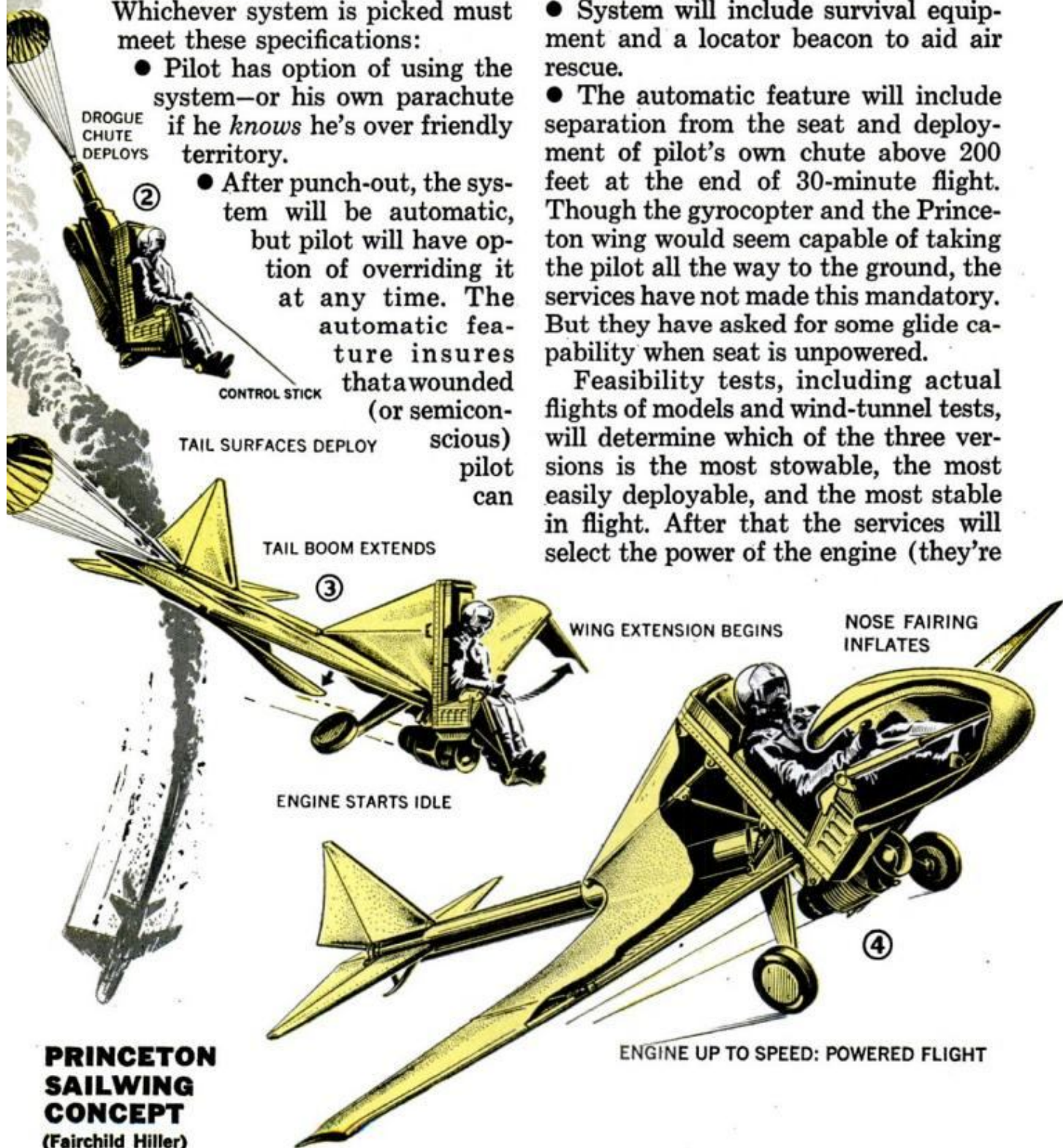

**PRINCETON
SAILWING
CONCEPT**
(Fairchild Hiller)

ROGALLO WING CONCEPT (Bell Aerosystems)

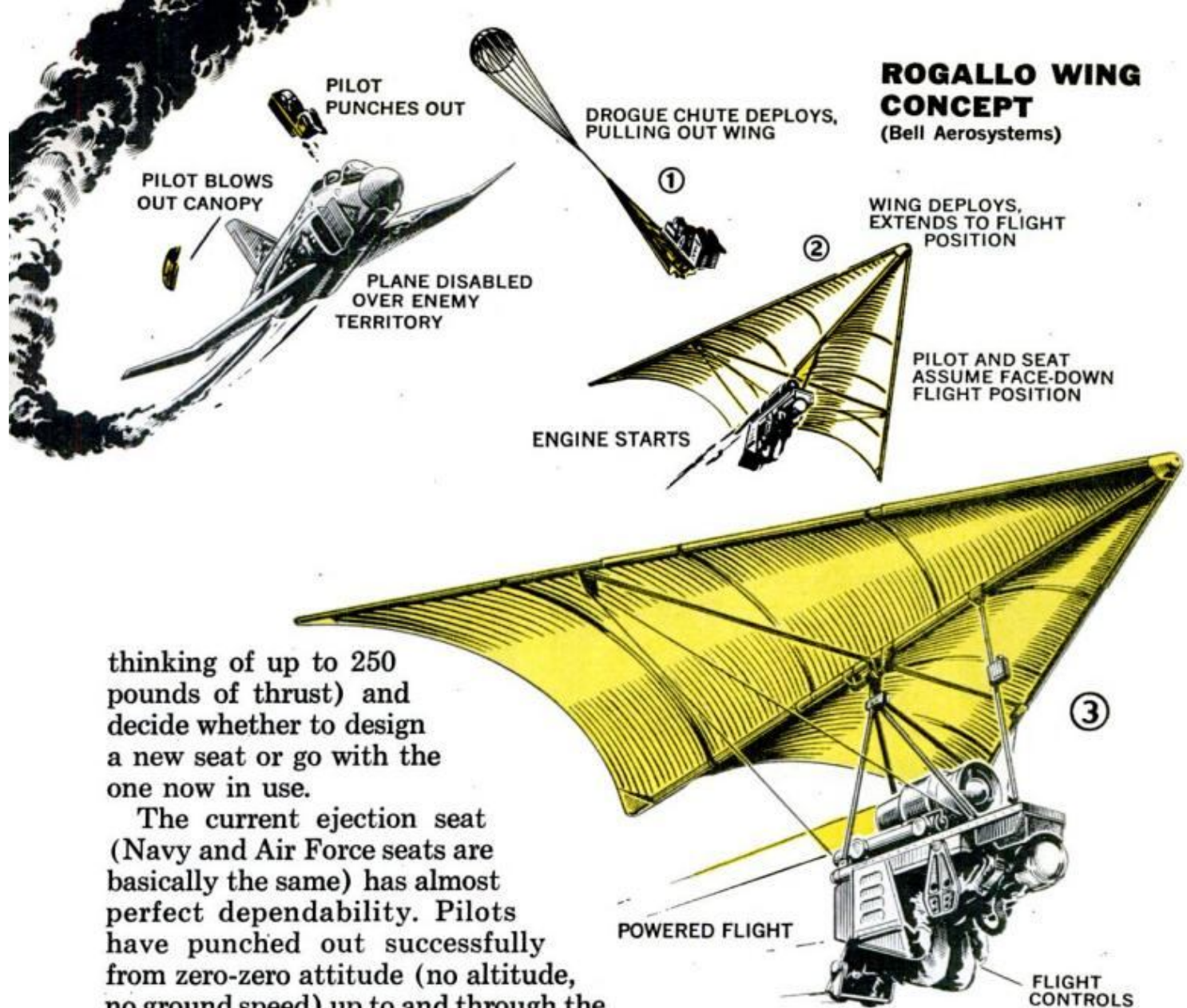

thinking of up to 250 pounds of thrust) and decide whether to design a new seat or go with the one now in use.

The current ejection seat (Navy and Air Force seats are basically the same) has almost perfect dependability. Pilots have punched out successfully from zero-zero attitude (no altitude, no ground speed) up to and through the sound barrier. Should ejection be necessary at high speeds with the new systems, built-in devices will slow down the seat before deployment begins.

Here's how a typical punch-out would work with each system, assuming an altitude below 10,000 feet and subsonic speeds. The initial sequence would be identical for all.

As in the present Air Force seat — to use it as an example — the pilot pulls up on two red handles alongside the seat below his knees and follows through until his helmet hits the head-

rest. Cables yank his feet back against seat to make certain his legs clear the instrument panel on the way out.

The canopy blows off, rockets ignite and seat rides on rails out of cockpit. The angle of ejection is slightly forward to brace pilot and seat against the rush of wind. In the current system, at this point pilot and seat separate, and pilot's chute opens.

With the new systems, a deceleration

(Please turn to page 197)



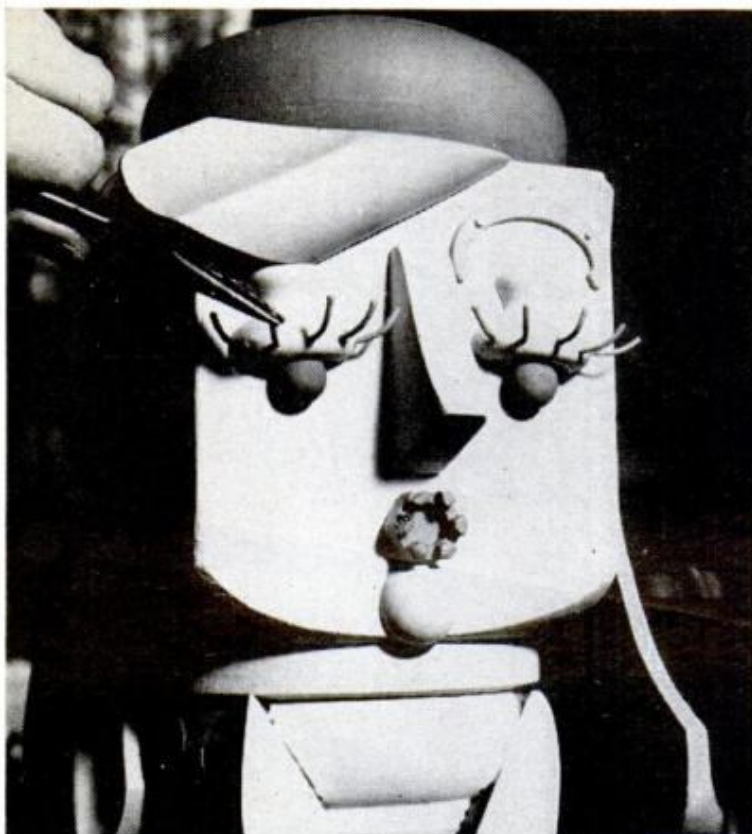

Art from old furniture

Old furniture and almost anything else that's been discarded—car parts, doorknobs, porch posts, false teeth, costume jewelry—are transformed into wood sculpture by Jacqueline Fogel of Queens, N.Y. The couple above are Bonnie and Clyde, who were created from odds and ends. At upper left, the artist curls nail eyelashes, and, at left, she selects a piece of raw material for a new sculpture. Several museums exhibit the pieces of art, and some items have sold for \$500 to \$650.



How to spoil a secretary

This ought to keep the office girls happy! A new secretary's desk, shown at a Hannover, Germany, exhibit, contains typewriter, tape recorder, filing cabinet, dry copier and, hidden inside the headrest, a telephone set.



SST is 'incredibly quiet'

"Incredibly, unbelievably quiet," reported Geoffrey Holmes, who took a sound reading 100 yards from the Concorde 002 as it came in for a landing. The reading was 91 decibels, which is less than some current airliners.



Horse lights

Two European inventions, a battery-powered stirrup light and a reflective leg band, light up horses at night for road safety.



Part of Russia's display at Paris

Appearing at the recent Paris Air Show were these two new Soviet aircraft. At top is the 155-mph MU-8 helicopter. At bottom is the Antonov An-22 heavy cargo transport. The Antonov flew with two starboard engines shut down and four contrarotating propellers feathered.

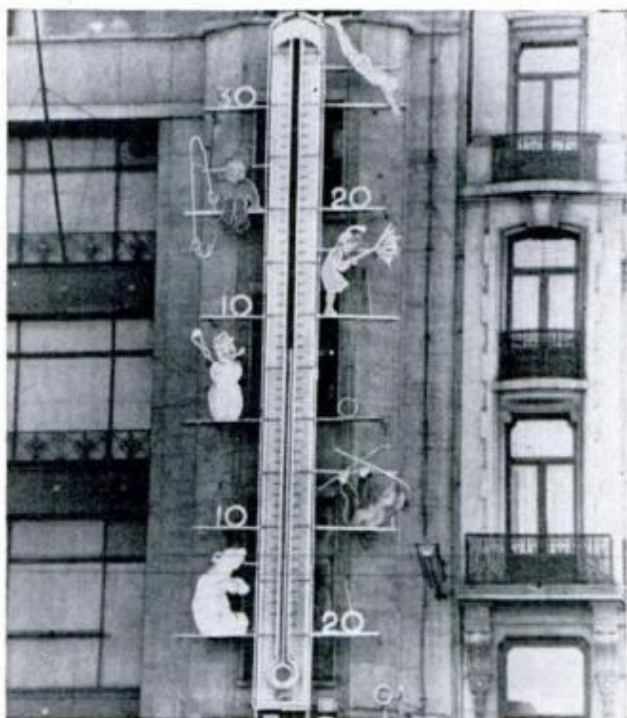

Not quite fishing weather

A Brussels department store has installed a giant thermometer that tells the degrees—and pictures the appropriate activity.



500-year-old skis

Local folk around Passau, Germany, used these "snow planks" as early as 1480 to get around in snow. Skis are in a museum there.

PM OWNERS REPORT PLYMOUTH VALIANT

A Nationwide Survey Based on
1,000,000 Owner-Driven Miles

Plain Jane With a Moneysaving Mill!



Photos by
Irv Dolin

By **BILL HARTFORD**
Technical Auto Editor

Owners turn thumbs down on snarling, faddish machines and get an economical, dependable ride without all the fanfare

IT'S REALLY NOT FAIR to judge a car by the shape of its skin. And Plymouth Valiant owners are smart enough not to. A lot of owners would pounce on a Massachusetts teacher who "praises" his car's appearance: "It's ugly enough to be uninteresting to vandals!" There *are* other ways of expressing the fact that the emphasis is certainly not on inspired styling.

Nevertheless, "the look of the car"

is actually a New Jersey computer programmer's praise. To a Michigan grinder it's "one of the two American-built cars that look sensible—the other is Rambler." A Louisiana warehouseman finds the "body more stylish than other compacts," and a New Jersey salesman says he is "a nut on straight body lines: All manufacturers can omit the waves, indentations and other fold-erols as far as I am concerned." "At-



WORKMANSHIP is criticized by almost 10 percent of owners. Door-pull armrest is among gripes

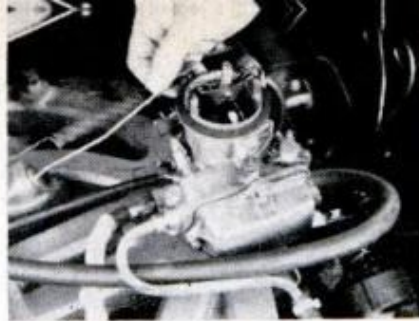

MECHANICAL TROUBLES are mostly minor. Most often mentioned are carburetor adjustments



MONEY-SAVING DESIGN places seat-back release at floor level. Owners would pay to raise it

tractive but conservative," observes a Michigan teacher. A Connecticut housewife and her family are fans of Valiant styling: "We wanted a Valiant because of the square shape." "It looks like an automobile; it's not overemphasized," says a retired New Mexico man.

What is emphasized by owners is the car's economy. It's why they bought it, why they like it and why over 80 percent will buy another. As an Indiana factory worker exclaims: "I hope there will always be a Valiant!" What the car is for most owners, as expressed by a Michigan foundry technician, is "a good blend of styling, economy, comfort and performance."

Purchase price isn't low enough to put an end to the declaration: What this country needs is a good \$2000 car, especially after making a few "necessary" concessions to vanity, creature comfort and the department of taxation. But, still, a stripped Valiant is just a bit over \$2000 and a good value. The price, as a Georgia warehouseman says, is only part of the story: "I needed a car that wouldn't cost much to operate." He's getting well over 20 mpg with his 225-cu.-in. Six—better than the average for this engine.

Almost all owners are satisfied with the fuel economy of the two sixes available in the Valiant and they like their operation. From a New Jersey jeweler, the ultimate compliment: He bought his '69 because his 1960 Valiant, which he still owns, "runs like a watch." Says he hasn't had his new car long enough to determine if it's equally smooth and reliable. One thing he doesn't like is the location of the distributor on his 170 engine. It's hard to



LOW LIFTOVER of Valiant trunk makes loading easy

HIGH MILEAGE is how owners view 16.9, 20.4 mpg

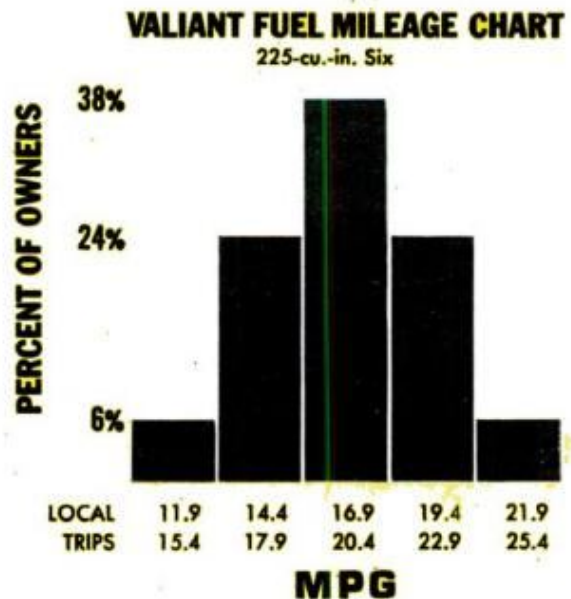



SQUARED-OFF LINES of rear deck are regarded as part and parcel of functional, economical approach

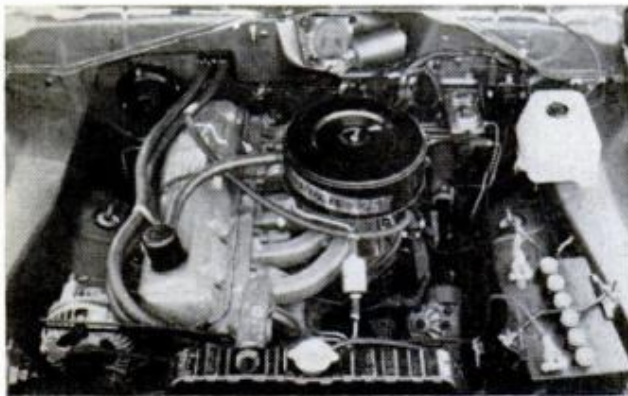

MOST POPULAR 225-cu.-in. Six gets owner praise. Do-it-yourselfers find distributor location rough



SIMPLE INSTRUMENT PANEL merits little praise, little blame. Owners like seatbelt buckle hold-downs



REAR SEAT is close in two-door models. Some owners want better front seats with more adjustments

reach when he does his own tune-ups. Other do-it-yourself owners, including a fire engineer in Illinois, agree.

Only a few six-cylinder owners feel they've sacrificed too much for economy. A Michigan manager is "satisfied with all-around performance except the pickup." A Kentucky lab technician finds his 170 too underpowered, says he'll order a 225 next time. And a Colorado mechanic with a 170 will go right to a V8 next time. But most find their six an excellent powerplant for their 2800 to 2900-pound Valiant.

The price, more than the weight, pits the Valiant against the import market and owners indicate they are well aware of the competition. An Illinois engineer, for example, drove a VW for 10 years before buying his Valiant—which he finds "a heavier, safer car." Next time around, though, he'll "consider an import (Toyota, Opel) if they offer more service facilities." A Michigan paper mill employee has both a VW and a Valiant, says his Plymouth is "a well-built automobile—seems as solid and as tight as my VW, with a lot more room." He says he would buy another Valiant. A New Jersey airline pilot mourns his choice: "I've been driving a Cortina for the past four years. The Valiant is a disappointment—it takes the fun out of driving." He won't buy another. Neither will a Michigan engineer: "Had foreign cars for twelve years—wanted an American compact for a change." But he's had too many problems: "Dealer had my Valiant 18 days to fix brakes and bad paint." He had a leaky



HANDLING is high up on the list of what owners like best. Few owners have power steering or brakes



OWNERS PREFER FOUR-DOOR MODEL about 60-40 over coupe-like two-door. Style is plain but likeable

left-front-wheel cylinder which took two trips to the dealer to get repaired and a "lousy paint job: blemishes on the hood and trunk."

Workmanship, although the biggest complaint of owners, is criticized by less than 10 percent. Most frequently mentioned is paint finish, with miscellaneous misalignments and misfits in body work and various "minor but irritating things," as an Illinois machinist says, rounding out the list.

Owners who have had Valiants prior to their '69 model have logged an impressive number of miles. "Drove my last Valiant 110,000 miles; cylinder head was never removed and it didn't burn oil," brags a Massachusetts mechanical engineer. A retired Michigan man drove his last one 105,850 miles. This is his fifth and "they've all been really troublefree." Most owners would agree with an Illinois custodian who reports: "It's just a good little car." ★ ★ ★

Summary of 1969 Plymouth Valiant Owners Reports*

Total miles driven 1,050,343

Average miles per gallon:

170-cu.-in. Six,
local driving . . . 18.0
long trips . . . 20.6

225-cu.-in. Six,
local driving . . . 16.9
long trips . . . 20.4

273-cu.-in. V8, local driving . . . 15.2
long trips . . . 18.0

318-cu.-in. V8 . . . n.a.

Specific likes:

Economy . . . 49.2%
Handling . . . 46.7
Styling . . . 21.9
Comfort . . . 14.5
Ride . . . 13.6
Size . . . 13.2
Performance . . . 11.6

Specific dislikes:

Workmanship . . . 9.8%
Gas mileage . . . 7.2
Brakes . . . 6.4
Ride . . . 5.5
Finish . . . 3.8
Rattles . . . 3.4
Cold starts . . . 3.4

What changes would you like?

Windshield wiper . . . 8.7%
Seat style/position . . . 6.1
Workmanship . . . 5.1
More legroom . . . 4.1

Styling . . . 4.1

Body style:

2-door sedan . . . 41.1%
4-door sedan . . . 58.9

Engine:

170-cu.-in. Six . . . 24.3%
225-cu.-in. Six . . . 65.2
273-cu.-in. V8 . . . 8.1
318-cu.-in. V8 . . . 2.4

Transmission:

Automatic . . . 82.4%
3-speed manual . . . 16.8
4-speed manual . . . 0.8

Had any mechanical trouble?

No . . . 72.6%
Yes . . . 27.4

What kind of trouble?

Carburetor . . . 15.7%
Brakes . . . 12.9
Oil leak . . . 10.0
Cold starts . . . 10.0
Windshield wipers . . . 10.0
Transmission . . . 8.6
Alternator . . . 8.6

Dealer repair satisfactory?

Yes . . . 69.2%
No . . . 30.8

Why the Valiant?

Economy . . . 40.7%

Past experience . . . 26.6
Size . . . 19.0
Style . . . 11.4
Reputation . . . 9.9
Performance . . . 4.6

Is the Valiant your only car?

Yes . . . 55.1%
No . . . 44.9

Other cars owned:

Plymouth . . . 45.9%
Chevrolet . . . 17.2
Dodge . . . 9.8
Volkswagen . . . 8.2
Mercury . . . 4.9
Buick . . . 4.9
Pontiac . . . 4.9

What options/accessories?

Radio . . . 54.2%
Power steering . . . 31.9
Whitewall tires . . . 16.5
Airconditioner . . . 13.6
Remote side-view mirror . . . 10.2
Wide-oval tires . . . 9.3
Courtesy lights . . . 8.9
Both power steering and
brakes . . . 6.9
Vinyl top . . . 6.8
Power brakes . . . 2.8

Age distribution of owners:

15-29 . . . 21.4%
30-49 . . . 41.5
50 plus . . . 37.0

*Where applicable, percentages may not equal 100 percent due to rounding and/or insufficient sample.

THE WORLD'S SHARPEST TOOL

They'll never make it to Tiffany's, but industrial diamonds can cut, grind and grip like nothing else on earth.

By ARTHUR S. FREESE

DIAMOND BLADE has proved valuable in surgery of eye

DIAMOND. Unless you're a baseball addict, the word probably conjures up visions of sparkling engagement rings, bracelets dripping from a movie queen's wrist, legendary, eye-popping stones like the Hope diamond. These are gem diamonds, rocks with glamour and fancy price tags. Though they set feminine hearts aflutter, they don't stir the interest of scientists the way their plain-Jane cousins, industrial diamonds, do.

About 75 percent of the world's output of diamonds (by weight) wind up at the business end of tools and instruments, not in jewelry-shop showcases. In 1969, an estimated 45 million carats (142 carats equal 1 ounce) will be bought by industrial and scientific users throughout the world, more than 10 times the consumption prior to World War II. And most of the selling will be done by South Africa's De Beers Co., which has a virtual monopoly of the world's

STEEL SURGICAL BLADE



DIAMOND BLADE

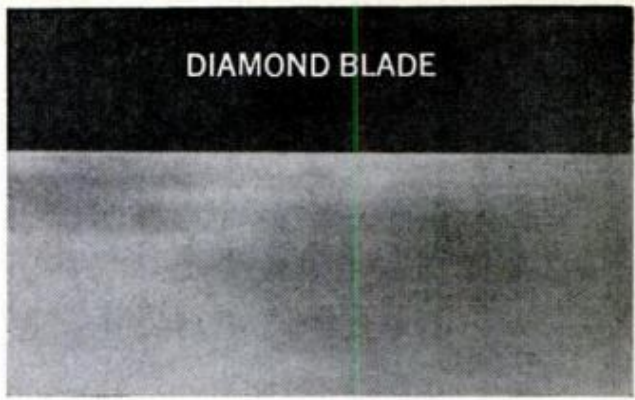

UNDER 1000-X MAGNIFICATION steel blade looks ragged as Alps while diamond still shows sharp edge

supply of industrial as well as gem diamonds.

Diamond is the hardest known substance, making it unequaled for tough cutting or grinding jobs. At the same time, it is unmatched for certain delicate medical tasks. Forceps with diamond-coated gripping surfaces are used by surgeons to hold human tissues that have no more consistency and strength than wet tissue paper. Because they have a low friction coefficient, diamonds can grip tissues firmly without tearing them.

A few years ago, Dr. Davis G. Durham, a Wilmington, Del., ophthalmologist, had a diamond-bladed knife made to his own design. Since then he has used the knife for some 200 eye operations. The instrument has proved such a success that it may be put on the market in the not-too-distant future. This type of knife, says Dr. Durham, would be excellent for operations in the inner ear or for blood-vessel grafts, procedures that require very fine cutting.

The blade in Dr. Durham's original knife was made from a diamond of gem quality and has a cutting edge the width of 12 carbon atoms—approximately 1/1000 the width of a human red blood cell. At 1000-X magnification, the edge of the diamond blade is a sharp unbroken line while that of the best surgical steel blade looks as jagged as the Alps.

Similar industrial stones of near-gem quality are used as blades in microtomes, medical laboratory instruments used to cut thin slices of tissues sent to the pathology lab for examination. The

microtome cuts slices so thin as to be virtually transparent—1/25,000 of an inch thick.

In contrast to diamond, graphite is one of the softest of substances, slippery and black. Yet both are carbon, differing only in their crystalline structure. Some chemical elements occur in two or more distinct forms, called allotropic forms. Allotropes differ either in crystalline structure—red and white phosphorous is another example—or in molecular makeup, as do oxygen (O_2) and ozone (O_3).

The carbon atoms in the graphite molecule are relatively far apart and lie in planes or flat sheets. The "pull"

DIAMOND-STUDED turning bar on highway planing rig cuts grooves that reduce hydroplaning effect

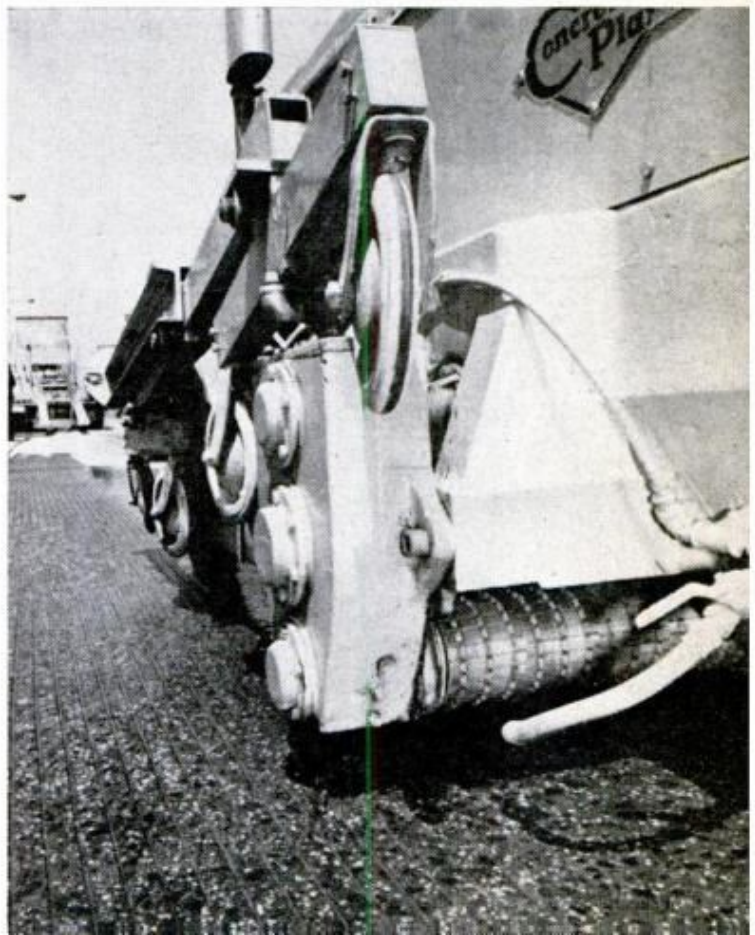

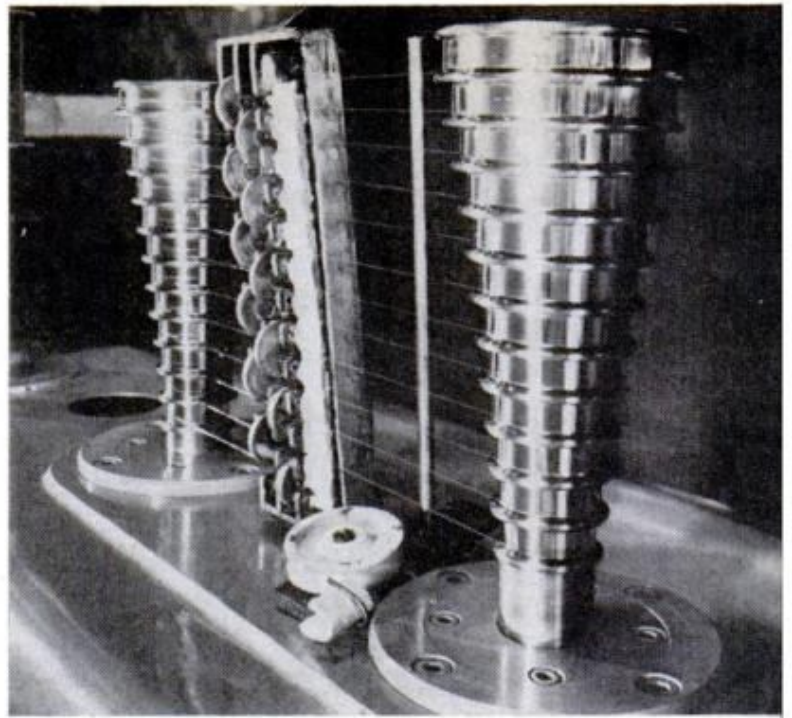

SUPER-SMOOTH FINISH is required for heat shield of Gemini space vehicle, shown (left) being machined with diamond tool. Photo above shows copper wire for electronic watches drawn through battery of diamond dies to reduce it to required fineness. Die holes are measured in millionths of an inch

between individual sheets is weak, giving the material a loose, slippery-quality. In diamond, the carbon atoms are packed closely together and are linked in three dimensions to form strong and hard crystals. The distance between carbon atoms in the diamond is 1.54/10,000,000 of an inch. When you squeeze atoms (or people) together, you cause tensions. When diamond is formed by nature's tremendous pressures, strains are left in the molecule so that the stone will sometimes actually explode when dug out from the rock in which it is buried.

Diamonds were created millions of years ago, deep in the Earth's mantle where the temperatures and pressures are high. Geophysicist George C. Kennedy of UCLA has suggested that if the Earth's surface could be stripped away to a depth of 120 miles, diamonds might be as common as beach sand.

Diamonds now being mined were brought to the surface ages ago by volcanic activity. Most of the stones have remained in the throats or "pipes" of ancient volcanoes, where the most fruitful mining has taken place. Some

were dispersed and washed into ancient rivers where they accumulated and were covered by sand or were carried to the sea. They were mined from stream gravel in India and Borneo in prehistoric times. Today, Marine Diamond Mining, a subsidiary of De Beers, is dredging diamonds from the sea floor off Southwest Africa.

If you take ordinary graphite and heat it to 4400° F. while squeezing it at 1,800,000 pounds per square inch, you'll make synthetic diamonds. So far none are of gem size (1/20 carat or larger) But so great is industry's demand for them that they are being produced in at least nine countries: the United States, Sweden, Ireland, Japan, The Netherlands, Belgium, Czechoslovakia, U.S.S.R. and South Africa. The United States alone takes some three tons of industrial diamonds a year, about 60 percent of the world's total natural and synthetic output.

In 1880, a chemist of Glasgow, Scotland, James B. Hannay, mixed one part of bone oil, nine parts of light paraffin oil and four grams of metallic lithium. He put the soup into an iron bomb

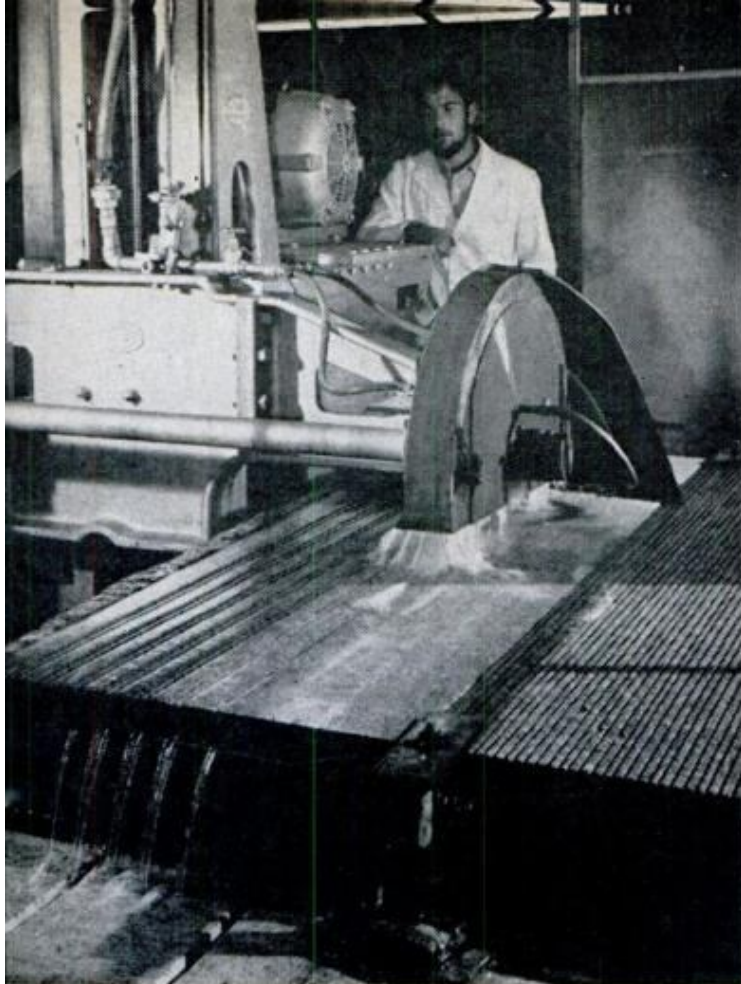

IF THERE'S A NEW WAY to use industrial diamonds, chances are it was developed at the big De Beers lab in Johannesburg, world center for diamond research. Its scientists probe basic structure of the diamond crystal as well as devise better ways to mine and extract the mineral. In 1952 De Beers researchers discovered that certain diamonds are semiconductors, which led to new applications. Photo at the left shows test of 14-inch diamond saw cutting blue granite. Below, a diamond wheel is shown grinding a flat surface on a crystal of natural quartz

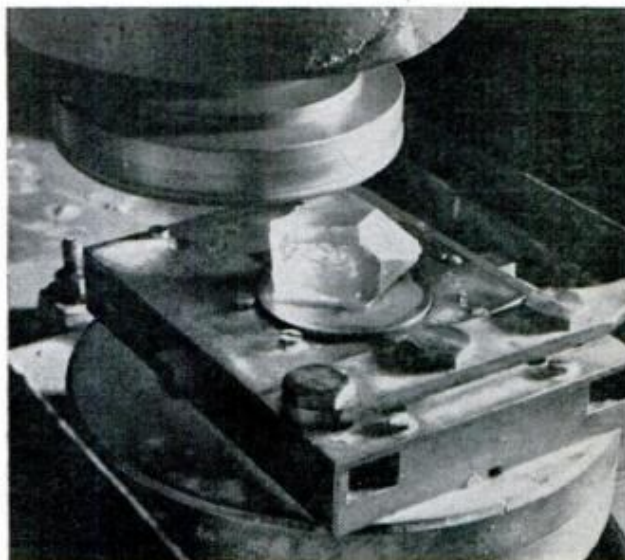

which he welded shut before heating to a red heat for 14 hours. After slow cooling, the bomb was opened to reveal a number of tiny crystals, which Hannay ultimately sent to the British Museum of Natural History in London. There they lay unnoticed until 1943 when an Englishman, Dr. K. Lonsdale, proved by X-ray analysis that the stones were diamonds.

No one has ever been able to duplicate Hannay's results. Experts such as Dr. Frederick A. Raal, a top research scientist for De Beers, doubt that the process would work. "From a consideration of all evidence," says Dr. Raal, "I would tend to favor the view that the Hannay diamonds are splinters of natural diamond which came to be in the reaction crucible as the result of the efforts of an overzealous assistant."

The first authenticated creation of synthetic diamonds was accomplished in Sweden in 1953 by scientists of the ASEA company. After 23 years of design and development work they had produced 40 small diamond crystals. Next to achieve this goal was General Electric in 1955, and then De Beers in

1958. The Swedes neglected to file for a patent, and GE was prevented from doing so because the U. S. government decided that the process should be kept secret. Later, De Beers, which had taken out a patent, and GE locked horns in court. Eventually the two giants settled the issue amicably.

Synthetic diamonds are very small, the largest measuring no more than 4/100-inch across. They are useful only for industrial purposes. They are not used for jewelry because of their size and color, which varies from a greenish-yellow to a grayish-black.

Industrial diamonds comprise a tremendous spectrum of sizes and qualities. In size, they range from micron powder up to stones of one carat or more. Sometimes called "diamond dust," micron powder is finer than household flour and is used as a polishing agent.

These diamonds are indispensable to industry for drilling, cutting, grinding and polishing a variety of materials ranging from ultrahard ceramics to metals, plastics, glass, rubber and spa-

(Please turn to page 218)

Just patented

PM'S PICK OF THE NEW INVENTIONS

Prepared in cooperation with Roger S. Shashoua, Director, International Inventors Assn., Inc.

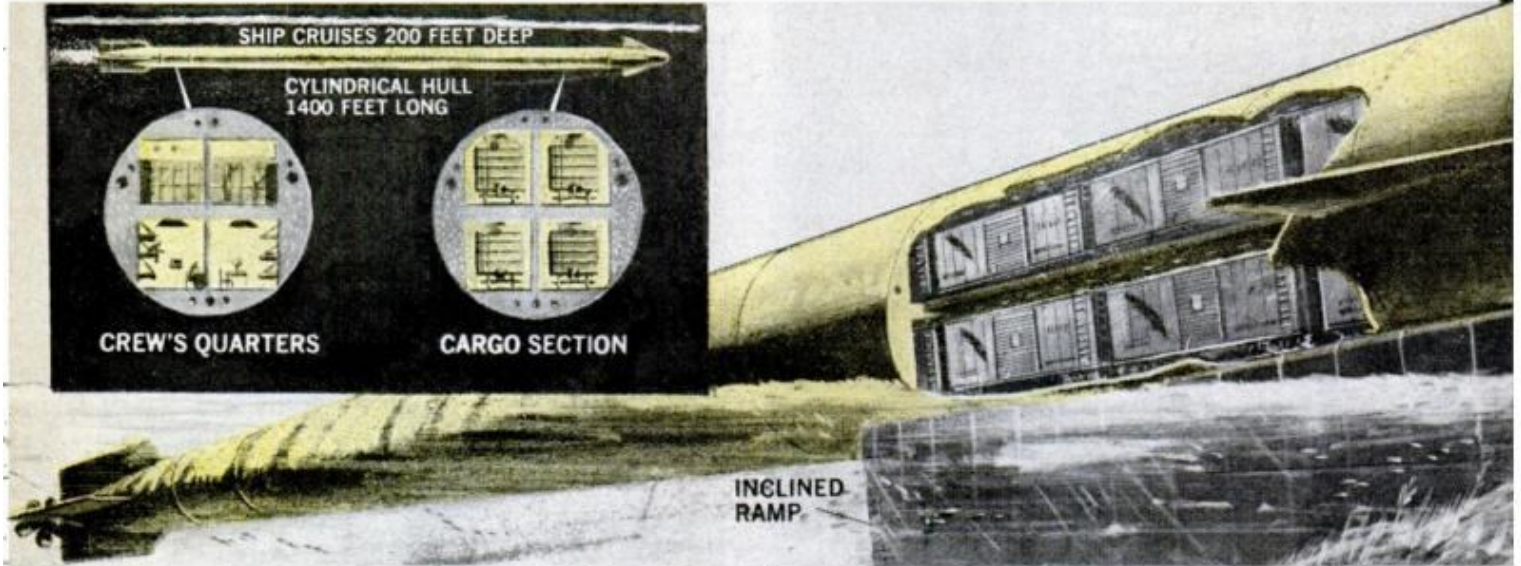

1. SLITHERING THROUGH THE WATER like a giant eel, this 1400-foot-long cargo submarine could carry loaded freight cars to world seaports at speeds up to 45 mph. The tubular atomic-powered ship holds 100 cars on four tracks and cruises 200 feet deep. At the end of its run, it slides up a shallow

ramp on shore. Its nose swings open and the inside tracks are linked to tracks on land for unloading the trains. The underwater freighter would be unaffected by surface storms and is so simple to run it would require a crew of only six or eight compared to the 40 to 50 needed on a conventional freighter

2. TRANSPLANTING SMALL TREES and bushes is a cinch with the mechanical digger below. You just pump a lever up and down with your foot and a sharp-edged cutting blade slices down and under the roots to free the tree from the ground. Each pump of the lever causes a spring-loaded pawl to engage a ratchet, advancing the cutter a few inches at a time. The blade's curved shape automatically leaves a ball of earth around the roots so that the tree can be replanted quickly and safely in another location

3. THE "KEY" IN THIS LOCK is a tiny magnet. Remove it and the box can't be opened. Slip it into the slot on front and the lid magically lifts up. Each key is magnetized in a different polar pattern. A magnet of matching pattern is built into the box. When the two are placed together, their combined fields trigger an electronic sensor inside the box, opening the lock. Only a magnet of the correct pattern will actuate the device. In larger versions, the lock could make burglarproof doors and safes

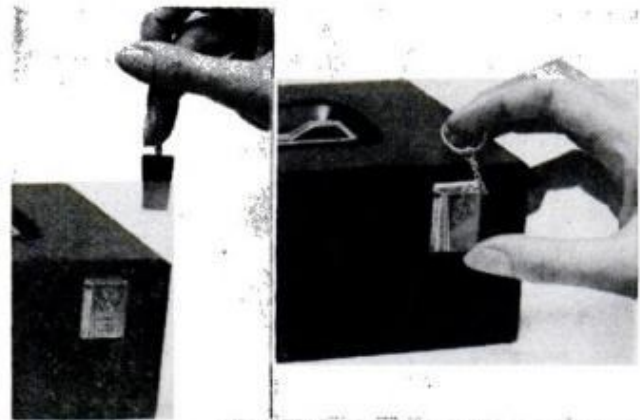
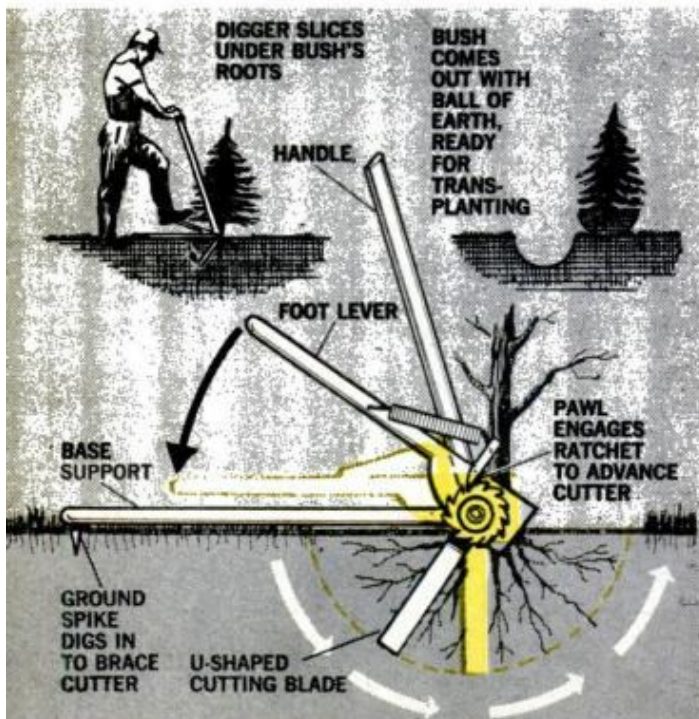

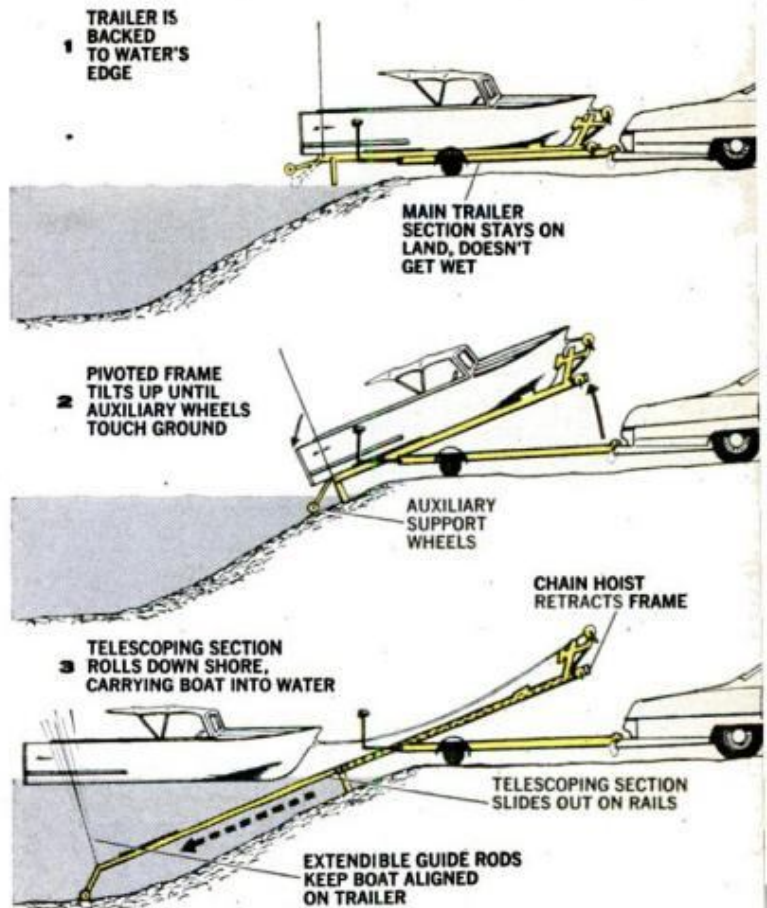
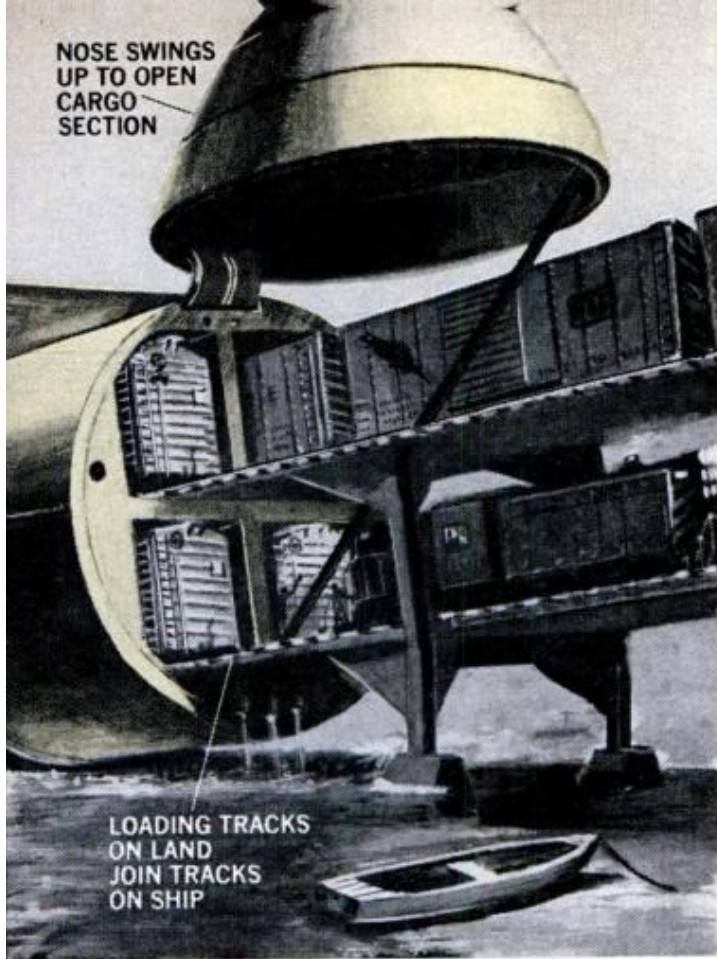

4. SELF-LOCKING SEAT BELT below leaves you free to move around comfortably in normal driving, but holds you tightly at the first sign of danger. A spring-loaded hub lets you pull the belt out so long as you do it slowly and gently. A sudden yank causes a ratched-toothed wheel to fly out sideways in a spiral guide, engaging a similarly toothed fixed ratchet and locking the belt. In a sudden stop or impact, two pins also fly out, catching in the fixed ratchet and stopping the belt. If there's a sideways impact, a rubber ring around the ratchet wheel snubs up against the housing. This keeps the ratchet from turning and forces it to ride out in the spiral guide, locking against the fixed ratchet

5. YOU CAN LAUNCH A BOAT from the telescoping trailer above without backing the trailer into the water. This keeps wheel bearings dry and lets you tackle slopes that would be too steep for a normal trailer. At the water's edge, the boat is tipped up on a pivoted inner frame. The cradle then slides out on two rails, riding down the bank on small wheels. As the boat is carried into the water, it floats free and the cradle is retracted by a hoist. Two extensible rods sticking up at the ends of the telescoping rails keep the boat lined up straight so that it can't drift sideways during the operation

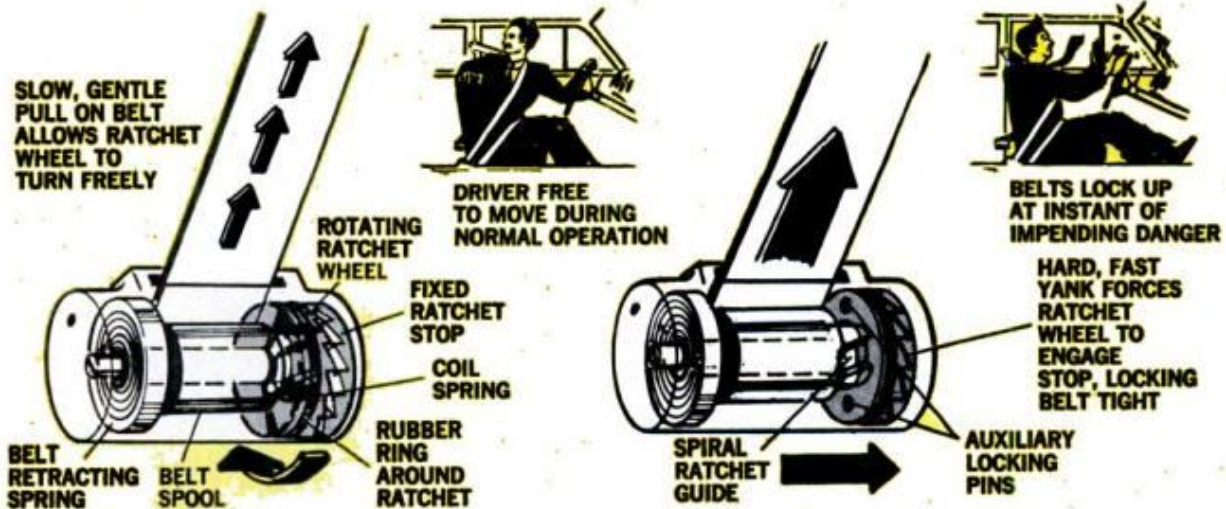

Inventors of the items shown on these pages are as follows: 1. Dr. Robert L. Whitelaw, Virginia Polytechnic Institute, Blacksburg, Va.; 2. Charles N. Dickey, 9836 Auburndale, Livonia, Mich. 48150; 3. Edwin Drescher, Melsunger Metallwerk, P.O. Box 268, 3508 Melsungen, West

Germany; 4. A. B. Svenska Metallverken, Upplands Vasby, Sweden; 5. Andrew Scott, 7366 Bannock Trail, Yucca Valley, Calif. 92284. Roger S. Shashoua can be reached at the International Inventors Assn., Inc., 680 Fifth Ave., New York, N. Y. 10019.

**PM OWNERS REPORT
JEEP WAGONEER**



A Nationwide
Survey
Based on
2,500,000
Owner-Driven
Miles

Over the River and Through the Woods —For a Stiff Price

By **BILL HARTFORD**, Technical Auto Editor/Photos by Irv Dolin

AT LEAST ONE THING that a Nevada credit manager, a Michigan nuclear powerplant operator, a West Virginia funeral director, a Florida insurance man and a North Carolina physician have in common is ownership of a 1969 Kaiser-Jeep Wagoneer. All use their four-wheel-drive Wagoneer for both business and pleasure; the fact that they can is the reason they bought it.

Representative of thousands of owners, they use their unique station wagon to go hunting; fishing; explore ghost towns; ride sand dunes; tow air boats, swamp buggies, feed and cattle trailers and just plain campers.

Whatever the off-the-road or on-the-road challenge—"mushrooming" for a Michigan physician, "looking for Indian ruins" for a New Mexico electronic engineer, "getting down to the

main road" for a California dam attendant, "\$100 worth of plowing per snowstorm" for a New Jersey engineer, "towing an animal chute" for a Nebraska veterinarian—Wagoneer own-

WAGONEER FUEL MILEAGE CHART

350-cu.-in. V8

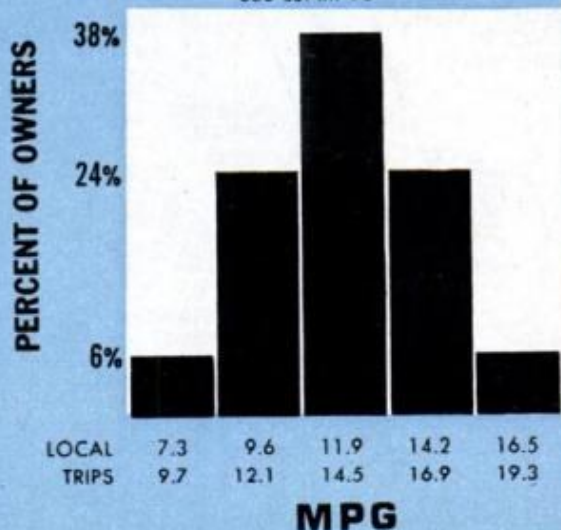

LOCAL TRIPS	7.3	9.6	11.9	14.2	16.5
	9.7	12.1	14.5	16.9	19.3

MPG



CARGO AREA HEIGHT beats that of any conventional station wagon, but you can't lay 4x8 material flat



RUGGED TAILGATE, floor are well-used by owners; a few would like option of a side-hinged tailgate

ers find their machine the only one to do the trick.

Although some, like a surveyor in Maine, find the Wagoneer's "dual-purpose feature essential to business," most owners put the emphasis on recreation. It's even therapeutic: "When I want to go, I go!" yells an Idaho small-job laborer and contractor. "We take to the hills every chance we get," says a Nevada bookkeeper. "I wanted a car I could drive the way I want and where I want to (and I do)," states a Washington barber. "To get away from the madding crowd—to go places others can't," adds a South Carolina physician. A retired Michigan man also likes to go when and where others can't: He's got a Cadillac for everyday driving, but keeps this, his "5th or 6th Jeep" as a "winter car."

That's certainly a practical approach, but the big boom is in four-wheel-driving just for fun. "Jeeping" is the term a Colorado airline pilot uses to describe his Wagoneer treks into the high country. Some owners are members of various four-wheel drive clubs—just for fun. The price of membership in the Wagoneer owners club, however, is steep. The purchase price for a Wagoneer is stiff, and the operating costs, due to what owners consider low fuel mileage, are high. A New Hampshire traffic manager getting 12 and 16 mpg, a little better than the average for the Buick 350-cu.-in. V8



REAR SEAT in the upright position is held by two spring-loaded pins which rattle and are hard to use



FOUR-WHEEL DRIVE to go where and do what conventional wagons can't is why owners bought Jeep



TRANSFER CASE between leaf-spring suspension puts power to front wheels at 1:1 and 2.03:1 ratios



4WD CONTROL LEVER has shift pattern outlined on knob; some find it hard to shift to 4wd low range



CONVENIENCE, comfort, roominess and visibility of passenger compartment are most praised by owners

option, has the complaint of one of every five owners: "Low gas mileage." He also articulates how some owners are affected by the relationship of overall quality to purchase price: "Poor workmanship considering the \$5000 price tag."

A mechanical engineer in California finds "the quality of finishing not consistent with price." An Illinois trucking company executive finds "workmanship just passable." A Michigan USAF navigator complains about



WORKMANSHIP in relation to price is mentioned often. Poor fits, rattles and paint are complaints

"high purchase price. Seems you pay an awful lot for four-wheel drive. Car in this price range (\$5500) shouldn't look quite this barren. Interior and exterior compare with \$2000 car. Didn't expect a luxury car, but could use more quality and workmanship for this amount of money." "Overpriced," says an Oregon physician, simply. He says, "Improve quality of the body."

Specifically, "My bumpers are already starting to rust," complains a Maine colormaker's helper. His car also has a "poor paint job," like a New York homemaker's. "Paint is popping off!" pops off an irate Indiana housewife. A Virginia general contractor has had his Wagoneer seven months and is "very pleased with it," but he says, "It's going to cost me \$125 to have a seven-month-old, \$5850 automobile painted. Jeep claims no warranty on paint."

A plumber and pipefitter in Nevada is also down on body work, but does emphasize "good to excellent" mechanical design and components. And a Massachusetts lawyer is especially happy with his 350 with automatic transmission: "With these options it is the best Jeep we've ever had—despite snowstorms over three feet, I've never used a snow shovel." A Kentucky-based Army NCO brags: "I haven't been stuck yet and I've been in mud up to the bumpers."

The four-wheel drivetrain serves owners well, and that's what counts with them. Despite complaints (long

Starcraft's Hefty Half-Pint

Here's a new all-terrain vehicle small enough to fit in the bed of a pickup. With luck it may sell for under \$1000



TOUGH TERRAIN is taken in stride by this small, one-man ATV being introduced by the Starcraft Corp.

By **DAN FALES**, Boating and Outdoors Editor/Photos by Bruce Moss



SPINNING A PATTERN with its wheels, this ATV shows it can turn in an area equal to its own length

IN THE SURPRISINGLY rugged back country of Indiana, I tested Starcraft's new mighty mite—a snappy all-terrain vehicle that weighs 430 pounds, is six feet long and four feet wide.

It was near Starcraft's home port of Goshen, Ind., that I rammed a prototype machine over land, into water and back over land.

It's this fall that Starcraft plans to hit the market with a new line of ATVs. The first one out will be this half-pint model priced, Starcraft hopes, under \$1000—or at least under \$1000 before accessories.

In testing the “amphibian,” I found the new ATV a good contender for the offroad market.

There are two unique features about

POPULAR MECHANICS

this six-wheeler. First is the size; second, stability.

Though there's enough room for two people, Starcraft has designed it primarily for one. The steering wheel sticks up right in the middle of the machine, while the foot-operated gas pedal is off to the right. There is no brake pedal. Turning the steering wheel to the left or right will lock up the wheels on that side. This gives you great maneuverability. Actually, the ATV can turn in its own length.

All the powertrains use chain and cable. There are no hydraulic systems in this design. Starcraft says that elimination of a special hydraulic system cuts the total cost. It is also felt that chains are more troublefree. I found the chain system quite efficient.

With only a seven-hp Briggs & Stratton four-cycle motor aboard, there was really no opportunity to slam the vehicle through a torture test. Starcraft does plan production of machines with larger engines.

But all the tests I did do with the seven-hp model were passed with flying colors. These involved several jump tests that should have really knocked the tires off the equipment, but didn't.

The only area where I found the ATV lacking was in the water. But the low-performance characteristics

in water are typical of all ATVs, not just Starcraft's.

I ran the machine into a quiet lake. The water was as smooth as a millpond. The wind was calm—no waves or ripples. The machine moved slowly because only the tread on the balloon tires propels it. I turned the little ATV by braking the wheels on the side I wanted to turn toward.

But I was surprised at the machine's stability. I wouldn't want to challenge the wake of the *Queen Elizabeth 2* in it, but for crossing streams and quiet lakes the Starcraft is okay.

In water and on snow, ATVs will move if the water's not too rough or the snow too deep. But the real area for these machines is land.

I found getting in and out of the water a snap where there was a ramp or shallow-angle bank. Where the bank was muddy and steep, I had difficulty.

Charging through meadows, up backwoods lanes, through swamps, I found the Starcraft easy to handle and quick to respond, a giant toy with get-up-and-go.

This small version of what Starcraft says will be an ever-expanding line is just right for breaking into the hot ATV field. Kids will have no trouble operating this machine. It's not hot enough to get them into trouble, yet

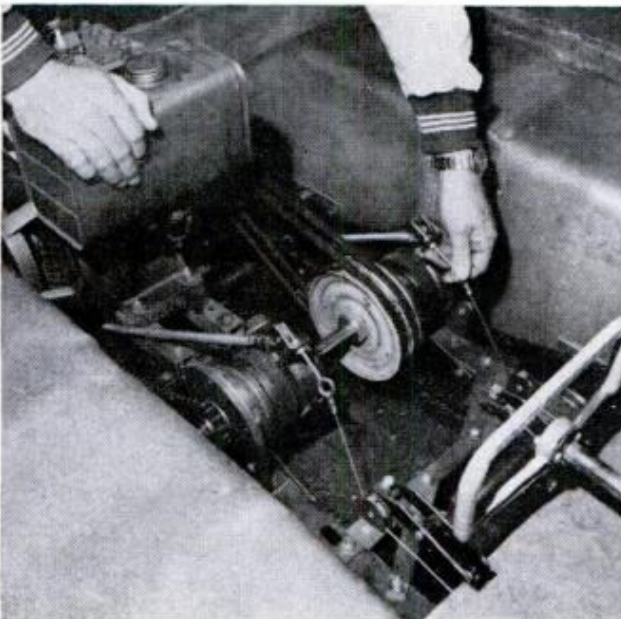

CABLES from the steering wheel to the transmission govern the stop-and-go movement of the wheels

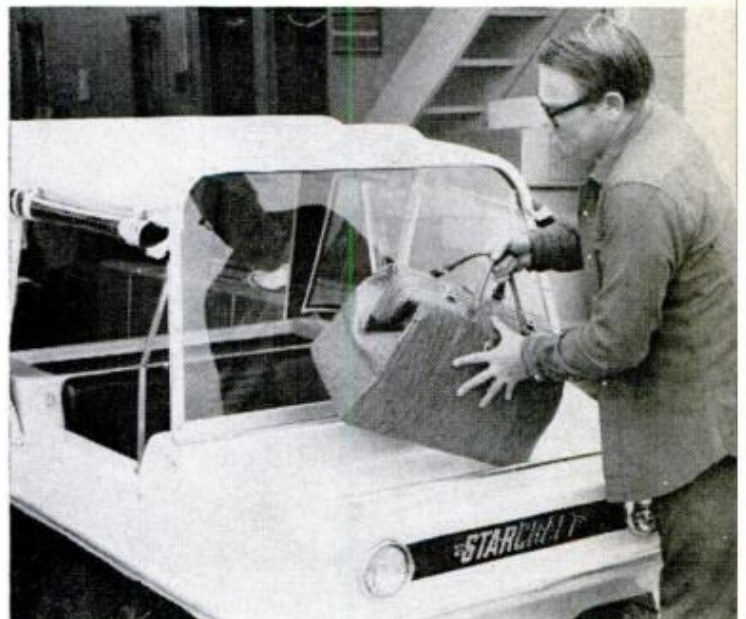

CARRYING DECK for game and gear is important design feature of Starcraft's all-fiberglass machine



AT WATER'S EDGE, this machine moves well, depending on how muddy the terrain and how steep the bank

it will go. A bigger machine with a 12-hp or larger motor is bound to give better performance over the really rough and steep terrain.

Starcraft in this prototype was trying to design features that will prove useful on bigger machines. The fold-down windshield is great for traveling. The four-foot width makes it easy to carry the ATV in a pickup truck; you won't have to use a trailer.

The front deck is a good carryall. Starcraft sees this deck as a good place

for hunters to haul game out of the woods.

The all-fiberglass body means sturdy construction and minimum maintenance. The addition of a canvas top and closed-in canvas side curtains lets you charge through the woods during rains without getting wet.

Starcraft wants to come out this month with a machine similar to the prototype I drove. Doubtless, there will be some changes when the machine goes into production.

Starcraft is entering a field that promises to be as active as snowmobiles—if not more so. Some observers say that before long there will be twice as many ATVs sold as there are snowmobiles each year. Others feel that annual sale of ATVs will top out at 300,000—about what snowmobiles are doing.

Whatever the final figures, ATVs are here to stay, and Starcraft's model will be right in the thick of things. ★★★

IN THE WATER (right) the ATV is more stable than I anticipated. Spinning wheels (upper right) propel it. The machine can bust right through lily pads (middle). Jumping machine (bottom) really tests it

TWO-PIECE BODY made entirely of fiberglass is what gives this ATV its strength and sturdiness

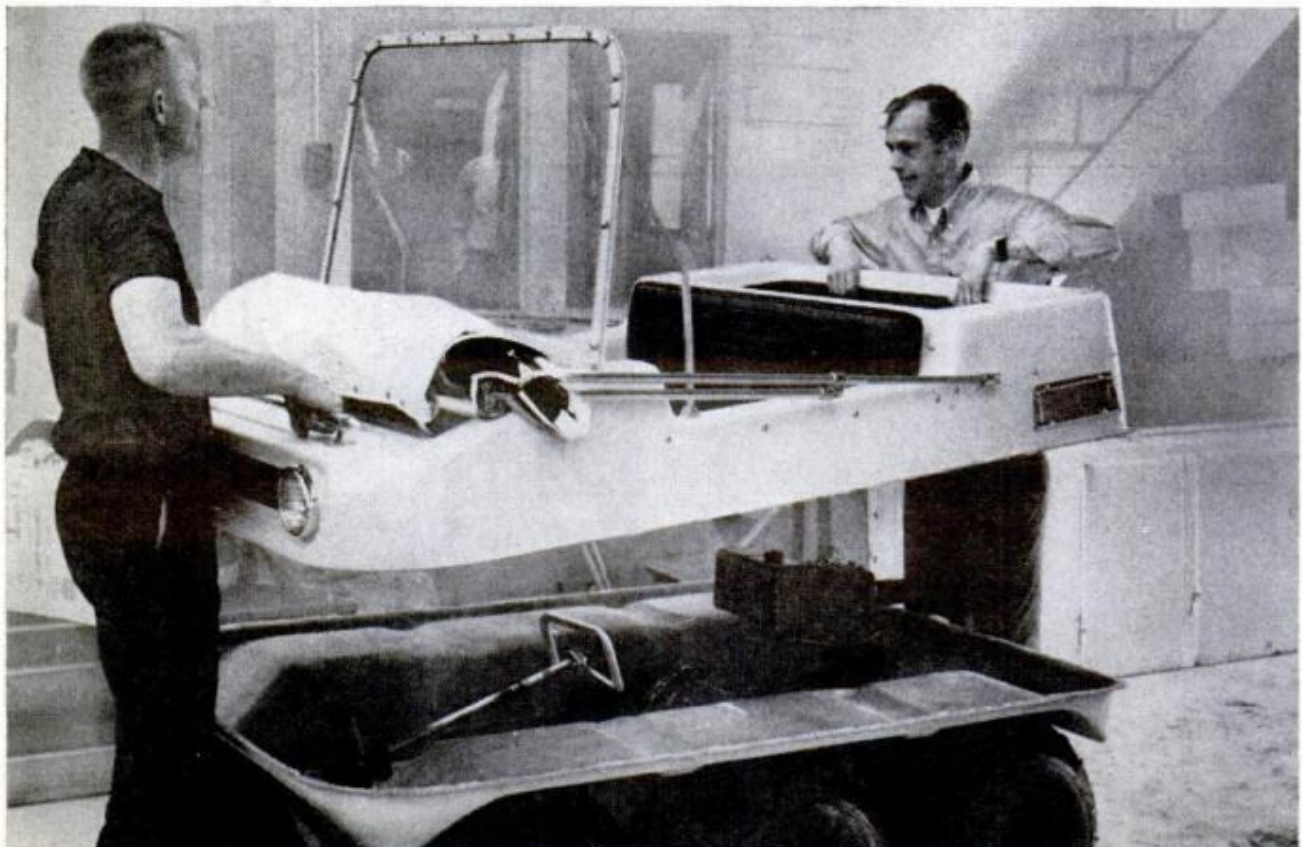



Russia's 50 nuclear subs spell trouble for the Navy's

Antisubmarine Warfare

forces. But amazing new weapons are making the 'nukes' easier to track and destroy.

By **BOB ZIMMERMAN**

Official U.S. Navy photos

A NEW COLD-WAR TWIST is turning the vast, dark world under the sea into a deadly hunting ground. The quarry is the elusive nuclear submarine.

The Russians, after sticking for years with diesel submarines, are now building nuclear subs in significant numbers. Some are said to be capable of launching missiles from submerged positions—like our own Polaris.

This spells trouble for the U.S. Navy's antisubmarine warfare forces. ASW—detecting, tracking and destroying a maneuvering target that can't be seen—has never been easy. Now the potential enemy is one many regard as the ultimate weapon of modern war: the fast, quiet, reactor-powered submarine that seldom needs to surface and can roam the world on a few pounds of fuel.

An urgent effort is under way to counter the new Soviet challenge. Ships, aircraft and our submarines are involved.

The Navy has just begun flying the most sophisticated sub-hunter ever fitted with wings—the Lockheed P3C Orion. Signals radioed to the plane from listening devices dropped in the water are run through a computer to produce a quick, reliable fix on a submerged sub and help launch torpedoes and depth bombs before it can escape.

Another new antisubmarine plane is on the drawing boards. It will be a compact version of the big shore-based P3C, small enough to be launched from carriers but still giving the advantage of an airborne computer.

New destroyers are joining the fleet with sonar systems powerful enough to bounce sound waves off the floor of the sea, thus extending their detection and tracking range. Some destroyers will have a new kind of sonar dome—made of rubber and pressurized—bulging under their hulls.

A new torpedo—more like an underwater guided missile—is adding uncan-

1. TACTICAL COORDINATOR sits at computer console. Electronic aids make it possible for plane to detect, localize and attack undersea targets "in a matter of minutes," says the Navy

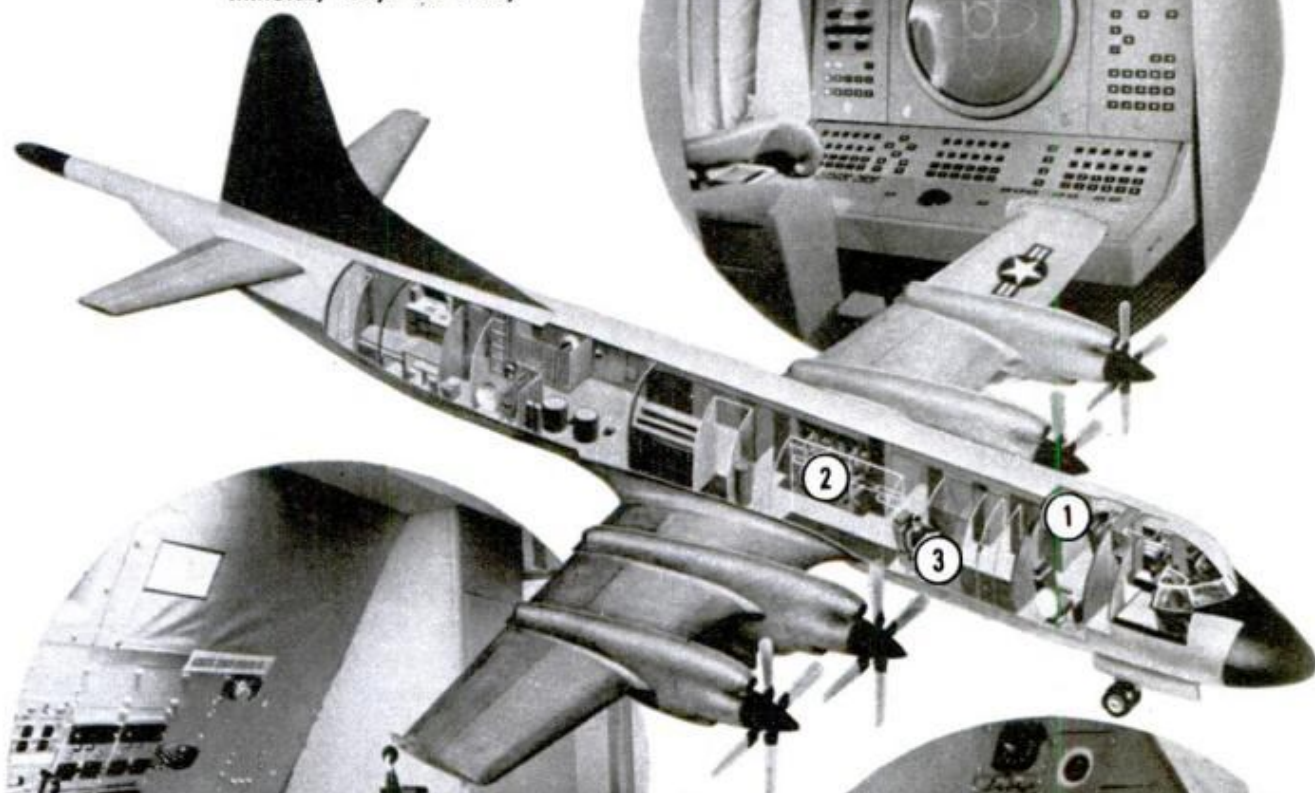

2. ACOUSTICAL OPERATORS receive signals relayed to plane from sonobuoys. Human judgment plays final role determining importance of data

ny accuracy to the firepower of these planes and ships. It carries a miniature sonar system so it can home on a fleeing submarine and follow it through the wildest evasive maneuvers. If the torpedo strikes and misses, it automatically turns and strikes again!

Other new weapons are still in the planning stage or are being developed in secrecy. These include antisubmarine mines that would release homing torpedoes when triggered by the sound of an approaching sub. The Navy is also experimenting with submerged unmanned listening posts. There may some day be a network of them off our coasts, ready to sound an alarm

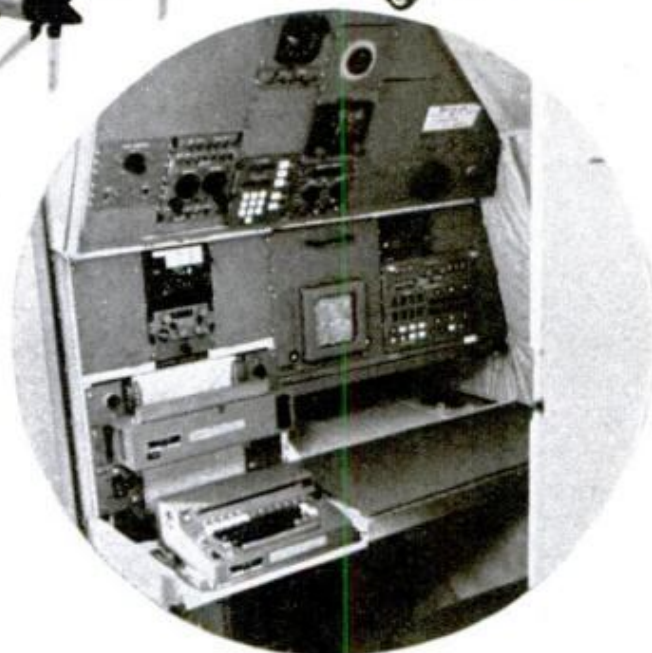

3. COMMUNICATOR is navigator-radio operator. He keeps track of plane's position, relays sub contacts to other aircraft and ships in the vicinity

ashore if any enemy sub approaches.

Undersea warfare could get the same kind of emphasis in the 1970s that was given to missile warfare in the decade now ending. Our own submarines—the only craft that can take on an enemy sub in its own element—may be entering a new stage of development.

Congress has voted funds for two ex-

SURFACE DETECTION AND ATTACK

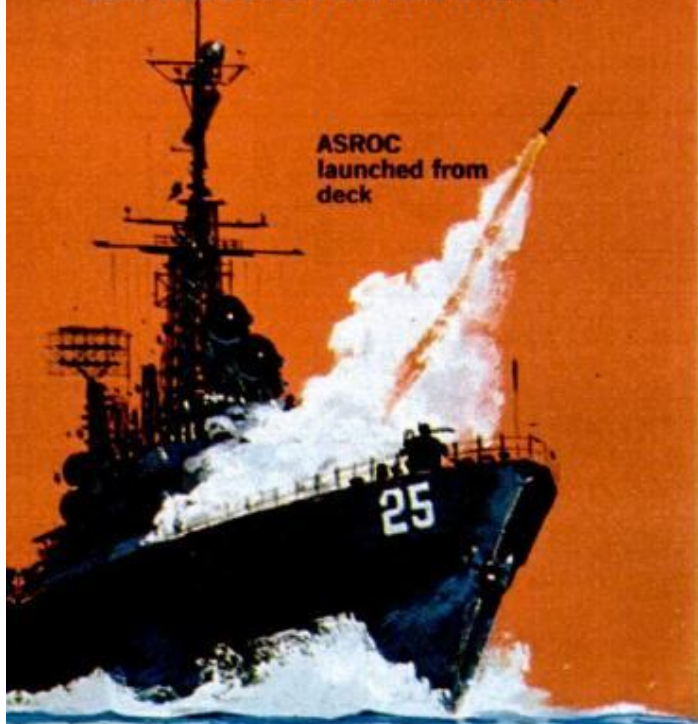

ASROC
launched from
deck



Sonar dome

Torpedo
homes on
target

LIMITED-AREA SWEEP



Copter
releases
torpedo

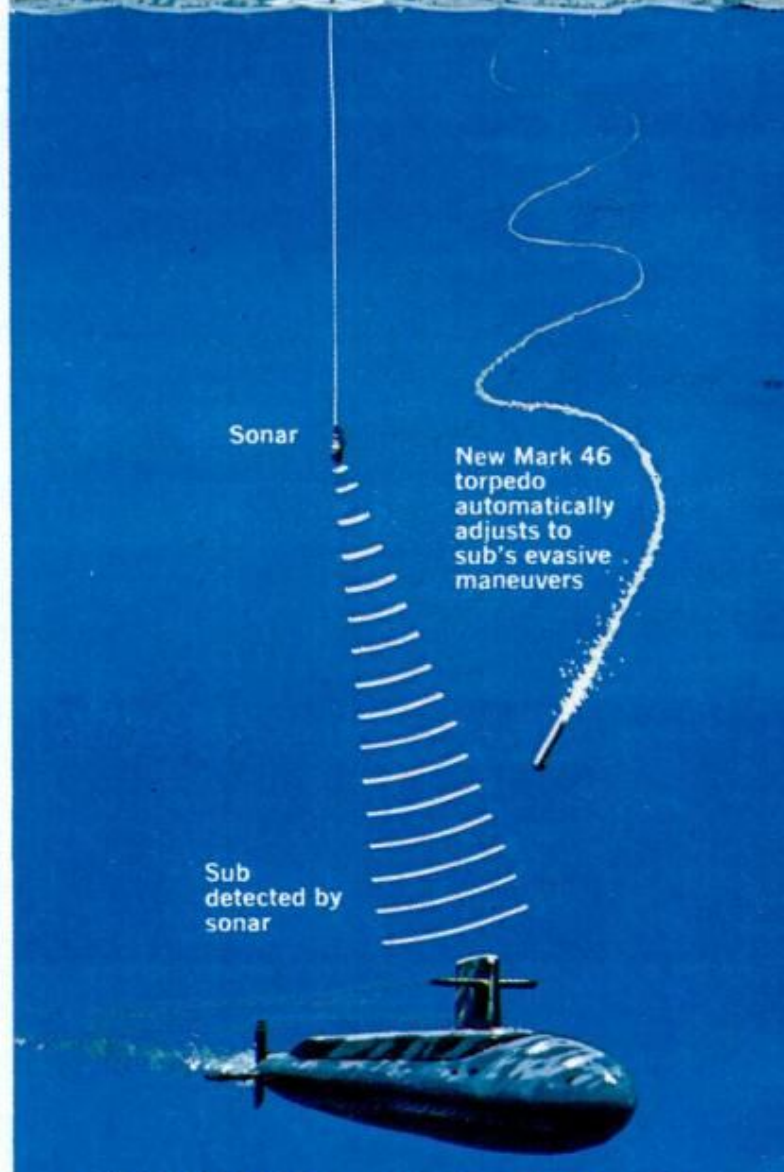

Sonar

Sub
detected by
sonar

New Mark 46
torpedo
automatically
adjusts to
sub's evasive
maneuvers

A DESTROYER'S SONAR DETECTION SYSTEM is still the most sophisticated and far-ranging. More powerful transmitters have resulted in radical changes in hull design. ASROC gives torpedo a rocket boost of several miles. Rocket drops away; parachute lowers torpedo and it homes on target.

SH3 HELICOPTERS (carrier-based) carry full-fledged sonar transducers that can send sonic waves and listen for echoes reflected from hull. Copters put full sonar into a sub chase at 180 mph and make possible constant tracking of a maneuvering target. SH3 can launch depth charges or torpedoes or relay fix to aircraft closer to target.

LARGE-AREA PATROL AND SURVEILLANCE



NAVY'S P3C PATROL PLANE gets quick fix on target by combining direction-finding sonobuoys with on-board computer. To detect an enemy lying silent and deep, P3C drops depth charge. Explosion echoing off hull is transmitted by hydrophones. When sub is under way, they pick up propeller noise.

UNDERWATER DETECTION AND ATTACK

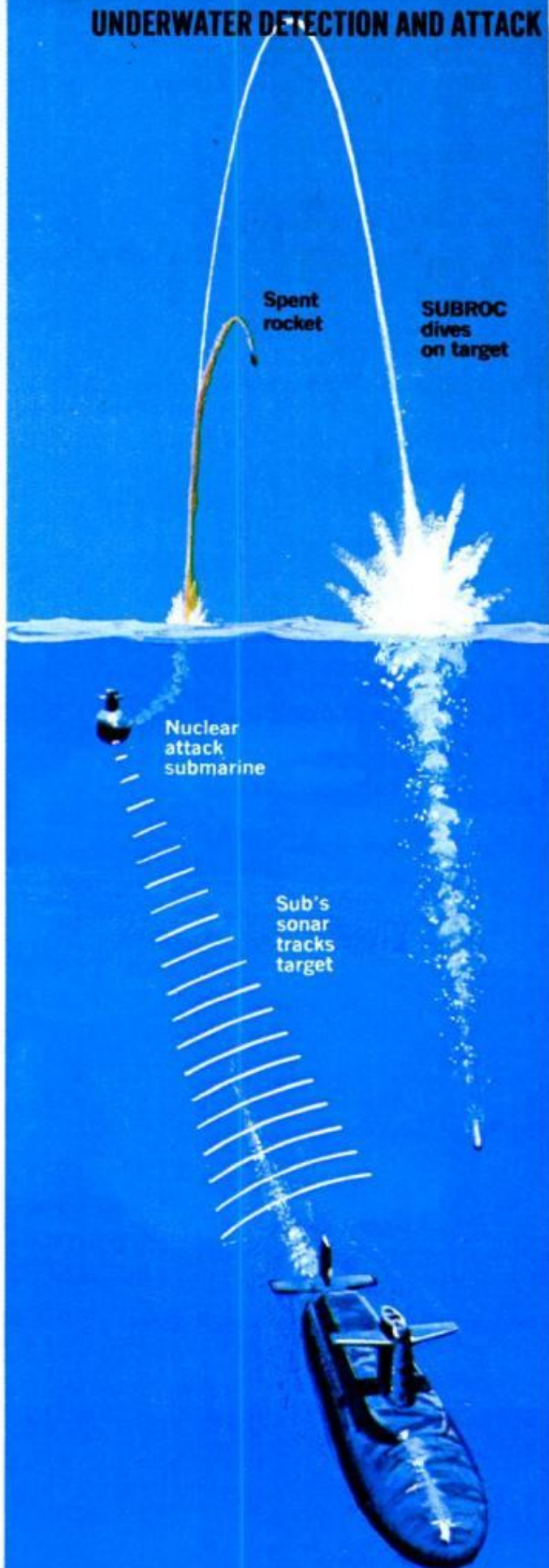

NUCLEAR ATTACK SUBMARINES are armed with SUBROC rocket-torpedo, a 4000-pound vehicle that surfaces as a rocket. Like ASROC, the rocket drops away in trajectory and the bomb dives on target. Attack sub pursues enemy (foreground) with passive sonar rather than with a sonar signal that would disclose its presence.

Illustration by Ed Valigursky

perimental new models. One would be designed to attain speeds now unheard of in underwater vehicles. The other would test a new nuclear-electric propulsion system that would make "nukes" even quieter than those we have now, which use a reactor to generate steam for turbine engines.

The submarine strength of the U.S. fleet is already formidable. Our 41 nuclear-powered Polaris subs can cruise submerged for 90 days at a time, ready in case of all-out war to launch missiles against inland targets up to 2500 miles away. We have 33 nuclear attack submarines, carrying torpedoes effective against subs and surface ships, with 36 more under construction or soon to have keels laid. Older diesel subs round out an American fleet that stands at about 150.

The Soviet Union has the largest submarine fleet in the world, currently estimated at between 350 and 400 vessels. Until recently this numerical superiority caused no special concern. Nearly all the Russian subs were slow, noisy diesel-electric jobs, obliged to surface frequently and limited in range by the

RUBBER SONAR DOMES on destroyer *Brownson* improve transmission of signal and the return of echo

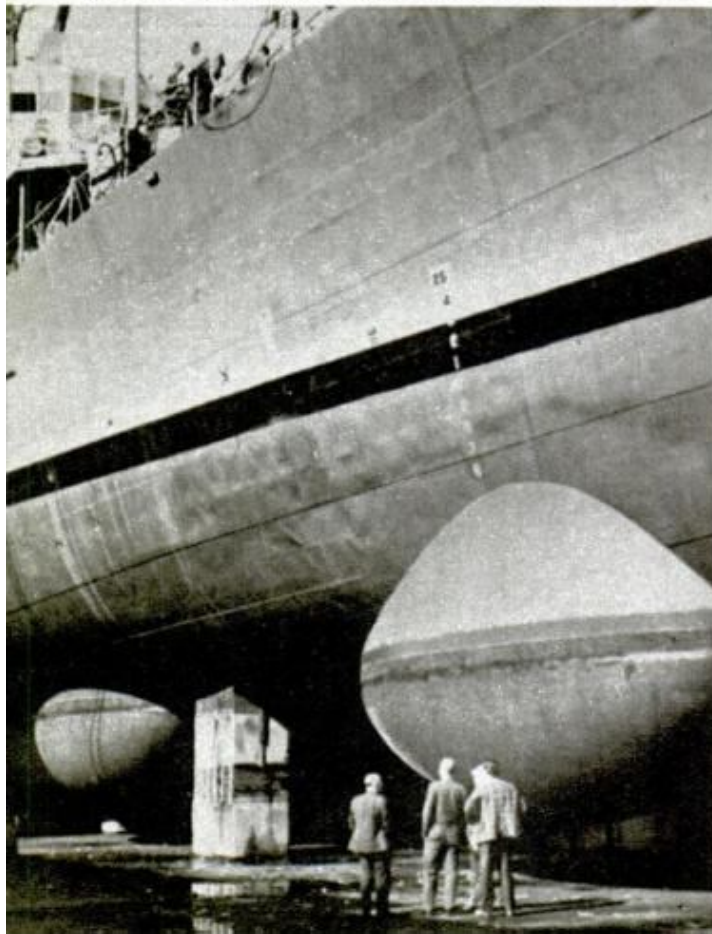

necessity to refuel. As recently as 1961 the Russians were reported to have only four nuclear subs.

This year, intelligence sources are saying the Russians have at least 50 nuclear subs and are building more. One breakdown lists 12 attack types, 25 equipped with short-range cruise missiles and 13 that can launch long-range ballistic missiles.

What the Soviet strategists have in mind is not clear. But one thing is known. Their newer nuclear subs are faster and quieter—and therefore harder to shadow—than their early models, and they're showing up in waters far from home. A threat of war would create an urgent need to monitor the hostile submarines in strategic areas, both to protect our own naval forces and to head off a strike by missile launchers prowling submerged off our coasts. The seas that cover four-fifths of the globe would be the no-man's-land of this tense confrontation.

Where do we stand? Weapons for detecting and destroying submarines have come a long way since World War I. Yet the basic technique has not changed. Submerged hydrophones can pick up the sound emitted by a submarine. Or a powerful transmitter can send sonic waves through the water while hydrophones listen for any echo produced when the sound is reflected from a submerged hull. The time lapse is used to calculate the distance of the target.

Extending the range and accuracy of sonar systems has kept naval scientists occupied for half a century. There is no sign of a breakthrough that could let man "see" through the dense curtain of the ocean the way radar can spot distant objects in the sky. (Electromagnetic radiation peters out quickly in water, which not only rules out undersea radar but creates a difficult problem in communicating with a submarine running submerged.)

A destroyer is doing well to pick up a submarine on sonar within 15 or 20 miles—although the new "bottom

bounce" technique promises some significant gains.

Because underwater acoustics are tricky, getting an accurate fix on a fast-moving submerged target can be as much an art as a science. The temperature of water, for instance, affects the behavior of sound waves. Thermal layers can bend and scatter sonar signals and throw a big error into calculations. And the more sensitive the hydrophone array, the more difficult it becomes to distinguish the "signature" of a submarine from the jumble of sound and echoes produced by the abundant natural life in the ocean. Many a sonar operator has reported a sub contact that turned out to be a whale!

Swift analysis of sonar signals is a critical factor if the quarry is a nuclear submarine. The enemy sub—if it is anything like the current U.S. nuclear subs—can run an evasive course at 30 to 40 knots and plunge as deep as 2000 feet to hide under thermal layers. Time would be precious in pinpointing the target for a kill. That's why the Navy's new P3C patrol plane is setting the pace for the coming era in antisubmarine warfare—combining the latest in listening devices and weapons with the split-second calculating ability of a computer.

If the P3C looks familiar, you're right—its airframe is the Lockheed Electra, already a civilian workhorse and a Navy veteran in the A and B versions of the P3 Orion. What makes the P3C so different is the \$5 million layout of electronics inside. Its heart is a Univac digital computer—no bigger than a cigarette machine.

With four Allison T-56 turboprop engines providing a top speed of more than 400 knots, the P3C sets out on patrols over what might look like a harmless, empty sea. To find out what's happening below, the crew releases four-foot cylinders called sonobuoys.

A hydrophone extending below each sonobuoy listens for the telltale churning of a submarine propeller. What it hears is relayed by radio to the aircraft. As many as 30 sonobuoys might



NAVY'S NEW MK 46, a solid-rocket-propellant torpedo, is carried by a drone helicopter in test at sea

be scattered in a single search operation. Taking the signals from each one and comparing them to figure the location, course and speed of a target calls for feats of memory and calculation that no human being could perform in a reasonable time. That's where Univac comes in.

The P3C's tactical coordinator, or TACCO—one of 10 crewmen aboard—can get immediate answers to these tough math problems at the flick of a switch at the computer console. The computer keeps track of the relative position of the sonobuoys and computes ranges and fixes of targets from their transmissions. It even serves as an electronic "bombsight," computing the best point to drop a depth bomb or torpedo to intercept a moving target.

In addition, the computer handles navigation chores to give an exact reading of the plane's position in case a search has to be coordinated with other naval units. It analyzes radar data if the plane catches a sub on the surface. And it codes and decodes messages.

What if an enemy sub commander

(Please turn to page 224)

Look What's

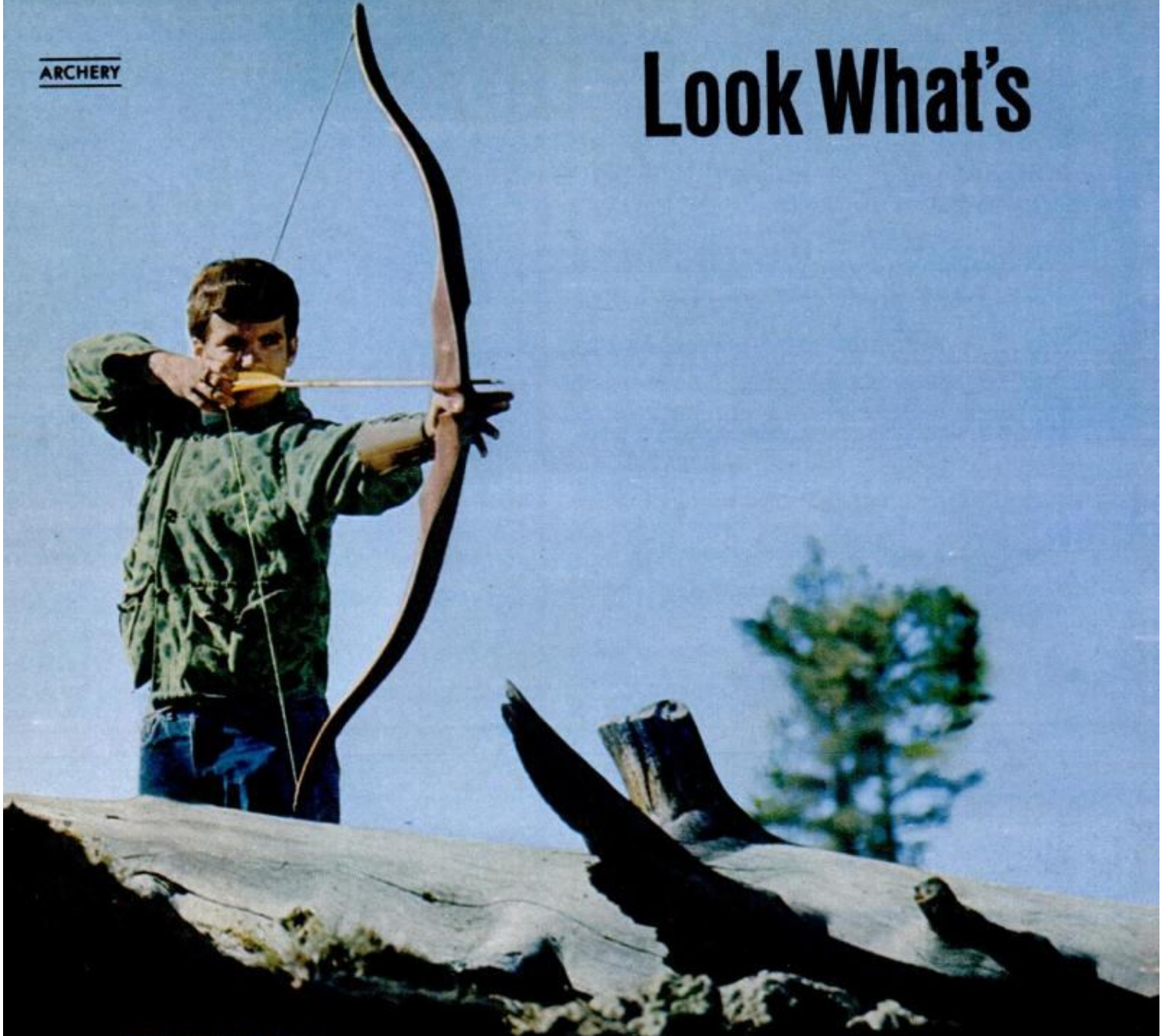

Field feathers are most common type



Flu-flu feathers are for short-range speed



Plastic vanes are sometimes used instead of feathers



Large feathers are for short range and high speed

Happened to Bows and Arrows

Archery's exciting new look is the result of computer design and the use of new materials. Now you can be an expert archer in no time flat

By NORMAN CARLISLE

A SHOUT WENT UP from spectators at the U.S. Archery Indoor Open in Las Vegas last year. Bob Bitner, using a strange-looking bow, had just shot the first perfect 300 in any major competition—300 arrows in succession into the white center of the target.

A short while later, another archer, Lester Gervais, duplicated the feat. Others came close, one with 298.

What happened? A sudden spurt in the skill of the archers? No. It's doubtful that the record breakers, all veteran archers, were any better than they'd been in previous contests. They were good all right, superbly so, but not *that* good. As they themselves

agreed, their achievement was made possible by radical new bows.

The new super bows have bowed in, with an arsenal of accessories, to give champion archers new power and most anyone skills that would have made Robin Hood bug-eyed.

What's so different about the new bows? Basically, it's engineered shape and new materials. Modern bows have the shape they do, not because it makes 'em look nice, but because it gives them balance and power.

Individual bowmakers add a curve here, a change of proportion there, as they incorporate a new metal, plastic or wood. However, for all the vari-

NEW DESIGNS for bows used in tournaments and for hunting are shown below. The first three and the fifth (from left to right) are competition bows made of laminated woods covered with a layer of fiberglass for strength. The fourth bow is used for big-game hunting

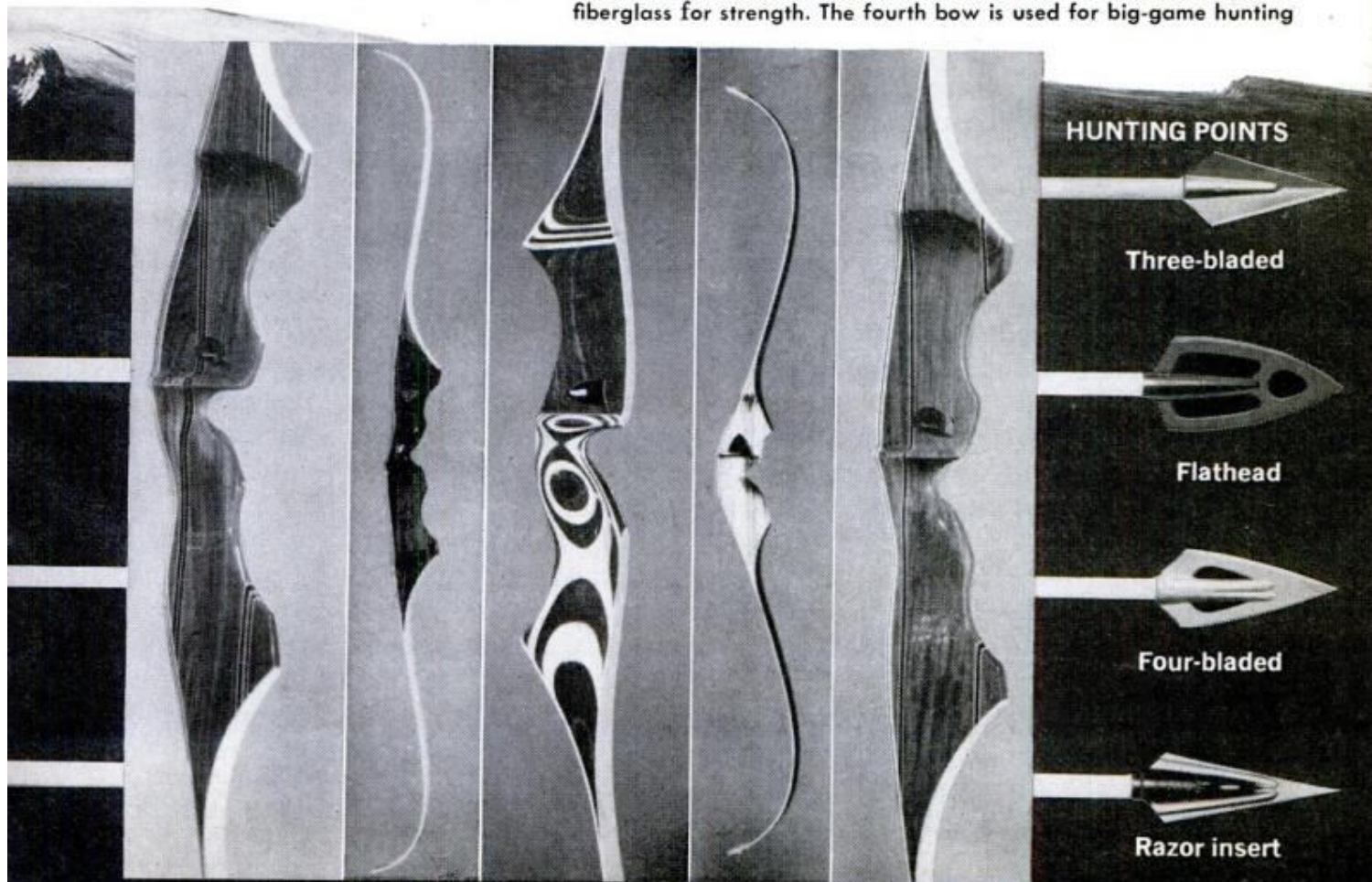

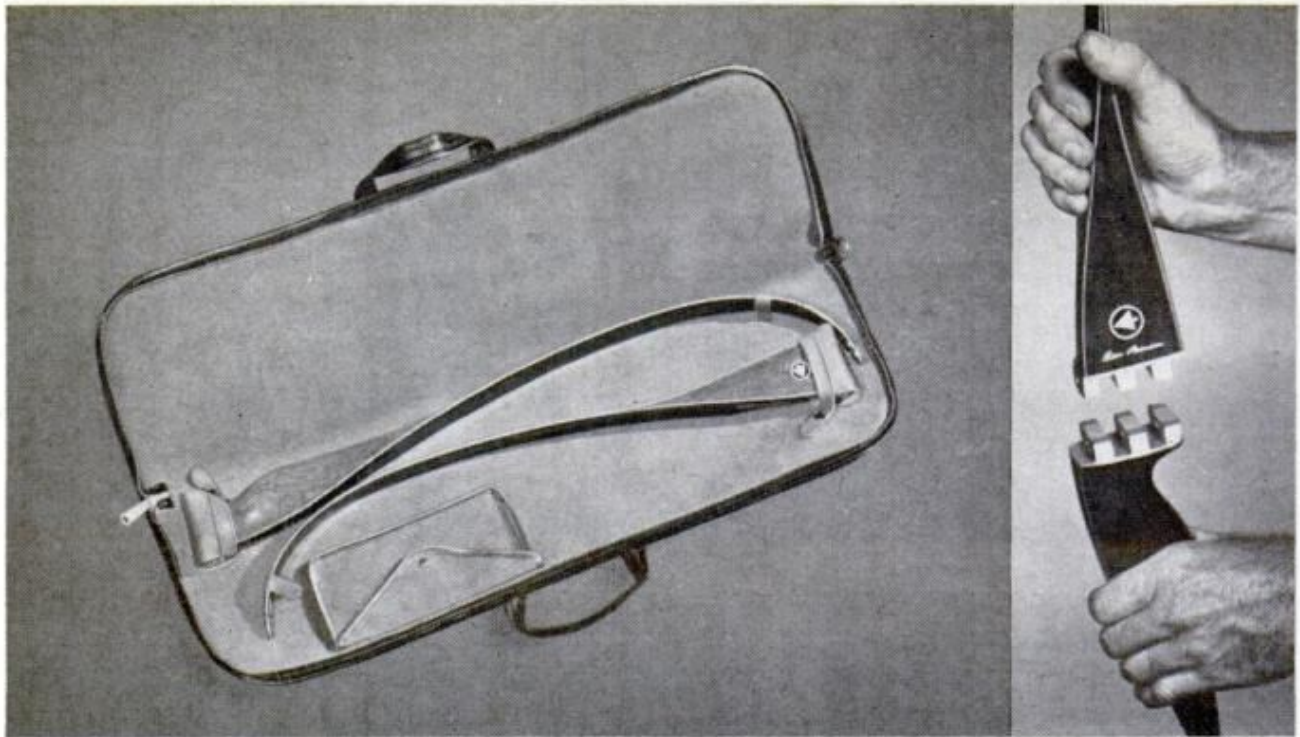

BOWS are so designed that they can be "broken down" (right) and made to fit into an easy-to-carry case

ations, modern bows almost all conform to a pattern of flowing curves and protuberances that scientists and mathematicians have laid out as the soundest design.

While bows in the modern shape can be made of wood alone, their real power and strength come from the use of a combination of wood and other materials. The key material in most of the new super bows is fiberglass, used in the limbs. Lighter and far stronger than wood, its resiliency makes it ideal stuff for packing a wallop.

Bowmakers are experimenting with other materials. One new bow uses thin strips of steel. The bows used by the champs who shot the perfect scores were made of die-cast aluminum.

But wood is still the basic material for modern bows, if only because of its appearance. Bowmakers use some exotic woods, including benge, zebra wood, sandalwood, rosewood, freijo, bubinga and imbuya. Since many of these rare woods tend to be heavy, and a modern bow weighs only four or five pounds, considerable ingenuity is called for in keeping the bow light enough. One trick is lamination of thin layers of different woods.

Another development is chemical

treatment of wood which produces a virtually new substance. Wood is impregnated with a plastic monomer—increasing its strength by 500 percent. A thin layer has little weight.

One of the biggest changes in bows is the method of sighting. Recently the bow and arrow wizards have come up with attachable sights that make any archer eagle-eyed. Some are pretty simple—little more than a metal ring with cross lines—selling for as little as \$2. Others employ complicated optical equipment and cost up to \$97.50.

When an arrow leaves a bow the kickback from its departure causes a recoil and a torque movement in the bow. No matter how hard the archer fights against this force, it affects the stability of the bow and the accuracy of the arrow. A skilled archer can overcome the vibration and "wobble" but it takes a lot of experience.

The archery engineers have now automated the stabilizing process, with a number of different systems of weights and balances that take up the vibration and torque. Many stabilizers take the form of metal arms which screw into the bow. One gives the bowman a choice of two carefully machined arms, one 14 inches long, the

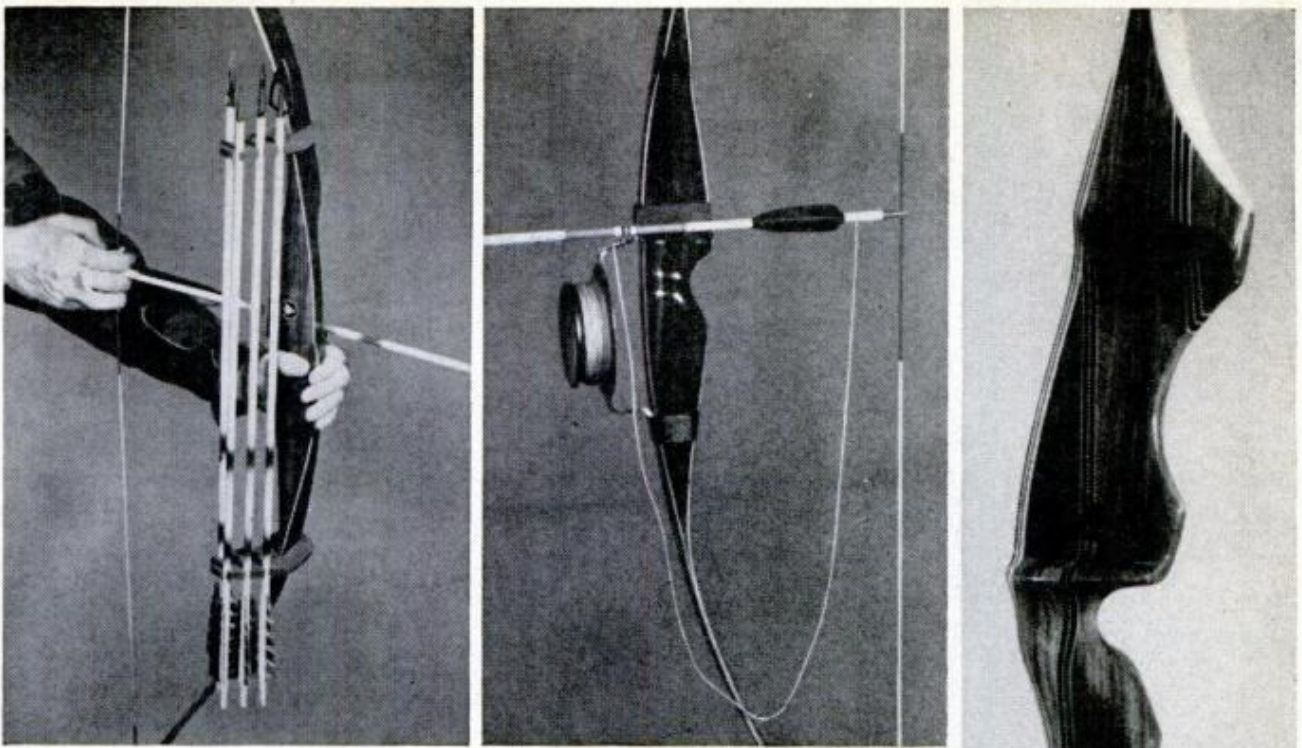

other 22 inches. Weighted metal heads screw onto the ends of the arms. The archer can use one arm, or both, with or without the weights. Experimentation gives him the stability best suited to his particular style of shooting.

Another stabilizer takes the form of a tuning fork. Weights are moved along the two tuning-fork-like arms to any point, where clamps then secure them. An archer is thus given a large number of possible adjustments, with a difference of an eighth of an inch in the location of a weight making a difference in the bow's stability.

Still another innovation in stabilizers turns to mercury for its effectiveness. It consists of a five-ounce container of mercury fastened to the tip of a screw-in aluminum rod. When you release an arrow, the mercury "explodes" in the container, absorbing energy that otherwise goes into torque and vibration.

It's not just the bow and the equipment that goes on it that's been changed by archery's artful engineers. The arrow, too, has undergone scientific remodeling to give it a performance that would have smacked of magic to an old-time fletcher. The new arrows are stronger and faster and, most important, truer than anything

HUNTING BOW (left) has an attachable arrow holder for easy carrying in the woods

FISHING BOW (above) is newest entry. A line extends from arrow to reel

WOBBLE DAMPENER (at right) is a long rod with a mercury-filled chamber at the end. It stabilizes bow

from the past. Aluminum and fiberglass are most widely used.

Modern aluminum arrows come in 22 different weights, ranging from small, slender arrows made of tubing with walls 13/1000ths of an inch thick to walls of 20/100ths of an inch thick for 75-pound, and upward, bows. They're made of powerful alloys with strengths of up to 100,000 pounds per square inch. Tolerances are so tight that weight varies from specification by less than 1/2000th of an ounce, and straightness by no more than 1/10,000th of an inch.

Have archery engineers taken the challenge out of archery by improvements that make practically anybody a good archer? No, they maintain. There's still plenty of room for skill. ★★★



Big Ambulance For Big Birds

By NORMAN SKLAREWITZ

Photos by James Pickerell

IF A QUIET IRISHMAN from California has his way, there will soon be a second building next to the fire station at every major airport. It will house a strange-looking array of heavy-duty equipment designed to recover, if at all possible, damaged planes.

The man is Albert Kelly, a World War II combat pilot and an expert in handling every kind of heavy load, from bridges to houses. Over the past six years, he's designed his aircraft retrieval gear and organized Air International Recovery, an outfit that's set up to lease Kelly's recovery "package" to such likely users as civilian and military airports.

When an airplane goes in, the tendency has always been to call in a junk dealer. But unless a plane has hit the side of a mountain, it's possible to repair it and put it back in the sky again.

The trick is to get it in from the accident site. That's where Al Kelly's A.I.R. comes in.

After studying his system, one major aircraft manufacturer called it the "fastest method known for aircraft recovery." Another credited him with being the "best method for retrieving damaged aircraft in existence."

At least one, and possibly two, major U.S. airports are expected to have A.I.R. recovery packages in place by the end of 1969.

When a jetliner makes a belly landing or plows off the end of a runway, it's a nightmare, even if no one is injured. An airport makes no friends by forcing other inbound planes to divert to another field because of a runway blocked with a disabled plane. One expert estimates the cost can go up to \$175,000 an hour when all expenses of

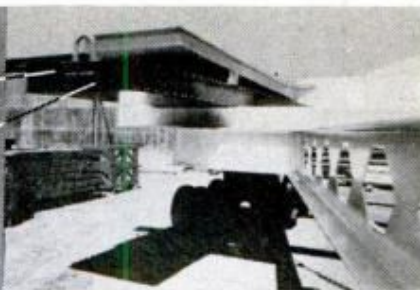
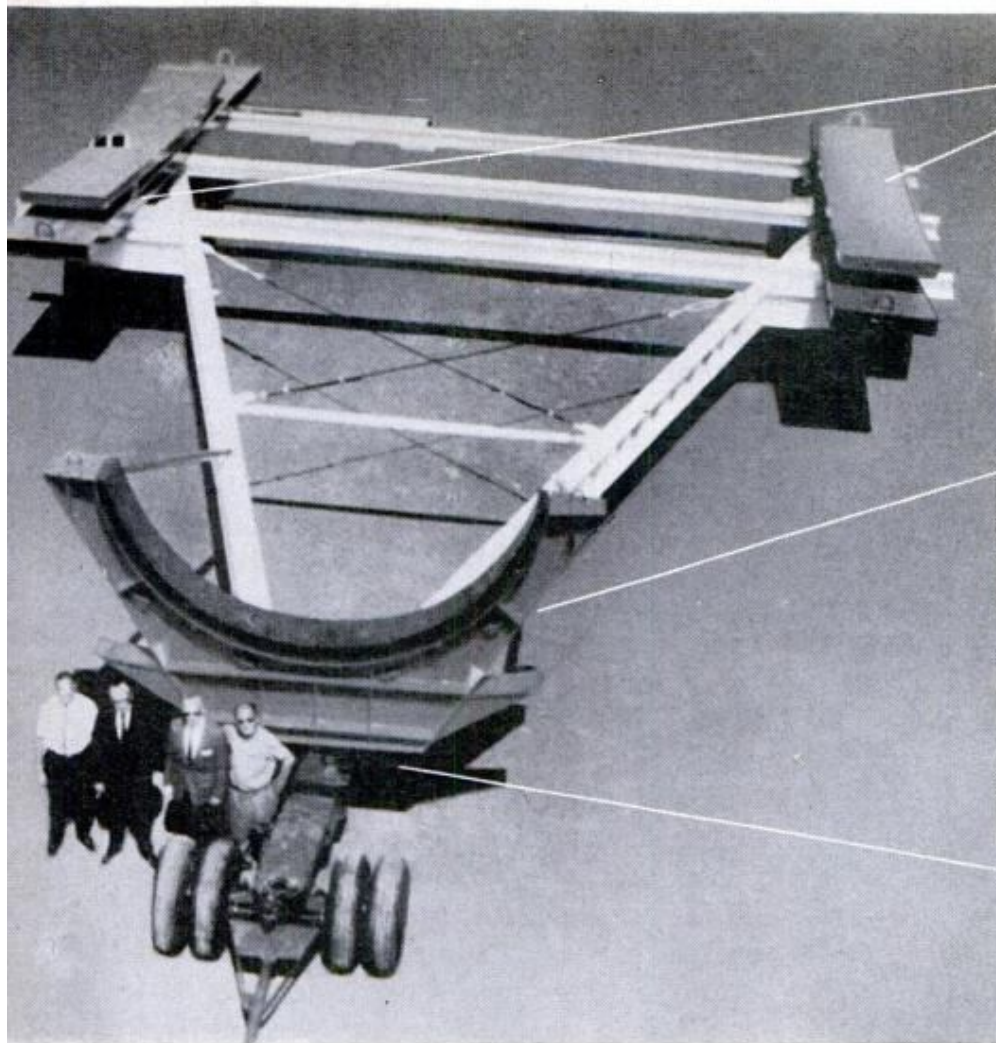

PICKUP POINT contoured to wing

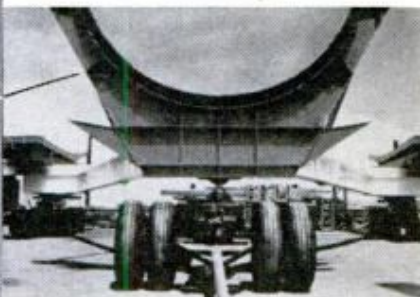

NOSE YOKE fits under fuselage

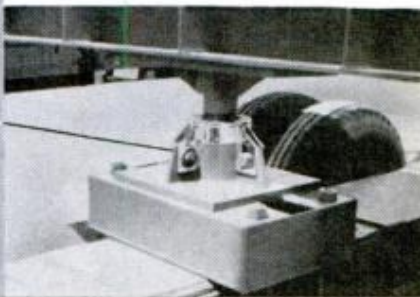

BALL PIVOT JOINTS allow ordinary airport tow motor to haul the big frame in any direction

MAIN COMPONENT of A.I.R. package system is 25-ton "A" frame that cradles a crippled plane at three points for safe removal to repair area. The 40-tire monster can carry any plane in service today

such diversions are considered. Generally, it takes at least 12 hours to move a damaged plane off a runway.

Even if the plane isn't too badly beat up by its emergency landing, efforts by ordinary crews to move it generally cause more damage than the original accident. By the time they've dragged even a slightly damaged plane out of the mud and back to a maintenance base, there's likely to be added, major structural damage.

An airline engineer charges that use of "outmoded and archaic" methods of recovery can cause both an "extreme amount of additional damage to the plane" and also be dangerous to crews attempting retrieval.

The heart of Kelly's system is a pair of patented steel lifting beams and a nose yoke. These permit a downed plane to be lifted by jacks or by ordi-

nary heavy-duty cranes or derricks—out of water, mud, off concrete or sand—and be transferred to whatever type of carrier the terrain requires.

As a flier, Kelly realized that a plane can be safely moved if it remains in the same horizontal plane. Any twisting immediately introduces stresses that can rack the aircraft out of alignment and make repairs uneconomical. The A.I.R. system reduces the stress to just three points.

Under-wing support is provided by two pivotal beams, each nine feet long and four feet wide. These are shaped to fit the general contour of the underside of a commercial transport wing, but can be easily adapted to fit larger or heavier planes, like bombers.

As the name indicates, these two pivotal beams ride on an offcenter pivot to permit a necessary degree of give. This



RECOVERY OF DC-8 that missed San Francisco runway, November 1968, proved value of A.I.R.'s system



LIFTING BEAMS under the wings are in place and barge-mounted cranes start to lift *Shiga* from water



NOSE HARNESS and lifting beams carry full weight of plane as it is swung by cranes to waiting barge



SAFE ON BARGE, DC-8 was later moved on landing gear to hangar. Job made A.I.R. known worldwide

prevents crushing strains during movement. Heavy steel springs at either end of the pivotal beams absorb whatever small up and down movement occurs during moving.

The beams are positioned 15 to 19 feet from the aircraft's center line, between the first inboard engine's nacelle and the fuselage. The wing load is distributed on the front and rear-wing spars.

The pivotal beams, in turn, ride on structural-steel lifting beams, 4 feet wide and 30 feet long. When a damaged plane is ready to be moved out of trouble, jacks or lifting cables are attached to these supporting beams.

A harness which slips under the plane's belly is carried around the nose, up and over the aircraft to a lifting cable. Depending on the type of terrain or the location of the plane, hydraulic jacks might be used. If the plane is to be lifted, the job is done by two 35-ton cranes for each wing and one 25-ton crane for the forward fuselage.

"With a trained supervisor on the job, any crew of ordinary construction company steel riggers and crane operators can handle an aircraft recovery job," says Kelly.

Just getting a damaged plane a few feet off the ground isn't the end of the airline's problems. The plane still has to be moved. That's when Kelly rolls out his 125-ton transporter, a 40-tire monster that can carry any plane in service today. Its chassis is a 25-ton structural steel "A" frame that takes a pair of the pivotal-lifting beams on either side. Up front is a ball-pivoted nose yoke.

The transporter is maneuvered under the plane which can then be let down onto the "A" frame. A yoke goes over the plane's nose to keep it from dancing up and down as the aircraft trundles along. The wounded bird can then be transported overland. An ordinary airport tow motor or truck can pull the transporter with no trouble.

The dress rehearsal for A. I. R. came on Nov. 22, 1968. Around 10:00 a.m.,

Al got an urgent call: a Japan Air Lines DC-8 Superjet had gone down in San Francisco Bay, three miles short of the International Airport. All 107 passengers and crew were safe and unhurt. The plane rested on the shallow bay's mudflats, virtually intact.

JAL officials made some quick decisions: They'd try to get their jetliner out of the saltwater before corrosion ate the guts out of the \$8.3 million plane. Bigge Drayage Co. was hired to be primary recovery contractor. Bigge immediately brought in Al Kelly and his A.I.R. system.

Recovery operations had to wait, however, until investigators from the National Transportation Safety Board studied the plane in an effort to determine cause of the short landing. Barges and floating cranes were brought in from their bases around Oakland and San Francisco. Everything was ready when finally, at 2:00 p.m. Nov. 23, the government experts released the *Shiga* for the recovery try.

Some 14,000 pounds of fuel was pumped out of the plane. Mail and baggage were ordered left aboard, even though they added to the weight that would eventually have to be lifted.

Steel riggers aided by scuba divers began the precise job of positioning Kelly's pivotal beams under the *Shiga's* wings. In order to get enough room to slip the beams, high-pressure air hoses had to be brought in to blast out the underwater mud.

Work had to stop at times as tides made operations dangerous. Floodlights permitted the cable rigging to continue at night. Al slipped away to get a few hours sleep. "Sunday's going to be a long day," he told a friend. It was.

The defueling turned out to have been incomplete. Some of the fuel tanks that were supposed to have been pumped dry were still full as a result of stuck valves. This meant the plane's center of gravity was critically back from where Kelly's calculations had placed it. The effect of the water-

SEPTEMBER 1969

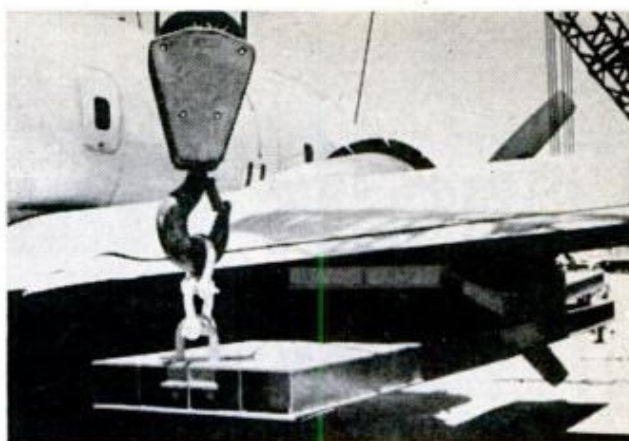

LIFTING BEAMS, with pivotal beams under wings, are jacked into place, jacks removed, cables attached



SUPPORTED BY FIVE CRANES, KC-97 dangles as transporter (with nose yoke open) is slid under plane

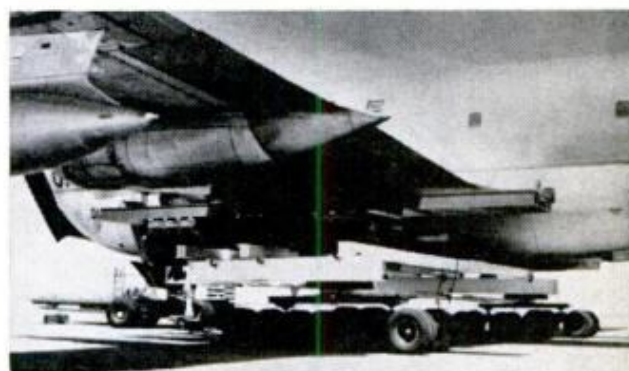

RESTING on 25-ton transporter, plane awaits removal. A.I.R. has raised planes in less than two hours

logged luggage and mail sacks, too, had to be estimated in positioning lifting cables.

The rigging went on all morning, past noon. A little after 4:00 p.m. the cables were in place; the tide was just right.

Bob Korst, Bigge's project director, stepped out in the clear at the forward end of a barge. It was time to lift. The small talk stopped but through the minds of the watching engineers and

(Please turn to page 208)

127

The ABCs of Chassis Frames and Suspensions

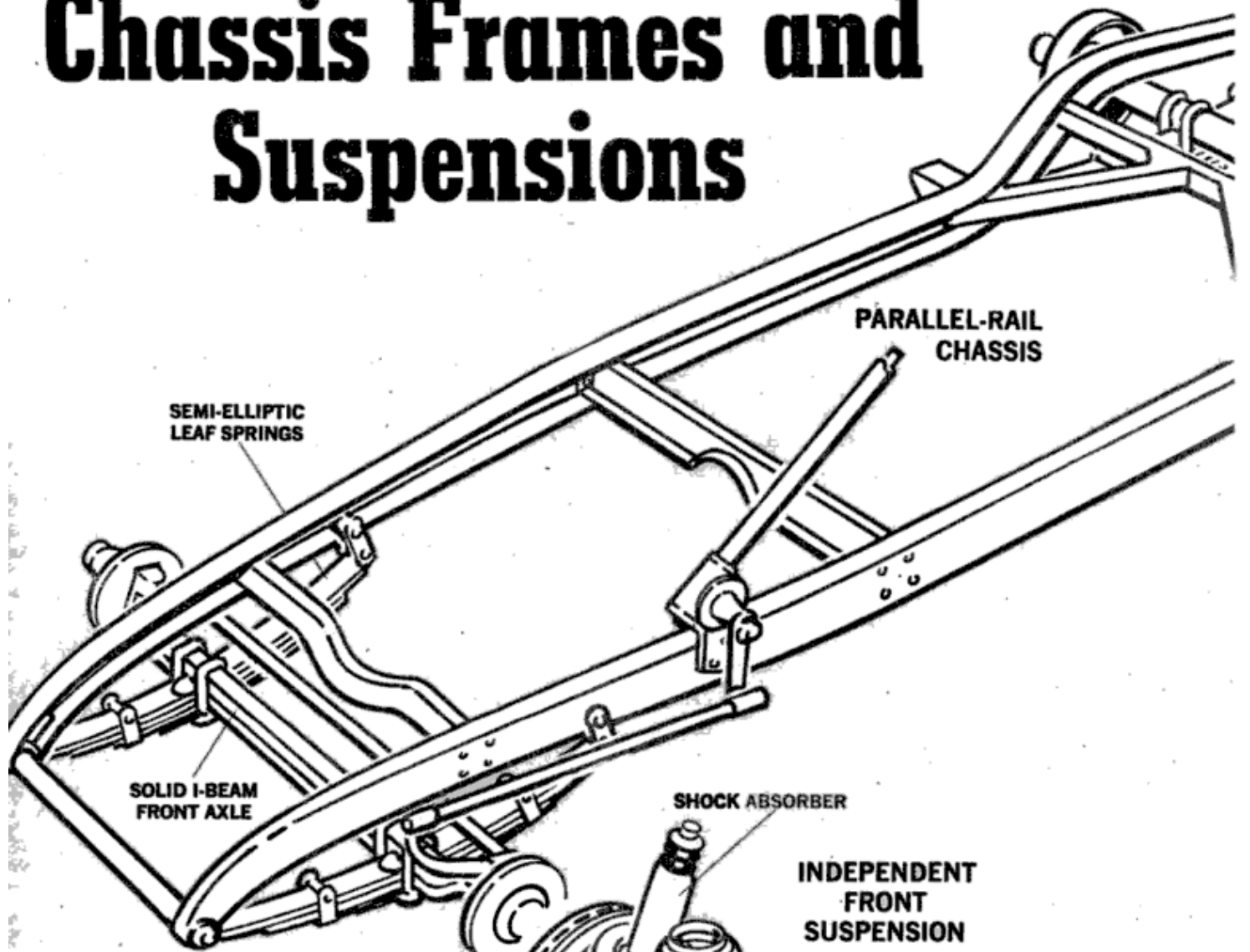

By **ROBERT W. TEMPLE**
Illustrations by the Author

THE SIMPLE soapbox racer uses a principle that's been around for centuries—two wheels on an axle clamped to a platform. In comparison, the classic parallel-rail chassis frame with axles suspended by semi-elliptic leaf springs, shown in Fig. 1, looks sophisticated. But it, too, has been around a long time—a lot longer than the automobile. Even though it was used on horse-drawn carriages it's not obsolete: It's still used on trucks.

The term "rides like a truck" originated in the fact that the unsprung weight of solid beam axles and the interleaf friction of leaf springs results in quite a rough

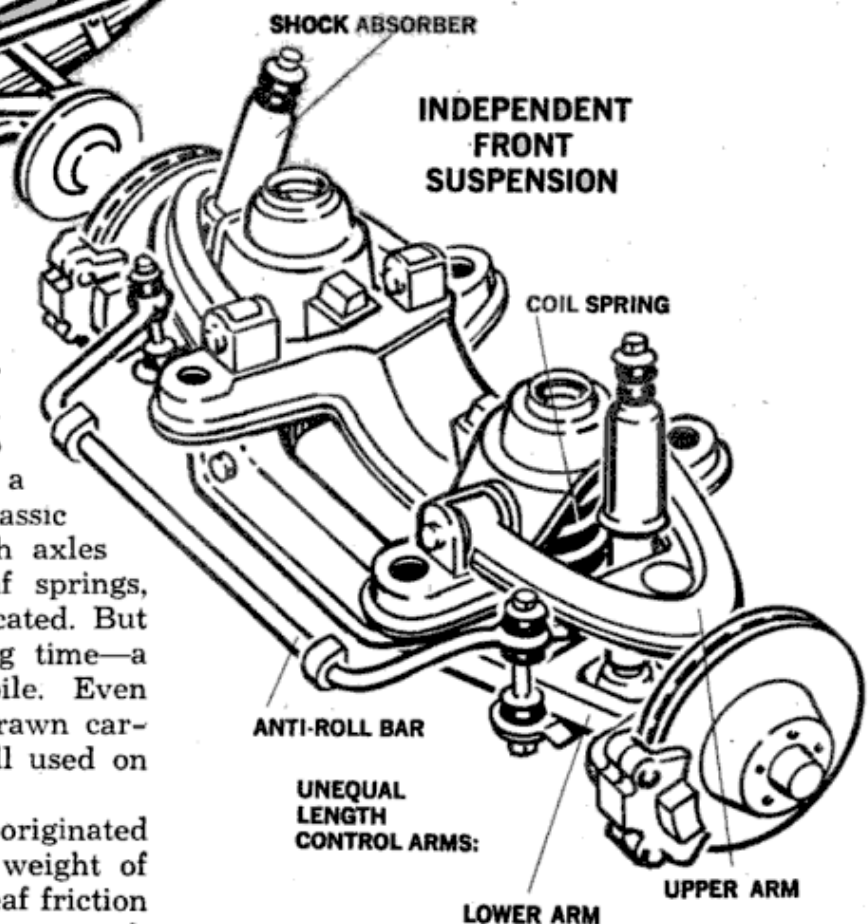

The manner in which four simple wheels are attached to some kind of platform to shape the undercarriage of your automobile has infinite variations and determines how your car rides and handles

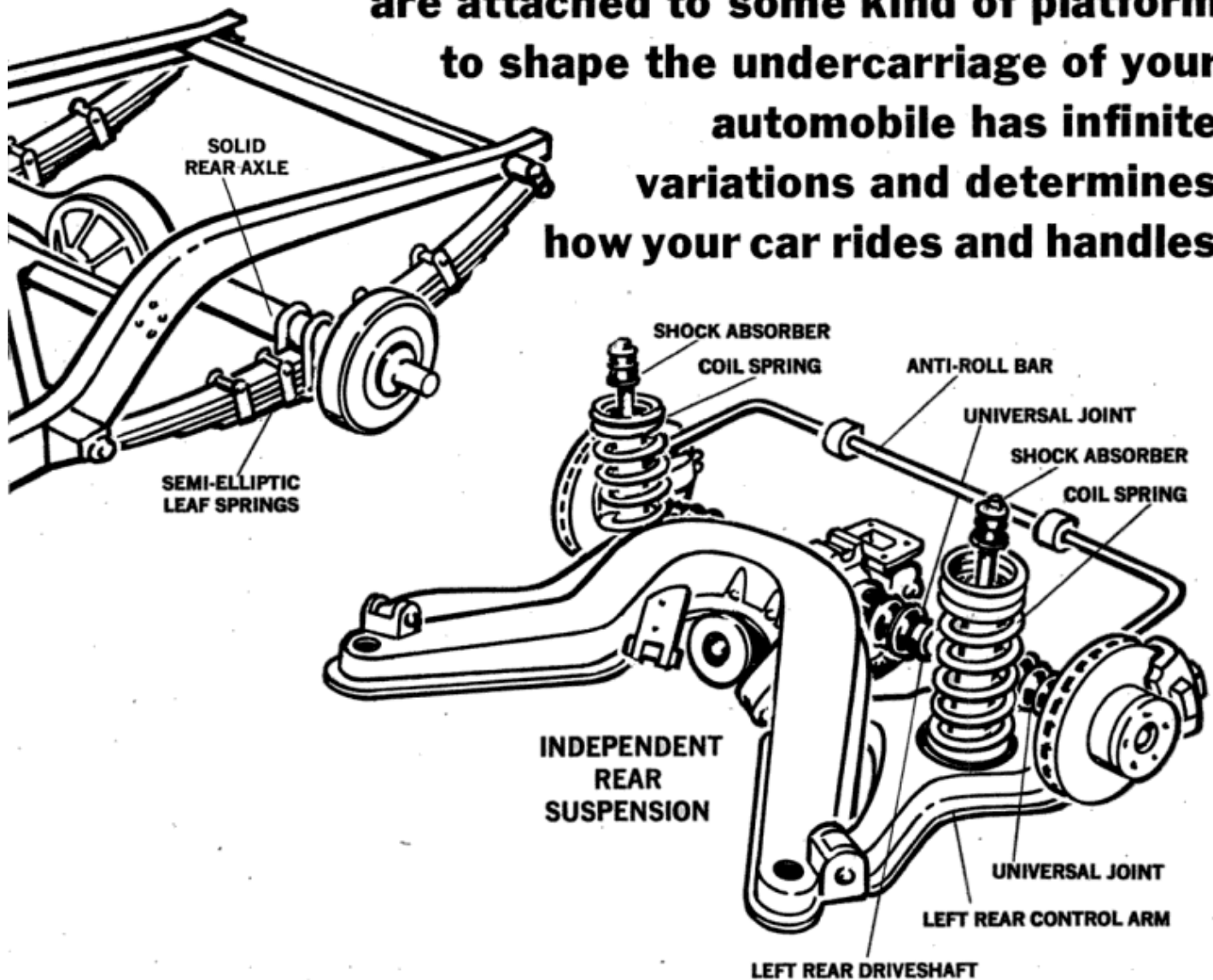

FIG. 1

ride. A good ride, on the other hand, is provided by each wheel having its own, or independent, suspension. A modern front and rear independent suspension, as shown in Fig. 1 does, of course, include other refinements. Anti-roll bars, coil springs, shock absorbers all contribute to improved overall handling and comfort. Before discussing suspensions, however, it's necessary to start first with a chassis frame.

In modern automobile construction, there are several approaches to frame design. Fig. 2A shows a unit-constructed concept, which is just that: The chassis frame and car body are welded into one integral assembly. It's rigid and lighter than the bolted-together type of construction. Other advantages are better

door and window fit and fewer leaks and rattles. Disadvantages are difficult assembly procedures because everything must be attached to the basic box, harsher and noisier ride because isolation of road shock and noise is more difficult, and higher damage repair bills because damage stresses "telegraph" throughout the structure.

Unitary construction, as shown in Fig. 2B, is similar to the unit-constructed version. The principal difference is that of manufacturing convenience. The body structure from the cowl rearward is very similar to unit-constructed types, but the part of the automobile from the cowl forward is built up as a separate assembly, and then either bolted or welded to the body.

FIG. 2A
UNIT
CONSTRUCTION

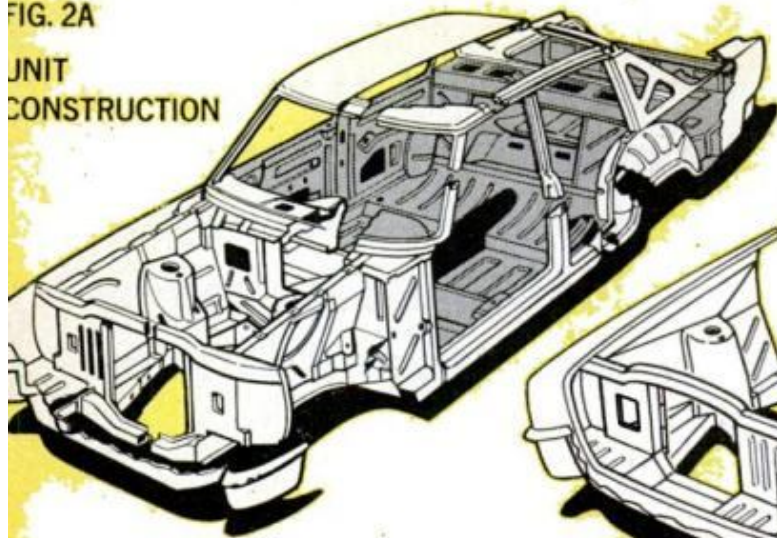

FIG. 2B
UNITARY
CONSTRUCTION

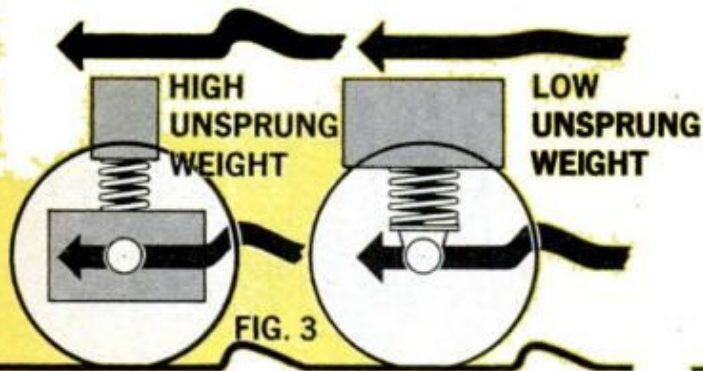
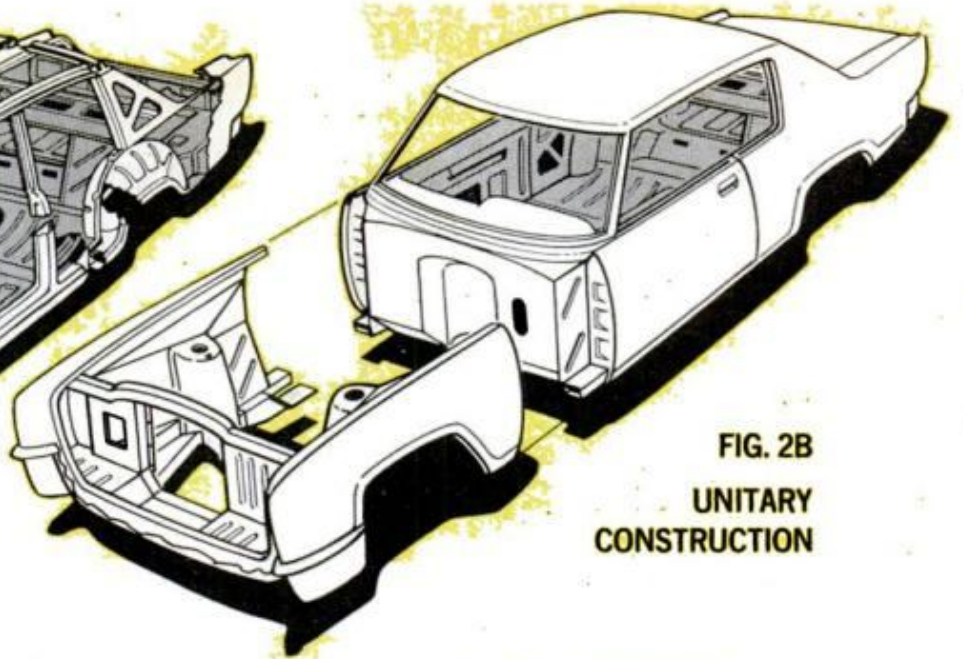

FIG. 3

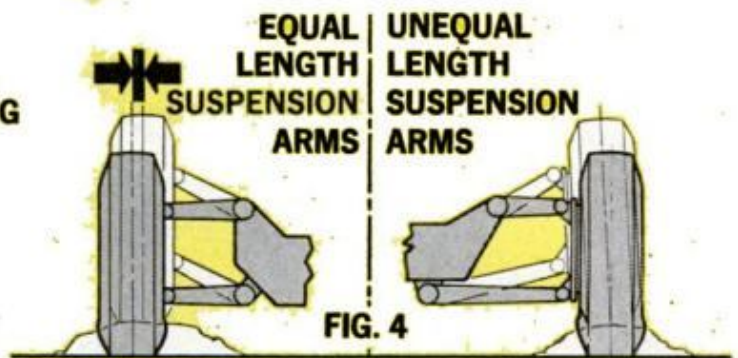
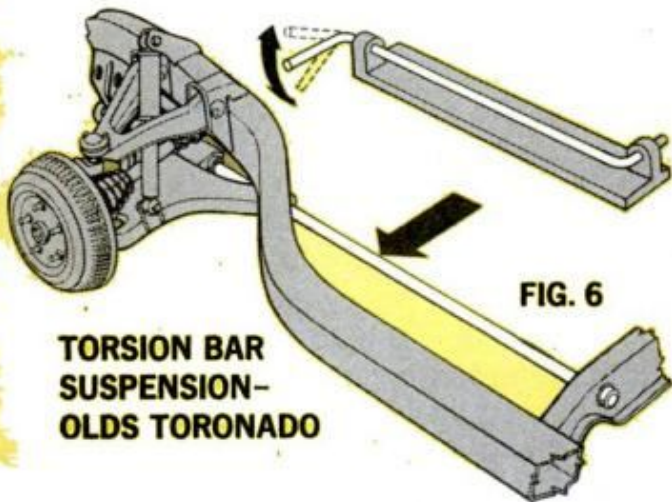
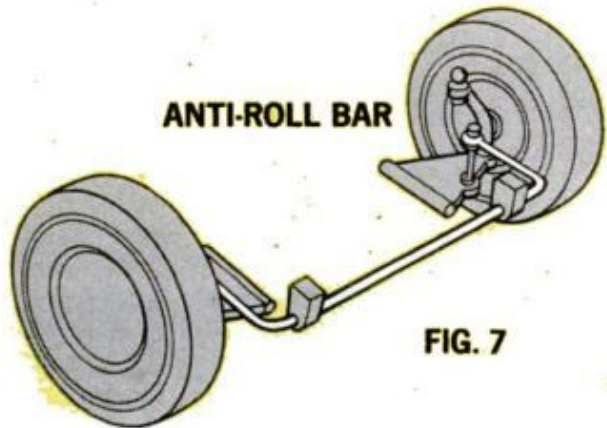

FIG. 4



TORSION BAR
SUSPENSION-
OLDS TORONADO

FIG. 6



ANTI-ROLL BAR

FIG. 7

The conventional method of construction for an automobile is the separate chassis frame with attached body, Fig. 2C. All of the mechanical components are assembled to a chassis frame, and then the body and front-end sheet metal are added. Advantages are ease of assembly, better isolation of road-shock and noise, and easier damage repair. Disadvantages are more weight, less rigidity, and consequently more leaks and rattles in the body.

Some 1969 model cars were the first

with frames designed to dissipate collision energy throughout the structure for reduction of passenger injuries. Among the changes are tapered frame sections, up-swept frame ends and S-shaped frames that dissipate energy into frame deformation, and plates on the frame ends to distribute stress over more of the frontal area. For the 1970 model year, more cars will have these energy-absorbing bends.

The big change in front suspensions began in 1934. The leaf spring and beam axle faded out with the introduction of

FIG. 2C

COMPOSITE
CONSTRUCTION

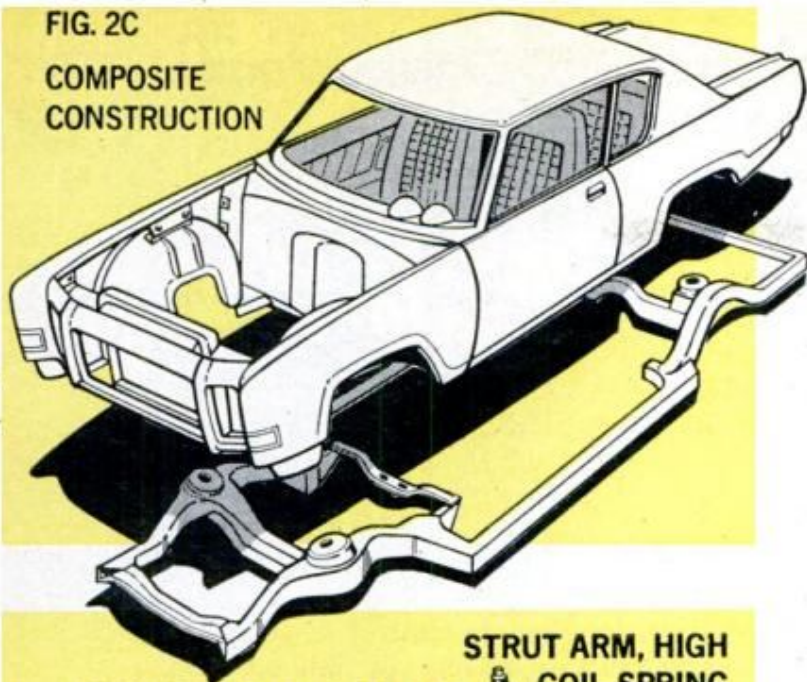

CONVENTIONAL A-FRAME
FRONT SUSPENSION

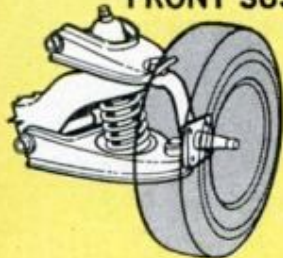

STRUT ARM, HIGH
COIL SPRING
SUSPENSION

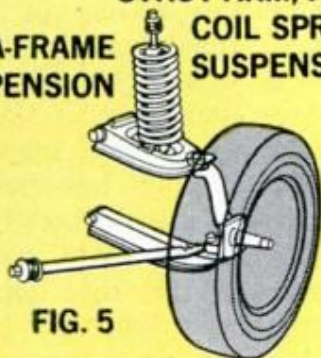
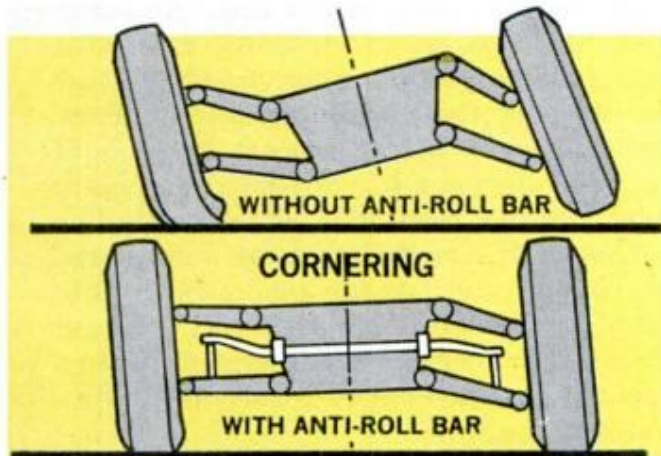

FIG. 5



independent front suspensions. IFS provided improved comfort and handling and better "unsprung weight ratio." This is the relationship of the weight of components which bounce over the road bumps, to the weight of the part of the vehicle that rides above the suspension. Fig. 3 illustrates this principle. The wheel at the left represents the situation with vehicles such as four-wheel drives, which have heavy axles and relatively lightweight chassis/body assemblies. With less weight below the springs and more above, as with the average pas-

senger car, the wheels and running gear bounce against the weight mass and inertia of the portion of the vehicle riding above the springs. The vehicle weight above the springs simply doesn't have time to react to the bumps, so the road shock is dissipated into the spring.

Early independent front-suspension systems tended toward the equal-length, parallel-arm type shown in Fig. 4 (left). This was a vast improvement over the old solid-axle concept, but was tough on tires. The road-contact tread dimension was at the maximum when the suspension arms were parallel to the ground, but any deviation above or below this position resulted in a progressively decreasing tread dimension. The result was continual sideways scrubbing of the tire on the road surface; the rubber was literally erased from the tire tread. By going to unequal length suspension arms, (Fig. 4, right) the wheel camber (tilt from perpendicular) can deviate sufficiently to compensate this tread change during jounce or rebound, to virtually eliminate the problem.

Coil spring arrangements used with A-arms are shown in Fig. 5. The spring is interposed between the lower A-arms and the chassis frame on automobiles with a separate frame. The type with the spring mounted on the upper A-arm is used on unit-constructed automobiles, the spring seating in a pocket high in the inner fender apron.

The third type of IFS uses a torsion bar to impart the spring action. The torsion bar provides spring action by resisting twist as shown in Fig. 6. The rear end of the bar is anchored to the chassis frame, and the forward end of the torsion bar to the lower suspension arm. A coil spring also achieves spring action by twist resistance of the bar from which it has been wound. Actually, a torsion bar can be considered an uncoiled coil spring.

One thing that is lost with independent suspension is roll resistance. That's because the old sea-leg bracing against the axle, that was characteristic with the beam types, is missing. Fig. 7 illustrates how the problem is

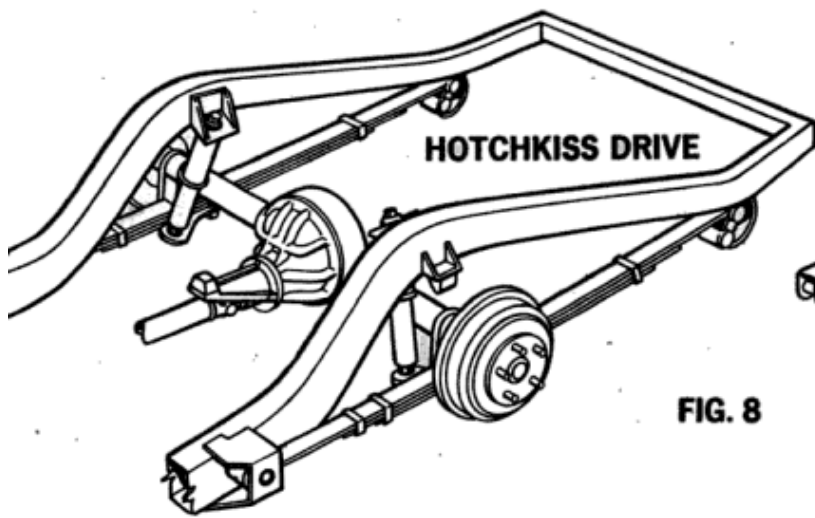

**LINK AND COIL
REAR SUSPENSION**

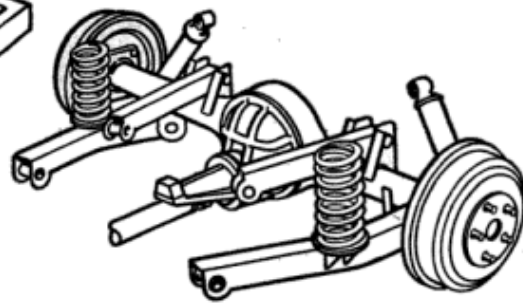

FIG. 8

overcome through use of a torsion-type anti-roll bar which pivots in frame mounts, and has the bar ends bent rearward to form levers. The lever ends are attached to the lower suspension arms by means of rubber-bushed links. In a curve as the body leans, pressure is applied downward to the outer suspension, and upward on the inner suspension members; tilting tendency is reduced by the resistance of the anti-roll bar to twist.

The live axle suspended on semi-elliptic springs, known as Hotchkiss drive, is still with us because it's rugged, economical to manufacture, and easy to install on a production line. This system helps provide roll resistance and lateral displacement of the axle is resisted by the width of the spring leaves; they flex readily up and down, but hardly at all horizontally. The old bugaboo of low-speed ride harshness of the multileaf spring has been reduced by the insertion of low-friction liners between the spring leaves. Comparison of the Hotchkiss system to link and coil rear suspension is shown in Fig. 8. Many cars use the link-located rear axle with a coil spring be-

cause of the reduction of low-speed ride harshness.

Better rear-axle control is possible because of the variety of linkage configurations. Insulation of road noise and shock is easier because the attaching links are cushioned at the pivot points.

Independent rear suspension in one form or another has been around the automotive scene, mostly abroad, for about 50 years. Only since World War II, however, has this approach received the attention it deserves.

Independent rear suspension in its simplest form is the swing axle. A swing axle, Fig. 9, is, in effect, a live axle with each half hinged on a universal joint at the sides of the chassis-mounted differential. Since a direct support line would be from the joint line to the tire contact point on the road, the effect is similar to that of the angling legs of a sawhorse. The differential has the tendency to pole vault on the end of the axle as the wheel kicks under. A more stable system utilizes unequal length control arms, also illustrated in Fig. 9.

Among American cars the Corvette

SWING AXLE MOVEMENT IN TURN

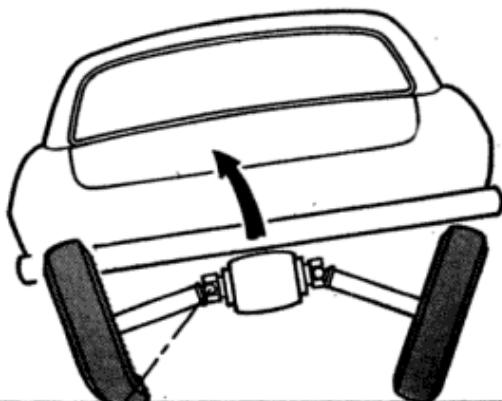

**STABILITY OF
UNEQUAL LENGTH ARM**

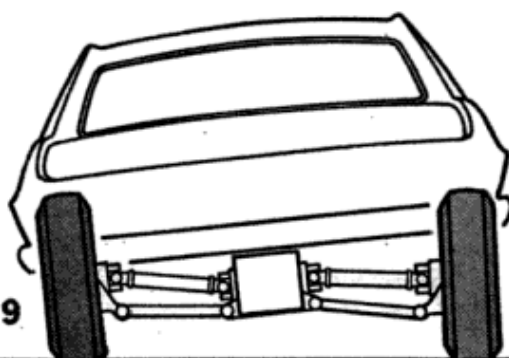
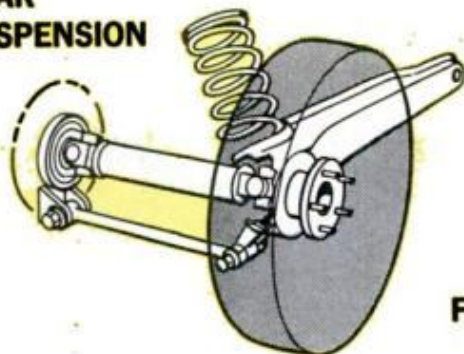

FIG. 9

**CORVAIR
REAR
SUSPENSION**



**CORVETTE
REAR
SUSPENSION**

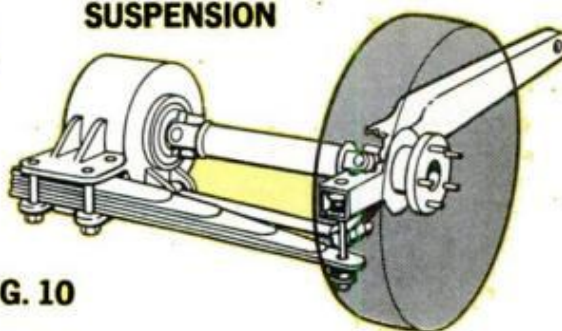

FIG. 10

and the now-discontinued Corvair have independent rear suspensions. The two systems are similar in operation; each type has the trailing arm from the chassis frame with a live spindle upon which the wheel, brake and hub are mounted. Each type has a lower pivoted arm from the differential to the trailing wheel arm, and with each, the universal-

jointed axle acts as the upper suspension arm because the universals are nonsliding and provide a positive lateral location from the differential to the wheel arm. The only difference is the coil spring for the Corvair passenger-car version, and the transverse leaf spring for the Corvette, with its stiffer, sports-car handling.

With any suspension system proper control of the action is important. Suspension control affects not only the riding characteristics of the vehicle but also the handling and road-holding ability. Control of the suspension and all its associated linkage is the function of the hydraulic shock absorber. Actually, the purpose of this unit is not shock absorption as such, but rebound control. The wheel bounces rather freely against the spring, and the mass of the sprung weight of the car, but rebound is retarded so your tires stay on the road rather than bound along like bouncing rubber balls.

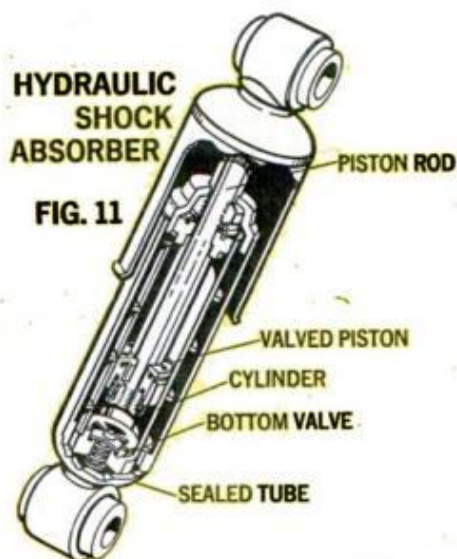
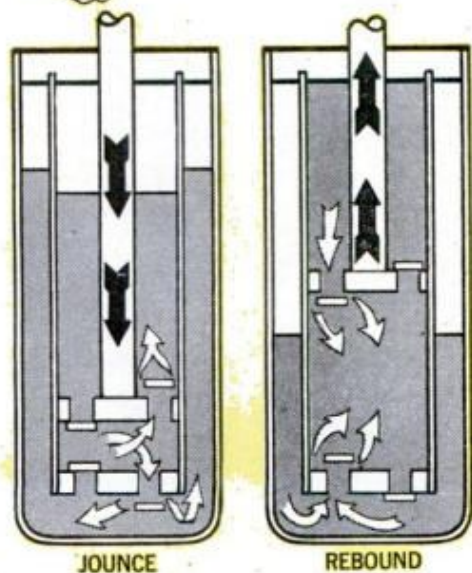

FIG. 11



Components of a typical hydraulic-strut type shock absorber are shown in Fig. 11: At the top is a piston rod attached to a valved piston operating inside a cylinder with a valved lower end. The cylinder-piston assembly is encased in a larger sealed tube serving as a fluid reservoir. The simplified diagram of jounce condition shows the piston being pushed into the cylinder. Large one-way valving in the piston and cylinder base allow rapid passage of the hydraulic fluid to the upper cylinder above the piston, and out through the cylinder base into the reservoir.

On rebound, the large valves in the piston and cylinder base close, and restricted one-way return valves open in both, allowing return of the fluid from the upper cylinder and the reservoir. This cycling occurs with every bounce, jounce, and jiggle of the suspension, so you can see how shock absorbers become weak and worn, and must be replaced occasionally.

Chassis frame and suspension systems are relegated pretty much to the "out of sight, out of mind" category, but get them checked periodically. They're important for safe riding. ★★★

Those New Tough-to-

Modern locks are more than a match for the petty thief. Even a professional burglar will find them a real challenge.

By STEVEN J. HOWARD

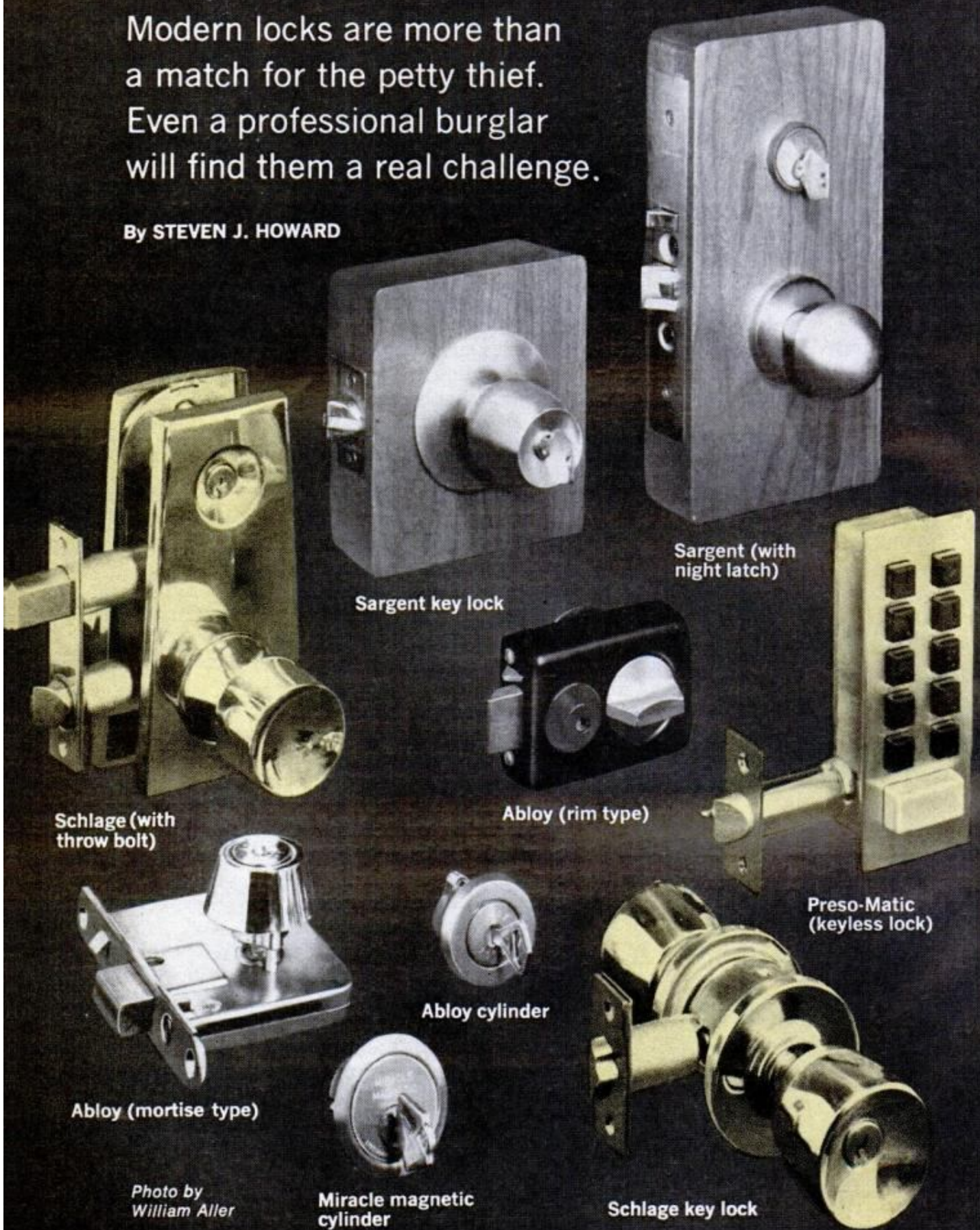

Sargent key lock

Sargent (with night latch)

Schlage (with throw bolt)

Abloy (rim type)

Preso-Matic (keyless lock)

Abloy (mortise type)

Abloy cylinder

Schlage key lock

Photo by William Aller

Miracle magnetic cylinder

Pick Door Locks

IF A BURGLAR WANTS IN badly enough, he'll break in regardless of the lock you have on your door. But any time you can make it tougher for him, he'll pass up your door for easier pickin's. There are just too many others that offer practically no challenge at all.

A plain pin-tumbler lock without a dead-latch locking mechanism offers little security. The professional house breaker can gain entry easily with such a simple tool as a business card. This is the trick whereby the spring bolt is depressed by the insertion of a card or thin piece of plastic between the door and frame. However, when the half-round trigger bolt (arrow) is depressed by the strike plate, the bolt cannot be pushed back. Many pin-tumbler locks do not have such a dead latch. It will pay to check yours.

HALF-ROUND TRIGGER BOLT

Just what is a pin-tumbler cylinder and how does it work? Whether your doors are equipped with mortise, rim or tubular locks, the pin-tumbler cylinder that each probably possesses works in the same way. The diagram on the following page shows how.

The mechanism is actually a cylinder within a cylinder. The inside part, called a plug, turns inside the outside part, called a shell, when the mechanism is unlocked.

In the locked position, spring-loaded pins and pin drivers bridge the joint between plug and shell, preventing the plug from turning. When the key is in-



Sargent's Maximum Security System

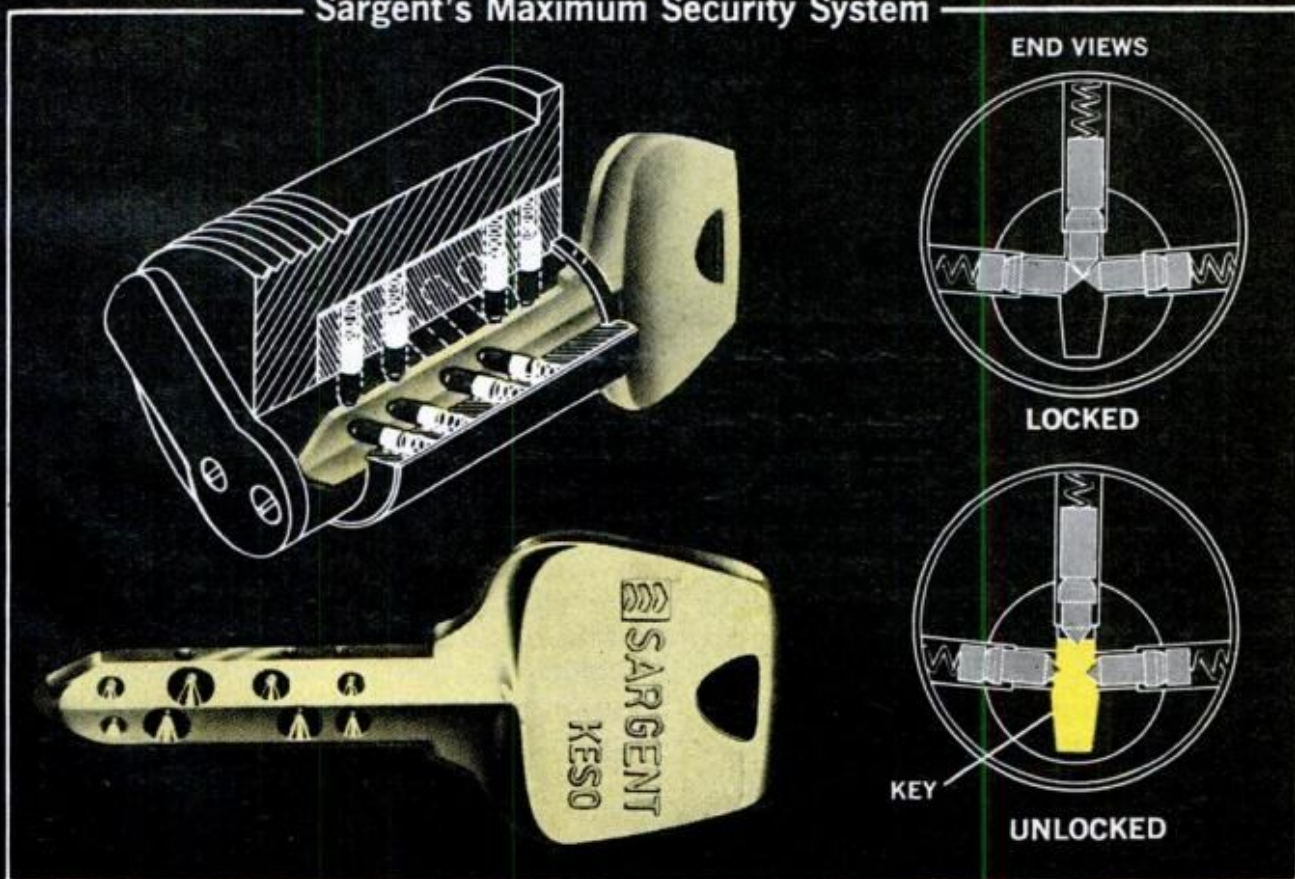

Working Parts of Schlage's "A" Lock

LOCKING TURNBUTTON

INSIDE KNOB

INSIDE ROSE

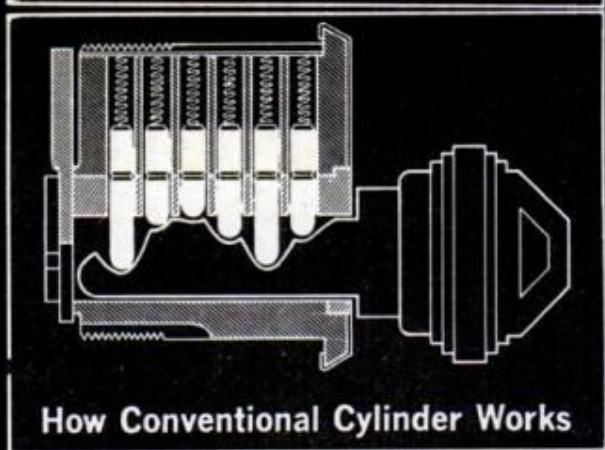

How Conventional Cylinder Works

HOUSING AND MECHANISM

OUTSIDE THREADED ROSE

LATCH-BOLT FACEPLATE

OUTSIDE CYLINDER KNOB

PIN-TUMBLER CYLINDER

PIN-TUMBLER KEY

HEADLOCKING LATCH BOLT

WITH KEY INSERTED in knob, rotating the plug activates a spindle which pulls latch from strike plate

serted into the plug, the bitting of the key raises each pin and pin driver, which are two separate parts, so that the joint between the two falls into perfect alignment with the "sheer line" of the plug and shell.

With all pins and pin drivers raised (there are usually five pins in residential locks—sometimes six), the plug is free to rotate. As the plug turns, it rotates a spindle which, in turn, pulls the latch or bolt from the strike.

The big disadvantage of the pin-tumbler mechanism is that springs can be

manipulated. A professional thief using lock picks can press pins until they align, turn the plug and open the door.

There are, however, two types of locking mechanisms that make lock-picking more difficult: the pin-magnetic tumbler and the disc tumbler.

The pin-magnetic tumbler is the newest locking mechanism. By combining both pin and magnetic tumblers into one cylinder, this mechanism provides two locking devices in one.

The pin-tumbler section of the cylinder

- A. The lock is closed when the tumbler discs are scrambled.
- B. When the key is inserted and turned clockwise 90° , it aligns the discs to form a straight groove.
- C. As the key turns past 90° , the locking bar is forced against angular surface on cylinder and drops into groove. This frees cylinder.
- D. To close the lock, the key is turned counterclockwise. This forces the locking bar from the groove and scrambles the discs once more.

functions like the pin tumbler described on page 136. But, in addition to spring-loaded pins, the cylinder contains magnets that provide a double-locking feature. These magnets create a magnetic field which prevents turning of the mechanism even if the pin tumblers are picked. How it works is shown on page 138.

Four floating magnets lie in position between the plug and shell. A pin that attracts these magnets is built into the shell. This attraction pin attracts the four floating magnets and exerts a pull that positions the "floaters" between the plug and shell. This blocks the plug, and it can't be turned.

The key for a pin-magnetic tumbler, in addition to normal bitting to activate the pin tumblers, has four magnets built into it. The magnets exert a stronger force than the attraction pin. When the key is inserted into the plug, its magnets pull the "floaters" out of the shell and into the plug. This releases the plug, and it can be rotated.

The pin-magnetic locking mechanism, manufactured by Miracle Lock Dor of Westbury, N.Y., sells for \$19.95. However, this is for the cylinder and key only. You must also buy the latch or bolt mechanism.

One manufacturer of locks who doesn't use the pin-tumbler concept, Abloy of Finland, invented a lock that uses rotating tumbler discs instead. This lock, and how it works, is shown at the right.

The tumbler disc lock is virtually pick-proof, because discs work on the "dead" principle. There are no springs. The only way to open the lock without the key is by meticulously turning discs into line, which takes more time than a thief can afford to spend in front of a victim's door. The lock has a series of parallel rotating detainer discs instead of locking pins. These discs can only be aligned by the correct key. Once the key has been turned 90° , the detainer discs are correctly aligned, a groove is formed for the locking bar, and unlocking starts when the key is

How Abloy Lock Works

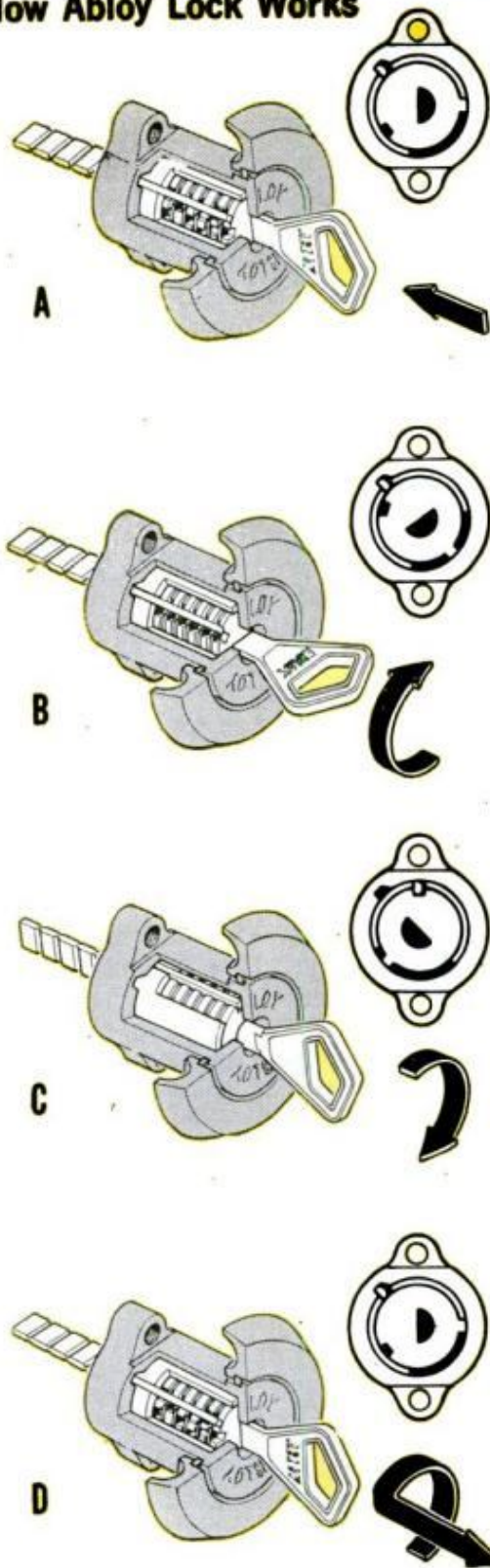

THE ABLOY CYLINDER (shown below) has rotating tumbler discs instead of spring-loaded pins. Discs can't be jarred back into position as can spring pins

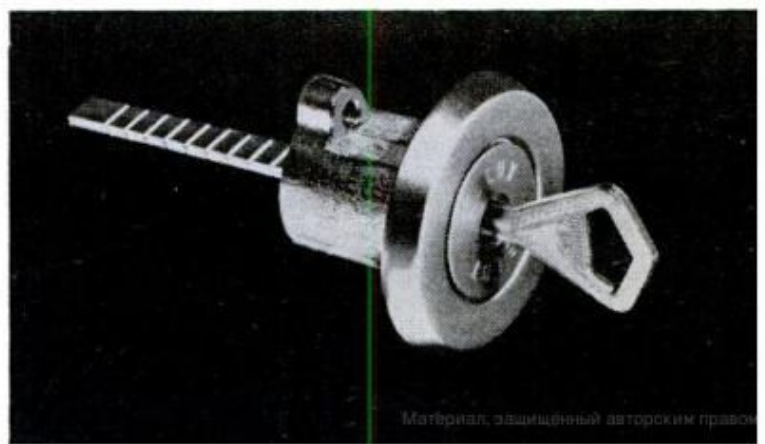

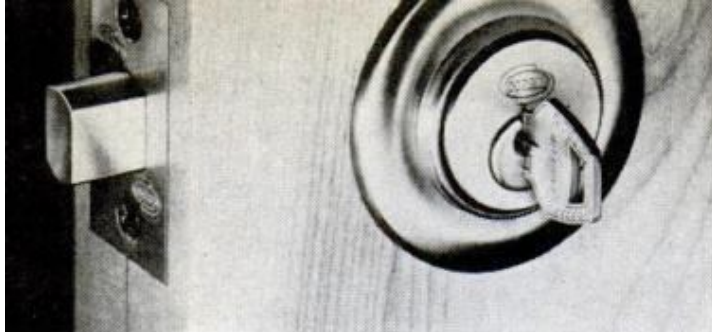

CORBIN LOCK CO. PHOTO

A DEAD BOLT HAS NO SPRINGS to allow compression of the bolt by slipping shim behind it. The locking mechanism must be turned to retract the bolt

turned further in a clockwise direction. The key must be brought back to the starting position before it can be withdrawn. Once the key has been withdrawn the combination is scrambled.

The disc-tumbler lock (complete with latch or bolt mechanism) sells for \$25 to \$40, depending upon style. Additional information can be obtained from Intertrade Industries Ltd., 5000 Buchan St., Montreal, Quebec 9, Canada.

Unlike the conventional pin-tumbler lock cylinder, which turns when the right key raises a single row of pins to the "shear line", the key in the Sargent maximum security system (shown on page

135) positions every pin in *three different rows* to a precisely predetermined height before the cylinder will "unlock." Moreover, the three rows of pins, which form a fan-shaped pattern within the cylinder, overlap when the key is withdrawn so as to baffle picking, "raking" and other techniques employed by skilled burglars.

Since these pins converge on the key from three different angles, the notches and grooves common to the conventional key have been replaced by a number of precisely milled hollows on both the edges and flat surfaces of the key. The key is tough to duplicate, designed to be reversible, and can never be inserted into the cylinder upside down. Duplicate keys can be obtained only from the lockmaker by authorized persons.

Up to now we've been discussing different innovations in locking mechanisms—the part that controls the latch or bolt. But what about latches or bolts themselves—what's new or different?

Two relatively new locksets that are more secure than the average lockset will discourage the amateur and petty criminal. However, they won't necessarily stop

(Please turn to page 204)

Technical Art by Dale Gustafson

Miracle's Magnetic Lock

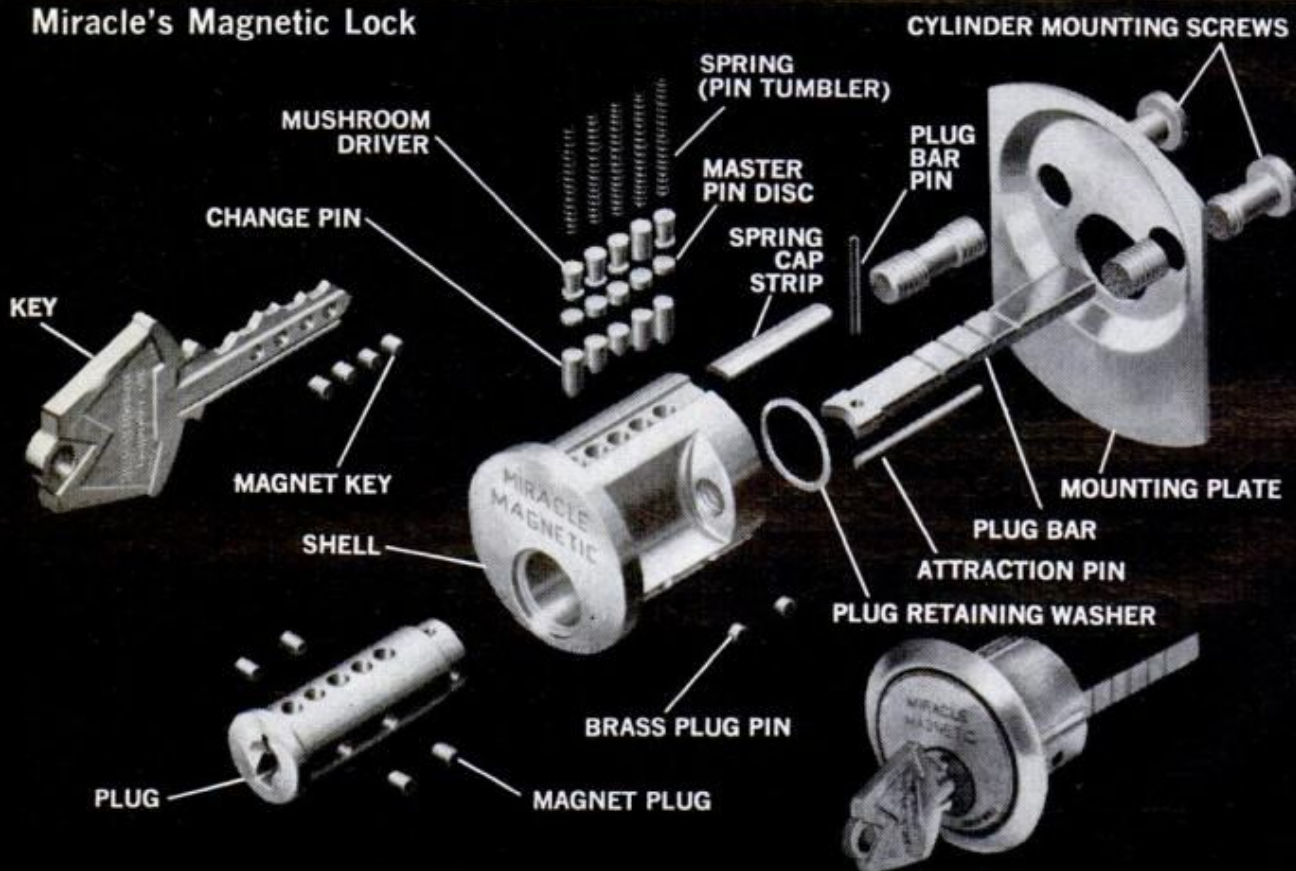

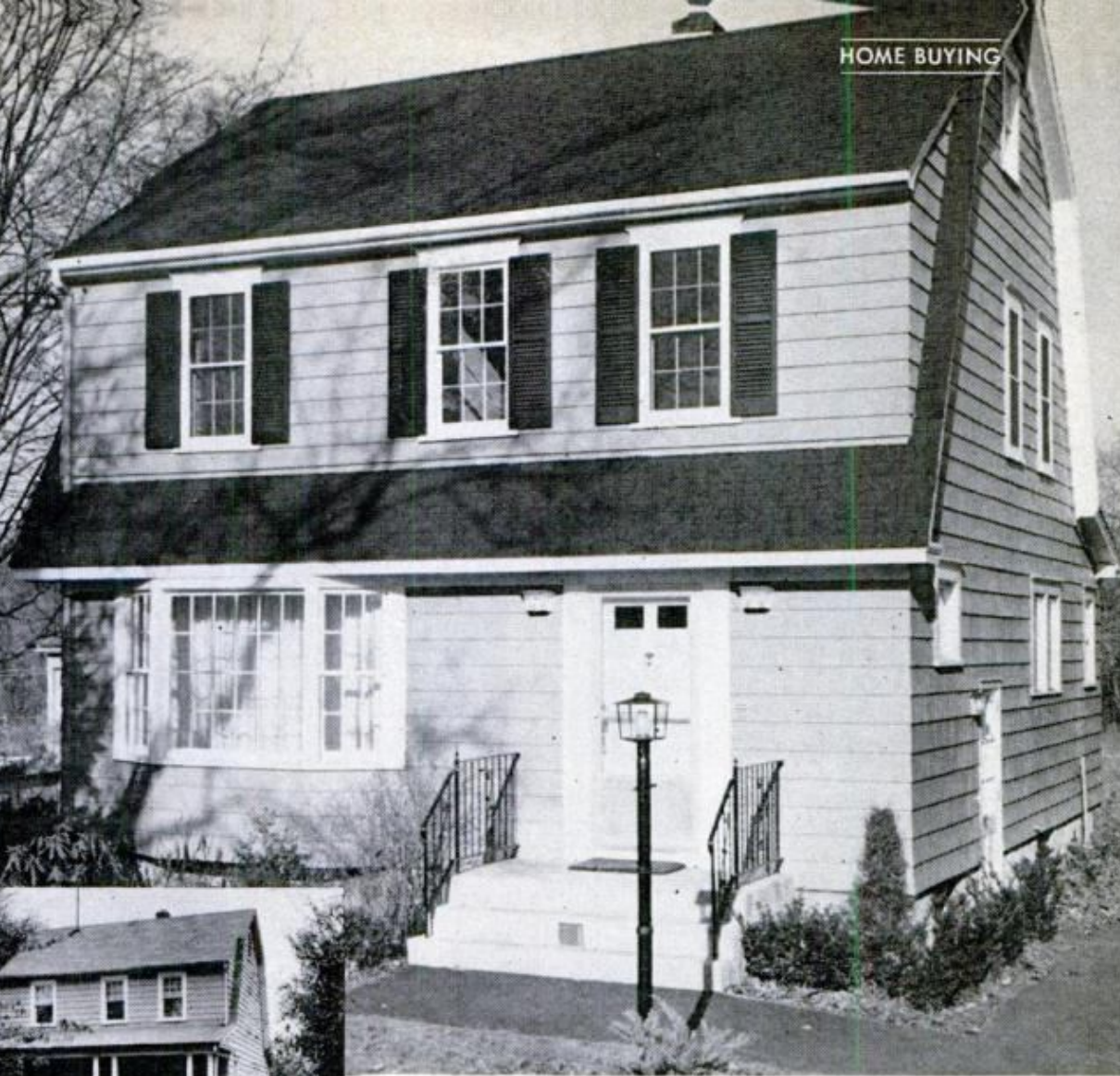

QUAINT-LOOKING BUT STURDY, the elderly two-story frame house at left proved to be an excellent buy because basic structure was sound. Above, old porch was removed and new steps and a bay window added to spruce up front. A new roof was also put on

How to Buy A GOOD Old House

By A. M. WATKINS

Author of the new book, *How to Avoid the 10 Biggest Home-Buying Traps*

An old house can be a bargain if it's sound—and a nightmare if it isn't. Here, an expert tells you what to watch out for and how much repairs may cost.

A YOUNG COUPLE bought a large old three-story house in downstate Illinois. It was priced at a mere \$15,500. It was rather run-down, but where else could they find such a big house at such a low price?

Taking stock of things two years later, they found they had poured over \$6000

into the house, plus a lot of their own labor. About that time, the old furnace chose to stop working, which called for another \$1000 or so for a replacement.

That was too much. They decided to throw in the towel and sell it for \$22,500. Then came the final blow. The most they could get for the house was \$18,500—a



EXTRA DIVIDENDS you sometimes get in an older home are fine hardwood floors, exposed beams and sturdy, well-made cabinets. Rooms are also likely to be more spacious than in compact modern houses

\$4000 loss they could ill afford. They had been trapped by an old-house lemon.

They had made two common errors. They had grossly underestimated the repairs and improvements that were needed. And they had overimproved the house for its location. As a result, they found the value of the house did not grow with the money they had poured into it.

There are three kinds of old houses. The first is the old house that is in good, if not excellent, condition. The second is the kind that will look deceptively sturdy and solid but contains serious flaws that are often difficult to detect. The third kind is the relic. Its run-down condition is far more obvious. The perplexing thing is that people continually buy such houses with the delusion that they've discovered a rare bargain.

There are good reasons for buying *some* old houses. Many offer much more space than a new house at the same price. There may be practically no moving-in expenses for a new lawn, landscaping, or anything else of the kind associated with new houses. And with an old house you generally can move into an established neighborhood, with shade trees and little likelihood of new taxes like those that result with new houses in expanding new suburbs. Many splendid old houses boast

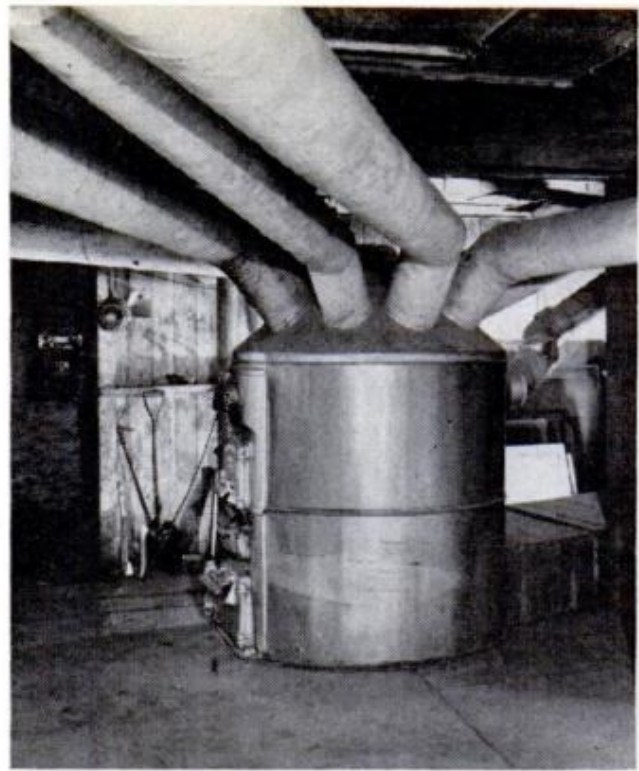

OCTOPUS TENTACLES streaming from an early-type hot-air furnace are a sign that heating system may need modernization. House may otherwise be sound, but allow for the cost of a new plant in your plans

thick stone walls, handsome oak plank flooring, high ceilings, tile roofs and hand-carved woodwork.

The other side of the coin, however, is that new houses also come with many a new feature unknown in old houses: excitingly modern new kitchens and bathrooms, central heating and airconditioning, fuel-saving insulation and rugged new materials.

An old house, however good, also can be difficult to buy because of the difficulty of financing it. A whopping down payment in cash is often required. But by far the biggest pitfall to avoid is the old house lemon—riddled with shortcomings and suffering from senile obsolescence.

The usual furnace will last about 15 to 20 years and repairs are inevitable. The usual roof covering is good for about the same period of time, after which it begins cracking and drying out. Wiring circuits become worn and frayed over the years, and grow increasingly inadequate to handle all the new appliances and other electrical equipment we pile into our homes.

There's a special old house to watch for warily. It's the one that has been in a family for years. The one or two surviving older people who stayed with the house do not mind a kitchen that is increasingly outmoded. There's only one operat-



YOU'D NEVER GUESS that the ramshackle pre-Civil War Virginia farmhouse at right could become the trim-looking suburban home shown above. Such structures generally require extensive work, are a good buy only if original cost is low

ing bathroom, but that, too, is perfectly adequate for the small demands put on it. That kind of house for sale should flash a red danger flag.

If you move in with a large family, the house will shortly begin gasping that it is incapable of meeting the heavy new demands put on it. Though formerly adequate for one or two older people, the plumbing will groan and begin slowing down. The furnace or the water heater or both will be forced to put out more, but now neither can heat very well. Various serious ailments sprout up.

How can you distinguish between the old house that's in fundamentally good condition and one that is not? Have the house inspected by an expert. The cost ordinarily will run about \$40 to perhaps \$75. Look in the classified telephone directory under "Home Inspection Services" or "Building Inspection Firms."

Next, determine the cost of essential repairs and modernization. Most older houses require some work. Any way you look at it, a \$22,000 house that requires \$3000 worth of work means that you are really buying a \$25,000 house.

An old house in run-down condition still can be a bargain if its price plus the cost of essential work adds up to a reasonable figure. You don't want to overimprove. Following is a listing of the most common defects found in used houses, together with the approximate cost of repair:

Old-fashioned kitchens and run-down bathrooms. These are two most prevalent shortcomings in old houses. How much modernization will be required



Published by permission of Meredith Press. From *HOW TO AVOID THE 10 BIGGEST HOME-BUYING TRAPS* by A. M. Watkins. Copyright 1968 by A. M. Watkins.

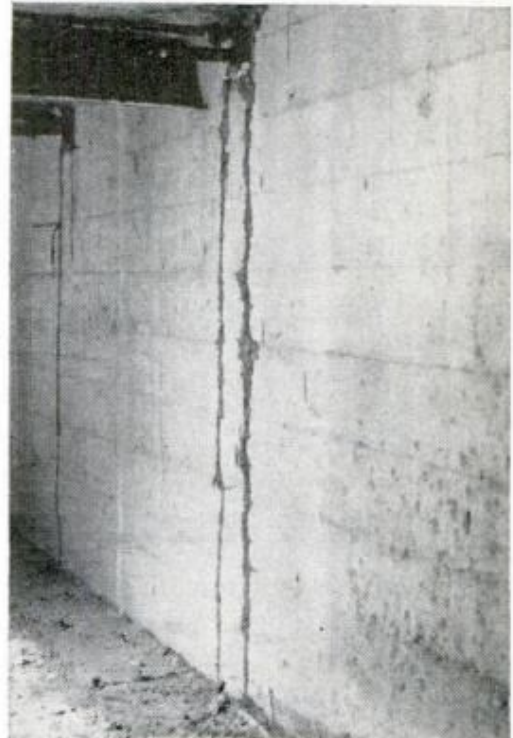

TERMITE TUNNELS like these are bad news. Such well-established trails usually indicate the wood-eating insects have been at work a long time. Check with an expert to find out how serious damage is

Modernization of an obsolete kitchen will cost \$2500 to \$4000, sometimes more . . .

depends on your personal standards. Full modernization of an obsolete kitchen ordinarily will cost \$2500 to \$4000, sometimes more if you want the very latest. A new half-bath installed where there was none usually will cost about \$750 to \$1000. Updating an obsolete full bathroom generally costs at least \$1500 to \$2500.

Defective septic tank system. If plumbing does not empty into a city sewer line, it usually empties into a septic tank system or a cesspool. Repairs or replacement can cost anywhere from \$500 to \$1500. But determining the operating condition of the system is not always easy.

If a house has a septic tank, ask the owner how well it works. Sometimes he'll say it's fine, though it isn't. Other times he'll frankly say that it isn't as good as it should be but you can live with it until new city sewers are installed. Hooking up to a new city sewer will cost a few hundred dollars. You can also call the local Public Health Office and ask how well septic tanks work in the area.

The condition of a cesspool also may be hard to determine. Some of them work for years with no trouble, others not. As with septic tanks, it depends largely on the kind of soil. A porous soil that drains well is a good sign, since it readily absorbs sewage overflow. A hard claylike soil is not a good sign.

Wet basements. The basic problem stems from a chronic wet soil condition coupled with poor drainage around a house. So much water piles up in the ground around a house that there's nowhere for it to go except press through the foundation into the basement. Ordinary black asphalt plastered on the walls won't necessarily keep it out, either.

The problem is encountered most with a house located on low-lying ground, in a valley, or in an area surrounded by higher ground from which rainwater flows down through underground streams. So look around at the terrain for the tell-tale high ground sources of shed water that can endanger the basement. Check the basement for signs of water stains, particularly on the walls facing the high ground outside.

A chronic wet basement should be

avoided because it can cause wood rot problems and spread mildew throughout the house. If the problem is chronic, the remedy can cost as much as \$1000 to \$1500. The ground must be dug up all around the foundation walls, the walls must be properly waterproofed and in addition, a new drain-tile system must be installed.

Puny wiring. The older the house, the more likely the wiring is obsolete and inadequate. It's because of the skyrocketing electrical demands in houses. In 1940, for example, only a dozen or so different kinds of electrical items were used in houses. A mere 30-ampere electric service was all you needed to power a house, including the lights. Now there are close to 100 different electric devices in houses. Some, such as an electric dryer or range, draw more electricity than could be supplied by the entire service in a 1940 house.

The average house today requires an electric service input of 240 volts and 100 amperes capacity. If it's a large house or has heavy electric users like electric heat, airconditioning, range or dryer, look for 240 volts and at least 150 to 200 amperes capacity.

Inspect the main electric switchbox. If it's a small one with a rating of less than 100 amperes, a new electric service is likely to be needed. Cost will run about \$125 to \$175. You're also likely to need new switches and outlets. Figure from \$8 to \$10 apiece for each new switch and double-outlet, up to \$25 to \$35 roughly for each new heavy appliance outlet needed for heavy equipment like an electric dryer. In all, total cost of new wiring for a typical seven or eight-room house will run about \$350 to \$500, more for a large house.

Clogged-up plumbing pipes. They're most likely in houses built prior to World War II, since corrosion-resistant copper and bronze plumbing pipe was not introduced for housing until just before the war. Before then, iron and steel pipes were the rule. Over several decades, such piping tends to choke up with rust and corrosion; little water can get through and the plumbing must be replaced.

Turn all the faucets on at once in a bathroom (an upstairs bathroom in a multifloor house). Make it a real test by flushing the toilet at the same time. If the water slows to a trickle, it's not good. It

(Please turn to page 212)



Carbon construction

A tough carbon fiber, invented at the Royal Aircraft Establishment, England, is being used for aircraft engine parts and also forms the body shell of this prototype racer.



Propellerless assault boat

A prototype of Navy's Assault Support Patrol Boat, built by Sikorsky, has a fiberglass hull and is driven by Buehler water-jet propulsion units rather than propellers.

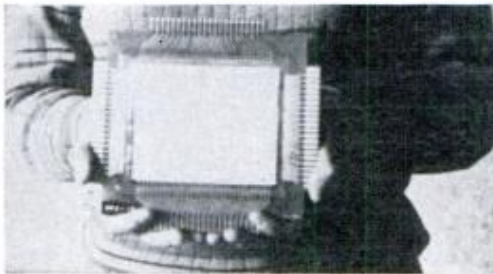

Tubeless television

A tubeless television set developed by the Mitsubishi Co. in Japan can be hung on a wall. The firm hopes to improve the image (right) so the set can be produced commercially within three to five years.



Dodge Charger Daytona is built for racing

Designed for racing, the new Dodge Charger Daytona is a limited production version of the 1969 Charger. Powered by a 426-cu.-in. Hemi V8, the Daytona will make its racing debut at the Alabama International Motor Speedway on Sept. 14. Principal changes from the '69 Charger include an elongated nose-cone wedge and an elevated, rear-deck spoiler.

How to Check Out Your

There are no tricks to working on fuel systems of one and two-cylinder outboard motors, regardless of make

By HENRY B. NOTROM

TYPICAL OUTBOARD CARBURETOR (TILLOTSON TYPE SHOWN)

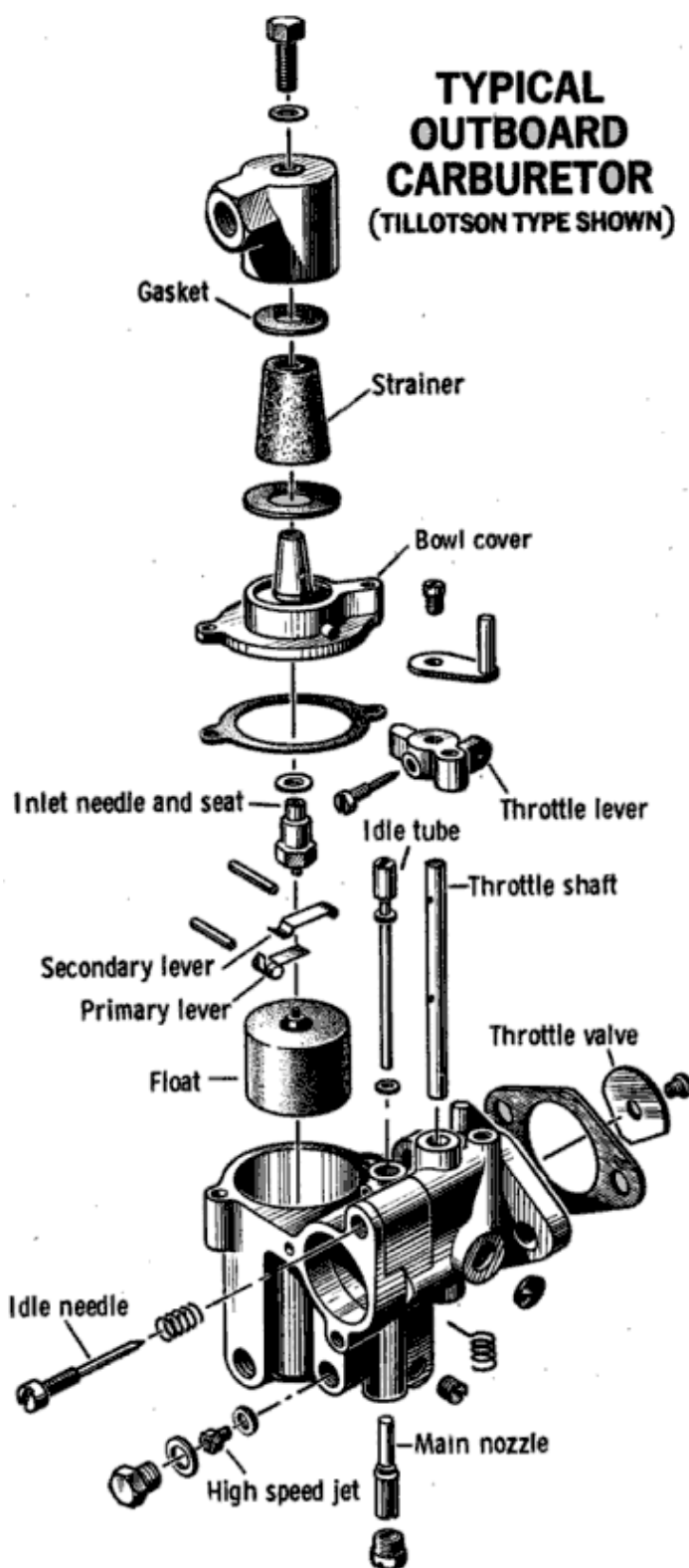

FUEL-SYSTEM ASSEMBLIES on outboard motors are simple in make-up and easy to repair. There are two types: gravity-feed (least common) and pressure-feed.

You can recognize a gravity-feed system by the fuel tank mounted on the powerhead above the carburetor. Fuel flows downward without pressure and enters the fuel bowl. Generally, gravity-feed is used on one-cylinder models.

In the more common pressure-feed system, fuel is contained in a tank that's remote from the carburetor and is forced into the bowl by a pump. Most two-cylinder outboards use this system. This article will concentrate on maintenance of a pressure-feed system; if you can repair it, you should have no trouble with gravity-feed.

A fuel pump consists of a diaphragm and a booster chamber that contains check valves for fuel to enter and leave the chamber (Photo 1). Some pumps, such as those used in OMC engines (Johnson and Evinrude), also contain a fine-mesh filter screen that removes impurities from fuel as it enters the pump.

Fuel-pump parts, including the filter, seldom need to be replaced. The only exception is the diaphragm which can become cracked and pitted. It should be replaced every year. Also check the condition of the diaphragm should your motor suddenly develop fuel-starvation problems.

To keep a fuel pump in good shape, unscrew the pump body, remove the filter if one's used, remove and replace the diaphragm, and remove the booster chamber. Wash the filter and booster

This is the third of five articles that will give you a ready-made service manual for your one and two-cylinder outboard motors. Clip and save them.

POPULAR MECHANICS

Fuel System

chamber in a solvent, such as kerosene. Let parts dry before putting them back.

How far you go in working on your carburetor depends on what's wrong. Usually, all that's needed is a takedown and a wash in solvent to remove dirt and varnish that can clog parts and passages. These impurities can come from the oil-gas mixture if allowed to settle inside a carburetor. You shouldn't have to replace the parts—just clean them.

When you remove a carburetor for cleaning, arm yourself with a gasket kit that you can buy from your local marine dealer. Make sure you get the right kit for your carburetor. Replace all gaskets with the new ones. These include the flange, bowl, fixed-jet, strainer cover and low-speed needle gaskets.

If parts of the carburetor show wear, replace them. If things are very bad, you may decide a complete overhaul is necessary. You'll need a rebuilding kit (about \$7) that contains, among other parts, a needle and seat, a filter screen for those carburetors with filter at the carburetor inlet, idle bypass, gaskets and jets.

If you're working with a fixed-jet carburetor, you'll need a fixed-jet tool (about \$1) or an exact-size screwdriver to remove and reinstall the jet.

Most outboards in the 5 to 20-hp class built since 1959 use the fixed-jet concept. The high-speed control is set at the factory. Generally, it doesn't have to be adjusted. But for operation above 4000-foot elevations a smaller orifice jet is needed. Outboards in the 20-hp and larger class

1. FUEL PUMP consists of diaphragm (left) and booster chambers (right). Replace a worn diaphragm

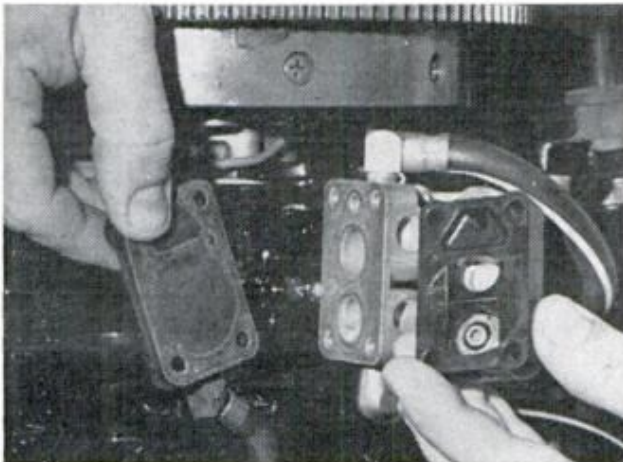

2. STRAINER COVER comes off the top of carburetor to reveal the filter, which should be cleaned

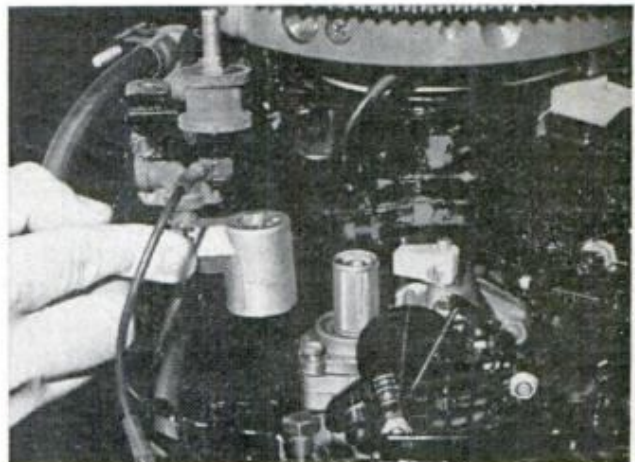

3. REMOVAL of upper float-level pin and the lever permits removal of the needle valve for inspection

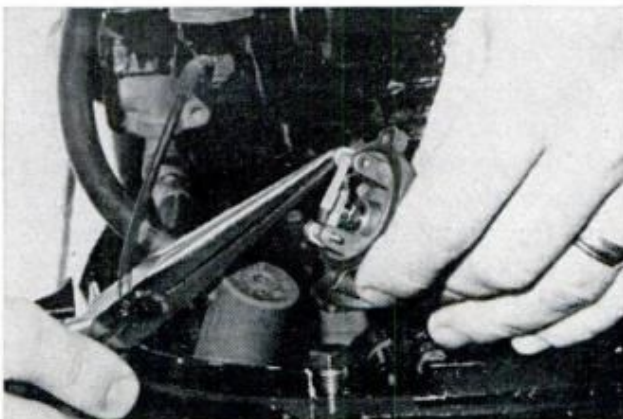

4. FLOAT is removed from bowl. Check condition. If damaged, replace. If hard rubber, clean in solvent

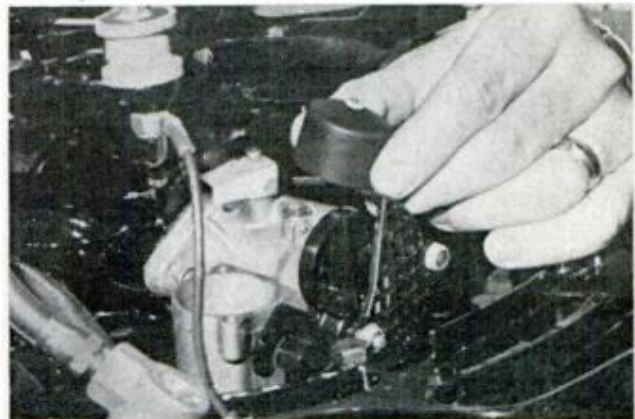



5. REMOVE fixed-jet by uncovering and unscrewing with a fixed-jet tool or an exact-size screwdriver

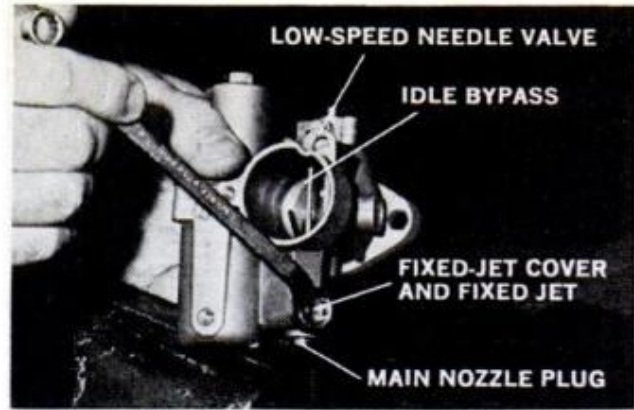

6. UNSCREW the idle bypass, low-speed needle valve and main nozzle plug. Check the parts for damage

require a high-speed adjustment (except Mercury—all of whose models use fixed-jet carburetion).

Here's how to disassemble a carburetor:

1. Remove the strainer cover and strainer (filter), provided the filter is at the carburetor inlet instead of in the fuel pump (Photo 2).

If the motor is having fuel-starvation problems, remove this filter and hold it to the light. If you can't see through it, it's clogged and needs cleaning.

2. Detach the float-bowl cover and discard the gasket. Remove the pin that holds the upper float lever and remove the lever (Photo 3).

3. Invert the float-bowl cover. The needle valve will drop into your hand. Inspect the tapered end of the valve for grooves, nicks and scratches. If the valve is damaged, replace it and its seat. Another indication of a worn needle valve or needle-valve seat is a carburetor that floods constantly. The seat is removed by loosening it from the float bowl cover.

4. Remove the float from the bowl (Photo 4). If the float is made of cork and has become oil-soaked, replace it. Do not wash a cork float in solvent. OMC engines in general use cork floats.

If the float is made of the hard-rubber compound used generally in Mercury and Chrysler outboard motors, it can be cleaned in solvent. If the float is damaged, replace it.

5. Unbolt carburetor body from engine.

6. If the carburetor is of the fixed-jet type, remove the fixed-jet cover and, with the right tool, remove the jet (Photo 5).

7. Unscrew the idle bypass, low-speed needle valve and main nozzle plug (Photo 6). If the carburetor isn't fixed-jet, remove

the high-speed needle valve. Check each part. If damaged, replace it.

Wash all parts in solvent and let them dry. Then, in reverse order, put them back into the carburetor body. Use the fixed-jet tool to run the jet up tight.

With the carburetor reassembled, and before putting the float bowl cover back, you have to adjust the float setting. Then, with the carburetor all in one piece, you have to adjust the low-speed needle valve according to the owner's manual. If the carburetor isn't a fixed-jet type, you also have to adjust the high-speed valve.

There is no single adjustment measurement for the float setting. It varies.

Mercury fixed-jet carburetors of the type seen in this article call for a setting of $\frac{13}{32}$ inch. The measurement is made as seen in Photo 8. To adjust, bend the lower float arm lever. (Photo 7).

With most OMC fixed-jet carburetors of modern vintage, the measurement is $\frac{17}{16}$ inches. Invert the float body so the float drops and measure from the bottom of the float to the bowl cover body (Photo 9). Adjust by bending the float arm.

To make the low-speed needle adjustment, warm the engine and idle it in forward gear. Open the needle until the engine starts to load up and fire unevenly. It's running rich.

Now, close the needle slowly until the motor slows down and starts to misfire. It's running lean. The best adjustment for the low-speed needle valve is halfway between these rich and lean settings.

By the way, if you can't make the adjustment, check the needle. It's probably damaged and has to be replaced.

In an engine without a fixed-jet, you have to adjust the high-speed needle. Warm up the engine and operate it at full



7. **BEND** the lower float-arm lever to make any adjustments to the float level on fixed-jet carbs

throttle. Run the needle up slowly until it is firm. Do not force it. Now, back it off from a half to three-quarters of a turn.

Now that the motor's adjusted, let's check the last part of the fuel system—the fuel tank. Remove the filter and clean it. A clogged filter cuts off fuel.

The only regular maintenance needed on the fuel system of your motor is a periodic cleaning of filters. Also, run the carburetor dry before stowing your motor for the day. This cuts the possibility of varnish and residue accumulating. ★★

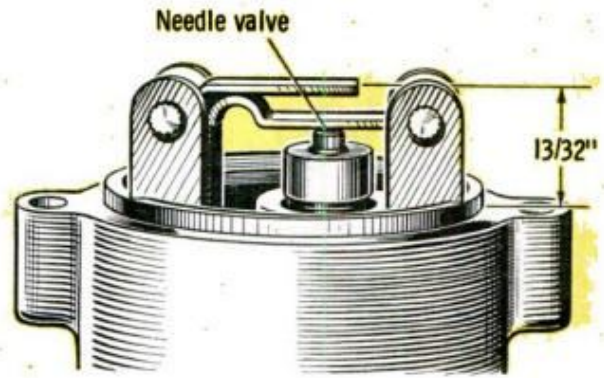

8. **ADJUSTMENT** of most fixed-jet carburetors is done with the carb upside down, as shown in this photo

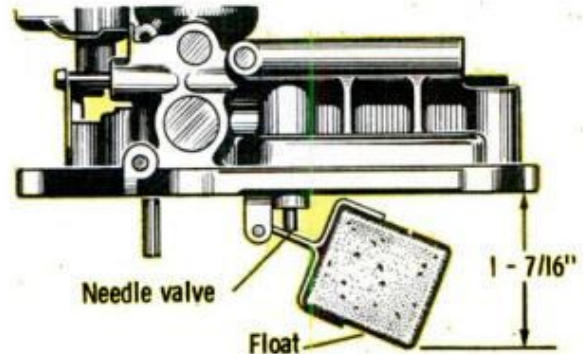

9. **FLOAT** of most OMC fixed-jet carbs is adjusted by bending cork-float arm to these measurements

FUEL-SYSTEM TROUBLESHOOTING CHART	
PROBLEM	POSSIBLE SOLUTION
Engine hard to start or won't start	<ul style="list-style-type: none"> • Make sure you have fuel • Check gas-tank vent to make sure it's open • Check fuel line for kinks • Check fuel for water. Let some fuel evaporate in your hand. Water, if any, will remain • Check fuel filter for clogging dirt • Check carburetor adjustments. The mixture could be on the lean side.
Motor misses at low speed, or motor doesn't idle smoothly	<ul style="list-style-type: none"> • Low-speed needle may be out of adjustment • Check fuel mixture
High-speed motor miss	<ul style="list-style-type: none"> • Check for water in fuel • Make sure fuel-pump cover is not leaking air • Check fuel-pump diaphragm
Engine coughs, spits, slows down	<ul style="list-style-type: none"> • Check high-speed adjustment. It might make mixture too lean. • Check float level. It might be too low • Check fuel-pump diaphragm for dirty check valves and loose cover • Check to see that fuel-tank filter is not clogged • Fuel passages in carburetor may need cleaning

HOW TO GET BETTER SOUND FROM YOUR TV SET

Hooking up an extension speaker or feeding the audio to your hi-fi set will greatly improve your listening pleasure. Here are several methods

By **FOREST H. BELT**

Technical Art by John Lind

YOU MAY NOT realize it, but the quality of TV sound is pretty good—at least when it leaves the broadcasting station. It's FM, and from most TV stations it can be rated as hi-fi.

What comes out of your TV set at home is another story. The cramped quarters inside a TV cabinet leave little room for a fine speaker system, and set manufacturers are more concerned with good picture quality in the design of their circuits. The speakers used are small, narrow-range, single-cone affairs not intended for hi-fi reproduction. You may not care on talk programs, but musical shows and concerts really suffer.

Good TV sound is there for the taking, however—all you have to do is get at it. There are three basic ways you can do this. The simplest method is to forget the tiny built-in speaker and hook up a bigger, better extension speaker in a separate enclosure. The accompanying drawings show how you can disconnect the set's speaker and run the same two wires to another speaker outside.

For your extension speaker, choose a wide-range coaxial type or a multi-



BOOKSHELF-TYPE SPEAKER is ideal size for many TV sets. Placed underneath or alongside, it makes a handsome arrangement, puts sound close to screen



How to Add an Extension TV Speaker

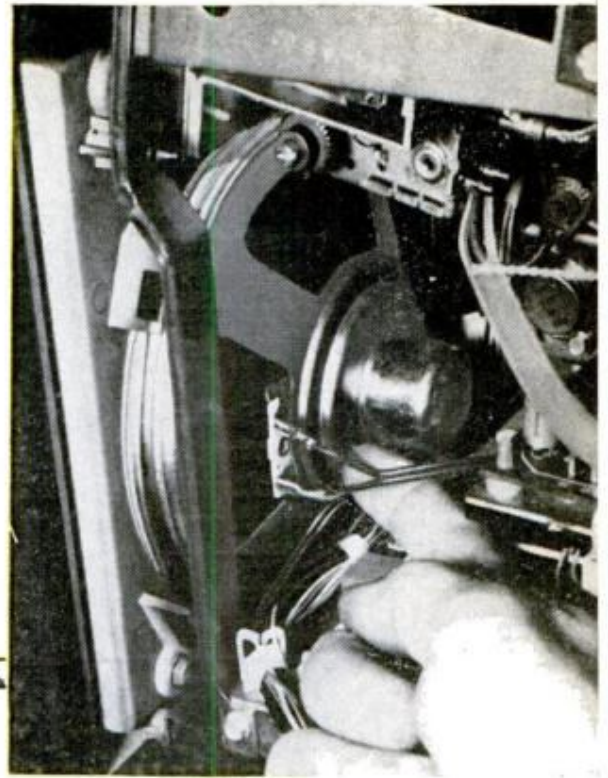
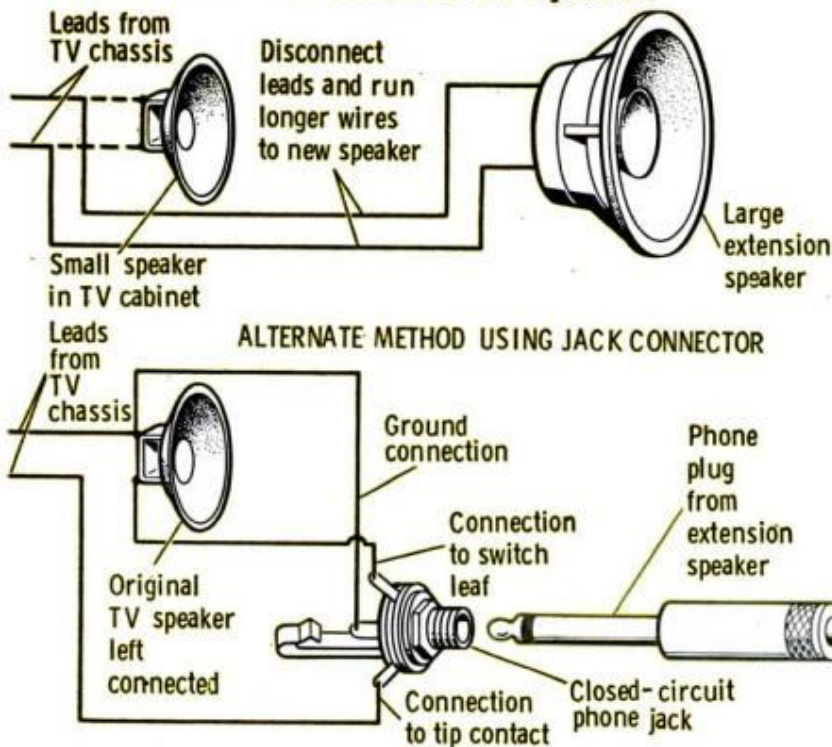

TYPICAL TV SPEAKER mounted inside cabinet is too small to deliver good sound. Disconnect two leads going to the speaker's coil, as shown in photo at right above, and run longer leads to an extension speaker outside the cabinet. Alternate wiring method above shows how you can leave set's speaker attached using a closed-circuit phone jack. This way, internal speaker plays when extension speaker is unplugged

speaker enclosure that includes a woofer, tweeter and perhaps a mid-range reproducer. The popular bookshelf-type enclosure that runs about 2 feet wide by 14 or 16 inches tall can make a handsome base for a portable set, or you can stand it upright alongside a console. The important thing is to get the speaker as close to the set as possible so the sound will appear to come from the screen. Most TV sets use

8-ohm speakers, so pick an extension speaker of the same impedance.

One convenient way to connect your extension speaker is with a phone-type plug and jack. The jack can be mounted easily in a hole drilled in the thin fiber-board back found on most TV sets. Pulling out the plug will let you disconnect the speaker quickly without unsoldering wires.

If you use a closed-circuit jack, you can

HOOKING UP HEADPHONES will improve TV sound and make your listening private to boot. If phones are of high-impedance type, they can't be connected directly to speaker leads but must be wired to terminals on volume control, as shown below. Use shielded cable and solder center lead to center tab on con-

trol. Solder shield to grounded tab at one end or to ground lug on chassis. (There will be a wire running from one of the tabs on the control to a spot on the metal chassis. This is the ground connection.) Drawing shows how to wire a stereo phone jack so monaural TV sound can be heard in both ears

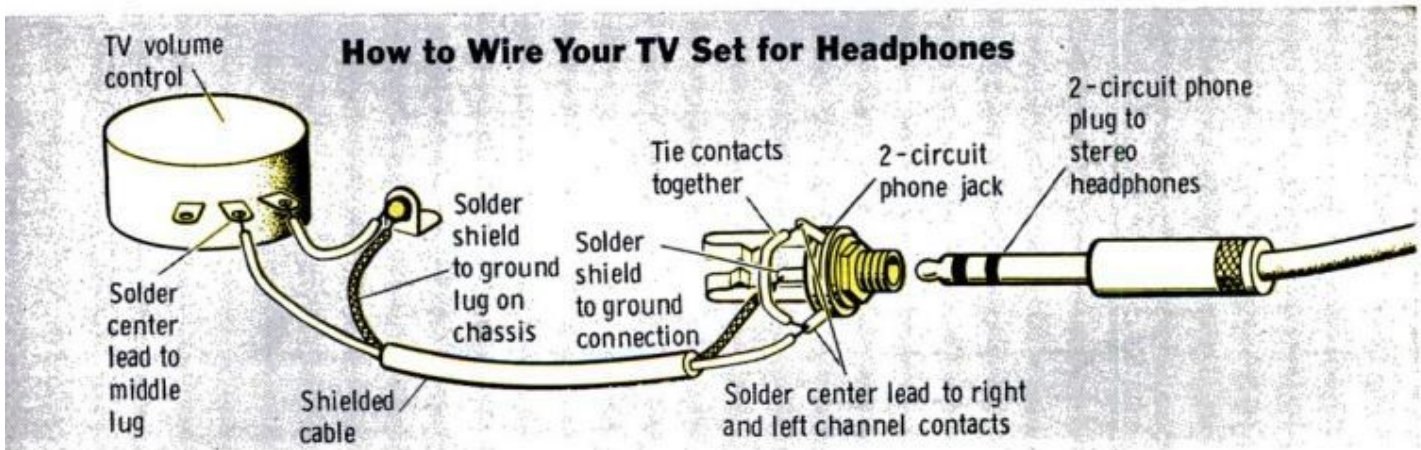

leave the set's internal speaker attached, as shown in the drawing. This type of jack has a built-in switching arrangement. With the extension speaker plugged in, the set's speaker is automatically cut out. If you unplug the extension speaker, the internal speaker will play. This is handy if you have a portable set that you may want to carry from room to room without having to lug the extension speaker around with it.

Plugs and jacks are available at radio stores and electronics-supply houses. In any case, don't wire your extension speaker in such a way that both it and the internal speaker play at the same time. This may overload the transistors in a

solid-state set and damage them. Also, don't turn on the set without either speaker connected as this, too, may damage the transistors.

If only one or two people are going to be listening at a time, you can rig your set to take earphones. Good-quality headsets—the kind hi-fi enthusiasts use for stereo listening—can improve TV sound immensely without costing much or taking up any space. This, too, can be done with a simple plug-and-jack arrangement. However, since TV sound is monaural and modern headsets are made for stereo, you'll need a special two-circuit stereo jack. A drawing (page 149) shows how to wire the jack's right and left-channel con-

How to Pipe TV Sound Through Your Hi-Fi Amplifier

VOLUME CONTROLLED
AT TV SET

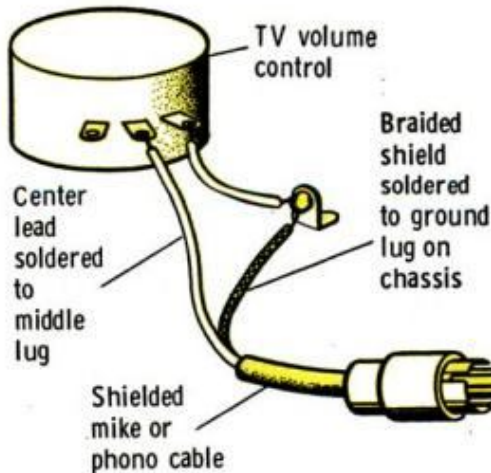

VOLUME CONTROLLED
AT HI-FI SET

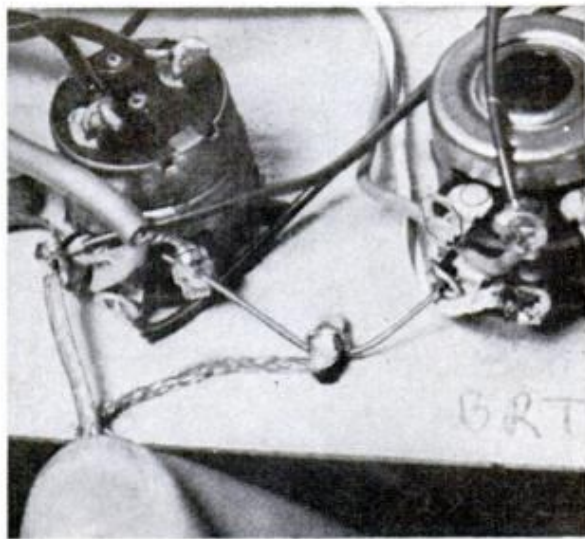
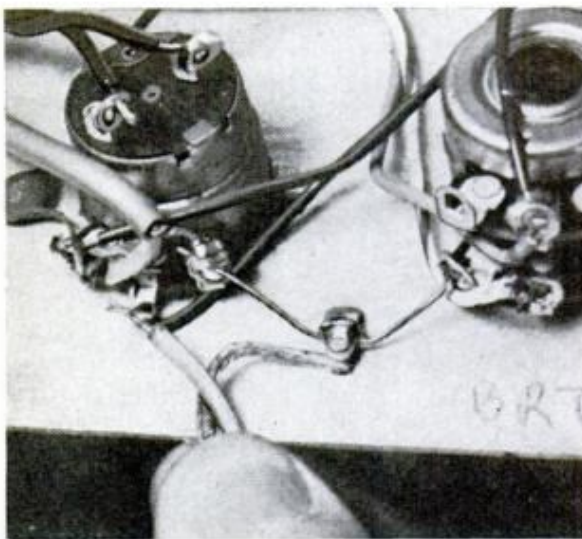
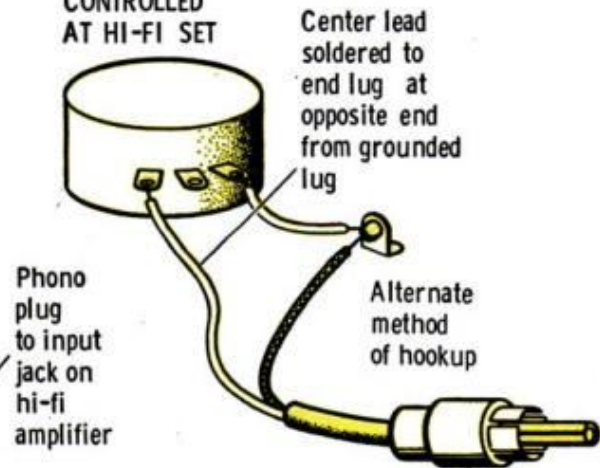

FOR BEST TV SOUND, tap off audio from set and feed it into your hi-fi amplifier. All you do is make two connections to the volume control using shielded cable. Two alternate methods are shown above. One at left allows you to control volume from the TV set. Run hot lead to center tab on volume control and shield to grounded tab (or, as in this case, to ground lug on chassis). To control volume from the hi-fi set, run hot lead to the end tab at opposite side from the grounded tab

tacts together so that sound is carried to both earpieces.

Note in the drawing that the jack is connected to the set's volume control rather than to the leads going to the speaker. This is necessary in order to get a proper impedance match for high-impedance headphones. The volume control is easy to locate since it's right behind the volume control knob on the front panel. In most newer sets, the control is on top of the chassis at one side and can be easily reached. In some cases, it may be underneath and it will be necessary to slide the chassis out of the cabinet and turn it gently on its side in order to get at the control's terminals. In either case, be

sure the set is turned off and touch only the parts indicated.

Use shielded cable and solder the center or "hot" lead to the center tab on the volume control. The outer shield goes to the end tab that's grounded to the chassis. At the jack, the shield goes to the ground tab that makes contact with the innermost section of the plug's barrel. The hot lead goes to the two contacts near the plug's tip, tying right and left channels together.

If you should have low-impedance 8-ohm headphones, you can ignore the volume-control hookup and wire your jack directly to the speaker leads. You can disconnect the speaker completely or wire it

(Please turn to page 216)

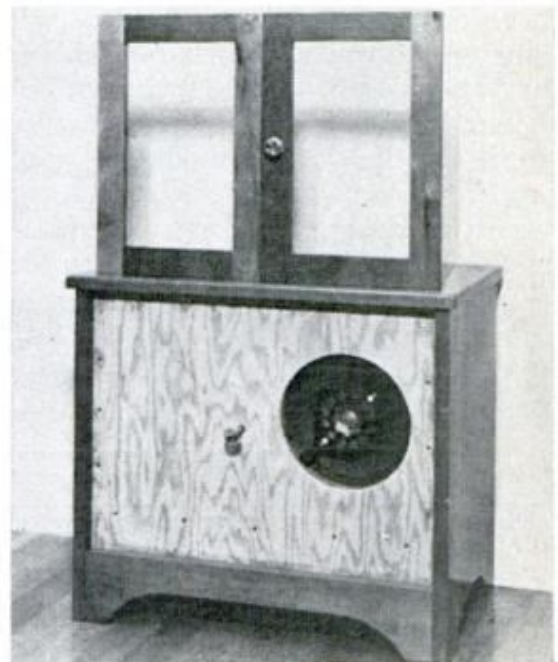

A CONVERTED CABINET makes an attractive stand for the TV set above and at the same time serves as a roomy enclosure for an extension speaker. Speaker is mounted in $\frac{3}{4}$ -inch plywood baffle at the front. Center panels were removed from the doors, leaving only the frames (shown on top of cabinet at upper right). Front was covered with grille cloth and the frames reattached to retain the look of doors. The back was also enclosed with a plywood panel

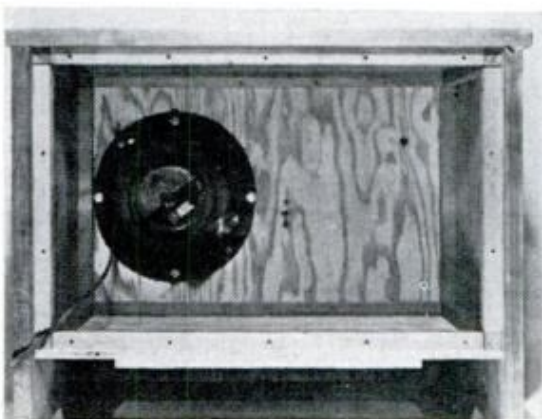

Stackable Shelf Modules Go Together Like 1-2-3

By LEONARD E. SABAL

SIMPLE SOLUTIONS to the problem of inadequate storage shelves often look simple—and ugly. Not so with this novel 1-2-3 system of shelf modules, however, especially as it displays a myriad of miscellaneous items while keeping them out of the way.

The 1-2-3 concept means simply that the three basic modules are built in proportions or multiples of 2 and 3. This means that the width of the smallest module shown below, for example, is one-third the width of the larger modules; while its height is two-thirds the width of the larger modules, and also equal to the height of the large units. Thus, it's possible to stack three of the small units side-by-side on top of a larger unit, or stack two small units on top of the large unit and then add a small module set on end.

The biggest single advantage of the system, however, lies in its flexibility—for with individual stacking modules such as these, you can vary the arrangement at any time, and also make other modules to suit special requirements. Thus, the four bottom modules in the center of this arrangement were made 18 in. deep to accommodate records and stereo equipment, while a 30x30 module and two 10x10s were needed to complete the system.

It's extremely important to make certain the modules are square and to use a good grade of 1/2-in. exterior plywood to eliminate the chances of eventual warpage. Finally, since your requirements will probably mean some deviation from the layout shown, make sure you plot your desired arrangement carefully to contain the number of modules you'll need. ★★★

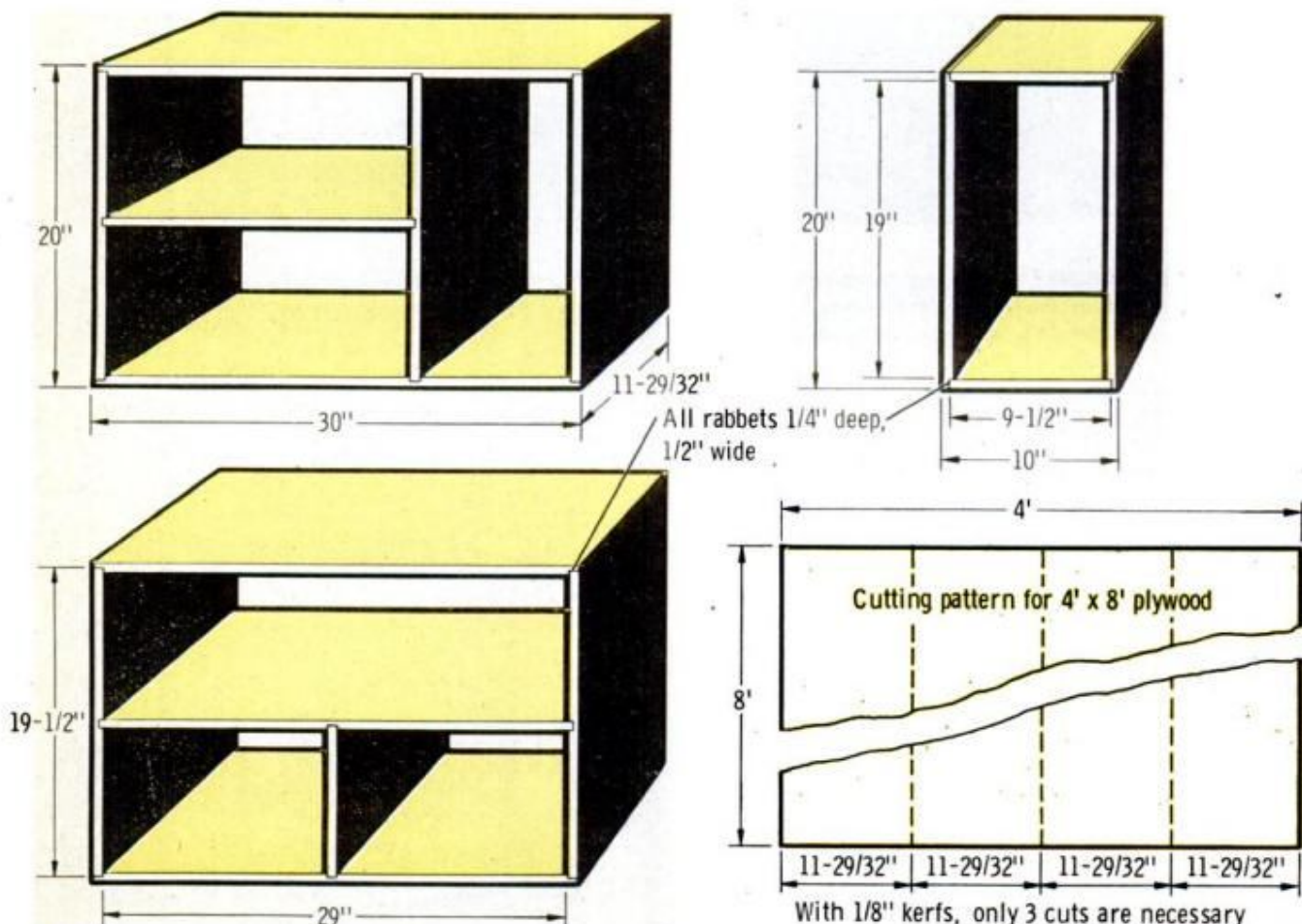



MISCELLANY OF ALL SORTS can be neatly stored in a wall of stackable modules. The units also can be used to form a see-through room divider, or fitted with back panels and used as bookcases

I Built This Driveway For a Mere \$100

By CRAIG WILSON

I COULDN'T SEE spending a thousand dollars for an 18x60-ft. poured driveway so I decided to roll up my sleeves and build one myself from brick rubble. Would you believe the one at right cost me less than \$100? What's more, the neighbors like mine better than theirs.

Where do you find brick rubble? Keep your eyes open for a demolition project in your area. If you are within 20 miles of an urban renewal area, your prospects are very good. Any demolition contractor who doesn't have an on-site excavation to fill will be glad to talk to you.

But don't buy just any brick rubble. Avoid bricks from a factory building. When the factory comes down, the bricks break instead of the masonry. Residential bricks are better. The low-grade masonry breaks away, leaving most bricks whole. The rest of the masonry will flake off with a few taps of a mason's chisel and hammer.

The rubble you get may include sidewalk and porch slabs, marble sills and sandstone blocks. Fine! You'll need all this for side and end reinforcements. An 8-lb. sledge will reduce anything you get to manageable size.

Know the cost of new brick before you negotiate. New brick in Ohio, for example, costs 7 cents a brick and up. Don't pay much more than 1 cent a brick. I paid \$10 each for four tractor-trailer loads.

That included hauling it 7 miles from the site to my home. My investment of \$40 yielded 5000 bricks, several tons of

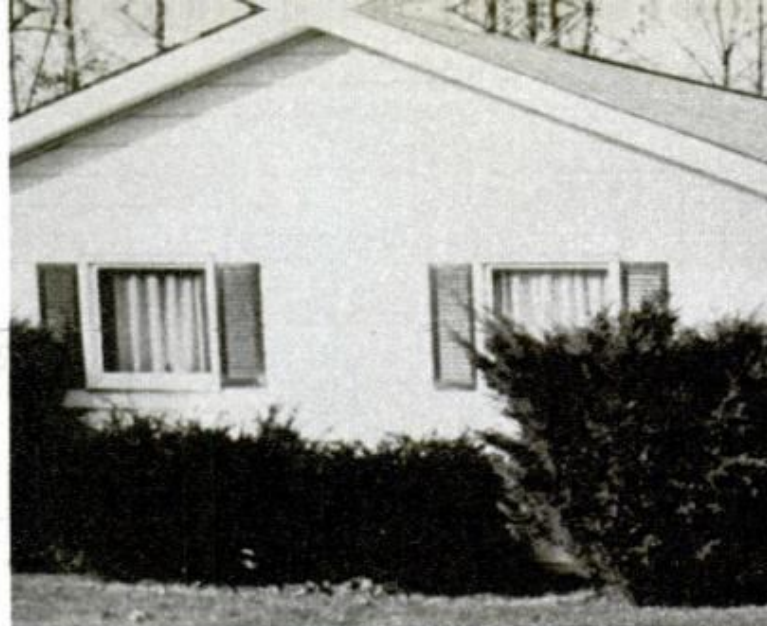

SPACE THE BRICKS $\frac{1}{8}$ to $\frac{1}{4}$ in. apart so white sand later can be swept into the cracks even with top

concrete slabs and about 2000 half bricks.

Wear gloves with leather fingers and palms when you separate the bricks (I wore out seven pairs at \$1.59 each).

Throw the good bricks to each side of the driveway and stack them in uniform amounts. Possibly one-third of the bricks will need no chipping at all.

Once you know how many bricks you have, lay out your driveway with pegs and twine. Allow as much width as possible with the quantity of bricks you have. It is best to have several courses of brick on either side beyond normal weight-bearing areas. Lay out a centerline as well as sidelines.

Ask the building inspector in your area whether or not you need a permit and then start by raking away the lumps and

(Please turn to page 210)

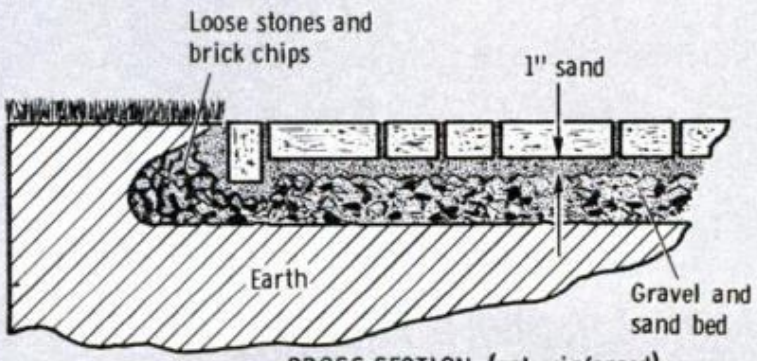

CROSS SECTION (not reinforced)

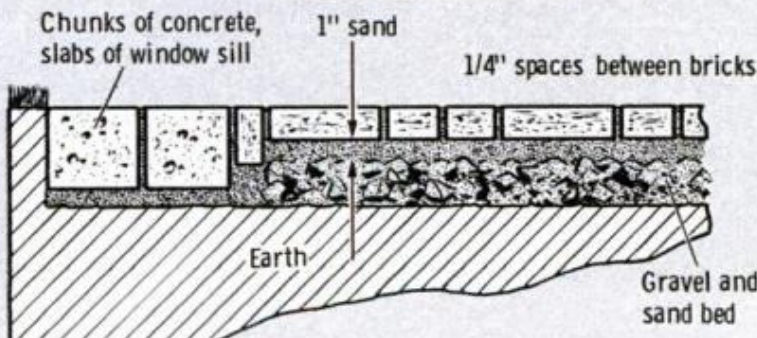

CROSS SECTION (reinforced)

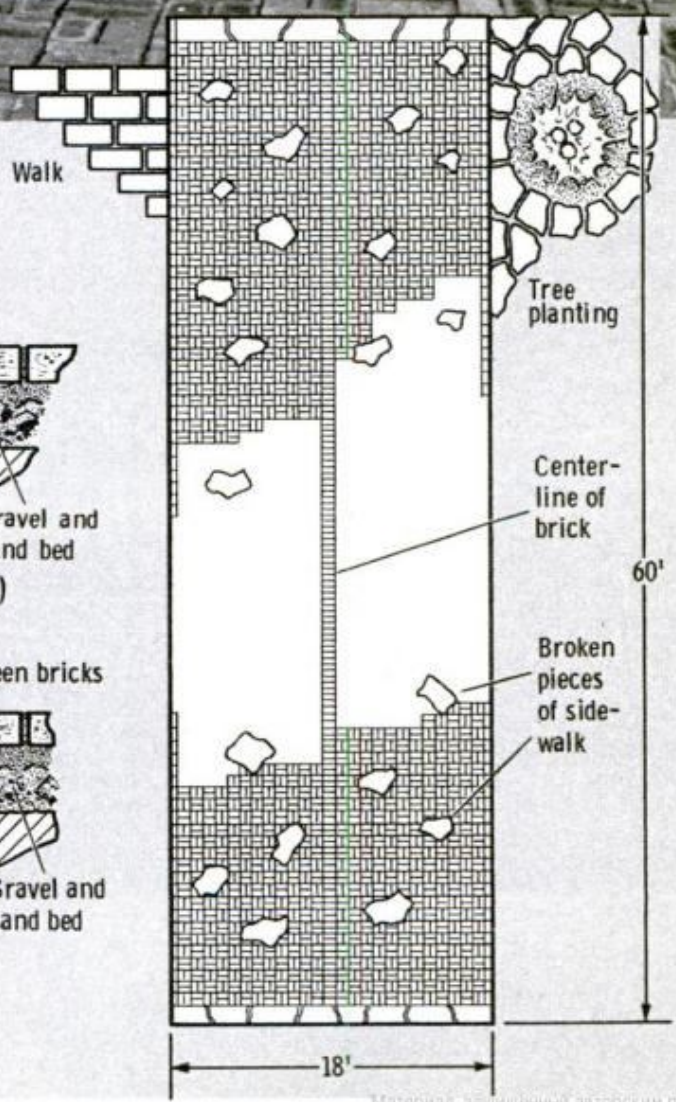

Packaged Fence Panels Offer Both Beauty and Privacy

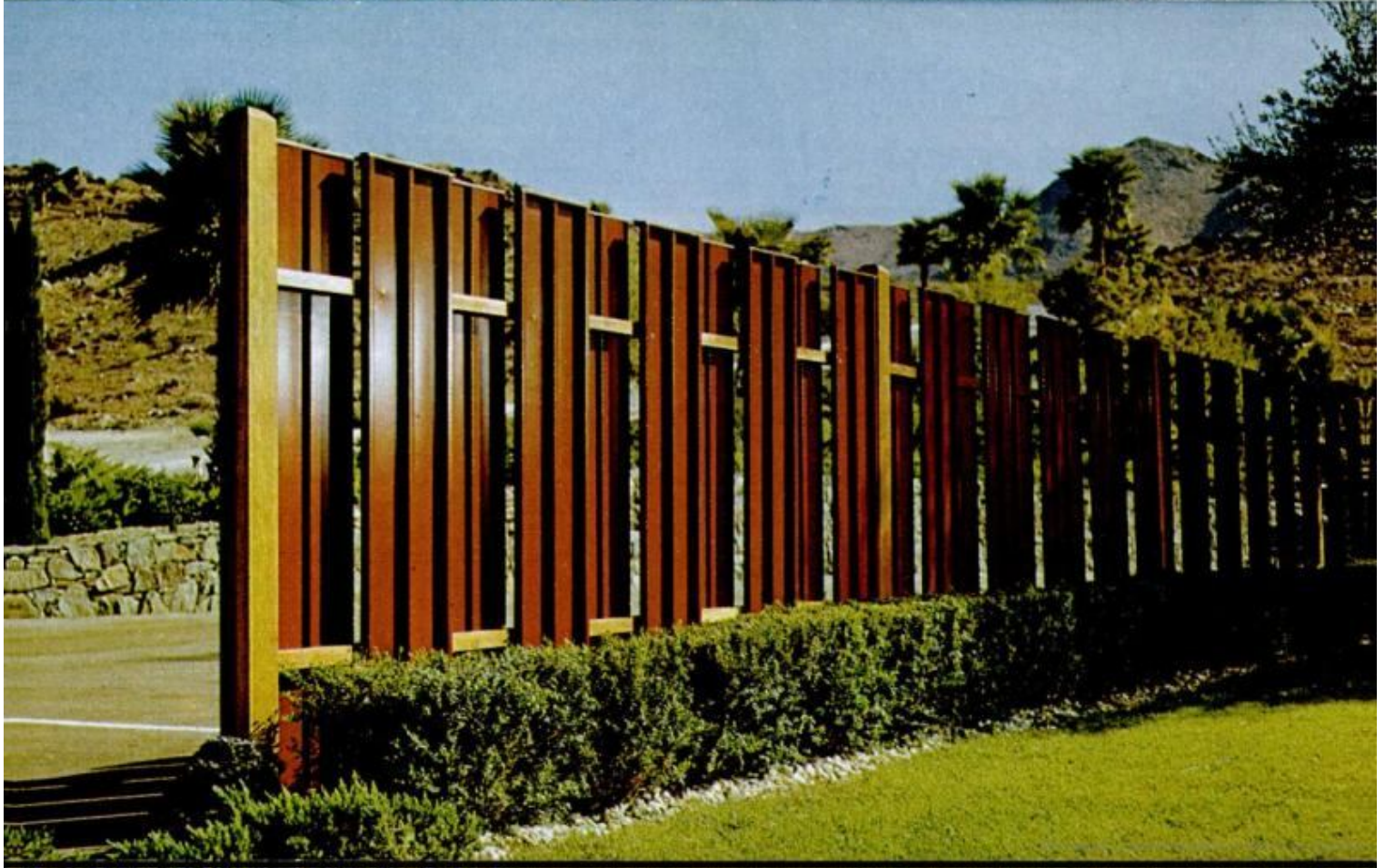



Prepainted aluminum panels are latest thing for building a long-lasting and maintenance-free 'board' fence

By WAYNE C. LECKEY, Home and Shop Editor

THE LESS THERE IS TO PAINT when it comes to a fence, the better. Ask anyone who has spent hours keeping a wooden one looking respectable.

But if it's a privacy enclosure you want, you just can't settle for a wire fence to beat the maintenance problem. So what's there to use that's maintenance free? Aluminum fence "boards."

With these never-need-painting panels, which come with a durable baked-on finish, fence upkeep is reduced to a minimum. After the initial painting or staining of the supporting posts and rails (if wood) you can practically forget the painting bugaboo.

Privacy Panels, as they are called, are made to order for the do-it-yourself fence builder. They come painted. They are lightweight, won't rust, warp or rot, will withstand an 80-mph wind and are actually fun to install. Best of all, you wind up with a fence that has the same good looks on both sides. Your neighbor sees the same attractive fence as you since the panels are applied alternately to front and back. There is no "bad" side.

The panels are sold ten to a carton (enough to build 10 lineal feet of fence), in a choice of white or redwood and in lengths of 4, 5 and 6 ft. The three lengths give you a choice of erecting a "see-over" enclosure, one with complete seclusion or

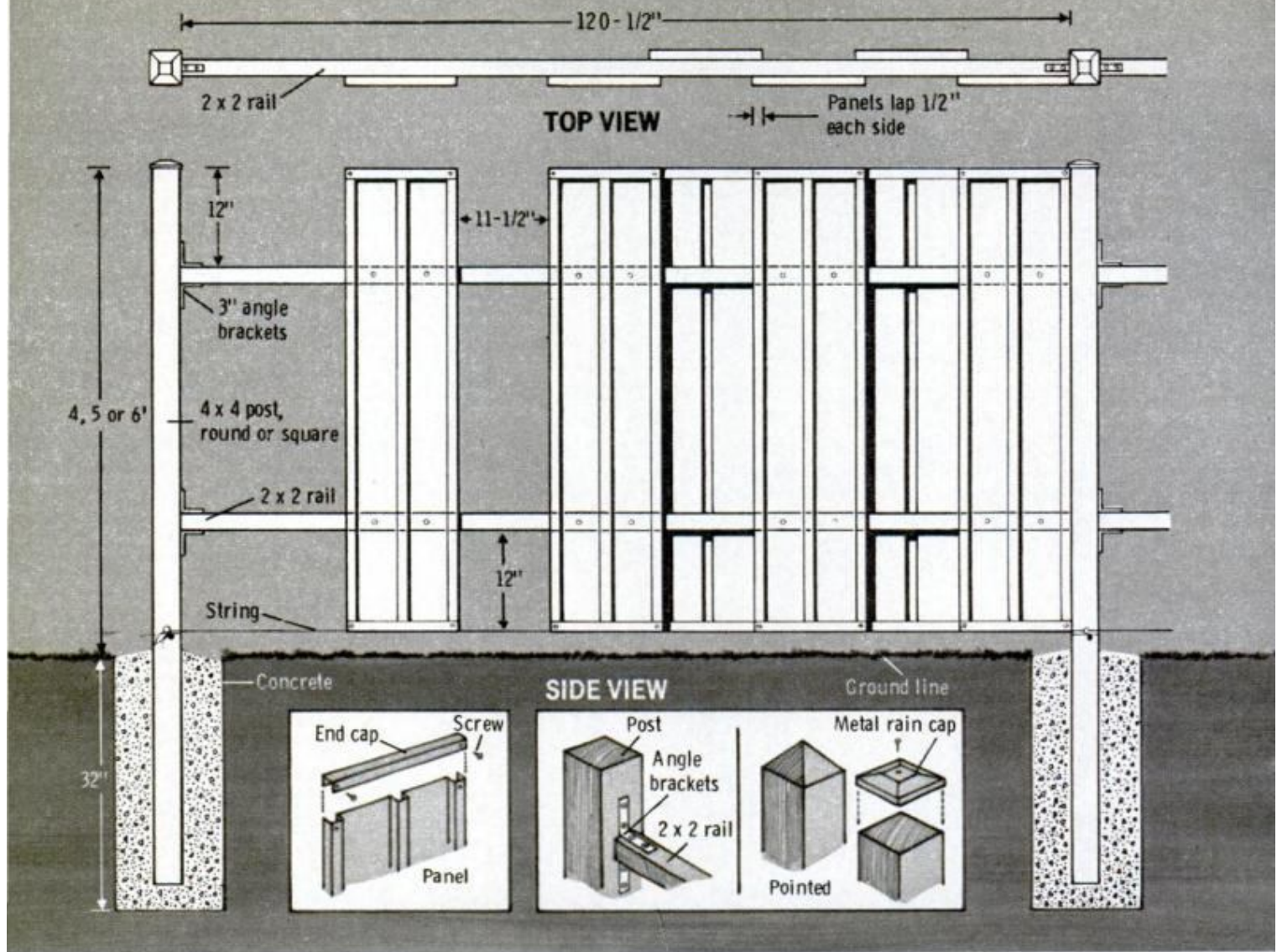

Technical Art by Adolph Brotman

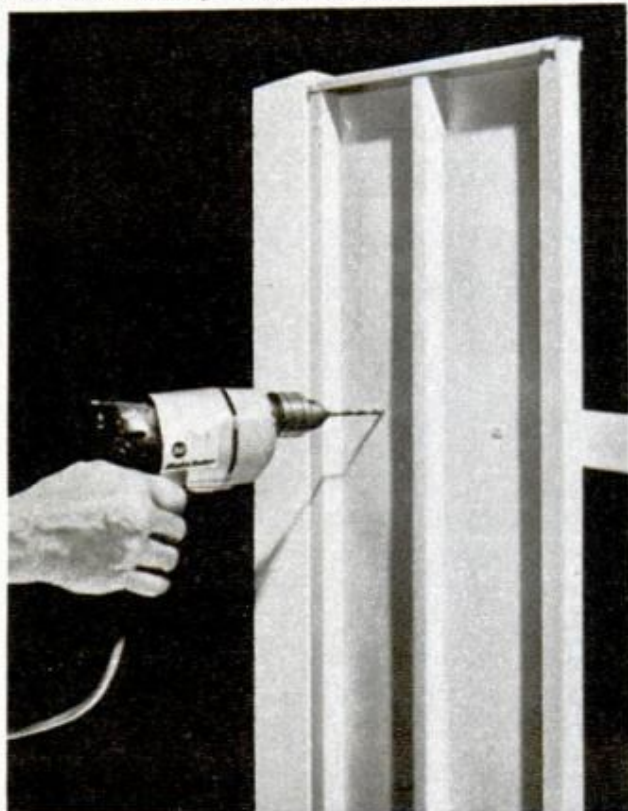

Holes ARE DRILLED when panels are screwed to pipe rails. Drilling is optional when panels are nailed to wood rails. Back up rail with brick when nailing

a combination of both. By combining all three heights you can create a stepped effect. By alternating the colors you can create a "light and shadow" effect. If you wish, you can paint the posts and rails a different color than the panels.

The ribbed panels come with end caps which are screwed to the top and bottom, plus all the fasteners needed to nail or screw the panels to either wood or metal rails. What you don't get are the posts and rails; these you provide, although if you want an all-metal enclosure, you can order aluminum posts and rails separately.

The supporting framework is erected in the usual manner, the posts being set in concrete and spaced 120½ in. apart to accept 10 panels, 6 on one side and 4 on the other. The ½-in. lap prevents direct "see-through" but permits free flow of air. The 2x2 rails can be attached to posts with angle brackets or toenailed.

Ten panels 4 ft. long sell for \$36.67; 5 ft., \$43.19 and 6 ft. for \$49.98. They are made by Nichols Wire and Aluminum Co., Box 3808, Davenport, Ia. 52808. ★ ★ ★

Now: Shutters You Don't Have to Paint

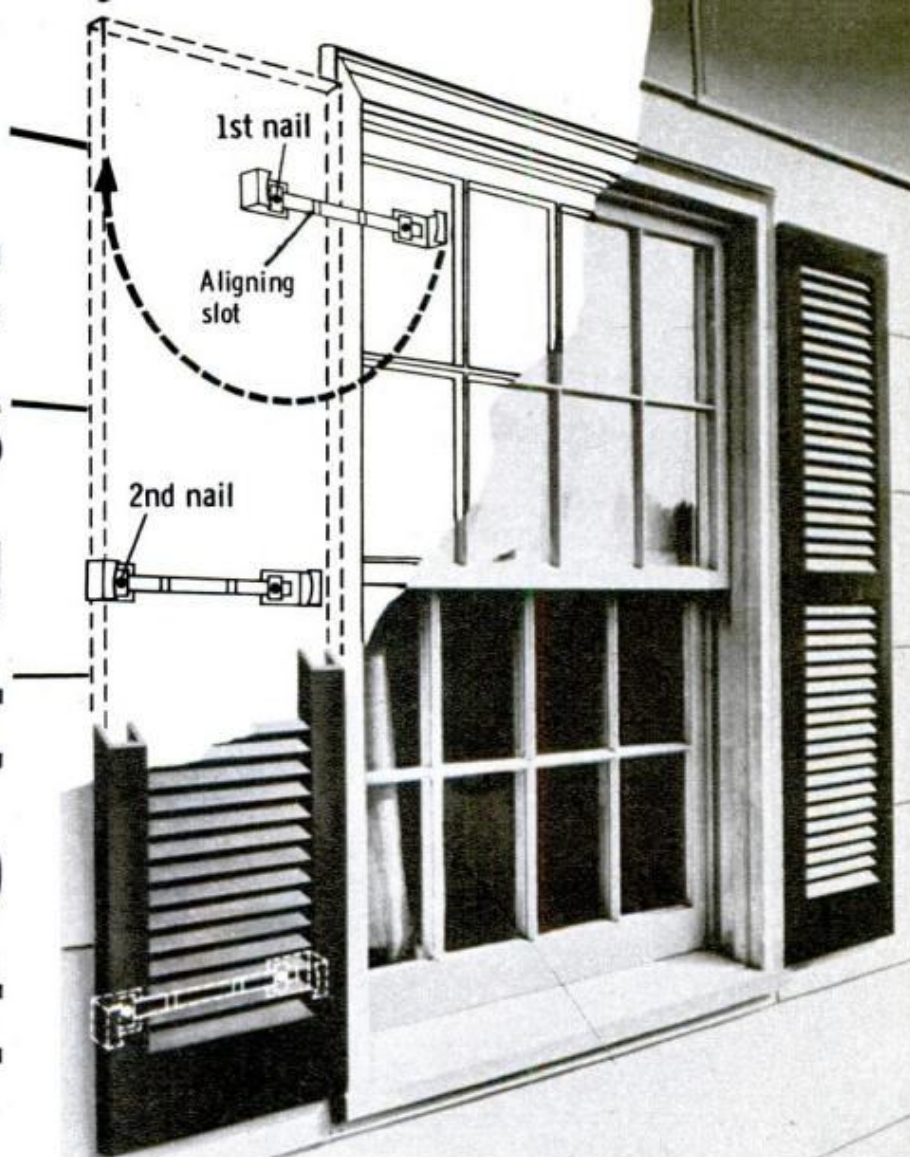

WINDOW SHUTTERS are mean things to paint, especially when you're perched high on the rung of a ladder. But that's all past.

Now, thanks to DuPont and nylon, there's a new molded shutter on the market that has the color built in. It needs no painting and is both weatherproof and rotproof. What's more, you'll find it's a snap to put up and take down since it snaps into place.

This quick-change act makes it possible to treat your home to a seasonal change of color. Two or more sets of "standby" shutters will let you switch from one color to another to give your house a periodic fresh new look.

The shutters are available in widths of 14 and 16 in. and in lengths of 35 to 71 in. for windows, 75 to 80 in. for doors. Basic colors are green, black and white, although there are some 16 other special colors you can order.

Three metal clips hold each shutter. To line them up you place a slot in the clip even with the window frame and drive a nail. Then you swing the clip 180° and drive a second nail. To mount each shutter you merely press it against the clips. Prices run about \$12 a pair for the 35-in. size to \$21 a pair for the 80-in. size. You'll find them at your local building supply house. ★ ★ ★

CLIPS HOLD SHUTTERS securely, wind can't blow them off, yet slight tug pulls them free when house needs painting. Hidden spring clips grip back of shutters. Molded channels on backs snap onto clips. Clips come to suit a particular shutter width



KEYS TO QUICK INSTALLATION are three metal clips which are nailed to the house

HOME AND YARD



Enhance Your Yard With a Garden Work Center

Here are basic construction details for building potting benches, storage bins and the structure itself.

USING A LITTLE IMAGINATION—and the construction know-how given on these pages—you can create a garden center as handsome as the one shown on the opposite page. Designed by the California Redwood Assn., it solves storage problems, gives a comfortable work area for gardening chores and adds beauty to your back yard.

Whether you stick close to the one pictured or design your own, there are three things to remember when selecting a garden center site: 1. Locate the center so that materials can be conveniently hauled to it from the car; 2. Study shade and sun patterns (and prevailing winds) at the exact location; 3. If you plan to erect a greenhouse adjacent to the center, locate it so that the greenhouse will face south and east (to avoid excessive solar heat).

The basic elements of a functional garden center are a bench for potting, transplanting, labeling and other gardening jobs and, a weatherproof storage locker for protection of garden tools and equipment. If you have the space, add

storage bins for bulk planting materials such as peat moss, sand, loam and fertilizer. A convenient water supply is a necessity and the structure should be built with a minimum 8-ft. headroom.

The center itself can be attached to an existing structure or built freestanding. Depth to which the 4x4-in. posts should be set can vary with soil and weather conditions but generally, 36 in. is adequate. The simplest method is to set

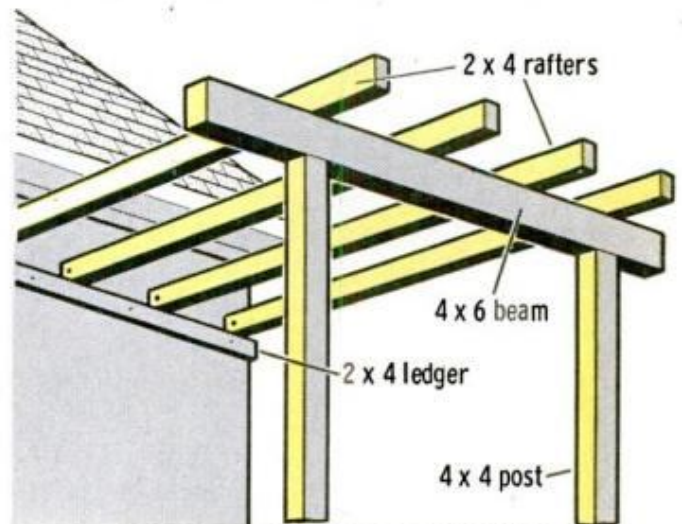

BASIC STRUCTURAL ELEMENTS

REDWOOD POTTING BENCHES

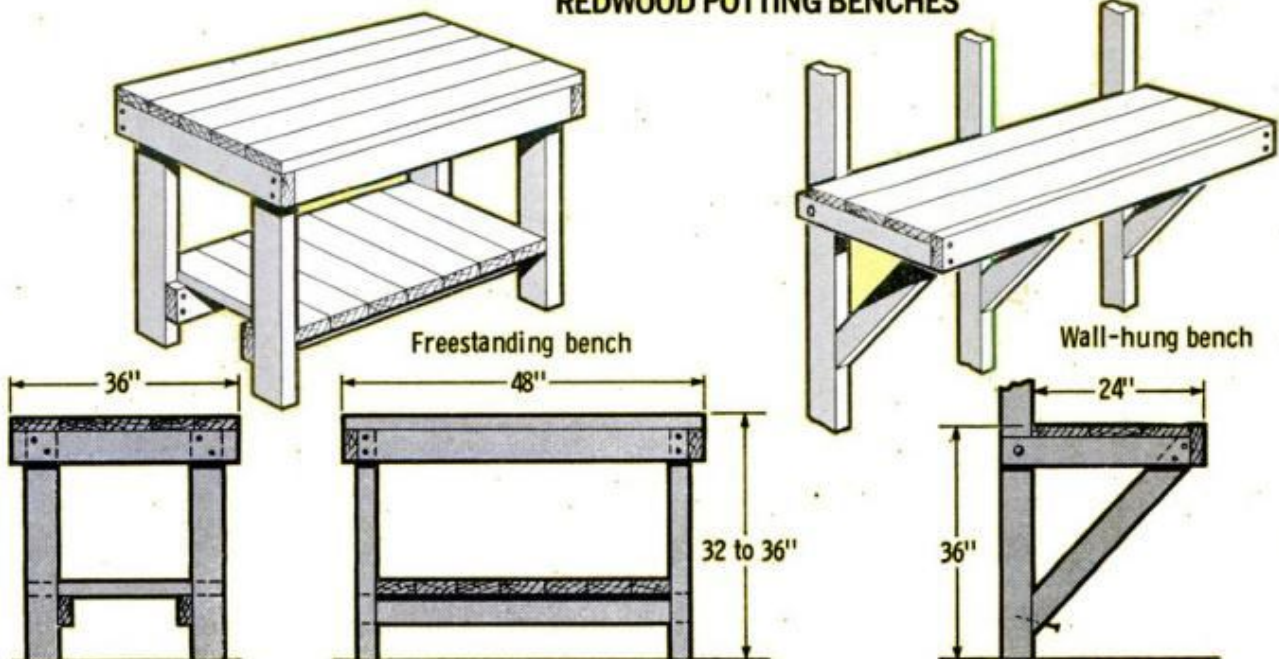

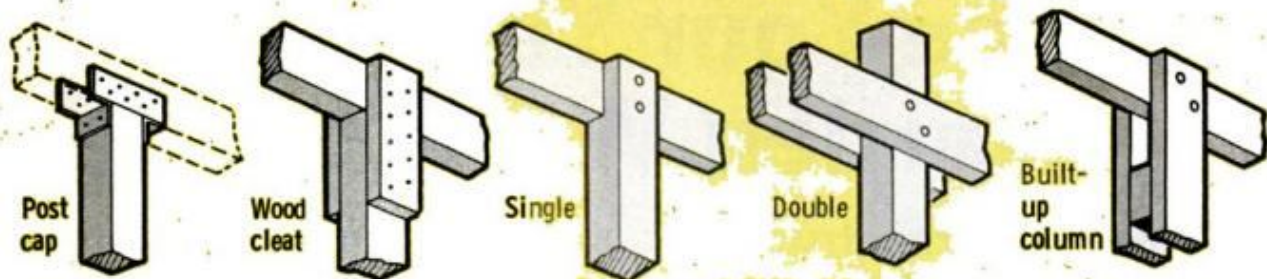

BOLTED ROOF SUPPORTS

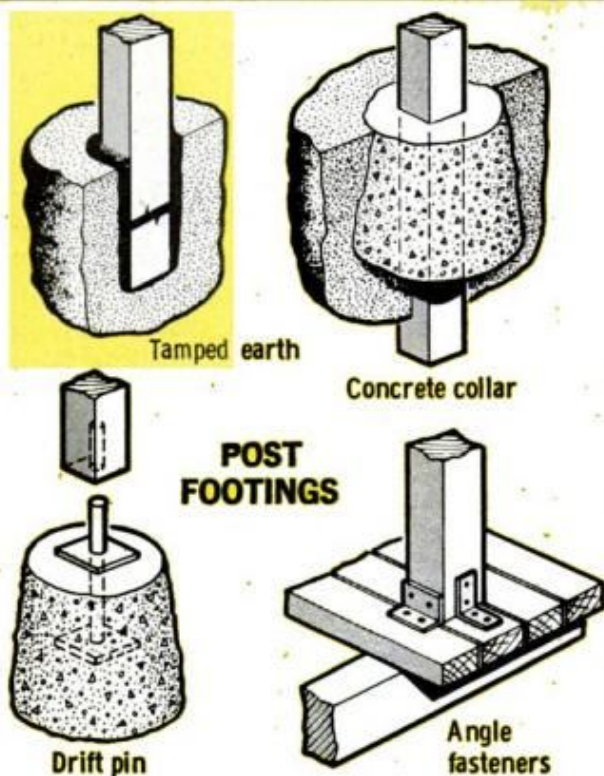

POST FOOTINGS

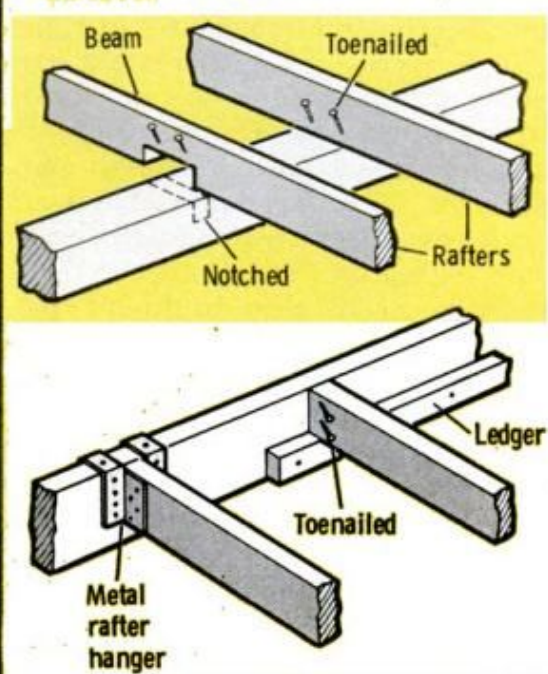

HOW TO SUPPORT RAFTERS

the post directly into the ground. However, if the soil is sandy or unstable, posts should be anchored in concrete.

The beams support the rafters and tie the posts together. Though the roof can be left open, in many areas this would be impractical. A wide variety of materials can be used to close-in the roof: shingles, reed fencing, bamboo, canvas, window screening, lath, glass or plastic are all good choices. If you decide to close in the roof, slope it to provide positive water runoff.

Construction tips. Highly resistant to both weather and decay-producing organisms, redwood is a logical material for garden center construction. Its natural resistance to the elements eliminates the need for preservatives which can be harmful to plants. For maximum holding power, use only noncorroding aluminum or quality, hot-dipped galvanized fastenings. Before you start, check with your local building department to determine if there are any legal restrictions or if a building permit will be required. ★★

STORAGE BIN

A BIN built of all-heart redwood stores fertilizer, other bulk garden materials. For greater mobility, bin can be set on casters

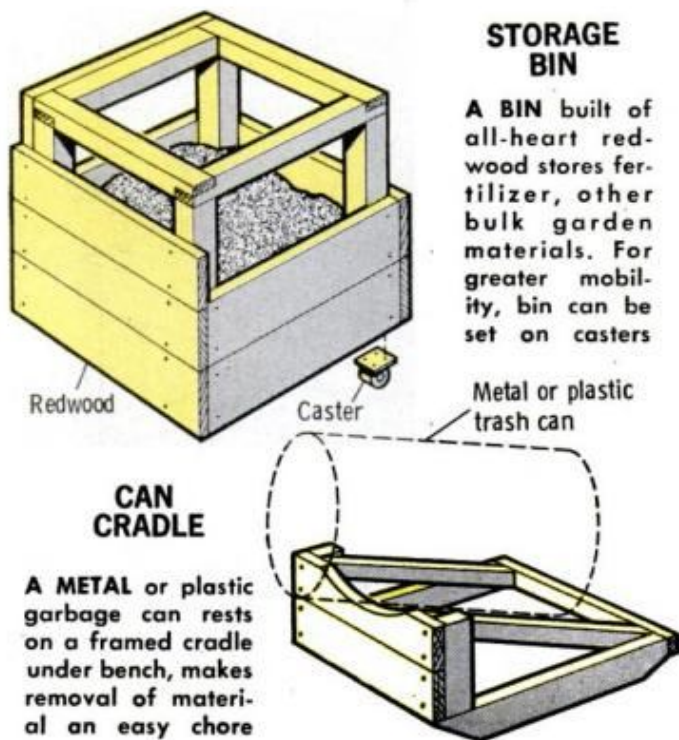

CAN CRADLE

A METAL or plastic garbage can rests on a framed cradle under bench, makes removal of material an easy chore

ALTERNATE METHODS for construction give all you need to know to build your garden center. Accessories (above) make gardening tasks more pleasant

Save by Making Your Own Colonial Door Frame

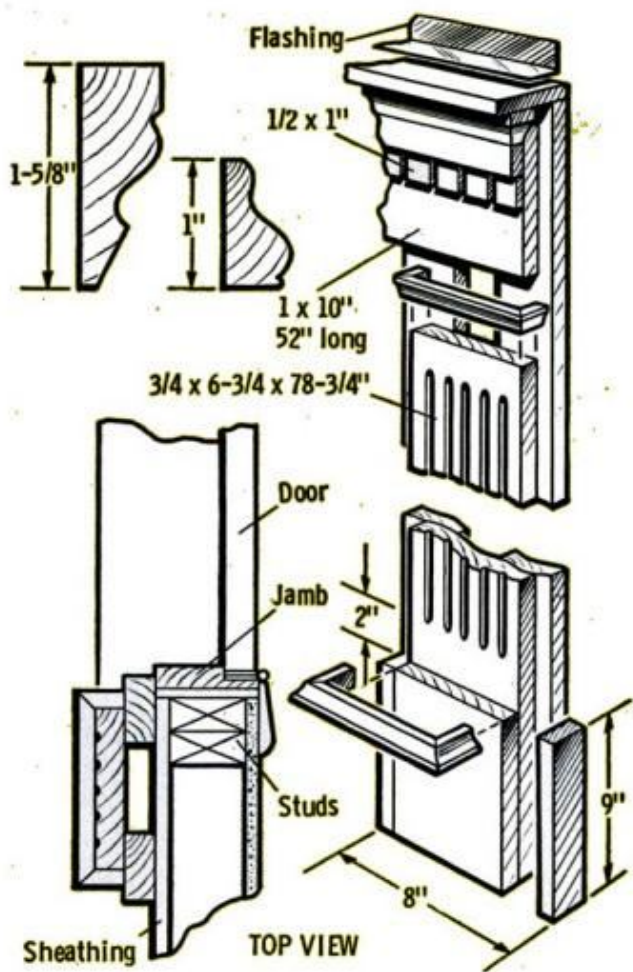

WHEN REMODELING the front of your home, nothing updates the entrance more than a colonial frame. You can buy such a frame for about \$60, but for \$15 worth of stock lumber and molding you can make it yourself and pocket the difference.

The drawing shows how each side pilaster is built up as a separate assembly by starting with a clear 1x8 pine board and fluting its face with a 1/2-in. core-box cutter in a portable router.

The fluted board is doubled up at the bottom with a 6 3/4 x 9-in. block, glued and screwed from the back. Then two side filler pieces are added and finally cove molding is mitered around the pilaster at top and bottom.

The side pilasters are joined across the top of the doorway with a separate pediment built up of four pieces. When installed, the pediment rests on the top cove of the pilasters.

To install, each pilaster is nailed to two 1x3s which are first plumbed and nailed to the house. Notice how the inner 1x3s are nailed to the edges of the door jamb

spaced to project 3/4 in. along each side of the pilaster. The pediment is likewise nailed to the 1x3 vertical members, flush with the outer edges. The top member of the pediment to which the flashing is added, is applied last. It is best to first prime the three separate assemblies with white paint before installing, and remember to use waterproof glue in building up the parts. The overall dimensions given are for a standard-size exterior door.

—Joseph Olivari

Instant hot water

The electric hot-water heater in my basement is about 20 ft. from the bathroom plumbing, and it was necessary to run the water awhile before hot water reached the faucet. This wasted water until I hit upon the idea of running a length of electric heat tape (the nonthermostat type) along the hot-water pipe from the heater and covering it with fiberglass insulation. Now we have hot water as soon as the faucet is turned. Oddly, we found no appreciable increase in our electric bill.

—Paul Murdock

HOW TO INSTALL GUTTERS AND DOWNSPOUTS

By RICHARD DAY

INSTALLING GUTTERS and leaders is actually an easy job. That's a strong statement, but the fact is that the worst part of the job for most do-it-yourselfers is the height. If height bothers you and you have a tall house, your best bet is to call in a pro to do the job. But, whether you decide to tackle the improvement yourself or not, the facts on these pages will let you know what a good gutter and leader system is all about.

Stated in simplest terms, a good roof-drainage system is designed to carry water away from the house quickly. To do it, gutters gather runoff water from the roof and move it to drop outlets. From here, leaders conduct the water into vertical downspouts (which should discharge directly into storm drainpipes or be extended away from the house to prevent foundation seepage).

Tools needed for gutter installation include a hammer, screwdriver, pliers, tin snips, hacksaw, ruler, level, chalkline, caulking gun, drill and, if the gutter material requires it, a Pop RivetTool. (Aluminum gutter, for example, calls for riveted connections.)

Gutter materials are available in many sizes and shapes, including half-round as well as style *K* or ogee box-gutter cross section. Gutter lengths are usually 10 ft.; but in some materials, 16, 20 and even 30-ft. sections are offered.

Downspouts come round, rectangular or square in corrugated or plain styles. The corrugated type is better in freezing climates because it expands with the freez-

GUTTER SEALANT, a nonhardening butyl rubber, is used on all joints (end cap here), prevents leaks



PLANNING No run from high point to downspout should be longer than 20 ft.

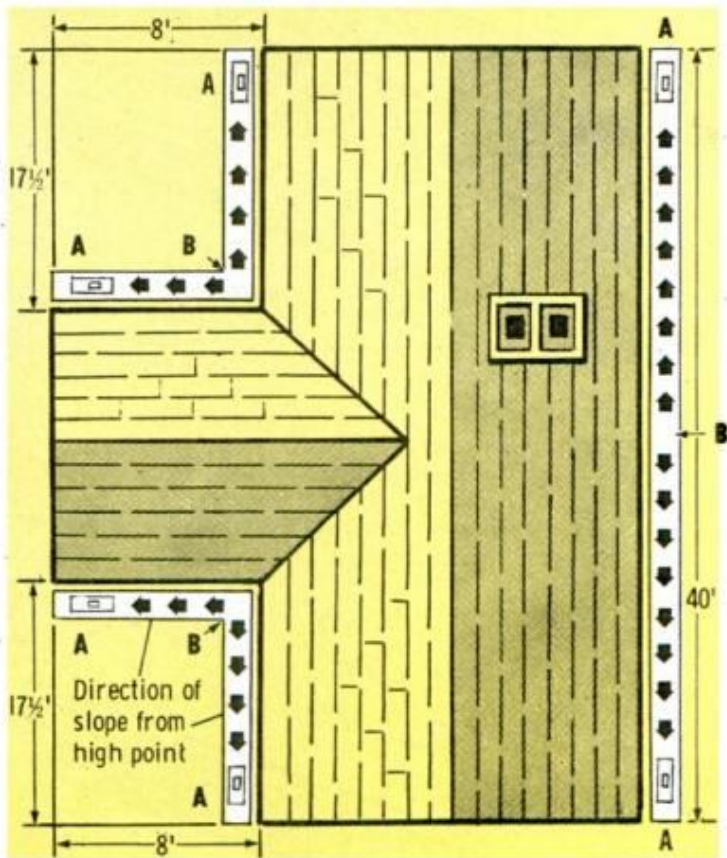

A- Gutter downspout
B- Gutter high point

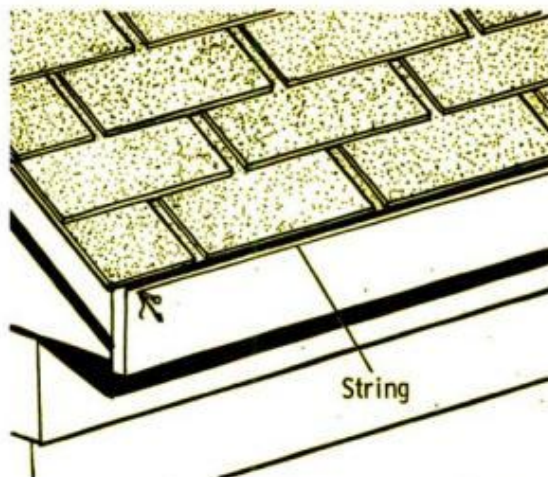

CHALKLINE IS TACKED with slight slope, then snapped. Homemade wire handle (below) suspended from nails, holds gutter for fastening

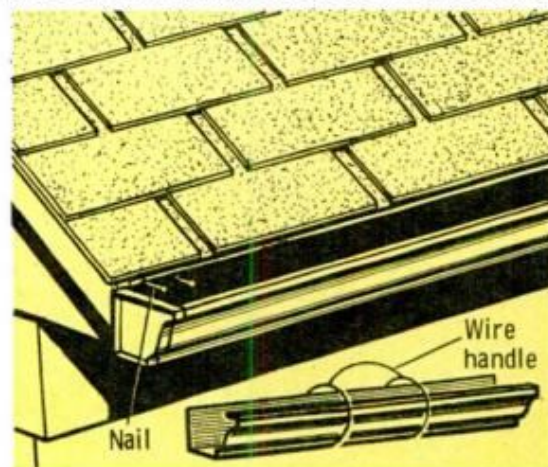

ing water. Elbows come in bends of 30, 45, 60, 75 and 90°. You can choose from among many types of gutter hangers. End caps are made to seal the ends of gutter sections (both right and left). Miters, or corners, can be bought for both inside and outside turns. Slip-joints or expansion joints are available to connect gutter lengths. All necessary hardware, including screws, rivets and nails, can be pur-

SLIP-JOINT CONNECTORS joining sections receive a generous bead of sealant first, give tight joint

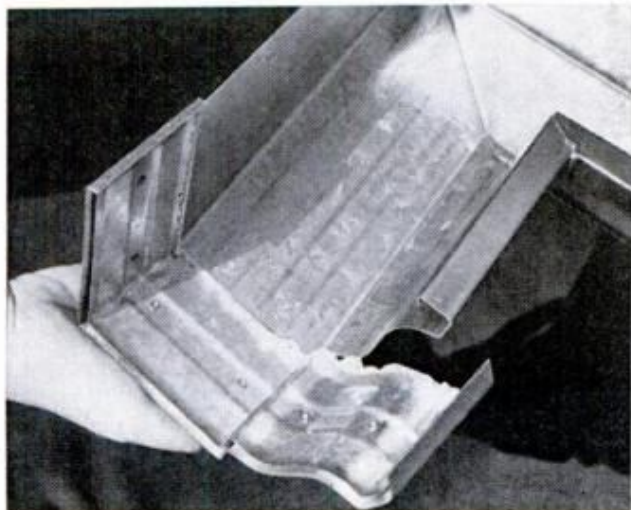

chased for compatibility with any system.

Gutter systems are available in galvanized steel, aluminum, copper, zinc, lead, vinyl and wood. Cost for a typical one-story ranch home ranges from about \$85 for steel up to approximately \$140 for aluminum.

Galvanized-steel gutters are generally the lowest in cost. They're now available with baked-on acrylic coatings that do away with the problem of painting raw galvanized surfaces. You simply add the finish coat of your choice after they're installed. Gutters come in varying gauges—the higher the number, the thinner the material. The most commonly used is 28 ga. but for extra strength use 26 ga. For economy, use 29 ga. Unlike steel, aluminum gutter material thickness is spelled out in inches (.027 and .032 in. are popular).

Never mix your metals, even small parts like screws. Electrolytic (galvanic) action between dissimilar metals will corrode them quickly. Choose one material and stick with it.

The problem is not so much in determining the size of the gutter, but in finding the size and number of downspouts to

ALUMINUM GUTTER

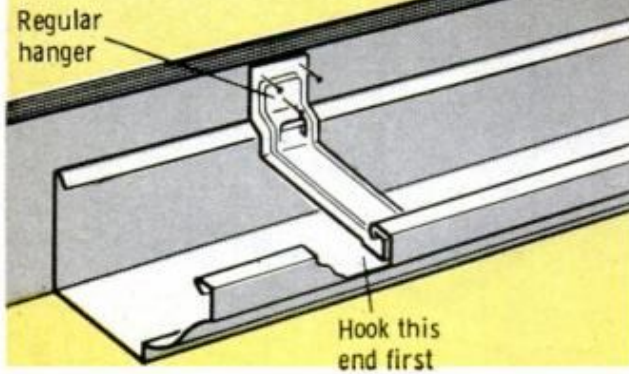

HANGERS ARE SPACED a minimum of 30 in. on center, preferably at rafters. Hanger strap is hooked to front and rear lips of gutter prior to nailing. Then, back of hanger is nailed to fascia at rafter points or directly to rafter where fascia boards are not installed. 1½-in. nails are used in all three holes

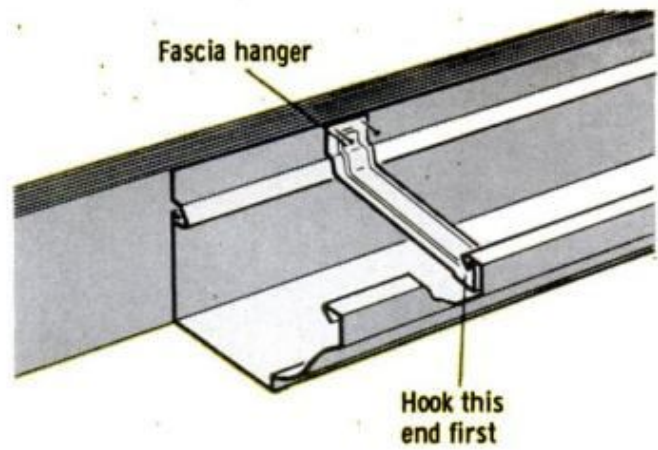

FASCIA HANGER and apron is used on jobs where the roofing material is already in. To install, hook of fascia apron is engaged along back of gutter and secured to fascia at 12-in. intervals. The fascia hangers are spaced 30 in. apart, hooked into front lip of gutter and through the apron to fascia

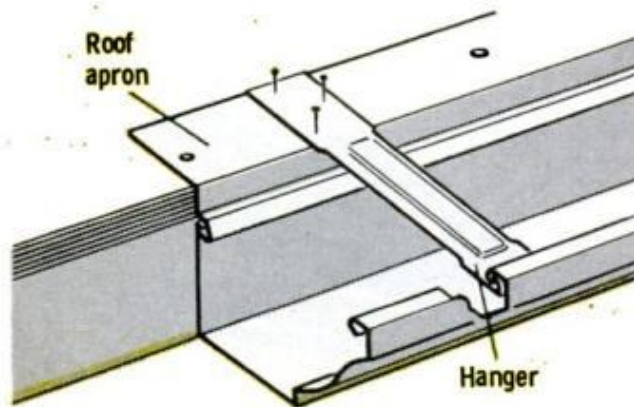

ROOF APRON and hangers can be used on new work, provide additional flashing. Here, apron is engaged to the gutter along the back, then nailed to the roof sheathing at 12-in. intervals. The hanger straps are hooked into the gutter's front lip and nailed over rafters every 30 in. Use 1½-in. aluminum nails

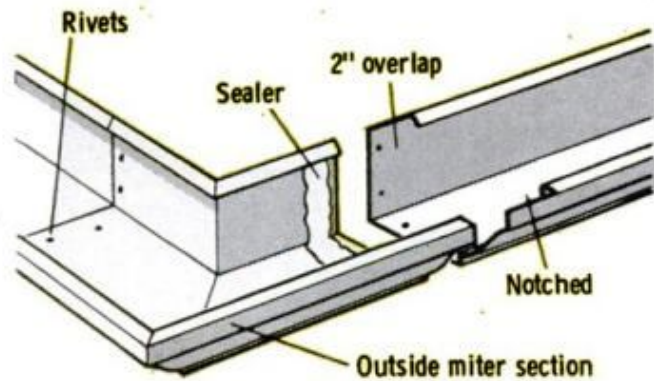

JOINING GUTTER AND MITER SECTIONS. Joint sealer is applied around one surface of entire joint. After notching top front bead and rear of gutter as shown, lap sections 2 in. Drill rivet holes and insert two rivets in each of three sides. Apply a bead of sealer along inside edges of all joints

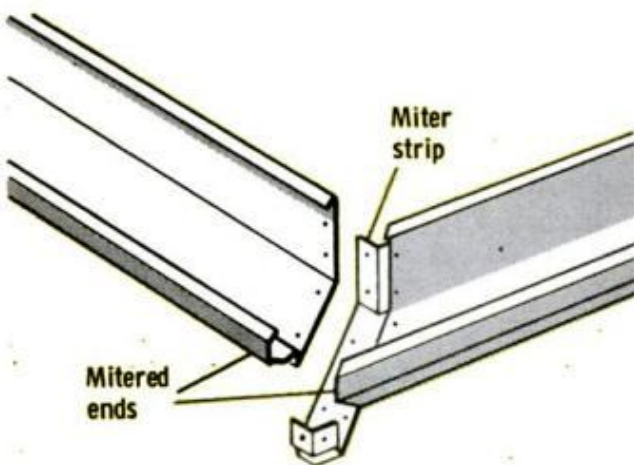

FIELD ASSEMBLY OF MITER STRIP. Cut both left and right-hand gutter sections at 45° angle for both inside and outside miter strips. Apply sealer to the miter strip and rivet to the butted ends of the gutter sections. Joint sealer should be applied to all rivet heads to prevent drip-producing holes

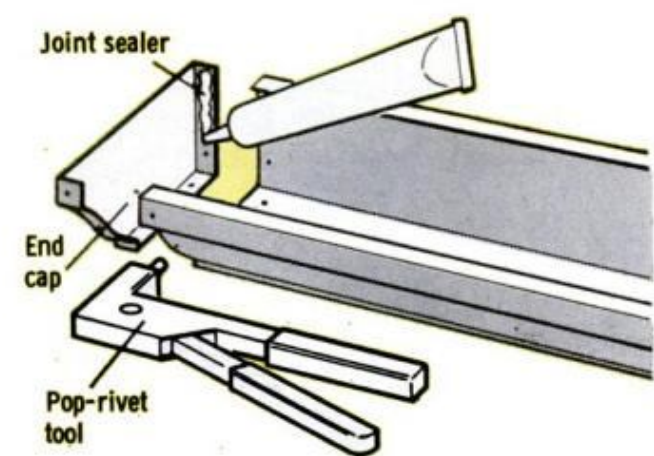

RIVET-TYPE END CAP installation is easy to do, gives neat-looking job. After applying joint sealer to end cap, it is slipped onto gutter section. Drill rivet holes and insert rivets. It's important to use adequate number of rivets since the joints have to bear the weight under snow and ice loads in winter months

carry water away from the gutter. A general rule is to use one outlet for each 600 sq. ft. of roof area. A gutter run of more than 20 ft. needs a downspout at each end. If shorter, put a downspout at one end.

Determine the actual roof area to be served, including all gables and roof surfaces. Don't use the horizontal length times width of your roof. Since rain seldom falls in a true vertical, all surface planes gather water during a storm. When the roof slope is increased, the roofline is raised accordingly and more surface is created to catch additional rainfall.

Downspouts should be placed near the corners of the house so that gutter water will not have to flow beyond the sharp turn. Of course, appearance plays a part in locating such outlets. If possible, keep them away from doorways and place downspouts flush against the front of the building when viewed from the street. If they protrude out to one side, downspouts can be an eyesore.

Size of gutter depends upon: (1) the number, size and spacing of outlets; (2) slope of the roof (a steep roof carries water to the gutter faster than a flat roof); (3) style of gutter used, and (4) the gutter's slope. Avoid a gutter less than 4 in. wide. And never use one that is smaller than the leader. If leaders are spaced 20 ft. or less, use a gutter the same size as the leader. But if they are more than 20 ft. apart, add 1 in. to the gutter width for every 30 ft. of additional spacing on peaked roofs. Add 1 in. for every additional 40 ft. of gutter length for flat roofs.

Gutter slope is a problem. It looks bad on the house, yet it is needed. The minimum slope from high point to downspout should be $\frac{1}{2}$ in. in a 20-ft. run. A better slope is 1 in 20. Though a gutter can be set dead level, it requires using larger gutters and downspouts to drain off the water. With no slope, water pockets are a possibility. They encourage corrosion.

Installing gutters

When installing a new gutter system, it's a good idea to first clean and paint the fascia boards. Next, stretch a chalkline along one fascia board to locate the top of the gutter. Allowing for slope to the downspout, run the line out to the other end of the fascia, then snap it.

Start gutter assembly at an end opposite the leader. Select the proper end



DOWNSPOUTS AND GUTTER sections are cut with a 32-point hacksaw. Support the section solidly and keep the blade flat as possible to avoid pinching

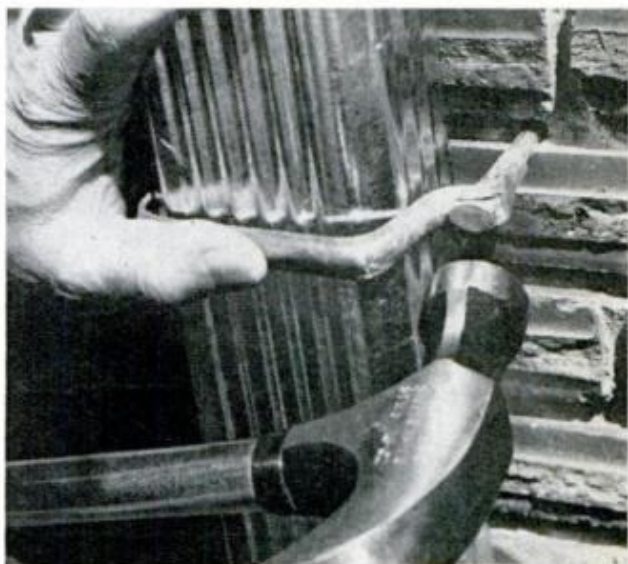

FASTEN DOWNSPOUT to wall with strap and nails. Straps differ for masonry and wood walls. In masonry, the studs should be driven into mortar joints



ELBOWS are used to bring the leader back from the roof overhang to a downspout on the house wall. After positioning, holes are drilled for the rivets

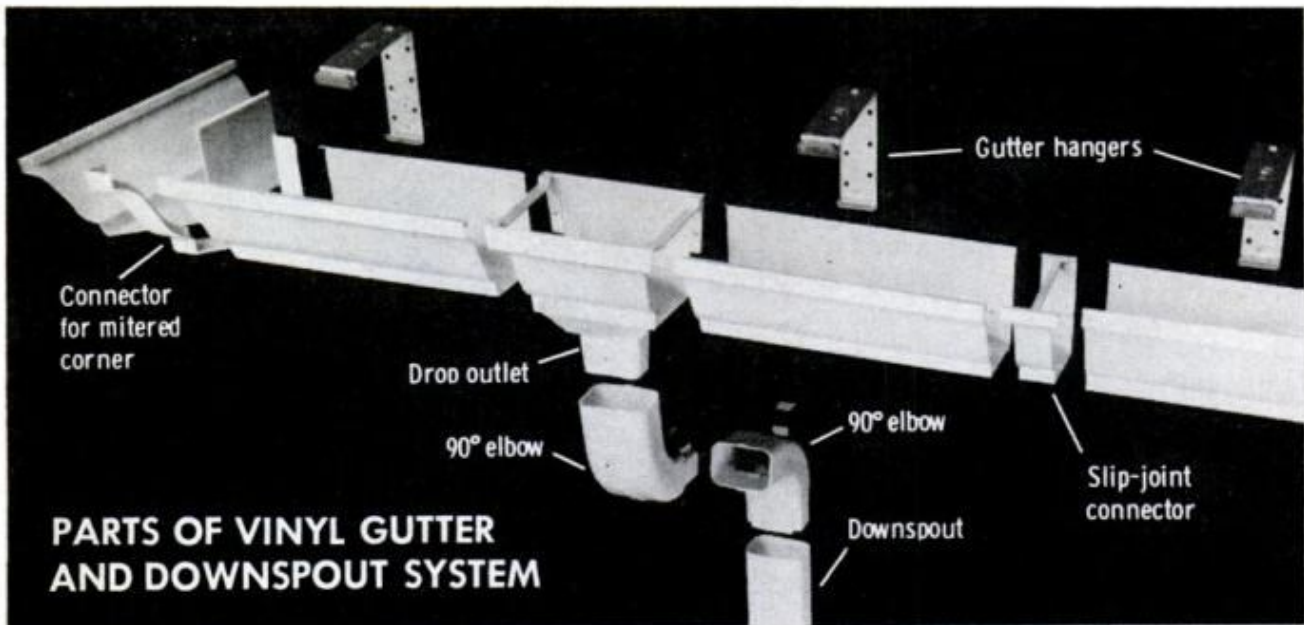

BIRD & SON, INC. PHOTO

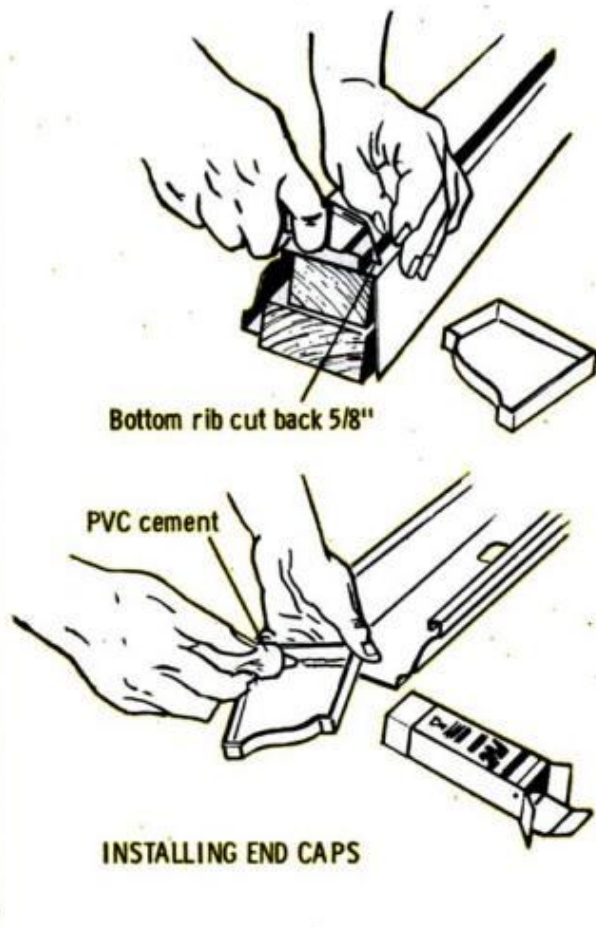
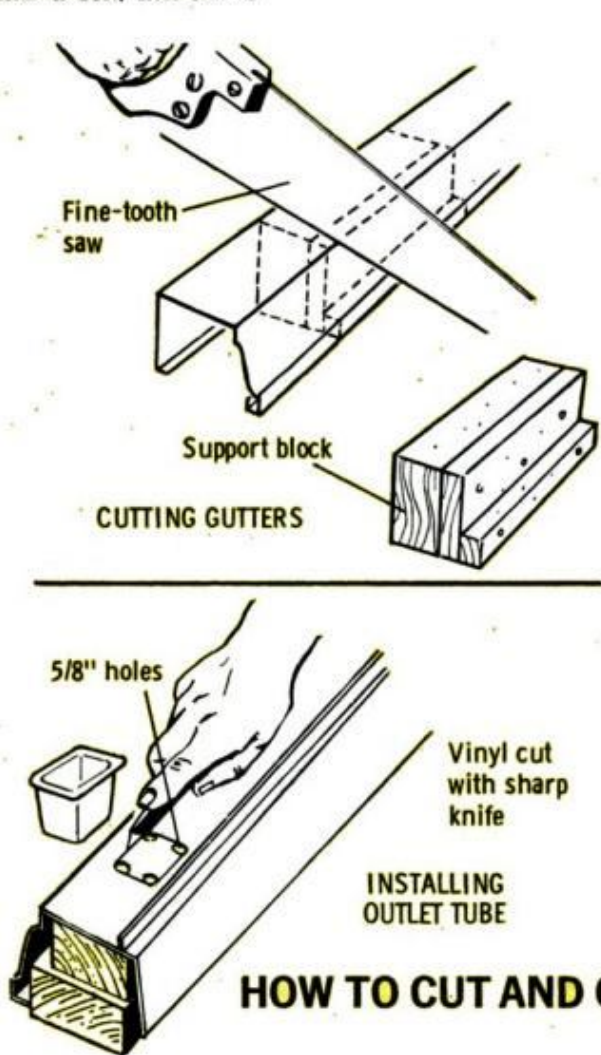

HOW TO CUT AND CEMENT VINYL GUTTER

cap, fill its grooves with gutter sealant and attach it to the gutter. A gutter should extend $\frac{1}{2}$ in. beyond the rake edge of the roof.

Complete assembly of a manageable section of gutter, then lift it into place. Working alone, rest one end of the assembly on a 10-ft. stepladder. Or, you can fashion wire loops (as shown) around

the gutter and hook them over nails tacked to the fascia or the roof.

When you reach a corner, attach either another end cap or an inside or outside miter. If the corner calls for a leader, use the special gutter section with a leader fabricated into it. The end cap or corner is then attached to this section.

Joints between lengths of gutter and

fittings can be made by overlapping, or with slip-joint connectors. For a water-proof joint, treat slip joints the same as end caps, filling their grooves with gutter sealant and sliding the gutters into them from each side.

Lap joints are my personal choice. To make them, cut the top flange of the bead back at an angle (see drawing). Spread two 1/4-in. rows of gutter sealant spaced about an inch apart on the uncut gutter. The beads should extend without gaps over the entire inside circumference of the gutter. Insert the cut length into the uncut one about 2 in., drill and rivet. The rivets and sealant provide a lasting, watertight bond.

With the assembled gutter tacked in place, attach the gutter hangers. Of two basic types, brackets fasten to the fascia and straps attach to the roof. Line up the top edges of the hangers with the chalk-line. Slip the gutter into each hanger, making sure the back edge of the gutter is under the top lip of the hanger and the rear bottom edge of the gutter rests on the bottom of the hanger. Depress the top hanger flange with a screwdriver and hammer it down. Then insert a hanger strap under the front lip of the gutter and place the strap's slot into the hanger's hook with a twist. Punch down the hook with a screwdriver and hammer it down to hold the strap securely.

The procedure for fastening strap hangers (which go under the roofing) is similar, but it means lifting shingles and sticking them down again with mastic. To use strap hangers, position the gutter section so that its top edge is flush with the guideline. Nail the gutter to the fascia board with one 6d nail every 32 in. Hook the hangers into the underside of the front bead of the gutter and nail them to the roof underneath the shingles.

The wraparound hanger works like a strap hanger, except that it locks around the gutter.

Another method of attaching gutters is the spike-and-ferrule system. Position the gutter, then temporarily nail it to the fascia with 6d common nails at several places. Place the ferrule inside the gutter at bead height, lined up with the end of a rafter. Drive the spike through the gutter bead, ferrule and fascia board into the rafter. Locate the spikes at the first rafter and at every second rafter.



LEAF GUARDS in strip form fit between shingles and gutter bead, keep gutter free of debris accumulation

Installing downspouts

If the gable end of the roof has an overhang, you'll have to add a 45° elbow, a short, straight piece and another 45° elbow from the outlet opening to carry the downspout system back toward the wall of the house.

Expansion joints should be used on all hip-roof installations, on straight runs of 40 ft. or more and in any other spots where normal expansion and contraction is restricted. The expansion joints devised by one manufacturer of aluminum are made of neoprene and aluminum to provide the needed flexibility. The neoprene section is in the center of two aluminum end pieces. When joining gutter sections with an expansion joint, follow the method used with regular slip joints. The neoprene section will be hidden by the overlapping ends of the gutter sections.

Note that each section of downspout pipe and elbow has one end slightly smaller than the other. The parts are joined by fitting the larger end over the smaller and forcing them together. The sections are then anchored with sheet-metal screws. The smaller end must be on top so that flowing water is always running into the larger end of the pipe section. After snugging the downspout section against the wall, use two straps for each 10-ft. section of pipe.

The bottom of the downspout is completed with an elbow (or shoe) and a 4-ft. extension or splash block to direct water away from the foundation. ★★★

New Building Products You Should Know About

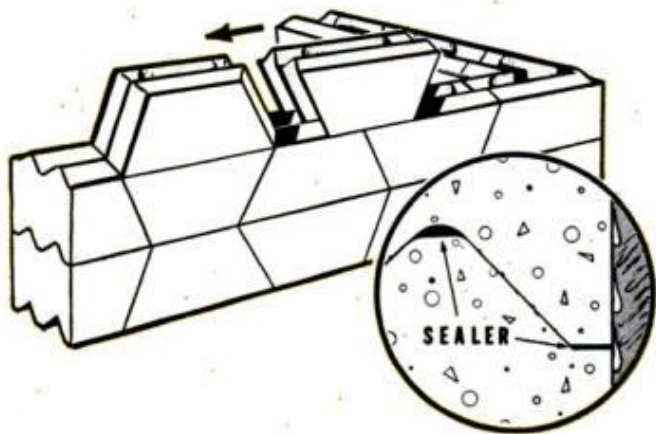

BUILDING BLOCKS claimed by the maker to be the world's fastest, Wedge-Blocks (above) differ two ways from standard blocks. They're wedge-shaped to keystone-lock with adjacent blocks in the same course and double V-grooved to tie into all surrounding blocks. Self-plumbing and self-aligning, they need no mortar to hold them together. Sold through masonry dealers, cost is about the same as conventional block. Wedge-Block Inc., 10439 Garibaldi St., St. Louis, Mo.



DOOR ENTRY SYSTEM by Berry Doors eliminates the need for storm doors because of insulation. Built of steel, these 1 $\frac{3}{4}$ -in. doors come complete with jamb and threshold components. Available in more than 30 styles, they can be used singly or in pairs to suit any architectural decor. Prices start at \$53. For information, write Berry Doors Div. of Stanley Works, Dept. PID, Birmingham, Mich. 48012.

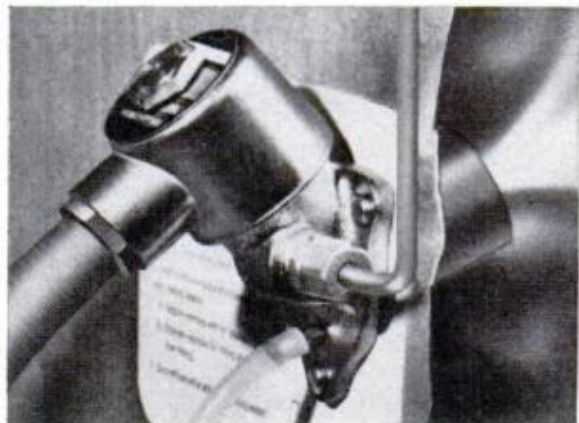

MOIST AIR costs less to heat than dry air, so you might want to add a Mistic Power Atomizing System to your heating plant. Closed water system has no reservoirs, floats, evaporating plates or motors; uses ordinary line pressure to power nozzle dispersing a water mist that evaporates instantly in the furnace. Costs about \$50. Lewbill Ind. Inc., Box 221, Scottsdale, Pa.

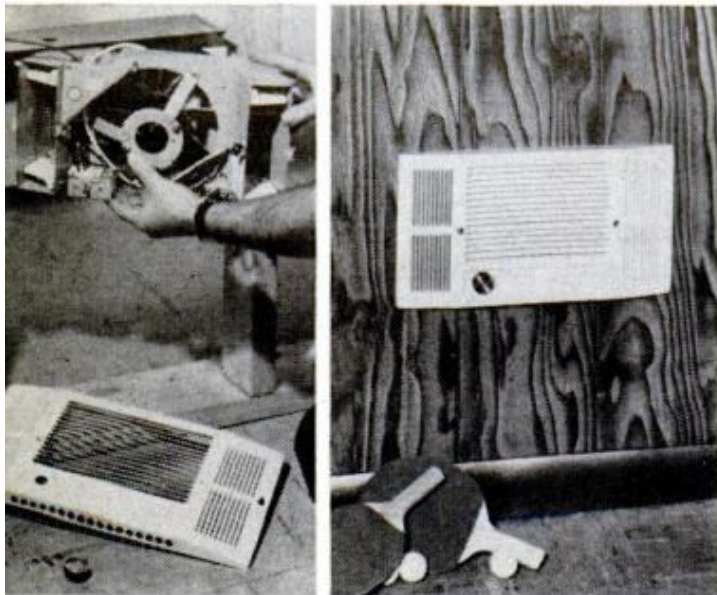

QUICKLY INSTALLED, the new Mini-Furnace fits between wall studs (photo, far left) to solve chill problems in hard-to-heat areas such as hallways and garages. Made by Berns Air King Corp., 3050 N. Rockwell St., Chicago, it has a cold-air intake and a heavy-duty blower which forces cold air over electric heating elements. At electric appliance dealers, \$36 and up.



HANDSOME VINYL FLOOR covering offered by Armstrong Cork captures the richness and natural texture of wood parquet. Dubbed American Oak Imperial Accotone, the material is available in 6, 9 and 12-ft. rolls. It features a moisture-resistant backing, thus can be used below, above or on grade. No adhesive is required.

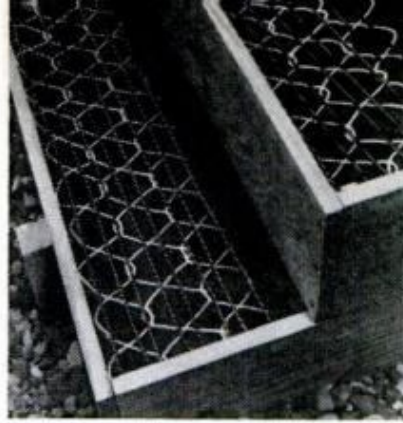

SNOW-MELTING MATS eliminate shoveling, are installed when steps are being built. The mats are constructed of a durable heating cable insulated with 90° polyvinyl chloride and bonded to a plastic mesh. All connections are waterproof. Prices start at \$17.50. Emerson Electric Co., 8100 Florissant Ave., St. Louis, Mo. 63136.



MINERAL-BASE SHINGLE that looks like weathered cedar shakes has been introduced by Johns-Manville. Called Bel-Air, the shingle carries a Class A fire rating and weighs about 420 pounds per square. It can be installed with a straight butt edge, or staggered as shown above. Sold in 6, 8 and 10-in. widths with a length of 16 in.

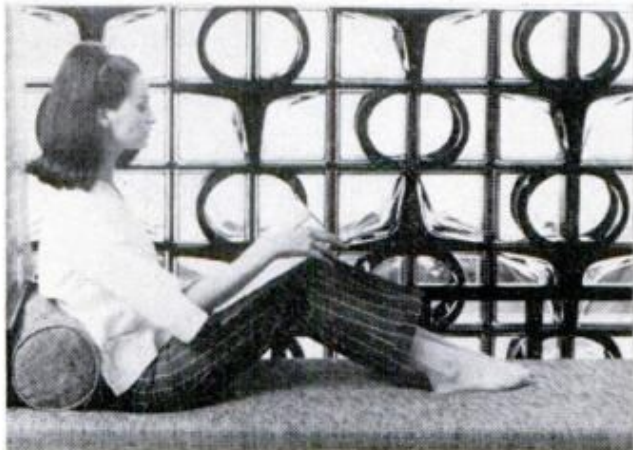

LATEST GLASS MASONRY DESIGN from Pittsburgh Corning is labeled Chiaro. Offered in two patterns, it has a raised decorative surface trimmed in baked-on black frit. Panels can be installed with caulking strips or mortar around the perimeter of the window opening; black mortar joints are recommended to integrate the window into the decor. Sold through masonry contractors. Pittsburgh-Corning Co., 1 Gateway Center, Pittsburgh, Pa.



NO EXTERIOR PAINTING for at least 10 years is the boast made for this double-hung window. The wood sash is prefinished, while frame and sill are clad in polyvinyl chloride. Called Perma-Shield Narroline by Andersen Corp., Bayport, Minn., the unit comes in 42 sizes. Other features include spring sash balances that hold the window where you want it, vinyl jamb and head liners for smooth operation, and worksaving removable muntins.



SEAMLESS FLOOR BEAUTY is possible with Uniflor vinyl flooring because the edges are pretrimmed to the contour of the particular design. The sheets are placed to create a joint that matches, then Uniflor seaming liquid is squeezed in (photo, far left). Next, vinyl sand is sprinkled generously into the seam, rubbed in and the excess sponged up. Both joint materials are packaged with each roll. Available in designs to suit all periods, the floor covering can be used at any grade level. National Floor Products, Inc., Box 354, Florence, Ala. 53218, is the maker.

WEEKEND

Kids' Play Center

Your kids will get \$50 worth of fun and then some from this combined stilt house, playground slide and monkey bars. That's about what it will cost you to build it, but remember, it's an item you'll be able to sell when your moppets outgrow it. With this in mind I made it in sections and bolted them together for easy dismantling. Other than the pipe bars, you'll find all materials at your lumberyard.

The drawings give you all the construction data you need. Set it on bricks so the legs don't sink in the ground. Coat the slide with a clear sealer and then paint the rest of the structure in bright colors.

—R. S. Hedin

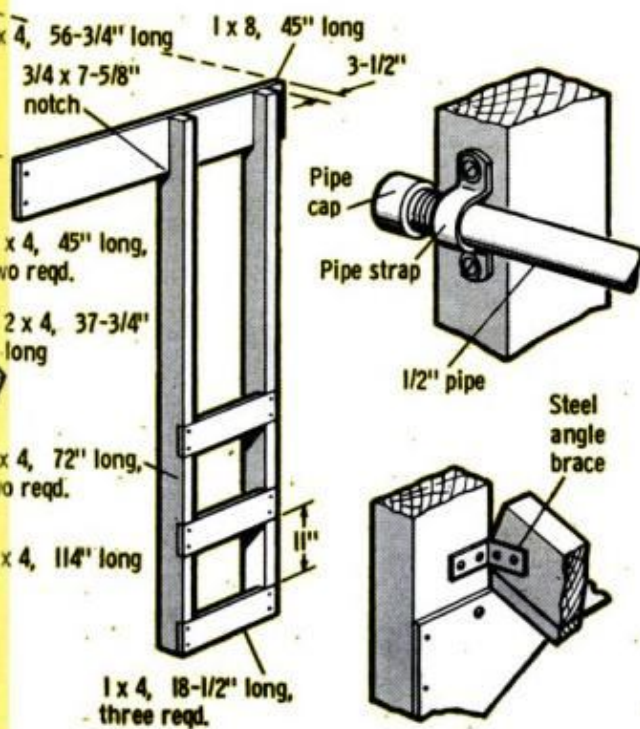
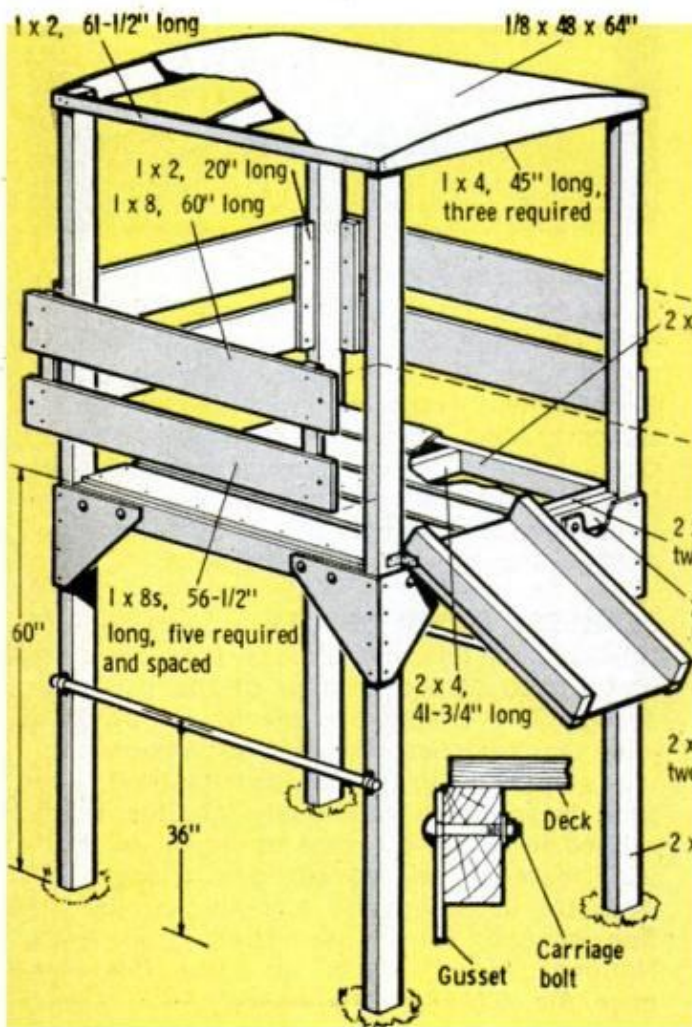

Technical Art
By John Lind

PROJECTS

Wastebasket on Legs

Any metal or plastic wastebasket will take on an elegant look when set in this three-legged stand of brass and walnut. The legs are simple cutouts joined together by three brass rods radiating from a center hub. The latter consists of two plywood discs drilled through the center for a 1/4-in. bolt. To drill the holes for the rods, bolt the two discs together with a cardboard shim between. Then carefully center the bit so it straddles the joint and drill to the center hole. Cardboard is discarded.—*Kenneth Wells*

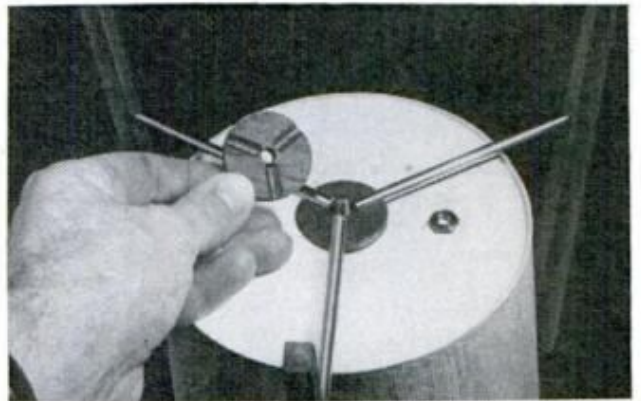
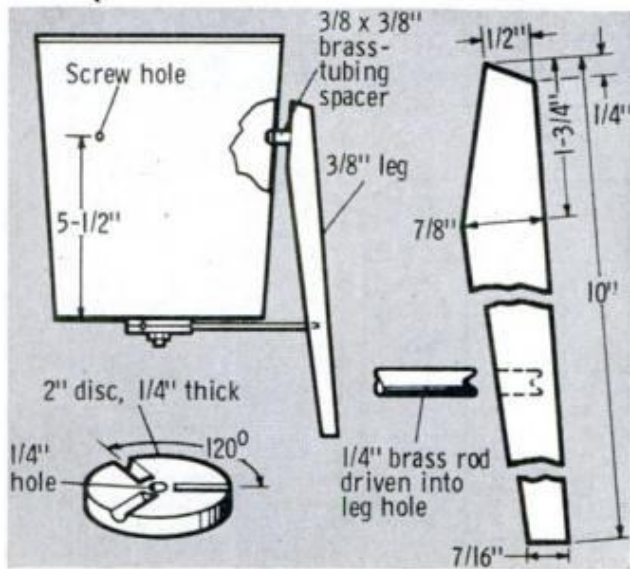
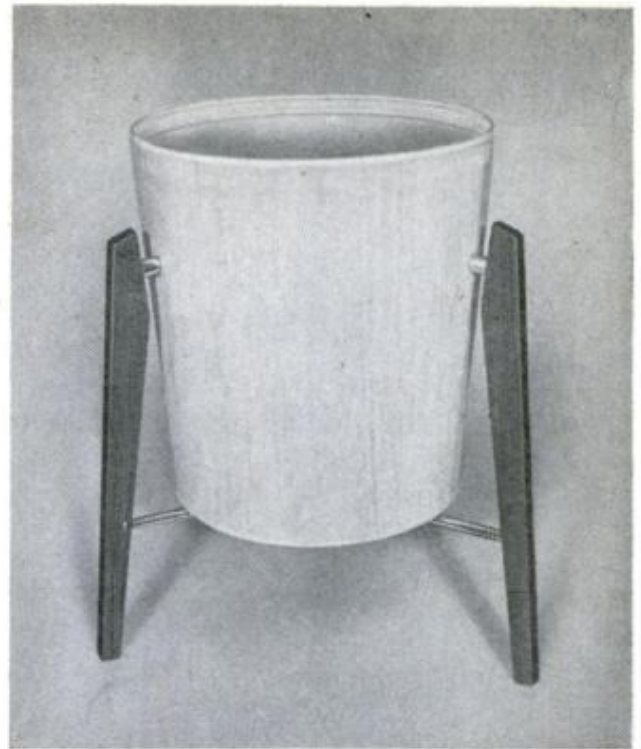

"SPLIT" PLYWOOD WASHERS lock brass leg braces together at center as you tighten bolt through center

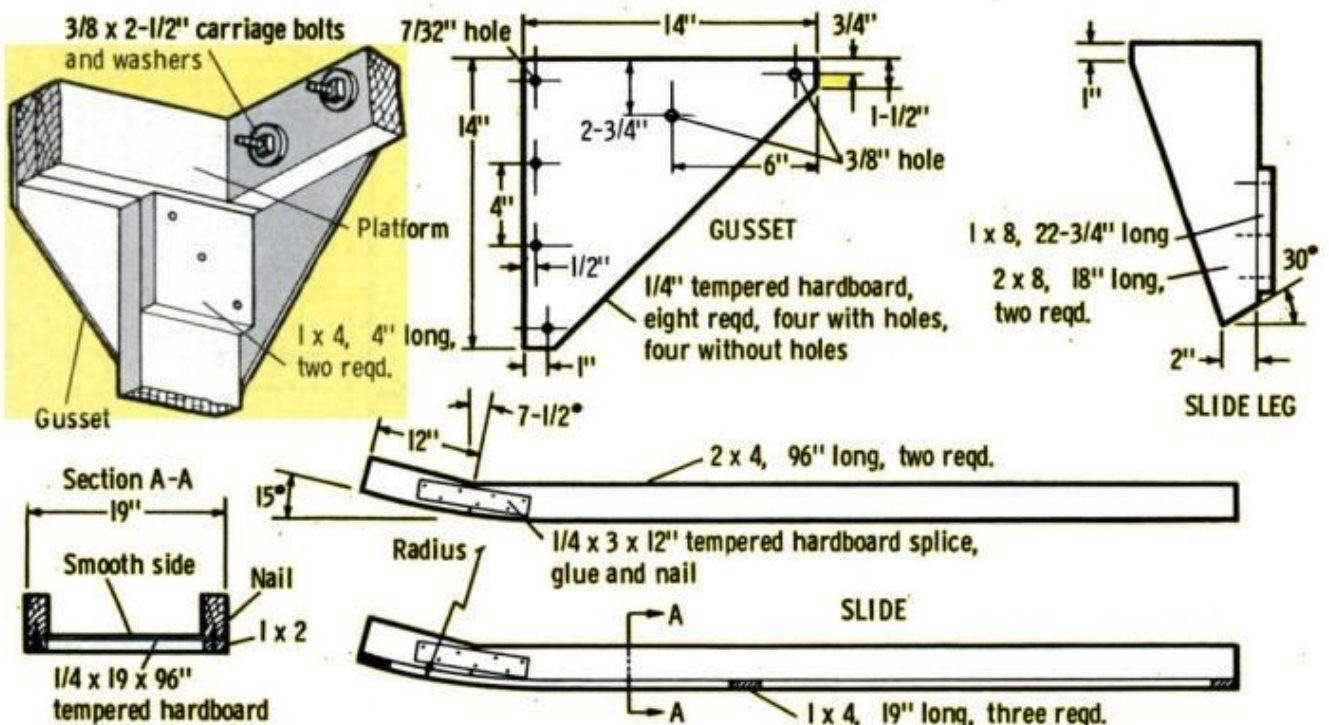

Magazine-Newspaper Tree

Here's something different in a newspaper and magazine holder. Standing 26½ in. high it will hold up to seven rolled magazines and papers, all within easy reach of your lounging chair.

The post is a piece 2⅞ in. sq. which is cross-bored on adjacent faces with a 2-in. power bit and fitted with a half-lapped "hall tree" base at the bottom and a lathe-turned finial at the top. If you don't have a lathe, you can forget the finial and simply point the end of the member like a fence post.

When boring the holes, clamp a scrap board to the underside of the work so you'll have clean-cut holes when the bit emerges. The boring should be done on a drill press. The cross base is fastened to the end of the post with 2-in. flathead wood screws and glue.—C. Wayne Close

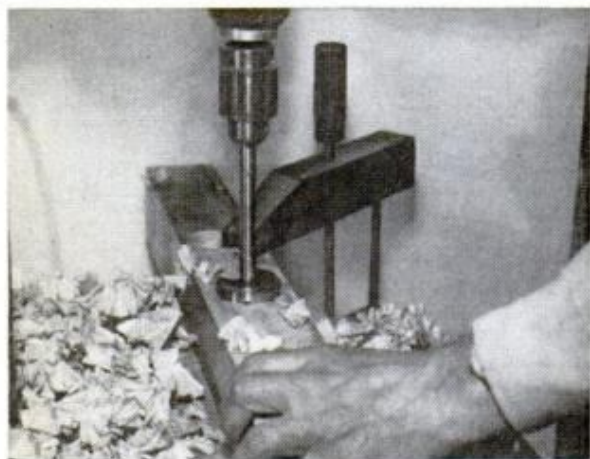
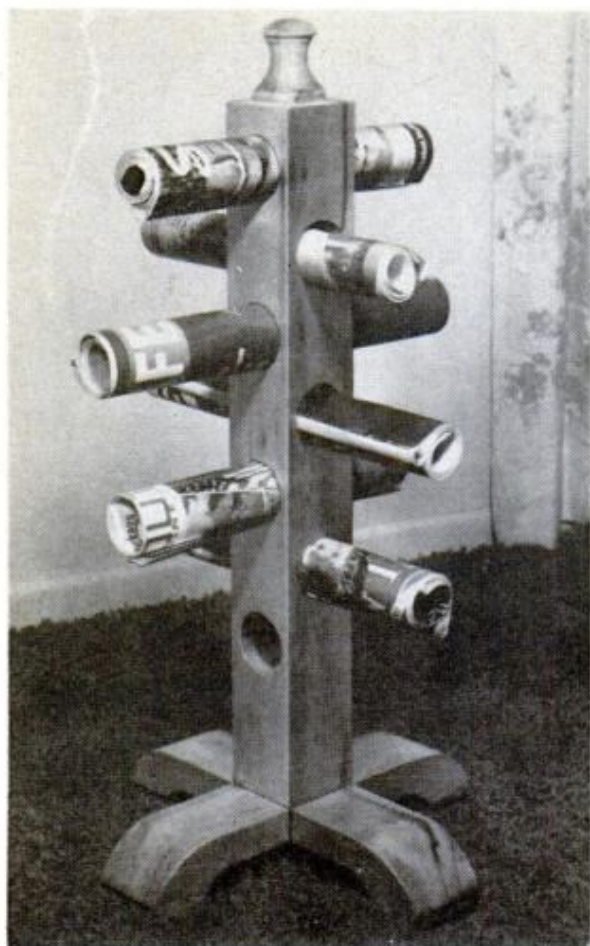

THE BYPASSING HOLES through post are made with 2-in. multi-spur bit chucked in drill press

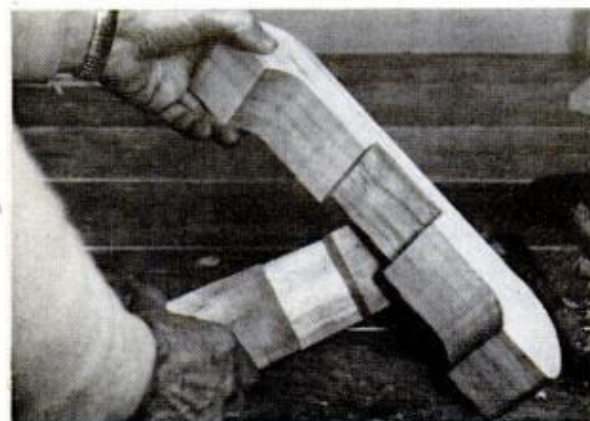

BASE MEMBERS are half-lapped by dadoing top and bottom surfaces before bandsawing pieces

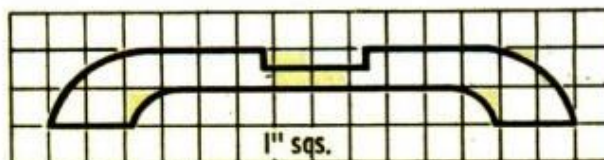
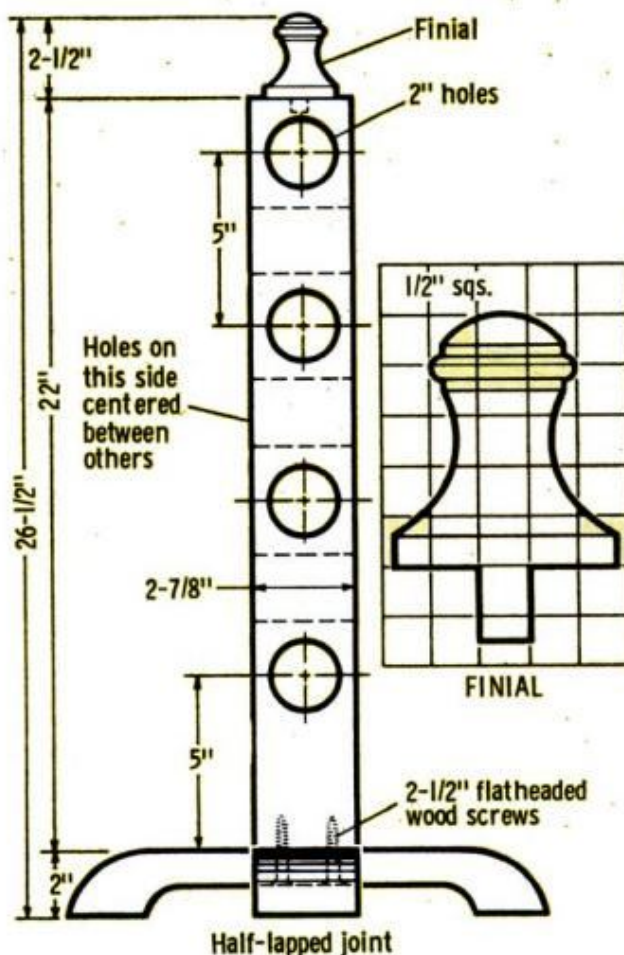



Warming-Tray Stall

Out of sight, out of mind certainly applies to an electric server such as a Salton Hotray. Store it in a drawer and you forget to use it, leave it out and it takes up counter space. The answer is a shallow stall such as this. The tray is always handy when it's parked in it, yet it doesn't rob you of a bit of space. To wipe under it, you just lift it off.

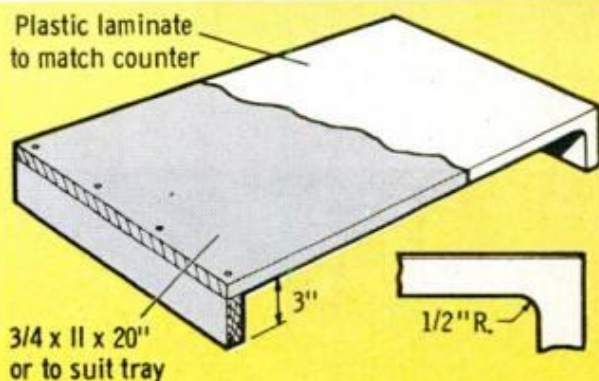

Trivets From Leftovers

As with scraps of prefinished paneling left over from a remodeling job, it's hard to throw out leftover ceramic tile, but what can you do with a dozen or so tile? Would you believe these smart looking trivets were made from such leftovers? All you have to do is cut out a $\frac{3}{4}$ -in. wood block that's shaped to suit the tile pattern, stain, varnish or paint it, stick the tile to the top with contact cement and glue a piece of cork to the bottom. Your trivet is ready to use. Designs are almost endless, and broken-lot tile are usually available for practically nothing at most tile stores as dealers, too, are often faced with the problem of what to do with leftovers from tiling jobs.—C. B. Hicks



Mini-Pump Powers



THIS IS THE PUMP that is hand or foot-operated

TWO NEW WORKHOLDING TOOLS, a vise and a collet chuck, powered by a mini air-hydraulic pump, provide both the home workshop and machine shop with clamping devices which are far superior to mechanical methods.

The hydraulic vise provides a multi-ton holding force (up to four tons) with precision control for those close-tolerance milling, drilling and grinding jobs. The vise also permits the operator to determine visually the workholding force exerted simply by inserting a hydraulic

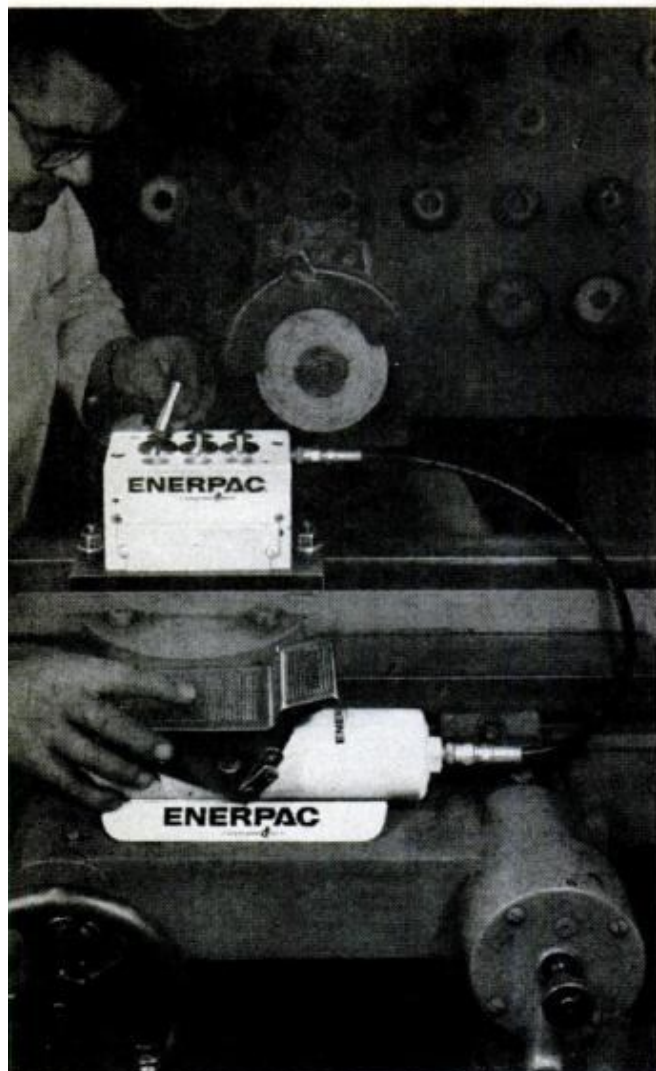

POWERED BY MINI-PUMP, collet chuck is being used to hold round gauge pins for grinding to right length



PUMP IS ACTIVATED by touch of foot which frees hands to drill workpiece held in the hydraulic vise

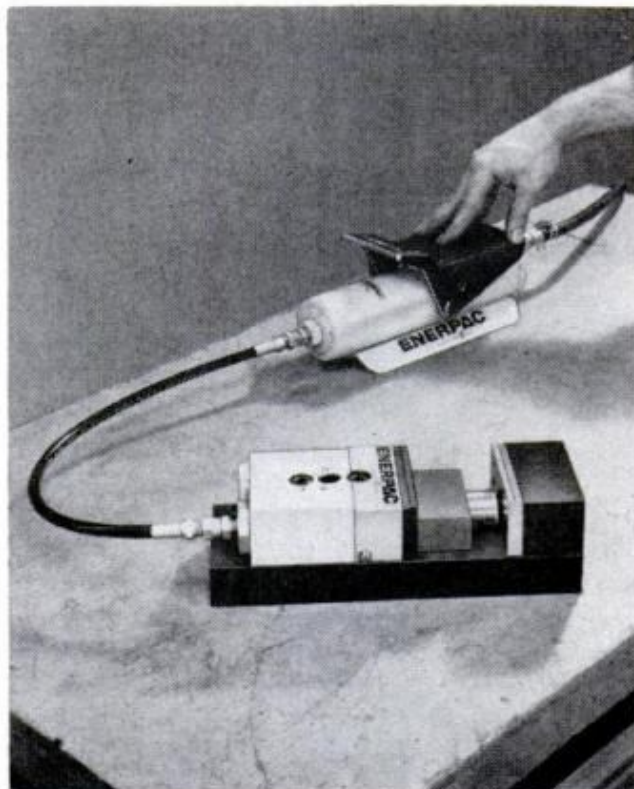

HAND PRESSURE ON PUMP produces power up to four tons. Vise can be in any position, even vertical

Two New Hydraulic Workholding Tools



HYDRAULIC COLLET CHUCK uses 5-C collets, holds one to three workpieces with up to six-ton force

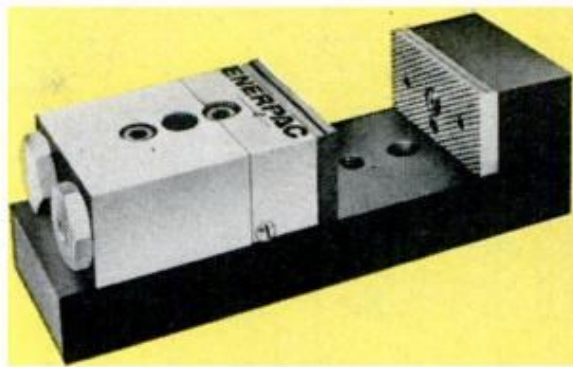

HYDRAULIC VISE handles work of various sizes, consists of powerhead and L-base for bolting to table

gauge in the line. Thus the holding forces can be adjusted either by varying the air-line pressure or adjusting the hydraulic pump to suit the workpiece.

The compact vise package (VP-4) consists of the powerhead (VR-4), which measures 4 x 5 $\frac{3}{8}$ x 2 in., and the L-base which mounts to the machine table. The powerhead includes a return stop to control minimum backward travel of the vise for fast, repetitive clamping operations. The powerhead may be used in conjunction with the L-type base plate for small work so the unit can be bolted as one complete unit to the machine table. Depending on the work involved, jaw plates for the hydraulic vise may be ordered smooth hard, serrated hard, smooth soft or V-grooved hard.

In addition, the vise package, when teamed up with the L-base plate, can be used as a miniature press for forming, staking, bending, stamping and seating bearings. Moreover, the hydraulic vise works in any position: vertically, diagonally or horizontally.

The hydraulic collet chuck (model CC-3) is a device capable of holding simultaneously one, two or three workpieces with up to six tons of clamping force. It holds hard-to-hold round, hex and square-type workpieces for easy machining. It utilizes standard 5-C collets and is ideally suited for production milling, drilling, slitting and boring operations. Its maximum clamping force of 12,000 lbs. holds unwieldy work absolutely rigid, even under extreme offcenter cutting situations. It provides instant

clamping and instant release for fast repetitive machining operations.

Like the vise, it can be easily adjusted to a maximum workholding force while permitting the operator to read visually the forces through a hydraulic gauge.

The collet chuck includes vernier depth stops for precision adjustment. Measuring 4 x 5 x 9 $\frac{3}{8}$ in. overall, it accepts any workpiece up to 1 $\frac{1}{16}$ in. in diameter. No adjustment is necessary for lot-size-diameter variations. The center-to-center spacing for collets is 1.550 in. Coolants may be circulated up through the collet slots for direct application to the cutting area.

The power source is a miniature air-powered hydraulic pump designed for hand or foot actuation. The PA-130 pump plugs into normal plant air lines, 30 to 120 p.s.i., to develop the necessary pressure in hydraulic forces. The power unit is just 13 $\frac{3}{16}$ in. long and weighs only 10 lbs. It may be operated in any position for actuation by hand or foot, as preferred.

The pump includes an adjustable relief valve for presetting the maximum desired working pressure. In addition, it has a three-way valve which permits the operator to actuate the pump to clamp the work. Then, when the foot or hand is released from the treadle, the pump will hold the load. To release the work, the operator simply reverses the action of the treadle and removes the piece. Should air pressure be turned off, the pump will still hold the work. The pump also eliminates idling noise since it operates only when work is being performed. ★★★

Solving home problems

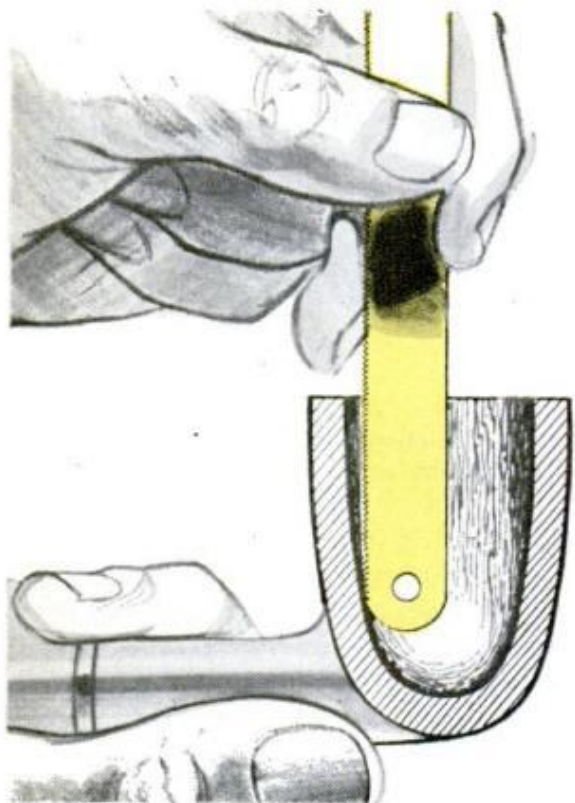

WHEN THE ASH COATING needs scraping from the bowl of your pipe, a piece of hacksaw blade makes a fine reamer. The teeth are perfect for scraping and rounded end of blade won't harm bowl.—*S. H. Rynk*

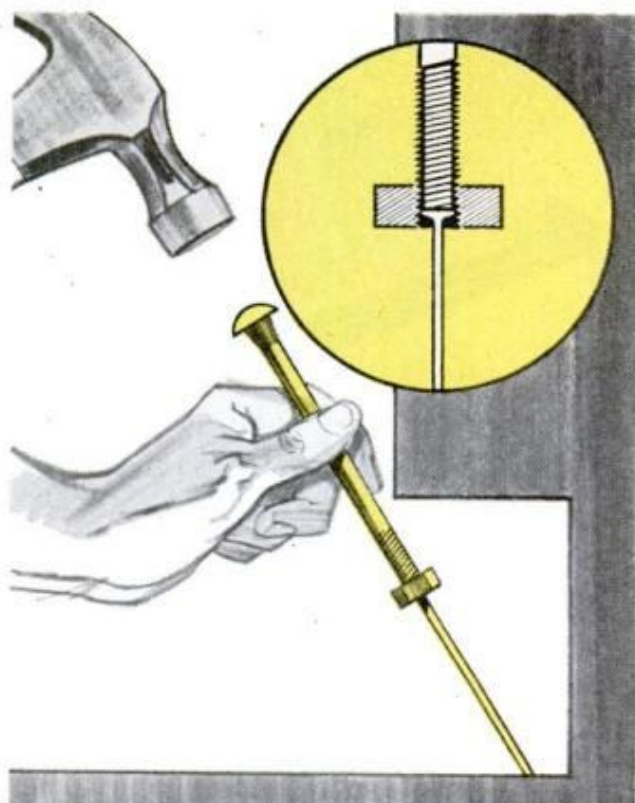

DRIVING A NAIL in an inaccessible spot is no problem if you use a carriage bolt. Turn nut partway on the end so bolt won't slip off the nail and use the bolt like a regular nailset.—*Victor H. Lamoy*



TO MAKE SURE an extension ladder won't slip when standing on wet grass, anchor it with a spading fork. Simply press it in the ground and secure the handle to the bottom rungs with wire.—*Victor H. Lamoy*

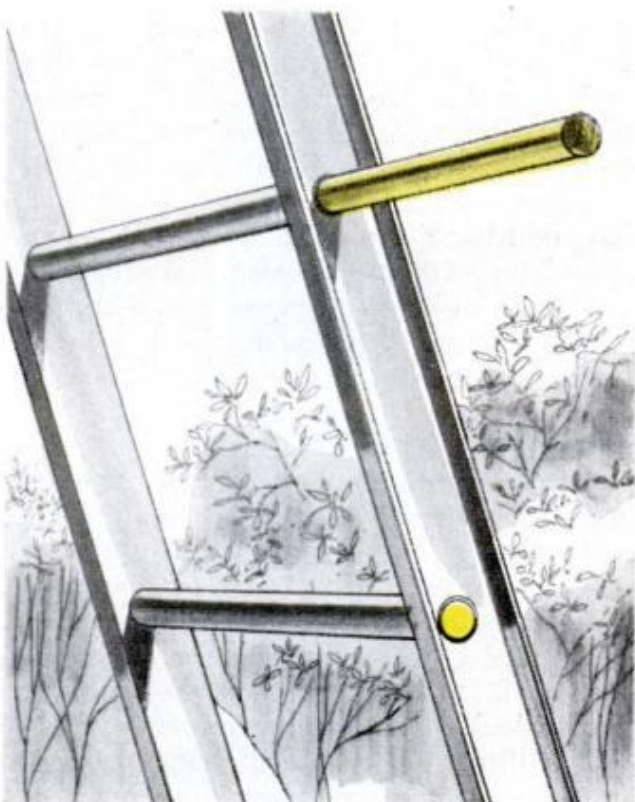

WHEN YOU BUY a new aluminum ladder with tubular rungs, it's a good idea to insert wood dowels in the rungs as soon as you get it. Snug-fitting dowels will keep the rungs from bending.—*John Krill*

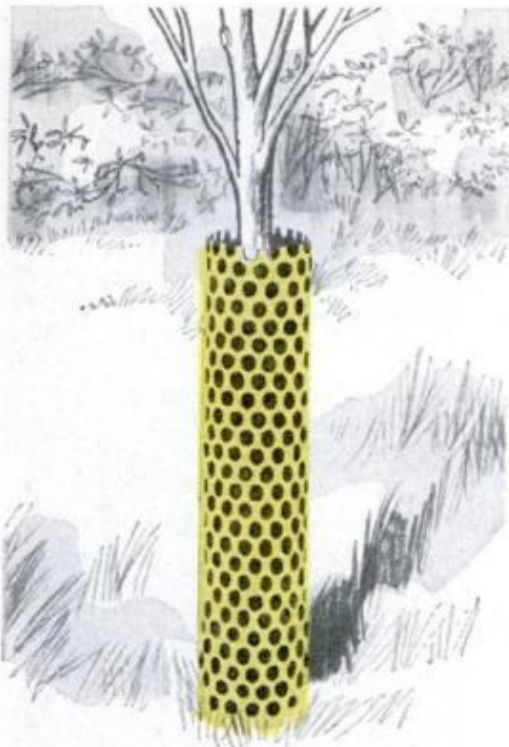

IF YOU'RE LOOKING for a way to protect a young fruit tree from gnawing rabbits, use a piece of expanded metal lath. Form it into a sleeve around the tree and embed the end in the ground. It's neat looking and will last indefinitely.—John Krill

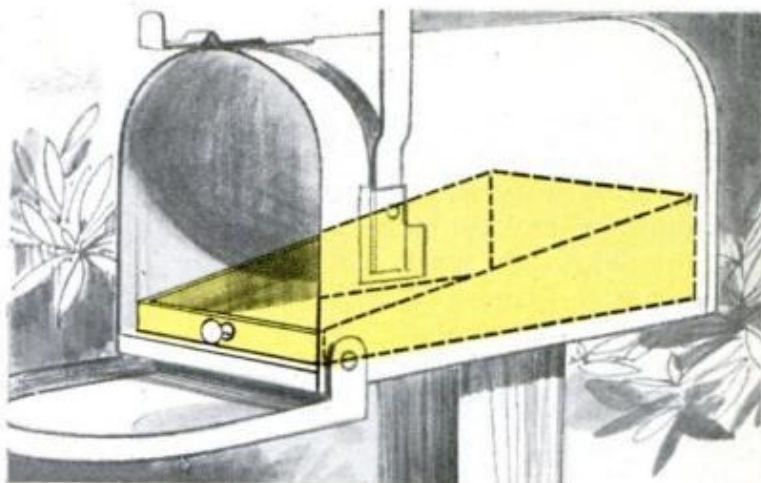

A TRAY IN YOUR MAILBOX will make it easy for short members of the family to reach letters in the back of the box. Form it as shown from sheet metal so it will slide easily in the box and add a small drawer knob to the front.—Victor H. Lamoy

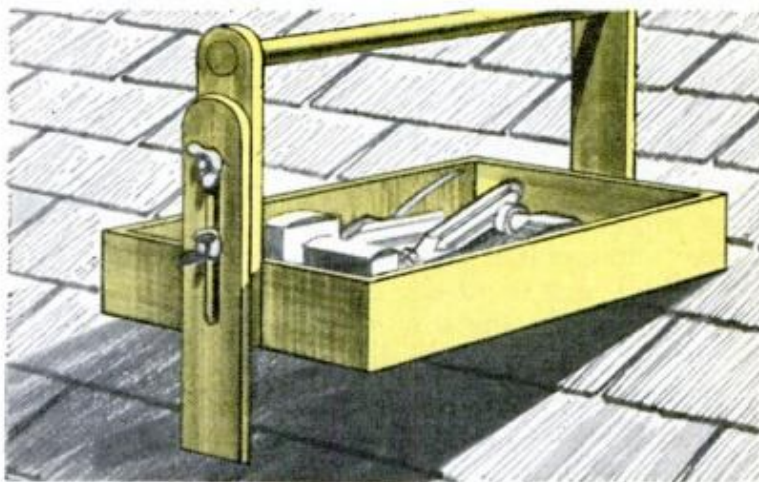

YOUR TOOL TRAY WILL SIT LEVEL on any roof if you fit it with an adjustable leg. Simply slot a narrow board to fit over two carriage bolts inserted through the tray handle and add wingnuts and washers to lock it at right height.—Daniel Bousha



AN OLD BROOM is a handy thing to use to hold the chisel when breaking up concrete. It will keep your hand a safe distance away, and the bristles will safeguard you from flying bits. Simply force chisel through the whisks.—Wilfred Beaver

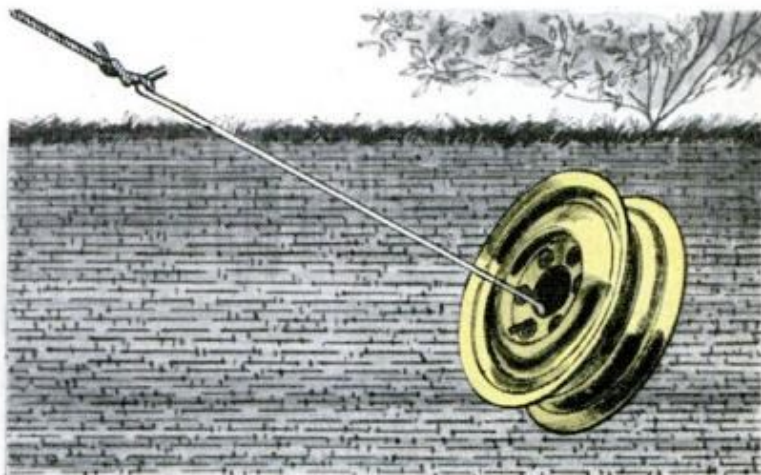

A BURIED AUTO WHEEL makes a dandy anchor for a fence brace. Form an eye at one end of a steel rod, a hook at the other and hook rod through a wheel lug hole. Then bury the wheel as shown and tamp dirt firmly around it.—Victor H. Lamoy

HINTS FROM READERS

Protect ax edge

A short length of inner tube pulled over an axhead keeps the cutting edge sharp and prevents accidental cuts and gouges where they are not wanted. And, since the tube seals off air, rusting is kept to a minimum and the edge stays bright. Conventional tubes work for most axes but, a double-bitted ax will require a larger one.—*C. F. Marley*



Small-parts storage rack

Storing those pesky, but often needed, small parts won't be a problem if you build this handy rack. Though I built mine to hold 10 of the commercially available plastic containers, by varying size of board to which they're attached, any number can be used. The board can be permanently fastened or fitted for perforated board mounting.—*A. L. Ramos*

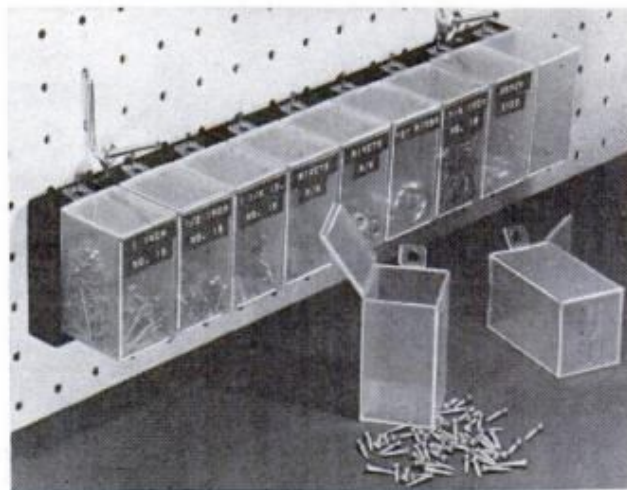

Increase saw-chain life

A properly broken-in saw chain lasts longer, says a spokesman for Omark Ind. The saw-chainmaker says to soak the new chain in oil, put it on the bar and adjust tension. Next, run the saw at idle speed to line up the chain with the bar groove and sprocket and make a few easy cuts at half throttle. Stop the saw and, after it cools, retension and re-oil.



Spillproof flower vase

Ordinary tin cans can be rigged to serve as attractive flower vases for the back yard, patio or cemetery grave. To prevent a can from blowing over, solder one or more large nails to the bottom. When pushed into the ground, the well-anchored vase will be tip-proof. To decorate the tin can, use colored metal foil or other weatherproof wrapping or paint with outside enamel.—*W.E. Burton*

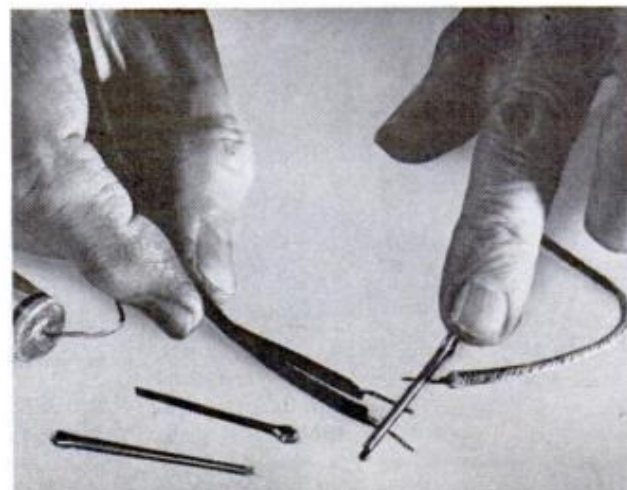

Another job for a crotter pin

An ordinary crotter pin can stand duty as a tool when you are testing low-voltage circuits. Used as a clamp (photo, right), it saves you the chore of twisting and untwisting the wires. A large pin will do the job best; it holds the wires securely, yet permits fast insertion and removal of the strands.—*V. H. Lamoy*

New Tools You Should Know About

Adjustable contour gauge

If you are planning a floor-tiling job, you couldn't have a better reason for owning this Arco contour gauge. Making perfect fits of the tile around pipes, door casings and other obstructions is a cinch with this gauge since it will duplicate exactly any contour you run up against. To use it, you simply press the gauge against the shape to be copied and its 175 tempered wires give you a perfect pattern to trace. Tiling is just one of dozens of jobs where you'll find the gauge extra handy. You can buy one for \$2.95 from Arco Tools, Inc., 421 W. 203rd St., New York, N. Y.

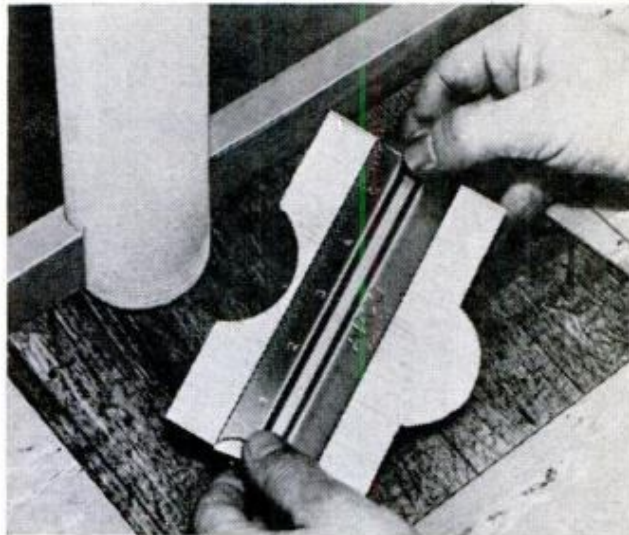

Portable keyseat cutter

Particularly handy for field service work where a new keyseat must be cut without dismantling the machine, this compact Woodruff keyseat cutter can also be used to cut keyseats on a metalworking lathe. When operated by hand, the cutter is turned with a ratchet wrench as a knurled handwheel is advanced to pull the cutter into the shaft. The portable tool will cut perfect keyseats in $\frac{3}{8}$ to $1\frac{1}{8}$ -in. shafts. The complete kit, priced at \$85, includes the tool, seven cutters and assorted keys. McDonald Tool Co., Box 41, Baldwin, Mo. 63011.

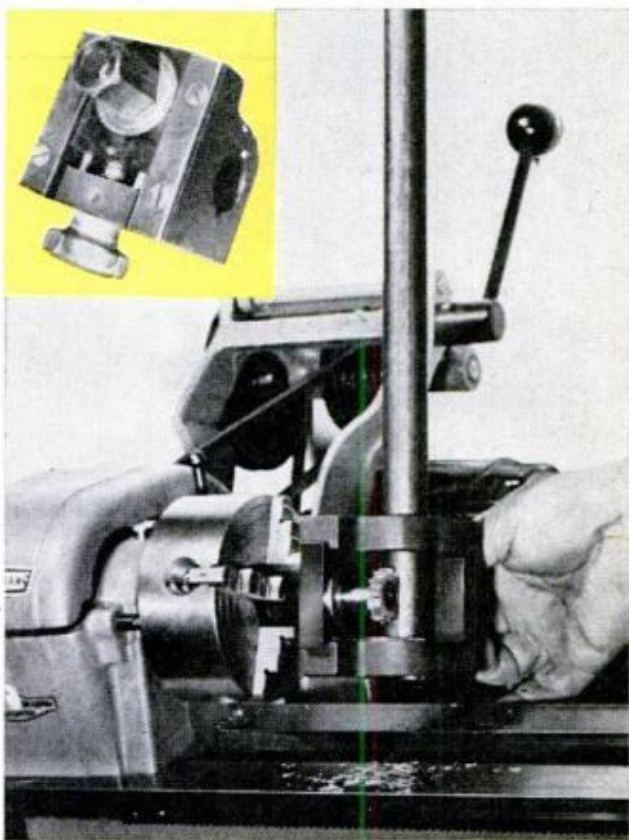

Bench tool rack

There's not a home workshop that cannot use Big John to help keep hand tools in order. Punched and pressed from heavy-gauge steel, it measures 36 in. long and has a two-step design which permits convenient storage of a double row of tools. It features a drill index which holds 14 twist drills from $\frac{1}{16}$ to $\frac{1}{4}$ in., and comes with holes for large and small screwdrivers, plus slots for chisels and files. It can be mounted quickly on the wall at the back of your bench. Priced at \$2.98 from Dalton Mfg. Co., 30 S. Central Ave., St. Louis, Mo. 63105.

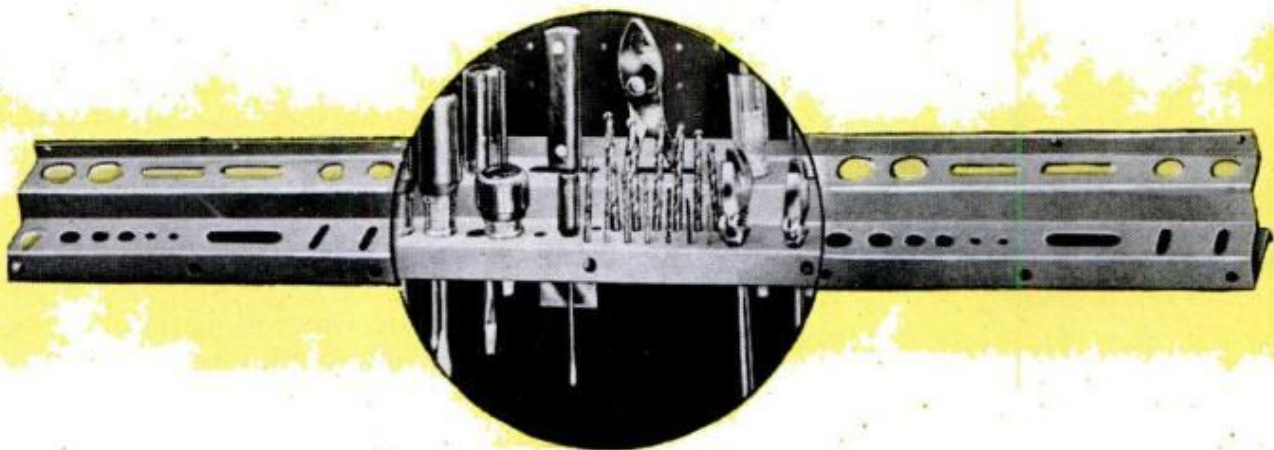

TEN CLUES TO HIDDEN

Hard starting and rough running can be caused by

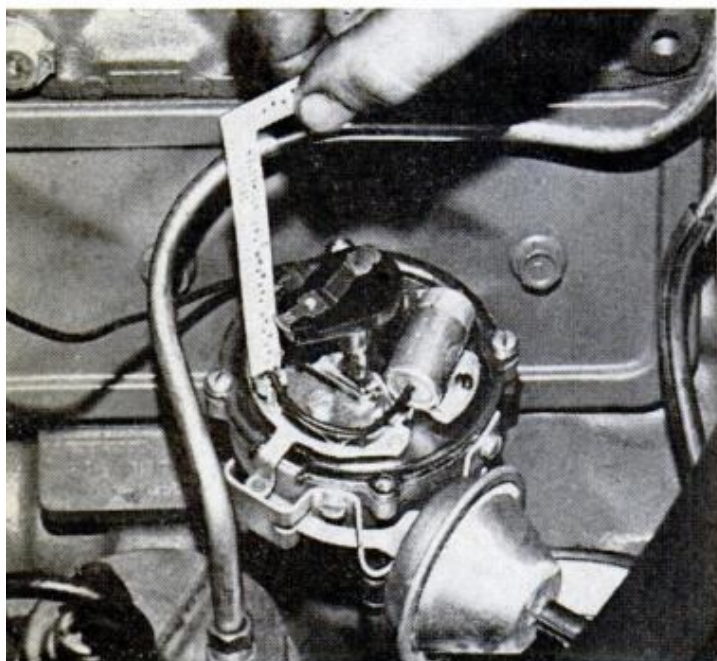

DISTRIBUTOR should be checked for clearance between rotor, other components. Gap of one-quarter inch or less between rotor tip and condenser lug, for example, will cause shorting, misfiring engine

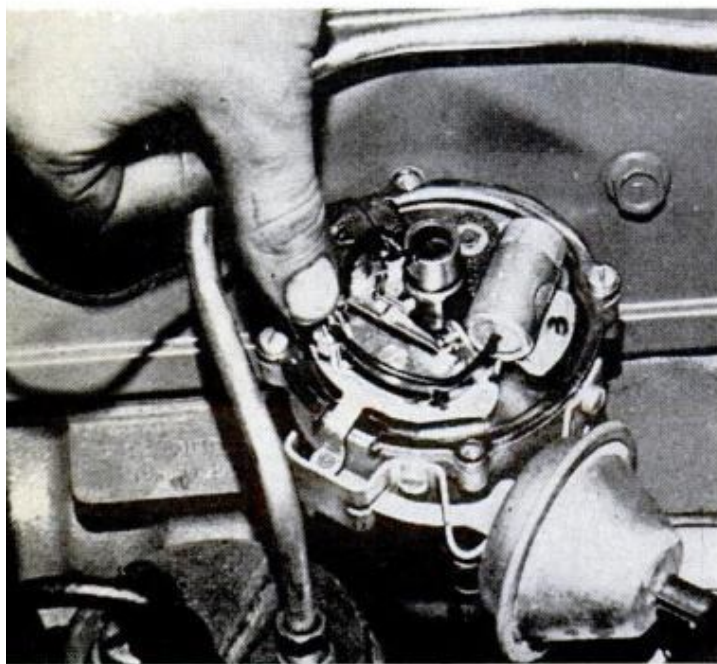

CONDENSER TERMINAL should be fully seated and kept seated while you tighten hardware. All distributor parts should be checked for tightness and alignment to prevent any possibility of erratic ignition

SOME IGNITION PROBLEMS can't be tracked down with troubleshooting charts. The causes just aren't in the book. A few clues may come in handy if you experience ignition problems for which there seems no possible solution.

Check rotor clearance. An engine that begins misfiring after a tune-up may indicate you didn't do something quite right. And you'd hunt all day to find it. Check the distributor closely; you may observe that the top of the rotor passes very close to the metal terminal on the condenser wire—close enough for a spark to jump the gap every time the rotor comes around. And all because you didn't fully seat the terminal when you replaced the points and condenser! Loosen the hardware and push that terminal down.

Check for "cold condenser." Adverse weather seems to intensify ignition problems. For example, I had a strange experience last winter with a 1965 Oldsmobile that refused to start on a zero-degree morning, but *would* start as soon as the temperature rose to 25°-30°. The car cranked okay, but wouldn't fire, and it had me stumped until I mentioned the problem to the service manager at an Oldsmobile dealership. "Sounds like a cold-weather condenser," he said.

It was a new one to me, but the condition prevails with some types of Delco-Remy condensers that were made around 1965-66. It could, however, occur with any condenser, so it pays to keep it in mind.

What happens is that in cold weather the metal laminations in the condenser contract, giving the effect of an open condenser. As the weather warms, the laminations expand, allowing the ignition to operate normally.

To prove it out, I put my hand over the condenser for a few minutes to warm it up next time the problem occurred. The engine fired right up.

Look for hairline cracks. Many drivers

IGNITION TROUBLES

faults that don't meet the eye and aren't in the 'book'

have trouble starting their cars when there's a heavy concentration of conductive moisture in the air. The cause of the difficulty can often be traced to a hairline crack in the distributor cap or a damaged rotor. Current follows the path of least resistance, which is the crack.

If you're having trouble starting your car when there's a heavy dew, examine the distributor cap and rotor. Look for damage and traces of carbon that current leaves as it passes through the crack.

Wetness also affects sparkplug boots that are dried out and cracked. Moisture around the crack provides a conductive path for current. Sparkplug flashover, which is a short-circuit along the outside of the plug insulator, occurs, causing misfire.

Check fiber block. A friend ran into a rough one not long ago. His car refused to start and a quick check showed no spark at all at the plugs. Because he had run across a similar condition a couple of years before, my friend found the cause of the problem quickly. He examined the distributor points to see if the little fiber block that rides on the cam was okay. This small piece controls the opening and closing of the points as the cam rotates. If it breaks off, the points remain closed at all times. Sure enough, it had broken off.

Look for faulty connections. Multiple electrical connectors are convenient items of hardware. However, these quick-disconnect plugs can lead to some pretty tricky ignition problems. Suppose, for example, one of the terminals is accidentally bent out of alignment or corrosion has formed. Either condition can interrupt the flow of current through a circuit and can cause such problems as hard starting or engine failure in the form of electrical cutoff while the car is rolling.

If one of the prongs is bent, straighten it carefully with pliers. If corrosion has formed over the prongs, clean it off by

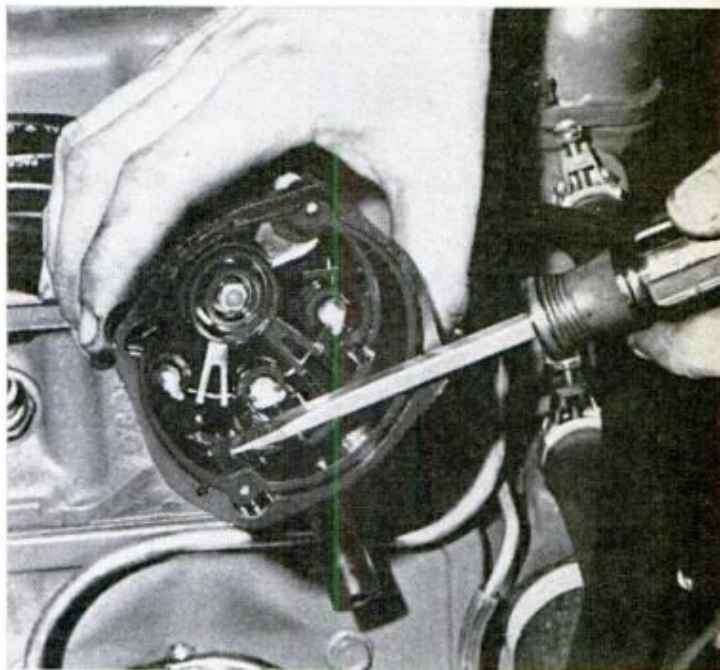

HAIRLINE CRACKS cause energy loss and lead to hard-starting problems. Check for cracks on the distributor cap around mounting hardware, posts and sides. Check inside of cap for other irregularities



ROTOR should be pulled and inspected carefully, especially to check that metal contact is not misaligned, loose or damaged. Also, on either side of the top inspect flanges which sometimes break off



CHECK PIGTAIL of the condenser for solid insulation. If bare wire grounds against the distributor body, you won't start. See text for another really hidden no-start condition due to "cold condenser"

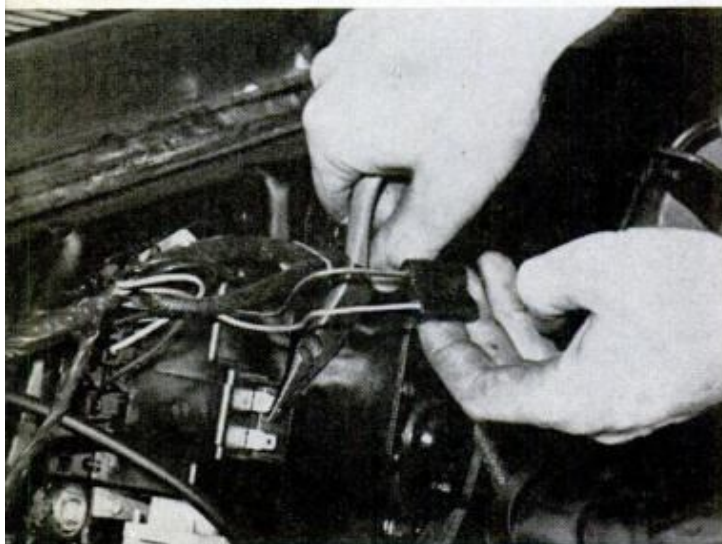

MULTIPLE CONNECTORS should be checked periodically before electrical or ignition trouble develops. Look for corrosion, bent prongs, tightness. Always inspect and replace wires with "dead" insulation

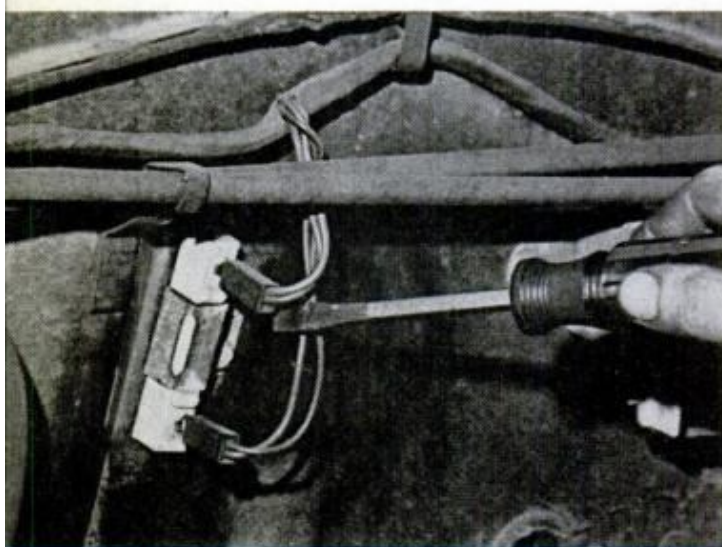

BALLAST RESISTOR, which controls ignition voltage, is located either on the firewall or fender well. If it changes value or breaks down, you'll have weakened, or no, spark at plugs. It's easily replaced

passing a strip of emery cloth lightly over the connector.

Check ballast resistor. The ballast resistor is an item that needs consideration if the engine refuses to start (the resistor could be opened or shorted) or if the engine has been lacking power (the resistor may have changed value).

A resistor allows the delivery of full battery voltage to the ignition coil for starting, but reduces this voltage by about half when the engine is running. Were it not for the resistance, the amount of current reaching the distributor breaker points would be too much for the points to handle, and they would soon burn or pit.

In time, a ballast resistor can change value, with an increase in resistance. This affects the voltage available to plugs.

Most cars prior to 1968 have external white ceramic resistors in the circuit between the battery and ignition coil. These are located on the firewall or fender well. Newer models have either this type or internal resistance in the form of a resistor wire between the ignition switch and coil.

Each manufacturer provides the resistance value of the resistor in his service manual (it's usually 1.30-1.40 ohms). Check for adequate resistance with an ohmmeter.

Look for arcing damage. A center-tower, high-tension cable which hasn't been firmly seated in the distributor and coil can lead to a starting problem that is one of the toughest to trace. Everything looks normal upon examination, until you pull the cable from the tower.

Over a period of time, a poorly connected cable can arc so badly as to burn away the terminal. After you disconnect wires from the distributor and coil, be sure that you reseal them firmly.

Look for contaminated breaker points. A friend of mine had to replace three sets of distributor points in six months. All were badly carboned. He assumed that the carbon was being caused by arcing, but such was not the case.

Carbonized breaker points can result if oil or exhaust vapor enters the distributor. These contaminants can be present under the following conditions:

- If the oil filler breather cap is clogged. This can cause a buildup in pressure in the crankcase, which will force oil or vapor into the distributor.
- If the distributor cam has been over-

lubricated. The cam should be lubricated with special cam lubricant when distributor points are replaced, but only with an amount equal in size to a matchhead.

Distributors of newer models ('67 on) have a wick that serves to lubricate the cam permanently. However, it's still recommended that a trace of cam lube be applied to the cam when contacts are replaced. This wick should be rotated at 12,000 miles and replaced at 24,000 miles.

● If springs or counterweights of the distributor advance plate have been lubricated. They should never be lubricated.

Look for steam damage. Steam cleaning an engine can make it look like new, but it can play havoc with your ignition if you're not careful around the distributor. Recently, a car sputtered into the shop of a mechanic I know. He learned that just prior to the car's acting up, the engine had been steam cleaned.

My friend opened the distributor and found the cam bone dry—not a drop of lubricant. The rubbing block was worn and this affected point dwell and timing. In addition, the points were badly burned.

Apparently, the steam had come too close to the distributor, and the cam lubricant had melted.

Check dual breaker points. Engines with two breaker-point assemblies inside a single distributor housing need careful servicing so you don't end up with burned sets of contacts.

The theory behind dual points is that they provide maximum coil saturation. One set remains closed while the other is opened. In effect, then, one set of points makes the primary circuit while the other set breaks the primary circuit.

Two sets of dwell-angle specifications are provided for such engines. First is the dwell angle for each set of points. It is generally about 27° to 32°. The other specification is the total dwell angle of both sets of points operating together. It's usually about 37° to 42°.

To make the adjustment, hook up your tach/dwell meter in the usual manner, and block off one set of points with a piece of clean paper or insulation material. Adjust the unblocked points to spec (27° to 32°). Now, switch the procedure, blocking off the adjusted set and setting the other.

When the adjustments have been made, remove the block from the points and read the total dwell angle. ★★ ★

SEPTEMBER 1969

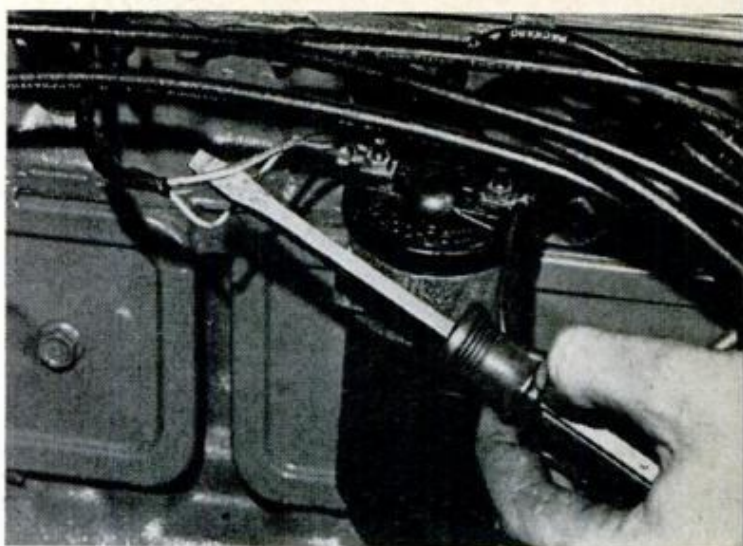

RESISTOR WIRE, between ignition switch and coil, is being used instead of ballast resistor on some new cars. If damaged or faulty, you can replace it by unraveling the harness and installing a new wire

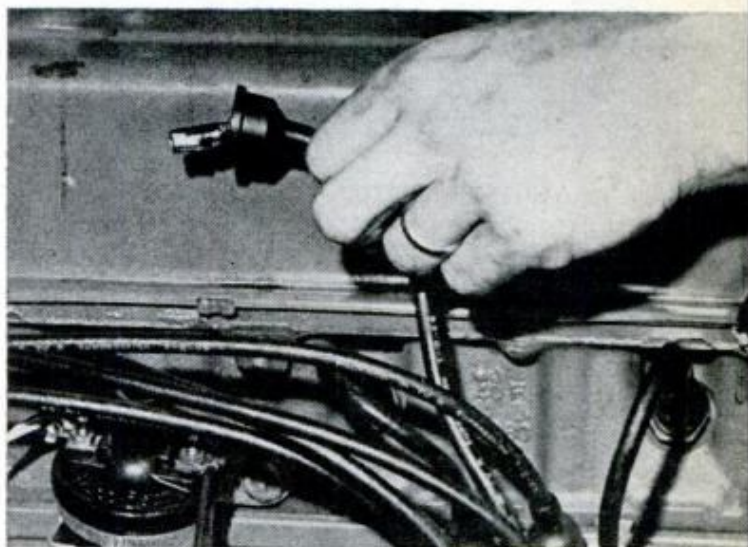

HIGH-TENSION WIRES should be pulled and inspected in the event of hard-starting condition. Blackened ends indicate arcing. Replace wires by pushing in-to distributor cap firmly so they are fully seated

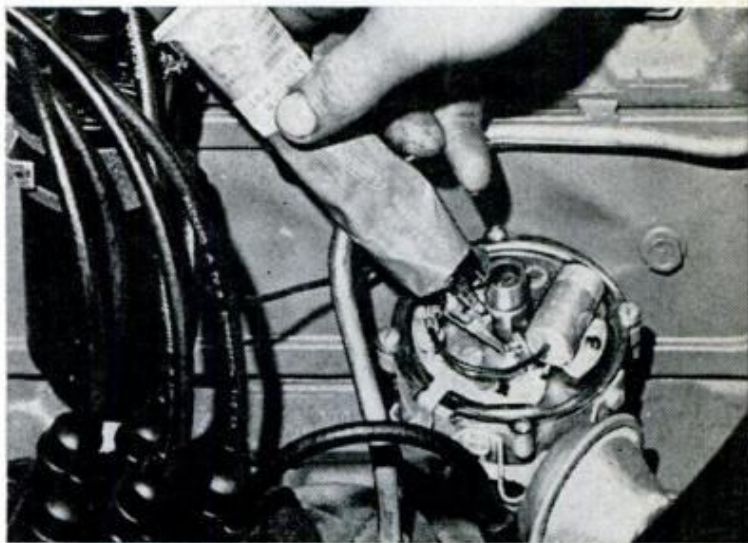

FIBER BLOCK rides on distributor cam which must be lubricated, but with only a thin film of special cam lubricant. Excessive lubrication will splatter inside the distributor and contaminate the points

Build This Fish and Meat Smoker



SALVAGED REFRIGERATOR makes ideal smoker. Grid-like shelves let smoke permeate meat from all angles.

CAUTION: Before setting up your smoker in garage or on patio, be sure to remove door-locking mechanism. To protect children, always keep unit padlocked

AN OLD box-type refrigerator, with its thickly insulated walls, can be quickly converted into a "smokehouse." Rigged with an electric hotplate rated at 95 watts, you can get the inside temperature up to about 120°. That's enough to make a shallow pie-tinful of hickory chips burn and smolder for hours. The resulting dense smoke delicately flavors meat, fish and fowl. I've learned several tricks you may want to use: First, stick with hickory chips; they burn slower than the sawdust I've tried. Second, after leaving it in the smoker for at least 10 hours, remove the food and check flavor to see if more smoking is needed.—A. L. Ramos

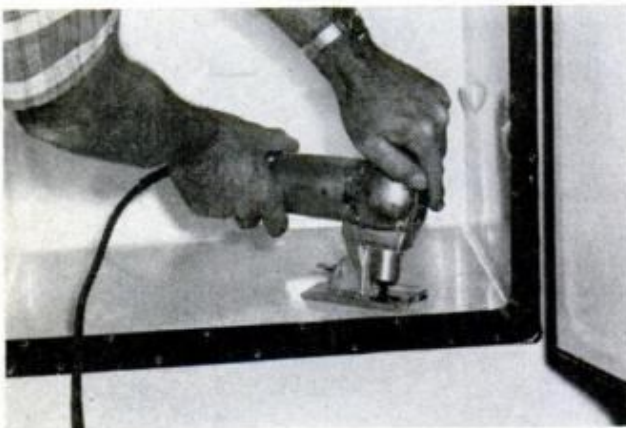

ELECTRIC-HEATER-CORD exit-hole is cut at bottom with sabre saw. Pilot hole makes this job go easier



GUTTER FITTING is used to protect line cord from sharp edges. To fasten, use No. 6 sheet-metal screws

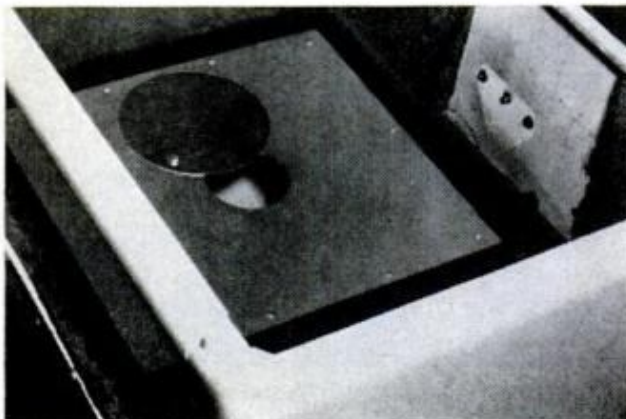

DAMPER PIVOTS on one screw, controls draft. Sheet metal covers hole left after removing compressor

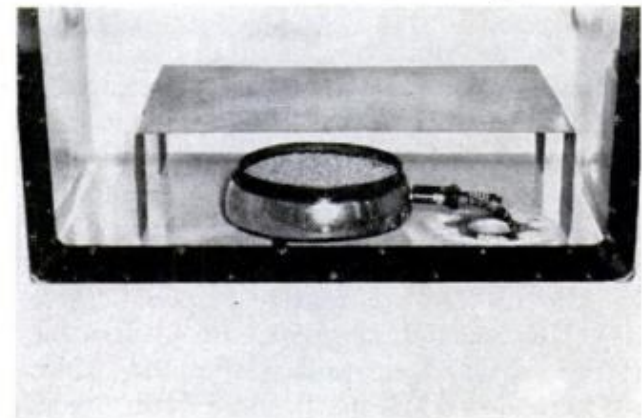

ELECTRIC HOTPLATE produces clouds of scented smoke. Sheet-metal drip-catcher prevents spatter

POPULAR MECHANICS

HINTS FROM READERS

Hound-dog mailbox

The average rural mailbox is fine for letters and magazines, but what about bulky packages? Earl Jordan of Montgomery County, Ill., came up with a "doggie" idea which solved the problem perfectly. He welded pipe legs to an oil drum body, attached the mailbox to a pipe neck, added a cultivator spring for a tail and reflective tape for mouth and eyes. Packages are chucked through a door in the end of the oil drum.—*C.F. Marley*



Pencil clip holds screws

When driving Phillips-head screws overhead, a pencil clip slipped over the shank of the screwdriver makes a dandy attachment to hold the screw for starting. When hooked over the screwhead, the ball end of the clip will hold the screw securely to end of the blade.—*Henry Josephs*

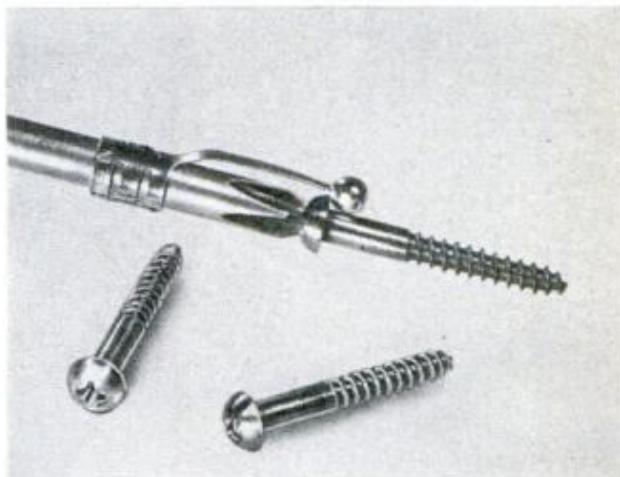

Wrist loop for flashlight

A loop of cord attached to the end of a flashlight and slipped over your wrist is a big help in keeping the light handy when you work in dimly lit areas. Dangling from the wrist, the flashlight is instantly available and saves tugging to get it out of a pocket. A small hole is drilled in the end of the cap and the cord knotted on the inside.—*Joseph Braunstein*



Sawing soft metals

When you use a bandsaw-type cutoff saw on soft metals such as aluminum, there is a tendency for the blade to jump and dig in, and sometimes break. To prevent this, remove the blade and turn it inside out so the teeth run backwards. It may be necessary to reset the counterweight to compensate for the different cutting angle of the teeth.—*Vern Dennis*

Voltage tester adapter

A neon-bulb voltage tester will be much easier to use for testing wall receptacles if you cut off the prods and attach the two wires to a common plug. To convert back to prods for normal testing, cut the cube receptacle from an extension cord, leaving about 5 in. of wire, and solder phone jacks to the ends. Then plug tester into cube.—*Henry R. Rosenblatt*

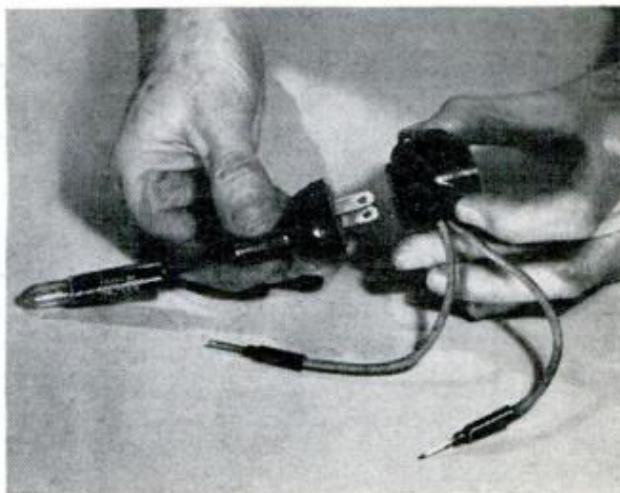

What's New for Polishing and Buffing



BUFFING COMPOUNDS can be identified by color: red, brown, dark gray, white. Start with a one-stick-of-each set, then buy replacement sticks individually

By JOHN BURROUGHS



BRIGHT-FINISHING METAL traditionally has been a two-part job: First the work is polished to cut out blemishes; then it's buffed to high luster.

Polishing, the cutting-down step, used to be accomplished on a headed cloth wheel (the wheel's periphery was glued, rolled in loose abrasive and, when dry, cracked for some flexibility). Since a polishing wheel's fixed abrasive grains plow off minute chips, polishing removes metal.

The second step, buffing, is really a

burnishing operation. The cloth wheel as it turns is simply rubbed intermittently with grease-stick abrasive compound. The greasy abrasive grains skid across the work without appreciable cutting action and burnish the surface to high brilliance, or *color*.

Things have changed. Today these two steps are no longer so clearly distinguishable.

Nowadays most production polishing is performed on fine-grit coated abrasive belts running over resilient contact

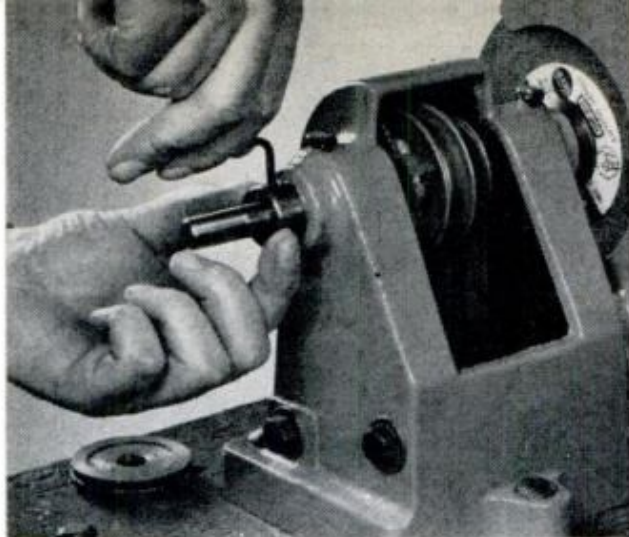

BELT-DRIVEN GRINDING HEAD with the right-hand wheel guard removed is the ideal tool for polishing and buffing. Slip on a shaft collar to retain spindle

wheels. For rough polishing, which is termed *dry fining*, the belts are used dry. For finish polishing, or *greasing out*, the belts are lubricated with grease, which improves finish by limiting the abrasive's penetration. Buffing compounds are available that simultaneously cut and color, and the bias buffs now widely used industrially (so called because the cloth strips from which they're made are bias-cut to minimize raveling) cut and color quite rapidly.

But whatever the equipment used, mirror-finishing metal is still a matter of working down the surface with progressively finer-grit abrasive.

Although belt-polishing takes special backstand machines, you can get similar results in a home shop using fine-grit aluminum oxide cloth discs, drums or flapwheels, which you can mount on nearly any power-tool spindle. For rough polishing use the cloth unlubricated. For fine polishing swab finer-grit cloth with grease or oil, wiping off and renewing the lubricant frequently as you work.

Cut-down buffing with fast-cutting compound on a bias buff gives a finish much like that obtained with greased-out abrasive cloth. The grease-base or glue-base binders used in coarse-grit buffing compounds are formulated to generate friction. The "drag" on the wheel makes the abrasive cut.

For cut-and-color buffing, an intermediate step that removes polishing scratches, you'll need a full-disc muslin wheel mounted on a spindle that turns fast enough to give the wheel a peripheral speed of at least 5000 surface feet per

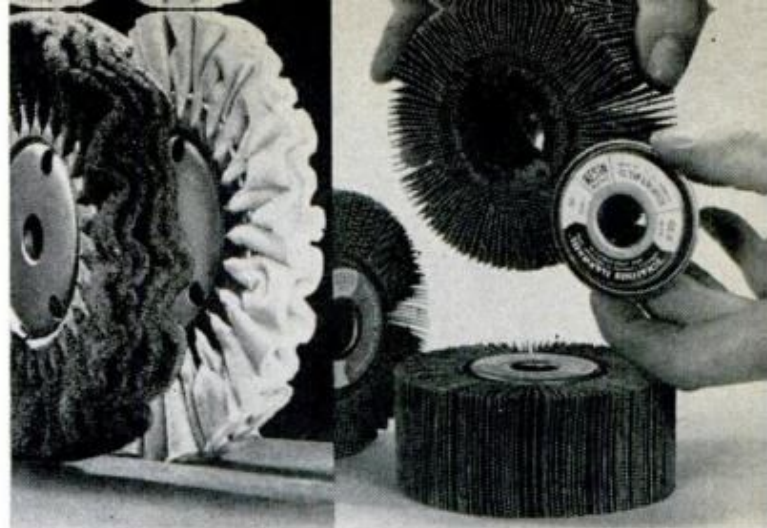

SCHAFFNER "SATI-BUFF" (left), made of shirred strips of nylon web impregnated with abrasive, gives metal a beautiful satin finish. Radial flapwheels (right), made of aluminum oxide cloth, are great for polishing irregularly shaped metalwork. Use an 80-grit wheel for cutting down; 180-grit wheel for finishing



GREASED ABRASIVE CLOTH gives metal a much higher shine than same cloth used dry. Apply grease stick or chassis grease, regreasing wheel frequently

SANDING DRUM faced with fine aluminum oxide cloth puts a high polish on flat tool blades. Abrasive cloth for the lapidary drum pictured comes in rolls

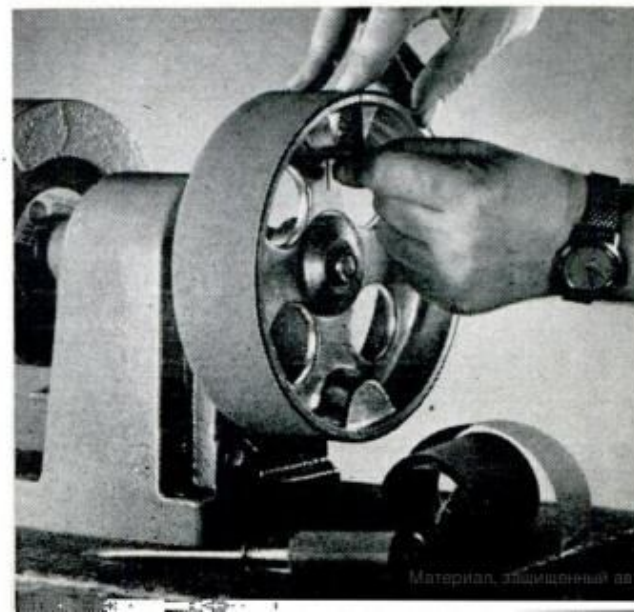



MUSLIN BUFFS come spiral sewed or unstitched. Loose buff sandwiched between sewed buffs makes wheel for heavy work



RAKING A NEW BUFF with a sharp-edged steel bar cleans the cloth and frays the wheel's periphery. Rerake the wheel thoroughly whenever you switch from coarse to fine compounds



ALUMINUM OR FLAT-BRASS STOCK can be polished ready for buffing with well-worn, fine-grit cloth in orbital sander

STEPS TO A MIRROR FINISH ON METAL

Polishing

DRY FINING—Rough polishing on a 100 to 150-grit abrasive cloth belt or disc without lubricant.

GREASING OUT—High polishing with greased 150 to 320-grit abrasive cloth belt or disc.

Buffing

CUTTING—Buffing with coarse grease compound on a firm cloth wheel. Removes some metal.

COLORING—Buffing to high luster with fine grease compound on a soft cloth wheel. Removes very little metal.

minute (2400 rpm for an 8-in.-dia. wheel; 3200 rpm for a 6-in.-dia. wheel) An inexpensive belt-driven bench grinder or large polishing head rigged with step-pulleys for speed control is the most convenient setup, but a lathe or drill press spindle can be used instead. Buffing takes more power than grinding or polishing. For an 8-in.-dia. wheel you'll need a 1/2-hp motor.

Sandwiching an unstitched buff between two spiral-stitched buffs on the arbor will give you a wheel with a 1-in.-wide face, wide enough for fast work.

You can identify cut-and-color buffing compounds by color. Use black emery compound or dark gray aluminum oxide compound for aggressive buffing on steel. Use brown tripoli compound to buff brass, copper, aluminum or zinc.

Buffing with light pressure to let the compound do the work generally gives best results. Apply compound frequently, rubbing the cake on the wheel slightly below center. Continue buffing until minute polishing scratches are cut away, but avoid overbuffing, which tends to pit the surface.

Since a buff throws off bits of compound, be sure to wear protective glasses, and wear heavy gloves whenever you're buffing sheet metal or other work with sharp edges that might snag in the wheel.

Though you can rake out the coarser compound and color your work on the same buff used for cut-and-color buffing, it's preferable to keep a second muslin wheel for final coloring.

White rouge, which generally contains lime, powdered silica or chrome oxide, is

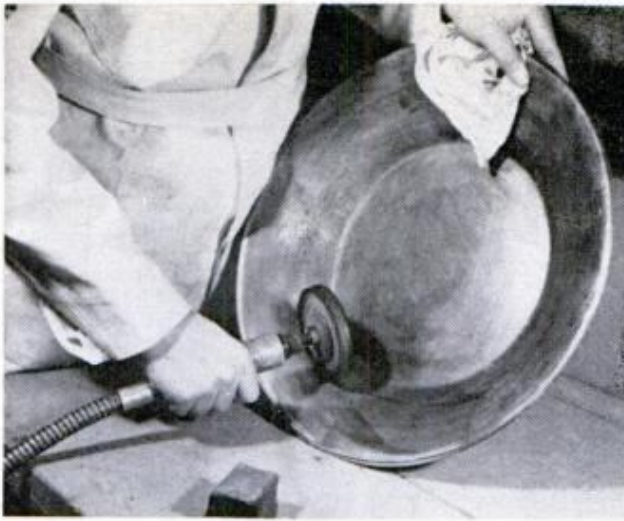

WORK THAT'S AWKWARD to buff on a stationary wheel can be shined up with a buff mounted on a flexible shaft. Use a 3400-rpm motor to drive the shaft

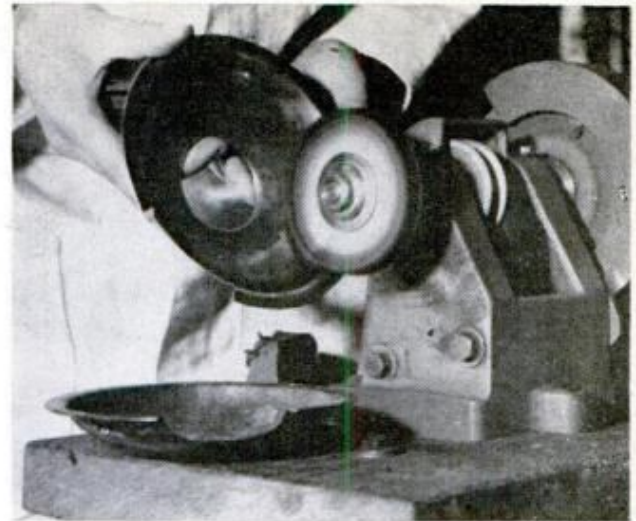

SAVE WORN-DOWN BUFFS for dirty jobs such as polishing range-element reflector bowls and rings and to clean corroded garden tools and greasy auto parts

the compound commonly used for coloring both ferrous and nonferrous metals. Applied to the wheel liberally, it has a very gentle cutting action—enough to remove light tarnish. Applied sparingly, it produces a mirror finish and leaves the work easy to wipe clean.

Jeweler's red rouge, which is compounded from the finest red iron oxide, colors work to extremely high brilliance while removing virtually no metal at all. Use this compound for buffing precious metals and plated ware. Some red rouge compounds are quite greasy and leave deposits on the work that, after buffing, must be cleaned off in solvent. To simplify cleaning, use the compound sparingly on a soft, high-speed buff.

Don't confuse red rouge with cake crocus, which is a coarser-grade iron oxide, cut-and-color compound.

Special wax-base compounds are available for buffing plastics. Use caution when buffing acrylic or other thermoplastic to avoid heavy pressure on the wheel, since frictional heat can soften the material. ★★★

Window shades corral sawdust

The one disadvantage I found with my radial-arm saw is that it threw sawdust everywhere. After purchasing a dust catcher and finding it really didn't do the trick, I hit upon the idea of building a "booth" around three sides of the saw with window shades. I attached them to the overhead joists in my shop and simply pull them down when I want to saw. When through, up go the shades and the collected sawdust is quickly swept up.—*Ralph H. Lewis*

SEPTEMBER 1969

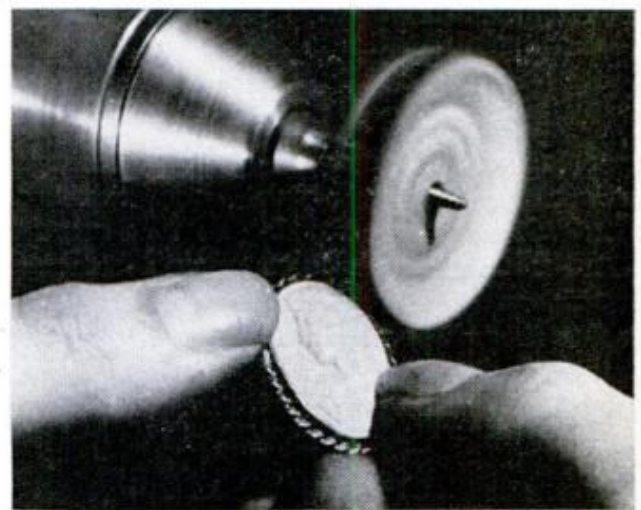

TO SHINE PRECIOUS METAL use a small unsewed buff charged very lightly with red rouge compound and buff with light pressure. Buff plated work similarly

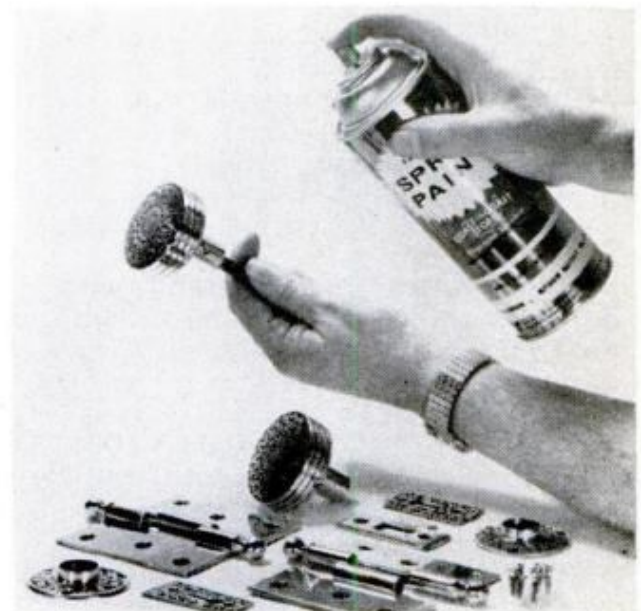

ACRYLIC LACQUER will prevent buffed brass or copper hardware from tarnishing. Clean work carefully with solvent and spray on several light, even coats

191

HINTS

FROM READERS



Washer and nut holder

There are many ways to keep different-size nuts and washers handy, but I have found that shower-curtain rings are better than glass jars, small-parts cabinets and other containers. When slipped on the rings, the nuts and washers can't spill, and if hung on your PegBoard tool panel, you can see what you have at a glance. Rings will also hold cotter pins, screw eyes and eye-bolts.—*Victor H. Lamoy*

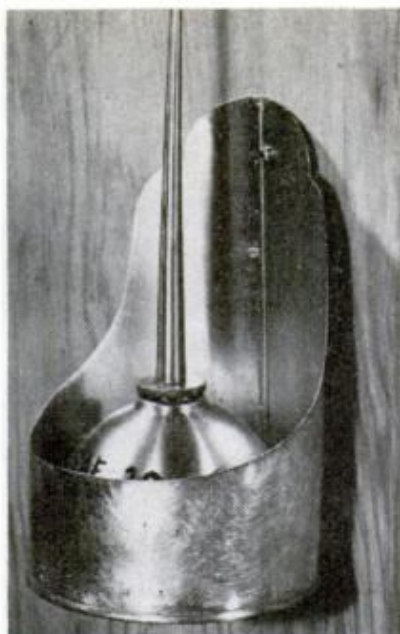

Oilcan holder

An oilcan can be a messy thing to have sitting on your bench. Often it will leave an oily spot and even get tipped over. A tin can makes a perfect wall holder for a shop oilcan when one side of the can is cut away with tin snips as shown. A standard No. 2 can will do in most cases; a large oilcan may need a fruit-juice can. Use tiny screws to hang the holder near your drill press.—*Jay H. New*

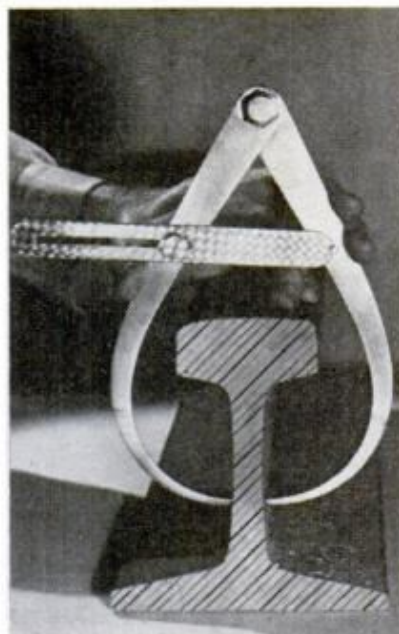

Caliper transfer tool

A sliding slotted arm will convert an outside caliper to an accurate transfer tool. Drill one leg for a shouldered stop pin and the other for a knurled clamping knob. To use, you take a reading, slide the arm against the stop pin, lock the knob and then open the caliper to remove it from the work. Closing the caliper against the stop pin returns it to the original setting.—*Albert T. Pippi*

NEXT MONTH IN SHOP AND CRAFTS

WHICH INSULATION SHOULD YOU USE? The wide variety of insulation materials available confuses many. To clear the air, next month *PM* tells the insulation story in simple do-it-yourself language. What's available, where to use and how to install it are reported. Vapor barriers and through venting, and their important relationship to insulating, are also discussed.

HOW TO INSTALL A WALL VAULT. Most important to the householder is the protection of insurance policies, wills, deeds, birth certificates, bonds and other vital records from fire. For this reason, every home should have a safe. It's a simple do-it-yourself job to install one as you'll see from the step-by-step photos in the October issue.

BUILD THIS BEAUTIFUL HALL CLOCK. Standing some 6 feet tall, this stately chime clock is a project the advanced craftsman will find both challenging and "timely." A two-part article begins next month. You'll want to make this elegant piece.

FIVE-TON PRESS FOR YOUR SHOP. Powered by a hand-operated hydraulic pump, this powerful little press is ideal for benchwork. It's a simple affair that's assembled from stock pieces of steel angle, channel and threaded rod. Both the home shop and the small machine shop will find a lot of use for it. Watch for it in the October *PM*.

HOT SEAT TO BRING 'EM BACK

(Continued from page 93)

chute about six feet in diameter would open. This would slow the seat to a safe speed before start of deployment sequence. If the pilot ejected at a high subsonic speed, say about 600 knots, the chute would remain reefed; that is, restricted by a cord from opening to its full diameter. After some speed was lost, the cord would be cut, and the chute would open fully, slowing down the seat even more.

Once the seat has decelerated, the sequence changes for the three systems.

● *Bell's Rogallo wing*, simplest of the three, may be deployed by a timer or by actuators triggered by pull of the deceleration chute. In either case, the V-shaped wing would peel off from the back of the seat and extend to a length of about 7 feet and a width, at the trailing edge, of 13 feet. Each of three keel bars would have at least two sections, one nesting inside the other when stowed. A spreader bar would also extend during deployment, holding the three keels rigid and insuring proper "fluff" to the cloth wing.

The wing will have an angle of attack of about 30°. The pilot, still strapped to his seat, lies face down. By moving a control stick, he can tilt the wing up to climb, down to descend or sideways to turn. The engine, on the back of the seat, starts when the wing deploys and is controlled manually by a throttle on an armrest.

While Bell's Rogallo-wing system has the advantage of simplicity, a pilot might feel awkward flying through the air face down. Also, he couldn't land strapped to a huge seat, so he has to jettison the seat and parachute down.

● *The Stratos Western version of the Princeton sailwing* looks like an airplane. With a lift-over-drag ratio of 5 to 1, it can glide long after fuel runs out.

Its deployment sequence goes like this: After deceleration chute has slowed down the seat, a tail boom—made up of sections nested inside one another—is extracted from its stowed position and extends to full length. The last section has notches in it that run almost the entire length. The tail surfaces are folded and stowed in these notches. When the section is exposed, the tail surfaces, under spring tension, pop out and lock in place. Aluminum spars, hinged at the forward end, form the leading edges, pulling cables taut to form the trailing edges. The tail surfaces are made of Dacron, and the horizontal stabilizers form an inverted V so that the notches are distributed evenly.

The wings are hinged at two points. The inboard section of the leading edge, also

made of aluminum, is hinged to the seat; the outboard section, which nests inside the inboard section, swings out further on a hinge at outer end of the inboard section. Fully extended, the wing locks in place and pulls taut the cable for the trailing edge, the cloth and two ribs that provide additional strength.

The fuselage is completed by blowing up a preformed rubberized-cloth nose section. This gives the system better aerodynamic qualities and lengthens the vehicle to 14 feet. Its wingspan is 16 feet.

A stick on the seat floor manipulates bladders (air bags) inside the wings, which warp the wings for pitch and roll.

The engine is attached to the bottom edge of the seat, and may also be controlled by a throttle on the armrest.

Stratos Western designers believe that pilots might feel more at home in the sailwing, since they sit straight up in something that resembles an airplane. Because pilots might be tempted to fly it all the way down, the designers added a small landing gear. But in most cases the pilot would separate from the unit above 200 feet.

● *The Kaman gyrocopter* is called SAVER (Stowable Aircrew Vehicle Escape Roto-seat). Engineers at Kaman Corp. say SAVER is the only system designed to take the pilot all the way to the ground without separation, although he still has the option of using his chute.

The engine is nested on the seat back, with two rotor blades folded behind it. At deployment, blades swing out and up, pulling their control arm along. They then swing down on hinges, extend to full length (15 feet) and lock into place. Meanwhile, stabilizing surfaces, shaped to fit along each side of the seat and still be aerodynamically correct, swing back and lock. The engine drops from its nested position and ignites. Forward thrust makes the rotor blades spin, and the blades alone provide lift and control.

A second version of the copter, being developed at Catholic University, Washington, D.C., closely resembles the Kaman vehicle and has a similar deployment sequence.

All three systems deploy relatively fast—from six seconds for the Rogallo wing to eight for the Princeton sailwing. No matter which version is chosen, engineers are thinking of adding refinements. Instruments might be built in to indicate speed, altitude and fuel consumption.

The final criterion will be dependability. And, whichever company's system proves itself in combat, pilots will surely come back to say, even to the two losers, "Bless you, one and all." ★ ★ ★



BEFORE

AFTER



**All it adds is the natural sheen
of a healthy animal**

© THE GILLETTE COMPANY, BOSTON, MASS. TM TRADE MARK

**A draftsman
can make
\$200 a week.
Can you?**

If you're thinking about a job, or if your present job is a low-paying dead end, maybe drafting is for you. Trained Draftsmen make big money and big advances. They choose where they work and what they work on.

So can you. Our program enables you to prepare for a rewarding Drafting career at home, in your spare time. A program that gets you ready for the big money. Write today.

ITT Technical Institute
1340 S. Michigan Avenue, Chicago, Ill. 60605 • Dept. 163-99
Please send FREE information on your program for Drafting and Design Engineering.

Name _____ Age _____
Address _____ Married
City _____ State _____ Zip _____ Single

Approved for Veterans Training
ITT TECHNICAL INSTITUTE
An educational service of
International Telephone & Telegraph Corporation **ITT**

OUR MIXED-UP SPEED LAWS

(Continued from page 83)

a maximum or *prima facie* limit. Your state's speed laws are explained in the driver's handbook you were supposed to have read when you got your license. To help you out, however, the American Automobile Assn. (AAA) has published a guide to various state speed laws. According to its *Digest of Motor Laws* (1969), they can be divided into three general groups:

● *States with fixed maximum speed limits:* Ala., Del., Fla., Ga., Ill., Iowa, Kans., Ky., Me., Mich., Miss., Mo., Neb., N. M., N. D., Okla., Pa., Tenn., Tex., Vt., Va., Wash. and Wyo.

● *States that combine the basic speed rule with prima facie limits:* Alaska, Ariz., Colo., Conn., D.C., Hawaii, Idaho, La., Md., Mass., Mont., N.H., Ohio, Ore., R.I., S.D. and Utah.

● *States with combinations of the above plus maximum limits:* Ark., Calif., Ind.,

ANSWERS TO SPEED QUIZ

1. B.—Your speed must be reasonable and prudent for conditions.
2. A.—If it's raining, foggy or icy, 40 mph may not be a reasonable speed for conditions.
3. D.—Under the basic speed rule, conditions determine the speed limit.
4. C.—Slow down and give way. Don't force him to break the law to pass you.
5. C.—260 ft., reaction and breaking distance. This does not include the distance it takes you to see a hazard and decide what to do about it.
6. B.—The area you can see in your headlight beams determines your clear distance on a dark road.
7. A.—25 mph.
8. C.—You're assumed—but not proven—to be going too fast for conditions.
9. C.—Let the conditions tell you. Most people drive too fast in the rain, for example. Don't make their mistake by copying their speed.

Minn., Nev., N.J., N.Y., N.C., S.C., W. Va. and Wis.

Know that if tagged for violating a maximum limit you have little or no defense. But if stopped for going over a *prima facie* limit, you've a chance.

Take this actual case. A driver had been pinched for doing 50 in a 35-mph zone. He fought the citation, offering in evidence the following: 1. Weather conditions and visibility were good; 2. It was 3:00 a.m. and there was no traffic; 3. The road was a good, four-lane divided highway; 4. His car was brand-new; 5. He was a good driver in good physical condition.

In this case, the driver's evidence convinced the court, which let him go.

You see, combining the basic speed rule with *prima facie* limits adds flexibility to the law. But this applies only under *good* conditions. It's a new ball game when conditions are bad.

"Your *prima facie* speed limits are usu-

ally posted, but don't have to be," says one traffic officer, explaining how he operates. "They're in your driver's handbook and you're supposed to know what they are. So if I catch a driver going over a *prima facie* limit, I cite him, even in good conditions.

"Now suppose it's raining, foggy, icy, dark, or there's a lot of traffic. Then I'll use the basic speed rule and cite him for driving too fast for conditions, even if he's going slower than the posted limit. He may be going only 10 mph, but if—at that speed—he hits another car, then obviously he was going too fast for conditions."

How strictly do most officers hold you to a posted limit? It varies with the cop.

In poor conditions, use your own judgment to calculate reasonable speed. But know that an officer's judgment has the edge. The posted limit on a curve may be 35, but if there's ice, a cop may nail you for going 15—particularly if you skid.

What about "speed traps?"—sneaky devices that time you over a measured stretch of highway without your knowing it. They're pretty much infallible and there's little point in trying to argue against their evidence.

WHAT ABOUT 'TOO SLOW'?

Lou Nova, the one-time heavyweight boxer, demonstrated that a driver can go to court and convince a jury that he has a right to exercise judgment in driving slow, too. Nova was arrested in December 1967, driving 50 mph in the center lane of Interstate 10 in California. The officer said he was not traveling fast enough to be moving with the flow of traffic, as California law requires. Nova asked for a jury trial, and the jury found him not guilty.

Someday traffic laws in this country may be standardized so that all of us will have the same set of rules. As it stands now, your best chance to avoid the blinking red light is to drive in a "reasonable and prudent" manner. Keep in mind the posted speed on many roads is based on the recorded speed of about 85 percent of the drivers who use the roads, and, in general, indicates a safe speed to travel—in daytime, under good road and weather conditions.

Under bad conditions, again, your judgment comes into play. You can no longer use average traffic speed as an indicator of "safe" speed, if only because most people drive too fast in bad conditions. Lower your speed to where you can control your car, regardless of what happens. Then you'll be safe—and legal.

Finally, you may never take a speeding ticket to court and win. Few do. The cards are definitely stacked in favor of the law and its enforcers. Still, you should know that in certain states under certain conditions you can at least *try* to fight a ticket. You might win. ★ ★ ★

**The Swingline
Tacker Gun does
everything the \$12.95
gun will do...**



for only \$8.95

Use the Model 800 Heavy-Duty Tacker Gun to install ceiling tile... repair screens... lay carpet... insulate... weather-strip... upholster... you-name-it!

Takes 5 staple sizes, from 1/4" to 9/16" — plus special Loktile® staples for ceiling tile installation. Easy to load — easy to operate.



Model 800

Write for free booklet,
TIPS ON TACKING
Dept. PM-99

Also available:

Model 101 Tacker Gun. Only \$5.95.
Takes 2 Staple Sizes 1/16" and 5/16"

Swingline®

Consumer Products Division, 32-00 Skillman Ave.,
Long Island City, N.Y. 11101.

SUPER SCOPE

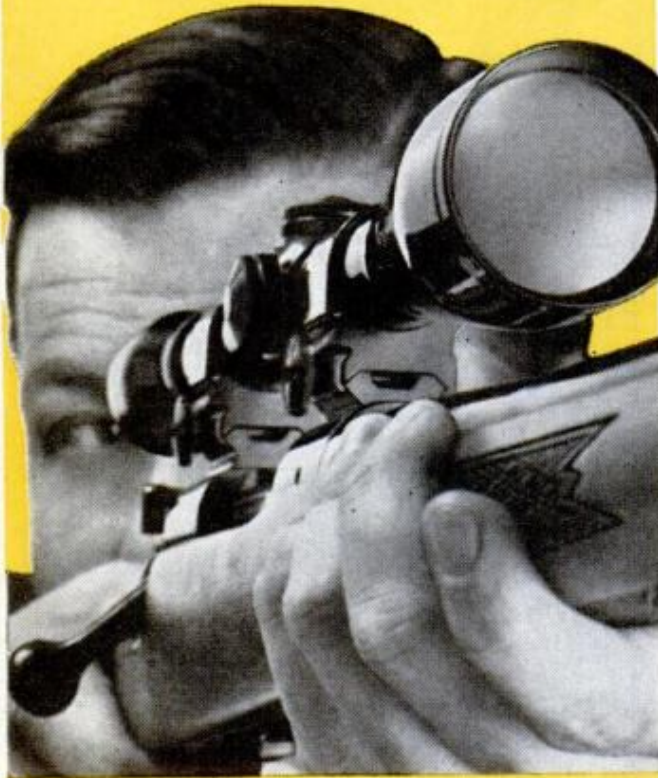

Super scope? Yes... because a Weaver K Model offers you the quickest, surest, most dependable way to improve your shooting accuracy.

Compare K Models with any other scopes. Check K Models' magnesium fluoride-coated lenses, strong steel tube, micrometer click adjustments, and exclusive triple weatherproofing.

See the super scope at your dealer... in eight models, from 1.5-power to 12-power. Choose from five reticle styles. Prices start at \$29.50.

WEAVER  **SCOPES**

WRITE FOR FREE CATALOG:
W. R. WEAVER COMPANY
DEPT. 91 / EL PASO, TEXAS 79915

©1968 W. R. Weaver Co.

SECRETS OF THE ANIMAL WORLD

(Continued from page 87)

learned the same lesson when they were young, and so on back to the origin of the species. However, poultts respond to hawks with cries of alarm even when separated from adult birds at birth. So much for Theory No. One.

"At this point," says Schleidt, "someone usually introduces the 'instinct' theory. Turkeys 'instinctively' recognize the fear-some hawk through a 'miracle of nature.'"

To modern scientists, "instinct" is no answer.

"The question still remained," Schleidt explains, "what specific characteristic of the predator triggers the fear response in the intended victim?"

Naturalists have been intrigued by the puzzle for years. In the 1930s, a German scientist performed a series of experiments that seemed to point the way. He developed a model that looked like a hawk when held in one position and like a goose when held

**Turkeys are afraid of hawks
because they are so rare . . .
They are afraid of the unknown**

in another position (see illustration, page 87). Then he flew both shapes over his turkeys, pulling the models over the heads of the birds on runners. His young turkeys fled from the hawk shape but ignored the goose shape. Whereupon the German scientist concluded that the shape of the predator triggers the fear response.

When other scientists tried to duplicate the experiment in the 1950s, however, they found that their turkeys didn't distinguish between the hawk and the goose. Surprisingly, though, they were terrified when a simple black disc was pulled overhead. No one knew why.

Then Prof. Schleidt got to work on the riddle. Like the other experimenters, he, too, used the hawk-goose model and the black disc. In addition, he developed a silhouette that looked like a predatory buzzard. Each model was "shown" to the turkey poultts five times.

The results couldn't have been more discouraging. Not only did the turkeys fail to distinguish between the hawk and the goose, they also didn't differentiate between the buzzard and the black disc. His turkeys couldn't care less what shape zoomed overhead. Schleidt was back on square one.

Suddenly Schleidt remembered an incident from his days as a young scientist

working in Europe. On the day in question, his experimental turkeys had grown extremely excitable. Looking up, Schleidt had seen a stork was flying overhead, sending his turkeys into a frenzy of fear.

He turned the incident over in his mind. What was there in the harmless stork that had frightened his turkeys?

The answer came in a flash: The stork is one of the rarest birds in the sky. So are hawks and other predators. Could rarity be the key?

Schleidt took his theory back into the laboratory. This time he flew the goose model 10 times before flying the hawk model once. His turkeys were absolutely terrified.

In mounting enthusiasm, Schleidt flew the goose another 10 times, then the buzzard. Finally he flew the goose 10 times more before showing his poults the round black disc. In these cases, too, the turkeys reacted with fear and agitation to the strange models.

As Schleidt put it: "The rarity of the shape is the significant parameter, not the shape itself. Turkeys are afraid of hawks because they are so rare. Like many humans, they are afraid of the unknown."

Riddle solved.

● *How does a badger stake out his territory?* Badgers are fiercely possessive. Strange badgers entering the territory of another male badger can expect to be attacked.

How does one badger know that he is entering another badger's territory?

The answer is an odor signal, produced by a secretion from a gland near the base of the badger's tail. To stake out his territory, the badger will make a barrier of smell by pressing his hindquarters against stones, tree trunks and patches of ground along the way.

Odor signals are not unique with badgers. The male antelope has glands near his antlers which he can open and close at will. He marks his territory by depositing a strong smelling secretion on bushes and trees. The brown bear uses urine to mark his boundaries. The bull hippopotamus uses a mixture of urine and solid droppings—it's better than barbed wire to warn off other hippos.

Even domesticated dogs use odor signals to mark trees along their usual route of way—often carrying out duels to see which one can place his mark higher than the other. The higher the mark, the higher the dog's rank. If you have ever seen a young puppy slink away from a tree where an especially large dog has left his sign, the reason why is obvious: The puppy knows from the signal who is boss. The badger's secret is no secret any more. ★ ★ ★

HEAVY DUTY WELDER
"BEST FOR THE MONEY"
LIFETIME GUARANTEE **10-DAY TRIAL**

FOUR-WAY ARC WELDER
FOUR-WAY
FLUX
WELDING MANUAL

WELD, BRAZE, SOLDER, CUT

Only \$18⁹⁵ Prepaid Complete Ready To Use

\$20.95 VALUE. WITH EXTRA \$2 PACK OF SUPPLIES

Every home, shop, and hobbyist needs this quality metal working machine. Use up to 1/8" welding rods and 1/4" carbons. Follow simple instructions to make or repair 1001 items including furniture, toys, auto bodies, fenders, trailers, boats, farm and garden tools and equipment. Operates on 110 V. 30A. for pennies—Adjustable Twin Carbon Arc Torch easily **REGULATES HEAT FOR EACH JOB**. Eliminates changing cables—replaces gas torches—no tanks or refills to buy—produces to 11,000° heat. **YOU CAN PAY MORE BUT YOU CAN'T GET A BETTER LOW COST WELDER.** Over 500,000 in use. Manufacturers of welders for over 30 years. **LIFETIME GUARANTEE.** Simply return prepaid. We will repair and reship **FREE** of charge. **YOU GET:** heavy duty welder in rugged metal cabinet, ground clamp, cables, combination torch and rod holder, welding manual and helmet, plus **Free \$2.00 pack "TOUCH WELD"** rods for instant and automatic arc, brazing rods, 1/4" carbons, solder and flux. Complete ready to use. Nothing else to buy.

FREE ONLY 4-WAY GIVES YOU AN EXTRA \$2.00 PACK WELDING & BRAZING RODS, CARBONS, FLUX AND SOLDER. 2 PACKS WITH ORDER.

ORDER TODAY ON MONEY BACK TRIAL. IF NOT COMPLETELY SATISFIED, RETURN IN 10 DAYS AND WE WILL REFUND PURCHASE PRICE. SEND ONLY \$2.00 and pay \$16.95 plus C.O.D. and delivery charges, or send only \$18.95 for postpaid shipment in Continental U.S.A. **FOUR-WAY WELDER CO., 1810 Federal St., Dept. R2-J, Chicago, Ill. 60616**

WORLD'S FINEST CORED SOLDER
ERSIN MULTICORE
5-CORE SOLDER
EASY DISPENSER
ONLY 69¢

BUY IT AT RADIO-TV PARTS STORES

Tear Out & Mail. No Letter Needed

Free New Catalog 2000 Novelties

Send for world famous catalog of novelties, live animals, scientific supplies, hobbies, funmakers, planes & boats, looms, magic tricks, joke articles, unusual seeds, gadget timesavers, cameras, optical goods, projectors, movies, lucky jewelry, religious novelties, disguises, musical instruments, stamps, coins, puzzles, fortune tellers, radios, auto & bike accessories, telescopes, magnifiers, compasses, banks, smokers' gadgets, artists supplies, printing sets, engines, motors, shockers, knives, billfolds, fireworks, guns, rifles, sports, books, games, plants, etc. Send postcard or this ad. No letter needed!

CHECK HERE **YES—I want FREE Catalog. My Name & Address Attached or on Envelope**

Johnson Smith Co., Dept. C109, Detroit, Mich. 48224

**MAKE
EXTRA
MONEY
IN YOUR
SPARE
TIME**

**LEARN PROFESSIONAL
"PLEXIGLAS"
SIGN
MAKING!**

\$13.75 brings you over 120
ACRYLIC LETTERS AND FREE
INSTRUCTIONS. Send your re-
mittance to:

DAYTONA PLASTIX

Box 6161, Daytona Beach, Florida 32022.

A Treasury of
**HARD-
TO-FIND TOOLS**

NEW CATALOG



Unique collection of hard-to-find ver-
satile hand tools and small power
tools rarely found in stores or other
catalogs. Large selection of unusual
knives, precision tweezers, jewelers' and electronics pliers, flexible
shaft machines, endless hacksaw, diamond glass cutter, soldering
jigs, carbide hacksaw blades, silver solder, micro-miniature tools
and scores of other fascinating items to make projects easier,
more fun. All are top quality tools. Used extensively by wood-
workers, machinists, craftsmen. Money back guarantee. Send 25¢.

BROOKSTONE CO.

9924 RIVER ROAD, WORTHINGTON, MASS. 01098

BELSAW PLANER · MOLDER · SAW!

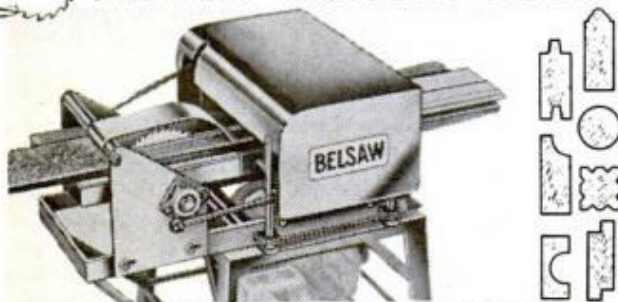

Now you can use this **ONE power-feed** shop to turn rough lum-
ber into moldings, trim, flooring, furniture . . . ALL popular pat-
terns. RIP . . . PLANE . . . MOLD . . . separately or all at once
with a one HP motor. Use 3 to 5 HP for high speed output. Low
Cost . . . You can own this power tool for only **\$30.00** down.

Send Postcard Today . . . No Salesman Will Call
BELSAW POWER TOOLS, 900S Field Bldg., Kansas City, Mo. 64111

ELECTRIC ARC WELDER \$9.99!



**NATIONALLY ADVERTISED
\$18.95 VALUE!—NOW 1/2
PRICE! WELDS—BRAZES—
SOLDERS—CUTS—ALL MET-
ALS!** Plugs into ANY 110 volt
socket. **MAKE—REPAIR 1001**
items for **CAR—HOME—BUSI-
NESS.** Lifetime **BURNOUT**
GUARANTEE 10 day money
back

back trial (if retnd). **HEAVY DUTY Design—Does \$85.00 welder**
work. No experience needed—**FREE WELDING LESSONS!**
SEND ONLY \$2.00 (cash, ck, M.O.) and pay postman \$7.99
COD postage or send \$9.99 plus \$1.00
postage for paid del. in U.S.A. **COMPLETE READY TO USE—In-**
cludes BIG pack steel, Brazing, Solder, Carbon "touch" rods,
ELECTROFLAME ARC TORCH! OFFER LIMITED—Order TODAY!
MIDWAY WELDER Dept. EPM-9 Kearney, Nebr. 68847

America's No. 1 Classified Section
Can Be Found On Page 55
In This Issue

**Build this
"Flying Volkswagen"
for less
than
\$600**



**At Last You Can Have the Thrilling
Experience of Flying Your Own Plane!
You Can Build *Jeanie's Teenie*—the
Amazing All-metal Airplane— With These
Remarkably Easy-to-follow plans.**

Here is a new breakthrough in the field of
homebuilt airplanes—one that even a
beginner can build. Until now, homebuilts cost
at least \$1,000 and up—and this for basically
wood-and-fabric. This new plane costs a
maximum of \$600! It's major advantages are—
a Volkswagen engine . . . all-metal construction
. . . easy-to-build design.

FLOWN BY POPULAR MECHANICS. The
original plane was certified by the FAA and
has been flown by Popular Mechanics' Aviation
editor.

Designed by Calvin Parker, *Jeanie's Teenie* is
the first model to be conceived with the VW
engine in mind—because it's light, dependable
and relatively inexpensive. Also, several
conversion kits make the engine easily
adaptable to airplane use.

USES STOCK PARTS AND SIMPLE TOOLS.
No complicated equipment or expensive tools
are necessary. The metal parts can be easily
purchased as stock items in any metal-
products shop. Also, they can be cut and
shaped with tools as simple as a plastic-headed
hammer and tin snips.

You will be thrilled with your *Jeanie's Teenie*
—its sporty open-air atmosphere—helmet,
goggles, silk scarf and all! This is truly a
remarkable breakthrough in amateur
construction.

SEND THIS COUPON TODAY FOR YOUR PLANS

**Popular Mechanics, Dept. BOI
575 Lexington Avenue
New York, N.Y. 10022**

I am enclosing my check (or money order) for
\$15.00. Please send me the complete step-by-step
instruction booklet and the 7 sheets of plans for
complete construction of *Jeanie's Teenie* all-metal
airplane.

Name

Address

City State Zip Code

EMJT/A

I-N-V-E-N-T-O-R-S

WE NEED INVENTIONS

Sell your invention for cash—need money for Patent?—Are technical problems holding you back? Universal Inventions has helped inventors all over the world—just like yourself—why not you? Inventions provide the magic spring-board to sudden riches. REMEMBER, we either sell your invention or pay you a cash bonus. Write for details. UNIVERSAL INVENTIONS, Dept. 13, Marion, Ohio

BASEMENT TOILET FLUSHES UP



TO OVERHEAD SEWER OR SEPTIC TANK. NO DIGGING UP FLOORS. INSTALLS EASY. Write McPHERSON, INC., BOX 15133, TAMPA, FLORIDA 33614

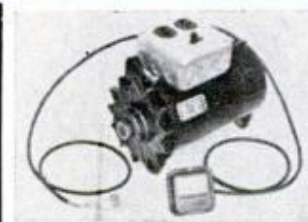

110-120 VOLT A.C. LIGHT PLANTS—60 CYCLES
Fanbelt driven from pickup or small gas engine. Operates saws, drills, pumps, freezers, T.V. X1000 Watts—Needs No Battery. Now \$62.50. 1500 Watts—6 and 12 volt vehicles. Now \$52.50. 3000 Watts—12 volt vehicles only. Now \$99.50. Guaranteed. Check or Money Order.

VIRDEN PERMA-BILT, Box 7066 P.M., Amarillo, Texas 79109

GUNK
ENGINE BRITE



ENGINE CLEANER and DEGREASER
Just spray it on . . . hose it off!

GUNK LABORATORIES, INC.
5829 W. 56TH, CHICAGO, ILL. 60638

HONEST OPPORTUNITY

Men and Women—enter the high profit custom picture framing business.

Start in your home in spare time and grow like the many full time businesses we now supply. You will assemble and sell the same high quality frames found in the best stores. No inventory, no equipment to buy. A small refundable deposit covers samples and supplies to start you on the way to immediate profit. Write today for complete free details.

Holliday Picture Frames, Box 1576PM, Hollidaysburg, Pa. 16648

MAKE BIG MONEY

MAKING COSTUME JEWELRY AT HOME!

Thrilling spare-time, MONEY-MAKING hobby! Make newest, beautiful jeweled earrings, necklaces, bracelets, pins, pendants, cuff links, tie clips! Quick, easy to make—easier to sell to friends, neighbors, stores, at big profit! Details FREE!

DON-BAR CO., Dept. G-199
2934 W. Fullerton Ave., Chicago, Ill. 60647



LAW FREE BOOK

THE LAW TRAINED MAN

Write today for a FREE copy of illustrated law book. "THE LAW TRAINED MAN," which shows how to earn the professional Bachelor of Laws (LL.B.) degree through home study of the famous Blackstone Law Course. All necessary books and lessons provided. Moderate cost; convenient monthly terms. Write for FREE law training book today.

Blackstone School of Law, 307 N. Michigan Ave.
Founded 1890 Dept. 56, Chicago, Illinois 60601

TREASURE

Find buried gold, silver, coins, treasures.

5 Powerful models.

Write for free catalog



RELCO DEPT. D-3 \$19.95 UP
BOX 10839, HOUSTON, TEX. 77018

Learn Profitable Profession in few months at Home

MEN AND WOMEN, 18 TO 60

\$4.00 to \$5.00 for 1-hour treatment is the established charge for a skilled operator. Easy to learn and do. Diploma awarded. Open your own office or earn good income from Doctors, Hospitals, Clubs and other health or recreational centers. Wonderful part-time profession. Low monthly payments. Write today for free Anatomy Charts and catalog. No obligation.

ANDERSON SCHOOL OF SCIENTIFIC MASSAGE
Dept. J-1, Princeton, Illinois



Career in ELECTRONICS?

Career training at home the new easy way with RCA Institutes. Lab work with first lesson. Easy payment plans. Send for free 64-page book.

RCA Institutes, Inc. Dept. PM-99
320 W. 31 St., N.Y., N.Y. 10001



MAKE MONEY RE-UPHOLSTERING AUTOS!

12 lesson course only \$4.95 ppd. Now! A complete 12 lesson course in auto upholstery even including rolls, pleats, from famed accredited Upholstery Trades School, just \$4.95 ppd. Learn at home—do your own car, build part or full time business or get hi-pay job. Money-back guarantee. Supply limited.

U.T.S., Dept. 5110-099, Little Falls, N.J. 07424

HEAVY DUTY BALL-BEARING PUMP



IRRIGATE • DRAIN • SPRAY • CIRCULATE • All-metal, rust-proof XB. Stainless shaft. Use 1/4 HP or larger. 1 HP for up to 5,200 GPH 60' high or 3,000 GPH from 25' well. 1 1/4" inlet. 1" outlet. For belt or direct drives. \$12.95

Type P won't rust or clog. Bronze bearing. Hundreds of thousands in use. Up to 2,400 GPH. 1" inlet. 3/4" outlet. \$8.95

P'pd. cash with order. MONEY BACK GUARANTEE.

LABAWCO, Box 2, Belle Mead, N.J. 08502

HEARING AIDS

2/3 OFF DEALER PRICES

LARGEST SELECTION of tiny, all-in-the-ear, behind the ear, eyeglass and pocket models. FREE HOME TRIAL. No obligation. Money back guarantee. No down payment. Easy terms. No salesmen or dealers. Order direct, save 65%. Write for free catalog. PRESTIGE, Dept. D-34 Box 10947, Houston, Tex. 77018.



LEARN MEAT CUTTING



Train quickly in 8 short weeks at Toledo for a bright future with security in vital meat business. Big pay full-time jobs—HAVE A PROFITABLE MARKET OF YOUR OWN! Time payment plan available. Diploma given. Job help. Thousands of successful graduates. OUR 46th YEAR! Send now for big new illustrated FREE

catalog. No obligation. G.I. Approved.
NATIONAL SCHOOL OF MEAT CUTTING
Dept. 50Y, Toledo, Ohio 43604

For more information on articles and products, write to the PM Bureau of Information for "Where-to-Find It" list.

Bean's Free Fall Catalog

Just Off the Press

Hunters, Campers and Fishermen will find many practical items in our fully illustrated Fall Catalog. Shows hunting footwear, clothing and other specialties of interest to both men and women. Many items are of our own manufacture.



Send Free Catalog

Name

Address

..... Zip

L. L. Bean, Inc.

386 Main St., Freeport, Maine 04032

Hunting, Fishing and Camping Specialties



BE YOUR OWN MAN— OPERATE HEAVY EQUIPMENT

- BULLDOZERS
- DRAG LINES
- SCRAPERS
- CLAM SHELLS
- BACK HOES
- GRADERS

Train NOW to operate earth-moving equipment. The Construction Business is Booming! Earn top money in this fast moving, action-packed field! Keep present job and train at home in your spare time followed by Resident Training in the actual operation of heavy earth-moving equipment under project conditions at our facilities near MIAMI, FLA. Excellent employment assistance.
Member American Road Builders' Assn.

CONTRACTORS: Information about our trained Operators available upon request

UNIVERSAL HEAVY CONSTRUCTION SCHOOLS
Dept. PM2- 1901 N.W. 7 STREET, MIAMI, FLORIDA 33125

Name.....

Address.....

City..... State..... Zip.....

Age..... Phone.....

TOUGH-TO-PICK DOOR LOCKS

(Continued from page 138)

the professional who makes a study of manipulating locking mechanisms.

One is the "G" lock made by Schlage Lock Co. of San Francisco. It provides double-locking security by combining a 1-in.-throw dead bolt (also called dead lock) with a 1/2-in.-throw dead latch within the same mechanism. With its two "dead" features, it is priced at \$40 to \$45, depending on style and finish.

A lock that can be snapped closed can be snapped open by means of surreptitious methods. This is the big disadvantage of spring-loaded devices. Unfortunately, many homeowners prefer spring-loaded locks, because they automatically spring into place and lock without need for physically turning a key.

A dead bolt has no springs. It must be turned physically to open and close it. The only way a thief can open a dead bolt is by picking the lock. He can't slip the bolt.

The mortise entrance lockset manufactured by Kwikset Co. of Anaheim, Calif., is similar to the "G" lock. It incorporates a 1-in.-throw dead bolt and a 1/2-in. latch bolt which doesn't have the dead latch feature. This lockset sells for about \$32.

Lock manufacturers pretty much agree that the door lock of the future will be keyless and electronic. If you want to pay the price, you can have one now.

An electronic, keyless lock called Cypher Access Control is made by Continental Instruments Corp. of Oceanside, N.Y. The least expensive model costs \$200.

The Cypher sending unit consists of a panel of 10 buttons to allow an almost infinite number of combinations. To open the door you simply push your combination, say 8639. The sending unit, which works off 110-volt current that's transformed to 12 volts, causes the electric door strike to rotate, releasing the latch. The access control remains energized for 15 seconds when it automatically relocks.

If necessary, you can easily change a combination by rearranging the numbered plugs in the control box which should be installed, of course, inside the home.

Although not electronic, the keyless doorlocks made by Simplex Lock Corp. of New York, N.Y. and Preso-Matic Lock Co. of Lyons, Ill., also use pushbutton combinations. By pushing the right buttons, you mechanically release the bolt, which unlocks automatically. There is no key to carry or lose. It locks by pressing a button on the inside, or a reset lock bar on the outside. The Preso-Matic lock is shown on page 134 and sells for approximately \$30. ★★★

The day Bill told off his boss

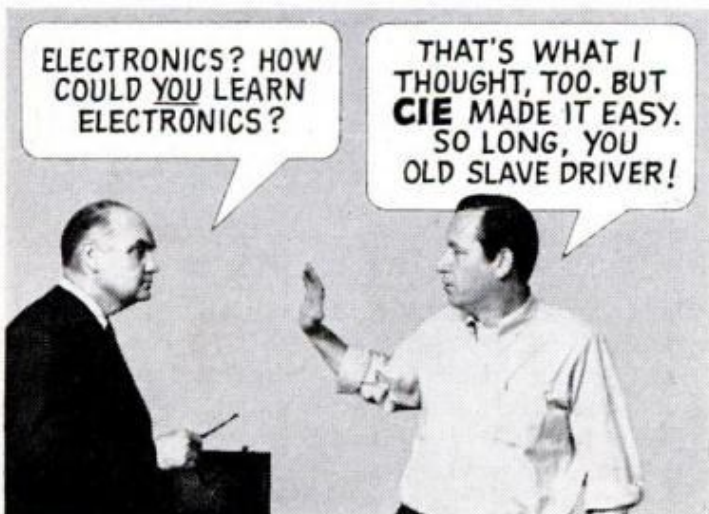
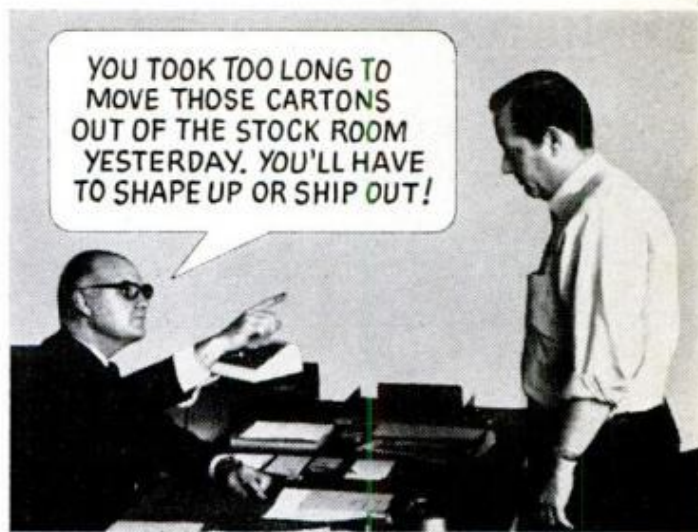

ARE YOU WORKING FOR PEANUTS IN A DEADEND JOB? GET SMART LIKE BILL... MAIL CARD FOR **2 FREE BOOKS** LIKE HE DID!

IF CARD IS MISSING, MAIL THIS COUPON

CIE
Cleveland Institute of Electronics
1776 East 17th Street, Cleveland, Ohio 44114

Please send me **2 FREE BOOKS** describing opportunities in Electronics and how to prepare for them.

Name _____
(Please print)

Address _____

City _____

State _____ Zip _____ Age _____

Veterans and Servicemen:
Check here for G.I. Bill information.

Accredited member National Home Study Council

PM-28

UNMASK hidden beauty



Costume masks, like old finishes, have a tendency to hide rather than enhance true beauty. Savogran's STRYPEEZE Semi-Paste paint remover will unmask the hidden beauty of natural wood furniture or antique pieces that have been disguised under old paint or varnish.



"AVAILABLE WHERE PAINT IS SOLD"

SAVOGRAN
NORWOOD, MASSACHUSETTS 02062

COASTAL®
ZIPPIDI-DO
ALL-PURPOSE CUTTING AND SANDING DISC

Zippidi-Do
even cuts a file

The most versatile power tool accessory... ever!

You can cut through ceramic tile, fiberglass, brick, slate, stone, all metals... even a hard file in minutes with the Zippidi-Do cutting and sanding disc. Silicon carbide grains embedded in nylon mesh give it amazing cutting ability. And the Zippidi-Do makes a great sanding and shaping disc for use on old paint, rust, wood, tile, all metals. The Zippidi-Do can be used with any electric drill or flexible shaft. It wears and wears and never clogs.

Complete kit contains Zippidi-Do disc, molded backing disc, arbor and flanges... only \$4.00 at hardware stores and depts. Coastal Abrasive and Tool Co., Inc., Trumbull, Conn. 06611.

BIG AMBULANCE FOR BIG BIRDS

(Continued from page 127)

riggers flashed a succession of things that could go wrong. A line could slip and dump the plane back. Unseen cracks in the fuselage could open and the *Shiga* could break in two.

If there was an accident only one man was to blame—Al Kelly. The concept for the recovery system was his. Even if the mishap was no fault of his, it would be the end for the A.I.R. system, the end of six years of work and an investment of \$500,000.

Korst held his arm out for a moment, then gave the rigger's signal to "lift." Crane operators eased clutches out, winches tightened, steel lines went taut. Then slowly, smoothly, the 125-ton jet-liner inched up until it was clear of the water.

Tough steel riggers let out a cheer. Those closest to Kelly thumped him on the back and shook his hand. They were all grins.

Said one, "We didn't think you could do it, but we're sure glad you did."

Al took it in stride. He had watched as his six-year-old theory became aviation history. "I never had any real doubt that the system would work," he said.

At 4:35 p.m. the *Shiga* was swung up and onto the deck of a 600-ton barge. The next morning, the plane was rolled on its own landing gear off the barge, down a steel-plate ramp at the airport's seaplane harbor and over to United Air Lines' maintenance building No. 12.

JAL's general manager for engineering looked over the plane and excitedly cabled his Tokyo home office: "Structural damage very slight." He was right.

Flying again in four months

Almost four months to the day after the *Shiga* skidded into San Francisco Bay, it roared off from International Airport on its first test flight, good as new. The recovery and repair of the DC-8 Superjet didn't come cheap. Unofficial estimates put the cost in excess of \$3 million.

A total loss would have cost the insurance company more than twice that. Besides, JAL would have had to wait nearly two years to get a replacement plane. As it was, the *Shiga* was back flying on JAL's global runs early this spring.

Since that dramatic weekend, Al Kelly has received cables and letters from aviation officials all over the world. He's now worked out details for a leasing program that'll permit an airport to have his equipment available to it around the clock.

★★★

Johns-Manville FGA[®] shingles give your roof a chance to outlast your mortgage

You can bank on a roof of Johns-Manville FGA Seal-O-Matic shingles.

They contain moisture-proof fiber glass and asbestos.

Materials that don't rot, don't swell or shrink. So your shingles don't move around. They just lie there. Beautifully. In any weather.

Look for FGA shingles—in a wide choice of attractive colors in several styles—at your nearest J-M dealer.

So you won't have to worry about your second or third roof while you're still working on your first mortgage. **JM**

Johns-Manville

Johns-Manville, Box 290-BA New York, N. Y. 10016.
Please send me more information on your FGA shingles.

Name _____

Address _____

City _____ State _____ Zip _____



If you own a '63 or older model U.S. car, you're entitled to a \$15 discount on Comfy-Kit Air Conditioners.

You see, we're overstocked with bracket kits for the older models — and it adds up to extra savings for you. Add the regular savings offered by Comfy-Kit, and you'll find you can enjoy air conditioned driving at really tremendous discounts — up to \$200 or more.

Quick 'n easy to install, Comfy-Kit units come complete with everything you need to do the job — including the loan of special tools if you need them.

Let someone else pay the high prices for air conditioning. You'll have a better unit — and save lots of money to boot.

Remember, if you have a '63 model or older car, deduct \$15 from the regular price shown on the coupon below. That's just \$118 for the Standard, \$133 for the Super and \$150 for the Supreme.

COMFY-KIT®
 P. O. Box 8585, Dept. PM 9 •
 Dallas, Texas 75216

Enclosed is \$133* for Standard Unit.
 Enclosed is \$148* for Super Unit.
 Enclosed is \$165* for Supreme Unit.
 Enclosed is \$30 deposit on a Super Standard Supreme Unit. I will pay the balance, plus C.O.D. charges when delivered.
 Enclosed is \$8.00 deposit for a set of four tools, which will be returned to me when I return the tools.
 I would like to see the instruction book before I order. I enclose \$1.00 for the instruction book only. I understand this will apply on any future Comfy-Kit order.
 I would like information on a Comfy-Kit dealership.

Name.....
 Address.....
 City.....State.....Zip.....
 My car is a.....(year).....(model)
 Engine displacement.....Horsepower.....
 Power Steering.....yes.....no
 Floor shift.....Steering column shift.....
 Smog pump.....yes.....no
 *plus state tax where applicable

BUILD DRIVEWAY FOR \$100

(Continued from page 154)

furrows in the old gravel roadway. Get in your licks every time it rains. Work the area over until it is flat, well compacted and about 3 in. below the final grade you want.

Order a truckload of coarse sand. (I found that 6 tons at a cost of \$18 was just right for my 1080-sq.-ft. area.) Have the sand dumped in several small heaps within the driveway. Rake out the sand until you have a 1-in. base over the entire area, and rake the excess sand, loose rocks and chipped brick to each side.

Lay the center-line brick first, using a carpenter's level and sighting along the taut string to maintain an even grade the length of the driveway. Check your work frequently. Relay the brick if the grade or direction becomes irregular. Allow a space of 1/8 to 1/4 in. between each brick for expansion.

Select a pattern you like; brick can be monotonous if you let it. However, the more complicated designs are hard to do well, particularly a herringbone pattern. I found a parquet pattern easy to lay and pleasing to the eye.

For additional variety, I dropped into the pattern here and there a hunk of broken sidewalk. As most slab material is 6 in. thick, you'll have to dig out 3 in. or so in your compacted surface. Seat each slab solidly and fill in around it with sand. Be sure it is level in all directions before bricking up to it. Use broken bricks for the small niches.

Loose stones and brick chips are useful side-reinforcing materials along the outermost courses of brick. Pack the material in tightly to about an inch below the final grade. This is high enough to anchor the brick but low enough to leave room for grass-bearing topsoil.

Edge sections where cars will stand frequently should be anchored with heavy stones, slabs and whatever you have. Anything heavy with one flat surface will be useful. Reinforcing stones may be arranged to form a decorative walkway along the driveway, a rock garden or retaining wall around a tree.

Now, spill white sand over the entire brick surface and sweep it into the cracks. (I used 1000 lbs. at a cost of \$3.) Hose down the surface lightly with water until the sand has washed into and filled up all the crevices. Save a little sand in case a few bricks sag. These can be lifted out and built up with sand.

Brighten up the finished driveway by rolling white latex paint onto the sidewalk slabs and reinforcing blocks. ★★

TWO GREAT SHOE BUYS!

ENGLISH MADE OXFORDS

2 pairs for \$18.00* **\$9.99***

We guarantee them. All the things you look for in a great utility oxford are built into this top-quality English made shoe: The best British leathers. Full cushion insole and arch support. Oil-resistant Nitrile® soles and heels. Cirrus quarter linings. British built on American lasts to fit American feet. But most important, our guarantee that you'll agree that this is a great shoe buy. Or your money back. No questions. **BUT ACT NOW. THE SUPPLY IS LIMITED.**



Available in the following sizes: D or EE width 7, 7½, 8, 8½, 9, 9½, 10, 10½, 11, 12, 13, 14. *Postpaid

ENGLISH-MADE WATERPROOF BOOTS GUARANTEED WATERPROOF.

\$39.99*

This boot is built expressly for outdoorsmen. It's made of the best silicone treated English leathers with top-quality leather linings. What's more it's insulated to -20°. And it's guaranteed waterproof as long as the sole and upper are not cut or scuffed through and the boot is periodically dressed with any good silicone dressing. The Waterproof boot comes in plain or moccasin toe in brown, and in plain toe black. Non-marking oil-resistant soles and heels. Waterproofs are a great boot buy for outdoorsmen.

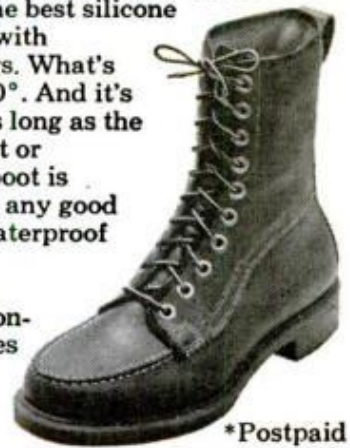

*Postpaid

Available in medium-wide width in sizes 7, 7½, 8, 8½, 9, 9½, 10, 10½, 11, 12, 13, 14.

Please send me _____ pair(s) of your English oxfords in size(s) _____ width(s) _____. Enclosed you'll find my check (money order) for \$9.99 (\$18.00). If I'm not completely satisfied, I may return the shoes for a full refund.

Please send me _____ pair(s) of English-made Waterproof boots.

My shoe size is _____. Enclosed you'll find my check (money order) for \$ _____. If I'm not completely satisfied, I may return my order for a full refund.

Plain Toe Moccasin Toe Black Brown

HI H. I. Company, Room # 503- G
22 Chestnut Place
Brookline, Massachusetts 02146

Name _____

Address _____

City _____ State _____ Zip _____

TRAIL-BREAKER® Goes anywhere



Outdoorsmen: Ride where you had to walk before. Revolutionary two-wheel drive vehicle climbs mountains, fords streams, hauls man-sized loads. Runs all day on a tank of gas.

Write Rokon, Inc., Dept. A
160 Emerald St., Keene, N.H. 03431

300 POWER.....

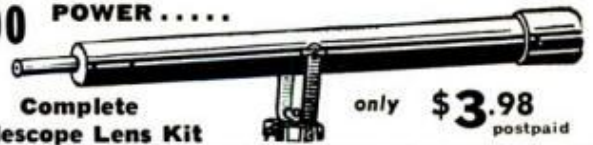

Complete only **\$3.98** postpaid
Telescope Lens Kit

Conquer Space, Explore the Universe, Planets, Moon craters, New Stars etc. Complete Lens Kit consists of 80 inch focal length ground and polished objective lens, eyepiece lenses for 50 POWER, 100 POWER, 150 POWER, 200 POWER, 250 POWER, 300 POWER, and all necessary lens fittings. Easy to make from simple step by step instructions. (Tripod and mount not included.) Money back guarantee.

BUSSE SALES, Dept. PM-14, Hartford, Conn. 06101

HEAVY DUTY WELDER



Does work of \$85.00 welder yet costs only **1895** POST PAID

Fits ordinary 110V outlet Not one • but 3 welding heats

Weld, braze, solder or cut most anything made of metal. No experience necessary. Follow simple instructions. Uses standard ¼" rods to weld iron, steel, brass, bronze, aluminum, other metals. Repair cars, farm implements, appliances, toys. Make campers, trailers boats. Pays for itself quickly. Comes complete with mask, \$2.00 pack of rods, flux, etc. NOTHING ELSE TO BUY.

3 WELDING HEATS . . . Not just one as with other low cost models. "High" for tough jobs, "Medium" or "Regular" for lighter work. 3 heat feature saves you money. New HEAVY DUTY Circuit gives more welding potential than ever before. Approved for homes, garages, factories, shops. Has power boost circuit for industrial uses. Raises heat to 4 TIMES that needed to melt toughest iron. No other welder has all three fine features.

FREE! Automatic arc striker now makes welding easy, even for beginners. Just plug welder into ordinary 110V outlet, touch automatic arc striker and start welding. You can't buy this important new Wel-Dex invention but it's yours free if you order from this ad.

10 day MONEY BACK TRIAL. Guaranteed against burnout. SEND \$2.00 and pay \$18.95 plus small C.O.D. when delivered or \$18.95 for postpaid shipment. Phone (713) 682-5811 for C.O.D.

WEL-DEX MFG. CO., Dept. W-10, Box 10776, Houston, Texas 77018

MAGIC MAIL PLAN

that comes with this Little Machine CAN MAKE YOU \$1200 AN HOUR

The machine is turning out a job that will bring operator \$2.58, by mail. Material cost, only 11c



Write today for free facts about the newest and most fascinating of all new home operated businesses. For the first time, a simplified machine brings the fabulous profits of Plastic Sealing and Plastic Laminating within reach of the small operator. Anyone can learn to operate it with a few minutes practice. Then—with our MAGIC MAIL PLAN—can get mail orders pouring in daily with cash in every envelope.

No Canvassing or Selling

Fill orders at home in spare time to start. Then expand to full time business. We even supply circulars to bring back cash and orders. Rush name for all the facts you need to start. A postcard will do. No charge.

WARNER ELECTRIC CO., Dept. LL-2-KS
1512 Jarvis, Chicago, Ill. 60626

THE FASTENER FIXER[®]

NO NAILING...AND THIS WATERPROOF DAP ADHESIVE PUTS UP PANELS, WALLBOARD AND TRIM FASTER. FASTENS FURRING TO CONCRETE, TOO. PREMIUM QUALITY TO ASSURE DEPENDABLE, PERMANENT ADHESION.



DAP[®]

PANEL and DRY WALL adhesive

DAP Inc., Dayton, Ohio 45401 / SUBSIDIARY OF Plough, Inc.
Also available in Canada



EARN HIGH WAGES
as a **HEAVY EQUIPMENT OPERATOR**

Train your way to high pay in the booming construction industry! Learn the skills you need to qualify, by actual field training on machines like the ones used by the industry. Huge training grounds in North Carolina, a million dollars worth of school-owned diesel-engined machines, experienced instructors, full 220-hour and 440-hour courses. National, the original school of heavy equipment operation, is a recognized leader. Member American Road Builders Assn., Services and Supply Division. Associate Member A.G.C. Full-time Job Advisory and Counseling Director on staff. VA approved. For men ages 17 to 56. Train Now-Pay Later plan... other payment plans also available. Write TODAY for FREE catalog and FREE copy of school newspaper reporting news of National School graduates. Accredited member NATTS.

NATIONAL SCHOOL
OF HEAVY EQUIPMENT OPERATION, Dept. D-31
P. O. Box 8529, Moores Chapel Road, Charlotte, N. C. 28201

Please send me FREE illustrated school catalog and complete information. I understand there's no obligation.

Name _____ Age _____

Address _____ Phone _____

City _____ State _____ Zip Code _____

HOW TO BUY A GOOD OLD HOUSE

(Continued from page 142)

could well signify serious trouble. New plumbing can cost from \$1000 to \$1500.

Sometimes, however, low water pressure is caused by insufficient water pressure from the street. The problem is usually caused by too small a water supply line. A new and larger line is the remedy at a cost ranging from \$250 to perhaps twice that, depending on the distance.

Termite and wood rot damage. First, there's no need to panic if there are termites. They may have entered relatively recently and it usually takes a few years before they cause real damage. If, however, they've been having a ball for some time, things can be quite serious. A minor termite condition often can be corrected for a few hundred dollars, but a major one can require several thousand dollars worth of repairs.

Wood rot is often mistaken for termite damage because of the similarity of appearance. It's caused by a fungus that attacks wood, eating and dismembering. It causes even more widespread damage than termites and can call for much timber replacement in a house. The man you hire for a termite check should also give you a report on wood rot.

Sagging structure. Major shoring up is a distinct possibility. Every house will settle a little over the years. But if the structure is wrenched severely out of shape something drastic is wrong. Stand back a few feet from each corner of the house and sight down each of the four walls. The lines should be square and true. A major bulge or awkward protuberance can spell trouble. A few inches out of plumb can be expected and is usually of no importance. Notice if the windows and doors line up squarely with each other and with the house frame. Windows and doors also should open and close easily.

A contractor can estimate the cost of repairs. A couple of new supporting posts in the cellar may be all that's needed at relatively low cost. Major work on the underpinnings can cost several thousand dollars.

Worn out roof and rain gutters. The condition of the roof usually can be judged simply by looking. Look for broken, cracked or missing shingles. Take a close look at the flashing around the chimney. That's where the first leaks generally show up. A typical asphalt-shingle roof, the most common cover on houses, ordinarily will last 15 to 20 years. The roof on a house that old, therefore, is likely to be a trouble spot.

New roofing for an old house generally

will cost between \$20 and \$35 a "square" (100 square feet of roof area).

Total cost of a new roof for the average house will, at those rates, run about \$350 to \$600. Figure another \$150 to \$250 if the gutters need replacement or repairs.

Worn-out water heater. Replacing this essential little item is a comparatively small expense (\$150 to \$200), but it's a common one. It's because many water heaters are undersized and you run out of hot water frequently in the middle of a shower, bath or clothes wash. It's also because a good many low-grade ones are found in houses. They sometimes last no more than three to four years.

Check the water heater for adequate capacity. Most families require a 40 to 50-gallon tank, though 30 gallons may be large enough if the nameplate says it is a "rapid recovery" model. Those are minimum capacities for gas and oil models. Electric water heaters should range from 80 gallons capacity and up. A smaller 60-gallon size will do only if the nameplate says it's a "high speed" or "high watt" model or if your family is small and has modest hot-water needs.

Also check the condition of the heater. The first signs of impending failure are rust and cracks at the bottom of the tank and sometimes a small leak, with water running onto the floor. Look at the bottom of the unit with a flashlight.

Check floors and woodwork

Besides the common flaws just listed, notice the condition of the house inside and out. Are the floors and woodwork in good shape? How do the attic and basement shape up? What about the workmanship? Look at the floor around the bathroom tub and shower and the kitchen floor below the sink and at the base of the cabinets. These are chronic splash water areas where evidence of rot and deterioration often show up first. Observe the condition of the foundation walls. Does the masonry contain many cracks?

How do you feel now about the condition of the house? If you have nagging doubts about it, don't push them out of your mind simply because you want to like the house. Is it really a good house or does it spell trouble? Is it really worth the price asked? Or is it worth buying only if you can get it at a reduced price to allow for repairs?

Ask yourself questions like these and then answer them realistically. If you realize that the house stirs serious doubts in you, watch out. But if it has been checked by an expert, has no serious flaws, and you really like it and want it, then you've found the right house. ★★

GOVT. SURPLUS AND OTHER BARGAINS SAVE UP TO 90%



SCAVENGE PUMP Miniature pump unit. 7 1/2" L x 2 3/4" W x 2 5/8" H. Positive displacement, rotary vane-type pump. 27 V.D.C. motor, continuous duty, explosion-proof. Pumps up to 165 GPH @ 6 PSI. Self-priming. Exc. for transfer of gas, diesel fuel, crankcase oil, etc. Pump ports 3/8" tube. Shpg. wt. 5 lbs. Govt. overhauled condition. Approx. GOVT COST \$231. Now **\$14.95** (Stk. #2026)

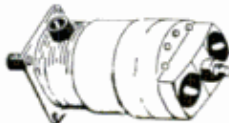

HYDRAULIC PUMP Rated 3 GPM @ 1500 RPM & 1500 PSI. Cu. In. Rev. is .600. Has built-in pressure adjustment reg. which varies pressure output from 1450 to 1600 PSI. Intake port 3/4" tube. Discharge port 1/2" tube. Bypass port 3/8" tube. Variable delivery. Clockwise or counter-clockwise rotation. Produces up to 8 GPM @ 3750 RPM continuous. Drive shaft is 3/8" twelve spline. 4 1/4" mounting base. Serviceable cond. Tested prior to shpg. Approx. GOVT COST \$320. Shpg. wt. 14 lbs. Special **\$14.50**



HEAVY DUTY BATTERY WINCH

Rugged, deluxe winch. Ball bearing construction thruout motor & gear train. High gear reduction. Rated cap 3000 lb. pull. Reversing switch. Rugged 3/8" plate steel mounting base with outrigger support. 22" L x 9" W x 8" H. Handles 250' of 1/4" cable. Built for 12 V. battery operation; also operates on 6 V at reduced cap. & speed. For Scouts, Jeeps, Trucks, Boat loading trailers, etc. Shpg. wt. 80 lbs. Approx. GOVT COST \$490. NEW. 90-day guarantee. Model E-D. **\$89.50** (Stk. #692)



NEW! BIG! 1969 CATALOG

Send 25c for amazing catalog with 1000's of bargains in hydraulics, electrical, marine, automotive items, etc. Order from ad. All prices FOB Culver City. 50% deposit required for COD. Cal. res. add 5% sales tax. Include zip. Satisfying world-wide customers since 1945.

AIRBORNE SALES CO. Dept. PM969
8501 Stellar Dr., Box 2727 • Culver City, Calif. 90230

"\$7,108.50 First Year SERVICING RADIATORS!"



— Hank Konter, Newcastle, Wyo.
Make good money servicing auto-truck-tractor radiators with new Inland 1-Piece Radiator Shop. Easy to test-clean-repair radiators. Inland, world's largest radiator equip. mfr., trains you free. Small down payment starts you. Easy-pay plan lets you pay from profits. Proved merchandising assures volume. Profitable dept. for garage or service station. **WRITE for Free Book.**
INLAND MFG. CO., Dept. PM9 1108 Jackson St., Omaha 2, Nebr.



Push-Pull Safety on top of stock behind Breech.

IT'S NOT OUR FAULT

We're Hard-Pressed to Keep Up with Orders for the **POWERFUL NEW BENJAMIN AIR RIFLE**

... It's Yours! (And We Thank You.)

When this Benjamin was introduced last Fall, we expected its sleek lines, superior performance and reliability to appeal strongly to shooters—young and old alike. But who ever dreamed we'd have to work like beavers to meet demand. Surprising? No. This fine single shot with its amazing peak power and higher standards of accuracy and safety opens a new world of shooting fun. And we judge that customers with an eye for value sense this fact the moment a dealer puts this Benjamin in their hands.

What does all this mean to you? First, we must be building these guns right. A slew of orders tells us more and more gunners are discovering the thrills this great air rifle adds to indoor/outdoor uses. Also, we predict another jump in demand in the days ahead. So don't take chances. See your dealer soon and be sure of getting the model you want. Choose from 3 calibers at moderate prices: Model 340 Cal. BB—Model 342 Cal. 22 Pellet—Model 347 Cal. 177 Pellet.

Use Benjamin H-C Pellets—Sized and Lubricated for Greater Accuracy.
BENJAMIN AIR RIFLE COMPANY
896 Marion St., St. Louis, Mo. 63104

FREE CATALOG WRITE

You Can **DEPEND** on **BENJAMIN**

SAVE ON WOOD

Imported & Domestic



CABINET HARDWARE - VENEERS - TOOLS
EVERYTHING for the Wood Shop

SEND FOR CATALOG NOW!

OVER 1500 ITEMS at MONEY SAVING PRICES! Finest domestic and imported hardwoods . . . all dimensions. Hardwood veneers. Power tools at discount prices. Hardware, lamp parts, upholstery supplies, mosaic tile. Hard to find inlays, bandings, etc. Get new catalog . . . send name, address and enclose 35¢ to pay postage, handling.

CRAFTSMAN WOOD SERVICE CO. Dept. A-99
 2729 S. MARY ST., CHICAGO, ILL. 60608

WHAT'S HE DOING!

Making a Concrete Flower Pot! . . . and **SO CAN YOU!**



Make and sell your own Ornamental Concrete items. Rush \$2.00 for book about Aluminum Molds with prices and production trade secrets direct from world's largest mold manufacturer. Over 350 designs to select from.

Send \$2.00 **CONCRETE MACHINERY COMPANY**
 Today To ➔ P. O. BOX 99 • HICKORY 2, N. C. 28601

LEARN TO BE A SKILLED LOCKSMITH

Professional Key Machine yours to keep!

Be your own boss. Earn steady, year-around income in your spare time at home. BELSAW INSTITUTE lessons show you how to make keys, open and repair locks on homes, cars, business buildings. Accredited Member NHSC. Approved for Veterans. All tools and supplies furnished including the \$125 Key Machine. Write for FREE BOOK. No salesman will call.

BELSAW INSTITUTE / 100S Field Bldg.
 Kansas City, Mo. 64111



DEFENDER OF WOMEN!

Instantly Stops Attacker

Assailants run screaming when sprayed in face with DEFENDER. When you're in danger, simply press top. Temporarily leaves attackers helpless. Dyes skin identifying

attacker for police. Effective up to 15 ft. Lip-Stick size-hides easily in palm of hand. Women buy on sight. Amazing profit! **SAMPLES for TRIAL** Sample offer sent to all who send name and once. Postcard will do. **SEND NO MONEY.** Just your name.
KRISTEE CO., Dept. 675, Akron, Ohio 44308

LIVE-CATCH ALL-PURPOSE TRAPS



Low as \$4.95

Write for **FREE CATALOG**

Traps without injury squirrels, chipmunks, rabbits, mink, fox, raccoons, stray animals, pests, etc. Sizes for every need. Also traps for fish, sparrows, pigeons, crabs, turtles, quail, etc. Save on our low factory prices. Send no money. Free catalog and trapping secrets. **MUSTANG MFG. CO., Dept. N-74, Box 10880, Houston, Tex. 77018**



\$7.50

That's all you'll pay for the PM Jet. The first do-it-yourself boat designed for turbojet propulsion. And that's one of our most expensive designs.

For three dollars you can buy the PM38, a sleek 13 foot runabout. And for \$38.00 you can build it. We don't have to tell you what a great buy that is.

And that's not all we've got to offer. We've got El Gato, a 12 foot, twin hulled catamaran. But we're not about to sell this beauty for three dollars. It will cost you four.

There are eight other models in the PM line. Some are less expensive, others will cost you more. We even sell one model that costs as much as ten dollars.

If you'd like to order the PM Jet, PM38 or El Gato just complete the coupon below and return it to us. If you want to see the rest of the fleet there's a place on the coupon for that too.

BOAT PLANS
POPULAR MECHANICS
 575 LEXINGTON AVENUE
 NEW YORK, NEW YORK 10022

PLEASE SEND ME THE FOLLOWING

Plans for the PM Jet at \$7.50 a set
 Plans for El Gato at \$4.00 a set
 Plans for PM 38 at \$3.00 a set
 Please send me information about the rest of the PM fleet.

NAME _____

ADDRESS _____

CITY _____ STATE _____ ZIP _____

FAMOUS



TEENUT® FASTENERS

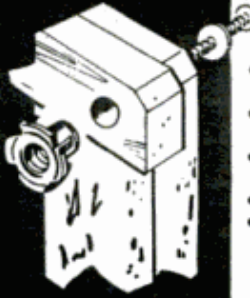

Can't slip, flush-mounted, strong, ONLY nut that gives steel threads in wood!

- Now available in bright NEW finish!
- NEW red and yellow, skin-pack cards!
- Look for colorful NEW display carton, too!
- Handymen need TEENUTS!
- Sold at hardware stores.

**COLUMBIA
FASTENER**

DIVISION OF UNITED-CARR
3229 South Ashland Avenue
Chicago, Illinois 60608

TEENUTS is a registered trademark of United-Carr

For more information on articles and products write to the PM Bureau of Information of "Where-to-Find-It" list.

Don't change your address without notifying us!

To insure uninterrupted service on your **Popular Mechanics** subscription, please notify us at least six weeks before you move.

1. Attach your address label from a recent issue in the space provided below... (If label not available, be sure to give us your old address, including Zip Code)
2. Print your name and new address below (be sure to include your Zip Code).

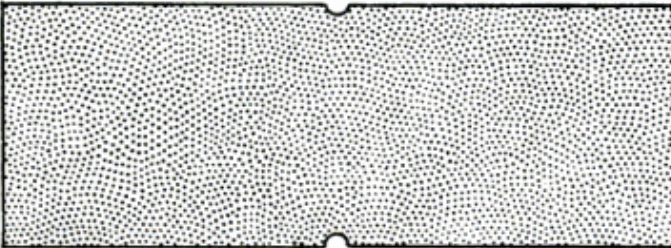

3. Mail entire notice to: **Subscription Service Dept.
Box No. 646
New York, N. Y. 10019**

Name _____ *Please Print*

New Address _____

City _____

State _____ Zip Code _____

Fox Mini Bike

DO IT
YOURSELF
OR FULLY
ASSEMBLED

from
\$99⁵⁰



SEND \$1 FOR BIG CATALOG Shows new line of the world's finest MINI-BIKES (street and trail models), plus Go Kart (R), parts, accessories and plans. Amazingly low prices! There's a Fox MINI-BIKE for everyone from age 10 to adults.

EXTRA BONUS Catalog shows radios, watches, walki-talkies, cameras, musical instruments, tools, appliances and many other items you can buy at practically wholesale prices. Free \$1 coupon.

FOX CORP., Box 797PM, Janesville, Wis. 53545

America's No. 1 Classified Section
Can Be Found On Page 55
In This Issue

YOU can build and fly



the compact Bensen Copter

WORLD'S MOST POPULAR HOMEBUILT AIRCRAFT

Enjoy this modern sport as others like you are doing in many parts of the world. Designed by aeronautical engineers, the Bensen Copter is fun to build, easy and inexpensive to fly. Holds 12 world records. Professional pilots and novices alike acclaim it. Ultralight, portable, lifts up to 300 lbs. Wheels and floats interchangeable. Plans and kits available. Send \$3 for 3-view Drawings, specs, photo.

**SEND
\$3
NOW**

BENSEN AIRCRAFT CORP. Dept. PM-99
Raleigh-Durham Airport, Raleigh, N. C. 27602

NAME _____

ADDRESS _____

New Discovery Makes Stuck Drawer Slide At Fingertip Touch—Without Oil!

A new spray lubricant so clean it won't soil linen or clothes in drawer.

One Sw-o-o-sh! And tight stuck drawers, windows and zippers slide easy when you spray new 3-IN-ONE DRY-LUBE. Eliminates friction without oil. The secret is a new spray lubricant so clean it won't soil your best clothes. Get 3-IN-ONE DRY-LUBE at all hardware outlets.



3-IN-ONE®
DRY LUBE

**BUILD CUSTOM CASES AT HOME FOR PROFIT...
GET ORDERS BY MAIL!**



Here is a spare time or full time Home Business so extensive that you will almost catch your breath when you see it for the first time. Learn how you can make Custom Cases in your home to tap a waiting, rich market—to make yourself financially independent for life. We supply materials, instructions, everything. No canvassing; No house to house selling; No salesmanship needed: Send for the full story of this amazing opportunity.

CUSTOM CASE SUPPLY CO.

Dept. C-209

7630 Gloria Avenue, Van Nuys, Cal. 91406



**EARN SPARE TIME MONEY...
Buy Lowest - Below Wholesale!**

SELL AT TOP PROFITS... Up to 800% Profit on Top Selling Specialties, Novelties, Gift Items, Mail Order Products, Toys—1000 Bargains!

EARN EXTRA INCOME—up to \$10,000-\$20,000 and more. Start your own Wholesale or Mail-Order Business in the booming specialty merchandise field. No experience needed. No franchise to "buy." No canvassing. Work at home part time or full time. Revolutionary marketing program brings you automatic orders. Make big money right from the start.

SPECIALTY MERCHANDISE CORP.

7630 Gloria Avenue, Dept. 5209 Van Nuys, Cal. 91406

WRITE FOR AMAZING FREE BOOK!



BUILD THE POPULAR MECHANICS MINI-BIKE

FROM 26-IN. BICYCLE FRAME

—with VARIABLE SPEED TRANSMISSION, as featured in June '67 issue. Step-by-Step plans, photos show you how. **PLANS, \$2.50**, refundable with order for wheels, engines, clutches, kits at Discount Prices. Order Plans, or send 25c for Catalog, today!



SAVE \$50 to \$150

GILLIOM MFG. CO. Dept. PM-9 St. Charles, Mo. 63301

BETTER SOUND FROM YOUR TV

(Continued from page 151)

to a closed-circuit jack in the same way as is shown for the extension speaker. With the latter arrangement, the internal speaker will play whenever the headphones are unplugged. This is useful for group listening or for programs where sound quality isn't critical. Remember, though, that you'll need a special stereo jack with the closed-circuit switching feature. This is different from the closed-circuit monaural jack used for the extension speaker.

If you use the volume-control hookup, you must, of course, disconnect the internal speaker or it will play along with the headphones. If you like, you can cut only one lead and run the ends to a toggle switch on the back of the cabinet. This way, you can flip the speaker on whenever the headphones aren't in use. If you want to use two pairs of headphones at a time, you can either wire two jacks in parallel or buy an accessory Y-connector to plug two headsets into one jack.

Connect TV to your hi-fi

For tops in TV sound, the ultimate improvement is to bypass the set's own audio circuits and feed the sound signals into your hi-fi amplifier. This way, you get better quality in the amplification stages as well as use of your high-performance speakers (illustrations, page 150).

Use the same arrangement for picking off the audio as you would for connecting high-impedance headphones. Run shielded cable to the volume control, soldering the hot lead to the center tab and the outer shield to the grounded tab. You can plug the other end into an unused auxiliary input on your amplifier. If it's a stereo system, use whichever channel is designated for monaural inputs—usually the left—and set the mode switch to monaural.

With this hookup, you can control the volume from the TV set—handy if your hi-fi is some distance away. An alternate wiring arrangement is shown in which the cable's hot lead is connected, not to the center lug on the volume control, but to the end lug at the opposite side from the grounded lug. With this method, volume is controlled from your hi-fi set instead of the TV. There's one advantage: You don't have to disconnect the speaker in the TV—turning down the set's own volume control will cut it off when you don't want it. With the hi-fi set disconnected, you can turn up the volume control on the TV set and listen to the speaker in the normal way if you wish.

★ ★ ★

The Elmer's Guide for Glue-It-Yourselfers

Elmer's® Glue-All. America's favorite all-purpose glue. It dries fast, clear, strong. On wood, cloth, leather, paper, pottery and all porous materials. (Wherever waterproof joints aren't essential.)

Elmer's Glue-All comes in handy squeeze-bottles, with mess-free applicator tops.

Elmer's Epoxy Glue

For "impossible" gluing jobs: Working with steel, iron, aluminum, bronze and brass for concrete, brick, tile, glass, porcelain, china, crockery. It's so strong, it even takes the place of riveting in many airplane assemblies.

Elmer's Panel Fast®

For panel installation of every kind. Forms a strong bond that lasts the life of the paneling. No more nail holes to fill or finish.

Elmer's Clear Cement

For repairing china, pottery, ceramics, wood, metal, paper, glass, leather and plastics. Strong, fast drying, waterproof and, most important, dishwasher-proof.

Elmer's Plastic Resin Glue

For high-grade furniture construction. Veneering. Laminating. Doweling. Edge gluing. It's highly water resistant, and will not stain acid woods (like oak and mahogany).

Elmer's Waterproof Glue

For outdoor do-it-yourself jobs. Use it on planter boxes and exterior doors. For patio repairs, and boat building and repair. For gunstocks, decoys, fish lures, surfboards, water-skis, or model boats and planes.

Elmer's Heavy Grip® Cement

For installation where nails, screws and ordinary glues won't hold. Use it to glue towel bars, hooks or shelf brackets to surfaces like tile, metal, concrete, brick, plastic, etc. It's water resistant and strong enough to hold most parts without support while it sets.

Elmer's Contact Cement

For gluing plastic laminates to coffee tables, home bars, or sink tops. Bonding leather, linoleum, synthetic rubber, etc. It's non-staining, transparent and odorless when dry. And, its strength increases with age.



Free. From the makers of Elmer's, Mystik and Krylon: a guide to gluing, taping and spray painting. Mail a stamped, self-addressed envelope to: Borden Inc./Chemical Div., 350 Madison Ave., N.Y., N.Y. 10017

If you like to work on cars, why not get paid for it?

Home study training makes the difference between a hobby and a big money job. Trained auto mechanics are in greater demand than ever before. And when you're in demand, you do the choosing. You choose where you work and what you work on.

You can have the same choice. Our program lets you prepare to become a mechanic at home, in your spare time. This program gets you ready for the big money. Write today.

ITT Technical Institute

1340 S. Michigan Avenue, Chicago, Ill. 60650 • Dept. 163-99
Please send FREE information on your program for Automotive Training.

Name _____ Age _____
Address _____ Married Single
City _____ State _____ Zip _____

Approved for Veterans Training

ITT TECHNICAL INSTITUTE

An educational service of
International Telephone & Telegraph Corporation



Print Your Own

Cards, Stationery, Advertising, Circulars, labels, photo and movie titles, church work, tags, greeting, sympathy, prayer cards, etc. Save money. Pays for itself in a short time.

Own a Printing Business

Good Profit. Raised printing like engraving too. Have home shop. We supply everything. Direct from factory, only. Easily followed rules. Write now for free details. **KELSEY PRESSES E-37 Meriden, Conn. 06450**

KELSEY PRESSES

PROFIT IN YOUR SPARE TIME

SMALL ENGINE REPAIR PAYS BIG!

Outboard • Powermower • Chain Saw • Tractor
MAKE EXTRA MONEY — or fix your own engines and SAVE! Illustrated, easy-to-learn Home Study Course qualifies you as expert. Approved for Veterans. Write today!

LINCOLN TECHNICAL INSTITUTE

SUITE 9-E, 472 MARKET ST., NEWARK, N.J. 07105

BUILD YOUR OWN CAMPER

SAVE UP TO 50%

Complete, easy to follow plans, instructions, materials list.

Camper Plans\$3.95
Travel Trailer\$3.95
Pickup Cover\$2.00
CONVERSION PLANS:
Econoline Type Van...\$2.95
Passenger Bus or
Delivery Van.....\$2.95
Satisfaction Guaranteed

EQUIPMENT CATALOG \$1.00

Refundable on First Order.
Send Dime for Details.
Save 50% on Camper Kit.
All items from catalog to build \$1,795. Camper, 8', 10', 10'6" or Chassis Unit.



VIKING CAMPER SUPPLY, INC.
99-BP Glenwood Ave.,
Minneapolis, Minn. 55403

Please send _____ for which I enclose \$_____

NAME _____
ADDRESS _____
CITY _____
STATE _____ ZIP _____

THE WORLD'S SHARPEST TOOL

(Continued from page 103)

ghetti. Yes, spaghetti—tough stuff in its raw state. Some European food processors have switched from steel to diamond saws to slice uncooked spaghetti into desired lengths. Steel saws become dull after about two hours' use, while diamond blades last for several months. Similarly, industrial diamonds are used to cut frozen fish sticks to package size.

The chief characteristics of the diamond—hardness and transparency—have made possible recent scientific investigations into the world of ultrahigh pressure. Alvin Van Valkenberg, National Bureau of Standards, Washington, D. C., helped to invent the diamond pressure cell—a machine small enough to fit into your pocket, yet able to develop pressures of nearly two million pounds per square inch. Two diamonds squeeze the test material between them. While this is going on, the researcher, using a microscope, can look

A diamond die can produce more than 6000 miles of wire before it shows wear

through the transparent diamonds to see how the test substance is reacting.

A very important use of the diamond is in drawing fine copper, steel and tungsten wire for electronic and aerospace applications. A modern aircraft, for example, may require 50 miles of wire and cable. Single stones of excellent quality (only their color may distinguish them from gems) must be used as wire-drawing dies. To fashion a die, a single tapered hole is made in the center of the diamond. The taper permits a wire to enter the die and be drawn through an exit hole smaller than the wire's initial diameter. Batteries of dies are used. The wire passes through smaller and smaller dies until it has reached the desired fineness. When the hole in a diamond increases in size through wear, the die is simply used for wire of large gauge. But a diamond die can produce more than 6000 miles of wire before it shows wear.

Special techniques are used to make the hole in the die. The usual method involves a fast-rotating steel needle dressed with a diamond powder. New techniques employ ultrasonic machines or lasers. It takes a laser beam about 30 seconds to penetrate a diamond to be used for a die.

Slightly smaller stones, but also of near-gem quality, are used in tools to

form the entire cutting point. Tools capable of cutting to extremely close tolerances are widely employed for the kind of delicate engraving needed to produce the dies for banknotes. Very small industrial stones are often used in clusters on various tools with from three to eight set in patterns on the cutting face.

Smaller stones—called “bort”—are graded according to the size of sieve they slip through, sometimes 10,000 stones per carat of bort. This diamond grit is bonded to the surface of grinding wheels to produce a highly efficient polishing paste.

Diamond even finds a place in dentistry, for it is used to grind teeth at speeds up to 500,000 rpm. A new tooth-colored plastic for crowns has this mineral embedded in it for added strength.

Diamond grit, bonded to metal on a blade 0.000008 inches thick, is used to slice silicon semiconductor wafers. Ultramicrotomes are used to slice germanium and uranium into layers about 1/10,000 the thickness of a human hair, for the study of atomic and molecular structure.

This mineral is ideal for use as styli because it retains its form better than anything else, and its low coefficient of friction causes it to pass readily over other substances. Often with a tip radius of 0.00005 inches, diamond styli are found in all research laboratories and industries where close tolerances are necessary. Diamonds are also used as phonograph needles and cutting tools to prepare original master phonograph records.

A small number of natural stones, found mainly in the famous Premier Mine near Pretoria, South Africa, are semiconductors, a characteristic due to the presence of an impurity, aluminum. They are usually blue in color and, if large, are extremely valuable as gem stones. The most famous “blue” of all, the Hope Diamond, was recently found to be a semiconductor, but no one is likely to chop it up for that purpose.

The semiconductors respond to any slight variation of temperature with a marked change in their electrical resistance. By measuring that resistance, temperature changes as small as 1/500°C. can be recorded. These diamonds are put to use in laboratories as thermistors. In medicine, for example, diamond thermistors are used to detect minute, but significant, changes in the temperature of human skin.

The diamond is a versatile tool, unmatched for handling many a tough or exacting job. Though it's as old as the hills, it has really come into its own in this space age. Today, the diamond is a lot more than “a girl's best friend.” ★ ★ ★



Unmistakable.

If you would rather shoot great pictures than worry about exposure settings, you're all set with the Kodak Instamatic 814 camera. It's the most automatic Kodak Instamatic camera of them all.

While you have the fun, it does the work.

Just drop in the film cartridge. The “814” automatically adjusts to the speed of the film. Aim it at the subject. It automatically computes and sets the proper exposure. Even warns you when to use a flashcube if the light is low. Snap the picture; a spring motor automatically advances both film and flashcube for the next picture.

So make no mistake. See the Kodak Instamatic 814 camera with its precision rangefinder and superb 4-element $f/2.8$ Ektar lens—less than \$145—at your Kodak dealer's.

Price subject to change without notice.

Kodak Instamatic® 814
camera

RIDGID

the toughest
pipe wrench
in the
joint.



Choice of 10 sizes 6" through 60"

Certainly RIDGID Heavy-Duty Pipe Wrenches are tough. That's the way we build them. Then we work test them just to be doubly sure that they'll outperform and outlast all others.

Tool steel hook jaw has patented spring suspension that gives instant, slip-proof grip. Jaws can't lock . . . always release fast. Handy pipe scale, always easy adjustment and comfort-grip I-beam handle all help make a genuine RIDGID your best pipe wrench buy. Try one.

Buy a time-saving RIDGID Pipe Wrench at your Dealer's. He has a complete stock of RIDGID Work Saver Tools from The Ridge Tool Company, **RIDGID** Elyria, Ohio 44035.

GET INTO ELECTRONICS

V.T.I. training leads to success as technicians, field engineers, specialists in communications, guided missiles, computers, radar, automation. Basic & advanced courses. Electronic Engineering Technology and Electronic Technology curricula both available. Assoc. degree in 29 mos. B.S. obtainable. G.I. approved. Start Sept., Feb. Dorms, campus. High School Graduate or equivalent. Catalog.

VALPARAISO TECHNICAL INSTITUTE
DEPARTMENT D, VALPARAISO, INDIANA 46383



You can make money in

WATCH REPAIR

Learn at home the low cost Sweazey Way

Watch repairing pays up to \$6 an hour, part time watch makers report on survey. Unique and modern Sweazey home study System starts you making repairs right away on Swiss and American watches. Professionally prepared training. No previous experience needed. Special tools provided for practice. Diploma Awarded. Free sample lesson and opportunity book give all facts. Write today. No obligation.

CHICAGO SCHOOL OF WATCHMAKING
Dept. 199 Fox River Grove, Illinois 60021

FREE BOOK and SAMPLE LESSON

CHICAGO SCHOOL OF WATCHMAKING
Dept. 199, Fox River Grove, Illinois 60021
Please rush FREE BOOK and Sample Home Study Lesson.

Name _____ Age _____

Address _____

City _____ State _____ Zip _____

When you see this mark you've seen the product in Popular Mechanics.



Very soon you'll start seeing products bearing Popular Mechanics "Product Feature" Mark appearing on many dealers shelves. This is a brand new service to our readers and will help you recognize the products that are advertised in your magazine.

Look for the mark on hang tags, stickers, counter cards and on the products themselves.

This is just another idea in a long line of new ideas from Popular Mechanics. Remember the Mark. Ask for it. Know and buy the products that wear it. They're the products advertised in your magazine.

THERE'S ALWAYS SOMETHING NEW AT POPULAR MECHANICS

NEW RUBBER STAMP BUSINESS PAYS BEGINNERS UP TO \$16.50 AN HR. START AT HOME IN SPARE TIME

The multi-million dollar Rubber Stamp business—once controlled by a few big companies—is now being taken over by small operators—one in each community throughout the United States. Men and Women who have this inexpensive machine can turn out huge quantities of Rubber Stamps with special wording that buyers once were forced to buy from big cities. Material costing only 27c makes a stamp that sells for \$2.75. The machine that does the work is simple and easy to operate and it turns out as many as six Rubber Stamps at a time, each with different wording such as names, addresses, notices, stock numbers, prices and other "copy" needed by offices, factories and individuals. Working full capacity, it can earn as much as \$33.00 an hour for the operator! Now you can get into the big-pay business yourself, with your own home as headquarters. You don't need experience. We supply everything, including complete instructions and eight ways to get business coming in fast. **We even help finance your start.** Start making up to \$16.50 an hour from the very beginning. Cash in on the profitable Rubber Stamp business in your community, right away. We'll mail full particulars FREE and no salesman will call. Be first in your locality. Rush coupon or send your name on postcard now to:

RUBBER STAMP DIV., Dept. R-2-KS
1512 Jarvis Ave. • Chicago, Illinois 60626

THIS LITTLE TABLE TOP MACHINE
MAKES EVERYTHING SIMPLE & EASY

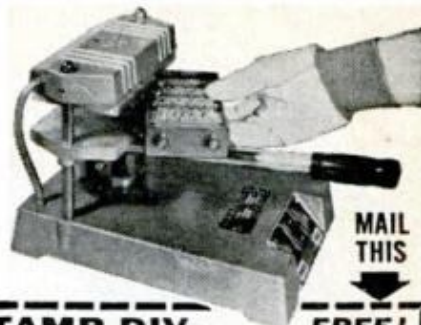

MAIL
THIS
↓

RUBBER STAMP DIV.

FREE!

1512 Jarvis Avenue Dept. R-2-KS, Chicago, Ill. 60626

Please rush full particulars about your financing plan and the little machine that can get me started in the profitable Rubber Stamp business at home in spare time. Everything you send me is FREE and no salesman will call.

Name

Address

City

State Zip Code

SPECIAL OFFER — ORDER TODAY

5 BIG FEATURES

- Gear Drive
- Automatic Chain Oiler
- Weighs Only 10 lbs. (including Bar and Chain)
- Instant Starting
- Industrial O & R Engine

FACTORY
ASSEMBLED
\$99⁹⁵

CALIF. — POWER



CHAIN SAW

KIT

ONLY \$79⁹⁵

80% Factory Assembled.

In California Add 5% Tax

C.O.D. Requires 50% Deposit—Send Check or Money Order

PRODUCTS' INC.

1940 H STREET FRESNO, CALIF. 93721

MAIL ORDER

For the first time, one of New York's leading mail-order advertising agencies is offering its services to a limited number of small, part-time, and beginning operators. Our new earn-as-you-learn program assures you of expert, step-by-step guidance as you break into the billion-dollar mail-order field. Age, education, and experience are not barriers. No inventories, no catalogues, no membership fees. For complete details of this exciting plan, write today for our FREE Profit Letter to: Maxwell, Justin and Adams, 143 E. 49th St., New York, N.Y. 10017, Dept. H9.

Use your Zip Code when
writing to advertisers

Now prepare exterior surfaces for painting
— in half the time!

New muralo[®]
exterior
spackle[®]



Practically eliminates burning, sanding, scraping. Patching compound, putty, glazing compound, caulk — all in one. Easy to apply, instantly dry. Won't flash through latex. Use on blisters, cracks, nailholes — any paintable surface. But be sure you ask for and get new EXTERIOR SPACKLE.

AT PAINT AND HARDWARE STORES

the muralo company inc.

New York/Bayonne/Chicago/Los Angeles

Train for top jobs, top earnings, in PHOTOGRAPHY

NYI trains you for the best jobs—or your own successful business. Learn by doing at home, quickly, easily the individualized NYI way. Low cost. No experience or expensive equipment needed. Earn while you learn. Easy pay plan. Approved for Veterans, Student Loans. Approved by N.Y. State Ed. Dept. Accredited member Natl. Home Study Council. FREE color career book. No salesman will call. RESIDENT TRAINING in all profitable phases of photography and Creative Motion Picture Course. Our 60th year.

NEW YORK INSTITUTE OF PHOTOGRAPHY • 10 West 33 St., New York, N.Y. 10001, Dept. 49-9

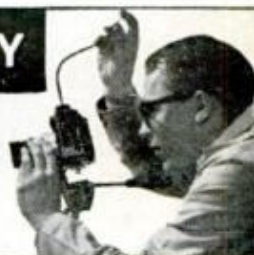



WIDE VARIETY OF MATERIALS, including many metals, is easy to cut with this new tool that sells for \$6 with choice of one blade or \$8 for three-blade set. Note pilot hole needed to start cut in furnace pipe (right)



All-Purpose Cutting Tool

HERE'S SOMETHING NEW in cutting tools: A hand-powered cutter that, surprisingly, doesn't get caught in the work. Unlike ordinary scissors or shears, it stays below or, if necessary, above the work to avoid the workpiece-shear entanglement common in cutting operations.

After testing this tool in my shop, I can say that—with a little practice—it works. Since its action is not like any tool I've used before, I felt a little clumsy at first. But, after a couple of trial runs, it was easy to cut the materials shown on this page, plus less stubborn materials such as cardboard and leather.

The cutting is done by a square-edged serrated blade positioned in an adjustable-width slot that separates the twin anvils of

the tool. By keeping the material parallel to the tool, and maintaining a firm forward pressure, you nibble accurately and cleanly, even on contours and curves.

Though I would prefer some configuration on the shear handle (my hand slipped when my palm was sweaty), I rate the tool a good buy. The complete set BernzCutter and the metal, plastic and shape-cutting blades—lets you tackle a wide variety of materials with minimum investment. If you lack power tools that perform these chores, this cutter should be a welcome addition to your toolbox.

Available now, the BernzCutter is marketed through lumberyards, hardware and department stores.

—Harry Wicks, Workshop Editor

Photos by Robert Borst

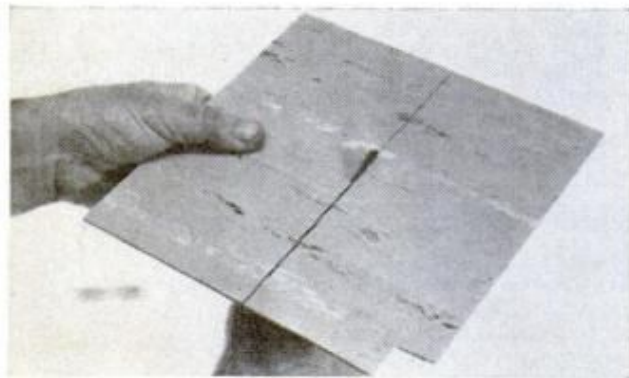

ASPHALT TILE can be notched to fit corners or cut in straight line. The trick is to use nibble bites



CUTTER STAYS BELOW WORK (Formica used here). Aluminum anvils must remain parallel to the work

For Sparetime or Full Time
Income, There's Good

MONEY IN SHARPENING

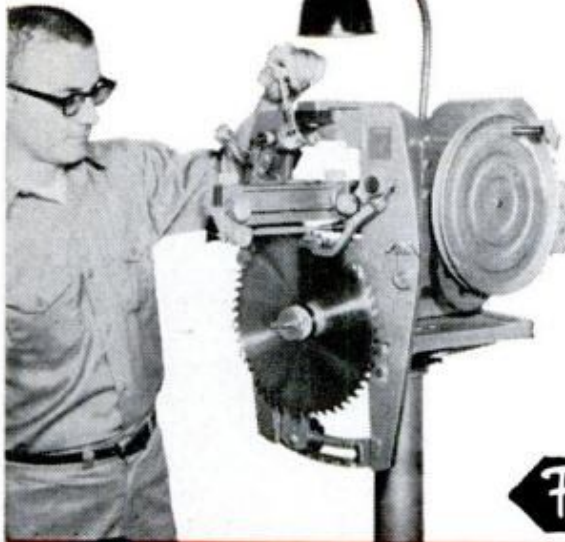

Here's a proven practical way to earn extra dollars in spare time—to develop a money-making repair business of your own. Investment is small. There's no overhead, no stock of goods to carry. No experience needed, no canvassing. You do it with the famous Foley Saw Filer that automatically sharpens all kinds of saws—and the Modern Lawn Mower Sharpener that precision sharpens all types of mowers.

EARN \$3 TO \$6 AN HOUR SPARETIME

Hundreds of people like yourself are making cash like this—\$20 to \$30 a week—right now in spare time. "My spare time saw filing business has made me \$952 these first ten months"—says R. T. Chapman. Many have built a complete sharpening service with such year-around profits. You can too, simply by following the sure, easy Foley Plan.



Foley

MANUFACTURING CO.
MINNEAPOLIS, MINN.



MONEY MAKING FACTS BOOKLET FREE!!!

This valuable book shows you how to start, how to get business from home owners, factories, carpenters, etc., and how to make profits fast. Mail coupon today. No salesman will call.

FOLEY MFG. CO. 916-9 Foley Bldg., Minneapolis, Minn. 55418
 Saw Filer information. Lawn Mower Sharpener information. Money Making Facts booklet.

NAME _____

ADDRESS _____

CITY _____ STATE _____

How good
a tire
did you have
in mind?



That's the kind
we make.

No "bargains" or
specials or gimmicks.
Just excellent tires.
At reasonable prices.
Like the Elite.

Tires you can trust
your family to.

Talk over your car,
your driving with
a Dunlop dealer.
He's a pro. Listed
in the Yellow Pages.

And if he gets
enthusiastic and starts
to sound like Dunlop
invented the tire,
be tolerant.
We did.



DUNLOP

... means quality in tires, tennis, and golf.
Buffalo, N.Y. 14240

ANTISUBMARINE WARFARE

(Continued from page 119)

figures out an aircraft is on his tail, and shuts down his engines to hide silently a hundred fathoms down? Do the listening buoys become worthless? Not at all. The P3C drops a depth charge. Echoes of the sound bouncing off the submarine hull are heard by the sonobuoys. Univac computes the echo ranges and gets a target fix!

The Navy has ordered 100 P3Cs from Lockheed, and they're joining the fleet just in time to use a new kind of sonobuoy called DIFAR. Ordinary sonobuoys cannot report the direction from which a sound is coming. The new ones can. This means fewer buoys have to be dropped to develop a fix on a target, and precious time is saved in the hunt.

P3C crewmen have still other sensors at their command. The long, stingerlike tail of their plane houses a system called MAD, for magnetic anomaly detector. It uses a magnetometer to detect distur-

Flying on two engines, the P3C can stay in the air for 17 hours

bances in the earth's magnetic field caused by the metal hull of a submarine. Its range is limited, but it helps pinpoint a target when closing in for the kill.

Where older antisubmarine planes carry searchlights to look for a surfaced submarine the P3C uses a low-light television system. Light from the moon or stars is sufficient for a camera on the nose of the plane to produce a vivid TV image of any vessel on the sea below—or the flashes of spray that a trained viewer would recognize as a periscope wake.

Another device makes the P3C an aerial bloodhound. Navy men call this one a "sniffer." It samples the air for traces of diesel exhaust. (If you're after a nuclear sub, of course, there's nothing to sniff.)

By flying on two engines the P3C can stay in the air for 17 hours and bring thousands of square miles of open sea into the scope of a single patrol. Even so, it has a limitation that could be significant in an antisubmarine strategy that may extend across entire oceans. Its size—135,000 pounds takeoff weight, a wingspan of 99 feet—dictates that it must fly from shore bases, and the Navy can't be sure it will always have air stations on foreign soil.

That's why the Navy is developing a smaller version of the P3C to fly from carriers. This has been called the VSX

during design studies and will be known as the S3A when it comes into service in the early 1970s.

The S3A will be too small to carry as complete a package of sensors and weaponry as found in the P3C, but its four crewmen will still have the benefit of high-speed data processing in their search for submarines. Sonobuoys will relay signals back to a small on-board computer to develop fixes on targets, and the plane will carry the same kind of rockets, bombs and torpedoes as its big brother, but fewer of them.

Powered by twin turbofan jet engines, the S3A will have twice the speed and range of the carrier plane it will replace—the S2 Tracker.

The Navy has given no indication that either of these new planes will crowd another flying sub-hunter out of the picture—the helicopter. And for an obvious reason. Passive sonobuoys, even when used with depth charges to make them momentarily active through explosive echo ranging, can't provide persistent tracking of a maneuvering underwater target. Only a full-fledged sonar transducer can do that. And only a helicopter can move one into a sub-chase at flying speeds.

Turbine-powered SH3 Sea King helicopters can move from the deck of a carrier and fly at 180 mph to an area where planes have detected a submarine. The helo hovers 40 feet above the water and "dunks" its sonar unit on a cable. Crewmen can then chart the range, course and speed of the sub, and can either launch depth charges or torpedoes themselves or relay their information to another aircraft closer to the target.

Both fixed-wing and rotary-wing aircraft fly from carriers in the Navy's "hunter-killer" task groups, a combination of air and surface forces assigned to antisubmarine patrol. These groups include a carrier and eight or ten destroyers.

All of the ASW carriers are converted attack carriers, some with names made famous in World War II—*Yorktown*, *Hornet*, *Wasp* for instance.

At full strength the carrier's air wing includes about 40 aircraft—two squadrons of S2 Trackers, a squadron of SH3 helicopters and three or four E1B Tracers. The latter are early-warning reconnaissance planes that fill a protective role.

Customarily, a hunter-killer ASW group is found wherever a large number of other Navy ships are operating. One is assigned regularly to the 7th Fleet in the western Pacific. Planes and helicopters from the ASW carrier—usually working

(Please turn to page 226)

FREE—Popular Mechanics Catalog of Publications and Projects



This FREE Booklet From Popular Mechanics Can Save You Hundreds of Dollars, And Bring You A Lifetime of Enjoyment!

Now You Can Have Your Own Sail Boat, Motor Boat, Swimming Pool, Built-in-Furniture—Almost Anything For The Home Or Week-end Fun—At A Fraction Of The Usual Cost.



Just imagine a fun-filled week-end like this! You can relax and enjoy playing the host, entertaining your friends on the patio or recreation room, have a cook-out, then a swim in the pool.

Or, perhaps you've been putting off that week-end project—building shelves and furniture . . . paneling a room . . . fixing a leaking faucet . . . or odd jobs that require repairing and painting.

Let the experts show you how you can have all these things and more. We'll

show you how easy it is! All you need are these step-by-step instructions from the experts—the editors of POPULAR MECHANICS.



Easy-to-follow plans are available for many wonderful additions and improvements for your home, from a simple bookcase to a complete house—projects you can do yourself in your own shop in your spare time. And think of the money you'll save—up to hundreds of dollars—by doing them yourself.

In addition, you save on expensive contractors

and long-term loans. Hundreds of practical, money-saving ideas—you'll find a goldmine of hard-to-locate information—literally hundreds of practical ideas, booklets and plans to enrich and beautify your home on such subjects as:

Boats and boating equipment/bookcases, shelves, cabinets, tables/clocks—early American, grand-fathers/camping trailers and equipment/working with glass/electric wiring/furniture; woodworking projects/hydroplane/models: ships, airplanes, sports cars, steam engine, etc./gardening equipment, planters, lawn and tree care/houses—complete architectural plans/painting, interior and exterior; wallpapering/TV, hi-fi and stereo equipment; cabinets/plastic molding/playhouses/how to do your own plumbing/repairing your roof/car repairs and tune up/swimming pools; filters/workshop projects/famous Popular Mechanics wall charts.

This is only a sampling of a multitude of moneysaving ideas and information that can bring you many hours of pleasure—something all the family can enjoy for many years to come.

Order Your Free Price-List Catalog Today

Just fill out and mail the coupon for your copy of the POPULAR MECHANICS CATALOG OF PUBLICATIONS AND PROJECTS. Please enclose a self-addressed stamped envelope, or 10¢ in coin to cover postage and handling. Your 16-page catalog will be sent by return mail listing hundreds of plans, books, projects and wall charts for your enjoyment and better living.

Popular Mechanics, Dept. BI-CA 575 Lexington Avenue • New York, N.Y. 10022

I am enclosing a self-addressed envelope (or 10¢ in coin). Please send me a copy of the Popular Mechanics CATALOG OF PUBLICATIONS AND PROJECTS. (If outside USA, please enclose 25¢ USA currency.)

Name _____ (please print)

Address _____ (please print)

City _____ State _____ Zip code _____

EMC/A



**STEP UP
TO A
HIGH-PAY CAREER
IN MOTEL MANAGEMENT**

NOW—regardless of your age or present occupation you can qualify for high-pay positions in the fast-growing motel industry. New motels must have trained managers, assistant managers, restaurant managers, etc. AMS is the **ONLY** management training program developed and supervised by one of America's largest motel chains. It's program is practical, simplified and designed for rapid completion in spare time. Does not interfere with present job. National placement assistance too! Join the many AMS graduates now enjoying happiness and security in glamorous motels throughout the nation. Mail the success coupon below for information on how you may also enjoy big opportunities and rich rewards in motel management.

MAIL THIS SUCCESS COUPON NOW

AMERICAN MOTEL SCHOOL A
 105-107 Campbell Ave., SW
 Roanoke, Virginia 24011
 Name _____ Age _____
 Address _____ Phone _____
 City _____ State _____ Zip _____

2 art lessons free



Do you like to sketch and draw?
 Why not develop your talent at home
 in your spare time through the Washington
 School of Art?

Learn drawing, oil and watercolor
 painting, advertising art, fashion illustration,
 T.V. art, etc.

Get detailed corrections with overlays,
 guidance from instructors who take a personal
 interest in you.

WSA has opened new doors for over
 130,000 people. Many hang their art with
 pride at home. Others sell paintings and
 earn money in commercial art.

Interested? Send name, address, and
 age for two free art lessons plus free booklet
 that describes the course.

**Washington School of Art, Studio 21010
 Port Washington, N.Y. 11050**

ANTISUBMARINE WARFARE

(Continued from page 224)

in teams of two or three—can fan out far ahead of an advancing task force to sweep its path for submarines, ready to press an attack themselves or relay word of any contacts to destroyers.

Destroyers have always been the heavies of antisubmarine warfare, and they still are. As sophisticated as airborne detection systems have become, they are puny by comparison with those that can be packed into a 2000-ton destroyer. And the effort to extend the range of ship-board sonars has led not only to more powerful transmitters but some radical changes in hull design.

Many destroyers in the next few years will have new domes installed under their hulls to house sonar transmitters and receivers. The domes will be made of thick black rubber. The B.F. Goodrich Co., their maker, says they are the largest single pieces of rubber ever molded.

Crewmen will work under two atmospheres of pressure to perform servicing jobs on equipment in the domes. But the advantage will be greater range for transmitted signals and a sharper ear for returning sounds. The rubber is more "acoustically transparent" than steel.

How far can a destroyer hear with such modern equipment? That's classified, and in some respects a question that has no firm answer. Sonar ranges can depend as much on sea conditions as on the equipment being used. The right combination of such factors as water depth and temperature layers can return a sonar "ping" from a target 100 miles away! The wrong combination can cut the range sharply.

One thing is certain: The Navy is developing weapons to sink submarines at greater distances from the ships that detect them. A system called ASROC—for antisubmarine rocket—gives torpedoes a rocket boost. A combination 15 feet long, the rocket and its torpedo-payload leave a launcher on the deck to arch over several miles of sea. Then the rocket drops away and a parachute lowers the torpedo into the water, where its own propulsion system kicks on and it dives to its target.

The same system can be used to lob an atomic depth charge at a distant submarine. The atomic weapon, code-named Lulu, is also carried aboard the P3C and other ASW aircraft.

Some destroyers boost their torpedo range with a drone helicopter called DASH. This radio-controlled helo lifts off with a torpedo slung underneath to be released after it flies within range of a submarine being tracked aboard its moth-

er ship. The difficulties of flying a helicopter by remote control have made DASH only a limited success, and the Navy is shopping for a helo that would be big enough to carry a two-man crew and a torpedo and yet small and light enough to fly from a pad on a destroyer's fantail.

The torpedoes which the Navy's ships and aircraft can fire are a far cry from the "fish" that used to churn blindly toward a target. The new Mark 46, says the Navy, can "overtake the most elusive submarine targets known"—meaning fast, maneuverable nuclear subs.

The Mark 46 burns a liquid rocket fuel that gives it extraordinary speed and endurance, and carries an acoustic homing system so versatile it can chase a submarine through dives and turns and if it loses the scent, start searching again.

Though only 102 inches long and a shade over one foot in diameter, the torpedo behaves like a robot submarine. Its active-passive sonar unit first operates in a search mode as the torpedo follows a snakelike course sweeping the surrounding water for its target. When it locks on, it shifts automatically into a pursuit-and-attack mode to follow the target through evasive maneuvers at a speed sufficient to overtake it. If the sub manages to break contact, the torpedo switches back to search mode and begins the sweeping maneuver until it finds the target again—or runs out of fuel.

Such homing torpedoes are geared to seek out only submerged targets—so they won't turn and attack a surface ship that launches them. Our own submarines, obviously, must use a different type so they won't be attacked by their own weapons.

Many strategists are convinced there is no better way to pursue and attack an enemy sub than with another submarine. Our nuclear attack submarines are armed primarily for antisubmarine warfare, and the latest development in their weapons is another rocket-torpedo combination, called SUBROC. The submarine launches a 21-foot, 4000-pound tandem vehicle that swims upward and breaks the surface to begin a rocket trajectory through the air. As with ASROC, the rocket finally drops away to let the torpedo re-enter the water and dive toward its target. Or the payload could be a nuclear depth charge.

Shrouded in greater secrecy is a submarine-launched torpedo called ASTOR—a monster four feet in diameter and 20 feet long. It's designed to carry a nuclear warhead, with guidance controlled by the sub that launches it. ASTOR has a range of more than 10 miles, enough to keep the launching sub safe from the two or three-

(Please turn to page 228)

Carpenters' Secret Makes Hinge Screw Holes Vanish

(Mr. W. C. B., Norristown, Pa.)

Fill unsightly hinge screw holes like professional carpenters do with PLASTIC WOOD. Handles like putty. Hardens like wood. Plane it. Sandpaper it. Varnish or paint it for perfect finish. Get PLASTIC WOOD in tube or can. Walnut, oak, mahogany or natural color. At all hardware outlets.

GENUINE
**PLASTIC
WOOD®**



CELLULOSE FIBRE FILLER

BUILD REFINISH
RESTORE
... anything of wood

LET Constantine's picture-packed Catalog-Manual help you build new furniture—help you restore and refinish beat-up cabinets, chairs, chests, tables. Find instantly whatever you need. Newest materials plus plans, instructions. Largest selection of beautiful woods. Specialty tools. Products not found in stores or by mail elsewhere. *Unsurpassed values.* Send for vast, illus. catalog NOW!



2,000

CRAFTSMAN PRODUCTS
Woods—Veneers—Inlays
Newest Workshop Tools
Wood Finishes—Moldings
Carving Woods & Patterns
Cane Kits—Lamp Parts
Hard-to-find Hardware

Tear out ad. Mail with 25¢
for vast new CATALOG
Plus New "101 Project Ideas"

CONSTANTINE

2050 Eastchester Rd., Bronx N.Y. 10461 Dept. M-5

INVENTORS

INVENTIONS—NEW PRODUCTS—IDEAS
DEVELOPED & PREPARED

For Commercial Appeal & Sales

DESIGN—MARKETING—PATENT RESEARCH—DRAWINGS

DIRECTOR: United States Patent Office former Patent Examiner

Member: United States Council Int'l Chamber Commerce

Second Decade of Reliable Service to

INVENTORS—MANUFACTURERS—ATTORNEYS

FREE CONSULTATION

THE RAYMOND LEE ORGANIZATION

230-Z Park Ave., New York 10017 (212-MU 6-8500)

SEND FREE "INVENTION RECORD" Form &
"IMPORTANT PATENT INFORMATION"

Name _____

Address _____

City _____

State _____

Zip _____

FREE!

Learn how you
can buy used
engines \$15 up,
new engines \$30
with FREE con-
fidential list and
coupons when you
order your plans

BUILD THIS MINI-BIKE!

Plans reveal step by step details!

BUILD A RACING KART!

Build frame for less than \$10!



RUSH \$2 for plans (indicate type) or
send 25¢ for circular describing plans
PLANS, Box 517, Omaha, Nebr. 68101

YOU CAN FIND HIDDEN TREASURE AND RELICS

WITH THE AMAZING "GOLDSTAR"
MORE POWER • MORE DEPTH
DETECTS COINS, GOLD,
METALS, RELICS, ORE, ETC. •
OUT-PERFORMS PROBE TYPE
IMPORTED MODELS

ULTRA-SENSITIVE AND POWERFUL
Detects through earth, wood, rock,
sand, water, etc. Comes with batteries
and ready to use. Send check, cash,
money order today! \$5.00 deposit on
COD orders. Immediate shipment.
JETCO P.O. BOX 132-PM1
HUNTSVILLE, TEXAS 77340



2 YEAR
GUARANTEE
\$2995
P.P.D.

DEAR MR. MAIL ORDER:

I have never sold anything by mail but I would like your
Free Report on how to start a big profit, spare time busi-
ness at home without buying inventory.

NAME _____

ADDRESS _____

CITY _____ STATE _____ ZIP _____

NOTE: Mail this coupon for "How to Make Money in
Mail Order" to Mr. Mail Order, 1554 S. Sepulveda, Dept.
C2259, Los Angeles, Calif. 90025.

Make your own Gems 39.50 F.O.B.

The Gem Maker comes complete with all
necessary equipment, including a super-charged
diamond blade for sawing, and all the wheels for
grinding, shaping and polishing; also complete
instructions. The complete equipment as shown,
less motor and belt for only \$39.50.
f.o.b., Burlington, Wisconsin. Write to-
day for information and litera-
ture.

B&I MANUFACTURING CO.
Dept. P, Burlington, Wis. 53105

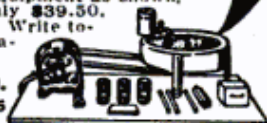

ENROLL—EARN YOUR DEGREE

of Bachelor of Bible Philosophy (B.Ph.B.), Master of Bible
Philosophy (M.Ph.B.), Graduate of Bible Philosophy
(G.Ph.B.), Doctor of Metaphysics (Ms.D.), or Doctor of
Divinity (D.D.). Chartered by State, Correspondence
Courses only. Please write for FREE BOOKLET.

AMERICAN BIBLE INSTITUTE

Dept. PM, Post Office Box 8748, Kansas City, Missouri 64114

A BUSINESS OF YOUR OWN REPAIR HYDRAULIC JACKS



Earn while you learn at home. Millions of jacks in gas and auto service
stations, trucking firms, body shops, riggers, factories and farms need
servicing . . . most of which you can learn to repair. We show you
HOW. Start spare time in your basement or garage. Big opportunity for
mechanics. ACT NOW! Write for folder PM-9, and free bonus offer

HYDRAULIC JACK REPAIR MANUAL CO., INC.

G. P. O. BOX 3 • STATEN ISLAND, N. Y. 10314

At Last a New Amazingly Simple

GAS TURBINE JET ENGINE

Build from easy to follow plans. Length 15",
Dia. 8 1/2", Wt. 15 lbs. Fuel: Gasoline or Kero.

"Screamin Demon" develops 20 H.P. Ideal project for serious-minded
hobbyists, students; scientific and industrial arts classes. Make on 9"
metal cutting lathe with milling attachment. For use on small racing
boats, midget cars, etc. Full size assembly drawings with critical
dimensions, bill of materials and photos. Price \$5.00. No C.O.D.

SAVOY SCIENTIFIC, BOX 1398, SANTA MONICA, CALIF. 90406



WHEN ANSWERING ADS
GIVE YOUR ZIP CODE

ANTISUBMARINE WARFARE

(Continued from page 227)

mile kill radius of its atomic explosive.

Since an enemy sub may have long-
range weapons, too, stealth is the trump
card of nuclear subs. Submariners prefer
to pursue an enemy by using passive lis-
tening devices rather than emitting an
active sonar signal that would disclose
their presence. News that the Russians
are building quieter subs means that our
own subs would have to seek them out at
closer range and would run a greater risk
of detection.

That's one reason why Adm. Hyman
Rickover, the father of the U.S. nuclear
fleet, is pressing for development of a
quieter model. Design work has already
started on a prototype. Where our present
nuclear subs use a reactor to generate
steam for turbine engines, the new one
will convert nuclear energy to electricity
to achieve a quieter drive.

Rickover also is fostering the develop-
ment of a faster sub—one that can do bet-
ter than the 35 to 40 knots said to be the
top speed of current models. And the
Navy would like to see the operating
depth of attack subs extended to the 6000
or 8000 feet attained by research subs.

Every move toward better submarines
calls for a comparable advance in anti-
submarine technology. To match the in-
creasing speed of nuclear subs, the Navy
is testing a 300-ton hydrofoil, the *Plain-
view*, (*The Biggest, Fastest 'Flying' Boat
Yet!*, page 88, Dec., '68 PM) with the
hope it may be the forerunner of a 70-
knot sub-chaser that could outrace the
fastest submarine in any sea condition.
At the same time, destroyers are experi-
menting with variable-depth sonar—a de-
tection unit lowered from the ship by
cable to get it farther from the noise of a
ship's screws and below the thermal lay-
ers where a nuclear sub could hide.

Conceivably, destroyers of the future
might skim above the surface of the sea
on foils while their sonars on cables probe
several hundred feet below!

Other programs are even more specula-
tive. Could sonobuoys like those now
sending signals to aircraft be scattered
over a wider area of the sea to be moni-
tored by a satellite in orbit high above?
Or could a satellite carry an infrared de-
tector so sensitive that it could trace the
passage of a submerged nuclear sub by
the heat from its reactor?

Already the weapons of antisubmarine
warfare have made the nuclear submarine
something less than an invulnerable foe.
The fastest, quietest submarine can ulti-
mately be detected. ★ ★ ★

Now! Get Your Own

**FULL COLOR
print of the
APOLLO 11
MOON
ROCKET**

Size: 19 x 25 inches

plus



THE SATURN V
LARGEST ROCKET IN THE WORLD
PHOTOGRAPHED BY
POPULAR MECHANICS
BY THOMAS HARRISON AND JOHN HARRISON

SPECIAL BONUS...

**Our
First
19
in
Space**



includes
MOON WALKERS
NEIL ARMSTRONG and
"BUZ" ALDRIN
and
COLUMBIA PILOT
MIKE COLLINS
of the
APOLLO 11
MOON MISSION

Both for only \$1.50 postpaid

Limited Quantity! Order now.

POPULAR MECHANICS, DEPT. JV, 575 LEXINGTON AVE., N.Y., N.Y. 10022

NAME _____

STREET _____

CITY _____ STATE _____ ZIP _____

FANTASTIC VALUES WITH THIS COUPON

AMERICAN MACHINE & TOOL CO., Dept. PM99, Royersford, Pa. 19468

Please send me the units checked. Payment in full enclosed \$.....
or \$3 deposit each item enclosed, balance C.O.D. I MUST BE FULLY
SATISFIED OR WILL RETURN UNIT WITHIN 10 DAYS FOR FULL REFUND.
No questions asked.

- | | |
|---|---|
| <input type="checkbox"/> 8" Power Saw at \$14.95 | <input type="checkbox"/> Belt Sander at \$14.95 |
| <input type="checkbox"/> Standard Rip Fence at \$3.50 | <input type="checkbox"/> Disc sander attach. at \$7.95 |
| <input type="checkbox"/> Long Rip Fence at \$4.50 | <input type="checkbox"/> Mitre Gauge for sander at \$1.95 |
| <input type="checkbox"/> Precision Ball Bearing Spindle at \$5.00 | <input type="checkbox"/> Lathe at \$9.85 |
| <input type="checkbox"/> Jointer Planer at \$19.95 | <input type="checkbox"/> Face Plate at \$2.50 |
| <input type="checkbox"/> Drill Press at \$29.95 | <input type="checkbox"/> Turning Chisels at \$4.95 |
- G.E. Motor \$18.80 (with other item) \$24.85 (purchased separately)

NAME

ADDRESS

CITY STATE ZIP

SAVE AS MUCH AS...
80% WITH
QUALITY 
POWER TOOLS

DIRECT FACTORY OFFER AND REVOLUTIONARY PATENTS decrease costs, increase efficiency. Full scale power tools of heavy duty 100% cast iron and steel. Streamlined design reduces weight, cuts material and production costs. Special patents provide added efficiency, accuracy, savings. Parts made, assembled, tested, packed right in our own factories shipped direct... save store profits.

ENDORSED BY AMERICA'S TOP MAGAZINES... Here is what the editors say:

"A good bit of sound—imaginative—engineering." Popular Science; "(saw) boasts many features of bigger brothers." Popular Mechanics; "Amazingly versatile." Workbench; "Highly substantial construction, sturdy enough for production line use." Industrial Woodworking. And Workbench awarded these tools their coveted "Work Tested" Seal.

OVER A MILLION USERS confirm their precision, versatility and rugged performance.

***10-YEAR FULL SERVICE GUARANTEE...** Any part or parts of any AMCO power tool (except motor) which may become inoperative for any reason within ten years after the purchase date will be repaired or replaced by the factory without cost to the purchaser. Your only cost: for postage.

UNCONDITIONAL MONEY BACK GUARANTEE

You must be fully satisfied. If not, return in 10 days, freight collect. Money promptly refunded in full.

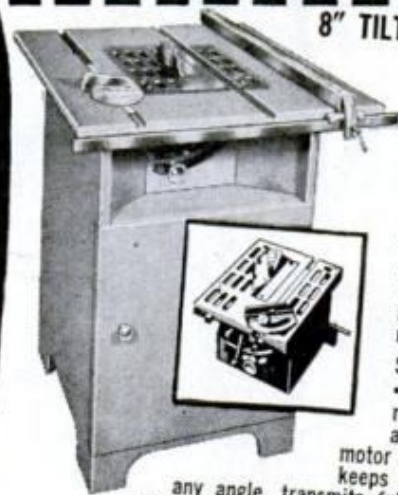

8" TILT ARBOR POWER SAW

DOES WORK OF \$75 BENCH SAW as is. Converts easily to equal any \$300 floor model cabinet units! Crosscuts, rips, mitres, cuts compound angles, dados, makes coves and mouldings.

\$1495 f.o.b. factory. Wt. 25 lbs. Includes completely assembled cast iron and steel 8" saw with ground cast iron table... less blade. RIP FENCE, if desired, for easier work alignment, \$3.50 add'l.

PRECISION BALL BEARING SPINDLE for Commercial Service, \$5.00 add'l.

SAW BLADE TILTS... TABLE STAYS LEVEL

Locks securely at any angle up to 50°, raises, lowers 0°-2¼". Patented tilt mechanism, accurate etched scale. Patented motor mount takes std. ¼ h.p. or larger motor, keeps belt tight, assures perfect alignment at any angle, transmits full power. Takes std. blade, saw insert removes to take dadoe heads, cutters, etc. (not incl.). Accurate mitre gauge assembly. Ground spindle. Enclosed steel base. "Compo" bearings. Access. Std. size (for bench saw) \$3.50; larger fence (for cabinet base, as ill'd.) \$4.50.

FREE CABINET BASE PLANS Use as portable bench saw as received (inset photo) or transform easily and inexpensively into floor model (as shown) guar. to do work of floor models costing \$300. FREE plans... all you'll need are a sheet of ¾" plywood and 3-4 hours. Use your AMCO saw for cutting. Plans provide 27" x 24" work surface, 33" height, tool storage compartment.

10-YEAR FULL SERVICE GUARANTEE*

6" SWING 3-FOOT LATHE



Optional faceplate for turning bowls, trays, lamp bases, rosettes, etc. \$2.50.
\$985 f.o.b. factory Wt. 14 lbs.

Set of 3 high speed turning chisels, \$4.95 add'l.

DOES THE WORK OF \$40 UNITS... with same precision and speed. Turns wood, plastic. Sturdy cast iron with tubular steel bed. Ball thrust cup center, spur center, T-rest assembly, lever action tail stock, 2-speed pulley. Fits any motor.

10-YEAR FULL SERVICE GUARANTEE*

PRECISION 4" x 36" BELT SANDER

f.o.b. factory. Wt. 15 lbs.



Mitre gauge: \$1.95 add'l.

\$1495 †Disc Sander attachment incl. disc bracket, ground cast table (tilts 0-45°): \$7.95 add'l.

DOES WORK OF \$50 SANDERS... The world's most talented belt sander. Heavy cast sander incl. 4" x 36" sanding belt, V-pulley drive, multi-purpose drive spindle. Changes from horizontal to vertical sanding in secs. Uses ½ hp or larger motor.

10-YEAR FULL SERVICE GUARANTEE*

FULL 22" JOINTER-PLANER LONG, 4½"

\$1995



f.o.b. factory. Wt.: 19 lbs. Complete as shown.

100% precision ground cast iron and steel.

DOES THE WORK OF \$60 UNITS... Professional power planing at a hand tool price. Make faster, more accurate joints, rabbets, bevvels for windows, doors, drawers, square tapered legs—Adjustable precision ground cast iron tables. Patent-pending design holds knife to table clearances at any depth. Rabbett depth ¾". Fence adjustable 0°-50°. Hardened, ground hi-speed steel knives. Dual cutter guards. Balanced cutter head.

10-YEAR FULL SERVICE GUARANTEE*

32" RADIAL DRILL PRESS

All cast iron and steel
f.o.b. factory **\$2995**
Wt. 30 lbs.

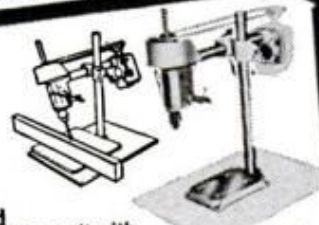

½" cap. Jacob's chuck incl.

DOES WORK OF \$90 UNITS... and much more. Industrial quality precision unit with all standard features, many extras. Head raises, lowers. Depth of throat up to 16". Pre-set to any angle for on-or-off table drilling, even horizontal drilling. 10-YEAR FULL SERVICE GUARANTEE.*

BRAND NEW  MOTOR

DEVELOPING FULL 1 HP... **\$18.80**

F.O.B. FACTORY

FOR ANY OF ABOVE MACHINES. WT. 17 LBS. PURCHASED SEPARATELY, \$24.85

5 milliseconds in the life of a "Power Piston" wad.

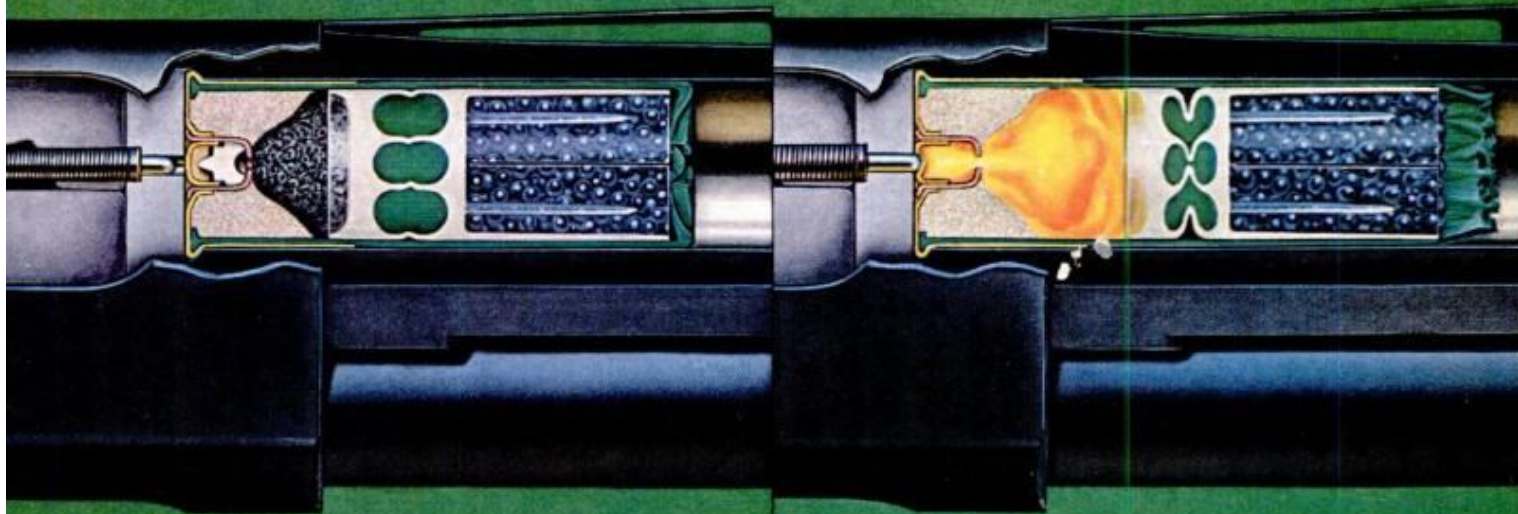

1 This is what the "Power Piston" one-piece wad (loaded in a Remington Express plastic shell) looks like from the time it leaves the factory until you pull the trigger.

2 Right after firing. The built-in shock absorber in the "Power Piston" compresses and absorbs the initial impact of the explosion, so the shot won't be crushed together.



3 Halfway down the gun barrel. The back end of the Remington "Power Piston" opens up to seal the barrel and keep the expanding gas from leaking past and losing power.

4 At the muzzle. Though the shot column is moving at top speed, the sides of the Remington "Power Piston" have kept it from touching the barrel and flattening the pellets.

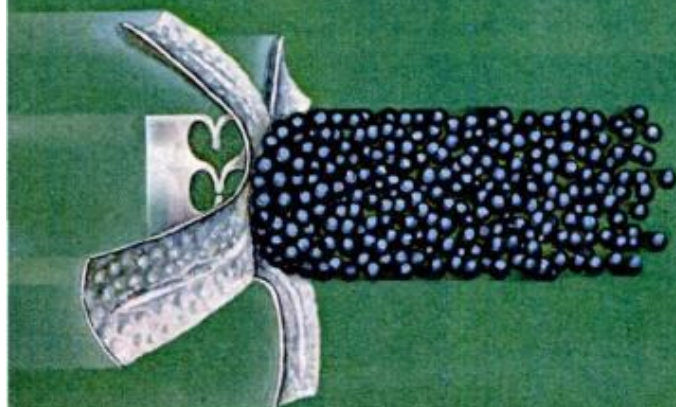

5 A few feet past the muzzle. The "Power Piston" now peels back and drops away, but the shot column is on its way at full power, with no flattened pellets to spoil the pattern.

For some time we've been telling you that Remington and Peters "Power Piston" wad shot shells shoot harder, keep your barrel clean longer and put up to 10% more shot in the pattern. But let's face it—you were just taking our word for it.

That's why this little demonstration. We feel that if we can show you what a "Power Piston" does, you'll have more confidence in our shells. Also we can clear up a common misunderstanding. The "Power Piston" does not make the pattern smaller. It just puts more pellets into it by eliminating "flyers"—flattened shot that goes wild. No matter what gauge you shoot—12, 16, 20 or 28. And that's a fact.



Remington OUTLINE **PETERS**

Try Remington/Peters shells with "Power Piston" wads—high or low base. See how good a shot you really are.

"Remington," "Peters," "Power Piston" and "Sinor Shot" are Reg. U. S. Pat. Off. and "Express" is a trademark of Remington Arms Company, Inc.



Take a Puff...
It is Springtime



*You can take
Salem out of the
country but...*

