

Build PM's Circular Game Table Page 148

POPULAR MECHANICS

AUG. 1969
50 CENTS

How
To Have
Good TV in
Every Room
Page 126

Maverick vs the Mob

How Ford's Fancy Little
Fastback Stacks Up
Against Foreign
'Friends' Page 73



GREAT
THINGS
TO MAKE

Early American Clock Shelf • Folding Hobby Center
Modern Bookcase-Desk • All-in-One Telephone Shelf
Working Model Beam Engine • Lightweight Backpack

**Taste the
golden age
of Schlitz**



©1989 Jos. Schlitz Brewing Co., Milwaukee and other great cities.

120 years ago, Joseph Schlitz took plenty of time to age his golden mellow beer. We still do. It's the golden age that makes Schlitz America's choicest premium beer.



“When you're out of Schlitz, you're out of beer.”

Материал, защищенный авторским правом

**For years you've supported the gasoline companies.
Let them support you for a change.**

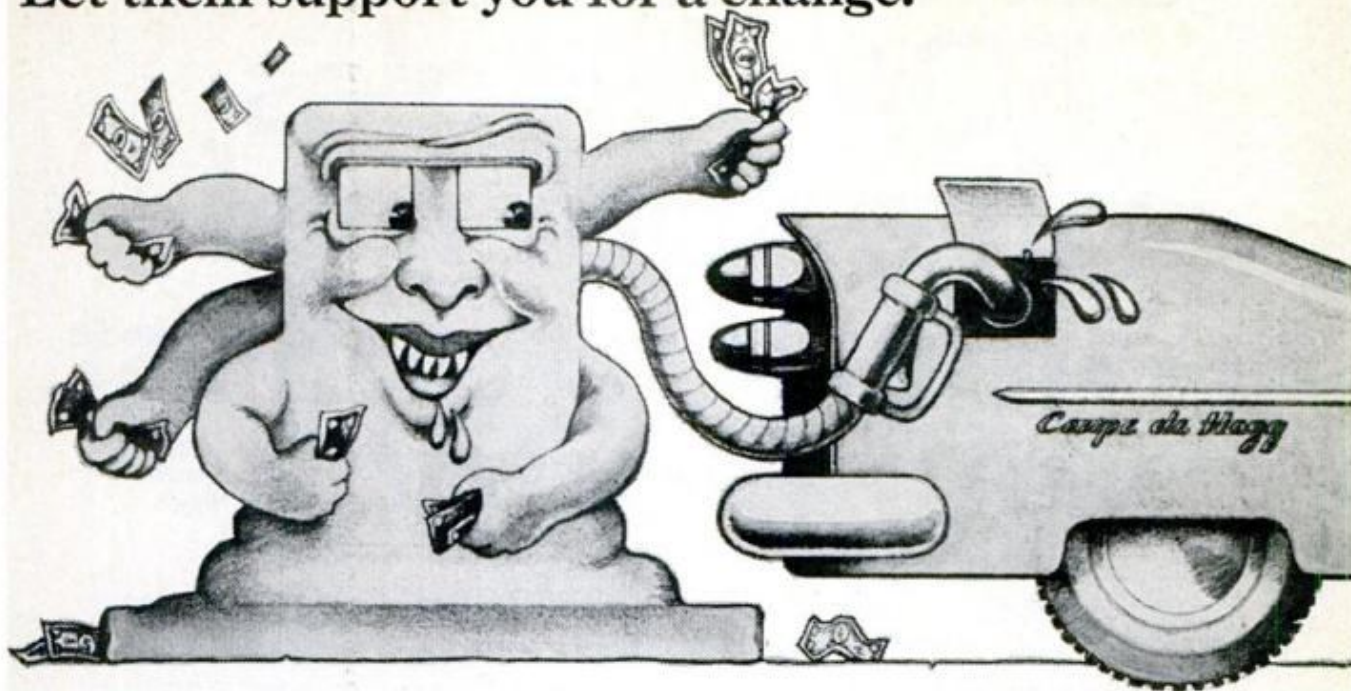

Every year, the average driver contributes about \$450 to the gasoline companies. That's because the average driver's average car gets about 12 miles to the gallon. The gas companies love the average driver—as well they might.

So turn the tables: Buy a Renault 10. Not only does the Renault 10 have 4 doors, posh seats, a roomy trunk and all that stuff—it also gets 35 miles to the gallon. Count 'em, 35.

In a year you'll save about \$300. That \$300 will let you buy some gasoline company stock—and take

advantage of all those drivers who do not drive Renaults.

In a few years, you can sell your stock. And with the profits you can buy a Renault 16 Sedan-Wagon.

Thus, you will have 2 cars: The Renault 10 which will save you a lot of money. And the Renault 16 (a sedan which converts to a station wagon). The 16 will save you a little less money, but it's awfully good for hauling your money around.

RENAULT 

For nearest dealer see the Yellow Pages or write Renault Inc., 100 Sylvan Ave., Englewood Cliffs, New Jersey 07632.



The Renault 10
\$1775.*—35 mpg.

The Renault 16
\$2445.*—30 mpg.

*P.O.E. East Coast.

Johns-Manville FGA[®] shingles give your roof a chance to outlast your mortgage

You can bank on a roof of Johns-Manville FGA Seal-O-Matic shingles.

They contain moisture-proof fiber glass and asbestos.

Materials that don't rot, don't swell or shrink. So your shingles don't move around. They just lie there. Beautifully. In any weather.

Look for FGA shingles—in a wide choice of attractive colors in several styles—at your nearest J-M dealer.

So you won't have to worry about your second or third roof while you're still working on your first mortgage. **JM**

Johns-Manville

Johns-Manville, Box 290-BA New York, N. Y. 10016.
Please send me more information on your FGA shingles.

Name _____

Address _____

City _____ State _____ Zip _____



NEW FINCO®

HOME ENTERTAINMENT DISTRIBUTION WIRING SYSTEM FOR DO-IT-YOURSELFERS



HWK-75 75 ohm
HWK-300 300 ohm

Everything needed to wire
your home for multiple set re-
ception – in easy-to-handle kit form.

● For Color TV – UHF/VHF ● Black & White TV ● FM/FM Stereo

Turn your whole house into a home entertainment center. Operate up to four sets, or be able to move your entertainment equipment from room to room. Kit includes all necessary parts, fittings and instructions.



THE FINNEY COMPANY

34 W. Interstate Street, Dept. PM-8
Bedford, Ohio 44146

Please send free brochure 20-520 on FINCO HOME TV
DISTRIBUTION KIT.

Name _____

Address _____

City _____

This One



T08Q-51B-KQRS

State _____ Zip _____

POPULAR MECHANICS®

INTERNATIONAL EDITIONS: AUSTRALIA, BRAZIL, CARIBBEAN, DENMARK, FRANCE, MEXICO, SOUTHERN HEMISPHERE, SWEDEN

AUTOMOBILES AND DRIVING

- 24 Drivin' With Dan
- 38 Detroit Listening Post
- 66 Automobile Clinic
- 73 Maverick Versus the Mob
- 90 Auto Racing's New Speedways
- 98 PM Owners Report: Chevrolet Impala
- 102 Off-Road Going . . . in Style
- 116 PM Owners Report: Olds Delta 88
- 138 Saturday Mechanic: Hot Tips on Engine Cooling

BOATING, OUTDOOR RECREATION

- 12 On-the-Go Camping
- 44 What's New Outdoors
- 102 Off-Road Going . . . in Style
- 106 What It Takes to Become a Surefooted Iceman
- 112 PM Tests Chris-Craft's Lancer
- 120 Portable Power for Camping Comfort
- 132 Outboard-Motor Service Guide No. 2: How to Check Your Starting System

SCIENCE AND INVENTION

- 20 Science Worldwide
- 30 Beefed-Up Tanker for Alaskan Oil
- 78 How They Keep You Safe Without Getting You Killed
- 82 Just Patented: PM's Pick of the New Inventions
- 106 What It Takes to Become a Surefooted Iceman

SPACE, AVIATION, MILITARY

- 84 They've Taken the Guesswork Out of War Games
- 94 Who Will Bell the Invisible CAT?

PHOTOGRAPHY

- 136 New in Photography

SHOP AND CRAFTS

- 144 Build This Foldaway Hobby Center
- 148 All-Time Greats No. 1: A Game Table for Your Playroom
- 152 Build This Phone Center
- 156 Build This Model Walking-Beam Engine
- 160 Weekend Workshop Projects
- 163 Hints From Readers
- 164 Build This Handsome Bookcase Desk
- 167 Hints From Readers
- 170 Here's a Dovetailing Device That's Really Different
- 173 Hints From Readers
- 179 Hints From Readers
- 180 Make This Back Holder and Use 'Upside-Down' Tool Bits

HOME AND YARD

- 14 New Building Products You Should Know About
- 70 Homeowners' Clinic
- 144 Build This Foldaway Hobby Center
- 148 All-Time Greats No. 1: A Game Table for Your Playroom
- 152 Build This Phone Center
- 154 Solving Home Problems
- 160 Weekend Workshop Projects
- 164 Build This Handsome Bookcase Desk
- 168 Exciting New Products
- 174 How, When and Why You Should De-Thatch Your Lawn

ELECTRONICS, RADIO AND TV

- 126 How to Have TV in Every Room in the House
- 142 Hi-Fi Compacts You Can Build From Kits

REGULAR FEATURES

- 6 Letters

Cover Photos by Stanley Rosenthal

Ford's Maverick and "friends" at the Pocono International Raceway, Pa.

NEXT MONTH IN POPULAR MECHANICS

Get Better Sound From Your TV. The quality is there; here's how to get it.
Fly-It-Home Ejection Seat: Pilots who bail out just keep on flying.
Our Crazy, Mixed-Up Speed Laws. The man in blue isn't always right.
ABCs of Chassis and Suspension Systems. Complete guide to a soft ride.
Antisubmarine Warfare. The Navy's sophisticated ways of finding deep subs.

ROBERT P. CROSSLEY

Editor

JAMES M. LISTON

Executive Editor

JOHN A. LINKLETTER

Managing Editor

WAYNE C. LECKEY

Home and Shop
Editor

SHELDON M. GALLAGER

Assistant Executive
Editor

THOMAS G. DAUER

Art Director

Published by The Hearst Corporation

RICHARD E. BERLIN, PRESIDENT

RICHARD E. DEEMS

President, Magazines Division

JOSEPH F. KERN

Publisher

WILLIAM KILPATRICK _____ Automotive
DANIEL C. FALES _____ Boating and Outdoors
SHELDON GALLAGER _____ Electronics and Photography
JOHN F. PEARSON _____ Science
BILL HARTFORD _____ Technical Automotive
HARRY WICKS _____ Home Workshop
GARRY WINTER _____ Copy and Production
RICHARD H. FUNK _____ Associate Copy and Production
JOHN ADKINS _____ Assistant Copy and Production
ALVIN KIETZ _____ Assistant Art Director
DON EVANS _____ Assistant Art Director
FRED A. LEERS _____ Assistant Art Director
GEORGE W. BLOW _____ Technical Art Director
CLIFFORD B. HICKS _____ Special Projects
SOPHIE GRONOWICZ _____ Director, Bureau of Information
EVERETT JOHNSON _____ Cabinetmaker

ADDRESS ALL EDITORIAL COMMUNICATIONS TO: 575 Lexington Ave., New York, N.Y. 10022. For additional sources of information on the articles and products in this issue, write to Bureau of Information, Popular Mechanics, for free "Where-to-Find-It" list.

DANIEL J. COLEMAN

Director of Advertising

ADVERTISING OFFICES: New York: 575 Lexington Ave., Murray Hill 8-8500; Chicago: 520 N. Michigan Ave., 527-2400; Detroit: General Motors Bldg., TRinity 5-8711; Cleveland: Hanna Bldg., 1422 Euclid Ave., PHospect 1-0456; Los Angeles: 601 North Vermont Ave., 666-6263; San Francisco: 1101 Hearst Bldg., YUkon 2-0823.

SUBSCRIPTION SERVICE: Mail all subscription orders, changes of address, correspondence concerning subscriptions, and Postmaster notices of undeliverable copies to Popular Mechanics, Box 646, New York, N.Y. 10019. Please enclose your latest address label for quickest service when writing about your subscription.

POPULAR MECHANICS IS PUBLISHED MONTHLY by The Hearst Corporation, 57th St. at 8th Ave., New York, N.Y. 10019, U.S.A. Richard E. Berlin, President; George Hearst, V-Pres.; Richard E. Deems, President of Magazines; John R. Miller, Executive V-Pres. of Magazines; Raymond J. Petersen, Senior V-Pres. of Magazines; William S. Campbell, V-Pres. of Magazines; Albert A. Rachoi, V-Pres. and Director of Circulation; Joseph F. Kern, V-Pres. for Popular Mechanics; Frank Massi, Executive V-Pres. and Treasurer; Harvey L. Lipton, Secy. Single copy in the United States and Canada, 50 cents. Subscription prices: United States and Possessions, \$4.00 for one year; \$7.00 for two years; \$10.00 for three years. Canada, add \$0.75 for each year. Pan American Postal Union countries, add \$1.00 for each year. All other countries, add \$2.00 for each year. When changing address, give old address as well as the new, with postal-zone number, if any, and allow six weeks for change to become effective. Second-class postage paid at New York, N.Y., and at additional mailing offices. Authorized as second-class mail by the Post Office Department, Ottawa, and for payment of postage in cash. Registered as second-class matter at the Post Office at Mexico D.F., Mexico, June 20, 1950. © 1969 by The Hearst Corporation. All rights reserved. Printed in U.S.A.

AUGUST 1969

86 Proof Early Times Distillery Co., Louisville, Ky. ©1968



let's make it

Make yourself the greatest home bartender in town. Just send \$3.50 to Early Times Glass Offer*— P. O. Box 1080, Louisville, Kentucky 40201. We'll send you a set of 6 Giant 15 oz. Early Times Jiggers. Or send \$3.00, for a set of 8 Early Times 10½ oz. Highball Glasses. They're beautiful, so get both sets while they last. Do it now.

*offer valid only where legal

THE TRUE OLD-STYLE KENTUCKY BOURBON

If the aroma of
Field & Stream
doesn't remind you
of a great autumn
day in the woods...

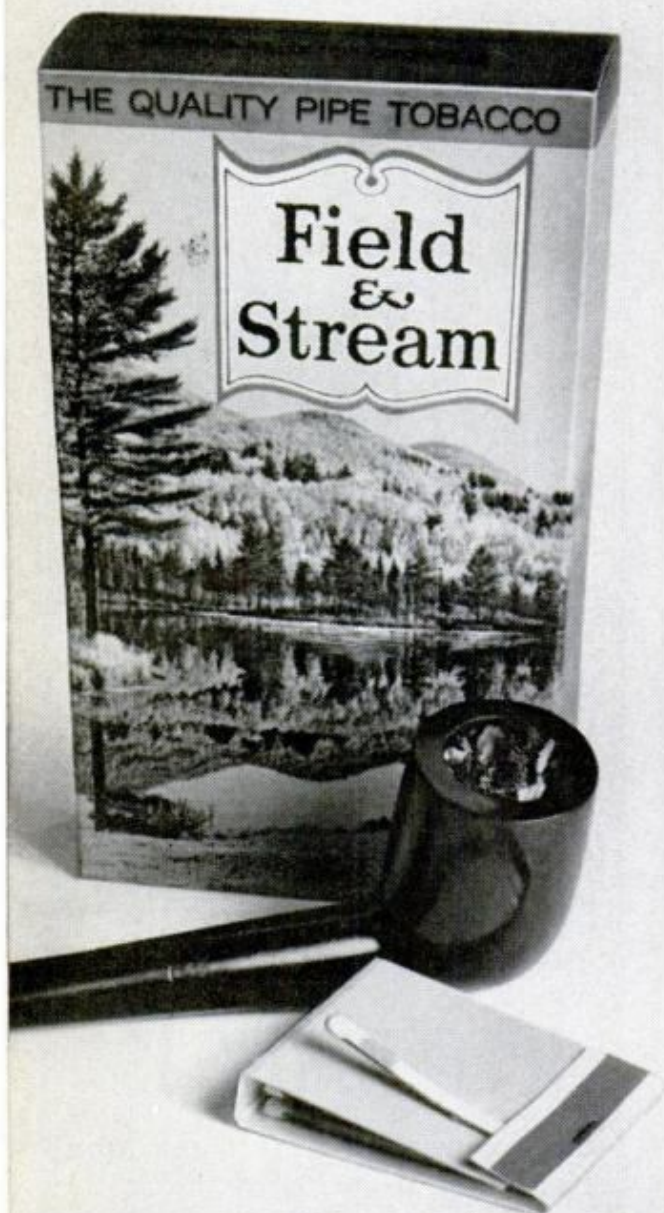

**you forgot
to light it.**

A quality product of Philip Morris U.S.A.

LETTERS

TO THE EDITOR

Has to be the best

The painting on pages 112 and 113 of your June issue (*Damn the Submarines! Turn on the Lights!*) has to be, by far, the finest depiction of air and sea action I've ever seen! Fabulous!

Can't quite make out the artist's name, but he deserves a 21-gun salute.

HAMDEN, CONN. VINCENT SHRIBER

We rarely fire guns around the office, so instead of saluting our artist, we paid him this time. His name is Ed Valigursky, (see the last line on page 111), and, we agree, he did a superb job.

In fact, the painting was so good we presented the original to the Chief of Naval Operations, and it now hangs in the Pentagon.

Anybody see Lola?

In your June story on Cam-Am racing (*Road Racing's Big Big League*, page 77, June PM), the caption on page 78 under the picture of Mark Donohue (you spelled his name wrong) says he is series champ. He never has been a Can-Am champ, but he has been USRRC champ.

Also, the car he is identified with is not a Lola; it is his last year's McLaren Mk 6B. The Lola 160 car has yet to prove itself in competition, where you state it proved impressive last year.

It bugs me when such gross inaccuracies appear in print in magazines that should know better—especially under Dan Gurney's byline.

MOTOR AGE STAN STEPHENSON
PHILADELPHIA MANAGING EDITOR

The caption is a staffer's, and he's now helping with the sweeping chores at night.

No. 6 is fifth

I hope that your Saturday mechanics have not purchased new distributor cams, since according to *How to Check Distributor Vacuum Advance* (page 152, May PM), a timing variation of more than 3° in cylinders that are actually 180° apart would indicate a worn distributor cam.

On page 216, you say "... disconnect the timing light from No. 1 cylinder and connect it to the sparkplug of the alternately firing cylinder. On V8 engines, this will be No. 5 cylinder in the firing order." The only cylinder using the same timing

(Please turn to page 8)

America's most famous hotels/motels want you, need you for a well-paid career



The demand for executives, supervisors and managers in these hotels/motels is so great that the American Hotel & Motel Association has now authorized LaSalle to train you in your spare time at home.

FAMOUS INDUSTRY LEADERS WHO ENDORSE AH&MA TRAINING

<i>Hilton Hotels</i>	Marriott MOTOR HOTELS
HOTEL CORPORATION OF AMERICA	Pick Hotels Corporation
INTER-CONTINENTAL HOTELS	RAMADA INNS
HOWARD JOHNSON'S MOTOR LODGES, INC.	SHERATON CORPORATION OF AMERICA
The Kahler Corporation	<i>Freemway Inns</i>
KNOTT HOTELS	WESTERN INTERNATIONAL HOTELS

How would you like a direct line to a prestige position in the fast-growing hotel/motel field? Where you'll not only be well paid, but also enjoy extras like great meals, housing, entertainment, recreation facilities? Where you will join in guest activities and meet some of the most interesting people in the world?

A booming field

The "hospitality" industry needs top managers. Department heads and assistants. Executives from the junior level and up. But there aren't enough trained people to fill all the 25,000 new openings each year.

So the Educational Institute of the American Hotel & Motel Association is offering its executive training courses to you through LaSalle, leader in the home study field.

That means you can now take the industry's own courses, endorsed and recognized by the industry's own leaders, in your spare time. Without giving up your present job until you're ready. And when you have the AH&MA's Graduate Diploma, their placement service will assist you in getting started. Every AH&MA graduate is now employed in an executive position!

LA SALLE HOTEL/MOTEL EXECUTIVE TRAINING

Authorized by the Educational Institute of the American Hotel & Motel Association
417 S. Dearborn Street, Chicago, Illinois 60605 © 1969 LaSalle Extension University

You're welcome regardless of age, sex, previous education

There are many kinds of openings in the hotel/motel field and opportunities for everybody. Whether you are a young man or woman seeking an exciting life-time career or of mature years and looking for good income in a congenial, prestigious field, you'll find the right opportunity waiting for you when you've trained. General manager. Front office executive. Banquet manager. Personnel director. Property manager. Social director. And scores more. Or you may want to go into a modest resort business of your own.

The better jobs in the industry pay \$10,000 to \$15,000 and frequently go much higher. When you add all the free extras that are yours living in plush resorts or big-city luxury hotels, these positions are among the most rewarding in the country.

Take the first step

Now is the time for you to get all of the facts about this fascinating field, the jobs available and the training offered. Send coupon for free booklet "Rewarding Careers in Hotel/Motel Management." No obligation, of course.



Mail this coupon for free booklet

La Salle Extension University
A Correspondence Institution
417 S. Dearborn Street,
Dept. 92-110, Chicago, Illinois 60605

Please send me your free illustrated booklet "Rewarding Careers in Hotel/Motel Management" and full details of the AH&MA courses and job placement services. No obligation, naturally. I am especially interested in the following: (please check)

- Hotel Executive Career Motel Management Career
 Retirement Career Business of My Own
 Other Hotel/Motel Careers (Specify)

Mr. _____ Age _____
Mrs. _____
Miss (Circle title and please print) _____ Apt. _____
Address _____ No. _____
City _____
State _____ Zip No. _____

008

The 100% Pure Pennsylvania Oil specially formulated to clean as it lubricates. Protects through all weather. Buy your oil the way you bought your car. Carefully. Wolf's Head Oil Refining Co., Oil City, Pa. 16301.

**Grime
Acid
Sludge
Grit
Crud**

**This
one
soaks it
up**

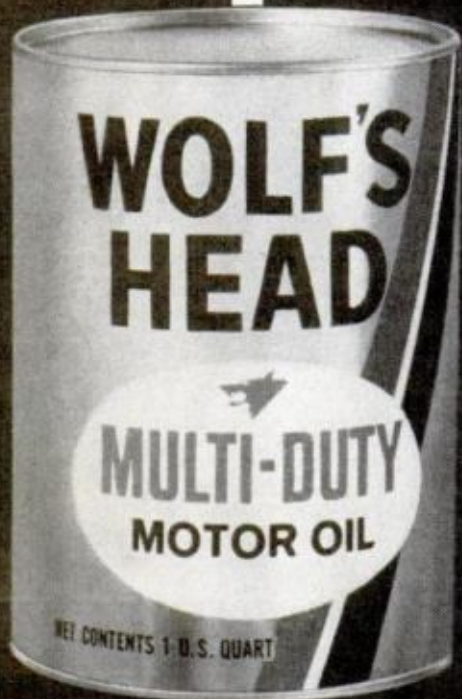

the uncommon motor oil
Exceeds car makers'
warranty requirements.

LETTERS

(Continued from page 6)

mark is No. 6—or the fifth cylinder in the firing order. No. 1 and No. 5 are 180° apart.
LEEDS, ALA. H. M. STEIN

It's a confusing situation, with confusion further compounded by our use of "No 5" when we should have said "fifth." In a V8, firing order goes this way: Nos. 1, 8, 4, 3, 6, 5, 7, 2. Thus, the fifth cylinder to fire is No. 6!

Longer years in Germany?

Was ist los? We know the Germans for an industrious people. But how much time does Heinz Schneider (*Suits of Shining Armor from the Junkyard*, page 129, June PM) devote to his selling job when he spends 10,000 hours a year making armor (50 suits at 200 hours per suit)?

In the United States there are only about 8760 hours in a year.

HINCKLEY, OHIO

JOHN ASCHERL

There's a very complicated formula that explains it all, but it has to be worked out by a guy who can't add.

Good old days department

Those good old days are back again. Both John Bentley (*So What Else Is New?* page 114, Feb. PM) and Don B. Harding (*Letters*, page 6, May PM) made a small error in their comments on the Cadillac.

The 1912 Cadillac was the first with an electric starter. The first Cadillac V8 was in the 1915 model—also the first left-hand drive.

Have been a reader of PM for over 50 years; hope you will be on the job 50 years from now.

BREMERTON, WASH.

O. J. POTTER

I worked as a mechanic from 1916 to 1940 and serviced quite a few Cadillacs. I owned six old ones, the first, a 1913 model.

The 1911 Cadillac had a compressed-air starter that didn't always work. The 1911, '13 and '14 all had copper-water-jacket-covered cylinders and were right-hand drives.

The 1913 was the first to have an electric starter.

The 1914 was different from the 1913. It had a two-speed rear end. The Model 53 (1915) was the first eight-cylinder, not the 1914.

I've had good, modern cars since 1930, but my heart is still with some of those old gals.

BRIDGEPORT, VT.

ROBERT R. MUNDY

POPULAR MECHANICS

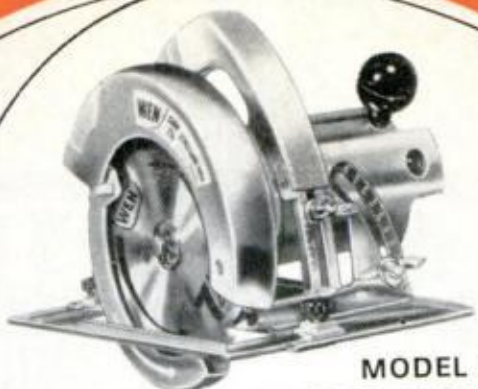

MODEL 1000
CONTRACTOR'S 7¼" CIRCULAR SAW

- POWERFUL 12 AMP. 2½ H.P. MOTOR
- POSITIVE DEPTH & ANGLE ADJUSTMENT
- CHROMED ALLOY COMBINATION BLADE

MFG. SUGG. LIST—\$59.95

MODEL 450K4
6-PC SOLDERING GUN KIT

- EXCLUSIVE WEN SINGLE POST DESIGN
- HEAT RANGE: 25 TO 450 WATTS
- SPACE-AGE TIP MATERIALS

MFG. SUGG. LIST—\$15.95



WEN Special Tool Values For August

See your nearest WEN dealer for special savings on these two "tools of the month." Compare quality — unique features — special prices.

All WEN tools and soldering guns are 100% American made to insure highest quality standards.

For the best in industrially listed home workshop tools and soldering guns—Just Say Wen.



WEN PRODUCTS, INC.

5808 NORTHWEST HIGHWAY, CHICAGO, ILLINOIS 60631 312/763/6060

the **BEAT** of the **BRASS**
HERB ALPERT & THE TIJUANA BRASS
D103255

DEAN MARTIN'S GREATEST HITS! VOL 1
Everybody Loves Somebody
D103313

THE ASSOCIATION GREATEST HITS
D103478

The Best Of **JIM REEVES**
HE'LL HAVE TO GO FOUR WALLS
D100267

Falliciano! Light My Fire
D103324

HAIR
E503292

ARETHA FRANKLIN
Aretha in Paris
D103452

THE SOUND OF MUSIC
E500046

ENGELBERT HUMPERDINCK
Engelbert
D110084

CREAM Goodbye
D110105

PORTER WAGONER DOLLY PARTON
Just The Two of Us
D102227

THE BEST OF **FLOYD CRAMER**
Last Date On the Rebound
D103455

RCA STEREO

Invites You to Accept



Take Any **3** STEREO 8 TAPE CARTRIDGES
for only **\$4.95**

Worth up to \$27.85 at regular Club price
You merely agree to buy as few as four more cartridges within a year from hundreds to be offered.

D110229

THE BEST OF **LYNN ANDERSON**
D103453

FRANK SINATRA Cycles
RAIN IN MY HEART
D103475

NANCY SINATRA LEE HAZLEWOOD NANCY & LEE
D103257

THE BEST OF **AL HIRT**
ANA • GOTTEN CANDY
D100100

ED AMES A Time For Living, A Time For Hope
D103522

SAMMY DAVIS JR. I Gotta Be Me
D103508

HENRY MANCINI A Warm Shade Of Love
D103498

RUBINSTEIN ORMANDY Philadelphia Orch.
CHOPIN Piano Concerto No. 2
D103471

STRAUSS WALTZES LONDON PHILHARMONIC
D110045

VAN CLIBURN ORMANDY Grieg Concerto Liszt Concerto No. 1
Philadelphia Orchestra
D103472

A POPS SERENADE Boston Pops Arthur Fiedler
D103542

VANILLA FUDGE ILLUSIONS OF MY CHILDHOOD
D100045

THE VOGUES III
D103534

JEFFERSON AIRPLANE Bless Its Pointed Little Head
D103493

TWIN PACKS Each has double the music—but counts as one selection!

23 STARS THE BEST OF TODAY'S HITS
G503423

MUSIC FOR A Sunday Drive
Living Strings & Voices
E100043

BOOTS RANDOLPH Sweet Talk The Yakin' Sax Man
E102878

TWIN-PACK PHASE 4 STAGE & SCREEN SPECTACULAR
ALL-TIME FAVORITES
G503499

TWIN-PACK Living Strings Doctor Chicago
E101989

THE BEST OF **GLENN MILLER** Vols. 1 & 2
G500953

TRADEMARKS USED IN THIS ADVT., ARE PROPERTY OF THE VARIOUS TRADEMARK OWNERS. THANKS TO RCA CORPORATION



D103346



D110107



D110047



D110076

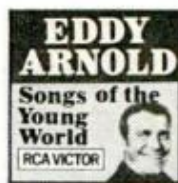

D103517



D103480

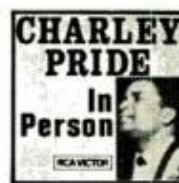

D103445

8 TAPE CLUB

this Spectacular Get-Acquainted Offer

Enjoy Fabulous Savings From the World's FIRST Stereo 8 Tape Cartridge Club!

NOW! Enjoy top Stereo 8 hits by top stars ...at top savings! Choose from renowned labels: RCA, A&M, London, Mercury, Warner Bros.-7 Arts, Reprise, Atlantic — in every music category. Look at these exclusive benefits:

• **Save NOW!** Choose THREE tapes for only \$4.95 (worth up to \$27.85 at suggested manufacturer's list price... optional with dealers). After trial membership, get one tape of equal value FREE for every two you buy at regular Club price (usually \$6.95). That's a 33 1/3% average saving!

• **Keep posted!** Monthly SOUND TRACK brings news of over 100 Stereo 8 releases, featuring a Selection of the Month. If you want this tape, do nothing — it will be shipped automatically. If you

want other tapes, or no tapes, indicate your choice on the Card provided, and return it by the date specified.

• **All tapes guaranteed!** Club's own Warranty unconditionally guarantees all tapes against defects for 1 full year.

• **Charge them!** Pay only after you receive tapes and are enjoying them!

• **Send no money!** Choose 3 of 51 hits shown here; we'll bill you \$4.95 plus small shipping charge later. You can cancel membership after accepting 4 more, or continue to enjoy savings of one-third for years to come, with no obligation to buy! Mail the coupon right NOW to: RCA Stereo 8 Tape Club, P.O. Box 26888, Lawrence, Ind. 46226



D103064



D103190

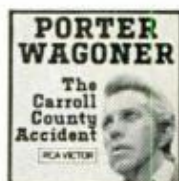

D103536



D110101

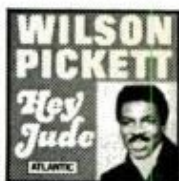

D110233

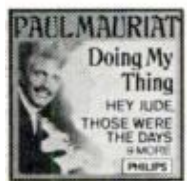

D110116



D103434



D110077



D103500



D103356



D110234

MAIL THIS COUPON TODAY!

Mail to: THE RCA STEREO 8 TAPE CLUB
P.O. BOX 26888, Lawrence, Indiana 46226

Yes, please accept my application for membership in The RCA Stereo 8 Tape Club, and send me the 3 cartridges I have selected for only \$4.95 plus small shipping-service charge. I understand I need buy as few as four more cartridges within a year to fulfill my trial membership, after which I will get one tape of equivalent value FREE for every two I buy at regular Club prices.

MAIL ME THESE THREE CARTRIDGES

--	--	--

I am most interested in the following type of music: (check one only)

- Popular (Instrumental/Vocal Moods)
 Country & Western Today's Sound (Rock/Soul/Folk)

Mr. Mrs. Miss (Please Print)

Address

City & State Zip

One Membership Per Family.
APO/FPO addresses write for special offer.

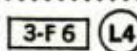

ON-THE-GO

CAMPING

BY WADE MITCHELL

RENTAL DEALERS AND CAMPGROUND CHAIN OFFER PACKAGED PLANS.

Now you can rent a coach for vacation and get certified overnight camping-site reservations along your route in one deal. That's the new plan being offered through cooperation of Kampgrounds of America and Open Road International. The usual worry of newcomers is "Where can we park each night?" This new combination, a U-Drive rental coach and KOA reservations, assures beginners of a smooth, worry-free vacation.

TRAILER COACH ONLY 8 FEET LONG? Yes, Little Fella, a new eight-foot travel trailer (10 feet overall, including tongue) sleeps four to six persons, has a compact kitchen range, sink, 75-pound icebox, 22-gallon water tank, 12-volt lights and a chemical toilet in a separate compartment. A swing-out back section handles *extra* sleepers. Little Fella runs away with *most-compact-design* of the year. Aimed at owners of 4x4 vehicles, the unit has rear *skid-plates* to prevent damage while being towed through rough country. (McNamee Coach Corp., 2501 Rosemead Blvd., South El Monte, Calif.)

NEW LOW-PROFILE, ROOFTOP AIRCONDITIONER for RVs cuts down on wind drag and eliminates the usual unsightly and unwanted limb-snagger on the coach roof. It's the Polar-Pal Mach I from Coleman Co. The sleek, aerodynamically designed cover is of supertough ABS plastic. Total weight for unit: 125 pounds. It'll fit into any standard 14 by 14-inch roof opening (vent-sized), and project only 1½ inches into headspace of coach. The Mach I delivers 10,000 B.T.U.s, and cold airflow is easily directed or divided to four directions. Filtered continuously, Polar-Pal has built-in thermostat and E-Z Start Kit (reduces motor-starting effort).

DON'T TILT THAT HITCH-BALL! Draw-Tite, world's largest hitchmaker, warns that a tilt angle of more than 5° off perpendicular will destroy the hitch-ball's ability to pivot freely as the designers intended. The firm claims that "most hitch-ball failures are induced by failure to maintain the ball in a perpendicular position." Company experts also warned users not to *over-tighten* the hitch-ball nut. Using an extra-long wrench handle stresses hitch-ball shank critically. It may snap under sudden strain that it normally could absorb. Draw-Tite's advice: Use maximum handle length of 12 inches when tightening shank-nut.

OWN A SELF-CONTAINED COACH? Then you know that storage of flexible sewer hose is a problem. One way to cut down on space needed is to use the new vinyl-coated *compressible* sewer hose constructed of high-tensile spring steel. A 10-foot length squeezes down to 20 inches. It's so new you may have to write the maker about availability: Aircor Chemical & Plastics, Room 327, 150 East 42nd St., New York, N.Y. 10017.

FUEL CELLS FOR CAMPING VEHICLES? Safety experts would like to see the aircraft technique utilized on recreational vehicles. In that system, urethane-foam inserts are stuffed inside gasoline tanks. The "foam cells" absorb gasoline without robbing much interior volume. In event of fuel-tank rupture, the foam cells will not allow sudden loss of fuel—thus averting an explosion.

WINNEBAGO INDUSTRIES SELLS \$2 MILLION IN RVs IN ONE WEEK! That is probably a new all-time record. One week in mid-May the company's total sales of Winnebago motor homes, travel trailers, pickup coaches and tent-trailers reached that astonishing volume. One company official described it as "exciting—but somewhat frightening!" Despite the fact that Winnebago has an almost completely automated factory (in Forest City, Iowa), its chief problem ahead will be greater production. ★★ ★

TOM McCAHILL SAYS:

"A Smart Guy Can Really Clean Up in the Appliance Repair Field"

Those electrical gadgets you have around your house are great on convenience, but if you're like a lot of do-it-tomorrow Johnnies, you don't know where to turn when one breaks down. So you call one of the busy Appliance Servicemen in your town, then drink instant until that fancy automatic coffee pot is perking again.

People have so many electrical appliances, it's no wonder Appliance Repairmen are busy as a bear in a bee nest. Count yours. The average home has at least a dozen, maybe more. There are better than 800 million appliances in the U.S.A. right now. No wonder the man who knows how to service appliances properly is pocketing \$4 to \$6 an hour, for as many hours as he cares to work!

If you're interested in making money (and who isn't), here is a job field crying for good men. And it's no sweat at all to get the training you need. Thousands have trained with National Radio Institute's Appliance Division. NRI has a great, low-cost home-study program covering every type of Appliance repair in detail. You study at home, in your spare time, learning through actual practice how to fix home, commercial and farm appliances. And not just the little stuff, either. Besides cantankerous coffee pots and toasters, you can learn how to repair air conditioners, refrigeration equipment, even small gasoline engines—and that's where the big bucks are, in the major appliances you'll fix.

NRI is one of the biggest and best schools in the home-study field. They have this Appliance Servicing course worked out to the most nit-picking detail. Yet, you'll be amazed at how little it costs. You even get a 25-buck professional Appliance Tester without extra cost. With your Tester and a few basic tools you probably have in your house, you'll be doing repair work long before you finish the course. And you can work anywhere—

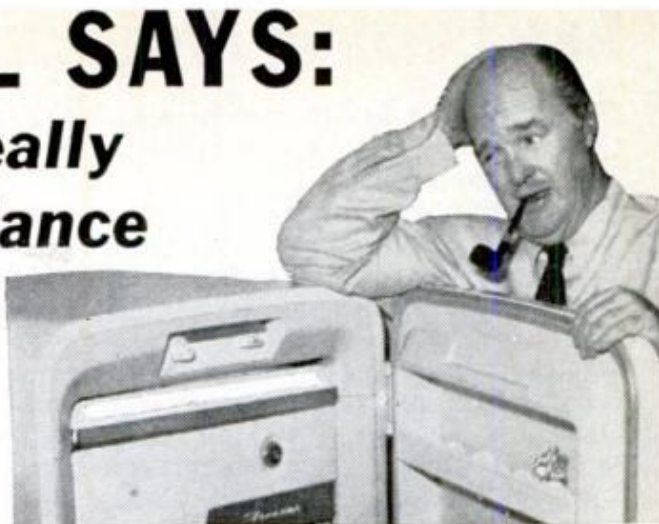

in a corner of your basement, in the garage, even on the kitchen table.

NRI has been in home-study education since 1914. Experienced, well-trained instructors on the staff of 150 in Washington, D. C., give you all the personal attention a man could ask. You don't even need a high school diploma. Take it from Uncle Tom . . . this can be one of the easiest and most rewarding businesses you'll find today, either full-time or in spare hours. As a matter of fact, knowing how to service Electrical Appliances can pay off even if you don't want to strike out on your own. That coffee pot on the fritz probably needed ten minutes of a repairman's time to be perking again like the mudpots in Yellowstone Park. You can do it yourself with the training NRI gives you. And if you're thinking about Social Security years, this is a great way to pick up some money and keep yourself busy at the same time.

There's nothing to lose except a postage stamp and the energy it takes to walk to the mailbox. What you'll get for your efforts is the newest NRI Appliance Servicing catalog. Nobody is going to ring your doorbell to pressure you into signing an enrollment blank. NRI doesn't employ salesmen.

Do yourself a favor and mail the coupon now—before you turn this page.

Tom McCahill

NATIONAL RADIO INSTITUTE, APPLIANCE DIVISION
3939 Wisconsin Avenue, Washington, D. C. 20016

APPROVED UNDER NEW GI BILL
If you served since January 31, 1955
or are in service, check GI line below.

600-089

OK—I want to see for myself. Send me the free book on Professional Appliance Servicing. No salesman will call.

Name Age.....

Address

City State Zip Code

Accredited Member National Home Study Council.

Check for facts on new GI Bill.

New Building Products You Should Know About

DEEP SHADOW LINES and random tabs of this new asphalt shingle produce the rugged look of a wood-shake roof. Known as Barrett Traditional Shake asphalt shingles, the material comes in three colors: Cedartone (simulating weathered wood); Slatetone (a rich gray-blue), and Woodtone (a blend of brown and tan granules). All are available from the Celotex Corp., 1500 N. Dale Mabry, Tampa, Fla. 33607. These shingles also can be found at building supply dealers and retail lumberyards. The shakes make an attractive roof finish for vacation homes and other shelters.

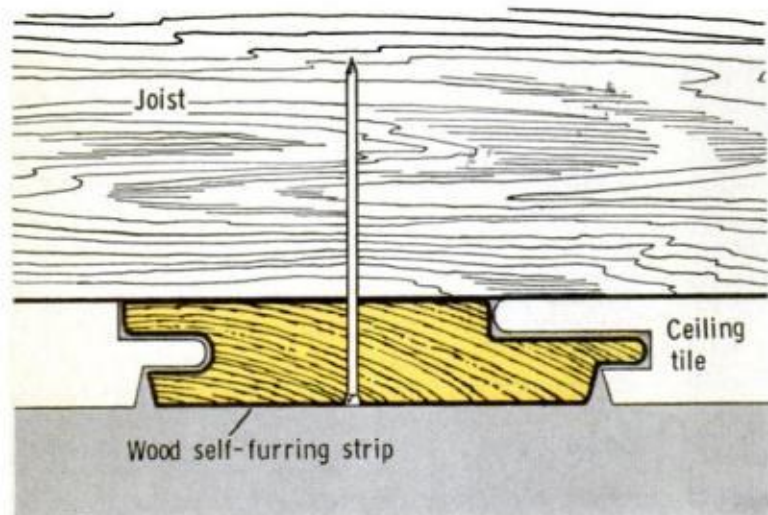

WHETHER YOU'RE PLANNING to cover an old ceiling or finish a new one in a room addition, the Beam-Line Ceiling Tile System is ready to do the job neatly and quickly. It uses walnut-grained beams that double as furring strips while holding 16x16-in. tongue-and groove Insulite ceiling tiles in place. Beveled edges of the tiles slip into the grooved "exposed" beams as shown in the sketch at left. These 1/2x2-in. beams are available in standard 8-ft. lengths. The system is manufactured by Boise Cascade Building Products, Box 7727, Boise, Idaho.

DISTINCTIVE ACCENT PANELS for interior walls are provided by Marlite's new Textured Carved Leaf planks. These planks can be alternated with other Marlite textured planks to gain an interesting wall effect. They are satin-finished in light and dark tones, 1/4 x 16 x 96 in. in size, and can be installed with adhesive or concealed metal clips over furring strips or old wall coverings. Only an occasional damp wiping is required to clean these plastic-finished hardboard planks made by Marlite Paneling, Dover, Ohio 44622 and available at building supply and lumberyards.



A FAST-HARDENING COMPOUND that's designed to fill the V-joint between wallboard panels, as well as to bed the tape joint, is Star-Smooth, which has been developed especially for use with the manufacturer's line of wallboard products. This material becomes hard in 1 1/2 hours to produce a firm bond with minimum shrinkage, after which a first and second finishing coat will complete the job. In addition, Star-Smooth Compound can be applied as the first coat on nail or screwheads, corner beads or casing beads, and also can be used when you're taping inside corners. It's made by National Gypsum Co., Buffalo, N.Y. 14225.

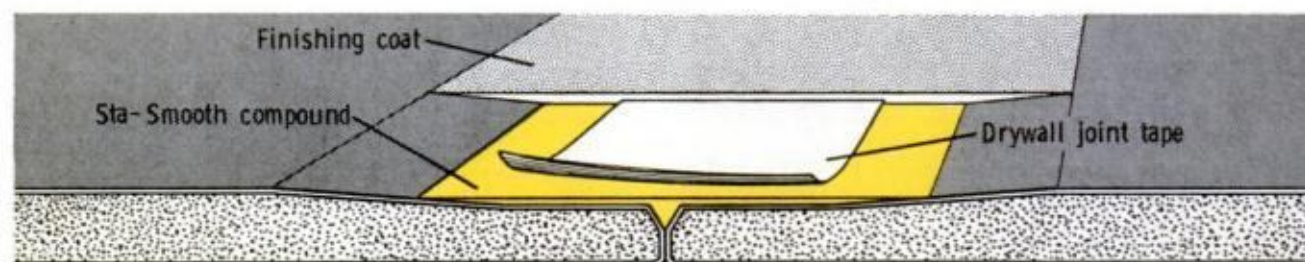

NEW RUBBER STAMP BUSINESS PAYS BEGINNERS UP TO \$16.50 AN HR.

**START AT HOME
IN SPARE TIME**
with Table Top Machine!

We Help Finance You
... at less than bank rates!

The multi-million dollar Rubber Stamp business—once controlled by a few big companies—is now being taken over by small operators—one in each community throughout the United States. Men and Women who have this inexpensive machine can turn out huge quantities of Rubber Stamps with special wording that buyers once were forced to buy from big cities. Material costing only 27c makes a stamp that sells for \$2.75. The machine that does the work is simple and easy to operate and it turns out as many as six Rubber Stamps at a time, each with different wording such as names, addresses, notices, stock numbers, prices and other "copy" needed by offices, factories and individuals. Working full capacity, it can earn as much as \$33.00 an hour for the operator! Now you can get into the big-pay business yourself, with your own home as headquarters. You don't need experience. We supply everything, including complete instructions and eight ways to get business coming in fast. **We even help finance your start.** Start making up to \$16.50 an hour from the very beginning. Cash in on the profitable Rubber Stamp business in your community, right away. We'll mail full particulars FREE and no salesman will call. Be first in your locality. Rush coupon today or send your name on postcard to:

RUBBER STAMP DIV., Dept. R-2-JS
1512 JARVIS AVENUE • CHICAGO, ILL. 60626



RUBBER STAMP DIV.
1512 Jarvis Ave., Dept. R-2-JS
Chicago, Illinois 60626

FREE!

Please rush full particulars about your financing plan and the little machine that can get me started in the profitable Rubber Stamp business at home in spare time. Everything you send me is FREE and no salesman will call.

NAME _____
ADDRESS _____
CITY _____ STATE _____ Zip Code _____

TOM McCAHILL SAYS:



"Buy ^{DIF} new
DIF.
It's got to be the
best way to clean
work-dirty hands
I've ever tried."

CONTAINS LANOLIN TO KEEP
HANDS FROM CHAPPING,
KEEP SKIN SMOOTH.

WATERLESS
OR POWDER



Marketed by Harrell International, Inc., Westport, Conn. 06880

APPROVED VETERANS

**These 3 BIG DRAFTING
KITS GIVEN TO YOU!**
... when you train at home
with NASD for a
**HIGH PAY JOB
IN DRAFTING!**

Take your pick of 1000s big salary jobs open to Draftsmen. U. S. Labor Dept. reports "42% more Draftsmen needed in next 10 years—not enough applicants to fill jobs available now." Easy home-study plan has helped 100s beginners toward \$\$\$\$\$, security, prestige as Draftsmen—many with only grade school training. Others report good earnings drafting part time while still learning. Why not you?

RUSH COUPON FOR FREE KIT!
Mail coupon for FREE "DRAFTING CAREER KIT," Sample Lesson, Drafting Aptitude Test including new 5-Way Drafting Instrument & 20-Page Book, "Your Future in Drafting"—ALL FREE. No salesman will call. G.I. approved. Write today.

NORTH AMERICAN SCHOOL OF DRAFTING, Dept. 4178,
4500 Campus Drive, Newport, California 92660
Rush "Drafting Career Kit," including Book, Sample Lesson, Aptitude Test & Drafting Instrument—All Free!

NAME _____ AGE _____
ADDRESS _____
CITY _____ STATE _____ ZIP _____

ACCOUNTING

Accounting (U.S.A.)
 Accounting (Canadian)
 Accounting for Business
 Programmers
 Accounting for
 Management Decisions
 Auditing
 Business Law (U.S.A.)
 Cost Accounting
 C.P.A. Review (U.S.A.)
 General Accounting
 Income Tax (U.S.A.)
 Industrial Accounting
 Junior Accounting
 Office Accounting
 Practical Accounting
 Public Accounting
 Small Business
 Accounting (U.S.A.)
 Starting & Managing a
 Small Bookkeeping
 Service (U.S.A.)

**ARCHITECTURE
AND BUILDING**

Architectural Drawing &
 Designing
 Architecture
 Building Contractor
 Building Estimator
 Building Inspector
 Building Maintenance
 Carpenter-Building
 Carpentry & Millwork
 Fundamentals of
 Urban Planning
 House Planning & Interior
 Design
 Mason
 Painting Contractor
 Reading Arch. Blueprints
 Review in Arch. Design &
 Practice
 Review of Mech. Systems
 in Buildings

ART

Amateur Artist
 Commercial Art
 Commercial Cartooning
 Illustrating with Options:
 —Magazine
 —Advertising Layout and
 Illustration
 Interior Decorating
 Oil Painting for Pleasure
 Show Card & Sign
 Production
 Show Card Writing
 Sign Painting & Designing
 Sketching & Painting

AUTOMOTIVE

Automatic Transmission
 Specialist
 Automobile Body
 Rebuilding & Refinishing
 Automobile Electrical
 Technician
 Automobile Engine Tune-Up
 Automobile Technician
 Automotive Mechanic
 Diesel-Gas Motor Vehicle
 Engines

BUSINESS

Advertising
 Business Administration
 Business Practice (Cond.)
 Canadian Business Course
 Condensed Marketing
 Direct Mail & Mail
 Order Advertising
 Industrial Psychology
 Inventory Control
 Magazine & Newspaper
 Advertising
 Managing a Retail Business
 Managing a Small Store
 Marketing Management
 Marketing Research
 Modern Executive
 Management
 Office Automation
 Office Management
 Production Management
 Purchasing Agent
 Retail & Local Advertising
 Retail Business
 Management
 Retail Merchandising
 Retail Selling
 Systems and Procedures
 Analysis

BUSINESS: SALES

Creative Salesmanship
 Real Estate Salesmanship
 Salesmanship
 Sales Management

**BUSINESS:
SUPERVISION**

Basic Supervision
 Industrial Foremanship
 Industrial Supervision
 Management,
 Salesmanship & Sales
 Modern Woman as a
 Supervisor
 Personality Development
 Personnel-Labor
 Relations (U.S.A.)
 Supervision

CHEMICAL

Chemical Engineering
 Analytical Chemistry
 Chemical Engineering Unit
 Operations
 Chemical Laboratory Tech'n
 Chemical Process Operator
 Elements of Nuclear Energy
 General Chemistry
 Instrumental Laboratory
 Analysis

CIVIL ENGINEERING

Civil Engineering
 Construction Engineering
 Technology
 Highway Engineering Tech.
 Principles of Surveying
 Reading Highway
 Blueprints
 Reading Struct. Blueprints
 Sanitary Engineering Tech.
 Sewage Plant Operator
 Structural Engineering
 Technology
 Surveying and Mapping
 Water Works Operator

COLLEGE COURSES

American History
 Calculus
 Economics

**CAST
 YOUR
 BALLOT
 FOR
 A
 SUCCESSFUL
 FUTURE!**

266 ICS

Special rates to members of U. S. Armed Forces

Approved for veterans under new G. I. Bill.



ICS is the oldest, largest school of its kind. Over 250 courses for men and women. High school, business, secretarial, interior decorating, engineering. One for **you**. Direct, job-related. Bedrock facts and theory plus practical

application. You learn from experts. Diploma to graduates.

Clip and mail the coupon **now**. You'll receive, absolutely **FREE**, 3 valuable booklets that have helped thousands. But don't delay. Cast **your** "ballot" today!



COMPUTERS

COBOL Programming
 Fortran Programming for Engineers
 Programming for Digital Computers
 Programming the IBM 1401 Computer
 Programming the IBM SYSTEM/360 Computer, Introduction

DRAFTING

Aircraft Drafting
 Architectural Drafting
 Design Drafting
 Drafting Technology
 Electrical Drafting
 Electrical Engineering Drafting
 Electronic Drafting
 Introductory Mechanical Drafting
 Mechanical Drafting
 Pressure-Vessel and Tank Print Reading
 Sheet Metal Layout for Air Conditioning
 Structural Drafting

ELECTRICAL

Electrical Engineering (Power option or Electronics option)
 Electrical Appliance Servicing
 Electrical Appliance Servicing with Equipment Training
 Electrical Contractor
 Electrical Engineering Tech.
 Electrical Home Maintenance
 Electrical Home Maintenance with Equipment Training
 Electrical Instrument Tech.
 Electrical Motor Repairman
 Industrial Electrical Tech.
 Power Line Design and Construction
 Power Plant Operator (Hydro or Steam Option)

ELECTRICAL (cont'd)

Practical Electrician
 Practical Electrician with Equipment Training
 Practical Lineman
 Reading Electrical Blueprints

ENGINEERING (Refresher Courses for Graduate Engineers)

Chemical
 Civil
 Electrical
 Industrial
 Mechanical
 Sanitary
 Structural

ENGLISH AND WRITING

Better Business Writing
 English for Spanish (U.S.A.)
 Free Lance Writing for Fun & Profit
 Introductory Technical Writing
 Modern Letter Writing
 Practical English
 Short Story Writing

HIGH SCHOOL

High School Business
 High School (Canadian)
 High School General
 High School Mathematics
 High School Secretarial
 High School Vocational
 High School College—Preparatory—Arts
 High School College Prep.—English & Science
 Preparatory Course for High School Equivalency Test

MACHINE SHOP PRACTICE

Drill Operator
 Foundry Practice
 Industrial Metallurgy
 Lathe Operator
 Machine Shop Inspection
 Machine Shop Practice
 Metallurgical Engineering Technology
 Milling Machine Operator
 Multicraft Maintenance Mechanic
 Practical Millwrighting
 Reading Shop Prints
 Rigging
 Tool Engineering Tech'gy
 Tool Grinder
 Toolmaking
 Turret Lathe Operator
 Welding Engineering Technology
 Welding Processes

MATHEMATICS

Advanced Mathematics
 Mathematics and Mechanics for Engineering Tech'ns
 Mathematics and Physics for Engineering Tech'ns

MECHANICAL

Mechanical Engineering
 Aircraft & Power Plant Mechanic
 Hydraulic & Pneumatic Power
 Industrial Engineering
 Industrial Engineering Tech.
 Industrial Instrumentation
 Machine Design
 Quality Control
 Safety Engineering Tech'gy
 Tool Design
 Vibration Analysis & Control

PETROLEUM

Natural Gas Production & Transmission
 Oil Field Technology
 Petroleum Production
 Petroleum Production Engineering Technology
 Petroleum Refinery Operator
 Pipeline Engineering Tech.

PLASTICS

Design of Plastic Products
 Plastics Technician

PLUMBING, HEATING AIR CONDITIONING

Air Conditioning
 Air Conditioning Maintenance
 Domestic Heating with Oil & Gas
 Domestic Refrigeration Heating
 Heating & Air Conditioning with Drawing
 Industrial Air Conditioning
 Industrial Heating
 Pipe Fitting
 Plumbing
 Plumbing & Heating
 Plumbing & Heating Estimator
 Practical Plumbing
 Refrigeration
 Refrigeration & Air Conditioning

PULP AND PAPER

Paper Machine Operator
 Paper Making
 Pulp Making
 Pulp & Paper Engineering Technician

SECRETARIAL

Clerk-Typist
 Commercial
 Secretary, Engineering
 Secretary, Legal
 Secretary, Medical
 Secretary, Professional
 Shorthand
 Stenographic
 Typewriting

STEAM AND DIESEL POWER

Boiler Inspector
 Industrial Building Engineer
 Power Plant Engineering
 Stationary Diesel Engines
 Stationary Fireman
 Stationary Steam Engineering

TEXTILES

Carding
 Carding and Spinning
 Dyeing & Finishing
 Loom Fixing
 Spinning
 Textile Designing
 Textile Mill Supervision
 Textile Technology
 Warping and Weaving

TRAFFIC

Motor Traffic Management
 Railway Rate Clerk
 Traffic Management

TV-RADIO-ELECTRONICS

Color Television Principles & Servicing
 Electronic Instrumentation & Servo Fundamentals
 Electronics Technician
 First Class Radiotelephone License
 Fundamentals of Electronic Computers
 General Electronics
 General Electronics with Equipment Training
 Hi-Fi Stereo and Sound Systems Servicing
 Industrial Electronics Technician
 Numerical Control Electronics & Maintenance
 Practical Telephony
 Principles of Semiconductor-Transistor Circuits
 Radio & TV Servicing
 Radio & TV Servicing with Equipment Training
 Second Class Radiotelephone License
 Sound Systems Specialist
 Telephony, Electronics and Radio Communications
 TV Receiver Servicing & Repair

COURSES

Clip coupon — and take your first big step to real success! ICS, Scranton, Penna. 18515

In Hawaii: P. O. Box 418, Honolulu
 In Canada: Mail to Scranton, Penna. Further service handled through ICS Canadian, Ltd.
 In other countries: ICS World, Ltd.

**FREE! THE ICS SUCCESS KIT!**

Three valuable booklets sent to you free when you mark and mail the ICS coupon. No obligation.

1. A new, exciting booklet on the principles of success that lets you evaluate yourself and your future in an entirely different way!
2. Complete catalog outlining job opportunities and outlook in your field of interest.
3. Illustrated brochure which demonstrates the success-proved ICS method of spare-time study.

Accredited Member, National Home Study Council

**INTERNATIONAL CORRESPONDENCE SCHOOLS**

Dept. N7569G, Scranton, Penna. 18515

I'm interested in a program of independent study. Send me, without cost, your booklet on the principles of success, your illustrated brochure on the ICS method, and your catalog for _____ (Select from listing above)

Name _____ Age _____
 (Indicate Mr., Mrs., or Miss)

Address _____

City _____ State _____ Zip code _____

Occupation _____ Working hours _____ A.M. to _____ P.M.

Employed by _____

Special ICS booklets for women Convenient Payment Plans

Weed seeds can kill mosquitoes. That report comes from the University of California at Riverside, where scientists discovered that mosquito larvae became stuck to certain weed seeds that had been dropped into lab bug hatcheries. The larvae invariably died, hopelessly glued to seeds that emit a mucilage upon contact with water. The scientists estimate that a pound of seed from a weed called shepherd's purse could eliminate 25 million larvae in a typical marshy breeding ground.

Earthquake toll in the United States from 1865 to 1966: over 1500 deaths and more than \$1.3 billion in property damage. Those facts are in a new publication, *Earthquake Investigation in the United States*, published by the National Earthquake Information Center of the Coast and Geodetic Survey. Most deaths for any state—935—occurred in California.

A small electric refrigerator shaped like a crash helmet has been developed by Soviet scientists for use in the operating room. It's designed to cool a patient's brain so that operations on the heart and other vital organs can be carried out with maximum safety. When the brain is cool, its oxygen requirements drop. The Russians claim their icy helmet can lower brain temperature to 72°F. in less than three minutes.

Oceanographers with healthy bank accounts might be interested in a new 50-volume reprint of a study of the sea originally published in England in the 19th century. Based on findings made during a three-and-a-half-year circumnavigation of the globe by H.M.S. *Challenger*, the study was produced by 76 scholars from many different countries. The reprint, which contains 29,500 pages and hundreds of illustrations, is priced at \$3850 by its New York publisher.

Holography is the key to a new information storage and retrieval system invented by a Connecticut scientist. He says that 1000 standard-sized book pages can be stored in a crystal only two inches square and a quarter-inch thick. Intense light from a laser is split, creating two beams, one of which is the information carrier. The two beams intersect at the storage "cube," which is composed of alkali halide crystals with colored centers. Certain wavelengths in the laser beams cause the color centers to change state, forming holograms. To obtain projected images of individual pages, all the librarian has to do is hit the cube with a laser beam.

One of the world's "most prolific" oil reserves may lie beneath the continental shelf between Taiwan and Japan. That's the opinion of U.S. geologists and oceanographers, and scientists from Nationalist China, Korea and Japan. The experts recently jointly investigated the area, recommending further detailed seismic surveys. The region is said to be equal in size to the combined areas of Texas, Oklahoma and New Mexico.

Any fresh meat will spoil if you don't refrigerate it. That's common knowledge. But it ain't necessarily so, according to researchers at Ohio State University, Columbus. As proof they can exhibit a chunk of fresh, juicy beef in a sealed test tube. Yet the meat is five years old. It contains no preservatives and is stored at room temperature. The secret is that the beef is sterile. It was taken from a freshly slaughtered animal under almost surgically sterile conditions and packed into a sterile test tube containing nitrogen. The inert gas replaced air in the tube, thus keeping out bacteria. The experiment is part of an investigation by OSU scientists into why and how meat deteriorates. Ten pounds of similar meat, slaughtered at about the same time, was sold to a leading research institute for experimental purposes. Cost: \$300 a pound.

★★★

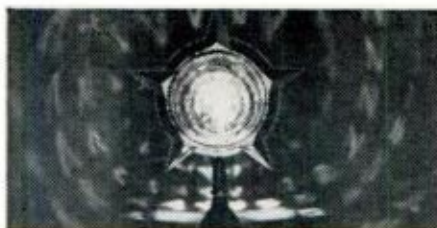

ROTATING MULTI-COLORED LIGHT

Dazzling colors stream endlessly from constantly rotating light. Faceted, transparent globe has louvered drum inside with red, green, blue & yellow stars. Bulb heat rotates drum which projects flickering star points on walls, ceilings, etc. while individual globe facets present constantly changing array of brilliant colors. 9 3/4" star—approx. 12" high on bell-shaped base. Surprisingly light. Easily placed on table, TV, fireplace—even top of Christmas tree or other display.

Stock No. 71,000H \$6.00 Ppd.

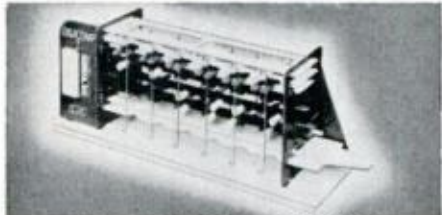

MODEL DIGITAL COMPUTER

Solve problems, teach logic, play games with miniature version of giant electronic brains! Adds, subtracts, multiplies, shifts, complements, carries, memorizes, counts, compares, sequences. Colored plastic parts easily assembled. 12" x 3 1/2" x 4 3/4". Incl. step-by-step assembly diagrams, 32-page instruction book covering operation, computer language (binary system) programming, problems and 15 experiments.

Stock No. 70,683H \$5.98 Ppd.



"FISH" WITH A MAGNET

Now go treasure hunting on the bottom! Great idea! Fascinating fun and sometimes tremendously profitable! Tie a line to our 5-lb. Magnet—drop it overboard in bay, river, lake or ocean. Troll it along the bottom—your "treasure" haul can be outboard motors, anchors, fishing tackle, all kinds of metal valuables. 5-lb. Magnet is war surplus—Alnico V Type—Gov't cost \$50. Lifts over 150 lbs. on land—much greater weights under water.

Stock No. 70,571H... 5 lb. .. \$12.50 Ppd.

Stock No. 70,570H... 3 1/2 lb. .. \$8.75 Ppd.

Stock No. 60,572H... 7 1/2 lb. .. \$18.75 Ppd.

Stock No. 85,152H... 15 1/4 lb. .. \$33.50 FOB



AMER. MADE OPAQUE PROJECTOR

Projects illustrations up to 3" x 3 1/2"—enlarges them to 35" x 30" if screen is 6 1/2 ft. from projector, larger if screen farther away. No film or negatives needed. Projects charts, diagrams, color, black-and-white. 115 V A.C. Operates on 60 W bulb, not incl. 12" x 8" x 4 1/2". 1 lb. 2 ozs. Plastic case.

Stock No. 70,199H \$7.95 Ppd.



SUPER 6" SPACE CONQUEROR

Share the wonders of space exploration. Features aluminized & overcoated 6" f/8 ground and polished pyrex parabolic mirror accurate to 1/4 wave. 48 F.L. 6X achromatic finder scope. 4 eyepieces—48X Kellner, 1/2" 96X & 1/4" 192X Ramsdens, Barlow to double or triple power—rack & pinion focusing mount. 4 7/8" aluminum tube. Electric clock drive w/manual slow-motion control. Setting circles. Heavy-duty equatorial mount. Pedestal base. Compares to \$295—\$350 models.

Stock No. 85,086H \$199.50 FOB

Stock No. 85,050H ... 3" ... \$29.95 Ppd.

4 1/4" REFLECTOR TELESCOPE

Stock No. 85,105H \$84.50 FOB



KEEP PACE WITH THE SPACE AGE!

AMAZING BARGAINS

for Fun • Study • Profit

from

EDMUND SCIENTIFIC CO.

300 Edscorp Building
Barrington, N. J. 08007



DIAGNOSE MECHANICAL TROUBLE

Professional Stethoscope. Designed for use by physicians, this super-sensitive Stethoscope is ideally suited for detecting faults in machines and engines, and in fluid, air and gas leakage. Dozens of uses in auto repair shops, labs and for hobby and educational applications.

Stock No. 50,270H \$7.50 Ppd.

BARGAIN PRICE STETHOSCOPE

Stock No. 50,223H \$3.25 Ppd.

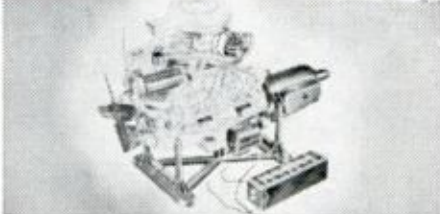

PLASTIC MODEL V-8 ENGINE

Hours of fun! Get thrill of building your own easily assembled engine from over 350 parts. Then push starter and watch it run. Crankshaft revolves, pistons move, valves open and close in sequence with spark plugs. Does everything but burn oil. 1/4 scale molded in 4 colors. Same motor used in many auto-mechanic courses. Excellent, easy-to-understand "tech manual".

Stock No. 70,448H \$12.95 Ppd.



INSTANT ELECTRONIC PROJECTS!

Build 56 electronic marvels in minutes—that actually work! Simply match symbols of amazing new solid state building blocks with those in easy-to-follow diagrams. Presto—instant radios, organs, alarms, etc. No soldering, wiring, tools. Magnetic connectors hold see-thru blocks containing proper components in place. Safe. Easy. New fun-way to learn electronics. Requires 9V transistor battery (not incl.).

No. 71,178H \$33.50 Ppd.

No. 71,177H ... 20 PROJECT .. \$12.00 Ppd.

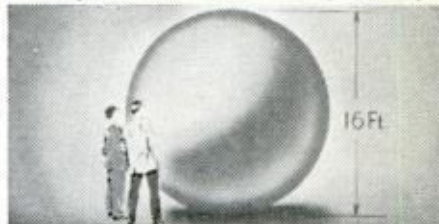

GIANT WEATHER BALLOONS

"Balls of fun" for kids, traffic stoppers for stores, terrific for amateur meteorologists. Create a neighborhood sensation. Great backyard fun. Exciting beach attraction. Amateur meteorologists use to measure cloud heights, wind speed and temp. Heavy duty neoprene. Inflate with vacuum cleaner or auto air hose; or locally available helium for high rise.

Stock No. 60,568H... 8' \$2.00 Ppd.

Stock No. 60,632H... 16' \$7.00 Ppd.



WOODEN SOLID PUZZLES

Here's a fascinating assortment of 12 different puzzles to provide hours of pleasure and stimulate ability to think and reason. Animals and geometric forms. Take them apart and reassemble them. Lots of fun for the whole family—young and old. Will test skill, patience and ability to solve problems. Order yours now.

Stock No. 70,205H \$4.00 Ppd.

MONEY-BACK GUARANTEE

Order by Stock No.—Send Check or M.O.

GIANT FREE CATALOG

148 Pages! More than 4,000

UNUSUAL BARGAINS



Completely new Catalog. Packed with huge selection of telescopes, microscopes, binoculars, magnets, magnifiers, prisms, photo components, parts, kits, accessories—many hard-to-get surplus bargains. 100's of charts, illustrations. For hobbyists, experimenters, schools, industry. Mail coupon for FREE Catalog "H".

EDMUND SCIENTIFIC CO., 300 Edscorp Building, Barrington, N. J. 08007.

NAME _____
ADDRESS _____
CITY _____
STATE _____ ZIP _____

100% more mileage on this new Atlas tire.

Tests proved it.

Our new Atlas Plycron 2 plus 2* belted bias tire was tested against complete sets of two-ply tires from production for most 1969 cars. Results showed that you'll get twice the mileage with this new Atlas tire that has tomorrow's lower, wider look.

Polyester-Fiberglass Construction.

We put fiberglass belts on a rugged Vicron polyester cord body. This unique "tread-saver" construction helps reduce scuff and squirm. One reason the tread lasts twice as long—gives you 100% more mileage.

For extra safety.

The combination of fiberglass belts and blended chlorobutyl liner provides increased resistance to cuts and punctures. See your Atlas dealer soon. And get equipped for 100% more mileage.

**ATLAS
PLYCRON
2 plus 2**

Atlas Tires • Batteries • Accessories
Sold at over 50,000 leading service stations.

Trademarks "Atlas," "Plycron," "Vicron," Reg. U.S. Pat. Off.
*Trademark © 1969 Atlas Supply Co.

POLYESTER
CORD BODY

FIBERGLASS
BELTS

2plus2

ATLAS® PL

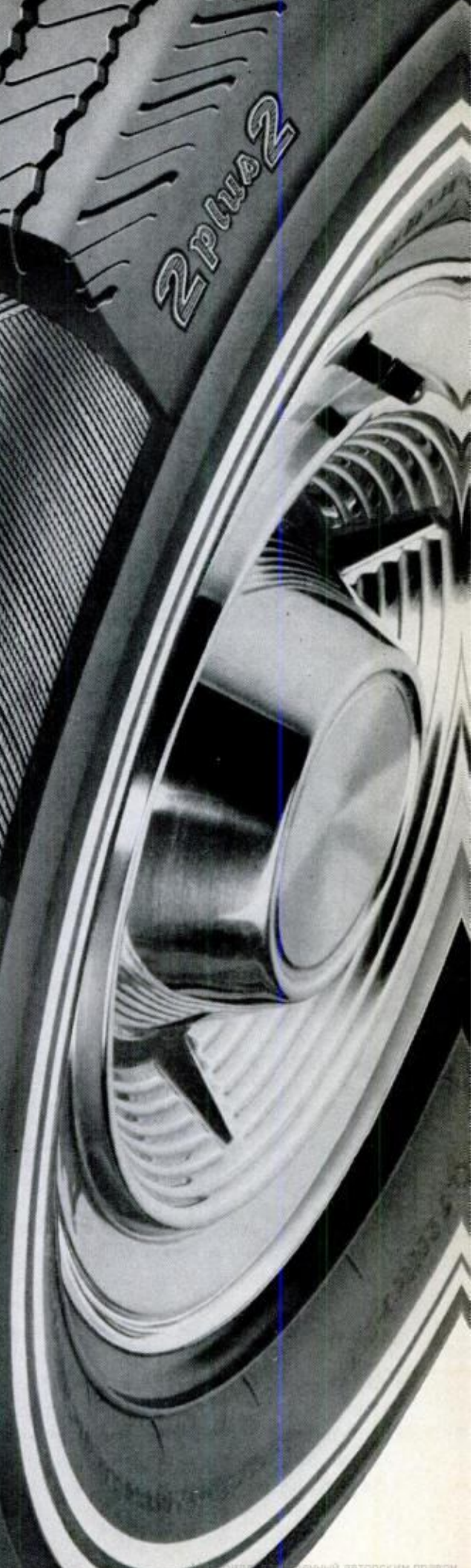

Drivin' with Dan

What will the U.S. Grand Prix pay this year? How do you feel about so-called auto stabilizers? What will the Ferrari be like in the new Can-Am Series? Dan Gurney answers these and other automotive questions



MOMENTS BEFORE THE START of the Indianapolis 500, PM's editor, Bob Crossley, listens in on a last-minute communication between Dan Gurney and Eagle team members Wayne Leary (left) and Hardy Allen (center). The Popular Mechanics sticker on car rode with Dan to second-place finish at an average speed of 155.337 mph, several mph faster than last year's winning speed in the Memorial Day race

Q. I understand you had to remove Popular Mechanics stickers that were to appear on your No. 48 car and Denny Hulme's No. 42 at Indy. How come?—Bob Greenblatt, Irvington, N.J.

A. We had to peel them off at the behest of the United States Auto Club which has a requirement that no one can have a sticker on a car unless they are a member of USAC. The logotypes went back on the cars the morning

of the 500, however, after PM officially joined the club.

Q. I think the stock-block engine is the only way to go at Indy, and I was bragging to a friend that your two consecutive seconds are a record at the speedway. Isn't that true?—Herb Perry, Tacoma, Wash.

A. I appreciate the support, Herb, but there are three other gentlemen who achieved two consecutive seconds at Indy: Bill Holland in 1947-48, Rex Mays in 1940-41, and Harry Hartz in 1922-23. There are also those who have done even better than back-to-back seconds, such as Wilbur Shaw's 1937, '39 and '40 victories and Bill Vukovich's consecutive wins in 1953-54. We were still operating at a deficit of more than 100 hp this year, however, and if the stock-block engine is to be competitive at Indy, the limit must be raised from 320 to 366-cu.-in. displacement.

Q. Does the United States Grand Prix pay \$50,000 total purse, or \$50,000 to win this year?—Bruce Barnett, Grand Rapids, Mich.

A. It is \$50,000 to the winner, by far the largest Grand Prix payoff in history. The total purse announced is \$206,000, ranking the Glen ahead of all races except Indy from a payoff standpoint.

Q. Do you like Trans-Am racing? I do, but some of my friends kid me about it being "minor league."—Dale Phillips, Chicago, Ill.

A. I like Trans-Am racing very much, both as a spectator and competitor. Although it does not have the big purses that some other types of racing award, it commands a lot of attention from Detroit and probably is as highly regarded by some manufacturers as
(Please turn to page 26)



I'd like to give this to my fellow men... while I am still able to help!

I was young once, as you may be—today I am older. Not too old to enjoy the fruits of my work, but older in the sense of being wiser. And once I was poor, desperately poor. Today almost any man can stretch his income to make ends meet. Today, there are few who hunger for bread and shelter. But in my youth I knew the pinch of poverty; the emptiness of hunger; the cold stare of the creditor who would not take excuses for money. Today, all that is past. And behind my city house, my

summer home, my Cadillacs, my winter-long vacations and my sense of independence—behind all the wealth of cash and deep inner satisfaction that I enjoy—there is one simple secret. It is this secret that I would like to impart to you. If you are satisfied with a humdrum life of service to another master, turn this page now—read no more. If you are interested in a fuller life, free from bosses, free from worries, free from fears, read further. This message may be meant for you.

By Victor B. Mason

I am printing my message in a magazine. It may come to the attention of thousands of eyes. But of all those thousands, only a few will have the vision to understand. Many may read; but of a thousand only you may have the intuition, the sensitivity, to understand that what I am writing may be intended for you—may be the tide that shapes your destiny, which, taken at the crest, carries you to levels of independence beyond the dreams of avarice.

Don't misunderstand me. There is no mysticism in this. I am not speaking of occult things, of innumerable laws of nature that will sweep you to success without effort on your part. That sort of talk is *rubbish!* And anyone who tries to tell you that you can *think* your way to riches without effort is a false friend. I am too much of a realist for that. And I hope you are.

I hope you are the kind of man—if you have read this far—who knows that anything worthwhile has to be *earned!* I hope you have learned that there is no reward without effort. If you have learned this, then you may be ready to take the next step in the development of your karma—you may be ready to learn and use the secret I have to impart.

I Have All The Money I Need

In my own life I have gone beyond the need of money. I have it. I have gone beyond the need of gain. I have two businesses that pay me an income well above any amount I have need for. And, in addition, I have the satisfaction—the deep satisfaction—of knowing that I have put more than three hundred other men in businesses of their own. Since I have no need for money, the greatest satisfaction I get from life is sharing my secret of personal independence with others—seeing them achieve the same heights of happiness that have come into my own life.

Please don't misunderstand this statement. I am not a philanthropist. I believe that charity is something that no proud man will accept. I have never seen a man who was worth his salt who would accept something for nothing. I have never met a highly successful man whom the world respected who did not sacrifice something to

gain his position. And, unless you are willing to make at least half the effort, I'm not interested in giving you a "leg up" to the achievement of your goal. Frankly, I'm going to charge you something for the secret I give you. Not a lot—but enough to make me believe that you are a little above the fellows who merely "wish" for success and are not willing to sacrifice something to get it.

A Fascinating and Peculiar Business

I have a business that is peculiar—one of my businesses. The unusual thing about it is that it is needed in every little community throughout this country. But it is a business that will never be invaded by the "big fellows." It has to be handled on a local basis. No giant octopus can ever gobble up the whole thing. No big combine is ever going to destroy it. It is essentially a "one man" business that can be operated without outside help. It is a business that is good summer and winter. It is a business that is growing each year. And, it is a business that can be started on an investment so small that it is within the reach of anyone who has a television set. But it has nothing to do with television.

This business has another peculiarity. It can be started at home in spare time. No risk to present job. No risk to present income. And no need to let anyone else know you are "on your own." It can be run as a spare time business for extra money. Or, as it grows to the point where it is paying more than your present salary, it can be expanded into a full time business—overnight. It can give you a sense of personal independence that will free you forever from the fear of lay-off, loss of job, depressions, or economic reverses.

Are You Mechanically Inclined?

While the operation of this business is partly automatic, it won't run itself. If you are to use it as a stepping stone to independence, you must be able to work with your hands, use such tools as hammer and screw driver, and enjoy getting into a pair of blue jeans and rolling up your sleeves. But two hours a day of manual work will keep your "factory" running 24 hours turning out a product that has a steady and

ready sale in every community. A half dollar spent for raw materials can bring you six dollars in cash—six times a day.

In this message I'm not going to try to tell you the entire story. There is not enough space on this page. And, I am not going to ask you to spend a penny now to learn the secret. I'll send you all the information, free. If you are interested in becoming independent, in becoming your own boss, in knowing the sweet fruits of success as I know them, send me your name. That's all. Just your name. I won't ask you for a penny. I'll send you all the information about one of the most fascinating businesses you can imagine. With these facts, you will make your own investigation. You will check up on conditions in your neighborhood. You will weigh and analyze the whole proposition. Then, and then only, if you decide to take the next step, I'll allow you to invest \$15.00. And even then, if you decide that your fifteen dollars has been badly invested I'll return it to you. Don't hesitate to send your name. I have no salesmen. I will merely write you a long letter and send you complete facts about the business I have found to be so successful. After that, you make the decisions.

Does Happiness Hang on Your Decision?

Don't put this off. It may be a coincidence that you are reading these words right now. Or, it may be a matter that is more deeply connected with your destiny than either of us can say. There is only one thing certain: If you have read this far you are interested in the kind of independence I enjoy. And if that is true, then you must take the next step. No coupon on this advertisement. If you don't think enough of your future happiness and prosperity to write your name on a postcard and mail it to me, forget the whole thing. But if you think there is a destiny that shapes men's lives, send your name now. What I send you may convince you of the truth of this proverb. And what I send you will not cost a penny, now or at any other time.

VICTOR B. MASON
1512 Jarvis Ave., Suite M-2-J5
CHICAGO, ILLINOIS 60626

Here's why Winnebago sells more pickup covers than any other company in the world.

Selection: Dozens of models to fit most any pickup.

Strength: Exclusive Winnebago Thermo-Panel[®] construction combines insulation with strength and light weight.

Comfort: Fully styrofoam insulated and lined with pre-finished plywood.

Safety: Safety glass windows to comply with all federal safety regulations.

Price: From less than \$200 to \$700.

Service: Over 170 assembler-dealers from coast to coast and Canada.

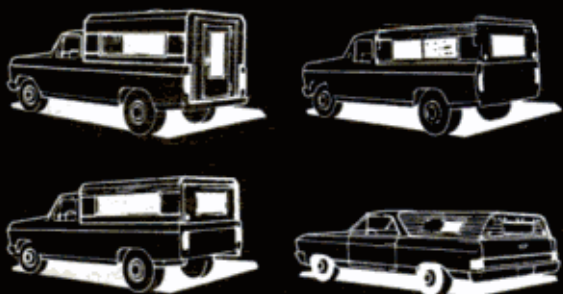

WINNEBAGO[®]

Designed from the inside out

Send for a free catalog and the name of your nearest dealer!

Thermo-Panel Div. Box 152 P8
Forest City, Iowa

NAME _____

ADDRESS _____

CITY _____

STATE _____ ZIP _____

DRIVIN' WITH DAN

(Continued from page 24)

any competition. I think you will see an increasing number of top drivers and teams competing in Trans-Am.

Q. Have you had a chance to test any of the so-called auto stabilizers that have appeared recently? They consist of a weight suspended in a rectangular box that mounts in the automobile trunk. I believe a couple of sash weights would be as effective. What do you think?—Howard Weaver, Circleville, Ohio.

A. No, I haven't tried any of these devices. I only know that for any action there is an opposite and equal reaction. Also, you don't seem to get something for nothing these days. I have a feeling that all that monkey-motion is a waste of time.

Q. I can appreciate the fact that you have to run where the money is, but can't you find time for just a couple of Grand Prix races this year—especially the American? And what kind of car might you be in?—L.O. Broderick, Boston, Mass.

A. I would certainly love to do that, and first of all with our Eagle. Although we have continued development of our V12 to the point that it looks competitive with anything in Formula 1 right now, I doubt that it would be possible to field our own car at Watkins Glen this year. I am seriously considering driving in the American Grand Prix for another team, but at this point I'm not sure which one it might be.

Q. What do they call the Ferrari that is supposed to run in the Can-Am series this year? And what will it be like?—Jerry Overbrook, Milwaukee, Wis.

A. It probably will be a slightly modified version of the car that showed up at Las Vegas last year. They call it the Ferrari 612. It was powered by a four-valved V12, with 380-cu.-in. displacement and an estimated 600+ hp. It also carried a mounted wing at the rear, and probably will be seen with Chris Amon driving it in at least a few of this year's Can-Am events.

Q. What is a Can-Am race, and what other kind of cars besides your McLeagle are used in this race?—David Nash, Eau Galli, Fla.

A. A Can-Am race is one of a group of races

(Please turn to page 28)

**Skoal® Tobacco isn't for smoking.
It isn't lit, puffed or inhaled. It sure beats smoking.**



Skoal is good, honest tobacco. With a cooling touch of wintergreen. Just a pinch between gum and cheek gives you everything you want from tobacco—without chewing. It sure beats smoking!



Skoal's partners:

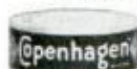

Copenhagen®
"straight"



Happy Days®
Raspberry Tobacco

For information on how to use Skoal, please write: Dept. PM
United States Tobacco Company, 630 Fifth Ave., New York, N.Y. 10020



"I Earn Two Incomes Now"

Says **JOHN BENNIE, Pittsburgh, Pennsylvania**

"Thanks to your wonderful training, I have been able to earn \$20 to \$25 extra each and every week doing little locksmith jobs at home and after work at my regular job. This is the best trade a man can take up."

Be a LOCKSMITH

Train at HOME—Earn While You Learn. Add 50%-100% to YOUR INCOME with easy spare time earnings. Cash in on the nation-wide shortage—trained locksmiths in great demand! Quickly step into a big pay opportunity job or start a high-profit shop of your own.

Earn Extra Money RIGHT AWAY! All Master Locksmiths Special Tools, Equipment and Supplies Furnished FREE for use with course.

Age, education, minor physical handicaps don't matter in this growing trade. You can quickly qualify as a skilled locksmith. It's like a fascinating hobby. Study at home as little as one hour a week. Gain practical experience through complete well-illustrated lessons. Do real jobs on car locks, house locks, padlocks and safe locks, under the guidance of experts. FREE Illustrated Book, write now.

LOCKSMITHING INSTITUTE,

(Div. Tech. Home Study Schools)

Dept. 1110-089 • Little Falls, New Jersey 07424

306
pieces of professional equipment
FREE
for use with course.

Professional Equipment includes
**LOCKS—PICKS—PARTS—KEYS
SPECIAL TOOLS & SUPPLIES**
all FREE for use with course.

MAIL COUPON for FREE ILLUSTRATED BOOK

For a future as your own boss or in a high-pay job, write now for FREE Illustrated Book. Only school of its kind. Licensed by State of New Jersey. Approved for Veterans.

Accredited, Nat'l Home Study Council.

MAIL COUPON NOW

**LOCKSMITHING INSTITUTE, Dept. 1110-089
Little Falls, New Jersey 07424**

Please send FREE Illustrated Book—"Your Big Opportunities in Locksmithing," complete Equipment folder and sample lesson pages—FREE of all obligation—(no salesman will call).

Name _____
Address _____
City _____ State _____ Zip _____



Win a TOP PAY Career as **SURVEYOR & MAP MAKER**



PREPARE NOW AT HOME

in spare time for rewarding Career in Surveying & Mapping. Prestige! Excitement! Fun! Imagine yourself as part of Surveying Team—in on planning highways, bridges, dams, airfields, subdivisions, etc. Wonderful Career for men who prefer outdoor work ... ideal for those who like to work with hands.

We Give You This **BIG 68-Piece Kit**

GOVERNMENT SEES HUGE SHORTAGE!

U.S. Bureau of Labor Statistics predicts shortage of 50,000 civil engineering technicians (Surveyors, etc.) by 1975.

...when you train at home with us for a **PRESTIGE SALARY CAREER IN SURVEYING & MAPPING**



You need no previous experience, no technical ability to qualify. We have trained 1000's of men to step into good paying outdoor-technician positions in every State. We guide you step by step ... give you equipment to use during training and throughout your Career as Professional Surveyor. Many North American students report good earnings part time while still learning. Thousands of men who are Surveyors today got their training through home-study. *You can too!*

Rush Coupon for FREE 'Surveying Career Kit'

... including 20-Page Book, Sample Lesson and Self-Scoring Surveying Aptitude Test. No cost or obligation, now or ever. No salesman will call. Rush coupon today.



NORTH AMERICAN SCHOOL OF SURVEYING & MAPPING Dept. 4178
4500 Campus Drive • Newport, Calif. 92660

Rush "SURVEYING CAREER KIT" including Book, Sample Lesson & Aptitude Test — **ALL FREE!**

Name _____ Age _____

Address _____

City _____ State _____ Zip _____

TO YOUR OWN DOCTOR'S PRESCRIPTION



EYEGASSES BY MAIL AT GREAT SAVINGS!

Mail orders filled by licensed optician from **\$9.95**

(Including single vision lenses, frame and case).

Doctor's prescription will be filled by a skilled, approved and licensed optician or your own prescription duplicated. Lenses are ground and manufactured to U.S. optical standards. Choose from complete catalog of men's, women's and children's glasses. Bifocals, trifocals, sunglasses or SAFETY HARDENED LENSES at low additional cost. We guarantee accuracy, perfect fit.

SEND FOR YOUR FREE CATALOG TODAY
PRISM OPTICAL INC.

Dept. PM-8 136 Liberty St., New York 6, N. Y.

DRIVIN' WITH DAN

(Continued from page 26)

officially named the Canadian-American Challenge Cup Series. This year there are eleven races on the calendar. They have FIA sanction so they are open to international racing drivers. The cars must have fenders, two seats, on-board starting, and they must run on pumped gas. Otherwise, the design is practically free. Any sort of piston engine is eligible for use. If you'd like to read more about Can-Am racing, take a look at my article, *Road Racing's Big Big League*, in the June PM (page 77). The article describes the cars and drivers in Can-Am competition and gives a calendar of races.

Q. Does USAC allow Formula I-type wings on championship cars?—Mike Bump, Broadalbin, N.Y.

A. USAC does not allow wings unless they are part of the body. They cannot be over 36 inches high. The wings have recently been banned in F-1 because they proved to be too unreliable. The suspension-mounted wings seem to break with regularity, causing very serious accidents.

Q. Why did Ford stop making the 352-cu.-in. V8? Is it a good engine to supe up?—Mike Stock, Sarnia, Canada.

A. I think the 352 was part of the same family of engines that spawned the 390, 406, and the 427 Ford. The 427 has been a great racing engine for Ford. The 352 was never very popular, and I think the speed equipment for it is scarce. The new 351 is a much better bet.

Q. I have a 289 Mustang and was passed and left on a slightly curvy road by what I thought was a Toyota. My friend said it was a BMW 2000. Do you think it was hopped up?—Curtis Benjamin, Asheville, N.C.

A. The BMW 2000 is a fine little German car and one of Europe's very best all-around performers. Chances are it was "stock." However, it probably cost quite a bit more than your Mustang, which could be modified fairly inexpensively, if that is any comfort to you. ★★★

If you have questions on racing, high-performance and everyday driving techniques, send them to "Drivin' with Dan," c/o Popular Mechanics, 575 Lexington Ave., New York, N.Y. 10022. Questions cannot be answered by individual letters. Questions on maintenance and repair should be addressed to the Auto Clinic (see page 66).

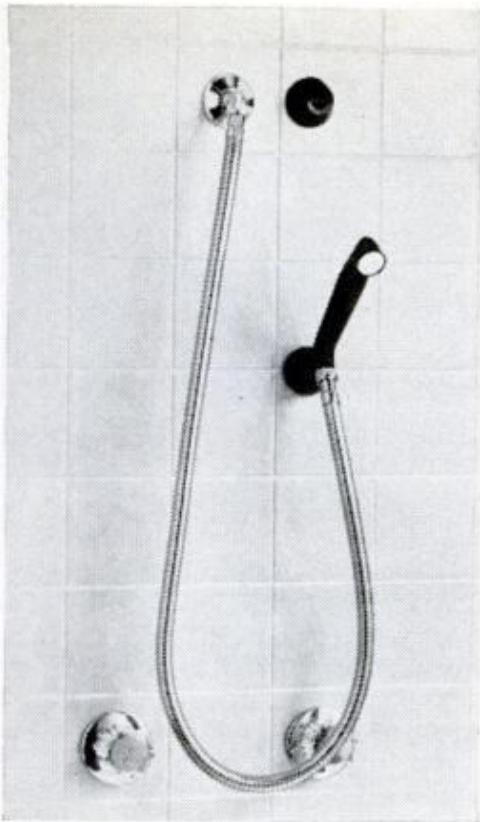

New...the do-it-yourself Kelta Mobile Shower.

(It's a tingling new experience in showering.)

- It's an overhead shower • A shoulder-height shower • A hand-held shower for shampooing
- An easy way to rinse the tub • Simply unscrew your present fixed shower head, screw Mobile Shower in.

Now you can take advantage of Kelta's advanced design and enjoy this new luxury in showering. The Mobile Shower offers 2 sockets for a choice of 6 spray angles. A chrome-plated flexible tube provides easy mobility and a beautifully styled handpiece lets you shower with either high density or fine needle spray.

Send check or MO. No COD's.
30-day money-back guarantee. \$11.95 ppd.

RICHARD FIFE, INC., Dept. PM-1
1140 Broadway, New York, N.Y. 10001

TUNE UP ELECTRONICALLY ANY CAR EVER MADE!



- ✓ COMPACT or LIMOUSINE ✓ 4, 6 or 8 CYLINDER
- ✓ DOMESTIC or FOREIGN ✓ 6 VOLT or 12 VOLT
- ✓ POSITIVE or NEGATIVE GROUND

With New Improved Model BT-162 DWELL TACHOMETER

ASSURE EASY STARTS, OPTIMUM PERFORMANCE and MAXIMUM GAS ECONOMY with MODEL BT-162
MADE ORIGINALLY FOR THE PROFESSIONAL AUTOMOTIVE TECHNICIAN, MODEL BT-162 WILL PAY FOR ITSELF MANY TIMES OVER FOR THE AUTOMOTIVE HOBBYIST AND EXPERIMENTER.

The Model BT-162 will perform the services specified below in addition to many other tasks too numerous to mention.

It is no longer necessary to file points to smoothness when using the Model BT-162. The instrument will automatically make allowance for any existing "pitting" or "wear." • Indicate the most effective point setting without removing the distributor cap. • Indicate the correct settings for external adjustment type distributors. • Car manufacturers' dwell angle recommendations are included in the manual provided with the Model BT-162. • To adjust for mathematically correct carburetor adjustment and thus insure maximum gas economy and quiet engine running, simply use

the Tachometer section of the Model BT-162. • To locate a "miss" you need only disconnect or "short" the spark plugs one at a time with the Model BT-162 switched to the Tachometer position. You will be able to instantly identify which particular plug (or frequently its wire lead) is responsible for the malfunction. • Cars with automatic transmissions function efficiently only if the fluid pressures are correctly maintained. Manufacturer's instructions always refer to RPM recommendations.

Operating manual includes manufacturer's dwell angle recommendations for all cars. The manual is yours to keep even if you decide to return the instrument. **\$29⁹⁵**

SEND NO MONEY WITH ORDER PAY POSTMAN NOTHING ON DELIVERY

Try it for 10 days before you buy. If completely satisfied remit \$29.95 plus postage and handling charge. (If you prefer you may use our Easy Payment Plan.) If not completely satisfied, return to us, no explanation necessary.

ACCURATE INSTRUMENT CO., INC. Dept. 676
2435 White Plains Road, Bronx, N. Y. 10487

Please rush me one Model BT-162. If satisfactory I agree to pay at the terms specified at left. If not satisfactory, I may return for cancellation of account.

Name _____
Address _____
City _____ Zone _____ State _____

Save money! Check here and enclose \$29.95 with coupon and we will pay all shipping and handling charges. You still retain privilege of returning after 10 day trial for full refund.

THE GREAT SHOE BUY! ENGLISH MADE OXFORDS

2 pairs for \$18.00* **\$9⁹⁹***

We guarantee them. All the things you look for in a great utility oxford are built into this top-quality English made shoe: The best British leathers. Full cushion insole and arch support. Oil-resistant Nitrile® soles and heels. Cirrus quarter linings. British built on American lasts to fit American feet. But most important, our guarantee that you'll agree that this is a great shoe buy. Or your money back. No questions.

**BUT ACT NOW.
THE SUPPLY IS LIMITED.**



Available in the following sizes: D or EE width 7, 7½, 8, 8½, 9, 9½, 10, 10½, 11, 12, 13, 14.
*Postpaid

H. I. Company, Room 503-D
22 Chestnut Place, Brookline, Mass. 02146

Please send me _____ pair(s) of your English oxfords in size(s) _____ width(s) _____. Enclosed you'll find my check (money order) for \$9.99 (\$18.00). If I'm not completely satisfied, I may return the shoes for a full refund.

Name _____
Address _____
City _____ State _____ Zip _____

Beefed-Up Tanker For Alaskan Oil



BIG HUNK OF SHIP—the *Manhattan's* forward section—leaves for Newport News, Va., yard. New ice-breaking bow (see drawing) was built in two parts

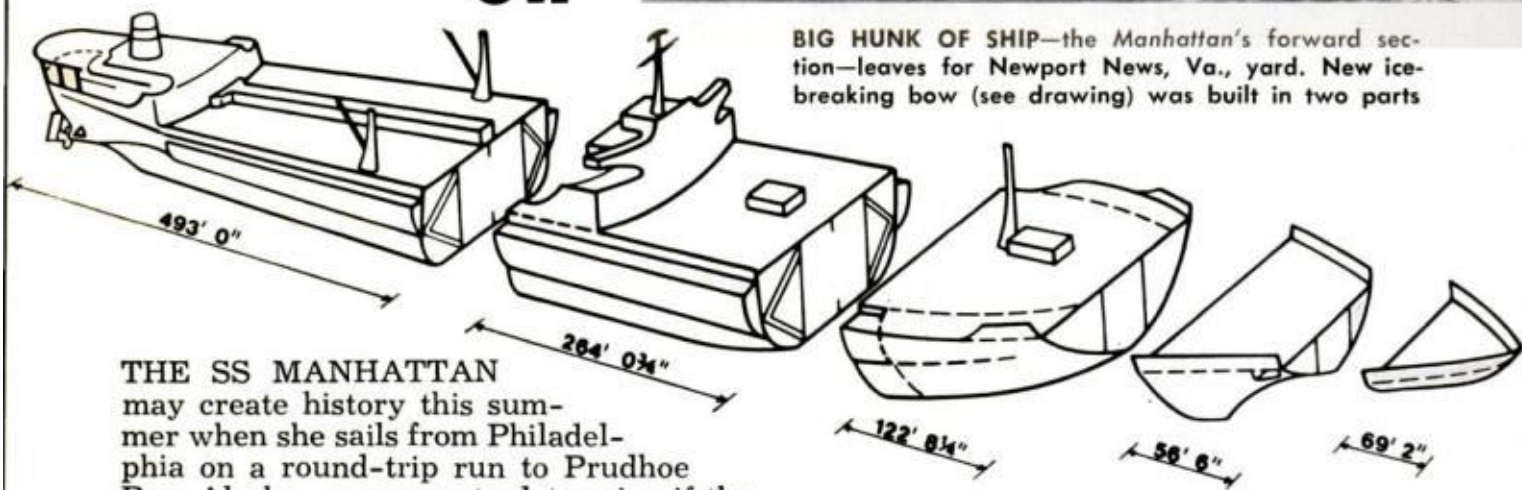

THE SS MANHATTAN may create history this summer when she sails from Philadelphia on a round-trip run to Prudhoe Bay, Alaska—a voyage to determine if the ice-clogged Northwest Passage can be used as a trade route. A successful trip will mean that oil can be shipped from the recently discovered reservoir at Prudhoe to the nation's East Coast. Humble Oil, main force behind the venture, chose the *Manhattan* (largest commercial vessel ever to fly the American flag) because her 115,000 tons were propelled by a huge powerplant. But the big tanker had to be beefed up for her icebreaking assignment. To save time, the ship was cut into four pieces at a Chester, Pa., yard. Two sections were towed to other yards in Alabama and Virginia, and a new icebreaking bow was built in Maine. The bow is designed to let the ship move up and over the ice until weight of the ship breaks through. A heavy "ice belt" was added to the sides of the ship and it was strengthened internally. When the pieces were re-assembled at Chester, it had grown from 940 to 1005 feet long, was 16 feet wider (now 148) and 9000 tons heavier. ★★



NEW... Ninth Edition of the

Small Engines Service Manual

Complete repair information on over 1,000 models of foreign and domestic small engines that power lawn mowers, tillers, go-karts, etc. ... 328 pages of factory "Know-How!"

9th Edition
4.95

Universally Accepted SMALL ENGINES SERVICE MANUAL

Outboard Motor Service Manual

Volume 1 Covers outboard motors built from 1955 to 1967! Every repair procedure from power head to prop. Over 35 different makes included. 239 pages.

4.95

Both Volumes \$8.50

Motorcycle Service Manual

Volume 1 208 pages devoted to over 75 models of 18 manufacturers. Includes nearly every 2-stroke "popper" thru 1967 and many '68 cycles.

2nd Edition
4.95

Both Volumes \$8.50

Outboard Motor Service Manual

Volume 2 Contains all pertinent service data on motors from 30 to 110 H.P. Same thorough model and year coverage as in Volume one. 208 pages.

4.95

Small Tractor Service Manual

Universal service manual for popular "compact" garden/utility tractors. Covers models ranging from 6 to 12½ HP.

2nd Edition
4.95

Motorcycle Service Manual

Volume 2 A total of 16 manufacturers represented. Complete instructions on everything... from brake adjustment to engine tear-down and reassembly. 232 big pages.

2nd Edition
4.95

Snowmobile Service Manual

Covers almost every machine built through 1968 and many '69 models! ... Engine section includes Hirth, JLO, Kohler, MAG, Sachs, Chrysler, OMC, Rotax, Lloyd, Yamaha and Wankel.

2nd Edition
4.95

Money Back Guarantee. Send check or money order and we pay postage.

TECHNICAL PUBLICATIONS DIV., Dept. PM-869
1014 Wyandotte, Kansas City, Mo. 64105

Carpenter's Secret Makes Ugly Nail Holes Vanish.

(Mr. W. C. B., Norristown, Pa.)

Repair ugly nail holes like professional carpenters do with PLASTIC WOOD. Handles like putty. Hardens like wood. Plane it. Sandpaper it. Varnish or paint it for perfect finish. Get PLASTIC WOOD in tube or can. Walnut, oak, mahogany or natural color. At all hardware outlets.

GENUINE
PLASTIC WOOD[®]

CELLULOSE FIBRE FILLER



MAKE UP TO \$12 AN HOUR AT HOME

Let Me Prove It To You FREE!

I'll show you how Plastic Sealing and Laminating at home, spare time, can give you as much as \$12 each hour you operate. Table-top machine sets up anywhere. Easy. Fun. No experience needed. We furnish everything. We'll even help finance you. No house-to-house selling. Orders come by mail. Write for facts FREE. No salesman will call.



WARNER ELECTRIC, 1512 Jarvis, Dept. L-2-JS, Chgo. Ill. 60626

SOME PEOPLE ARE GOING TO PAY \$200 TOO MUCH FOR THEIR AUTO AIR CONDITIONER THIS YEAR

Just be sure it's not you!

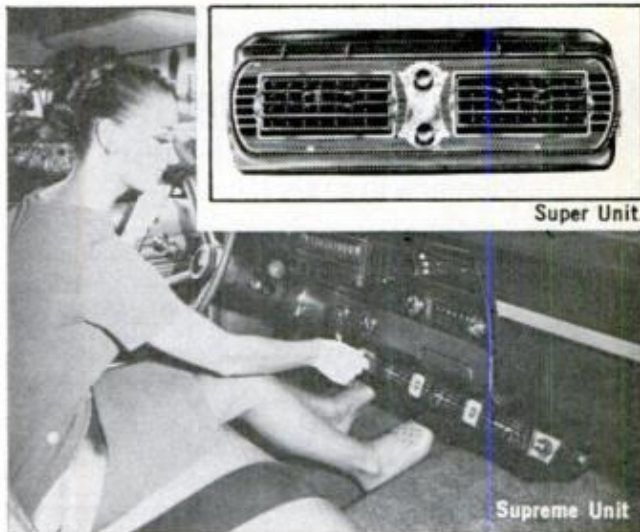

Comfy-Kit gives you all the cooling power you can use. It's trim, sleek appearance actually enhances the looks of your car's interior. You can easily install it yourself in a half day — and save up to \$200 or more doing it. That's like being paid up to \$50 an hour for your time — and you have the satisfaction of doing it yourself.

You get everything you need for installation — even the loan of special tools if you need them. You get an easy-to-follow instruction book and a 12-month/12,000 mile warranty.

So, let someone else pay those high prices for air conditioning. You'll get better — more efficient cooling — for a lot less money. Join the thousands of satisfied users of Comfy-Kit... America's only install-it-yourself auto air conditioner. Fill out... and send in your coupon today.

COMFY-KIT[®] P. O. Box 8585, Dept. PM 8
Dallas, Texas 75216

- Enclosed is \$133* for Standard Unit.
- Enclosed is \$148* for Super Unit.
- Enclosed is \$165* for Supreme Unit.
- Enclosed is \$30 deposit on a Super Standard Supreme Unit. I will pay the balance, plus C.O.D. charges when delivered.
- Enclosed is \$8.00 deposit for a set of four tools, which will be returned to me when I return the tools.
- I would like to see the instruction book before I order. I enclose \$1.00 for the instruction book only. I understand this will apply on any future Comfy-Kit order.

Name.....

Address.....

City..... State..... Zip.....

My car is a..... (year)..... (model)

Engine displacement..... Horsepower.....

Power Steering..... yes..... no.....

Floor shift..... Steering column shift.....

Smog pump..... yes..... no.....

*plus state sales tax where applicable

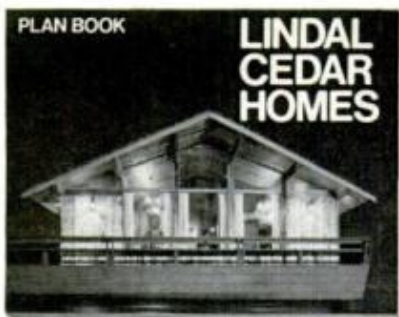

Your leisure home is in this book.

88 imaginative, family-tested designs in dramatic color!

This handsome 36-page book is chock-full of ideas for your vacation home. Full-color interiors and exteriors with easy-to-read floor plans. Lindal Cedar Homes are masterpieces of good taste, with the careful attention to detail and craftsmanship you'd expect of the world's largest cedar-home maker. Wide range of sizes and prices. Every home is pre-cut, ready for quick, easy assembly on your site. Shipping costs tailored to meet competition anywhere.

Lindal Cedar Homes, Dept. R 8, Tacoma, Wa. 98465
Enclosed is \$1 for my Lindal Cedar Homes Plan Book

Name _____

Address _____

City _____ State _____ Zip _____

ARROW

HEAVY DUTY T-50

STAPLE GUN



Uses 6 staple sizes from 1/4" to 9/16", including CEILTILE

\$12.95

A HANDY CHECKLIST OF HOUSEHOLD FASTENING USES

<ul style="list-style-type: none"> • Install ceiling tile • Apply insulation • Fasten weatherstripping • Reupholster chairs • Fasten fence wire to posts • Repair window screens • Secure antenna wiring • Tack down stair treads • Replace worn window shades • Attach vines to trellises • Tack carpet underpadding 	<ul style="list-style-type: none"> • Apply polyethylene vapor barriers • Make window boxes • Trim kitchen shelves • Line closets • Fasten burlap around tree trunks • Cover valances • Hang drapes • Affix wall decorations • Install plastic wall brick
--	---

SHOOT A STAPLE WHEREVER YOU'D DRIVE A NAIL!
FASTER . . . BETTER . . . CHEAPER . . .

At Hardware, Lumber and Building Supply, Stationery and other retail outlets

ARROW FASTENER COMPANY, INC., Saddle Brook, N. J. 07663

NEWS BRIEFS



Russian giant

Dwarfing a passenger car is Russia's 75-ton Belaz-549, a dump truck that's widely used in huge earth-moving and mining jobs.

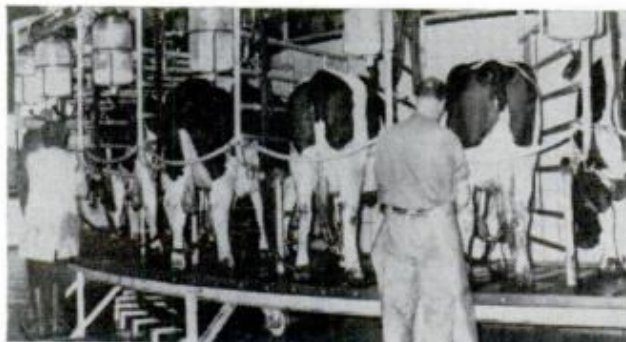

Cow carousel

While being milked by machine, cows in an Essen, Germany, dairy ride on a slow-moving carousel past workers on the "assembly line."



Camera for jumpers

This helmet-mounted 16-mm camera was specially designed by a British experimental group for use by free-falling parachutists.

The less you use, the more you like it.



An oil's reputation often depends on how little you use. Quaker State comes by this reputation naturally.

Refined from 100% Pure Pennsylvania Grade Crude Oil, it has a special lubricating power to protect engine parts longer. Prevents oxidation and break-

down, even in the fierce heat today's engines generate.

Others prefer Quaker State for a practical reason. It exceeds all car makers' warranty requirements.

But most drivers who have used Quaker State within the past 50 years prefer it for the first reason.

You use less.



Quaker State your car to keep it running young.

SPECIAL OFFER — ORDER TODAY

5 BIG FEATURES

- Gear Drive
- Automatic Chain Oiler
- Weighs Only 10 lbs. (including Bar and Chain)
- Instant Starting
- Industrial O & R Engine

FACTORY
ASSEMBLED
\$99⁹⁵

CALIF. — POWER



ONLY \$79⁹⁵
CHAIN SAW KIT
80% Factory Assembled.

In California Add 5% Tax
C.O.D. Requires 50% Deposit—Send Check or Money Order

and PRODUCTS, INC.

1940 H STREET FRESNO, CALIF. 93721

*our
biggest
catalog
ever!*



552
PAGES

FREE

1970 ALLIED CATALOG

Brand new! Fresh off the press! Allied's 1970 Catalog... 552 fascinating pages jam-packed with the very latest in Hi-Fi, Tape Recorders, CB, Kits, Radios, Tools, Electronic Parts, Books. Probably nowhere else on earth will you find such a complete selection of everything electronic... including Allied's own brand; fabulous values you'll find nowhere else in the world but Allied! Literally thousands of items... many of them never shown before. Allied's all new 1970 Catalog makes wonderful reading... and it's yours absolutely FREE! Tear off the card... mail it in today... and we'll rush you your own personal copy of the newest and most complete book of what's new in electronics... Allied's 1970 Catalog!

TEAR OUT AND MAIL CARD AT RIGHT... OR WRITE

ALLIED RADIO

**P.O. BOX 4398
CHICAGO, ILLINOIS 60680**

2 art lessons free



Do you like to sketch and draw?
Why not develop your talent at home
in your spare time through the Washington
School of Art?

Learn drawing, oil and watercolor
painting, advertising art, fashion illustration,
T.V. art, etc.

Get detailed corrections with overlays,
guidance from instructors who take a personal
interest in you.

WSA has opened new doors for over
130,000 people. Many hang their art with
pride at home. Others sell paintings and
earn money in commercial art.

Interested? Send name, address, and
age for two free art lessons plus free booklet
that describes the course.

**Washington School of Art, Studio 20012
Port Washington, N.Y. 11050**

**See what owners
say about the
Plymouth Valiant
(after 1,000,000
miles) and the
Jeep Wagoneer
(after 2,500,000
miles)**

In the Sept. PM

LEARN TO BE A SKILLED LOCKSMITH



Change combi-
nation of pin
tumbler cylinder
EARN \$1.50 in
15 MIN.

Owner loses
key; pick car
trunk—
EARN \$5.50 in
10 or 20 MIN.

**TYPICAL
JOBS EARN
YOU \$271
PART TIME
(in only 53
hours!)**



Install new knob door
lock—EARN \$15.00
in 30 MIN.

After-hour emergency
opening—EARN \$2.50
to \$5.50 in 20 MIN.

Hundreds have succeeded like these Belsaw Graduates:

R. W. Davis, St. Louis, Mo.: "I am doing a
wonderful business thanks to your course in
locksmithing. Last Saturday I took in \$110.00."

Pierson Crook, Los Angeles, Calif.: "I am
making \$200 a month extra income with the
Belsaw Locksmith Course. I would recom-
mend your course to anyone."

Big demand for skilled Locksmiths! Earn
big money spare time in your own home. Be
your own boss. No layoffs. Steady year 'round
income. Age and schooling are no handicap.

BELSAW INSTITUTE training...approved by
master locksmiths...helps you start faster
with easy picture lessons guided by your
own mail instructor.

Get thorough job training on all types of
locks. We supply tools, equipment and busi-
ness help: how to start, how to charge, how
to get jobs, how to earn while you learn and
build a lifetime cash-profit business. Ac-
credited Member National Home Study
Council. Approved by State Board of Educa-
tion. Approved for Veterans.



**This \$125
key machine
is yours to keep!**

MAIL COUPON—NO SALESMAN WILL CALL

**BELSAW INSTITUTE, 100P Field Bldg.
Kansas City, Mo. 64111**

Send FREE book, "Keys To Your Future!"



Name _____

Address _____

City _____ State _____ Zip _____

DETROIT

LISTENING POST

BY BILL KILPATRICK

CHRYSLER WILL DIVE into the so-called subcompact market in another year or so with two small cars, one a Plymouth, the other a Dodge. Cars will be all new, not rehashes of Chrysler's French-made Simca line. Brass has been dragging its feet re this particular market segment, even now won't confirm or deny the chatter around town. But look for two new cars, maybe as early as the '71 models.

FORD'S MAVERICK, reported alive and well in the marketplace, will definitely have a smaller running mate by '71. The new car, code-named Phoenix, has been given the green light, meaning production plans are underway. Many observers thought the car would be sidetracked—even abandoned—if Maverick proved something less than a smash sales success. But Ford management is said to have a "damn the torpedoes" attitude about the Phoenix, feeling it can succeed regardless of how well the Maverick sells. The new car—sized and priced right along with the VW Beetle and, say, the Toyota Corolla—will be a four-banger with a minimum option list.

Speaking of option lists, by the time this appears Ford might well be offering a V8 option for the Maverick, possibly a mildly reworked version of the 302. As mentioned here a month or so ago, the dearth of Maverick options has driven owners to specialty shops and service stations. But now Ford dealers are pressuring the factory to bring out an exclusive line of options and accessories for the car a waggish peer of mine has dubbed the Henry F.

OLDSMOBILE may pop with a new wiper/washer option for certain of its '70 models. GM has for some time been looking into the possibility of locating the controls somewhere other than the dash, the idea being that the present setup is awkward, requires leaning forward, fumbling in potential emergency situations (for example, splashed and blinding slush). Olds and Pontiac have been doing most of the active work, with Olds given the nod on a "let's see" basis. So, look for Lansing to offer a steering column-mounted arrangement, again possibly on the cars debuting next month.

AMERICAN MOTORS will drop the "Rambler" name from its line of cars this year, meaning the end of a link that goes back to the earliest days of American motoring. The first Rambler appeared shortly after the turn of the century, and the name has popped up on and off ever since. Decision to drop the name was made because AMC feels Rambler doesn't project the company's new image. Once again nostalgia bites the dust.

OLDER TEENAGERS won't like this a bit, but studies made and reported by a University of Michigan psychologist show them to be the most dangerous drivers on the road. Dr. Donald C. Pelz, of the University's Survey Research Center, reported that drivers aged 18 to 20 had more crashes and received more traffic citations than any other age group studied. Oddly enough, and contrary to popular opinion, Dr. Pelz said beginning male drivers—those aged 16-17—tend to drive cautiously.

"They were also driving less," Dr. Pelz pointed out, "but that fact alone did not account for their relatively low rate of infractions. Upon moving up to ages 18 to 20, they not only drove more but also became bolder and began incurring crashes and tickets in excess of what could be expected from their additional mileage."

Dr. Pelz said that young men who had been driving two years tend to be self-confident about their ability, but that their actual experience on the road was not sufficient to justify this confidence.

In the group studied by Dr. Pelz, he reported, "The onset of adulthood just before 21 was an intersection point of several motivational trends—hostility and thrill-seeking were still high, driving confidence was rising, and life changes and new responsibilities

were maximum. This turbulent combination may help explain the excessive hazard of the 18-to-20-year-old male."

SLOW-MOVING VEHICLE safety legislation is now in effect in 14 states, the laws requiring or permitting use of a special triangular stick-on emblem to help prevent rear-end collisions between cars and vehicles that travel at slow speeds on streets and highways. Recent studies have shown there are about 12 million such vehicles and in an average year they are involved in about 8000 rear-end smackups.

The new reflective emblem is 16 in. wide, 15 high, was designed to be mounted



TRIANGULAR SMV EMBLEM has yellow-orange fluorescent center that "glows" vividly in daylight (top) and border of red reflective sheeting that "bounces" light back to the oncoming cars at night (below)



on the rear of vehicles that operate at speeds of 25 mph or less—farm tractors, construction machinery, highway maintenance equipment and so on. Use of the triangle follows a general trend among highway safety engineers to use the shape as an overall symbol for danger ahead.

The SMV (for Slow Moving Vehicle) emblem is mandatory in Rhode Island, North Dakota, Idaho and Montana; required in Ohio, Oregon, Indiana, Michigan, Minnesota and Nebraska; permitted in California, Iowa, Oklahoma and Vermont.

In Michigan, studies by the State University showed the number of collisions between cars and farm machinery was reduced 32 percent in the first nine months after the legislation was enacted. ★★

If your car's burning oil, it's time to trade it in.

Or read this.

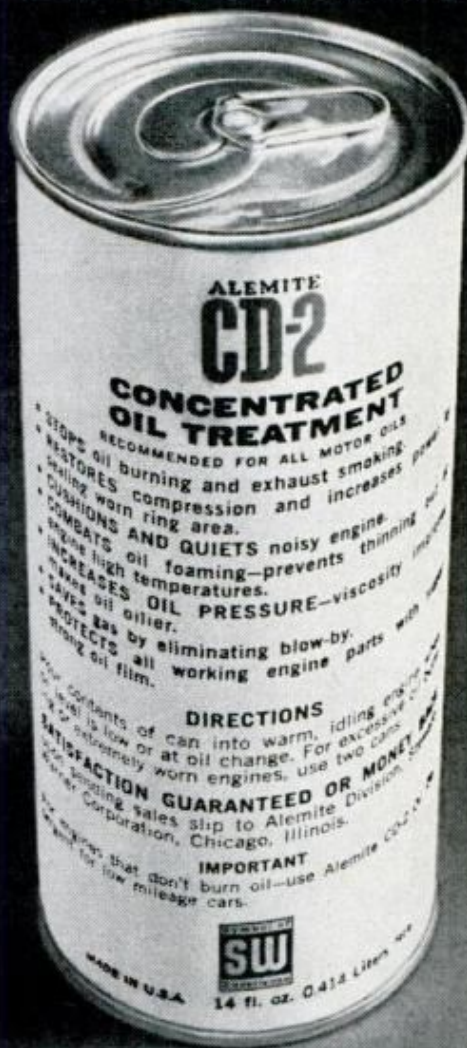

The back of a can of CD-2 tells how you might get another ten or twenty thousand miles out of a car that's burning oil and losing power. If you use what's inside.

The other CD-2. Don't get mixed up. There's a different CD-2 for low-mileage cars that don't burn oil. If we only made one kind, it couldn't do either job as well.

Two more great products by Stewart-Warner.



The bargain hunter

Disposable Water Purifier

Attaches
in
Seconds
Lasts
for
Four
Months



The only tried, proven, and accepted inexpensive throwaway water purifier. . . . no installation costs . . . no maintenance. Removes bad taste, odor, chlorine, etc. from water. Removes taste of steel or plastic tank storage. Can be used in home, camper, trailer, boat—attaches easily on all faucets. 100% guaranteed or money back. **ONLY \$3.95 ppd.**

USE THIS HANDY COUPON FOR ORDERING YOUR IMPERIAL WATER PURIFIER

Please send me _____ Imperial Water Purifiers. The cost of EACH water purifier is \$3.95. (California residents add 5% for tax). Enclosed is my check or money order in the amount of _____

Name _____

Address _____

City _____ State _____ Zone _____

MOUNTAIN FRESH WATER PURIFIER CO.

5403 W. Pico Boulevard
Los Angeles, California 90019

"Dealer and manufacturer inquiries attached to letterhead will receive our immediate attention. (213-938-2953)"



HOW MANY HANDY DANDYS DO YOU NEED?

Handy Dandys are plastic caps that snap onto pegboard and hold quarter-twist glass jars, such as used for baby food and which can usually be had FREE! Ideal for storing all kind of supplies, parts and small tools. Sample pack of caps only 10 for \$1. ** 36 for \$3.50 ** 72 for \$6.00 ** 144 for \$11.50. Postage prepaid in U.S.A. No C.O.D.'s. Wickliffe Industries, Inc., P.O. Box 286-PM-8, Wickliffe, Ohio 44092.

MOMENTOS of the infamous 3rd REICH. 10"x12"x1 1/4" Cast HEER Wall plaque. Bronze finish with wood grain frame. While they last \$6.00 Postpaid.



Our fully illustrated relief collectors CATALOG of . . . Helmets, Hats, Medals, Pins, Badges, Books, Photos, Posters, Manuals, Stamps, Flags, Decals, Arm Bands & other hard-to-find items. CATALOG free with order or Air Mailed to you for \$1.00. W.W. #2 M Ltd., Box 2063, St. Louis, Mo. 63158

TREASURE & COIN DETECTOR

10-DAY FREE TRIAL

New electronic circuit guarantees at least **TWICE THE DETECTION ABILITY** of any detector in this price range or your money back. Find gold, silver, coins, old weapons, etc. Works through earth, beach sand, water, wood, rock, etc. New circuit gives more power, more depth. Not a "probe" type but a fully electronic, 1969 model detector never offered before and available only from VIKING. Only detector in this price range sold on unconditional **MONEY BACK GUARANTEE!** You must



29⁹⁵
POST PAID

agree it will outperform any detector costing **TWICE** this low price or return in 10 days for refund of cost. Only VIKING dares make this offer.

Fully transistorized, uses ordinary 9V battery, weighs 2 pounds. Gives loud, clear signal when object is detected.

NOTHING ELSE TO BUY.

Complete, ready to operate. Send \$29.95, check, cash or M.O. for postpaid shipment or \$3.00 and pay postman \$26.95 plus small C.O.D. when delivered.

VIKING DETECTORS
Dept. V-2, Box 10880
Houston, Texas 77018

YOUR NAME IN DIE CAST LETTERS

Everyone has a good reason to identify something they own, something they've made, something they like—with a name, a phrase, a greeting; and nothing identifies better than Die Cast Letters. Now you can individualize your home, your car, your prize possessions with distinction that befits a King. Die Cast Letters offer a NEW mode in home decoration by personalizing unique ideas at a remarkably low cost. **FREE BOOKLET.** Tells how Wellman Die Cast Letters can be used to identify, beautify and boost your ego. Available in a variety of styles from 1/2" to 3". **WELLMAN PRODUCTS COMPANY, 1445 East 49th Street, Cleveland, Ohio 44103.**



AIR LIFT AUTO LEVELERS

These tough, inflatable butyl cylinders raise the rear of your vacation-loaded car to safe, normal riding level. Air Lift Auto Levelers literally lift excess weight from overworked springs . . . also minimize sway on turns and absorb impact of bumps. Simple to install—no parts to remove from car. Ideal for camping, a "must" for trailering. Low as \$33.95 per set—tell us model of car. Free literature.

AIR LIFT COMPANY
Dept. PM, 2710 Snow Road, Lansing, Mich.



FREE!!! POWERFUL MUSCLES FAST!

Fantastic New Discoveries in the science of bodybuilding. Now, in the privacy of your bedroom, our method will add inches of powerful muscles to arms, chest, shoulders & legs. Learn secrets on trimming the waist with ultra-modern methods—fast! Results Guaranteed! Send for free brochure. Universal Bodybuilding, Box 5327, M-18, Northeastern, Dearborn, Mich. 48126.

Now! Silver Dollar Over 80 Years Old

Yours only \$3

Uncirculated, bright US Silver Dollar just as it came from Mint over 80 years ago. Limit: one to a customer. Sent with Free Catalog plus selections of coins to examine. Buy any or none, return balance. Cancel service at anytime. Send \$3 plus name & address to: **LITTLETON COIN CO., Dept. EM-28, Littleton, New Hampshire 03561**



IMPORTED LOCK BLADE STILETTO

ONLY \$2.75 Ea.

9" Overall Length
5" When Closed

- Opens instantly
- Sharp and Tough
- Stainless Steel Blade

Flips open instantly and locks automatically to prevent accidental closing. Razor sharp tough stainless steel blade for reliable use and hard, long service. Money back in 5 days if not satisfied. Send \$2.75 plus 25¢ to cover postage and handling.



WESTBURY SALES CO.
P.O. BOX 415 WESTBURY, N.Y. 11591
DEPT. L-2

WHEN ANSWERING ADS GIVE YOUR ZIP CODE

The bargain hunter

HOLD EVERYTHING!

With handy Magnagrip magnetized holders. Mount easily on any surface.



only \$295 p.p.

TOOLS are orderly, safe when hung on MAGNABAR. Hardwood natural finish. Holds any metal tools. 1" wide by 12" long. Other lengths available.



Only \$395 p.p.

KITCHEN KNIVES always handy on styled white MAGNAGRIP MARK X. Gift-boxed.



Only \$198 p.p. SOAP hangs in air wherever you want, dries fast with **MAGNAGRIP SOAP HOLDER**. Easy to install.

Write for complete line folder. Magnagrip guaranteed or money back. Send check to Dept. B

PHELON MAGNAGRIP COMPANY, INC.
East Longmeadow, Mass. 01028

Guaranteed 10 Years!

\$1.98



The knife for hunting, fishing and all around use. Mirror polished, imported stainless steel blade honed to a razor's edge. Rugged. Opens with flick of finger. Locks into position. Blade will not close when in use. Press button in handle to close. Safety finger guard. Sure-grip handle. Balanced for target throwing. **IF BROKEN WITHIN 10 YEARS WE WILL REPLACE AT NO CHARGE!** Use 30 days. Money back if not pleased. Only \$1.98 plus \$.27 postage and handling. **ORDER NOW!** Midwest Knife Co., 9043 S. Western Ave., Dept. RC-608, Chicago, Ill. 60620. Established 1936.

LEARN UPHOLSTERY! AT HOME



SEND FOR FREE ILLUSTRATED BOOK

on home study course for upholstering sofas, chairs, foot-stools, built-ins. New methods, all styles including fabulous new Naugahydes (above). Free special upholsterer's tools. Fine spare time income, high-paying job opportunities all over. Earn while you learn in spare time. Fascinating. Write for free book, free sample lesson to

Modern Upholstery Institute
Box 899-BYR, Orange, Calif. 92669

Please rush illustrated career book, sample lesson, facts on MUI home training — all FREE, without obligation.

Name _____

Address _____

City _____ State _____ Zip _____

APPROVED FOR VETERANS



Thousands of exciting tool values!

SILVO (BRAND NAME) TOOL CATALOG

Thousands of Exciting Tool Values! Stanley, Millers Falls, Skil, Thor, Wen, Disston, Wiss, Wellsaw, Dremel, Speedy Sprayers, Plumb, Huot, Kennedy, Channellock, Porter-Cable, Rockwell, Helios, Vise-Grip, Crescent, Ridgid, Pony Clamps, Unimat, Foredom and many other Nationally Advertised brands of Tools & Supplies. We ship Coast to Coast at prices Hard to Beat. Send 25¢ for our big 132-page tool catalog, today. Silvo Hardware Co., PM-8, 107 Walnut St., Philadelphia, Pa. 19106.



FREE MUSCLE COURSE!

Want a new Jet-Charged body? In 15 minutes I'll prove you can slap on 4" of muscles to your chest—3" to each arm—give you life-guard shoulders, trim your waist to athletic size—give you speedy athletic legs. I don't care if you're short or tall (skinny or fat) young or not so young, expect a muscle building miracle when you send for my free course. Send only 25¢ to cover postage and handling to Joe Weider, Dept. 38-89D2, 531 32nd St., Union City, N.J.

AMERICA'S NO. 1 CLASSIFIED SECTION CAN BE FOUND ON PAGE 48 IN THIS ISSUE



BC1500SH

BIG BIKE POWER MINI

Outdigs the big ones! This hot mini with a 5-speed 100 cc Honda engine accelerates from 0 to 50 faster than most heavyweights that cost \$1000 more! Even more big bike features have been added for '69. 8 models, starting at \$69.95. Send 25¢ for brochure, \$1 (refundable) for packet on entire line. Dept. PM89 1775 S. First St., San Jose, California 95112.

BONANZA®



BOAT PLANS

FULL SIZE PATTERNS
FRAME KITS



CATALOG \$1

96 PAGES—OVER 80 DESIGNS—\$1.00

Sail, Inboards, Outboards, Hydros, Houseboats, Hot Boats & boat trailers. New \$1.00 catalog includes all styles from 8' to 36'. Glen I. plans, patterns and frame kits are specially prepared for amateurs. Books: Inboard Motor Installations in Small Boats \$6.00; Boat Building With Plywood \$7.50; How To Build Boat Trailers \$4.00. Glen I. 9152T Rosecrans, Bellflower, Calif. 90706.

Stamp Your Name PERMANENTLY



\$4.50 p.pd.

EVERSTAMP

DIE TOOL

Hardened tool steel. Lasts a lifetime. Comparable to a \$10 die tool, still available at this special price. Stamps almost anything you own with a single blow. Made only by the Henry A. Evers Co., Inc., makers of quality marking devices since 1898.

HENRY A. EVERS CO., INC.

Dept. PM, 72 Oxford St., Prov., R. I. 02905

Enclosed is payment for die tool:

Reg. size 1/16". 15 letters max.

@ \$4.50 p.pd.

Large size 3/32". 10 letters max.

@ \$5.75 p.pd.

NAME..... Please Print

STREET.....

CITY..... STATE..... ZIP.....

HANDBOOK OF Knots and Splices

By CHARLES E. GIBSON

Now tie knots for every purpose—useful, ornamental, fun-to-make! Book gives complete "1-2-3" sketches and instructions for every hitch, splice, bend, sling, lashing or whipping you'll ever need for boating, camping, climbing, fishing, hunting . . . for patio awnings, swings, hammocks, rope fences, "welcome" mats . . . ornamental lamps, vases, bell ropes, key chains, buggy whips, cat-o'-nine tails, rope handcuffs, play quilts, etc. They're all here . . . over 100 kinds of knots and ropework! From the simple square knot to such fancy numbers as the Manrope, Stopper, Shroud, Crown, Turk's Head, and Pineapple knots. Also covers plaiting, braiding, much more! "Highly recommended."—Library Journal. Profusely illustrated. **ORDER NOW!** 10-day Money-Back Guarantee. Send only \$4.95 to EMERSON BOOKS, Inc., Dept. 232-S, 251 West 19 St., New York, N. Y. 10011.



MOLDS

for making
Ornamental Concrete
Items . . .

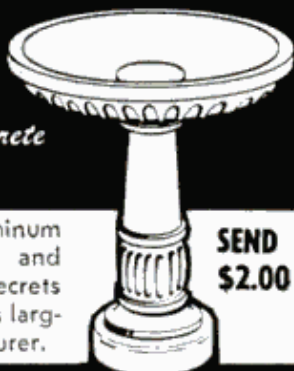

Book about Aluminum
Molds with prices and
production trade secrets
direct from world's larg-
est mold manufacturer.

SEND
\$2.00

CONCRETE MACHINERY COMPANY, INC.

P. O. BOX 99 • HICKORY 2, N. C. 28601

BECOME A TECHNICIAN IN PHYSICAL THERAPY

Men, Women, 18 to 60—LEARN AT HOME

Medicare has increased demand for persons skilled in techniques of Electro-therapy, Hydro-therapy, Scientific Massage, Remedial Exercises and Muscle Re-education. Earn good income from doctors, hospitals, nursing homes, clubs, health and recreational centers. Many earn \$4.00 to \$10.00 an hour in their own business specializing in massage, reducing, etc. Diploma awarded. Low monthly payments. Write today for free Anatomy Charts and catalog. No obligation. **Anderson School of Scientific Massage and Physical Therapy**
Dept. H-1, Princeton, Illinois 61356



BUY GOV'T SURPLUS SAVE TO 85%



Send 25¢ (Coins or Stamps)
For BIG BARGAIN CATALOG

"SATISFACTION OR MONEY
BACK GUARANTEE"

1000's Of Bargains; Surplus, Excess Inventory,
Brand Name Equipment
COMPRESSORS • WINCHES • GEAR MOTORS • CB RADIOS
SURVEYING INSTRUMENTS • TEST INSTRUMENTS • PUMPS
WALKIE-TALKIES • TAPE RECORDERS • POWER PLANTS
ELECTRONICS • TELEPHONES • BINOCULARS • WELDERS
SCREW JACKS • TARPULINS • AIR TOOLS • HYDRAULICS

SURPLUS CENTER PM-089 Lincoln, Nebraska
Zip Code 68501

"\$33,000 LAST YEAR" OPERATING AUTO RADIATOR SHOP

—Mercier Bros., Lowell, Mass.

START SHOP OR ADD TO BUSINESS.
Market growing. More cars each
year. Packaged radiator shop incl.:
equipment, training, 98-page manual,
initial supplies. Proven merchandising
attracts business. Pay-as-you-profit plan. Write.



INLAND MFG. CO., PM-8 1108 Jackson St., Omaha, Neb. 68102

\$\$ TREASURE \$\$



New revolutionary analytical transistorized metal detector will distinguish a gold bar from a tin can. No more unnecessary digging for tin cans, nails, bottle caps, etc. Also features push button tuning, automatic tuning, loud-speaker. Negligible ground pickup. Greatest detection range, etc. Many models — free catalog.

GARDINER ELECTRONICS CO.

Dept. 8, 4729 No. 7th Ave., Phoenix, Ariz. 85013

locksmithing and key making

PRACTICAL UP-TO-DATE COURSE — ONLY \$6.95

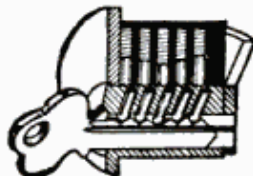

Teaches you how to pick locks, de-code, make master keys, repair, install, service, etc. New self-instruction lessons for every handyman, homeowner, carpenter, mechanic, service station operator, fix-it shop, hardware dealer, gunsmith. 53 easy illustrated lessons. Full price only \$6.95, post-paid. Satisfaction or refund guaranteed. Mail order today!

NELSON-HALL CO., Dept. HR-2
325 W. Jackson Blvd., Chicago 60606

LOOSENS RUSTED NUTS, BOLTS, PARTS



LIQUID WRENCH

AT HARDWARE & AUTO STORES

START YOUR OWN MONEY MAKING BUSINESS

Clean rugs on customers' floors — upholstery in their homes — even painted walls — with highly efficient electric machines which are making big money for others and giving them independence. Write today for complete information. It's FREE!

VON SCHRADER MFG. CO., Dept. D810 "R" Pl., Racine, Wis. 53403



Print Your Own

Cards, Stationery, Advertising, Circulars, labels, photo and movie titles, church work, tags, greeting, sympathy, prayer cards, etc. Save money. Pays for itself in a short time.

Own a Printing Business

Good Profit. Raised printing like engraving too. Have home shop. We supply everything. Direct from factory, only. Easily followed rules. Write now for free details. **KELSEY PRESSES E-37 Meriden, Conn. 06450**

Career in ELECTRONICS?

Career training at home the new easy way with RCA Institutes. Lab work with first lesson. Easy payment plans. Send for free 64-page book.

RCA Institutes, Inc. Dept. PM-89
320 W. 31 St., N.Y., N.Y. 10001

RCA

I-N-V-E-N-T-O-R-S WE NEED INVENTIONS

Sell your invention for cash—need money for Patent?—Are technical problems holding you back? Universal Inventions has helped inventors all over the world—just like yourself—why not you? Inventions provide the magic spring-board to sudden riches. REMEMBER, we either sell your invention or pay you a cash bonus. Write for details.

UNIVERSAL INVENTIONS, Dept. 13, Marion, Ohio

Fox Mini Bike

DO IT
YOURSELF
OR FULLY
ASSEMBLED

from
\$99⁵⁰



SEND \$1 FOR BIG CATALOG Shows new line of the world's finest MINI-BIKES (street and trail models), plus Go Kart. ®, parts, accessories and plans. Amazingly low prices! There's a Fox MINI-BIKE for everyone from age 10 to adults.

EXTRA BONUS Catalog shows radios, watches, walki-talkies, cameras, musical instruments, tools, appliances and many other items you can buy at practically wholesale prices. Free \$1 coupon.

FOX CORP., Box 797PM, Janesville, Wis. 53545

WHY LOSE! WIN \$151 A RACE DAY GET UP TO \$2

"I WAS DEPRESSED—I'd lost again. This guy joked that with \$20 stakes he'd made \$1,516 profit, also \$874, and \$1082 other days. Then I found out he *wasn't joking*, he had PENCLIFF, world's top race computer." SENSATIONAL—space age—scientific, yet so easy to use. All purchasers get facts. Over 4 years checkable. Big Win Pencliff results. Over 3,000 Big Win Pencliff Payouts to \$2 stakes incl. \$89, \$106, \$169. Big Pencliff Track Wins—\$2 on all predictions in the 9 races incl. \$87, \$108, \$151 clear net profit on the day. Magnificent 28% approx. aver. Win all races, and investing only in races with 10 or less entries you can get up to 100%. Win at meetings on the day. Learn how an accident on the inventor's yacht, his 25 years horse race knowledge, the aid of 12 other expert Handicappers, and a giant-I.B.M. computer all led to the invention of amazing PENCLIFF.

R.H.P. Co. Box 5715-PME1, Carmel, Calif. 93921
Tear out this ad NOW and mail with name, address, & zip.

DRAINS pools, cellars, laundry tubs \$8.95 IRRIGATES — CIRCULATES — SPRAYS



Type P Pump. 1,001 uses. Stainless shaft. Won't rust or clog! Use 1/8 HP motor or larger . . . 3/4 HP for up to 2,400 GPH; 450 GPH 80' high; or 1,800 GPH from 25' well. 1" inlet; 3/4" outlet. Coupling included free . . . \$8.95

HEAVY-DUTY BALL-BEARING PUMP. Up to 5,200 GPH; or 3,000 GPH from 25' well. 1 1/4" inlet; 1" outlet . . . \$12.95

P'pd cash with order. **MONEY BACK GUARANTEE**
LABAWCO, Box 7, Belle Mead, N.J. 08502

HEAVY DUTY WELDER 18⁹⁵ POST PAID WELD • BRAZE • SOLDER • CUT



10-DAY FREE TRIAL • LIFETIME GUARANTEE 110 Volt • Not One—But 3 welding heats

Weld, braze, solder or cut any metal — even aluminum. No experience necessary. Follow simple instructions to make repairs on cars, trailers, farm and lawn equipment, bicycles, appliances, etc. Make campers, boats, furniture, hundreds of valuable items. **NOTHING ELSE TO BUY!** Comes complete with full face shield, \$2.00 pack of welding and brazing rods, heavy duty power cables, special electric torch attachment, ground clamp, flux, easy-to-follow illustrated instructions, rod holder, etc. Uses standard 1/4" rods and 1/4" carbons to weld iron, steel, brass, bronze, aluminum, other metals. New improved HEAVY DUTY circuit gives more welding power. Gives 4 times the heat needed to melt toughest iron. Plugs into ordinary 110V outlet. **3 WELDING HEATS . . .** Not just one as with other low cost models. Use "high" for tough jobs, "medium" or "regular" for lighter work. This important feature saves you money and time. Makes it possible for even beginners to start welding professionally the very first day. Pays for itself quickly. **10 day MONEY BACK GUARANTEE.** You must be satisfied or return for refund. **FREE** automatic arc striker. Weld with push-button ease.

SEND ONLY \$2.00. Pay postman \$16.95 plus postage when delivered, or send \$18.95 cash, ck., M.O., for fast post-paid shipment. **WEL-DEX MFG. CO.**
Dept. W-106 , Box 10776, Houston, Texas 77018

ACCORDIONS and AMPLIFIERS



BIG SAVINGS up to 1/2 or more on famous make accordions. Over 40 models. Standard and new electronic models. Buy direct at low discount prices. Get five-day home trial. Small down payment, easy terms. Free gifts. Trade in allowance. Money back guarantee. Rush coupon for color catalogs, discount price list. Accordion Corp. of America, Dept. R-89, 5535 W. Belmont Ave., Chicago, Illinois 60641

COUPON BRINGS FREE COLOR CATALOG & DISCOUNT PRICES

ACCORDION CORP. of AMERICA—Dept. R-89
5535 W. Belmont Ave., Chicago, Illinois 60641
Send FREE Color catalogs and discount prices. Include special information checked:

Amplifiers Button Type Accordions

Name _____
Address _____
City _____ State _____ Zip _____

Train for top jobs, top earnings, in PHOTOGRAPHY

NYI trains you for the best jobs—or your own successful business. Learn by doing at home, quickly, easily the individualized NYI way. Low cost. No experience or expensive equipment needed. Earn while you learn. Easy pay plan. Approved for Veterans, Student Loans. Approved by N.Y. State Ed. Dept. Accredited member Natl. Home Study Council. FREE color career book. No salesman will call. **RESIDENT TRAINING** in all profitable phases of photography and Creative Motion Picture Course. Our 60th year.

NEW YORK INSTITUTE OF PHOTOGRAPHY • 10 West 33 St., New York, N.Y. 10001, Dept. 49-8

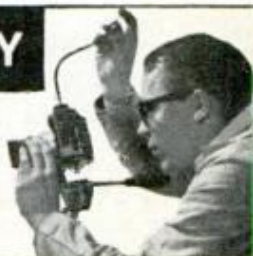

On the road



On the water



In your back yard



GUMOUT Cleans carburetors

Every carburetor gets dirty and gummed-up. GUMOUT is the easy way to clean carburetors fast.

Just add GUMOUT to the gas tank. Cures ROUGH IDLING, STALLING, POWER LOSS and HARD STARTING. You'll quickly notice the big difference.

Enjoy a really smooth running engine. Buy GUMOUT at leading Auto Supply Stores, Service Stations—wherever fine auto products are sold.



GUMOUT DIVISION
Pennsylvania Refining Co., Cleveland, Ohio 44104

WHAT'S NEW OUTDOORS

BY DAN FALES

WINDS OF 75 MPH will scare the sails off any boatman, unless he's a hardy English sailing aficionado. For the latter, such a wind is just one more trial to be reckoned with. This is true of K. Adlard Coles whose new book treats gales as though they were just another wind in true British understatement. Mr. Coles' book is titled *Heavy Weather Sailing* and is just that. For chapter after chapter he recites his experiences during gales encountered around the British Isles and during trans-Atlantic sailboat races. In rather droll terms—more scientific than salty—he explains how he sailed each boat during each gale. He explains what weather information he collected after the gale to substantiate wind velocity. And he gives a critique of what he learned.

It's these lessons in the storms that are fascinating. Many's the tip a sailor can glean from Mr. Coles' experiences. The book is almost textlike in its exactness. Too bad Mr. Coles isn't an adventure writer. If rephrased and re-emphasized, *Heavy Weather Sailing* could be an adventure in reading for sailors and landlubbers alike. Nevertheless, *Heavy Weather Sailing* is a good book—packed with valuable information—for the average weekend sailor who might once or twice find himself caught in a big storm. The book is published by John DeGraft of New York and sells for \$12.50.

FITTING NYLON SCREENS over windows is a good idea for those who plan to camp in a station wagon or car. You



make a loose-fitting nylon sack that will easily slip over the window frame on most vehicles. The net will not interfere with the door operation. ★★★

I still have to pinch myself every week when I open my pay envelope—it seems too good to be true!

Especially when I remember how sorry everyone felt for me because I couldn't go on to college with the others in my high school class. "How are you ever going to make it now?" people kept asking me. "Without college, it's a losing battle. Everybody knows that!"

Well, the college boys left for school, and I got my first job. And it was tough going for a while, I'll admit that—one dull, routine thing after another. From pumping gas to driving a cab to working on an assembly line in a factory. I worked hard but never "struck it big."

Then I read an announcement like this one about the opportunities in Electronics.

I discovered that, with proper training, I could have my pick of thousands of glamour jobs—in fields like radio and TV broadcasting, automation, computer servicing, or even the aerospace program.

And I found out that as you move up the ladder in this booming field of Electronics, you can earn the kind of money that even a college man could be proud of—up to \$5, \$6, \$7 an hour...\$200, \$250 a week...\$10,000, \$11,000, even \$12,000 a year!

And—most important—I realized how easy it would be to get the training I needed to break into this great field. The announcement said I could learn everything I needed to know, right at home in my spare time, with a home study course from the Cleveland Institute of Electronics.

Well, to make a long story short, I enrolled with CIE. I found that their courses had taken what seemed like a complicated subject and broken it down into easy steps. Sympathetic instructors sent me letters helping me over the rough spots. I really learned fast. And here I am now, a respected Electronics man—earning so much money I still have to pinch myself.

Thanks to CIE, I don't have to envy the college boys anymore. In fact, there are some that envy *me!*

Send for 2 FREE BOOKS

This composite story is typical of hundreds told by CIE students who are now enjoying exciting new careers in Electronics.

CIE

Cleveland Institute of Electronics

1776 East 17th Street, Cleveland, Ohio 44114

Please send me 2 FREE books describing opportunities in Electronics and how to prepare for them.

Name _____
(Please print)

Address _____

City _____

State _____ Zip _____ Age _____

Check here for G.I. Bill information.

Accredited Member National Home Study Council. A Leader in Electronics Training
... Since 1934



PM-27

Most of them decided on their new careers after reading our famous books, "How To Succeed In Electronics," and "How To Get A Commercial FCC License." These books describe in detail the many electronics careers open to men with proper training. And they tell which CIE courses will best prepare you for the work you want.

Both books are *FREE* when you mail the bound-in card, or with the coupon above. So send for them, and get ready to pinch yourself for not writing to us sooner. CIE, 1776 E. 17th St., Cleveland, Ohio 44114.

ENROLL UNDER NEW G.I. BILL—All CIE courses are available under the new G.I. Bill. If you served on active duty since January 21, 1955, or are in service now, check box for G.I. Bill information.

Who'd have thought I'd make so much money without going to college?



CLASSIFIED ADVERTISEMENTS

Rate: \$1.85 per word payable in advance each insertion. Capitalized words—75¢ per word additional. Minimum insertion ten words. To be inserted under the proper classification, copy must be in our office by the 15th of the second month preceding date of issue. The next available issue to place an advertisement in America's No. 1 Classified Section is October. The closing date is August 15th. Send remittance and order to C. A. Martin, Popular Mechanics, 575 Lexington Avenue, New York, New York 10022. Please make remittance payable to Popular Mechanics.

AUTOMOBILES

HOW TO TUNE UP YOUR CAR. Illustrated booklet, send \$1.00—G & B Associates, P.O. Box 398, Hasbrouck Heights, New Jersey 07604.

SELL Your car for more money send \$1.00 for information E. J. Vaillancourt, 1817 Ferry Street, Easton, Pa. 18042.

MIDGET CARS

OUR First 19 In Space. This limited edition lithograph has been created as a tribute to Americas Gallant Astronauts. 12 X 18 inch chart ready for framing. Only 75 cents. Popular Mechanics, Dept. GWP, 575 Lexington Avenue, New York, New York 10022.

AUTO SUPPLIES AND EQUIPMENT

VOLKSWAGEN Replacement parts at 20% to 50% discounts. Free Catalog. Western Distributors, Box 316 D, Cedar Crest, New Mexico 87008.

BUGGIE-BIN, under-seat drawer for V-W "Beetle". \$4.50 pair; \$2.65 single. Mini-Max, 748 So. Trenton, Seattle, Wash. 98108.

PARTS: Army jeep and truck parts. Spare Parts & Equipment Co., P. O. Box 751, Lexington, Ky. 40502.

TACH-DWELL Meter. Save 75% building yourself. Plans \$1.00. Harrison, Box 201, Bound Brook, N.J. 08805.

RING And Valve job complete while you drive. Reduces oil burning, increases gas mileage and raises compression. Just drop Motaloy tablets in tank. \$6.00 and money back Guarantee. Mail Order Service, P.O. Box 1041, Metairie, La. 70004.

NEW heavy duty CD ignition system. Details free. Kits \$28.95. Assembled \$39.95. Dealers invited. Delta International Ltd., Box 1946PM, Grand Junction, Colo. 81501.

JEEP Owners—V8 conversions. Read Jeep Owners, ad. page 201.

TRANSMISSION OVERHEATING—90% of automatic transmission failures are due to excessive heat buildup. \$1.00 (refundable) brings heat range chart and info. Bill Tugend, P.O. Box 4293, Panorama City, Ca. 91412.

GAS-OIL HOG??? . . . Smoking?? . . . No Pep?? . . . Hard Starting?? (Save \$150-\$250) with Motaloy Ring-Valve Job While driving (\$6.50 postpaid) Advertised here every month for years! Continues saving money on repairs, gas, oil for 100,000 miles! Absolutely true! (new engines too) Nothing compares! . . . Money-back guarantee. You can't lose! Motaloy, Grantham, Penna. 17027.

CAR VACUUM CLEANER. Cleans interior fast. Plugs into cigarette lighter of 12 Volt car. Only \$7.50. No C.O.D.'s. Mrs Powell Mail Order House, 505 4th Street, Montgomery, Alabama 36110.

CHEVROLET V8 PARTS BELOW WHOLESALE. Oil Pumps \$6.50. Racing Pistons, Pins And Rings \$49.45. Complete Gasket Set \$6.50. List, Decals, Literature \$1.00. Calparts, Box 1251, Wilmington, Calif. 90744.

AUTO Parts for old and new Cars. All makes. Catalogue \$1.10. Antique Auto, Milwaukee, Wisconsin 53204.

CROSLEY. Foreign, American, Parts. Discounts. Accessory Catalog. 616 Burnside, Inwood, New York 11696.

OUR Wear Detector tells you when brakes need relining, without pulling wheels. \$8.95 postpaid. Send for details. Neate Co., 3627 W. 86th St., Chicago, Ill. 60652.

NEW INGRAHAM CAR CLOCK. Instant installation. Guaranteed. \$6.00. Pompa Industries, 79 Furlong Road, Rochester, N.Y. 14623.

EMERGENCY Blinker switch instantly converts 6 or 12 volt car directional lights into warning signals. Only \$3.98 plus 30¢ handling charges. Geno's, Box 2555, Cheyenne, Wyoming 82001.

AUTO TRAILERS

CAMPER Plans. Compact buses, Vans—Volkswagens, Econoline, Dodges. Build yourself—Save! Details—Dot Campers, Box 2115M, Culver City, California 90230.

PICKUP Camper, Trailer or Pickup—Cover . . . Build yourself. Save! Complete plans \$3.95 each. Cover plans \$2.00. Conversion Plans—econoline type van \$2.95; passenger bus or delivery van \$2.95. Satisfaction Guaranteed. Equipment catalog \$1.00 (refundable). Details 10¢. Viking Camper Supply, 99-F Glenwood, Minneapolis, Minn. 55403

BUILD Your Pickup Camper. Precut Kits, Blueprints, Supplies. Literature 25¢. Comstock Trailers, Dept. 664, Parsons, Kansas 67357.

BLUEPRINTS Manual To Build Campers Trailers And Supply Catalog \$2.00. Catalog 50¢. Kamcraft, Box 1153, Milwaukee, Wis. 53201.

MOTORCYCLES, BICYCLES, MOTORSCOOTERS AND SUPPLIES

HARLEY-Davidsons—Used bargains. New, used parts, accessories, all models. Bulletin 35¢. Knuth's (Factory Dealer). 1753 Muskego, Milwaukee, Wis. 53204.

MOTORCYCLE TURN SIGNALS. Accessories. Catalog 25¢. Houston, PM Lockport, Illinois 60441.

HONDA 50-90-160 Speed Equipment. Cams—Big-Bore-Stroker. Columbia Engineering, 2105 E. 37 St., Los Angeles, Calif. 90058.

BUILD "Popular Mechanics" MINI-BIKE featured June 1967 issue. Detail plans, photographs \$2.50 refundable. Kits, parts, engines; factory discount prices. Catalog 25¢. Gilliom Mfg.; PMC; St. Charles, Missouri 63301.

RECONDITIONED Motorcycle motors. Indian, Mustang, Royal Enfield, Suzuki. Parts, Accessories. "Minibikes." Indian Motorcycle Sales, Kansas City, Missouri 64127.

SNOW VEHICLE & KART Hop up accessory CATALOG. Speed and performance equipment—manifolds, engine mounts, exhaust systems. Send 25¢. G.E.M. PRODUCTS, 436 Roosevelt Rd., Glen Ellyn, Illinois.

BUILD Motorbike From Bicycle! Plans . . . \$2; Go-Cart Plans . . . \$2; Snowmobile Plans . . . \$3; Go-Byk Industries, Rothsay, Minn. 56579.

MINI-BIKES. Go-Carts, Clutches. Wholesale Catalog 25¢. Loren Products, Danville, Illinois 61832.

CONVERT Your bicycle to electric drive. Using old auto starter for motor. Plans, photos and instructions \$1.00. Jager, 115 West 37th St., Long Beach, California 90807.



AVIATION

BE A Government licensed aviation mechanic. Practical training. Free information. Aero Mechanics School, Municipal Airport, Kansas City, Missouri 64116.

TREMENDOUS OPPORTUNITIES IN AVIATION. Learn Aerosciences at home: Navigation, Aerodynamics, Communications, Weather. Free Information: United Aerosciences, P.O. Box 4106, Torrance California 90503.

BARTLETT FLYING SAUCER. Amazing machine hovers 200 lb. man over land/water, powered by ordinary lawn mower engine. Easy to build. Fun to fly. Complete Plans, Kit Brochure and Photo Review \$3.00. Write: Herb Bartlett, Box 3234-C, Scottsdale, Arizona 85257.

FREE Catalog. 1000 Aviation Space Books. Aero Publishers, 329 Aviation, Fallbrook, Calif. 92028.

HELICOPTER. One-Man, Portable. Kits, Plans, Information 10¢. Photos and three-view drawings \$1.00 Comcomp, Box 1267, Redwood City, California 94064.

AIRBOAT. Propellers, Engines, Plans, Kits, Supplies. Complete Airboats, Outboard Airdrives. Catalog \$1.00. Banks-Maxwell, Box 3301E, Ft. Worth, Texas 76105.

HOVERCRAFT Plans \$3.00. Catalog \$1.00. Propellers. Esco-M, Box 3379, Sarasota, Florida 33578.

AERO-CAR. Amazing Hovercraft built easily with ordinary tools. Lawnmower engine power. Carries one man plus. Hovers, flies forward, backward, sideways over land/snow/water. Complete construction plans and brochure, \$5.25. Aero-Projects, Box 5118PM, Clinton, N.J. 08809.

HOMEBUILT. Real enclosed helicopter, 24 pages ideas, information, \$2.50. Build "executive" helicopter, drawings, specifications, \$2.00. Helicopter Development, Box PM147, Washington, New Jersey 07882.



BOATS

CANOEES! Kayaks! Factory-direct quality kits, from \$25.00. Many different models. Canvas hulls. Strongest construction materials. Free literature. Sportscraft, Box 8393-PM, Columbus, Ohio 43201.

BOAT PLANS, FRAME KITS, BOAT KITS. World's largest catalog—Over 200 top design for the amateur builders. New catalog includes Cruisers, Runabouts, Deep vee's, Catamarans, Trimarans, Houseboats, Sailboats from small sail fish to 34 ft. motor sailers, large selection of inboard and outboard Hydroplanes. Send \$1.00 for large new plan & kit catalog or \$2.00 for catalog plus Boat Builder's Guide. Clark Craft Boat Company, 16-P Aqua Lane, Tonawanda, New York 14150.

BUILD Your own boat from our large-scale blueprints. Books of plans give how-to-build help. Hundreds of professional designs—motor, sail or auxiliary—for amateur builders. Free catalog. MoToR Boat-Ing, 959 Eight Ave., Dept. PM-RS, New York, N.Y. 10019.

FIBERGLASS Cloth and resin. World's finest cloth and non-run resin, at direct mill prices. Flotation foam. Complete line of plastics, silicon bronze and brass screws, save 60%. No Sales tax. Boat Plans. Catalog 25¢. Freight prepaid. Stiles Boat Supply, Box 11P, Linden Ave., Mantua Hts., N.J. 08051.

PLANS FULL-SIZE PATTERNS. FRAME KITS with step-by-step instructions specially for amateurs. Send \$1.00 for new 96 page catalog of over 80 designs, 8' to 36' Sail. Jets. Inboards. Outboards, Cruisers, Houseboats, Hot Boats, Catamarans, Hydros "plus" boat trailers. New "How To Build Boat Trailers" book \$4.00 ppd. Glen Designs, 9152 Rosecrans, Bellflower, Calif. 90706.

KAYAKS—One-man \$21.00; two-man \$26.00; Sailboats \$45.50. Exciting Sitka Kayak Kits known world wide for speed and safety. Assemble in one afternoon. Free pictorial literature. Box 582-P, Willoughby, Ohio 44094.

FIBERGLASS CANOES. Four Exciting Models. Easily Assembled Kits. \$39.95 up. Factory Direct. Free Literature. Riverside Canoes, Box 5595-B, Riverside, California 92507.

BOAT maintenance information. LIFE-CALK. "GIT"-ROT. RUB-R-COTE. Finishes & Cleaners. Send for "How to do-where to do" literature. FREE. Boatlife. 5-45 49th Av., L.I.C., N.Y. 11101.

FREE CATALOG from manufacturer of nylon and Dacron rope. Direct to you at dealer cost. Other important accessories. Write: West Products, Dept. 20, Box 707, Newark, New Jersey 07101.

BOAT Kits. Molded Fiberglass. Save money—assemble yourself. Factory molded sections bond into one-piece craft. 30 models—14' to 32'. Cruisers, Runabouts, Houseboats, Sailboats. Big line accessories, motors, trailers. Easy terms. Free 80 page catalog. Luger, Dept. BC-69, 1300 East Cliff Road, Burnsville, Minnesota 55378.

NEW 1968 McCulloch And Other Outboards 4 H.P. \$109 . . . 7½ \$218 . . . 9 Electric \$268 . . . 18 \$332 . . . 40 Electric \$548 . . . 55 Electric \$728 . . . All Sizes Literature 50¢ . . . Electra Marine, 1427 Broadway, Brooklyn, N.Y. 11221.

KAYAK Boat kits, Nylon covering never needs paint or dope, assembles in one day. Fast & easy to handle. Circular with photos 15¢. Stratford Trailers, 376PK Stony Creek, Conn. 06405.

SUPER Or simple: Canoe, Kayak, Sailing Rig, Accessory plans. Free catalogue. Quicksilver, 115 McGavock, Nashville, Tenn. 37214.

SAILBOAT, tough plastic coated 12-ft. hull, 65 sq. ft. nylon sail, \$164.95 complete. Free brochure. ADECO, Painters Run Road, Pittsburgh, Penna. 15241.

MARINE EQUIPMENT AND SERVICES

CONVERT Auto engines to marine. 68 Page Catalog, 50¢. Lehman Manufacturing Company, 800 Elizabeth Avenue, Linden 4, New Jersey 07036.

NEW. Used, rebuilt marine motors. Marine conversions, fittings. Free catalog. Stokes Marine Supply, Dept. 24, Coldwater, Michigan 49036.

BIG Discounts—Conversion Kits—Marine Engines—Manifolds—Transmissions—Outdrives—Free Brochure. Star Marine, Berkeley, California 94710.

FREE Catalog—Gray inboard, inboard-outboard marine engines—gasoline, diesel. Graymarine Corporation, Coldwater, Michigan 49036 or Berkeley, California 94710.

ATHLETIC AND BODY BUILDING COURSES

"GIANT Arms." Dr. Young's, D.C. revolutionary discovery. \$2. Satisfaction or refund. Gaucho, Box 9309-S7, Chicago 60690.

BIG Muscles fast, complete course \$5.00. Olympus Bodybuilding, Box 431, Garden City, Michigan 48135.

POWERFUL Muscles fast! Free brochure! Universal Bodybuilding, Box 4327-C, Dearborn, Michigan 48126.

BEAUTIFUL MUSCLES FOREVER. ORDER TODAY—COMPLETE COURSE ARRIVES IN ONE WEEK—APPLY DILIGENTLY FOR 150 DAYS—HAVE FAITH, NEVER GIVE UP . . . THAT'S ALL, FABULOUS BUILD MUST RESULT. FAILURE IMPOSSIBLE. SATISFACTION OR REFUND. \$2. SUCCESS A-89. BOX 1434, MUSKOGEE, OKLAHOMA 74401.

FEAR No bully! Master authentic Chinese Kungfu unbeatable techniques! Defeat within seconds any attacker including giant judo-karate experts. Free details by air. Write Asia's greatest master. Leongfu (/MI/41/) 119, Anderson Road, Ipoh, Malaysia.

SPORTING GOODS AND EQUIPMENT

FREE . . . Wholesale Catalog, Arrow Shafts, Broadheads, Fletchings, Fisharrow Parts, Tools, Bows, Finnyports. (22G), Toledo, Ohio 43614.

FREE 1969 Catalog. Guaranteed Lowest Prices! Rods Reels, Lures, Accessories—Thousands of Items. Cabela's Inc., Dept S, Sidney, Nebraska 69162.

IF YOU Fish or Hunt 9 Tools In One makes your trip complete. Finest Rust Resistant Drop Forged Steel. Details Free. F. McBride, 480 Pepper Street, Pasadena, California 91103.



FISHING, TACKLE, LURES

SEND for FREE Wholesale Catalog. The most complete and fully illustrated catalog of reels, rods, beads, spinners, jigs, bodies and parts, sinker molds, feathers, tools, hooks, rod blanks, rod parts, swivels, wire, etc. FINNYSPORTS, ME Sports Bldg., Toledo, Ohio 43614.

MOLDS—For casting your own fishing sinkers. Free illustrated booklet. Reading Instrument Co., Box P78, Reading, Pa. 19603.

CLEAN-A-fish (Filleting and cleaning boards) Let you clean and fillet fish without mess. Long lasting quality. Satisfaction guaranteed. 6" X 24" \$7.95. 7" X 36" \$9.95. Complete Kit \$24.95. Prince Brown Products, 2323 Joppa Avenue 1-D, Zion, Ill. 60099.

EARTHWORMS, LIVE BAIT

EARN Money raising fishworms for us! Exciting details free! Oakhaven—56, Cedar Hill, Texas 75104.

HYBRID Redworms—3,000—\$5.75, 5,000—\$8.00, 10,000—\$14.00. Bedruns 20,000—\$18., postpaid with raising instructions. Brazos Bait Farms, R-9, Waco, Tex. 76705.

MAKE Money growing Fishworms. Outstanding new breed. Large size, tough, hardy. Plenty of action. They sell on sight. Free information. Fain's Hatchery-31, Edison, Georgia 31746.

FROGS, FISH, REPTILES

YOUNG Frogs and Giant Breeders. Stock your lakes and ponds. Nu-Tex Frog Farm, Box 4029, Corpus Christi, Texas.



HUNTING, GUNS, DECOYS

IMPORTED Hunter's knife, famous Solingen 5" stainless blade simulated stag handle. Gift boxed with guarantee certificate. \$8.95 Postpaid. Marianca, Box 176, Bergenfield, N.J. 07621.



DOGS AND KENNELS

EXTRA Income at home in Spare Time! Booklet shows you how to start your own business with Classified Advertising. Only \$1.00. Refundable with first insertion order. C. A. Martin, Popular Mechanics Dept. PM, 575 Lexington Ave., New York 10022.



GAME BIRDS

QUAILS, Incubators, cages, supplies catalog. Marsh, 14216 Brookhurst, Garden Grove, Calif. 92640.

RABBITS—FUR BEARING ANIMALS

RAISE Rabbits for us on \$500 month plan. Free details. White's Rabbitry, Mt. Vernon, Ohio 43050.

RAISE Rabbits successfully by knowing facts. 48 page illustrated book describing 25 breeds. Housing, breeding, feeding, markets, marketing etc. 25 cents. American Rabbit Association, 36 Arba Building, Pittsburgh, Penn. 15217.

MAKE Big Money raising chinchillas, rabbits, guinea pigs for us. Catalog—25¢. Keeney Brothers, New Freedom, Pa. 17349.

EARN \$10,000 Yearly raising angora rabbit wool, and breeding stock for us. Information 25¢ coin. American Angora Company, Malta 12, Montana 59538.

MAKE Money raising rabbits for us. Free Details. Delta, Box 1184, Hereford, Texas 79045.

\$500-\$800 MONTHLY. Raise small laboratory-breeding stock for us. We supply equipment, breeders, and instructions. Illinois Research Farms, Dept. MPB-8, McHenry, Illinois 60050.

TAXIDERMY

EXTRA Income at home in Spare Time! Booklet shows you how to start your own business with Classified Advertising. Only \$1.00. C. A. Martin, Popular Mechanics Dept. PM, 575 Lexington Ave., New York 10022.

PETS—BIRDS, CATS, HAMSTERS, ETC.

LIVE SEAHORSES, marine specimens, aquarium supplies. Illustrated catalog 15¢. Marine, Box 248-310, Dania, Florida 33004.

LIVE Traps, all sizes, mouse to dog. Collapsible or rigid. Carrying Cages. Free literature. National Live Traps, Tomahawk, Wisconsin 54487.

HAWKS, Reptiles, raccoons, skunks, squirrels. Catalogue 25¢. Trails End Zoo, St. Stephens, S.C. 29479.

CHICK-U-BATOR, see eggs hatch before your eyes, complete with instructions \$6.95. Collectors Wonderland, Box 1170, New York 10008.

HORSES, LIVESTOCK

"HOW To Train Horses"—Everyone who likes horses or ponies should have this book; Free. Write Beery School, 1108, Pleasant Hill, Ohio 45359.

CAMPING EQUIPMENT AND TENTS

SAVINGS Plus dividends! Campers-fishermen-outdoorsmen cooperative. Free 68-page catalog. Recreational Equipment, Inc., 1525-P 11th, Seattle, Washington 98122.

CAMPING

YOUR Ad in Popular Mechanics will be seen by more than 5,000,000 active buyers for your products and services. It costs only \$1.85 per word. And, if you wish to run all or part of your ad in capital letters—you can do so for as little as 75¢ per word additional. Act now! Place your classified ad in Popular Mechanics today.

TRAVEL AND RESORTS

WILDERNESS CANOE TRIPS. Free brochure. Bill Rom's Outfitting, Ely, Minnesota 55731.

ELECTRICAL SUPPLIES

METERS—Surplus, new, used, panel and portable. Send for list. Hanchett, Box 5577, Riverside, Calif. 92507.

LAMP Parts. Catalog, prices, wiring instructions, 50¢. Refunded first order. Gyro, 5218P N.W. 35 Ave., Miami 42, Fla. 33133.

LAMP—Appliance parts. Wholesale catalogue 25¢. SECO, 109 South 20th Street, Birmingham, Alabama 35233.

BATTERIES, GENERATORS

BATTERY Reconditioning Kit, includes molds, material, instructions. Battery Shop, Route 1-188D, Blythe, Calif. 92225.

ENGINES, MOTORS

WINDING Data, 275 motors, \$1.20. Data Company, 512 Kensington, Kansas City, Mo. 64124.

LIVE Steam powered backyard railroads! All sizes. Complete "bolt-together-kits," and rough castings. Excellent drawings. 100 page catalog \$1.00. Little Engines, Lomita, Calif. 90717.

CLEARANCE! Half Price! Synchronous Timer Motors, 110 v.a.c. 10 r.p.m. Extremely accurate. Excellent for experimenting, models & revolving displays. Send \$6.00 ppd. to: Motors, P.O. Box 383, Adrian, Michigan 49221.

MACHINERY, TOOLS AND SUPPLIES

SMALL Foundry furnaces, Supplies. Free literature. Pyramid Products, 3736 South 7th Avenue, Phoenix, Arizona 85041.

MILLING MACHINES, INEXPENSIVE Construction Kits Ready, 17 X 11 Blueprints \$2.00. Mailed Promptly. Microm, Box 2313-C, Santa Ana, California 92707.

MONAGRAM STEEL STAMP Permanently stamps up to three script initials on almost anything you own. \$5.75. John Fullam, 23 Ivory Rock Road, Levittown, Penna. 19057.

MICROMETERS—Indicators—Rods—Lathes—Accessories. Campbell, 1424 Barclay, Springfield, Ohio 45505.

WELDING, SOLDERING, PLATING

CHROME Plating equipment, supplies. All other finishes. Home workshop and production sizes. Send \$2.00 (refundable) for formulas, operating data, equipment guide and catalog. HBS Equipment Division L50, 3543 East 16th, Los Angeles, Calif. 90023.

WELDERS—110/220, 150 Amperes, \$53.50. Morris, 1070 Inner, Schenectady, New York, 12303.

GOVERNMENT SURPLUS

GOV'T Surplus. How and where to buy in your area. Send \$1.00. Surplus Information, Headquarters Building, P.M., Washington, D.C. 20036.

1969 SURPLUS Army, Navy store illustrated catalog. Send 25¢ (refundable with first \$5.00 order). Ruvel, 707 Junior Terrace, Dept. 9-J, Chicago, Illinois 60613.

JEEPS Typically From \$53.90 . . . Trucks From \$78.40 . . . Airplanes, Typewriters, Boats, Clothing, Camping, Sporting, Photographic, Electronics Equipment. Wide Variety, Condition, 100,000 Bid Bargains Direct From Government Nationwide. Complete Sales Directory and Surplus Catalog \$1.00 (Deductible First \$10.00 Order). Surplus Service, Box 820-A, Holland, Michigan 49423.

JEEPS From—\$52.50; Typewriters from—\$4.15; Cars from—\$31.50. Walkie-talkies, motorcycles, airplanes, boats. Typical "As Is" bid bargains from Uncle Sam. Tremendous variety. Exciting free list. Write: Enterprises, Box 402x49, Jamaica, New York 11430.

HOBBIES AND COLLECTIONS

50 GORGEOUS Jungle butterflies \$2.50. Collectors Wonderland, Box 1170, New York, 10008.

OUR FIRST 19 IN SPACE. This limited edition lithograph has been created as a tribute to Americas Gallant Astronauts. 12 X 18 inch chart ready for framing. Only 75 cents. Popular Mechanics, Dept. GWP, 575 Lexington Avenue, New York, New York 10022.

PRESIDENTIAL Campaign buttons. Free list. Bristow, Box 1460-P, Los Gatos, Calif. 95030.



STAMP COLLECTING

PENNY! Approvals! Regardless catalogue! Kloster, 4164 52nd St., San Diego 5, Calif. 92105.

500 DIFFERENT Stamps, \$1.00. Smith, 508-A Brooks, College Station, Texas 77840.

50 YEARS Old, fifteen different United States, over fifty years old—10¢ with approvals. Jaxon, Box 145-P, Brooklyn, New York 11230.

50 DIFFERENT United States, only 10¢. with Approvals. Shelton, Box 547C, North Miami, Florida 33161.

"AFRICA." 25 beauties, 10¢. Approvals, Gorliz, Box 1915PM, Naples, Florida 33940.

MILLIONS Foreign Stamps! 2¢ each! Send for gigantic approvals! ABC, Box 6000-MB, San Francisco, California 94101.

FREE Surprise collection sent with approvals. Gould, 1784 Union, San Francisco 94123.

50 DIFFERENT Old U.S. Revenue stamps 50¢. Winchester Stamps, Box 1592, Mansfield, Ohio 44907.

U.S. Mint specials! Flag set, complete \$1.00, 1¢, 2¢, 3¢ famous Americans (21 different) \$1.00. Free list. Brooks, 2601 Avenue "U," Brooklyn, N.Y. 11229.

ONE Pound value Geo. VI Bermuda, plus 100 worldwide 10¢. approvals. Stevens, Box 105A, Homecrest Sta., Brooklyn, N.Y. 11229.

NEW Issues—Free weekly illustrated list. Brooks, 2601N Avenue "U," Brooklyn, N.Y. 11229.

225 STAMPS for only 10¢! Airmails, Pictorials; stamps from strange countries cataloging up to 25¢ each! Plus unusual stamps to examine. Buy any or none return balance, cancel service anytime. Mystic Stamp Co., Camden 80, New York 13116.

FREE!! Two Beautiful Multi-Colored Complete Mint Sets. Approvals. Hamilton, 1246 Pratt, Chicago OE-8, Illinois 60626.

U.S. Bargain, 50 different 10¢, with beautiful worldwide approvals. Stamp Center, Kennebunk, Maine 04043.

FREE Mint Set. Approvals accompany. Stamps, Box 22092, Memphis, Tenn. 38122.

RUSSIA High-Value Collection, 32 different Russia—some over 50 years old! Commemoratives, Czarist Issues, Airmails, Catalog price \$2.50. Special Get-Acquainted Offer—all for only 10¢! H. E. Harris, Dept. GG-49, Boston, Mass. 02117.

FREE 50 Worldwide. Approvals. University Stamps, P.O. Box 1471, Lake Worth, Florida 33460.

FREE! Triangles, Scout, 25 others. Approvals. Cambridge, Box 411, Cambridge, Ohio 43725.

50 DIFFERENT U.S. Commemoratives, 10¢. Approvals. Cambridge, Box 411, Cambridge, Ohio 43725.

BARGAINS In Old Used U.S. Seconds. Karl Swartz. Mountain Home, No. Car. 28758.

"RUSSIAN Bear in Berlin Set. Only 10¢. Approvals. Ken Zielski, Box 364-M, Morton Grove, Illinois 60053."

WORLDWIDE Approvals. Humphrey, 805 24th Ave., Santa Cruz, Calif. 95060.

UNITED States commemorative collection containing 33 different—10¢. Approvals. White, 516-A Avenue L, Brooklyn 30, New York.

GIANT Stamp Collection including: Astronauts, Satellites, Moonrockets, Boy Scout issue, Complete U.N. Set, recent Olympic and Sport issues from many countries, etc., Plus Big Stamp Dictionary and approvals. Everything, 10¢! Stampex, Box 47-RM, White Plains, N.Y.

ABSOLUTELY Free 25 different United States Commemoratives when requesting United States Approvals. K & B, Box 70, Brooklyn, N.Y. 11223.

"INVERTED ERROR" Dag Hammarskjöld, 6¢ with approvals. Belmont Stamps, Washington, D. C. 20015.

PENNY Stamps! 1000 Mounted in book at 1¢ each. Trust Stamp Company, P.O.B. 132-P, Jamaica, N.Y. 11435.

1500 FOREIGN \$1.00; 5000 \$3.00; 9000 \$5.00, 5000 USA \$3.00, contains airs, dues, 19th Century, presidentials, revenues, high values, etc. 200 large size only (your choice of USA or foreign) pictorials and commemoratives \$1.00; 700 \$3.00; 3000 \$12.00. No approvals. Meyers, 5321 Fleming, Richmond, Calif.

NEW Countries, New Issues. Free gift with approvals. Ernest, 1784 Union, San Francisco 94123.

VATICAN Xmas Set 60¢ Approvals. Baricks, POB 7154, Detroit, Mich. 48202.

EXCHANGE. Send 100-200 Different stamps with 25¢. Receive different. Paterson, Lancaster, New York 14086.

100 OLD United States between 1861 and 1935. \$1.00. Roush Stamps, 51 Chestnut, Mansfield, Ohio 44903.

255 DIFFERENT Worldwide: 15¢. Approvals. Tibbets, 8675 Meadow, Downey, Calif. 90242.

14,000 DIFFERENT! AMAZING new plan builds your collection systematically, country by country. Only 50¢ weekly. Ware, Monroe, Conn. 06468.

RUSSIAN Space set 10¢. Russian approvals. Snedco, Box 68-P, Waldwick, N.J.

TOPICALS—Three Colorful Sets. 10¢! Approvals. COLE, Box 223-A, Buffalo, N.Y. 14221.

U.S. Approvals Low prices. Eagle, 2221 Romine Ave., Pittsburgh, Pa. 15226.

2,000,000 STAMPS, 150 Countries, 2¢ each. Belden, Box 4175, Dearborn, Mich. 48126.

65 DIFFERENT Colombians Stamps \$1.00. Registered Delivery, Eplata, Airmail Box 3845, Bogota, Colombia.

500 WORLDWIDE \$1.00! Other offers! Ross, Box 152, Wayne, Pa. 19087.

WORLD'S Largest Diamond "Orchids", latest German Commemoratives—Free! Approvals plus 101 Bonus Sets, William Deems, 226 Race, Ravenswood, West Virginia 26164.

FREE! Big Bargain Catalog—New Edition listing thousands of bargains including U.S. & B.N.A. stamps, packets, albums, accessories and supplies. Also, fine stamps from our approval service which you may return without purchases and cancel service at any time. Jamestown Stamp, Dept. E89PM, Jamestown, N.Y. 14701.

WOW! 110 All Different Germany 10¢ Commemoratives, Airmails, High Values, Big catalog, bargain lists. Also, fine stamps from our approval service, which you may return without purchases and cancel service at any time. Jamestown Stamp, Dept. A89PM, Jamestown, N.Y. 14701.

NEW African Stamp Collection—including Burundi, Guinea, Mali, Rwanda, Togo, and others, 10¢ with approvals. Clark Stamps, Dept. No. 57B, Muskegon, Michigan 49444.

PAKISTAN 25 Different 5¢. Approvals, Hijop Box 505, Norristown, Pa. 19404.

STAMPS Free! New issues, new countries, triangles, rockets, Olympics, Scouts, birds, flowers, animals. Also old Canadian and U.S. Stamps. Plus complete illustrated Canadian stamps catalog. Send 10¢ for mailing. Gray Stamp Co., Toronto, Canada.

PICTORIALS Galore—Large Beauties! Terrific Collection includes exciting Outer Space, colorful sports, animals, unusual triangles, diamonds plus many others. Only 10¢. Approvals accompany. Send Today! Shaw, Drawer E-44, Montevallo, Alabama 35115.

\$25.00 CATALOGUE VALUE!!! All Different, only \$5.00. Edward Roth, Walker, W.Va. 26180.

COUNTRY Collections: Free List. High Value Packet \$2. Persille, 436 New York Ave., Brooklyn, N.Y. 11225.

U.S. APPROVALS. Postage paid both ways. Cross, 1212 Lynch, St. Louis, Mo. 63118.

FREE Stamp Wallet with approvals. Wide choice collections by countries. Clark, Box 28-P, Wilmette, Ill. 60091.

95 DIFFERENT Foreign Catalogue \$10.00 for \$1.00. Satisfaction Guaranteed! Used Catalogues for sale. Popstamps, Valrico, Florida 33594.

QUALITY AND LOW PRICE. EXCELLENT For advanced or beginner. Mounted approvals 2¢ up, all countries in Scott's order. Preview Stamps, P.O. Box 9809M, San Diego, California 92109.

SOUVENIR sheet free. Request Approvals, Lee Hoover, Box 3594, Portland, Ore. 97208.

50 PICTORIAL BEAUTIES of Europe 10¢ with approvals. Collector, Box 3304, Huntington Park, Calif. 90255.

400 FINE Mixed U.S. 15¢. Wright, Box 753-M, Hagerstown, Maryland.

SUMMER DISCOUNTS! Save now on everything in my price lists of Europe, British Empire, packets, sets, singles, U.S.! Lists sent free! Faville, Box 4164 Brookwood, Madison, Wis. 53711.

NUDE Goya (1930), Scott value \$1.00, superb sparkling mint, only 50¢. Approvals, George Bell, Barnes, Milton, Florida 32570.

COLORFUL Lunar Landing envelope mailed from Cape. \$1.00. Stout, Drawer J, Cape Canaveral, Fla. 32920.

TEN Different Nudes: 20¢. Approvals. Stamp Farm, 2M9 Oxford, Wis. 53952.

SURPRISE COLLECTION! Exotic mint British Colonials, absolutely free with approvals. VIKING, Great Neck 8, N.Y.

DWIGHT EISENHOWER Memorial stamp on special cacheted envelope addressed to you. Will have official Oct. 14 First day postal marking from Abilene, Kansas. 35¢ each or 3 for \$1. K. M. Walsh, Box 308, Tuckahoe, N.Y. 10707.

COINS, TOKENS, CURRENCY

PRICE List Send 10¢. Village Coin Shop, Dept. P, Plaistow, N.H. 03865.

SCARCE Date Jefferson nickels. All V.G. Satisfaction Guaranteed. 1942-D—1949S—1950—50¢ each. 1943D—1951S—1955—75¢ each. 1939S—\$1.25. 1938D—\$1.65. 1938S—\$3.25. 1939D—\$5.00. 1950D—\$14.50. Dates not listed 20¢ each. Bryson Inc., 612A White, Toledo, Ohio 43605.

UNITED STATES Specials: Half Dime before 1873, \$3.00; Large Cent before 1857, \$3.00; 1893 Columbian World's Fair Half Dollar, \$3.00; Old style Large \$5.00 bill, \$12.00; All four offers \$20.00. Moneyback Guarantee. Rarcoa, 31-A, North Clark, Chicago 60602.

UNCIRCULATED Dollars, 1880-81-82 S, 1883-84-85-1899-1900 01-02 O mint. \$3.50 ea. Catalogue 50¢. Shultz, Salt Lake City, Utah 84110.

SCARCE! JEFFERSON Nickels. VG-Fine 100% Satisfaction Guaranteed. 1942-D—1949-S—1950—45¢ each. 1943-D—1951-S—1955—75¢ each. 1939-S—\$1.00. 1938-D—\$1.50—1938S—\$2.95. 1939-D—\$4.95. 1950-D—\$13.95. Other dates 20¢ each. PREMIERE COINS, Box 7771, Spokane, Washington 99208.

5,000 PENNIES GUARANTEED unpicked from our vending machines. 55.00 First Vending Company, Box PM, 5322 Belmont, Chicago, Illinois 60641.

50 MIXED "S" cents, includes uncirculated 1955S, new 1968S, 1969S. Only \$1.95. BONANZA, Box 820P, Cupertino, Calif. 95014.

LINCOLNS: 22 "S" including 1955S, \$1.60. 26 1909-1939, \$1.60. 10 "S" Jeffersons, \$1.60. 10 "S" Roosevelts (1946S-1955S complete), \$3.25. All different. All four \$7.75. Silver Dollars \$2.45 each. Price-list 10¢. Robert HARRIS, 2373P Pruneridge, Santa Clara, California 95050.

OLD Coins Bought. Illustrated Catalog 25¢. Hutchinson's, Box 6256, Philadelphia, Pa. 19136.

NEW List Free. Postage 12¢. Doktor, Box 8915, Oak Park, Mich. 48237.

PRIVATE Collector Selling Out! Stamped envelope gets list. Jim Fulks, Capitol Hotel, Louisville, Ky. 40202.

BRILLIANT Uncirculated Silver Dollars—1881-O, 1882-O, 1883-O, 1884-O, 1885-O, 1886, 1887, 1889, 1899-O, 1900-O, 1901-O each \$3.75, all Eleven \$36.95. Bargain Lists 25¢. Bebee's, Incorp., Omaha, Nebraska 68111.

LINCOLNS: 1919, 1920, 1926. Only 10¢. Stevens, Box 546F, North Miami, Florida 33161.

SILVER BARS 900 Fine (90%), \$2.30 Per Troy Oz. Min. 3 Oz. Universal, Box 403, Salinas, Ca. 93901.

FREE Bargain Lists—35 Different brilliant uncirculated Lincolns plus 2 Free Albums (\$6.95 Value) Special \$3.50; Ten Indianheads \$2.75; Five V-Nickels \$1.50; Silver Dollars \$2.25 Each. Pacificcoin, Box 274-M, Downey, California 90240.

COINS Cheap. Catalog 10¢. Buying Catalog 25¢. Winters, Box 7055BL, Minneapolis, Minnesota 55411.

40-PAGE Illustrated United States and Canadian coin list 10¢. Stoney, 260 Washington, Boston 8, Mass.

20 UNCIRCULATED Foreign Coins \$1.00. Coins, Box 35041, Minneapolis, Minnesota 55435.

ESTATE Sales, Free Lists. Wesley Rood, West Union, 9, Iowa 52175.

FIFTY Indian and Lincoln Cents before 1930 \$3.50. Fairway, 121-P, Rye, New York 10580.

INDIANHEAD Cent 35¢ Reduced Prices! Coins Wanted! Buying list 25¢. Nelson, 346-P, Rye, New York 10580.

GOLD COINS of the World. Beautiful low prices. Plus thousands of United States Coins. Free price list. Please send long, airmail envelope, self-addressed, stamped, Silver Center, Box 22171-M, San Francisco, California 94122.

ANTIQUES, RELICS, INDIAN GOODS AND CURIOS

LIST Indian relics, 10 Arrowheads \$3.00. Hyde's, Box 2304, Santa Fe, New Mexico 87501.

TONS Of antique gun parts and supplies. All reproduction muzzle loading guns. Send \$1.00 for enlarged illustrated catalog No. 118-A. Dixie Gun Works, Union City 12, Tennessee.

PURPLE GLASS! Secret For Purpling Indoors Revealed. \$1.00 Postpaid. Coinland, 1505 P-C-H., Redondo Beach, California 90277.

SWORDS—Engraved, Gold/Nickel Finish. \$24.95. Send 75¢ for Brochure. Toledo Imports, Dept. PM, Box 504, Winston-Salem, N.C.

MODELS—SHIPS, TRAINS, PLANES, ETC.

ROCKETS: Real flying models—flights up to 2500 ft. New illustrated catalog 25¢. Single and multistage kits, cones, engines, launchers, trackers, rocket aerial cameras, technical information. Fast service. Estes Industries, Penrose 2, Colorado 81240.

SHIP And yacht model fittings: Fine construction hull kits: blueprints. Send 50¢ for illustrated catalog. A. J. Fisher, Inc., 1002 Etowah Avenue, Royal Oak, Michigan 48067.

SHIP Model kits and fittings: clippers, frigates, etc. Catalog paint-tool list, 1969 catalog 50¢. Models Shipways, Box 65, Bogota, N.J. 07603.

SHIP Models, Kits, fittings, plans, books, tools, engines, motors. Big illustrated catalog 50¢. Mass. residents add 3% tax. James Bliss & Co., Dept. SM, Route 128, Dedham, Mass. 02026.

CANNONS, Flying Saucers, Hot Air Balloons, Rockets, Etc. Free Catalog. Zeller, Box 69, Hudson, Mich. 49247.

SHIP Models catalog 25¢. Scientific, Inc., 100 Monroe, Newark, N.J. 07105.

SCALE Building materials. 1/4" & 1/8" scale. Windows, doors, siding, roofing, lumber and structural shapes. Send 50¢ for catalog. Small Sales Co., P.O. Box 177, Shawnee Mission, Kansas 66201.

SOLAR Flying Saucer Lifts Animals—See Spacetratics Ad Under Science-Chemistry Column.

GAMES, TOYS, PUZZLES, NOVELTIES

"ROULETTE DICE" . . . guaranteed to roll a thirteen or better more often than not! Only \$2.00 a pair. Details free. D.E. Products, Box 488, Worcester, Mass. 01601.

FREE Rocket sent with catalog 25¢. Scientific, 8886 Melvin, Livonia, Michigan 48154.

MAGIC TRICKS, JOKES, VENTRILOQUISM

HOUDINI'S Original Magic Shop. Established 1856. Send 25 cents for Illustrated Catalog containing 5000 Tricks, Mindreading, Puzzles, Hypnotism and Jokes. Flossie-Hornmann, 304 West 34th St., N.Y. 10001.

HOUDINI Magic Catalog!! Giant Professional Deluxe Edition!! 1000 World's Greatest Tricks!! 25¢ with Free Gift Certificate!! House of 1000 Mysteries, Dept. PM9C, Northeast Fifth Ave., Ft. Lauderdale, Florida 33308.

500 TRICKS Catalog. 1969 Edition, showing latest magic for pocket, parlor, stage. Only 10¢. Fastest mail service for 45 years. Douglas Magicland, Dept. 11, Dallas, Texas 75221.

BE A Magician! Two booklets explaining sixty-eight tricks plus large professional catalog. \$1.00. Magic, Inc., 5082 Lincoln, Chicago, Illinois 60625.

VENTRILOQUISM! Information free! Dummy catalog. 25¢. State age. Maher, Studio H, Box 8356, Kensington Station, Detroit, Michigan 48224.

MAGIC Catalog. World's finest 3000 tricks. (340) pages \$2.50. Beginners, amateurs, professionals. Kanter's, A-200 South 13th St., Philadelphia, Pa. 19107.

COMPLETELY Illustrated catalog. 84 pages. 25¢. Manhattan Magic, Box 334-M, N.Y.C. 10011.

WORLD'S Finest professional magic tricks. Joker's Novelties. Giant illustrated catalog 10¢. Top Hat, Evanston, Illinois.

MAGIC MAGAZINE—Monthly since 1936. 44 pages. All phases. 3 month trial \$1.00. Genii, P.O. Box 36068, Los Angeles, CA 90036.

AMATEUR and PROFESSIONAL MAGICIANS all new magic tricks and gags catalog 25¢. Our specialty same day service. Fabulous Trick and Magic, 3319 E. Charleston, Las Vegas, Nevada 89104.

CATALOG \$26, 175 pages, 25¢ (1,500-399 tricks, jokes, novelties). Elbee, 7408-P, San Antonio, Texas 78207.

FREE Trick. New Magic Catalog. Send 25¢. Ace Magic, Box 329, Evanston, Ill. 60204.

FREE Trick, Magic Magazine and Catalog 25¢. Magic & Fun, Box 9-PM, New York, N.Y. 10022.

VENTRILOQUISM! Unique "listen-and-learn" method. Write. Show-Biz, 1735-P East 26th Street, Brooklyn, N.Y. 11229.

BOOKS, CATALOGS, NEWSPAPERS

BUSINESS Books and Directories. List 10¢. Cricket, Box 527, Ardmore, Penna. 19003.

NATIONAL Geographic Magazines, 1888-1967, any issue. Buxbaum, Box 465-PM, Wilmington, Delaware 19899.

PROPHET Elijah coming before Christ. Wonderful book free. E. Megiddo Mission, 481 Thurston Rd., Rochester, New York 14619.

DISCOVER Advanced techniques Self-Improvement—Free information: Horning, Box 25M, Mastic, New York 11950.

HOW to Sell your Way to Financial Freedom. A Salesman's Treasury of Selling Secrets \$1.50, includes postage.—Brighten Sales, P.O. Box 09193, Chicago, Ill. 60609.

POWER To Change your Life. 256 Page Book "THINKING BIG" Reveals Secrets that make men rich. Send \$2.00. Morgan House, D-1147, Presque Isle, Maine 04769.

BACK Date Magazines! Send needs. Midtown, Box 917-PM, Maywood, N.J. 07607.

FREE List instructive, enlightening Books. Distributors, 2574 North Cornelia, Fresno, Calif. 93705.

HOW To Plan Adequate Life Income. Other helpful Books. Practical. Inspirational. Free information. Write Bert Hadley, 624 North Cherry, Galesburg, Illinois 61401.

SEND for a FASCINATING List of OCCULT Books to The Aquarian Age, Dept. 7-74 Winthrop Street, Cambridge, Massachusetts 02138.

FINEST, Self-Help, Mailorder books available, others. Send stamp. Rightway, Box 885 P.M., Moorhead, Minnesota 56560.

NOW! New 9th Edition Antique Dealers Handbook. Only \$7.95. Diohn Gifts, 928 West 2nd, Sioux Falls, South Dakota 57104.

FREE Brochure. Interesting Books, True Value Products. Box 903, Salt Lake City, Utah 84110.

SECRET Of Bowling Strikes \$2. Gene Chiasson, 507 West 8th Street, Dept. 694, Thibodaux, Louisiana 70301.

FREE Circulars, low cost popular Self-Improvement Books. Alyce Enterprises, PM8, Box 1087, Fort Lee, N.J. 07024.

PAPERBACK Catalogue, 270 pages. 15,000 titles, subject indexed. \$1.00, credited toward order. New York Book, 4 P West 43 Street, N.Y.C. 10036.

WANT A RAISE? Better Job? Be Worth More! Free Brochure 73 Beautifully Written Self-Development Books. Woodard Supply Co., 2818D Hanson, Charlotte, N.C. 28207.

PLAYS, STORIES, MANUSCRIPTS

WANT Your book published? Learn how we publish, advertise, promote, distribute. Many successes. Free booklet PM, Van-tage, 120 West 31, New York City.

FREE: HOW TO GET YOUR BOOK PUBLISHED right away, at low cost. For valuable, fact-filled book, FREE, write: Pageant Press International, Dept. N-1, 101 Fifth Avenue, New York, N.Y. 10003.

BUSINESS OPPORTUNITIES

HUGE Profits! Mail order importing. Free information. ITIS, PM-8, Box 454, Hollywood, Calif. 90028.

BOOKKEEPERS Earn \$1000.00 month. Operate simplified Bookkeeping tax service. Universal, Box 664-M, Springfield, Missouri 65801.

WANT To make big money at home? \$10.00 profit in an hour possible with invisible mending. Make tears, holes disappear from clothing, fabrics. Steady year-round demand from cleaners, laundries, homes. Details free. Fabricon, 1585 Howard, Chicago 60626.

CONCRETE FACTS: Highly profitable home business. Experience unnecessary. Unlimited unique pottery designs easily made without moulds. Birdbaths, fountains, wishing-wells, benches, etc. Chemical coloring formulas, marbling. FREE illustrated brochure. Hollywood Cementcraft, 602 Athens Street, Altadena, California 91001.

WORLD'S Largest supply. Merchandise 25% to 40% under wholesale. Bankrupts, closeouts 10¢ on dollar. Imports. Hong-kong clothes. Automobile discounts. Free details. International Buyers, Box 4633-MM, Colorado Springs, Colo. 80909.

RAISE Rabbits for us on \$500 month plan. Free details. White's Rabbitry, Mt. Vernon, Ohio 43050.

FREE "Franchise Profit Letter" tells how unique NFR service is helping thousands seeking profitable businesses. Write today. National Franchise Reports, W-528, 333 North Michigan, Chicago 60601.

\$400.00 MONTHLY Raising giant fishworms. Soilless method. Charlie Morgan, Bushnell, Florida 33513.

EARN Money raising fishworms for us! Write: Oakhaven-38, Cedar Hill, Texas 75104.

400,000 BARGAINS Below wholesale! Many free. Liquidations . . . closeouts . . . job lots . . . single samples. Free details. Bargainhunters Opportunities, Box 730A, Holland, Michigan 49423.

BUILD Custom Cases at home for profit. Get orders by mail. We supply materials, instruction—everything. Free home business details. Custom Case Supply Co., 7630-CPH, Gloria Ave., Van Nuys, Calif. 91496.

VENDING Machines. No selling. Operate a route of coin machines and earn amazing profits. 32-page catalogue free. Parkway Machine Corporation, 715 PMB Ensor Street, Baltimore, Maryland 21202.

PIANO Tuning Learned quickly at Home. Tremendous field. Musical knowledge unnecessary. GI approved. Information free. Empire School, Miami, Florida 33145.

ADDRESSERS And mailers needed. Send stamp for information. Lindbloom, 3636 West Peterson, Chicago 60645.

FREE Book "990 Successful, Little-Known Businesses." Work Home! Plymouth-372-H, Brooklyn, New York 11218.

MAKE \$75.00 daily distributing tools to service stations. Free Plan. INKA, 2401 Crocker, Houston, Texas 77006.

ESTABLISH Profitable Catalog Mailorder Business! Vikari's, Box 1312PM-H, Salt Lake City, Utah 84110.

STOP Throwing Away Those Boxtops! They're worth money, some 25¢ each! Write: Boxtops—BO, Cedar Hill, Texas 75104.

ADVERTISING BUSINESS—YOU own it. \$350 First Week or Money Back. Electric Neon Action Ad Clock, 229 W. Illinois, Chicago 60610.

JOIN "MONEY GETTER'S GUILD". Receive hundreds money-making. Business Building Propositions. Year's membership only 25¢. Write: Fourstars, Box 839, Long Beach, New York 11561.

\$21.00 HOUR Profit—From Home Picture Framing Business. (Clampless Assembly Method) Write: Japs, 126-PM Seventh North, Hopkins, Minnesota 55343.

UNLOCK Your Future. Become professional Locksmith by spare time home-study. Make up to \$6 per hour. All tools, equipment incl. Facts free. Send name. Locksmithing Inst., Dept. 1310-089, Little Falls, New Jersey 07424.

I MADE \$40,000.00 Year by Mailorder! Helped others make money! Start with \$10.00—Free proof! Torrey, Box 318-Y, Ypsilanti, Michigan 48197.

MAIL Baby Catalogs imprinted with your address to New Mothers for Big Profits! Details 25¢. Volz-PM, Ypsilanti, Michigan 48197.

\$112,000.00 YEAR. Mailorder. Can make you money. **PROOF.** Write Williams, 4464 H, Los Angeles 90044.

MAKE big money growing ginseng! \$3.-000-\$30,000 annually. We buy your crop. Send \$2 for seed sample and information. Glass' Ginseng Exchange, Box 1969, Springfield, Mass. 01101.

OVER \$3,000.00 my mail profit monthly! 53 years showing others how. Send stamped self-addressed envelope. Free samples, proof, testimonials. Brewster, Box 1348-PM, Clearwater, Florida 33517.

AMAZING Automatic Fishhooks. 200% Profits. Sample \$1.00 Refundable. Aron, Postbox 61-PM, Mastic Beach, New York 11951.

MAKE Money mailing catalogs. Free Details. Newton, P.O. Box—F-PM Detroit, Mich. 48208.

READ Progressive Mailtrade, the magazine that tells how to make money by mail. Quarter brings sample and special offer. Mailtrade, P.O. Box 357, Sheboygan, Wis. 53082.

FREE Catalogs. Repair air conditioning refrigeration. Tools, supplies, full instructions. Doolin, 2016 Canton, Dallas, Texas 75201.

VENDING Machine big catalog. Rake, 523 A Spring Garden, Philadelphia, Pa. 19123.

56 ACTIVE Franchise opportunities available all over USA. Brochure details 56 franchise chances for you to have your own business tied with successful national companies. Send name, address to P. Stewart, 1085 Walnut, Des Plaines, Illinois 60016.

CLIP Newspaper items. \$1.60-\$5.00 each. Details free. Walter, Box 1360-PA, Erie, Pa. 16512.

SELL Lifetime, Metal, Social Security Plates. Big Profits! Sample and Sales Kit Free. Russell, Box 286-PM, Pulaski, Tennessee 38478.

SPARE Time Cash—Sell Advertising Book Matches—every business a prospect—no investment—no experience needed to build steady repeat business. Daily Cash commission in advance. Write today—We'll send your sure-fire selling kit by return mail. Dept. MX 869, Superior Match Co., 7530 S. Greenwood, Chicago, Illinois 60619

COPUBLISH "Mail Sale Advertiser," leading mailorder paper. Copy and details 25¢: U.S.A. only. Vanroy Shirk, Lebanon, Pa. 17042.

MAILORDER Records help get Increased Business! Complete 32 page Record Book shows your inquiries, orders, advertising expense, etc. Only \$1.00. Martin, Popular Mechanics, Dept. PM, 575 Lexington, New York 10022.

TREMENDOUS Mailorder Profits! Write George, Box 2188A, Cypress, California 90630.

\$70.00 WEEKLY—home, spare time. Simplified mail bookkeeping. Immediate income easy. Auditax, 34741A, Los Angeles 90034.

I MAKE \$1,200 MONTH IN ACCOUNTING. You start, train fast. Only 10 lessons. Certificate awarded. Work from home or office. Mail \$2. first lesson. Jenkins, Box 571, Taft, California, 93268.

START BIG-PAY Business at home in spare time. No experience needed to operate little table-top machine for bronzing baby shoes. Make \$7.32 profit on every pair. Full particulars free. Send postcard to: Mason, 1512 Jarvis, Room CM-2-C, Chicago, Illinois 60626.

SUPPLY Fried Chicken Dinners on \$500 week home plan. Free information. White's Chicken Dinners-PM, Mt. Vernon, Ohio 43050.

UP To \$5.00 each for newspaper clippings! Free details. Philip, Box 368-S, Southfield, Michigan 48075.

DRAFTSMEN! Operate own **DRAFTING SERVICE!** Full, Part Time; Experience unnecessary; Details: Roberts Drafting, 1741 Circle Road, Baltimore, Maryland 21204.

EARN more than many Professional men! \$1000.00 monthly operating Mail Order Collection Agency. Continental, Box 2023-A, Des Moines, Iowa 50310.

SELL Books by mail. 400% profit. Royal, Box 450-X, Cleveland, Ohio 44127.

MAKE Money Operating Home Mailorder Business. No Inventory. Write Purple Enterprises, Box 16291-AH, Jacksonville, Fla. 32216.

MAKE Money from old tires. Operators clearing \$800, weekly. Equipment costs \$1500. Get facts S & S Patents, Inc., 3752 N. Damen, Chicago 60618.

CALIFORNIA MANUFACTURER NEEDS man to assemble our product and be local agent, experience unnecessary. May start while presently employed. Five-figure income for responsible applicant. S.K.R.M. Manufacturers, 2540 Olive Avenue, Long Beach, California 90806.

MAKE \$46 from square foot plywood: jigsaw or bandsaw necessary. Free details. Woodar, Bridgewater, Mass. 02324.

INSTANT Mail Order Business—All you need is a mailbox. Details \$1 (Refundable). Mall Marketing Services, Benton, Illinois 62812.

MAILORDER Beginner's catalog. 10¢. Guaranteed. Sullins, Box 2068-M, Forsyth, Georgia 31029.

\$6 CAN START YOU IN BUSINESS. Investigate 100 business opportunities in every monthly issue of Franchise Journal. Get the facts, figures, company histories, profit potential, investment requirements, etc. Send \$6 for 12 exciting copies to Franchise Journal, 892-G W. 16 St., Newport Beach, Calif. 92660.

\$60.00 DAY. Manufacturing concrete Posts, Blocks, Mold Equipment Catalog \$1.00 refundable. Carlayne, Route One, Box 106-T, Rapid City, South Dakota 57701.

MORE Sales, Profits! 88 Ways to Promote, Build Your Business. Free details. Write today. Graybow, Box 141, Brampton, Ontario, Canada.

HOW to start your own typewriting service. Wonderful profits. Free Gift—free details. Coach House, Box 834D, Bangor, Maine, 04401.

IMPORT Export opportunity, profitable world-wide, mail-order business from home, without capital; or travel abroad. We ship proven plan, for no risk examination. Experience unnecessary. Free details. Mellinger, Dept. C2708, Los Angeles 90025.

"MAILORDER" HOW TO PREPARE YOUR OWN CATALOG For pennies . . . including popular products . . . without merchandise investment! Free Catalog-Proof! Obie, 5711-MG—14th, Brooklyn, New York 11219.

LIQUID Molding rubber also liquid plastic. Free information. Chaney's, 5415-A San Jose Blvd., Jacksonville, Fla. 32207.

AUCTIONEERING Home Study Course—\$15.00—Diploma—American Auctioneer College, Box 316, Terra Ceia, Florida.

ESTABLISHED, Profitable, Simple, no selling, home. Free Information. Northern Survey, Suite 204-F, 1255 University, Montreal 110.

PROFITABLE WATCH REPAIR. Sample lesson free. No obligation. Watchmaking YVB, Fox River Grove, Illinois 60021.

NEW Plan! Pays up to \$25.00 an hour! Little as 4 hours weekly. Place Thrifted self-service displays in stores. No cost to merchants. No experience needed. Free details. Lux Company Incorporated, Dept. 1225, Elkhart, Indiana 46514.

SELL Gifts, Household Items—Make extra money. Toys, Jewelry, Stationery, Greeting cards. 600 items. Experience unnecessary. Salable Samples on approval. Free—Catalog, Personalized Christmas Card Album. Hedenkamp, 361 Broadway, Dept. PM-101, New York 10013.

INSTALL Burglar alarms without previous experience or costly equipment. Big profit. Free details. Nasco, 11071 Massachusetts, Dept. C2708, Los Angeles 90025.

HOW And Where To Get Capital. I got \$250,000—helped others. Free details. Counselor-17, Kerrville, Texas 78028.

MAILORDER—Profitable products; drop shipped. No merchandise investment. Everything supplied—catalogs, ads, mailing lists. Gift-Guide, 1137 Crenshaw, Los Angeles 90019.

OPERATE Restaurant. Free booklet reveals profitable plan. Write Restaurant Business School, Dept. EC 89, 1920 Sunnyside, Chicago, Illinois 60640.

SECRETS! Mail Order Success. Internationally famous expert reveals how to make home business fortunes. Beginners: Get free copy "Make Money By Mail." Discloses free advertising, profitable products. Malico, 1554 Sepulveda, Dept. C2708, Los Angeles 90025.

\$500-\$800 MONTHLY. Raise small laboratory-breeding stock for us. We supply equipment, breeders, and instructions. Illinois Research Farms, Dept. MPD-8, McHenry, Illinois 60050.

\$100 WEEKLY Possible! Homework, mailing circulars. Information, send stamped, self-addressed envelope. Martin's, Box 445-D, Sonoma, Calif. 95476.

BECOME Tax consultant. Our students earn \$1,000—\$3,000 every tax season preparing returns evenings. State approved. National Tax School, Monsey 2HB, New York 10952.

\$2.00 PER DOZEN Cash Profits. Assemble New Art Foam Products. All Supplies Furnished. Showcase Box 55392D Indianapolis, Indiana 46205.

INVEST. Make as much as \$15 per \$1000 per Month of Investment. That's \$180 per Year. For information send \$1.00 to: Investment Properties, 198 Lewis St., Bridgeport, Conn. 06605.

WILL Forms—Two \$1.00. Goddall Printing, 68-N Joost, San Francisco, Calif. 94131.

MAIL Baby Catalogs, Imprint, to new Mothers. Big Profits! Details \$1.00. Krefski, 609 Lee, Plymouth, Pa. 18651.

INCREASE mailorder profits! Tested proven methods. Details free. Barry, 89-22A 218 Place, Queens Village, New York 11427.

START Successful home business! Spare-time Full-time. No experience necessary. Learn how! Write Alyce Enterprises, PM8, Box 1087, Fort Lee, N.J. 07024.

DROP-SHIPING 1,000,000 Items! Camille, 202-PX Brownell Street, New Bedford, Mass. 02740.

\$200.00 DAILY in your mailbox! Your opportunity to do what mailorder experts do. Free details. Associates, Box 136-A, Holland, Michigan 49423.

VACUUM Plastic Molding & Liquid Plastic Casting—At Home! Make hundreds of full 3-D plastic products. Big profit in spare time. Free facts, samples. Nationwide Plastics, Dept. HF, 4140 Eagle Rock Blvd., L.A., Calif. 90065.

MAKE Two to three times your cost on hundreds of products. Gift items, novelties, toys, carded merchandise, 1001 others. \$1.00 brings giant catalog. Refundable on first order. Lakes, 15844B Madison, Cleveland 44107.

CASH for magazine clippings. Up to \$2.00 each. Details free! Bowden Enterprises Box 585-BB, Rahway, New Jersey 07065.

MAKE. Sell magnetic car signs. Write PM-1834 Edgeland, Louisville, Ky. 40204.

LEARN To earn \$\$\$ in spare time. Send \$1.00 for mail order plan. P.O. Box 1033, Bloomfield, New Jersey 07003.

WOULD YOU INVEST \$500 TO MAKE \$10,000 A YEAR AND BE YOUR OWN BOSS? Write for free information. Then, decide for yourself if you want to start your own business on a full or part time basis. You can get into business for yourself with an easy-to-operate Texture Spraying Unit and Glitter Gun. Contractors will use your services for texture-spraying and glitter finishing. You can spray mill mixes, dry-wall mud, acoustics, texture paints, water-proofing and many other vital materials. The field is unlimited. The profits are big. Write for free information. No obligation. Write: Mr. Si Kraft, Sales Manager, Goldblatt Tool Company, 579 Osage, Kansas City, Kansas 66110.

TAKE Catalog orders. We drop-ship 1001 best selling specialty products. Guaranteed lowest below wholesale prices. Fantastic spare-full time home business. Free book shows you how. SMC 7530SPH Gloria Avenue, Van Nuys, California 91406.

JEWELRYCRAFT—It's easy! Big profits! Catalog, 25¢. Modern Craft, 12790 US 19, Clearwater, Florida 33516.

EXCLUSIVE DISTRIBUTORSHIPS AVAILABLE. Four Complete Lines—Call on Retailers—Contractors—Truckers—Schools. Unlimited Earnings. Send \$3.00 (Refundable) Unitek Corp., 815 So. Nixon Avenue, Lima, Ohio 45805.

HOMEWORK, mailing circulars! Free details! Cam Co., Dept. 155-XO Verona, N.J. 07044.

RECEIVE Hundreds of Moneymaking Opportunities. Perrone, Box 203, Bronx, N.Y. 10458.

HOME Business in spare time. Choose ideas. Full details—\$1.00. Hayne Enterprises, 437 Arcade Building, Sacramento, Calif. 95815.

MONEYMAKING OPPORTUNITIES

\$200.00 FROM Sheet 1/4" plywood (scrap). Details 25¢. Novelties, 610 So. 24th, Elwood, Indiana 46036.

EARN \$240.00 a month at home. Spare time, doing only two \$5.00 invisible mending jobs a day. Big money paid for service that makes cuts, tears disappear from fabrics. Steady demand. Details free. Fabricon, 1532 Howard, Chicago 60626.

MAKE Statuettes, novelties, imitation marble. Sell to stores or start gift shop. Free details. Marbleizing, 41 Waverton, St. Louis, Mo. 63124.

HOW To Make money writing short paragraphs. Information free. Barrett, Dept. C-27-U1, 6216 N. Clark, Chicago 60626.

VENDING Machines. No selling. Operate a route of coin machines and earn amazing profits 32-page catalogue, free. Parkway Machine Corporation, 715 PMM Ensor Street, Baltimore, Maryland 21202.

FREE Copy of world's leading contest magazine! Write Prizewinner, Box 11569, St. Petersburg, Fla. 33733.

CASH/Royalties for romantic songpoems! Castle's, 203-M West 46th, New York City 10036.

HOMEWORK. Mailing circulars. Free details! Cam Company Dept. 155-KP, Verona, N.J. 07044.

FREE. 206 Easy Ways to make money taking orders for exciting new products—spare time. Send name, age for 5 months free subscription. Opportunity Magazine, 1460 Hancock Center, Dept. 17-HM, Chicago 60611.

HIGHLY Profitable spare-time business. Bronzing & PearlKoting baby shoes. Complete set-up on credit available. 31 year old company. Send 25¢ for brochure. Kik-tavi, Box 4187PM, Compton, Calif. 90224.

SCIENTIFIC Massage: Big Earnings uncrowded profession. Learn spare time at home. Diploma awarded. Free catalog. Write Anderson School, Dept. H-1C, Princeton, Illinois 61356.

CLIP Newspaper items. \$1.00-\$5.00 each. Details free. Walter, Box 1360-P, Erie, Pa. 16512.

SPARE Time Cash—Sell Advertising Book Matches—every business a prospect—no investment—no experience needed to build steady repeat business. Daily Cash commission in advance. Write today—We'll send your sure-fire selling kit by return mail. Dept. MA-869, Superior Match Co., 7530 S. Greenwood, Chicago, Illinois 60619.

MONEY—Become a Finance Broker. Full or part time. RMP & Co., P.O. Box 901, Desk 10, El Reno, Oklahoma 73036.

MAKE: \$12.00 Profit each dozen assembling Belts. Details Free. (Stamp appreciated.) Redikut's-40, Richland Center, Wis.

HOW MUCH does being your own boss or making \$25,000.00 per year interest you? The Warner breakthrough in the Engraving field could be your future. Write: Warner, Room CE-2-C, 1512 Jarvis, Chicago, Ill. 60626.

SELL What You Write, Instantly! Beginners Market List tells where, how, and what to write. Send stamped, self-addressed envelope, free proof. Economy Box 1348G, Clearwater, Florida 33517.

\$400.00 MONTHLY Possible in your home woodwork shop. Experience unnecessary. Free Information—send stamp. Mission Industries, Box 755, Shawnee Mission, Kansas 66201.

NEW Free Moneymaking Mail Order Catalog Write Fitz, Freeville, New York 13068.

HOW TO GET RICH!! Free "Money-making Brochure"! Success International, Box 2447-C, Livonia, Mich. 48151.

MONEY—SPARETIME OPPORTUNITY PANELISTS AT HOME WANTED BY NEW YORK RESEARCHER. Leading research firm seeking people to furnish honest opinions by mail from home. Pays cash for all opinions rendered. Clients' products supplied at no cost. For information write: Research 669 Mineola, N.Y. 11501, Dept. PM-24.

HIGHER INCOME, Security and Power, 256 page Book =WB-123, "Thinking Big" reveals secrets that make men Rich! Send \$2.00. TONY'S, 3924 Suel, Tyler, Texas 75701.

CLIP Newspaper Items. Earn \$1.00-\$5.00. Information Free. Ideas, 6210C Hampton Boulevard, Norfolk, Virginia 23508.

LYRIC WRITERS write songs with writers who write hits for top Nashville artists. Globe, 420 Broad, Dept. PM, Nashville, Tenn. 37203.

MECHANICALLY inclined? Learn profitable WATCH REPAIRING. Free sample lesson. Watchmaking, YVA, Fox River Grove, Illinois 60021.

MAKE \$5,000 yearly, sparetime, raising mink, chinchilla, nutria, etc. Free booklet reveals proven plan. Write: Furs, Dept. R, Bewdley, Ont. Canada.

SELL Greeting Cards—Make extra money. Show friends Gifts, Toys, Jewelry, Stationery, 600 items. Experience unnecessary. Salable Samples on approval. Free Catalog, Personalized Christmas Card Album. Hedenkamp, 361 Broadway, Dept. PM-102, New York 10013.

DATACRAFT Agency. One-Man Business. Tax news, Realty lists, Credit advice, Job aids, Legal reports, Billing services, 25-plans-in-one. Big profits. Full training course & dealership Write: Datacraft-22, Kerrville, Texas 78028.

FRUIT Jars bringing from \$1.00 to \$1,-000.00 each. Current Price Book No. 1, lists over 400 jars with description and price, where to sell, and where to find them. One jar will more than pay for the book. Price \$2.00, airmail \$3.00. E&O Publishers, Dept. 610, Box 4037, Dallas, Texas 75208.

\$500-\$800 MONTHLY. Raise small laboratory-breeding stock for us. We supply equipment, breeders, and instructions. Illinois Research Farms, Dept. MP-8, McHenry, Illinois 60050.

POWERFUL shortcuts to lucrative mail-order enterprises. Proof. Literature. Eddie's, 4809-MG North Montclare, Chicago, Illinois 60656.

INVESTORS or Person with Cash needed to develop new type boat. Please send \$1.00 to cover mailing to: Hammercraft, 198 Lewis St., Bridgeport, Conn. 06605.

STOCK Market Calculator! Details Free! Ross, 837 Glenway, Inglewood, California 90302.

\$10,000 INCOME Producing Items at Home. Details FREE. Lockett, 4153 Lancaster Ave., Philadelphia, Pa. 19104.

HIGHER INCOME, Security and Power, 256 page Book "Thinking Big" reveals secrets that make men Rich! Send \$2.00. Jones, 1715 Longhill, Monterey Park, Calif. 91754.

START A profitable subscription business in spare time. We need men and women (young and old) as representatives for all leading national magazines. Liberal commissions on all subscriptions. Supplies free. No experience needed. Send this ad with your name and address to Popular Mechanics, Room 8-O, 250 W. 55th St., New York, N.Y. 10010.

OVER \$2,500.00 Weekly average income in mail order by originator of Guaranteed Program. Free details. Enterprise Books, (PM8), Box 188, Seabrook, Texas 77586.

GAIN! Success, Wealth, Happiness, Health, Personality. Post Card brings free list. Elston House, 35 Stonecliff Road, Centerville, Mass. 02632.

MAKE Big Easy Profits making costume jewelry at home. Spare time. Quick, easy to make; easier to sell! Details Free! Donbar, 2934 Fullerton, Dept. J-209, Chicago, Illinois 60647.

HOMEWORKERS! 200 companies—48 page Directory. FREE details. Quest, Box 6029, Dept. 18, San Jose, California 95150.

LEARN The secrets of repairing junk batteries "Fabulous Profits" at home. Batteryman, Route 1-188D, Blythe, Calif. 92225.

ADD 50% To your Money in five years. Write to Paramount Investment Co. P.O. Box 7434, New Haven, Conn. 06519.

SEWING MACHINES! Dealerships available most areas. Huge Profit Margins! Confidential Sales Kit \$2.00, refundable first order. Warehouse Distributors, Box 5608, Buena Park, California 90622.

101 COMPANIES offering home employment! Names, addresses, types of employment offered plus applications forms, yours for \$1.00. Jobguide, Dept. PM-8, 69-29 Queens Blvd., Woodside, New York 11377.

PROFITABLE OCCUPATIONS

BECOME A mortgage broker, earn \$10,-000 to \$50,000 a year. Details free. United, Box 6284A, Marietta, Georgia 30060.

HOW To Make Money Writing Short Paragraphs. Information Free. Barrett, Dept. C-27-U2, 6216 N. Clark, Chicago 60626.

CHROME Plating. Instructions, equipment and supplies. Platers' Supply, P.O. Box 565, Lugo Station, Los Angeles, Calif. 90023.

FT. SMITH Auction School. Ft. Smith, Ark. Residents & Home study. Veteran approved.

FREE Book "990 Successful, Little-Known Businesses." Work Home! Plymouth-37-H, Brooklyn, New York 11218.

SHARPEN Scissors, Pinkers. Inexpensive equipment, tools, supplies. Blackhawk's, Sheldahl, Iowa 50243.

YOUR Own Sign shop. Signs, 410-S So. Western, Springfield, Ohio 45506.

EARN \$240.00 A month at home, spare time, doing only two \$5.00 invisible mending jobs a day. Big money paid for service that makes cuts, tears disappear from fabrics. Steady demand. Details free. Fabricon, 1586 Howard, Chicago 60026.

\$500-\$800 MONTHLY. Raise small laboratory-breeding stock for us. We supply equipment, breeders, and instructions. Illinois Research Farms, Dept. MPA-8, McHenry, Illinois 60050.

START Your own profitable business. Amazing book tells how. Free details, Snell's, Box 682-A, Bath, New York 14810.

START A magazine subscription business. Earn generous commissions on popular Mechanics, Good Housekeeping and all others. Best commissions, bonus, all material sent free. No experience needed. Write Popular Mechanics, Room 8-P, 250 West 55th St., New York, N.Y. 10019.

MAKE MONEY WRITING SHORT FILLERS AT HOME. No skill needed, only sentences in plain English. Secrets reveal what, how to write, where to send. Programmed complete 10 lesson course ONLY \$4.95. Receive \$5.00, \$10.00 checks while learning. Mazel Tov, Dept. PM-8, 6412 North Glenwood, Chicago, Illinois 60626.

SALESMAN—DISTRIBUTORS

EARN Terrific commissions listing delinquent accounts. General Finance Company, 304-A Pickwick Building, Kansas City, Mo. 64106.

EARN Big Commission Full or Part Time. Show America's largest line Low Priced Business Printing and Advertising Specialties Plus calendars in season. No experience. No investment. No collections or deliveries. On-the-spot commissions. Big Free Sales Kit samples hundred items used daily by businessmen. Merchandise bonuses for you. Build profitable repeat business. Start now. National Press, Dept. 91F, North Chicago, Ill. 60064.

FREE. 206 Easy Ways to make money taking orders for exciting new products—spare time. Send name, age for 5 months free subscription. Opportunity Magazine, 1460 Hancock Center, Dept. 17-HS, Chicago 60611.

100% PROFIT—Sweet Georgia Brown Cosmetics sell fast. Write for Sample Case offer. Valmor, Dept. H, 2411 Prairie, Chicago 60616.

SELL Advertising book matches. Write us today. We put you in business by return mail, handling complete line ad book matches in demand by every business right in your town! No investment; everything furnished free! Top commissions daily: Superior Match, Dept. M869, 7530 S. Greenwood, Chicago, Illinois 60619.

SELL Advertising Ball Pens, Calendars, Ad-Specialties—Build Own Repeat Business—Free Kit—Fleming, Dept. A, 6535 Cottage Grove, Chicago 60637.

BIG earnings selling Hertel Bibles. New 3-dimension cover, finest reference edition sells fast. Demonstrator furnished. Big commission. International Book, Dept. PM, Box 118, Wichita, Kansas 67201.

\$100 A WEEK Sparetime opportunity. Man Contact Service Stations. Cyclo Manufacturing, 3816 Dahlia, Dept. 164, Denver, Colorado.

MAKE extra \$25 to \$75 spare time! Take orders for double air cushion Bronson Shoes. Amazing comfort. Terrific men's, women's line for dress, work, play. Highest commissions. Shoes for yourself. Big outfit Free. Write Bronson, Dept. 167, Minneapolis, Minnesota 55408.

FREE! Money Making Opportunities! Your Own Business! Write name, address, zip, today. Bradley, Box 509-D, Mt. Kisco, New York 10549.

SPACE Energizer Fantastic Window attraction drives wheels suspended in space. Free Information. Adult Toys, 800 Borite, Reno, Nevada 89502.

HOUSEHOLD And food products route. \$25.00 or more daily profit. Larger repeat orders. Man, woman. Full, part time. McNess, Freeport 2689, Illinois 61032.

AGENTS WANTED

YOUR Own business—Used suits \$1.50; overcoats 65¢; mackinaws 35¢; shoes 12½¢; ladies coats 30¢; dresses 15¢. Enormous profits. Catalog free. Nathan Portnoy Associates, 2109-AA Roosevelt Road, Chicago Ill. 60608.

LIFETIME Income. Business Loan Representative Write: Financial 28 E. Jackson, Suite 1204-X3, Chicago 60604.

EVERY Man a prospect. Refundable sales kit offer showing line belt buckles, tie clasps, money clips, cuff links, lapels, identification badges, individualized with customer's name and emblems. Cap badges for trucking, bus, taxi, police, firemen, also postal, letter carriers and heavy construction emblems. Choice 3000 emblems. Hook-Fast, Box 1088PM, Providence, R.I. 02901.

PRINTING. Advertising Salesmen—Excellent moneymaking sideline selling Decalomania Name Plates, small quantities. Advertising Specialties, sign letters. Free Samples. Ralco XL, Boston, Mass. 02119.

CHRISTMAS CARDS—Business and Personal. Customer's name imprinted. Earn unusually high commissions from this medium—and high-priced line. No investment. No inventory. Free Sample Album. Process Corp. (our 48th year), 3436 S. 54th Ave., Chicago, Ill. 60650.

WANT TO MAKE UP TO \$100 A WEEK Spare time, and get free shoes for life, too? No investment. Rush card for free details. Mason Shoes, K-622, Chippewa Falls, Wisconsin 54729.

WILL You test new items in your home? Surprisingly big pay. Latest conveniences for home, car. Send no money. Just your name. Kristee, 118, Akron, Ohio 44308.

MAKE Extra Money—Show friends, neighbors—Gifts. Stationery, Toys, Jewelry, Greeting Cards, 600 items. Experience unnecessary. Salable Samples on approval. Free—Catalog. Personalized Christmas Card Album. Hedenkamp, 361 Broadway, Dept. PM-100, New York 10013.

HOW To Make Money distributing gift catalogs. Send for Free sample, Terry Gifts, 21-A13 Union Ave., Westfield, Mass. 01085.

AGENTS Wanted: Fast selling new product needed by every man and woman. Big profits, steady reorders. M. O. Enterprise, Dept. 12031-PM Parkville, Mo. 64152.

ESTABLISH Your own business. Low prices on used clothing, shoes, household goods. Unlimited profits. Free catalog. Northwestern Distributors, 2129 No. Western Avenue, Chicago, Illinois 60647.

\$50 SELLING Business cards samples 25¢. Talbert, 216 Landon, Buffalo, New York 14208.

EMPLOYMENT INFORMATION

FOREIGN And USA job opportunities available now. Construction, all trades. Earnings to \$3,000.00 monthly. Paid overtime, travel, bonuses. Write: Universal Employment, Woodbridge, Conn. 06525.

HIGH Paying overseas jobs. Construction, other projects. Bonuses, Travel Expenses, Extras. International Information, 124, Cortez, Florida 33522.

AUSTRALIA, AUSTRALIA, AUSTRALIA! Jobs Galore!! Government assisted transportation, 1969 Handbook \$1.00. Satisfaction Guaranteed!! Associated, Box 17-B98, Lafayette, California.

AUSTRALIA WANTS YOU! Government Assisted Passage, 50,000 Jobs. Latest Government Information and Forms \$1.00. Special Reports on Employment, Business, Taxes, Housing, Education, RANCHING, Farming, Teaching, Maps, Etc. AUSTCO, Box 3623-E, Long Beach, California 90803.

CANADA. Employment guide to Montreal, Toronto, Vancouver. Send \$1.00. Personnel Publications, Suite 101, 30 Bloor Street, West, Toronto 189.

COMING TO CALIFORNIA. Check Jobs, Rentals First Complete Los Angeles Classified Section \$1.00. Box 2546, Anaheim, Calif. 92804 Free Map.

WORK In developing Mexico. Rapid advancement. Negligible taxes. Inexpensive entertainment. Pleasant Living. Free information. Infomex, P.O. Box 20237, Cleveland, Ohio 44120.

BOOMING AUSTRALIA wants You! Good jobs, Adventure. Forms and Australian Handbook (1969) describing Australian assisted passage, passport-visa, advantages, opportunities \$1.00. Buckeye, Box 1032-MQ, Fairborn, Ohio 45324.

HELP WANTED

OVERSEAS Jobs—Europe, South America, Australia, Far East, etc. 2000 openings all trades. Construction, Office, Engineering Sales, etc. \$400 to \$2,500 month. Expenses paid. Free Information. Write Overseas Jobs, International Airport, Box 536-M, Miami, Florida 33148.

GAS APPLIANCE SERVICEMEN: No experience necessary, will train. 52 weeks work guaranteed annually including paid vacations and holidays; insurance; opportunities for promotions; most managers started as servicemen. Apply managers Baltimore, Boston, Chicago, Cleveland, Detroit, Los Angeles, Philadelphia, Pittsburgh, St. Louis, San Francisco, Washington, D.C., Dallas offices (we're in phone book). GAS CONSUMER SERVICE.

OVERSEAS Jobs—Australia, Europe, South America, Far East, etc. Openings in all trades and professions. \$400 to \$2,500 monthly, free information write Foreign Employment Mart, Box 2235 A.M.F. Miami, Florida 33159.

REAL ESTATE & FARMS

CANADIAN Vacation lands: Full price \$385.00, 40 acres, \$10 month. Suitable cottage sites, hunting, fishing, investment. Free information. Land Corporation, 3768-C Bathurst, Downsview, Ontario, Canada.

\$1 ACRE—Canadian Border—hundreds campsites, islands, farmlands, directly from tax authorities. (Non-profit). Lists, photographs mailed. Register, Room 10, 110 Church Street, Toronto 1, Canada.

CENTRAL Ontario—Choice 640 acre Sportsmen's paradises still available—\$20.00 plus \$6.50 taxes yearly. Maps, pictures. \$2.00 (Refundable). Information Bureau, Norval 4, Ontario, Canada.

GOVERNMENT LANDS . . . Low, as \$1.00 acre. Millions acres. For exclusive copyrighted report . . . plus "Land Opportunity Digest" listing lands available throughout U.S., send \$1.00. Satisfaction guaranteed. Land Disposal, Box 9091-PH, Washington, D.C. 20003.

NEW FREE Journal! Arkansas bargains! Statewide Realty Co., 310-AE Pyramid Life Bldg., Little Rock, Ark. 72201.

BUY CANADA \$10.00—10 ACRES Thousands of Tax Sale properties direct from Municipal Authorities. No middlemen. Over 80 years of land bargains. Atlantic to Pacific. Hunting. Fishing. Cottages. Farms. Investing. Easy driving distance U.S.-Canadian border crossings. Areas researched. Most unique land service in whole wide world. Guaranteed risk free. Photos, maps, lists, mailed. **BUREAU OF CANADIAN TAX LAND SALES**, 16 Quinby Court, Thistleton 613 Ontario, Canada.

FREE CATALOG! Summer Edition. Farms, Ranches, Business, Recreational and Investment Property. 18 States. Pictures Galore. Note State desired. Banner Adv., Box 3333, 19-A, Springfield, Mo. 65804 "Real Estate Our Specialty."

VACATION Lands: Canada: \$4.00 acre. Free information. Tax Corp., Suite 204-F, 1255 University, Montreal 110.

THE Only "No-Risk Land Purchase Plan" in America—10 year money-back guarantee on any Vacation. Retirement or Investment homesite in Boiling Spring Lakes—the multi-million dollar, 14,000-acre development on the Carolina Coast. All facilities, electricity, roads, motel, golf course, country club, already in. Private ocean beach, 50 fresh water lakes, 1/2-acre homesites as low as \$695.00; \$8.00 down, \$7.65 monthly. Write for free literature. (Not offered to residents of California, Florida, New York.) **B-I-I-I-I Spring Lakes**, Southport 1-M, North Carolina 28461.

FREE 208-page real estate catalog. All types property, coast to coast! **UNITED FARM AGENCY**, 612-PM, West 47th St., Kansas City, Mo. 64112.

TOP BARGAINS! FREE Journal! Arkansas properties! Statewide Realty Co., 507-AE Pyramid Bldg., Little Rock, Ark. 72201.

NEW!—FREE CATALOG! Giant Fall-Holidays edition! Over 4,000 properties described, pictured—Land, Farms, Homes, Businesses—Recreation, Retirement. Selected Best thruout the U.S.! 69 Years' service. 515 Offices. 40 states Coast to Coast. Mailed **FREE** from the World's Largest! **STROUT REALTY**, 60-RX E. 42nd St., N.Y., N.Y. 10017; 7-RX S. Dearborn, Chicago, Ill. 60603; 521-RX E. Green, Pasadena, Cal. 90013.

CANADA'S Finest lands. \$4.00 an acre and up. Acquired through Estate liquidations. Suitable for hunting, fishing, camps, cottages, farming, timber, minerals, investment. Small monthly payments. Free descriptive booklet. **Canadian Estate Land**, Dept. PMC, 194 Wilson Ave, Suite 101, Toronto, 12, Canada.

NORTHWEST TIMBERED ACREAGES AS LOW AS \$950. TOTAL PRICE \$50 DOWN \$25 MONTH. 5-10-20-40 acres for people who love the land—A tract of Recreation Land to have for YOUR own! In Northern Idaho, Northeastern Washington, and Western Montana. In the heart of lakes and big game country. All covered with growing timber. Access, Title insurance with each tract. This is select land with natural beauty, recreational and investment values. We have tracts of many types and sizes from which to choose, including beautiful Northwest Waterfront property on the Pend Oreille, Priest and Kettle Rivers; and property on Pend Oreille Lake. Your inspection welcomed. Write us for free list, maps and complete information. Write to: Dept. PH, Re-forestation, Inc., P.O. Box 8146, Spokane, Wash. 99203.

10 to 40 ACRE Tracts. Lake Superior, Marquette, Michigan area. \$99.00 acre, \$2.00 month. Write Hiawatha Lake Acres, 17129 Chrysler Drive, Detroit, Michigan 48203.

FARM & GARDEN EQUIPMENT

EXTRA Income at home in Spare Time! Booklet shows you how to start your own business with Classified Advertising. Only \$1.00 (Refundable with first order.) C. A. Martin, Popular Mechanics, Dept. PM575 Lexington Avenue, New York 10022.



FLOWERS, PLANTS & NURSERY SUPPLIES

LEARN Landscaping and the growing of plants. Start a profitable business part or full time. Free information without obligation. Lifetime Career Schools, Dept. A-647, 2251 Barry Avenue, Los Angeles, California 90064.



DRINKING WATER—PURIFIER

EXTRA Income at home in Spare Time! Booklet shows you how to start your own business with Classified Advertising. Only \$1.00. Refundable with first insertion order. C. A. Martin, Popular Mechanics Dept. PM, 575 Lexington Ave., New York 10022.

HOME CRAFTSMEN

CABINETMAKING MADE EASY and "How to Make Formica Counter Tops," two excellent guides let you build kitchen cabinets and counter tops like professionals. Extraordinary guides bring master craftsmen's shortcut methods. Satisfaction guaranteed. Write: Japs, 126-P Seventh North, Hopkins, Minn. 55343.

SPANISH FURNITURE PLANS. Send stamped, addressed envelope for circular. R. S. Plans, Box 12091, Parkville, Mo. 64152.

FREE Popular Mechanics 16 page illustrated catalog of publications, plans and projects. Booklet covers an extremely wide variety of do-it-yourself data on home remodeling, shop tools and machines, car repair, hobbies, crafts, boating, games, lawn and garden and hundreds of others. For your free copy write to Service Bureau, Dept. PE, Popular Mechanics, 575 Lexington Ave., New York, N.Y. 10022.

PLANS For pool table with extra two-face top for table tennis and model railroad. Blueprints B1209 and building instructions \$3.50. Popular Mechanics Service Bureau, 575-M Lexington Ave., New York, N.Y. 10022.

WOODWORKING Catalog and Manual 25¢. Plus free "101 Project Ideas." World's most beautiful veneers, lumber, plywood! Wood finishing, upholstery supplies. Cane Lamp parts. Furniture hardware. Animal whittling blocks. 2,000 workshop products. Constantine, 2051M, Eastchester Road, Bronx 10461.

FULL SIZE FURNITURE PLANS. Traditional, Early American, Danish Modern. Catalog 50¢. Furniture Designs, Dept. P-8, 1425 Sherman, Evanston, Illinois 60201.

WALNUT And Cherry tapered legs, lumber, gunstock blanks, picture frame moulding. Midland Lumber Company, Box 262, Savannah, Missouri 64485.

101 PATTERNS Of smart Gifts. Novelties, Shelves, Action Windmills, plus "Make Money Jig Sawing." \$1.00. Mastercraft, 85M, 7041 Olcott, Chicago 60631.

FOUNDRYETTE 2400 F. 1 1/2 to 48 lb. capacity. Circular 10¢. Kansas City Specialties, Box 193-P-8, Middleton, Wisconsin 53562.

GOLDEN 5 Way Handyman's Knife. \$1.00 Prepaid. Elmo, 2136A 71 Street, Brooklyn, New York 11204.

FREE Wholesale Industrial—Homecraft. Tool—Supply Catalog. McKilligan, Maine, New York 13802.

"GETTING Started In Stained Glass" 25¢ Whittemore, Box 2065Y, Hanover, Mass. 02339.

BUILD Yourself Plans. SONIC SLIDE, swingset, Treehouse, ROCKET, etc. Plans and specifications \$2.00 each. Complete listing 25¢. Ebco, Box 4441, Chattanooga, Tenn. 37415

UPHOLSTERY

MAILORDER Records help get Increased Business! Complete 32 Page Record Book shows your inquiries, orders, advertising, expense, etc. Only \$1.00. C. A. Martin, Popular Mechanics, Dept. PM, 575 Lexington Ave., New York 10022.

DO-IT-YOURSELF

WATER!! Drill your own well the easy, economical way with Amazing New Invention. Save 75%. Free information. Deep-Rock Drilling Company, Opelika, Alabama 36801.

STEAM Powered lawn mower, with flash boiler. Pictures discriptions. Also fire tube boiler burners, small steam engines all parts numbered, several sheets. \$2.00 Postpaid. Travis Tool Company, Box 118, Sidney, Iowa 51652.

EXERCISE At home on build-it-yourself physical fitness equipment, including bicycle exerciser, rowing machine, belt massager, and abdominal board. Send \$2.50 for blueprints B1208 and instructions. Popular Mechanics Service Bureau, 575-K Lexington Ave., New York, N.Y. 10022.

14 WEATHER Instrument Plans \$2.00. Saco, Box 2513A, South Bend, Ind. 46614.

PAINT insecticide—Mix with paint—Kills insects. 3 oz. Bottle treats 1 Gallon. \$1.49 (Guaranteed). Di-All Chemical, Box 14347, Orlando, Florida 32807.

MAKE Your own multicolor duplicator for less than one-dollar instructions \$1.00. Reiter's, 6707 Shawnee, N. Tonawanda, New York 14120.

VIBRATOR Motors, 3 Speed. SAVE \$\$\$ Make your own Relaxer. Write: Falcon, Inc., Box 331, Hialeah, Fla. 33011.

REFRIGERATOR Door gaskets—Electric Range and Washer Parts. Send Make and model for cost. Box 5465, Hamden, Conn. 06518.

WHISKEY MAKING—Bourbon in small quantities on kitchen stove. New manual explains how and gives recipes. \$3.00 to Paterson, Box 1044, Silver Spring, Md. 20910.

PLANS. Prefab starter cabin, 8X12, \$2.00. 12 Volt generator runs off power mower, \$2.00. Record, P.O. Box 271, New Hyde Park, N.Y. 11040.

BURGLAR-FIRE ALARM Systems and Supplies. Free Catalog. Informer Alarm Mfg., 715B Ensor Street, Baltimore, Maryland 21202.

ARTS AND CRAFTS

MAKE Figurines, plaques, lawn ornaments, Molds, plastercraft kits, liquid rubber. Sample and catalogue 10¢. Wooley Company, Box 29-B, Peoria, Illinois 61601.

FREE: New 136 page handicraft catalog. Supreme Handicrafts, Box 395-PM Sioux Falls, South Dakota 57101

BINOCULARS, TELESCOPES, MICROSCOPES, MAGNIFIERS

BINOCULAR Specialists, Repairs And Sales. Free Catalog. Tele-Optics, 5514 Lawrence, Chicago, Ill. 60630.

BINOCULARS Direct from manufacturer. Finest quality, tremendous savings! Request catalog. Koyu, 3860 Crenshaw Blvd., Los Angeles, Calif. 90008.

SCIENCE Bargains! Lenses, telescopes, binoculars, microscopes, kits, parts, war surplus. Send \$1.50 for beginner's 10-lens kit with instruction booklet. Order Stock 2-CH. Request free 148 page Catalog CH. Edmund Scientific Co., 300 Edscorp Bldg., Barrington, New Jersey 08007.

WORLD Famous "Dynascope" Telescope. Build your own reflector telescope, mirrors, eyepieces, tripods, accessories. Request free brochures. Criterion Manufacturing, Dept. PP34, Hartford, Connecticut 06101.

MANON Binoculars. Special sale. Write: Manon, Box 1386, Huntington Beach, Calif. 92647.



CAMERAS AND EQUIPMENT

WORLD'S Largest Buying Guide—800 Illustrations—50¢—Deductible With Your Order—Olden Camera—1265 Broadway, New York, N.Y. 10001.

FREE! FREE!—Photographic and optical bargain book, Jimco, Dept. IAE, 9006 Waukegan Road, Morton Grove, Ill. 60053.

PHOTO SUPPLIES

YOUR Ad in Popular Mechanics will be seen by more than 5,000,000 active buyers for your products and services. It costs only \$1.85 per word. And, if you wish to run all or part of your ad in capital letters—you can do so for as little as 75¢ per word additional. Act now! Place your classified ad in Popular Mechanics today.

PHOTO FINISHING

A FREE Kodak roll returned with each black and white or Kodachrome developed and printed, fast service, lowest prices, guaranteed quality send for free mailers. Economy Photo Service, Dept. P.M., Box 1111, Albany, N.Y. 12201.

SPECIAL WITH THIS AD—Kodachrome developed 12 prints \$2.25. Black & White developed 2 prints each Jumbo size—12 exposure 70¢. LENS PHOTOS, Dept. J-4, Janesville, Wis. 53545.

CAMERA FANS! Expert photofinishing by one of Country's largest labs at lowest prices. Fast service and free "Foto-Fan" Stamps you quickly redeem for valuable Photo Supplies. 8MM Kodachrome \$1.29; 8 Exp. Kodachrome \$1.79; 35MM Kodachrome, 20 Slides \$1.39; 8 Exp. Black White 69¢. Satisfaction guaranteed. Send exposed film or request free mailers, complete Price List and Gift Catalog. Direct Mail Photo, Box 8352-PM, Pittsburgh, Pa. 15218.

LOOK—Save Money on Pictures! Jumbo Size Prints from your Kodachrome Rolls, \$1.98. Black & White, 69¢. Huge Discounts on Supplies. Enclose Advertisement. Wisconsin Film Service, Dept. 33, La Crosse, Wisconsin 54601.

SPECIAL: BLACK-White, 8-45¢; 12-55¢. Kodachrome, 8-\$1.89; 12-\$2.09. Astro Photo Service, Box 166M, Waterloo, New York 13165.

INTRODUCTORY SPECIAL—12-Exposure Kodachrome Developed for \$2.00 with this ad. Free Gift. Expires February 1, 1970. Paul Bunyan Photo, Box 309030, Brainerd, Minnesota 56401.

PHOTOGRAPHY For Pleasure or profit. Learn at home. Practical basic training. Long established school. Free booklet. American School of Photography, 835 Diversey Parkway, Dept. 674-028, Chicago, Illinois 60614.

50% DISCOUNT "get-acquainted" offer to 126 Instamatic Camera owners for one month only . . . \$1.50 for 12 exposure (regular \$3.00). We develop, print ONLY 126 Instamatic film . . . no black and white. Send \$1.50 today. I/T/K CO., Dept. B, Ishpeming, Mich. 49849.

COLOR SLIDES

OUR FIRST 19 IN SPACE. This limited edition lithograph has been created as a tribute to Americas Gallant Astronauts. 12 X 18 inch chart ready for framing. Only 75 cents. Popular Mechanics, Dept. GWP, 575 Lexington Avenue, New York, New York 10022.

MOTION PICTURES AND SOUND EQUIPMENT

16MM Sound Features, Shorts. New, used for Sale. Free Catalog. National Cinema, 333 W. 57th. St.-N.Y.C., N.Y. 10019.

FREE! 64-page catalog. 8-16mm film, supplies, processing equipment. Superior, 448 N. Wells, Chicago 60610.

35MM. COLOR SLIDE SAMPLER . . . 20 "best" 2" x 2" . . . \$1.00. Free catalog. Hundreds of sets . . . travel, circus, wildlife, flowers, railroads, wars, etc. Order today. Blackhawk Films, 862 Eastin-Phelan Bldg., Davenport, Iowa 52808.

175-FOOT 8MM. PREVUE MOVIE . . . ONLY \$1.99. See Laurel & Hardy, Chaplin, Fairbanks, Keystone Cops, Gish, Pickford, Chaney . . . comedy, drama, adventure, history from the silents! Taste the fun of great movies right at home! Order today . . . specify standard or Super 8. Free catalog. Blackhawk Films, 861 Eastin-Phelan Bldg., Davenport, Iowa 52808.

UNUSUAL Movie supplies. Free circular. Esor, 47th Holly, Kansas City, Missouri 64112.

5,000 8-16MM MOVIE Films. Free catalogues. International. Greenvale, L.I., N.Y. 11548.

RADIO, TELEVISION AND HAM EQUIPMENT

33¢ RADIO & TV tubes. Free list. Cornell, 4213-17 University, San Diego, California 92105.

TUBES—Lowest prices in the world. Hard to get British, German, Foreign and American obsolete and present day special purpose transmitting tubes. Send for giant tube and parts catalog. United Radio Company, Dept. Z-56 Ferry St., Newark, N.J. 07105.

GOVERNMENT Surplus receivers, transmitters, snooperscopes, parts. Catalog, 25¢. Meshna, Nahant, Mass. 09108.

FREE Brochure MONITOR Fire, Police RADIOS with MINIVERTER II, full SQUELCH easy installation. Scientific Associates, Box 276(MX), South Glastonbury, Conn. 06073.

MODULES! Seal electronic circuits in tough epoxy! 1 pound—\$2.54, 2 pounds—\$4.46, 3 pounds—\$6.34. Color—ebony. For tan—add 20%. ABSCO, Box 45275M, Chicago 60645.

HIFI, RECORDS AND ELECTRONICS

FREE Catalogues, 2000 hard to find unusual records. Rose's, 300 Chelsea, Louisville, Ky. 40207.

TAPE Recorders, hi-fi components. Sleep learning equipment, tapes. Unusual values. Free catalog. Dressner, 1523C Jericho Tpke., New Hyde Park, N.Y. 11040.

RECORDS! Discounts on all LP's. Free details. Citadel Record Club, Symphonette Sq., Dept. 2, Larchmont, N.Y. 10538.

CASSETTES AT HONG KONG PRICES! Lifetime Moneyback Guarantee! Three C-60s—\$4.75. Three C-90s—\$7.25. Three C-120s—\$8.75. Custom Record Development, Box 3, Mamaroneck, N.Y. 10543.

HOME Electronics Course Only \$26.95. Free literature. Edu-Kits, Department 716B, Hewlett, New York 11557.

TAPES . . . Blank recording . . . pre-recorded music. Catalog 10¢. Tower, Lafayette Hills, Pa. 19444.

MUSIC AND MUSICAL INSTRUMENTS

PLAYER Piano Rebuilding—get details from: Vestal Press, Vestal 11, N.Y. 13850.

GUITAR, Banjo Making books Plans, woods, necks, tools. List 25¢. Satinwood, 510 East 11th Street, New York, N.Y. 10009.

ACCORDION Manufacturing, 6846-P North Avenue, Chicago, Illinois 60635. Concertinas, Hohners, Chromatics, Guitars, Drums, New, Used, Tuning, Repairing. Wholesale Catalogs Free.

POEMS, Songs wanted for new song hits and recordings by America's most popular studio. Tin Pan Alley, 1650-PM Broadway, New York 10019.

VIOLIN and Guitar makers—send for latest Free Catalogue of woods & accessories. International Violin, PM8, 414 East Baltimore St., Baltimore, Md. 21202.

POEMS Wanted for new songs and records by America's largest song studio. Send poems. Free examination. Five Star Music, 6M Beacon, Boston, Mass. 02108.

30% DISCOUNT Any Name Brand musical instruments. Write for low price. Freeport Music, 127 W. Sunrise Highway, Freeport, New York 11520.

SONG Writers—Send Poems, Songs to: Weiss Music Company, 1472 Broadway, New York, New York 10036.

GUITAR Chord system most modern ever devised. Send \$3.50. Johnny Carlton, Canton Plaza, Marietta, Georgia 30060.

WHOLESALE Musical Instruments Catalog. Allied, 406 East 189, Bronx, N.Y. 10458.

ELECTRIFY Player Pianos, Pump Organs quickly, inexpensively with Lee Silent Suction Units. Write Lee Music, 525 Venezia Avenue, Venice, California 90291.

POEMS Wanted For Songs. Nashville Music Productions, Box 9001-P, Nashville, Tennessee 37204.

ACCORDION Top brands. Buy direct. Tremendous discounts. Trade accepted. Free brochure PM. Accordion-O-Rama, 874 Broadway, N.Y.C. 10003.

DRUMS, Electric guitars, amps, organs. Free catalog M: A.L.A.S. Import Company, 31 East 18th Street, NYC. 10003.

GUITARS, MANDOLINS, BANJOS. Complete stock of Gibson Martin guitars. Free 100 page catalog, parts and accessories. Big Savings. New York discount prices. Send 50¢ postage handling. Eddie Bell Guitar, 201 West 49, New York 10019.

SONGPOEMS Wanted! Write with Professional Songwriters. Share Royalties. Songwriters Contact, 888-8th Avenue, New York 10019.

WE PAY ALL RECORDING COSTS on accepted material! Need new Song Material for immediate recording! GRAND RECORDING, 1354-PM Hancock St., Quincy, Mass. 02169.

ACCORDIONS, Guitars, Band Instruments! Save to 50%. Famous makes. Easiest terms. Trades accepted. Free home trial. Free discount catalog. Mention instrument. International Music Mart, 5535-R, Belmont, Chicago 60641.

BUILD YOUR OWN ELECTRIC GUITAR—Complete kits that include everything. All machine work done, use hand tools only. Solid body \$29.95, Bass \$34.95, Hollow body \$39.95. Write to Kapa Music Company, 7221 Wisconsin Ave., Bethesda, Maryland 20014.

HANDMADE classical, flamenco guitars. Martin, Gibson, Accessories, woods, tools. The Guitar, 4668 Hollywood Blvd., Hollywood 90027.

SONGS, Poems, Offer, Newart Pubs, Box 693, Syracuse, New York 13201.

LEARN 5-String Banjo. Play Bluegrass the first week. \$4.95 Postpaid. Satisfaction guaranteed. Blaylock, Box 25-M, Marietta, Georgia 30060.

EDUCATION AND INSTRUCTION

LEARN Auctioneering. Term soon. Free catalog. Reich Auction College, Box 850, Mason City, Iowa 50401.

PIANO Tuning quickly learned with home study course. Diploma granted. American Tuning School, Gilroy, Calif. 95020.

PIANO Tuning pays. Big money in spare time. Learn at home. No musical knowledge necessary. Phonograph, records, tools and instructions furnished. Electronic tuning also taught. Free catalog. Capital Tuning School, 3160 S.W. 16th Court, Ft. Lauderdale, Fla.

BOOKKEEPERS. Operate your own "Dollar-A-Week" system. Ellis, Box 200, Cedar Grove, North Carolina.

PENMANSHIP Corrector. Improve poor penmanship quickly. Details free. Ozment, Box 665-34, St. Louis, Mo. 63188.

OWN Collection agency. "Little Gold Mine!" Franklin Credit, Roanoke, Virginia 24004.

EARN \$125 A week and up. Learn a trade with a future. Learn auto diesel mechanics in our shops. You learn with tools on real equipment. Earn while you learn. Many of our graduates earn \$125 a week and up. Write for free bulletin: Dept. 256, Auto Diesel College, Nashville, Tennessee 37219.

SWEDISH Massage and physical culture pays big profits. Learn at home. Diploma. Free catalog. National Institute, Dept. E-89, 307 North Michigan, Chicago 60601.

USED CORRESPONDENCE Courses and Books sold and rented. Money back guarantee. Catalog free. (Courses bought). Lee Mountain, Pisgah, Alabama 35765.

MISSOURI Auction School. GI Approved. Free Catalog! 424-03 Nichols Road, Kansas City, Mo. 64112.

LEARN Asleep or awake! Records, tapes, equipment! Free catalog! Drawer, PM-400, Ruidoso, New Mexico 88345.

SUPERIOR Auction School. Nation's top Auctioneers own and instruct. 120 East Cerrogorro, Decatur, Ill. 62523.

BE A POLICEMAN. Complete Course and Diploma, only \$10.00 Southern Police Academy, P.O. Box #306 Fairfield, Alabama 35064.

FCC First Class License in six weeks—Nations highest success rate—Approved for Veteran's Training. Schools in Dallas, Atlanta, Chicago, New Orleans, Minneapolis and Houston. Write Elkins Institute, 2603D Inwood Road, Dallas, Texas 75235.

HIGHLY effective home study courses in Electronics Engineering Technology and Electronics Engineering Mathematics. Earn your Degree. Write for Free Descriptive Literature. Cook's Institute of Electronics Engineering, (Dept. 10), P.O. Box 10634, Jackson, Miss. 39209. (Established 1945).

EARN College degree at home. All subjects. Ohio Christian College, 1156 Striebel Road, Columbus, Ohio 43227.

LEARN Bartending. Correspondence School, 426C East Seventh Street, Tucson, Arizona 85705.

PROFITABLE National Camera Repair School training at home! PM-8, Englewood, Colorado.

DETECTIVE Course. Free information. Universal Detectives, Box 8180-F, Universal City, California 91608.

HIGH School diploma at home. Licensed teachers. Send age, highest grade completed for free details. No salesman will call. Southern States Academy, Westbury Square Professional Bldg., Dept. 16, Houston, Texas 77035.

USED Courses! Books! List 10¢. Smith's, 124 Marlborough, Salem, Mass. 01970.

COMPLETE YOUR HIGH SCHOOL At home in spare time with 72-year-old school. Texts furnished. No classes. Diploma. Information brochure free. American School, Dept. XC45, Drexel at 58th, Chicago, Illinois 60637.

ORDAINED? Free credentials! Request information! NSU, 708 South Bragg, Monroe, North Carolina 28110.

AUCTIONEERING Resident or Home Study Course Free Catalog. Nashville Auction School, 2004 West End, Nashville, Tennessee 37203.

BARTENDING—Home Study course. Box 3191-P, North Las Vegas, Nevada 89030.

PIANO Technology—Electronic organ servicing, learned easily at home. G.I. Approved. Free booklet. Niles Bryant School, Dept. P, 3631 Stockton, Sacramento, California 95820.

BE A REAL Estate Broker. Big earnings. Prepare quickly, easily. GI approved. Free Catalog. Weaver School, 3519-P Broadway, Kansas City, Missouri 64111.

AUTOSUGGESTION. Sleep-learning headquarters! Tapes, records, books. Giant catalog free. Research Association, Box 24-PM, Olympia, Washington.

LEARN AUTOMOTIVE AIR CONDITIONING. Low Cost Plan. Free Folder PM-8. Technical Center, Box 59, Buena Park, Calif. 90620.

PHOTO RETOUCHING. Interesting, profitable career at home; full or part-time. Easily learned. Hamilton Studios, Dept. PR-39, Claymont, Del. 19703.

CARPET Layers earn \$1000 Monthly. Easy home training. Big demand. Write Carpet Crafts, 144 East Huntington Drive, Arcadia, California 91006.

WATCH REPAIRING. Unique course develops skills at home. Free sample lesson. Chicago School, YV, Fox River Grove, Illinois 60021.

LEARN Civil and criminal investigation at home. Earn steady, good pay. State age. Institute Applied Science, 1920 Sunnyside, Department 168, Chicago, Illinois 60640.

ART Talent? Don't waste it. Turn it into a fabulous career in the high paying art field, with simple courses or self-teaching manuals guaranteed to show you how. Free brochure. Famous American Studios, Dept. PM, Spring Park, Minn. 55384.

BIBLE—College correspondence degree courses. Catalog! Box 647A, Morgantown, Kentucky 42261.

GET A British Degree. Divinity, Philosophy, Radionics. 35 Courses. Prospectus free. Brantridge Forest School, Highfield, Dane Hill, Sussex, England.

BOOKS. Bought, sold, rented. Sidney Gross, Box 522P, Port Washington, N.Y. 11050.

LEARN AUTO AIR CONDITIONING. Low Cost Plan. Free Folder PM-8, Technical Center, Box 59, Buena Park, California 90620.

LEARN ACCIDENT INVESTIGATION. Train at home to earn \$750 to \$1,000 monthly. Car furnished. Expenses paid. No selling. No college needed. Full or spare time. Men urgently needed. Free placement service. Write for FREE information. No obligation. Universal Schools, CPM-8, 6801 Hillcrest, Dallas, Texas 75205.

COLLEGE Degree at home. Includes law. Easy tuition plan. Williams College, 111-PM West College, Covina, California 91722.

MILLIONS OF SEWING MACHINES NEED REPAIR. New book shows how. \$7.95. Sincere Press, Box 10422, Phoenix, Arizona 85018.

FOR INVENTORS

PATENT Searches complete and thorough. Related copies Air Mailed with maximum speed \$6.00. Free "Protection Forms" and "Patent Information." Write American Patent Search Company, Dept. 27, 711 14th St., N.W. Washington, D.C. 20008.

PATENT Application Financing. Free patent search plan. Global Patent Division, 2420 77th, Oakland, Calif. 94605.

PATENT And invention development by licensed professional patent engineer and U.S. Patent Office former examiner, and engineering specialists. Your inventions and ideas engineered for patent protection and commercial value. Inventions developed by us negotiated for cash or royalties with our nationwide contacts. Send for free protection "Invention Certificates" and further interesting, valuable patent information. George Spector, Licensed Professional Patent Engineer, Woolworth Building, New York.

U.S. Patent Office Searches, 234 Broadway, Room 3615, New York. Free invention certificates.

IMMEDIATE Cash, for patent applications. Free patent searches. Write for details. Universal Patents, 184-D, Marion, Ohio.

INVENTORS: Your ideas and inventions (patented; unpatented) expertly searched, developed for commercial appeal and cash/royalty sales to manufacturers by professional Invention Developer with excellent record of experience. B.S., Industrial Engineering; United States Patent Office former Patent Examiner, United States Government former Patent Advisor, Second decade reliable service! Member: United States Chamber Commerce. Free "Invention Record" and "Recommended Protection Procedure." Airmailed! Write: Raymond Lee, Invention Developer, 230-P Park Ave., New York City 10017.

PATENT Searches, including copies of related U.S. patents. Inventors attorneys, manufacturers use our "worldwide" airmail service! "Invention Record" form and "Information Every Inventor Needs," sent free! Hayward Company, 1029P Vermont, Washington 5, D.C.

FREE PAMPHLET: "Tips on Safeguarding Your Invention." Write: United States Inventors Service Company, 501P Thirteenth Street N.W., Washington, D.C. 20004.

MANUFACTURERS NEED New Products! FREE Literature explains "How To Submit Your Invention." Congress Invention Company, 911-C Warner Building, Washington, D.C. 20004.

NEEDING ASSISTANCE? INVENTION DEVELOPMENT FOUNDATION, 1823 Jefferson Place, N.W., Washington, D.C. 20036. CANADIAN OFFICE: 155 Kent, Ottawa 4, Ontario.

IF Your invention is adaptable to promoting we will contract for selling on cash or royalty. Free booklet outlines royalty rates, requirements. Kessler Corporation, C-58-F1, Fremont, Ohio.

INVENTIONS WANTED

INVENTIONS Wanted. Patented; unpatented. Tremendous manufacturers lists. Global Marketing Service, 2420G 77th, Oakland, California 94605.

INVENTORS! Sell your invention for cash or royalties! Our client manufacturers eagerly seek new items. Patented. Unpatented. Financial assistance if needed. 25 Years proven performance. For free information, write Dept. 15, Gilbert Adams, Invention Broker, 80 Wall St., New York, N.Y. 10005.

INVENTORS! We will develop, sell your idea or invention patented or unpatented. Our national manufacturer-clients are urgently seeking new items for highest outright cash sale or royalties. Financial assistance available. 10 years proven performance. For free information write Dept. 47, Wall Street Invention Brokerage, 79 Wall Street, New York, N.Y. 10005.

INVENTORS! Don't sell your invention, patented or unpatented, until you receive our offer. Eagle Development Company, Dept. H, 79 Wall Street, New York 5, N.Y.

WE Either sell your invention or pay cash bonus. Write for details. Universal Inventions, 298-E, Marion, Ohio.

FREE "Directory of 500 Corporations Seeking new Products." For information regarding development, sale, licensing of your patented/unpatented invention. Write: Raymond Lee Organization, 230-N Park Avenue, New York City 10017.

INVENTORS! Protect your ideas! Free "Recommended Procedures." Washington Inventors Service, 422F, Washington Building, District of Columbia 5.

INVENTORS—Do you want to sell or license your invention on cash or royalty basis? Write: Kessler Corporation, C-58-IW, Fremont, Ohio.

PATENTS FOR SALE

PUSH-BUTTON WATERSAVER. Sale/Royalty. Pat # 3 334 359. A. Weingartner, Box 73, Franklin, N.J. 07416. Phone 201-697-7150.

MANUFACTURING

INVENTORS Ideas developed. Research. Models. Manufacturing. Sales. Free brochure. William Parker, 32 Westminster, Worcester, Mass. 01605.

BUY IT WHOLESALE

500,000 BARGAINS BELOW WHOLESALE. New, name brand merchandise. Buy at 10¢ on the dollar. Closeouts, surplus, bankrupts, liquidations, imports. Free details. International Buyers, Box 4633-M, Colorado Springs, Colo. 80909.

20 WHOLESALE Catalogs! List \$1.00. Zashop, 216 PM-8, West Jackson, Chicago 60606.

BARGAINS! Buy wholesale and below. Name brands. Appliances, furniture, sports equipment, televisions, cameras, watches, jewelry, thousands more. Huge discounts to \$1,000.00 on new automobiles. All makes. Free details. Write today: Worldwide Bargainhunters, Box 730-A, Holland, Michigan 49423.

800,000 PRODUCTS Wholesale! Terrific Bargains! Wholesalers, 1265-M, Broadway, New York, N.Y. 10001.

EXPORT-IMPORT

JAPAN: 1200 Products Directory. Illustrated Manufacturers' names, addresses, \$3.00. Send cash. Yamagata Office, 814 Togin Bldg., Marunouchi, Tokyo.

DIRECTORY—230 Suppliers in 40 Countries. \$3.00. World Shoppers, Box 151-W, Oklahoma City, Oklahoma 73123.

KNIVES—101 imported. Novelty knives—catalogue (50¢). Friedmar Imports, Box (533-PM), Montebello, Calif. 90640.

FOR THE HOME

FOOLPROOF! Fire-Burglar Alarms. Tamperproof! Low, Low, Prices. Free trial and literature. Agents plan. Your inquiry invited. Alarms, P492M, Williamsburg, Ohio 45176.

BURGLAR-FIRE Alarms. Home units complete \$14.95 up. Brochure 25¢. The Securitratics Co., P.O. Box 371, Frankfort, Indiana 46041.

PATIO. Easy ceramic granule coating. Free information. Gateway, 6851 Plainfield, Cincinnati, Ohio 45236.

FREE List of products for sale. Write to, Edward Anton, 2945 N. Halsted, Chicago, Illinois 60657.

OF INTEREST TO WOMEN

WOMEN! Make big money at home. \$10.00 profit in an hour possible with invisible mending. Make holes, tears disappear from clothing, fabrics. Steady year-round demand from cleaners, laundries, homes. Details free. Fabricon, 1533 Howard, Chicago 60626.

HOW To make money writing short paragraphs. Information free. Barrett, Dept. C-27-U3, 6216 N. Clark, Chicago 60626.

\$500 MONTHLY POSSIBLE—clipping news at home. No experience. Free information—send stamp. American, Excelsior Springs, Mo. 64024.

NEWSPAPER Clippings Urgently Needed. Highest prices paid. Send stamped, addressed envelope, free details. Brewster, Box 1348-NCWL, Clearwater, Florida 33517.

DRIVE New car, wear new clothes, buy color TV. Get daily cash income. Put spare hours to work. Write for 5 months free subscription Opportunity Magazine, see hundreds easy ways to make money. Opportunity, 1460 Hancock Center, Dept. 17-HO, Chicago 60611.

WOMEN: Big Money! Studio Girl Cosmetics needs women in all States including Hawaii, Alaska, Puerto Rico and American Samoa. Full or part time. No experience required. No territory restrictions. Take orders anywhere. Highest profits. 500 Good Housekeeping approved cosmetics. Everything furnished. Credit extended. No stock to carry. No franchise fees. No stock investment. For full information by mail, plus 3 free samples, write Harry Taylor, Chairman, Studio Girl Cosmetics, Dept. BC353, 11461 Hart Street, No. Hollywood, Calif. 91605. Also immediate big profit earnings for experienced City and State managers and former party plan operators.

WANTED! Addressers—Commission Mailers. Stamp required. Ooton Distributors, 4120P Duke Drive, Portsmouth, Virginia 23703.

\$100 WEEKLY Possible—Home Typing. Immediate earnings! Employers list, complete instructions. Details 25 cents. Typing, Box 593, PM-8, Bettendorf, Iowa 52722.

\$100 WEEKLY POSSIBLE. HOME TYPING. Instructions, employers' list, \$1.00. Satisfaction or refund. Summithouse, Box 377-PMO, Corte Madera, California 94925.

MAKE Extra Money—Show friends, neighbors—Gifts, Stationery, Toys, Jewelry, Greeting Cards. 600 items. Experience unnecessary. Salable Samples on approval. Free—Catalog, Personalized Christmas Card Album, Hedenkamp, 361 Broadway, Dept. PM-100, New York 10013.

EARN \$100.00 Fast Lacing Beautiful Products! Write: Cowboy, Warsaw 9, Indiana 46580.

\$75.00 THOUSAND. Home addressing! Longhand, typewriter. Information, send stamped self-addressed envelope. Brewster, Box 1348-YL Clearwater, Florida 33517.

AMAZING New Wholesale Discount Plan makes money quickly and easily for yourself, church or club. Delightful items sell themselves. Samples on approval. Thomas Terry Studios, 20-S13 Union Ave., Westfield, Mass. 01085.

DO PROFITABLE Home Typing. Addressing, \$400.00 Monthly Possible. Details, 25¢. Ellis, 224-PH, Prospect Heights, Illinois 60070.

LOSE Weight—No Pills or Exercise—Eat same type food—Complete method \$1.00. Verco, P.O. Box 423, Silsbee, Texas 77656.

HOMEWORKERS! \$85 weekly addressing mail for firms. Start immediately! Details, send stamped self addressed envelope. Enterprises, Box 16143-PM, Phoenix, Arizona 85011.

FULL Length Mirror—Unbreakable—Purse size—\$1.00! Ross, Box 152, Wayne, Pa. 19087.

SPARE Time earnings from selling our home care products. International firm and product guarantee. Grosh, Drawer 66259, Chicago, Illinois 60666.

GIFT SHOPPING

GET FREE GIFTS Send for new catalog. Harry Haines, Route 1, Mill Hall, Pennsylvania 17751.

FREE Distinctive Gift Catalog! Chen, PM-809, 244 W. 99, Rm-302, New York 10025.

FREE CATALOG 32 Pages distinctive gifts. Koenig's Mail Order Service, 2032 Midwood Lane, Anaheim, California 92804.

FREE Catalog, unusual novelty gifts. Imported, Domestic. Alyce Enterprises, PM8, Box 1087, Fort Lee, N.J. 07024.

WATCHES, OLD GOLD, JEWELRY

WATCH And clock repairing books. Free catalog. North American, Box-77-AH, Fox River Grove, Illinois 60021.

HIGHEST CASH for Gold, Jewelry, Gold Teeth, Rings, Diamonds, Watches, Silver, Platinum, Mail Articles Today. Free gift with information. Chicago Gold & Precious Metals, 6 E. Monroe, Dept. 758, Chicago, 60603.

USED Wrist, pocket watches—\$3.00 up. Free list. Southern Watches, 5-PM South Wabash, Chicago 60603.

CASH Immediately for old gold, jewelry, gold teeth, watches, diamonds, silverware, spectacles, platinum, mercury. Free information. Rose Industries, 29-A East Madison, Chicago 60602.

WANTED—gold, silver, platinum (any form), mercury. Information free. Willmot's, 1069 Bridge Street, Grand Rapids, Michigan 49504.

WEARING APPAREL

MEN—Buy your Outerwear Coats and Jackets WHOLESALE directly from manufacturer. Write now for free illustrated booklet showing styles for Fall 1969. Sharob Corp., Carbondale, Penna. 18407.

HEARING AIDS

HEARING Aids, Batteries, wholesale. Catalog 25¢. Fiston, Box 1444, New Preston, Conn. 06777.

HEARING Aids below wholesale. Regular, eyeglass, completely hidden models. Smallest, most powerful. Free home trial. No Salesman will call. Free details. Write Prestige-C6, Box 10880, Houston, Texas 77018.

HEARING AIDS—Batteries Wholesale! Brochures—Hearing Center, Box 211, St. Petersburg, Florida.



SCIENCE AND CHEMISTRY

ROCKETS: Real flying models—flights up to 2500 ft. New illustrated catalog 25¢. Single and multistage kit, cones, engines, launchers, trackers, rocket aerial cameras, technical information. Fast service. Estes Industries, Penrose 7, Colorado 81240.

ROCKETS!! Real flying models—2500 feet altitude with powerful motors. Terrific Science Projects. Tubes—Cones—Parachutes—Launchers—Igniters. Gigantic catalog—rocket data—diagrams—25¢. Fast Delivery. Centuri Rockets, Box 1988, Phoenix, Arizona 55001.

CHEMICALS, Apparatus, Microscopes, Biological Supplies. 1969 Catalog 35¢. Sheard Science Supplies, Inc., Columbus, Wisconsin 53925.

LASER PISTOL—\$1.00. How to build. PHASER PISTOL—\$1.00. (Add 25¢ postage.) New catalogue—25¢. Roy Davis Laboratories, Dept. PM, 118 West Adams St., Jacksonville, Florida 32202.

FREE Periodic classification of elements and conversion tables with catalog 35¢. Chemicals, apparatus, biology. Mid-States Scientific, 7053 N. Clark, Chicago, Ill. 60626.

CHEMICALS And apparatus for industrial, analytical, and private laboratories. Catalog 50¢. Dept. M-50, Biological Supply Co., 1176 Mt. Hope Ave., Rochester, N.Y. 14620.

SEARCHING For economically priced Laboratory Supplies? Gifts with catalogue—25¢. Hagenow Laboratories; Manitowoc, Wisconsin 54220.

SEARCHING For Economically Priced Chemicals And Apparatus? Gifts With Catalogue—35¢. Starr Scientific, Manitowoc, Wisconsin 54220.

LABORATORY Supplies At Discount Prices. Catalog—35¢. Deluxe Scientific; Manitowoc, Wisconsin 54220.

SOLAR Flying Saucers. (Brand New—Solid State Engine—Fantastic Performance—Flies Miles on Sun's Power—lifts animals—sends messages—parachutes—Build Many—Easily Inexpensively with Everyday Materials. Complete plans, descriptions, drawings, plus Free Spacetratics Catalog -\$1. Single Catalog -25¢. Spacetratics, Box 31043-PMS, San Francisco, California 94131

35,000 VOLT CONTINUOUS Spark Generator, cheaply made in minutes. Plans, \$1.00 and self-addressed, stamped envelope. Lawrence Engineering, Box 18366, Phila., Pa. 19120.

AMAZING New Book Of Science Experiments, formulas and Catalogue of Laboratory Supplies. Only 35¢. National Scientific Co., Dept. PM-8, 9 S. Park Avenue, Lombard, Illinois 60148.

ROCKETS, Launching Materials, Flying Saucers, Hot Air Balloons, Cannons, etc. Free Catalog. Zeller, Box 70, Hudson, Mich. 49247.

FUEL CELL PLANS only \$1.50, U.E.L. Box 1236, Provo, Utah 84601.

TINY ROCKETS from ordinary paper sodastraws blast in smoke and flame nearly out of sight! Copyrighted Instructions \$1.00 Microrockets, RR2G, Hagerstown, Indiana 47346.

ROCKETS! Flying models, engines, igniters. Send 25¢ for News-A-Log. Rocket Development Corporation, Route 3-M, Seymour, Ind. 47274.

FREE CATALOG On rocket, missile, space books. Rocketlab, Dept. PM, Box 5636, China Lake, Calif. 93555.

100 ONE Minute time delay fuses! \$1.00 240—\$2.00, 700—\$5.00. Use with rockets, experiments, etc. Kenrus-G, 42 Crocus, Woodbridge, New Jersey 07095.

CATALOG Of Ver-ry Interesting Products—25¢. (Free with any purchase—see our other Kenrus ads!) Kenrus-G, 42 Crocus, Woodbridge, New Jersey 07095.

GET Smart. Science, Chemistry, Technology Books. Many fields. Catalog 45¢. See our interesting ads in back issues of PM. Bilton, Box 28, River Edge, N.J. 07661.

FORMULAS, PLANS, ETC.

ANY Formula \$3.00. Catalog—Treatise 10¢. Belfort, 192 N. Clark, Chicago 60601.

SAVE \$50.00 WATERPROOF PAINT for masonry walls. Buy Ingredients locally. Formula \$1.00. Mason, Vandalla, Illinois 62471.

PLASTICS

PLASTIC Embedders, jewelry workers. We have everything. Findings, moulds. New catalog 25¢. David Co., 861 Broad St., Dept. M, Providence, R.I. 02907.

CASTOLITE Liquid Plastic pours like water and hardens like glass without heat. Clear, Colors. Embed real flowers, butterflies, photos, coins. Also new molding formulas for perfect reproductions. Illustrated booklet shows HOW. Send 25¢—Dept. 9/101J. CASTOLITE, Woodstock, Ill. 60098.

PLASTIC, DECALS

EXTRA Income at home in Spare Time! Booklet shows you how to start your own business with Classified Advertising. Only \$1.00 (Refundable with first order.) C. A. Martin, Popular Mechanics, Dept. PM, 575 Lexington Avenue, New York 10022.

TREASURE FINDERS

TREASURE Hunters! Prospectors! Relco's new instruments detect buried gold, silver, coins, minerals, historical relics. Transistorized. Weighs 3 pounds. \$19.95 up. Free catalog. Relco-A40, Box 10839, Houston, Texas 77018.

TREASURE LOCATORS, MOST COMPLETE LINE. FREE INFORMATION. TESOROS, APARTADO 7-948, MEXICO 7, MEXICO.

FREE 128 Page detector catalog. General Electronic Detection Co., Box 67, Bellflower, California 90706.

FISHER DETECTORS! Treasure fun and profit with new professional quality solid-state models. Unsurpassed sensitivity, reliability. Guaranteed. Free literature. FISHER RESEARCH, Dept. PM-8, Palo Alto, California 94303.

POWERFUL Metrotech locators detect gold, silver, coins, relics. Moneyback guarantee, terms. Free information. Underground Explorations, Dept. A, Box 793, Menlo Park, California 94025.

ULTRA-SENSITIVE AND POWERFUL METAL DETECTORS—join the many who are finding buried coins, minerals, relics and artifacts. Don't buy till you see our FREE catalog of new models. Write Jetco—Box 132, PM-6, Huntsville, Texas 77340.

TREASURE BOOKLET. Excellent information on treasure hunting and metal detectors. Send 25¢. BOOKLET, Dept. 8-PM, Box 243, San Gabriel, California 91778.

FIND Buried treasure with new revolutionary analytical metal detector. Features push button tuning, automatic tuning, loudspeaker, negligible ground pickup, greatest range. Free catalog. Gardiner Electronics, Dept. 9, 4729 N. 7th Ave., Phoenix, Ariz. 85013.

URECON Metal finder. 8" head, transistorized. \$40.00 delivered. Urpa 6304 Beechwood, Sarasota, Fla. 33581.

"METAL Locators—Accessories. Write: Detectors, Inc., Box 101-D, Springfield, Va. 22150."

TREASURE, Gold, silver, relics. New 1969 detectors now available. Free information. Rayscope, Box 715, North Hollywood, California 91603.

GOLDAK Treasure Locators—New for '69! A hobby you'll enjoy for fun and profit. Find coins, gold, silver. Goldak, Dept. PMC, 1101A Airway, Glendale, California 91201.

AUTHENTIC TREASURE MAP And Guide to over 200 Sunken Ships Exciting Fun Informative includes Book References and Sources of Information. \$4.00 P. P. No C.O.D. Aldo's, Box 507, Elfers, Florida Dept. 8A 33531.

PRECIOUS STONES AND MINERALS

EARTH Science Rockhound Magazine. Subscription \$2.50. Sample 35¢. Box-550-PM, Downers Grove, Ill. 60515.

GET Free catalog no serious rockhound, gem cutter, jewelry maker, hobbyist or craftsman can be without. Full of bargains, exclusive items, low prices from largest suppliers and authorities in the field. Free new catalog just off the press, yours for the asking. Write Grieger's, Dept. C-12, 1633 E. Walnut, Pasadena, California 91106.

100 COLORFUL, Polished gemstones. \$1.00. Tumblecraft, 5401 James North, Minneapolis, Minnesota 55431.

SEMI-Precious uncut gems. Ten different for \$1.00. Request list -35. Prospectors Shop, 201 San Francisco, Santa Fe, New Mexico 87501.

LARGE, POLISHED, GEMSTONES. 15 different \$1.00. Colorful crystal specimens, 3 different \$1.00. Lists with order. Sering 1705 E. Michigan, Indianapolis, Indiana.

100 POLISH Gem Stones From Pacific Ocean. Empire Gem's, Trinidad, Calif. 95570.

CARTOONING, COMMERCIAL ARTS, SHOWCARD & SIGN PAINTING

COMPACT 23 lesson Cartoon Course and Cartoonist's Magazine, \$2.00. Hartman, Box 30367, Lincoln, Nebraska 68510.

LEARN Sign painting at home. Free talent test. Ben Kerns, Box 812-PM, Greenville, S.C. 29601.

SIGN Painting - Free Catalogue. Instructions, Equipment. Kaufmann Signs, Centertown, Missouri. 65023.

"HOW TO MAKE MONEY WITH SIMPLE CARTOONS"—Everyone who likes to draw should have this book; FREE. Write Cartoonists' Exchange, 98, Pleasant Hill, Ohio 45359.

LEARN Profitable tattooing. Illustrated information and instruction \$3.00. Zeis, 2220-P Delcy Dr., Rockford, Illinois 61107.

SIGN Painting, Fascinating System—Straley, 410 So. Western, Springfield, Ohio 45506.

ART Instruction, Supply Bargain offers, year \$1. Midwest Arts, Box 95, Hamilton, Michigan 49419.

ADVERTISING AGENCIES, ADV. SERVICE, MAILING LISTS

MAILING Lists most all kinds 1000 \$5.00. Free folder. Your circulars mailed \$4.00 1000. Dixie Mailers, King, N.C. 27021.

ADVERTISING Ratebook leading newspapers, magazines. 25¢. Chicago Advertising Agency, 28-E Jackson, Chicago 60604.

TYPEWRITERS, DUPLICATORS, OFFICE EQUIPMENT

FREE Plan. Start printing, lettershop. Offset Presses, Mimeograph Copy machines. DixieGraph, King, N. Car. 27021.

RUBBER STAMPS AND OFFICE SUPPLIES

FREE 40 Page catalog. Rubber stamps, office supplies. Youngers Stamp Shop, Princeton, Iowa 52768.

RUBBER Stamps 4 Lines \$1.25. Catalog. Bilmar, 10024 Oxborough Road, Minneapolis, Minnesota 55431.

CATALOG. Address Stamp \$1.50, Signature \$2.80. Carol's, McLoud, Okla. 74851.

PRINTING PRESSES, RUBBER STAMP OUTFITS

PRINTING Presses, type, supplies. Lists. 5¢. Turnbaugh Service, Mechanicsburg, Pennsylvania 17055.

SIMPLE-X RUBBER STAMP PRESSES, hydraulic operated, electrically heated. Sizes 5"x8", 8"x12", 10"x15". Starting outfits. Orders for presses, supplies shipped day received. Free catalog low supply prices. Custom Manufacturers, 406-P East Elm, Springfield, Mo. 65801.

TYPE Catalog No. 11, 96 pages. Send One Dollar. Deductible First Order. Acme Type, 732 Federal, Chicago, Illinois 60605.

SAME Day shipment on rubber stamp supplies. Revised wholesale price list No. 6 free. Star Stamp Supply, 732 Federal, Chicago, Ill. 60605.

MAKE your own self-molding rubber stamps and printing cuts. Plexirubber, Argyle-1, Wisconsin.

LOW Priced Rubber Stamp Manufacturing Supplies. Starting Outfits. Martin, 1432 Major, Jefferson City, Mo. 65101.

RUBBER Stamp outfits, supplies. Kiewiet, 2025 Barney Road, Kalamazoo, Mich. 49007.

RUBBER Stamp Manufacturers Supplies. Presses, starting outfits. Best Prices, Service. Catalog. Jackson Supply, Box 443-A Franklin Park, Ill. 60131.

PRINTING-Rubber Stamps. Prompt service, reasonable prices, catalog 10¢, refundable. Lamkin Printing, Box (M) 623, Independence, Mo. 64052.

PRINTING AND SUPPLIES

FREE Literature, Address Labels, Business Cards, Printing, Rubber Stamps. Jordan's, 552 West O'Connor, Lima, Ohio 45801.

AMAZING business printing values. Quotations, Print Shop, Box 576, Greenville, R.I. 02828.

FREE Information: Business Cards, Beautifully Embossed, 3 Colors, Spartan, 8210 170th Ave., Stanwood, Mich. 49346.

DO Your own printing. Save money. Simple rules. We supply everything. Print for others; good profit. Raised printing like engraving too. Have home shop. Details free. Kelsey Presses, V-11, Meriden, Connecticut 06450.

BUSINESS CARDS, \$5.00 per thousand. Send for FREE samples. GRAHAM ENTERPRISES, Box 2304, Falls Church, Virginia 22042.

8 HOUR PRINTING-Free Booklet "Secrets of Cutting Printing Cost" Nationwide Printing, Atlanta, Ill. 61723.

BUSINESS CARDS, \$7.95, 1000. Offering complete printing services. Box 322, North Dayton Station, Dayton, Ohio 45404.

SIMULGRAVE Business Cards; 1,000 \$5.00 postpaid, 72 hour service. Ernst-National, Box 1750P, Seattle 98111.

1,000 BUSINESS Cards \$4.00 2-Color \$5.00. Connolly, Harrison, N.J. 07029.

IMPRINTED Envelopes—all kinds! Information: Ross, Box 152, Wayne, Pa. 19087.

MAIL Order Printing Directory. Save up to 50% on printing and office supplies costs! New book reveals over 100 sources. \$2.00 Postpaid. Eagle Press, P.O. Box 113, Lexington, Ky. 40501.

GUMMED LABELS

1,000 GUMMED Address labels \$1.00. Walt's, Box 966A, South Bend, Indiana 46624.

REMAILING SERVICE

CONVENTION City Remails 25¢. Colorful Postcards. Schoen, Box 1963-P, Chicago, Illinois 60690.

MIAMI Remails 25¢. Monthly rates. Marie, Box 1266, Coral Gables, Fla. 33134.

KANSAS CITY Remails 25¢. Receiving-Forwarding. Midway 3115-F South 45th. Kansas City, Kansas 66106.

SECRET Receiving and remailing. Discreet and confidential. Remail 25¢. Pine Park, 8080 Main, Houston, Texas 77025.

REMAIL \$3.00 Monthly. Harold Dalton, Box 1867, Daytona Beach, Fla. 32015

NEW YORK 25¢. \$3.00 monthly. Reliable. Snow, 458 Vermont Street, Brooklyn 11207.

NEW YORK CITY. Remails 25¢. Monthly \$3.00. Forwarding-Receiving. Thomas, Box 158P, Staten Island, N.Y. 10309.

RECEIVING-Forwarding, \$4 Monthly. Hedgpath, 406-M South Second, Alhambra, Calif. 91802.

REMAILS 25¢. Receiving-Forwarding \$3.00. Mailway, Drawer 9037PM, San Jose, California 95117.

ASTRODOME City Confidential Remailing Service. 25¢. Dept-102, Box 14621, Houston, Texas 77021.

TIMES Square Mail Address. \$3.00 Month. Remails 25¢. Details Free. Birnhan, 152 West 42 St., New York 10036.

PHOENIX, Receiving, forwarding, remailing. Confidential. Troen, Box 2386, Phoenix, Arizona 85002.

ENTERSULL. Your secret address. Prompt. Reliable. Box 1888M, Forsyth, Ga. 31029.

RECEIVING-Forwarding \$3. Monthly. Free Address Labels. Remails 25¢. Romae, 6641-A Bo Peep, Jacksonville, Florida 32210.

CALIFORNIA Remails 25¢. Receiving, Forwarding. \$3.00 monthly. Colorful Postcards 10 for \$1.00. Confidential, prompt. Mickens, Box 94-C, Pasadena, Calif. 91104.

NATION Capital Remails 25¢ \$3.00 monthly BROWN, P.O. Box 3177-M, Washington, D.C. 20010.

DETROIT—Grosse Pointe; Confidential. 25¢—\$3.00 Monthly. 3476-M Balfour, Detroit, Michigan 48224.

GLAMOROUS, CENTRAL FLORIDA Remails 25¢. Monthly \$3. 9 postcards \$1. JACKSON, Drawer 1535-PM, Bartow, Fla. 33830.

HOLLYWOOD CALIFORNIA 25¢ Each \$3.00 Monthly. Summers, P.O. Box 1693, Hollywood, California 90028.

KANSAS CITY, MISSOURI 64111, Hudson, Box 10234. Remails 20¢, 3/55¢. \$2.75 Monthly. Prompt, Confidential.

ST. LOUIS Remails 25¢; monthly \$3. Foley, Box 746, St. Louis, Mo. 63188.

HARTFORD—Confidential 25¢ each. \$3 monthly. Marshall Balfe, P.O. Box 14117, Hartford, Conn. 06114.

BOSTON—Singles—25¢—Monthly \$3.00 unlimited. P-Dad, Box 651, Waltham, Massachusetts 02154.

LOS ANGELES, HOLLYWOOD, Receiving, forwarding. Confidential-prompt 25¢. \$3.00 monthly. Cureton, 11117 Herrick, Pacoima, California 91331.

REPAIRS AND SERVICING

EXTRA Income at home in Spare Time! Booklet shows you how to start your own business with Classified Advertising. Only \$1.00 (Refundable with first order.) C. A. Martin, Popular Mechanics, Dept. PM, 575 Lexington Avenue, New York 10022.

SPECIAL SERVICES

INFORMATION On anything. Ferguson Research Specialists, 83-45 Viator Ave., Elmhurst, N.Y. 11373.

REPRODUCTIONS Transferred to Artists' Canvas, P.O. Box 20367, Sacramento, Cal. 95820.

TOBACCO

LARGE Samples Smoking—Chewing 10¢. Jolley Farms, Dresden, Tenn. 38225.

STOP SMOKING! Donald L. Fuller, Hypnotist (A.A.E.H.) will send you Trance inducing Tape with Proper Suggestions To Stop Smoking Forever. How much is your Life worth to you? Send \$5.00. 9218 Archdale, Detroit, Michigan "48228."

RAZORS

EXTRA Income at home in Spare Time! Booklet shows you how to start your own business with Classified Advertising. Only \$1.00 (Refundable with first order.) C. A. Martin, Popular Mechanics, Dept. PM, 575 Lexington Avenue, New York 10022.

PERSONAL

INVESTIGATORS. Latest Electronic Aids. Free Literature. Clifton, 11500-P NW 7th Ave. Miami Florida 33168.

PENMANSHIP Improver: Improve Penmanship Quickly! Details free. Tevis, Chillicothe, Mo. 64601.

BIBLE Questions answered. Stamped envelope. Bylon, 17167 Bentler, Detroit, Michigan 48219.

GET OUT OF DEBT in 90 minutes, legally without borrowing or bankruptcy. Anderson, 8873E Kenwood, Cincinnati, Ohio 45242.

RUPTURED. Relief and comfort. No understraps, elastic or steel. Write Hand-Lock Products, Preston 4, Ont., Canada.

WIN MONEY EVERY MONTH working contests and puzzles. Free details. . . NO MINORS. International Contest Club, Box 10153, Dept. PM-6, Kansas City, Missouri 64111.

SECRET LOANS BY MAIL. Borrow \$100 to \$1500 for any good reason in absolute privacy. No interviews, no endorsers, no co-signers. Fast service. Write Dial Finance Co., Dept. H-214, 410 Kilpatrick Bldg., Omaha, Nebraska 68102.

MAKE YOUR WILL. Get 4 Will Forms and attorney's informative book. \$1.00. Legal Forms Company, Department 124, 1967 Guardian Building, Detroit, Michigan 48226.

UNIQUE! Personal! Your photo on postage size stamps. Gummied, glossy, perforated, 100—\$3.00. Large 50—\$3.00. Chapman Photo Stamps, Box 631, Hurst, Texas 76053.

MAKE NEW FRIENDS Worldwide. Meet Marriage minded Girls through our illustrated Catalog. 1200 Ladies's Fotos and Descriptions \$2.00. I. C. B., Box 12, Toronto, 16, Canada.

SUBCONSCIOUS Conditioning remakes personality while you sleep. Free details. Sleep-Learning, Box 24N, Olympia, Washington 98551.

SUB-MINIATURE LISTENING DEVICES. Low Priced, High performance, direct from Manufacturer. Dealers Welcome. Audiotronics, P8, 156 5th Avenue, New York, New York 10010.

"READ Bert Hadley's Ad under Books, Catalogs. Interesting. Services reliable."

NEW Seeker's Guide.—Unusual Organizations. Free Details. AUREAW, Allenhurst, New Jersey 07711.

BORROW \$1,205 AIRMAIL! Repay \$47 for 36 months. State licensed. Postal Finance, Dept. 17-N, 200 Keeline Building, Omaha, Nebraska 68102.

BORROW Up To \$1,000 By Mail. Money on your signature for any purpose. Write: World Finance Company; Dept. LW-0135, 620 Symes Building, Denver, Colorado 80202.

HOW To Escape Debts. Be Rich, 1000 sources. \$500 to \$2 million. Free details. Counselor-7, Kerrville, Texas 78028.

UNUSUAL domestic, foreign items. Free catalog series. Bohey Sales, Dep't. 3710P, Santa Monica, Calif. 90403.

ANY Black and White Film Developed. 4" x 5" Prints \$3.00 Roll, 5" x 7" Prints \$4.00 Roll Postpaid. Atlas Photo, P.O. Box 2411, S. Portland, Maine 04106.

TEN years successful operation. We find marriage partners for Lonely Men and Women. "INTRODUCTIONS", P.O. Box 1547, Eugene, Oregon.

INTELLIGENCE Tests. Ages 9 through adult. Prepared by recognized Educators. Instructions, Answers, Rankings. Only \$1.00 complete. Educational Testing Associates, 305 Walbridge Building, Buffalo, New York 14202.

SELF IMPROVEMENT Low cost books! RELAX! End tension! No sedatives, no pills. 114 pages. \$1.00. IMPROVE Your personality! Make a new man of yourself. 110 pages. \$1.00. GAIN Confidence and Power in dealing with people. Create good impressions. 164 pages. \$2.00. FINANCIAL Security! Higher Income! Power. Learn secrets. 256 pages. \$2.00. WHERE to retire and vacation economically. Handy volume. \$2.00. From GARLAND GIFTS, Dept. PM-8, 259 Bennett Avenue, New York, New York 10040. Include 10¢ postage. New York residents add sales tax. FREE Booklist available.

POLLUTION Is Robbing our Oxygen! Start drinking Oxygen Tonic. Be more alert. Increases Pep, Energy, Health. Simple to make. Factual report and instructions only \$1.50. Way Scientific, P.O. Box 725, Pontiac, Michigan 48056.

HYPNOTISM SECRETS. Lowest prices. Free information. Merlin Enterprises, P.O. Box 613, Los Gatos, Calif. 95030.

WANTED—MISCELLANEOUS

MERCURY. Gold, Silver, Platinum; Ores assayed. Wholesale Terminal, Norwood, Mass. 02062.

YOUR Ad in Popular Mechanics will be seen by more than 5,000,000 active buyers for your products and services. It costs only \$1.85 per word. And, if you wish to run all or part of your ad in capital letters—you can do so for as little as 75¢ per word additional. Act now! Place your classified ad in Popular Mechanics today.

MISCELLANEOUS

ORNAMENTAL Iron designs. Book of 1600 beautiful, practical designs for railings, columns, etc. Free literature. Cunningham, 3881 South 3200 West, Salt Lake City, Utah 84119.

SILENCERS For pistols and rifles. Complete details for construction and operation, \$1.00. Gunsmith, Box 185, Fairfield, Alabama 35064.

YOUR Name sent to 1000 importers, publishers, mailers, wholesalers, etc. on our mailing list. Year \$1.00, Dixie Mailers, King, N. Car. 27021.

HEARING Aid batteries wholesale. Free list. Habs, Box 51, York, Penna. 17405.

WINEMAKERS—Free catalog and recipes. Kraus, Box 451-L, Nevada, Missouri 64772.

CIGARETTES 12¢ a pack. Improved roller makes 20 filtertip, plain, king or regular for 12¢. Facts Free. Moberly, Box 954, Owensboro, Kentucky 42301.

BIRTH Certificates, Marriage Certificates, Diplomas! 2 blank forms \$1.00. Sample 10¢. Standard Forms, Box 482-M, Washington, D.C. 20044.

WANT Greatest Cash Crop working for you? Write, Ginseng, Asheville 53, N.C.

WINEMAKING . . . Grape, Elderberry, Dandelion, Frozen Juices, etc. Brewmasters' secrets revealed! Powerful Methods! Instructions, Recipes, and Supplies Catalog, \$1.00. Continental, Box 11071-PH, Indianapolis, Indiana 46201.

BOOKS On antiques and their prices. Free circular! P. Warman Publishers, Uniontown, Penna. 15401.

AMAZING Books, jewelry-sweaters-watches. Lynn's, Box 1573, Waco, Texas 76703.

WINEMAKERS. Free illustrated catalog of yeasts, equipment. Semplex, Box 12276, Minneapolis, Minn. 55412.

PSYCHEDELIC Catalog send 25¢. Hole, 6055 Lankershim, North Hollywood, Calif. 91606.

KILL Mosquitoes, Insects, electrically. Free information. Insect Control, Box P374, Royal Oak, Michigan 48068.

PROTECTO-CARRY! Magic Seal Plastic Pouch, 6x10, For Hand Tools, Etc. 50¢ 3 for \$1.00. Postage 10¢. Belwood's, Box 4494, Glendale, California 91202.

MAILBOX EMPTY AGAIN? Don't be left out. \$1.00 starts mail coming. Plus FREE GIFT, The Stewart Co., Dept. 117, Box 7237, Sacramento, Calif. 95826.

WINEMAKERS! New Illustrated Supplies Catalog . . . Free! Write Today! Winemakers, Box 11211-RU, Indianapolis, Indiana 46201.

OREGON HOPS (Quart Bag) with 101 recipes: Winemaking, Sourdoughs, Hop-breads, \$1. Nichols Hops, 1190 North, Albany, Oregon 97321.

ORLON Socks usually \$1.15. Sample pair 35¢. Meyer, 2924 Central, Evanston, Ill. 60201.

SLOT & PINBALL machines, etc. Catalog 35¢, refunded with order. COPFCO, Dept. B, P.O. Box 522, Lake Zurich, Ill. 60047.

SEND 25¢ (coin) for samples, an unusual gift. Eichel, Box 121, McArthur, California 96056.

AMAZING new Falk's camfo cream relieves sunburn, chafing, insect bites, tired feet. \$1.50 postpaid. Guaranteed. Forest Studios, 2830 Urbandale, Wayzata, Minnesota 55391.

INTERESTED in Home remedies? Homework? What? Write: Box 792, Battle Creek, 49014.

ARE You thinking of answering these ads? For every 20 you answer it will cost you \$1.00. Midcity will have 100 companies send you their offers for only \$1.00. 200 for \$2.00 300 for \$3.00. Satisfaction guaranteed. Midcity M3, Box 174, Elmhurst, Illinois 60126.

ENCYCLOPEDIA OF WINE MAKING EQUIPMENT. Handsomely bound book of wine-making knowledge. Over 200 items described and illustrated with full instructions for use. Send \$1.00 (refundable). Vino Corp., Box 7885-AT, Rochester, N.Y. 14606.

WINEMAKING Kit—\$4.95 Postpaid. Free Catalog—Jim Dandy Wine Supplies, Box 30230M, Cincinnati, Ohio 45230.

TRANSMITTER—world's smallest! Fantastic range! Free details. Acoustics, Dept. PM-8, 69-29 Queens Blvd., Woodside, New York 11377.

INVENTORS

INVENTIONS—NEW PRODUCTS—IDEAS DEVELOPED & PREPARED
For Commercial Appeal & Sales

DESIGN—MARKETING—PATENT SEARCHES—DRAWINGS
United States Patent Office former Patent Examiner
United States Dept. of Army former Patent Adviser
Member: United States Chamber of Commerce
Second Decade of Reliable Service to

INVENTORS—MANUFACTURERS—ATTORNEYS
FREE CONSULTATION

THE RAYMOND LEE ORGANIZATION
230-Z Park Ave., New York 10017 (212-MU 6-8500)

SEND FREE "INVENTION RECORD" Form & "IMPORTANT PATENT INFORMATION"

Name _____
Address _____
City _____ State _____ Zip _____

MAKE EXTRA MONEY IN YOUR SPARE TIME

LEARN PROFESSIONAL "PLEXIGLAS" SIGN MAKING!

\$13.75 brings you over 120 ACRYLIC LETTERS AND FREE INSTRUCTIONS. Send your re- mittance to:

DAYTONA PLASTIX
Box 6161, Daytona Beach, Florida 32022.

BUILD YOUR OWN CAMPER

SAVE UP TO 50%



Complete, easy to follow plans, instructions, materials list.

Camper Plans	\$3.95
Travel Trailer	\$3.95
Pickup Cover	\$2.00

CONVERSION PLANS:

Econoline Type Van.	\$2.95
Passenger Bus or Delivery Van.	\$2.95

Satisfaction Guaranteed

EQUIPMENT CATALOG \$1.00
Refundable on First Order. Send Dime for Details. Save 50% on Camper Kit. All items from catalog to build \$1,795. Camper, 8', 10', 10'6" or Chassis Unit.

VIKING

VIKING CAMPER SUPPLY, INC.
99-BP Glenwood Ave., Minneapolis, Minn. 55403
Please send _____ for which I enclose \$ _____

NAME _____
ADDRESS _____
CITY _____
STATE _____ ZIP _____

EARN MONEY FAST!

REPAIR HYDRAULIC JACKS

Earn while you learn at home. Millions of jacks in gas and auto service stations, trucking firms, body shops, riggers, factories and farms need servicing . . . most of which you can learn to repair. We show you HOW. Start spare time in your basement or garage. Big opportunity for mechanics. ACT NOW!
Write for folder PM-8 and free bonus offer



HYDRAULIC JACK REPAIR MANUAL CO., INC.
G. P. O. BOX 3 • STATEN ISLAND, N. Y. 10314

BASEMENT TOILET FLUSHES UP



TO OVERHEAD SEWER OR SEPTIC TANK. NO DIGGING UP FLOORS. INSTALLS EASY. Write McPHERSON, INC., BOX 15133, TAMPA, FLORIDA 33614

Материал, защищенный авторским правом

Take this \$3.49 book FREE!

Let these 257 experts show you how to attain the skills of a real pro!

You get this giant 8¼" x 11" illustrated volume of exciting "how-to" projects for your family, home, garden, car, boat, vacation—as an outright gift—nothing to buy. It is crammed with reliable shop-tested, do-it-yourself techniques and practical show-how pictures. Use these hundreds of do-it-yourself plans, projects, tips and hints to polish your own shopwork and hobby skills! Here is a brief glimpse of all your FREE Volume brings:



• Having car engine trouble? Fix 8 common problems quickly without having to pay a garage mechanic anything he chooses to charge you.

• Professional tips for expert sanding show how to bring out the best finish in woods and metals with power and hand tools.

• Complete plans help you build an inexpensive 3 x 4 foot plywood table to give any small band saw big-machine capacity and flexibility.

• Need extra space? Turn an unfinished attic or basement into handsome, usable areas with practical, money-saving plans.

• Save on band saw blade costs. Build brazing fixture to make your own blades.

• Do your own auto body repair expertly with simple tools and methods.

• Build a boat designed just for fun. Step-by-step plans and materials list included.

• Home too hot for comfort? Follow complete directions for air conditioning your home.



• Bothered by a wet basement? Cure it yourself and save \$200 to \$2,000 under what professionals charge.

• Need better burglar protection? Build effective power alarm for a safer home.

• Refinish furniture perfectly. Hands-at-work pictures show you how.

• You'll wonder how you ever got along without an air supply in your shop once you've built and used the "foot-bellows" system.

• Build a gas-fired barbecue for more back-yard fun.

• New soundproofing techniques enable you to relax in quiet.

• Anyone can hand-letter signs with the "Project-A-Plan" method.

• Special trouble-shooting chart pin points malfunctions in an auto electrical system so you can fix it quickly.

• Target practice in the living room? Believe it or not you can blast away indoors without harming anything.

• Build your children model planes that fly higher than any others.

• Special tricks-of-the-trade save you time and effort in handling power tools.

• Save hundreds of dollars on buying and servicing appliances.

Plus hundreds of other exciting plans and do-it-yourself ideas to save you big money and add thousands of hours of pleasure to your hobby, sport and vacation projects.

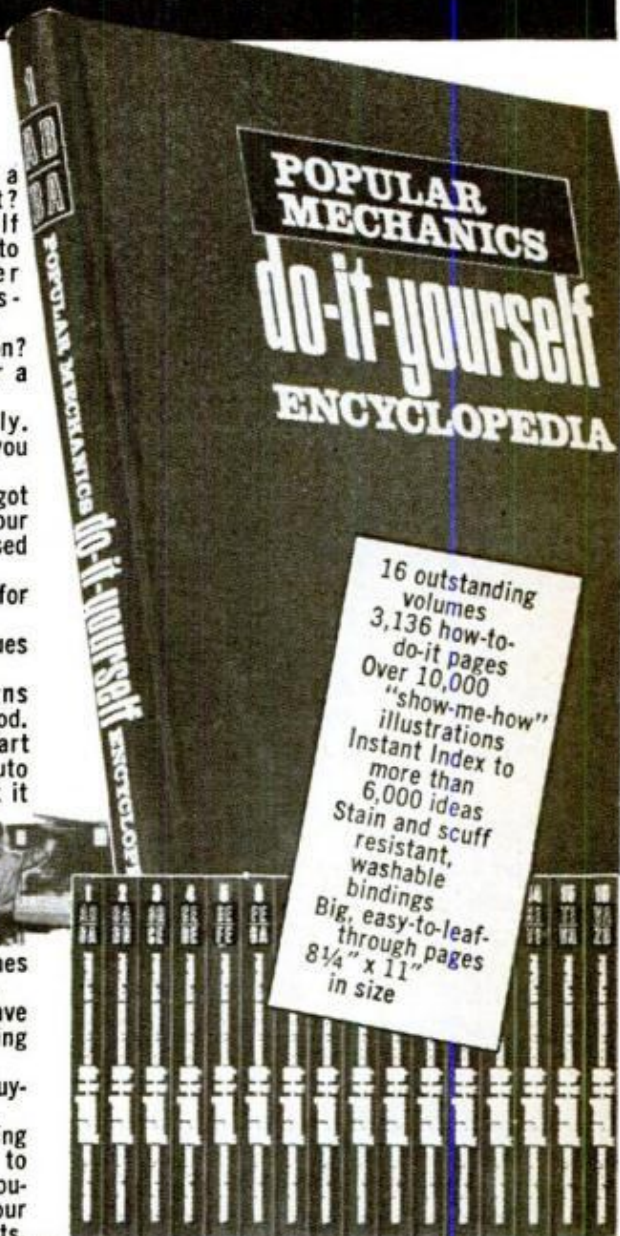

16 outstanding volumes
3,136 how-to-do-it pages
Over 10,000 "show-me-how" illustrations
Instant Index to more than 6,000 ideas
Stain and scuff resistant, washable bindings
Big, easy-to-leaf-through pages
8¼" x 11" in size

Why you receive this practical do-it-yourself handbook ABSOLUTELY FREE!

The reason you get this brand-new \$3.49 book as an outright gift is simple. This gold mine of "how-to" projects and money-saving plans is the first volume in POPULAR MECHANICS DO-IT-YOURSELF ENCYCLOPEDIA—an amazingly useful guide created by the editors of *Popular Mechanics*—experts in do-it-yourself techniques for over 65 years. The Encyclopedia gives you over 6,000 projects, repairs and improvements you can do by yourself to save hundreds of dollars on labor and materials. 257 experts lead you through every step of every project you select. They give you thousands of practical pointers to sharpen your skills in carpentry, car repair, metalwork, plumbing, masonry, electrical work, electronics, hi-fi, stereo, painting and decorating.

We believe that if you browse through the first volume—select a plan or project—use it at your workbench—try some of the money-saving shortcuts, shop-tested methods—you will be anxious to receive the others. Therefore, you may enjoy future volumes as they are published for 14 days' FREE EXAMINATION. You may buy one, two, the whole set, or none at all. But the first volume is yours to keep without obligation, no matter what you decide. Mail coupon today, to be sure of getting your FREE Volume.

FREE GIFT CERTIFICATE

Popular Mechanics Book Division, Dept. 918
250 West 55th Street, New York, N.Y. 10019

Please send me, ENTIRELY FREE of any charge, my complimentary copy of Volume One of the all-new, illustrated POPULAR MECHANICS DO-IT-YOURSELF ENCYCLOPEDIA. I am not obligated to buy anything—now or later.

I understand I will be entitled to receive additional volumes for my FREE EXAMINATION as they are published each month. After examining each volume FREE for 14 days, I will either return it and owe nothing—or keep it and remit low subscriber price of only \$3.49 a volume, plus a few cents for shipping.

I reserve the right to cancel any time I wish—even immediately after receiving my FREE Volume 1—without obligation. Whatever I decide, Volume 1 is mine to keep FREE.

Name _____

(Please Print)

Address _____

City _____

State _____ Zip

Signature _____

SOLUTIONS FOR MECHANICAL HEADACHES

AUTOMOBILE CLINIC

BY MORT SCHULTZ

Transmission trouble

Because I was experiencing improper shifting of the Cruise-a-Matic transmission in my 1966 Mercury, I had the bands tightened, transmission fluid changed and modulator replaced. The mechanic said he found evidence of gasoline in the modulator. How does this happen and can I prevent a recurrence?
—Charles J. Dugan, Warminster, Pa.

Oddly enough, it is possible for gasoline to get into the transmission modulator. The modulator's vacuum line runs to the intake manifold. Fuel in a gaseous state can enter this line and condense to a liquid, then it can drip back to the modulator. To fix the problem, make a loop in the vacuum line between the manifold and the modulator.

Persistent rough idle

For some time, I've been experiencing a rough idle with my 1968 Dodge Dart GTS with 340-cu.-in. engine. Several tune-ups and a trouble diagnosis have failed to find the cause. Is there something about this car that we've overlooked?—Martin Meyer, Columbia, S.C.

There is the possibility of very slight rubbing between rocker arm and the edge of valve springs. This can result in a noise similar to tappet noise and/or rough idle. Inspect the rocker arms and valve springs. If one or more are rubbing, the top outer edge of the spring or retainer will have a shiny spot and there will be corresponding wear on the rocker arm. To correct the trouble, replace the affected rocker arm with part No. 3418425 (right bank) or with part No. 3418424 (left bank). There's a service bulletin covering this (D68-9-10, Jan. 22, 1969). Your dealer should make the change.

Hemming and hawing

The crankcase rear-bearing-shaft seal of my 1964 Chevrolet is leaking oil. A new seal, the installation of which involves dropping the pan, will cost about \$50. Would a can of one of the "stop leak" preparations soften up the seal enough to stop this leak?—Will Casey, Chattanooga, Tenn.

I doubt it. The seal has probably ruptured, and a "stop leak" solution won't put it back together again. However, every time I take a dogmatic view about one of these preparations, someone always writes to say how it worked for him. So, let me hedge. Try it. You have nothing to lose except a few cents. The preparation certainly won't harm anything.

Hot or cold

I had a rear-window defroster installed on my 1969 Buick Le Sabre. I get cold air out of it. What can I do to make it right?—Tony Stanich, Gig Harbor, Wash.

It is right, Tony. This is not a defroster in the same sense as your front windshield defroster. It's a defogger. The thing is only a fan that's designed to clear humidity-caused fog off the rear windshield.

Buzzing around

When I turn the key to start my 1963 Buick Special, I frequently get only a buzzing. It may happen one time or six before the engine catches and starts. I've cleaned and tightened the battery cables, and it hasn't helped. What's your opinion?
—Robert E. Partridge, Peoria, Ill.

There are only two things that cause this: (1) dirty or loose battery-cable terminals and posts; (2) a bad starter solenoid. I hope that when you cleaned the battery-cable terminals you took them off the posts and cleaned them thoroughly on the inside with a battery-cleaning tool. Make sure, too, that posts are sparkling clean and that there's a tight connection between terminals and posts. If the car still acts up, replace the starter solenoid.

Trailer brakes

Are there any precautions to follow when connecting the hydraulic brakes of a travel trailer to a car or pickup having a dual brake system?—C.H. Proctor, Englewood, Colo.

Generally, you should tap the trailer brakes into the hydraulic line feeding the
(Please turn to page 68)

Now! Do car repairs this quick, easy way

You can "breeze through" engine jobs, tune-ups, front end jobs, brake repairs, steering adjustments, carburetor adjustments, alternator servicing — almost ANY car service or repair job **ON THE VERY FIRST TRY!**

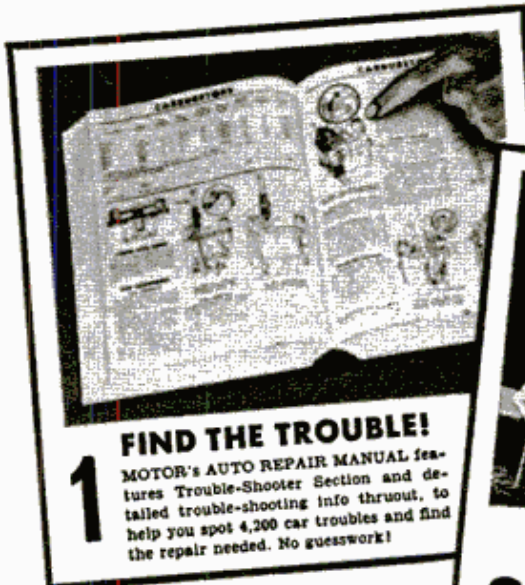

1 FIND THE TROUBLE!

MOTOR's AUTO REPAIR MANUAL features Trouble-Shooter Section and detailed trouble-shooting info thruout, to help you spot 4,200 car troubles and find the repair needed. No guesswork!



2 FIX THE TROUBLE!

Step-by-step instructions, photos, diagrams show you where to start, what tools to use. Factory experts practically guide your hands through every move. You can't go wrong!

1,104-PAGE ILLUSTRATED GUIDE SHOWS YOU

How to Fix Almost Any Part of Any Car

YES! MOTOR's giant new AUTO REPAIR MANUAL is the answer to practically all your car repair problems. Almost every car repair on popular-make cars built since 1963 is explained and illustrated in fool-proof detail. You will develop new speed and confidence on any repair job you tackle.

Try it FREE for 10 Days

Words can't possibly describe the vast contents . . . the thousands of photos and diagrams . . . the easy-as-pie instructions . . . the wonderful feeling when you know you've got that car running like new again!

You've got to see it, use it for yourself! That's why we offer to send it to you, at our risk, for FREE ten-day trial. Try it. See how it makes even the toughest jobs seem like child's play. If you're not 100% satisfied, just send it back and you won't owe a penny!

are guided by the men who actually build the cars, for this book "boils down" the time-cutting and work-saving methods from 300 official factory shop manuals.

This NEW, REVISED EDITION gives you just about everything you need to know to service or repair engines, transmissions, brakes, ignition systems, automatic level controls, exhaust emission controls, speed controls, air conditioning, concealed headlamps, steering, alternators, etc., etc.—practically every part of the car makes listed below.

1,104 double-size pages include 3,000 pictures, 365 Quick-Check charts, 55,000 essential specifications — more than 225,000 service and repair facts! It includes all the new 1969 models.

No wonder you'll see copies of MOTOR's Manual on almost every garage workbench in the country. No wonder it's used by schools, factories, the U.S. Army & Navy. Over 5,000,000 copies sold.

SEND NO MONEY

Just mail the coupon. Use the Manual for 10 whole days FREE. If it doesn't pay for itself in time and money saved within 10 days, return it and owe nothing. But act now! MOTOR BOOK DEPT., 250 W. 55th Street, New York, New York 10019. (Schools Bookstores: Write for Discounts.)

Same Offer on MOTOR's AUTO ENGINES & ELECTRICAL SYSTEMS

1,300 pics. how-to text on principles, design, upkeep of engine & electrical systems. Check box in coupon.

Almost Everything You Need to Know to Fix Cars Like a Crack Mechanic

The instructions and pictures are so complete, so clear, you just can't go wrong. Your hands

FIX ALL THESE CARS

Volkswagen	Dart	Dodge	Tempest
Mustang	Mercury	Oldsmobile	Corvette
Barracuda	Ford	Ford Bronco	Valiant
Jean	Chevelle	Buick	Cougar
Chevy II	Chevrolet	Special	Toronado
Pontiac	Camaro	Comet	Riviera
Thunderbird	Scout	Corvair	Firebird
Buick	Chrysler	American	Eldorado
Imperial	Plymouth	Olds F-85	Marlin
Cadillac	Fury	Falcon	Javelin
Continental	Bombler	Fairlane	Montego
		Lancer	etc.

FREE 10-DAY TRIAL

Return and Pay Nothing if Not Satisfied

MOTOR'S
AUTO REPAIR
MANUAL

Nearly 1 FOOT HIGH
3,200 Illustrations
Over 1,100 Pages

5,000,000 COPIES SOLD

PRaised BY BEGINNER AND EXPERT MECHANICS ALIKE . . .



"I am a racing 'bug' and expect the most out of my cars. Your Manual has been of excellent help to me." — Duane Davis, Indiana (Racing Advisor)



"I always rely on my Motor Books. They're well illustrated — it for all makes and models." — Mr. Erv Jenes, Minnesota (Garage Owner)



"Motor's Auto Repair Manual is invaluable to me. I depend on it for all makes and models." — Mr. W. W. Farlines, Virginia (Mechanic)

MAIL COUPON NOW FOR 10-DAY FREE TRIAL

MOTOR BOOK DEPT., Desk 918
250 W. 55th St., New York, N.Y. 10019

Rush to me at once MOTOR's New AUTO REPAIR MANUAL. If O.K., I will remit \$2 in 10 days, \$3 monthly for 2 months and a final payment of \$1.95 plus delivery charge and sales tax, if any, one month after that. Otherwise I will return the book postpaid in 10 days.

Print Name.....Age.....

Address.....

City & State..... Zip Code.....

Also send me for 10-day Free Trial MOTOR's AUTO ENGINES & ELECTRICAL SYSTEMS. If O.K., I will remit \$6.95, plus delivery charge and sales tax, if any, in 10 days. Otherwise I will return book postpaid in 10 days.

Check box and save shipping charge by enclosing WITH coupon payment of \$9.95 for AUTO MANUAL (or \$8.95 for AUTO ENGINES) plus sales tax, if any. Same return privilege.

AUTOMOBILE CLINIC

(Continued from page 66)

rear brakes of your car or pickup. This is a safety consideration. The subject of brakes is most vital for you fellows who tow trailers. I suggest that you contact a brake company that is interested in promoting safe trailering to get that company's recommendation. Kelsey Hayes in Romulus, Mich., for example, will send you information. Tell them the make and model of both vehicles.

Drowning Opel

My 1967 Opel Kadett is afraid of wet weather. Whenever it rains, the engine quits. Won't start—even stalls out dead cold if it's running along and suddenly the rain comes. Tune-ups haven't helped. Help!—Billy B. Booth, New Orleans, La.

The cure is a new kit at the Buick/Opel dealer which contains a new coil, relay and resistor wiring. The problem with your water-shy Opel is that there isn't enough insulation on the parts in the car to keep the ignition from drowning out. If you're still in warranty, the change will be free.

Leaky windshield

My 1967 Rambler Rebel is leaking like a sieve. Water's coming in on both the driver and passenger sides. I've had as much as an inch of water on the floor after 30 minutes of a fairly heavy rain, but I can't trace the source. Has this been a problem with the car?—Robert Goldsmith, Fort Myers, Fla.

It has. A poor sealing job around the front windshield on these Rebels has caused other guys just as much woe. I suggest you remove the molding around the glass and do a thorough resealing job using windshield sealer you can buy at an auto-body supply shop. Naturally, if the car's still under warranty, let Rambler do it.

Check the spec

It seems that I have excessive pedal travel in the power brake of my 1968 Pontiac LeMans. The dealer says no. Is he trying to duck something?—Robert Berry, Streator, Ill.

Pontiac uses an indentation in the floor pan to allow a lower pedal so you can apply the brake without lifting your foot. If you still have doubts, take a ruler and, without applying the brake, measure from the bottom back of the pedal to the highest spot on the floor directly beneath the pedal. There should be a clearance of 2½ in. If so, you've got no squawk. If not, something's wrong—like maybe they installed the wrong brake pedal at the factory. In any event, you now have proof positive to present to the dealer that he can't argue with. After all, that 2½-in. spec is Pontiac's—not yours.

Two cars—one problem

I own two '68 Plymouths—one Satellite; one VIP. They have one common problem. They vibrate and shake when I apply the brake at 40 mph and above. Why?—Arlo E. Hinkle, Pocono Summit, Pa.

Because the brake drums on these cars have become distorted. Take both cars back to the dealer and have him correct the condition by machining the drums. He'll follow the procedure in service bulletin 69-5-3. The date on it is 1/31/69.

SERVICE TIPS

● Chevrolet says it has a way to get rid of that oily film which is forming on the inside surfaces of windows. The haze is caused by volatilization of the solvents and plasticizing agents used in some of the synthetic materials put in cars. It smears when wiped and leaves a residue if you try to use a commercial glass cleaner. Instead, wipe the glass with a cloth soaked in vinegar. Then, wipe with a dry cloth. (My suggestion—not Chevy's—is that you then spray the inside of the car with a room deodorizer to get rid of that vinegar smell.)

● Chrysler-built cars with 383, 426 and 440-cu.-in. engines and manual transmissions now coming off the assembly line are getting new and better clutch-pressure plates than those installed in 1968 and early 1969 models. If your pressure plate suddenly goes poop, make sure the mechanic puts in this new one which has stronger eyebolts and lever pins. The part numbers are 3410182 (383 engine), 3410183 (426 engine) and 3410184 (440 engine). ★ ★ ★

GOT A PROBLEM WITH YOUR CAR? Ask Mort about it. Send your question to Auto Clinic, Popular Mechanics, 575 Lexington Ave., New York, N.Y. 10022. Letters cannot be answered individually, but problems of general interest will be published in the column.



IT'S ALMOST LIKE PRINTING YOUR OWN MONEY!

9¢ WORTH OF RAW MATERIAL *becomes* **\$125** in less than 60 seconds—and ANYONE can LEARN to do it in a FEW SHORT HOURS!

Since 1922, Warner has enabled thousands of men and women to establish a business of their own—to reap the benefits of their own labor and have the personal satisfaction, and independence, that comes with operating a business of their own.

Now, a revolutionary new machine makes it possible for an Independent Business Man with no "PULL" . . . No Big Money to Invest . . . and, No Experience — to start a business of his own, at home in his spare time. Here's what J. H. of Pennsylvania says:

Now you can get into this highly lucrative business, and use your own home as headquarters. No experience needed because we supply everything. The new Warner Success Program, "Engraving as a Profitable Business," is now ready for you. We will send you a FREE illustrated brochure and no salesman will call. Send no money — just your name and address on the coupon or on a postcard. Be the first in your locality to cash in on this ground floor opportunity.

**Warner Electric Co., Dept. E-2-JS
1512 Jarvis Ave., Chicago, Ill. 60626**

\$7,280.00 for 1 to 1½ hours work an evening in my spare time—and without advertising. When I start to advertise I will have my own full-time business. Right now I am using the extra income to give my family the luxuries my present job does not afford.

Engraving Division, Dept. E-2-JS **SEND NO MONEY**
1512 Jarvis Ave., Chicago, Ill. 60626
Please rush your free illustrated brochure to:

Name _____
Address _____
City, State, Zip _____



BE A MAN—GET A MAN'S JOB OPERATING HEAVY EQUIPMENT

- BULLDOZERS • BACK HOES • GRADERS
- DRAG LINES • CLAM SHELLS • SCRAPERS

Train NOW to operate earth-moving equipment. **The Construction Business is Booming!** You can earn top money in this fast moving, action packed-field! Keep present job and train at home in your spare time followed by Resident Training in the actual operation of heavy earth-moving equipment under project conditions at our school owned facilities near **MIAMI, FLORIDA**. Excellent employment assistance. For details without obligation, fill out coupon and mail today.

CONTRACTORS:
Information about our trained Operators available upon request

UNIVERSAL HEAVY CONSTRUCTION SCHOOLS, Dept. P M
1901 N.W. 7 Street, Miami, Fla. 33125

Name _____ Age _____
Address _____
City _____ State _____
Zip _____ Phone _____

HOMEOWNERS' CLINIC

BY W. CLYDE LAMMEY

Mottled ceiling

I've just painted a plaster ceiling that was in bad shape. Though I had filled the digs and gouges with a prepared filler, or patcher, now it looks as bad as ever—every patch shows as a flat spot or streak through two rolled coats of paint. Any suggestions?—T.P., Ga.

What did you use as a "patcher"? Without knowing, I suppose that it must have absorbed the paint faster than the adjacent area did, thus creating the "flat" spots and streaks. There seems no simple solution, but perhaps all is not lost. I would attempt salvage by coating the flat spots with the same paint you used for the two top coats. Apply it with a small brush only to the areas affected and take care to brush it out to a smooth uniform film. After letting this dry thoroughly, roll on another coat slightly darker in tone.

Rusty saw table

I've just bought a used table saw and a wood lathe. Both saw table and lathe bed are of cast iron and very rusty all over the work surfaces. How can I clean them so that they will be usable? I'd like them shiny and smooth as they once were.—I.K., Ariz.

You can never achieve the shiny, smooth surface of the originals, unless you have them resurfaced on the same type of surfacer which did this originally. This would be expensive, of course. But you can remove most of the rust and get the saw table and lathe bed sufficiently smooth for practical use. Rent a portable belt sander from your local paint dealer or tool-rental shop, and buy one or two each of medium and fine-grade, aluminum-oxide belts, also one or two each of the same grades for hand abrading as a preparatory step. Attach a strip of the medium grade to a block of wood and remove the worst of the rust and discoloration by hand, using the two grades of abrasive alternately. Then, using a medium-grade abrasive belt on the sander, run slightly overlapping strokes from side to side of the saw table, being sure the strokes are straight. When the rust has been removed, change to the fine

belt and repeat until you have a reasonably smooth, bright surface. Proceed much the same with the lathe bed, after removing the head and tailstocks and the tool-rest. Then coat the renovated surfaces with paste wax and polish with a soft, lintless cloth.

Condensation on floor

We're going to build a small home on a concrete slab floor. Several neighbors with similar homes have warned of the trouble they've had with sweating floors, especially around the outside walls. We want to avoid this. What is the cause, and is it preventable?—W.H., Minn.

Put simply, the cause usually is a variation in temperature between that of the floor at the periphery of the structure and air in the rooms. Slab floors poured improperly or tiny hairline cracks in the concrete also invite trouble by permitting moisture to migrate from underneath to the top side. This is especially true of slabs poured directly over earth rather than screened gravel or crushed-stone beds properly tamped. The best construction generally requires that the site be graded to provide adequate drainage away from the walls and that the slab be poured over a tamped gravel or crushed-stone bed; that the concrete slab be wire-reinforced; that there be a suitable vapor barrier over the top surface and on top of this a foam-plastic insulation—minimum thickness 1 in.—over the whole. This is then topped with ½-in. (minimum thickness) tongue-and-groove plywood over which wall-to-wall carpeting or tile may be laid. You can get more detailed information from your local building materials dealer or your state university extension service. Contact them directly.

Self-finishing wood

I used new redwood paneling in my basement recreation room on the advice of a friend. He says it will not be damaged by water should my basement flood due to water backing from the storm sewer. How can I preserve it as is?—D.N., Ohio.

It can be left without any finish at all—redwood might be called a "self-finishing" wood. In time it will mellow to a somewhat deeper reddish-brown with some variation between the light and dark tones. Should the basement flood, the wood will not be harmed noticeably provided the water drains within a relatively short time and paneling was applied according to accepted practice. ★ ★ ★

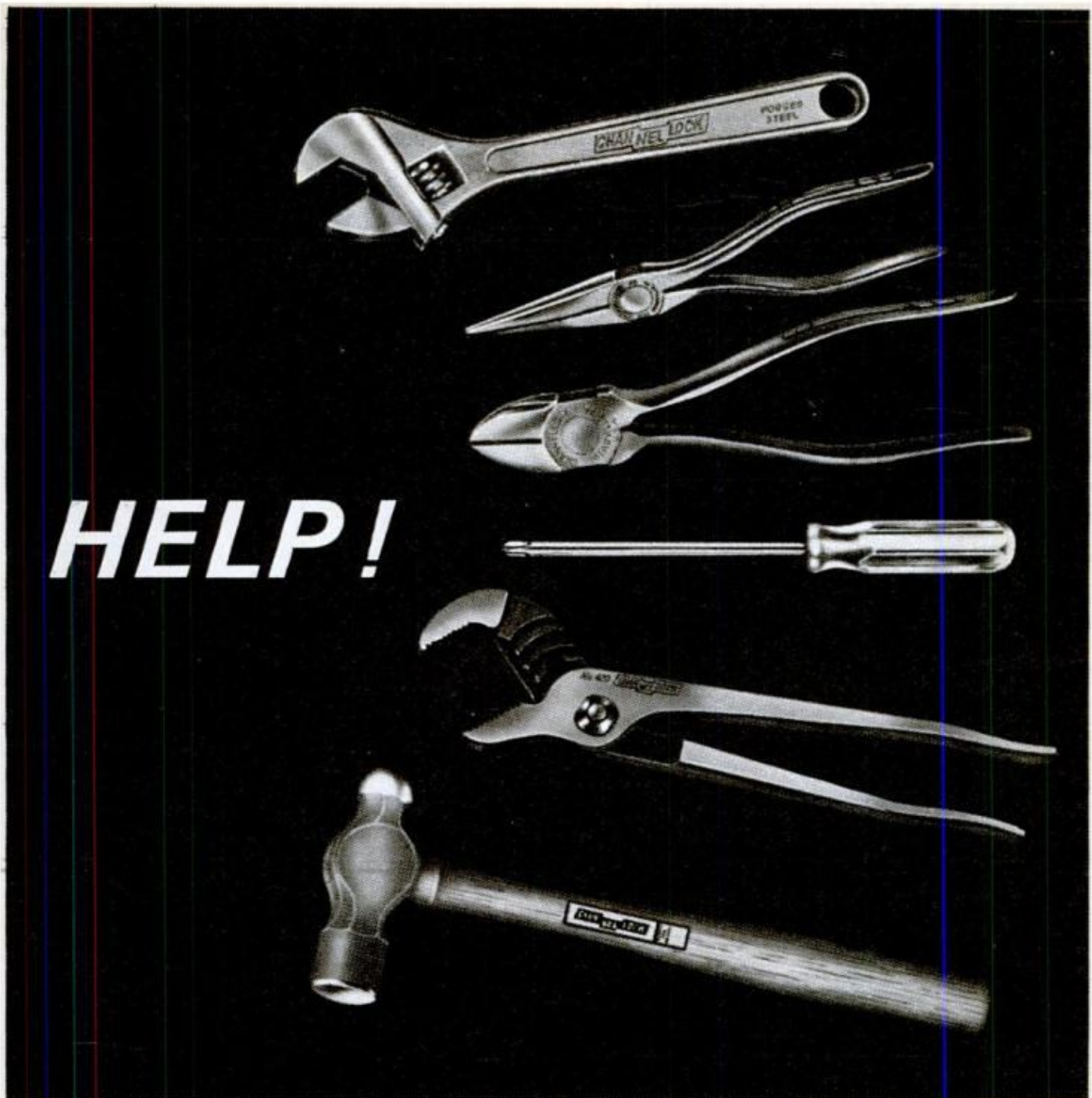

HELP!

...Yours When You Reach For Tools By CHANNELLOCK

Whenever you want to hold, cut, strip, drive, grip, bend, pull, twist, straighten, tighten or loosen . . . man, you need help! The kind of help that not only gets the job done faster *now* but year after year as well. The kind of help you get only from hand tools by Channellock. Doubt it? Take hold of a Channellock tool.

See and feel the fine-polished drop-forged steel . . . the precision-machined, smooth-working moving parts . . . the skillfully hand-honed cutting edges. You'll know then why Channellock is the favorite brand with men who know good tools and won't tolerate less. Men like you.

TOOLS BY
CHAN NEL LOCK
 MEADVILLE, PA.

We brew every bottle of Miller High Life as if it were the only one



Miller
makes it
right...
The Champagne of Bottle Beer

Next Month in Popular Mechanics

Owners Reports on the Plymouth Valiant and Jeep Wagoneer

After driving more than a million miles in a car they bought for economy, Valiant owners report they are getting what they want: economy. But they complain mildly about workmanship. Jeep Wagoneer owners, who bought because they want four-wheel drive, are happy using that feature for hunting, fishing and camping. But they're complaining about mileage.

What's the Truth About Speed Laws?

You pay a fine, the other guy gets off. How come? There are times when courts *don't* agree with the man in blue, and it helps to know when those signs mean what they say.

How to Buy a GOOD Old House

An old house can be a bargain if it's sound—and a nightmare if it isn't. In September, an expert tells you what to watch out for and how much repairs may cost.

10 Clues for Finding Hidden Ignition Troubles

Next month *Saturday Mechanic* describes some overlooked sources of ignition trouble and what you can do to fix them.

Packaged Fence Panels Offer Both Beauty and Privacy

You can choose from a wide variety of attractive enclosures if you play "musical chairs" with these new interlocking, pre-painted aluminum panels.

Look What's Happened to Bows and Arrows

Archery's exciting new look is the result of computer design and the use of new materials. Now you can be an expert archer in no time flat.

The World's Sharpest Tool

They'll never make it to Tiffany's, but industrial diamonds can cut, grind and grip like nothing else on earth.

Antisubmarine Warfare

Russia's 50 nuclear subs spell trouble for the U.S. Navy's ASW forces. But amazing new weapons are making the "nukes" easier to track and destroy.

The ABCs of Chassis Frames and Suspensions

The manner in which four simple wheels are attached to a platform to shape the undercarriage of your automobile has infinite variations and determines how your car rides and handles.

Big Ambulance for Big Birds

When a jetliner makes a belly landing, the blocked runway can cause traffic diversions that may cost up to \$175,000 per hour. Now a Californian has a huge retrieval rig that will clear the runway with no further damage to the airplane.



It's a banner year for Number One.

Pure Firebird® Racing Gasoline is winning more races, setting more records, than all the other brands combined this year. Like any other year. That's why Pure is the Number One choice of the men who race . . . and why Pure knows how to make a powerful gasoline for you. It's called Pure Firebird Super—from the Number One name in racing.



UNI 76

Pure Oil Division



Maverick Versus The Mob

Ford says its new subcompact's main target is the economy imports. Could be, but after our side-by-side comparison tests, we doubt if they'll drop dead.

By BILL KILPATRICK, Auto Editor

THERE'S A STORY going around—it might even be true—that Henry Ford personally turned thumbs down on certain of the advertising gimmicks and slogans his troops dreamed up to launch the Maverick. One rumored reject was a takeoff on the old movie cartoon signature, the twist being, "Th-th-that's all, Volks."

If the story is true, Mr. Ford is a per-



STACKED UP against Ford's \$1995 Maverick for the test are, from top to bottom, the \$1799 Volkswagen 1500 Beetle, the Renault R-10 four-door sedan at \$1775 and the \$2135 Toyota Corona two-door hardtop



CORONA interior is smart. It's the only car to offer both 2 and 4-door models



MAVERICK interior features sweeping dash, wide bench, cornball upholstery



VOLKSWAGEN interior is austere, but functional; workmanship is impressive



RENAULT interior is most comfortable; ignition key on the left is annoying

ceptive man, a realist who appreciates that verbal gymnastics won't make Volkswagen or any of the other established economy imports go away. VW, Opel, Toyota, Datsun, Fiat, Renault, Austin, Simca et al are hard-nosed facts on today's U.S. automotive scene, their sales accounting for some 60 percent of the so-called "small car" market. For Detroit to make significant inroads therein will take more than so-so puns.

Happily, despite the imperial thumb apparently being turned up to such precious nonsense as paint jobs called "Thanks Vermillion," "Freudian Gilt" and so on, the Maverick is real substance behind a shadow. It could—indeed does—stand by itself as a car capable of making it on its own. But the American appetite for drama, or competition, or whatever, seems to demand that we have good guys and bad guys. Thus the public fancy, abetted by a lot of nervous advertising, tends to compare the car with the economy imports.

More accurately and meaningfully, the Maverick should be compared with, say, the Rambler or the Valiant. All are American in style, execution, "feel." But Ford (the company and—seemingly—the man) seems to feel its hay is to be made in wooing buyers away from the imports. Can the Maverick accomplish that difficult task? The answer has to be double-edged.

The first part of the answer has to do with hardware—what you get for your money, how much car, how much performance, and so on. The second part has to do with a sort of auto marketing Never-Never Land—the psychological fulfillment a buyer gets from owning and driving a certain type or make of car. First things first.

For our tests we picked the VW "Beetle" because Ford has zeroed in on it as Maverick's No. 1 "enemy," the Toyota Corona because we thought of it as being the zippiest of the economy imports, thus most likely to approach the more powerful Maverick in performance, and the

WINNING STYLE is captured as Maverick starts fastest 0-60 run





IN THE PITS at Pocono Raceway, the Maverick is readied for its acceleration and fuel economy runs

Renault R-10 because it offers certain creature comforts (marvelous seats, for example) lacking in the others. East Coast port-of-entry prices are \$1799 for the VW, \$2135 for the Corona hardtop (\$1950 for four-door sedan), \$1775 for the Renault. The basic Maverick (which our test car was) is pegged at \$1995. All cars were "as is," and all had manual transmissions. Specifics:

VOLKSWAGEN 1500 2-DOOR SEDAN

Engine: Horizontally-opposed air-cooled 4-cyl. in rear, 91.1-cu.-in. displacement, 53 hp @ 4200 rpm
Gearbox: 4-speed all synchromesh
Brake type (front/rear): drum/drum
Dimensions: 158.6 long, 61 wide, 59.1 high, 94.5 wheelbase, 1808 weight

TOYOTA CORONA 2-DOOR HARDTOP

Engine: In-line 4, 115.8-cu.-in. displacement, 90 hp @ 4600 rpm
Gearbox: 4-speed all synchromesh
Brake type (front/rear): drum/drum
Dimensions: 162.4 long, 61.6 wide, 54.1 high, 95.3 wheelbase, 2260 weight

RENAULT R-10 4-DOOR SEDAN

Engine: In-line 4 in rear, 67.6-cu.-in. displacement, 48 hp @ 4600 rpm
Gearbox: 4-speed all synchromesh
Brake type (front/rear): disc/disc
Dimensions: 167.5 long, 60 wide, 55.5 high, 89 wheelbase, 1825 weight

FORD MAVERICK 2-DOOR SEDAN

Engine: In-line 6, 170-cu.-in. displacement, 105 hp @ 4200 rpm
Gearbox: 3-speed all synchromesh
Brake type (front/rear): drum/drum
Dimensions: 179.4 long, 70.6 wide, 52.3 high, 103 wheelbase, 2501 weight

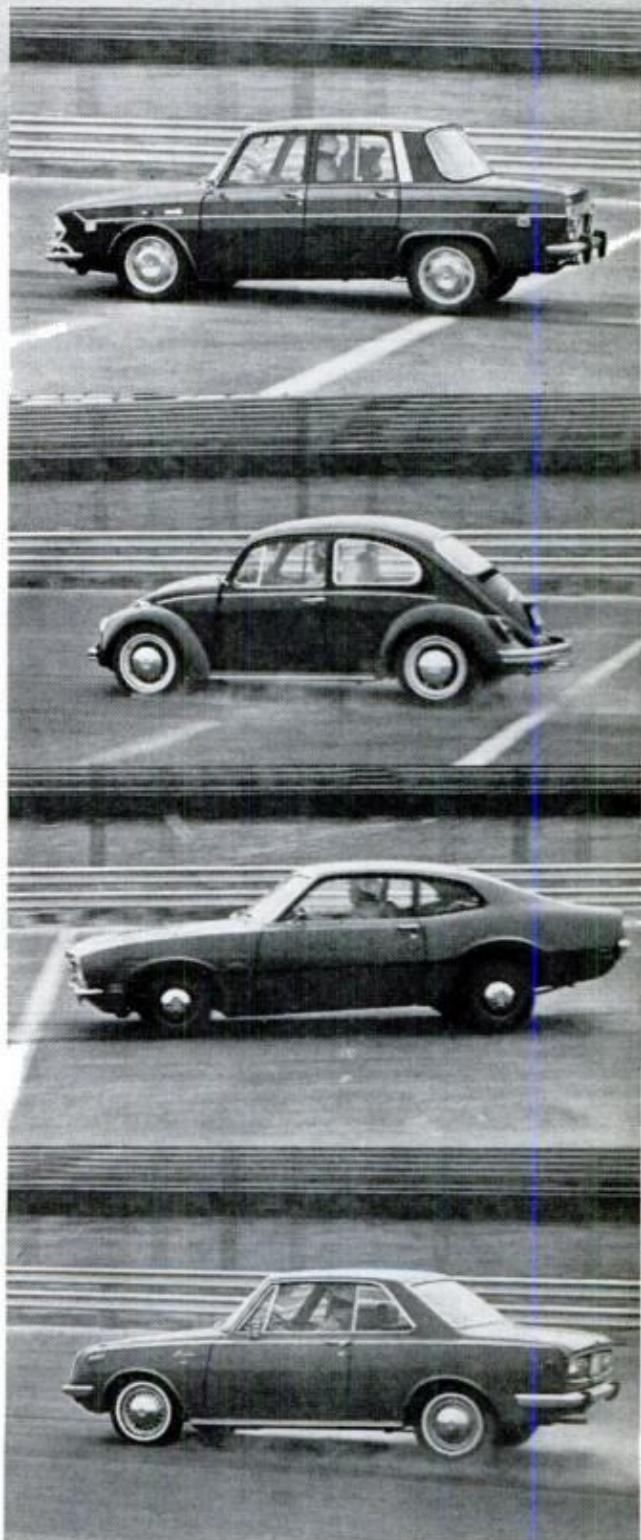

BRAKING TESTS had Renault with its four-wheel discs hauling down fast and straight; VW and Maverick had good controlled stops; Toyota got persnickety

We tested the cars at Pocono In-
AUGUST 1969

Photos by Stanley Rosenthal

PERFORMANCE AND ECONOMY—HOW THEY COMPARE

	ACCELERATION 0-60 MPH (Sec.)								MPG RANGE (Normal Driving)								
MAVERICK																	
RENAULT																	
TOYOTA																	
VW																	
	14	16	18	20	22	24	26	28	20	22	24	26	28	30	32	34	36

ternational Raceway, a still-building racing complex in the mini-mountains of Eastern Pennsylvania. But getting there from New York, our test crew had an opportunity to drive each of the cars over a variety of surfaces in traffic, on open highways, and up and down some tricky, narrow roads. Thus our overall impressions covered a reasonably broad fair-weather spectrum of driving conditions.

The first test at the Raceway—using our “fifth wheel”—was for out-and-out acceleration. We had one driver take four timed runs, two in each direction to allow for the wind. The VW went from 0-60 mph in an average of 24.5 seconds, the Toyota in 18 flat, the Renault in 22.5, the Maverick in 15 flat. To get from 40-60 mph in high gear—the thought being to simulate a typical passing situation, again four runs, two in each direction—took the VW 22 seconds flat, the Toyota 13.1,

the Renault 22 and the Maverick 14.2.

Looking at the results, the conclusion would have to be that the Maverick gets off the dime quicker than the others, but that the Toyota has the best mid-range pickup.

Next we looked into the tricky business of miles-per-gallon economy. We say “tricky” because—while absolutes can be measured—mpg is subject to so many variables that coming up with a single figure is often inconclusive. Take the wind, for example; it can be steady in a given direction for one car, and, a few minutes later, gusty and erratic for another. So the best bet, we feel, is to report a *range* of mpg, as shown in the accompanying chart.

Another tricky thing to measure is braking. A so-called “panic stop,” for example, when brakes are slammed on at, say, 60 mph and the wheels lock and the car skids to a halt, is as much a test of tire “stickiness” as it is of anything else. All things being equal, the tread on Brand X may stick a bit better than the tread on Brand Y. So here again we give a *subjective* report of our braking test results.

From 60 mph, we did four panic stops with each car and four “controlled” stops (i. e., bringing the car to a halt without locking the wheels). In both tests, the Renault stopped in the shortest distance with the least variance from a straight line. Close in stopping distance and only slightly off-line was the VW. The Toyota proved a bit of an adventure; we stopped in a



EDITORS KILPATRICK AND HARTFORD suit up in the Maverick; timing gear and meters are between them

reasonable distance, but we sashayed over a good bit of road in the process. The Maverick hauled down fine (albeit, over a greater distance, which figures because of its heavier weight) in the controlled stops, but the rear end bounced like a rubber ball in the panic stops, the result being—again—sashaying over a lot of road.

The rest of our four-car "shoot-out" consisted pretty much of personal opinion. We all liked the Maverick's room, the Renault's seating comfort, the Toyota's pep, the VW's workmanship. But after agreeing on these points, opinion became fragmented. For example, I didn't particularly mind the VW's noise, but Alex Markovich did. Bill Hartford was almost indignant about having to really slam the Maverick's doors to get them shut tightly, but to me that's almost Detroit standard operating procedure. Bill didn't mind hard cornering in the VW, but Alex and I think it's an adventure. We all found ourselves apprehensive about taking tight bends in the Renault, yet none of us actually felt we were ever in trouble. Body lean was greater in the Toyota, but again not to the point of making one prematurely gray.

Bill would like to see a four-speed floor-mounted stick in the Maverick. Agreed. While I found the R-10 the most comfortable of the four cars, I don't much care for the idea of having the steering wheel and foot-control pedals off-center to the right; it just doesn't *feel* right. Speaking of "feel," I thought the Toyota felt best, was more a part of me than any of the others. Bill liked the VW for the same reason. Alex thought the VW's speedometer redlines for each gear were far too conservative, that each must be exceeded by as much as 50 percent for decent, safe acceleration (and without harming the engine). When it comes to shifting, I tend to "drive by ear," never mind the redlines.

We could go on, feature by feature, but what we'd be doing is more or less answering both parts of that double-edged question we asked before: Can the Maverick woo buyers away from the imports?

To answer the first part—head-to-head comparison—assuming the slight price dif-

(Please turn to page 196)

AUGUST 1969



MAVERICK goes in hard; controls retain feel



RENAULT comes out of turn with minimum roll



TOYOTA has the most body roll but is stable



VOLKSWAGEN goes through with some oversteer

77

How They Keep Without Getting

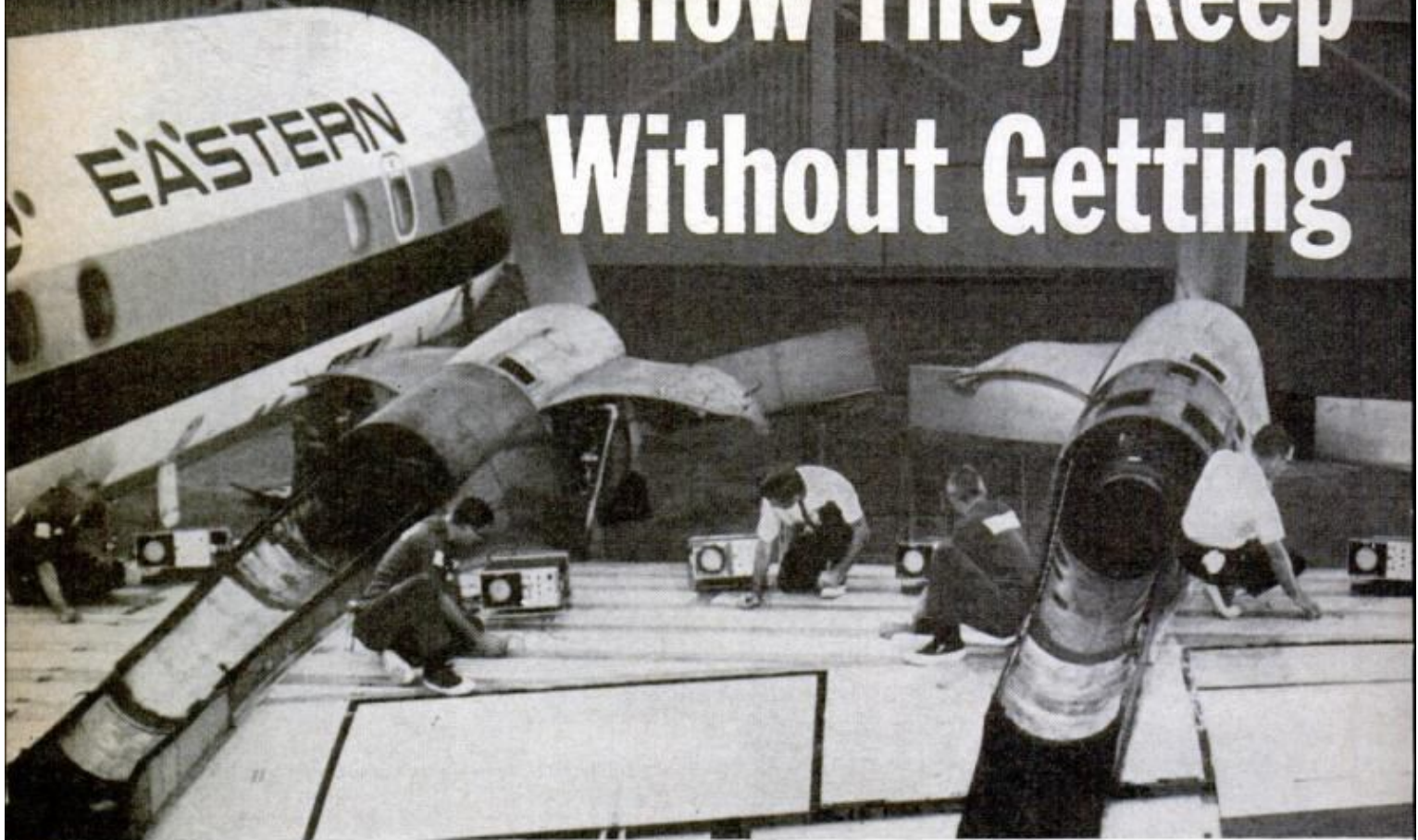

Old-fashioned test methods often wrecked the very thing they were supposed to protect. Now a fascinating science called Nondestructive Testing checks out bridges, buildings, wings on airplanes, even candy bars—without touching them at all

THEY USED TO TEST airplane wings by piling sandbags on them. A wing that held was considered safe. If, later, it dropped off in flight, everyone was surprised. How could it? Normal stress in flight was much less than the thousands of pounds of sandbags used in the test. That a wing could support a tremendous load for a brief period but not necessarily over and over again, day in and day out, was never considered.

This was typical of early testing methods that consisted mainly of seeing if a thing would break by trying to break it or by running a piece of machinery until it almost fell apart. The

assumption was that if a mechanism worked perfectly 1000 times in a row without a miss, it would continue to work indefinitely. But sometimes it failed on the thousand-and-first try.

Often, overtesting a delicate mechanism might cause it to fail sooner than if it hadn't been tested at all. Some of our early space rockets that exploded in flight or never got off the launch pad were found to have been tested to death. The parts had all been so carefully tried over and over again before the flight that, by the time of actual countdown, they were simply worn out.

Today, your life depends—literally—on a spectacular new space-age tech-

You Safe— You Killed

By ARTHUR S. FREESE

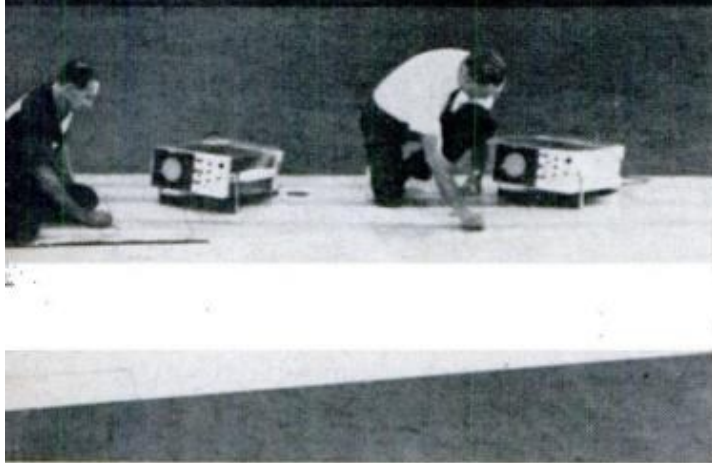

SWARMING OVER THE WING of an Eastern Airlines Electra turboprop, eight inspectors simultaneously check for hidden flaws inside the honeycomb structure

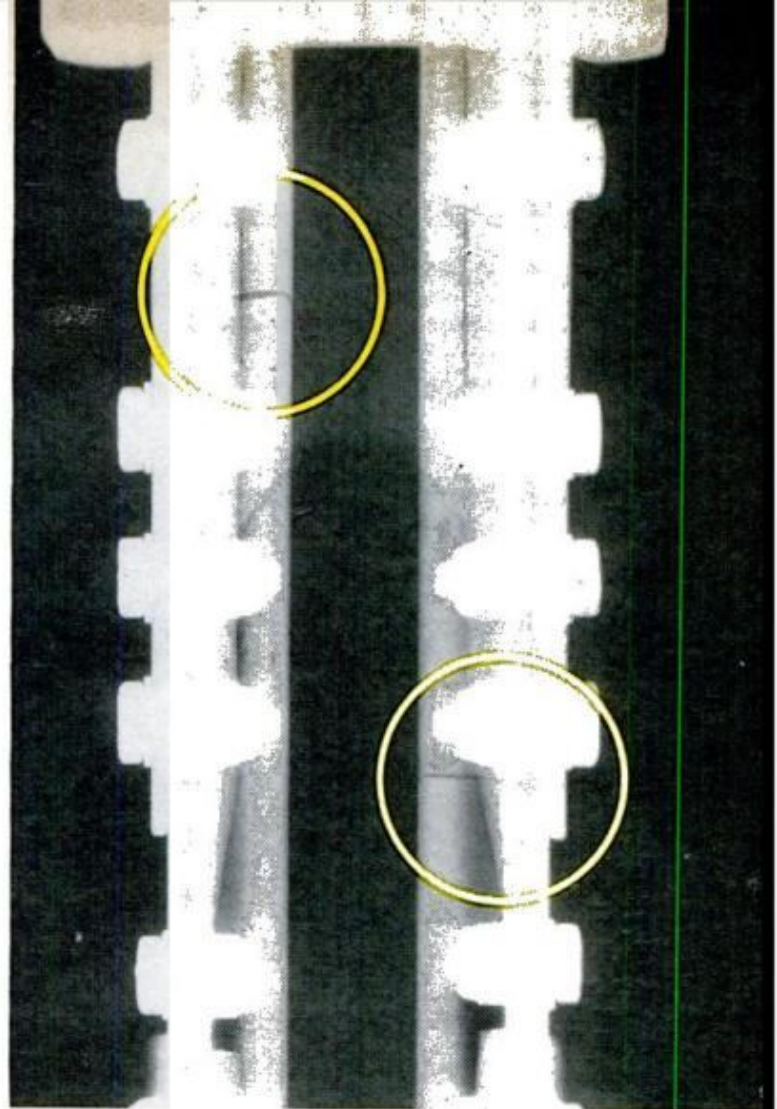

using ultrasonic test instruments. At right, a radio-graph reveals dangerous hairline cracks (circled in color) in the wing spar of another airliner



SMASHED CARS AND TRUCKS lie in the twisted wreckage of the Silver Bridge, which collapsed shortly before Christmas in 1967, killing 46. Spanning the Ohio River near Point Pleasant, W. Va., the structure is believed to have failed because a connecting pin gave way. One of these pins, joining several bridge links, can be seen in the foreground at right. Modern testing methods using NDT principles make a repetition of such a disaster unlikely

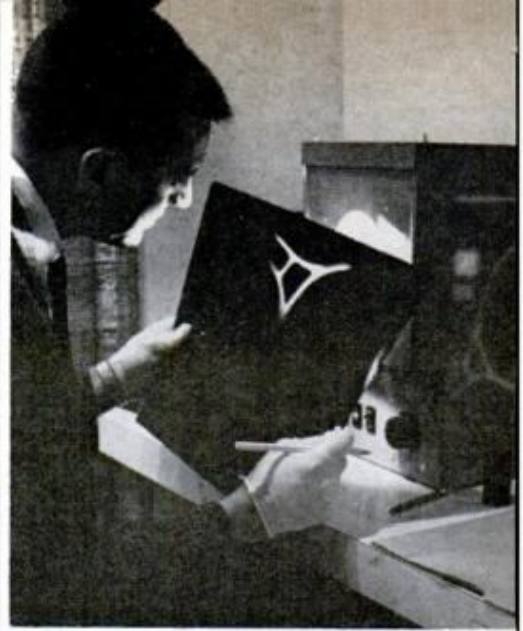

EVEN TENNIS RACKETS are tested by modern NDT methods. This one-piece magnesium-alloy Centurion is first checked for surface flaws with fluorescent

dye (center). Frame is then X-rayed to spot deeper defects that might weaken it (right). This permits racket to be made lighter with no loss of strength

nology called Nondestructive Testing—testing without destroying the object being examined. Called NDT for short, it makes it safer to drive a car, fly a plane, ride in a train, heat your home, or eat a piece of candy.

You can't test an elevator by running it until the cables are worn out or check a bridge by jumping up and down on it. NDT makes sure that such structures are sound without endanger-

ing your life in the process.

The need for safe, foolproof test methods was dramatically demonstrated by the tragic collapse in December, 1967, of the Silver Bridge over the Ohio River near Point Pleasant, W. Va. Jammed with homeward-bound commuters and holiday shoppers on a Friday night shortly before Christmas, the span crashed without warning into the black and icy waters below, carry-

OPEN WIDE: One of the largest X-rays ever made shows an entire jet engine in cross section. To make such X-rays without dismantling the engine, a radioactive probe is inserted in the jet's throat

ENLARGED X-RAYS of a toggle switch help Cutler-Hammer engineers design foolproof controls for space exploration. Taking such a switch apart to see inside it often destroys the results of a test

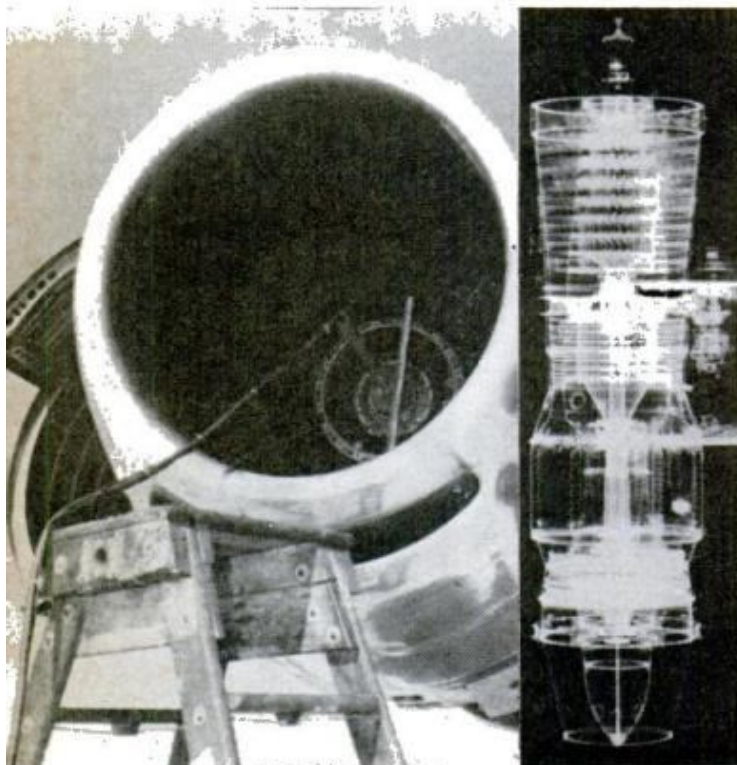



NEW WELDED BRIDGES are constantly checked with penetrating dyes for sound joints. A tell-tale dye streak (right) indicates cracked weld



A GIANT VALVE for a high-pressure pipeline is X-rayed in same way as a dentist X-rays your teeth. Defects appear as dark spots on film—just like cavities

ing 46 to their deaths and injuring scores of others.

Relatively young as bridges go, the 40-year-old structure used an unusual link-suspension design in which bars were joined at their ends by steel cross pins. While the official verdict has not yet been made public, it is widely believed that one of the pins gave way, throwing abnormal stresses on surrounding pins. One by one, the others snapped in rapid-fire succession—like a row of tumbling dominoes—plunging the bridge into the water.

Today, engineers know that metals get tired, just like people, and that the ravages of rust, corrosion, wracking winds and relentless vibrations can topple the mightiest of structures unless they're carefully and periodically checked. Now NDT experts can "look inside" an airplane wing or bridge girder and spot the tiniest flaw—sometimes only the hint of abnormal stress or wear—long before it becomes a major disaster. These exotic techniques include the use of X-rays, holography, liquid crystals, ultrasonics, dye penetrants and magnetic fields. Like a doc-

(Please turn to page 188)

MOUNTED ON WHEELS, the unusual self-propelled X-ray machine at right crawls through miles of pipeline to check welded joints from the inside. The Picker Corp. device is powered by batteries, travels 39 feet a minute, can even go up and down hills



STRAIN LINES show up dramatically in Bell Labs' hologram of metal pulled apart 50/1000ths of an inch

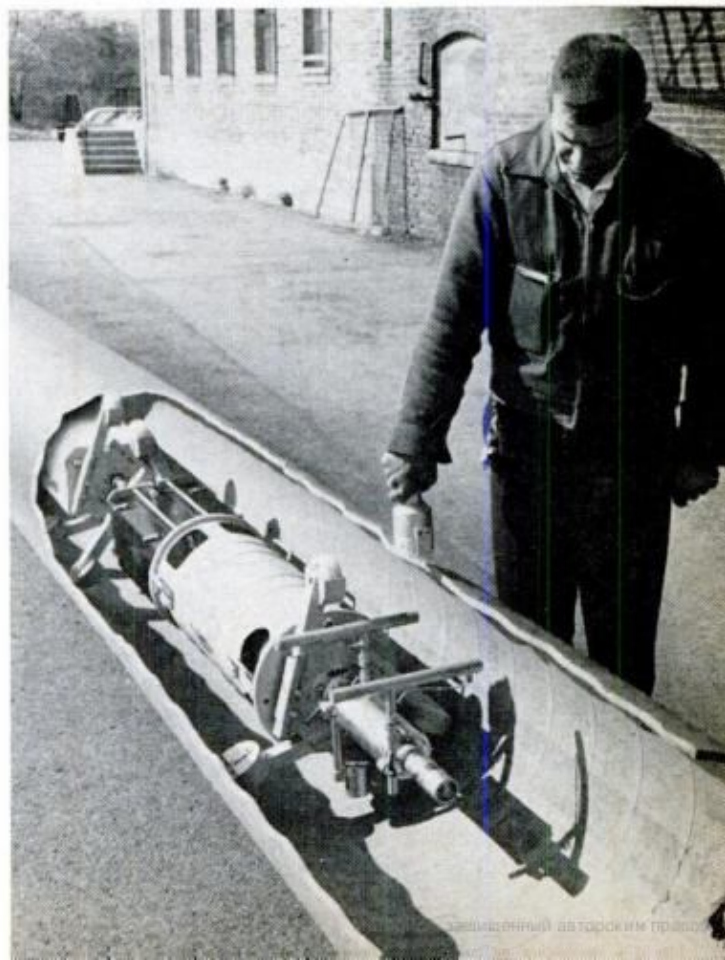

Just patented

PM'S PICK OF THE NEW INVENTIONS

Prepared in cooperation with Roger S. Shashoua, Director, International Inventors Assn., Inc.

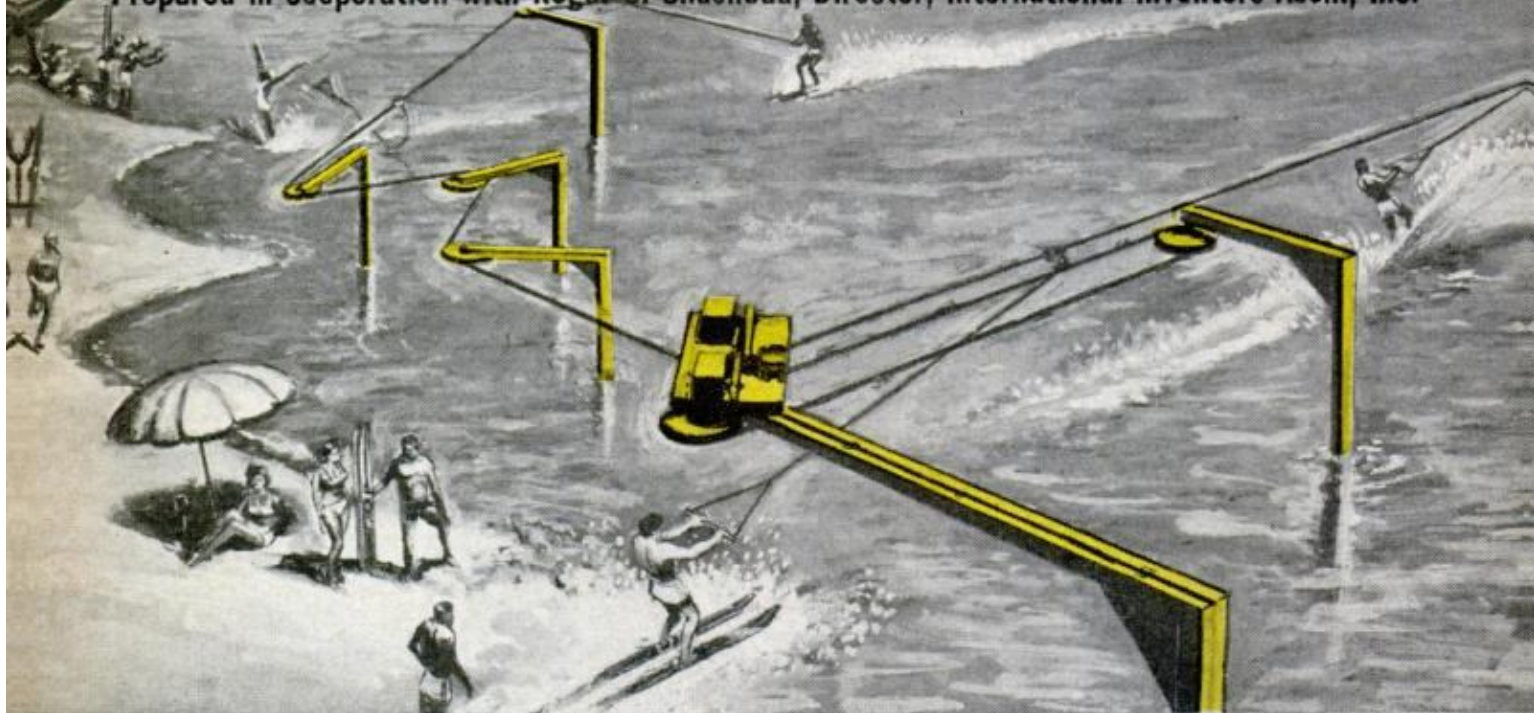

1. YOU DON'T NEED A BOAT to go water skiing with this ingenious towing device. A motor-driven cable supported by pulleys on poles pulls skiers around a course about the size of a football field. To hook on, a skier starts out on a special acceleration towline that gradually brings him up to

the speed of the main tow cable. As his speed increases, a cone-shaped rubber stop on the cable, traveling slightly faster than the acceleration line, picks off the hook, transferring the skier to the main towline. At the end of the run, the skier lets go of his towrope and skis onto the beach

2. UNUSUAL RUDDER FOR SHIPS does more than just steer. It consists of a half-ring that can be rotated around the propeller. The half-ring has a foil shape like an airplane wing and works in the same way. Water driven by the prop rushes past the inner surface much faster than water on the outside. This creates a low-pressure area on the inside, and the higher outside pressure forces the

rudder sideways—to the right when it's turned to the left and vice versa. This steers the ship without the drag of a conventional rudder. The same effect is also used in two other ways. In the bottom position, the rudder exerts an upward thrust that lifts the stern and increases speed in good weather. In the top position, it forces the stern downward, thus helping to reduce pitching in rough seas

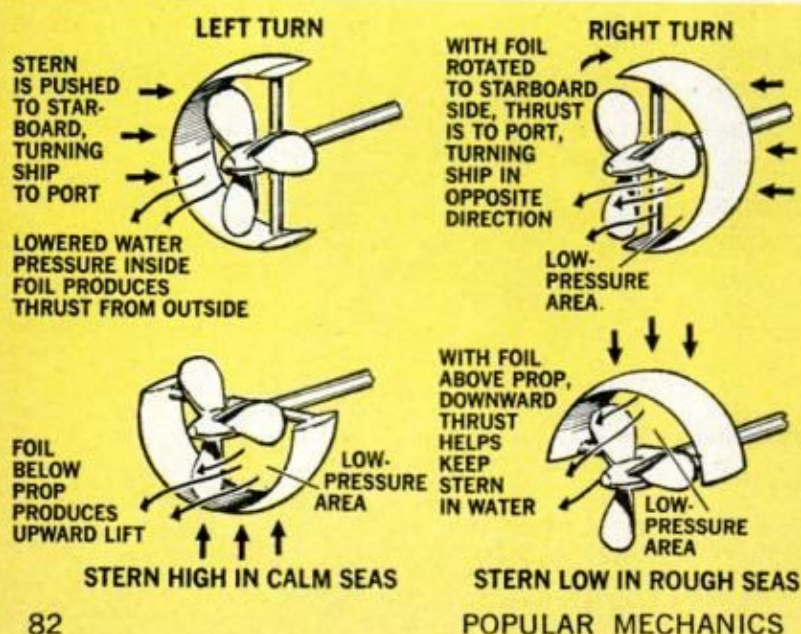

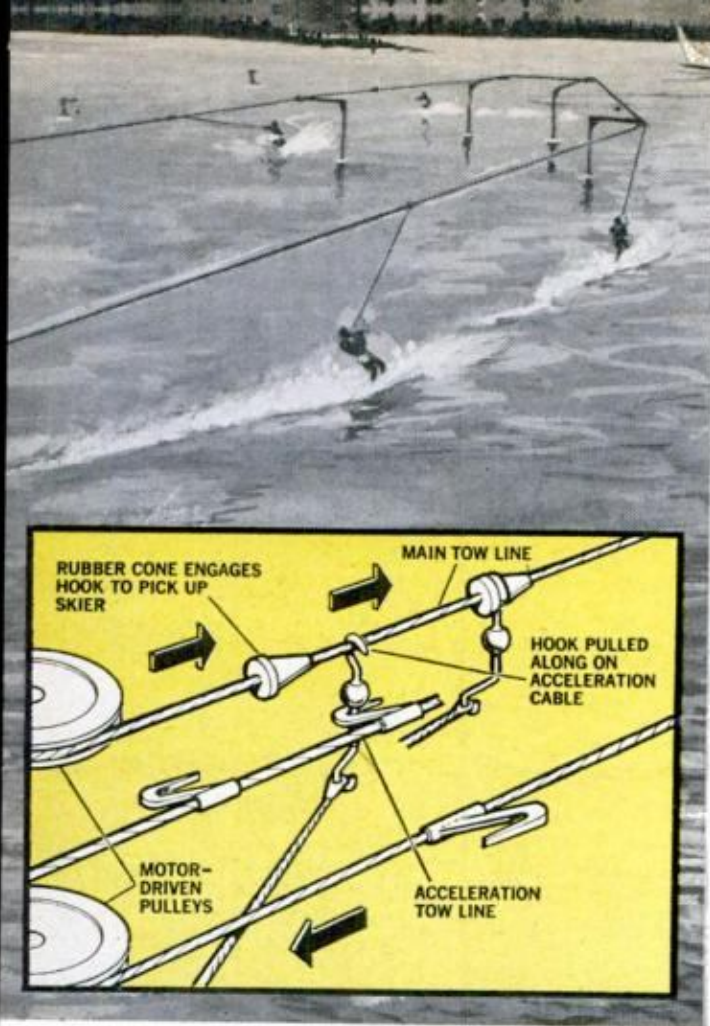

3. ROCKING CRADLE FOR CARS is designed to eliminate the need for expensive hydraulic lifts when making underneath repairs. You drive up a ramp onto two tracks, then roll the car sideways on two large rocker-like supports at the ends. At the desired tilt, the cradle is locked rigid by chains and braces. The arrangement provides enough clearance for most types of underbody repair work

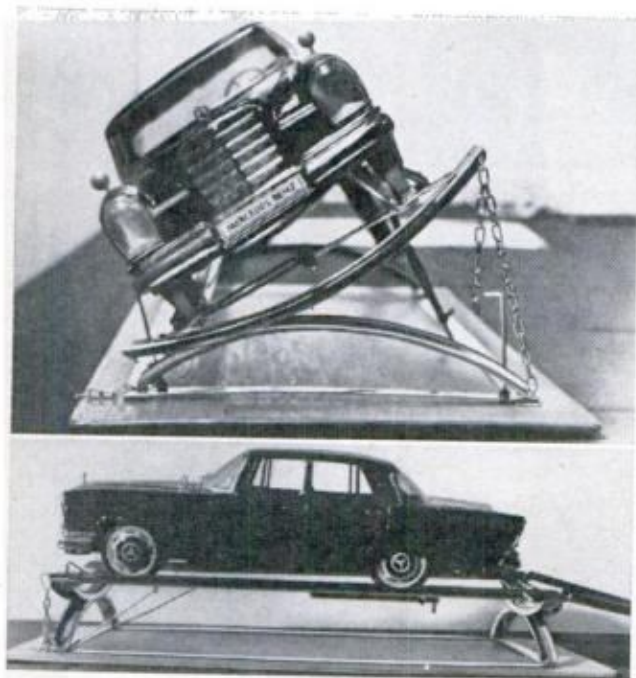

Inventors of the items shown on these pages are as follows: 1. John T. Hancock, 8750 W. Dakota Ave., Denver, Colo.; 2. Lt. Peter T. Tarpgaard and Lt. Samuel J. Gordon, Massachusetts Institute of Technology, Cambridge, Mass.; 3. Licencia Oy, Ltd., P.O. Box 14170, Helsinki, Finland;

AUGUST 1969

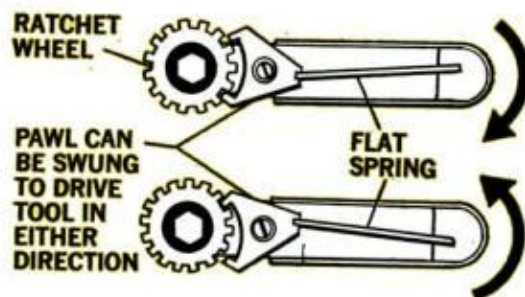

4. RATCHET-ACTION SCREWDRIVER above makes it easy to drive screws in tough materials and hard-to-reach places. You just flip the side lever back and forth and a pawl engages a ratchet to turn the screwdriver blade. Reversing the pawl lets you remove screws as well. Slip out the screwdriver and you can insert other accessories such as drill bits and nut drivers

5. YOUR COAT CAN'T BE STOLEN off the coat rack shown below. As you hang it up, you draw a chain through each sleeve. The ends of the chains, fitted with metal balls, are dropped into the metal container, along with your hat, gloves and other small possessions. When the lid is closed and locked, the balls prevent the chains from being pulled out, thus making it impossible to remove the coat



4. James T. and Manuel Vosbikian, Hardware & Industrial Tool Co., 20th and Oxford Sts., Philadelphia, Pa.; 5. Gilbert Borel, Le Cachot, Switzerland. Roger Shashoua can be reached at the International Inventors Assn., Inc., 680 Fifth Ave., New York, N. Y. 10019.



MOBILE
COMPUTER
STATION

TANK SIGNALLED DESTROYED
HIT SIGNALLED TO COMPUTER
CURRENT PULSE (CODED FOR TANK FIRE)

SIGNAL TO COMPUTER MAN IS HIT

FIRING OF WEAPON
TRANSMITTED TO
COMPUTER

PHOTODETECTOR
(8 PER MAN)

ANTENNA

RANGE
MEASURING
SYSTEM

RF TRANSMITTER
AND PREAMP

SIGNAL CORDS
(TO FIRE LASER
AND BLANK
SIMULTANEOUSLY;
TO DEACTIVATE
TRANSMITTER OF
"KILLED" SOLDIER)

REALISTIC COMBAT TRAINING is now possible with rifle and tank-mounted infrared light beam transmitters. Men and equipment are automatically signaled when they have been hit. A mobile computer eliminates the need for umpires to arbitrate disagreements, determine the "kills" and the outcome of the battle

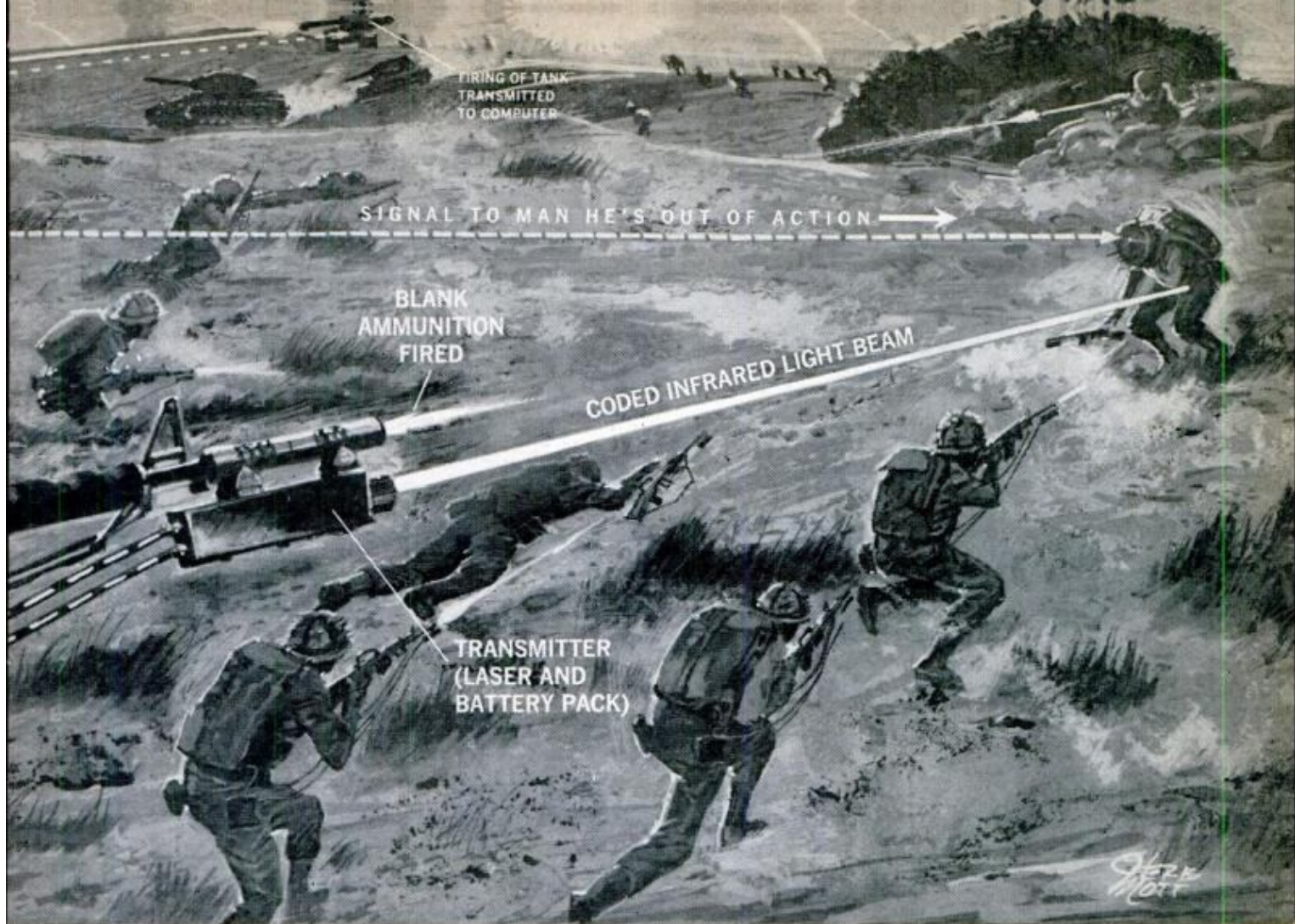

They've Taken the Guesswork Out of War Games

Infantrymen drop in their tracks when hit, tanks go up in smoke, and a computer keeps score of the battle. It's as real as war—but nobody is killed

By MORT SCHULTZ | Illustration by Herb Mott

AN INVISIBLE BEAM OF LIGHT is helping save the lives of American soldiers by taking the "mock" out of mock battles.

Although produced by a single laser diode that's no bigger than a grain of pepper, the light can, when necessary, be cast 3000 meters. That's almost two miles.

During maneuvers, it allows a soldier to aim and fire his M16 rifle at another GI and see him fall to the ground. It permits a U. S. tank to fire its giant gun at another U. S. tank and have it go up in smoke.

In time, the infrared light beam will allow two jets to engage in a no-holds-barred dogfight, permit ground-to-air missiles to knock planes from the sky, and let helicopters and other aircraft strafe installations.

If at this point you're starting to confuse maneuvers with combat, you have the idea behind development of the direct-fire simulator of which this laser light beam



INFANTRYMAN ON MANEUVERS has two-pound laser transmitter, four detectors on helmet, four on his body

is the key element. It makes war games so much like combat that it's frightening if you let your imagination get out of hand.

Anyone who ever took part in maneuvers can appreciate the importance of this development to a young GI who's training for combat. No longer do war games resemble a game of cops and robbers.

Imagine yourself for a minute on maneuvers at the Hunter Liggett Military Reservation in California where direct-fire simulators are getting their first severe test. You're a member of a tank-reinforced infantry company, and your orders are to defend Hill 502 from Blue Company.

Enemy troops supported by a tank are advancing toward your position. On your flank you see one of your tanks traverse its gun and fire. Almost immediately, smoke billows from the enemy tank and it grinds to a halt. Direct hit.

Without support, Blue Company infantry charge your position. You raise your rifle, sight on a target and pull the trigger. As the report of discharging ammunition echoes in your ears, you see your target fall to the ground.

There's no need for an umpire to rush over and tell the man he's been shot. He knows it as surely as if you had fired live ammunition instead of blanks.

Realistic combat simulation is something the Army has always tried to achieve. Not much headway was made, although some equipment was developed that promised more than it could deliver.

For example, about eight years ago a hit-kill indicator (HKI) was developed. It also used infrared light, but because of its giant-searchlight size the light source was too cumbersome to be supported by a rifle. It had to be worn by the soldier while the detector was placed on the soldier's weapon. This drawback created a situation that wasn't much more realistic than training exercises without HKI.

When a soldier saw an enemy and fired his weapon, all enemy soldiers in the vicinity were given an RF signal to light their infrared sources, because the only way an umpire could determine who was shot was to trace visually the light source on the target to the detector on the rifle.

HKI was all but dismissed by the Army and for a time it appeared that realism in combat-simulation training was a dream. Then, a new type of light source called a gallium arsenide laser (GaAs) was developed. So tiny that you can hardly see it with the naked eye, the GaAs diode once again offers the promise that simulated combat can be realistic and not a farce.

With DFS, umpires who accompanied opposing sides during maneuvers to arbitrate disagreements and determine who was killed and which side won the battle, are unnecessary. All action is automated. Men and equipment are automatically signaled when they've been knocked out of action. Photodetectors on the soldiers and tanks send a signal to a central computer system when they're "hit" by the infrared light beam. The computer, in turn, notifies the target that it has been destroyed.

A soldier who is shot is notified by



FRONT (lens) end of transmitter. Case contains battery power pack

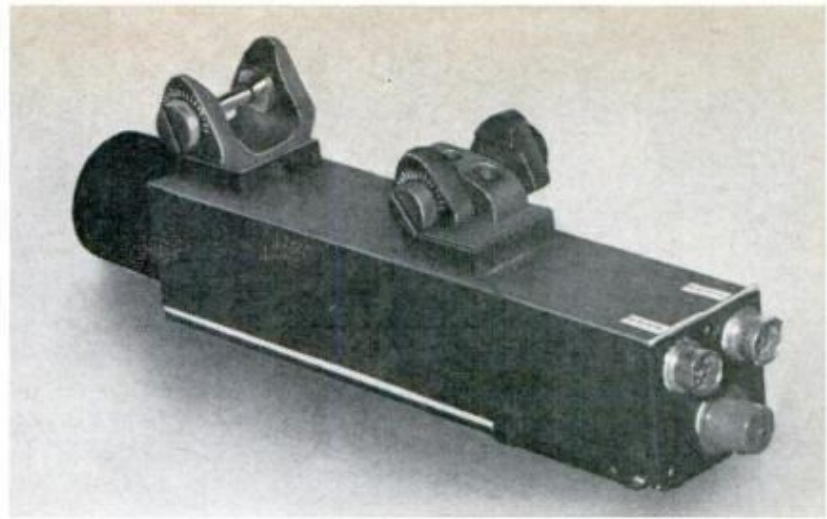

INPUTS on transmitter sense blank has been fired and trigger laser, deactivate transmitter if "killed," select code assigned to transmitter

means of an audible signal transmitted to a small receiver he carries in his helmet.

Every detail of the combat, from the "killing" of soldiers to the "destruction" of tanks, is transmitted to a central computer station where it is automatically plotted on a giant grid map. Tactical experts can get the big picture of how the combat and the theories concerning combat are progressing.

It may sound like all this needs a great deal of time to take place, and realism suffers because of it. The fact is that it takes less than one second from the time a soldier shoots at a target to the time the target learns that he or it is a casualty.

The heart of DFS is the gallium arsenide laser that's encased in a transmitter weighing less than two pounds. The transmitter is attached to rifles, machine guns and other direct fire weapons, including tank guns.

A GaAs laser has an extremely low energy output and isn't harmful to humans. In fact, the Army Surgeon General's office has established that the energy produced by a GaAs diode is perfectly safe. It's interesting to note, though, that should several of these diodes be wired together in series the energy they emit would be sufficient to burn the retina from a person's eye—just like any other type of laser.

However, I held my eye inches away from a GaAs transmitter, which uses a

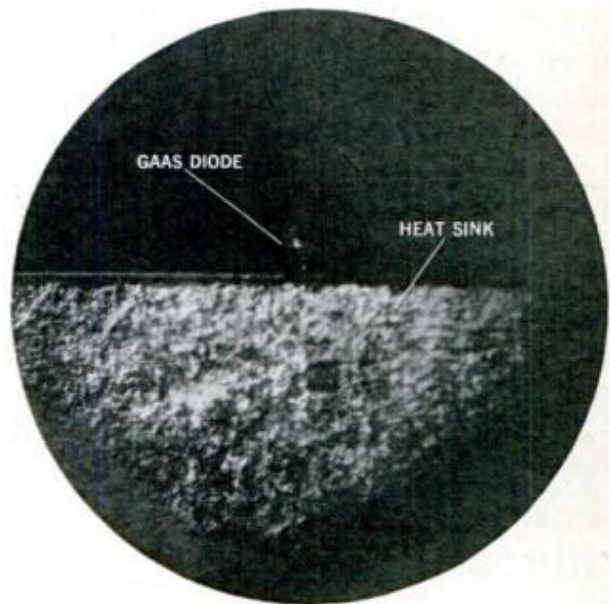

DIODE (enlarged 42 times) is embedded in a copper heat sink to protect it from heat of transmitter

single diode, for a full minute without effect. You can't even look into a flashlight without feeling some sensation.

The semiconductor diode is made by diffusing arsenide to gallium. When current is introduced, an infrared light beam of about 9000 angstroms is generated. The visible portion of the spectrum is about 3000 to 7000 angstroms.

Electric current is provided by a battery pack in the transmitter. The beam of light cast by the GaAs diode is variable to simulate the range of the particular weapon to which it's attached. For example, transmitters that simulate rifle fire are programmed to cast their beams about 500 meters (approximately 550 yards). Those attached to tank

(Please turn to page 196)



Cathedral from trash

One of the lowest-cost construction jobs in history is this model of the Lincoln Cathedral by Freddie Brasher. It's made of junk—matchsticks, matchboxes, bleach bottles, egg boxes and the like—contributed by friends.

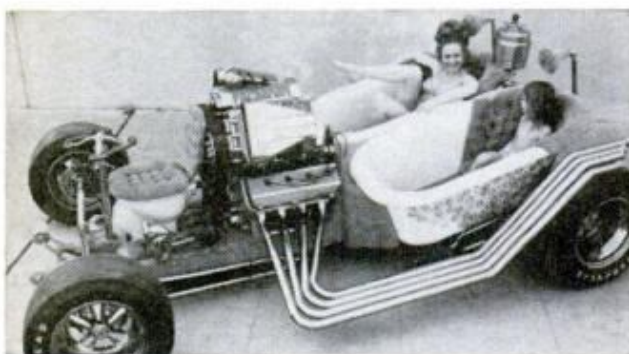
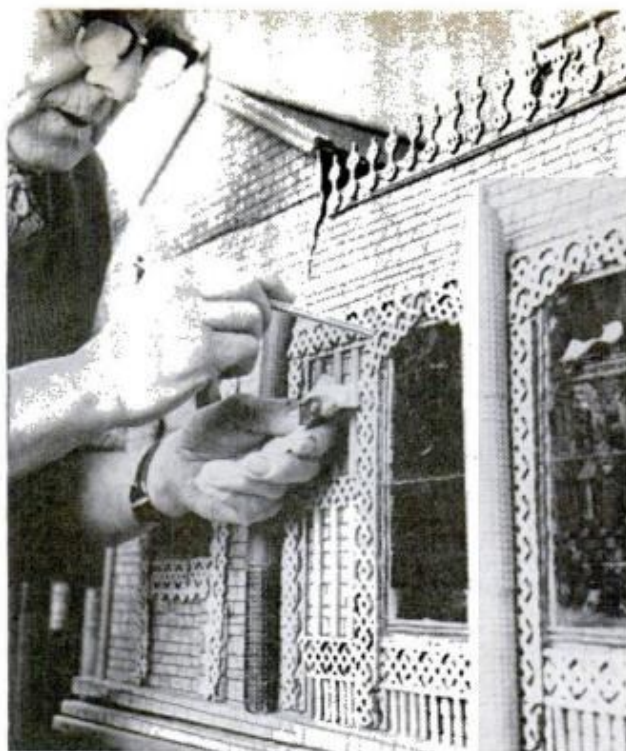

Bathroom on wheels

Two bathtubs for passengers and a commode for the driver, plus a supercharged Chrysler engine, make this one of the strangest cars on wheels. Builder is Bob Reisner.



New traffic circle

A once-congested intersection in Stuttgart now has a "roundabout" that lets traffic flow through on three different levels and, in addition, affords parking for 150 autos.

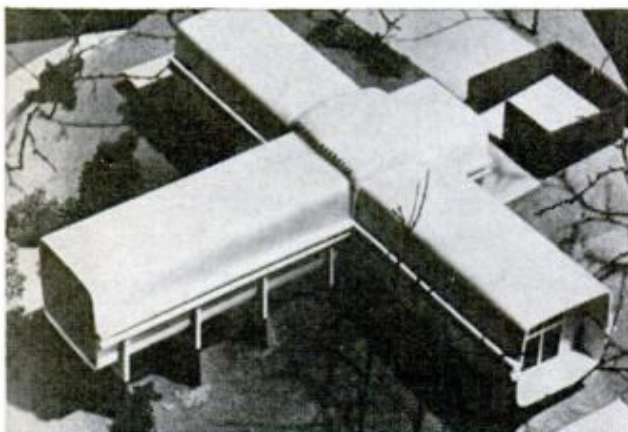

Mobile home Down Under

Mobile components are the building blocks of the "Mobile Habitation" proposed by a group of Australian designers. The ready-made fiberglass wings are designed to be trucked to the building site and bolted together.



Drinking man's automat

Just speak into the microphone and this automat will deliver your order: water, schnapps or whiskey. A Swedish professor programmed it to respond to three different sounds; he adds that it could be made to offer 10 choices.



'Cave for living in'

An 11-year-old English schoolboy, as a class project, designed this bit of foam-padded furniture and called it a "cave for living in." A manufacturer now wants to produce it.

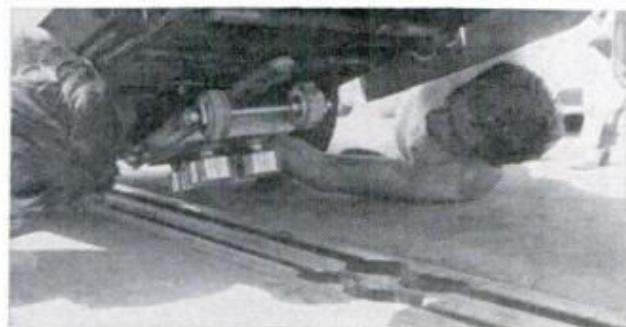

Slot cars you ride in

Anyone over 10 can zip around the Scat Track, Scottsdale, Ariz., at speeds up to 50 mph and never fear collision or rollover. The racers travel around the one-fifth-mile course firmly attached to a channeled track by dollies (bottom photo).

AUGUST 1969

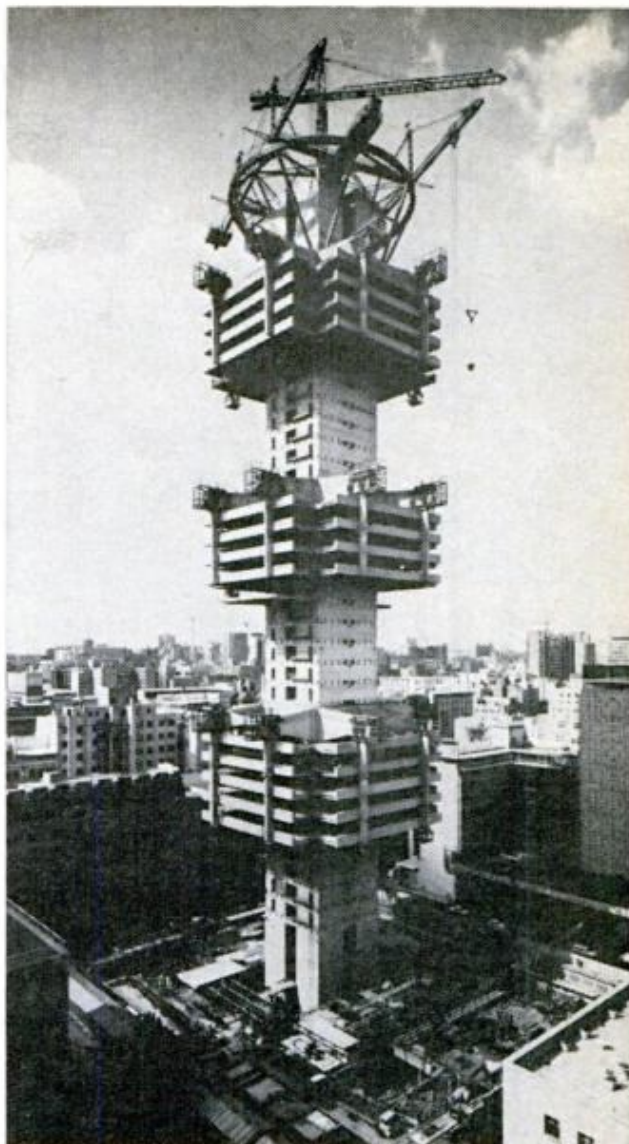

Built like a tree

Standard Bank Centre in Johannesburg, South Africa, will appear to be floating on air. Each of 27 office floors is suspended by prestressed cantilevered hangers from a central core with no supporting pillars. Architects have likened the building to a tree, where branches are supported by the trunk. A 50-ton beam slipped, delaying work, but completion is expected by December of this year.



Britain's biggest

Largest ship ever built in Britain, the 253,000-ton tanker *Esso Northumbria*, was recently launched from Swan Hunter shipyard.

89



AUTO RACING'S NEW SPEEDWAYS

Now second only to horse racing as the major American spectator sport, auto racing's mushrooming growth demands new facilities

By **BILL KILPATRICK**, Auto Editor

PROPHETS may be without honor here and there these days, but in the world of auto racing they're nothing short of demigods.

When they estimate—and accurately—that some 50-plus million Americans will storm the gates of the nation's ovals, drag strips and road courses this year, a small army of promoters, drivers, crewmen, car and accessory manufacturers, track officials and assorted hangers-on can hardly contain their glee. *This* is box-office action even the dimmest of bulbs can appreciate.

Underlining just how well the revenue produced by auto racing is appreciated is the interest in the sport shown by

some really big shakers—conservative Wall Street investment types—a breed known to be interested only in “locked” propositions. Coupled with this interest by money men—in some cases the result of it—is the recent building of at least four major new tracks in such diverse locales as Michigan, Alabama, Texas and California.

The track in Michigan is located about 65 miles southwest of Detroit and is called Michigan International Speedway. It opened last October and drew a crowd of 55,000 to see a 250-mile race featuring big-name drivers in Championship (Indy-type) cars.

The Alabama International Motor

Model shows how Ontario Motor Speedway will look when completed

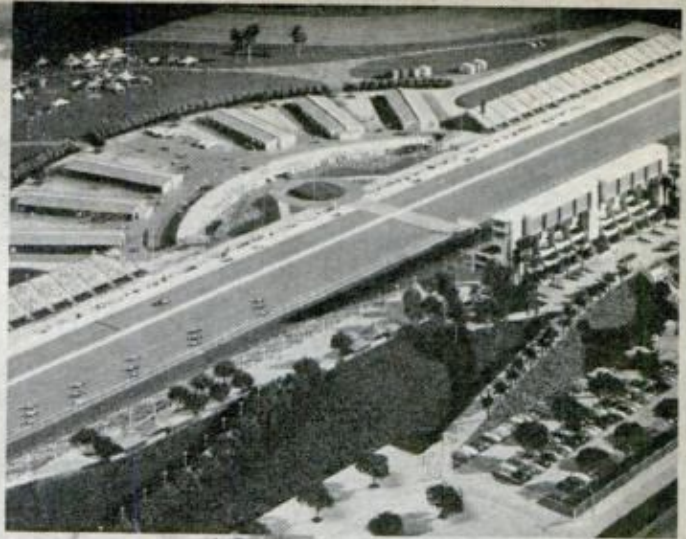

Texas International Speedway will feature a two-mile tri-oval and both infield and road course

MICHIGAN INTERNATIONAL SPEEDWAY

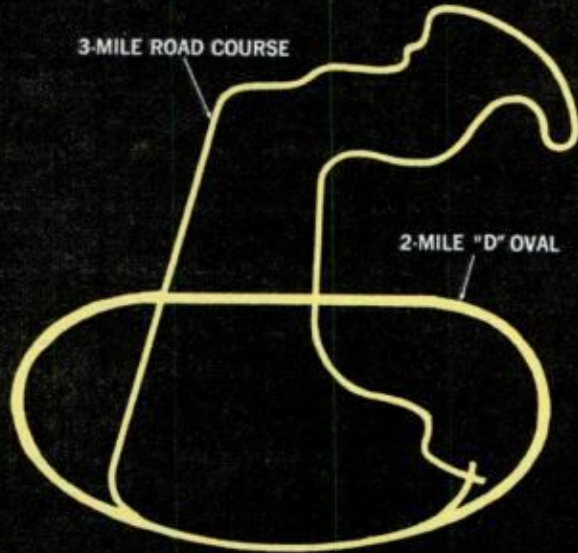

TEXAS INTERNATIONAL SPEEDWAY

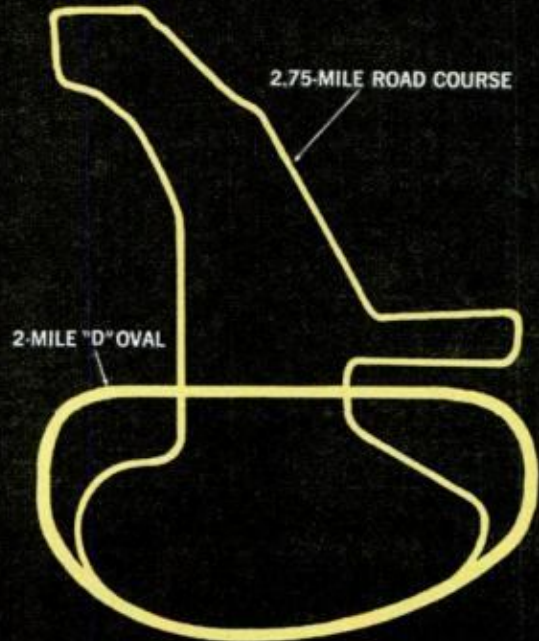

ONTARIO MOTOR SPEEDWAY (CALIF.)

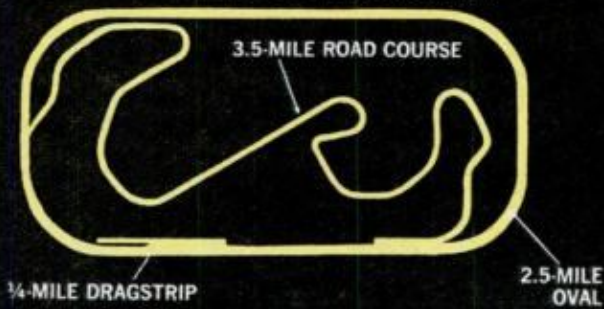

ALABAMA INTERNATIONAL MOTOR SPEEDWAY

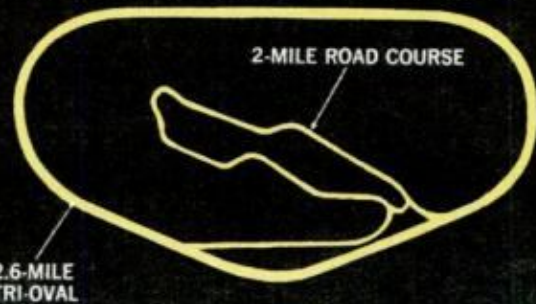

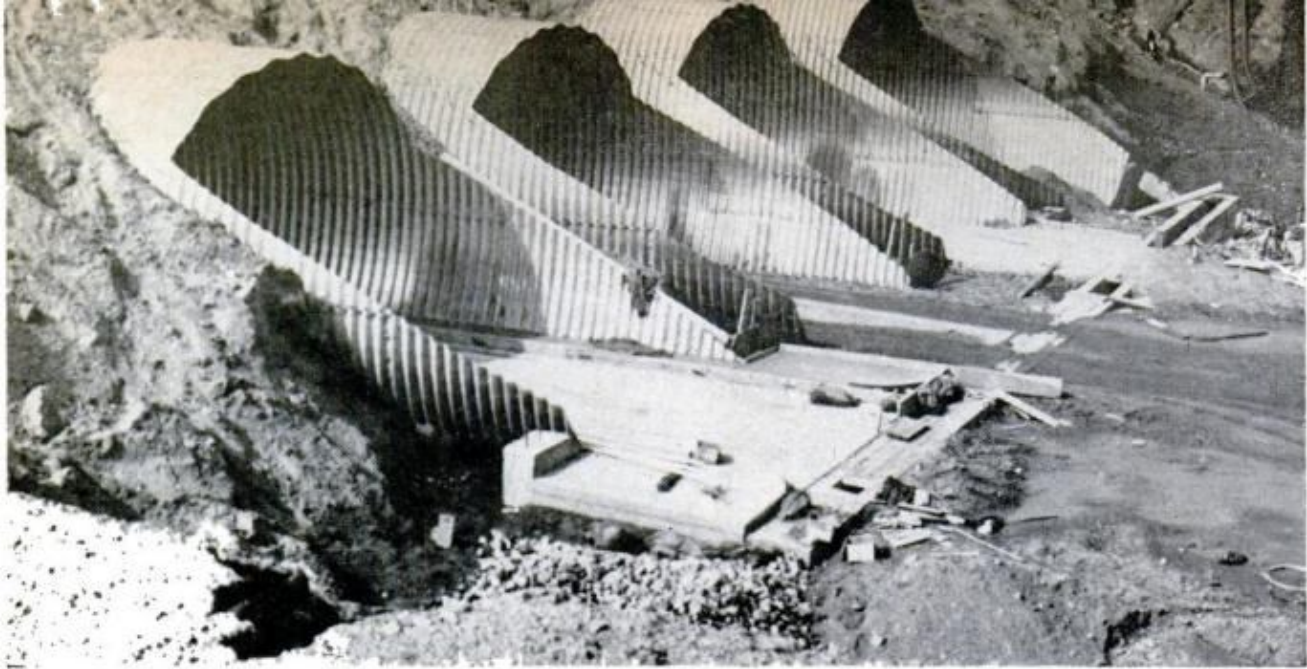

FEATURE of new speedways is good infield access. New Michigan track has four tunnels under main straight

Speedway is about 40 miles east of Birmingham on some 1800 acres in the shadow of the Talladega Mountains. (The track is popularly known as "Talladega" and in fact is the inspiration for the Ford car model of that name.) It's due to open next month with a big weekend of racing September 13-14. The main event will be a 500-miler featuring the stars of the NASCAR Grand National stock-car circuit. Thanks to Talladega's 33° banking, speeds could top 200 mph.

Due to open this November is Texas International Speedway, located about 70 miles northwest of Houston. Management is the same as that of the Michigan track. (Incidentally, the group—headed by Detroit financier Lawrence LoPatin—recently acquired Riverside International Speedway in California, along with its popular promoter, Les Richter, who is now director of operations of all of LoPatin's tracks, including the 1½-mile oval at Atlanta.) The new Texas facility is being built on a 2600-acre site near College Station, home of Texas A&M. Action gets under way Nov. 9 with a 200-mile Can-Am race. NASCAR will also use it.

What may be the most ambitious of the new tracks is under construction at Ontario, Calif., about 40 miles east of Los Angeles. When completed (it's due to open next July), Ontario Motor

Speedway will offer seating for 140,000 including permanent grandstand seating for 85,000 (Indianapolis can seat over 200,000). The track is being built on a 700-acre site, 30 acres of which will be infield set up to handle an additional 70,000. Ontario is located about 20 miles closer to Los Angeles than the established Riverside track, and insiders forecast a tremendous rivalry between the two. This could mean escalated purses for drivers and car owners.

Another potential major-league racing complex is under construction on

MOUNTAINS of earth must be moved to carve new track. Here engineers check Talladega infield access





SPEEDS approaching 200 mph are forecast for the new Talladega racetrack, thanks to its high 33° banks

over 1000 acres 75 miles north of Philadelphia in the Pocono Mountains. Called Pocono International Raceway, the track, scheduled to be completed next spring, will offer a 2.5-mile oval and a 3/4-mile oval and dragstrip.

Still another major racing facility is being planned for the megalopolitan area around New York by Michigan's LoPatin and his associates. No site has as yet been announced but when and if the track is completed it will have a potential fan population second to none.

What kind of money is involved in building these tracks? *Big* money, and lots of it!

Michigan cost almost \$6 million to build, about what it will cost to finish the Texas facility. Talladega will wind up costing its backers well over \$5 million. Ontario, again the most ambitious undertaking of the lot, is earmarked at a cost of \$25.5 million, \$6 million of which was spent just acquiring the land upon which the track is being built. Pocono, the financing of which has been a drawn-out, close-to-the-vest affair, will have cost more than \$5 million by the time it has been completed.

Just in these tracks alone, upwards of \$50 million is being spent, an eye-popping investment in a sport that just a few years ago was confined to three or four major speedways and scores of small-time "bull rings" scattered throughout the country. And best of

all for the money men is that profits seem as inevitable as taxes.

As a rule, unless they are going under, racetrack managements are reluctant to disclose just how much their box-office action amounts to. But in 1968, the International Speedway Corp., proprietor of the famed 2.5-mile superspeedway at Daytona and the track under construction at Talladega, took in some \$1.6 million in admissions alone. Add to this additional income (concessions, track rental for testing and so on) of \$0.5 million taken in during 1968 and you get a fair idea of why Wall Street ears go up at the mention of auto racing.

Actually, however, favorable earning potential is only part—the major part, granted—of the impetus behind the big boom in racetrack construction. Also to be considered is that space-age technology is boosting speeds up and up, meaning most existing tracks—particularly the smaller ones—just can't handle today's race cars and racing. Additionally, although still an extremely hazardous, give-no-quarter business, auto racing is losing its old bloodthirsty, roughneck image. Around most tracks these days clean fingernails outnumber dirty ones and down in the pits or up in the stands one is very apt to find the man-next-door.

Finally, of course, there's auto racing's ultimate appeal . . . its fantastic spectacle. ★★★

Who Will Bell the Invisible CAT?

By FRANK A. TINKER

Air Force, Federal agencies, plane-makers, airlines—they're all trying to find better ways of combating a sky foe called Clear-Air Turbulence

IT SEEMED TO BE a routine flight, well above the clouds and in air so smooth that half the passengers had been lulled to sleep. Why, then, the sudden excitement among the observers up forward who were clustered around a "black box" instrument?

Two warning lights on the box had begun to glow. "About three and a half away," said one of the engineers in the group. There was sufficient time, the observers knew, to alert the flight crew, switch on the seat-belt sign, and slow the big jet to a speed at which it would better withstand penetration into turbulent air.

Turbulence—in this clear sky? Yet, three and a half minutes after the black box's first warning, a shudder ran through the plane. For several minutes

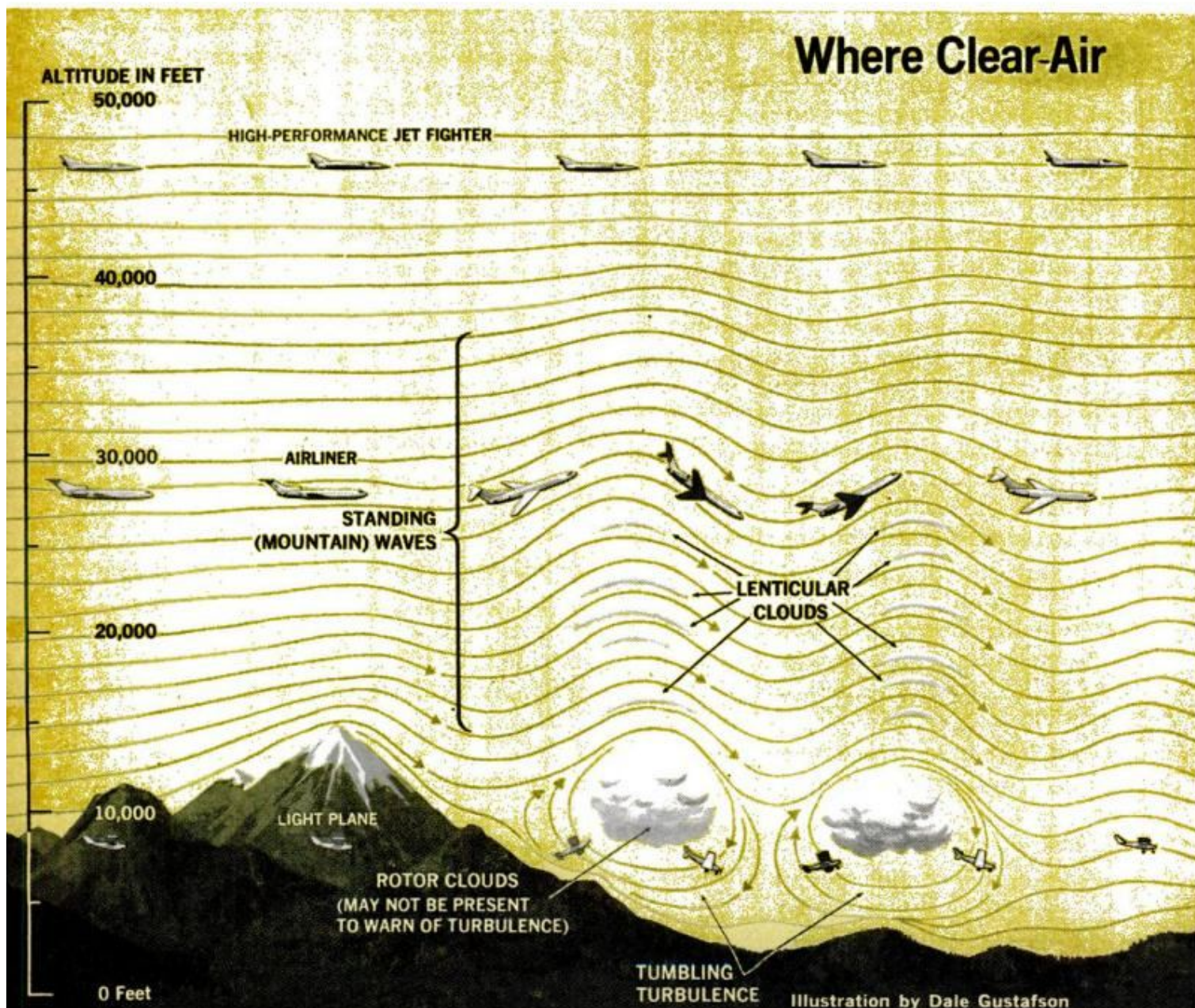

the craft pitched, rolled and surged as if it had suddenly entered an invisible thunderstorm. Objects not secured went skidding off passengers' laps. Bodies strained against seat belts, and passengers glanced in concern and puzzlement at the seemingly tranquil skies outside. Then, as suddenly as it had begun, the turbulence subsided.

"We hit that kitten right on the nose," said one of the observers.

They had, indeed, and it is hoped that such test flights, similar to many recently flown on regularly scheduled runs, will eventually succeed in belling the same cat. For this is no ordinary feline. It is a high-living, vicious CAT—Clear-Air Turbulence—which has claimed lives and aircraft.

In 1964 a highly instrumented B-52 flew over Colorado's Sangre de Cristo

SENSITIVE VANES at end of 8-foot boom register wind velocities in this high-flying CAT-hunting U-2



Turbulence Lurks

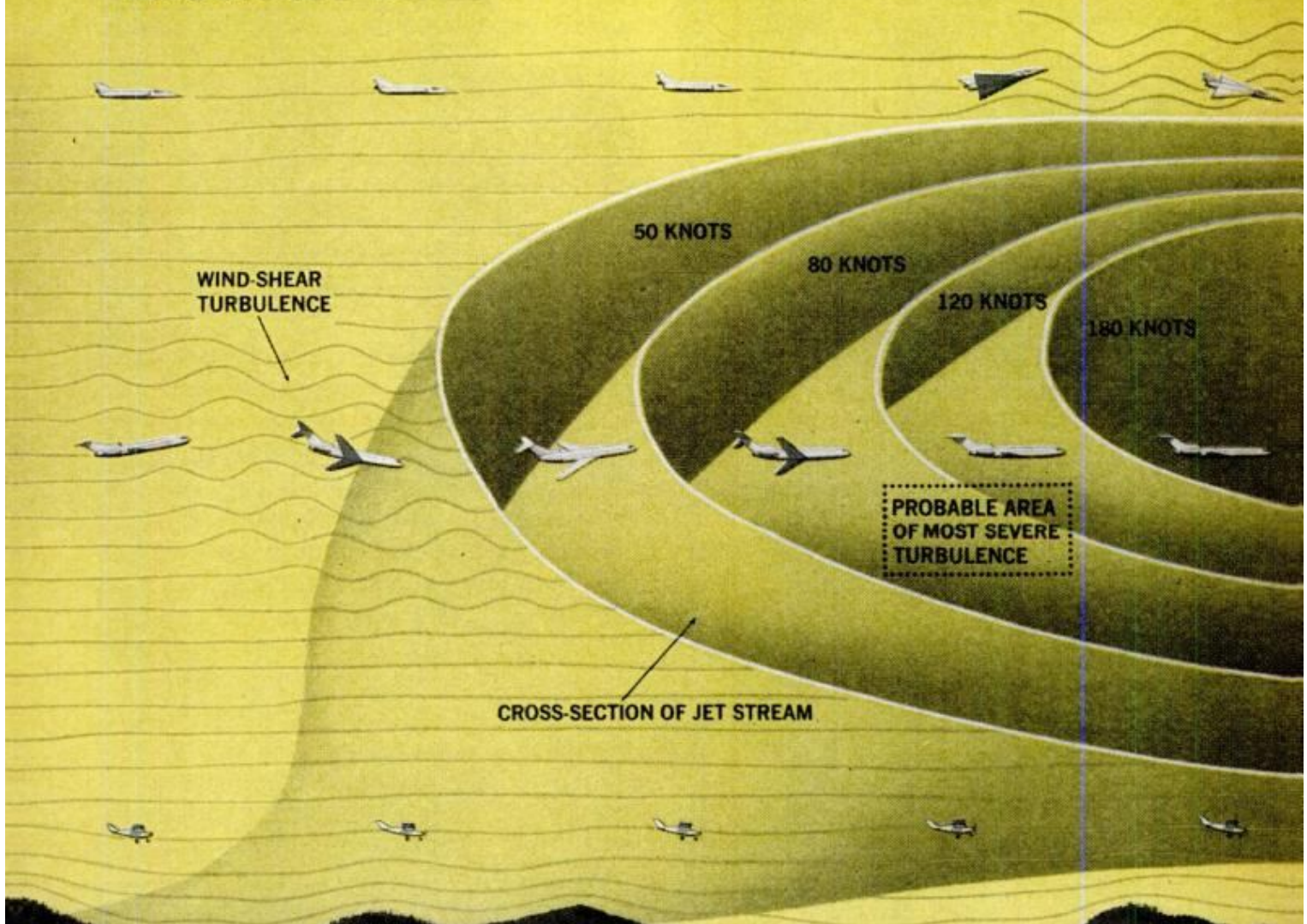

FATAL CRASHES HAVE BEEN TRACED to clear air turbulence, an elusive enemy of aircraft. Diagram shows where it may be found



CAT INDICATOR IS INSTALLED on engineer's panel of Pan Am 707. When indicator shows a sudden temperature change, crew knows CAT may be ahead

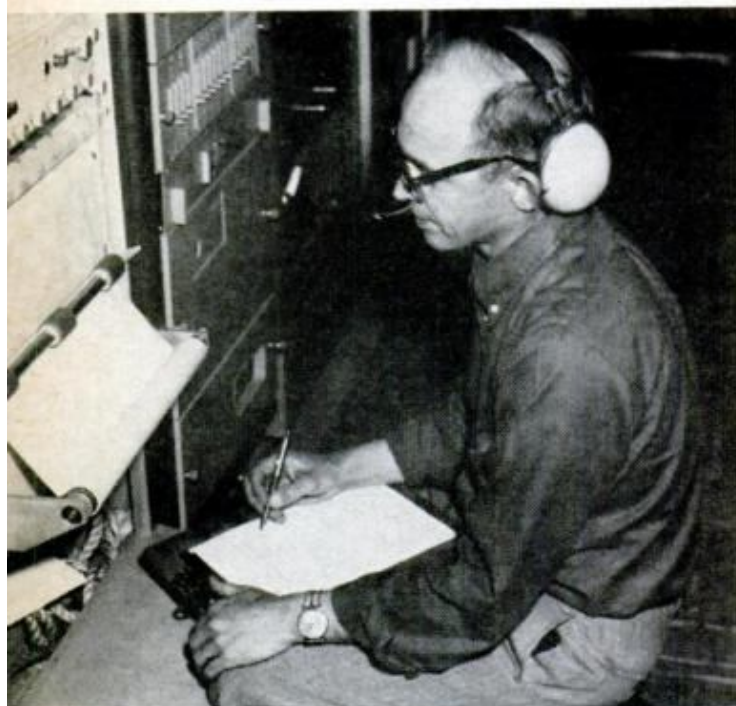

DATA RECORDED ON FLIGHT is checked out by technician prior to laboratory analysis. Many research flights are made over regular commercial air routes, but some cover mountain areas known for extreme turbulence. Before leaving on CAT-seeking mission, Air Force pilot (below) gets briefing by forecaster



Mountains in search of gusty weather in which to carry out structural tests. The plane hit stronger blasts than its crew had bargained for. Seized by CAT, the craft threatened to go out of control. Powerful gusts ripped the rudder completely off and stripped the vertical stabilizer down to a bare stub. It took real piloting and good luck to bring the plane to a safe landing.

Civilian airliners have not been immune. In 1968 a United Air Lines jet was on a routine flight over Wyoming in otherwise ideal conditions when struck by CAT. It plunged 8000 feet. A passenger who unfastened his seat belt to assist another was bludgeoned to death against the cabin ceiling.

The year before, a British airliner ventured too near the unseen gusts which often swirl over Japan's Mount Fuji. It was literally torn apart by the turbulence, bringing death to all on board. On numerous other occasions flight personnel, passengers and baggage have been flung about the cabins of CAT-clawed aircraft. In addition, CAT is suspected of being a major cause of structural damage that doesn't show up immediately and is an important factor in unsolved crashes.

Not long ago it was assumed that the greater the altitude, the smoother the flight. Today we know that this isn't necessarily so.

Designers of high-flying craft, particularly supersonic transports, must take into consideration stresses associated with clear-air turbulence. The inherent flight stability of swept-wing jets may be especially vulnerable to CAT. At lower speeds the choppy jolts and severe lateral gusts might not be critical, but at 2000 mph the rapid cycles of vibration set up by these forces might result in structural failure.

To coordinate a broad investigation of the problem, a National Committee for Clear-Air Turbulence was set up in 1966. One of its first recommendations was that, although aircraft had to be able to survive CAT if encountered, the best way to deal with it was to

avoid such encounters. But how? That angle is still being investigated.

The Air Force has a long-standing interest in CAT, whose disruptive forces may play particular havoc with mid-air refueling operations. Early research was focused on a particular phenomenon, the jet stream, which was soon linked with CAT. World War II pilots first reported finding the jet stream, but were scoffed at by weather people. Now it is known that this wind system is a flow of fast air that may be from 50 to 300 miles wide and 3000 feet thick. It is a west-to-east stream that shifts its course almost hourly, with winds of from 100 to 300 mph. Near its edges the jet stream collides and "shears" with the surrounding air, creating severe turbulence. In addition, the stream it-

vanes so sensitive they can detect a man's breath. Long-winged U-2s and Lockheed SR 71s have detected CAT as high as 80,000 feet.

As a result of these many probes the Air Force has confirmed the potential hazard of CAT to planes flying at supersonic speeds. To avoid this hazard, aviation thus far has had to rely mainly upon forecasters, who can predict general areas of possible turbulence.

Most of the predictable turbulence, however, occurs at just those levels—20,000 to 40,000 feet—where most jets in the civil, airline and military fleets must operate.

A typical CAT forecast zone is huge—400 miles long, 120 miles wide and 15,000 feet thick—and there may be several forecast at the same time.



PILOTING SKILL AND LUCK joined forces to bring this B-52 back safely from mission in mountains over Colorado. Seeking gusty weather, research plane was hit by CAT that chewed its vertical stabilizer to a stub

self may contain waves of wind which produce the curious "chop" frequently associated with CAT.

The Air Force program is divided according to altitudes—Locat, Medcat and Hicat. Much of this effort initially went into investigating Medcat—from 20,000 to 40,000 feet—where the jet stream normally occurs. But with the first U-2 and B-58 flights came a surprising discovery—CAT also lurked well beyond those altitudes. For several years now such planes have roamed the skies over Puerto Rico, Alaska and Australia. The U-2 is fitted for these missions with an eight-foot boom jutting from its nose. At the end of the boom are several

Pointing this out in a special report, the National CAT Committee states that such forecasts still are "too gross to be of much value for (flight) planning purposes and the chance of encountering CAT is almost as great outside the forecast area as within."

Radar, so useful in detecting and avoiding "cells" of precipitation and presumed turbulence in thunderstorms, has proved of almost no value in detecting CAT. Radar needs something "solid"—rain or clouds—to reflect it. Investigators finally hit on one possible CAT indicator: The jet stream or any rapidly rising or falling current may

(Please turn to page 198)



A Nifty and Thrifty Buy, But How the Money Goes for Gas!

By **BILL HARTFORD**, Technical Auto Editor/Photos by *Irv Dolin*

OWNING AN IMPALA is a simple economic proposition. Owners have to drive to live: "Faithfully gets me to work and back—80 miles a day," states a Minnesota foreman. Take the best price from among a couple of quotes for the car with the comfort, style and performance needed, add on depreciation, approximate miles per year, figure in maintenance, repairs and so on, and reach a conclusion: "It's a car to keep for two years; if it doesn't fall apart it's served its purpose. I don't marry a car, it's inanimate," explains a New Jersey stockbroker.

It's something to use and throw away at the least possible expense. "It's good for the average income family; got good trade-in or resale," deduces an Arkansas rural mail carrier.

According to owners, it's arithmetical gymnastics that swings them to the Impala. "It's cheaper than other cars. It cost me \$1000 less than the same size Pontiac. I try to trade every year; I'll buy a Chevy in 1970 only if other cars are so highly priced to allow me terrific



REAR VISIBILITY is much complained about. Owners can't see the rear fenders for parking and backing



REAR-SEAT KNEEROOM is a bit tight even in four-door model, but owners like comfort and upholstery

savings by staying with Chevrolet. Best \$ value," analyzes an Alabama program analyst.

After putting all the facts into their mental computers, owners reach a dollars-per-day figure that tells them how much they've got left for apple pie or reminds them how much we need more mass transportation. "Less depreciation during ownership than with other cars," observes a Nebraska salesman. "Retains a high trade-in value," says a Colorado rehabilitation counselor.

Many owners sell or trade just before they figure the original battery and tires will poop out, or even before the radiator has to be flushed, as the case may be: "Fourth Impala in four years," is the tally of an Illinois housewife. "I buy one each year," says a retired Indiana man. An Illinois manufacturing coordinator and others do the same. A rural mail carrier quips, "I've driven 11 Impalas in the last six years—all satisfactory."

What begins as an economic proposition often becomes an allegiance of affection and pride—or habit. A retired teacher in Indiana has been driving Impalas since Chevrolet introduced the marque. "After 40 years with GM cars—Chevys and Buicks," a Louisiana revenue auditor bought his '69 Impala. An Indiana book-



DRIVER'S ASHTRAY is too close to knee; it's only one in front; passengers can't reach it, say owners



CONTROLS, INSTRUMENTS are liked. Exception is hard-to-use horn buttons; owners want ring



SMART FRONT-END STYLING is only one element of Impala's overall design that excites owners

IMPALA FUEL MILEAGE CHART
327-cu.-in. V8

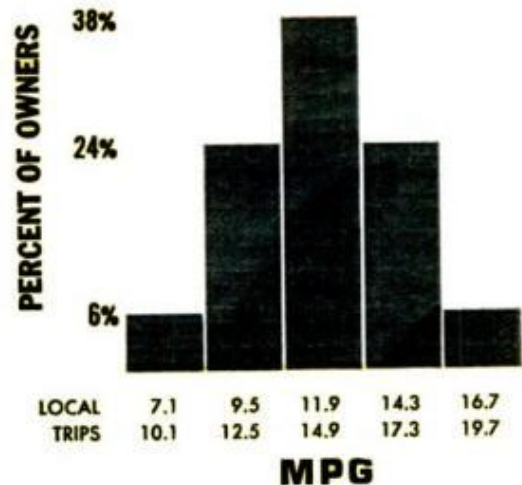



ON-THE-ROAD, OWNERS average 14.9 mpg, around town, 11.9 with most popular 327 V8—and they don't like it



BEHIND-THE-WHEEL POSITION is comfortable; front visibility to the right is interrupted by the mirror

keeper put 100,000 miles on his '64 "with no major trouble"; that's why he bought a new one. In fact, good past experience with Chevrolets (specifically, Impalas) brought most '69 owners into the showroom ready to buy.

Now that these owners have, cumulatively, over a million miles on the road, they've had a chance to discover the things that they don't like about their Impala. Fuel consumption is, by far, most disturbing. Over half of owners have the 327-cu.-in. V8 and are averaging 11.9 and 14.9 miles per gallon in town and on trips, respectively. They voice their complaints regardless of whether their mileage is below, above or the same as the average. "Gas mileage is poor," mourns a Delaware accountant getting 7.5 and 10 mpg. "Gas mileage is pathetic!" exclaims a

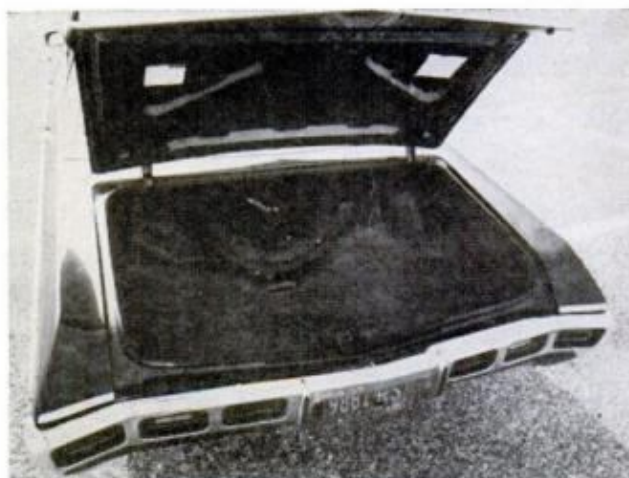

IN THE TRUNK there's all the room owners need; only a few mentioned the spare tire being in the way

Virginia electrical engineer getting 10 and 12 mpg. "Poor gas mileage," complains a Connecticut truck driver with an above-average 14 and 17 mpg.

A New Jersey modelmaker says that "after all these years of automotive engineering experience, the industry owes more to a customer than a drop from 25 mpg in 1933 to 8.4 mpg in 1969 regardless of the hp race." That's the mileage he's getting with his 396 engine. His mileage has decreased progressively over the years as he indicates in a comprehensive log of his family's Chevys, vintage 1933, '40, '41, '54, '62, '64, '66, '67 and '69.

Dissatisfaction with fuel economy overshadows other things about the Impala. Complaints about rear visibility and lapses in workmanship are mild in comparison. Only the "lemon" the-



CHOICE OF MODEL is overwhelmingly four-door sedan or hardtop. It's only car for half of owners surveyed

ory or some mysterious psychological reason for owner dissatisfaction can explain such a strong but rare comment like that made by an Alabama truck driver: "I'll drive it until it wears out, but at the rate it's going it won't be long." Similarly, a Delaware accountant complains about poor visibility out the rear window of his four-door sedan. "There's absolutely no good rear view, and I've bumped into another car twice because of this." He's the only owner for whom it's *that* bad.

After the best and worst things about the Impala are listed, all the remaining praise and criticism balance out. For every owner who got the royal treatment from his dealer, an-

IN THE TURNS owners find Impala predictable; like handling second to style; comfort and ride are next

other got the runaround; for every owner who likes the horn buttons, another wants the familiar horn ring back; for every owner who wants a side vent window back, another owner is glad it's gone; for every owner who dislikes the use of plastics, another praises it; for every owner who wants a second ashtray up front for the passenger, another has no need for it; for every New Jersey safety inspector who says, "The car rattles like a tin can," there's a Nebraska machinist who brags, "You can race the car every day and it will take it." But when it comes to balancing the budget, most owners agree with a Delaware salesman; simply, "It's a good investment." ★★★

Summary of 1969 Chevrolet Impala Owners Report*

Total miles driven1,288,272

Average miles per gallon:

327-cu.-in. V8, local driving	11.9
long trips	14.9
350-cu.-in. V8, local driving	12.3
long trips	15.0
396-cu.-in. V8, local driving	10.9
long trips	14.5
250-cu.-in. Six, 427-cu.-in. V8: not available	

Specific likes:

Style	36.4%
Handling	29.9
Comfort	28.0
Ride	27.6
Economy	15.4
Performance	15.0
Power	8.9

Specific dislikes:

Gas mileage	21.9%
Workmanship	13.2
Dealer service	7.5
Wind noise	7.0
Rear visibility	6.6
Rattles	5.7
Tire quality	5.3

What changes would you like?

Rear visibility	14.4%
Workmanship	9.9
Quality of materials	8.3
Side vent window	6.6
Ashtray location	4.4

Body style:

4-door sedan	42.0%
4-door sport sedan	25.1
2-door sport coupe	20.6
2-door custom coupe	6.2
2-door convertible	6.2

Engine:

250-cu.-in. Six	0.4%
327-cu.-in. V8	55.7
350-cu.-in. V8	35.7
396-cu.-in. V8	6.6
427-cu.-in. V8	1.6

Transmission:

Automatic	94.2%
3-speed manual	3.7
4-speed manual	2.1

Had any mechanical trouble?

No	71.4%
Yes	28.6

What kind of trouble?

Windshield wipers	15.7%
Power steering	14.3
Transmission	11.4
Oil leak	11.4
Carburetor	10.0
Cold starts	10.0

Dealer repair satisfactory?

Yes	62.1%
No	37.9

Why the Impala?

Past experience	46.2%
Economy	28.2
Style	19.5
Performance	5.5
Service (dealer)	5.0

Is the Impala your only car?

Yes	50.6%
No	49.4

Other cars owned:

Chevrolet	57.1%
Ford	13.4
Corvair	7.6
Volkswagen	6.7
Oldsmobile	5.9
Buick	5.0

What options/accessories?

Both power steering and brakes	56.0%
Radio	54.2
Airconditioning	51.4
Power steering	40.7
Tinted glass	25.5
Whitewall tires	18.5
Clock	13.0
Vinyl top	9.3
Rear speaker	7.9

Age distribution of owners:

15-29	16.3%
30-49	51.0
50 plus	32.7

*Where applicable percentages may not equal 100 percent due to rounding and/or insufficient sample.

Off-Road Going ...In Style

In May we reported on our first quick look at International's new Scout Aristocrat. On our second look, we wrung it out in the rugged Smokies

By BILL KILPATRICK, Auto Editor

HEADED SOUTHEAST out of Knoxville on U.S. 441, I noticed other drivers giving me the eye whenever I zipped by on the inside lane. It must have been obvious I was driving something different. The fact I was zipping by at all probably was the main reason for the curiosity; 4x4s aren't supposed to blow the doors off Buicks.

Yet there I was, doing the limit and—occasionally in passing situations—a bit more. And when the name “International” is coupled to a squarish box-on-wheels that on any day can get right out there and march with the rest . . . well, we have a genuine vehicular curiosity, that's what we have.

The vehicle was International's plush, new Aristocrat, a once-was meat-and-potatoes Scout 800A with clean fingernails and slick hair, and the reason I could show my heels now and then was a 304-cu.-in., 193-hp V8.

Add splashes of chrome trim and such go gear as mag-type wheels and wide, performance-type tires, and we have even more of a curiosity—the sort one figures to see only around Los



VERSATILE ARISTOCRAT takes shallow streams with ease. Below, mag-type wheels and front locking hubs

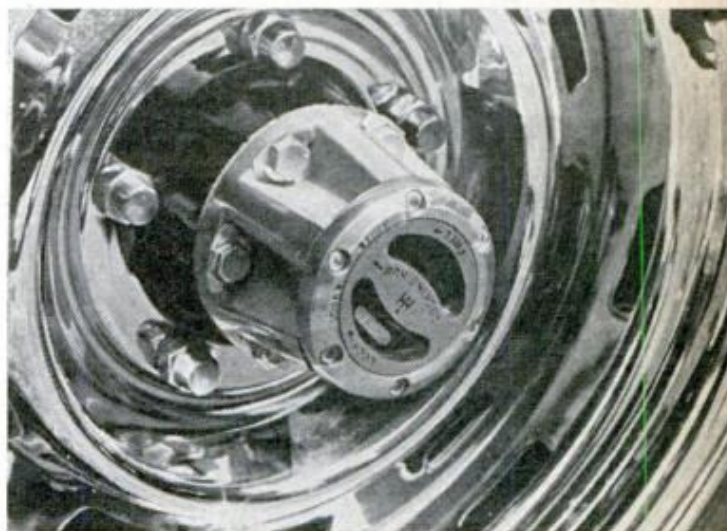

ACCESS to rear seat is via fixed, forward-pivoting passenger seat. Aristocrat comes carpeted throughout

PHOTOS BY DON HUNTER

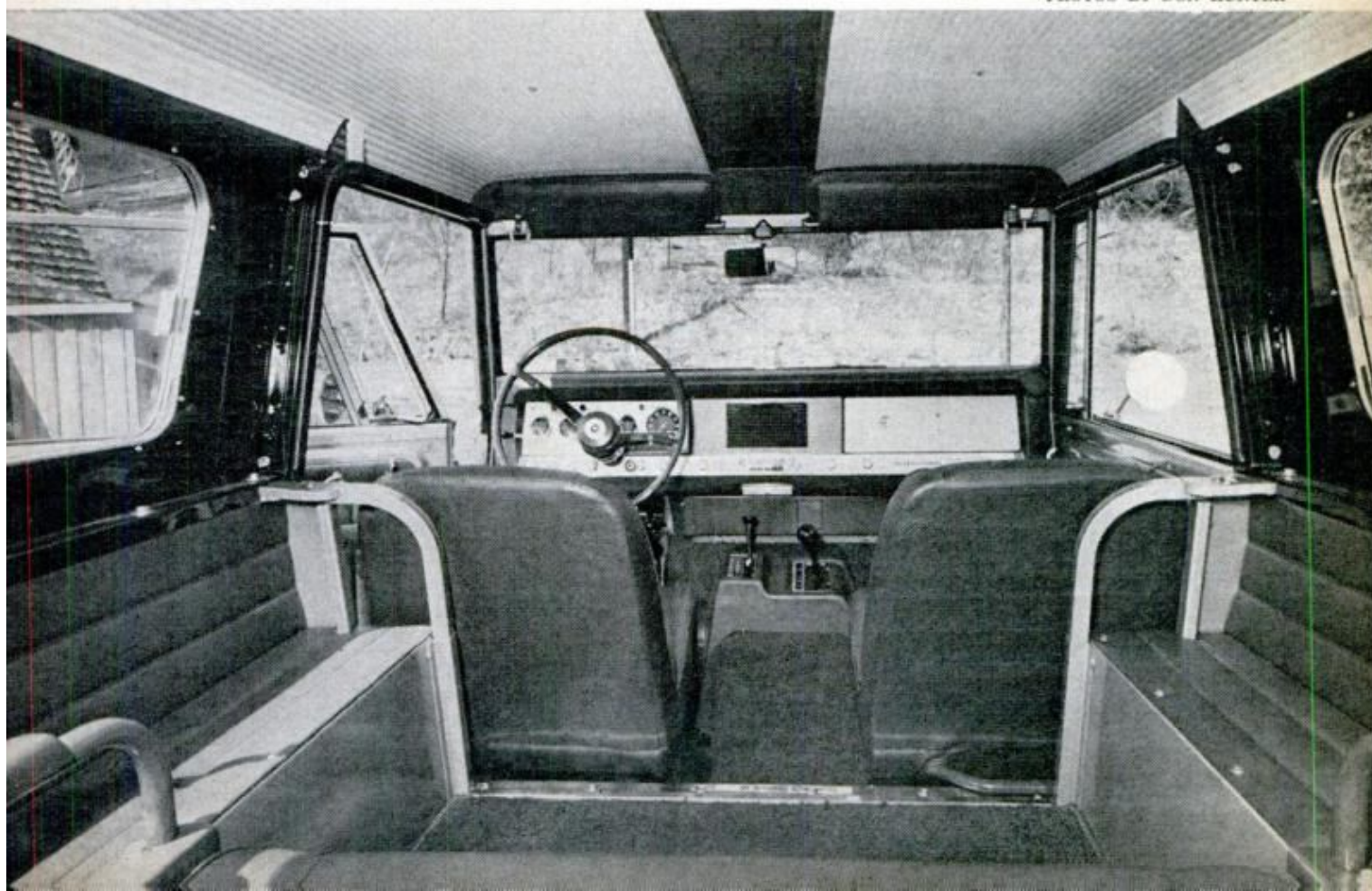

Angeles. There were some startled Mustang faces when I went bombing by.

But speed and styling dash aren't supposed to be the name of the 4x4 game. The idea of such a rig is go-anywhere versatility—through streams, up steep inclines, punching out trails in the bush, threading trees and so on. Could the Aristocrat—for all its zip and grooming—still slog along in rough country like a regular Scout? Finding the answer is why guys who test-drive automobiles occasionally complain of aches and pains.

A few months ago, *PM* executive editor Jim Liston got to drive briefly a prototype Aristocrat (see *It Separates the Ranchers From the Cowboys*, page 90, June *PM*) and returned impressed.

"It's an interesting concept," he reported, "but I didn't get a chance to find out just how interesting. See if you can set up a real test."

So there I was, southeast of Knoxville, flailing my way through a maze of roadside signs in the first Aristocrat off International's Fort Wayne production line. Ahead was my "test track"—the Great Smoky Mountains. There I would find the sort of rugged backwash deemed a 4x4's meat.

It was, too. I drove the Aristocrat back and forth through a couple of rocky streams, up and down crude trails and roads, through a sharply inclined meadow, up and down over sharply-cornered switchbacks—all the while admonishing myself to not judge the unit as an automobile, but rather as the unique type of vehicle it was.

For example, personal handling criteria I would apply to, say, a Plymouth Road Runner has no bearing on a 4x4. With each yaw, pitch, and jolt to my spine, I kept reminding myself that I wouldn't be there in a Plymouth in the first place; a fisherman intent on getting back in where the lunkers lurk isn't too concerned about independent suspension. He wants to get there. The Aristocrat will do handily... and in style.

But the ride is rough. There are solid axles fore and aft, the former slung

beneath eight-leaf springs on either side, the latter, four. The front seats are quite comfortable, albeit the driver's seat didn't slide back far enough for me. The passenger seat is fixed. The rear seat is little more than a two-man, padded fixed bench and a half-hour back there is plenty.

There was too much play in the steering wheel of the unit I drove; coming down to the Great Smokies I was at the whim of every little crosswind. But don't forget the unit was the first one off the line and hadn't been thoroughly checked out at the factory. Also, I thought the turning radius was too large for a 100-in. wheelbase vehicle; taking advantage of available power in a cornering situation can get you into a somewhat scary understeer condition.

Getting the Aristocrat in and out of four-wheel drive is quick and simple. The transverse case is most easily operated while the vehicle is in motion. Operating the case is via a single lever.

The unit I drove had a three-speed automatic transmission, power brakes, twin gas tanks (controlled via a floor-mounted valve), and such niceties as a map light, radio and individually-controlled windshield wipers. Power, as mentioned, was a V8, although you can get either a Four or a Six. Atop the unit there's a chrome luggage rack and inside there's carpeting throughout.

In all, a pretty (for the type), spunky, rugged little package. And it ought to be. The sticker price on the unit I drove was \$4097, a goodly sum for what is—essentially—a recreational vehicle. But if you want it for workaday use, it's nice to have all those luxury touches, and being able to keep up with—even pass if need be—the mass-produced prides of Detroit is almost worth the price of admission. But hurry; International doesn't plan to make more than 2500 Aristocrats. ★★

ROUGH ROADS, steep inclines are duck soup for the Aristocrat. Four-wheel drive coupled with V8 power provides outstanding off-road performance. Chromed-steel luggage rack is standard equipment





ICE SCREWS are used to climb overhanging ice cliff on glacier

What It Takes

Ice climbing on mountain glaciers is a fast-growing sport. What you need in nerve and equipment is demonstrated here by expert guides who now must be certified in National Parks

By BOB and IRA SPRING

Photos by the Authors

MOUNTAIN CLIMBING is literally an uphill fight. Nevertheless, tens of thousands of people this year are being attracted to the steep slopes and high altitudes of mountains in our National Parks.

It's the new lightweight equipment that makes this rugged sport more appealing. The rapid increase in climbing popularity is outpacing the Park Service's ability to know, personally, the good climbing guides. Thus the Service

GUIDE LOUIS WHITTAKER rappels from a large ice tower on Cowlitz Glacier

POPULAR MECHANICS

has set up a new certification program.

Professional guides now must show off their talents to the NPS and get a permit before they can lead the uneducated up precarious peaks. Tests are more demanding if the peaks are covered with ice.

Head of the guide-testing program is Louis Whittaker—twin of Jim Whittaker who was the first American to reach the top of Mount Everest.

Guides specializing in ice climbing will be put through their paces at Camp Muir—a small hut on a wind-swept ridge 10,000 feet up Mount Rainier, Wash. The test “ground” is the nearby ice of Cowlitz and Muir glaciers.

The examination goes far beyond a guide's ability to climb—he must prove he can lead. The guide is responsible for his party. On a mountain his word must be law. To gain this leadership experience, a potential guide must spend a year or more as an apprentice



DANGEROUS SNOWBRIDGES cover crevasses, making them traps for unsuspecting glacier climbers. Self-arrest and self-rescue are important when climbing ice

to Become a Surefooted Iceman

no matter how great a climber. But there's more than leadership.

A professional guide will be tested on glacier knowledge and on his savvy of strange mountain weather.

He will guide people with little or no knowledge of climbing. He will have to tie the climbing ropes of his party with simple foolproof knots. The guide must remember that in case of a fall, the novice doesn't know how to stop himself. And the novice is more likely to fall. The guide must take special pains with novices, yet do it so the climb is not delayed. He must pass these tests.

Guides must be able to teach their parties the basic technique of walking on snow; of self-arrest in case of falls;

MODERN EQUIPMENT now makes climbing a much easier sport. Ice screws hang from climber's belt



Surefooted Iceman

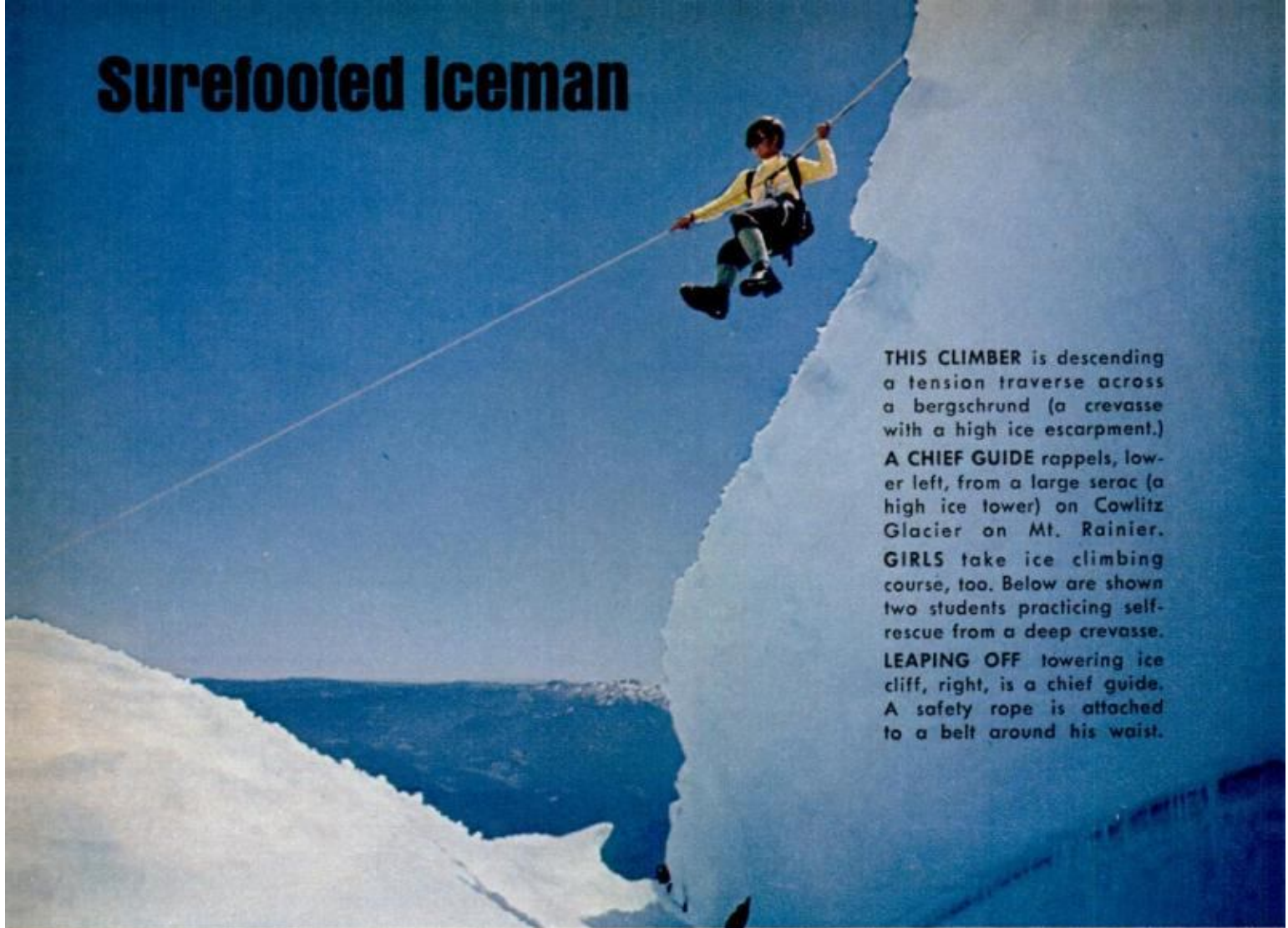

THIS CLIMBER is descending a tension traverse across a bergschrund (a crevasse with a high ice escarpment.)
A CHIEF GUIDE rappels, lower left, from a large serac (a high ice tower) on Cowlitz Glacier on Mt. Rainier.
GIRLS take ice climbing course, too. Below are shown two students practicing self-rescue from a deep crevasse.
LEAPING OFF towering ice cliff, right, is a chief guide. A safety rope is attached to a belt around his waist.

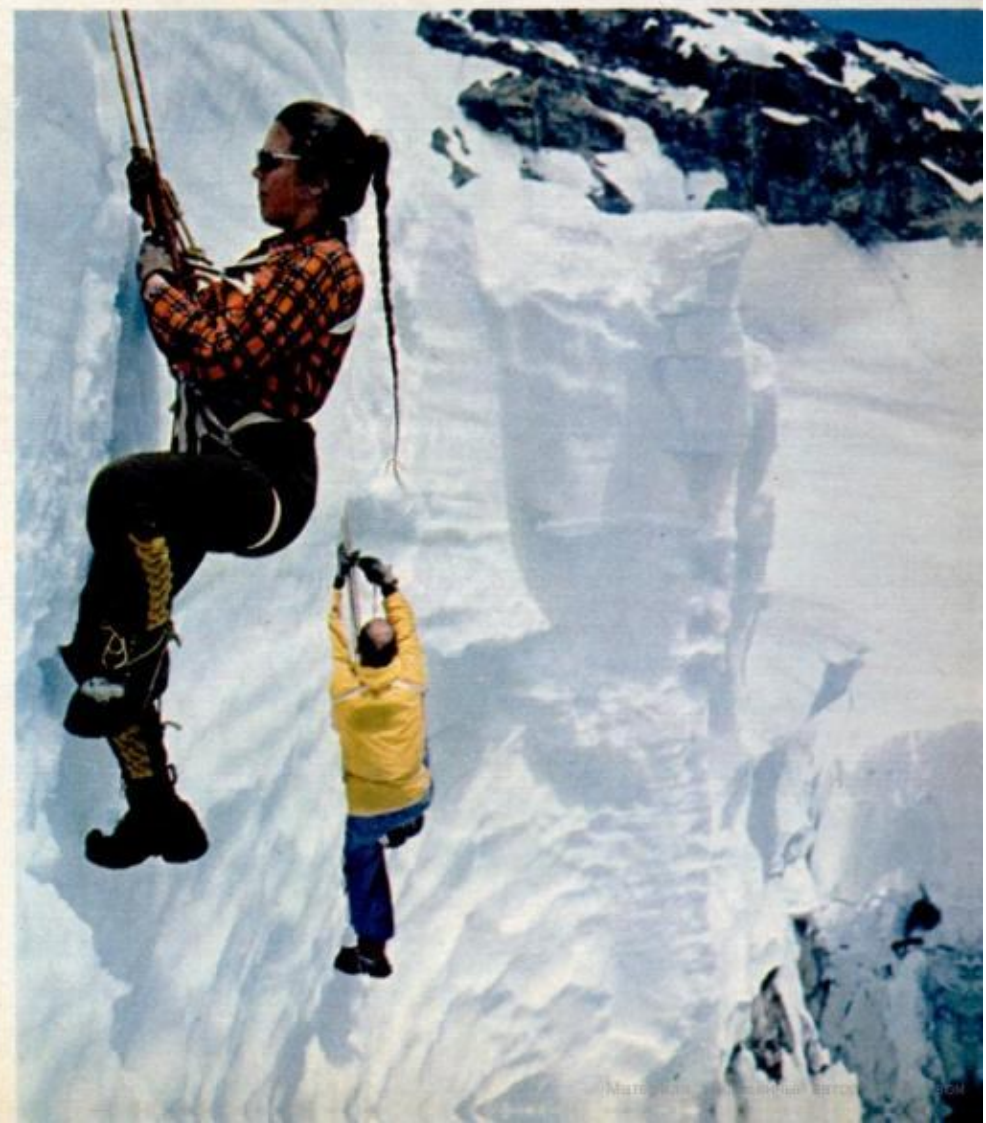



THE JUMAR ASCENDER is an important new device used by mountain climbers to get up and down guide ropes more easily. It was developed in Switzerland



TWELVE-POINTED ICE CLEATS are now being used on new double-thick climbing boots. The new cleats allow for two forward spikes, useful on ice and snow

of crevasse rescue. The techniques used are different for ice climbing than for rock ascents.

Hand and footholds on a rock cliff don't exist on glaciers. Pitons driven into tiny cracks in rocks for vertical climbing are completely useless in ice. With rock there is relatively little danger of a peak collapsing or of a climber falling into a hidden crevasse. But then again, ice climbers can cut steps in cliffs—tough to do in rock.

Ice guides must know about ice screws and what hardness of ice takes which type of screw. The potential

guide is tested on use of the Jumar ascender—a mechanical device which slides up and down climbing ropes.

Coathangers are important, too. These are large wooden ice screws which freeze in position.

And finally, the guide must know how to make a bridge when a crevasse is too large to walk around. He lowers himself to the bottom, then using ice screws, climbs out the other side. Once on top, he engineers a rope bridge for his party. Those who pass the Park Service certification test can truly call themselves surefooted icemen. ★★



TUBULAR ICE SCREWS (left) are used in soft snow. Snow in hollow middle freezes, helps keep screws in place. Other important gear (below) includes coathanger screws (bottom left) and snap rings





Crewless minesweeper

A radio-controlled, 23-foot-long drone (MSD) has been developed for the dangerous job of minesweeping close to shore in Vietnam. The high-speed drone (foreground) is operated from a Minesweeper, Patrol (MSR).



Tent from a poncho

The ponchos that British soldiers wore during recent exercises in Iceland had a second use. With pegs and poles, the garments were converted into tents. Each soldier carried from 60 to 80 pounds of gear.

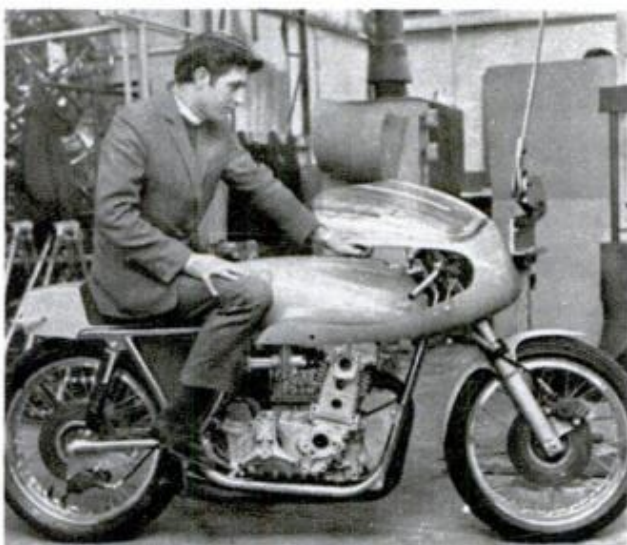

New challenger

Phil Read, champion racing cyclist, inspects a mock-up of the Read-Weslake 500-cc. Grand Prix challenger. The engine is designed to produce 70 to 75 bhp—which will make it Britain's most powerful twin-cylinder.



Zoo with invisible bars

No bars or glass confines birds in the Antwerp Zoo. Only fear of the darkened room in which visitors stand keeps the diurnal birds from leaving lighted displays. After visiting hours, blinds (shown) close off the displays.



Sweet-shooting slingshot

Sailors on the USS *Whitfield County* make friends among Vietnamese children by shooting candy ashore on a super slingshot.



Lifesaving boat

A new British lifesaving boat that looks like an outrigger canoe has a rear deck on which victims can be placed for resuscitation.

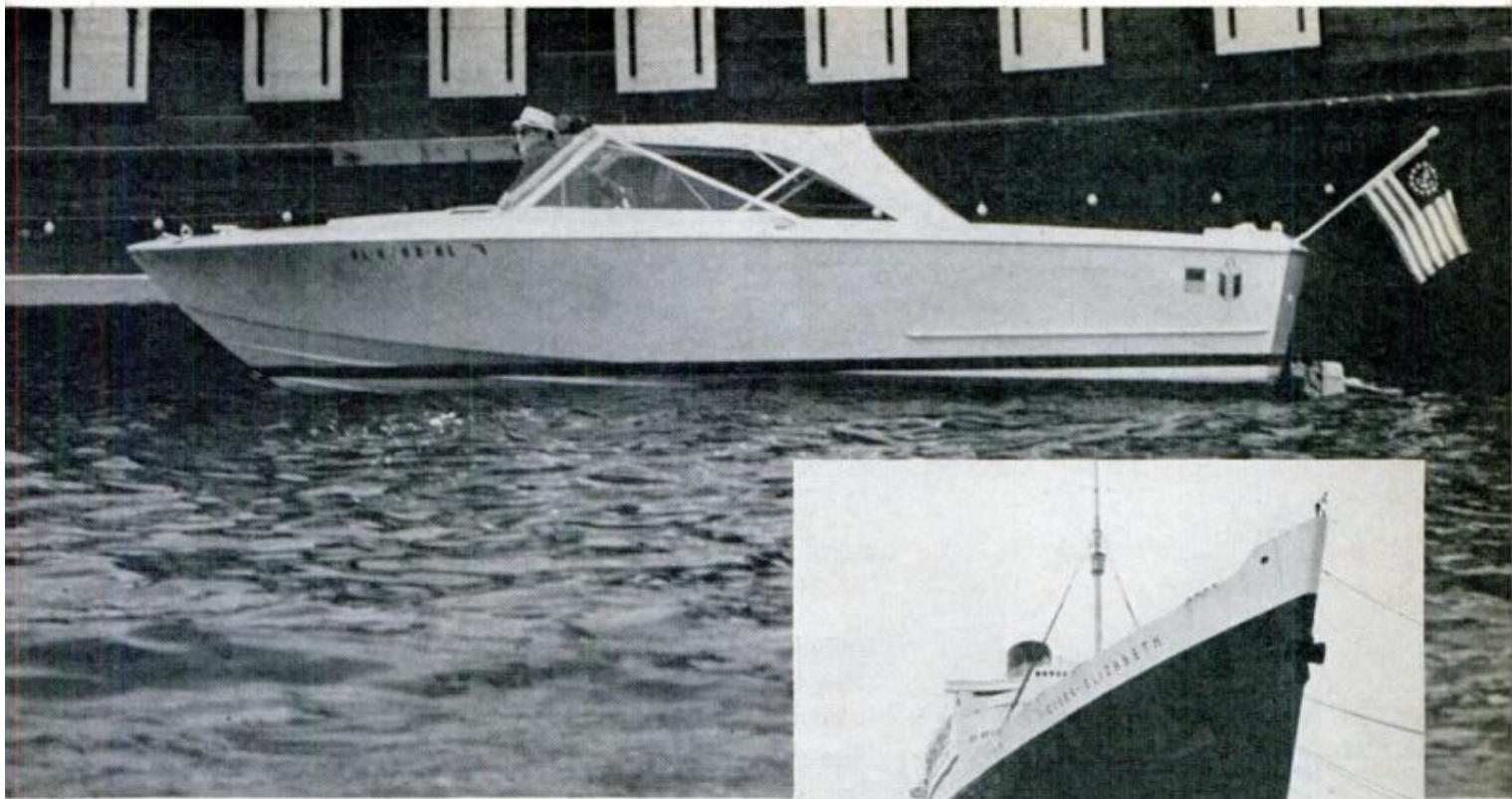

EVEN WITH TOP UP on Lancer, you can still get to the bow through the new center-swing windshield

By DAN FALES, Boating Editor

Photos by Burton McNeely

WITH 4000 POUNDS of boat you can smooth out the roughest of cruiser wakes like oil on water. This I'm finding out as I slowpoke down Florida's busiest waterway.

Local boatmen thought I was nuts to take a pleasure trip through this crowded section of the Intracoastal Waterway. But I chose it for sightseeing fun. I wanted to see the luxurious yachts, big hotels and million-dollar homes. So I climbed aboard a Chris-Craft 23-foot Lancer for a trip from Pompano Beach to Key Largo.

I planned this run as a two-day trip—a day to get to Largo, a day to get back. Besides, I wanted to see Florida's John Pennekamp Coral Reef State Park. This is the only state park that has 75 square miles of protected ocean waters. The park is 21 miles long and 3½ miles wide, all in the Atlantic Ocean off Key Largo. It's great diving and fishing grounds. When the tide's coming in and there's a west wind, the water's clear for scuba diving. The park is fa-

AUGUST 1969

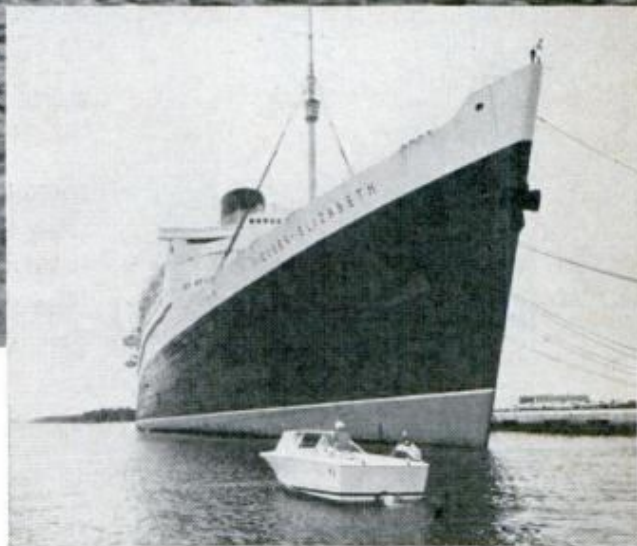

THE QUEEN ELIZABETH, tied to her permanent dock on Intracoastal Waterway, still has an elegant look



FOLDOUT LOUNGE CHAIRS, each six feet long, show the amount of space available in the cockpit



BAIT WELL in the stern is a welcome asset for fishermen. The low engine cover lets you get to it

113

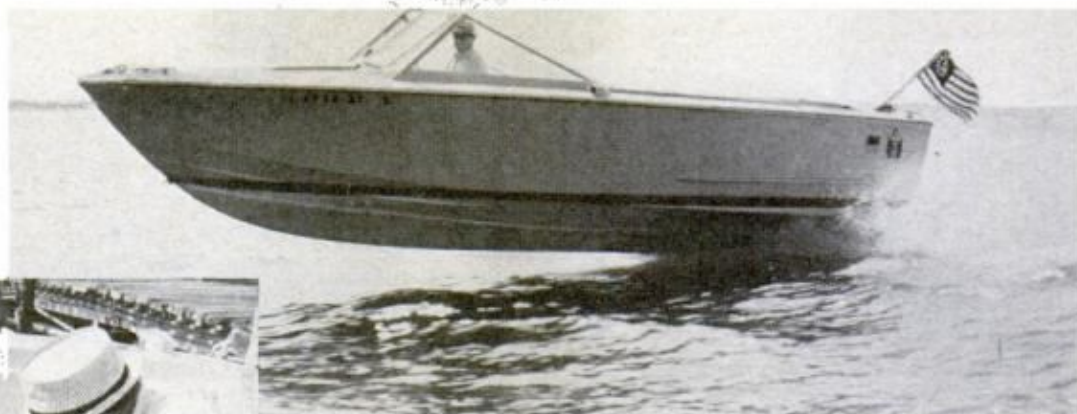

WAKE JUMPING is an easy maneuver for this 4000-pound boat. She doesn't clear the water by much which means quick recovery

mous for its variety of coral and species of tropical fish.

Starting down the waterway from Pompano Beach, I notice that there's plenty of legroom in Lancer around the driver's seat. Lancer is a big boat which permits a lot of open cockpit space. This is all-important for fishermen.

My Lancer is powered by a 150-hp stern-drive unit. You can get as options a 185-hp single or twin 150-hp drives with counter-rotating props. These power arrangements will enable Lancer to hit speeds of around 43 mph.

It is only half an hour out of Pompano that I spot the tall red and black stacks of the stately *Queen Elizabeth*. She's tied to a pier on the waterway near Fort Lauderdale. She looks very much out of place in this tropical setting.

Having seen the *Queen* often in New York Harbor, I must admit she looks now like an aging dowager relegated to dining at lunch counters.

On down the waterway I go, past hundreds of new homes under construction. If anyone says the Florida building boom is over, he hasn't been in this section. New homes and hotels are going up at a rapid pace.

So far, Lancer hasn't had a chance to show off. With all the no-wake laws along this section of waterway, I've hardly had her up on plane. But at low speeds I find no problems. Lancer handles like a lady. I've put up the canvas top for protection from the sun. The top is easy to handle. But I do find that the side windows are a little confining; they're good for keeping water out of the helmsman's seat, but you cannot lean on the "window sill" with an elbow as you do in a car.

Now I get a chance to open Lancer up as I

(Please turn to page 192)



LOW POSITION of the engine means more usable cockpit space in Lancer



WALK-THROUGH WINDSHIELD allows easy access to bow to tend the lines



THERE'S STORAGE SPACE in cockpit floor, also room for fish bins

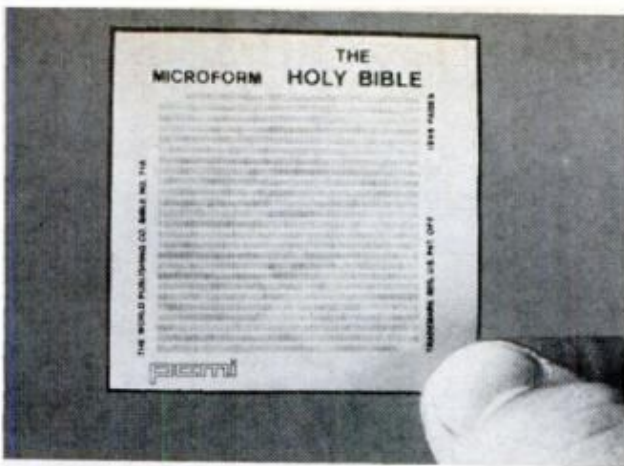

Tiniest Bible

All 773,746 words of the Bible appear on this 1 5/16-inch-square piece of film. Edmund Scientific Co. says the words, reproduced by a new photochromic, micro-image technique, can be read with a 100x 'scope.

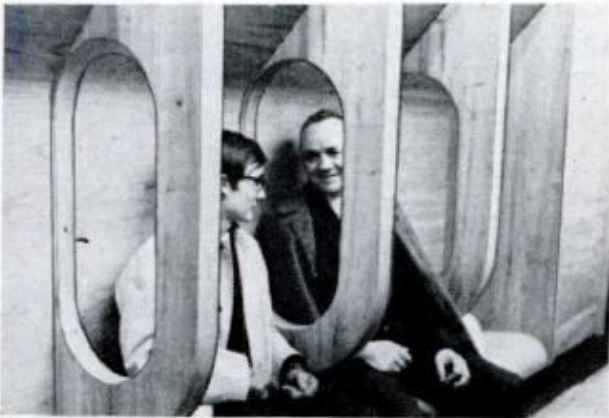

Framed commuters

Dividers between seats in the new station of the Paris Metro give commuters an unusual, framed view of one another.



Lightweight superstructure

The USS *Connole*, first of 27 destroyer escorts with aluminum superstructures being built for the Navy, is launched at New Orleans. Aluminum makes her lighter and faster.

AUGUST 1969

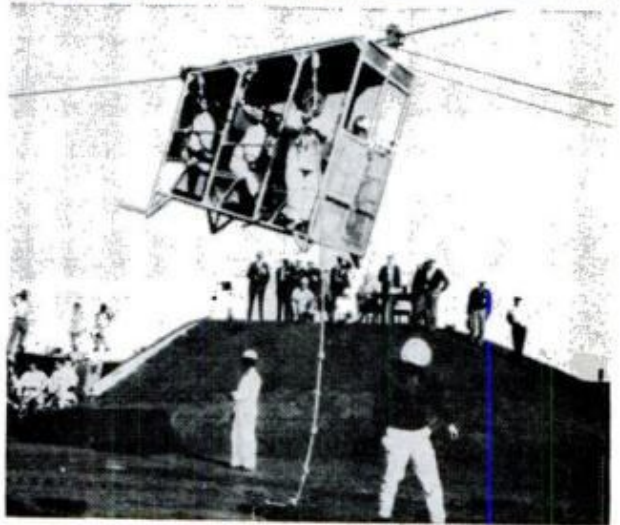
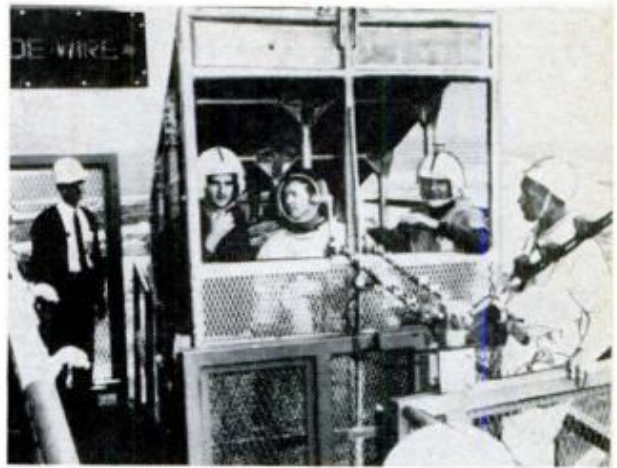

Quick getaway

Nine men can make an emergency escape from the 320-foot level of the Apollo-Saturn V space vehicle in this cable car. The system, set up just before the Apollo 9 launch, takes the men 2000 feet from the rocket. At the end of the run, the men descend to the ground on a rope (lower photo).



Looks almost like fun

No drill hangs menacingly over the patient who reclines in the new Sirona 2000 dental chair. However, there's still a drill (naturally!), operated by a 350,000-rpm motor.

Olds 88: Eye-Catching Lines,

By **BILL HARTFORD**, Technical Auto Editor

"IT'S MY TYPE OF CAR," says a Michigan inventory analyst. That's why he bought a Delta 88. Another Michigan man, a salesman, says his reason was "habit—been buying Oldsmobiles since 1958." And a New York department store manager has the same reason, habit. A rural mail carrier in Ohio explains a little more fully: "I had three Oldsmobiles before and like their dependability."

Whether the Delta is their second, third, or, for a retired Florida couple, their twenty-third Oldsmobile, owners attribute their choice to good past experience. And what about first-time owners? For most the choice represents a step up, and interestingly, as many owners indicate, a step up from a Chevrolet: "Only \$200 more than a Chevy," relates a Louisiana stewardess. "Wanted to move up from a Chevy," says a New Jersey shop teacher. "Wanted a heavier car with more power than I had with the Chevy," says a retired Florida man. And a GM auto-

motive engineer in Michigan muses, "We kept our old Chevy too long; should have got the Olds sooner."

How do owners feel about their Delta once it's in the driveway? It's style that tops their list of likes (and is also the second biggest reason for buying the car). "Great looks, great handling," observes a stone company v.p. in Ohio. It's handling, in fact, that ties with smooth riding for second best attribute. Comfort, next best thing, rounds out what most impressed owners.

Very impressed is a South Carolina foreman: "Best driving car we've ever owned." A Georgia truck driver "tried a smaller car but didn't like the way it handled," so he bought his third Olds.

It's not all raves for the Delta, however. A Michigan carpenter may say, "I don't see how they could make a better car," but lots of owners say they can think of quite a few things and they tell you what to watch for.

Like a Michigan staff engineer, you may find the front floor too small. He

DELTA 88 FUEL MILEAGE CHART

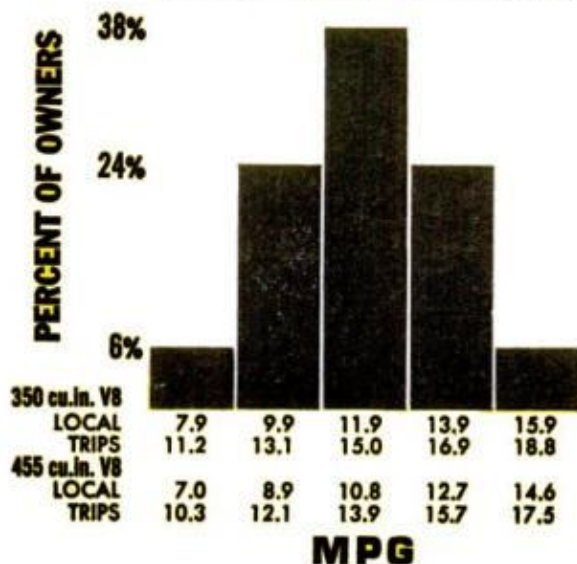

TRUNK ROOM is only fair for size of car. Some owners complain about placement of the spare tire

900,000 Owner-Driven Miles

Neck-Stretching Visibility

Photos by Irv Dolin

wants a larger flat floorboard area: "I wear a size 14 shoe!" he says. Headroom may be a problem, as it is for a barber and hair stylist, also from Michigan. "My head hits the roof with my high hairdos," he says. "Matching seat-belt pairs" may be as big a problem to you as to an Ohio farmer. And be forewarned that the "cut" of the Delta steering wheel may, after "two or three hours of driving, tend to apply too much pressure to the joints on the palm side of your hand," as it does to an Army major in Georgia.

All isolated complaints, subjective and trivial if you will, but very real. After tabulating many such comments, there emerges a list of what bothers owners most. It's no coincidence that a salesman in Michigan and a dentist

DELTA IN THE DRIVEWAY: Owners bought 88s, first and foremost, because they've had good luck with Oldsmobiles. Style, ride, handling and comfort are tops; rear visibility, fuel economy get thumbs down





INSTRUMENT LAYOUT is smart and functional. Only exception is hard-to-see clock on the right side

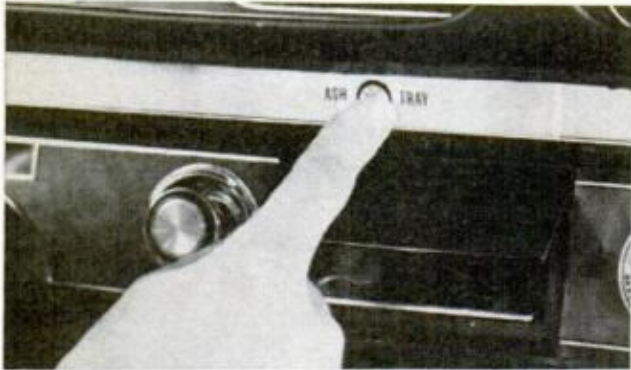

PUSHBUTTON ASHTRAY is probably wasted engineering; nary an owner has anything to say about it



DELTA 88 INTERIORS are comfortable and spacious; legroom in two-door models is criticized, however

in Florida "have trouble seeing out the back window." So do a few hundred other owners. The poor rear visibility tops the list of what owners would like to see changed or improved.

A university professor in Wisconsin couldn't be more emphatic: "I don't like the shortened rear deck which leaves the rear invisible from the driver's position. Backing up is blind!! BAD!!" The point is, as an Illinois office manager says, "It's impossible to see rear of auto through rear window from driver's seat." Some owners, like the professor and this Illinois maintenance supervisor, blame the rear deck: "Trunk line doesn't allow you to see the tail end." Others blame the rear quarter panels, or the window: "Lower rear window or do something so you can see rear deck and fenders," says a Massachusetts sheet-metal worker. And a Michigan registered nurse says "I'd like to see where my car ends." Of course, this isn't unique to the Delta. Many other '69 car owners must dead-reckon their way into parking spots.

Delta 88 owners are also down on the number of miles they're getting per gallon of gas. As a Wisconsin manufacturing engineer says, "The price of gas goes up and the mileage goes down." He gets 10 mph around town and 15 on trips (winter driving) with his 350-cu.-in. V8. That's close to the average of 11.9 and 15 mpg. Of course, if that's the average, some owners are getting more



WORKMANSHIP is considered quite good by owners. On car photographed, however, the "88" marque is upside down and sloppy weld of spare tire retaining-rod plate left holes around it in trunk. Style is tops with owners but the few who have reservations refer to "swollen" fenders and sides vulnerable to dents

Summary of 1969 Oldsmobile Delta 88 Owners Reports*

Total miles driven: 909,954

Average miles per gallon:

350-cu.-in. V8, local driving 11.9
 long trips 15.0
 435-cu.-in. V8, local driving 10.8
 long trips 13.9

Specific likes:

Style 37.5%
 Ride 36.4
 Handling 36.1
 Comfort 30.0
 Performance 18.9
 Economy 5.4
 Power 5.4

Specific dislikes:

Economy 17.2%
 Rear visibility 10.5
 Wind noise 9.5
 Workmanship 7.7
 Dealer service 3.9

What changes would you like?

Rear visibility 15.3%
 Vent windows 10.3
 Legroom 7.2
 Workmanship 7.2
 Trunk room 6.3
 Gas mileage 5.8
 Windshield wipers 4.0
 Seat shape 3.6

Quality of materials 3.6

Engine:

350-cu.-in. V8 49.3%
 455-cu.-in. V8 50.7

Model:

Holiday coupe 35.5%
 Holiday sedan 30.7
 Convertible 4.2
 Town sedan 29.6

Transmission:

3-speed manual 0.7%
 Automatic 99.3

Had any mechanical trouble?

No 74.0%
 Yes 26.0

What kind of trouble?

Electrical 12.1%
 Airconditioning 9.1
 Carburetor 9.1
 Brakes 7.6
 Alternator 7.6
 Power steering 7.6
 Heat riser 7.6
 Transmission 7.6

Dealer repair satisfactory?

Yes 78.4%
 No 20.3

Why the Delta 88?

Past experience 38.4%
 Style 25.2
 Economy 20.2
 Size 7.6
 Reputation 5.0

Is the Delta 88 your only car?

Yes 52.5%
 No 47.5

Other cars owned:

Chevrolet 26.0%
 Oldsmobile 19.9
 Ford 12.3
 Volkswagen 11.0
 Rambler 6.2

What options/accessories:

Power steering 67.9%
 Power brakes 67.5
 Radio 56.0
 Airconditioning 53.0
 Vinyl top 17.9
 Rear defroster 14.2
 Whitewall tires 13.4
 Tilt-steering wheel 12.3
 Clock 11.6

Age distribution of owners:

15-29 16.0%
 30-49 49.3
 50 plus 34.6

*Where applicable percentages may not equal 100 percent due to rounding and/or insufficient sample.

and some, like a New Hampshire traffic manager, are getting less: A whopping "five miles to the gallon," he says. And there's an anonymous owner who's overwrought at getting "five blocks to the gallon!"

Owners didn't come right out and praise workmanship, but the fact that it's low on the list of complaints indicates it must be quite good. One chap, a Georgia PR man, says his car has "squeaks, rattles, etc., etc., *ad nauseum*," but the great number of owners who had no complaints speaks louder for what they must think a solid piece of machinery. ★★★



HARD CORNERING results in only moderate roll which is not at all objectionable to Delta owners

"HOP-UP" STYLE, however mild, is partially responsible for limited rear visibility complaints

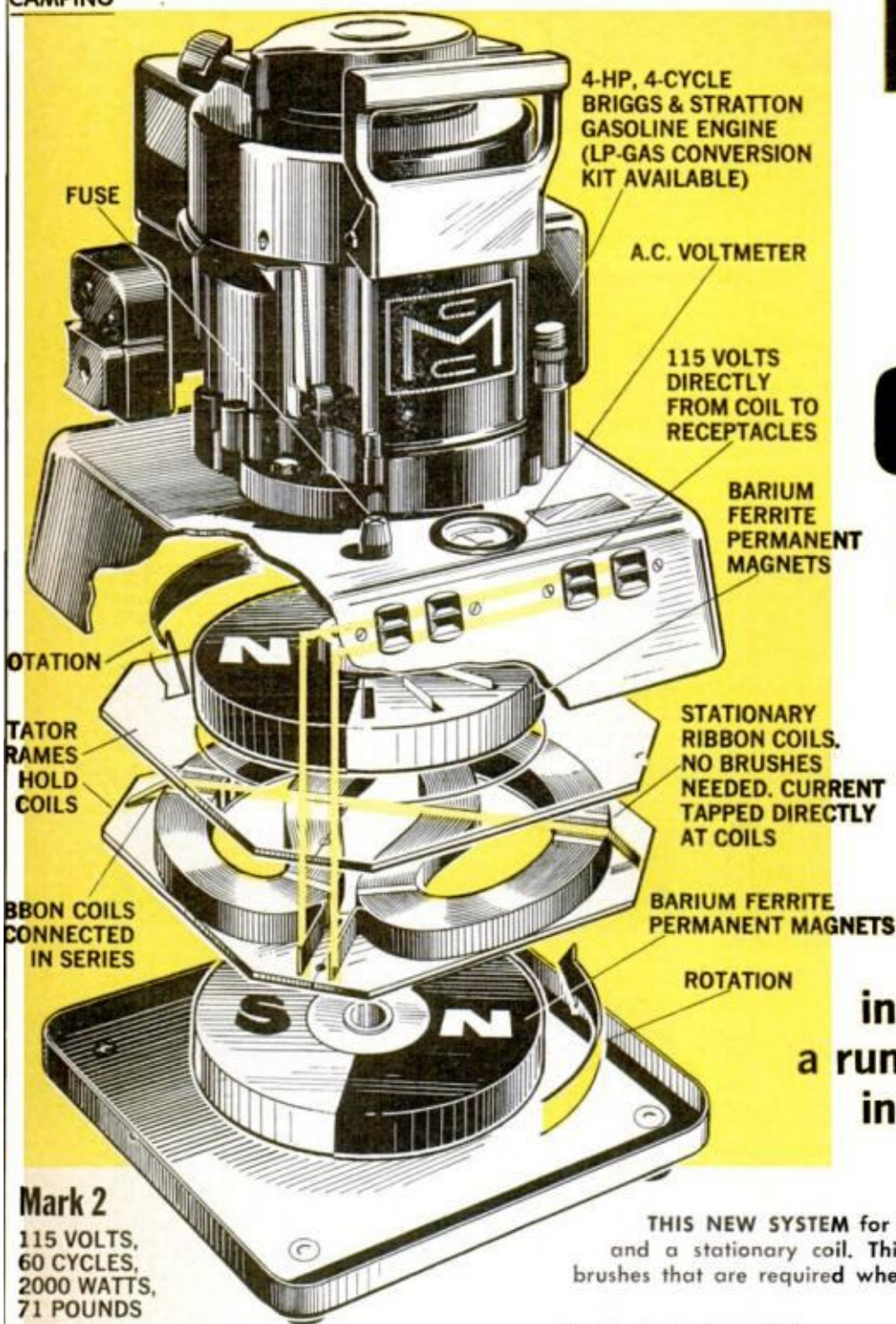

**Mark 2**

115 VOLTS,
60 CYCLES,
2000 WATTS,
71 POUNDS

THIS NEW SYSTEM for power uses rotating magnets and a stationary coil. This eliminates a need for the brushes that are required when coil rotates around magnet

By V. LEE OERTLE

Portable Power For Camping Comfort

Light and sturdy electric generators are now packaged so you can have take-along power in your camper. Here's a rundown on what's new in the generator field.

YOU'RE IN FOR A SURPRISE when you check into portable electric generators for your camper. Today's portable powerplants weigh about one-third less than those sold only 10 years ago. You'll find generators that run on gasoline, diesel fuel, LP gas and natural gas.

The new generators are quieter, too, thanks to improvements in silent mufflers. The vibration levels have been vastly reduced. In fact, on a recent road test my motor home had been fitted with a 5000-watt generator mounted in a compartment under the rear bed. Although the generator came on automatically every hour or two (to handle the airconditioner and refrigerator), it never disturbed my sleep. Considering the fact that a six-hp gasoline engine was spinning the generator I was amazed at the virtually noiseless operation. Frame vibrations, too, were held to a minimum with special damping pads.

You'll find campers all across the country using portable electric power to drive

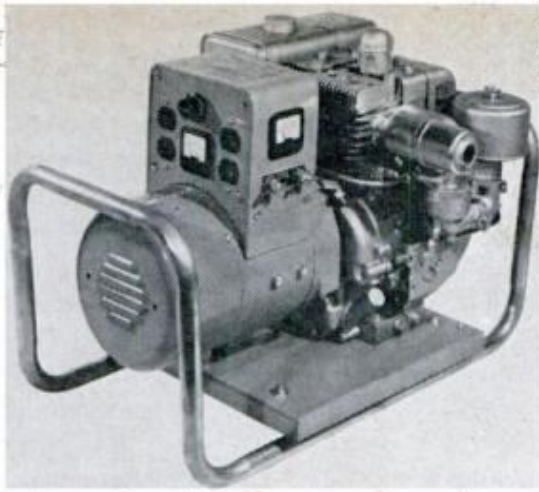

MERC-O-TRONIC rheostat-controlled portable generator has both a.c. receptacles and d.c. power tap

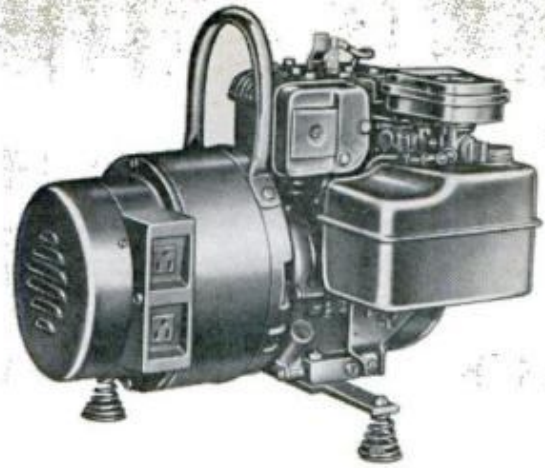

THIS WIN-POWER MODEL is rated at 2000 watts of 115-volt a.c. power. Entire package weighs 74 lbs.

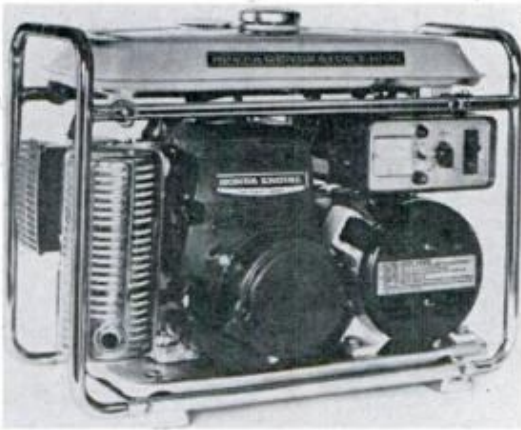

NEW HONDA E-1000 weighs 136.7 lbs. This unit has battery-charging ability. It uses silent muffler



KOHLER 3000-WATT unit has a 7-hp engine. The entire engine and generator weigh about 158 pounds

airconditioners, refrigerators, power tools, lights, fans, radios—anything that runs on 110-115 volts.

You can buy two general types of portable generators:

- Completely portable models ranging from 500 watts to about 2500 watts. Total weight of generators in this class ranges from less than 50 to about 150 pounds. In fact, the new McCulloch Mite-E-Lite puts out 1500 watts and weighs only 61 pounds.
- Models installed permanently on recreational vehicles. These begin at about 3500 watts and go to 5000 watts.

When you buy a generator, know its rated electrical output in watts and its gross weight. It should be light enough for a person to handle *alone*. This usually limits portable models to about 125 to 150 pounds. When I say handle, I refer to moving the powerplant from the storage bin to the ground, then back inside.

From personal experience, I know most buyers will eventually decide on a perma-

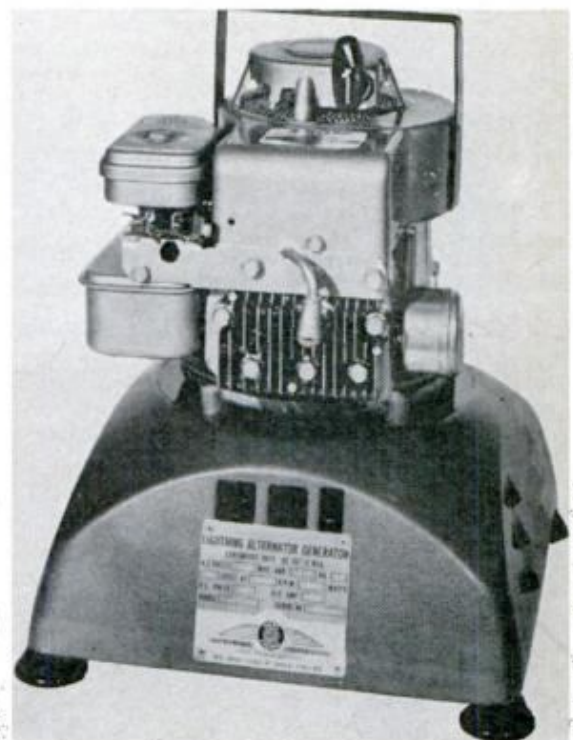

1250-WATT MERC-O-TRONIC operates with a revolving permanent-magnet field. No brushes are used

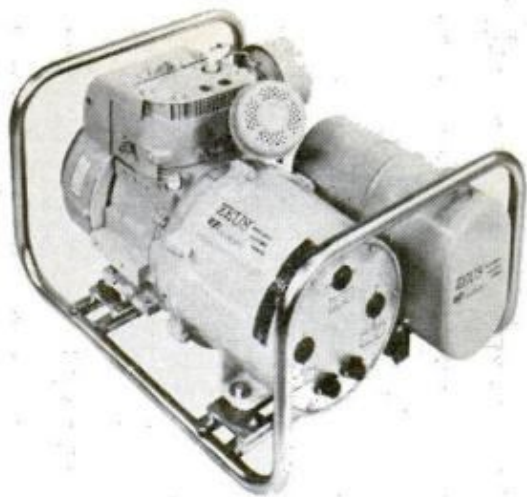

ZEUS 3000-WATT portable generator has three power receptables—one for 3000 watts, two for 1500 watts

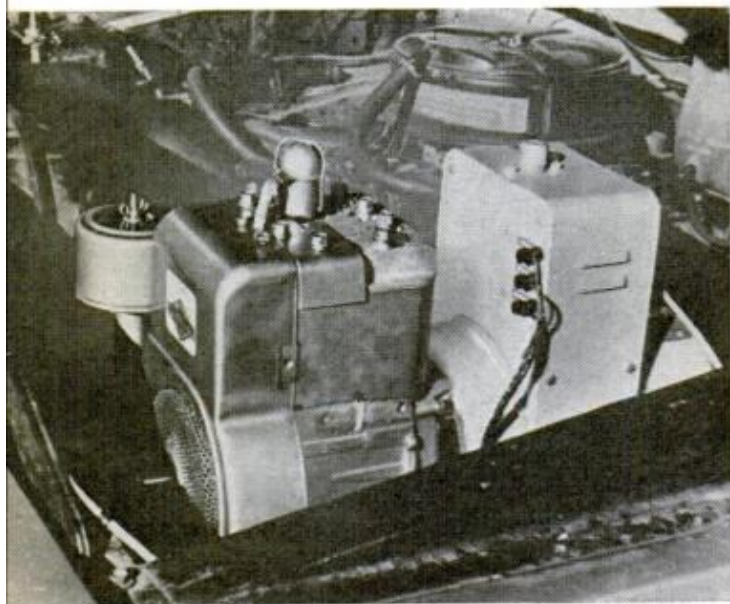

UNDER THE HOOD of a pickup truck or other camp vehicle is a popular place to install generators

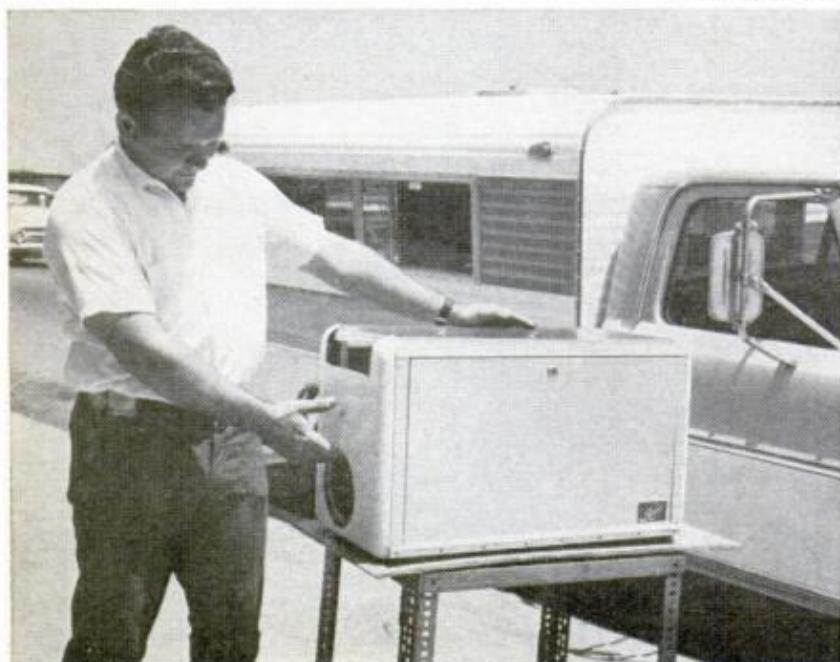

RALPH LIGHT PLANT is an insulated, self-contained 3000-watt unit. In a sealed metal cabinet, it has its own intake and exhaust vents

ment installation. But where to put it? Here are five suggestions:

1. *Under the hood of a pickup truck.* Surprisingly enough, there's plenty of room for a 1500-watt generator under most pickup hoods atop a fender well. One supplier charges \$450 for a complete installation in this location. That price covers a 1500-watt, 115-volt generator, mounting brackets and labor.

2. *In a storage compartment along the side of a coach.* All that's necessary is to remove gear and make sure that dimensions are adequate. The bin door can be used but it should have vent louvers added so that the gas engine can breathe. One new model (the Ralph Pur-Fected unit) is already built inside a metal cabinet. You simply cut out a section of coach wall and insert the packaged generator. It has its own hinged door, exhaust ports and intake vents.

3. *Mounted in place of the LP-gas tanks.* This is feasible when you remove the tanks in favor of all-electric operation.

4. *Attached to a front-mounted platform ahead of the car or truck radiator.* I don't like this arrangement because it blocks cooling air to the radiator. It also seems mighty vulnerable to collision damage.

5. *In a car trunk.* Yes, one trailer-tower installed a special platform inside his trunk and bolted the portable powerplant to it. At the campsite, he parks the car a short distance from the trailer, lifts the trunk lid, and fires up the gas engine on the generator. He uses a flexible metal exhaust pipe to rid the car trunk of carbon monoxide and heat. However, he must shut off the generator to move the car.

In the past, generators have been unpopular—especially with other campers. Here are some operating tips that show the trouble and suggest solutions.

- *Operating a gas-engine generator too close to other campers.* The generator owner should select a site on the edge of a camping area, when possible.

- *Operating a generator on the ground without placing*

PORTABLE GENERATORS FOR RECREATIONAL VEHICLES

Manufacturer	Power in watts	Approx. weight	Price range
HOMELITE	500 to 5000	38 to 225 lbs.	\$260 to \$895
HONDA	300 to 1000	39 to 136 lbs.	\$144 to \$251
KOHLER	500 to 10,000	95 lbs. and up	\$325 to \$1495
LINCOLN	3500 to 5000	347 to 701 lbs.	\$355 to \$740
MITE-E-LITE	1500 to 3000	61 to 165 lbs.	\$320 to \$820
MERC-O-TRONIC	1250 to 4000	70 to 194 lbs.	(Prices NA)*
ONAN	500 to 10,000	82 to 305 lbs.	(Prices NA)*
RALPH LIGHT PLANTS	1500 to 4100	94 to 170 lbs.	\$350 to \$650
WIN-POWER	2000 to 20,000	74 to 627 lbs.	\$305 to \$1145
ZEUS	500 to 3000	46 to 215 lbs.	(Prices NA)*

*Because of variations in engine types, generator types, options, and shipping charges, some companies declined to offer retail prices. Hence, NA means Not Announced. Contact each company for specific details.

All models above rated at 60-cycle, 115-volts a.c.

a cardboard deflector shield around it. Such a shield is easy to make from a cardboard box. Just prop up the cardboard deflectors in such a way that the sound of the engine will be aimed away from camp.

Placement of the generator also counts. For instance, it'll make the most noise sitting on pavement or other hard surfaces—the least noise when it's resting on sand, loose dirt or an absorbent pad.

● *Operating a generator continuously.* Never run your generator after 9:00 o'clock in the evening if the campground is crowded. If it's necessary to operate the unit almost continuously on occasion (during spells of hot weather, for example) make sure that the compartment door carries extra insulation. It is even more important that you are parked downwind of most other campers.

The newest portable generators are so quiet that from 50 feet away they sound like an electric fan. That isn't objectionable to most people. The noise level is already down to a gentle humming inside completely sealed compartments, such as the Ralph unit, and the Onan fiberglass-housed powerplant.

The secret in making a good purchase of an electric generator is to buy one large enough for your average requirements. Picking the right model is merely a matter of listing your personal power demands.

Appliances in the following list are the most popular with campers. Pick those items you use most frequently and total the wattage. Remember, you won't run all appliances at the same time. For example, the refrigerator is on much of the time. But a toaster, electric blanket, vacuum cleaner or power tool is used only intermittently.

Item	Wattage
Refrigerator	250-500
Electric fan	25-75
Radio	20-200
Television set	150-400
110-volt bulbs (10)	1000
Airconditioner	3500
Electric iron	500-1200
Toaster	1000
Water heater	2500-4000
Hotplate (per burner)	800-1000
Battery charger	200-300
Vacuum cleaner	200-800

Once you know the amount of output you need, pick a generator that runs on your choice of fuel. Depending on your need, you can order a generator powered by an engine that runs on gasoline, diesel fuel, LP gas, natural gas, or a combination of gasoline or natural gas. Yes, you can get a new Onan with a natural gas-gasoline carburetor which will handle *either* type of fuel. ★★



One-man U-boat

A new, one-man fiberglass submarine was recently demonstrated in Munich. The sub, powered by two electric motors, can dive to about 150 feet and remain four or five hours.



Need people? Build 'em!

Hiring 50,000 extras to fill the stands for filming scenes in *The Games* would have been prohibitively costly, so the film company made its crowd by molding plastic figures.



Underwater escape suit

Shooting out of the water (above) is a petty officer demonstrating a new submarine escape suit used by the British Navy. To escape from a sunken sub, a crewman puts on the suit, inflates it with air and shoots to the surface. The demonstration was conducted from a submarine 150 feet down.

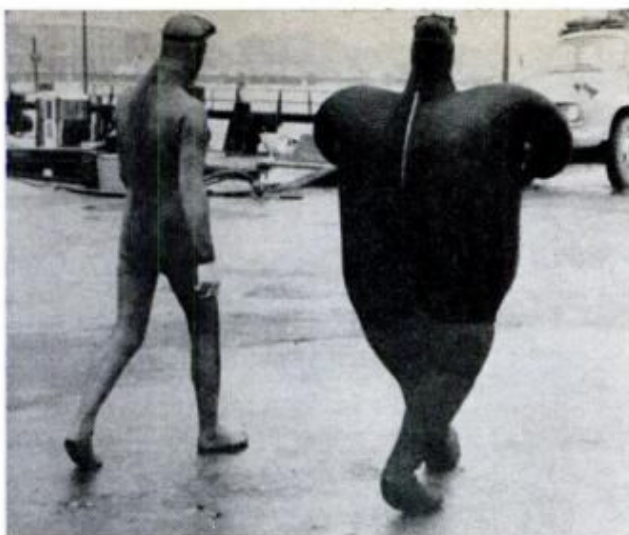

Shape up, mate

The suit at right is the same as the one at left, except that the Danish Navy frogman inside is demonstrating how the suit can be blown up with air from pressure bottles so that it turns into a buoyant lifejacket.

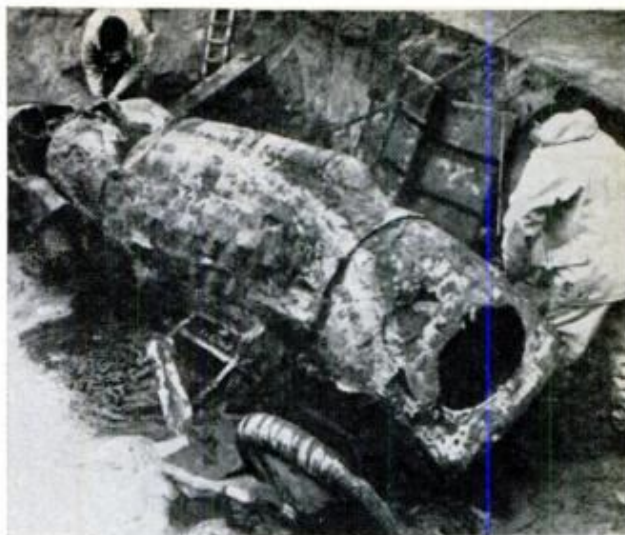

Resurrected machine

Being lifted from the grave where it was buried in 1927 is the racing car in which Parry Thomas was killed on a speed-record attempt. Friends interred the car as a mark of respect. The 400-hp racer will be restored.



Hitchhiking buggy

Bonanza's new Minibuggy is designed to fit inside a station wagon so it can be carried easily to driving sites. A 15-hp engine moves the 300-pound buggy up to 40 mph.



Clip-on camper

With a Caraboot camping outfit added, this Mini Traveller gains a sleeping room for two on top and sitting room and kitchen behind. The bedroom roof converts to a rowing dinghy.



It's mine, all mine

The technical center of Medusa Portland Cement Co. is located in an abandoned limestone mine at Wampum, Pa. Maintaining a comfortable air temperature in the 40-room center is easy; the mine stays a constant 54° F. and needs only heat and dehumidification.



How to Have TV in Every Room in the House

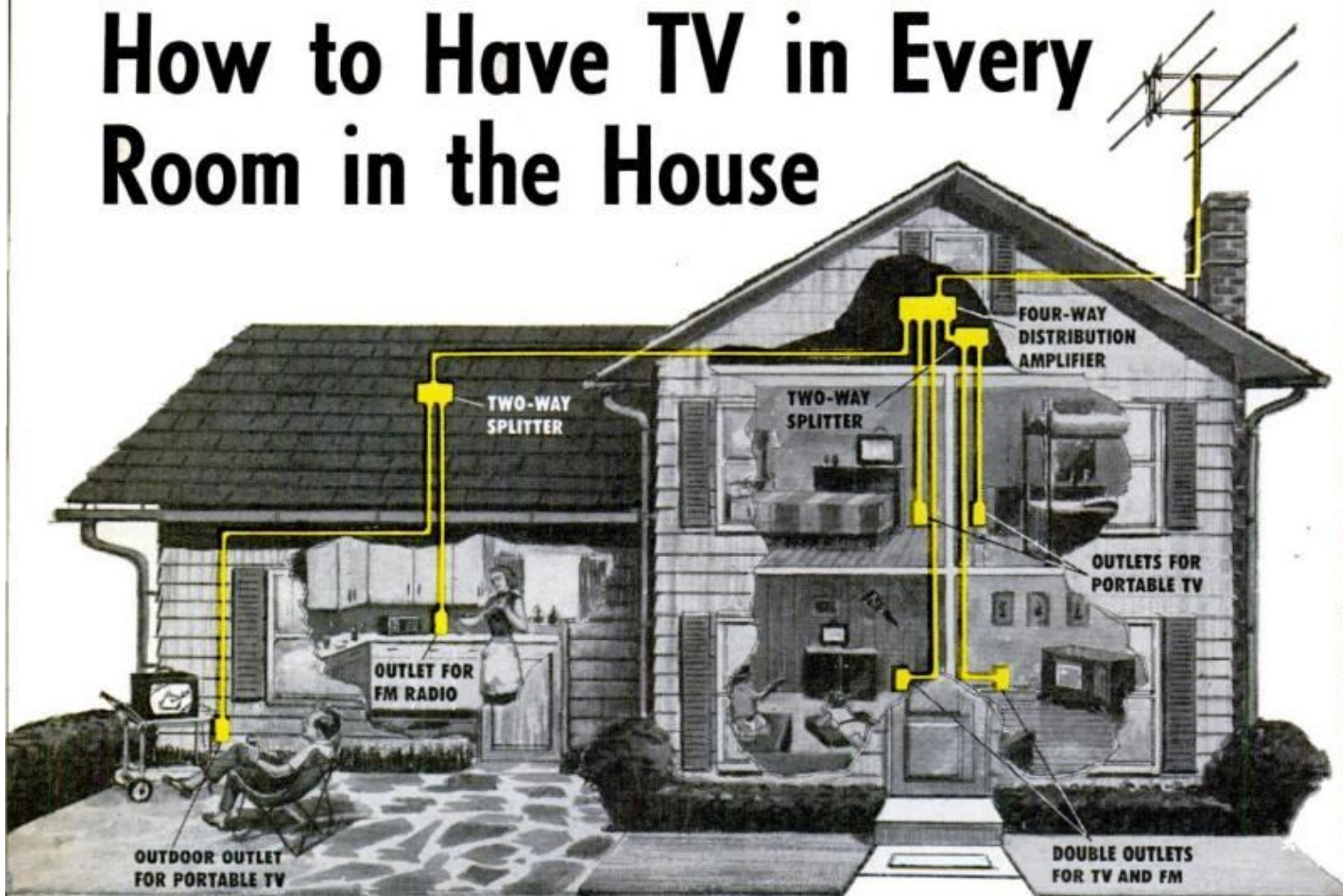

A master antenna system will let you operate two or more sets simultaneously in different locations and give you extra outlets anywhere you want them. Here's how to work out a plan to suit you and your home

By FOREST H. BELT

Photos by Robert D. Borst

YOU PROBABLY OWN more than one TV set or soon will. It's estimated that 18 million homes already have two or more sets, with the number increasing every day. New color sets are coming along to bump the old black-and-white into a playroom or den. Often there's a third, portable set that's lugged around from room to room.

If you're operating these extra sets without a rooftop antenna, chances are you're not getting as good reception as you could. You don't have to install a separate antenna for each set, though. The answer is MATV—Master Antenna Television. This is a system that lets you connect two, four, eight or even more TV sets to a single antenna without any loss of signal or interference between the sets.

Apartment buildings use MATV sys-

tems to feed antenna signals to hundreds of sets. You can install a miniature version in your own home. You need only a few pieces of equipment and some connecting cable. Not only will such a system feed several sets simultaneously, but it will let you watch TV anywhere you want. You can have an antenna outlet in every room—even outdoors. Connecting a TV is as simple as plugging a lamp into a wall socket. You can enjoy the luxury of watching the Late Show in bed or a ball game out on the patio while relaxing in the sun. When a youngster wants to see something, he can pack a portable off to his own room and leave you undisturbed.

Because FM frequencies fall within the TV range, they can be picked off the same antenna. A MATV system makes it possible to split the FM and TV signals so

WHAT YOU NEED FOR A MASTER ANTENNA SYSTEM

TYPICAL BRANCH-LINE HOOKUP

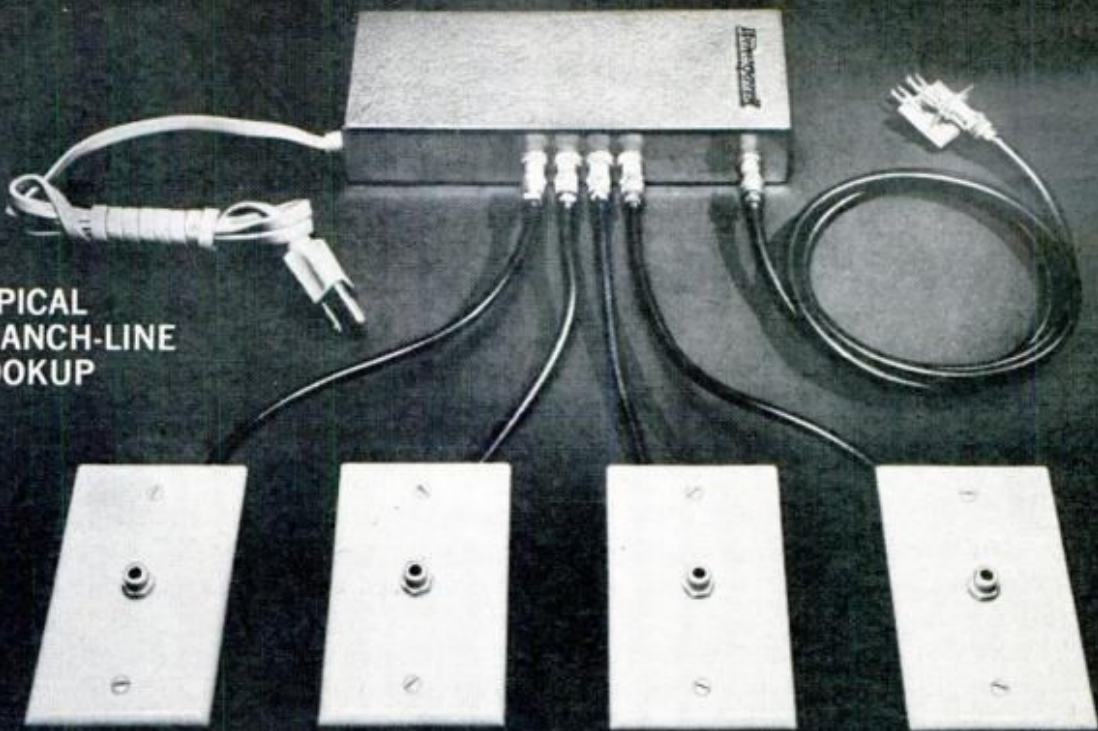

YOU CAN FEED FOUR TV SETS simultaneously from a single antenna with a setup like this. The amplifier at top connects to the antenna and has four

outlet terminals for running branch lines to wall outlets in four different locations. Fifth terminal at right is for the input line from the antenna



DISTRIBUTION AMPLIFIERS

BASICALLY SIMILAR, distribution amplifiers are available in a variety of makes and models. Those here are all four-way types designed to feed four

TV outlets. Makers are, from left to right, Finco, Winegard, JFD and Jerrold. Amplifiers are powered by house current, need a nearby outlet to plug into

TV AND FM WALL OUTLETS



DESIGNED TO FIT standard electrical wall boxes, antenna outlets come in several styles to suit different needs. One at left provides single 75-ohm tap for a TV set. Combination outlet at center has

a 75-ohm tap for TV and 300-ohm terminals for an FM radio. At right is a dual outlet with one tap for either FM radio or TV and a multi-conductor receptacle for plugging in an antenna rotor control

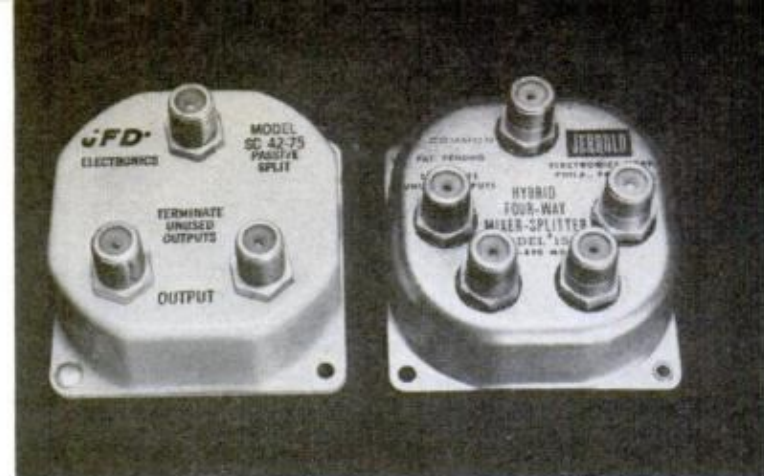

INSIDES OF A TYPICAL amplified coupler look like a miniature radio chassis. This transistorized Finco model has one input at the top for antenna lead and four outputs at the bottom for branch lines

PASSIVE SPLITTERS divide antenna signals, but add no amplification. They can be combined with amplifiers to add more branch lines. Left to right above are two-way JFD model and four-way Jerrold

you can feed them to different sets. FM reception is often improved, especially on stereo, because the signal, in addition to being split off, is given a boost in power. Color TV, which also needs a powerful signal, frequently benefits in the same way from the installation of a MATV system.

merely isolates the receivers; it doesn't boost or amplify the TV signal. In fact, it introduces a slight loss as it divides the signal in two.

Most TV-antenna manufacturers and electronic-supply houses sell the parts for a MATV system. You can have all sorts of hookups. The first thing to decide is how many outlets you're going to need. If you just want to connect two TV sets to one antenna, you can buy what is called a passive splitter. This connects to your antenna's download and provides two outlets for running branch lines to two receivers. It's called "passive" because it

A passive splitter is all right if you have a sensitive antenna or live in a strong signal area where the loss won't be noticed. If your signal is questionable or you want a whole string of outlets throughout the house, you're better off with an amplified coupler, also known as a distribution amplifier. This contains a miniature electronic amplifier that gives the signal a boost to overcome the loss of splitting. In some cases, the signal reaching the set is actually stronger than when it arrived at the antenna.

Distribution amplifiers come in different models depending on the number of out-

3 WAYS TO ADD EXTRA OUTLETS FOR TV AND FM

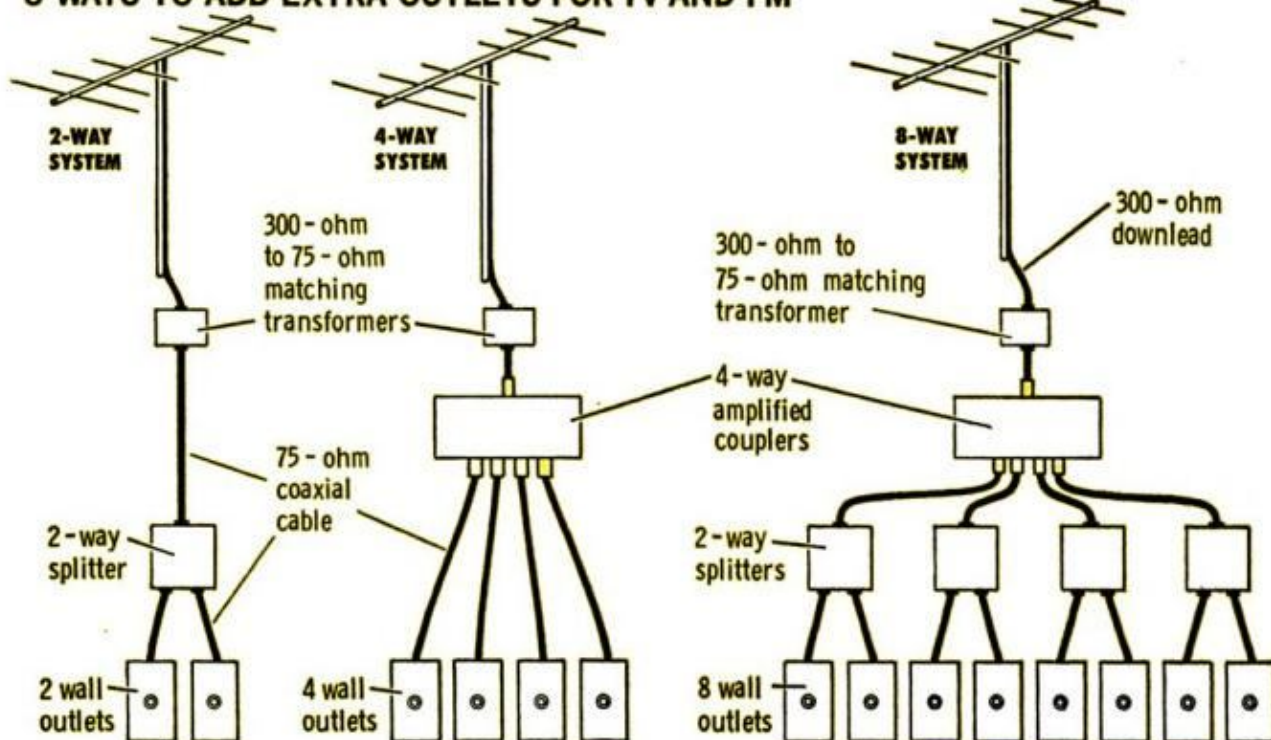

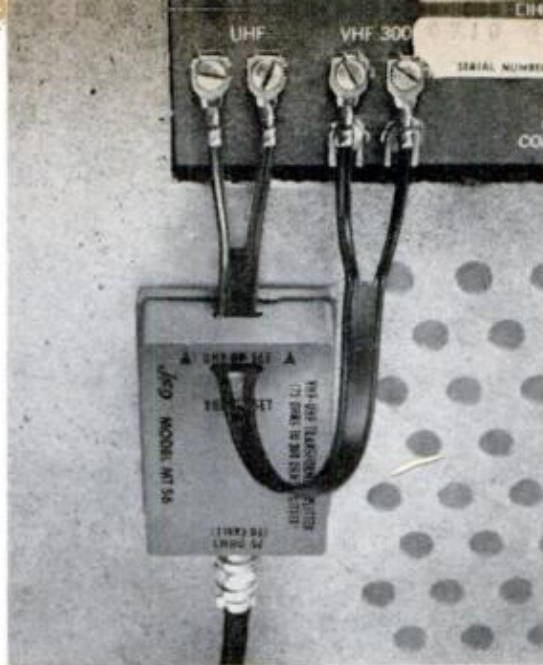

MATCHING TRANSFORMERS like this JFD model mount on back of TV and convert 75-ohm antenna-line impedance to 300 ohms for receiver. They also split VHF and UHF signals



HANDY ACCESSORIES for installing a master antenna system are shown above. At left is a short 75-ohm coaxial cable for hooking TV set to a wall outlet. It comes with connectors attached and a matching transformer. At center is a 100-foot roll of coaxial cable with an antenna-matching transformer on one end and set-matching transformer on the other. At right is a separate kit of matching transformers without cable. Accessories are made by Winegard

lets you want. One of the most common types for home use is a four-way coupler that gives you connections for four branch lines. If you need more outlets, you can install a splitter in each branch line, dividing it in two and giving you a total of eight lines. Or you can connect additional amplifiers to the first amplifier, providing even more capacity.

Splitters and amplifiers can be combined in almost endless arrangements to give you the number of outlets you want. The accompanying diagram shows a few typical arrangements.

The second decision to make is on the type of connecting cable to use. You have a choice between familiar flat, 300-ohm twinlead and newer 75-ohm round coaxial cable. Coaxial cable is more expensive, but is less bothered by electrical interference because it is surrounded by shielding. It also is more rugged and longer lasting. It does however, require a sensitive antenna and a powerful distribution amplifier as it introduces more signal loss than 300-ohm twinlead. Its advantage is that you can run it anywhere, even along

(Please turn to page 200)

BUYER'S GUIDE TO MULTI-SET TV ANTENNA SYSTEMS

Models listed are for 75-ohm systems. 300-ohm equivalents are available.

Maker	4-Way Amplified Couplers	2-Way Passive Splitters	Antenna-Matching Transformers** (300-75 ohm)	Set-Matching Transformers (Split UHF and VHF)	Cable Kits With Connectors	Single Wall Outlets (For TV only)	Double Wall Outlets (For TV & FM)
Blonder-Tongue*	DA4 U/V	A102 U/V	(Not needed)	4539		3649	3650
Finco (Finney Co.)	M-118	M-204	7512-A	7520	CX-283 (50, 75, 100 ft.)	M309	M304
JFD Electronics	PC4782-CD	SC42-75	(Included with PC4782-CD)	MT56	CS-81 (10, 50, 75, 100 ft.)	TT-7575	TF-3030
Jerrold	TAC-4	1596	CAT-2	FSX-1314	CAC (50, 75, 100 ft.)	UT-18	UT-13
Winegard	BC-782	CS-775	T-283M	MSJ5	CL-50, CL-75, CL-100 (50, 75, 100 ft.)	T-77	T-32

*300-ohm system only. **Not needed with 75-ohm antenna.

Manufacturers' Addresses: Blonder-Tongue Laboratories, Inc., 9 Alling St., Newark, N.J. 07102.
 Finney Co., 34 W. Interstate St., Bedford, Ohio 44014.
 JFD Electronics Co., 15th Ave. at 62nd St., Brooklyn, N.Y. 11219.
 Jerrold Electronics Corp., 401 Walnut St., Philadelphia, Pa. 19105.
 Winegard Co., 3000 Kirkwood St., Burlington, Iowa 52601.

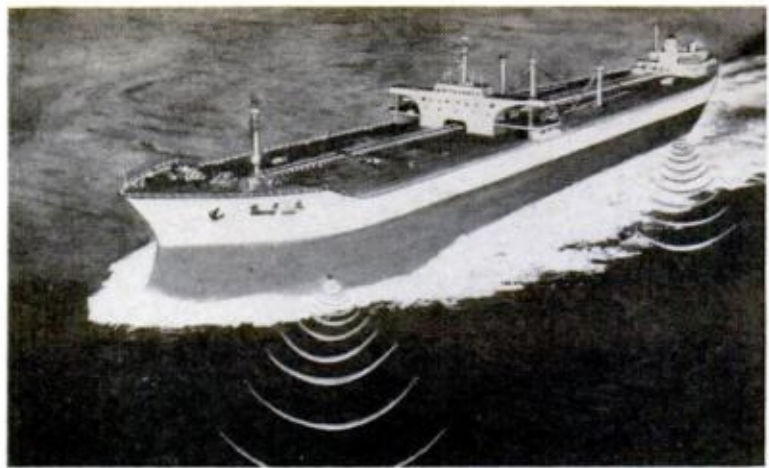
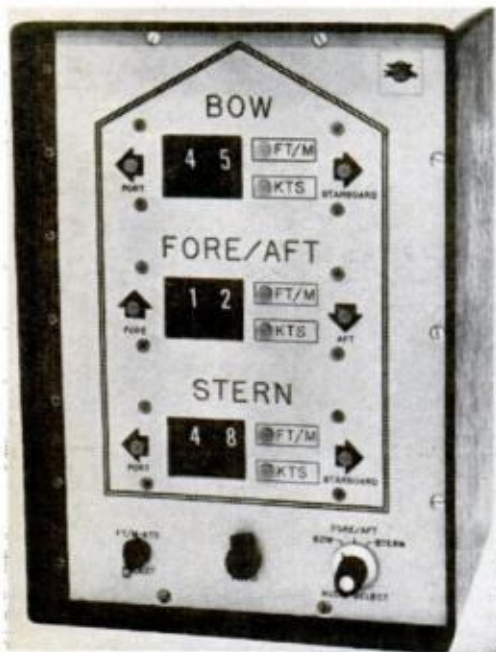

Docking help for supertankers

Skippers of giant new ships will get help in docking from Edo Western's "Navtrack" Docking System. Bouncing sonar signals off the bottom, the gear gives a readout in feet per minute (left) of the ship's fore-and-aft speed and of the lateral movement of bow and stern. Figures indicate actual over-the-bottom speeds.



British-French rocket seeks out radar targets

Martel, a rocket developed by the British and French, seeks out radar stations and destroys them. At left, a rocket leaves a Mirage jet fighter; at right is the destroyed target.

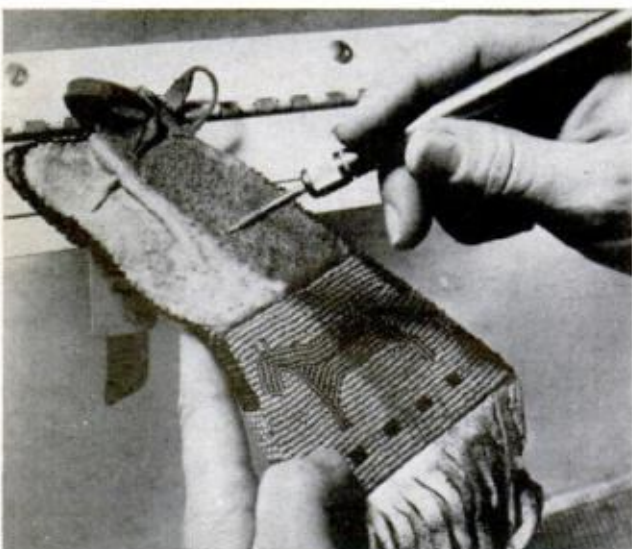

Airborne beads clean leather

Valuable Indian leatherwork in the Smithsonian Institution is safely and effectively cleaned by tiny glass beads propelled by an 80-p.s.i. air blast through this nozzle.

One for the road

Fixed to a rod that is inserted into a car's lighter socket, the Paluxette coffeemaker brews two cups in 15 minutes—then pivots on the rod for easy pouring.



Desert flame thrower

When weeds began to take over the irrigation canals of the Wellton-Mohawk Irrigation Div. of Yuma, Ariz., shop workers put together this flame thrower to fight back. The device mixes diesel fuel and air to produce a flame that keeps canal banks free of weeds.



The Earth in fiberglass

Newly charted undersea terrain is shown in relief on the 6-foot, 3-inch fiberglass globe at the American Museum of Natural History.

AUGUST 1969



Custom built for backs

A driver can tailor his car seat for best back support with "Lumback," which consists of two pillows that cling to a perforated plastic cloth on the back of the car seat.



Start of a quasar-watcher

Under construction in Germany is one of the world's largest radiotelescopes. It will be used for observing quasars.

131

How to Check Out Your

Electric-start and manual-start are the easiest systems in your motor to troubleshoot and the simplest to repair.

By HENRY B. NOTROM

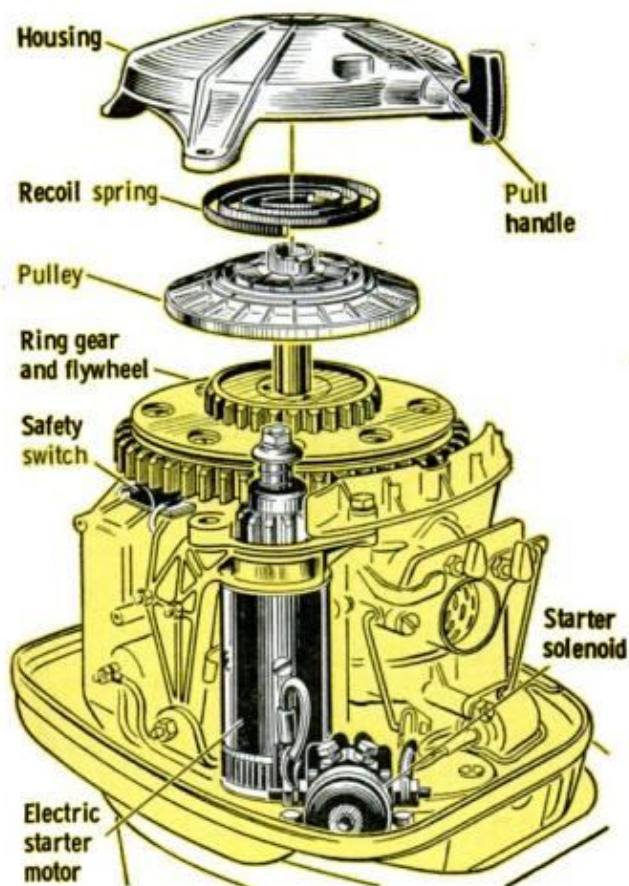

UPPER THREE PARTS are used in manual-start systems, the lower parts are used in electric-start systems.

1. REMOVE PAWLS from starter housing (some are shown in lower part of housing). Check them for wear

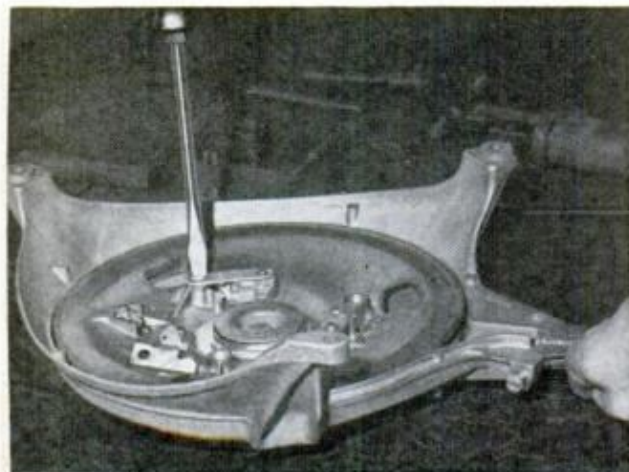

OUTBOARD MOTORS have manual starters or electric starters, or both. We'll explain how to repair a manual starter first; then we'll talk about electric.

Most outboard motors employ a manual starter of the type similar to that shown in the drawing (left).

Manual starters are extremely reliable. Most will last the life of an outboard motor if treated properly. The commonest problem is a damaged rewind spring. This happens most often when the operator steps back and gives the rope a yank that

This is the second of five articles that will give you a ready-made service manual for your one and two-cylinder outboard motors. Clip and save them.

exceeds its length. It's also possible for the rope to break, but this isn't as common as some people believe. Starter ropes are exceedingly strong.

You'll need a spring rewind tool to repair a manual starter. It costs about \$5. You'll also need a rope-threading tool to pull the rope through the handle. It costs a few cents.

You must be very careful in handling

2. REMOVE SPINDLE from housing. Hold housing and pulley together until ready to separate the two



Starting System

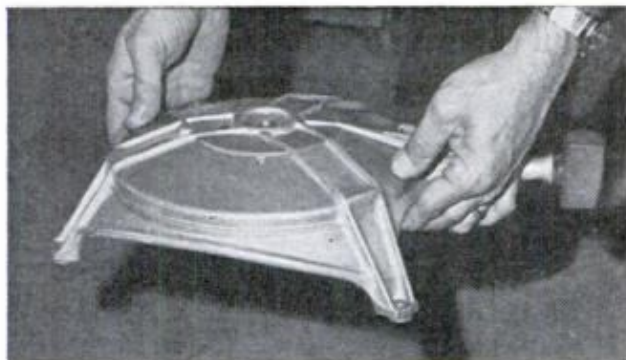

3. DROP ASSEMBLY. Step back quickly to avoid being struck by rewind spring located in the assembly

manual starter repairs. The rewind spring is under great tension and could cause serious injury if allowed to fly loose. Wear safety glasses. Also make sure you hold the starter housing and pulley parts firmly together once the connecting spindle has been removed. This will prevent the rewind spring from slipping loose.

Here is how to repair a manual starter:

1. Remove the attaching screws holding the starter housing to the powerhead and lift the housing from place.

2. Remove the pawl retainers, pawls, spindle, and friction ring (Photos 1 and 2). Examine the pawls. If worn, replace. Note how parts come out of the housing so that replacement will be simplified.

3. Now, drop the starter, bottom side down, on the floor (Photo 3). This will separate the housing, pulley and spring (Photo 4).

5. REWIND TOOL is needed to reassemble spring into pulley. Crank until spring is tight. Insert dowel



AUGUST 1969

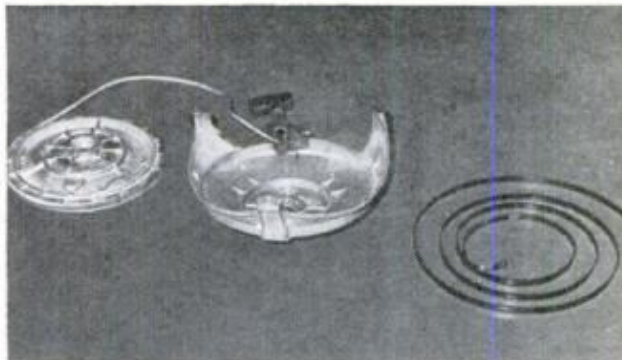

4. THE THREE MANUAL-START PARTS can be worked on. If there's an "S" in the spring, untwist and reuse

4. If it isn't broken, pull the starter rope out far enough for you to tie a slipknot. Then pry open the rope anchor and remove the rope.

5. Spread some Type A lubricant on the end of the rope to allow easy removal of the handle.

6. Replace a damaged starter rope or rewind spring.

7. To put the starter back together, insert the base plate of the rewind tool into a vise. Place the starter pulley in position on the base plate, making sure that the center pin fits into the center loop of the spring. Insert the tool's bushing and handle into the pulley and base plate, and crank up the rewind spring (Photo 5).

8. When the spring is tight, release it slowly until you're able to slide the dowel pin through the hole in the pulley and into the spring loop. This pin holds the spring

6. DOWEL PIN, inserted in pulley, holds spring in place until pulley is fitted into starter housing

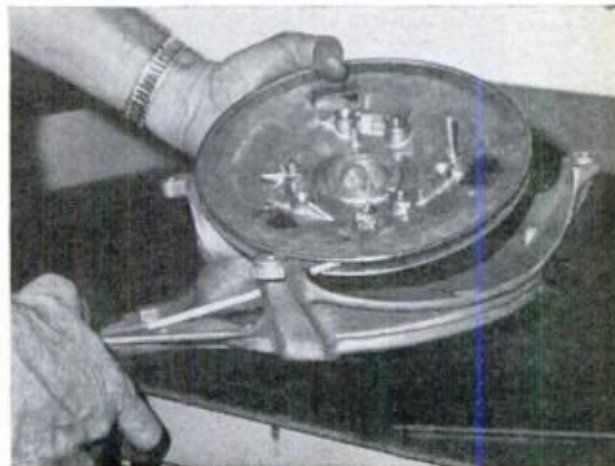

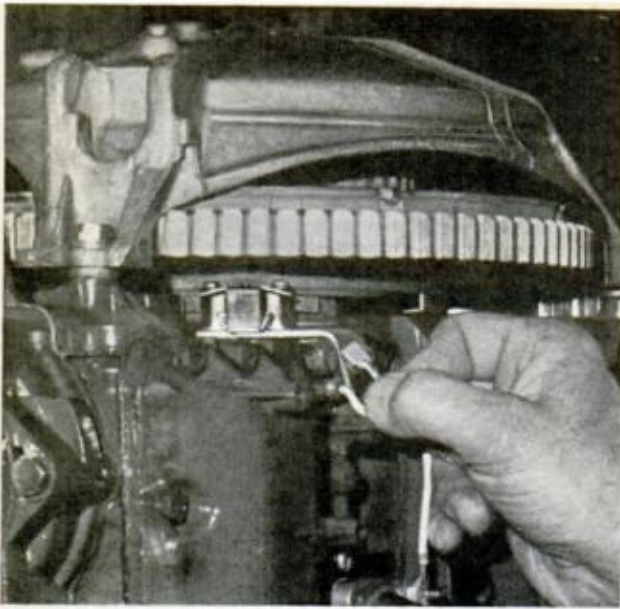

7. GROUNDING SAFETY-SWITCH WIRE should make motor operate. If not, the switch could be bad

in place while you reassemble the starter.

9. Lubricate the spring with some Type A grease and place the pulley and spring into the starter housing, making sure that the outside spring loop is on top of its stud in the housing (Photo 6). Press down so the stud forces the dowel pin out.

10. Tie a slipknot into the rope to keep it from winding up. Now, reassemble the starter.

11. A tough job is usually that of putting the handle back on the rope. If the rope is too stiff, use plenty of lubricant.

Next is the repair of an electric starting system which consists of a storage battery, starter motor, starter solenoid, safety switch and cables. This is a very easy system to troubleshoot, and it's one of the simplest in your entire outboard engine to repair.

To do the work, you should be equipped

with a battery hydrometer to test battery condition and a voltmeter to check the voltage drop of the starter motor. The voltmeter should be graduated in tenths of a volt, but it doesn't have to be an elaborate instrument.

You will need a "growler" for testing starter-motor components if the motor has to be disassembled. However, I wouldn't advise buying this instrument, which costs about \$30, for the rare time you might need it. First, check your local rental center—A to Z, or the like—to see if you can rent one. If not, try to borrow one from the gas station with which you do business. Growler testing takes only two minutes.

If you can't borrow a growler, take the starter motor to a starter repair shop and get it tested. Cost: about \$3.

How do you know when you have a problem in the starting system? Either the starter won't function or it will grind away very slowly (r-r-r-r-r) without the engine starting.

Should you experience a malfunction, such as starter grind or no-start, the cause could be loose or dirty electrical connections. The next most likely cause is a weak battery, followed by a defective starter solenoid or a bad safety switch. Seldom will you experience a breakdown within the starter motor itself although it can happen.

At the first sign of a starter-system failure, remove all electrical connections at the battery, starter solenoid and starter motor. Scrape them clean with a wire brush. Then reattach them firmly, making sure that attaching bolts are securely fastened.

Coat connections with liquid neoprene

8. THE SAFETY SWITCH is usually held in place by one bolt. This is easy to remove and to replace

9. THE PLUNGER of the safety switch is so positioned that it actually rides on cam seen at lower left

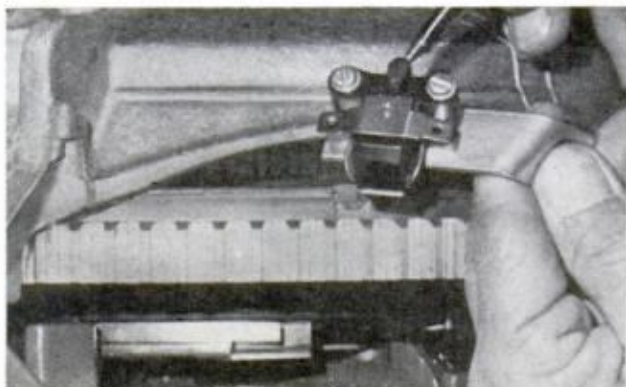
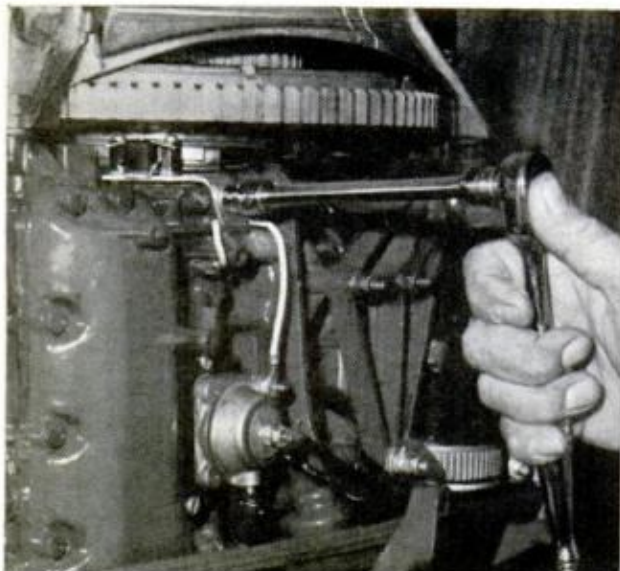

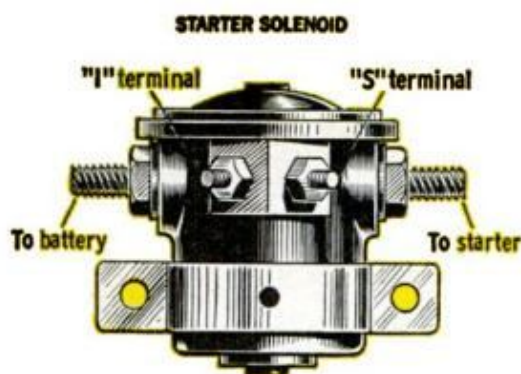

10. STARTER SOLENOID (above) is the key to the electric-start system. Jumper wires (right) connected to the solenoid terminals help you to determine whether or not the solenoid is in good condition

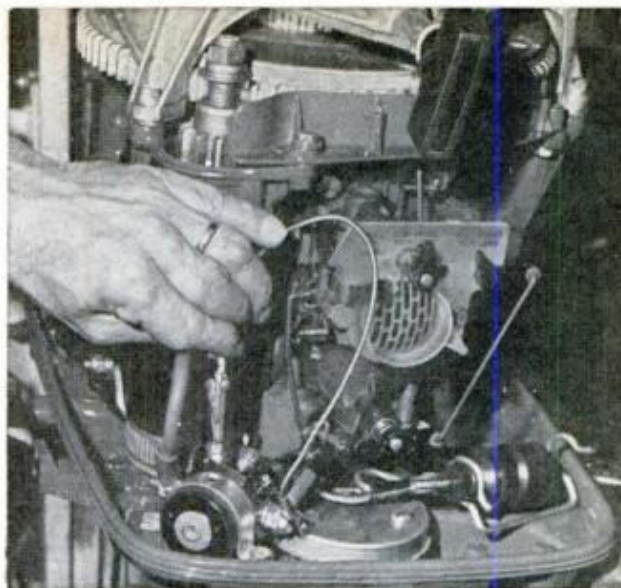

to seal them and prevent further corrosion. Liquid neoprene can be purchased from a dealer of marine supplies.

Next, check the battery by taking a specific gravity reading of the electrolyte with a battery hydrometer. In selecting a hydrometer, buy one that has a built-in thermometer and correction chart.

To take a specific gravity reading, draw electrolyte from each cell in turn. Be sure that the hydrometer float is free, hold the hydrometer at eye level, and note the reading. Be sure to return the electrolyte back to the cell from which it was taken.

The specific gravity of a fully charged battery is 1.260, but a battery with a specific gravity of 1.150 could start your motor. However, if specific gravity is this low, have the battery charged. If charging does not result in an increase in specific gravity in each cell, the battery has just about had it.

Now go to the safety switch and starter solenoid. The purpose of the safety switch is to prevent the engine from starting in gear and in neutral at too high an rpm. The switch also completes the ground circuit of the starter solenoid.

The starter solenoid makes and breaks the electrical circuit between the battery and the starter motor. If the safety switch or starter solenoid fails, there will be no starting.

To check the functioning of the safety switch, disconnect the starter terminal wire. There's only one wire. Hold the wire terminal to ground, bypassing the safety switch, and activate the ignition (Photo 7). If you get starter-motor action, it means the safety switch is either out of adjustment or is bad.

To readjust the switch, loosen it and work it back and forth (Photo 8). Place the switch's plunger on the cam of the armature plate (Photo 9). Try starting. If there is still no start, replace the safety switch.

To check the starter solenoid, place a jumper wire from either the "s" or "i" terminal to ground, and connect another jumper from the solenoid's battery terminal to either the "s" or "i" terminal—that is, the terminal not possessing the grounded jumper (Photo 10). Turn on the ignition. If the solenoid switch is in good condition, you'll hear it clicking away and the starter motor will crank as you activate ignition. If not, replace the starter solenoid.

Before replacing the safety switch or starter solenoid, there is one test you'd better make. There's always the possibility—*(Please turn to page 194)*

11. TURNING THE ARMATURE of the starter motor in growler is the best way to check for malfunctions

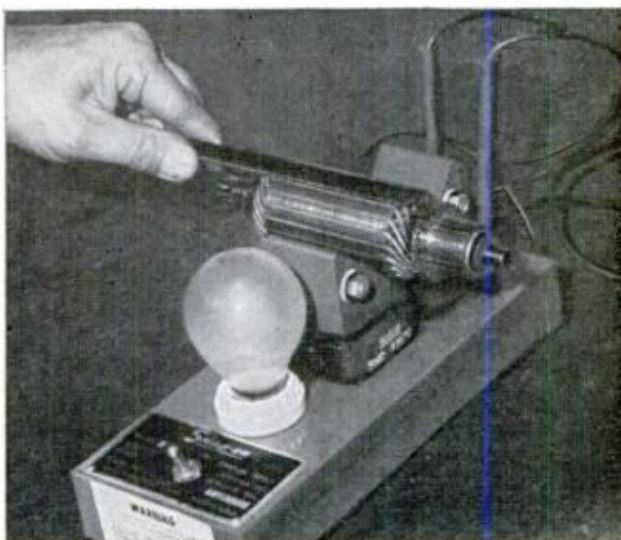

NEW IN

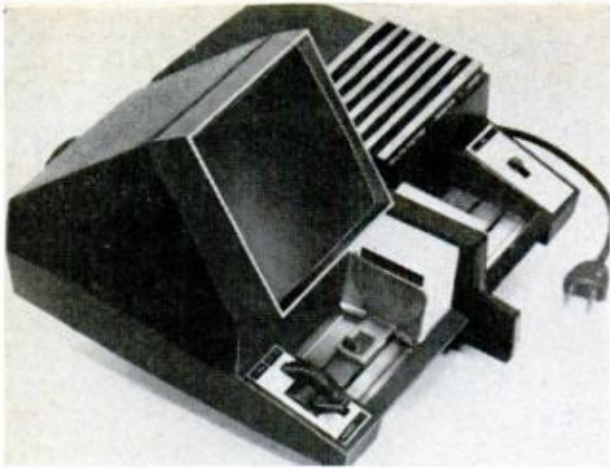

YOU CAN VIEW SLIDES and project them at the same time with the new two-way Sawyer's model above. For editing or previewing slides, the images appear on a built-in translucent screen. Flipping a switch converts the machine to a projector for showing slides on a large screen. The stack loader holds 36 slides. \$29.95. GAF Corp., 140 W. 51st St., New York.



INSTAMATIC OWNERS who have long been wanting a fast black-and-white film now have it. Kodak's Tri-X film, rated at ASA 400, now comes in 12-exposure cassettes. It should be used only in more advanced models, however, so check with a dealer before trying it in yours.



THIS BABY TANK lets you develop 35-mm film in broad daylight right in the cartridge. You slip the cartridge onto a spindle, insert it in the developer, then twirl the spindle back and forth to agitate the film. Pixmat tank comes with developer for \$1.98 in 20-exposure size, \$2.25 for 36 exposures. Burleigh Brooks, 44 Burlews Ct., Hackensack, N. J.



YOU CAN WASH ROLL FILM in four minutes with this handy tank. Jets of water feed into it from a hose connected to a faucet. As the water rushes in, a siphon effect draws in air through tiny holes, creating a turbulent bubbling action. This agitates the film and speeds the removal of fixer. Dirty wash water drains off at the top. Different models for 35-mm, 120 and 220 reels are \$22.95 to \$37.95. Pfefer Products, 6232 Atoll Ave., Van Nuys, Calif.



ACCESSORY LENSES for Instamatic cameras give you a telephoto or wide-angle effect even though the cameras don't take interchangeable lenses. The supplementary elements slip over the existing lens. Telephoto and wide angle are each \$10.95; sizes fit all Instamatic models. An auxiliary viewfinder is \$7.50. Kalimar, 2644 Michigan Ave., St. Louis, Mo.

PHOTOGRAPHY

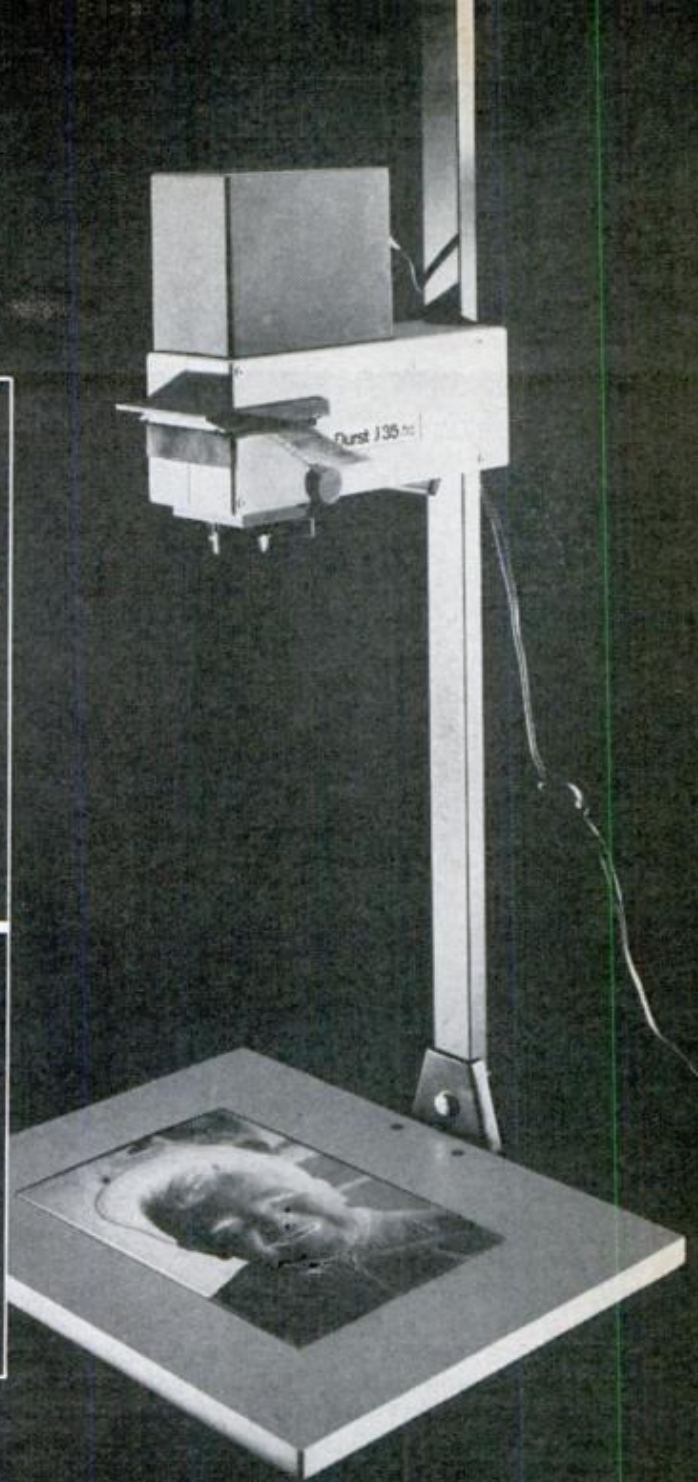
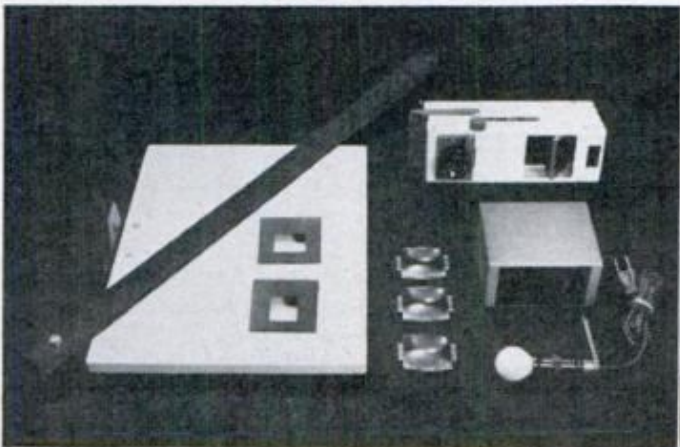
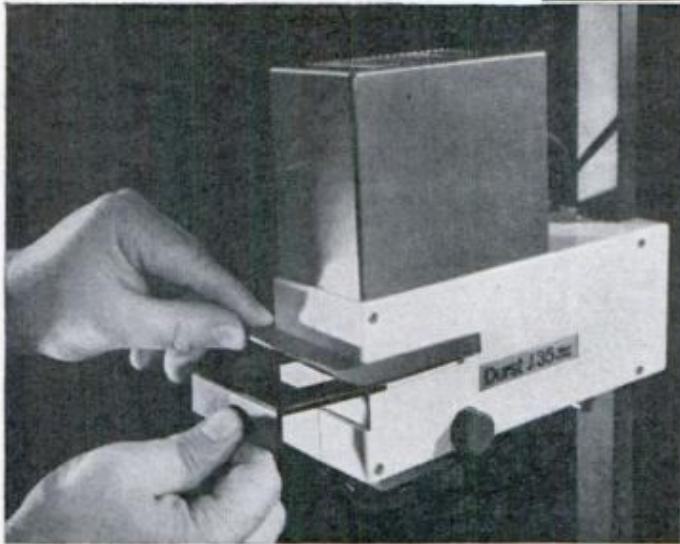

Looking for a

Low-Cost Enlarger? Here's One for Under \$37

If you'd like to make occasional blowups of your snapshots without a heavy investment in complicated equipment, here's an ideal answer. It's a low-cost enlarger designed especially for small-format negatives. It will take either 35-mm film or the 126 size produced by inexpensive Instamatic cameras. Enlargements up to 8x10 inches can be made in the conventional way on the baseboard. For bigger blowups, you can project images onto the floor by reversing the column so the enlarging head hangs over the edge of a table.

The enlarger comes knocked down, as shown in the lower photo at left, and can be assembled in a few minutes. To save space,

you can quickly disassemble the rig and store it in a closet or bureau drawer whenever it's not in use. The optics consist of a three-lens condenser system that produces surprisingly bright, sharp images. The enlarging head slides up and down on the column to vary the magnification from 1.8 times to 10 times. For focusing, there's a smooth rack-and-pinion adjustment with dual knobs, so you can use either hand—just as on big enlargers.

Interchangeable negative carriers—one for 35 mm and one for 126—slip easily into the head, as in the upper photo at left. Price for the Durst J35 enlarger is \$36.95. Durst, Inc., 623 Stewart Ave., Garden City, N.Y.

Hot Tips on

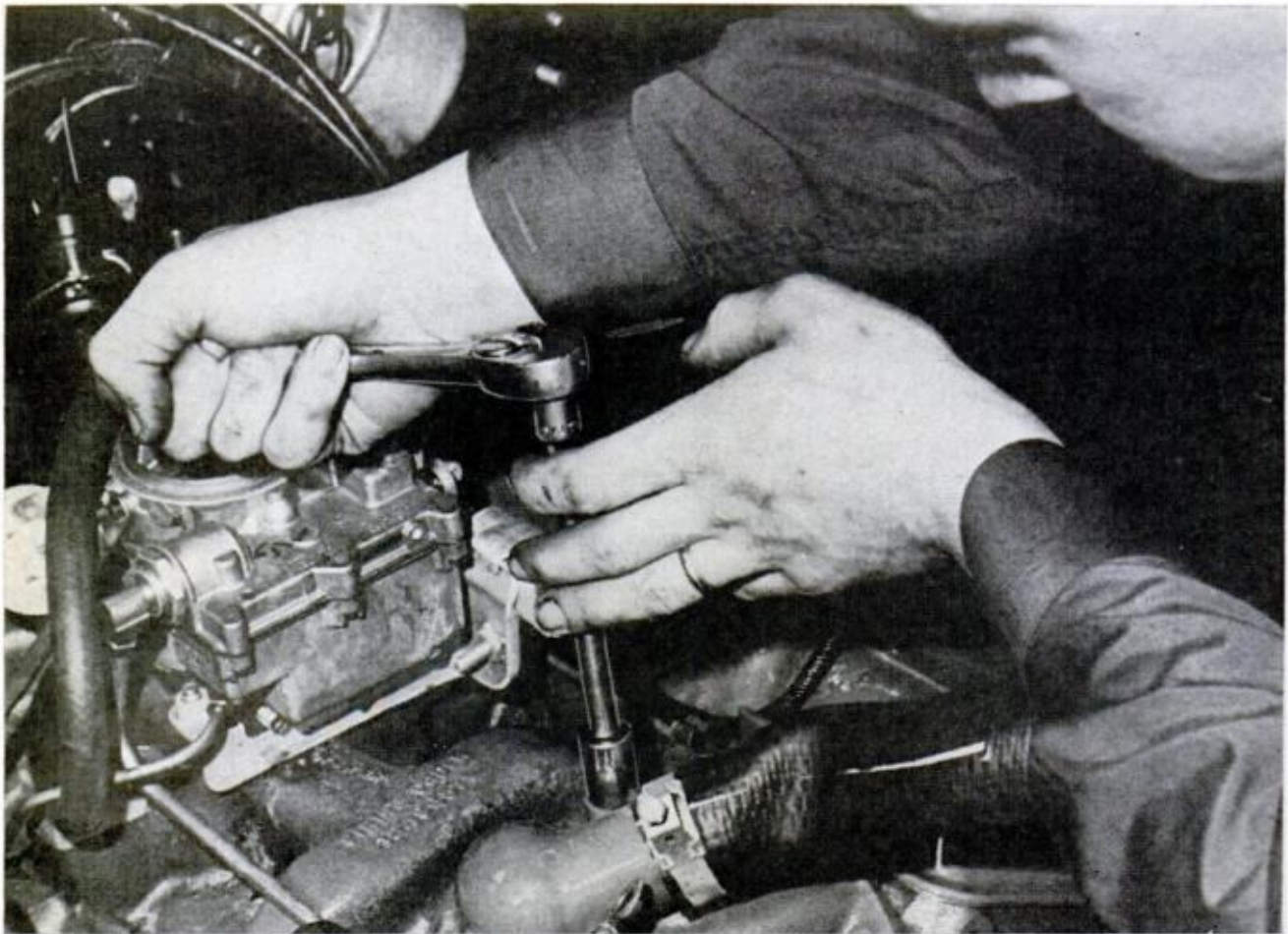

THERMOSTAT HOUSING, where top radiator hose connects to engine block, is removed for access to thermostat. Check for proper temperature operation. Radiator pressure tester checks cap for pressure rating. Tester also attaches to radiator neck to pressurize entire system in test for leaks

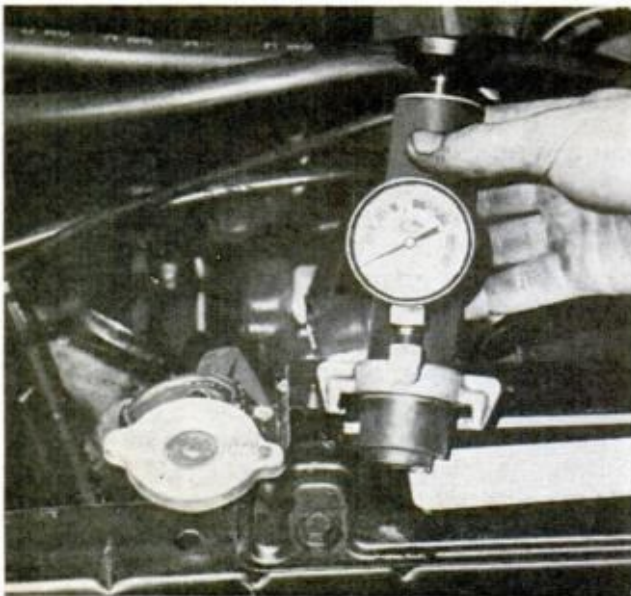

WHEN YOU STAND BACK and watch your radiator erupt like a geyser you feel pretty helpless. Don't let it happen ever—or again as the case may be. A little conditioning for your cooling system once a year will make the possibility quite remote.

Start with your radiator pressure cap. The cap allows pressure to build up in the cooling system. When a liquid is put under pressure, its boiling point increases. Radiator pressure caps raise the boiling point of coolant by about 3°F. for each pound of pressure for which the cap is rated. Thus, a 15-lb. pressure cap increases the boiling point of the coolant by about 45°. This is enough to keep the engine from overheating during periods of extreme heat load, such as when driving long hours at superhighway speed.

To test the cap, you'll need a radiator and pressure-cap tester. It costs about

Engine Cooling

\$15, but maybe your service station will check it as a courtesy. No harm in asking.

First, wash the cap in clean water and attach it to the tester. Pump up pressure to its stamped rating. If pressure drops, the cap is faulty and should be replaced.

Make sure the cap you buy carries the same model number as the old one. There are different types. What works in your neighbor's car probably won't in yours.

When you test the cap, check the radiator filler neck for foreign matter and nicks that could keep the cap from seating properly. A strip of emery cloth or wire brush will get rid of minor nicks.

Most radiator leakage problems are due to failure of soldered joints. They can be repaired.

Attach the pressure tester to the filler neck and pump it up to the pressure stamped on the cap. If pressure drops rapidly, inspect external parts for leaks. Replace a leaking hose or water pump.

If a radiator is leaking, you can try a stop-leak and sealer chemical. Be sure to follow instructions on the package, but keep in mind that this is a temporary fix for small leaks. Leaks along seams, around the filler and outlet necks, or around drain cocks will have to be plugged permanently by resoldering.

Now, if there is no external leak, but pressure continues to drop during the test, inspect the engine oil by means of the dipstick to determine if coolant is leaking into the crankcase. If the oil looks white, you have a cracked cylinder block or, if lucky, a leaking head gasket.

You can use the tester to check for combustion leakage into the cooling system, too. Warm the engine to operating temperature and install the tester. With engine running, pump the system up to the cap's rating. A fluctuating tester-dial needle indicates a combustion leak.

If torquing of the cylinder head to specification doesn't stop this fluctuation, replace the cylinder-head gasket. Don't allow a combustion leak to continue. Gases leaking into the cooling system combine



COOLING SYSTEM LEAKS, otherwise difficult to detect, are quickly revealed when entire system is put under pressure with radiator pressure tester. Check water pump as possible source of cooling system leak. As shown below, area around diaphragm should be inspected with system under pressure

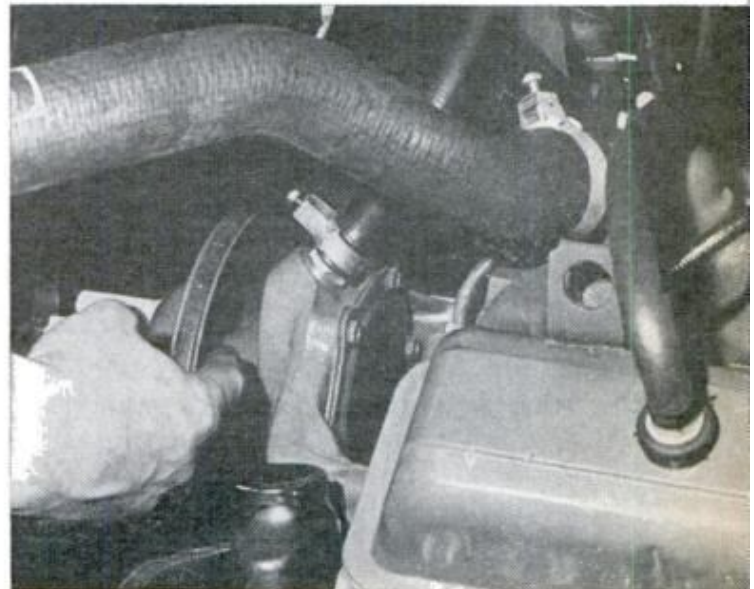

with coolant to form acid that eats away at cooling system and engine parts.

Check for coolant circulation by warming the engine to operating temperature and then shutting it off. Feel the radiator. It should be hot at the top and warm at the bottom, with an even temperature rise from bottom to top. Cold spots indicate a clogged section. A good cleaning, described below, should clear it.

To check functioning of the water pump, run the engine and squeeze the upper radiator hose. If you feel pressure surges, the water pump's okay. By the way, most water pumps have a vent that can get plugged and hamper operation. Clean it out before condemning the pump.

Once a year you should flush and clean the system even though you use a so-called "permanent" antifreeze. It contains rust inhibitors that lose their effectiveness in a year's time. You can use a good cleaning solution to flush out the system. Follow package instructions carefully, and always flush out thoroughly with water.

Fill the system with clean water. Open the heater control fully, so the heating system is flushed, too, and run the engine long enough to open the thermostat—say, for a good 30 minutes. Drain by opening all drain points.

Now, fill the system with fresh coolant. You should use a good quality ethylene glycol antifreeze mixed with water to provide protection to minus 20 F. This solution does a couple of things as well in summer as winter.

First, a good-quality ethylene glycol contains inhibitors which help to prevent rust. Secondly, it guards the system against overheating—a summer problem. Water boils at 248°F. in most cooling systems. But a 44 percent ethylene glycol, 56 percent water solution (protection to minus 20°) boils at 264°F. This difference could be a critical factor. *Never* use straight, undiluted ethylene glycol. It doesn't dissipate heat as rapidly as a mixture of ethylene glycol and water, for one thing, and you'll be wasting money.

Your hoses, although they may not be leaking, could be rotting inside, sending particles into the system. Feel the hoses. Replace any that are soft and spongy.

When replacing a hose, clean the pipe connection with a wire brush and apply a nonhardening rubber-hose sealing compound, such as Permatex, which you can

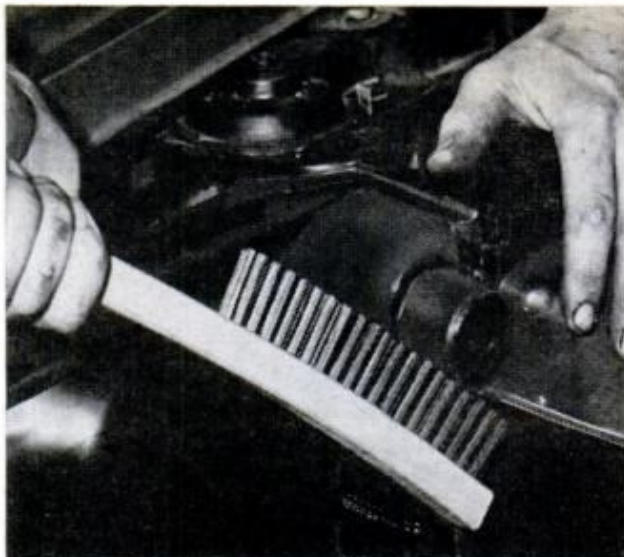

HOSE CONNECTIONS are important for a tight cooling system. To insure a good seal, clean inlets and outlets; use a nonhardening sealing compound



HOSE CLAMPS, if they are the screw-down type, should be tight for a good connection. Using a ratchet wrench is easier than using a screwdriver

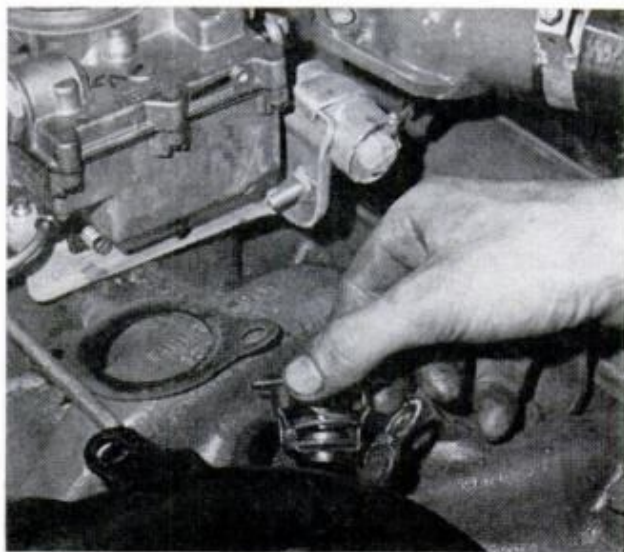

THERMOSTAT is lifted from its seat for inspection and testing (see text). Gasket came off in one piece but should be replaced nevertheless

buy at an auto supply store. Secure clamps tightly; a pressurized cooling system can blow a hose right off its seat.

Here's another tip. The lower hose from engine to radiator contains a spring coil that keeps it from collapsing under high pressure. If your car suddenly starts to overheat at high speed for no reason, replace the hose. The spring may have lost tension.

Check your thermostat next. This is especially important if your car has an idiot light instead of a water temperature gauge. You can't tell if the engine is operating at correct temperature, since most of these lights go off at 125°.

Before adding fresh coolant to the system after cleaning, take the thermostat from its housing and place it in water

which is heated to a temperature that is 25° above that stamped on the thermostat housing. Agitate the water thoroughly to get even temperature distribution throughout, and watch the stat valve. It should open fully.

Remove the stat and place it in another bucket of water which is 10° below the specification. Again agitate and watch the valve. It should close. If not, replace the stat with a new one. Even if you reinstall the same part, use a new housing gasket.

The radiator overflow tube, usually rubber, hangs from the filler neck down the side or back of the radiator. It lets excess coolant leave the system. Be sure the tube is there and in good shape.

By the way, never remove the radiator cap when the engine is at or near operating temperature. *Check coolant when the engine is cool.* When the radiator cap is removed, the cooling system is no longer under pressure and the coolant will start to boil. You'll lose coolant out the top or out the overflow tube.

You'll also lose coolant out the overflow tube if you overfill the radiator. When it's filled above the recommended level, usually one inch below the filler neck with the engine cold, no room is left for expansion. Overflowing coolant may lead you to think your car's overheating.

Removing foreign matter from radiator fins is important for proper cooling. Bugs and leaves can obstruct the flow of air through the radiator core. Blow out the core with compressed air from the rear.

A slipping fan belt prevents the water pump from circulating sufficient coolant. Make sure belts are in good shape and tightened to specification. And, don't forget to set ignition timing. Timing, especially overadvanced timing, can cause an engine to run hot.

Finally, don't forget the possibility of *overcooling* when winter comes. This condition can cause partial fuel combustion and crankcase oil dilution. If allowed to continue, cylinders, rings, pistons and bearings can suffer.

Overcooling most often results from a thermostat stuck in open position. The coolant isn't kept in the engine long enough for it to warm up. Signs of this are an increase in fuel consumption and sparkplug fouling. If plug tips are black or sooty, combustion is not complete, possibly due to overcooling. ★ ★ ★

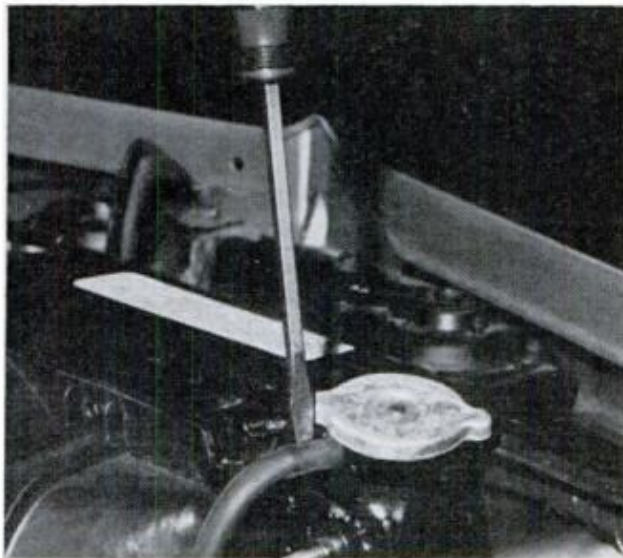

RADIATOR OVERFLOW TUBE extends from the filler neck down the side or back of the radiator to relieve the system of excess coolant when necessary

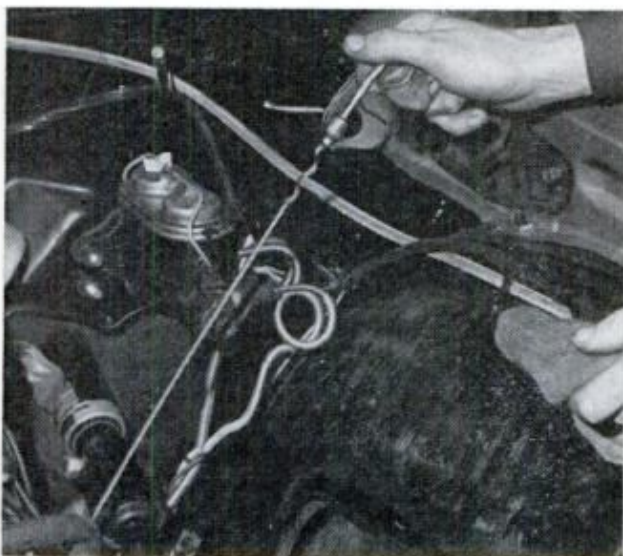

ENGINE CRANKCASE should be checked in case of a mysterious loss of coolant. Oil will be whitish if coolant's leaking through crack or past gasket



RECORD CHANGER and FM/FM-stereo receiver are stacked together in a space-saving piggyback design in this Knight-Kit compact by Allied. Wiring is simplified by printed-circuit boards and easily joined subassemblies (upper left)

Hi-Fi Compacts

BY JOHN A. LINKLETTER and SHELDON M. GALLAGER

THE GROWING POPULARITY of the stereo compact is bringing with it a new breed of kit—a build-it-yourself home entertainment center that combines virtually all of the basic hi-fi components you need in a single, stylishly designed package. Two of these kits, assembled by *PM* editors, are the Knight-Kit KG-980 above, sold by Allied, and the Heathkit AD-27 shown on the opposite page.

Both units consist of a solid-state FM/FM-stereo receiver and an automatic turntable that plays records singly or in stacks. The receiver also doubles as an auxiliary amplifier for powering other components, such as a tape recorder. The Knight-Kit model is rated at 25 watts per channel and the Heathkit at 15.

The two models offer a choice of different styles. The Knight-Kit is an over-under affair with the turntable squatting on top of the receiver. The Heathkit uses a side-by-side arrangement with the receiver's control panel facing upward next to the turntable. Both come with trim walnut cabinets. An added feature on the Heathkit is a tambour door that slides out to cover the top and front.

Both kits were assembled over a period of several weekends. Construction time ran to about 38 hours on the Heath-

kit and 45 hours on the Knight-Kit. For the first-time kit-builder, the immense piles of parts that emerge as you open the boxes may seem like a staggering undertaking to face, but the work goes smoothly and surprisingly fast considering the complexity of the circuits. One reason is that modern solid-state circuits, while more complicated, are actually easier to wire than older tube circuits. Instead of

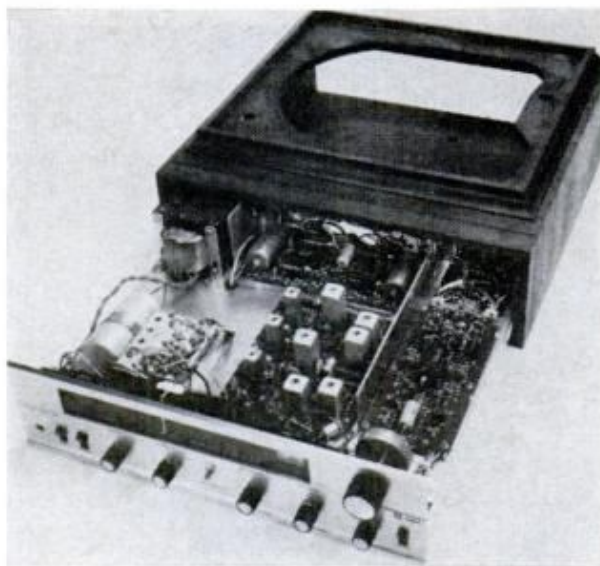

COMPLETED KNIGHT-KIT CHASSIS slides neatly into walnut cabinet like a drawer. Motor on record changer hangs down in open space on top of chassis



SLICKLY STYLED HEATHKIT COMPACT has unusual top-mounted control panel that nestles right alongside the automatic turntable. A disappearing tambour door slides forward from the rear to cover the top and front, keeping out dust and giving a trim appearance

You Can Build From Kits

Those nifty space-saver radio-phono hybrids now come in knockdown versions you can assemble yourself. Here are two that offer kit-building fun as well as cost savings

fumbling around in a cramped chassis, you do all your main wiring on three or four printed-circuit boards out in the open where you can reach the parts easily. It then takes only a few wires to join these subassemblies for the final hookup.

The Heath and Knight-Kit instruction manuals are remarkably detailed and easy

to follow. Allied follows its traditional practice of supplying resistors on numbered cards. All you do is look for the right number without having to identify each resistor by its color coding. The Heath manual includes a handy checkout guide for testing resistances before you turn on the power. This way, you aren't likely to burn anything out when you fire up the set for the first time.

The Knight-Kit KG-980 comes with two matching preassembled speaker enclosures for \$339.95. The speakers sell separately for \$75 apiece so you can figure that the compact itself represents about a \$190 value. The Heathkit AD-27 sells without speakers for \$169.95. Speaker enclosures for use with the Heath unit are available in kits for about \$40 to \$60 each.

The phonograph mechanisms come preassembled, and both are four-speed types. The Knight-Kit incorporates a Garrard SL65 and the Heathkit a BSR McDonald 500—both fine turntables. The Knight-Kit KG-980 is available from Allied Radio, 100 N. Western Ave., Chicago, Ill. 60680. The Heathkit AD-27 is sold by the Heath Co., Benton Harbor, Mich. 49022. ★★★

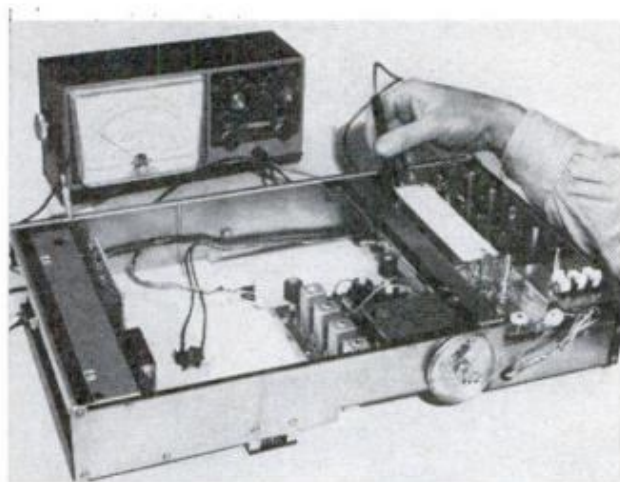

MAKING FINAL CHECKS on Heathkit chassis with an ohmmeter tells you wiring is okay before turning on power. Meter isn't essential, but is an added help

BUILD THIS FOLDAWAY HOBBY CENTER

Compact wall cabinet serves both father and son in providing the ultimate in a place to tinker or get lost in a hobby

By HANK CLARK

Technical Art by Fred Wolff

ANY HOBBY can be twice the fun when you have a place all your own to work. A place that's off limits to other members of the family, that has everything within easy reach and can be closed up for safe keeping when you walk away.

Whatever your hobby—model building, slot cars, electronics, trains or just plain tinkering—this hobby center is the ultimate in a place to work. You can come and go without having to clean up each time; there are shelves, drawers and tool panels galore, and it all folds up into a compact wall cabinet that's only 18 in. deep.

The center is unique in the way it unfolds for work. It has a 24x48-in. "workbench" that lets down like a drawing board, nesting tool-panels that swing out and a bank of drawers that swing with a door to reveal inner shelves for paints, airplane dope and parts. A sound-absorbing pinup board of acoustical tile across

the back lets you stick up what you can't hang up. There's a nook for books and room to display your "works of art." What's more, there's a tray under the hinged drawing-board workbench for storing drawing paper, plans and other drafting essentials, and when the workbench swings up, you have a second pinup board on the underside. A strip line outlet across the back of the work center provides convenient plug-ins for a hand grinder, soldering iron and glue gun.

A handy lamp on an adjustable swiveling arm is attached to the upper shelf so it can be aimed right down on your work. The lids of baby-food jars screwed to the underside of the upper shelf let you store countless small parts in glass jars, and the four large drawers under the counter give you more storage space than you'll know what to do with.

The slanting workbench is supported by

SHALLOW TRAY hinged to underside of drawing-board workbench provides storage for plans, papers

HOW CENTER LOOKS WHEN CLOSED. Celotex bottom in tray provides pinup board for clippings and photos



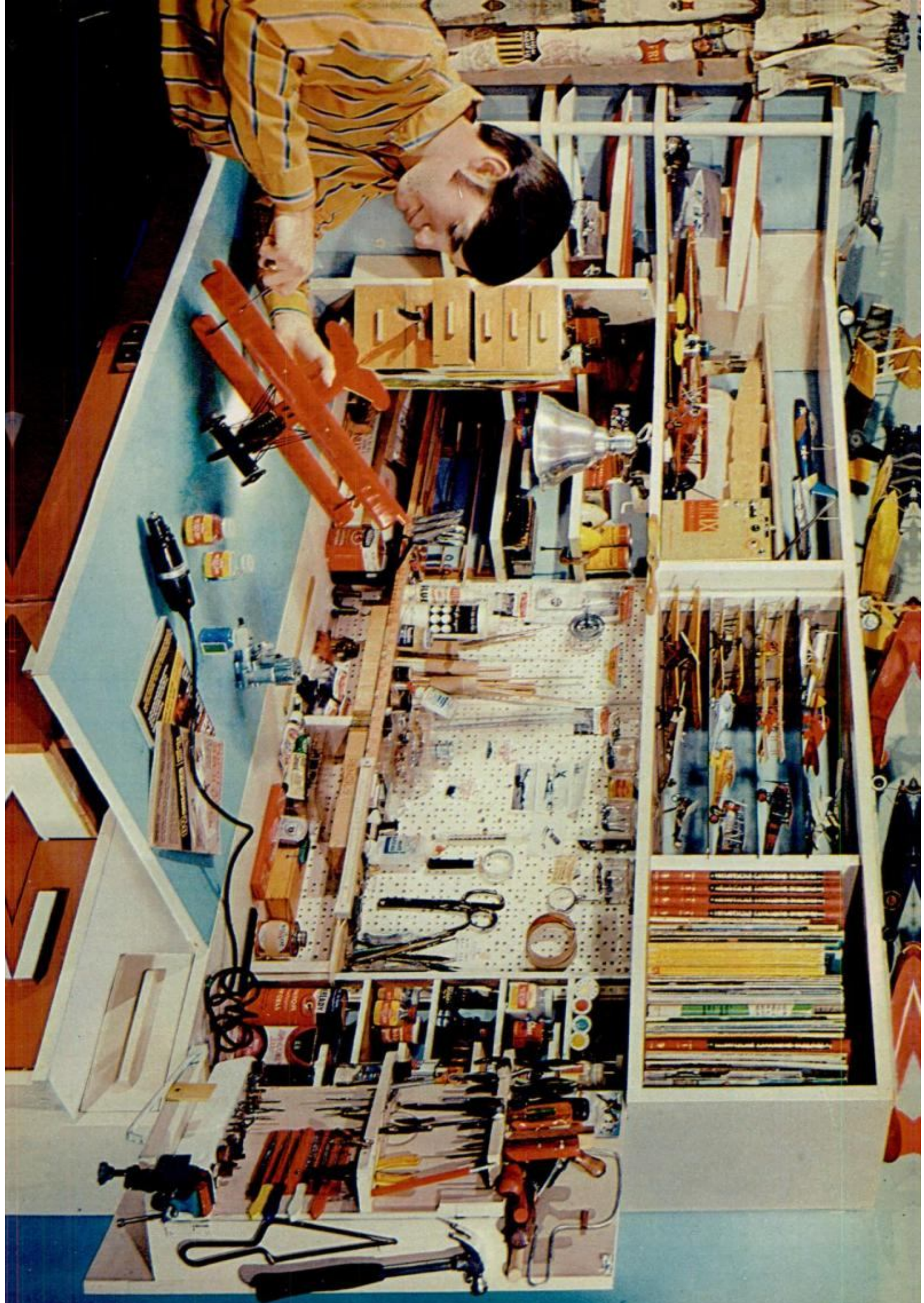

BASIC CONSTRUCTION DETAILS

two drawers which have turnbutton legs attached to the inside. The legs swing down inside the drawers to let you close them. To clear the workbench for swinging it up, materials and work can be pushed back under the 12-in. bottom shelf. A cupboard catch screwed to the upper shelf holds the workbench in a vertical position.

Your hobby center should be a minimum of 6 ft. long to accommodate a 48-in. long workbench. The end pieces of the cabinet are 18-in.-wide plywood and cut back to 11½ in. at a point 29 in. from the lower end. The ends are joined with a 1x12 shelf placed 11 in. down from the top and with an 18-in. wide counter. Then a second 1x12 shelf is placed between the ends, 5 in. above the counter. Next, a 1x6 is placed vertically between the two 1x12 shelves 16 in. in from the right-hand end and flush with the back of the cabinet. Four short shelves are fitted between the 1x6 and the cabinet end. A second 1x6 is installed vertically at the opposite end of the center tool panel and another shelf is placed between the 1x6s, 5 in. up from the lower 1x12. The area above this shelf is filled with a Celotex or cork pinup board.

The slanting workbench in hinged to the edge of the 1x12. When it swings up it laps the two swing-out doors. ★★★

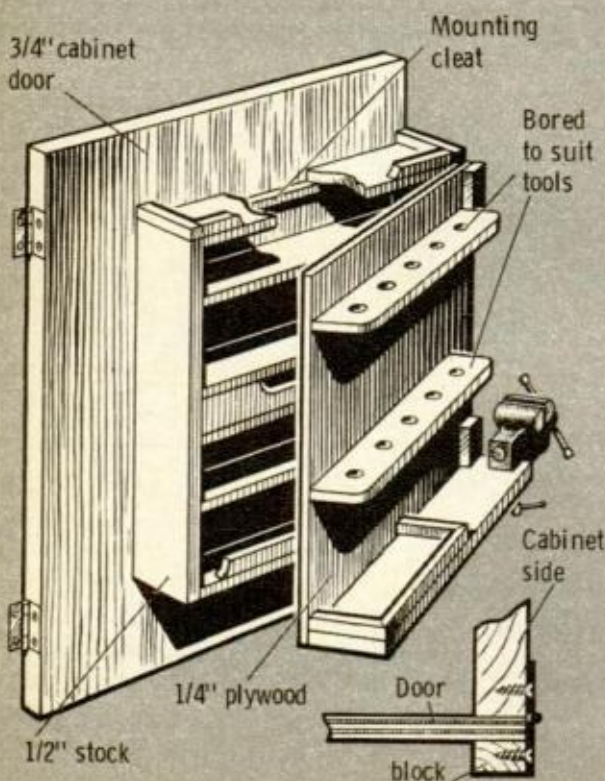
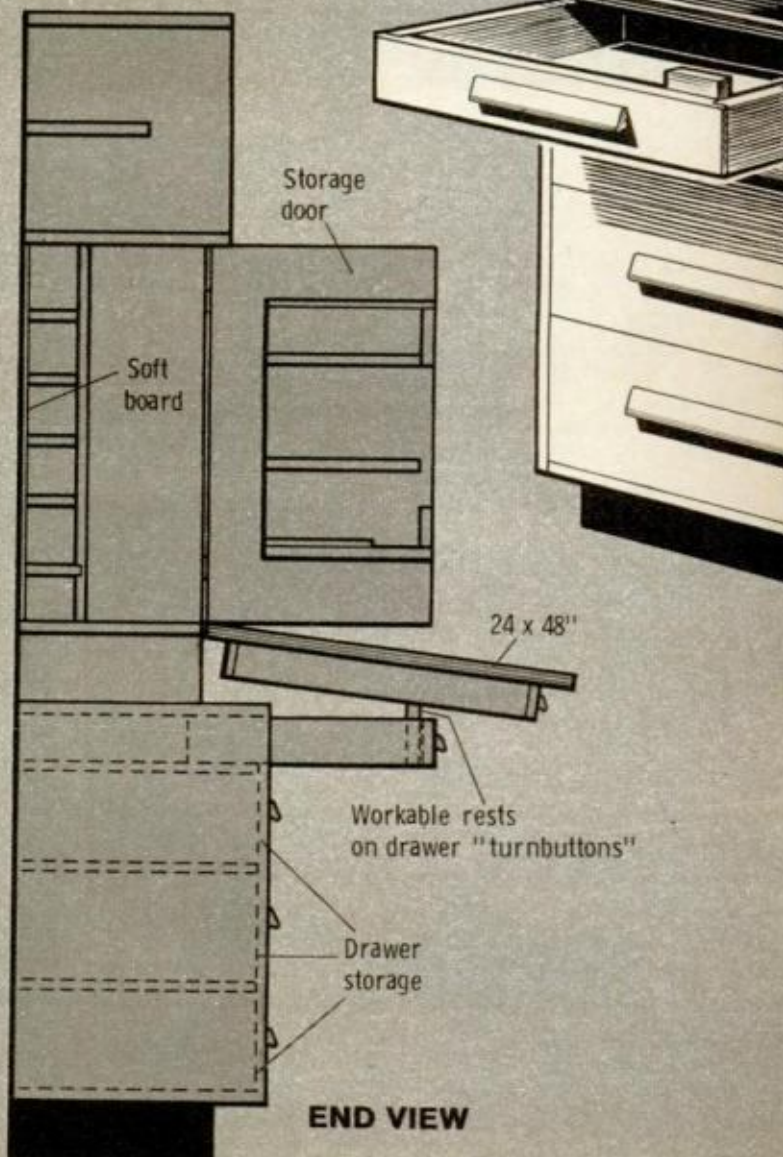
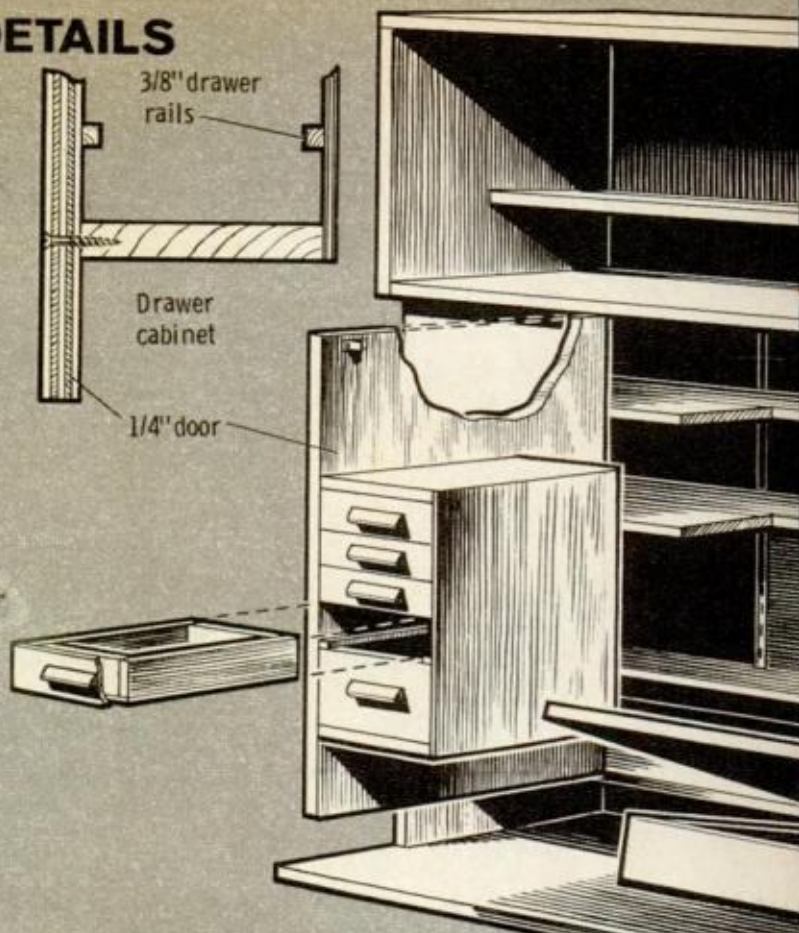

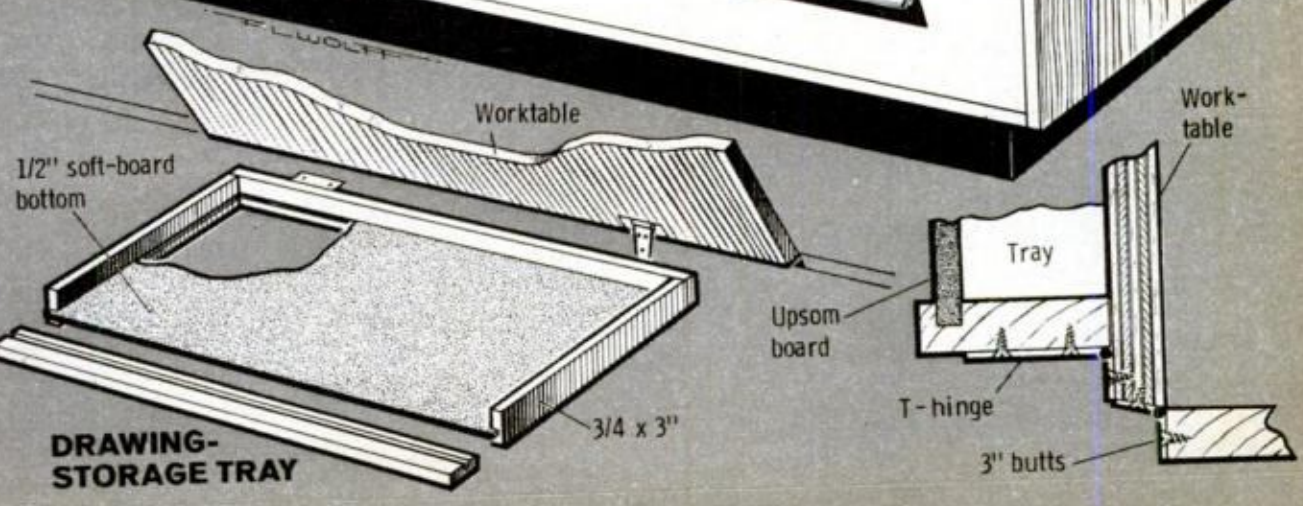
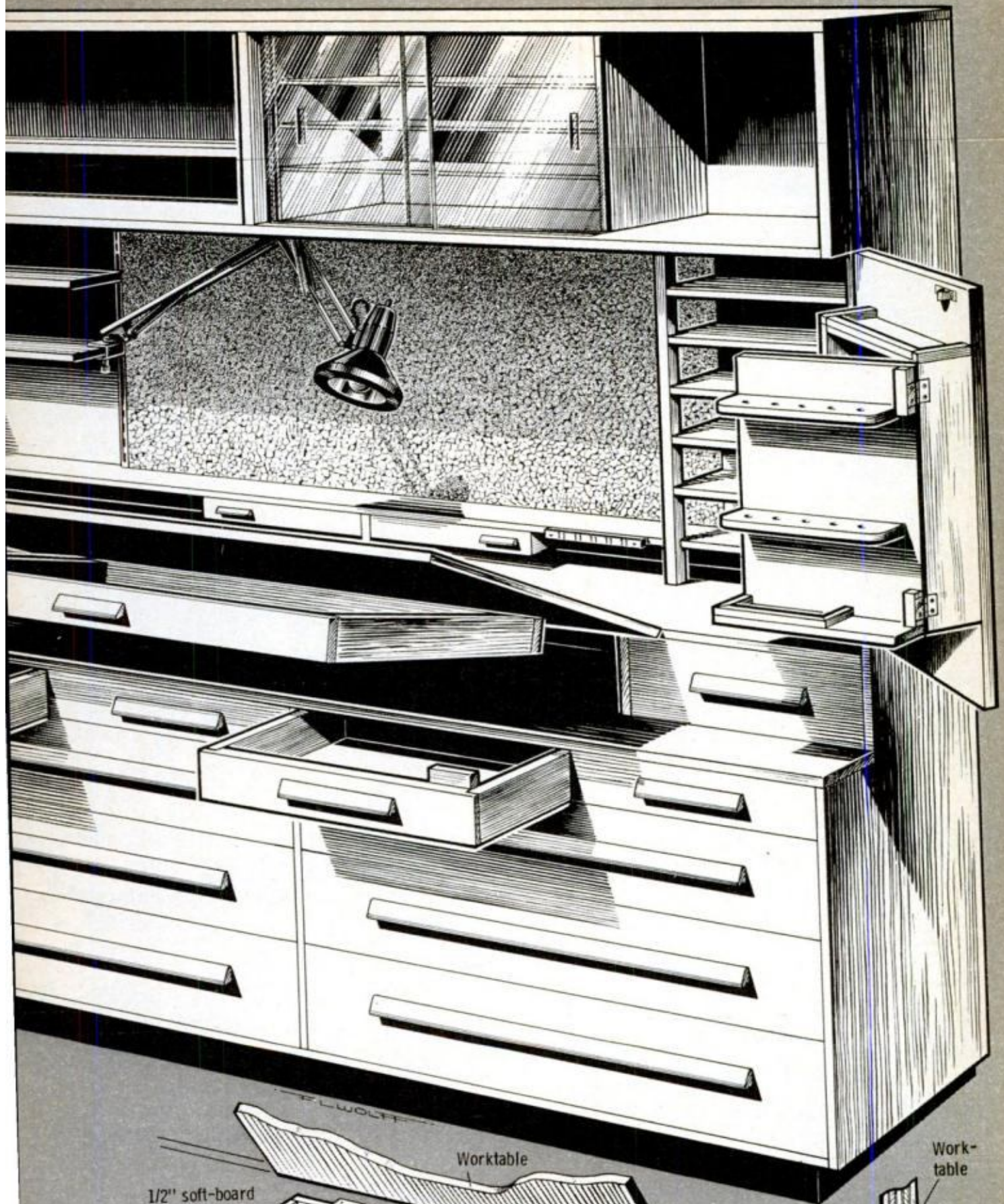

DRAWING-STORAGE TRAY

ALL-TIME GREATS



No. 1: A Game Table For Your Playroom

Great projects never die, but sometimes we forget how popular they were. Here's one that made a hit in PM 11 years ago, updated and restyled for 1969

WHAT MAKES ONE PROJECT more popular than another? Built by more, enjoyed by more? It's hard to say, but over the years there have been extra-special ones that have made such a hit that countless readers have written us and proudly sent snapshots of how they turned out. One such project is this family game table, first published in October 1958. It's truly one of PM's "all time greats." We'll bring you others in the months to come. Readers who remember the original table by John Bergen will notice that we have updated its construction and simplified the job of making it. Basically, it consists of three circular assemblies—a bottom chip-and-glass tray, a center disc and a felt-covered top—all cut from plywood to nest one on top of the other. Start with the center disc. If you have a router, you can cut a perfect circle by tethering it to a strip of wood with a nail in the end. If you don't have a router, use your sabre saw. Four quarter-circle segments are cut from $\frac{1}{4}$ -in. plywood and

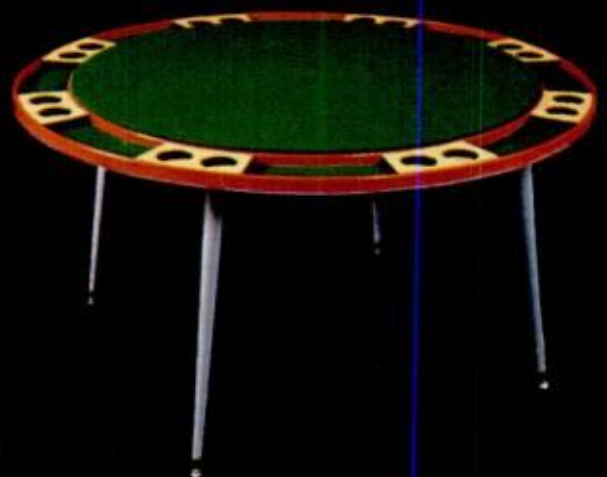

Color Photos by William Aller

PLAN VIEW OF TABLETOP

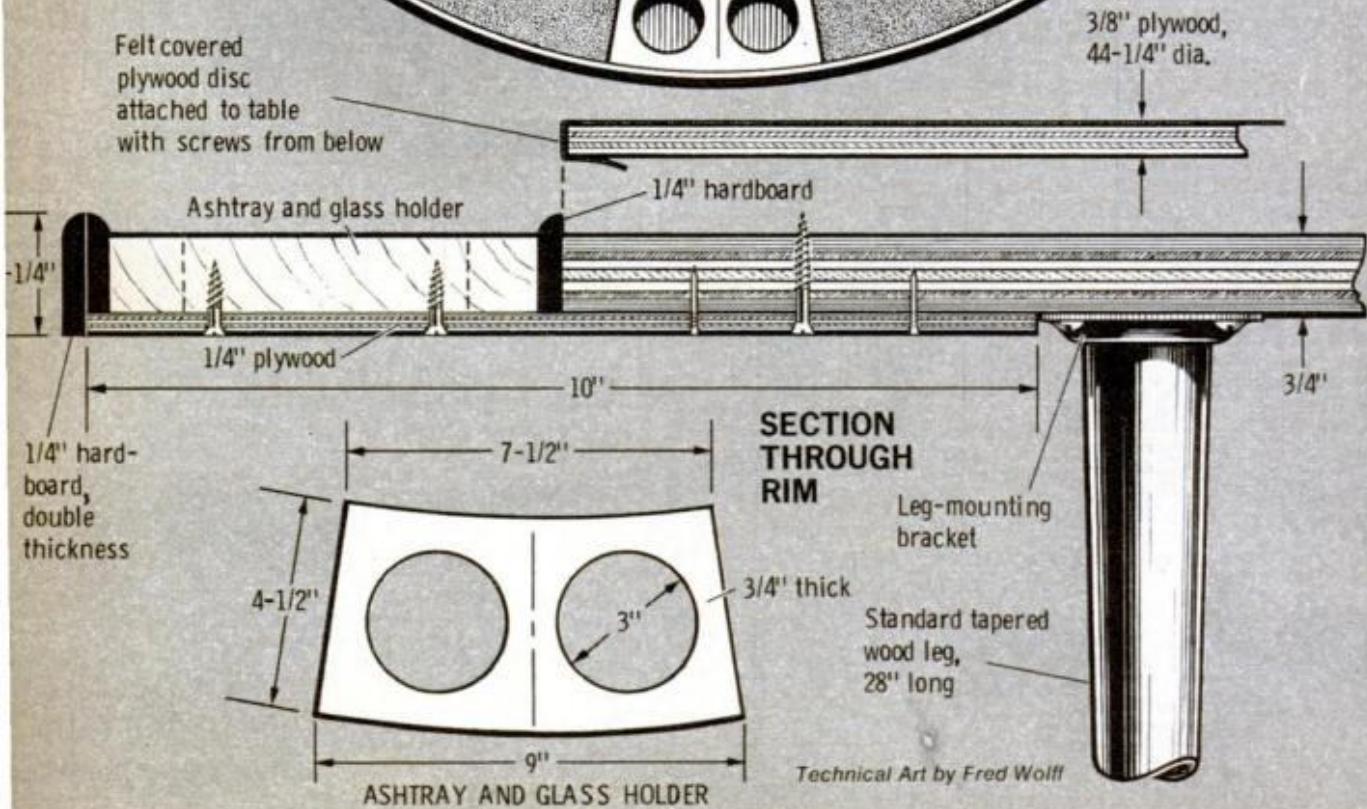
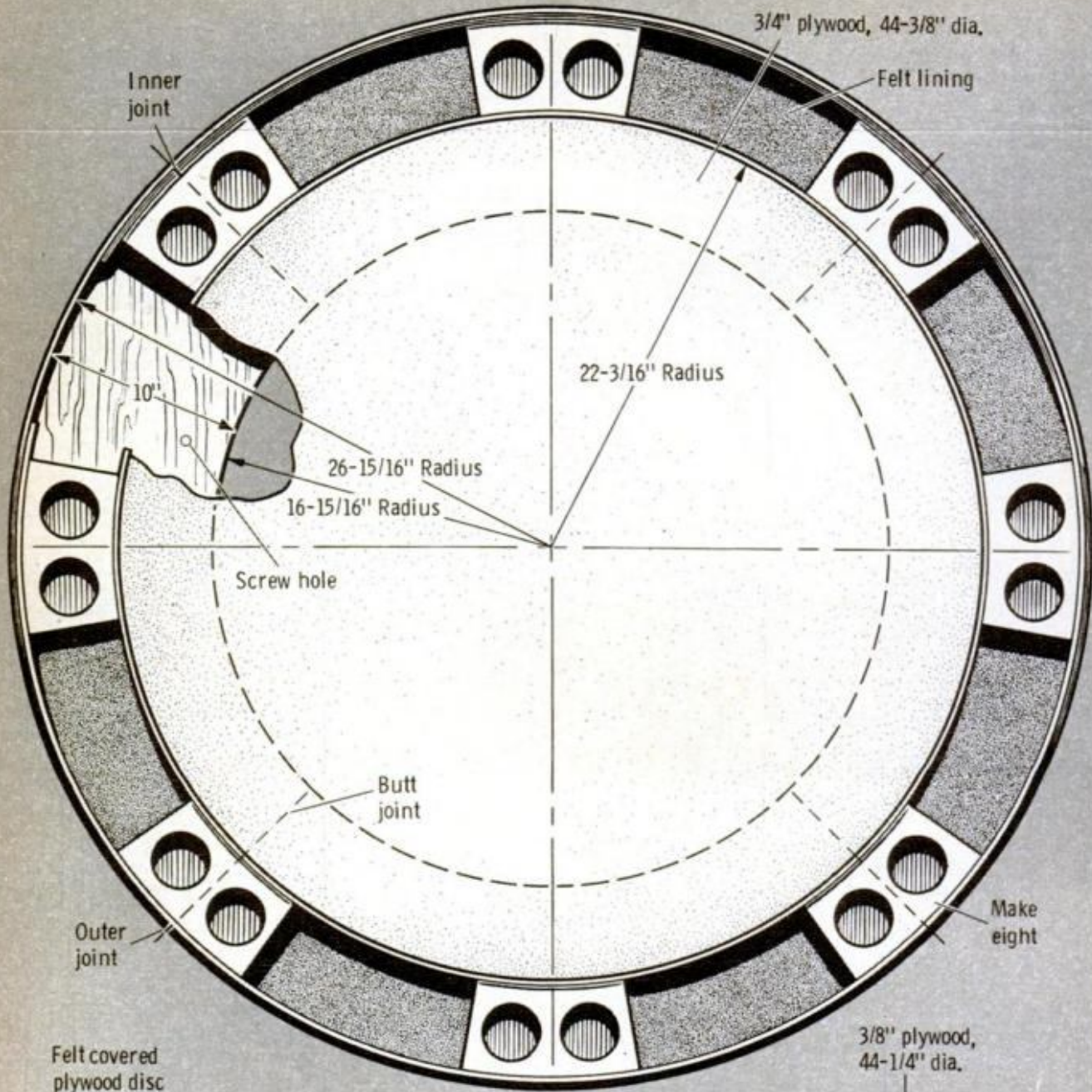

ASHTRAY AND GLASS HOLDER

Technical Art by Fred Wolff

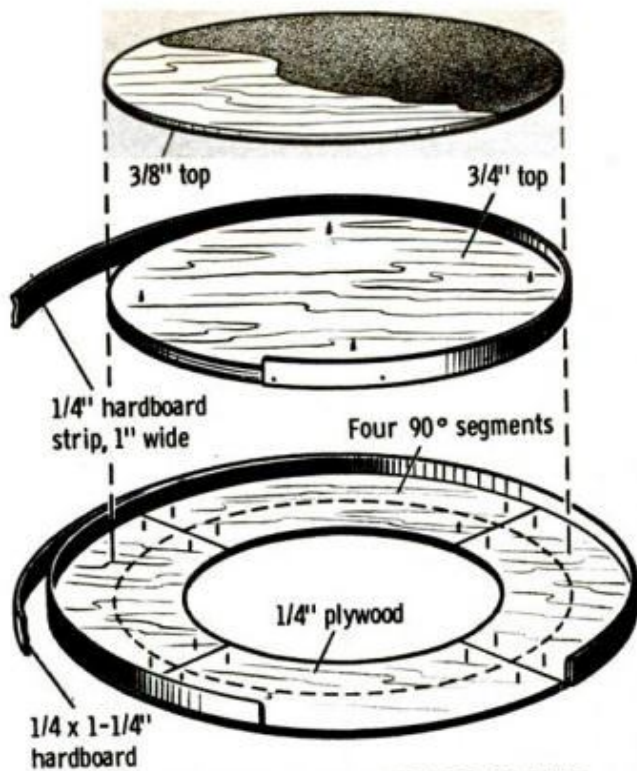

HOW THE PARTS SANDWICH TOGETHER



OPTIONAL SUPPORT

Card table can be used to support top if you wish

FELT CAN BE STRETCHED without puckering if you first staple one edge and then the edge directly opposite



YOU CAN BUY ready-made legs that screw into mountplates, or simply use a card table to support top

nailed to the underside of the center disc to form a tray. Then the edge of the disc is "wrapped" with a 1-in.-wide strip of 1/4-in. hardboard and nailed and glued. Next eight glass-holder dividers are added equidistantly around the plywood tray, four of them being placed over the butted joints. Finally, the outer edge is wrapped with a double strip of hardboard. Glue and nail one at a time and place the joints of the two strips 180° apart. The top playing surface is a 3/8-in. plywood disc, which is covered with green felt stapled to the underside, and attached with screws. The legs screw into metal mounting plates. ***

A CAN OF SPRAY PAINT is the simplest way of finishing ready-made wooden legs any color you wish



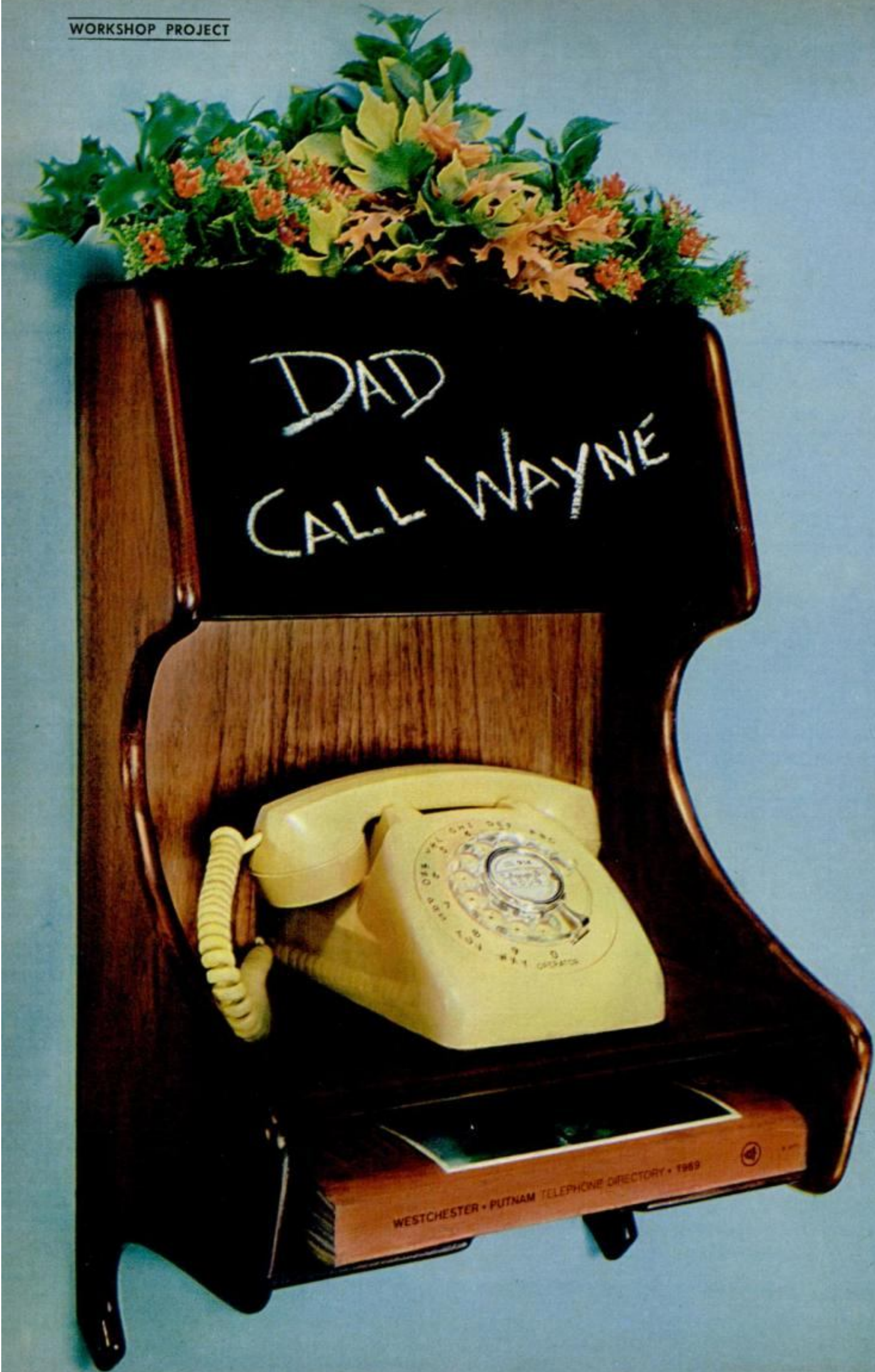

DAD
CALL WAYNE

WESTCHESTER • PUTNAM TELEPHONE DIRECTORY • 1969

Build This Phone Center

A WALL PHONE IS HANDY, to be sure, but not handy enough when it comes to making or taking a call. There's never a directory at hand for you to look up a number, and no place to jot down a message. That's all changed with this hanging phone center. There's a built-in compartment big enough to hold the fattest phone book, and a blackboard where you scribble a message no one will fail to see. There's storage behind the blackboard for an eraser, chalk, pencils and pad. As you can see, it's a handsome piece when made of walnut and "planted" with plastic greenery.

If you are working with walnut, the best construction is to fit and glue the three shelves in $\frac{1}{4}$ -in.-deep dadoes cut in the sides; if plywood and to be painted, you can simply butt the shelves and nail them through the sides. Both side members are twins, but made right and left-hand. The blind shelf dadoes are made before the sides are cut out, then rabbets are run for the $\frac{1}{4}$ -in. back. The planter box for the Styrofoam "soil" is assembled from $\frac{1}{4}$ -in. plywood and merely glued in place. The hinged drop-front is given two coats of special blackboard paint, and tiny brass hinges and chain are attached to hinge and support it. Shaped edges always give a project a professional look. If you have a corner-rounding router bit, you might use it to relieve the square edges of the sides and two bottom shelves. ★★★

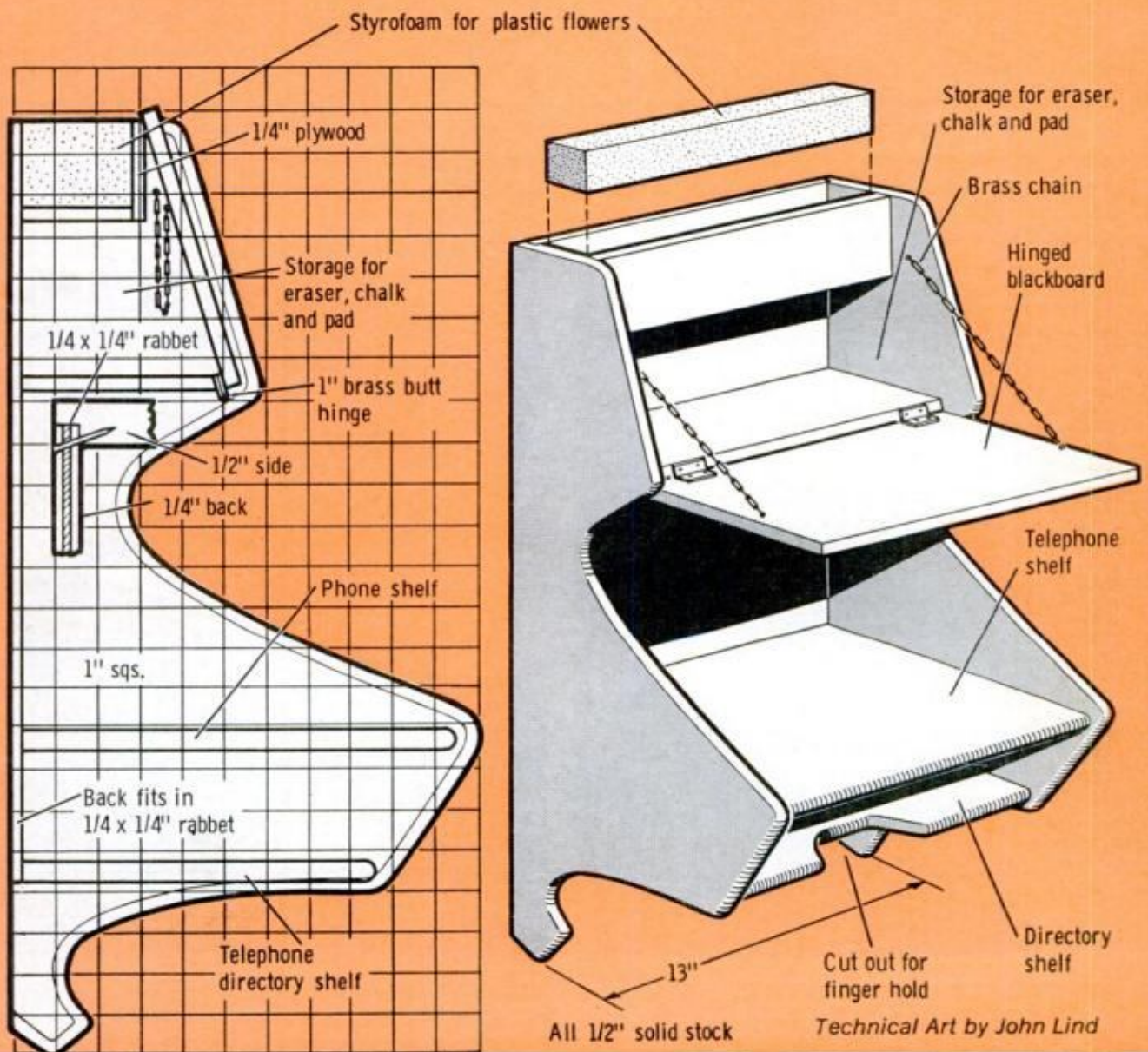

Solving home problems



NOVEL QUONSET ROOF for home-built doghouse is provided by half an oil drum. Cut lengthwise through drum at point 1 in. past the centerline, using a metal-cutting blade in a sabre saw.—Victor H. Lamoy

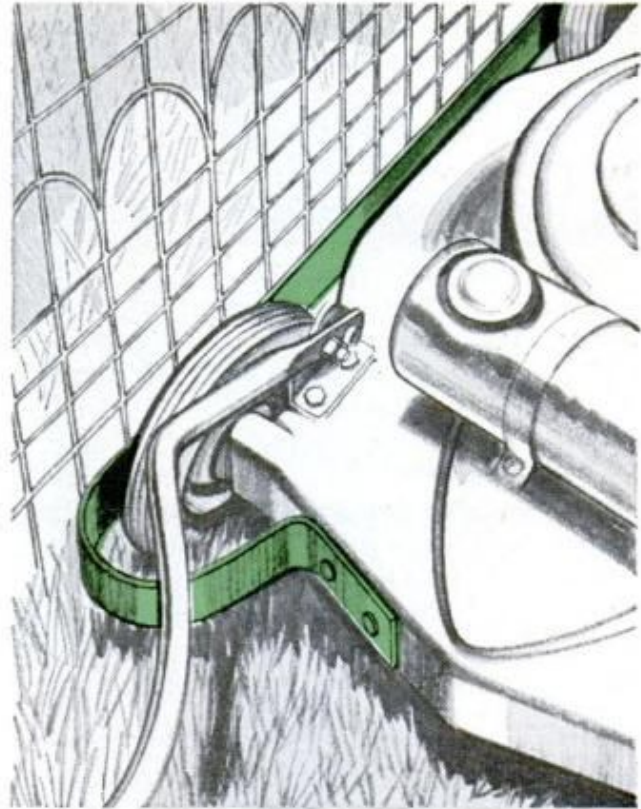

WRAPAROUND "FENDER" for rotary mower permits mowing close to fence without catching wheel in the wire. It consists of $\frac{1}{8}$ x 2-in. flat iron bent around wheel, attached with stovebolts.—Carl H. Hubachek



WHEN STAINING LARGE SURFACES, such as wall paneling, your wiping cloth soon becomes saturated. You can avoid winding up with a stained hand by using a plastic sandwich bag for a glove.—Victor H. Lamoy

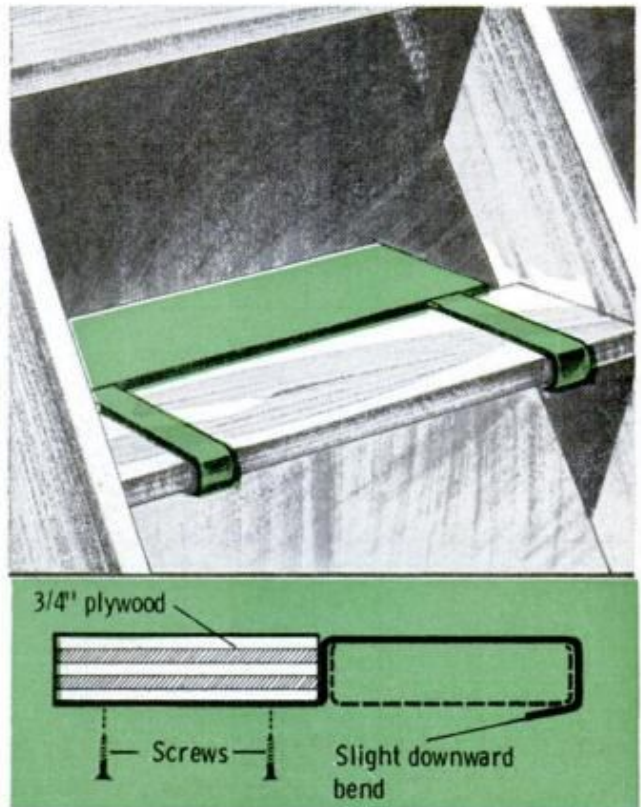

STANDING ON A LADDER for a length of time can be tiring, even when it's a stepladder. This hook-on toe rest will widen the step to provide a greater surface and make standing less tiring.—Victor H. Lamoy

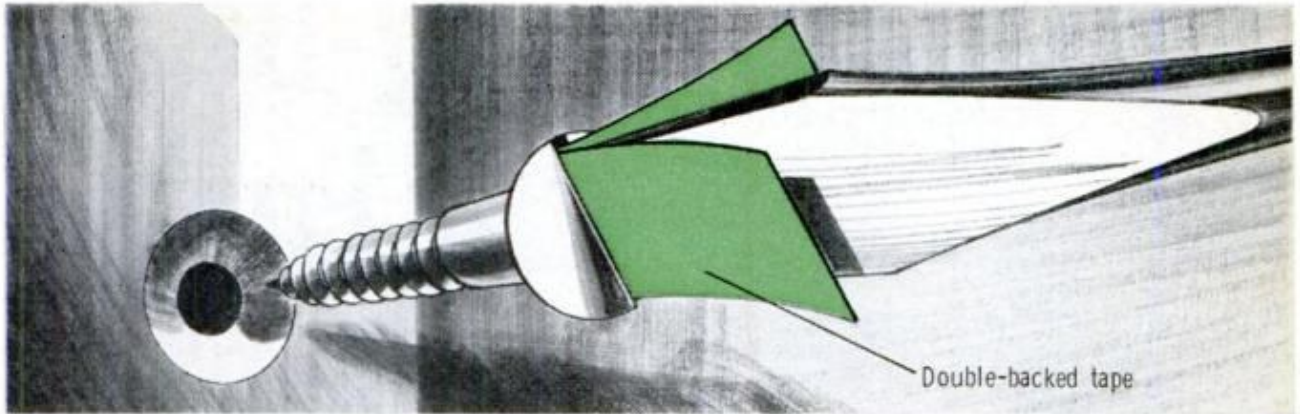

DRIVING A SCREW in an awkward place overhead presents a problem when you can use only one hand. For a simple way to hold the screw to the end of the screwdriver, use double-backed tape.—Michael Ligocki

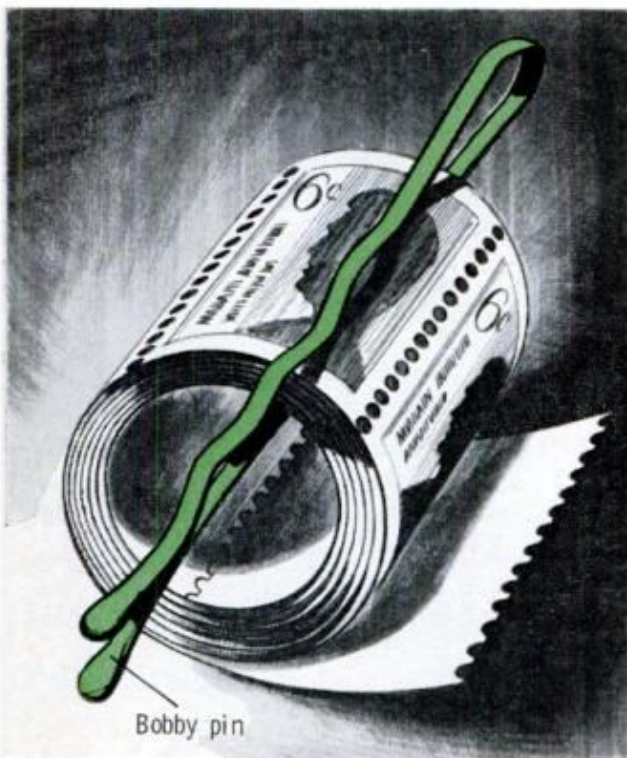

ROLL OF STAMPS can be kept in tow as you use it with one of your wife's bobby pins used as a slip-on clamp. Spring tension of the pin is sufficient to grip the roll, yet it still permits unrolling stamps.—John Krill

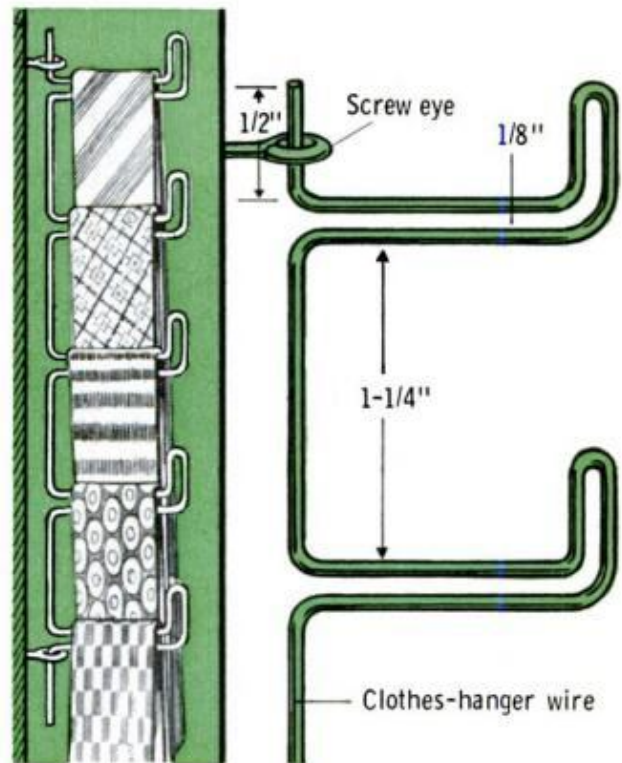

SWINGING TIE RACK, shaped as shown from coat-hanger wire and pivoted in two screw eyes, takes little space since it can fold flat against wall. Part of each tie hangs in front for quick selection.—Frank Shore

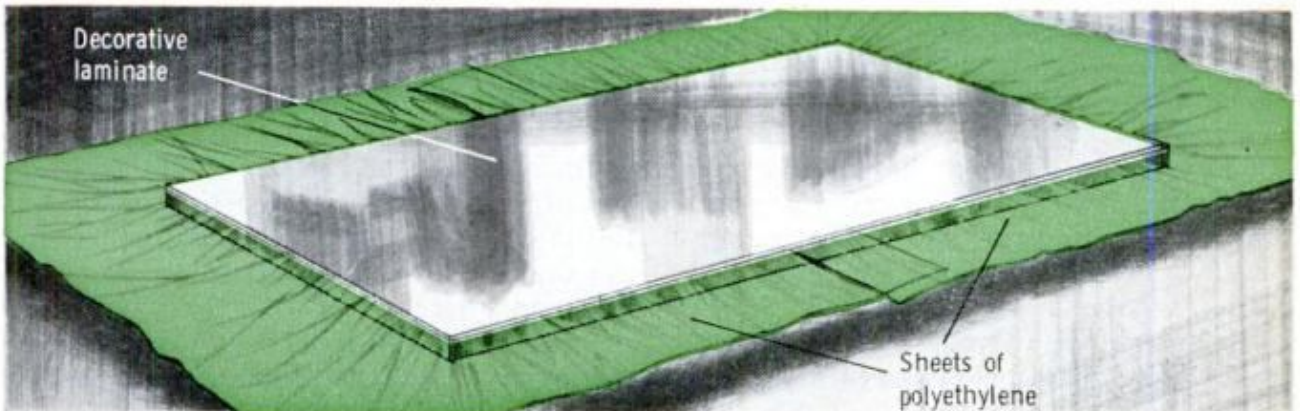

WHEN BONDING PLASTIC LAMINATE to a countertop, you'll find polyethylene is better than wrapping paper for separator sheets. The plastic sheets will pull out easily without sticking like paper.—Victor H. Lamoy

Build This Model Walking-Beam Engine

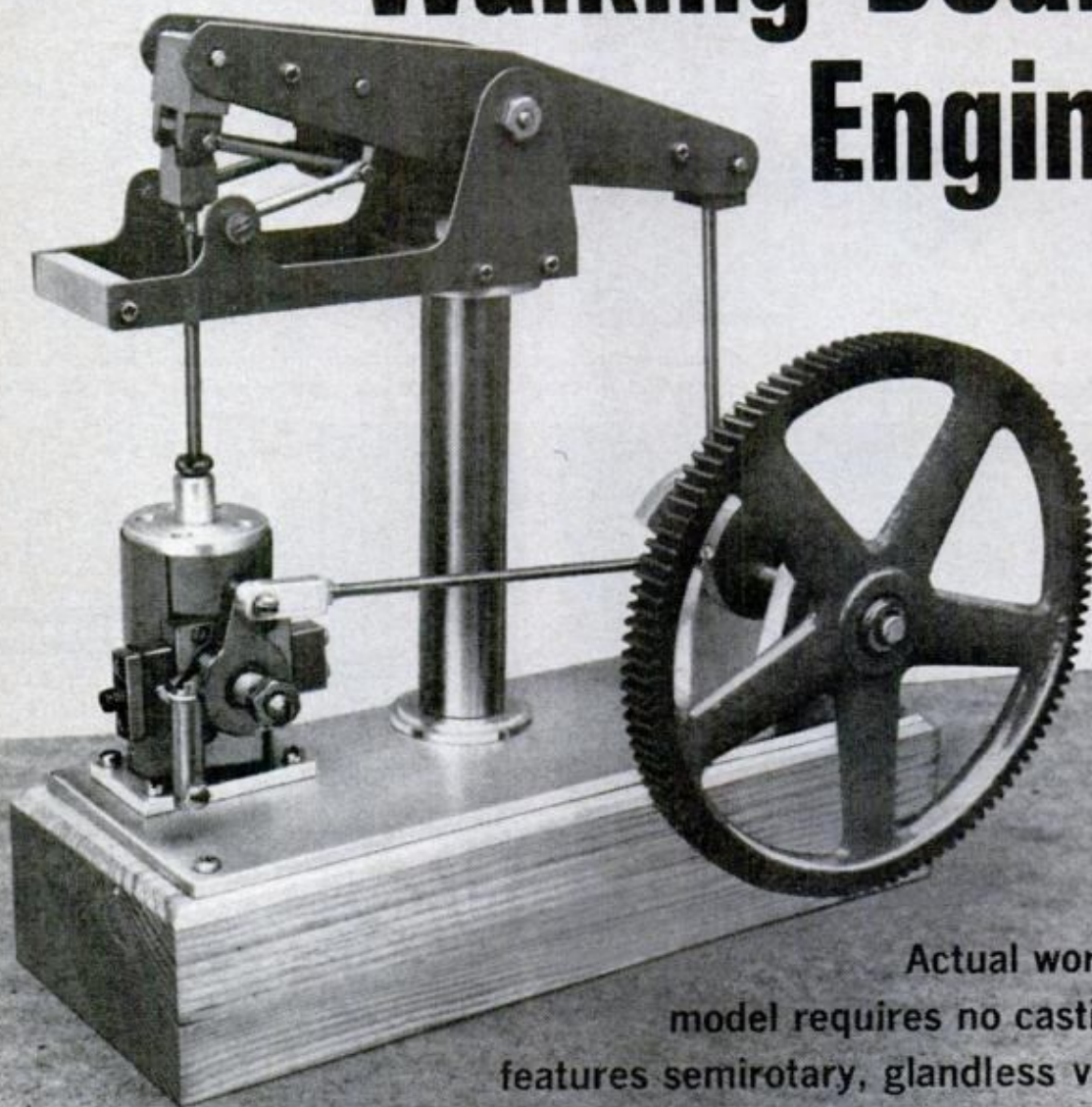

Actual working model requires no castings, features semirotary, glandless valve.

By RUDY KOUHOPT

Technical Art by Fred Wolff

AS A PRIME MOVER, the steam engine came into existence over two centuries ago. From its humble beginnings, James Watt improved upon the operation of the steam engine until he raised it to the position of a great industrial and economic force. One of his innovations, the parallel link motion, functions in this captivating miniature just as Watt specified in his patent of 1784.

Briefly, this is how it works: Steam, regulated by the valve, drives the piston up and down in the cylinder in a vertical, straight line. The piston rod, likewise, travels in a straight line but is connected

to one end of the beam. This is where the parallel link motion comes in. It is interposed between the piston rod and the beam. There it converts the linear motion of the piston rod into the radial motion necessary for the beam to oscillate, or walk, about its midpoint. At the opposite end of the beam, the connecting rod drops to the crank to impart a rotary motion to the crankshaft. An eccentric mounted on the crankshaft controls the valve so that steam is admitted to and exhausted from the cylinder in the proper sequence of events. The cylinder is double action.

Begin construction of your miniature

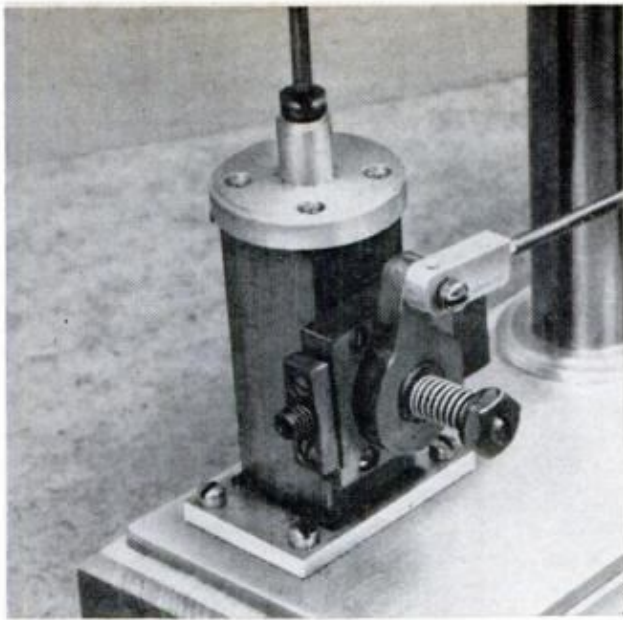

THIN SHEET METAL is rolled in a sleeve to form an insulating lagging or cover around the cylinder

engine by cutting out the wood base and then mark out the bedplate on $\frac{1}{8}$ -in. Dural and drill the holes for the mounting screws and column. Two wood screws, through the holes in diagonal corners, hold the bedplate to the base.

The complete column assembly is composed of the column, the two column ends, and the entablature. Machine the column first, then the ends for an exact fit. When all parts are finished, pass a $\frac{1}{4}$ x 5-in. bolt through them and anchor the assembly to the bedplate with a nut on the underside.

Next, mark out the outline and hole centers of one spring beam on $\frac{1}{32}$ -in. sheet metal. Drill it and use it as a guide when drilling the second piece. Bolt the two pieces together with 2-56 screws through the smaller holes and cut out both parts at the same time with a fine hacksaw. Finish to the mark by filing. Attach one to either side of the entablature with two 2-56 screws. Now make the stretcher and place it between the spring beam ends.

Next, make the gudgeon which spans the spring beams and acts as the main pivot for the beam. Four nuts on the threaded ends of the gudgeon hold it in place; one nut goes on each side of each spring beam. Make the two link gudgeons next. Screw one into each spring beam and add a locknut.

Follow the same basic procedure on the beam side members as you did on the spring beams. Assemble the beam by putting the shouldered ends of the center spacer through the $\frac{5}{16}$ -in. holes in the beam sides. Put the other spacers in place,

AUGUST 1969

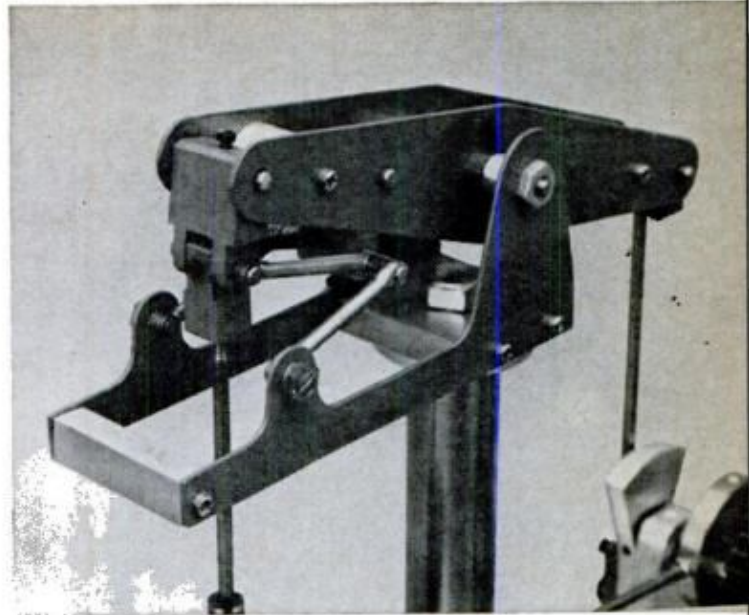

TWO PARALLEL LINKS go between the back and main links and two more between back link and gudgeons

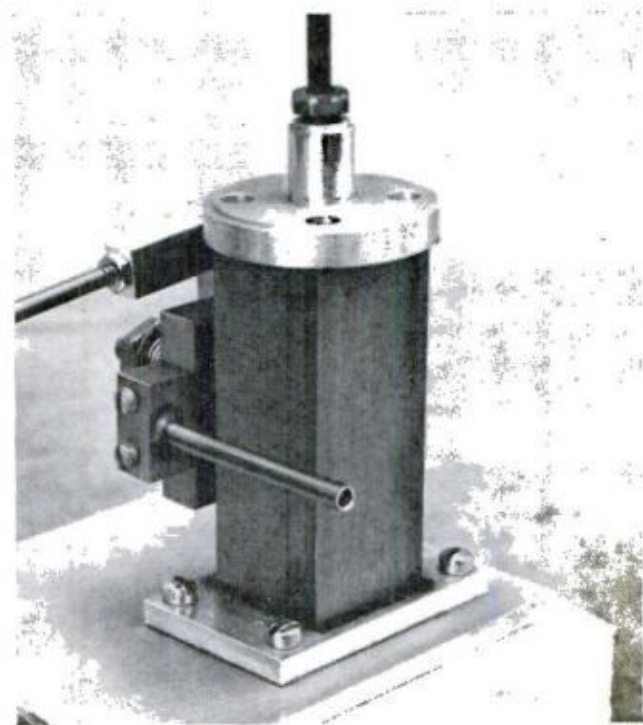

BRASS TUBING is sweat-soldered into an elbow flange to form the exhaust fitting for the cylinder

using 2-56 machine screws through the sides. The $\frac{1}{8}$ -in. openings are for the pins on which the connecting rod and links move. Mount the beam on the column by passing the gudgeon through the spacer.

Shape the main and back links as shown and install with pins made from $1\frac{3}{16}$ -in. lengths of $\frac{1}{8}$ -in. steel rod. The top screws in the links will hold the pins in place. Assemble the four parallel links on a simple jig to insure that all will be exactly the same length. The jig consists of two $\frac{1}{8}$ -in. steel pins accurately placed $1\frac{1}{4}$ in. apart in a wooden block. Cut eight pieces of

157

PULL-APART ASSEMBLY DRAWING

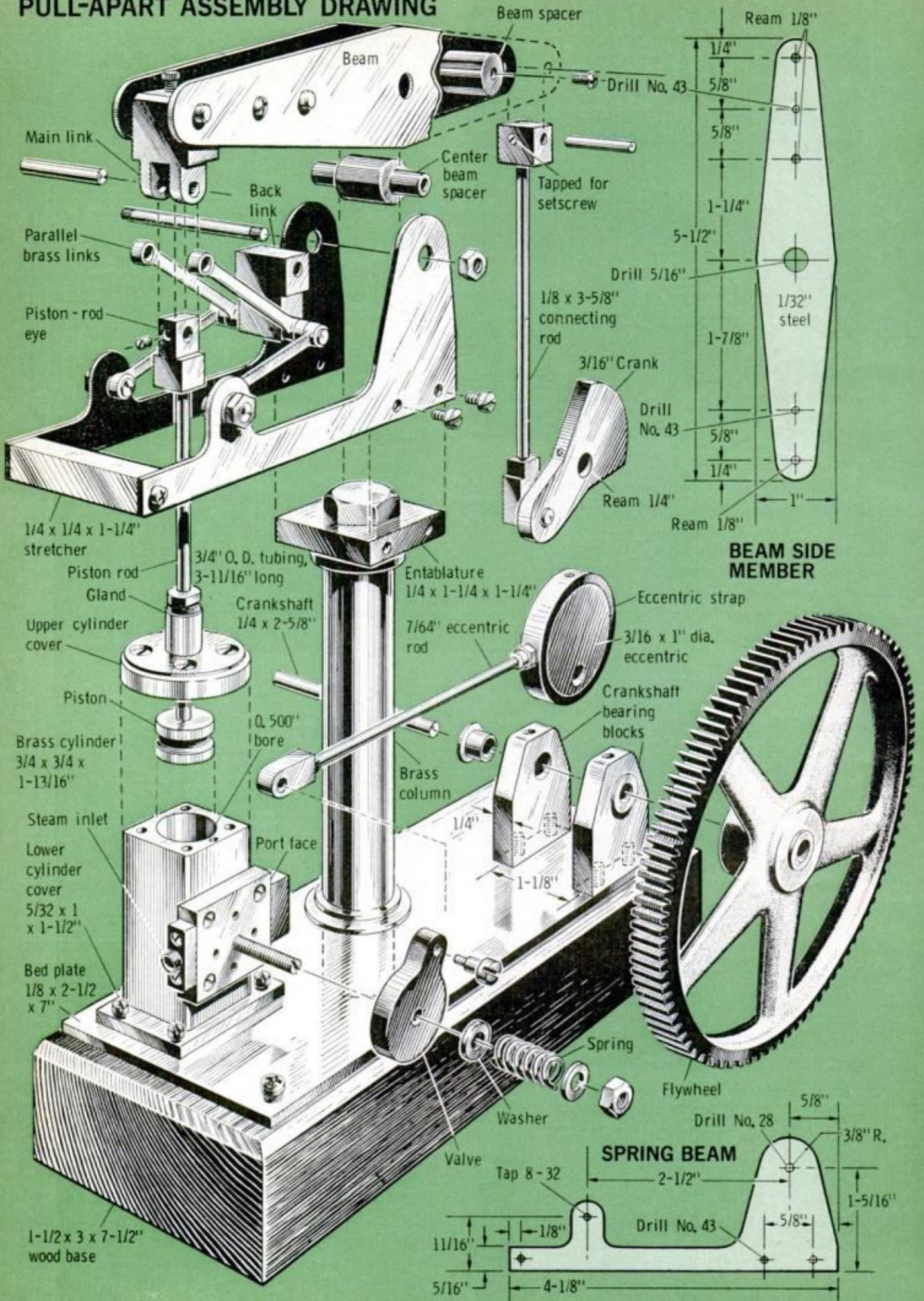

$\frac{1}{8}$ -in. i.d. brass tubing, each $\frac{3}{16}$ in. long, to form the eyes of the links. Put one over each pin in the jig, and cut a length of $\frac{3}{16}$ -in. brass rod to go between. Solder the two eyes and the rod together. Remove from jig, and repeat until all links are done.

Cut $1\frac{1}{2}$ -in. and $\frac{3}{4}$ -in. lengths of $\frac{1}{8}$ -in. steel rod to form the lower pins in the back and main links, respectively. Spacers about $\frac{1}{8}$ in. long must be placed between the parallel links on the lower pin of the back link. Exact size of the spacers and setting of the link gudgeons must be determined individually so the beam will swing freely and evenly.

Cut a $3\frac{5}{8}$ -in. length of $\frac{1}{8}$ -in. steel rod for the crankshaft connecting rod and add the big and small ends. After assembling the three parts, install the assembly in the beam by passing a pin through the beam and the transverse hole in the big end. The pin is a $1\frac{3}{16}$ -in. length of $\frac{1}{8}$ -in. steel rod.

Shape the crankshaft bearing blocks as shown, and mount them on the bedplate with 4-40 screws from the underside. Use bronze bearing stock for the crankshaft bearings which should be a light press fit in the blocks. Pass a $\frac{1}{4}$ -in. reamer through the bearings after mounting to be sure that all is well aligned.

Turn the crankshaft between centers for the best job, then make the crank and crankpin and mount them on the crankshaft. Put the crankpin through the small end of the connecting rod and adjust its length by the setscrews.

Its length must be such that the beam is horizontal when the crank is at mid-stroke. The beam ends must move symmetrically, $\frac{5}{8}$ in. above and below the horizontal, when the crank is at either end of the stroke.

Use a block of $\frac{3}{4}$ -in. square brass for the cylinder. Set it up in a four-jaw chuck, face the ends to bring it to length and mark the center of the ends. Start the bore with twist drills, bringing it up to about $\frac{7}{16}$ in. The bore can be finished in several ways, including the use of a sharp parallel reamer. My favorite method is to use a between-centers boring bar with the cylinder mounted on the lathe saddle. Block the cylinder up and clamp it so its center coincides with the axis of the lathe. Feed the work slowly on power feed, increasing the bore a little at a time. This method will produce a cylinder in which

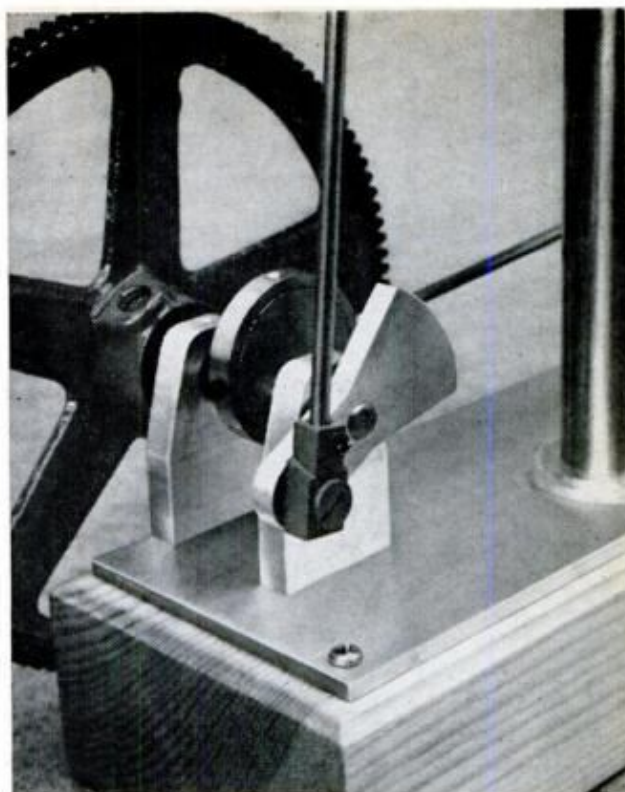

THE ECCENTRIC STRAP must be a good running fit on eccentric with retaining screw loose in the groove

the walls are absolutely parallel throughout their entire length.

With the boring complete, mark out the two steam passages on the midline, $\frac{39}{64}$ in. from either end. Drill these punch marks $\frac{3}{64}$ in. deep with drill No. 52. Mark the ends of the cylinder where the steam passages come out half way between the cylinder bore and outer wall. Drill $\frac{5}{8}$ in. deep from either end with drill No. 52 to form the complete passages which will be L-shaped at this point. Use a small file or end mill to remove about $\frac{1}{32}$ in. of the wall between the end of each passage and the bore to give free entry of steam.

Mark the locations of the four screws which will hold the port face to the cylinder, then drill $\frac{3}{16}$ in. deep, and tap 2-56.

Cut a 1-in. square of $\frac{1}{4}$ -in. brass for the port face. Accurately locate the center as a reference point. Working from the center, locate the four steam ports. The two ports on the vertical centerline are drilled No. 52 right through to meet the passages in the cylinder wall. The two ports on the horizontal centerline are drilled No. 52 to a depth of $\frac{1}{8}$ in.

Connecting passages are drilled on the horizontal centerline from each side to serve as steam inlet and exhaust. Mark out and drill locations of the four mounting screws, then counterbore to form re-

(Please turn to page 202)

Weekend Workshop

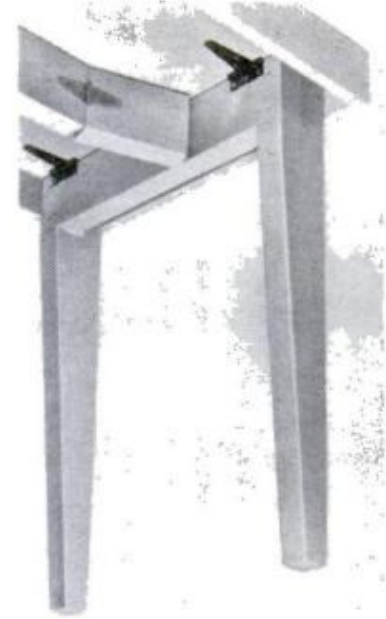
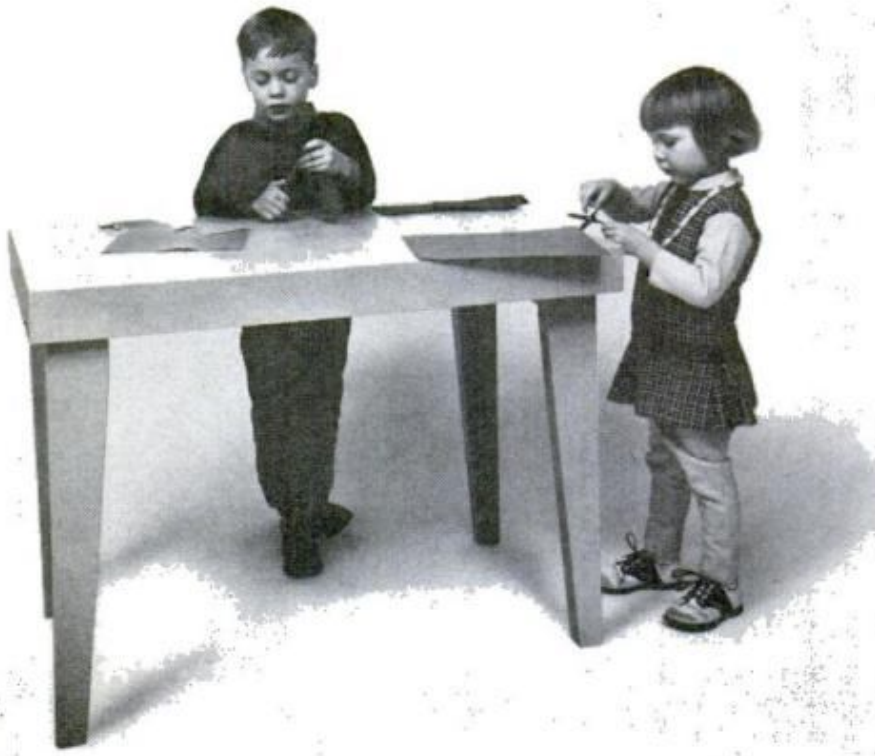

PIVOTING BLOCKS hold legs rigid in an open position by wedging against leg's cross rail

Kid's play-work table

When a rainy day keeps youngsters penned inside, that's when a play table like this comes in handy. It's just the thing to stand at for cutting, pasting and painting; no one cares how messy it gets. Best of all, the legs fold inside so you can stow the table in 5 in. of space.

The underside view shows how the hinged leg assemblies are offset to nest

alongside each other when folded, and also shows how the hinged leg-locking blocks "store" in the folded position.

You can change the size of the top if you wish but keep the legs 26 in. For tykes the legs can be 18 to 20 in. The top is plywood, the skirts are 1x4s and other pieces, 2x4s. T-hinges are used to hinge the legs, strap hinges to pivot the locking blocks. Note that the latter hinges are on opposite sides.—R. S. Hedin

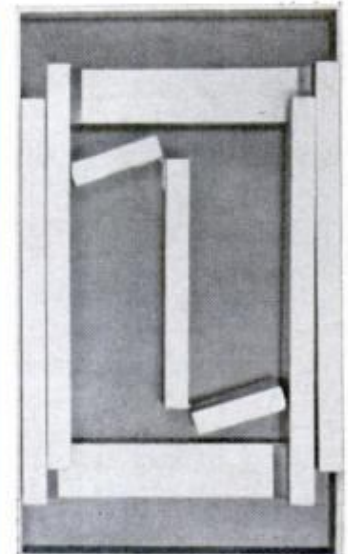
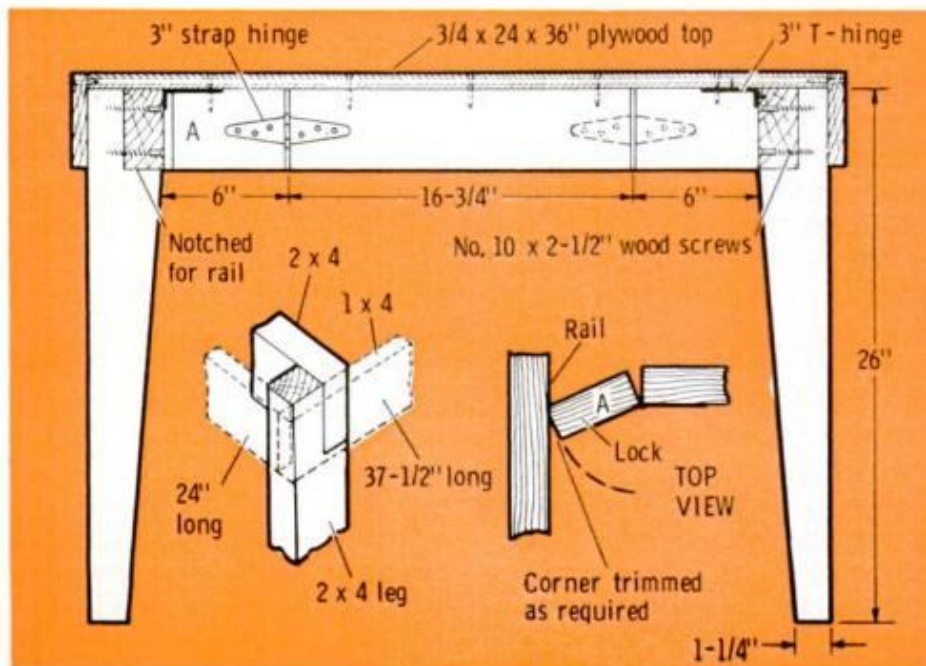

UNDERSIDE VIEW shows legs and twin locking blocks nested in top when folded

POPULAR MECHANICS

Projects

Aluminum pack frame

When it comes to backpacking heavy gear like tents and sleeping bags, nothing works so well as a pack frame. This aluminum one accepts a standard-size packsack or lets you lash the load to it.

Follow the drawing in making it from Reynolds do-it-yourself aluminum and use a Pop Rivettool to put it together. Then round all sharp edges with a file.

The shoulder straps and back bands may be canvas or nylon webbing. The straps are attached to $\frac{1}{4}$ -in. eyebolts spaced 5 in. apart in the top member. The bolts are left loose to turn with the straps by peening the ends. At the lower end, the straps are secured to eyebolts in the sides. The back bands are located so the upper band is behind the shoulder blades and the lower one is in the small of the back.

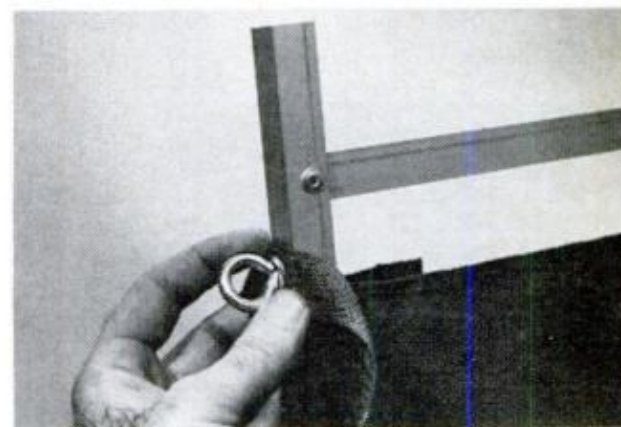
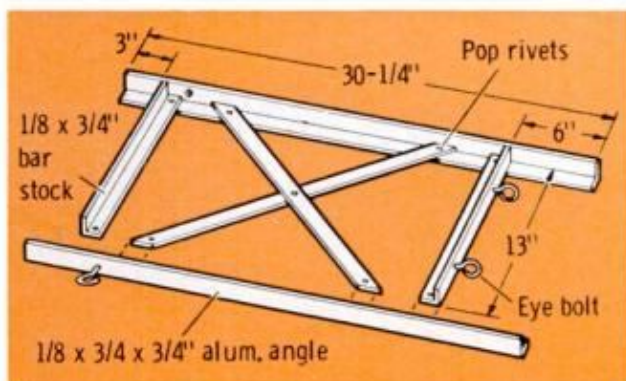

SHOULDER-STRAP EYEBOLTS should be left loose to swivel. Shorten bolts andpeen ends to lock nuts

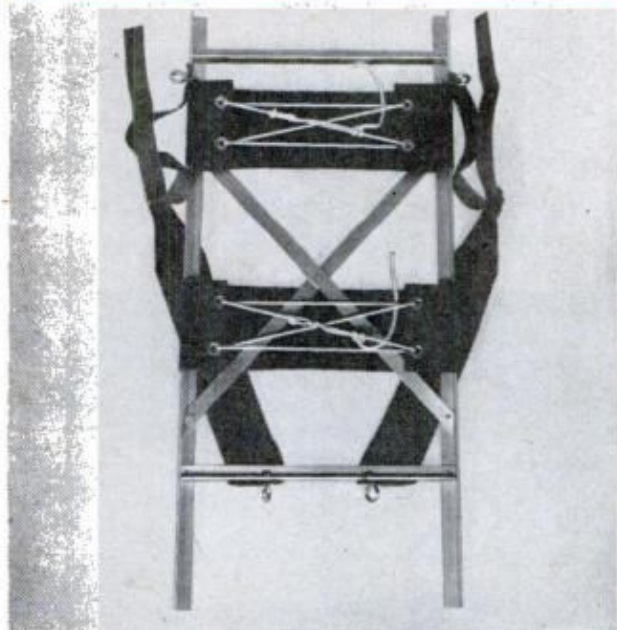

BANDS ARE LACED as shown. Upper band is placed behind shoulder blades, lower one is in small of back

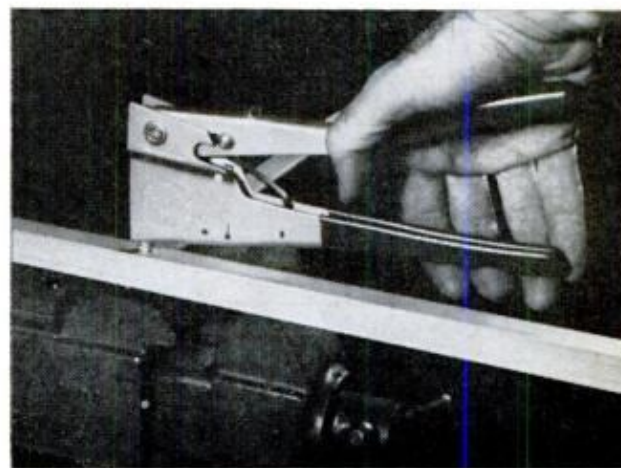

POP-RIVET FASTENERS provide quickest and neatest method of fastening six aluminum frame members

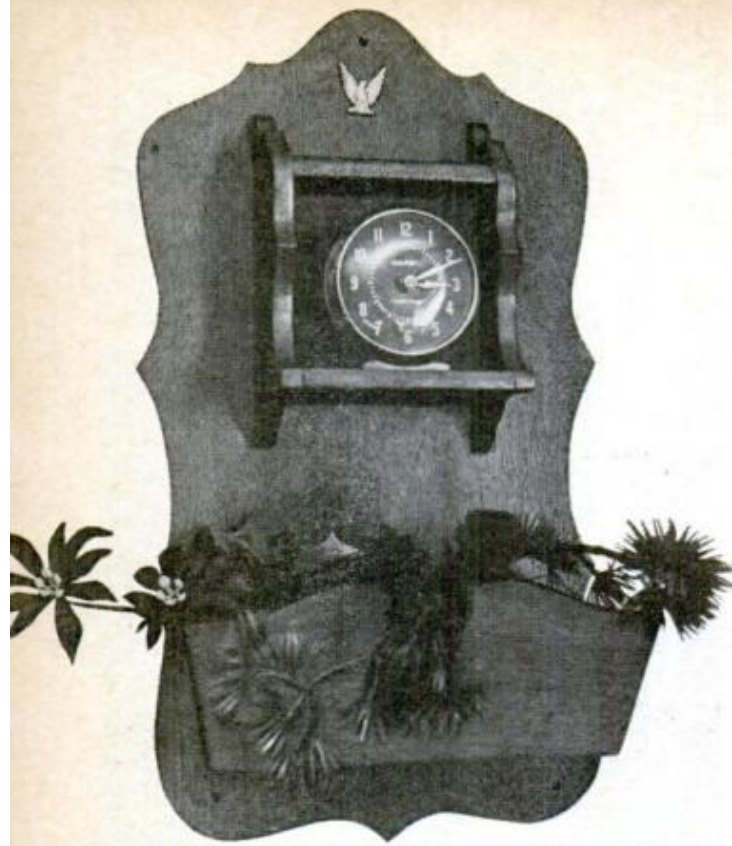

Early American clock-planter

If you have cast aside an old, yet serviceable, alarm clock for a modern clock-radio, you can find new use for it as a wall clock in this handsome Early American piece. A shelf at the top holds the clock and a trough at the bottom holds a plant.

Make paper patterns of all the parts and trace them on $\frac{1}{2}$ -in. material. Cherry, pine and walnut are appropriate woods. Chances are you'll have to glue up the $10\frac{1}{4}$ -in. back from two or more pieces to build up the width. Simple butt joints are used throughout; screws from the back attach the clock shelf and the planter. If you happen to own a router, you can add a finishing touch to the project by shaping the edges of all parts before assembling. A Styrofoam block in the planter will hold plastic plants.—Don Shiner

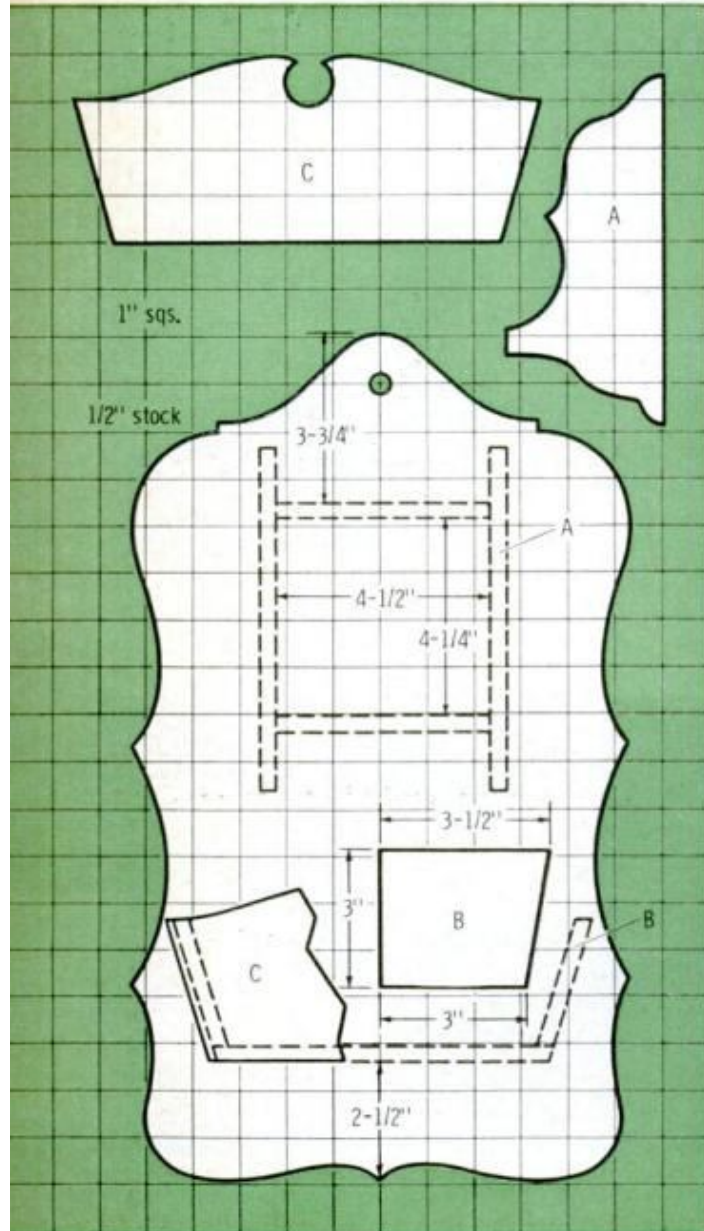

POSITION THE CLOCK SHELF $3\frac{3}{4}$ in. down from the top and attach it to plaque with flat-headed screws



BAND OR JIGSAW makes quick work of sawing out plaque and the three other scroll-cut parts required

POPULAR MECHANICS

HINTS FROM READERS

Unplug that tube—easily

Once you snip the tip on a caulking cartridge, any leftovers will soon cake the spout if you don't plug the end. A flathead nail makes about the best plug you can find since it's long enough to extend all the way into the cartridge and its head is easy to grip and pull out. The nail keeps a hole free of caulk the full length of the spout.—*Anthony S. Walters*



Quickie letter holder

A few parallel saw kerfs, $\frac{1}{2}$ in. deep and 1 in. apart, cut lengthwise in a block of fine cabinet wood make it an instant letter holder. If the edges are shaped and the wood given a couple coats of a self-rubbing finish, the holder can be an attractive desk accessory. A $\frac{3}{4}$ x 7 x $10\frac{1}{2}$ -in. block is about right. Some of the kerfs can be wider than others.

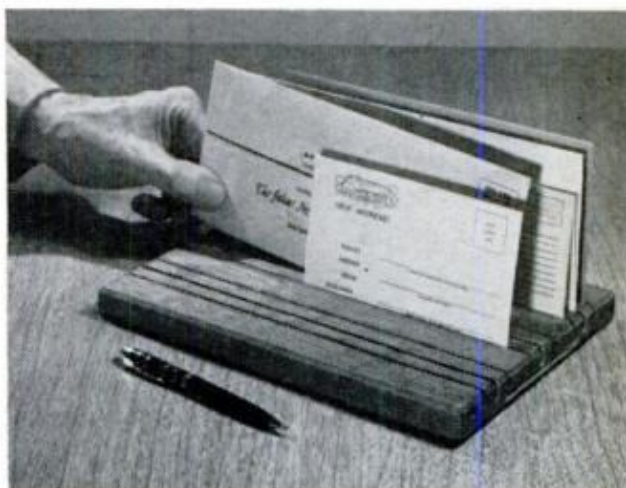

Fishline locks machine screws

Regular self-locking machine screws have a slot milled in the shank for a nylon pellet. The resiliency of the nylon exerts constant pressure against the nut, thus keeping it from working loose. Practically the same self-locking feature can be obtained with any bolt by first inserting a piece or two of nylon fishline in the hole.

—*Robert G. Lanzit*



Extra use for bulb holder

The throwaway holder you get with GE miniature flashbulbs can be put to good use as a holder for pins, small screws, cotter pins and the like. You'll find the slit plastic holder ideal for holding a supply of bank pins used in modelmaking. Ordinarily difficult to pick up, the pins are simply slid off the end of the tube as needed.—*Joseph Braunstein*

Gear shaves wood dowel

The next time you want to reduce the diameter of a wood dowel or taper it to form a handle for a small tool, try using a steel gear as a shaving tool. Simply clamp the gear in the vise and pull the dowel between two teeth, so that the sharp corners will shave the wood. When the gear gets dull, resharpen it by filing across its flat surface.—*Walter E. Burton*

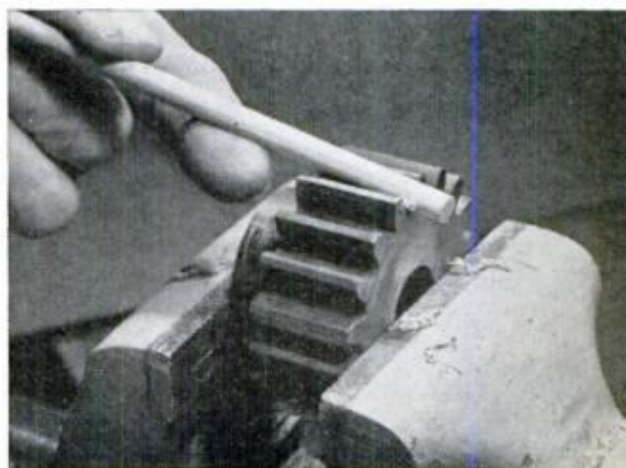

Build This Handsome

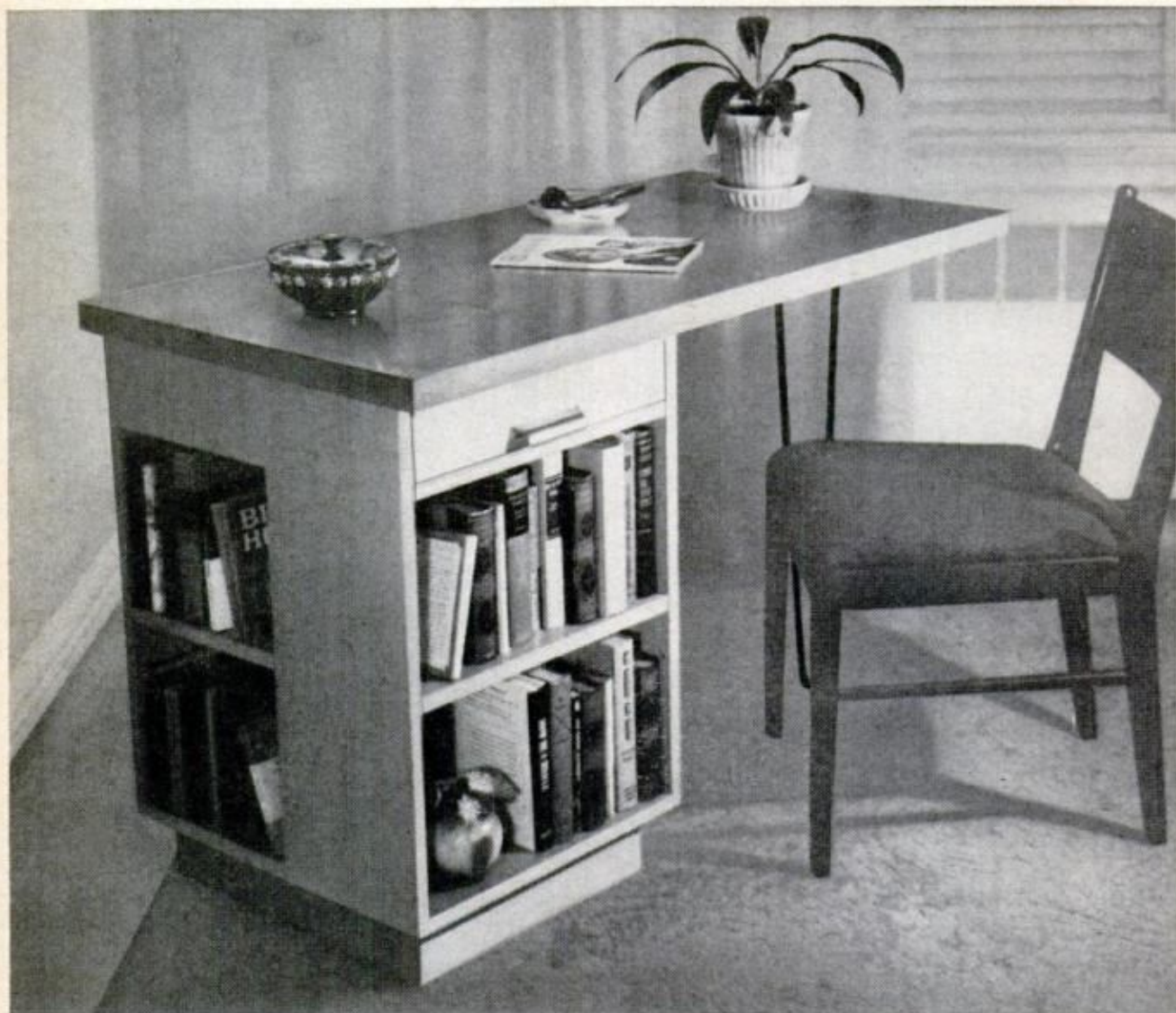

KEEPING BOOKS HANDY is no problem in this clever desk which features its own built-in bookcase. Pigeon-hole compartments in the base hold dozens of books within easy reach, and their weight helps to make the desk's cantilevered top exceptionally sturdy. A wrought-iron leg supports its outboard end, and there's a shallow but roomy drawer at the top of the book compartments. The desk-top is a standard flush door which is cut down to a 4-ft. length and covered with slick countertop plastic.

Cut the various pieces to the sizes given and assemble them in the following order, using glue and 2-in. finishing nails. First nail side A to bottom B. Then add divider C. Follow with divider D, middle shelf E and dividers F and G. Next add top pieces H and I, followed by J. Finally, install parts K and L. Set the nailheads below



DESK IS DESIGNED to be placed at right angle to wall to make its bookcase accessible from all sides

POPULAR MECHANICS

Bookcase Desk

By ALVARO ALTOMARE

CONSTRUCTION DETAILS

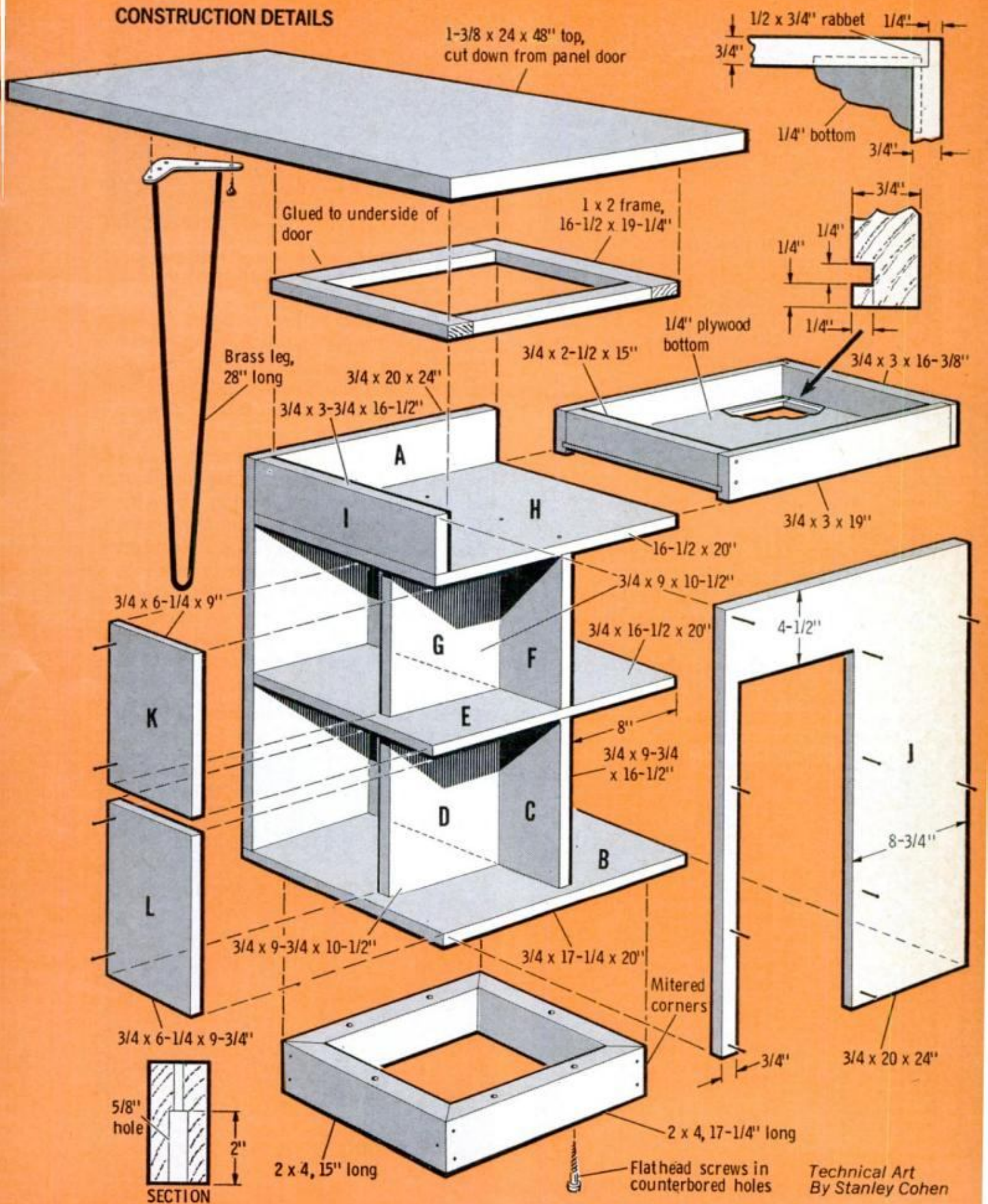



BUTT JOINTS ARE USED throughout in gluing and nailing parts together. Set nailheads, putty over them

the surface and fill the depressions with matching wood putty.

When shortening the hollow-core door, you'll have to glue in a wood strip to fill the open end. This will be covered later with plastic laminate.

Contact cement is used to bond the plastic to the desktop. Start with the edges and cut strips of plastic $\frac{1}{4}$ in. oversize. Apply a coat of cement to the wood and a

AFTER EDGES ARE COVERED, plastic laminate is applied to cement-coated surface of top, trimmed flush

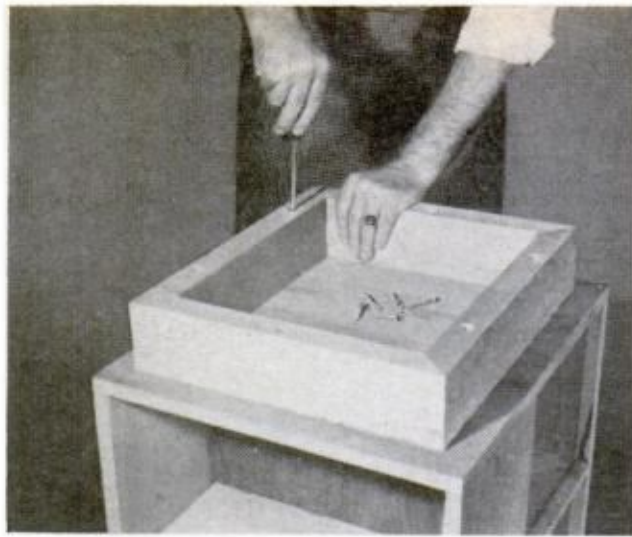

THE SETBACK BASE, which is made of 2x4 stock, is attached with screws placed in counterbored holes

coat to the plastic and set aside until both surfaces are dry to the touch.

Now center each plastic strip over the edge and when you have it just where you want it, let both surfaces touch. Remember, once they touch you can no longer shift them. Tap each strip with a wood block and hammer for a good bond and file down the strips to bring the edges flush with the top and bottom surfaces.

Now you cover the desktop with plastic letting it overhang the plastic on the edges about $\frac{1}{8}$ in. all around. A trick to use in positioning the plastic prior to sticking it down is to cover the top with a couple pieces of wrapping paper and place the

OUTBOARD END of desktop is supported by wrought-iron leg which is screwed to solid end of door's core





SHALLOW DRAWER is made to fit compartment. Side clearance, plus wax, will make drawer slide freely

plastic on top. This lets you shift the plastic without fear of it sticking. When you have it where you want it, pull out one of the papers and press down. Pull out the others and go over the whole top with a block and hammer. Finish up by filing the overhanging edges flush with the edge banding, first using a sharp plane and finishing up with a file. Watch that you don't scratch the edges.

The top is attached to the bookcase base by a 1x2 frame made to fit the well above the drawer space. The frame is glued to the underside of the desktop. Typical drawer joinery is followed in assembling and fitting the drawer. ★★★

TOP IS JOINED to bookcase section by frame that's glued to underside. Frame, in turn, is glued to case



AUGUST 1969



Plastic bag is layout aid

When you do layout work on small pieces of polished metal or plastic, many scratches can be avoided by slipping the material inside a plastic sandwich bag. You'll have no difficulty seeing through the plastic, and it's thin enough to be pierced easily by scribes, dividers or punch. You can protect large work in the same manner by taping roll plastic to the top of the material.—Herbert Y. Moon

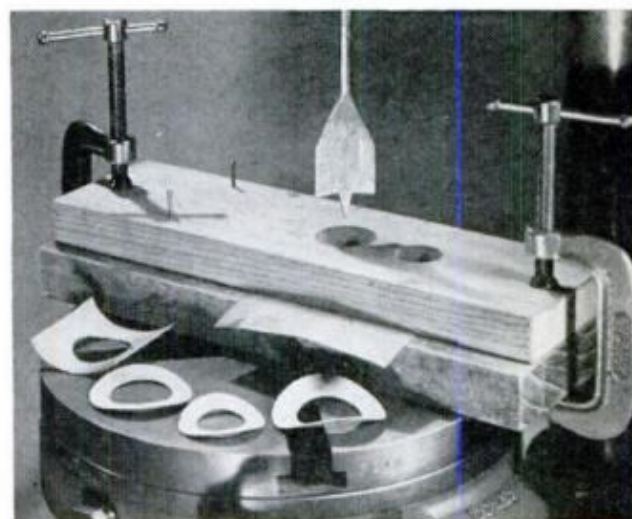

Ring gaskets by the dozen

An easy and accurate method for cutting the inside hole when making small ring gaskets is to sandwich the sheet cork between two blocks of wood and bore all three with a wood bit in a drill press. After drilling, cut the outside of the gasket with scissors. A couple of nails will keep holes in the blocks in register and still let you slip in the cork when making duplicate gaskets.—Wilbur H. Fulker

167

EXCITING NEW PRODUCTS

By CATHERINE BILSKI



HIGHWAY EMERGENCIES are easier for you to handle if you're prepared for them with this Highway Safety Kit. It contains a 60-second tire inflator and puncture sealer, a U.L.-approved disposable dry chemical fire extinguisher, a "Help" flag, two fusee emergency flares and eight Wash n' Dry towelettes. The 14-piece kit (TK-3) sells for \$12.50 and is made by Bernzomatic Corp., 740 Driving Park Ave., Rochester, N.Y.



HERE'S THE ANSWER to your changing storage needs. Have additional space whenever you need it with the Add-A-Drawer Chest. Individual drawers stack to any height and lock together to form a single solid chest. Finished in handsome walnut wood grain, the corrugated fiberboard construction is reinforced with a rigid steel frame to assure ample strength for any storage need. Drawers slide in and out freely even when fully loaded. Manufactured by Safo Products Co., 7425 Laurel Ave., South Golden Valley, Minn.



PORTABLE PUMPING SYSTEM that offers power in a compact size that's ideal for homeowner use is the Mini Vac. The high-rpm electric motor and 250-gallon-per-hour pump will lift water 20 feet straight up. The system, which includes a pump, motor and 12 feet of input-output hose fitted with standard plugs, sells for \$39.95. It's manufactured by the Simer Pump Co., 207 Humboldt Ave. North, Minneapolis, Minn.

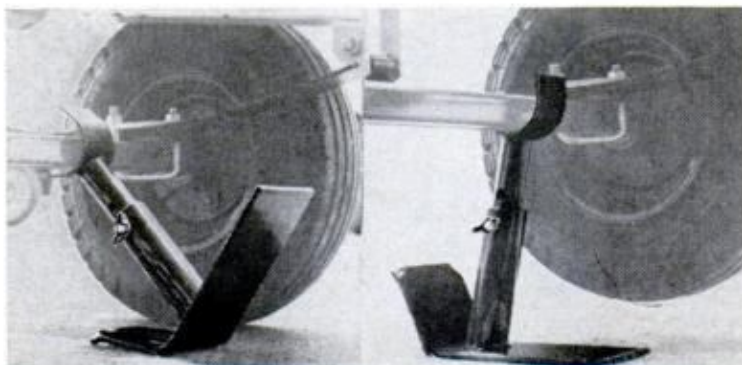

FIX THAT FLAT fast and easy with the Trailer Jak, a simple one-piece mechanism. When it is placed under the axle of a flat-tired trailer and the car moved forward one foot, the Trailer Jak rocks to an "up" position and rests on its 28-sq.-in. base. Adjustable for many different heights of axles by merely changing a bolt and wingnut to a different set of holes. It's priced at \$9.95. Made by Central Specialties Co., 6032 Northwest Highway, Chicago, Ill. 60631.



DRY-COATING LUBRICANT called Emralon 327 adds a slick surface to your table saw and jointer, makes windows and drawers slide without binding, even keeps snow from sticking to shovels. Comes in 4 and 16-ounce spray cans, air-dries to touch in five minutes, is fully hard in two hours. Four-ounce can has handy extension tube for lubricating sliding tracks of aluminum windows. Available from Colloids Co., Port Huron, Mich.

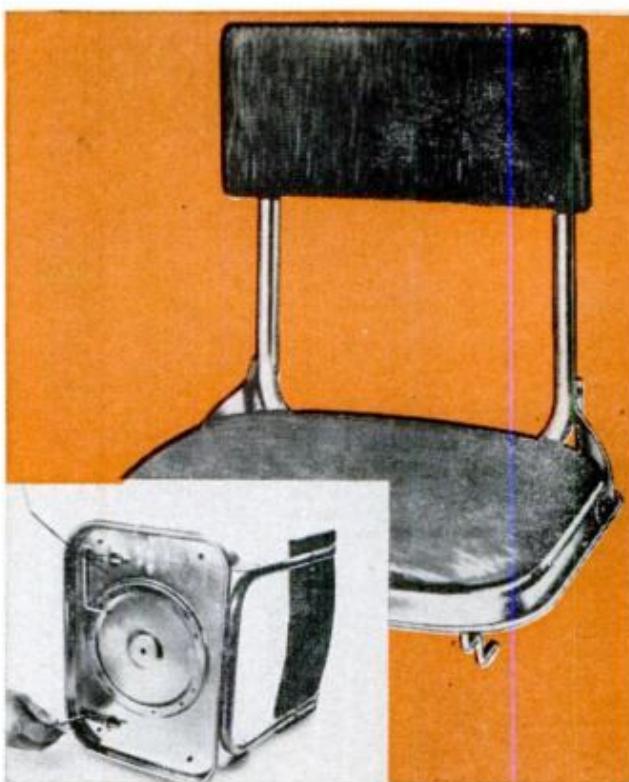

FOR SPECTATOR COMFORT, this folding stadium seat is designed to be either portable or permanently installed. It has spring-loaded locking clamps which hook over edge of any bleacher-board seat, and comes upholstered in red or green all-weather vinyl. Fitted with snaps, the seat is easy to remove. Its hinged back will support 300 pounds. \$7.95 postpaid from C. A. Bittner, Dept. P-5, Box 4732, Inglewood, Calif. 90302.

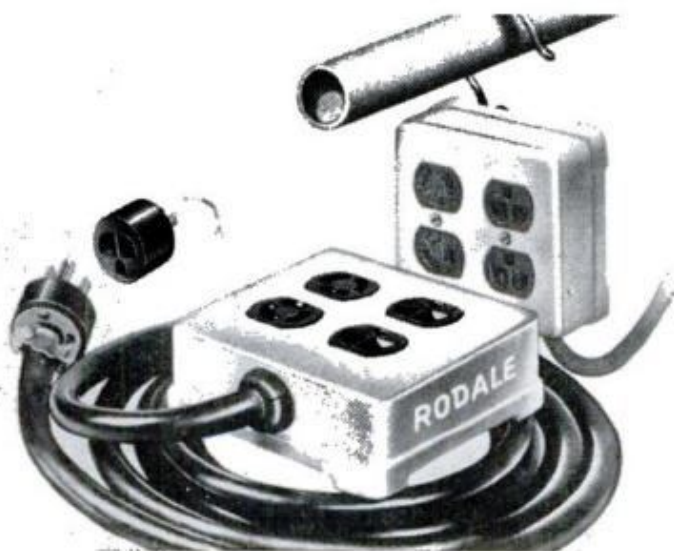

EXTENSION-CORD POWER BLOCKS provide a four-in-one receptacle for plugging in several power tools or photo-flood lamps. The No. 381 model features two parallel-blade duplex receptacles; No. 385, two three-wire, U-blade duplex receptacles. Each unit, rated at 15 amperes and 125 volts, comes with handy snap-on hook for hanging, and measures only $1\frac{3}{4} \times 4\frac{1}{2} \times 4\frac{1}{2}$ in. They're wired with two and three-conductor, No. 16 cables in four different lengths. Made by Rodale Manufacturing Co., Inc., Sixth and Minor Sts., Emmaus, Pa.



NO MORE OVERWATERING or underwatering. With the Melnor Water Timer you set it for the exact amount of water your lawn needs and it shuts off any sprinkler automatically when watering is done. Delivers up to 750 gallons per setting. Water Timer No. 100 sells for \$6.49. Melnor Industries, Moonachie, N.J. 10070.

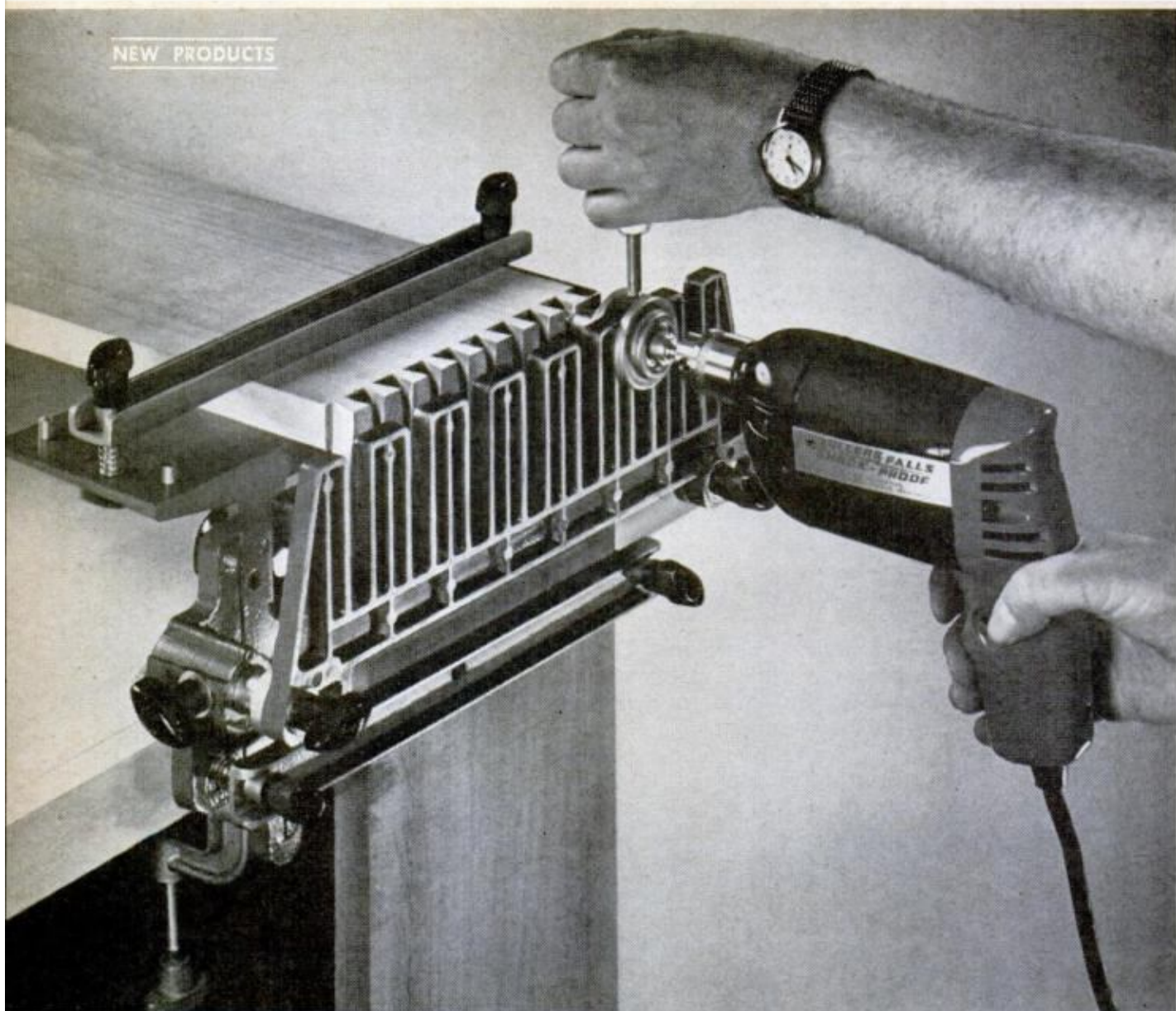

Here's a Dovetailing Device

Routers are used with most dovetailing jigs but with this one a portable drill does the cutting

By JOHN BURROUGHS

MADE IN ENGLAND, this unusual tool was designed as an accessory for Arcoy's high-speed Buccaneer drills, which turn at 3000 rpm. Although most U.S.-built drills aren't geared to that high a speed, any fairly high-rpm $\frac{1}{4}$ -in. drill, and the higher the speed the better, will drive the dovetailer's cutter satisfactorily.

The three cutters supplied—short, medium and long—blind-dovetail lumber from $\frac{3}{8}$ to 1 in. thick. These bits have short threaded shanks that screw into a

cutter head, which is simply a stub spindle turning freely in a bearing set in a grooved mount. With the cutter head's spindle inserted in the drill's chuck, the rotating cutter can be guided down slots in the jig's comb with the head's handle.

The cutter carves out matching tenons and mortises simultaneously. The two pieces of lumber to be dovetailed are securely clamped face-side down, ends lapped, to the jig's right-angle plates. Registration pins on the plates offset the two pieces $\frac{3}{8}$ -in., or one-half the dove-

tail's $\frac{3}{4}$ -in. pitch. Then the comb, which mounts on studs, is set against the vertical board.

The comb shifts sideways, mounting in either of two positions, and each position cuts alternate dovetails. First the comb is set in one position and the cutting head is run down each slot; then it's shifted to the other position and the cutter head is again run down each slot. A depth-of-cut setting on the comb adjusts the dovetail's tightness of fit.

When the dovetails have been cut, the work is unclamped and the backs of the

tenons are rounded off, or simply chamfered, by hand with a knife before the joint is assembled. This is necessary since the cutter does not automatically round the tenons as in the case of a regular dovetailing fixture.

A substantial tool, the all-metal dovetailer has machined die-cast angle plates with heavy channel clamps that hold lumber up to 9 in. wide. The cutters can be resharpened. The cutter head slides smoothly in the comb's slots.

The drill-driven cutters, however, do not cut as cleanly as high-speed router

PORTABLE DRILL that turns up to 3000 rpm does the smoothest job, but any ordinary $\frac{1}{4}$ -in. drill can be used if you apply the cutter with slow, even feed

THREADED-SHANK CUTTERS screw into a cutter head that slides in the comb's slots. The three cutters furnished dovetail boards from $\frac{3}{8}$ to 1 in. thick

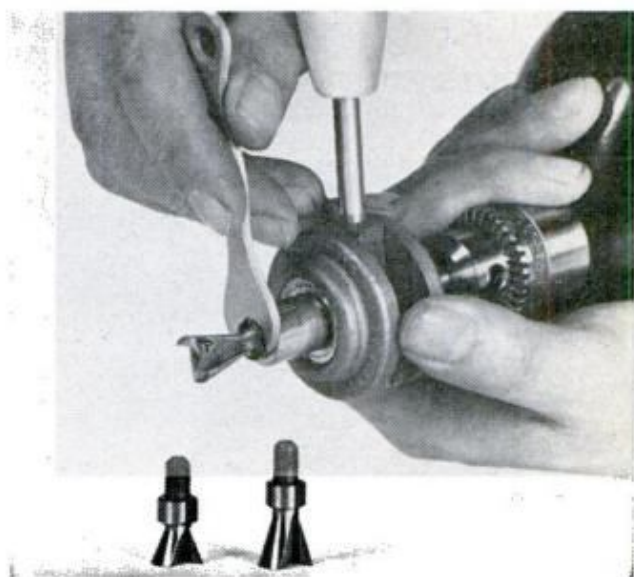
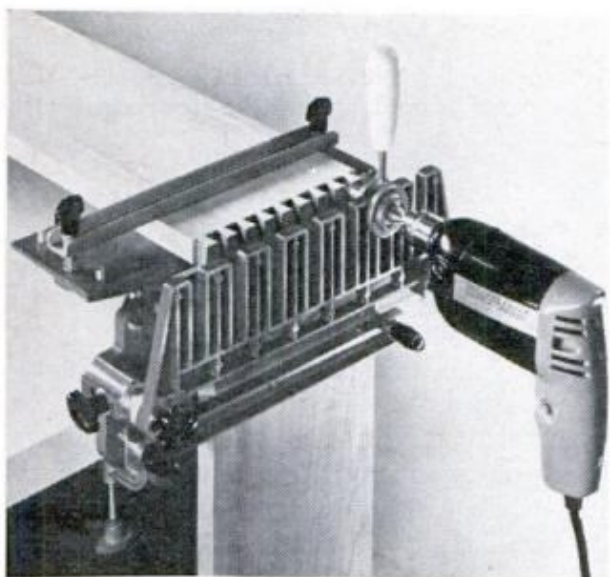

That's Really Different

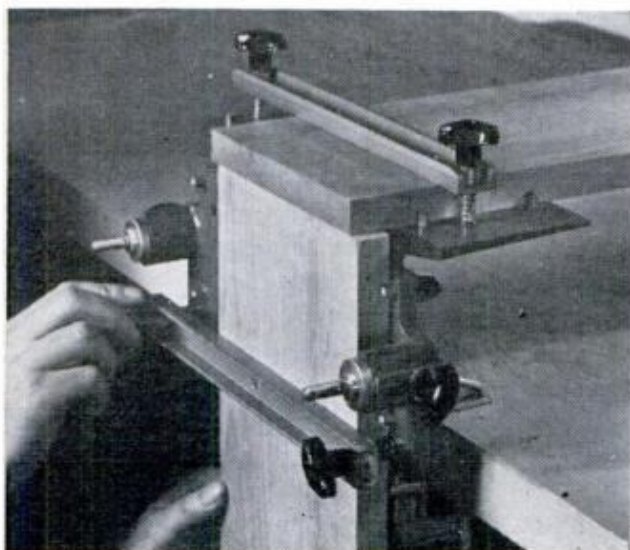

WORK TO BE DOVETAILED is clamped to the jig's angle plates and against registration pins which offset the boards $\frac{3}{8}$ in. Lumber ends must be square

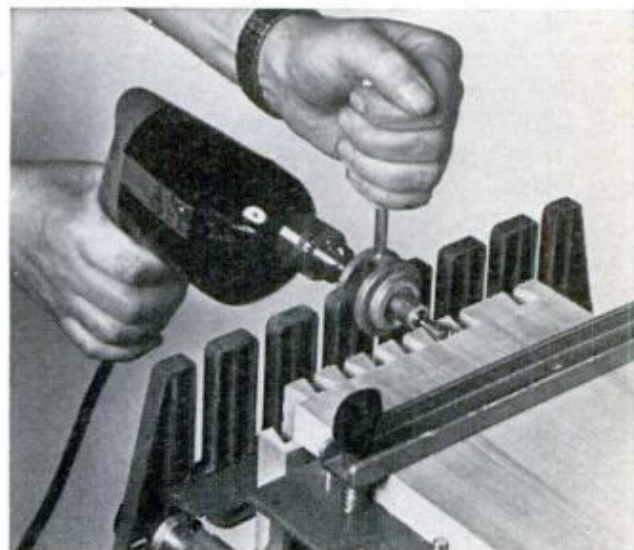

COMB GUIDE SHIFTS SIDeways and locks in either of two positions, with each position cutting alternate dovetails. Slots in the comb have $1\frac{1}{2}$ -in. spacing

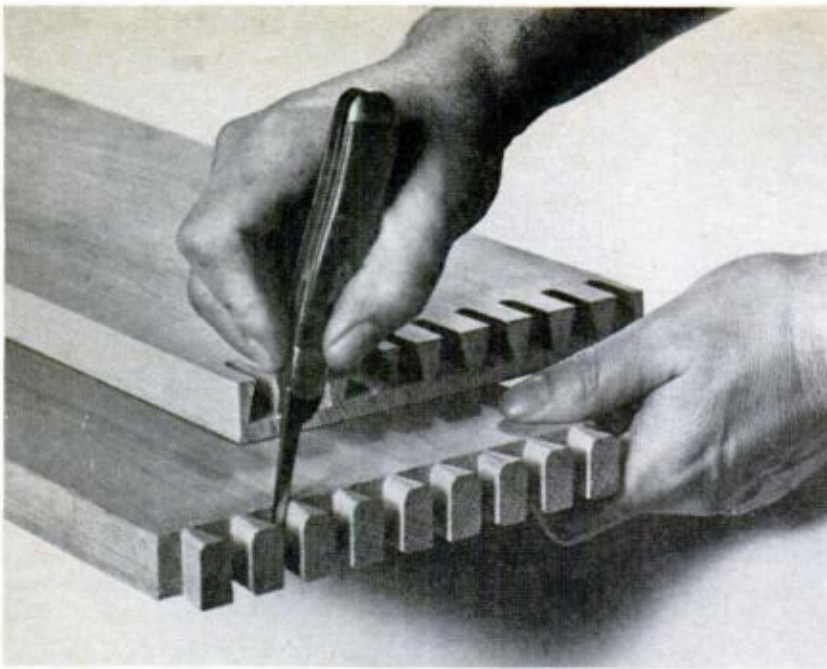

CUTTER DOESN'T ROUND the backs of the tenons. They must be rounded by hand with a knife to fit rounded mortises made by cutter

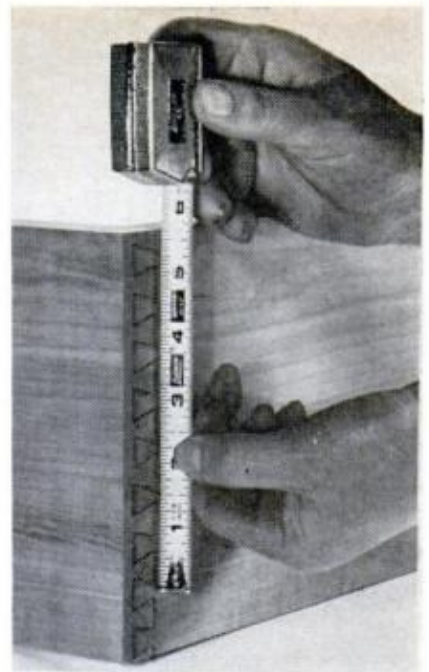

DOVETAIL TENONS have the standard pitch: $\frac{3}{4}$ -in. center to center

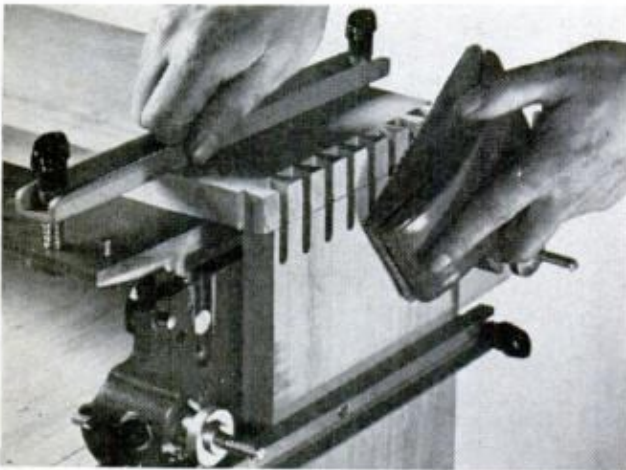

APPLY CUTTER to comb with slow, even feed. A little sanding with block removes the fuzz and splinters

bits, and when you're dovetailing softwoods, the cutter head must be run into the comb's slots with firmly controlled slow feed, and without side-to-side wobble, to prevent the bit from digging in and splintering.

New to the American market, the dove-tailer (without drill) retails at \$39.95. An attachment for cutting housing joints (dovetails running lengthwise) and a multi-pitch attachment (for dovetails with other than standard $\frac{3}{4}$ -in. pitch) are available for the tool. Address inquiries to the importer, the Hargay Co., 3570 Warrensville Center Road, Shaker Heights, Ohio 44122. ★★★

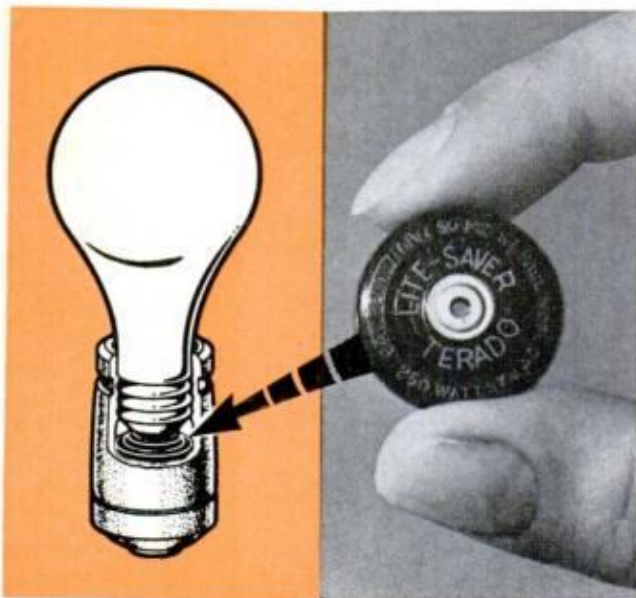

Wafer increases lamp life

Tired of periodically replacing burned-out light bulbs? Lite-Saver, placed face down in the socket, extends 800-hour lamp life of regular incandescent bulb to 50,000 hours. About the size of the button on your coat, this solid-state device operates in series with the lamp, thus the filament burns cooler and lasts longer. The one hitch is that it reduces light output approximately 50 percent, requires doubling bulb wattage for full brilliance. Ideal for exit lights, yard lights, signs, hallways, and particularly where lights are hard to reach. Retails for \$1.20 from Terado Corp., 1068 Raymond Ave., St. Paul, Minn. 55108.

HINTS FROM READERS

Ink cartridge spreads glue

Fitted with a "paint-roller" handle, an empty fountain-pen ink cartridge makes a dandy glue spreader. The plastic cartridge is virtually self-cleaning since most adhesives can be easily peeled off when dry. Unlike a paint roller, the cartridge does not turn. It fits tightly on its wire handle and simply spreads the adhesive with a wiping action.—*Walter E. Burton*



Clothespin provides safe grip

The problem of holding small-diameter tubing, plastic rod and other fragile work in a vise without damaging it is quickly solved with a spring-type clothespin. Cradled between the wooden jaws, the work is cushioned and protected and can be safely clamped in a regular vise. You should exert only a little pressure when tightening the vise.—*Victor H. Lamoy*

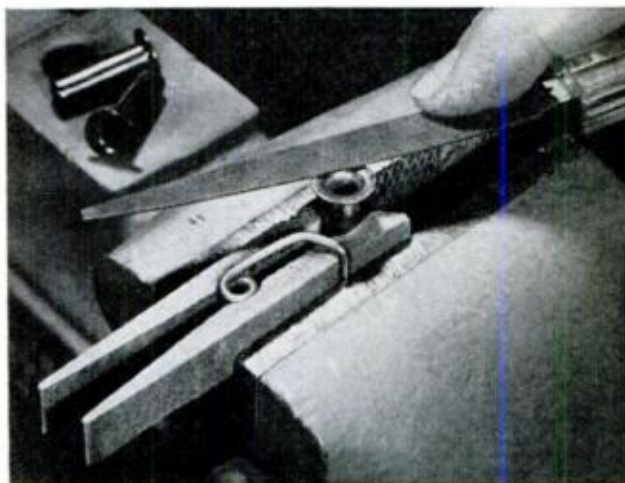

Outlet 'map' pinpoints circuit

I have found it a timesaver to have a numbered map posted near the circuit-breaker or fuse box which shows all the electrical outlets in the house. This way when a fuse blows, I can pinpoint it quickly, or if I want to kill a certain circuit to work on it, I know immediately what breaker controls it by its number.

To make such a map, draw a floor plan of each floor and spot the outlets and ceiling lights on it. Now trace through the lights on each circuit by killing them, one at a time, and noting which outlets each controls. Most fuse and breaker boxes have each circuit numbered and each outlet on the map is given a corresponding number. This way, for example, if you want to kill a bedroom outlet marked No. 3 on the map, you snap circuit switch No. 3.—*Herbert Y. Moon*

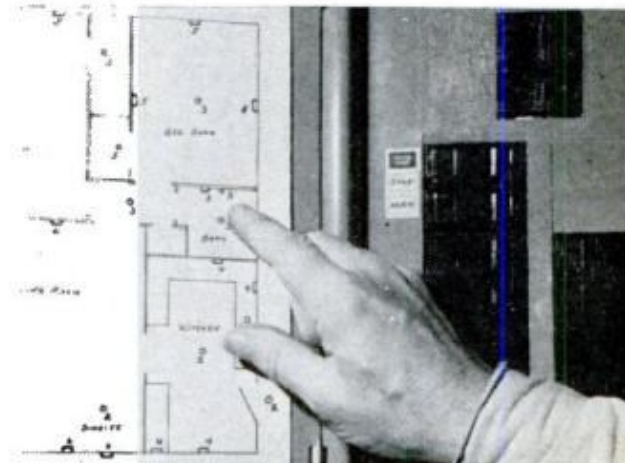

Benchtop sharpening pad

An abrasive-covered wood block fastened to the bench where it will not interfere with other work will be found extra handy for keeping a keen edge on a knifeblade or other cutting-edge tools. Pick a fine-grit abrasive, cloth or paper, and glue it to the block, then fasten the block to the benchtop with two small brads. Brush away all dirt before using.

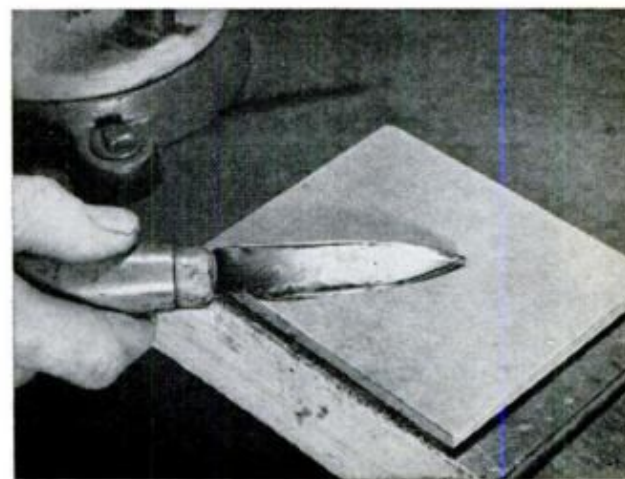

How, When and Why You Should De-Thatch and Aerate Your Lawn

Take a tip from landscaping pros and remove the "blanket" that's smothering your lawn. You can do it yourself with rental equipment



AFTER ALL THE TIME and money you've invested in fertilizing, weed killing, and watering, does the appearance of your lawn still leave something to be desired? If so, is it possible your soil is not getting its share of air, water and nutrients, in spite of your conscientious efforts? Your lawn could be "starving" in the midst of plenty, due to thatch deposits on the ground, overcompacted soil or both.

Thatch is the accumulation of dead grass, leaves and other undecomposed organic matter. As this deposit grows it forms an almost impermeable, matlike layer that hinders penetration of air, water and fertilizer into the soil. Deep root development is thereby discouraged, and the lawn begins to thin out, paving the way for weed growth.

There are other reasons why thatch harms your lawn. According to Richard Delano, University of Illinois extension horticulturist, it can be an ideal breeding ground for lawn insects. Even worse, because many kinds of fungal spores can thrive in it, thatch encourages development of diseases such as striped smut, leaf spot and dollar spot in bluegrasses, and brown patch in bent grasses.

An overabundance of uncollected clippings is a major contributor to thatch formation. Soil acidity is another factor, since an alkaline soil condition is necessary for effective decomposition to take place. Some pesticides may also reduce the rate of decomposition, since in the process of eliminating undesirable insects they also destroy the microorganisms that carry out the decomposition process.

Another major reason for ineffective penetration of air, water and nutrients is excessive soil compaction, which closes off the network of pores and capillaries—the "breathing system" of the ground.

Compaction is likely to be most severe where there is a good deal of traffic; for example, where children play regularly. It's also caused when too many of Mother Nature's aerators—earthworms, ants and other insects—are killed by fertilizers and other chemicals applied to lawns.

Is your lawn in trouble? Try a quick experiment. Take a screwdriver with a 4-in. blade, and try to insert the blade completely into the ground. If you require some effort to push it in completely, chances are your lawn needs aerifying.

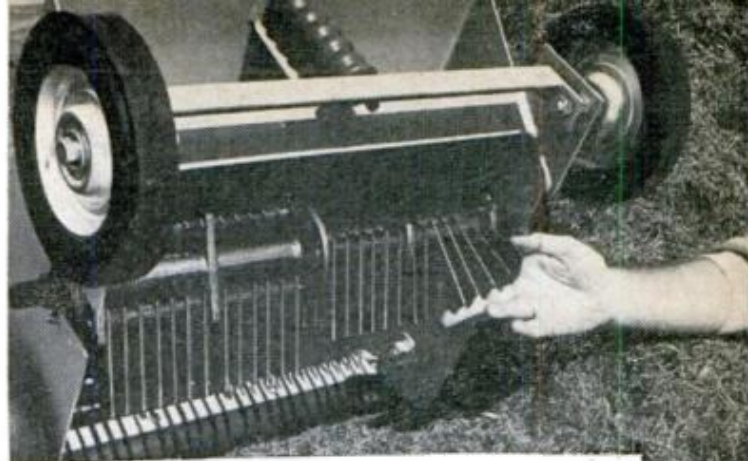

STANDARD DE-THATCHING ROTOR has 52 blades, individually removable for medium, light combing

Now, pull the blade out carefully so you won't dislodge any deposits, and examine it. (You might want to try this part of the experiment with a knife blade instead.) Do you see a peatlike layer above the soil deposit on the blade? If so, and if this layer is $\frac{1}{2}$ in. thick, or greater, you have a thatch problem as well.

Now that you know you have problems, what do you do about them? A vigorous hand raking in the spring and fall would help prevent thatch formation. However, once thatch is present the only effective way to deal with it is to remove it by mechanical means, just as the only complete answer to an overcompacted lawn is mechanical aeration.

Those masters of turf care, golf-course superintendents, are well acquainted with the benefits of de-thatching and aerifying, and follow these practices religiously on their greens.

"There has been very little done on aerifying of home lawns, yet this is a procedure that should be carried out regularly," states Paul N. Voykin, golf

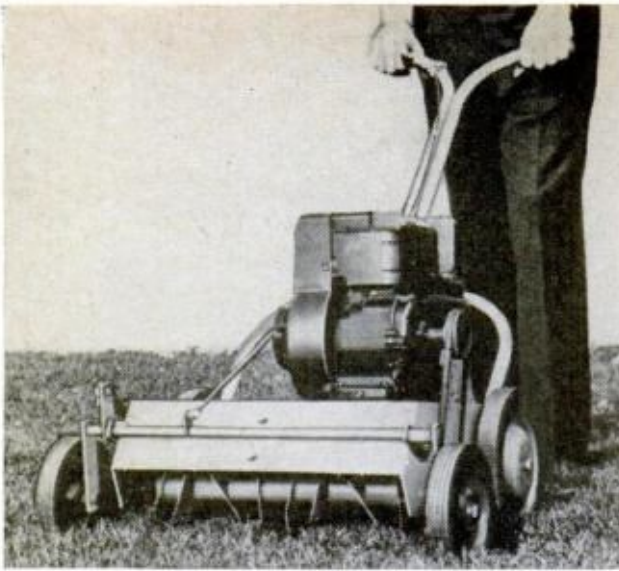

THIS VERTICAL-CUTTING MOWER cuts out dead plant matter with eight oil-tempered, spring-steel blades



THIS DE-THATCHING MACHINE comes equipped with three interchangeable reels: tine, knife and flail, which are pictured in that order below the machine

course superintendent at the Briarwood Country Club in Deerfield, Ill. "One drawback is that the average homeowner is not acquainted with what aerifying does," he continues. "The other is that an aerifying machine is expensive, and will usually not be used more than once or twice a year. The same is true of de-thatching equipment."

However, Voykin notes that the current boom in rental equipment is right up the alley for homeowners who have only sporadic need for large, relatively costly machines.

"It's interesting to note that today homeowners have available to them, at modest cost, equipment that just five short years ago was used only by professional landscapers," observes Mason Warner, president of A to Z Rental, Inc., one of the nation's largest equipment-renting organizations with about 450 rental centers.

There are several varieties of de-thatching machines, all designed to pull out the thatch layer and deposit it on the surface of the lawn. Some remove more living grass in the process than others, and this may not be an important factor, depending on the type and condition of your lawn.

A de-thatching machine, sometimes called a vertical mower, consists basically of a reel having blades, tines or knives positioned around the circumference of the reel shaft. The machine is generally powered by a gasoline engine, and can normally cover 5000 square feet in about one hour. Following are some popular types of de-thatchers:

1. *Blade or flail type.* The reel on this version is equipped with from 30 to 60 hardened steel, rectangular blades, each about $\frac{1}{8}$ x 1 x 4 in. in size. In some cases, one end of the blade may be sharpened to a point. Depending on the manufacturer, the blades may be free-swinging, or rigidly attached to the rotor. As the reel turns, the thin, high-speed blades pass vertically through the living grass, cutting through and lifting out the thatch below. In the process, the blades cut narrow slits in the soil, making an ideal bed in which tiny roots of newly germinated seed can flourish. This type machine is also useful for renovating poor lawns that are to be reseeded, and can break up clods after tilling in preparation of seed beds.

A flail-type reel is well suited for use

on bluegrass lawns in northern and some middle sectors of the United States. One version permits removal of some blades in order to achieve optimum thinning and slicing action needed on southern, bent-type lawns.

2. *Tine type.* The reel on this machine uses thin, wire-like, flexible tines in place of flails. Typically, about 100 tines are employed. This unit provides a combing-type action, and minimizes removal of living grass. It is particularly designed for use on established bluegrass lawns.

3. *Knife type.* This reel uses anywhere from 25 to 50 knife-like elements which depopulate plant growth by removing some living grass as well as loose thatch. This unit is particularly effective on Bermuda, zoysia, St. Augustine and centipede grasses, more commonly found in the southern sector of the United States. It is also useful for controlling growth of weeds such as wild fescue, crabgrass and nimblewill.

Tests have shown that up to 20 to 30 bushels of thatch may be obtained from just 1000 square feet of lawn. The resultant debris must now be removed from the surface of the lawn, and the most effective way is with a power sweeper, which is also available at rental centers. The sweepers generally operate by vacuum or with brushes. The debris can then be transferred to plastic bags for disposal.

If you have a garden and can afford the space, you might consider using at least part of the recovered thatch, which is largely grass clippings, to form a compost pile. Mix in some black soil, and you will duplicate the compost-making activities of the earthworm, who does his work by bringing black soil up over dead grass.

Like de-thatching machines, aeration equipment utilizes a reel equipped with a number of elements positioned around the rotor shaft, powered by a gasoline engine. In principle, an aerating machine removes small plugs of soil from the ground, thereby alleviating compaction and opening up pore spaces for penetration of air,

water and fertilizer. The action encourages development of deep, drought-resistant root systems.

One type of aerating machine utilizes hollow tines that penetrate about 2½ in. into the ground on 5-in. centers. In operation, a plug of soil is forced into the central core of the tine, which on the next revolution is forced out by a new, incoming plug.

Another type employs an open, half-round "spoon" that scoops out a core of soil to give surrounding earth room to expand. The action provides a loosening effect without disturbing grass.

The soil cores that have been deposited on the surface of the ground can be removed by sweeping, but it would be more beneficial to the lawn to leave them and let the soil work its way back in.

A distinction should be made at this point between aerating machines and equipment having solid tines or spikes. The latter type does not aerate, but actually increases compaction. Unlike aerifying, it does not remove any soil cores. It is sometimes used in the hot, dry months,



AERIFYING MACHINE penetrates up to 2½ in. on 5-in. centers, to cut out soil plugs like those above

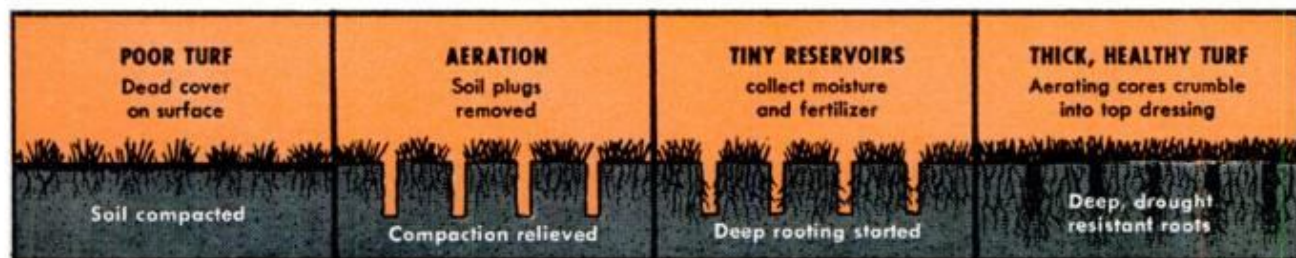

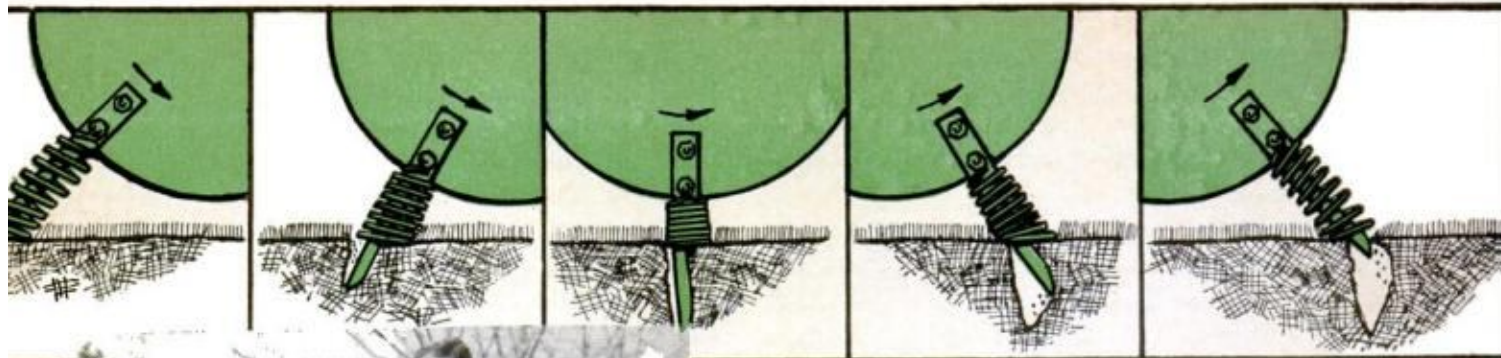

THIS AERIFYING MACHINE has "spoons" that scoop out cores of soil in manner shown in diagram above

in order to open the surface crust of soil, thus permitting water penetration and preventing runoff.

Although there are differences of opinion among authorities, it's generally agreed that spring and fall, when grass grows most vigorously, are the best times for de-thatching and aerifying.

After thinning-out of dead matter by de-thatching, it is desirable to stimulate a fresh, strong growth of grass so as to prevent further thinning out. Likewise, vigorous grass growth is important after aerifying, so that deep-rooted grass fills up the holes that have been left in the ground.

Of the two seasons, fall is probably slightly preferable for aerifying, since some natural aeration takes place in spring through freezing and thawing action. On the other hand, the most vigorous growth occurs in spring, so this may be the best time to de-thatch. Many authorities recommend performing de-thatching and aerifying at different times,

since their combined action could have a shock effect on the turf.

Generally, it is recommended that each be done once a year. A good maintenance program, then, might be de-thatching in the spring and aerifying in the fall.

One note of caution is in order for aerifying in fall. Preferably, this should be done before mid-October; if aerifying is done too late in the year, there is a possibility that some holes will remain open all the winter. Then, if there is little snow and a general lack of moisture, wind action can have a damaging drying effect on the lawn.

These generalizations will have to be modified to fit individual situations, and the homeowner will have to exercise his own judgment. Some grasses decompose more slowly than others, thereby providing more of a thatch problem. This is particularly true of such grasses as Bermuda and zoysia, which are fibrous in nature and resistant to decay. With such lawns, more frequent de-thatching may be desirable. Again, in parts of Florida and the southwest, where the soil is quite sandy, compaction is not much of a problem, and very little aeration is necessary.

Thorough watering to stimulate growth is desirable after both de-thatching and aerifying. These are also excellent times for applying fertilizer and reseeding, if needed.

A good way to minimize thatch accumulation is by adopting consistent mowing habits. This is especially important in spring, when a few days' procrastination during a lush growth period will result in an overabundance of clippings when mowing is finally performed. At such times, even a good grass catcher will not be effective enough.

When starting a new lawn, use 4 to 6 in. of black topsoil and mix in plenty of sand to minimize compaction problems that may occur later on. ★★★

HINTS FROM READERS

Grinder mount saves space

If a machinist's vise is already taking up valuable workbench space, you can hardly afford to have a grinder permanently bolted to it also. Since a grinder is used far less frequently than a vise, here's a way you can mount it to swing up out of the way when not in use. Bolt it to a 1x12 board and hinge it to a 1x4 block screwed to the wall. Mount the block at a height to bring the grinder level with the top of the vise. A 3 or 4-in. vise will hold the grinder at a nice working height. A couple of sturdy hooks and eyes will stow the grinder against the wall.—*B. F. McNamee*

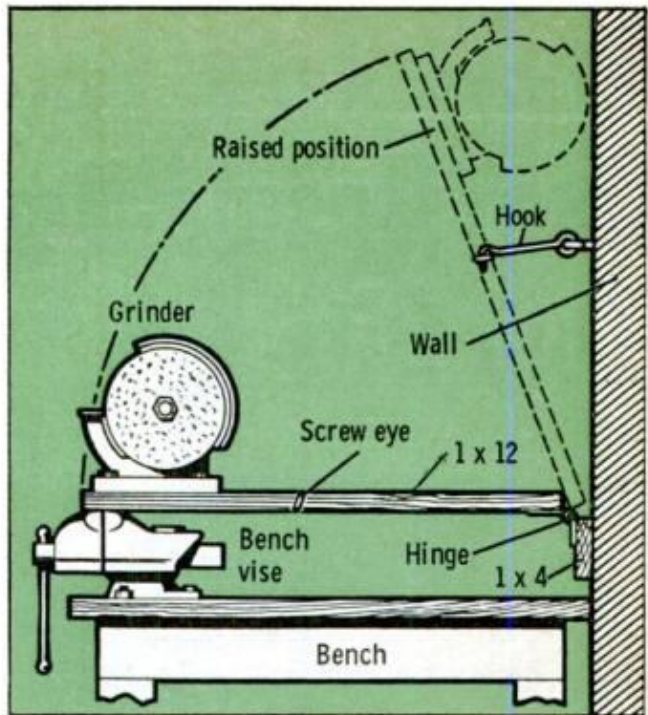

No more pinched fingers

Sooner or later you're going to pinch your fingers when using a spiral ratchet screwdriver. You can avoid this happening by placing a collar over the chuck as shown. A split lock washer, annealed, flattened, spread apart and forced over the knurled grip, will do the trick nicely. To anneal the washer, heat it to a dull red, then let it cool slowly.—*H. Josephs*

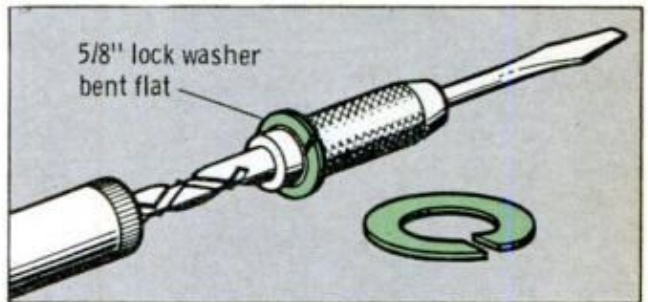

Making sawhorse handier

There are three things you can do to make a wooden sawhorse handier when it comes to keeping track of your tools. Cut a slot in one end for the saw, tack a piece of flooring (groove side up) to hold a framing square and attach a loop for your hammer. You'll know right where these tools are when you're looking for them.

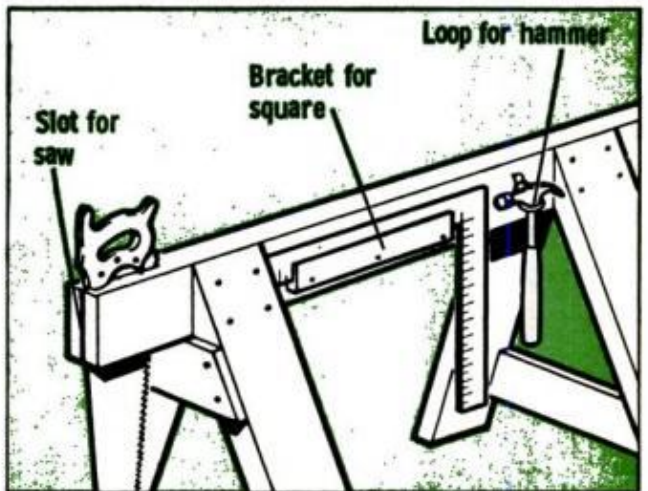

A backward idea that works

When cutting corrugated aluminum roofing, I have found that the regular skip-tooth blade of an electric saw will cut across the "hills and valleys" much faster if the blade is put on backward. Makes a smoother cut, too.—*Keith N. House*

Silencing noisy bearing

The bearing next to the pulley on our lathe motor started to run noisily. Suspecting that constant belt tension had caused the outer raceway of the bearing to wear, I rotated the bearing housing 180°. This brought a new surface to the top to resist belt pull. It stopped the noise.

—*Emil Wittman*

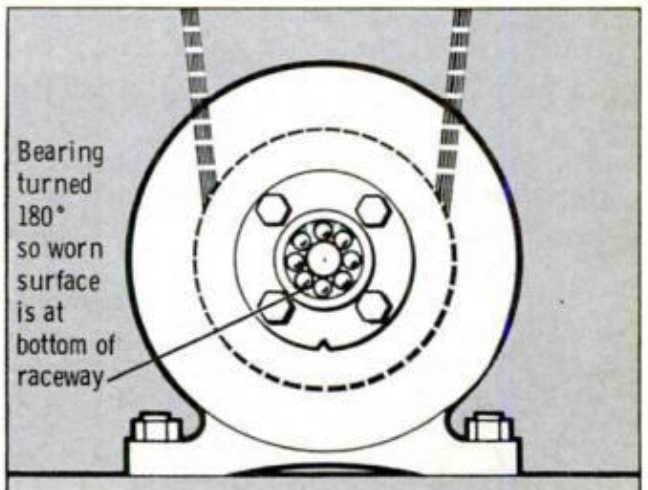

Make This Back Holder and Use 'Upside-Down' Tool Bits

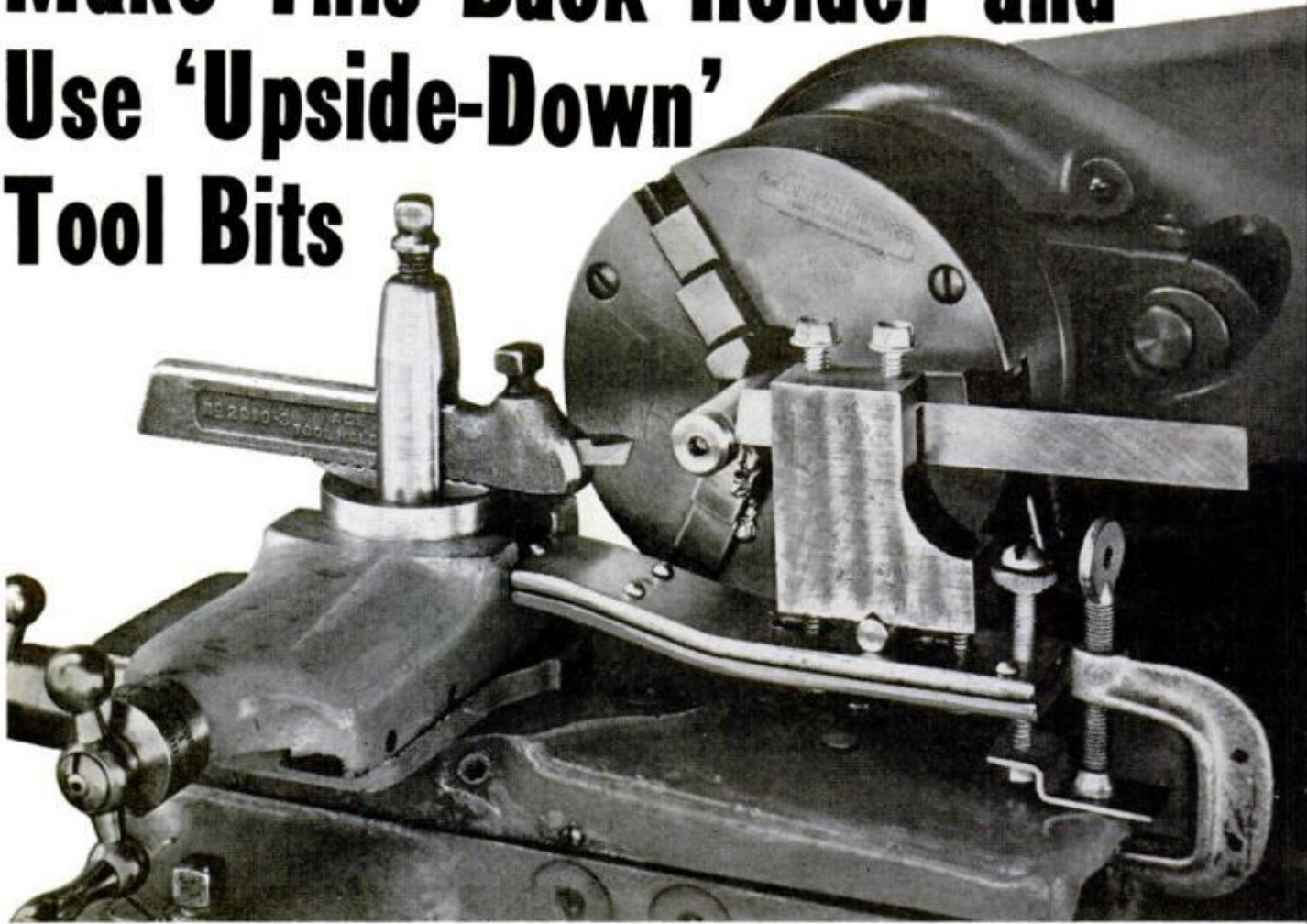

SETUP FOR CUTTING A RING from round stock with inverted parting tool mounted at rear of the cross slide

By borrowing an idea from turret lathes you can speed up and improve many operations on a metalworking lathe

By **WALTER E. BURTON**

THIS BACKWARD IDEA is the reverse of normal lathe technique—you invert the tool bit and mount it behind the workpiece. Such a “back” position has been found to be particularly effective for cutoff (parting) tools. By using a back toolholder in conjunction with a conventional front one, the number of cutting bits immediately available for an operation can be doubled or better, and work is correspondingly speeded. You may find an inverted tool often cuts more smoothly than the same tool right-side-up.

There are numerous ways of providing a backholder for upside-down tool bits. (Practically all tools have to be inverted when fed from the back so they will function as the workpiece is revolving forward in the usual manner.)

For some lathes, special cross slides

Technical Art by Associated Technical Services, Inc.

having slots for mounting toolholders in both front and rear of the workpiece may be obtainable. The lathe owner should not find it difficult to work out a way of adding a rear toolpost to his particular machine when such a cross slide or attachment is not available. Such a unit can be designed to operate on the cross slide after the compound has been removed; or the compound can be left in place and used as a support—as was done for the attachments described here.

The illustrations show two systems (one on a 9-in. bench lathe, the other on a Unimat) which do not require any modification of the lathe itself. The attachments can be installed or removed in a minute or so, and thus rank with conventional toolholders for convenience. On the 9-in. lathe, the compound, on which the front

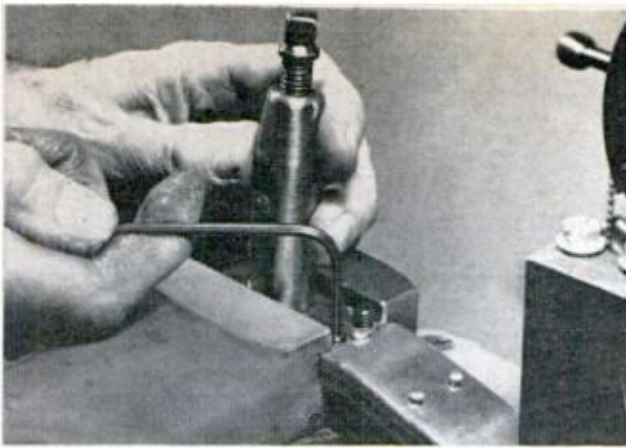

TWO SETSCREWS lock attachment to toolpost slot so it can't shift when post is loosened for adjustment

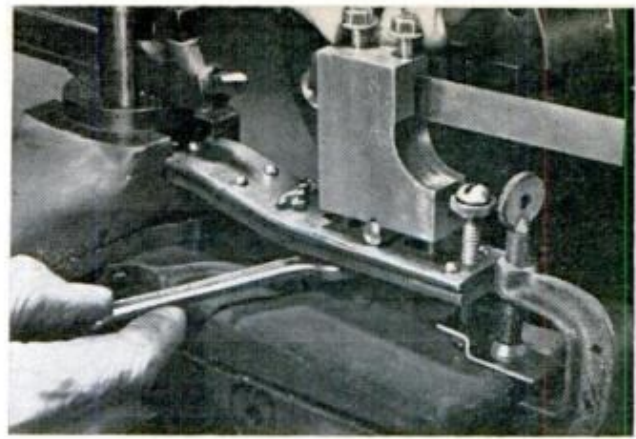

FINE ADJUSTMENT of toolpoint position is had by turning two bolts that clamp block B over fulcrum pin

end of the attachment is anchored, is swung parallel to the lathe bed and is not moved during machining operations.

In any kind of back-tool support, it is important that there be a high degree of rigidity to reduce chatter and any tendency of the tool to climb on the work. The front end of the base piece of each attachment is secured in the regular toolpost slot of the carriage, and the back end is restrained by a clamping arrangement. It is possible to use the units without anchoring the "loose" ends, but tool-climbing, vibration and chatter can be expected to be greater.

So, for the base piece of an upside-down toolholder, the stock should be as thick and rigid as feasible. In the drawings, piece A is the base for the 9-in. lathe attachment. It was bent to position the back toolholder somewhat below the level of the toolpost slot in the compound

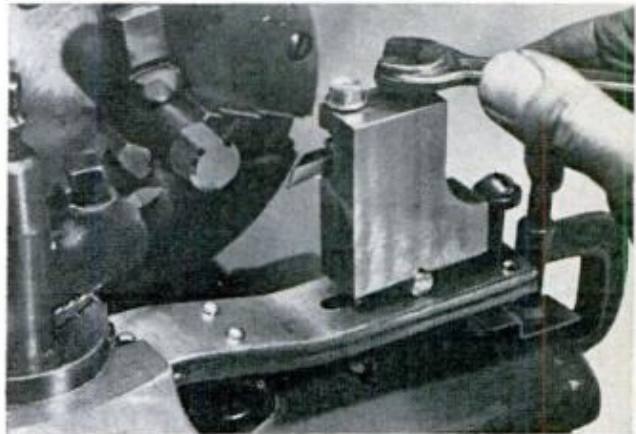

REAR TOOLHOLDER will accommodate conventional square bits also. Two bolts lock the bits securely

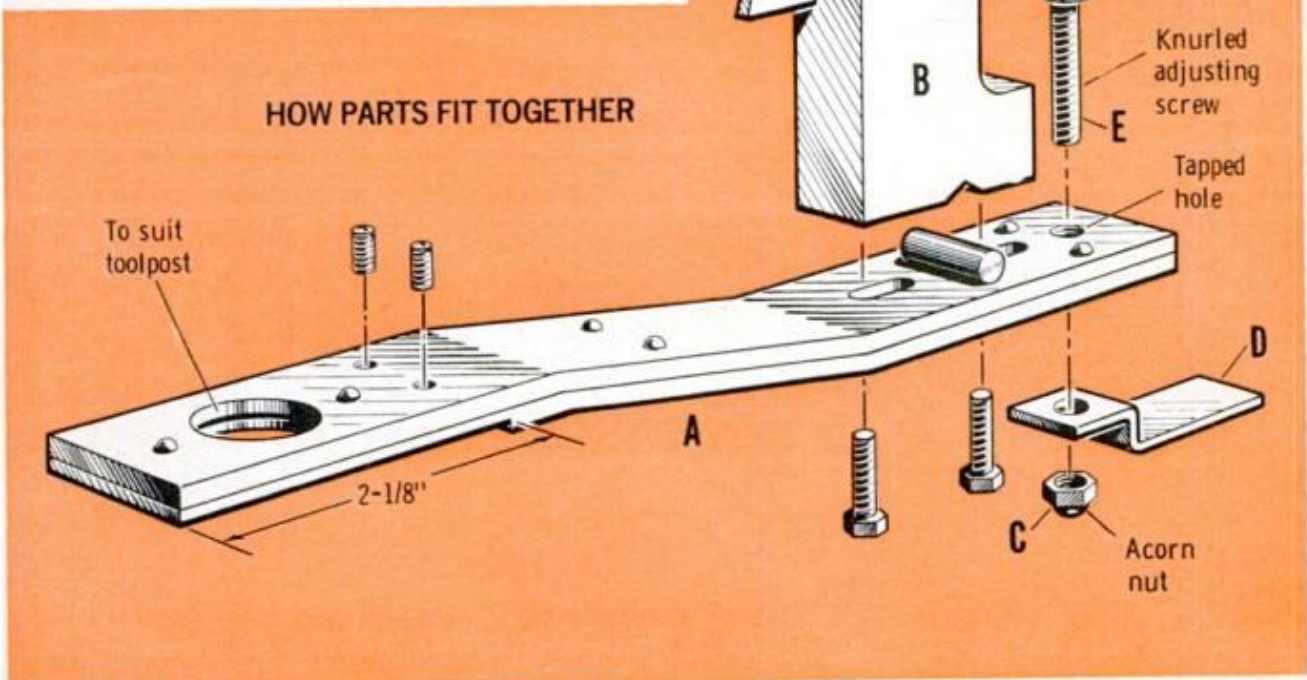

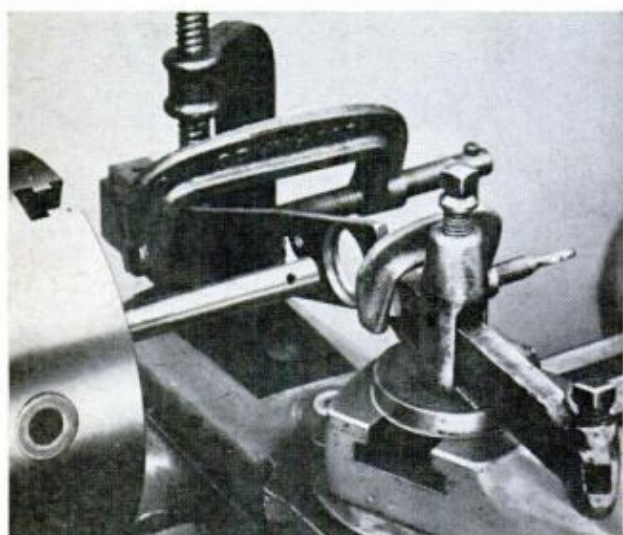
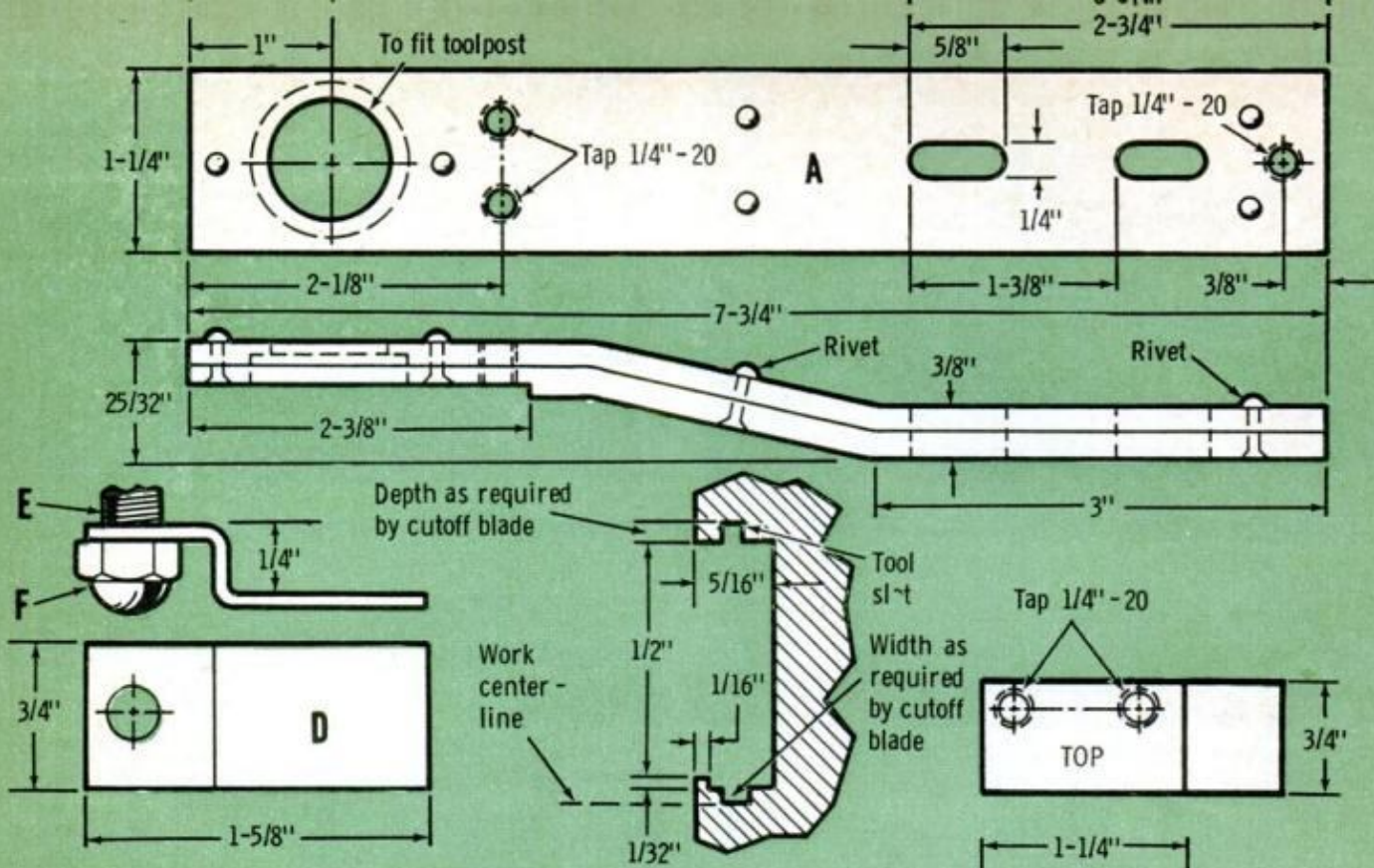

TO FINISH-BORE TOOLPOST HOLE in bar, work is clamped to regular toolpost holder and to a steel block clamped to rear end of cross slide with C-clamps

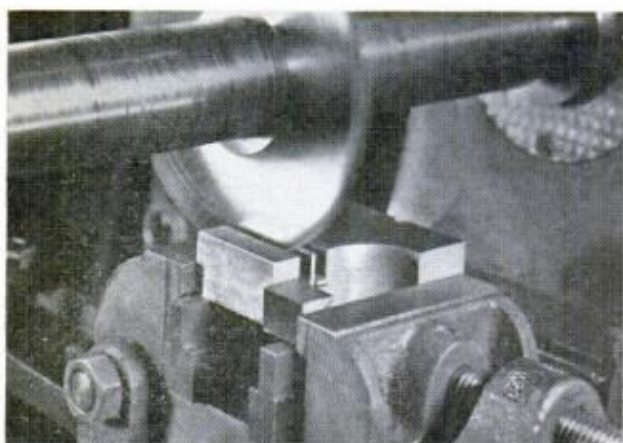
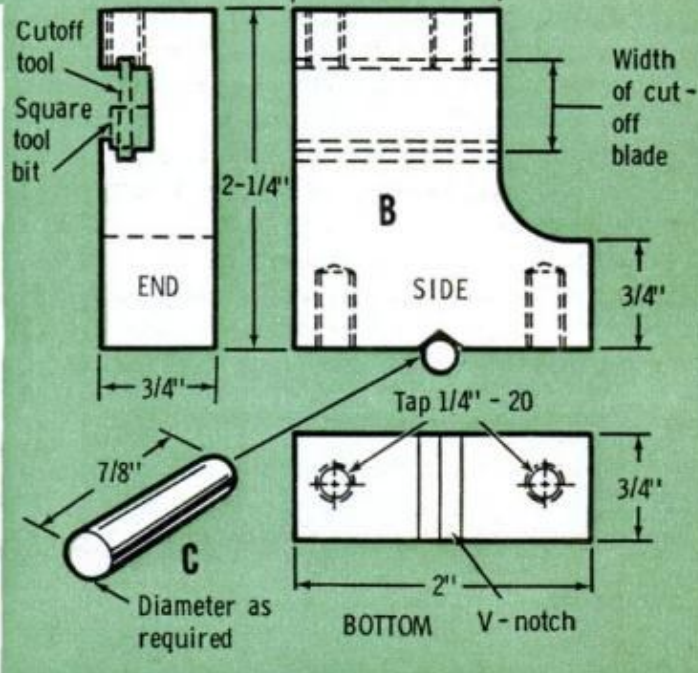

TOOL SLOT IN BLOCK is roughed out on a milling machine with two saws, then center web is removed

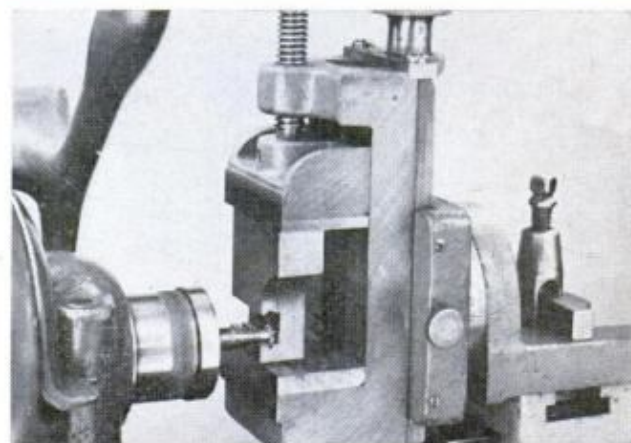

SLOTS FOR CUTOFF BLADE in bottom of main groove are made with keyway cutter similar to a Woodruff

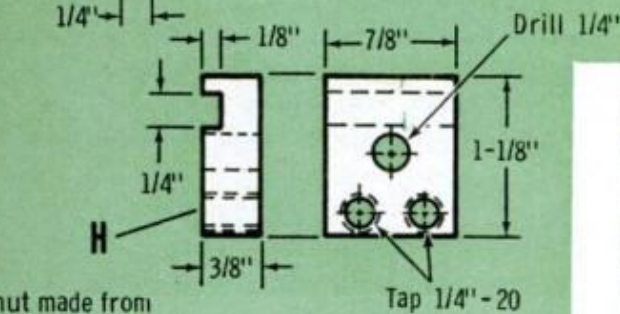
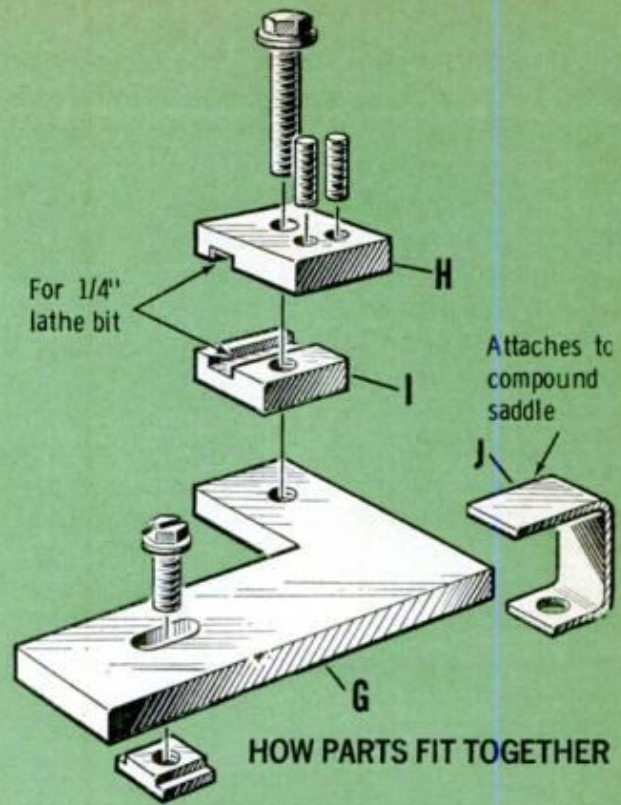
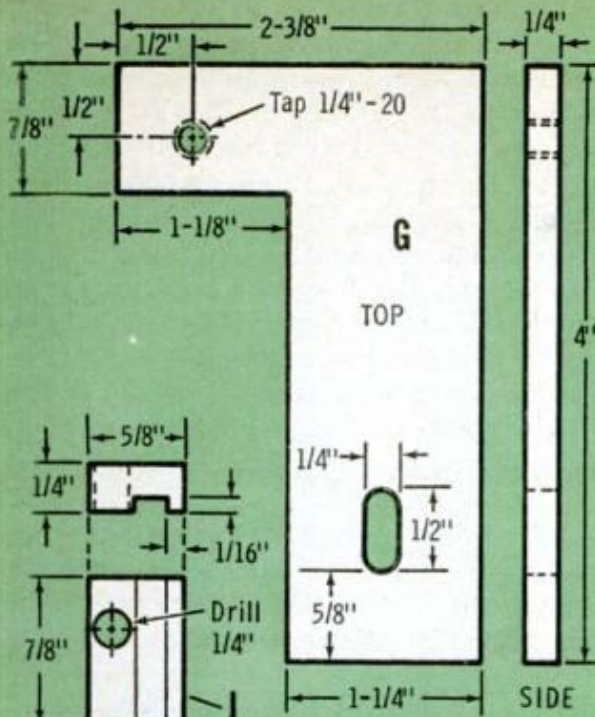

T-nut made from common square nut

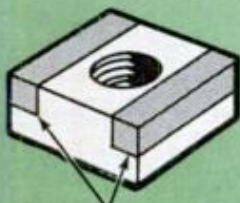

Cut away shaded portions

Size to accommodate carriage lock bolt

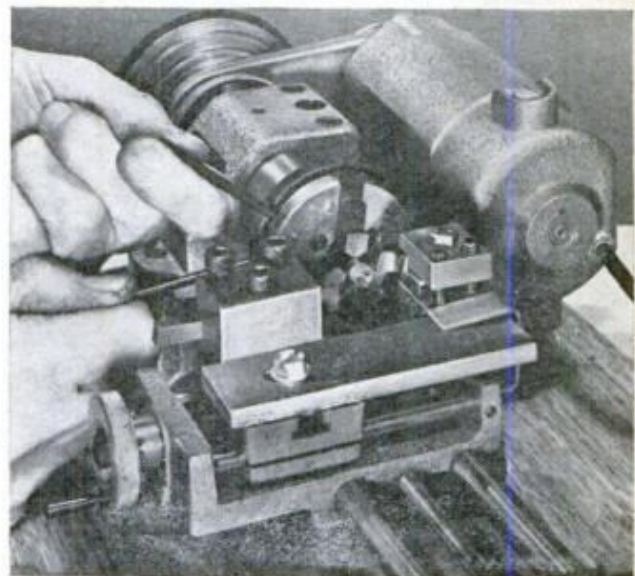
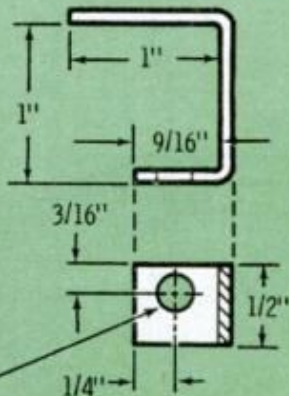

SECOND ATTACHMENT, designed for Unimat lathe, uses square bit for both cutoff and facing operations

slide. This creates more space under the lathe spindle. However, the piece could have been straight without coming too close to chuck jaws for most small-diameter work. When I was making the attachment, there was a typical small-shop problem: No bar stock of sufficient thickness was at hand, so piece A was made by riveting together two thicknesses of $\frac{3}{16}$ -in. steel bar.

Piece A is locked in the slot on the compound slide by the regular toolpost, which passes through a hole near the front end. Near this hole, two $\frac{1}{4}$ -20 set-screws were installed to bear against the

slot bottom, so the attachment will not shift when the toolpost screw is loosened for adjustment—especially during setup. The portion of the bar that enters the toolpost slot must, of course, be machined to width and thickness for a snug fit.

The rear toolholding block, part B, must be adjustable for tool height, so the tool tip can be aligned properly with the work. The seesaw arrangement permits both rough and fine adjustment with ease. The block rests on a steel pin under a central V-notch in the bottom, and is secured by two bolts extending upward through slots in piece A. By selecting a pin of proper

diameter, the tool tip is positioned approximately level with the workpiece centerline. Then, by loosening one bolt and tightening the other, the block is tilted forward or backward for almost micrometer adjustment. To obtain enough clearance with some chucks, it may be desirable to set the block farther back on piece A than the drawings indicate, and to use a steadying bolt E that does not extend upward enough to interfere with the block.

The horizontal slot in block B was designed to hold either a standard $\frac{3}{32} \times \frac{5}{8}$ -in. high-speed-steel cutoff bit or a conventional $\frac{1}{4} \times \frac{1}{4}$ -in. tool bit. Bits are locked in place by two $\frac{1}{4}$ -20 hold-down bolts. A shim can be used under the bolt ends if the bolts are not long enough for the smaller bits.

No matter how massive base A is made, it probably will tend to spring and vibrate (when cutter is being used) if its tail end is not anchored. One way of anchoring would be with a bolt engaging a threaded hole in the cross-slide top; but largely to avoid marring the slide, the lower end of the bolt was provided with a bracket, D, which is anchored with a small C-clamp positioned so as not to interfere with cross-feed operation. It was found desirable to use a locknut (not shown) on the bolt, jamming it against the bottom of piece A. Nut F on the bolt tip is

a roundhead type, turned tight. Bracket D is shaped to exert downward pressure on the nut when the clamp is tightened.

Movement of tools in the back holder and conventional front toolpost is controlled by cross-feed and carriage screws.

An attachment for using inverted back tools on a Unimat lathe is shown in drawings G to J. The base piece, G, was made from $\frac{1}{4}$ -in. steel plate. A $\frac{1}{4}$ -20 bolt engaging a T-nut in the toolpost slot fastens the plate to the carriage, alongside the regular toolpost. Two grooved steel blocks, H and I, are used to mount a $\frac{1}{4}$ -in.-square tool bit on the plate.

The square groove in I is cut so it normally will lower the tool point somewhat below the workpiece centerline, and a shim directly under the bit or block I elevates the point to the proper level. Then if, in resharpening, the bit is ground so the point shifts upward, the shim can be changed or removed to bring the tool tip back into alignment.

Two $\frac{1}{4}$ -in. setscrews in H are used as a fulcrum to apply locking pressure on the bit by tightening the $\frac{1}{4}$ -20 hold-down bolt. The bit can be swung at various angles around the bolt, for aligning the cutting edge in forming bevels.

The tail end of plate G is steadied by bracket J, fastened to the lathe carriage by the regular carriage-locking bolt. The

(Please turn to page 193)

NEXT MONTH IN SHOP AND CRAFTS

WHAT'S NEW FOR POLISHING AND BUFFING. Traditionally, the polishing of metal has been done solely with cloth buffing wheels. Now most production polishing is done with coated abrasive belts, first with a dry belt, then with a belt lubricated with grease. Read how you can practice this new technique in *PM* next month.

HOW TO INSTALL GUTTERS AND DOWNSPOUTS. If the roof on your house is sky high, you'd do best to leave a new gutter job to the pros. It's not worth risking your neck. However, if it's only one-story high, you can easily take on the job yourself and save money. Aluminum and vinyl gutters go together like the parts of an Erector set, without tricky soldering. If your gutters need replacing, be sure to read this timely home repair story in the September *PM*.

THOSE TOUGH-TO-PICK LOCKS. How pickproof are the locks on the doors of your house? If they're a common pin-and-tumbler type without a dead bolt, any petty thief would find it easy pickings to walk in at will. Such locks are common because of price. For your own sense of security check the locks on your doors, then pick up the September issue to see what's new in pick resistant locks.

BUILD YOUR OWN FENCE WITH PRIVACY PANELS. Packaged fence "boards" of pressed aluminum are the latest things to use in building a smart custom-made fence for your yard. Available in white and redwood, and in three different lengths, they're applied to a framework of wood or pipe in a pattern of your own design. Read about this new idea in fence building in the September issue.

OVER 100,000 MEN CAN TELL YOU:

“NTS HOME-TRAINING REALLY WORKS!”

AND PUTS YOU WHERE THE BIG MONEY IS!



If you think you can't learn a new technical skill with NTS Home-Training, you're wrong. Over 100,000 men have done it in the past half-century since the school was established.

And so can you.

NTS Project Method makes learning fast, easy and exciting. Takes only a few hours a week. Hours any man can fit into his life.

So, stop wasting time. Pick from these big money-making fields. We'll send you all you need to know to get started towards a new, better job. It's a sure thing!

ELECTRONICS DIVISION (295 SQ. IN. PICTURE COLOR TV)

Train with the biggest, most exciting package of electronics kits ever offered! Beautiful new Color TV kits included in color TV courses. No kit deposits — no extra cost. All-new Communications and Industrial Electronics Kits & Courses — put you two steps ahead of tomorrow. Check coupon for choice of Project Method Courses and New Free Color Catalog.

MECHANICS DIVISION (New Test Equipment)

NTS makes you a skilled Mechanic — Diagnostic Technician in a hurry! You get professional engine analysis test instruments at no extra cost! Special Engine Diagnostic and High Performance lessons included — everything you need to be a pro. Four fields from which to choose. Service your own car — earn while you learn. Check the coupon for new catalog.

AIR-CONDITIONING, REFRIGERATION DIV. (New Kits)

A wide-open field. NTS opens it up for you — fast and easy! Trains you to handle the big jobs. Start your own business with either of the two courses in this division. We give you the tools, tester, and instruments you need at no extra cost. No kit deposits! Check the coupon below and get rolling!

HOME APPLIANCES DIV. (New Circuit-Trainer)

Dig deep into the Major Home Appliance repair field for the big money! NEW, EXCLUSIVE! THE NTS CIRCUIT-TRAINER! Shows you the ins and outs of major appliance circuitry. Makes training a snap. Puts you in line for a piece of the billion-dollar appliance repair field. New Kits! New Catalog. Check coupon for earn-while-you-learn courses.

HIGH SCHOOL AT HOME

National offers accredited High School programs. Take only subjects you need. Study at your own pace. Everything included at one low tuition. Check special High School box in coupon for full information and FREE catalog.



CLASSROOM TRAINING AT LOS ANGELES.

You can take classroom training at Los Angeles in Sunny Southern California. NTS occupies a city block with over a million dollars in training facilities.

NATIONAL TECHNICAL SCHOOLS

WORLD-WIDE TRAINING SINCE 1969
4000 So. Figueroa St.
Los Angeles, Calif. 90037
No obligation.
No salesman will call.

SEND POSTCARD FOR FREE BOOK AND SAMPLE LESSON

TEAR OUT AND MAIL THIS CARD TODAY. CHECK ONE ONLY.

ELECTRONICS DIVISION

- MASTER COURSE IN COLOR TV SERVICING
- COLOR TV SERVICING
- MASTER COURSE IN TV & RADIO SERVICING
- PRACTICAL TV & RADIO SERVICING
- MASTER COURSE IN ELECTRONIC COMMUNICATIONS
- FCC LICENSE COURSE
- MASTER COURSE IN ELECTRONICS TECHNOLOGY
- INDUSTRIAL AND AUTOMATION ELECTRONICS
- COMPUTER ELECTRONICS
- BASIC ELECTRONICS

HOME APPLIANCES DIVISION

- HOME APPLIANCES MASTER TECHNICIAN'S COURSE
- HOME APPLIANCES SERVICING
- HANDYMAN APPLIANCE REPAIR

AUTO-MECHANICS DIVISION

- MASTER COURSE IN AUTO & TRUCK MECHANICS
- AUTOMOTIVE MECHANICS
- TRUCK & HEAVY DUTY MECHANICS
- ENGINE TUNE-UP & ELECTRICITY

AIR CONDITIONING/REFRIGERATION HEATING DIVISION

- MASTER COURSE IN AIR CONDITIONING, REFRIGERATION & HEATING
- AIR CONDITIONING & HEATING
- REFRIGERATION

HIGH SCHOOL DEPARTMENT

- HIGH SCHOOL AT HOME Dept. 201-89



NAME _____ AGE _____

ADDRESS _____

CITY _____ STATE _____

Please fill in Zip Code for fast service _____

- Check if interested in veteran training under the new GI Bill.
- Check if interested ONLY in classroom training at Los Angeles.

GET OFF THE DIME. HERE'S 4 WAYS TO BOOST YOUR INCOME!



COLOR TV
295 SQ. IN.
PICTURE



ELECTRONICS DIVISION

New color catalog

NTS Project-Method home training makes it easy for you to make your mark in Electronics. To get the big-paying job you want. Learn more, faster, with exciting kit equipment included at no extra cost. There's no better time than right now to do it! Send the coupon!



MECHANICS DIVISION

NTS gives you professional engine analyzing equipment. And top mechanics' know-how in diagnosis... speed... performance. Industry needs over 200,000 trained mechanics right now. And you can be one of them. Mail the coupon for our new catalog today!



AIR CONDITIONING, REFRIGERATION DIV.

We give you the tools, tester, instruments. Show you how to service giant industrial cooling systems and commercial refrigeration installations. There's a big job waiting for you here. All it takes to get it is the skill we give you. Don't wait any longer.



HOME APPLIANCES DIVISION

Learn to service major home appliances. Get the new, exclusive NTS CIRCUIT-TRAINER! It helps train you faster for the big jobs. Learn troubleshooting, open your own business, be your own boss. So get off the dime. Mail the coupon. We'll send you all the facts in our new catalog.



 **FILL OUT AND MAIL CARD TODAY**

GET FULL COURSE DETAILS AND LEARN ABOUT THESE NTS EXTRAS:

1. BONUS CLASSROOM TRAINING
2. JOB PLACEMENT CONSULTATION
3. BUSINESS CONSULTATION

NO OBLIGATION. NO SALESMAN WILL CALL. APPROVED FOR VETERANS

 Accredited Member National Home Study Council

 Accredited Member National Association of Trade and Technical Schools

FIRST CLASS
Permit No. 3087
Los Angeles, Calif.

VIA AIR MAIL

BUSINESS REPLY MAIL

No Postage Stamp Necessary if Mailed in the United States

POSTAGE WILL BE PAID BY

NATIONAL TECHNICAL SCHOOLS

4000 South Figueroa Street
Los Angeles, California 90037

RADIAL ARM SAW KIT... for under \$100



Buy direct from factory, assemble yourself. Incl. 1/2 h.p. G.E. motor, easy to follow instructions, all parts, nuts and bolts. Guar. for life pat. pend. radial arm track; twice the usual bearings for extra rigidity, greater precision. Rips 24", crosscuts 12"; belt brake. \$99. complete, freight col. Kit less motor (any stand. 1/2 h.p. or larger will do) \$84.85. With optional G.E. motor developing 1 h.p. \$108.65. Money back guaranteed by one of world's largest manufacturers of bench power tools. Write for brochure. Terms if desired or check or M.O. to American Machine & Tool Co., Dept. PM89, Royersford, Pa. 19468

FIND BURIED TREASURE!

Treasure Probe

12.95
PPD

10-DAY MONEY BACK
GUARANTEE

ALL TRANSISTORIZED

Find buried gold, silver, coins, war relics with new sensitive detector. Fully transistorized. 1969 model. Ideal for beach combing, treasure and coin hunting, prospecting for gold. So sensitive it will detect a single coin or gold nugget. Nothing else to buy. Gives loud, clear signal, when metal is detected. WEIGHS

1 1/2 POUNDS

Each model includes battery, earphone.

3 ft. portable detector

3 MODELS AVAILABLE

Complete kit with assembly instruction \$12.95 PPD.

Fully assembled and instrument aligned at factory for peak performance, \$16.95 PPD

Fully assembled with powerful built-in loudspeaker and plug-in earphone. Your best buy, \$22.95 PPD

TO ORDER—send cash, check, or money order.

\$3.00 deposit for C.O.D.

In N.J. add 4% sales tax

TREASURE HOUSE

Dept. PAB P.O. Box 3 Tenent, New Jersey 07763

RECHARGE ALL BATTERIES

Only Everlite

- Charges 6 batteries
- Charges 3 times faster
- Charges all batteries

Including hearing aid, flashlight, lantern, radio, in fact any battery up to 12V. Save Money and have the convenience of fresh batteries always. Simple and 100% Safe. Plugs into any 115V. outlet. Guar. for one year. Send \$6.95 plus \$.65 for shipping

695



MASTER MECHANIC MFG. CO., Dept. A-89 Burlington, Wis.

Southern Customers write Dept. A-89, Box 65, Sarasota, Florida

More Security With FALSE TEETH At Any Time

Don't be so afraid that your false teeth will come loose or drop just at the wrong time. For more security and more comfort, just sprinkle a little FASTEETH on your plates. FASTEETH holds both uppers and lowers firmer longer. Makes eating easier. FASTEETH is alkaline. No gummy, pasty taste! Dentures that fit are essential to health. See your dentist regularly. Get FASTEETH today at all drug counters.

America's No. 1 Classified Section
Can Be Found On Page 48
In This Issue

AUGUST 1969

THE SPECIFIED FIXER®

DAP CAULK IS TOUGH ENOUGH TO BE SPECIFIED BY ARCHITECTS. FILLS AND SEALS CRACKS AND JOINTS BEFORE PAINTING. PREVENTS DRAFTS AND HEAT LOSS. STAYS FLEXIBLE.



DAP®

architectural
grade
CAULK

DAP Inc., Dayton, Ohio 45401 / SUBSIDIARY OF Plough, Inc.

Also available in Canada

MY SPARE TIME HOBBY MAKES ME

\$500 an hour

CASH PROFIT

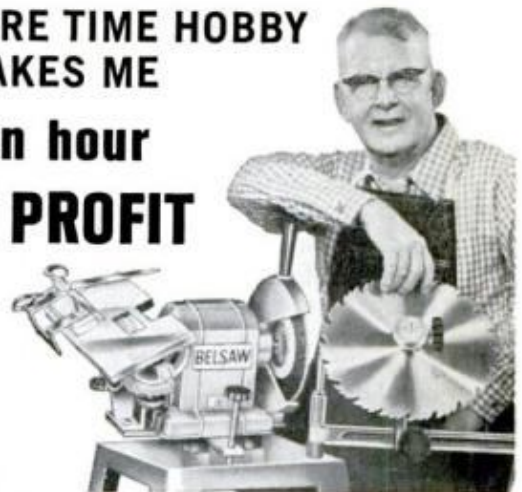

START YOUR OWN SPARE TIME BUSINESS

You can turn your spare time into Big Cash Profits with your own COMPLETE SHARPENING SHOP... Grind saws, knives, scissors, skates, lawn mower blades... all cutting edges. Your Own Cash Business with no inventory... right at home... no experience needed.

FREE BOOK tells how you can start your own spare time business while you are still working at your regular job. Low Cost-time payments only \$15.00 a month. Send coupon today.

No Salesman Will Call.

FREE BOOK

BELSAW SHARP-ALL CO., 710P Field Bldg., Kansas City, Mo. 64111

Send Free Book, "LIFETIME SECURITY." No obligation.

Name _____

Address _____

City _____ State _____ Zip _____

187

HOW THEY KEEP YOU SAFE

(Continued from page 81)

tor examining your chest with a fluoroscope, each reveals the innermost region of a structure without actually touching or affecting it.

NDT has grown in importance with the complexity of our civilization. In the early days of railroading, it was sufficient to test new wheels by hitting them with a sledgehammer. A clear, bell-like tone indicated that a wheel was free from cracks or other defects. Suddenly, one foundry began getting 100 percent rejects—all of the wheels sounded dull. When the remakes also testified faulty, someone thought to check the sledgehammer—it was cracked.

Today, life is too complex and fast-paced for such quaint measures. We are constantly surrounded by scores of man-made hazards. Every time you step into an airplane or come near a high-pressure steam boiler, you are in the presence of a

X-raying solid-fuel rocket propellants assures there are no air pockets . . .

potential bomb as deadly as any military type. Boiler explosions were once a common occurrence. In Mark Twain's days on the Mississippi, one steamboat a day, on the average, blew up.

Gas mains under city streets need constant examination. Once a break starts, a gas pipe can split open faster than the speed of sound, causing tremendous devastation for thousands of feet along its length. In mid-January, 1967, such an explosion ripped through four blocks in Jamaica, N.Y., demolishing many houses. Early this year, another gas-main blast caved in a street in lower Manhattan.

Similarly, a defect as small as a burr on a rivet can produce a lethal effect in an airplane. It's estimated that a plane flying at 35,000 feet and pressurized to 10,000 feet stores about as much blast energy as a 200-pound high-explosive bomb. One tiny leak in the fuselage and the plane would burst apart like a balloon stuck with a pin.

Only modern NDT methods can prevent accidents like these. Philip D. Johnson, managing director of the American Society for Nondestructive Testing, says that the NDT market, pegged at \$125 million annually, is expected to as much as double within five years. The technique achieves savings in the neighborhood of millions

of dollars a week and employs some 500,000 people. The American Navy was the first organization to recognize that this technology could be trusted to test the safety of welded steam vessels.

NDT is now indispensable in virtually every area of American life—industrial, scientific, medical and consumer. It's essential because all materials have defects. The traditional system of spot-checking items rolling off an assembly line tells only that an occasional sample is all right. It reveals nothing about all the others. With NDT, every single item can be checked—an important point in an age when it would be catastrophic to test one out of every 10 wing spars and assume that the other nine were okay.

The most frequently used NDT technique is radiographic inspection. X-rays or gamma rays are used to make internal pictures of objects either on permanent film or on a fluoroscope screen. Defects show up as dark areas just as a bone fracture does on a doctor's X-ray.

One of the most powerful radioisotope units is the Picker Corp.'s "Cyclops." Using a pill of radioactive cobalt-60 less than half an inch in diameter, it can X-ray 6-inch-thick steel in six minutes. X-raying solid-fuel rocket propellants assures that there are no air pockets and that the material will burn evenly.

Dr. Werner Kirchner, vice-president of Aerojet-General Corp., tells of an X-ray of a newly manufactured rocket combustion chamber that revealed, in the chamber wall, an employee's identification badge with its easily read name! Another radiograph, said to be at Cape Kennedy, shows a large steel nut in the middle of a rocket. A tiny, six-pound X-ray tube was designed to slip through a 3½-inch opening to check the integrity of 1300 brazed joints in the tightly packed plumbing of the Apollo Lunar Module.

Many consumer products are routinely X-rayed to protect you from foreign objects in everything from cosmetics to jelly beans. The technique even saved your wife's wash from black rubber that got into an entire day's production of a well-known detergent. Cloetta, a leading Swedish candy manufacturer, has used fluoroscopic examinations for 20 years. An average day's run of 3000 boxes usually reveals six boxes with suspicious objects. The company's technical director has collected 120,000 of these, including stones, chips of plaster, nails and screws of all sizes and shapes.

The flash X-ray technique, using a sudden burst of energy lasting one 50-millionth of a second, was originally de-

(Please turn to page 190)

It only tastes expensive

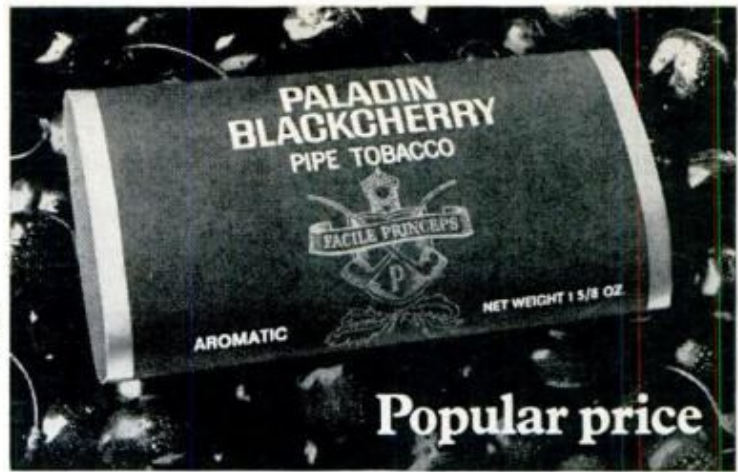

Popular price

"Get my new Signature Kit...a \$5.50 value for only \$3.00."

By Dick Kotis, President, Fred Arbogast Company, Inc.



The Jitterbug®...for surface fishing The Hawaiian Wiggler®...for middepths The Arbogaster®...for bottom fishing

Also included:

New Bait Equipment Selector
Colorful 1969 Arbogast Catalog
Handy plastic utility box

Value: \$5.50; yours for only \$3.00. Specify casting or spinning size.
Send check or money order to Fred Arbogast Co., Inc.,
1808 W. North St., Akron, Ohio 44303. Order today!

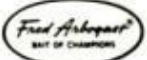

Doctors Find Way To Shrink Hemorrhoids



And Promptly Stop Itching,
Relieve Pain In Most Cases.

Science has found a medication with the ability, in most cases—to stop burning itch, relieve pain and actually shrink hemorrhoids.

In case after case doctors proved, while gently relieving pain and itching, actual reduction (shrinkage) took place.

The answer is *Preparation H*®—there is no other formula like it for hemorrhoids. Preparation H also soothes inflamed, irritated tissues and helps prevent further infection. In ointment or suppository form.



**BUILD THIS MINI-BIKE—YOURSELF
NO WELDING NEEDED**

Lightweight, Rugged. Compares with the finest mini-bike you can purchase. Simple, inexpensive construction allows you to assemble your mini-bike with ordinary hobby shop tools. Illustrated plans, instructions and suppliers parts list Satisfaction Guaranteed. **Plans Only \$200**

WESTATE ENTERPRISES
Dept. P-8, Box 9216, San Jose, Calif. 95117

AUGUST 1969



**TAKES THE
DRUDGERY OUT OF
PAINTING**



Easy-Mask, the *only* one-piece paper-tape combination
• Protects carpet, woodwork, tile, linoleum. • Catches spills, splatters, drops, mist. • 4 ideal sizes: (4" x 60', 4" x 120', 6" x 60', 6" x 120'). Available at leading paint, hardware and building supply stores.

Easy-Mask puts pleasure into painting!

DAUBERT CHEMICAL CO.
CONSUMER PRODUCTS DIVISION
Oak Brook, Illinois 60521 312/582-1000

189

(Continued from page 188)

veloped for research into space programs and ballistic weapons. It can "stop" objects traveling at speeds of more than 68,000 mph and obtains X-rays of bullets in flight. It now also tests the performance of such everyday items as hair-spray bottles.

Three-dimensional X-rays are being tried, and an Argonne National Laboratory team recently described the production of color radiographs. Since the eye is more sensitive to color than to shades of gray, these films give more precise definition and faster interpretation.

Ultrasonic NDT checks air safety

Ultrasonic testing is another NDT technique. In this method, electronically produced sound waves at frequencies far above the audible range are transmitted through liquids and metals at the speed of sound. The waves are reflected back to be displayed on an oscilloscope. Defects such as cracks, air pockets and bond failures deflect the waves and show up as sharp peaks in the trace pattern.

Your airplane safety is becoming ever more dependent upon ultrasonic NDT, which now checks the wings, wheels and landing gear. The world's tallest all-welded building, a 52-story skyscraper in Lower Manhattan, is also kept safe with ultrasonic NDT. Daily, it protects thousands of cars and trucks crossing the Cumberland Thruway Viaduct in Cumberland, Md. This was the first steel bridge structure to have all its critical field-welds checked by ultrasonics.

Bridges were once entirely riveted. After the rivets were inserted, an inspector would put his thumb on one side of the rivet and hit the other with a hammer. If he felt any kind of movement, the rivet was removed and another inserted. Only NDT has made possible the use of welded joints to build simpler, more delicate and yet stronger bridges that add beauty to America's landscape.

Still another NDT technique makes use of small eddy currents induced in metallic objects by applying a magnetic field. Any flaw in the material interrupts the eddy currents and shows up on a meter. Some 10 years ago, airlines were plagued by cracked wheel flanges that broke off in landing. With this new NDT method, cracks smaller than a 1/64th of an inch can be spotted. Every hour, Oldsmobile checks up to 10,000 critical bolts in its cars. Ford uses the same method to check automatic-transmission output shafts.

Magnetic-particle NDT reveals cracks

It's easy to thread pipe with a RIDGID Drop Head Threader



And it cuts a perfect thread every time. We've seen to that. Every RIDGID threader gets a brutal workout before it ever leaves the factory. We check dies for accuracy, strength, smooth operation. We treat them rough, because we figure you'll do the same. Dies are reversible; let you thread right up to a wall. What's more, heads are locked in—can't fall out until released.

RIDGID offers 3 exposed ratchet models for 1/8" through 2"; plus 2 enclosed models for 1/8" through 1 1/4". See them at your Dealers. The Ridge Tool Company, Elyria, Ohio 44035.



Just Pick the Kind of Body YOU Want

CHECK THE COUPON BELOW

...Prove to Yourself How **EASILY** You Can Have It...Almost Overnight!

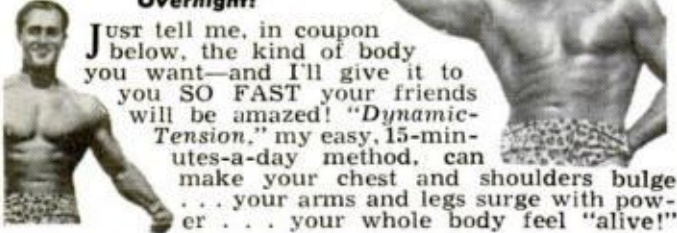

Just tell me, in coupon below, the kind of body you want—and I'll give it to you SO FAST your friends will be amazed! "Dynamic-Tension," my easy, 15-minutes-a-day method, can make your chest and shoulders bulge... your arms and legs surge with power... your whole body feel "alive!"

FREE 32-page Illustrated Book

32 Pages on how "Dynamic-Tension" changed me from a 97-lb. weakling into "World's Most Perfectly Developed Man" and what it has done for others. Mail coupon NOW. Charles Atlas, Dept. 88, 115 E. 23rd St., N. Y., N. Y. 10010.



CHARLES ATLAS, Dept. 88
115 East 23rd St., New York, N. Y. 10010
Dear Charles Atlas - Here's the Kind of Body I Want:
(Check as many as you like)

- Broader Chest, Shoulders
- Slimmer Waist, Hips
- More Weight, Solid
- More Powerful Arms, Grip
- More Powerful Legs
- Better Energy, Sleep

Send me, absolutely FREE, a copy of your famous book showing how "Dynamic-Tension" can make me a new man. 32 Pages, crammed with photographs, answers to vital questions, and valuable advice. No obligation.

Name _____ Age _____

Address _____

City & State _____ Zip Code _____

In England, send to Charles Atlas, Chitty St., London W. 1

at or near the surface, but only with a metal that can be magnetized. Ferrous metal filings are sprinkled over the surface to be tested. They adhere to the material in a pattern representing lines of magnetic force. Any cracks disturb the magnetic field and produce a corresponding change in the pattern of filings. This test is used in more than 3000 U.S. manufacturing plants, from aircraft makers to petroleum producers.

One of the simplest forms of NDT is the dye penetrant, important for examining nonporous materials for surface defects. Some dyes are visible, others fluoresce brilliantly under special lights. Sprayed over a surface and then washed away, the telltale dye remains only where there are cracks or other faults to seep into, revealing their locations.

New method uses liquid crystals

One of the newest, and certainly the most colorful, of NDT methods uses liquid crystals. These amazing compounds pour like liquids but scatter light like crystals, changing color according to changes in temperature. They have proven sensors over a range from 5° below zero F. to 480° above, indicating differences as slight as .047°. Where tiny variations in temperature can signal a coming malfunction, these liquid crystals can spot the trouble quickly and surely. Unlike temperature paints, they can be used repeatedly, for the color changes are reversible.

Even newer tests are constantly being devised—like the use of microwaves to check your bowling ball for cracks. Picker Corp. has invented an X-ray machine that crawls through pipelines to check the joints. Tiremakers have long been faced with the problem of making sure that a tire is sound without cutting it open to find out. Now the Uniroyal people make holographic pictures—three-dimensional images created with a laser beam—of each tire as it swells slightly under pressure. If it expands uniformly, it's sound. But if there's the tiniest bump, blister or other irregularity, indicating an internal fault, the interference patterns produced by the reflected laser light spot it immediately.

NDT is truly the way of the future. Structures to be built on the moon and in space as orbiting platforms will probably be assembled by electron-beam welding and checked almost simultaneously by instruments monitoring the progress. Someday you will use a form of NDT to check out the condition of that house you're thinking of buying. And disasters like the Silver Bridge one will be unheard of. ★★ ★

Here's the bow built to last a lifetime: the new Fred Bear Take-Down Hunting Bow. It could very well be the last bow you'll ever have to buy.

The handle section is made of carefully selected hardwood, injected with special materials which give it weight, stability and strength far greater than any natural wood. Under normal care, this handle can actually last a lifetime and be passed along from father to son, like a fine shotgun.

The new Take-Down Bow assembles like a fine gun too. No tools are needed to lock its precision-milled limbs into place. No extra parts to lose, either. Three sets of limb lengths are available in draw weights of 35 to 70 lbs. Select the combination you want for any hunting or practice situation.

See this truly remarkable bow now at your Bear dealer's. See it, shoot it. It could be the last hunting bow you'll ever buy.



Fred Bear demonstrates the simplicity of his new Take-Down Bow. Note that no tools or extra parts are needed to completely assemble this remarkable new bow!



 **BEAR ARCHERY**

DIVISION  VICTOR COMPTOMETER CORPORATION
Dept. PM-8 • Rural Route One • Grayling, Mich. 49738

Enjoy Independence



**With A Sparetime
BUSINESS
OF YOUR OWN**

Here's a proven, practical way to earn sparetime cash while you develop a money-making business of your own. Investment is small. There's no overhead, no stock to carry, no selling involved. Automatic Foley Saw Filer, easy to operate, files combination saws, hand, band and circular saws. No experience needed.

Earn \$3 to \$6 An Hour In Sparetime

Get started now and watch your business grow! Thousands are earning cash this easy way—many build a complete sharpening service with year around profits. You can, too, with the easy-to-follow Foley Plan—write us today!



FREE BOOKLET SHOWS HOW

Fact filled booklet tells you how to start a sparetime business; how to get new business. Rush coupon, get "Money Making Facts" and details on Easy Payment Plan. No salesman will call.

Foley Manufacturing Co.
816-9 Foley Bldg., Minneapolis, Minn. 55418

Send FREE BOOK—"Money Making Facts", and Time Payment Plan.

Name _____

Address _____

City _____ State _____ Zip Code _____



BIG BOSS WELDER

PRICE SLASHED TO COMPETE WITH THE COM-PACTS. Regular \$29.95. Now only \$18.95.

New 110 Volt FULL SIZE, full performance welder for home workshop, garages, industry. Not a compact but a HEAVY DUTY 1969 model welder that is powerful enough for even tough jobs yet portable enough to carry anywhere with one hand. Works from ordinary 110V outlet. Uses standard 1/8" rods to weld, braze, or cut most anything made of metal. Easy to use. No experience necessary. NOTHING ELSE TO BUY! Comes complete with mask, rods, rod holder, power cables, ground clamp, instructions, etc. as illustrated at left. 5-year parts and

service guarantee. 10-day MONEY BACK GUARANTEE. Send \$18.95 check, cash or M.O. for postpaid shipment or \$3.00 deposit and pay \$15.95 plus C.O.D. when delivered. BIG BOSS WELDER, Dept. BW-9. Box 10947, Houston, Tex. 77018.

NOW PRICED LOWER THAN EVER

GIANT BALLOONS 25 ft.

\$1 10 ft. Guaranteed brand - new surplus. Durable heavy-duty neoprene rubber. 5' size -2 for \$1 + 25¢ pp. 10' size-\$1 + 25¢ pp. Great fun at beach or

play. Huge 25' size: Inflate with auto air hose or vacuum cleaner or fill with locally available gas. Fly advt. sign high in sky. Terrific crowd gatherer for sales, openings, sports, meteorologists, etc. Nat'lly adv. at \$10—now only \$4 + 50¢ pp-2 for \$7 + \$1 pp-3 for \$10 + \$1.50 pp. No COD's. NOVEL PROD. 31-2nd Ave. Dept. B21, NYC 10003



CHRIS-CRAFT'S LANCER

(Continued from page 114)

cruise into upper Biscayne Bay. Her deep-V hull parts the water like a knife. On my right I see the skyline of Miami. From this angle it looks like Chicago as seen from Lake Michigan. But it's not. A quick look to port and all thought of the North passes. There, sticking high into an azure sky, are the hotels of the Gold Coast—white and gleaming in the morning sun.

The water traffic in this area is terrific. There's everything—60-foot yachts; 110-foot Coast Guard cutters; fast, zipping hydrofoils; tugs of all sizes; steamers, and a replica of a Mississippi sternwheeler.

Now to the open water. The Bay of Biscayne is quiet today. Lancer charges at 4000 rpm over the smooth water. I noticed a slight vibration as the tach passed 3100. But it seemed to die out at 4000 revs.

I try some sharp turns and wake jumps. There's no question about Lancer's handling ability. She's neat, clean and solid.

It's about 6:00 in the evening as I nose up to the dock at Pennekamp State Park on the Atlantic side of Key Largo. I find that Lancer's walk-through windshield and sliding-bow hatch make it easier to cleat bow lines than it is in those boats that have no way to the bow.

Resting at the dock, I get a chance to give Lancer a full inspection. First, there's plenty of storage space under the foredeck and along the sides, even under the flooring. Two large storage cavities are big enough to install optional fish bins.

Besides storage space under the foredeck, there are two bunks and space for a head. Two fold-down lounge chairs are positioned in the cockpit.

One great benefit of Lancer's design is the low-profile engine cover. It does not fill the stern from floor to aft deck. This makes it easy to get to the bait well astern.

Checking workmanship, I find it's excellent.

After overnighting at Pennekamp, and then doing some early morning diving, I head back for Pompano Beach.

Returning through the open stretches of Biscayne Bay, I find Lancer behaves nicely. The eight-foot beam makes her quite stable. Her high freeboard—33¾ inches forward, 29½ inches aft—makes her a good open-water boat for ocean fishing.

One of the best features of Lancer's design is minimum bow-rise when getting on plane. At no time was my vision completely obstructed as is the case with many other boats when getting up on the step.

Lancer is a lot of boat for the suggested retail price of about \$7000. ★ ★ ★

'UPSIDE DOWN' TOOL BITS

(Continued from page 184)

upper end of the bracket is adjusted so it presses firmly against the plate, and oil is used to reduce friction as the plate slides beneath it.

Tests will indicate satisfactory speeds to use for various operations involving upside-down bits. For cutting-off work, the normal rpm often will be okay, although in the case of a very small, high-speed lathe, it was found that a reduced spindle speed was helpful in producing smooth cutting. And for all cutting-off work, a slow feed usually is best. Cutting lubricant should be used, particularly on steel, as for conventional machining.

It is important that cutoff tools be kept sharp and their positions properly adjusted. Production of a clean, easy flowing chip indicates when these conditions are about right. A cutoff tool can be ground in various ways: for instance, its tip can be angled so the piece separated will not have a taggle of metal at its center; and its sides can be ground to round the edges of either the cutoff piece or the remaining bar, or both.

How to avoid jamming

It is common practice to use a cutoff tool as close to the chuck or steady-rest jaws as practicable, say, no farther away than $\frac{1}{2}$ in. for a $\frac{1}{2}$ -in. diameter bar. To reduce the likelihood of jamming and "collapsing" of the workpiece about the bit when the work is between centers, the parting tool can be used to cut most of the way through the workpiece, and a hacksaw employed to finish the cut after the lathe has been stopped. Jamming also has been attributed to such things as improper side clearance on the bit, too-fast feed, dull cutting edges and headstock-spindle play. If these conditions cannot be remedied, the operator may try to avoid jamming by cutting, in alternate steps, a groove wider than the bit while using plenty of cutting fluid (such as sulfurized oil for steel).

A conventional high-speed-steel cutoff bit has tapered sides for clearance. It is sharpened by grinding the end and top (bottom when inverted) surfaces. A newer type, used on turret lathes, is T-shaped in cross section, and is said to be easier to sharpen. Cutoff bits can be ground from standard square-section (or other) lathe-bit blanks.

Such blanks also can be ground to form upside-down tools for numerous other operations—such as beveling, rounding edges, grooving, turning to diameters, shouldering and producing fillets. ★ ★ ★

Fox Mini-Bike

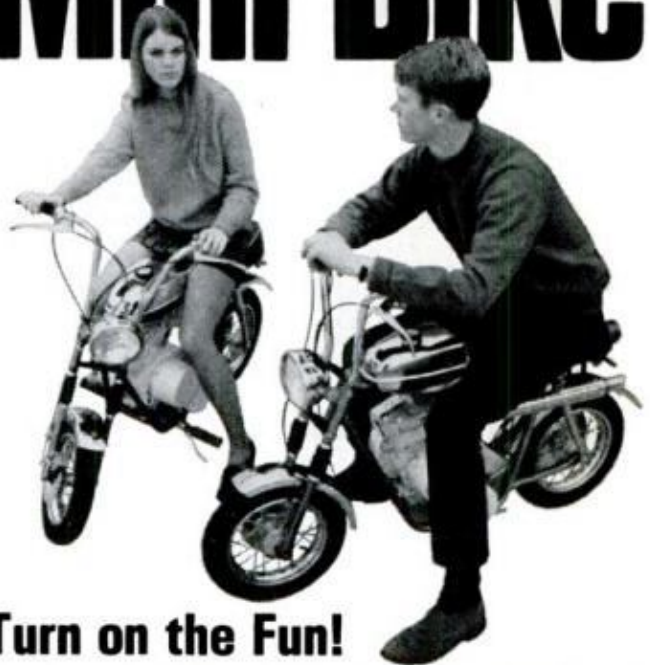

Turn on the Fun!

Outclass and Outperform Anything that Goes!

Fox builds the world's most wanted mini-bikes! *Exciting trail models* for Trail Blazing, hunting, fishing and camping... *Finest campus bikes* for swingers, shoppers, swimmers... A "hot dogger" scrambler that's not a bit timid for the field or track. Many models are street licensable.

797PM

FOX CORPORATION

Janesville, Wisconsin 53545

Also makers of the World Famous
FOX TRAC SNOWMOBILES and GO KART®



PLANER · MOLDER · SAW!

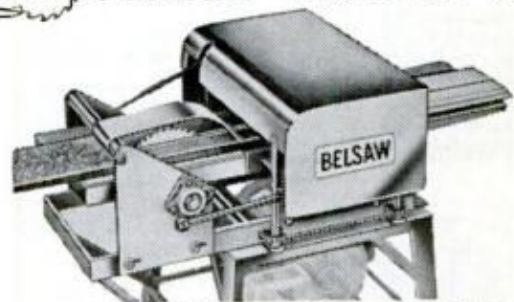

Now you can use this ONE power-feed shop to turn rough lumber into moldings, trim, flooring, furniture... ALL popular patterns. RIP... PLANE... MOLD... separately or all at once with a one HP motor. Use 3 to 5 HP for high speed output. Low Cost... You can own this power tool for only \$30.00 down.

Send Postcard Today... No Salesman Will Call
BELSAW POWER TOOLS, 900P Field Bldg., Kansas City, Mo. 64111

ELECTRIC ARC WELDER \$9.99!



NATIONALLY ADVERTISED \$18.95 VALUE!—NOW 1/2 PRICE! WELDS—BRAZES—SOLDERS—CUTS—ALL METALS! Plugs into ANY 110 volt socket. **MAKE—REPAIR 1001 items for CAR—HOME—BUSINESS.** Lifetime **BURNOUT GUARANTEE** 10 day money back trial (if retrnd). **HEAVY DUTY Design—Does \$85.00 welder work.** No experience needed—**FREE WELDING LESSONS!** cash, ck. M.O. and pay postman \$7.99 **SEND ONLY \$2.00** COD postage or send \$9.99 plus \$1.00 postage for paid del. in U.S.A. **COMPLETE READY TO USE—Includes BIG pack steel, Brazing, Solder, Carbon "touch" rods, ELECTROFLAME ARC TORCH! OFFER LIMITED—Order TODAY!** **MIDWAY WELDER Dept. EPM-8 Kearney, Nebr. 68847**

REAL ESTATE

BE A BROKER

FREE BOOK TELLS HOW

PAYS BIG! SEND FOR BIG FREE CATALOG NOW! Graduates report making substantial incomes. Operate your own business quickly. Men, Women, all ages, learn easily. Course covers Sales, Appraising, Loans, Mortgages, & related subjects. **STUDY AT HOME** or in class-rooms in leading cities. **Diploma Awarded. Write Today for FREE Book!** Accredited Member National Home Study Council. (Est. 1936) G. I. Approved. **WEAVER SCHOOL OF REAL ESTATE** 3521-P Broadway Kansas City, Mo. 64111

PROFIT IN YOUR SPARE TIME



SMALL ENGINE REPAIR PAYS BIG! Outboard • Powermower • Chain Saw • Tractor **MAKE EXTRA MONEY** — or fix your own engines and **SAVE!** Illustrated, easy-to-learn Home Study Course qualifies you as expert. Approved for Veterans. Write today!

LINCOLN TECHNICAL INSTITUTE SUITE 8-E, 472 MARKET ST., NEWARK, N.J. 07105

BRAND NEW BOOKLET REVEALS HOW TO LIVE BETTER, FOR LESS IN FLORIDA

Gives full facts on Florida mobile home living, its wonderful advantages. Learn how to enjoy the outdoors; fishing, boating, sun bathing. Shows how to save thousands of dollars, gives tips for an easier life. Send 10c to Florida Researchers, 3132 Ponce de Leon Blvd., Coral Gables, Fla. 33134, Dept. D



LAW FREE BOOK

THE LAW TRAINED MAN

Write today for a FREE copy of illustrated law book, "THE LAW TRAINED MAN," which shows how to earn the professional Bachelor of Laws (LL.B.) degree through home study of the famous Blackstone Law Course. All necessary books and lessons provided. Moderate cost; convenient monthly terms. Write for FREE law training book today.

Blackstone School of Law, 307 N. Michigan Ave. Founded 1890 Dept. 50C, Chicago, Illinois 60601

FREE!

Learn how you can buy used engines \$15 up, new engines \$30 with FREE confidential list and coupons when you order your plans

- **BUILD THIS MINI-BIKE!** Plans reveal step by step details!
- **BUILD A RACING KART!** Build frame for less than \$10!



RUSH \$2 for plans (indicate type) or send 25c for circular describing plans **PLANS, Box 517, Omaha, Nebr. 68101**

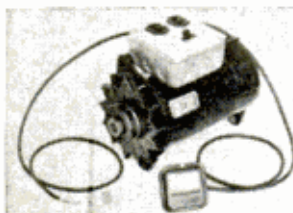

110-120 VOLT A.C. LIGHT PLANTS—60 CYCLES

Fanbelt driven from pickup or small gas engine. Operates saws, drills, pumps, freezers, T.V. X1000 Watts—Needs No Battery. Now \$62.50. 1500 Watts—6 and 12 volt vehicles. Now \$52.50. 3000 Watts—12 volt vehicles only. Now \$99.50. *Guaranteed.* Check or Money Order.

VIRDEN PERMA-BILT, Box 7066 P.M., Amarillo, Texas 79109

OUTBOARD STARTING CHECK

(Continued from page 135)

ity that the ignition switch and its wiring, which technically aren't part of the starter system, could be bad and thus make starting impossible.

To test the ignition switch circuit, probe the "i" ignition terminal of the starter solenoid to ground with a 12-v. test light or voltmeter. If the light doesn't glow, it means that juice is not getting to the starter solenoid and, consequently, not to the safety switch either. There's a failure either with the ignition switch or with the wiring that extends from the switch to the starter solenoid.

If switch and solenoid check out, go to the starter motor. Connect a voltmeter to the starter motor terminal. Be sure to determine the polarity of your electrical system first. Generally, Mercury, Chrysler and OMC engines are negative-grounded. Thus, the positive lead of the voltmeter is connected to the starter motor terminal, and the negative lead of the meter is grounded.

Crank the engine and observe the meter. A reading of about 9.2 volts is normal. If the drop is excessive—let's say 7 volts or less—there's a problem inside the starter. It will have to be disassembled and checked for a dirty or worn commutator, shorted turns in the armature, damaged armature windings and condition of the brushes. Here's where you need the growler (Photo 11).

Check side play in starter drive

Before doing this, however, see if the starter drive is worn by checking it for side-to-side play. Play should be just about perceptible. Excessive movement indicates a worn starter drive.

Whether you want to have a bad starter motor repaired or buy another is something you'll have to decide for yourself, but sometimes it costs just as much to turn a worn and pitted commutator on a lathe, for example, as it does to buy a rebuilt starter motor. It's advisable to check prices. Naturally, only a single part, such as brushes or an armature, may be needed. Replacement parts for starters can be purchased.

Both electric and manual starters are practically maintenance-free. The only part that actually requires periodic servicing is the battery of an electric starting system.

Keep the top surface clean by flushing it with water every so often. Make sure posts and terminals are free of corrosion. And be sure the electrolyte is up to level at all times. ★★

WOOD VENEERS • TOOLS
Shop Equipment • Supplies
POWER TOOLS
at Lowest
Discount Prices!

SAVE MONEY on finest domestic and imported hardwoods . . . all dimensions. Over 1500 items for the home craftsman and woodworking hobbyist. Lamp parts, upholstery supplies, tile, power tools at discounts. **NEW CATALOG READY** 132 pages. Full Color. Send name, address and 35¢ to cover handling, and postage. Write . . . **CRAFTSMAN Wood Service Co.** Dept. A-89 2729 Mary St., Chicago, Ill. 60608

75 POWER TELESCOPE \$4.98
25X-45X-75X

NEW 3 in one telescopes, 3 variable 25X-45X-75X magnification. Brass bound. 25 power for ultra bright images. 45 & 75 power for long range. Guaranteed to bring distant stars, moons, objects, sports 75 times closer.

Most powerful scope anywhere at this amazing-low price. 5 sections. Opens 30" closes 1 ft.; contains 4 ground & polished lenses. Can also be used as powerful microscope. American made. Mass production enables us to offer telescope complete including case \$4.98 post paid. Money back guarantee.

CRITERION CO., Dept. PBM-54, 331 Church St., Hartford, Conn. 06101

For more information on articles and products write to the PM Bureau of Information for "Where-to-Find-It" list.

Don't change your address without notifying us!

To insure uninterrupted service on your **Popular Mechanics** subscription, please notify us at least six weeks before you move.

1. Attach your address label from a recent issue in the space provided below. . . (if label not available, be sure to give us your old address, including Zip Code)
2. Print your name and new address below (be sure to include your Zip Code).

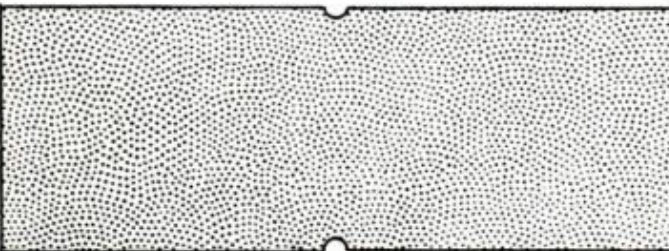

3. Mail entire notice to: **Subscription Service Dept.**
Box No. 646
New York, N. Y. 10019

Name _____ *Please Print*

New Address _____

City _____

State _____ Zip Code _____

New Improved HEAVY DUTY
FOUR-WAY
AMERICA'S ORIGINAL LOW-COST
ARC WELDER
AND ELECTRIC TORCH

10 DAY TRIAL

LIFETIME GUARANTEE



Only \$18.95 Prepaid Complete Ready To Use
WELD, BRAZE, SOLDER, CUT
All Metals Including Aluminum

Every home, shop, and hobbyist needs this quality metal working machine. Anyone can use. **No experience needed.** Use up to 1/8" welding rods and 1/4" carbons to make or repair 1001 items including furniture, garden tools, toys, auto bodies, fenders, trailers, boats, farm equipment. Operates on 110 V. 30A. for pennies—replaces gas torches—no tanks or refills to buy — produces to 11,000° heat. Twin Carbon Arc Torch easily controls heat for each job **YOU CAN PAY MORE BUT YOU CAN'T GET A BETTER LOW COST WELDER.** Over 500,000 in use. Manufacturers of welders for over 30 years. **LIFETIME UNCONDITIONAL GUARANTEE.** Simply return. We will repair or replace and ship **FREE** of charge. **YOU GET:** heavy duty welder in rugged metal cabinet, ground clamp, cables, combination torch and rod holder, welding manual and helmet, plus Free \$2 pack "TOUCH WELD" rods for instant and automatic arc, brazing rods, 1/4" carbons, solder and flux.

FREE Additional Extra \$2.00 pack welding & brazing rods, carbons, flux & solder.
ORDER TODAY ON 10-DAY UNCONDITIONAL MONEY BACK TRIAL
SEND ONLY \$2.00 and pay \$16.95 plus C.O.D. and delivery charges, or send only \$18.95 for postpaid shipment in Continental U.S.A.

FOUR-WAY WELDER CO.

1810 S. Federal St. Dept. R2-H, Chicago, Ill. 60616

POLICE CALL CONVERTER



TUNER CONVERTERS. Use with standard radios. Hear dramatic events while they happen. American made, solid state.

- 6117. For Police & Fire Calls. High Band (150-164) . . . \$5.95
- 6120. For Police & Fire Calls. Low Band (30-50) . . . \$5.95
- 6119. For Aircraft & Control Tower Calls . . . \$5.95

\$5.95

- 6118. World Wide Short Wave. 25, 31, 41 Meters (7-12) . . . \$5.95
- 6125. TV Wireless Microphone Transmitter . . . \$8.50

Money back guarantee. Order now from:
Johnson Smith Company, Dept. 108, Detroit, Mich. 48224
Send for catalog of 2000 Scientific, Hobby & Novelty Items.

WAR GAMES

(Continued from page 87)

guns are programmed to cast their beams 3000 meters (about 3300 yards).

Every time a soldier squeezes the trigger for semiautomatic or automatic fire, a beam of invisible light is simultaneously fired with the blank ammunition. If necessary, the transmitter can fire up to 6000 rounds per minute, well in excess of any gun the Army has.

Every soldier in the maneuver is also outfitted with eight photodetectors—four on his helmet, two on his upper torso and two on the lower part of his body. They are tied in to the central computer station. Here's what happens when a rifle (or other weapon) is fired at a target:

Each gun has special code

The transmitter casts a beam of infrared light with its own special wave pattern (code). If the beam strikes a man, it's wide enough to strike one of the detectors.

The detector converts the coded beam to a coded current pulse—such as a particular series of dots and dashes—and amplifies and transmits it to the central computer station by means of a tiny preamplifier and RF transmitter each soldier carries in a hip pack. This equipment, which weighs about 20 ounces, is capable of sending the signal about a mile.

When it receives the coded pulse, the computer determines which man shot his weapon, which man was hit and the probability of kill. For instance, if the computer determines that the rifleman has used his allotted quota of ammunition, which is information that's programmed into the computer beforehand, it disregards the signal. The soldier-target, who doesn't realize he's been shot, is allowed to continue with the maneuver.

If the rifleman scores a hit, the computer records it and transmits an audible signal back to a small receiver inside the soldier-target's helmet or hip pack. This wailing signal tells the soldier that he's out of action. He's expected to fall down and play dead.

But just to make sure that he doesn't get exuberant and return to action, the signal from the computer also trips a flip-flop switch in his equipment that puts his laser beam transmitter out of commission. As far as the computer is concerned, he doesn't exist.

Essentially the same sequence of events occurs with equipment, such as a tank. However, there's a novel twist.

When a laser beam strikes one of a tank's 13 photodetectors, it discharges a smoke generator attached to the tank's

hull. Smoke comes billowing from the tank for 30 seconds, just as if it had been blasted by a live shell.

This points up why it's important that each weapon involved in the maneuver has its own special code. In combat, it would be ridiculous to think that a man with a rifle can knock out a tank. Thus, if a rifleman shoots a tank with his laser, the computer disregards the signal. If a tank or antitank weapon shoots a tank, the computer is programmed to recognize the signal.

The value of DFS is not just in its ability to provide realistic combat simulation. According to Gabe Schlisser of Holobeam, Inc., which has worked with the Army's Combat Development Experimentation Command in developing DFS, "DFS allows the training of troops under realistic combat conditions. A simplified version can be used to improve marksmanship."

DFS allows theorists to make judgments concerning tactics. It will help answer such questions as whether in a particular situation tanks should remain under cover or whether a particular formation is best.

There is, of course, a valuable spin-off to DFS. The laser-beam equipped system could allow two quarreling nations to fight a war and determine by computer who won—without a single soldier dying. ★★★

MAVERICK VERSUS THE MOB

(Continued from page 77)

ferential isn't all-important, a prudent man would probably say "Yes." Maverick offers more room, more power, a bigger trunk, predictable handling, decent braking, good economy, attractive styling, comparatively easy serviceability, Ford dealers in every town and hamlet, a highly competitive price, and on and on, point-by-point down the line.

But in answering the second part of the question the Maverick encounters heavy weather. What it *doesn't* offer, sad to say, is *uniqueness*. Even its most enthusiastic advocates must admit it's a scaled-down Falcon, a *good* car, yet a car lacking in any one or two outstanding features that would endear it to those who would normally buy an import.

Years ago someone wrote a mash note to Volkswagen saying he liked his VW "because it *needs* me." Now that sort of appeal—that special sort of "come out and play with me" rapport offered by the imports to those willing to put up with their undeniable shortcomings—is as foreign to Ford's philosophy about the Maverick as the imports themselves. ★★★

HEAVY DUTY BALL-BEARING PUMP



IRRIGATE • DRAIN • SPRAY • CIRCULATE • All-metal, rust-proof XB. Stainless shaft. Use 1/4 HP or larger. 1 HP for up to 5,200 GPH 60' high or 3,000 GPH from 25' well. 1 1/4" inlet. 1" outlet. For belt or direct drives \$12.95

Type P won't rust or clog. Bronze bearing. Hundreds of thousands in use. Up to 2,400 GPH, 1" inlet. 3/4" outlet. \$8.95
P'pd. cash with order. **MONEY BACK GUARANTEE.**

LABAWCO, Box 2, Belle Mead, N.J. 08502

GET INTO ELECTRONICS

V.T.I. training leads to success as technicians, field engineers, specialists in communications, guided missiles, computers, radar, automation. Basic & advanced courses. Electronic Engineering Technology and Electronic Technology curricula both available. Assoc. degree in 29 mos. B.S. obtainable. G.I. approved. Start Sept., Feb. Dorms. campus. High School Graduate or equivalent. Catalog:

VALPARAISO TECHNICAL INSTITUTE
DEPARTMENT D, VALPARAISO, INDIANA 46383



ENROLL—EARN YOUR DEGREE

of Bachelor of Bible Philosophy (B.Ph.B.), Master of Bible Philosophy (M.Ph.B.), Graduate of Bible Philosophy (G.Ph.B.), Doctor of Metaphysics (Ms.D.), or Doctor of Divinity (D.D.). Chartered by State, Correspondence Courses only. Please write for FREE BOOKLET.

AMERICAN BIBLE INSTITUTE
Dept. PM, Post Office Box 8748, Kansas City, Missouri 64114

HEARING AIDS

2/3 OFF DEALER PRICES

LARGEST SELECTION of tiny, all-in-the-ear, behind the ear, eyeglass and pocket models. FREE HOME TRIAL. No obligation. Money back guarantee. No down payment. Easy terms. No salesmen or dealers. Order direct, save 65%. Write for free catalog. **PRESTIGE**, Dept. D-34 Box 10947, Houston, Tex. 77018.



BE A TAX CONSULTANT



Earn big money in ever growing profession. Our students are earning lucrative fees in dignified full or part time home-office business preparing income tax returns. Pays BIG in a very short time! No bookkeeping experience necessary. We train you at home and help you start. Licensed by N.Y. Education Dept. Write for free literature. Accredited Member NIISC. Vet Approved.
National Tax Training School
Monsey, 20HB, N.Y. 10952



Solves Repair Problems

Durham's fills cracks and holes in plaster, wood and tile. Won't shrink or fall out. Economical, easy to use. Big 4-lb. can, only \$1.80 at lumber, paint, and hardware dealers, or shipped direct postpaid in U. S. for \$2.25. Money-back guarantee. Order now. Donald Durham Co., Box 804, Des Moines, Iowa 50304



BIG PROFITS IN PLASTICS

PLASTIC LAMINATING — Most profitable of all home-operated businesses. In an hour, turn a few ounces of plastic into \$18.00 profit with an AMERICAN "400" Hydraulic Press. Conduct business at home by mail in spare or full time. Minimum investment for complete, ready-to-operate business. Write —

American Machine Manufacturing Co.
Box 4313-MT Chattanooga, Tenn. 37415

SPECIAL OFFER!

Two PM wall charts (\$2.00 value) for \$1.50 **SATURN V**, world's largest rocket printed in full color. Size 19x25 in. (Reg. price \$1.25) **OUR FIRST 19 IN SPACE**. Photographs of the first U. S. astronauts in space. Size 12x18 in. (Reg. price 75¢) Hurry, get your set by sending \$1.50 plus 20¢ to Popular Mechanics, Dept. CM, 575 Lexington Ave., New York, N. Y. 10022.

Now Annoying Squeaky Hinges Can Be Sprayed Quiet.

One sw-o-o-sh is all it takes to get rid of the nerve-racking squeak of a stubborn hinge when you apply new 3-IN-ONE Oil Spray. Lubricates. Cleans. Polishes. Prevents rust and tarnish. Get 3-IN-ONE can or new aerosol spray at all hardware stores.



3-IN-ONE®

HOUSEHOLD OIL

MINI-BIKES



TACO TRAIL 100 — New, rugged, big-wheel performer — \$219.50. Other models as low as \$119.95. Kits less engine, clutch, chain at \$49.95. Send 25c for brochure, free decal. 130-p. catalog — \$1

STEEN'S BOX 2276-W ALHAMBRA, CA. 91803

HOW TO MAKE MONEY IN MAIL ORDER

MAILCO, Dept. C2258, 1554 Sepulveda, Los Angeles, Ca 90025

FREE report shows men, women how to start full-part time Home Mail Order Business. Millionaire reveals plan. NO SALESMAN WILL CALL. Write:

FREE REPORT Shows How

Name _____ Age _____
Address _____
City _____ State _____ Zip _____

FIND BURIED TREASURE!

★ Detect buried gold, silver, Write for free catalog
5 Powerful models.



\$13⁹⁵ Ppd
to
\$34⁹⁵ Ppd

ALL TRANSISTORIZED
DEALER INQUIRES INVITED
TREASURE PROBE DEPT. PAS
PO Box 64 LAKEWOOD N.J. 08701

POLICE-FIRE-EMERGENCY-CAR RADIO \$9.99

works with regular CAR RADIO and ANTENNA! NO special wiring or installation. Mounts UNDER DASH in 5 minutes in ANY CAR OR TRUCK. Panel switches INSTANTLY from REGULAR to POLICE-FIRE-EMERGENCY radio CALLS—Receives ALL stations in your AREA within range Size only 2"x3 1/2"—Two tone steel cabinet.

SEND ONLY \$2.00 (Cash, Ck, M.O.) and pay or send \$9.99 for ppd Del in USA. COMPLETE ready to clip in your CAR with all parts and instructions. (One year parts and service Warranty—10 day money back trial (if retrnd). **AMAZING OFFER** good only by mail and from:
WESTERN RADIO Dept. BPM-8 Kearney, Nebr. 68847





**EARN
HIGH
WAGES
as a HEAVY
EQUIPMENT
OPERATOR**

Train your way to high pay in the booming construction industry! Learn the skills you need to qualify, by actual field training on machines like the ones used by the industry. Huge training grounds in North Carolina, a million dollars worth of school-owned diesel-engined machines, experienced instructors, full 220-hour and 440-hour courses. National, the original school of heavy equipment operation, is a recognized leader. Member American Road Builders Assn., Services and Supply Division. Associate Member A.G.C. Full-time Job Advisory and Counseling Director on staff. VA approved. For men ages 17 to 56. Train Now-Pay Later plan . . . other payment plans also available. Write TODAY for FREE catalog and FREE copy of school newspaper reporting news of National School graduates. Accredited member NATTS.

**NATIONAL SCHOOL
OF HEAVY EQUIPMENT OPERATION, Dept. D-30**
P. O. Box 8529, Moores Chapel Road, Charlotte, N. C. 28201

Please send me FREE illustrated school catalog and complete information. I understand there's no obligation.

Name _____ Age _____

Address _____ Phone _____

City _____ State _____ Zip Code _____

\$5.95

less bell

DIAL TELEPHONES

With bell \$8.95. If plug is required add \$2.00. Factory reconditioned, Guaranteed. Many other phones available, write for free list.

All shipments FOB Waymart, Pa.



SURPLUS SAVING CENTER

Dept. PM-869, Waymart, Penna. 18472



You can make money in

**WATCH
REPAIR**

Learn at home the low cost Sweazey Way

Watch repairing pays up to \$6 an hour, part time watch makers report on survey. Unique and modern Sweazey home study System starts you making repairs right away on Swiss and American watches. Professionally prepared training. No previous experience needed. Special tools provided for practice. Diploma Awarded. Free sample lesson and opportunity book give all facts. Write today. No obligation.

CHICAGO SCHOOL OF WATCHMAKING
Dept. 189 Fox River Grove, Illinois 60021

FREE BOOK and SAMPLE LESSON

CHICAGO SCHOOL OF WATCHMAKING
Dept. 189, Fox River Grove, Illinois 60021
Please rush FREE BOOK and Sample Home Study Lesson.

Name _____ Age _____

Address _____

City _____ State _____ Zip _____

WHO WILL BELL THE CAT?

(Continued from page 97)

show a temperature difference of a few degrees from the surrounding air.

Eastern Airline's meteorology department, working under contract to the FAA and Weather Bureau, investigated this angle in 1960. Data from more than 1000 flights indicated that when a plane encountered a sudden change of air temperature—either a drop or rise—the jet stream, CAT, or both, lay ahead. Planes traveling at three-fourths the speed of sound recorded a change of 2° F. per minute and a total change of 3.5° F.

For an instrument to spot such temperature changes, engineers turned to techniques of infrared detection and radiometers. This method is based on the principle that every object above absolute zero radiates infrared energy.

The black box in the airliner referred to at the beginning of this article is an advanced type of radiometer specifically designed for use in tracking CAT. The heart of the sensor is a thermistor, a metal strip whose electrical resistance changes in response to the radiant energy striking it. In this way, infrared energy is translated

**. . . a sudden change of air
temperature—the jet stream,
CAT, or both, lay ahead.**

into an electrical current that is metered to provide readings.

A "chopper," or fanlike mirror, is placed in the system so the detector receives regularly interrupted radiation from the outside target source. As the chopper blade intervenes, its mirrored surface reflects to the thermistor the radiation from a "black body" of controlled temperature. This provides a reference temperature with which the outside radiation is compared. By allowing radiation of selected wave lengths to enter the detector, which is done by filters, the distance of the radiation source can be determined.

A two-year test of a similar detection system was recently completed. A sailplane equipped with an infrared sensing device developed by the Barnes Engineering Co. made more than 150 flights over Mount Washington, N.H., and the Continental Divide. The sailplane was used because of its ability to withstand stress and its slow flight penetration into known areas of turbulence. The Barnes sensing device, researchers reported, detected temperature changes 25 miles away in di-

rect, horizontal line of flight. They also reported that temperature changes ranging from 3.5° F. to 9° F. were found to be a "constant characteristic of clear-air turbulence."

For the last six months of the project a sensor was tested in a Pan Am Boeing 707 to determine if warning temperature changes could be detected far enough ahead of a plane moving at 600 mph to take evasive action. Results were encouraging. At this writing, Pan Am, Eastern, TWA and United plan to carry out a two-year program in which the Barnes infrared sensing device will be tested on regular passenger flights.

Another detector, made by the Autonetics Div. of North American Aviation, was used in a number of test flights in 1966 and 1967. North American's engineers reported that they received advance warning in 13 out of 14 encounters with CAT. The average warning time was three and a half minutes and the maximum detection range was reported as 48 miles.

Although it seems promising, there remain drawbacks to infrared detection. One handicap is that it does not indicate the severity of turbulence. Another is its relatively limited range. A critical minimum warning for a subsonic jet is considered to be 20 miles, or two minutes. If the plane were an SST cruising at 2000 mph, the range of the best detectors being tested today would have to be doubled to be effective.

The detector may also sound false alarms when it senses distant aircraft or other sources of radiant energy.

Another factor to consider in the use of any detector is that all high-flying craft are now on tightly controlled instrument flight plans. Except in an emergency, to deviate from these plans requires explicit permission from ground controllers. A diversion in course or altitude by one plane to avoid CAT could affect many other aircraft which are following or approaching that plane's route.

Clear-air turbulence is recognized as one of those obstacles which are discovered and overcome as each new aviation frontier is opened. Though a good start has been made toward belling the CAT, the full potential of supersonic air travel may not be realized until the job is completed. ★★★

COMING NEXT MONTH

Fly-It-Home Ejection Seat: New pilot-saver.
Tougher-to-Pick Locks: Keep thieves out!
Get Better Sound From TV: Here's how.
Mixed-Up Speed Laws: Look out for 'em.



← This point lets you bore holes up to 1½" with small electric drill

IT'S HOLLOW GROUND to bore cleaner, faster at any angle

Now step-up the boring range of your small electric drill or drill press to 1½" with Irwin Speedbor "88" wood bits. ¼" shank chucks perfectly. No wobble. No run-out. Sharp cutting edges on exclusive hollow ground point start holes faster, let spade type cutters bore up to 5 times faster. You get clean, accurate holes in any wood at any cutting angle.

Each Irwin Speedbor "88" forged from single bar of finest tool steel. Each machine-sharpened and heat tempered full length for long life. 17 sizes, ¼" to 1½", and sets. See your Irwin hardware or building supply dealer soon.

\$.85 each **\$.95 each** **\$ 1.50 each**
 ¼" to ⅝" ⅝" to 1" 1½" to 1½"

IRWIN SPEEDBOR "88" WOOD BITS

at Wilmington, Ohio, Since 1885



This is TOP GUN

A new kind of hunting garment that gives you the kind of comfort and convenience you've dreamed about... available only from AMERICAN FIELD dealers. We'll send your dealer's name and valuable booklet, "Camping Tents & Tips"... send 10¢ to

HETRICK, Dept. PM-C, Statesville, N. C. 28677

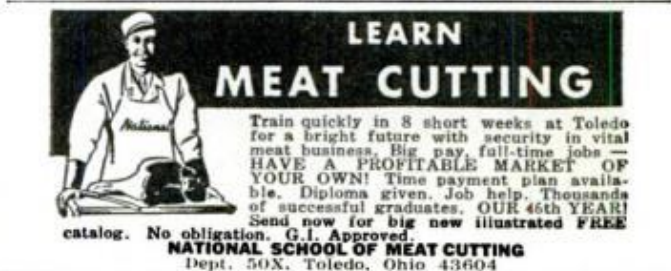

LEARN MEAT CUTTING

Train quickly in 8 short weeks at Toledo for a bright future with security in vital meat business. Big pay, full-time jobs — HAVE A PROFITABLE MARKET OF YOUR OWN! Time payment plan available. Diploma given. Job help. Thousands of successful graduates. OUR 46th YEAR! Send now for big new illustrated FREE catalog. No obligation. G.I. Approved. NATIONAL SCHOOL OF MEAT CUTTING Dept. 50X, Toledo, Ohio 43604



HOLD IT!
 the glue that never lets go!

write for FREE glue and caulk selector guides

WILHOLD

WILHOLD GLUES, INC.
 8707 Millergrove Dr., Santa Fe Springs, Cal. 90670



WRIST ROCKET
 AMERICA'S Pat. HARDEST U.S. HITTING SLING
 Range 225 yd. — 232 fps
 Matched spare rubbers and pouch assembly, \$1.00.
 Write **WRIST ROCKET**® \$3.00 Post Pd.
 2654 44th Ave. Columbus, Nebr. 68601 **PT** No C.O.D.'s

TIES—TIES—TIES

TIE
TRADE-IN
GIGANTIC
TIE BARGAIN
6 FOR \$3.00



EVERYONE IS TAKING ADVANTAGE OF THIS AMAZING TIE VALUE. SIMPLY GO TO YOUR TIE RACK AND SELECT SIX OF YOUR OLD TIES THAT YOU SELDOM OR NEVER WEAR. SEND THEM ALONG WITH 3.00 DOLLARS TO THE



TIE EXCHANGE
P. O. BOX 447
MADISON, TENNESSEE



YOU WILL RECEIVE IN RETURN A HANDSOME ASSORTMENT OF SIX BEAUTIFUL STYLISH TIES. DON'T DELAY, JOIN THE THOUSANDS OF OTHERS WHO HAVE TAKEN ADVANTAGE OF THIS DELIGHTFUL METHOD OF RESTOCKING THEIR TIE RACK.

DON'T FORGET RETURN ADDRESS

TV IN EVERY ROOM

(Continued from page 129)

metal pipes and heating ducts, without fear of interference.

If you decide on coaxial cable, you may need to add a small matching transformer between it and the antenna to match the cable's 75-ohm impedance to the antenna's 300-ohm impedance. This is inexpensive and simple to install. If your antenna has been up for a while, it's pretty safe to assume you'll need one. At the other end of the line, you'll need another transformer to convert the cable's 75-ohm impedance back to 300 ohms to match the input on the TV set or FM radio. This also has another function. It divides the VHF and UHF frequencies so you can feed the signals to separate inputs on TV sets that have provision for receiving both VHF and UHF channels.

Splitters and couplers come with connections for either 300-ohm twinlead or 75-ohm coaxial cable. Pick the type that matches the system you decide to use. Wall outlets are also available in a choice of connections. You can plug in either 300-ohm twinlead or a 75-ohm coaxial line

Keep all cables as short as possible, especially the main downlead

depending on your system. Some offer a combination of outlets—one 75-ohm connection for a TV set and one 300-ohm one for an FM radio. In this case, there's a built-in transformer for the 300-ohm FM outlet, but you still need a transformer at the TV set for the 75-ohm line.

In shopping for parts, you'll probably come across a special wall outlet called a "tapoff." This is designed for systems in which all outlets are connected together in a continuous string instead of being on individual branch lines. It has some advantages for use in large apartment buildings, but is not needed in small home jobs and is more complicated to install as you have to calculate the signal drop from outlet to outlet.

In laying out your system, keep all cables as short as possible, especially the main downlead from the antenna. Mount the distribution amplifier as near as you can to where the downlead enters the house—preferably in the attic, if possible. The amplifier operates on house current and will need a 115-volt outlet nearby to plug into.

Be sure there's a lightning arrester between your antenna and the amplifier. A



Unimat

Convertible precision lathe is vertical miller, drill press, surface grinder, polisher too! \$139.50, incl. motor & parts. Request free catalog, or send \$1 for 40 pg. detailed handbook.

AMERICAN EDELSTAAL, INC.
BH9 / 350 Broadway / NYC 10013

For more information on articles and products write to the PM Bureau of Information of "Where-to-Find-It" list.

LEARN TO EARN!



**NO HOME STUDY
CONTRACTOR OWNED
VA APPROVED**

- Live at school • Train on actual machines / qualified instructors
- Graduates readily accepted for construction employment

**WESTERN SCHOOL
OF HEAVY EQUIPMENT OPERATION**

BOX 510 • WEISER, IDAHO 83672

SEND TODAY FOR FREE SCHOOL CATALOG
DEPT. M-4

NAME _____

ADDRESS _____

CITY _____ STATE _____

few amplifiers have built-in lightning-discharge protection, but even these will be better if they are protected by an outside arrester.

Two outlets per room are desirable, with more recommended for a large living room or playroom to give you flexibility in moving furniture around. The outlets are designed to fit into standard electrical wall boxes, but they can be clamped into wall openings with special clips, eliminating the metal boxes. You can also surface-mount them if you'd rather not cut openings in your walls.

If you're using twinlead, don't run your lines near each other for more than a few feet as the interaction of signals between them can impair your reception. Also, you'll need insulated standoffs to support twinlead. Coaxial cable can be fastened directly to joists, baseboards and other surfaces with no problem. There are special clips for this.

The only tricky part about using coaxial cable is in preparing the ends for making connections. The shielding must be rolled back and a collar crimped on with pliers or a special crimping tool. You can usually rent or buy the crimping tool from the store where you get the parts. You can also buy cables with connectors already attached in 10, 50, 75 and 100-foot lengths. These are handy if they happen to match the lengths you need, but don't permit a lot of excess cable—that just wastes signal power.

Twinlead is even simpler to attach—you don't have to strip off the insulation in most cases. You just slide the end under two serrated washers and tighten the washers down with screws. The serrated edges bite through the insulation and make contact with the wires.

How much your MATV system will cost depends, of course, on the size of your house and the number of outlets you want. Distribution amplifiers providing four outlets sell for about \$20 to \$45. Passive splitters go for \$8 to \$12. Wall outlets vary from about \$1.50 to \$3.50 depending on the type. Antenna-matching and set-matching transformers are \$4 to \$6. Twinlead costs only a few dollars for a 100-foot roll, but coaxial will run you \$15 to \$20 for the same amount.

The nice thing about a MATV system is that you don't have to buy it all at one time. You can start with a simple splitter, then replace it with an amplified coupler later on, using the splitter in one of the branch lines. The system is so flexible that you can rearrange or add to it at any time as your requirements change without wasting any of the work you've already put into it. ★★

GOVT. SURPLUS AND OTHER BARGAINS SAVE UP TO 90%



HYDRAULIC PUMP & MOTOR Miniature hydraulic unit consists of pump & 26 V.D.C. motor. Pump output 1000 PSI @ 3/4 GPM. Runs well on 12 V.D.C. @ 1000 PSI @ 1/4 GPM. Inlet port 1/2" — 18. Outlet port 7/16" — 20. Gear type intermittent duty. Exc. for small hydraulic tail gates, automotive lowering systems, etc. 3" L x 3 1/2" H x 5" W. Tested prior to shipment. GOVT COST \$184. Shpg. wt. 7 lbs. **\$17.50** (Stk. #2467)

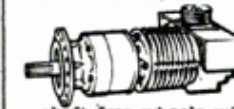

ELECTRIC GEAR MOTOR

Heavy duty, all ball bearing const. Rated approx. 3 H.P. @ 24 V.D.C. Turns 400 RPM no load on 12 V.D.C. 750 RPM on 24 V.D.C. Contains magnetic clutch. 1 1/8" shaft free wheels with power off. Reversible. 16 1/2" L x 5 1/2" dia. Like NEW. Tested prior to shpg. Approx. GOVT COST \$250. Shpg. wt. 40 lbs. **\$27.50** (Stk. #2410)



ELECTRIC UTILITY PUMP

Output up to 360 gal. per hr. @ 18 PSI. Exc. for water, fuel, insecticides, etc. Aluminum construction. Runs on 12 or 24 V.D.C. Explosion-proof motor. Inlet & Outlet ports are 1/2" pipe. Draws 5.2 amps. 9 3/4" H x 6" W. Approx. GOVT COST \$150. Shpg. wt. 8 lbs. NEW. **\$14.50** (Stk. #2486A)



NEW! BIG! 1969 CATALOG

Send 25c for amazing catalog with 1000's of bargains in hydraulics; electrical, marine, automotive items, etc. Order from ad. All prices FOB Culver City. 50% deposit required for COD. Cal. res. add 5% sales tax. Include zip. Satisfying world-wide customers since 1945.

AIRBORNE SALES CO. Dept. PM869
8501 Stellar Dr., Box 2727 • Culver City, Calif. 90230



REPOWER with a 6 or V-8. H.D. ADAPTORS for using Car, Compact and some Truck engines. "State year & model, Jeep or Scout." Want fast action? Give us **FULL INFORMATION**. Send \$25.00 Dep. and we will ship correct kit, bal. COD. Send full amount for prepaid shipment. Wire, phone or write today. Details FREE

HOOSIER MACHINE PRODUCTS CO.
312 S. E. 6th St., Phone 276-3442, Pendleton, Oregon 97801

TREASURE

Find buried gold, silver, coins, treasures.

5 Powerful models.

Write for free catalog



RELCO DEPT. D-3 **\$19.95** UP
BOX 10839, HOUSTON, TEX. 77018



POPULAR MECHANICS MINI-BIKE

FROM 26-IN. BICYCLE FRAME

—with VARIABLE SPEED TRANSMISSION, as featured in June '67 issue. Step-by-Step plans, photos show you how. **PLANS, \$2.50**, refundable with order for wheels, engines, clutches, kits at Discount Prices. Order Plans, or send 25c for Catalog, today!

GILLIOM MFG. CO. Dept. PM-8 St. Charles, Mo. 63301



ALL FAMOUS BRANDS! **FARM TRUCK AUTO TIRES!** AT LESS THAN WHOLESALE
SAVINGS NEVER LESS THAN 50% up to 70% OFF REG. PRICE!
HEADQUARTERS for ALL SPORT CAR TIRE SIZES
FREE • SEND FOR YOUR FREE CATALOG • FREE!

RELIABLE TIRE DIST., 1111 Chestnut St., Camden, N. J.

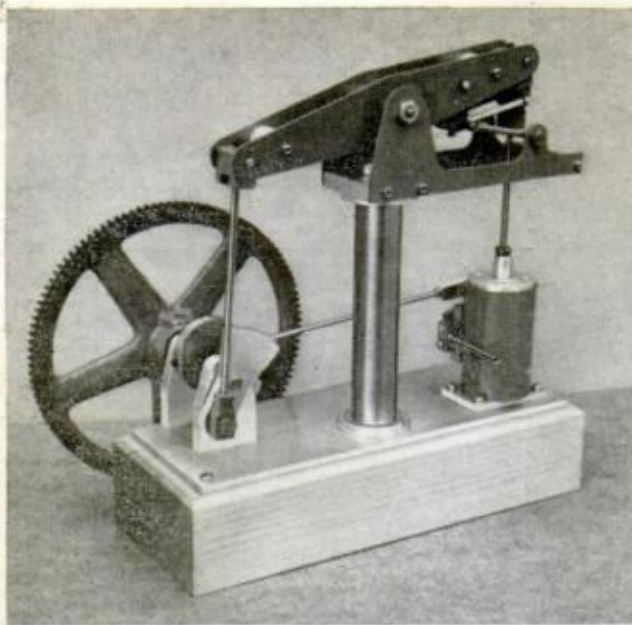

REAR SIDE OF ENGINE shows exhaust outlet alongside cylinder. Gear serving as flywheel in original model could be lathe-turned disc of brass or steel

MODEL WALKING-BEAM ENGINE

(Continued from page 159)

cesses for the screwheads. Now drill through the center reference point and tap 10-32 for the valve pivot. Put a gasket between the port face and cylinder side.

Machine the upper and lower cylinder covers from Dural. Use the cylinder as a ring gauge to check the register diameters. Drill the covers for the mounting screws, then spot the cylinder ends from the covers and drill and tap for the mounting screws.

Chuck a piece of Dural for the piston, drill through for the piston rod and machine the packing groove. Bring the o.d. to about .0002 in. oversize. Make the piston rod and mount the piston on it. The piston is held in place by a thin nut ($\frac{3}{16}$ -in.) on either side. Next, chuck the piston rod with the piston on it and, with a very sharp tool, skim the piston to finish diameter.

Pack the piston with graphite-asbestos string rolled into the groove. Use commercial packing split down fine. Assemble the cylinder and covers with the piston in place and gaskets under the covers. Put some packing into the stuffing box and screw in the gland.

Fit the piston-rod eye to the rod with a locknut on the rod. You can now mount the cylinder on the bedplate by means of 4-40 screws through the big holes in the lower cover. Connect the piston-rod eye to the main link by its lower pin. Gently rotate the crankshaft to adjust the piston rod in the eye. Its length must be such that the piston will not contact the covers at the ends of the stroke. When you have

added the steam inlet flange and exhaust fitting to the port face, you are ready to tackle the valve and its associated parts.

Make up the valve pivot first and screw it right into position in the port face. Mark out the valve on a piece of $\frac{3}{16}$ -in. brass and work from the pivot center as your reference point. Steam grooves in the valve face are best formed by end-milling with a $\frac{1}{16}$ -in. dental burr. Set up a false pivot by mounting a $\frac{3}{16}$ -in. rod horizontally on the lathe saddle. Mount the valve on the pivot with its face toward the headstock and the mill gripped in a chuck. Set the pivot $\frac{19}{64}$ in. off center to correspond to the radius of curvature of the groove. Feed the work in slowly, rotating the valve manually on the pivot through the proper angle. Lap the valve face and port face with jeweler's rouge to make the joint steam tight. Mount the valve on the pivot, holding it against the port face with a light spring and nut.

Chuck a piece of brass for the eccentric, and machine the o.d. and the groove for the retaining screw which prevents the eccentric strap from moving sideways. Then sever with a parting tool. Use the center mark from parting off as a reference point to locate the crankshaft opening. The setscrew must pass through the broad part of the eccentric.

Put a locknut on each end of the eccentric rod for length of adjustment. Use a shouldered screw for connecting the eccentric rod's small end to the valve.

Making final assembly

Mount the eccentric on the crankshaft in any position for now and hook up the valve through the eccentric strap and rod. Adjust the length of the eccentric rod so that the division between the steam grooves in the valve face will move equal distances back and forth across the ports on the vertical centerline of the port face as the crankshaft is rotated. The last adjustment is the eccentric position relative to the crank. The eccentric should form an angle of about 165° to the crankpin. Adjust it so that the valve will be just starting to admit steam to the appropriate port when the piston is at the end of its stroke and is about to change direction.

My lathe is not big enough to handle the flywheel, so I hunted around and found the old gear which serves admirably. With a heavy flywheel and long stroke, the engine runs very smoothly on either air or steam. The proper operating speed for a beam engine is 50 to 60 rpm.

Complete plans detailing each part of the model can be obtained for \$3.50 from Beam Engine Plans, 691 Garretson Road, Somerville, N. J. 28876. ★★

**When your car is worth caring for...
Pennzoil is worth asking for.**



"You better believe it!"



**U.S. Government figures
show Pall Mall Gold 100's
lower in "tar" than the
best-selling filter king.**

Longer-yet milder

