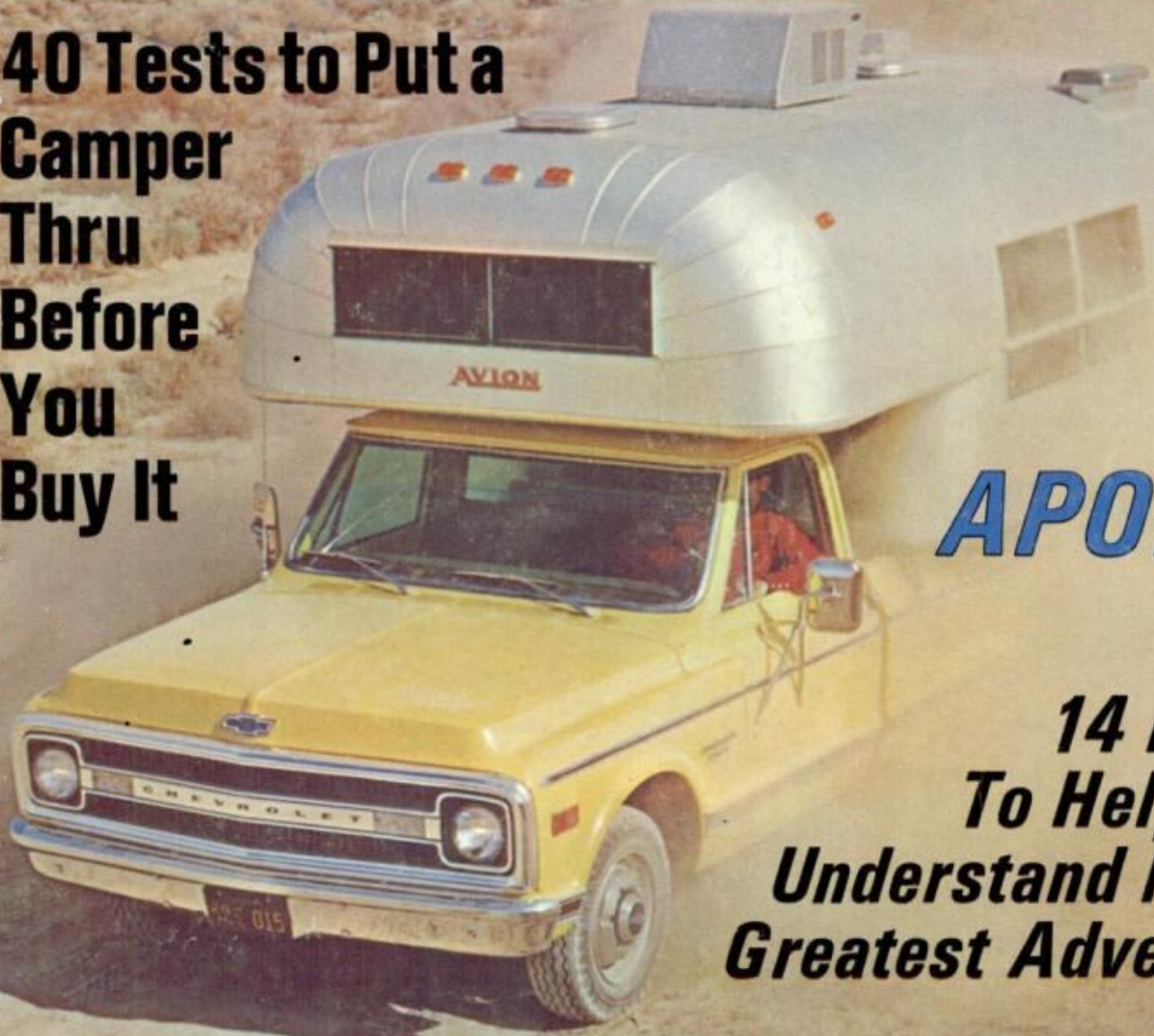


How to Turn a Beetle Into a Beauty Page 156

POPULAR MECHANICS

JULY 1969
50 CENTS

**40 Tests to Put a
Camper
Thru
Before
You
Buy It**



***APOLLO
11***

***14 Pages
To Help You
Understand Man's
Greatest Adventure***

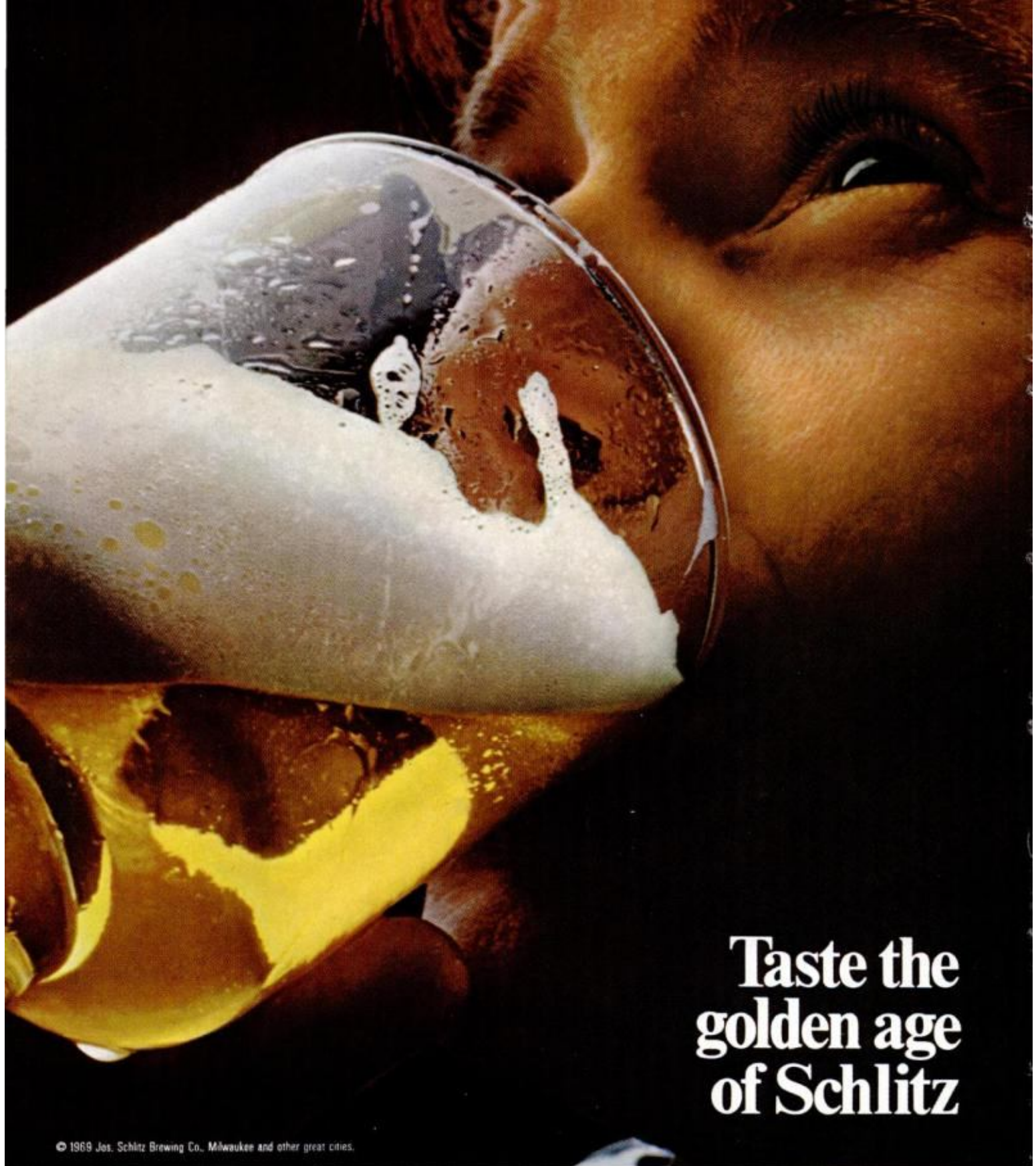
Those Wild New Bicycles—Page 150

How to Service Outboard Ignition Systems

Owners Reports: Cadillac and Ambassador

Trailer Hitches: Tips to Keep You Out of Trouble

Firepit for Your Patio, Plus Four Weekend Projects



Taste the golden age of Schlitz

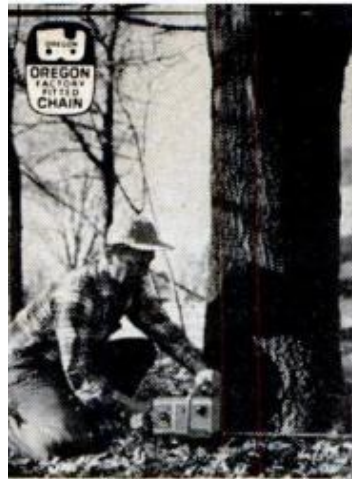
© 1969 Jos. Schlitz Brewing Co., Milwaukee and other great cities.

120 years ago, Joseph Schlitz took plenty of time to age his golden mellow beer. We still do. It's the golden age that makes Schlitz America's choicest premium beer.



“When you're out of Schlitz, you're out of beer.”

Материал, защищенный авторским правом



Look what you
can do with the
lightest Homelite®
chain saw
ever built

Leave it to Homelite to come up with a chain saw that combines light weight, smooth power, balance, and cutting speed in a neat, trim package that weighs only 8½ pounds!

Homelite named it the E-Z because it's easy to start, easy to run, makes any woodcutting job easier: felling a tree, cutting firewood, clearing storm damage, pruning and limbing, or doing weekend rustic projects. Homelite E-Z chain saws fell trees to 3 feet in diameter, cut through an 8" hardwood log in 6 seconds, an 8" softwood log in only 3½ seconds!

See your Homelite dealer and test cut the new E-Z against any other super lightweight chain saw. See why Homelite chain saws are so popular. Feel "Floating Power*" that lets you cut more, cut longer, with less fatigue. Your Homelite dealer is in the Yellow Pages.

THE NEW E-ZTM CHAIN SAW

HOMELITE

10207 RIVERDALE AVE., PORT CHESTER, N.Y.

A **Textron**
DIVISION



NEW!
HARD TIP

* less cutting attachments
* Trade Marks of Homelite

HOMELITE CHAIN SAWS ARE THE WORLD'S FASTEST SELLING - MORE THAN 2 MILLION BUILT AND SOLD

Материал защищен авторским правом

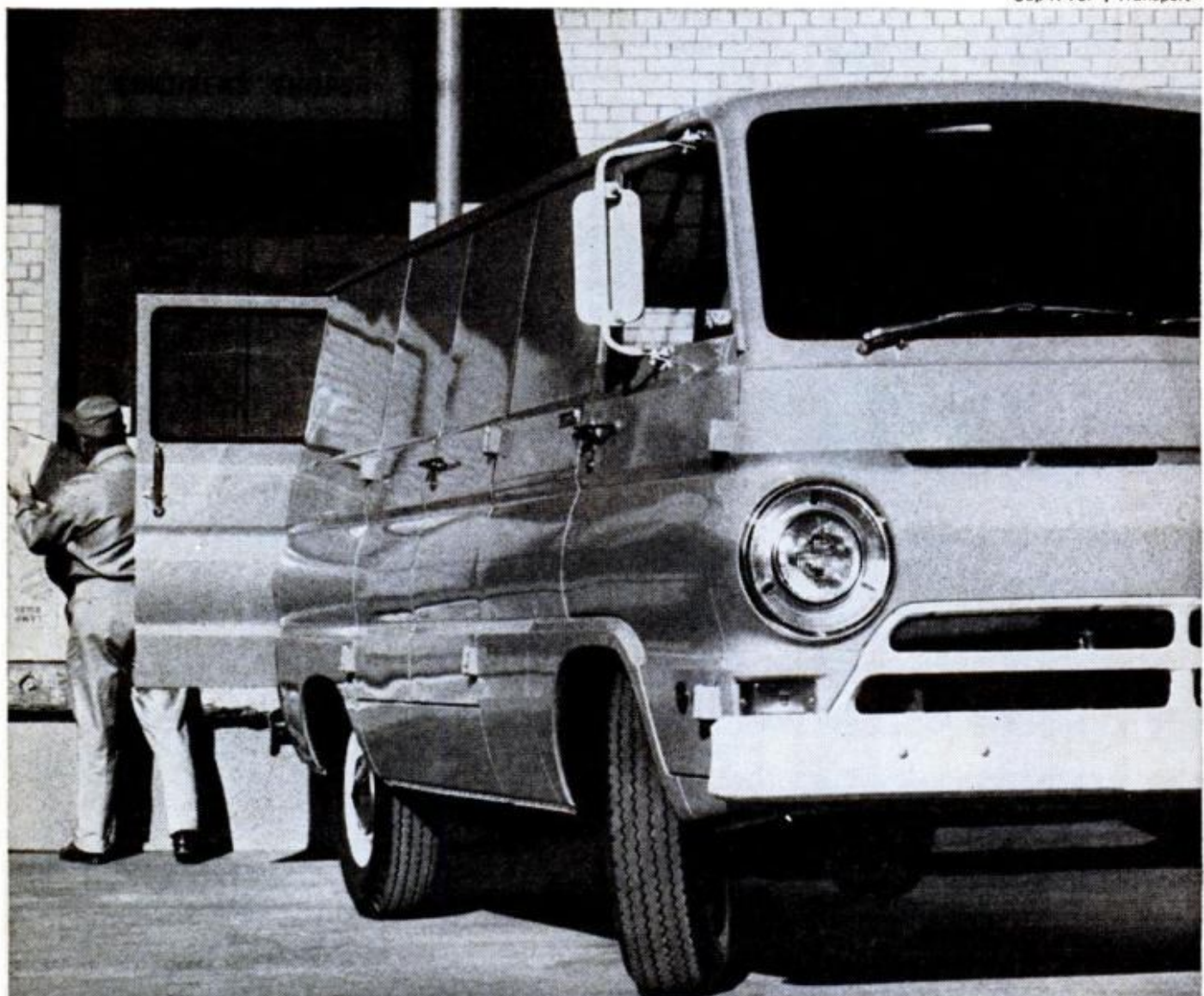
A Firestone truck tire priced as low as a car tire.

The Transport nylon cord truck tire. Everything you're looking for in a pickup or light-truck tire. With a low price that'll make you money.

It features a rugged Shock-Fortified nylon cord body for extra strength. Higher ply ratings for more load capacity. Exclusive Sup-R-Tuf rubber for long, long mileage. And a non-skid tread for sure starts and safe stops.

Our low-cost Transport truck tire. Long run, short money. Get it at your nearby Firestone Dealer or Store.

Sup-R-Tuf[®], Transport[®]



Firestone

**Cars built to do 175 need
all the protection they can
get from a motor oil.**



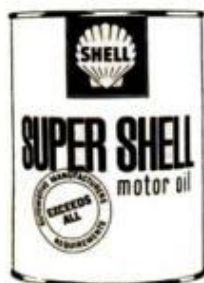
So does your car.

Strange as it may sound, the engine that averages thirty and rarely gets hot needs protection just as much as one that races around at a hundred plus.

Super Shell Motor Oil is all the protection your car could possibly need.

It exceeds all U.S. car manufacturers' requirements.

Just because you don't drive like you need a crash helmet doesn't mean your engine needs any less protection.



This One



SWRO-ASA-Y60Y

POPULAR MECHANICS®

INTERNATIONAL EDITIONS: AUSTRALIA, BRAZIL, CARIBBEAN, DENMARK, FRANCE, MEXICO, SOUTHERN HEMISPHERE, SWEDEN

AUTOMOBILES AND DRIVING

- [22 Drivin' With Dan](#)
- [38 Detroit Listening Post](#)
- [42 Saab's New 99](#)
- [70 Automobile Clinic](#)
- [77 40 Ways to Test a Camper Before You Buy It](#)
- [98 When Will We Have Service Centers Like These?](#)
- [102 PM Owners Report: AMC Ambassador](#)
- [122 PM Owners Report: Cadillac's Eldorado](#)
- [134 Trailer Hitches: Tips to Keep You Out of Trouble](#)
- [142 Saturday Mechanic: How to Keep the Cool in Your Airconditioner](#)
- [156 New One-Piece Body Turns 'Bug' Into a Beauty](#)

SPECIAL SECTION ON APOLLO II

- [80 The Dream Comes True](#)
- [84 Man's First Day on the Moon](#)
- [88 How They Fly the LM and Apollo](#)
- [90 . . . and Now, Back to Mission Control](#)
- [92 How You'll See Our Men on the Moon](#)

BOATING, OUTDOOR RECREATION

- [30 What's New Outdoors](#)
- [40 On-the-Go Camping](#)
- [77 40 Ways to Test a Camper Before You Buy It](#)
- [112 How to Get Your Boat to Pose for Better Pictures](#)
- [134 Trailer Hitches: Tips to Keep You Out of Trouble](#)
- [138 Outboard-Motor Service Guide No. 1: How to Check Your Ignition System](#)
- [150 Those Wild New Bikes](#)
- [172 Fit Your Swimming Mask With Glasses](#)

REGULAR FEATURES

- [6 Letters](#)

SHOP AND CRAFTS

- [164 'Instant' Freestanding Shelves](#)
- [166 Handiest Tool in Your Shop](#)
- [167 Hints From Readers](#)
- [168 Easy Projects for Summer Weekends](#)
- [172 Fit Your Swimming Mask With Glasses](#)
- [173 Second Table Permits Compound Drilling](#)
- [174 Sharpening Twist Drills Like a Pro](#)
- [177 Hints From Readers](#)
- [178 Build These Power-Tool Stands](#)
- [183 Hints From Readers](#)
- [184 Mount Grinding Wheels With Epoxy](#)
- [188 Hints From Readers](#)

SCIENCE AND ADVENTURE

- [20 Science Worldwide](#)
- [96 Just Patented: PM's Pick of the New Inventions](#)
- [106 The Death of World Glory](#)
- [116 In Florida Today: Ranchers Get Rough on Rustlers](#)
- [126 Popular Mechanical People](#)

HOME AND YARD

- [74 Homeowners' Clinic](#)
- [146 Exciting New Products](#)
- [148 Build This Patio Firepit](#)
- [162 Solving Home Problems](#)
- [164 'Instant' Freestanding Shelves](#)
- [168 Easy Projects for Summer Weekends](#)
- [187 New Hardware You Should Know About](#)

ELECTRONICS, RADIO AND TV

- [46 Hot New Multiband Portables](#)
- [130 Wire Your House for Intercoms—Without Wiring at All](#)

PHOTOGRAPHY

- [112 How to Get Your Boat to Pose for Better Pictures](#)

Cover Photo by Joe Munroe

Outdoors Editor Dan Fales tests an Avion camper on a dusty road near Las Vegas

NEXT MONTH IN POPULAR MECHANICS

- Ford's New Maverick:** How does it stack up against the "mob"?
- Single Antenna System:** It can serve all your TV and FM sets.
- PM Owners Reports:** Praise and gripes for Olds Delta 88 and Chevy Impala.
- Surefooted Icemen:** Rugged tests challenge the skill of mountain guides.

ROBERT P. CROSSLEY

Editor

JAMES M. LISTON

Executive Editor

JOHN A. LINKLETTER

Managing Editor

WAYNE C. LECKEY

Home and Shop
Editor

SHELDON M. GALLAGER

Assistant Executive
Editor

THOMAS G. DAUER

Art Director

Published by The Hearst Corporation

RICHARD E. BERLIN, PRESIDENT

RICHARD E. DEEMS

President, Magazines Division

JOSEPH F. KERN

Publisher

WILLIAM KILPATRICK _____ Automotive
DANIEL C. FALES _____ Boating and Outdoors
SHELDON GALLAGER _____ Electronics and Photography
JOHN F. PEARSON _____ Science
BILL HARTFORD _____ Technical Automotive
HARRY WICKS _____ Home Workshop
GARRY WINTER _____ Copy and Production
RICHARD H. FUNK _____ Associate Copy and Production
JOHN ADKINS _____ Assistant Copy and Production
ALVIN KIETZ _____ Assistant Art Director
DON EVANS _____ Assistant Art Director
FRED A. LEERS _____ Assistant Art Director
GEORGE W. BLOW _____ Technical Art Director
CLIFFORD B. HICKS _____ Special Projects
SOPHIE GRONOWICZ _____ Director, Bureau of Information
EVERETT JOHNSON _____ Cabinetmaker

ADDRESS ALL EDITORIAL COMMUNICATIONS TO: 575 Lexington Ave., New York, N.Y. 10022. For additional sources of information on the articles and products in this issue, write to Bureau of Information, Popular Mechanics, for free "Where-to-Find-It" list.

DANIEL J. COLEMAN

Director of Advertising

ADVERTISING OFFICES: New York: 575 Lexington Ave., Murray Hill 8-8500; Chicago: 520 N. Michigan Ave., 527-2400; Detroit: General Motors Bldg., TRinity 5-8711; Cleveland: Hanna Bldg., 1422 Euclid Ave., Prospect 1-0456; Los Angeles: 601 North Vermont Ave., 666-6263; San Francisco: 1101 Hearst Bldg., YUKon 2-0823.

SUBSCRIPTION SERVICE: Mail all subscription orders, changes of address, correspondence concerning subscriptions, and Postmaster notices of undeliverable copies to Popular Mechanics, Box 646, New York, N.Y. 10019. Please enclose your latest address label for quickest service when writing about your subscription.

POPULAR MECHANICS IS PUBLISHED MONTHLY by The Hearst Corporation, 57th St. at 8th Ave., New York, N.Y. 10019, U.S.A. Richard E. Berlin, President; George Hearst, V-Pres.; Richard E. Deems, President of Magazines; John R. Miller, Executive V-Pres. of Magazines; Raymond J. Petersen, Senior V-Pres. of Magazines; William S. Campbell, V-Pres. of Magazines; Albert A. Kachol, V-Pres. and Director of Circulation; Joseph F. Kern, V-Pres. for Popular Mechanics; Frank Massi, Executive V-Pres. and Treasurer; Harvey L. Lipton, Secy. Single copy in the United States and Canada, 50 cents. Subscription prices: United States and Possessions, \$4.00 for one year; \$7.00 for two years; \$10.00 for three years. Canada, add \$0.75 for each year. Pan American Postal Union countries, add \$1.00 for each year. All other countries, add \$2.00 for each year. When changing address, give old address as well as the new, with postal-zone number, if any, and allow six weeks for change to become effective. Second-class postage paid at New York, N.Y., and at additional mailing offices. Authorized as second-class mail by the Post Office Department, Ottawa, and for payment of postage in cash. Registered as second-class matter at the Post Office at Mexico D.F., Mexico, June 20, 1950. © 1969 by The Hearst Corporation. All rights reserved. Printed in U.S.A.

JULY 1969

A workshop without metal-hungry Nicholson hacks



is like
an awl
without
its point.



Nicholson hacksaw blades are masters of any metal-cutting situation.

Rugged. Flexible. Long lasting. Look for 'em in their colorful, protective skin-packs at your hardware dealer's.

There's never a dull moment with

Nicholson

Nicholson File Co., Providence, R.I.





Revelation hasn't changed since Dad's favorite club was called a mashie-niblick.

Revelation's not made of sugar and spice, boys. Just tobacco: 5 great tobaccos. Revelation's for the experienced pipe smoker.



A quality product of Philip Morris U.S.A.

LETTERS

TO THE EDITOR

Comeback Town comes back

In 1964 Crescent City was almost wiped off the map by the tidal wave that was created by the Alaska earthquake. Now, in *A Rugged New Camper . . . A Controversial New Park* (page 124, May PM), you have moved Crescent City almost 100 miles south.

Crescent City is known as "Comeback Town, U.S.A.," so we would appreciate it if you would put us back where we belong.
CRESCENT CITY, CALIF. DALE ZIEMER

How about that! You moved 100 miles and didn't feel a thing. Just to show our heart's in the right place, we're moving both Crescent City and Eureka back to where they were before we published our May issue. (And we've moved our cartographer to Siberia.)

Let there be light, maybe

So the Port of New York Authority finally got around to finding out that it's safer to drive with parking lights on (*Detroit Listening Post*, page 10, May PM). How could they not be aware of this?

Both the Checker Taxi Co. of Chicago and the Greyhound Bus Co. have been driving their vehicles with the headlights on for some years now. Both found the number of daylight accidents significantly and consistently reduced. This information has been published several times.
CHICAGO KEN GREENBERG

Driving with your parking lights on day or night creates a hazard due to the fact that parking lights create the optical illusion that a car is at a great distance—whereas it may be close by. For daytime safety, drive with your headlights on.

In California it is a violation of traffic laws to drive with parking lights on at any time.

ELK GROVE, CALIF. DALLAS POSTON,
SAFETY ENGINEER,
STATE OF CALIFORNIA


Fly those speedy trains

I wish your table of comparisons for high-speed trains could be reprinted in every Canadian newspaper (*Those Fast, New Trains*, page 98, May PM).

I've been trying to get an article on tracked hovercraft published in Canadian
(Please turn to page 8)


WHO ELSE WANTS A BIG RAISE IN PAY?

"My salary has increased 400% as a direct result of my LaSalle studies"




Rudolph Urbatis,
Port Chester, N.Y.

"Salary more than doubled since enrolling"




William T. Black,
Canoga Park, Calif.

"Income has increased 100 per cent since graduation"



James L. Yaning,
Manhattan, Kansas

"I now earn three and a half times my former pay"



Robert Fisher,
Holbrook, Ariz.

Stuck in a rut? Tired of your dead-end job? Here's proof you can step up to a high-salary position with prestige and security through LaSalle spare-time training.

JUST LOOK at these enthusiastic letters. Have you ever seen anything like them? They are just a few of many hundreds of similar statements in letters that come from LaSalle students week after week, month after month, year after year.

LaSalle students have one ambition in common—to get out of the ranks of the untrained and earn big money, prestige and security in a key job. Isn't that your goal too?

Without interfering with your present work—and by devoting only a little of your spare time—you too can prepare rapidly for advancement in the field of your choice through LaSalle home study. The cost is surprisingly low.

LaSalle has been an acknowledged leader in home education for over sixty years. It has provided training in business, high school and technical subjects to more than 1,500,000 ambitious men and women. Its distinguished faculty includes some of the country's most outstanding authorities. That is why your LaSalle diploma is a credential recognized and respected by employers.

Check the subject you are interested in—then send the coupon below for FREE booklet. No obligation. Mail to LaSalle, 417 S. Dearborn Street, Chicago, Illinois 60605.

LA SALLE EXTENSION UNIVERSITY

A Correspondence Institution • 417 S. Dearborn Street, Dept. 91-084, Chicago, Illinois 60605

Please send me, without cost or obligation, FREE booklet and full information on the field I have checked below:

- | | | | | |
|--|---|---|--|---|
| <p>ACCOUNTING</p> <input type="checkbox"/> Complete Accounting
<input type="checkbox"/> Income Tax
<input type="checkbox"/> Accounting Fundamentals
<input type="checkbox"/> CPA Training
<input type="checkbox"/> Modern Bookkeeping <p>BUSINESS MANAGEMENT</p> <input type="checkbox"/> Complete Business Management
<input type="checkbox"/> Credit and Collections
<input type="checkbox"/> Office Management
<input type="checkbox"/> Personnel Management
<input type="checkbox"/> Sales Management <p>REAL ESTATE</p> <input type="checkbox"/> Complete Real Estate
<input type="checkbox"/> Real Estate Brokerage
<input type="checkbox"/> Real Estate Management | <p>COMPUTER PROGRAMMING</p> <input type="checkbox"/> Complete Training <p>LAW COURSES</p> <input type="checkbox"/> Bachelor of Laws Degree
<input type="checkbox"/> Business Law
<input type="checkbox"/> Insurance Law
<input type="checkbox"/> Claim Adjusting Law
<input type="checkbox"/> Law for Police Officers <p>STENOTYPE</p> <input type="checkbox"/> Machine Shorthand <p>TECHNICAL COURSES</p> <input type="checkbox"/> Air Conditioning, Refrigeration, Heating
<input type="checkbox"/> Diesel <p>TRAFFIC & TRANSPORTATION</p> <input type="checkbox"/> Complete Traffic Mgt. Truck, Air, Rail, Sea | <p>DRAFTING</p> <input type="checkbox"/> Complete Drafting <p>INTERIOR DECORATION</p> <input type="checkbox"/> Professional Training <p>ART TRAINING</p> <input type="checkbox"/> Commercial Art
<input type="checkbox"/> Oil, Water Color Painting
<input type="checkbox"/> Complete Training | <p>HIGH SCHOOL</p> <input type="checkbox"/> High School Diploma <p>LANGUAGE INSTRUCTION</p> <input type="checkbox"/> French
<input type="checkbox"/> Spanish <p>HOTEL/MOTEL MANAGEMENT</p> <input type="checkbox"/> Executive Training | <p>CAREERS FOR WOMEN</p> <input type="checkbox"/> Accounting
<input type="checkbox"/> Bookkeeping
<input type="checkbox"/> Commercial Art
<input type="checkbox"/> Computer Programming
<input type="checkbox"/> Dental Assistant
<input type="checkbox"/> Hotel/Motel Mgmt.
<input type="checkbox"/> Interior Decorator
<input type="checkbox"/> Real Estate
<input type="checkbox"/> Secretarial
<input type="checkbox"/> Stenotype |
|--|---|---|--|---|

Interested in a career not listed? Write here: _____

Mr. _____ Age.....
 Mrs. _____
 Miss _____ (Circle title and please print)

Address..... Apt.No.....

City & State..... Zip No.....

Best way to keep your bearings

100% Pure Pennsylvania oil refined and fortified to keep your outboard from choking up. Buy your oil the way you bought your boat. Carefully. Wolf's Head Oil Refining Co., Oil City, Pa. 16301.



the uncommon motor oil

LETTERS

(Continued from page 6)

journals, without success. It's very encouraging to see that you say what I've been attempting to get across: Very fast trains and level crossings don't mix.

UNIVERSITY OF WATERLOO J. C. MCKEGNEY
WATERLOO, ONT.

Rondette roundup

As suggested in your article *Rondette—Prefab House in the Round* (page 172, April PM), I called Rondesics, Inc., in Asheville, N.C., and was advised that Rondettes are franchised and could not be sold direct to me. I was referred to Presidential Homes in Pemberton, N.J., which, at my request, mailed me a brochure which indicated that a two-bedroom Rondette costs \$15,990. This model compares with the one described in your magazine. I feel that you should publish a correction indicating that the Rondette costs \$15,990, not \$6702.

FOREST HILLS, N.Y.

G. E. JACOBUS

Despite the fact that Rondesics literature says "Even do-it-yourselfers have taken advantage of our complete building package and now have themselves a dramatic second home they can point to with pride," it seems nigh impossible to get the prefab house so you can build it yourself. That is, unless, as Presidential Homes points out, you are "a builder and can so prove to our satisfaction." Its current price for the erected house is \$15,990.

Look at yourself, truck driver

Running through *How You Look to a Truck Driver* (page 93, May PM) is the unstated assumption that a truck driver—and possibly a bus driver, too—is always justified in any action that will prevent him from losing a little time, even if the wretched passenger-car driver may "risk getting hit."

Perhaps it would be better if more truck drivers spent a little less time thinking of how skilled they are, and a little more about the greater value of other drivers' peace of mind and safety.

NEW YORK

ROBERT TYSON

We are sincerely unhappy that two corrections have to be made after such a fine job of writing. Our company, referred to as Carolina Lines, is correctly called Carolina Freight Carriers Corp. Also, mention was made that Carolina serves 30 states; it can serve any state in the Union on an interchange basis, but serves 19 directly.

CHERRYVALE, N.C.

JIM BOOKER

TORO's automatic sprinkler system* will turn your neighbors green.



To say nothing about your lawn.



Think of it . . . lush green turf that stays that way when the rest of the neighborhood is turning parched-brown.

Think of having an underground system (installed so fast your neighbors won't know what you're up to) that works so automatically you can set it and forget it. From then on in, you relax—it does the

sprinkling thinking for you!

Think you can't afford it? Why not invest a quarter to find out that you can. Send for our booklet that tells you *everything* you have to know about an underground system, including the approximate cost for a lawn *your* size.

Think of it . . . green neighbors!

TORO

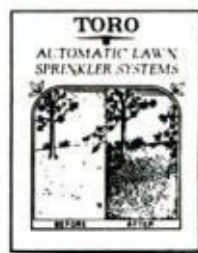
AUTOMATIC LAWN
SPRINKLER SYSTEMS

*TORO calls it Moist O'MATIC®

To: TORO MANUFACTURING CORPORATION
8111 Lyndale Avenue South PM2
Minneapolis, Minnesota 55420

Send me the Moist O'MATIC story.
I'm enclosing 25¢ to cover handling
and mailing.

NAME _____
STREET _____
CITY _____
STATE _____ ZIP _____



Bob Winkelmann and the 4525 mile road race.



(He won it with a new motor oil.)

From Bob Winkelmann's house in Mill Valley, California, to the Mid America Raceway in Wentzville, Missouri, it is 2100.5 miles.

A few months back, Bob filled his station wagon's crankcase with Gulfpride[®] Formula G, towed his racer to Wentzville, filled it with Formula G, won a 50 miler, loaded it back on the trailer, drove 1000 miles overnight to

Penwell, Texas, and won another 50 mile race.

Then he went home.

Obviously, Mr. Winkelmann likes to race. So does every other owner/driver who competes in SCCA point races.

We introduced some of them to Formula G; told them about it being the best protection against wear and overheating they could buy. On or off the track.

Since the word got around, Formula G's track record has included 130 first place finishers in SCCA point races, the World's Manufacturers Championship and the Can-Am Championship. There isn't a car coming off a production line anywhere with an engine too big or too hot for Formula G to handle.

Have a few words about it with your Gulf dealer.



Gulf Oil Co.—U. S.

"We want to test your aptitude for accounting"

by Byron Menides

Here is your opportunity to discover whether you have the aptitude to succeed in one of the world's best-paid professions—accounting. All you need do is take our free Accounting Aptitude Test at home, in your spare time. We'll tell you if you can be trained for success in this rewarding field.

Thousands of people who have taken this Aptitude Test and developed their skill through our training, have gone on to successful careers as accountants, office managers, auditors, controllers and business executives.

It makes no difference what kind of job you have now. If you have a high school diploma or equivalent—if you like working with figures—then one of the world's best-paid careers is wide open to you.

How you learn the skills of accounting

Since 1903, the International Accountants Society has been training people, right at home, to be accountants.

One key to the school's success is its practical technique of teaching: *you learn by doing*. You do what accountants do—face the problems they face—just as though you were learning on the job. You see your skills grow, lesson by lesson. And every step of the way, you are guided by faculty members who are all Certified Public Accountants.

Our students succeed

This personalized training has helped men all over the country find prestige jobs in accounting.

"When I completed my first I.A.S. lesson, I was only a clerk...Today my salary is \$15,000 per year as Director of Purchasing for a multi-million dollar business."—Robert J. Slinkard, Window Rock, Ariz.

"International Accountants Society has helped me gain a much better position...The future looks excellent; another promotion only 30 days after receiving my diploma. My three promotions doubled my salary."—John C. Miller, Sturgis, Michigan

"My salary has increased many fold since I started studying with I.A.S. Your inspiration and guidance have been of priceless value, and your course has proved to be a key to my success."—R. W. Engelhorn, Los Angeles, California

"In six months from the time I started the course I have changed jobs, increasing my pay approxi-



Byron Menides is the President of the International Accountants Society. He was formerly a specialist in international surveys with Arthur Andersen & Co., one of the world's largest accounting firms, and has held other top positions in the business and educational fields.

mately 75 to 100%. Words cannot express my gratitude to the International Accountants Society for the training given me."—George B. Simmons, Murfreesboro, Tennessee

Send for free Aptitude Test

Find out if you have the ability to become a successful accountant. Take that all-important first step by sending for your free Aptitude Test and an informative brochure today. Just fill out and mail the coupon below. There is no cost or obligation.

International Accountants Society, Inc.
A Home Study School Since 1903
Dept. 8949, 209 W. Jackson Blvd.
Chicago, Illinois 60606



Please send me your free Aptitude Test and brochure, "Your Business Success through Accounting." I understand there is no obligation.

Mr. _____
Mrs. _____
Miss _____ [Circle one and please print] Age _____

Street _____

City _____

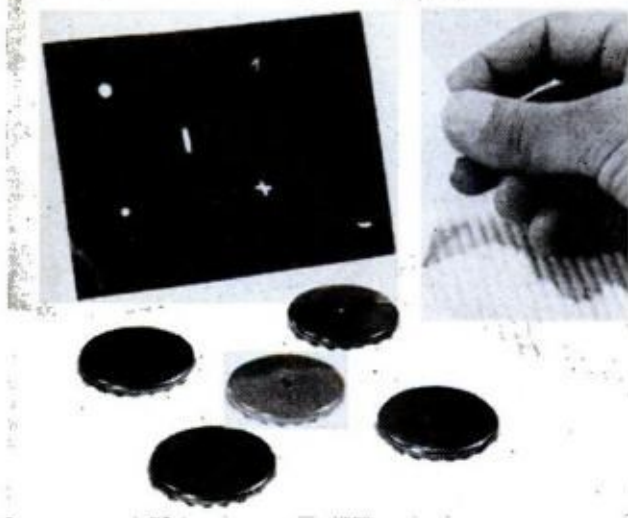
State _____ Zip _____

Approved under the New GI Bill.

Check here if entitled to GI Bill benefits.

Accredited Member, Natl. Home Study Council

NEWS BRIEFS



Marked money in nuclear age

Money can be given secret markings by irradiating it with radioisotope. Markings are detected (lower photo) by placing the money in contact with special film. Treated money is said not to pose a health hazard.



New thatch doesn't burn

Cute "fire bug" can't touch off a new Danish thatched roof that is impregnated with a fire-resistant material. Factory-made, the picturesque roofs come ready to be installed.



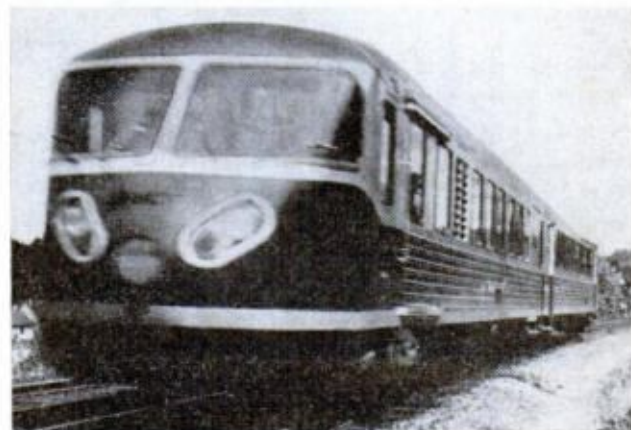
'Spillguard' for oil slicks

Oil spills on water can now be encircled and contained with a fence made of asbestos-rubber sheets combined with a flotation material. The barrier comes in 10-foot sections.



Water gun with a jolt

"Mobuster" is a riot-control gun that can disperse unruly crowds by squirting jets of electrified water, according to its English inventor, shown holding it. The electrical kick, he says, comes from batteries.



Fast trains for France

Gas-turbine-powered trains with operating speeds of over 100 mph will go into service in France this year. Slated for medium-distance runs, the four-car trains will have 192 seats.



How a man turns work into play.

Dave Brodie, here, for example. When he's not busy as sales manager for a cosmetic house, Dave spends some time with a Skilsaw Power Saw. Result: items like this handsome playhouse.

"It's a lot easier to build than you might think", says Dave. "Especially with the Skilsaw Power Saw. It cuts through lumber in nothing flat. And just about anything else.

"Fact is you can use the Skilsaw Power Saw on all kinds of jobs. Like cutting paneling

or steel rain gutters or even to slit flagstone. "If you get the idea this is one power tool I wouldn't be without, you're right. It really makes the work go."



Go! With the how-to-do-it book for people who don't know how to do it, "Skil Makes It Easy".

It's filled with projects (like playhouses) plus simple construction details, tips on materials and proper use of tools. 48 pages in all. To order, send 50c to Skil Corp., Box 5309, Chicago, Ill. 60680.

Dept. 513-S

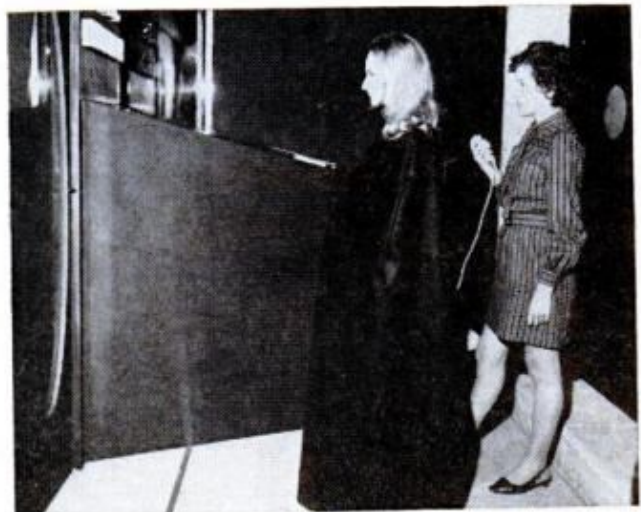
SKIL® makes it easy

Материал, защищенный авторским правом



Fully automatic gas station

Night or day, there never is an attendant at Britain's first "ghost petrol station." The customer inserts paper money in a slot and gets his change in coins. After pumping gas, he can buy oil or get a car wash by using coin machines. Water, air and a vacuum cleaner (left) are free. Key to the success of the operation is a selector mechanism that rejects forged or badly crumpled bills, and issues dated receipts.



No disrobing needed

London shops have the answer for women who like to try on lots of dresses. With her body draped in black, only the shopper's head appears in special mirror-projection screen. The projected dress image is scaled to proportions of shopper, who can "try on" 50 dresses in nothing flat. Clerk handles projector.

How good
a tire
did you have
in mind?



You know that blank feeling.

Tires are a strange world. Tube or tubeless? Two-ply or four-ply? Bias or radial or bias-belted? Premium or first-line or cheap?

Just what is "good"?

Try a Dunlop dealer, from the Yellow Pages. He's a pro. No stories or "bargains." Just excellent tires like these radials.

At reasonable prices.

He'll tell you what is right for your car and driving. And why.

And if he starts sounding like Dunlop invented the tire, it's all right. We did.



DUNLOP

... means quality in tires, tennis and golf.
Buffalo, N. Y. 14240

**FIND
buried treasure**



Many valuable pieces of furniture and antiques have been found buried under layers of old finishes. Savogran's heavy-bodied, non-benzol paint removers uncover treasures of beautifully grained wood faster, more efficiently, with less effort. Savogran offers 3 types of heavy-bodied paint removers: General Purpose (STRYPEEZE Semi-Paste), Nonflammable (STRYPEEZE Nonflammable), Water Rinsing (H2OFF).

"AVAILABLE WHERE PAINT IS SOLD"

SAVOGRAN

NORWOOD, MASSACHUSETTS 02062



JULY 1969

ARROW
HEAVY DUTY T-50

**STAPLE
GUN**

Uses 6 staple
sizes from 1/4"
to 9/16".
including
CEILTILE



**A
HANDY
CHECKLIST
OF HOUSEHOLD
FASTENING USES**

- Install ceiling tile
- Apply insulation
- Fasten weatherstripping
- Reupholster chairs
- Fasten fence wire to posts
- Repair window screens
- Secure antenna wiring
- Tack down stair treads
- Replace worn window shades
- Attach vines to trellises
- Tack carpet underpadding
- Apply polyethylene vapor barriers
- Make window boxes
- Trim kitchen shelves
- Line closets
- Fasten burlap around tree trunks
- Cover valances
- Hang drapes
- Affix wall decorations
- Install plastic wall brick

**SHOOT A STAPLE WHEREVER YOU'D DRIVE A NAIL!
FASTER . . . BETTER . . . CHEAPER . . .**

At Hardware, Lumber and Building Supply, Stationery and other retail outlets

ARROW FASTENER COMPANY, INC., Saddle Brook, N. J. 07663

SOME PEOPLE ARE GOING TO PAY \$200 TOO MUCH FOR THEIR AUTO AIR CONDITIONER THIS YEAR

Just be sure it's not you!



Super Unit.

Comfy-Kit gives you all the cooling power you can use. It's trim, sleek appearance actually enhances the looks of your car's interior. You can easily install it yourself in a half day — and save up to \$200 or more doing it. That's like being paid up to \$50 an hour for your time — and you have the satisfaction of doing it yourself.

You get everything you need for installation — even the loan of special tools if you need them. You get an easy-to-follow instruction book and a 12-month/12,000 mile warranty.

So, let someone else pay those high prices for air conditioning. You'll get better — more efficient cooling — for a lot less money. Join the thousands of satisfied users of Comfy-Kit... America's only install-it-yourself auto air conditioner. Fill out... and send in your coupon today. Get the jump on sweltering summer with Comfy-Kit.

COMFY-KIT P.O. Box 8585, Dept. PM-7
Dallas, Texas 75216

- Enclosed is \$133* for Standard Unit.
- Enclosed is \$148* for Super Unit.
- Enclosed is \$165* for Supreme Unit.
- Enclosed is \$30 deposit on a Super Standard Supreme Unit. I will pay the balance, plus C O D charges when delivered.
- Enclosed is \$8 00 deposit for a set of four tools, which will be returned to me when I return the tools.
- I would like to see the instruction book before I order. I enclose \$1 00 for the instruction book only. I understand this will apply on any future Comfy-Kit order.

Name

Address

City State Zip

My car is a (year) (model)

Engine displacement Horsepower

Power Steering yes no

Floor shift Steering column shift

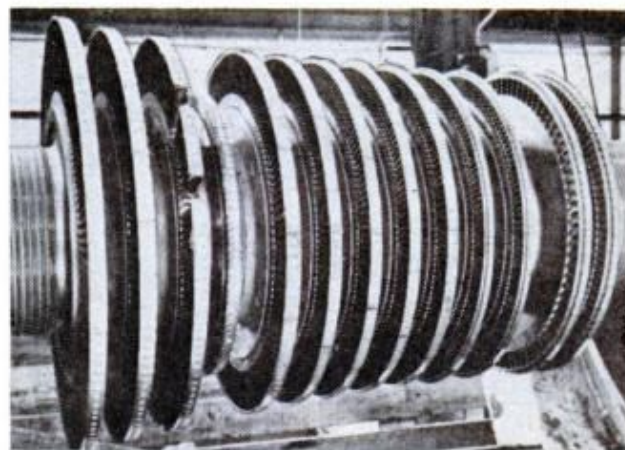
Smog pump yes no

*plus state sales tax where applicable



Programmed toy

Programmed cards, inserted into the toy electric Computacar, cause it to perform any sequence of maneuvers a child wants.



Cause of the delay

This damaged turbine (the fourth rotor ring sheared off) delayed the first voyage to New York of the new *Queen Elizabeth 2*.



Stretches tire mileage

A used tire with a wood disc inside and casters below make up the Buffer Roll About, a new British toy.

Cast your ballot for a successful future!

266 ICS COURSES



You get the widest choice from ICS—oldest, largest home study school. Check the list. (Also available, programs tailored to your special needs.) You receive individual instruction, plus success-proved facts

and theory you can apply immediately. Mastery of subject is assured. No skimping. You **earn** your diploma. Why mark time when you can mark the coupon and get a fast, sure fix on **your** best course to success.

ACCOUNTING
Accounting (U.S.A.)
Accounting (Canadian)
Accounting for Business
Programmers
Accounting for
Management Decisions
Auditing
Business Law (U.S.A.)
Cost Accounting
CPA Review (U.S.A.)
General Accounting
Income Tax (U.S.A.)
Industrial Accounting
Junior Accounting
Practical Accounting
Public Accounting
Small Business
Accounting (U.S.A.)
Starting and Managing a
Small Bookkeeping
Service (U.S.A.)

**ARCHITECTURE
AND BUILDING**
Architectural Drawing
and Designing
Architecture
Building Contractor
Building Estimator
Building Inspector
Building Maintenance
Carpenter-Builder
Carpentry and Millwork
Fundamentals of
Urban Planning
House Planning and
Interior Design
Mason
Painting Contractor
Reading Arch. Blueprints
Review in Architectural
Design and Practice
Review of Mechanical
Systems in Buildings

ART
Amateur Artist
Commercial Art
Commercial Cartooning
Illustrating with Options:
—Magazine
—Advertising Layout and
Illustration
Interior Decorating
Oil Painting for Pleasure
Show Card and
Sign Production
Show Card Writing
Sign Painting and Design's
Sketching and Painting

AUTOMOTIVE
Automatic Transmission
Specialist
Automobile Body
Rebuilding & Refinishing
Automobile Elec. Tech'n
Automobile Engine Tune-Up
Automobile Mechanic
Automobile Technician
Diesel-Gas Motor Vehicle
Engines

BUSINESS
Advertising
Business Administration
Business Practice (Cond.)
Canadian Business Course
Condensed Marketing
Direct Mail and Mail
Order Advertising
Industrial Psychology
Inventory Control
Mag. & News'p'r Adv.
Managing a Retail Business
Managing a Small Store
Marketing Management
Marketing Research
Modern Executive Mgmt.
Office Automation
Office Management
Production Management
Purchasing Agent
Retail & Local Advertising
Retail Bus. Management
Retail Merchandising
Retail Selling
Systems and Procedures
Analysis

BUSINESS: SALES
Creative Salesmanship
Real Estate Salesmanship
Salesmanship
Sales Management

**BUSINESS:
SUPERVISION**
Basic Supervision
Industrial Foremanship
Industrial Supervision
Management,
Salesmanship and Sales
Modern Woman as a
Supervisor
Personality Development
Personnel-Labor Relations
(U.S.A.)
Supervision

CHEMICAL
Chemical Engineering
Analytical Chemistry
Chemical Engineering
Unit Operations

Chemical Laboratory Tech'n
Chemical Process Operator
Elements of Nuclear Energy
General Chemistry
Instrumental Laboratory
Analysis

**CIVIL
ENGINEERING**
Civil Engineering
Construction Eng'r'g Tech.
Highway Engineering Tech.
Principles of Surveying
Reading Highway B'pts
Reading Structural B'pts
Sanitary Engineering Tech.
Sewage Plant Operator
Structural Eng'r'g Tech.
Surveying and Mapping
Water Works Operator

**COLLEGE
COURSES**
American History
Calculus Economics

COMPUTERS
COBOL Programming
Fortran Programming for
Engineers
Programming for Digital
Computers
Programming the IBM
1401 Computer
Programming the IBM
System/360 Computer,
Introduction

DRAFTING
Aircraft Drafting
Architectural Drafting
Design Drafting
Drafting Technology
Electrical Drafting
Electrical Eng'r'g Drafting
Electronic Drafting
Introductory Mech. Drafting
Mechanical Drafting
Pressure-Vessel and Tank
Print Reading
Sheet Metal Layout for
Air Conditioning
Structural Drafting

ELECTRICAL
Electrical Engineering
—Electronics Option
—Power Option
Electrical Appliance Serv'g
Electrical Appliance Serv'g
with Equipment Training
Electrical Contractor
Electrical Eng'r'g Tech.
Electrical Home Maint.

Electrical Home Maint.
with Equipment Training
Electrical Instrument Tech.
Electric Motor Repairman
Industrial Electrical Tech.
Power-Line Design & Const.
Power Plant Operator
—Hydro Option
—Steam Option
Practical Electrician
Practical Electrician with
Equipment Training
Practical Lineman
Reading Electrical B'pts

**ENGINEERING
(Refresher Courses
for Graduate
Engineers)**
Chemical Civil Electrical
Industrial Mechanical
Sanitary Structural

**ENGLISH AND
BETTER WRITING**
Better Business Writing
English for Spanish (U.S.A.)
Free Lance Writing for
Fun and Profit
Introductory Tech. Writing
Modern Letter Writing
Practical English
Short Story Writing

HIGH SCHOOL
High School Business
High School (Canadian)
High School General
High School Mathematics
High School Secretarial
High School Vocational
High School College
Preparatory—Arts
High School College Prep.
—Eng'r'g and Science
Preparatory Course for
High School Equiv. Test

**MACHINE SHOP
PRACTICE**
Drill Operator
Foundry Practice
Industrial Metallurgy
Lathe Operator
Machine Shop Inspection
Machine Shop Practice
Metallurgical Eng'r'g Tech.
Milling Machine Operator
Multicraft Maint. Mech.
Practical Millwrighting
Reading Shop Prints
Rigging
Tool Engineering Tech.
Tool Grinder Tool Making

Turret Lathe Operator
Welding Engineering Tech.
Welding Process
MATHEMATICS
Advanced Mathematics
Math and Mechanics for
Engineering Technicians
Math and Physics for
Engineering Technicians

MECHANICAL
Mechanical Engineering
Aircraft and Power
Plant Mechanic
Hydraulic & Pneu. Power
Industrial Engineering
Industrial Eng'r'g Tech.
Industrial Instrumentation
Machine Design
Quality Control
Safety Engineering Tech.
Tool Design
Vibration Analysis
and Control

PETROLEUM
Natural Gas Production
and Transmission
Oil Field Technology
Petroleum Production
Petroleum Production
Engineering Technology
Petroleum Refinery Oper.
Pipeline Engineering Tech.

PLASTICS
Design of Plastic Products
Plastics Technician

**PLUMBING,
HEATING AND AIR
CONDITIONING**
Air Conditioning
Air Conditioning Maint.
Domestic Heating with
Gas and Oil
Domestic Refrigeration
Heating
Heating & Air Conditioning
with Drawing
Industrial Air Conditioning
Industrial Heating
Pipe Fitting Plumbing
Plumbing and Heating
Plumbing & Heating Est.
Practical Plumbing
Refrigeration
Refrigeration and
Air Conditioning

PULP AND PAPER
Paper Machine Operator
Paper Making Pulp Mak'g
Pulp & Paper Eng'r'g Tech.

SECRETARIAL
Clerk-Typist Commercial
Secretary, Engineering
Secretary, Legal
Secretary, Medical
Secretary, Professional
Shorthand Stenographic
Typewriting

**STEAM AND
DIESEL POWER**
Boiler Inspector
Industrial Building Eng'r
Power Plant Engineering
Stationary Diesel Engines
Stationary Fireman
Stationary Steam Eng'r'g

TEXTILES
Carding
Carding and Spinning
Dyeing and Finishing
Loom Fixing Spinning
Textile Designing
Textile Mill Supervision
Textile Technology
Warping and Weaving

TRAFFIC
Motor Traffic Management
Railway Rate Clerk
Traffic Management

**TV-RADIO-
ELECTRONICS**
Color Television Principles
and Servicing
Electronics Instrumentation
and Servo Fundamentals
Electronics Technician
First Class Radio-
telephone License
Fundamentals of Electronic
Computers

General Electronics
General Electronics with
Equipment Training
HI-FI Stereo and Sound
System Servicing
Industrial Electronics Tech.
Numerical Control
Electronics and Maint.
Practical Telephony
Principles of Semiconductor
Radio & TV Servicing
Radio & TV Servicing
with Equipment Training
Second Class Radio-
telephone License
Sound Systems Specialist
TV Servicing and Repair
Telephony, Electronics, &
Radio Communications

Clip coupon here . . . take your first step to real success! ICS, Scranton, Penna. 18515



Approved for veterans
under the G.I. Bill.
Accredited member,
National Home Study Council.
Convenient payment plan.
Special Canadian courses
in French and English.
Special rates to members
of the U.S. Armed Forces.

INTERNATIONAL CORRESPONDENCE SCHOOLS Dept. N4569F, Scranton, Penna. 18515

(In Hawaii: P.O. Box 418, Honolulu. Canadian residents mail to Scranton address—further service handled by ICS Canadian Ltd.)

I'm interested in a program of independent study. Send me your free 3-booklet Success Kit:

(1) "How to Succeed," 30 pages of valuable job tips,

(2) Sample self-instruction text, (3) Catalog for subject indicated.

(Print name of course. See list.)

Miss _____ Age _____

Mr. _____

Address _____

City _____ State _____ Zip Code _____

Occupation _____ Employed by _____ Working Hours _____ A.M. to _____ P.M.

Science Worldwide

BY JOHN F. PEARSON

If this month's Apollo 11 mission is a success, some of the moon soil brought back by astronauts Neil Armstrong, Edwin Aldrin and Michael Collins will be used to grow such common plants as corn, potatoes, tomatoes and tobacco. The microscopic structure of the plants will be analyzed and compared to the structure of plants grown in Earth soil. But before planting takes place at NASA's Lunar Receiving Laboratory, Houston, scientists will test the moon soil to see if it contains any factors that might be dangerous to Earth life.

The possibility of predicting and preventing stroke—said to be the nation's third leading cause of death—was forecast by a research team from NASA's Ames Research Center and Stanford University School of Medicine. The researchers have developed a new method of identifying potential stroke victims. A radioactive drug is injected into the bloodstream and monitored by a detection device as it passes through the brain. Computer analysis of the data provides a pattern of blood-flow rate in the brain. A low flow rate, say the researchers, might be the result of hardening and narrowing of the arteries of the brain.

Silicone membranes may be the roofing material of the future. That prediction comes from General Electric scientists who have field-tested the rubberlike material over a period of years. An .022-inch-thick membrane provides the same protection as two to four inches of asphalt, say the researchers. Because silicone membranes are flexible, they are not cracked by small expansions and contractions in underlying roof surfaces.

If you spot an unusual bug or observe abnormally heavy insect damage to flowers, trees, lawn, vegetable garden or house, inform your county agricultural agent or state or federal authorities. That request comes from U.S. Department of Agriculture officials who explain such evidence could mean that a foreign bug has sneaked past quarantine barriers or that an established pest is building up to dangerous proportions in areas where it has not previously been seen. Plant-pest-control experts stress the important part played by private citizens in discovering new insect enemies. It was a Florida homeowner's curiosity about the larvae he found in a grapefruit that triggered the successful campaign in 1956 against the destructive Mediterranean fruit fly.

A dirigible for use on big construction projects is being built in the Soviet Union, according to the newspaper *Sovietskaya Rossiya*. The airship reportedly will be able to lift five-ton loads as high as 1500 feet and will initially be used in putting up a big oil refinery. Tethered at the site, the dirigible will be maneuvered by means of a system of cables. Russian engineers plan to use the ship on the upper stages of construction projects, at levels too high for efficient crane operation.

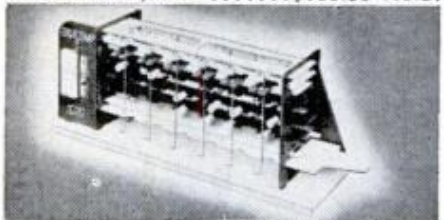
Hormones that make a man masculine also trim years off his potential life span. That conclusion was arrived at by researchers at New York City's Downstate Medical Center after a study of 1032 male inmates—297 of them eunuchs—at an institution for the mentally retarded. Inmates who had been castrated had a median length of life of 69.3 years as against 55.7 for intact males. And those castrated before sexual maturity were longer lived than those castrated after, report the researchers, who note that the same thing holds true for cats. How the hormones shorten life span has yet to be determined.

Improving the breed. That's the goal of a program underway at the Lexington, Ky., office of the Jockey Club, the organization responsible for the registration of racehorses in the United States. Pedigree and performance data on 357,000 thoroughbreds are being taped for use in a computer system. "We are working on a system for rating horses based on their genetic makeup and racing performance," explains a club official. "Using this computer-compiled information for selective breeding should ultimately result in a better strain of racehorses—stronger, faster and more competitive." ★ ★ ★



SUPER 6" SPACE CONQUEROR

Superb Astronomical Reflector—Up to 576X. Capable of revealing faint stars of nearly 13th magnitude, split double stars separated by less than 1 sec. of arc. Features aluminized & overcoated 6" f/8 ground and polished pyrex parabolic mirror accurate to 1/4 wave, 48 F.L. 6X achromatic finder scope. 4 eyepieces—48X Kellner, 1/2" 96X & 1/4" 192X Ramsdens. Barlow to double or triple power—rack & pinion focusing mount. 47 3/4" aluminum tube. Electric clock drive w/manual slow-motion control. Setting circles. Heavy-duty equatorial mount. Pedestal base. Compares to \$295—\$350 models.
Stock No. 85,086H\$199.50 F.O.B.



MODEL DIGITAL COMPUTER

Solve problems, teach logic, play games with miniature version of giant electronic brains! Adds, subtracts, multiplies, shifts, complements, carries, memorizes, counts, compares, sequences. Colored plastic parts easily assembled. 12" x 3 1/2" x 4 3/4". Incl. step-by-step assembly diagrams, 32-page instruction book covering operation, computer language (binary system) programming, problems and 15 experiments.
Stock No. 70,683H\$5.98 Ppd.



"FISH" WITH A MAGNET

Now go treasure hunting on the bottom! Great idea! Fascinating fun and sometimes tremendously profitable! Tie a line to our 5-lb. Magnet—drop it overboard in bay, river, lake or ocean. Troll it along the bottom—your "treasure" haul can be outboard motors, anchors, fishing tackle, all kinds of metal valuables. 5-lb. Magnet is war surplus—Alnico V Type—Gov't cost \$50. Lifts over 150 lbs. on land—much greater weights under water.
Stock No. 70,571H... 5-lb. ...\$12.50 Ppd.
Stock No. 70,570H... 3 1/2 lb. ...\$8.75 Ppd.



AMER. MADE OPAQUE PROJECTOR

Projects illustrations up to 3" x 3 1/2"—enlarges them to 35" x 30" if screen is 6 1/2 ft. from projector, larger if screen farther away. No film or negatives needed. Projects charts, diagrams, color, black-and-white. 115 V A.C. Operates on 60 W bulb, not incl. 12" x 8" x 4 1/2". 1 lb. 2 ozs. Plastic case.
Stock No. 70,199H\$7.95 Ppd.

JULY 1969



SEE MUSIC IN DAZZLING ACTION

Music Vision Dramatic Breakthrough in Audio-Visual Enjoyment

Actually see favorite musical selections translated into fantastic patterns of beautiful color—each individual note creating its own unique, twisting, radiating shape... each shape dancing and prancing, whirling and swirling in perfect time with the music. Attach to stereo, radio, tape recorder. Send 25¢ for booklet #9096H.
8" DO-IT-YOURSELF KIT
Stock No. 71,009H\$22.50 Ppd.
8" SET
Stock No. 71,030H\$45.00 Ppd.
WALNUT CABINET MODEL
Stock No. 85,181H\$99.50 FOB

KEEP PACE WITH THE SPACE AGE!

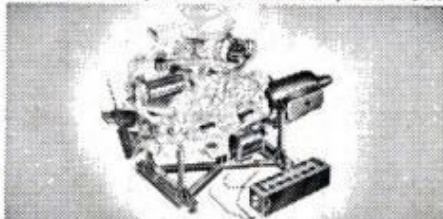
AMAZING BARGAINS

for Fun • Study • Profit
from
EDMUND SCIENTIFIC CO.
300 Edscorp Building
Barrington, N. J. 08007



DIAGNOSE MECHANICAL TROUBLE

Professional Stethoscope. Designed for use by physicians, this super-sensitive Stethoscope is ideally suited for detecting faults in machines and engines, and in fluid, air and gas leakage. Dozens of uses in auto repair shops, labs and for hobby and educational applications.
Stock No. 50,270H\$7.50 Ppd.
BARGAIN PRICE STETHOSCOPE
Stock No. 50,223H\$3.25 Ppd.



PLASTIC MODEL V-8 ENGINE

Hours of fun! Get thrill of building your own easily assembled engine from over 350 parts. Then push starter and watch it run. Crankshaft revolves, pistons move, valves open and close in sequence with spark plugs. Does everything but burn oil. 1/4 scale molded in 4 colors. Same motor used in many auto-mechanic courses. Excellent, easy-to-understand "tech manual".
Stock No. 70,448H\$12.95 Ppd.



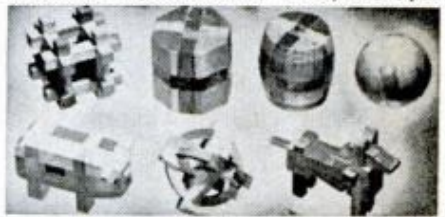
INSTANT ELECTRONIC PROJECTS!

Build 56 electronic marvels in minutes—that actually work! Simply match symbols of amazing new solid state building blocks with those in easy-to-follow diagrams. Presto—instant radios, organs, alarms, etc. No soldering, wiring, tools. Magnetic connectors hold see-thru blocks containing proper components in place. Safe. Easy. New fun-way to learn electronics. Requires 9V trans. batt. (not incl.).
No. 71,178H\$33.50 Ppd.
No. 71,177H ...20 PROJECT...\$12.00 Ppd.



GIANT WEATHER BALLOONS

"Balls of fun" for kids, traffic stoppers for stores, terrific for amateur meteorologists. Create a neighborhood sensation. Great backyard fun. Exciting beach attraction. Amateur meteorologists use to measure cloud heights, wind speed and temp. Heavy duty neoprene. Inflate with vacuum cleaner or auto air hose; or locally available helium for high rise.
Stock No. 60,568H... 8'\$2.00 Ppd.
Stock No. 60,632H... 16'\$7.00 Ppd.



WOODEN SOLID PUZZLES

Here's a fascinating assortment of 12 different puzzles to provide hours of pleasure and stimulate ability to think and reason. Animals and geometric forms. Take them apart and reassemble them. Lots of fun for the whole family—young and old. Will test skill, patience and ability to solve problems. Order yours now.
Stock No. 70,205H.....\$4.00 Ppd.

MONEY-BACK GUARANTEE

Order by Stock No.—Send Check or M.O.

GIANT FREE CATALOG

148 Pages! More than 4,000

UNUSUAL BARGAINS

Completely new Catalog. Packed with huge selection of telescopes, microscopes, binoculars, magnifiers, magnets, magnifiers, prisms, photo components, parts, kits, accessories—many hard-to-

get surplus bargains, 100's of charts, illustrations. For hobbyists, experimenters, schools, industry. Mail coupon for FREE Catalog "H".

EDMUND SCIENTIFIC CO., 300 Edscorp Building, Barrington, N. J. 08007.

NAME _____
ADDRESS _____
CITY _____
STATE _____ ZIP _____

Drivin' with Dan

How does a scoop affect performance of passenger and drag cars? Is Ford planning a 494-cu.-in. V8 for racing? Are race drivers who don't finish paid? Dan Gurney answers these and other automotive questions



DAN GURNEY got a big kick out of fussing around with this Ruger Sports Tourer during the New York Auto Show. Dan admired the car, likened it to a classic Bentley. The Ruger is powered by a 427 Ford

Q. What effect does a scoop have on performance in passenger and drag cars, and does it have anything to do with the amount of fuel used? What effect does fuel injection have on performance?—Tommy Douthitt, Frederick, Okla.

A. A properly designed scoop placed in the right position does increase the power in passenger and drag cars. As a rule, the engine requires slightly more fuel because the scoop gives it more air. There are many different kinds of fuel injection—some constant-flow, some timed, some high-pressure, some low-pressure, some injecting to various parts of the inlet port, some injected into various parts

of the cylinder itself. It often does not increase the horsepower over a carburetor for each port. However, it does away with all the problems inherent in trying to maintain a constant float level in the carburetor under heavy braking, cornering and acceleration. All engines that run on exotic racing fuels require so much fuel it has to be delivered under pressure. In other words, even with large fueling lines, gravity can't do the job.

Q. I'm contemplating the modification of a 1958-59 Volvo sedan for street and road courses. I want to drop a 327 Chevy engine and complete Chevy drive train in it. Does this sound feasible to you? What class would a car of this type race in? Do you know of any source of information for construction of this type car?—D. Cooper, APO San Francisco.

A. Yes, it's certainly feasible. I suggest writing to the Sports Car Club of America, Box 791, Westport, Conn., to find out what class—if any—there is for this car to race in. A library would probably be the best source of construction information. Look up back issues of enthusiast magazines, check to see if there's a "how to" book on the subject.

Q. I read where Ford may introduce a 400-cu.-in. V8 and a 494-cu.-in. V8. Will you confirm this for me? If so, will they be used for racing—either drag or track? If Ford does develop a 494, will it be the largest ever marketed in respect to cubic inches?—Dennis Dvorak, Milligan, Neb.

A. I believe what you read means that Ford has one engine which is capable of running anywhere from 302 cu. in. all the way up to 400 cu. in., and another one which runs from 429 cu. in. all the way up to 494. Ford has built some of these 494s for use in offshore racing boats, but I don't believe the engine

(Please turn to page 24)

The Round Tire is



Tread-ier

It gives you extra mileage, extra safety.

What do we mean by "tread-ier"? This: The Round Tire—Atlas Plycron*—has a rugged construction that's topped by a muscular tread made of tough, long-lasting rubber compounds.

This unique Atlas Plycron tread is designed

to put more rubber on the road, where you need it. And it's backed by all the strength of four full plies.

Road tests against complete sets of tires for new 1969 cars again proved that Atlas Plycron delivers thousands more miles than new-car 2-ply

tires. And do we test Atlas Plycron tires for the safety you want? You bet. Fifty-four different ways. You can't buy a more reliable tire.

Get Atlas Plycron tires and start thousands of miles ahead!

ATLAS

Tires • Batteries • Accessories
Sold at over 50,000 leading service stations

ATLAS

*Trade-marks "Atlas" "Plycron" Reg. U.S. Pat. Off. ©1969 Atlas Supply Co.

Any car wax will bead water.



Swell, but water isn't what ruins your car's paint. What will ruin it is bad stuff like industrial smog, road tar, tree sap, and you-know-what. To keep bad stuff from your car's paint, give it the protection of the hardest, most durable wax known, carnauba wax, the secret of Classic Wax.

Just rub on Classic Wax with a damp cloth, then dust off. Takes about an hour for a full size car.

Classic Wax. The good stuff that keeps off the bad stuff.



CLASSIC PRODUCTS, LTD.
2616 N. Tamarind Ave., West Palm Beach, Fla. 33407
Gentlemen: I don't want to bother going to a dealer.
Please rush _____tins of Classic Car Wax at \$5 each.
Enclosed is my check or money order.

Name

Address

City

State

Zip

DRIVIN' WITH DAN

(Continued from page 22)

is intended for installation in any standard production car. As for the last part of your question, I don't know about "largest ever," but the biggest production engine right now is, I think, Cadillac's 472.

Q. Could a Boss 429 take a 'Vette in the quarter? What are the backlight louvers on the Boss 302 for? Could the 302 take the Z-28 Camaro on a road course?—George Shaw, Newtown, Conn.

A. I am not saying it would, but it certainly could. To my knowledge, the backlight louvers on the 302 are for styling to differentiate between a Boss 302 and a standard Mustang. As for your last question, the 302s will be racing the Z-28 Camaro on road courses all during the Trans-Am season this year and we won't know who comes out on top until the end of the year. It could be extremely close.

Q. What does the "ELF" decal mean on Jackie Stewart's Matra?—Frank Gabriel, Philadelphia.

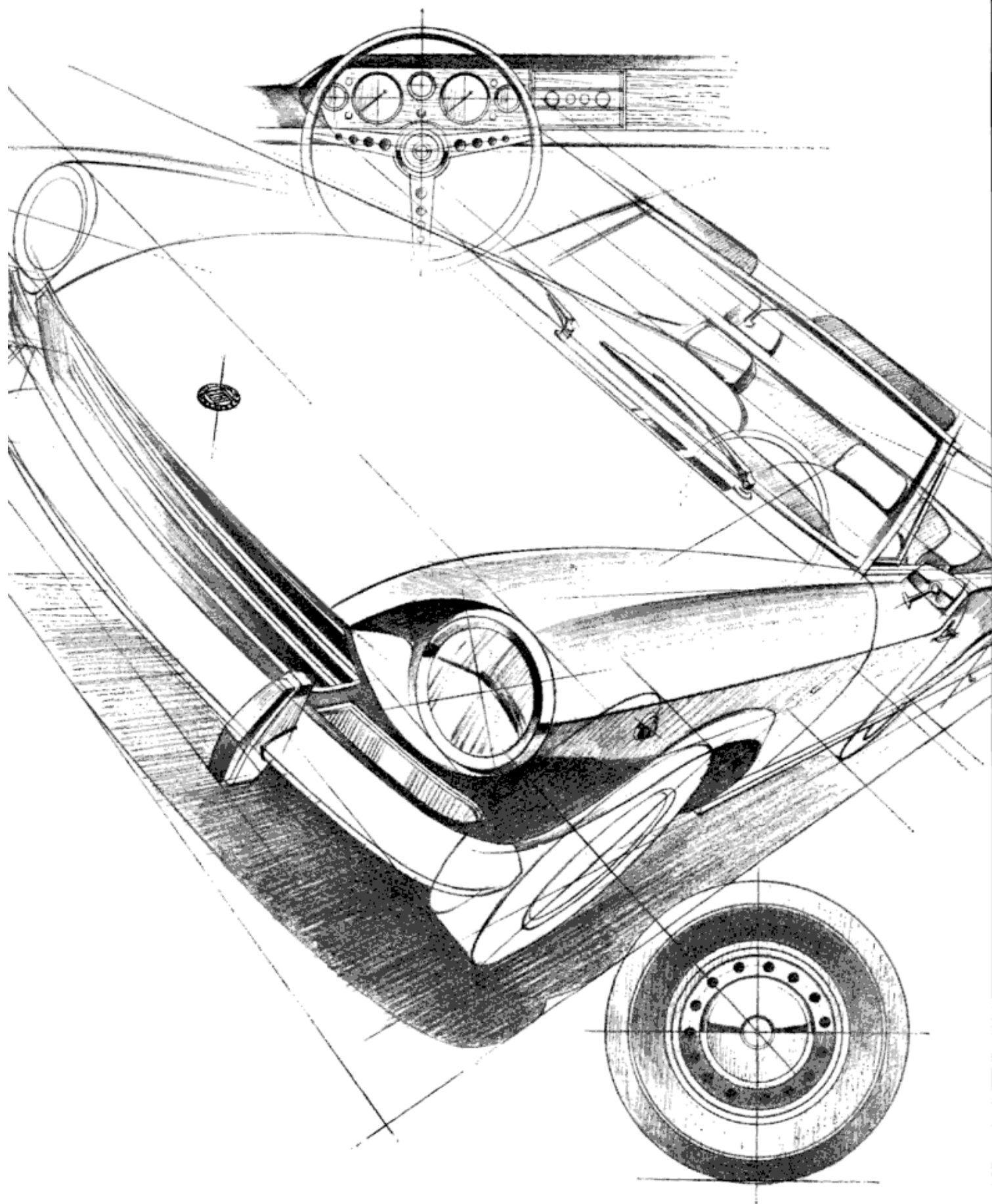
A. ELF is a French national fuel company that sponsors Jackie's Matra just as Shell sponsors Team Lotus and Team Ferrari.

Q. Besides an updated but aging GT-40 and the Mini-Mirage, has Ford power gone out of Group 6 and Group 4 scenes? Are you going to drive a Gurney-Eagle-headed Cougar in the Trans-Am races? Will you use a 429 alloy block in your Can-Am effort?—Bill Abbott, Pine City, Minn.

A. Ford power has not gone out of the Group 6 or 4 scenes; it's just that Chevy competition-engine parts are more readily available. Ford management realizes this and is busy turning heaven and earth to rectify the situation. With parts becoming more available, I think we will see more Ford-powered race cars in the future. As for the Gurney-Eagle-headed Cougar, alas, the heads have not been homologated, although we are on the verge of getting a Ford part number attached to them. At the moment there are no 429 alloy blocks available to us, so we are going to base our engine on the 351, either alloy or cast iron.

Q. In racing—Grand National stock car, sports car, Grand Prix, and so on—do the drivers who

(Please turn to page 26)



Fiat 124 Spider \$3240.

Suggested price p. o. e. New York.

JULY 1969

25

Материал, защищенный авторским правом

START A BUSINESS this quick way



Sharpen Hand or Power
Saws with the

FOLEY SAW FILER

Start your business in sparetime and make CASH PROFITS right away. No stock to carry, no selling involved, no experience needed—the Foley Saw Filer or mower sharpener does every sharpening job **automatically!** Earn up to \$6 an hour sparetime in your own garage or basement.

FREE BOOK shows how you can make money as thousands of others have. Send coupon today. There's no obligation, and no salesman will call—so write today!



FOLEY MFG. CO.
716-9 Foley Bldg., Minneapolis, Minn. 55418
Send for FREE book on Money-Making facts about the sharpening business and Special Combination Offer.

NAME _____

ADDRESS _____



LAWN MOWER SHARPENER

Precision-grind all hand and power lawn mowers—perfect job every time.

TOM McCAHILL SAYS:



"Buy ^{DIF} new
DIF
It's got to be the
best way to clean
work-dirty hands
I've ever tried."

CONTAINS LANOLIN TO KEEP
HANDS FROM CHAPPING,
KEEP SKIN SMOOTH.

WATERLESS
OR POWDER



Marketed by Harrell International, Inc., Westport, Conn. 06880

DRIVIN' WITH DAN

(Continued from page 24)

don't finish a race get paid? If so, how much?
—Kevin Lappi, Brainard, N.Y.

A. There is no fixed rule in Grand National racing and Indy car racing. All cars that qualify for the race are paid depending on where they finish and on the size of the event. Indianapolis, where 33 cars start the race, pays something over \$9000 to last place. Sports-car racing pays the least for last place, often as little as \$100. Grand Prix racing usually does not pay past the sixth place finisher—and there may have been as many as 22 starters. However, Grand Prix does have starting money, which amounts to a minimum of \$1000.

Q. I saw you drive at Bridgehampton last year, and wondered what caused you to spend so much time in the pits.—Skip Dowling, Garden City, N.Y.

A. I was having problems with the steering and handling, which were so bad that I thought something was breaking. We checked, I was convinced it was okay, so I pressed on, embarrassed and bitter.

Q. When was the first Indy race, who won it, what kind of car won, what was the top speed and who drove it?—Bernard Etcheverry, Los Banas, Calif.

A. 1911. Ray Harroun in a Marmon. The average speed was 74.59 mph. I'd guess that the top speed was around 115 mph.

Q. I've heard that mountain driving is the best way to break in a new car. Is this true?—Kenneth Berg, USAF Academy, Colo.

A. I have never heard this, but I'd say that mountain driving would be a little tough on the car. If you had a long, hard pull you might overheat things. Most modern cars are not difficult to break in. But if you're determined to take to the mountains, try the Appalachians rather than the Himalayas.

If you have questions on racing, high-performance and everyday driving techniques, send them to "Drivin' with Dan," c/o Popular Mechanics, 575 Lexington Ave., New York, N.Y. 10022. Questions cannot be answered by individual letters. Questions on maintenance and repair should be addressed to the Auto Clinic (see page 70).

In What Business of Your Own Can You MAKE BACK YOUR INITIAL INVESTMENT in as little as TWO WEEKS?

You Can Do It When You're a Successful MERLITE PRESTO SHINE DEALER!

The initial investment in a Merlite Presto Shine Dealership is so modest, and the earnings you can make are so surprisingly high, that it's possible for you to earn back your initial investment in as little as 2 to 4 weeks! How many other business opportunities permit you to recoup so quickly?

Imagine! You Offer a Genuine SIMONIZ PASTE WAX JOB FOR ONLY \$5.95

When you're a Merlite Presto Shine Dealer, the equipment which we supply you and the system which we teach you, enable you to clean, wax and polish a car with genuine Simoniz Paste Wax in as little as 20 minutes! You charge only \$5.95 for this genuine Simoniz wax job—about 1/3 the usual professional charge. Yet you make up to \$5.75 gross profit on every car! Weekly gross profit up to \$500.00 and more is possible—as much as \$25,000-\$30,000 in a year!

NOW, HERE'S WHAT WE OFFER YOU:

1. REMARKABLE PATENTED INVENTION.

You get authorized use of patented HM Polishing Machine (U.S. Patent No. 2,967,315), which amazingly duplicates the motion of the human hand, enables you to start with a dirty car and bring it to a lustrous, gleaming, protected Simoniz Wax finish within as little as 20 minutes!

2. PERSONAL TRAINING IN YOUR AREA WITHOUT A PENNY OF RISK!

Even before you decide to become a Merlite Presto Shine Dealer, we will send one of our skilled instructors to train you in the use of the HM Polishing Machine and the astonishing Merlite Presto Shine speed method. So easy, even a child can do it, after a little training! After your personal instruction, if you decide not to become a Merlite Presto Shine Dealer, you're not out a penny! You take no risk!

3. PRACTICALLY NO OVERHEAD . . . YOU CAN WORK FROM YOUR HOME.

The HM Polishing Machine operates on ordinary house current, so you can do all the work right at your home, if you wish, and save overhead expenses. Supplies and materials cost you about 20¢ per car, so your gross profit on a \$5.95 Simoniz Wax job is approximately \$5.75!

4. START IN YOUR SPARE TIME.

Many of our most successful Merlite Presto Shine Dealers held on to their full-time jobs, started out in spare time—evenings and weekends. Then, when they saw how much more money per hour they were making with Merlite Presto Shine, they went into full-time business of their own, and stopped punching the timeclock. You can do it, too!

5. TREMENDOUS DEMAND EVERYWHERE.

Your astounding low \$5.95 price draws a steady stream of motorist-customers. You also get big commercial accounts: new and used car dealers, fleet operators such as taxicabs, rent-a-cars, etc., plus service stations, garages and car washes. You need never run out of customers!

**COMPLETE PROSPECTUS—FREE . . .
MAIL THIS COUPON TODAY . . .**

MERLITE PRESTO SHINE CORP.
1081 Bristol Road, Dept. Y-15R, Mountainside, N.J. 07092



"Above you see one of our Merlite Presto Shine Dealerships, operated in conjunction with a parking lot. You can set up your own Merlite Presto Shine Dealership in practically any location—even at home."

Read What Merlite Presto Shine Dealers Say About This Great Opportunity:

Larry Drain of Illinois: "Within 13 days of getting started, profits from the business paid for the initial investment—and that includes my TV and radio advertising. Since then I have been averaging between \$1,000 and \$1,300 a week! Because I cannot handle the business myself, I now have 3 employees who work full time."

Peter J. Strikwerda of New York State: "Yesterday I did a 60' x 12' 1-year-old trailer. I hope this is a good beginning in this area, because it was accomplished with ease and resulted in a great sense of satisfaction when I saw the trailer glistening. You can imagine the dirt, grime and film that had accumulated in one year. Now I would like to get 3 more machines."

David J. Paradise of Massachusetts: "Just two years ago my wife and I returned to Mass. from Arizona. We were broke. I got a job in a factory and then read about Merlite Presto Shine. Then presto, I got my dealership and started making money as they said. Today I have a steady flow of customers, and we now own our own home with an acre of land."

Pedro Ramirez of Puerto Rico: "As a Merlite Presto Shine Dealer, I do Simoniz wax jobs on aircraft on a contract basis. Already I have steady business contracts totaling \$500.00 a month. Recently a domestic airline signed a contract for me to do their 12-passenger Beechcrafts at \$75.00 per plane per month, and a plane takes me only 5 hours to do."

Steven Schorr of Long Island, N.Y.: "I am 15 years old and in junior high school. My dad will let me do only 10 cars on a weekend, although I could do a lot more, if I didn't have to do homework. Even so, I make about \$50.00 a weekend, which will go to my college education. This summer I've lined up 2 beach clubs, and 2 of my friends to do the work for me."

Merlite Presto Shine Corp., Dept. Y-15R
1081 Bristol Road, Mountainside, N.J. 07092

Rush me complete Prospectus of my opportunity to make big profits in a business of my own as a Merlite Presto Shine Dealer. Everything comes to me by mail, prepaid, absolutely FREE, and entirely without obligation.

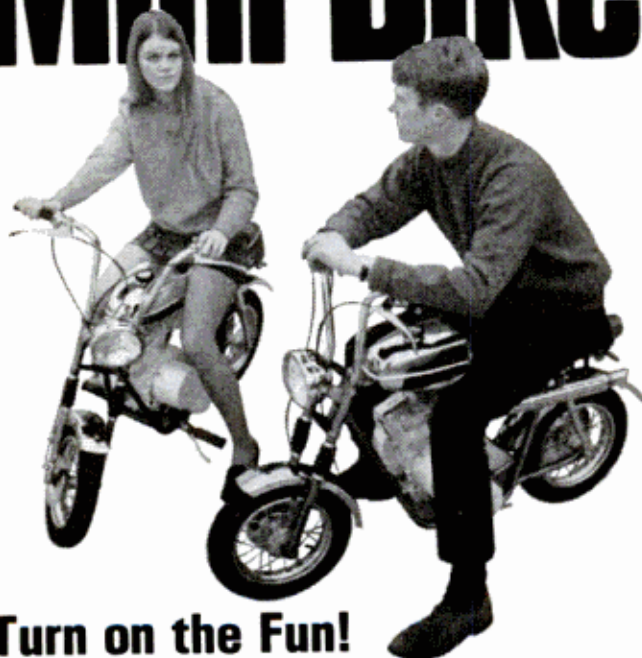
NAME _____

ADDRESS _____

CITY _____ STATE _____ ZIP _____

In Canada: Merlite Presto Shine
675 King St. W., Toronto, Ont.

FOX Mini-Bike



Turn on the Fun!

Outclass and Outperform Anything that Goes!

Fox builds the world's most wanted mini-bikes! *Exciting trail models* for Trail Blazing, hunting, fishing and camping... *Finest campus bikes* for swingers, shoppers, swimmers... *A "hot dogger" scrambler* that's not a bit timid for the field or track. Many models are street licensable.

FOX CORPORATION

Janesville, Wisconsin 53545

Also makers of the World Famous

FOX TRAC SNOWMOBILES and GO KARTS®

FIND BURIED TREASURE!

Treasure Probe

12.95 PPD

10-DAY MONEY BACK
GUARANTEE

ALL TRANSISTORIZED

Find buried gold, silver, coins, war relics with new sensitive detector. Fully transistorized. 1969 model. Ideal for beach combing, treasure and coin hunting, prospecting for gold. So sensitive it will detect a single coin or gold nugget. Nothing else to buy. Gives loud, clear signal, when metal is detected. WEIGHS

1 1/2 POUNDS

3 ft. portable detector

3 MODELS AVAILABLE

Complete kit with assembly instruction \$12.95 PPD.

Fully assembled and instrument aligned at factory for peak performance, \$16.95 PPD

Fully assembled with powerful built-in loudspeaker and plug-in earphone. Your best buy, \$22.95 PPD

TO ORDER—send cash, check, or money order.

\$3.00 deposit for C.O.D. In N.J. add 4% sales tax

TREASURE HOUSE

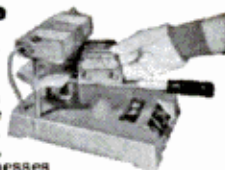
Dept. PAA P.O. Box 3 Tennent, New Jersey 07763

Each model includes battery, earphone.

New Table Top Invention Puts You In... PROFITABLE RUBBER STAMP BUSINESS

Home Operators now make \$16.50 AN HOUR in Business once monopolized by a few big companies

Special rubber stamps bring high prices—cost only pennies to make on new, low-cost table top machine. Take 27 cents worth of material, make perfect stamps, the kind businesses and offices now buy by the dozen at \$2.75 each. Make up to \$16.50 an hour. Start in spare time in your own home. Run machine on kitchen table using ordinary electrical outlet. Make any kind of stamp. We'll send you free information without obligation about this established, highly profitable business. We'll even help finance your start. For free information send name and address today on a postcard to: Rubber Stamp Div., 1512 Jarvis, Dept. R-2-HS, Chicago, Ill. 60626



STOCK SIGNS

WEATHERPROOF ENAMEL. VIVID COLORS
also HAND LETTERED SIGNS at \$1.00 & UP
SEND \$1. (DEDUCTIBLE FROM FIRST ORDER) FOR ILLUSTRATED LIST
DEALER INQUIRIES INVITED

EACH
POST-PAID

FOOTHILL SIGN CO. STUDIO K F
9009 SANTA MONICA BLVD. LOS ANGELES, CA. 90069

Travel the SHORT way

avoid wrong turns —
save time, money
and frustration with



... at
leading
stores
everywhere!

AIRWAY COMPASS, Mexico, Indiana 46958

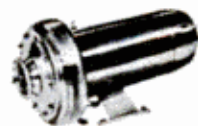
At Last a New Amazingly Simple

GAS TURBINE JET ENGINE

Build from easy to follow plans. Length 15",
Dia. 8 1/2", Wt. 15 lbs. Fuel: Gasoline or Kero.

"Screamin' Demon" develops 20 H.P. Ideal project for serious-minded hobbyists, students; scientific and industrial arts classes. Make on 9" metal cutting lathe with milling attachment. For use on small racing boats, midget cars, etc. Full size assembly drawings with critical dimensions, bill of materials and photos. Price \$5.00. No C.O.D.

SAVOY SCIENTIFIC, BOX 1398, SANTA MONICA, CALIF. 90406



HEAVY DUTY BALL-BEARING PUMP

IRRIGATE • DRAIN • SPRAY • CIRCULATE • All-metal, rust-proof XB. Stainless shaft. Use 1/4 HP or larger. 1 HP for up to 5,200 GPH 60' high or 3,000 GPH from 25' well. 1 1/4" inlet. 1" outlet. For belt or direct drives \$12.95



Type P won't rust or clog. Bronze bearing. Hundreds of thousands in use. Up to 2,400 GPH. 1" inlet. 3/4" outlet. \$8.95

P'pd. cash with order. MONEY BACK GUARANTEE. LABAWCO, Box 2, Belle Mead, N.J. 08502

I-N-V-E-N-T-O-R-S WE NEED INVENTIONS

Sell your invention for cash—need money for Patent?—Are technical problems holding you back? Universal Inventions has helped inventors all over the world—just like yourself—why not you? Inventions provide the magic spring-board to sudden riches. REMEMBER, we either sell your invention or pay you a cash bonus. Write for details. UNIVERSAL INVENTIONS, Dept. 13, Marion, Ohio

America's No. 1 Classified Section
Can Be Found On Page 53
In This Issue

POPULAR MECHANICS

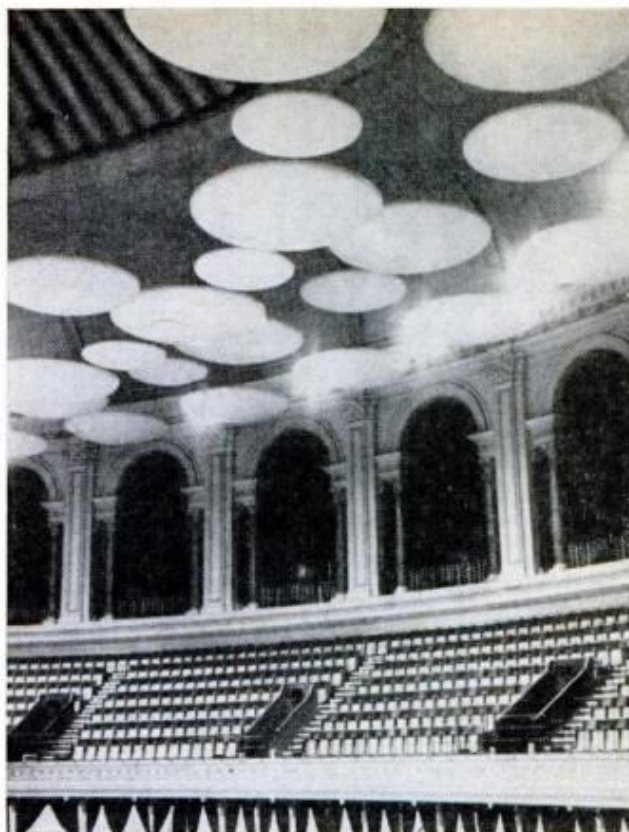
Материал, защищенный авторским правом

NEWS BRIEFS



X-rays reveal gold wings

Her name was Per-en-Bast. She was a young dancer in Egypt about 700 B.C. When she died at age 18, she was so highly regarded that priests placed a pair of solid gold wings on her chest to protect her in her after-life. For 26 centuries the golden wings were hidden, undetected under her wrappings. They have now been revealed by X-ray photographs taken at the Manchester Museum, Lancashire, by Roy White, an amateur Egyptologist. Museum officials said that they would never unwrap the mummy.



Saucers to stop echoes

Fiberglass "flying saucers" were recently suspended from the ceiling of the Royal Albert Hall to rid it of its notorious echo.

This great **RIDGID** Tube Cutter gives you 3 tools for the price of 1.

It's the RIDGID No. 15 tube cutter, and it's one of the handiest tools ever invented!

One. It's the smoothest little tube cutter available for all $\frac{3}{16}$ " through $1\frac{1}{8}$ " copper, brass and aluminum tube, also thin-wall conduit.

Two. Our tool is also a reamer. The blade folds into the frame where it's out of the way but always handy.

Three. The No. 15 is also a gas cylinder wrench. The key is cut right into the blade... it can't get lost.

So get 3 tools for the price of 1. Get a RIDGID No. 15 Tube Cutter at your Dealer's. He carries a complete stock of Work Saver Tools from The Ridge Tool Company, Elyria, Ohio 44035.



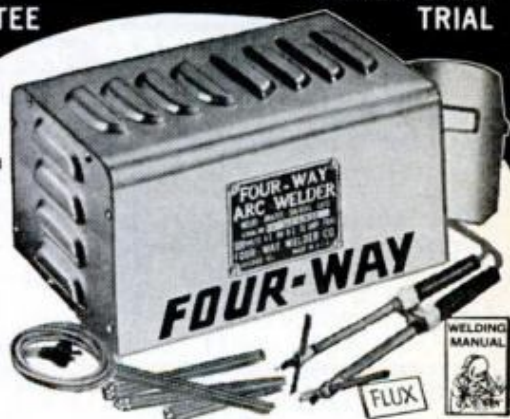
RIDGID

HEAVY DUTY WELDER "BEST FOR THE MONEY"

LIFETIME
GUARANTEE

MONEY BACK
TRIAL

\$18.95
Delivered
**WELD,
BRAZE,
SOLDER,
CUT ALL
METALS**



ANYONE CAN USE. No experience needed. Make or repair 1,001 items. Operates on 110 V., 30A. for pennies. No tanks or refills to buy—produces to 11,000° heat. Twin Carbon Torch controls heat for each job. **YOU CAN'T GET A BETTER LOW COST WELDER.** 500,000 in use. **LIFETIME GUARANTEE.** If unoperative, simply return. We repair or replace and ship free. **COMPLETE, READY-TO-USE. YOU GET:** heavy duty welder in rugged metal cabinet, ground clamp, cables, combination torch and rod holder, welding manual and helmet, plus Free \$2 pack "TOUCH WELD" rods for instant and automatic arc, brazing rods, $\frac{1}{4}$ " carbons, solder and flux.

FREE Additional extra \$2.00 pack welding, brazing rods, carbons, flux & solder.

ORDER TODAY ON 10-DAY MONEY BACK TRIAL

Send only \$2.00 and pay \$16.95 plus C.O.D. and delivery charges or send \$18.95 and we pay delivery in continental U.S.A.

FOUR-WAY WELDER CO.

1810 S. Federal Street Dept. R2-G, Chicago, Illinois 60616

MAKE IT BIG WITH NTS

PROJECT METHOD

HOME TRAINING

IN INDUSTRY...
IN YOUR OWN BUSINESS...
IN MILITARY OR GOVERNMENT

ELECTRONICS DIVISION

- Master Course in Color TV Servicing
- Color TV Servicing
- Master Course in TV & Radio Servicing
- Practical TV & Radio Servicing
- Master Course in Electronic Communications
- FCC License Course
- Master Course in Electronics Technology
- Industrial and Automation Electronics
- Computer Electronics
- Basic Electronics



AIR CONDITIONING, REFRIGERATION DIV.

- Master Course in Air Conditioning, Refrigeration & Heating
- Air Conditioning & Heating
- Refrigeration



MECHANICS DIVISION

- Master Course in Auto & Truck Mechanics
- Automotive Mechanics
- Truck & Heavy Duty Mechanics
- Engine Tune-Up & Electricity



HOME APPLIANCES DIVISION

- Home Appliances Master Technician's Course
- Home Appliances Servicing
- Handyman Appliance Repair



includes new Exclusive Circuit Trainer

NATIONAL TECHNICAL SCHOOLS

WORLD-WIDE TRAINING SINCE 1905

4000 South Figueroa Street Los Angeles, Calif 90037

APPROVED FOR VETERANS

CLASSROOM TRAINING AT LOS ANGELES

NTS occupies a city block with over a million dollars in training facilities. Check special box for details.



FREE BOOK & SAMPLE LESSON

NATIONAL TECHNICAL SCHOOLS

WORLD-WIDE TRAINING SINCE 1905

4000 So. Figueroa St., Los Angeles, Calif. 90037

Please rush FREE OPPORTUNITY BOOK & SAMPLE LESSON for division checked below. Check one only.

- ELECTRONICS DIVISION
- AIR CONDITIONING, REFRIGERATION DIV.
- MECHANICS DIVISION
- HOME APPLIANCES DIVISION (Dept. 201-79)

Name _____ Age _____

Address _____

City _____ State _____ Zip _____

- Check for veteran training under new G. I. Bill.
- Check if interested ONLY in classroom training at Los Angeles

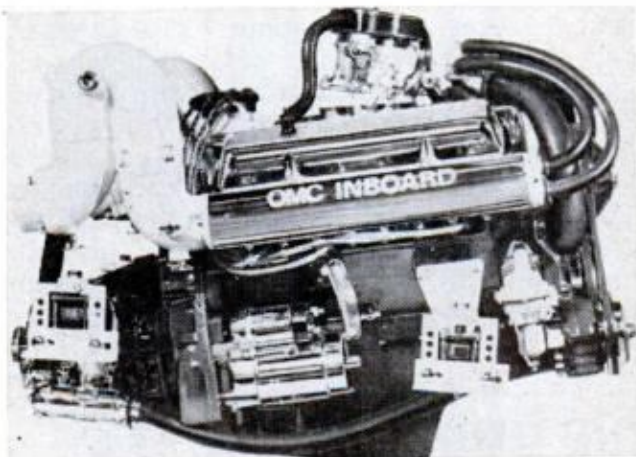


WHAT'S NEW OUTDOORS

BY DAN FALES

THE FIRST INBOARD ENGINES ever offered by Outboard Marine Corp. are now available. Gale Products Div. of OMC is making 210 and 250-hp models. Both are overhead-valve V8s of 307 and 350-cu.-in. displacement, respectively.

Standard features on both engines include solid-state electrical regulator; Quadra-Jet, four-barrel carburetor; removable stainless-steel inserts in water pump, and OMC four-point cushioned engine mounts with micro-adjustment. The engines have standard water intake cooling



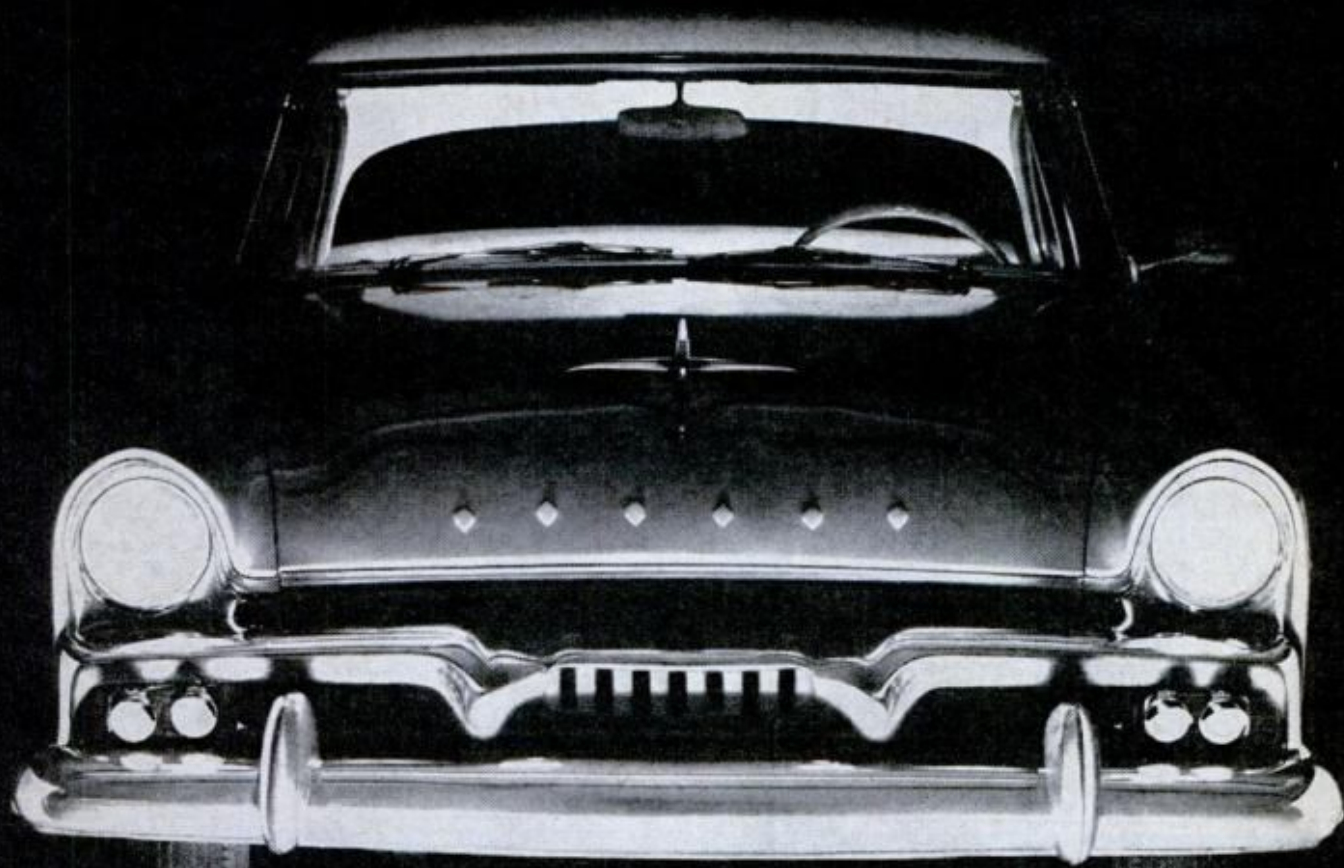
with fresh-water cooling systems available. Each has a hydraulic marine-transmission—Warner model 71—with available gear ratios of 1-to-1; 1.5-to-1 or 1.91-to-1.

Gale Products is producing these inboard engines both on an original-equipment basis for boat manufacturers and for the replacement market for those of you who want an OMC inboard.

A NEW, LIGHT CHAIN SAW from Pioneer will be on the market very soon. The superlight Holiday II weighs in at just a little over nine pounds. Though this isn't the lightest saw on the market, Pioneer hopes it will be the least expensive of the superlights. Holiday II has a 12-in. blade; an automatic chain-lubricating system and a 2½-hp motor. ★★★



POPULAR MECHANICS



Who knows what evil lurks in the hearts of used cars?

A Volkswagen dealer knows.

He knows that a used car can be a thing of beauty on the outside and a mass of corruption on the inside.

By what extraordinary power has he been able to unlock these deep, dark secrets?

By something un-mysteriously called the VW 16-point inspection.

It takes him to parts of the car rarely traveled by used car dealers . . . the farthest reaches of

the transmission . . . the wilds of the electrical system . . . the depths of the engine.

If he finds the car to be pure at heart, he rewards it with a sign that says "The dealer guarantees 100% to repair or replace the engine, transmission, rear axle, front axle assemblies, brake system, electrical system for 30 days or 1000 miles, whichever comes first."

Good can still triumph over evil.



archery

a man's game, a woman's sport, a child's play!



World-famous archer and bowhunter, Fred Bear, can't give your family personal instructions, but he can do the next best thing. He can see to it that only the finest bows, arrows and archery accessories are produced in his plant in Grayling, Michigan. Drop Fred a line. He'll see to it that you receive his new full color catalog right away. There's a bow and price range for every member of the family, from little beginners to seasoned hunters.

 **BEAR ARCHERY**

DIVISION  VICTOR COMPTOMETER CORPORATION
Rural Route One • Grayling, Michigan 49738

Train for top jobs, top earnings, in PHOTOGRAPHY

NYI trains you for the best jobs—or your own successful business. Learn by doing at home, quickly, easily the individualized NYI way. Low cost. No experience or expensive equipment needed. Earn while you learn. Easy pay plan. Approved for Veterans, Student Loans. Approved by N.Y. State Ed. Dept. Accredited member Nati. Home Study Council. FREE color career book. No salesman will call. RESIDENT TRAINING in all profitable phases of photography and Creative Motion Picture Course. Our 60th year. NEW YORK INSTITUTE OF PHOTOGRAPHY • 10 West 33 St., New York, N.Y. 10001, Dept. 49-7





Unimat

Convertible precision lathe is vertical miller, drill press, surface grinder, polisher too! \$139.50, incl. motor & parts. Request free catalog or send \$1 for 40 pg. detailed handbook.

AMERICAN EDELSTAAL, INC.
BG-9 / 350 Broadway / NYC 10013



TRAIL-BREAKER® Goes anywhere



Outdoorsmen: Ride where you had to walk before. Revolutionary two-wheel drive vehicle climbs mountains, fords streams, hauls man-sized loads. Runs all day on a tank of gas.

Write Rokon, Inc, 160 Emerald St. Keene, N. H. 03431

POLICE CALL CONVERTER



\$5.95

6118. World Wide Short Wave, 25, 31, 41 Meters (7-12)\$5.95
6125. TV Wireless Microphone Transmitter.....\$8.50

Money back guarantee. Order now from:

Johnson Smith Company, Dept. 107, Detroit, Mich. 48224

Send for catalog of 2000 Scientific, Hobby & Novelty Items.

TUNER CONVERTERS. Use with standard radios. Hear dramatic events while they happen. American made, solid state.

6117. For Police & Fire Calls, High Band (150-164) ..\$5.95
6120. For Police & Fire Calls, Low Band (30-50)\$5.95
6119. For Aircraft & Control Tower Calls\$5.95

Electric Razor
1.70



Calendar Watch 2.44



Auto \$954



START IMPORTING IN 10 MINUTES

MEN/WOMEN—BIG MONEY AT HOME First day profits! Make your first import transaction order 10 minutes after you get my plan. Thousands more dazzling products from overseas. Deal direct—below whole-sale prices. No product investment. Full or part time. Write for FREE BOOK today to...

MELLINGER, Dept. C2257, 1554 S. Sepulveda, Los Angeles, CA 90025

Print Your Own

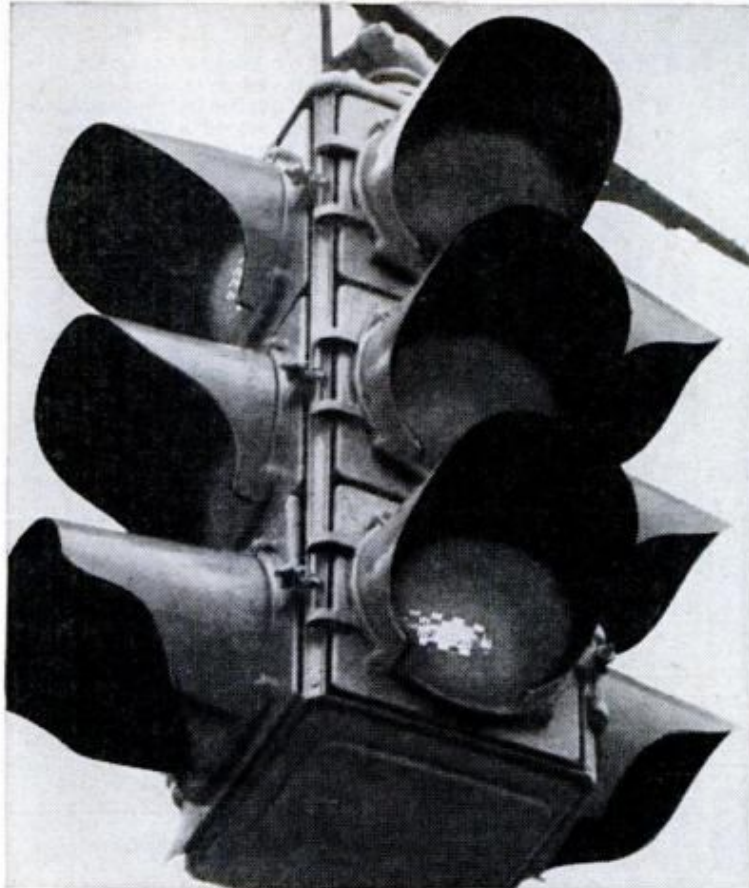


Cards, Stationery, Advertising, Circulars, labels, photo and movie titles, church work, tags, greeting, sympathy, prayer cards, etc. Save money. Pays for itself in a short time.

Own a Printing Business

Good Profit. Raised printing like engraving too. Have home shop. We supply everything. Direct from factory, only. Easily followed rules. Write now for free details. **KELSEY PRESSES E-37 Meriden, Conn. 06450**

The oil killer.



Traffic signals can be murder on motor oil.

But Quaker State has a natural ability to resist harmful effects of stop-and-go driving. It's refined by lubrication specialists from 100% Pure Pennsylvania Grade Crude

Oil, the world's choicest. Then it's fortified for extra protection against the rust, acid and varnish caused by an idling engine.

You can't avoid those short trips. But with the right oil, you can make more of them.



Quaker State your car to keep it running young.

PUBLICATIONS **WORTH WRITING FOR** BY CATHERINE BILSKI

UNCOVER THE TRUTH about flooring with the booklet *Nine Questions to Ask When You Shop for Floor Covering*. The free brochure explains what the backing, weight and number of stitches to the inch mean, and compares the qualities of various fibers with such factors as durability,

texture, resilience, resistance to fading, cleanability and removability of spots and stains. Specify the booklet number (No. CG 4A) and write to Johns-Manville, Box 290-F, Murray Hill Station, New York, N.Y. 10016.

TEST YOUR OWN HOME WATER supply for invisible hardness with the water test kit. If your water has any degree of hardness, a simple chart lets you determine the approximate cost of softening it. What hard water is, what a home water softener does and why it pays to soften water are explained. The kit is free from Culligan, Inc., Northbrook, Ill. 60062. ★★

THE STAIN FIXER

INCOLAC DOES WHAT REGULAR PRIMER-SEALERS CAN'T DO. SEALS OFF TOUGH STAINS LIKE CREASOTE. PRIMES OVER "HOT" PLASTER. EVEN PRIMES VARNISHED SURFACES TO TAKE PAINT. FLAT WHITE.



DAP®

DAP Inc., Dayton, Ohio 45401 / SUBSIDIARY OF *Plough, Inc.*
Also available in Canada

Incolac PRIMER SEALER

Be a SURVEYOR AND MAP MAKER



JOIN A SURVEYING TEAM— get in on planning of highways, bridges, dams, subdivisions, etc. 1000s big pay jobs open now to qualified men. U.S. Bureau of Labor Statistics predicts shortage of 50,000 civil engineering technicians (Surveyors, etc.) by 1975. Easy home-study plan trains you. Send for "SURVEYING CAREER KIT"—ALL FREE! No salesman will call. Write & state age.

NORTH AMERICAN SCHOOL OF SURVEYING & MAPPING 4500 Campus Drive • Dept. 4177, Newport, Ca 92660

ACCORDIONS and AMPLIFIERS



BIG SAVINGS up to 1/2 or more on famous make accordions. Over 40 models. Standard and new electronic models. Buy direct at low discount prices. Get five-day home trial. Small down payment, easy terms. Free gifts. Trade in allowance. Money back guarantee. Rush coupon for color catalogs, discount price list. **Accordion Corp. of America, Dept. R-79, 5535 W. Belmont Ave., Chicago, Illinois 60641**

COUPON BRINGS FREE COLOR CATALOG & DISCOUNT PRICES	ACCORDION CORP. of AMERICA—Dept. R-79 5535 W. Belmont Ave., Chicago, Illinois 60641 Send FREE Color catalogs and discount prices. Include special information checked:	
	<input type="checkbox"/> Amplifiers	<input type="checkbox"/> Button Type Accordions
	Name _____	
	Address _____	
	City _____ State _____ Zip _____	

RADIAL ARM SAW KIT... for under \$100



Buy direct from factory, assemble yourself. Incl. 1/2 h.p. G.E. motor, easy to follow instructions, all parts, nuts and bolts. Guar. for life pat. pend. radial arm track; twice the usual bearings for extra rigidity, greater precision. Rips 24", crosscuts 12"; belt brake. \$99. complete, freight col. Kit less motor (any stand. 1/2 h.p. or larger will do) \$84.85. With optional G.E. motor developing 1 h.p. \$108.65. Money back guaranteed by one of world's largest manufacturers of bench power tools. Write for brochure. Terms if desired or check or M.O. to **American Machine & Tool Co., Dept. PM79, Royersford, Pa. 19468**

Two or four-wheel drive
JEEP or SCOUT
owners

REPOWER with a 6 or V-8. H.D. ADAPTORS for using Car, Compact and some Truck engines. "State year & model, Jeep or Scout." Want fast action? Give us **FULL INFORMATION**. Send \$25.00 Dep. and we will ship correct kit, bal. COD. Send full amount for prepaid shipment. Wire, phone or write today. Details **FREE**

HOOSIER MACHINE PRODUCTS CO.

312 S. E. 6th St., Phone 276-3442, Pendleton, Oregon 97801



BUILD THE POPULAR MECHANICS MINI-BIKE FROM 26-IN. BICYCLE FRAME

—with **VARIABLE SPEED TRANSMISSION**, as featured in June '67 issue. Step-by-Step plans, photos show you how. **PLANS, \$2.50**, refundable with order for wheels, engines, clutches, kits at **Discount Prices**. Order Plans, or send 25c for Catalog, today!

GILLIOM MFG. CO. Dept. PM-7 St. Charles, Mo. 63301

See what owners say about the Chevy Impala (after 1,250,000* miles) and the Olds Delta 88 (after 900,000* miles)

In the August PM

* Cumulative

This can be your **"Big Break"**
if you're a man who's ever said...

**"There must be
a better way
to make
a living!"**



ANOTHER WEEK ON
THIS CRUMMY JOB!
AND WHAT HAVE I
GOT TO SHOW FOR
IT?

MUST BE A
BETTER WAY TO
MAKE A LIVING
THAN THIS...



HEY, GUYS!
GIVE YOU A LIFT?

PETE! HAVEN'T SEEN
YOU SINCE YOU
QUIT THE FACTORY!



SOME CAR! YOU MUST
BE DOING ALRIGHT
FOR YOURSELF, PETE!

YOU BET! I'M IN ELECTRONICS NOW!
ALL THIS NEW GEAR YOU READ
ABOUT IN THE PAPERS - I'M ONE
OF THE GUYS WHO KEEP IT
RUNNING!



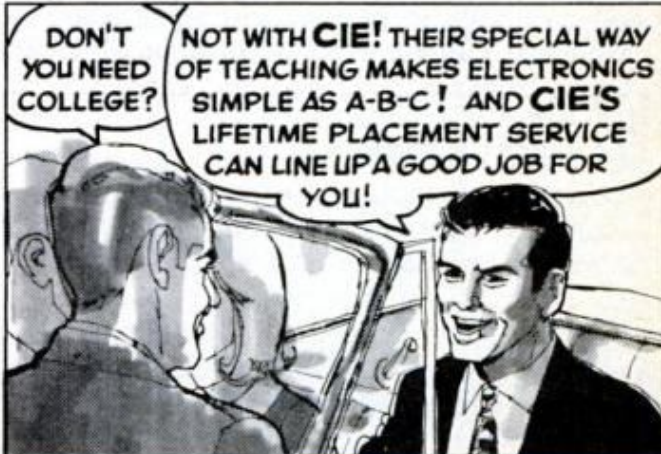
SOUNDS GREAT!
BUT HOW'D YOU
BREAK IN?

EASIER THAN YOU MIGHT THINK!
I LEARNED EVERYTHING I NEEDED
TO KNOW IN MY SPARE TIME, AT
HOME... WITH
CIE!



DON'T
YOU NEED
COLLEGE?

NOT WITH **CIE!** THEIR SPECIAL WAY
OF TEACHING MAKES ELECTRONICS
SIMPLE AS A-B-C! AND **CIE'S**
LIFETIME PLACEMENT SERVICE
CAN LINE UP A GOOD JOB FOR
YOU!



HOW ABOUT YOU? WANT A GREAT JOB
IN **ELECTRONICS**, TOO? GET FULL
FACTS IN **CIE'S 2 FREE BOOKS!**
SEND BOUND-IN
CARD **NOW!**



IF CARD IS MISSING, MAIL THIS COUPON

CIE **Cleveland Institute of Electronics**
1776 East 17th Street, Cleveland, Ohio 44114

Please send me 2 FREE books describing opportunities in
Electronics and how to prepare for them.

Name _____ Age _____
(please print)

Address _____

City _____ State _____ Zip _____

Veterans & Servicemen: check here for G.I. Bill information
Accredited Member National Home Study Council **PM-26**

DETROIT

LISTENING POST

BY BILL KILPATRICK

FORD'S NEW MAVERICK, introduced in April, is already battling a rising price balloon. Having pegged it at \$1995 in stark trim, Ford has held the option list to the minimum, the idea being to keep the car competitive with the lower-priced imports. But potential buyers are said to be pressuring dealers for both luxury and performance options, a move that—if heeded—will drive the “as delivered” price of the car far out of the range Ford’s trying to hold. A possibility is a boom in add-on items sold and installed by independents. Ford could find itself in an ironic profit dilemma: trying to hold the price down to keep Maverick competitive on the one hand, and on the other, watching all that nice option gravy go elsewhere.

LOOK FOR HOTTER SIX-CYLINDER ENGINES in the near future. U.S. auto-makers, anxious to hold retail prices down to stave off encroaching imports, are turning over all stones in an effort to cut costs, yet still give buyers the performance they seem to want. One approach is to engineer and produce higher-performing, less-expensive Sixes that will be smooth, reliable, provide plenty of go, still have enough left to operate such power-robbing extras as airconditioning. Advent of the subcompacts could provide a big push in this direction.

MID-ENGINE CARS, touted in this space as being the sporty car wave of the future, are a hot topic here with at least three—possibly four—auto companies working on experimental units. In that the design as presently conceived (and executed by Italy’s Ferrari, for example) restricts seating to two, look for outfits fostering a go-go image to pop with the first models. Known to have their hats in the mid-engine ring are Chevy, AMC, Ford, possibly Pontiac. The concept could precede a Detroit trend toward racier-looking cars, said to be on tap for the mid-’70s.

PLASTIC BUMPERS—tough, cheap, resilient—are more and more a fact of life. Look for all makers to go heavy on ’em when the new ’70s bow this fall, particularly Chrysler, perhaps even Ford. General Motors introduced such rigs on Pontiac’s GTO a year or so back, but is said to be “taking a second look” before ordering their installation all up and down the line. One clue as to why GM is taking that “second look” might be its work on a new bumper concept that will do away with the wraparound part, replace it with a plastic or rubber half-ball designed to stick out from the lower outside corner of the front fender. If GM goes this route, presumably its future bumpers will consist of the half-ball fender extensions plus a straight, flat bar, probably made of some form of chromed plastic.

DESPITE RUMORS bandied about, the likelihood of either Chevrolet or Pontiac dropping their “no racing” pretense is as remote as ever. Top-level GM policy continues to turn thumbs down on any active, open racing effort by any of its divisions. An open fact, however, is that those who *do* go racing with GM components can get all the factory cooperation they might need or want. But President Ed Cole told us that chances of seeing a GM factory team on major race circuits are nil.

CHRYSLER STYLISTS have done an outstanding job in giving Dodge’s new Challenger a distinctive appearance apart from its sister car, Plymouth’s new Barracuda. Both cars, due this fall, share much in common, including body shells. Yet buyers will have no trouble telling which is which, thanks to styling touches unique to each car. The Challenger, for example, has a side panel crease running the length of the car. The Barracuda doesn’t. The Challenger has an open, rectangular grille; the Bar-

racuda, a grille that's bold, well defined.

CONVERTIBLES in the next few years will go the way of fender wells, running boards and rumble seats as automotive memories. Industry stylists, supersensitive to buyer whims, have noted that softtop sales in what one would imagine to be "convertible country" (Florida, Southern California, for example) have dropped almost out of sight, buyers apparently opting for airconditioning rather than ruffled hair and rattles. Our guess is that Detroit will drop convertibles altogether by 1975, perhaps sooner.

YOU CAN FORGET those exotic automotive powerplants you've been hearing about—steamers, electrics, hybrid gasoline-electrics and so on. That's the opinion of GM president Ed Cole, anyway. Speaking at a recent GM-sponsored press conference on automotive power systems, Cole said present and immediately foreseeable technology dictates the internal combustion engine as the best all-around power source for cars. Cole admitted such engines contributed to air pollution, but said refinement of present designs could and will reduce car emissions by 80 percent and more. Regarding turbines, Cole said GM would have turbine-powered trucks on the road in another couple of years, but that high materials costs and certain performance drawbacks precluded their becoming a major power source for automobiles. Demonstrated at the conference were several GM experimental cars, including a steam-powered Pontiac Grand Prix (complete with power accessories and airconditioning) and four mini-compact 512 "commuters" powered by electric, hybrid, and conventional engines, one type of which is shown below.



The 511 Commuter is a three-wheeler powered by a conventional four-cylinder engine capable of moving the car at a top speed of 80 mph. Transmission is a torque-converter type three-speed automatic. Car is 149 in. long (a VW "Beetle" is 158 in. long), 63 in. wide, 40 in. high, seats two. GM said it had no plans to produce the car. ★★★

If you change your oil every 3,000 miles, we have bad news for you.

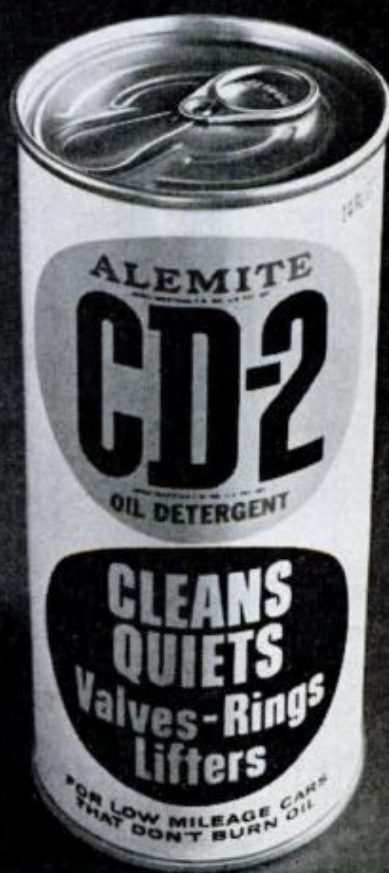
At three or four thousand miles, if you drive like most people, your engine has made more sludge than the detergent in the oil can handle.

So instead of going into the oil filter, the stuff starts to settle inside your engine. You could change your oil sooner.

Or you could put in a can of CD-2 for low mileage cars. Add it when the oil's changed. Or at 2,000 miles, if you'd rather.

This CD-2 is a concentrated detergent, not a thick "additive." It'll keep your engine clean, like a new one.

So it'll act like a new one longer.



The other CD-2. We also make a CD-2 that stops oil burning in older cars. So be sure and get the right one. It may be confusing, but one kind couldn't do both jobs.

ON-THE-GO

CAMPING

BY WADE MITCHELL

NOW IT'S ELECTRIC WINDOWS ON COACHES! Several coach manufacturers have negotiated with Japanese firms to buy tiny electric servo motors for trailers, campers, motor homes. Suggested uses include opening and closing roof vents, side vents, and even some of the louvered windows with short-throw movements from closed to full-open position. Think of the convenience of flipping a switch on a hot night to open distant windows or vents. And of being able to close such windows without getting out of bed when cold winds blow. Powered coach windows are inevitable, and soon.

BUILT-IN "ROLL BARS" NEXT? Factory literature from some coach companies (such as Glastron) already refers to steel overhead channels as *roll-bar protection*, which is undoubtedly a good idea. If roll bars can protect life and property on race-tracks, why not extend the same built-in protection to coach owners facing the dangers of everyday traffic? It makes sense. And it shouldn't add much to the total production cost.

ONE-PIECE FIBERGLASS BATHROOMS are taking over the RV coach market. These supercompact units include a shower, toilet, sink, shelving, ceiling and all-plastic seamless exterior. The coachmaker simply drops the one-piece bathroom into place and plumbs it. Lower maintenance costs, elimination of leaks and faster installation are some reasons cited.

LUMINOUS PAINTS FOR COACHES? An expert with the nation's largest paint manufacturer reports that some coachmakers would like to coat the back walls of trailers, campers and vans with luminous, fluorescent or reflective paint. Object: to prevent rear-end collisions when visibility is bad. Reflective paints could be a nuisance on open roads. (Who wants to follow a blinding white coach?) But in foggy, stormy regions reflective paints could save lives.

ALL-ELECTRIC COACHES COMING. Butane-propane fuel can be eliminated entirely by portable electric generators with dash-mounted, pushbutton start. Advantages include the ability to power everything from the refrigerator to a powerful airconditioner from *one power source*. Motor homes already have large gasoline tanks, a ready fuel supply without special modifications. All-electric coaches are only months away from the sales lot.

METAL UNDERBELLIES MORE POPULAR. As the advantages of full metal underbellies are understood, more buyers demand them. Protective skin under the coach blocks out rust and corrosion due to splashed water, mud and salts. It also eliminates heat loss, entry of vermin and cold floors. In rough country, metal belly-pans protect against damage to plumbing and exposed electrical lines under the frame.

DIAMOND-REO OFFERS FLATBED CAMPER CARRIER. This long-familiar name brings back nostalgic memories for many of us. Now the company is offering a special truck bed that can be used for regular stake-truck duty during the week and as a heavy-duty coach carrier on weekends. Installation of the coach is handled with four corner-mounted cam latches. Standard equipment on the Trend Country Wagon (Reo's nameplate) includes a 327-cu.-in. V8 engine, five-speed all-synchro Clark transmission, and other complementary equipment for coach duty. The coach can be a house-car body, motor-coach body, or even a travel trailer with the axle assembly and wheels removed.

★★★

Bronco, Toyota and all the rest ate 'Jeep' dust.

**'Jeep'
4-wheel drive
wins the
toughest
off-road race
ever run.**



'Jeep' 4-wheel drive
The 2-Car Cars.

The Mint 400. 400 miles of dust, sand, gravel, gullies, rocks in the scorching Nevada desert. Ford was there. Along with other 4-wheelers. And some of the world's best racing drivers. Of the 32 starters, only 7 finished. 3 were 'Jeep' vehicles. In first place? A 'Jeepster Commando' Roadster... complete with options like V-6 and automatic transmission. Second place? A 'Jeep' Universal... the old reliable. Just goes to show: 'Jeep' 4-wheel drive is still number one. See your 'Jeep' dealer. Test drive any of the 2-Car Cars. *You've got to drive it to believe it.*

KAISER Jeep CORPORATION
TOLEDO, OHIO 43801





UNDER POWER, the 99 held road well in wet



STYLING features crisp, purposeful lines



THE NEW 99 is a real goer on ice and snow
INTERIOR is roomy, tasteful, comfortable



Sleek, Luxurious, Rugged Saab's New 99

This newest entry from Sweden adds up to an attractive buy in the medium-priced import field

By **BILL KILPATRICK**, Auto Editor

TEARING AROUND a multicurved, snow-banked course plowed out on the ice of a Swedish lake may not be everyone's idea of a perfect testing ground for a new car, but it sure is fun. So is driving through lovely snow-filled pine forests over winding, up-and-down roads.

I got to do all this, plus a lot of highway driving, during a trip to Sweden this past winter to preview the new Saab 99, a stylish, somewhat sporty sedan recently introduced to the U.S. market. Also, I've driven it over many of our own highways, so I feel I know it fairly well.

This new Saab, while incorporating many features of its predecessors—front drive, roll cage construction, off/on free-wheeling, for example—is nevertheless a quite different car. It's six in. longer and four wider than the familiar Saab 96 and boasts a 30-percent boost in interior dimensions. In fact, thanks principally to the absence of a center drive tunnel, the rear bench seat will take three average-sized adults in reasonable comfort. Offhand, I can't think of any of the 99's price competitors (around \$2900

(Please turn to page 44)

Johns-Manville FGA[®] shingles give your roof a chance to outlast your mortgage

You can bank on a roof of Johns-Manville FGA Seal-O-Matic shingles.

They contain moisture-proof fiber glass and asbestos.

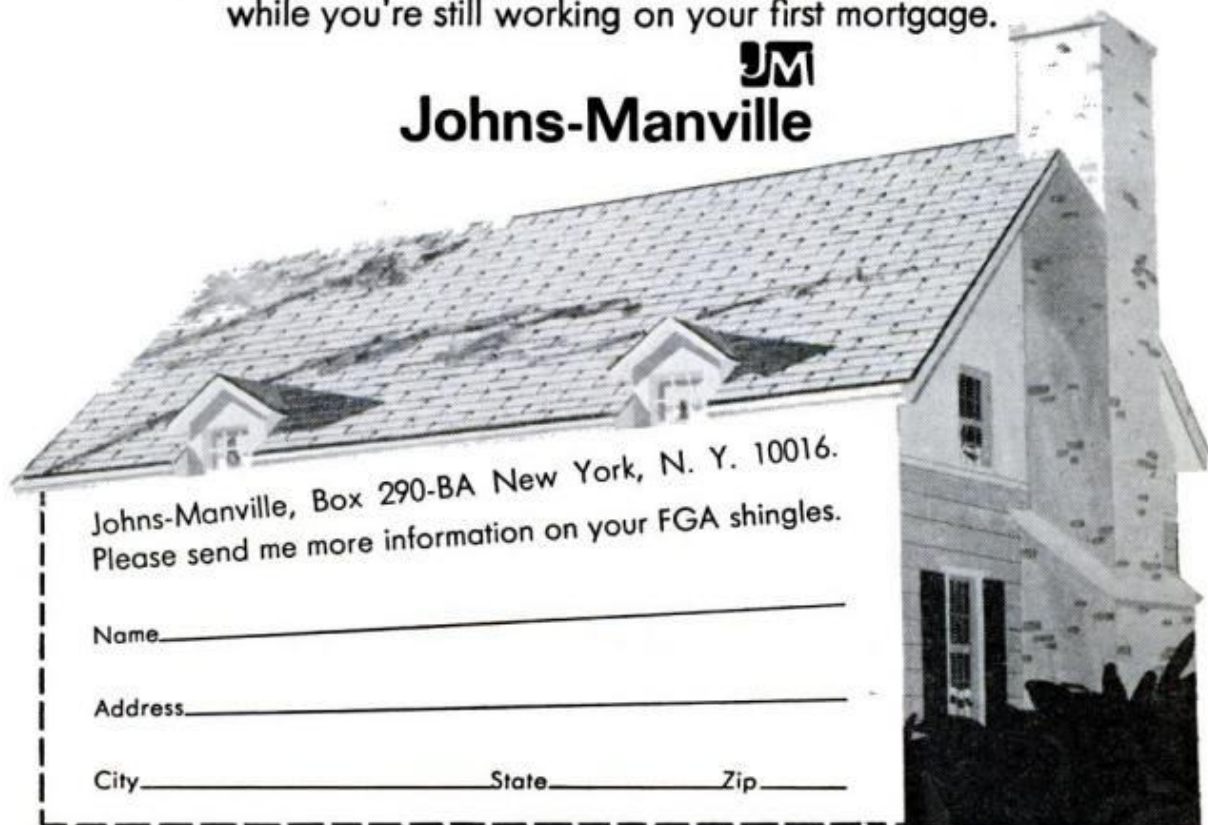
Materials that don't rot, don't swell or shrink. So your shingles don't move around. They just lie there. Beautifully. In any weather.

Look for FGA shingles—in a wide choice of attractive colors in several styles—at your nearest J-M dealer.

So you won't have to worry about your second or third roof while you're still working on your first mortgage.



Johns-Manville



Johns-Manville, Box 290-BA New York, N. Y. 10016.
Please send me more information on your FGA shingles.

Name _____

Address _____

City _____

State _____

Zip _____

APPROVED BY VETERANS

These 3 BIG DRAFTING KITS GIVEN TO YOU!

... when you train at home with NASD for a **HIGH PAY JOB IN DRAFTING!**



1 Take your pick of 1000s big salary jobs open to Draftsmen. U.S. Labor Dept. reports "42% more Draftsmen needed in next 10 years—not enough applicants to fill jobs available now." Easy home-study plan has helped 100s beginners toward \$\$\$\$\$, security, prestige as Draftsmen—many with only grade school training. Others report good earnings drafting part time while still learning. Why not you?

2

3

RUSH COUPON FOR FREE KIT!


Mail coupon for FREE "DRAFTING CAREER KIT," Sample Lesson, Drafting Aptitude Test including new 5-Way Drafting Instrument & 20-Page Book, "Your Future in Drafting"—ALL FREE. No salesman will call. G.I. approved. Write today.



NORTH AMERICAN SCHOOL OF DRAFTING, Dept. 4177, 4500 Campus Drive, Newport, California 92660
 Rush "Drafting Career Kit," including Book, Sample Lesson, Aptitude Test & Drafting Instrument—All Free!

NAME _____ AGE _____
 ADDRESS _____
 CITY _____ STATE _____ ZIP _____

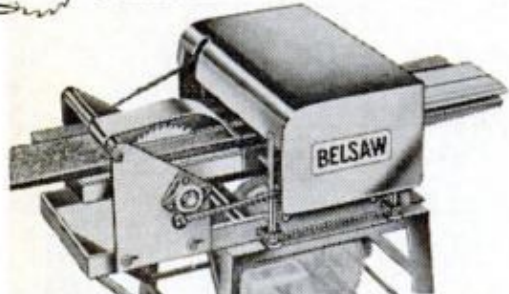
MINI-BIKES



TACO TRAIL 100 — New, rugged, big-wheel performer — \$219.50. Other models as low as \$119.95. Kits less engine, clutch, chain at \$49.95. Send 25c for brochure, free decal. 130-p. catalog — \$1

STEEN'S BOX 2276-W ALHAMBRA, CA. 91803

BELSAW PLANER · MOLDER · SAW!



Now you can use this ONE power-feed shop to turn rough lumber into moldings, trim, flooring, furniture... ALL popular patterns. RIP... PLANE... MOLD... separately or all at once with a one HP motor. Use 3 to 5 HP for high speed output. Low Cost... You can own this power tool for only \$30.00 down.

Send Postcard Today... No Salesman Will Call

BELSAW POWER TOOLS, 900K Field Bldg., Kansas City, Mo. 64111

SAAB'S NEW 99
 (Continued from page 42)

East Coast P.O.E.) among current imports than can offer similar accommodations and still keep a straight face.

Up front, driver and passenger get what may be two of the most comfortable bucket seats extant. Done in nylon velour, the seats adjust back and forth, up and down. The backs are adjustable for rake down to almost flat for roadside snoozing. And the unique "doughnut" head restraint doesn't interfere with the 99's good allaround visibility.

The dash is simple, easy to read, and all controls are highly accessible. The ignition switch is on the floor between the front seats, as is a unique handbrake that works front drums independently of the four-wheel, power disc brakes. Also on the floor is a smooth, short-throw four-speed gearshift.

Under the hood is a new, quiet in-line four-cylinder overhead-cam engine built for Saab by British Leyland. Because the engine was designed for all-weather operation, including instant starts in Scandinavia's often-numbing winters, manifold has been somewhat restricted meaning power isn't all it could be with freer breathing. Even so, 100 mph is possible, this from a 107-cu.-in. engine cranking out a modest 87 hp.

Pure driving pleasure

For all its nice touches, however, it's in pure driving pleasure that the 99 comes on like Gangbusters. If, as a thing to drive, the car has any drawbacks, it's the want of a bit more power. Still, I found myself overlooking even this minor complaint as I gloried in the great kick of ramming the 99 through corners.

I personally found the 99's suspension about right—stiff enough to keep my mind on what I was doing, yet gentle enough to let me drive long distances without feeling I'd been put through a wringer. There's independent wheel suspension up front, a lightweight solid axle aft, coil springs and telescopic shocks all around.

I drove the car in bitter cold and found the heater/defroster setup a cozy comfort. In heavy rain, though, I wasn't too impressed with the system's ability to defog the windows, but the flow-through ventilation was fine.

Adding it up, this new one from Saab has a lot going for it. It's a nice, well-thought-out car, and the workmanship is outstanding. I think it's well worth your attention, particularly if you have to do most of your driving in hilly country subject to the "joys" of ice and snow. ★ ★ ★

Now one soldering tool combines all the advantages of a lightweight pencil type iron —a fast heating soldering gun —and tip temperature control.

NEW WELLER TEMPMATIC®

Temperature
Controlled
Soldering Tool



Weller®

WELLER ELECTRIC CORP., Easton, Pa.
World Leader in Soldering Tools

featuring Weller's
exclusive new **POWERHEAD**

The long-life, high efficiency **POWERHEAD** is another great innovation from Weller. It contains the Weller temperature control system. The **POWERHEAD** gives maximum

component protection even in the most delicate work situations. And it eliminates frequent tip changes and filing.

The entire tool weighs only 7 ounces. Yet it can be used for light or heavy duty soldering. Trigger turns heat

on and off. Ideal for electrical work, hi-fi, models, hobbies.

Choice of models—\$12.95 list

Model GT-7A has 700°F.
3/16" chisel point **POWERHEAD**

Model GT-6B has 600°F.
1/8" conical point **POWERHEAD**



"I Earn Two Incomes Now"

Says **JOHN BENNIE, Pittsburgh, Pennsylvania**

"Thanks to your wonderful training, I have been able to earn \$20 to \$25 extra each and every week doing little locksmith jobs at home and after work at my regular job. This is the best trade a man can take up."

Be a LOCKSMITH

Train at **HOME**—Earn While You Learn. Add 50%-100% to **YOUR INCOME** with easy spare time earnings. Cash in on the nation-wide shortage—trained locksmiths in great demand! Quickly step into a big pay opportunity job or start a high-profit shop of your own.

Earn Extra Money RIGHT AWAY! All Master Locksmiths Special Tools, Equipment and Supplies Furnished **FREE** for use with course.

Age, education, minor physical handicaps don't matter in this growing trade. You can quickly qualify as a skilled locksmith. It's like a fascinating hobby. Study at home as little as one hour a week. Gain practical experience through complete well-illustrated lessons. Do real jobs on car locks, house locks, padlocks and safe locks, under the guidance of experts. **FREE** Illustrated Book, write now.

LOCKSMITHING INSTITUTE,
(Div. Tech. Home Study Schools)

Dept. 1110-079 • Little Falls, New Jersey 07424

JULY 1969

306
pieces of professional equipment
FREE
for use with course.

Professional Equipment includes
**LOCKS—PICKS—PARTS—KEYS
SPECIAL TOOLS & SUPPLIES
all FREE for use with course.**

MAIL
COUPON
for **FREE**
ILLUSTRATED
BOOK

For a future as your own boss or in a high-pay job, write now for **FREE** Illustrated Book. Only school of its kind. Licensed by State of New Jersey. Approved for Veterans.

Accredited, Nat'l Home Study Council.

---MAIL COUPON NOW---

**LOCKSMITHING INSTITUTE, Dept. 1110-079
Little Falls, New Jersey 07424**

Please send **FREE** Illustrated Book—"Your Big Opportunities in Locksmithing," complete Equipment folder and sample lesson pages—**FREE** of all obligation—(no salesman will call).

Name _____
Address _____
City _____ State _____ Zip _____



Hot, New Multiband Portables



LARGE DIAL on Allied's new wide-range portable makes it easy to tune any of eight separate receiving bands. On flip-up lid is a world map and time-zone indicator. For portable use, the set runs on four flashlight batteries in a handy clip (below)



Allied's 8-band receiver brings in police, aircraft and marine broadcasts as well as regular AM and FM

By **FOREST H. BELT**

THE RADIO CRACKLED into life: "Car 906, stand by at freeway exit 3. A small plane's in trouble and may have to land on the road."

Those words, coming from a new multiband portable on the desk beside me, were the beginning of a fascinating vicarious adventure one afternoon recently.

The radio voice spoke again: "Car 906, the airport says the plane is down in your vicinity. Please check and advise."

The car responded: "Can't spot anything except a small plane circling over by the racetrack. Maybe he can see something. Can the airport call him?"

"Will do, 906. Let you know." I gave up trying to work and switched to the emergency aircraft frequency, 121.5. Sure enough, the tower was talking to the circling plane. The pilot reported seeing the other aircraft head down for an emergency landing near a water tower. Quickly, I switched back to the police frequency as the airport relayed the information to the police dispatcher.

"Car 906, airport says the plane is down near a water tower."

The tension mounted as the minutes passed, then came the final message, short but sweet:

"This is car 906. I'm at the plane. Negative injuries."

This kind of excitement is yours for the tuning if you have a radio that can bring in shortwave broadcasts as well as commercial stations. In the past, listening in on various broadcast bands usually meant owning three or four different sets, each with its own narrow range of coverage. Today, versatile, new multiband portables cover so many radio services they let you

(Please turn to page 52)

Tune In Almost Anything

Zenith's luxury-loaded Trans-Oceanic has 11 bands, even functions as a marine radio direction finder

By **SHELDON M. GALLAGER**

ZENITH'S FAMOUS Trans-Oceanic portable, an outstanding multi-band receiver since its introduction in 1939, is up to some new tricks. The latest model, the Royal 7000, has 11 receiving bands—more than most wide-range receivers. It also has a pretuned, crystal-controlled weather channel on which you can get instant weather reports around the clock.

The most ingenious new feature is a swivel base that lets you use the portable as a marine radio direction finder. You rotate the set on the base until it points toward a known radio station on shore. You can then plot compass bearings from an azimuth dial on the hinged front cover. A BFO (beat frequency oscillator) makes it possible to receive code as well as Consol and Consolan navigational bearing signals. A tuning meter helps you bring in stations sharply and locates the precise "null" point needed for accurate direction finding.

In addition to the pretuned weather channel, the other 10 bands cover regular AM and FM, aircraft and overseas broadcasts on 150 to 400 kHz, marine and amateur shortwave in two ranges from 1.6 to 9 MHz, and five international shortwave bands from 13 to 31 meters. These 11 bands let you get in on just about any shortwave, foreign or commercial broadcast on the airwaves.

The solid-state receiver operates on batteries or house current. The flip-up top panel contains a world map and time-zone indicator. There are two built-in antennas plus a connection for an external antenna. Price is \$269.95. The swivel base, an accessory, is \$13.95. Zenith Radio Corp., 1900 N. Austin Ave., Chicago, Ill. 60639. ★★★



WANT TO KNOW where you are? This new Zenith 11-band portable can be mounted on a swivel base and used as a radio direction finder for navigating at sea, as shown below. Battery compartment in back holds nine flashlight cells in tubes (inset above)



The bargain hunter

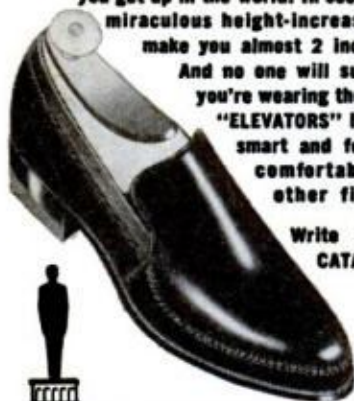


Today let these
**AMAZING
SHOES**
ADD INCHES TO
YOUR HEIGHT!

Nothing like a pair of "ELEVATORS" to help you get up in the world! In seconds, these miraculous height-increasing shoes make you almost 2 inches taller!

And no one will suspect that you're wearing them because "ELEVATORS" look just as smart and feel just as comfortable as any other fine shoes.

Write for FREE CATALOG today.



ELEVATORS®
HEIGHT-INCREASING SHOES

Brockton Footwear, Inc.
Dept. 5107K, Brockton, Mass. 02403
Please send free catalog

Name _____
Street _____
City _____ State _____

CLIP AND MAIL COUPON NOW

**LESS THAN 15¢ PER OIL
FILTER CHANGE WITH
AMAZING**

STILKO



**ETERNAL
OIL CLEANER**

Full-flow oil filtering system uses the best-known filtering material available anywhere—toilet tissue—already proven in thousands of automobiles. Recommended for all types of cars and trucks. Keeps oil cleaner sludge-free and carbon-free. No costly installation or maintenance—simply spins on in place of regular throw-away filter! Each filter change costs less than 15¢ and oil lasts longer (some users report never changing oil). Fully guaranteed. Send check or MO for \$24.95. Or send \$5.00 and pay balance COD. Include Make, Model & Year of car, engine type and no. of cylinders.

STILKO ETERNAL OIL CLEANER
7445 Convoy Court
San Diego, Calif. 92111



**HOW MANY HANDY DANDYS
DO YOU NEED?**

Handy Dandys are plastic caps that snap onto pegboard and hold quarter-twist glass jars, such as used for baby food and which can usually be had FREE! Ideal for storing all kind of supplies, parts and small tools. Sample pack of caps only 8 for \$1.00 36 for \$3.50 ** 72 for \$6.00 ** 500 for \$36.50. Postage prepaid in U.S.A. No C.O.D.'s. Wickliffe Industries, Inc., P.O. Box 286-PM-7, Wickliffe, Ohio 44092.

TREASURE & COIN DETECTOR

10-DAY FREE TRIAL

New electronic circuit guarantees at least **TWICE THE DETECTION ABILITY** of any detector in this price range or your money back. Find gold, silver, coins, old weapons, etc. Works through earth, beach sand, water, wood, rock, etc. New circuit gives more power, more depth. Not a "probe" type but a fully electronic, 1969 model detector never offered before and available only from VIKING. Only detector in this price range sold on unconditional **MONEY BACK GUARANTEE!** You must



29.95
POST PAID

agree it will outperform any detector costing **TWICE** this low price or return in 10 days for refund of cost. Only VIKING dares make this offer. Fully transistorized, uses ordinary 9V battery, weighs 2 pounds. Gives loud, clear signal when object is detected.

NOTHING ELSE TO BUY. Complete, ready to operate. Send \$29.95, check, cash or M.O. for postpaid shipment or \$3.00 and pay postman \$26.95 plus small C.O.D. when delivered.

VIKING DETECTORS
Dept. V-2, Box 10880
Houston, Texas 77018



JIFFY KNOT

**ELIMINATES KNOT PROBLEMS,
GUARANTEED TO HOLD!**

FAST TIE AND RELEASE with this new device of many uses: Tent ropes, boat mooring and anchor lines, clothes lines, car-top carrier ropes, truck or trailer cover ropes, etc. Heavy Steel. Can be permanently mounted with screws or bolts, 4 for \$1.00. Shipped U. S. A. postage prepaid, no C.O.D.'s.

**CAPRI CO., 448 W. North St.,
Kalamazoo, Mich. 49007.**

**IMPORTED
STILETTO POCKET
KNIFE**

9" Overall Length
5" When Closed

- Opens instantly
- Sharp and Tough
- Stainless Steel Blade



ONLY
\$1.75

Opens instantly — folding finger guard snaps into position automatically. Razor sharp tough stainless steel blade holds its edge for years of long hard service. A knife you will be proud to own. Guaranteed. Money back in five days if not satisfied. Send \$1.75 plus 25¢ to cover postage and handling. **NOT SOLD TO MINORS.** Please state age.

**WESTBURY SALES CO., DEPT. S1A
P. O. BOX 415, WESTBURY, N. Y.**



FREE!!! POWERFUL MUSCLES FAST!

Fantastic New Discoveries in the science of bodybuilding. Now, in the privacy of your bedroom, our method will add inches of powerful muscles to arms, chest, shoulders & legs. Learn secrets on trimming the waist with ultra-modern methods—fast! Results Guaranteed! Send for free brochure, Universal Bodybuilding, Box 5327, M-17, Northeastern, Dearborn, Mich. 48126.

**PER-FEC
DRILL SHARP-NER**

**GUARANTEED TO BE THE
FASTEST & EASIEST DRILL
SHARPENER IN THE
MARKET. POSITIVE
RESULTS**



SIMPLE &
EASY TO USE

ORDER NOW \$

4.95
PPD

GRINDING WHEEL NOT INCLUDED, DEALERS WANTED

◆◆ T. W. SIMPKINS CO. ◆◆
4510-B MONTANA / EL PASO, TEXAS 79903

STEREO TAPES—Cas-
settes, 4 track, 8 track
cartridges, open reels.
10% discount off manufacturers list
price. 160 page catalog 30¢ de-
ductible on first order. Plus free
mailings on all new releases. (IF
IT'S ON TAPE, WE HAVE IT).
STEREO TAPES UNLIMITED
2318 SHEFFIELD, DEPT. P.M. 7
CHICAGO, ILL. 60614

The bargain hunter

“Flip”



YOU FOR IT"

You Can't Lose With This Two-Headed Magic Coin!

This half dollar looks real because it is real . . . except for the fact that it's the same on both sides. Made from two actual coins. . . it defies detection. Great lucky piece and conversation piece. Order either "Heads" or "Tails" and you're headed for fun.

ONLY \$3.95 POSTPAID

Send check or money order to

NOVELTY COINS

Dept. #P • P. O. Box 111

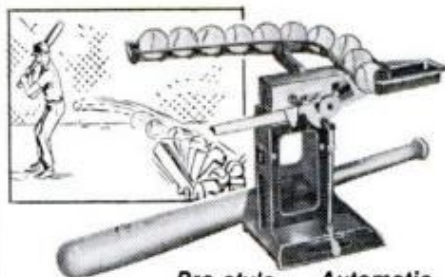
Painesville, Ohio 44077

YOUR NAME IN DIE CAST LETTERS

Everyone has a good reason to identify something they own, something they've made, something they like—with a name, a phrase, a greeting; and nothing identifies better than Die Cast Letters. Now you can individualize your home, your car, your prize possessions with distinction that befits a King. Die Cast Letters offer a NEW mode in home decoration by personalizing unique ideas at a remarkably low cost. **FREE BOOKLET.** Tells how Wellman Die Cast Letters can be used to identify, beautify and boost your ego. Available in a variety of styles from 1/2" to 2". **WELLMAN PRODUCTS COMPANY, 1445 East 49th Street, Cleveland, Ohio 44103.**



NEW SLIM-GARD Trims inches off your middle, waist, hips & lower back without dieting—without exercising! All you do is wear it. Stretches approx. 6". Made of finest, most resistant neoprene rubber. Easy to slip off & on. Sizes: S, M, L. \$9.98. Slim-Gard Co., 531-32nd St., Dept. 38-79D2, Union City, N. J. 07087.



Pro-style Automatic Batting Practice Machine

battery operated — with 10 plastic balls & bat. Safe indoors! **\$9.98**

A boy's dream come true (and his pop's, too)—his own batting machine! Serves up balls automatically, just like the ones the big leagues use! Battery-operated machine pitches 10 polyethylene balls with adjustments for height of sluggers, and distance adjustments for speed. Specially constructed hollow balls, completely safe indoors, stay round no matter how hard they're hit.

With polyethylene bat, 10 balls. (Uses single flashlight battery, not included.) **\$9.98 plus 75¢ for postage and handling.**

Prompt shipment. Satisfaction guaranteed. Send check or money order—no C.O.D.'s. Send for **FREE** color catalog of unique gifts.

HOBBI Dept. PX-79
7 Delaware Drive
Lake Success, N.Y. 11040



ONLY 1.98
AUTOMATIC
100 SHOT
PELLET STINGER

The pellet is harmless but STINGS. Holds and fires 100 pellets automatically—as fast as you can pull the trigger—to knock most stubborn assailants off guard, keep them off guard. Made of high impact styrene, fully guaranteed. Keeps dogs and animal pests off your property—is more humane than kicking or hitting. Send \$1.98 in cash, cheque or money order plus 27¢ for cover handling. 50 pellets included. Not sold in N.Y.C. or if under 16 (State age on order.) (100 pellets \$1; 250 pellets \$2; 1000 pellets \$5)

NATIONAL SURPLUS Dept. PM-7GU
BOX 826, NIAGARA FALLS, N. Y. 14302

**WHEN
ANSWERING ADS
GIVE YOUR
ZIP CODE**

Disposable Water Purifier

Attaches
in
Seconds
Lasts
for
Four
Months



The only tried, proven, and accepted inexpensive throwaway water purifier. . . . no installation costs . . . no maintenance. Removes bad taste, odor, chlorine, etc. from water. Removes taste of steel or plastic tank storage. Can be used in home, camper, trailer, boat attaches easily on all faucets. 100% guaranteed or money back. **ONLY \$3.95 ppd.**

USE THIS HANDY COUPON FOR ORDERING YOUR IMPERIAL WATER PURIFIER

Please send me _____ Imperial Water Purifiers. The cost of EACH water purifier is \$3.95. (California residents add 5% for tax). Enclosed is my check or money order in the amount of _____

Name _____

Address _____

City _____ State _____ Zone _____

**MOUNTAIN FRESH WATER
PURIFIER CO.**

5403 W. Pico Boulevard

Los Angeles, California 90019

*Dealer and manufacturer inquiries attached to letterhead will receive our immediate attention. (213-938-2953)



Thousands of
exciting tool
values!

SILVO (BRAND NAME) TOOL CATALOG

Thousands of Exciting Tool Values! Stanley, Millers Falls, Skil, Thor, Wen, Disston, Wiss, Wellisaw, Dremel, Speedy Sprayers, Plumb, Huot, Kennedy, Chantre-Hook, Porter-Cable, Rockwell, Helios, Vise-Grip, Crescent, Rigid, Pony Clamps, Unimat, Foredom and many other Nationally Advertised brands of Tools & Supplies. We ship Coast to Coast at prices Hard to Beat. Send 25¢ for our big 132-page tool catalog, today. Silvo Hardware Co., PM-7, 107 Walnut St., Philadelphia, Pa. 19106.

HEALTH CAN BE CHEAP

Physical Fitness Gym Set Plans for only \$2.00. Why pay Hundreds of Dollars for expensive equipment. With my plans you can build your own Gym for less than \$10.00 complete with weights, bar bells, etc. The whole family will love to help build this do-it-yourself Gym Set. Plus how to stop smoking and not gain weight.

Send \$2.00 to
PIERCE HOME GYM AND HEALTH CLUB,
Martinsburg, Ohio 43037.

The bargain hunter

START YOUR NEW CAREER NOW!
without overhead, any place, any age!

UPHOLSTERING JUST ONE CHAIR can

pay you as much as your present weekly paycheck!

you don't even have to quit your present job!



Start Learning NOW!
At home, or in the garage, in your spare time.

SEND FOR FREE UPHOLSTERY CAREER BOOK



Start as a part-time hobby... then, as you learn you just slip into the immense flow of upholstery work! Earnings to \$10 an hour! Learn to re-upholster sofas, lounging chairs, ottomans, built-ins, trailers, boats, campers, autos. Once you learn, you will have one of the most fantastic, money-making skills in America which no one can ever take away from you! Work the hours you choose—in any location you choose—big city, small town, farm, beach, mountains, anywhere. Six big furniture kits included FREE! Send for free UPHOLSTERY CAREER BOOK today—plus free sample lesson. M.U.I. approved by Calif. Superintendent of Public Instruction. Send for free information and free career book now!

APPROVED FOR VETERANS

MODERN UPHOLSTERY INSTITUTE, Box 899-BWJ
Orange, Calif. 92669



BC1500SH

BIG BIKE POWER MINI

Outdigs the big ones! This hot mini with a 5-speed 100 cc Hodaka engine accelerates from 0 to 50 faster than most heavyweights that cost \$1000 more! ■ Even more big bike features have been added for '69. 8 models, starting at \$69.95. ■ Send 25¢ for brochure, \$1 (refundable) for packet on entire line. Dept. PM79 1775 S. First St., San Jose, California 95112.

BONANZA®

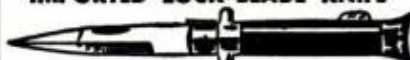
GIVE YOUR

ZIP CODE

WHEN ANSWERING

ADS

IMPORTED LOCK-BLADE KNIFE



OPENS quickly, easily locks into position. Blade can't shut when in use. PUSH BUTTON release. Handy pocket size, yet rugged. Fine quality, polished stainless steel razor-sharp blade. PIERCES METAL. Narrow tapered blade with thick rigid backbone for heavy duty trouble-free use. Fine outdoor knife for sportsmen. Comfortable handle. Safety guards.

\$1.88

Free Postage Order now.



Metal Piercing Throwing Knife

Great for hunting game. Weighted, balanced for sure throwing accuracy. Hits with a hard smack. FAST, EASY TO THROW. Use for self defense, hunting, thrills, targets. Razor sharp cutlery steel. 10" long—Double edge. Wrapped leather handle. 99¢ (2 for \$1.88) (3 for \$2.75). Knife-throwing instructions FREE. Order Now. 99¢.

REGENCY MAIL-ORDER Dept. PM699
BOX 826, NIAGARA FALLS, N.Y. 14302



ONLY \$4.95

FRONTIER DOUBLE DERRINGER

SOLID METAL NOT A PLASTIC IMITATION
• EUROPEAN MADE

• FIRES POWERFUL 22 CAL. CRIMPED BLANKS
Looks and feels like the original Remington Derringer —The Hide-Out Gun of Wild Bill Hickock.

Now this beauty can be yours at this amazing low price. Positive reliable European Made—it fires two quick shots from its double barrels. Perfect for dog training, stage use, sporting events, personal defense. No bulky cylinder, it lays flat in the pocket ready for instant action. Purchaser must be over 21. Just send \$4.95 plus 30 cents postage and handling. State age when ordering. Not sold in New York City or California. Money back guarantee if not satisfied.

WESTBURY SALES CO., DEPT. DR-53-A
P.O. BOX 434, WESTBURY, N.Y. 11590

FIND BURIED TREASURE!

★ Detect buried, gold, silver,
Write for free catalog
5 Powerful models.



\$13⁹⁵ Ppd
to
\$34⁹⁵ Ppd

ALL TRANSISTORIZED
DEALER INQUIRES INVITED
TREASURE PROBE DEPT. P.A.R.
PO Box 64 LAKEWOOD N.J. 08701

HEARING AIDS

2/3 OFF DEALER PRICES

LARGEST SELECTION of tiny, all-in-the-ear, behind the ear, eyeglass and pocket models. FREE HOME TRIAL. No obligation. Money back guarantee. No down payment. Easy terms. No salesmen or dealers. Order direct and save 65%. Write for free catalog. PRESTIGE, Dept. D-34, Box 10947, Houston, Tex. 77018



When you see
this mark

POPULAR
MECHANICS
PRODUCT FEATURE

you've seen the product in
Popular Mechanics

POPULAR MECHANICS

Материал, защищенный авторским правом

INVENTORS

INVENTIONS—NEW PRODUCTS—IDEAS
DEVELOPED & PREPARED

For Commercial Appeal & Sales

DESIGN—MARKETING—PATENT SEARCHES—DRAWINGS

United States Patent Office former Patent Examiner

United States Dept. of Army former Patent Adviser

Member: United States Chamber of Commerce

Second Decade of Reliable Service to

INVENTORS—MANUFACTURERS—ATTORNEYS

FREE CONSULTATION

THE RAYMOND LEE ORGANIZATION

230-Z Park Ave., New York 10017 (212-MU 6-8500)

SEND FREE "INVENTION RECORD" Form & "IMPORTANT PATENT INFORMATION"

Name _____

Address _____

City _____ State _____ Zip _____

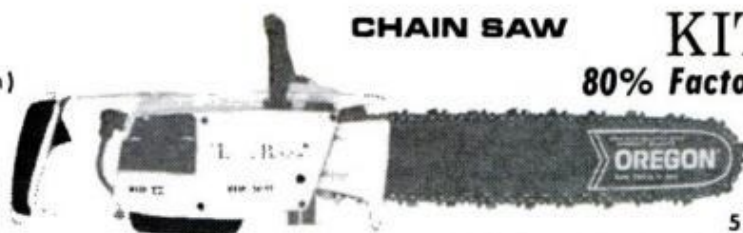
SPECIAL OFFER — ORDER TODAY

5 BIG FEATURES

- Gear Drive
- Automatic Chain Oiler
- Weighs Only 10 lbs. (including Bar and Chain)
- Instant Starting
- Industrial O & R Engine

FACTORY
ASSEMBLED
99⁹⁵

CALIF. — POWER



CHAIN SAW

KIT

80% Factory Assembled.

5% California Tax

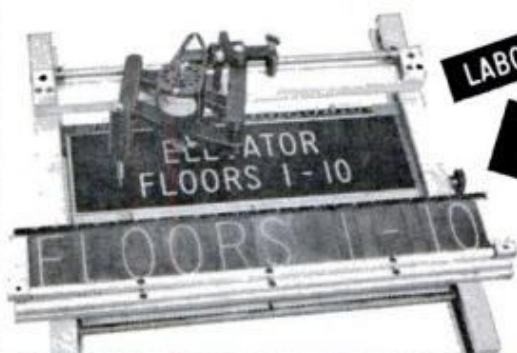
C.O.D. Requires 50% Deposit—Send Check or Money Order

INC.

1940 H STREET FRESNO, CALIF. 93721

POWER PRODUCTS

DOUBLE YOUR INCOME! MAKING ENGRAVED PLASTIC SIGNS ON A SCOTT ENGRAVER



LABORATORY

269

Make professional engraved signs in minutes. Scott engraved signs have a markup of up to 500%. Work 2 hours a day and earn up to \$150 a week extra. Complete with accessories—everything you need to start—from \$130. Write for free catalog. Dept. PM 769.

SCOTT MACHINE DEVELOPMENT CORP.
215 PROSPECT AVE.
P. O. BOX 217 • WALTON, NEW YORK 13856

Next Month in Popular Mechanics

Maverick vs the Mob

Ford says its new subcompact's main competition is the economy import. Could be . . . but after our side-by-side comparison tests, we're not so sure that Ford is right.

Portable Power for Camping Comfort

Light and sturdy electric generators are now packaged so you can have take-along power in your camper. PM gives you a rundown on what's new in portable generators.

Build This Foldaway Hobby Center

It's a hobbyist's dream, a work center that has everything. Swinging panels, roomy drawers and lots of shelves provide plenty of storage, and it folds into a compact unit.

How They Keep You Safe—Without Getting You Killed

Old-fashioned test methods often wrecked the very thing they were supposed to protect. Now a fascinating science called Nondestructive Testing checks out bridges, buildings, wings on airplanes even candy bars—without touching them at all.

NEW MULTIBAND PORTABLES

(Continued from page 46)

tune in virtually anything you want to hear on a single dial.

I like to listen to FM music while I work. On some days, like the afternoon the plane went down, I have fun eavesdropping on local police calls. At night I listen in on hams talking around the world or pick up overseas shortwave broadcasts. On weekends, it's exciting to tune in tower conversations from a nearby airport. From local highway patrols, you can get a line on traffic and road conditions, especially helpful in bad-weather winter driving.

All of these things are possible with a multiband receiver. For my own use, I chose Allied's new Model 2682 eight-band portable. For news and other commercial broadcasts, there's regular AM. For fine music listening, there's also FM. For marine transmissions and other medium-wave listening, there's an AM band from 1.7 to 5 MHz (megahertz.) Two bands provide continuous shortwave coverage from 5 to 24 MHz. Then there's the aircraft VHF AM band from 108 to 136 MHz. Finally, land-mobile services are covered on two FM bands—the low range from 30

to 50 MHz and the high range from 148 to 176 MHz. These are the bands that carry police, fire, taxi, railroad, radio-telephone and industrial two-way communications. The only service missing is the Citizens Band.

The solid-state portable plays anywhere you want to take it on batteries and can be switched over to run on house current when you're home. It has a sensitive telescoping dipole antenna, plus a connection for an external antenna when you're using the set at a fixed location. There's also a jack you can use for plugging in earphones in addition to the built-in speaker.

The front cover swings up and on the inside are a worldwide time-zone chart and a dial for converting foreign times to local time. The FM band has AFC—automatic frequency control—and there's a noise limiter on the VHF frequencies to clip out interference from passing cars. There's a tuning meter that also doubles as a battery tester to warn you when your power is getting low.

The Allied portable sells for \$89.95 and is one of the best buys in multiband listening I've found. It's available from Allied Radio Corp., 100 N. Western Ave., Chicago, Ill. 60680. ★★★

START A MONEY-MAKING BUSINESS FOR LESS THAN \$50!



You can have your own lifetime business right at home . . . work in spare time . . . and make up to \$200 a month CASH! My FREE PLAN gives you all the facts: How to start, how to grow. You don't need previous experience. You don't have to sell. I'll even finance you. People bring you the work and pay cash. Over 90¢ of every dollar you collect is clear cash profit. And you work when you want to. Let me prove you can't find a more certain, lower cost, higher paying business of your own.

Just Mail Coupon—No Salesman Will Call
BELSAW SHARP-ALL CO., Stan Field, Pres.
710K Field Bldg., Kansas City, Mo. 64111

Name _____
Address _____
City _____ State _____ Zip _____

FREE
BOOK

TUNE UP ELECTRONICALLY ANY CAR EVER MADE!



✓ COMPACT or LIMOUSINE ✓ 4, 6 or 8 CYLINDER
✓ DOMESTIC or FOREIGN ✓ 6 VOLT or 12 VOLT
✓ POSITIVE or NEGATIVE GROUND

With New Improved Model BT-162

DWELL TACHOMETER

ASSURE EASY STARTS, OPTIMUM PERFORMANCE and MAXIMUM GAS ECONOMY with MODEL BT-162

MADE ORIGINALLY FOR THE PROFESSIONAL AUTOMOTIVE TECHNICIAN, MODEL BT-162 WILL PAY FOR ITSELF MANY TIMES OVER FOR THE AUTOMOTIVE HOBBYIST AND EXPERIMENTER.

The Model BT-162 will perform the services specified below in addition to many other tasks too numerous to mention:

It is no longer necessary to file points to smoothness when using the Model BT-162. The instrument will automatically make allowance for any existing "pitting" or "wear." • Indicate the most effective point setting without removing the distributor cap. • Indicate the correct settings for external adjustment type distributors. • Car manufacturers' dwell angle recommendations are included in the manual provided with the Model BT-162. • To adjust for mathematically correct carburetor adjustment and thus insure maximum gas economy and quiet engine running, simply use

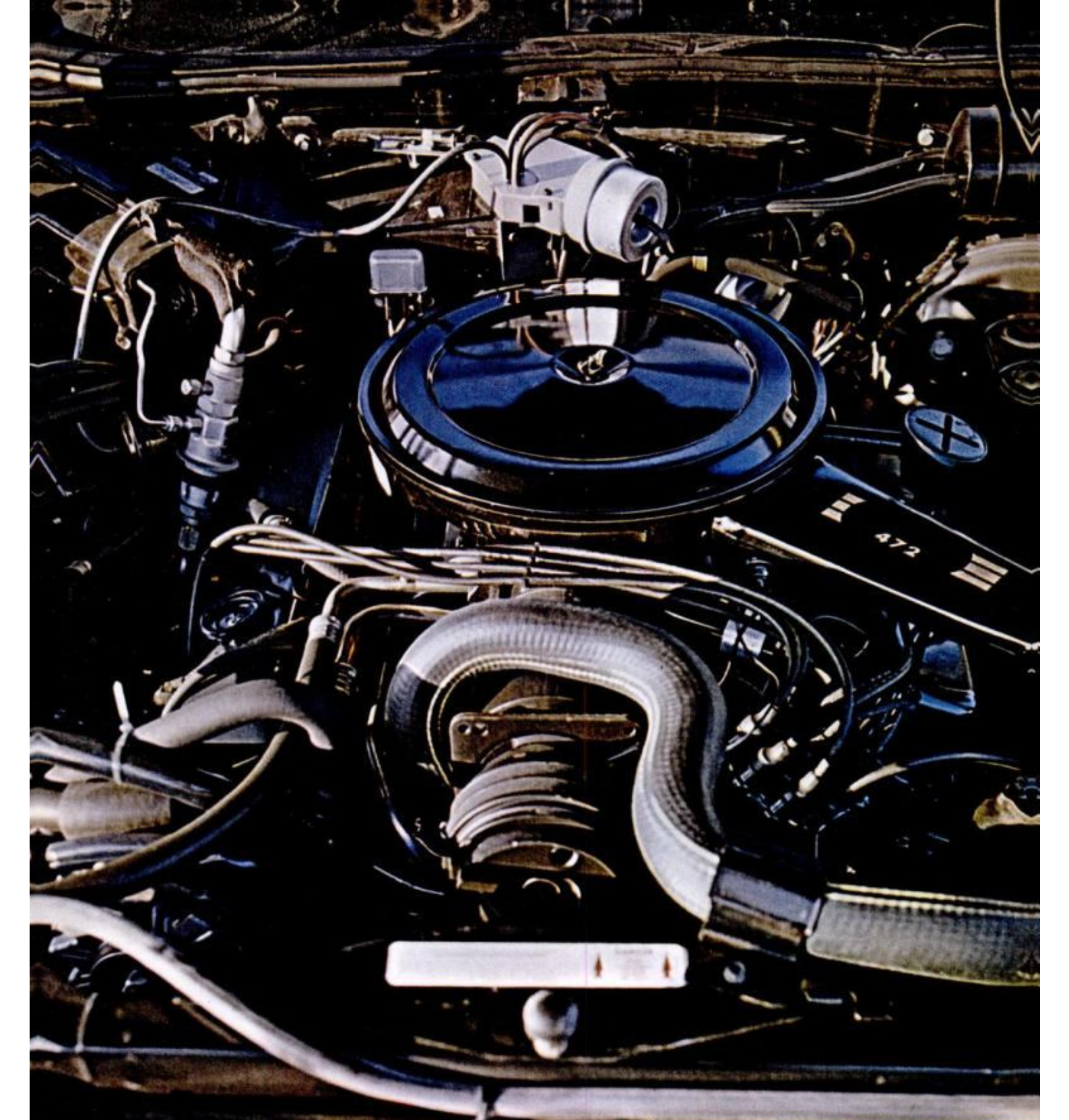
the Tachometer section of the Model BT-162. • To locate a "miss" you need only disconnect or "short" the spark plugs one at a time with the Model BT-162 switched to the Tachometer position. You will be able to instantly identify which particular plug (or frequently its wire lead) is responsible for the malfunction. • Cars with automatic transmissions function efficiently only if the fluid pressures are correctly maintained. Manufacturer's instructions always refer to RPM recommendations.

Operating manual includes manufacturer's dwell angle recommendations for all cars. The manual is yours to keep even if you decide to return the instrument. \$2

SEND NO MONEY
PAY POSTMAN

Try it for 10 days before you buy. If completely satisfied remit \$29.95 plus postage and handling charge. (If you prefer you may use our Easy Payment Plan.) If not completely satisfied, return to us, no explanation necessary.

ACCUR
2435
Plus
at 10
No



**Anyone can make it go.
We make it last.**

Getting started's easy.

Keeping it going takes care. We have a motor oil that does what it takes. Takes care of the engine cleaning, while it's working on the vital parts.

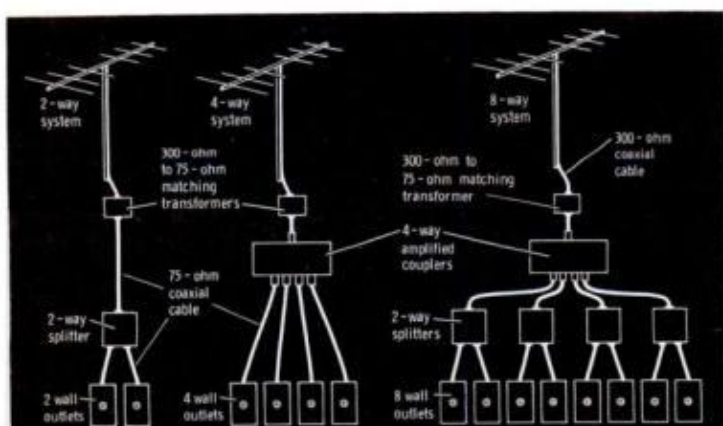
Royal Triton motor oil gets along with all kinds of engines. We've started some beautiful working relationships.

Make peace with your engine.



If you miss the August PM, you won't know...

*...how Ford's
new Maverick
stacks up
against
the 'mob'*



*...or how to set
up a single
antenna system
for all your
TV and FM sets*

*...or what
owners say
about the
Olds Delta 88
and Impala*



Be the smartest guy on your block in August

Read Popular Mechanics

CLASSIFIED ADVERTISEMENTS

Rate: \$1.85 per word payable in advance each insertion. Capitalized words—75¢ per word additional. Minimum insertion ten words. To be inserted under the proper classification, copy must be in our office by the 15th of the second month preceding date of issue. The next available issue to place an advertisement in America's No. 1 Classified Section is September. The closing date is July 15th. Send remittance and order to C. A. Martin, Popular Mechanics, 575 Lexington Avenue, New York, New York 10022. Please make remittance payable to Popular Mechanics.

AUTOMOBILES

Your Ad in Popular Mechanics will be seen by more than 5,000,000 active buyers for your products and services. It costs only \$1.85 per word. And, if you wish to run all or part of your ad in capital letters—you can do so for as little as 75¢ per word additional. Act now! Place your classified ad in Popular Mechanics today.

HOW TO TUNE UP YOUR CAR. Our experience gives easy to understand know-how. \$1.00 G and B Associates, P.O. Box 398 Prms. Hasbrouck Heights, New Jersey 07604.

YOUR Car worth \$50.00 to \$200.00 more on trade. Full Instructions. \$4.95 Pettit Body Shop, 6198 W. Mich., Ann Arbor, Mich. 48104.

MIDGET CARS

OUR First 19 In Space. This limited edition lithograph has been created as a tribute to Americas Gallant Astronauts. 12 X 18 inch chart ready for framing. Only 75 cents. Popular Mechanics, Dept. GWP, 575 Lexington Avenue, New York, New York 10022.

AUTO SUPPLIES AND EQUIPMENT

CROSLY And foreign car parts. Box 7, Elmont, N.Y. 11003.

VOLKSWAGEN Hop-Up Accessories and Dune Buggy parts and pieces. Send \$1.50 for complete jumbo catalog. GEM Products, Box 845, Carol Stream, Ill. 60187.

FIRESTONE PREMIUM GLASS BELT-ED Wide Treads. New—No seconds. Any Size 2/\$50.00, 4/\$99.00, FET \$2.77 per tire. Prepaid/Check/Money Order. Money Back Guarantee. Wide Trac Discount Center, 1119 N. Las Palmas, Los Angeles, Cal. 90038.

AUTO Parts for old cars and new. All makes. Catalogue \$1.10. Antique Auto, Milwaukee, Wisconsin 53240.

JEEP Owners—V8 conversions. Read Jeep Owners, ad. page 34.

VOLKSWAGEN Replacement parts at 20% to 50% discounts. Free Catalog. Western Distributors, Box 316 D, Cedar Crest, New Mexico 87008.

INVEST \$10. Save cent a mile or money back free details—Berger Humid Gas Saver. Erskine, Minn. 56535.

TRANSMISSION OVERHEATING—90% of automatic transmission failures are due to excessive heat buildup. \$1.00 (refundable) brings heat range chart and info. Bill Tugerdt, P.O. Box 4293, Panorama City, Ca. 91412.

GAS-OIL HOG??? . . . Smoking?? . . . No Pep?? . . . Hard Starting?? (Save \$150-\$250) with Motaloy Ring-Valve Job While driving (\$6.50 postpaid) Advertised here every month for years! Continues saving money on repairs, gas, oil for 100,000 miles! Absolutely true! (new engines too) Nothing compares! . . . Money-back guarantee. You can't lose! Motaloy, Grantham, Penna. 17027.

BUGGIE-BIN, under-seat drawer for V-W "Beetle". \$4.50 pair; \$2.65 single. Mini-Max, 748 So. Trenton, Seattle, Wash. 98108.

PARTS: Army jeep and truck parts. Spare Parts & Equipment Co., P. O. Box 751, Lexington, Ky. 40502.

HYDRAULIC Jack repair kits, parts and supplies. Catalog 50¢ (in coin). Hydraulic Jack Packing & Tool Co., Inc., General, P.O. Box 3, Staten Island, N.Y. 10314.

TACH-DWELL Meter. Save 75% building yourself. Plans \$1.00. Harrison, Box 201, Bound Brook, N.J. 08805.

VAPOR Injector—works on any car, uses water and pat. Solution. Improve gas mileage, switch to regular gas, reduces carbon, smog, more power. Guaranteed. \$39.95 P.P. Box 14154, Omaha, Nebraska 68114.

SAVE GAS More power with new Fin Gas saver, 5 min. to install. Guaranteed. Details \$1.50. Illustrated plans \$4.25. Kelly Interprises, Drawer O, Gollad, Texas 77963.

RING And Valve job complete while you drive. Reduces oil burning, increases gas mileage and raises compression. Just drop Motaloy tablets in tank. \$6.00 and money back Guarantee. Mail Order Service, P.O. Box 1041, Metairie, La. 70004.

NEW heavy duty CD ignition system. Details free. Kits \$28.95. Assembled \$39.95. Dealers invited. Delta International Ltd., Box 1946PM, Grand Junction, Colo. 81501.

FEDERAL-MOGUL Rod & Main Bearings With Precision Reground—.010 X—.010 Crankshaft \$24.95. No Exchange. 295-83" Chev. Ford 239-72-92". Send \$1.00 For WHOLESALE LIST, Decals & Literature. Calparts, Box 1251, Wilmington, Cal. 90744.

AUTO TRAILERS

BUILD Your Pickup Camper. Precut Kits. Blueprints. Supplies. Literature 10¢. Comstock Trailers, Dept. 664, Parsons, Kansas 67357.

CAMPER Plans. Compact buses, Vans—Volkswagens, Econoliner, Dodges. Build yourself—Save! Details—Dot Campers, Box 2115M, Culver City, California 90230.

CAMPING Trailer kit tent top 16" size \$333.00 complete plans and instructions \$3.00, circular 15¢. Stratford Trailers, Stony Creek, Conn. 06405.

PICKUP Camper, Trailer or Pickup—Cover . . . Build yourself. Save! Complete plans \$3.95 each. Cover plans \$2.00. Conversion Plans—econoline type van \$2.95; passenger bus or delivery van \$2.95. Satisfaction Guaranteed. Equipment catalog \$1.00 (refundable). Details 10¢. Viking Camper Supply, 99-F Glenwood, Minneapolis, Minn. 55403

MOTORCYCLES, BICYCLES, MOTORSCOOTERS AND SUPPLIES

HARLEY-Davidsons—Used bargains. New, used parts, accessories, all models. Bulletin 35¢. Knuth's (Factory Dealer), 1753 Muskego, Milwaukee, Wis. 53204.

MOTORCYCLE TURN SIGNALS, Accessories. Catalog 25¢. Houston, PM Lockport, Illinois 60441.

HONDA 50-90-160 Speed Equipment. Cams—Big-Bore-Stroker. Columbia Engineering, 2105 E. 37 St., Los Angeles, Calif. 90058.

BUILD "Popular Mechanics" MINI-BIKE featured June 1967 issue. Detail plans, photographs \$2.50 refundable. Kits, parts, engines: factory discount prices. Catalog 25¢. Gilliom Mfg.: PMC; St. Charles, Missouri 63301.

RECONDITIONED Motorcycle motors. Indian, Mustang, Royal Enfield, Suzuki. Parts, Accessories. "Minibikes." Indian Motorcycle Sales, Kansas City, Missouri 64127.

BUILD Motorbike From Bicycle! Plans . . . \$2; Go-Cart Plans . . . \$2; Snowmobile Plans . . . \$5; Go-Byk Industries, Rothsay, Minn. 56579.

SNOW VEHICLE & KART Hcp up accessory CATALOG. Speed and performance equipment—manifolds, engine mounts, exhaust systems. Send 25¢. G.E.M. PRODUCTS, 436 Roosevelt Rd., Glen Ellyn, Illinois.

BUILD Your own minibike! NO WELDING REQUIRED! Plans \$2.00. Westate Enterprises, Dept. PM-7, Box 9216, San Jose, California 95117.

MOTORSCOOTER, \$110. Minibike complete with engine \$50. Mo-ped \$15. Briggs and Stratton engine \$12. (Mail order only) send 35¢ for the Midget Motors Directory listing these and other bargains individuals have listed with us for sale. Midget Motors Directory, Athens, Ohio 45701.

MINI-BIKES. Go-Carts. Clutches. Wholesale Catalog 25¢. Loren Products, Danville, Illinois 61832.



AVIATION

BE A Government licensed aviation mechanic. Practical training. Free information. Aero Mechanics School, Municipal Airport, Kansas City, Missouri 64116.

TREMENDOUS OPPORTUNITIES IN AVIATION. Learn Aeresciences at home: Navigation, Aerodynamics, Communications, Weather. Free Information: United Aeresciences, P.O. Box 4106, Torrance California 90503.

BARTLETT FLYING SAUCER. Amazing machine hovers 200 lb. man over land/water, powered by ordinary lawn mower engine. Easy to build, Fun to fly. Complete Plans, Kit Brochure and Photo Review \$3.00. Write: Herb Bartlett, Box 3234-C, Scottsdale, Arizona 85257.

AIRBOAT, Propellers, Engines, Plans, Kits, Supplies. Complete Airboats, Outboard Airdrives. Catalog \$1.00. Banks-Maxwell, Box 3301E, Ft. Worth, Texas 76105.

JEANIES Teenie homebuilt airplane. All aluminum, Volkswagen powered. Photo.—Specifications—Material lists—Flight reports \$5.00. Money order only. Calvin Parker, Box 727, Daphne, Alabama 36526.

HOMEBUILT. Real enclosed helicopter, 24 pages ideas, information, \$2.50. Build "executive" helicopter, drawings, specifications, \$2.00. Helicopter Development, Box PM147, Washington, New Jersey 07882.

AERO-CAR. Amazing Hovercraft built easily with ordinary tools. Lawnmower engine power. Carries one man plus. Hovers, flies forward, backward, sideways over land/snow/water. Complete construction plans and brochure, \$5.25. Aero-Projects, Box 5118, Clinton, N.J. 08809.

FREE Catalog. 1000 Aviation Space Books. Aero Publishers, 329 Aviation, Fallbrook, Calif. 92028.

HELICOPTER. One-Man, Portable, Kits, Plans, Information 10¢. Photos and three-view drawings \$1.00 Compco, Box 1267, Redwood City, California 94064.



BOATS

CANOES! Kayaks! Factory-direct quality kits, from \$20.00. Many different models. Canvas hulls. Strongest construction materials. Free literature. Sportscraft, Box 8393-PM, Columbus, Ohio 43201.

BOAT PLANS, FRAME KITS, BOAT KITS. World's largest catalog—Over 200 top design for the amateur builders. New catalog includes Cruisers, Runabouts, Deep vee's, Catamarans, Trimarans, Houseboats, Sailboats from small sail fish to 34 ft. motor sailers, large selection of inboard and outboard Hydroplanes. Send \$1.00 for large new plan & kit catalog or \$2.00 for catalog plus Boat Builder's Guide. Clark Craft Boat Company, 16-P Aqua Lane, Tonawanda, New York 14150.

BUILD Your own boat from our large-scale blueprints. Books of plans give how-to-build help. Hundreds of professional designs—motor, sail or auxiliary—for amateur builders. Free catalog. MoToR Boat-Ing, 959 Eight Ave., Dept. PM-RS, New York, N.Y. 10019.

FIBERGLASS Cloth and resin. World's finest cloth and non-run resin, at direct mill prices. Flotation foam. Complete line of plastics, silicon bronze and brass screws, save 60%. No Sales tax. Boat Plans, Catalog 25¢. Freight prepaid. Stiles Boat Supply, Box 11P, Linden Ave., Mantua Hts., N.J. 08051.

FREE Catalogue—plans for canoes, kayaks, accessories. Quicksilver, 115 McGavock Pike, Nashville, Tenn. 32714.

KAYAK Boat kits. Nylon covering never needs paint or dope, assemblies in one day. Fast & easy to handle. Circular with photos 15¢. Stratford Trailers, 376p Stony Creek, Conn. 06405.

PLANS, FULL-SIZE PATTERNS, FRAME KITS with step-by-step instructions specially for amateurs. Send \$1.00 for new 96 page catalog of over 80 designs, 8' to 36' Sail, Jets, Inboards, Outboards, Cruisers, Houseboats, Hot Boats, Catamarans, Hydros "plus" boat trailers. New "How To Build Boat Trailers" book \$4.00 ppd. Glen Designs, 9152 Rosecrans, Bellflower, Calif. 90706.

KAYAKS—One-man \$21.00; two-man \$26.00; Sailboats \$45.50. Exciting Sitka Kayak Kits known world wide for speed and safety. Assemble in one afternoon. Free pictorial literature. Box 582-P, Willoughby, Ohio 44094.

FIBERGLASS CANOES. Four Exciting Models. Easily Assembled Kits. \$39.95 up. Factory Direct. Free Literature. Riverside Canoes, Box 5595-B, Riverside, California 92507.

BOAT maintenance information. LIFE-CALK, "GIT"-ROT, RUB-R-COTE, Finishes & Cleaners. Send for "How to do-Where to do" literature. FREE. Boatlife, 5-45 49th Av., L.I.C., N.Y. 11101.

FREE CATALOG from manufacturer of nylon and Dacron rope. Direct to you at dealer cost. Other important accessories. Write: West Products, Dept. 20, Box 707, Newark, New Jersey 07101.

BOAT Kits. Molded Fiberglass. Save money—assemble yourself. Factory molded sections bond into one-piece craft. 30 models—14' to 32'. Cruisers, Runabouts, Houseboats, Sailboats. Big line accessories, motors, trailers. Easy terms. Free 80 page catalog. Luger, Dept. BC-69, 1300 East Cliff Road, Burnsville, Minnesota 55378.

NEW 1968 McCulloch And Other Outboards 4 H.P. \$109 7 1/2 \$218 9 Electric \$268 18 \$332 40 Electric \$548 55 Electric \$728 All Sizes Literature 50¢ Electra Marine, 1427 Broadway, Brooklyn, N.Y. 11221.

RACE BOAT PLANS, KITS HDWE. Hydros, SK.s, Runabouts, Inboard and Outboard. 24 Model catalog. 50¢. Champion Boats, 816 Schley, Wilmington, Calif. 90744.

MARINE EQUIPMENT AND SERVICES

CONVERT Auto engines to marine. 68 Page Catalog. 50¢. Lehman Manufacturing Company, 800 Elizabeth Avenue, Linden 4, New Jersey 07036.

FREE 1969 Catalog—Gray inboard, inboard-outboard marine engines, gasoline and diesel. Graymarine Corporation, Coldwater, Michigan 49036.

NEW. Used, rebuilt marine motors. Marine conversions, fittings. Free catalog. Stokes Marine Supply, Dept. 24, Coldwater, Michigan 49036.

PROFESSIONAL Marine engines from Star Marine Kits. Engines—Gears—Props—Everything necessary for your boat propulsion. Write for free brochure, Star Marine Engine Works, Berkeley, California 94710.

ATHLETIC AND BODY BUILDING COURSES

"GIANT Arms." Dr. Young's, D.C. revolutionary discovery. \$2. Satisfaction or refund. Gaucho, Box 9309-S7, Chicago 60690.

BIG Muscles fast, complete course \$5.00. Olympus Bodybuilding, Box 431, Garden City, Michigan 48135.

POWERFUL Muscles fast! Free brochure! Universal Bodybuilding, Box 4327-C, Dearborn, Michigan 48126.

TRIM Or Build. Isometric exerciser with instructions, \$3.95. J. W. Schroeder, 10934 Langdon, Houston, Texas 77072.

BEAUTIFUL MUSCLES FOREVER. . . . ORDER TODAY—COMPLETE COURSE ARRIVES IN ONE WEEK—APPLY DILIGENTLY FOR 150 DAYS—HAVE FAITH, NEVER GIVE UP . . . THAT'S ALL, FABULOUS BUILD MUST RESULT. FAILURE IMPOSSIBLE, SATISFACTION OR REFUND. \$2. SUCCESS A79, BOX 1434, MUSKOGEE, OKLAHOMA 74401.

SPORTING GOODS AND EQUIPMENT

FREE . . . Wholesale Catalog, Arrow Shafts, Broadheads, Fletchings, Fisharrow Parts, Tools, Bows, Fynnysports. (22G). Toledo, Ohio 43614.

FREE 1969 Catalog. Guaranteed Lowest Prices! Rods Reels, Lures, Accessories—Thousands of Items. Cabela's Inc., Dept S, Sidney, Nebraska 69162.



FISHING, TACKLE, LURES

SEND for FREE Wholesale Catalog. The most complete and fully illustrated catalog of reels, rods, beads, spinners, jigs, bodies and parts, sinker molds, feathers, tools, hooks, rod blanks, rod parts, swivels, wire, etc. FINNYSPTS, ME Sports Bldg., Toledo, Ohio 43614.

MOLDS—For casting your own fishing sinkers. Free illustrated booklet. Reading Instrument Co., Box P78, Reading, Pa. 19603.

MOLDS For fisherman's sinkers, jigs, squids, casting and spinning lures. Free catalog. Sweets Molds, Tonawanda 1, New York 14150.

CLEAN-A-fish (Filleting and cleaning boards) Let you clean and fillet fish without mess. Long lasting quality. Satisfaction guaranteed. 6" X 24" \$7.95, 7" X 36" \$9.95. Complete Kit \$24.95. Prince Brown Products, 2323 Joppa Avenue 1-D, Zion, Ill. 60099.

FISHERMAN'S Lure Wallet—Worn on belt, conveniently holds, protects lures, flies, sinkers on sheepskin pad, untangled, ready for instant use! Separate license pocket; loop for pliers. Handsome, pliable Naugahyde with waterproof zipper opening. \$1.95—3 for \$5.00, postpaid. DMA, Box 572-A, Beverly Hills, California 90213.

EARTHWORMS, LIVE BAIT

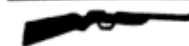
BIG Money growing fishworms, giant African Crawlers, crickets. Free Literature. Fain's Hatchery-31, Edison, Georgia 31846.

EARN Money raising fishworms for us! Exciting details free! Oakhaven—56, Cedar Hill, Texas 75104.

AFRICAN Nightcrawlers. Wholesale, shipped prepaid. BONANZA WORM RANCH, LODA, ILLINOIS 60948 Phone: 217-386-2111

FROGS, FISH, REPTILES

YOUNG Frogs and Giant Breeders. Stock your lakes and ponds. Nu-Tex Frog Farm, Box 4029, Corpus Christi, Texas.



HUNTING, GUNS, DECOYS

EXTRA Income at home in Spare Time! Booklet shows you how to start your own business with Classified Advertising. Only \$1.00. Refundable with first order. C. A. Martin, Popular Mechanics Dept. PM, 575 Lexington Ave., New York 10022.



DOGS AND KENNELS

EXTRA Income at home in Spare Time! Booklet shows you how to start your own business with Classified Advertising. Only \$1.00. Refundable with first insertion order. C. A. Martin, Popular Mechanics Dept. PM, 575 Lexington Ave., New York 10022.



GAME BIRDS

MAILORDER Records help get Increased Business! Complete 32 Page Record Book shows your inquiries orders, advertising, expense, etc. Only \$1.00. C. A. Martin, Popular Mechanics, Dept. PM, 575 Lexington Ave., New York 10022.

QUAILS, Incubators, cages, supplies catalog. Marsh, 14216 Brookhurst, Garden Grove, Calif. 92640.

HAWKS, FALCONS

HAWKS, Eagles, Falcons, Owls for hunting. Send \$1.00 for complete price list. Slocum, Box 30-13, Grove, Oklahoma 74344—Telephone 918 786-2201.

RABBITS—FUR BEARING ANIMALS

RAISE Rabbits for us on \$500 month plan. Free details. White's Rabbitry, Mt. Vernon, Ohio 43050.

RAISE Rabbits successfully by knowing facts. 48 page illustrated book describing 25 breeds, housing, breeding, feeding, markets, marketing etc. 25 cents. American Rabbit Association, 36 Arba Building, Pittsburgh, Penn. 15217.

MAKE Big Money raising chinchillas, rabbits, guinea pigs for us. Catalog—25¢. Keeney Brothers, New Freedom, Pa. 17349.

EARN \$10,000 Yearly raising angora rabbit wool, and breeding stock for us. Information 25¢ coin. American Angora Company, Malta 12, Montana 59538.

\$500-\$800 MONTHLY. Raise small laboratory-breeding stock for us. We supply equipment, breeders, and instructions. Illinois Research Farms, Dept. MPB-7, McHenry, Illinois 60050.

TAXIDERMY

EXTRA Income at home in Spare Time! Booklet shows you how to start your own business with Classified Advertising. Only \$1.00. C. A. Martin, Popular Mechanics Dept. PM, 575 Lexington Ave., New York 10022.

PETS—BIRDS, CATS, HAMSTERS, ETC.

LIVE SEAHORSES, marine specimens, aquarium supplies. Illustrated catalog 15¢. Marine, Box 248-310, Dania, Florida 33004.

LIVE Traps, all sizes, mouse to dog. Collapsible or rigid. Carrying Cages. Free literature. National Live Traps, Tomahawk, Wisconsin 54487.

LIVE SEA MONKEYS in Minutes. Hatch in Fishbowl. Amazing Pets. Watch Families Grow. Free Food Instructions \$1.79. Guaranteed. Alyce Enterprises, Dept. PM7, Box 1087 Fort Lee, New Jersey 07024.

HORSES, LIVESTOCK

"HOW To Train Horses"—Everyone who likes horses or ponies should have this book: Free. Write Beery School, 1107 Pleasant Hill, Ohio 45359.

CAMPING EQUIPMENT AND TENTS

SAVINGS Plus dividends! Campers-fishermen-outdoorsmen cooperative. Free 68-page catalog. Recreational Equipment, Inc., 1525-P 11th, Seattle, Washington 98122.

CAMPING

YOUR Ad in Popular Mechanics will be seen by more than 5,000,000 active buyers for your products and services. It costs only \$1.85 per word. And, if you wish to run all or part of your ad in capital letters—you can do so for as little as 75¢ per word additional. Act now! Place your classified ad in Popular Mechanics today.

TRAVEL AND RESORTS

WILDERNESS CANOE TRIPS. Free brochure. Bill Rom's Outfitting, Ely, Minnesota 55731.

"AMERICA BY CAR" Names Best Places to Eat and Stay, Scenic Routes, Parks, Historic Sites. 170,000 Word Book. Only \$2.50! House of Eldon, 26 Virginia Road, Arlington, Mass. 02174.

ELECTRICAL SUPPLIES

METERS—Surplus, new, used, panel and portable. Send for list. Hanchett, Box 5577, Riverside, Calif. 92507.

UNUSUAL Electrical and Lamp Specialties. Free Catalog. Homecrafters, 4605 State, Drexel Hill, Pa. 19026.

LAMP Parts. Catalog, prices, wiring instructions, 50¢. Refunded first order. Gyro, 5218P N.W. 35 Ave., Miami 42, Fla. 33133.

LAMP parts for building, repairing, converting. Catalog 40 cents. Refunded with first order. Brown Lamp Co., Box 11305, Clayton, Mo. 63105.

LAMP—Appliance parts. Wholesale catalogue 25¢. SECO, 109 South 20th Street, Birmingham, Alabama 35233.

BATTERIES, GENERATORS

BATTERY Reconditioning Kit, includes molds, material, instructions. Battery Shop, Route 1-88D, Blythe, Calif. 92225.

COMPLETE Hydraulic Jack Servicing Manual \$3.00. C.O.D. accepted. Bayerco, 938 Betty Avenue, Neenah, Wisc. 54956.

ENGINES, MOTORS

WINDING Data, 275 motors, \$1.20. Data Company, 512 Kensington, Kansas City, Mo. 64124.

LIVE Steam powered backyard railroads! All sizes. Complete "bolt-together-kits," and rough castings. Excellent drawings. 100 page catalog \$1.00. Little Engines, Lomita, Calif. 90717.

MACHINERY, TOOLS AND SUPPLIES

SMALL Foundry furnaces, Supplies. Free literature. Pyramid Products, 3736 South 7th Avenue, Phoenix, Arizona 85041.

MICROMETERS—Indicators—Small lathes. Direct Supply, 1424 Barclay, Springfield, Ohio 45505.

ROUTER Bits, 1/4" shank, high speed, used; excellent condition. \$2.50 dozen postpaid. Lillian's, Box 17165, Chicago, Illinois 60617.

BIG 170 Page tool and hardware catalog \$1.00. Refunded. Elwick, Dept. 110, 230 Woods Lane, Somerdale, N.J. 08083.

SCRIBER resembles push button pen \$1.20 ppd. Lawson Engineering, Lakeside Rd., RD3, Newburgh, N.Y. 12550.

WELDING, SOLDERING, PLATING

CHROME Plating equipment, supplies. All other finishes. Home workshop and production sizes. Send \$2.00 (refundable) for formulas, operating data, equipment guide and catalog. HBS Equipment Division L50, 3543 East 16th, Los Angeles, Calif. 90023.

WELDERS—110 220, 150 Amperes, \$53.50. Morris, 1070 Inner, Schenectady, New York, 12303.

GOVERNMENT SURPLUS

GOV'T Surplus. How and where to buy in your area. Send \$1.00. Surplus information. Headquarters Building, P.M., Washington, D.C. 20036.

1969 SURPLUS Army, Navy store illustrated catalog. Send 25¢ (refundable with first \$5.00 order). Ruvel, 707 Junior Terrace, Dept. 9-J, Chicago, Illinois 60613.

JEEPS Typically From \$53.90 . . . Trucks From \$78.40 . . . Airplanes, Typewriters, Boats, Clothing, Camping, Sporting, Photographic, Electronics Equipment, Wide Variety, Condition. 100,000 Bid Bargains Direct From Government Nationwide. Complete Sales Directory and Surplus Catalog \$1.00 (Deductible First \$10.00 Order). Surplus Service, Box 820-A, Holland, Michigan 49423.

JEEP and Government Surplus Buying Manual (Jeeps pictured) 50¢. Surplus Bargain Catalogue 50¢. Both \$1. Bargain Surplus, Box 1TFP, Spring Grove, Pennsylvania 17362.

JEEPS From—\$52.50; Typewriters from \$4.15; Cars from—\$31.50. Walkie-talkies, motorcycles, airplanes, boats. Typical "As Is" bid bargains from Uncle Sam. Tremendous variety. Exciting free list. Write: Enterprises, Box 402X48, Jamaica, New York 11430.

HOBBIES AND COLLECTIONS

50 GORGEOUS Jungle butterflies \$2.50. Collectors Wonderland, Box 1170, New York, 10008.

OUR FIRST 19 IN SPACE. This limited edition lithograph has been created as a tribute to Americas Gallant Astronauts. 12 X 18 inch chart ready for framing. Only 75 cents. Popular Mechanics, Dept. GWP, 575 Lexington Avenue, New York, New York 10022.

EMBLEMS, BRASSARDS, PATCHES

YOUR Ad in Popular Mechanics will be seen by more than 5,000,000 active buyers for your products and services. It costs only \$1.85 per word. And, if you wish to run all or part of your ad in capital letters—you can do so for as little as 75¢ per word additional. Act now! Place your classified ad in Popular Mechanics today.



STAMP COLLECTING

PENNY! Approvals! Regardless catalogue! Kloster, 4164 52nd St., San Diego 5, Calif. 92105.

500 DIFFERENT Stamps, \$1.00. Smith, 508-A Brooks, College Station, Texas 77840.

50 YEARS Old, fifteen different United States, over fifty years old—10¢ with approvals. Jaxon, Box 145-P, Brooklyn, New York 11230.

50 DIFFERENT United States, only 10¢ with Approvals. Shelron, Box 547C, North Miami, Florida 33161.

"AFRICA," 25 beauties, 10¢. Approvals. Gortiz, Box 1915PM, Naples, Florida 33940.

MILLIONS Foreign Stamps! 2¢ each! Send for gigantic approvals! ABC, Box 6000-MB, San Francisco, California 94101.

100 OLD United States between 1861 and 1935, \$1.00. Roush Stamps, 51 Chestnut, Mansfield, Ohio 44903.

FREE Surprise collection sent with approvals. Gould, 1784 Union, San Francisco 94123.

255 DIFFERENT Worldwide; 15¢. Approvals. Tibbets, 8675 Meadow, Downey, Calif. 90242.

50 DIFFERENT Old U.S. Revenue stamps 50¢. Winchester Stamps, Box 1592, Mansfield, Ohio 44907.

U.S. Mint specials! Flag set, complete \$1.00, 1¢, 2¢, 3¢ famous Americans (21 different) \$1.00. Free list. Brooks, 2601 Avenue "U," Brooklyn, N.Y. 11229.

ONE Pound value Geo. VI Bermuda, plus 100 worldwide 10¢. approvals. Stevens, Box 105A, Homecrest Sta., Brooklyn, N.Y. 11229.

NEW Issues—Free weekly illustrated list. Brooks, 2601N Avenue "U," Brooklyn, N.Y. 11229.

225 STAMPS for only 10¢! Airmails, Pictorials: stamps from strange countries cataloging up to 25¢ each! Plus unusual stamps to examine. Buy any or none return balance, cancel service anytime. Mystic Stamp Co., Camden 80, New York 13316.

FREE!! Two Beautiful Multi-Colored Complete Mint Sets. Approvals. Hamilton, 1246 Pratt, Chicago OE-7, Illinois 60626.

701 U.S.A. (PLENTY Commemoratives) —25¢. Approval purchase required. Horace Gatewood, Winston-Salem, North Carolina 27102.

U.S. Bargain, 50 different 10¢, with beautiful worldwide approvals. Stamp Center, Kennebunk, Maine 04043.

TERRIFIC Stamp Bargain—125 Different! Includes beautiful Germany and Asiatic Pictorials plus colorful and exciting space Topicals. Only 10¢ with Request for Approvals. Send Today! Shaw, Drawer E-14, Montevallo, Alabama 35115.

FREE Mint Set. Approvals accompany. Stamps, Box 22092, Memphis, Tenn. 38122.

RUSSIA High-Value Collection, 32 different Russia—some over 50 years old! Commemoratives, Czarist Issues, Airmails. Catalog price \$2.50. Special Get-Acquainted Offer—all for only 10¢! H. E. Harris, Dept. GG-49, Boston, Mass. 02117.

FREE! Big Bargain Catalog—New Edition listing thousands of bargains including U.S. & B.N.A. stamps, packets, albums, accessories and supplies. Also, fine stamps from our approval service which you may return without purchases and cancel service at any time. Jamestown Stamp, Dept. E-79PM, Jamestown, N. Y. 14701.

FREE 50 Worldwide. Approvals. University Stamps. P.O. Box 1471. Lake Worth, Florida 33460.

FREE! Triangles, Scout, 25 others. Approvals. Cambridge, Box 411, Cambridge, Ohio 43725.

14,000 DIFFERENT! AMAZING new plan builds your collection systematically, country by country. Only 50¢ weekly. Ware, Monroe, Conn. 06468.

210 DIFFERENT U.S. Commemoratives \$1.00. Stamps, 7607 Larchview Drive, Dallas, Texas 75240.

50 DIFFERENT U.S. Commemoratives. 10¢. Approvals. Cambridge, Box 411, Cambridge, Ohio 43725.

RUSSIAN Space set 10¢. Russian approvals. Snedco, Box 68-P, Waldwick, N.J.

BARGAINS In Old Used U.S. Seconds. Karl Swartz, Mountain Home, No. Car. 28758.

"RUSSIAN Bear in Berlin Set. Only 10¢. Approvals. Ken Zielski, Box 364-M, Morton Grove, Illinois 60053."

SUMMER DISCOUNTS! Save now on everything in my price lists of packets, sets, singles, U.S., U.N., Canada, foreign! Lists sent free! Faville, 400 West Broadway, Monona, Wis. 53716

WORLDWIDE Approvals. Humphrey, 805 24th Ave., Santa Cruz, Calif. 95060.

UNITED States commemorative collection containing 33 different—10¢. Approvals. White, 516-A Avenue L, Brooklyn 30, New York.

GIANT Stamp Collection including: Astronauts, Satellites, Moonrockets, Boy Scout issue, Complete U.N. Set, recent Olympic and Sport issues from many countries, etc., Plus Big Stamp Dictionary and approvals. Everything, 10¢! Stampex, Box 47-RM, White Plains, N.Y.

ABSOLUTELY Free 25 different United States Commemoratives when requesting United States Approvals. K & B, Box 70, Brooklyn, N.Y. 11223.

ANNUAL Spring Sale. Excellent Values. Mounted Approvals. Preview Stamps. Box 9809M, San Diego, Calif. 92109.

THOUSANDS Worldwide 2¢ each, on approval. King Penny Stamps, 4517 Tioga, Canton, Ohio 44708.

TOPICALS—Three Colorful Sets, 10¢! Approvals. COLE, Box 223-A, Buffalo, N.Y. 14221.

PROSPECTOR'S PACK. File folder packed with album pages, sets, packets, covers, etc. \$5 postpaid, satisfaction guaranteed. Wood, 7855 West 16th Ave., Lakewood, Colorado 80215.

BEAUTIFUL TROPICAL SET Plus Bonus Packet, 10¢. Sets or Packet Approvals. Packman, Box 97, Fort Collins, Colorado 80521.

"INVERTED ERROR" Dag Hammarskjöld, 6¢ with approvals. Belmont Stamps, Washington, D. C. 20015.

U.S. Approvals Low prices. Eagle, 2221 Romine Ave., Pittsburgh, Pa. 15226.

PENNY Stamps! 1000 Mounted in book at 1¢ each. Trust Stamp Company, P.O.B. 132-P, Jamaica, N.Y. 11435.

2,000,000 STAMPS, 150 Countries, 2¢ each. Belden, Box 4175, Dearborn, Mich. 48126.

500 WORLDWIDE \$1.00! 200 Latin America \$1.00! Ross, Box 152, Wayne, Pa. 19387.

FREE \$1 Your choice from our stamps. Tobey, 14291 Foothill, Sylmar, California 91342.

I PAY \$250 EACH for 1924 1¢ green Franklin stamps rotary perforated 11 (\$2.50 unused). Send 25¢ for illustrated folders showing amazing prices paid for old stamps, coins, collections. Vincent, 85 PM, Bronx, New York 10458.

CHILI 25 Different 5¢. Approvals. Hijop Box 505, Norristown, Pa. 19404.

1500 FOREIGN \$1.00; 5000 \$3.00; 9000 \$5.00. 5000 USA \$3.00, contains airs, dues, 19th Century, presidentials, revenues, high values, etc. 200 large size only (your choice of USA or foreign) pictorials and commemoratives \$1.00; 700 \$3.00; 3000 \$12.00. No approvals. Meyers, 5321 Fleming, Richmond, Calif.

EXPLOSIVE Near East always in the news. We are offering a nice collection of stamps from Israel, Egypt, Jordan, Syria, Iraq, etc. for only 10¢ to approval applicants. Clark Stamps, Dept. 57C, Muskegon, Mich. 49444.

FAMOUS PAINTINGS—Giant stamps, 40 different \$1. Philatelic Mart, Box 262M, McGregor, Texas 76657.

POLAND—25 Different beauties, 10¢. Approvals. Tarheel Philatelics, Siler City, North Carolina 27344.

NUDE Painting set. Amazing Trade-in Exchange Plan. Approvals, 25¢ Stamp Club Unlimited, Box 5332-PM1, Inglewood, Cal. 90310.

PAINTINGS 20 Giant Beauties! Only 25¢ with Approvals. Roger Williams Stamp Co., Box 1281-PM, Pawtucket, R.I. 02862.

NEW Countries, New Issues. Free gift with approvals. Ernest, 1784 Union, San Francisco 94123.

FREE 400 Genuine Postage Stamps. Worth \$10.00 at catalogue prices. Africa, Europe, Asia, British Emp.—a fascinating valuable mixture from foreign convents, banks, etc. Who knows what you will find. Also free valuable booklet and "Lucky" giant Buddha Airmail from Laos. Adults Only. Approvals enclosed. Frasek Co., Inc. PM7 White Plains, N.Y. 10601.

EXQUISITE Art Set FREE. Approvals. Sherman, Box 445, Monterey Park, California 91754.

WOW! 110 All Different Germany 10¢. Commemoratives, Airmails, High Values. Big catalog, bargain lists. Also, fine stamps from our approval service, which you may return without purchases and cancel service at any time. Jamestown Stamp, Dept. A79PM, Jamestown, N.Y. 14701.

100 DIFFERENT! Free 1/4¢ upward British Commonwealth or world approvals. Bush, 1677 Wimborne Road, Bournemouth, England.

VATICAN Xmas Set 60¢ Approvals. Baricks, POB 7154, Detroit, Mich. 48202.

FRENCH Art "Renoir" Painting 25¢. Request Worldwide Approvals. C&F Stamps, 655 Forbes Street, East Hartford, Conn. 06118.

PRESIDENT Kennedy stamps from Uruguay, Togo, Colombia, etc. plus big illustrated catalog sent Free! Littleton Stamp Co., Littleton, JF1, N. H. 03561.

RARE stamp free. Also new packet Aden to Urundi with Kennedy, triangles, space, sports, ships, dogs, cats, reptiles plus others. All free. Send 10¢ for mailing. Empire Stamp Co., Toronto, Canada.

EXCHANGE. Send 100-200 Different stamps with 25¢. Receive different. Patterson, Lancaster, New York 14086.

TEN Different Nudes: 20¢. Approvals. Stamp Farm, 2M8, Oxford, Wis. 53952.

FOR \$1.00 Will send a surprise packet of stamps, some Nfid. Guaranteed to please. Philpott's Stamps, Box 306, Botwood, Nfid.

JUMBO JETS are coming—before they do get yourself some historic covers from the early pioneer Jet flights now becoming scarce. Official postmarkings indicate routes they flew. 50¢ each or 5 all different for \$2. K. M. Walsh, Box 308-A, Tuckahoe, N.Y. 10707.

COINS, TOKENS, CURRENCY

OLD Coins Bought. Illustrated Catalog 25¢. Hutchinson's, Box 6256, Philadelphia, Pa. 19136.

PRICE List. Send 10¢. Village Coin Shop, Dept. P, Plaistow, N.H. 03865.

SCARCE Date Jefferson nickels. All V.G. Satisfaction Guaranteed. 1942-D—1949S—1950—50¢ each. 1943D—1951S—1955—75¢ each. 1939S—\$1.25. 1938D—\$1.65. 1938S—\$3.25. 1939D—\$5.00. 1950D—\$14.50. Dates not listed 20¢ each. Bryson Inc., 612A White, Toledo, Ohio 43605.

BEFORE 1835 Large Cent. \$3.25. Doktor, Box 8915, Oak Park, Mich. 48237.

UNITED STATES Specials: Half Dime before 1873, \$3.00; Large Cent before 1857, \$3.00; 1893 Columbian World's Fair Half Dollar, \$3.00; Old style Large \$5.00 bill, \$12.00; All four offers \$20.00. Moneyback Guarantee. Barcoa, 31-A, North Clark, Chicago 60602.

21 UNCIRCULATED Lincolns . . . 1959 PD—1969PDS \$1.00. Catalog! 10¢. Mohawk, Box 82M Crane, Schenectady, New York 12303.

UNCIRCULATED Dollars, 1880-81-82 S, 1883-84-85-1899-1900 01-02 O mint, \$3.50 ea. Catalogue 50¢. Shultz, Salt Lake City, Utah 84110.

BARGAINS \$1.00 EACH—ALL DIFFERENT. Fourteen (S) Lincolns, two Liberty quarters, two Barber quarters, three Barber dimes, six War nickels, six Mercury's, six Roosevelt's, nine Buffalo's, four Indians, four Liberty nickels. SPECIALS: —Large cent, two cent piece, three cent nickel \$2.00 each. U.S. list plus 1969S cent 25¢. Schultheis, Box 151M, New Hyde Park, N.Y. 11040.

BARGAINS—Latest coin price list, 10¢. Ron Farley, Metamora, Ill. 61548.

1969S CENT. Wooden Nickel and price list 10¢. Lawrence, Anamosa, Iowa 52205.

LINCOLNS: 1940 PDS. To 1954 PDS. Each 10¢. Stevens, Box 546F, North Miami, Fla. 33161.

50 MIXED "S" cents, includes uncirculated 1955S, new 1968S, 1969S. Only \$1.95. BONANZA. Box 820P, Cupertino, Calif. 95014.

20 UNCIRCULATED Foreign Coins \$1.00. Coins, Box 35041, Minneapolis, Minnesota 55435.

SCARCE! JEFFERSON Nickels. VG-Fine 100% Satisfaction Guaranteed. 1942-D—1949-S—1950—45¢ each. 1943-D—1951-S—1955—75¢ each. 1939-S—\$1.00. 1938-D—\$1.50—1938S—\$2.95. 1939-D—\$4.95. 1950-D—\$13.95. Other dates 20¢ each. PREMIERE COINS, Box 7771, Spokane, Washington 99208.

LINCOLNS: 22 "S" including 1955S, \$1.60. 26 1909-1939, \$1.60. 10 "S" Jeffersons, \$1.60. 10 "S" Roosevelts (1946S-1955S complete), \$3.25. All different. All four \$7.75. Silver Dollars \$2.45 each. Price-list 10¢. Robert Harris, 2373P Pruneridge, Santa Clara, California 95050.

SILVER Dime, Quarter And Half \$2.00. Nelson, #346-P, Rye, New York 10580.

5,000 PENNIES GUARANTEED unpicked from our vending machines. 55.00 First Vending Company, Box PM, 5322 Belmont, Chicago, Illinois 60641.

BARGAINS—Crisp New \$2.00 Bill. \$3.95; 1950-D Nickel Uncirculated \$12.95; 1931-S Cent ExFine \$22.95. Bargain Lists 25¢. Beebe's, Incorp., Omaha, Nebraska 68111.

ANTIQUES, RELICS, INDIAN GOODS AND CURIOS

LIST Indian relics, 10 Arrowheads \$3.00. Hyde's, Box 2304, Santa Fe, New Mexico 87501.

TONS Of antique gun parts and supplies. All reproduction muzzle loading guns. Send \$1.00 for enlarged illustrated catalog No. 118-A. Dixie Gun Works, Union City 12, Tennessee.

FORTY MILLION YEARS OLD. Limestone caste of clams. Postpaid \$3.00 each, two for \$5.00. AGE CERTIFICATION included. Supply limited. Satisfaction guaranteed. Horizons, Box 330A, Beaufort, N.C. 28516.

PURPLE GLASS! Secret For Purpling Indoors Revealed. \$1.00 Postpaid. Coinland, 1505 P-C-H., Redondo Beach, California 90277.

MODELS—SHIPS, TRAINS, PLANES, ETC.

ROCKETS: Real flying models—flights up to 2500 ft. New illustrated catalog 25¢. Single and multistage kits, cones, engines, launchers, trackers, rocket aerial cameras, technical information. Fast service. Estes Industries, Penrose 2, Colorado 81240.

SHIP And yacht model fittings; Pine construction hull kits; blueprints. Send 50¢ for illustrated catalog. A. J. Fisher, Inc., 1002 Etowah Avenue, Royal Oak, Michigan 48067.

SHIP Model kits and fittings: clippers, frigates, etc. Catalog paint-tool list, 1969 catalog 50¢. Models Shipways, Box 65, Bogota, N.J. 07603.

SHIP Models, Kits, fittings, plans, books, tools, engines, motors. Big illustrated catalog 50¢. Mass. residents add 3% tax. James Bliss & Co., Dept. SM, Route 128, Dedham, Mass. 02026.

CANNONS, Flying Saucers, Hot Air Balloons, Rockets, Etc. Free Catalog. Zeller, Box 69, Hudson, Mich. 49247.

SHIP Models catalog 25¢. Scientific, Inc., 100 Monroe, Newark, N.J. 07105.

SCALE Building materials. 1/4" & 1/8" scale. Windows, doors, siding, roofing, lumber and structural shapes. Send 50¢ for catalog. Small Sales Co., P.O. Box 177, Shawnee Mission, Kansas 66201.

SOLAR Flying Saucer Lifts Animals—See Spaceonics Ad Under Science-Chemistry

GAMES, TOYS, PUZZLES, NOVELTIES

"ROULETTE DICE" . . . A pair of dice that have a range of thirty-six different numbers. \$2.00, details free. D. E. Products & Co., Box 488, Worcester, Mass. 01601.

UNUSUAL Items—latest novelties scientific games—Free Brochure Write 'Arctco', 215 Woodside Ave., Ridgewood, N.J. 07450.

MAGIC TRICKS, JOKES, VENTRILOQUISM

HOUDINI'S Original Magic Shop. Established 1856. Send 25 cents for Illustrated Catalog containing 5000 Tricks, Mindreading, Puzzles, Hypnotism and Jokes. Flossie-Hornmann, 304 West 34th St., N.Y. 10001.

HOUDINI Magic Catalog!! Giant Professional Deluxe Edition!! 1000 World's Greatest Tricks!! 25¢ with Free Gift Certificate!! House of 1000 Mysteries. Dept. PM9C, Northeast Fifth Ave., Ft. Lauderdale, Florida 33308.

500 TRICKS Catalog. 1969 Edition, showing latest magic for pocket, parlor, stage. Only 10¢. Fastest mail service for 45 years. Douglas Magicland, Dept. 11, Dallas, Texas 75221.

BE A Magician! Two booklets explaining sixty-eight tricks plus large professional catalog. \$1.00. Magic, Inc., 5082 Lincoln, Chicago, Illinois 60625.

VENTRILOQUISM! Information free! Dummy catalog, 25¢. State age. Maher, Studio G, Box 8356, Kensington Station, Detroit, Michigan 48224.

MAGIC Catalog. World's finest 3000 tricks. (340) pages \$2.50. Beginners, amateurs, professionals. Kanter's, A-200 South 13th St., Philadelphia, Pa. 19107.

FREE Trick. New Magic Catalog. Send 25¢. Ace Magic, Box 329, Evanston, Ill. 60204.

COMPLETELY Illustrated catalog. 84 pages, 25¢. Manhattan Magic, Box 334-M, N.Y.C. 10011.

WORLD'S Finest professional magic tricks. Joker's Novelties. Giant illustrated catalog 10¢. Top Hat, Evanston, Illinois.

MAGIC MAGAZINE—Monthly since 1936. 44 pages. All phases. 3 month trial \$1.00. Genii, P.O. Box 36068, Los Angeles, CA 90036.

AMATEUR and PROFESSIONAL MAGICIANS all new magic tricks and gags catalog 25¢. Our specialty same day service. Fabulous Trick and Magic, 3319 E. Charleston, Las Vegas, Nevada 89104.

CATALOG \$26, 175 pages, 25¢ (1,500-399 tricks, jokes, novelties). Elbee, 7408-P, San Antonio, Texas 78207.

BOOKS, CATALOGS, NEWSPAPERS

BUSINESS Books and Directories. List 10¢. Cricket, Box 527, Ardmore, Penna. 19003.

FREE Catalog. Self-help books. Write Wilshire, 12015 Sherman Road, North Hollywood, Calif. 91605.

NATIONAL Geographic Magazines, 1888-1967, any issue. Buxbaum, Box 465-PM, Wilmington, Delaware 19899.

PROPHET Elijah coming before Christ. Wonderful book free. E. Megiddo Mission, 481 Thurston Rd., Rochester, New York 14619.

SENSATIONAL Book. HOW TO GET WHAT YOU WANT. Free brochure describes this and others. Richard Allen Sales, 110 Birch Street, Midland Park, N.J. 07432.

AMERICA By car tells Scenic and Historic places =HP-20T \$2.50 plus Postage! D. H. Lincoln, PM 1431 Los Robles, Sacramento, California 95838. California Resident 5% Tax.

NEW 24 Page Catalog, guns., Guerrilla Warfare, Police Science—10¢. Variety, Box 395-PM, McDonald, Ohio 44437.

PUBLISH Your book! Join our successful authors: All subjects invited. Send for free appraisal and detailed booklet. Carlton Press, Dept. PMS, 84 Fifth Avenue, New York 10011.

PAPERBACK Catalogue, 270 pages, 15-000 titles, subject indexed. \$2.00. Credited toward order. New York Book, 4 P West 43 Street, N.Y.C. 10036.

FREE List of practical books on success, self help and sports. McAllister Sales, PM7, Box 13128, St. Louis, Mo. 63119.

SELF-IMPROVEMENT Books. Free Descriptive List. Write Crawfords, PM-79, 363 Poppy, Long Beach, California 90805.

ORIGINAL German copies of "MEIN KAMPF" direct from Germany for only \$12.00 (48 DM). Hermann Kempf, 7030 Boeblingen, Postfach 202, Germany.

PLAYS, STORIES, MANUSCRIPTS

WANT Your book published? Learn how we publish, advertise, promote, distribute. Many successes. Free booklet PM, Vantage, 120 West 31, New York City.

BUSINESS OPPORTUNITIES

HUGE Profits! Mail order importing. Free information. ITIS, PM-7, Box 454, Hollywood, Calif. 90028.

BOOKKEEPERS Earn \$1000.00 month. Operate simplified Bookkeeping tax service. Universal, Box 664-M, Springfield, Missouri 65801.

WANT To make big money at home? \$10.00 profit in an hour possible with invisible mending. Make tears, holes disappear from clothing, fabrics. Steady year-round demand from cleaners, laundries, homes. Details free. Fabricon, 1585 Howard, Chicago 60626.

CONCRETE FACTS: Highly profitable home business. Experience unnecessary. Unlimited unique pottery designs easily made without moulds. Birdbaths, fountains, wishing-wells, benches, etc. Chemical coloring formulas, marbling. FREE illustrated brochure. Hollywood Cementcraft, 602 Athens Street, Altadena, California 91001.

WORLD'S Largest supply. Merchandise 25% to 40% under wholesale. Bankrupts, closeouts 10¢ on dollar. Imports. Hong-kong clothes. Automobile discounts. Free details. International Buyers, Box 4633-MM, Colorado Springs, Colo. 80909.

RAISE Rabbits for us on \$500 month plan. Free details. White's Rabbitry, Mt. Vernon, Ohio 43050.

UP To \$5.00 each for newspaper clippings! Free details. Philip, Box 368-S, Southfield, Michigan 48075.

FREE "Franchise Profit Letter" tells how unique NFR service is helping thousands seeking profitable businesses. Write today. National Franchise Reports, W-528, 333 North Michigan, Chicago 60601.

\$400.00 MONTHLY Raising giant fishworms. Soilless method. Charlie Morgan, Bushnell, Florida 33513.

EARN Money raising fishworms for us! Write: Oakhaven-38, Cedar Hill, Texas 75104.

400,000 BARGAINS Below wholesale! Many free. Liquidations . . . closeouts . . . job lots . . . single samples. Free details. Bargainhunters Opportunities, Box 730A, Holland, Michigan 49423.

\$200.00 DAILY In your mailbox! Your opportunity to do what mailorder experts do. Free details. Associates, Box 136-A, Holland, Michigan 49423.

BUILD Custom Cases at home for profit. Get orders by mail. We supply materials, instruction—everything. Free home business details. Custom Case Supply Co., 7630-CPG, Gloria Ave., Van Nuys, Calif. 91496.

VENDING Machines. No selling. Operate a route of coin machines and earn amazing profits. 32-page catalogue free. Parkway Machine Corporation, 715 PMB Ensor Street, Baltimore, Maryland 21202.

PIANO Tuning Learned quickly at Home. Tremendous field. Musical knowledge unnecessary. GI approved. Information free. Empire School, Miami, Florida 33145.

ADDRESSERS And mailers needed. Send stamp for information. Lindbloom, 3636 West Peterson, Chicago 60645.

FREE Book "990 Successful, Little-Known Businesses." Work Home! Plymouth-372-G, Brooklyn, New York 11218.

MAKE \$75.00 daily distributing tools to service stations. Free Plan. INKA, 2401 Crocker, Houston, Texas 77006.

EARN \$60.00 DAILY manufacturing Concrete Fence Posts. Practically no investment. Free information. Send stamp. American, Excelsior Springs, Mo. 64024.

DRAFTSMEN! Operate own **DRAFTING SERVICE!** Full, Part Time; Experience unnecessary; Details: Roberts Drafting, 1741 Circle Road, Baltimore, Maryland 21204.

ESTABLISH Profitable Catalog Mailorder Business! Vikari's, Box 1312PM-G, Salt Lake City, Utah 84110.

STOP Throwing Away Those Bxotops! They're worth money, some 25¢ each! Write: Bxotops—BO, Cedar Hill, Texas 75104.

ADVERTISING BUSINESS—YOU own it, \$350 First Week or Money Back. Electric Neon Action Ad Clock, 229 W. Illinois, Chicago 60610.

HOW TO PREPARE YOUR OWN MAIL-ORDER CATALOG for pennies. . . . Including All Popular Merchandise! Free Catalog-Proof! Obie, 5711-ML-14TH, Brooklyn, New York 11219.

EARN more than many Professional men! \$1000.00 monthly operating Mail Order Collection Agency, Continental, Box 2023-A, Des Moines, Iowa 50310.

JOIN "MONEY GETTER'S GUILD". Receive hundreds money-making, Business Building Propositions. Year's membership only 25¢. Write: Fourstars, Box 839, Long Beach, New York 11561.

\$21.00 HOUR Profit—From Home Picture Framing Business. (Clampless Assembly Method) Write: Japs, 126-PM Seventh North, Hopkins, Minnesota 55343.

MAILORDER — Profitable products; dropshipped. No merchandise investment. Everything supplied—catalogs, ads, mailing lists, Gift-Guide, 3408½ Motor, Dept. 161, Los Angeles 90034.

UNLOCK Your Future. Become professional Locksmith by spare time home-study. Make up to \$6 per hour. All tools, equipment incl. Facts free. Send name. Locksmithing Inst., Dept. 1310-079, Little Falls, New Jersey 07424.

FREE Advertising? 500 Publications. Write: Dee, 10639-PM Riverside, North Hollywood, Calif. 91602.

I MADE \$40,000.00 Year by Mailorder! Helped others make money! Start with \$10.00—Free proof! Torrey, Box 318-Y, Ypsilanti, Michigan 48197.

MAIL Baby Catalogs imprinted with your address to New Mothers for Big Profits! Details 25¢. Volz-PM, Ypsilanti, Michigan 48197.

SELL Books by mail. 400% profit. Royal, Box 450-X, Cleveland, Ohio 44127.

MAKE \$32 from 49¢ piece vinyl. M-1834 Edgeland, Louisville, Ky. 40204.

MAKE Money Operating Home Mailorder Business. No Inventory. Write Purple Enterprises, Box 16291AG, Jacksonville, Fla. 32216.

MAKE Money from old tires. Operators clearing \$800, weekly. Equipment costs \$1500. Get facts. S & S Patents, Inc., 3752 N. Damen, Chicago 60618.

LIST Your Name with Importers, Manufacturers Etc. Year, \$1.00. Includes Sample product. Cal-Mail, Box 1264, Canga Park, California 91304.

\$112,000.00 YEAR. Mailorder. Can make you money. PROOF. Write Williams, 44646 H. Los Angeles 90044.

MAKE big money growing ginseng! \$3,000-\$30,000 annually. We buy your crop. Send \$2 for seed sample and information. Glass' Ginseng Exchange, Box 1969, Springfield, Mass. 01101.

INSTALL Burglar alarms without previous experience or costly equipment. Big profit. Free details. Nasco, 11071 Massachusetts, Dept. C-2707, Los Angeles 90025.

OVER \$3,000.00 my mail profit monthly! 53 years showing others how. Send stamped self-addressed envelope. Free samples, proof, testimonials. Brewster, Box 1348-PM, Clearwater, Florida 33517.

START Your own profitable business. Amazing book tells how. Free details. Snell's, Box 682-A, Bath, New York 14810.

AMAZING Automatic Fishhooks. 200% Profits. Sample \$1.00 Refundable. Aron, Postbox 61-PM, Mastic Beach, New York 11951.

MAKE Money mailing catalogs. Free Details. Newton, P.O. Box—F-PM Detroit, Mich. 48208.

CALIFORNIA MANUFACTURER NEEDS man to assemble our product and be local agent, experience unnecessary. May start while presently employed. Five-figure income for responsible applicant. S.K.R.M. Manufacturers, 2540 Olive Avenue, Long Beach, California 90806.

READ Progressive Mailtrade, the magazine that tells how to make money by mail. Quarter brings sample and special offer. Mailtrade, P.O. Box 357, Sheboygan, Wis. 53082.

GENERAL ELECTRIC invites you to investigate the profit opportunities, open to Popular Mechanics readers with a little capital, in the coin-operated laundry field. Your background may qualify you even if you do not have prior experience. Send for new brochure with information on how to get started. Write General Electric Co., Dept. 401, Box 1515, Louisville, Ky. 40201.

FREE Catalogs. Repair air conditioning refrigeration. Tools, supplies, full instructions. Doolin, 2016 Canton, Dallas, Texas 75201.

VENDING Machine big catalog. Rake, 523 A Spring Garden, Philadelphia, Pa. 19123.

56 ACTIVE Franchise opportunities available all over USA. Brochure details 56 franchise chances for you to have your own business tied with successful national companies. Send name, address to P. Stewart, 1085 Walnut, Des Plaines, Illinois 60016.

CLIP Newspaper items. \$1.60-\$5.00 each. Details free. Walter, Box 1360-PA, Erie, Pa. 16512.

SELL Lifetime. Metal, Social Security Plates, Big Profits! Sample and Sales Kit Free. Russell, Box 286-PM, Pulaski, Tennessee 38478.

MAKE 2 to 3 times your cost wholesaling 1001 products. Gifts, Mail Order Specialties, Toys, Novelties, Carded Merchandise. Guaranteed lowest below wholesale prices. Free home business details SMC 7630 SPG, Gloria Ave., Van Nuys, Calif. 91406.

SPARE Time Cash—Sell Advertising Book Matches—every business a prospect—no investment—no experience needed to build steady repeat business. Daily Cash commission in advance. Write today—We'll send your sure-fire selling kit by return mail. Dept. MX 769, Superior Match Co., 7530 S. Greenwood, Chicago, Illinois 60619.

COPUBLISH "Mail Sale Advertiser," leading mailorder paper. Copy and details 25¢: U.S.A. only. Vanroy Shirk, Lebanon, Pa. 17042.

MAILORDER Records help get Increased Business! Complete 32 page Record Book shows your inquiries, orders, advertising expense, etc. Only \$1.00. Martin, Popular Mechanics, Dept. PM, 575 Lexington, New York 10022.

TREMENDOUS Mailorder Profits! Write George, Box 2188A, Cypress, California 90630.

MAKE \$46 from square foot plywood: jigsaw or bandsaw necessary. Free details. Woodar, Bridgewater, Mass. 02324.

\$70.00 WEEKLY—home, spare time. Simplified mail bookkeeping. Immediate income easy. Auditax, 34741A, Los Angeles 90034.

\$2.00 PER Dozen Cash Profits. Assemble New Art Foam Products. All Supplies Furnished. Showcase, Box 55392D, Indianapolis, Indiana 46205.

WATCH REPAIRING piles up extra cash fast. Free sample lesson. Watchmaking. YTB, Fox River Grove, Illinois 60021.

"WHOLESALE BY MAIL," "FOREIGN TRADE THESAURUS." Details. Matthews, Box 114, Vernonia, Oregon 97064.

I MAKE \$1,200 MONTH IN ACCOUNTING. You start, train fast. Only 10 lessons. Certificate awarded. Work from home or office. Mail \$2, first lesson. Jenkins, Box 571, Taft, California, 93268.

JEWELRYCRAFT—It's easy! Big profits! Catalog, 25¢. Modern Crafts, 12790 US 19, Clearwater, Florida 33516.

\$500-\$800 MONTHLY. Raise small laboratory-breeding stock for us. We supply equipment, breeders, and instructions. Illinois Research Farms, Dept. MPD-7, McHenry, Illinois 60050.

SELL Gifts, Household Items—Make extra money. Toys, Jewelry, Stationery, Greeting Cards, 600 items. Experience unnecessary. Salable Samples on approval. Free—Catalog. Personalized Christmas Card Album. Hedenkamp, 361 Broadway, Dept. PM-101, New York 10013.

START BIG-PAY Business at home in spare time. No experience needed to operate little table-top machine for bronzing baby shoes. Make \$7.32 profit on every pair. Full particulars free. Send postcard to: Mason, 1512 Jarvis, Room CM-2-C, Chicago, Illinois 60626.

OPERATE Restaurant. Free booklet reveals profitable plan. Write Restaurant Business School, Dept. EC79, 1923 Sunny-side, Chicago, Illinois 60640.

PREPARE Tax Returns—Housewife Jo Ann Netzley made \$5,500 last season. Train at home. VA Approved. National Tax School, Monsey 2GB, New York 10952.

WAYS TO RAISE CAPITAL. Write Buntings, P.O. Box 11244-PM, Clayton, Missouri 63105.

PROFITABLE Mail order! For first time you can join mail order professional who has produced millions of dollars in cash mail order sales. Opportunity of lifetime! Associate, Box 3798-PM, Glenstone Station, Springfield, Missouri 65804.

AMAZING Profits! Sell by mail quality self-improvement books. Drop-shipped by reliable publisher, Graphic, 1033-PM S.W. 53rd, Oklahoma City, Oklahoma 73109.

IMPORTING made easy. Manual \$3.00 Crown-Royal Enterprises, Dept. M-1, 1126 Broadway, Burlingame, California 94010.

INSTANT Mail Order Business—All you need is a mailbox. Details \$1 (Refundable). Mail Marketing Services, Benton, Illinois 62812.

MAILORDER Beginner's catalog, 10¢. Guaranteed, Sullins, Box 2067-M, Forsyth, Georgia 31029.

DATA-CRAFT Agency. "The Unfranchise" \$65 establishes you. Work at home spare-time. Merchants, doctors, banks buy regularly. Course trains you, 25-businesses-in-1. Datacraft-A, Kerrville, Texas 78028.

SECRETS! Mail Order Success. Internationally famous expert reveals how to make home business fortunes. Beginners: Get free copy "Make Money By Mail." Discloses free advertising, profitable products. Mailco, 1554 Sepulveda, Dept. C2707, Los Angeles 90025.

FREE \$1000 Report. Become rich on borrowed money. No-risk plan. Counselor-17, Kerrville, Texas 78028.

ESTABLISHED. Profitable, simple, no selling, home. Free information. Northern Survey, 206-F Bloor W., Toronto 181.

SELL Information By Mail. 2400% Gross Profit! 15,000-word Instruction Manual. \$2.00. Satisfaction Guaranteed! Sax, Dept. C-17, Milan, Ohio 44846.

SUPPLY Fried Chicken Dinners on \$500 week home plan. Free information. White's Chicken Dinners-PM, Mt. Vernon, Ohio 43050.

MAGNETIC SIGN BUSINESS. Plastic forming machine, supplies for complete Business \$19.95. Magnavac, Post Office Box 411, Bessemer, Ala. 35020.

\$6 CAN START YOU IN BUSINESS. Investigate 100 business opportunities in every monthly issue of Franchise Journal. Get the facts, figures, company histories, profit potential, investment requirements, etc. Send \$6 for 12 exciting copies to Franchise Journal, 892-G W. 16 St., Newport Beach, Calif. 92660.

\$25.00—\$100.00 WEEKLY; your own Home Typing, or, Duplicating Business. Methods, helps, machines. Free information. National, Box 1975-MMAI, Little Rock, Ark. 72203.

HOW TO GET STARTED FARMING. Detailed step by step booklet. Start with \$150 to \$1000 and build into a 3000 acre operation in 5 years. Send \$2.00 to ROBB-I, Danville, Kansas 67036.

\$60.00 DAY. Manufacturing concrete Posts, Blocks, Mold Equipment Catalog \$1.00 refundable. Carlayne, Route One, Box 106-T, Rapid City, South Dakota 57701.

MAIL Baby catalogs, Imprint, To New Mothers. Big Profits! Details \$1.00. Krefski, 609 Lee, Plymouth, Penna. 18651.

FREE REPORT. 609 Unusually successful businesses. Write: Associated, Box 238-B97, Lafayette, California.

DONUTS Earn high profits for your business, organizations, or church. Complete information. Stork-Ville Donut Co. Inc., G-4402 Calkins Rd., Flint, Mich. 48504.

TESTED. Proven Business Opportunities. Step by step guidance. Details free. Eddie's, 4809 N. Montclare Ave., Chicago, Ill. 60656.

MONEYMAKING OPPORTUNITIES

\$200.00 FROM Sheet 1/4" plywood (scrap). Details 25¢. Novelties, 610 So. 24th, Elwood, Indiana 46036.

EARN \$240.00 a month at home, spare time, doing only two \$5.00 invisible mending jobs a day. Big money paid for service that makes cuts, tears disappear from fabrics. Steady demand. Details free. Fabri-con, 1532 Howard, Chicago 60626.

RAISE Rabbits and fishworms on \$500 month plan. Free details. White's Rabbitry, Mt. Vernon, Ohio 43050.

MAKE Statuettes, novelties, imitation marble. Sell to stores or start gift shop. Free details. Marbleizing, 41 Waverton, St. Louis, Mo. 63124.

HOW To Make money writing short paragraphs. Information free. Barrett, Dept. C-27-U1, 6216 N. Clark, Chicago 60626.

VENDING Machines. No selling. Operate a route of coin machines and earn amazing profits 32-page catalogue, free. Parkway Machine Corporation, 715 PMM EnSor Street, Baltimore, Maryland 21202.

FREE Copy of world's leading contest magazine! Write Prizewinner, Box 11569, St. Petersburg, Fla. 33733.

CASH/Royalties for romantic songpoems! Castle's, 203-M West 46th, New York City 10036.

HOMEWORK. Mailing circulars. Free details! Cam Company, Dept. 155-KP, Verona, N.J. 07044.

FREE. 206 Easy Ways to make money taking orders for exciting new products—spare time. Send name, age for 5 months free subscription. Opportunity Magazine, 1460 Hancock Center, Dept. 17-GM, Chicago 60611.

\$2.40 HOURLY Making simple wood novelties. Free details! Gene's, 55 Boxwood, Falmouth, Mass. 02540.

HIGHLY Profitable spare-time business. Bronzing & PearlKoting baby shoes. Complete set-up on credit available. 31 year old company. Send 25¢ for brochure. Kik-tavi, Box 4187PM, Compton, Calif. 90224.

MAKE Two to Three TIMES your cost on hundreds of products, gift items, novelties, toys, Carded merchandise, 1001 others. The Robinson Co., 443 Encinitas Ave., San Diego, Calif. 92114.

PLASTERCRAFT HANDBOOK Illustrated instructions statuary pouring, finishing, selling and mold making. Also where to obtain all materials. Only \$3.00 postpaid. Guaranteed, Wolfe, Box 561G, Melbourne Beach, Florida 32951.

DEALERS Make Money My Way. Send Stamp, Hall's Mail Order Supplies, Box 72146, Los Angeles, California 90002.

SCIENTIFIC Massage: Big Earnings uncrowded profession. Learn spare time at home. Diploma awarded. Free catalog. Write Anderson School, Dept. G-1C, Princeton, Illinois 61356.

CLIP Newspaper items. \$1.00—\$5.00 each. Details free. Walter, Box 1360-P, Erie, Pa. 16512.

SPARE Time Cash—Sell Advertising Book Matches—every business a prospect—no investment—no experience needed to build steady repeat business. Daily Cash commission in advance. Write today—We'll send your sure-fire selling kit by return mail, Dept. MA-769, Superior Match Co., 7530 S. Greenwood, Chicago, Illinois 60619.

MONEY—Become a Finance Broker. Full or part time. RMP & Co., P.O. Box 901, Desk 10, El Reno, Oklahoma 73036.

MAKE 450%!!! "Profits In Mailorder"—Sample Book, Money-making Details! \$1.00. Hildreth, Box 82M Crane, Schenectady, New York 12303.

THE TRUTH About starting your own mailorder business. \$1.00 Guaranteed. Idea Mart, Box 71, Perrine, Florida 33157.

MAKE! \$12.00 Profit each dozen assembling Belts. Details Free. (Stamp appreciated.) Redikut's-40, Richland Center, Wisc.

BECOME Notary Public! Free particulars. Stationers, 405-PM Richardt, Evansville, Indiana 47711.

HOMEWORKERS! 200 companies—48 page Directory. FREE details. Quest Enterprises, Box 6029, Dept. 17, San Jose, California 95150.

WATCH REPAIRING makes every day a payday. Learn at home. Free details. Watchmaking, YTA, Fox River Grove, Illinois 60021.

\$10. TO \$100. OUNCE! Collect Pollens. Available Free. Latest methods. Complete information. \$3. Pollen, Box 17138, Wichita, Kansas 67217.

\$500—\$800 MONTHLY Raise small laboratory-breeding stock for us. We supply equipment, breeders, and instructions. Illinois Research Farms, Dept. MP-7, McHenry, Illinois 60050.

SELL Greeting Cards—Make extra money. Show friends Gifts, Toys, Jewelry, Stationery, 600 items. Experience unnecessary. Salable Samples on approval. Free—Catalog, Personalized Christmas Card Album, Hedenkamp, 361 Broadway, Dept. PM-102, New York 10013.

HOW MUCH does being your own boss or making \$25,000.00 per year interest you? The Warner breakthrough in the Engraving field could be your future. Write: Warner, Room CE-2-C, 1512 Jarvis, Chicago, Ill. 60626.

SELL What You Write. Instantly! Beginners Market List tells where, how, and what to write. Send stamped, self-addressed envelope, free proof. Economy Box 1348G, Clearwater, Florida 33517.

RAISE MONEY PLUS GREEN STAMPS For Church, Club, School Groups, Our Easy Way. Hughes Company, Box 216, Easton, Missouri 64443.

SELL Fast mailorder "Money-Makers." Free details. Taylor, Drawer AA, Newport, N.C. 28570.

CLIP Newspaper Items for Cash! Details free. Kirkman, 1-PM Ann Street, Woodbridge, Virginia 22191.

\$10.00 DAILY writing short Articles at Home. BEGIN immediately. Copyrighted Report reveals HOW and WHERE. SEND \$1.00. THOMAS GIFTS, 5565 SCHOFIELD RD., COLLEGE PARK, GA. 30337.

LEARN The secrets of repairing junk batteries "Fabulous Profits" at home. Batteryman, Route 1-88D, Blythe, Calif. 92225.

ADD 50% To your Money in five years. Write Paramount Investment Co., P.O. Box 7434, New Haven, Conn. 06519.

MAILORDER BEGINNERS. Save Time, Money, Avoid Mistakes. Write: Barry Enterprises, 89-22 218 Place, Queens Village, New York 11427.

BUILD Part Time Business To Independence. Local Interviews. Harris, 156 Kuulei Rd., Kailua, Hawaii 96734.

\$400.00 MONTHLY Possible in your home woodwork shop. Experience unnecessary. Free information—send stamp. Mission Industries, Box 755, Shawnee Mission, Kansas 66201.

NEW Free Money-making Mail Order Catalog Write Fitz, Freeville, New York 13068.

MAKE BIG MONEY Selling Jokes, Tricks and Novelties. Catalog and Details \$2.00. B. R. Willis and Sons, Box 1047, Battle Creek, Mich. 49016.

1,000 MONEY Making Tips Only 50¢. Forney, 6225 Wheeling, West Virginia 26003.

MONEYMAKING Opportunities, self-development books. Free information. Treasures, 6210A Hampton Boulevard, Norfolk, Virginia 23508.

USE YOUR TABLE SAW—Make big Money from scrap lumber with New Patented Attachment—no competition—unlimited market—free details—Booth Manufacturing—15133 Wayside—Phila., Pa. 19116.

WRITE Persuading Letters. Profitable. Samples. Eljay, 603-B Navarro. San Antonio, Texas 78205.

HOW TO GET RICH!! Free "Money-making Brochure"! Success International, Box 2447-C, Livonia, Mich. 48151.

SILK Screen Artistic Color Artwork. Home, No Machines, full, part time. Instructions \$1.00. Screenco, Box 862, Waukesha, Wis. 53186.

MONEY—SPARETIME OPPORTUNITY PANELISTS AT HOME WANTED BY NEW YORK RESEARCHER. Leading research firm seeking people to furnish honest opinions by mail from home. Pays cash for all opinions rendered. Clients' products supplied at no cost. For information write: Research 669 Mineola, N.Y. 11501, Dept. PM-24.

PROFITABLE OCCUPATIONS

BECOME A mortgage broker, earn \$10,000 to \$50,000 a year. Details free. United, Box 6284A, Marietta, Georgia 30060.

YOUR Own Sign shop. Signs, 410-S So. Western, Springfield, Ohio 45506.

HOW To Make Money Writing Short Paragraphs. Information Free. Barrett, Dept. C-27-U2, 6216 N. Clark, Chicago 60626.

CHROME Plating. Instructions, equipment and supplies. Platers' Supply, P.O. Box 565, Lugo Station, Los Angeles, Calif. 90023.

FT. SMITH Auction School, Ft. Smith, Ark. Residents & Home study. Veteran approved.

FREE Book "990 Successful, Little-Known Businesses." Work Home! Plymouth-37-G, Brooklyn, New York 11218.

SHARPEN Scissors, Pinkers, Inexpensive equipment, tools, supplies. Blackhawk's, Sheldahl, Iowa 50243.

INSTALL Aluminum Storm Windows, doors, jalousies, etc. Instruction book \$10. Stoloff, Box 100, Inwood, N.Y. 11696.

\$500-\$800 MONTHLY. Raise small laboratory-breeding stock for us. We supply equipment, breeders, and instructions. Illinois Research Farms, Dept. MPA-7, McHenry, Illinois 60050.

RAISE Catfish at home for Fun and Profit. Instructions \$1.00. Sexton Seafoods, 206 Maund, Jennings, La. 70546.

CLIP Newspaper Items. Earn \$1.00-\$5.00. Free information. Ideas, 6210B Hampton Boulevard, Norfolk, Virginia 23508.

EARN \$15,000 Yearly as Insurance Adjuster or Professional Damage Appraiser. Write for aptitude test today. National Adjusters Institute, Satellite Beach, Fla. 32935.

SALESMAN—DISTRIBUTORS

EARN Terrific commissions listing delinquent accounts. General Finance Company, 304-A Pickwick Building, Kansas City, Mo. 64106.

EARN Big Commission Full or Part Time. Show America's largest line Low Priced Business Printing and Advertising Specialties Plus calendars in season. No experience. No investment. No collections or deliveries. On-the-spot commissions. Big Free Sales Kit samples hundred items used daily by businessmen. Merchandise bonuses for you. Build profitable repeat business. Start now. National Press, Dept. 91F, North Chicago, Ill. 60064.

FREE. 206 Easy Ways to make money taking orders for exciting new products—spare time. Send name, age for 5 months free subscription. Opportunity Magazine, 1460 Hancock Center, Dept. 17-GS, Chicago 60611.

FREE! Money Making Opportunities! Send name, address, zip. Bradley, Box 509-D, Mt. Kisco, New York 10549

100% PROFIT—Sweet Georgia Brown Cosmetics sell fast. Write for Sample Case offer. Valmor, Dept. H, 2411 Prairie, Chicago 60616.

SELL Advertising book matches. Write us today. We put you in business by return mail, handling complete line ad book matches in demand by every business right in your town! No investment; everything furnished free! Top commissions daily: Superior Match, Dept. M769, 7530 S. Greenwood, Chicago, Illinois 60619.

SELL BIBLES—24 Editions—DIRECT from PUBLISHER! Wholesale discounts! Highest profits! Free Circulars, sales course, write: Bible Publishers, Dept. PM-7, Box 5065, San Antonio, Texas 78201.

WANTED: Man contact service stations. Part time. Cyclo Manufacturing, 3816 Dahlia, Dept. 158, Denver, Colorado 80201.

SELL Hertel Bibles—Part Time. Finest reference Bible available. Demonstrator and supplies furnished. Excellent commissions. Write International Book, Dept. PM, Box 118, Wichita, Kansas 67201.

MAKE extra \$25 to \$75 spare time! Take orders for double air cushion Bronson Shoes. Amazing comfort. Terrific men's, women's line for dress, work, play. Highest commissions. Shoes for yourself. Big outfit Free. Write Bronson, Dept. 166, Minneapolis, Minnesota 55408.

SALESMEN Make more Sales! Increase your income! 164 page book tells how to make people say "Yes". Confidence and good impressions. \$2.00. SILHOUETTE ASSOCIATES, 81 Corbin Avenue, Dept. 268P, Shirley, New York 11967.

SELL Colorful PLASTIC BUSINESS CARDS, calendars, rulers, bookmarks. Free sales kit. Nu-Spur Co., Village Office Park, Reading, Massachusetts 01867.

FREE! Money Making Opportunities! Send name, address, zip. Bradley, Box 509-D, Mt. Kisco, New York 10549.

AGENTS WANTED

YOUR Own business—Used suits \$1.50; overcoats 65¢; mackinaws 35¢; shoes 12½¢; ladies coats 30¢; dresses 15¢. Enormous profits. Catalog free. Nathan Portnoy Associates, 2109-AA Roosevelt Road, Chicago Ill. 60608.

LIFETIME Income. Business Loan Representative Write: Financial 28 E. Jackson, Suite 1204-X3, Chicago 60604.

EVERY Man a prospect. Refundable sales kit offer showing line belt buckles, tie clasps, money clips, cuff links, lapels, identification badges, individualized with customer's name and emblems. Cap badges for trucking, bus, taxi, police, firemen, also postal, letter carriers and heavy construction emblems. Choice 3000 emblems. Hook-Fast, Box 1088PM, Providence, R.I. 02901.

PRINTING. Advertising Salesmen—Excellent moneymaking sideline selling Decalcomania Name Plates, small quantities. Advertising Specialties, sign letters. Free Samples. Ralco XL, Boston, Mass. 02119.

CHRISTMAS CARDS—Business and Personal. Customer's name imprinted. Earn unusually high commissions from this medium—and high-priced line. No investment. No inventory. Free Sample Album. Process Corp. (our 48th year), 3436 S. 54th Ave., Chicago, Ill. 60650.

MAKE Extra Money—Show friends, neighbors—Gifts, Stationery, Toys, Jewelry, Greeting Cards, 600 items. Experience unnecessary. Salable Samples on approval. Free—Catalog. Personalized Christmas Card album. Hedenkamp, 361 Broadway, Dept. PM-100, New York 10013.

RISING COST OF LIVING GOT YOU DOWN? Beat Inflation Today—Make \$100 a week extra in SPARE TIME—and get FREE SHOES FOR LIFE! No investment. Interested? Rush card today for Free Details. Mason Shoes, K-621, Chippewa Falls, Wis. 54729.

BE The Popular Mechanics representative in your neighborhood and earn big profits in your spare time. Write Popular Mechanics, Room 7A, 250 West 55th St., New York 19, N.Y.

EMPLOYMENT INFORMATION

AUSTRALIA Wants You! Government assisted passage. Unlimited Opportunities. Latest Government Information and Forms \$1.00 Austco, Box 3623-E, Long Beach, California 90803.

HIGH Paying overseas jobs. Construction, other projects. Bonuses, Travel Expenses. Extras. International Information, 124. Cortez, Florida 33522.

JOBS! JOBS! and more JOBS! Men, Women, Students, Teachers, FOREIGN, U.S.A. Year-round and Summer Jobs, All Occupations and Trades. For Information, Write: (enclose \$1.00 postage/handling—Refundable) "JOBS", 475M, Lodi, Calif. 95240.

FOREIGN And USA job opportunities available now. Construction, all trades. Earnings to \$3,000.00 monthly. Paid overtime, travel, bonuses. Write: Universal Employment, Woodbridge, Conn. 06525.

COMPANIES Needing help desperately, willing to pay good money, choice locations, expenses paid guaranteed, send \$1.00 for their names, Opportunity, Box 6099, Pensacola, Florida 32503.

AUSTRALIA, AUSTRALIA, AUSTRALIA! Jobs Galore!! Government assisted transportation. 1969 Handbook \$1.00. Satisfaction Guaranteed!! Associated, Box 17-B97, Lafayette, California.

INTERNATIONAL. U.S.A. jobs now!! Free Details!! Write: Global Employment, Box 249-C97, Lafayette, California.

HELP WANTED

OVERSEAS Jobs—Europe, South America, Australia, Far East, etc. 2000 openings all trades. Construction, Office, Engineering Sales, etc. \$400 to \$2,500 month. Expenses paid. Free Information. Write Overseas Jobs, International Airport, Box 536-M, Miami, Florida 33148.

50,000 AUSTRALIAN Jobs! New Directory of 300 U.S.-Invested Businesses in Australia Seeking Help, \$1.00 Austco, Box 3623-E2, Long Beach, California 90803

GAS APPLIANCE SERVICEMEN: No experience necessary, will train. 52 weeks work guaranteed annually including paid vacations and holidays; insurance; opportunities for promotions; most managers started as servicemen. Apply managers Baltimore, Boston, Chicago, Cleveland, Detroit, Los Angeles, Philadelphia, Pittsburgh, St. Louis, San Francisco, Washington, D.C., Dallas offices (we're in phone book). GAS CONSUMER SERVICE.

OVERSEAS Jobs—Australia, Europe, South America, Far East, etc. Openings in all trades and professions. \$400. to \$2,500 monthly, free information write Foreign Employment Mart, Box 2235 A.M.P. Miami, Florida 33159.

A BETTER JOB FOR YOU. Ted Wilson, Nationally famous placement expert, unlocks private employment agencies secrets which assist millions of highly paid professionals improve their employment. \$3.00. Placement Publications, Box 14161, Washington, D.C. 20044.

REAL ESTATE & FARMS

CANADA'S Finest lands, \$4.00 an acre and up. Acquired through estate liquidations. Suitable for hunting, fishing, camps, cottages, farming, timber, minerals, investment. Small monthly payments. Free descriptive booklet. Canadian Estate Land, Dept. 20, 194 Wilson Ave., Suite 101, Toronto, 12 Canada.

CANADIAN Vacation lands: Full price \$385.00, 40 acres, \$10 month. Suitable cottage sites, hunting, fishing, investment. Free information. Land Corporation, 3768-C Bathurst, Downsview, Ontario, Canada.

\$1 ACRE—Canadian Border—hundreds campsites, islands, farmlands, directly from tax authorities. (Non-profit). Lists, photographs mailed. Register, Room 10, 110 Church Street, Toronto 1, Canada.

CENTRAL Ontario—Choice 640 acre Sportsmen's paradises still available—\$20.00 plus \$6.50 taxes yearly. Maps, pictures. \$2.00 (Refundable). Information Bureau, Norval 4, Ontario, Canada.

GOVERNMENT LANDS . . . Low, as \$1.00 acre. Millions acres. For exclusive copyrighted report . . . plus "Land Opportunity Digest" listing lands available throughout U.S., send \$1.00. Satisfaction guaranteed. Land Disposal, Box 9091-PG, Washington, D.C. 20003.

NORTHWEST WOODED WILDLANDS AS LOW AS \$950. TOTAL PRICE \$50 DOWN \$25 MONTH. 5-10-20-40 acres for people who love the land. . . . A piece of wilderness to preserve for your own forever. In Northern Idaho, Northeastern Washington, and Western Montana. In the heart of lakes and big game country. All covered with growing timber. Access, Title insurance with each tract. This is select land with natural beauty, recreational and investment values. We have tracts of many types and sizes from which to choose, including beautiful Northwest Waterfront property on the Pend Oreille, Priest and Kettle Rivers; and property on Pend Oreille Lake. Your inspection welcomed. Write us for free list, maps and complete information. Write to: Dept. PG, Reforestation, Inc., P.O. Box 8146, Spokane, Wash. 99203.

FREE 208-page real estate catalog. All types property, coast to coast! UNITED FARM AGENCY, 612-PM West 47th St., Kansas City, Mo. 64112.

BUY Without risk for Retirement, Vacation, or Investment—under America's only "No-Risk Purchase Plan"—in Carolina Coast multi-million dollar, 14,000-acre development, 10 year money-back guarantee. 1/2 acre homesites as low as \$695.00; \$8.00 down, \$7.65 monthly. Motel, hunting, fishing, golf, country club, right on property. Private ocean beach, 50 fresh water lakes. Write for free literature. (Not offered to residents of California, Florida, New York.) Boiling Spring Lakes, Southport I-L, North Carolina 28461.

NEW FREE Journal! Arkansas bargains! Statewide Realty Co., 310-AE Pyramid Life Bldg., Little Rock, Ark. 72201.

BUY CANADA \$10.00—10 ACRES Thousands of Tax Sale properties direct from Municipal Authorities. No middlemen. Over 80 years of land bargains. Atlantic to Pacific. Hunting, Fishing, Cottages, Farms, Investing. Easy driving distance U.S.—Canadian border crossings. Areas researched. Most unique land service in whole wide world. Guaranteed risk free. Photos, maps, lists, mailed. BUREAU OF CANADIAN TAX LAND SALES, 16 Quinby Court, Thistleton 613 Ontario, Canada.

VACATION Lands, Canada, \$1.00 acre. Free information. Tax Corp., 206-F Bloor W., Toronto 181, Canada.

FARM & GARDEN EQUIPMENT

EXTRA Income at home in Spare Time! Booklet shows you how to start your own business with Classified Advertising. Only \$1.00 (Refundable with first order.) C. A. Martin, Popular Mechanics, Dept. PM575 Lexington Avenue, New York 10022.



FLOWERS, PLANTS & NURSERY SUPPLIES

MAILORDER Records help get Increased Business! Complete 32 Page Record Book shows your inquiries orders, advertising, expense, etc. Only \$1.00 C. A. Martin, Popular Mechanics, Dept. PM, 575 Lexington Ave., New York 10022



DRINKING WATER—PURIFIER

EXTRA Income at home in Spare Time! Booklet shows you how to start your own business with Classified Advertising. Only \$1.00. Refundable with first insertion order. C. A. Martin, Popular Mechanics Dept. PM, 575 Lexington Ave., New York 10022.

A WATER PURIFIER That fits on ANY kitchen faucet. No Installation Necessary. Replaces Bottled Water. Lasts 3-4 Months. Performance Guaranteed. Only \$4.25 Prepaid. Free Information. Bal-Park Distributors, Box 700, Baldwin Park, California 91706.

HOME CRAFTSMEN

CABINETMAKING MADE EASY and "How to Make Formica Counter Tops," two excellent guides let you build kitchen cabinets and counter tops like professionals. Extraordinary guides bring master craftsmen's shortcut methods. Satisfaction guaranteed. Write: Japs, 126-P Seventh North, Hopkins, Minn. 55343.

FULL SIZE FURNITURE PLANS. Traditional, Early American, Danish Modern. Catalog 50c. Furniture Designs, Dept. P-7, 1425 Sherman, Evanston, Illinois 60201.

FOUNDRYETTE 2400 F. 1 1/2 to 48 lb. capacity. Circular 10c. Kansas City Speciates, Box 193-P-7, Middleton, Wisconsin 53562.

SPANISH FURNITURE PLANS. Send stamped, addressed envelope for circular. R. S. Plans, Box 12091, Parkville, Mo. 64152.

WALNUT And Cherry tapered legs, lumber, gunstock blanks, picture frame moulding. Midland Lumber Company, Box 262, Savannah, Missouri 64485.

FREE Popular Mechanics 16 page illustrated catalog of publications, plans and projects. Booklet covers an extremely wide variety of do-it-yourself data on home remodeling, shop tools and machines, car repair, hobbies, crafts, boating, games, lawn and garden and hundreds of others. For your free copy write to Service Bureau, Dept. PE, Popular Mechanics, 575 Lexington Ave., New York, N.Y. 10022.

PLANS For pool table with extra two-face top for table tennis and model railroad. Blueprints B1209 and building instructions \$3.50. Popular Mechanics Service Bureau, 575-M Lexington Ave., New York, N.Y. 10022.

SENSATIONAL New Miter Clamp, clamps any degree miter up to 160°. Unsurpassed for picture frame assembly. Set of four clamps, \$2.00. Schmidtgrub Industries, 24 Grant St., Latrobe, Pa. 15650.

WOODWORKING Catalog and Manual 25c. Plus free "101 Project Ideas." World's most beautiful veneers, lumber, plywood! Wood finishing, upholstery supplies. Cane Lamp parts. Furniture hardware. Animal whittling blocks, 2,000 workshop products. Constantine, 2051K, Eastchester Road, Bronx 10461.

101 PATTERNS of smart Gifts. Novelties, Shelves, Action Windmills, plus "Make Money Jig Sawing." \$1.00. Mastercraft, 75M, 7041 Olcott, Chicago 60631.

UPHOLSTERY

MAILORDER Records help get Increased Business! Complete 32 Page Record Book shows your inquiries, orders, advertising, expense, etc. Only \$1.00. C. A. Martin, Popular Mechanics, Dept. PM, 575 Lexington Ave., New York 10022.

DO-IT-YOURSELF

WATER!! Drill your own well the easy, economical way with Amazing New Invention. Save 75%. Free information. Deep-Rock Drilling Company, Opelika, Alabama 36801.

BURGLAR-FIRE Alarm supplies and information. Free Catalog. Protecto Alarm Sales, Box 357, Birch Run, Michigan 48415.

STEAM Powered lawn mower, with flash boiler. Pictures descriptions. Also fire tube boiler burners, small steam engines all parts numbered, several sheets. \$2.00 Postpaid. Travis Tool Company, Box 118, Sidney, Iowa 51552.

BURGLAR-Fire Alarms. Automatic Police Telephoning, Gas, Bells, Supplies. Free Catalog, Specify: business-residence. Alarm Supply, 7294 Glenview, Fort Worth, Texas 76118.

BURGLAR-FIRE ALARM Systems and Supplies. Free Catalog. Informer Alarm Mfg., 715B Gusor Street, Baltimore, Maryland 21202

EXERCISE At home on build-it-yourself physical fitness equipment, including bicycle exerciser, rowing machine, belt massager, and abdominal board. Send \$2.50 for blueprints B1208 and instructions. Popular Mechanics Service Bureau, 575-K Lexington Ave., New York, N.Y. 10022.

14 WEATHER Instrument Plans \$2.00. Saco, Box 2513A, South Bend, Ind. 46614.

HOLE IN SHOE SOLE? Repair with amazing new genuine leather putty. Flexible, fast drying, unnoticeable, strong. Only \$1.00 PPD. Generous Supply and instructions. GUARANTEED FULLY. B. H. Bindery, Box 22291 Dallas, Texas 75222.

ENJOY Camping inside Volkswagen Beetle. Do it yourself plans \$2.00. Mathur, 38 Allie, Montreal 970.

BURGLAR Alarm sticker scares Burglars away, sample 50c, 10 for \$2.00. Box 1018, Plattsburg, New York 12901.

PAINT insecticide—Mix with paint—Kills insects. 3 oz. Bottle treats 1 Gallon. \$1.49 (Guaranteed). Di-All Chemical, Box 14347, Orlando, Florida 32807.

UNIQUE PATIO COVER. New, beautiful, fiberglass multiple-canopy. Colored, opaque, oval panels. Nothing like it anywhere. Plans \$3.00. 'CASTLEDOME', Box 1291, Newport Beach, California 92663.

FLUORESCENT Tubes rejuvenated at no cost. Instructions \$1.00. Rejuvenators, 172 Bolton St., Portland, Me. 04102.

SAVE Your old vacuum cleaner with amazing new hose. Write Pat's, Box 2311, Los Angeles 90028.

ARTS AND CRAFTS

MAKE Figurines, plaques, lawn ornaments, Molds, plastercraft kits, liquid rubber. Sample and catalogue 10c. Woolley Company, Box 29-B, Peoria, Illinois 61601.

FREE: New 136 page handicraft catalog. Supreme Handicrafts, Box 395-PM Sicux Falls, South Dakota 57101

MYRTLE WOOD Lumber For Gifts & Novelties & Gunst-cks & Cabinets. Send \$1.00 for sample for a fast growing business. Use Bankamericard. Dundee Lumber Co., Box 12, Dundee, Oreg. n 97115.

BINOCULARS, TELESCOPES, MICROSCOPES, MAGNIFIERS

SCIENCE Bargains! Lenses, telescopes, binoculars, microscopes, kits, parts, war surplus. Send \$1.50 for beginner's 10-lens kit with instruction booklet. Order Stock 2-CH. Request free 148 page Catalog CH. Edmund Scientific Co., Barrington, New Jersey 08007.

BINOCULAR Specialists. Repairs And Sales. Free Catalog. Tele-Optics, 5514 Lawrence, Chicago, Ill. 60630.

BINOCULARS Direct from manufacturer. Finest quality, tremendous savings! Request catalog. Koyu, 3860 Crenshaw Blvd., Los Angeles, Calif. 90008.

BINOCULAR Sale! Free color catalog 100 models \$9.95-\$250.00. Write, United, 9043 So. Western, BCAT-208, Chicago 60620.

WORLD Famous "Dynascope" Telescope. Build your own reflector telescope, mirrors, eyepieces, tripods, accessories. Request free brochures. Criterion Manufacturing, Dept. PP 33, Hartford, Connecticut 06101.



CAMERAS AND EQUIPMENT

WORLD'S Largest Buying Guide—800 Illustrations—50¢—Deductible With Your Order—Olden Camera—1265 Broadway, New York, N.Y. 10001.

FREE! FREE!—Photographic and optical bargain book. Jimco, Dept. 1AG, 9006 Waukegan Road, Morton Grove, Ill. 60053.

PHOTO SUPPLIES

ANSCOCHROME-DYNACHROME-FILM—Save by mail—free price list—Hillis Products, Dept. M, Box 1182, Kokomo, Indiana 46901.

PHOTO FINISHING

A FREE Kodak roll returned with each black and white or Kodacolor developed and printed, fast service, lowest prices, guaranteed quality send for free mailers. Economy Photo Service, Dept. P.M., Box 1111, Albany, N.Y. 12201.

SPECIAL WITH THIS AD—Kodacolor developed 12 prints \$2.25. Black & White developed 2 prints each Jumbo size—12 exposure 70¢. LENS PHOTOS, Dept. J-4, Janesville, Wis. 53545.

CAMERA FANS! Expert photofinishing by one of Country's largest labs at lowest prices. Fast service and free "Foto-Fan" Stamps you quickly redeem for valuable Photo Supplies. 8MM Kodachrome \$1.29; 8 Exp. Kodacolor \$1.79; 35MM Kodachrome, 20 Slides \$1.39; 8 Exp. Black White 69¢. Satisfaction guaranteed. Send exposed film or request free mailers, complete Price List and Gift Catalog. Direct Mail Photo, Box 8352-PM, Pittsburgh, Pa. 15218.

LOOK—Save Money on Pictures! Jumbo Size Prints from your Kodacolor Rolls, \$1.98. Black & White, 69¢. Huge Discounts on Supplies. Enclose Advertisement. Wisconsin Film Service, Dept. 33, La Crosse, Wisconsin 54601.

SPECIAL: BLACK-White, 8-45¢; 12-55¢. Kodacolor 8-\$1.89; 12-\$2.09. Astro Photo Service, Box 166M, Waterloo, New York 13165.

COLOR SLIDES

OUR FIRST 19 IN SPACE. This limited edition lithograph has been created as a tribute to Americas Gallant Astronauts. 12 X 18 inch chart ready for framing. Only 75 cents. Popular Mechanics, Dept. GWP, 575 Lexington Avenue, New York, New York 10022.

MOTION PICTURES AND SOUND EQUIPMENT

UNUSUAL Movie supplies. Free circular. Esor, 47th Holly, Kansas City, Missouri 64112.

16MM Sound Features, Shorts. New, used for Sale. Free Catalog. National Cinema, 333 W. 57th. St.-N.Y.C., N.Y. 10019.

FREE! 64-page catalog. 8-16mm film, supplies, processing equipment. Superior, 448 N. Wells, Chicago 60610.

5,000 8-16MM MOVIE Films. Free catalogues. International, Greenvale, L.I., N.Y. 11548.

35MM. COLOR SLIDE SAMPLER . . . 20 "best" 2" x 2" . . . \$1.00. Free catalog. Hundreds of sets . . . travel, circus, wildlife, flowers, railroads, wars, etc. Order today. Blackhawk Films, 862 Eastin-Pheasant Bldg., Davenport, Iowa 52808.

175-FOOT 8MM. PREVUE MOVIE . . . ONLY \$1.99. See Laurel & Hardy, Chaplin, Fairbanks, Keystone Cops, Gish, Pickford, Chaney . . . comedy, drama, adventure, history from the silents! Taste the fun of great movies right at home! Order today . . . specify standard or Super 8. Free catalog. Blackhawk Films, 861 Eastin-Pheasant Bldg., Davenport, Iowa 52808.

8-16 MM. Used! Listings, 6¢ stamp. Hilton, 52 Columbia, Albany, New York 12207.

16MM CLASSICS. Catalog 25¢. Manbeck Pictures, 3621-PM Wakonda Drive, Des Moines, Iowa 50321.

RADIO, TELEVISION AND HAM EQUIPMENT

33¢ RADIO & TV tubes. Free list. Cornell, 4213-17 University, San Diego, California 92105.

TUBES—Lowest prices in the world. Hard to get British, German, Foreign and American obsolete and present day special purpose transmitting tubes. Send for giant tube and parts catalog. United Radio Company, Dept. Z-56 Ferry St., Newark, N.J. 07105.

GOVERNMENT Surplus receivers, transmitters, snooper scopes, parts. Catalog, 25¢. Meshna, Nahant, Mass. 09108.

FREE Brochure MONITOR Fire. Police RADIOS with MINVERTER II, full SQUELCH easy installation. Scientific Associates, Box 276(MX), South Glastonbury, Conn. 06073.

BATTERY Eliminator charge for Transistor Radios. Lifetime Guarantee. Box 1018, Plattsburg, New York 12901.

HIFI. RECORDS AND ELECTRONICS

FREE Catalogues, 2000 hard to find unusual records. Rose's, 300 Chelsea, Louisville, Ky. 40207.

TAPE Recorders, hi-fi components. Sleep learning equipment, tapes. Unusual values. Free catalog. Dressner, 1523C Jericho Tpke., New Hyde Park, N.Y. 11040.

RECORDS! Discounts on all LP's. Free details. Citadel Record Club. Symphonette Sq., Dept. 2, Larchmont, N.Y. 10538.

SCOTCH Recording Tapes. Wollensak Recorders Catalog 6¢. Tower, Lafayette Hill, Pa. 19444.

HOME Electronics Course only \$26.95. Free Literature. Edu-Kits, Department 715B, Hewlett, New York 11557.

STEREO TAPES: Cartridges, cassettes, reels, 33% discount. Largest selections, unavailable elsewhere. Mail 20¢—catalogs. STAR RECORDINGS, Box 1055, El Paso, Texas 79946.

45 R.P.M. RECORD and list 25¢ post-paid. Neal, Box 8892, Nashville, Tenn. 37211.

CASSETTES AT HONG KONG PRICES! Lifetime Moneyback Guarantee! Three C-60s-\$4.75, Three C-90s-\$7.25, Three C-120s-\$8.75, Custom Record Development, Box 3, Mamaroneck, N.Y. 10543.



MUSIC AND MUSICAL INSTRUMENTS

PLAYER Piano Rebuilding—get details from: Vestal Press, Vestal 11, N.Y. 13850.

GUITAR, Banjo Making books Plans, woods, necks, tools. List 25¢. Satinwood, 510 East 11th Street, New York, N.Y. 10009.

ACCORDION Manufacturing, 6846-P North Avenue, Chicago, Illinois 60635. Concertinas, Hohners, Chromatics, Guitars, Drums, New, Used, Tuning, Repairing, Wholesale Catalogs Free.

POEMS, Songs wanted for new song hits and recordings by America's most popular studio. Tin Pan Alley, 1650-PM Broadway, New York 10019.

VIOLIN and Guitar makers—send for latest Free Catalogue of woods & accessories. International Violin, PM8, 414 East Baltimore St., Baltimore, Md. 21202.

POEMS Set to music. Songs recorded. Send poems, songs. Crown Music, 49-C West 32, New York 10001.

POEMS Wanted For Songs. Nashville Music Productions. Box 9001-P, Nashville, Tennessee 37204.

POEMS Wanted for new songs and records by America's largest song studio. Send poems. Free examination. Five Star Music, 6M Beacon, Boston, Mass. 02108.

30% DISCOUNT Any Name Brand musical instruments. Write for low price. Freeport Music, 127 W. Sunrise Highway, Freeport, New York 11520.

SONG Writers—Send Poems, Songs to: Weiss Music Company, 1472 Broadway, New York, New York 10036.

ACCORDION Top brands. Buy direct. Tremendous discounts. Trade accepted. Free brochure PM. Accordion-O-Rama, 874 Broadway, N.Y.C. 10003.

DRUMS. Electric guitars, amps, organs. Free catalog M: A.L.A.S. Import Company, 31 East 18th Street, NYC. 10003.

GUITARS, MANDOLINS, BANJOS, Complete stock of Gibson Martin guitars. Free 100 page catalog, parts and accessories. Big Savings. New York discount prices. Send 50¢ postage handling. Eddie Bell Guitar, 201 West 49, New York 10019.

SWISS Musical Movements. Mechanical-Electrical. Spielman, 131 West 42nd. New York 10036.

GUITAR Chord system most modern ever devised. Send \$3.50. Johnny Carlton, Canton Plaza, Marietta, Georgia 30060.

WHOLESALE Musical Instruments Catalog. Allied, 406 East 189, Bronx, N.Y. 10458.

LEARN Banjo. 5-string bluegrass. Easy fun. No music. Free details. Blaylock, Box 25-M, Marietta, Georgia 30060.

ACCORDIONS, Guitars, Band Instruments! Save to 50%. Famous makes. Easiest terms. Trades accepted. Free home trial. Free discount catalog. Mention instrument. International Music Mart, 5535-R Belmont, Chicago 60641.

ELECTRIFY Player Pianos, Pump Organs quickly, inexpensively with Lee Silent Suction Units. Write Lee Music, 525 Venezia Ave, Venice, California 90291.

SONGS, Poems wanted! Accepted songs published, recorded at our expense! Talent, 17-PM, Longwood Road, Quincy, Mass. 02169.

GUITARS, Amps, Drums, 30% to 50% off. Name brands, Specials. Send brand, model for low price. Free Literature. Warehouse P2, Box 9352, Fort Worth, Texas 76107.

PLAY Organ easily. Amazing Method. Free Information. Kegley, 1016 Kelly, Joliet, Illinois 60435.

EDUCATION AND INSTRUCTION

LEARN Auctioneering. Term soon. Free catalog. Reisch Auction College, Box 850, Mason City, Iowa 50401.

PIANO Tuning quickly learned with home study course. Diploma granted. American Tuning School, Gilroy, Calif. 95020.

PIANO Tuning pays. Big money in spare time. Learn at home. No musical knowledge necessary. Phonograph, records, tools and instructions furnished. Electronic tuning also taught. Free catalog. Capital Tuning School, 3160 S.W. 16th Court, Ft. Lauderdale, Fla.

BOOKKEEPERS. Operate your own "Dollar-A-Week" system. Ellis, Box 200, Cedar Grove, North Carolina.

PENMANSHIP Corrector. Improve poor penmanship quickly. Details free. Ozment, Box 665-34, St. Louis, Mo. 63188.

OWN Collection agency. "Little Gold Mine!" Franklin Credit, Roanoke, Virginia 24004.

EARN \$125 A week and up. Learn a trade with a future. Learn auto diesel mechanics in our shops. You learn with tools on real equipment. Earn while you learn. Many of our graduates earn \$125 a week and up. Write for free bulletin: Dept. 256, Auto Diesel College, Nashville, Tennessee 37219.

SWEDISH Massage and physical culture pays big profits. Learn at home. Diploma. Free catalog. National Institute, Dept. E-79, 307 North Michigan, Chicago 60601.

USED CORRESPONDENCE Courses and Books sold and rented. Money back guarantee. Catalog free. (Courses bought). Lee Mountain, Pisgah, Alabama 35765.

MISSOURI Auction School. GI Approved. Free Catalog! 424-03 Nichols Road, Kansas City, Mo. 64112.

LEARN Asleep or awake! Records, tapes, equipment! Free catalog! Drawer, PM-400, Ruidoso, New Mexico 88345.

SUPERIOR Auction School. Nation's top Auctioneers own and instruct. 120 East Cerrogrande, Decatur, Ill. 62523.

BE A POLICEMAN. Complete Course and Diploma, only \$10.00 Southern Police Academy, P.O. Box 306, Fairfield, Alabama 35064.

AUTOSUGGESTION. Sleep-learning headquarters! Tapes, records, books. Gigantic catalog free. Research Association, Box 24-PM, Olympia, Washington.

FCC First Class License in six weeks—Nation's highest success rate—Approved for Veteran's Training. Schools in Dallas, Atlanta, Chicago, New Orleans, Minneapolis and Houston. Write Elkins Institute, 2603D Inwood Road, Dallas, Texas 75235.

HIGHLY effective home study courses in Electronics Engineering Technology and Electronics Engineering Mathematics. Earn your Degree. Write for Free Descriptive Literature. Cook's Institute of Electronics Engineering, (Dept. 10), P.O. Box 10634, Jackson, Miss. 39209. (Established 1945).

EARN College degree at home. All subjects. Ohio Christian College, 1156 Striebel Road, Columbus, Ohio 43227.

LEARN Bartending. Correspondence School, 426C East Seventh Street, Tucson, Arizona 85705.

"KEY to a Cartoon Career." Write: Cartooning, Box b3176, Colorado Springs, Colo. 80907.

PROFITABLE National Camera Repair School training at home! PM-7, Englewood, Colorado.

MINISTERIAL Bible College. Christian Education. Ordination, and Degree Courses. Write: Soms, 887 West Spruce, Ravenna, Ohio 44266.

DETECTIVE Course. Free information. Universal Detectives, Box 8180-P, Universal City, California 91608.

HIGH School diploma at home. Licensed teachers. Send age, highest grade completed for free details. No salesman will call. Southern States Academy, Westbury Square Professional Bldg., Dept. 16, Houston, Texas 77035.

GET A British degree. Divinity, Philosophy, Radionics, 35 courses. Prospectus free. Brantridge Forest School, "Lodge" Brantridge Forest, Balcombe, Sussex, England.

USED Courses! Books! List 10¢. Smith's, 124 Marlborough, Salem, Mass. 01970.

ACCIDENT INVESTIGATION career training. Learn at home to earn up to \$8 an hour. Car furnished. Expenses paid. No selling. Free placement service. Men urgently needed. No college or experience required to train. Write for FREE information. No obligation. Universal Schools, CPM-7, 6801 Hillcrest, Dallas, Texas 75205.

COMPLETE YOUR HIGH SCHOOL at home in spare time with 72-year-old school. Texts furnished. No classes. Diploma. Information brochure free. American School, Dept. XB45, Drexel at 58th, Chicago, Illinois 60637.

ORDAINED? Free credentials! Request information! NSU, 708 South Bragg, Monroe, North Carolina 28110.

PHOTO RETOUCHING. Interesting, profitable career at home; full or part-time. Easily learned. Hamilton Studios, Dept. PR-39, Claymont, Del. 19703.

AUCTIONEERING Resident or Home Study Course Free Catalog. Nashville Auction School, 2004 West End, Nashville, Tennessee 37203.

BARTENDING—Home Study course. Box 3191-P, North Las Vegas, Nevada 89030.

AUTOMOTIVE AIR Conditioning. Start your own business with small cash outlay. Write for free folder No. PM-7. Technical Center, P.O. Box 59, Buena Park, Calif. 90620.

PIANO Technology—Electronic organ servicing. learned easily at home. G.I. Approved. Free booklet. Niles Bryant School, Dept. P, 3631 Stockton, Sacramento, California 95820.

COMPLETE home training in lucrative Watch Repair. Free sample lesson. Chicago School, Y.T., Fox River Grove, Illinois 60021.

SECOND Chance For High School Drop-outs. Get diploma at home in spare time. Full credit for previous schooling. No classes. Given Free: Booklet on finishing high school at home. Government advice for drop-outs, aptitude test. Write: Academy for Home Study, 425 S. Dearborn, Dept. 91-926, Chicago, Illinois 60605.

BE A REAL Estate Broker. Big earnings. Prepare quickly, easily. GI approved. Free Catalog. Weaver School, 3519-P Broadway, Kansas City, Missouri 64111.

LEARN Civil and criminal investigation at home. Earn steady, good pay. State age. Institute Applied Science, 1920 Sunnyside, Department 167, Chicago, Illinois 60640.

WE GUARANTEE you to pass all civil service examinations, send stamped envelope, Unique Distributors, Box 6099, Pensacola, Florida 32503.

LEARN Spanish With My Conversational Handbooks \$1.00/Set. Satisfaction Guaranteed. Rochin, 821 Rayandra, DeSoto, Texas 75115.

BEGINNING Reading Programmed to High School level for all Ages. Instructor's manual, \$4.95. Primitive Press, P. O. Box 4614, Pittsburgh, Pa. 15206.

FOR INVENTORS

PATENT Searches complete and thorough. Related copies Air Mailed with maximum speed \$6.00. Free "Protection Forms" and "Patent Information." Write American Patent Search Company, Dept. 27, 711 14th St., N.W. Washington, D.C. 20005.

PATENT Application Financing. Free patent search plan. Global Patent Division, 2420 77th, Oakland, Calif. 94605.

PATENT And invention development by licensed professional patent engineer and U.S. Patent Office former examiner, and engineering specialists. Your inventions and ideas engineered for patent protection and commercial value. Inventions developed by us negotiated for cash or royalties with our nationwide contacts. Send for free protection "Invention Certificates" and further interesting, valuable patent information. George Spector, Licensed Professional Patent Engineer, Woolworth Building, New York.

U.S. Patent Office Searches, 234 Broadway. Room 3615, New York. Free invention certificates.

IMMEDIATE Cash. for patent applications. Free patent searches. Write for details. Universal Patents, 184-D, Marion, Ohio.

INVENTORS Wanted immediately for promoting on cash or royalty. Patented, unpatented. Free booklet outlines royalty rates, requirements. Write Kessler Corporation, C-57-F1, Fremont, Ohio.

INVENTORS: Your ideas and inventions (patented; unpatented) expertly searched, developed for commercial appeal and cash/royalty sales to manufacturers by professional Invention Developer with excellent record of experience. B.S., Industrial Engineering; United States Patent Office former Patent Examiner, United States Government former Patent Advisor, Second decade reliable service! Member: United States Chamber Commerce. Free "Invention Record" and "Recommended Protection Procedure." Airmailed! Write: Raymond Lee, Invention Developer, 230-P Park Ave., New York City 10017.

PATENT Searches, including copies of related U.S. patents. Inventors attorneys, manufacturers use our "worldwide" airmail service! "Invention Record" form and "Information Every Inventor Needs," sent free! Hayward Company, 1029P Vermont, Washington 5, D.C.

FREE PAMPHLET: "Tips on Safeguarding Your Invention." Write: United States Inventors Service Company, 501P Thirteenth Street N.W., Washington, D.C. 20004.

MANUFACTURERS NEED New Products! FREE Literature explains "How To Submit Your Invention." Congress Invention Company, 911-C Warner Building, Washington, D.C. 20004.

INVENTIONS WANTED

INVENTIONS Wanted. Patented; unpatented. Tremendous manufacturers lists. Global Marketing Service, 2420G 77th, Oakland, California 94605.

INVENTORS! Sell your invention for cash or royalties! Our client manufacturers eagerly seek new items. Patented. Unpatented. Financial assistance if needed. 25 Years proven performance. For free information, write Dept. 15, Gilbert Adams, Invention Broker, 80 Wall St., New York, N.Y. 10005.

INVENTORS! We will develop, sell your idea or invention patented or unpatented. Our national manufacturer-clients are urgently seeking new items for highest outright cash sale or royalties. Financial assistance available. 10 years proven performance. For free information write Dept. 47, Wall Street Invention Brokerage, 79 Wall Street, New York, N.Y. 10005.

WE Either sell your invention or pay cash bonus. Write for details. Universal Inventions, 298-E. Marion, Ohio.

INVENTIONS Wanted immediately for promoting on cash or royalty. Patented, unpatented. Free booklet outlines royalty rates, requirements. Write Kessler Corporation, C-57-IW, Fremont, Ohio.

FREE "Directory of 500 Corporations Seeking new Products." For information regarding development, sale, licensing of your patented/unpatented invention. Write: Raymond Lee Organization, 230-N Park Avenue, New York City 10017.

INVENTORS! Protect your ideas! Free "Recommended Procedures." Washington Inventors Service, 422F, Washington Building, District of Columbia 5.

INVENTORS! Don't sell your invention, patented or unpatented, until you receive our offer. Eagle Development Company, Dept. H, 79 Wall Street, New York 5, N.Y.

PATENTS FOR SALE

EXTRA Income at home in Spare Time! Booklet shows you how to start your own business with Classified Advertising. Only \$1.00. Refundable with first insertion order. C. A. Martin, Popular Mechanics Dept. PM, 575 Lexington Ave., New York 10022.

MANUFACTURING

INVENTORS Ideas developed. Research. Models. Manufacturing. Sales. Free brochure. William Parker, 32 Westminster, Worcester, Mass. 01605.

MODELS — small lot manufacturing. Metals, plastics, etc. Milburn, Burlington, Kentucky 41005.

BUY IT WHOLESALE

500,000 BARGAINS BELOW WHOLESALE. New, name brand merchandise. Buy at 10¢ on the dollar. Closeouts, surplus, bankrupts, liquidations, imports. Free details. International Buyers, Box 4633-M, Colorado Springs, Colo. 80909.

20 WHOLESALE Catalogs!! List \$1.00. Zashop, 216 PM-7, West Jackson, Chicago 60606.

BARGAINS! Buy wholesale and below. Name brands. Appliances, furniture, sports equipment, televisions, cameras, watches, jewelry, thousands more. Huge discounts to \$1,000.00 on new automobiles. All makes. Free details. Write today: Worldwide Bargainhunters, Box 730-A, Holland, Michigan 49423.

EXPORT-IMPORT

JAPAN: 1200 Products Directory. Illustrated Manufacturers' names, addresses, \$3.00. Send cash. Yamagata Office, 814 Togin Bldg., Marunouchi, Tokyo.

DIRECTORY—230 Suppliers in 40 Countries, \$3.00. World Shoppers, Box 151-W, Oklahoma City, Oklahoma 73123.

FOR THE HOME

PATIO Easy ceramic granule coating. Free information. Gateway, 6851 Plainfield, Cincinnati, Ohio 45236

BURGLAR-FIRE Alarms. Home units complete \$14.95 up. Brochure 25¢. The Securtronics Co., P.O. Box 371, Frankfort, Indiana 46041.

FOOLPROOF! Fire-Burglar Alarms. Tamperproof! Low, Low, Prices. Free trial and literature. Agents plan. Your inquiry invited. Alarms, P492M, Williamsburg, Ohio 45176.

FOR PARENTS

PUSH-BUTTON WATERSAVER. Sale/Royalty. Pat. = 3 334 359. A. Weingartner, Box 73, Franklin, N.J. 07416. Phone 201-697-7150.

OF INTEREST TO WOMEN

WOMEN! Make big money at home. \$10.00 profit in an hour possible with invisible mending. Make holes, tears disappear from clothing, fabrics. Steady year-round demand from cleaners, laundries, homes. Details free. Fabricon, 1533 Howard, Chicago 60626.

HOW To make money writing short paragraphs. Information free. Barrett, Dept. C-27-U3, 6216 N. Clark, Chicago 60626.

\$500 MONTHLY POSSIBLE—clipping news at home. No experience. Free information—send stamp. American, Excelsior Springs, Mo. 64024.

NEWSPAPER Clippings Urgently Needed. Highest prices paid. Send stamped, addressed envelope, free details. Brewster, Box 1348-NCWL, Clearwater, Florida 33517.

DRIVE New car, wear new clothes, buy color TV. Get daily cash income. Put spare hours to work. Write for 5 months free subscription Opportunity Magazine, see hundreds easy ways to make money. Opportunity, 1460 Hancock Center, Dept. 17-GO, Chicago 60611.

WOMEN: Big Money! Studio Girl Cosmetics needs women in all States including Hawaii, Alaska, Puerto Rico and American Samoa. Full or part time. No experience required. No territory restrictions. Take orders anywhere. Highest profits. 500 Good Housekeeping approved cosmetics. Everything furnished. Credit extended. No stock to carry. No franchise fees. No stock investment. For full information by mail, plus 3 free samples, write Harry Taylor, Chairman, Studio Girl Cosmetics, Dept. BC329, 11461 Hart Street, No. Hollywood, Calif. 91605. Also immediate big profit earnings for experienced City and State managers and former party plan operators.

\$100 WEEKLY POSSIBLE. HOME TYPING. Instructions, employers' list, \$1.00. Satisfaction or refund. Summithouse, Box 377-PMO, Corte Madera, California 94925.

WANTED! Addressers—Commission Makers. Stamp required. Ooton Distributors, 4120P Duke Drive, Portsmouth, Virginia 23703.

\$100 WEEKLY Possible—Home Typing. Immediate earnings! Employers list, complete instructions. Details 25 cents. Typing, Box 593, PM7, Bettendorf, Iowa 52722.

MAKE Extra Money—Show friends, neighbors—Gifts, Stationery, Toys, Jewelry, Greeting Cards. 600 items. Experience unnecessary. Salable Samples on approval. Free—Catalog, Personalized Christmas Card Album, Hedenkamp, 361 Broadway, Dept. PM-100, New York 10013.

HOMEWORKERS! 85 weekly addressing mail for firms. Start immediately! Details, send stamped self-addressed envelope. Enterprises, Box 16143-PM, Phoenix, Arizona 85011.

WORTHWHILE Home Earnings. Choose from 21 profit producing projects. Few dollars starts. Free information. National, Box 1975-WCAI, Little Rock, Ark. 72203.

\$75.00 THOUSAND. Home addressing! Longhand, typewriter. Information, send stamped self-addressed envelope. Brewster, Box 1348-YL, Clearwater, Florida 33517.

\$350 MONTH Addressing Possible! Everything Furnished, Mail \$2.00. Satisfaction Guaranteed. Happy-A, Box 1161, Battle Creek, Michigan 49016.

MAKE Money At Home . . . Addressing and mailing our sales letters! Everything furnished! Smith, Box 2469-PM8, Newark, New Jersey 07114.

GIFT SHOPPING

HANDCRAFTED Gifts, home furnishings. Free catalog. Kilton Krafts, 1225 Kilby Terrace, Anniston, Ala. 36201.

WATCHES, OLD GOLD, JEWELRY

WATCH And clock repairing books. Free catalog. North American, Box-77-AG, Fox River Grove, Illinois 60021.

HIGHEST CASH for Gold, Jewelry, Gold Teeth, Rings, Diamonds, Watches, Silver, Platinum. Mail Articles Today. Free gift with information. Chicago Gold & Precious Metals, 6 E. Monroe, Dept. 658, Chicago, 60603.

USED Wrist, pocket watches—\$3.00 up. Free list. Southern Watches, 5-PM South Wabash, Chicago 60603.

CASH Immediately for old gold, jewelry, gold teeth, watches, diamonds, silverware, spectacles, platinum, mercury. Free information. Rose Industries, 29-A East Madison, Chicago 60602.

WATCHMAKERS'—Jewelers' Catalog: Surprise; \$1.00. Watchmaking Course; Tools; \$35.00. Bengal's, 17942 Ventura, Encino, California 91316.

WEARING APPAREL

EXTRA Income at home in Spare Time! Booklet shows you how to start your own business with Classified Advertising. Only \$1.00 (Refundable with first order.) C. A. Martin, Popular Mechanics, Dept. PM, 575 Lexington Avenue, New York 10022.

HEARING AIDS

HEARING Aids, Batteries, wholesale. Catalog 25¢. Fiston, Box 1444 New Preston, Conn. 06777.

HEARING Aids below wholesale. Regular, eyeglass, completely hidden models. Smallest, most powerful. Free home trial. No Salesman will call. Free details. Write Prestige-C6, Box 10880, Houston, Texas 77018.

HEARING AIDS—Batteries Wholesale! Brochures—Hearing Center, Box 211, St. Petersburg, Florida.



SCIENCE AND CHEMISTRY

ROCKETS: Real flying models—flights up to 2500 ft. New illustrated catalog 25¢. Single and multistage kit, cones, engines, launchers, trackers, rocket aerial cameras. Technical information. Fast service. Estes Industries, Penrose 7, Colorado 81240.

ROCKETS!! Real flying models—2500 feet altitude with powerful motors. Terrific Science Projects. Tubes—Cones—Parachutes—Launchers—Igniters. Gigantic catalog—rocket data—diagrams—25¢. Fast Delivery. Centuri Rockets, Box 1988, Phoenix, Arizona 55001.

CHEMICALS, Apparatus, Microscopes. Biological Supplies. 1969 Catalog 35¢. Sheard Science Supplies, Inc., Columbus, Wisconsin 53925.

ROCKETS, Single, multi-stage kits, parts amazing Accelerometer, Illustrated catalogue 25¢. Rocket Supply, Box 51B, Tappan, New York 10983.

UNDERWATER Fuse 3 3/2" Diameter, 25 feet \$1.00—125 feet \$4.00 Postpaid. Free Catalog. Zeller, Box 646, Hudson, Mich. 49247.

LABORATORY chemicals supplies 1969 catalogs has over 400 listings many scientific publications catalogues \$25 Caseco, Dept. M P.O. Box 77 Riverdale, New Jersey 07457.

LASER PISTOL—\$1.00. How to build. **PHASER PISTOL**—\$1.00. (Add 25¢ postage.) New catalogue—25¢. Roy Davis Laboratories, Dept. PM, 118 West Adams St., Jacksonville, Florida 32202.

SEARCHING For economically priced Laboratory Supplies? Gifts with catalogue—25¢. Hagenow Laboratories; Manitowoc, Wisconsin 54220.

SEARCHING For Economically Priced Chemicals And Apparatus? Gifts With Catalogue—35¢. Starr Scientific, Manitowoc, Wisconsin 54220.

LABORATORY Supplies At Discount Prices. Catalog—35¢. Deluxe Scientific; Manitowoc, Wisconsin 54220.

GIANT Science Catalog 35¢. Xercon, Department PM-769, 8542 Oglesby, Chicago, Illinois 60617.

FREE Periodic classification of elements and conversion tables with catalog 35¢. Chemicals, apparatus, biology. Mid-States Scientific, 7053 N. Clark, Chicago, Ill. 60626.

CHEMICALS And apparatus for industrial, analytical, and private laboratories. Catalog 50¢. Dept. M-50, Biological Supply Co., 1176 Mt. Hope Ave., Rochester, N.Y. 14620.

CASINGS, Stars, devices of all types. Send 50¢ for samples. Ecco, Box 189, Northvale, New Jersey 07647.

SAVE On casings, endcaps. Underwater fuse 75 feet \$1.00. Professional Red Fuse 50 feet \$1.00. Catalog 25¢. with samples 50¢. Bilton, Box 28, River Edge, New Jersey 07661.

SOLAR Flying Saucers. (Brand New-Solid State Engine—Fantastic Performance—Flies Miles on Sun's Power—lifts animals—sends messages—parachutes—Build Many—Easily Inexpensively with Everyday Materials. Complete plans, descriptions, drawings, plus Free Spacetratics Catalog—\$1. Single Catalog—25¢. Spacetratics, Box 31043-PMS, San Francisco, California 94131

CATALOG Of Ver-ry Interesting Products—25¢. (Free with any purchase—see our other Kenrus ads!) Kenrus-L, 42 Crocus, Woodbridge, New Jersey 07095.

100 ONE Minute time delay fuses! \$1.00 240—\$2.00. 700—\$5.00. Use with rockets, experiments, etc. Kenrus-L, 42 Crocus, Woodbridge, New Jersey 07095.

FREE! 2 insect eating plants when you send for our 60¢ catalog! A \$1.50 value! Free Merchandise! See catalog for details! Franks Scientific Co., P.O. Box 156, Martelle, Iowa 52305.

TINY-ROCKETS From ordinary paper sodastraws blast in smoke and flame nearly out of sight. Copyrighted Instructions \$1.00. Microrockets, RR2E, Hagerstown, Indiana 47346.

SOLID ROCKET FUEL Developed By U.S. Army For Amateurs. \$2.50 a pound, 10 pounds for \$12.00. Rocket Booklet 50¢. Fast Delivery. Cincy Rocket Club, 4780 Miami Road, Cincinnati, Ohio 45243.

PROFESSIONAL Model rocket ignition fuse, burns underwater, 75 feet, \$1.00. Ed-colabs, Box 99, Berlin, New Jersey 08009.

GIRANDOLE, Petard casings. Lowest prices. Underwater fuse 75' \$1.00. **PROFESSIONAL** "Red Devil" Fuse 50' \$1.00. Catalog 25¢. Samples 50¢. Arwel, Box 236, Hasbrouck Heights, N.J. 07604.

FORMULAS, PLANS, ETC.

ANY Formula \$3.00. Catalog—Treatise 10¢. Belfort, 192 N. Clark, Chicago 60601.

PLASTIC, LAMINATING

PLASTIC Embedders, jewelry workers. We have everything. Findings, moulds. New catalog 25¢. David Co., 861 Broad St., Dept. M, Providence, R.I. 02907.

NEW Liquid Plastic hardens like glass without heat. Clear, Colors. Embed real flowers, photos, coins. Create unusual craft objects for big profits at home. Illustrated HOW Booklet—25¢. Dept. 9101H; **CASTOLITE**; Woodstock, Ill. 60098.

PLASTIC, DECALS

SELF-ADHESIVE Company. Club or Product Decals to your design. Vinyls, Mylars, Metallics, Scotchlite and **MAGNETICS** for off-and-on use! Make Cars, Trucks, Airplanes and Equipment your Permanent Traveling Advertisement! Low Cost! **PLASTIC DECAL COMPANY**, Box 602B, Janesville, Wisconsin 53545.

TREASURE FINDERS

URECON Metal finder, 8" head, transistorized, \$40.00 delivered. Urpa 6304 Beechwood, Sarasota, Fla. 33581.

TREASURE Hunters! Prospectors! Relco's new instruments detect buried gold, silver, coins, minerals, historical relics. Transistorized. Weighs 3 pounds. \$19.95 up. Free catalog. Relco-A40, Box 10839, Houston, Texas 77018.

TREASURE LOCATORS, MOST COMPLETE LINE, FREE INFORMATION, **TESOROS**, APARTADO 7-948, MEXICO 7, MEXICO.

FREE 128 Page detector catalog. General Electronic Detection Co., Box 67, Bellflower, California 90706.

FISHER DETECTORS! Treasure fun and profit with new professional quality solid-state models. Unsurpassed sensitivity, reliability. Guaranteed. Free literature. **FISHER RESEARCH**, Dept. PM-7, Palo Alto, California 94303.

"**METAL** Locators—Accessories. Write: Detectors, Inc., Box 101-D, Springfield, Va. 22150."

TREASURE, Gold, silver, relics. New 1969 detectors now available. Free information. Rayscope, Box 715, North Hollywood, California 91603.

POWERFUL Metrotech locators detect gold, silver, coins, relics. Moneyback guarantee, terms. Free information. Underground Explorations, Dept. A, Box 793, Menlo Park, California 94025.

TREASUREPROBE Metal detector as kit (\$12.88) assembled (\$18.88), with powerful built-in speaker (\$24.88) a schematic, parts list, and instructions (\$1.00). Money back guarantee. Free catalog. **TREASUREPROBE** Dept. PG-L, P.O. Box 64, Lakewood, N.J. 08701.

GOLDAK Treasure Locators—New for '69! A hobby you'll enjoy for fun and profit. Find coins, gold, silver, Goldak, Dept. PMC, 1101A Airway, Glendale, California 91201.

ULTRA-SENSITIVE AND POWERFUL METAL DETECTORS—Join the many who are finding buried coins, minerals, relics and artifacts. Don't buy till you see our FREE catalog of new models. Write Jetco—Box 132, PM75-Huntsville, Texas 77340.

TREASURE BOOKLET, Excellent information on treasure hunting and metal detectors. Send 25¢. **BOOKLET**, Dept. 7-PM, Box 243, San Gabriel, California 91778.

DETECTOR Buyers! Wait! "Selectmatic", professional "New Dimension" detector—finds money on every hunt. Quickly rejects iron, tinfoil. Guaranteed. Patents granted. Literature, pictures—enclose \$1.00. Treasure Electronics, Plain Dealing, La. 71064.

FIND Buried treasure with new revolutionary analytical metal detector. Features push button tuning, automatic tuning, loudspeaker, negligible ground pickup, greatest range. Free catalog. Gardiner Electronics, Dept. 9, 4729 N. 7th Ave., Phoenix, Ariz. 85013.

PRECIOUS STONES AND MINERALS

EARTH Science Rockhound Magazine. Subscription \$2.50. Sample 35¢. Box-550-PM, Downers Grove, Ill. 60515.

GET Free catalog no serious rockhound, gem cutter, jewelry maker, hobbyist or craftsman can be without. Full of bargains, exclusive items, low prices from largest suppliers and authorities in the field. Free new catalog just off the press, yours for the asking. Write Grieger's, Dept. C-12, 1633 E. Walnut, Pasadena, California 91106.

100 COLORFUL, Polished gemstones, \$1.00. Tumblecraft, 5401 James North, Minneapolis, Minnesota 55431.

SEMI-Precious uncut gems. Ten different for \$1.00. Request list =35. Prospectors Shop, 201 San Francisco, Santa Fe, New Mexico 87501.

LARGE, POLISHED, GEMSTONES, 15 different \$1.00. Colorful crystal specimens, 3 different \$1.00. Lists with order. Sering 1705 E. Michigan, Indianapolis, Indiana.

100 POLISH Gem Stones From Pacific Ocean. Empire Gem's, Trinidad, Calif. 95570.

CARTOONING, COMMERCIAL ARTS, SHOWCARD & SIGN PAINTING

SIGN Painting, Fascinating System—Straley, 410 So. Western, Springfield, Ohio 45506.

COMPACT 23 lesson Cartoon Course and Cartoonist's Magazine. \$2.00. Hartman, Box 30367, Lincoln, Nebraska 68510.

LEARN Sign painting at home. Free talent test. Ben Kerns, Box 812-PM, Greenville, S.C. 29601.

SIGN Painting - Free Catalogue. Instructions, Equipment, Kaufmann Signs, Centertown, Missouri. 65023.

LEARN Profitable tattooing. Illustrated information and instruction \$3.00. Zeis, 2220-P Deley Dr., Rockford, Illinois 61107.

"**HOW TO MAKE MONEY WITH SIMPLE CARTOONS**"—Everyone who likes to draw should have this book; FREE. Write Cartoonists' Exchange, 97, Pleasant Hill, Ohio 45359.

2 FREE ART LESSONS. Develop professional skills in drawing, painting, ad art, cartooning, TV art. Study by mail, at home, in spare time. Send name, address, zip, and age for free booklet and free art lessons. No obligation. Washington School of Art, Studio 19-011, Port Washington, N.Y. 11050.

ADVERTISING AGENCIES, ADV. SERVICE, MAILING LISTS

MAILING Lists most all kinds 1000 \$5.00. Free folder. Your circulars mailed \$4.00 1000. Dixie Mailers, King, N.C. 27021.

ADVERTISING Ratebook leading newspapers, magazines, 25¢. Chicago Advertising Agency, 28-E Jackson, Chicago 60604.

OUR clients' mail order advertisements in Popular Mechanics have to pay and they do. If yours don't, write to John O. Powers Co., Advertising Agency, 116 John Street, New York City 10038.

TYPEWRITERS, DUPLICATORS, OFFICE EQUIPMENT

FREE Plan. Start printing, lettershop. Offset Presses, Mimeograph Copy machines. DixieGraph, King, N. Car. 27021.

RUBBER STAMPS AND OFFICE SUPPLIES

RUBBER Stamps 4 Lines \$1.25. Catalog. Bilmar, 10024 Oxborough Road, Minneapolis, Minnesota 55431.

FREE 48 Page catalog. Signature \$2.80. Carol's, McLoud, Okla. 74851.

FREE 40 Page catalog. Rubber stamps, office supplies. Youngers Stamp Shop, Princeton, Iowa 52768.

ADDRESS Rubber Stamp \$1.00. Postpaid. Arrowhead, Dept. C. 5521 Warwick Avenue, Chicago, Illinois 60641.

RUBBER Stamp outfits, supplies. Klewiet, 2025 Barney Road, Kalamazoo, Mich. 49007.

4 LINE Stamp \$1.00. Script style 3 lines \$1.50. Pads 75¢. H. Henton, 95 3rd Street, Brooklyn, N.Y. 11231.

PRINTING PRESSES, RUBBER STAMP OUTFITS

PRINTING Presses, type, supplies. Lists, 5¢. Turnbaugh Service, Mechanicsburg, Pennsylvania 17055.

SIMPLE-X RUBBER STAMP PRESSES, hydraulic operated, electrically heated. Sizes 5"x8", 8"x12", 10"x15". Starting outfits. Orders for presses, supplies shipped day received. Free catalog low supply prices. Custom Manufacturers, 406-P East Elm, Springfield, Mo. 65801.

TYPE Catalog No. 11, 96 pages. Send One Dollar. Deductible First Order. Acme Type, 732 Federal, Chicago, Illinois 60605.

SAME Day shipment on rubber stamp supplies. Revised wholesale price list No. 6 free. Star Stamp Supply, 732 Federal Chicago, Ill. 60605.

MAKE your own self-molding rubber stamps and printing cuts. Plexirubber, Argyle -1-, Wisconsin.

PRINTING AND SUPPLIES

8 HOUR PRINTING-Free Booklet "Secrets of Cutting Printing Cost" Nationwide Printing, Atlanta, Ill. 61723.

FREE Literature. Address Labels, Business Cards, Printing, Rubber Stamps. Jordan's, 552 West O'Connor, Lima, Ohio 45801.

AMAZING business printing values. Quotations, Print Shop, Box 576, Greenville, R.I. 02828.

FREE Information: Business Cards. Beautifully Embossed, 3 Colors, Spartan, 8210 170th Ave., Stanwood, Mich. 49346.

DO Your own printing. Save money. Simple rules. We supply everything. Print for others; good profit. Raised printing like engraving too. Have home shop. Details free. Kelsey Presses, V-11, Meriden, Connecticut 06450.

TOP QUALITY OFFSET. 1000 8 1/2 x 11. 20 lbs. bond. \$6.75 postpaid. Special handling, Biscayne, Box 346 Wall Street, New York, New York 10005. Write for catalog.

BUSINESS CARDS, \$5.00 per thousand. Send for FREE samples. GRAHAM ENTERPRISES, Box 2304, Falls Church, Virginia 22042.

QUALITY Printing, cards, letterheads, Etc. Samples, price list. Printer, Box 659, Venice, Calif. 90291.

100 TWO Colors Porcelain Business Cards \$1.50. Eslick's Craft Studio, Delavan, Wisconsin 53115.

SAVE Money On Quality Printing, Samples Free. Write National, 1906-Pine, Niagara Falls, New York 14301.

MULTIGRAPH, MIMEOGRAPH

EXTRA Income at home in Spare Time! Booklet shows you how to start your own business with Classified Advertising. Only \$1.00. Refundable with first order. C. A. Martin, Popular Mechanics Dept. PM, 575 Lexington Ave., New York 10022.

GUMMED LABELS

1,000 GUMMED Address labels \$1.00. Walt's, Box 966A, South Bend, Indiana 46624.

REMAILING SERVICE

CONVENTION City Remails 25¢. Colorful Postcards. Schoen, Box 1963-P, Chicago, Illinois 60690.

MIAMI Remails 25¢. Monthly rates. Marle, Box 1266, Coral Gables, Fla. 33134.

KANSAS CITY Remails 25¢. Receiving-Forwarding. Midway 3115-F South 45th. Kansas City, Kansas 66106.

PHOENIX. Receiving, forwarding, remailing. Confidential. Troen, Box 2386, Phoenix, Arizona 85002.

RECEIVING Forwarding \$3 Monthly. Additional Confidential Services. Redjack, 2401 Banner, Dearborn, Michigan 48124.

ENTERSULL. Your secret address. Prompt. Reliable. Box 1887M, Forsyth, Ga. 31029.

SECRET Receiving and remailing. Discreet and confidential. Remail 25¢. Pine Park, 8080 Main, Houston, Texas 77025.

REMAIL \$3.00 Monthly. Harold Dalton, Box 1867, Daytona Beach, Fla. 32015

NEW YORK 25¢. \$3.00 monthly. Reliable. Snow, 458 Vermont Street, Brooklyn 11207.

SAN DIEGO Remails \$25 Monthly \$3.00 Universal, Box 16146A, San Diego, California 92116.

INDIANA 25¢. \$3.00 Monthly. Miller, 1113 S. Englewood, Evansville, Indiana 47714.

NEW YORK CITY. Remails 25¢. Monthly \$3.00. Forwarding-Receiving. Thomas, Box 158P, Staten Island, N.Y. 10309.

HARTFORD, Reliable-Confidential 25¢ each, \$3.00 monthly. Marshall Balfe, P.O. Box 14117, Hartford, Conn. 06114.

RECEIVING-Forwarding, \$4 Monthly. Hedspeth, 406-M South Second, Alhambra, Calif. 91802.

REMAILS 25¢. Receiving-Forwarding \$3.00. Mailway, Drawer 9037PM, San Jose, California 95117.

PARADISE, California 95969. Your secret mailing address. MYOB-II, Box 658-M.

ROSEBURG Remails 25¢-\$3.00 Monthly Confidential. Glen Bowles, Winchester, Oregon 97495.

ASTRODOME City Confidential Re-mailing Service, 25¢. Dept-102, Box 14621, Houston, Texas 77021.

BOSTON Confidential-Request Special Receiving-Forwarding Rates. Remails 25¢. Postcards 7/\$1.00. D A D PM, Box 651, Waltham, Massachusetts 02154.

MAIL SERVICE Keep your address SECRET-Executive, 7215 Bellefontaine, Kansas City, Mo. 64132.

CALIFORNIA Remails 25¢. Receiving. Forwarding. \$3.00 monthly. Colorful Postcards 10 for \$1.00. Confidential, prompt, Mickens, Box 94-C, Pasadena, Calif. 91104.

RECEIVING-Forwarding \$3. Monthly. Free Address Labels, Remails 25¢. Romae, 6641-A Bo Peep, Jacksonville, Florida 32210.

MICHIGAN, 50¢ Individual and business. Free Information: Motor City Remails, Box 890, Dearborn, Michigan 48120.

REMAILING. 1/75¢. 3/2.00. Rapid Remail Co., (not inc.) Box 20732, Orlando, Florida 32814.

TIMES Square Mail Address. \$3.00 Month. Remails 25¢. Details Free. Birnhan, 152 West 42 St., New York 10036.

TEXAS Remails 25¢. Prompt, confidential. Quigley, 180P Liveoak, Bridge City, Texas 77611.

TEXAS 25¢. Forwarding \$3.00 Monthly. Delk, Box 8224, Corpus Christi, Texas 78412.

REPAIRS AND SERVICING

EXTRA Income at home in Spare Time! Booklet shows you how to start your own business with Classified Advertising. Only \$1.00 (Refundable with first order.) C. A. Martin, Popular Mechanics, Dept. PM, 575 Lexington Avenue, New York 10022.

SPECIAL SERVICES

INFORMATION On anything. Ferguson Research Specialists, 83-45 Vietor Ave., Elmhurst, N.Y. 11373.

REPRODUCTIONS Transferred to Artists' Canvas, P.O. Box 20367, Sacramento, Cal. 95820.

AUSTRALIA: Remailing, Souvenirs, Coins, Enquiries, Representation. Professional Services, Box 38, Northbridge, NSW, Australia.

UNITED STATES DEPARTMENT OF AGRICULTURE FOOD STAMPS Are being purchased daily thruout the country—performance of FOOD STAMPS operate as CASH thru normal channels of retail trade stores—(I PURCHASE EIGHTEEN DOLLARS WORTH OF FOOD STAMPS FOR FIFTY CENTS)—(others in excess) —KNOW THE AUTHORITATIVE FACTS AND PARTICULARS—LOW AND MIDDLE INCOME FAMILIES—INDIVIDUALS employed or other-wise—HOMEOWNERS and especially RETIRED are strongly urged to supplement their FOOD INCOME PURCHASING POWER—for your convenience and swift service our code FOOD STAMPS on below address indicates your order/and ship to senders return name and address/—simply insert your expression of two dollars—money order—personal check into envelope and mail to—SPECIAL SERVICE ACCOMMODATIVE—DEPT—FOOD STAMPS—907 SUMMIT AVENUE—JERSEY CITY—NEW JERSEY —07307 registered Hudson County—state of New Jersey.

TOBACCO

OUR FIRST 19 IN SPACE. This limited edition lithograph has been created as a tribute to Americas Gallant Astronauts. 12 X 18 inch chart ready for framing. Only 75 cents. Popular Mechanics, Dept. GWP, 575 Lexington Avenue, New York, New York 10022.

RAZORS

EXTRA Income at home in Spare Time! Booklet shows you how to start your own business with Classified Advertising. Only \$1.00 (Refundable with first order.) C. A. Martin, Popular Mechanics, Dept. PM, 575 Lexington Avenue, New York 10022.

PERSONAL

INVESTIGATORS. Latest Electronic Aids. Free Literature. Clifton, 11500-P NW 7th Ave. Miami Florida 33168.

PENMANSHIP Improver: Improve Penmanship Quickly! Details free. Tevis, Chillicothe, Mo. 64601.

BIBLE Questions answered. Stamped envelope. Bylon, 17167 Bentler, Detroit, Michigan 48219.

SUBCONSCIOUS Conditioning remakes personality while you sleep. Free details. Sleep-Learning, Box 24N, Olympia, Washington 98551.

GET OUT OF DEBT in 90 minutes, legally without borrowing or bankruptcy. Anderson, 8873E Kenwood, Cincinnati, Ohio 45242.

RUPTURED. Relief and comfort. No understraps, elastic or steel. Write Hand-Lock Products. Preston 4, Ont., Canada.

WIN MONEY EVERY MONTH working contests and puzzles. Free details. . . . NO MINORS. International Contest Club, Box 10153, Dept. PM-6, Kansas City, Missouri 64111.

SECRET LOANS BY MAIL. Borrow \$100 to \$1500 for any good reason in absolute privacy. No interviews, no endorsers, no co-signers. Fast service. Write Dial Finance Co., Dept. G-214, 410 Kilpatrick Bldg., Omaha, Nebraska 68102.

ASTROLOGY. Self-Improvement books. Free Literature. D. W. Bahr, 5890-A Lilac Lane, Hales Corners, Wisconsin 53130.

SMOKING HAS NO POWER! You Are Power—Truth! Save Health, \$\$\$\$. Feel Better. Stop Now Forever! New 96 page book shows step-by-step method how. Send \$2.00 Ray-O-Lite Co., Dept. PM-7, 130 Sylvan Ave., New Haven, Conn. 06519.

PAY BILLS! Have cash left over. \$39.65 repays \$1000 in 36 months. Write for details. American Loan Plan, Dept. KA-010B, City National Bldg., Omaha, Nebraska 68102.

BORROW Up To \$1500 By Mail on convenient terms! State licensed. Postal Finance, Dept. (17-N), 200 Keeline Building Omaha, Nebraska 68102.

MAKE YOUR WILL. Get 4 Will Forms and attorney's informative book. \$1.00. Legal Forms Company, Department 124, 1967 Guardian Building, Detroit, Michigan 48226.

HOW To Escape Debts. Clear Credit. \$1000 loan sources. Free details—helped others. Counselor-7, Kerrville, Texas.

UNIQUE! Personal! Your photo on postage size stamps. Gummied, glossy, perforated. 100—\$3.00. Large 50—\$3.00. Chapman Photo Stamps, Box 631, Hurst, Texas 76053.

POLLUTION Is Robbing Our Oxygen! Start Drinking Oxygen Tonic. Be more alert, Increases Pep, Energy, Health. Simple to make. FACTUAL Report and Instructions Only \$1.50. Way Scientific, 568 E. Columbia, Pontiac, Mich. 48053.

KNOW Your I.Q. Test and Score yourself at home. Send \$2.00 to Manton Testing, 1111 Alpha, Turlock, Calif. 95380.

PORTRAIT. Yours in Poetry. Send dime for sample and information required. WILLIAMS PUBLISHING COMPANY, P.O. Box 128, Portage, Indiana 46368.

MAKE NEW FRIENDS Worldwide. Meet Marriage minded Girls through our illustrated Catalog, 1200 Ladies's Fotos and Descriptions \$2.00. I. C. B., Box 12, Toronto, 16, Canada.

HANDWRITING Analyzed. Details free. O'shay Antell, 236 Ogden Canyon, Ogden, Utah 84401.

STOP Smoking! DONALD Fuller, Hypnotist (A.A.E.H.) will send you Trance inducing Tape with Proper Suggestions To Stop Sm'king Forever. How much is your Life worth to you? Send \$5.00. 9218 Archdale, Detroit, Michigan "48228"

SUB-MINIATURE LISTENING DEVICES. Low Priced, High performance, direct from Manufacturer. Dealers Welcome. Auditronics, P7, 156 5th Avenue, New York, New York 10010.

DRAFT Card, Karate & Press \$1.00. Identification - Box 25 - Brooklyn, N.Y. 11204.

DIGGERS For Facts—Amazing book reveals recent archaeological discoveries proving Bible true. \$5.00 Hank Zamora, 1501B Dolores North West, Albuquerque, New Mexico 87105.

SECRET Loans By Mail. Borrow \$100 to \$1500 for any good reason in absolute privacy. No interviews, no endorsers, no co-signers. Fast service. Write Dial Finance Co., Dept. G-214, 410 Kilpatrick Bldg., Omaha, Nebraska 68102.

WANTED—MISCELLANEOUS

MERCURY, Gold, Silver, Platinum; Ores assayed. Wholesale Terminal, Norwood, Mass. 02062.

YOUR Ad in Popular Mechanics will be seen by more than 5,000,000 active buyers for your products and services. It costs only \$1.85 per word. And, if you wish to run all or part of your ad in capital letters—you can do so for as little as 75¢ per word additional. Act now! Place your classified ad in Popular Mechanics today.

MISCELLANEOUS

ORNAMENTAL Iron designs. Book of 1600 beautiful, practical designs for railings, columns, etc. Free literature. Cunningham, 3881 South 3200 West, Salt Lake City, Utah 84119.

SILENCERS For pistols and rifles. Complete details for construction and operation. \$1.00. Gunsmith, Box 185, Fairfield, Alabama 35064.

YOUR Name sent to 1000 importers, publishers, mailers, wholesalers, etc. on our mailing list. Year \$1.00, Dixie Mailers, King, N. Car. 27021.

HEARING Aid batteries wholesale. Free list. Habs, Box 51, York, Penna. 17405.

WINEMAKERS—Free catalog and recipes. Kraus, Box 451-L, Nevada, Missouri 64772.

CIGARETTES 12¢ a pack. Improved roller makes 20 filtertip, plain, king or regular for 12¢. Facts Free. Moberly, Box 954, Owensboro, Kentucky 42301.

BIRTH Certificates, Marriage Certificates, Diplomas! 2 blank forms \$1.00. Sample 10¢. Standard Forms, Box 482-M, Washington, D.C. 20044.

WANT Greatest Cash Crop working for you? Write, Ginseng, Asheville 53, N.C.

WINEMAKING . . . Grape, Elderberry, Dandelion, Frozen Juices, etc. Brewmasters' secrets revealed! Powerful Methods! Instructions, Recipes, and Supplies Catalog, \$1.00. Continental, Box 11071-PG, Indianapolis, Indiana 46201.

BOOKS On antiques and their prices. Free circular! P. Warman Publishers, Uniontown, Penna. 15401.

AMAZING Books, jewelry-sweaters-watches. Lynn's, Box 1573, Waco, Texas 76703.

FRESH, Tasty Wines & Liqueurs 12¢ Gallon. Tested Recipes—Instructions 32 pages, \$1.00. Guaranteed. TAST—RITE, Box 196-P7, Stafford, Va. 22554.

WINEMAKERS. Free illustrated catalog of yeasts, equipment, Simplex, Box 12276, Minneapolis, Minn. 55412.

PSYCHEDELIC Catalog send 25¢. Hole, 6055 Lankershim, North Hollywood, Calif. 91606.

KILL Mosquitoes, Insects, electrically. Free information. Insect Control, Box P374, Royal Oak, Michigan 48068.

PROTECTO-CARRY! Magic Seal Plastic Pouch, 6x10, For Hand Tools, Etc. 50¢ 3 for \$1.00. Postage 10¢. Belwood's, Box 4494, Glendale, California 91202.

MAILBOX EMPTY AGAIN? Don't be left out, \$1.00 starts mail coming. Plus FREE GIFT, The Stewart Co., Dept. 117, Box 7237, Sacramento, Calif. 95826.

"PLANS. Analog Computer Programmed to make optimal strategy decisions in BLACKJACK. \$5.00. D Tweedy, Box 11282, Santa Ana, California 92711."

PEACH Brandy, Wines—Strongest Formulas, \$2.25. (hydrometers and supplies catalog included)—Research Enterprises, 29-SN35 Samoset, Woburn, Mass. 01801.

SLOT & PINBALL machines, etc. Catalog 35¢. Coffco, Dept. B, P.O. Box 522, Lake Zurich, Illinois 60047.

WINEMAKERS! New Illustrated Supplies Catalog . . . Free! Write Today! Winemakers, Box 11211-RT, Indianapolis, Indiana 46201.

2,000 YEAR Calendar—Year one to 2,000 A.D. \$1.00 postpaid. Martin-Drawer G—Phoenix, Arizona 85010.

MAGNETS. All types. Specials—20 disc magnets, or 2 stick magnets, or 10 small bar magnets, or 8 assorted magnets. \$1.00. Maryland Magnet Company, 5412-A Gist, Baltimore, Maryland 21215.

IMITATION WHISKEY! Tastes like real. No distilling! No special equipment. Powerful recipes \$2.00. Silvey, 227 East 89th, N.Y.C. 10028.

ARE You thinking of answering any of these classified ads? For every 20 you answer it will cost \$1.00. Midcity will have 100 companies send you their offers for only \$1.00, 200 for \$2.00, 300 for \$3.00. Satisfaction guaranteed. Midcity M2, Box 174, Elmhurst, Illinois 60126.

WINEMAKING KIT—\$4.95 Postpaid. FREE CATALOG—Jim Dandy Wine Supplies, Box 30230—Cincinnati, Ohio 45230.

NEW Eyeglass Rack keeps glasses safe and handy. For Auto, Home, anywhere. \$1.00. William Stanley, P.O. Box 191, Rockwood, Mich. 48173.

ZOOLOGY

YOUR Ad in Popular Mechanics will be seen by more than 5,000,000 active buyers for your products and services. It costs only \$1.85 per word. And, if you wish to run all or part of your ad in capital letters—you can do so for as little as 75¢ per word additional. Act now! Place your classified ad in Popular Mechanics today.

BENJAMIN
INTRODUCES A FABULOUS NEW
AIR RIFLE
 ... that takes up where
 the Ol' Reliable Super
 Single Shot leaves off.
 You Can **DEPEND** on **BENJAMIN**

Push-Pull Safety on top
 of Stock behind Breech.



\$35.95 MODEL 348 CAL. .85
 MODEL 342 CAL. .22
 PELLET—MODEL 347
 CAL. .177 PELLET.

A no-nonsense gun that means business every time you fire, this New Benjamin combines all the superb Quality and Performance features of its famous Predecessor with extra improvements for your shooting pleasure. Foremost, is a Thumb Operated Top Safety. The only pneu-

matic to offer this Advanced feature for more efficient fire control, it also includes a new Ramp Front Sight and adjustable Stepped Leaf Rear Sight to bring out the full Accuracy potential of the New Model. Shoot target, small game. This Benjamin stands alone for its Power — Convenience — Safety — Reliability. At your Benjamin Dealer's.

Use Benjamin H-C Pellets—Sized & Lubricated.

BENJAMIN AIR RIFLE COMPANY, 896 Marion St., St. Louis, Mo. 63104 **FREE CATALOG! Write**



DODGE XPLOER MOTOR HOME
PASSENGER CAR SIZE

Self-contained—Running Water—Full Time Double Bed—Furnace—L.P. Gas Stove—Dinette—Closet—Bathroom—Sleeps up to six.

A Motor Home you can use every day of the year—Will go into a 7' garage—Low center of gravity for safety and excellent roadability. See Your Dodge Dealer!!!!

XPLOER MOTOR HOMES, INC.
 P.O. Box 70-PM, Brown City, Michigan 48416

MAGIC MAIL PLAN
 that comes with this Little Machine
CAN MAKE YOU \$1200 AN HOUR

The machine is turning out a job that will bring operator \$2.58, by mail. Material cost, only 11c



Write today for free facts about the newest and most fascinating of all new home operated businesses. For the first time, a simplified machine brings the fabulous profits of Plastic Sealing and Plastic Laminating within reach of the small operator. Anyone can learn to operate it with a few minutes practice. Then—with our **MAGIC MAIL PLAN**—can get mail orders pouring in daily with cash in every envelope.

No Canvassing or Selling

Fill orders at home in spare time to start. Then expand to full time business. We even supply circulars to bring back cash and orders. Rush name for all the facts you need to start. A postcard will do. No charge.

WARNER ELECTRIC CO., Dept L-2-HS
 1512 Jarvis, Chicago, Ill. 60626

DRAINS pools, cellars, laundry tubs \$8.95
IRRIGATES — CIRCULATES — SPRAYS



Type P Pump. 1,001 uses. Stainless shaft. Won't rust or clog! Use 1/8 HP motor or larger . . . 3/4 HP for up to 2,400 GPH; 450 GPH 80' high; or 1,800 GPH from 25' well. 1" inlet; 3/4" outlet. Coupling included free **\$8.95**
HEAVY-DUTY BALL-BEARING PUMP. Up to 5,200 GPH; or 3,000 GPH from 25' well. 1 1/4" inlet; 1" outlet **\$12.95**
 P'pd cash with order. **MONEY BACK GUARANTEE**
LABAWCO, Box 7, Belle Mead, N.J. 08502

WHEN ANSWERING ADS
GIVE YOUR ZIP CODE

ELECTRIC ARC WELDER \$9.99!



NATIONALLY ADVERTISED \$18.95 VALUE!—NOW 1/2 PRICE! WELDS—BRAZES—SOLDERS—CUTS—ALL METALS! Plugs into ANY 110 volt socket. **MAKE—REPAIR 1001 items for CAR—HOME—BUSINESS.** Lifetime **BURNOUT GUARANTEE** 10 day money back trial (if retrnd). **HEAVY DUTY Design—Does \$85.00 welder work. No experience needed—FREE WELDING LESSONS!**
SEND ONLY \$2.00 cash, e.k. M.O.) and pay postman \$7.99 COD postage or send \$9.99 plus \$1.00 postage for paid del. in U.S.A. **COMPLETE READY TO USE—Includes BIG pack steel, Brazing, Solder, Carbon "touch" rods, ELECTROFLAME ARC TORCH! OFFER LIMITED—Order TODAY!**
MIDWAY WELDER Dept. EPM-7 Kearney, Nebr. 68847

300 POWER

Complete Telescope Lens Kit only \$3.98
 postpaid

Comper Space, Explore the Universe, Planets, Moon craters, New Stars etc. Complete Lens Kit consists of 80 Inch focal length ground and polished objective lens, eyepiece lenses for 50 POWER, 100 POWER, 150 POWER, 200 POWER, 250 POWER, 300 POWER, and all necessary lens fittings. Easy to make from simple step by step instructions. (Tripod and mount not included.) Money back guarantee.

BUSSE SALES, Dept. PM13, Hartford, Conn. 06101

WOOD VENEERS • TOOLS
 Shop Equipment • Supplies
POWER TOOLS
 at Lowest
Discount Prices!

SAVE MONEY on finest domestic and imported hardwoods . . . all dimensions. Over 1500 items for the home craftsman and woodworking hobbyist. Lamp parts, upholstery supplies, tile, power tools at discounts. **NEW CATALOG READY** 132 pages. Full Color. Send name, address and 35¢ to cover handling, and postage. Write . . .

CRAFTSMAN Wood Service Co. Dept. A-79
 2729 S. Mary, Chicago, Ill. 60608

LIKE TO DRAW?

Enjoy a high-pay career or fascinating art hobby. Study Painting, Advertising Art, Illustration, Fine Art at home in spare time. Personalized lessons by 11 master artists. Educational, unlimited opportunities . . . Art is "in." Remarkably low cost. Send name, address, age, and Zip, today for our **FREE Booklet, WASHINGTON SCHOOL OF ART, STUDIO 19-010, Port Washington, N.Y. 11050. Accredited Member NHSC.**



HOLD IT!
 the glue that never lets go!

write for **FREE** glue and caulk selector guides



WILHOLD GLUES, INC.
 8707 Millergrove Dr., Santa Fe Springs, Cal. 90670



When you see this mark you've seen the product in Popular Mechanics.



FIX your appliances,
car,
house,

SAVE

on home improvements,
air conditioning,
power tools and more

WITH THIS

FREE \$3.49
VALUE
GIFT VOLUME

Just look back over the past few years and figure how much you have spent on repairs for your home, your car, your appliances. Wouldn't you like to keep these high-priced repair fees for yourself? Well, now you can.

As a reader of *Popular Mechanics* the chances are that you already have a considerable degree of skill with tools. Nevertheless, you may have hesitated to tackle more complicated repairs, improvements or hobby projects.

Now, however, this FREE Book—packed with the combined skill and know-how of 257 *Popular Mechanics* expert editors, consultants and designers—can put a professional edge on your do-it-yourself skills.

The most difficult jobs will soon become easy

Before you know it, you'll be able to fix car engine troubles... transform unfinished attic space into an extra bedroom... catch more fish using homemade lures... learn "tricks-of-the-trade" in handling power tools... save hundreds of dollars when buying and servicing appliances.

These are just a few of more than 6,000 exciting "how-to" ideas, plans, and valuable projects you'll find in *POPULAR MECHANICS DO-IT-YOURSELF ENCYCLOPEDIA*. You'll learn how to get more professional-looking results than ever before in your carpentry, metalwork, plumbing, masonry, electrical wiring, electronics, hi-fi, stereo, car repair, painting, decorating... PLUS exciting new ways to help you get more fun out of your hobbies, sports, vacations. Experts lead you step-by-step through every project you select. Without question, here is the most helpful, reliable, "how-to-do-it" guide you've ever seen—and Volume 1—a \$3.49 value—is yours ENTIRELY FREE!

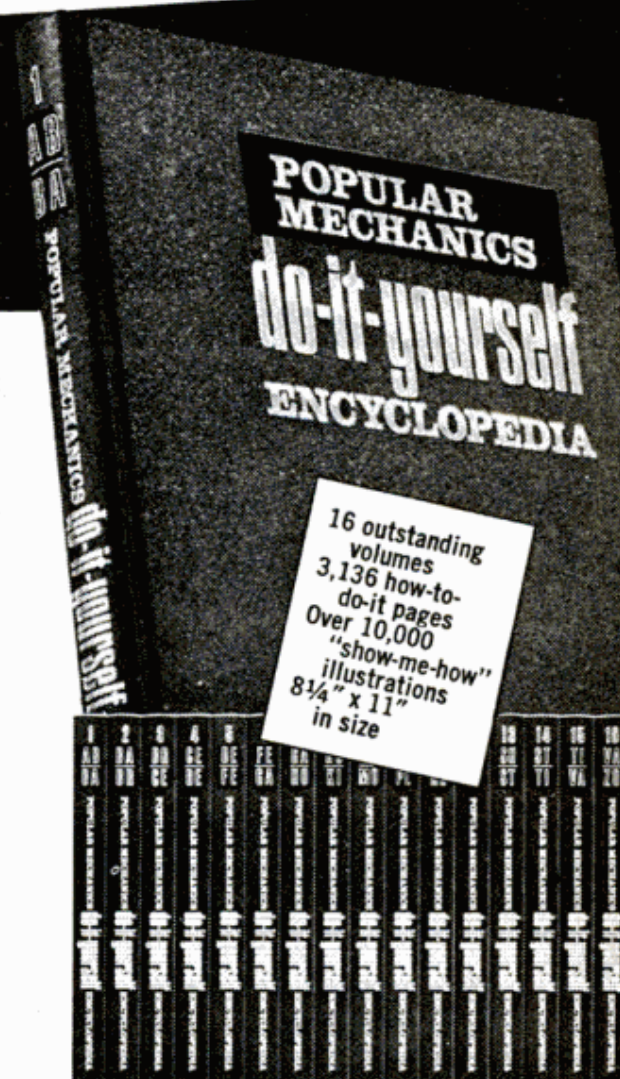
You risk nothing on this FREE Book offer!

As soon as your gift book comes, browse through it—try some of the exciting ideas—use some of the money-saving tips. We're sure you'll get so much valuable help from this book, you'll want to see the other volumes as they are published. You can see future volumes without risk—on a 14-day FREE TRIAL basis. But this first volume is yours as an outright gift—whether you buy one, two, five, the whole set, or none at all. But please hurry. Our supply of gift volumes is definitely limited. To be sure of getting your copy FREE, mail the coupon today.

Here is a brief glimpse of all your FREE Volume brings you:

- Fix 8 common car engine problems and save garage fees
- Save money air conditioning your entire home
- Cure a wet basement and save \$200 to \$2,000 under what professionals charge
- Burglarproof your home with special power alarm
- Professional tips for expert sanding
- Learn arc welding basics in 6 hours of easy practice
- How to save on band saw blade costs by making your own
- Build a gas-fired barbecue for more back-yard fun

PLUS much, much more.



16 outstanding
volumes
3,136 how-to-
do-it pages
Over 10,000
"show-me-how"
illustrations
8 1/4" x 11"
in size

MAIL COUPON TODAY!

Popular Mechanics Book Division, Dept. 917
250 West 55th Street, New York, N.Y. 10019

Please send me, ENTIRELY FREE of any charge, my complimentary copy of Volume One of the all-new, illustrated *POPULAR MECHANICS DO-IT-YOURSELF ENCYCLOPEDIA*. I am not obligated to buy anything—now or later.

I understand I will be entitled to receive additional volumes for my FREE EXAMINATION as they are published each month. After examining each volume FREE for 14 days, I will either return it and owe nothing—or keep it and remit low subscriber price of only \$3.49 a volume, plus a few cents for shipping.

I reserve the right to cancel any time I wish—even immediately after receiving my FREE Volume 1—without obligation. Whatever I decide, Volume 1 is mine to keep FREE.

Name _____
(Please Print)

Address _____

City _____

State _____ Zip

Signature _____

SOLUTIONS FOR MECHANICAL HEADACHES

AUTOMOBILE CLINIC

BY MORT SCHULTZ

Hesitation headache

Any idea what causes my 1967 Ford Fairlane V8 to hesitate on the pickup at about 25 mph? Here's what's been done—new plugs, points, condenser, distributor cap and rotor, ignition wiring, carburetor and vacuum advance. The car checks out okay on the scope, but not on the road.—Charles E. Rulon, Richmond, Calif.

There's a chance that although you have a new vacuum advance, the engine's not getting sufficient advance and the distributor spring tension of the vacuum chamber has to be recalibrated. This is spelled out in service bulletin 1031 (3/31/67), which tells the dealer to shim up the vacuum chamber with washers to increase the advance. He takes off the vacuum chamber nut. Inside at the back of the nut is where shimming washers go.

Engine cut-out

What can cause my 1966 Chevrolet Impala to cut out on occasion? I've checked fuel and ignition systems, but no luck.—John Allison, Knoxville, Tenn.

Some things you may have overlooked are a loose wiring harness plug at the firewall; sparkplugs that foul slightly and then clean themselves under harder operation; and, if the cut-out occurs during high-speed operation, fuel starvation. The latter is tough to pin down and may necessitate a complete rebuilding of the carburetor.

Filters flipped

Following some extensive work on a customer's 1965 Plymouth with Torqueflite, the transmission started to shift erratically and make a clicking sound. I'm at a loss to know why, because I do careful work that was double checked by my partner. Maybe you can give me a hint? (Please don't use my name for obvious reasons.)—X Transmission Shop, S.D.

If you replaced the internal oil filter, you may have created the trouble without realizing it. There are two filters on supply shelves, and interchanging them can cause problems. A one-hole filter (part No. 2801655) can be used only on 1966

through 1969 Torqueflites that do not have a rear oil pump. Its use in a 1963 through 1965 Torqueflite can cause the rear pump to score because of lack of lubrication. The erratic shifting and noise may be the prelude to this. The other filter (part No. 2466849) has two holes. It can be used on any Torqueflite transmission from 1963 through 1969. Did you use a one-hole filter when you should have used the one with two holes?

Engine whistle

We have a 1968 Buick Electra that has a whistle in the engine when I let up on the accelerator. What can cause this?—Frank Kesler, Laddonia, Mo.

More than likely a loose intake manifold or carburetor.

Balled-up ball joints

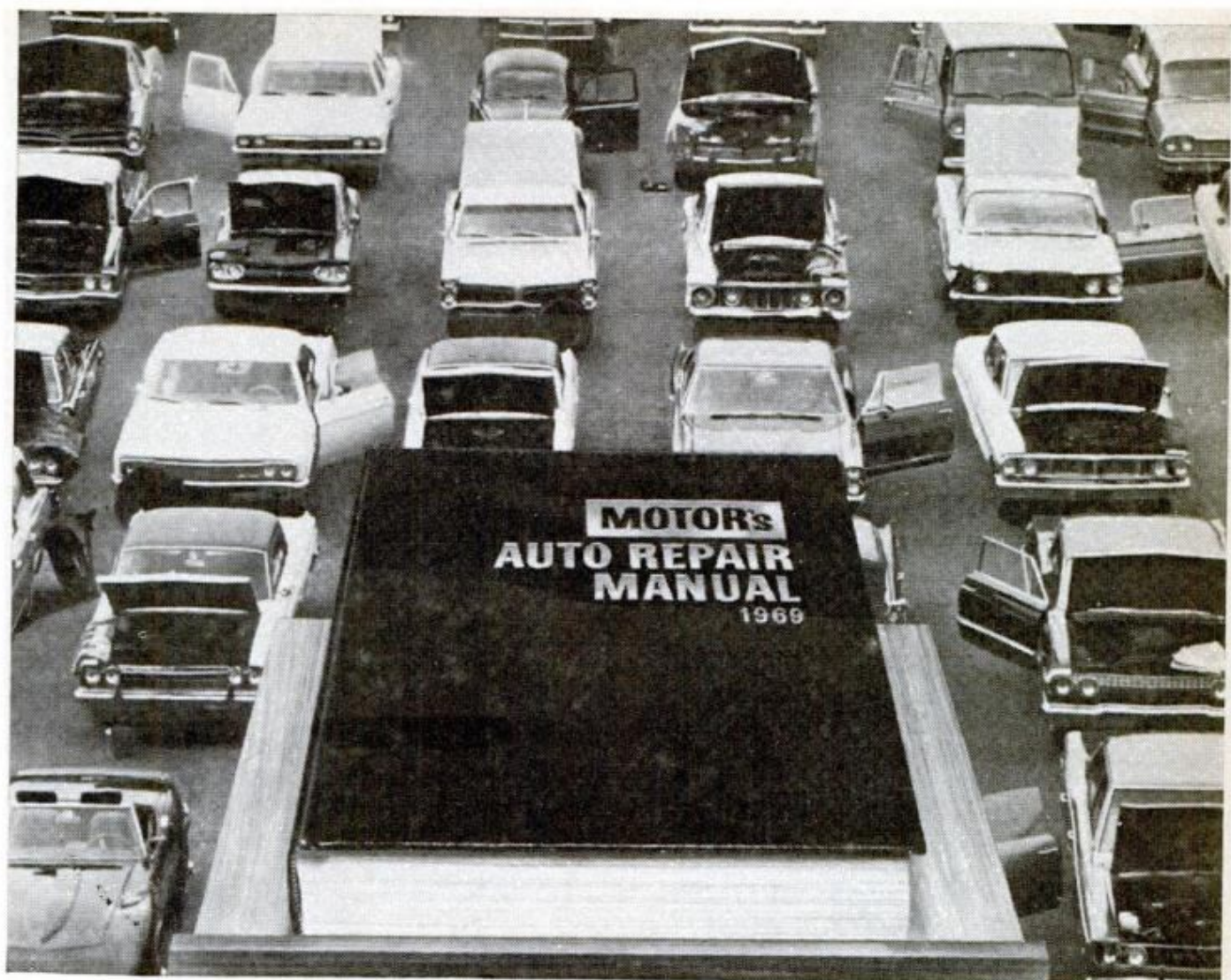
I was told by a man who owns an independent alignment and brake shop that the ball joints of my 1969 Pontiac had more than 1/4-in. movement and should be replaced. The dealer insists they're okay. Who's right?—Ray S. Johnson, Homewood, Ill.

More than 1/4-in. travel measured at the periphery of the tire surely indicates worn ball joints, looseness at the upper or lower control-arm shaft, or both situations. But very often someone checking for ball-joint movement will not perform the check properly. Pontiacs, for instance, have to be raised at the lower control arm so the outside spring seat is supported and the upper control arm is free of the rebound rubber bumper. In short, before ball joints are rejected they should be inspected by the book. I suggest you get other opinions. Your dealer should call in a factory field representative when there's a question which can't be solved.

Blinking eyes

If our 1969 Thunderbird hasn't been run for a day or so, the headlight covers raise by themselves. Is this normal?—Bruce Celenza, Lodi, N.J.

Sure is. In accordance with orders is—
(Please turn to page 72)



How to fix almost any part of any car

Now, whether you're a green beginner or expert mechanic, you can breeze through almost any auto repair job on all the cars listed here built from 1963 to 1969.

All you need is the new 1969 Edition of MOTOR'S AUTO REPAIR MANUAL—the famous illustrated guide that makes practically every operation on almost any car as easy to do as A-B-C.

Special Trouble-Shooter Section

The special Trouble-Shooter Section in MOTOR'S Manual, plus detailed trouble-shooting information throughout, helps you pinpoint any of 4,200 car troubles in a jiffy . . . spots exactly where the trouble is in engines, transmissions, axles, etc.

Big New 1969 Edition

1,000 Big Pages—Over 3,000 Pictures!

This newest, most up-to-date Edition covers everything you need to know to fix 2,300 car models from 1963 through 1969, including all compacts and intermediate cars. Plus tune-up and front-end alignment specs on all models from 1941 through 1962. 1,000 giant double-sized pages, over 3,000 pictures. 365 "Quick-Check" charts, 55,000 essential repair specifications. Over 225,000 service and repair facts.

The "Meat" of 300 Official Shop Manuals

The editors of MOTOR gathered together a wealth of know-how from 300 official shop manuals and hundreds of factory bulletins, and boiled it down into crystal-clear terms in one big illustrated book.

All These Makes Covered

TORONADO	JEEP	CHEVELLE
BARRACUDA	THUNDERBIRD	CAMARO
PONTIAC	CADILLAC	OLDSMOBILE
IMPERIAL	CONTINENTAL	CORVAIR
DART	CHEVROLET	OLDS F-85
FORD	PLYMOUTH	LANCER
CHRYSLER	DODGE	VALIANT
RAMBLER	COMET	JAVELIN
BRONCO	AMERICAN	MONTEGO
BUICK	FAIRLANE	TORINO
SPECIAL	CORVETTE	LINCOLN
FALCON	MUSTANG	FRONT-DRIVE
TEMPEST	CHEVY II	CADILLAC
COUGAR	BUICK	MARK III-AMX
VOLKSWAGEN	MERCURY	

Not only do you get the latest up-to-the-minute "how-to" information on each car listed above, you also get service data on Transmissions, Steering, Brakes, Generators, Alternators, Fuel Pumps, Ignition Systems, Engines, much more!

No wonder over *five million copies* have been sold!

Try This Book at Our Risk—FREE

Send no money. Just mail the coupon and we'll send the giant 1969 Edition of MOTOR'S AUTO REPAIR MANUAL right to your home or shop. Try this famous guide for 10 full days—FREE! If this book doesn't pay for itself in the first 10 days, just return it and owe nothing.

Mail coupon to MOTOR Book Department, 250 West 55th Street, New York, N.Y. 10019. (Schools, Bookstores: Write for discounts.)

Brand-New 1969 Edition ★ Used by Repair Shops, U.S. Armed Forces, Schools, Etc.



SAME 10-DAY FREE TRIAL ON AUTO ENGINES AND ELECTRICAL SYSTEMS Explains engines and electrical systems thoroughly, showing how and why they work. Over 600 pages. Only \$8.95.

MOTOR BOOK DEPT., Desk 917
250 W. 55th St., New York, N.Y. 10019

Please send me the book(s) checked below, for 10-day free examination. If I decide to keep them, I will remit payment as indicated.

MOTOR'S AUTO REPAIR MANUAL, \$9.95, for which I will remit \$2.00 in ten days, \$3.00 monthly for two months, and a final payment of \$1.95 (plus delivery charge and sales tax, if any).

MOTOR'S AUTO ENGINES & ELECTRICAL SYSTEMS, \$8.95. I will remit \$3.00 in ten days, \$2.00 monthly for two months, and final payment of \$1.95 (plus delivery charges and sales tax, if any).

Please Print Name _____

Age _____

Address _____

City _____

State _____

Zip Code _____

Save shipping charge by enclosing WITH coupon in envelope entire payment of \$9.95 for AUTO REPAIR MANUAL (or \$8.95 for AUTO ENGINES & ELECTRICAL SYSTEMS) plus sales tax, if any. Same 10-day return-for-refund privilege applies.

AUTOMOBILE CLINIC

(Continued from page 70)

sued by the National Highway Safety Bureau, springs have been installed in the control motor of a disappearing headlight system that automatically causes lids to open when there's a drop in vacuum. A vacuum drop occurs by natural means if the car isn't started for a time. As long as those eyelids close by themselves when you start the engine and open when you turn on the headlight switch, you have a properly operating system.

What makes it run?

I have a 1968 144 Volvo sedan. Since the day I bought the car, it's continued to run after I've shut off the ignition. The dealer tells me to put the car in gear when I turn off the motor. Is this a solution or a gimmick?—Maurice E. Ordreay, Santa Rosa, Calif.

Aha! The after-running problem being experienced by owners of late-model American-made cars with the closed anti-smog emission control system is spreading to foreign-car owners. Why not? They, too, have the system. As the carmakers will tell you, the fast and slow idle, and ignition timing must be set exactly to shop manual specs to minimize the dieseling condition. However, if the problem persists, the dealer's suggestion should work. This is such a widespread condition of late that we'll devote an entire *Saturday Mechanic* article to it in an upcoming issue of *PM*.

Hesitate, stumble and backfire

A new carburetor, several complete tune-ups, and a new intake manifold gasket have failed to keep my 1968 Rambler American 232 (automatic transmission) from hesitating, stumbling and backfiring through the carburetor from 1 to 65 mph. The car starts great when cold, however. It has 19,000 miles on the odometer, and has never run right during the entire time. Can you help me?—Hershel L. Bugg, Wilmington, Ohio.

Several different things can cause this trouble; I can't put my finger on it without checking the car myself. This problem is

not common to this model, though, and no manufacturer bulletins deal with it. I would take a compression test to make sure there's no internal hang-up like a bad valve. Other things to look for are carbon accumulation which is hampering the operation of the manifold heat-control valve, a faulty spark-advance unit and a fouled-up PCV system. As I've suggested many times before, if your dealer can't solve the problem, get him to call in a factory-trained field representative.

Playing the numbers

We were given a wrong part number, so we in turn fed it to you. I'm talking about the Oldsmobile product for cleaning stains and discoloration from the back windows of convertibles, as mentioned in the Feb. 1969 *Auto Clinic*. The number we gave, 982066, would get you 1946 back-up lamps! The right one is 1050253.

Service Tips

● **1969 Chevy V8 drive belts** are tough to adjust unless you know the trick. The alternator mounting bracket is shaped and located in such a way that you can't pry against the alternator housing by using the bracket for leverage. But a 15-in. length of chain with a hook on one end and a loop on the other will solve the problem. Drop the hooked end of the chain down between the alternator and bracket until the hook can be attached to the lower attaching bolt. Insert a long-shanked screwdriver through the loop end of the chain. Now, to make the adjustment, pry against the alternator housing by pulling the screwdriver back against the looped chain.

● **How to locate the source of wind noise** is a subject about which Oldsmobile has recently issued instructions that can help all of us who have this problem. The noise can be found by pressurizing the body and dispensing a powder through suspected areas. As the powder-laden air is drawn out of the body through the leaky zone, you can clearly see it. To "pressurize" the body, close windows and air vents and turn the heater blower on high and drive the car. Olds recommends that dealers use a Borozin A. C. Gun which uses either Borozin powder or ordinary cornstarch. E. Vernon Hill, Inc., Box 14248, San Francisco, Calif. sells it. Why not use a Johnson's Baby Powder dispenser? ★★

GOT A PROBLEM WITH YOUR CAR? Ask Mort about it. Send your question to Auto Clinic Popular Mechanics, 575 Lexington Ave., New York, N.Y. 10022. Letters cannot be answered individually, but problems of general interest will be published in the column.



The do-it-yourself Scout.

See what you can do with all the power, performance and pizzazz options we offer you

People are using the SCOUT® so many different ways we figure they ought to be able to get 'em any way they want 'em.

So we offer you more engines, transmissions, rear axles, seating arrangements, and unusual accessories than anybody else in the class.

You can option yourself into any kind of SCOUT from a sassy little runabout to a gutsy beast that'll take off straight up . . .

. . . from a stick shift that's sync-ed in all three gears to a four-on-the-floor to a smooth automatic . . .

. . . from a stripped-down workhorse to

a jazzy creampuff with color-keyed interiors, bucket seats, padding all over and even a stereo tape deck.

Two-wheel drive if you're the conservative type, all-wheel drive if you're not.

We'll start you off with 100 rugged inches of wheelbase . . . and from there on your SCOUT is the most exciting do-it-yourself project you ever tackled.

Your INTERNATIONAL SCOUT Dealer has all the tools and a good price.

IH INTERNATIONAL HARVESTER
 COMPANY CHICAGO, ILLINOIS 60611

HOMEOWNERS' CLINIC

BY W. CLYDE LAMMEY

Tiling basement floor

My basement floor is concrete: smooth, level and dry. I'd like to lay tile over part of it but I'm told there are certain precautions to be taken. What are the preparatory steps and what kind of tile must I use?—D.H., S.D.

Your floor may appear dry, but is it really dry? One way to find out is to coat several test spots with the black liquid primer available from your local dealer in floor coverings. Apply this liquid to a small area in each corner and several small spots over the floor. Let it stand for 24 hours or so. Then, if you can scrape off this coating with a putty knife, your floor is *not* dry enough to lay tile safely. Open all basement windows during clear, breezy weather, or operate a dehumidifier to reduce the moisture content of the air in the area. Then test again.

If the primer sticks solidly, apply it over the whole floor. When dry, apply a tile cement suitable for use on concrete below grade. Follow the manufacturer's instructions for laying tile on basement floors; you can get them from your local dealer in floor coverings.

As a rule only asphalt tiles are recommended for use on concrete floors below grade. Thoroughly clean and dust the floor before applying primer. It is advisable to vacuum-clean the floor to make sure that all fine dust has been removed.

Sticky wallpaper

I moved recently and want to remove the paper on the upper part of the bathroom walls. I can't get it off with any amount of soaking with a sponge. I want to paint the walls, but how do I get the old paper off without damaging the plaster?—O.T., Md.

You refer to the present covering as "paper," so I assume that's what it is, and not some other covering. Many of the newer wallpapers have a plastic coating that is so very nearly waterproof it is difficult to remove by sponging. One way to break the plastic coating sufficiently to permit water to penetrate it and soften the paste is to tack a strip of coarse sandpaper to a 2x4 block about 6 in. long and then go over the surface lightly,

overlapping the strokes a trifle. Don't bear down unduly or you may cut through the wallpaper and scratch the plaster. Once over should do it.

For somewhat faster removal, you can rent a steamer from your local wall-covering or paint dealer. Lift a corner of each sheet of the old paper so that you can direct the steam jet to the underside. Once you get the feel of this procedure, you can unhang the old paper fast with comparatively little effort.

Wash the walls to remove all traces of old paste before applying paint or enamel.

Kinky handsaw

I purchased a handsaw at an auction and, after examining it closely, discovered there is a kink, or sharp bend, about midway along the length of the blade. It's not possible to use it in this condition. I've thought I might heat the blade to straighten it, but am told this won't do. How can I straighten it?—A.N., Tex.

Don't heat the blade. The heat may "draw" the temper, even warp the blade. I doubt if the saw is worth saving for use but if the tool appeals to you especially then this may be worth trying. Lay the blade flat on a smooth surface—a length of hardwood is just the thing—with the bend, or kink, up. Then hammer the blade lightly with a soft hammer (not a nail hammer). Tap lightly around the raised portion, working inward to the center. It will take some time and considerable tapping to straighten the kink so that the saw will not bind in the kerf.

Old alarm clock?

I have an old shelf clock and inside the case, at the left of the bell, gong, or whatever—the thing on which it strikes the hours—is what appears to be another striking affair with a key winder and a small bell. A neighbor tells me this is an alarm mechanism. Can he be right about so old a clock? And if so, how does it work?—G.R., La.

He is right. Alarm clocks are nothing new. There will be an opening in the center of the dial and in this is a disc having the same numerals as those on the dial. Suppose, for example, you want the alarm to let go at 6:00 a.m. Any time after 6:00 p.m. turn this small dial until the numeral "6" or "VI" is directly under the hour hand. Then wind the alarm mechanism until the spring is fairly tight. If the mechanism is in working order and properly connected to the setting dial just back of the hands, the alarm will ring at 6:00 a.m. the following morning. ★★★

Fox Mini Bike

DO IT YOURSELF
OR FULLY ASSEMBLED

FROM

\$79⁵⁰



12 MODELS
3 TO 5 HP

SEND \$1 FOR BIG CATALOG

Shows new 1969 line of the world's finest **MINI-BIKES** (most are licensable for street use), plus parts, accessories and plans. Big selection! Amazingly low prices! There's a Fox **MINI-BIKE** for everyone — from age 10 to adults.

EXTRA BONUS—Catalog shows radios, watches, walki-talkies, cameras, musical instruments, tools, appliances and many other items you can buy at practically wholesale prices. Free \$1 coupon.

FOX CORP., Box 797 PM Janesville, Wis. 53545

WHEN ANSWERING ADS
GIVE YOUR ZIP CODE



NEW PREVAL* SPRAYMAKER

**SPRAYS ANY COLOR,
ANY FINISH!**

With this disposable power sprayer you can spray paint, varnish, stain, lacquer—custom-mixed or right-off-the-shelf. Use the same paint you use with brush or roller. No mess, no bother. It even sprays itself clean! Then fill with lubricant or rust-protector and protect tools and equipment. Sprays any household liquid. Better buy several. You'll find dozens of uses for them. Available at paint, hardware and hobby counters—wherever quality do-it-yourself products are sold.

**ONLY
\$149**

Complete
Suggested
retail price

**One Power Unit Sprays up to 16 oz.
Extra Power Units available**

* Reg. Trademark of Precision Valve Corp., Yonkers, N.Y.

Get your own full-color print of the

SATURN V

THE APOLLO 11 MOON ROCKET

Beautifully printed on heavy
paper suitable for framing.

(Size: 19 by 25 inches)

\$1.25 postpaid



Saturn V, Popular Mechanics, 575 Lexington Ave., New York, New York 10022

Please send me _____
copies of PM's Saturn V
painting. Enclosed find
\$1.25 for each.

Name _____
Street _____
City _____ State _____ Zip _____



DISCOVER THE TIMBERLINE

You packed the night before. Sleeping bags. Food. Rifles. Around four, you pulled out of a warm sack and headed for the timberline. Late that afternoon you found this place. Snug against the tall trees. Joy water nearby. Getting there was half the fun. Your 175 Single Enduro has 5-port power for better combustion. More muscle. The special Enduro forks take it all in stride. Separate tachometer. And reset speedometer. And Autolube, an automatic oil injection system. Tonight you'll turn in early. Tomorrow you'll take your Yamaha and go after a big one.

175 Single Enduro CT-1

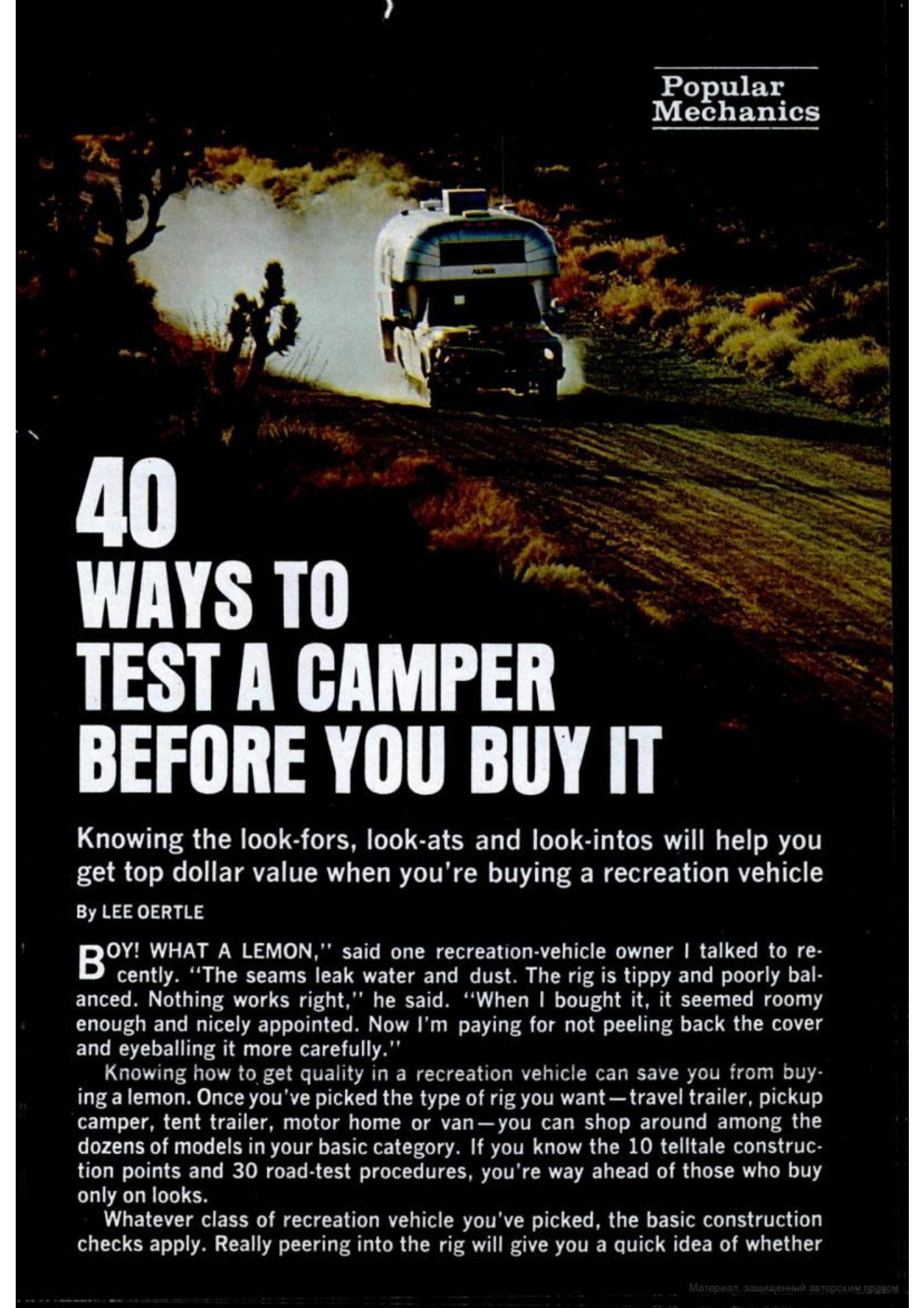


Yamaha International Corporation
P.O. Box 54540 Los Angeles, California 90054

YAMAHA

It's a better machine





40 WAYS TO TEST A CAMPER BEFORE YOU BUY IT

Knowing the look-fors, look-ats and look-intos will help you get top dollar value when you're buying a recreation vehicle

By LEE OERTLE

BOY! WHAT A LEMON," said one recreation-vehicle owner I talked to recently. "The seams leak water and dust. The rig is tippy and poorly balanced. Nothing works right," he said. "When I bought it, it seemed roomy enough and nicely appointed. Now I'm paying for not peeling back the cover and eyeballing it more carefully."

Knowing how to get quality in a recreation vehicle can save you from buying a lemon. Once you've picked the type of rig you want—travel trailer, pickup camper, tent trailer, motor home or van—you can shop around among the dozens of models in your basic category. If you know the 10 telltale construction points and 30 road-test procedures, you're way ahead of those who buy only on looks.

Whatever class of recreation vehicle you've picked, the basic construction checks apply. Really peering into the rig will give you a quick idea of whether



CHECK for service convenience. Ask dealer for location of dipstick, battery, oil fill and radiator fill

you want to go as far as road-testing this make and model.

It's the splinter test that tells the most about quality. Run a finger under bottom edges of cabinet doors, molding and wood trim inside the coach. You may snag your finger on wood in some cheap units. In other rigs, the under-edge finish is so bad you can see splinters several feet away.

Next is the hop and grab test. This will clue you on construction strength. Hop up and down on the coach floor. Hop up and down on the coach floor. It's a bad sign if it feels spongy or soft—or if it squeaks. Quality coaches will have solid-feeling floors that are firm and quiet. Now grab an overhead bunk and shake it vigorously. If the walls tremble and move an inch or so—reject the coach.

COMPARE TYPES of rigs before buying. Motor home (left) costs the same as pickup and coach (below). For the same money, you can pick from four different classes of vehicle—each with its own features

Outside the coach, examine metal seams. They should be tightly sealed, with no gaps for wind or water. Crooked seams driven in on a slant mean poor construction.

Open cabinet and bin doors. They should be finished on the inside. If not, judge quality to be low.

Open cabinet doors closest to the floor. In cheap coaches, the tile or other covering stops at the cabinets.

Pull out drawers and examine the workmanship. Cheap drawers are stapled together. Quality drawers are glued, screwed, or screw-nailed in several places. The best drawers slide smoothly. Cheap ones balk and grab.

Where plumbing and electrical lines enter the coach, tough, weathertight rubber bushings should be used. In a cheap coach, large gaps will be found around the lines.

Lift the dinette seat cushions and turn them over. Are the backs covered with a durable material? Cheap cushions might have thin cotton fabric or even a burlaplike material, or perhaps no backing at all.

Windows can be louvered, sliding, or swing-out. The important point is that they should close tightly against dust, water and drafts. Try squirting a high-pressure hose up against the closed panels to see if any water enters.

If a dealer balks at any of the tests you can bet he's hiding something. Regardless of the brand name, check it out! The company with a high-quality item will be delighted. All others had



better be able to explain why they object to a close physical inspection. Some salesmen are quite ingenious at dodging issues. One hotshot told me the coach floors were "patented," and he could not let anyone look inside the cabinet areas until after they'd purchased the coach!

Now you should road-test your chosen recreational vehicle.

Here are a few items to remember when testing a travel trailer. A dealer will make the towing test with a company car, usually a heavy sedan, with all kinds of special heavy-duty towing equipment on it. No experienced dealer would think of making a demo-run with an ordinary hitch. He uses a load-



GROUND CLEARANCE is important. It can vary from 4 inches on sedans to 11 inches on pickups and vans

Checks for Any Rig

- Take your test unit over a two-mile stretch of dusty road. Stop and inspect the interior. The more dust it contains, the lower the quality.
- Check for special equipment needed to operate the camping vehicle. The less, the better. There's one exception to this rule—get a good load-equalizing hitch for a trailer over 1500 pounds total weight.
- Check for storage space. Some coaches have a lot, some have a little.
- Check the water system. It should have a larger-than-average capacity—say, 20 to 25 gallons.
- Check lighting systems. The best coaches will offer three systems as standard equipment: 12-volt, 110-volt and butane lamp.

equalizing hitch. The improvement in towing control is amazing: fishtailing is eliminated and hard crosswinds have virtually no effect on a car towing a large trailer. Also, the dealer will take his customers over a preselected "milk-run" that he knows well. On this road he could tow a trailer through gale-force winds without a wiggle!

Don't blame the dealer for this. He

(Please turn to page 190)

WHEN TESTING A TRAILER, pick a steep grade and sharp bends. Trailer should ride level with the car



SETUP TIME is important in a camp trailer (above). Before buying, open and close unit several times



The Dream Comes True

Seventeen years ago experts told how a lunar expedition could be made. How accurate their plan turned out to be is described here, the first of five features in this issue devoted to man's next giant step in space—a moon landing.

Original painting created by Rolf Klep in 1952

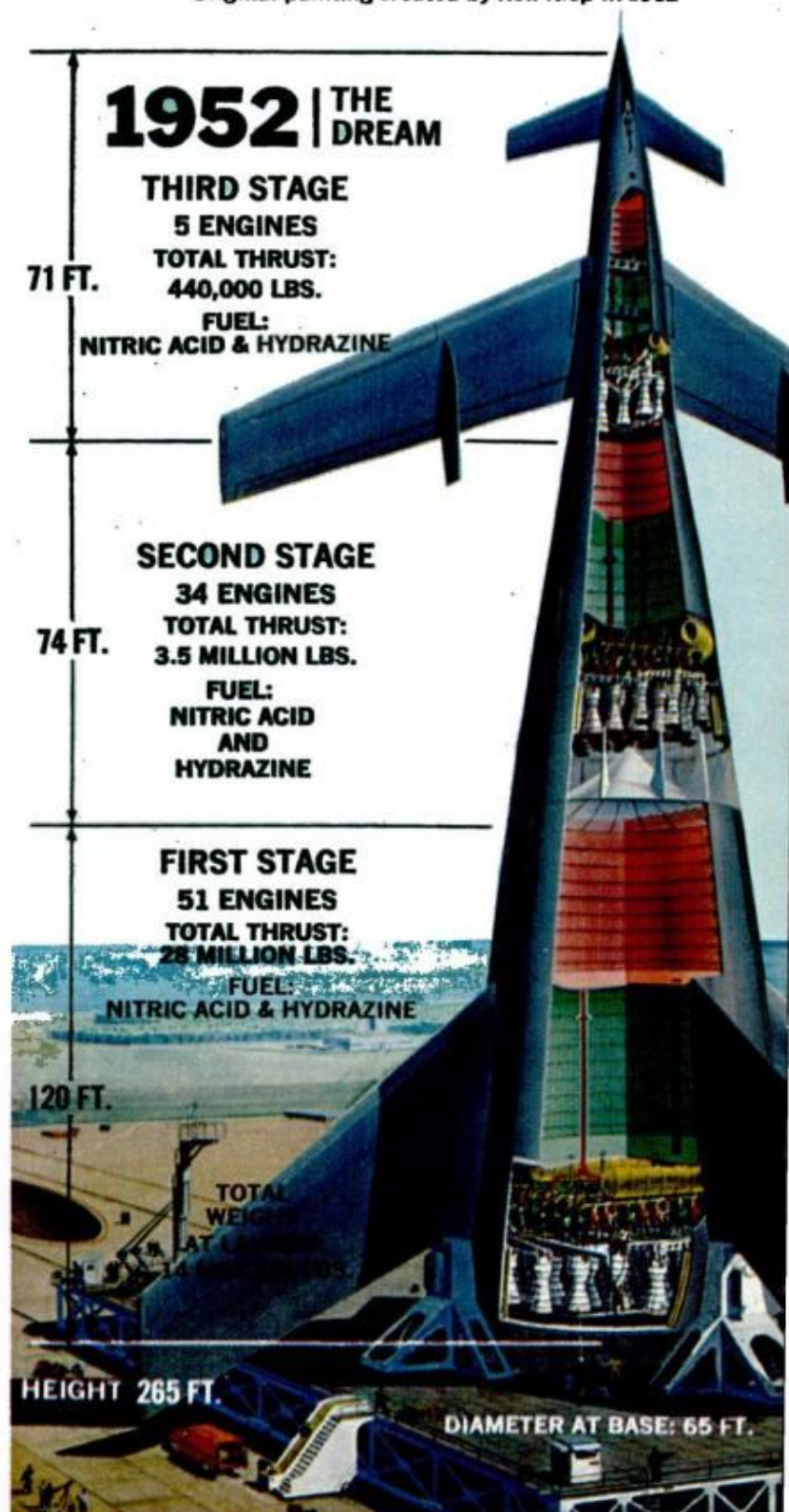
By JOHN F. PEARSON

OUR TRIP TO THE MOON will not be a simple nonstop flight from the Earth. We'd need too large and expensive a rocket ship for that. Instead, we'll make a stopover in space. We'll change vehicles, shifting from one especially designed to break away from the Earth's atmosphere into one specifically designed for moon voyage . . ."

Sound familiar? This statement might have been written as recently as a few months ago. Actually, it appeared in a 1952 issue of *Collier's* as part of a series of articles by Wernher von Braun, Willy Ley and Fred L. Whipple.

Dr. von Braun, famous as the co-designer of the German V-2 rocket, had joined the rocket-development effort in the United States following World War II. Ley, a pioneer writer about space, was a founder of the German Rocket Society. Dr. Whipple, was chairman of the astronomy department at Harvard. They were men of sound credentials and soaring dreams, superbly qualified to lay out a blueprint for a moon voyage and exploration.

How accurate was their crystal ball? You can judge for yourself by comparing their rocket concept (right) with the Saturn 5 and their moonship (page 82) with the LM. Remember, this team did its brainstorming 17 years ago when Buck Rogers still was the biggest



1969 | THE REALITY

LAUNCH
ESCAPE 33 FT
SYSTEM

APOLLO
COMMAND
AND
SERVICE
MODULES

53 FT.

LUNAR
MODULE
ADAPTER

THIRD
STAGE

1 ENGINE
THRUST:
230,000 LBS.

58.5 FT.

FUEL:
LIQUID OXYGEN
AND
LIQUID
HYDROGEN

SECOND
STAGE

5 ENGINES
TOTAL THRUST:
1 MILLION LBS.

81.5 FT.

FUEL:
LIQUID
OXYGEN
AND
LIQUID
HYDROGEN

FIRST
STAGE

5 ENGINES
TOTAL THRUST:
7.5
MILLION LBS.

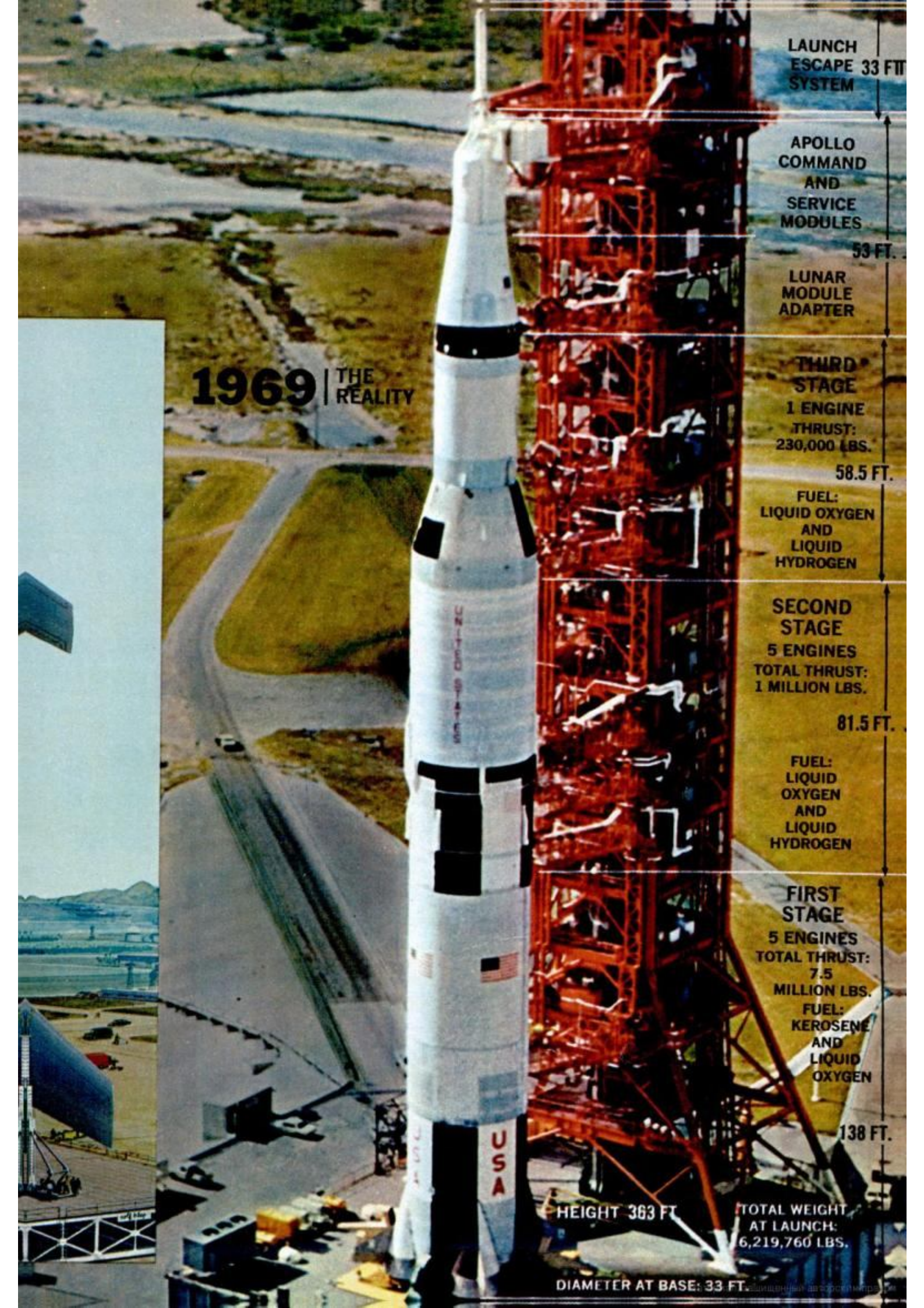
FUEL:
KEROSENE
AND
LIQUID
OXYGEN

138 FT.

HEIGHT 363 FT

TOTAL WEIGHT
AT LAUNCH:
6,219,760 LBS.

DIAMETER AT BASE: 33 FT.



name in space. That was five years before Russia astounded the world with the launch of Sputnik 1 in 1957 and nearly 10 years before John Glenn successfully rode around the world in a Mercury capsule. Small wonder, then, that skeptics regarded the blueprint as science-fiction.

"We will go to the moon in the next 25 years," the three "dreamers" announced in revealing their carefully worked-out plan. The rocket they envisioned was a huge three-stage vehicle,

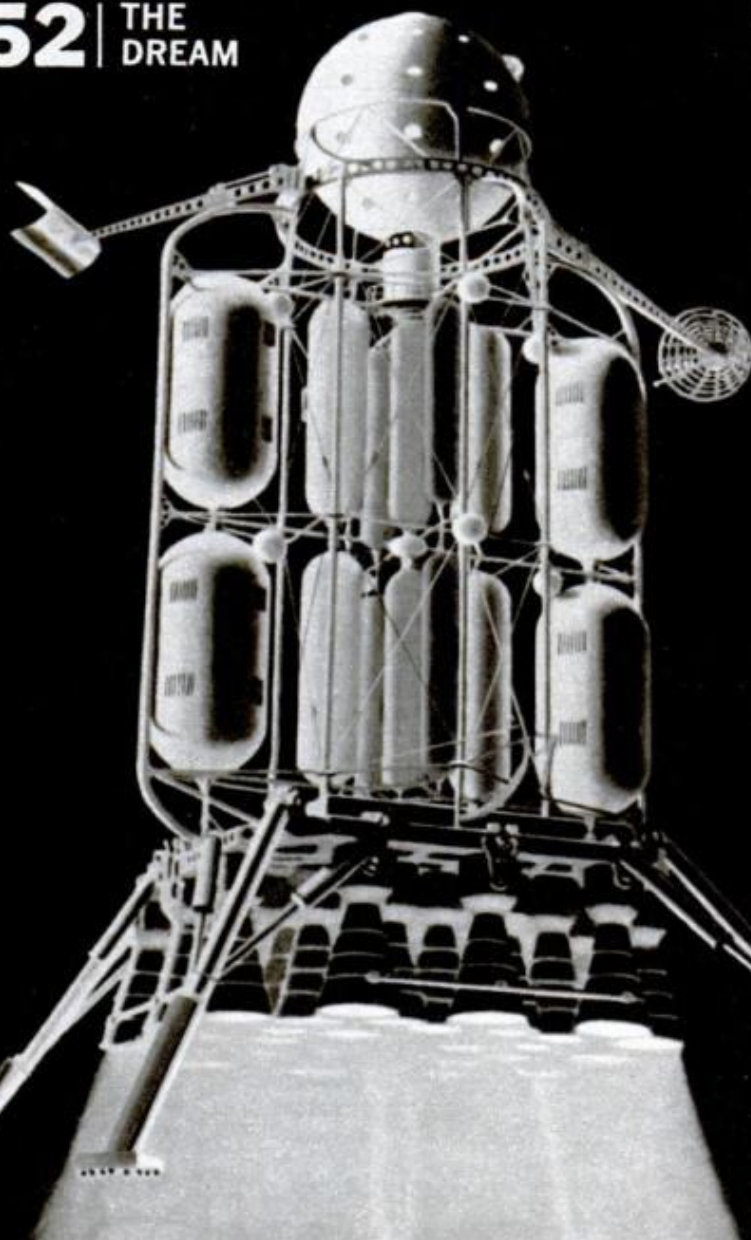
though not as tall as the Saturn 5.

The only features of the rocket that appear unusual to us today are the big stabilizer fins on the first stage and the airplane-type wings sported by the third stage. The presence of the wings points to the major difference between the '52 blueprint and the way the Apollo missions are executed.

As late as 1962, our space scientists were debating the best way to land a man on the moon. Discussions centered on the two major objectives: how to

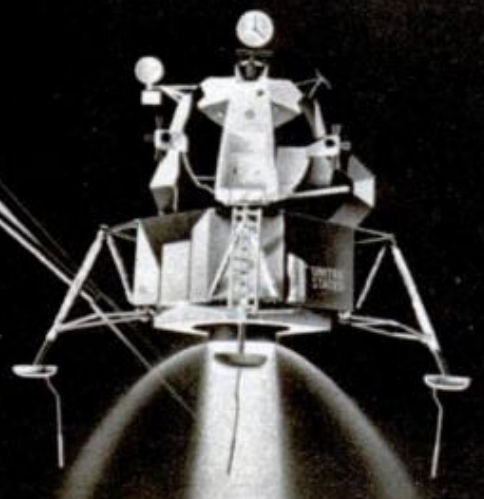
Original painting created by Chesley Bonestell in 1952

1952 | THE DREAM



UNDER THE LM's thin aluminum skin is a configuration of fuel and oxygen tanks similar to that of its '52 cousin. The earlier "spider" was 160 feet high and 110 wide, designed to carry 20 men on a round trip from Earth orbit to the moon. The 23-foot-high LM is built to carry two men 140 miles and is destined to be jettisoned after doing its job

1969 | THE REALITY



Subject of debate: the best way to get men there and back

provide enough power to break away from Earth's gravity and make a lunar landing, and how to return the astronauts safely to Earth.

Four methods were considered:

- Send a rocket directly to the moon. This called for a rocket of monster proportions and the ability to land it gently, tail down, on the moon. Launching it for the return trip would be another major problem. (Buck Rogers would have felt right at home aboard this one.)

- Send several rockets, some carrying only fuel and supplies. The idea was that the astronauts could refuel their ships by using the supplies landed on the moon. But there would be no way of knowing if the supplies had landed intact or even within reach.

- Use an Earth orbit rendezvous (EOR), which called for placing sections of a moon vehicle in Earth orbit, there to be assembled for lunar flight.

- Use a lunar orbit rendezvous (LOR). A large rocket would achieve moon orbit, permitting a smaller vehicle to be detached for a lunar landing.

Because it appeared to be the fastest, LOR was the method finally adopted by NASA. This decision might not have been made if it weren't for a NASA engineer, Dr. John C. Houbolt, who

waged a lonely campaign for the concept early in the 1960s. Some scientists remained unconvinced, however, pointing out that LOR required carrying out critical maneuvers—rendezvous and docking—230,000 miles from Earth, too far to send help to a crew in trouble.

Many experts still favored an Earth-orbit method. According to the original von Braun-Ley-Whipple plan, three-stage rockets would place sections of a space station in a 1075-mile Earth orbit. Assembled, the station would be the base for the moon voyage. Moon ships would be shipped in pieces for assembly.

One of the keys to the project was the use of the rockets' third stages (the only stages to achieve orbit) in a shuttle system. After delivering cargo, the third stages would be sent back to Earth. In cutting through the atmosphere they would use their wings, functioning as rocket planes with the ability to land at an airstrip.

The major advantage of this plan over the others would have been that the space station is orbiting at 15,840 mph, according to von Braun and his fellow authors, so that an added push of only 6260 mph is needed to send ships to the moon. The moon-landing craft they de-

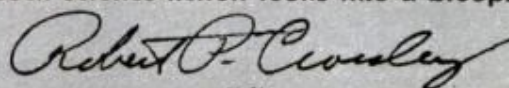
(Please turn to page 203)

FOLKS LAUGHED, back in 1952, when *Collier's* magazine ran a series of articles showing how man would go to the moon within 25 years. They called the editors "space cadets" and ridiculed two of the authors, Wernher von Braun and Willy Ley, as a couple of nutty Germans. But space achievements since then have quieted the laughter.

On the eve of our first attempt to land men on the moon (eight years ahead of schedule, you might say), *Popular Mechanics* thought you might be interested in looking at the concepts shown in the paintings that illustrated the '52 articles. Aerospace artist Fred L. Wolff, we discovered, had the file of *Collier's* articles. But tracking down the original artwork was not that simple, for *Collier's* has been dead 11 years.

We called Roger Dakin, former *Collier's* editor and now an executive of General Foods, and Cornelius Ryan, author of *The Longest Day*, who, as a *Collier's* staffer, supervised the series. Finally, art director Tom Dauer located Rolf Klep living in Oregon. Klep made his '52 painting of a moon rocket available to us so that we could run it with a photo of the Saturn 5. Chesley Bonestell's painting of the huge moon-landing vehicle had long-since vanished, but Bonestell, still a space enthusiast at 81, agreed to recreate it for *Popular Mechanics*.

Compare the real hardware of 1969 with the dreams of 1952. Amazing, isn't it, how similar they are. What seemed so much science-fiction looks like a blueprint today.



Editor



Man's First Day On the Moon

After scanning the desolate moonscape, Neil Armstrong will descend the LM's ladder to become the first man ever to set foot to the moon. Serious exploration then begins

By JAMES R. BERRY

IT WILL HAPPEN ANY DAY NOW. In what history will record as the drama of the century, two men, after voyaging some 230,000 miles from their mother planet, will scout the first stepping stone to the solar system—our moon.

Barring a last-minute change, it will be Neil Armstrong and Buzz Aldrin who will view the arid lunar terrain as the spidery lunar module settles on the moon's surface. To get them there the United States will have devoted almost a decade of scientific effort and about \$24-billion. And, the very first decision—one that has to be made within two minutes after touchdown—is whether the astronauts should come straight home.

"The way the orbits work, the ascent stage of the lunar module (LM) can blast off and reunite with the command module orbiting above within the first 120 seconds," says Dick Green, NASA's manager of the Apollo Surface Exploration Program. "In that time we've got to make sure that the fuel tanks aren't leaking, that the power is fully operative, and that no other systems are beginning to fail. If something is wrong, they come right back."

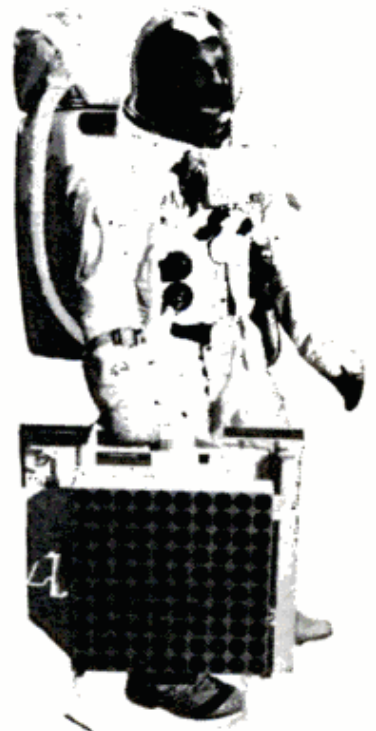
Chances are everything will function. The pair will then spend the next 22 hours on the moon, with at least two hours—and possibly closer to three

—exploring the satellite's surface. The exact timetable they'll follow is, at this writing, not completely decided. Any given task can be changed, eliminated, or switched in priority.

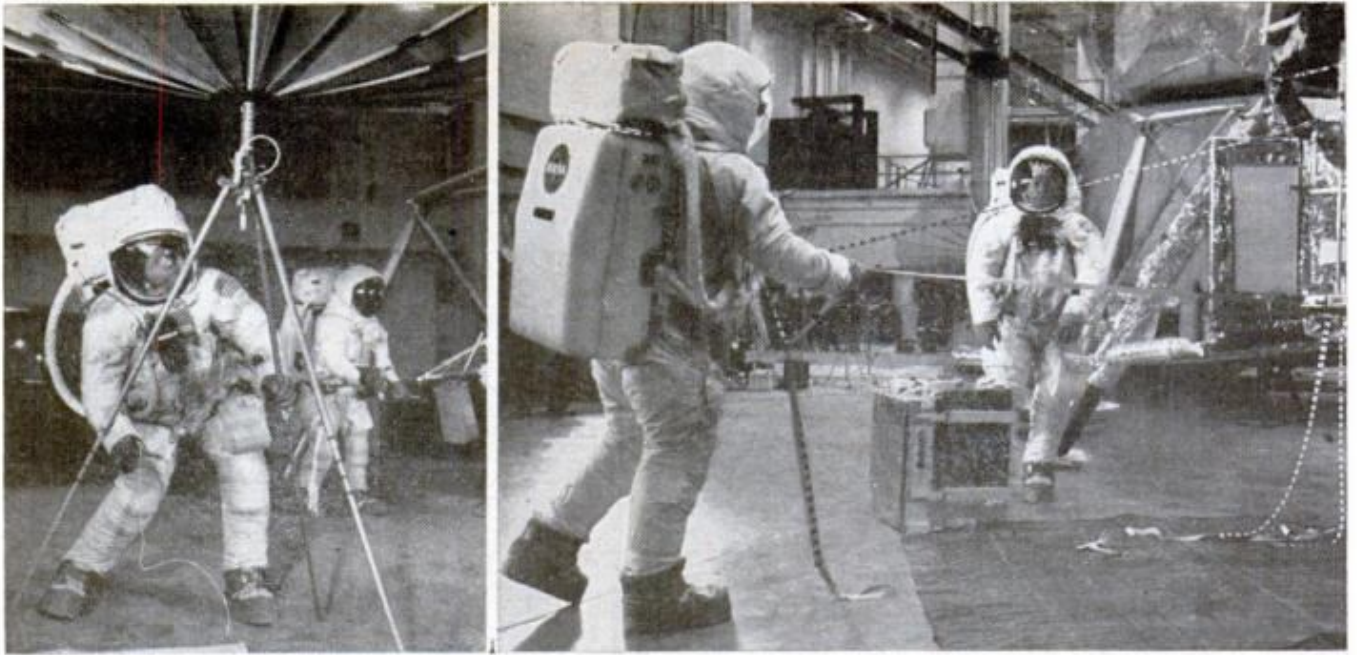
For two hours after landing, Aldrin and Armstrong will run through a complete countdown of the LM—just as though they had already completed the mission. If any problem develops, the pair will spend time solving it. Otherwise, the countdown will end 10 minutes short of blast-off.

When NASA is satisfied that the LM is in perfect operating condition, the men will prepare for the extravehicular activity (EVA), the space agency's term for a stroll on the moon.

Getting ready for EVA is no easy matter. The men will need almost an hour to don the backpack life-support system, referred to as PLISS. When combined with the space suits, the backpacks turn the astronauts into independent, man-powered satellites that are able to operate in total vacuum and in a temperature range



IF TIME PERMITS, astronauts will set up this instrument near landing site. A panel of optical reflectors, it will serve as target for Earth-based laser systems. Reflected laser beams can be used to measure precise distance from Earth to moon



WEEKS BEFORE LAUNCH DATE, astronauts Neil Armstrong and Edwin E. Aldrin go through their moon routine. Armstrong positions dish antenna (left) and Aldrin practices lowering experiment from mockup of LM

of from minus 250° F. to plus 325° F.

The astronauts will spend another 15 minutes checking the communications, oxygen, temperature control and other systems of their suits and backpacks; the slightest problem will scratch the EVA. If everything operates normally, NASA will radio its permission to begin man's first exploration of the moon. Here is the elapsed-time schedule:

00 Minutes. Armstrong and Aldrin switch off the LM's internal oxygen supply and open the hatch. In a fraction of a second, the compartment's interior becomes a near-perfect vacuum. The only sounds they hear are the crackle of their radios and the hum generated by backpack pumps forcing oxygen and water through their suits.

At this writing, according to a NASA announcement, it will be Neil Armstrong—the command pilot—who lowers the gold-plated sunshield on his helmet and crawls through the open hatch to a ledge just outside.

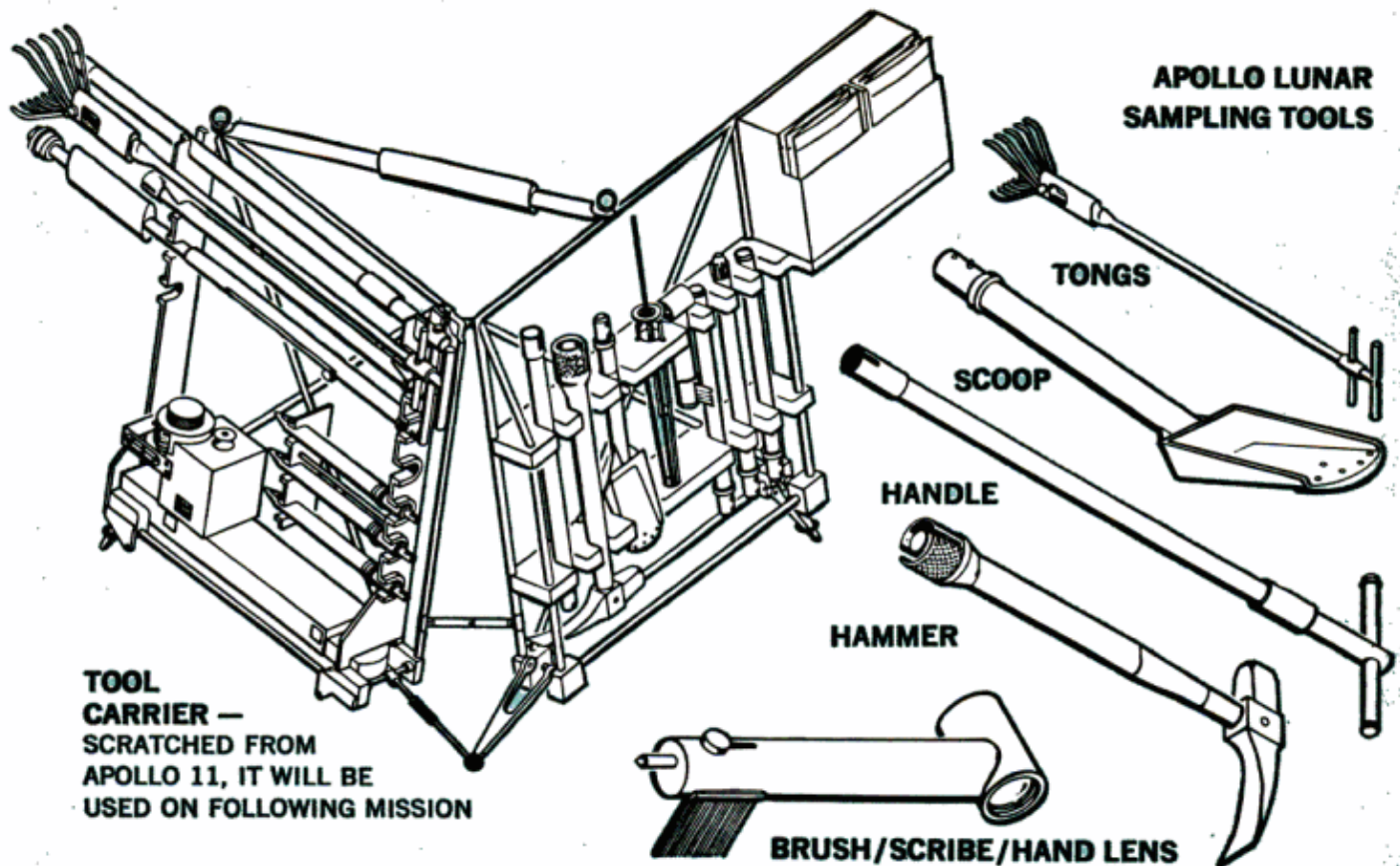
10 Minutes. For the next seven to ten minutes, Armstrong cautiously climbs down a nine-runged ladder leading from the LM's platform. Ultracautious, NASA insists that he rest almost a minute at every step, acclimating himself to working in one-sixth of Earth's gravity.

As he pauses on the third rung, Armstrong reaches to his right and pulls a D-ring handle jutting from the LM's side. A compartment called the modular equipment stowage area (MESA) slides out from the craft's lower left side at a 45° angle. In the MESA are geological tools, scientific equipment and a TV camera.

The camera points toward the ladder and automatically begins transmitting as the MESA slides out. If the LM is within range of NASA's 85-foot dish antenna in Goldstone, Calif., we'll see on our screens Armstrong groping down the remaining six rungs to reach moon soil. If the Goldstone antenna is out of range, that historic moment will be caught by a 16-mm sequence camera at the LM's window.

20 Minutes. No one knows how low gravity and a bulky space suit inflated to 3.75 p.s.i. will affect an astronaut's movements. So, like a butterfly just emerged from its chrysalis, Armstrong's first job is to gauge stability and mobility. Holding the ladder with one hand, he gently moves alternate arms and legs, and flexes his knees.

Then comes paydirt. Carrying out a top-priority assignment, Armstrong pulls what looks like a small butterfly net with an extension handle from a



roomy thigh pocket. After extending the handle, he scoops moon dust into the plastic bag at the instrument's end and stows the bag in his pocket. He throws the handle away; it is the first piece of moon litter.

"With this contingency sample of lunar soil, we'll have *something* from the moon even if the astronauts come back immediately after," explains NASA's Dick Green.

Armstrong next takes a few dozen photos with a battery-activated, 70-mm Hasselblad camera strung around his neck. Nasa wants him to get shots of the LM's feet, his own boots, and the terrain.

35 Minutes. During this time, technicians at NASA headquarters will be monitoring the oxygen supply, temperature, and other systems of the space suits and backpacks. They will also watch the heart and respiration rates of each astronaut—information relayed by transducers taped to the men. If NASA is satisfied with the readings, Armstrong will get word to walk the six or seven feet to the MESA.

These steps could prove a big effort. The moon's low gravity cuts friction between feet and ground, making stop-

ping a problem. Consequently, Armstrong will adopt a shuffle to reduce momentum and avoid bouncing, a motion that could lead to a tumble.

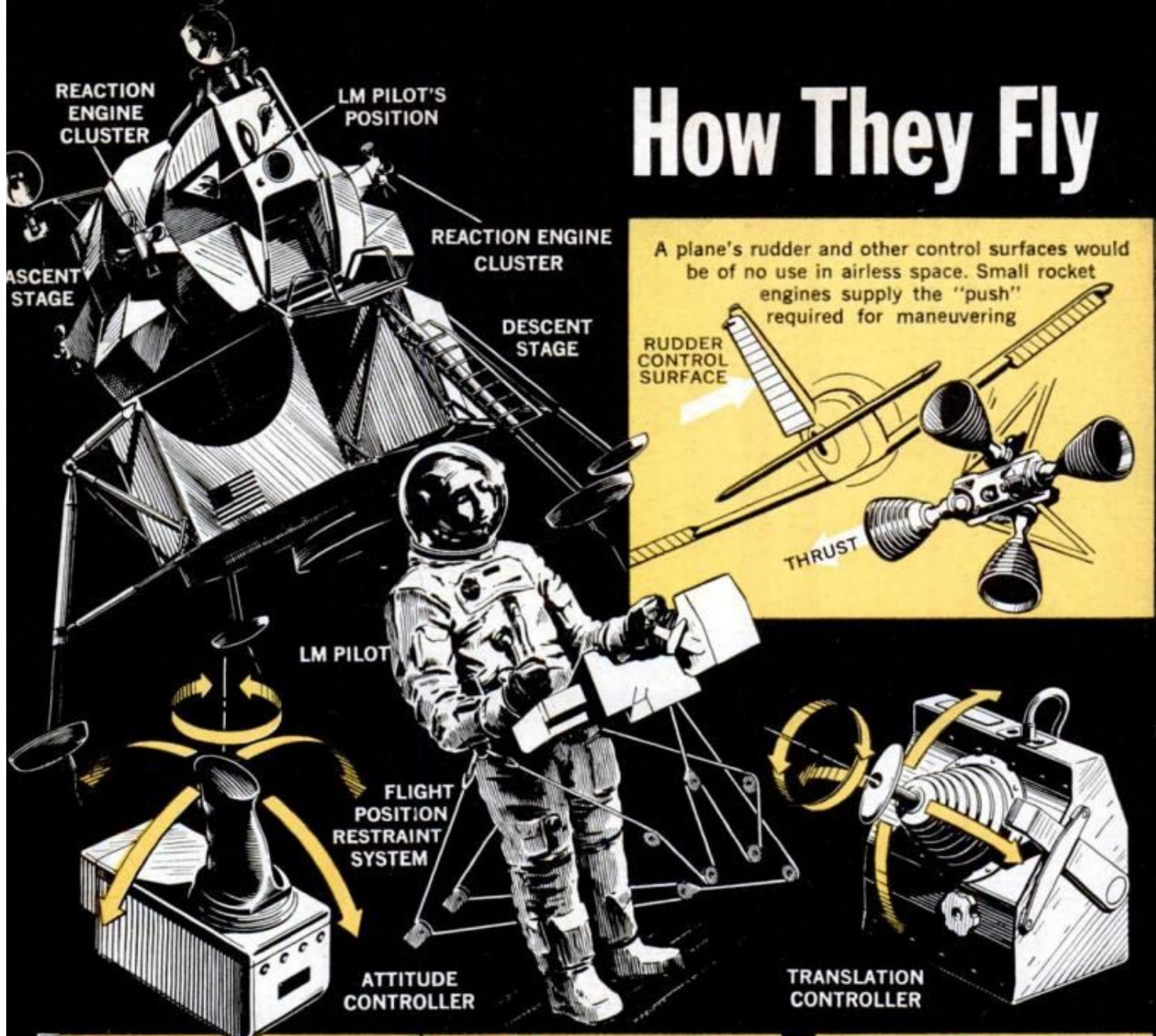
Many NASA experts believe that working in low gravity will be exhausting. Others think that it will be easier than on Earth. No one knows for sure, and teams of NASA specialists will be eyeing Armstrong's oxygen consumption and other physiological details as he continues his assignments.

Once at the MESA, Armstrong lifts out the TV camera and a tripod, carries them 20 feet or so away, and points the camera toward the LM. Next, he sets up another tripod, also contained in the MESA, some 30 yards off. From the top of this tripod, he unrolls a sheet of ultrapure aluminum foil and points it toward the sun. The apparatus, called the solar wind composition experiment, looks like a home movie screen.

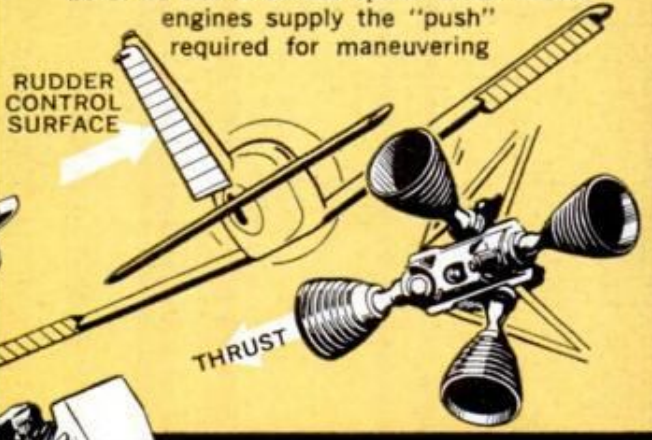
In the moon's vacuum, atoms of noble gases such as argon and krypton will be captured in the aluminum. On earth, chemical analysis of the aluminum will show how much of what gas struck the foil. This information will

(Please turn to page 196)

How They Fly



A plane's rudder and other control surfaces would be of no use in airless space. Small rocket engines supply the "push" required for maneuvering



APOLLO MODULES	ROLL RIGHT	ROLL LEFT	PITCH UP
	LUNAR MODULE		
TILT RIGHT		TILT LEFT	PULL BACK
ATTITUDE CONTROLLER			

the LM and Apollo

Ever wonder what it's like to pilot a spacecraft? Here, PM puts you at the controls of our moon-mission ships.

AIR SPELLS THE DIFFERENCE between flying an airplane and a spaceship. With no air to work against, the LM and the Apollo modules use rockets to alter position in orbit or to go into a different orbit. Both craft have four clusters of engines to provide control of three basic motions: roll; pitch (nose swings up or down); yaw (nose swings right or left). Attitude control is also achieved by gimbaling (tilting) the main propulsion engine of the service module or of the LM's descent stage. Each craft has two primary manual flying controls: At the pilot's right hand is a pistol-grip **attitude controller**, similar to a plane's joy stick, which is used to select and fire engines; his left hand operates a T-handle **translation controller**, a throttle regulating the power put out by the engines. The controls are standardized so that the same pilot can handle either craft. ★★★

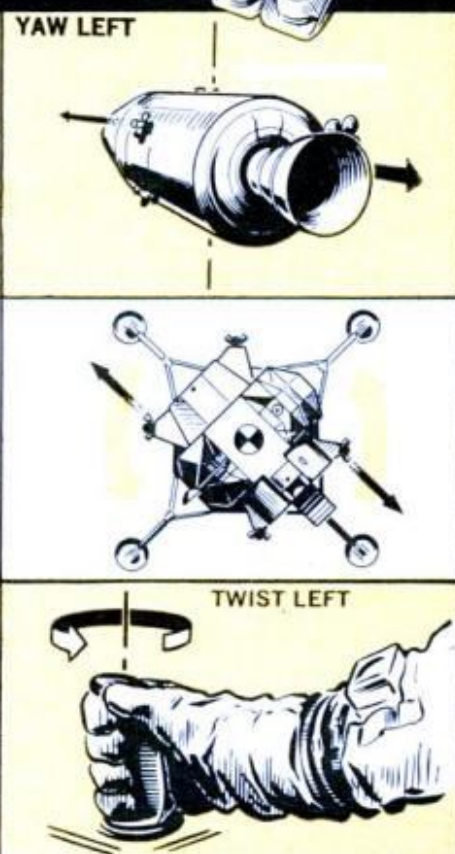
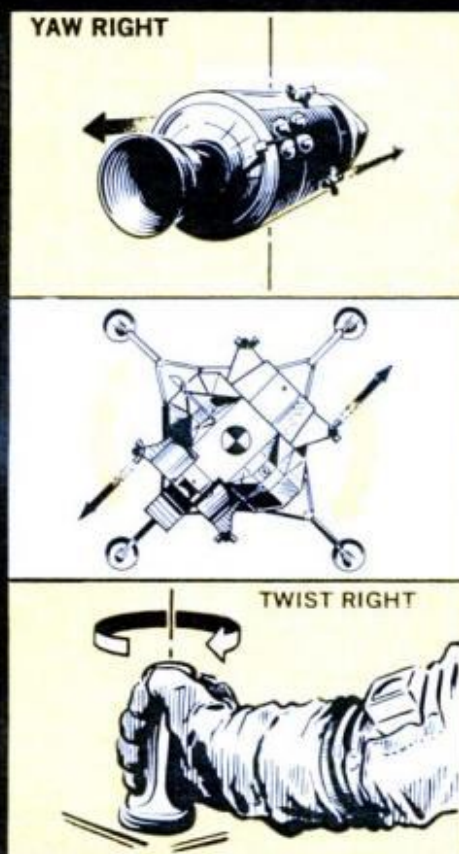
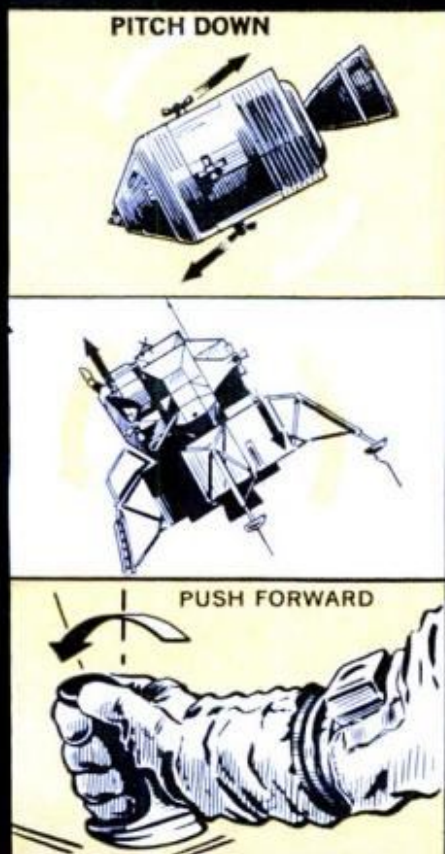
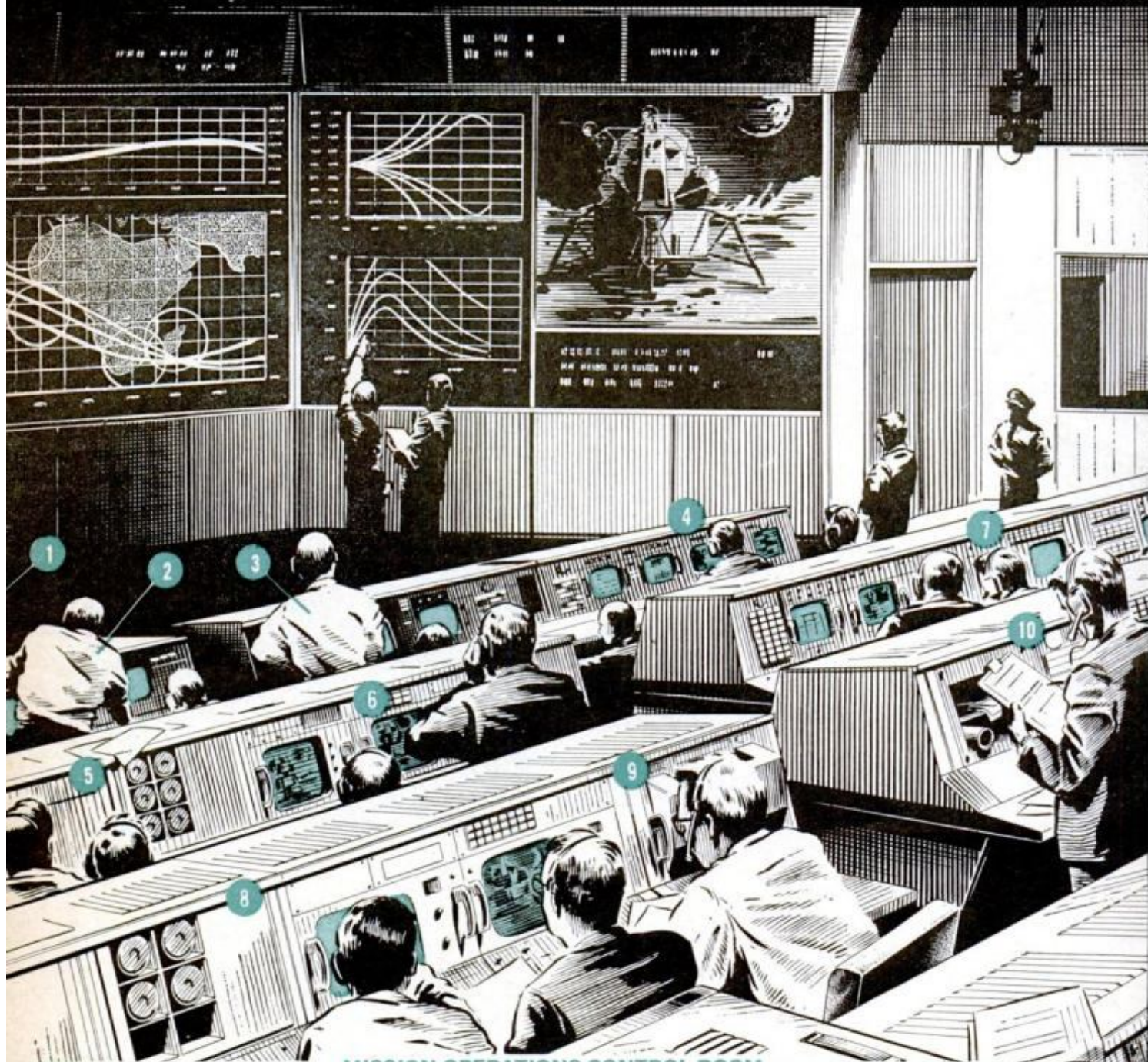


Illustration created for Popular Mechanics by aerospace artist Fred L. Wolff

...and Now,



MISSION OPERATIONS CONTROL ROOM

At the front are projection plotboards, digital clocks and a 10-foot-square TV screen for pictures and displays from any of 90 channels. All consoles contain similar equipment: keysets for calling up information; teleprinters; high resolution TV monitors; digital TV displays; pneumatic tubes for in-house communications. Areas of responsibility:

1 Booster Systems Engineer—advises flight crew and Flight Director of abnormalities; **2** Retrofire Officer—determines retrofire times; **3** Flight Dynamics Officer—gives "go" or "abort" recommendations; **4** Guidance Officer—monitors deviations in programmed events; **5** Flight Surgeon—directs all operational medical activities; **6** Spacecraft Communicator—handles voice communications with astronauts; **7** Vehicle Systems Engineers—evaluate performance of electrical, mechanical and life-support equipment; **8** Operations and Procedures Officer—responsible to Flight Director for ground support systems; **9** Assistant Flight Director; **10** Flight Director—responsible for detailed control of mission from liftoff to conclusion of flight; **11** Experiments and Flight Planning—monitors accomplishment of flight planning and scientific experiments; **12** Network Controller—responsible for operational control of worldwide data acquisition network; **13** Public Affairs Officer—channels information to the public; **14** Flight Operations Director—responsible for successful completion of flight operations; **15** Mission Director—overall mission responsibility; **16** Department of Defense Representative—control of armed forces supporting mission. ★★

Back to Mission Control

Illustration created for Popular Mechanics by aerospace artist Fred L. Wolff

THE MEN WHO SIT AT THESE CONSOLES are probably the most serious-minded eavesdroppers of all time. Day after day, the attention of flight controllers, scientists and technicians in the Mission Operations Control Room of the Manned Spacecraft Center, Houston, is trained on a speck in space named Apollo. They must make the key decisions during time-critical periods that will mean success or failure of the flight. They depend on a continuous torrent of information: tracking and telemetry data from a worldwide network of land stations, and instrumented ships and planes; immediate data and reference material from a computer complex; data from voice communications with the astronauts. You've seen this team in action on your TV. Perhaps you've wondered what individual members were looking at and what they were responsible for. Here, *Popular Mechanics* shows you in an exclusive "inside" view. ★ ★ ★



How You'll See

A half-pint camera and a mere whisper of power are teamed to beam clear, strong images across 230,000 miles of space. Here's how this remarkable setup works.

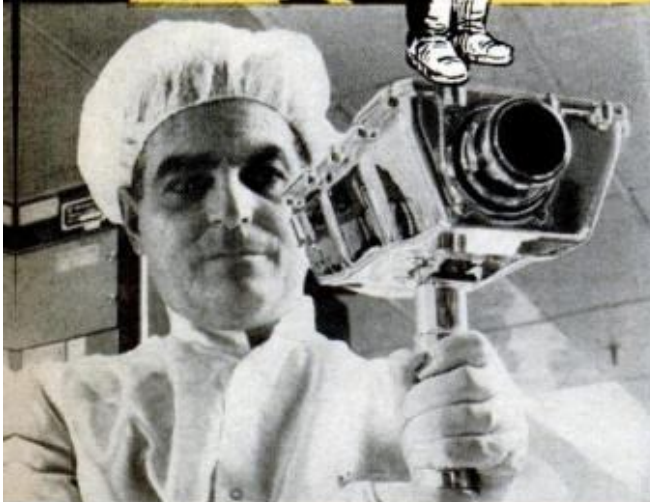
By PHIL GERACI

MOVING WITH CAUTION, the bulky, helmeted astronaut descends the ladder one rung at a time. He reaches the last rung, about 18 inches above ground level, and pauses for a full minute. Then he lowers a heavily booted foot until it touches moon soil, the first man in history to take that giant step.

That scene will be viewed on TV in homes across America and in many other lands if our astronauts follow the Apollo 11 "script" and if no gremlins get into the act between the launch at Kennedy Space Center and arrival at the moon.

The ability to send back clear TV pictures from space was impressively demonstrated during the Apollo 8 mission. The highlight came Christmas Eve, 1968, when Frank Borman, Jim Lovell and Bill Anders sent greetings some 230,000 miles to Earth. Viewers were amazed and perhaps a bit puzzled. They may have wondered how it was that local programs, beamed with 50,000 watts, sometimes didn't come in as well as the pictures from the reaches of space. How could a tiny 20-watt transmitter push a good signal so far?

Four technological accomplishments, in addition to all those that made the flight itself possible, made a reality of what many NASA technicians had feared might be a disappointing failure. The first of these was an RCA television camera so small it weighs only 4.5 pounds. Filled with row upon row



NEW APOLLO TV CAMERA is so sensitive it can produce pictures in the darkness of the lunar night. Designed by Westinghouse, it is built to operate in the extremes of temperature—250°F. to minus 280°F.—found on our barren satellite.

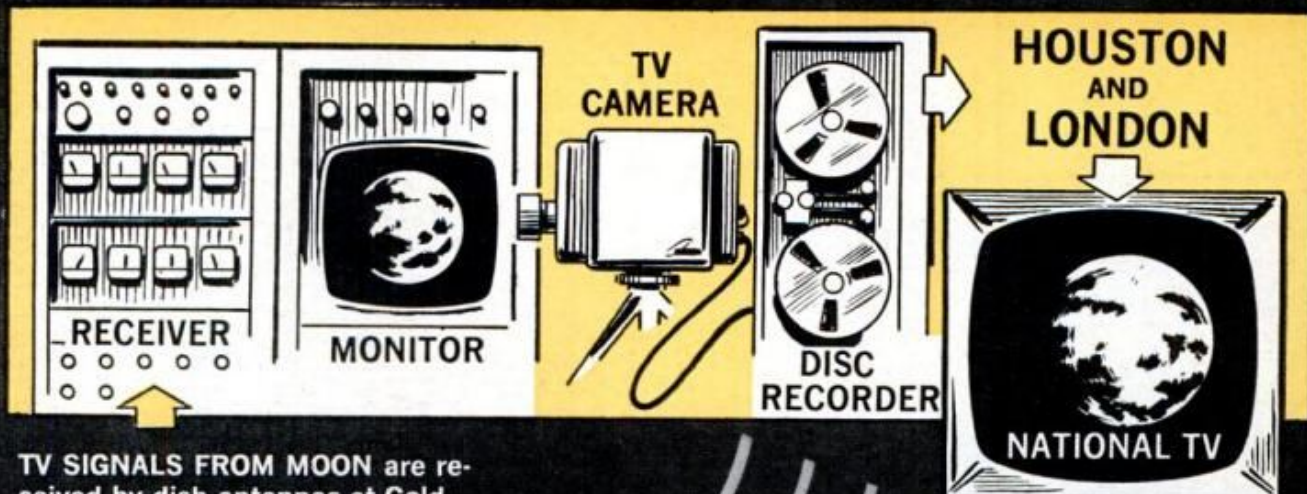
Our Men on the Moon

of integrated circuits, each smaller than a pinhead but capable of functions which a few years ago would have required several pounds of vacuum-tube circuits, the tiny instrument became a spaceborne eye for more viewers than had ever before been served by a single TV camera.

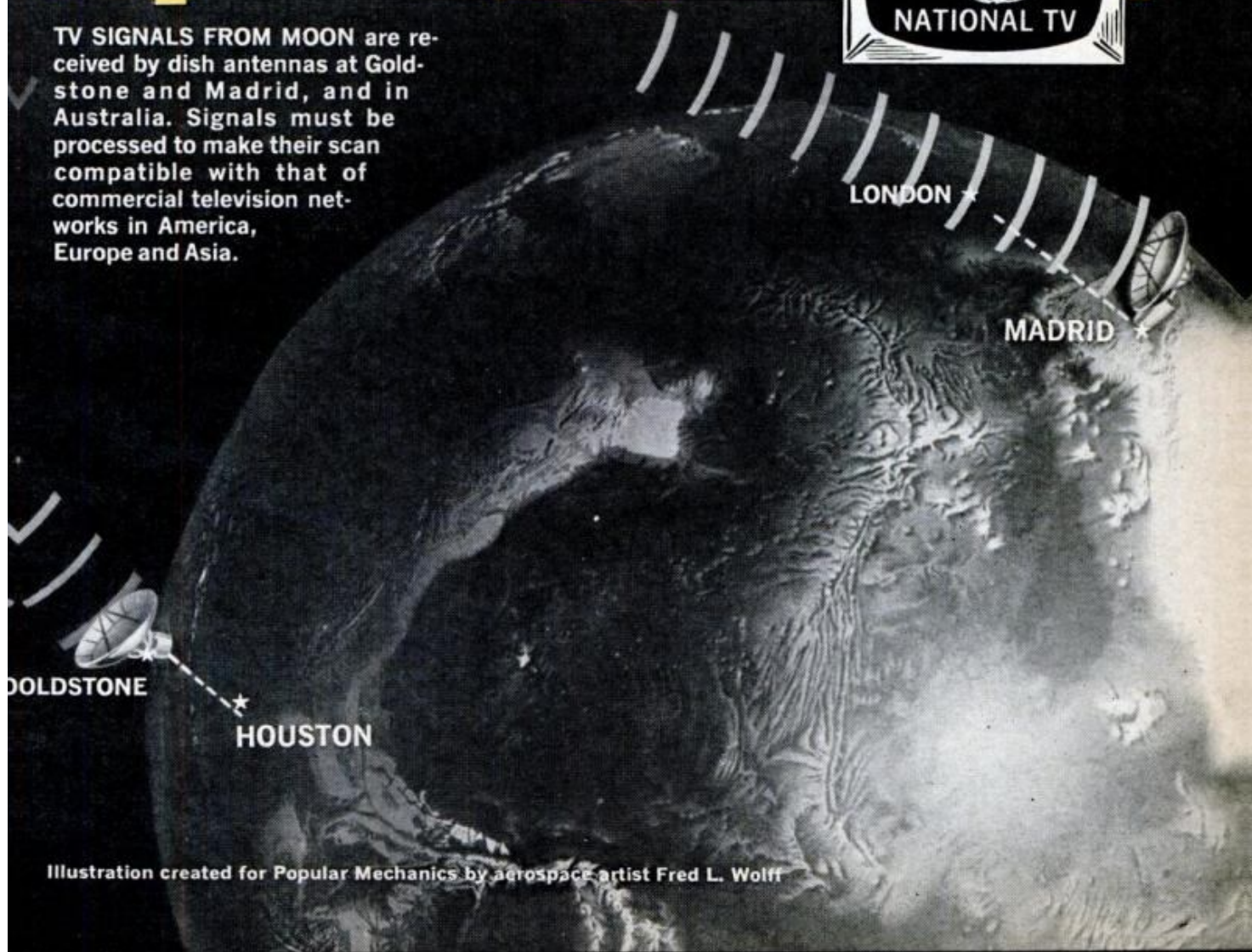
Another factor, perhaps even more

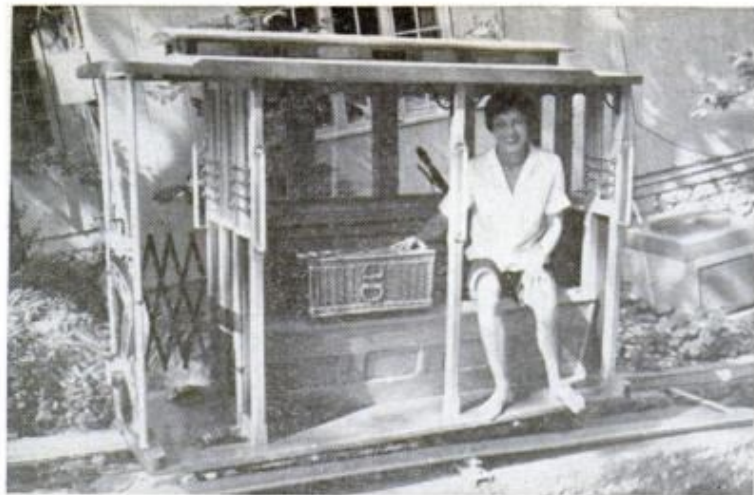
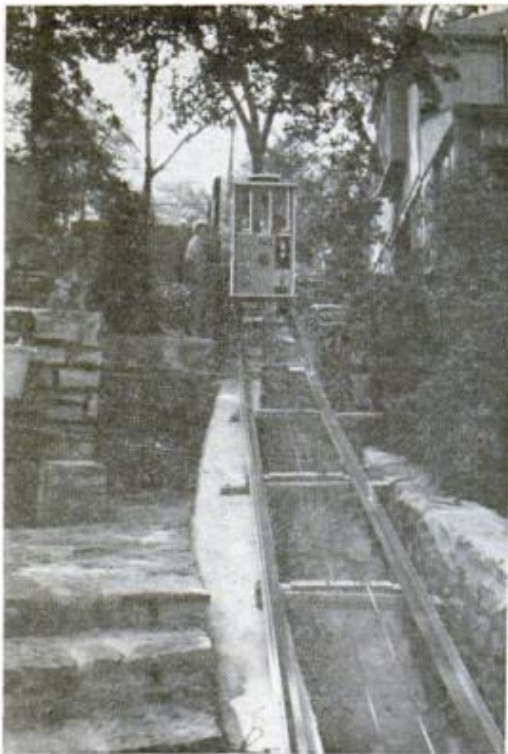
vital, was a new high-gain antenna aboard Apollo 8. Tucked into the side of the spacecraft during liftoff, the antenna popped into position on command and turned its four 30-inch steerable dishes toward earth, now just a basketball in space, and began to pour out its S-band transmissions. This

(Please turn to page 189)



TV SIGNALS FROM MOON are received by dish antennas at Goldstone and Madrid, and in Australia. Signals must be processed to make their scan compatible with that of commercial television networks in America, Europe and Asia.





'San Francisco' in the Midwest

There's a bit of old San Francisco at the lake home of N. C. Coates of Kansas City, who built a four-passenger replica of a San Francisco cable car to carry people and supplies up and down a 135-foot hill. Authentic even to paint, the car is driven by a 2-hp motor; automatic hydraulic brakes take over if cable fails.



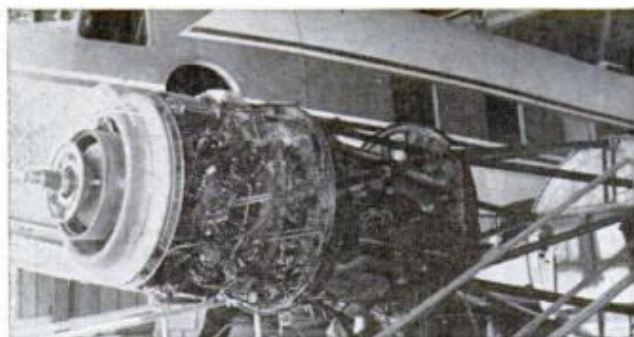
How'd you like to curl up on a banana or slice of bread?

This outside banana and slice of bread are really pieces of furniture—the banana's a sofa and the bread "a sort of rug." They're made and sold by London designer Neville Green.



Air-cushion airplane

Floating along on its air-cushion landing gear, the test aircraft of Textron's Bell Aero-systems Co. proved it could glide over mud, ice and even stumps. The 2-foot-thick air-cushion bag deflates and stows flat when the aircraft is in flight.



New power for DC-3

Rolls-Royce Dart engines are being fitted to the venerable DC-3 by Conroy Aircraft Corp. in Santa Barbara, Calif., giving the old-timer new performance characteristics. The turbo-prop engines are from Viscount airliners being phased out of passenger-carrying service.



Balloons that save lives

Large balloons made of rubberized fabric can be inflated rapidly to hoist wrecked vehicles off trapped occupants (above) or keep tottering walls from falling on cave-in victims (right). The balloons, inflated by exhaust fumes of an emergency vehicle or by compressed air, are being used by firemen in Bedfordshire, England.



24 hours in a plastic bag

Two men spent 24 hours in this plastic bag testing the life-support system that will go into a low-cost, inflatable underwater house being developed at London University. The house, the same size as the plastic bag, will be tested off Malta this summer. The goal of the project is to develop an underwater station for small firms and research teams.



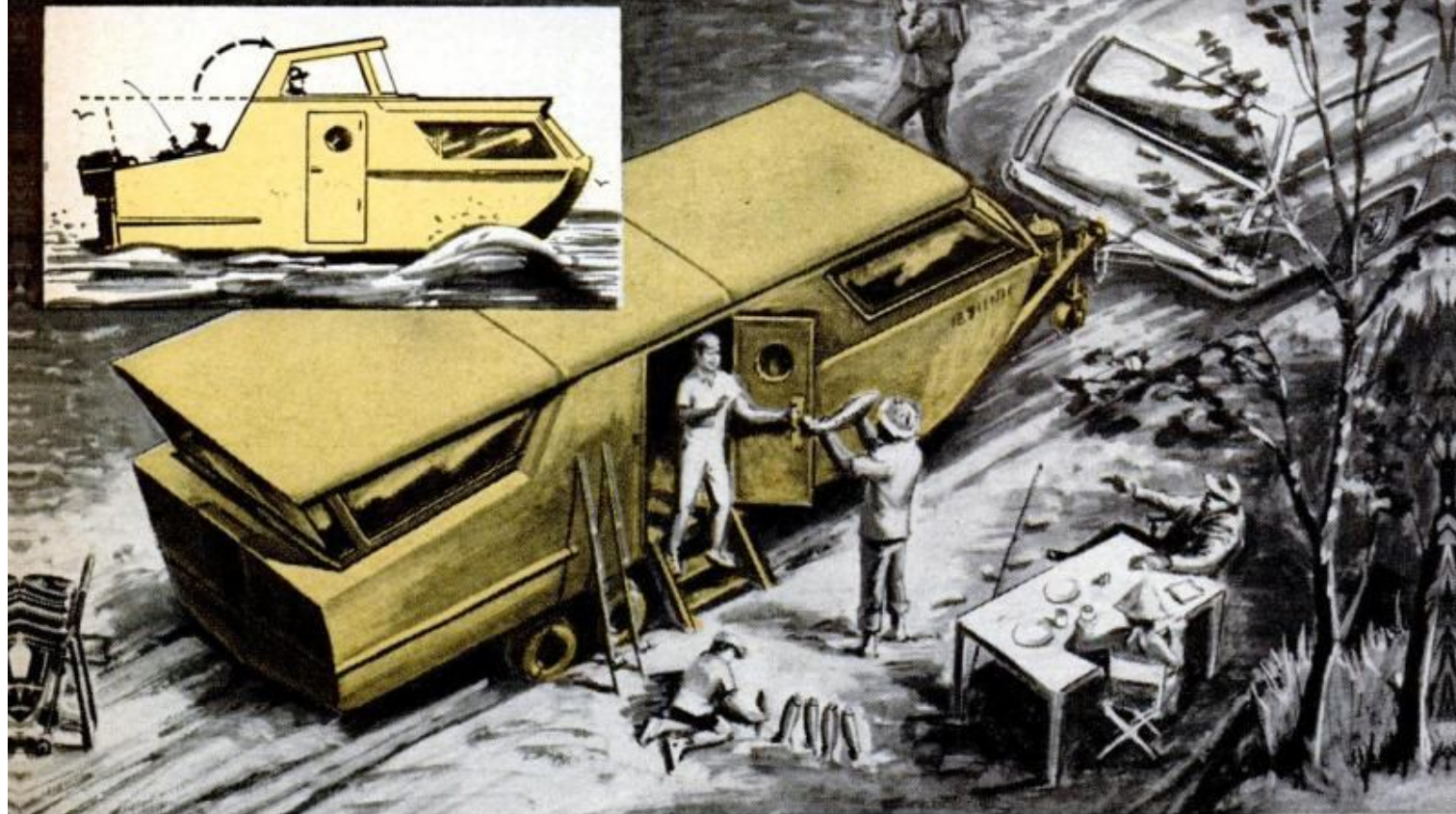
Knight life, King Henry style

No telling what'll happen if you slip into something comfortable—like a suit of armor that's identical to the hardware worn by Henry VIII. At least that's the story from Robert Normansell, Ltd., a British firm that is manufacturing the reproductions for sale in America. Main problem so far: Making enough suits to keep up with the demand.

Just patented

PM'S PICK OF THE NEW INVENTIONS

Prepared in cooperation with Roger S. Shashoua, Director, International Inventors Assn., Inc.

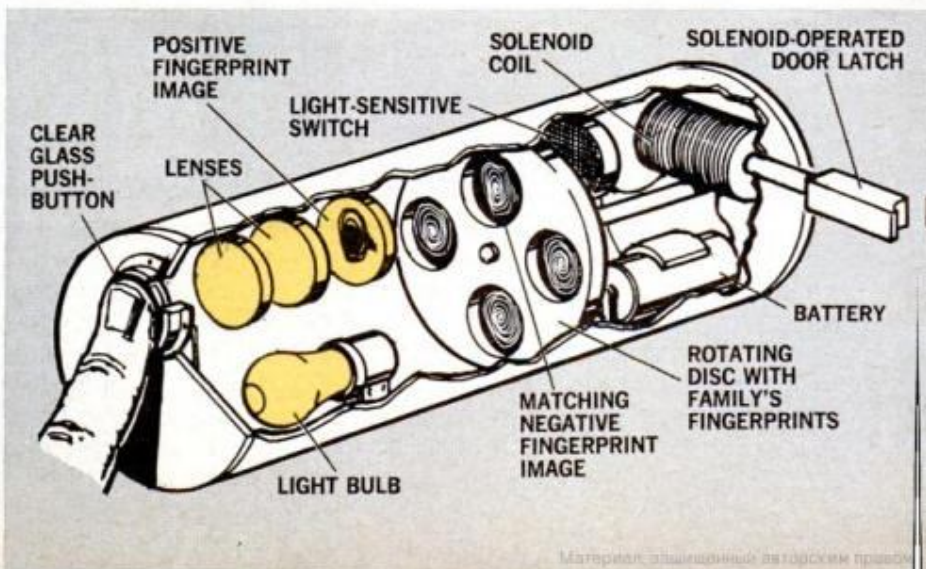


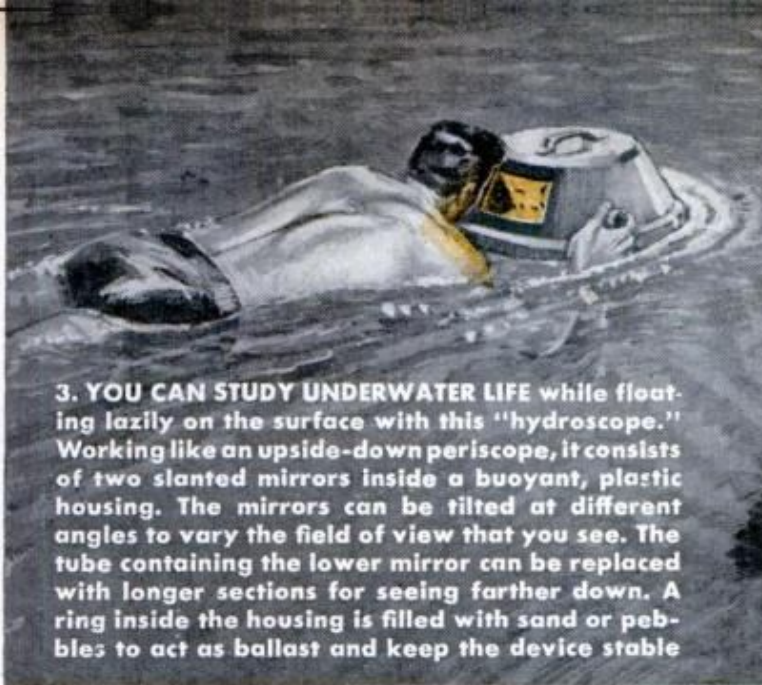
1. YOU CAN VACATION on both land and water with this convertible cruiser-trailer. When you're on the road, you use the bunks, kitchen and other facilities just as if it were a house trailer. When you come to a lake or river, you launch it like

any boat on a trailer and it becomes an outboard-powered cruiser so you can continue on the water. A hinged canopy swings down to form windows for roadside living and up to provide a windshield for cruising. A watertight gasket seals the side door

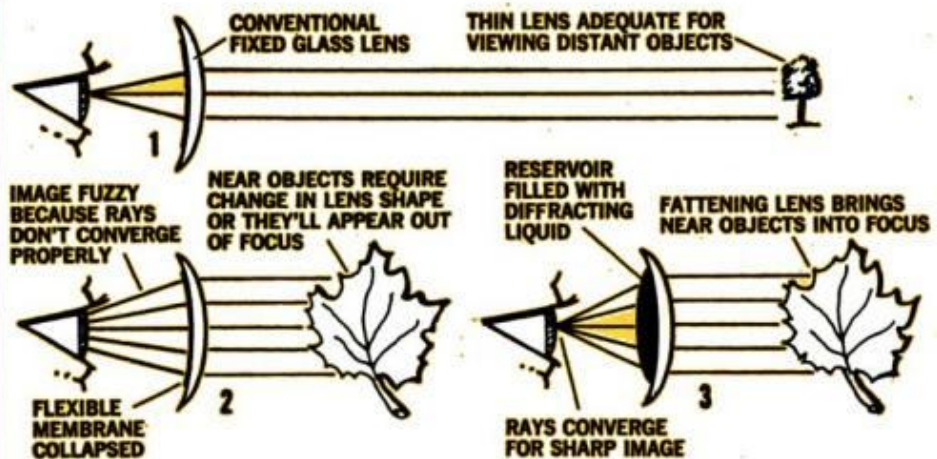
2. BURGLARPROOF DOOR LATCH below opens only if the right person presses the button. It checks a caller's fingerprint against prints of the people who live in the house, stored on a rotating disc inside the lock. Here's how it works: When a caller presses the button, a light projects a positive image of his fingerprint onto a tiny screen. Behind this

is a negative image of one of the stored prints. If the two prints are identical, they block out the light and a solenoid slides back the latch bolt. If the prints don't match, the light passes through and falls on a light-sensitive photocell. This trips a switch that shuts off power to the solenoid, thus preventing the latch from opening





3. YOU CAN STUDY UNDERWATER LIFE while floating lazily on the surface with this "hydroscope." Working like an upside-down periscope, it consists of two slanted mirrors inside a buoyant, plastic housing. The mirrors can be tilted at different angles to vary the field of view that you see. The tube containing the lower mirror can be replaced with longer sections for seeing farther down. A ring inside the housing is filled with sand or pebbles to act as ballast and keep the device stable



4. SELF-FOCUSING EYEGLASSES above are designed to eliminate the need for different pairs of glasses and bifocals. You can adjust them for viewing close or distant objects by moving a tiny lever on one earpiece. Each lens has a flexible membrane on the back. Moving the lever pumps a diffracting liquid

into the space between the glass and membrane. This has the effect of changing the curvature of the lens, causing it to focus at different distances. With the membrane filled, the lens is fatter and near objects can be seen clearly. Without the liquid, the glass functions as a long-distance lens


5. CAR THIEVES or other drivers who refuse to stop at police barricades won't get very far if this sharp idea is put in use. A flexible strip containing removable spikes is stretched across the road. If a car runs over the strip, the spikes pull free and embed themselves in the tires. The spikes are hollow with a small hole at the tip, letting air escape at a controlled rate. The tires go flat in 200 yards, bringing the runaway to a safe halt without damaging the car



Inventors of the items shown on these pages are as follows: 1. John P. and Robert W. Forsyth, 1517 N. 3rd Ave., Upland, Calif. (No. 3,376,586); 2. Salvatore Benenati, 1603 Givan Ave., Bronx, N. Y. (3,398,558); 3. Raymond and Michel Doret, 65-84 Booth St., Forest Hills, N. Y.;

4. Dr. B. M. Wright, National Institute for Medical Research, The Ridgeway, Millhill, London N. W. 7, England; 5. Swedish government police, Stockholm, Sweden. Roger S. Shashoua can be reached at the International Inventors Assn., Inc., 680 Fifth Ave., New York, N. Y. 10019.

FIAT SERVIZIO



When Will WE Have Factory Service Centers Like These?

Repairs Italian style, at Fiat's company-run service centers, are quick, efficient and assuring—sure to be an envy of American car owners

By **BILL HARTFORD**, Technical Auto Editor

OFF THE BEATEN PATH for most tourists is Turin, or Torino, Italy. It's not Florence and it's not Rome, but it's got some of the most fascinating Roman ruins; superb Piedmontese cuisine; great skiing in the surrounding Alps; the exquisite Sabauda Gallery; the fabulous Museo dell' Automobile; and lost somewhere among the old, historic *corso*, *via* and *strada*, the little leather shop of Vittorio Marangoni where handbags feel like butter, the atmosphere is strictly *simpatico* and you'll never find yourself unless you've got the navigational sense of a Vespucci.

Impossible to miss, because it is everywhere in Torino, is Fiat, the *Fabbrica Italiana Automobili Torino*. This industrial giant, founded in 1899, is now so big and brash that it could well kick Chrysler out of the No. 3 spot for world automobile production.

They must be doing something right. And that something is simply putting the right cars in the right places at the right time, selling at the right prices . . . and selling and selling. They're professional salesmen, yes, but they're also professional craftsmen and they know what all professionals



SERVICE STARTS HERE. Check-in counters at Turin servizio receive customers' cars, record work to be done

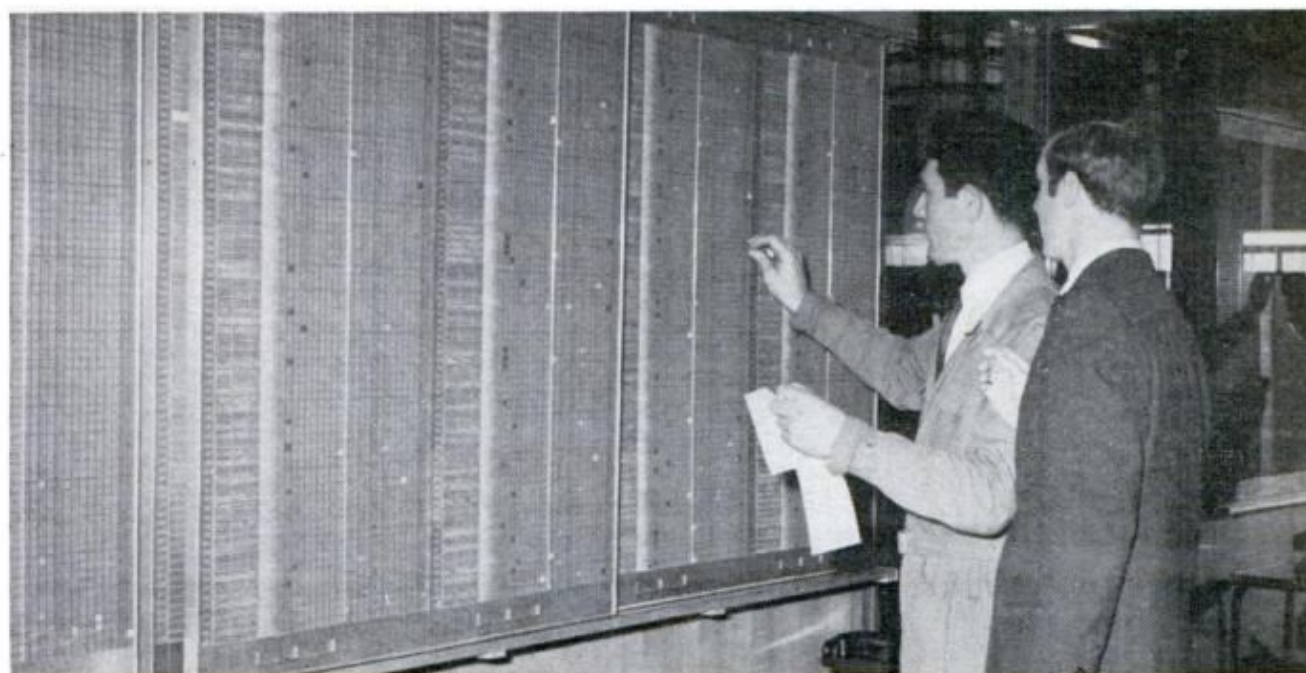
know: Always carry through! In the case of the automobile, with *service!*

If you find yourself motoring through Torino, or almost any other part of Italy, and your motorcar makes an unscheduled stop on the *autostrada*, you'll find out what service Fiat-style is all about. Don't start walking because chances are a roving van marked *FIAT A.C.I.* will come along loaded with spare parts and a competent mechanic to help you get on your way. If you need a tow, your destination will be one of 30 factory-run service centers.

Of the two in Torino, I visited the

one on *Corso Francia*. When you pull up in front, the huge power doors of the 60,000-square-foot garage roll back to reveal a half-dozen lanes that run up to individual check-in booths. You describe your problem or request the maintenance you want. Your car will be assigned a number and become one of 150 to 200 cars that go through the *servizio* daily. One-day service is the rule, not the exception.

First impression of the service retailing center is that maybe it's a front for something? They can't be servicing cars here: No dirt. No grease. Maybe



WORK-FLOW BOARD pinpoints location and status of cars with color discs. It's soon to be computerized



GREASE PITS seem to be individual, primitive forerunners of hydraulic lifts, but take a look underneath ➤

it's a spanking new setup? No. This assembly-line service center has been satisfying customers for five years!

It's not easy to keep such an operation free of the garage grime that turns away customers. It takes 10 men, *servizio* custodians, working full time to do it. Cleanup at the end of the day would be impossible. Cleaning goes on full time. Custodians are only part of the crew of 200 mechanics, body men and technicians. Another 40 men and women make up the administrative staff.

The cleaning *and* the service is a full-time thing. Service isn't a "necessary evil" sandwiched in between new-car preparation or other sales activities. Cars get their number and then show up in a slot on the huge, master-control, work-flow board pictured on the previous page. Color discs are moved to indicate just what is being

done and where your car is at any particular time, or if work is complete and your car is ready for pickup. Smooth. No customers' cars lost among new cars and cars needing service in the shuffle of vehicles in a cluttered dealership.

In the *servizio*, cars actually move along the equivalent of an assembly line. They pass numbered stations where all lube points are given their due, lubricants and water levels are topped off, electrical and ignition functions are checked and, after additional specing and checking, the cars are ready for the road. Adjacent work bays or "grease pits" make undercarriage work easy. Even body work is done at the *servizio*, and a well-ventilated and lighted paint shop puts back the shine on a dented car—all under one roof.

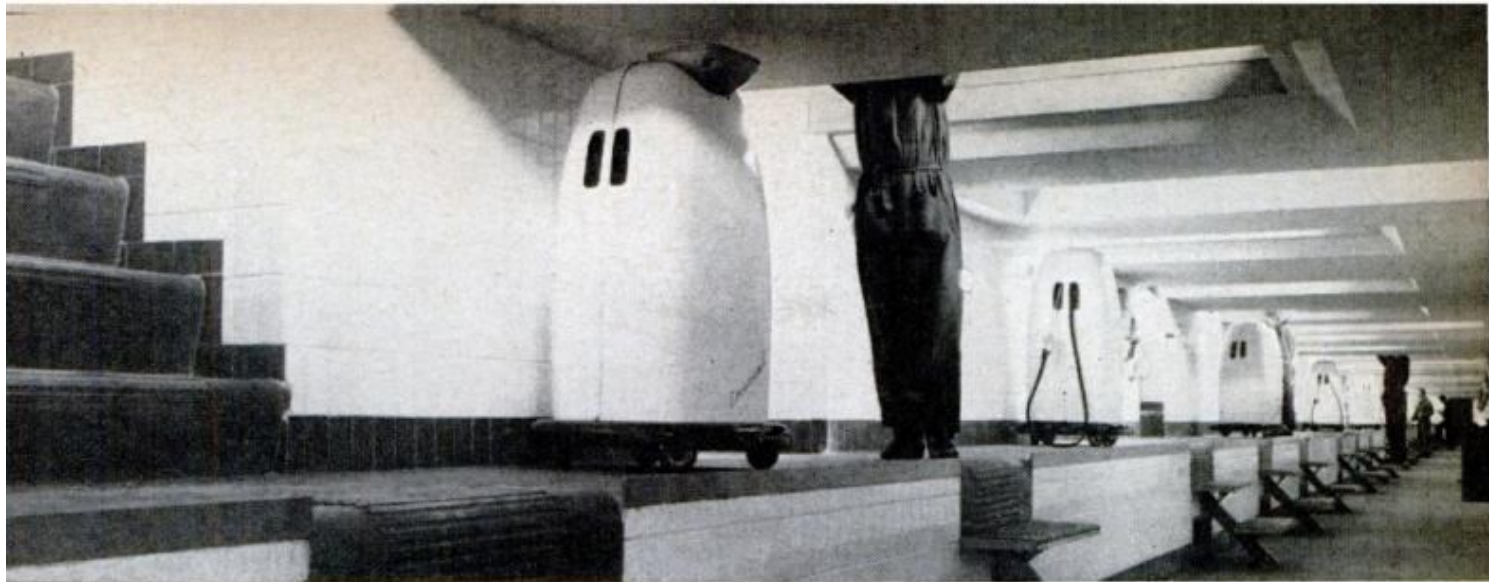
Will the growing service problem in the United States spur manufacturers



DIAGNOSTIC EQUIPMENT is explained by manager of Fiat *servizio* which services 150 to 200 cars a day



HEADLIGHT ALIGNMENT is set while customer looks on. Most of service is while-you-wait or one-day



WORKING FROM BELOW, mechanics find the grease pit approach well-organized, safe and efficient

to set up service retailing centers? Not yet. Right now it's up to the dealers to keep their fingers in the dike against a problem swelling in urgency and magnitude. As one relief, Chrysler has a predelivery center operating successfully in Chicago. It does the make-ready on dealers' cars, thereby freeing their stalls and mechanics for repair and maintenance work. A second center is being built in Los Angeles. Dealer participation is voluntary.

Meanwhile, Detroit's customers try to be patient in the battle for a service appointment, and the *servizios* continue to keep the ubiquitous Fiat 500s and increasingly larger and more powerful automobiles of Italy on the move.

If you want to see for yourself, don't look here. The *servizio* is a mass-pro-



FRONT-WHEEL ALIGNMENT of camber, caster, toe-in is done at one of several stations along the line

duction service operation and Fiat-Roosevelt, the marketing arm of Fiat in the States, shares the "small" import market with lots of other makes. You have to go all the way to the Old World to see a good way to get modern, efficient service on your car. ★★★

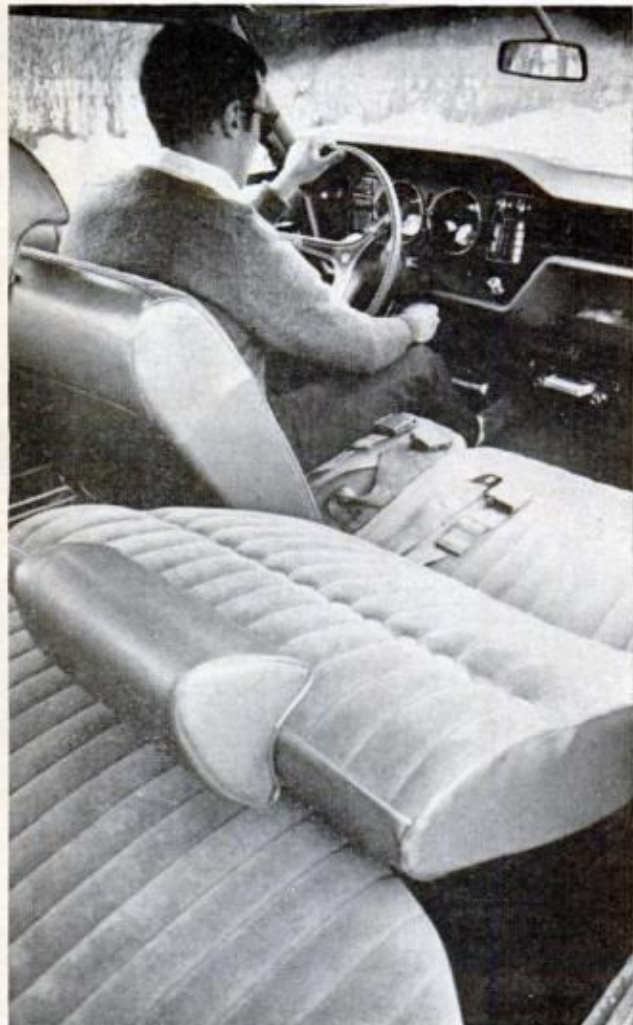
AT END OF SERVICE LINE customers watch their Fiat 500s, 850s, other makes and models getting final check



**PM OWNERS REPORT
AMC AMBASSADOR**



POOR MAN'S CADILLAC is the way owners describe their car's elegant style at a price they can afford



SUPERIOR INTERIOR COMFORT is one joy of owning an Ambassador. Most owners like velour upholstery, but criticize ignition location, raised area of dash

IT'S GREAT TO GET A BARGAIN and that's what Ambassador owners say they got when they bought their car. As an Illinois maintenance supervisor says, "I feel I'm buying a Cadillac at an Ambassador price." A California flight purser analyzes: "More value and luxury than any other car at comparable cost." "I consider it a poor man's Cadillac," says a Minnesota construction supervisor. To a Georgia serviceman, it "offers more value for



SHOULDER BELT, a mystery to stow, is hard to use, interferes with rear-seat passengers and clanks around

*Photos by
Irv Dolin*

A Nationwide Survey Based on 1,800,000 Owner-Driven Miles

Lot of Car for The Money; Some Lapses in Workmanship

By BILL HARTFORD, Technical Auto Editor

the dollar than any other car made."

A Pennsylvania building contractor, believe it or not, tells us: "I traded in a '67 Cadillac and I think the Ambassador is three times the automobile that the Cadillac was!" A retired mechanical engineer in California gives an alternate choice: "The only other car I would get would be a Mercedes." A Nebraska oil company division manager ends all comparisons: "Compared to others, there's no comparison."

The fact that airconditioning is standard on all Ambassador models is part of the bargain, but not reason enough alone to buy the car. For every owner who says he was hooked by the "free" air, another requested it be optional, probably because they don't use it and the price would be lower.

Ambassador prices start at roughly \$3000 for a six-cylinder model and go up to \$4000 for the SST, V8 station wagon. Few owners have the six and an unusually high percentage have station wagons—23 percent.

On a wheelbase of 122 inches and with a length of 206.5 inches, the Ambassador is a big intermediate or a small family car. And this size makes almost every owner happy. For a Michigan private detective, the Am-

bassador fills his requirement for a "more compact car" and to an Ohio lad, for a bigger one: "I feel like I'm in a limousine in this car." The lad's mother, owner of the car, observes that the size is right and the value is good, but workmanship is "fair to poor." Evidence of less-than-satisfactory-workmanship—mostly inside—and too much use of plastic are what owners dislike most about the construction.

Not only is everything plastic, say owners, but it's poorly done. "I don't think the dash should be plastic," says an Illinois laborer and, not only that, says a California firefighter, the "dash panel is misaligned." The whole car was "misassembled," says a Florida merchant.

The "plastic trim on the inside" is the only complaint of a Massachusetts parts manager. The plastic is all over: "Too much plastic in dashboard, around the seats, the door locks, etc.," complains a New York machinist. "Sloppy work installing front-door moldings, two screws missing from dash panel, doors squeak while driving, armrests coming off," starts an Ohio accountant's list.

It's not all bad, though. An Iowa bartender who sees "poor workmanship



RECLINING FRONT SEATS are a big feature for owners; mechanism can be tricky, however



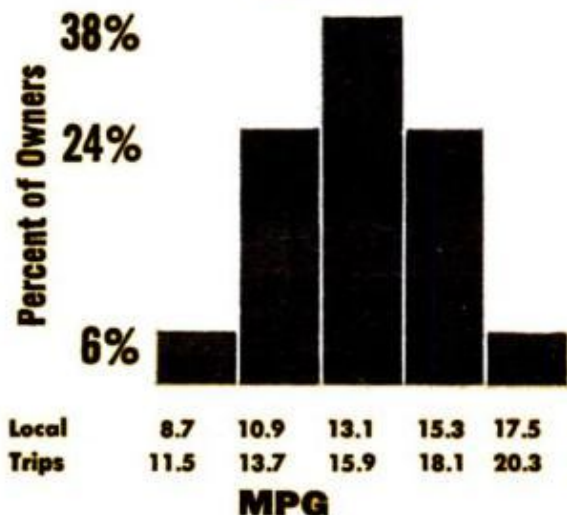
SPLIT FRONT SEAT combines advantage of bench, comfort and convenience of individually adjustable buckets. Ashtray is hard to use for some owners



WORKMANSHIP and quality of materials rank high on dislikes list. Poor fits refer to edge of dash (shown here), doors, other opening and closing parts. Extensive use of plastics in passenger section is poorly received

AMBASSADOR FUEL MILEAGE CHART

343-cu.-in. V8



on the interior," and complains about the plastic, still says, "I don't want to mislead anyone—the Ambassador's interior is still superior to other makes in the same price range." A Michigan painter who finds workmanship "not bad" says that before he bought his Ambassador he actually "refused to accept delivery on another make of '69 because of its poor condition."

The single most enjoyable thing to the greatest number of owners is handling. "Handles well!" beams a New Jersey fire captain who moved up from a Javelin. An Ohio insurance man says it "handles very well, safely and with ease." A racing engine builder from New Jersey owns a wagon: "Handles well for a station wagon; steering is effortless but retains good road feel."

He also comments on good interior styling and comfort. Two of the big comfort features, of course, are the individually reclining front seats that most people have come to regard as an AMC trademark. They come standard on the SST Ambassadors—the car bought by over half the owners surveyed—but are a \$58 option on the basic car and DPL.

Owners like the seats and they like the velour upholstery. Some indicate they actually bought the car because of the reclining seats and would like to see them on all American cars.

The comfortable interior is not al-

Summary of 1969 Ambassador Owners Reports*

Total miles driven: 1,818,859

Average miles per gallon:

232-cu.-in. Six,
 local driving 13.7
 long trips 16.4
 290-cu.-in. V8, local driving 13.4
 long trips 16.4
 343-cu.-in. V8, local driving 13.1
 long trips 15.9
 390-cu.-in. V8 n.a.

Specific likes:

Handling 43.1%
 Comfort 33.2
 Styling 32.0
 Ride 27.3
 Economy 25.8
 Performance 13.2

Specific dislikes:

Workmanship 11.9%
 Gas mileage 10.1
 Rattles 6.5
 Heater 6.2
 Wind noise 6.2
 Quality 4.8

What changes would you like?

Quality of materials 10.1%
 Style 9.4
 Better workmanship 6.1
 Heater improved 6.1
 Gas mileage 5.4

Dash layout 5.0

Engine:

232-cu.-in. Six 6.4%
 290-cu.-in. V8 37.1
 343-cu.-in. V8 49.6
 390-cu.-in. V8 7.0

Transmission:

Automatic 99.4%
 3-speed manual 0.6

Body style:

2-door hardtop 24.1%
 4-door sedan 53.0
 Station wagon 22.9

Had any mechanical trouble?

No 69.6%
 Yes 30.4

What kind of trouble?

Carburetor 22.7%
 Transmission 15.5
 Windshield wipers 10.9
 Electrical 8.2
 Choke 6.4

Dealer repair satisfactory?

Yes 75.5%
 No 24.5

Why the Ambassador?

Past experience 42.5%

Economy 18.7
 Style 17.3
 Size 7.1
 Service 4.9
 Comfort 4.5

Is the Ambassador your only car?

Yes 57.1%
 No 42.9

Other cars owned:

Rambler 46.4%
 Chevrolet 13.6
 Ford 9.0
 Volkswagen 8.4
 Javelin 6.4

What options/accessories?

Power steering, power
 brakes 75.9%
 Airconditioning 60.4
 Radio 49.8
 Power steering 23.8
 Tinted glass 20.4
 Tilt steering wheel 14.1
 Whitewall tires 10.5
 Vinyl top 10.2
 Cruise control 9.6
 Courtesy lighting 9.3

Age distribution of owners:

15-29 12.3%
 30-49 48.0
 50 plus 39.7

*Where applicable percentages may not equal 100 percent due to rounding and/or insufficient sample.

ways that comfortable—especially on cold days. “No heat reaches floor. Please! Please! More heat vents on floor,” cries a frostbitten Illinois salesman. Heater complaints are primarily for insufficient heat available at floor level and in the back seat. Complicated controls and noisy fan are also mentioned, and a “heater that can’t be turned off” is making a Maine college instructor hot under the collar.

Also bugging a disproportionately large number of owners is the Ambassador’s shoulder belt arrangement—a

“sloppy” one, winces a California systems analyst. “They’re in the way getting in and out of the back seat and when not in use” and annoying enough to an Ohio PR man for them to be his “No. 1 gripe.” A New York housewife could get rich if she patents what she’d like to see: “disappearing seat belts.”

The Ambassador is an Illinois truck driver’s fifth AMC automobile and it’s almost perfect—but not quite: “Windshield is hard to clean inside because the instrument panel hood is too close to the glass.” Maybe next year . . . ★★



HANDLING gets top honors from Ambassador owners; suspension has coil springs in front and rear

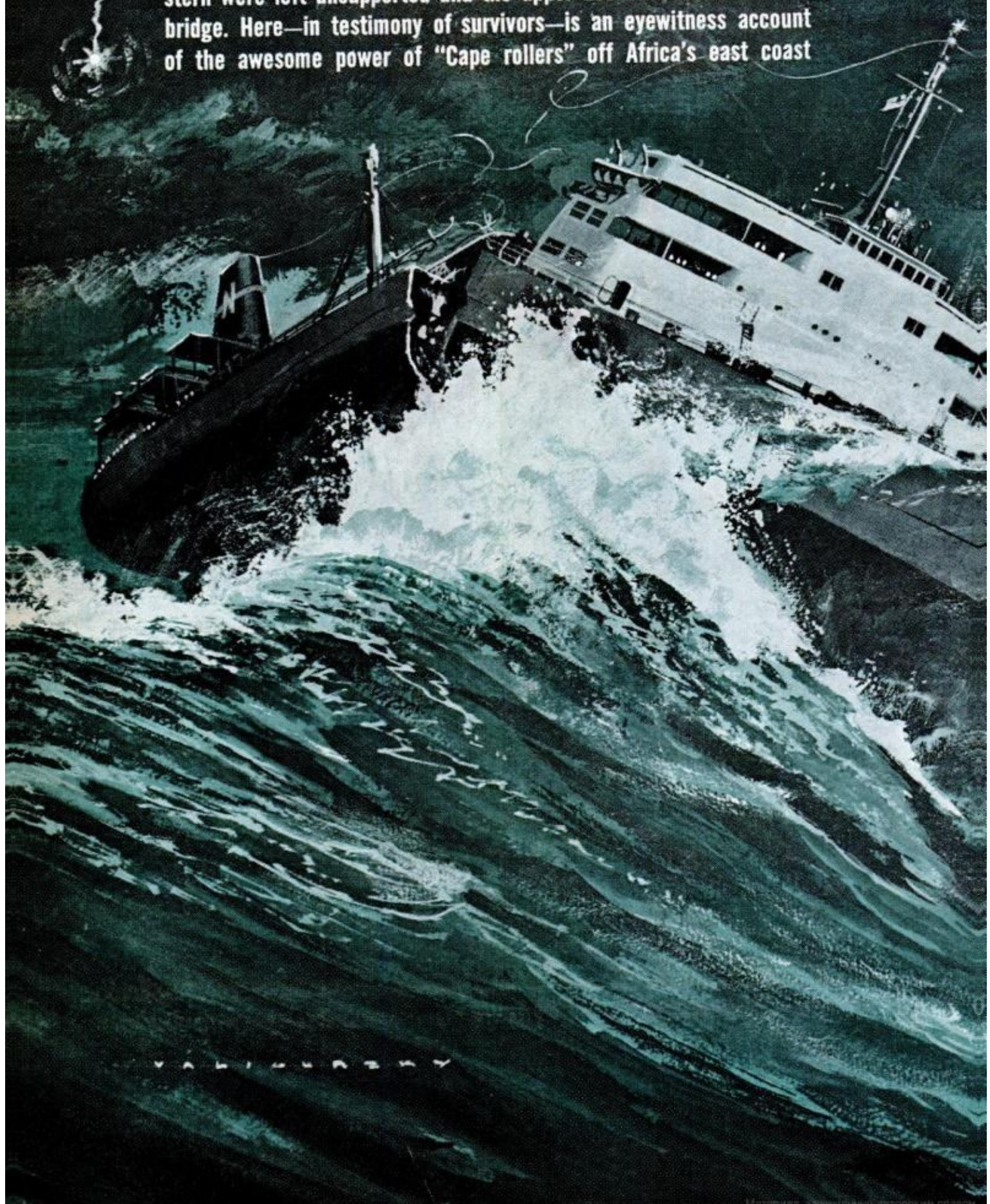


COLD-WEATHER DRIVING draws complaints about the heater: inadequate heat around floor, in rear seat

PM EXCLUSIVE

The Death of

The giant tanker buried her nose in the 70-foot wave. The bow and stern were left unsupported and the upper deck cracked aft of the bridge. Here—in testimony of survivors—is an eyewitness account of the awesome power of “Cape rollers” off Africa’s east coast



Y A N I C H E R E Y

World Glory

By RICHARD PETROW

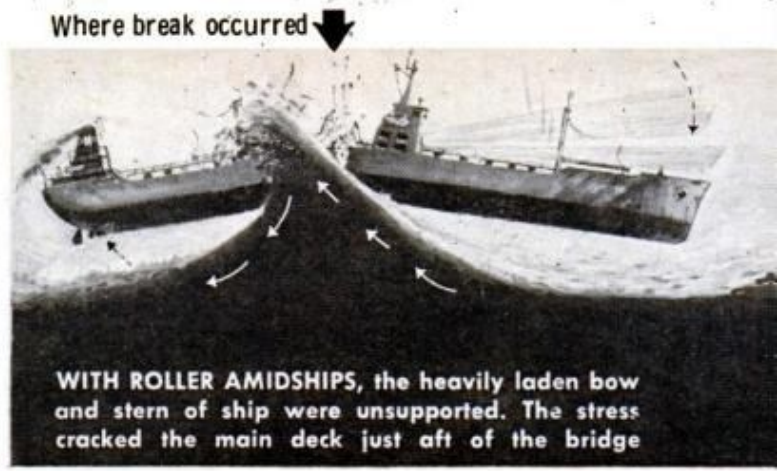
WHEN THE TANKER *World Glory* cast free her lines and moved majestically out of Mina al Ahmadi at high noon on May 31, 1968, there was not a captain or seafaring expert in that Persian Gulf oil port who had reason to doubt that the ship would eventually arrive at her destination. Every master knows, of course, that his ship can be a candidate for disaster. Vessels collide and sink. Ships run aground and break up on reefs. Explosions and fires break out. But if these disasters can be avoided, modern vessels assume they are home safe. While the sea herself is still respected, she is no longer feared by vessels built to stringent design standards with the best of materials.

On these terms, then, *World Glory* would arrive in Huelva, Spain, to off-load her cargo of 48,823 tons of "spiked" Kuwait crude oil, on schedule and in good shape. Instead, she wound up on the bottom of the Indian Ocean, her back broken by the sea as easily as you can snap a brittle twig





WORLD GLORY BURIES HER BOW in "Cape roller" and begins climb to crest. Seamen saw waves level with the king posts—70 feet above water line



WITH ROLLER AMIDSHIPS, the heavily laden bow and stern of ship were unsupported. The stress cracked the main deck just aft of the bridge

across your knee. Twenty-four of her officers and crew perished and the 10 exhausted and oil-smearing survivors who were picked up the next day will never again minimize the awesome power of the sea, no matter how large and modern the vessel they sail on.

World Glory was built by Bethlehem Steel in Quincy, Mass., in 1954. She was the first tanker of more than 45,000 deadweight tons to sail the high seas. Her length was 737 feet, and she could carry enough oil to fill a caravan of highway tank trucks 30 miles long.

When Greek fleet owner Stavros Niarchos ordered her built, she was approximately 50 percent larger than any other tanker afloat. Only one larger commercial vessel had been built in America—the SS *United States*. When launched, only four other commercial vessels exceeded her in size, the *Queen Mary*, the *Queen Elizabeth*, the *Liberte* and the *Ile de France*. She was the first supertanker and the glory of the Niarchos fleet.

On Jan. 18, 1956, *World Glory* arrived in San Francisco with a cargo of 43,600 tons of crude oil from the Persian Gulf, setting a double record. At the time, the cargo was the largest of any kind that had entered a Pacific port and *World Glory* was the largest ship of any kind to appear in San Francisco. Today, *World Glory* would rank as a medium-sized tanker. There are tankers afloat now that can carry more than 300,000 tons of oil and there is talk of building ships with capacities as high as 800,000 or even 1 million tons. Until her last voyage, however, the vessel, flying a Liberian flag, lived

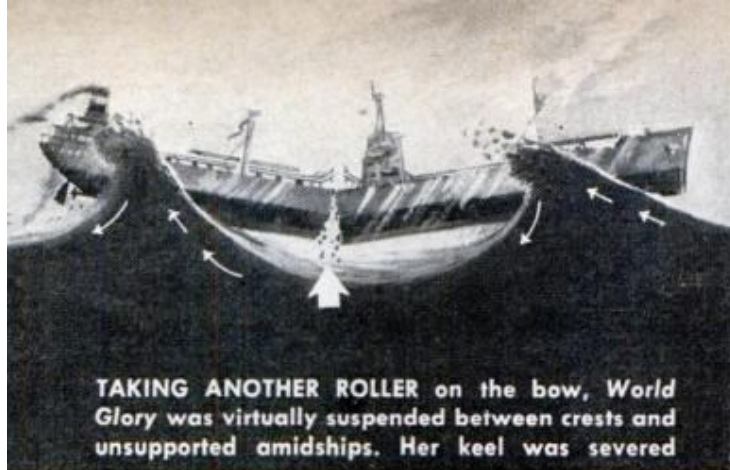
up to her name: She was a glory afloat. Her last voyage turned glory to disaster.

It began at noon on a Friday—May 31, 1968—when *World Glory* departed Mina al Ahmadi in the Arabian sheikdom of Kuwait for the refinery port of Huelva, Spain. The crude oil carried had been "spiked" with lighter elements, kerosene and gasoline. In Kuwait, some crude oil is broken down into bunker C fuel oil, used by ships, and into kerosene and gasoline, for which there is little market in the desert sheikdom. Instead of throwing the kerosene and gasoline away, it is injected into crude oil cargoes. Hence the "spiked cargo."

At the time of her departure, *World Glory* was "tight, staunch and strong and well and adequately manned and victualled." Her 40-year-old master, Captain Dimitrios Androutsopoulos, was an experienced seaman who had served with distinction as an officer in the Greek Navy. Her complement, all Greek with one exception, was also experienced and wise to the ways of the sea. The ship herself had been inspected in Oct., 1967, for the American Bureau of Shipping. The thickness of her steel plates was gauged by supersonic measurements, a method known as "audio-gauging." All plates were found in good shape.

As her last voyage began, *World Glory* was fit and ready for sea.

The weather on May 31 was perfect. A scorching Arabian sun shone down on the Persian Gulf as the tanker, on time charter to Gulf Oil Corp., moved south through Persian waters. Her



TAKING ANOTHER ROLLER on the bow, *World Glory* was virtually suspended between crests and unsupported amidships. Her keel was severed



COMPLETELY SEVERED, the two halves drifted apart. Oil containing kerosene and gasoline spewed out of tanker and set the water ablaze

route would take her through the gulf, then southwestward through the Arabian Sea and Indian Ocean until she rounded the Cape of Good Hope to enter the southern Atlantic.

In years past, the route was feared by masters of sailing vessels. The Indian Ocean off the east coast of South Africa had a vicious reputation.

Masters spoke with awe of the mountainous "Cape rollers" which swept up the east coast of Africa, sometimes higher than the masts of sailing vessels. The rollers took their toll. In 1908, the Blue Anchor line's *Waratah* disappeared without a trace on a run from Durban to Capetown. Two hundred eleven perished. The mystery of her disappearance was never solved, but mariners are convinced she was broken apart by Cape rollers.

As traffic through the Suez Canal increased, the number of ships traversing these waters decreased. Over the decades, the reputation of the Cape rollers dimmed in the minds of many captains. When the Suez Canal was shut, in June, 1967, as a result of the

Israeli-Arab War, many experienced masters had never sailed the waters in question, nor had even heard the term "Cape rollers."

In 1968, *World Glory* was to learn that Cape rollers still swept up the coast with awesome ferocity.

The first 12 days of *World Glory's* last voyage were uneventful. Chief Officer Stavros Ananiadis, one of 10 from the tanker to survive the disaster, testified later that the ship experienced normal sailing conditions as far as Natal on the southeastern coast of Africa. Until then, the weather was good, seas moderate, and *World Glory* pushed ahead at a normal cruising speed of 16 knots.

The first word of the approaching storm was received by Radio Officer David Barry, a 28-year-old Irishman from County Cork. At 1100 hours on June 12, the day before the disaster, Capetown Radio warned that moderate to strong southwesterly winds and a moderate to rough sea could be expected.

Ten hours later, there was a gale

THE FIRST SUPERTANKER, *World Glory* in 1954 was exceeded in size by only four other commercial vessels



warning for the area south of *World Glory*. That was all the warning *World Glory* got. The storm hit suddenly at 0500 hours on June 13, a Thursday. Captain Androutsopoulos hastened to the bridge. When he saw the size of the seas, he immediately ordered the ship's speed reduced. At 0520 hours, he ordered a second reduction, to about five knots. From then on, he maneuvered his vessel at slow speeds, keeping her head into the wind and waves. *World Glory* smashed head-on into the oncoming seas. Huge rollers sent green water crashing over the bow and swirling around the bridge.

In testimony taken later in Greece, Chief Officer Ananiadis described the sea in this fashion: "The waves were very steep and two-thirds the ship's length. The king posts of the ship were level with the top of the waves."

Fireman Constantine Markakis of Athens had never seen such waves during his eight years at sea. He stood watch from 0800 to 1200 hours and was concerned because the sea was "very confused and very abrupt." Helmsman

'We were taking it green over the bows and it was hitting the bridge.'

Angelos Mantzaris was also on duty from 0800 to 1200 and he too was awed by the strength of the sea. "Never in all my life have I seen such waves," he said.

As the storm built up, Second Engineer Mitsopoulos Apostolos, on duty in the engine room, heard ominous poundings from deep within the ship—strange rumbling sounds the like of which he had never heard before. It was the sea banging on the vessel's steel plates.

Driven by the southwesterly wind that grew stronger with each hour, the height of the waves built up to mountainous proportions. Fifty-foot giants racked and buffeted the tanker.

"There was no rolling, only pitch-

ing," Chief Officer Ananiadis reported. "We were taking it green over the bows and it was hitting the bridge."

Again and again *World Glory* shook off the mass of water and plowed gamely ahead. On the bridge, Captain Androutsopoulos reduced speed still further, until his vessel was barely making headway. He had his vessel in the best possible position, bow directly into the sea. He could only wait for the storm to blow itself out.

Shortly before noon, Radio Durban in South Africa broadcast a special warning, forecasting strong southwesterly gales for 18 hours, with no moderation expected. Seas—very rough. Swell—very heavy. Durban also reported that the storm had already taken its toll of life. Two seamen from the German vessel *Wildenfels* had been swept overboard.

Within three hours, the storm would claim additional victims.

Electrician Socrates Vandoros was the only survivor who saw the first killer wave hit. The time was 1455 hours. Vandoros, who was off duty, had decided to get a cup of coffee from the galley in the stern section. On his way aft, he passed a door that looked forward over the length of the tanker. Vandoros could observe the violent pitching of the ship's bow and the swirling flow of green water over the tanker's deck as oncoming waves broke over the ship.

Then, as he later testified, "I saw an enormous wave ahead of the ship. The ship buried her nose in the wave. As the wave came sweeping aft, I saw the bows rising again and I immediately was aware that the bows were taking an unnatural angle."

It took Vandoros a few seconds to comprehend: *The ship was beginning to break up before his eyes.*

The giant wave had lifted the loaded tanker high above the water. As the huge wave—estimated at 70 feet—passed under the ship amidships the bow and stern of the ship were left unsupported. Their weight caused the



NATAL MERCURY PHOTO

AERIAL VIEW of the *World Glory's* bow taken the morning after the disaster. The bridge went under soon after the accident, but air trapped in compartments kept bow afloat; it drifted 40 miles before sinking

upper deck to crack aft of the bridge.

Radio Officer Barry first heard a loud crack and then felt the ship shudder. The lights in the radio room blacked out immediately.

He ran to a porthole and looked aft. His radio antennas were broken and hanging down, like so many severed tendons. Then he spotted something unbelievable—a crack across the main deck three or four inches wide.

"I watched the crack for a few seconds," Barry testified, "as I could not believe my eyes. The crack was opening and closing a little with the movement of the ship."

Barry had the impression that the two parts of the ship were still attached at the keel. The two halves were still in the same longitudinal plane. The catwalk was bending, but had not yet broken. Handrails along the catwalk, however, were broken and pointed up.

Then another massive roller swept up to *World Glory*, raising her bow sharply skyward. Once again the wounded vessel shuddered violently and her officers and crew heard the terrifying sound of metal being ripped

and pulled apart. The back of *World Glory*, which had first been cracked on the upper deck, now snapped apart deep in the guts of the ship.

Chief Officer Ananiadis was in his cabin when the waves hit. He raced for a porthole. He saw that the ship had split in two. The two sections were about a yard apart. Ananiadis was on the forward section. He threw on his lifejacket and went to the bridge.

Third Engineer Johannis Kalaras of Corinth was on watch in the engine room when the ship broke up. He felt a violent shudder and "then felt a big bow-down angle." He was sure the ship must have broken in half.

Kalaras stopped the engines, immediately and got on the phone to the bridge. His call never got through. By then, the forward section of the tanker, containing the bridge and the wheelhouse, was separated by several yards of open water from the aft section, where Kalaras was futilely trying to use the engine-room telephone.

Fireman Constantine Markakis of Athens, who was also in his cabin, dis-

(Please turn to page 198)

CLOSE-UPS make dramatic shots even if they don't show the whole boat. This below-the-sail view heightens the feeling of excitement and is nicely framed by the mast and boom

How to Get Your Boat to Pose for Better Pictures

Whether it's a tiny sailboard or a seagoing yacht, it can provide eye-catching photos. Here are tricks you can use to make any boat appear more exciting and dramatic.

By PHIL GERACI

Illustrations by Fred Wolff

THERE'S SOMETHING about a boat that makes you want to take its picture. The sleek, flowing lines and the exciting drama of a rolling sea combine to make boats an ideal photographic subject. The trouble is that boats—like pets and children—can be tricky to capture on film. Their constantly changing angles and the need, usually, to shoot them on the run can make them difficult to pose. They won't sit still—and they shouldn't. You have to let them act naturally, then catch them at just the right instant and angle to come up with a really eye-catching picture.

So specialized is marine photography



ACTION SHOTS MAKE THE

SHOW YOUR BOAT doing what it does best naturally. If it's a ski boat, shoot it in the act of pulling skiers. Scene above was shot from a diving



GET AS NEAR AS YOU CAN. Biggest mistake most people make is to shoot from too far away, making boat a tiny speck. Shot at left above was made with normal 50-mm lens at about 150 feet, but boat appears much farther away—a typical problem in water

scenes. Shot at center was made from same distance but with 135-mm telephoto lens, emphasizing value of long lenses in marine photography. At right, the combination of telephoto lens plus moving to within 50 feet brings the boat even closer

that professionals who have mastered the art make names for themselves shooting virtually nothing but boats. One such well-known marine photographer is Marion Warren whose open-air studio is the whole of Chesapeake Bay. His distinguished clients have included the U.S. Naval Academy and Presidential families. Warren passes on these tips for shooting better boat pictures based on his years of professional experience:

“First, you must know your subject,” he advises. “Watch it in the water. Ob-

serve the way the sun flashes on the sails or hull. Note the best angles—head on, off-bow or full astern. All boats have their best side, and that’s the side you should photograph.”

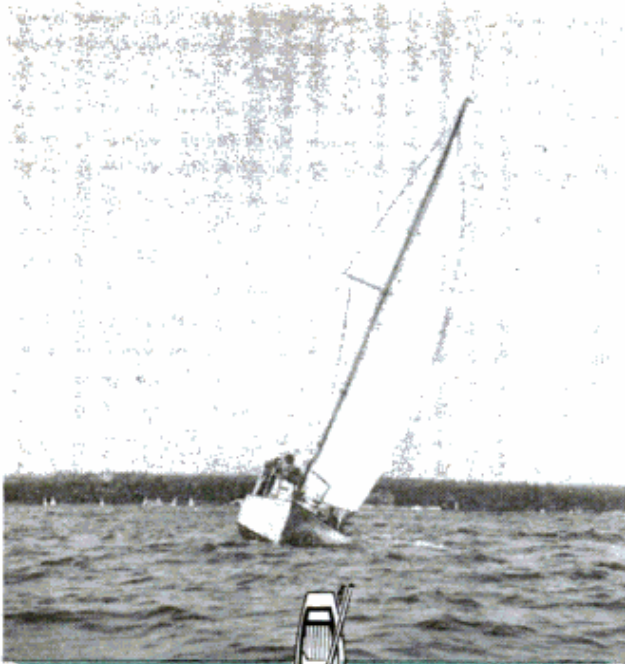
The biggest single mistake that most amateurs make, Warren believes, is that “they shoot from too far away, so the boat is just a tiny dot in the center of the frame.” Ideally, it’s best to use a telephoto if your camera takes interchangeable lenses. On a 35-mm camera, moderate teles from 135 mm to 200 mm work well. Longer lenses should



BEST BOATING PICTURES

platform to get high angle that shows both boat and skiers clearly. If you use your boat for fishing, try to catch someone hauling in a whopper.

Cruiser portrait above, made by marine photographer Marion Warren, illustrates classic boat-shooting rules. Note the slight off-bow angle instead of a flat side view. The waves add good motion and the sun casts sparkling highlights on the water



DEAD-ON
BOW VIEW



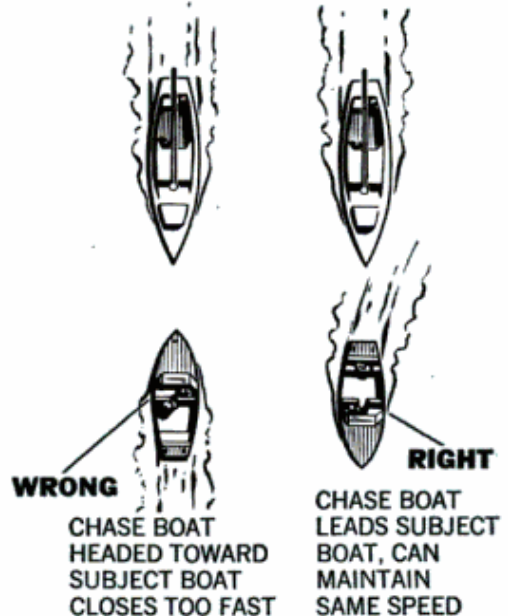
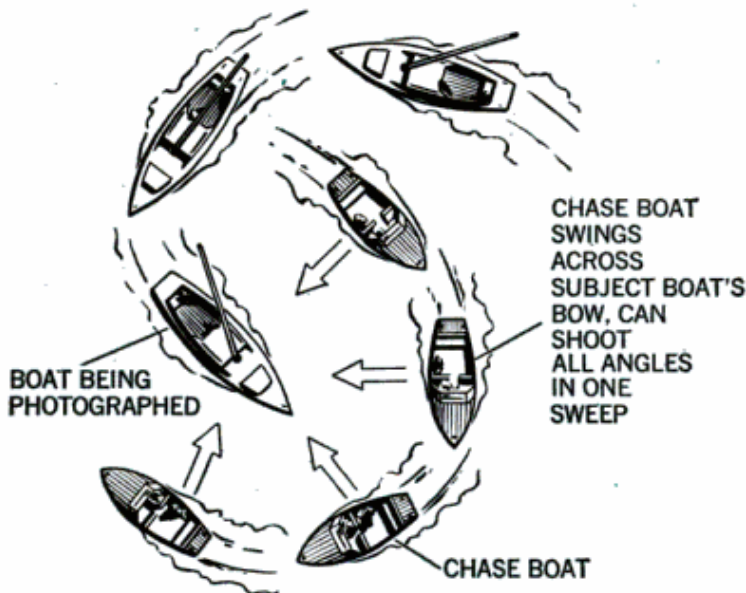
THREE-
QUARTER
BOW VIEW



WHAT A BOAT LOOKS LIKE from different angles is seen in this series taken from a chase boat circling a sloop. The dead-on bow view shows no hull lines and often gives a boat an odd appearance, but it

can produce a dramatic coming-at-you shot. The flat side view, though frequently requested by owners, is actually uninteresting because it minimizes motion and obscures a sailboat's natural lean. Most

TIPS ON FINDING THE BEST SHOOTING ANGLES





FLAT
SIDE
VIEW



THREE-
QUARTER
STERN VIEW



pros favor an off-the-bow view as best compromise. It shows hull lines fairly well, gives subject a jaunty, racy look and, on sailboats, lets you see the tilt of the mast. Stern views are

considered less dramatic because the action is going away from the camera, but they sometimes offer a change of pace. In shooting a sailboat, take care not to block its wind or the sails may go slack

be avoided as they bunch up the background too much and cause objectionable distortion.

What a telephoto does is let you get up close without actually being that close. You can make a cruiser look like it's about to run you down and still be a safe couple of hundred feet away. If you're shooting with a normal lens, get as near as you can. Make the image of the boat fill the full frame. In some cases, you can create dramatic pictures by including only a portion of the boat

(Please turn to page 200)



THREE SHOTS OF A SLOOP show how small differences in setting up a picture can make a big difference in the results. Boat at far right, standing at anchor in calm water with its sails furled, looks static and unexciting. Now contrast this with shot at near right showing boat under full sail in choppy water, giving a sense of drama and action. Still better is backlit shot at top in which the sun, shining toward the camera, puts a shimmering glow on the water. Such shots require a lens shade to keep sun from striking the film directly





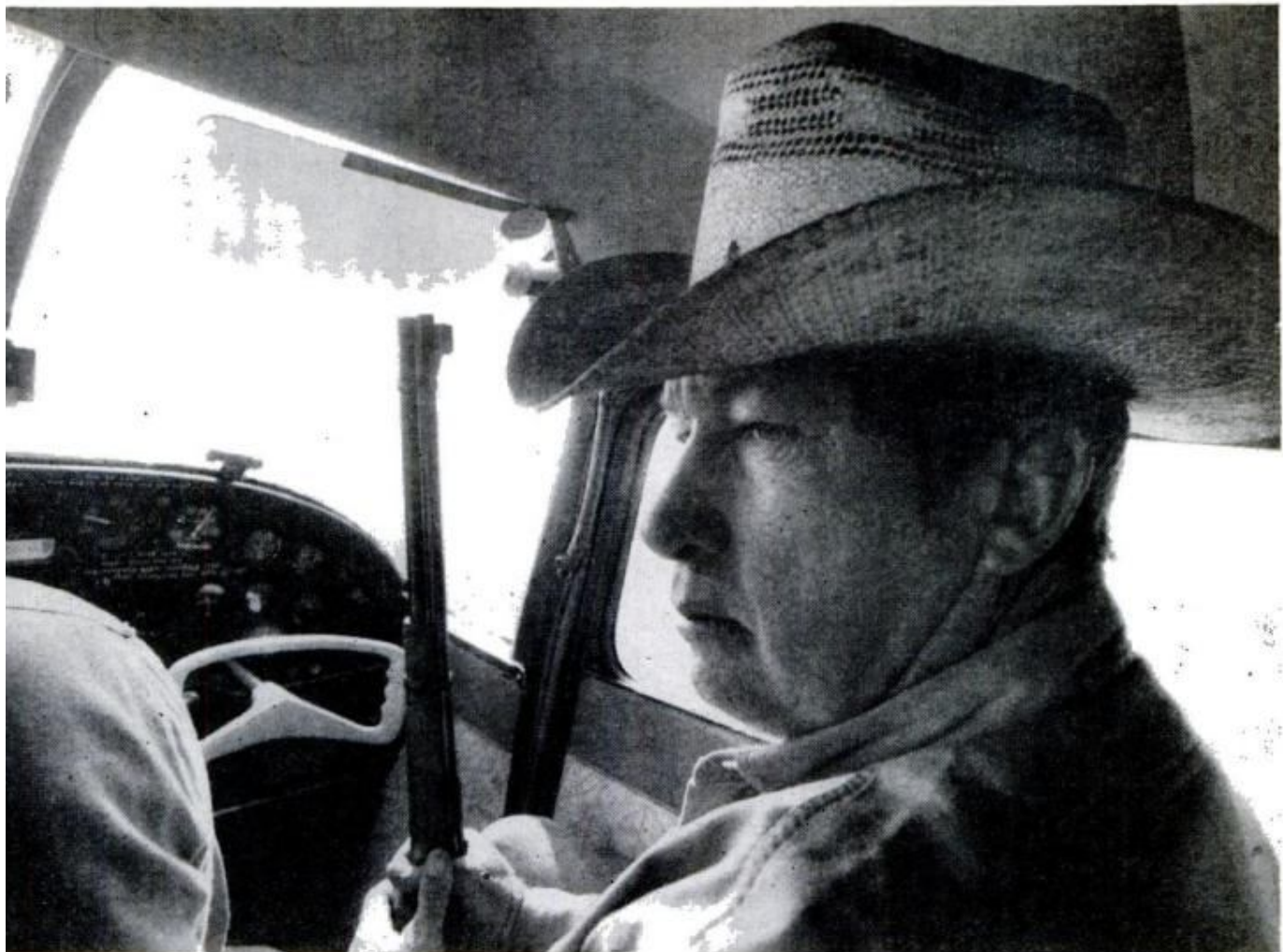
JEEP PATROL lies in wait for rustlers who strike at dawn and dusk. Ranches are patrolled day and night

In Florida Today: Ranchers



PISTOL - PACKING cowboy also carries 30-30 in saddle holster. Cowhands use walkie-talkies to report to ranch, which calls spotter plane or Jeep for reinforcements

PHOTOS BY SCHULKE, BLACK STAR



FROM SPOTTER PLANE, Bar D foreman, Leo Matchett, surveys the 26,000-acre spread for signs of rustlers

Get Rough on Rustlers

Losing 135 head a week—\$27,000—to rustlers, Florida ranchers are fighting mad and ready to shoot from horseback, Jeep or plane

By RICHARD PETROW

OUR CESSNA 180, with pilot Jim Henry at the controls, jolted down the rough runway of Florida's Bar D Ranch and bounced aloft. As we gained altitude, Henry shifted the revolver strapped to his hip to a more comfortable position.

To Henry's right sat the Bar D's granite-faced foreman, Leo Matchett, a deputy sheriff. He tucked a Winchester 30-30 between the two forward seats.

Henry banked the Cessna toward the southern boundary of the 26,000-acre ranch, which supports one of the finest

herds of Brahman cattle in Florida. To our right, Lake Okeechobee shimmered in the morning sun. To our left, pines and palmettos swept toward the horizon. Behind us, a lone car sped along Route 76. Ahead, a blue ribbon stretched across our flight path. It was the canal linking Lake Okeechobee with Palm Beach and it marked the southern boundary of the Bar D.

Henry leveled off at 2000 feet. He picked up the microphone. "Calling base. Everything looks quiet."

"Check out the southeast quarter,"

the ground controller advised. "One of the cowboys has run across fresh tire tracks."

A tense alertness filled the cabin, for we were on no ordinary sightseeing flight, but on rustler patrol. Our job—to make sure that no cattle-rustling hoodlums were invading Bar D property to make off with beef cows worth up to \$250 a head.

Cattle rustling in Florida? Absolutely. It's a major problem, growing worse every month. Until World War II the local cattle were small and scrawny. After the war, with the great growth of the resort and restaurant trades, cattlemen began improving their herds to provide top-grade beef to plush eating places.

Today Florida is the third largest cattle state east of the Mississippi, with more than 2 million head of cattle, most of them beef cattle. And with the cattle have come rustlers.

One ranch alone, in Brevard County, within sound of Cape Kennedy's launching pads, loses approximately 150 cows a year. At an average price of \$200 a head, that's a loss of \$30,000 a year. So alarmed have Brevard cattlemen become that they have organized a county-wide force of deputized ranchers, empowered to go anywhere in the county in the pursuit of rustlers.

Statewide, the Florida Cattlemen's Assn. places the loss at 135 head a week, \$27,000 a week, or close to \$1.5 million a year.

Rustlers today are no longer grim, armed bandits who sneak up on a herd on horseback to drive them over an open range to a distant market town. They are grim, armed men who work with pickup trucks and wire clippers.

To protect their herds, ranchers have mechanized, too. They fly daily air patrols and send out armed men to crisscross the pastures in Jeeps and trucks. Mounted cowboys patrol the pastures—looking every bit the same as

they did in the wild days of the West—and they carry walkie-talkies to keep in touch with the base camp. The planes are used to spot the rustlers; the Jeeps to pursue them; the men on horseback to patrol inaccessible areas.

From the air, the terrain of the Bar D didn't appear to offer any hiding place. Lone trees were scattered over the countryside. Herds of cattle grazed on improved pastures. Nowhere was there a clump of foliage thick enough to hide a man.

Suddenly a lone rider materialized below. I poked Henry's shoulder and pointed. "He's okay," Henry shouted. "That's John Powell, on wire patrol."

Powell's job, I learned later, is to check the barbed wire that encircles the Bar D, looking for breaks where rustlers have entered. He was the one who had reported the fresh tire tracks.

Now, as we swooped low, Powell pointed toward the southeast. But we were too late. Far to the east, beyond Bar D property, we could see a pickup truck raising dust as it moved down an unpaved back lane.

Henry turned away in disgust.

"Can't tell if they were rustlers after cattle," he shouted over the engine, "or hunters after our deer. Hunters often



BRAHMAN CATTLE, imported from India to improve Florida herds, are crossed with native cows to yield cattle suited to climate



MORE BARB on the wire is provided by gun-toting ranchers who have been made deputy sheriffs. Bar D Ranch employs four men who do nothing but patrol its fenced-in pastures. Rustlers are known to be armed and ready to shoot it out if caught

are just as bad as rustlers. If they can't bag a deer, they'll take themselves a cow instead."

After we landed, the Bar D's owner, John DuPuis, filled me in on cattle rustling. As chairman of the Cattle-men's Assn. Brands and Theft Committee, DuPuis deals with the problem of rustling every day, on a statewide basis.

"One cow," he explained, "breaks down into 400 pounds of hooves, hide and offal, and 600 pounds of meat. One man might handle one cow—gutting

it and making off with choice portions. It's a way to restock the family freezer.

"But it takes an organization to handle more than 75,000 pounds of beef a week. We figure the meat is going to crooked resort hotels and restaurants; we figure the Mafia has moved in."

With that, DuPuis turned me over again to foreman Leo Matchett, who had ridden shotgun in our plane. He would take me out on a Jeep patrol.

"I've told Leo," DuPuis grumbled, "that he should shoot to kill."

Would Matchett really do it? His answer came in a slow drawl. "Better that than get killed," he said. "There sure are some tough hombres in these parts."

Matchett's problem was a thorny one—protecting 26,000 acres of Florida ranchland from rustlers who could bide their time and then hit and run when and where they chose.

"There's easy access to our ranch from the east, where we meet a hunting preserve," Matchett explained, "and from the west, where there's a country road. But the easiest way in is from the south. Over the canal."

Two years ago, during a period of very high water, Bar D riders couldn't get their horses or Jeeps through to the back pasture near the canal. Rustlers took advantage of this to sweep across



the canal. They made off with one-third of the year's calf crop, about 200 young animals, plus 75 mature cows. The loss was close to \$35,000.

Almost every rancher has rustler tales to tell. Near Cocoa, Fla., George Francis, general manager for the 44,000-acre Duda Ranch, was called by one of his ranchhands earlier this year. What he found was too strong, even for a man who has spent all his life on a ranch. The butchered cow had been a healthy animal. The rustlers had made off with only the choice portions. Standard operating procedure.

Nearby, in a gully, Francis ran across a pitiful sight—a calf that had been roped and tied, but managed to break loose. The rustlers had tied ropes around each ankle. Then they had tied the ropes together. In breaking loose, the calf had parted the ropes between her ankles, but couldn't break the ropes around each ankle. By the time Francis

**We set out on our patrol
... everyone carried a
30-30 and a revolver.**

found her—and it appeared to have been days after the rustlers had hit—the flesh had swollen so much that the calf looked as if she had a balloon growing on each leg, tucked in the middle by a ring of cruel rope. There was nothing he could do to save her.

Court records reveal that rustling attracts a wide cross section of criminal types. In one county a former deputy sheriff was arrested and charged with stealing 14 head of Angus cattle worth several thousand dollars.

One Merritt Island rancher, the proud owner of a large herd of purebred cows, was arrested with 12 Brahman cows and one Angus cow in his cattle pen. All belonged to other ranchers. In the days of the Old West, stealing cows from your neighbor was a time-honored way to raise a herd cheaply and quickly. Apparently it's still being practiced in Florida.

So is another Western tradition: altering brands. In the old days, rustlers used "running irons" to change a "P" into a "B" or an "S" into an "8." An Okeechobee rancher was convicted of altering brands on seven cows.

If you look at a large Florida cattle ranch today, you'll get an idea of the difficulty cattlemen have in protecting stock. Bar D Ranch, for instance, employs four men who do nothing but patrol its fenced-in pastures. I met two: John Powell, a bearded cowboy and deputy sheriff who patrols the wire perimeter of the ranch on horseback, and John Rimes, who usually patrols by Jeep.

Powell changes his schedule daily, so anyone observing his actions cannot pick out a pattern. Rimes, in the Jeep, varies his routine too, crawling along the sandy paths of the ranch, stopping, listening, then moving along again.

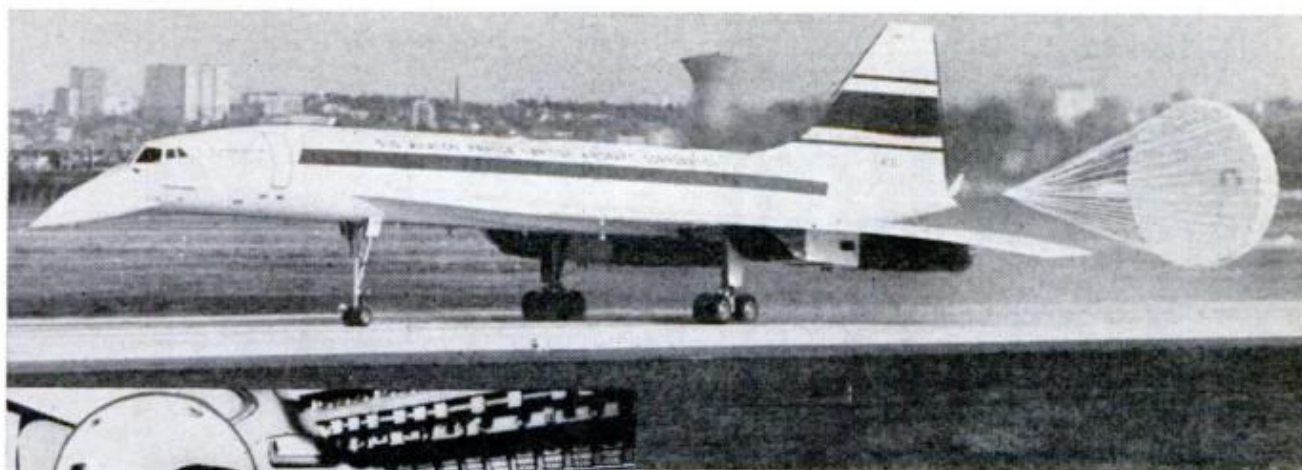
We set out on our patrol late in the afternoon. Everyone carried two weapons, a Winchester 30-30 and a revolver. We moved out from the cattle pen through a field where a herd of young Brahman bulls romped. As we moved deeper into the ranch, a lone shot rang out in the distance. I looked quickly at Matchett. He shook his head: "That's from the direction of our hunting lodge," he explained. "Must be one of the ranch guests."

We moved on through the disappearing afternoon. An armadillo scurried away as we approached. Two small Florida deer, a doe and a buck, leaped off through the bush. Herds of cattle gazed curiously at our approach, then pounded off. Everywhere there was life, and motion, but no rustlers.

We headed back for our point of departure, stopping now and then to listen for the faint sound of a pickup truck in the distance or the sharp clap of a rifle. All was still.

When we got back, Matchett turned to me and apologized for not producing any rustlers. Then he added:

"Maybe you wouldn't like to see what happened to them if we did." ★ ★ ★



Concordes are flying

Both prototypes of the Anglo-French supersonic transport, the Concorde, were successfully test flown this spring. Pilot of the French Concorde was Andre Turcat, shown at left at the controls of the plane; the plane's first landing is pictured above. The maiden flight took place at Toulouse. The British plane, piloted by Brian Trubshaw, later flew from RAF base at Fairford. (See *You, Too, Can Break the Sound Barrier*, page 111, March '68 PM.)



Looking for comfort

Using a technique called electromyography, researchers at the British Furniture Research Assn. are trying to learn what makes the perfect chair. People of various shapes and sizes sit for hours in chairs while a recorder (above) keeps track of every movement they make seeking the most comfortable position. The fewer the movements, the better the chair.



Quick exit

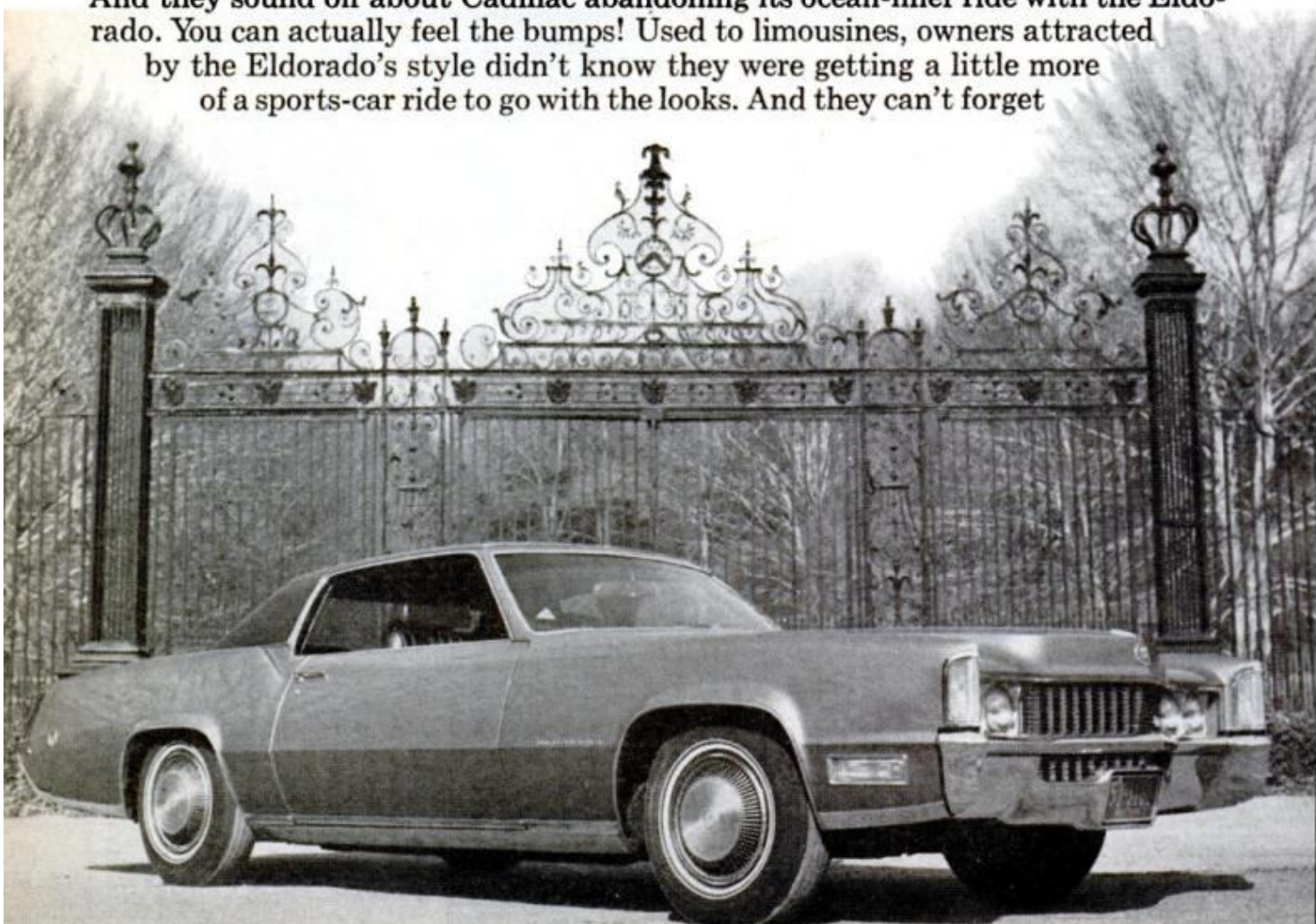
A system of inflatable slides, capable of evacuating passengers and crew of a 747 sup-jet in 90 seconds, has been developed for Boeing by B.F. Goodrich Co. The slides, stowed in the aircraft's doors, can be activated in seconds by opening the doors from the inside. Inflation is by combined action of cool-gas generator and ambient air aspirator.

Too Rough a Ride For the Soft Life

By **BILL HARTFORD**, Technical Auto Editor / Photos by Irv Dolin

YOU WON'T FIND A CADILLAC ELDORADO in the starting line-up of an SCCA Trans-Am sedan race, but a lot of Eldorado owners might look for it. They think their car is that sporty in looks and ride. That's what's good about it and that's what's bad. It has the sports-car look that they like, but it also has a suspension that affluent owners find is a lot stiffer than the price.

Suspension stiffness, to most of us who drive a car just to get around, is a very subjective thing. One man's slush bucket is another man's flat-cornering F1. Eldorado owners' reactions to ride are subjective and relative: For almost 90 percent this is not their first Cadillac. Twenty-nine percent have had nine or more! They are experts when it comes to what this "Standard of the World" should be. And they sound off about Cadillac abandoning its ocean-liner ride with the Eldorado. You can actually feel the bumps! Used to limousines, owners attracted by the Eldorado's style didn't know they were getting a little more of a sports-car ride to go with the looks. And they can't forget



CREATURE COMFORT is part and parcel of the Cadillac marque, but owner acceptance of the Eldorado +2 area is mixed. Individual, sculptured seats are luxurious and comfortable in themselves, but the rear passenger compartment draws complaints. Legroom is limited and visibility is severely restricted by the high front seats and hardtop roof line. Hard exit and entry and too low a seat are among other gripes

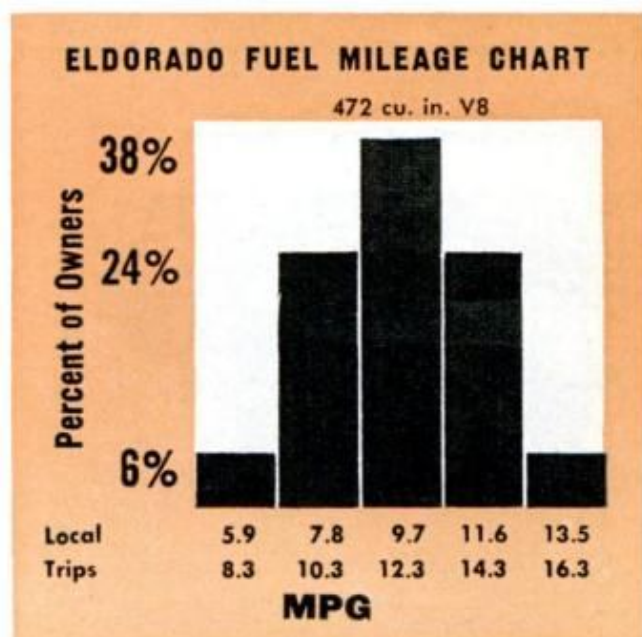


what they've given up for it: "Riding comfort doesn't compare with a regular Cadillac," "not as smooth riding as the Coupe De Ville," "ride is too firm," "bumpy ride," "rough ride," "hard on bumps," "rides too hard," "needs softer springing," and so on go the remarks from owners of all ages, not just the many retired folks who own Eldorados.

Even first-time owners, like the young housewife and model from New York who says, "Not a smooth ride," voice a desire for a more sponge-cake car. Seems they want what an Iowan, a chairman of the board in his 60s, calls the Eldorado: "Really a two-passenger, old-man's sports car."

Most owners distinguish between the firm ride and great handling. An Indiana tool-and-die-shop owner, for example: Handling and cornering are what he likes even if he finds the ride "a little too rough." An Illinois restaurant owner speaks for most owners when he says "Front-wheel drive is terrific!" In the words of a Kansas banker, the Eldorado's merits are "feel of stability, lack of sway, excellent road holding in cross winds." And a retired Michigan man finds "safety on slippery roads" with his car and likes its "sports-car feel." An Indiana dentist, too, likes wet-weather handling, especially in snow: "Don't need snow tires, no fishtailing." And, front-wheel drive "eliminates skidding" for a Kentucky manufacturer.

The price owners pay for their cars is



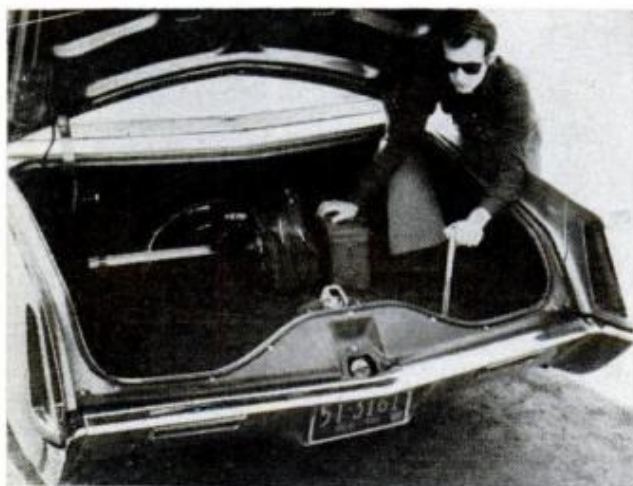
KNEE-KNOCKER bumper and taillight protrusions and the limited rear visibility are accentuated here



FRONT-WHEEL DRIVE, available only on the Eldorado and Olds Toronado among mass-produced domestic cars, receives much praise from owners for contributing to good handling



DRIVERS AND PASSENGERS like the flat-floor benefit of front-wheel drive, seating comfort and luxury; a few desire a larger glove box

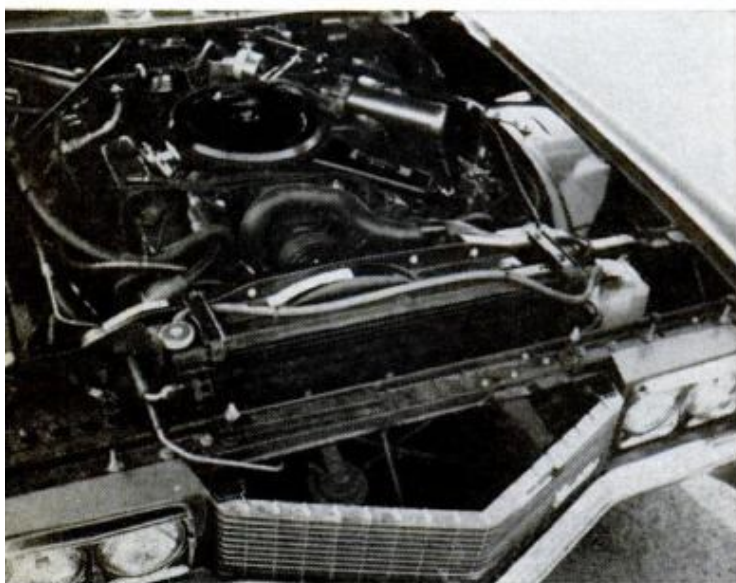


LARGE TRUNK is not as deep as most, especially near edge of the lid, but owners are happy with it

high coming and going. Of those who mentioned purchase price, most paid between \$8000 and \$9000, some more, even though \$6700 is the starting price. That means they've got add-on equipment equal in price to a compact car! When asked just what add-ons, many, like a New York builder, said simply, "\$2017.00 worth" or whatever the figure. Ho hum.

The price of the ride from tankful to tankful shouldn't matter much and it doesn't to a lot of owners—like the New Jersey wholesale business manager who gets five and eight mpg and doesn't even comment on the fact. A Texas real estate broker sums up the situation: "I have no idea of my mileage, I just fill it up once a day or so."

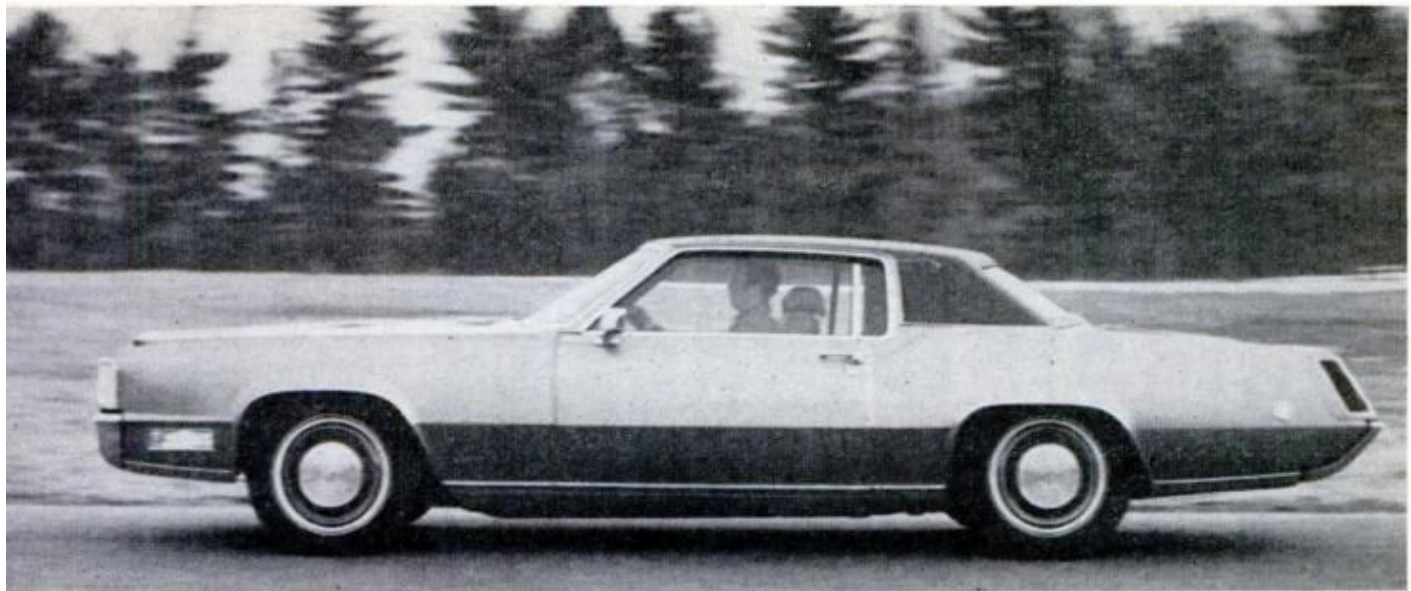
But enough owners *are* sitting up



ACCESSORY-LADEN ELDORADO with 472-cu.-in. engine gives no mechanical problems to 8 of 10 owners



DASH LAYOUT is disliked for tight grouping of controls around wheel and protruding dash divider



SPORTY STYLING AND SIZE are well liked; some owners want smaller car, find doors too large and heavy

and taking notice of their all-too-active gas gauges to make fuel economy a chief complaint. A Washington, D.C., restaurant owner says, "Don't know what I'm getting but it's not many mpg." Actually, 9.7 and 12.3 are the average local and long distance figures, respectively. Economy with a car like the Eldorado can't really be viewed objectively, however. An Illinois dentist getting six to eight mpg demands "an improvement." Yet, a New Hampshire insurance man getting about the same says his Eldorado "is a most economical prestige car."

A prestige car is certainly what any

Cadillac is and that, quite a few owners confess, is the reason for getting the Eldorado. It's also the reason a California consultant *hasn't* bought a Cadillac up until now: "I can afford a fine car but I've been influenced by the stigma that goes with owning one. The Eldorado, with its front-wheel drive, etc. and its sports-car leanings, changed my mind."

And then, coming up with the last word, is a Texas owner who says, "There are too many of them on the road. The price should be raised to \$15,000 to keep everyday people from owning them." ★★★

Summary of 1969 Cadillac Eldorado Owners Reports*

Total miles driven	989,200
Average miles per gallon (472 cu. in. V8, 1-4 bbl. carb., automatic transmission):	
local driving	9.7
long trips	12.3
Specific likes:	
Styling	49.4%
Handling	34.6
Comfort	26.5
Performance	22.8
Ride	18.5
Front-wheel drive	17.3
Specific dislikes:	
Economy	16.9%
Ride	16.3
Workmanship	10.8
Visibility	6.0
Dash layout	4.8
Tire quality	4.8
What changes would you like?	
Ride	14.5%

Dash layout	11.0
Styling	10.3
Rear visibility	9.7
Quality of materials	6.9
Had any mechanical trouble?	
No	80.3%
Yes	19.7
What kind of trouble?	
Windshield wipers	14.7%
Power steering	8.8
Ignition	8.8
Dealer repair satisfactory?	
Yes	70.6%
No	29.4
Why the Eldorado?	
Style	47.7%
Front-wheel drive	22.1
Past experience	13.4
Prestige	11.6
Quality	8.7
Performance	8.1

Is the Eldorado your only car?	
No	74.2%
Yes	25.8
Other cars owned:	
Chevrolet	26.0%
Buick	19.1
Pontiac	16.8
Oldsmobile	13.7
Ford	12.2
Cadillac	9.9
What options/accessories?	
Stereo tape	50.5%
Radio	49.5
Airconditioning	45.6
Cruise control	35.9
Tinted windshield	32.0
Power locks	30.1
Leather seats	21.4
Age distribution of owners:	
15-29	10.1%
30-49	47.1
50 plus	43.0

*Where applicable percentages may not equal 100 percent due to rounding and/or insufficient sample.

Popular Mechanical People

Three prim 18th century dolls in Switzerland are the forerunners of today's automated factories

By ARTHUR WHITMAN



EUROPE'S FIRST mechanical robots are prized possessions of a museum in Neuchatel, Switzerland. Built in 1770 by Pierre Jaquet-Dor, a Neuchatel watchmaker, the child-sized figures are stuffed with ingenious wind-up mechanisms that

are still modern nearly 200 years later.

"The writer" pens brief notes in any language. One set of works in the body controls a "spinal column" of three sets of 40 cams each. Each set actuates levers to move the wrist three ways. Another



"THE WRITER" (left), "the lady" and "the artist" have long been a popular Neuchatel tourist attraction



WOUND UP, the writer fires off another of the multilingual notes he has written in 200 years



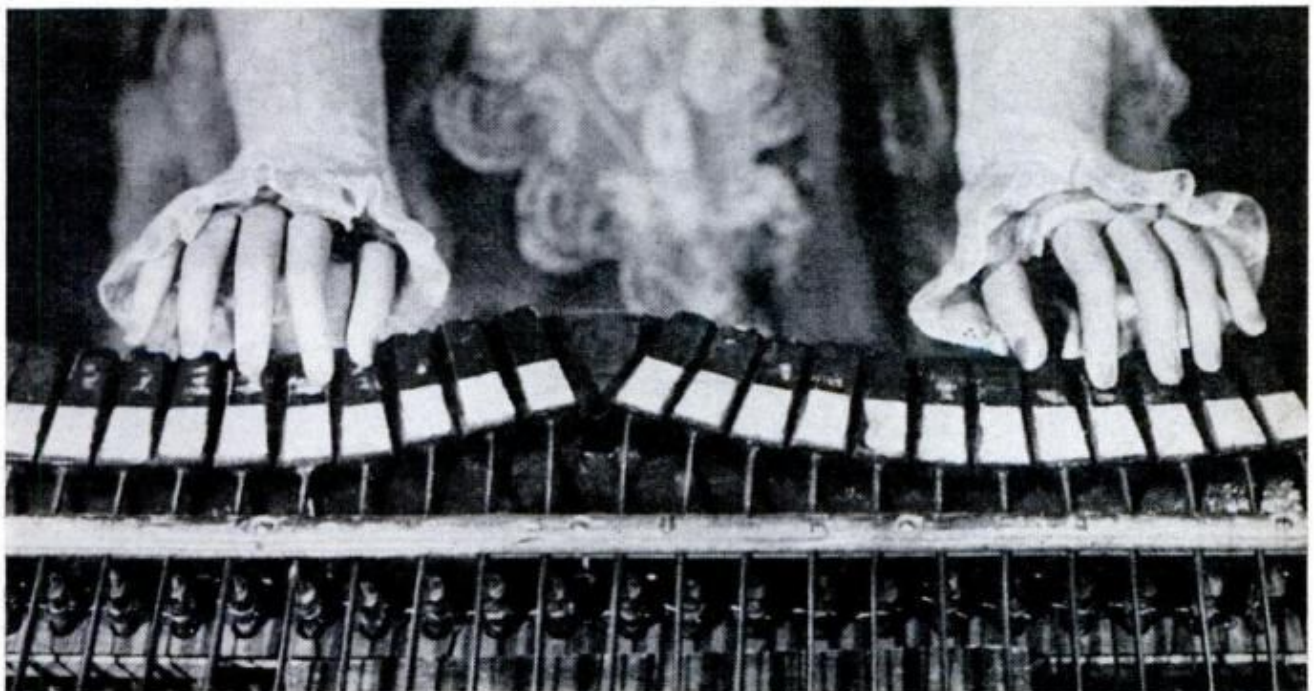
"SPINAL COLUMN" of the writer consists of cams and pegs controlling wrist motions to form letters

mechanism determines letters to be formed. By changing the angle of steel pegs, the writer can be "taught" any alphabet.

"The artist" is also actuated by cams: each turn of a cam executes a fragment of a "programmed" drawing.

"The lady" plays an organ when two brass drums, each with five rows of studs, move levers to make a finger strike keys.

Robots in today's factories and the 200-year-old dolls are alike in principle: electricity is the only difference. ★★★



"THE LADY'S" FINGERS are graceful levers actuated by studded drums. Another mechanism pumps organ

NEWS BRIEFS



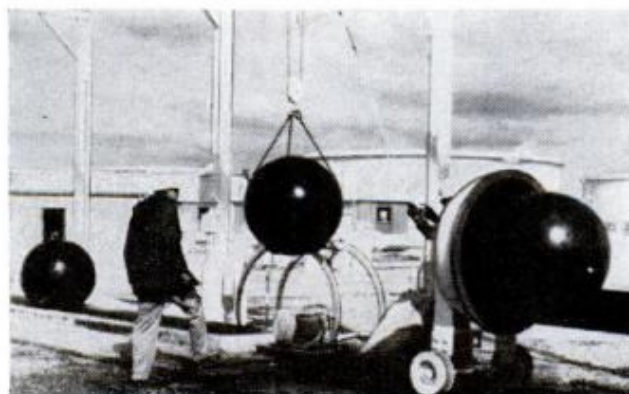
Pedals replace paddles in boat

Running about in the new Toocan boat is a little like riding a tandem bike: Both riders share the work. Seated facing one another, the boat's occupants operate sets of pedals that supply power through a gearbox to a marine propeller. The boat is made in England.



Navy's new F-14A

The Navy's F-14A variable-wing jet fighter, expected to fly in 1971, is shown here as a mock-up in the Grumman plant. The twin-engine supersonic plane will carry a crew of two.



Put this in your pipe

These 40-inch rubber balls are periodically sent through a 630-mile crude-oil pipeline to clean out sludge and saltwater. The line runs from St. James, La., to Patoka, Ill.



Low-flying speedster

Stabilizing "wings" fore and aft distinguish the new 190-mph TS5 Formula 5000 racing cars built by John Surtees in England. Several builders are producing cars of this class.



Snowmobiles' granddad

Still running in Minnesota is one of the many Fords that were converted into snow vehicles when Model T was king of the road. Even then, they were called "snowmobiles."



Moneybag-snatcher is caught in the 'Spider' web

A fleeing pouch-snatcher has to escape fast these days or the "Spider" will get him. The Spider (shown being loaded at upper left), carried by a bank messenger, fires a net attached to four projectiles at anyone who tries to make off with the money pouch. The net travels up to 25 yards to ensnare the villain (lower right). Colin Brown is the inventor.



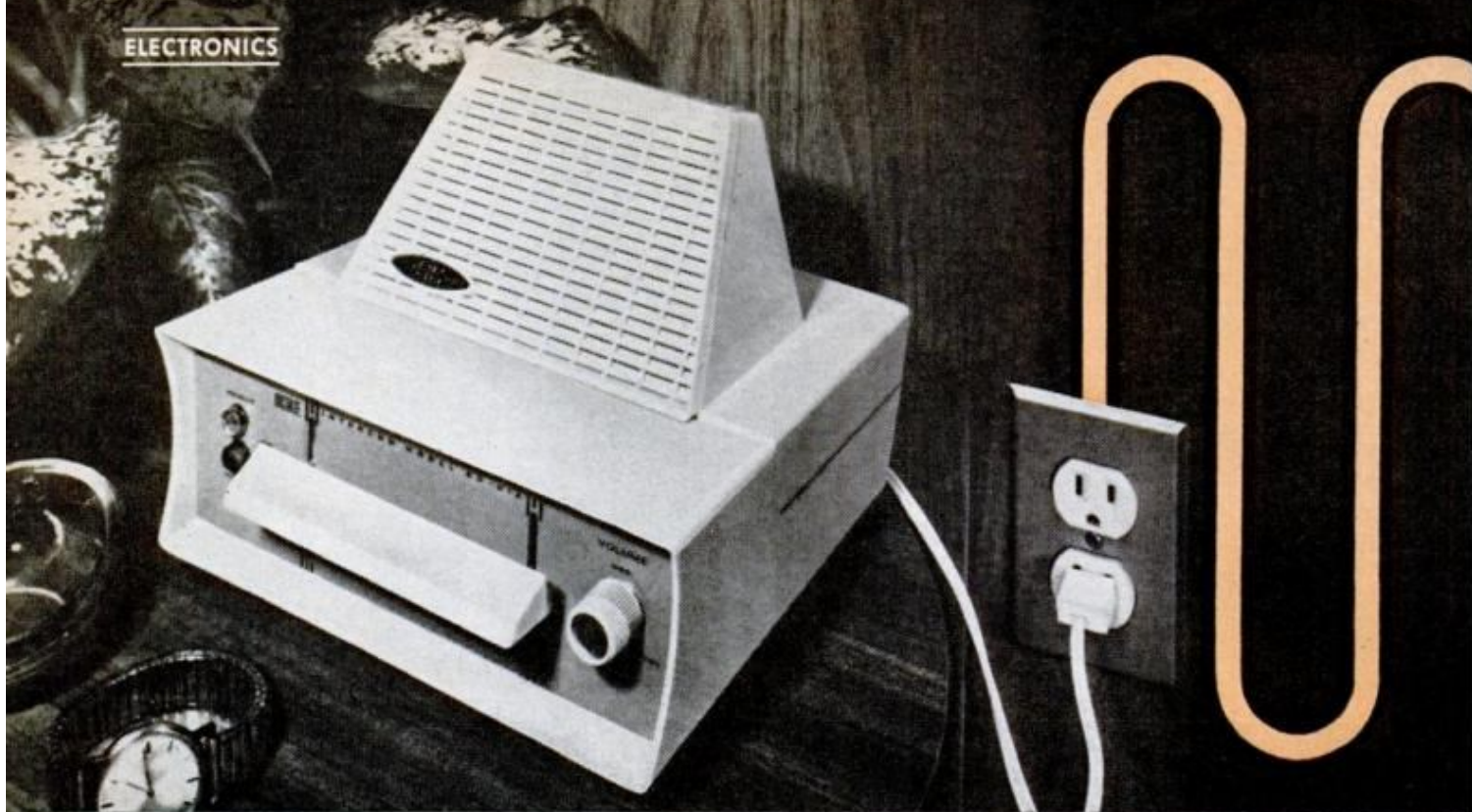
Canadian air-cushion vehicle

Hover Rover, a new air-cushion sports vehicle, is the product of Canahover, a Canadian firm. The aluminum and fiberglass machine can carry 600 pounds and travel 50 mph.



Retractable gear for boat

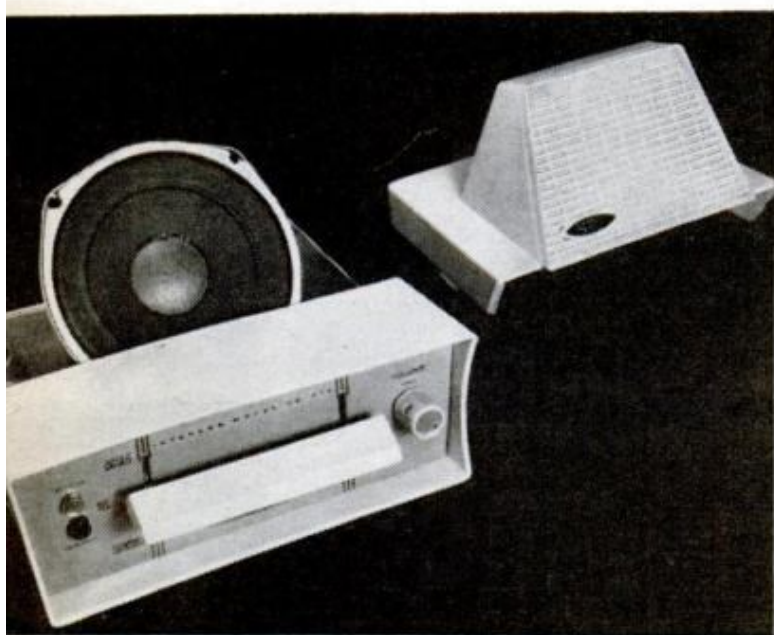
For the short overland trek from his home to water, Keith Trask converted his boat into an amphibian by adding a retractable wheel and 1½-hp inboard motor to power it.



PLUG-IN INTERCOMS broadcast over the power lines in your walls, let you call any-

Wire Your House for Intercoms

Handy plug-in-anywhere units let you talk from room to room over existing house wiring with no need to string new lines. Here's how they work and tips on installing your own

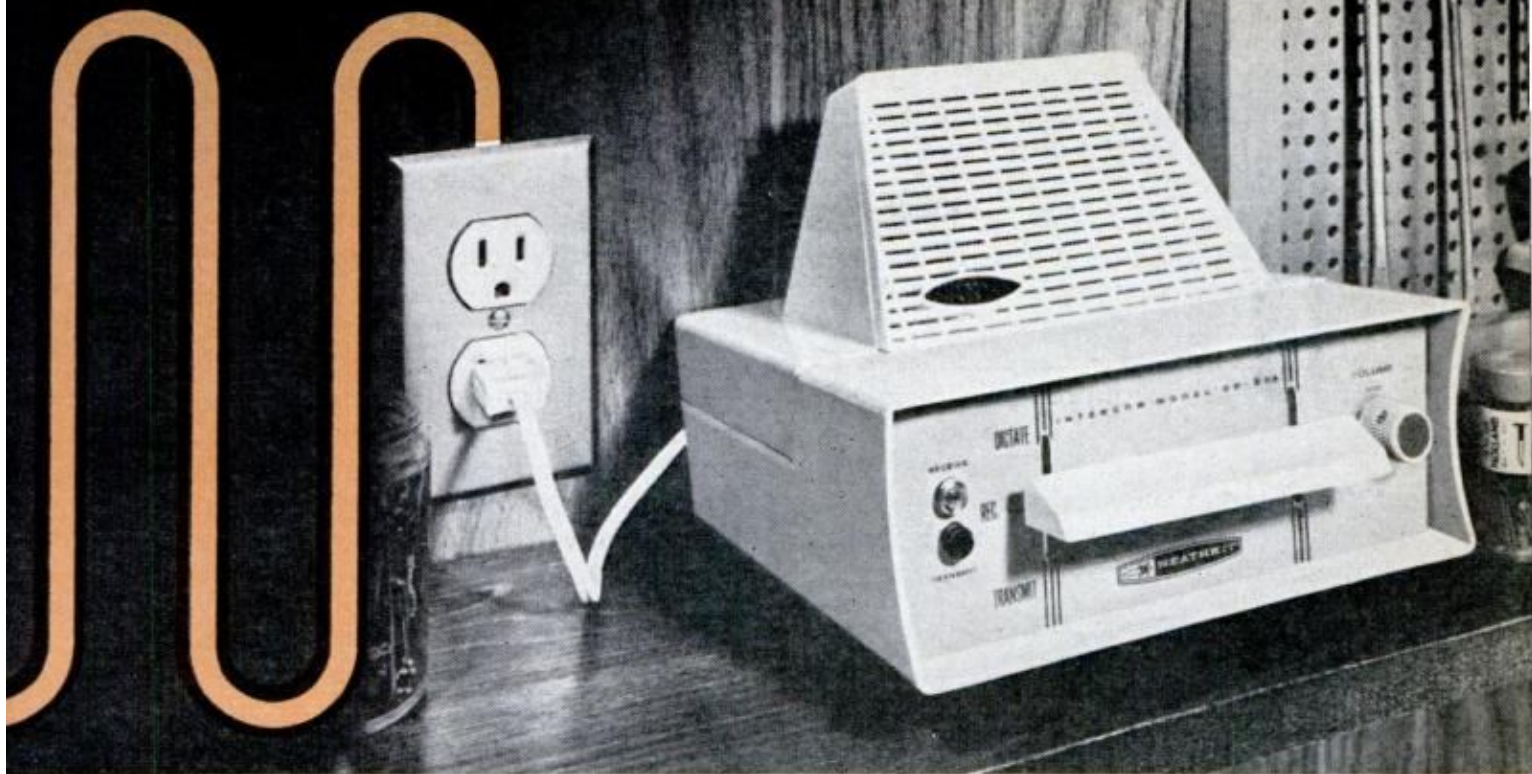


UNUSUALLY BIG SPEAKER is feature of Heathkit intercom shown here and at top of the page. Large size is made possible by angling speaker upward behind a sloping grill—ideal for use on a shelf or a desktop

INSTALLING INTERCOMS usually calls for snaking a lot of wires inside walls and under floors to get from room to room. But this doesn't have to be. A special breed, known as the "wireless" intercom, eliminates all the fuss of stringing wires. You merely plug it into a wall outlet. Plug a second unit into an outlet in another room and you can talk back and forth—without running a single wire.

Wireless intercoms transmit their signals over the existing 115-volt wiring in your house, using what is called "carrier current." Low-frequency radio-like waves are broadcast over the wires from one unit and are received by another unit in a different part of the house. The process is like radio transmission except that the signals go through the wires instead of the air. You can install a whole three or four-

POPULAR MECHANICS



where there's an outlet. These slickly styled Heathkit units sell for \$45.90 a pair

— Without Wiring at All

By WALTER G. SALM

Technical Art
By John Lind

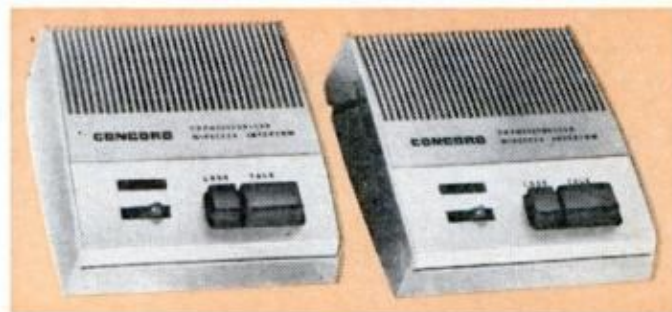
station system in five minutes.

Prices are moderate. They start at about \$20 for a pair of units and range to about \$60, with a number of popular models in the \$30 to \$50 range. A few heavy-duty, deluxe types go on up to around \$100 a pair.

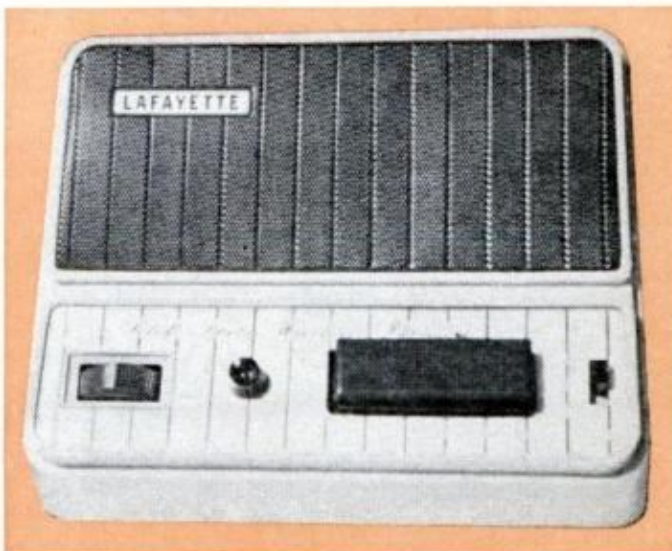
In addition to easy installation, wireless intercoms have other advantages. In a typical wired system, there is usually one "master" station and several "slave" or "satellite" stations. Slave stations can only call the master—not each other. Adding units tends to complicate the wiring, especially if there is to be more than one master station.

By contrast, in a wireless system, any station can call any other station since all units are on the same line. Adding stations is simple because you just plug them in—as many as you want—wherever you have wall outlets. You can move them around as needs change and take them with you if you move—not easily done with a permanently wired system.

The main disadvantage of wireless intercoms is that they aren't selective. In a wired system, you can call any



UP TO THREE CONVERSATIONS can be carried on simultaneously with three-channel Lafayette intercoms of the type shown below. They sell for \$39.95 per pair. Above are two-channel Concord units for \$59.90 a pair



station from a master without being heard at the other stations. In a wireless system, a voice speaking into one unit comes out all the others. This could be a nuisance where you don't want noise, such as in a room where someone is sleeping or sick.

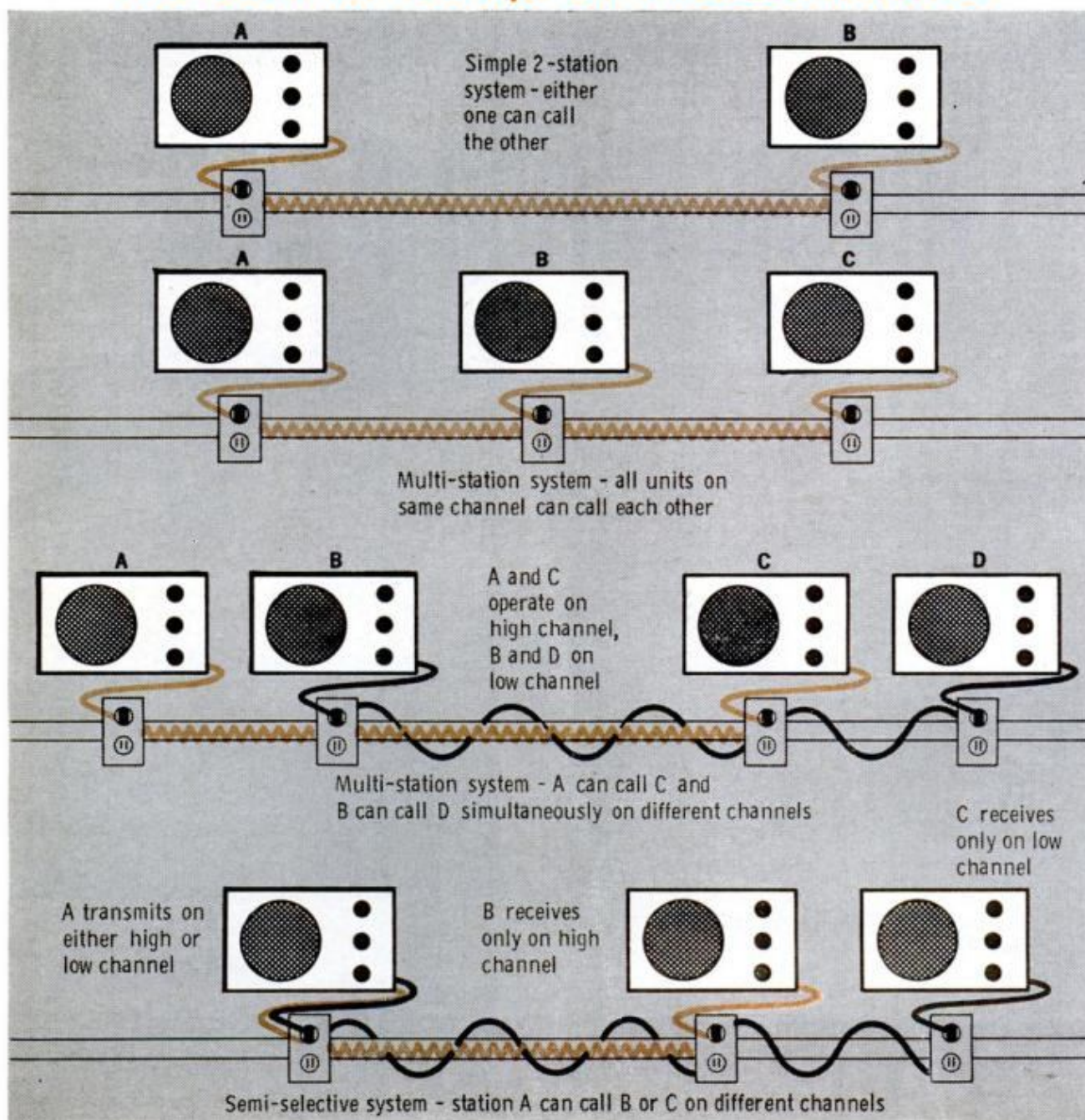
Some of the tricks that wireless intercoms can do make up for their shortcomings, however. Since they transmit over power lines, it's possible to broadcast messages to your neighbor next door so long as there is no pole transformer between the two houses to interrupt the circuit. We frequently baby-sit our young son from across the street merely by placing one intercom by his bed and plugging another into our neighbor's current. The

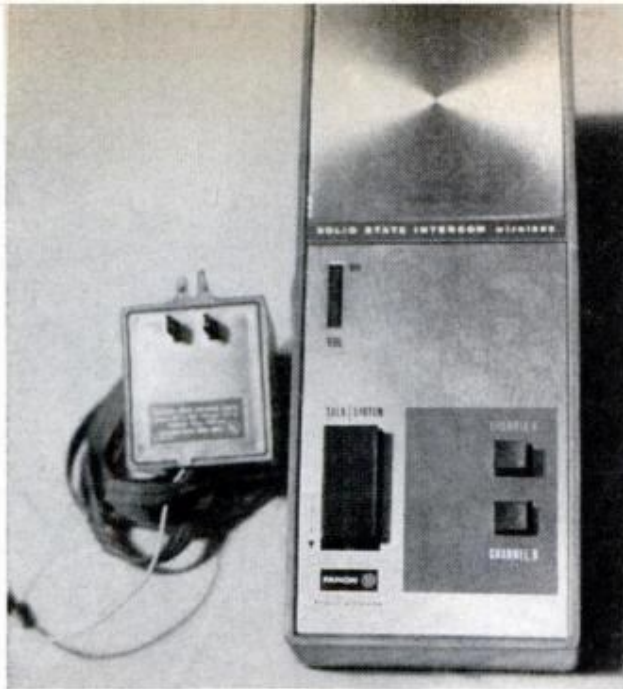
slightest cough or other noise is easily heard while we enjoy a night out.

This baby-sitting feature is one of the charms of a wireless intercom system. All units have some kind of push-to-talk switch or lever that can be locked in the "on" position. This way, the intercom is always sending. Set one up in the baby's nursery, plug in another unit wherever you or your wife happen to be, and you can keep tabs on the youngster without interrupting your work. The current draw is so small you can leave wireless intercoms turned on for hours without fear of wasting power or burning them up.

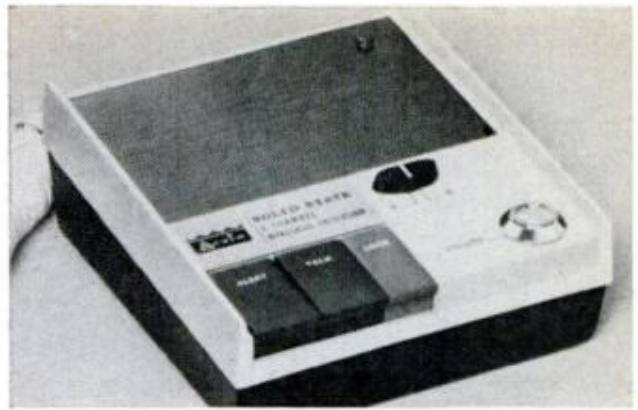
Inexpensive intercoms broadcast on only one frequency, but the better units

Four Common Hookups for Wireless Intercoms





TYPICAL DUAL-CHANNEL INTERCOMS are the three shown here. Above is Fanon's top model, the F1W-2, priced at \$59.95 a pair. At upper right is Arvin's 40Y55 at \$39.95 a pair. Directly right is Radio Shack's Realistic 43-225 at \$19.95 each. All of the units have easily accessible pushbutton controls

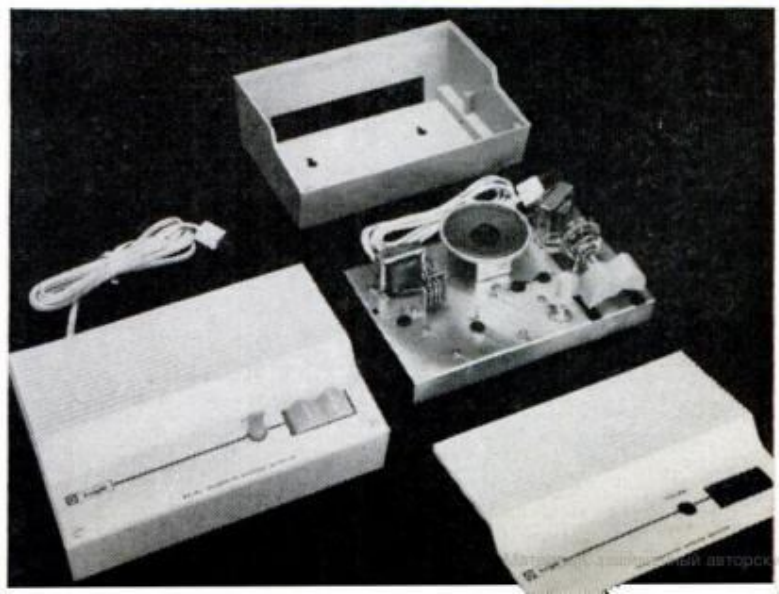
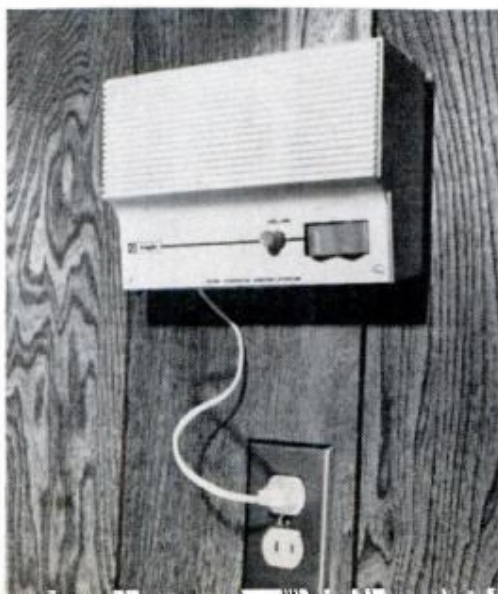
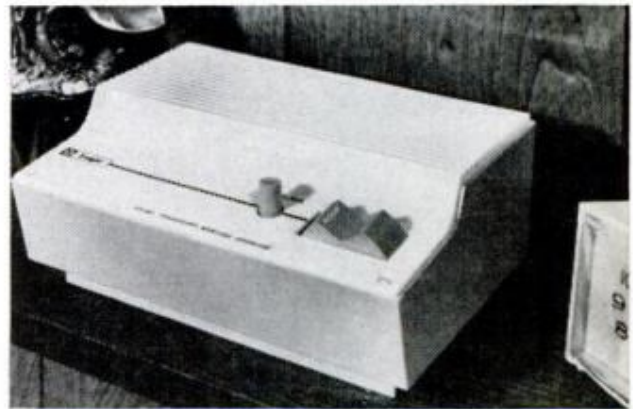


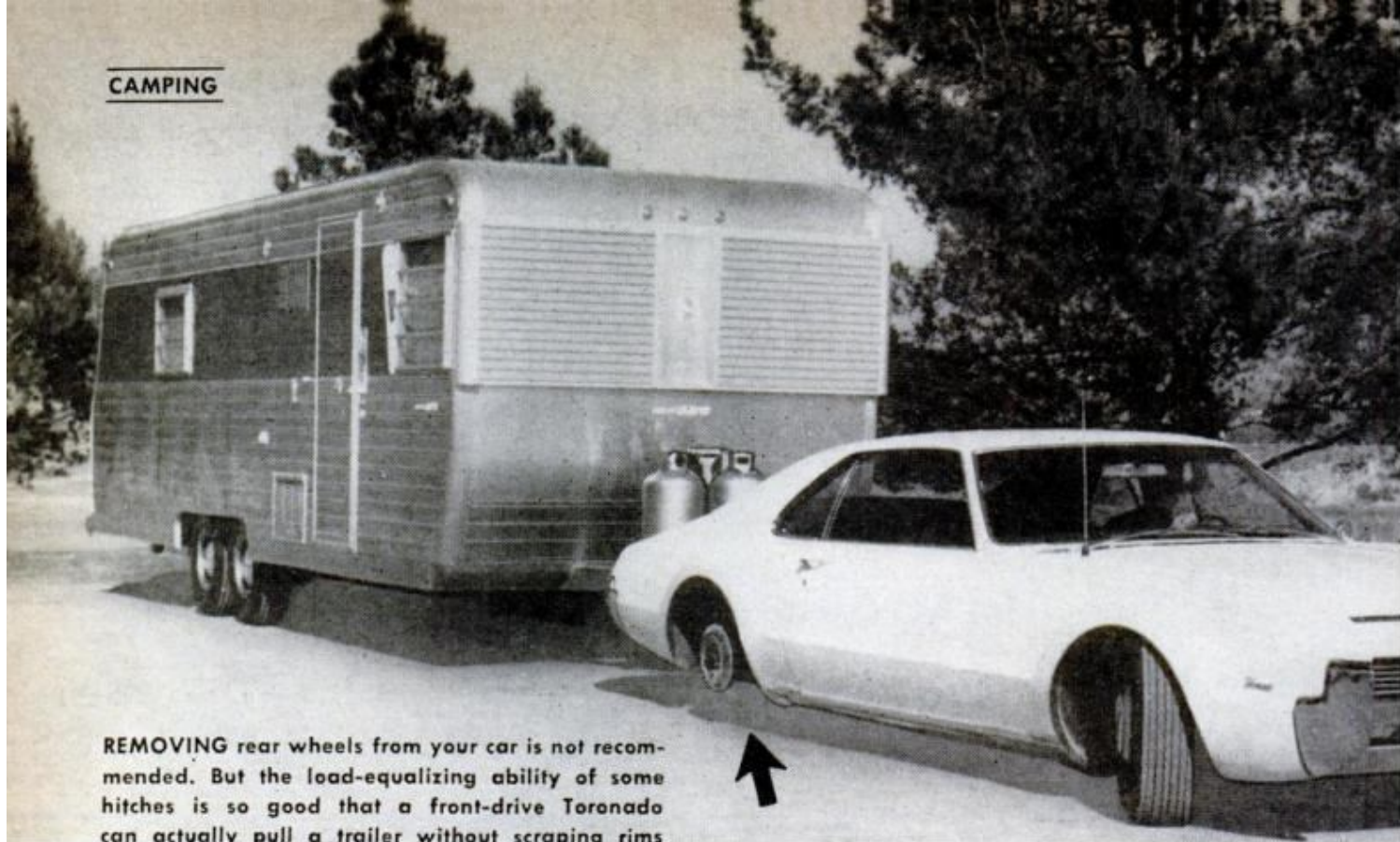
offer a choice of two or three. These extra channels are handy to have for several reasons. If a nearby neighbor happens to have the same units as you and you find yourselves listening in on each other's conversations, you can each agree to operate on a different channel and thus keep your communications private. You may also find that one channel is bothered by noisy interference of some sort that's hard to get rid of. Having a second channel to switch to lets you pick the clearest one.

The biggest advantage of multiple channels, however, is that they give you flexibility. You can set up one pair of intercoms to operate on one channel and another pair to operate on the second channel. This way, you can actually carry on two

(Please turn to page 202)

YOU HAVE A CHOICE of either flat or vertical mounting with some intercoms. This Knight-Kit model sold by Allied Radio has handy keyhole slots in the bottom panel that let you hang the unit on a wall, as shown at left, below. With many units, a wall mounting makes it easier to speak into the microphone without bending over. Photo at right, below, shows a small center cone that serves as both microphone and speaker—a typical intercom arrangement





REMOVING rear wheels from your car is not recommended. But the load-equalizing ability of some hitches is so good that a front-drive Toronado can actually pull a trailer without scraping rims

TRAILER HITCHES: Tips to Keep You Out of Trouble

To tow a trailer level and without trouble, the right hitch is essential. Here are six different types of hitches to balance your trailer—and your budget. **By LEE OERTLE**

WITH TRAILER-TONGUES now weighing from 250 to 1200 pounds, old-style bumper hitches just won't do the job. A whole new generation of safe, strong, reliable hitches has grown up with the trailer boom.

One of the newer hitches is the Watson Trailer Dolly. This is a bracket unit which attaches to the front of a trailer frame. Extending down from the bracket is a large, round hydraulic shock absorber. Depending on trailer weight involved, either two or four small-diameter wheels are used on the dolly. Because of a special pivoting front yoke, the dolly coupler is free to rotate on the hitch ball, as usual, but it also can pivot vertically at the side mountings.

The trailer-dolly wheels remove all the hitch weight from the car. Thus, the car

tows the trailer but does *not* carry the tongue load. Result: No rear-end sag and no stress on front-end or suspension components. (In order to control possible side sway, Watson recommends an antisway device.)

The principal advantage in using a trailer dolly is that you don't need to worry about tremendous tongue loads or complex devices attached to the car. The dolly carries all the trailer-tongue weight. It's easy to disconnect, too. Trailer Dolly handles tongue weight from 600 to 1300 pounds. Cost: \$50 to \$280.

Another type of hitch is called pintle and receiver. To my knowledge, there is presently only one company manufacturing a pintle-type hitch: Hayden-Robot. The Robot is sometimes referred to as a fifth-wheel device. The hitch ball is only

incidental because, for practical purposes, it does no towing. The Robot device attaches to the trailer frame and the pintle. It is inserted into the special receiver which is mounted on your car. Other than the *shape* of this receiver, the towbar is attached pretty much like any load-equalizer mounting under the car.

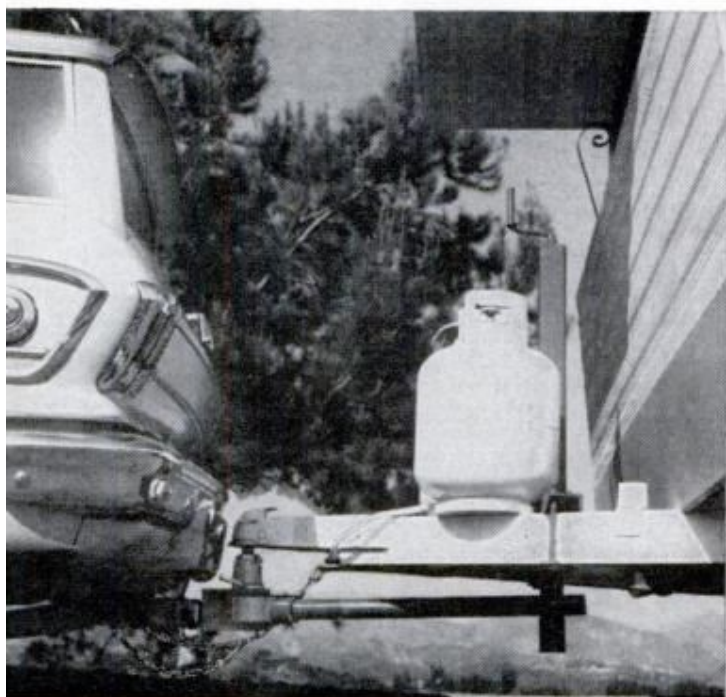
The Robot pintle has axial rotation in the receiver and also rotates in the horizontal plane about a vertical bolt when turning.

One of the big selling points of the Robot hitch is that it is said to operate effectively when the trailer-tongue load is as little as four percent of the gross trailer load. Other types of load equalizers work best when 10 to 15 percent of the gross trailer load rests on the hitch ball. Robot is designed for use with a tongue weight from 400 to 900 pounds. It costs from \$99.50 to \$228.50.

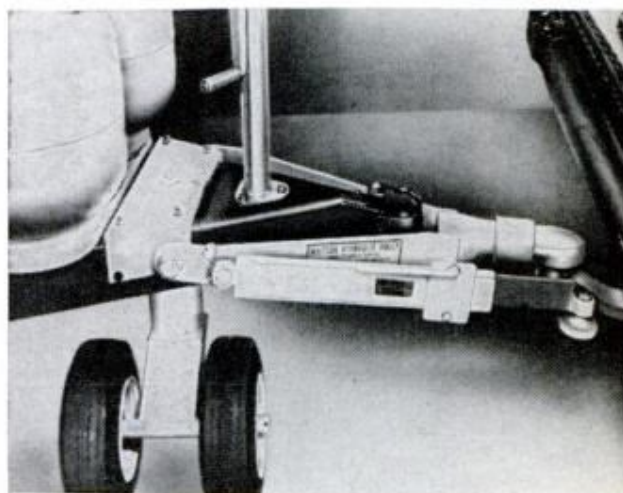
The so-called load-equalizer is also commonly referred to as a "load-leveler" hitch. Many people simply refer to them as "equalizers." The object of this type of hitch is to remove some of the load on the hitch ball and transfer it to areas of the car that are better able to support weight.

There is nothing gimmicky or mysterious about an equalizer hitch. It's a scientific device. Through ingenious use of the laws of leverage, a 900-pound trailer tongue load can be divided three ways.

SINGLE-BAR EQUALIZED HITCH rests in lower end of jack cradle on trailer. Rotating jack levels rig



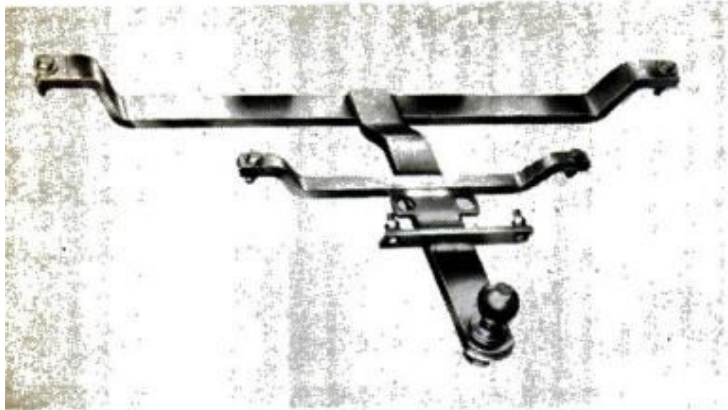
LOAD-EQUALIZING HITCH (above) makes car and trailer one unit. Adjusting tension on spring bars levels rig. **TRAILER DOLLY** (below) eliminates tongue weight from hitch ball. Note antisway bar, front, going from trailer wheel plate to pin on car hitch unit



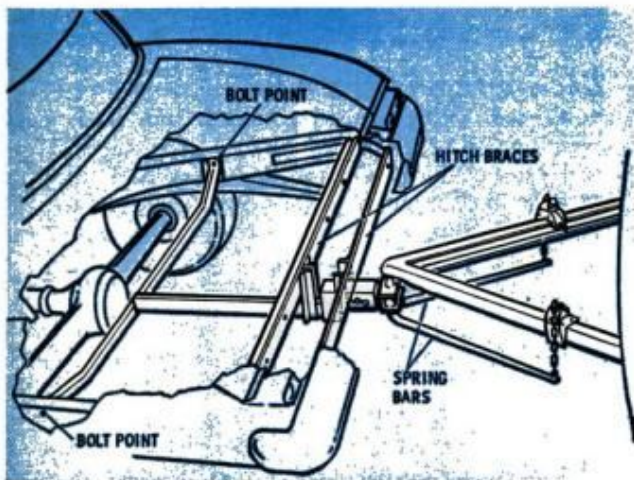
Roughly a third of the tongue load is shifted forward onto the front wheels. Another third is transferred back to the trailer axle(s). The remaining 300 pounds is on the hitch ball.

A favorite engineer's expression is that an equalizer hitch builds a bridge between a car and trailer. In effect, a car and its trailer react as a single unit to certain forces.

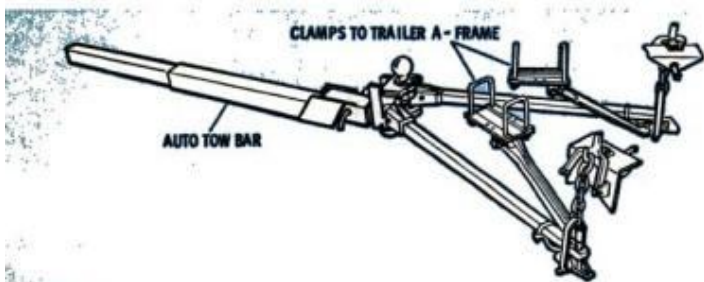
Leverage is applied through use of spring bars. One end of each spring bar inserts into a socket on the hitch head. The head rotates freely while supporting the weight. The other end of the spring bar is carried in a special "cradle" on the trailer frame, as it is suspended from a short chain attached to the trailer frame. By cinching up on the cradles, chains, or



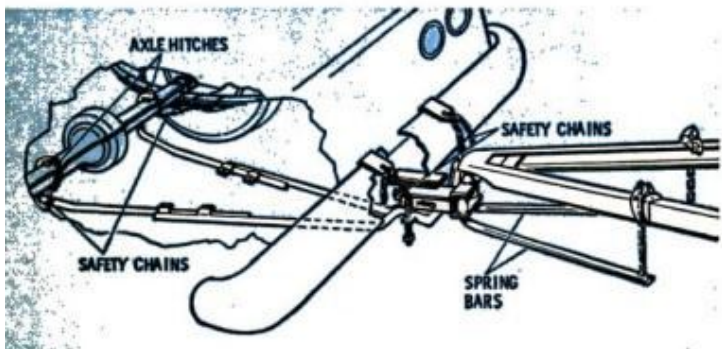
NONEQUALIZING FRAME HITCH will withstand rugged abuse and terrific strains of sudden starts and stops. Good for trailers with low tongue weights



FRAME-MOUNTED EQUALIZER transfers trailer tongue weight through long towbar to front of the car. Spring bars exert lifting force, keeping rig level



SINGLE-BAR EQUALIZER uses springs bars and cam-action device for two-way control when cornering and on straight roads. V-unit hooks on trailer frame



AXLE-MOUNTED EQUALIZER transfers about 90 percent of the tongue weight to rear axle of your tow car. No trailer weight is carried by the suspension

cams the spring bars can exert enough force to lift the back end of the car several inches.

In fact, in one amazing demonstration with a front-drive Toronado, the rear wheels of the towing car were removed completely and the equalizer hitch carried the entire weight. What's more, the car was able to drive in that ridiculous position, towing the trailer!

There are three different types of equalizer hitches: single-bar, axle mounted, frame mounted.

The frame-mounted equalizer requires from five to seven attachment points on your car frame. This hitch is by far the most popular. The superlong towbar (from bumper to differential) passes the stresses and load weight of the trailer along to the front wheels of the car, and also tilts some of the weight back to the trailer axle. Most of the load-equalizer hitches are installed by bolting them to the car.

You cinch up on the spring bars until the trailer and the car frame are in a horizontal position while at rest. If the tongue of the trailer is high, or if the rear end of the car is low, the hookup is wrong. Make them level no matter what any so-called expert says about towing the front of the trailer high "on a rake." With the hitch level, when the car passes over a chuck-hole or dip in the pavement, the spring bars help absorb the strain. In most cases a load-equalizer hitch will prevent excessive fishtailing. Not always, but in most cases.

Names of some frame-equalizers include Bait Stabi-Lev; Big Boy; Bock; Eaz-Lift; Equal-I-Zer; Reese and Saf-Tow. Tongue-weight capacity ranges from 250 to 1100 pounds. Prices run from \$50 to \$126.

Axle-mounted load-equalizers utilize spring bars and yokes, but with an important difference: The towbar attaches directly to the rear-axle housing of your car rather than to the frame. Approximately 90 percent of the tongue load of the trailer is carried on the rear wheels of the towing vehicle.

The principal advantage of this kind of hitch is that it attaches without your having to drill holes for bolts or welding parts to your car. The forward towbar ends attach to the axle housing with V-bolts and clamps or chains. The hitch head and back

end of the towbar is suspended from the bumper by two strong chain clamps. When tension is increased on the spring bars, more load is shifted to the rear wheels of the car. Less tension on the spring bars has the opposite effect.

This type of axle-mounted hitch is used by many of the trailer rental agencies because there is a minimum of installation work involved.

However, I must caution that virtually every automobile manufacturer includes a clause in his warranty which specifically prohibits the use of axle-mounted hitches, at the risk of voiding the warranty. On the other hand, one of the largest manufacturers of axle hitches says that in 20 years of service records he has had only a half-dozen complaints about axle-mounted hitches.

The problems are generally associated with extreme wheel-bearing wear and strain on the axle housing. The suspension system of the car carries no trailer load whatever when an axle-mounted hitch is used. Axle hitches are made by Quick-Eaz and Reese. Their tongue-weight capacity goes from 400 to 2000 pounds, and prices run from \$92 to \$143.95.

The newest load-equalizer system, which has come along only during the past two seasons, is called the single-bar equalizer. The Mono-Bar, made by Saf-Tow, was the first such system. It takes tongue weights from 400 to 800 pounds. Cost is about \$100. Reese Products also makes one which handles 300 pounds and costs from \$45 to \$93.

The single-bar system uses only *one* bar, instead of two. It rotates inside a single socket directly under the hitch ball. The back end of the single-bar equalizer is suspended from the trailer tongue by a cross bar or by a hook-and-chain arrangement.

The single-bar equalizer is a real boon to boat owners. The single tongue of most boat trailers defies the use of ordinary twin-bar equalizers unless a crossbar is welded or bolted to the trailer frame to accept it. The single-bar effectively distributes much of the tongue load away from the hitch ball to prevent rear-end sag on the towing vehicle. The Reese single-bar equalizer can be used with either an axle-mounted towbar or frame-mounted assembly.

The ordinary nonequalizing frame hitch

still tows *more* trailers than any other kind, despite all the glittering newcomers in trailer-towing equipment. It's simple, durable and reliable—up to a point. An ordinary frame hitch should be attached to side-frame rails so they will not be dependent on the bumper or rear-frame brace. The only problem with ordinary frame hitches is that it is so easy to overload the car.

When trailer tongue loads exceed about 200 pounds on small cars and about 250 to 300 pounds on full-sized cars, you've gone beyond the ability of your car to handle the load safely or efficiently with an ordinary hitch. Rear-end sag develops. The trailer tongue will dip so low that it might actually "bottom" when the car tows it over a dip or chuckhole.

Even though it is possible to find frame

8 Rules for Hitch Buyers

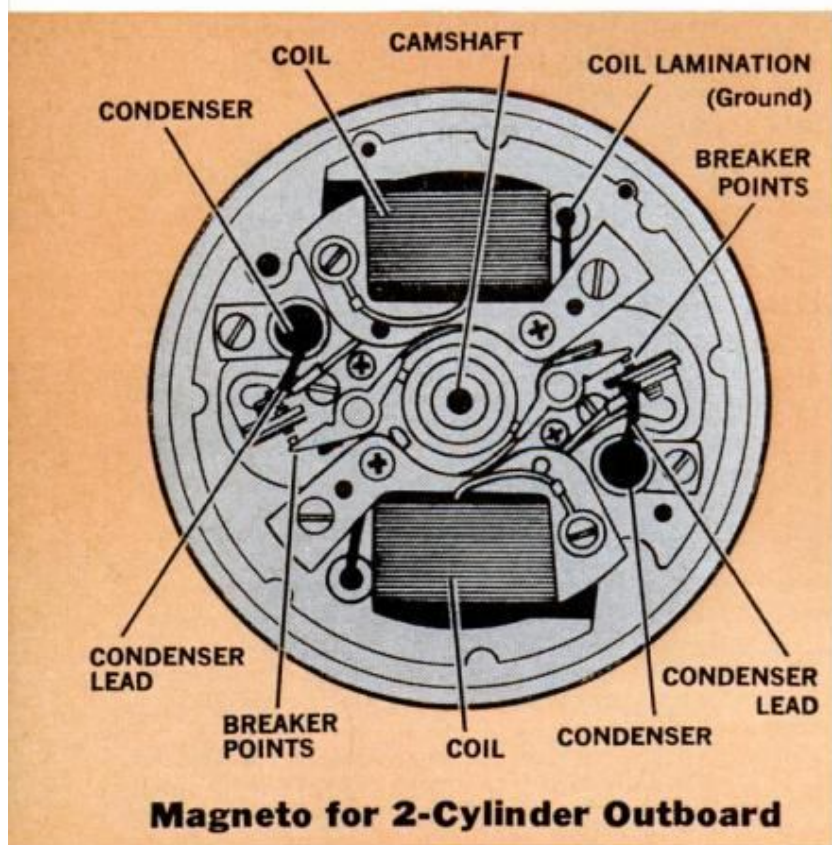
1. Check weight capacity of hitch. Hitches are generally rated according to trailer tongue loads (or according to gross trailer weight in some cases) which can be handled safely.
2. Make sure you ask for the full price of a hitch plus installation charges. In some cases, labor costs on installing hitches are higher than the prices of the hitches.
3. Look into at least two or three different brands of hitches before buying. Know what's available and for what price before buying.
4. Don't use an ordinary nonequalized frame hitch when tongue loads will exceed 300 to 350 pounds.
5. Use one of the load-equalizer hitches or a dolly type when trailer tongue loads will be greater than 350 pounds.
6. Ask your dealer to demonstrate the hitch before you buy.
7. Remember to balance the cost of your car and trailer against the possible cost of damage that could result from towing with an inadequate hitch. If you can afford several thousand dollars for car and trailer, another \$100 for a professional hitch and installation is certainly reasonable.
8. Never tow with an unsupported bumper clamp hitch. It's as unsafe as using magnum powder loads in a twist-shell shotgun barrel.

hitches manufactured with an advertised load limit of 500 pounds tongue weight, don't be tempted! While the hitch may well be strong enough, the car isn't. When your trailer tongue loads exceed 300 pounds, you should advance to a scientific load-equalizing or other special-duty hitch. ★ ★ ★

How to Check Out Your

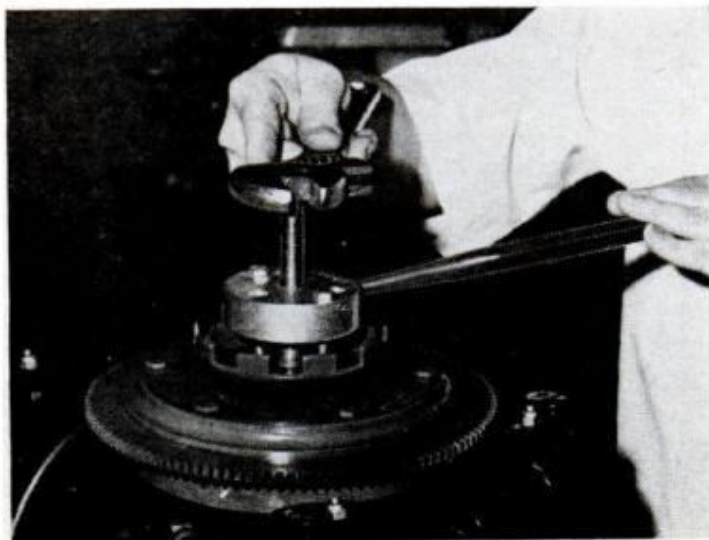
No start, hard start, missing and loss of full power can be traced to ignition trouble. Here's what to check in any outboard from sparkplug to magneto

By HENRY B. NOTROM



Magneto for 2-Cylinder Outboard

1. WITH FLYWHEEL NUT and attaching screws removed, use puller to remove flywheel. This uncovers magneto



THE IGNITION SYSTEM of every one and two-cylinder outboard engine consists of a magneto, sparkplugs and high-tension cables. This is true of every Chrysler outboard up to 55 hp, OMC (Evinrude and Johnson) up to 40 hp, McCulloch up to 45 up, and Mercury up to 35 hp.

Heart of this system is a magneto. They're all pretty much the same—if you can repair one, you can repair all. You'll need two pieces of equipment—a flywheel puller, which costs about \$15, and a magneto analyzer, which costs about \$120.

You can get both from a dealer of outboard equipment. Be sure the magneto tester is accompanied by an instruction book. You can use one made by Graham, Stevens or Merc-O-Tronic (no affiliation with Mercury outboards).

Keep in mind that all components of the ignition system should be tested once you pull the flywheel, even though you may find and replace a bad part at the start of your checks. New breaker points, for instance, may increase the spark. But if a weak condenser (that caused failure of the points in the first place) goes undetected, the trouble will soon reappear.

Ignitions of two-cylinder engines have two of everything: plugs, points condensers, coils. In one-cylinder engines there's one of each.

How do you know when your out-

This is the first of five articles that will give you a ready-made service manual for your one and two-cylinder outboard motors. Clip and save them.

Ignition System

board ignition system is giving trouble? If the engine refuses to start or is hard to start, pull a sparkplug after cranking the engine to see if fuel is getting to the cylinders. If the plug is wet, but the motor isn't starting, the trouble is undoubtedly ignition. Occasionally, an engine that misses at high speed or won't get up to full speed signifies an ignition breakdown.

You can check for ignition trouble another, more positive, way. Remove a sparkplug lead and hold it $\frac{3}{16}$ -in. away from a ground on the engine block. Crank the motor. A spark should jump the gap.

Another way to test for spark is to start the engine and pull a lead from a plug. Hold it $\frac{3}{16}$ -in. away from the plug terminal to see if a spark jumps the gap. Be careful if you do it this way. Make the test for just an instant. It puts a strain on the coils and might cause a good coil to break down.

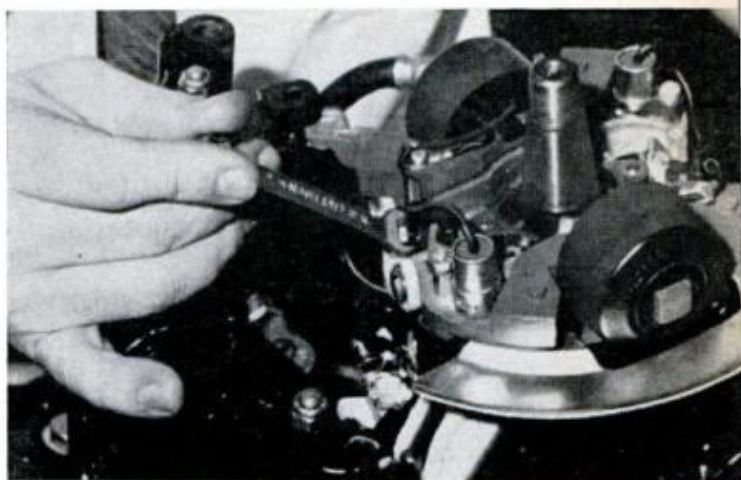
Sparkplugs, loose or shorted wiring, and breaker points account for practically all ignition failure. Occasionally, a condenser or coil will go bad. Rarely, if ever, do the magnets in the flywheel give trouble.

What follows is how to test, replace and adjust each ignition component. Keep in mind that the specifications we give are general; that is, they apply to most of the newer-model outboards (1965 and later). However, it's advisable to get the exact specifications for your engine from a dealer or from the manufacturer.

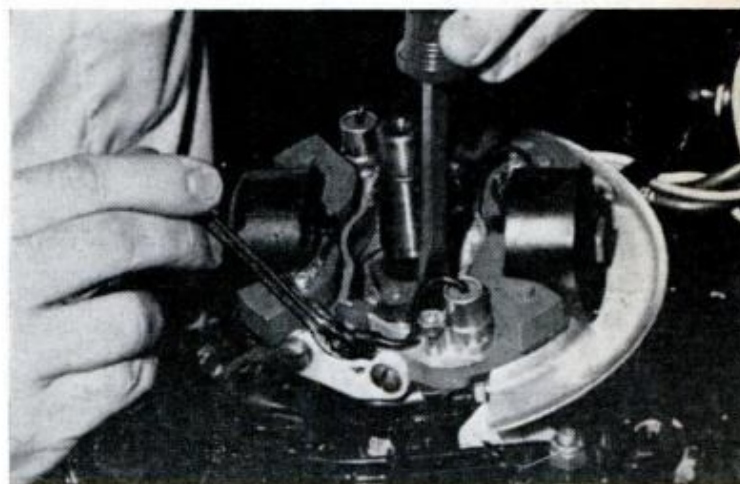
Start with sparkplugs. If you find them the reason for your ignition failure, you don't have to go further. Look for dirty plugs, improper electrode gap, worn electrodes, broken or cracked insulator and plugs of the wrong heat range.

Heat range is important. If plug insulator tips are blistered, indicating that the plugs have been running hot, switch to the next colder plug. If they are fouled, indicating improper combustion, they are running too cold, so switch to the next hotter plug.

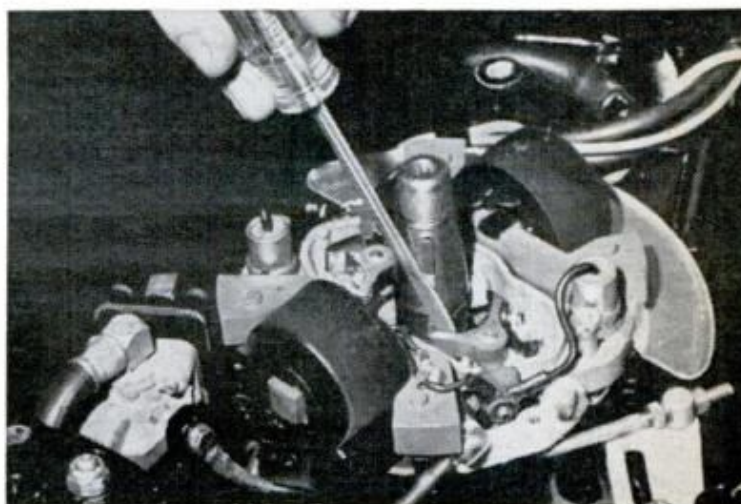
Replace damaged plugs, and those that have a ground electrode worn to $\frac{1}{16}$ -in. below the edge of the shell. Clean dirty electrodes with a strip of emery cloth



2. **TIGHT CONNECTIONS** are a must. A critical one is where the condenser lead joins the coil primary leads



3. **REPLACE BREAKER POINTS** by disconnecting condenser lead and unscrewing points. Parts lift out



4. **BREAKER-POINT SPRING TENSION** should be 33 to 37 lbs. Replace if point tension is not firm to touch

and check gap. That for OMC and Chrysler engines is 0.030 in. Plugs in Mercury engines are gapped to 0.025 in. Those in McCulloch outboards are gapped to 0.035 in. To adjust gap, bend the side electrode only.

In replacing plugs, torque to 20 ft.-lbs. A loose plug will cause loss of compression; a tight plug will overheat.

Give sparkplug cables a close inspection. Replace if cracked or split, and check boots, too. Discard if damaged. You will give each high-tension lead a closer test for leakage when you test the coils later.

If sparkplugs are not the cause of trouble, you must now remove the flywheel to investigate further. All flywheels are removed in much the same way. Unscrew the flywheel nut and screws (usually two or three) holding the flywheel to the magneto armature plate. To remove the flywheel nut, you have to hold the flywheel steady. This can be done with a strap wrench. Using the flywheel puller, remove flywheel from the crankshaft (Photo 1).

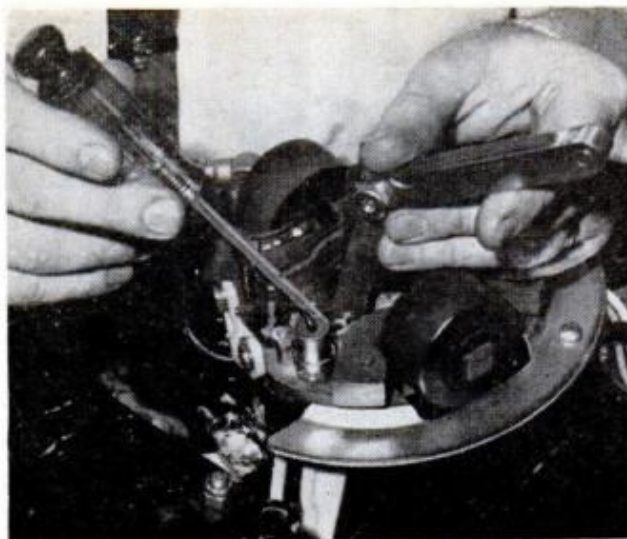
(Remember that when you reinstall the flywheel it is important that the nut be torqued to proper specifications. This spec is normally 40 to 50 ft.-lbs.)

Next, check all electrical wires for tightness at connections and for frayed insulation. If a section of wire is bare or the insulation is worn, shorts will keep the engine from running. If insulation isn't too badly frayed, repair it with a strip of insulating tape. If shot, replace the part. Notice that each component of the magneto (Photo 2)—points, condensers, coils—is held by a screw or screws. Replacement is easy by removing the screw(s) and lifting the components from place (Photo 3).

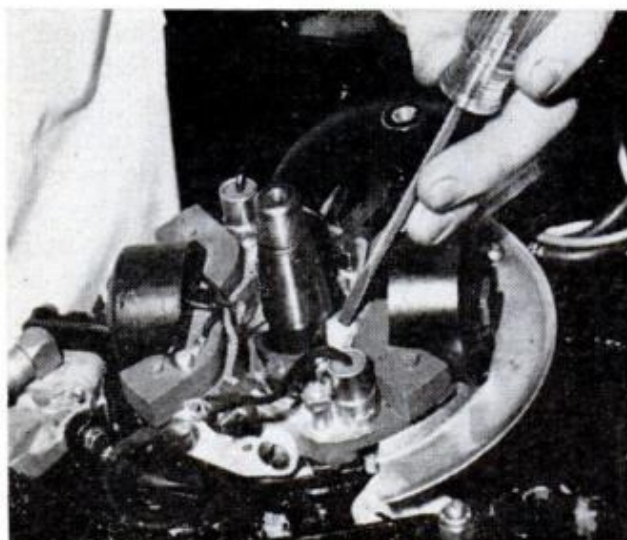
Breaker points can wear, become dirty and go out of adjustment. To check them, first inspect for corrosion and wear. Test the tension of the breaker arm with your finger or a screwdriver (Photo 4). It should be firm. Replace points that are questionable.

Although dirty and oily points affect good performance, they can usually be salvaged by cleaning. Apply a drop of alcohol or trichlorethylene to the points and pass a strip of bias tape up and down between them. Never file points. You'll ruin a good set and make a bad set worse.

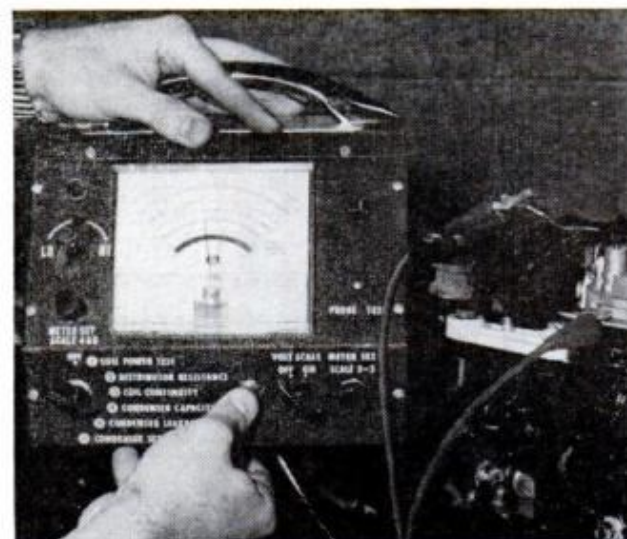
Use the magneto analyzer to test points for good electrical contact. Connect the



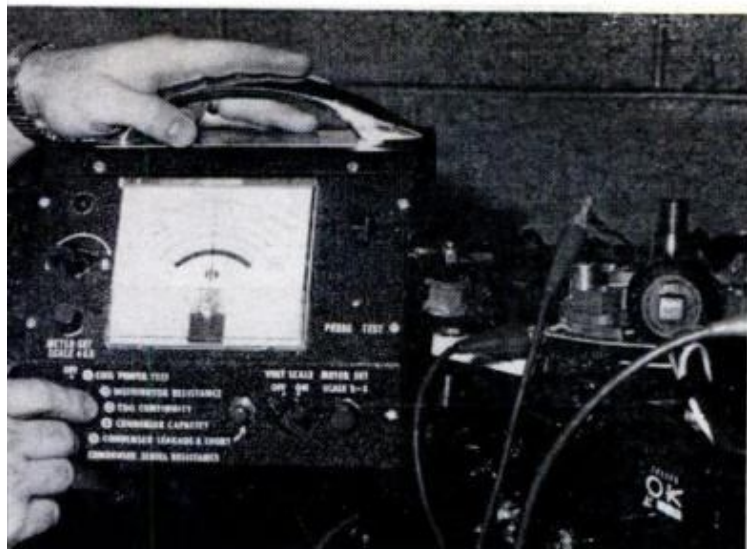
5. WHEN ADJUSTING POINTS, the important thing to remember is that the breaker arm must be on the high lobe of the cam so that the points are fully open



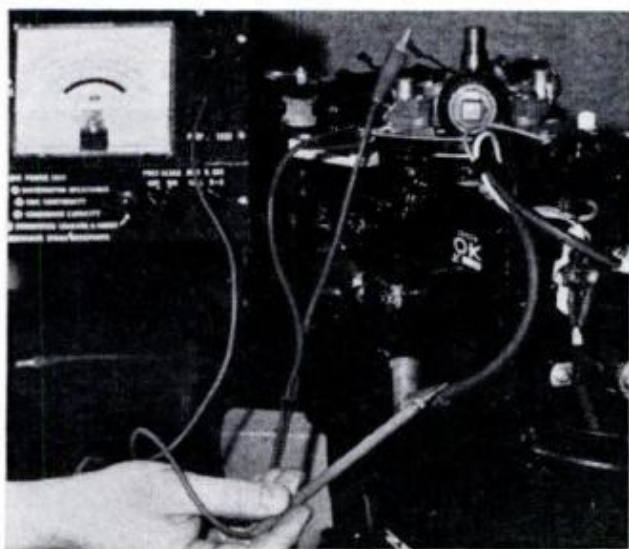
6. CAM LUBRICATOR WICK is shown here. It's good for about 100 hours of operation. You should replace wick whenever you replace the breaker points



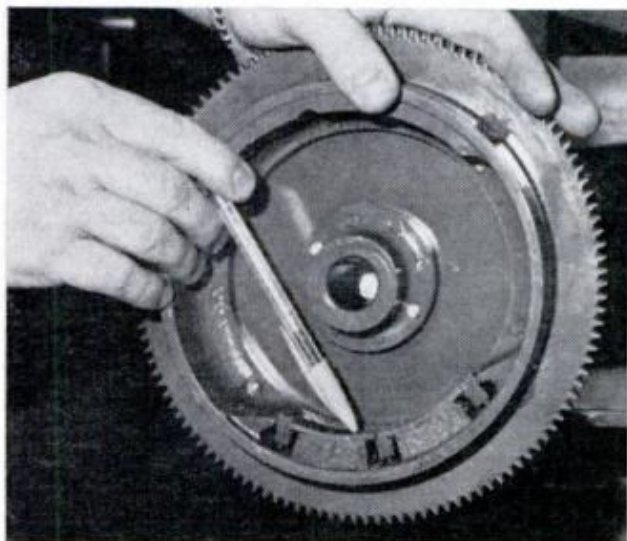
7. WITHOUT A MAGNETO ANALYZER to check motor properly, you can merely replace different parts. Condenser capacity (note lead hookup) shows 0.17 mfd.



8. TO TEST COIL, use the magneto analyzer instruction book for the correct way to make the right hookup and proper way to set meter for coil check



9. WITH A LEAKING HIGH-TENSION LEAD, you'll get a flash between the lead and the meter test probe. If there's a flash, replacing the leads is necessary



10. MAGNETS IN THE MAGNETO should hold up for the life of the outboard. But should a sharp blow damage them, you will have to replace the flywheel

proper test lead to the breaker-arm lead and the other test lead to ground. Consult the magneto-tester instruction book for exact details on how to use it.

Set the analyzer for the breaker point test. If the meter needle shows that point contact is poor, make sure test-lead connections are tight before rejecting the points. Tight connections are necessary for accurate test results.

The final service done to breaker points, whether new or old, is to adjust them. This is important and must be done exactly to specifications since the breaker-point gap controls the timing of the ignition by the number of degrees the points open before the piston reaches top dead center. Mercury, OMC, Chrysler and McCulloch engines have a breaker-point gap adjustment of 0.020 in.

To set gap, make sure the points are fully open by having the breaker arm on the high lobe of the cam (Photo 5). Use a feeler gauge and adjust by loosening the breaker-arm screw and moving the points wider or closer together. When one set of points is gapped properly, rotate the crankshaft 180° clockwise to open the other set. Repeat the procedure.

Every magneto has a wick for lubricating the cam. No additional lubricant should ever be added. A new cam wick is usually supplied with new breaker points and should be installed when points are changed (Photo 6).

Condensers may look discolored. Don't worry about that. Discoloration doesn't affect condenser functioning.

Each condenser is tested for leakage, capacity and resistance. Leakage must be more than one megohm, but the capacity depends on the condenser. Most are rated from 0.17 to 0.22 microfarads (mfd.). However, some have different values. For example, some Mercury engines use condensers that have an mfd. capacity of 0.15 to 0.19 and 0.22 to 0.27. Check with a dealer or the manufacturer of your engine.

To test a condenser, disconnect the condenser lead to the breaker point assembly. Connect one test lead of the magneto analyzer to this pigtail and the other test lead to ground. Check the condenser for each of the parameters mentioned above by switching from one to the other on your analyzer (Photo 7).

Be careful during the leakage test. High

(Please turn to page 192)

How to Keep the Cool in Your Airconditioner

It's a hot option that needs attention sooner or later; an amateur can rout only some of the bugs, or invest in some equipment and find and fix everything like a pro

By MORT SCHULTZ

YOU DON'T HAVE TO BE a cooling-system specialist to fix the two most prevalent automobile airconditioner problems: a loose drive belt and a bad fuse. Of course, there's a lot more that can go wrong, but first things first.





All automotive airconditioners are basically the same. The three main units—condenser, compressor and evaporator—take power from your engine via a drive belt and from the electrical system through a fuse—usually 30 amperes.

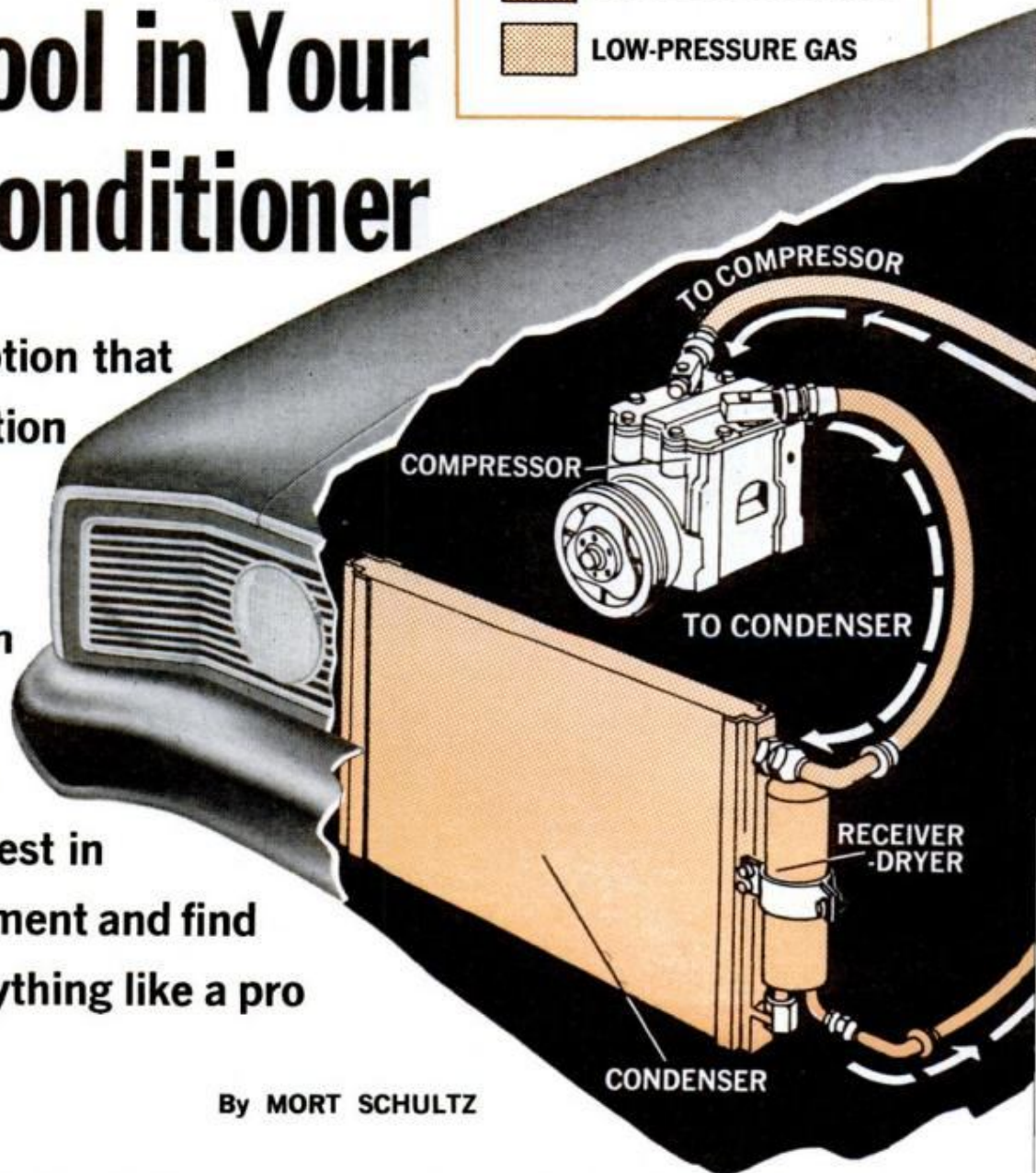
The condenser cools heat-laden, vaporized refrigerant returning from the evaporator.

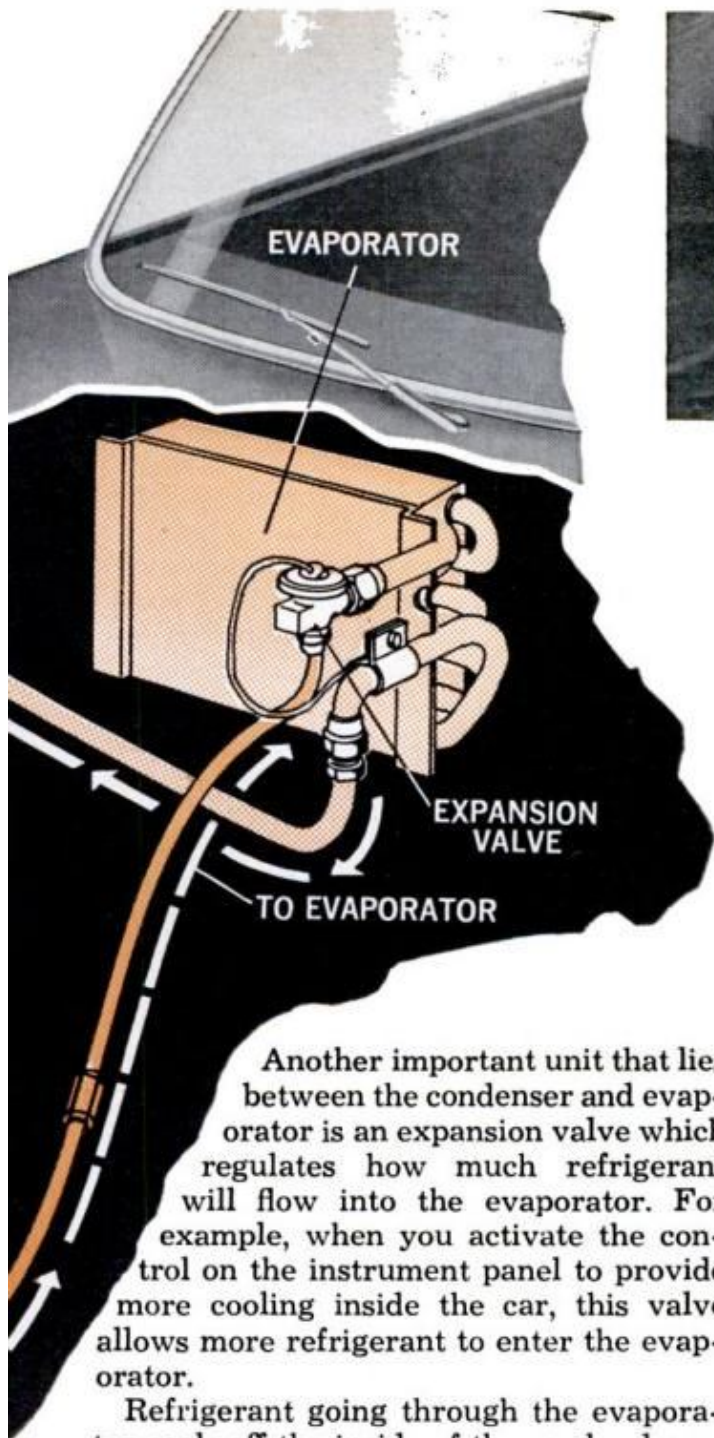
As it's cooled, the refrigerant reverts to a liquid state and is directed back to the evaporator.

Between the condenser and evaporator is a small tank called the receiver-dryer. It receives the cooled, liquid refrigerant and holds it until it's needed by the evaporator. This "way station" also filters out traces of moisture that may have accumulated in the system and which were picked up by the traveling refrigerant. Moisture that builds up and remains in an airconditioner can eventually cause the system to break down.

KEY TO FLOW DIAGRAM

-  HIGH-PRESSURE LIQUID
-  HIGH-PRESSURE GAS
-  LOW-PRESSURE LIQUID
-  LOW-PRESSURE GAS

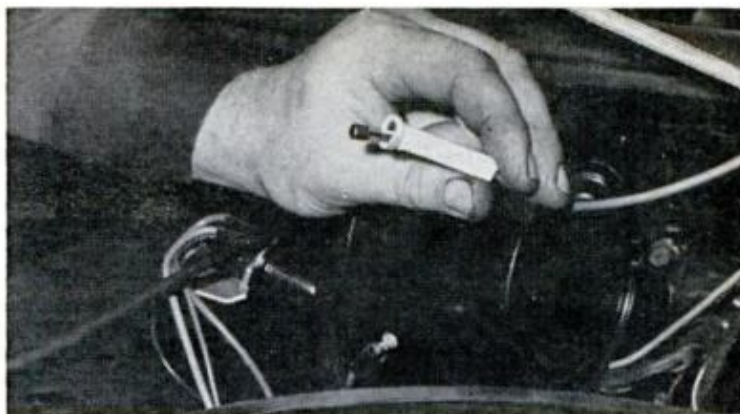




Another important unit that lies between the condenser and evaporator is an expansion valve which regulates how much refrigerant will flow into the evaporator. For example, when you activate the control on the instrument panel to provide more cooling inside the car, this valve allows more refrigerant to enter the evaporator.

Refrigerant going through the evaporator cools off the inside of the car by drawing off hot air. Thus, the evaporator has to be positioned where it can best absorb heat. It's placed in or on the firewall between the passenger and engine compartments. The belt-driven compressor's job is to take the hot vaporized refrigerant coming from the evaporator, compress it and push it on to the condenser.

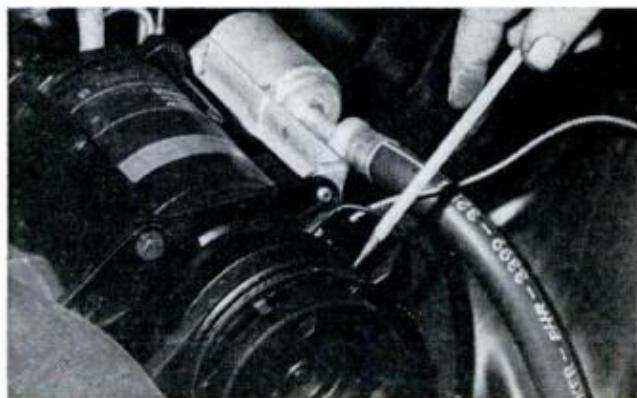
The two main complaints you'll get about airconditioning are insufficient cooling and a system that doesn't operate. Most times the trouble is a blown fuse or fuses. Check beneath the dash for the air conditioner fuse. If it isn't there or there's another, you may need a schematic of the circuit to find it. You can get drawings by writing to the manufacturer of the



SECOND FUSE in air conditioner circuit may be hard to find; look for fuse holder in engine compartment



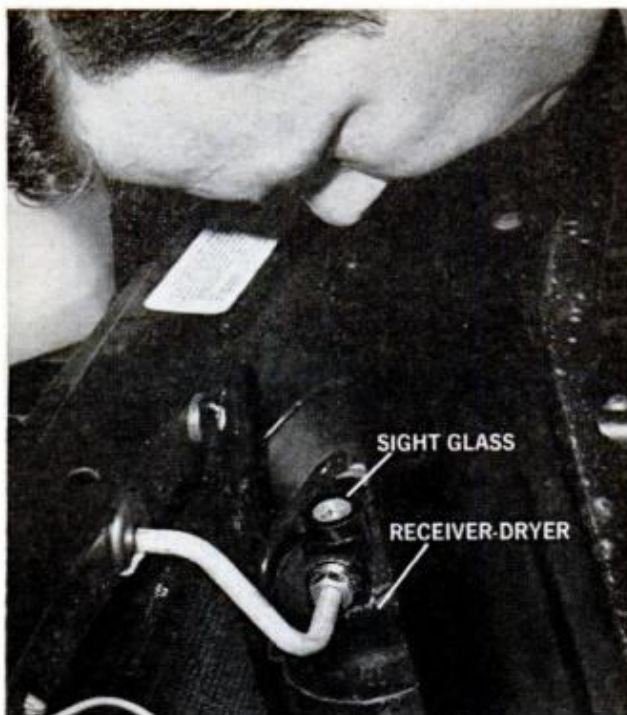
COMPRESSOR NAMEPLATE identifies manufacturer, gives amount of refrigerant charge, test pressures



MAGNETIC CLUTCH on front end of the compressor is checked for proper rotation with air conditioner on



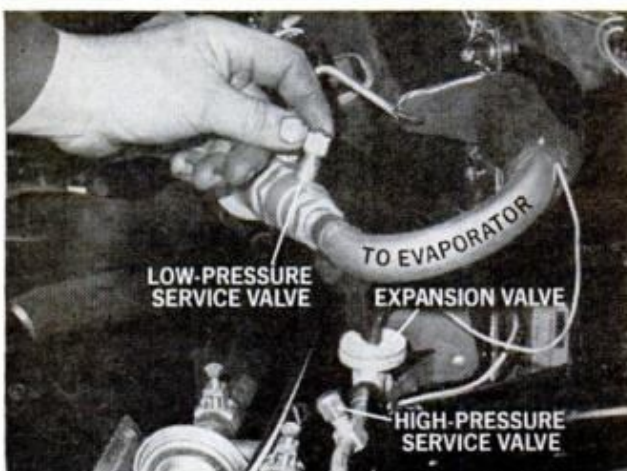
CONDENSER is ahead of radiator. Clean out debris by blowing compressed air through both from rear



SIGHT GLASS on top of the receiver-dryer allows you to determine state of charge of air conditioner



PROPANE TORCH, with an adapter and sniffer tube attached, is used to check for leaks in system. Leaking refrigerant will change color of the flame



SERVICE VALVE CAPS, high and low pressure, are unscrewed to connect gauges for checking the system

unit. While a fuse may look okay, replace it with a spare—as a check. You can't always detect a bad fuse by looking at it.

Try these other preliminary checks:

- *Operate the unit and check the controls.* Many times insufficient cooling is caused by improper use of controls.

- *Check the compressor drive belt.* If it's loose or glazed and slipping, the compressor won't function properly. Start the engine and turn on the air conditioner. If the belt's slipping badly, the pulley won't rotate or will rotate and stop. Tighten the belt as much as possible or replace it if it's damaged.

- *Check the compressor's magnetic clutch,* which is the inner section of the compressor pulley, with air conditioner operating. If it isn't rotating, the clutch should be examined and repaired.

- *Inspect the condenser core.* It could be clogged by bugs, leaves and other debris, reducing cooling action. If clogged, blow out the core with compressed air pressure or use a soft bristle brush.

- *Operate conditioner at maximum cooling for about five minutes* and feel the receiver-dryer outlet. If the outlet is cold, the receiver-dryer filter is clogged, restricting the flow of refrigerant. Cooling will be insufficient. The receiver-dryer must be replaced. Before you can do this, though, the system will have to be discharged—a procedure discussed later.

- *Inspect engine side of the firewall closely.* Any opening through which wires, hoses or cables pass is an opening where hot air can leak into the passenger compartment, reducing the effectiveness of the air conditioner. Seal these with automotive caulking compound.

If operations so far fail to increase cooling efficiency, the problem is most likely an undercharge of refrigerant. To check this, clean the sight glass on the top of the receiver-dryer, run the engine at fast idle and set the conditioner controls for maximum cooling.

If you see bubbles in the sight glass, the system is undercharged. Lack of bubbles indicates either a full charge or a complete loss of refrigerant in which case there will be no cooling.

Whenever loss of refrigerant is indicated, lines and connections should be checked for leaks. You'll need a propane leak detector. This, along with a manifold gauge set and vacuum evacuator pump, is

special equipment you'll need from here on in. Since the gauge set and leak detector cost about \$50 and a ¼-hp vacuum pump about \$100, you'll hesitate carrying do-it-yourself any further. An idea, however, is to make the investment and become the neighborhood airconditioner serviceman. In time, every auto airconditioner needs rejuvenation. Small amounts of refrigerant are lost through fittings. This loss becomes substantial enough in two or three years to affect cooling. The system should then be cleaned out and recharged. Professional servicemen get about \$15 for this.

To use the leak detector, put the sniffer hose in contact with lines and fittings. Light the torch and adjust the valve to provide a small flame. Pass the sniffer hose slowly from point to point over lines and especially around connections. Keep the open end of the sniffer hose below the point being tested since refrigerant is heavier than air.

The torch flame is normally almost colorless. Any change to green or bluish-green signifies a refrigerant leak. If the leak is coming from a threaded connector, tighten it and test again.

If a connector or hose needs to be replaced, the airconditioner system must be discharged. To do this, hook up the manifold gauge set. Connect the inlet-suction (low-pressure) gauge to the low-pressure service valve. Hook the outlet (high-pressure) gauge to the high-pressure service valve.

Extend the gauge's exhaust line and direct it away from you. Work out-of-doors if you can or in a very well ventilated area. Wear goggles to keep dangerous Freon from getting into your eyes.

Now, slowly open the valves of the manifold gauge set to allow the refrigerant to discharge slowly through the exhaust line. Don't let the refrigerant rush out, since oil in the compressor can be forced out with it. When the needles of the gauges reach zero, the system is clear.

The system should be vacuumed to remove moisture and air. Leave the manifold gauge set in place and connect its exhaust line to the vacuum pump. Open all valves of the gauge set and start the pump. Let the pump operate for at least 15 minutes. You'll notice that the inlet-suction gauge has dropped to past zero. This indicates the existence of an almost



SYSTEM IS DISCHARGED by opening high and low-pressure valves of gauge set; gauges drop to zero



PROFESSIONAL EQUIPMENT, above, makes recharging easy. Right amount of refrigerant is measured out

perfect vacuum inside the cooling system.

The last task is to fully recharge the system with refrigerant available in cans at auto supply stores. Generally, systems are recharged by connecting the manifold-gauge charging hose to the can's discharge valve; the can is then placed in water at 125°F. to force the gas from the tank. The engine is run at a specified rpm (differs from car to car), and the airconditioner turned on. Then, the inlet suction valve is opened until the suction gauge registers the specified reading (differs from system to system) that allows the refrigerant to enter the system.

Refrigerant is added until all foam disappears from the sight glass, and system pressures are checked with the manifold gauge set. Usually, a little more refrigerant (about ½ pound) is added. ★★★

EXCITING NEW PRODUCTS

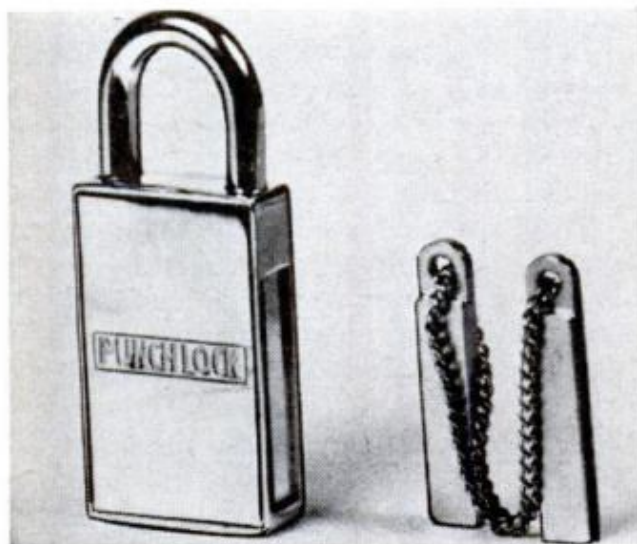
By CATHERINE BILSKI



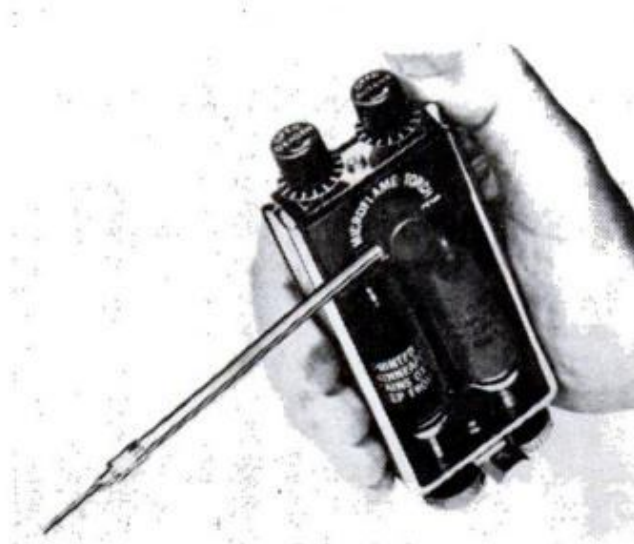
DESIGNED FOR CAMPING TRIPS or back-yard family cook-outs—any place you need self-contained cooking facilities—is this new Primus "Camp Kitchen." Priced at \$123.80, the unit includes a two-burner stove, glare-free 200-watt lantern, cookstand, refillable 10-lb. propane cylinder, and a unique "Safety Post" that affords operation of two appliances from the same cylinder. By Primus-Sievert, 47 Larkin St., Stamford, Conn. 06906.



YOU ALWAYS HAVE ICE CUBES with this trim Coldspot countertop unit from Sears. The compact unit, also ideal for built-in installations, cranks out 380 "crescents" of ice in 24 hours. As you use the ice the unit automatically produces more for storage in an easily-cleaned removable bin. Could be just the thing for kitchen, recreation room, or boat use. Available at all Sears stores or through the catalog for \$169.95.



NEW-TYPE PADLOCK is this magnetic one without a keyhole. To open it, all you do is apply the magnetic key to the side of the lock. The punchlock itself is unlocked by action of magnets within the lock. Infinite combinations are available and only the maker can duplicate any key of a certain combination. The maker claims it's pickproof, will last 100 years. Priced at \$4.95, it's available from Central Products Co., Central City, Pa. 15926.

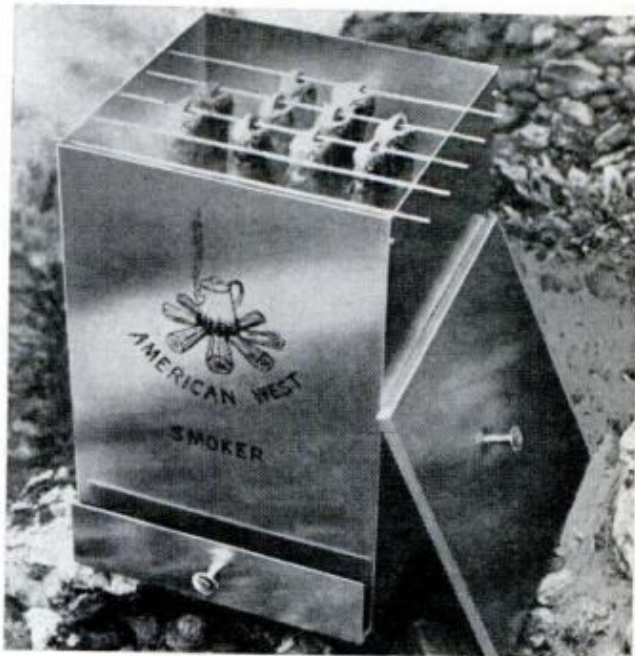


HANDY for soldering and welding in home shop is this miniature torch kit by Microflame. Kit contains the torch unit, six oxygen cylinders, three LP-gas cylinders, three welding tips, four six-inch alloy brazing rods, a two-way mounting bracket, plus a booklet on how to solder and weld. No wires or connections needed. All this for \$29.95 from the Microflame Div. of Printed Circuits, Inc., 7800 Computer Ave., Minneapolis, Minn. 55435.



HERE'S A FIRE WARNING SIGNAL that works every time. Perfect for home, boat, factory or store—anywhere fire might break out—the Watsco Fire Alarm Model No. MFA-1 blasts into action when surrounding temperatures reach 130-160°F., the first stage of any fire. Easily installed; replacement units are available from the factory. Priced at only \$6.95 from Watsco Inc., 1800 W. 4th Ave., Hialeah, Fla. 33010.

ARE YOU HUNGRY for that hickory-smoked flavor? This new smoker by American West enables you to smoke fish, fowl, or your favorite meat—and without electricity or butane. Efficient use of charcoal briquets is the secret, enabling you to assure proper cooking, thorough smoking. Knocked down, the smoker is easily assembled with a screwdriver. Sold at \$24.95 by American West Products, 5140 W. 106th St., Inglewood, Calif.



CAR THIEVES will have a hard time stealing your car when you have the Steal 'N Stall antitheft device installed in it. The thief may be able to drive off, but the engine will stall moments later and no one but you can restart it. The gadget installs in minutes and operates off any 6 or 12-v. ignition system. Priced at \$4.95, it's an inexpensive way to safeguard your car. From Worth D. Walters Import Export, 5047 Medina St., Woodland Hills, Calif.

ADD COLORFUL PROTECTION to your bathtub with "Flowergarden" rubber safety treads. These blossoms and stems are made of soft, resilient, textured rubber with a grip-tight adhesive backing. Odorless, mildew-resistant, and requiring no special cleaning, they can be removed without marring or scratching the tub surface. Set of 17 stems and five blossoms, available in assorted colors, is priced at \$3.95. Made by Slip-X Safety Tread Inc., 1015 East Adams St., Box 999, Springfield, Ill.





PLAN VIEW

a patio firepit can be a lot of fun whatever the occasion.

I built the one you see here for roughly \$15 which is what I paid for 111 bricks, a half sack of cement and four buckets of sand. A couple of common lath will be needed too, plus a length of clothesline. As you see, I also bought a valve and burner so I

WHETHER it's used to grill a sizzling steak, toast marshmallows or provide a cozy campfire around which to congregate on a chilly evening at poolside,

can ignite the logs with butane gas.

You can make the pit as high as you want although three tiers provide a convenient seat height and will give enough depth to build a good wood fire or bed of coals. A 30-in. inside diameter will accommodate a regular fireplace grate or basket.

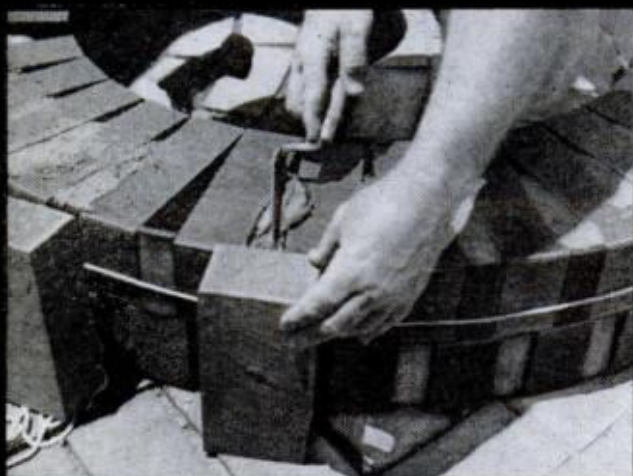
Each tier requires 37 standard paver bricks ($2\frac{1}{2} \times 3\frac{3}{4} \times 8\frac{1}{8}$ in.), and after a circle is drawn with chalk the bricks are placed on edge (without mortar) around the outside of the circle. The bricks touch at the inside but fan out at the outside, evenly spaced with mortar dams of $1\frac{3}{8}$ -in. lath between the bricks. The dams are inserted completely around the tier and when they



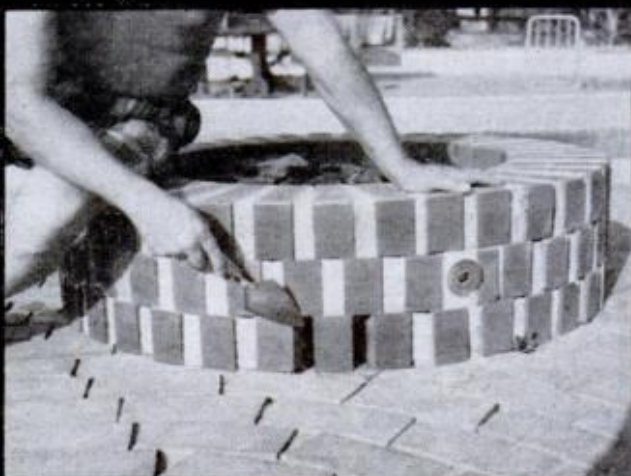
FIRST DRIVE NAIL and swing 30-inch circle with chalk and string. Bricks are placed around the circle



BRICKS ARE SPACED at outer edge by inserting wood spacers, then tying the circle of bricks with cord



BRICK AGAINST LATH DAM prevents mortar from pushing out dam when you fill joint flush with top



JOINTS LEFT OPEN in the bottom tier provide drain holes. Note butane-gas valve mortared in second tier

PATIO FIREPIT

Color Photo by John C. Hellyer

are all in place, the tier is wrapped with cord and drawn up tight to hold the wood spacers in place flush with the ends of the bricks.

The pie-shaped pockets formed by the dams are now filled with mortar. A good mix is sand, 3 parts, and cement, 1 part. Bag mixes, which need only water, such as Sakrete, are also available. The mortar should be wet enough to settle and tamp firmly in the spaces. Be sure to see that you don't get it either too dry or too soupy. It's important, too, that the bricks be soaked in water first so they will not absorb moisture from the mortar. Also, avoid laying the pit in the hot sun. Try the area and, if you

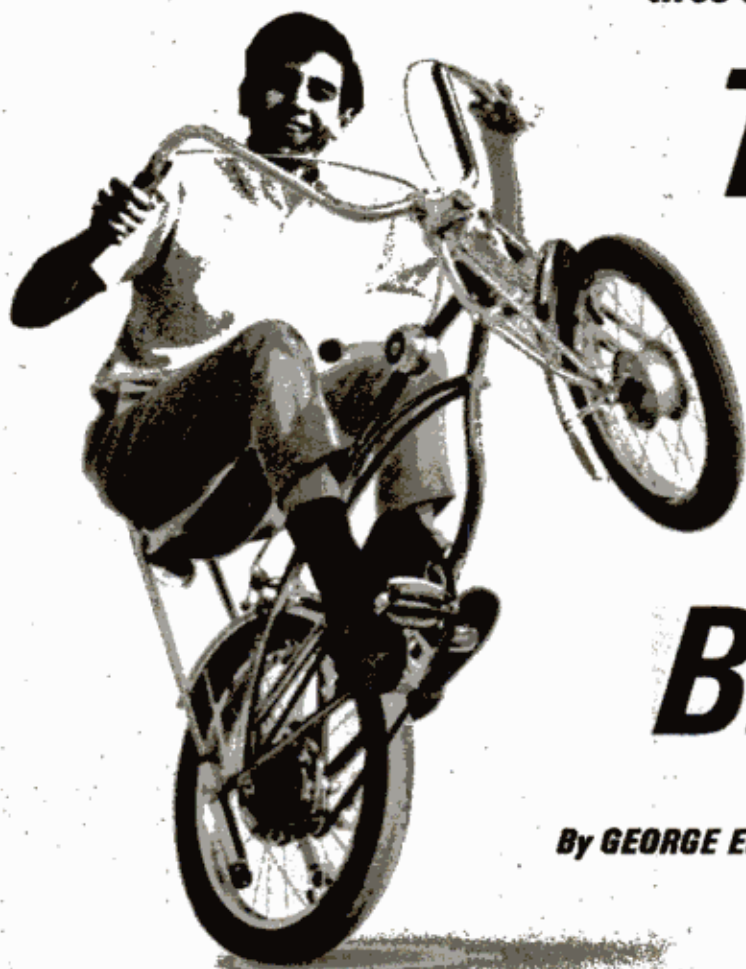
leave the project, protect the mortar from rapid drying by covering the work with damp burlap. Leave a couple of joints open in the bottom tier so there's a drain. Succeeding tiers will help bond these unmortared joints.

Let the mortar set a few hours before untying the cord and removing the dams. Then wash any mortar stains from the tops of the bricks and start your second tier, this time placing the bricks over the mortar joints in the tier below. You'll notice that the $\frac{3}{8}$ -in. thickness of the dams produces a pleasing "pointed" or recessed joint which gives an interesting shadow effect. A brick placed against the dam when filling the joint will keep the dam from being pushed out. * * *

to shade
have to



**Console gearshifts, 10-speed drives,
banana seats, bull-horn handlebars and color
tires are the latest grabbers on**



THOSE WILD NEW BIKES

By **GEORGE EMORY**

GREAT SPORT on a high-riser is doing the "wheelie," a trick whereby the rider rears back and pedals in a balanced position on one wheel

IF YOU HAVEN'T NOTICED, bicycles aren't just bikes anymore. They're about the wildest, most exciting things on wheels. Completely new in looks and action, they sport such "Detroit sounding" names as Grabber, Hugger, Stingray, Avenger and Spoiler.

Cyclemakers like General Tire, Columbia, Schwinn, Huffman, Murray, Sears and AMF are offering bikes that feature a whole new bag of tricks. The banana seat and the sissy bar (a bike version of a roll bar) have replaced the famous Troxel saddle of old, the coaster brake has taken a back seat to sophisticated gearing and caliper brakes, and balloon tires have given way to slim jims and slick rear tires that have the look and feel of a drag racer. To top it off, tires now come in wild colors: orange, red, blue, yellow and green.

The five most popular bikes are shown above. Not shown are such exotic vehicles as unicycles, tandems and folding imports. Even the front-wheel "high-wheeler" of the 1880s is making a strong comeback.

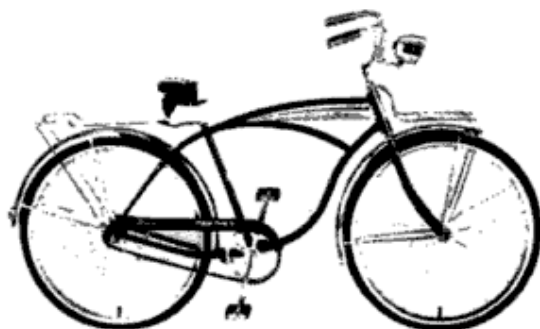
● *The high riser*, hot rod of the industry, was concocted from stray parts by a group of junior cyclists six years ago in San Diego. An instant smash hit, handmade models appeared in such numbers that big-time bikemakers like Huffman and Schwinn got into the act, followed by just about everybody in the industry, and it paid off. Fastest selling style of all time, the high riser now accounts for three-fourths of all sales. For a school-ager, it's the dreamboat. Essentially, the design (now with many variations) consists of a 20-in.-wheel-size junior bike adapted to longer legs by means of a high banana seat and wildly upswept handlebars. The



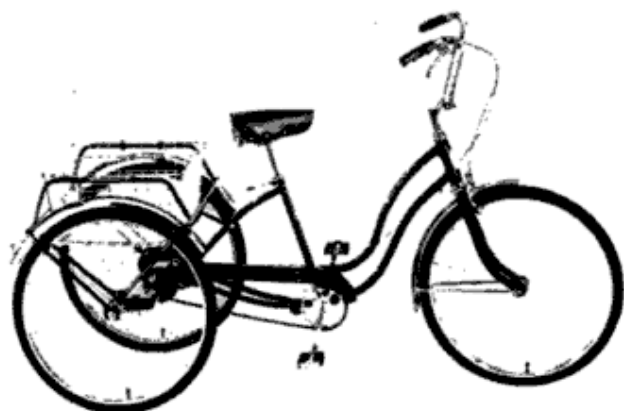
DERAILLEUR



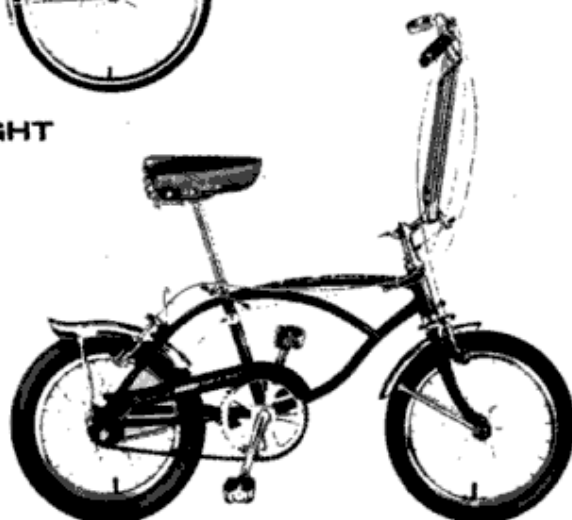
HIGH RISER



MIDDLEWEIGHT



TRI-WHEELER



MINI BIKE

short wheelbase lets it turn on a dime, while the long seat provides a fore-and-aft choice of riding positions. It also lets the rider perform an antic called a "wheelie." Prices start around \$35, run to \$80 or more with extras.

● *The middleweight* is the old familiar standard on which you may have learned to ride. However, it's usually identified by its fairly wide tires (labeled 1.75, 1¾, sometimes 2.125 balloon), rather than by its average weight of 45 lbs. Rugged, easy-going and gentle on the pocketbook (priced from around \$28), it's a top choice for today's adult riders. Wheel diameters include 26-in. for adults, 24, 20, and 16-in. for juniors. Kits are available at around \$8 to convert junior sizes (priced in \$25-\$30 range) to high risers as small riders grow bigger. Important: Buy the kit to fit the brand of bike.

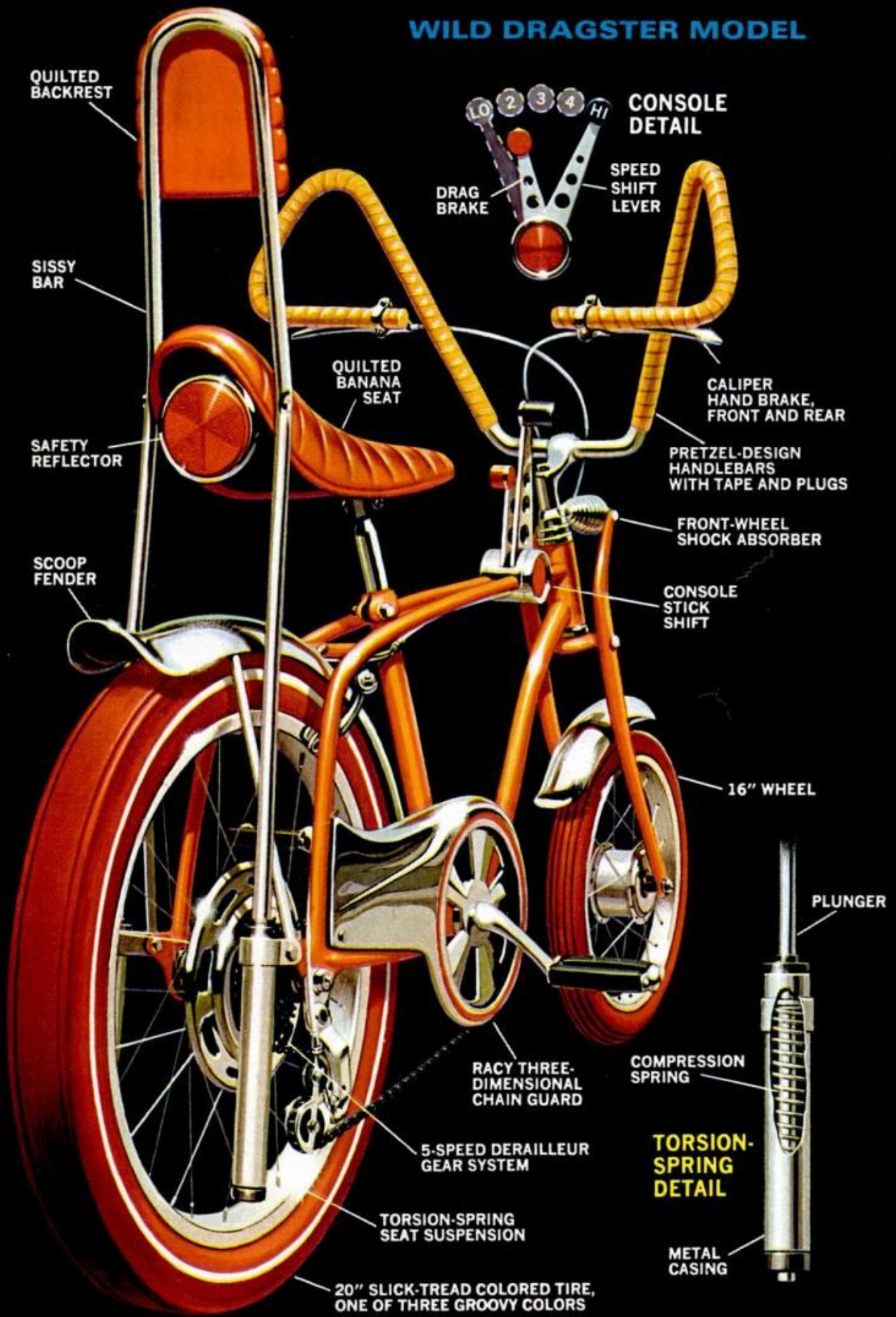
● *The lightweight* has slimmer tires (typically labeled 1⅜ or 1.375) and other features that skim typical models down near the 35-lb. class. It's built to make the most mileage with the least effort in touring or racing, but not for rough-house handling. If you're a cross-country rider with a thirst for speed, this is your bike. Prices start around \$35 for a simple coaster-brake model, or \$55 with 10-speed shift.

● *The minibike*, portable and marvelous for the city adult, has small wheels and frame but is geared like its big brother for adult handling ease. Many come apart for easy storage and car-trunk toting.

● *The triwheeler* is a fine solution for the biking needs of senior citizens or anyone to whom a fall from a two-wheeler could be dangerous. Some three-wheelers come with baskets and canopies.

Gearshifts take two basic forms. The

WILD DRAGSTER MODEL



QUILTED BACKREST

SISSY BAR

SAFETY REFLECTOR

SCOOP FENDER

LO 2 3 4 HI
DRAG BRAKE

CONSOLE
DETAIL

SPEED
SHIFT
LEVER

QUILTED BANANA
SEAT

CALIPER
HAND BRAKE,
FRONT AND REAR

PRETZEL-DESIGN
HANDLEBARS
WITH TAPE AND PLUGS

FRONT-WHEEL
SHOCK ABSORBER

CONSOLE
STICK
SHIFT

16" WHEEL

PLUNGER

RACY THREE-
DIMENSIONAL
CHAIN GUARD

COMPRESSION
SPRING

TORSION-
SPRING
DETAIL

5-SPEED DERAILLEUR
GEAR SYSTEM

METAL
CASING

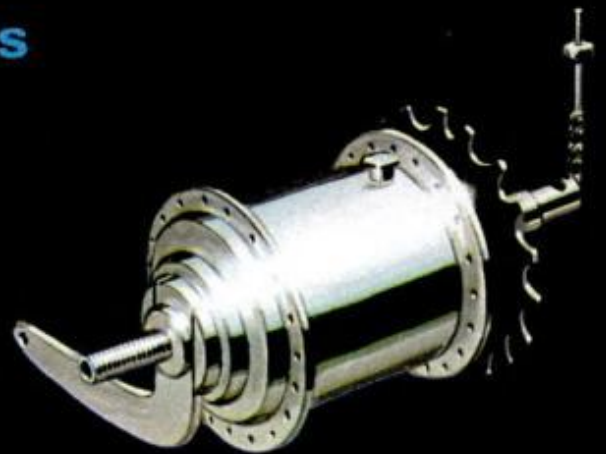
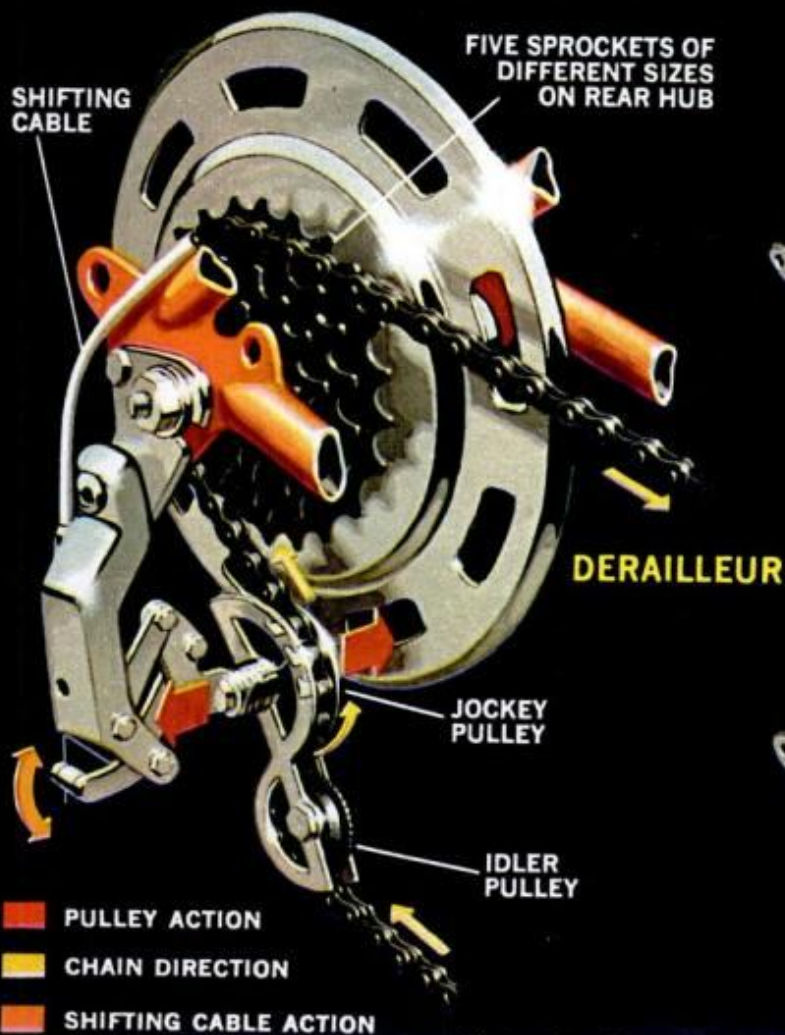
TORSION-SPRING
SEAT SUSPENSION

20" SLICK-TREAD COLORED TIRE,
ONE OF THREE GROOVY COLORS

WHAT'S AVAILABLE IN ZANY HANDLEBARS

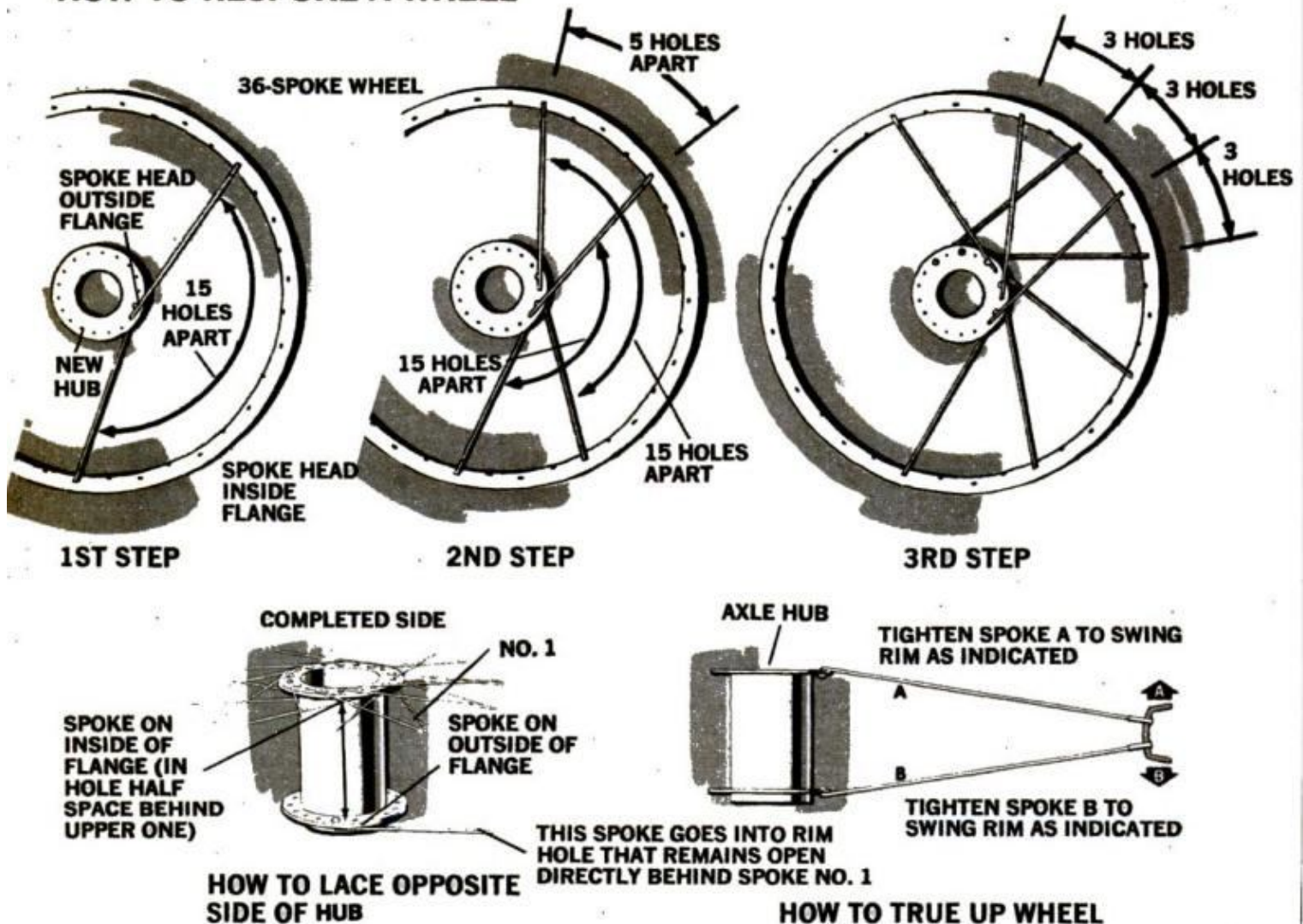


DERAILLEUR AND HUB GEARS



Illustrations Created Exclusively for Popular Mechanics by Dale Gustafson

HOW TO RESPOKE A WHEEL

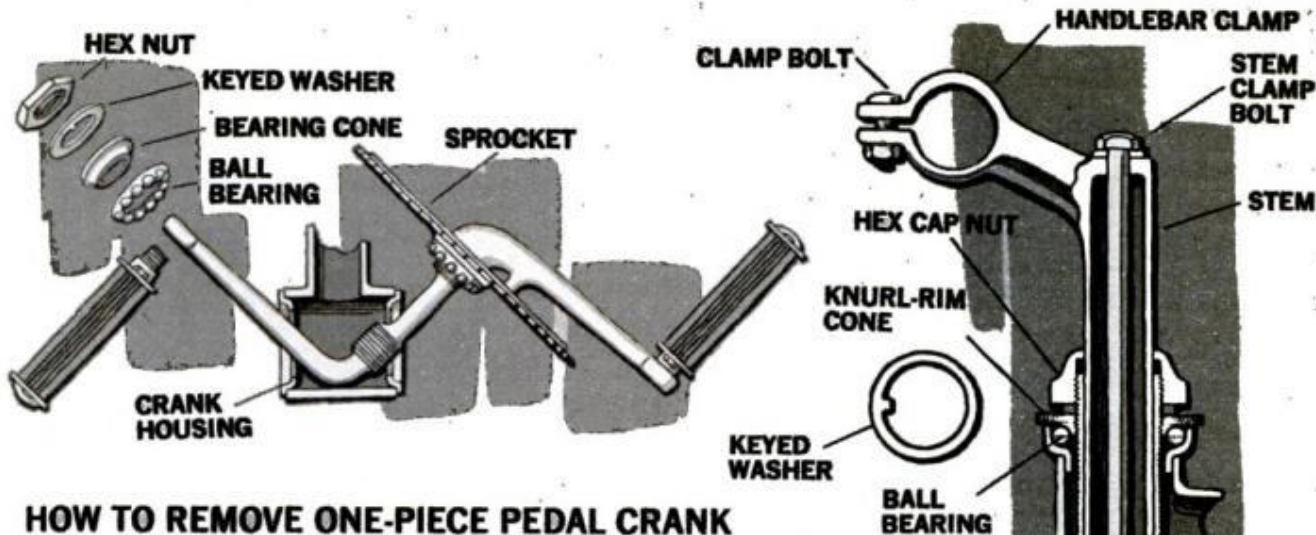


internal type, with a miniature transmission built into the rear-wheel hub, can provide up to three speeds plus coaster brake, or five speeds without the coaster brake in most brands. A cable-connected stick shift does the speed changing except in the Bendix two-speed automatic (which also has a built-in coaster brake). Having no cables or levers, the latter can be added to any bike in minutes simply by installing a new rear wheel with the Bendix in it (priced around \$20). To shift speeds, just push lightly on the pedal (not enough for braking).

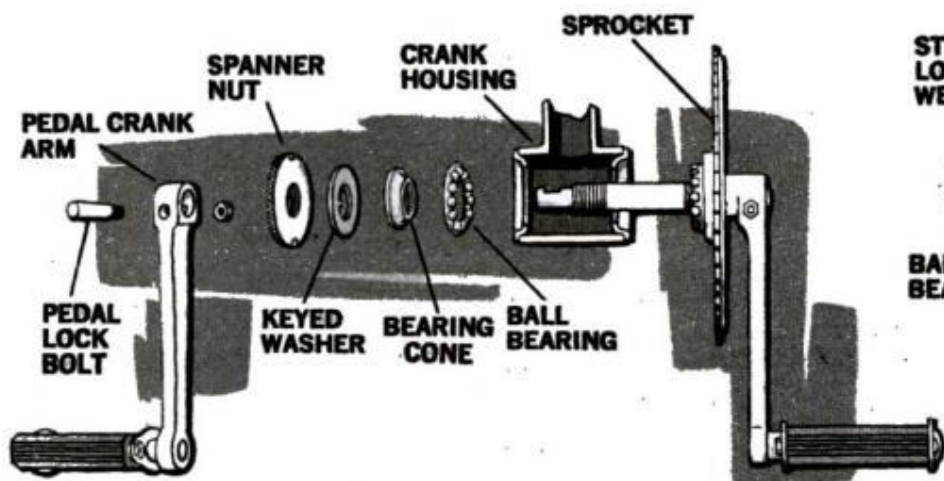
The derailleur shift system, with up to 5 graduated sprockets on the rear wheel and up to 3 on the pedal shaft, provides as many as 15 speeds. With 5 rear sprockets and one chain wheel at the pedals you get 5 speeds. Add another chain wheel and you have 10 speeds; use 3 for 15 speeds. Ratios are changed by a guidecage that "derails" the chain from one sprocket to another, while a spring-loaded idler takes up the slack. Five-speed models with a

single chain wheel at the pedals are cable-operated from a single stick shift. Shifting gears from high to low is done with the pedals turning but with no load on them, as if pedaling lightly while coasting. The shift lever should not be operated when pedals are stopped, and no back pedaling should be done during shifting. In low gear, the chain runs from the pedal wheel to the largest sprocket of derailleur. In high gear, the chain runs to the smallest sprocket. Intermediate ratios are produced by shifting to the intermediate sprockets. Multiple chain wheels at the pedal crank call for dual stick shifts. Huffy has a five-gear shift in the handlebar grip to make shifting less confusing. You twist the wrist to shift. It helps take the guesswork out of changing gears.

The term, "gear," is a unit of drive ratio based on the front-wheel diameter of "high wheel" bikes used in the past century. It's still in use because it tells the complete story simply with one number. As the pedal crank arms were attached



HOW TO REMOVE ONE-PIECE PEDAL CRANK



HOW TO REMOVE THREE-PIECE PEDAL CRANK

HOW TO CHANGE HANDLEBARS

directly to the ends of the front axle on the high wheelers a single revolution carried you farther ahead with a large-diameter wheel than with a small one. So "gear" was expressed in inches of wheel diameter. A 72 gear moves your bike forward (with one revolution of the pedals) as far as one full revolution of a 6-ft.-dia. wheel. A 36 gear moves your bike as far as one revolution of a 3-ft.-dia. wheel. Today's bikes, of course, have smaller wheels, but produce the desired "gear" with chain-sprocket ratios. Typical 10-speed derailleurs like the French Huret Allvit units on Huff's lightweights offer 38 to 100 gear.

Brakes are either of the coaster type with metal-to-metal shoes or discs inside the rear-wheel hub, or the caliper type that grips the wheel rim from both sides with fiber shoes. The coaster brake, more familiar to U.S. riders, takes its grip when you give the pedals a backward push. In disc types, 50 percent of the discs key to the axles, 50 percent to the hub. Back

pedaling presses them together for friction grip between hub and axle. The metal-shoe type works like an auto brake. Calipers, long established in England and Europe, are cable-operated by levers on the handlebars—the right-hand lever for the rear brake, left-hand for the front.

Favor the type you know how to use, both if you want everything. Typical combination: rear-wheel coaster brake, caliper on the front. You can buy a caliper brake assembly complete with hand lever and cable for either wheel for \$3 to \$5. Some call for a drilled hole in the front fork, some don't. Check before you buy. Coaster-brake prices (premounted in a new wheel) start around \$10; without wheel, around \$6.

Tires for bikes sold in the United States are largely of two basic types, "hooked bead" and "flat side." Most American-made bikes take the hooked-bead tire, but Schwinn and many British makes require the flat-side type. Most bike shops

(Please turn to page 193)

KIT REPORT

AZTEC AVENGER GT-12

GUARANTEED to draw crowds and a barrage of questions, the GT-12 fits on any VW sedan chassis and can be driven away the same day



Color Photos by Ken Goldberg

New One-Piece Body Turns 'Bug' Into a Beauty

By LEONARD E. SABAL

It comes complete with roll-up windows, VDO instrumentation, hinged and adjusted doors, windshield wipers, fitted lights, and all locks and switches. All that's missing is a VW chassis

PEDESTRIANS STOP DEAD in their tracks—cars zoom up behind you, then suddenly brake to take a better look; crowds gather whenever you park—and the first question is always the same: "What is it?"

The reply "It's a hybrid" is not understood. "It's a Volkswagen" seems unfair, and "It's a Fiberfab" just brings more questions. Actually, it's all of these and more, for the GT-12 is a one-of-a-kind automobile that you build.

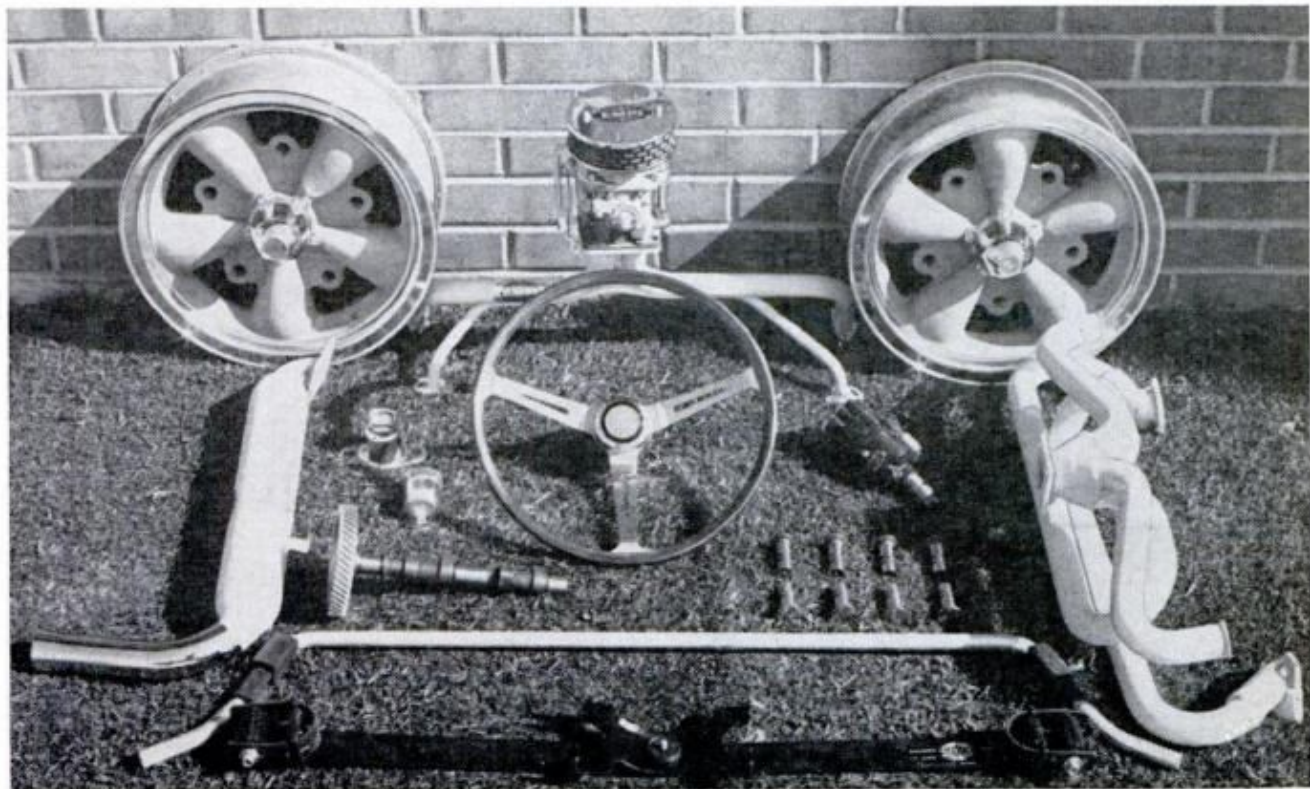
All you need to get started is a VW sedan chassis and Fiberfab's new one-piece body. Add a few extras for looks and performance, blend with some VW-

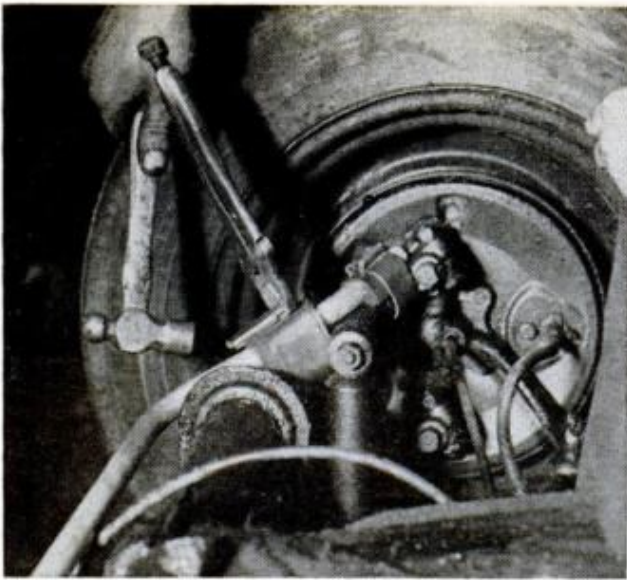
tuning knowledge and—presto—you've transformed your old "bug" into a real GT beauty.

For both the chassis preparation and necessary knowledge, I turned to Arlo Automotive in Westbury, N.Y., for assistance and advice—sorely needed in view of my unfamiliarity with air-cooled engines. Co-owner Ed Arnold and his chief mechanic, Bruce Sherman, are VW specialists. (Arnold once produced a 1961 1176-cc supercharged VW sedan that turned the quarter-mile at Westhampton in 13.08 seconds at a terminal speed of 117 mph!)

With Sherman's chassis and body

ACCESSORIES NOT IN KIT include Empi wheels, ram induction, ¼ cam, sway bars, Big Bore (not shown)





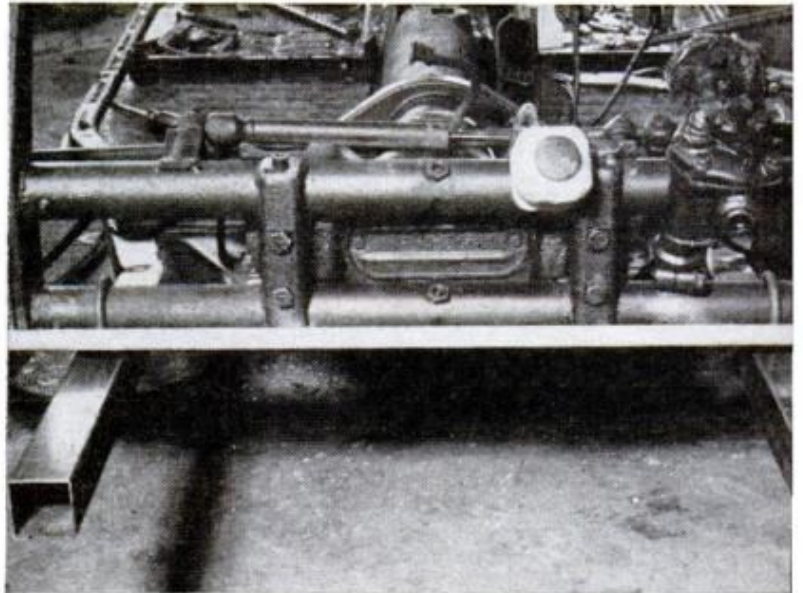
WITH CHASSIS FLIPPED OVER, the front antisway bar goes on with clips in two or three minutes



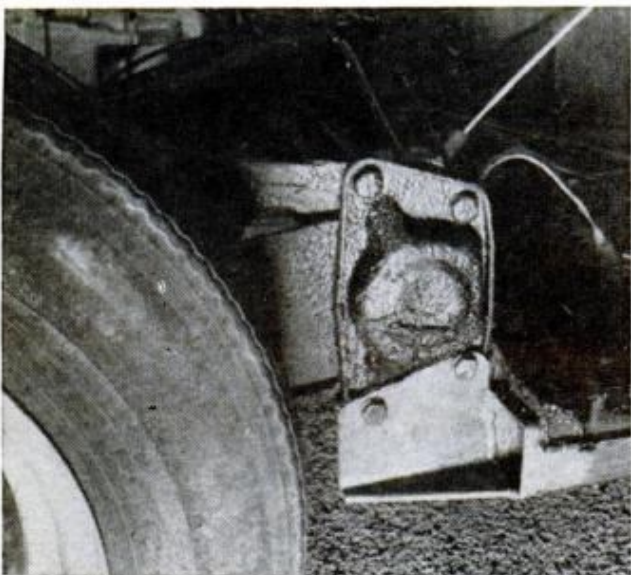
REAR CAMBER COMPENSATOR is bolted to the transmission housing, and then to independent axles



HOLDING SIDE-RAIL STIFFENER, Bruce Sherman discusses an installation with Ed Martincic of Cleveland



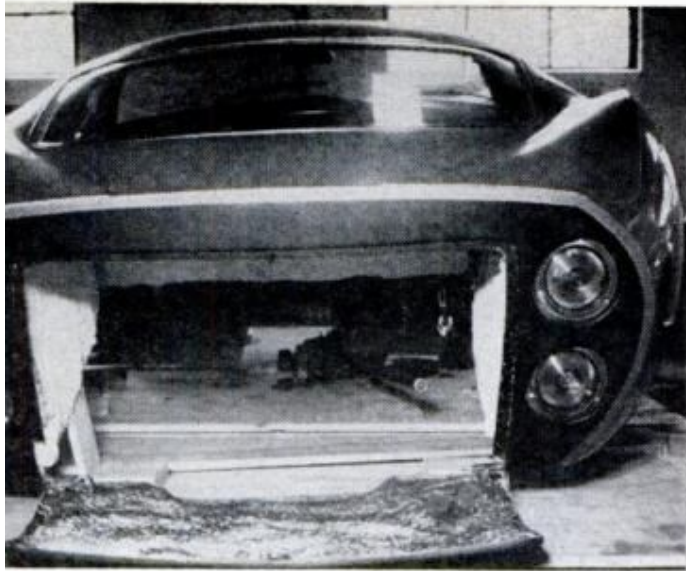
U-BOLTS secure rail stiffeners to the lower bar of front suspension. White rod is an antisway bar



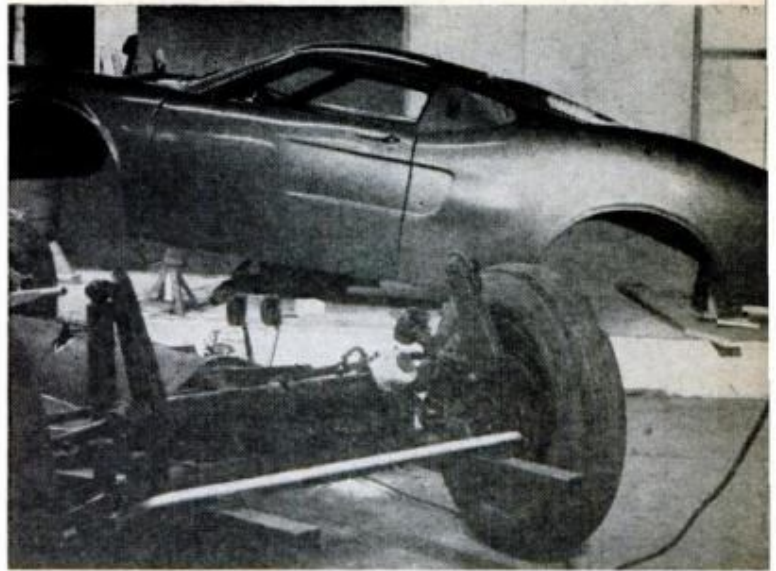
REAR OF STIFFENER is bolted to rear torsion bar. After body is fitted, bolt floor pan to the rails

know-how, it took only 14 hours to complete the conversion. Six hours went into chassis cleaning and preparation and eight hours were required for the actual fitting of the body—without the benefit of Fiberfab's instruction book which hadn't yet been printed. At the time, this was one of the two car bodies available in the country. It was trucked to New York by Ed Martincic, owner of Martin Enterprises (Fiberfab's Cleveland distributor) in order to meet our deadline.

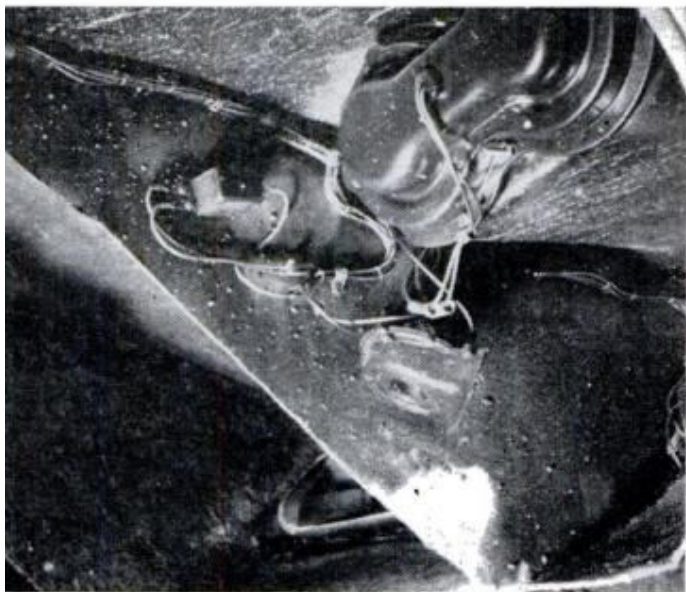
The photo at top left of the facing page shows the body as it arrived on a heavy pallet. Normally, the body is crated in a box suitable for a Boy Scout troop—48 in. high, 81½ in. wide and 14 ft. long. The shipping weight is 1000 lbs., although the



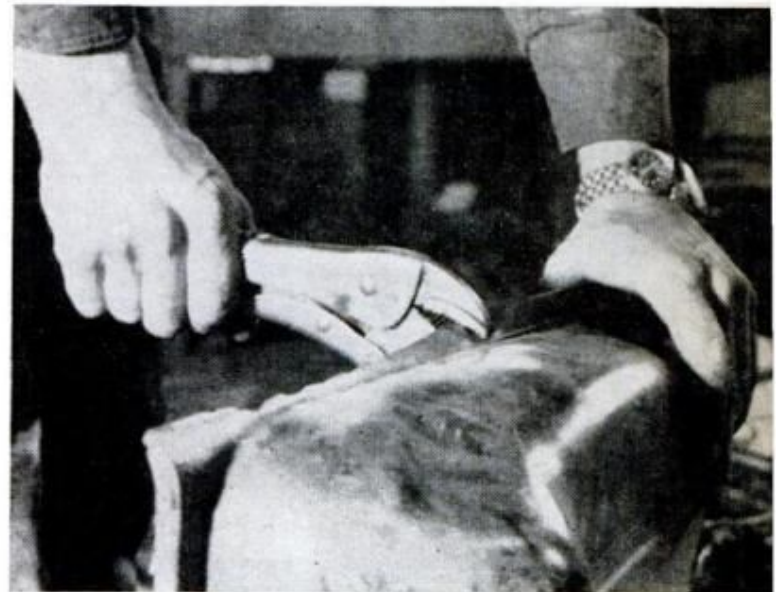
ENGINE COMPARTMENT ACCESS is through trunk-like door in the rear. There is no baggage trunk



LEAVE REAR OF BODY screwed to upright supports so that front can be pivoted up when fitting tank



LOOKING FORWARD under the front wheel-well, you can see headlights, directionals, horn already wired



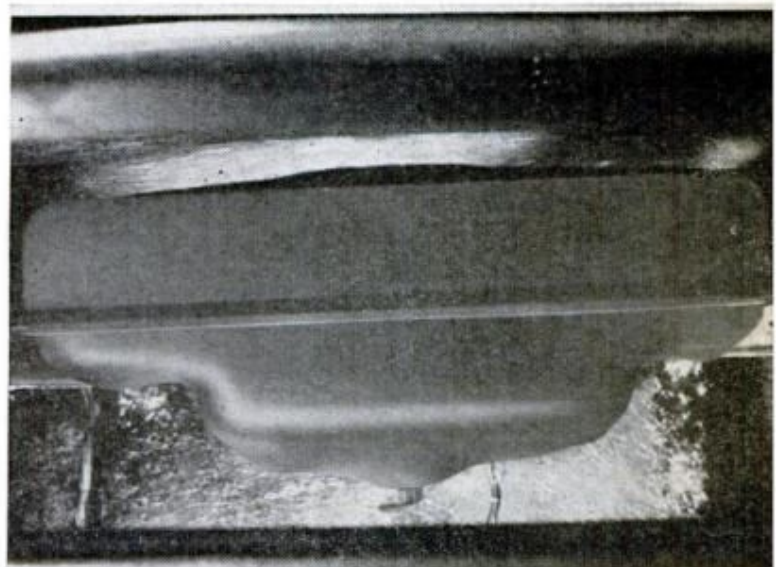
LIP OF GAS TANK must be bent down on two sides to squeeze it into the forward area under hood

body itself weighs just under 500 lbs.

Following the installation of the side-rail stiffeners, we encountered the only real problem in the entire project—installing the gas tank. A '68 or '69 tank is required, but even this, we found, wouldn't fit the available space between the hood rib supports without bending down the tank flanges as shown, (center, right). Also, we did away with the gas-tank support frame and simply used side supports fibreglassed to the firewall and bolted to the hood rib supports (right).

Once the tank is installed, the rest of the assembly—or fitting, actually—is quite uncomplicated.

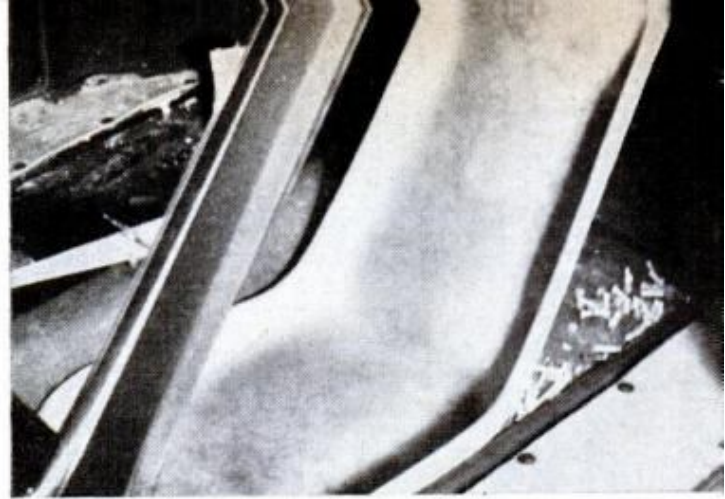
Temporarily remove the transmission shift selector, slip the body over the chas-



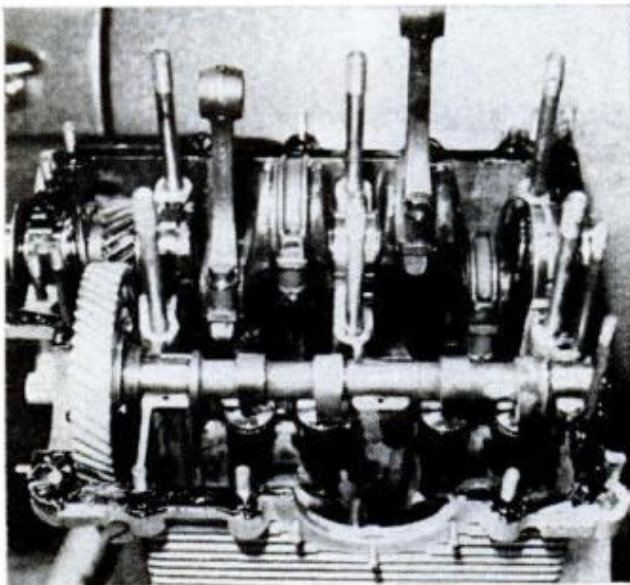
TANK NESTLES SNUGLY on two supports held by fiberglass and bolts. Then lip is screwed to supports



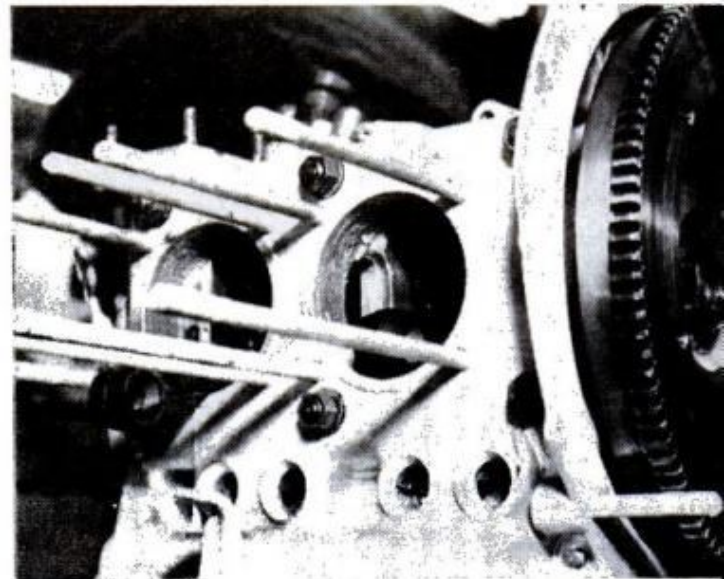
WEATHERPROOF RUBBER STRIP should be renewed, if necessary, to insure dry and comfortable rides



BODY FINALLY IS FITTED, then holes are drilled up through floorpan for black-capped, lag-type bolts

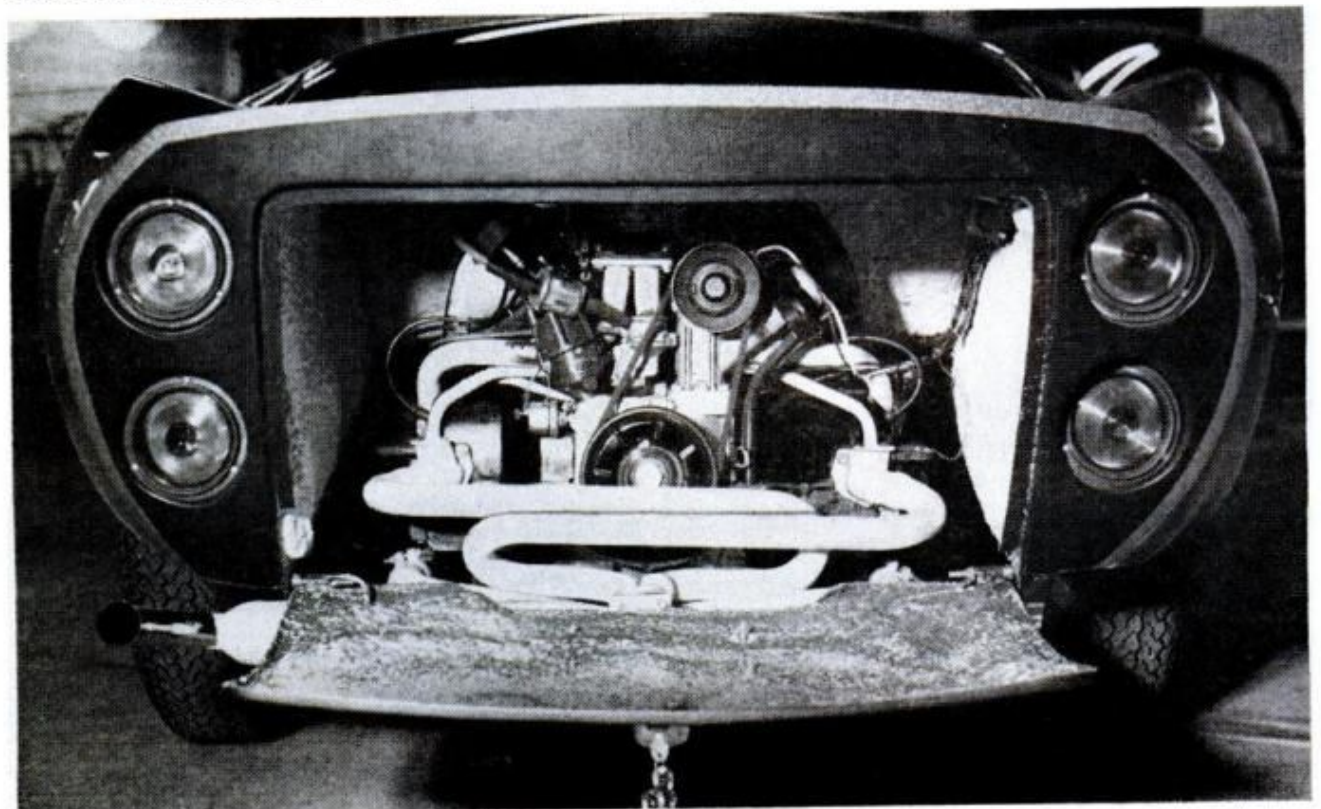


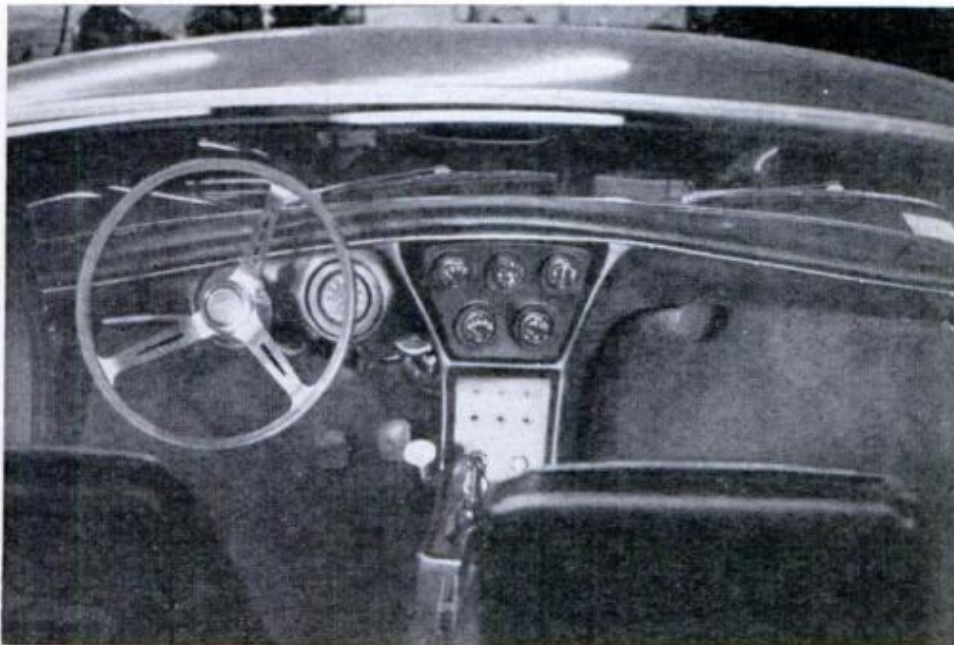
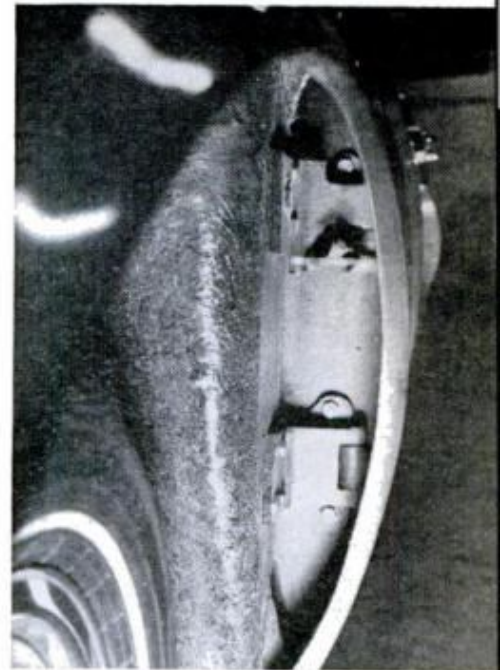
CAREFULLY REBUILT ENGINE has $\frac{3}{4}$ cam. Note the metal-flake finish of the car in background



AWAITING FINAL ASSEMBLY, rebuilt looks like new. Big delay was late arrival of 82-mm Big Bore kit

NEAT INSTALLATION runs well, too. After careful debugging, car was run at 123 mph (calculated by rpm)





TOP LEFT: Compartment in front of right rear wheel hides battery. To check it is a problem.

ABOVE: Looking to rear from front wheel, you see massive steel door hinges. Doors fit well.

LEFT: From waist level, interior of the low-slung hybrid looks like this—through a Mustang 2+2 rear window. Windshield is from a Corvair, side windows from Ford LTD, body a Permaglass custom job. Engine can be VW, Porsche or Corvair. Dunlop FR-70-15 tires are from England, the chassis, of course, from Germany. That's why I say: "It's a hybrid"

sis (the more hands, the better) and position it so it lies flush with all interior floor edges. You'll now be aware of how much wider the body is than the regular floorpan. Drill up through the holes in the VW chassis, using the lag-type bolts provided, and secure the body to the chassis. Add the seats (provided in the kit), a steering column, a 12-v. battery and complete the wiring—you're ready to drive it.

Insofar as wiring is concerned, the built-in wiring harness makes quick work of the hookup, although it proved worrisome (without the instructions) trying to decide if the wire tagged 25, for example, was "hot", or whether it was No. 26 I wanted.

You're wondering now, of course, "How much?" Cost of the chassis and the run-

ning gear you decide to use will naturally vary, but the price for the one-piece body is the same: \$2495. The body is also available in rough unfinished sections which can be assembled for less money. ★★★

MANUFACTURERS' LIST

Fiberfab, Div. of Velocidad, Inc.
2365 Lafayette, Santa Clara, Calif.

Makers of front or rear-engine car bodies in kit form, as well as one-piece GT-12. Also dune-buggy bodies, some accessories.

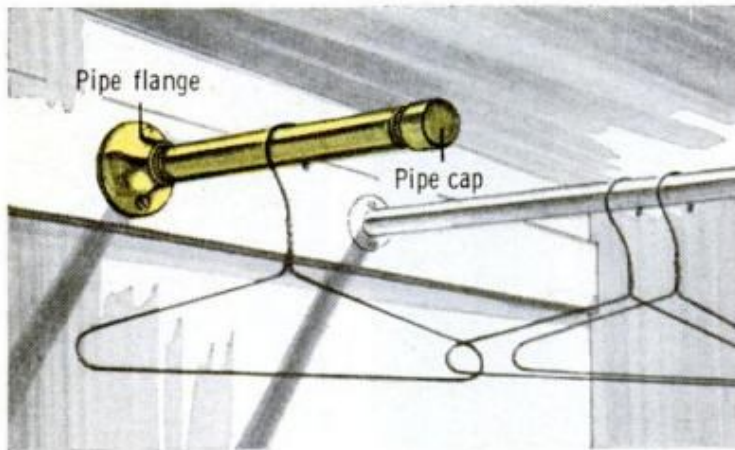
Arlo Automotive
10 Central Ave., Westbury, N.Y.

Builders of modified VW engines, including a 200 hp VW (for \$2000).

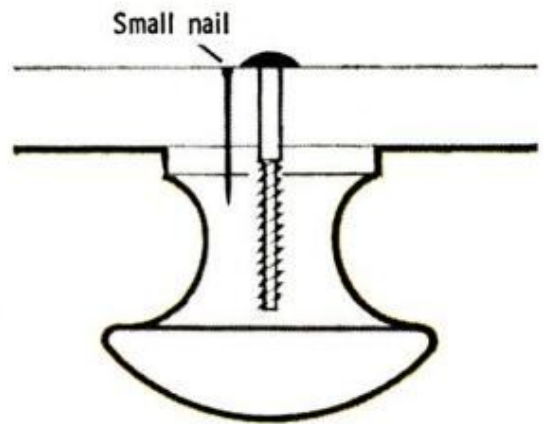
Engineered Motor Products, Inc. (Empi)
Box 1120, Riverside, Calif.

Accessories, performance parts.

Solving home problems



BETTER THAN HOOKS for gaining extra hanging space in a walk-in closet, stub rods projecting from the wall will hold up to six hangers. Made of pipefittings (flange, cap and 12-in. nipple) they screw to the closet rail.—*Conrad Hegstrom*



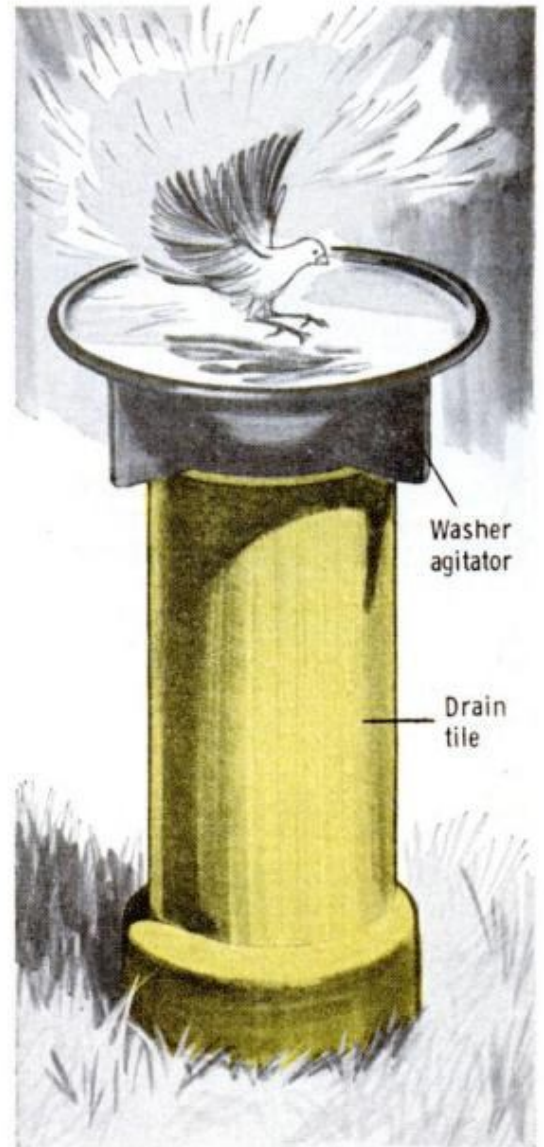
SURE WAY to prevent wooden knob from loosening is to drive a small nail through the drawer front alongside the screw. Nail point in knob won't let it turn.—*Victor Lamoy*



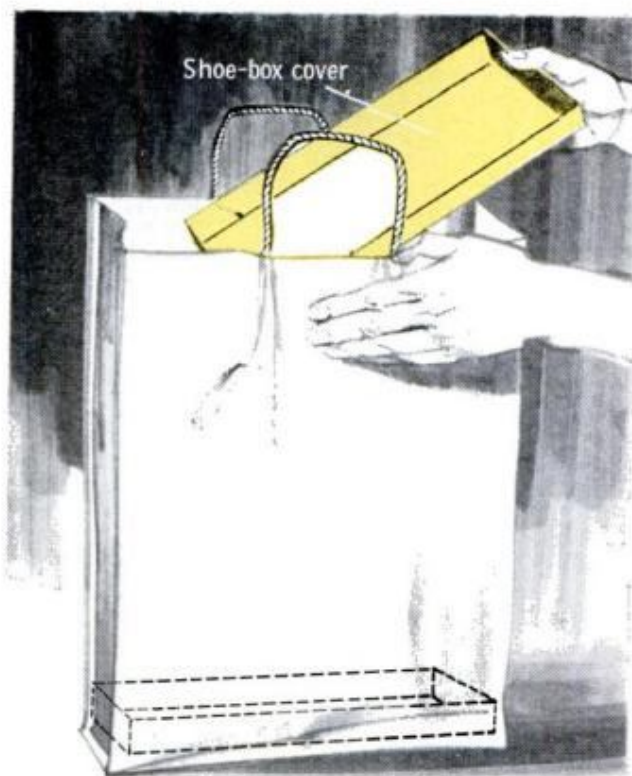
WHEN YOU CARRY a heavy shopping bag for a distance, the cord handles start to cut into your hand. Next time toss a wooden clothespin in the bag before taking off for the market. You'll find it makes a comfortable handle.—*William Swallow*



FANCY FRETWORK NECK on a bridge lamp can be murder to fish a new wire through. After almost giving up, I hit upon the idea of first flushing a string through it with water and then pulling the new wire through with the string.—*F. P. Thomas*



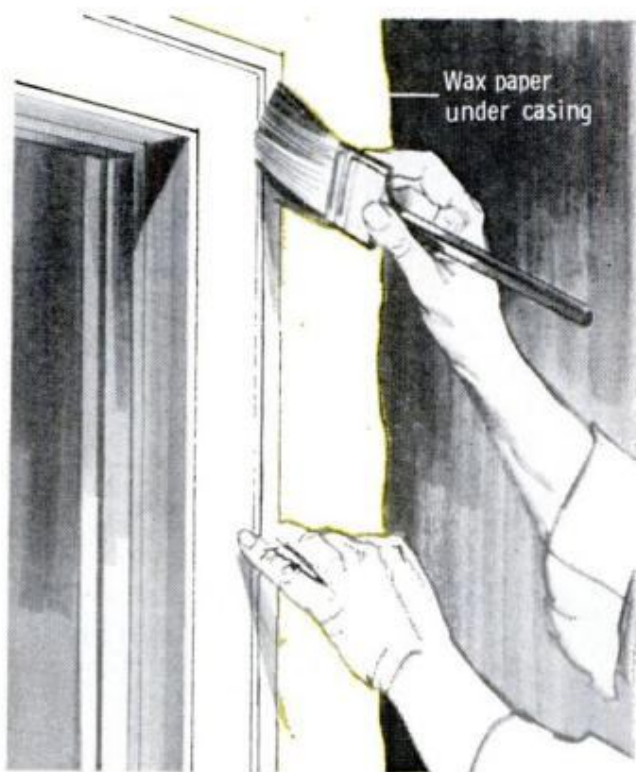
NEAT BIRDBATH for the yard can be made by taking the agitator of a junked washing machine and placing it upside down in the small end of a 2-ft. drain tile.—*John Krill*



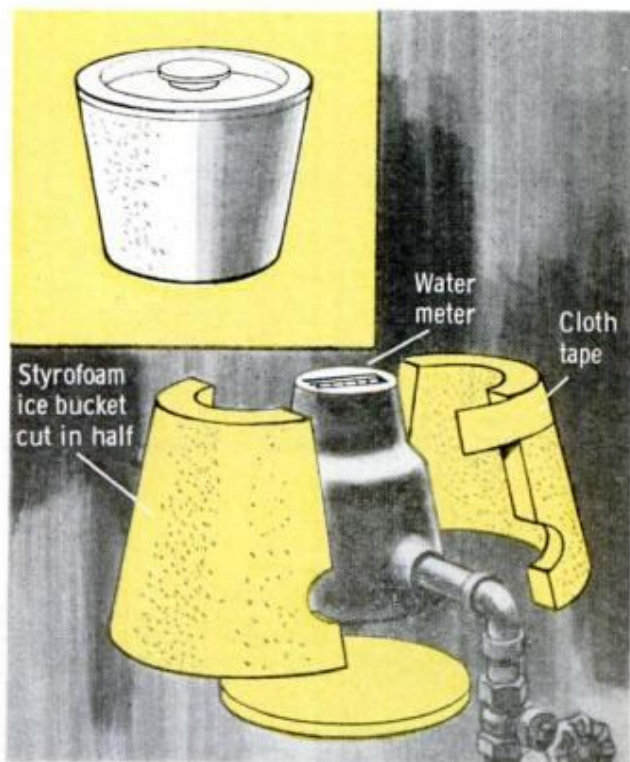
PLAY IT SAFE when using a shopping bag to carry heavy items and slip the lid of a shoe box in bottom. Reinforced by the cardboard, bottom becomes twice as strong by distributing weight evenly.—William Swallow



GROUND SPIKE HANDLE lets you move hose without stooping when watering flowerbeds. Consists of 3-ft. pointed rod with a broom clamp riveted 8 in. from end. Hose snaps securely in clamp.—William Waggoner



WHEN INSTALLING NEW TRIM on doors and windows, slip a 6-in. strip of wax paper under it before nailing. It will simplify painting the trim, and it pulls out easily when the paint is dry.—Richard Martinson



FOAM ICE BUCKET makes perfect jacket for insulating water meter so it won't sweat. Slit bucket in half, remove bottom, cut to fit around pipes, invert and bind parts with tape as shown.—Herman Muenchen

'Instant' Freestanding Shelves



By **ARNOLD R. JOHNSON**

Technical Art by John Lind

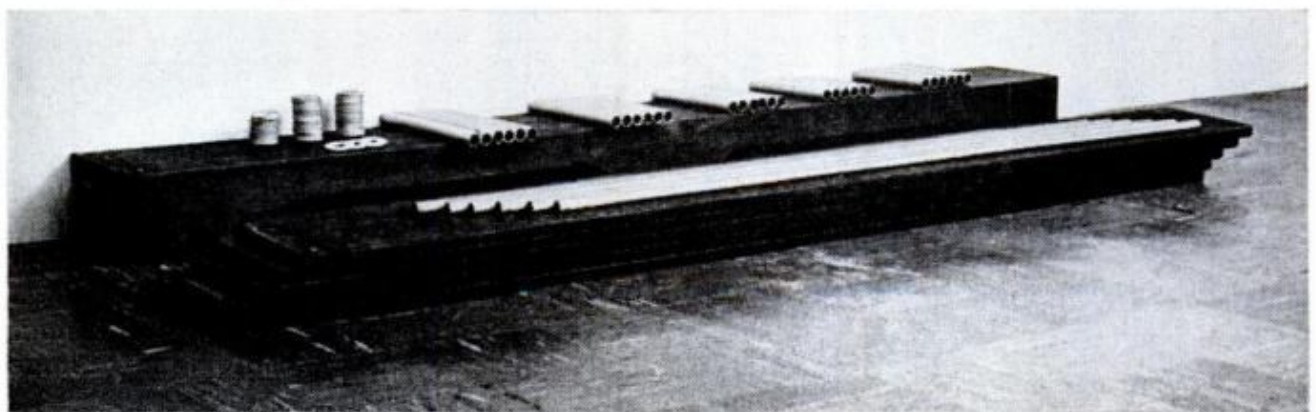
TALK ABOUT knockdown bookshelves! This unit winds up in the neat pile of pieces you see below, which makes it simple to move from place to place. It goes together without a single nail or screw and, oddly enough, the more you weight it, the sturdier it gets.

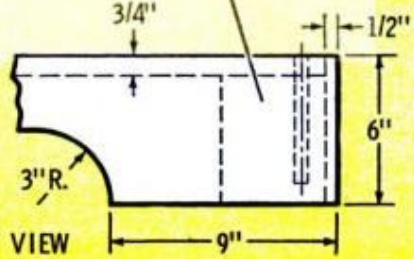
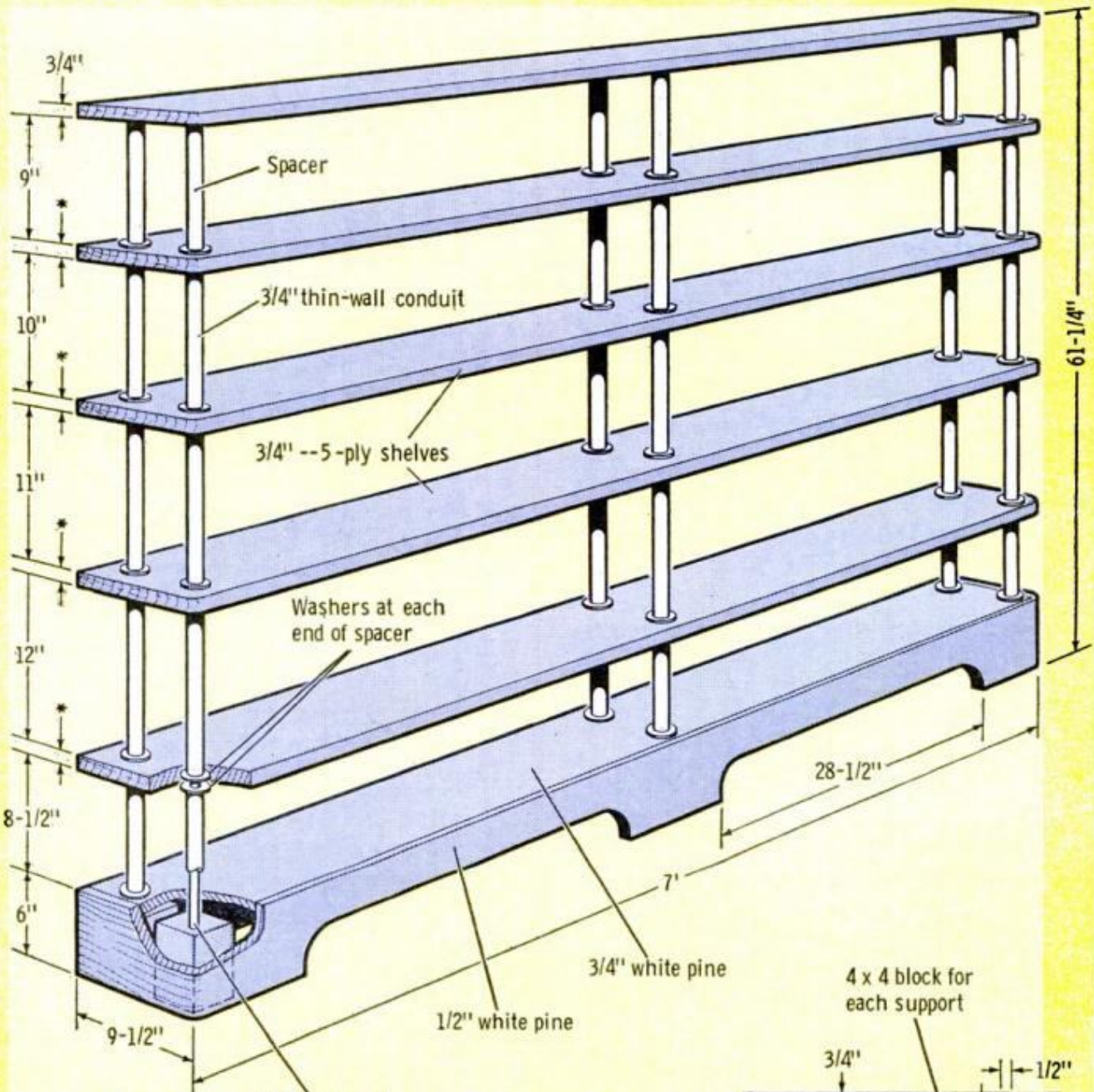
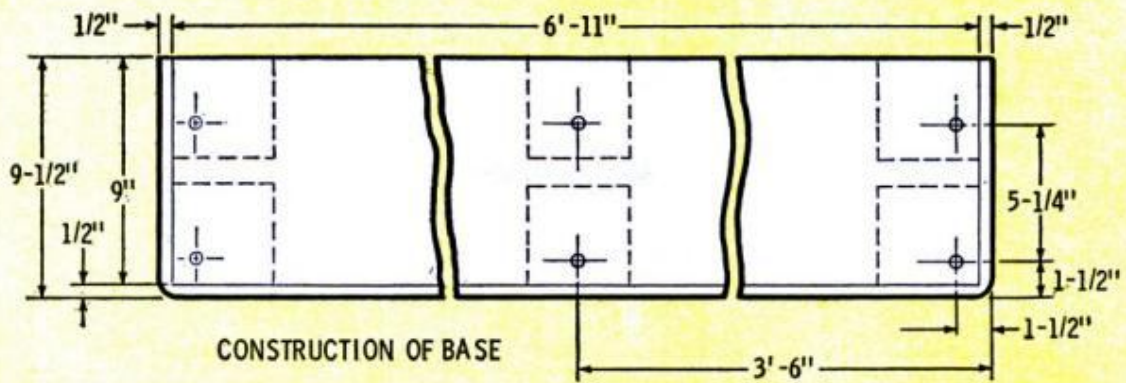
Providing 42 feet of shelf space, it can be built for about 75 cents per foot per shelf, whether 6, 7 or 8 ft. long.

The five shelves slip over six vertical "rods" of 1/2-in. thinwall electrical conduit which stand in holes drilled in the

base. Each shelf is supported by washers and 3/4-in. conduit spacers which slip over the rods. One shelf is used as a pattern when drilling the others. Length of the spacers can vary from shelf to shelf and it will pay to buy a tubing cutter to cut them to uniform length. Far better than a hacksaw, it will assure neat, square-cut ends. Conduit is sold in 10-ft. lengths and you'll need three lengths of each size. Washers and spacers are sprayed the desired color and the shelves are finished before they are assembled. ★★★

WHEN THIS PILE OF PARTS is assembled, it becomes the attractive, six-shelf bookcase you see above



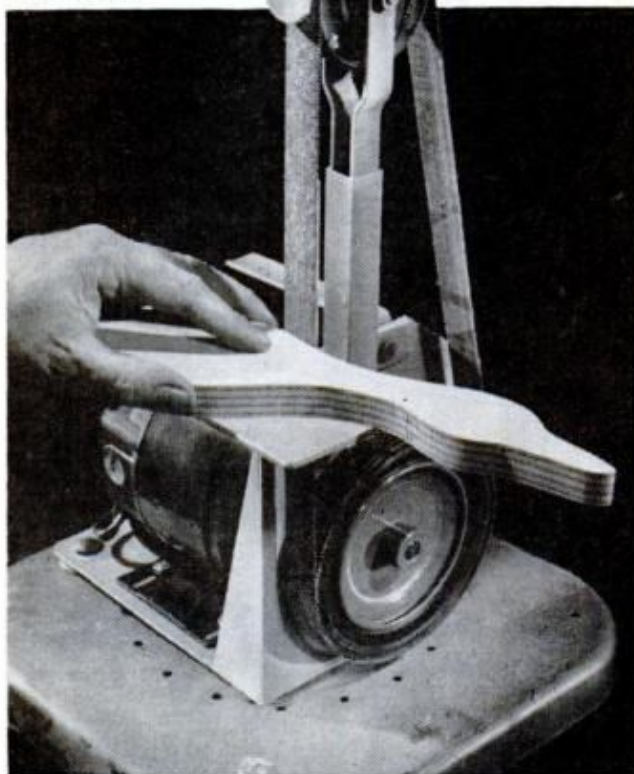


* Thickness of 5-ply and 2 washers equals approximately 1"

1/2" thin-wall supports

Handiest Tool You Can Have in Your Shop

Photos by Bob Borst



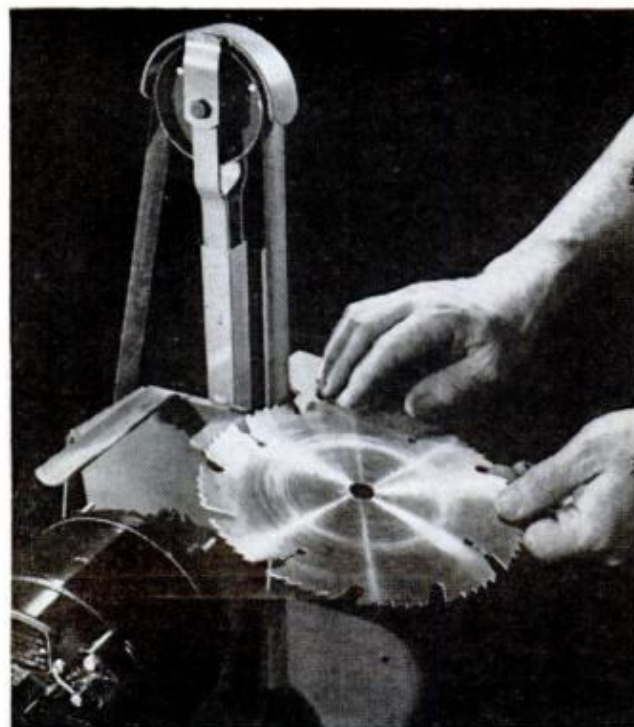
ON ALL OUTSIDE EDGES machine's 1-in. abrasive belt does a slick job, but it can't do internal sanding

IF YOU HAVE A SPARE $\frac{1}{4}$ -hp motor with a $\frac{1}{2}$ -in. shaft sitting around and \$20 burning a hole in your workshop pocket, there's a vertical belt sander/grinder on the market which I have found to be one of the handiest little machines in my shop.

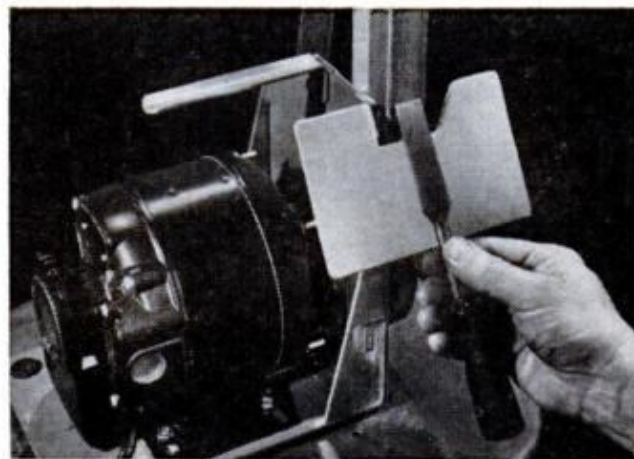
While toy-like in appearance compared to its huskier big brothers, it's far from a weakling when putting a smooth edge on rough scroll-cut work. As a sander alone it makes a perfect companion for a band-saw or jigsaw; in being more than just a sander, the little machine, when fitted with the right abrasive belt, can even put an edge on a wood chisel or touch up the teeth of a circular saw blade.

The machine is exceptionally smooth running and ridiculously simple. For example, the drive pulley is a 6-in. rubber-tired wheel and it's the crown of the tire that keeps the sanding belt tracking on the upper pulley. The latter is spring-loaded to provide constant and proper belt tension. To change the 1-in. abrasive belt, you simply press down on the top pulley. The machine comes dismantled in five parts which go together in minutes. It features a table that tilts 45° , rubber suction feet and a handle.

You can buy it for \$19.95 (less motor) from Arco Mfg. Co., Box 817, Grand Forks, N. D.—*Wayne C. Leckey, Shop Editor*



TO TOUCH UP A DULL BLADE, fit machine with 120-grit belt and hold blade freehand against edge of belt

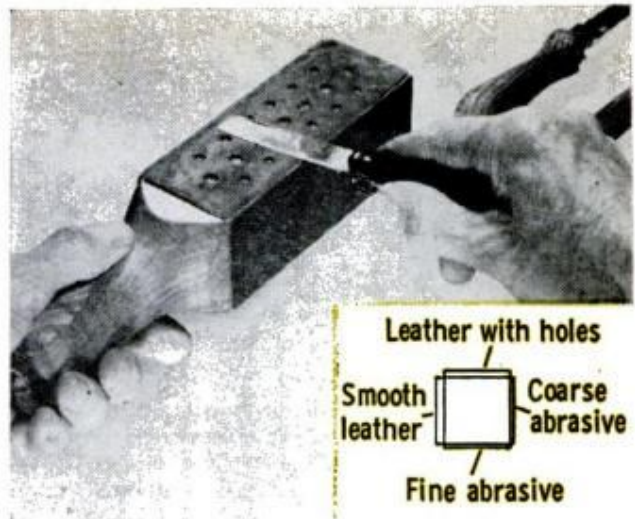


FOR USE AS A GRINDER to sharpen chisels, plane irons, tilt the machine's table to suit cutting bevel

HINTS FROM READERS

Four-sided sharpening paddle

A few strokes on each side of this four-sided sharpening paddle will keep your knives razor sharp. It's lathe-turned from a 2-in.-sq. block 9 in. long to provide a comfortable handle and then fitted with a screw eye for hanging. One face of the paddle is covered with medium-coarse emery cloth and the next with fine emery cloth. The third face is covered with a thick piece of soft leather which has 1/4-in. holes punched in it and filled with valve-grinding compound. The fourth side is covered with smooth leather for final stropping. Rubber cement is used to hold the emery cloth since it will need



to be replaced from time to time. Regular glue is used to attach the leather.

Start with the coarse emery cloth and work around to the smooth leather to put a keen edge on any knife.—*J. W. Clement*

Three factors are important in figuring size of room airconditioner

When it comes to selecting a room air-conditioner, it's important that you match the unit to the specific area to be cooled. Room size alone, however, is not the determining factor. Wall exposure and ceiling insulation are equally important in picking the right size unit.

The chart below, prepared by airconditioning experts at Chrysler Airtemp, offers a general guide to follow when calculating the number of BTUs needed. First, you determine the amount of out-

door wall exposure and its position (north, east, south or west) then you should note whether the ceiling is under an occupied room, under an insulated attic, or if it's under an uninsulated attic. Now figure the square feet of floor area by multiplying length times width. The total is your key number. Find the number in the chart that's closest to your key number. The left-hand column will give you the estimated BTUs required to cool the particular room. ★★★

ROOM AIRCONDITIONER SELECTION GUIDE

BTUs	WEST		SOUTH		EAST		NORTH	
	Ceiling under occupied room or insulated ceiling under attic	Un-insulated ceiling under attic	Ceiling under occupied room or insulated ceiling under attic	Un-insulated ceiling under attic	Ceiling under occupied room or insulated ceiling under attic	Un-insulated ceiling under attic	Ceiling under occupied room or insulated ceiling under attic	Un-insulated ceiling under attic
33,000	1740	1000	1820	1050	1920	1090	2150	1230
27,000	1440	830	1510	870	1590	900	1785	1010
23,000	1140	670	1300	710	1270	730	1420	830
18,000	860	510	920	540	970	560	1060	620
17,000	800	475	870	505	915	525	1005	585
16,000	750	440	820	470	860	490	950	545
15,000	685	405	750	430	790	450	870	500
14,000	620	370	680	390	720	410	790	450
13,000	595	330	605	350	645	365	680	405
12,000	470	285	530	305	570	325	625	355
11,000	442	268	445	265	535	305	555	320
10,000	365	205	360	225	390	235	425	260
8,500	290	180	310	200	355	215	380	235
8,000	230	140	250	160	290	185	330	210
7,500	170	125	220	140	240	160	280	180
6,000	150	100	170	110	190	120	205	130
5,000	130	90	145	100	170	110	180	110

4 Easy Projects

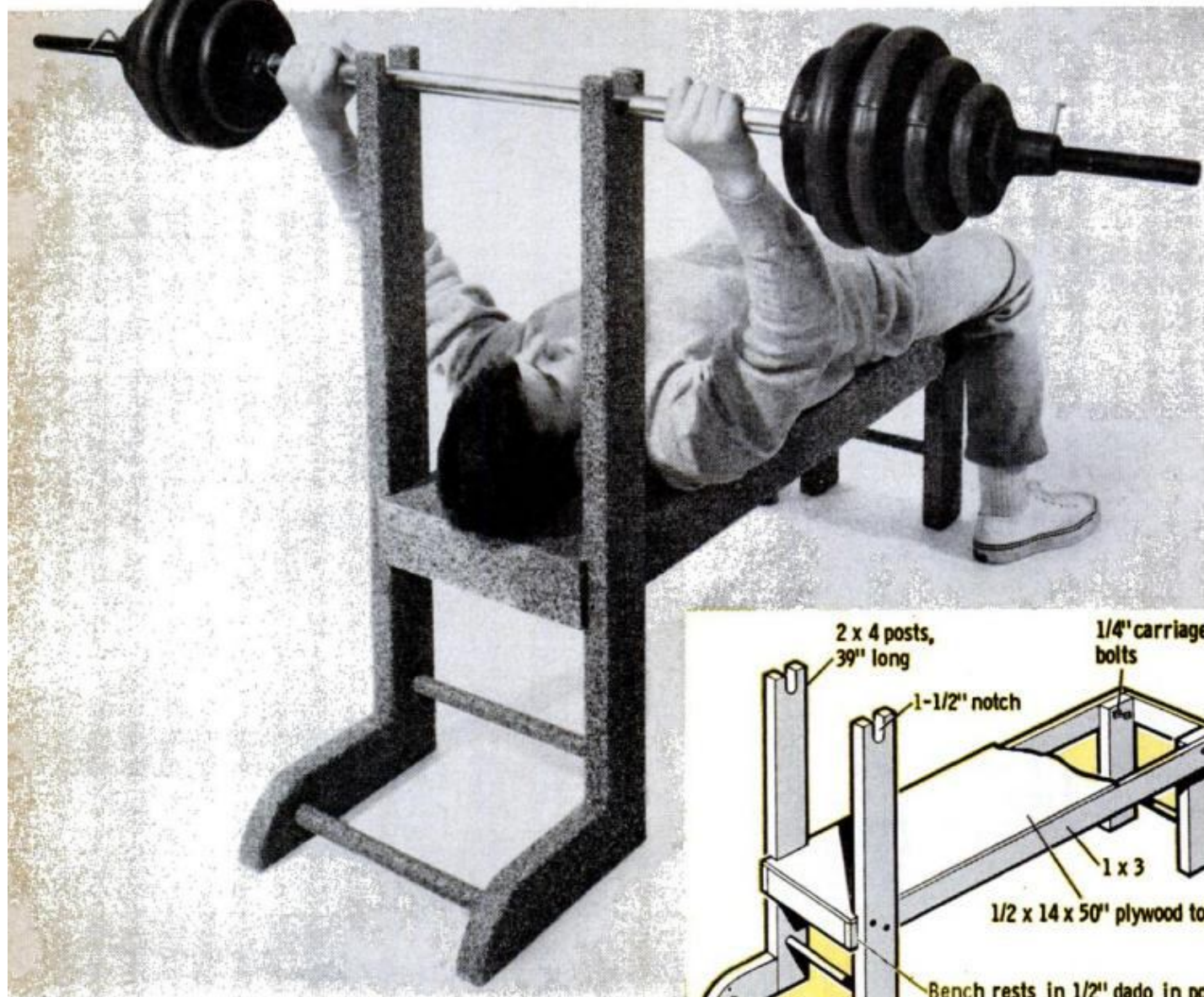


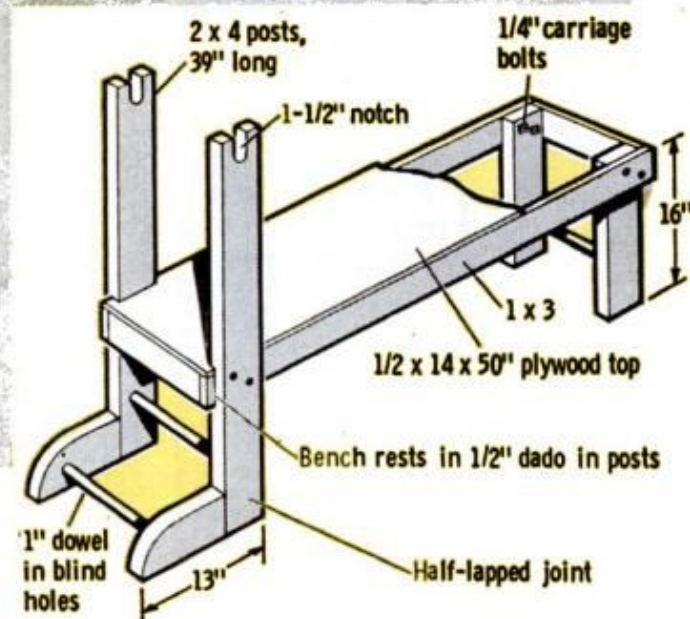
Photo by Robert Borst

Exercise Bench

Anyone who works out with weights will find this barbell bench a great convenience. Made comfortable with a cushion of foam rubber, it lets you do presses, squats and leg exercises, and permits parking the weights overhead while taking a breather.

You can buy such a bench for around \$30 but you can make this one for less than \$5 from a few pieces of 2x4, 1x3, a dowel and a scrap of plywood.

Make the bench top first by nailing together a frame of 1x3s and covering the top with 1/2-in. plywood. Two 16-in. legs support the bench at one end and two 39-in. posts at the other. Height of the posts and length of the bench should be



BARBELL NOTCHES in ends of posts are made by first boring 1/2-in. holes, then sawing in from the edge

tailored to the person. Note that the bench top rests in 1/2-in.-deep dadoes cut in the posts to prevent rocking. Foot extensions join the posts in half-lapped joints and the two L-shaped assemblies join together as a unit with 1-in.-dowel rungs glued in blind holes. The feet prevent tipping when the weights are stored on the posts. Bolts alone can be used to assemble the parts which will permit dismantling for storage; for a more rigid assembly, add glue.—Heath Winston

for Summer Weekends

Floor-Stand Globe

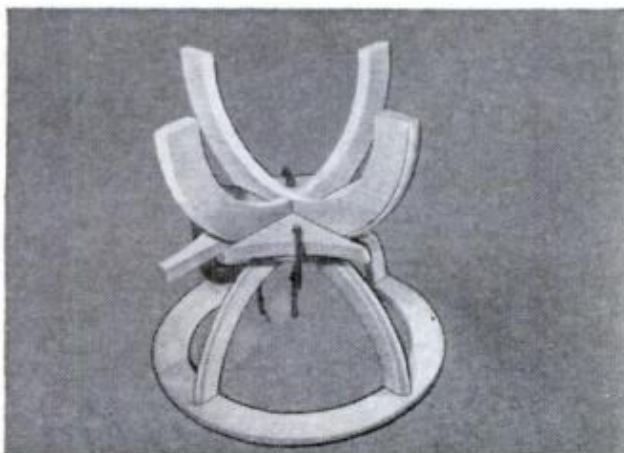
You'll find a world globe much handier when it stands at armchair height. Mounted in this elegant stand the globe is not only extra convenient to use from a sitting position but it becomes an attractive piece of furniture. Dimensioned for a 12-in. globe, the stand is about 23 in. high. If you plan to stain it, use walnut or mahogany. If you paint it, you can cut the parts from $\frac{3}{4}$ -in. plywood. Plywood, of course, will save you the work of gluing up solid stock for the equatorial ring which has a $16\frac{3}{4}$ -in. outer diameter and a $12\frac{3}{4}$ -in. inner diameter.

Both half circles in each pair are duplicates except for the position of the half-lap notches. Saw them out with a band-saw or jigsaw and sand the edges smooth. If you have a router, run a small cove on all outside edges to give the piece a professional look. The curved parts are glued together and then glued and doweled to a 6-in. disc. Short dowels and glue are used to attach the ring.

Mount the globe so its polar axis is vertical or at a $23\frac{1}{2}^\circ$ angle. In the latter case, a brass support is formed and added to keep the globe centered.—C. M. Morley

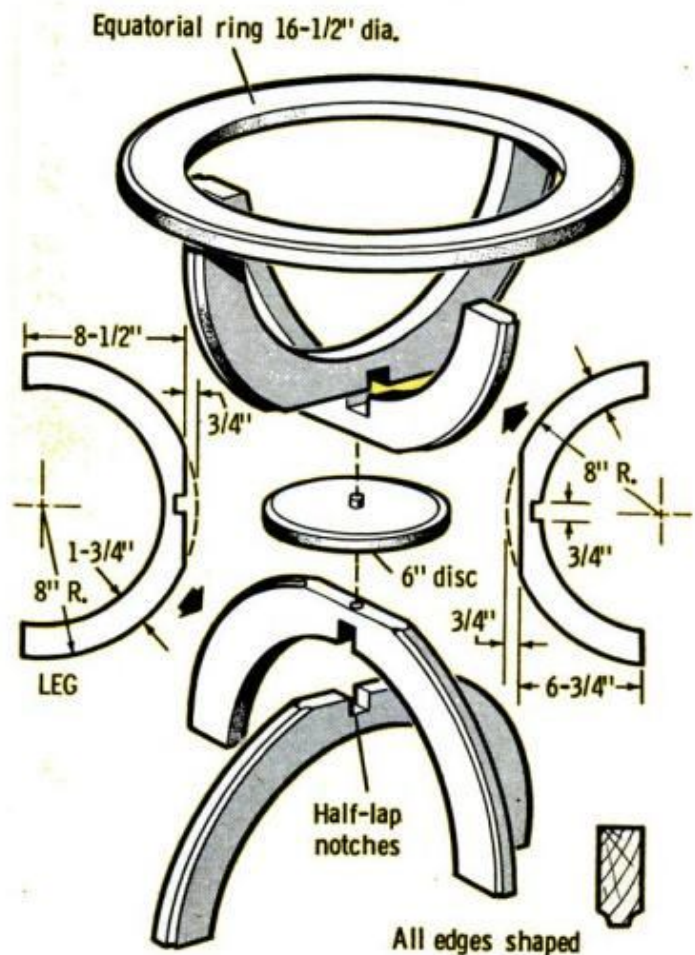


TABLE-MODEL GLOBE is more convenient to use when it's mounted in an elegant floor stand such as this



RIGHT-ANGLE BLOCKS clamped to middle disc hold circular leg assembly in alignment with upper half

JULY 1969



Styrofoam-Cooler Caddy

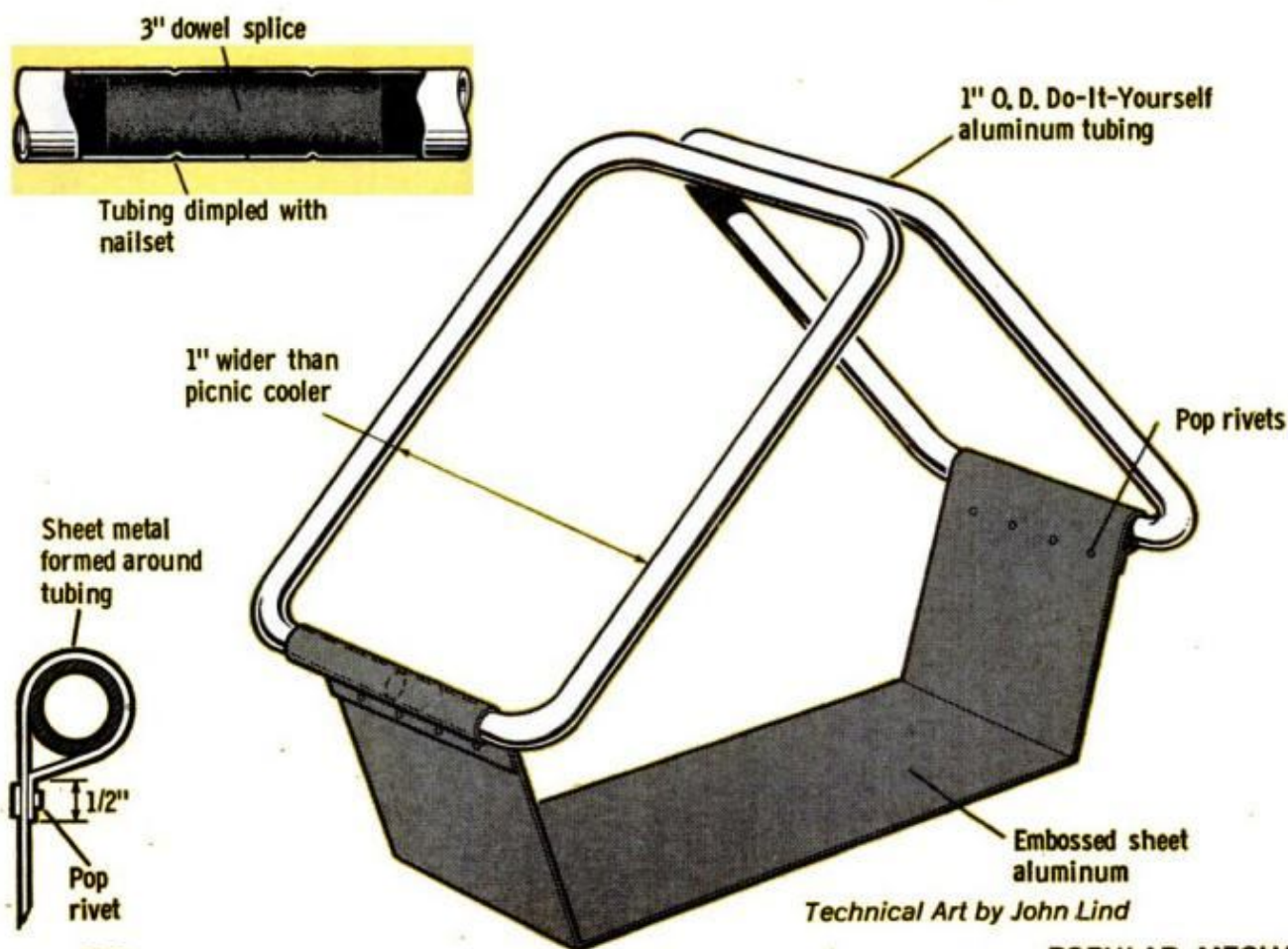
You can make a Styrofoam food and beverage cooler a lot easier to carry if you cradle it in a lightweight caddy like this. It's made entirely of Reynolds Do-It-Yourself aluminum which you can buy at most hardware stores, and has fold-down handles for complete access to the cooler.

The handles require two 6-ft. lengths of $\frac{3}{4}$ -in. tubing, each being bent as required and joined together with a dowel. Before bending, plug one end of the tubing with a cork, fill with damp sand and cork the other end. Sand will prevent the metal from kinking at the bends. Make the bends so ends of the tubing overlap, then saw across both (or use a tubing cutter) to make a neat butt joint. Insert a 3-in. piece of dowel halfway in the ends of the tubing and lock it in place by dimpling metal into the wood with a nailset.

The strip of embossed aluminum which cradles the cooler is cut slightly narrower than the bottom and tailored to fit by bending the ends. Half-inch 90° flanges are formed at the ends and $\frac{1}{16}$ -in. holes are made through both thicknesses of metal after wrapping the aluminum around the handles. Four Pop rivets fasten the flanges.



WITH HANDLES which fold like ones on a hamper, this aluminum caddy makes foam cooler easy to tote



Self-Watering Window Box

Virtually rot-free, this durable self-watering window box should last as long as your house. It differs from the conventional flowerbox in that it has no bottom and the plants are watered from below. The plant box itself rests in a metal pan which sits in a shallow wood tray supported by wrought-iron brackets. The pan is filled with water which the soil absorbs through 1/2-in. holes along the lower edges of the box.

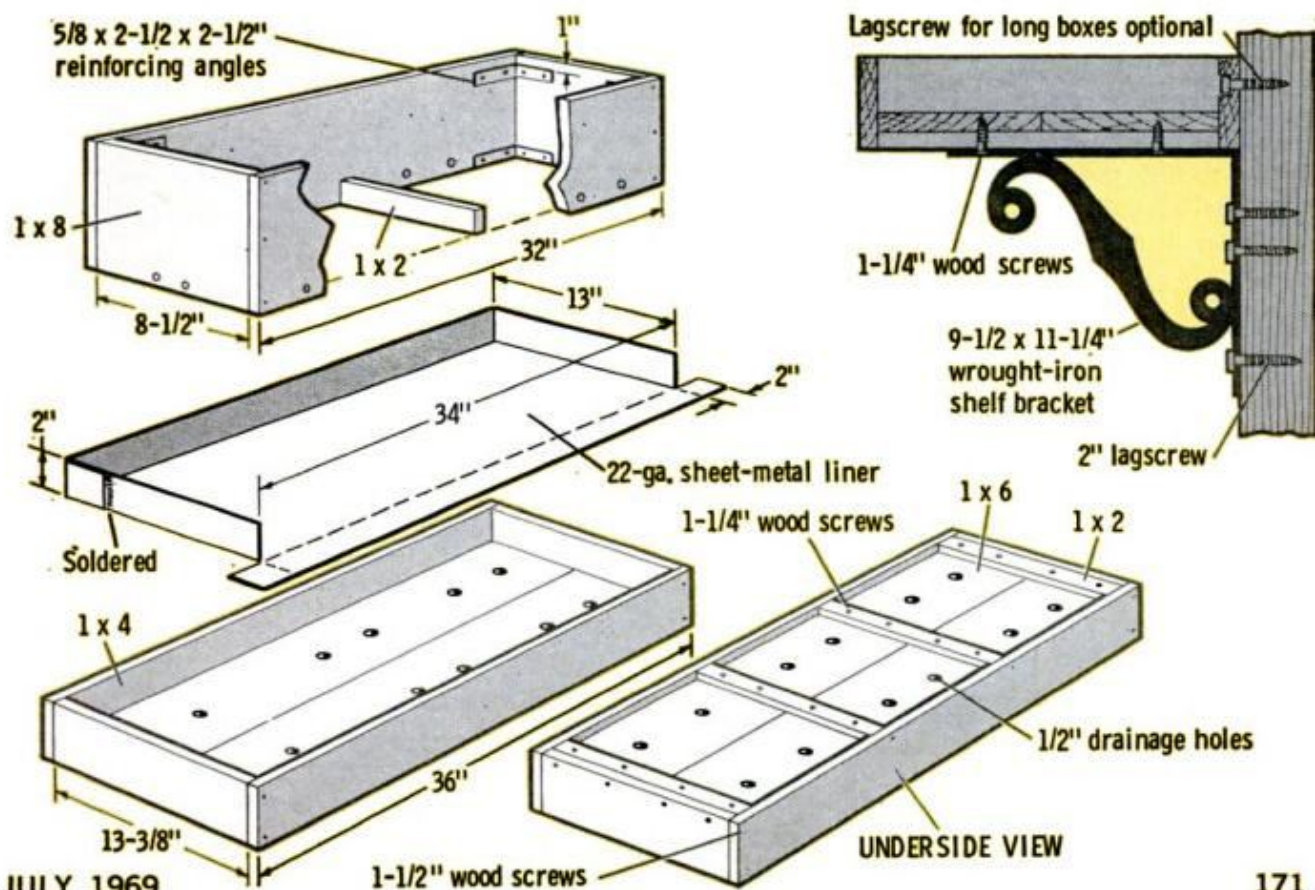
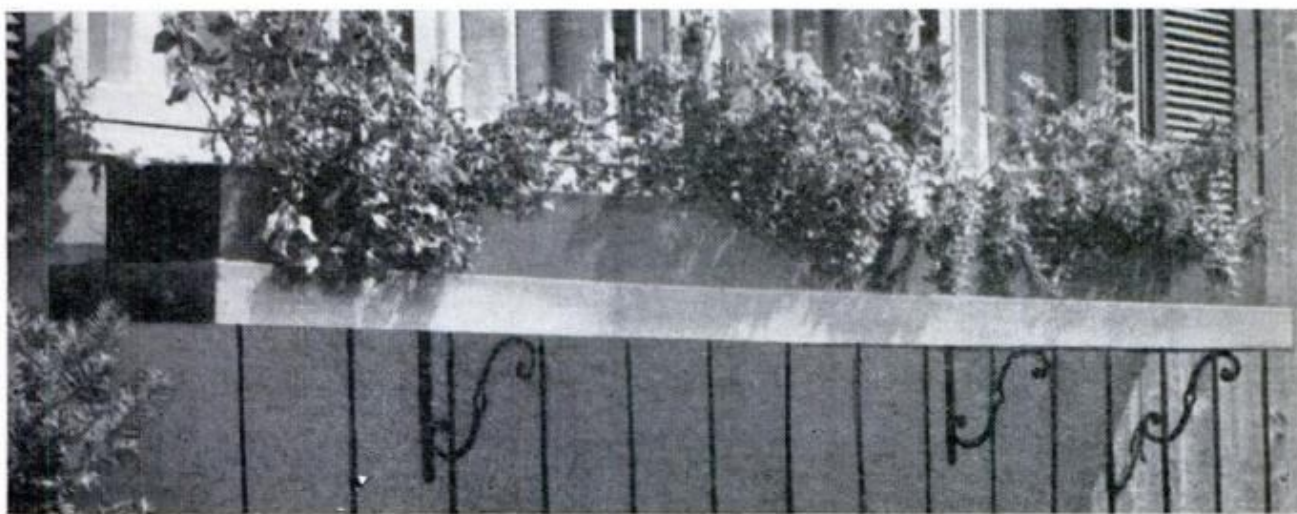
The length of the box is determined by the window. The water pan is always 2 in. longer and 3 in. wider than the plant box

so there will be a 1 to 1 1/2-in. moat all around. Drain holes in the wood tray will take care of any water that runs down under the pan.

Make the box and tray of redwood and assemble them with screws in counter-bored holes. Reinforce inside corners of the box with metal angle irons. Cross-pieces in the bottom of the box are placed every 18 in., while those on the underside of the tray are spaced 12 in. apart.

Place a 1-in. layer of coarse gravel in the bottom of the plant box and fill with a good mixture of soil. Fill the tray with water until the soil is moist, then add your plants.—*M. S. Schroeder*

DAILY WATERING IS ELIMINATED since water in pan is only drawn up into vital root area as the soil demands



Fit Your Swimming Mask With Glasses

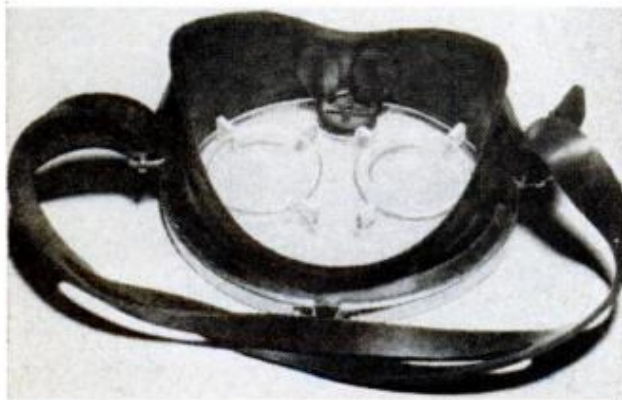


DO YOU PLAY blindman's buff every time you go swimming? Are you always stepping on sharp shells or misjudging distances underwater—because all you can see without glasses are fuzzy blurs?

Now for about \$15 (less than one-third the commercial cost) and three hours of work on your part, you can have your own custom-made, prescription swimming mask. The only tools needed are a jigsaw, ruler, grease pencil, and plastic cement.

Your glasses' prescription must be ground by an optician on 50-mm lens blanks. Have the optician mark the lens as to which one is for the left eye and which one is for the right. He can also easily mark the exact center of the lens for you.

If you have an astigmatism, also have the optician notch the center of the top edge of the lens so that you can orient the lens axis properly when mounting the lens.



ORIGINAL GLASS WINDOW of mask is discarded and replaced with plastic one cut from $\frac{1}{8}$ -in. Plexiglas

The next job is to make the plastic insert to hold the lens. First disassemble the swimming mask itself. Trace the outline of its glass faceplate on the plastic. Leave the protective paper on the plastic while doing this to keep from scratching the surface. Draw the outline for the insert $\frac{1}{4}$ in. inside the traced outline, then cut out the insert using a jigsaw.

Determine the horizontal and vertical center lines of the plastic insert and draw these lines in with a pencil on the protective paper. Notice that these lines cross at the insert's exact center. Have your optician measure the distance between the centers of the pupils of your eyes—the interpupillary distance.

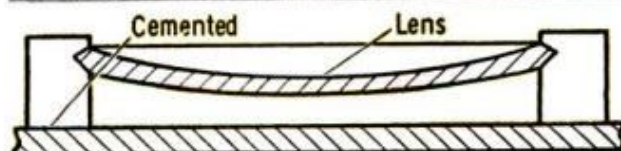
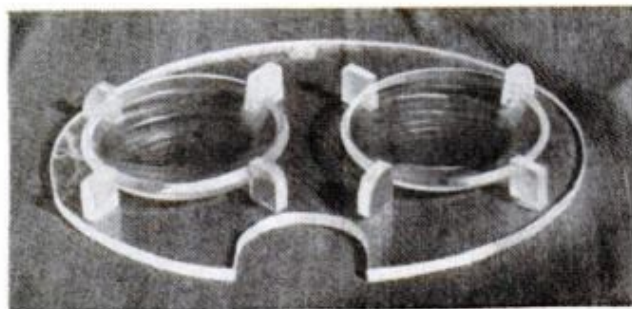
Starting at the point on the insert where the horizontal and vertical center lines cross, measure off half the interpupillary distance horizontally to the right of the vertical center line and half to the left. Mark this point on each side of the insert.

Align the lenses' center lines exactly on top of the inserts' center line and trace the lens outline on the protective paper.

The height of the "stilts," or stand-offs, which hold the lens out from the insert, will vary from person to person because each person's nose height is different. Decide how far the lens are to be from your eyes (about the same distance as your regular glasses are from your eyes). Subtract this distance from the distance between your eye and the mask's faceplate. This will be the height of the stilts.

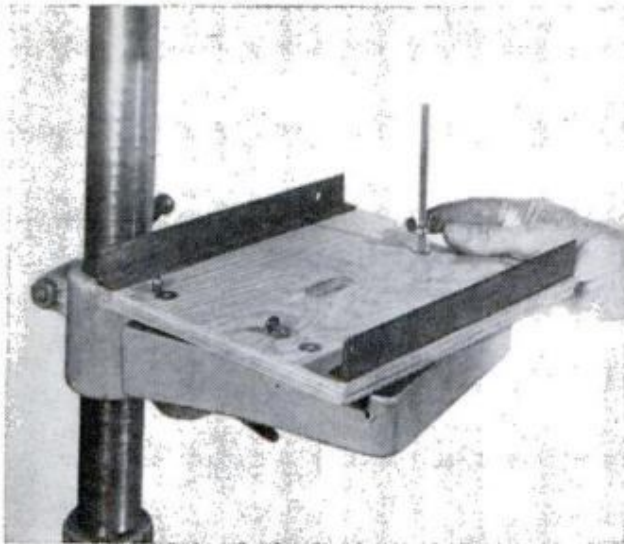
Cut a strip of plastic the required height (the stilts on my mask are $\frac{3}{16}$ in.

(Please turn to page 193)



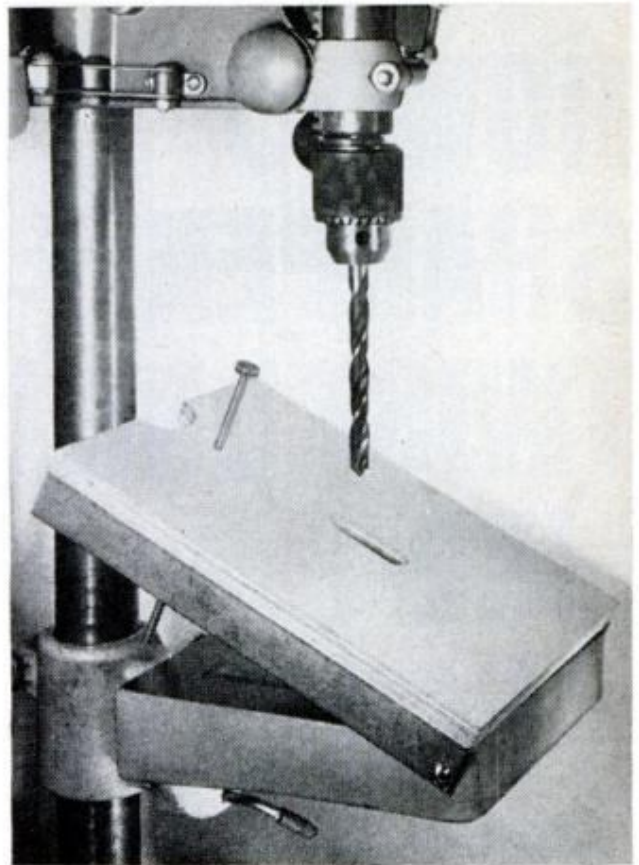
FOUR STANDOFF POSTS cemented to plastic window hold each lens correct distance from swimmer's eye

Second Table Permits Compound Drilling



Even if the table on your drill press tilts already, there comes a time—when drilling holes at a compound angle, for example—that you need a table which tilts two ways.

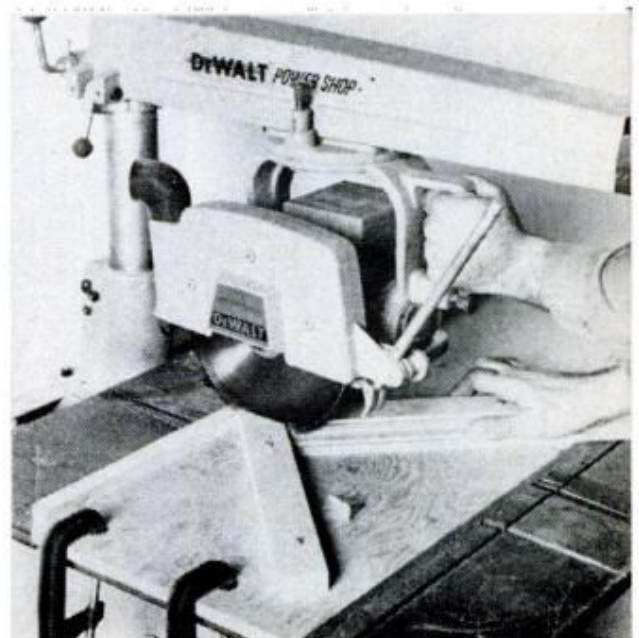
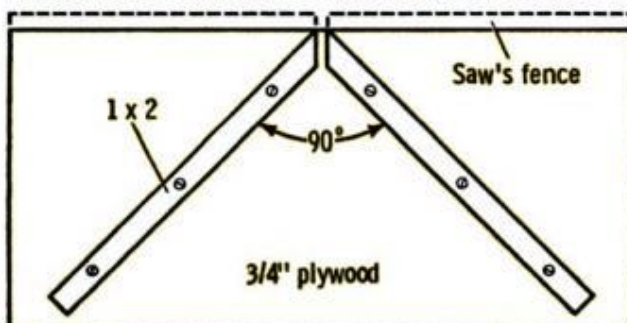
Such an auxiliary table can be readily attached to any drill-press table that has straight sides. This one consists of two lengths of 1-in. angle attached to the edges of a piece of 1/2-in. plywood and drilled at one end for a stovebolt. The latter pivots the table and screws in holes drilled and tapped in the apron of the drill-press table. Note that a 1/2-in. elongated hole is made in the center of the plywood to provide bit clearance when the table is tilted, and a half-round notch is cut at the back to



clear the column. The table is made adjustable by a long thumbscrew which turns in a threaded hole made in the plywood. It bears against the table collar which slides on the column. A wingnut on the underside of the table locks the tilt-setting bolt. Table can be lowered for normal drilling.—James P. Marshall

Mitering Jig Saves Swinging Radial-Arm Saw

As is true with a bench saw, a mitering jig can save a lot of switching back and forth when making right and left-hand miters on a radial saw. Here the jig is simply a flat plywood board to which 1x2 cleats are fastened at an exact 45° angle to the blade. In use, the apex of the angle is aligned with the blade and the jig clamped in place.—Victor H. Lamoy



HOW TO SHARPEN TWIST DRILLS LIKE A PRO

By FRED W. SCHULETER
Master Machinist, Formerly of
Stevens Institute of Technology

IT TAKES A PRO just a few deft strokes on a grinding wheel to sharpen a twist drill, but his know-how just didn't happen. He, too, was once told the importance of maintaining equal lips.

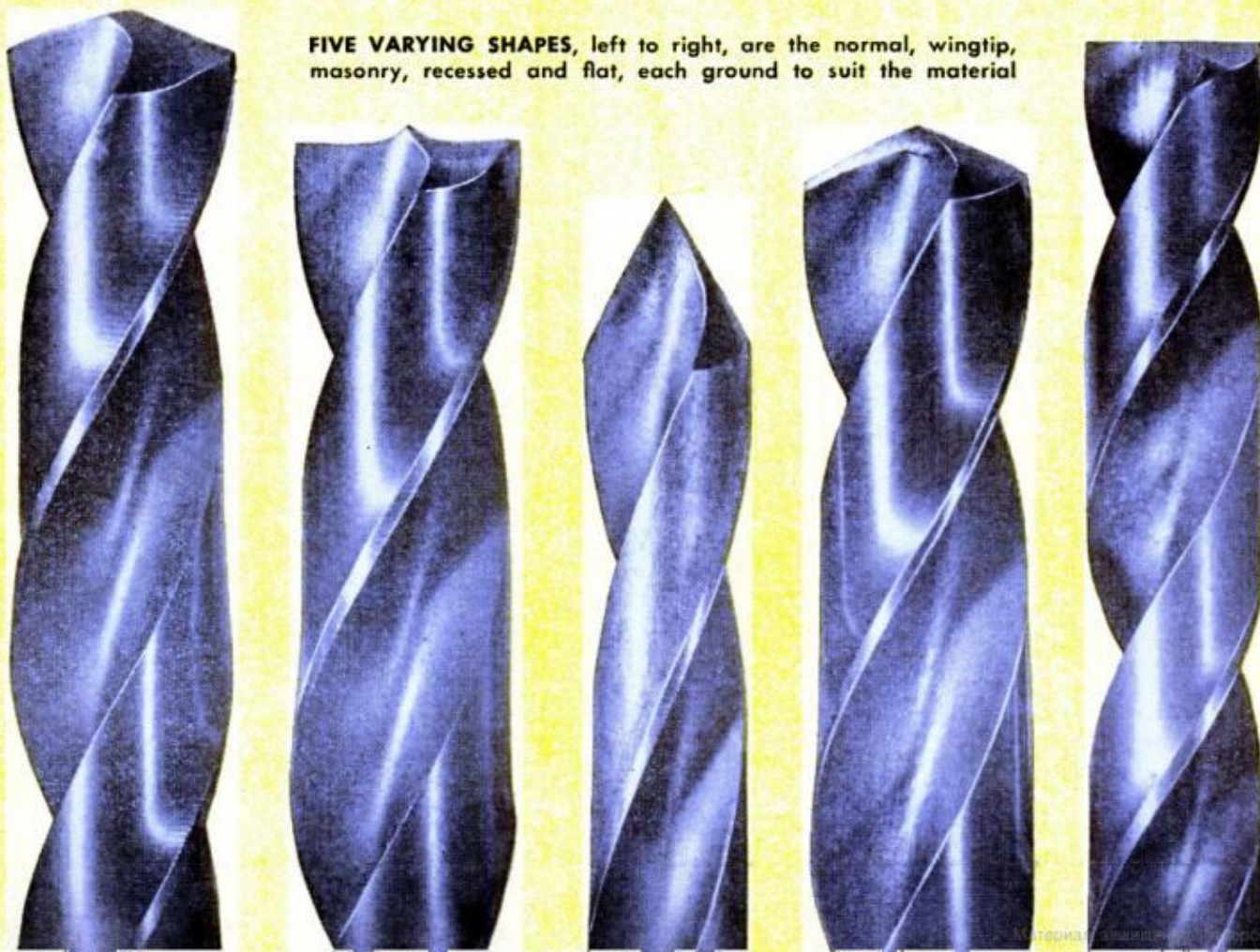
This is the cardinal rule to follow when grinding a twist drill since it's the perfectness of the lips that determines the roundness of the hole.

Upon examining a new drill you will note the angle is rather blunt. This is fine for drilling hard materials like alloy steels, but it doesn't work as well when drilling soft materials like aluminum, brass and plastics. The standard blunt end just doesn't work for all materials. Here is where it's worthwhile to know how to alter the original shape to produce clean, burrless holes in any material.

While lip clearance is not critical, and the angle can be anywhere from 5° to 15°, the degree of angle *must* be the same on each side. If you have normal vision, it's fairly easy to see when the lips are even, but it's still good practice to check them with a drill scale. If you find one side has been ground lower than the other, take a little off the high side.

It takes practice and a certain deftness to do this freehand. First you hold the drill with both hands, as in the photo at the right, and gently touch the lip of the drill to the flat of the wheel. At the same

FIVE VARYING SHAPES, left to right, are the normal, wingtip, masonry, recessed and flat, each ground to suit the material



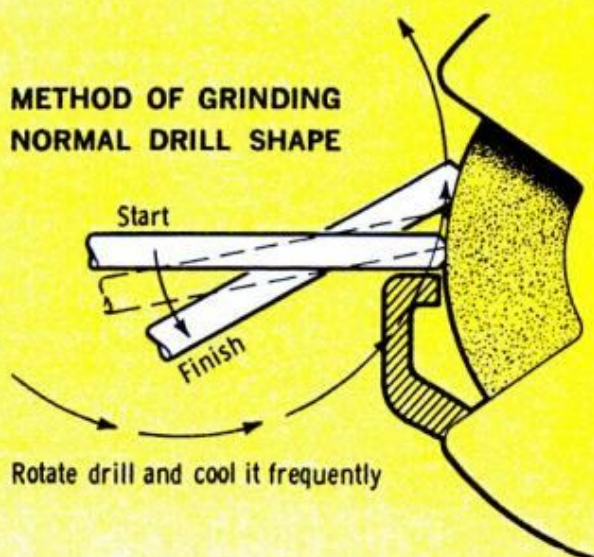
time you give the drill an upward sweep with a rotating motion as shown in the drawing. Do this several times to each side while holding the drill at a 15 to 30° angle. Dip the tip in water or oil occasionally so it doesn't overheat and turn blue. You'll wind up with an extremely sharp cutting edge which will go through the toughest of materials, including stainless steel.

To drill soft materials you need a bit which has the same lip clearance as for steel but a recess ground on the face of the lip. The recess prevents sudden catching of the drill in the work—which often results in breakage—and produces a clean, burrless hole upon breakthrough. To grind the recess, you hold the drill vertically at a 45° angle with the point down as shown in the upper left-hand photo on page 176. Then, with just slight pressure against the edge of the wheel, let the contour of the lip be your guide in a forward motion. As before, it is important to grind both sides so that they will be equally recessed.

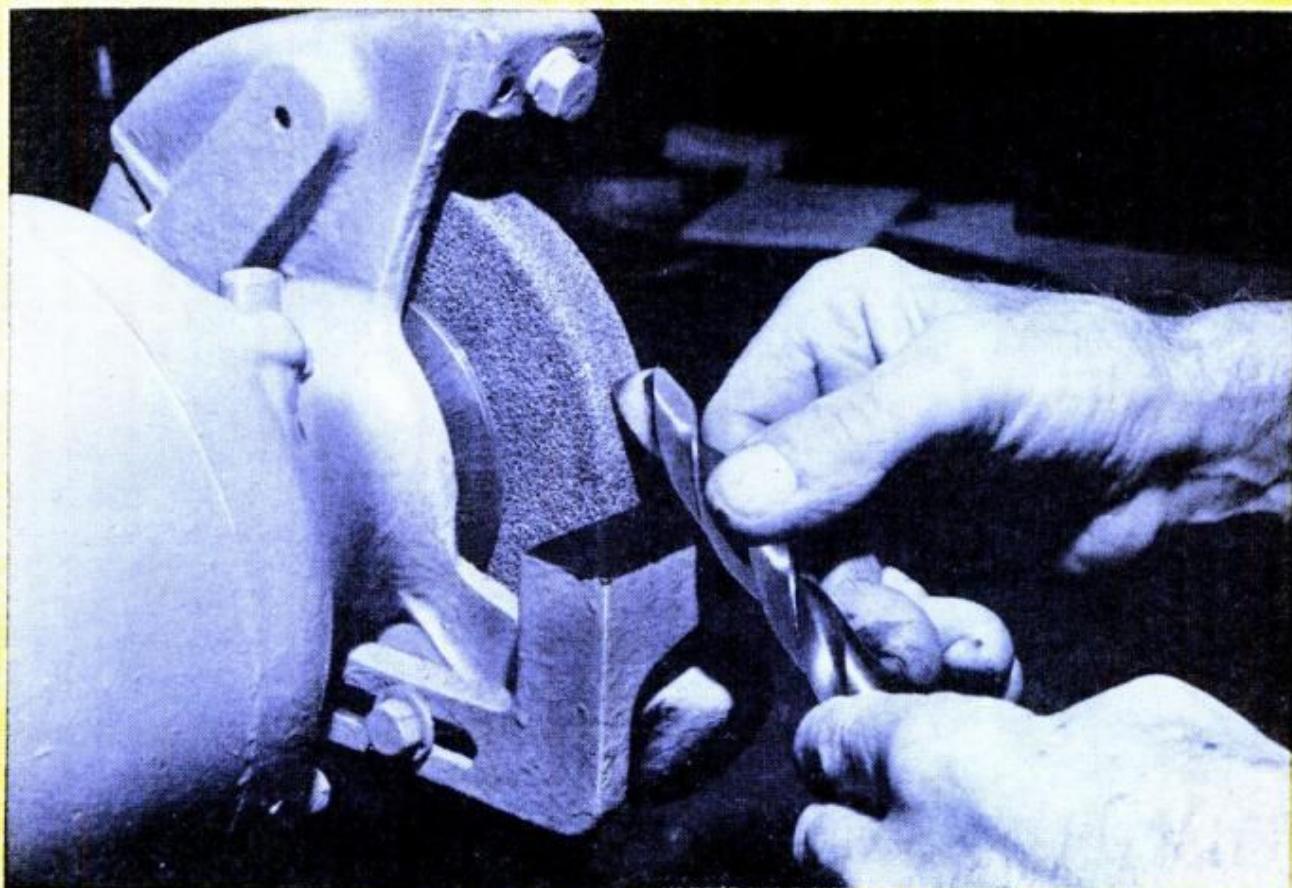
A most versatile shape is the wingtip which produces a perfect burrless hole in

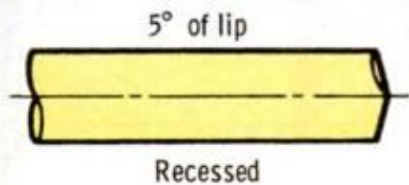
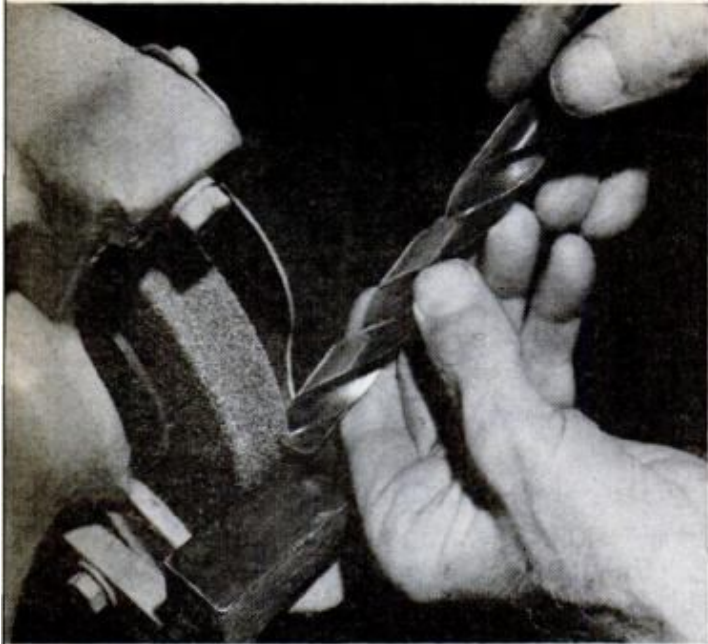
the thinnest metals. The point acts much like the screw point on an auger bit in locating itself on a centerpunch mark. To grind a wingtip on a bit place the lip at the right-hand edge of the wheel. Hold it at an opposite 5° angle and follow the same upward motion as used before. Remember to rotate the sides and grind a little at a time.

Another shape often required is the 60° angle used for drilling masonry, plaster and tile. It's wise to use an old drill on these materials since there's a chance that you may break it, particularly when you're using the bit in a portable elec-

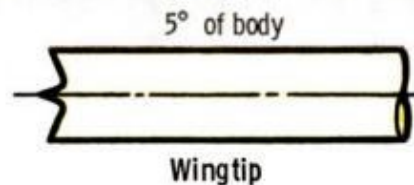
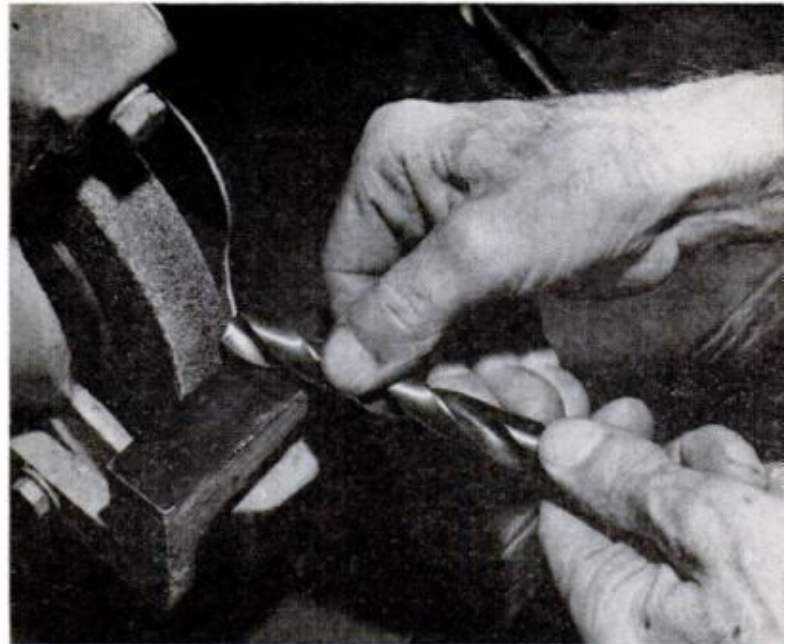


DRAWING AND PHOTO illustrate proper way to hold and grind normal 5 to 15° shape best for steel





TO GRIND RECESSED LIP hold twist drill at corner of wheel, with point downward, and at a 45° angle. Touch wheel lightly and give drill usual upward swing

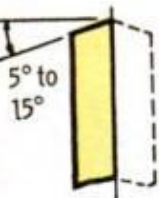


TO GRIND WINGTIP place lip against right-hand corner of wheel, give drill upward swing while holding at 5° angle. Do it on each side to form point

15° to 30° of body



Normal



Lip clearance 5° to 15° (not critical)

60° of body



Masonry

WHEN GRINDING a normal or masonry shape, always rotate twist drill so it won't overheat and turn blue. Dip the end in water occasionally to cool drill

tric drill. To grind such a point, you simply hold the drill as before, but at a 60° angle.

By grinding both sides of the drill completely square you can make a bit which will produce a flat-bottom hole. Lip clearance is needed here, but only slightly.

The proper speed is important when drilling and should be determined by the material and the size of the twist drill. A general rule to follow is use a slow speed for hard stock and a fast speed for soft stock. The larger the drill, the slower the speed. The smaller the drill, the higher the speed. In all cases, use normal pressure. Don't force the drill, let it do the work.

When drilling a deep hole, it is good practice to withdraw the drill occasionally to free it of chips. This is particularly important when drilling aluminum and plastic. Also, when you near breakthrough in drilling, ease up on pressure and let the bit slowly sink through. You'll wind up with a neat, clean-cut hole. ★★★



HINTS FROM READERS

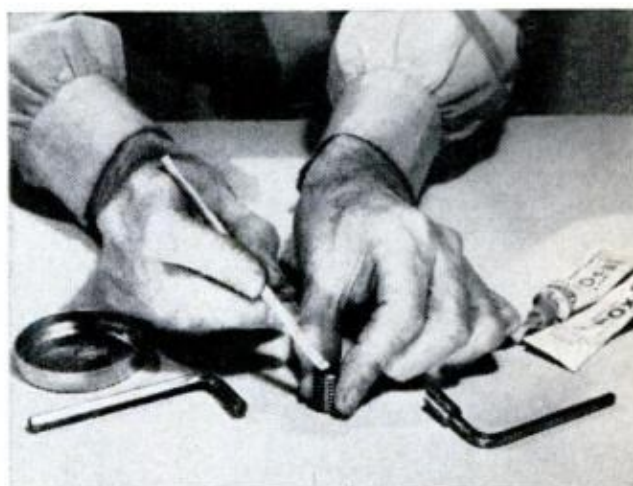
Slotted block for drafting

It's often difficult to pick up drafting templates and triangles—especially when they're lying flat on a drawing board or table. It's also hard to keep them clean when they're slid from one end of the board to another. One draftsman found the solution in a slotted board to hold the templates upright. The slots are simply saw kerfs.—*Victor J. Lamoy*



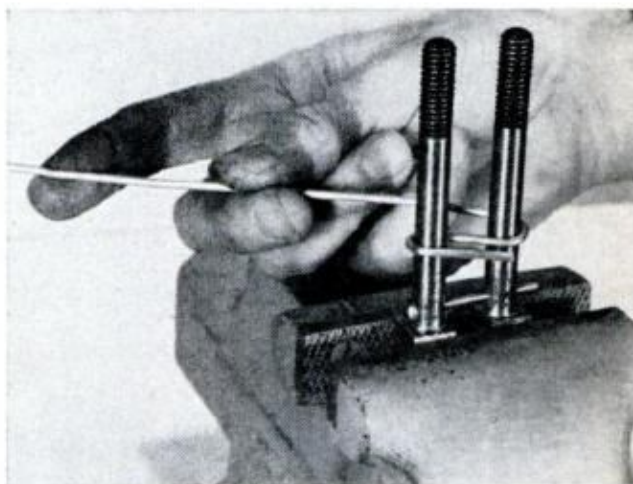
Permanent handles for Allen screws

With power tools such as jigsaws, belt-disc sanders or Unimat lathes, Allen screws are often used as temporary adjusting screws or setscrews. In such cases, I often find it advantageous to epoxy the Allen wrenches permanently to the setscrews so as to avoid the problem of searching for the right-size wrench. Before applying a drop or two of epoxy, however, tighten the screw to make sure the handle of the wrench will remain out of the way.—*Jay K. Wallace*



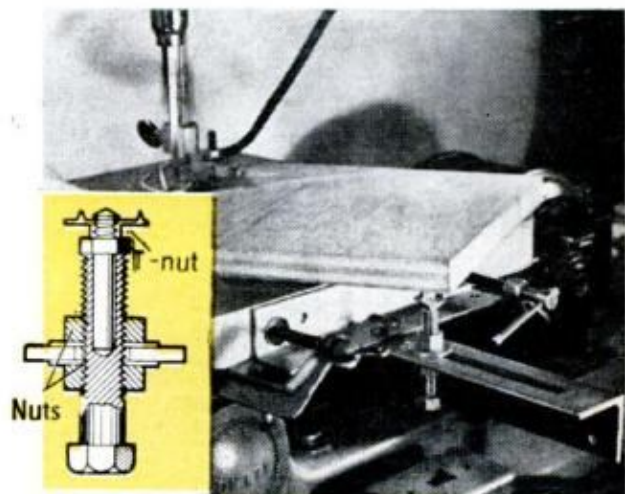
Wire bender from bolts

This wire bender is easily made and adjustable so you can grip it in your vise for bending wires of different sizes. It consists of two square-headed bolts having one sides of their heads cut flush with their shank. The bolts are clamped with the cut sides together, then a hole is drilled through the shank's sides. One is reamed for a slide fit, the other tapped for the adjusting screw. Bolts are spaced for the size of the wire to be bent, then the jig is clamped in a vise.—*Peter Legon*



Disc-cutting guide

An adjustable pivot sliding in a slotted length of angle iron that's attached to the table of your jigsaw, makes a handy fixture for cutting true discs. The detail shows how the pivot and its Tee-nut point rests in a blind hole drilled in a machine screw. This permits removing the pivot and driving it into the underside of the work. How the fixture is attached to the machine depends on the table itself. If it has a lip, like the one shown, it can be attached with C-clamps.—*Peter Legon*





Build These Power-Tool Stands

By JACKSON HAND

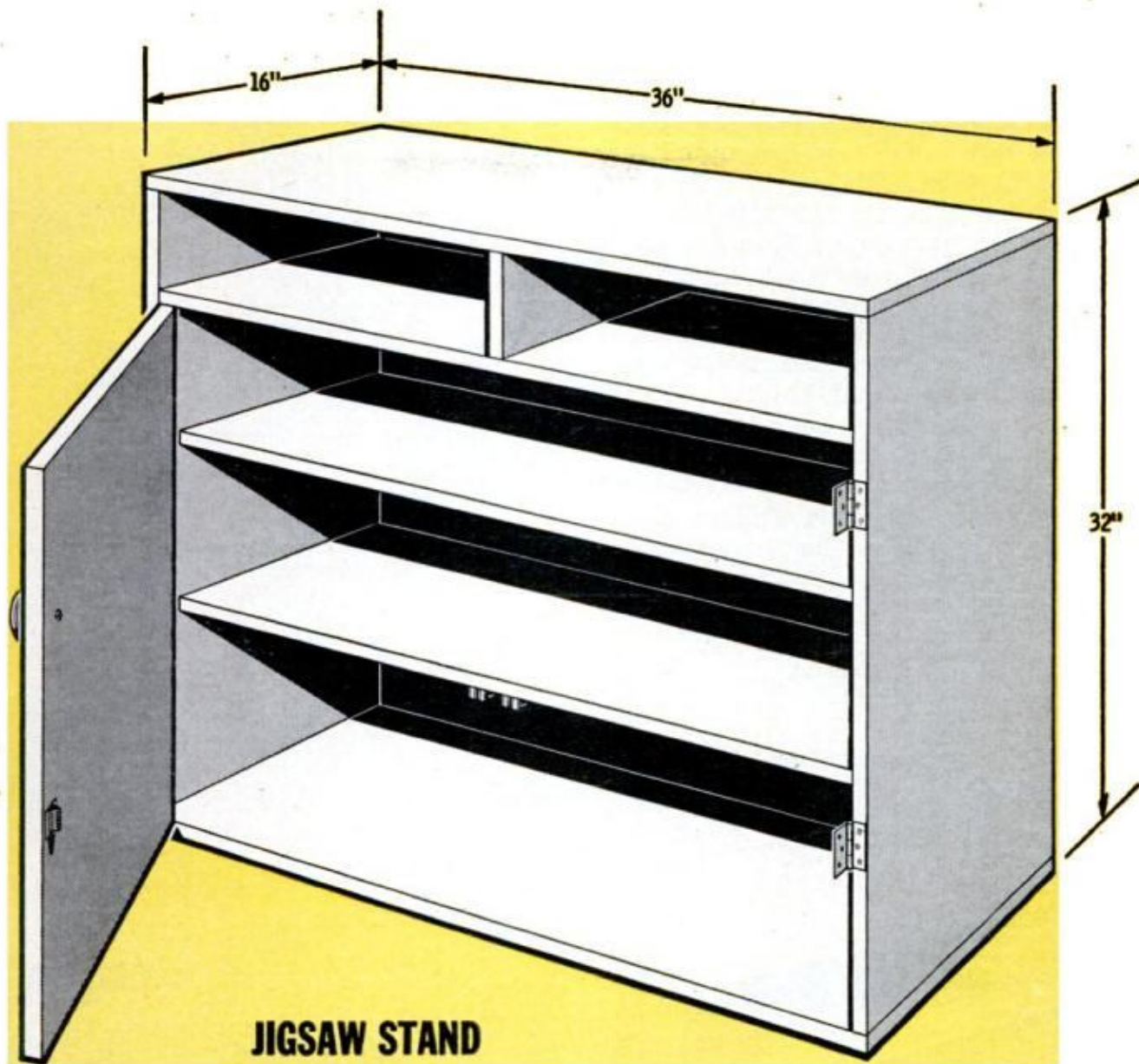
Photos by the Author

LIKE THE SPACE under a pool table or baby grand, there's a lot of it going to waste under your workshop machines. The typical open-type stand offers little more than a shelf when it could be housing a roomy built-in cabinet to increase your shop's storage space.

The four cabinet-style bases shown here have an expensive look, but actually were made at an average cost of about \$15 each for plywood, nails, glue, paint and a set of good, husky casters.

Each of these tool stands was made of sheathing-grade plywood, which is a couple dollars cheaper per sheet than A-D plywood. The rough surface of the sheathing makes little difference, but if you like things a little smoother, use A-D plywood.

To capitalize on the 4x8-ft. sheet, dimensions are kept at 12, 16, 24 and 32 in. when possible. Actually these dimensions are minus half the width of a saw kerf so that a sheet will cut up, for instance, into three pieces a shy 16 in. wide.



for Your Shop

Technical Art by Fred Wolff

Nails and glue are used throughout, except for fastening the drawer dividers and glides to the sidewalls of the drill-press unit. These are screwed and glued. Since there is a back (or a divider as in the case of the bandsaw base) to prevent the unit from racking, nail-and-glue assembly is sufficiently strong. Quarter-inch plywood or 1/8-in. hardboard work best for cabinet backs, drawer bottoms and dividers.

You'll thank yourself for going whole hog on the casters. If they are big enough

JULY 1969

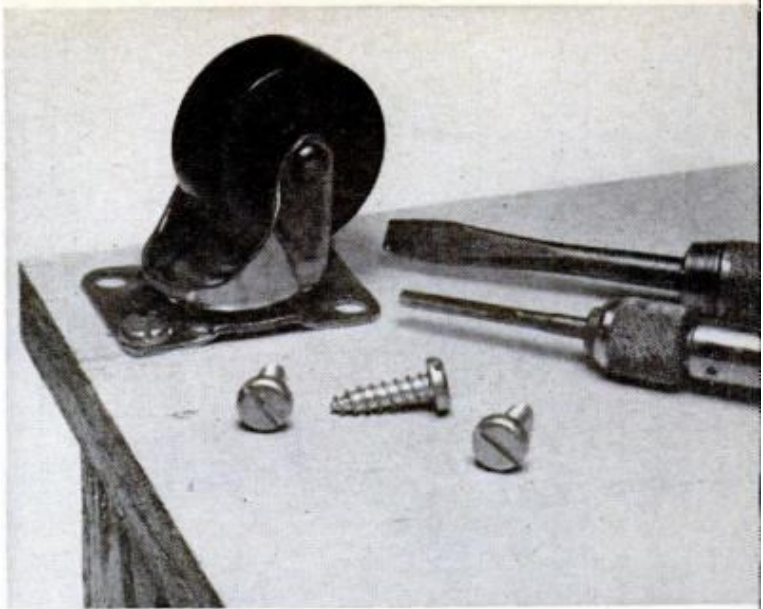


TYPICAL OPEN STAND is space waster compared to cabinet shown at left

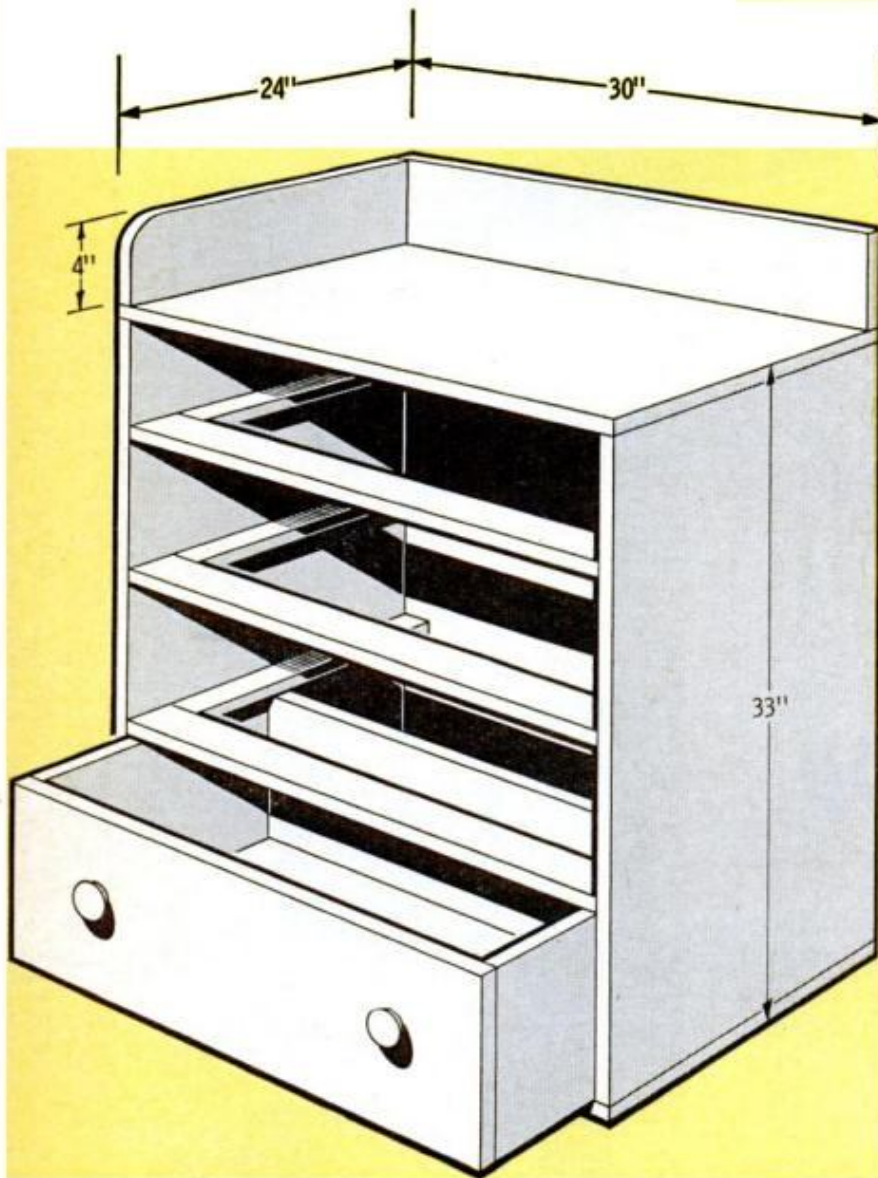
(2-in. wheels) and well made, you'll roll tools around a concrete floor with ease. Cheap, small casters roll poorly, and are blocked by the smallest sliver on the floor. For your guidance, the casters used on all the tools except the saw-jointer unit are Bassick No. 9706G-OC, at about \$5 a set. The same casters were selected for the saw-jointer, but with a 2½-in. wheel.

The drill-press base is largely a "set" design for its use and its shape. You need a work surface beside a drill press for handy handling of the materials you use. The front-to-back depth (24 in.) makes it the best of the four stands for drawers. The other three, however, can be adapted or intermixed to suit your requirements.

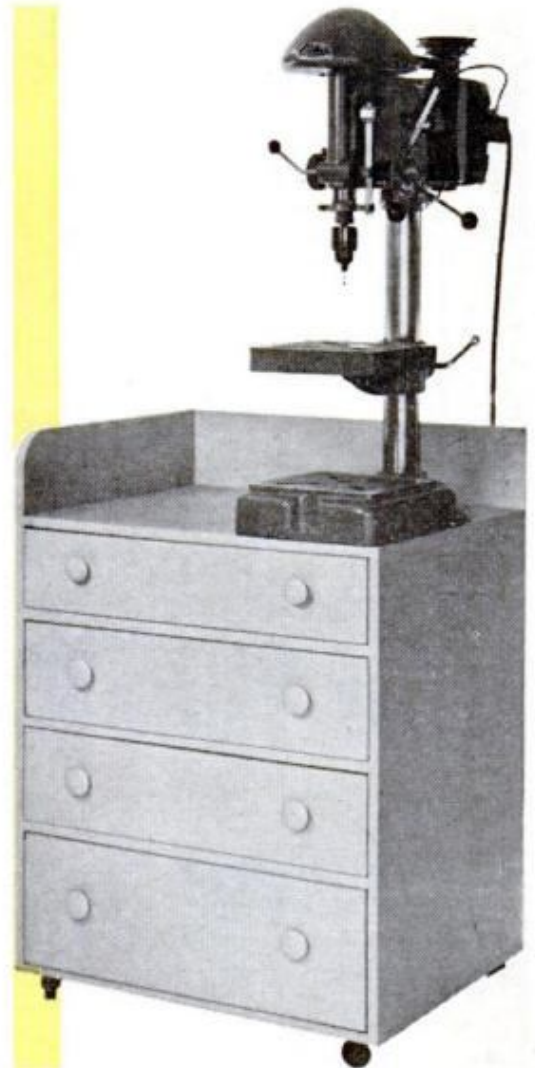
For instance, the open shelves of the jigsaw stand would be just as useful un-

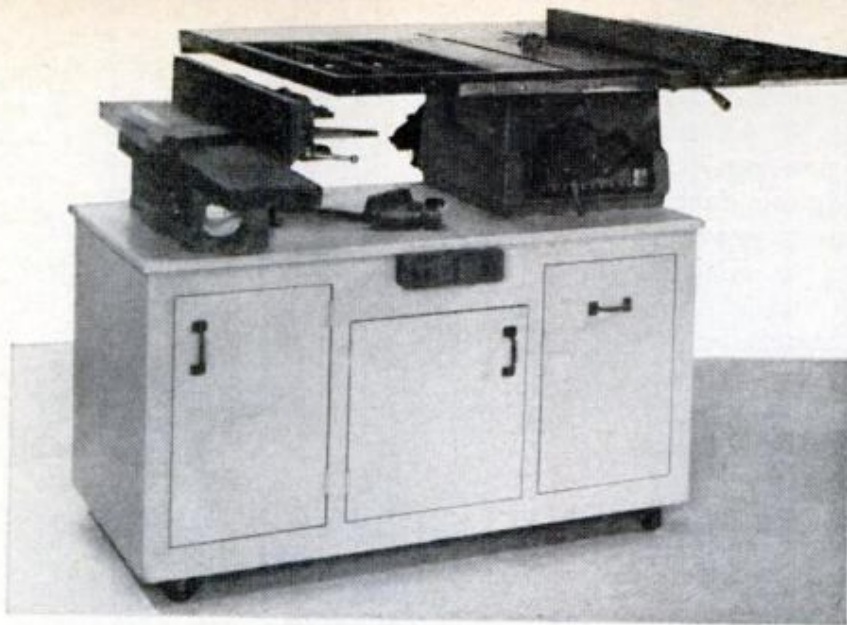


HUSKY SWIVEL CASTERS let stands roll easily over floor debris. Use sheet-metal screws to attach them

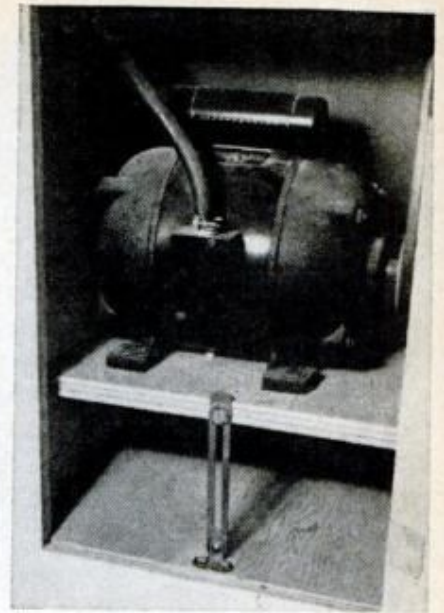


DRILL-PRESS STAND

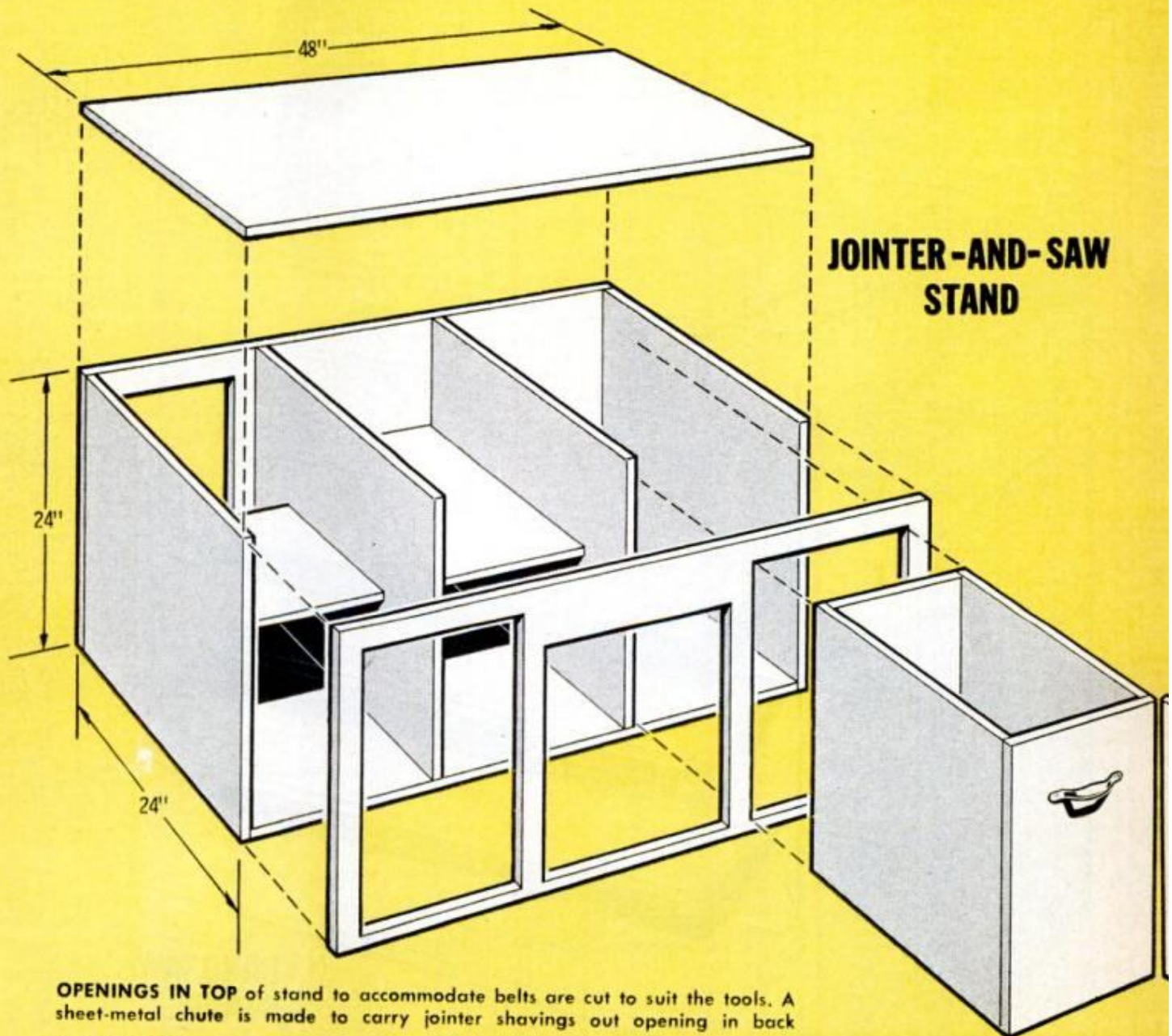




SAW AND JOINTER should always be side by side on a single stand. This one has storage, sawdust bin and a jointer chute built in



JOINTER MOTOR on hinged shelf adjusts to give proper belt tension



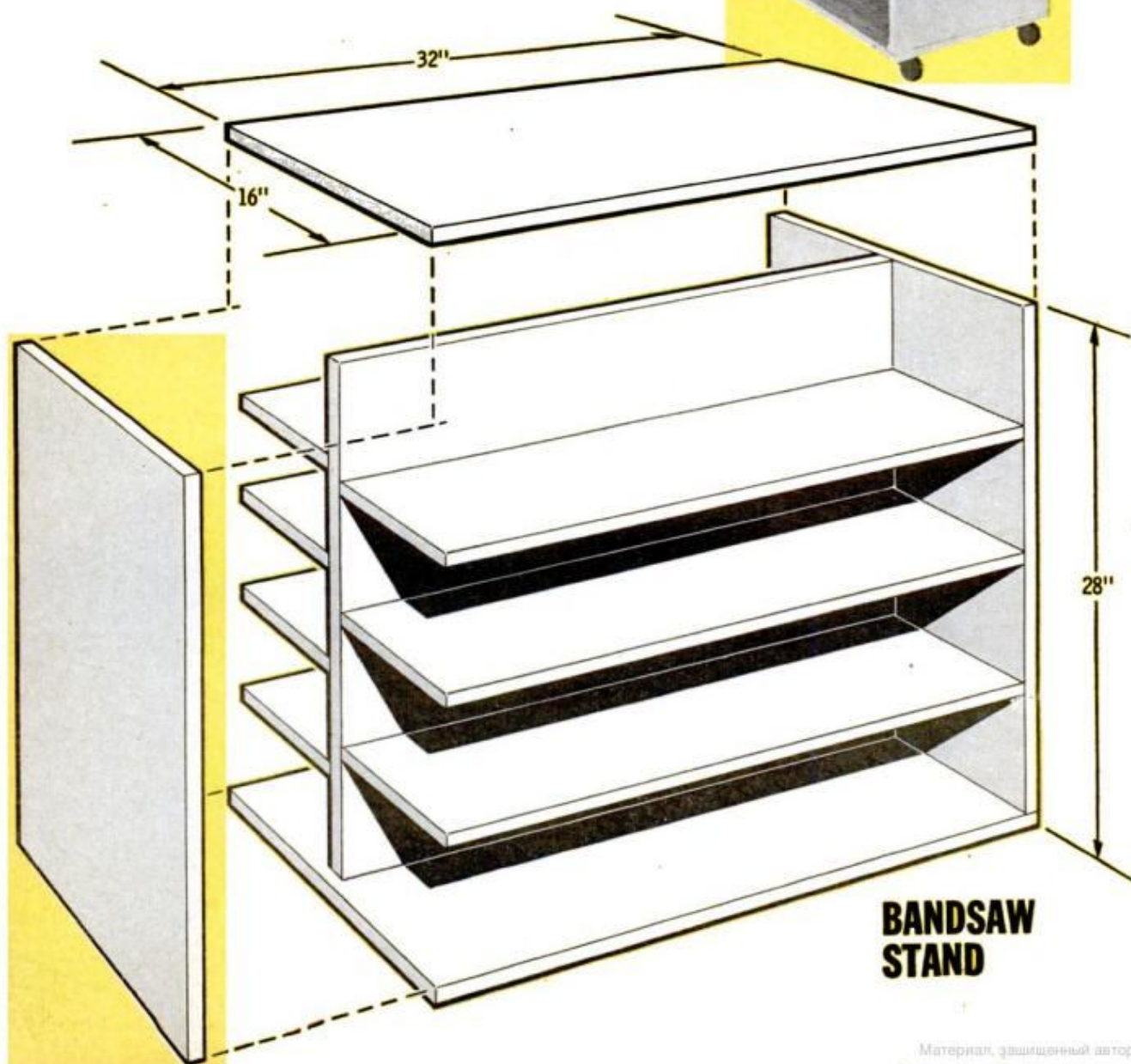
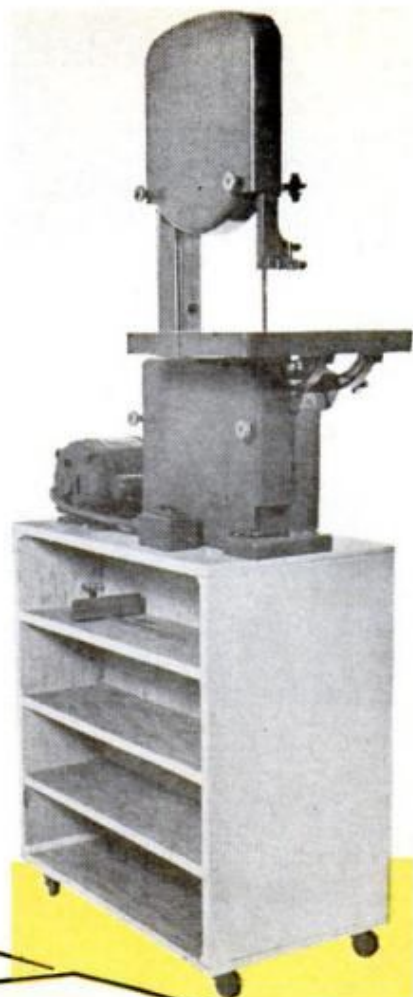
OPENINGS IN TOP of stand to accommodate belts are cut to suit the tools. A sheet-metal chute is made to carry jointer shavings out opening in back

JULY 1969

der the bandsaw. Or, let's say you don't want to bother with cabinet doors. Then you install plain shelf units in all the bases. As another variation, you can put doors on one side of the double-faced shelf design under the bandsaw to provide storage for things you want to shelter from workshop dust and dirt.

Got a lathe? A perfect stand for it would be a three-section modification of the jigsaw stand. Make it 5 ft. long (20 in. to a section) and the open shelves will be perfect for lathe tools. You can get at them, but they are protected from burial under lathe shavings. The 32-in. height is just about right.

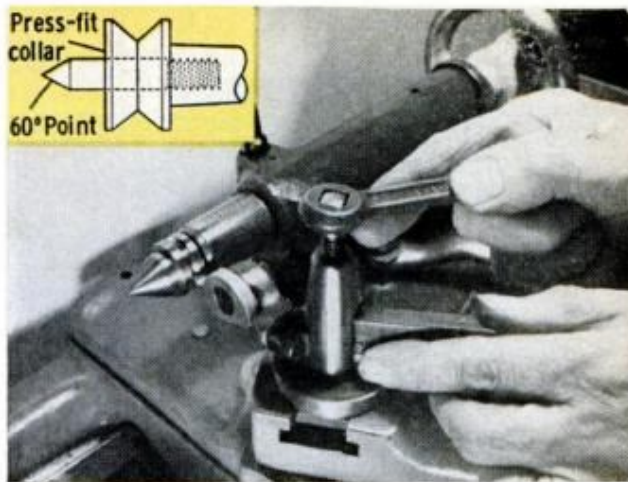
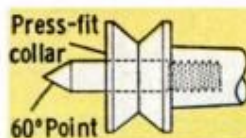
Keep in mind the way you'll station the tools when they are out of action. If a tool will stand flat against the wall, the cabinet-style base is good. If it will stand with one end against the wall, there is extra utility in the two-sided, open-design bandsaw stand. ★★★



HINTS FROM READERS

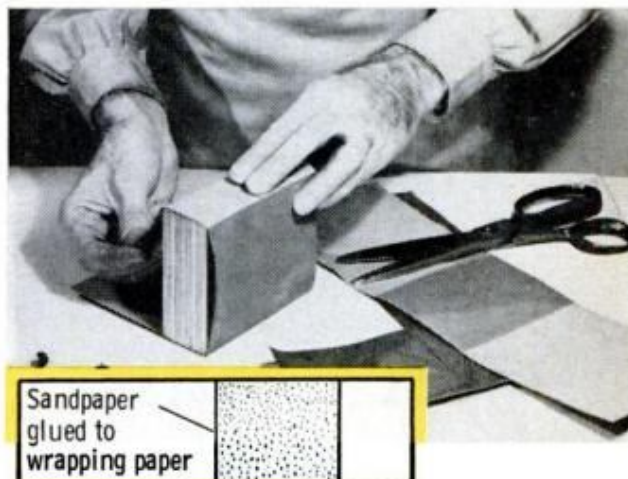
Tail-center threading gauge

To save time when setting my threading tool I replaced my regular tailstock center with a special one having a vee. Now I simply run the toolpost over to it and center the tool in the vee. I made the center from a No. 2 Morse taper shank, drilled and tapped it for a hardened 60° center, pressed on a collar and turned a vee in it with a threading tool.—*Peter Legon*



No sandpaper waste

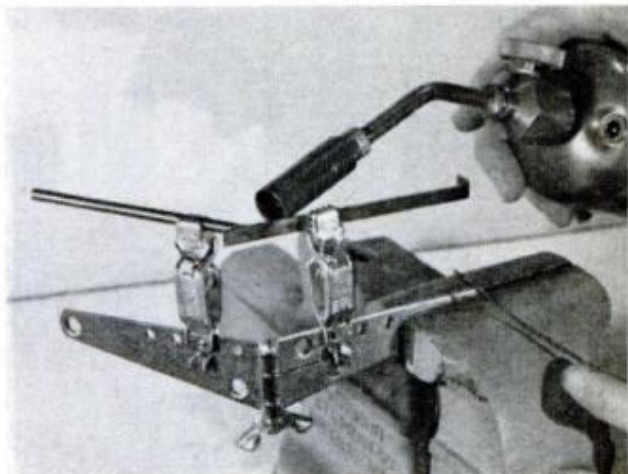
Common practice of tearing a sheet of sandpaper in strips and wrapping them around a block is actually wasteful. You just can't use every square inch of the abrasive because there's no way to grip it. I get full mileage from each 9x11-in. sheet by starting with a 1½ x 3⅝ x 4½-in. block and several 4½ x 14-in. strips of tough wrapping paper. I glue each abrasive sheet to the center of the paper strip with rubber cement and wrap the ends around the block.—*Andrew Vena*



Sandpaper glued to wrapping paper

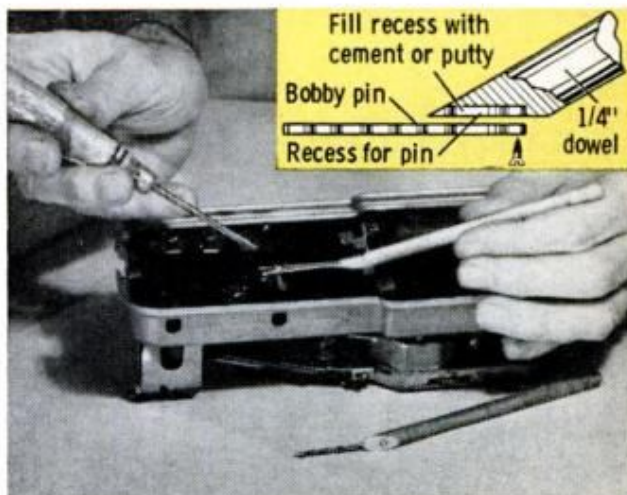
Adjustable workholder

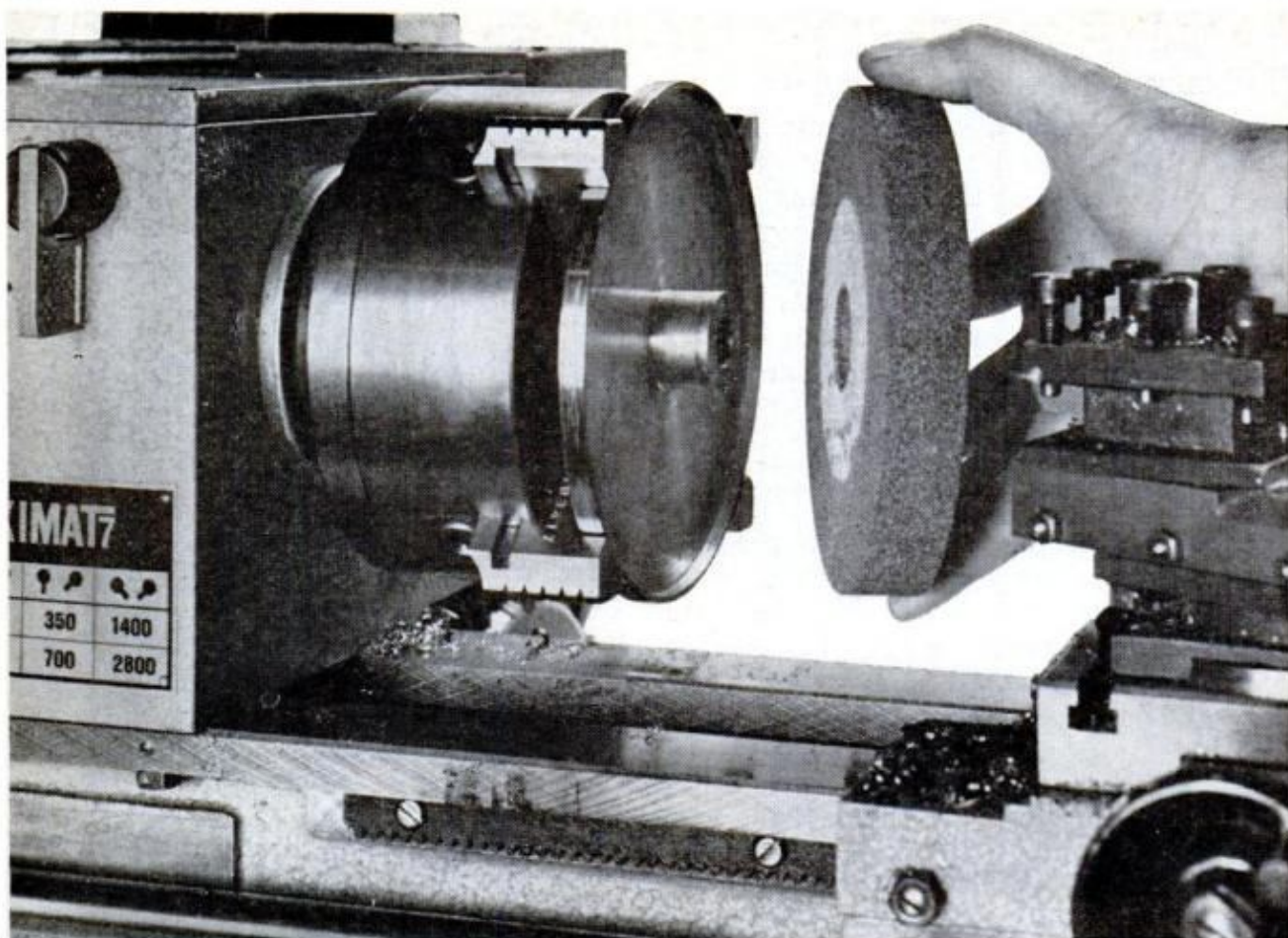
Holding work for soldering is made ridiculously simple with a jig improvised from a common strap hinge. You drive the pin from the hinge and replace it with a bolt and wingnut. Then drill a row of holes along the edge of each hinge leaf for two alligator clips attached with small stovebolts. In use, the hinge is held in a vise and the work is clamped in the clips. Then the hinge is adjusted to hold the work at the angle you want and the wingnut tightened.—*Daniel Bousha*



Bobby-pin 'fingers'

Sneak a bobby pin from your wife's dressing table and you have the makings of a handy tweezer-like tool for holding the tiniest of screws. Fitted with a dowel handle, the pin is extra handy for model-work or repairing cameras and other delicate instruments where the screws are just too small to hold with the fingers. You form a groove in the beveled end of the dowel, place the pin in it, drive a tiny screw through its loop and fill the groove with epoxy cement.—*Walter E. Burton*





VITRIFIED GRINDING WHEEL cemented to turned steel backing plate with epoxy won't shatter and fly apart

How to Mount Grinding Wheels With Epoxy

Cementing a wheel to an arbor or backing plate adapts it for special grinding jobs

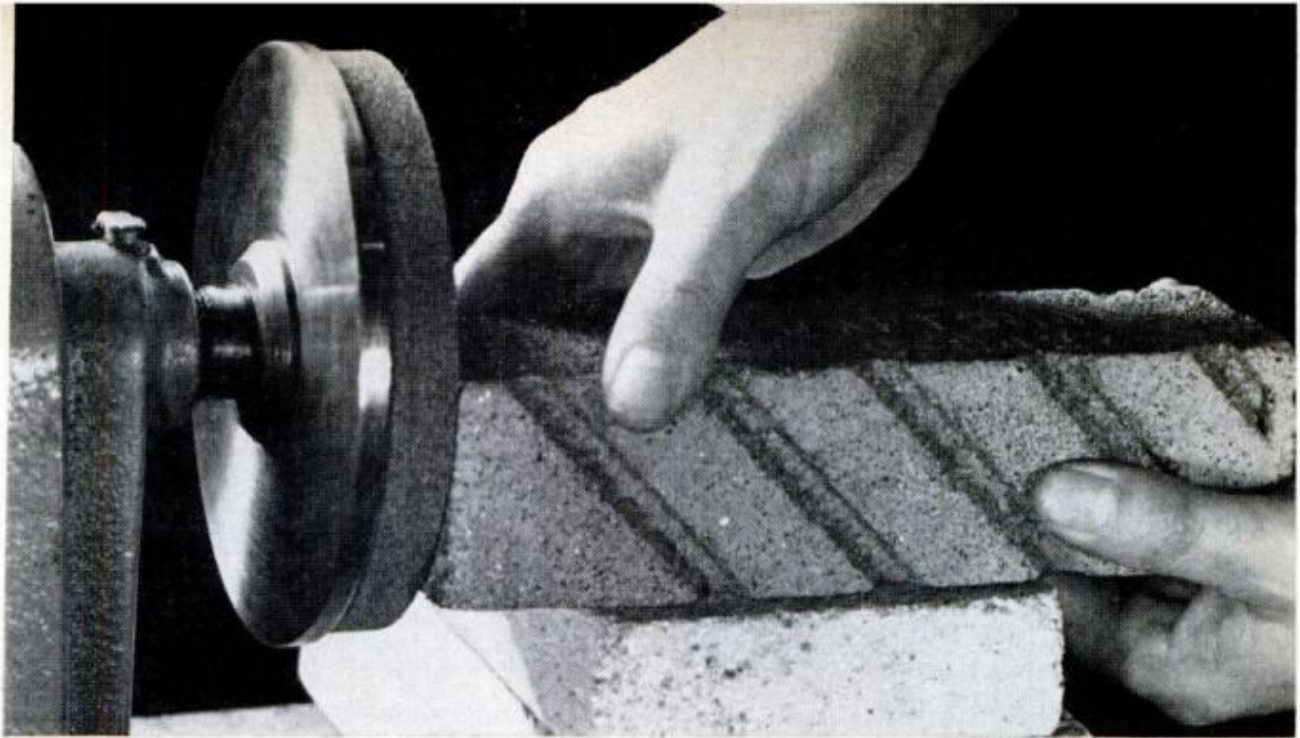
By JOHN BURROUGHS

S SMALL GRINDING POINTS made for use in hand grinders are cemented on steel shanks. Large grinding wheels used industrially for surface grinding are cemented in cast-iron driving rings. But for many home-workshop applications, you can use filled epoxy cement (available from Sears) to bond ordinary vitrified grinding wheels to special arbors, rings or plates—safely and permanently.

Using such a wheel, it's easier to regrind

twist drills and flat-beveled cutting tools offhand on the grinding wheel's flat side than on its convex face. But grinding on the side of a flange-mounted straight wheel isn't safe practice, since the side pressure may fracture the wheel.

To overcome this disadvantage, you can make a special wheel designed to withstand lateral pressure—as simply as cementing an ordinary straight wheel to a lathe-turned, steel backing plate. If you



AFTER MOUNTING, wheel's flat side is dressed true with end of silicon concrete-rubbing brick. Wear glasses

turn the backing plate with a raised rim and cement the wheel in the recess, the wheel will be self-guarded. A 60-grit aluminum-oxide wheel, medium grade, is the best choice for most offhand tool grinding. No toolrest is needed.

Similarly, if you cement a 3-in.-dia. cup wheel on a turned arbor that can be inserted in a chuck, you'll be able to use the cup in a lathe, radial saw or drill press for otherwise difficult surface-grinding jobs. Either a flared or straight cup, of medium grade, is suitable. Turn the arbor with a flange to reinforce top of the wheel.

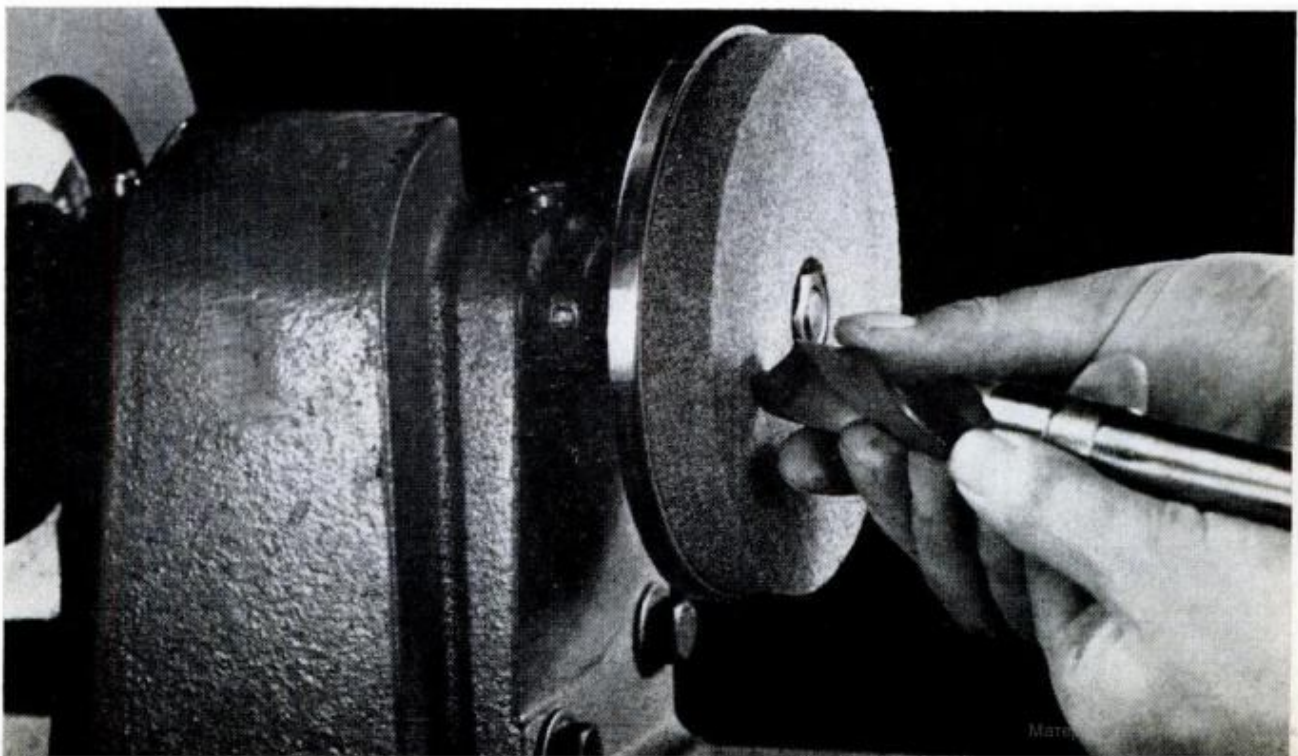
To use the mounted cup in a metal lathe, chuck it in the spindle and clamp the work

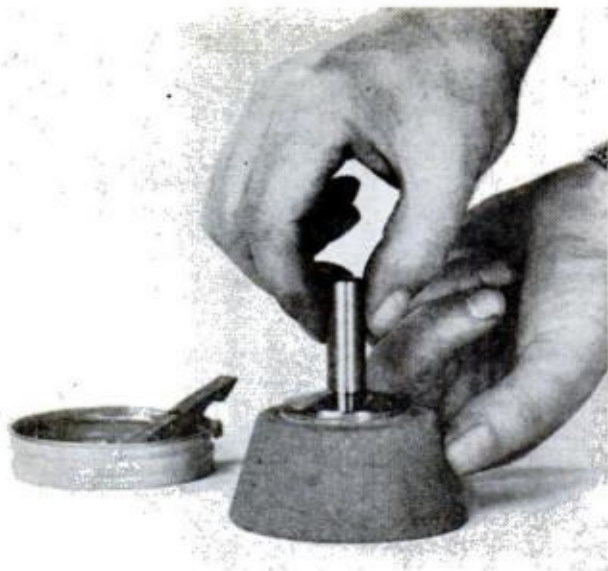
to the compound. To use it on a radial saw, chuck the cup in a Jacob's-type chuck screwed on the saw arbor and secure the work in a machine vise fixed to the saw's table. To use it in a drill press, chuck the cup in the spindle and mount the work in a vise that you can slide along a straight-edge clamped to the table.

You needn't worry that an epoxy-mounted wheel might fly off its mount. Filled epoxy (the filler is powdered metal) bonds tenaciously to clean steel and a clean vitrified wheel. An epoxy bond several square inches in area has surprising strength and shock-resistance.

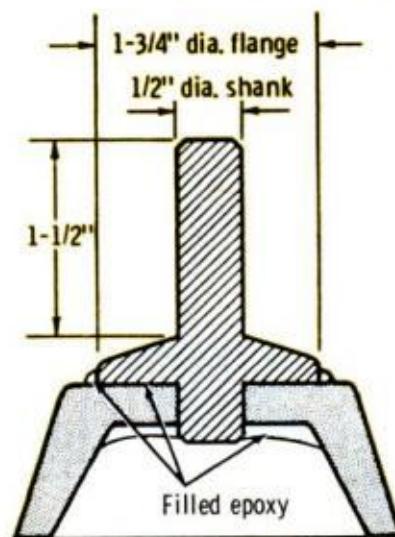
Warming the two-part cement as you

WHEEL BACKED BY STEEL PLATE makes it safe to use the face side. Paper discs and bushing are removed





CEMENTING A 3-IN. CUP WHEEL on lathe-turned arbor adapts wheel for use in drill press or collet chuck



TURNUD ARBOR FOR 3"-DIA. CUP WHEEL

mix it lowers its viscosity and insures thorough mixing without air entrapment. Let the epoxy cure for several days at room temperature before using the wheel. You can easily dress the mounted wheel perfectly true with the end of a silicon carbide rubbing brick, which is better for this particular purpose than a star-type wheel dresser.

Observe the cardinal safety precautions for using any abrasive wheel: *always wear protective glasses* and *never stand with your face in line with the wheel*—you can safely use a small cup wheel for machine-grinding without a wheel guard. Use a spindle speed roughly half the maximum speed recommended by the wheel's manufacturer.

Turning at relatively low speed, the wheel will remove metal more slowly,

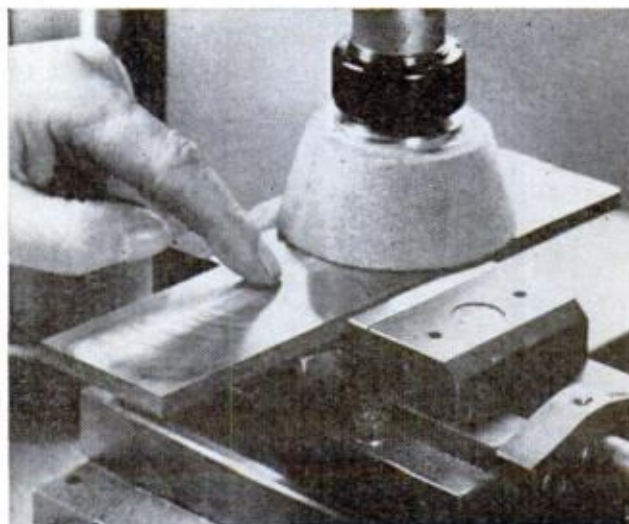
generate heat more slowly, and act "soft"; that is, it will wear slightly faster when used at slow speed than it would if used at the usual 5000 surface ft./min. A slow spindle speed, then, helps prevent work being ground from overheating and also helps prevent the wheel from loading.

When surface grinding with the cup, take successive light cuts. Rough cuts can be perhaps three thousandths deep. For finish grinding take a final very light pass—around half a thousandth deep—using very slow, even feed.

A "Dutch finish" is a toolmaker's term for the attractive pattern of lapped circular grinding marks a cup wheel leaves on the work. The precision-ground Dutch finish you can give to your metalwork projects makes it well worth having a small epoxy-mounted cup. ★★★

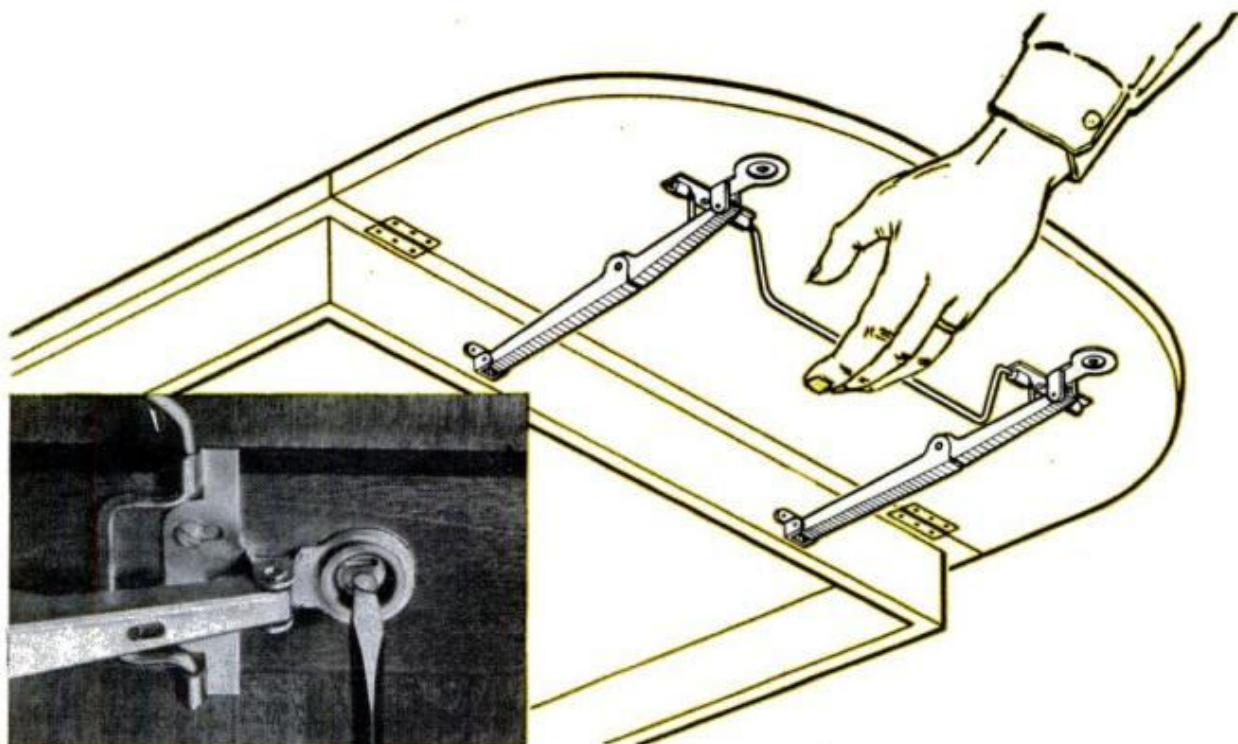


TO GRIND CUTTING EDGES with a cup wheel, use 1700-2500-rpm speed, take light cuts to avoid burning



WITH CUP CHUCKED, lathe or drill press can be used for surface grinding. Cup gives work lap-swirl finish

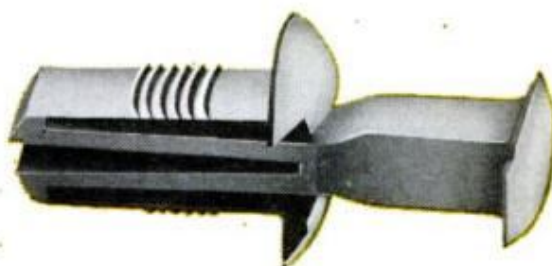
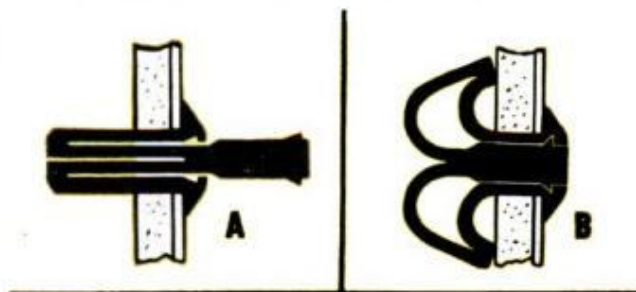
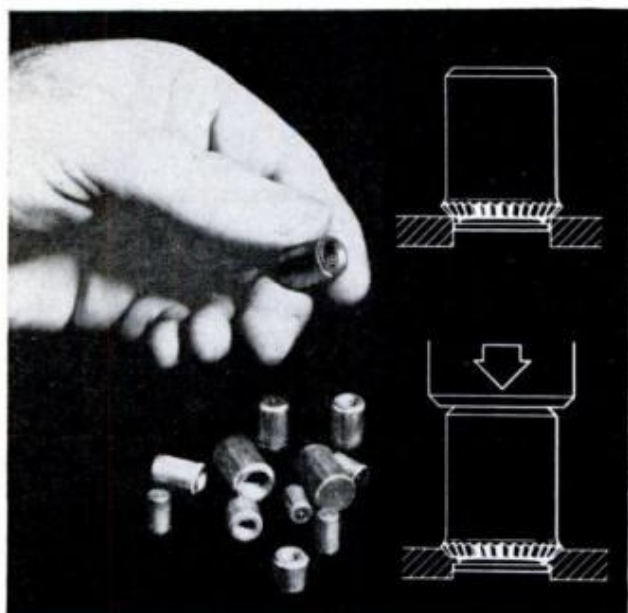
New Hardware You Should Know About



NO MORE DROOPY LEAVES with Wabash adjustable supports which permit leveling the leaf of any drop-leaf table with just a screwdriver. To level a leaf you loosen the support screws, insert a screwdriver in the slot of an eccentric disc and turn clockwise. Then tighten the screws. Comes with single and dual-release handles to end fumbling and pinched fingers, and for tables with or without aprons. Manufactured by B. Walter & Co., Inc., Wabash, Ind.

THREAD INSERTS FOR SHEET METAL attach solidly to gauges as thin as .036 in., have closed ends so threaded hole provided cannot admit dust, chips, light or moisture when screw is removed. Inserts are set by pressing into chamfered hole. Sharp knurls bite into edge of hole, forcing metal into circumferential groove. Inserts come in six thread sizes, 4/40 to 1/4-20, are made by Southco, Inc., 200 Industrial Highway, Lester, Pa.

ONE-PIECE NYLON FASTENER, called Jif-Lok, blind-fastens hooks, signs, license plates, drapery hardware and bath fixtures with light blow of hammer. Automatically anchors itself, yet is removable, reusable and can't rust. To install, drill 1/4-in. hole, insert fastener through fixture and hole and strike projecting end of fastener (A). This causes flanges on head to interlock (B). Jordan Industries, Inc., 3030 N.W. 75th St., Miami, Fla.



HINTS FROM READERS



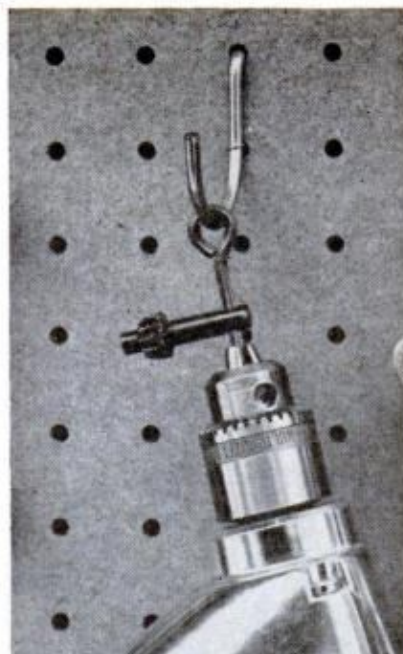
Wax-paper holder

If your wife has been hounding you to make a holder for her wax paper, aluminum foil and food wrap, start looking for a soft-drink carton. You'll find that the bottle compartments are just the right size to hold six standard cutter boxes on end. Best of all, the carton is ready-made, letting you get back to that other project she's been hounding you about. — *William Swallow*



Substitute nailset

Where it's important to avoid hammer marks when driving common nails, the hinge pin of a 3-in. butt is better than a regular nailset to set the nails flush. Its blunt end "fits" the large nailhead and is less apt to slip, and its ball end provides a good striking surface. Such pins make fine substitutes for a nailset when the ends are ground down to a 1/8-in. tapered point. — *Wilfred Beaver*



Key-chuck hook

A portable electric drill can be a problem to hang from a Peg-Board hook. Most drills just aren't designed to hang up. Sometimes you can do it by the cord. However, a most clever way is to make the chuck key double as a hook. Simply drive out the original crossbar and replace with a tight-fitting eyebolt. Just hand-tighten the chuck to clamp the key for hanging. — *Peter Legon*

NEXT MONTH IN SHOP AND CRAFTS

GREAT PROJECTS OF THE PAST. Of the many projects published in *Popular Mechanics* down through the years there have been those which were exceptionally popular with readers. One such project was a family game table published in October 1958. In this first of several "all-time greats," we are repeating the plans for this popular workshop project in our August issue. Others will follow from time to time.

BUILD THIS MODEL BEAM ENGINE. Our many readers who found great delight in modeling the 24-pounder in our February issue will experience even greater enjoyment in building this actual working model of a walking-beam engine. Requires no castings. If you like to build models, don't miss this beauty next month.

UPSIDE-DOWN TURNING. By inverting the tool bit and mounting it behind the workpiece instead of in front, you'll be able to speed and improve many operations on your metalworking lathe with this "backward" technique. It requires no modification of the lathe, and the added attachments can be removed in a jiffy. Learn more about this unorthodox procedure in the August issue.

FOLDAWAY HOBBY CENTER. Here's a hobbyist's dream, a work center that has everything to provide the ultimate in a place to work. Swinging panels, roomy drawers and countless shelves provide storage galore, and it all folds into a compact unit when you walk away. Whatever your hobbies, this work center is for you. Complete plans are in the August *PM*.

SEE OUR MEN ON THE MOON

(Continued from page 93)

brought a cheer from the people back at Mission Control.

In the vacuum of space, radio waves and other forms of electromagnetic energy flash straight across the voids. There are no hills to deflect them or metallic rocks to absorb them, as on Earth. The signals that left Apollo 8 as 20 watts arrived at Earth only slightly diminished.

There, the third key element came into play—85-foot, S-band receiving antennas spaced 120° apart around the globe so that at least one of them has the moon in "view" at all times. The big dishes are located at Goldstone, Calif.; Canberra, Australia, and Madrid.

Apollo 8's TV signal required processing. Here on Earth, the TV spot flashes across our screens at a rate of 30 frames per second, 60 fields per second, covering 525 lines each time. This makes for flicker-free, sharp viewing. But such an operating mode requires heavy, high-powered equipment.

The camera system RCA designed for Apollo 8 produces only 10 frames per second, made up of only 320 lines—not quite

The camera will function both in bright sunlight and nearly total darkness

as clear, nor quite as sharp as commercial TV, and prone to jerkiness when either astronauts or camera move too rapidly. It was, however, eminently viewable.

The Apollo TV system and commercial systems are not electronically compatible. That is, one can't simply be plugged into the other without fouling up the picture.

RCA solved this problem with "scan conversion" equipment—the fourth key technological accomplishment. A commercial vidicon camera was set up in front of a slow-scan monitor, its output linked to a magnetic disc recorder (the same kind used for "stop motion" football plays). The disc recorder did the trick by repeating the 10-frames-per-second Apollo pictures enough times to make up the 60 fields needed for commercial TV. For each second of broadcast there were only 10 actual changes of image; the others were repeats.

Scan conversion equipment was installed at Goldstone and Madrid. Goldstone sent the converted signal through regular coaxial cable channels to Mission Control in Houston. From there the

broadcasts were distributed through conventional channels across the United States.

In Spain, a similar operation was carried out. Converted images were sent by coaxial cable to London for distribution to all of Europe and Asia.

But Apollo 8 was really just a beginning. Apollo 9 roared into Earth orbit with even more sophisticated television equipment aboard. The camera on Apollo 9, slated for later use during the actual moon landings, is designed to function both in bright sunlight and in the nearly total darkness of the lunar night.

Key to this capability is a secondary electron conduction (SEC) tube invented by scientists at the Westinghouse Research Laboratories in Pittsburgh and installed in the 7.25-pound camera.

SEC tubes convert light into electrical signals which then are amplified hundreds of times before being converted back into visible images. In scientific terms, the Westinghouse camera has a light range of from 0.007 to 12,600 foot-lamberts. On the moon, that means from bright sunshine to dim earthshine.

While the camera's main use will be to let us watch from Earth as astronauts walk about the moon's surface, it can also be used for scientific purposes. A fine-detail, slow-scan rate of $\frac{5}{8}$ frames per second will transmit moon views to Earth with a resolution of 1280 lines. That approaches the quality associated with standard photographic camera systems.

The Apollo missions have dramatically demonstrated that the days of solitude in space are over. Thanks to TV, we're all space travelers now. ★ ★ ★

Tactile vision for the blind

Blind persons can "see" with their skin using a vision substitution system recently developed in San Francisco.

In utilizing the system—called Tactile Vision Substitution System—a blind person scans objects with a television camera. The image received by the camera is broken down into electrical impulses, then transmitted to stimulators. The stimulators recreate the picture on the observer's back by means of plastic-tipped vibrators. Thus, the user is "seeing" with his skin.

Developers of the system are Drs. Paul Bach-y-Rita, Carter C. Collins and their associates at the Smith-Kettlewell Institute of Visual Sciences, Pacific Medical Center.

The bulky, 50-pound prototype can be developed into a portable system weighing about five pounds and costing less than \$1000, the developers believe.

40 WAYS TO TEST A CAMPER

(Continued from page 79)

has a perfect right to set up his demo runs with a minimum of friction. He might even argue, with some truth, that a properly equipped car and experienced driver is the best way to demonstrate trailer-towing. The point here is that you won't be sure how the trailer will react with your car, on roads you select, under conditions very different from those the salesman selects for you. Insist on choosing the route yourself. Insist on driving the demo car for part of the towing test. Better still, tow the trailer with your car. If the dealer's insurance provisions will not allow the use of another car, then you've got to base your judgment on the test with the company car. Make sure you inspect the car. Know what extra towing equipment it has.

When the trailer is attached and equalizer-hitch spring bars are cinched up properly, the car and trailer should be level. Frames will be on a different plane separated by several inches, but both frames must be level when parked on level ground. If the rear end of the car sags, cinch up on spring bars until it

**Never let anyone tell you
that the trailer should
be towed tongue-high . . .**

comes up to level. If the sag cannot be corrected mechanically, the trailer is too heavy for your car.

If the trailer sags in the rear and tilts in front, the hitch spring bars are adjusted too high. Drop down one or two links. Never let anyone tell you that the trailer should be towed tongue-high, sometimes referred to as a "rake."

Any trailer weighing over 1500 pounds should be equipped with its own separate brake system, controlled from the car's foot-pedal brakes. Ask about the type of brake controller. Automobile manufacturers now say they prefer there be no tap-in of hydraulic lines on the towing vehicle. You can get around this by using an all-electric trailer-brake controller. (Chrysler Corp. recently stated that direct connection of hydraulic brakes on the car to the trailer is "not acceptable." Other auto companies have stated similar views, but in language less specific.)

Regardless of trailer weight, when you're on the highway the trailer should track smoothly through corners. It should change lanes without wobbling. In gen-

eral, the trailer should act like part of the car. A trailer that "surges" forward-and-back is out of balance. A trailer that slams down violently over dips in the road, then rocks in a rough pitch-and-yaw motion, is a poor handler.

When testing a truck-mounted camper, remember that the way a coach handles on a pickup depends on the platform underneath it. An old truck with worn springs and flabby tires will not give the coach a fair test-ride! But if the truck is less than two years old, you can safely consider it a good carrier for the check-out. It isn't likely that a coach dealer will load a new camper on your truck for a demo run. Most often, he uses his own company truck. The truck will be equipped with heavy-duty suspension and husky wide tires. It will have a long wheelbase. (These three options are the most important for pickup campers.)

After loading, give the truck a quick visual check. It shouldn't tip more than an inch in the rear. The springs will depress slightly, but on a horizontal plane. I'd go along with a two or three-inch drop vertically, so long as that rear end doesn't sag. Now stand on one end of the truck's rear bumper. Bounce up and down. When you step off, the bounce should stop almost instantly.

Make sure that the loaded weight of a coach does not exceed the payload capacity of your particular pickup. For example, let's say you have a 1967 Ford pickup with 7500 pounds gross vehicle weight. The truck will weigh about 4000 pounds empty. That leaves 3500 pounds for "payload." This means that you can safely haul loads up to 3500 pounds, but I like a safety factor of 500 to 800 pounds. In other words, total coach weight—loaded—could be 2500 to 3000 pounds, sufficient for almost any slide-in coach now in production.

On the highway, deliberately make jackrabbit starts and a few slow-speed panic stops. At low speeds, whip the steering wheel just a little to test lateral roll. If the coach wobbles constantly, tilts under the pressure of even a light breeze—watch out. A well balanced coach will have most of its weight concentrated below the belt-line—below the top of the trucks' cargo-box sides. Water tank (at about 200 pounds or more), storage batteries and other heavy items should be below that line. Appliances like rangetop stoves and iceboxes really don't weigh much, though I like to see them installed as low as is practical inside the coach.

If there is a stretch of windy road somewhere close by, head for it. I can't think of a test more inclined to tattle on a poorly balanced camper coach. Hard winds

will push the coach over into a slight tilt, which is normal. But when the gust stops, a good coach will right itself instantly without wobbling.

Changing lanes rapidly will unearth the same trouble in an unbalanced rig. Remember, pickup-truck engines are available at 200 to 310 hp, which is enough latitude, even for demanding buyers. Actually drive the truck yourself for 30 minutes or so.

The critical factor in a truck-mounted coach is stability. If it handles smoothly, without excessive wobbling or sagging or bouncing, it's a good prospect.

To test a motor home or van, pick a stretch of very rough road. The larger the unit, the more important the suspension system. The ride should be firm but comfortable. Pick a hill and try a few steep ascents and descents. The brakes should hold without fading. The engine should have adequate climbing power.

Observe the gauges. The engine temperature may climb a bit, but it should not operate in the red zone. If the engine is a large one, yet the vehicle seems to be straining to climb hills, perhaps the axle ratio is incorrect for that particular tire and engine situation. Tracking and steering should not require unusual physical effort. The seating in the cockpit of a motor home should allow good vision all around, and it should not be a cramped, tiring position.

Servicing of vans and motor homes should be easy, including checking oil, adding water to the radiator and making minor adjustments to the engine.

Checking out a fold-up camping trailer should begin with the lifting mechanism. Some are raised manually. Others require a cranking or ratcheting action. Some new models are raised by tiny electric servo motors at the touch of a button. Look for the following: Lifting action should be uniformly smooth. All four corners should lift together, with no lagging or dragging effect. If the crank requires unusual physical effort, that's bad. Some trailers have a dual-choice lift: One side raises the top faster, but requires extra effort; the other side lifts slowly, but more easily. The time required to raise the top of a trailer should be only one-fourth the get-ready time. Rate the trailer's *simplicity* with high marks.

One well-known trailer requires 27 minutes to raise, snap down fabric, install door and fold out the bedroom wings. That's too much. Total get-ready time should be about 10 minutes.

Testing the recreation vehicle you want before you buy can assure top quality for the money you want to spend. ★★★

HEAVY DUTY WELDER 18⁹⁵ POST PAID
WELD • BRAZE • SOLDER • CUT

10-DAY FREE TRIAL • LIFETIME GUARANTEE
110 Volt • Not One—But 3 welding heats

Weld, braze, solder or cut any metal — even aluminum. No experience necessary. Follow simple instructions to make repairs on cars, trailers, farm and lawn equipment, bicycles, appliances, etc. Make campers, boats, furniture, hundreds of valuable items. **NOTHING ELSE TO BUY!** Comes complete with full face shield, \$2.00 pack of welding and brazing rods, heavy duty power cables, special electric torch attachment, ground clamp, flux, easy-to-follow illustrated instructions, rod holder, etc. Uses standard 1/8" rods and 1/4" carbons to weld iron, steel, brass, bronze, aluminum, other metals. New improved **HEAVY DUTY** circuit gives more welding power. Gives 4 times the heat needed to melt toughest iron. Plugs into ordinary 110V outlet. **3 WELDING HEATS** . . . Not just one as with other low cost models. Use "high" for tough jobs, "medium" or "regular" for lighter work. This important feature saves you money and time. Makes it possible for even beginners to start welding professionally the very first day. Pays for itself quickly. **10 day MONEY BACK GUARANTEE.** You must be satisfied or return for refund. **FREE** automatic arc striker. Weld with push-button ease. **SEND ONLY \$2.00.** Pay postman \$16.95 plus postage when delivered, or send \$18.95 cash, c.k., M.O., for fast post-paid shipment. **WEL-DEX MFG. CO.**
Dept. W-106 , Box 10776, Houston, Texas 77018

NOW — FLY A BENSEN OF YOUR OWN!



THE GYROCOPTER
EASY TO BUILD
SIMPLEST, SAFEST TO FLY
 Acclaimed by novices and pros around the world. Lowest cost flying. Kits available, also building plans and flying instructions. Get 3-View Drawings, photo, specs, Rotorcraft Dictionary for \$3, or of Gyroglider \$2. Send today!

BENSEN AIRCRAFT CORP., Dept. PM-79
 Raleigh-Durham Airport, Raleigh, N. C. 27602
 NAME _____
 ADDRESS _____

LEARN

ELECTRONICS

MAIL COUPON FOR FREE BOOK

Coyne Electronics Institute Dept. B9-C3
 1501 W. Congress Pkwy., Chicago, Ill. 60607

Send Information as checked below

- HOME TRAINING in TV, Radio and Color TV Servicing.
 RESIDENT SCHOOL COURSES in Electronics, Electricity, Engineering Technology, Television, Refrigeration, and Air Conditioning.

Name.....Age.....

Address.....

City.....State.....Zip.....

APPROVED FOR VETERANS

Accredited Member: National Association Trade and Technical Schools.



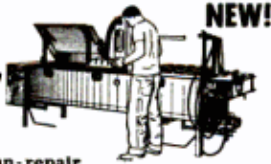
Career in ELECTRONICS?

Career training at home the new easy way with RCA Institutes. Lab work with first lesson. Easy payment plans. Send for free 64-page book.

RCA Institutes, Inc. Dept. PM-79
320 W. 31 St., N.Y., N.Y. 10001

RCA

"\$7,108.50 First Year
SERVICING RADIATORS!"



— Hank Konter, Newcastle, Wyo.
Make good money servicing auto-truck-tractor radiators with new Inland 1-Piece Radiator Shop. Easy to test-clean-repair radiators. Inland, world's largest radiator equip. mfr., trains you free. Small down payment starts you. Easy-pay plan lets you pay from profits. Proved merchandising assures volume. Profitable dept. for garage or service station. **WRITE for Free Book.**
INLAND MFG. CO., Dept. PM71108 Jackson St., Omaha 2, Nebr.

REAL ESTATE

BE A BROKER

FREE BOOK TELLS HOW

PAYS BIG! SEND FOR BIG FREE CATALOG NOW! Graduates report making substantial incomes. Operate your own business quickly. Men, Women, all ages, learn easily. Course covers Sales, Appraising, Loans, Mortgages, & related subjects. **STUDY AT HOME** or in classrooms in leading cities. **Diploma Awarded. Write Today for FREE Book!** Accredited Member National Home Study Council. (Est. 1936) G. I. Approved.
WEAVER SCHOOL OF REAL ESTATE
3521-P Broadway Kansas City, Mo. 64111

BASEMENT TOILET FLUSHES UP



TO OVERHEAD SEWER OR SEPTIC TANK. NO DIGGING UP FLOORS. INSTALLS EASY. Write

McPHERSON, INC., BOX 15133, TAMPA, FLORIDA 33614

HYDRAULIC JACK REPAIRS



Earn While You Learn at Home

Earn while you learn at home. Millions of jacks in gas and auto service stations, trucking firms, body shops, riggers, factories and farms need servicing... most of which you can learn to repair. We show you HOW. Start spare time in your basement or garage. Big opportunity for mechanics. **ACT NOW!** Write for folder No. PM-7 and free bonus offer.

HYDRAULIC JACK REPAIR MANUAL CO., INC.

G. P. O. BOX 3 • STATEN ISLAND, N. Y. 10314

110-120 VOLT A.C. LIGHT PLANTS—60 CYCLES

Fanbelt driven from pickup or small gas engine. Operates saws, drills, pumps, freezers, T.V. X1000 Watts—Needs No Battery. Now \$62.50. 1500 Watts—6 and 12 volt vehicles. Now \$52.50. 3000 Watts—12 volt vehicles only. Now \$99.50. **Guaranteed. Check or Money Order.**

VIRDEN PERMA-BILT, Box 7066 P.M., Amarillo, Texas 79109

PROFIT IN YOUR SPARE TIME

SMALL ENGINE REPAIR PAYS BIG!

Outboard • Powermower • Chain Saw • Tractor
MAKE EXTRA MONEY — or fix your own engines and **SAVE!** Illustrated, easy-to-learn Home Study Course qualifies you as expert. Approved for Veterans. Write today!

LINCOLN TECHNICAL INSTITUTE
SUITE 7-E, 427 MARKET ST., NEWARK, N.J. 07105

START YOUR OWN MONEY MAKING BUSINESS

Clean rugs on customers' floors — upholstery in their homes — even painted walls — with highly efficient electric machines which are making big money for others and giving them independence. Write today for complete information. It's **FREE!**

VON SCHRADER MFG. CO., Dept. D710 "R" Pl., Racine, Wis. 53403

OUTBOARD IGNITION CHECK

(Continued from page 141)

voltage is being applied to the condenser by the analyzer. Don't handle test leads. Before disconnecting the leads from the condenser, be sure the turn selector switch of the analyzer is off.

In newer outboard engines, a coil that's removed from the magneto and then reinstalled can go on in only one way—the right way. This is not true of all magnetos, however. In some, a correct airspace has to be left between a coil and its core.

To be on the safe side, if you have to remove a coil, first measure exactly the distance between the face of the coil and the edge of the coil seat. When putting the coil back in place, set it to this specification. Do not tamper with the core...

When connected to the magneto condenser, the coil is tested under actual operating conditions. The analyzer provides an interrupted primary current and measures the induced secondary voltage. If the coil's okay, the meter will show it.

Test leads from the magneto analyzer are connected to ground, to the coil primary and to the secondary (Photo 8). Adjust the meter as specified in the instruction book. Note the meter reading.

A low reading means that the coil is weak and must be replaced. You can get a higher reading by increasing primary current, but this is false. The coil is shot if it won't come up to spec with the primary current that's specified in the instruction book.

Now, check the coil for leakage by running a test probe over the housing. Replace any coil that's leaking.

To test a sparkplug high-tension lead with its respective coil, disconnect the meter lead that runs to the secondary. Leave the other leads in place and probe the entire surface of the sparkplug lead (Photo 9). If insulation has broken down, you'll get flashover. Replace the lead.

Magnets are located in the flywheel (Photo 10). They could be damaged by a hammer blow or a dropped flywheel, so be careful. Before replacing the flywheel, use mineral spirits to clean magnets of foreign matter that could hamper their function.

The importance of periodic inspection of sparkplugs, followed by cleaning or replacement, cannot be overemphasized in your preventive maintenance of an outboard ignition system. Dirty or worn plugs are the major cause of ignition failure.

When installing new plugs, be sure gaskets are replaced. Start the plug into the cylinder with your fingers to avoid cross-threading. Run them up finger-tight and torque to 20 ft.-lbs. ★ ★ ★

FIT YOUR SWIMMING MASK

(Continued from page 172)

high) and run a $\frac{1}{16}$ -in. groove in the plastic $\frac{1}{8}$ in. from the top. Then slice the strip into eight pieces $\frac{1}{4}$ in. wide.

Divide the circles previously traced around the lenses into four equal divisions. Make holes in the insert's protective paper large enough to mark the plastic with a grease pencil at the division points and then remove the protective paper.

Cement three of the stilts for one of the lens to the plastic insert on top of the pencil marks. Make sure before cementing the stilts that the notches are facing exactly where the lens is going to be. Don't allow any of the cement to get on the surface of the insert except where you need it because it will cloud the surface so that you can't see through it.

Let the cement dry for five minutes, then insert one lens, being sure that the lens is the correct one for the particular eye. If there is an astigmatism involved, make sure the lens is properly oriented with the notched edge at the top. Line up the fourth stilt and cement it. Hold the lens firmly in place for five minutes, or until the cement is dry. Repeat the procedure for the second lens.

Place the faceplate insert on the inside of the glass faceplate and reassemble the swimming mask. Now you should be able to see where you are going underwater—even though you do faintly resemble a bug-eyed monster.—Allen Browning

THOSE WILD NEW BIKES

(Continued from page 155)

(but not all discount houses) stock both types, but take the old tire along if in doubt when you buy a replacement, as neither type fits the other's rim. A hook bead's inner diameter is a shade too small for a Schwinn wheel, and a Schwinn tire is just a bit too loose to seat where a hook bead should be. You can tell them apart by their labels. Flat-sided tires are usually width-marked in fractions, as $26 \times 1\frac{3}{8}$ (lightweight) or $26 \times 1\frac{3}{4}$ (middle-weight), while hook-bead types of the same sizes are generally marked in decimals, as 26×1.375 and 26×1.75 .

Converting an old bike to a high-riser takes but a few minutes. Kits include banana-style seat, high-rise handlebars, reflector and all fittings. Some come with a sissy bar. Mainly for looks, the bars provide some protection from back flips when doing the "wheelie."

A derailleur can be added to any bike

(Please turn to page 194)



The KODAK INSTAMATIC 814 Camera lets you shoot sharper, clearer pictures your very first time out. For three reasons. One, it has the superb new super-sharp 4-element $f/2.8$ KODAK EKTAR Lens. Two, it has a coupled rangefinder. And three, it does practically everything for you automatically.



Just drop in the film. Automatically, the "814" adjusts for the film speed. Automatically adjusts for the light, too... tells you if the batteries are okay... warns when to use flash. And for easy shooting, both film and flashcube advance automatically.

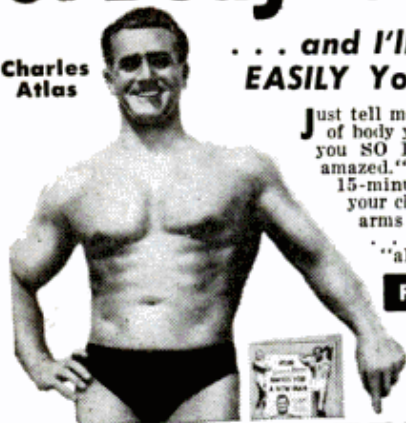
See this sharper shooter, less than \$145, at your Kodak dealer's.

Price subject to change without notice.

Kodak Instamatic®814
Camera.

Check the Kind of Body You Want

Charles Atlas



... and I'll Show You How EASILY You Can Have It!

Just tell me, in coupon below, the kind of body you want—and I'll give it to you SO FAST your friends will be amazed. "Dynamic-Tension," my easy, 15-minute-a-day method, will make your chest and shoulders bulge... arms and legs surge with power... you: whole body feel "alive!"

FREE BOOK

Learn how I became "World's Most Perfectly Developed Man"—Mail coupon! CHARLES ATLAS, Dept. 87, 115 East 23rd Street, New York City, N. Y. 10010

CHARLES ATLAS, Dept. 87
115 East 23rd St., New York, N. Y. 10010

Dear Charles Atlas: Here's the Kind of Body I want:
(Check as many as you like)

- | | |
|---|--|
| <input type="checkbox"/> Broader Chest, Shoulders | <input type="checkbox"/> Powerful Arms, Legs, Grip |
| <input type="checkbox"/> More weight—Solid— | <input type="checkbox"/> Slimmer Waist, Hips |
| in the Right Places | <input type="checkbox"/> Better Sleep, More Energy |

Send me absolutely FREE a copy of your famous book showing how "Dynamic-Tension" can make me a new man—32 pages, crammed with photographs, answers to vital questions, and valuable advice. No obligation.

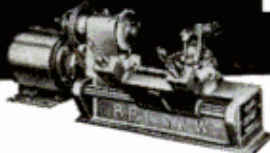
PRINT NAME..... AGE.....

ADDRESS.....

CITY..... STATE..... ZIP CODE.....

In England send to: Charles Atlas, Chitty St., London, W. 1

Learn To Be A LOCKSMITH



PROFESSIONAL KEY MACHINE YOURS TO KEEP!

Big demand for skilled Locksmiths! Earn big money spare time in your own home. Be your own boss: earn steady, year 'round income with no layoffs. BELSAW INSTITUTE training, approved by master locksmiths, teaches you to make keys, open and repair locks on homes, cars and buildings. Easy, illustrated lessons complete with ALL tools and supplies, including the \$125 Key Machine which is yours to keep. Shows you how to get jobs, how to charge, how to earn while you learn and how to build a lifetime, cash-profit business.

Read These Reports from Belsaw Graduates:

Oscar Larson, Long Beach, Calif.: "I have all the locksmith work I can handle in spare time. I give hearty thanks for your wonderful training."

Herbert Bernard, Point Pleasant, N. J.: "I recommend your course highly. Locksmithing gives me real enjoyment and extra money."

J. Marko, Ferndale, Mich.: "With me locksmithing is full time. I sincerely thank you for giving me this chance to better myself."

J. W. Cookman, Lakeland, Fla.: "I've been in full time locksmithing for three months. Thanks for your fine cooperation."

Accredited Member National Home Study Council. Approved for Veterans. Mail coupon today... no salesman will call.

BELSAW INSTITUTE
100K Field Bldg., Kansas City, Mo. 64111

Send FREE book, "Keys To Your Future!"

Name.....

Address.....

City..... State..... Zip.....



THOSE WILD NEW BIKES

(Continued from page 193)

that has a wide frame spacing at the rear wheel, otherwise an internal shift must be used. To change over to an internal-shift hub, the wheel has to be respoked, or "relaced" as the pros call it. To do this you first remove the old spokes with a nipple wrench and then relace with new spokes. A nipple is the name of the "nut" which anchors the threaded end of the spoke to the rim.

Start lacing by slipping one spoke through any hole in the hub's flange and placing the spoke's head on the inside. Then insert the threaded end in any hole in the rim and tighten the nipple. Insert the second spoke next to the first one in the flange but with its head on the outside, and insert its threaded end in the rim, 15 holes from the first, and tighten. The third spoke is inserted in the next hole in the flange and then in the rim, five holes from the first spoke. The fourth spoke is inserted the same way as the second, 15 holes from the third. Follow this procedure around the rim. Spokes are kept in rim holes which are on the same side as those in the hub's flange.

When one side of the hub is laced, you turn the wheel over and lace the other. Since the holes in one flange are not directly opposite those in the other, you start the first spoke in a hole which is just aft of its mating one in the opposite flange. You can determine the right hole by passing a straight wire from one side to the other. From here on you follow the same lacing pattern as before.

Finally, you true up the wheel by resting it in the front fork and finger-tightening the nipples one by one and little by little until the wobble is eliminated. This may require loosening one and tightening another. When the wheel runs true, tighten all the spokes the same amount with a special wrench. They should "ping" when tightened properly.

When you want to raise or lower handlebars, you must remove the stem from the fork tube. To do this you back out the stem clamp bolt for about 1/4 in. and give the bolt head a sharp tap with a hammer. This frees the stem locking wedge at the lower end. The stem is raised or lowered by twisting the handle bars from side to side as you lift up or bear down.

To change from old to new handlebars you must pass them through the handlebar clamp. To do this, remove one handle grip and loosen the clamp bolt. If it won't slip through, tap the handlebar sharply with a wood block and hammer. ★★★

FREE—Popular Mechanics Catalog of Publications and Projects



This FREE Booklet From Popular Mechanics Can Save You Hundreds of Dollars, And Bring You A Lifetime of Enjoyment!

Now You Can Have Your Own Sail Boat, Motor Boat, Swimming Pool, Built-in-Furniture—Almost Anything For The Home Or Week-end Fun—At A Fraction Of The Usual Cost.

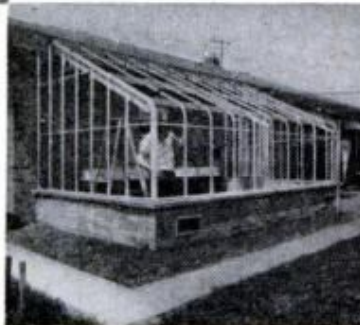


Just imagine a fun-filled week-end like this! You can relax and enjoy playing the host, entertaining your friends on the patio or recreation room, have a cook-out, then a swim in the pool.

Or, perhaps you've been putting off that week-end project—building shelves and furniture . . . paneling a room . . . fixing a leaking faucet . . . or odd jobs that require repairing and painting.

Let the experts show you how you can have all these things and more. We'll

show you how easy it is! All you need are these step-by-step instructions from the experts — the editors of POPULAR MECHANICS.



Easy-to-follow plans are available for many wonderful additions and improvements for your home, from a simple bookcase to a complete house —projects you can do yourself in your own shop in your spare time. And think of the money you'll save —up to hundreds of dollars—by doing them yourself.

In addition, you save on expensive contractors

and long-term loans. Hundreds of practical, money-saving ideas—you'll find a goldmine of hard-to-locate information—literally hundreds of practical ideas, booklets and plans to enrich and beautify your home on such subjects as:

Boats and boating equipment/bookcases, shelves, cabinets, tables/clocks—early American, grand-fathers/camping trailers and equipment/working with glass/electric wiring/furniture; woodworking projects/hydroplane/models: ships, airplanes, sports cars, steam engine, etc./gardening equipment, planters, lawn and tree care/houses—complete architectural plans/painting, interior and exterior; wallpapering/TV, hi-fi and stereo equipment; cabinets/plastic molding/playhouses/how to do your own plumbing/repairing your roof/car repairs and tune up/swimming pools; filters/workshop projects/famous Popular Mechanics wall charts.

This is only a sampling of a multitude of moneysaving ideas and information that can bring you many hours of pleasure—something all the family can enjoy for many years to come.

Order Your Free Price-List Catalog Today

Just fill out and mail the coupon for your copy of the POPULAR MECHANICS CATALOG OF PUBLICATIONS AND PROJECTS. Please enclose a self-addressed stamped envelope, or 10¢ in coin to cover postage and handling. Your 16-page catalog will be sent by return mail listing hundreds of plans, books, projects and wall charts for your enjoyment and better living.

Popular Mechanics, Dept. BI-CA 575 Lexington Avenue • New York, N.Y. 10022

I am enclosing a self-addressed envelope (or 10¢ in coin). Please send me a copy of the Popular Mechanics CATALOG OF PUBLICATIONS AND PROJECTS. (If outside USA, please enclose 25¢ USA currency.)

Name _____ (please print)

Address _____ (please print)

City _____ State _____ Zip code _____

EMC/A

FIRST DAY ON THE MOON

(Continued from page 87)

give physicists precious data on the composition of the solar wind that breezes through space.

Now, Armstrong makes a reconnaissance of the LM, circling the craft and taking pictures of the landing site and surrounding terrain. He ends this walking tour on the side opposite the MESA.

55 Minutes. If Goldstone and the other big antennas in NASA's network are out of optimum range, Armstrong pulls out a six-foot dish antenna folded inside a hatch of the LM's body. He unfolds it and points it toward Earth. Inside the LM, Buzz Aldrin thumbs a switch that transfers TV transmission to the highly efficient parabolic antenna just erected. One and a half seconds later, the time needed for the signal to reach Earth, home TV screens should light up with the scene of Armstrong lumbering toward the LM.

1 Hour 30 Minutes. At the MESA, Aldrin lifts what looks like a large toolbox onto a waist-high, two-foot-square table that unfolded as the MESA slid out. From the aluminum box he unloads a hammer, scoop, tongs and an extension handle that

... solar-cell seismometer picks up any rumbles inside the moon and radios the information to Earth.

fits all the tools. The astronauts can't bend over. At most, and only in an emergency, will they kneel. So, Aldrin attaches the extension handle to the scoop, and shovels moon "gravel" into the box. When it's filled, he closes the lid and pulls the levers on metal straps around the box. Teflon seals preserve the moon vacuum inside.

1 Hour 40 Minutes. About the time Aldrin is sealing the rock box, NASA makes a crucial decision. The backpacks are designed to hold a four-hour oxygen supply. But, depending on how much oxygen the pair actually has consumed—a measure of the efforts needed to work in low gravity—and how tired they are, NASA will opt for a three-hour EVA or call a halt after two hours.

If it's a three-hour EVA, Armstrong sets up two instruments that will stay on the moon. The first is a solar-cell-powered seismometer, which he deposits 30 feet or so from the LM. The device, which stays active for more than a year, picks up any rumbles inside the moon and ra-

diates the information to Earth. Such data could provide clues to the moon's origin.

The second instrument is a panel of optical reflectors that Armstrong points toward Earth. Laser light beamed from various Earth stations and reflected by the device can be seen through telescopes. The information gleaned from these reflections will pinpoint the distance between Earth and moon, various continents and even locations within a given country.

Meanwhile, Aldrin has three important jobs to do. After shuffling some 40 feet from the LM (probably still within range of the TV camera's wide-angle lens), he'll plunge a hollow tube into moon soil. As he does so, two metal paddles will sweep away the soil's top layers, exposing a pure sample underneath. On Earth, biologists will examine the sample, automatically sealed in a plastic bag when Aldrin withdraws the tube, for evidence of microorganisms.

Next, he fills up a jar-sized container with moon pebbles. A special seal preserves a perfect vacuum, which will allow geologists to determine how much, if at all, other moon samples became altered through exposure to even a few molecules of air. The last task is to hammer a hollow tube a few inches into moon soil. This core sample may tell geologists how the sun's rays have altered minerals on the moon's surface.

2 Hours 15 Minutes. For the next half hour, the pair load up another box with lunar rocks, ambling as far as 300 feet from the LM to get a varied selection.

2 Hours 40 Minutes. The pair wind up the EVA. Armstrong walks to the solar wind experiment, folds up the aluminum foil, and puts it into the rock box, which he carries. Aldrin climbs into the LM and hauls up both rock boxes with a small pulley. Once Armstrong enters the compartment and closes the hatch, the LM is repressurized. The pair take off their backpacks and connect their suits to the LM's internal oxygen supply.

The LM can carry only about 18 extra moon pounds (equal to 108 Earth pounds) on its return to the command module. So, the men remove the film cartridges from their cameras and throw out their Hasselblads and backpacks. They seal the hatch again and repressurize the compartment.

The astronauts finish their moon stay with a meal, eight hours of rest, and another countdown of the LM. When the command module orbits to a rendezvous position, they blast off to meet it, leaving behind the descent stage of the LM plus a good deal of expensive equipment.

Man's first day on the moon has come to an end. ★★★

**MAKE
EXTRA
MONEY
IN YOUR
SPARE
TIME**

**LEARN PROFESSIONAL
"PLEXIGLAS"
SIGN
MAKING!**

\$13.75 brings you over 120
ACRYLIC LETTERS AND FREE
INSTRUCTIONS. Send your re-
mittance to:

DAYTONA PLASTIX

Box 6161, Daytona Beach, Florida 32022.

NOW PRICED LOWER THAN EVER

GIANT BALLOONS 25 ft.

10 ft. Guaranteed size brand - new surplus. Durable heavy-duty neoprene rubber. 5" size -2 for \$1 + 25¢ pp. 10" size-\$1 + 25¢ pp. Great fun at beach or play. Huge 25" size: Inflate with auto air hose or vacuum cleaner or fill with locally available gas. Fly advt, sign high in sky. Terrific crowd gatherer for sales, openings, sports, meteorologists, etc. Nat'l adv. at \$10—now only \$4 + 50¢ pp—2 for \$7 + \$1 pp—3 for \$10 + \$1.50 pp. No COD's. **NOVEL PROD.** 31-2nd Ave. Dept. B20, NYC 10003

10 ft. Guaranteed size brand - new surplus. Durable heavy-duty neoprene rubber. 5" size -2 for \$1 + 25¢ pp. 10" size-\$1 + 25¢ pp. Great fun at beach or play. Huge 25" size: Inflate with auto air hose or vacuum cleaner or fill with locally available gas. Fly advt, sign high in sky. Terrific crowd gatherer for sales, openings, sports, meteorologists, etc. Nat'l adv. at \$10—now only \$4 + 50¢ pp—2 for \$7 + \$1 pp—3 for \$10 + \$1.50 pp. No COD's. **NOVEL PROD.** 31-2nd Ave. Dept. B20, NYC 10003



Repair any watch

... SWISS OR AMERICAN

Unique, modern Sweazey System starts you making repairs right away. Develops skill step by step at home in spare time. Diploma awarded. Free sample lesson. No obligation.

CHICAGO SCHOOL OF WATCHMAKING
Dept. 179, Fox River Grove, Ill. 60021



BLAST CARBON
from every engine with
Fuel Mix Tune-Up Concentrate
New! from **GUMOUT**

LATHES-MILLS-SHAPERS

Metal lathe \$140—Vertical. Mill in Kit form \$127—Hand. Shaper \$125.

Send \$2 for catalog

CALDWELL INDUSTRIES

Box 170—Luling, Texas 78648

TREASURE

Find buried gold, silver, coins, treasures.

5 Powerful models.

Write for free catalog



RELCO DEPT. D-3 **\$19.95 UP**
BOX 10839, HOUSTON, TEX. 77018

**to get more work
out of a power drill...**

drive
and
remove
screws



run nuts,
bolts,
on
or off

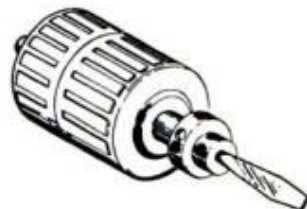


drill in
concrete
or hard
steel



**get a Versamatic®
Reversible Speed Reducer**

A portable drill can be seven times more powerful when you add the ultimate accessory... the RIDGID/Supreme Versamatic. Use this extra power to drive or remove screws, drill in steel or concrete. A free folder tells the whole story: Request "How to double the value of your power drill." The Ridge Tool Company, 400 Clark Street, Elyria, Ohio 44035, U.S.A.



**RIDGID
Supreme**

Ridge Tool Subsidiary
Emerson Electric Co.
EMERSON



**EARN
HIGH
WAGES**
as a **HEAVY
EQUIPMENT
OPERATOR**

Train your way to high pay in the booming construction industry! Learn the skills you need to qualify, by actual field training on machines like the ones used by the industry. Huge training grounds in North Carolina, a million dollars worth of school-owned diesel-engined machines, experienced instructors, full 220-hour and 440-hour courses. National, the original school of heavy equipment operation, is a recognized leader. Member American Road Builders Assn., Services and Supply Division. Associate Member A.G.C. Full-time Job Advisory and Counseling Director on staff. VA approved. For men ages 17 to 56. Train Now—Pay Later plan... other payment plans also available. Write TODAY for FREE catalog and FREE copy of school newspaper reporting news of National School graduates. Accredited member NATTS.

**NATIONAL SCHOOL
OF HEAVY EQUIPMENT OPERATION, Dept. D-29**
P. O. Box 8529, Moores Chapel Road, Charlotte, N. C. 28201
Please send me FREE illustrated school catalog and complete information. I understand there's no obligation.

Name _____ Age _____

Address _____ Phone _____

City _____ State _____ Zip Code _____

THE DEATH OF WORLD GLORY

(Continued from page 111)

tinctly remembers two "big noises" and he felt the ship "rear up twice."

Markakis later testified in Greece: "The motion was quite unlike anything I had ever felt. It was very abrupt and very violent. The movement up and down was extraordinary for a ship that size. The speed of the up and down motion was incredible."

When Markakis got on deck, he saw the vessel was in two parts. As the sections separated, oil began pouring into the water between the sections.

Suddenly the shout went up: "Fire!"

The oil in the water was ablaze and threatened to turn the severed halves of *World Glory* into flaming tombs for the men aboard.

Exactly what happened next is hard to determine. Only pieces of action and isolated comments can be patched together from reports of survivors. They tell a story of confusion and uncertainty, but also one of admirable calmness and courage under threat of death.

How many men were swept overboard during the breakup will never be known, but eight men gathered in the pilot house on the forward section after the breakup—Captain Androutsopoulos, Chief Officer

He saw the officer for the last time . . . still standing stoically in the wheelhouse

Ananiadis, Radio Officer Barry, two able-bodied seamen, the second officer, the third officer and a messman.

Chief Officer Ananiadis began firing red parachute flares to attract passing vessels. One ship was visible on the horizon. She was later identified as the tanker *Chevron Frankfurt*. Two flares burst high above the ship, then the third exploded in Ananiadis' hand. He had inadvertently grasped the wrong end. By then the fire between the two halves of his ship was burning so fiercely that he considered the blaze an adequate signal of distress.

Captain Androutsopoulos, after a quick evaluation of the situation, shouted an order to Radio Officer Barry: "Send an SOS."

Barry, who had come to the bridge from the radio room on orders from the chief officer, now hurried back to his radio shack to find the room covered with crude oil. The portholes had been stove in and each successive wave brought more crude

oil, mixed with seawater, swirling through the room.

Back on the bridge, Barry made his report: "My equipment is unworkable. I can't send a distress message."

But there was still a secondary transmitter located in the chartroom. Barry and one of the seamen pushed their way into it. Just as quickly, they were pushed out by seawater and oil that came flooding in. The sailor was actually washed from the chartroom into the wheelhouse. The message was never sent.

As the forward section settled farther into the sea, the other seaman struggled through to the bridge to report that the port lifeboat was in danger of coming adrift. Captain Androutsopoulos and Chief Officer Ananiadis rushed onto the port wing of the bridge just as another roller washed over the ship. Both men disappeared overboard; Captain Androutsopoulos was never seen again.

The six men remaining on the bridge retreated to the starboard side, away from the brunt of the sea. Then one by one, four men jumped into the sea. The forward section was sinking bow high. Only Radio Officer Barry and the second officer remained. Barry wore a lifejacket. The second officer did not.

In growing panic, the young Irishman urged the Greek officer to don a jacket, too: "I'm going to jump. Come with me."

Disdainfully, the second officer pointed to the raging sea and asked, "Where are you going?"

He made no attempt to leave the ship and neither did he don a lifejacket. As Barry was washed away by a wave, he saw the *World Glory's* second officer for the last time—still standing stoically in the wheelhouse.

On the stern section, an even larger group gathered on deck following the breakup. With the oil still ablaze between the sections, the chief engineer—fearing an explosion—ordered the men to launch the starboard lifeboat.

Before the lifeboat could be lowered, another towering roller swept down on what was left of *World Glory*, snuffing out the fire in its wake. The chief engineer, seeing the fire had been extinguished and that the stern section was still afloat, ordered the men out of the lifeboat. Within minutes, the lifeboat was battered into splinters against the side of the ship.

The men had one hope to ride out the storm. All watertight doors were shut and all overboard discharges closed. Watchkeepers were organized.

One man flashed an SOS to the *Chevron Frankfurt*, which acknowledged the message. It was the *Chevron Frankfurt*, in

fact, that first flashed the word of *World Glory's* distress.

On the stern, hopes rose as the section appeared to be holding its own against the sea. For two and a half hours, the stern bounced crazily in the stormy seas.

About 1730, however, the struggle took a turn for the worse. The forward section of the stern sloped downward. Heavy seas crashed into it. Great gushes of oil poured out as internal bulkheads cracked and split. At 1900 hours, two tremendous seas hit the stern. She started to go under.

Men still aboard gathered at the fantail where they slid into the oil-covered water. The stern upended and plunged toward the bottom, sending the last of the crew into the ocean. The ship's propeller was etched against the evening sky as the stern sank. The Cape rollers had claimed another victim.

It is incredible that any of the men survived that stormy sea. That any did can be attributed to the warmth of the water and air. The last reading before the disaster placed both water and air temperature 70°F.

Bitter ordeal for 10 survivors

Even so, it was a long and bitter ordeal. Chief Officer Ananiadis swam for 24 hours before being picked up by a whaler. Radio Officer Barry, not a strong swimmer, was kept afloat by his lifejacket for 23 hours before another whaler rescued him.

Third Engineer Kalaras was in the water 18 hours. Fireman Markaris, his eyes blinded by oil, floated for 20 hours before he was rescued. All survivors were in the water through the long night and well into the next day.

By the next evening, when the search ended, four vessels had rescued 10 men. All were weak, in a state of shock, and close to death. The identities of the four rescue vessels were listed as the whaler *Hovelmeier*, another whaler in the books simply by her number, "29," and two other ships, the *Natal* and *Forrest Hill*.

With the Suez Canal still closed, the fate of *World Glory* serves as a grim reminder to captains that Cape rollers off the African coast have little regard for the size of today's supertankers. And with more than 600 tankers a year now rounding the Cape of Good Hope, the *World Glory* disaster is a warning to South Africa of the growing oil-pollution threat to her coast. Oil from *World Glory* spread 130 miles and came within two miles of the beaches. South Africa used three crop-spraying planes and 12 ships to disperse the oil slick with detergents. Not until 12 days later, with favorable winds and currents, was the danger passed. ★★★

GOVT. SURPLUS AND OTHER BARGAINS SAVE UP TO 90%



SCAVENGE PUMP Miniature pump unit. 7 1/2" L x 2 3/4" W x 2 5/8" H. Positive displacement, rotary vane-type pump. 27 V.D.C. motor, continuous duty, explosion-proof. Pumps up to 165 GPH @ 6 PSI. Self-priming. Exc. for transfer of gas, diesel fuel, crankcase oil, etc. Pump ports 3/8" tube. Shpg. wt. 5 lbs. Govt. overhauled condition. Approx. GOVT COST \$231. Now **\$14.95** (Stk. #2026)



HYDRAULIC PUMP Rated 3 GPM @ 1500 RPM & 1500 PSI. Cu. In. Rev. is .800. Has built-in pressure adjustment reg. which varies pressure output from 1450 to 1600 PSI. Intake port 3/4" tube. Discharge port 1/2" tube. Bypass port 3/8" tube. Variable delivery. Clockwise or counter-clockwise rotation. Produces up to 8 GPM @ 3750 RPM continuous. Drive shaft is 3/8" twelve spline. 4 1/4" mounting base. Serviceable cond. Tested prior to shpg. Approx. GOVT COST \$320. Shpg. wt. 14 lbs. Special **\$14.50**



HEAVY DUTY BATTERY WINCH

Rugged, deluxe winch. Ball bearing construction thruout motor & gear train. High gear reduction. Rated cap. 3000 lb. pull. Reversing switch. Rugged 3/8" plate steel mounting base with outrigger support. 22" L x 9" W x 8" H. Handles 250' of 1/4" cable. Built for 12 V battery operation; also operates on 6 V at reduced cap. & speed. For Scouts, Jeeps, Trucks, Boat loading trailers, etc. Shpg. wt. 80 lbs. Approx. GOVT COST \$490. NEW. 90-day guarantee. Model E-D. **\$89.50** (Stk. #692)



NEW! BIG! 1969 CATALOG

Send 25c for amazing catalog with 1000's of bargains in hydraulics, electrical, marine, automotive items, etc. Order from ad. All prices FOB Culver City. 50% deposit required for COD. Cal. res. add 5% sales tax. Include zip. Satisfying world-wide customers since 1945.

AIRBORNE SALES CO. Dept. PM769
8501 Stellar Dr., Box 2727 • Culver City, Calif. 90230

—OIL LEASES—

\$15,799.20 - \$10,400.00 - \$9,600.00 - \$8,000.00 - \$7,800.00 - \$7,000.00 profits in recent sales by our clients of U. S. Government Oil & Gas Leases we recommended. If you are a citizen, you qualify. For complete information and how to get your lease write:

FEDERAL OIL LEASE SERVICE DEPT. PM
P. O. Box 867, Fort Worth, Texas 76101

LAW FREE BOOK THE LAW TRAINED MAN

Write today for a FREE copy of illustrated law book, "THE LAW TRAINED MAN," which shows how to earn the professional Bachelor of Laws (LL.B.) degree through home study of the famous Blackstone Law Course. All necessary books and lessons provided. Moderate cost; convenient monthly terms. Write for FREE law training book today:

Blackstone School of Law, 307 N. Michigan Ave.
Founded 1890 Dept. 50B, Chicago, Illinois 60601

WHEN ANSWERING ADS
GIVE YOUR ZIP CODE

EARN \$20.00/HOUR



Assemble MINI-DOZERS

for resale and make big money in your spare time! It's easy. Just order this unique garden-tractor kit at our low, factory-direct price, assemble (in 6 hrs. avg.) and resell profitably to local customers. Keep one to enjoy and demonstrate. Order complete kit or any parts desired. Full line of

attachments. To see how Dozer works, send for Plans and Parts Price List — only \$5.00. Cost deducted from kit purchase price. 16 page illustrated Catalog — 50c. Order now!

C.F. STRUCK CORP., Dept. PM-79, Cedarburg, Wis. 53012

PHOTOGRAPHING YOUR BOAT

(Continued from page 115)

—a stern view with someone at the helm or a shot across the bow into a blazing sunset.

Warren prefers his subjects out in open water. Dockside shots are too passive, he believes. Besides, the dock gets in the way, and you can't change the sun's direction if necessary to illuminate the boat's best angle.

To shoot in the open, you need a chase boat to follow your subject. It should be fast and as stable as possible. Get someone to do the driving so you can be free to concentrate on the picture-taking.

"Circle the boat being photographed," says Warren, "to find its best angle and to see which side is best for the sun. Then pick a spot, back off, and signal the operator to move your subject boat to the spot you've picked. When it gets there, start shooting."

Warren says never to shoot a sailboat when it's tacking because the sails go slack. Also, the crew is busy then and may not be in the most photogenic positions. He likes people on the boats he photographs to add reality. Best spots, he finds, are at the helm or tiller. If possible,

Fog adds drama, is often effective in eliminating an offensive background

he likes to use a low angle to silhouette them against the sky.

With 35-mm cameras, filters are seldom necessary for rich, dark skies, Warren has found. But he cautions against overexposure, which can block up highlights. "There's more light out on the water than most people think. Proper exposure is essential." A good guide is one stop less than needed for the same sky conditions on land.

If you want to experiment with filters, a yellow K2 or deep yellow G will darken a light, colorless sky. Spectacular black-sky effects can be achieved with a red A filter. With color films, you can use a Polar-Screen, which will darken the sky without changing the color of the picture. It will also banish sun glare from the water's surface and kill harsh reflections from windshields, portholes and shiny hulls.

Camera shake can be a serious problem when the chase boat pitches and rolls under the photographer. Warren suggests a shutter speed of at least $\frac{1}{500}$ th of a second, never slower. In heavy seas, $\frac{1}{1000}$ th

of a second may be necessary, especially to freeze droplets of spray.

Warren prefers a shooting angle just off the bow for most kinds of boats. Side shots, often requested by clients, are bad because they lack action and perspective, he feels. "They're fine engineering aids, but poor photography."

He tries to fill the full negative and to keep the image sharp for crisp enlargements. When composing, he tries to position the boat so it runs from corner to corner, rather than side to side. "Looks more active that way," he says.

Don't be afraid to let some background show. Warren likes to include a portion of shoreline or other boats. He feels that the right kind of background adds credibility to a photograph. He also likes to include a part of the chase boat in the foreground, framing under a sail or over a rail.

Photographing in fog adds drama and often is an effective way to eliminate an offensive background. This calls for caution, however, as there is always the danger of collision with other boats.

Warren prefers windy weather, just after a front has passed through when the air sparkles and the wind whips the water into a frothy texture. Flat, calm water makes a boat look dead and uninteresting.

Boats in poor condition pose problems. "You can never really hide a poor paint job. Quickie touchups aren't much help, either." About the only thing you can do with a hull that's seen better days is to use strong backlighting, exposing for the background and letting the boat go dark. This is one of Warren's favorite techniques, even when the boat is in pristine condition. "Backlighting glamorizes the subject, making a pictorial out of what might have been just a routine snapshot."

Cameras require special protection out on the water. Windy weather means spray. Warren advises wrapping all but the lens in a plastic bag and keeping the camera under your coat when spray is flying. Check the lens often, drying it carefully with soft tissue and brushing off the lint.

Back on land, dry the camera thoroughly, then go over metal parts with a slightly oiled, soft rag. Clean the lens with lens-cleaning fluid. Salt water and spray are the nautical photographer's worst enemies. ★★★

COMING NEXT MONTH

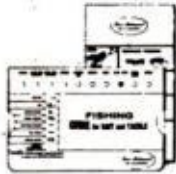
Maverick vs the 'Mob': PM editors test 'em.
Circular Game Table: An "all-time" great.
Good TV in Every Room: Multi-set antenna.
Chevy Impala and Olds 88: Owners Reports.
Folding Hobby Center: Keeps it all neat.

"Get my new Signature Kit...a \$5.50 value for only \$3.00."

By Dick Kotis, President, Fred Arbogast Company, Inc.

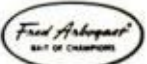


The Jitterbug...for surface fishing The Hawaiian Wiggler...for middepths The Arbogaster...for bottom fishing



Also included:
New Bait Equipment Selector
Colorful 1969 Arbogast Catalog
Handy plastic utility box

Value: \$5.50; yours for only \$3.00. Specify casting or spinning size.
 Send check or money order to Fred Arbogast Co., Inc.,
 1807 W. North St., Akron, Ohio 44303. Order today!



Now Many Wear **FALSE TEETH** With More Comfort

Here is a pleasant way to overcome loose plate discomfort. FASTEETH — an improved powder sprinkled on upper and lower plates — holds dentures firmer so they feel more comfortable. No gummy, gooey, pasty taste or feeling. FASTEETH is alkaline. Doesn't sour. Helps check "dental plate odor". Dentures that fit are essential to health. See your dentist regularly. Get FASTEETH at all drug counters.



GUNK ENGINE BRITE

ENGINE CLEANER and DEGREASER

Just spray it on... hose it off!

GUNK LABORATORIES, INC.
 5429 N. 84TH, CHICAGO, ILL. 60638

PROFITABLE NEW HOME BUSINESS

Nets \$1,000-\$3,000 and more in 3-month tax season helping people prepare returns. 25% to 50% average annual business growth. Learning easy, quick with ONLY nationally accredited home training course. Vet approved. Send name, address, zip for full free facts from National Tax Training School, Monsey, 20GB, N.Y. 10952. No salesman will call.

ENROLL—EARN YOUR DEGREE

of Bachelor of Bible Philosophy (B.Ph.B.), Master of Bible Philosophy (M.Ph.B.), Graduate of Bible Philosophy (G.Ph.B.), Doctor of Metaphysics (Ms.D.), or Doctor of Divinity (D.D.). Chartered by State, Correspondence Courses only. Please write for FREE BOOKLET.

AMERICAN BIBLE INSTITUTE

Dept. PM, Post Office Box 8748, Kansas City, Missouri 64114

FREE!

Learn how you can buy used engines \$15 up, new engines \$30 with FREE confidential list and coupons when you order your plans

- **BUILD THIS MINI-BIKE!**
Plans reveal step by step details!
- **BUILD A RACING KART!**
Build frame for less than \$10!



RUSH \$2 for plans (indicate type) or send 25¢ for circular describing plans
PLANS, Box 517, Omaha, Nebr. 68101



Now! Use your Bank Americard

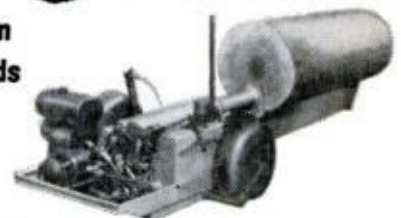
5000° OXYGEN WELDING TORCH
\$34.95 New portable SOLIDOX welding torch goes anywhere. Only 4 lbs. Burns amazing solid oxygen pellets & propane. Flame exceeds 5000°F. Braze weld, silver solder, melt 1/4" steel. Complete kit: torch, pellets, propane, glasses, braze rods, lighter, etc. Ideal for shops, hobby, metal repair. Professional results. Low-cost SOLIDOX pellets available by mail. SOLIDOX is simple and safe. Money-back guarantee. Only \$34.95 ppd.

SEND ONLY \$5.00

Write for free brochure.
 pay postman \$29.95 plus postage on delivery.
Cleanweld Products Co., PM-7 Box 1061, South Gate, Calif. 90280

LICKITY SPLITTER

Splits Big Profits from toughest woods — Ends Splitting Drudgery with 18 ton hydraulic power!



7 H.P. trailer unit squats under power to load logs without dead lift. Has 2 speeds, auto-shift, auto-stroke. 26" ram travel splits logs up to 34", any diameter — with extended frame and adjustable wedge splits up to 60". **NEW LOW COST** Economy model for farmers and small wood lots. Also ask about the 60L Series for logs up to 8 1/2 ft. long—Details free.

Piqua Engineering Inc., Dept. P, Box 605, Piqua, Ohio

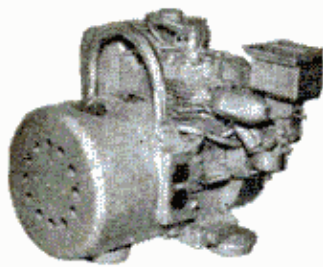
AMERICA'S NO. 1
 CLASSIFIED SECTION CAN BE FOUND
 ON PAGE 53 IN THIS ISSUE



You can't miss in **CARTOONING & COMMERCIAL ART!**
ANYONE can learn to draw...

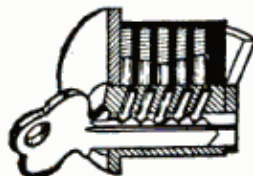
Some people waste natural talent. Others develop their into richer, fuller, more rewarding careers. New easier methods and personal instructions show you how. Or get our self-teaching manuals. FREE brochure.
 Your Satisfaction Guaranteed.

Famous American Studios
 Dept. P2 SPRING PARK, MINNESOTA 55384

EVERLITE**World's THRIFTIEST Light Plants****THE CHAMPION \$149.50**

The Champion—1200 watts 115 volts AC for only \$149.50
 Unbelievable but true—Brand new production methods now make possible world's finest design in a service free alternator light plant at this unprecedented price. Plant puts out a steady 1200 watts of 115 volt AC power to run power tools, oil burners, pumps, TV, or anything that requires up to 1200 watts. Powered by a rugged 3 HP, 4 cycle, easy start gas engine with 1 year factory warranty. Complete with carry handle and shock mounts. Why fool with short life 2 cycle plants when you can buy this rugged top quality machine at our factory price.
 Item # 1265 **\$149.50**
 wt. 65 lbs.

MASTER MECHANIC MFG. CO., Dept. A-79, Burlington, Wis.
 Southern Customers write Dept. A-79, Box 65, Sarasota, Florida

locksmithing and key making**PRACTICAL UP-TO-DATE COURSE—ONLY \$6.95**

Teaches you how to pick locks, de-code, make master keys, repair, install, service, etc. New self-instruction lessons for every handyman, homeowner, carpenter, mechanic, service station operator, fix-it shop, hardware dealer, gunsmith. 53 easy illustrated lessons. Full price only \$6.95, post-paid. Satisfaction or refund guaranteed. Mail order today!

NELSON-HALL CO., Dept. GR-2
 325 W. Jackson Blvd., Chicago 60606

**LEARN MEAT CUTTING**

Train quickly in 8 short weeks at Toledo for a bright future with security in vital meat business. Big pay full-time jobs—**HAVE A PROFITABLE MARKET OF YOUR OWN!** Time payment plan available. Diploma given. Job help. Thousands of successful graduates. **OUR 46th YEAR!** Send now for big new illustrated FREE catalog. No obligation. G.I. Approved.
NATIONAL SCHOOL OF MEAT CUTTING
 Dept. 50W, Toledo, Ohio 43604

POLICE-FIRE-EMERGENCY-CAR RADIO \$9.99

Works with regular **CAR RADIO** and **ANTENNA!** NO special wiring or installation. Mounts **UNDER DASH** in 5 minutes in **ANY CAR OR TRUCK.** Panel switches **INSTANTLY** from **REGULAR** to **POLICE-FIRE-EMERGENCY** radio **CALLS**—Receives **ALL** stations in your **AREA** within range. Size only 2"x3 1/2"—Two tone steel cabinet. **SEND ONLY \$2.00** (Cash, Ck, M.O.) and pay postman \$7.95 plus **COD** postage or send \$9.99 for **ppd** Del in USA. **COMPLETE** ready to clip in your **CAR** with all parts and instructions. One year parts and service **Warranty**—10 day money back trial (if retnd). **AMAZING OFFER** good only by mail and from:
WESTERN RADIO Dept. BPM-7 Kearney, Nebr. 68847

**BUY GOV'T SURPLUS SAVE TO 85%**

Send 25¢ (Coin or Stamp) **1000's Of Bargains; Surplus, Excess Inventory, Brand Name Equipment**
For BIG BARGAIN CATALOG
 "SATISFACTION OR MONEY BACK GUARANTEE"
 COMPRESSORS • WINCHES • GEAR MOTORS • CB RADIOS
 SURVEYING INSTRUMENTS • TEST INSTRUMENTS • PUMPS
 WALKIE-TALKIES • TAPE RECORDERS • POWER PLANTS
 ELECTRONICS • TELEPHONES • BINOCULARS • WELDERS
 SCREW JACKS • TARPAULINS • AIR TOOLS • HYDRAULICS

SURPLUS CENTER PM-079 Lincoln, Nebraska Zip Code 68501

BUILD YOUR OWN CAMPER**SAVE UP TO 50%**

Complete, easy to follow plans, instructions, materials list.

- Camper Plans \$3.95
- Travel Trailer \$3.95
- Pickup Cover \$2.00
- CONVERSION PLANS:**
- Eonoline Type Van..... \$2.95
- Passenger Bus or Delivery Van..... \$2.95
- Satisfaction Guaranteed

VIKING CAMPER SUPPLY, INC.
 99-EP Glenwood Ave., Minneapolis, Minn. 55403
 Please send _____ for which I enclose \$ _____
 NAME _____
 ADDRESS _____
 CITY _____
 STATE _____ ZIP _____

EQUIPMENT CATALOG \$1.00
 Refundable on First Order. Send Dime for Details. Save 50% on Camper Kit. All items from catalog to build \$1,795. Camper, 8', 10', 10'6" or Chassis Unit.
VIKING

WIRELESS INTERCOMS*(Continued from page 133)*

separate conversations simultaneously. As the diagrams show, you can also set up one unit as a master so it transmits to one slave on one frequency and to another slave on a different frequency. This lets you call either of two rooms, depending on which frequency you select, without disturbing someone in the other room. To call one slave from another slave with this arrangement, you'll have to switch the channel on one or the other of the units so their broadcast frequencies match.

If you're going to be doing a lot of channel switching, choose units that have an easily accessible frequency-selector switch. This is sometimes on the front panel, sometimes at the back, and sometimes concealed inside under the cover. Makers who hide the switch do so on the theory that it prevents tampering or an accidental mixup of channels once the best operating frequency has been established and all units have been set to it.

In setting up a system, don't try to intermix different makes of intercoms. Usually, their frequencies will not match, and you won't be able to call from one to another.

In addition to the number of channels offered, different brands vary somewhat in appearance, sensitivity and power. In general, the more expensive units transmit over a longer range and are more sensitive. They may also incorporate special features like a sensitivity control or a muting circuit to quiet line noise. Among the better-known makes are Fanon, Lafayette, Concord, Radio Shack's Realistic, Arvin and General Electric. For the kit-builder, there are two major brands to choose from—the Heathkit GD-51-2, priced at \$45.90 a pair, and Allied's Knight-Kit KG-225, tagged at \$37.90 for two. Each offers two operating channels.

In installing wireless intercoms, there is one possible problem to watch out for. This is where two units end up on opposite sides of a three-wire, 240-volt system. There will be no communication between them, and it may be necessary to connect a ground wire from each one to the screw on the wall plate. Some units have ground wires or terminals for attaching a ground, if necessary.

If there's still no communication after the grounds have been attached, try reversing the power plug on one unit. If this doesn't do it, reverse the plug on the other unit. If you still don't get anything, go back to the first unit and reverse its plug again. One combination will solve the problem, provided both intercoms are set to the same channel. ★★

THE DREAM COMES TRUE

(Continued from page 83)

signed bears a close resemblance to the LM, which may not be immediately apparent. The difference is the LM's thin aluminum skin. Peel it away and you find a configuration of fuel and oxygen tanks similar to that of the '52 model.

The main difference between the vehicles is size. The creators of the '52 plan envisioned an exploration project in which 50 men would spend six weeks on the moon. They planned to transport 20 men in each of two moonships and 10 in a third. Each ship was 160 feet high, about 110 feet wide, and sported 30 rocket engines. The LM, by contrast, is a modest 23 feet tall and 31 feet wide (with legs extended), providing room for but two men. The '52 ship was designed for a round trip of nearly 500,000 miles, the LM a round trip of about 140 miles.

Even though the United States has done so well with the LOR method, this doesn't mean that the space-station plan is dead. Far from it. NASA scientists are now working on plans for stations big enough to accommodate 100 men. Target date for the launch of the first module of a space station is 1975.

The Soviets appear headed in the same direction. It would be ironic if Russia's moon hop is made from Earth orbit, for some 50 years ago a self-educated Russian mechanic named Yuri Kondratyuk proposed a lunar landing by the LOR method. Though Kondratyuk is credited with originating the idea and published a book on interplanetary travel, it seems the Soviet government paid him scant attention.

A venture as bold as a moon landing takes a lot of dreaming and doing. But now that dream is about to come true, thanks to men like Kondratyuk, Houbolt, von Braun, Ley, Whipple. And men like Dr. Kurt H. Debus, director of the Kennedy Space Center; Dr. Robert R. Gilruth, director of the Manned Spacecraft Center, Houston; Dr. George E. Mueller, NASA's associate administrator for Manned Space Flight; George M. Low, manager of the Apollo Program; Lt. Gen. Sam C. Phillips (USAF), Apollo Program director, and James E. Webb, former NASA administrator. There are many others, too, for the list is long.

But if you want further proof of how accurate some dreams can be, dig up a copy of the March, 1962, issue of *Popular Mechanics*. In it you'll find a story of interest. Its title: "Our First Trip to the Moon Started at 4:30 the Morning of July 1, 1969." ★★★

WHAT'S HE DOING!

Making a Concrete Flower Pot! ... and
SO CAN YOU!

Make and sell your own Ornamental Concrete items. Rush \$2.00 for book about Aluminum Molds with prices and production trade secrets direct from world's largest mold manufacturer. Over 350 designs to select from.



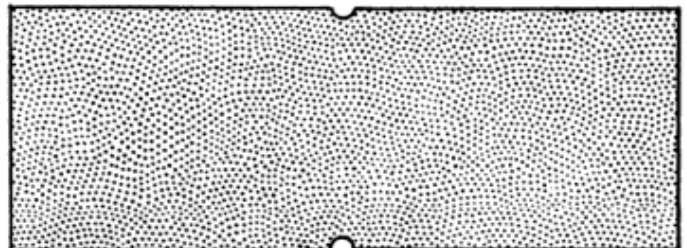
Send \$2.00 **CONCRETE MACHINERY COMPANY**
Today To ➔ P. O. BOX 99 • HICKORY 2, N. C. 28601

WHEN
ANSWERING ADS
GIVE YOUR
ZIP CODE

Don't change your address without notifying us!

To insure uninterrupted service on your **Popular Mechanics** subscription, please notify us at least six weeks before you move.

1. Attach your address label from a recent issue in the space provided below... (If label not available, be sure to give us your old address, including Zip Code)
2. Print your name and new address below (be sure to include your Zip Code).



3. Mail entire notice to: **Subscription Service Dept.
Box No. 646
New York, N. Y. 10019**

Name _____ **Please Print**

New Address _____

City _____

State _____ Zip Code _____

POPULAR MECHANICS Readers: Take this Big \$2.98 Picture-Filled Volume.. **FREE!**

(with no obligation to buy even one book in this program)

It's Crammed with Hundreds of Exciting Fun-Filled Ideas, Plans, Projects for Home, Hobby, Yard, Car, Boat, Camp, Garden, etc.! 196 giant money-saving pages! 400 how-to pictures!

Why do we give you this exciting do-it-yourself Volume FREE? Because we want you to live like a millionaire! Thrill to the good things in life! Enjoy Vacation Cabins — Barbecues — Sailboats — Cabin Cruisers — smart Furniture for every room—luxurious Patio—Finished Basement — Extra Attic Apartment — super Workshop — Playroom — Added Bedroom — House-Trailer — Fishing Pram — Landscape Gardens — every type of improvement for HOME and OUTDOORS!

We give you this first Volume FREE — with no obligation to buy anything — to prove to you how the famous PRACTICAL HANDYMAN'S ENCYCLOPEDIA will bring more fun into your life — bring you literally thousands of projects to save you money — keep entire family happy — keep yourself joyfully busy for pleasure and profit.

Here are clear, picturized instructions and plans for making all manner of wonderful things — from an acoustically damped microphone for \$2.00 to winterizing a vacation cottage for year-round living! And the cash savings you make by doing things yourself range from \$20.00 on a simple one-room paint job up to \$2,200.00 on a cabin cruiser — or over \$2,000.00 on a summer cabin or hunting lodge.

Books also show you how to save \$65.00 laying your own tile floor; \$30.00 on a stereo record player; \$1,000.00 building your own garage! How to build a fishing pram for under \$20; barbecue for under \$10... modernize your entire kitchen for under \$200! All these money-saving projects and MUCH MORE!

First Volume FREE — Nothing to Buy Ever!

Just mail the attached Gift Card and the giant FREE VOLUME will be yours to keep forever. This large 7 3/4" x 11 1/4" volume is a foretaste of the help you'll get from the complete PRACTICAL HANDYMAN'S ENCYCLOPEDIA! 22 superb volumes, 4,056 fact-filled pages, over 7,250 show-how illustrations, thousands of ideas and do-it-yourself projects. Build 1,001 things you've always yearned for—Modern Kitchen and Bath, Breezeway, Patio Terrace... fascinating projects in Ceramics, Sculpture... etc.

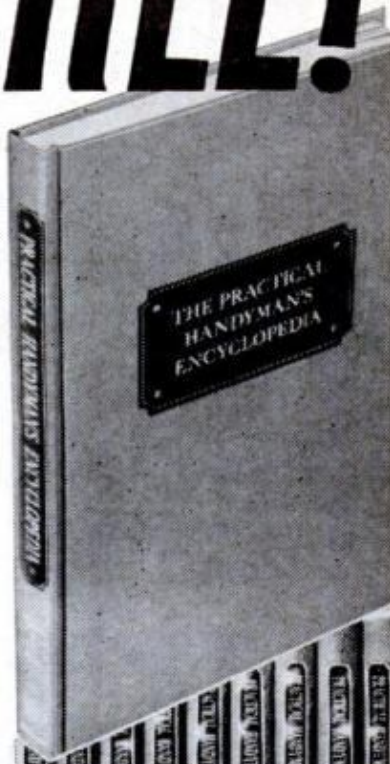
Claim FREE GIFT Volume NOW!

After you have seen and used your FREE volume you may, if you wish, go on to collect other volumes in the Encyclopedia. Each volume comes ENTIRELY ON APPROVAL for 7 days FREE EXAMINATION — no obligation to keep or buy. Volumes 2, 3 and 4 come to you about one a month; remaining volumes come in two shipments... all ON APPROVAL. You may return any shipment within 7 days and owe nothing, or you may remit subscriber's low price of only \$2.98 per volume plus a few cents shipping — for only one book each month.

But—even if you decide not to buy any books — the giant first volume is still yours to keep FREE. So HURRY! Mail the attached Free Gift Card Today. No postage needed. If card has been removed, send a post card NOW to...

PRACTICAL HANDYMAN, Dept. PM-769
100 Sixth Ave., N.Y., N.Y. 10013

PH-4R



Book gives plans for scores of wonderful toys.

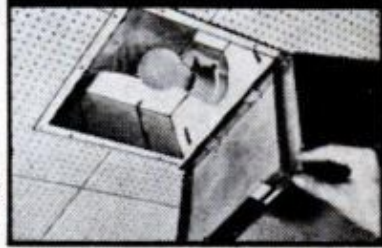
IDEA! add an extra bedroom virtually for cost of materials alone. Save up to \$1,000!



IDEA! Build this outdoor grill. Enjoy 1,001 other money-saving projects!



IDEA! Install a new, modern ceiling — complete with recessed lighting! Save \$50 to \$100!



Your FREE Book Brings You over 100 Great Projects and Ideas — See Attached No-Stamp Card — Mail TODAY!



How to plan a home workshop, buy, care for, and use Hand & Power Tools—work with Metals, Wood, Plastics, etc.

SEE HOW COMPLETE... Encyclopedia is in all do-it-yourself fields. For example, you will be delighted to find...

19 BOATS Sailboats, Rowboats, Racers, Skiffs, Sloops, Cabin Cruisers, Inboards and Outboards, a Zippy Hydro. Smooth-riding Catamaran. Glass-bottom "Peepers,"... PLUS complete plans for bathhouses, docks, trailers, water skis.

8 CABINS You get Designs for Hideout Cabin, Spring Bay, Seneca, Hiawatha Lodges and 4 more cabins—plus know-how for kitchens, plumbing, heating, built-in furniture, even conversion to year-round use!

25 HOMES Year-round low-cost homes with Photos, Floor Plans and Costs! ...MUCH MORE!

SEND NO MONEY — MAIL TODAY



Easy as 1-2-3 illustrated directions show the lady of the house how to Decorate, Finish Furniture—save money.



Exclusive Flex-O-Matic rear suspension automatically adjusts spring stiffness to loads.

Works like a truck. Rides like a car.

You win across the board with Ford. And the reason is better ideas—ideas like road-smoothing Twin-I-Beam front suspension. Two forged I-beams give it strength, coil springs supply the easy going. Your winnings include Ford's comfortable cab, roomiest of them all... the choice of smooth Sixes or powerful 390-cu. in. V-8... optional air conditioning, power disc brakes, SelectShift Cruise-O-Matic transmission. So ride and win with Ford. It's a smooth track, all the way.



A better idea
for smooth riding:
Twin-I-Beam
Suspension—
only Ford has it!

Either way, you win.

Farm & Ranch, Contractor, Heavy-Duty and Camper Special models available



FORD PICKUPS



I thought I saw a Pussycat



You did. You did. The Pussycat is a delightful new orange-sweet sour that mixes up about as quick as a cat. This national prize winning drink is made with a packet of "Instant Pussycat Mix," water and Early Times. Have fun with a Pussycat. It's playful. Ask for Instant Pussycat Mix at your favorite Food or Liquor Store.