

Build PM's '\$100' Jogger for \$30 Page 156

POPULAR MECHANICS

JUNE 1969
50 CENTS

The New Big League
In Auto Racing
By Dan Gurney

'70 Cars:
How New Will
They Really Be?
Page 92

A Great World
War II Naval
Painting

Through
Swamp and
Snow in OMC's
New Go-Anywhere Crawler

Testing Ford's \$4800 Motor Home
In Texas' Big Bend Country

Taking Underwater Pictures With an Instamatic • One-Man Golf Cart
How to Color Concrete • How Good Are Those Low-Cost Arc Welders?
The Facts About Stereo Speakers • Five Great Weekend Projects

**Our all-new 25 hp Sea-Horse
may be the lightest 25 ever built...**

You'll want to add
racing stripes.



**but there's no "maybe"
about what it can do.
We call it a
"total performer."
You can ski it...
fish it...cruise it...**

**race it...work it
...and still lift it.**

We've towed a 195-lb skier from a deep-water start... clocked it at 30-plus mph on a 14-footer... yet it trolls like our 9½. No maybes about its efficiency, either. New big-bore carb, stainless steel reed valves, new-design manifold and combustion chambers make the most of our economical 50 to 1 gas/oil mix.



**Its innovation-loaded powerhead
spins an innovation-loaded prop,
so you can do almost everything
the big boys do,
on less money.**

The computer-designed prop (cousin to our GT-115 prop) performs like "added cubic inches" going all out. And—pleasant surprise—it does well in weeds.

**See all 16 new or improved Johnsons
for 1969 — 1½ to 115 hp —
all with 2-year warranty*.**

At your Johnson dealer's now—he's in the Yellow Pages—or write for FREE 36-page catalog. Johnson Motors, Waukegan, Ill. 60085, Dept. PM-96

*For 24 months after purchase, Johnson Motors will replace or repair without cost to the original purchaser any part of its manufacture which, upon inspection, proves to have failed in normal pleasure use due to faulty material or workmanship.

Johnson
FIRST IN DEPENDABILITY Division Outboard Marine Corporation

In 1874 Remington introduced a great target rifle -the famous Creedmoor.

In 1873 the Irish, champions of the British Isles, challenged Americans to their first international rifle match, at 800, 900 and 1,000 yards. The Irish were seasoned shooters with proven muzzle-loading match rifles. The Americans had no special long-range target rifles and had never competed at ranges over 600 yards. No one gave the U.S. team a ghost of a chance to win.

The N.R.A. asked both Remington and Sharps for help.

Each company designed a new 44 caliber breech-loading rifle.

The big match was held at Creedmoor, Long Island, in September, 1874. Col. John Bodine, shooting a Remington, fired the last and deciding shot to give the U.S. a 934-to-931 win.

The Remington Creedmoor rifle soon became the favorite target rifle of American marksmen.

In 1969 Remington introduces another great target rifle-the 540X.

In the 95 years since we built the Creedmoor, Remington has learned a lot more about precision shooting. Here you see the latest product of this experience - the new 22 caliber Remington Model 540X.

We believe that the 540X gives more for the money than any other rifle ever seen on a target range. Look what you get for only \$89.95*.

There's a heavy, ordnance-steel barrel that can give you minute-of-angle groups.

There's the fastest lock time you can get in a rifle. Practically instantaneous. The bullet from a 540X leaves the barrel before the bullet leaves the cartridge case in competitive models. A big plus in four-position shooting, particularly in offhand events.

There's an adjustable match trigger, a modern thumb-cut stock and a five-way adjustable butt plate.

There's everything you need to win matches... everything to make the Remington 540X as respected by today's shooters as the Remington Creedmoor was in its day.

SPECIFICATIONS: ACTION - Bolt, single-shot. CALIBER - 22 cal. rim fire, long rifle only. SIGHTS - Redfield #63 front, Redfield #75 rear (optional). SAFETY - Thumb-type, positive. RECEIVER - Drilled and tapped for iron sights or scope blocks, rear-sight bracket. BARREL LENGTH - 26". Overall length 43½" to 47". LENGTH OF PULL - 12½" to 16". STOCK LENGTH - 30½", thumb cuts, butt plate adjustable for length of pull, vertical, pitch or cant, rail (front swivel block and sling strap optional), common sight alignment with scope or iron sights. WEIGHT - With sights, 8 lbs. 8 oz.

For our new catalog, write Remington Arms Company, Inc., Dept. 540-B, Bridgeport, Conn. 06602.

Remington® **DU PONT**

* Fair Trade prices in states having Fair Trade laws.

35 reassuring words from your Volkswagen dealer.

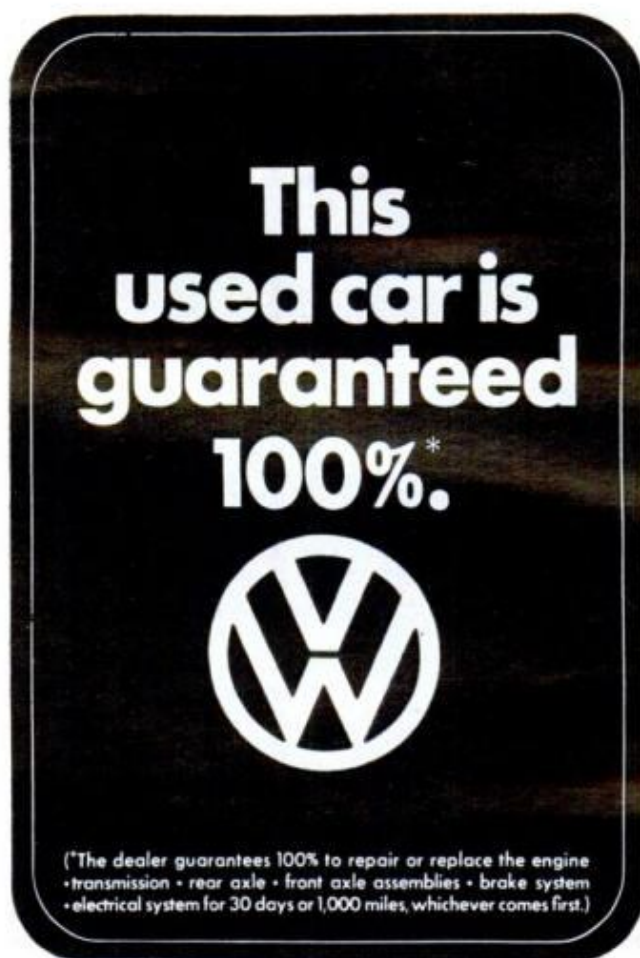

*This sign appears only in cars selected by your VW dealer.

© VOLKSWAGEN OF AMERICA, INC.

Like getting two tires in one.

New Firestone Sup-R-Belt Wide Oval.

Twice the mileage.



Because it's twice the tire. Polyester cord body. Reinforced with two fiberglass Sup-R-Belts. Belts stabilize the tread—keep it from rubbing side to side. This gives you up to twice the mileage you'd get from a regular-ply wide tire.  FIRESTONE T.M.

Extra protection.



Inside every fiberglass cord are over 3,000 fibers. In early fiberglass tires, these fibers rubbed against each other, weakened themselves. We found a way to add more protective coating. Result: Cord stays strong.

©The Firestone Tire & Rubber Co. 1969.



This One



R841-UHX-9S8E

Firestone

High-Performance Tirepower.

POPULAR MECHANICS

INTERNATIONAL EDITIONS: AUSTRALIA, BRAZIL, CARIBBEAN, DENMARK, FRANCE, MEXICO, SOUTHERN HEMISPHERE, SWEDEN

AUTOMOBILES AND DRIVING

- [10 Detroit Listening Post](#)
- [24 Drivin' With Dan](#)
- [40 This Trail Bike Is Really Put Together!](#)
- [52 Mini-Boot: The First 4x4 Dune Buggy for Under \\$2500](#)
- [72 Automobile Clinic](#)
- [77 Road Racing's Big Big League](#)
- [92 What to Look for in the 1970 Cars](#)
- [98 PM Owners Report: Mercury's Montego](#)
- [102 PM Tests OMC's 'Secret Green Machine'](#)
- [116 PM Tests Ford's New \\$4800 Motor Home](#)
- [122 PM Owners Report: Chrysler's New Yorker](#)
- [142 Saturday Mechanic: Rundown on Rubber](#)

BOATING, OUTDOOR RECREATION

- [32 On-the-Go Camping](#)
- [38 What's New Outdoors](#)
- [86 Marooned at 12,000 Feet](#)
- [130 How to Know the Lay of the Land](#)
- [138 PM Tests FrontRunner: The Boat That Wants to Be a 'VW Bus'](#)
- [176 Build This One-Man Golf Cart](#)

ELECTRONICS, RADIO AND TV

- [126 New in Electronics](#)
- [134 Modern Hi-Fi Speakers: Big Sound in a Small Box](#)

SPACE, AVIATION, MILITARY

- [111 'Damn the Submarines! Turn on the Lights!'](#)

PHOTOGRAPHY

- [107 Now: Shoot Underwater Photos for Under \\$20](#)

SHOP AND CRAFTS

- [156 Build This Jogger-Walker for \\$30](#)
- [165 Hints From Readers](#)
- [167 Hints From Readers](#)
- [168 Five Weekend Workshop Projects](#)
- [172 Make This Simple Fixture to Set Boring Bars Accurately](#)
- [175 Hints From Readers](#)
- [176 Build This One-Man Golf Cart](#)
- [180 Make Your Wife a 'Toolbox' of Her Own](#)
- [181 Hints From Readers](#)
- [182 Are Small 110-v.a.c. Arc Welders Really Any Good?](#)
- [187 New Tools You Should Know About](#)
- [188 Hints From Readers](#)

HOME AND YARD

- [76 Homeowners' Clinic](#)
- [146 Exciting New Products](#)
- [148 Now: Furniture You Can Blow Up](#)
- [150 Build This All-in-One Kitchen Planning Center](#)
- [152 How to Color Concrete](#)
- [156 Build This Jogger-Walker for \\$30](#)
- [160 Solving Home Problems](#)
- [162 Window Screens Aren't Just Screens Anymore](#)
- [166 Rooftop Patio](#)
- [168 Five Weekend Workshop Projects](#)
- [174 Empty Caulking Cartridge Makes Pump](#)

SCIENCE AND INVENTIONS

- [20 Science Worldwide](#)
- [80 Alone in a Body Counter](#)
- [96 Just Patented: PM's Pick of the New Inventions](#)

REGULAR FEATURES

- [6 Letters](#)

Cover Photo by C. R. Toomey

Bill Hartford, PM's Technical Auto Editor, tests OMC's new go-anywhere crawler

NEXT MONTH IN POPULAR MECHANICS

Apollo 11. Fourteen pages to help you understand man's greatest adventure.
Owners Reports: Cadillac and Ambassador. Gripes, praises from those who own 'em.
40 Tests for a Camper Before You Buy. Be an expert before you put down money.
How to Turn a Beetle Into a Beauty. A slick, new fiberglass body for VW chassis.

ROBERT P. CROSSLEY

Editor

JAMES M. LISTON
Executive Editor

JOHN A. LINKLETTER
Managing Editor

WAYNE C. LECKEY
Home and Shop
Editor

SHELDON M. GALLAGER
Assistant Executive
Editor

THOMAS G. DAUER
Art Director

Published by The Hearst Corporation
RICHARD E. BERLIN, PRESIDENT

RICHARD E. DEEMS
President, Magazines Division

JOSEPH F. KERN
Publisher

WILLIAM KILPATRICK _____ Automotive
DANIEL C. FALES _____ Boating and Outdoors
SHELDON GALLAGER _____ Electronics and Photography
JOHN F. PEARSON _____ Science
BILL HARTFORD _____ Associate Automotive
LEONARD E. SABAL _____ Home Workshop
GARRY WINTER _____ Copy and Production
RICHARD H. FUNK _____ Associate Copy and Production
JOHN ADKINS _____ Assistant Copy and Production
ALVIN KIETZ _____ Assistant Art Director
DON EVANS _____ Assistant Art Director
FRED A. LEERS _____ Assistant Art Director
GEORGE W. BLOW _____ Technical Art Director
CLIFFORD B. HICKS _____ Special Projects
SOPHIE GRONOWICZ _____ Director, Bureau of Information
EVERETT JOHNSON _____ Cabinetmaker

ADDRESS ALL EDITORIAL COMMUNICATIONS TO: 575 Lexington Ave., New York, N.Y. 10022. For additional sources of information on the articles and products in this issue, write to Bureau of Information, Popular Mechanics, for free "Where-to-Find-It" list.

DANIEL J. COLEMAN
Director of Advertising

ADVERTISING OFFICES: New York: 575 Lexington Ave., Murray Hill 8-8500; Chicago: 520 N. Michigan Ave., 527-2400; Detroit: General Motors Bldg., TRinity 5-8711; Cleveland: Hanna Bldg., 1422 Euclid Ave., PRospect 1-0456; Los Angeles: 601 North Vermont Ave., 666-6263; San Francisco: 1101 Hearst Bldg., YUkon 2-0823.

SUBSCRIPTION SERVICE: Mail all subscription orders, changes of address, correspondence concerning subscriptions, and Postmaster notices of undeliverable copies to Popular Mechanics, Box 646, New York, N.Y. 10019. Please enclose your latest address label for quickest service when writing about your subscription.

POPULAR MECHANICS IS PUBLISHED MONTHLY by The Hearst Corporation, 57th St. at 8th Ave., New York, N.Y. 10019, U.S.A. Richard E. Berlin, President; George Hearst, V-Pres.; Richard E. Deems, President of Magazines; John R. Miller, Executive V-Pres. of Magazines; Raymond J. Petersen, Senior V-Pres. of Magazines; William S. Campbell, V-Pres. of Magazines; Albert A. Rachol, V-Pres. and Director of Circulation; Joseph F. Kern, V-Pres. for Popular Mechanics; Frank Massi, Executive V-Pres. and Treasurer; Harvey L. Lipton, Secy. Single copy in the United States and Canada, 50 cents. Subscription prices: United States and Possessions, \$4.00 for one year; \$7.00 for two years; \$10.00 for three years. Canada, add \$0.75 for each year. Pan American Postal Union countries, add \$1.00 for each year. All other countries, add \$2.00 for each year. When changing address, give old address as well as the new, with postal-zone number, if any, and allow six weeks for change to become effective. Second-class postage paid at New York, N.Y., and at additional mailing offices. Authorized as second-class mail by the Post Office Department, Ottawa, and for payment of postage in cash. Registered as second-class matter at the Post Office at Mexico D.F., Mexico, June 20, 1950. © 1969 by The Hearst Corporation. All rights reserved. Printed in U.S.A.

JUNE 1969

*Offer valid only where legal—for a limited time only



86 PROOF • EARLY TIMES DISTILLERY CO., LOUISVILLE, KY. © ETCC 1969

I thought I saw a Pussycat

You did. You did. The Pussycat is a delightful new orange-sweet sour that mixes up about as quick as a cat. This national prize winning drink can be made with a packet of "Instant Pussycat Mix," water and Early Times. Have some fun with The Pussycat. It's playful.



To get a set of 4-10½ oz. Pussycat glasses and 4 packets of Instant Pussycat Mix, send \$2.95 to:
EARLY TIMES PUSSYCAT GLASSES
P. O. BOX 377, MAPLE PLAIN, MINNESOTA 55359

5

LETTERS

TO THE EDITOR

Let's enforce the laws

Your article *Driver Training: Does It Really Do Any Good?* (page 93, April PM) is like all of these articles—trying to change the system instead of the driver.

I wonder how the people who write all these articles about driver education and car inspections can justify them when, in fact, all records indicate that about 99 percent of all accidents are caused by one or both drivers.

Sure, they all pass some kind of test and answer questions about rules of the road to get the license. Then, as soon as the license is given, they forget them. So what good is all this driver education?

The cops should crack down on these infractions, as they did a few months ago on Long Island. They gave out hundreds of tickets for violations and the accidents were reduced to almost nothing. Let's strictly enforce the laws that we have.
MILLTOWN, N.J. ROBERT J. BAIER

That was our author's question: What good is driver education? He concluded the article by agreeing with the critics who say we ought to find out before we commit more money to it. As for stricter law enforcement, fine. We're for that, motherhood, the flag and more pay for editors.

The purpose of driver ed., in my day anyway, was to teach the kids the rules and safe techniques of driving—not to turn out perfect drivers. That is up to us. I've been driving well over 10 years and have never had an accident or a ticket.

Maybe the fault is the way it is taught. You use "education" and "training" interchangeably. Our driver ed. instructor always began his course by saying, "You train animals; you educate people."

DES MOINES, IOWA MRS. MARY ANN GASS

Mini-Edsel?

I'll bet dollars to donuts that time will show that Ford hasn't created a compact at all (*Ford's New Maverick*, page 42, April PM), but a mini-Edsel instead.

NAHCOTTA, WASH. RAY STONE

Money and power

In *Bill Lear's Steam Car* (page 128, April PM) my 14-year-old was quick to point out the statement that William P. Lear is a "multi-millionaire who never

(Please turn to page 8)

The Lazy Pipe Tobacco

There are some things in this world that you just can't rush. If you're a pipe-smoker, you should know that Bond Street is one of them. A single pipeful, in fact, should last long enough for the little woman to finish up the lawn (depending, of course, on the size of the lawn). You'll certainly enjoy the taste of Bond Street. It's a rich combination of plugs and flakes that delivers a smooth and steady glow. (And if your neighbor's wife drops over, don't be surprised if she has something nice to say about the aroma.) If you think you're lazy, forget it. You're probably a speed demon compared to your pipe tobacco.



Lights easy—
takes its own good
time about burning.

This free booklet will tell you how you can become a Computer Programmer

50,000 more programmers needed now!
500,000 more will be needed in a few years!

...and how you can train at home for big earnings in the world's newest, most exciting profession.

IF YOU'RE dissatisfied with your present job, why don't you become a programmer? So great is the demand for programmers, you'll have your choice of openings, with a growing future ahead.

For the vast majority of good positions, a high school education, a logical mind and the right preparation are all that are required. LaSalle, world leader in home education, will train you as a programmer in your spare time.

Why not plan for bigger success in the field where employers are looking for you? *Authorities agree that for many years to come there will be more openings in computer programming than people to fill them!* Even beginners are paid well; and with experience, programmers can fill major supervisory positions at salaries of \$12,000 to \$15,000 a year — often as much as \$20,000.

Without leaving your present position, you can start your training now — at very low cost. You can study at home, in hours of your own choosing. Experienced LaSalle instructors will guide you by mail every step of the way. Industry experts say this is the most thorough course of its kind that they have seen. The ease and rapidity with which you learn will surprise you.

LaSalle has just published a fascinating booklet "How To Become a Computer Programmer." In simple, non-technical language this booklet tells you what computer programming is; what the programmer does; how you can train by mail through the school that has enrolled more than 1,500,000 people in its many success courses. Mail the coupon for your free copy or write to LaSalle, 417 S. Dearborn, Chicago, Illinois 60605.

© 1967 LaSalle Extension University



LA SALLE EXTENSION UNIVERSITY

A Correspondence Institution

417 S. Dearborn Street, Dept. 90-069, Chicago, Illinois 60605

Please mail to me the free illustrated booklet "How To Become a Computer Programmer."

Name..... Age.....

Address..... County.....

City & State..... Zip No.....

Occupation..... Working Hours..... A.M..... P.M.

551

**The Swingline
Tacker Gun does
everything the \$12.95
gun will do...**



for only \$8.95

Use the Model 800 Heavy-Duty Tacker Gun to install ceiling tile... repair screens... lay carpet... insulate... weather-strip... upholster... you-name-it! Takes 5 staple sizes, from $\frac{1}{4}$ " to $\frac{5}{16}$ " — plus special Loktile® staples for ceiling tile installation. Easy to load — easy to operate.



Model 800

Write for
free booklet,
TIPS ON TACKING
Dept. PM-69

Also available:

Model 101 Tacker Gun. Only \$5.95.
Takes 2 Staple Sizes $\frac{1}{16}$ " and $\frac{5}{16}$ "

Swingline®
Consumer Products Division, 32-00 Skillman Ave.,
Long Island City, N.Y. 11101.

LETTERS

(Continued from page 6)

finished high school . . ." This statement doesn't help us parents when we tell the kids why they should stay in school.

I know you were just stating facts and not encouraging school dropouts, but please try not to make it sound profitable.
OSBORNE, KANS. MRS. WILMA GRIEVE

Tell your boy the only reason we mentioned Mr. Lear's wealth in connection with his not finishing school is that it's an unusual combination. Most of us need all the school we can get just to survive.

Your author asserts that the Lear engine develops its 450 bhp "either at stall or at top rpm." Not so. No engine develops any power at stall. Torque, yes, but not power. Power is the time rate of doing work. Work corresponds to moving a force through a distance. If an engine isn't moving, it sure isn't going to do any work.

Apart from that, the article was okay, and the artwork was worth the price of admission.
PHILADELPHIA, PA. PETER W. MCCALLUM

Then add parking meters

The idea of converting almost your entire front yard into a parking lot is ridiculous (*Eight Ways to Get More Off-Street Parking*, page 148, March PM). The author said that you risk having an accident when you back out of your driveway. This may be true, but is it necessary to cement in your front yard because of this? A small area in which to turn your car around should be adequate.

WAUWATOSA, WIS. DOUGLAS F. MANN

But with less lawn to mow, you have more time for guests and parties . . . so you need more parking space . . . so you cement more lawn . . .

No strings

I am greatly upset by *How to Restring a Tennis Racket* (page 182, April PM), in which Moody & Co. is mentioned as a source where readers may obtain tennis strings and stringing supplies.

Moody & Co. and the other two companies mentioned as sources for strings, etc., are all strictly wholesale suppliers. We do NOT sell to the general public.

MOODY & Co., INC. FRANK C. J. FIALA
MILFORD, CONN. PRESIDENT

Sorry; our author is a pro who apparently thought everybody could buy where he does. Try your local sports shop. ★★



“Either that bulge goes, or I do!”

A girl can't stomach a guy with a pot belly. Especially when he's in a swim suit for all the world to see. It does nothing for her image to be associated with a Mr. Lard Belly. And it doesn't do a blessed thing for him, either. Until now there was no simple, foolproof way to quickly trim your waist — reduce your weight in a matter of days — and keep it there. But now there is. It's Joe Weider's famous **Slimmers Formula** — a ridiculously easy way for a Slim Jim to trim his waistline and shape up. And for a chubby Charley to lose up to a pound-a-day, 14 pounds in 14 days. The **Slimmers Formula** is a guaranteed, simple 3-part program that really works — making you look years younger. Age is no problem: yes, 20, 30, 50 or even 70, you'll look and feel like a new man — fast, or you get every penny back. This is the only guaranteed way to lose inches off your waist, hips or any other part of your body and regain that youthful, athletic look in the privacy of your home — regardless of your years. There just isn't any other way. It's so good it's endorsed by coaches, physical education instructors and physique champions everywhere.

1 THE "SLIM GARD"

The Instant Slimmer — Trims inches off your waist, hips and lower back — without dieting — without exercising.

For a speedy "Getaway" on the Slimmers Formula, slip on Slim-Gard . . . then take it easy, for while you're sitting around, watching TV, relaxing or eating, your waist, hips and small of the back are getting an effortless "going over" that takes inches off your soft belly without your even knowing it. It hugs your body gently but firmly, keeping warm air in — cool air out — trimming inches effortlessly away! Slim-Gard works effectively for the fat or slender man. Instructions are included for the fat man who wants to quickly lose 20 to 100 pounds . . . and for the slender fellow who wants to lose only a few inches without losing weight. And Slim-Gard is hidden — no one knows — nothing shows . . . except the inches that go! You're guaranteed impressive results in 10 days or your money back.

Building a natural Muscle Girdle that holds in your waist for life is easy, when you buy and use



SLIM GARD
and The Slimmers Routine. Only **\$9.98**

2 "SLIMMER" SHAKE

Helps You Lose Up to a Pound-A-Day — 14 Pounds in 14 Days — Without Losing Your Strength and Vigor.

If you're 10 to 100 pounds overweight and want even faster weight losses — up to a-pound-a-day — Part 2 of Joe Weider's famous Slimmers Formula is the easiest and most delicious way to do it. It's called The **Slimmer Shake** — a scrumptuous protein-enriched milkshake-flavored drink. It supplies nutrients to your body that charge it with power and vim while it slenderizes you. Even chubby guys who won't even lift a finger can lose up to a-pound-a-day, 14 pounds in 14 days — just drinking The **Slimmer Shake!** It's the first and the best for fast weight losses . . . that's why even the world's strongest and best-built men and Olympic champions drink it to get in shape quickly.



For fast overall weight losses you should order

SLIMMER SHAKE

and The Slimmers Routine. Only **\$11.98**
(2 weeks supply)
(Choice of Chocolate or Vanilla)

SLIM DOWN — SHAPE UP — OR IT COSTS YOU NOTHING!



SEE INCHES GO FAST—OR EVERY PENNY BACK!

FREE! THE SLIMMERS ROUTINE

Savvy Slimming Tricks To Shape You Up and Trim You Down



Here's Part 3 of the Slimming Formula the surprisingly effortless "Aerobic/Circuit" Training routine used by athletes, coaches and the world's best-built men to get in shape fast. Within 10 days, you'll instantly start slimming down — your muscles grow stronger — your chest expands — shoulders broaden — waist tapers down — to create a more exciting, youthful you. You need this "Aerobic/Circuit" routine NOW! — because it's the youthful-appearing man who gets and stays ahead!

SPECIAL OFFER!

3 SLIM GARD and SLIMMERS SHAKE

and The Slimmers Routine
ALL THREE **\$17.96**
(a \$21.98 value) For only

MONEY BACK GUARANTEE

I am so positive this is the only simple, safe and effortless way you can see impressive results in just 10 days — Inches Must Go Fast — or every penny back.

Joe Weider

Trainer of the champions . . . with more than 2,000,000 successful students

NOW!—START MOVING YOUR BELT BACK A FEW NOTCHES—AND KEEP IT THERE

It's so easy — so simple to slim down and shape up for life with my effortless guaranteed 1-2-3 Slimmers Formula. Attack your weight problem these 3-ways: (1) Wear Slim-Gard to slim inches off your flabby belly and hips. (2) Drink The Slimmer Shake to lose weight all over — up to a pound-a-day, 14 pounds in 14 days. (3) Do the effortless "Slimmer Routine." WHY NOT GET STARTED RIGHT AWAY? 10 days from now you'll be so happy you did! Don't miss out on this once-in-a-lifetime Guaranteed "Get Slim" offer. Clip and mail the NO RISK COUPON NOW — while it's still handy.



JOE WEIDER Dept. 88-6986
Famous Fitness School
531 - 32nd Street
Union City, N.J. 07087

Dear Joe: YES! I want to start slimming down at your risk! I am enclosing only the special low price for the plan I need to "SLIM DOWN" and "SHAPE UP." If I am not completely satisfied, I can return the unused material within 5 days for a full refund of the purchase price.

CHECK THE "SLIMMING DOWN" PLAN YOU NEED BELOW:

1. SLIM GARD and Free Course Only \$ 9.98
2. SLIMMERS SHAKE and Free Course Only \$11.98
3. SPECIAL OFFER: Slim Gard, Slimmer Shake and Course \$17.96

I enclose check or money order for: \$.....

NAME _____ AGE _____
ADDRESS _____
CITY _____ STATE _____ ZIP _____

DETROIT

LISTENING POST

BY BILL KILPATRICK

CHEVROLET'S XP-887, General Motors' entry in Detroit's "Beat Back the Imports" campaign, may not bow on schedule. The little car that's named like an experimental aircraft is due to be introduced along about mid-May of next year. However, it may get shoved back because of its possible use of a new type of transmission. If Chevy decides to go with an existing transmission the car will debut as expected. But if the brass hats decide the world is ready for something new (and it is, it is), the car won't appear until late summer. A possible consideration in Chevy's decision will be public reception of Ford's Maverick; if Dearborn's Darling takes off on the sales charts, look for Chevy to rush to market. But if—even by now—the Maverick looks "soft," Chevy will probably bide its time, decide in favor of the new drive train.

REAR LIGHTING SYSTEMS on current U.S. production cars have been given a vote of no confidence by investigators at the Univ. of Michigan's Highway Safety Research Institute. Researchers found that experimental setups wherein there was a separate light of a different color for each function were far more effective as safe driving aids than the present all-in-one lamps. An impetus to revising present systems may be the coming generation of small cars; lights may be moved to the roof area atop the rear window in order to make the cars visible in heavy traffic.

The idea of separate taillights, turn and stop signals isn't new, has in fact been used on certain European cars for years. But part of the multilamp system's effectiveness is its novelty; once that wears off, we're willing to bet drivers will go on smacking each other with the same old merry abandon.

FORD DEFINITELY HAS A NEW ENGINE on tap for its new subcompact, code-named Phoenix and due next spring. Company will most likely pop with an in-line Four, a spin-off of the engine originally developed for the abandoned Cardinal. However, scuttlebutt has it that Ford is also considering a new Six, possibly an even further reworked version of the Falcon engine it already reworked for the new Maverick. Also due on the Phoenix—if and when it goes to the post—is a whole new concept of component servicing; components will be highly accessible, easily removable and replaceable. In fact, some observers see the Phoenix—in its simple, straightforward design, coupled with its snap-out, snap-in components—as a first step toward eventual development of a truly disposable car . . . drive it 'til quits, throw it out, get another.

THE HORNET may be a little late this year. American Motors planned to bring the car out this fall when it introduced its entire '70 line. Certain component suppliers, however, are said to be a bit behind schedule, meaning the car's debut could be moved back a month or more. As reported elsewhere in this issue (see *What To Look For in the 1970 Cars*, page 92), AMC will have an all-new mini-car ready next spring.

LOOK FOR BRITAIN'S LOTUS to make a major marketing effort here. About the only small European manufacturer to rework its model line-up to comply with U.S. federal safety and antipollution regulations, Lotus hopes to sell over 1000 units here this year, double that next year. Lotus plans to stick to sports cars, will offer four models—the Elan S.4 coupe and convertible, the sleek Europa S.2 and the Elan Plus 2. Definitely *not* in the works are rumored plans to develop an all-out luxury sedan in the \$10,000-plus category. Nor will Lotus enter the small sports aircraft business—another bit of gossip that has been making the rounds.

BRITAIN'S STRICT "NO BOOZE" DRIVING LAWS empowering police to stop any motorist at any time and submit him to a "breath test" to determine whether or not

he has been drinking are producing results. In one period—from October 1967, when the legislation went into effect, until October 1968—there were 1152 fewer highway fatalities than during the preceding 12 months. Additionally, there were 11,177 fewer people seriously injured during the same period. System seems to work because laws are rigidly enforced and drivers apparently know it—meaning they think twice before venturing forth under even a mild buzz.

CHRYSLER IS DEVELOPING—may already have in production—a semi-automatic transmission for its French-made Simca 1204. The front-drive car sells here for about \$1800 as a basic two-door sedan, goes up to \$2160 for a four-door wagon. The new transmission will add about \$145 to the basic price of all the 1204s.

FIRESTONE'S "HIS" AND "HERS" tires, mildly kidded in this space recently as proof positive we live in a giddy age, turn out to be for real. The "His" model—wide tread, deep grooves, no frills—is going to be standard equipment on one of the '70 cars, all of which gives you a clue as to this reporter's sagacity.

ANTISKID BRAKE SYSTEMS, available on a couple of big-ticket cars (e.g., Lincoln's Mark III, Ford's Thunderbird), are running into pricing problems. Ford's unit sells for slightly less than \$200, far more than most of us will want to pay for installation on our less exotic cars. GM's unit, yet to appear officially, is also rumored to be priced right up there with the competition. Some safety critics are pressuring carmakers to install the units as standard equipment, but manufacturers are reluctant to pass along their cost to high-volume, lower-priced buyers. Beating the cost bugaboo will delay widespread use of the devices for at least another two years.

A TELEPHONE IN YOUR CAR may be a great way to carry on your business or to impress friends and neighbors, but telephone companies wish you'd try to find some other means of flaunting the fact you've made it big. Right now, applicants for phones for car use are being advised there'll be at least a two-year delay before the application can be considered, let alone acted upon. Primary reason for the big delay is a tremendous shortage of appropriate radio frequencies, with no immediate prospect of the shortage being eased. So bad is the situation, it's reported phone companies will neither sell or lease equipment for car use. ★★★

If your
car's burning oil,
it's time
to trade it in.

Or read this.

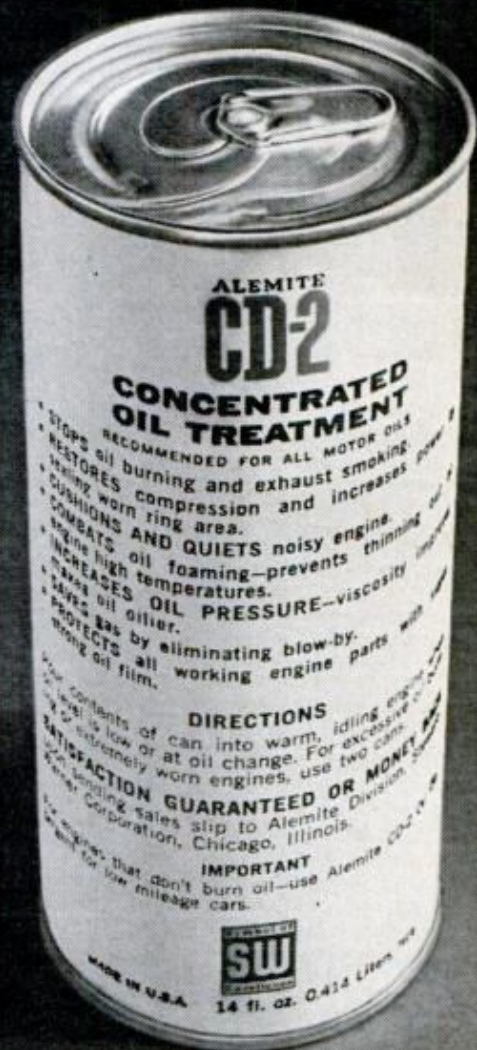

The back of a can of CD-2 tells how you might get another ten or twenty thousand miles out of a car that's burning oil and losing power. If you use what's inside.

The other CD-2. Don't get mixed up. There's a different CD-2 for low-mileage cars that don't burn oil. If we only made one kind, it couldn't do either job as well.

Two more great products by Stewart-Warner.



MAKE IT BIG WITH NTS

PROJECT METHOD

HOME TRAINING

IN INDUSTRY...

IN YOUR OWN BUSINESS...

IN MILITARY OR GOVERNMENT

ELECTRONICS DIVISION

- Master Course in Color TV Servicing
- Color TV Servicing
- Master Course in TV & Radio Servicing
- Practical TV & Radio Servicing
- Master Course in Electronic Communications
- FCC License Course
- Master Course in Electronics Technology
- Industrial and Automation Electronics
- Computer Electronics
- Basic Electronics



AIR CONDITIONING, REFRIGERATION DIV.

- Master Course in Air Conditioning, Refrigeration & Heating
- Air Conditioning & Heating
- Refrigeration



MECHANICS DIVISION

- Master Course in Auto & Truck Mechanics
- Automotive Mechanics
- Truck & Heavy Duty Mechanics
- Engine Tune-Up & Electricity



HOME APPLIANCES DIVISION

- Home Appliances Master Technician's Course
- Home Appliances Servicing
- Handyman Appliance Repair



Includes new Exclusive Circuit Trainer

NATIONAL TECHNICAL SCHOOLS

WORLD-WIDE TRAINING SINCE 1905

4000 South Figueroa Street Los Angeles, Calif 90037

APPROVED FOR VETERANS

CLASSROOM TRAINING AT LOS ANGELES

NTS occupies a city block with over a million dollars in training facilities. Check special box for details.

FREE BOOK & SAMPLE LESSON



NATIONAL TECHNICAL SCHOOLS

WORLD-WIDE TRAINING SINCE 1905

4000 So. Figueroa St., Los Angeles, Calif. 90037

Please rush FREE OPPORTUNITY BOOK & SAMPLE LESSON for division checked below. Check one only.

- ELECTRONICS DIVISION
- AIR CONDITIONING, REFRIGERATION DIV.
- MECHANICS DIVISION
- HOME APPLIANCES DIVISION (Dept. 201-69)

Name _____ Age _____

Address _____

City _____ State _____ Zip _____

- Check for veteran training under new G. I. Bill.
- Check if interested ONLY in classroom training at Los Angeles



The original "Wedge-Type" screwdriver

QUICK-WEDGE

SCREW HOLDING SCREWDRIVER

Just ONE Screwdriver does all the job!

HOLDS STARTS DRIVES AND SETS THE SCREW to normal tightness! Only QUICK-WEDGE does the whole job —

GET A SET TODAY!

At Your Dealers or Write

KEDMAN COMPANY

P. O. Box 267 Salt Lake City, Utah 84110

© 1968 by Kedman Co.

ARROW T-50

HEAVY DUTY

STAPLE GUN

Uses 6 staple sizes from 1/4" to 9/16", including CEILTILE

A HANDY CHECKLIST OF HOUSEHOLD FASTENING USES

\$12.95

- Install ceiling tile
- Apply insulation
- Fasten weatherstripping
- Reupholster chairs
- Fasten fence wire to posts
- Repair window screens
- Secure antenna wiring
- Tack down stair treads
- Replace worn window shades
- Attach vines to trellises
- Tack carpet underpadding
- Apply polyethylene vapor barriers
- Make window boxes
- Trim kitchen shelves
- Line closets
- Fasten burlap around tree trunks
- Cover valances
- Hang drapes
- Affix wall decorations
- Install plastic wall brick

SHOOT A STAPLE WHEREVER YOU'D DRIVE A NAIL!
FASTER . . . BETTER . . . CHEAPER . . .

At Hardware, Lumber and Building Supply, Stationery and other retail outlets

ARROW FASTENER COMPANY, INC., Saddle Brook, N. J. 07663

Less work for Father

when he uses tools coated with TEFLON-S*. With TEFLON-S, handsaws won't bind, pruners and other garden tools won't gum up with sap, wood planes glide smoother and won't drag, power saw blades last longer and cut cleaner. And all TEFLON-S coated tools resist rust. TEFLON-S will make your father's days a little smoother.

*Reg. U.S. Pat. Off. for Du Pont's non-stick finishes.



DU PONT
REG. U.S. PAT. OFF.

Better things for better living
...through chemistry

© 1978 DuPont de Nemours and Company, Inc. All rights reserved. Registered trademark of DuPont de Nemours and Company, Inc.



**So you won't lose
your cool
or your heat...**

**follow this handy "R/Value" chart
when you order J-M Foil-Faced
Fiber Glass Insulation.**

Installation	J-M Foil-Faced Fiber Glass Insulation Recommended	Recommended R/Value
Ceiling	Super-Thik Ful-Thik	R-19 R-13
Wall	Medium	R-10
Floor	Ful-Thik	R-15

*The higher the R/Value, the better the insulating value.
So, for economy of operation with electric heat and/or
air conditioning—use higher R/Value products.*

Johns-Manville puts an R/Value on Foil-Faced insulation to be sure you get the protection you need. The R means Resistance—resistance to heat escaping in winter, or entering in summer. Higher numbers mean higher resistance. It's that simple. And it's simple to install J-M Foil-Faced insulation yourself. Because it's so compact and light. With finer glass fibers to trap that escaping heat . . . or cool . . . more effectively. And foil facing for superior protection. Complete details are at your nearest J-M dealer. Or write Johns-Manville, Box 290-BA, New York, N.Y. 10016.

Johns-Manville

POPULAR MECHANICS

TAKE YOUR CHOICE... \$1.00
OR ALL FOUR FOR \$3.00

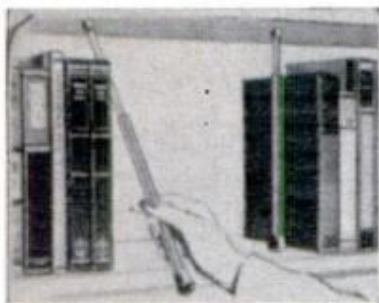

BOOK POLES—Brass-tone aluminum, rubber-tipped, springs inside, tension holds them. Fit shelves 9½" to 13" high. \$1 per pair.



POCKET-SIZED ADDING MACHINE & CALCULATOR — Metal constructed, can add, subtract, multiply, in seconds. Instructions included. \$1 each.



INSTANT DRIP STOPPERS—Self-installing neoprene ball-sealers. Just drop into any faucet—no more washers to replace! Set of 12 in 4 standard sizes. \$1 per dozen. Please add 50¢ per item for postage and packing. Order from:

The Better Mouse Trap Shoppe
 234 5th Avenue, New York 10001

SIX-FOOT VINYL SIPHON—Starts with a squeeze. A must for every motorist for emergencies! Transfers a gallon in 90 seconds. \$1 each.

HOW TO FIND OUT IF YOUR IDEA CAN BE PATENTED... FREE!

Take Advantage of The Services Offered by U.S. Patent Office!

At Last! New easy-to-follow manual—written for the amateur—clears up the mysteries about obtaining a patent. Protect your ideas! In complete secrecy—from your home—and at no cost whatever—you can check to see if your idea has been previously patented, and look over patents of a similar nature.

Did you know that your Patent Office issues about 100 patents each day, and that about 40% go to independent inventors from all walks of life? The basic requirements for a patent are "it must be new—it must be useful—and it must work."

This manual shows how to seek financial assistance if required—how you can list your patent for sale in the Department's "Official Gazette" which is read by the big corporations who pay millions in Royalties for new inventions—gives lists of publications and services available to inventors, for pennies from the Government Printing Office.

Crammed with facts, years of research have gone into this Manual!

Just off the press, it is available by mail for \$3.00 from Independent Inventors Assn., 234 5th Avenue, New York 10001.

GUARANTEE: Your money back immediately and without question, if not delighted!

LAKEFRONT LANDS FOR SALE

IN ONTARIO, CANADA—ONE OF THE WORLD'S BEAUTY SPOTS



Booming Ontario, land of a quarter million lakes, Canada's wealthiest province, welcomes visitors, settlers and investors. A country of four distinct seasons—Gentle Springs, lush, warm Summers, breathtaking Falls, and Invigorating Winters.

Accessible by fine 4-lane toll-free roads, radiating into the land, right from U.S. Border. Friendly people to welcome YOU! U.S. citizens may buy, build and sell real estate in Canada, under the same conditions as Canadian citizens. You are not obliged to live on any property you own or carry out any improvements.

HERE ARE A FEW OF HUNDREDS OF PROPERTIES AVAILABLE:

- 35 Acres in mineral-rich Huffman Township on Shore of Rice Lake. \$1003.
- 21 Acres lying along lazy Spanish River in Sheddon Township on Lake Huron. \$1460.
- Building lot right in town, close to stores, school and all facilities at Larder Lake. \$174.
- 115 Wooded acres in Westmeath Township—Great deer country. \$1763.
- 50 Acres in rugged Strong Township—crystal streams bulge with fighting trout. \$1365.
- 80 Acre Farmland Retreat in Cane Township with good roads and services. \$1278.

There are many, many more properties available at similar prices on Lakes, Rivers, and Streams of interest to sportsmen, farmers, and investors. Write for a descriptive booklet, together with very detailed maps and complete descriptions. Sold on monthly terms. Please remit \$2.00 to cover maps, postage, packaging. (Refundable)

Municipal Tax Land Disposal Agency, 36 Shelly St., Georgetown, Ontario, Canada. Attn: Henry G. Janssen. Phone: (416) 366-4349 Cables: MUNTAX.

The Better Mouse Trap Shoppe

234 5th AVENUE, NEW YORK 10001

Fox Mini-Bike

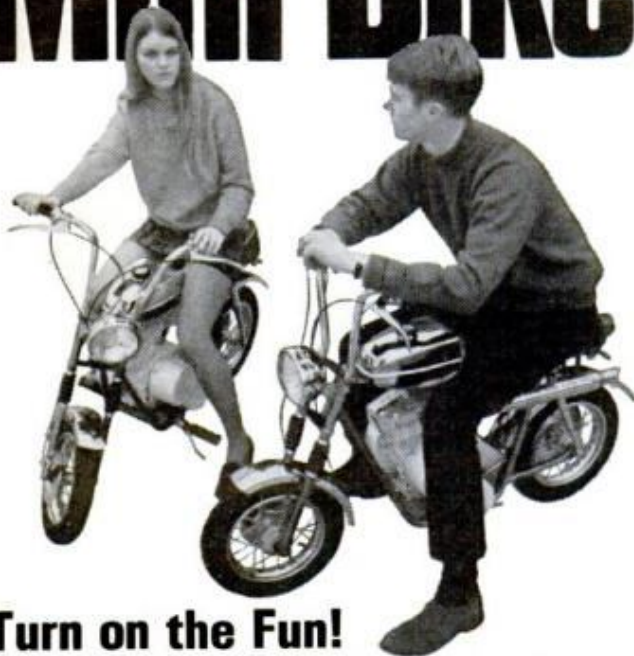

Turn on the Fun!

Outclass and Outperform Anything that Goes!

Fox builds the world's most wanted mini-bikes! *Exciting trail models* for Trail Blazing, hunting, fishing and camping... *Finest campus bikes* for swingers, shoppers, swimmers... A "hot dogger" scrambler that's not a bit timid for the field or track. Many models are street licensable.

FOX CORPORATION

Janesville, Wisconsin 53545
Also makers of the World Famous
FOX TRAC SNOWMOBILES and GO KARTS®

Be a SURVEYOR & MAP MAKER



Join a Surveying Team—get in on planning of America's highways, bridges, dams, subdivisions, etc. Wonderful outdoor work. Ideal for those who like to work with their hands. 1000s exciting big pay jobs open now to qualified men. U.S. Bureau of Labor Statistics predicts shortage of 50,000 civil engineering technicians (Surveyors, etc.) by 1975 as construction of highways, airfields, waterways skyrockets upward. Our easy step-by-step home-study plans have helped 1000s beginners toward prestige salary, security. Big 68-piece Surveying Kit (training transit, drawing, instruments, etc.) given to you when you enroll. Thousands of Surveyors got their start through home-study. You can too! Send for "SURVEYING CAREER KIT"—ALL FREE! No salesman will call. Write & state age.

NORTH AMERICAN SCHOOL OF SURVEYING & MAPPING
4500 Campus Drive • Dept. 4176, University Plaza, Newport, Calif. 92660

MOLDS

for making
Ornamental Concrete
Items...



Book about Aluminum
Molds with prices and
production trade secrets
direct from world's larg-
est mold manufacturer.

SEND
\$2.00

CONCRETE MACHINERY COMPANY, INC.

P. O. BOX 99 • HICKORY 2, N. C. 28601

ENJOY YOUR OWN BUSINESS

Start earning at once—No special experience required

A SHOP
IN ITSELF
AUTOMATIC
FOOLPROOF

STAND-ALL Model 7

Sharpens & Retoots Hand
Saws 3 point through 16
point. SHARPENS—BAND
SAWS—HACK SAWS—
WOOD AND METAL
CUTTING SAWS
with straight back
and identical tooth profile.

SMITH-NIELSEN
EQUIPMENT CO.

P-69
Mfg. of Saw Grinders—Distributor of Complete Saw Shop Equip.
Box 2505 Terminal Annex, Spokane, Washington 99220 FA 8-6680

WORLD'S FINEST CORED SOLDER

ERSIN MULTICORE 5-CORE SOLDER

BUY IT AT
RADIO-TV
PARTS STORES

EASY DISPENSER
ONLY 69¢

NEW PORTABLE MACHINE STAMPS BIG PROFITS!



"ENGRAVE" Social Security Plates, Identifi-
cation Plates, Fraternal, Religious, Door/
Name Plates, Medical Plates & Tags, Dog
Tags, Key Protectors, etc.

WE SUPPLY EVERYTHING! Print name,
address, zip code and Social Security Number; enclose 50c for
your personal Social Security Plate with Carrying Case, plus
24 page booklet "Big Money in Home Business"
FREE Supply Catalog (in color with pictures)
Social Security Earnings (your personal record)

PERMA-PRODUCTS, INC. 16511 N.E. 6th Ave., Dept. M-9
North Miami Beach, Fla. 33162



Bob Jones boosted his salary 300%*. Could you do the same?

A few years ago, he was just another guy. Putting in long hours in a monotonous job. Barely able to make ends meet. No prestige. And no opportunity to get ahead.

But Bob Jones had determination. He looked around and saw other men being promoted. Men with no more on the ball than he had. Except for one thing. Specialized training that made them worth more to their employers.

So then and there Bob made up his mind to get out of the rut he was in. He read an ad for International Correspondence

Schools, and mailed the coupon. (The same coupon you see at the bottom of this page.) And though he didn't know it, he'd already taken his first step up.

Soon, Bob was busy studying in his spare time. Learning new skills, and applying them in his work. It wasn't long before he was offered a better job, with a fat increase in pay. Then came other promotions—and each time, more money. Bob Jones was starting to go places. The future was bright. Today, his salary has skyrocketed 300%!

Bob Jones' success story isn't unique. It simply proves what determination can do. You can do it, too, if you're even half as interested in making good. Pick the position you want, and I.C.S. will help you prepare for it. Just as it helped Bob Jones, and hundreds of thousands of others.

Clip this coupon now. Mail it at once. You'll receive 3 valuable booklets—free. They'll prove to you that Bob Jones' success story can be yours!

*The true story of Robert E. Jones, Houston, Texas. From the success files of I.C.S.

More than 7,000,000 men and women have already enrolled with I.C.S.

ICS® International Correspondence Schools Division of Intext

ICS, Scranton, Pa. 18515
Canadian residents use this address for service from ICS Canadian, Ltd. In Hawaii: P.O. Box 418, Honolulu.

Take your first step . . . mail this coupon today . . . ICS, Scranton, Pa. 18515.

I'm interested in a program of independent study. Send me your free 3-booklet Success Kit: (1) "How to Succeed," 30 pages of valuable job tips, (2) Sample text demonstrating famous ICS method, (3) Catalog for subject checked below . . .

Miss _____ Age _____
Mrs. _____
Mr. (Please print) _____
Address _____
City _____ State _____ Zip Code _____
Occupation _____ Employed by _____ Working Hours _____ A.M. to _____ P.M.

ACCOUNTING
 Accounting (U.S. or Can.)
 Cost Accounting
 General Accounting
 Practical Accounting
 Public Accounting

ARCHITECTURE and BUILDING TRADES
 Air Conditioning
 Air Conditioning Maint.
 Architecture
 Arch. Drawing & Design
 Building Contractor
 Carpenter-Building
 Carpentry & Millwork
 Heating & Air Conditioning with Drawing
 House Planning, Int. Design
 Plumbing
 Plumbing & Heating
 Reading Arch. Blueprints
 Refrigeration

ART and DESIGN
 Commercial Art
 Commercial Cartooning

Interior Decorating
 Sign Painting & Design
 Sketching & Painting

AUTOMOTIVE
 Auto Body Rebuilding & Refinishing
 Auto Mechanic-Techn.
 Diesel-Gas-Motor Vehicle Engines
 Auto. Electrical Techn.
 Engine Tune-Up
 Transmission Specialist

BUSINESS
 Advertising
 Business Administration
 Industrial Psychology
 Managing a Small Store
 Personnel-Lab. Ref'ns
 Purchasing Agent
 Retail Business Mgmt.
 Traffic Management

BUSINESS: SALES
 Creative Salesmanship
 Real Estate Sales
 Sales & Sales Mgmt.

CHEMICAL
 Analytical Chemistry
 Chemical Engineering
 Chem. Lab. Technician
 General Chemistry
 Plastics Technician

CIVIL ENGINEERING
 Civil Engineering
 Highway Eng. Tech.
 Sewer Plant Operator
 Surveying & Mapping
 Water-Works Operator

COLLEGE COURSES
 American History
 Calculus Economics

COMPUTERS
 COBOL Programming
 Fortran Programming
 Programming for Digital Computers
 Programming the 360
 Programming the 1401

DRAFTING
 Aircraft Drafting
 Architectural Drafting

Blueprint Reading
 Design Drafting
 Drafting Technology
 Electrical and Electronic
 Mechanical
 Structural

ELECTRICAL
 Electrical Engineering
 Appliance Servicing
 Elec. Eng. Technician
 Industrial Elec. Technician
 Motor Repairman
 Practical Electrician
 Practical Lineman

ENGINEERING (Refresher Courses for Graduate Engineers)
 Chemical Civil
 Electrical Industrial
 Mechanical
 Sanitary Structural

HIGH SCHOOL
 High School Business
 High School General

High School Math.
 High School Secretarial
 High School Vocational
 College Preparatory
 Preparatory Course for H.S. Equivalency Test

MACH. SHOP PRACTICE
 Machine Shop Practice
 Maintenance Mechanic
 Reading Shop Prints
 Tool & Die Maker
 Welding, Gas & Elec.

MECHANICAL
 Mechanical Engineering
 Aircraft Mechanic
 Hydraulic, Pneumatic Power
 Industrial Engineering
 Industrial Instrumentation
 Machine Design
 Power Plant Engineering
 Quality Control
 Refrig., Air Conditioning
 Tool Design

Vibration Analysis and Control
SECRETARIAL
 Clerk-Typist
 Secretary, Legal
 Secretary, Medical
 Secretary, Professional
 Shorthand
 Stenographic Typist

TV-RADIO-ELECTRONICS
 Color TV Servicing
 Electronics Fundamentals
 Electronic Technician
 General Electronics
 Indust. Electronics Tech.
 Practical Telephony
 Radio Telephone License
 TV and Radio Servicing with Equip. Training

WRITING
 English and Writing
 Free-Lance Writing
 Other (Please specify)

L1569E

Science Worldwide BY JOHN F. PEARSON

Formaldehyde, the most complex molecule ever discovered in space, has been identified by astrophysicists using the 140-foot radio telescope at West Virginia's National Radio Astronomy Observatory. They say the molecule—made up of two hydrogen atoms and an oxygen atom bonded to carbon—is widely distributed in interstellar clouds of dust and gases. Scientists believe that formaldehyde may play a role in the origin of planetary life.

Concrete can be made four times stronger than normal with the addition of plastic, according to the Atomic Energy Commission. Hardened concrete is soaked in a bath to allow its pores to sop up a liquid plastic. Irradiation with cobalt 60 for several hours turns the liquid into a tough polymer, in which individual units of plastic (monomers) are joined in chains. In addition to providing added strength, says the AEC, the plastic prevents water from entering the concrete and reduces the effects of abrasion, erosion and corrosion.

The level of DDT is so high in the Baltic Sea that it's dangerous to eat regularly certain fish from those waters. That's the finding of Swedish Institute of Public Health researchers, who say that the Baltic is now the most polluted area of water in the world. Baltic seals, for example, are reported to contain 125 milligrams of DDT per kilogram (2.2 lbs.) of fat, more than eight times the amount of DDT found in seals in the North Sea. Except for a strait (to the North Sea) between Sweden and Denmark, the Baltic is landlocked and has many rivers emptying into it.

A crystal power pack provides the oomph for a family of radical new industrial devices invented at Ohio State University. One device, which contains two flat crystals separated by copper electrodes and compressed tightly within a steel housing, changes electricity into sonic energy powerful enough to melt a common nail or to weld thick steel bars. The secret is that the crystals are piezoelectric: When they are compressed they give off an electric current; when a current is fed into them, they change in size and vibrate. Power packs also enable motors to convert electricity into mechanical motion with 97.5 percent efficiency, a big gain over the 80 percent efficiency associated with the common electric motor.

Soothing music may be played to cattle before slaughter—if research at Kansas State University continues to demonstrate that loud noises cause "dark cutters" in beef. The meat of dark cutters is abnormally dark in color and is considered less desirable by the consumer. In one Kansas State experiment a group of cattle was subjected to playbacks of traffic noises, the roar of jet engines and the clanking of heavy equipment at work. A control group was provided a normal acoustical environment. The results: The stressed animals produced darker meat than the control group. The Kansas State research was prompted by observations at a commercial packing plant that when the background music usually provided workers was turned off there was an increase in the number of dark cutters produced.

A system of automatic identification of railway cars is scheduled for nationwide use next year. Color-coded reflective strips on the sides of cars will provide information such as the type of car, identification number and owner. The strips are read by wayside scanners—electro-optical devices—as cars pass checkpoints. The scanners convert the optical signals into electrical impulses that are processed by a decoding mechanism. The information is then fed to a central computer which keeps track of cars en route in all sections of the country. A total of 1.8 million cars will be in the system.

"Fingertip sight" enables blind operators to work switchboards of a New South Wales, Australia, powerplant, according to *Medical World News*. The operator wears a small sensor—a light-sensitive probe—on his index finger. When it detects light, the probe emits an audio signal. The operator runs his finger along the switchboard until the probe zeros in on the particular key that's lighted. ★★★



"FISH" WITH A MAGNET

Go treasure hunting on the bottom! Great idea! Fascinating fun and sometimes tremendously profitable! Tie a line to this powerful, but lightweight Magnet—drop it overboard in bay, river, lake or ocean. Troll along the bottom—your "treasure" haul can be outboard motors, anchors, fishing tackle—all kinds of metal valuables. Specially designed plastic coated horse-shoe-shaped with $3\frac{1}{8}$ " sq. gripping surface. Tremendous lifting power—over 150 lbs. on land, much more under water. NO. 71,135H...150 LB. PULL...\$12.50 Ppd. NO. 71,150H...75 LB. PULL...\$8.75 Ppd.

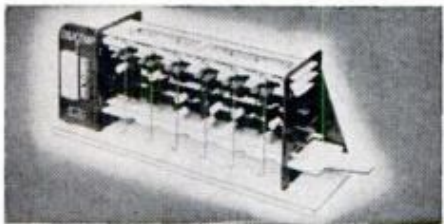

MODEL DIGITAL COMPUTER

Solve problems, teach logic, play games with miniature version of giant electronic brains! Adds, subtracts, multiplies, shifts, complements, carries, memorizes, counts, compares, sequences. Colored plastic parts easily assembled. $12" \times 3\frac{1}{2}" \times 4\frac{3}{4}"$. Incl. step-by-step assembly diagrams, 32-page instruction book covering operation, computer language (binary system) programming, problems and 15 experiments.

Stock No. 70,683H\$5.98 Ppd.



AMER. MADE OPAQUE PROJECTOR

Projects illustrations up to $3" \times 3\frac{1}{2}"$ —enlarges them to $35" \times 30"$ if screen is $6\frac{1}{2}$ ft. from projector, larger if screen farther away. No film or negatives needed. Projects charts, diagrams, color, black-and-white. 115 V A.C. Operates on 60 W bulb, not incl. $12" \times 8" \times 4\frac{1}{2}"$. 1 lb. 2 ozs. Plastic case.

Stock No. 70,199H\$7.95 Ppd.

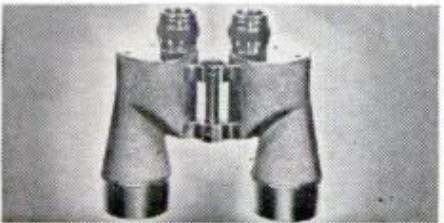

AMERICAN-MADE 7x50 BINOCULARS

Big savings! Brand new! Crystal-clear viewing—7 power. Every optical element is coated. An excellent night glass—the size recommended for satellite viewing. Individual eye focus. Exit pupil 7 mm. Approx. field at 1,000 yds. is 376 ft. Carrying Case included. American 7 x 50's normally cost \$274.50. Our war surplus price saves you real money.

Stock No. 1544H\$74.80 Ppd.
Stock No. 963H...6x30...\$40.00 Ppd.



SEE MUSIC IN DAZZLING ACTION

Music Vision Dramatic Breakthrough in Audio-Visual Enjoyment

Actually see favorite musical selections translated into fantastic patterns of beautiful color—each individual note creating its own unique, twisting, radiating shape . . . each shape dancing and prancing, whirling and swirling in perfect time with the music. Attach to stereo, radio, tape recorder. Send 25¢ for booklet #9096H.

8" DO-IT-YOURSELF KIT
Stock No. 71,009H\$22.50 Ppd.

8" SET
Stock No. 71,030H\$45.00 Ppd.

WALNUT CABINET MODEL
Stock No. 85,181H\$99.50 FOB

KEEP PACE WITH THE SPACE AGE!

AMAZING BARGAINS

for Fun • Study • Profit
from
EDMUND SCIENTIFIC CO.
300 Edscorp Building
Barrington, N. J. 08007



DIAGNOSE MECHANICAL TROUBLE

Professional Stethoscope. Designed for use by physicians, this super-sensitive Stethoscope is ideally suited for detecting faults in machines and engines, and in fluid, air and gas leakage. Dozens of uses in auto repair shops, labs and for hobby and educational applications.

Stock No. 50,270H\$7.50 Ppd.

BARGAIN PRICE STETHOSCOPE

Stock No. 50,223H\$3.25 Ppd.

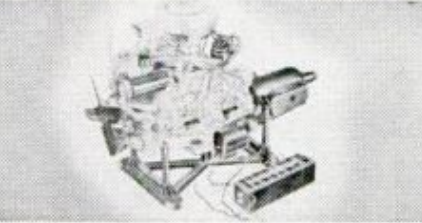

PLASTIC MODEL V-8 ENGINE

Hours of fun! Get thrill of building your own easily assembled engine from over 350 parts. Then push starter and watch it run. Crankshaft revolves, pistons move, valves open and close in sequence with spark plugs. Does everything but burn oil. $\frac{1}{4}$ scale molded in 4 colors. Same motor used in many auto-mechanic courses. Excellent, easy-to-understand "tech manual".

Stock No. 70,448H\$12.95 Ppd.



FLY 9-FT. HOT AIR BALLOON

9 Ft. tall. Rises to amazing heights on just hot air. Tether attached, can be used repeatedly. Easy to make, launch, fly, loads of fun. Great for celebrations, science fairs, plain fun. Will lift model gliders, parachutes, instruments, etc.—anything up to $\frac{1}{2}$ lb. Approx. 5 ft. diam. when fully inflated. Kit contains 10 pre-cut red & white gores (No. 1 model paper), 6 ft. 14-gauge wire for bottom ring, top, "tie-off" cord, complete instructions.

Stock No. 60,691H\$2.00 Ppd.



GIANT WEATHER BALLOONS

"Balls of fun" for kids, traffic stoppers for stores, terrific for amateur meteorologists. Create a neighborhood sensation. Great backyard fun. Exciting beach attraction. Amateur meteorologists use to measure cloud heights, wind speed and temp. Heavy duty neoprene. Inflate with vacuum cleaner or auto air hose; or locally available helium for high rise.

Stock No. 60,568H...8'\$2.00 Ppd.

Stock No. 60,632H...16'\$7.00 Ppd.



WOODEN SOLID PUZZLES

Here's a fascinating assortment of 12 different puzzles to provide hours of pleasure and stimulate ability to think and reason. Animals and geometric forms. Take them apart and reassemble them. Lots of fun for the whole family—young and old. Will test skill, patience and ability to solve problems. Order yours now.

Stock No. 70,205H\$4.00 Ppd.

MONEY-BACK GUARANTEE

Order by Stock No.—Send Check or M.O.

GIANT FREE CATALOG

148 Pages! More than 4,000

UNUSUAL BARGAINS

Completely new Catalog. Packed with huge selection of telescopes, microscopes, binoculars, magnets, magnifiers, prisms, photo components, parts, kits, accessories—many hard-to-get surplus bargains. 100's of charts, illustrations. For hobbyists, experimenters, schools, industry. Mail coupon for FREE Catalog "H".

EDMUND SCIENTIFIC CO., 300 Edscorp Building, Barrington, N. J. 08007.

NAME _____
ADDRESS _____
CITY _____
STATE _____ ZIP _____

Introducing: Elmer's improvements on the nail and screw.



Elmer's® new Heavy Grip® Cement does what nails and screws can't.

It installs things like towel bars and brackets to tile, metal, concrete, brick, plastic. Just about anything.

And it's so strong that parts need no support while Heavy Grip is setting.

Elmer's Panel Fast® eliminates nails and screws. You can install any kind of paneling with it. You can even reposition a panel while Panel Fast is setting.

And, if a stud or furring strip is set back too far, Panel Fast will fill in the gap.

These improvements are brought to you by the makers of Elmer's® Glue-All, America's favorite glue.

Free. A guide to gluing, taping and spray painting. Mail a stamped, self-addressed envelope to: Borden Inc./Chemical Division, Dept. B-2, 350 Madison Ave., N.Y., N.Y. 10017.



THIS IS IT!!!

Now you can give permanent new beauty to any sound floor (tile, wood, concrete) . . . in one day or less! Roll-on amazing 1-2-3-Floor for a long-lasting gloss finish that never needs waxing, won't scuff or dent. Apply it wall-to-wall seamlessly . . . choose from wide range of colors to match your decor. Perfect for counter tops, tables, walls, too. 1-2-3-Floor goes on easy as 1-2-3:



1. Apply base coat on pre-cleaned floor with roller (or brush).



2. Apply clear plastic, sprinkle on decorator chips and seal with another coat of clear plastic.



3. Lightly sand, then finish with final coat of clear plastic.

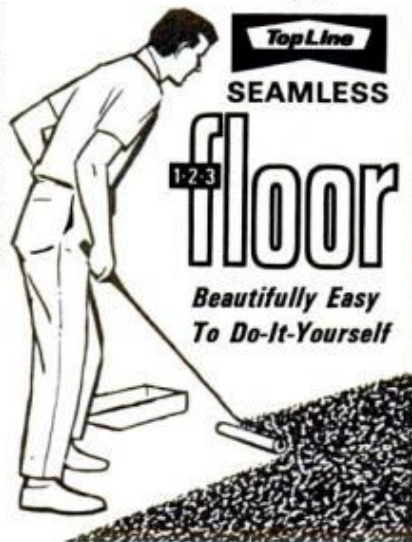

Ask your hardware dealer or write
TOP LINE DIV. OF OATEY CO.
Cleveland, Ohio 44135

MY SPARE TIME HOBBY MAKES ME

\$500 an hour

CASH PROFIT

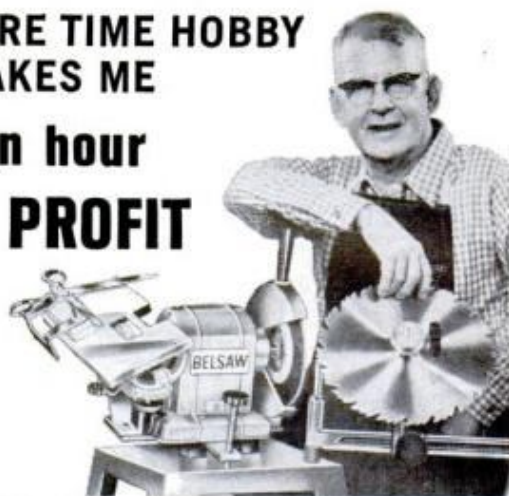

START YOUR OWN SPARE TIME BUSINESS

You can turn your spare time into Big Cash Profits with your own **COMPLETE SHARPENING SHOP** . . . Grind saws, knives, scissors, skates, lawn mower blades . . . all cutting edges. Your Own Cash Business with no inventory . . . right at home . . . no experience needed.

FREE BOOK tells how you can start your own spare time business while you are still working at your regular job. Low Cost—time payments only \$15.00 a month. **Send coupon today.**
No Salesman Will Call.

FREE BOOK

BELSAW SHARP-ALL CO., 719H Field Bldg., Kansas City, Mo. 64111
Send Free Book, "LIFETIME SECURITY." No obligation.

Name _____

Address _____

City _____ State _____ Zip _____

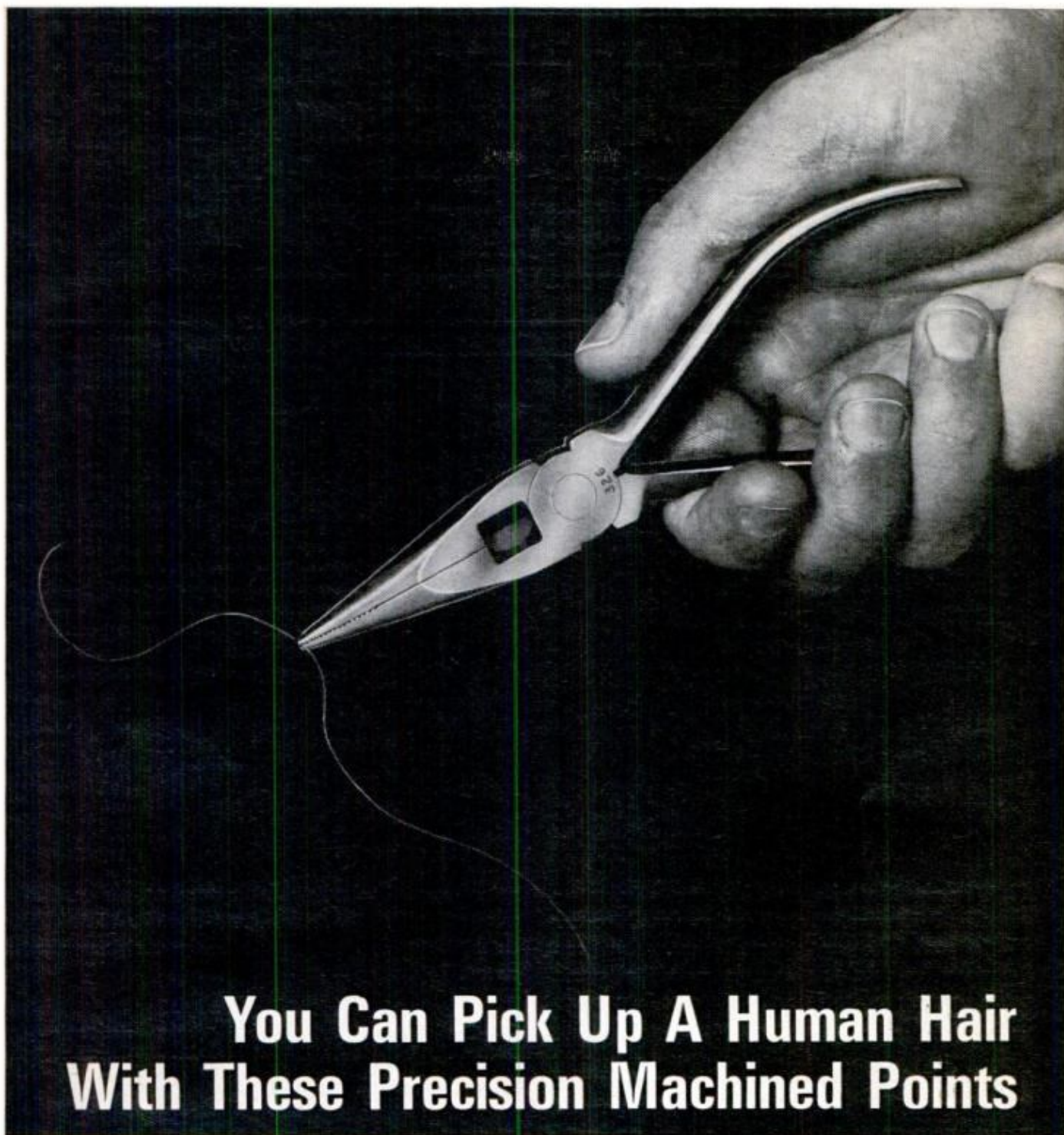

You Can Pick Up A Human Hair With These Precision Machined Points

Dentists would call the exact matching of the fine teeth and jaws of this plier "perfect occlusion." You'll call it the niftiest long nose plier you've ever used. It's precision made of full-polished highest quality drop-forged steel with smooth working moving parts and hand honed cutting edges — in short, designed and

made to do a better job, time after time, year after year. And the expert craftsmanship you see here is typical of the entire line of Channel-lock hand tools . . . good reason why Channel-lock is the first choice of discriminating tool users the world over.— Let us send you our catalog, no charge.

TOOLS BY
CHAN NEL LOCK[®]
MEADVILLE, PA.

Drivin' with Dan

How are compression and torque measured? Why are they eliminating overdrive? What do you think of women drivers? What's the right way to down-shift? Dan Gurney answers these and other automotive questions



GURNEY (right) with stock-car ace Cale Yarborough (center) and drag-racing king Don Nicholson, each a member of Mercury's Sports Panel. The three were gathered to demonstrate to the press the different types of steed in which each has roared his way to racing stardom

Q. Why are the auto manufacturers eliminating overdrive? The fuel savings on an overdrive car will almost buy an air conditioner. How can American automakers be persuaded to again make overdrive available?—Richard Schwanke, Glen Ellyn, Ill.

A. I think that overdrive has been replaced by automatic transmissions, or four-speed manuals, plus the wide range of optional gear ratios available and equivalent to the overdrive ratios. Think of an overdrive as a complicated and inefficient way of having a four-speed and maybe you can trick yourself into not missing it too much. I used to like it, too!

Q. I would like to know if you ever plan to enter off-road racing, and if so, what type vehicle would you use—motorcycle, jeep or dune-buggy?—John Ross, Santa Monica, Calif.

A. I would like to do it sometime. Although motorcycles have been tops so far, I'd probably choose a four-wheel drive vehicle of

some sort. I don't ride a motorcycle well enough to be really serious about it. I should do better with four wheels. The racing sounds great.

Q. Could you tell me what torque and compression ratios are and how they are measured?—Tony Capitelli, Pittsburgh.

A. In the United States, torque is expressed in foot-pounds of force. Normally, it is measured on a dynamometer, which is a form of brake. (You could actually use a brake drum or disc as a dyno if you could keep it cool enough.) Anyway, you get the engine running and apply the brake to the drive shaft. Then imagine the brake being attached to an arm one foot long extended out from the center line of the shaft. The shaft tries to twist the brake. This amount of twist can be measured with a scale at the end of the arm. A scale reading of 300 lbs. would, of course, be 300 ft.-lbs. of torque. Measure the volume in the cylinder and combustion

(Please turn to page 28)

The first alternative to the station wagon.



Until now, if you wanted a car that could carry a lot, you had to buy a station wagon. The trouble with a station wagon is, one—it looks like a small truck and, two—most

of the time it travels around empty, anyway.

Renault 16. It carries a lot without looking like a truck. Something we've achieved through a more intelligent use of interior space. The back seat has an ingenious way of folding out of the way, while a huge back door makes all the room easy to get to.

Of course, there's more to superior traction. The front seats recline for sleeping. It has 4-wheel independent suspension, disc brakes up front, a top speed of 93 m.p.h., and squeezes 30 miles out of a gallon of gas.



of the time it travels around empty, anyway.

Thanks to Renault you now have an alternative. The

Of course, there's more to



the Renault 16 than just empty space. The front-wheel drive, for instance, gives you



Consider everything about the Renault 16 Sedan-Wagon, including the \$2,445* price.

Is there any alternative?

RENAULT 

For information see your dealer or write Renault Inc., 100 Sylvan Avenue, Englewood Cliffs, New Jersey 07632.

*P.O.E. East Coast.



Copenhagen[®] Tobacco isn't for smoking. It isn't lit, puffed or inhaled. It's too good to smoke.



Put a pinch between gum and cheek, and enjoy it. Without even chewing. It's too good to smoke. Copenhagen gives you all the satisfaction of prime aged tobaccos. It costs less, too. Sure beats smoking!



For information on how to use Copenhagen, please write: Dept. PM
United States Tobacco Company, 630 Fifth Ave., New York, N.Y. 10020

Copenhagen's partners: Skoal[®] Wintergreen Happy Days[®] Raspberry Tobacco

Bore 35 standard holes with just one tool

New IRWIN Expansive Bit lets you dial your size

Just turn the dial and you're set to go with this new Irwin Expansive bit. No hunting for the size you need. Fits all hand bit braces. Clean, fast, accurate boring action from $\frac{7}{8}$ " to 3"—35 standard hole sizes in all!

And what a really fine precision tool to own. It's drop-forged from special bit steel, heat treated full length, machined for accuracy and sharpness, highly polished, too. Two cutters supplied with each bit. Model No. 21 with $\frac{5}{8}$ " to $1\frac{3}{4}$ " boring range also available. Ideal for home handyman, professional woodworker, or farm. See your independent hardware or building supply dealer soon.



**No. 22
Micro
Dial
only
\$5.00**
 $\frac{7}{8}$ " to 3"
boring
range

IRWIN every bit as good
as the name

at Wilmington, Ohio, since 1885



EARN HIGH WAGES as a HEAVY EQUIPMENT OPERATOR

Train your way to high pay in the booming construction industry! Learn the skills you need to qualify, by actual field training on machines like the ones used by the industry. Huge training grounds in North Carolina, a million dollars worth of school-owned diesel-engined machines, experienced instructors, full 220-hour and 440-hour courses. National, the original school of heavy equipment operation, is a recognized leader. Member American Road Builders Assn., Services and Supply Division. Associate Member A.G.C. Full-time Job Advisory and Counseling Director on staff. VA approved. For men ages 17 to 56. Train Now-Pay Later plan . . . other payment plans also available. Write TODAY for FREE catalog and FREE copy of school newspaper reporting news of National School graduates. Accredited member NATTS.

NATIONAL SCHOOL
OF HEAVY EQUIPMENT OPERATION, Dept. D-28
P. O. Box 1686, Moores Chapel Road, Charlotte, N. C. 28201
Please send me FREE illustrated school catalog and complete information. I understand there's no obligation.

Name _____ Age _____
Address _____ Phone _____
City _____ State _____ Zip Code _____

106

Pc.

PROFESSIONAL

SOCKET WRENCH & TOOL SET

DO ANY JOB • FASTER • BETTER • EASIER!

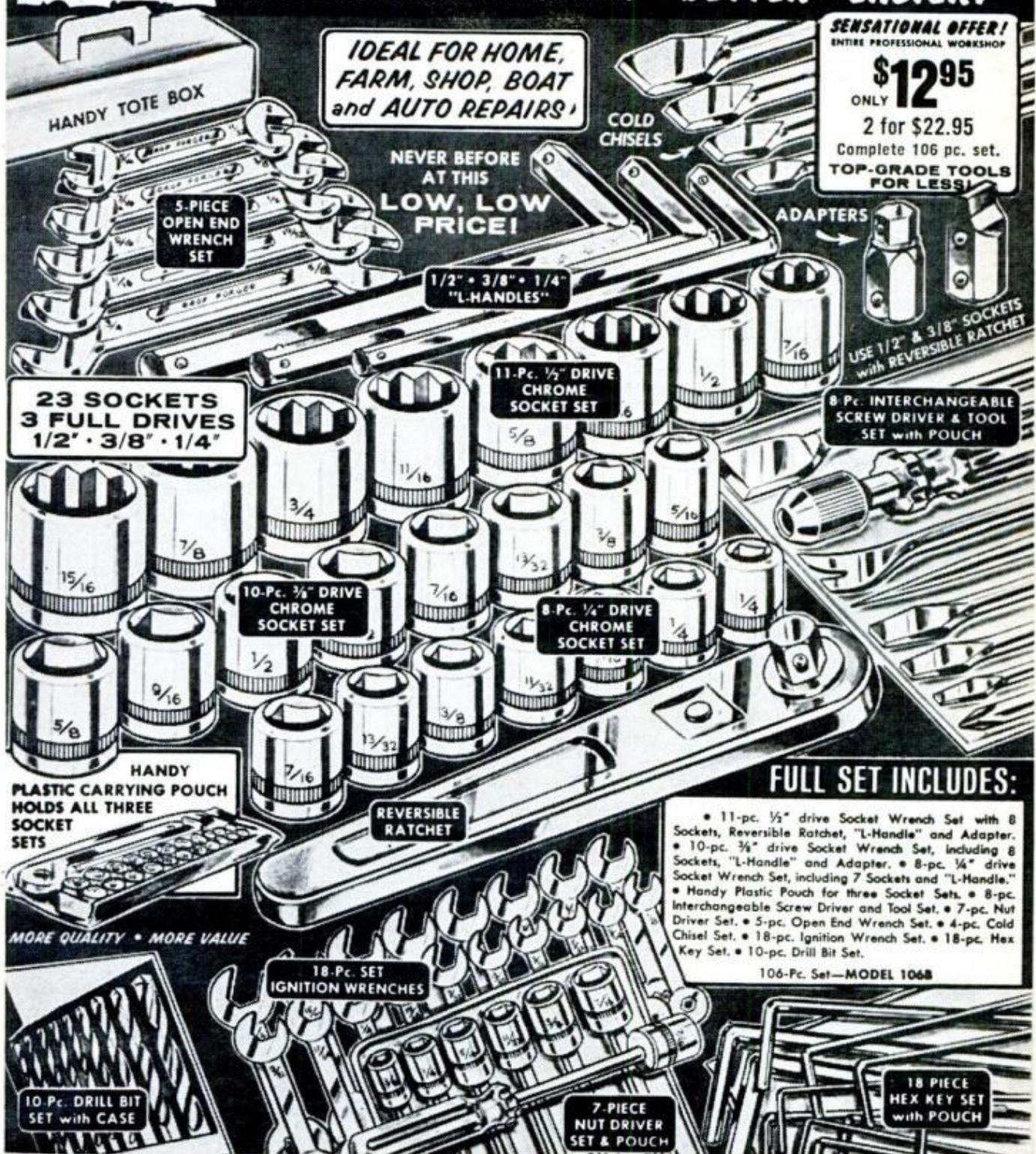

SENSATIONAL OFFER!
ENTIRE PROFESSIONAL WORKSHOP

\$12.95

ONLY
2 for \$22.95

Complete 106 pc. set.
TOP-GRADE TOOLS FOR LESS!

**IDEAL FOR HOME,
FARM, SHOP, BOAT
and AUTO REPAIRS!**

**NEVER BEFORE
AT THIS
LOW, LOW
PRICE!**

HANDY TOTE BOX

5-PIECE
OPEN END
WRENCH
SET

COLD
CHISELS

ADAPTERS

1/2" • 3/8" • 1/4"
"L-HANDLES"

USE 1/2" & 3/8" SOCKETS
with REVERSIBLE RATCHET

23 SOCKETS
3 FULL DRIVES
1/2" • 3/8" • 1/4"

11-Pc. 1/2" DRIVE
CHROME
SOCKET SET

8-Pc. INTERCHANGEABLE
SCREW DRIVER & TOOL
SET with POUCH

10-Pc. 3/8" DRIVE
CHROME
SOCKET SET

8-Pc. 1/4" DRIVE
CHROME
SOCKET SET

HANDY
PLASTIC CARRYING POUCH
HOLDS ALL THREE
SOCKET
SETS

REVERSIBLE
RATCHET

FULL SET INCLUDES:

- 11-pc. 1/2" drive Socket Wrench Set with 8 Sockets, Reversible Ratchet, "L-Handle" and Adapter.
- 10-pc. 3/8" drive Socket Wrench Set, including 8 Sockets, "L-Handle" and Adapter.
- 8-pc. 1/4" drive Socket Wrench Set, including 7 Sockets and "L-Handle."
- Handy Plastic Pouch for three Socket Sets.
- 8-pc. Interchangeable Screw Driver and Tool Set.
- 7-pc. Nut Driver Set.
- 5-pc. Open End Wrench Set.
- 4-pc. Cold Chisel Set.
- 18-pc. Ignition Wrench Set.
- 18-pc. Hex Key Set.

106-Pc. Set—MODEL 106B

MORE QUALITY • MORE VALUE

18-Pc. SET
IGNITION WRENCHES

10-Pc. DRILL BIT
SET with CASE

7-PIECE
NUT DRIVER
SET & POUCH

18 PIECE
HEX KEY SET
with POUCH

106 WAYS TO SAVE BIG MONEY YEAR AFTER YEAR!

Home handyman, amateur mechanic, or just plain tinkerer — here's your chance to get a whole workshop of professional quality hand tools . . . in their own handy tote box — all at an unbeatable low price! Equip yourself with this tremendously versatile, amazingly complete outfit . . . and you're ready for just about any repair job that comes along!

JAY NORRIS CORP.,

Dept. ME-3, 31 Hanse Ave., Freeport, N.Y. 11520

MONEY BACK IF NOT DELIGHTED

JAY NORRIS CORP., Dept. ME-3, 31 Hanse Ave., Freeport, N.Y. 11520

Please rush me the following 106-Pc.

Professional Socket Wrench Tool Sets:

1 Set for \$12.95 2 Sets for \$22.95

I enclose 25% deposit—send C.O.D.

Enclosed is check. money order.

Chge. Diners Club# _____

Name _____

(Print) Address _____

City _____

State _____ Zip _____

ADD 10% for pstg., handling and ins.

DRIVIN' WITH DAN

(Continued from page 24)

chamber with the piston all the way down, then measure it with the piston all the way up. Divide the second into the first and the answer is the ratio expressed as an X-to-1 compression ratio.

Q. *In your opinion, which is the better car, the Lotus-Ford or the BRM?*—Robert Whitbeck, Brighton, Iowa.

A. In my opinion, the current Lotus-Ford is better than the current BRM.

Q. *What do you think the potential of the all-French Matra engine is?*—Dave McMullen, Belleville, N.J.

A. It has excellent potential. Ferrari still seems to maintain a slight edge as far as 12-cylinder engines go, but the Matra engines are extremely capable. Time will tell.

Q. *What is the proper way to down-shift a car with a standard three or four-speed transmission? Should it be done fast, should you double-clutch, and should engine speed be kept up?*—William Klimesh, Calmar, Iowa.

A. I suggest that a tachometer and a speedometer can help you in learning to do it properly. Down-shifting usually involves application of the brakes at the same time, so you should learn to brake with the left part of your right foot and operate the accelerator with the right part. First you depress the clutch pedal, shift to neutral, let the clutch pedal up again, then rev up your engine to the rpm needed to run the car in low gear at the speed it will be traveling at the moment you select the lower gear. If you did it perfectly, you wouldn't need the clutch. But it's better to use it, so depress the clutch pedal and select the gear you want. It takes a little practice, but it's fun if you do it properly. It's not necessary to do it very fast. Instead, at first, try for smoothness.

Q. *Do you know if Jim Hall will race his Chaparral in this year's Can-Am series? Just how bad was he hurt at Las Vegas?*—Mike McLellan, Sunnyvale, Calif.

A. I don't believe he will drive in the 1969 series, but I expect both Jim and the Chaparrals to be on hand, probably with John

Surtees doing most of the driving. Jim was badly hurt, with a broken leg and hip and facial cuts, but is looking forward to a complete recovery without any permanent injuries. I'm told his doctors forecast one year for recovery.

Q. *What do you think of women drivers? Both on the street and on the track?*—Nancy Stoudt, East Greenville, Pa.

A. For one thing, they're better looking. They generally are not as aggressive on the street or on a track. However, women can be very good drivers.

Q. *Dodge offers a 426-cu.-in. engine which produces 425 hp. Chevrolet offers a 427-cu.-in. engine producing 435 hp. Ford offers a 428-cu.-in. engine which produces only 335 hp. Why doesn't FoMoCo beef up its engine to keep up with Dodge and Chevy?*—Mike Garrett, Atmore, Ala.

A. It is all pretty much a numbers game. Most companies offer various versions of their engines. Keep in mind Fords win a lot of races. All the big engines can put out over 500 hp with the right accessories.

Q. *How wide are the tires on your Can-Am cars? What cars will you be using this year?*—Mike Mahanay, Oklahoma City.

A. Approximately 15 inches of tread width on the ground. A modified McLaren or Lola powered by Ford.

Q. *Power steering is wonderful, but what happens on a mountain road, for instance, if it fails to work? Also power brakes? Can you still stop on the downgrade?*—Mrs. Olive Wendling, Chicago.

A. If you have a car with power steering, find a safe place to try it. Just shut your engine off, coast along and steer the car. You'll find it takes more effort, but it can be done. The same goes for power brakes, but I doubt if you could adjust yourself adequately to the effort requirements in an emergency situation. But yes, you can still stop.

If you have questions on racing, high-performance and everyday driving techniques, send them to "Drivin' with Dan," c/o Popular Mechanics, 575 Lexington Ave., New York, N.Y. 10022. Questions cannot be answered by individual letters. Questions on maintenance and repair should be addressed to the Auto Clinic (see page 72).



Now don't you wish you had the DieHard®?

The day is hers. The car is yours.
And she'll never let you forget.

Why is it old batteries never seem to die at a convenient time.

Never.

The convenient thing to do is buy the DieHard before your old battery drops dead.

America's most powerful car battery of its size.

The DieHard is no bigger on the outside but it is on the inside, all because of its polypropylene case. Because the case is a lot stronger, the walls can be a lot thinner and that leaves a lot more room inside. Result: bigger plates and more

acid than any conventional battery. So much bigger plates and so much more acid the DieHard delivers more usable starting power than the best battery anyone else makes.

That's enough power that Sears guarantees the DieHard will keep working for five long years. And that's probably longer than your love affair with your present car will last.

The Sears 5-year guarantee: "Free replacement within 90 days of purchase if battery proves defective.

After 90 days we replace the battery, if defective, and charge you only for the period of ownership, based on the regular price less trade-in at the time of return, prorated over number of months of guarantee."

The DieHard. Sold only at Sears. \$29.95 with trade-in. In Canada, at Simpsons-Sears at slightly higher prices.



Sears
ALLSTATE

DieHard batteries now fit 97% of the 12-volt cars. Sears carries a complete line of other fine batteries, in a wide range of prices. Charge It on your Sears Revolving Charge at over 2500 Sears, Roebuck and Co. stores.

Материал, защищенный авторским правом

START A BUSINESS

in your neighborhood



Sharpen Hand or Power Saws with the

FOLEY SAW FILER

Start your business in sparetime and make CASH PROFITS right away. No stock to carry, no selling involved, no experience needed—the Foley Saw Filer does every sharpening job **automatically!** Earn \$3 to \$6 an hour sparetime in your own garage or basement. Profit 90c on every dollar.

Best of all, every saw you sharpen, will be resharpened again and again—watch your repeat business grow! Add cash to your income now, while you build retirement security with the Foley Saw Filer.



FREE BOOK shows how you can make money as thousands of others have. Send coupon today. There's no obligation, and no salesman will call—so write today!

Foley Manufacturing Co.
616-9 Foley Bldg., Minneapolis, Minn. 55418
Send for **FREE** book on Money-Making facts about the sharpening business.

NAME _____
ADDRESS _____
CITY _____ STATE _____ ZIP CODE _____



MOWER SHARPENER

Precision-grind all hand and power lawn mowers—a perfect job every time.

75 POWER TELESCOPE 25X-45X-75X \$498

NEW 3 in one telescopes, 3 variable 25X, 45X-75X magnification. Brass bound, 25 power for ultra bright images 45 & 75 power for long range. Guaranteed to bring distant stars, moons, objects, sports 75 times closer.

Most powerful scope anywhere at this amazing-low price. 5 sections. Opens 34" closes 1 ft.; contains 4 ground & polished lenses. Can also be used as powerful microscope. American made. Mass production enables us to offer telescope complete including case \$4.98 post paid. Money back guarantee.

CRITERION CO., Dept. PBM-53, 331 Church St., Hartford, Conn. 06101

FREE!
Learn how you can buy used engines \$15 up, new engines \$30 with **FREE** confidential list and coupons when you order your plans

- **BUILD THIS MINI-BIKE!**
Plans reveal step by step details!
- **BUILD A RACING KART!**
Build frame for less than \$10!



RUSH \$2 for plans (indicate type) or send 25¢ for circular describing plans **PLANS**, Box 517, Omaha, Nebr. 68101

TREASURE

Find buried gold, silver, coins, treasures.

5 Powerful models.

Write for free catalog



RELCO DEPT. D-3 **\$19.95 UP**
BOX 10839, HOUSTON, TEX. 77018

WHEN ANSWERING ADS
GIVE YOUR ZIP CODE

LEARN ELECTRONICS

COYNE ELECTRONICS INSTITUTE

- Electronics Engineering Technology—Degree (2 Yrs.)
- Electrical-Electronics Technician—Diploma (40 Wks.)
- TV-Radio-Electronics Technician—Diploma (48 Wks.)
- Complete Electronics Technician—Diploma (88 Wks.)
- Practical Electrical Maintenance—Diploma (32 Wks.)
- Practical Refrigeration Air Conditioning and Appliance Repair—Diploma (24 Wks.)

Special finance plans. Graduate employment service.

MAIL COUPON FOR FREE BOOK

Coyne Electronics Institute Dept. A9-C3
1501 W. Congress Pkwy., Chicago, Ill. 60607
Send information as checked below

- HOME TRAINING in TV, Radio and Color TV Servicing.
- RESIDENT SCHOOL COURSES in Electronics, Electricity, Engineering Technology, Television, Refrigeration, and Air Conditioning.

Name.....Age.....
Address.....
City.....State.....Zip.....

APPROVED FOR VETERANS
Accredited Member: National Association Trade and Technical Schools.



CHARLES ATLAS Says: MY FREE BODY-BUILDING BOOK

Shows How YOU Can Become A REAL HE-MAN



Ashamed of your body? Then tell me, in the coupon below, the kind of body you *do* want. I'll give it to you **FAST**—with my easy, 15-minutes-a-day method of "Dynamic-Tension." I'll make your chest and shoulders bulge, your arms and legs surge with power. I'll give you the kind of body women admire and men envy. *Your friends* will be amazed. *You* will feel like a tiger!

FREE BOOK. Learn how "Dynamic-Tension" made me "World's Most Perfectly Developed Man"—and how I can change YOU. Mail coupon to me: **CHARLES ATLAS**, Dept. 86, 115 E. 23rd St., N.Y., N.Y. 10010.

CHARLES ATLAS, Dept. 86
115 East 23rd St., New York, N. Y. 10010

Dear Charles Atlas, Here's the Kind of Body I Want: (Check as many as you like)

- Broader Chest, Shoulders
 - Iron-Hard Biceps, Grip
 - Powerful Arms, Legs
 - More Solid Weight
- Show me how "Dynamic-Tension" can make me a new man. Send your famous 32-page **FREE** book, full of pictures, valuable advice. No obligation.

PRINT NAME.....AGE.....
ADDRESS.....
CITY & STATE.....ZIP CODE.....
In England: Atlas, Chitty St., London, W.1

In What Business of Your Own Can You MAKE BACK YOUR INITIAL INVESTMENT in as little as TWO WEEKS?

You Can Do It When You're a Successful MERLITE PRESTO SHINE DEALER!

The initial investment in a Merlite Presto Shine Dealership is so modest, and the earnings you can make are so surprisingly high, that it's possible for you to earn back your initial investment in as little as 2 to 4 weeks! How many other business opportunities permit you to recoup so quickly?

Imagine! You Offer a Genuine SIMONIZ PASTE WAX JOB FOR ONLY \$5.95

When you're a Merlite Presto Shine Dealer, the equipment which we supply you and the system which we teach you, enable you to clean, wax and polish a car with genuine Simoniz Paste Wax in as little as 20 minutes! You charge only \$5.95 for this genuine Simoniz wax job—about 1/3 the usual professional charge. Yet you make up to \$5.75 gross profit on every car! Weekly gross profit up to \$500.00 and more is possible—as much as \$25,000-\$30,000 in a year!

NOW, HERE'S WHAT WE OFFER YOU:

1. REMARKABLE PATENTED INVENTION.

You get authorized use of patented HM Polishing Machine (U.S. Patent No. 2,967,315), which amazingly duplicates the motion of the human hand, enables you to start with a dirty car and bring it to a lustrous, gleaming, protected Simoniz Wax finish within as little as 20 minutes!

2. PERSONAL TRAINING IN YOUR AREA WITHOUT A PENNY OF RISK!

Even before you decide to become a Merlite Presto Shine Dealer, we will send one of our skilled Instructors to train you in the use of the HM Polishing Machine and the astonishing Merlite Presto Shine speed method. So easy, even a child can do it, after a little training! After your personal instruction, if you decide not to become a Merlite Presto Shine Dealer, you're not out a penny! You take no risk!

3. PRACTICALLY NO OVERHEAD . . . YOU CAN WORK FROM YOUR HOME.

The HM Polishing Machine operates on ordinary house current, so you can do all the work right at your home, if you wish, and save overhead expenses. Supplies and materials cost you about 20¢ per car, so your gross profit on a \$5.95 Simoniz Wax job is approximately \$5.75!

4. START IN YOUR SPARE TIME.

Many of our most successful Merlite Presto Shine Dealers held on to their full-time jobs, started out in spare time—evenings and weekends. Then, when they saw how much more money per hour they were making with Merlite Presto Shine, they went into full-time business of their own, and stopped punching the timeclock. You can do it, too!

5. TREMENDOUS DEMAND EVERYWHERE.

Your astounding low \$5.95 price draws a steady stream of motorist-customers. You also get big commercial accounts: new and used car dealers, fleet operators such as taxicabs, rent-a-cars, etc., plus service stations, garages and car washes. You need never run out of customers!

COMPLETE PROSPECTUS—FREE . . .
MAIL THIS COUPON TODAY . . .

MERLITE PRESTO SHINE CORP.
1081 Bristol Road, Dept. Y-15P Mountainside, N.J. 07092



"Above you see one of our Merlite Presto Shine Dealerships, operated in conjunction with a parking lot. You can set up your own Merlite Presto Shine Dealership in practically any location—even at home."

Read What Merlite Presto Shine Dealers Say About This Great Opportunity:

Larry Drain of Illinois: "Within 13 days of getting started, profits from the business paid for the initial investment—and that includes my TV and radio advertising. Since then I have been averaging between \$1,000 and \$1,300 a week! Because I cannot handle the business myself, I now have 3 employees who work full time."

Peter J. Strikwerda of New York State: "Yesterday I did a 60' x 12' 1-year-old trailer. I hope this is a good beginning in this area, because it was accomplished with ease and resulted in a great sense of satisfaction when I saw the trailer glistening. You can imagine the dirt, grime and film that had accumulated in one year. Now I would like to get 3 more machines."

David J. Paradise of Massachusetts: "Just two years ago my wife and I returned to Mass. from Arizona. We were broke. I got a job in a factory and then read about Merlite Presto Shine. Then presto. I got my dealership and started making money as they said. Today I have a steady flow of customers, and we now own our own home with an acre of land."

Pedro Ramirez of Puerto Rico: "As a Merlite Presto Shine Dealer, I do Simoniz wax jobs on aircraft on a contract basis. Already I have steady business contracts totaling \$500.00 a month. Recently a domestic airline signed a contract for me to do their 12-passenger Beechcrafts at \$75.00 per plane per month, and a plane takes me only 5 hours to do."

Steven Schorr of Long Island, N.Y.: "I am 15 years old and in junior high school. My dad will let me do only 10 cars on a weekend, although I could do a lot more, if I didn't have to do homework. Even so, I make about \$50.00 a weekend, which will go to my college education. This summer I've lined up 2 beach clubs, and 2 of my friends to do the work for me."

Merlite Presto Shine Corp., Dept. Y-15P
1081 Bristol Road, Mountainside, N.J. 07092

Rush me complete Prospectus of my opportunity to make big profits in a business of my own as a Merlite Presto Shine Dealer. Everything comes to me by mail, prepaid, absolutely FREE, and entirely without obligation.

NAME _____
ADDRESS _____
CITY _____ STATE _____ ZIP _____

In Canada: Merlite Presto Shine
675 King St. W., Toronto, Ont.

ON-THE-GO

CAMPING

BY WADE MITCHELL

ENGINEERS ASK RV MANUFACTURERS TO TEST BRAKES. Some experts say that within a year the Department of Transportation may require brake performance certification on all RVs. The Society of Automotive Engineers wants manufacturers to help set up workable standards. Eventually, every trailer, van and motor coach may be required to carry a plate specifying brake-stopping distances.

DISC BRAKES FOR TRAVEL TRAILERS. One of the largest manufacturers told *PM* privately that "disc brakes are inevitable on travel trailers." Reasons cited include the disc brakes' proven advantages on downhill grades, through water and in panic stops. They start stopping sooner, almost never fade. Currently, all trailers have drum brakes as standard equipment. Disc-brake kits are available now, but the question of how to power a trailer-installed disc brake is not yet settled.

CAMPER CONVERSION BOLTS TO VAN BACK! That's right—the new Bovan unit is a compact coach-section designed to attach to the tail end of such vans as the Ford Econoline series, Dodge A-100 series and Chevy and GMC vans. The maker claims it will fit any Detroit van built since 1962 without modifications. To install a Bovan (for Back of Van) the buyer merely removes the van's rear doors and rear bumper. The Bovan then slips into position like a glove. (Installers may use the same holes formerly used for doors. Rail clamps will complete the installation.) Bovan says that you can add one in only 30 minutes. Inside the add-a-coach section are a dinette, bed, toilet and kitchen unit. Bovan is made by Easom Engineering, Detroit, Mich.

IS A SUPER-LIGHT TENT TRAILER COMING? The sudden interest in subcompact cars has prompted new tent-trailer designs that can be towed by any of them, according to experts. Ford is already selling the Maverick and the even smaller Ford Phoenix is due in 1971. Chevrolet may market the XP 887. American Motors is expected to announce a subcompact reviving the famous name of Hornet. Can such cars tow a trailer? Maybe yes, maybe no. The aggressive tent-trailer industry won't take chances. Scaled-down versions of the most successful deluxe models may be announced in late 1969.

HOW ABOUT AN ALL-CANVAS CAMPER TOP? You can get one now with a peaked roof, rear door and sidewall curtains in a shape amazingly similar to wood coaches. The new canvas model from Off-Road Campers, Inc., Box 158, Dearborn, Mich. 48121, weighs about 198 pounds, has nylon strip slides on all moving surfaces, independent tent-bow construction and ozone-resistant and weathertight seals. For the family with a coach-storage problem, this may be one answer.

WRAPAROUND CONTROL PANELS FOR PICKUP TRUCKS? The GMC Truck and Coach Div. has been experimenting with new control panels which monitor virtually every moving part of the vehicle. Dash instruments start to the left of the driver, then sweep across in front of him and around to his right. Everything is easily read and operated without reaching. Though the system was designed for heavy-duty carriers, the concept of wraparound control panels for pickup trucks is obviously worthwhile.

CHEVROLET ANNOUNCES AUTOMATIC VEHICLE SELECTOR. Anyone interested in Chevrolet camper vehicles can get instant statistics such as gross weight, suspension capacity, transmission options, axle ratios, trailer-hitch type and many other facts on a handy new slide-rule calculator. This highly attractive tool, called Vehicle Selector, is now available from Chevrolet dealers. It should help solve problems caused by salesmen who lack knowledge about recreation vehicles. ★★★

The Satisfier: Bolens

**Just
ask
an
owner**

At Bolens we don't just put together pieces to make outdoor power equipment. We innovate. We literally architect our compact tractors. Our hydrostatic transmission tractors have an exclusive foot-pedal control. We pamper every part; right down to the gears we manufacture ourselves. We know, for example, that attachments will be easy to change, grease fittings accessible, and that the rugged front axle will take the punishment of rough terrain and heavy front-end loads. We've minimized aggravating, puzzling and knuckle-busting situations everywhere we've found them. We've even made a hydraulic lift standard equipment on larger tractors, where raising and lowering implements could be back-straining labor. But the real measure is satisfaction. How our units perform on your lawn and garden. That's where our customers become our best salesmen. Once they've owned a Bolens, they'll never be satisfied with anything else. So if you're in the market for a compact tractor, get an opinion from a Bolens owner. Better still, see the differences, at your Bolens dealer. Do it for your own satisfaction.

For the location of the Bolens dealer in your area, phone **800-243-0355** any hour, any day, free. (In Connecticut call collect 853-3600.) Dial just as you normally dial long distance.



Sgt. William H. White, Air Force mechanic, Dover, Del. "I looked at four or five of the leading brands and this Bolens 770 tractor beat them all. There was no comparison for the machine that had to do a tough job. The Bolens was the best built and the best engineered of them all, and I have never been sorry on my selection."



Mr. Jerry Nellenback, Lake City, Florida. "I needed a tractor because I have a two acre lawn to mow. I looked over several makes and models before deciding on Bolens 1050. The performance has been everything the dealer said it would be. I wouldn't hesitate to recommend it to my neighbors. And, by the way, I've cut 10 hours mowing time in half."



BOLENS

BOLENS'S DIVISION, FMC CORPORATION DEPT. 642HF, PORT WASHINGTON, WIS.

8 COMPACT TRACTORS, 7 TO 14 HP, STANDARD AND HYDROSTATIC • RIDING AND WALKING POWER MOWERS • TILLERS • SNOW THROWERS • SNOWMOBILES

Men Wanted NOW

TO TRAIN AS CLAIMS ADJUSTERS

Insurance Adjusters and Investigators are badly needed due to the tremendous increase of claims resulting from automobile accidents, fires, burglaries, riots, storms, and industrial accidents. Over 50 million dollars worth of claims paid each day. **Top money** can be earned in this exciting, fast moving field, full or part time. Work at your present job and train at home, then attend resident training for two weeks at MIAMI BEACH, FLA. or LAS VEGAS, NEVADA. Excellent employment assistance. For details without obligation, fill out coupon and mail today.



Accredited Member National Home Study Council.

APPROVED FOR VETERANS

UNDER NEW G I BILL

INSURANCE ADJUSTERS SCHOOLS DEPT. PM
1872 N.W. 7 St. / Miami, Florida 33125

Name.....

Address.....

City..... State..... Zip.....

Age..... Phone.....

RADIAL ARM SAW KIT...

for under \$100

Buy direct from factory, assemble yourself. Incl. 1/2 h.p. G.E. motor, easy to follow instructions, all parts, nuts and bolts. Guar. for life pat. pend. radial arm track; twice the usual bearings for extra rigidity, greater precision. Rips 24", crosscuts 12"; belt brake. \$99. complete, freight col. Kit less motor (any stand. 1/2 h.p. or larger will do) \$84.85. With optional G.E. motor developing 1 h.p. \$108.65. Money back guaranteed by one of world's largest manufacturers of bench power tools. Write for brochure. Terms if desired or check or M.O. to American Machine & Tool Co., Dept. PM6R, Royersford, Pa. 19468



MEN/WOMEN...

Buy Below Wholesale



MELLINGER, Dept. C2256, 1554 S. Sepulveda, Los Angeles, CA 90025

BIG PROFIT HOME IMPORT BUSINESS. My plan starts you fast. Deal direct with overseas sources at prices shown. Thousands other dazzling bargains with no investment. Any age or location. Full or part time. You keep all profits. Write for FREE BOOK to...

be a TAX CONSULTANT

Income unlimited in ever growing profession. Our students are earning lucrative fees in dignified full or part time home-office business preparing income tax returns during busy tax season. Many operate profitable Business Tax Service with steady monthly fees of \$10-\$50. No bookkeeping experience necessary. We train you at home and help you start. Licensed by N.Y. Education Dep't. No agent will call. Write for free literature. Accredited Member NHSC. Approved For Veterans. NATIONAL TAX TRAINING SCHOOL, Monsey, 20EB, N. Y. 10952



HANDEE®

the most versatile tool in your workshop

Cut, carve, sand, grind, drill, engrave, polish, clean. Complete line of accessories, including: Drill Press, Bench Holder, Tool Post Adapter, Foot Speed Control. No. 7001 Drill Set (No. 61 thru No. 80) and No. 38A Drill Chuck for model builders. Fully guaranteed against defects in material and workmanship.

No. 6000 Handee with 3/2" collet, 1/8" collet, and wrench **\$28.50**

No. 6009 Handee with 7 accessories **\$29.50**

No. 6010 Handee with 45 accessories and case **\$39.50**

Free micro-oiler with each Handee ordered on coupon below. (\$1.00 value)

See your Handee Dealer or Order direct

CHICAGO WHEEL & MFG. CO.
Dept. PM-6, 1101 W. Monroe St., Chicago, Ill. 60607

Enclosed is payment for set No. (add 60¢ to cost of each set for postage and handling).

Please send me Handee catalog.

NAME.....

STREET.....

CITY..... STATE..... ZIP.....

HEAVY DUTY WELDER 18⁹⁵ POST PAID

WELD • BRAZE • SOLDER • CUT

10-DAY FREE TRIAL • LIFETIME GUARANTEE

110 Volt • Not One—But 3 welding heats

Weld, braze, solder or cut any metal — even aluminum. No experience necessary. Follow simple instructions to make repairs on cars, trailers, farm and lawn equipment, bicycles, appliances, etc. Make campers, boats, furniture, hundreds of valuable items. **NOTHING ELSE TO BUY!** Comes complete with full face shield, \$2.00 pack of welding and brazing rods, heavy duty power cables, special electric torch attachment, ground clamp, flux, easy-to-follow illustrated instructions, rod holder, etc. Uses standard 1/4" rods and 1/4" carbons to weld iron, steel, brass, bronze, aluminum, other metals. New improved HEAVY DUTY circuit gives more welding power. Gives 4 times the heat needed to melt toughest iron. Plugs into ordinary 110V outlet. 3 WELDING HEATS... Not just one as with other low cost models. Use "high" for tough jobs, "medium" or "regular" for lighter work. This important feature saves you money and time. Makes it possible for even beginners to start welding professionally the very first day. Pays for itself quickly. 10 day MONEY BACK GUARANTEE. You must be satisfied or return for refund. **FREE** automatic arc striker. Weld with push-button ease.

SEND ONLY \$2.00. Pay postman \$16.95 plus postage when delivered, or send \$18.95 cash, c.k., M.O., for fast post-paid shipment. **WEL-DEX MFG. CO.**
Dept. W-106 , Box 10776, Houston, Texas 77018

Discover for yourself how easily you can prepare in your spare time, at home, for an exciting high-pay career in today's "blue-chip" profession... Electronics

ARE YOU fed up with being stuck in a dull, routine job that pays peanuts? If so, here's your opportunity to get out of "dead end" work for good—and to start on the road to an exciting, high-pay career.

As you read this, there are thousands of career openings waiting for qualified men in today's big "growth" profession—Electronics. With training, you can be one of these men. You can have your pick of "glamor" jobs any man would be proud of—in TV and radio broadcasting, automation, the aerospace program.

And as you move up the ladder in this booming field, you can earn the kind of money many men only dream of: \$5, \$6, \$7 an hour... \$200, \$225, \$250 a week... \$10,000, \$11,000, even \$12,000 a year!

Getting the training you need to break into this field is easier than you might have thought possible. You don't need college—or even a high-school diploma. As a matter of fact, you can prepare right at home, in your spare time.

Want full details? Just mail us the bound-in postpaid card. We'll send you 2 FREE books that tell about career opportunities in Electronics and how you can prepare to cash in on them.

Why not take the first step on the road to success by mailing the card right now? If card has been removed, use coupon below. Cleveland Institute of Electronics, 1776 East 17th Street, Cleveland, Ohio 44114.

ENROLL UNDER NEW G.I. BILL

All CIE courses are available under the new G.I. Bill. If you served on active duty since January 31, 1955, or are in service now, check box on reply card for G.I. Bill information.

CIE Cleveland Institute of Electronics

1776 East 17th Street, Cleveland, Ohio 44114

Please send me 2 FREE books describing opportunities in Electronics and how to prepare for them.

Name _____ Age _____

(please print)

Address _____

City _____

State _____ Zip _____

Check here for G.I. Bill information

Accredited Member National Home Study Council PM-25

**Now! In just
2 minutes,
find out
how you can
SAY GOODBYE
FOREVER TO
DULL, LOW-PAY WORK**

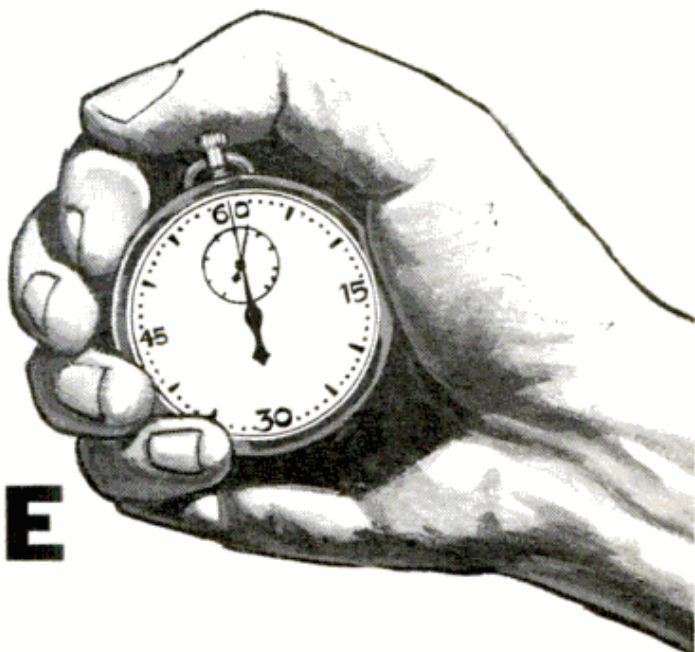

WHAT'S NEW OUTDOORS

BY DAN FALES

NEW FROM SEA-DOO this summer is a more powerful model (below) with new design features. The firm announced last year an 18-hp water-jet scooter (Sea-Doo, page 91, Aug. PM). Now there's Model 372—with a 372-cc, 24-hp engine. Model 372 and the lower-powered Model 320 both use Berkley jet pumps instead of props, and draw only three inches. Suggested retail on the 320 is \$995; on the 372, \$1295. Sea-Doos are made by Bombardier, Ltd., maker of Sea-Doo snowmobiles.



JET BOARD is an 11-ft. surfboard powered by a small water jet. The 65-pound, aluminum board houses a 6.2-hp motor that shuts down immediately when a magnetic "cork" is yanked free. Should the rider fall off the board, a cord that extends from his waist to the "cork" will activate the shut-down system. The jet-propelled board will go 10 mph, and will run for four hours on one tank of fuel. A dial throttle controlled either by hand or foot governs the speed. The Jet Board costs about \$495. ★★★



"I Earn Two Incomes Now"

Says **JOHN BENNIE, Pittsburgh, Pennsylvania**

"Thanks to your wonderful training, I have been able to earn \$20 to \$25 extra each and every week doing little locksmith jobs at home and after work at my regular job. This is the best trade a man can take up."

Be a LOCKSMITH

Train at HOME—Earn While You Learn. Add 50%-100% to YOUR INCOME with easy spare time earnings. Cash in on the nation-wide shortage-trained locksmiths in great demand! Quickly step into a big pay opportunity job or start a high-profit shop of your own.

Earn Extra Money RIGHT AWAY! All Master Locksmiths Special Tools, Equipment and Supplies Furnished FREE for use with course.

Age, education, minor physical handicaps don't matter in this growing trade. You can quickly qualify as a skilled locksmith. It's like a fascinating hobby. Study at home as little as one hour a week. Gain practical experience through complete well-illustrated lessons. Do real jobs on car locks, house locks, padlocks and safe locks, under the guidance of experts. FREE Illustrated Book, write now.

LOCKSMITHING INSTITUTE,

(Div. Tech. Home Study Schools)

Dept. 1110-069 • Little Falls, New Jersey 07424

306 pieces of professional equipment
FREE for use with course.

Professional Equipment includes
LOCKS—PICKS—PARTS—KEYS
SPECIAL TOOLS & SUPPLIES
all FREE for use with course.

MAIL COUPON for FREE ILLUSTRATED BOOK

For a future as your own boss or in a high-pay job, write now for FREE Illustrated Book.

Only school of its kind. Licensed by State of New Jersey. Approved for Veterans.

MAIL COUPON NOW

LOCKSMITHING INSTITUTE, Dept. 1110-069 Little Falls, New Jersey 07424

Please send FREE Illustrated Book—"Your Big Opportunities in Locksmithing," complete Equipment folder and sample lesson pages—FREE of all obligation—(no salesman will call).

Name _____
Address _____
City _____ State _____ Zip _____



Rowan and Martin show you how easy it is to take inches off your waistline without exercise

■ If you thought there must be some easier way to make your waistline slim and youthful without exercising, jogging, twisting, panting, hooking yourself up to electrical gadgets—or hoping for a miracle—WELL THERE IS! It's the new AMF TONE-O-MATIC way to reduce your waistline while you don't do a darn thing. All you do is slip this belt on and go about your regular activities (even if that is just sitting at your desk or watching TV) and the TONE-O-MATIC firms up your belly muscles . . . takes inches from your waist.

USED BY STARS OF SPORTS AND FILMS

- **TOMMY BOLT**, former National Open Champion says: "The TONE-O-MATIC is the best way of keeping in top form I've seen yet."
- **FOREST TUCKER**, Movie and TV Star says: "The TONE-O-MATIC belt is a lazy man's isometrics."



Tone-O-Matic by AMF



• **JAMES BOWEN BROWN** . . . Star of TV and MGM Movies says: "Exercising in my normal natural movement with the TONE-O-MATIC has me back playing Tennis Tournaments."

YOU WILL BE AS PLEASED WITH THE RESULTS AS THESE FAMOUS PEOPLE

Just slip the belt on. It looks like a handsome cummerbund. Is adjustable to your size. It strengthens those sagging muscles. Firms you up. Puts you in shape. You wear it until you get tired . . . and then each day wear it a little longer. In just 30 days you can lose up to 3 inches or more.

TRY IT FOR 30 DAYS AND SEE IF YOUR WAISTLINE DOESN'T GET SMALLER WITHOUT ANY WORK ON YOUR PART. If you aren't pleased with the results . . . if you don't look better, feel better . . . act more youthful and vigorous . . . just return for a full refund.

FOR MEN:

In Black—Sizes small (31" to 35") medium (35" to 39") and large (39" to 44").

FOR WOMEN:

In White—Sizes extra small (25" to 30"), small (30" to 34").

#1566 TONE-O-MATIC by AMF
.... \$20.00 plus \$1.00 P.P. & Hdlg.

ALEXANDER SALES CORP

26 South 6th Avenue,
Mount Vernon, N.Y. 10551



MAIL HANDY COUPON TODAY

ALEXANDER SALES CORP.

26 South 6th Avenue, Mount Vernon, N.Y. 10551

Please send me #1566 Tone-O-Matic(s) at \$20 ea. plus \$1 pp. & hdlg. on a satisfaction guaranteed basis.

FOR MEN: In Black—Sizes small (31" to 35")
 medium (35" to 39") large (39" to 44").

FOR WOMEN: In White—Sizes extra small (25" to 30"),
 small (30" to 34").

Charge Diners Club Charge American Express

Account #

Name

Address

City State Zip

N.Y. Residents include appropriate sales tax.

PM-669

This Trail Bike Is Really Put Together!

By **BILL HARTFORD**
Technical Auto Editor

Photos by Irv Dolin



It's a new Heathkit—a build-it-yourself mini-trail with lots of rubber for running on or off the road, even through snow with a snap-on ski

THE PARALYZING SNOWFALL couldn't have been more welcome! The ski went on in a flash, and out in the snarled suburbs only a single tire was going anywhere—the monster 18 x 8.50 on the rear of the Boonie-Bike. Streaking through the soft snow was even more fun than bouncing through the boon-docks to photograph the machine the day before!

Of course, there's nothing unique about a mini-bike in kit form. Fox and Bird machines, for example, have been around for years. Complete kits or a few parts at a time crisscross the country every day as kids slowly get a bike together by sending in their weekly allowance for sprockets, cables, little wheels and ball bearings. What is unique about the Heath bike you'll find out fast from these kids. "What an outasight tire!" "Somethin' else!" ". . . that a snowmobile?" They can't swing many nickels and dimes and they find five horses really prestigious. And they blink at the Heathkit logotype on the saddle. To these young do-it-yourselfers, Heathkit means all types of

(Please turn to page 42)

CONVERSION TO SNOW BIKE is simple with optional (\$17) ski. Just place axle in strut jaws, jump on pegs to seat struts in brackets



WIN CASH BY SOLVING PUZZLES

\$100.00 - \$3,000.00 IT COSTS YOU NOTHING TO TRY

EVERY MONTH, THROUGHOUT THE U.S.A., MEN AND WOMEN ARE WINNING BIG CASH PRIZES IN THEIR SPARE TIME!



"Received the telegram saying I won. I was so surprised," MRS. MARTHA SCHROEDER, Spencer, Ohio.

All you need to start winning extra cash is a pencil or a pen and better than average brains. And if you're not sure about your brainpower, you can find out without spending a penny. Fill in the coupon below (you must be over 18) and mail it this instant. We'll send you a FREE copy of our *PUZZLE LOVERS NEWSPAPER*, jammed with contests that offer you from \$100.00 to \$3,000.00 in cash. You can solve our puzzles in the privacy of your own home. Try it. Determine for yourself whether you can join our fun and our winners. We pay cash prizes every month.

THIS COUPON IS THE FASTEST WAY TO FIND OUT



"Never, even in my wildest nightmares, did I dream of winning," H. L. BRYANT, North Little Rock, Ark.

PUZZLE LOVERS CLUB

Box 2, Prince Street Station
New York City, New York 10012

Gentlemen:

I read your ad and want to find out if I can win your cash prizes. Send me a FREE copy of your newspaper with a batch of contests. I am under no obligation at all. Thank you.

Name _____

Address _____

City _____ State _____ Zip _____

WIN CASH
MAIL NOW

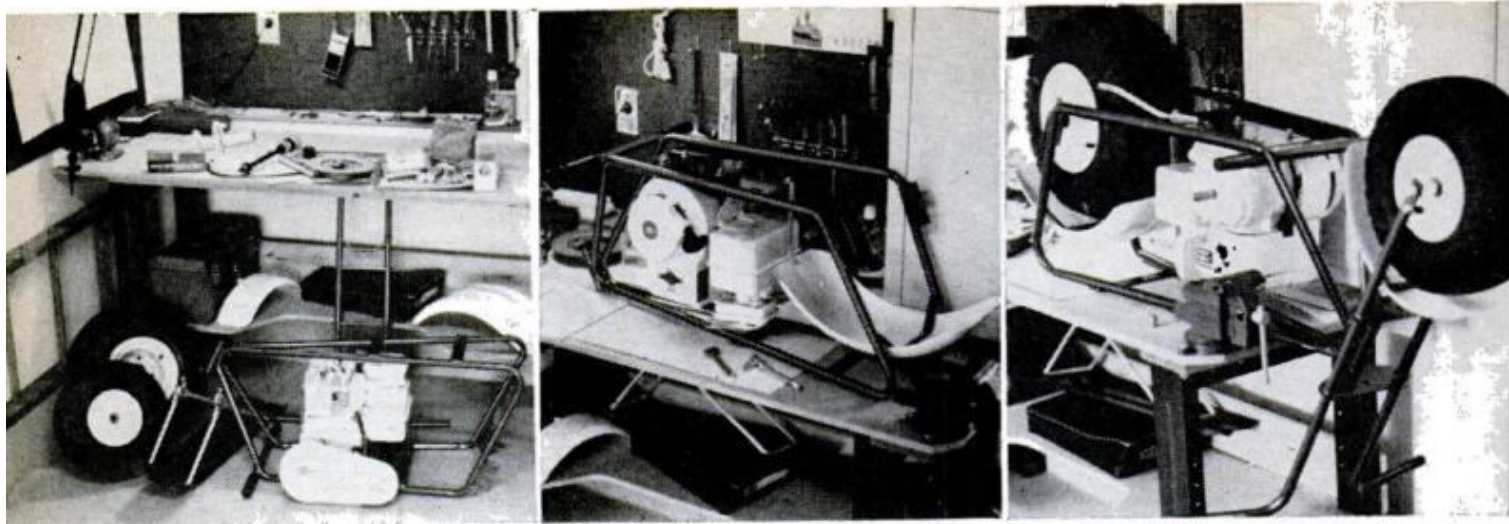

ALL PARTS OF SEMIKIT are laid out on and in front of workbench. Engine comes mounted on frame which is inverted on workbench to start assembly. After major components are installed, bike is moved to floor

TRAIL BIKE KIT

(Continued from page 40)

electronic kits. But the Boonie-Bike is a whole new bag of parts. A big-time bike priced at \$200.

As a semikit—meaning that the engine is already mounted on the frame and tires are inflated on the wheels—the model GT-18 has been advertised to be built in an evening. Don't believe it. You could do it only if you built them for a living. Take a weekend. That way you'll have time to unpack the one huge carton the bike comes in, get familiar with all the parts, take your time, go out Saturday night and be able to spend Sunday afternoon scooting up and down the driveway.

The first steps of assembling the wheels and transmission to the frame are performed with the frame inverted on your workbench. You need access to the 116-pound machine from both sides which means you'll have to do a little juggling if your bench is against a wall.

Heath probably figured it too obvious to mention, but be careful when installing the brake assembly in the brake drum. If grease or oil from your hands gets on the shoes you'll be a long time stopping.

After installing the drive chain from the transmission sprocket to the brake drum sprocket, you're ready to set the bike on the floor and install in the following order: shift lever and cable; centrifugal clutch and primary drive chains; chain guard; saddle; and throttle control, brake lever and their cables. You just can't get away from the need for a soldering gun to build a Heathkit: You need it to tin the ends of these cables!

Check the brake lever for proper actuation of the brake arm and you've finished assembly. Fill the crankcase of the four-stroker with 1¼ pints of the right viscosity oil for the season, top off the

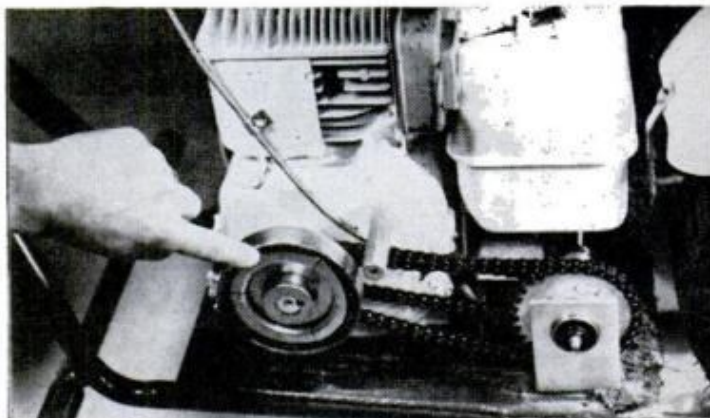

CENTRIFUGAL CLUTCH, mounted on shaft of engine, engages when rpm is increased above idle speed. Chains run to two-speed transmission shaft. Riding wet trails causes accumulation of mud on platform

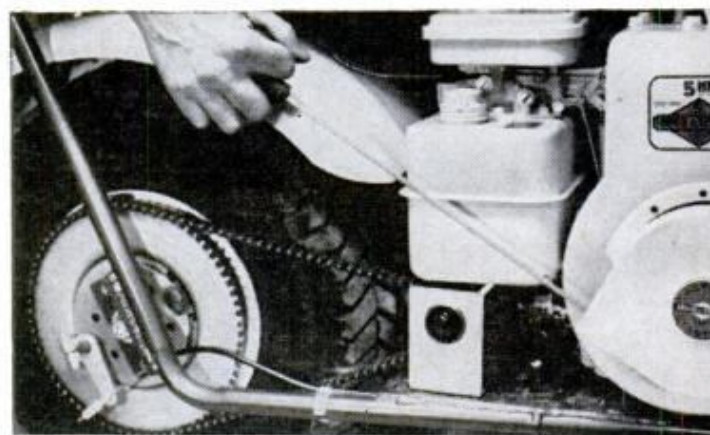

ARM-SAVING FEATURE of 5-hp Briggs & Stratton four-cycle engine is Easy Spin starting. Tank holds three quarts for two hours or 60 miles of riding

tank with regular grade gasoline, follow the Heath manual to the letter and you'll be headed right with the initial tests.

In addition to the assembly manual, with its sections on operation, maintenance and troubleshooting, you get a special operating and maintenance booklet from Briggs & Stratton and a valuable

(Please turn to page 44)

POPULAR MECHANICS

Материал, защищенный авторским правом

Small Nylon Bearing Makes Big Performance Difference

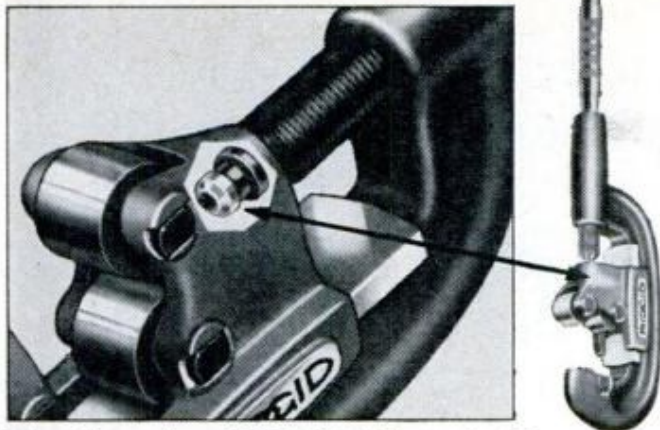

That's why RIDGID Pipe Cutters are easiest to use . . . cut the straightest!

Cuts all 1/4" through 2" pipe and conduit

Start feeding a RIDGID Cutter into a pipe and you'll feel a remarkable difference. Its smooth, cushioned action makes cutting easier, faster and more accurate. Why? Because the feed screw turns freely on a nylon bearing. This same bearing also absorbs shocks, resulting from uneven pipe surfaces, to let the cutter wheel track smoothly. This means less work for you... and straight, even cuts every time.

The Ridge Tool Company, Elyria, Ohio 44035, U. S. A.

You can get this Cutter and other RIDGID Work Saver Tools at your Dealers.



Make Rubber Stamps for BIG PAY



Need more money? Earn \$60-\$75 a week, spare time, at home making rubber stamps for offices, factories, individuals. Hundreds of uses. Hundreds of prospects—everywhere. Right in your own community. Turn out special stamps for names, addresses, notices, prices, etc., in minutes with table-top machine. We furnish everything and help finance you, at less than bank rates. Write for free facts. No salesman will call.

Rubber Stamp Div., 1512 Jarvis, Dept. R-2-FS, Chicago 60626

Mavericks, your car is ready!



Order your 1/25 scale model of the new Ford Maverick now! Send \$1 to

Maverick, P.O. Box 5397, Dept. U, Detroit, Michigan 48211. Offer ends 7-31-69.

find it fast

new Heathkit® Metal Locator

NOW Heath offers a metal detector at one-third the cost of comparable detectors. Dozens of uses for hobbyists, treasure hunters, beachcombers, contractors, surveyors, public utility company personnel, etc. Packed with professional features: all solid-state circuitry for long trouble-free rugged reliability; battery operated; completely portable . . . weighs just 3 lbs.; advanced design for extremely high sensitivity . . . probes to 7'; handy front-panel controls; adjustable sensitivity control; built-in speaker signals presence of metal; meter gives visual indication; built-in headphone jack; telescoping shaft for height adjustment; easy to use; simple to build. Order yours now!

Kit GD-48, 4 lbs. \$59.95*
GD-396 Headphones, 2000 ohm (Superex), 1 lb. . . . \$3.50*

NEW Kit GD-48 Only

\$59.95*

(GDA-48-1, 9 volt battery \$1.30)



HEATH COMPANY, Dept. 17-6
Benton Harbor, Michigan 49022
a Schlumberger company

Rush my FREE Heathkit Catalog.
 Enclosed is \$_____

Please send model(s) _____

Name _____
Address _____
City _____ State _____ Zip _____

Prices & specifications subject to change without notice.
*Mail order prices; F.O.B. factory. GX-185

**Mechanic's Tip
Loosens Nuts & Bolts
Rusted For Years.**

New 12-Inch Jet Sprays, Penetrates, De-Rusts Surfaces Oil Can Doesn't Reach.

Mr. J. R. W. of Erdenheim, Pa. eases off stuck nuts and bolts in tight places with 3-IN-ONE Penetrating Oil. 12-Inch Jet Stream sprays it where you want it. Coats surfaces with colloidal graphite. Loosens rust. Get 3-IN-ONE Penetrating Oil. Squeeze can or aerosol, at any hardware outlets.



3-IN-ONE®
PENETRATING OIL

NEW FROM COMFY-KIT . . .
IMPORTED CAR OWNERS
SAVE ON
AUTO AIR CONDITIONERS!



Opel, Toyota, Datsun unit.
 (Facade similar to Supreme unit on opposite page)



Special Comfy-Kit models are now available for Volkswagen, Opel, Toyota, and Datsun cars. You can save up to \$100, \$200 or even more.

Comfy-Kit is easy to install. Everything is included you'll need. Easy-to-follow instruction book — even the loan of tools if you need them.

Thousands of happy Comfy-Kit owners are already enjoying cool, comfortable driving. You can too. And without spending a lot of money.

So, if you drive a Volkswagen, Opel, Toyota or Datsun, fill in the coupon below, and mail today. You'll get a superbly engineered Comfy-Kit air conditioner — designed especially for the car you drive . . . just \$189.

COMFY-KIT P.O. Box 8585, Dept. PM 6
 Dallas, Texas 75216

Enclosed is \$189* for Volkswagen Opel Toyota Datsun Comfy-Kit.

Enclosed is \$30 deposit on a Volkswagen Opel Toyota Datsun Comfy-Kit. I will pay the balance, plus C.O.D. charges when delivered.

Enclosed is \$8.00 deposit for a set of four tools, which will be returned to me when I return the tools.

I would like to see the instruction book before I order. I enclose \$1.00 for the instruction book only. I understand this will apply on any future Comfy-Kit order.

I would like more information before I order.

Name

Address

City State Zip

My car is a: Volkswagen 1300 (1967), 1500 (1968-69); Opel 55hp (1966-68) 80hp (1968-69), 102hp (1968-69); Toyota Corolla 60hp (1969), Corona 90hp (1967-69); Datsun 67hp (1966-69), 96hp (1968-69).

*plus state tax where applicable



BIKE MOVES at 30 mph in high gear; 15 mph in low. A five-inch internal expanding rear brake stops it

TRAIL BIKE KIT

(Continued from page 42)

theory of operation manual which covers compression, carburetion and ignition.

Before starting the engine, block up the rear wheels as told. If you don't and the engine kicks off at a higher rpm than needed to engage the centrifugal clutch, the bike will run away. Idle adjustment is important. If it's just a bit too fast, the clutch may be gently engaging but slipping if you're sitting on the bike; leave the bike kickstand with no weight on it, and it'll start to creep and down it'll go.

Heath suggests getting your first feel for the machine with the transmission in high, and for good reason. There's lots of torque in low and a slip of your throttle wrist will have you so busy hanging on that you may forget how to decelerate.

We took the mini-trail (the closest generic description of this type machine) right out into the rough. The bulbous, low-pressure tires, front coil spring and hefty saddle give an easy ride, and this type of bike with its 25½-inch-high saddle has superb control. When the going gets rough climbing steep grades or slipping in muddy ruts, just use your feet as outriggers and nothing can stop you. (You can ride the road with a light and horn street package for \$30.)

Until the big snowfall started topping seven inches, we were literally dashing through it (laughing all the way). Any deeper and you start to bog down. Deep drifts can be plowed through, however, if you've got some speed. Eight and one-half inches of tread in the rear doesn't make it a snowmobile, however, and you've got to watch your step in packed ruts and on hard, glazed snow. You can lose it. We did once, but, still laughing, lived to tell the story!

★★★

POLICE - FIRE - EMERGENCY - CAR RADIO \$9.99

works with regular CAR RADIO and AN-TENNA! NO special wiring or installation. Mounts UNDER DASH in 5 minutes in ANY CAR OR TRUCK. Panel switches INSTANTLY from REGULAR to POLICE-FIRE-EMERGENCY radio CALLS—Receives ALL stations in your AREA within range. Size only 2"x3 1/2"—Two tone steel cabinet. (Cash, Ck., M.O.) and pay **SEND ONLY \$2.00** postman \$7.95 plus COD postg or send \$9.99 for pnd Del in USA. COMPLETE ready to clip in your CAR with all parts and instructions. One year parts and service Warranty—10 day money back trial (if retnd). **AMAZING OFFER** good only by mail and from: **WESTERN RADIO Dept. BPM-6 Kearney, Nebr. 68847**



locksmithing and key making

PRACTICAL UP-TO-DATE COURSE — ONLY \$6.95

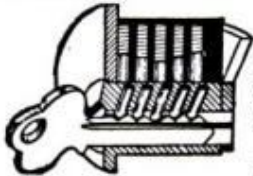

Teaches you how to pick locks, de-code, make master keys, repair, install, service, etc. New self-instruction lessons for every handyman, homeowner, carpenter, mechanic, service station operator, fix-it shop, hardware dealer, gunsmith. 53 easy illustrated lessons. Full price only \$6.95, post-paid. Satisfaction or refund guaranteed. Mail order today!

**NELSON-HALL CO., Dept. FR-2
325 W. Jackson Blvd., Chicago 60606**

ALL FAMOUS BRANDS! **FARM TRUCK AUTO** **AT LEAST THAN WHOLESALE**

TIRES! SAVINGS NEVER LESS THAN 50% up to 70% OFF REG. PRICE!

HEADQUARTERS for ALL SPORT CAR TIRE SIZES
FREE • SEND FOR YOUR FREE CATALOG • FREE!

RELIABLE TIRE DIST., 1111 Chestnut St., Camden, N. J.

LOOSENS RUSTED NUTS, BOLTS, PARTS



LIQUID WRENCH

AT HARDWARE & AUTO STORES

\$5.95

less bell

DIAL TELEPHONES

With bell \$8.95. If plug is required add \$2.00. Factory reconditioned, Guaranteed. Many other phones available, write for free list.

All shipments FOB Waymart, Pa.

SURPLUS SAVING CENTER

Dept. PM-569, Waymart, Penna. 18472



Learn at Home **FIX YOUR OWN APPLIANCES**

NRI shows you — fix home, farm, commercial appliances, power tools, motors, generators, house wiring, air conditioners, refrigeration units. Short, easy, low cost training. Earn \$5 to \$7 an hour soon. Fix appliances for others. Rush coupon for FREE CATALOG. No salesman will call. Accredited: National Home Study Council. Appliance Division, NRI, Wash., D.C. 20016

NATIONAL RADIO INSTITUTE 600-069
Appliance Division Check for facts on GI BILL
Washington, D.C. 20016

Name _____
Address _____
City _____ State _____ Zip _____

SOME PEOPLE ARE GOING TO PAY \$200 TOO MUCH FOR THEIR AUTO AIR CONDITIONER THIS YEAR

Just be sure it's not you!



Super Unit.

Comfy-Kit gives you all the cooling power you can use. It's trim, sleek appearance actually enhances the looks of your car's interior. You can easily install it yourself in a half day — and save up to \$200 or more doing it. That's like being paid up to \$50 an hour for your time — and you have the satisfaction of doing it yourself.

You get everything you need for installation — even the loan of special tools if you need them. You get an easy-to-follow instruction book and a 12-month/12,000 mile warranty.

So, let someone else pay those high prices for air conditioning. You'll get better — more efficient cooling — for a lot less money. Join the thousands of satisfied users of Comfy-Kit... America's only install-it-yourself auto air conditioner. Fill out... and send in your coupon today. Get the jump on sweltering summer with Comfy-Kit.

COMFY-KIT P.O. Box 8585, Dept. PM 6
Dallas, Texas 75216

- Enclosed is \$133* for Standard Unit.
- Enclosed is \$148* for Super Unit.
- Enclosed is \$165* for Supreme Unit.
- Enclosed is \$30 deposit on a Super Standard Supreme Unit. I will pay the balance, plus C.O.D. charges when delivered.
- Enclosed is \$8.00 deposit for a set of four tools, which will be returned to me when I return the tools.
- I would like to see the instruction book before I order. I enclose \$1.00 for the instruction book only. I understand this will apply on any future Comfy-Kit order

Name

Address

City State Zip

My car is a (year) (model)

Engine displacement Horsepower

Power Steering yes no

Floor shift Steering column shift

Smog pump yes no

*plus state sales tax where applicable

It only tastes expensive



Popular price

Train for top jobs, top earnings, in PHOTOGRAPHY

NYI trains you for the best jobs—or your own successful business. Learn by doing at home, quickly, easily the individualized NYI way. Low cost. No experience or expensive equipment needed. Earn while you learn. Easy pay plan. Approved for Veterans, Student Loans. Approved by N.Y. State Ed. Dept. Accredited member Natl. Home Study Council. FREE color career book. No salesman will call. RESIDENT TRAINING in all profitable phases of photography and Creative Motion Picture Course. Our 59th year. **NEW YORK INSTITUTE OF PHOTOGRAPHY • 10 West 33 St., New York, N.Y. 10001, Dept. 49-6**



Now! Use your
Bank Americard



5000° OXYGEN WELDING TORCH
\$34.95 New portable SOLIDOX welding torch goes anywhere. Only 4 lbs. Burns amazing solid oxygen pellets & propane. Flame exceeds 5000°F. Braze weld, silver solder, melt 1/4" steel. Complete kit: torch, pellets, propane, glasses, braze rods, lighter, etc. Ideal for shops, hobby, metal repair. Professional results. Low-cost SOLIDOX pellets available by mail. SOLIDOX is simple and safe. Money-back guarantee. Only \$34.95 ppd.

SEND ONLY \$5.00

Write for free brochure.

pay postman \$29.95 plus postage on delivery.
Cleanweld Products Co., PM-6 Box 1061, South Gate, Calif. 90280

TO YOUR OWN DOCTOR'S PRESCRIPTION

EYEGLASSES BY MAIL AT GREAT SAVINGS!



Mail orders filled by **\$9.95** licensed optician from
 (Including single vision lenses, frame and case).

Doctor's prescription will be filled by a skilled, approved and licensed optician or your own prescription duplicated. Lenses are ground and manufactured to U.S. optical standards. Choose from complete catalog of men's, women's and children's glasses. Bifocals, trifocals, sunglasses or SAFETY HARDENED LENSES at low additional cost. We guarantee accuracy, perfect fit.

SEND FOR YOUR FREE CATALOG TODAY
PRISM OPTICAL INC.
 Dept. PM-6 136 Liberty St., New York 6, N. Y.

WHEN ANSWERING ADS
GIVE YOUR ZIP CODE

INVENTORS

INVENTIONS—NEW PRODUCTS—IDEAS DEVELOPED & PREPARED
For Commercial Appeal & Sales

DESIGN—MARKETING—PATENT SEARCHES—DRAWINGS
*United States Patent Office former Patent Examiner
 United States Dept. of Army former Patent Adviser
 Member: United States Chamber of Commerce
 Second Decade of Reliable Service to*

INVENTORS—MANUFACTURERS—ATTORNEYS
FREE CONSULTATION

THE RAYMOND LEE ORGANIZATION
 230-Z Park Ave., New York 10017 (212-MU 6-8500)

SEND FREE "INVENTION RECORD" Form & "IMPORTANT PATENT INFORMATION"

Name _____
 Address _____
 City _____ State _____ Zip _____

ACCORDIONS and AMPLIFIERS



BIG SAVINGS up to 1/2 or more on famous make accordions. Over 40 models. Standard and new electronic models. Buy direct at low discount prices. Get five-day home trial. Small down payment, easy terms. Free gifts. Trade in allowance. Money back guarantee. Rush coupon for color catalogs, discount price list. **Accordion Corp. of America, Dept. R-69, 5535 W. Belmont Ave., Chicago, Illinois 60641**

COUPON BRINGS FREE COLOR CATALOG & DISCOUNT PRICES	ACCORDION CORP. of AMERICA—Dept. R-69 5535 W. Belmont Ave., Chicago, Illinois 60641
	Send FREE Color catalogs and discount prices. Include special information checked:
	<input type="checkbox"/> Amplifiers <input type="checkbox"/> Button Type Accordions
	Name _____
	Address _____
City _____ State _____ Zip _____	

The bargain hunter

AMERICA'S ORIGINAL LOW-COST ARC WELDER AND ELECTRIC TORCH

10 DAY
TRIAL

LIFETIME
GUARANTEE

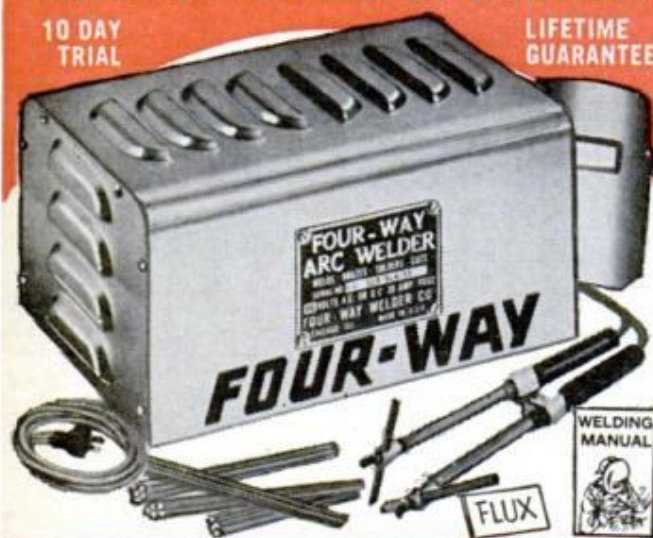

New Improved HEAVY DUTY FOUR-WAY

Only \$18⁹⁵ Prepaid Complete Ready To Use
WELD, BRAZE, SOLDER, CUT
All Metals Including Aluminum

Every home, shop, and hobbyist needs this quality metal working machine. Anyone can use. No experience needed. Use up to 1/8" welding rods and 1/4" carbons to make or repair 1001 items including furniture, garden tools, toys, auto bodies, fenders, trailers, boats, farm equipment. Operates on 110 V. line for pennies—replaces gas torches—no tanks or refills to buy — produces to 11,000° heat. Twin Carbon Arc Torch easily controls heat for each job YOU CAN PAY MORE BUT YOU CAN'T GET A BETTER LOW COST WELDER. Over 500,000 in use. Manufacturers of welders for over 30 years. LIFETIME UNCONDITIONAL GUARANTEE. Simply return. We will repair or replace and ship FREE of charge. YOU GET: heavy duty welder in rugged metal cabinet, ground clamp, cables, combination torch and rod holder, welding manual and helmet, plus Free \$2 pack "TOUCH WELD" rods for instant and automatic arc, brazing rods, 1/4" carbons, solder and flux.

ORDER TODAY ON 10-DAY UNCONDITIONAL MONEY BACK TRIAL.

MAIL THIS ORDER COUPON NOW!

Four-Way Welder Co., Dept. R2-F,
1810 S. Federal St., Chicago, 60616

Please send welder as indicated below and include FREE gift of
 Wrench Kit or, Wire Tool or, Welding Rod Pack.

Enclosed \$18.95. Ship Enclosed \$2.00. I will pay \$16.95
postpaid in U.S.A. plus C.O.D. and delivery charges.

NAME _____

ADDRESS _____

CITY _____ STATE _____ ZIP _____

FREE EXTRA BONUS GIFT with your order. Choice of:

1. 10-piece wrench, plier and screw driver kit in case, or,
2. Wire forming tool. Forms wire to weld valuable items, or
3. Big pack welding & brazing rods, carbons, flux & solder.

SPECIFY CHOICE OF FREE GIFT WITH YOUR ORDER

SEND ONLY \$2.00

and pay \$16.95 plus C.O.D. and
delivery charges, or send only
\$18.95 and we pay delivery in Continental U.S.A.

FOUR-WAY WELDER CO.

1810 S. Federal St., Dept. R2-F, Chicago, 60616



HOW MANY HANDY DANDYS DO YOU NEED?

Handy Dandys are plastic caps that snap onto pegboard and hold quarter-twist glass jars, such as used for baby food and which can usually be had FREE! Ideal for storing all kind of supplies, parts and small tools. Sample pack of caps only 8 for \$1 ** 36 for \$3.50 ** 72 for \$6.00 ** 500 for \$36.50. Postage prepaid in U.S.A. No C.O.D.'s. Wickliffe Industries, Inc., P.O. Box 286-PM-6, Wickliffe, Ohio 44092.



Thousands of
exciting tool
values!

SILVO (BRAND NAME) TOOL CATALOG

Thousands of Exciting Tool Values! Stanley, Millers Falls, Skil, Thor, Wen, Disston, Wiss, Wellsaw, Dremel, Speedy Sprayers, Plumb, Huot, Kennedy, Channellock, Porter-Cable, Rockwell, Helios, Vise-Grip, Crescent, Ridgid, Pony Clamps, Unimat, Foredom and many other Nationally Advertised brands of Tools & Supplies. We ship Coast to Coast at prices Hard to Beat. Send 25c for our big 132-page tool catalog, today. Silvo Hardware Co., PM-6, 107 Walnut St., Philadelphia, Pa. 19106.



COMPLETE SPECIAL INVESTIGATOR KIT

★ BADGE ★ CARRYING CASE
★ SPECIAL I. D. CARD ONLY \$275

First time ever offered! Professional type detective badge kit and case. Includes professionally styled silver badge of extra heavy nickel for use by private and special investigators PLUS authentic type carrying case AND I. D. Card. Limited supply. Order Now. Satisfaction Guaranteed or immed. refund. Only \$2.75 plus 25c to cover post. & handling. WESTBURY SALES CO., D. D. Dept. GK-51 P. O. Box 434, Westbury, N. Y. 11590

FREE CATALOG—Popular Mechanics 16 page illustrated catalog of publications and projects. Lists hundreds of items for the home and shop. Covers tools and machines, hobbies, boating, home repair and maintenance, hundreds of others. You name it, we have it! For your free copy write to Popular Mechanics, Dept. LH, 575 Lexington Ave., New York, N.Y. 10022. Enclose self-addressed envelope or 10¢ in coin mailing charge.

The bargain hunter

LOCK BLADE PANTHER KNIFE ONLY \$1.50

- GLEAMING STAINLESS STEEL BLADE
- OVERALL LENGTH 7½"
- LOCKS AUTOMATICALLY
- OPENS EASILY
- RAZOR EDGE



GROOVIEST POCKET KNIFE EVER MADE.

Flip open instantly and locks automatically to prevent accidental closing. Polished razor sharp stainless steel blade. Authentic Panther Emblem on handle. Only \$1.50 Plus 25¢ postage and handling. Money Back in 5 days if not satisfied.

WESTBURY SALES CO.
Dept. Z P-1 P.O. Box 434, Westbury, New York 11590



Secrets of Teaching Yourself MUSIC

Revealed in Your Home
This Money-Saving Way

YES! Now you can teach yourself to play Piano, Guitar, ANY instrument in your spare time—even if you've never played a note in your life! Famous proven Course makes it simple as A-B-C. Pictured lessons show you how. No teacher. It's amazingly easy! Surprise your friends by playing favorite music. Write today for FREE illustrated booklet. **U.S. SCHOOL OF MUSIC, Studio A306, Port Washington, New York 11050.** (Est. 1898. Approved, N.Y. State Educa. Dept.) Tear out as a reminder.

BOAT PLANS

PATTERNS • FRAME KITS

NEW CATALOG—OVER 80 DESIGNS—\$1.00 Sail, Inboards, Outboards, Hydros, Houseboats, Hot Boats, Ski Boats & boat trailers—Send \$1.00 for new 96-page Glen L catalog including all boat styles from 8' to 36'. Glen L plans, patterns and frame kits include step-by-step instructions specially for amateur builders. Books: Inboard Motor Installations in Small Boats \$6.00 p.p.d.; Boat Building With Plywood \$7.50 p.p.d.; How To Build Boat Trailers \$4.00 p.p.d. Glen L 9152T Rosecrans, Bellflower, Calif. 90706.

TAX SALE - \$1 ACRE

Properties now being sold for municipal tax arrears. Hundreds of cottages, farms, hunt-camps, timberlands, homes from coast to coast along Canadian Border. Purchase direct from Tax authorities—NON PROFIT! For lists, pictures, regulations, write: Register, Room 23, 110 Church Street, Toronto, Canada.

Now Available
in true-to-life

MICRO-COLOR® COMMEMORATIVE PORTFOLIO



Man's Journey to the Moon

Ready for framing—4 big 9" x 12" FULL COLOR prints of NASA PHOTOS taken by Apollo Astronauts show you the Earth in Space... Moon... Launch Site... Middle East. Free Photo of Astronauts also included. All for \$1.98, postpaid.



W. A. KRUEGER CO.
Dept. PM, P.O. Box 1633, Milwaukee, Wis. 53201

Send New Commemorative Space Portfolio.
\$1.98 enclosed.

NAME _____
ADDRESS _____
CITY _____
STATE _____ ZIP _____

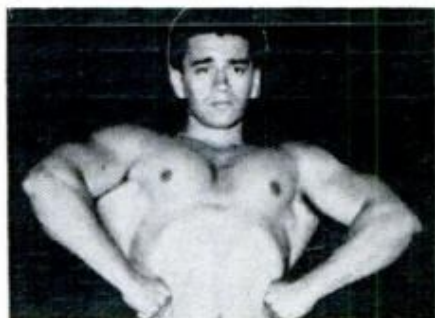

FREE!!! POWERFUL MUSCLES FAST!

Fantastic New Discoveries in the science of bodybuilding. Now, in the privacy of your bedroom, our method will add inches of powerful muscles to arms, chest, shoulders & legs. Learn secrets on trimming the waist with ultra-modern methods—fast! Results Guaranteed! Send for free brochure. Universal Bodybuilding, Box 5327, M-16, Northeastern, Dearborn, Mich. 48126.

PERFECT GIFT

Homemakers love compact, handy **MAGNAGRIP MARK X**. Holds all metal kitchen or shop tools magnetically, orderly. Mounts easily on any surface. Styled in white for any decor.



Gift-boxed
Only \$3.95 p.p.

Soap hangs magnetically, dries fast, always handy with famous **MAGNAGRIP SOAP HOLDER**. Mounts anywhere. Gift-boxed.



Only \$1.98 p.p.

Complete line folder on request. Money-back guarantee. Send check or M.O. to Dept. B

PHELON MAGNAGRIP COMPANY, INC.
East Longmeadow, Mass. 01028

FOLLOW APOLLO!



Like NASA's moon rockets,
VASHON ROCKETS
are LIQUID FUELED!

Altitudes over 1,000 feet • Polished aluminum body • Electrically fired • Parachute recovery • Safe — not explosive or flammable • Available anywhere in the U.S.A.
INFO-PACKED CATALOG Complete Vashon liquid rocket line and accessories — 125¢

VASHON INDUSTRIES, INC.
Box 309-MP, Vashon, Washington 98070

The bargain hunter

- Increase Your Car's Power and Gas Mileage
- Reduce Engine Maintenance
- Instant Starting in All Climates!

CAPACITIVE DISCHARGE IGNITION SYSTEM



ONLY \$29.95 ppd

Completely wired, ready-to-install (not a kit)

- Easy installation (use original coil)
- Solid state reliability
- G-10 type spacecraft circuit board
- Distributor points last lifetime of car
- Spark plugs last 3 to 10 times longer
- No changes required on timing or dwell
- Switch built-in for instant change from CD unit to original ignition system
- For 12-volt negative ground systems only
- 1-year written guarantee

ORDER NOW!

Bay PRODUCTS, INC. P-6
P.O. Box 9562, Houston, Texas 77011

Enclosed is \$29.95 for Model SW100 Capacitive Discharge Ignition System ready for installation.

Name _____
Address _____
City _____ State _____ Zip _____

Searching?

Should you wait years to meet your match?? Establish new friend NOW! The computer has smashed the social time barrier. Request free questionnaire \$10 fee payable when you return questionnaire.



COM/PAIR SYSTEMS, Inc., PM-9
194 Nassau St., Princeton, N.J. 08540
OR use new West Coast address
234 Cazares Circle, Sonoma, Calif. 95476

Name _____
Address _____
City _____ State _____
® COM/PAIR

LESS THAN 15¢ PER OIL FILTER CHANGE WITH AMAZING

STILKO



ETERNAL OIL CLEANER

Full-flow oil filtering system uses the best-known filtering material available anywhere—toilet tissue—already proven in thousands of automobiles. Recommended for all types of cars and trucks. Keeps oil cleaner sludge-free and carbon-free. No costly installation or maintenance—simply spins on in place of regular throw-away filter! Each filter change costs less than 15¢ and oil lasts longer (some users report never changing oil). Fully guaranteed. Send check or MO for \$24.95. Or send \$5.00 and pay balance COD. Include Make, Model & Year of car, engine type and no. of cylinders.

STILKO ETERNAL OIL CLEANER
7445 Convoy Court
San Diego, Calif. 92111

APPROVED FOR VETERANS

An old beat-up-chair started us on a...
BIG NEW CAREER



LEARN UPHOLSTERING AT HOME... SPARE TIME

Send for **FREE** ILLUSTRATED CAREER BOOK...

...on famous home training which shows how to upholster chairs, divans, ottomans, all fine furniture. Pick up old, worn out furniture for pennies at junk stores, turn into beautiful, professional conversation pieces that sell for BIG PROFITS. Fascinating, clean hobby or business. Operate from spare room or garage, without investment or overhead. No age limits, no experience needed. Save big \$\$\$ re-doing own furniture and learn right at home. Send for FREE career book today. **Modern Upholstery Institute** Box 899 -BSP, Orange, Calif. 92669

APPROVED FOR VETERANS

TREASURE & COIN DETECTOR

10-DAY FREE TRIAL

New electronic circuit guarantees at least **TWICE THE DETECTION ABILITY** of any detector in this price range or your money back. Find gold, silver, coins, old weapons, etc. Works through earth, beach sand, water, wood, rock, etc. New circuit gives more power, more depth. Not a "probe" type but a fully electronic, 1969 model detector never offered before and available only from **VIKING**. Only detector in this price range sold on unconditional **MONEY BACK GUARANTEE!** You must



29.95 POST PAID

agree it will out-perform any detector costing **TWICE** this low price or return in 10 days for refund of cost. Only **VIKING** dares make this offer. Fully transistorized, uses ordinary 9V battery, weighs 2 pounds. Gives loud, clear signal when object is detected. **NOTHING ELSE TO BUY.** Complete, ready to operate. Send \$29.95, check, cash or M.O. for postpaid shipment or \$3.00 and pay postman \$26.95 plus small C.O.D. when delivered.

VIKING DETECTORS
Dept. V-2, Box 10880
Houston, Texas 77018

Guaranteed 10 Years!

\$1.98



The knife for hunting, fishing and all around use. Mirror polished, imported stainless steel blade honed to a razor's edge. Rugged. Opens with flick of finger. Locks into position. Blade will not close when in use. Press button in handle to close. Safety finger guard. Sure-grip handle. Balanced for target throwing. **IF BROKEN WITHIN 10 YEARS WE WILL REPLACE AT NO CHARGE!** Use 30 days. Money back if not pleased. Only \$1.98 plus \$.27 postage and handling. **ORDER NOW!** Midwest Knife Co., 9043 S. Western Ave., Dept. RC-9808, Chicago, Ill. 60620. Established 1936.



GOLD !!! and the rush to the West... was on...! Buy a share of authentic Gold tailings with map and legend; a provocative conversation piece, wall decoration or 'show & tell' for school. Send \$1 per pouch to: **LADRE DE ORO** P.O. Box 494, Verdugo City, California 91046

WHEN ANSWERING ADS GIVE YOUR ZIP CODE

PUBLICATIONS **WORTH**
WRITING FOR
 BY CATHERINE BILSKI

TERMITES are everywhere and are costing the United States from \$200 to \$250 million annually in damage alone. For a guide on detecting and controlling this pest, obtain a free copy of *The Truth About Termites* by writing to Termites, 341 East Ohio St., Chicago, Ill. 60611.

ENJOY THE BEAUTY of *Moving Water and Low-Voltage Outdoor Lighting* is a 32-page booklet illustrating the installation of fountain rings, pumps, pool liners, how to build a waterfall and tips on outdoor lighting. Send 25 cents to Little Giant Pump Co., 3810 North Tulsa, Oklahoma City, Okla. 73112.

FISHING ENTHUSIASTS, learn the where-to and what-to-use basics for 20 of the most popular salt and freshwater gamefish. *The Arbogast Fishing Guide and Bait Selector* matches proper equipment to each fish and automatically tells which baits to use under different fishing conditions—from the surface to the bottom of the lake and for all the fishing seasons. You can get it for 25 cents by writing to the Fred Arbogast Co., Inc., 313 West North St., Akron, Ohio 44303.

Disposable Water Purifier

Attaches
 in
 Seconds
 Lasts
 for
 Four
 Months



The only tried, proven, and accepted inexpensive throwaway water purifier. . . . no installation costs . . . no maintenance. Removes bad taste, odor, chlorine, etc. from water. Removes taste of steel or plastic tank storage. Can be used in home, camper, trailer, boat -- attaches easily on all faucets. 100% guaranteed or money back. **ONLY \$3.95 ppd.**

USE THIS HANDY COUPON FOR ORDERING YOUR IMPERIAL WATER PURIFIER

Please send me _____ Imperial Water Purifiers. The cost of EACH water purifier is \$3.95. (California residents add 5% for tax). Enclosed is my check or money order in the amount of _____

Name _____

Address _____

City _____ State _____ Zone _____

MOUNTAIN FRESH WATER PURIFIER CO.

5103 W. Pico Boulevard
 Los Angeles, California 90019

*Dealer and manufacturer inquiries attached to letterhead will receive our immediate attention. (213-938-2953)

You Can Build This Four-Place BD-4



Featured in the May, 1969, issue of *Popular Mechanics*, the BD-4 is another of those famous Jim Bede designs. Lots of thought went into making it a smooth performer (186 mph with a 150-hp engine) and a fully detailed project for the home craftsman. For a complete set of plans, send your check or money order for \$30 along with the coupon below to:

Bureau of Information (Dept. KM), POPULAR MECHANICS, 575 Lexington Ave., New York, N.Y. 10022.

Please send a set of BD-4 plans to:

Name _____

Street _____

City _____ State _____ Zip _____

MINI-BOOT: The First 4x4 Dune Buggy For Under \$2500

By LEE OERTLE



JUDGING from my wild test-ride, you'll hear a lot about the new Mini-Boot during the year ahead. This hot new machine, which I drove before its public debut, is so startlingly different from other dune buggies that an army of owner-builders will probably take after it in hot pursuit.

From engine to subframe assembly, Mini-Boot is an all-American machine. It outsimplifies the VW-type buggy. Consider these features: full-time 4x4 power delivery; four-wheel disc brakes; automatic transmission; four-cylinder Chevy II engine with up to 140 hp; a full 10½ inches of ground clearance, and independent suspension.

Mini-Boot sits on a 90-in. wheelbase and a 60-in. track. At full throttle it'll hold an 88-foot circle with about 1 G of lateral force. Steering requires only two and a half turns lock-to-lock.

Driving the Mini-Boot is unlike handling any other dune buggy. Drop it into low range and the automatic transmission takes care of the busy work underfoot while you concentrate on steering over sand dunes or through a rocky ravine. When you reach a stream bed or a long stretch of blow-sand don't worry about stopping to engage front-drive hubs

for the Mini-Boot system is full-time 4x4.

In just one demonstration ride I found that the Mini-Boot can be driven full-throttle around a pair of steel drums set less than 50 yards apart, over a bumpy dirt track. If there were such a word as "un-rollable," I'd say that's the way it feels. Uncanny tractive ability almost completely eliminates steering-wheel lash and arm-jolting kickback. Through dirt or sand, mud or water, Mini-Boot claws its way out under no strain whatever. Most 4x4s offer 7½ p.s.i. ground pressure. Mini-Boot has 3¾ p.s.i.

On or off the pavement its traction, flotation and stability are the best this reporter has ever experienced. Prices start at around \$2000 for the two-wheel-drive version and something under \$2500 for the full-time 4x4 model.

The Mini-Boot will be sold as a partially assembled kit with all components, engine, drivelines, suspension systems, wheels, tires and brakes—but without body. (Choice of body is left to the buyer). Vic Hickey, Mini-Boot's dynamic designer, is a widely known consultant and former GM engineer.

The Mini-Boot will be manufactured by Desert Dynamics, 5829 Firestone Blvd., South Gate, Calif. 90280. ★★★

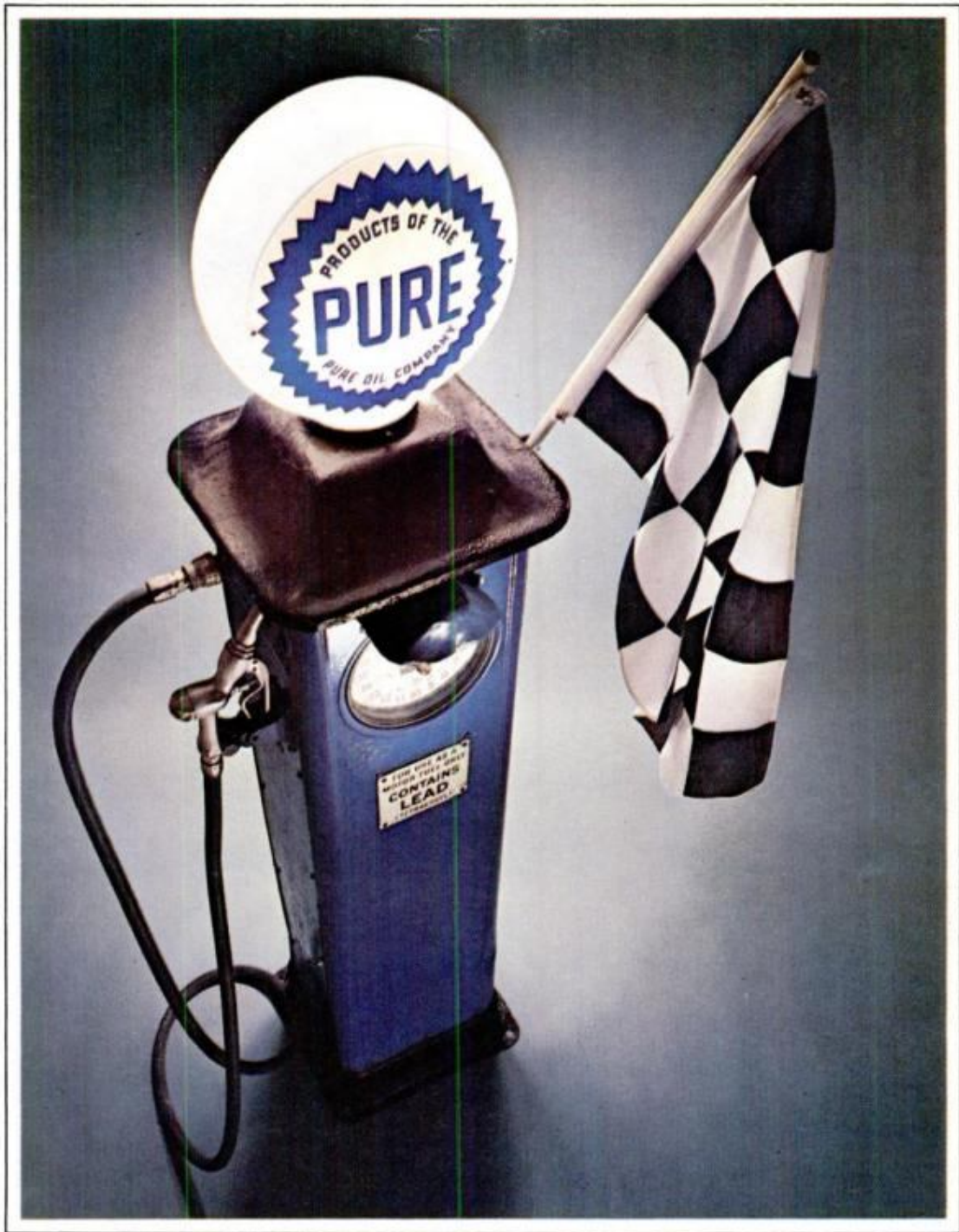

Our checkered past. It made us what we are today.

Number One.

Pure's been winning races since 1915 . . . the year a Pure-powered Stutz gave Earl Cooper a checkered flag on the Minneapolis-St. Paul Speedway.

Since then, Pure Firebird® Racing Gasoline has been winning more races, setting more records, than all the other brands combined. That's why Pure is the Number One choice

of the men who race.

Pure knows a lot about powerful gasolines. And Pure makes one for you. Pure Firebird Super . . . from the Number One name in racing.



UNI 76

Pure Oil Division

This \$100,000 car was built to break the world land speed record. They didn't scrimp on anything. They used Autolite spark plugs. Like you buy. About \$1 each.



This wheeled projectile is 30 feet long and 37 inches high. It looks a lot like a bullet. And it goes like one, too. On one of the early runs it topped 400 miles per hour easily. And it was just warming up then.

It has two 427-SOHC Ford engines. A conventionally aspirated one producing 810 horses up front. And a supercharged one producing 1260 horses in the rear. These engines cost over \$6,000 apiece.

The spark plugs? About a dollar a throw. They're Autolite plugs. The same kind you buy.

Autolite plugs are specially constructed to keep performing at the highest peak regardless of how rough the going gets. The hermetic glass seal is designed to stay intact despite extremes in heat, pressure, or stress. That means that compression can't leak off just when you need it most.

Why \$1 spark plugs in a \$100,000 car? Because there are no better plugs. Not at any price. So put Autolite spark plugs in your car. Whatever kind of car you drive.

Autolite is the only name you need to know for spark plugs, batteries, filters, shock absorbers, and complete ignition systems.

Autolite 



CLASSIFIED ADVERTISEMENTS

Rate: \$1.85 per word payable in advance each insertion. Capitalized words—75¢ per word additional. Minimum insertion ten words. To be inserted under the proper classification, copy must be in our office by the 15th of the second month preceding date of issue. The next available issue to place an advertisement in America's No. 1 Classified Section is August. The closing date is June 15th. Send remittance and order to C. A. Martin, Popular Mechanics, 575 Lexington Avenue, New York, New York 10022. Please make remittance payable to Popular Mechanics.

AUTOMOBILES

YOUR Car Worth \$50.00 to \$200.00 More on trade. Full instructions, \$4.95. Pettit Body Shop, 6198 West Michigan, Ann Arbor, Mich. 48104.

HOW TO TUNE UP YOUR CAR. Our experience gives easy to understand know-how. \$1.00—G & B Associates, P.O. Box 398, Hasbrouck Heights, New Jersey 07604

Your Ad in Popular Mechanics will be seen by more than 5,000,000 active buyers for your products and services. It costs only \$1.85 per word. And, if you wish to run all or part of your ad in capital letters—you can do so for as little as 75¢ per word additional. Act now! Place your classified ad in Popular Mechanics today.

MIDGET CARS

SAVE YOUR LIFE!! With revolutionary new publication on driving techniques. Includes over 200 scientific methods to avoid accidents. Send only \$1.98 to exclusive distributor: John Burch, 5204 LaForest, LaCanada, Calif. 91011

AUTO SUPPLIES AND EQUIPMENT

CROSLEY And foreign car parts. Box 7, Elmont, N.Y. 11003.

AUTO Parts for old cars and new. All makes. Catalogue \$1.10. Antique Auto, Milwaukee, Wisconsin 53240.

JEEP Owners—V8 conversions. Read Jeep Owners, ad, page 199.

TRANSMISSION OVERHEATING—90% of automatic transmission failures are due to excessive heat buildup. \$1.00 (refundable) brings heat range chart and info. Bill Tugend, P.O. Box 4293, Panorama City, Ca. 91412.

GAS-OIL HOG??? . . . Smoking?? . . . No Pep?? . . . Hard Starting?? (Save \$150-\$250) with Motaloy Ring-Valve Job While driving (\$6.50 postpaid) Advertised here every month for years! Continues saving money on repairs, gas, oil for 100,000 miles! Absolutely true! (new engines too) Nothing compares! . . . Money-back guarantee. You can't lose! Motaloy, Grantham, Penna. 17027.

VOLKSWAGEN Replacement parts at 20% to 50% discounts. Free Catalog. Western Distributors, Box 316 D. Cedar Crest, New Mexico 87008.

ESPECIALLY WRITTEN MANUAL FOR HOMEOWNERS. Important facts will save you many service calls by servicing your own air conditioning and heating. \$3. Imperial Mail Order, Box 7786, Tulsa, Okla. 74105.

REDUCE Road Noise. Plymouth, Dodge, Chrysler. Simple, inexpensive. Instructions \$3.00. C. Howlett, 1002 Calvert St., Nashville, Tenn. 37216.

STOP Thief. Anti-auto theft system electronically detects attempt to start engine, open hood, trunk, doors. \$13.95 write: STOP THIEF, Dept. 6B, P.O. Box 462, TUJUNGA, CALIF. 91042.

"DON'T BUY car radio reverberators. Anyone can install better system FREE in minutes. Instructions \$1.00. R & T Enterprises Dept. 3, Box 1752, Vallejo, Calif. 94590."

VOLKSWAGEN Hop-Up Accessories and Dune Buggy parts and pieces. Send \$1.50 for complete jumbo catalog. GEM Products, Box 845, Carol Stream, Ill. 60187.

BE Your own ignition expert. Free details. Q-arc, Box 47876, Los Angeles, Calif. 90047

INVEST \$10. Save cent a mile or money back free details—Berger Humid Gas Saver, Erskine, Minn. 56535.

MAXIMUM MILEAGE, PERFORMANCE, ENGINE LIFE AND MINIMUM MAINTENANCE using special materials, equipment, services provided by us to many major operators of Airlines, Buses, Trucks, Cars, Taxicabs, Boats, Steamships, Farm Equipment. Detailed information \$2.00. Automotive Service Consultants, Division of B&T Services, Incorporated, 2300 Government, Baton Rouge, La. 70806

MODEL "T" FORD COILS—Specially Made For School Projects "Jacobs Ladder" Etc., or Shocking the Neighbors Dog. All units are 100% New Material, Postage (U.S.A.) Insurance and Instructions Included. \$7.00 Each. Antique, Box 458, Rosemead, Calif. 91770.

DUNE BUGGY CATALOG—Frames, Bodies, Complete Chassis Components And Accessories—Over 20 Pages, \$1.00 (Refundable). Sand Techniques, 9103 E. Garvy Ave., Rosemead, Calif. 91771.

AUTOMOTIVE DECALS. Ford, Chev, Mopar, Mustang and many more. Generous packet over 15 full size—50 coin U.S.A. Limit 2 packs per order—Haynes Dist., Box 387, Arcadia, Calif. 91006.

FIRESTONE PREMIUM GLASS BELT-ED Wide Treads. New—No seconds. Any Size 2/\$50.00, 4/\$99.00, FET \$2.77 per tire. Prepaid/Check/Money Order. Money Back Guarantee. Wide Trac Discount Center, 1119 N. Las Palmas, Los Angeles, Cal. 90038.

THIEF PROOF Your Car. Kit installed, 20 minutes. Send \$2.00 with Car Make. Standard Electric, Box 81, Fruitport, Mich. 49415

AUTO TRAILERS

BUILD Your Pickup Camper. Precut Kits. Blueprints. Supplies. Literature 10¢. Comstock Trailers, Dept. 664, Parsons, Kansas 67357.

CAMPER Plans. Compact buses, Vans—Volkswagens, Econoliner, Dodges. Build yourself—Save! Details—Dot Campers, Box 2115M, Culver City, California 90230.

PICKUP Camper, Trailer or Pickup—Cover . . . Build yourself. Save! Complete plans \$3.95 each. Cover plans \$2.00. Conversion Plans—econoline type van \$2.95; passenger bus or delivery van \$2.95. Satisfaction Guaranteed. Equipment catalog \$1.00 (refundable). Details 10¢. Viking Camper Supply, 99-F Glenwood, Minneapolis, Minn. 55403

CAMPING Trailer kit tent top 16" size \$333.00 complete plans and instructions \$3.00, circular 15¢. Stratford Trailers, Stony Creek, Conn. 06405.

MOTORCYCLES, BICYCLES, MOTORSCOOTERS AND SUPPLIES

HARLEY-Davidsons — Used bargains. New, used parts, accessories, all models. Bulletin 35¢. Knuth's (Factory Dealer), 1753 Muskego, Milwaukee, Wis. 53204.

MOTORCYCLE TURN SIGNALS, Accessories. Catalog 25¢. Houston, PM Lockport, Illinois 60441.

BUILD Your own minibike! NO WELDING REQUIRED! Plans \$2.00. Westate Enterprises, Dept. PM-6, Box 9216, San Jose, California 95117.

HONDA 50-90-160 Speed Equipment. Cams—Big-Bore-Stroker, Columbia Engineering, 2105 E. 37 St., Los Angeles, Calif. 90058.

EVERY PART for Kart or Mini-bike. Bargain prices. Giant catalog \$1.00. Brown's Motorsports, 19 Central St., Worcester, Mass. 01608.

BUILD "Popular Mechanics" MINI-BIKE featured June 1967 issue. Detail plans, photographs \$2.50 refundable. Kits, parts, engines; factory discount prices. Catalog 25¢. Gilliam Mfg.; PMC; St. Charles, Missouri 63301.

RECONDITIONED Motorcycle motors. Indian, Mustang, Royal Enfield, Suzuki. Parts, Accessories. "Minibikes." Indian Motorcycle Sales, Kansas City, Missouri 64127.

BUILD Motorbike From Bicycle! Plans . . . \$2; Go-Cart Plans . . . \$2; Snowmobile Plans . . . \$5; Go-Byk Industries, Rothsay, Minn. 56579.

HONDA \$25, other Bargains. Send 50¢. McKinney, P443, Bend, Oregon 97701.

SNOW VEHICLE & KART Hop up accessory CATALOG. Speed and performance equipment—manifolds, engine mounts, exhaust systems. Send 25¢. G.E.M. PRODUCTS, 436 Roosevelt Rd., Glen Ellyn, Illinois.

STUDDER Custom Leather Jewelry Brochure 25¢. A Taste of Leather. Box 5009-PM, San Francisco. 94101

MINI-BIKES. Motorcycle, Supplies. Wholesale Catalog, 25¢. Loren Products, Danville, Illinois 61832.



AVIATION

BE A Government licensed aviation mechanic. Practical training. Free information. Aero Mechanics School, Municipal Airport, Kansas City, Missouri 64116.

TREMENDOUS OPPORTUNITIES IN AVIATION. Learn Aerosciences at home: Navigation, Aerodynamics, Communications, Weather. Free Information: United Aerosciences, P.O. Box 4106, Torrance California 90503.

HOME BUILT. Real enclosed helicopter, 24 pages ideas, information, \$2.50. Build "executive" helicopter, drawings, specifications, \$2.00. Helicopter Development, Box PM147, Washington, New Jersey 07882.

AERO-CAR. Amazing Hovercraft built easily with ordinary tools. Lawnmower engine power. Carries one man plus. Hovers, flies forward, backward, sideways over land/snow/water. Complete construction plans and brochure, \$5.25. Aero-Projects, Box 5118, Clinton, N.J. 08809.

BARTLETT FLYING SAUCER. Amazing machine hovers 200 lb. man over land/water, powered by ordinary lawn mower engine. Easy to build. Fun to fly. Complete Plans, Kit Brochure and Photo Review \$3.00. Write: Herb Bartlett, Box 3234-C, Scottsdale, Arizona 85257.

AIRBOAT. Propellers, Engines, Plans, Kits, Supplies. Complete Airboats, Outboard Airdrives, Catalog \$1.00. Banks-Maxwell, Box 3301E, Ft. Worth, Texas 76105.

HELICOPTER. One-man. Portable. Information 10¢. Kit information 10¢. Photos 25¢. Three-view drawings 25¢. Plans \$1.00. Compco, Box 1267, Redwood City, California 94064.

JEANIES Teenie homebuilt airplane. All aluminum, Volkswagen powered. Photos—Specifications—Material lists—Flight reports \$5.00. Money order only. Calvin Parker, Box 727, Daphne, Alabama 36526.

AIRBOAT. 12' Long. With 18 H.P. Engine. Excellent Performance. Construction Plans \$19.95. Kits, and Engines Catalog \$3.00. Aero Sports Craft, 28 E. Jackson Blvd., Chicago, Illinois 60604.

VOLKSWAGEN CONVERSION MANUAL: Must for JEANNIES TEENIE builders. 6 Component drawings, hub, text, etc. \$7.95. Ted Barker Experimental Engines, 8801 Regal, Anaheim, California 92604.

BUILD 60' Piloted LPG Hot Air Balloon. Details \$1.00. Plans, parts list, FAA requirements, prints, \$5.00. Balloonetics, Box 63, Reseda, Calif. 91335.



BOATS

CANOES! Kayaks! Factory-direct quality kits, from \$20.00. Many different models. Canvas hulls. Strongest construction materials. Free literature. Sportsraft, Box 8393-PM, Columbus, Ohio 43201.

BOAT PLANS, FRAME KITS, BOAT KITS. World's largest catalog—Over 200 top design for the amateur builders. New catalog includes Cruisers, Runabouts, Deep vee's, Catamarans, Trimarans, Houseboats, Sailboats from small sail fish to 34 ft. motor sailers, large selection of inboard and outboard Hydroplanes. Send \$1.00 for large new plan & kit catalog or \$2.00 for catalog plus Boat Builder's Guide. Clark Craft Boat Company, 16-P Aqua Lane, Tonawanda, New York 14150.

BUILD Your own boat from our large-scale blueprints. Books of plans give how-to-build help. Hundreds of professional designs—motor, sail or auxiliary—for amateur builders. Free catalog. MoToR Boating, 959 Eight Ave., Dept. PM-RS, New York, N.Y. 10019.

NEW 1968 McCulloch and other outboards. 4 H.P. \$108.00. . . . 7½ \$224.00. . . . 9 Electric Start \$288.00. . . . 18 \$316.00. . . . 40 Electric \$514.00. . . . 65 Electric \$698.00. . . . All sizes. Literature 50¢. Electra Marine 1427 Broadway, Brooklyn, N. Y. 11221.

FIBERGLASS Cloth and resin. World's finest cloth and non-run resin, at direct mill prices. Flotation foam. Complete line of plastics, silicon bronze and brass screws, save 60%. No Sales tax. Boat Plans, Catalog 25¢. Freight prepaid. Stiles Boat Supply, Box 11P, Linden Ave., Mantua Hts., N.J. 08051.

FREE Catalogue—plans for canoes, kayaks, accessories. Quicksilver, 115 McGavock Pike, Nashville, Tenn. 32714.

FIBERGLASS CANOES. Four Exciting Models. Easily Assembled Kits. \$39.95 up. Factory Direct. Free Literature. Riverside Canoes, Box 5595-B, Riverside, California 92507.

SAILBOAT, tough plastic coated 12-ft. hull, 65 sq. ft. nylon sail, \$164.95 complete. Free brochure. ADECO, Painters Run Road, Pittsburgh, Penna. 15241.

KAYAK Boat kits, Nylon covering never needs paint or dope, assembles in one day. Fast & easy to handle. Circular with photos 15¢. Stratford Trailers, 376p Stony Creek, Conn. 06405.

BOAT maintenance information. LIFE-CALK, "GIT"-ROT, RUB-R-COTE, Finishes & Cleaners. Send for "How to do Where to do" literature. FREE. Boatlife, 5-45 49th Av., L.I.C., N.Y. 11101.

BOAT KITS. Molded Fiberglass. Save money—assemble yourself. Factory molded sections bond into one-piece craft. 30 models—14' to 33'. Cruisers, Runabouts, Houseboats, Sailboats. Big line accessories, motors, trailers. Easy terms. Free 88 page catalog. Luger, Dept. BC-69, 9200 Interstate 35W South, Minneapolis, Minnesota 55431.

PLANS, FULL-SIZE PATTERNS, FRAME KITS with step-by-step instructions specially for amateurs. Send \$1.00 for new 96 page catalog of over 80 designs, 8' to 36' Sail, Jets, Inboards, Outboards, Cruisers, Houseboats, Hot Boats, Catamarans, Hydros "plus" boat trailers. New "How To Build Boat Trailers" book \$4.00 ppd. Glen Designs, 9152 Rosecrans, Bellflower, Calif. 90706.

KAYAKS—One-man \$21.00; two-man \$26.00; Sailboats \$45.50. Exciting Sitka Kayak Kits known world wide for speed and safety. Assemble in one afternoon. Free pictorial literature. Box 582-P, Willoughby, Ohio 44094.

FREE CATALOG from manufacturer of nylon and Dacron rope. Direct to you at dealer cost. Other important accessories. Write: West Products, Dept 20, Box 707, Newark, New Jersey 07101.

AIR PRESSURE ELIMINATES RUSTY BEARINGS. Pendleton Seals, 6345 Gregory, Whittier, Calif. 90601

FIBERGLASS Cloth, matt, polyester, epoxy and foam resins. Lowest prices. Seifert's, Box 1206-M, Green Bay, Wis. 54305.

WATERSKIBOARD Now pre-school children can join in family sport. Build for under \$5.00. Plans \$2.25. MAJCO, A69, 219 West California Street, Glendale, California 91203.

DRY ROT CAN BE REPAIRED! NOW. with Re' Store. You apply it with brush or syringe, depending on accessibility of infected area. It permeates dry rotted deck, hull or trim—hardens in hours to leave wood stronger than ever before! One quart is enough for the average boat. Costs only \$13.95 PREPAID in U.S. Application Kit for interior of keel or other hard-to-reach areas only \$1.95 more. Satisfaction guaranteed or money refunded. Send check or money order to: Royale Research Company, Dept. P.M., P.O. Box: 1751, Grand Rapids, Michigan 49501.

200 Boat Plans, patterns, Kits, Catalogs: Powerboat \$1.00, condensed 50¢, sailboat 40¢. Marinecraft, Box 161-M Brighton, Mass. 02134.

MARINE EQUIPMENT AND SERVICES

NEW, Used, rebuilt marine motors. Marine conversions, fittings. Free catalog. Stokes Marine Supply, Dept. 24, Coldwater, Michigan 49036.

CONVERT Auto engines to marine. 68 Page Catalog, 50¢. Lehman Manufacturing Company, 800 Elizabeth Avenue, Linden 4, New Jersey 07036.

PROFESSIONAL Marine engines from Star Marine Kits. Engines—Gears—Props—Everything necessary for your boat propulsion. Write for free brochure. Star Marine Engine Works, Berkeley, California 94710.

FREE 1969 Catalog—Gray inboard, inboard-outboard marine engines, gasoline and diesel. Graymarine Corporation, Coldwater, Michigan 49036.

FREE Pontoon Boat Catalog, Dock Brackets, Float Brackets, Mooring Bars, Dock Ladders, Perma—D Marine Products, Dept. 35, 2308 Central Ave., Minneapolis, Minn. 55418.

ATHLETIC AND BODY BUILDING COURSES

"GIANT Arms." Dr. Young's, D.C. revolutionary discovery. \$2. Satisfaction or refund. Gaucho, Box 9309-S7, Chicago 60690.

BIG Muscles fast, complete course \$5.00. Olympus Bodybuilding, Box 431, Garden City, Michigan 48135.

POWERFUL Muscles fast! Free brochure! Universal Bodybuilding, Box 4327-C, Dearborn, Michigan 48126.

FABULOUS Simple inexpensive Home Gym apparatus for chinups, dips, etc! Plans, parts list. \$1. Tibu, Box 6, Capistrano, California. 92675.

ISOMETRIC Exercisor \$2. Send chest size. Box 6074, Hollywood, Florida.

FEAR No Bully! Master authentic Chinese Kungfu unbeatable techniques! Defeat within seconds any attacker including giant judo-karate experts. Free details by air, write Asia's greatest master, Leongfu (MI/40), 119 Anderson Road, Ipoh, Malaysia.

TRIM Or Build. Isometric exercisor with instructions. \$3.95. J. W. Schroeder, 10934 Langdon, Houston, Texas 77072.

SPORTING GOODS AND EQUIPMENT

FREE . . . Wholesale Catalog, Arrow Shafts, Broadheads, Fletchings, Fisharrow Parts, Tools, Bows, Finnsports. (22G), Toledo, Ohio 43614.

THE Amazing Long Play Golf Ball is Guaranteed against splitting. Conforms with U.S.G.A. Rules \$6.95 per Doz. Send Check or Money Order To Tenute Supply Co., Dept. =40, Lisle, Ill. 60532.

FREE 1969 Catalog. Guaranteed Lowest Prices! Rods Reels, Lures, Accessories—Thousands of Items. Cabela's Inc., Dept S, Sidney, Nebraska 69162.

FISHING, TACKLE, LURES

MOLDS—For casting your own fishing sinkers. Free illustrated booklet. Reading Instrument Co., Box P78, Reading, Pa. 19603.

BIG Discount "1969" Bargain Catalog Fishing Tackle, Reels, Rods, Clothes, Boots, Scopes. Prices you never dreamed possible. Don't buy until you get Catalog =116-50¢. Lombard's, Rte 59, Nanuet, New York.

SEND for FREE Wholesale Catalog. The most complete and fully illustrated catalog of reels, rods, beads, spinners, jigs, bodies and parts, sinker molds, feathers, tools, hooks, rod blanks, rod parts, swivels, wire, etc. FINNSPORTS, ME Sports Bldg., Toledo, Ohio 43614.

MOLDS For fisherman's sinkers, jigs, squids, casting and spinning lures. Free catalog. Sweets Molds, Tonawanda 1, New York 14150.

SAVE 60% Monofilament Line U.S.A. MANUFACTURED 500 YARD SPOOLS 6, 8, 10, or 12 test POSTPAID \$1.25 each. 3 Spools \$3.50. GUARANTEED. Golden Eagle, Box 7186-S, Miami Florida 33155

FISHERMEN: Flip your wrist, and the "De-Hooker" flips the fish off the hook. Send \$1.00 to Western Mail-Order 121 Echo Ave. Oakland, Calif. 94611

UNHOOK Fish with Ease. Ami-flip fish De-hooker \$1.00. To: TRI-OUR Assoc. Post Office Box 44, Langhorne, Pa. 19047.

EARTHWORMS, LIVE BAIT

BIG Money growing fishworms, giant African Crawlers, crickets. Free Literature. Fain's Hatchery-31, Edison, Georgia 31846.

EARN Money raising fishworms for us! Exciting details free! Oakhaven-56, Cedar Hill, Texas 75104.

AFRICAN Nightcrawlers. Wholesales, shipped prepaid. **BONANZA WORM RANCH, LODA, ILLINOIS 60948** Phone: 217-386-2111

FROGS, FISH, REPTILES

YOUNG Frogs and Giant Breeders. Stock your lakes and ponds. Nu-Tex Frog Farm, Box 4029, Corpus Christi, Texas.



HUNTING GUNS, DECOYS

EXTRA Income at home in Spare Time! Booklet shows you how to start your own business with Classified Advertising. Only \$1.00. Refundable with first order. C. A. Martin, Popular Mechanics Dept. PM, 575 Lexington Ave., New York 10022.



DOGS AND KENNELS

EXTRA Income at home in Spare Time! Booklet shows you how to start your own business with Classified Advertising. Only \$1.00. Refundable with first insertion order. C. A. Martin, Popular Mechanics Dept. PM, 575 Lexington Ave., New York 10022.



GAME BIRDS

FREE Big quail color catalog. Marsh, 14216 Brookhurst, Garden Grove, Calif. 92640.

DAY Old ringneck pheasant chicks as hatched \$38.00 Per Hundred. Postpaid. Minimum order 100. Gibson Hollow Game Farm, Route =2, Box 202, Mt. Pleasant, Tennessee 38474. Phone: 615-379-7481.

HAWKS, FALCONS

HAWKS, Eagles, Falcons, Owls for hunting. Send \$1.00 for complete price list. Slocum, Box 30-13, Grove, Oklahoma 74344—Telephone 918 786-2201.

RABBITS—FUR BEARING ANIMALS

RAISE Rabbits for us on \$500 month plan. Free details. White's Rabbitry, Mt. Vernon, Ohio 43050.

RAISE Rabbits successfully by knowing facts. 48 page illustrated book describing 25 breeds. Housing, breeding, feeding, markets, marketing etc. 25 cents. American Rabbit Association, 36 Arba Building, Pittsburgh, Penn. 15217.

MAKE Big Money raising chinchillas, rabbits, guinea pigs for us. Catalog—25¢. Keeney Brothers, New Freedom, Pa. 17349.

\$500—\$800 MONTHLY Raise small laboratory-breeding stock for us. We supply equipment, breeders, instructions. Illinois Research Farms, Dept. MPB-6, McHenry, Illinois 60050.

EARN \$10,000 Yearly raising angora rabbit wool, and breeding stock for us. Information 25¢ coin. American Angora Company, Malta 12, Montana 59538.

TAXIDERMY

EXTRA Income at home in Spare Time! Booklet shows you how to start your own business with Classified Advertising. Only \$1.00. C. A. Martin, Popular Mechanics Dept. PM, 575 Lexington Ave., New York 10022.

PETS—BIRDS, CATS, HAMSTERS, ETC.

LIVE SEAHORSES, marine specimens, aquarium supplies. Illustrated catalog 15¢. Marine, Box 248-210, Dania, Florida 33004.

LIVE Traps, all sizes, mouse to dog. Collapsible or rigid. Carrying Cages. Free literature. National Live Traps, Tomahawk, Wisconsin 54487.

HAWKS, Reptiles, raccoons, skunks, squirrels. Catalogue 25¢. Trails End Zoo, St. Stephens, S.C. 29479.

FLYING Squirrel Book \$1.50. 950 Picture Pet Hobby Poultry Book 50¢. "Everything—You Name It." Stromberg's Pets Unlimited, Fort Dodge 25, Iowa 50501.

HORSES, LIVESTOCK

"HOW To Train Horses"—Everyone who likes horses or ponies should have this book: Free. Write Beery School, 1106 Pleasant Hill, Ohio 45359.

CAMPING EQUIPMENT AND TENTS

SAVINGS Plus dividends! Campers-fishermen-outdoorsmen cooperative. Free 68-page catalog. Recreational Equipment, Inc., 1525-P 11th, Seattle, Washington 98122.

CAMPING Equipment, Tents, Sleeping Bags. World's largest selection. Free giant catalogue. Morsan, 810-R Route 17, Paramus, New Jersey 07652 or 1999 Route 110, Farmingdale, New York 11735.

PREFAB Starter cabin, 8 x 12. Plans, instructions. \$1. Record, Box 271, New Hyde Park, N.Y. 11040.

CAMPING

"101 CAMPING Tips"—\$1. Camping Questions Answered—\$2. Free list of Guides. Lazy Camper (PM), Box 85, Winthrop, Massachusetts 02152

"FLORIDA Keys Trailer Camp site. \$1.00. Information, 11896 Curwood, Grand Blanc, Michigan 48439."

TRAVEL AND RESORTS

WILDERNESS CANOE TRIPS. Free brochure. Bill Rom's Outfitting, Ely, Minnesota 55731.

ELECTRICAL SUPPLIES

METERS—Surplus, new, used, panel and portable. Send for list. Hanchett, Box 5577, Riverside, Calif. 92507.

UNUSUAL Electrical and Lamp Specialties. Free Catalog. Homecrafters, 4605 State, Drexel Hill, Pa. 19026.

LAMP Parts. Catalog, prices, wiring instructions. 50¢. Refunded first order. Gyro, 5218P N.W. 35 Ave., Miami 42, Fla. 33133.

LAMP parts for building, repairing, converting. Catalog 40 cents. Refunded with first order. Brown Lamp Co., Box 11305, Clayton, Mo. 63105.

APPLIANCE—Lamp parts. Wholesale catalogue 25¢. Seco, 109 South 20th Street Birmingham, Alabama 35233.

BATTERIES, GENERATORS

BATTERY Reconditioning Kit, includes molds, material, instructions. Battery Shop, 878, Palm Desert, California 92260.

ENGINES, MOTORS

WINDING Data, 275 motors, \$1.20. Data Company, 512 Kensington, Kansas City, Mo. 64124.

BIG Steam Engines, Kits Catalog 50¢. Reliable Industries, New Baltimore, Mich. 48047.

LIVE Steam powered backyard railroad! All sizes. Complete "bolt-together-kits," and rough castings. Excellent drawings. 100 page catalog \$1.00. Little Engines, Lomita, Calif. 90717.

OPERATE Three phase motors from single phase. Three ways \$2.00. Donald Howell, Barnesville, Ohio, 43713.

MACHINERY, TOOLS AND SUPPLIES

SMALL Foundry furnaces, Supplies. Free literature. Pyramid Products, 3736 South 7th, Avenue, Phoenix, Arizona 85041.

MICROMETERS—Indicators—Small lathes. Direct Supply, 1424 Barclay, Springfield, Ohio 45505.

CEMENT MIXER—Build 3 cubic foot powered unit for fraction of commercial model cost using hand tools. Plans \$2.50. Home Side Enterprises, Box 112; Layton, Utah 84041.

WELDING, SOLDERING, PLATING

CHROME Plating equipment, supplies. All other finishes. Home workshop and production sizes. Send \$2.00 (refundable) for formulas, operating data, equipment guide and catalog. HBS Equipment Division L50, 3543 East 16th, Los Angeles, Calif. 90023.

WELDERS—110/220, 150 Amperes, \$53.50. Morris, 1070 Inner, Schenectady, New York, 12303.

BUILD Your own Arc Welder 110/220, 170 Amperage for less than \$20. Plans \$2.00. Box 7434, Postal Station O, Vancouver, British Columbia, Canada.

GOVERNMENT SURPLUS

1969 SURPLUS Army, Navy store illustrated catalog. Send 25¢ (refundable with first \$5.00 order). Ruvel, 707 Junior Terrace, Dept. 9-J, Chicago, Illinois 60613.

JEEPS Typically From \$53.90 . . . Trucks From \$78.40 . . . Airplanes, Typewriters, Boats, Clothing, Camping, Sporting, Photographic, Electronics Equipment. Wide Variety. Condition. 100,000 Bid Bargains Direct From Government Nationwide. Complete Sales Directory and Surplus Catalog \$1.00 (Deductible First \$10.00 Order). Surplus Service, Box 820-A, Holland, Michigan 49423.

GOV'T Surplus. How and where to buy in your area. Send \$1.00. Surplus information. Headquarters Building, P.M., Washington, D.C. 20036.

JEEPS From—\$52.50; Typewriters from—\$4.15; Cars from—\$31.50. Walkie-talkies, motorcycles, airplanes, boats. Typical "As Is" bid bargains from Uncle Sam. Tremendous variety. Exciting free list. Write: Enterprises, Box 402X47, Jamaica, New York 11430.

JEEPS \$178. Airplanes \$159. Boats \$7.88. Generators \$2.68. Typewriters \$8.79; typical Government Surplus Sale Prices. Buy 10,001 items wholesale Direct. Full details and procedure only \$1.00. Surplus Catalogue included free. Surplus Box 8PM, Thomasville, Penna. 17364.

DIRECTORY of Government Surplus Sales Offices. How to Buy Direct. Bidders Lists, etc. Complete Details. \$1.00. Refundable. Crawford PM-69, 363 Poppy, Long Beach, California 90805.

HOBBIES AND COLLECTIONS

50 GORGEOUS Jungle butterflies \$2.50. Collectors Wonderland, Box 1170, New York, 10008.

OUR FIRST 19 IN SPACE. This limited edition lithograph has been created as a tribute to Americas Gallant Astronauts. 12 X 18 inch chart ready for framing. Only 75 cents. Popular Mechanics, Dept. GWP, 575 Lexington Avenue, New York, New York 10022.

TELEGRAPHER'S TREASURE available for sale - Sounders, telegraph keys, Relays, Resonators and other memorabilia from the 19th Century. Catalog 50¢. J. H. Bunnell Co. 920 Essex Street, Brooklyn, N.Y. 11208



STAMP COLLECTING

PENNY! Approvals! Regardless catalogue! Kloster, 4164 52nd St., San Diego 5, Calif. 92105.

500 DIFFERENT Stamps. \$1.00. Smith, 508-A Brooks, College Station, Texas 77840.

UNITED States commemorative collection containing 33 different—10¢. Approvals. White, 516-A Avenue L, Brooklyn 30, New York.

50 YEARS Old, fifteen different United States, over fifty years old—10¢ with approvals. Jaxon, Box 145-P, Brooklyn, New York 11230.

GIANT Stamp Collection including: Astronauts, Satellites, Moonrockets, Boy Scout issue, Complete U.N. Set, recent Olympic and Sport issues from many countries, etc., Plus Big Stamp Dictionary and approvals. Everything, 10¢! Stampex, Box 47-RM, White Plains, N.Y.

ABSOLUTELY Free 25 different United States Commemoratives when requesting United States Approvals. K & B, Box 70, Brooklyn, N.Y. 11223.

1500 FOREIGN \$1.00; 5000 \$3.00. 5000 USA commemoratives, revenues, airmails, presidentials, 19th Century, high values \$3.00. 300 pre-1939 USA commemoratives \$2.00. 1000 foreign pre-1940 \$3.00; 5000 \$12.00. No approvals. Meyers, 5321 Fleming, Richmond, California. Zip code 94804.

50 DIFFERENT United States, only 10¢, with Approvals. Shelton, Box 547C, North Miami, Florida 33161.

"AFRICA," 25 beauties, 10¢. Approvals. Gorliz, Box 1915PM, Naples, Florida 33940.

PAINTINGS 20 Different giant multi-colored beauties 25¢. Beautiful paintings sets on approval. Roger Williams Stamp Co., Box 1281-P, Pawtucket, Rhode Island 02862.

CLOSEOUTS! Grab Bags 50¢ each! Ross, Box 152, Wayne, Pa. 19087.

MILLIONS Foreign Stamps! 2¢ each! Send for gigantic approvals! ABC, Box 6000-MB, San Francisco, California 94101.

100 OLD United States between 1861 and 1935, \$1.00. Roush Stamps, 51 Chestnut, Mansfield, Ohio 44903.

FREE Surprise collection sent with approvals. Gould, 1784 Union, San Francisco 94123.

"INVERTED ERROR" Dag Hammarskjöld, 6¢ with approvals. Belmont Stamps, Washington, D. C. 20015.

U.S. Approvals Low prices. Eagle, 2221 Romine Ave., Pittsburgh, Pa. 15226.

255 DIFFERENT Worldwide: 15¢. Approvals. Tibbets, 8675 Meadow, Downey, Calif. 90242.

50 DIFFERENT Old U.S. Revenue stamps 50¢. Winchester Stamps, Box 1592, Mansfield, Ohio 44907.

U.S. Mint specials! Flag set, complete \$1.00. 1¢, 2¢, 3¢ famous Americans (21 different) \$1.00. Frecc list, Brooks, 2601 Avenue "U," Brooklyn, N.Y. 11229.

ONE Pound value Geo. VI Bermuda, plus 100 worldwide 10¢, approvals. Stevens, Box 105A, Homecrest Sta., Brooklyn, N.Y. 11229.

NEW Issues—Free weekly illustrated list. Brooks, 2601N Avenue "U," Brooklyn, N.Y. 11229.

PENNY Stamps! 1000 Mounted in book at 1¢ each. Trust Stamp Company, P.O.B. 132-P, Jamaica, N.Y. 11435.

225 STAMPS for only 10¢! Airmails. Pictorials; stamps from strange countries cataloging up to 25¢ each! Plus unusual stamps to examine. Buy any or none return balance. cancel service anytime. Mystic Stamp Co., Camden 80, New York 13316.

FREE!! Two Beautiful Multi-Colored Complete Mint Sets. Approvals. Hamilton, 1246 Pratt, Chicago OE-6, Illinois 60626.

50 DIFFERENT AFRICA plus SOUVENIR SHEET 25¢—Approvals accompany. Quynn's, Scotland, Penn. 17254.

701 U.S.A. (PLENTY Commemoratives)—25¢. Approval purchase required. Horace Gatewood, Winston-Salem, North Carolina 27102.

50 POLAND Large Pictorials 25¢. Approvals accompany. World, 1784 Union, San Francisco 94123.

U.S. Bargain, 50 different 10¢, with beautiful worldwide approvals. Stamp Center, Kennebunk, Maine 04043.

ANNUAL Spring Sale. Excellent Values. Mounted Approvals. Preview Stamps. Box 9809M, San Diego, Calif. 92109.

121 DIFFERENT Flag stamps free. Approvals. W-B Stamps, Wilkes-Barre, Pa. 18703.

TERRIFIC Stamp Bargain—125 Different! Includes beautiful Germany and Asiatic Pictorials plus colorful and exciting space Topicals. Only 10¢ with Request for Approvals. Send Today! Shaw, Drawer E-14, Montevallo, Alabama 35115.

FREE Mint Set. Approvals accompany. Stamps, Box 22092, Memphis, Tenn. 38122.

2,000,000 STAMPS, 150 Countries, 2¢ each. Belden, Box 4175, Dearborn, Mich. 48126.

THOUSANDS Worldwide 2¢ each, on approval. King Penny Stamps, 4517 Tioga, Canton, Ohio 44708.

511 DIFFERENT WORLDWIDE, a \$12.50 value only \$1. Philatelic Mart, Box 262M, McGregor, Texas 76657.

WOW! 110 All Different Germany 10¢ Commemoratives, Airmails, High Values, Big Catalog, bargain lists also, fine stamps from our approval service, which you may return without purchases and cancel service at any time. Jamestown Stamp, Dept. A69, PM, Jamestown, N. Y. 14701.

RUSSIA High-Value Collection. 32 different Russia—some over 50 years old! Commemoratives, Czarist Issues, Airmails, Catalog price \$2.50. Special Get-Acquainted Offer—all for only 10¢! H. E. Harris, Dept. GG-49, Boston, Mass. 02117.

GORGEOUS Sets free! Request approvals. Martell, Box 421, Westerly, Rhode Island 02891.

FREE! Big Bargain Catalog—New Edition listing thousands of bargains including U.S. & B.N.A. stamps, packets, albums, accessories and supplies. Also, fine stamps from our approval service which you may return without purchases and cancel service at any time. Jamestown Stamp, Dept. E69PM, Jamestown, N. Y. 14701.

CLOSEOUT Sale! Unbelievable low Prices. Generous lots 30 cts.. Assortments \$1.. High Value Packets \$2.. Persile, 436 New York Ave., Brooklyn, N.Y. 11225.

FREE 50 Worldwide. Approvals. University Stamps, P.O. Box 1471, Lake Worth, Florida 33460.

FREE! Triangles, Scout, 25 others. Approvals. Cambridge, Box 411, Cambridge, Ohio 43725.

14,000 DIFFERENT! AMAZING new plan builds your collection systematically, country by country. Only 50¢ weekly. Ware, Monroe, Conn. 06468.

VIETNAM 25 Different 10¢ approval. Sam Chazen, Box 95, Ozone Park, N.Y. 11417.

210 DIFFERENT U.S. Commemoratives \$1.00. Stamps, 7607 Larchview Drive, Dallas, Texas 75240.

50 DIFFERENT U.S. Commemoratives, 10¢. Approvals. Cambridge, Box 411, Cambridge, Ohio 43725.

TOPICALS—Three Colorful Sets, 10¢! Approvals. COLE, Box 223-A, Buffalo, N.Y. 14221.

RUSSIAN Space set 10¢. Russian approvals. Snedco, Box 68-P, Waldwick, N.J.

ROMANIA 30 different cataloging \$4.50 plus \$1.00 bonus only. 10¢. Cappelli, 6243-A Ogontz, Philadelphia, Pennsylvania 19141.

SENSATIONAL Clearance: Forty Different Packets \$1.00. No Approvals. Norge, Ho-Ho-Kus, New Jersey 07423.

450 FINE Mixed U.S. 15¢. Wright, Box 753-M, Hagerstown, Maryland 21740.

FREE Stamp Wallet with approvals. Wide choice collections by countries. Clark, Box 28-P, Wilmette, Ill. 60091.

BARGAINS In Old Used U.S. Seconds. Karl Swartz, Mountain Home, No. Car. 28758.

AFRICA 25 Different 5¢. Approvals. Hi-jop Box 505, Norristown, Pa. 19404.

FAR East Assortment—Stamps from Viet Nam, Japan, Korea, Formosa and others only 10¢ with world-wide approvals. Clark Stamps, Dept. 57V, Muskegon, Mich. 49444.

"RUSSIAN Bear in Berlin Set. Only 10¢. Approvals. Ken Zielski, Box 364-M, Morton Grove, Illinois 60053."

25 LARGE Poland stamps. 10¢. No approvals. Jack Field, 2109 N. Argonaut, Stockton, Calif. 95204.

PROSPECTOR'S PACK. File folder packed with album pages, sets, packets, covers, etc. \$5 postpaid, satisfaction guaranteed. Wood, 7855 West 16th Ave., Lakewood, Colorado 80215.

\$10 SCOTT Catalogue. Foreign \$1. Funkhouser, 4501 Tracy, Kansas City, Mo. 64110

MINT U.S.: Flags 95¢. Famous Americans \$5.95. Tipex 55¢. Spa 27¢. Cipex 28¢. Pipex \$1.25. LaBrecque Box 10, Boston, Mass. 02101

SUMMER DISCOUNTS! Save now on everything in my price lists of packets, sets, singles, U.S., U.N., Canada, foreign! Lists sent free! Faville, 400 West Broadway, Monona, Wis. 53716

RUSSIAN PICTORIALS 25 Diff. 10¢. Approvals. Bridgeco 7200P University, La Mesa, Calif. 92041

STAMPS Free! New issues, new countries, triangles, rockets, Olympics, Scouts, birds, flowers, animals. Also old Canadian and U.S. Stamps. Plus complete illustrated Canadian stamps catalog. Send 10¢ for mailing. Gray Stamp Co., Toronto, Canada.

TEN Giant Paintings: 20¢. Approvals. Stamp Farm, FAM7, Oxford, Wis. 53952

500 CANADA Mixed 25¢. Approvals. Continental, 271 Pinacove, Burlington, Ontario, Canada

WORLDWIDE Approvals. Humphrey, 805 24th Ave., Santa Cruz, Calif. 95060.

BEAUTIFUL TROPICAL SET Plus Bonus Packet, 10¢. Sets or Packet Approvals. Packman, Box 97, Fort Collins, Colorado 80521.

ROCKETS Flags, Diamonds, Triangles, 55 Others 5¢ with approvals. Dealing, Box 185, Long Lake, Minnesota 55356.

NUDE Paintings, Romania's latest 1969 Bosom Beauties—Free! Approvals plus 101 Bonus Offers. William Deems, 226B Race, Ravenswood, West Virginia 26164.

FREE 50 Different Stamps to approval Applicants. Write I. J. Stamps, Box 644, Bloomington, Ill. 61701.

FREE—Mint British Colonials from Sabah, Seychelles, Tristan Cunha, Sarawak, Negri Sembilan, Caymans, South Georgia. Free with approvals. Viking, Great Neck, N. Y.

COINS, TOKENS, CURRENCY

UNCIRCULATED Dollars, 1880-81-82 S, 1883-84-85-1899-1900 01-02 O mint. \$3.50 ea. Catalogue 50¢. Shultz, Salt Lake City, Utah 84110.

OLD Coins Bought. Illustrated Catalog 25¢. Hutchinson's, Box 6256, Philadelphia, Pa. 19136.

PRICE List. Send 10¢. Village Coin Shop, Dept. P, Plaistow, N.H. 03865.

LINCOLNS: 30 Different Brilliant Uncirculated 1954PDS-1968PDS complete (Regularly \$5.95)—Special \$2.95. Silver Dollars \$2.45 each, BONANZA, Box 4491P, San Jose, California 95126.

22 "S" LINCOLN Cents, including rare 1955S, \$1.60, 26 1909-1939, \$1.60, 10 "S" Jeffersons, \$1.60. All different. All three \$4.50. Bargain pricelists included with order. HARRIS, 2373 P Pruneridge, Santa Clara, California 95050.

BARGAINS \$1.00 EACH—ALL DIFFERENT. Fourteen (S) Lincolns, two Liberty quarters, two Barber quarters, three Barber dimes, six War nickels, six Mercury's, six Roosevelt's, nine Buffalo's, four Indians, four Liberty nickels. **SPECIALS:** —Large cent, two cent piece, three cent nickel \$2.00 each. U.S. list plus 1969S cent 25¢. Schultheis, Box 151M, New Hyde Park, N.Y. 11040.

50 BUFFALO Nickels, full dates, includes earlies, Special \$7.95. Three different Silver Dollars, \$6.95. New type 1969S Cents, 30 for \$2.00. SERENDIPITY, Box 820P, Cupertino, California 95014.

UNITED STATES Specials: Half Dime before 1873, \$3.00; Large Cent before 1857, \$3.00; 1893 Columbian World's Fair Half Dollar, \$3.00; Old style Large \$5.00 bill, \$12.00; All four offers \$20.00. Moneyback Guarantee. Rarcoa, 31-A, North Clark, Chicago 60602.

COINS Wanted! Immediate cash! Fairway Company, Box 121-P, Rye, New York 10580.

BARGAINS—Latest coin price list, 10¢. Ron Farley, Metamora, Ill. 61548.

"SEVEN Different liberty nickels—\$2.00—Bargain listing—Dime—Huber—200 Baker Building, Minneapolis 55402.

COLLECT Silver Dollars! Join "Dollarama Club." Interesting, profitable hobby. Free Details. Monterey Coins, 311-PM Homeland N.W., Albuquerque, New Mexico 87114.

SCARCE Date Jefferson nickels. All V.G. Satisfaction Guaranteed. 1942-D—1949S—1950—50¢ each. 1943D—1951S—1955—75¢ each. 1939S—\$1.25. 1938D—\$1.65. 1938S—\$3.25. 1939D—\$5.00. 1950D—\$14.50. Dates not listed 20¢ each. Bryson Inc., 612A White, Toledo, Ohio 43605.

QUARTERS: 1925P To 1930P. Each 50¢. Stevens, Box 546F, North Miami, Florida 33161.

21 UNCIRCULATED Lincolns . . . 1959 PD—1969PDS \$1.00. Catalog! 10¢. Mohawk, Box 82M Crane, Schenectady, New York 12303.

20 UNCIRCULATED Foreign Coins \$1.00. Coins, Box 35041, Minneapolis, Minnesota 55435.

BEFORE 1835 Large Cent, \$3.25. Doktor, Box 8915, Oak Park, Mich. 48237.

BRILLIANT Uncirculated Commemorative Half Dollars—Arkansas Centennial, Oregon Trail, Pilgrim Tercentenary, Daniel Boone, each \$14.95. Bargain Lists 25¢. Bebee's Incorp., Omaha, Nebraska 68111.

100 INDIAN, Lincoln Cents, 1920's and older. \$5.00. Wesley Road, West Union, Iowa 52175.

30 DIFFERENT Foreign Coins \$1.00 post-paid. Neal, Box 8892, Nashville, Tenn. 37211.

FIND Out who is buying Silver and Coins. List \$1.00 Infocoin Box 117 Gettsville, N.Y. 14068

RARE 1969S Cent, wooden nickel and bargain coin list 10¢. Lawrence, Anamosa, Iowa 52205

GOLD COINS of the World. Beautiful low prices. Plus thousands of United States Coins. Free price list. Please send long, airmail envelope, self-addressed, stamped, Silver Center, Box 22171-M, San Francisco, California 94122.

RARE 1909VDB Uncirculated Cent \$5.00. 1857 Flying Eagle Cent \$5.00. Both \$9.50. 5 Rolls 1969S Uncirculated Cents \$6.25. RDY, Box 10144, Oakland, California 94610.

CHINA Dollar (nickel silver) for 50th year of Free China only 10¢ with big catalog and approvals. Littleton Coin Co., Littleton KCI, N.H. 03561.

BIG Profits collecting coins. Learn the Secrets! Get the true facts. Revealing booklet, \$1.00. Rafco Enterprises, Dept. 172, 2012 Greensburg Road, North Canton, Ohio 44720.

40-PAGE Illustrated United States and Canadian coin list 10¢. Stoney, 260 Washington, Boston 8, Mass.

COINS Cheap. Catalog 10¢. Buying Catalog 25¢. Winters, Box 7055BH, Minneapolis, Minnesota 55411.

ANTIQUES, RELICS, INDIAN GOODS AND CURIOS

LIST Indian relics, 10 Arrowheads \$3.00. Hyde's, Box 2304, Santa Fe, New Mexico 87501.

TONS of antique gun parts and supplies. All reproduction muzzle loading guns. Send \$1.00 for enlarged illustrated catalog No. 118-A. Dixie Gun Works, Union City 12, Tennessee.

RARE SIKH WAR SWORDS ANTIQUE. 100 years old, from India museum, \$19.50. Pair \$35.00. 75¢ each postage. CENTURY, St. Albans, Vermont 05478.

OFFICIAL GUIDE TO POPULAR ANTIQUES, CURIOS. 352 pages price to buy sell. Complete listing, pricing of thousands of items. Many pictured. Best seller. Only \$5.00 prepaid. Request free list. Luke Coin Supply, Box 7170, Fort Worth, Texas 76111.

REAL Ox Shoes (unused) send \$3.50 pair Post Paid. Coffey Hardware Co. (since 1879) Bryson City, N.C. 28713.

10 BEAUTIFUL Arrowheads Two Dollars. Guajardo's, 8713 Shaver, El Paso Texas 79925

SELTZER (Siphon) Bottles, Complete; Siphon Tubes, Pewter Tops, \$4.00 Each, \$6.00 Pair. Lillian's, Box 17165, Chicago, Illinois 60617.

INDIAN Collectors, arrowheads 25¢ each, complete inventory indian silver and turquoise jewelry, baskets, Navajo rugs, AUCTIONS and shows nationwide. THOUSANDS of artifacts. FREE lists, NATIONAL INDIAN CENTER, P.O. Box 912 ELCAJON, CALIFORNIA 92022.

MODELS—SHIPS, TRAINS, PLANES, ETC.

SHIP Models catalog 25¢. Scientific, Inc., 100 Monroe, Newark, N.J. 07105.

ROCKETS: Real flying models—flights up to 2500 ft. New illustrated catalog 25¢. Single and multistage kits, cones, engines, launchers, trackers, rocket aerial cameras, technical information. Fast service. Estes Industries, Penrose 2, Colorado 81240.

SHIP And yacht model fittings; Pine construction hull kits; blueprints. Send 50¢ for illustrated catalog. A. J. Fisher, Inc., 1002 Etowah Avenue, Royal Oak, Michigan 48067.

SHIP Model kits and fittings; clippers, frigates, etc. Catalog paint-tool list, 1969 catalog 50¢. Models Shipways, Box 65, Bogota, N.J. 07603.

SHIP Models, Kits, fittings, plans, books, tools, engines, motors. Big illustrated catalog 50¢. Mass. residents add 3% tax. James Bliss & Co., Dept. SM, Route 128, Dedham, Mass. 02026.

CANNONS, Flying Saucers, Hot Air Balloons, Rockets, Etc. Free Catalog. Zeller, Box 69, Hudson, Mich. 49247.

SOLAR Flying Saucer Lifts Animals—See Spacetratics Ad Under Science-Chemistry Column.

MODEL Airplanes—Big 220 Page Catalog 50¢. Sig Company, Montezuma, Iowa 50171.

SCALE Building materials, 1/4" & 1/8" scale. Windows, doors, siding, roofing, lumber and structural shapes. Send 50¢ for catalog. Small Sales Co., P.O. Box 177, Shawnee Mission, Kansas 66201.

GAMES, TOYS, PUZZLES, NOVELTIES

"ROULETTE DICE" . . . a pair of dice that have a range of thirty-six different numbers. Free information, write D. E. Products & Co., Box 488, Worcester, Mass. 01601.

MAGIC TRICKS, JOKES, VENTRILOQUISM

COMPLETELY Illustrated catalog, 84 pages, 25¢. Manhattan Magic, Box 334-M, N.Y.C. 10011.

WORLD'S Finest professional magic tricks. Joker's Novelties, Giant illustrated catalog 10¢. Top Hat, Evanston, Illinois.

HOUDINI'S Original Magic Shop. Established 1856. Send 25 cents for Illustrated Catalog containing 5000 Tricks, Mindreading, Puzzles, Hypnotism and Jokes. Flossie-Hornmann, 304 West 34th St., N.Y. 10001.

HOUDINI Magic Catalog!! Giant Professional Deluxe Edition!! 1000 World's Greatest Tricks!! 25¢ with Free Gift Certificate!! House of 1000 Mysteries. Dept. PM9C, Northeast Fifth Ave., Ft. Lauderdale, Florida 33308.

500 TRICKS Catalog. 1969 Edition, showing latest magic for pocket, parlor, stage. Only 10¢. Fastest mail service for 45 years. Douglas Magicland, Dept. 11, Dallas, Texas 75221.

MAGIC MAGAZINE—Monthly since 1936. 44 pages. All phases. 3 month trial \$1.00. Genil, P.O. Box 36068, Los Angeles, CA 90036.

BE A Magician! Two booklets explaining sixty-eight tricks plus large professional catalog. \$1.00. Magic, Inc., 5082 Lincoln, Chicago, Illinois 60625.

VENTRILOQUISM! Information free! Dummy catalog, 25¢. State age. Maher, Studio F, Box 8356, Kensington Station, Detroit, Michigan 48224.

MAGIC Catalog. World's finest 3000 tricks. (340) pages \$2.50. Beginners, amateurs, professionals. Kanter's, A-200 South 13th St., Philadelphia, Pa. 19107.

AMATEUR and PROFESSIONAL MAGICIANS all new magic tricks and gags catalog 25¢. Our specialty same day service. Fabulous Trick and Magic, 3319 E. Charleston, Las Vegas, Nevada 89104.

FREE Trick. New Magic Catalog. Send 25¢. Ace Magic, Box 329, Evanston, Ill. 60204.

CATALOG =26, 175 pages, 25¢ (1,500-399 tricks, jokes, novelties). Elbee, 7408-P, San Antonio, Texas 78207.

BOOKS, CATALOGS, NEWSPAPERS

PROPHET Elijah coming before Christ. Wonderful book free. E. Megiddo Mission, 481 Thurston Rd., Rochester, New York 14619.

BACK Date Magazines! Send needs. Midtown, Box 917-PM, Maywood, N. J. 07607.

BUSINESS Books and Directories. List 10¢. Cricket, Box 527, Ardmore, Penna. 19003.

PAPERBACK Catalogue, 270 pages, 15000 titles, subject indexed, \$2.00 credited toward order. New York Book, 4 P West 43 Street, N.Y.C. 10036.

WHY Wait until Someday? Make Plans Today To Own your Liesure Home. Design Catalog \$1.00. Wm. Simkulet Jr., Skaneateles Falls, New York 13153.

FREE Catalog. Self-help books. Write Wilshire, 12015 Sherman Road, North Hollywood, Calif. 91605.

NATIONAL Geographic Magazines, 1888-1967, any issue. Buxbaum, Box 465-PM, Wilmington, Delaware 19899.

WHERE TO VACATION OR RETIRE—100,000 word book covers hundreds of World Paradises to fit any budget. Only \$2.00 "Satisfaction Guaranteed." Fogg Co., Warner Street, Groton, Conn. 06340. Dept. 1169.

SENSATIONAL Book. **HOW TO GET WHAT YOU WANT.** Free brochure describes this and others. Richard Allen Sales, 110 Birch Street, Midland Park, N.J. 07432.

BOOKS By Leading Publishers—12% discount on most. Universal Books, P.O. Box 2247, Orange, California 92667.

BOWLERS—"The Secret of Bowling Strikes." Illustrated, 128 pages, \$2.00. Tempo Center, 6355 N. Encinita, Temple City, Calif. 91780.

HOW To have Confidence and Power—with Other People. Good First-Impressions. 164 Page-Book—Reveals Ways. Send \$2.00. Devon Gift's, 450 Woodland Drive, Devon, Conn. 06460.

PAPERBACK Books unlimited, all subjects, free lists. Shore Co., Dept. P., 122 Delray Avenue, Syracuse, N.Y. 13224.

PLAYS, STORIES, MANUSCRIPTS

WANT Your book published? Learn how we publish, advertise, promote, distribute. Many successes. Free booklet PM. Vantage, 120 West 31, New York City.

BUSINESS OPPORTUNITIES

HUGE Profits! Mail order importing. Free information. ITIS, PM-6, Box 454, Hollywood, Calif. 90028.

BOOKKEEPERS Earn \$1000.00 month. Operate simplified Bookkeeping tax service. Universal, Box 664-M, Springfield, Missouri 65801.

WANT To make big money at home? \$10.00 profit in an hour possible with invisible mending. Make tears, holes disappear from clothing, fabrics. Steady year-round demand from cleaners, laundries, homes. Details free. Fabricon, 1585 Howard, Chicago 60626.

CONCRETE FACTS: Highly profitable home business. Experience unnecessary. Unlimited unique pottery designs easily made without moulds. Birdbaths, fountains, wishing-wells, benches, etc. Chemical coloring formulas, marbling. FREE illustrated brochure. Hollywood Cementcraft, 602 Athens Street, Altadena, California 91001.

WORLD'S Largest supply. Merchandise 25% to 40% under wholesale. Bankrupts, closeouts 10¢ on dollar. Imports. Hongkong clothes. Automobile discounts. Free details. International Buyers, Box 4633-MM, Colorado Springs, Colo. 80909.

RAISE Rabbits for us on \$500 month plan. Free details. White's Rabbitry, Mt. Vernon, Ohio 43050.

UP To \$5.00 each for newspaper clippings! Free details. Philip, Box 368-S, Southfield, Michigan 48075.

FREE Catalogs. Repair air conditioning refrigeration. Tools, supplies, full instructions. Doolin, 2016 Canton, Dallas, Texas 75201.

FREE "Franchise Profit Letter" tells how unique NFR service is helping thousands seeking profitable businesses. Write today. National Franchise Reports, W-528, 333 North Michigan, Chicago 60601.

VENDING Machine big catalog. Rake, 523 A Spring Garden, Philadelphia, Pa. 19123.

56 ACTIVE Franchise opportunities available all over USA. Brochure details 56 franchise chances for you to have your own business tied with successful national companies. Send name, address to P. Stewart, 1085 Walnut, Des Plaines, Illinois 60016.

\$400.00 MONTHLY Raising giant fishworms. Soilless method. Charlie Morgan, Bushnell, Florida 33513.

EARN Money raising fishworms for us! Write: Oakhaven-38, Cedar Hill, Texas 75104.

400,000 BARGAINS Below wholesale! Many free. Liquidations . . . closeouts . . . job lots . . . single samples. Free details. Bargainhunters Opportunities, Box 730A, Holland, Michigan 49423.

\$200.00 DAILY In your mailbox! Your opportunity to do what mailorder experts do. Free details. Associates, Box 136-A, Holland, Michigan 49423.

CLIP Newspaper items. \$1.60-\$5.00 each. Details free. Walter, Box 1360-PA, Erie, Pa. 16512.

SELL Lifetime, Metal, Social Security Plates. Big Profits! Sample and Sales Kit Free. Russell, Box 286-PM, Pulaski, Tennessee 38478.

MAKE 2 to 3 times your cost wholesaling 1001 products. Gifts, Mail Order Specialties, Toys, Novelties, Carded Merchandise . . . Guaranteed lowest below wholesale prices. Free home business details SMC 7630 SPF, Gloria Ave., Van Nuys, Calif. 91406.

BIG Profits—Operating your own plastic laminating business with low cost equipment and supplies, money making methods included. Money back guarantee. Jiffy—Box 23485P, Los Angeles, Calif. 90023.

BUILD Custom Cases at home for profit. Get orders by mail. We supply materials, instruction—everything. Free home business details. Custom Case Supply Co., 7630-CPF, Gloria Ave., Van Nuys, Calif. 91406.

VENDING Machines. No selling. Operate a route of coin machines and earn amazing profits. 32-page catalogue free. Parkway Machine Corporation, 715 PMB Ensor Street, Baltimore, Maryland 21202.

PIANO Tuning Learned quickly at Home. Tremendous field. Musical knowledge unnecessary. GI approved. Information free. Empire School, Miami, Florida 33145.

ADDRESSERS And mailers needed. Send stamp for information. Lindbloom, 3636 West Peterson, Chicago 60645.

FREE Book "990 Successful, Little-Known Businesses." Work Home! Plymouth-372-L, Brooklyn, New York 11218.

MAKE \$75.00 daily distributing tools to service stations. Free Plan. INKA, 2401 Crocker, Houston, Texas 77006.

SPARE Time Cash—Sell Advertising Book Matches—every business a prospect—no investment—no experience needed to build steady repeat business. Daily Cash commission in advance. Write today—We'll send your sure-fire selling kit by return mail. Dept. MX 669, Superior Match Co., 7530 S. Greenwood, Chicago, Illinois 60619

EARN \$60.00 DAILY manufacturing Concrete Fence Posts. Practically no investment. Free information. Send stamp. American, Excelsior Springs, Mo. 64024.

DRAFTSMEN! Operate own DRAFTING SERVICE! Full, Part Time; Experience unnecessary; Details: Roberts Drafting, 1741 Circle Road, Baltimore, Maryland 21204.

ESTABLISH Profitable Catalog Mailorder Business! Vikari's, Box 1312PME, Salt Lake City, Utah 84110.

STOP Throwing Away Those Boxtops! They're worth money, some 25¢ each! Write: Boxtops—BO, Cedar Hill, Texas 75104.

\$500—\$800 MONTHLY Raise small laboratory-breeding stock for us. We supply equipment, breeders, instructions. Illinois Research Farms, Dept. MPD-6, McHenry, Illinois 60050.

ADVERTISING BUSINESS—YOU own it. \$350 First Week or Money Back. Electric Neon Action Ad Clock, 229 W. Illinois, Chicago 60610.

HOW TO PREPARE YOUR OWN MAIL-ORDER CATALOG for pennies. . . . Including All Popular Merchandise! Free Catalog—Proof! Obie, 5711-MU-14TH, Brooklyn, New York 11219.

PLASTERCRAFT Molds, liquid rubber, plasters, flocks, candle supplies. Catalog and manual free. Blue Rapids Supply, Blue Rapids, Kansas 66411.

EARN more than many Professional men! \$1000.00 monthly operating Mail Order Collection Agency. Continental, Box 2023-A, Des Moines, Iowa 50310.

OPERATE Home mailorder business! Free info. Vosacek Printing, Box 1217A, Garden Grove, California 92640.

OVER \$16.50 an hour. Spare time at home! Rubber Stamp industry needs small manufacturers. We furnish all equipment and know-how! Particulars free! Write Roberts, 1512 Jarvis, Room CR-2-B, Chicago, Ill. 60626.

JOIN "MONEY GETTER'S GUILD". Receive hundreds money-making. Business Building Propositions. Year's membership only 25¢. Write: Fourstars, Box 839, Long Beach, New York 11561.

OPERATE A Business of your own from home. Everything furnished. Royce, Box 204-G Dolton, Illinois 60419.

\$21.00 HOUR Profit—From Home Picture Framing Business. (Clampless Assembly Method) Write: Japs, 126-PM Seventh North, Hopkins, Minnesota 55343.

MAILORDER — Profitable products; dropshipped. No merchandise investment. Everything supplied—catalogs, ads, mailing lists. Gif-Guide, 3408½ Motor, Dept. 148, Los Angeles 90034.

FREE! 60 Lazy Ways To Strike It Rich! Stamped, Self-addressed envelope. Pinderhood, (PM-27) 15 West 38th, N.Y. 10018.

UNLOCK Your Future. Become professional Locksmith by spare time home-study. Make up to \$6 per hour. All tools, equipment incl. Facts free. Send name. Locksmithing Inst., Dept. 1310-069, Little Falls, New Jersey 07424.

PLEXIGLAS SIGN MAKING Simple instructions and supplies lets you make **PROFESSIONAL PLEXIGLAS SIGNS.** Starting kit \$12.50 for over 120 Acrylic letters and Acrylic background. Unlimited uses, great profit. Daytona Plastic, Dept. M., Box 6161, Daytona Beach, Florida 32022.

SUPPLY Fried chicken dinners on \$500 Week Home Plan. Free Information. White's Chicken Dinners-PM, Mt. Vernon, Ohio 43050.

FREE Advertising? 500 Publications. Write: Dee, 10639-PM Riverside, North Hollywood, Calif. 91602.

DONUTS Earn high profits for your business, organizations, or church. Complete information. Stork-Ville Donut Co. Inc., G-4402 Calkins Rd., Flint, Mich. 48504.

I MADE \$40,000.00 Year by Mailorder! Helped others make money! Start with \$10.00—Free proof! Torrey, Box 318-Y, Ypsilanti, Michigan 48197.

MAIL Baby Catalogs imprinted with your address to New Mothers for Big Profits! Details 25¢. Volz-PM, Ypsilanti, Michigan 48197.

SELL Books by mail. 400% profit. Royal, Box 450-X, Cleveland, Ohio 44127.

\$60.00 DAY. Manufacturing concrete Posts, Blocks, Mold Equipment Catalog \$1.00 refundable. Carlayne, 1803 Fremont, Rapid City, South Dakota 57701.

MAKE \$46 from square foot plywood; jigsaw or bandsaw necessary. Free details. Woodar, Bridgewater, Mass. 02324.

MAKE \$32 from 49¢ piece vinyl. M-1834 Edgeland, Louisville, Ky. 40204.

MAKE Money Operating Home Mailorder Business. No Inventory. Write Purple Enterprises, Box 1629AF, Jacksonville, Fla. 32216.

COPUBLISH "Mail Sale Advertiser," leading mailorder paper. Copy and details 25¢: U.S.A. only. Vanroy Shirk, Lebanon, Pa. 17042.

MAILORDER Records help get Increased Business! Complete 32 page Record Book shows your inquiries, orders, advertising expense, etc. Only \$1.00. Martin, Popular Mechanics, Dept. PM, 575 Lexington, New York 10022.

\$70.00 WEEKLY—home, spare time. Simplified mail bookkeeping. Immediate income easy. Auditax, 34741A, Los Angeles 90034.

MAKE Money from old tires. Operators clearing \$800, weekly. Equipment costs \$1500. Get facts. S & S Patents, Inc., 3752 N. Damen, Chicago 60618.

FREE FRANCHISE JOURNAL MAGAZINE with over 100 business opportunities. Franchise Journal, 892-G West 16th St., Newport Beach, California 92660.

BECOME PROFESSIONAL DRIVING INSTRUCTOR. Earn \$10.00 Hour. \$300 Week. Part Time—Full Time business for yourself. Free details. Howard David, 1818 Everts St., Phila., Pa. 19152.

AUCTIONEERING Home Study Course—\$15.00—Diploma—American Auctioneer College, Box 316, Terra Ceia, Florida.

LIQUID Molding rubber also liquid plastic. Free information. Chaney's, 5415-A San Jose Blvd., Jacksonville, Fla. 32207.

LIST Your Name with Importers, Manufacturers Etc. Year, \$1.00. Includes Sample product. Cal-Mail, Box 1264, Canoga Park, California 91304.

\$112,000.00 YEAR. Mailorder. Can make you money. **PROOF.** Write Williams, 44646 H. Los Angeles 90044.

MAILORDER Business. Free circular. Harry Andrews, 160 Bleecker, New York, N.Y. 10012.

FRANCHISE Digest. Lists 933 National Franchise Opportunities. Send \$2.00. Refundable. FDPM, 21651 Kipling, Detroit, Mich. 48237.

HOME Business in spare time, choose ideas, literature free. Hayne Enterprises, 347 Arcade Blvd., Sacramento, California 95815.

SELL Information By Mail. 2400% Gross Profit! 15,000-word Instruction Manual, \$2.00. Satisfaction Guaranteed! SAX, Dept. C-16, Milan, Ohio 44846.

REVEALED . . . COMPLETE METHOD FOR operating profitable Mail Order business. Details free! Donnybrooke, Box 1128 Burnsville, Minnesota 55378.

BIG MONEY in USED FURNITURE. Inside information and important tips explaining how to start your own **SECOND HAND STORE.** With list of **PROVEN FAST SELLING ITEMS.** A/L for \$1.00. **JOHN'S BOX 4311, MUSKEGON HTS., MICHIGAN 49444.**

PREPARE TAX Returns—Policeman Albert Myers made \$2300 his very first season. Train at home. VA Approved. National Tax School, Monsey, 2EB, N.Y. 10952.

HOW To Finance Your Own Business. 1000 sources, \$500 to \$2 million. Free details. Counselor-17, Harlingen, Texas 78550.

DATA-CRAFT Agency. Write short reports. Merchants, banks, & doctors subscribe. Dealership home-study course—Easy terms. Datacraft-71A, Harlingen, Texas 78550.

MAKE big money growing ginseng! \$3,000-\$30,000 annually. We buy your crop. Send \$2 for seed sample and information. Glass Ginseng Exchange, Box 1969, Springfield, Mass. 01101.

SECRETS! Mail Order success. Internationally famous expert reveals how to make home business fortunes. Beginners: Get free copy "Make Money By Mail." Discloses free advertising, profitable products. Malco, 1554 Sepulveda, Dept. C2706, Los Angeles 90025.

IMPORT Export opportunity. profitable world-wide, mail-order business from home, without capital; or travel abroad. We ship proven plan, for no risk examination. Experience unnecessary. Free details. Mellinger, Dept. C2706, Los Angeles 90025.

APPLIANCE REPAIR—Learn to repair Washers, Dryers, Motors, Stoves, Clocks, Toasters. Experimental kits included. Free fact pack. I.T.I. Dept. 65161 815 E. Rosecrans, Los Angeles 90059.

OPERATE Restaurant. Free booklet reveals profitable plan. Write Restaurant Business School, Dept. EC-69 1920 Sunny-side, Chicago, Illinois 60640.

INSTALL Burglar alarms without previous experience or costly equipment. Big profit. Free details. Nasco, 11071 Massachusetts, Dept. C-2706, Los Angeles 90025.

250,000 NEW MOTHERS EVERY MONTH! Bonanza for Bronzed Baby Shoes. \$50.00 a day profit. No investment, no inventory. Full or spare time. Exciting details Free. Sentimental, 1919 Memory Lane, Dept. 8F, Columbus, Ohio 43209.

REPAIR WATCHES. Step up income. Unique home course. Watchmaking. YSB, Pcx River Grove, Illinois 60021.

TO WOULD-BE OWNER-MANAGERS! Ready to work and grow as an independent businessman in your own right? It's time you investigated ServiceMaster, the world-wide system that specializes in setting up qualified men in profitable businesses of their own. ServiceMaster offers you comprehensive basic training to start an advanced managerial education from then on. Write today for a free booklet that tells you all about this opportunity, at no obligation. Write now, ServiceMaster Serv-Opp Int'l Corp. Dept. 137, 2300 Warrenville Road, Downers Grove, Illinois 60515.

MAILORDER BUSINESS interest you? Start immediately! Mailorder beginner's catalog, 10¢. Sullins, Box 2066M, Forsyth, Georgia 31029.

TREMENDOUS Mailorder Profits! Write George, Box 2188A, Cypress, California 90630.

I Make \$1,200 month in Accounting. You start, train fast. Only 10 lessons. Certificate Awarded. Work from home or office. Mail \$2 first lesson. Jenkins, Box 571, Taft, Calif. 93268.

OVER \$3,000.00 my mail profit monthly! 53 years showing others how. Send stamped self-addressed envelope. Free samples, proof, testimonials. Brewster, Box 1348-PM, Clearwater, Florida 33517.

MAILORDER IMPORTING Free information J. & J. Enterprises 417 West 64th Street, Inglewood, California 90302.

START Your own profitable business. Amazing book tells how. Free details. Snell's, Box 682-A, Bath, New York 14810.

BIG Profits Wholesale gifts items novelties toys carded merchandise in full or spare time. Goldman, Dept. A98, 931 N. Ditman Ave., Los Angeles, Calif. 90063.

AMAZING Automatic Fishhooks. 200% Profits. Sample \$1.00 Refundable. Aron, Postbox 61-PM, Mastic Beach, New York 11951.

IMPORT Now! Your own profitable business. Free details. Exotic Imports, Box 503A, Carmichael, Cal. 95608.

MAKE Money mailing catalogs. Free Details. Newton, P.O. Box—F-PM Detroit, Mich. 48208.

CALIFORNIA MANUFACTURER NEEDS man to assemble our product and be local agent, experience unnecessary. May start while presently employed. Five-figure income for responsible applicant. S.K.R.M. Manufacturers, 2540 Olive Avenue, Long Beach, California 90806.

\$300.00 WEEKLY possible at Home. Listing Service. Capital unnecessary. Complete instructions \$1.00 Lambert, Box 3442M Orange, California 92665

MAIL, baby catalogs imprint to new mothers. Big profits! Details \$1.00. Krefski, 609 Lee, Plymouth, Penna. 18651

HOW to get the right job. Improve yourself! Be completely satisfied. Details free. Write today. Coach House, Box 834J, Bangor, Maine 04401

WRITE to sell. Established author offers help. Free details, Coach House, Box 834N, Bangor, Maine 04401

PROVEN Import & Mailorder Procedures. Revealing—Profitable—Practical. Write: N.D.B.R., Box 13011-H, Kansas City, Missouri 64199

MAILORDER! Ridiculous prices. Overseas directory \$5. Techrefco, Hilo-1001, Hawaii, 96720.

MAKE Money sparetime. Home operated Mail Order Business. News-Messenger, South Lancaster, Mass. 01561

MAKE \$128, Invest \$12.00, selling Perfumes. Free details. Reveille Enterprises, 110 West 47th Street, New York, New York 10036 Suite 600

\$50.00 DAILY! Little Known Store Type Business. Free Details! Cam, Box 351-P, Hollywood, Florida 33022.

2000% PROFIT Bronzing shoes—Free Literature. NBC-Box 11069—Kansas City 64119.

NEW Product Sources. Import by air parcel, details. Bakers, 313 Harrison, Sullivan, Ill. 61951.

WANTED! Home producers to operate easy-to-start home business. Excellent Profits. Act Now! Send for free details—W. Churchill, Dept. B0169, 5915 Wellesley, Pittsburgh, Pa. 15206.

SELL Gifts, Household Items—Make extra money. Toys, Jewelry, Stationery, Greeting Cards, 600 Items. Experience unnecessary. Salable Samples on approval. Free—Catalog, Personalized Christmas Card Album, Hedenkamp, 361 Broadway, Dept. PM-101, New York 10013.

\$3000.00—\$5000.00 MORE Extra Income Few Weeks As Tax Consultant, Foren, Box 409 Boston, Mass. 02123.

READ Progressive Mailtrade, the magazine that tells how to make money by mail. Quarter brings sample and special offer. Mailtrade, P.O. Box 357, Sheboygan, Wis. 53082.

GENERAL ELECTRIC Invites you to investigate the profit opportunities, open to Popular Mechanics readers with a little capital, in the coin-operated laundry field. Your background may qualify you even if you do not have prior experience. Send for new brochure with information on how to get started. Write General Electric Co., Dept. 401, Box 1515, Louisville, Ky. 40201.

SELL Book by mail. Tremendous profits! Forney, 6225-S, Wheeling, W. Va. 26003.

PROFIT With Popular Mechanics' subscription plan. No investment, no experience needed. Earnings begin immediately when you obtain subscription for Popular Mechanics, Good Housekeeping and others. High commissions, bonus. No experience needed. Deal directly with the publisher. Write Popular Mechanics, Room 6B, 250 West 55th St., New York 19, N.Y.

GENERAL INSTRUCTIONS BIG OPPORTUNITY SELLING HOME IMPROVEMENT. I SHOW YOU HOW \$10,000, \$30,000, YEARLY, EASY. FREE INFORMATION. ACT IMMEDIATELY. Herbert Skeen, TOWN HOUSE IMPROVEMENT, RT. #3 BRANDONWOOD DRIVE, JOHNSON CITY, TENN. 37601

\$140.00—DAY'S Homework! How? Mey-West, 10808 Canterbury, Sun City, Arizona 85351

UNIQUE ORGANIZATION OUTSMARTS STOCK market. Join us, 15,000+ yearly. Information \$1. Satisfaction or Refund. GEI, 7109 Gibraltar, Richmond, Virginia 23228.

MONEYMAKING OPPORTUNITIES

\$200.00 FROM Sheet 1/4" plywood (scrap). Details 25¢. Novelties, 610 So. 24th, Elwood, Indiana 46036.

EARN \$240.00 a month at home, spare time, doing only two \$5.00 invisible mending jobs a day. Big money paid for service that makes cuts, tears disappear from fabrics. Steady demand. Details free. Fabricon, 1532 Howard, Chicago 60626.

RAISE Rabbits and fishworms on \$500 month plan. Free details. White's Rabbitry, Mt. Vernon, Ohio 43050.

MAKE Statuettes, novelties, imitation marble. Sell to stores or start gift shop. Free details. Marbleizing, 41 Waverton, St. Louis, Mo. 63124.

HOW To Make money writing short paragraphs. Information free. Barrett, Dept. C-27-R1, 6216 N. Clark, Chicago 60626.

CLIP Newspaper items. \$1.00-\$5.00 each. Details free. Walter, Box 1360-P, Erie, Pa. 16512.

VENDING Machines. No selling. Operate a route of coin machines and earn amazing profits 32-page catalogue, free. Parkway Machine Corporation, 715 PMM Ensor Street, Baltimore, Maryland 21202.

WHEELER-DEALERS! Free. Little-known opportunities; foxy-smart angles. Stamped, self-addressed envelope. Wheeler-Dealer Association. (PM-37), 15 West 38th., New York 10018.

FREE Copy of world's leading contest magazine! Write Prizewinner, Box 11569, St. Petersburg, Fla. 33733.

\$500—\$800 MONTHLY Raise small laboratory-breeding stock for us. We supply equipment, breeders, instructions. Illinois Research Farms, Dept. MP-6, McHenry, Illinois 60050.

SPARE Time Cash—Sell Advertising Book Matches—every business a prospect—no investment—no experience needed to build steady repeat business. Daily Cash commission in advance. Write today—We'll send your sure-fire selling kit by return mail. Dept. MA-669, Superior Match Co., 7530 S. Greenwood, Chicago, Illinois 60619.

CASH/Royalties for romantic songpoems! Castle's, 203-M West 46th, New York City 10036.

MONEY—Become a Finance Broker. Full or part time. RMP & Co., P.O. Box 901, Desk 10, El Reno, Oklahoma 73036.

LEARN The secrets of repairing junk batteries. "Fabulous Profits" at home. Batteryman, 878, Palm Desert, California 92260.

MEN—Women! Start money-making Plastic Laminating business at home in spare time. Material that costs 11¢ brings back \$2.58. No canvassing or selling but mail orders bring in \$20 a day. Write for full particulars free. Rush name on postcard to: Warner, Room CL-2-B, 1512 Jarvis, Chgo., Ill. 60626.

HOMEWORK. Mailing circulars. Free details! Cam Company, Dept. 155-KP, Verona, N.J. 07044.

FREE. 206 Easy Ways to make money taking orders for exciting new products—spare time. Send name, age for 5 months free subscription. Opportunity Magazine, 1460 Hancock Center, Dept. 17-FM, Chicago 60611.

LYRIC WRITERS write songs with writers who write hits for top Nashville artists. Globe, 420 Broad, Dept. PM, Nashville, Tenn. 37203.

BECOME Notary Public! Free particulars. Stationers, 405-PM Richardt, Evansville, Indiana 47711.

\$2.40 HOURLY Making simple wood novelties. Free details! Gene's, 55 Boxwood, Falmouth, Mass. 02540.

HIGHLY Profitable spare-time business. Bronzing & PearlKoting baby shoes. Complete set-up on credit available. 31 year old company. Send 25¢ for brochure. Kiktavi, Box 4187PM, Compton, Calif. 90224.

MONEY—SPARETIME OPPORTUNITY PANELISTS AT HOME WANTED BY NEW YORK RESEARCHER. Leading research firm seeking people to furnish honest opinions by mail from home. Pays cash for all opinions rendered. Clients' products supplied at no cost. For information write: Research 669 Mineola, N.Y. 11501, Dept. PM-24.

MAILING LIST, POTENTIAL BUYERS OF MASONIC Bibles, Jewelry, Ashtrays, Bookends, Plaques etc. 100 Names \$4.00—500 \$15.00—1000 \$25.00. Texcraft, P.O. Box 4344 John Foster Station, Pasadena, Texas 77502.

SELL Your Photos. Report tells how, where. Color Slide Markets, Only \$1.00. Hollenbeck House, 1192 Hollenbeck Avenue, Sunnyvale, California 94087.

\$140.00 DAY'S Homework! How? IGY-Ensenat, Box 223, Hillsdale, New Jersey 07642.

CRAFTSMEN/Hobbyists: If you are capable of fine quality work in any area contact Craftsmen, Box 802 Laguna Beach, Calif. 92652.

MAKE 450%!!! "Profits In Mailorder"—Sample Book, Moneymaking Details! \$1.00. Hildreth, Box 82M Crane, Schenectady, New York 12303.

MAKE Two to Three TIMES your cost on hundreds of products, gift items, novelties, toys, Carded merchandise, 1001 others. The Robinson Co., 443 Encinitas Ave., San Diego, Calif. 92114.

SHARP \$\$\$ opportunity! One low-cost machine sharpens-serrates knives, scissors, pinking shears. Earn \$6-\$9 hourly in spare time. Professional results without experience. Free details. Beaver Grinder, 369C Nielsen Building, Eugene, Oregon 97402.

WATCH REPAIRING multiplies earnings. Free information and sample lesson. Watchmaking, YSA, Fox River Grove, Illinois 60021.

SILK Screen Artistic Color Artwork, Home, full, part time. Detailed Instructions, \$1.00. Screenco, Box 862, Waukesha, Wis. 53186.

MAIL LETTERS Featuring REAL MERCHANDISE. Get \$12.00 orders in every mail, \$8.00 profit! Everything furnished. Write: Henderson House, 4712 Military Rd., Niagara Falls, N.Y. 14305.

THE TRUTH About starting your own mailorder business. \$1.00 Guaranteed. Idea Mart, Box 71, Perrine, Florida 33157.

RECEIVE \$250.00 From \$3.00 investment! Guaranteed method and instructions—\$1.00. Wayne Bailey, Porterdale, Georgia 30270.

PROFITABLE Way to retire without money. Details free. Benson & Sons, Dept. B-2, P.O. Box 589, Auburn, Calif. 95603.

EARN Home Profits. Booklet 50¢ (Guaranteed). Kirkman, 1-PM Ann Street, Woodbridge, Virginia 22191.

FREE Details! Moneymaking Opportunities, Self-Improvement Books! Treasures, 6210A Hampton Boulevard, Norfolk, Virginia 23508.

\$650.00 WEEK MAILING CATALOGS details \$1.00 (refundable). HAROLD, 13598 Cedar, Cleveland, Ohio 44118.

MONEY in fillers, free details. Soprano 1101-A North Lehigh Ave. Sayre, Penna. 18840

ADD 50% To your Money in five years. Write Paramont Investment Co. P.O. Box 7434, New Haven, Conn. 06519

SUCCESS Can be yours. Enlightening book shows how. Free details. Shamrock Sales, Dept. F Box 65, London, Ontario, Canada.

BEWARE "Miracle" Mailorder Businesses!! Honest \$2.00 Book Exposes Schemes, Misrepresentations, Money-Back Guarantee. Protect Yourself! Justice, Box 5276-EF, Riverside, California.

PLASTERCRAFT HANDBOOK Illustrated instructions statuary pouring, finishing, selling and mold making. Also where to obtain all materials. Only \$3.00 postpaid. Guaranteed. Wolfe, Box 561G, Melbourne Beach, Florida 32951.

RADIATION Emission checking for Col-r Televisions, Box 967, Stony Brook, N.Y. 11790.

MAKE: \$12.00 Profit each dozen assembling Belts. Details Free. (Stamp appreciated.) Redikut's-40, Richland Center, Wis.

DEALERS Make Money My Way. Send Stamp. Hall's Mail Order Supplies, Box 72145, Los Angeles, California 90002.

AMAZINGLY PROFITABLE! Opportunity to earn \$8.00 profit from each \$12.00 order. No Obligation! Write W. Churchill, Dept. M0169, 5915 Wellesley, Pittsburgh, Pa. 15206.

SIGN Painting! Profitable! Fascinating! Easy with letter patterns. Paulow, 1935 Stardust, Waukesha, Wis. 53186.

HOMEWORKERS! 200 companies—48 page Directory. FREE details. Quest Enterprises, Box 6029, Dept. 16, San Jose, California 95150.

SCIENTIFIC Massage: Big Earnings uncrowded profession. Learn spare time at home. Diploma awarded. Free catalog. Write Anderson School, Dept. F-1C, Princeton, Illinois 61356.

SELL Greeting Cards—Make extra money. Show friends Gifts, Toys, Jewelry, Stationery, 600 items. Experience unnecessary. Salable Samples on approval. Free—Catalog, Personalized Christmas Card Album. Hedenkamp, 361 Broadway, Dept. PM-102, New York 10013.

BLACK Widow Spider ranchers needed!! Tremendous profits! Complete Program \$1 (refundable). NBWC, Box 260-PM1, Brigham City, Utah 84302.

100% PROFIT Selling Lifetime Social Security Plates. Starter Kit Including Sample Free! Specialty's, Box 66, Crestline, Ohio 44827.

MAKE \$5,000 yearly, sparetime, raising mink, chinchilla, nutria, etc. Free booklet reveals proven plan. Write: Furs, Dept. R, Bewdley, Ont. Canada.

PROFITABLE OCCUPATIONS

BECOME A mortgage broker, earn \$10,000 to \$50,000 a year. Details free. United, Box 6284A, Marietta, Georgia 30060.

RAISE Rabbits for us on \$500 month plan. Free details. White's Rabbitry, Mt. Vernon, Ohio 43050.

YOUR Own Sign shop. Signs, 410-S So. Western, Springfield, Ohio 45506.

HOW To Make Money Writing Short Paragraphs. Information Free. Barrett, Dept. C-27-R2, 6216 N. Clark, Chicago 60626.

CHROME Plating. Instructions, equipment and supplies. Platers' Supply, P.O. Box 565, Lugo Station, Los Angeles, Calif. 90023.

FT. SMITH Auction School, Ft. Smith, Ark. Residents & Home study. Veteran approved.

FREE Book "990 Successful, Little-Known Businesses." Work Home! Plymouth-37-L, Brooklyn, New York 11218.

EARN \$240.00 A month at home, spare time, doing only two \$5.00 invisible mending jobs a day. Big money paid for service that makes cuts, tears disappear from fabrics. Steady demand. Details free. Fabricon, 1586 Howard, Chicago 60026.

SHARPEN Scissors, Pinkers, inexpensive equipment, tools, supplies. Blackhawk's, Sheldahl, Iowa 50243.

INVESTIGATE ACCIDENTS: Earn \$750 to \$1000 monthly. Car furnished. Expenses paid. No selling. No college education necessary. Pick own job location. Investigate full time or earn to \$8 hour spare time. Men urgently needed Write for FREE information. No obligation. Universal Schools, CPM-6, Hillcrest, Dallas, Texas 75205.

\$500—\$800 MONTHLY Raise small laboratory-breeding stock for us. We supply equipment, breeders, instructions. Illinois Research Farm, Dept. MPA-6, McHenry, Illinois 60050.

HOW To Make Money In Home Portrait Photography. Manual gives complete instructions. Satisfaction Guaranteed. \$2.00 Riverpress, P.O. Box 2831-PM, Rockyriver, Ohio 44116.

INSTALL Aluminum Storm Windows, doors, jalousies, etc. Instruction book \$10. Stoloff, Box 100, Inwood, N.Y. 11696.

MONEY—Writing short articles. How, what to write. Where to sell. \$1.00 brings COMPLETE. David's, Dept. PM-6, 2464 Westwood Drive, Columbus, Ohio 43204

SALESMAN—DISTRIBUTORS

EARN Terrific commissions listing delinquent accounts. General Finance Company, 304-A Pickwick Building, Kansas City, Mo. 64106.

100% PROFIT—Sweet Georgia Brown Cosmetics sell fast. Write for Sample Case offer. Valmor, Dept. H, 2411 Prairie, Chicago 60616.

EARN Big Commission Full or Part Time. Show America's largest line Low Priced Business Printing and Advertising Specialties Plus calendars in season. No experience. No investment. No collections or deliveries. On-the-spot commissions. Big Free Sales Kit samples hundred items used daily by businessmen. Merchandise bonuses for you. Build profitable repeat business. Start now. National Press, Dept. 91F, North Chicago, Ill. 60064.

SELL Advertising book matches. Write us today. We put you in business by return mail, handling complete line ad book matches in demand by every business right in your town! No investment; everything furnished free! Top commissions daily: Superior Match, Dept. M669, 7530 S. Greenwood, Chicago, Illinois 60619.

FREE. 206 Easy Ways to make money taking orders for exciting new products—spare time. Send name, age for 5 months free subscription. Opportunity Magazine, 1460 Hancock Center, Dept. 17-FS, Chicago 60611.

BIG Profits Selling Revolutionary Laundry Aid Discovery. Details Free. Thompson, 1018 South Waugh, Kokomo, Indiana 46901.

FREE! Money Making Opportunities! Send name, address, zip. Bradley, Box 509-D, Mt. Kisco, New York 10549

SELL Advertising Ball Pens, Calendars, Ad-Specialties—Build Own Repeat Business—Free Kit—Fleming, Dept. A, 6535 Cottage Grove, Chicago 60637.

MAKE extra \$25 to \$75 spare time! Take orders for double air cushion Bronson Shoes. Amazing comfort. Terrific men's, women's line for dress, work, play. Highest commissions. Shoes for yourself. Big outfit Free. Write Bronson, Dept. 165, Minneapolis, Minnesota 55408.

BIG Earnings selling Hertel Bibles. New 3-dimension cover, finest reference edition sells fast. Demonstrator furnished. Big commissions. International Book, Dept. PM, Box 118, Wichita, Kansas 67201.

WANTED: Man contact service stations. Full or part time. Needed invention. Huge profits. Write Cyclo, 3816 Dahlia, Dept. 151, Denver, Colorado 80201.

BE A distributor in your area for magnetic 3-D formed plastic signs directly from one of our 76 strategically located Plexi-lite factories—40% commission. Write PLEXI-LITE in care of Production Products, Inc., 9440 Science Center Drive, Minneapolis, Minnesota 55428.

AGENTS WANTED

PRINTING, Advertising Salesmen—Excellent moneymaking sideline selling Decalomania Name Plates, small quantities. Advertising Specialties, sign letters. Free Samples. Ralco XL, Boston, Mass. 02119.

YOUR Own business—Used suits \$1.50; overcoats 65¢; mackinaws 35¢; shoes 12½¢; ladies coats 30¢; dresses 15¢. Enormous profits. Catalog free. Nathan Portnoy Associates, 2109-AA Roosevelt Road, Chicago Ill. 60608.

LIFETIME Income. Business Loan Representative Write: Financial 28 E. Jackson, Suite 1204-X3, Chicago 60604.

EVERY Man a prospect. Refundable sales kit offer showing line belt buckles, tie clasps, money clips, cuff links, lapels, identification badges, individualized with customer's name and emblems. Cap badges for trucking, bus, taxi, police, firemen, also postal, letter carriers and heavy construction emblems. Choice 3000 emblems. Hook-Fast, Box 1088PM, Providence, R.I. 02901.

FREE. 206 Easy Ways to make money taking orders for exciting new products—spare time. Send name, age for 5 months free subscription. Opportunity Magazine, 1460 Hancock Center, Dept. 17-FA, Chicago 60611.

BIG PROFITS! Consignment Selling Full/Spare Time. Others Sell For You. Details FREE. W. Churchill, Dept. AW169, 5915 Wellesley, Pittsburgh, Pa. 15206.

MAKE Extra Money—Show friends neighbors—Gifts, Stationery, Toys, Jewelry, Greeting Cards, 600 Items. Experience unnecessary. Salable Samples on approval. Free-Catalog. Personalized Christmas Card Album. Hedenkamp, 361 Broadway, Dept. PM-100, New York 10013.

EMPLOYMENT INFORMATION

AUSTRALIA Wants You! Government assisted passage. Unlimited Opportunities. Latest Government Information and Forms \$1.00 Austco, Box 3623-E, Long Beach, California 90803.

FOREIGN And USA job opportunities available now. Construction, all trades. Earnings to \$3,000.00 monthly. Paid overtime, travel, bonuses. Write: Universal Employment, Woodbridge, Conn. 06525.

HIGH Paying overseas jobs. Construction, other projects. Bonuses, Travel Expenses, Extras. International Information, 124, Cortez, Florida 33522.

BOOMING AUSTRALIA wants You! Good jobs, Adventure. Forms and Australian Handbook (1969) describing Australian assisted passage, passport-visa, advantages, opportunities \$1.00. Buckeye, Box 1032MP, Fairborn, Ohio 45324.

JOBS! JOBS! and more JOBS! Men, Women, Students, Teachers. FOREIGN, U.S.A. Year-round and Summer Jobs. All Occupations and Trades. For Information, Write: (enclose \$1.00 postage handling—Refundable) "JOBS", 475M, Lodi, Calif. 95240.

AUSTRALIA!!! AUSTRALIA!!! AUSTRALIA!!! Jobs Galore! Government assisted Transportation. 1969 Handbook \$1.00. Satisfaction Guaranteed! Associated, Box 17B96, Lafayette, California.

HELP WANTED

OVERSEAS Jobs—Europe, South America, Australia, Far East, etc. 2000 openings all trades. Construction, Office, Engineering Sales, etc. \$400 to \$2,500 month. Expenses paid. Free Information. Write Overseas Jobs, International Airport, Box 536-M, Miami, Florida 33148.

OVERSEAS Jobs—Australia, Europe, South America, Far East, etc. Openings in all trades and professions. \$400 to \$2,500 monthly, free information: Write Foreign Employment Mart, Box 2235 A.M.F. Miami, Florida 33159.

50,000 AUSTRALIAN Jobs! New Directory of 300 U.S.-Invested Businesses in Australia Seeking Help. \$1.00 Austco, Box 3623-E2, Long Beach, California 90803

REAL ESTATE & FARMS

CANADA'S Finest lands. \$4.00 an acre and up. Acquired through estate liquidations. Suitable for hunting, fishing, camps, cottages, farming, timber, minerals, investment. Small monthly payments. Free descriptive booklet. Canadian Estate Land, Dept. 20, 194 Wilson Ave., Suite 101, Toronto, 12 Canada.

CANADIAN Vacation lands: Full price \$385.00. 40 acres, \$10 month. Suitable cottage sites, hunting, fishing, investment. Free information. Land Corporation, 3768-C Bathurst, Downsview, Ontario, Canada.

\$1 ACRE—Canadian Border—hundreds campsites, islands, farmlands, directly from tax authorities. (Non-profit). Lists, photographs mailed. Register, Room 10, 110 Church Street, Toronto 1, Canada.

CENTRAL Ontario—Choice 640 acre Sportsmen's paradises still available—\$20.00 plus \$6.50 taxes yearly. Maps, pictures. \$2.00 (Refundable). Information Bureau, Norval 4, Ontario, Canada.

GOVERNMENT LANDS . . . Low, as \$1.00 acre. Millions acres. For exclusive copyrighted report . . . plus "Land Opportunity Digest" listing lands available throughout U.S., send \$1.00. Satisfaction guaranteed. Land Disposal, Box 9091-PF, Washington, D.C. 20003.

VACATION Lands, Canada. \$1.00 acre. Free information. Tax Corp., 206-F Bloor W., Toronto 5, Canada.

CANADIAN Lands, seized and sold for taxes. Our 52nd annual series of lists, describe many choice properties, situated from coast to coast, acquired by us through Tax Sale. Priced as low as five dollars per acre, guaranteed perfect title, small monthly payments, no mortgage. Beautifully situated hunting and fishing camps, where there is real sport; summer cottage sites, heavily wooded acreages. Now is the time to invest in Canada's minerals, forests and farms. Write to-day for free booklet with full explanation. Tax Sale Service, Room 301-D, 85 Bloor St., East, Toronto 5, Canada.

NORTHWEST WOODED WILDLANDS AS LOW AS \$950. TOTAL PRICE \$50 DOWN \$25 MONTH. 5-10-20-40 acres for people who love the land. . . . A piece of wilderness to preserve for your own forever. In Northern Idaho, Northeastern Washington, and Western Montana. In the heart of lakes and big game country. All covered with growing timber. Access, Title insurance with each tract. This is select land with natural beauty, recreational and investment values. We have tracts of many types and sizes from which to choose, including beautiful Northwest Waterfront property on the Pend Oreille, Priest and Kettle Rivers; and property on Pend Oreille Lake. Your inspection welcomed. Write us for free list, maps and complete information. Write to: Dept. PF, Reforestation, Inc., P.O. Box 8146, Spokane, Wash. 99203.

FREE 208-page real estate catalog. All types property, coast to coast! **UNITED FARM AGENCY**, 612-PM West 47th St., Kansas City, Mo. 64112.

MONTANA—Sportsmen, for sale on the beautiful Kootenai River, building sites for your cabin, in the Montana Rockies. \$10.00 down, \$10.00 per month. Mountain Empire Company, Box 203-P, Libby, Montana 59923.

FREE CATALOG! Giant **SUMMER** edition! Over 4,000 properties described, pictured—Land, Farms, Homes, Businesses—Recreation, Retirement. Selected Best throughout the U.S.! 69 Years' service, 515 Offices, 40 states Coast to Coast. Mailed **FREE** from the World's Largest! **STROUT REALTY**, 60-RX E. 42nd St., N.Y., N.Y. 10017; 7-RX S. Dearborn, Chicago, Ill. 60603; 521-RX E. Green, Pasadena, Cal. 90013.

THE Only "No-Risk Land Purchase Plan" in America—10 year money-back guarantee on any Vacation, Retirement or Investment homesite in Boiling Spring Lakes—the multi-million dollar, 14,000-acre development on the Carolina Coast. All facilities, electricity, roads, motel, golf course, country club, already in. Private ocean beach, 50 fresh water lakes, 1/2-acre homesites as low as \$695.00; \$8.00 down, \$7.65 monthly. Write for free literature. (Not offered to residents of California, Florida, New York.) Boiling Spring Lakes, Southport 1K, North Carolina 28461.

WESTPORT, Massachusetts, 8 acres Farm Woodland, Russell, 1059 Pleasant Street, Fall River, Mass. 02720.

LESS Than 1 mile to Disney property. Lake living, 1/4 acre. Private ramp, beach 11 mi. to Orlando. \$24 mo., \$50 down. **BLOCH BROS.**, 1 North Rosalind, Orlando 26, Florida 32801 AD65LS169-L.

FARM & GARDEN EQUIPMENT

EXTRA Income at home in Spare Time! Booklet shows you how to start your own business with Classified Advertising. Only \$1.00 (Refundable with first order.) C. A. Martin, Popular Mechanics, Dept. PM575 Lexington Avenue, New York 10022.



FLOWERS, PLANTS & NURSERY SUPPLIES

MAILORDER Records help get Increased Business! Complete 32 Page Record Book shows your inquiries orders, advertising, expense, etc. Only \$1.00 C. A. Martin, Popular Mechanics, Dept. PM, 575 Lexington Ave., New York 10022

EXTRA Income at home in Spare Time! Booklet shows you how to start your own business with Classified Advertising. Only \$1.00 (Refundable with first order.) C. A. Martin, Popular Mechanics, Dept. PM, 575 Lexington Avenue, New York 10022.



DRINKING WATER—PURIFIER

EXTRA Income at home in Spare Time! Booklet shows you how to start your own business with Classified Advertising. Only \$1.00. Refundable with first insertion order. C. A. Martin, Popular Mechanics Dept. PM, 575 Lexington Ave., New York 10022.

HOME CRAFTSMEN

CABINETMAKING MADE EASY and "How to Make Formica Counter Tops," two excellent guides let you build kitchen cabinets and counter tops like professionals. Extraordinary guides bring master craftsmen's shortcut methods. Satisfaction guaranteed. Write: Japs, 126-P Seventh North, Hopkins, Minn. 55343.

PLANS, Bird houses. Send 15¢ for brochure and free feeder plan. Yeager, 1665 Linden, Homewood, Ill. 60430.

FULL SIZE FURNITURE PLANS. Traditional, Early American, Danish Modern. Catalog 50¢. Furniture Designs, Dept. P-6, 1425 Sherman, Evanston, Illinois 60201.

FOUNDRYETTE 2400 F, 1 1/2 to 48 lb. capacity. Circular 10¢. Kansas City Speciaties, Box 193-P-6, Middleton, Wisconsin 53562.

SPANISH FURNITURE PLANS. Send stamped, addressed envelope for circular. R., S. Plans, Box 12091, Parkville, Mo. 64152.

WALNUT And Cherry tapered legs, lumber, gunstock blanks, picture frame moulding. Midland Lumber Company, Box 262, Savannah, Missouri 64485.

FREE Popular Mechanics 16 page illustrated catalog of publications, plans and projects. Booklet covers an extremely wide variety of do-it-yourself data on home remodeling, shop tools and machines, car repair, hobbies, crafts, boating, games, lawn and garden and hundreds of others. For your free copy write to Service Bureau, Dept. PE, Popular Mechanics, 575 Lexington Ave., New York, N.Y. 10022.

PLANS For pool table with extra two-face top for table tennis and model railroad. Blueprints B1209 and building instructions \$3.50. Popular Mechanics Service Bureau, 575-M Lexington Ave., New York, N.Y. 10022.

101 PATTERNS of smart Gifts. Novelties. Shelves, Action Windmills, plus "Make Money Jig Sawing." \$1.00. Mastercraft, 65M, 7041 Olcott, Chicago 60631.

NO NAILS SCREWS OR GLUE. Amazing, strong, sturdy, child's chair. Cut from 3/8" ply wood. Full size pattern \$1.00. Werts-Wood-Products, Box 41097, Cincinnati, Ohio 45241.

PICTURE Frame mouldings free list R. E. Burt Corp., Cuba, New York 14727.

LAWN FURNITURE PLANS, Picnic Table \$1.75, Chaislounge \$1.75, Chair \$1.50. All Three \$4.25, GB Engineering, Route 4, Box 721-A1, Ledyard, Connecticut 06339.

WALNUT, BIRCH, CHERRY. For the Home Craftsman. Write for Price List. Jay's Wood Shop, P. O. Box 337, Clay, Kentucky, 42404.

UPHOLSTERY

MAILORDER Records help get Increased Business! Complete 32 Page Record Book shows your inquiries, orders, advertising, expense, etc. Only \$1.00. C. A. Martin, Popular Mechanics, Dept. PM, 575 Lexington Ave., New York 10022.

DO-IT-YOURSELF

WATER!! Drill your own well the easy, economical way with Amazing New Invention. Save 75%. Free information. Deep-Rock Drilling Company, Opelika, Alabama 36801.

BURGLAR-FIRE Alarm supplies and information. Free Catalog. Protecto Alarm Sales, Box 357, Birch Run, Michigan 48415.

DO-IT-YOURSELF simplified Central Air Conditioning. Approximately \$400 for homes with forced air furnace. Write for step-by-step brochure. McGraw-Edison Company, 705 N. Clark St., Albion, Michigan 49224.

STEAM Powered lawn mower, with flash boiler. Pictures discriptions. Also fire tube boiler burners, small steam engines all parts numbered, several sheets. \$2.00 Postpaid, Travis Tool Company, Box 118, Sidney, Iowa 51652.

BURGLAR-Fire Alarms. Automatic Police Telephoning, Gas, Bells, Supplies. Free Catalog. Specify; business-residence. Alarm Supply, 7294 Glenview, Fort Worth, Texas 76118.

SAVE \$\$\$. Tells how to service, repair your own power mower and air-cooled engines in minutes. Send \$1.00. Power Mower Tune-up, Box 910, Lancaster, Ohio 43130.

CONVERT Refrigerators Into Freezers Inexpensively, Easily. Instructions, Schematics \$2.00. Silin's Enterprises, 62 Lorraine, Island Park, N.Y. 11558.

EXERCISE At home on build-it-yourself physical fitness equipment, including bicycle exerciser, rowing machine, belt massager, and abdominal board. Send \$2.50 for blueprints B1208 and instructions. Popular Mechanics Service Bureau, 575-K Lexington Ave., New York, N.Y. 10022.

REPAIR Manuals, automatic washers, dryers, dishwashers, 20 different manuals, \$2.75 each Ppd. Send make and model number. Major Appliances, 13106 Caine Ave., Cleveland, Ohio 44105.

AIR Compressors from old mower engines? Instructions, sketches, **SPECIAL VALVE** \$2.75; photos 50¢ with order. R-T Mfg. Co., Box 5443, Reno, Nev. 89503.

MAKING Household Fabrics Flame Resistant, Easy. Send \$1.00. Share Ent., P.O. Box 277, Hollywood, California 90028.

A-FRAME, Cabin Plans, Kits, Catalog \$1.00. Leisure Homes, 11623 Tescord, St. Louis Mo. 63128.

FENCE!! Save 1/2. Residential Chain Link. Illustrated Instructions \$2.00. Bendle Fence Co. 5287 Nichols Rd., Swartz Creek, Mich. 48473.

90% SAVINGS Possible on small pumps: Plans and Information, \$2.00; V.R.E., 1313 Alaska, Anacortes, Washington 98221.

"HOME FIX-IT BOOK" covers 1,000-plus Do-It-Yourself repairs. Chock full of tips, short cuts, easy instructions. Send \$6.95. Hillcrest Enterprises, 2222-P Ham Road, Centralia, Wash. 98531.

REFRIGERATOR Door gaskets—Electric Range and Washer Parts. Send Make and model for cost. Box 5465, Hamden, Conn. 06518.

BURGLAR-FIRE ALARM Systems and Supplies. Free Catalog. Informer Alarm Mfg., 715B Gusor Street, Baltimore, Maryland 21202

ARTS AND CRAFTS

MAKE Figurines, plaques, lawn ornaments, Molds, plastercraft kits, liquid rubber. Sample and catalogue 10¢. Wooley Company, Box 29-B, Peoria, Illinois 61601.

FREE! World's largest leathercraft catalog. Hundreds of Make-it Ideas. Tandy Leather Co., Dept. I-67, Fort Worth, Texas 76107.

JEWELRYCRAFT—It's easy! Big profits! Catalog, 25¢. Modern Crafts, 12790 US 19, Clearwater, Florida 33516.

FREE: New 136 page handicraft catalog. Supreme Handicrafts, Box 395-PM Sioux Falls, South Dakota 57101

BINOCULARS, TELESCOPES, MICROSCOPES, MAGNIFIERS

BINOCULARS Direct from manufacturer. Finest quality, tremendous savings! Request catalog. Koyu, 3860 Crenshaw Blvd., Los Angeles, Calif. 90008.

SCIENCE Bargains! Lenses, telescopes, binoculars, microscopes, kits, parts, war surplus. Send \$1.50 for beginner's 10-lens kit with instruction booklet. Order Stock 2-CH. Request free 148 page Catalog CH. Edmund Scientific Co., Barrington, New Jersey 08007.

BINOCULAR Specialists. Repairs And Sales. Free Catalog. Tele-Optics, 5514 Lawrence, Chicago, Ill. 60630.

WORLD Famous "Dyroscope" Telescope. Build your own reflector telescope, mirrors, eyepieces, tripods, accessories. Request free brochures. Criterion Manufacturing, Dept. PP 32 Hartford, Connecticut 06101.



CAMERAS AND EQUIPMENT

WORLD'S Largest Buying Guide—800 Illustrations—50¢—Deductible With Your Order—Olden Camera—1265 Broadway, New York, N.Y. 10001.

FREE! Free!—Photographic and optical bargain book. Jimco, Dept. 1A1F, 9006 Waukegan Road, Morton Grove, Ill. 60053.

PHOTO SUPPLIES

ATTENTION: WEEKEND PROFESSIONAL PHOTOGRAPHERS. Photo-mounts, albums, mailers—all your home portrait, candid and wedding presentation needs from one source. **WHOLESALE PRICES. SHIPPED POSTPAID.** Catalog 25¢. CROWN PRODUCTS, 2150 Superior, Cleveland, Ohio 44114.

ANSCOCHROME-DYNACHROME-FILM—save by mail. Free price list. Hillis Products, Dept. M, Box 1182, Kokomo, Indiana 46901.

PHOTO FINISHING

CAMERA Fans! Expert photo-finishing and fresh Kodak film returned: **8MM** Kodachrome \$3.45; 8 exp. Kodacolor \$3.40; **35MM** Kodachrome, 20 slides, \$3.15; 8 exp. black & white 99¢. We give you free photo stamps to redeem for gifts. Satisfaction guaranteed. Send exposed film or request mailers and complete price list. Direct Mail Photo, Box 8352-PM, Pittsburgh, Pa. 15218.

A **FREE** Kodak roll returned with each black and white or Kodacolor developed and printed, fast service, lowest prices, guaranteed quality send for free mailers. Economy Photo Service, Dept. P.M., Box 1111, Albany, N.Y. 12201.

KODACOLOR—With this advertisement only—8-12 exposure, \$1.19. Astro Photo Service, Box 166M, Waterloo, New York 13165.

LOOK—Save Money On Pictures! Jumbo Size Prints from your Kodacolor Rolls, \$1.98. Black & White, 69¢. Huge Discounts on Supplies. Enclose Advertisement. Wisconsin Film Service, La Crosse, Wisconsin 54601.

INTRODUCTORY Special—12-Exposure Kodacolor Developed for \$2.00 with this ad. **FREE** GIFT Expires December 1, 1969. Paul Bunyan Photo, Box 309M30, Brainerd, Minnesota 56401.

SPECIAL WITH THIS AD—Kodacolor developed 12 prints \$2.25. Black & White developed 2 prints each Jumbo size—12 exposure 70¢. **LENS PHOTOS**, Dept. J-4, Janesville, Wis. 53545.

COLOR SLIDES

OUR FIRST 19 IN SPACE. This limited edition lithograph has been created as a tribute to Americas Gallant Astronauts. 12 X 18 inch chart ready for framing. Only 75 cents. Popular Mechanics, Dept. GWP, 575 Lexington Avenue, New York, New York 10022.

MOTION PICTURES AND SOUND EQUIPMENT

FREE! 64-page catalog. 8-16mm film, supplies, processing equipment. Superior, 448 N. Wells, Chicago 60610.

5,000 8-16MM MOVIE Films. Free catalogues. International, Greenvale, L.I., N.Y. 11548.

UNUSUAL Movie supplies. Free circular. Esor, 47th Holly, Kansas City, Missouri 64112.

16MM Sound Features, Shorts, New, used for Sale. Free Catalog. National Cinema, 333 W. 57th St.-N.Y.C., N.Y. 10019.

35MM. COLOR SLIDE SAMPLER . . . 20 "best" 2" x 2" . . . \$1.00. Free catalog. Hundreds of sets . . . travel, circus, wildlife, flowers, railroads, wars, etc. Order today. Blackhawk Films, 862 Eastin-Phelan Bldg., Davenport, Iowa 52808.

175-FOOT 8MM. PREVUE MOVIE . . . ONLY \$1.99. See Laurel & Hardy, Chaplin, Fairbanks, Keystone Cops, Gish, Pickford, Chaney . . . comedy, drama, adventure, history from the silents! Taste the fun of great movies right at home! Order today . . . specify standard or Super 8. Free catalog. Blackhawk Films, 861 Eastin-Phelan Bldg., Davenport, Iowa 52808.

RADIO, TELEVISION AND HAM EQUIPMENT

33¢ RADIO & TV tubes. Free list. Cornell, 4213-17 University, San Diego, California 92105.

TUBES—Lowest prices in the world. Hard to get British, German, Foreign and American obsolete and present day special purpose transmitting tubes. Send for giant tube and parts catalog. United Radio Company, Dept. Z-56 Ferry St., Newark, N.J. 07105.

HEAR POLICE & Fire Radio Dispatchers! Stamp brings catalog: Receivers, exclusive "Confidential" Directories of Dispatcher Stations! Communications, Box 56-PM, Commack, N.Y. 11725.

"ELECTRONICS AT WORK" Nationally advertised Electronics Course Books now made available to all. Published in six units of 15 lessons each, (12 books, 656 pages, 360 drawings, self tests and experiments.) Lessons 1-15 Electrostatics and DC Circuit Principles, 16-30 Electromagnetism and its Applications, 31-45 Power Supplies and Basic Electronic Components, 46-60 Vacuum Tubes and Reactive Circuits, 61-75 Audio Communication Systems, 76-90 Television Communication Systems, \$24.80 postpaid. Wentworth Corporation, Dept. 13, Box 666, West Columbia, S.C. 29169.

GOVERNMENT Surplus receivers, transmitters, snooper scopes, parts. Catalog, 25¢. Meshna, Nahant, Mass. 09108.

GOVERNMENT Surplus receivers, transmitters, snooper scopes, parts. Catalog, 25¢. Meshna, Nahant, Mass. 09108.

SONAR Fire And Police Monitor Receivers, Tuners, Accessories, Details, Free Antenna Offer: Griffin's 322 M West State Ithaca N.Y. 14850

HIFI, RECORDS AND ELECTRONICS

FREE Catalogues, 2000 hard to find unusual records. Rose's, 300 Chelsea, Louisville, Ky. 40207.

TAPE Recorders, hi-fi components. Sleep learning equipment, tapes. Unusual values. Free catalog. Dressner, 1523C Jericho Tpke., New Hyde Park, N.Y. 11040.

RECORDS! Discounts on all LP's. Free details. Citadel Record Club. Symphonette Sq., Dept. 2, Larchmont, N.Y. 10538.

FREE 40 PAGE CATALOG offers hundreds of recordings of rare Renaissance, Baroque and Classical music. Some records priced as low as \$1.00 each! All late recordings in stereo only. **MHS RECORDS**, Box 932 PM, New York, New York 10023.

HOME Electronics Course only \$26.95. Free literature. Edu-Kits, Department 714 B, Hewlett, New York 11557.

SCOTCH Recording Tapes. Wollensak Recorders. Catalog 6¢. Tower, Lafayette Hill, Pa. 19444.

STEREO TAPES: Cartridges, cassettes, reels, 33% discount. Largest selections, unavailable elsewhere. Mail 20¢—catalogs. **STAR RECORDINGS**, Box 1055, El Paso, Texas 97746.

STEREO TAPES Cassettes 4Track 8Track Cartridges, Open Reel 10% Discount Off Manufacturers List Price. 160 Page Catalog 30¢ Deductible 1st Order. Stereo Tapes Unlimited, 2318 Sheffield, Chicago, Ill. 60614.



MUSIC AND MUSICAL INSTRUMENTS

PLAYER Piano Rebuilding—get details from: Vestal Press, Vestal 11, N.Y. 13850.

GUITAR, Banjo Making books Plans, woods, necks, tools. List 25¢. Satinwood, 510 East 11th Street, New York, N.Y. 10009.

ACCORDION Manufacturing. 6846-P North Avenue, Chicago, Illinois 60635. Concertinas, Hohners, Chromatics, Guitars, Drums, New, Used, Tuning, Repairing, Wholesale Catalogs Free.

POEMS. Songs wanted for new song hits and recordings by America's most popular studio. Tin Pan Alley, 1650-PM Broadway, New York 10019.

VIOLIN and Guitar makers—send for latest Free Catalogue of woods & accessories. International Violin, PM8, 414 East Baltimore St., Baltimore, Md. 21202.

ELECTRIFY Player pianos, pump organs quickly, inexpensively with Lee Silent Suction Units. Write Lee Music, Box 595F, Tujunga, California 91042.

POEMS Set to music. Songs recorded. Send poems, songs. Crown Music, 49-C West 32, New York 10001.

POEMS Wanted For Songs. Nashville Music Productions, Box 9001-P, Nashville, Tennessee 37204.

POEMS Wanted for new songs and records by America's largest song studio. Send poems. Free examination. Five Star Music, 6M Beacon, Boston, Mass. 02108.

30% DISCOUNT Any Name Brand musical instruments. Write for low price. Freeport Music, 127 W. Sunrise Highway, Freeport, New York 11520.

FREE Circular Country Records. Uncle Jim O'Neal, Box A, Arcadia, Calif. 91006.

SONG Writers—Send Poems. Songs to: Weiss Music Company, 1472 Broadway, New York, New York 10036.

ACCORDION Top brands. Buy direct. Tremendous discounts. Trade accepted. Free brochure PM. Accordion-O-Rama, 874 Broadway, N.Y.C. 10003.

DRUMS, Electric guitars, amps, organs. Free catalog M: A.L.A.S. Import Company, 31 East 18th Street, NYC. 10003.

SONGPOEMS Wanted! Write with Professional Songwriters. Share Royalties. Songwriters Contact, 888-8th Avenue, New York 10019.

ELECTRIC Guitars, amplifiers, wholesale. Catalog 25¢. Carvin, P.M.M., Valley Center, Calif. 92082.

FREE. Song marketing information. Peerless Publications, Box 193-A, Bloomfield, Conn. 06002.

ACCORDIONS, Guitars, Band Instruments! Save to 50%. Famous makes. Easiest terms. Trades accepted. Free home trial. Free discount catalog. Mention instrument. International Music Mart, 55-35-R, Belmont, Chicago 60641.

FREE Guitar Pick Lessons. Self addressed & Stamped Envelope: Jimmy James, Rt. 1, Bluefield, West Virginia 24701.

WE Pay all recording costs on accepted material! Need new song material for immediate recording! Free examination! Grand Recording, 835-PM Dorchester Ave., Dorchester, Mass. 02125.

GUITARS, **MANDOLINS**, **BANJOS**. Complete stock of Gibson Martin guitars. Free 100 page catalog, parts and accessories. Big Savings. New York discount prices. Send 50¢ postage handling. Eddie Bell Guitar, 201 West 49, New York 10019.

SWISS Musical Movements. Mechanical-Electrical. Spielman, 131 West 42nd. New York 10036.

LEARN Banjo. 5-string bluegrass. Easy fun. No music. Free details. Blaylock, Box 25-M, Marietta, Georgia 30060.

GUITAR Chord system most modern ever devised. Send \$3.50. Johnny Carlton, Canton Plaza, Marietta, Georgia 30060.

GUITARS, Amps, drums. 30% to 50% off list. Name brands. Send brand, model number. Fast answer. Literature. Warehouse P, P.O. Box 9352, Ft. Worth, Tex. 76107.

WHOLESALE Musical Instruments Catalog. Allied, 406 East 189, Bronx, N.Y. 10458.

EDUCATION AND INSTRUCTION

LEARN Auctioneering. Term soon. Free catalog. Reisch Auction College, Box 850, Mason City, Iowa 50401.

PIANO Tuning quickly learned with home study course. Diploma granted. American Tuning School, Gilroy, Calif. 95020.

PIANO Tuning pays. Big money in spare time. Learn at home. No musical knowledge necessary. Phonograph, records, tools and instructions furnished. Electronic tuning also taught. Free catalog. Capital Tuning School, 3160 S.W. 16th Court, Ft. Lauderdale, Fla.

DETECTIVE Course. Free information. Universal Detectives, Box 8180-F, Universal City, California 91608.

BOOKKEEPERS. Operate your own "Dollar-A-Week" system. Ellis, Box 200, Cedar Grove, North Carolina.

PENMANSHIP Corrector. Improve poor penmanship quickly. Details free. Ozment, Box 665-34, St. Louis, Mo. 63188.

AUCTIONEERING Free Catalog Resident or Home Study Course. Nashville Auction School, 2004 West End, Nashville, Tenn. 27203. Veteran approved.

OWN Collection agency. "Little Gold Mine!" Franklin Credit, Roanoke, Virginia 24004.

EARN \$125 A week and up. Learn a trade with a future. Learn auto diesel mechanics in our shops. You learn with tools on real equipment. Earn while you learn. Many of our graduates earn \$125 a week and up. Write for free bulletin: Dept. 256, Auto Diesel College, Nashville, Tennessee 37219.

SWEDISH Massage and physical culture pays big profits. Learn at home. Diploma. Free catalog. National Institute, Dept. E-69, 307 North Michigan, Chicago 60601.

HIGH School diploma at home. Licensed teachers. Send age, highest grade completed for free details. No salesman will call. Southern States Academy, Westbury Square Professional Bldg., Dept. 16, Houston, Texas 77035.

USED CORRESPONDENCE Courses and Books sold and rented. Money back guarantee. Catalog free. (Courses bought). Lee Mountain, Pisgah, Alabama 35765.

MISSOURI Auction School. GI Approved. Free Catalog! 424-03 Nichols Road, Kansas City, Mo. 64112.

GET A British degree. Divinity, Philosophy, Radionics, 35 courses. Prospectus free. Brantridge Forest School, "Lodge" Brantridge Forest, Balcombe, Sussex, England.

USED Courses! Books! List 10¢. Smith's, 124 Marlborough, Salem, Mass. 01970.

LEARN Landscaping and the growing of plants. Start a profitable business part or full time. Free information without obligation. Lifetime Career Schools, Dept. A-602, 2251 Barry Avenue, Los Angeles, California 90064.

LEARN Asleep or awake! Records, tapes, equipment! Free catalog! Drawer, PM-400, Ruidoso, New Mexico 88345.

SUPERIOR Auction School. Nation's top Auctioneers own and instruct. 120 East Cerrogorro, Decatur, Ill. 62523.

BE A POLICEMAN. Complete Course and Diploma, only \$10.00 Southern Police Academy, P.O. Box #306 Fairfield, Alabama 35064.

AUTOSUGGESTION. Sleep-learning headquarters! Tapes, records, books. Gigantic catalog free. Research Association, Box 24-PM, Olympia, Washington.

FREE! List of low cost popular self-improvement books. Write Dixie Gift Mart, 1384-C Monroe Drive, N.E., Atlanta, Georgia 30324.

ACCIDENT INVESTIGATION career training. Learn at home to earn up to \$8 an hour. Car furnished. Expenses paid. No selling. Free placement service. Men urgently needed. No college or experience required to train. Write for FREE information. No obligation. Universal Schools, CPM-6, 6801 Hillcrest, Dallas, Texas 75205.

INFORMATIVE, Inspirational Books. Free Brochure. John A. Wonsley Company, 15024-C Joy Road, Detroit, Michigan 48228

SINGING, 3 Page lesson \$1.00. Nelson, Box 190, Hobart, Ind. 46342

FCC First Class License in six weeks—Nations highest success rate—Approved for Veteran's Training. Schools in Dallas, Atlanta, Chicago, New Orleans, Minneapolis and Houston. Write Elkins Institute, 2603D Inwood Road, Dallas, Texas 75235.

DIAMOND CUTTING. Eligible Federal Student Loans. GI approved. American School Diamond Cutting, Gardnerville, Nevada 89410.

HIGHLY effective home study courses in Electronics Engineering Technology and Electronics Engineering Mathematics. Earn your Degree. Write for Free Descriptive Literature. Cook's Institute of Electronics Engineering, (Dept. 10), P.O. Box 10634, Jackson, Miss. 39209. (Established 1945).

EARN College degree at home. All subjects. Ohio Christian College, 1156 Striebel Road, Columbus, Ohio 43227.

LEARN Bartending. Correspondence School, 426C East Seventh Street, Tucson, Arizona 85705.

"**KEY** to a Cartoon Career." Write: Cartooning, Box b3176, Colorado Springs, Colo. 80907.

LEARN Civil and criminal investigation at home. Earn steady, good pay. State age. Institute Applied Science, 1920 Sunnyside, Department 166, Chicago, Illinois 60640.

WATCH REPAIRING. Learn to repair American and Swiss watches in spare time at home. Diploma awarded. Free sample lesson. No obligation. Chicago School, Dept. YS, Fox River Grove, Illinois 60021.

AVOID Hell Fire Eternal Punishment. Tracts, Box 233, Newport News, Va. 23607.

PROFITABLE National Camera Repair School training at home! PM6, Englewood, Colorado.

CALENDAR MATHEMATICS. Entertain. \$2.00. Write for information. Send no money. Oscar Manzano, 1844 S. Fairfield St., Chicago, Illinois 60608.

MINISTERIAL Bible College. Christian Education, Ordination, and Degree Courses. Write: Soms, 887 West Spruce, Ravenna, Ohio 44266.

COMPUTER CAREERS. Free Information. H. J. Couto Associates, P.O. Box 615, Eatontown, N.J. 07724.

ART Talent? Don't waste it. Turn it into a fabulous career in the high paying art field, with simple courses or self-teaching manuals guaranteed to show you how. Free brochure. Famous American Studios, Dept. PM, Spring Park, Minn. 55384.

BARTENDING-Home Study Course **FREE BROCHURE** Box 3191-P North Las Vegas, Nevada 89030

AUCTIONEERING Resident or Home Study Course Free Catalog. Nashville Auction School, 2004 West End, Nashville, Tennessee 37203

AUTOMOTIVE Air conditioning. Start your own business with small cash outlay. Write for free folder No. PM-2. Technical Center, P.O. Box 59, Buena Park, Calif. 90620

FOR INVENTORS

PATENT Searches complete and thorough. Related copies Air Mailed with maximum speed \$6.00. Free "Protection Forms" and "Patent Information." Write American Patent Search Company, Dept. 27, 711 14th St., N.W. Washington, D.C. 20005.

PATENT Application Financing. Free patent search plan. Global Patent Division, 2420 77th, Oakland, Calif. 94605.

PATENT And invention development by licensed professional patent engineer and U.S. Patent Office former examiner, and engineering specialists. Your inventions and ideas engineered for patent protection and commercial value. Inventions developed by us negotiated for cash or royalties with our nationwide contacts. Send for free protection "Invention Certificates" and further interesting, valuable patent information. George Spector, Licensed Professional Patent Engineer, Woolworth Building, New York.

U.S. Patent Office Searches, 234 Broadway, Room 3615, New York. Free invention certificates.

IMMEDIATE Cash, for patent applications. Free patent searches. Write for details. Universal Patents, 184-D, Marion, Ohio.

INVENTORS—Do you want to sell or license your invention on cash or royalty basis? Write: Kessler Corporation, C-56-F1, Fremont, Ohio.

INVENTORS: Your ideas and inventions (patented; unpatented) expertly searched, developed for commercial appeal and cash royalty sales to manufacturers by professional Invention Developer with excellent record of experience. B.S., Industrial Engineering; United States Patent Office former Patent Examiner, United States Government former Patent Advisor. Second decade reliable service! Member: United States Chamber Commerce. Free "Invention Record" and "Recommended Protection Procedure." Airmailed! Write: Raymond Lee, Invention Developer, 230-P Park Ave., New York City 10017.

PATENT Searches, including copies of related U.S. patents. Inventors attorneys, manufacturers use our "worldwide" airmail service! "Invention Record" form and "Information Every Inventor Needs," sent free! Hayward Company, 1029P Vermont, Washington 5, D.C.

FREE PAMPHLET: "Tips on Safeguarding Your Invention." Write: Unnted States Inventors Service Company, 501P Thirteenth Street N.W., Washington, D.C. 20004.

MANUFACTURERS NEED New Products! FREE Literature explains "How To Submit Your Invention." Congress Invention Company, 911-C Warner Building, Washington, D.C. 20004.

SUCCESSFUL INVENTING Booklet by inventor with 40 years experience. Copyrighted. 2.25 PP. Box 606, Westfield, N.J. 07090

INVENTIONS WANTED

INVENTIONS Wanted. Patented; unpatented. Tremendous manufacturers lists. Global Marketing Service, 2420G 77th, Oakland, California 94605.

INVENTORS! Sell your invention for cash or royalties! Our client manufacturers eagerly seek new items. Patented. Unpatented. Financial assistance if needed. 25 Years proven performance. For free information, write Dept. 15, Gilbert Adams, Invention Broker, 80 Wall St., New York, N.Y. 10005.

INVENTORS! We will develop, sell your idea or invention patented or unpatented. Our national manufacturer-clients are urgently seeking new items for highest outright cash sale or royalties. Financial assistance available. 10 years proven performance. For free information write Dept. 47, Wall Street Invention Brokerage, 79 Wall Street, New York, N.Y. 10005.

WE Either sell your invention or pay cash bonus. Write for details. Universal Inventions, 298-E, Marion, Ohio.

IF Your invention is adaptable to promoting we will contract for selling on cash or royalty. Free booklet outlines royalty rates, requirements. Kessler Corporation, C-56-IW, Fremont, Ohio.

FREE "Directory of 500 Corporations Seeking new Products." For information regarding development, sale, licensing of your patented/unpatented invention. Write: Raymond Lee Organization, 230-N Park Avenue, New York City 10017.

INVENTORS! Protect your ideas! Free "Recommended Procedure." Washington Inventors Service, 422F, Washington Building, District of Columbia 5.

WHAT TO INVENT Detailed list of most wanted inventions. For both professionals and amateurs. \$4.00 Inventor's Newsletter P.O. Box 851 Gloucester, Mass. 01930

PATENTS FOR SALE

EXTRA Income at home in Spare Time! Booklet shows you how to start your own business with Classified Advertising. Only \$1.00. Refundable with first insertion order. C. A. Martin, Popular Mechanics Dept. PM, 575 Lexington Ave., New York 10022.

MANUFACTURING

INVENTORS Ideas developed. Research. Models. Manufacturing. Sales. Free brochure. William Parker, 32 Westminster, Worcester, Mass. 01605.

MODELS — small lot manufacturing. Metals, plastics, etc. Milburn, Burlington, Kentucky 41005.

BUY IT WHOLESALE

500,000 BARGAINS BELOW WHOLESALE. New, name brand merchandise. Buy at 10¢ on the dollar. Closeouts, surplus, bankrupts, liquidations, imports. Free details. International Buyers, Box 4633-M, Colorado Springs, Colo. 80909.

BARGAINS! Buy wholesale and below. Name brands. Appliances, furniture, sports equipment, televisions, cameras, watches, jewelry, thousands more. Huge discounts to \$1,000.00 on new automobiles. All makes. Free details. Write today: Worldwide Bargainhunters, Box 730-A, Holland, Michigan 49423.

20 WHOLESALE Catalogs!! List \$1.00. Zashop, 216 PM-6, West Jackson, Chicago 60606.

ELECTRIC Guitars, amplifiers, wholesale. Catalog 25¢. Carvin PMW, Valley Center, Calif. 92082.

EXPORT-IMPORT

JAPAN: 1200 Products Directory, Illustrated Manufacturers' names, addresses, \$3.00. Send cash. Yamagata Office, 814 Togin Bldg., Marunouchi, Tokyo.

MAILORDER IMPORTS. Report Reveals Foreign Drop-Ship Sources, World Trader's Digest, Ideal Mailorder Items, Send \$1.00. W. Churchill, Dept. E1169 5915 Wellesley, Pittsburgh, Pa. 15206.

DIRECT From Africa! Something new and exciting!! Home Decoration!!! Complete set of 20 pieces, Wild Animals Beautiful Wood Carvings. Send Cheque for US \$42 only. Packing insurance and freight included. Fic (Africa) Ltd., Box 4606 Kampala, Uganda, East Africa.

FOR THE HOME

FIRE ALARM \$5.75. BURGLAR ALARM \$3.75. Foolproof, guaranteed, self contained. Free literature. ALARMS, 492 E. Main, Williamsburg, Ohio 45176.

PATIO Easy ceramic granule coating. Free information. Gateway, 6851 Plainfield, Cincinnati, Ohio 45236

CESSPOOL SEPTIC PROBLEMS effectively solved. Amazing product. JUNE MARTIN ASSOCIATES, Box 65 PM, Com-mack, N.Y. 11725.

ROOT BEER—Genuine, Sparkling, non-carbonated! Simplest, Economical Process \$1. J. Straughan, 3546 N. First, San Jose, Calif. 95131.

FOR PARENTS

KEEP KIDS BUSY. Free details. Barber Enterprises, 3206 Park Blvd., Oakland, Calif. 94610.

OF INTEREST TO WOMEN

WOMEN! Make big money at home. \$10.00 profit in an hour possible with invisible mending. Make holes, tears disappear from clothing, fabrics. Steady year-round demand from cleaners, laundries, homes. Details free. Fabicon, 1533 Howard, Chicago 60626.

HOW To make money writing short paragraphs. Information free. Barrett, Dept. C-27-R3, 6216 N. Clark, Chicago 60626.

\$500 MONTHLY POSSIBLE—clipping news at home. No experience. Free information—send stamp. American, Excelsior Springs, Mo. 64024.

NEWSPAPER Clippings Urgently Needed. Highest prices paid. Send stamped, addressed envelope, free details. Brewster, Box 1348-NCWL, Clearwater, Florida 33517.

\$500—\$800 MONTHLY Raise small laboratory-breeding stock for us. We supply equipment, breeders, instructions. Illinois Research Farms, Dept. MPC-6, McHenry, Illinois 60050.

DRIVE New car, wear new clothes, buy color TV. Get daily cash income. Put spare hours to work. Write for 5 months free subscription Opportunity Magazine, see hundreds easy ways to make money. Opportunity, 1460 Hancock Center, Dept. 17-FO, Chicago 60611.

WOMEN: Big Money! Studio Girl Cosmetics needs women in all States including Hawaii, Alaska, Puerto Rico and American Samoa. Full or part time. No experience required. No territory restrictions. Take orders anywhere. Highest profits. 500 Good Housekeeping approved cosmetics. Everything furnished. Credit extended. No stock to carry. No franchise fees. No stock investment. For full information by mail, plus 3 free samples, write Harry Taylor, Chairman, Studio Girl Cosmetics, Dept. BC287, 11461 Hart Street, No. Hollywood, Calif. 91605. Also immediate big profit earnings for experienced City and State managers and former party plan operators.

\$100 WEEKLY POSSIBLE. HOME TYPING. Instructions, employers' list, \$1.00. Satisfaction or refund. Summithouse, Box 377-PMO, Corte Madera, California 94925.

\$100 WEEKLY Possible—Home Typing. Immediate earnings! Employers list, complete instructions. Details 25 cents. Typing, Box 593, PM6, Bettendorf, Iowa 52722.

HOMEWORKERS! \$85 WEEKLY addressing mail for firms. Start immediately! Details, send stamped self addressed envelope. Enterprises, Box 16143-PM, Phoenix, Arizona 85011.

WANTED! Addressers—Commission Mailers. Stamp required. Ooton Distributors, 4120P Duke Drive, Portsmouth, Virginia 23703.

\$75.00 THOUSAND. Home addressing! Longhand, typewriter. Information, send stamped self-addressed envelope. Brewster, Box 1348-YL Clearwater, Florida 33517.

\$2.00 PER Dozen Cash Profits. Assemble New Art Foam Products. All Supplies Furnished. Showcase, Box 55392D, Indianapolis, Indiana 46205.

MAKE Extra Money—Show friends, neighbors—Gifts, Stationery, Toys, Jewelry, Greeting Cards. 600 items. Experience unnecessary. Salable Samples on approval. Free—Catalog Personalized Christmas Card Album. Hedenkamp, 361 Broadway, Dept. PM-100, New York, 10013.

HOUSEWIVES, Teachers, students, office workers. If you need extra cash each week but household or other duties prevent you from taking a part-time job, learn how you can earn by accepting orders to Popular Mechanics. Good Housekeeping and all other magazines. No experience needed. Write Popular Mechanics, Room 6W, 250 West 55th St., New York 19, New York.

NEEDLE'S For Sewing Machines, any Type Guaranteed. Send Make and Model, \$1.00. Dozen, Shore S.C., 9241 Frankford Ave., Phila., Pennsylvania 19114.

RAISE MONEY: For churches, schools, clubs. Investigate our easy way. Hughes Co., Box 216, Easton, Missouri 64443.

GIFT SHOPPING

FREE Catalog Wonderful Gifts for all. Ben-Nita Gifts, 493 South Tenth Street, Newark, N.J. 07103.

FREE Catalog, unusual novelty gifts, imported, domestic. Alyce Enterprises Box 1087 Dept. PM6 Fort Lee, N.J. 07024

EXCITING And practical gifts. Free catalog. Burkart, 10723-K Farallone Dr., Cupertino, California 95014.

WATCHES, OLD GOLD, JEWELRY

WATCH And clock repairing books. Free catalog. North American, Box-77-AF, Fox River Grove, Illinois 60021.

USED Wrist, pocket watches—\$3.00 up. Free list. Southern Watches, 5-PM South Wabash, Chicago 60603.

CASH Immediately for old gold, jewelry, gold teeth, watches, diamonds, silverware, spectacles, platinum, mercury. Free information. Rose Industries, 29-A East Madison, Chicago 60602.

HIGHEST CASH for Gold, Jewelry, Gold Teeth, Rings, Diamonds, Watches, Silver, Platinum, Mail Articles Today. Free gift with information. Chicago Gold & Precious Metals, 6 E. Monroe, Dept. 558, Chicago, 60603.

WEARING APPAREL

EXTRA Income at home in Spare Time! Booklet shows you how to start your own business with Classified Advertising. Only \$1.00 (Refundable with first order.) C. A. Martin, Popular Mechanics, Dept. PM, 575 Lexington Avenue, New York 10022.

HEARING AIDS

HEARING AIDS—Batteries Wholesale! Brochures—Hearing Center, Box 211, St. Petersburg, Florida.

HEARING Aids, Batteries, wholesale. Catalog 25¢. Fiston, Box 1444 New Preston, Conn. 06777.

HEARING Aids below wholesale. Regular, eyeglass, completely hidden models. Smallest, most powerful. Free home trial. No Salesman will call. Free details. Write Prestige-C6, Box 10880, Houston, Texas 77018.



SCIENCE AND CHEMISTRY

ROCKETS: Real flying models—flights up to 2500 ft. New illustrated catalog 25¢. Single and multistage kit, cones, engines, launchers, trackers, rocket aerial cameras, technical information. Fast service. Estes Industries, Penrose 7, Colorado 81240.

ROCKETS!! Real flying models—2500 feet altitude with powerful motors. Terrific Science Projects. Tubes—Cones—Parachutes—Launchers—Igniters. Gigantic catalog—rocket data—diagrams—25¢. Fast Delivery. Centuri Rockets, Box 1988, Phoenix, Arizona 55001.

CHEMICALS, Apparatus, Microscopes, Biological Supplies. 1969 Catalog 35¢. Sheard Science Supplies, Inc., Columbus, Wisconsin 53925.

ROCKETS. Single, multi-stage kits, parts amazing Accelerometer. Illustrated catalogue 25¢. Rocket Supply, Box 51B, Tappan, New York 10983.

UNDERWATER Fuse 3/32" Diameter, 25 feet \$1.00—125 feet \$4.00 Postpaid. Free Catalog. Zeller, Box 646, Hudson, Mich. 49247.

LABORATORY chemicals supplies 1969 catalogs has over 400 listings many scientific publications cataloges \$.25 Casco, Dept. M P.O. Box 77 Riverdale, New Jersey 07457.

LASER PISTOL—\$1.00. How to build. PHASER PISTOL—\$1.00. (Add 25¢ postage.) New catalogue—10¢. Roy Davis Laboratories, Dept. PM, 118 West Adams St., Jacksonville, Florida 32202.

SEARCHING For economically priced Laboratory Supplies? Gifts with catalogue—25¢. Hagenow Laboratories; Manitowoc, Wisconsin 54220.

SEARCHING For Economically Priced Chemicals And Apparatus? Gifts With Catalogue—35¢. Starr Scientific, Manitowoc, Wisconsin 54220.

CHEMICALS Thousands of Items \$1.00 each postpaid—Pricelist \$1.00—deductible from 1st Order Spectro-chem 1354 Ellison, Louisville, Ky. 40204.

FREE Periodic classification of elements and conversion tables with catalog 35¢. Chemicals, apparatus, biology. Mid-States Scientific, 7053 N. Clark, Chicago, Ill. 60626.

CHEMICALS, laboratory supplies, fuse, casings, LOWEST prices, FASTEST service anywhere! Illustrated catalogue plus formulas, Instructions—50¢. Pyrocenter, Box 9591, Arlington, Virginia 22209.

SOLAR Flying Saucers. (Brand New-Solid State Engine—Fantastic Performance—Flies Miles on Sun's Power—lifts animals—sends messages—parachutes—Build Many—Easily Inexpensively with Everyday Materials. Complete plans, descriptions, drawings, plus Free Spacetratics Catalog—\$1. Single Catalog—25¢. Spacetratics, Box 31043-PMS, San Francisco, California 94131

LABORATORY Supplies At Discount Prices. Catalog—35¢. Deluxe Scientific; Manitowoc, Wisconsin 54220.

CHEMICALS And apparatus for industrial, analytical, and private laboratories. Catalog 50¢. Dept. M-50, Biological Supply Co., 1176 Mt. Hope Ave., Rochester, N.Y. 14620.

CASINGS, Stars, devices of all types. Send 50¢ for samples. Ecco, Box 189, Northvale, New Jersey 07647.

SOLAR ENERGY Literature and Equipment Listing—Free: Solar Multi-Dynamics, Box 181, Thompsonville, Conn. 06082.

GIANT Science Catalog 35¢. Xercon, Department PM-669, 8542 Oglesby, Chicago, Illinois 60617.

PROFESSIONAL Model rocket ignition fuse, burns underwater, 75 feet, \$1.00. Ed-colabs, Box 99, Berlin, New Jersey 08009.

FORMULA For Chemical Blackjack! Same used by most LAW Enforcement Agencies. \$1.00 M. P. Griffin, P. O. Box 258, Gary, Indiana 46402.

FREE! 2 Insect eating plants when you send for our 50¢ catalog! A \$1.50 value! Free merchandise! See back of our catalog for details! Franks Scientific Co., P.O. Box 156, Martelle Iowa 52305.

CATALOG Of Ver-ry Interesting Products—25¢. (Free with any purchase—see our other Kenrus ads!) Kenrus-U, 42 Crocus, Woodbridge, New Jersey 07095.

100 ONE Minute time delay fuses! \$1.00 240—\$2.00. 700—\$5.00. Use with rockets, experiments, etc. Kenrus-U, 42 Crocus, Woodbridge, New Jersey 07095.

GIRANDOLE, Petard casings. Lowest prices. Underwater fuse 75' \$1.00 PROFESSIONAL "Red Devil" Fuse 50' \$1.00. Samples 50¢. Arwel, Box 236, Hasbrouck Heights, New Jersey 07604.

SAVE On casings, endcaps. Underwater fuse 75 feet \$1.00. Professional Red Fuse 50 feet \$1.00. Catalog 25¢. with samples 50¢. Bilton, Box 28, River Edge, New Jersey 07661.

COMPLETE Catalog 15¢ postage. Laboratory Sales, Box 161-A, Brighton, Mass. 02135.

FORMULAS, PLANS, ETC.

ANY Formula \$3.00. Catalog—Treatise 10¢. Belfort, 192 N. Clark, Chicago 60601.

ARTHRITIS RHEUMATISM HEMORRHOIDS Money back guaranteed permanent pain relief to those who follow copy-righted formula. No drugs, no medicine, no operation. Publication copy can be secured by mailing \$15.00 to Alvie J. Beal, Inc., Post Office Box 643, Manito, Illinois 61546.

HOUSE PLANS. Ranchers—Split Levels, Colonials. FREE CATALOG. T & T Sales, Dept. 1613, 1915 Fox, Hyattsville, Maryland 20783

PLASTIC, LAMINATING

CASTOLITE Liquid Plastic pours like water and hardens like glass without heat. Clear, Colors. Embed real flowers, butterflies, photos, coins. Also new molding formulas for perfect reproductions. Illustrated booklet shows HOW. Send 25¢—Dept. 9C1G. CASTOLITE: Woodstock Ill. 60098.

PLASTIC Embedders, jewelry workers. We have everything. Findings, moulds. New catalog 25¢. David Co., 861 Broad St., Dept. M, Providence, R.I. 02907.

PLASTIC, DECALS

SELF-ADHESIVE Company. Club or Product Decals to your design. Vinyls, Mylars, Metallics, Scotchlite and MAGNETICS for off-and-on use! Make Cars, Trucks, Airplanes and Equipment your Permanent Traveling Advertisement! Low Cost! PLASTIC DECAL COMPANY, Box 602B, Janesville, Wisconsin 53545.

TREASURE FINDERS

URECON Metal finder. 8" head, transistorized, \$40.00 delivered. Urpa 6304 Beechwood, Sarasota, Fla. 33581.

TREASURE Hunters! Prospectors! Relco's new instruments detect buried gold, silver, coins, minerals, historical relics. Transistorized. Weighs 3 pounds. \$19.95 up. Free catalog. Relco-A40, Box 10839, Houston, Texas 77018.

POWERFUL Metrotech locators detect gold, silver, coins, relics. Moneyback guarantee, terms. Free information. Underground Explorations, Dept. A, Box 793, Menlo Park, California 94025.

TREASURE LOCATORS. MOST COMPLETE LINE. FREE INFORMATION. TESOROS, APARTADO 7-948, MEXICO 7, MEXICO.

LOCATE—Underground streams Water, Tile Lines, Sewer Pipes Etc. Make Locator 5 minutes, Few cents Hardware. Full Instructions \$1.00. FAR, Box 141, Watertown, Wisconsin 53094.

FREE 128 Page detector catalog. General Electronic Detection Co., Box 67, Bellflower, California 90706.

TREASUREPROBE Metal detector as kit (\$12.88) assembled (\$18.88), with powerful builtin speaker (\$24.88) a schematic, parts list and instructions (\$1.00). Money back guarantee. Free catalog. TREASURE-PROBE Dept. PG-K, P.O. Box 64, Lakewood, N.J. 08701.

FISHER DETECTORS! Treasure fun and profit with new professional quality solid-state models. Unsurpassed sensitivity, reliability. Guaranteed. Free literature. FISHER RESEARCH, Dept. PM-6, Palo Alto, California 94303.

"METAL Locators—Accessories. Write: Detectors, Inc., Box 101-D, Springfield, Va. 22150."

TREASURE, Gold, silver, relics. New 1969 detectors now available. Free information. Rayscope, Box 715, North Hollywood, California 91603.

ULTRA-SENSITIVE AND POWERFUL METAL DETECTORS—join the many who are finding buried coins, minerals, relics and artifacts. Don't buy till you see our FREE catalog of new models. Write Jetco—Box 132, PM-4-Huntsville, Texas 77340.

TREASURE BOOKLET. Excellent information on treasure hunting and metal detectors. Send 25¢. **BOOKLET.** Dept. 6-PM, Box 243, San Gabriel, California 91778.

GOLDAK Treasure Locators—New for '69! A hobby you'll enjoy for fun and profit. Find coins, gold, silver. Goldak, Dept. PMC, 1101A Airway, Glendale, California 91201.

PRECIOUS STONES AND MINERALS

EARTH Science Rockhound Magazine. Subscription \$2.50. Sample 35¢. Box-550-PM, Downers Grove, Ill. 60515.

GET Free catalog no serious rockhound, gem cutter, jewelry maker, hobbyist or craftsman can be without. Full of bargains, exclusive items, low prices from largest suppliers and authorities in the field. Free new catalog just off the press, yours for the asking. Write Grieger's, Dept. C-12, 1633 E. Walnut, Pasadena, California 91106.

100 **COLORFUL**, Polished gemstones, \$1.00. Tumblecraft, 5401 James North, Minneapolis, Minnesota 55431.

GOLD—10 Small Nuggets Panned from Oregon Streams, \$1.00, Robert Brandt, Sweet Home, Oregon 97386.

SEMI-Precious uncut gems. Ten different for \$1.00. Request list = 35. Prospectors Shop, 201 San Francisco, Santa Fe, New Mexico 87501.

LARGE, POLISHED, GEMSTONES. 15 different \$1.00. Colorful crystal specimens, 3 different \$1.00. Lists with order. Sering, 1705 E. Michigan, Indianapolis, Indiana.

12 **POLISH** Gem Stone's of the World, Name and Location \$1.00. Empire Gem's, P.O. Box 133, Trinidad, Calif. 95570.

CARTOONING, COMMERCIAL ARTS, SHOWCARD & SIGN PAINTING

SIGN Painting, Fascinating System—Straley, 410 So. Western, Springfield, Ohio 45506.

COMPACT 23 lesson Cartoon Course and Cartoonist's Magazine, \$2.00. Hartman, Box 30367, Lincoln, Nebraska 68510.

"HOW TO MAKE MONEY WITH SIMPLE CARTOONS"—Everyone who likes to draw should have this book: **FREE.** Write Cartoonists' Exchange, 96 Pleasant Hill, Ohio 45359.

LEARN Sign painting at home. Free talent test. Ben Kerns, Box 812-PM, Greenville, S.C. 29601.

SIGN Painting - Free Catalogue. Instructions, Equipment, Kaufmann Signs, Centertown, Missouri, 65023.

LEARN Profitable tattooing. Illustrated information and instruction \$3.00. Zeis, 2220-P Delcy Dr., Rockford, Illinois 61107.

MAKE A bundle with Portraits! Others are!! JRM Enterprises, 1769 Rosedale, East Cleveland, Ohio 44112. Free Literature.

ADVERTISING AGENCIES, ADV. SERVICE, MAILING LISTS

MAILING Lists most all kinds 1000 \$5.00. Free folder. Your circulars mailed \$4.00 1000. Dixie Mailers, King, N.C. 27021.

ADVERTISING Ratebook leading newspapers, magazines, 25¢. Chicago Advertising Agency, 28-E Jackson, Chicago 60604.

"WOODEN NICKELS" FOR ADVERTISING PURPOSES & COLLECTORS. POPULAR ASSORTMENTS: All 50 States with official state seals \$2.50; 100 different wooden nickels \$4.00. Send 25¢ for 6 Wooden Nickels and listings of other interesting assortments and literature on Custom Advertising with wooden nickels. The Wooden Nickel Co., P.O. Box 2134-PM, San Antonio, Texas 78206.

"WOODEN NICKELS" FOR ADVERTISING PURPOSES & COLLECTORS. POPULAR ASSORTMENTS: All 50 States with official state seals \$2.50; 100 different wooden nickels \$4.00. Send 25¢ for 6 Wooden Nickels and listings of other interesting assortments and literature on Custom Advertising with wooden nickels. The Wooden Nickel Co., P.O. Box 2134-PM, San Antonio, Texas 78206.

Our clients' mail order advertisements in Popular Mechanics have to pay and they do. Write to John O. Powers Co., Advertising Agency, 116 John Street, New York 10038.

TYPEWRITERS, DUPLICATORS, OFFICE EQUIPMENT

FREE Plan. Start printing, lettershop. Offset Presses, Mimeograph Copy machines, DixieGraph, King, N. Car. 27021.

RUBBER STAMPS AND OFFICE SUPPLIES

TYPE Catalog No. 11, 96 pages. Send One Dollar. Deductible First Order. Acme Type, 732 Federal, Chicago, Illinois 60605.

RUBBER Stamps 4 Lines \$1.25. Catalog. Bilmar, 10024 Oxborough Road, Minneapolis, Minnesota 55431.

SAME Day shipment on rubber stamp supplies. Revised wholesale price list No. 6 free. Star Stamp Supply, 732 Federal, Chicago, Ill. 60605.

FREE 48 Page catalog. Signature \$2.80. Carol's, McCloud, Okla. 74851.

FREE 40 Page catalog. Rubber stamps, office supplies. Youngers Stamp Shop, Princeton, Iowa 52768.

RUBBER Stamps 50% Discount. Free Catalog. Contessa, 1955A-S Bonsall, Philadelphia, Penna. 19145.

RUBBER Stamp outfits, supplies. Kiewiet, 2025 Barney Road, Kalamazoo, Mich. 49007.

ADDRESS Rubber Stamp \$1.00. Postpaid. Arrowhead, Dept. C, 5521 Warwick Avenue, Chicago, Illinois 60641.

ENGRAVED Nameplates, Doorplates, Directional Signs, \$1.00 each. Printing. Brochure. Morris, 410 West Oaklane, Lake Charles, Louisiana 70601.

ADDRESS Stamp, Handle Mount, \$1.25. Phillips, Box 164A, Staten Island, New York 10314

BUSINESS Cards, Rubber Stamps. Smith, Route 3, Box 96-c, Bangor, Maine 04401.

MAKE your own self-molding rubber stamps and printing cuts. Plexirubber, Argyle-1-, Wisconsin.

PRINTING PRESSES, RUBBER STAMP OUTFITS

PRINTING Presses, type, supplies. Lists, 5¢. Turnbaugh Service, Mechanicsburg, Pennsylvania 17055.

SIMPLE-X RUBBER STAMP PRESSES, hydraulic operated, electrically heated. Sizes 5"x8", 8"x12", 10"x15". Starting outfits. Orders for presses, supplies shipped day received. Free catalog low supply prices. Custom Manufacturers, 406-P East Elm, Springfield, Mo. 65801.

NEW 1968-69 Printers Supply Catalog 264 page 9" x 12" book. Hundreds of new items. Rubber stamp presses and supplies, hot stamping equipment, hand and power printing presses, proof presses, paper cutters, folding machines, composing room equipment, offset equipment, drawing equipment, thousands of items. The most complete Graphic Arts book published. All items illustrated. Postpaid, \$5.00 American Printing Equipment & Supply Co. 42-25 Ninth St., Long Island City, N.Y. 11101.

PRINTING AND SUPPLIES

PRINTING Free catalog with samples. Rosie, Box 901, Waycross, Georgia 31501.

TOP QUALITY OFFSET. 1000 8 1/2 x 11. 20 lbs. bond. \$6.75 postpaid. Special handling. Biscayne, Box 346 Wall Street, New York, New York 10005. Write for catalog.

8 HOUR PRINTING—Free Booklet "Secrets of Cutting Printing Cost" Nationwide Printing, Atlanta, Ill. 61723.

FREE Literature, Address Labels, Business Cards, Printing, Rubber Stamps. Jordan's, 552 West O'Connor, Lima, Ohio 45801.

AMAZING business printing values. Quotations, Print Shop, Box 576, Greenville, R.I. 02828.

DO Your own printing. Save money. Simple rules. We supply everything. Print for others; good profit. Raised printing like engraving too. Have home shop. Details free. Kelsey Presses, V-11, Meriden, Connecticut 06450.

PRINTING. Samples Free! Write: National, 1511 Pine Avenue, Niagara Falls, New York 14301.

BEAUTIFUL EMBOSSED BUSINESS CARDS. 1-Color \$5.50 Per 1000. 2-Color \$6.50 Per 1000. Free Samples. Postage Prepaid. Westwood House, 4819 Beloit Avenue, Culver City, California 90230.

MULTIGRAPH, MIMEOGRAPH

EXTRA Income at home in Spare Time! Booklet shows you how to start your own business with Classified Advertising. Only \$1.00. Refundable with first order. C. A. Martin, Popular Mechanics Dept. PM, 575 Lexington Ave., New York 10022.

GUMMED LABELS

1,000 **RETURN** Address Labels 75¢. Satisfaction Guaranteed. Maxwell's, 7359-24th N. W. Seattle, Wash. 98107.

1,000 **GUMMED** Address labels \$1.00. Walt's, Box 966A, South Bend, Indiana 46624.

REMAILING SERVICE

RECEIVING—Forwarding, \$3 Monthly. Hedgpath, 406-M South Second, Alhambra, Calif. 91802.

CONVENTION City Remails 25¢. Colorful Postcards. Schoen, Box 1963-P, Chicago, Illinois 60690.

MIAMI Remails 25¢. Monthly rates. Marie, Box 1266, Coral Gables, Fla. 33134.

KANSAS CITY Remails 25¢. Receiving—Forwarding. Midway 3115-F South 45th. Kansas City, Kansas 66106.

DICK'S Confidential—Fast Excellent Rates. Box 6171, San Jose, California 95150.

PHOENIX. Receiving, forwarding, remailing. Confidential. Troen, Box 2386, Phoenix, Arizona 85002.

MILWAUKEE Receiving-Forwarding 25¢. \$3.00 Monthly. Box 90036, Milwaukee, Wisc. 53202.

RECEIVING Forwarding \$3 Monthly. Additional Confidential Services. Redjack, 2401 Banner, Dearborn, Michigan 48124.

REMAILS. Prompt, Confidential, 25¢ Singles; \$3.00 Monthly. Mickens, Box 94-C Pasadena, California 91104.

NEW YORK 25¢. \$3.00 monthly. Reliable, Snow, 458 Vermont Street, Brooklyn 11207.

MIAMI 25¢ Appear here. 3'60¢ Magic City Services, Box 27, Olympia Br., Miami, Florida 33165

REMAILS 25¢, forwarding \$3.00 monthly. Deik, Box 8224, Corpus Christi, Texas 78412.

ENTERSULL. Your secret address, Prompt. Reliable. Box 1886M, Forsyth, Ga. 31029.

REMAILS 25¢. Receiving-Forwarding, EC Mailway, Drawer 9037PM03, San Jose, CALIFORNIA 95117.

CHICAGO-Remailings! 25¢ Singles, \$3.00 Monthly. Modern, Box 27056-P, Chicago 60627.

SECRET Receiving and remailing. Discreet and confidential. Remail 25¢. Pine Park, 8080 Main, Houston, Texas 77025.

BOSTON Confidential Request Special Receiving-Forwarding Rates Remails 25¢. Dad, Box 651, Waltham, Massachusetts 02150.

REMAIL \$3.00 Monthly. Harold Dalton, Box 1867, Daytona Beach, Fla. 32015

REMAILS 1/75¢. 3 \$2.00. Rapid Remail Company, (Not. Inc.) Box 20732, Orlando, Fla. 32814.

HELL. Forwarding 25¢ Devilish Postcards 75¢. McGowan, 3925 Monks, Pinckney, Michigan 48169.

REPAIRS AND SERVICING

EXTRA Income at home in Spare Time! Booklet shows you how to start your own business with Classified Advertising. Only \$1.00 (Refundable with first order.) C. A. Martin, Popular Mechanics, Dept. PM, 575 Lexington Avenue, New York 10022.

SPECIAL SERVICES

INFORMATION On anything. Ferguson Research Specialists, 83-45 Vietor Ave., Elmhurst, N.Y. 11373.

AUTHORITATIVE INFORMATION On Anything! \$2.00 (deductible). Metzler Research, P. O. Box 2206PF, Long Island City, New York 11102.

TOBACCO

OUR FIRST 19 IN SPACE. This limited edition lithograph has been created as a tribute to Americas Gallant Astronauts. 12 X 18 inch chart ready for framing. Only 75 cents. Popular Mechanics, Dept. GWP, 575 Lexington Avenue, New York, New York 10022.

RAZORS

EXTRA Income at home in Spare Time! Booklet shows you how to start your own business with Classified Advertising. Only \$1.00 (Refundable with first order.) C. A. Martin, Popular Mechanics, Dept. PM, 575 Lexington Avenue, New York 10022.

PERSONAL

RUPTURED. Relief and comfort. No understraps, elastic or steel. Write Hand-Lock Products. Preston 4, Ont., Canada.

INVESTIGATORS. Latest Electronic Aids. Free Literature. Clifton, 11500-P NW 7th Ave. Miami Florida 33168.

PENMANSHIP Improver: Improve Penmanship Quickly! Details free. Tevis, Chillicothe, Mo. 64601.

BORROW \$100 to \$1,500 by Mail. Quick, Easy, Private. No Co-Signers. Repay in 36 small monthly payments. For the amount you want write today to Dial Finance Co., 410 Kilpatrick Bldg., Dept. F-214, Omaha, Nebraska 68102.

BE A winner! "Twelve Steps to a Real Life" \$10.00, guaranteed. Gift, details \$1.00. Now! Box 2013R, Atlanta 30301.

MAKE NEW FRIENDS. . . . Worldwide! Meet marriage minded Girls through our illustrated Catalog. \$2.00. I.C.B., Box 12, Toronto 16, Ontario, Canada.

NAGGING Bills? Accounts serviced up to \$20,000. You can't borrow your way out of debt. We are not a lending institution. Write for free details. Nationwide Budget Systems, Dept. PM 1227 Plainfield St., Johnston, R. I. 02919

IMPROVE YOUR PERSONALITY! Be popular! 110 page book—"Dynamic thinking" shows how. Send \$1.00 AL; P. Fields, 708 S. Peter St. Garrett, Ind. 46738

LITTLE KNOWN HEALTH FORMULAS For everyday use. \$2.00. Duffy Family, P. O. Box 447, El Toro, California 92630.

WIN MONEY EVERY MONTH working contests and puzzles. Free details. . . . NO MINORS. International Contest Club, Box 10153, Dept. PM-6, Kansas City, Missouri 64111.

BIBLE Questions answered. Stamped envelope. Bylon, 17167 Bentler, Detroit, Michigan 48219.

SUBCONSCIOUS Conditioning remakes personality while you sleep. Free details. Sleep-Learning, Box 24N, Olympia, Washington 98511.

WIPE Out All Debts. Clear credit. 1000 sources of loans. Free details. Counselor-7, Harlingen, Texas 78550.

PAY Bills! Have cash left over. \$39.65 repays \$1000 in 36 months. Write for details. Budget Financing Co., Dept. HB-010B, 317 South 20th, Omaha, Nebraska 68102.

BORROW \$1,205 AIRMAIL! Repay \$47 for 36 months. State licensed. Postal Finance, Dept. 17-E, 200 Keeline Building, Omaha, Nebraska 68102.

DICE Or Black Jack. Possible to make \$1,000.00 per week. Mail \$1.00. M. L. Cornbleth, 1603 Sherman Place, Long Beach, California 90804.

"WILLS". Prepare own. Four standard forms; instructions, \$1.00. Willforms, Box 8585-A, Kansas City, Missouri 64114.

SUB-MINATURE LISTENING DEVICES. Low Priced, High performance, direct from Manufacturer. Dealers Welcome. Auditronics, P6, 156 5th Avenue, New York, New York 10010.

GET OUT OF DEBT in 90 minutes. legally without borrowing or bankruptcy. Anderson, 8873E Kenwood, Cincinnati, Ohio 45242.

WANTED—MISCELLANEOUS

MERCURY. Gold, Silver, Platinum; Ores assayed. Wholesale Terminal, Norwood, Mass. 02062.

MISCELLANEOUS

ORNAMENTAL Iron designs. Book of 1600 beautiful, practical designs for railings, columns, etc. Free literature. Cunningham, 3881 South 3200 West, Salt Lake City, Utah 84119.

SILENCERS For pistols and rifles. Complete details for construction and operation, \$1.00. Gunsmith, Box 185, Fairfield, Alabama 35064.

YOUR Name sent to 1000 importers, publishers, mailers, wholesalers, etc. on our mailing list. Year \$1.00. Dixie Mailers, King, N. Car. 27021.

HEARING Aid batteries wholesale. Free list. Habs, Box 61, York, Penna. 17405.

WINEMAKERS—Free catalog and recipes. Kraus, Box 451-L, Nevada, Missouri 64772.

QUART Oregon Hops with 101 recipes—Homebrewing, Winemaking, Hoppreads, Catalogue, \$1. Nichols Hops, 1190 North, Albany, Oregon 97321.

CIGARETTES 12¢ a pack. Improved roller makes 20 filtertip, plain, King or regular for 12¢. Facts Free. Moberly, Box 954, Owensboro, Kentucky 42301.

BIRTH Certificates, Marriage Certificates, Diplomas! 2 blank forms \$1.00. Sample 10¢. Standard Forms, Box 482-M, Washington, D.C. 20044.

WINEMAKERS. Free illustrated catalog of yeasts, equipment, Simplex, Box 12276, Minneapolis, Minn. 55412.

WANT Greatest Cash Crop working for you? Write, Ginseng, Asheville 53, N.C.

WINEMAKING . . . Grape, Elderberry, Dandelion, Frozen Juices, etc. Brewmasters' secrets revealed! Powerful Methods! Instructions, Recipes, and Supplies Catalog, \$1.00. Continental, Box 11071-PF, Indianapolis, Indiana 46201.

BOOKS On antiques and their prices. Free circular! P. Warman Publishers, Uniontown, Penna. 15401.

RECEIVE Magazines-Samples-Catalogues-Agency-Homeowner Offers. Get listed—35¢. Roricke, Mailers-Pleasant Plain-Ohio-45162

SLOT MACHINES, Pinball Machines, etc. Catalog 50¢. Coffco Distributors, Dept. 101, Lake Zurich, Illinois 60047

"PERPETUAL" CALENDAR—Post card size—Fits shirt pocket or purse—Any month from 1880 to 2004—\$1.00 post paid—Satisfaction or refund, Sweeney Enterprises, PO Box 7493, Arlington, California 92503.

AMAZING Books, jewelry-sweaters-watches. Lynn's, Box 1573, Waco, Texas 76703.

BEAT INFLATION—Save \$1000'S. Building your new Home, System Details \$2.00. Bonus plan, Box 521, Helena, Montana 59601.

PETRIFIED Wood chunks from vicinity Arizona Petrified Forest. \$1.00 P.P. U.S.A. The Stockade, P.O. Box 574, LaKese, Ariz. 85929.

MANUAL Alphabet Cards—"A language that is mute; a silence that speaks"—3/25¢. Unconditionally Refundable! BUSINESS-BUILDER, Box 764, Long Beach, California 90801.

ARE You Thinking of Answering These Ads? For every 20 you Answer, It will cost you \$1.00. Mid-City will have 100 companies send you their offers For only \$1.00, 200 for \$2.00, 300 for \$3.00. Satisfaction Guaranteed. Mid-City M1, P.O. Box 174, Elmhurst, Ill. 60126.

"315 FREE Magazines". Details 25¢ (Guaranteed). Kirkman, 1-PM Ann Street, Woodbridge, Virginia 22191.

SCRIBER resembles push button pen \$1.20 ppd. Lawson Engineering, Lakeside Rd, RD3, Newburgh, N.Y. 12550.

KILL Mosquitoes, Insects, electrically. Free information. Insect Control, Box P374, Royal Oak, Michigan 48068.

PSYCHEDELIC Catalog send 25¢. Hole, 6055 Lankershim, North Hollywood, Calif. 91606.

HAPPY-HOUR HOME BREW!! Secret Crockless Method—Miracle Savings. \$2.00 brings procedure. Free Hydrometer. Abundant Satisfaction Guaranteed! Hoffbrau, Box 5276-AF Riverside, California.

ENTER NEW PUZZLE CONTEST. WRITE CODEGAME, 408 OLIVE, ST. LOUIS, MISSOURI 63102.

CIGARETTES—Make your own—Pocket size Machine, Lifetime Guaranty, \$3.00 Postpaid, Rothschild, 375 Riverside Drive, New York 10025.

POKER. A GUARANTEED INCOME FOR LIFE by using the **ADVANCED CONCEPTS OF POKER.** Dr. Wallace's new 100,000-word hardbound manual is now available for \$9.95 postpaid. FREE brochure available. I & O Publishing Company, Box 644-W, Wilmington, Delaware 19899

PEACH Brandy, Wines—Strongest Formulas, \$2.25. (hydrometers and supplies catalog included)—Research Enterprises, 29-SN35 Samoset, Woburn, Mass. 01801.

FRESH, Tasty Wines & Liqueurs 12¢ Gallon. Tested Recipes—Instructions 32 pages, \$1.00. Guaranteed. TAST—RITE, Box 196-P, Stafford, Va. 22554.



TEST DRIVE THE 83 LATEST THINGS ON WHEELS.

Test drive a whole new kind of pickup. The INTERNATIONAL.[®]

Experience its 83 advancements in engineering and design.

Enjoy its remarkably smooth ride, its ease of handling, its responsive steering. The finest in any pickup.

Try its smoother clutching and the strongest pickup brake system anywhere.

See the proud new styling, new metallic colors, new color-keyed interiors. Feel its quick,



sure power, from three big V-8 engines, or the new Power Thrift Six that delivers up to 10% more gas mileage.

Discover the greater visibility, roomier cab, wider options, and everything else the new INTERNATIONAL offers.

It's a whole new kind of pickup. But don't take our word for it.

Take a test drive. Free.

IH INTERNATIONAL HARVESTER COMPANY
CHICAGO, ILLINOIS 60611

TAKE A TEST DRIVE. CALL 800-553-9550. FREE.

SOLUTIONS FOR MECHANICAL HEADACHES

AUTOMOBILE CLINIC

BY MORT SCHULTZ

Annoying after-run

Many of my friends who own late model cars and I—mine's a 1967 Oldsmobile Cutlass—have the same problem. The engine keeps running for several seconds after the ignition is turned off. The dealers tell us the problem is a result of the antismog emission control system. They have no idea how to stop it. Do you?—P. Heron, Greenwich, Conn.

If the fast and slow carburetor idles are set to specification, and if ignition timing is on the nose, this condition should clear up. Until you have a chance to get this done, though, try shutting off the ignition while the transmission is in Drive position. This puts a drag on the engine, reducing the chance of it running after the ignition is shut off.

Pinging problem

My 1966 Pontiac Catalina (389-cu.-in V8 engine) pings terribly. The service department advised me to try different types and grades of gasoline, which I did without success. Do you have an answer?—Alexander Kassay, Easton, Pa.

If the pinging occurs between 30 and 50 mph and the car is tuned, install a vacuum advance unit with part No. 1116163. This unit should also be used in '64 and '65 Pontiac V8 engines with the same problem. If pinging occurs at wide open throttle, it's often caused by excessive carbon building up in combustion chambers. Solution, I'm afraid, is a carbon job, but first be sure pinging isn't a result of improper tuning, malfunctioning distributor centrifugal advance, carburetor set on lean side, or engine vacuum leak.

Stop passing the buck

The front tires of my 1968 Ford Country Squire station wagon are worn and cupped on the outside edges. The car has 7600 miles on the speedometer. The Ford agency tells me it's not a mechanical problem—that the tires are at fault. The tire people tell me the opposite. I don't care who's right or wrong. I just want the problem fixed.—H.J. Hoot, Canton, Ohio.

It's practically a sure bet that toe-in is

out of whack and the wheels are out of balance, but I would also check caster and camber. I assume that tire pressure is at recommended level.

Airconditioner leak

The automatic temperature-controlled, factory-installed airconditioner of my 1968 Dodge Polara leaks water on the floor after running a while. The dealer can't find the cause. Do you have a solution?—Dr. E.S. Lukec, Fort Huachuca, Ariz.

There are two tubes that run out the firewall from a drip pan. This setup, when intact, drains condensation to the outside of the car. Apparently, one of these tubes has separated from the drip pan and condensation is dripping into the car instead. The heater unit will have to be backed out and the separated tube resoldered to the drip pan.

Emergency brake freeze-up

The company I work for has two Chevrolet ½-ton pickups (a 1965 and a 1967). In winter, the emergency brakes freeze and won't release. The local Chevy dealer tells us that nothing can be done—"just don't use the emergency brake in winter." This is crazy. We're responsible for these vehicles and should something happen, we'll get the blame. Help.—John Royston, Hudson, Mich.

Sorry, John, I can't. This emergency brake setup is the same in practically every car. The linkage and cross-shaft are exposed to the elements and will freeze up in winter. Until Detroit's engineering brains can figure out a solution, you'll have to keep the emergency brake released in cold weather. I realize this is compromising safety, but you have no choice.

Cylinder headache

What would cause the No. 2 cylinder in my 1965 six-cylinder Comet to misfire? A full tune-up with new parts, including plugs, points, rotor and distributor cap, hasn't helped. My mechanic has given up.—Fred Wagner, Bellevue, Iowa.

I'd say it's a burned valve or a bad
[\(Please turn to page 74\)](#)

Allstate protects you against loss from more home hazards than you can count— and for less money.

Allstate Deluxe Homeowners Insurance is a package of protection against loss from the countless hazards your home faces every day. Yet, Allstate costs less than you'd pay with most other companies for similar protection.

Is your home under-insured? Chances are, inflation has increased its value beyond the limits of the insurance you

bought just a few years ago. For very little more, you can insure your house to its replacement value with Allstate.

Find out how little it will cost to get increased coverage on your home.

Talk to the "good hands" people.

**You're in good hands
with Allstate**



Policy and savings described available in most states. Standard rates in Texas.



Fire



Falling objects



Lightning



Personal liability

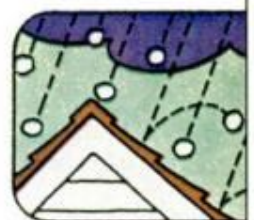

Hail



Explosion



Smoke damage



Damage from vehicles



Damage from aircraft



Add'l. living expenses



Vandalism



Robbery



Fire on contents

**Allstate Deluxe
Homeowners
Insurance**

Allstate Insurance Company,
Northbrook, Illinois



Court costs



AUTOMOBILE CLINIC

(Continued from page 72)

valve guide. If the latter, you might have to replace the cylinder head.

Cooling off

On hot days only, the temperature idiot light of my 1966 Buick Special flashes on. The radiator has been flow-tested, a new thermostat installed, hoses checked, cooling system flushed and back flushed, new sender switch for the temperature light installed, and belt tension checked. The radiator seldom needs water. What could be wrong?—Jerry J. Jaffe, Gulfport, Fla.

I notice that you live in Florida, and I'm wondering if you use water as your coolant instead of ethylene glycol. If so, I suggest you switch to an ethylene glycol solution that provides protection down to minus 20° F. This isn't done to protect the engine against a cold snap but to raise the boiling point of your coolant and prevent overheating. If you are presently using ethylene glycol, then I suggest you install a lower temperature thermostat than the 190° stat used in these cars. One on the order of 165° may solve the problem.

Screecher

A year after I bought my 1966 Mustang Six with three-speed floor shift, it started to screech every time I started off in first gear. I had the throwout bearing replaced but the trouble is still there. Can you help?—Sgt. Wayne S. Moorefield, Bien Hoa, Vietnam.

You may think I'm a kook, but replace the fan belt. I'll bet a stretched (slipping) belt, which has been a problem with this car, is causing the noise.

More weird wipers

Here's a weird one that occurs with my 1963 Oldsmobile Dynamic 88. When I switch off the windshield wipers, they won't stop. I've replaced the switch, but I still have the problem. What remedy can you suggest?—Arnold Mergenthal, Palo Alto, Calif.

The parking pawl assembly in the wiper motor is worn out and is slipping past the

trip lever that shuts off the wipers. Replace the assembly.

Hardtop what?

Have you heard of hardtop boom? That's the problem my dealer says I have with my 1968 Torino. It's a buffeting sound that comes on strong between 60-80 mph. The dealer swears it's not mechanical, but a kind of phenomenon and says nothing can be done. Is he feeding me a line?—Doug Carter, Georgetown, Ohio.

According to Ford, the problem in 1967 and 1968 models is caused by drive-train vibration. To solve it, the company issued special service letter No. 46 (10/11/67) telling dealers how to diagnosis and fix the trouble that gives "hardtop boom."

Service Tips

● **1968 Chevrolet owners** who want to avoid replacing compressor shaft seals in the air-conditioner compressor should have a leak-detection test taken to verify that a leak actually exists. You may think there's a leak from the compressor clutch when you spot oil on the underside of the hood. But throwing of some compressor oil into this area is normal.

● **1969 Plymouth, Chrysler, Imperial or Dodge hardtop owners:** If your dealer has failed to fix the rear-door rattle in your car, remind him of the service bulletin in his file that tells him how. For Dodge, it's D69-23-6 (11/5/68); for the other cars, it's No. 69-23-8 (11/4/68).

● **Drive your Rambler on unpaved roads** on occasion? If so, save yourself a possible headache by having a choke clear-air kit put on your car. This prevents dirt from being drawn through the exhaust manifold heat tube and causing choke malfunction. The kit has part No. 4486877. Have your dealer follow the installation instruction in service bulletin 4 (12/11/68).

● **Lincoln-Mercury** has issued a series of service bulletins to help their dealers in solving wind noise and water leakage problems. They are Nos. 7 (11/4/68), 7A (12/2/68) and 7B (1/27/69). If you have trouble like this with your 1969 Mercury or Lincoln, it would be foolish not to have it fixed now that your dealer has the word. ★★

GOT A PROBLEM WITH YOUR CAR? Ask Mort about it. Send your question to Auto Clinic, Popular Mechanics, 575 Lexington Ave., New York, N.Y. 10022. Letters cannot be answered individually, but problems of general interest will be published in the column.

The great 'Jeep' escape.

New family camper for your 'Jeep' Universal.



With 'Jeep' 4-wheel drive, you say goodbye to crowded campsites! Put this new 'Jeep' Camper on any CJ-5 'Jeep' Universal with V-6 engine. Room for the whole family. Notice how smoothly you cruise the highway. How easily the whole rig handles!



Back in the boondocks park your camper and cut loose! You can really "take it or leave it." Take off and go hunting, fishing, exploring.



Inside, it's like a small yacht on wheels. Sleeps 4. All the floor space and features you expect: kitchen, running water, toilet, ice box, etc.



Go shopping in your Universal. Tackle any job. It's truly one of the 'Jeep' 2-Car Cars. Winches, etc. available. See your 'Jeep' dealer. You've got to drive it to believe it.

Jeep'. The 2-Car Cars. 

4-wheel drive KAISER Jeep CORPORATION TOLEDO, OHIO 43601

HOMEOWNERS' CLINIC

BY W. CLYDE LAMMEY

Walking on water

During the colder months I'm almost literally walking on water in my carpeted living room. Both carpet and pad are nearly wet enough to go squoosh at every step. My home is built on a concrete slab; carpet and pad are laid over the slab. What can I do before another winter comes to prevent the concrete from drawing water up from the ground?—S.M., Md.

It isn't "drawing water up from the ground"; it's "drawing" moisture from the air in the room. In simple terms, the floor is a few degrees colder than the air; moisture in the air condenses because of the variation in temperature. This problem doesn't have a simple, inexpensive remedy.

I hesitate to tell you to cut your carpet or dispose of it, but I'm thinking of the one remedy that usually works. You can either cut your wall-to-wall carpet and pad back about 10 in. from the walls all the way around the room, or replace it with new carpeting that's about 10 in. shorter than the length and width of the room. Leaving this 10-in-wide bare strip of concrete may not be 100 percent reliable, but I know it is effective in the majority of cases.

Concealing fingernail marks

I have birch kitchen cabinets. When we moved here the doors were badly disfigured by repeated scratching and gouging of fingernails around the latches. It appears impossible to sand out this defect. Cabinets are finished natural and I don't want to paint them. How can I best conceal this unsightliness?—H.A., Mass.

Why not use a decorative plate cut from polished sheet aluminum—or better, sheet brass—under each latch, large enough to conceal the deep scratches? Sheet brass in about 18 ga. is, of course, somewhat more expensive than aluminum but is generally more attractive and will take a high polish. Work out a simple design and cut it in duplicate with a coping saw fitted with a fine-toothed metal-cutting blade. Then polish the plates and drill openings for the parts of the latch that must pass through. Drill holes for small roundhead

brass screws to hold the plates in place. Polish the screwheads. It's a good idea to fill the depressions around or above the latches before you place the plates. Coat the polished brass with a metal lacquer before placement. This will last for some time before needing renewal and will prevent tarnishing.

New face on cork floor

I have a cork floor in my dining room. It's quite old, dirty and finished with something that isn't very attractive. I've tried washing it with a cleanser but no good. It's still in fairly good condition and I'd like to freshen it up a bit. But how?—L.O., La.

Old cork floors often can be refreshed by sanding but you have to be extra cautious. Make absolutely sure that all the cork tiles are solidly adhered to the subfloor, or the underlayment, whichever is underneath. If any are loose or "blistered" they must be slit, so that adhesive can be forced underneath. The tiles are then weighted until the adhesive is thoroughly dry. You can machine-sand a cork floor but it's always risky. You'll probably do as well by hand-sanding, especially on an older floor where the tiles are likely to be worn thin in the travel areas. Make a sanding block from a short length of 2x4, plane one face smooth and true and attach medium-grade sandpaper with a thumbtack at each end. Sand in one direction only and keep the strokes as straight as possible. If the sandpaper tends to fill with dirt and old-finish residues, it helps to "paint" the sandpaper surface occasionally with turpentine. Apply just a stroke of the turps with a small brush. After sanding to a satisfactory surface, apply any of the newer finishes suitable for use on cork tile. Your paint dealer will have them.

Sanding wood tile floor

The floor in two rooms of my home is of wood tile which, I suppose, is a parquet floor. Each tile consists of small pieces with grain running at right angles. The floors need sanding but how does one do this with a sanding machine without running across the grain?—P.L., Ky.

You sand this type of floor with a sanding machine just as you would any other wood floor, assuming, of course, that all tiles are solidly adhered to the subfloor. Any that are loose should be recemented. Just use a finer grade of sandpaper on the machine than you would normally use on a hardwood board floor. ★★ ★

don't forget to wish your car a happy birthday

Or Happy Anniversary.

Or however you remember the day your car is due for its annual checkup.

While you're at it, remember it's time to make your car a present of a new Fram air filter. Because the old one's all choked up.

And what wouldn't be after a year of guzzling dirty air at a rate of 9,000 gallons for every gallon of gas? Ycccch!

So give the old car a breath of fresh air and a second wind for the coming twelve months. And have a Happy New Year.

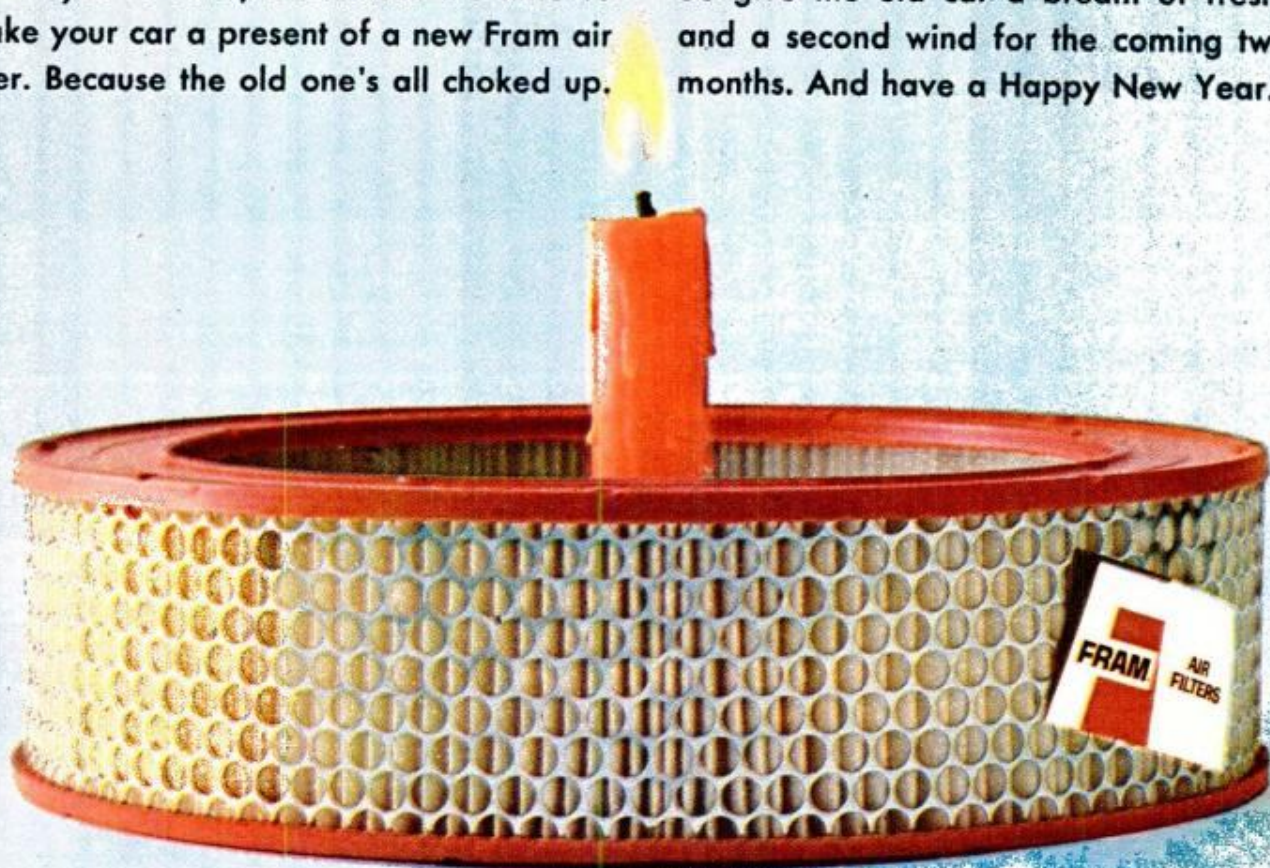

A man's world. Shiny wood, smoke, pretzels,
good conversation, and best of all, the best of all,
Miller High Life. For over six generations,
the great premium beer.

Miller makes it right!



Road Racing's Big Big League

By Dan Gurney

Big engines, big cars, big purses, big names drawing big crowds—that's why some say Can-Am is the newest, fastest, most exciting racing in the world

TAKE A SERIES of auto races whose combined prize money totals over \$1 million, add rules allowing liberal power and chassis innovation, stage the events at select, picturesque road courses, and what do you have?

Officially, you have the Canadian-American Challenge Cup series. Unofficially, you have racing called "Can-Am." But more importantly, you have the fastest, most exciting road racing to be found anywhere.

Can-Am racing has proved a tremendous hit with fans everywhere the races have been run. Crowds are growing in size and enthusiasm. And equally enthusiastic are drivers (many of them international stars), car owners and sponsors.

The fourth season in this annual series gets underway this month. In fact, by the time you may be reading this, the first race will have been run June 1 at Canada's Mosport

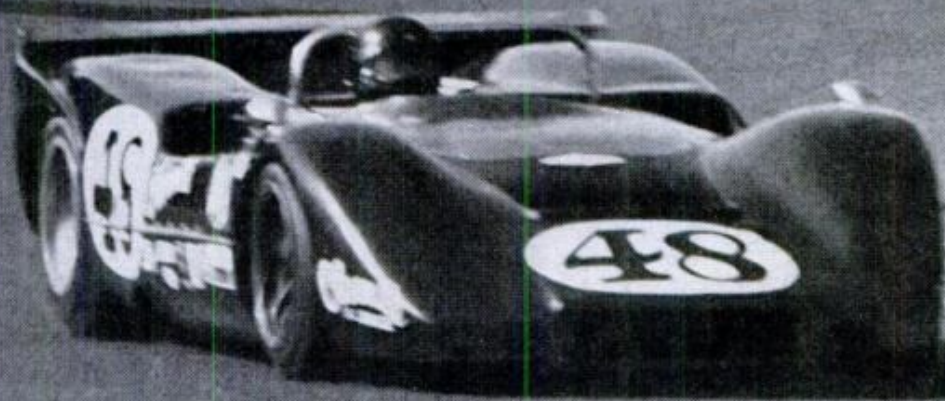

Park. The next race in the series will be June 15 at Mont Tremblant, again in Canada. I'll give you the rest of the Can-Am schedule later on.

As to what to look for in the series this year, the McLaren factory entries of Bruce McLaren and Denis Hulme completely dominated Can-Am racing over the past two years and presumably will again be the team to beat. They'll be campaigning new aerodynamically-modified cars — McLaren M8Bs powered by big 427-cu.-in. Chevrolet engines putting out more than 600 hp. They won the series last year (Denis was the champion) with the en-

gine putting out about 600 hp. But gossip along racing's grapevine these days has it that Bruce and his group have managed to tweak the engine just that much more without sacrificing much-needed reliability. If all the talk is on the button, the McLarens stack up as hard to beat.

Arrayed against this formidable entry will be a number of proven Can-Am contenders, among them Jim Hall and his Chevy-powered Chaparrals. Jim's car was very quick last year (if anyone campaigned with a larger-than-life 427 Chevy, it was Jim), but was dogged by bad luck. He himself was in-

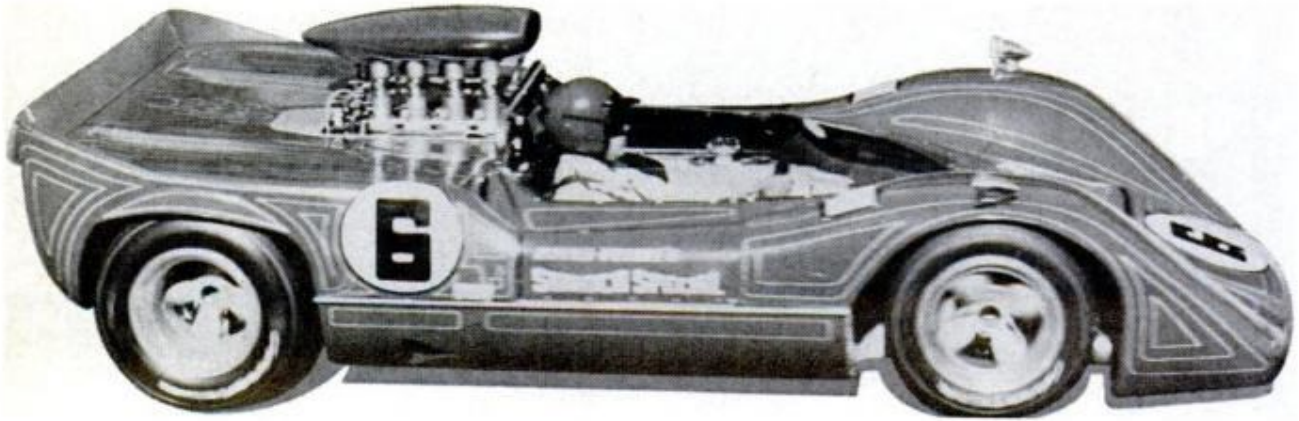

ALWAYS A THREAT in a Can-Am race is former series champion Mark Donahue, above in his Lola T160 that last year turned in several impressive efforts. To the left is a view of a typical Can-Am pit row. The series features sleek, aerodynamic bodies, huge engines that make the cars very fast on road courses

jured in the season's finale at Las Vegas and probably won't be back in shape to drive this year. However, he'll act as manager of a team headed by former World Champion John Surtees, a combination that adds up to a powerful threat to McLaren supremacy.

Another tough customer will be former Can-Am champion Mark Donahue in Roger Penske's T160 Lola-Chevy. The T160 was just about race-ready when introduced on the circuits last year and throughout the season turned in some impressive performances.

Still another car we'll all have our eyes on is the new 6.2-liter, 12-cylinder,

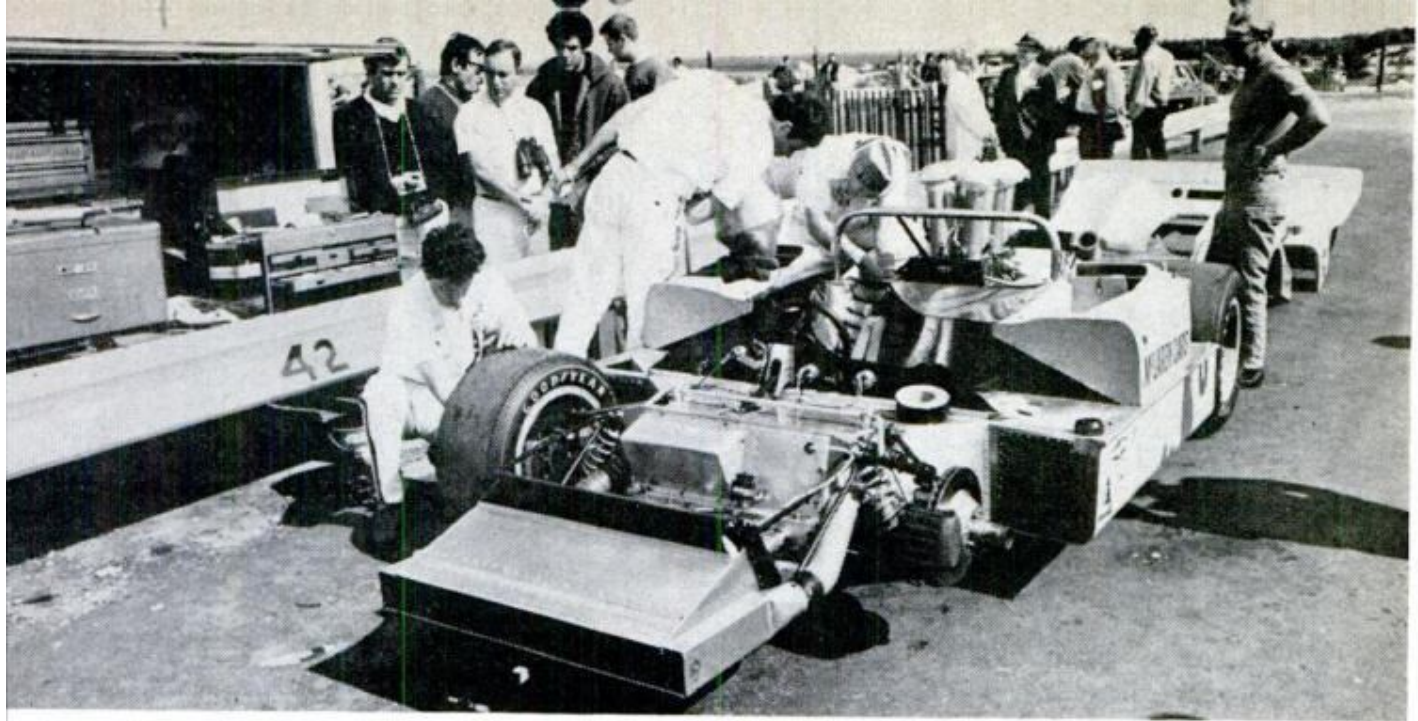

THEIR SKIN PEELED AWAY, Can-Am cars prove to be marvels of chassis innovation and construction. Above is a skinless McLaren M8A, winner of the series last year. To the right is Charlie Hayes' wedge car, a possible shape of Can-Am cars in the future. Rules this year allow tires of up to 20-in. tread width, but whether or not they will see service depends upon how much faster—if at all—they prove to be. Part of appeal of Can-Am racing for drivers and car owners is attributed to latitude of rules pertaining to chassis and engine, making possible some really hot racing cars

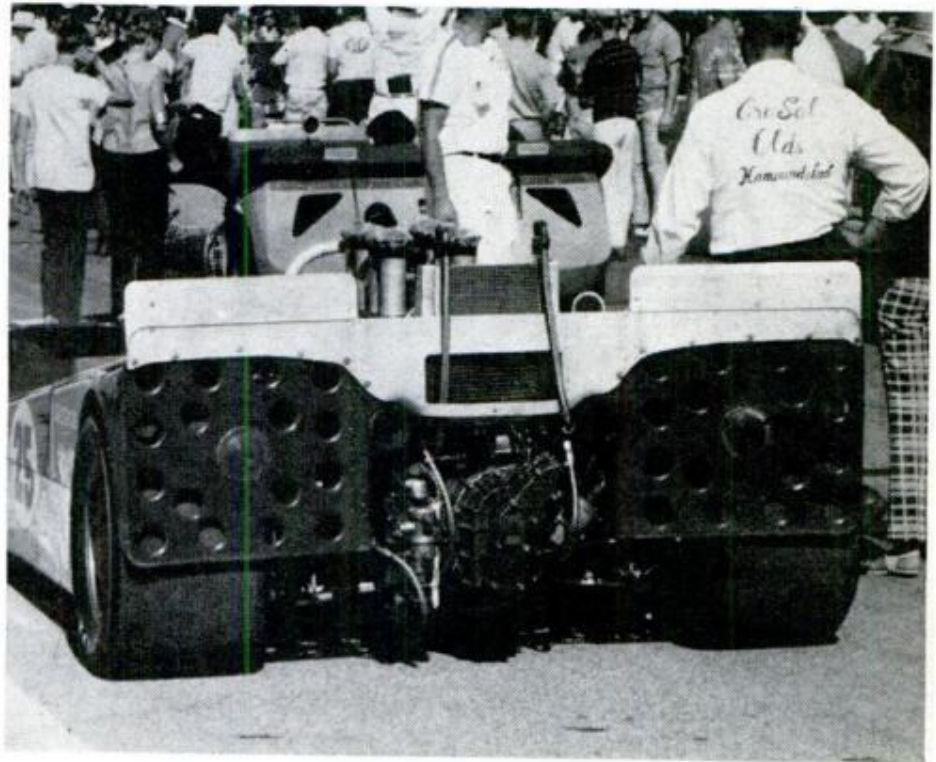

double overhead camshaft (DOHC) Ferrari to be driven by Chris Amon. The car made a spectacular debut at Las Vegas last year and this year may well turn out to be *the* Chevy-beater. One never knows whether or not Ferrari is going to be in a race until they show up, but the Modena masters obviously have an appetite for this type of racing and could be genuine threats.

A possible entry in this year's series is the new 4.5-liter Porsche. Although the jungle drums have it that the engine is having teething troubles, I've heard reports that it cranks out up to 600 hp, more than enough to make the

car a contender. At this point I don't know who would be the Porsche drivers.

As for the Eagles of All-American Racers, we'll be on hand with a two-car team. Our young hopeful, Swede Savage (for whom, incidentally, railbirds at this year's Daytona 500 had high praise) will pilot a reworked Lola, while I plan to campaign a McLaren we've modified to such an extent we call it a "McLeagle." My Can-Am effort in this car last year was pretty much a shakedown, meaning that this year we'll be out there with a much im-

(Please turn to page 201)

The body counter—in effect a giant Geiger counter—records the tiny nuclear explosions in living tissue. It was counting how much of me was alive. I was curious about that.

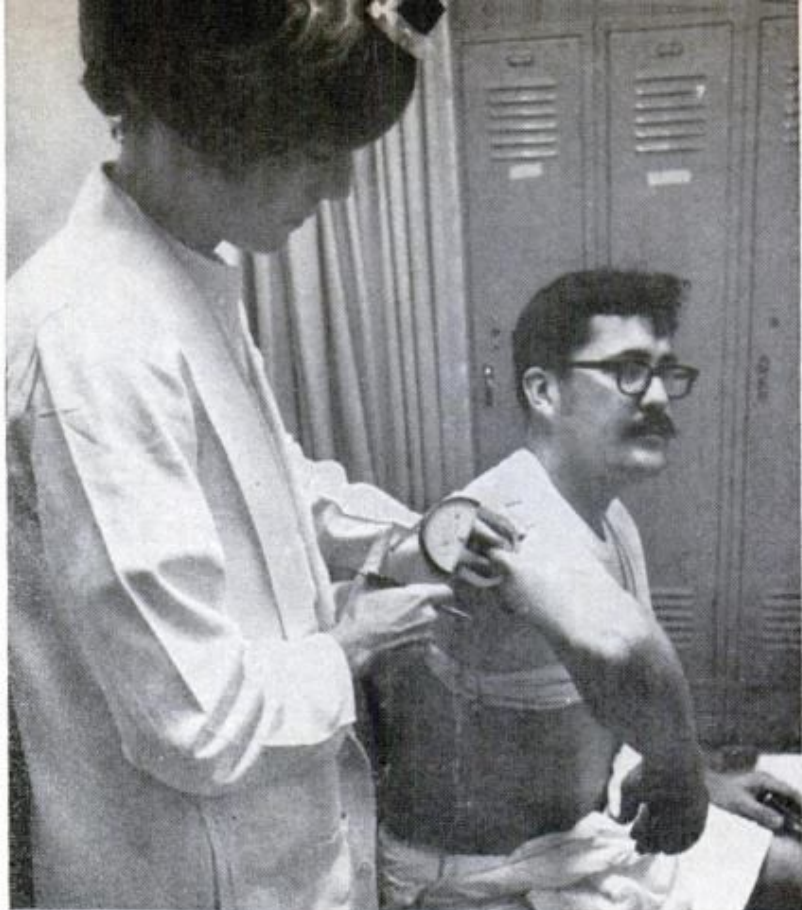

THE NURSE measured my fat by pinching me with a skin calipers

Alone In a Body Counter

By JAMES R. BERRY

LYING IN PADDED WIRE BASKET, I clutched the box in one hand. The basket began sliding into casing

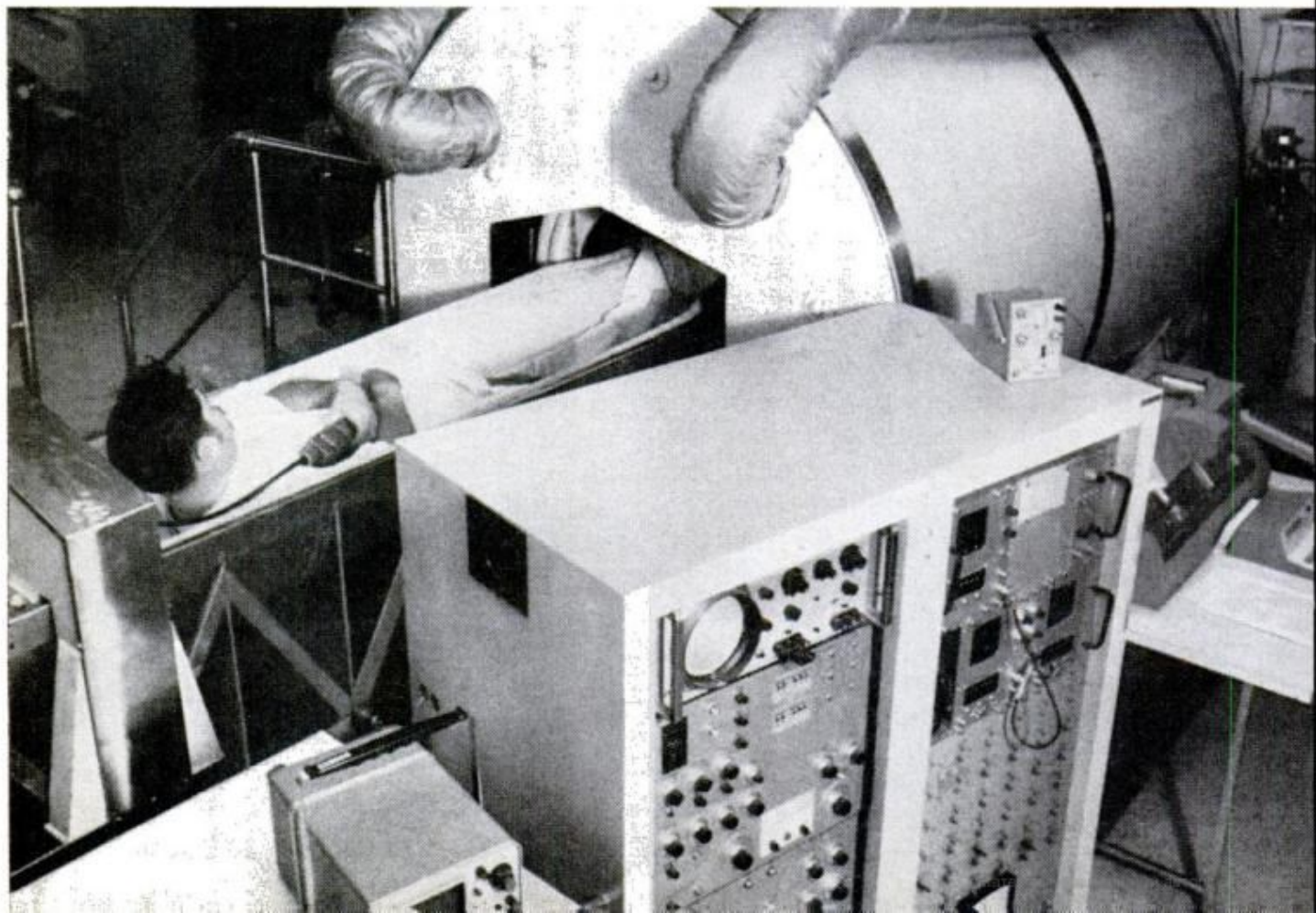

"ARE YOU ALL RIGHT?" came the cheery voice of nurse Geri McCauley through a tiny loudspeaker above my head.

Sure I was. Except for being crammed into a padded wire basket, arms folded like a corpse, and lying in a 20-inch-diameter chamber at the heart of what resembled a giant iron lung, what more could one want? I breathed; my heart beat; I could hear.

"Sure, I'm fine," I replied, a tiny mike picking up my words. To prove it I tossed out a joke: "Except that I know what it's like in a coffin." Nurse McCauley shrugged that off with professional disdain. "Oh don't worry; everybody comes out just fine," she replied. I remember thinking: *That's everybody else. How about me?*

A few minutes before, in a small room of the radioisotope laboratory of St. Luke's Hospital Center, New York City, Nurse McCauley had noted my medical history on a chart. After I had slipped a floppy hospital gown over my underclothes, she measured the amount of fat I carry by pinching my

arms, torso and thighs with an instrument called the skin calipers. Finally, she led me to a nearby, instrument-jammed room containing a 15-ton instrument called, simply, the body counter.

The word "instrument" hardly fits the massive steel device, which at first sight somehow reminded me of a giant cannon breech. Yet, for all its size, the body counter accomplishes a delicate and heretofore impossible job: It pinpoints the quantity of cells in a human body. In this case, my body.

To enter the counter I stepped up a small ladder and climbed into the cushioned basket. Nurse McCauley handed me a box with a huge button on it. "Just press the button if you have to come out," she said. Somehow her tone indicated that only chickens ever press the button.

Clutching the box in one hand, I stretched out and crossed my arms. With a small jolt, the basket began sliding into the heart of the steel casing and a heavy door clanked shut with the finality of a bank vault being

SCINTILLATION COUNTERS tally gamma ray flashes given off by radioactive potassium within living cells

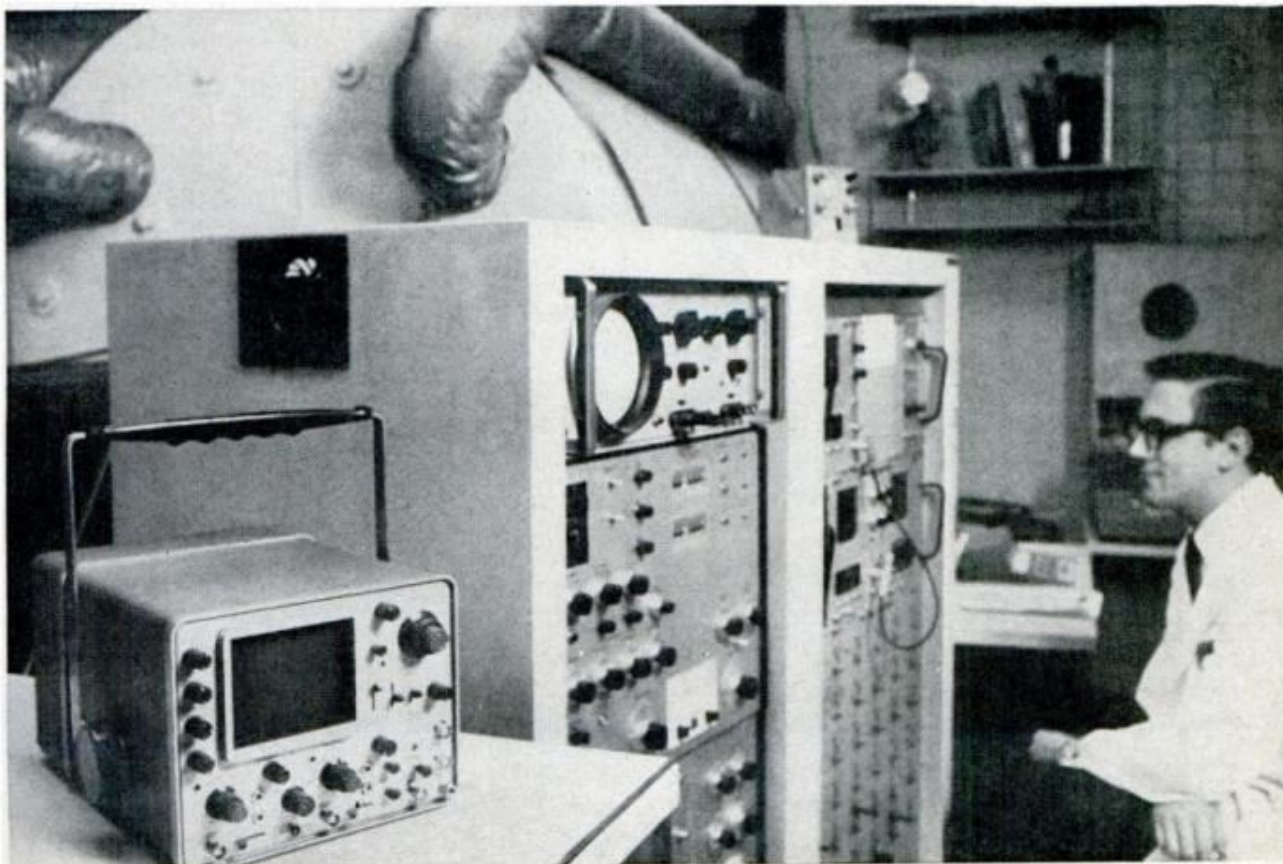



RADIATION "PICTURE" from seven scans of a man's body. Bright spot in lung shows abnormal condition

sealed. I was alone, the feeble light of a single electric bulb reflecting from the polished steel tube encasing me.

Worried? Hah, not me. But somehow I could see the next day's headlines if a power failure suddenly struck: "Man Entombed Hours In Research Instrument." On the other

hand, it *was* quiet. No radios, no loud voices, no ringing telephones and absolutely nothing I could do. So I didn't do anything but close my eyes and begin to relax.

I had just started to enjoy the calm when Nurse McCauley's pert voice echoed: "You're coming out." I heard a clank as the vault door opened and with a jolt that let me know rest time was really over I slid back into the world. My R&R had lasted exactly five minutes.

During this time, the body counter had done its job: count the tiny nuclear explosions originating in all living tissue. With this information, researchers would determine what to them—and me—is an increasingly important physiological fact: how much of me is really alive.

"You see, living cells compose only about 35 percent of a person's weight," explains Dr. Richard N. Pierson Jr., director of St. Luke's radioisotope laboratory. "The rest comes from fat, fluids outside of living cells, and dead matter such as outer skin and bones. Knowing the weight of all living cells, something we call the body cell mass, can be extremely valuable for administering drugs, diagnosing certain diseases, gauging treatments, and learning how certain illnesses affect the body. With the body counter, we can measure the body cell mass easily and accurately."

The instrument accomplishes its feat by acting as a giant Geiger counter. A human body contains about five ounces of potassium, most of which is concentrated within living cells. A small but precise percentage of this potassium is a radioactive variety that shoots out gamma rays when it decays. A human being experiences about 300 such nuclear explosions each second.

Surrounding the body counter's inner chamber is a chemically complex fluid that flashes with a pinpoint spark of light when struck by a gamma ray. Sensitive scintillation counters note each of these flashes. Surrounding this fluid is a five-inch-thick steel casing

that screens out most background radiation.

"One of the problems in building the body counter was finding pre-atomic-age steel," explains Dr. Pierson, a man of enthusiastic energy whose rapid-fire speech is as precise as a radio announcer's. "Steel made after atomic explosions contains slight amounts of radioactivity that would confuse results. So, our body counter is made from steel taken from the gun turret of an old, sunken battleship."

The number of flashes tallied by the scintillation counters pinpoints the amount of radioactive potassium in the cells. This figure pegs the total amount of potassium, which—in turn—indicates the number of cells, or body-cell mass (BCM). The sequence is straightforward enough. But such statistical variables as stray radiation and the small amounts of other radioactive elements in the body skyrocket the number of necessary calculations. So, researchers use a computer to figure out each person's BCM.

The St. Luke's body counter—the only one, among a handful in this country, operating in a bustling general hospital—began service in October, 1967. One of the preliminary jobs assigned to the unit was pinning down the BCM norms for various population groups. "Of several 150-pound people, one individual might have a very different proportion of fat, water and body-cell mass from another," explains Dr. Pierson. "We have to establish the normal proportion of body components at different ages in order to detect abnormalities."

These reference standards are still being honed up. But some important facts have already emerged. Children, for example, may look plump to parents. But a normal two or three-year-old has much more muscle, proportionate to his weight, than an adult. Also, the BCM of males steadily increases up to about 35 years, then begins a slow decline; women peak at about 25 years. And, not surprisingly,

when people gain weight it's usually due to added fat and fat replacing muscle.

To add more data on a person's body composition, St. Luke's researchers use skin calipers to measure the amount of fat. Sometimes they also take urine samples of a patient who has drunk a radioactive tracer fluid to determine the quantity of body fluids. "In some diseases, the concentration of potassium in body cells may change. So, we have these other measurements to check our results," adds Dr. Pierson.

Establishing BCM norms is now only a small part of the body counter's work. Almost as soon as the St. Luke's unit began operation, specialists with medical research projects geared to the instrument flocked to the hospital. "Today we have 10 basically different programs, and many subsets of these

' . . . body-cell mass of known heart patients offers a good measurement of how serious their troubles are.'

programs, using the body counter," says Dr. Pierson.

Some body-counter studies have already edged into clinical use. Among them is estimating the degree of body damage caused by certain heart defects.

"If cells don't receive a good blood supply they wither somewhat, just as plants shrink if they're not watered," explains Dr. Pierson. "Determining the body-cell mass of known heart patients offers a good measurement of how serious their troubles are. The less body-cell mass they have, the more damage their heart disease is causing."

Besides indicating the extent of cardiac troubles, the body counter is viewed as a possible aid in determining what kind of heart operation to perform. In one project, heart surgeon Colin McCord measures the BCM of patients with impaired heart valves

(Please turn to page 194)

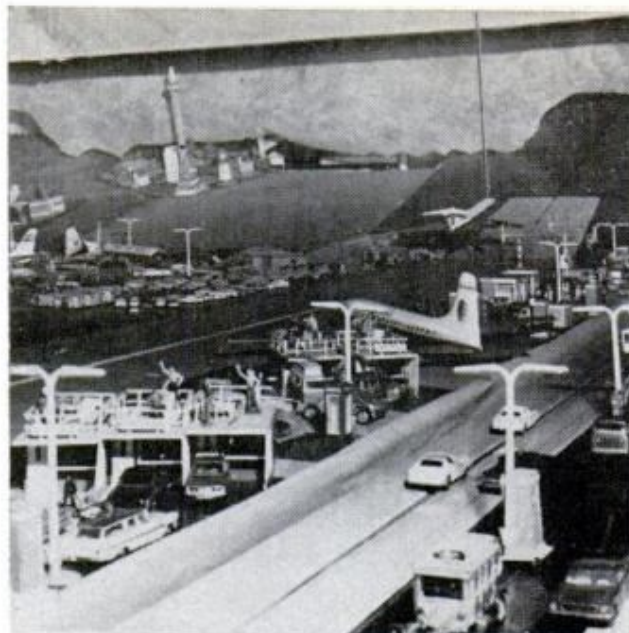

Biggest little airport is a busy place

When Capt. Brian Carney, airline pilot, retired in London, he took over the operation of an entire airport—including 100 planes and 1000 land vehicles. His hobby, building and exhibiting the largest small airport in the world, involves all the activities of a real terminal. Cars circle the field, planes land and take off, lights flash and a tape recorder adds sound effects. (A jet taking off is indicated by the long, black arrow in the second photo.)



Giant crane for shipbuilding

Towering over a dock at Malmo, Sweden, is the largest frame crane in the world. The crane, 196 feet high and 267 feet wide, is used to lift ship components from the building and place them in position for ship construction. The giant lift was built by Krupp.



Bathroom bridge

A bathroom may seem a strange place for salvaged nautical gear, though in this case, it turns out to be quite logical. This ship's telegraph, taken by Eric Hope from the bridge of an icebreaker, gives a satisfying clang when operated—and flushes the toilet.



Spray-on stove

A spray-on, graphite-based coating formed the "burners" on which this girl is cooking breakfast. Connected to a household current, the material can be heated to a maximum of 500°F. The coating is made by Acheson Colloids Co., Port Huron, Mich.



Single ski for both feet

Once you've mastered the art of skiing on two skis, you can now try it on one. The Uniski, an aluminum attachment that has a plate with bindings for both feet, gives skiers a chance to try something a bit different (and, it would appear, a bit difficult).



MAROONED At 12,000 Feet

They were trapped on the sheer North Face of Grand Teton and their rescuers knew they could never lift both from the ledge

By E. D. FALES JR.

Illustrations by Bill Johnson

IN THE DEAD OF NIGHT, Ranger Ralph Tingey awoke to hear someone pounding on his cabin door. The time was 1:00 a.m., Aug. 22, 1967, and the place the Jenny Lake settlement in Grand Teton National Park, Wyo.

When Tingey opened the door he saw two exhausted climbers. "We've just come down off Owen Peak," they said. "We heard rocks falling—a great noise—and after that we thought we heard people calling. But whether they were cries for help we're not sure. Then we started down."

Tingey stepped into the night. Glittering under stars was the snow-tipped wall of the Tetons, which run north and south for 50 miles. Directly west rose 12,922-foot Mount Owen. And to the left, and south of Owen rose another, the gigantic 13,777-foot Grand Teton, monarch of the range.

"We think," said one climber, "that the calls came from the Grand Teton—from the North Face." Tingey, a sandy-haired man whose slight figure belies his strength, studied the dark peaks. The Teton rangers have saved many



climbers in distress, have seen a few die. And the North Face was one place they hoped *never* to attempt a rescue.

"When did you hear cries?" Tingey asked. "About 3 o'clock yesterday afternoon," the climbers said. "Or it could have been the wind."

"Or stones," Tingey said. The Tetons are always falling, helped by wind, ice, sonic booms. The rain of rocks sometimes sounds like voices. Tingey knew, too, that the wind nearly three miles above sea level moans and cries.

When the climbers had gone, Tingey stood watching. Anyone who had fallen off the terrible North Face would be dead. Presently he got his car, drove to a place where he could clearly see the North Face, and flashed his lights. It was hard to believe anyone was up there. Few climbers try the North Face.

For 30 minutes Tingey switched his lights on and off. Seeing no signal, he returned to bed to save strength for what might come at dawn.

Hit by exploding rock

Gaylord K. "Gay" Campbell, 26, of Mahopac, N.Y., had climbed many peaks in Europe and America; Lorraine "Lorri" Hough, 21, of Sandwich, Ill., was the first woman to climb Canada's Mount Robeson.

On Aug. 20 they'd climbed Teton Glacier. Then at dawn Aug. 21 they'd started up the North Face. At 11,200 feet, the face rises sheer from the glacier. Then, 2500 feet up, it ends in a pinnacle, 13,777 feet high. By midafternoon they were roughly 925 feet from the top. Gay was on a dizzy, tilting slab called the Second Ledge. Coming up behind the rope was Lorri, now on a ledge 60 feet below.

All day, they had ducked showers of rock. At 3:00 p.m. they heard a sound like a truck dumping gravel. "*Rock,*" cried Gay. Lorri hid her head. A boulder hit the Second Ledge and burst like a bomb. It hurled Gay head-over-heels along the ledge. A fragment went through his hand and came out the other side. Then a chunk as big as a cannonball shattered his leg.

When he came to, pain swept over him, but he was still on the ledge. He found one leg smashed in three places. The bone poked through, blood gushed out. The rope that tied him to Lorri was cut. He picked up an end. The nylon was not sliced, but *fused* by heat of friction from that bursting rock. He cried, "Lorri! Are you all right?"

Below, he heard her: "*I'm coming up.*" Minutes later the plucky girl bent over him. She had free-climbed 60 feet of cliff without a rope.

She dragged Gay back from the edge and tied him to a piton with what was left of the rope. "We've got to set that leg," she said. To spare her, Gay said, "You just hold it, I'll push it

THE RESCUERS braced themselves, belayed the rope and lowered Tingey and the injured Campbell over the side

together." In agony, he forced the bone ends back inside. Blood was making the steep ledge slippery. "I've got to splint the leg," Lorri said; for a splint she used the handle of an ice ax. When blood still flowed she packed the leg in ice.

They called, but their voices drifted into empty air. After that they saved their strength, calling every 15 minutes. After awhile they took the splint off, afraid of frostbite. Gay took tetracycline from his first-aid kit to ward off gangrene. Blood flowed again. To make up for its loss, he took salt pills and water. He knew he might die of shock and leave Lorri alone.

When darkness closed in, they signaled with a flashlight. Far below they could see pinpoints of light—cars on the Jackson Hole highway. But no one saw them. Then at 1:15 a.m. Lorri saw headlights winking. "A signal!" she cried. But when she tried to signal back, the flashlight was dead.

At dawn Ranger Tingey again drove to a place where he could see the North Face. Through a 60-power spotting scope, he scanned the wall but saw nothing.

But later, as the sun tipped the peak in rosy light, the lens found something, a girl in a blue parka, sitting alone on a ledge. Then he saw a second figure, prone in a red jacket.

Had two climbers been caught by darkness on the ledge? If so, they'd soon continue. Tingey watched. When an hour passed and they did not move, he knew something was wrong. He drove to the ranger station, reported to District Ranger Doug McLaren, and helped organize an 11-man team in case it should be needed.

The rangers knew that two other crack climbers, Ranger Bob Irvine and Leigh Ortenburger, a guide, had begun an ascent the day before and might now be on the Grand Teton, *but on the south side*. They might see—and investigate—the pair. This was a slim chance, but it was a chance.

At noon a helicopter arrived from Casper. The pilot took two rangers aboard and started up to see what the trouble was.

Irvine and Ortenburger were now on the Grand Teton. At dawn they had left their camp in a high notch called the Lower Saddle. Inching up, they reached the top at noon. From the pinnacle they could see a hundred miles. It was a wonderful day.

They had just started down when Ortenburger asked, "Did

NORTH FACE OF GRAND TETON

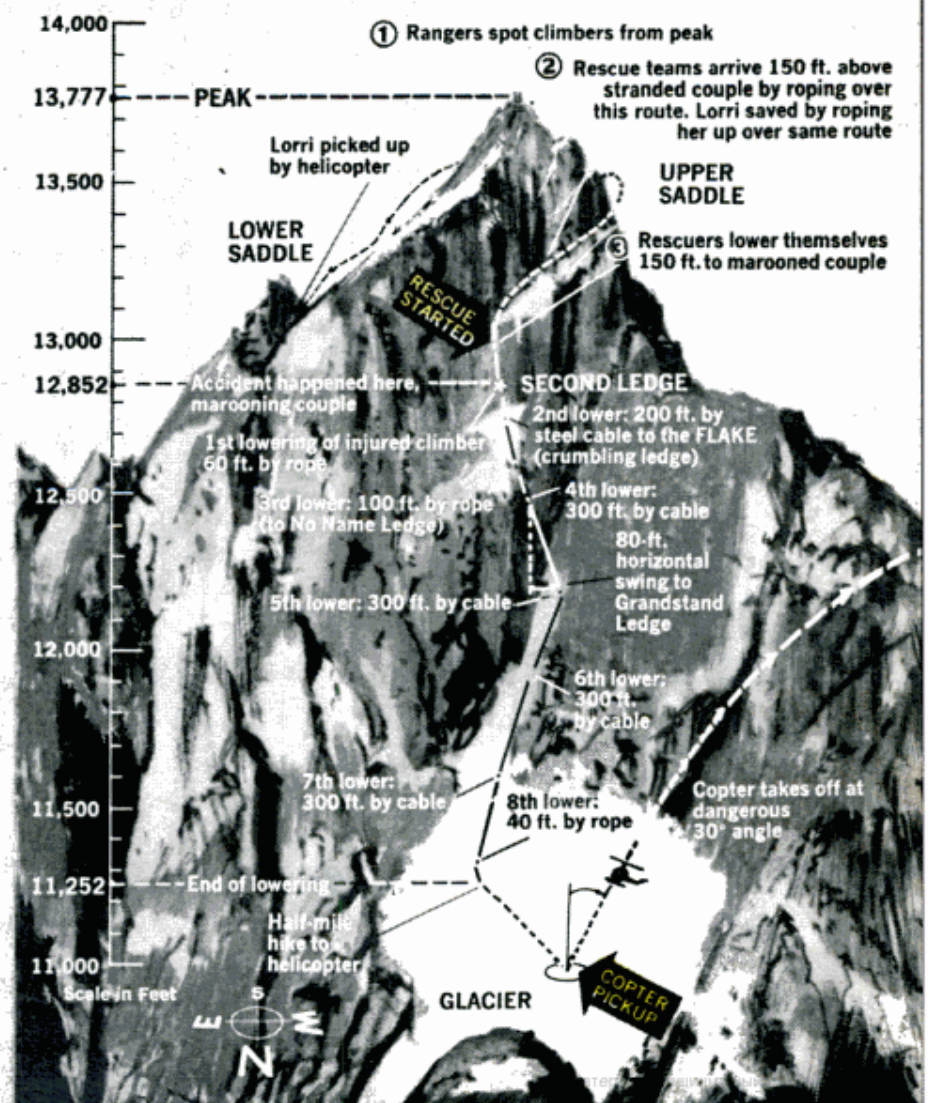



you hear something?" Irvine said, "I sure did." Faint in the wind had come calls that sounded like cries for help.

But who was in trouble and where? When they heard nothing more, Irvine said, "I think I'll go up once more." From the top he looked far down over the North Face but saw no one. The two men scrambled to a ledge where they could get a better look straight down. And at 2:10 p.m. Ortenburger heard Irvine shout, "There are people down there — *two people!*"

Nearly 900 feet below, the girl heard their shouts and looked up. She waved frantically, broke into a dance of relief and joy. She began to scream and they barely heard, "*Leg broken in two places!*" Ortenburger yelled a warning. "Stay where you are! We'll help."

The veteran guide looked at Irvine. It was impossible to get down there. No rope would ever work. How could they help?

"We could try around the west side," he said. "But we'll need help." Just then they heard a motor and saw the helicopter.

The air at 13,000 feet is thin; the chopper fought for altitude. In it, ready with a bullhorn, stood Ranger Leon "Pete" Sinclair. As the chopper neared the North Face, Sinclair saw a dizzy, tilted ledge, 20 feet wide in some places, inches in others. And there he saw a girl in a blue parka *dancing*. The altimeter read 12,850 feet. Through the horn he roared, "Take it easy! We'll help you. Wave if you can hear me." The girl, deafened by the rotor, did not wave. The chopper fell away.

What he had seen shocked Sinclair. Beside her in a red jacket lay a man — he judged him a solid 170-pounder — and he had bled horribly. He looked as if he might die. As for the girl, she might collapse from exhaustion or panic and fall.

For years Sinclair had dreaded the day when a North Face rescue might be necessary. But now he felt a strange exhilaration. It would have to be attempted.

The chopper made several trips, lifting Sinclair and 10 others to the south slope and the Lower Saddle. Here base camp was set up. Then a five-man rescue team roped for a spiral ascent. They would work upward around the south and west sides. Driving iron pitons into the ice and rotting granite, they'd head out on the North Face. This, if successful, would bring them out on a ledge that overhung the one on which the victims were. Then they would rappel — walk backwards — down 150 feet of wall to the couple.

In the climbing team,

(Please turn to page 197)

AT THE WEST END of its swing, the cable had snagged a knob of rock. There it held precariously, ready to slip



Sprightly midget

Demonstrating the prototype of an autogyro that he hopes to put on the market for about \$7500 is inventor Kenneth Wallis, former RAF wing commander. The little craft takes off in a distance of less than 1000 feet and can land almost vertically. With a 1600-cc. engine, it can fly up to 100 mph and has a range of 150 miles. A pusher propeller provides forward thrust, the horizontal overhead blades are not powered. In event of power failure, the rotors allow the craft to settle safely to the ground. Wallis's manufacturing plant is in Cambridge, England.

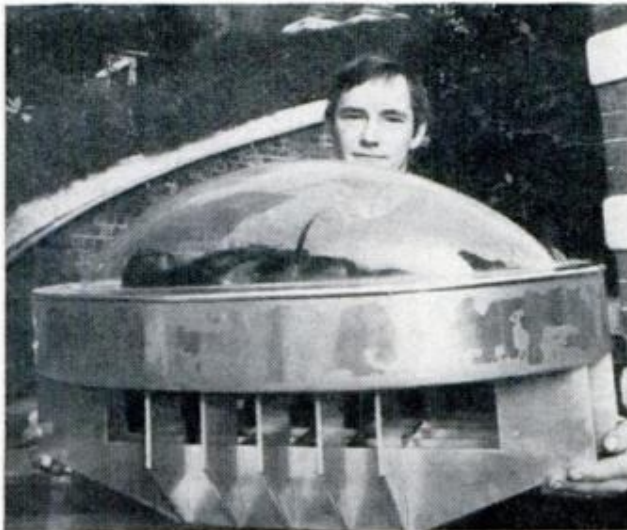

Classy way to go

Things are looking up tombwise. This nifty new model will hold the ashes of an entire family, plus a pet or two—all neatly packaged under a photograph visible through the clear plastic dome. London art student Sam Lord has also designed a bigger tomb for an entire body—also with a photo on display.



Rail for air-cushion train

The French are serious about developing an air-cushion train and are starting to build a section of elevated track for the Paris-Orleans run. The concrete "rail" is in the form of an inverted T; the propeller-driven train straddles the T and slides along over the concrete on a thin cushion of air.

What to Look For in the 1970 Cars



MERCURY X-100 features a new "gunsight" grille and hood scoop up front, new rear end, longer wheelbase

Dealer showrooms this year will feature big changes in the sporty cars, fewer convertibles and wagons, a couple of new models, and sleek face-lifts all around

By **BILL KILPATRICK**, Auto Editor // Illustrations by Paul Hills

DETROIT'S AUTO WIZARDS, not always modest purveyors of The Good Life, have magic lamps ready for the rubbing come this fall and the introduction of the 1970 cars.

Among the genies to be uncorked before your hopefully dazzled eyes are: two brand-new models, extensively restyled intermediates, some variations on the luxury and compact themes, and—later in the year—some all-new versions of the sporty cars, plus three new subcompacts aimed at beating back the invaders from abroad.

Other rabbits to be pulled out of the hat include more widespread use of existing safety devices and bias-belted

fiberglass tires as standard equipment.

And buried in there somewhere, of course, will be at least one far-from-new surprise—higher prices. Biggest factor in price boosts will be the new tires, slated to add about \$50. However, they are said to last up to 40 percent longer, so you may come out ahead. Other reasons for the higher prices include increased costs of materials, tooling and labor.

Don't look for anything dramatic in the full-size "family" cars; they were extensively restyled (by Detroit standards, anyway) for the 1969 model year and aren't due for a rehash 'til next year, as are the big, "personal" cars

CHEVROLET MONTE CARLO will be new to line, is based on GM's G-body. Car will be all-luxury both inside and out



(Riviera, Toronado, et al).

Specifically, make by make, here's what to look for come the annual fall jamboree:

● **American Motors**—AMC will introduce a subcompact called the Hornet. All-new, it will replace the Rambler, and is aimed to compete with the Maverick (see *Ford's New Maverick*, page 43, April PM). Shorter overall than the present Rambler, the car nevertheless will have a wheelbase up 2 in. to 108. The Hornet will come only in two and four-door sedans with standard power the 232-cu.-in. Six. The 199 Six will be dropped.

The Rebel and the Ambassador will get new grilles and rear-end styling,

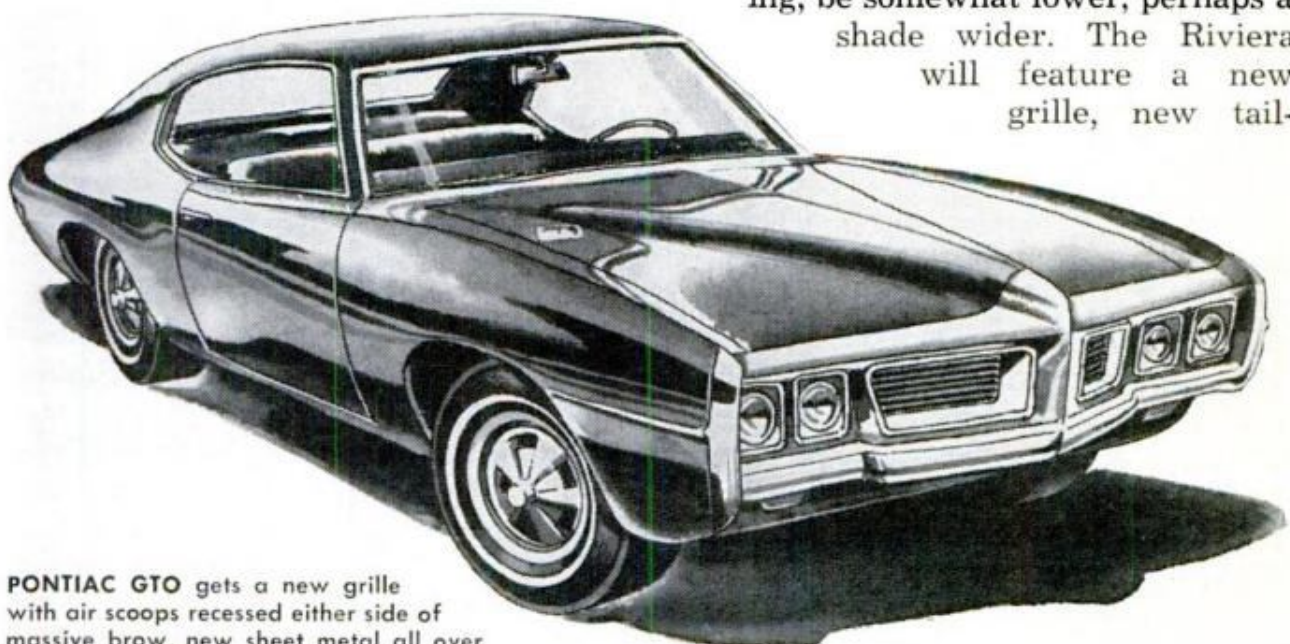

PONTIAC GTO gets a new grille with air scoops recessed either side of massive brow, new sheet metal all over

making both somewhat longer overall.

The Rebel will have a new, sportier roof line. The AMX and Javelin will stretch 2 in., mainly via new front-end sheet metal and somewhat different taillight arrangements. Engines will be bigger. The 290 V8 is going to 305, the 343 to 360, the 390 to 401, indicating that AMC is serious about racing. A Rebel or two could bow on major stock-car tracks next season.

In the wings for introduction later in the model year is an even smaller subcompact to be built on the AMX's 97-in. wheelbase. It'll be a fastback, period. In the immediate future—possibly '71—is a mid-engine sports car.

● **Buick**—Nothing too new here. The big Buicks will have mildly restyled front ends, may drop the wraparound bumpers that have been a styling keynote. The Special will have new styling, be somewhat lower, perhaps a shade wider. The Riviera will feature a new grille, new tail-

lights, revised rear quarter panels. Buick will probably offer GM's 455 V8 as a power option for its bigger cars. The intermediate wagon will be dropped.

● **Cadillac**—Tradition reigns supreme here. Styling changes are strictly minor, things only a real car nut will detect. But Cadillac will probably jack its big 472-cu.-in. V8 up to 500, if only for the Eldorado.

● **Chevrolet**—There'll be a new car here, tentatively called the Monte

styling changes aimed at interim competition for the Maverick until Chevy brings out its own subcompact—dubbed XP-887—later in the year. The Camaro will be all-new next spring, probably as a fastback. This fall, it will feature a new headlight arrangement and minor styling changes, mostly up front. The Corvette will remain pretty much as is, while word has it the Corvair will finally pass on to That Great Car Museum In The Sky.

Chevy will probably drop the 396 V8, replace it with the new 400 engine.

● **Chrysler**—The '69 models, including the Imperial, were all-new, so don't look for anything startling. Rear ends will be re-

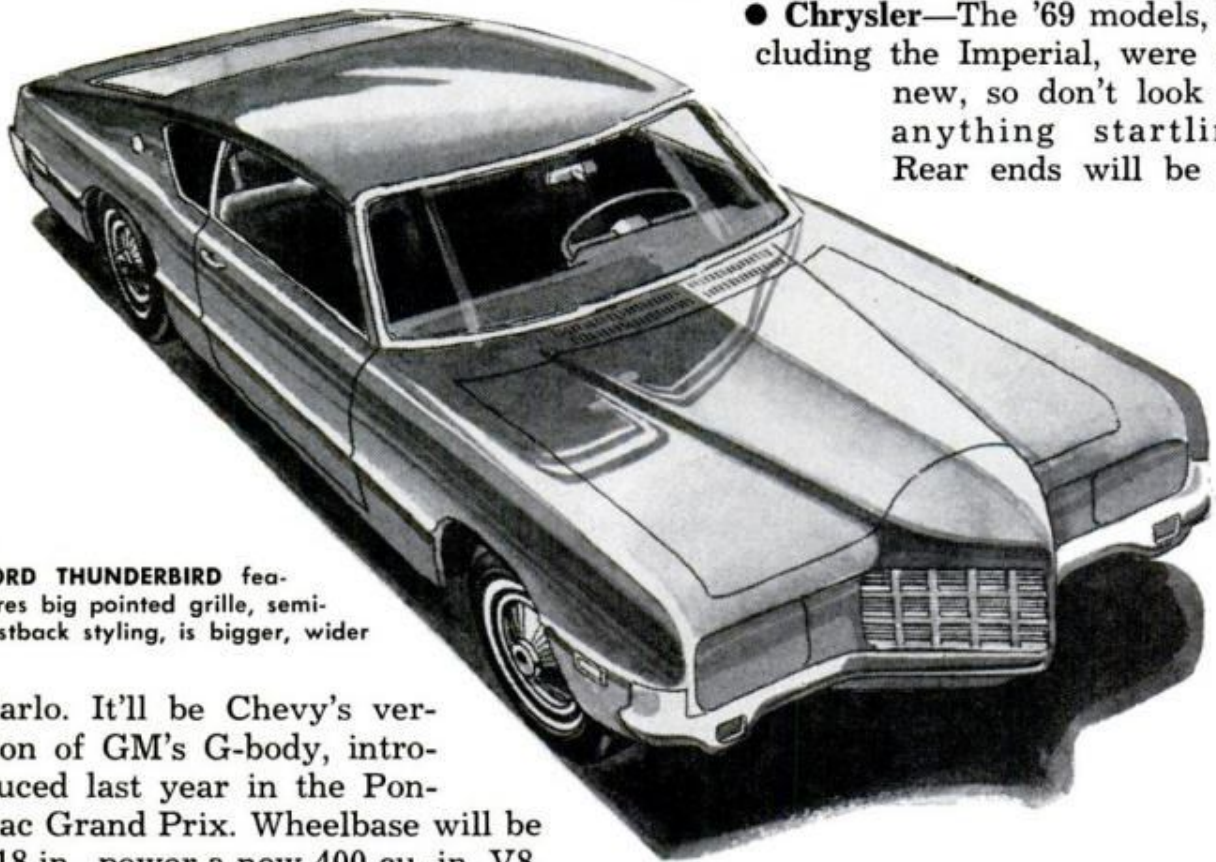

FORD THUNDERBIRD features big pointed grille, semi-fastback styling, is bigger, wider

Carlo. It'll be Chevy's version of GM's G-body, introduced last year in the Pontiac Grand Prix. Wheelbase will be 118 in., power a new 400-cu.-in. V8.

Car will be a real luxury job, may bow at top of Chevy line or as a separate thing. Unlike the Grand Prix, the Monte Carlo will feature a relatively flat grille, but retain the long hood, short rear-deck look. It'll be available as a two-door hardtop and a convertible.

Changes in the full-size Chevys will be slight, although you can look for a new grille and bumper setup, perhaps an added inch or so in overall length.

The Chevelle will have all-new sheet metal and a new rectangular grille. A new grille is also due on the Nova, which will bow with several specific

vamped, the most obvious changes centering around the taillights and new rear bumpers. There'll be new grilles on all Chrysler models and the Imperial. The latter will also get a new parking light setup.

● **Dodge**—Dodge will introduce a new car—the Challenger—a sporty two-door hardtop featuring dual headlights and hood slots, a "traditional" Dodge grille, and a 440 V8 as standard. Presumably it's Dodge's "answer" to the Mustang-type design; also presumably, it will knock a couple of Dart models (the GTs, say) out of the market. The remaining Darts will get new grilles

FORD FAIRLANE is new from wheels up, has new grille, roof, hood line, sculpturing. Car is lower, wider, almost 5 in. longer

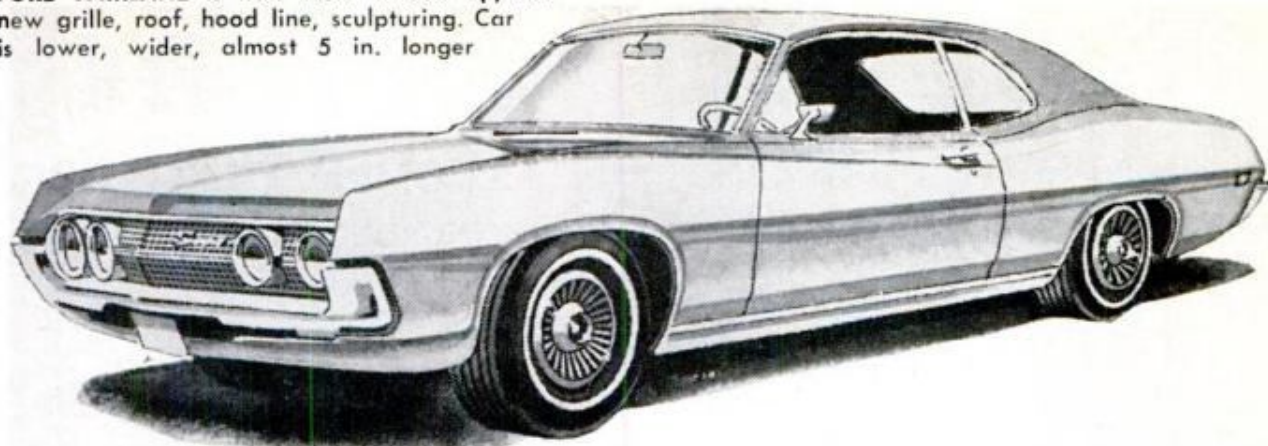

and taillights, as will the full-size Polara and Monaco.

Due for new sheet metal and major overall restyling are the intermediate Coronet and Charger.

● **Ford**—Big news here is a completely restyled T-bird and Fairlane. The T-bird will have a pointed snout much like the one on present Pontiacs. It'll also have a semifastback look, concealed headlights. Thanks to the new nose, the car will be about 4 in. longer overall. The Fairlane will feature a low hood line, a new roof, special side sculpturing and a new V-shaped grille. Wheelbase will be up an inch to 117, overall length up about 5 in. Windshield wipers will be hidden.

The Mustang will remain much as is, albeit with a new grille and a somewhat longer length. A Mustang featuring major restyling will bow later in the year. The full-size Fords were all-new for '69 and in '70 will have only minor grille and styling changes.

Maverick will be carried

over intact, but the car may be offered with a V8 power option. In any event, it figures to slice heavily into Falcon sales, may eventually replace that car. The Falcon wagon will probably be dropped.

Along about next spring Ford will probably pop with another new small car, at present code-named Phoenix. Talk has it as having an inch shorter wheelbase than the VW, at which it will be dead-aimed, but an inch more overall length. Power will probably be the in-line Four Ford developed for its abortive Cardinal effort a few years back.

● **Lincoln**—This car will be all-new, but won't necessarily look it. Wheelbase and overall length are up about an inch and there'll be some major changes underneath. The most obvious change will be up front with a new Mark III Continental-type grille. Headlights and windshield wipers will be

(Please turn to page 204)



AMERICAN MOTORS HORNET is new entry in subcompact market, will replace AMC's Rambler in two and four-door-sedan versions

Just patented

PM'S PICK OF THE NEW INVENTIONS

Prepared in cooperation with Roger S. Shashoua, Director, International Inventors Assn., Inc.

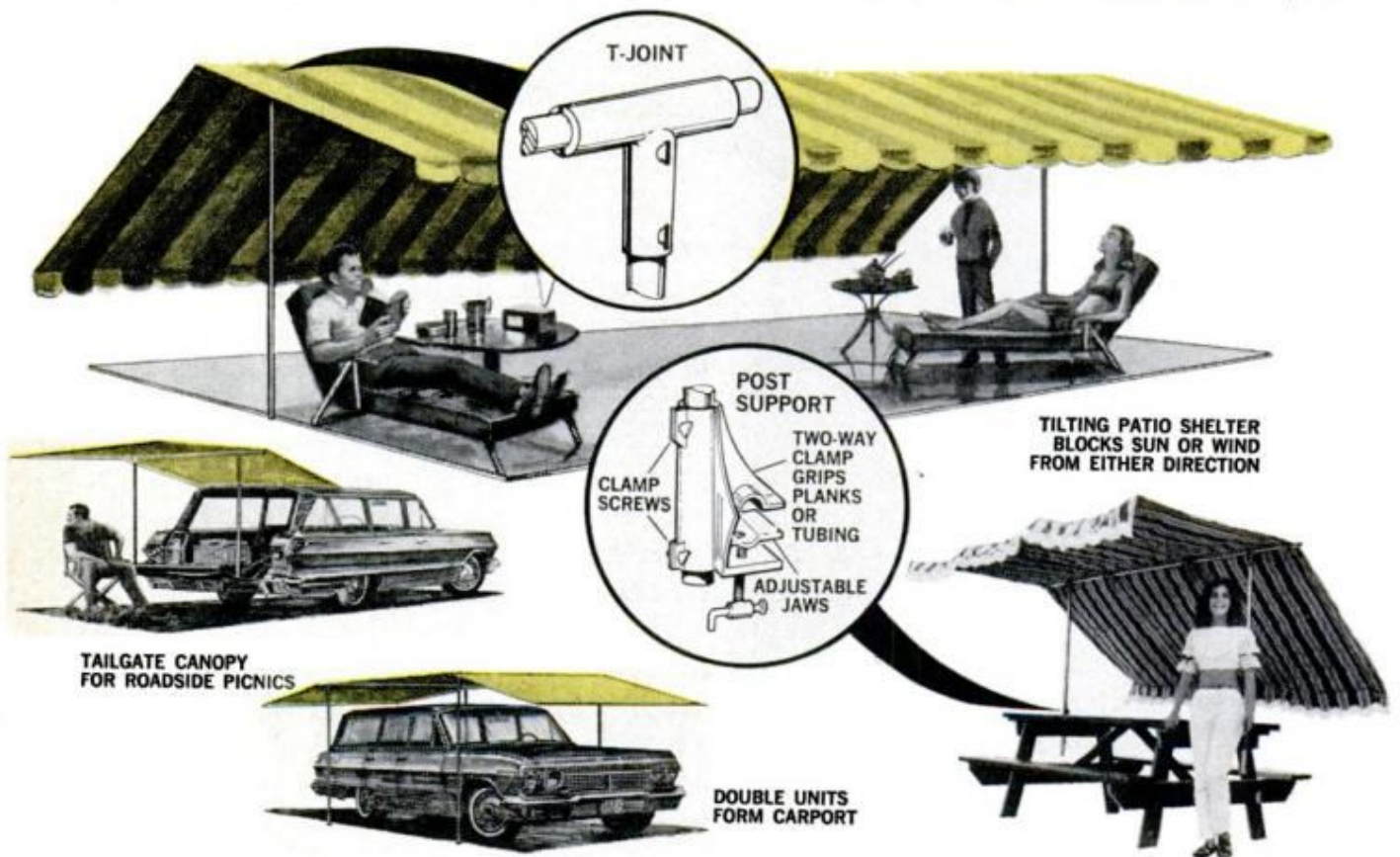

1. YOU CAN MAKE UP practically any kind of yard or camp shelter with these versatile slip-together fittings for tubing. The basic unit consists of a shallow V-shaped canvas frame. A large one serves as a tilting shade for a patio or poolside cabana.

Smaller versions make clamp-on canopies for a picnic table, lounge chair, sandbox or station-wagon tailgate. Two set end-to-end form a temporary carport. Only three fittings, a T-joint, V-joint and post clamp, are needed to make the various shapes

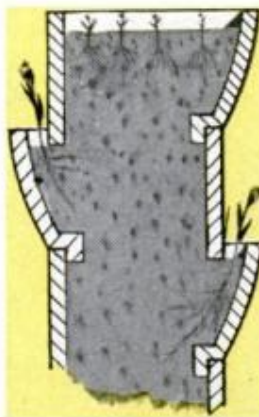
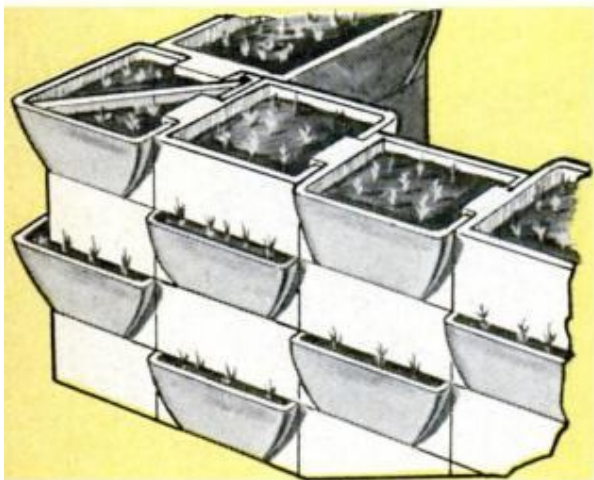

2. PLANT-GROWING BLOCKS are designed to create the effect of a rock garden in areas where there is no natural slope. They also eliminate the work of building walls with stone. You just stack the hollow blocks together and fill them with earth. Each block has an outward-curving lip that forms a pocket of earth for growing flowers along the wall's sides. Intended for low patio walls and similar yard structures, the interlocking sections can be arranged in any order and mixed with plain-sided blocks to form a variety of decorative patterns

Inventors of the devices shown on these pages are as follows: 1. Charles Grunfeld, 32 Corbin Place, Brooklyn, N. Y. (No. 3,303,851); 2. Ernest Haile, 30 Cadwalader Terrace, Trenton, N.J. (No. 3,389,499); 3. Jack De Ment, 4847 S.E. Division St., Portland, Ore. (No. 3,414,838);

4. Acme Missiles and Construction Corp., 43 N. Village Ave., Rockville Centre, N.Y.; 5. Solomon Forst, 666 W. 118th St., New York, N.Y. (No. 3,399,789). Roger S. Shashoua can be reached at the International Inventors Assn., Inc., 680 Fifth Ave., New York, N. Y. 10019

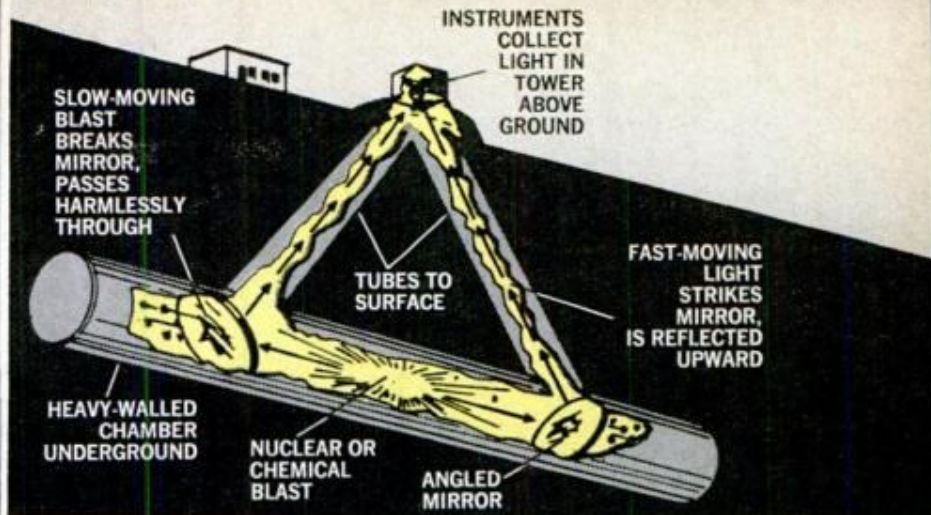

3. HARVESTING VALUABLE LIGHT ENERGY from violent explosions is the aim of the ingenious scheme shown above. Blasts are set off deep underground in a heavy tube fitted with an angled mirror near each end. The fast-moving light waves strike the mirrors and are reflected upward to instruments above ground. The slower-moving shock waves follow, breaking the mirrors and dissipating harmlessly in

the ends of the tube. The intense, brilliant light from explosions could make superpowerful laser beams and be useful in medical and industrial research. Until now, however, no one had figured out how to separate the light from a blast without getting blown up. A small working model is shown in the photo at left. In this case, the blast is vertical and the light energy is tapped off at a port centered on the side

4. PUSHBUTTON JACK at the right takes the sweat out of changing a tire. It raises a car while all you do is stand by and watch. The jack's elevating screw is driven by a small 12-volt electric motor, powered by the car's regular battery. To connect the jack, you just plug a cord into the cigaret-lighter socket on the dashboard. The device is said to support 6000 pounds and lift a car in 65 seconds. Battery drain is no more than is required to operate an electric car window. The tool weighs less than 20 pounds and is approximately the size of a conventional bumper jack



5. YOU DON'T HAVE TO DRIVE UP long, winding ramps to get into this novel parking garage—the whole building comes to you. Moving up and down like an elevator, the rotating circular structure rides in spiral tracks, driven by a motor at its rim. Cars

roll straight in and out at ground level, saving space and time. To increase handling speed, additional entrances could be installed at different levels so that the garage would have to make no more than half a turn in order to reach any car at any floor

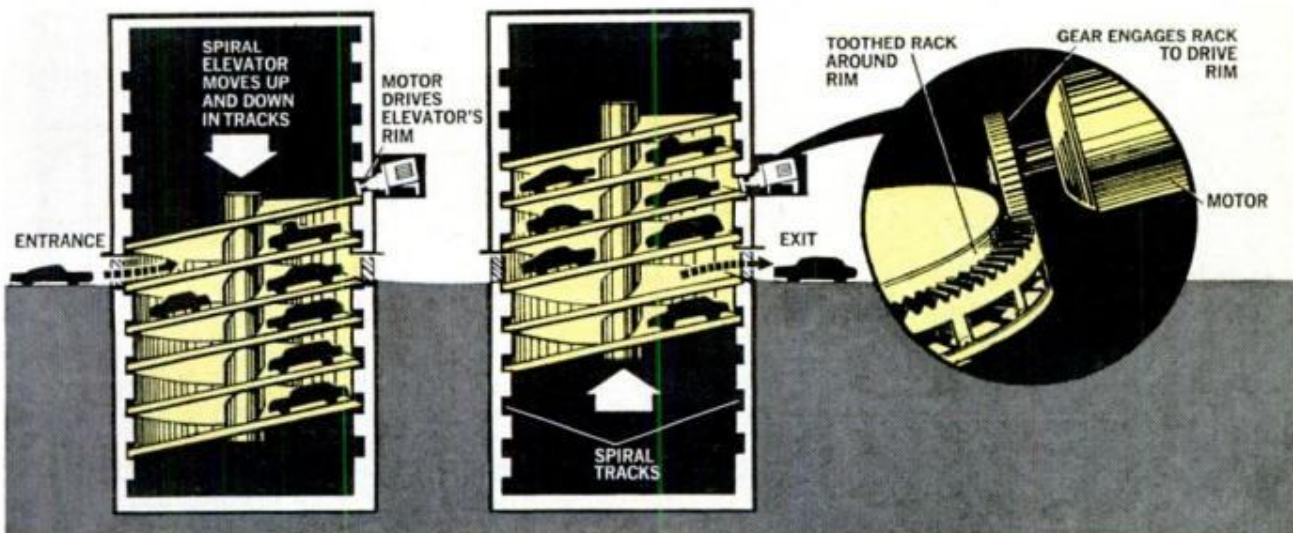



CYCLONE CJ is the fastback muscle-car option in Lincoln-Mercury's Montego lineup. Regardless of model, owners like the car for its style and handling



FASTBACK STYLE of Cyclone poses difficulties for owners. Rear visibility is limited, rear seat puts passengers up tight physically and headroom is scant

MONTEGO FUEL MILEAGE CHART

302-cu.-in. V8

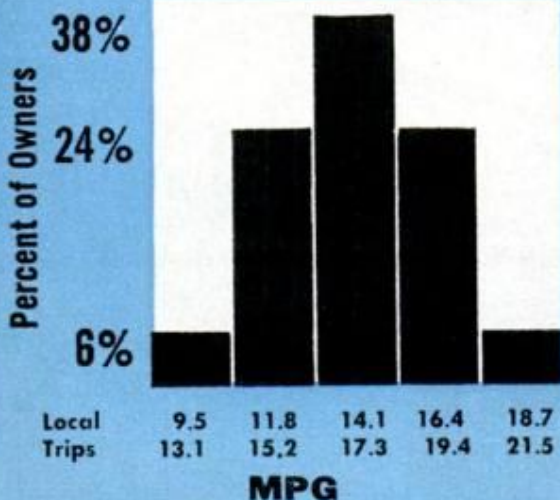

PM OWNERS REPORT MERCURY MONTEGO

A Nationwide Survey Based on
775,000 Owner-Driven Miles

FORM FOLLOWS FUNCTION, supposedly. Take the case of the Mercury Cyclone CJ, the production version of the moving Mercury Spoiler that roared to victory at the Atlanta 500 this year. Designed to cut the air with as little disturbance as possible at, oh, maybe 200 mph, all that sheet metal, as any FoMoCo factory-backed Grand National NASCAR driver will tell you, is stamped out just to get him home first.

He rides alone in that buttressed and braced fastback. It's just him and his fire extinguisher, and his drinking-water bag and plastic tube. Not much luggage. No passengers. He's not going anywhere. He starts and finishes his trip at the same line. Full speed ahead and don't look back.

And what about the street version? Why, its function is to *look* like it just

Rear Visibility and Headroom: Thrown To the Wind!



That's the price you pay for aerodynamics, and owners are paying it gladly for the smooth style of this wind-tunnel wonder

By **BILL HARTFORD**, Technical Auto Editor/Photos by Irving Dolin

rolled off the tri-oval, of course. You can't miss it. Bright orange and throbbing through town. Out to get the girls. "Rev it in her ear and she'll follow you anywhere!" is the latest call of the wild. Fine. But what about after the catch? After the muscle car flexes, it's got work to do, back-seat passengers to carry. Then form forgets function.

Of all the Montego owners surveyed by *PM*, less than 10 percent own the Cyclone version yet criticisms of what would seem to be only fastback drawbacks—headroom and rear seat for primordial ancestors only, and rear visibility that makes reverse gear a safety hazard—were legion.

An Ohio grinder bought what he mistakenly considered a "practical" Montego two-door hardtop: "I can't understand why they give up head and leg comfort for outside looks; put more

emphasis on inside comfort." "Back seat needs more legroom," observes a Virginia retail management man. And "raise the roof," demands a West Virginia deputy sheriff who likes the body style of his MX two-door.

Cyclone owners—almost all in their tender twenties—like the neck-snapping torque and don't worry too much about rear-seat comfort or having to take off their lids while driving. Some remark, "Back is rather small," "back seat should be moved back," "rear seatback is too straight up and down," "little hard to see out of rear glass," but their comments are made more matter of factly than unhappily. Best line is from an Ohio computer operator who finds his fastback too "fast" inside!

Fast on the road is something else. A New Jersey research technician's MX Brougham "runs like a scalded dog."

Summary of 1969 Mercury Montego Owners Reports*

Total miles driven775,771

Average miles per gallon:

250-cu.-in. Six,	
local driving	15.0
long trips	19.0
302-cu.-in. V8,	
local driving	14.1
long trips	17.3
351-cu.-in. V8,	
local driving	13.6
long trips	16.6
390-cu.-in. V8,	
local driving	12.3
long trips	15.7
427-cu.-in. V8	n.a.
428-cu.-in. V8	n.a.

Specific likes:

Style	45.1%
Handling	42.3
Comfort	25.3
Economy	23.3
Ride	22.5
Performance	17.4
Power	7.1

Specific dislikes:

Workmanship	11.3%
Economy	8.2
Rear visibility	7.4
Headroom	5.9
Rattles	4.3
Wind noise	3.9
Dealer service	3.1

What changes would you like?

Headroom	9.5%
Rear visibility	7.5
Legroom	7.0
Workmanship	4.5
Vent windows	4.5

Ashtray location 4.0

Model:

Comet	0.4%
Montego	23.3
Montego MX	58.4
Montego MX Brougham	9.7
Cyclone	7.2
Cyclone CJ	1.1

Body style:

2-door hardtop	53.0%
4-door sedan	33.3
Convertible	0.4
Station wagon	8.3

Engine:

250-cu.-in. Six	9.0%
302-cu.-in. V8	54.1
351-cu.-in. V8	30.8
390-cu.-in. V8	5.6
427-cu.-in. V8	n.a.
428-cu.-in. V8	n.a.

Transmission:

3-speed manual	4.6%
4-speed manual	3.2
Automatic	92.2

Had any mechanical trouble?

No	73.2%
Yes	26.8

What kind of trouble?

Carburetor	16.2%
Transmission	13.5
Accelerator	6.8
Choke	6.8

Dealer repair satisfactory?

Yes	72.2%
No	27.8

Why the Montego?

Style	37.1%
Size	20.5
Economy	18.4
Past experience	15.9
Reputation	7.1

Is the Montego your only car?

Yes	54.6%
No	45.5

Other cars owned:

Mercury	21.8%
Chevrolet	17.3
Ford	13.5
Oldsmobile	9.0
Volkswagen	8.3
Mustang	7.5
Pontiac	6.8

What options/accessories?

Power steering	63.5%
Radio	61.9
Airconditioning	28.1
Whitewall tires	21.9
Tinted glass	18.8
Power brakes	17.7
Vinyl top	16.2
Disc brakes	16.2
Remote side mirror	14.2

Age distribution of owners:

15-29	27.1%
30-49	41.2
50 plus	31.8

*Where applicable percentages may not equal 100 percent due to rounding and/or insufficient sample.

That's with a mild 302-cu.-in., engine, the smallest V8 available. Other engine options step up from 351 to 390 to 427 and 428-cu.-in. monsters. Less than a handful of owners mention brute power, however, and even less were lured to 427s and 428s, probably because of the cubic dollars involved. It seems most are happy (thank goodness) having a car that looks like a race car than one whose power and pollution production is completely out of whack with a sane concept of public transportation.

Despite shortcomings of the interior,

TRUNK LID is small but inside room is enough for most. Fuel fill pipe, spare are in the way, however

owners mention the size of their Montegos as being very sane. Not too big, not too small. It's an intermediate, actually, with all models on a 116-inch wheelbase and having a length of 206.2 inches except the Cyclone at 203.2. Interestingly, a New York insurance agent finds the car "comfortable—considering it's a 'compact.'" To a Florida secretary, it's a "pretty little car."

A frequent complaint among those directed at small things is about push-button door locks, especially on two-door models. The lock, near the back of the door, is hard to reach (see

INSTRUMENT CLUSTER is pleasing feature of the car, is included in owners' praise for style of Montegos

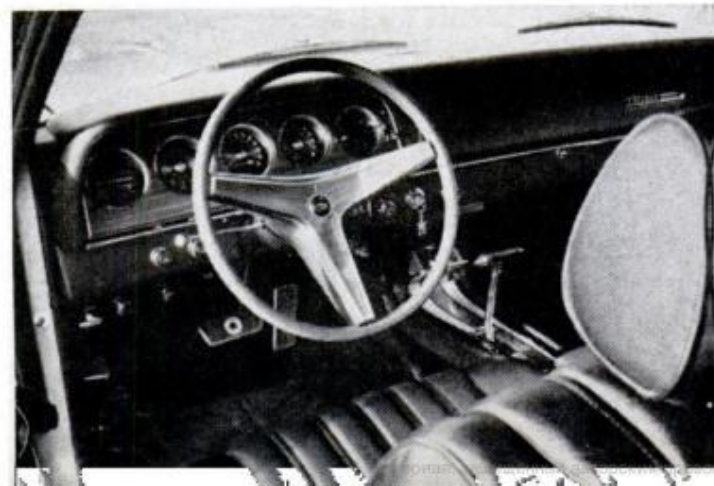
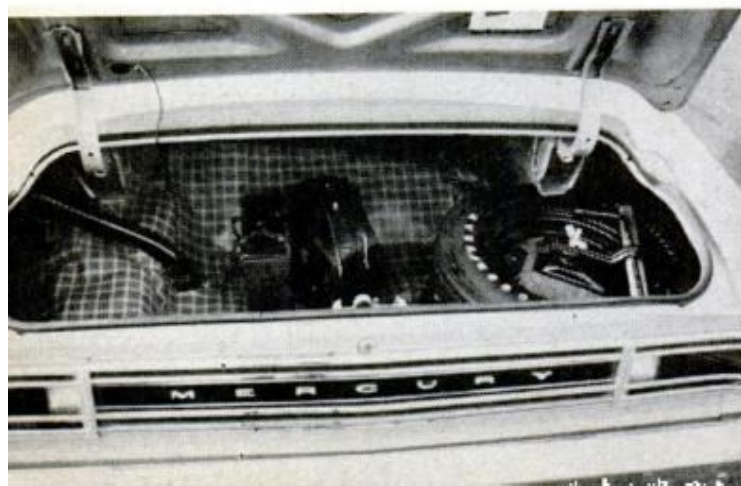



MADE TO MOVE, the Mercury Cyclone is designed to minimize drag. Even the racing mirror is faired. Scoop is for Ram Air

photo) without severe stretching and straining. There's no reason why the lock can't pop up when the inside door handle is actuated, says one owner. The tots sit safely in back, so why not? Either that or move the lock into range!

Also getting an honorable mention is the lack of chrome strip along the side of the Montego. Cars are taking a beating in the parking lot from those hit-and-run door openers. It's annoying and it's a problem a chrome strip won't always solve.

Another "little" thing that some owners mention and something they say should be standard: a split bench seat. Keep the bench type but split it into two individually adjustable halves, say owners. Some cars have them, why not all?

A few Montego owners bring up the now old bugaboo about lap belts and shoulder harnesses cluttering their car and head restraints being a nuisance. I guess they are things you must learn to *live* with. Until there is a better, more convenient way of restraining occupants, we can at least try to be as safe on the street as a race-car driver is on the raceway.

Many prospective new-car buyers find it downright dangerous to set foot in a dealer showroom—they can't take the pouncing. One of five Montego owners say they were pounced on by high-pressure salesmen. But that's about normal. One owner, a law school student from New York, may be the envy of us all. He says of his dealer, "If anything, he wasn't aggressive enough—didn't tell me about the options I could have ordered."

Otherwise, regarding repair and maintenance service, courtesy, fair dealing and sales methods, three of four owners found Linc-Merc relationships good to excellent. A decent average in the expensive, hard-driving world of wheels. ★★ ★

JUNE 1969



POOR DESIGN locates front door locks in an almost inaccessible spot on the door



DRIVING POSITION is comfortable, but headroom front and rear is at a minimum



REAR SEAT is too far forward to sit straight. Shelf under backlight is huge

101



PM Tests OMC's 'SECRET

Here's the first test report of any kind on a new type of all-terrain vehicle planned by Outboard Marine Corporation.

By **BILL KILPATRICK**, Auto Editor

IF THE THOUGHT of a thoroughly urbanized dude test-driving a prototype all-terrain, strictly fresh-air vehicle in the wide-open spaces of Nebraska in the dead of winter strikes you as both a bit wacky and laughable, you're right on both counts.

The vehicle in question was a brand new ATV (All-Terrain Vehicle) idea from Outboard Marine Corp., an idea so new there seemed nothing appropriate to call it other than the Green

Machine. But regardless of what it's called, it's a remarkable machine offering outstanding performance under a wide variety of load conditions and operating attitudes.

It is, for example, the only such rig I've ever driven that will scoot up a steeply (and I mean *steep!*) graded bank of loose sand. It's the only rig I know of that will slog through a form of bubble gum Nebraskans laughingly call mud. In my experience, no foolin',

it's the most stable, easiest-to-operate, most controllable vehicle of its type.

Just how steady things are was brought home to me rather emphatically when, at one point, trying to climb a sand bank an idiot would have had brains enough to avoid, I found both me and the Green Machine pointed almost straight up.

"Kilpatrick," I thought, "you've just bought the farm. This thing's gonna flip over on its back and pound you right down to China."

But it didn't. The center of gravity is so low the beastie's nose slid off to the left and I found the two of us clawing our way up this impossible grade on a crabbing, diagonal course.

Is the Green Machine forgiving? Is it outstandingly controllable? Pass that Bible; my right hand's already raised.

Heart of the control system is a single T-handle linked through hydrostatic transmissions to each of the tank-like rubber-compound tracks. For operating purposes, the T-handle controls speed, forward and reverse, steering and braking. There are no belts, no chains, no up-and-down shifting of gears.

To get things under way, you turn



OMC ATV goes uphill through stumps, over brush. If bottom is cleared, rubber tracks will climb stumps



OPERATIONAL CONTROL of ATV is via single T-handle mounted on dash directly in front of driver

GREEN MACHINE'



TRANSPORT of ATV to jumping-off spot is easy via a pickup or trailer. ATV is 60 in. wide, 89 in. long



GREEN MACHINE will run on top of deep snow. Its tracks also have outstanding traction on icy glaze

ALL-ROUND STABILITY is a feature of this new ATV. Here, Bill Hartford holds on tight, remains upright

the ignition on, pull the choke out a little, shove the electric starter lever forward (there's an auxiliary rope-pull starter should you be out of juice), back off on the choke, give it throttle, ram it in gear and take off. Everything else, from the barest momentum to an all-out 15 mph forward (7 in reverse) is controlled via the single T-handle.

You steer by twisting the cross member of the T-handle right or left. The more you twist, the sharper you turn. In fact, twisting the handle to full lock, you can make a spin-turn right on the spot, even at speed. You back up by placing the gear lockout lever in reverse and pulling the T-handle back toward you. Thanks to the "fluid drive" of the hydrostatic transmissions linked to each track, bringing the T-handle to a neutral position acts as a brake. Works, too. When the handle is dead center in neutral, the deep-tread tracks are locked, enabling you to hold just about any position you want.

Power for this little wonder is OMC's 25-hp air-cooled, die-cast aluminum two-cycle engine, the same plant OMC uses on its snowmobiles. Suspension is via two sets of die-cast aluminum bogie wheels individually suspended by rubber torsilastic mounts and steel springs. These wheels follow the inside of the track and



"give" to meet all terrain conditions. Track pressure is so uniform and balanced that the Green Machine—despite its weight of about 1000 pounds with operator—scoots over deep snow.

The fiberglass body is watertight and will float with two people aboard. If a lot of water operation is planned, free-board height can be increased by optional bolt-on sideboards. The body is protected by large tubular bumpers. Also at each end are two hitches.

Construction of the Green Machine is simple, thoughtful. The engine, transmissions and axle assembly—complete with all controls—are put together as a separate unit and bolted in place. So is the bogie-wheel system and its supporting frame. The design of both major assemblies has been worked out so that all components can be serviced without removing the entire thing.

The Green Machine is a little over 60 in. wide, almost 89 in. long, and 44 in. high. Fuel capacity is 10 gallons, enough for an average day's operation. The electrical system is 12-volt, the battery a standard automotive type.

As mentioned above, the Green Machine is still a prototype. Whether or not OMC will go ahead full bore with it depends upon what the company's marketing experts see in the crystal ball. Right now, things look



UNABASHED FUN is a great part of ATV's appeal. I had a great time whipping through snow-filled woods

good. If OMC *does* push the "go" button the basic machine price will probably be around \$2300, which makes it a sort of Cadillac of ATVs.

Is it worth that kind of money? Well, I've already said I think it's the best such rig I've ever driven. Sidekick Bill Hartford (that's him on the cover) drove it in a garden spot called Wetumpka, Ala., and came back to the office raving about the ATV's ability to climb stumps, crunch its way over sugar-cane stubble, flatten brush and stay right side up in potentially hairy situations. He, too, reported it as being a delight in which to bomb around.

A potential buyer would have to conclude, it seems, that such outstanding performance—plus the undeniable fun involved—costs money. ★★★

FREEBOARD for operation in water can be increased almost a foot by bolting on the optional sideboards



JUNE 1969

BUSINESS END of ATV's drive system is via these heavy-duty sprocket arms that drive the track lugs



AUXILIARY ROPE-PULL STARTER is handy in the event of battery failure. Throttle sits atop grab handle

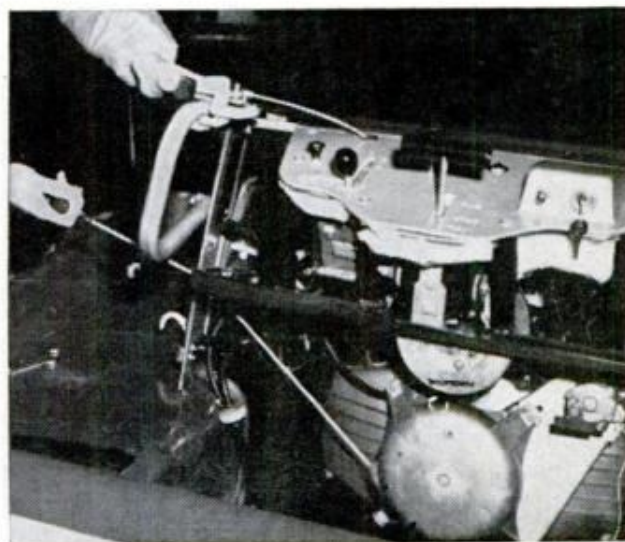

105

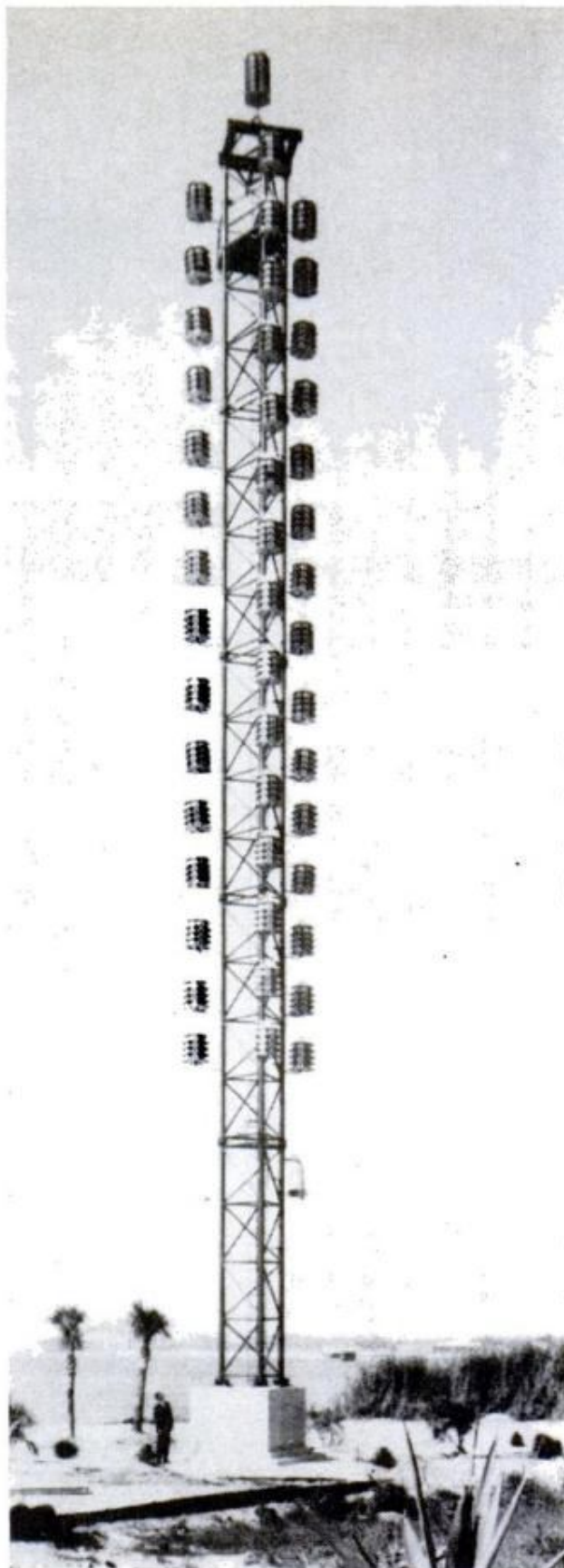
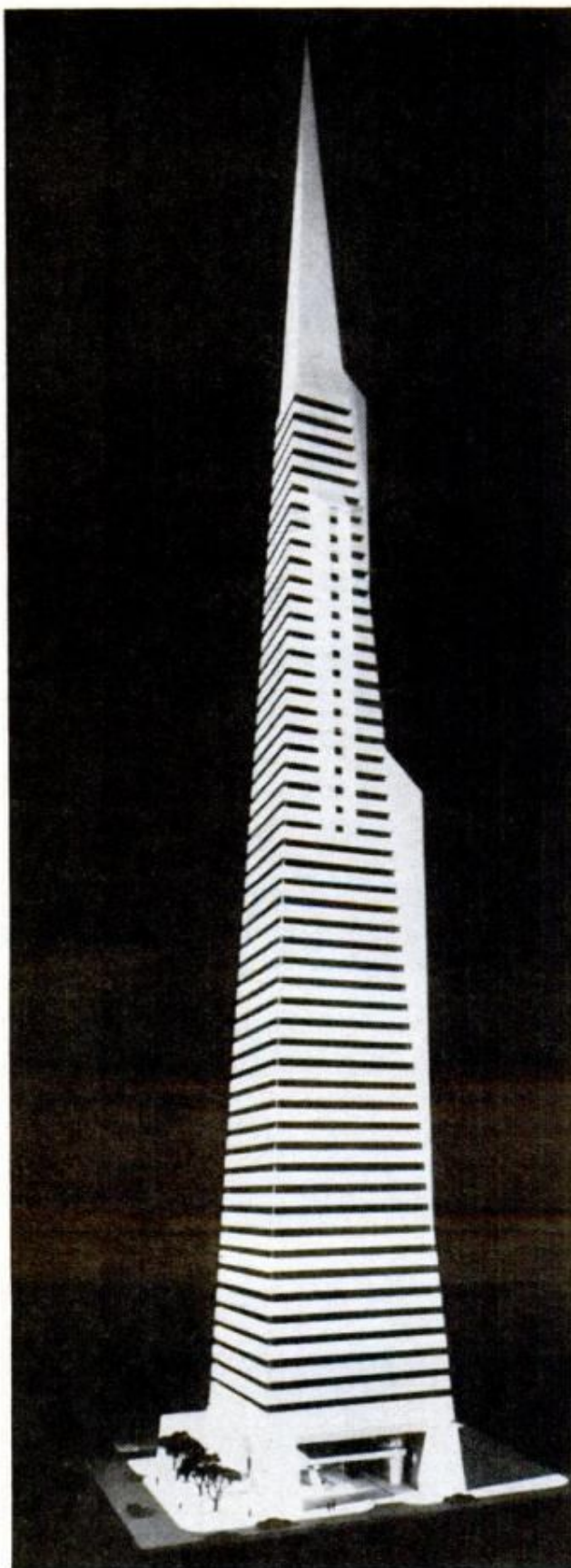

Two tall ones . . . one for people and one for birds

Shown in an artist's rendering at left is a white pyramidal office building that will probably become part of the San Francisco skyline in 1972. The 55-story building, topped by a 240-foot spire, will tower 1000 feet above street level, according to plans announced by Transamerica Corp., which will have its headquarters in the new structure. The 120-foot steel tower at right is believed to be the largest birdhouse in the world. Built at Lake Charles, La., as a memorial to Vietnam War veterans, the tower has compartments attached to its sides that have enough space to house 5280 purple martins.

Now: Shoot Underwater Photos for Under \$20

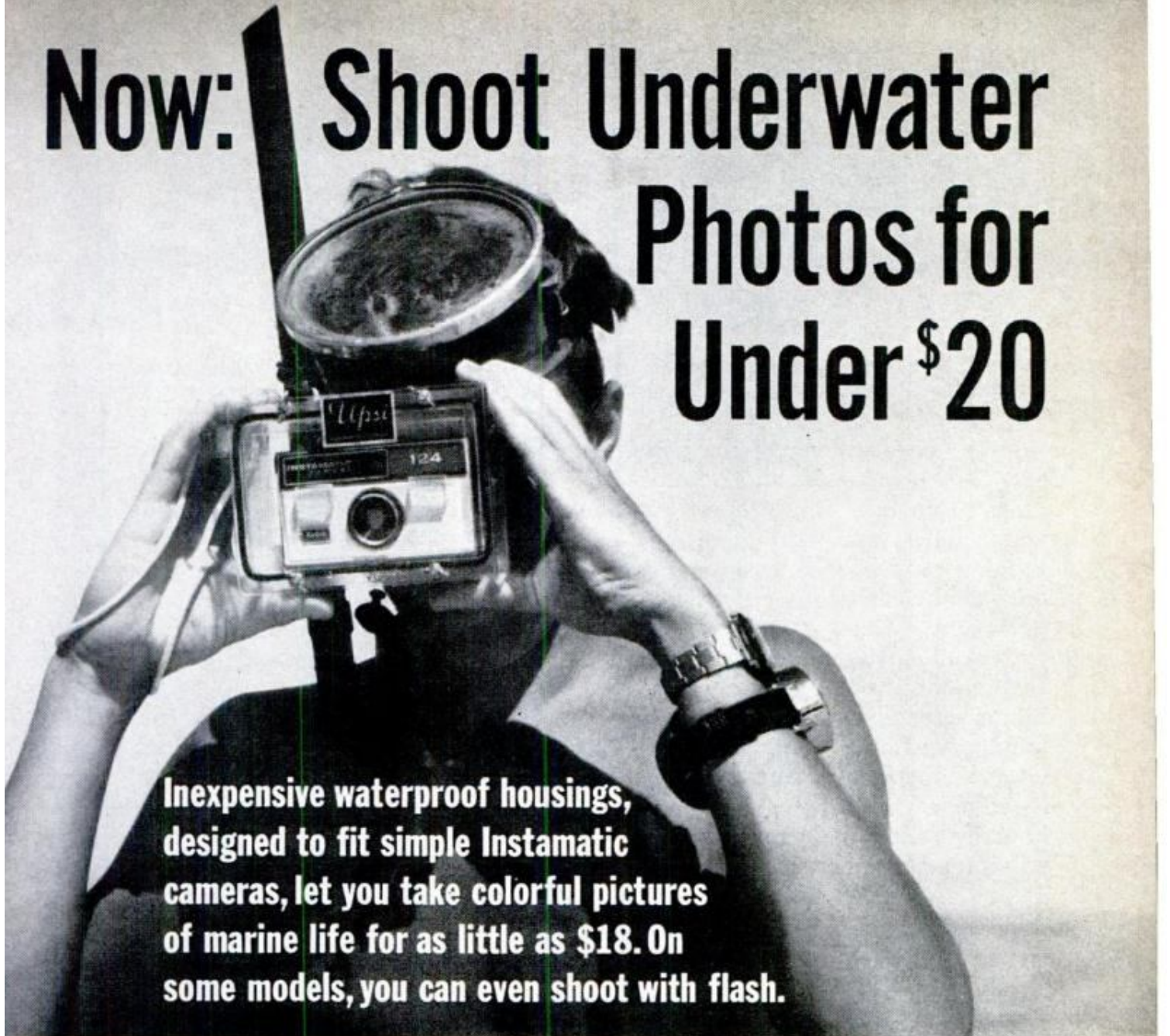

Inexpensive waterproof housings, designed to fit simple Instamatic cameras, let you take colorful pictures of marine life for as little as \$18. On some models, you can even shoot with flash.

By **CLIFFORD B.** and **DOUGLAS L. HICKS**

YOU USUALLY THINK of underwater photography as a rich man's hobby, with special waterproof camera housings costing up to several hundred dollars. Here's a surprise: If you own an Instamatic camera, you can shoot underwater photos for less than \$20.

What makes this possible are a number of low-cost plastic housings designed especially to fit Kodak's line of inexpensive cameras. Cases start as low as \$17.95. If you don't already own an Instamatic, you can buy both camera and housing for as little as \$35 to \$40. Fancier housings, including provision for underwater flash, go on up to about \$60.

Best of all, because the cameras are simple, you don't need to be an expert photographer or a trained scuba diver.

We recently checked out four of the simple underwater rigs in the Bahamas. It was the first time we'd ever snapped a shutter underwater, and we brought home scores of genuinely exciting shots—delicately undulating sea fans, baleful barracuda, magnificent coral heads, huge manta rays and the exquisite little four-eyed butterfly fish.

Here's what you should know to get your feet wet in underwater photography:

Instamatic cameras are ideal for underwater work because they are compact, simple to operate (and therefore

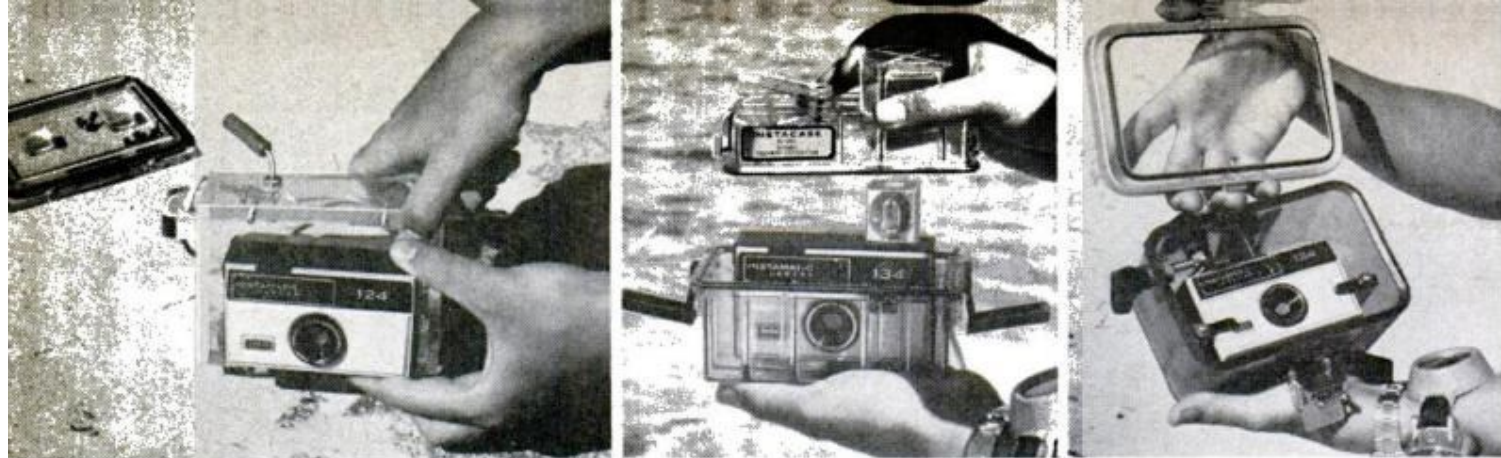

SIMPLEST HOUSING, the Upsi at left, has ingenious single control lever that both advances the film and trips the shutter. OEC Instacase (center) has a plastic dome that provides space for rotating flash-cube inside housing. Extra-rugged Ikelite (right) is guaranteed to withstand pressures down to 200 feet

easy to operate through the housings), and they'll take 20 shots before you have to change film. Depending upon water clarity and light conditions, even the least expensive Instamatics, with or without electric eye, work well underwater.

Periodically, changes are made in the Instamatic line that sometimes produce minor changes in dimensions. For example, we found that the Model 124 is an eyelash thicker than the 104, which it replaced. Obviously, you should get a housing tailor-made to your camera if possible, but the dimensional differ-

ences are so slight that you can make almost any housing fit almost any low-cost Instamatic, either by filing down the retaining ribs inside the housing to make the opening bigger, or by padding the back to make it smaller.

There are a number of housings available for Instamatics. We tested the following four:

The Upsi housing retails for \$17.95, is extremely compact, and has an excellent seal. Only one control lever passes through the case. You rotate the lever to advance the film, then pull it up and pivot it forward until it is directly above the shutter. A simple push downward then snaps the picture. The low-cost model that we used has no flash, but other models equipped with flash are available. The Upsi housing is manufactured by Underwater Photographic Scien-

FOUR UNDERWATER HOUSINGS designed for Instamatic cameras give you a wide choice of prices and features. They are, from left to right: Upsi, OEC Instacase, Dacor and Ikelite. Least expensive is the Upsi at \$17.95. Fanciest is the Dacor at \$58.95. It features twin hand grips at the sides and a detachable flashgun that clips on top

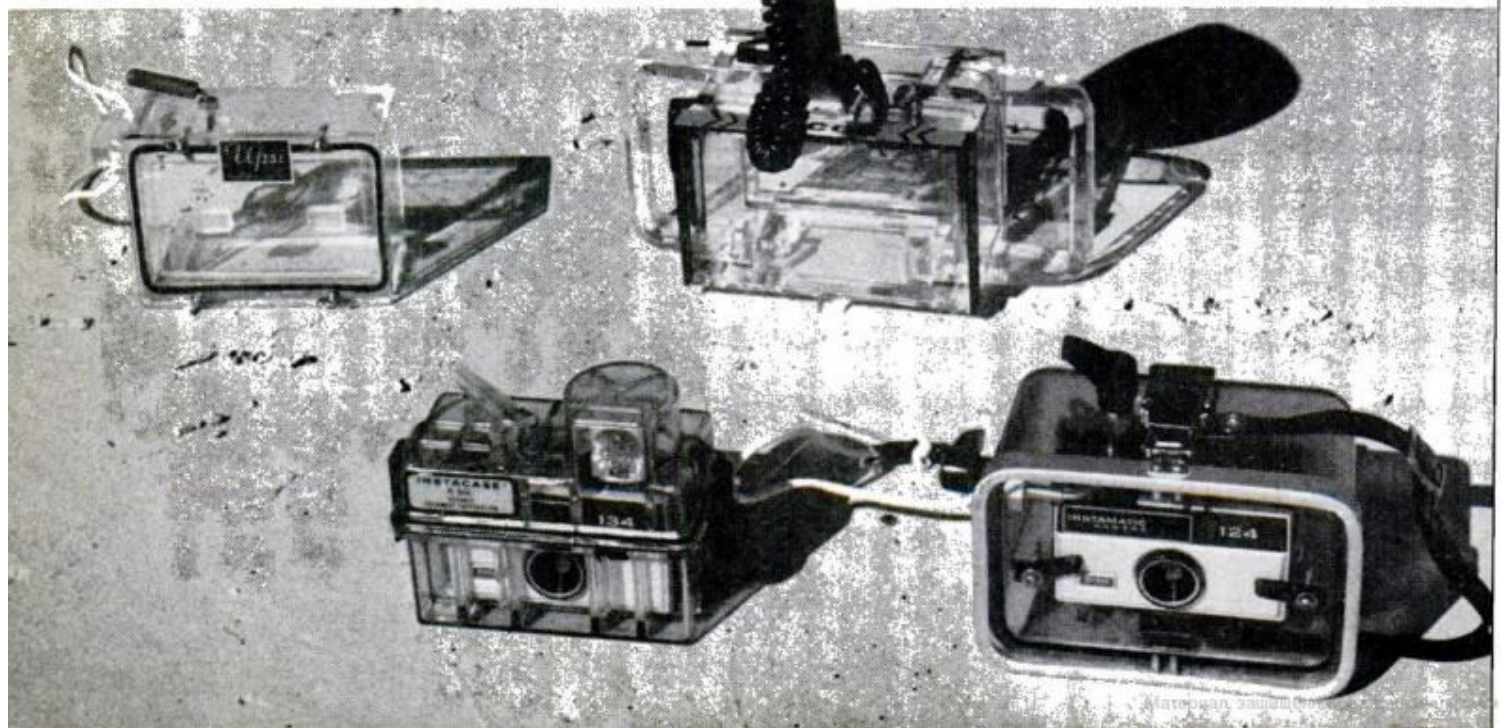



ACTUAL UNDERWATER PHOTOS made with an Instamatic camera show the fun you can have at little cost. Below, brilliant blue reef fish swarm past a large brain coral in tropical waters. Shot was made on Ektachrome-X at a depth of 10 feet with flash. At top, silvery fish reflect both sunlight from overhead and flash from the side





EASIEST WAY TO AIM is to hold camera with arms outstretched, pointing straight ahead. Mask and housing prevent use of the regular viewfinder



tific Inventions Inc., Box 26, Marathon, Fla. 33050.

The OEC housing retails for \$19.95, is the easiest to open and close (two snap latches) and the controls are easiest to operate. A raised dome accommodates a flashcube inside the case, permitting you to take four flash pictures without opening the housing. This particular housing is a very snug fit around the camera. A close-up lens will not fit inside it. The OEC is manufactured by Oceanic Equipment Corp., 2223 N.W. 14th St., Miami, Fla. 33125.

The Ikelite housing, retailing for \$39.95, is the strongest case of the four, and has two powerful spring snaps that lock the faceplate in place, making it relatively easy to insert or remove the camera. You can't use flashcubes with this housing, but an exterior flash unit is available as an accessory. The housing is manufactured by Ikelite, 3301 N. Illinois St., Indianapolis, Ind. 46208.

The Dacor housing, at \$58.95 including exterior flash, is a quality instrument throughout. It has a positive seal that, in our experience, never leaked. The exterior-mounted flash has gold-plated contacts to prevent corrosion (we never had a bulb fail), and the flash unit can be detached from the housing for side-lighting. You can use the more powerful No. 5 and No. 25 bulbs. The reflector is molded of a new white plastic for excellent light diffusion underwater. The housing is made by Dacor, 5190 Church St., Skokie, Ill. 60076.

Ektachrome X is recommended for underwater slides because it has somewhat greater contrast

(Please turn to page 200)

REMOVABLE FLASHGUN on the Dacor housing can be held up to three feet away from the camera for side-lighting effects. This helps to keep light from bouncing straight back into the lens from clouds of invisible plankton found in seawater. Gun is connected by handy coil cord, plugs into camera's flashcube socket

'Damn the submarines! Turn on the lights!'

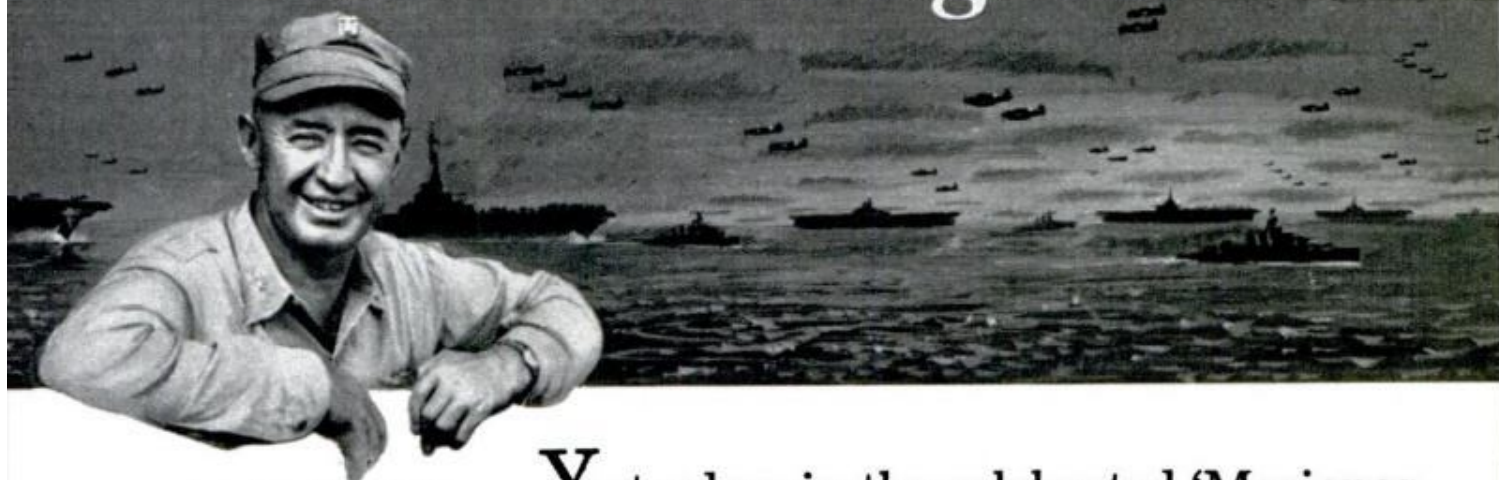

★ ★ Rear Admiral (later Admiral) J. J. "Jocko" Clark

Yesterday, in the celebrated 'Marianas Turkey Shoot,' the Hellcats of Task Force 58 had knocked more than 300 Japanese planes from the sky. Today, joined by Avengers, Dauntlesses and Helldivers, they had struck the Imperial Fleet itself. But now it was pitch-dark, and the returning pilots were low on gas.

By Robert P. Crossley, Editor

THE DAY BEFORE was the big one—the one that knocked the Japanese out of the war, even though they didn't give up for another 14 months.

Vice Adm. Jisaburo Ozawa's "Mobile Fleet," the front line of the Imperial Navy, had come charging out of the Philippines to stop the U.S. invasion of the Marianas. On June 19, 1944, from points 280 to 400 miles west of Saipan, Ozawa launched four strikes, planning to hit American warships on the way in, then land, refuel and rearm on Guam and clobber them again on the way home.

It hadn't worked. Japan's once invincible Zero was outmatched by America's new Hellcats. Attrition had replaced the superbly trained Japanese aviators of Pearl Harbor and Midway with pilots with less flying time than those of Vice Adm. Marc Mitscher's Task Force 58.

Ozawa sent off 373 planes. Before the day was over, fighters from Task Force 58's 15 fast carriers had shot down more than 300 of them. The U.S. lost only 30. Somebody called it the

(Text continues on page 114)

TURN THE PAGE for a dramatic re-creation of the night (June 20, 1944) when Rear Adm. J. J. "Jocko" Clark risked submarine attack by ordering all his ships to turn on the lights to guide battle-worn pilots back to their carriers. As the *Yorktown* plows ahead, fuel-short planes jockey for their approaches, a pilot leaves his ditched Hellcat and a smoking Avenger searches for home

Painted for Popular Mechanics by Ed Valigursky





The night Jocko Clark broke the blackout

"Marianas Turkey Shoot." It was America's greatest aerial victory in the Pacific, and when it was over the Japanese were through as a naval air power. From then on they turned in desperation to the Kamikazes.

Ozawa had lost most of his planes, but his fleet was intact, except for two carriers sunk by U.S. submarines independently of the air action. It still included seven carriers, five battleships (including the 85,000-ton *Yamato* and *Musashi*, whose 18.1 guns made them the most powerful in the world), 13 cruisers and 28 destroyers. Mitscher didn't want them to get away.

At dawn, patrols started searching for Ozawa, but it was 1540 before Lt. R. S. Nelson, of the *Enterprise*, reported the Japanese fleet 275 miles northwest of Task Force 58. At 1553 Mitscher passed the word: "Expect to launch everything we have, probably have to recover at night." Mitscher was taking a gamble; a 275-mile strike stretched the limit of his planes' fuel capacity. They would have a half-hour at most over the target. Then they would have to fly back in the dark, find the fleet, and land at night. Only a handful of his fighters were experienced at night landing. It would be touch and go.

At 1621 the carriers turned into the wind. At 1625 launching commenced. By 1635 216 planes—fighters, dive bombers and torpedo planes—were on the way. The 10-minute launch was a record for getting so many planes off so many ships.

At 1840 flight leader Lt. Comdr. B. M. "Smoke" Streat, of the *Yorktown*, sighted the Japanese fleet. It was 60 miles farther west than first reported and spread over 30 miles of ocean. The attack was a wild free-for-all. With the sun going down, there was no time for precision. Ozawa maneuvered wildly, hoping to evade the Americans for 20 minutes until dark. He sent up 75 of the planes he had left. Some 65 were shot down. His ships sent up a desperate anti-aircraft barrage, including even the main batteries of battleships and cruisers.

A shot hit the Avenger of Lt. (j.g.) George M. Brown, of the *Belleau Wood*. His two crewmen bailed out, but he buzzed the flight deck of the carrier *Hiyo* to draw anti-aircraft fire while Lt. (j.g.) Warren R. Omark in another Avenger sent a torpedo into the ship. Brown's two crewmen, who were rescued the next day, watched the *Hiyo* sink two hours later. Brown started for home, but was never seen again.

By 1900 it was dark. The Americans swore to themselves as gas



VICE ADM. Marc A. Mitscher
aboard the carrier USS *Lexington*
off Saipan, June 19, 1944

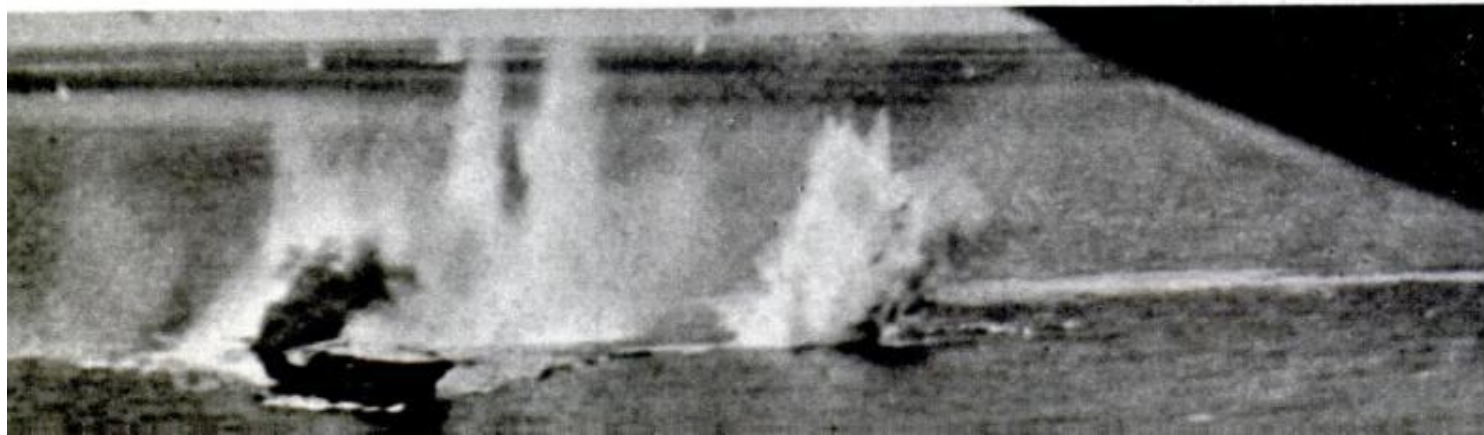



ABOARD THE HORNET, Aug. 26, 1944 (l. to r.): Vice Adm. Mitscher, Capt. Arleigh Burke, Rear Adm. J. J. "Jocko" Clark

gauges dropped to the one-half mark. Tired from two days of combat, worried about running out of gas and about finding their ships in the dark, some 190 of the original 216 started for home. Some went into the sea en route, but most made it back to the task force before their engines began to sputter. The first returning plane was spotted at 2030, and the fleet turned into the wind at 22 knots for recovery.

Rear Adm. (later Adm.) J. J. "Jocko" Clark, whose Task Group 58.1 included the *Yorktown* and *Belleau Wood*, as well as the *Bataan* and his flagship, the *Hornet*, was nearest the returning planes. He describes the scene in his exciting autobiography, *Carrier Admiral* (David McKay, 1967, \$6.95):

"Pitch-black darkness had already descended as the running lights of the first of our returning planes appeared over the horizon. In understandable anxiety, for I had flown at night from carriers myself, I made a drastic decision. I ordered all my ships to turn on all their lights. Of course, this was taking a chance that no enemy submarines were lurking nearby. To identify my task group, I ordered *Hornet* in addition to display a vertical searchlight beam. Then at once I notified Admiral Mitscher of my action, and he promptly signified his approval by ordering all the ships of the entire task force to turn on their lights. This was indeed one of the war's supreme moments—a multitude of ships emblazoned the skies for many miles as a calculated risk to provide greater safety for the return of our battleworn airmen.

"... Recovery of the returning planes, however, was a wild scramble, as the exhausted pilots rushed to get on board before their fuel gave out. We ordered them to land on any carrier they could find, which they did. Some deck crashes fouled flight decks for a few minutes, but very few flight personnel were injured.

"Many planes landed in the water, but destroyers

[\(Please turn to page 203\)](#)

"Planes were running out of gas."



FLIGHT LEADER Lt. Cmdr. B. M. "Smoke" Streat, now Vice Admiral, Chief of Naval Air Training. (Below) Navy bombers hit a Japanese carrier off Luzon



PM Tests: Ford's New



BIG BEND NATIONAL PARK was the rugged area for PM's test of the MiniHome. Based on the Econoline 300 with 123.5-inch wheelbase, it has an outside service hatch for routine servicing. MiniHome was parked at edge of rain-swollen Rio Grande while we forded river on burros (left) to visit Boquillas, Mexico. Campgrounds in the Basin of the Chisos Mountains are excellent, surrounded by peaks on all sides. The compact motor home was ideal for negotiating tight switchbacks on mountain roads; parking it was easy

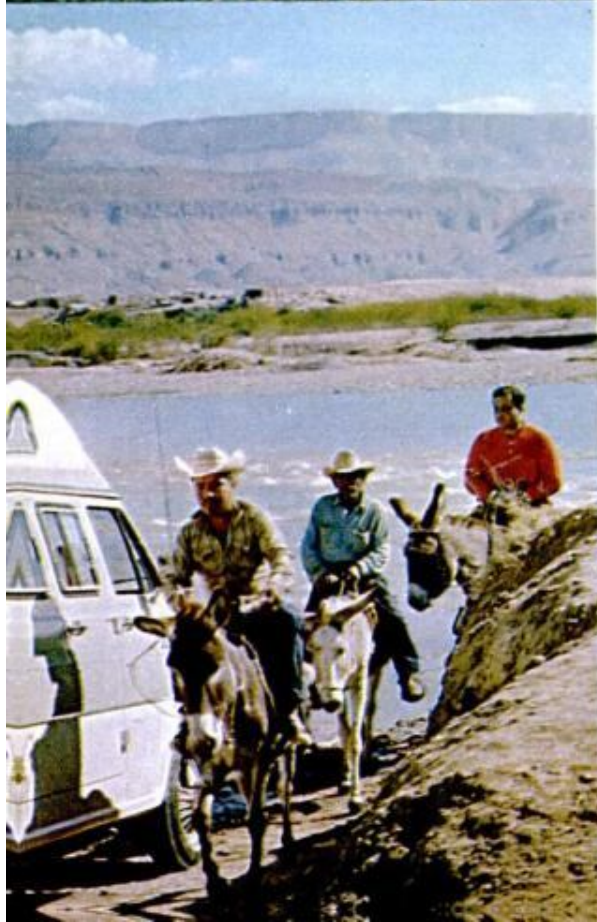

\$4800 Motor Home

Texas' Big Bend National Park is an ideal test ground for Ford's MiniHome—a conversion of the 123-inch Super Econoline equipped for on-the-go living.

By ALEX MARKOVICH

IT'S A ROLLING HOME that can sleep a vacationing family of five; a mobile lodge for hunters, a weekend beach house, and a roomy, everyday "station wagon"—all rolled into one new, compact, well-designed motor home.

It's all the term "motor home" implies except for the price. Ford's new MiniHome starts as low as \$4800, far less than that of any similar rig. The price is best appreciated in terms of a vacation home (which the Ford MiniHome is) that goes anywhere (which most homes don't) and lets you travel for what it costs to live at home. With cooking and dining facilities, running water and toilet (costs extra), the self-contained MiniHome can spend the night anywhere. No searching for trailer parks. No motel or restaurant bills.

We discovered first-hand just how much of a bargain the MiniHome is.

PM Executive Editor Jim Liston and I spent four days and nights eating, sleeping, and traveling in the second unit off the production line. Our 1119-mile trip took us from Kerrville, Tex., all through Big Bend National Park in the Southwestern part of the state and back to San Antonio. We were looking for a rugged, varied test course, and the mountains and deserts of Big Bend filled the bill.

Our groceries for the trip cost \$17.89—less than \$2.25 per person daily. And that included steak dinners. The same meals in a restaurant would have cost each of us at least \$7.50 a day. Add \$12 for double accommodations in a modest motel and you have a daily total of \$13.50 per person—six times what we spent!

The MiniHome basically is a long-wheelbase Ford Econoline van with plastic surgery by Motor Homes, Inc., of



STABLE RIDE is demonstrated by cup on engine shroud. Insulation against engine heat and noise is excellent

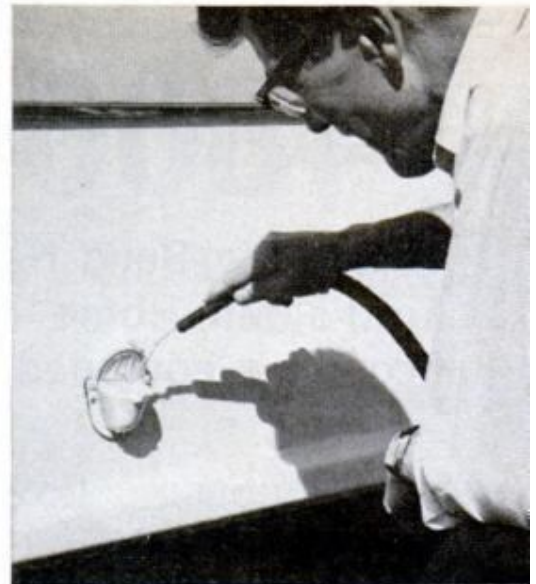
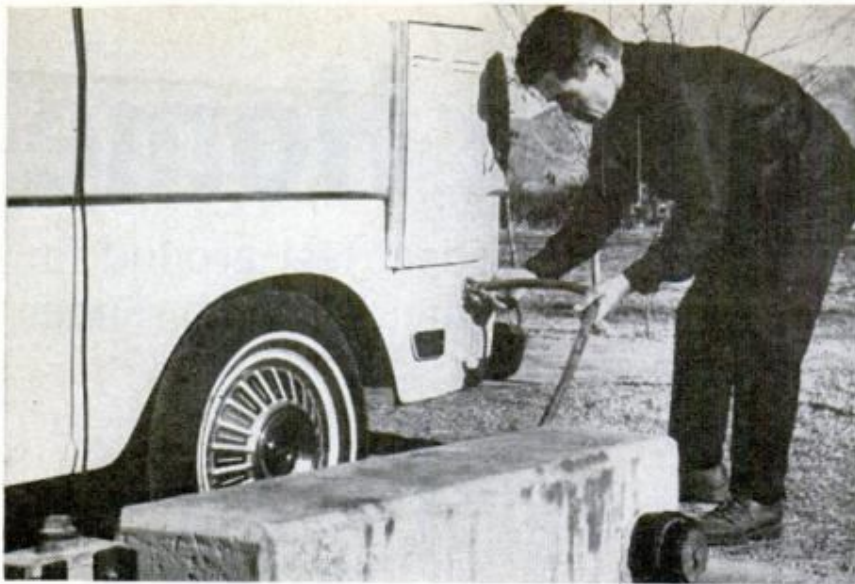

AT TRAILER PARK with hookups for electric, water and sewer service, we tried these conveniences. Bottled gas is carried above hose

WATER TANK inlet is at side of vehicle. The tank holds 20 gallons

Lorain, Ohio. The fixed fiberglass roof gives six-foot-two headroom (handy for stretching on long trips) and eliminates the dust and moisture-sealing problems of most pop-up tops. However, the 97 $\frac{3}{4}$ -inch overall height is too much for most garages. You'll park this rig in your driveway.

The 121-inch-long cargo area (longest of any panel van) houses a table that folds against the wall, a dinette seat that converts into a real bed with foam mattress, a stainless-steel sink, and lots of small cabinets and drawers.

Our test rig carried \$1454 worth of extras. The butane furnace (\$119) is a must for year-round camping; the 50-pound-capacity, a.c.-d.c. refrigerator (\$200), which replaces the standard

icebox, saves you the bother of shopping for ice; and the Porta-Potti chemical toilet (\$140) makes the vehicle self-contained—which means you aren't dependent on restrooms. The rest of the options, including automatic shift; whitewalls; chromed grille and bumpers; built-in three-burner butane range and oven instead of the standard portable Coleman stove; electric instead of manual water pump; butane water heater; vinyl headliner, and carpeting instead of linoleum, are nifty but not necessary for enjoyable travel. Also available are three foldaway overhead hammocks. These are necessary for children.

We started from Kerrville at 9:00 p.m.; it was great to know we didn't



BIG STORAGE AREA above front seats is possible with 6.2-foot headroom in rear



FIBERGLASS TOP has sliding, screened windows both sides. Water heater is at lower left; space heater next to door

have to look for motel accommodations on a road that didn't offer many.

Lack of light on the shift quadrant was annoying. But on the plus side, the 302-cu.-in. V8 was smooth and remarkably quiet, the ride was comfortable over all kinds of roads, and the aerodynamically designed roof produced no wind noise. The biggest surprise was the MiniHome's stability and ease of handling, even in crosswinds. We held the needle at 65 mph.

We parked for the night in Sonora, behind a service station, and soon discovered that the window curtains gapped when drawn. Metal snaps would have helped. The bed unfolded easily, proved roomy and comfortably firm.

Next morning we stocked up on food. While Jim cooked bacon and eggs, I tackled the folding table. (It took me a few days to get the hang of propping it up with my head while working the latches.)

We rolled along at an easy 70 mph west to Fort Stockton and then south. All went well until the pavement became a dirt road and finally a narrow, rutted trail. Could we have made a wrong turn? We were headed in the right direction, so we bounced on. The suspension took the punishment well, bottoming only on the worst dips.

The dirt road brought out another problem: Our dust cloud was being

(Please turn to page 202)

OUR GALLEY had optional range-oven, electric refrigerator, electric water pump, standard cabinets



REAL BED WITH FOAM MATTRESS folds out of lounge. Seatback locks in position to serve as night table



DRIVER'S AND PASSENGER'S SEATS swivel to face dinette table which is lighted by high-intensity spot

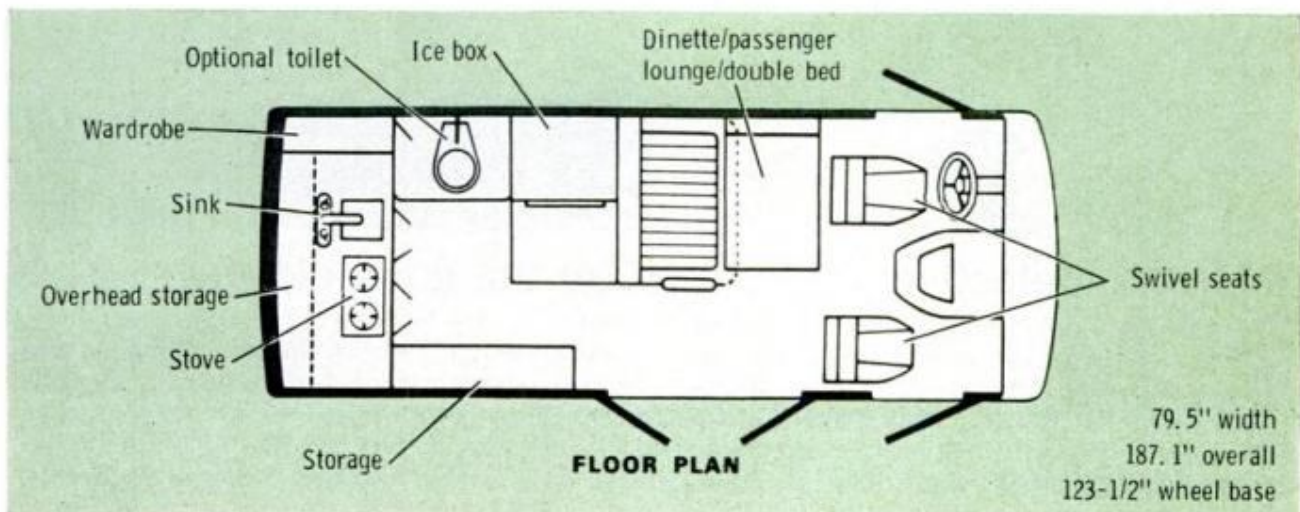



City at their feet

When city councillors in Hannover, West Germany, need a map of their city during meetings, they just look at the floor. The entire city is laid out in mosaic, and their seats are arranged around it like a horseshoe.



Electronic detective

This RCA light detector can seek out flashes of light too weak or too brief to be perceived by the human eye. The device, which utilizes an amplifying section made of gallium phosphide, can be used to detect light from pulsars, see more deeply into the structure of atoms and learn how plants use sunlight.



Triumph's newest

Latest in the TR line, the TR-6 has a six-cylinder, 2½-liter engine, new body lines and aircraft-type instruments. The classic two-seater softtop is \$3275 on the East Coast.



High-speed sled

A rocket-propelled air-cushion test vehicle reached Mach 1.2 speed at Cazeaux, France.

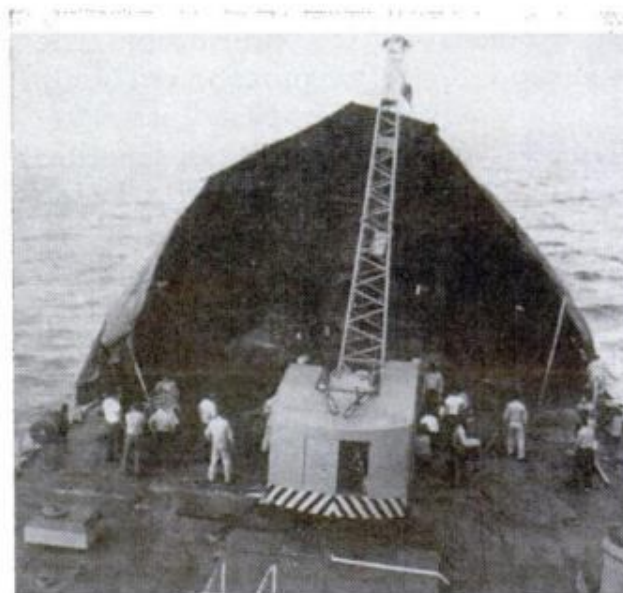

Like the good old days

Luckily, the Navy landing ship, USS *Hickman County*, had an Army 20-man tent aboard when one of her two main engines failed during a cruise from Vietnam to Japan. Lt. John Faricy directed the hoisting of the tent on the ship's crane, and the makeshift sail helped make up for the engine loss.

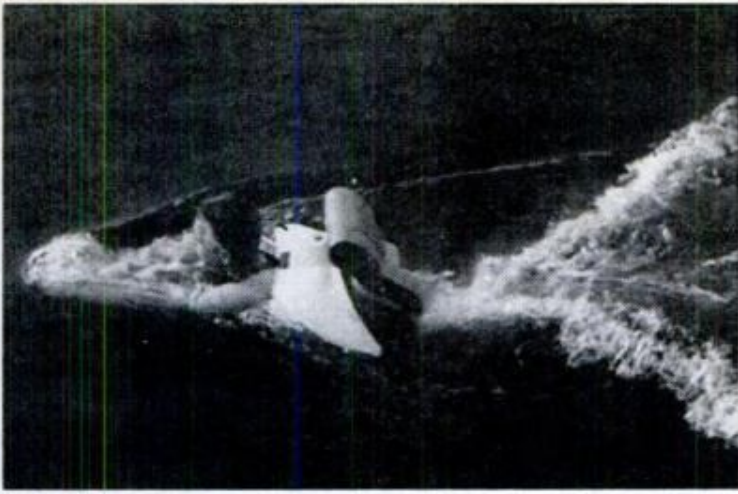

Easy way to swim fast

An outboard motor that can propel a swimmer at twice the speed of an Olympic champion has been developed by a retired RAF officer. Called the Aquazip, the 3-hp unit is worn like a rucksack. Steering is done by hands and feet, and the engine is controlled by a hand throttle. The 33-pound unit, which can float by itself, is made of fiberglass, aluminum and steel.



'Proving ground' for houses

In Sweden, new houses are checked with a rain machine that blows water against them to see if they're weatherproof.

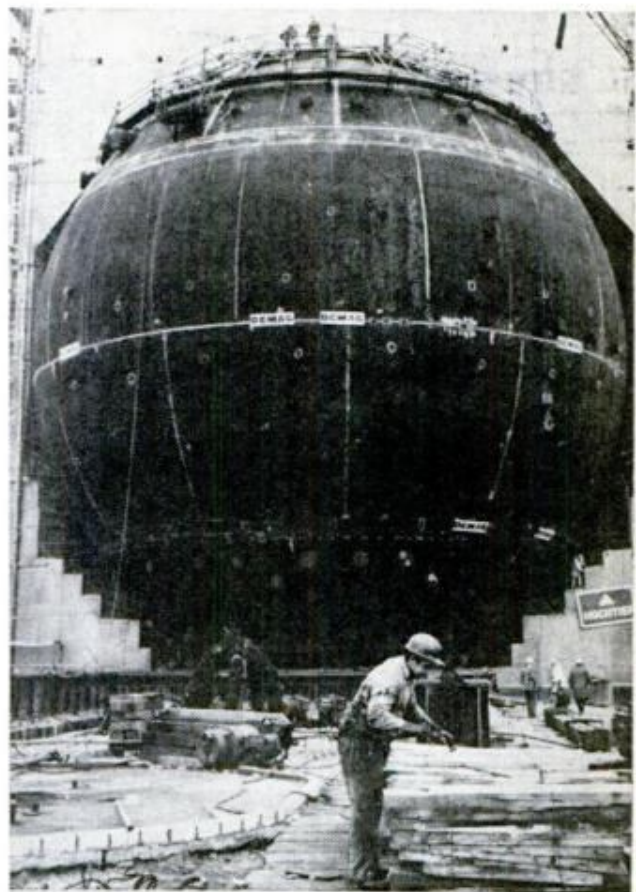

English lord adds to fleet

The 4-ton, 47-foot *Southern Cross* (left) recently joined the *Northern Star* at Stapleton Park, the estate of Lord Gretton, where the two ships take visitors on a 12-minute tour of a lake on the estate. The new *Southern Cross* carries 38 passengers at a speed of 6 to 7 knots.

Side-by-side construction

German engineers saved about eight months' construction time on a nuclear powerplant by working simultaneously on a spherical steel pressure chamber and the plant building. They left one side of the building open and moved the completed sphere into it—then finished the building.



Lots of Luxury, Lots of Leaks

It's all there—comfort, class, luxury and a big investment—but the workmanship?

By **BILL HARTFORD**, Technical Auto Editor / Photos by Irv Dolin

DE-FECTS ON DE-LIV-ERY / dē-fekts on di-liv-(ə-)rē / n [from a Chrysler New Yorker owner, a federal employee residing in Georgia, 1969] 1: incomplete assembly or lack of evidence of reasonable craftsmanship in assembly of an automobile 2: sometimes used as a defects-on-delivery ratio, defined as number of discernible defects per total dollars paid for the vehicle. Ratio should decrease as price increases, but doesn't always.

So one owner coins a term to define the problem that's driving New Yorker fans back to their dealers in droves. Owners—some numbed with despair, some disgusted and some forgiving—have a sorry tale and desperately want to tell it.

"Please forward my questionnaire to Chrysler," asks a Pennsylvania civil en-

gineer disturbed by workmanship "inside and out." "Displeased and dissatisfied," a Connecticut supervisor wants to know: "To whom may I complain?" Owners are frustrated in their desire to communicate their problems to an understanding listener. Even an Illinois priest isn't the one to tell. He wants PM to "please tell Chrysler" about his disappointment with the New Yorker: "The car shouldn't have been let out of the factory." He won't buy another. A Pennsylvania clergyman, too, says of workmanship: "Not too good!" He hath understanding and won't give up on Chrysler—yet.

Some owners have already given up—like the New Jersey foreman who has already traded in, and the Texas physician and Georgia manufacturer who wish they had their '66 New York-



BEHIND THE WHEEL, owners find lots of comfort. Individual seats, space and controls all contribute



SIMPLE CONVENIENCES like cup depressions in the bottom-hinged glove-box are very well received

ers back again. "Close the factory!" screams an irate, anonymous owner.

A Pennsylvania housewife explains: "We love the style and performance. If only the car came through almost put together so we wouldn't have to torture the poor dealer." Poor assembly is "a Chrysler trademark," observes a California airframe specialist. An Arkansas industrial engineer, luckily a do-it-yourselfer, says, "I worked three days to assemble my new car." Just take a little more time and tighten things a little better" is all a Pennsylvania machine attendant asks.

Some of the "things" include the gas pedal. "It fell off," report a New Jersey businessman and an Indiana homemaker. "Muffler wasn't bolted on," says a Georgia interior decorator. Loose and missing chrome and loose and missing bolts are also on the list. From the sublime—missing and broken Chrysler emblems, those regal marques—to the ridiculous: "Horn was mounted backwards in the engine compartment. It blasted into the car scaring the hell out of me!" That, from the Arkansas industrial engineer.

Owners are unhappy about spending \$6000 for their New Yorkers, because they "could have had the same or better quality in a \$3500 car," as a self-employed Tennessee owner puts it. An Indiana school vice-principal is

IGNITION-KEY LOCATION borders left edge of dash and on the sadistic. Reaching it with shoulder belt on is near impossible; owners want switch on right

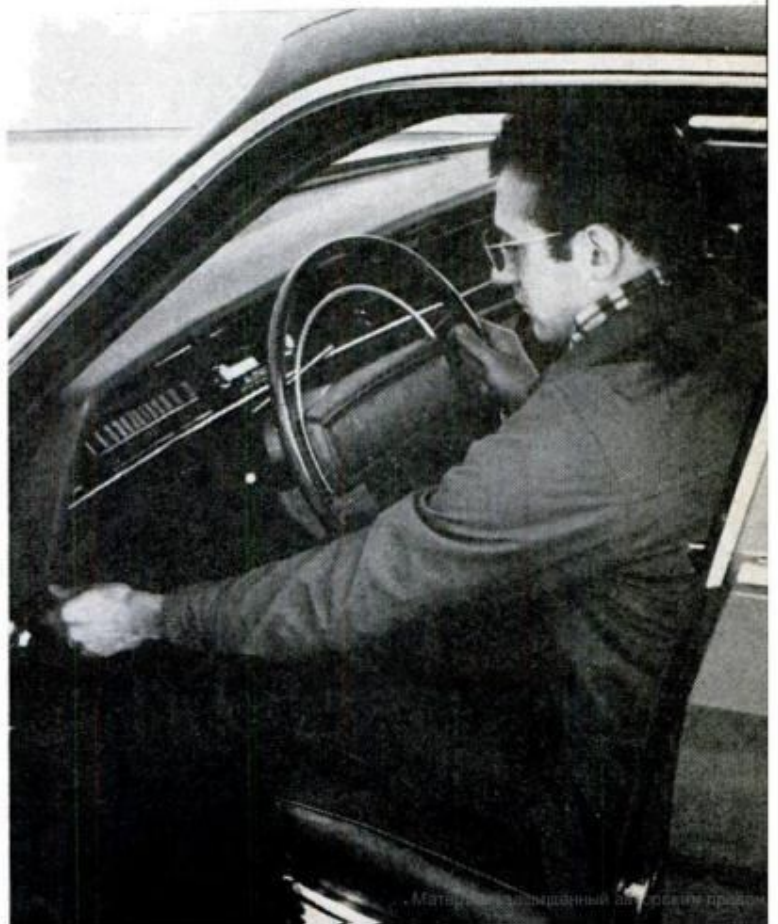
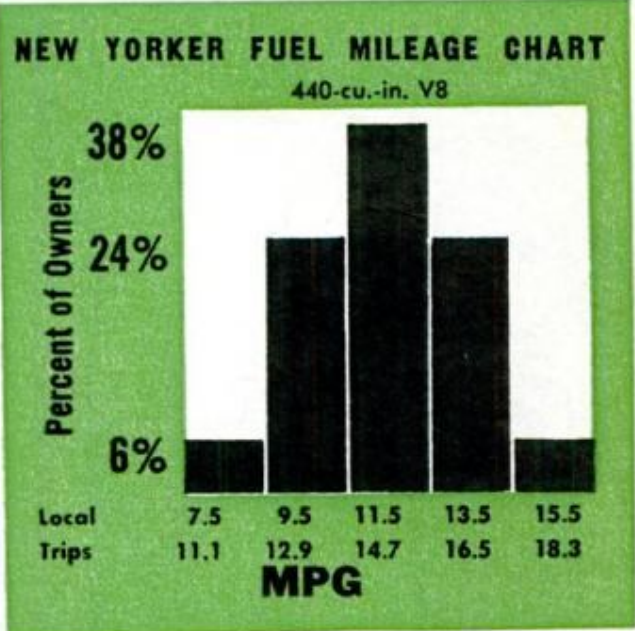

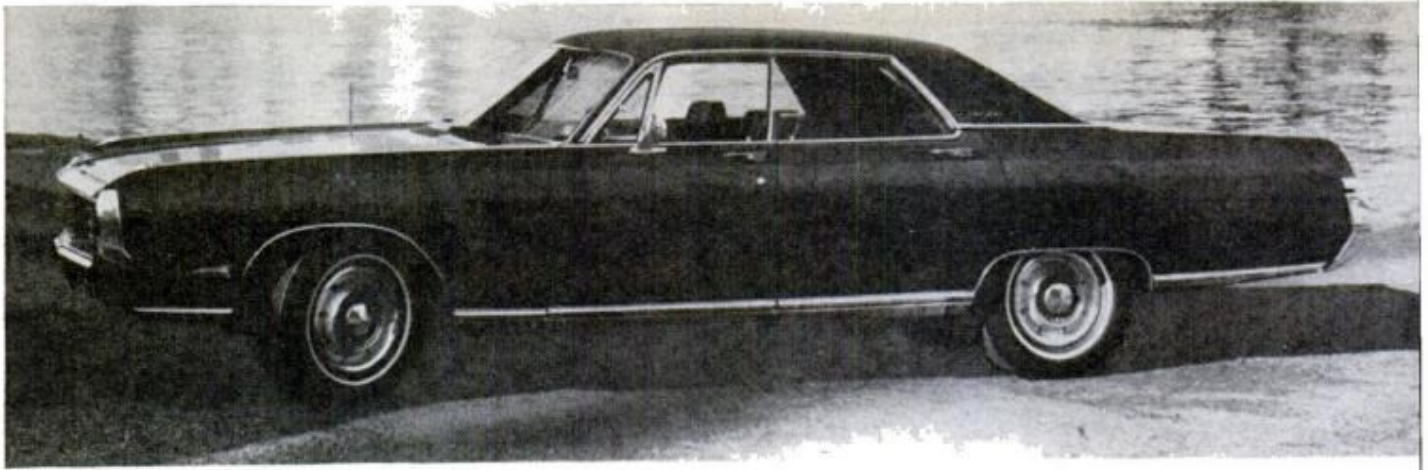

STYLING is big with owners. Even though car still has side vent windows, wind noise is a complaint

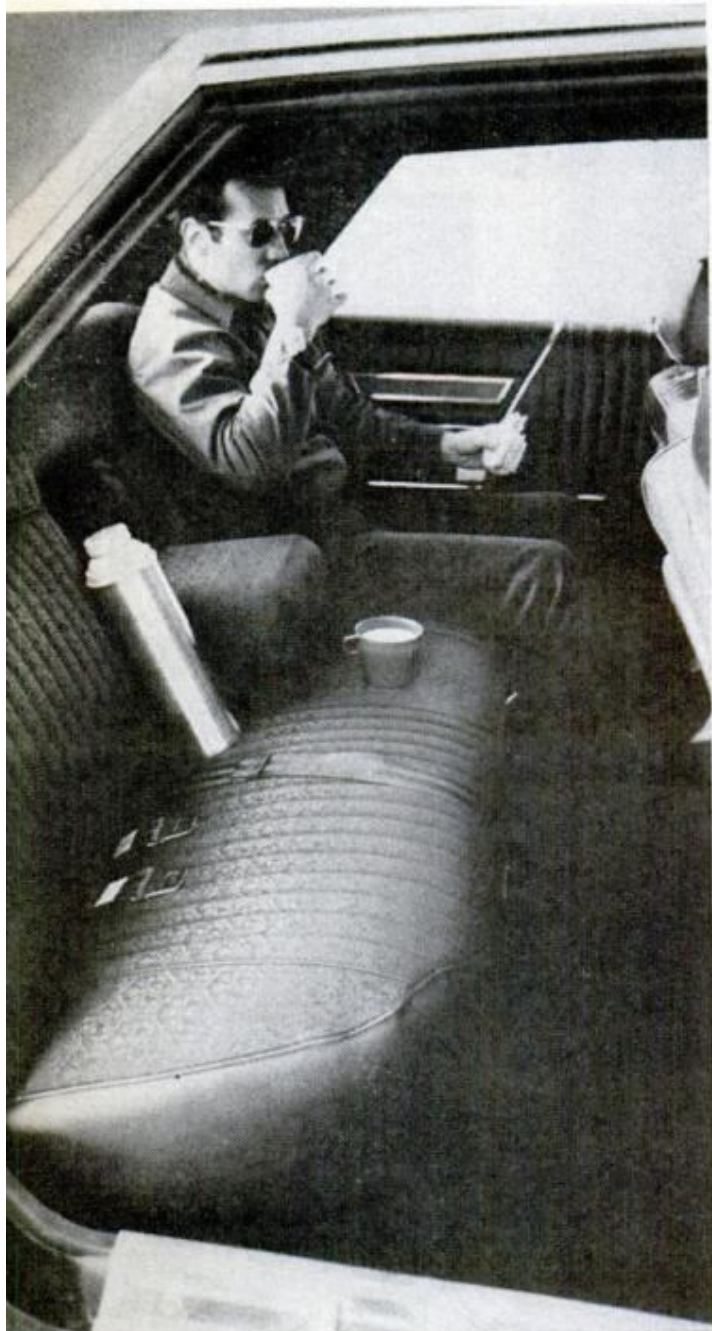

REAR-SEAT COMFORT is excellent; both front and rear comfort is most appreciated on long trips, say owners who have logged trips of 500 to 7000 miles

quite explicit: "My New Yorker fails to do any of the following to justify the price differential over a Plymouth or Newport: a. Superior or even reasonable craftsmanship. b. Superior functional characteristics such as quiet interior, better ventilation . . ."

Some owners suggest solutions: Cars should get a federal or state inspection before they leave the factory implies an Illinois truck driver. A New Jersey telephone installer feels "the dealer should be limited in sales to the size of his service department." That would go over like a ton of loose bolts!

If owners don't hesitate to complain, neither do they withhold deserved praise. Many of the same owners who have the often mentioned problem of water leaks around the trunk, for example, have "only praise for the car's road performance"—exact words of a Jersey union rep. The California owner



TRUNK COMFORT, because of its roominess, anyway, is also excellent. New Yorker owners like spare up on shelf that leaves a full, flat floor area for luggage



PRESTIGE OF OWNING is mentioned by many New Yorker fans. But they don't like workmanship faults. Some of those mentioned are leaks around backlight and doors, bubbles in the vinyl top and some rattles

who criticized assembly applauds the "almost total mechanical reliability." "Mechanically excellent," observes a Pennsylvania diner owner. "Engine and running gear very good," says a California lithographing executive. He made a two-week sprint up to Alaska and back in temperatures ranging from 10° above to 42 below. After his 7000-mile run he concludes: "A great car!"

Also enthused about the big-three qualities of comfort, ride and handling is a large sampling of folks from east to west. "I think the New Yorker is way above average in comfort and ride"; "Tops in comfort and handling" are typical comments.

When they like it, they like it! And even though some criticism of workmanship appears devastating to Chrysler, these owners are still the manufacturer's best friends. They just want to be heard, just want their faith restored. They'd just as soon stick with Chrysler as they move up. Like the Jersey manufacturer, who says he wanted a New Yorker since he can remember, "I finally made it! It's a reliable, comfortable, aristocratic car." Still, he's got "water leaks around rear window and trunk."

The New Yorker owners' story is one of getting their money's worth. It's time for a happy ending. ★★

Summary of 1969 Chrysler New Yorker Owners Reports*

Total miles driven:1,193,169

Average miles per gallon:
440-cu.-in. V8, local driving 11.5
long trips.....14.7

Specific likes:
Comfort 37.2%
Ride 34.5
Handling 28.0
Style 27.6
Performance 24.1
Economy 10.3
Power 9.2

Specific Dislikes:
Workmanship 25.7%
Door water leaks..... 13.0
Wind noise 8.9
Quality 8.6
Rattles 8.6
Dealer service 7.1

What changes would you like?
Ignition key location..... 20.4%
Better workmanship 19.0
Quality of materials..... 9.7
Hidden windshield wiper design 6.5
Ashtray location 4.2

Wind noise 4.2

Body style:
2-door hardtop 18.3%
4-door hardtop 52.5
4-door sedan 29.1

Had any mechanical trouble?
No 56.6%
Yes 43.4

What kind of trouble?
Power steering 15.2%
Electrical 12.0
Carburetor 10.4
Airconditioning 9.6
Windshield wiper/washer 8.8
Cold starts 7.2

Dealer repair satisfactory?
Yes 60.3%
No 38.0

Why the New Yorker?
Past experience 35.4%
Style 17.7
Economy 7.6
Reputation 7.2
Comfort 6.5
Quality 6.5
Size 6.1

Is the New Yorker your only car?
No 59.6%
Yes 40.4

Other cars owned:
Plymouth 30.6%
Chevrolet 15.9
Chrysler 12.4
Ford 11.2
Dodge 8.2
Buick 5.9

What options/accessories?
Power brakes 86.6%
Power steering 83.3
Power windows 65.5
Airconditioning 62.6
Power seats 53.3
Radio 50.9
Power antenna 23.2
Tinted glass 18.7
Rear defroster 12.6
Vinyl top 11.7

Age distribution of owners:
15-29 6.4%
30-49 50.3
50 plus 43.3

*Where applicable percentages may not equal 100 percent due to rounding and/or insufficient sample.



Want a Guitar Amplifier? You Can Build This One From a Kit

If there's a youngster in the family who's been bugging you for a guitar or combo amplifier, you can save money and have some fun at the same time by assembling this versatile solid-state kit, priced well below most ready-made amps. The Knight-Kit Model KG-387 has 90 watts peak power and all necessary controls for creating special mu-

sical effects. There are two separate channels, each with two inputs. One handles mikes and instruments requiring straight amplification, and the other provides reverb and tremolo effects. Bass, treble, tremolo and reverb are all independently variable. There's also a plug-in foot switch for remote control of reverb and tremolo. Construction is

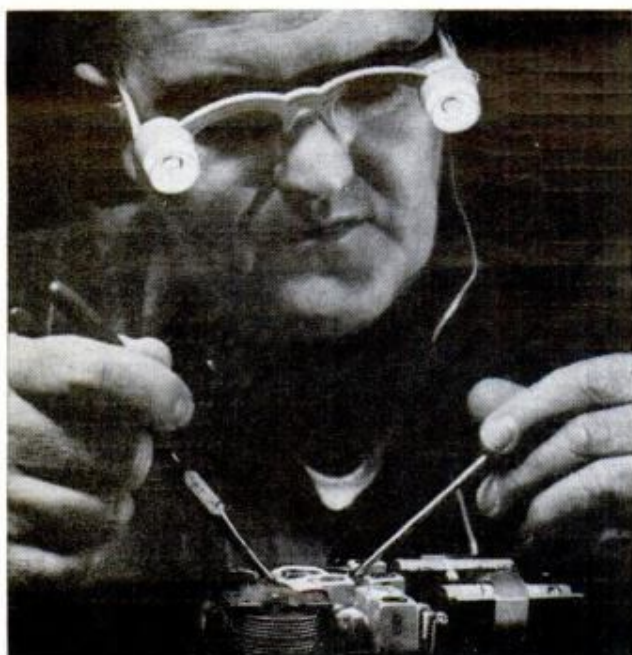

WORN LIKE GLASSES, these tiny spotlights make it easier to see what you're doing on delicate wiring and other fix-it jobs, while keeping hands free. Powered by two C-size batteries, they're ideal for kit building and similar work. Price is \$4.98. Leonard's Gift Center, 1404 N. 40th Ave., Hollywood, Fla.

ELECTRONICS



simplified by handy, easy-to-reach parts. The main power amplifier is attached to the back panel and slides out like a drawer (right). All other circuit boards mount compactly on rear of front panel, also removable. Speaker enclosure comes preassembled with two 12-inch Jensen speakers. Speaker and amplifier units cost \$169.95. Allied Radio, 100 N. Western Ave., Chicago, Ill. 60680.



SPROUTING TWIN ANTENNAS, the new Panasonic headphones at left let you enjoy FM broadcasts anywhere, with no radio connection. A miniature FM stereo receiver is built into headband. Price \$99.95.

WANT TO MAKE secret phone calls that no one can listen in on? You can now have your own private voice scrambler like that below. Sunset Equipment Corp., Westbury, N. Y., leases it for \$20 a month.





Sea stopper

Protecting the German coastline near Wilhelmshaven from the pounding of the North Sea is a huge dike faced with steel-reinforced concrete. Concrete blocks jutting from the face help stop the powerful breakers.



Pumpless gas station

There are no gasoline pumps in the new "pumpless petrol station" in Birmingham, England. To service a car, the attendant simply pushes a button that causes the hose nozzle to descend from the ceiling; after each use, the hose goes back up—out of the way.

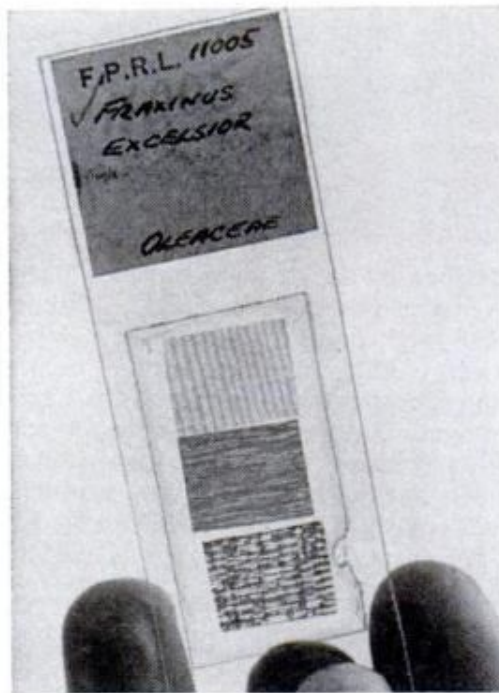

No light reading here

Although the shelves of this library appear to be filled with books, anyone who examines a "volume" will find that it's solid wood. In fact, there are 30,000 specimens of wood lining the walls of the library at the Forest Products Research Laboratory in Prince Risborough, England. The collection is classified on special cards which list the properties of each wood. The library also has microscopic slides (above) of the timber in the collection. Each year the library personnel identify more than 1000 types of wood at the request of builders, furniture makers and other members of the timber industry. Each new sample is chemically treated to kill insects that might harm the collection.

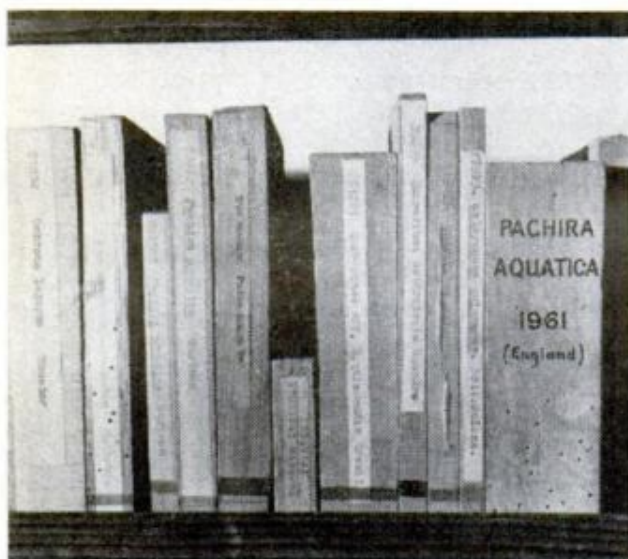

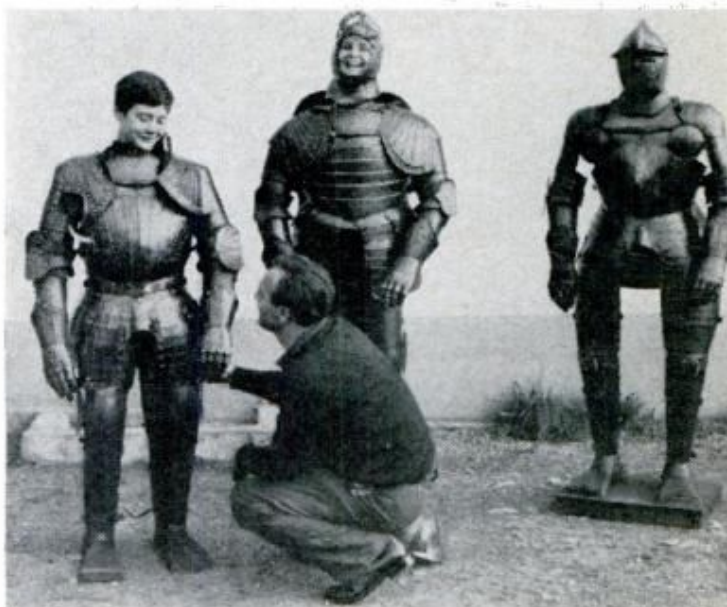

Suits of shining armor from the junkyard

Junked cars yield excellent raw materials for making medieval suits of armor, according to Heinz Schneider of Wurzburg, Germany, who annually turns out some 50 such outfits. Traveling about the country as a salesman, he searches junkyards for materials (upper left), brings the auto parts home and turns them into armor (above right and lower left). It takes him about 200 hours to fabricate a suit that sells for \$400 to \$750.

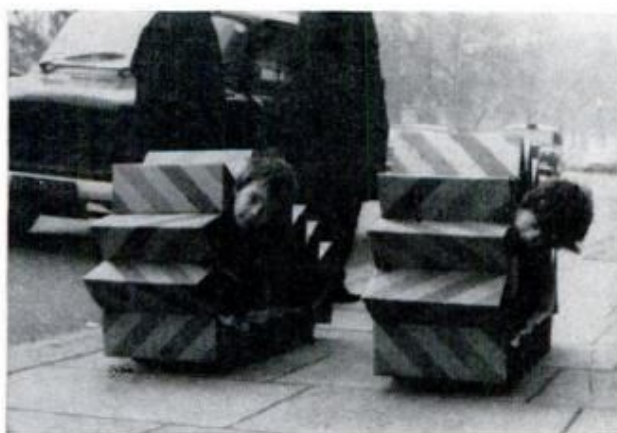

One-childpower 'tanks'

The "Lunar Track" is a cardboard toy from Britain that operates something like a tank tread. The child simply gets inside the track and starts crawling forward to make it move.

JUNE 1969

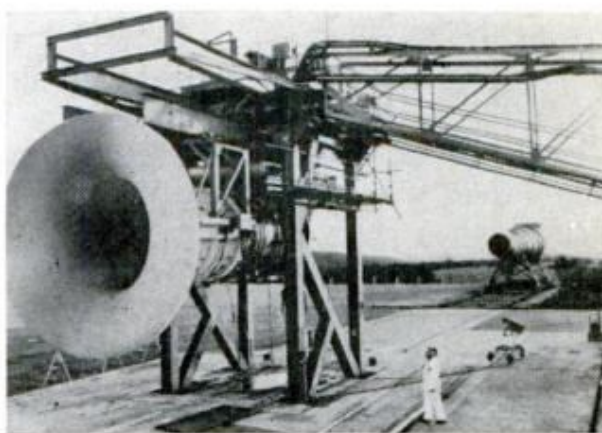

Test bed for aircraft engines

A large, open-air test bed has been built near Derby, England, to measure the performance and take basic noise readings on the new RB 211 three-shaft Rolls-Royce engine.

129

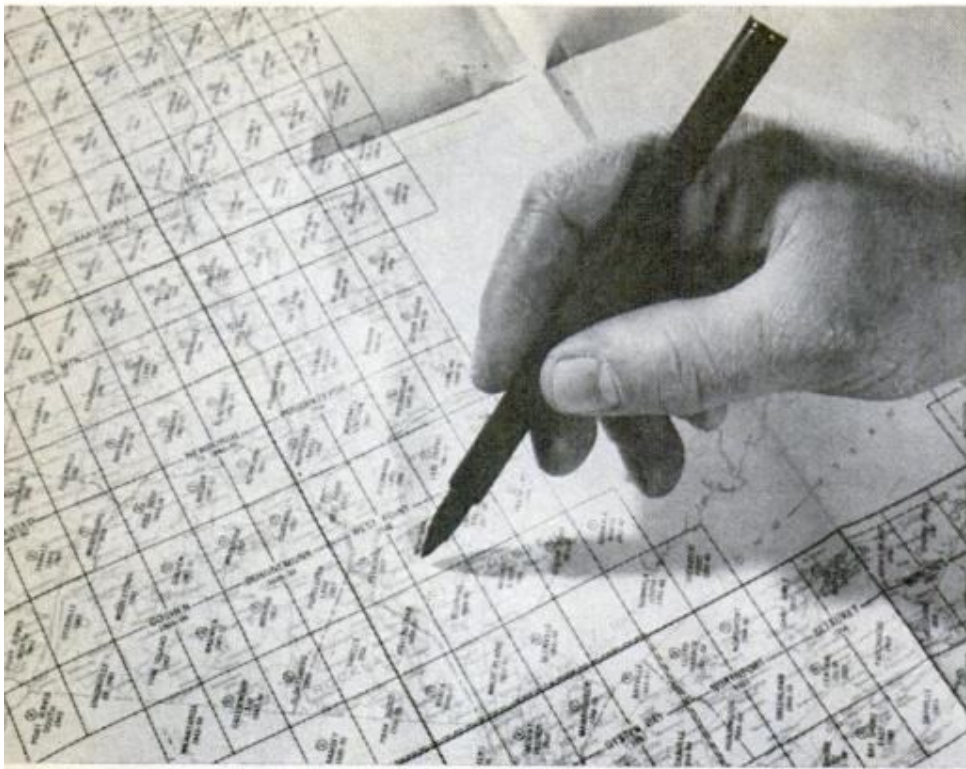

How to

By **NORMAN CARLISLE**

FINDING THE RIGHT MAP for a particular area is easy. You first get a USGS index map for the state you live in or plan to visit. These are marked off into small sections, as shown at left. The sections represent available maps and are identified by names. When you locate the area you want, you order the corresponding map section

THE FARMER shook his head hopelessly. "It's way back there in the woods and no trails to it," he said, "You'll never find it."

The native Vermonter who gave me this firm opinion about a marsh I wanted to get to turned out to be wrong. I, a first-time visitor to this wilderness region of forest-clad ridges and dashing streams, was able to go right to it.

I can't attribute my success to any feat of superior woodsmanship. It was just that I had a map and he didn't—not an ordinary map, but one of the unique topographical maps put out by the U.S. Geological Survey.

These remarkable maps, bargain-priced at 50 to 75 cents each, give you a picture of the landscape you can't get any other way. On the scale they're drawn, they show not only roads and natural features of the land, but also man-made additions such as footbridges, mine shafts, gravel pits, fence lines, even individual houses. If you're an outdoor man of any kind—fisherman, hunter, hiker, birdwatcher, rockhound, amateur prospector or nature photographer—a USGS map will get you around strange territory with sure-footed confidence. You *know* the lay of

the land even before you get there.

As a motorist, you'll find that USGS maps can add a new dimension to family vacation fun. They're the perfect tool for the shun-piker, the guy who wants to get away from the smooth boredom of the turnpike once in a while and see some parts of the country that can only be seen on back roads. If you're heading for a national park or monument, a USGS map will pinpoint



Know the Lay of the Land

Big-scale U.S. Geological Survey maps show every hill, pond, brook, backwoods road, maybe even your own house. They add fun and excitement to camping, hiking and exploring trips, cost only a few cents. Here's how to get one for any area

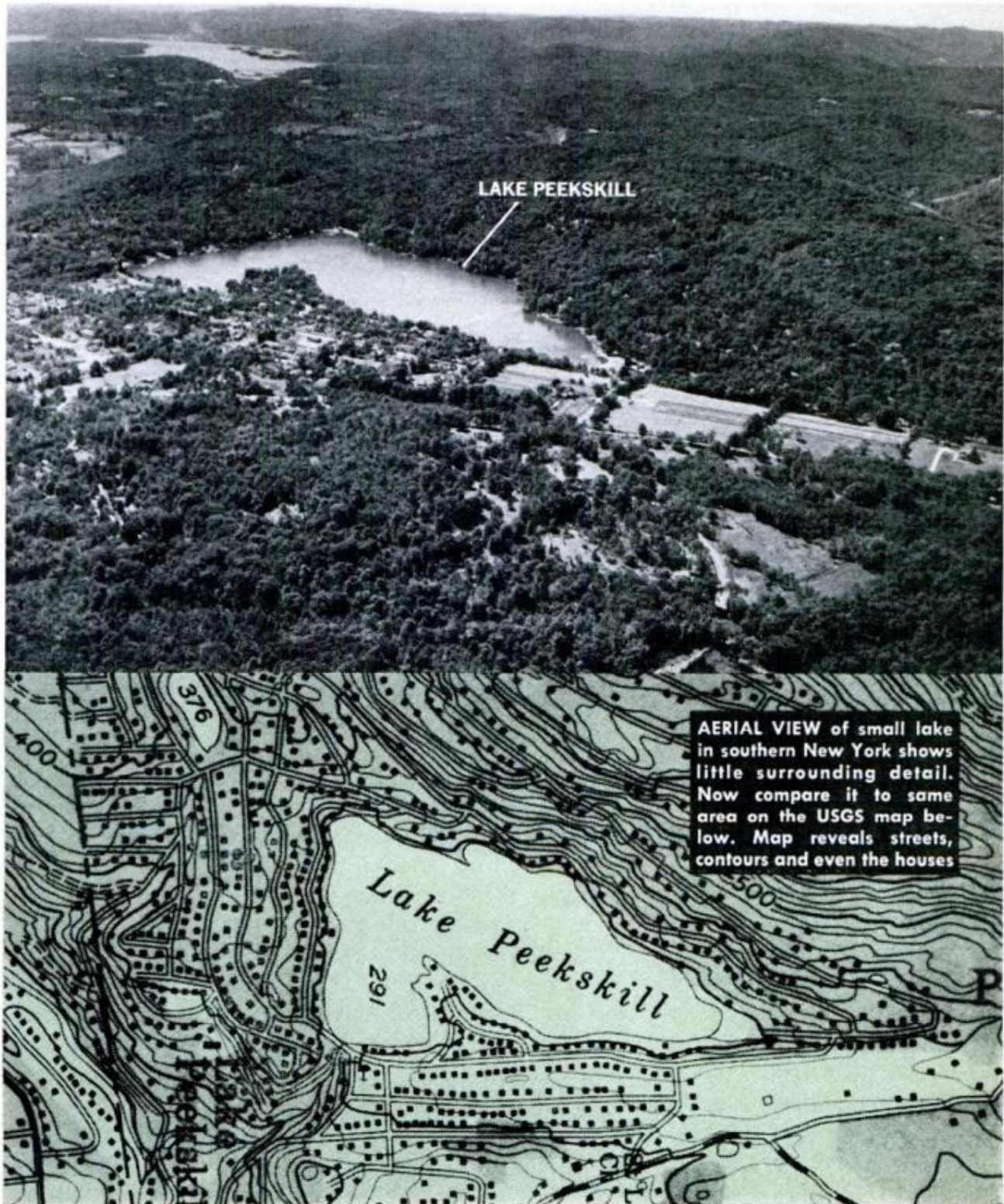

hundreds of features most tourists miss.

Closer to home, in territory you *think* you know, you're in for a surprise when you unroll a USGS map. If you live in the country or in a small town, it may even have your house on it. You're likely to see on it a lot of stuff you didn't know was there—a jeep trail too unimportant to be marked on an ordinary road map, a pond you've missed because you can't see it from the road.

What gives USGS maps their unique usefulness is their scale. It's much larger than those of other maps. A typical USGS scale is 1 to 24,000. This means that one inch on the map equals 24,000 inches of actual land. That's 2000 feet or less than half a mile. By contrast, one inch on a road map equals anywhere from 5 to 10 miles or more. Other USGS scales used are 1 to 62,500, where an inch equals about one mile, and 1 to 125,000, where an inch is two miles.

Scales like these enable the USGS to cram in a tremendous amount of detail. The use of carefully designed colored symbols lets you easily identify objects as small as a water tank or an earth dam across a creek. A few of these symbols are shown in an accompanying table.

You'll also find a lot of squiggly brown lines wandering over the map. These are contour lines and they tell at a glance how the land lies. If you're accustomed to maps that show all land as being equally flat, these contours will come as a great joy. Each one is an imaginary line connecting points of similar altitude above sea level. Depending on the map, the lines represent heights from 10 to 80 feet apart.



TWO LAKES viewed from a hillside in photo above appear different from actual shapes shown in corresponding USGS map at top. Such maps help to reveal land features that you can't see by eye

The closer the lines are together, the steeper the slope. A lot of lines bunched together would indicate a cliff. Exact elevations are printed in brown at various points along the lines.

For easier reading, the map makers print index contours. Every fourth or fifth line is a darker shade of brown. It's easier to run your finger along this darker line, and the distance between such index lines will give you a clear picture of the rate of climb. You'll feel like a pro when you can look at a map and tell that you're going to climb exactly 320 feet in a given stretch of trail.

In mountain country where you're

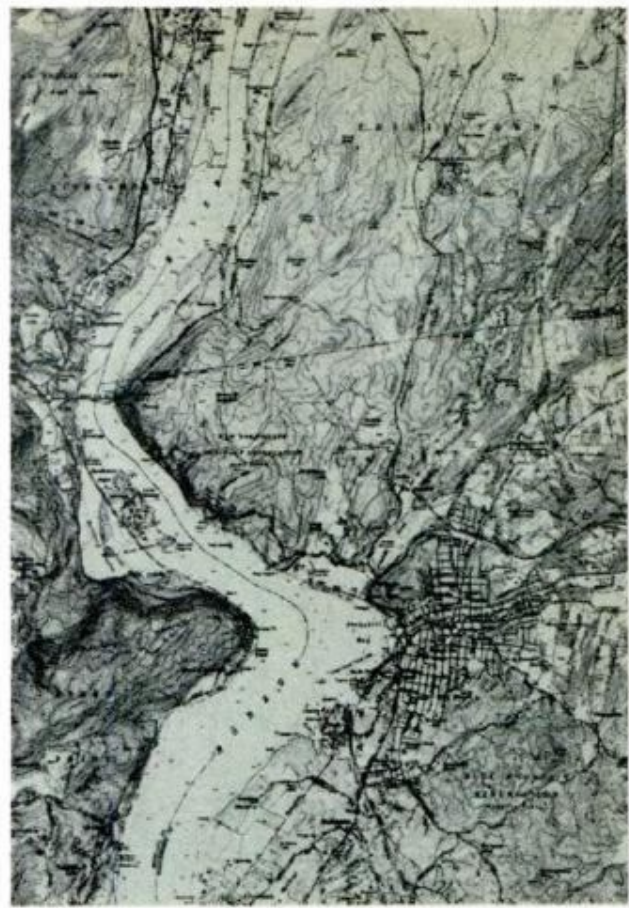

CALLED QUADRANGLES, USGS maps commonly come in two scales, as shown in diagram at right. Large scale covers $7\frac{1}{2}$ minutes of latitude and longitude. Smaller scale includes four times as much area or 15 minutes of latitude and longitude. Maps above, containing sections of Hudson River in southern New York, show how the two scales differ. Full map at left represents 15 minutes of area. One at right is a $7\frac{1}{2}$ -minute section taken from its lower left-hand corner. In some cases, such a portion is referred to as the southwest section of the larger quadrangle. Additional maps cover the northwest, northeast and southeast sections. Note how much detail the $7\frac{1}{2}$ -minute quadrangle shows—important when you're exploring an unknown region. The 15-minute maps are useful as wall decorations or when you want to study a larger area in a more general way

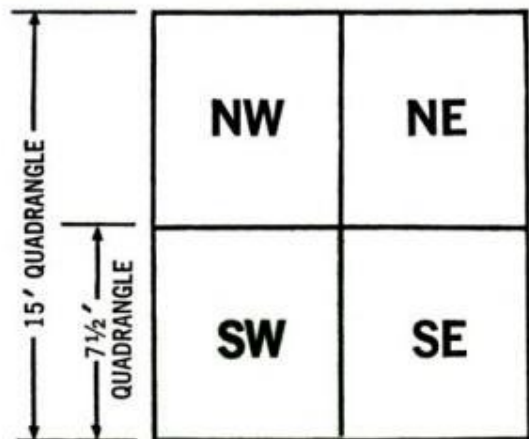

picking your own trail, you can find the easiest route by following the contour lines. The shallowest grade will be where the lines are farthest apart.

For some areas, the Survey has prepared shaded relief maps. These will give you an even better idea of terrain than the regular maps, as the shading accentuates the physical features. Most of the National Park and Monument maps are available in this form, as are those of many states.

It's a good idea to know just how old your map is so you can make allowances for possible changes that may have occurred since the map was made.

Some USGS maps go back several years. I remember a time when I was exploring a section of Vermont with my sons, using a 1950 map. We came over a rise and looked down where the map said a farmhouse should be. But no house was in sight. Was the map wrong?

We decided to continue on. As we broke out of the trees into a clearing, there was the answer—an empty excavation, some charred timbers and a stone doorstep overgrown with brush. A little bit of history had been written since the map was made.

The year in which a map was first
(Please turn to page 205)

Modern Hi-Fi Speakers: Big Sound in a Small Box

Clever advances in acoustics engineering now give you concert-hall realism from trim, compact enclosures that hide on a bookshelf or double as an end table. Here's how to choose a system to suit your entertainment needs

By HANS FANTEL

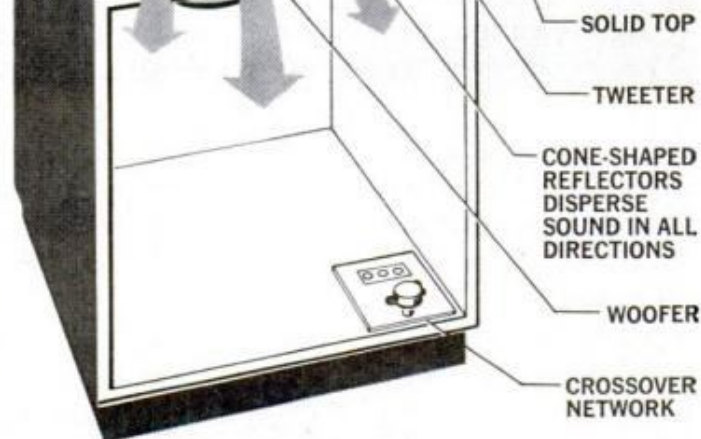
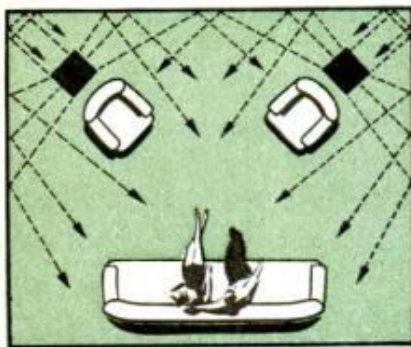

ONE OF LATEST ADVANCES in speaker design is omnidirectional enclosure that scatters sound instead of beaming it right at the listener. In Harman-Kardon's new HK-50 models above, woofer and tweeter actually lie flat, facing upward. Sound is dispersed in all directions by cone-shaped baffles overhead. Because of this, speakers can be placed almost anywhere, even behind furniture, as shown in sketch at left. Sound bounces off walls to fill the entire room

YOU USED TO BE ABLE to tell how good a speaker was by its size. The bigger, the better. A speaker had to be big to move a large volume of air. To be really fine, it had to stand four to five feet high and fill up the corner of a room. For stereo, it meant finding space for two of these monsters.

Today's slimmed-down speakers are trim little boxes that sit on a bookshelf. Some are designed to double as

chairside cocktail tables so they become useful furniture. Inside, you'll find three or four separate speakers, plus dividing networks and balance controls, all shoehorned into an enclosure little bigger than a grocery carton.

New materials and advances in engineering know-how make it possible to get big sound out of a small box, but you have to know what to look for in making a choice. There are good small

7 TYPICAL SPEAKER ARRANGEMENTS

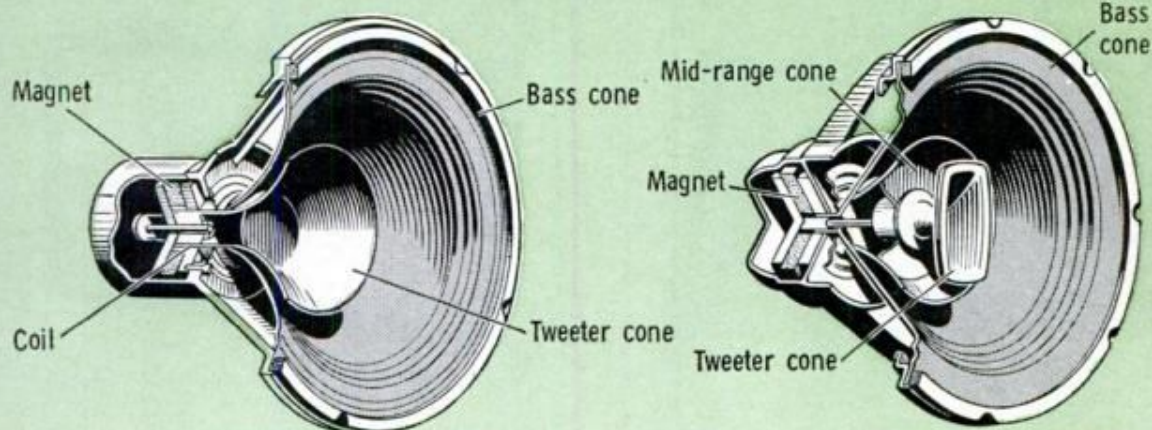

2-WAY COAXIAL SPEAKER

3-WAY COAXIAL SPEAKER

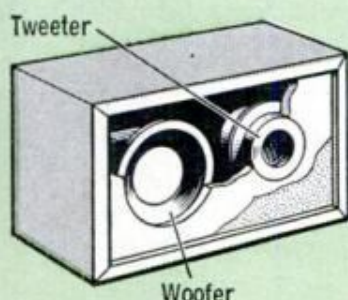

2-WAY CABINET

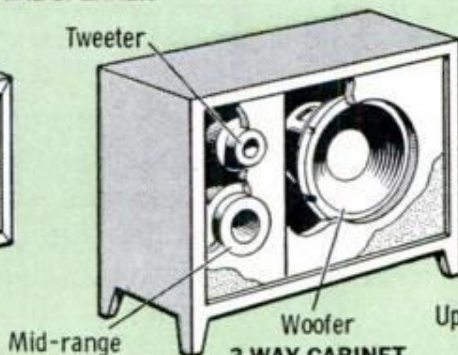

3-WAY CABINET

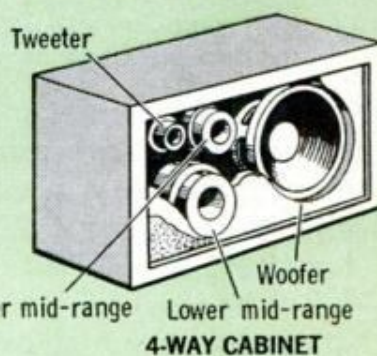

4-WAY CABINET

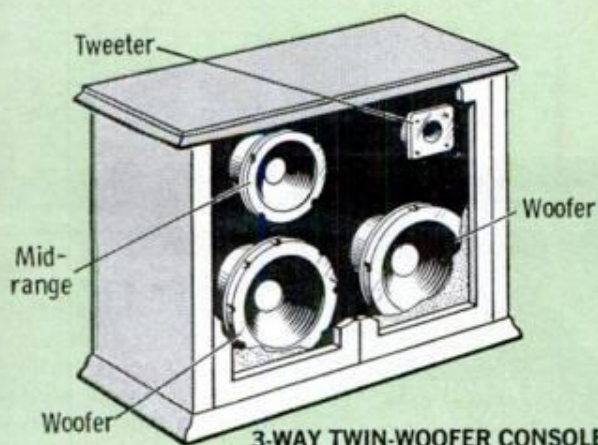

3-WAY TWIN-WOOFER CONSOLE

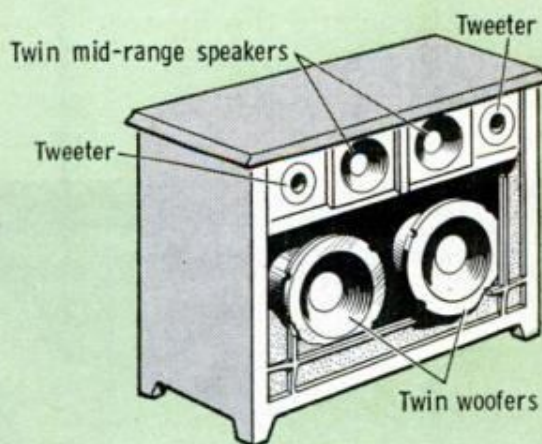

3-WAY 6-SPEAKER CONSOLE

GIANT SINGLE SPEAKERS have given way to smaller multiple units, each designed to handle a particular frequency range more efficiently. Even coaxial speakers now come with up to three concentric cones. Compact bookshelf enclosures may have as many as

four individual speakers. In four-way models, mid-range is split between two speakers to handle upper and lower middle frequencies separately. Consoles offer still more speakers in the form of dual woofers or of dual woofer-tweeter-mid-range combinations

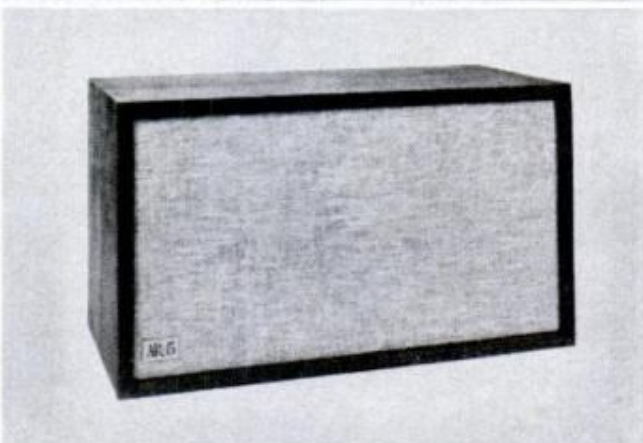
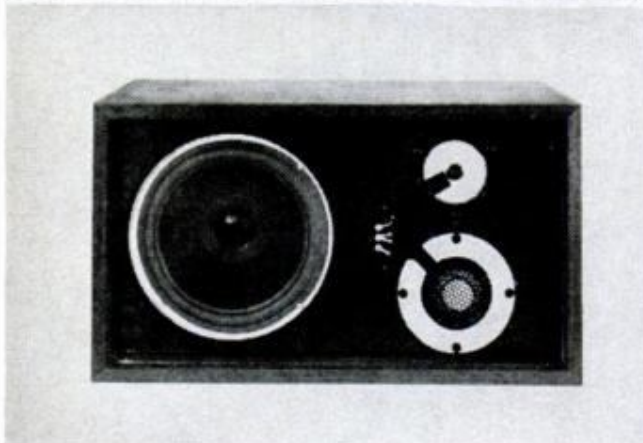
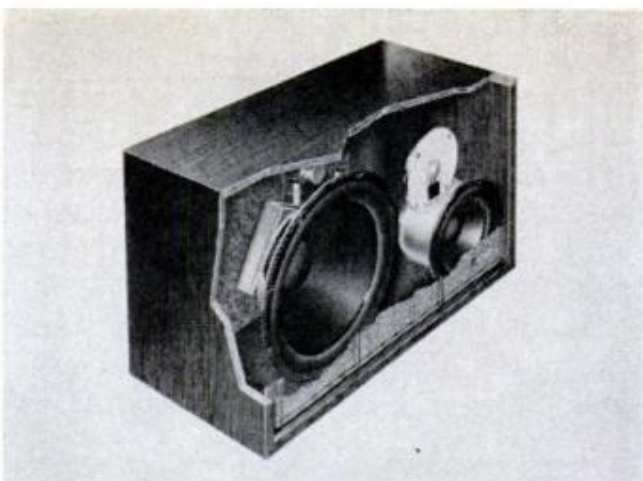

TYPICAL BOOKSHELF SPEAKERS are these two well-known models—Electro-Voice's E-V Four, shown in upper photos, and Acoustic Research's AR-5 at bottom. Only two feet wide and about a foot deep,

both are three-way types, incorporating a woofer, tweeter and mid-range speaker. The E-V Four sells for \$138. Prices on AR-5 range from \$156 to \$175 depending on the type of cabinet finish selected

speakers and poor small speakers—you can no longer use size to indicate quality.

The engineers are also trying out radically new designs. Harman-Kardon, for example, has just introduced a new kind of speaker, the Model HK-50, that spreads sound all over the place, reflecting from walls and corners of the room before reaching the listener.

Harman-Kardon engineers believe this kind of "round sound" is more realistic than straight-line sound

squirting from conventional speakers. "Conventional stereo speakers," they say, "beam sound at the listener like two headlights glaring at him. Our omnidirectional sound scatter might be compared to an indirectly lighted room. The light—or sound—is diffused all over."

In theory, this comes closer to concert-hall sound. An orchestra, too, scatters sound the same way. It travels in every direction from the stage, and

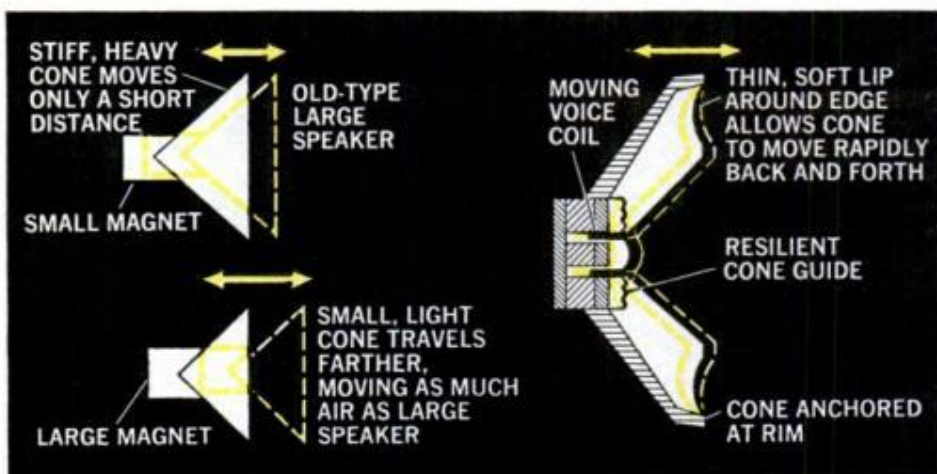

WHY SPEAKERS are getting smaller is shown at left. In older speakers, cone moved only a short distance, thus had to be large to push a sufficient volume of air. In newer models, cone is lighter and travels farther, enabling a small speaker to move as much air as larger one. Drawing at near left shows how ring of special soft material around speaker's rim allows cone to move in and out freely. Use of more powerful magnets also increases cone travel

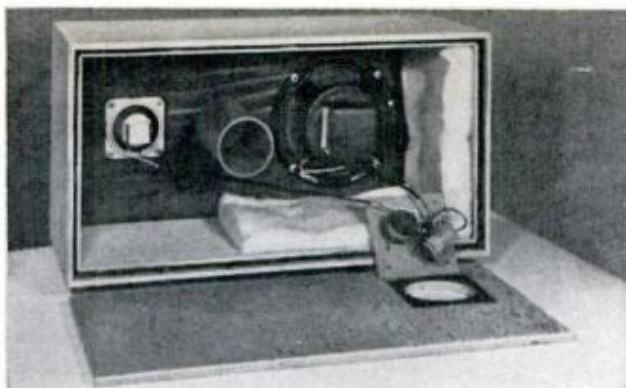

REAR VIEW of a typical bookshelf enclosure reveals thick padding used to damp out unwanted back waves from bass speaker. Padding generally covers bottom and one side, isn't needed over whole area



ABOUT AS SMALL as you can get for a true three-way speaker, this University bantam is only 15 inches wide by 6 inches deep. The Mini-Flex II has a woofer, mid-range and tweeter, sells for \$49.50

the listener hears most of it reflected at all angles from walls and ceiling. The Harman-Kardon design also makes speaker placement less critical. Good stereo effect is obtained in almost any spot.

Harman-Kardon is not the only company to come up with reflected-sound speakers lately. A deluxe speaker system by Bose (Model 901) throws 89

MANY UNUSUAL SPEAKER DESIGNS are appearing these days. Among them is this clever ball-shaped model that can be placed anywhere. The sound radi-

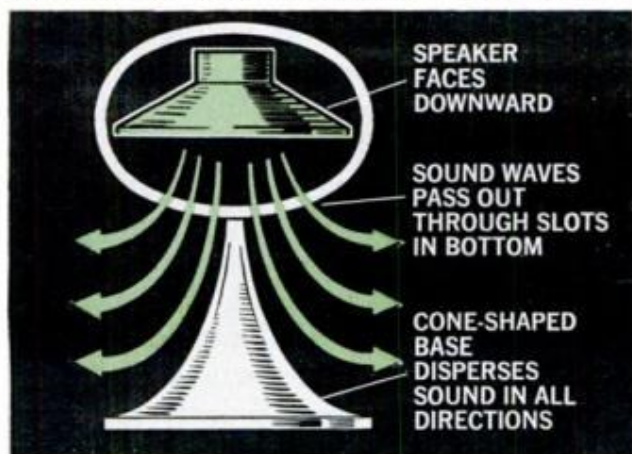

SPEAKER KITS let you do the assembly work yourself and still be assured of proper acoustic design. These Allied Radio Model 2330AK speakers come knocked down for \$59.95 each or \$74.95 assembled. The three-way units incorporate woofer, mid-range and tweeter, have a response of 30 to 18,000 cycles

percent of its total sound output toward the rear to create indirect sound reflections. Zenith's new "Circle of Sound" compact stereo system uses a 360° dispersion pattern. So does the globe-shape Model 5303 just introduced by JVC (Japanese Victor Co.) at \$199.95

These offbeat models are stirring up excited shoptalk, but most audio engi-

(Please turn to page 206)

ates downward and is dispersed in all directions by the cone-shaped pedestal. The Realistic "Futura" speaker is sold by Radio Shack in Boston for \$19.95



PM Tests FrontRunner: The Boat That Wants To Be a 'VW Bus'



Johnson's new 16-foot utility boat looks to some like a compact van. But it sure doesn't handle like one

By DAN FALES, Boating Editor

FRONTRUNNER is the name given Johnson's newly designed 16-foot boat. When you look at it, the reason for the name becomes obvious—you handle the boat from a driver's seat right up front in the bow.

There are great advantages to this arrangement, and some drawbacks.

It was in Georgia's Lake Lanier, about 40 miles north of Atlanta, that I tested this runabout utility boat. Lake Lanier is a good recreational boating lake as well as a good bass and trout "pond." The lake is formed by Buford Dam, with water backing up from the dam for 21 miles.

But there was a problem that day at

Lake Lanier. It rained so hard that it was suggested we test the boat on Peachtree Street in downtown Atlanta. However, the foul weather turned out to be an advantage. With rain and wind, the lake was no millpond. The water was rippled enough to give FrontRunner a good chance to show her performance characteristics.

The first advantage of this up-front boat design is visibility. I found that you can almost see the bow parting the water. From the helmsman's seat you look right down into the water. You feel more comfortable when cruising at high speed. You can plainly see any obstructions in the water ahead.



FOR A 16-FOOTER there's an enormous amount of space in the cockpit of FrontRunner, plus great visibility

You'll also find great visibility when going up on plane. In most boats, there's a time when getting on the step that you lose all view ahead. When you're sitting amidships or back from the bow, the bow itself can block your vision for a few seconds. But in FrontRunner, you're right out front. You can see all during this critical period. The bow doesn't rise as much as other boats either. The weight of driver and passenger keeps bowrise to a minimum.

The great visibility works in your

favor when you're leaving a docking slip. With the boat facing out into the channel, you can see all other traffic in your immediate vicinity before you even leave the slip. Of course, getting FrontRunner into the slip so you're facing out means backing the boat.

I found it easier to back FrontRunner than any other single-screw boat I've ever handled. The secret is to ease her back, not gun her. In other boats, if you're sitting near the middle it's harder to judge stern movement to the left

LINING UP on a trailer is an easy maneuver with this boat because you can see directly in front of you. Johnson also has a trailer designed for FrontRunner

SITTING UP FRONT lets you look for traffic on both port and starboard when leaving slip. Backing the boat into such a slip is easy once you get knack



or right as you back. But sitting right in the bow you can get a better idea of how far and how fast the stern is moving. It's like sitting on the pivot point of a pendulum. It's easier to judge the full motion of the swing arm from that point than if you are sitting halfway down the arm.

Once you've backed into a slip you'll find it quite easy to tie a docking line without getting away from the controls. There's a cleat at your right elbow. Though this cleat sometimes is bothersome when underway, it's sure handy when docking.

When I first left the dock, I got a sensation that I was towing a trailer. But that feeling soon disappeared as I put FrontRunner through the paces.

Though the boat has a brand-new interior design, Johnson is using the gull-wing hull with slight modifications. The gull-wing is also the hull used on other Johnson boats. In FrontRunner, though, the center hull is four inches deeper than usual, increasing the dead rise by eight percent. This makes for a deeper vee configuration.

When you first take FrontRunner out, you'll notice another sensation. You'll feel like you're on cotton. When jumping a wake or going off a wave, you get the feeling that you'll never hit bottom. It's the softest ride yet. It's a cushion ride similar to that found in air-cushion vehicles. Actually, you are riding on air. When you're in the driver's seat you're literally out of the water when the boat's on plane.

With two people aboard, I found that though FrontRunner turned easily and flatly, there was some cavitation on real sharp high-speed turns. With just myself aboard, there was no cavitation on turns, no matter what I did.

The beauty of FrontRunner is not only visibility, but cockpit space. On this 16-footer, there are 55 square feet of unobstructed space, except for the front two seats.

As an option you can get two fold-down seats for that cockpit area. With these in place you can seat six, includ-



STORAGE COMPARTMENT between seats is good for a small anchor, line and other nautical items. Note positioning of gauges to the left of the driver's seat

ing yourself. The boat is rated to carry seven 170-pound people.

There are a couple of drawbacks to FrontRunner. First off, the legroom for the driver is a bit cramped. For short trips across a lake or such this doesn't matter at all. But when you're on a longer safari you may find that a change of driving position is in order after a few hours.

The other problem is a slight tendency to "porpoise" when you're running flat out on a smooth lake surface. However, this up and down rocking

LIFTING EYES are great for attaching water-skiing towline. There's also a lifting eye in the bow. Power tilt on OMC stern drive is standard equipment





CONVERTIBLE TOP on FrontRunner is standard equipment. It's one of the easiest to erect that I've used

motion in the bow can be kind of fun.

FrontRunner comes with a 155-hp OMC stern-drive unit. This is the only power now available for the boat.

Suggested price of FrontRunner is \$4400 equipped with a 155-hp engine, tach, speedometer, ammeter, fuel gauge, running lights, an anchor light, interior light, cigaret lighter, bilge pump and blower, horn, walk-through tinted tempered safety-plate-glass windshield with folding center panel, two aft jump seats, two forward bucket seats, storage troughs, anchor locker,

compartment with removable cooler, 18-gal. fuel tank, convertible top and boot, battery, deck cleats, lifting eyes, electric-power tilt drive unit, power pointer steering and master electric disconnect switch.

There's also a trailer specifically designed for FrontRunner. With hydraulic surge brakes, it runs for \$700 suggested retail; without, about \$550.

Exact specifications of FrontRunner are: length, 16 ft. 2 in.; beam, 85 in.; cockpit length, 116 in.; cockpit width, 68 in. ★ ★ ★

THERE'S NO SLIDING TRACK for convertible top. You just snap braces over nipples and put top up. This eliminates the sticking problem found with tracks

CLEAT at driver's elbow makes it very easy and quick to secure a docking line when you're alone. Note good visibility out windshield from driver's seat



Rundown

There's much more of it on your car than you think. Some rubber components need no checking; others shouldn't be neglected

THERE ARE approximately 230 pounds of rubber in the average-size car. Five tires account for only 100 pounds; where's the rest?

Let's rephrase the question: There are 550 to 600 rubber parts in cars of the full-size Plymouth-Chevy-Ford class. Tires are only one. Can you name 100 others?

There's rubber all over your car. Some of it you can see—like tires, drive belts, hoses. Other parts are hidden—like gaskets, seals, tip of the carburetor needle valve.

When you realize the amount of rubber used, you wonder why its care isn't emphasized more.

First, it just isn't practical to inspect some rubber parts. You wouldn't take a water pump apart every six months to inspect its seal. You'd wait for the pump to start leaking, then replace the seal.

Second, some items can outlive the car itself. For example, when was the last time you replaced a headlight lens gasket?

Third, when a component associated with rubber becomes bad or is worked on, you automatically replace the rubber. For instance, when you drop the oil pan, you replace the oil-pan gasket with a new one. When you replace a tailpipe, you replace its support bracket, too.

Most rubber components need little or no attention. However, some require frequent inspection to avoid serious consequences, including drive belts, windshield wipers, electrical insulation, a multitude of hoses and, of course, tires. To a lesser degree, motor mounts and weatherstripping should be kept in mind. Let's look at each and see what's required.

Rubber belts are used to drive the



TIRES are the obvious rubber on your automobile and most likely to get your regular attention. Keep an eye out for cuts, gouges, depth of tread and uneven wear as shown above. The greater rate of wear on the inside of this tire indicates a problem of faulty camber which needs correcting



BRAKE HOSES are exposed to hazards of the road and should be wiped down and checked periodically. This examination should be considered a supplement to a good habit of looking over garage floor for possible leaks of fluid (which also has a distinctive and easily detectable smell)

on Rubber

By MORT SCHULTZ



PULLEY BELTS should be carefully examined for cuts, frays, glazing, and proper tension which is most important for operation of your automobile's various systems, including cooling fan, power-assisted steering and airconditioning. Check belt deflection spec for your car and then push back on the accessor; to obtain it. Use a pry bar if necessary, being careful to apply pressure only to a strong area such as the bracket shown above. Tighten the accessory while maintaining correct tension, then torque to specification for your car

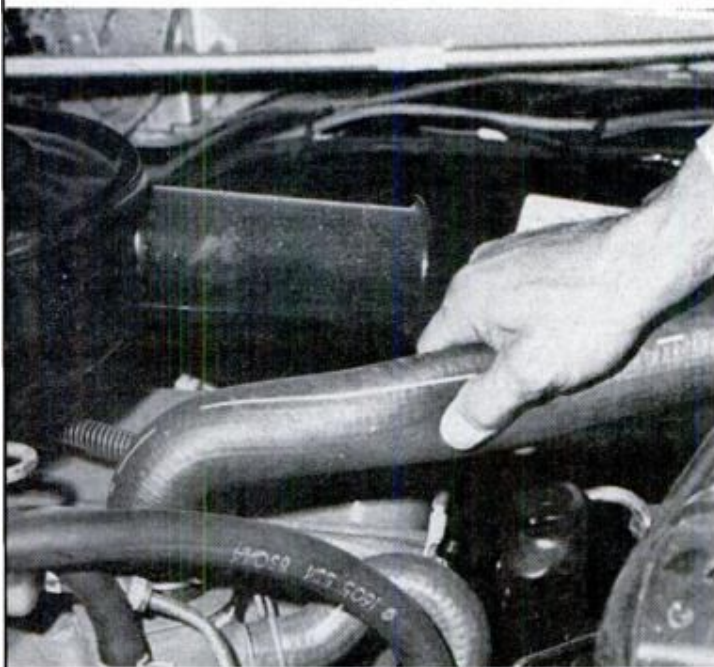

COOLING FLUID HOSES should be firm. If a hose looks good but is spongy and can be compressed easily, like the one shown here, chances are it is deteriorating internally and should be replaced. A weakened hose can collapse and cut off coolant flow

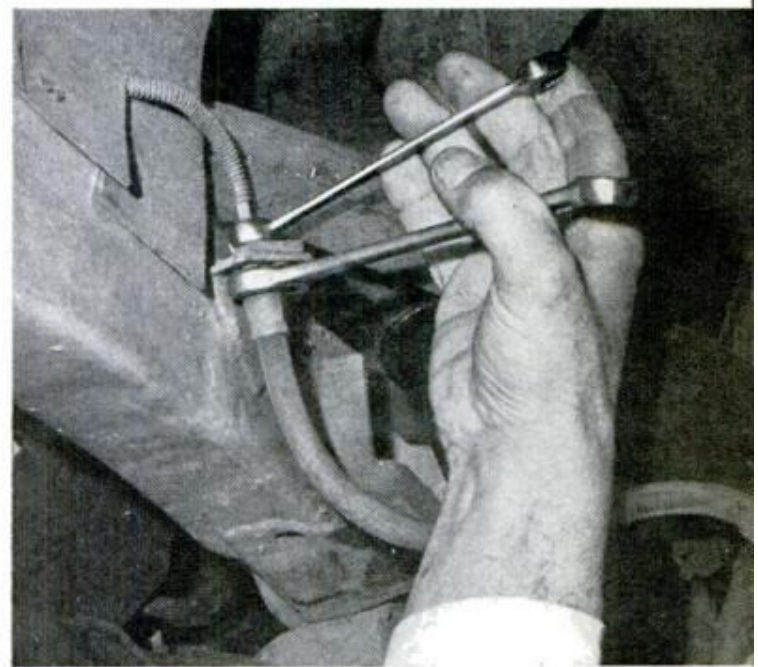

ENDS OF RUBBER HOSES should be checked as possible trouble spots. Also check the connections for tightness as is being done with the brake hose above. A pair of wrenches is needed for tightening. Turn wrenches at same time in opposite directions

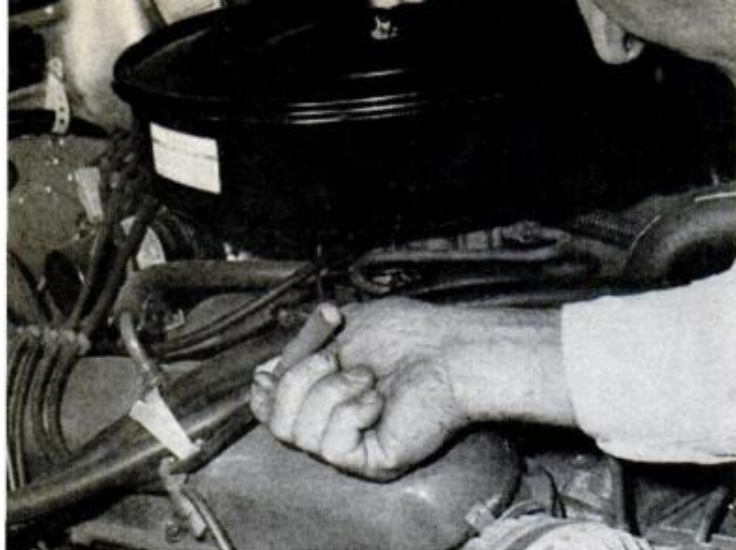

SPARKPLUG BOOTS should be checked to make sure rubber is "alive." Also check for black carbon deposits indicating arcing and resultant voltage loss

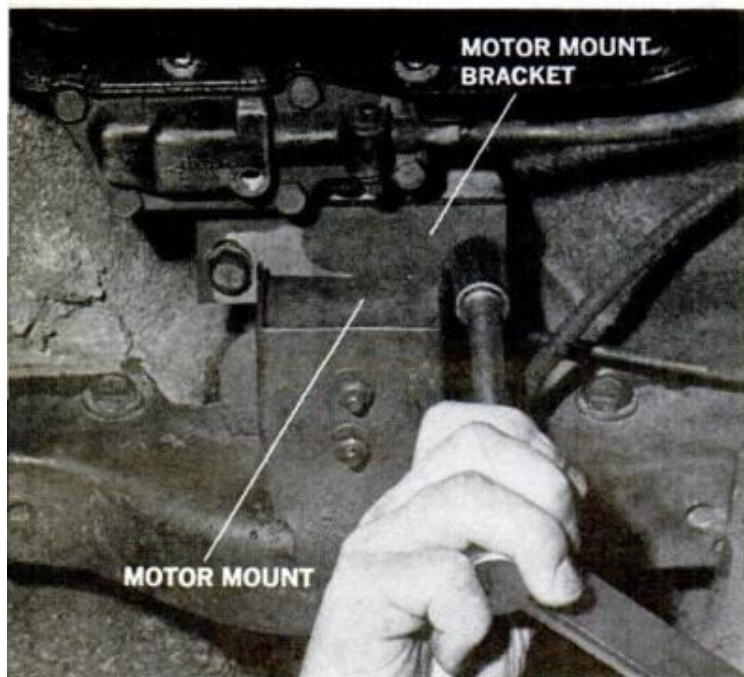

RUBBER ENGINE MOUNTS usually last for life of the car, but if they fail you can get big trouble in drivetrain. Engine must be lifted to replace them. Below: Weatherstripping that has dried out and deteriorated with age is replaced with an adhesive



alternator, water pump, power-steering pump, airconditioner and fan. If belts are damaged or not properly adjusted, the units will not work at peak efficiency. For example, if correct tension is not maintained, belt slippage can cause engine overheating, loss of airconditioner capacity, lack of power-steering assist and damage to the belt itself.

Inspect all belts closely every 6000 miles. If a belt is cut, frayed or glazed, replace it. Then adjust each belt to the specification given in your service manual.

There are two ways of obtaining proper belt tension: by measuring belt deflection or belt tension, the latter with a special tension gauge the pros use. The tension method is the most accurate, but requires the hard-to-find gauge. Since manufacturers also specify amount of deflection, the best way for you to do it at home is to measure the belt deflection midway between the two pulleys. Loosen the mounting bolts of the accessory and, if necessary, use a pry bar to apply tension to the belt as you measure deflection. Tighten the accessory and check deflection again. If not to spec, repeat the procedure.

Usually, a deflection of $\frac{1}{8}$ to $\frac{1}{4}$ inch is required. If you use a pry bar, place it against the strongest part of the accessory so you won't damage the case. Tighten accessory bolts with a torque wrench.

Gallons of fluid flow through your car to do such things as cool the engine, stop the vehicle, assist in steering or cool the passengers. The chief means of transferring these fluids is by rubber hose. These hoses can be harmed by vibration, torque, heat, oil and chafing. Therefore, it's wise to include their inspection in your periodic maintenance program.

For example, suppose a brake hose splits or a connection works loose. Brake fluid will be lost and so will your stopping ability. If a cooling-system hose starts to rot on the inside, rubber particles will flake off, enter the cooling system and contribute to clogging. Also the hose can collapse under high-speed driving, shutting off the flow of coolant to the engine. Overheating is the unhappy result.

Look for damaged hoses—those that are split, dried out, cracked or kinked—and replace them. By the way, a split airconditioner hose can be detected by the presence of an oily film on the hose. It tells you that Freon is leaking. Each

hose, especially cooling system and heater hoses, should feel firm—not mushy. Make sure all connections are tight. Finally, check that hoses do not rub anywhere. In time, a chafed spot can wear through.

Your electrical and ignition systems use a fair amount of rubber or rubber substitute. Wire and cable insulation, is subject to deterioration. Dried-out or cracked rubber insulation can cause voltage loss. Replace the wire.

Dried-out or split sparkplug boots and rubber nipples at the distributor and coil can also lose vital voltage. Replace these, too. Look inside the boots and nipples. A black smudge of carbon indicates arcing, probably due to a damaged wire. Best bet is to replace the wire.

Most cars have three motor mounts—two on each side of the engine, midway between front and rear, and one at the transmission. These strong, pliable blocks of rubber last for years—many for the life of the car. But they can become oil-soaked, causing them to deteriorate.

When a motor mount deteriorates and loses its resiliency, engine vibration increases and trouble starts. Often, it affects parts near the engine; for example, the clutch can be thrown out of alignment.

The most serious problem resulting from bad motor mounts, though, is a misaligned motor. This makes itself known by loud rumbling and excessive vibration that can be felt throughout the car, difficulty in shifting gears and a sticking accelerator pedal. There is really no way to test motor mounts for damage. So, if any of these conditions appear, replace the motor mounts.

Replacing a motor mount isn't tough. Jacking up the engine to take the load off the mounts is the hard part. Then, loosen the mounting bolts, and replace the rubber slab and its bracket.

Dried-out and loose weatherstripping, especially around doors, leads to air leaks and rattles. Every so often, check the rubber. If in bad condition, rip it out and replace with new weatherstripping. Clean the surface with gasoline to remove old adhesive and particles of weatherstripping. Apply an automotive weatherstripping adhesive available at auto-parts stores. Let the adhesive dry, then press the rubber weatherstripping into place.

Your wipers see lots of weather—they bake in the sun and work hard in the

winter. If they streak the windshield, get a couple of wiper replacements.

Unless tires are given care, they can create a safety hazard and result in expensive replacement. But what care? Frankly, it would take an article ten times as long as this one to discuss tires alone. Much valuable information can be found in two publications available from the Rubber Manufacturers Assn., 444 Madison Ave., New York, N.Y. 10022.

The pamphlet called *Consumer Guide to Tire Care and Safety* hits the high points for the average motorist. It's free. As a *Saturday Mechanic*, though, you will be more interested in the booklet, *Care and Servicing of Passenger Car Tires*. Written for professional servicemen and tire dealers, it provides information about tire care, troubleshooting pointers, data about

**. . . store snow tires in
a clean, dry, dark, cool
area away from oil, water
and electric motors . . .**

things that affect tires such as wheel balancing, how to mount tires, and so on. It costs 50 cents.

Here are a few tips regarding tire care that you can use as a start:

- During warm weather, store snow tires in a clean, dry, dark, cool area away from oil, water and electric motors that can damage them. Electric motors give off ozone that can harm rubber. Stack tires flat—not standing on their treads. If they are whitewalls, lay them whitewall to whitewall to protect them from scuffing and dirt.

- Never rotate metal-studded winter tires. Rotating reverses the normal wear pattern, causing studs to revolve in the tread which can unseat them. Mark the tires with chalk to show position (driver or passenger side) before removing them.

- Tire pressure rises with temperature. Thus, frequent checking of pressures in cold weather is even more important than in summer to assure that tires are not driven in an underinflated condition.

- A set of new tires can be ruined in less than 1000 miles if your front end is out of alignment. Tire manufacturers generally recommend a front-end check every 5000 miles for camber, caster, toe-in, toe-out and worn parts. ★★ ★

EXCITING NEW PRODUCTS

By CATHERINE BILSKI



STAIN WOOD the easy way with Foam-N-Tone designed for use on all unpainted wood surfaces and furniture. The aerosol foam is easy to apply, quick-drying and washes off hands and tools with soap and water. Priced at \$1.98 per 6 oz. can, it's manufactured by U.S. Plywood Div. of U.S. Plywood-Champion Papers, Inc., 777 Third Ave., New York, N.Y. 10017.

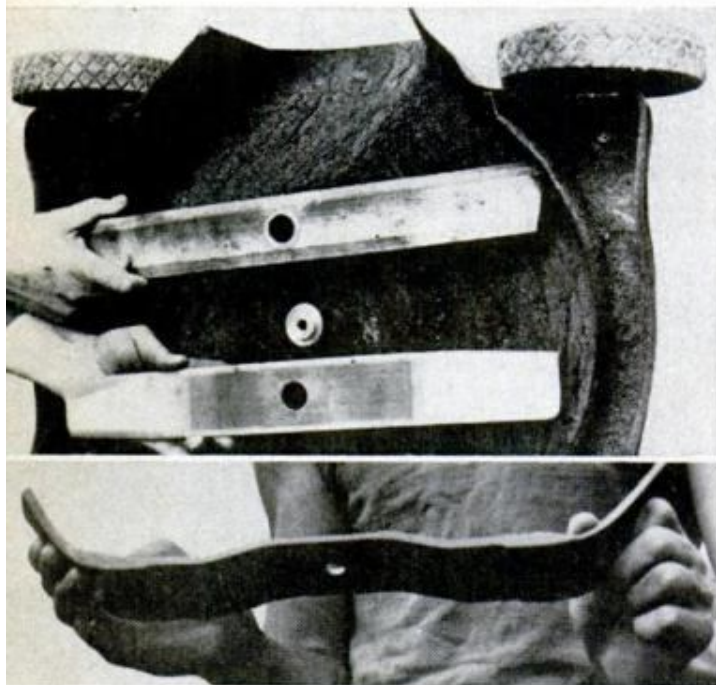

SAFE ROTARY-MOWER BLADE will not cause toe or foot amputations. The flexible nature of the new Dayco blade permits it to strike a glancing blow, rather than a cutting one, upon contact with the foot or hand. It's made of a rubberlike elastic material and is available in sizes up to 30 in. The unit sells for \$7.95 from Dayco Corp., 233 West First St., Dayton, Ohio 45401.

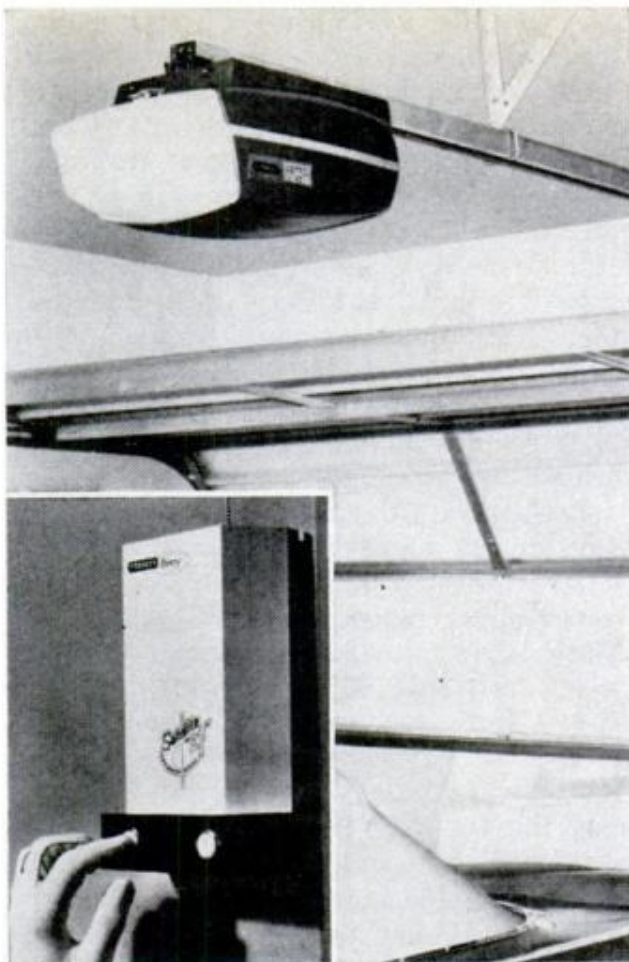

DELUXE GARAGE-DOOR OPENER, the Stanley-Astro "125" features a completely enclosed mechanism and a wall-mounted receiver that snaps out for service and replacement. Its hand-held, solid-state radio transmitter has a concealed magnetic coin holder for dash mounting. The opener is powered by a 1/4-hp motor and sells for \$169.95 from Berry Doors, Dept. PID, Birmingham, Mich. 48012.

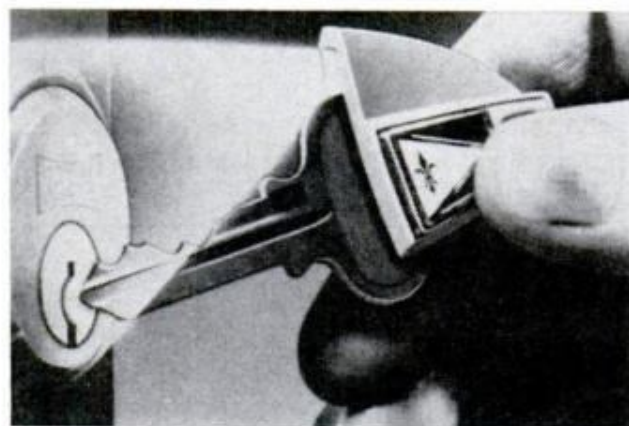

END FUMBLING IN THE DARK trying to find the keyhole to open your car, garage or house door. Here's a light that becomes a part of any key and fits any key ring or chain. Simply squeeze the holder and it illuminates the lock you want to open. Called Key Beam, the unit is priced at \$3.95 post-paid from C. A. Bittner, Dept. P-5, P.O. Box 4732, Inglewood, Calif. 90302.



TAKE THE GUESSWORK out of watering your lawn. The Sprink-L-Guide tells you at a glance if moisture is reaching the roots, tests moisture penetration to a depth of 10 inches and cuts down on overwatering, thus conserving water. Just push it into the soil and read. It's battery operated and sells for \$10.95 postpaid, including battery. Available at most department and sporting goods stores, it's manufactured by Columbine Products Co., 9119 Jotipa Dr., Longmont, Colo. 80501.



ELIMINATE WASTED PAINT, stop spills and control or regulate paint flow into trays and paint sprayers with the Pour-Ezee Snap-On Paint-Can Cover. It fits standard gallon paint cans and has its own snap-on, airtight cap permanently attached. The reusable plastic cover costs 59 cents from Weil Tool Co., P.O. Box 64, Woodmere, N.Y. 11598.



KEEP YOUR LAWN and flower beds in order with green-colored Plastic Lawn Edging. It prevents root spread and soil erosion. A 25-ft. roll is available in widths of 4 or 6 in., costs \$1.79 and \$3.79, respectively. Available at department and hardware stores or order directly from the manufacturer, Patrician Products, Inc., 483 East 99th St., Brooklyn, N.Y. 11236.

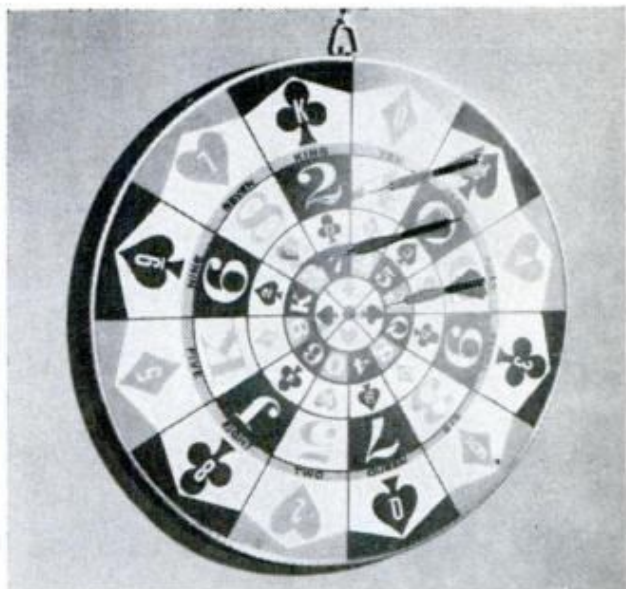

POKER DARTS is a game that combines skill with chance. More than 25 card games can be played on the Poker Dart Board, and dozens of others can be improvised. The game comes complete with an 18-in. dart board, six steel tipped 6-in. darts, rules for dozens of games and a short history of poker. Priced at \$9.95 and made by Oggi Products, Inc., 80 Fifth Ave., New York, N.Y.

WITH A BIT of huffing and puffing—and not too much money—you can have a roomful of colorful, contemporary furniture like that at the right.

When you consider that the low-slung “mod” chairs shown in the color photo cost only \$14.95—compared to similar inflatable chairs that cost \$45 and more—you can easily visualize how your family room would look when it’s redecorated and furnished in complementary MAD furniture. MAD, by the way, stands for Modern Air Decor.

There are actually seven major styles or pieces presently available: mod or modern chairs; modern foot rest; square chair; round chair; triangular table-hassock; round hassock and square hassock. The gigantic lounge shown on the bottom of the opposite page, incidentally, is simply called a sofa, and also is available for a fraction of the price of comparable inflatable pieces.

Other innovative styles, says the manu-

facturer, are either in the final testing stages or on the drawing board.

A one-year guarantee is offered by the manufacturer, Divers International, Inc., of New Haven, Conn. Made of 16-gauge, 0.4-mm thick vinyl, the MAD pieces are not flammable but will melt if a cigaret, for example, is held on the surface. Even this type of burn, however, is repairable using the repair kit provided with each piece.

To inflate the furniture, you can use either the hand or foot pump (as shown in the photo below) or a suitable paint compressor pump. In either case, the leak-proof flap-valve provided in each piece of furniture makes it difficult for party pranksters, for example, to deflate the furniture.

Through the use of the seven different colors offered as standard (white, black, red, yellow, green, blue and orange), plus the highly popular transparent material, it’s possible to mix colorful pieces to suit

Now: Furniture You Can



SIMPLE HAND PUMP has nozzle that slips into a flap-valve and inflates furniture in a short period

almost any room decor for a minimal price.

Other suggested applications for the inflatable pieces of furniture include use aboard boats, with campers, around pools and patios, in children’s playrooms and in vacation homes. In all of these cases, an important advantage to using inflatable furniture is the ease of storage and transportation of any number of deflated pieces.

Each chair weighs less than a pound and is small enough to store in a desk drawer when not in use.

The full line of MAD furniture is available though large department stores nationally and also can be ordered from certain mail-order houses, such as the Essex Whaler, Essex, Conn. Retail prices range from \$2.95 for a square hassock to about \$15 for the modern chair. The handy foot pump sells for \$1.97.—*Leonard E. Sabal*

Color Photos by Robert Borst

POPULAR MECHANICS



Blow Up

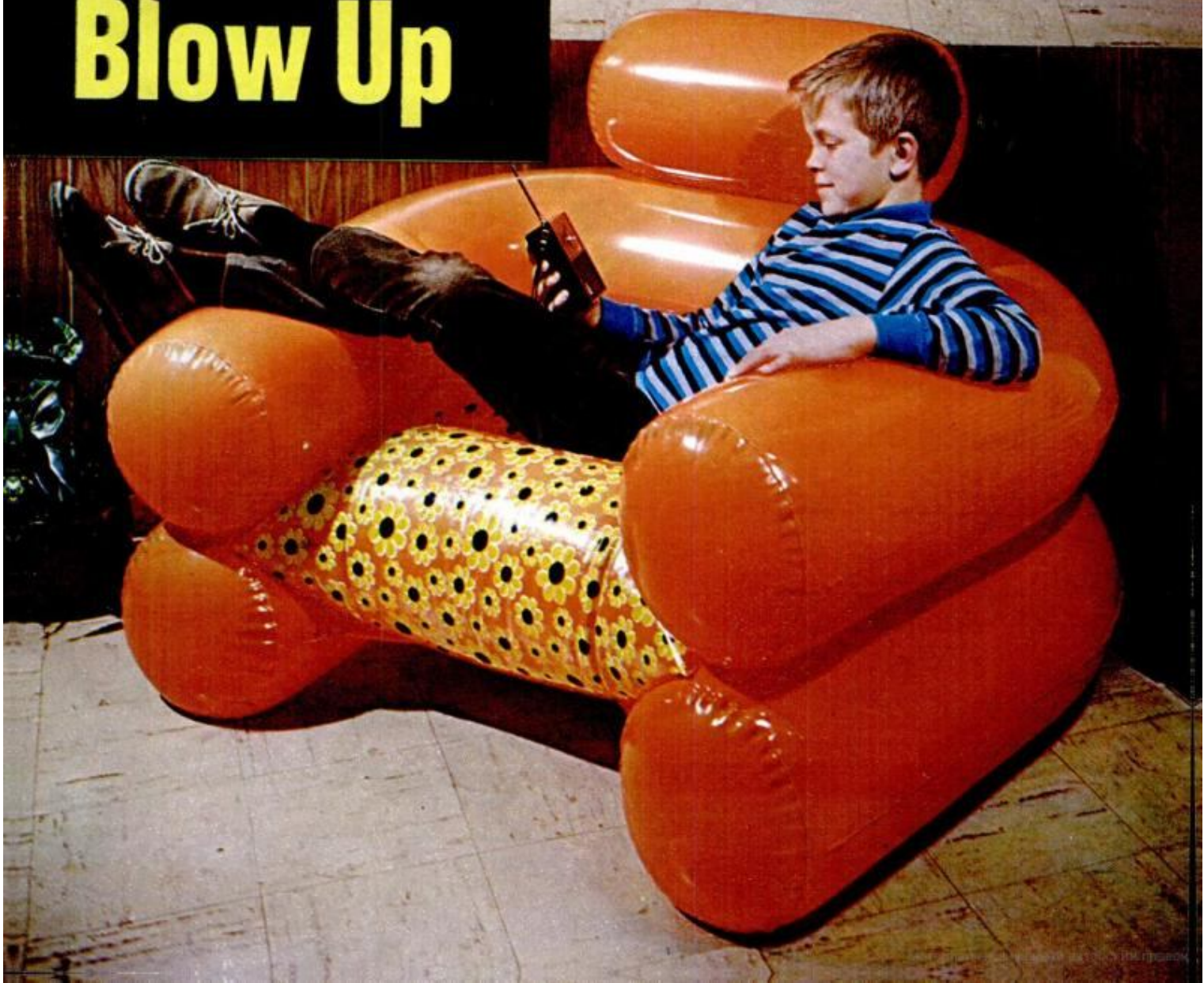



Build This All-in-One Kitchen Planning Center

By RICHARD C. HOUSE

Technical Art by Stanley Cohen



THIS SINGLE UNIT can help make an efficiency expert of your wife, since it houses telephone, cook books, expense records and other household-planning necessities.

The 18x28-in. desktop drops down to reveal a generous working area with a number of pigeon-holes to hold the many small items that otherwise would make the planning center untidy. Because the desk is narrow in relation to its height, it is unbalanced when open. For this reason, it should be screwed to at least two wall studs.

Plan to finish the planning center to match the cabinets in your kitchen—otherwise, the center will look like a sore thumb instead of a neat-looking, built-in efficiency center. ★★ ★

POPULAR MECHANICS

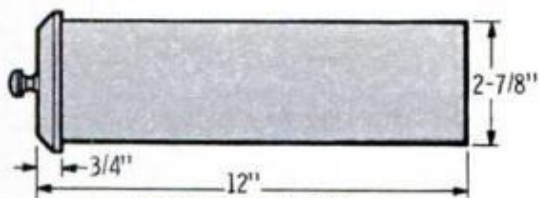

DESK DRAWERS

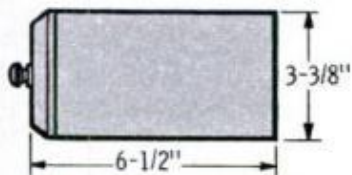

CARD FILE DRAWERS

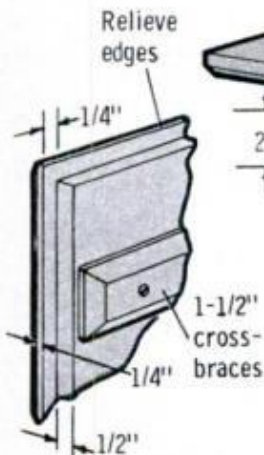

DOOR DETAIL

Overall door dimensions are 12-1/4 x 17"

Shelf and floor supported by 3/4" supports

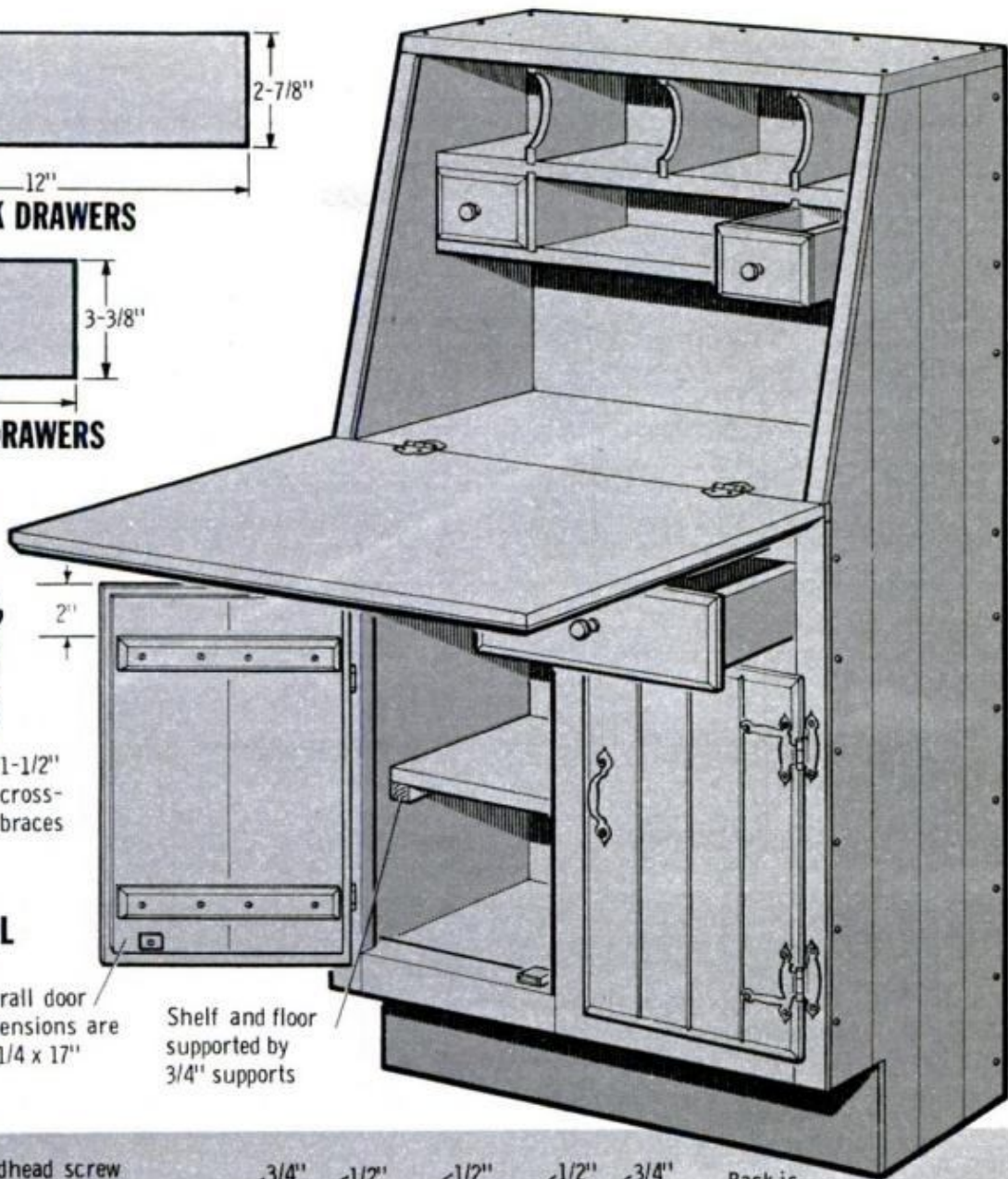

Roundhead screw on bottom acts as stop

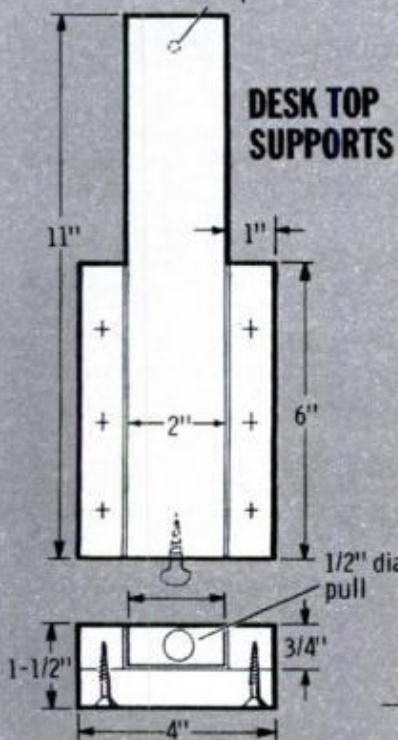

DESK TOP SUPPORTS

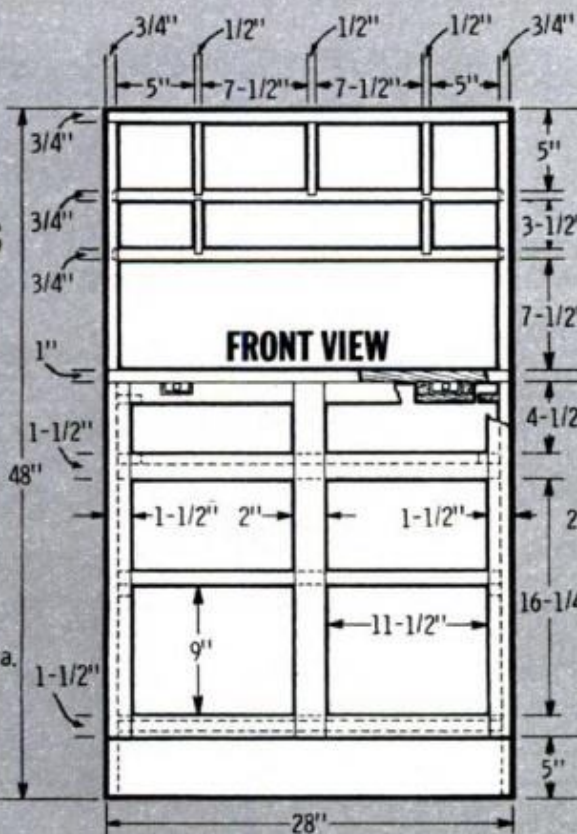

FRONT VIEW

Back is 3/8" ply, set in 3/8 x 1/2" rabbet on both sides

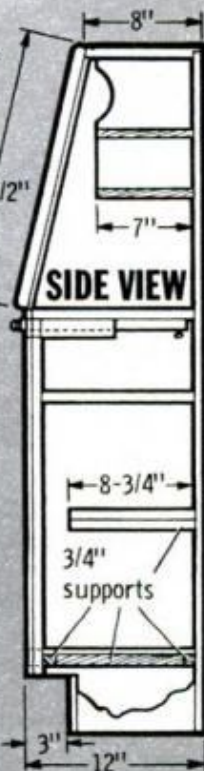

SIDE VIEW



How to Color Concrete

By RICHARD DAY

T IRED OF LOOKING at a great expanse of plain gray concrete around your home? For a few extra dollars your next project can be distinctively colorful. Or you can, at small cost, put color into or onto the concrete you already have.

There is no magic to coloring concrete. You have a choice of four ways to do it: stain, paint, mix color in integrally or dust it on. Which method is best for each case naturally depends on the project.

If possible, you should color concrete integrally by adding powdered color pigment to the fresh concrete mix. Since

the color reaches all the way through the wall or slab, it can't chip or wear off. Integrally colored concrete can be either mix-it-yourself or ready-mix.

The cost of colored ready-mix is only \$3 to \$6 per cubic yard more than plain gray ready-mix. Exact cost depends on color and shade. You can save money by using integral coloring only in the top course of a two-course slab casting job. In that case you might have to mix the topping yourself. There wouldn't be enough for a profitable ready-mix load.

Color pigments also can be added to concrete in the mixer, coloring it inte-



UNCOLORED GRAY concrete is the first sample. Second sample was made of a 50/50 mixture of 7-lb. brown and 4-lb. black. Last two samples in first row are white concrete mixed with white sand and beige sand. Pastel colors in the second and third rows were mixed in proportions of 1½ lbs. per bag of cement. Colors used were black, blue, green, yellow, goldenrod, brown, terra cotta, and red. The bottom two rows are samples of medium-tone colors mixed in ratio of 7 lbs. of synthetic pigment per bag of white cement

You can add color to a batch of freshly mixed concrete; you can dust color on fresh concrete surfaces, or you can even paint concrete surfaces most any color

SIFT DUST-ON COLOR through your fingers to cover evenly just-floated concrete slab surface

IMMEDIATELY FLOAT color into surface with a wood or metal float, being sure to get even color



grally. The cost of these varies depending on color, but averages about 70 cents a pound. Dark red costs the least; blue and green, the most. There are several types of pigments, all fine powders like cement. The best ones, from the standpoint of fade-resistance, are the synthetic mineral oxides. These include chromium oxide (green), iron oxides (buff, beige, maroon, red, brown and black), and cobalt oxide (blue). (For information on where to get a complete line of colors write the Frank D. Davis Co., 3285 East 25th St., Los Angeles, Calif. 90023.)

The two most difficult and expensive colors to achieve are blue and green. Cobalt blue oxide does a good job, but is expensive in the pure form. The only suitable green is chromium oxide. Black is the hardest color to maintain. The slightest efflorescence (bleeding out of soluble salts) causes a white haze.

Color pigment should always be proportioned by weight to assure uniform color from batch to batch. A good way to do this is to weigh it on a postal scale. Proportioning color by volume—the teaspoon way—is a guarantee *against* uniformity.

Always mix coloring powders with dry cement. Add water and other materials to the mixer only after the cement has been uniformly colored. Pigment does not dye the mix. It colors by coating each particle of cement and you must mix until the process is complete. Also, after everything has been added to the mixer drum, the mixing time should be longer than normal for color uniformity. Be careful to keep constant the proportion of water in each batch. Watery batches are likely to turn out lighter in color than normal ones.

Never use more than 10 percent pigment by weight of cement. It weakens the mix. Full-strength pigments normally create good colors when used at a rate of 7 lbs. per bag of cement. Used at a rate of only 1½ lbs. per bag, they produce pleasant pastels. With carbon black pigment, ½ to 1 lb. per bag of cement is enough to produce a rich black.

White portland cement makes cleaner, brighter colors and, except for black or dark colors, should be used wherever practical in place of normal gray portland cement. White cement costs about twice as much as gray cement.

The weight of color added is always



YOU CAN ROLL several coats of latex on a porch floor in a single day. Be sure, however, that all scale has been removed from the concrete surface first

based on the weight of cement. Amounts of sand and gravel don't count. However, the color of the sand and coarse aggregate influences the appearance of a color. Use white silica sand in light pastel mixes if you want to avoid sandy undertones.

The surest way to tell what a color will be like is to make a few samples with varying amounts of pigment. Let them cure, then compare. An easy way of doing this is to cast samples in 1-in. lengths cut from 3-in.-dia. plastic pipe. Slit the sections down one side so they can be loosened easily and use them as forms. After your samples set up, remove the forms and pop them into a warm oven. Let dry for a few hours. If the finished job is to be waxed or sealed, do this to your samples before judging them.

Coloring agents to avoid in concrete are weak iron oxides and those containing high percentages of calcium sulphate, such as Prussian blue, chrome yellow, chrome green, lampblack and boneblack. Carbon black may be used to color concrete, though it's tough to handle.

To lay an economical two-course slab, make the first, or bottom, course with your normal mix. Strike it off ½ to 1 in. below the slab's top. Then pour a ½ to 1 in. layer of colored concrete topping before the base course has a chance to harden. The saving in materials normally will be worth the extra labor required to build a two-course slab. Your two courses will bond into a single monolithic structure.

Avoid overtraweling of colored concrete slabs. One or two floatings with a



KEY TO COLORING CONCRETE is to use weighing method of mixing, not coloring by volume. This is true of both dust-on and integral-mixing techniques

wood float are sufficient if followed by a light steel-troweling. If a rougher surface is wanted, float with an aluminum or magnesium float but do not trowel.

Ample curing is essential for colored concrete. Cure for six days by keeping the concrete continuously wet with a soaker hose or polyethylene blanket covering and dump sand on it to insure continuous tight contact. Bubbles leave a spotty surface color. A wet sand covering can be used directly if it's clean enough to prevent staining your colored surface.

The dust-on coloring method is a great money-saver, but it requires careful finishing for uniform coloring. Only the top $\frac{1}{8}$ to $\frac{1}{4}$ in. of the slab is colored, but that's the only part you see.

Dust-on material is a mixture of color pigment (the same as that used for integral coloring), white portland cement and sand. Your best bet is to buy the mixture in ready-to-use 100-lb. bags. Most manufacturers recommend use of 40 to 50 lbs. of coloring per 100 sq. ft. of concrete. Commercial dust-ons include *Colorcron*, by Master Builders, and *Colorundum*, by A. C. Horn Div., Dewey & Almy Chemical Co.

If you mix your own dust-on, mix enough for the whole job at one time. If you don't, color variations may creep in. Weigh out two parts of gray, preferably white, cement and add two to three parts of dry, screened sand and one part synthetic mineral oxide pigment of the desired color. Figure about 6 lbs. of pigment for each 100 sq. ft. of colored surface. Mix the ingredients dry until all color-

streaking has disappeared. Then your dust-on is ready.

Concrete for dust-on coloring should be low in water content to prevent bleeding. It also should be air-entrained, since this helps prevent bleeding, too. If you use ready-mix, order it with six bags of cement per cu. yd., a maximum of 6 gals. of water per bag of cement and 6 percent entrained air.

Place, strike off and darby the concrete as usual, then wait until all free water has evaporated from the surface. If it lingers, try squeegeeing it off by dragging a garden hose over the surface. Then float. Floating brings up just enough water to combine with the coloring material, also removes any ridges and depressions that might collect pigment and cause color-streaking. Since slab edges often dry up before the center, you may need to color them first.

Right after floating, bend low over the slab with handfuls of dusting mixture and sift pigment evenly onto the slab. Work at getting an even spread over the entire slab. The first dust-on application should use up about two-thirds of the total amount of material.

After the dry material absorbs water from the fresh concrete, it's ready for floating. Float just enough to spread the coloring evenly into the surface, the less floating the better. All tooled edges and joints should be run before and after dust-on applications. Right after the first color-floating, dust on the rest of the mixture and float again. Take care to get a uniform color throughout the slab.

Follow the final color-floating immediately with steel-troweling. For a fully dense and smooth texture, give it a second steel-troweling after waiting for the concrete to increase its set. A fine, soft-bristle broom may be drawn over the surface to produce a roughened texture for good traction under foot. Indoor surfaces may get a third troweling for real smoothness. If smoothness isn't wanted, skip all troweling and leave the surface with a float finish, wood or metal. A metal float leaves a smoother surface.

After they are completely cured in a few weeks, integrally-colored and dust-on-colored interior concrete slabs may be given two or more coats of concrete floor wax the same color as your pigment. Take care to avoid staining the floor before it

(Please turn to page 190)

Build This



Jogger-Walker for \$30

By JOHN CAPOTOSTO

Color Photo by William Aller

WHETHER WE BLAME IT on the family car or not, walking has become a lost art. The idea of walking any distance has become unheard of, yet we all know that brisk walks are probably the most beneficial form of exercise there is for people of all ages. Doctors will tell you that walking and jogging stimulate circulation of the blood, flex the muscles and joints and strengthen heart and lungs. They slim you down and make you look and feel tip-top.

The great outdoors is the best place there is to walk or jog. But it takes real willpower to go around the block when it's a hundred in the shade, raining cats and dogs, or 10 below. So you don't exercise.

However, with a jogging machine such as this one, you can forget the weather and do your roadwork every day of the year in the comfort and privacy of your home, whenever you want, for as long as you want and dressed as you please. Done daily over a period of time, workouts on your jogger-walker will make a new man (or woman) of you, health and trimwise.

A 15-minute workout equals an hour's walk outdoors. A pedometer works off the flywheel to keep track of your speed and distance; 100,000 revolutions on the counter approximate a quarter mile.

The jogger-walker is basically a foot-operated treadmill raised at the front to provide an uphill climb. A tension bar on the underside of the belt adjusts to increase the walking or jogging effort. The cast-iron flywheel keeps the belt moving smoothly once you start. Its scooter-type handle lets you walk, trot or run safely.

You can buy a comparable exerciser for a pretty penny, but this do-it-yourself model can be built for as little as \$30. You can get nearly all the materials at your lumberyard and hardware store. You can order the flywheel, pedometer and bearings from a source given later.

Take time to study the drawing thoroughly so you understand how the jogger works and how it goes together. The 14-in.-wide belt is supported by 22 wooden rollers, of which 20 are cut $1\frac{7}{8}$

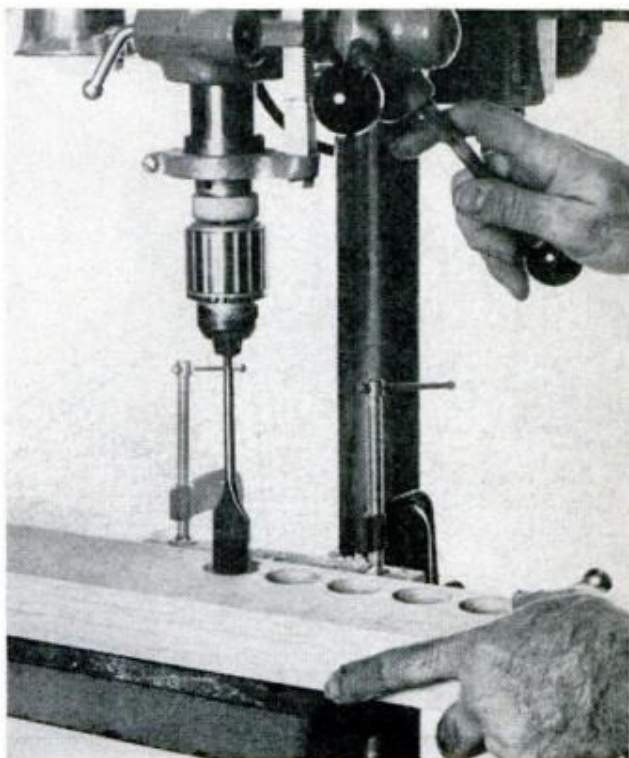
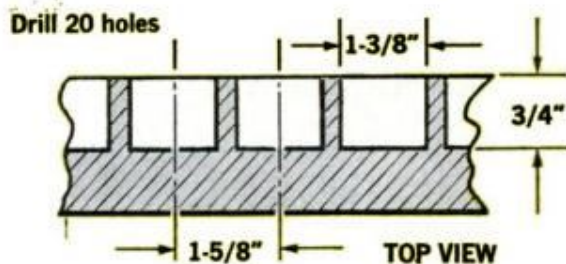

BLIND HOLES are bored in side rails by clamping a fence to drill-press table and setting depth stop



EACH END ROLLER is made by slipping 21 wooden plugs (cut with a hole saw) on a $\frac{3}{8}$ -in. steel shaft

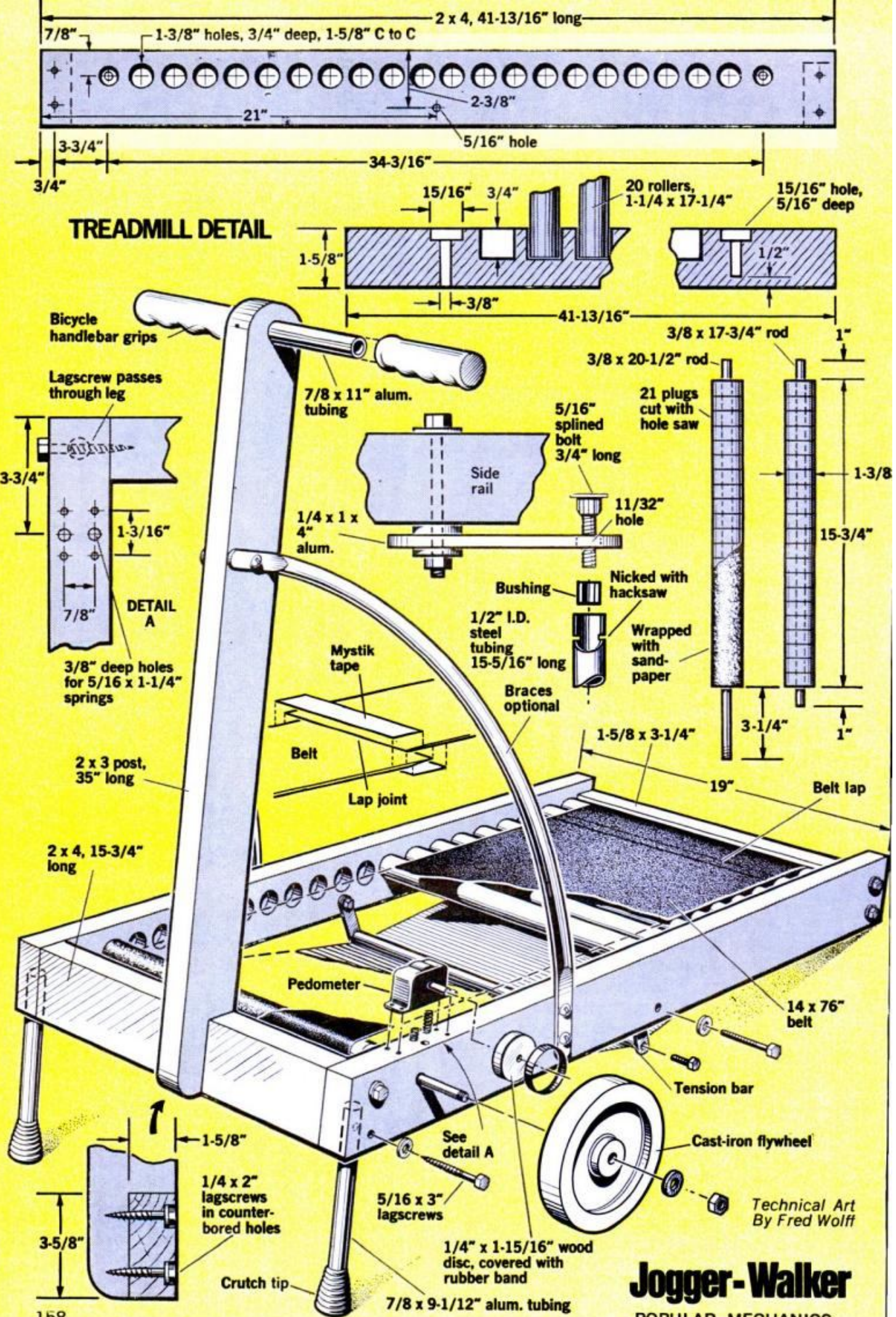

Technical Art
By Fred Wolff

Jogger-Walker
POPULAR MECHANICS

in. long from 1¼-in. closet or drapery-rod stock. Except for the two end ones, the rollers turn in rows of oversize blind holes bored ¾ in. deep in the 2x4 side rails of the frame. The holes are made ⅛ in. larger than the rollers and the ends of the latter are chamfered a bit with sandpaper, then coated with stick paraffin to make them turn freely in the blind holes.

Each end roller is built up by slipping wood plugs (which you cut with a hole saw) on a ⅜-in. steel shaft. Since the center drill on most hole saws is ¼ in., the holes in the plugs are rebored with a ⅜-in. bit. A dab of glue is applied to each plug as it's slipped on the shaft. The front-roller shaft is longer since it passes through the left frame member and carries the flywheel. Also, the front roller is covered with coarse sandpaper, grit side up, to increase belt traction. End-roller shafts turn in ball bearings seated in counterbored holes.

Pick clear, knot-free 2x4s for the frame. The rear cross member is made narrower than the rest to provide heel clearance. After you bore the blind holes in the side rails, bore holes for the front aluminum legs and holes for the lagscrews. Holes at the front are bored right through the legs. Since all rollers must be in place as the frame is being glued and bolted, you'll need help to line things up.

The post for the cross handle is a 2x3. If you can pick a strong straight-grain piece, chances are you won't need the extra support of the curved tubular braces. The post can be attached to the frame with lagscrews as shown, or simply bolted on from the front. Sand all sharp edges.

The belt is made from a 14x76-in. length of plastic upholstery (such as Naugahyde or Boltaflex) and lapped and joined with Mystik tape, top and bottom. The plastic upholstery comes 54-in. wide, which means you can expect waste in using a single 76-in. piece. A more economical way, although it means two seams, would be to make the belt from two 38-in. lengths.

The tension bar bears against the belt to take up belt stretch and keep the belt tracking evenly on the rollers. The latter is accomplished by twisting the tensioner.

The flywheel, pedometer and a set of six bearings (two bronze, four ball) can be ordered for \$23 from the Armor Co., Box 290, Deer Park, N. Y. 11729. ★★★



SHAFTS OF END ROLLERS turn in ball bearings seated flush in counterbored holes drilled ½ in. deep



BELT-TENSION BAR (which is tubing) spins on two bronze bearings slipped over ends of splined bolts



BELT TENSION IS REGULATED by moving bar toward or away from rollers and locking by tightening bolts

SPRINGS UNDER PEDIOMETER keep rubber-faced pulley riding against recessed rim of cast-iron flywheel



Solving home problems

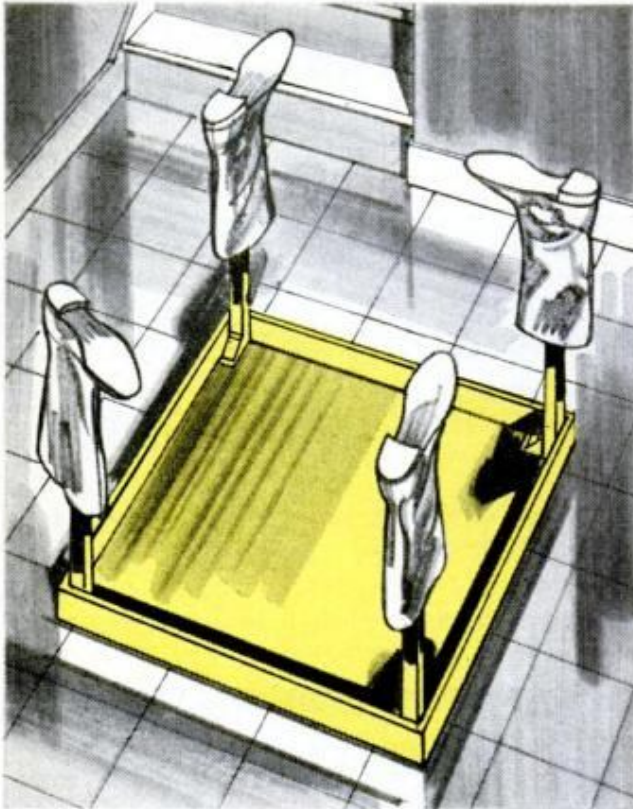

THE PROBLEM OF DRYING BOOTS becomes a simple one when you have an old card table. Turned upside down, its legs provide handy "trees" on which to place the boots. Air circulates freely.—*Isabel Cluen*

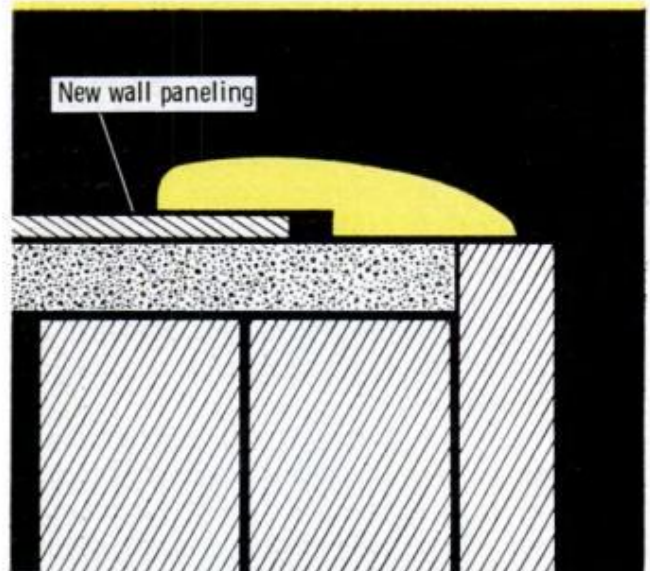
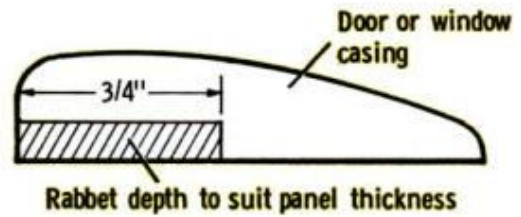

WHEN PANELING A ROOM, it's no easy trick to cut the material to fit accurately against window and door casings. This is easier if the casings are rabbeted on back to fit over paneling.—*Joe Reinhardt*

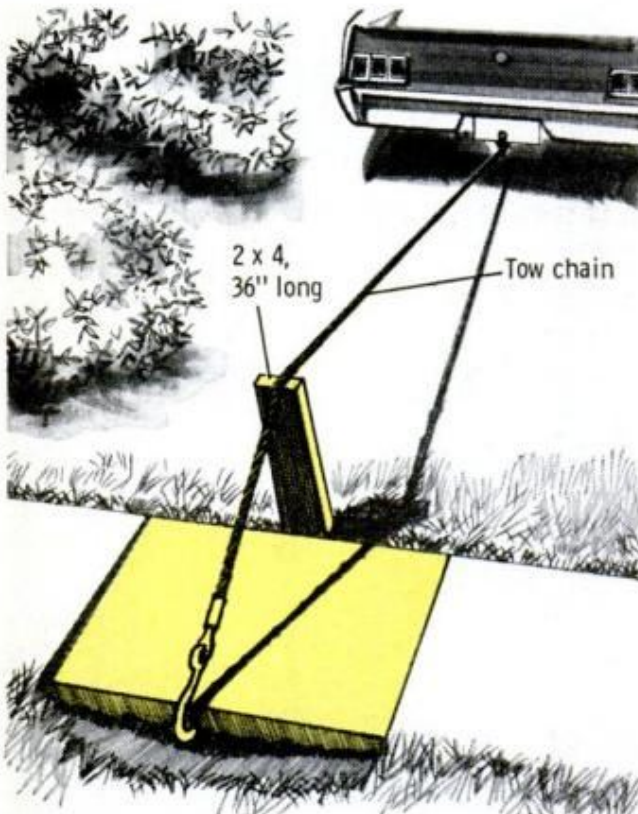

WHEN A SECTION OF SIDEWALK SANK toward the house I wondered how I could raise it to crowd in fill underneath. Then I thought of using my car, its tow chain and a piece of 2x4.—*G. A. Mayerchak*



AFTER NOTICING HOW MY WIFE was ruining the window sills with her flowerpots, I suggested that she use the plastic covers from coffee cans as coasters. They make real neat protectors.—*Albert Pippi*

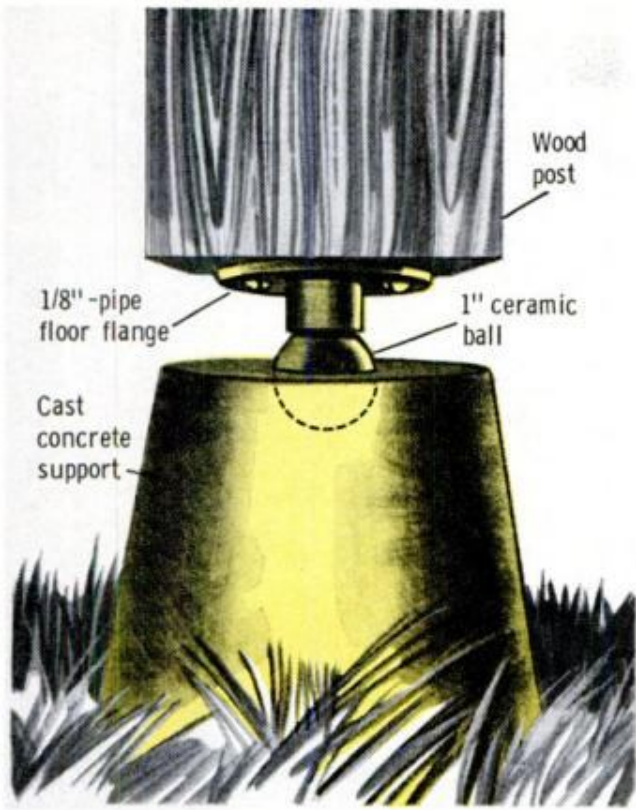

PORCH POSTS WON'T ROT when supported on piers like this. Ceramic ball half embedded in concrete poured in one-gallon paper pail, provides self-centering point for post's flanges to rest.—*Gerald Sporre*



TO STOP RUST FORMING on bottom edge of metal shower stall, wipe joint dry where sides meet plastic base and apply 1/4-in. layer of GE's silicone. Run a bead all around base with finger.—*John Goffin*

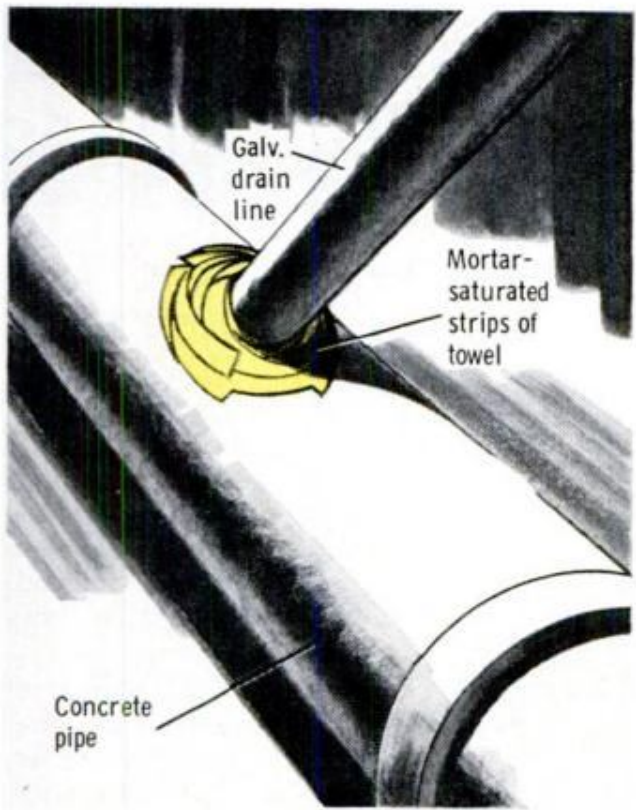

BREAKING INTO A CONCRETE PIPE to insert a drain line often leaves a ragged hole. To seal joint, dip strips of terry-cloth towel in a soupy mortar mix and wrap strips around end of pipe.—*Jean Dunn*

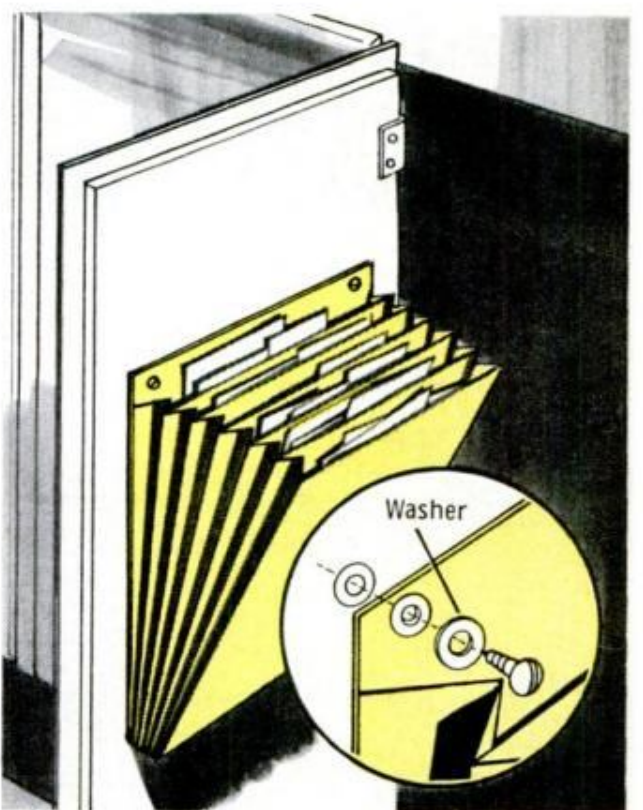

EXPANDING FILE HOLDERS attached to inside of cupboard doors put waste surfaces to work in the kitchen. Your wife will find them handy for storing paper bags, kettle lids and the like.—*Victor Lamoy*



Window Screens Aren't Just Screens Anymore

They've taken on glamorous color, they're easier to see through and they're cooler on the house

By WAYNE C. LECKEY, Home and Shop Editor



THE HEAT OF AN IRON is all it takes to fuse a patch when repairing a hole in fiberglass screening

THERE WAS A TIME when you had no choice—you bought black-enameled steel wire, tacked it on your window screens and put them up. If you pampered them, took them down in winter and wiped the wire with light oil, with luck they'd last three or four seasons.

Later you could buy galvanized wire and, eventually, plain aluminum and copper wire. While the latter licked the rust bugaboo, it was expensive, and while both galvanized and aluminum lasted longer than plain steel wire, they all had two faults in common—being wire, you could dent and belly them if not careful, and

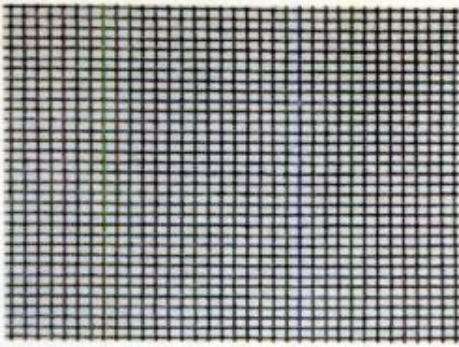

SUN SCREEN. Blocks heat while retaining its see-through visibility. The screen's heavy mesh reflects sunlight

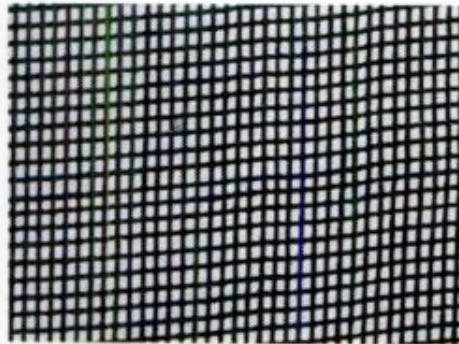

INSECT SCREEN. Comes up to 84 in. wide to permit a one-piece picture-window effect. It's exceptionally strong



WIND SCREEN. Vinyl-covered fiberglass lets in the light but keeps out dust, dirt and pollen. Great for pools

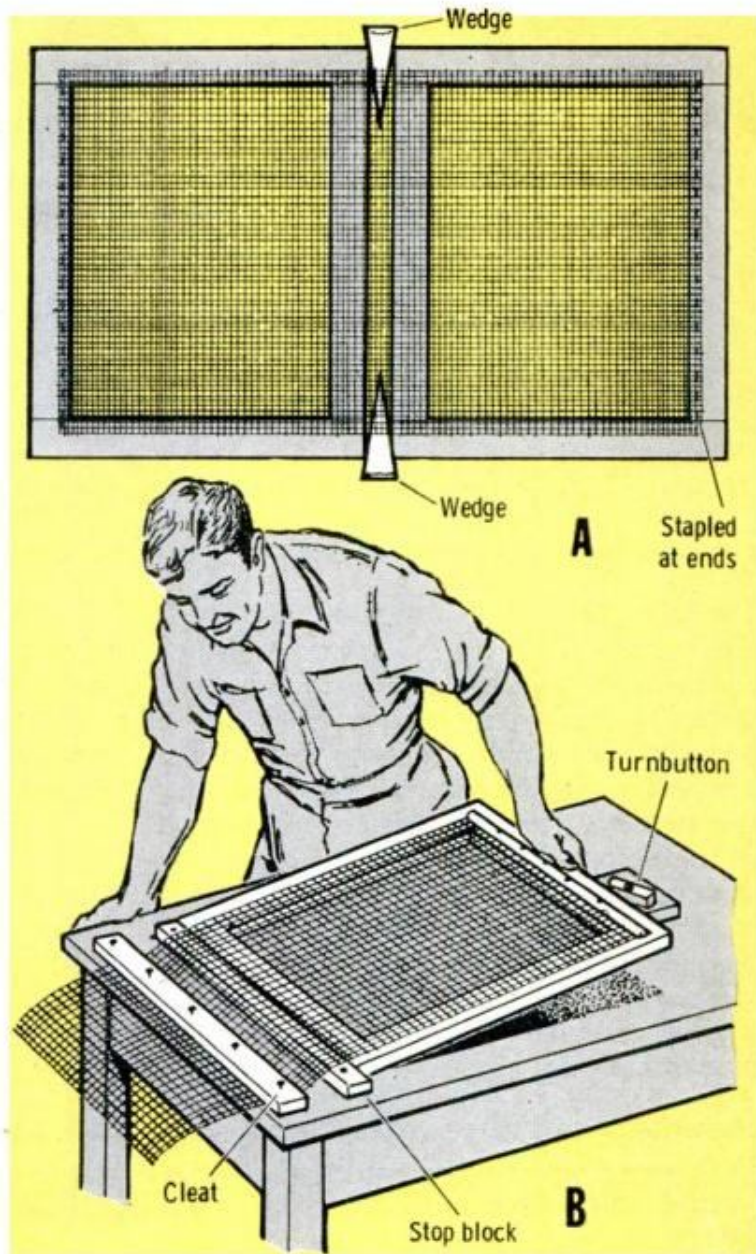

IF YOU HAVE TWO SCREENS TO COVER, method A shows how wedges force frames apart to stretch the wire smoothly. **Method B** shows how to do it when you have but one window frame to cover

being metal, they gave off heat. And while aluminum outlasted galvanized, it was not the perfect answer. Aluminum corrodes.

You can still buy galvanized and plain aluminum wire, but the latter has been upgraded with a coating to resist corrosion. After the wire is alodized, it's given a baked-enamel coating to add an attractive metallic finish that tends to eliminate the glare from new aluminum wire.

But while a lot of metal screening is still sold, it's gradually giving way to a new and glamorous "wire" made of fiberglass. Owens-Corning and Chicopee offer it in gray, white, green, gold, aqua and charcoal colors to add new eye appeal to windows and porch screens. It's crease-

resistant, dent and rustproof, easy to see through, simpler to clean, keeps out cold and comes up to a whopping 84 in. wide.

One type combines glass-fiber yarn laminated to a sheet of clear vinyl film to form a colorful windscreen. It's ideal for enclosing a pool area since it lets in daylight but stops wind, dust and pollen.

Another type is a sun screen which has see-through visibility and the ability to cut down penetration of the sun's heat. Its heavy mesh actually stops the sun's rays and reflects them back outside. This feature keeps rooms cooler, reduces air-conditioning costs and saves drapes and carpets from fading.

Fiberglass screening is made of pure

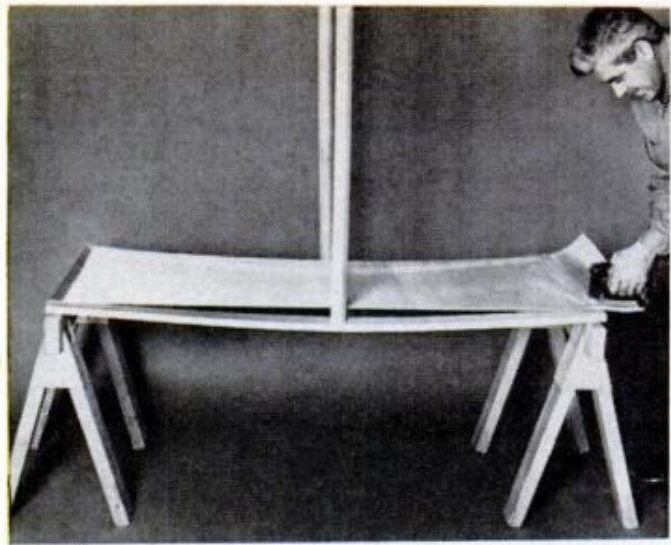
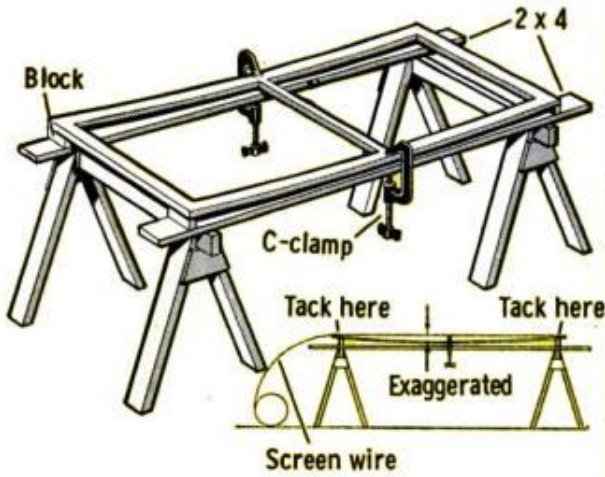

TWO WAYS TO BOW A FRAME so screening will be taut. C-clamps are used in one, ceiling props in other

glass fibers finer than a human hair. Hundreds of the fibers are wrapped together to form a single strand. A colorful vinyl coating is then permanently fused to the glass strands which are woven into the strongest screening you can buy. Screens covered with fiberglass are easily cleaned by mere dry brushing, vacuuming or washing with a mild detergent. And if you should poke a hole through the fiberglass, you can repair it easily with a fiberglass patch and a hot iron.

Staple guns have made screen repair go twice as fast but there's still the problem

of doing a neat job of stretching the screen taut when applying it to conventional wood frames.

If two small screens are to be covered, you can use the method shown in detail A, page 163. Here the wire is pulled taut by driving two wedges between the two frames after the screening is stapled to opposite ends. In another method (shown below) the frames are raised an inch off the floor on blocks placed at opposite ends. After the screening is stapled to opposite ends of the two frames, the blocks are removed, which automatically pulls the

ANOTHER WAY TO STRETCH WIRE on frames two at a time. Removal of blocks at ends pulls screening taut

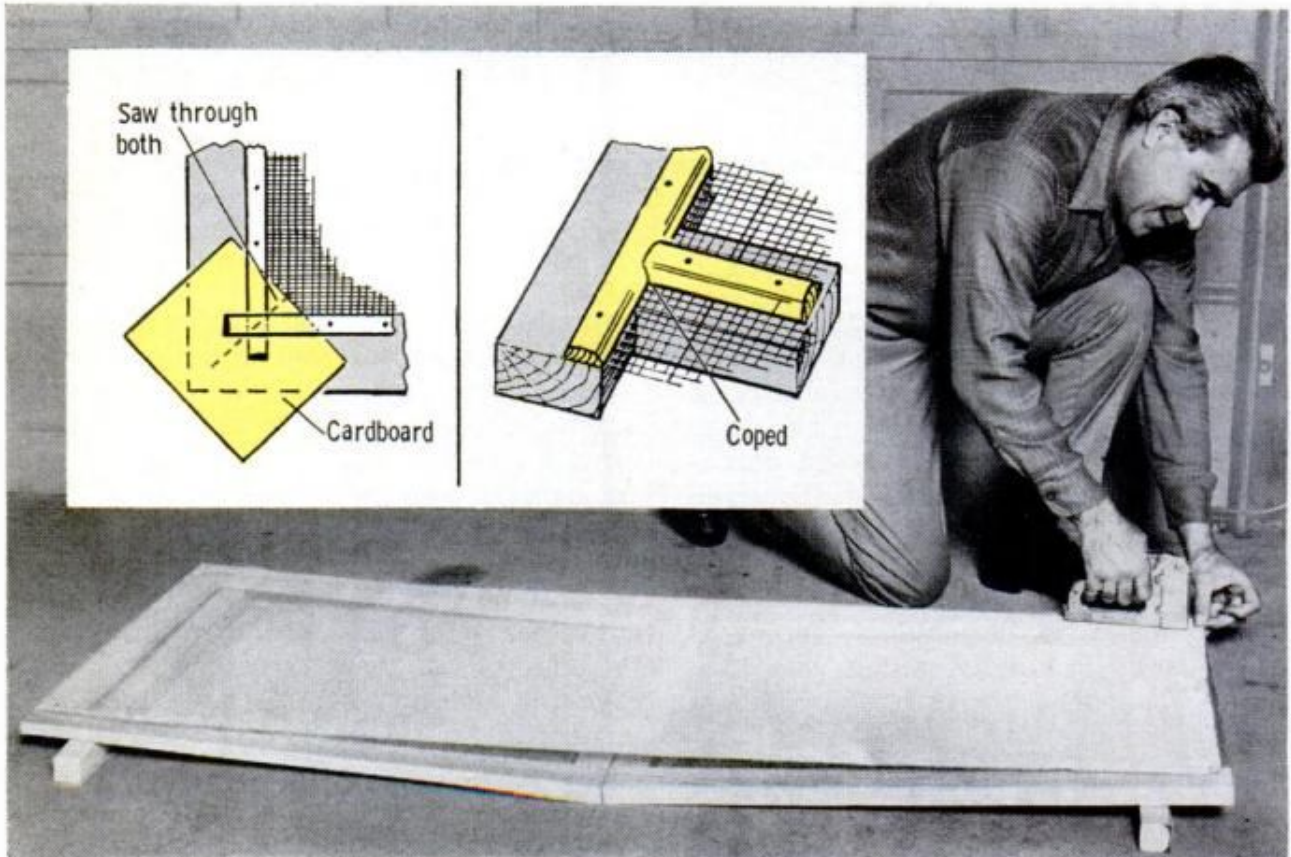

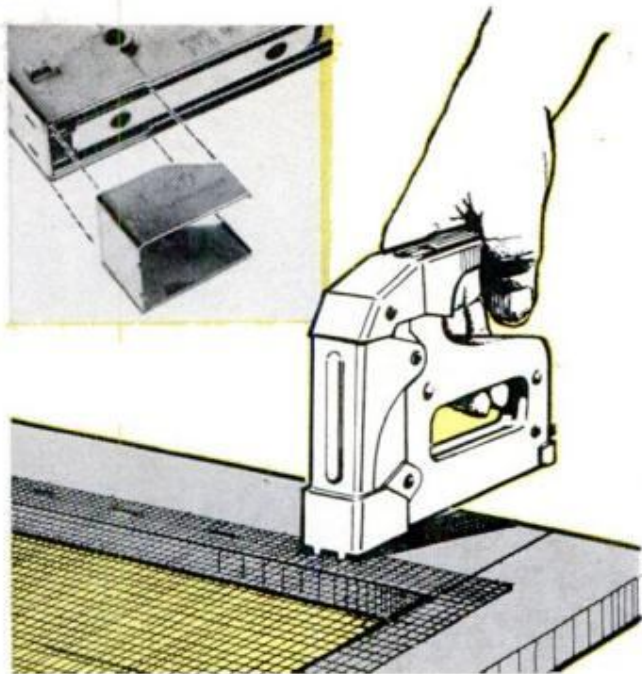

SLIP-ON ATTACHMENT for T-50 Arrow gun has teeth which pull the wire smoothly as it is stapled

screening smooth and taut. In method A, there is a slight waste of screening.

Where there's only one small frame to be covered, you can use the method shown in detail B. page 163. One end of the screening is stapled to the frame, the other to the bench. With the frame placed against a stop nailed to the bench, you merely press down on the raised end to pull the wire taut.

When covering a full-length frame, bowing it slightly beforehand will pull the screening taut when the frame straightens out. If working on horses in the basement or garage, you can bow the frame by wedging props against its sides and the ceiling. If working outside, the frame can be bowed by blocking it up at the ends and pulling it down with C-clamps to two 2x4s placed across the horses.

Where you might not be able to reuse the old screen molding, there's a stunt which beats regular mitering to cut and fit the molding at the corners. Simply let the pieces lap each other and saw through both at a 45° angle. Molding tacked over screening at the center of the frame is always coped at the ends to make it butt neatly against the side molding.

How to do aluminum frames

Of course, if your house has aluminum screens and storms, you won't use colorful fiberglass if you have to renew the screening in one of them. You'll be more apt to

(Please turn to page 211)

HINTS FROM READERS

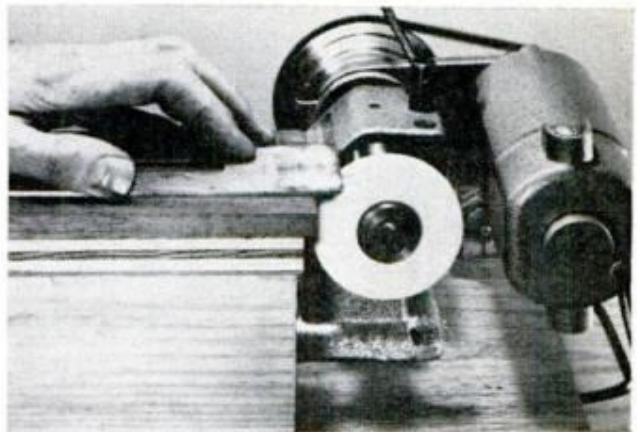

Supporting plane iron

How do you support a plane iron when grinding it on a wheel mounted on a polishing head or lathe headstock and there's no angle attachment handy? One simple way is to place the plane iron face down on a stack of wood blocks placed in front of the wheel. By building the stack high enough you can arrive at the same degree of bevel and be reasonably sure of a straight edge, provided you are careful in guiding the blade squarely across the face of the grinding wheel.

Extension handle aids boring

Boring large holes with a brace and bit can take a lot of muscle, particularly when working with hardwood. Such a tough job can be made easier if you take the time to first make an extension handle for the brace. Made 12 in. or so long, the handle will increase the leverage of the regular handle considerably so that less effort is required to turn the auger bit. As you can see, the handle is quickly made by screwing together standard pipe fittings. Of course, you should be careful not to bend the brace.

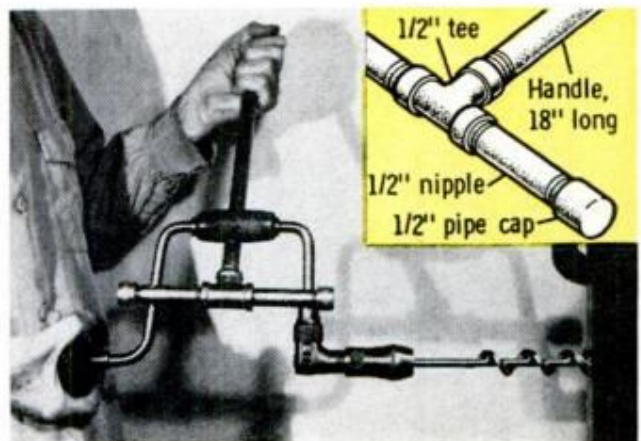

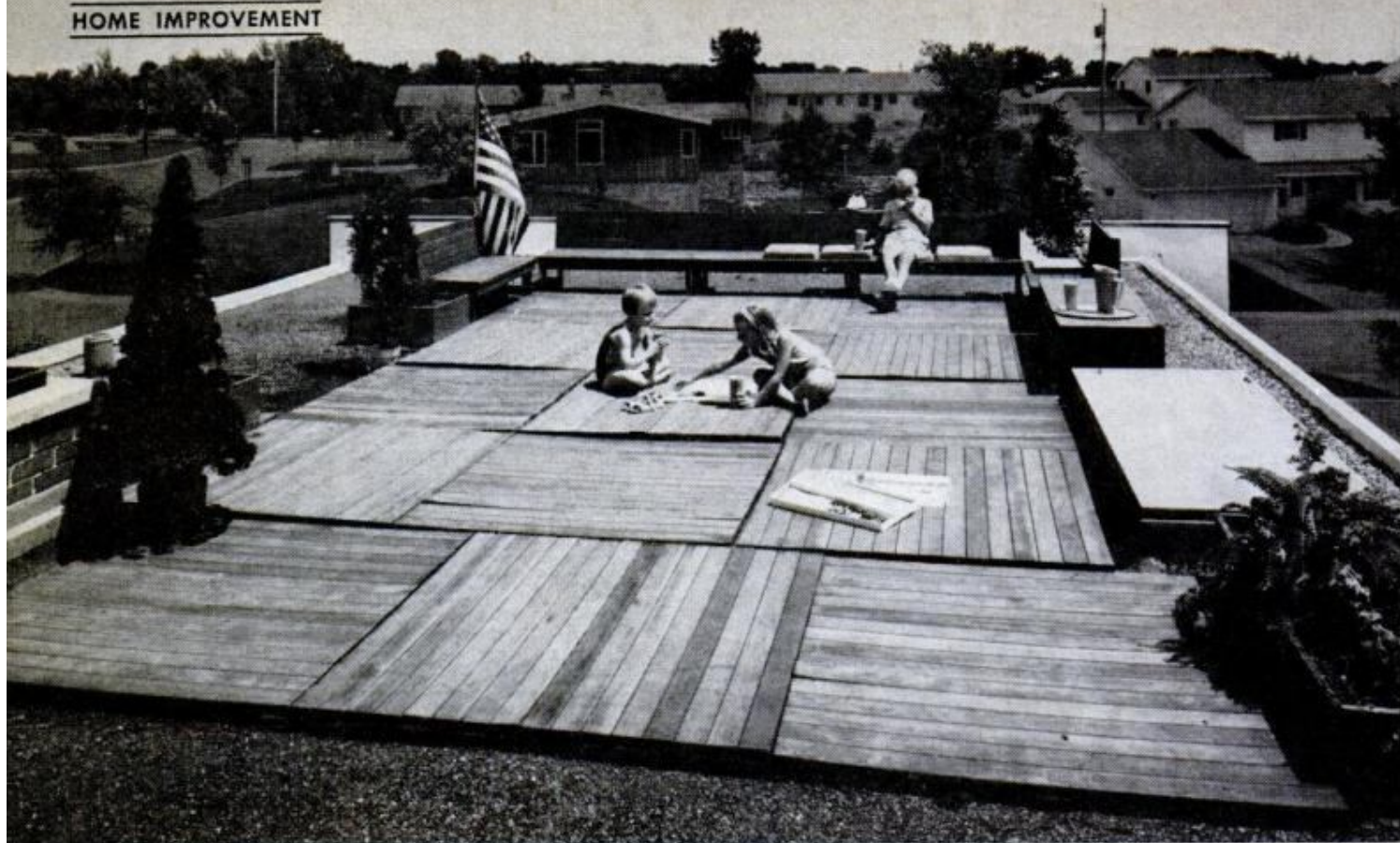

ROOFTOP PATIO

HERE'S ONE FAMILY'S SOLUTION to the problem of where to put the patio—it's on the roof!

Complete with a roof garden, telephone and electrical outlets and built-in benches of redwood, the patio has truly become an outdoor living center for the Ray Hedelson family of Edina, Minn.

Originally designed as a redwood deck to be used for sunbathing, the patio soon became a high-traffic relaxation and entertainment area for the entire family.

Though your roof-line may not permit building a patio atop your home, the hand-



BENCHES ARE BUILT facing inward to discourage children and visitors from venturing to roof's edge

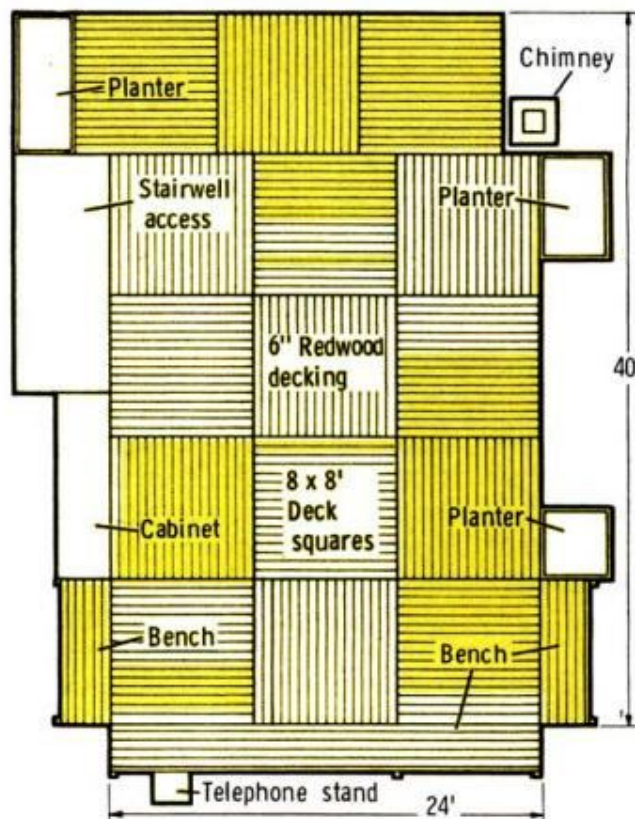

some design could be used in your back yard or possibly atop an attached garage. Redwood decking 6 in. wide is used to form 8x8-ft. squares, like oversize parquet flooring. Similarly, you can borrow ideas on bench and cabinet construction from the photos and drawing. Redwood planters complete the patio nicely—whether on a roof or in a yard.—Annette I. Sukor

Tape 'Joints' Turn Slab into Tiled Patio

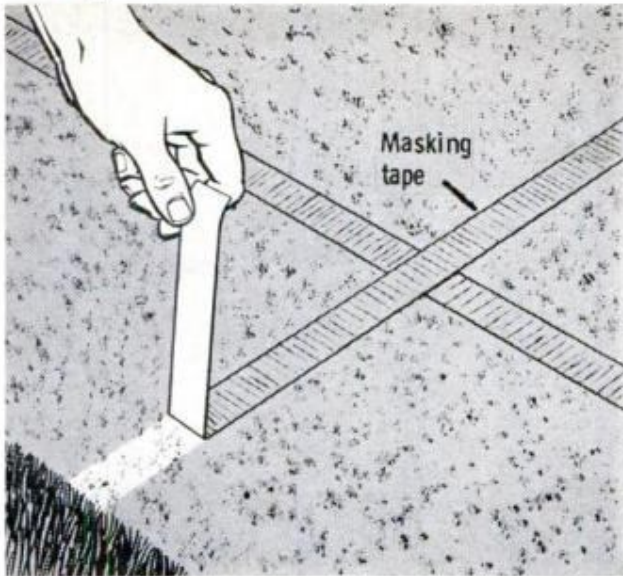

THE QUICK WAY to build a patio is to pour a slab. But that's just what it looks like—a slab. However, if you have such a drab expanse of concrete, you can "tile" it overnight by the tape trick and wind up with a mighty attractive patio.

Masking tape is applied to the concrete in a tile pattern. Then concrete paint is rolled or brushed over the patio, tape and all. Next day when the paint is dry, the tape is peeled off. Presto!—you have instant mortar joints between colorful tiles.

You can mask your patio in uniform squares or tape it to create tiles of irregu-

lar shapes. You can even paint the tiles different colors. Any paint seepage under the tape only enhances the overall effect.

Paints especially made for concrete are the most durable since they are scuff resistant. Some require an etching of the concrete beforehand to produce the best bond. Here the bare concrete is scrubbed with a mild solution of muriatic acid and water and then hosed off with clear water. This roughens the surface like sandpaper and gives a tooth for the paint. The acid, however, can be hard on grass.

—Myron Sartain

Concrete Perimeter Keeps Patio Bricks in Place

The big problem when building a patio of bricks or blocks is keeping them in place. When blocks are set side by side on a bed of sand, there's nothing to hold them there. I solved the problem by pouring a concrete retaining ledge around three sides to keep the free-standing bricks from shifting. The ledge also permitted setting the bricks above ground level and made it easier to mow around the sides.

I first scooped out the area to a depth of about 8 in. and then staked a form board around three sides, making sure it was level. Next, I filled the area with damp sand, kept it about 3 in. away from the form board and tamped it to form a firm base 6 in. thick. I placed bricks on the sand in straight rows and $\frac{1}{4}$ in. apart. Then I filled the trench around the perimeter with concrete, troweled it level with form boards, filled spaces between bricks with white silica sand and brushed off the excess.—Eugene E. Florida

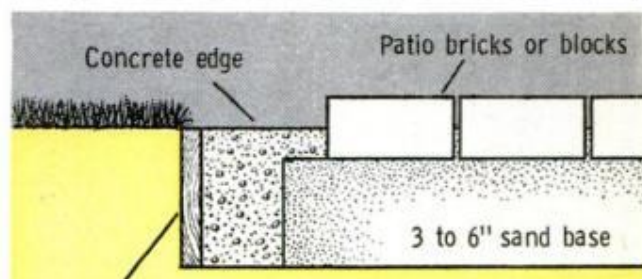

1" form board removed after concrete cures

Five Weekend Workshop

Ministool for Mini Uses

What could be handier than a pair of these little padded stools? Being higher than the average chair, they'll be just right for pre-schoolers to sit up to the table at mealtime, and guests will find them better than the floor when seating runs short.

The drawing shows how simple it is to make one. You'll need a lathe to turn the legs and rung, but if you don't have one, you can substitute regular tapered legs bought in a store and use a plain dowel for the rung. Here the threaded stud is removed from the end of each leg and a tenon is hand-fashioned to fit a 1-in. hole. Holes for the legs are drilled at a slight angle to splay them. Glue is used in addition to wedges to lock the legs in place, after which the tenons are sanded flush. The seat frame is padded with foam rubber.—*Kenneth Wells*

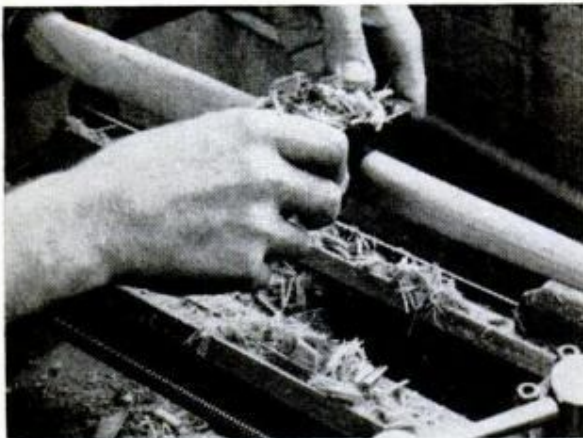

A BLOCK PLANE is better than a lathe chisel for turning straight and tapered sections of legs

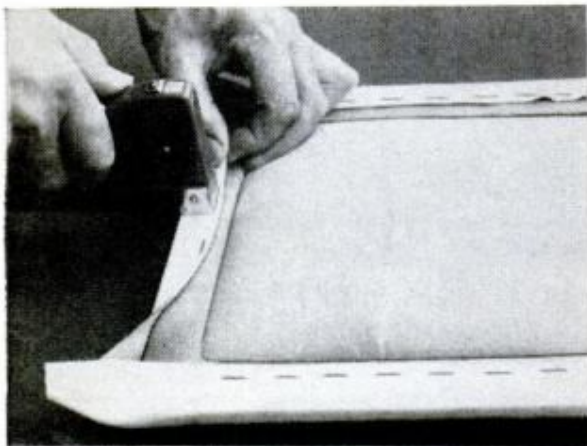

AFTER PADDING SEAT, vinyl covering is stapled to underside. Screws below hold seat to stool

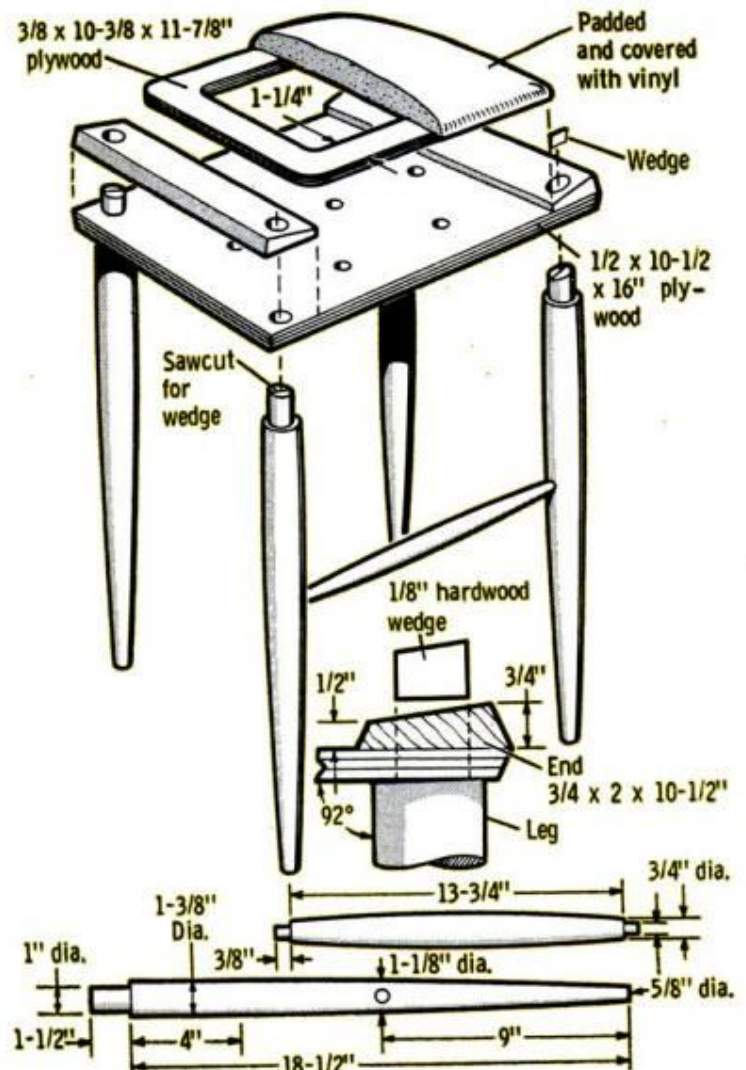

Projects

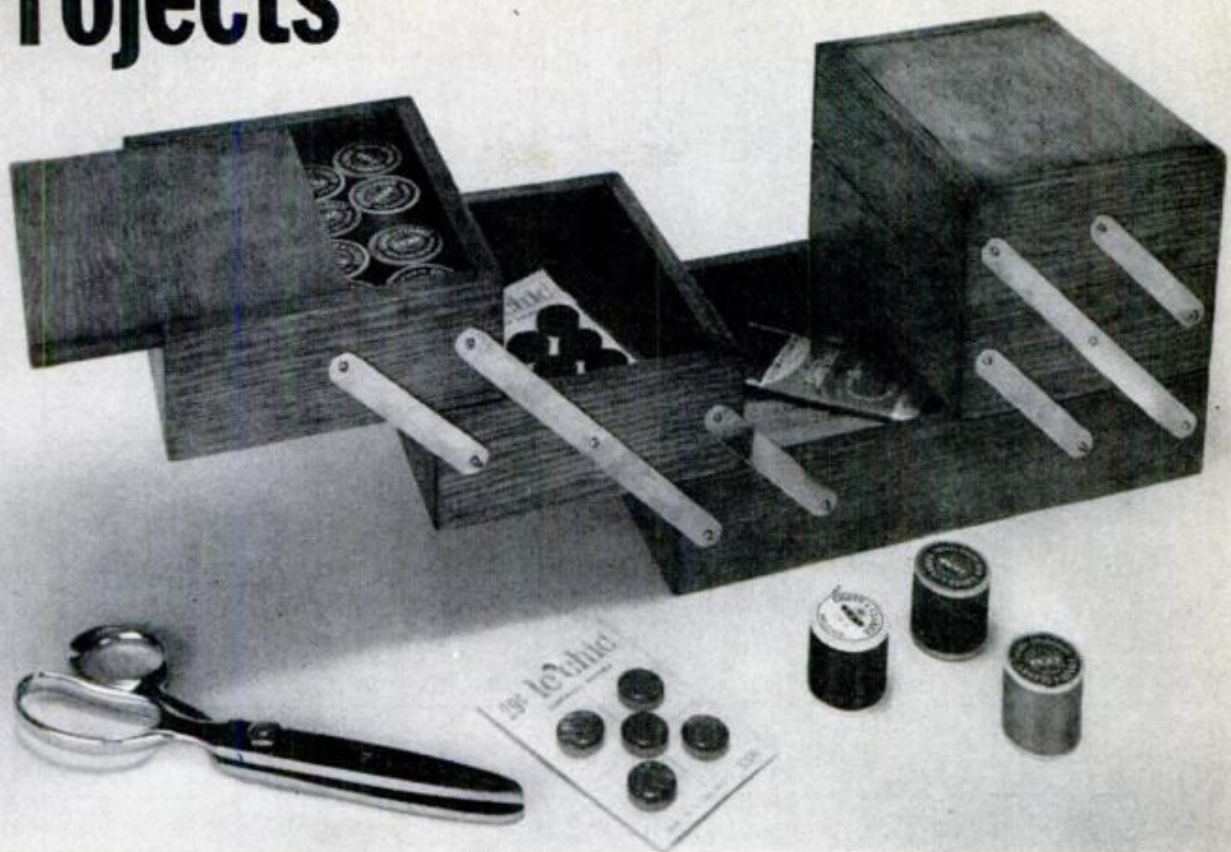

Pivoting links made from 1/16 x 1/2" brass

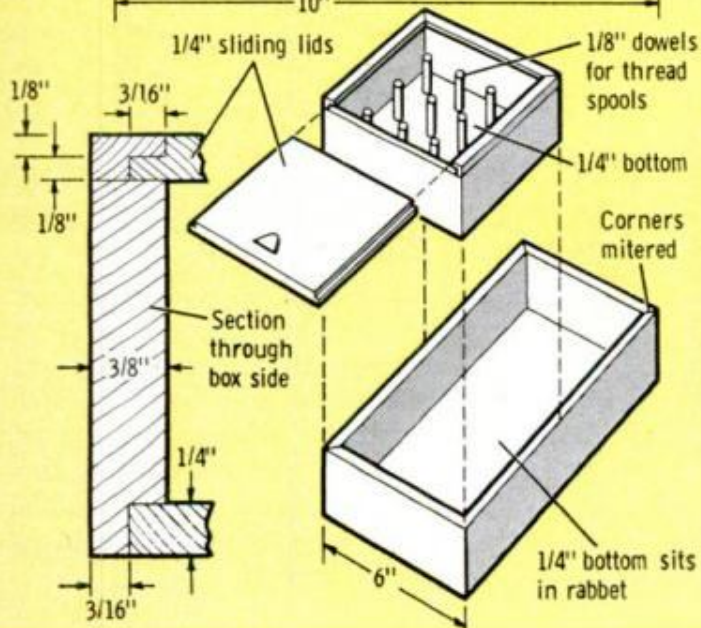
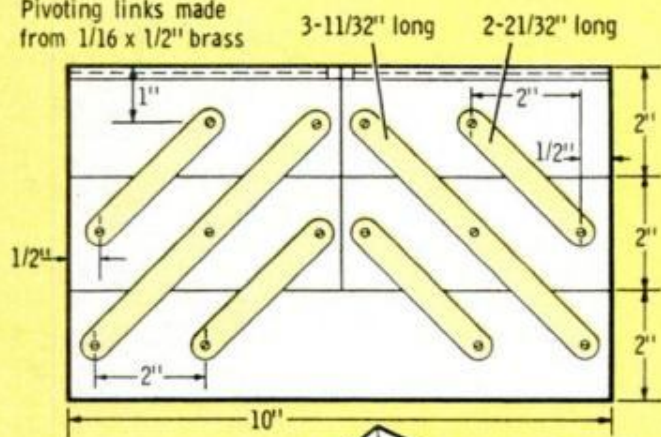

Sewing Box

Your wife will find this novel sewing box as handy today as when we first published it back in September 1953. It's a stack of boxes linked together to swing open in unison. Four of the box-like trays are basically alike, except two have sliding lids. The latter are rabbeted on three sides to slide in grooves formed by nailing 1/4 x 3/8-in. rabbeted strips to the box. Box bottoms and lids are 1/4-in. thick; the sides, 3/8 in.

You'll need twelve links of 1/16 x 1/2-in. flat brass—eight short ones and four long. Drill all of equal size at the same time to assure identical spacing of the holes. The links are placed at a 45° angle and you'll do best to locate the short ones first, 1 in. down from the top and 1/2 in. in from the sides. Use the smallest roundheaded screws you can find to pivot the links and don't draw them up tight. Bottoms of the two top trays are drilled for short 1/4-in. dowels to provide spindles for spools.

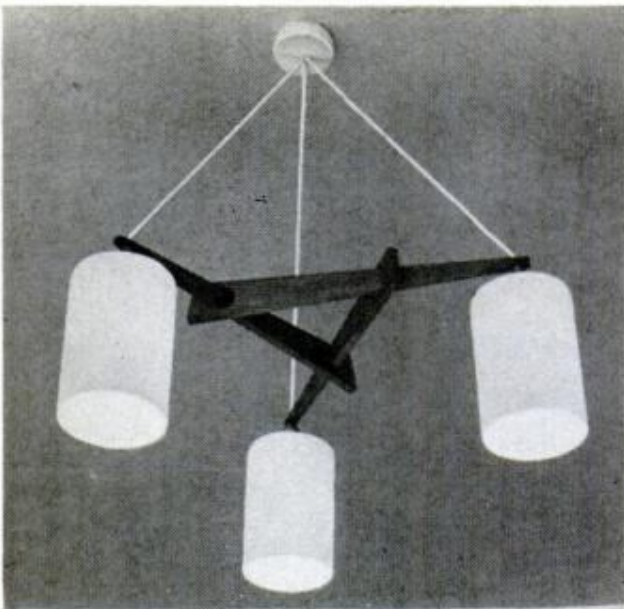

Modern Hanging Fixture

Ridiculously simple to make, this attractive light fixture requires only three identical wood parts. All interlock to form supporting arms for common sockets and modern cylindrical shades which, in turn, are suspended from a ceiling canopy.

Use plastic covered wire for wiring the fixture and run a length from the ceiling canopy to each socket. Connect all three black wires together and all three whites together. Then connect the twisted ends to the 110-v. black and white wires in the ceiling outlet. You may find it necessary to enlarge the hole in the canopy.

—Kenneth Wells

HARDWOOD ARM 3 reqd. 7/16" thick

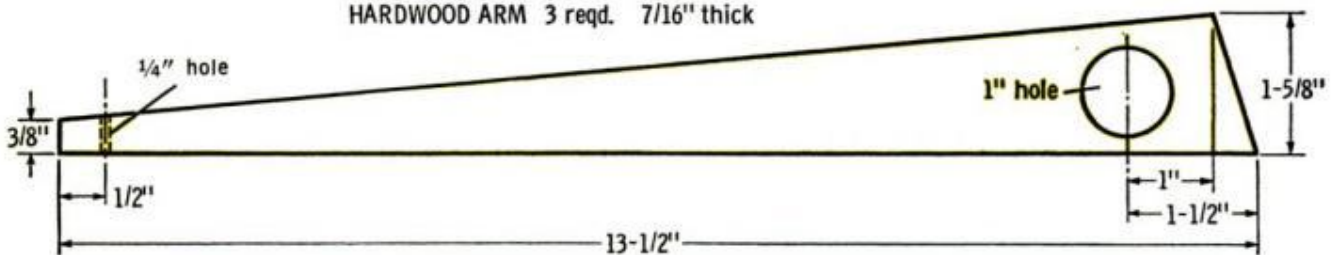

SUITABLE SPICE JARS can be purchased at most variety stores. Final finish can be varnish or paint

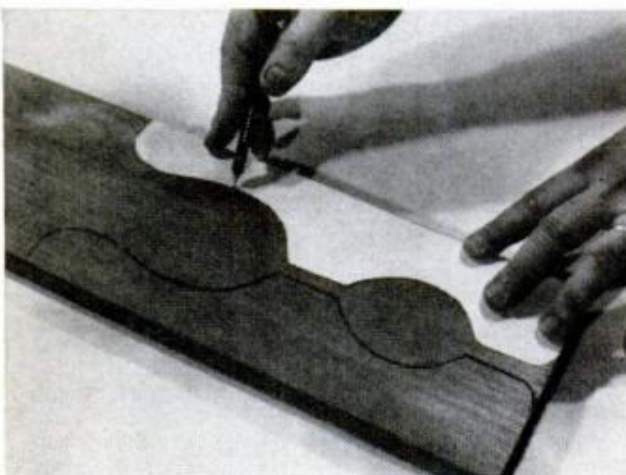

PAPER PATTERN FOR ENDS is traced on 3/4-in. wood. Both ends will be identical if sawed at same time

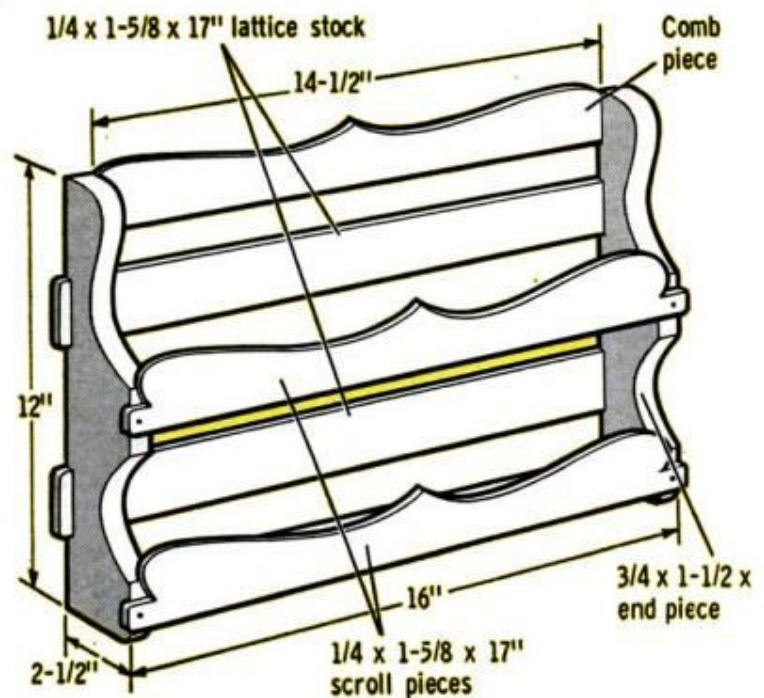

Kitchen Spice Rack

Designed to keep 16 jars of spices at fingertips, this little spice rack will prove to be more than just handy—it will also add a decorative touch to the kitchen. It's probably wise to have your spice jars at hand and dimension the rack accordingly. Holes for a couple of hanging screws are made behind the jars.—Bob Corely

Magazine Rack

Here's about as simple a magazine rack as you can make. It consists of a board base which is slotted on your bench saw to accept three hardboard panels. The center slot is a 90° saw cut, while the outside ones are cut at 80° to flare the panels. Perforated hardboard helps to add extra eye appeal, although if you prefer, all three panels can be cut from plain material. The handle, glued to the center panel, is simply a short dowel slotted lengthwise to fit over the edge of the hardboard.

The decorative initial overlay is optional. For the neatest job, paint all parts before they are glued and assembled. Hardboard always takes on a better finish if the material is first sealed with a flat enamel undercoater that is applied with a roller. In the case of perforated hardboard a roller is better than a brush since it won't fill the holes.—Heath Winston

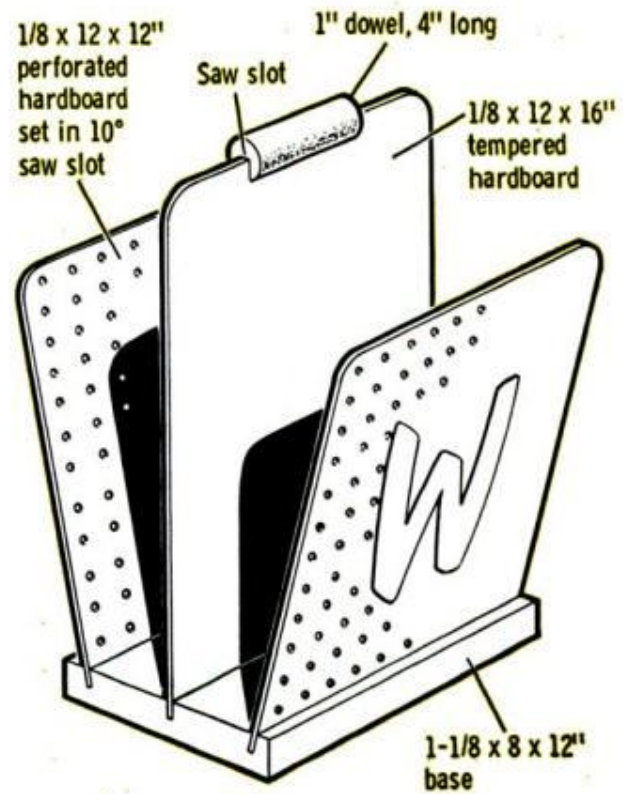

IF DESIRED, a dowel rung can be added across each end at the top to support slanting side panels

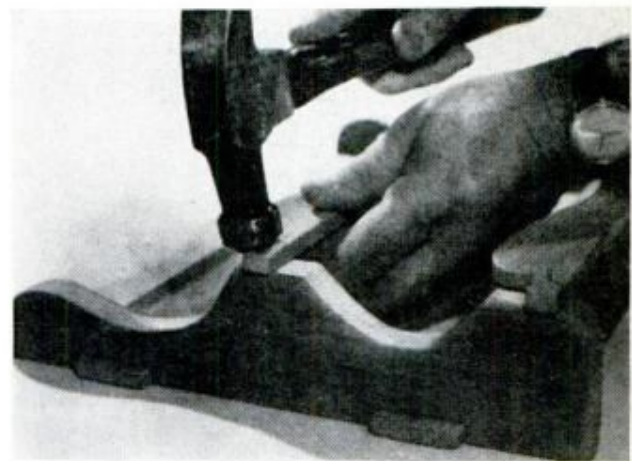
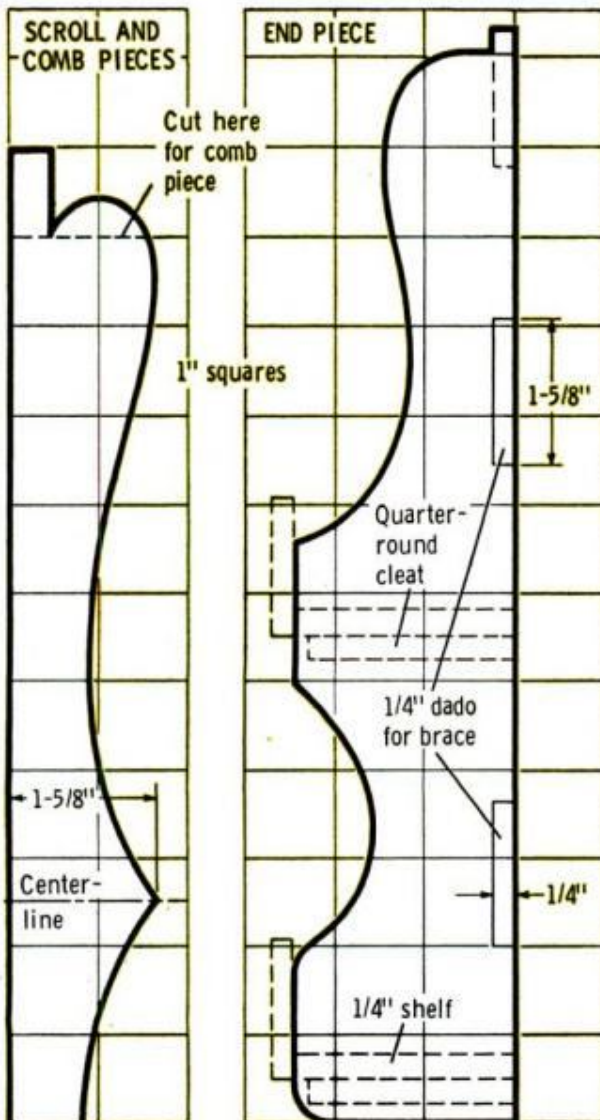

TWO FRONT SCROLLS are lapped and nailed to ends, whereas shelves are supported by 1/4-round cleats

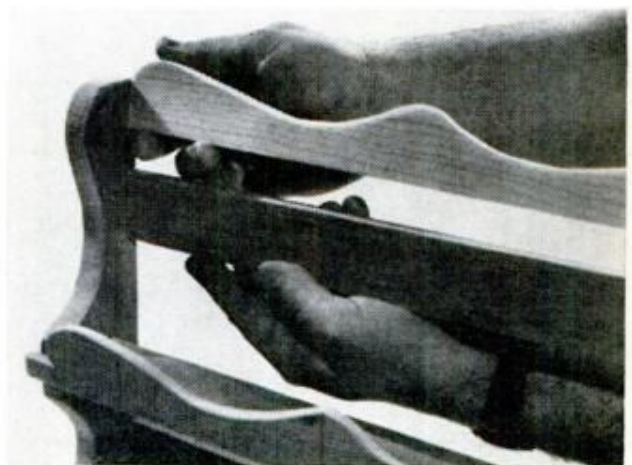

TOP SCROLL fits between the ends and is nailed from the outside. Lattice pieces rest in dados

Make This Simple Fixture to

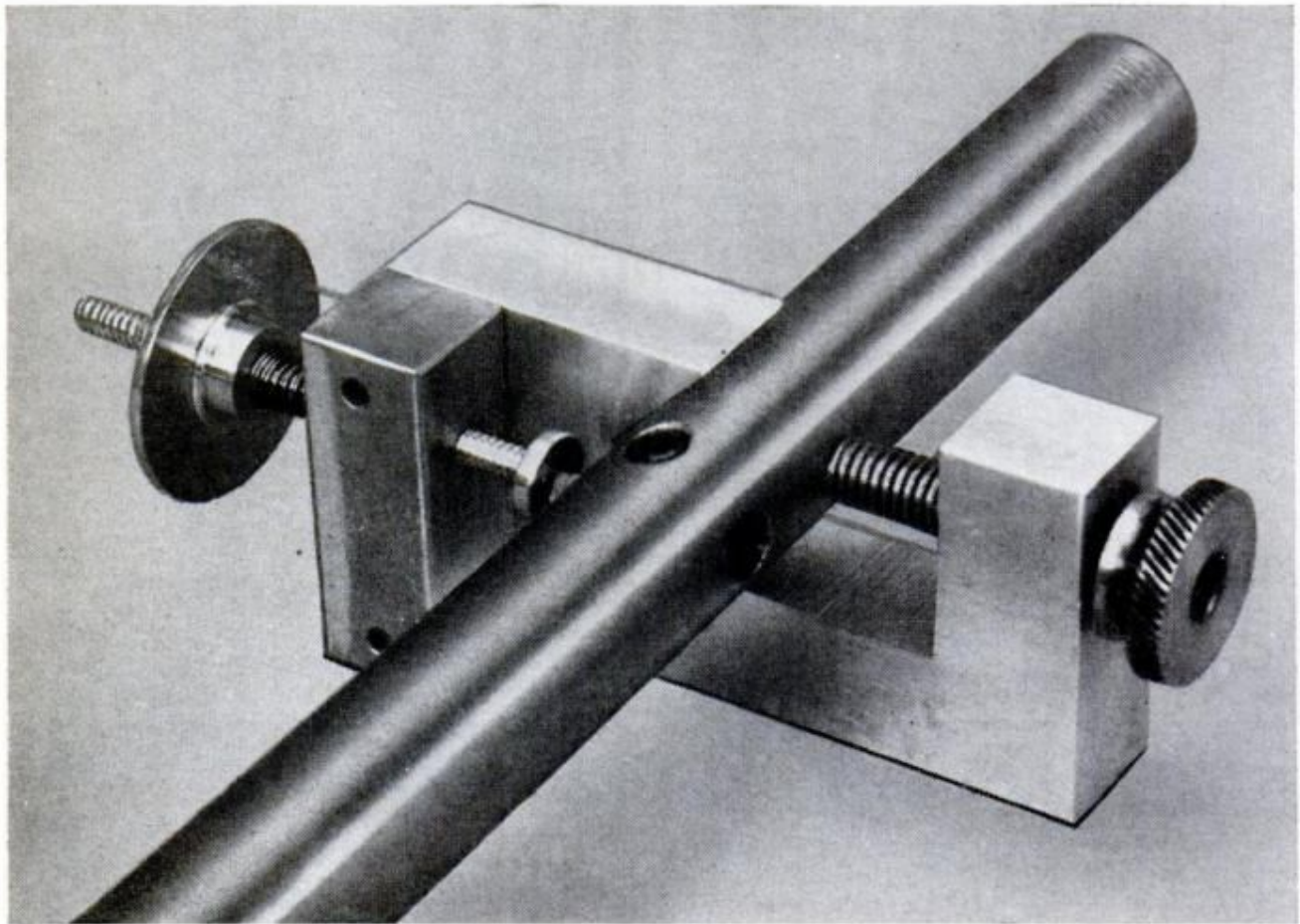

Technical Art by Graphic Presentations

By RUDY KOUHOUP

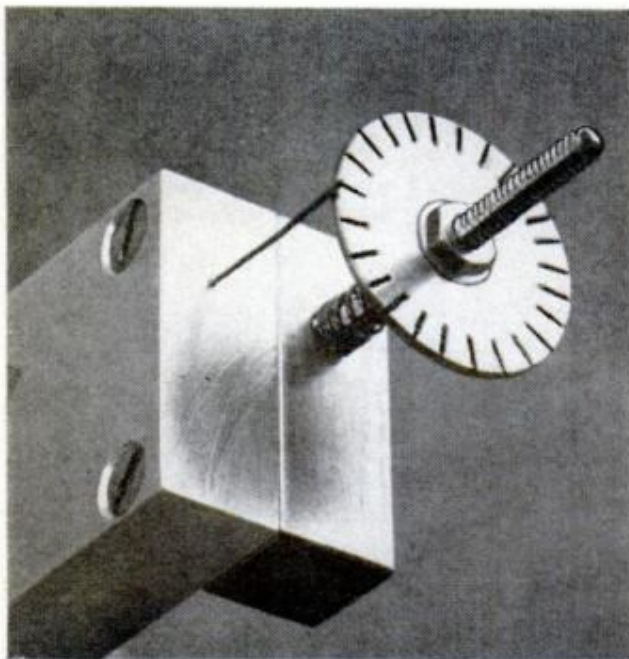

EACH DIVISION on the index wheel represents one thousandth of an inch. Spring-wire pointer should barely make contact with the edge of the index wheel. Coil spring on shaft provides a positive action

BORING BARS used in a lathe provide a superior way to make round holes with true parallel walls, especially when mounted between centers. They are a natural for boring engine cylinders, lens adapters and similar precision parts. However, there is the ever-present problem of setting a bar's single movable cutting point to produce a hole of an exact predetermined diameter.

With this simple adjuster, the machinist can routinely preset his bar to bore to the nearest thousandth-inch. After some practice, he'll be able to split thousandths.

Dimensions in the drawing are for an adjuster accommodating bars with an outside diameter of $\frac{5}{8}$ -in. or less. Simply increase them for larger bars, but maintain the essential basic proportions.

Make the clamp first from a 1x2-in. piece of $\frac{3}{8}$ -in. Dural. Dress the edges square, then scribe the vertical center line passing through the apex of the 90°

Set Boring Bars Accurately

notch which forms the seat for the bar.

Remove the bulk of the metal from the notch area by drilling and hacksawing. The surfaces which form the V and actually seat the bar must be finished carefully; upon their flatness and trueness rests the accuracy of the adjuster. I used an end mill for finishing, but you can do it by hand, working with small files.

Drill and tap the underside of the clamp for the thumbscrew, after locating the hole on the reference centerline so the screw will hold the boring bar squarely in the V of the notch. Drill and countersink holes for two 3-56 x 5/8-in. flathead screws to hold the positioning block to the side of the clamp. The block is made from a 1-in. length of 3/8-in. key stock. Dress the ends square, then mark the mounting-screw locations, which are drilled and tapped 3-56. Attach block with the two screws.

Now, working from the center line on the clamp, locate the hole for the vertical adjusting screw, drill and tap 4-40. A 40-t.p.i. tap is used here for the same reason it's used on a micrometer spindle; it pro-

vides 25 exact divisions around the index wheel, each representing 1/1000 in.

Machine down a bit of 1/4-in. brass rod to form the adjusting screw. Note that it is threaded 4-40 and has a 1/16-in.-thick foot to contact the tip of the cutter.

Turn the index wheel from brass also. It's best to add the scale divisions while the wheel is mounted in the lathe chuck—after the face is trued. Set the lathe's dividing head to produce 25 divisions at the spindle. Mount a sharp tool in the toolpost and advance it so it will scribe about 0.004 in. into the face of the wheel. Crossfeed the tool to make a mark about 1/8-in. long. Back off the tool, rotate the spindle one point and repeat. Do this all around the wheel. Finally, while the wheel is still in the chuck, drill through its center and tap 4-40.

Thread the wheel onto the adjusting screw and place a small compression spring between the wheel and end of the clamp. Secure the wheel with a locknut.

The pointer is added next. Spot a hole

(Please turn to page 211)

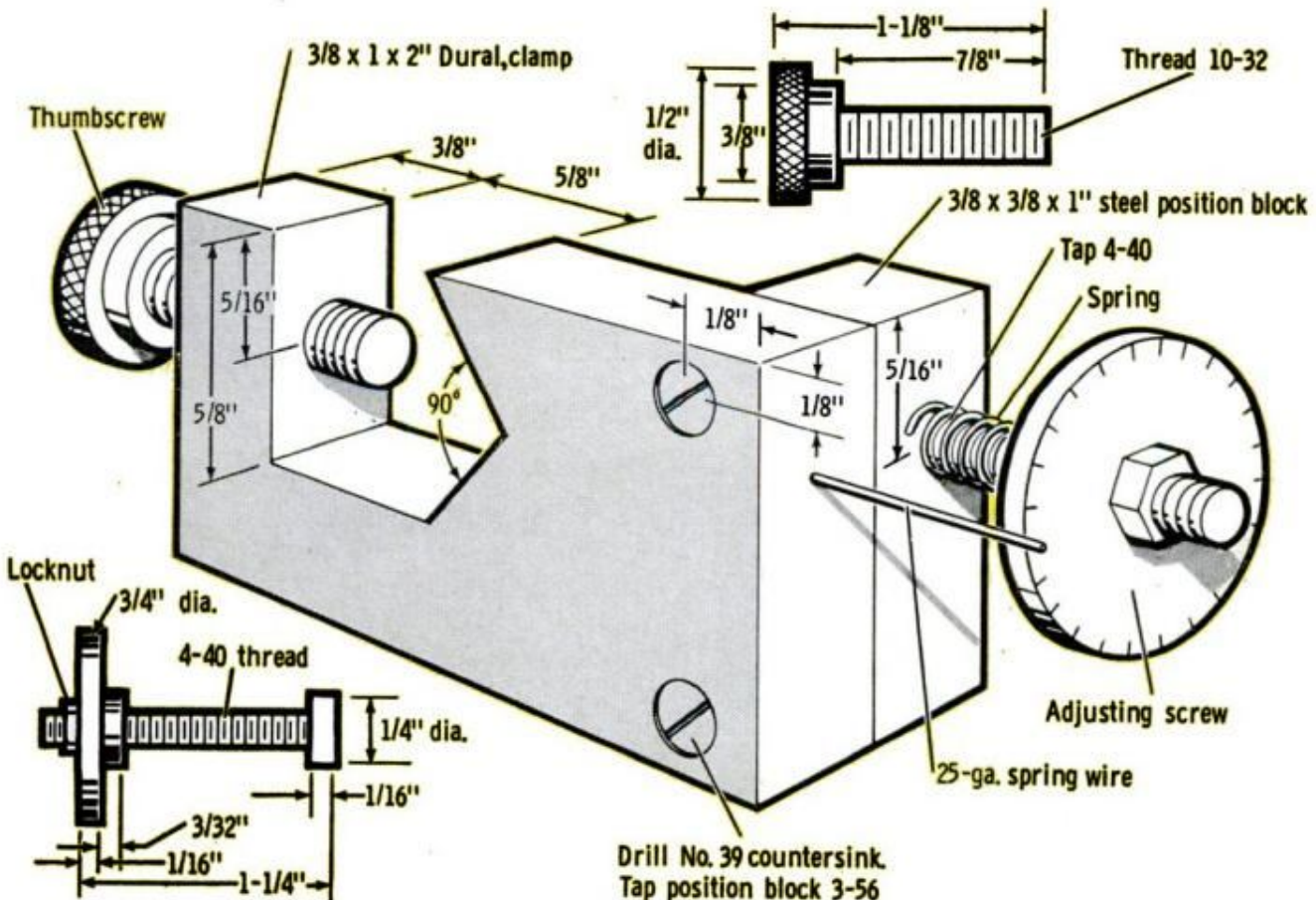

Empty Caulking Cartridge Makes Pump



DRAWING UP ON PUMP HANDLE will suck leftover gas from power mower when storing it for winter

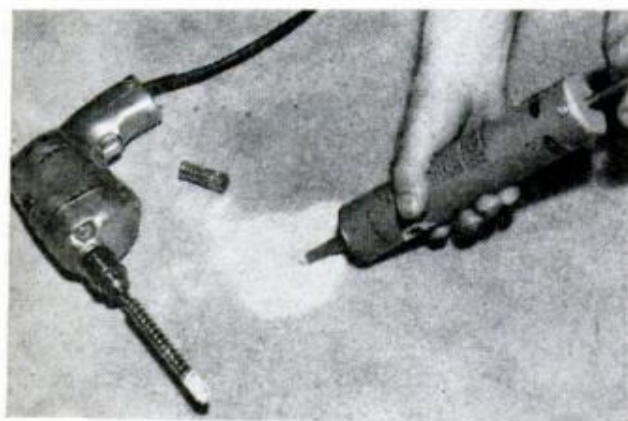

PUSHING IN ON HANDLE causes pump to blow strong jet of air, fine to blow dust from drilled hole



PUMP BECOMES GREASE GUN by filling cartridge with lubricant and squirting it out tapered nozzle

WHEN IT'S EMPTY, you might not think a caulking cartridge could be of much use, but that's where you're wrong. Fitted with a piston and handle it becomes a dandy little hand pump.

With it you can fill a gear case with grease, suck the gas out of a power mower when putting it away for the season or bail those last few cupfuls of water from your boat. You'll also find it handy when you need to blow chips or dust from a hole drilled in concrete.

It's simple enough to make as shown in the drawing. The piston consists of a threaded rod fitted with two plastic cups placed back to back with a plywood washer between. One of these cups is in each cartridge—it's what forces the caulking out the nozzle.

The pump works best when the cups rub firmly against the sides of the tube. By tightening the nuts a little, you can flare the cups a bit for a better fit. A drop of oil or a little grease on the cups will improve the seal and ease pumping.

When the pump is to be used only as a blowgun, one plastic cup on the piston (with its lip toward the nozzle) is enough. For extra reach a length of plastic hose can be forced over the nozzle. To start a siphon, you hold the pump at a point lower than the level of the liquid and slowly pull up on the piston. This fills the hose with liquid and if you then remove the hose from the pump, the liquid should siphon by itself.—Ray Shoberg

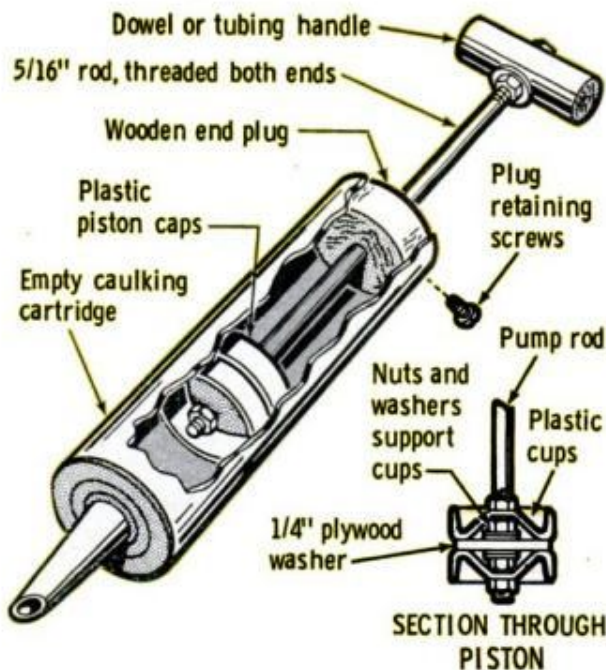

HINTS FROM READERS

Plastic lid holds tubing

The plastic lid taken from a 2-lb. coffee can will securely grip thinwall tubing in a bench vise without damaging it in any way. Simply wrap the plastic lid around the tube or length of conduit, then bend the ends and pinch them in the jaws of a bench vise. This is especially handy when working with plated tubing that could be scratched or cracked.—*Albert Pippi*

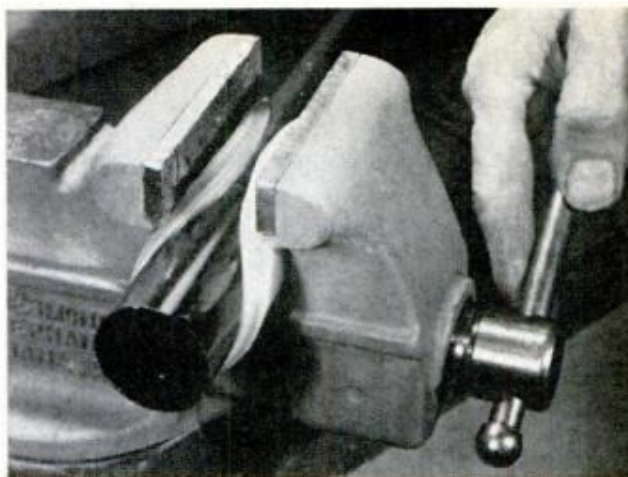

Holes avoid sawdust accumulation

Here's a way you can make your radial-arm saw table self-clearing of any build-up of sawdust along the fence. Simply bore a row of $\frac{3}{4}$ -in. holes along the edge of the front table insert. Thus when you slide the work along the fence to position it, the board automatically pushes the sawdust down through the holes to the floor. If you prefer, you can achieve the same results by making the holes in the edge of an auxiliary table and use it as shown in the photo.—*Victor J. Lamoy*

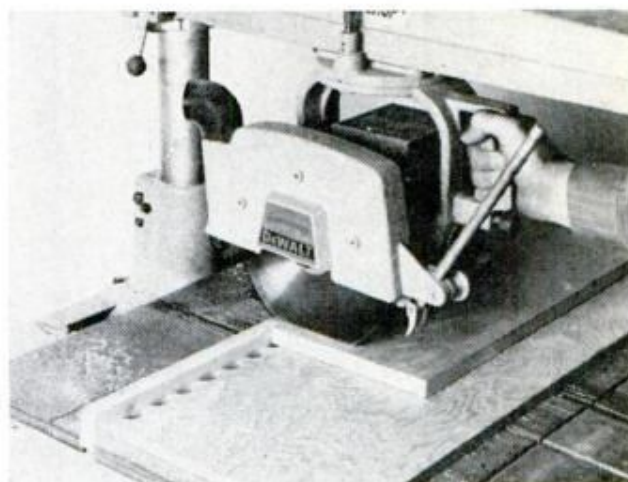

C-clamp as miniature vise

When you find yourself working with tiny parts that could possibly be damaged in the knurled jaws of a conventional bench vise, consider this handy trick. First clamp the work in the jaws of a small C-clamp, then secure the backbone of the clamp in the jaws of the vise. Now you can quickly insert or remove pieces of work without removing the clamp from the vise. If you use a regular clamp with a long adjusting handle, be sure the handle will clear the vise.—*Martin Steinagle*

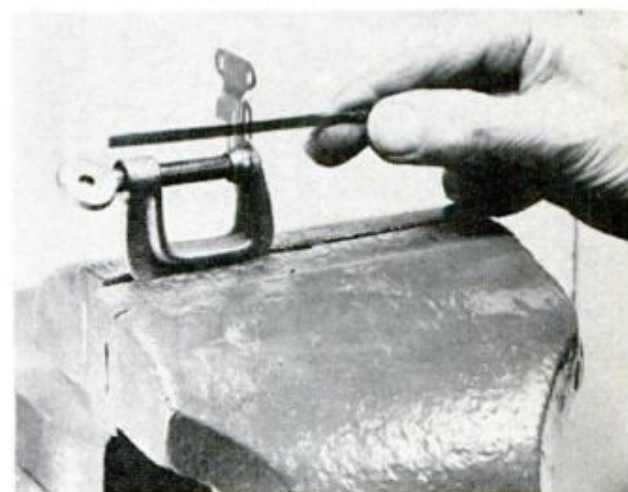

Miterbox scrolling jig

It often can be a major problem trying to cut small pieces of wood or metal with a sabre saw, since only one end of the work can be supported in a vise—the other end, when left free, vibrates erratically. I recently solved this problem by setting the work over a miterbox, letting the saw blade cut between the two uprights. If you don't have a suitably deep miterbox, try improvising a simple sawing jig from a length of 2x4 and a few pieces of scrap pine.—*Harold Miglin*



Build This One-Man Golf Cart

You make the chassis and seat from scratch and assemble the rest from standard components



By EMILE ALLINE

Technical Art by Fred Wolff

THE FRINGE BENEFITS of owning your own golf cart are many, particularly when it's a cart which is small enough to tote and store in the trunk of your car. Here it can stay along with your clubs from weekend to weekend; there's no waiting to rent a cart when you get to the clubhouse and, being a one seater, it's a lot easier to handle and operate than its big brother. You can play two rounds of 18 holes on a 2-qt. tank of gas.

It weighs approximately 65 lbs. but breaks down into three lightweight sections, so it's no hefty thing to lift in and out of the trunk.

You can build this cart for about \$140 (less if you can do your own welding) from standard go-kart parts and odds and ends around your shop. If you have an old lawnmower engine, it will cost you still

less. It's powered by a 3-hp gasoline engine which is fitted with an oversize muffler to reduce noise to a minimum. You start it with a conventional cord and stop it with a pushbutton switch. To tote it you detach the hinged seat and pull off the front wheel assembly by removing three wingnuts. A bracket in front holds your golf bag, and a receptacle on the steering post keeps extra balls, score card and tees handy.

To build the cart you start with the frame. This is bent from 7/8-in. airplane tubing, using a regular pipe bender. The frame measures 16 in. wide and 39½ in. long, and turns up at the front at a 60° angle for a distance of 11 in. Cross braces are welded to the side members at each end of the engine compartment, then one is added up the middle to brace the floor and footboard, and finally two short braces

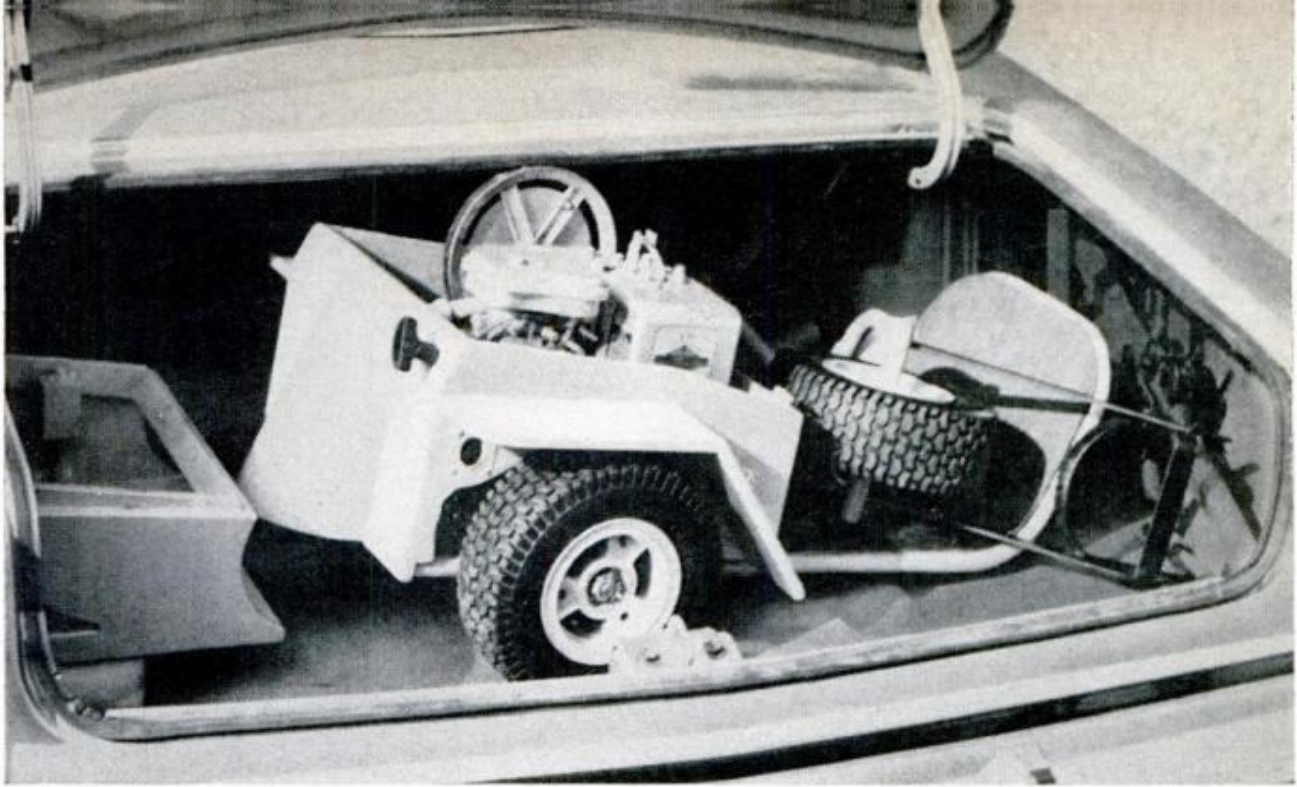

CART COMES APART in three lightweight sections in order to fit easily in trunk of the average-size car

are welded at a point where the frame bends upward.

Next a $\frac{1}{8}$ x $9\frac{1}{2}$ x $10\frac{1}{2}$ -in. steel engine-mounting plate is welded to the frame just back and to one side of the second cross brace. This is drilled to suit the mounting holes in the engine.

Four 2-in. lengths of angle iron are added to the corners of the frame, $\frac{1}{2}$ in. in each way, for attaching the plywood engine hood. These are drilled for machine screws and spot-welded on end.

Next, two bearing flanges for the axle are welded to each side of the frame 6 in. from the end. The floor is decked with

FLIP-OPEN TOP of engine compartment makes it easy to add fuel and to service the drive mechanism



aluminum plate and attached to the frame with Pop rivets, after which black rubber stair tread is cemented to the aluminum.

The fork for the front-wheel steering post is a 6-in. length of $\frac{7}{8}$ -in. i.d. tubing which is welded to a $\frac{1}{8}$ -in. steel mounting plate. This plate is drilled for three mounting bolts which project through the frame. The heads are spot-welded in place and the bolts are fitted with wing-nuts. This plate is what holds the front-

CLOSEUP VIEW of clutch and chain drive. Note muffler of pilot model which extends outward at rear

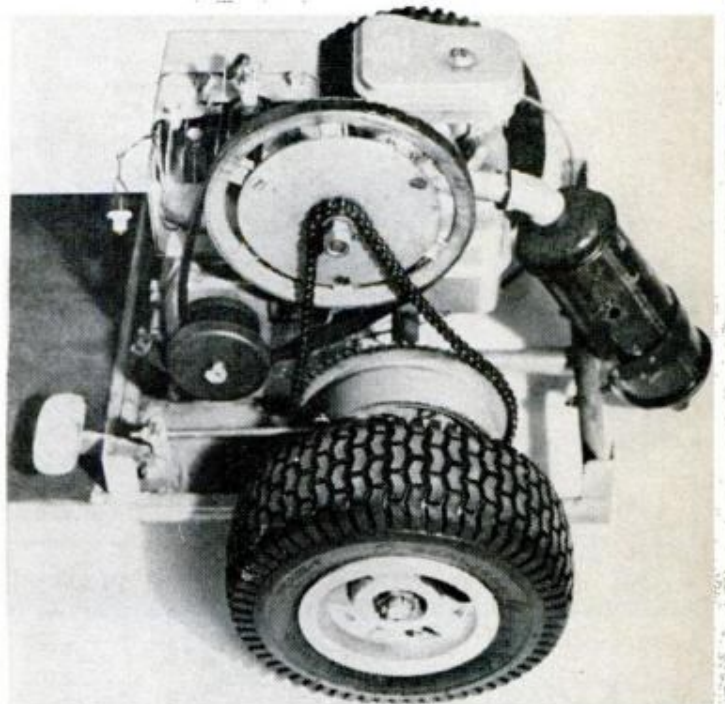

BASIC CONSTRUCTION DETAILS

wheel assembly to the rest of the cart.

The steering post is permanently positioned in the fork by two washers which, when welded to the post at the top and bottom of the fork, form bearing shoulders. The wheel yoke is bent from tubing to accommodate the wheel and then is welded to two short sleeves which hold an 8-in. axle. Spacers 1-in. long are necessary on each side of the wheel. Cross bolts through the sleeves and axle lock the latter in place. Self-tapping sheet-metal screws are used to pivot the golf-bag bracket to the wheel yoke. A second screw on each side of the yoke serves as a stop for the bracket.

Now you install the engine, line up the pulley-sprocket-clutch-brake assembly and rig the gas and brake pedals. A flexible cable runs from the gas pedal to the engine. After a trial spin to check out performance, the two-section compartment is built around the engine as shown. The flip-up, lift-off seat section is hinged with specially formed hinges. The barrel of one hinge leaf is opened into a hook to engage a pin left in the other leaf. Be sure to add sufficient cutouts in the front and sides of the seat section to cool the engine.

A comfortable cushion is made by padding a piece of plywood with 4 in. of foam rubber and covering it with vinyl. Two bolts first placed in the plywood are used to attach the seat to the top of the compartment. ★★★

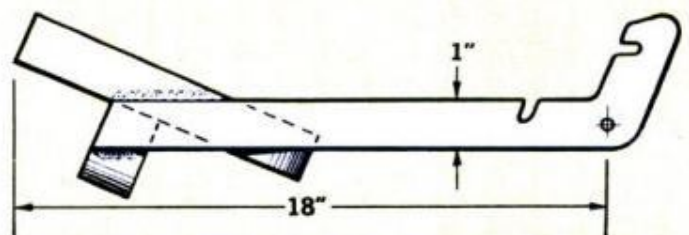
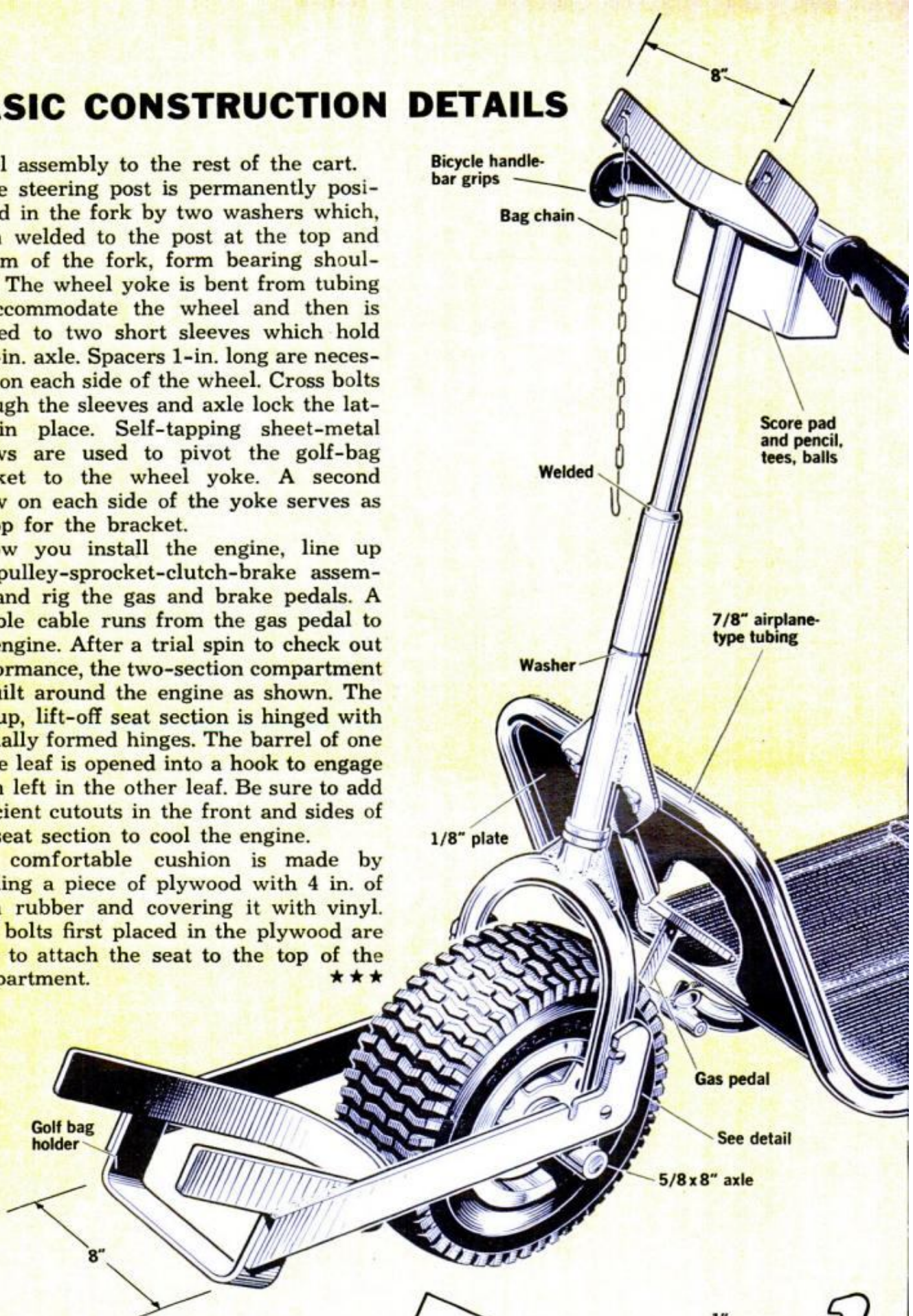

BAG HOLDER DETAIL

WANT TO WORK FROM LARGE PLANS?

You can obtain a set of two 18 x 28-in. sheets, complete with materials list and sources for go-kart parts by sending \$5 to Custom Designing, 6331 Caldwell Drive, New Orleans, La. 70122.

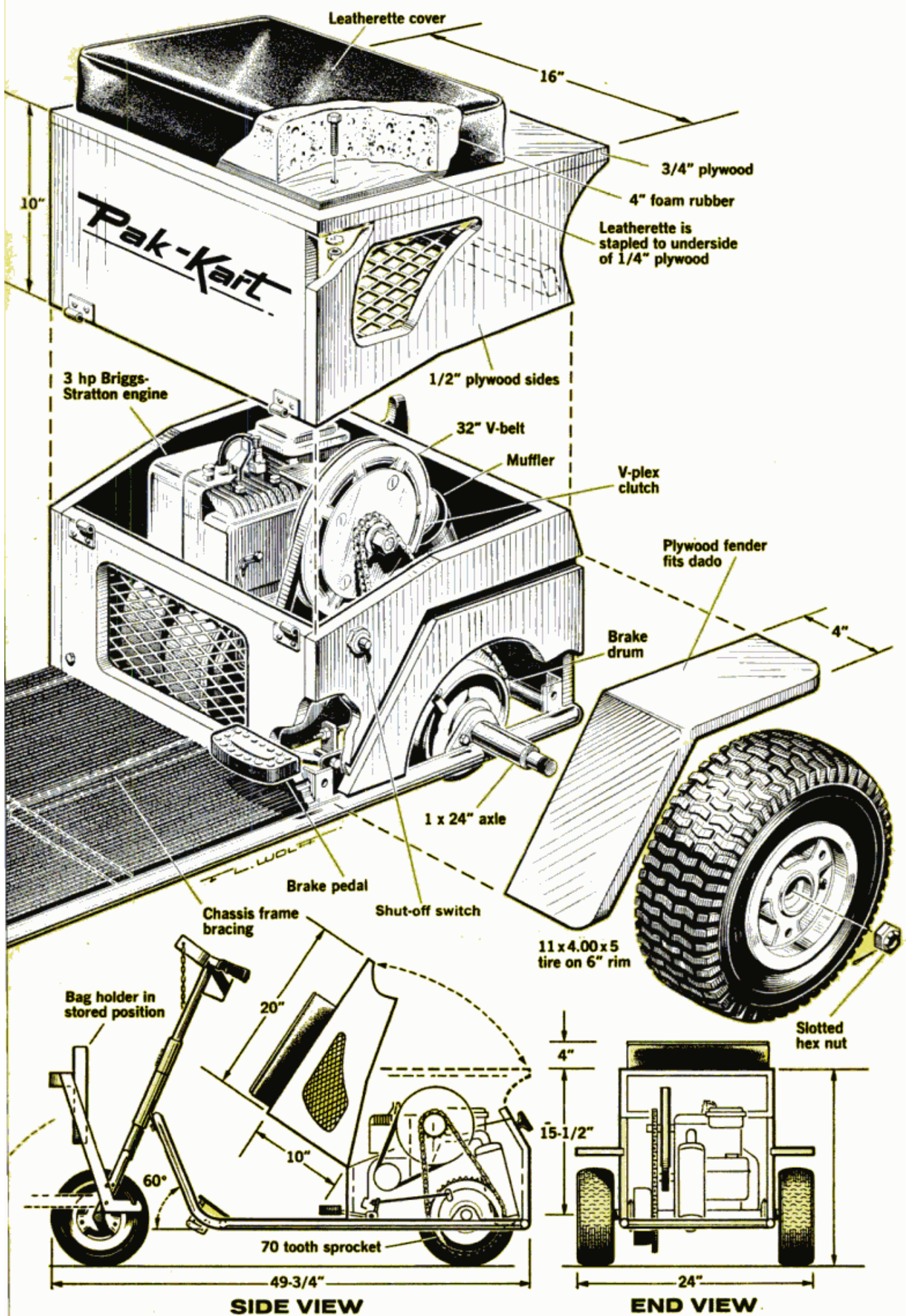

Make Your Wife a 'Toolbox' of Her Own

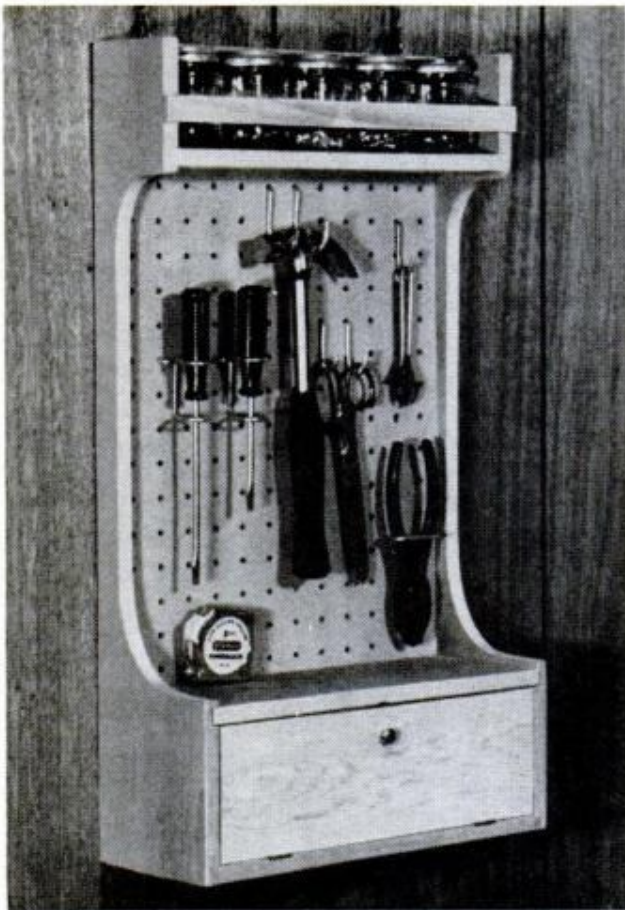

ONE SURE WAY of keeping your toolbox "off limits" to your better half is to fix her up with one of her own. This hanging tool bar, when stocked with hammer, pliers, steel tape, adjustable wrench and screwdrivers, plus nails, screws and tacks, will give her everything she'll need to hang a curtain rod, retack a sagging chair bottom or change the plug on a lamp. No longer will she need to help herself to yours, or bother you with trivial jobs.

It's simple to make as shown. Shelves fit in dadoes and rabbets cut in matching sides, and the perforated tool panel sets in $\frac{1}{2}$ in. from the back to provide clearance for standard pegboard hooks. I made the one you see here from $\frac{1}{2}$ -in. cedar but $\frac{1}{2}$ -in. plywood could be used. When laying out the sides, remember that they must be made right and left-hand insofar as dadoes and rabbets are concerned. When sawing them out, it's smart to tack both pieces back to back and saw at one time. The completed rack can be hung on a wall or back of a door with L-hooks and screw eyes.—C. Wayne Close

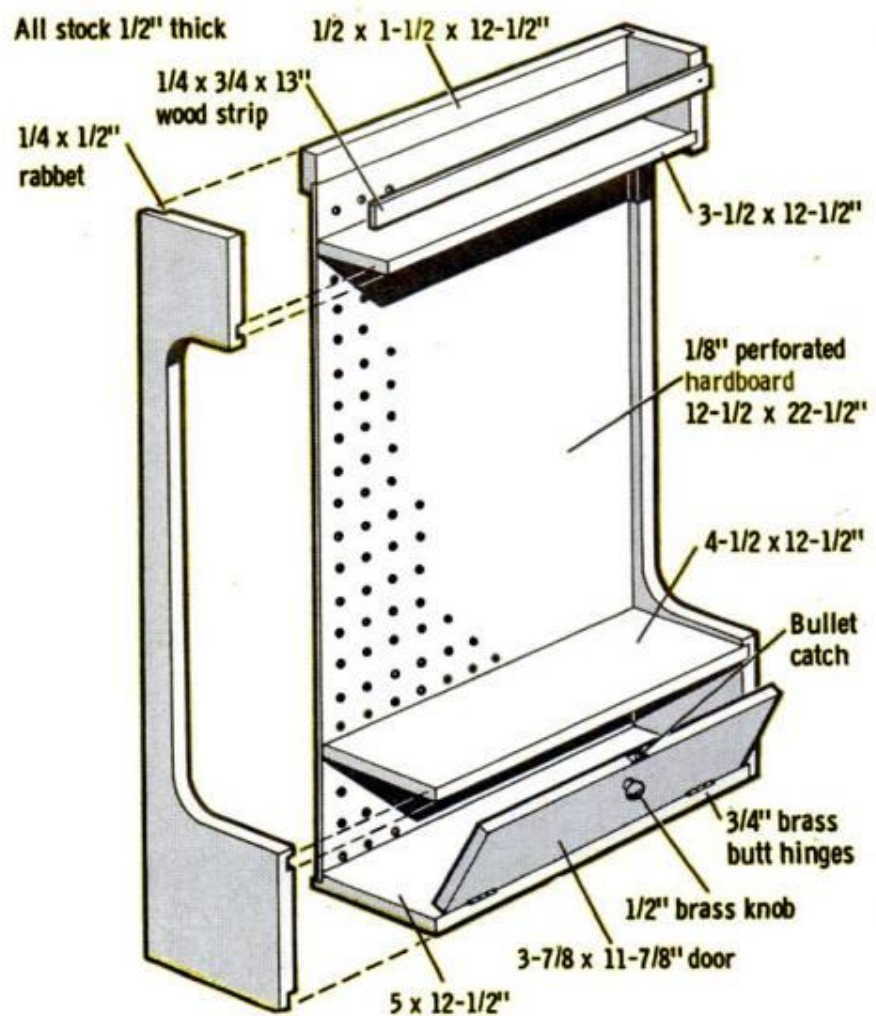
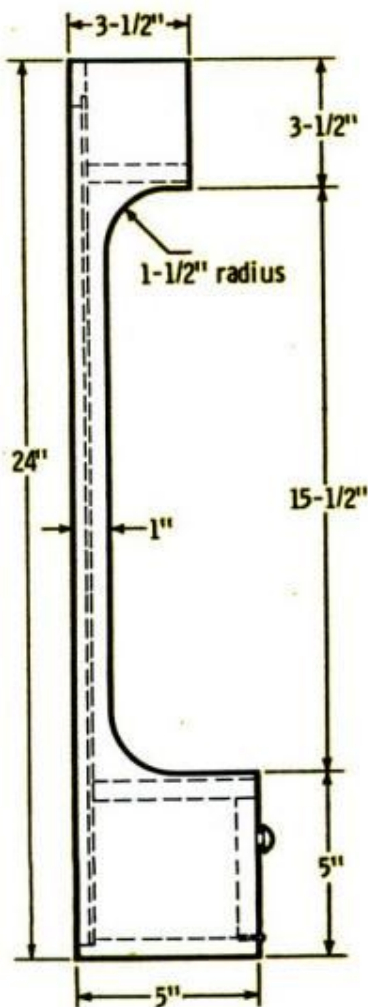

HINTS FROM READERS

Drill stand as thickness gauge

To measure the diameter of a rod, wire, bolt or screw shank when you don't have a regular caliper, try using your drill-bit stand. The holes are conveniently marked in fractions or decimals from about 1/16 to 1/2 in. Letter-type drill stands can also be used—but an equivalent table (in most shop handbooks) is needed to convert the letter to a decimal.—*Andrew Vena*

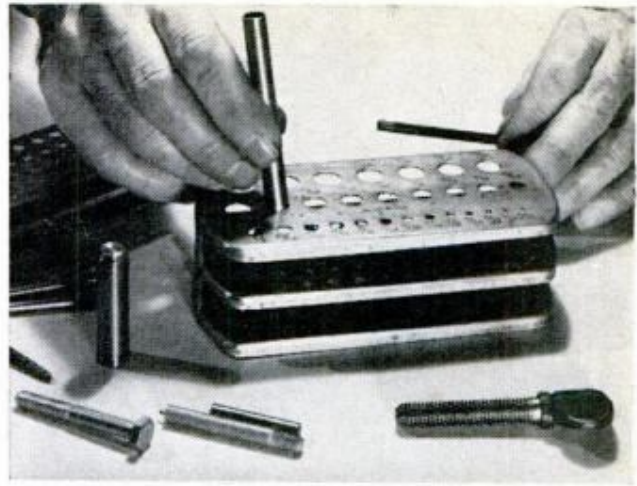

Removing scratches in plastic

To remove a number of fine scratches from a clear plastic box, a bit of liquid brass polish can't be beat. Simply charge a clean cloth pad with the polish and rub the scratched area (gently does it) for a minute or two. Then use another clean cloth to remove excess polish and bring out the shine. Various other materials of a mildly abrasive nature can be used—however, also try them on a piece of scrap, or on an area that will be hidden, before coating the entire object.—*Walter E. Burton*



Hemostats help in shop

Hemostats are instruments normally used in surgery to clamp blood vessels, and they make a handy addition to most any shop. They look like pliers and scissors combined, and usually have two or three locking notches as a part of the handle. Thus, they are particularly useful as heat sinks, soldering clamps, or third hands, especially when you work with tiny screws and nuts. The quick-release, quick-clamping action soon makes a hemostat a tool you use most frequently.

—*Walter E. Burton*

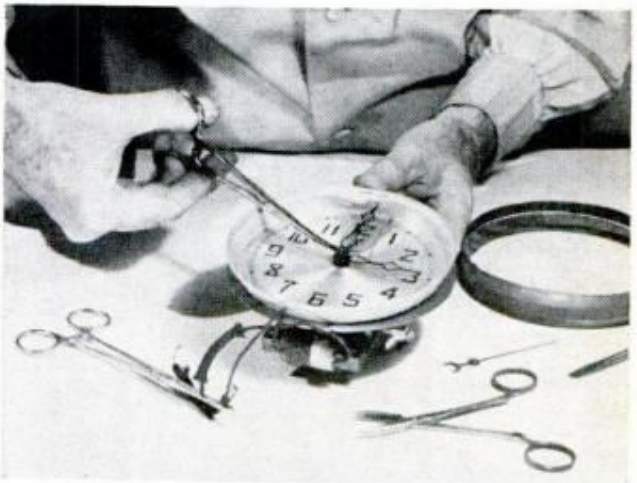

Capping oil cans

Like most homeowners, I have a partially empty oil can that I use when it's time to fill mowers, chain saws and other gasoline-power tools. But keeping the oil free of contaminants was a problem for which I needed a solution. Recently, I found that the covering of the oil can with the plastic lid of a pound coffee can did the trick. The lid fits a quart-sized oil can snugly, keeps the oil clean and is easy to snap on and off as needed.

—*William H. Kauffman*



Are Small 110-v.a.c. Arc Welders Really Any Good?

By JOHN BURROUGHS

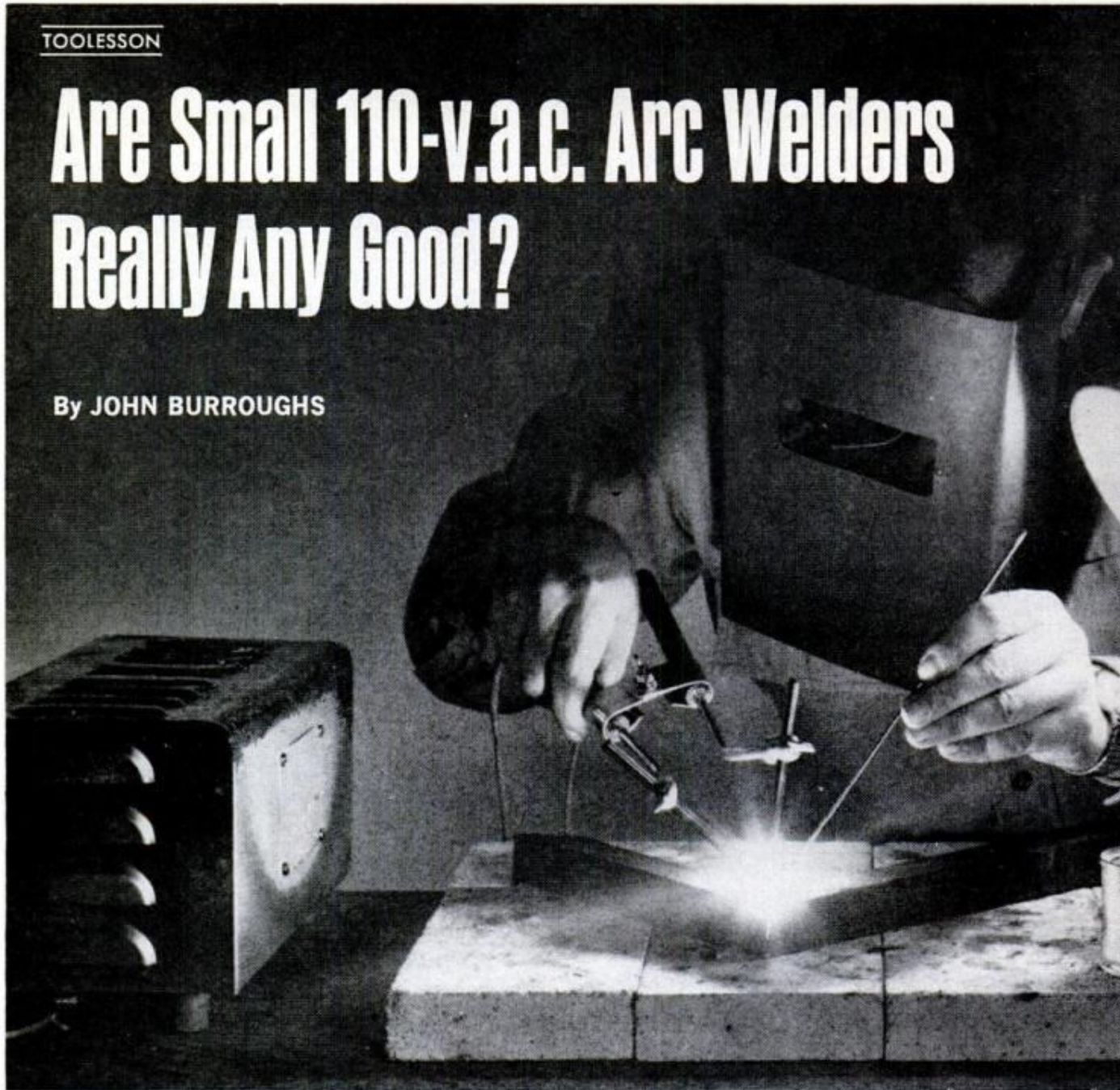

If you learn how to use them, keep safety in mind at all times, and recognize a resistance-type welder's limitations, you'll find that one of these units can be a worthwhile addition to your shop

IF YOU EXPECT a 110-volt arc-welding outfit that costs \$20 to perform like a 220-volt, 180-ampere welder priced in the \$100 to \$200 range, you're going to be disappointed.

Resistance-type 110-v. welders deliver only 20 to 30 amps. of welding current. That's roughly the output of a professional transformer-type arc welder at its lowest amperage setting (generally used for welding 16-ga. sheet metal). With a 110-v. outfit you'll be able to weld light work with 1/16-in.-dia. coated electrodes. You

won't be able to weld heavy work satisfactorily.

However, despite its limited output, one of these small welders can be a useful tool. In addition to light-duty, coated-electrode welding, you can also use it for twin-carbon-arc torch work—brazing, silver soldering and heat-treating. For these lower-heat-requirement jobs it performs well, although a 110-v. welder is more useful for arc brazing than for welding.

The several makes of welding outfits



STRONG LIGHT from photo-flood bulb lets you see work through helmet's filter. Plug bulb in a separate circuit

MODELS TESTED

- 1** \$18.95—Four-Way Arc Welder
1810 S. Federal St.
Chicago, Ill. 60616
- 2** \$18.95—Wel-Dex Arc Welder
Dept. W-10, Box 10776
Houston, Tex. 77018
- 3** \$18.95—National Electric Welder
Dept. PM-12, Box 48-544
Miami, Fla. 33148
- 4** \$29.95—Big Boss Arc Welder
Box 10947
Houston, Tex. 77018

Note: Quoted prices are postpaid

1



2



3



4



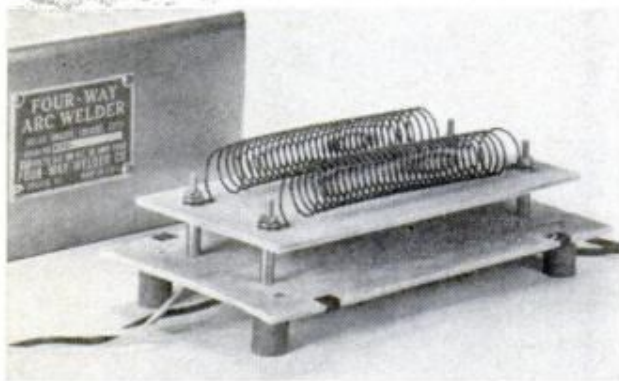

EACH WELDER is basically a resistance unit consisting of two enclosed nichrome-wire elements

sold by mail order are very similar. The "welder" itself is simply a voltage-dropping series-resistance box. The twin-carbon-arc torch that's supplied (either pliers or tong-type) can be separated into halves to permit using one half as a holder for coated electrodes and the other as a ground clamp. All outfits also include helmet, rods, flux and instructions.

The instruction booklets recommend replacing the 20-amp. fuse protecting the

COPPER-PLATED STEEL RODS sold by welding supply houses can be brazed to form racks, bins or grills

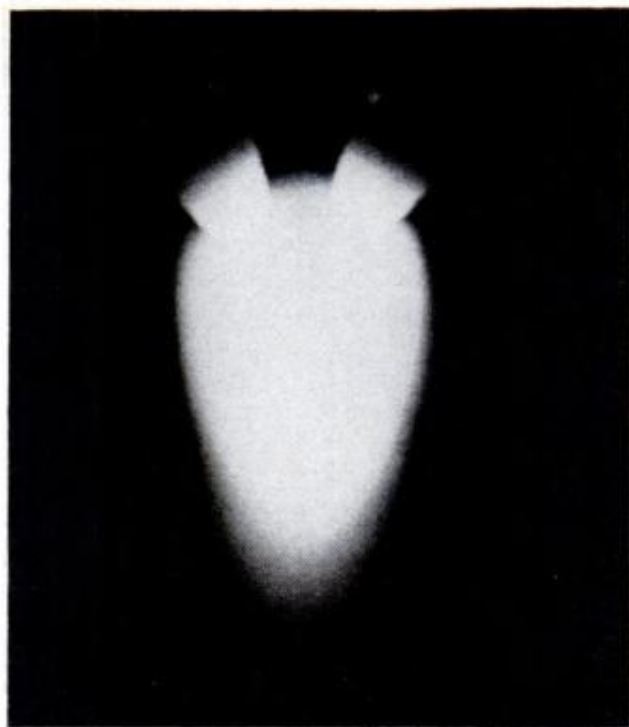

TEARDROP FLAME, photographed through helmet's filter, has a temperature range of 2000° to 5000° F.

outlet with a slow-blow 25 or 30-amp. fuse. While this is questionable electrical practice, an intermittent 25-amp. load won't seriously overheat ordinary No. 12 house wiring. No. 10 wiring can carry 30 amps. intermittently. Always be sure there's no other load on the circuit, and always use your welder for only short periods. It's not safe to use 110-v. welders on circuits with wire smaller than No. 12.

There's no special skill required to use a

USE TWIN-CARBON TORCH to weld thin sheet steel, along with two 1/16-in.-dia. steel filler rods and flux

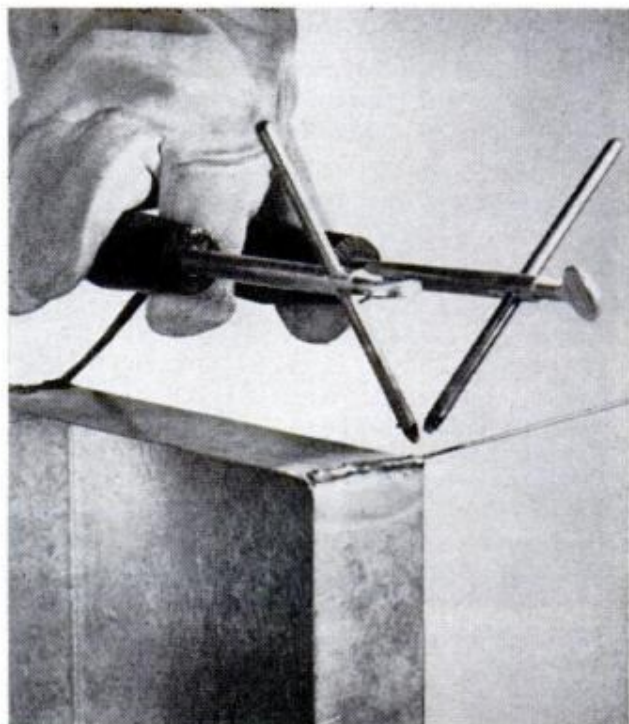



RUN PRACTICE BEADS on 1/16-in.-thick steel to learn knack of welding with flux-coated electrodes

twin-carbon torch. With the two 1/4-in.-dia., copper-clad carbons adjusted to form a 60° V., touch the tips together to start the arc and then draw the carbons about 1/8-in. apart. The arc's teardrop-shaped flame then can be played on the work much as you'd handle a propane torch.

Making neat brazed joints with the arc is just a matter of heating the joint evenly, keeping the arc flame moving until the work is hot enough to flow the brazing

TWO METHODS in which the tested models can be used are shown below. Line must have separate fuse

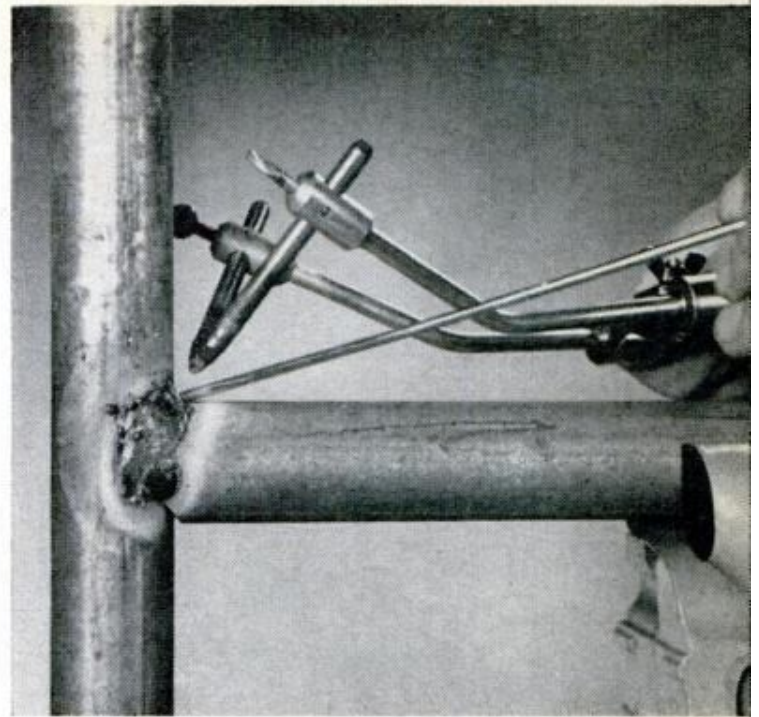

TO BRAZE PIPE, fit and chamfer joint, then fill V-joint with brass or bronze rod, using borax flux

alloy used. As the brazing rod begins to melt, dip its hot end in borax flux. Flow the filler rod into the joint with the edge of the flame to avoid overheating the molten alloy, which, if too hot, will bubble and won't bond. The glassy flux can be chipped off when the brazed joint cools.

Using 1/8-in.-dia. bronze filler rod, which melts at red heat, you can readily braze mild steel angle, strap or pipe as much as 1/8 in. thick; with patience, you might

FLUX-COATED ELECTRODES are needed to weld metal 1/16 to 3/32-in. thick. First tack-weld the metal

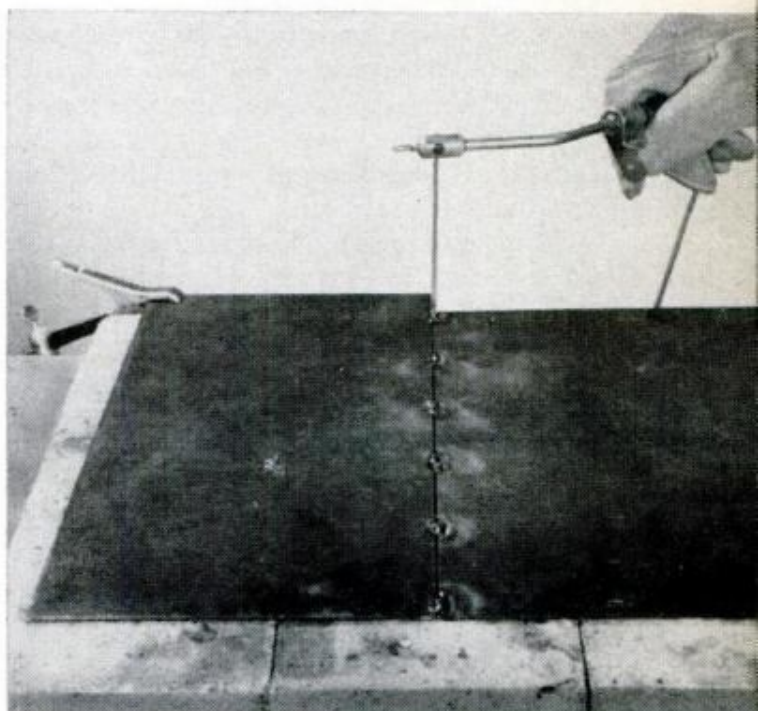
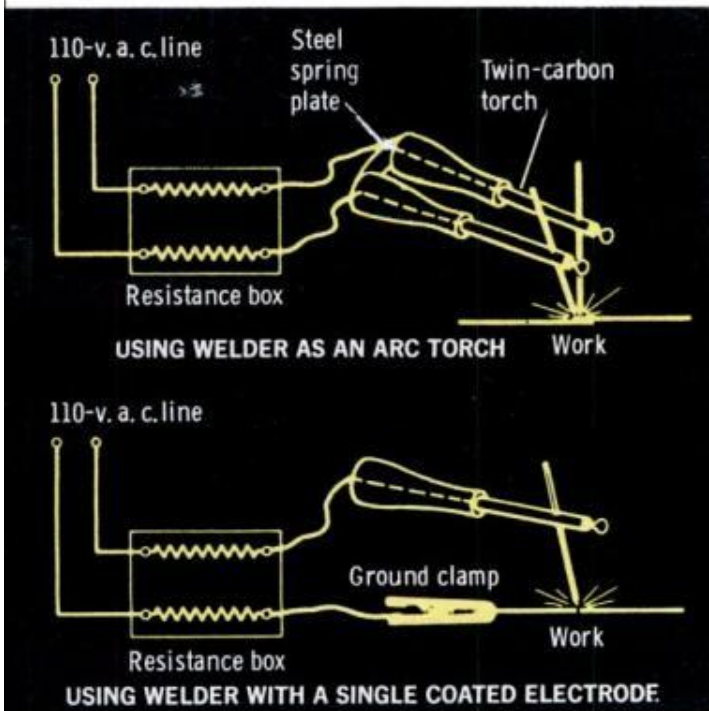



CASE-HARDEN MILD STEEL by heating it until red hot, then fuse on carburizing compound and quench

even be able to braze small pieces of 3/16 or 1/4-in. thick plate. Special filler rods are available for braze-welding non-ferrous metals.

You can also use the torch for soldering and general-purpose heating. The arc is a fine heat source for soldering aluminum with a 500° to 600° F. aluminum solder and special flux.

It's possible to fusion-weld thin-gauge sheet steel with the twin-carbon torch and 1/16-in.-dia. mild-steel filler rod, the same rod used for gas welding. To make satisfactory welds, heat the joint to the fusion point—don't simply melt the filler rod on the work surface.

Welding with coated electrodes is a bit more difficult. In coated-electrode welding, one lead from the welder is connected to the work, and the arc is struck between the work and an electrode. Striking the arc is much like striking a match. As the arc burns it melts off the end of the wire electrode and deposits a bead of metal along the joint being welded. The electrode's flux coating, which concentrates the flame and shields the molten weld metal from atmospheric oxygen and nitrogen, forms a slag that can be chipped or brushed off when the weld cools.

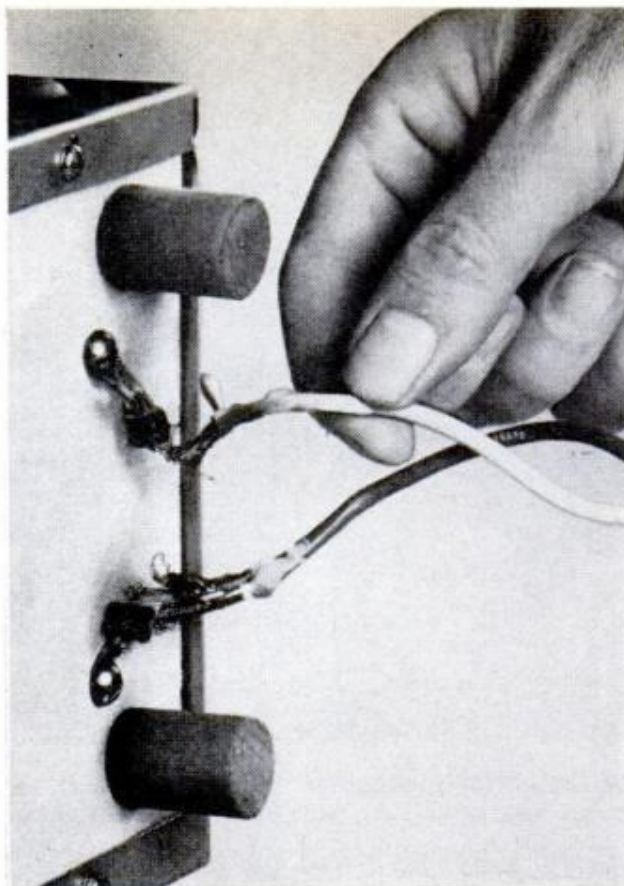

ELECTRICAL CONNECTIONS should be checked before each use since they can get hot enough to burn off

When trying this with a 110-v. welder you'll encounter two problems:

- Manipulating the arc to leave a reasonably even bead of weld metal. You'll soon learn how if you run some practice beads on 1/16-in.-thick scrap sheet steel.
- Controlling the weld's penetration. As the arc burns it produces a crater-like puddle of molten metal. If it's too shallow, you'll get a weak weld.

With 220-v. welding equipment you can adjust the welding circuit's amperage to increase or decrease the size of the arc for a deeper or shallower weld. With a 110-v. welder, since you're working with a relatively low, fixed amperage, you achieve suitable penetration by other means.

One way to increase the depth of a weld is to gap or V-bevel the joint. Another way is to preheat the work with a propane torch before you weld it. Preheated work absorbs heat more slowly as it's welded and the arc melts a deeper crater.

If the work is both beveled and preheated, it's possible to weld small pieces of steel up to about 1/8 in. thick, when using 1/16-in.-dia. electrodes.

When using a resistance-type welder, remember to take common-sense safety

(Please turn to page 210)

New Tools You Should Know About

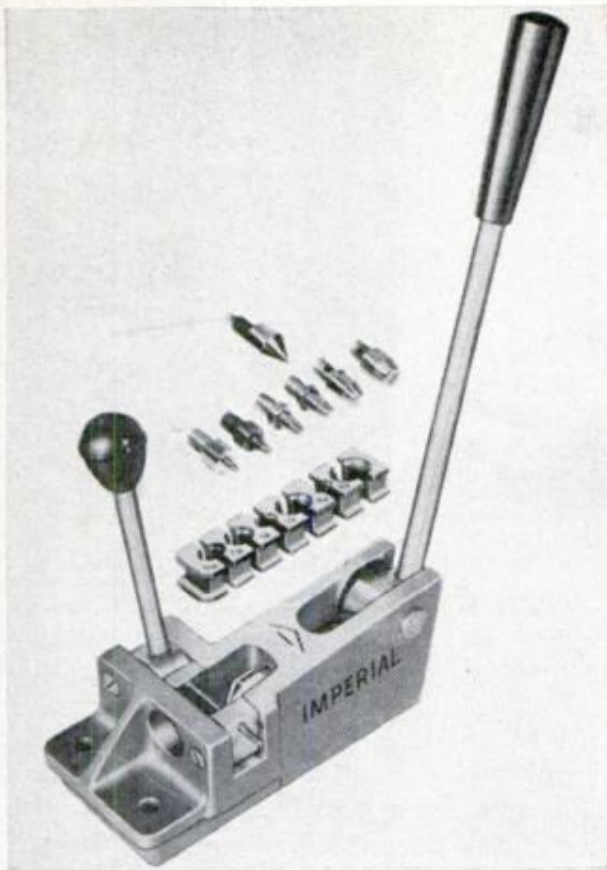

Two-in-one tubing tool

Featuring fast cam-lever operation, the 555-FS flares or swages soft copper, aluminum or brass tubing, and also can form both 37° and 45° flares in tubes ranging from 3/16 to 5/8-in. o.d. The tool weighs 6½ lbs. and can be used in a vise or on a bench. Priced at \$75.15 from Imperial-Eastman, 6300 W. Howard St., Chicago, Ill. 60648.

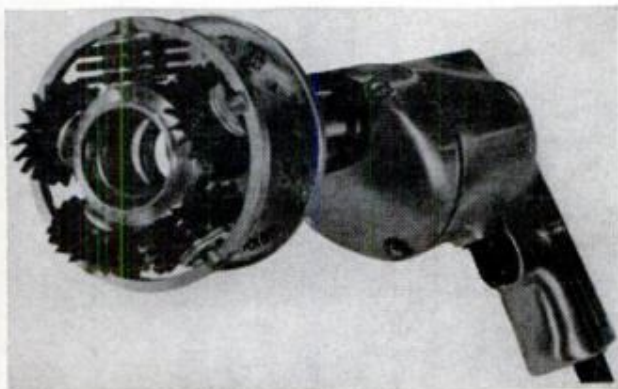

Quarter-inch rotary scraper

Chucked into a ¼-in. drill, this 3¼-in.-dia. scraper makes fast work of removing rust, scale, barnacles, paint and other coatings. Model 805 has 15 replaceable cutters and should be used at 1800 to 3000 rpm. \$14.95 from Goodmark Sales, 16007 Kingside Dr., Covina, Calif. 91722.

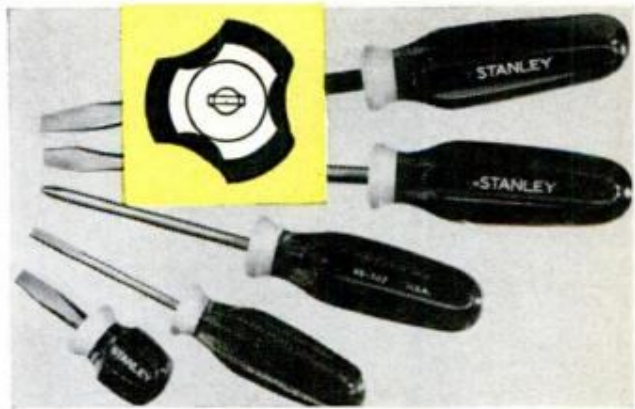

New screwdriver handles

The Stanley Workmaster screwdriver handle has three fluted sides shaped to fit the triangular pocket formed by your hand whenever you grip a screwdriver. This enables you to exert more torque, or twist, on hard-to-drive or hard-to-loosen screws. Available at hardware stores for \$.89 to \$1.85.



Sixteen-foot measuring tapes

Model L16K features a locking device and automatic return, while model 16KW is a push-pull tape. Both have a mylar-coated blade specially cupped for 60-in. rigid "stand-out." Respective prices are \$5.40 and \$4.95. At hardware stores, or from Evans Rule Co., 412 Trumbull St., Elizabeth, N.J.

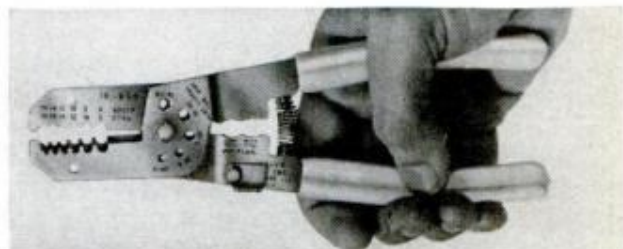

Seven-use wiring tool

The Big-7 wiring tool can strip, cut, loop and size wire; cut bolts; crimp terminals, and ream conduit. When not being used, the tool is held closed with a cam lock. Price is \$4.95, overall length is 8 in., and weight is 7 oz. Holub Industries, Inc., 414 De Kalb Ave., Sycamore, Ill. 60178.

HINTS FROM READERS



Cutting insulation

Plastic jackets and inner insulation on all types of cable, microphone leads and stranded wire can be cut without nicking the inner braid or conductors. Simply bend the cable into a loop, then carefully press a sharp knife into the insulation. The insulation will separate before the blade has cut all the way through to the braid or inner conductors. Then the insulation can be slid off or stripped off by pulling with a pair of pliers.—
Robert F. Lewis

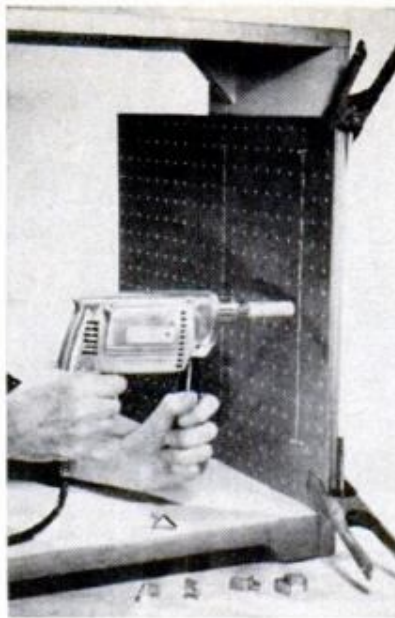

Drilling guide

To simplify the job of drilling evenly spaced holes to hold shelf supports, use a piece of scrap perforated hardboard as a drilling guide. Clamp it to the side of the cabinet or bookcase and, after making sure it's level, drill through holes. Use a depth gauge when drilling—one can be made from a $\frac{3}{4}$ -in. dowel drilled through its center. Cut the dowel so the drill extends $1\frac{3}{16}$ in. (for $\frac{1}{4}$ -in. size board), or $1\frac{1}{16}$ -in. (for $\frac{1}{8}$ -in. size).—
H.L. Miller

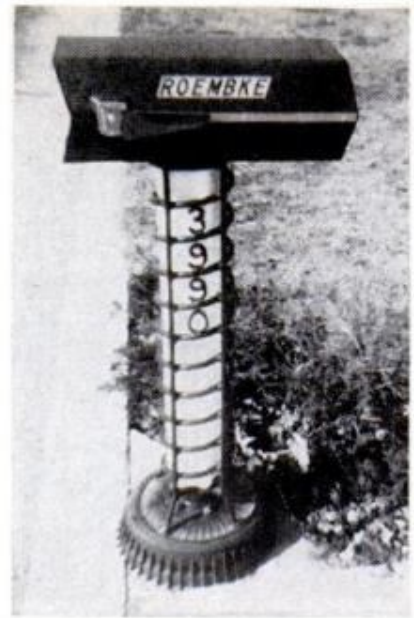

Illuminated mailbox

Visitors find it easy to read your address at night with an illuminated mailbox like this in your front yard. The column for the box is made of a fiberglass cylinder surrounded by two old coil springs welded together to protect the fiberglass and the fluorescent light inside. Power for the light is provided through an underground cable, and a weatherproof outlet is also fitted for outdoor displays. The base shown is an old brake drum.—
H.L. Miller

NEXT MONTH IN SHOP AND CRAFTS

THE WILD NEW BIKES. In case you haven't noticed, bikes are not just bikes anymore. They're the wildest looking and most exciting things you can imagine. For a look at what has happened to the lowly two-wheeler in the way of sophisticated shifting mechanisms, crazy seats and handlebars, even zany colored tires, be sure to read our July story and see the bikes in beautiful full color.

BUILDING FIBERFAB'S NEW AZTEC AVENGER GT-12. Take one old VW, strip off the body, bolt on this new one-piece sports car body and what do you have—a stunning traffic stopper! Then, go one step further, as *PM* did, and perform certain modifications to turn the "bug" into a true GT, as shown in color in July *PM*.

POWER-TOOL STANDS YOU SHOULD BUILD. Increase storage space, eliminate clutter and enjoy working convenience by building these easy-to-make stands for all your power tools. Some of the stands shown are for a drill press, jigsaw and bench saw.

THE RIGHT WAY TO SHARPEN DRILLS. For the complete story on how to sharpen masonry and concrete drills, as opposed to the proper method of sharpening twist drills for wood or metal, next month's *Toolless* can't be beat.

**Taste the
golden age
of Schlitz**

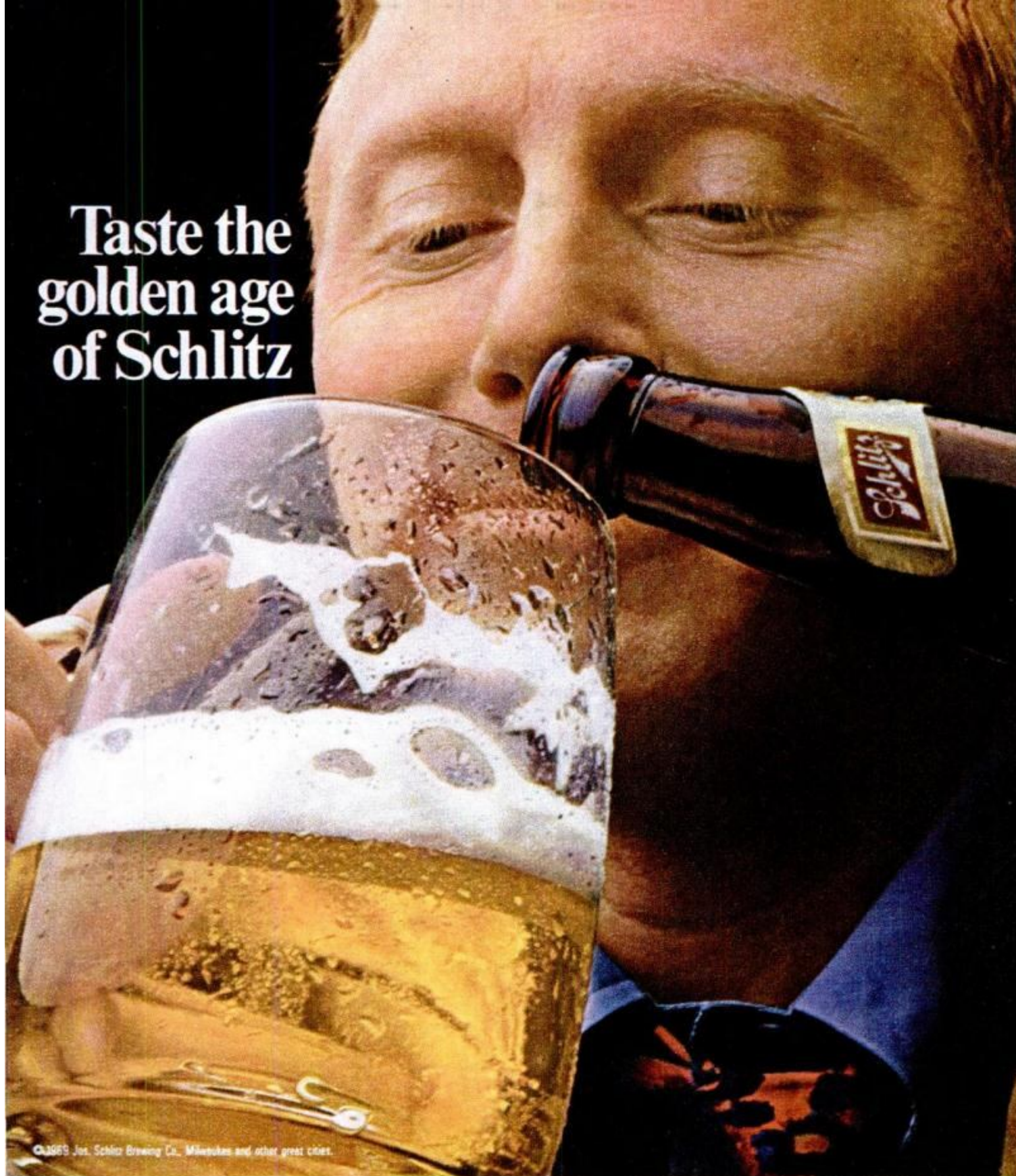

©1989 Jos. Schlitz Brewing Co., Milwaukee and other great cities.

120 years ago, Joseph Schlitz took plenty of time to age his golden mellow beer. We still do. It's the golden age that makes Schlitz America's choicest premium beer.



“When you're out of Schlitz, you're out of beer.”

Материал, защищенный авторским правом

HOW TO COLOR CONCRETE

(Continued from page 155)

can be waxed. If you must use the floor, lay scuffproof building paper over it to protect the surface.

Existing concrete must either be painted or stained. If you paint a slab, use a paint designed for floors. Paint also offers the widest possible choice of colors. Other methods are slightly limited in color selection.

The best method of coloring existing concrete slabs is by staining. Stains are especially popular on tennis courts, pool decks, patios and basement floors. A few really good concrete stains, both organic and inorganic, are available. When used according to directions, they last many years. A nine-year life is claimed for one type when used in a mild climate. Some stained-in colors tend to be weak, but can be strengthened considerably by waxing (best indoors) or coating with a polyvinyl chloride resin color toner (best outdoors). With wax, occasional rewaxing is necessary, depending on foot traffic.

Before it's stained, concrete must be clean and free of oil, grease, wax, soap and paint. To remove wax and surface grease, pour *hot* water on the slab, sprinkle on trisodium phosphate and scrub hard with a stiff brush. Rinse thoroughly and let dry.

Read the directions before applying stain. Don't stain concrete less than six weeks old. Some stains require an acid-etch before application, others don't.

Most stains are applied in two coats. Although the coverage varies with surface porosity, a gallon of stain is usually enough to two-coat 200 sq. ft. of concrete. Per-coat coverage of wax is 600 to 900 sq. ft. per gallon.

An inorganic stain is usually applied in two coats with a 4-in. paintbrush. Take care to avoid overlapping of brush strokes into an area that has dried. It may create dark strips. Stain that collects in low spots makes them darker than surrounding concrete. Keep it well brushed out. There should be from four hours to five days between coats of stain. Timing depends on the concrete, drying conditions and stain. The finish coat is mopped and scrubbed to remove the residue and bring out the true stain color. It often takes several days for concrete to reach its ultimate color.

Don't apply inorganic stains over integrally colored concrete. Also, inorganic stains are most effective on new concrete. Avoid using them at all on slabs of varying ages. The colors may differ.

Some popular stains are Kemiko Con-

crete Stain and Col-r-tone Finish, Cabot Cement Floor Stain, Rez Color-Tones, Flor-Dye by Truscon Laboratories, *Color-Rox* by Tamms Industries and Thompson *Color Waterseal*.

Kemiko stains are inorganic. Complete directions for use are included with every container of stain. These stains are not affected by alkali in the concrete. Instead they react with calcium present in concrete to form their color. With them the most success is achieved in staining concrete less than 20 years old and in decent condition. Inorganic stains don't hide patches and other imperfections. A coating of toner does the trick, however, giving a uniform opaque matte finish. Kemiko's *Col-r-tone* toner can be used outdoors or indoors for a flat, nonskid surface.

Cabot and Rez stains are organic oil stains, much like those for wood. They cost less and hide imperfections well, but may not wear as well as inorganic stains. Ordinary oil stains for wood also work well on concrete. But first knock out surface alkalinity by soaking with a solution of two to three pounds of zinc sulphate per gallon of water. Spread it over the surface, let it set for two days, then thoroughly wash with water to remove crystals that have formed. After thorough drying, the oil stain can be applied. Concrete can thus be made to look like wood, especially if it has been cast against rough-textured wood forms.

All stains eventually dissipate. Waxing will brighten the color when they do, but don't use a wax without a stain under it. You won't like the results.

Try staining a small out-of-the-way area first. If it works well, start staining at the back door and work around to the front.

Properly applied, paint can be a good way of getting color onto concrete. Eventually it will either wear off or (outdoors) chalk. For long wear, the catalytic coatings are best. Used outdoors, though, they chalk heavily. Chlorinated rubber paint takes wear well and is excellent for slabs. Floor-type oil-base and latex paints are easiest to use but tend to lift off wherever car tires rest on them. Thus, avoid latex paints for garage and driveway slabs. Portland cement paints are fine for walls, but wear off floors too easily. The drawback to using them on walls is that curing is needed for several days after application.

Concrete must be several months old before painting. Some paints require that concrete be acid-etched first, especially if it's smooth-troweled. Chlorinated rubber

(Please turn to page 194)

How do you make a boat go faster, ride softer, and save gas doing it?



This Sportsman has the answer.

If you thought last year's 16' Sportsman was the ultimate in soft-riding performance, you had lots of company.

But that wasn't good enough for our designers. They proved again what some competitors found out the hard



way. That a little change in shape here and there can make a big difference in performance — for better, or worse!

From the drawing board, the computer, and numerous test hulls we came up with a new shape. A deeper hull, with a foot more freeboard forward. A softer-riding hull that rides higher on a cushion of spray and trapped air bubbles. And goes 4 miles an hour faster — with fuel savings resulting from increased speed and efficiency.

If you know much about boats, you'd expect an Evinrude Gull Wing hull to outperform conventional boats several feet longer. And since it doesn't have a pointed nose, there's no waste space. It's bigger inside and smaller outside.

The wide track hull is wide open from bow to stern. A folding windshield gives you easy access to the foredeck, making the Sportsman about 40% larger than conventional boats of the same length. But you can also button it up like a snug sports car with its front tonneau cover and convertible top. Not the least of its luxury features is its full flotation, molded in as an integral, structural part of the hull. It's the toughest boat ever built, as our test drivers prove every day.

You have a choice of seating, and a choice of power — an economy 120 hp inline-4, or a sizzling 155 hp V-6.

It's a lot of boat for its size. And a lot of boat for the money.

CATALOG FREE, Write Evinrude Motors,
4037 N. 27th St., Milwaukee, Wis. 53216

EVINRUDE  **first
in
outboards**
Div. of Outboard Marine Corporation



SEE FOR YOURSELF

How to Fix Almost Any Part of Any Car!

QUICKLY, EASILY and RIGHT on the very first try

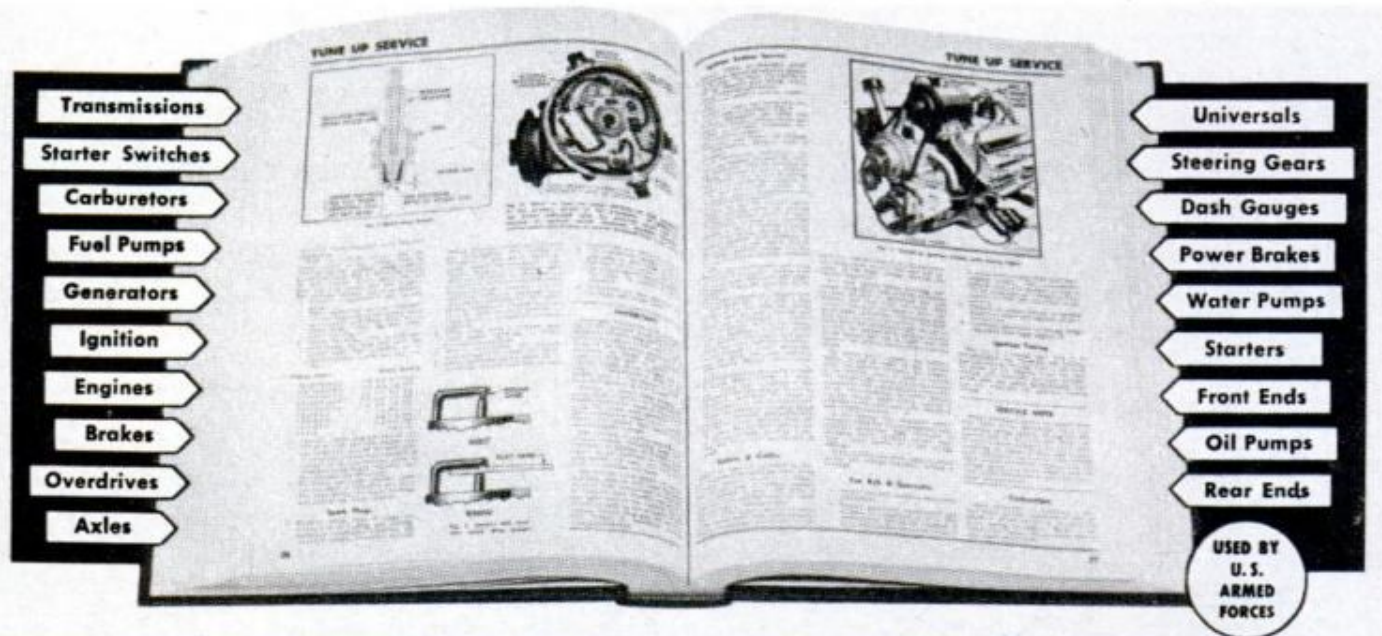

USED BY
U. S.
ARMED
FORCES

THIS GIANT PICTURE BOOK SHOWS YOU STEP-BY-STEP HOW TO REPAIR PRACTICALLY EVERY CAR BUILT FROM 1963 THRU 1969

Whether You're a Beginner or an Expert Mechanic—This Manual Can Help You "Breeze Through" the Toughest Auto Repair Job

OVER 5,000,000 COPIES SOLD!

Don't waste time, money, energy by trying to guess how to fix a car! Do what the experts do. Whether it's a simple carburetor adjustment or a complete overhaul — simply look up the job in the index of MOTOR's New AUTO REPAIR MANUAL. Turn to page covering job. Follow clear, illustrated, step-by-step instructions. See for yourself how easy it is!

No guesswork! MOTOR's Manual takes nothing for granted. Tells you where to start. What tools to use. Then it leads you easily and quickly through the entire operation!

Over 3,000 Pictures! So Complete, So Simple, You CAN'T Go Wrong!

BRAND NEW! Covers all major makes. 1963 thru 1969, including all new compacts, 1,104 giant pages, 3,200 "This-Is-How" pictures, 365 "Quick-Check" charts, 55,000 essential specifications. Over 225,000 service and repair facts. Instructions and pictures are so crystal-clear you just can't go wrong!

Same FREE 10-DAY Offer on AUTO ENGINES & ELECTRICAL SYSTEMS

1,300 big pictures. Clear how-to text on principles, design, maintenance of all parts of engines & entire electrical system. For FREE trial, check coupon.

Meat of 300 Official Shop Manuals

Engineers from every automobile plant in America worked out these time-saving procedures for their own motor car line. Now this wealth of "Know-How" from 300 Official Shop Manuals has been "boiled down" into crystal-clear terms in one handy indexed book! No wonder Manual is used by so many schools!

SEND NO MONEY
Try Book for 10 Days FREE

Just mail coupon. We'll send you this 1969 Edition to use FREE for 10 days. Test book in your own garage or shop. It's GUARANTEED to pay for itself in 10 days. If it doesn't, return it, and owe nothing. Rush coupon now. MOTOR Book Dept., 250 W. 55th St., New York, N. Y. 10019. (SCHOOLS, BOOKSTORES: Write for discounts.)

CLEAR UP 'MYSTERIES'. "I always rely on Motor when I do a repair I am not familiar with."
—E. Jones, Minnesota (Shop Owner)



GREAT HELP FOR STUDENT. "Motor pulled me out of some rough spots in high school, and now in the Armed Forces motor pool."
—W. Bekemerer, Missouri (Apprentice)

MAIL COUPON FOR
FREE
10-DAY TRIAL
OF MOTOR'S AUTO REPAIR MANUAL

No obligation. No risk.
If not delighted, return book and owe nothing.

MAIL COUPON NOW FOR 10-DAY FREE TRIAL

MOTOR BOOK DEPT., Dept. 916
250 W. 55th St., New York, N. Y. 10019

Rush to me at once (check box opposite book you want):

MOTOR's New AUTO REPAIR MANUAL. If O.K., I will remit \$2 in 10 days, \$3 monthly for 2 months and a final payment of \$1.95 (plus delivery charge and sales tax if any) one month after that. Otherwise I will return the book postpaid in 10 days.

Print Name..... Age.....

Address.....

City & State..... Zip Code.....

Also send me for 10-day Free Trial MOTOR's AUTO ENGINES & ELECTRICAL SYSTEMS. If O.K., I will remit \$8.95 plus delivery charge and sales tax, if any, in 10 days. Otherwise I will return book postpaid in 10 days.

Check box and save shipping charge by enclosing WITH coupon payment of \$9.95 for AUTO MANUAL (or \$8.95 for AUTO ENGINES) plus sales tax, if any. Same 10-day return-for-refund privilege.

A fast new way to blast carbon out of your car's engine.

Sure, you know what happens when carbon deposits build up in an engine. You know how power drops. How pickup slackens off. How you start burning more gas and oil. How knocks and pings creep in.

You know all this. But sometimes it takes the jolting cost of an overhaul to make you really aware of the damage carbon deposits can do.

Carbon plus lead equals trouble. You get carbon deposits with everything you burn—logs in your fireplace or gasoline in your engine. But why can't the deposits in your engine be brushed away as easily as the soot that collects in a fireplace? Because gasoline contains lead compounds and other non-combustible elements. These additives, under enormous heat of combustion, combine with carbon particles to form tough, flinty deposits that build up, layer by layer, on pistons, valves and cylinder heads.

You sometimes see products that promise to dissolve the carbon in your engine. Don't be taken in. This kind of carbon is almost indestructible. Nothing on earth can dissolve it. You can't *dissolve* carbon deposits any more than you can dissolve diamonds.

But, with remarkable new Fuel Mix Tune-up Concentrate, you can rid your engine of carbon deposits, quickly and easily. As easily as pouring a can of it into your fuel tank. Fuel Mix doesn't do a thing to carbon. But it's murder on the lead compounds that "cement" the carbon particles together. It reacts chemically with these compounds, breaks them down so effectively that carbon deposits magically flake off—and are blasted out through your exhaust system.



In the combustion chamber, hard, crusty carbon deposits build up on pistons, cylinder heads and valves to cause knock, ping, fuel waste.

Good for engine break-in, too. Fuel Mix also protects your engine by lubricating the hot, oil-starved upper cylinder area to improve valve and ring action. Add a can to each tank of gas during the first 1,000 miles you drive a new car or rebuilt engine. It'll help prevent excess wear during those first critical miles of driving.

Use Fuel Mix regularly every 1,000 miles. You'll notice a big difference in engine performance almost immediately. Smoother, quieter running. Eager response. And power you forgot you had. But please don't take our word for it. Look for Fuel Mix wherever fine automotive products are sold, and give it a try. Prove to yourself that it really works.



Before Fuel Mix is added to the fuel tank, cylinder heads are encrusted with layer upon layer of deposits of carbon and lead compounds.

After 4½ hours of driving, Fuel Mix has already removed most of the deposits, to improve engine performance and fuel economy.

GUMOUT Pennsylvania Refining Company
Cleveland, Ohio 44104

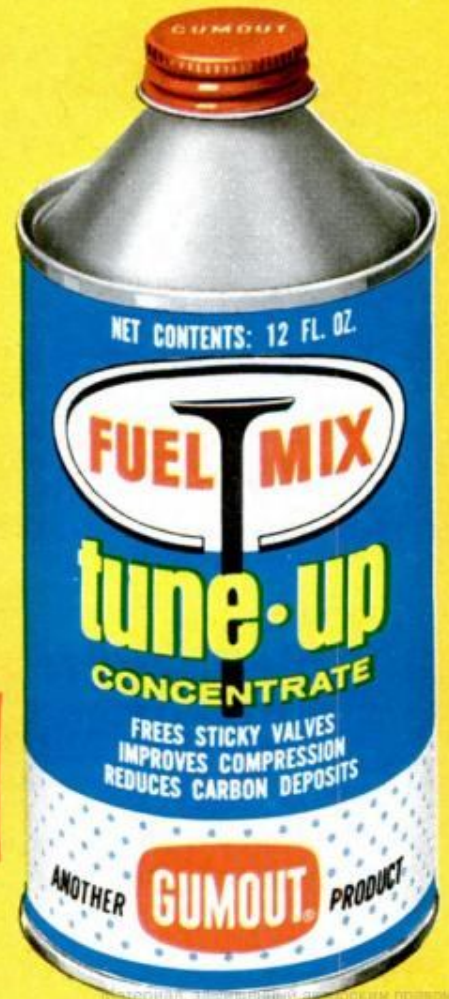

A fast new way to
BLAST CARBON
out of your car's engine.
And it really works.

ALONE IN A BODY COUNTER

(Continued from page 83)

before an operation. After surgery, he regularly notes any changes in the patient's BCM. Though the study is still in its infancy, Dr. McCord has come up with at least one important fact. Some patients respond to a given surgical technique twice as rapidly as others. Right now, Dr. McCord is attempting to discover why a specific surgical method builds up the BCM faster in one patient than in another. When he does, chances of more successful heart-valve surgery may soar.

St. Luke's body counter is also helping the attack on muscular dystrophy—a dreaded disease that causes severe muscle deterioration. So far, there's no cure for muscular dystrophy. But even gauging effectiveness of special diets, physical therapy, or new drugs was difficult before the body counter.

"There just wasn't a good objective test of muscle deterioration," explains Dr. Pierson. "Since loss of body-cell mass in muscular dystrophics is almost always due to loss of muscle, the body counter gives us a yardstick that measures the disease's progress. So, now we can begin to appreciate its subtleties, perhaps diagnose it earlier, and quickly see if new treatments are of help."

Will spark new discoveries

But the most valuable contribution expected of the body counter in fighting muscular dystrophy is by sparking new discoveries. "Physicians got interested in body temperature as an aid to diagnosis after they had a convenient tool to do the measuring, the thermometer," adds Dr. Pierson. "We feel the body counter is a new diagnostic tool that will accelerate research into muscular dystrophy and other such diseases."

Muscular dystrophy, an illness that causes muscle weakness, and eventually death, is an inherited disease, which can occur in several different forms, with different types of inheritance. St. Luke's researchers found that MD patients suffer a marked depletion of their BCM. They also discovered that some close relatives of MD patients have a lower than normal BCM, indicating that they are carrying the defective gene, although the disease itself is not present. The most common kind of muscular dystrophy is caused by a gene which is carried in this hidden or "carrier" state by females, but will produce the disease in the half of their sons who receive the gene from their mother. Another common kind of muscular dystrophy is caused by a double dose of a

defective gene, which must be present in the carrier state in *both* parents for the disease to be found in their offspring.

"The body counter might help to determine which individuals in a family with a history of MD are carriers, and thus likely to transmit the disease to their offspring," says Dr. Pierson. "Once the carrier state can be recognized, precise estimates of the risk for a couple can help them decide if they want to have children."

The body counter's most obvious applications deal with physical illnesses. But at least in one case, the instrument is being used to explore causes of mental disease.

Some evidence hints that patients with manic depressive psychosis have a lower amount of potassium in their cells than normal. No one knows if the low potassium is a cause or symptom, or if restoring the potassium balance will cure the sickness. With the help of the body counter, physicians at St. Luke's are finding out.

"We're using the instrument to measure the potassium of manic depressive patients over a long time," explains Dr. Pierson. "We hope to discover if the potassium level fluctuates with the intensity of the illness. If it does, the next step is to find ways of holding the potassium balance steady or replenish it when low. Perhaps this will be an effective treatment for the illness."

Meanwhile, all evidence so far gathered from the body counter indicates that Americans are suffering from a national disease. Me included.

A few days after emerging from the body counter, I called Dr. Pierson for the results. "The counter showed . . . well, what you have isn't really abnormal," Dr. Pierson said. "Your body-cell mass is fine. But," he added, "just lose about 15 pounds and your all-over-body composition will be perfect."

Later I told my wife the results. She gave me a sidewise glance that told me I was under inspection, then commented: "I've been telling you *that* for months." At least in one case, wives can diagnose as accurately as the body counter. ★★

HOW TO COLOR CONCRETE

(Continued from page 190)

floor paint will adhere, even to a glazed surface, without an acid-etch.

Loose, scaling paint should be removed by scraping and wire-brushing. Oil-base paints are best applied in three coats, the first containing equal amounts of thinner and paint. The second coat should contain a little thinner. The final coat may be applied full strength. ★★

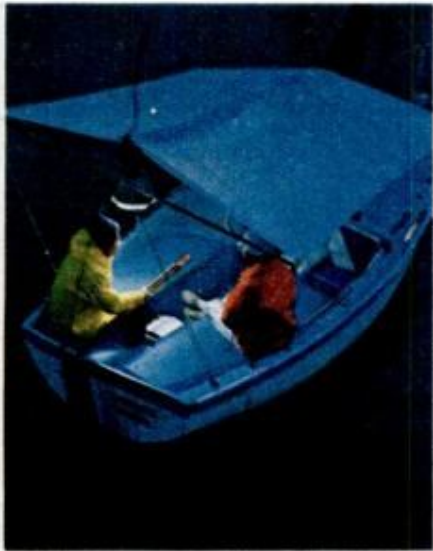

Power to light lights.



Drill holes.



Barbecue dinner.

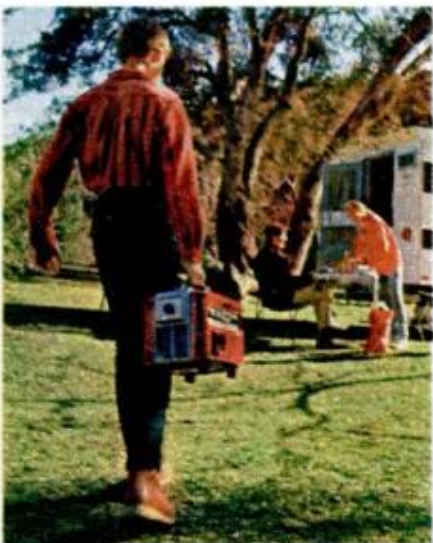

Light enough to carry.

PORTABLE POWER

Honda generators
weigh less, do more,
and keep on doing it.

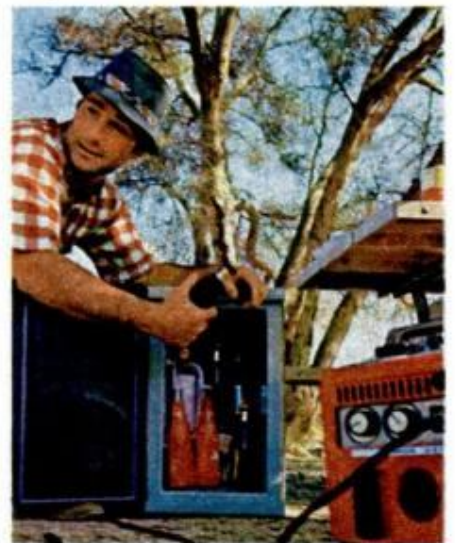

Produces 400 watts at
117 volts A.C.

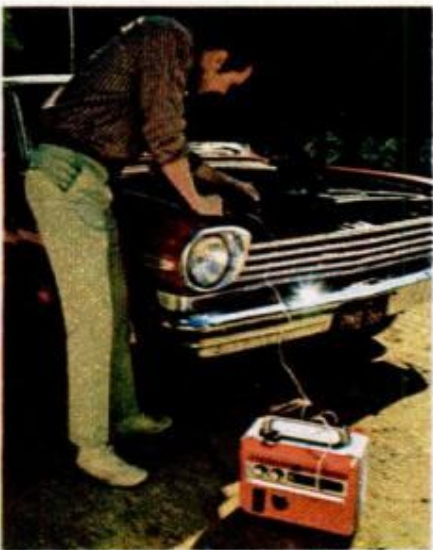

Or 100 watts at
12 volts D.C.

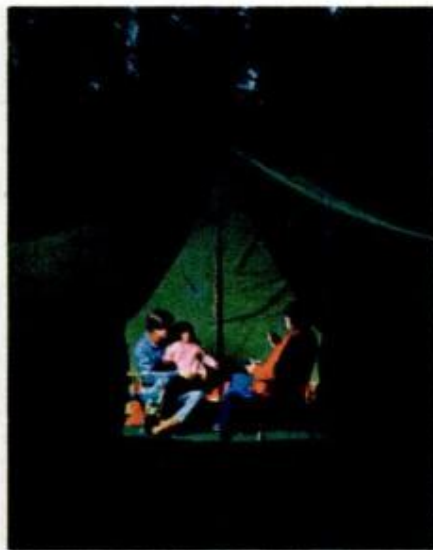

For power away from
home, here's the answer:



The Honda Generators

Shown is the E-300. Also available, a new 1500-watt unit. For the name of your dealer, write:
American Honda Motor Co., Inc., Generator Dept. HG-17, Box 50, Gardena, California 90247. © 1969 AHM.



What's new in campers is what's new from Chevrolet.

Like Chevy's new Blazer—the most spirited go-anywhere run-about that ever took off up a mountain. Only vehicle in its class with wide-track stability and full power. Or the Longhorn pickup, specially designed for toting king-sized camper bodies. Or Chevy's new motor home chassis. There's no more solid foundation for great vacations on wheels.

These new recreational vehicles round out a lineup that includes a big choice of pickups, chassis-cabs, Sportvans, Suburbans and El Caminos. Chevrolets for every purpose and pocketbook. If you've got the travel itch, travel to your Chevrolet dealer first. He'll show you all the new ways to go. . . . Chevrolet Division of General Motors, Detroit, Mich.



SPORTS-RECREATION
DEPARTMENT

POPULAR MECHANICS

Материал, защищенный авторским правом

MAROONED AT 12,000 FEET

(Continued from page 90)

besides Tingey and Sinclair, were Rangers Ted Wilson, Mike Ermarth and Dick Reese, all trained rescue men. On the west side of the peak they caught up with Ortenburger and Irvine. These two, seeing the helicopter, had guessed that it was bringing help and had waited.

"At this time we were worried about that one bad spot," says Tingey. In order to get onto the North Face at all, the climbers would have to go through a high notch called the Upper Saddle. Then, working around the peak at 13,100 feet, they would come to an ice gully and a 1400-foot traverse across a crumbling cliff. Irvine led the way, first on the ice, then across the rotting granite. Soon he had a row of soft iron piton anchors hammered into the wall, and a rope stretched. The others now committed themselves and soon all seven were safely across. Rick Reese now led the way in a traverse across a slippery wall, then down the 150-foot rappel.

And so at last, at 3:50 p. m., seven men came spidering down the North Face to the bloodstained ledge. The girl was in good spirits, but Campbell was badly injured. The first problem was to substitute an inflatable splint for the ice ax.

Now the rescue ordeal began. There were three problems: to save the girl, get morphine for Campbell, and get him down the mountain. At 6:00 p. m. four men—Sinclair, Ermath, Tingey and Reese—tried roping up and across with the girl. It worked. Four hours later, at the Upper Saddle, they turned her over to a support party that had come up from the base camp. While the latter started down with the girl the four rescuers stayed at the Upper Saddle, huddling, cold and hungry until dawn. To save weight, no fuel had been brought, no sleeping bags, and only a few snacks of C-ration and candy.

At 3:00 a. m. it became too cold to sleep. During the night they radioed for morphine, a litter, more ropes and a 325-foot steel cable with a lowering drum that could be anchored to the rock.

Down on the ledge with Campbell, Ortenburger, Irvine and Wilson tried to sleep tied to the cliff. But the rain of rocks was endless. Now and then Campbell would grit his teeth and moan. They waited for him to cry out; he never did. But they knew that they could never take him up the wall on someone's back with that smashed leg. It would kill him, and it could kill several men if the rock let go.

Ortenburger looked over the side. Far below glimmered the glacier. That's where

they'd have to lower their man! *But what a lower: 1600 feet straight down. Could Campbell stand it? Could they?*

In the morning the helicopter thundered up. In its open door District Ranger McLaren leaned out perilously. With all his might he hurled something straight at the ledge. "It dropped right in my lap," says Ortenburger. The morphine had arrived. The scary work of lowering could now begin. Meanwhile, the four men who had taken the girl to the Upper Saddle the evening before rappelled down to rejoin the other rescuers—and Campbell—on the ledge. They brought a big aluminum litter and the extra rope.

Over the edge 12,850 feet up

It took an hour to set the first anchor: three pitons. The question was: Who could go with Campbell? A rider was needed to keep the litter from tipping over, from smashing against rock or getting hung up on ledges.

Tingey volunteered. The others roped him in a sitting position so he could bend over Campbell and shield him. Now the rescuers braced themselves, belayed the rope and lowered the two men over the side.

Climbers get scared. ("It's what keeps us from falling," says Tingey.) But victims being rescued sometimes get paralyzed with fear. Pete Sinclair (who now assumed charge) and Ted Wilson had seen victims try to leap from rescue litters in fright. And so they waited for Campbell to come unglued.

The descent had just begun when the rock bombardment got worse. One put a dent in Wilson's hard hat. Sinclair got hit.

But the lowering went on. The first drop put Campbell and Tingey on a ledge 60 feet down. And then, with 1540 feet still to go, they ran into real trouble.

The next good ledge they could see below, a big one called the Grandstand, was a long way down. To judge the distance, Ortenburger dropped a rock over the side and began counting. Suddenly the echo came back. The rock had hit. "Six seconds!" announced Ortenburger. "Six hundred feet!" The others demurred. They'd counted *eight* seconds. A two-second error could be life or death.

Ortenburger peered over. He felt sure his estimate was right. They could never make a 600-foot lower but they might make two 300-foot ones. They had the 325-foot steel cable, with the drum over which it had to be lowered. They also had one 300-foot nylon rope and two 150-foot nylon ropes. These totaled 925 feet.

But even so, they could never lower

(Please turn to page 198)

MAROONED AT 12,000 FEET

(Continued from page 197)

more than 300 feet at once. Climbers never just tie their ropes to an anchor, then slide down and leave them. Ropes must be run through a piton ring and used *double*. The climber takes both ends down with him—so that when he reaches a ledge he can pull the rope down and use it again for the next lower. Thus a pair of 150-foot ropes reach only 150 feet altogether. The 300-foot nylon rope would reach another 150 feet. And even the 325-foot cable, by the time it was wound around the drum, with some left over for handling by the men controlling it, would reach only 300 feet.

Ortenburger knew they might reach the Grandstand ledge if they could find one or two small intermediate ledges, called "inter-ledges." Anxiously everyone scanned the wall. But the men now in danger of being stranded could see no inter-ledge.

Suddenly Ortenburger shouldered his pack. "Well, there's one way to find out," he said. Using the 300-foot rope, he went over the side, a small radio in his pack. He went down—sometimes walking backward in a rappel, sometimes swinging free. A half hour passed and then his voice crackled over the radio: "I've got one!" He'd landed on a little ledge about 200 feet down.

Triumphantly, the others began lowering again. But when, two hours later, all were on the ledge they were stunned. The "ledge" was merely a huge crumbling slab cracking away from the wall. Climbers call such a slab a "flake." Under their weight this one could go at any moment.

The day was growing late. Gingerly, they drove another anchor into the crack itself to save time. The teetering flake held and in another hour they were on a firmer inter-ledge another 100 feet down. If the Grandstand now was only 300 feet farther down they could make it.

But was it? To lower the litter and *fail* by even a few feet to reach a ledge could mean disaster. Campbell would be left swinging in the night. Getting him back up would be all but impossible.

The sun was setting, blazing red, when Ortenburger again went over to see. He was tiring and hungry. No one had had more than a few bites of candy for strength. If Ortenburger's rope proved too short he'd never have strength to climb back 300 feet and he might never be lifted. While others waited, he inched downward. Nearly an hour passed. Then the rope went slack. At last he radioed. "I've found another one."

"He's down!" someone said. "Let's go." They wanted to get off the mountain tonight.

But Ortenburger was only barely down. As he stepped onto the ledge in the dark he could see the tip of his 300-foot rope dangling beside him *chest-high*. His own rope had reached without an inch to spare. Campbell's rope might be a few feet short!

While Ortenburger was wondering what to do, night fell. Then a dim light appeared above. What was this? Suddenly Ortenburger knew, and his heart sank: It was Sinclair's electric headlamp, all but burned out, and it was coming down the cliff. They were lowering Campbell *too soon*—and Sinclair was riding with Campbell on the litter. Ortenburger shouted a warning into his radio but it was too late.

He heard Sinclair fighting the wall with boots and gloves, scraping, punching, kicking, trying to keep it from upsetting or swinging out of control.

The cable was too short!

And then, with no warning, the lowering stopped. There wasn't enough cable! Swinging on the litter, Sinclair saw the mistake. If the anchors above had been rigged just a few feet farther *west* on the wall they could have made it, could have landed on a high point on the tilted ledge—a point just within reach. But now they were hanging in space, a *hopeless 20 feet too short*.

Sinclair, now tired and angry, began fighting. Again Ortenburger heard him scraping and punching the wall. By sheer strength he was trying to *drag* himself and the litter west across the cliff. He seemed to be succeeding when something gave and the litter broke away in a deadly pendulum swing. Back and forth it went, battering both men on the wall.

And then with a jolt the cable caught somewhere. The swinging stopped. "*Watch it!*" cried Ortenburger. His flashlight stabbed the dark. At the west end of its swing the cable had snagged a tiny knob of rock no more than two inches thick. There it held precariously, ready to slip. But both rangers knew that this was an incredible bit of luck. For one brief instant Sinclair's boots touched the high corner of the ledge. Ortenburger scrambled up, grabbed the litter, held it—and it was safe.

But in spite of this remarkable luck it soon became clear that no one would get off the mountain this night. Furthermore, the party now was split: two men on the Grandstand with Campbell, four still on the ledge above. In the darkness all work stopped and the rescuers prepared for

(Please turn to page 200)

Repair any watch

... SWISS OR AMERICAN

Unique, modern Sweazey System starts you making repairs right away. Develops skill step by step at home in spare time. Diploma awarded. Free sample lesson. No obligation.

CHICAGO SCHOOL OF WATCHMAKING
Dept. 169, Fox River Grove, Ill. 60021

Two or four-wheel drive
JEEP OR SCOUT OWNERS

REPOWER with a 6 or V-8. H.D. ADAPTORS for using Car, Compact and some Truck engines. "State year & model, Jeep or Scout." Want fast action? Give us **FULL INFORMATION**. Send \$25.00 Dep. and we will ship correct kit, bal. COD. Send full amount for prepaid shipment. Wire, phone or write today. Details **FREE**

HOOSIER MACHINE PRODUCTS CO.
312 S. E. 6th St., Phone 276-3442, Pendleton, Oregon 97801

LAW FREE BOOK THE LAW TRAINED MAN

Write today for a **FREE** copy of illustrated law book, "THE LAW TRAINED MAN," which shows how to earn the professional Bachelor of Laws (LL.B.) degree through home study of the famous Blackstone Law Course. All necessary books and lessons provided. Moderate cost; convenient monthly terms. Write for **FREE** law training book today.

Blackstone School of Law, 307 N. Michigan Ave.
Founded 1890 Dept. 50A, Chicago, Illinois 60601

GET INTO ELECTRONICS

V.T.I. training leads to success as technicians, field engineers, specialists in communications, guided missiles, computers, radar, automation, basic & advanced courses. Electronic Engineering Technology and Electronic Technology curricula both available. Assoc. degree in 29 mos. B.S. obtainable. G.I. approved. Start Sept., Feb. Dorms, campus. High School Graduate or equivalent. Catalog.

VALPARAISO TECHNICAL INSTITUTE
DEPARTMENT D. VALPARAISO, INDIANA 46383

Career in ELECTRONICS?

Career training at home the new easy way with RCA Institutes. Lab work with first lesson. Pay as you go. Send for free 64-page book.

RCA

RCA Institutes, Inc. Dept. PM-69
320 W. 31 St., N.Y., N.Y. 10001

WOOD VENEERS • TOOLS

Shop Equipment • Supplies
POWER TOOLS
at Lowest Discount Prices!

SAVE MONEY on finest domestic and imported hardwoods ... all dimensions. Over 1500 items for the home craftsman and woodworking hobbyist. Lamp parts, upholstery supplies, tile, power tools at discounts.

NEW CATALOG READY
132 pages. Full Color. Send name, address and 35¢ to cover handling, and postage. Write...

CRAFTSMAN Wood Service Co. Dept. A-69
2729 S. Mary, Chicago, Ill. 60608

BASEMENT TOILET FLUSHES UP

TO OVERHEAD SEWER OR SEPTIC TANK.
NO DIGGING UP FLOORS. INSTALLS EASY. Write

McPHERSON, INC., BOX 15133, TAMPA, FLORIDA 33614

JUNE 1969

THE 20-YEAR FIXER®

MAKE YOUR NEXT CAULK JOB OUTLAST THE MORTGAGE. **DAP BUTYL-FLEX®** HAS EXTRA-HIGH BUTYL RUBBER CONTENT FOR LONGER-LASTING SEALS AROUND DOORS, WINDOWS, SIDING ... EVEN ROOF VENTS AND FLASHINGS. COSTS A BIT MORE AND WORTH IT.



DAP® **BUTYL-FLEX® CAULK**

DAP Inc., Dayton, Ohio 45401 / SUBSIDIARY OF Plough, Inc.
Also available in Canada

BUILD THE POPULAR MECHANICS MINI-BIKE

FROM 26-IN. BICYCLE FRAME

—with **VARIABLE SPEED TRANSMISSION**, as featured in June '67 issue. Step-by-Step plans, photos show you how. **PLANS, \$2.50**, refundable with order for wheels, engines, clutches, kits at **Discount Prices**. Order Plans, or send 25c for Catalog, today!

SAVE \$50 to \$150

GILLIOM MFG. CO. Dept. PM-6 St. Charles, Mo. 63301

Cut this COUPON!
Learn to Cut Out worry and Down on grass cutting costs! Send Coupon today!

Send me FREE Literature on Locke REEL MOWER
... and also on Devere-Locke rotary and Manco-Locke highwheel mowers. I'd like the name of closest dealer too.

(name) (street)
(city) (state) (ZIP)

Locke Mfg. Cos., Inc. 5675-L MacCorkle Ave., S.W. South Charleston, W.Va.

UNDERWATER PHOTOS

(Continued from page 110)

than Kodachrome X. However, we got some excellent shots with both. Use Kodacolor X film, of course, if you want color prints. It's wise to label your exposed film "Underwater Photos" when submitting it for processing. Ektachrome X, especially, lends itself to modification during processing that will strengthen colors lost under water.

The biggest problem in underwater photography is rapid fall-off in light intensity and color as you go deeper. The surface itself reflects some light. The higher the sun, the more light you'll get beneath, so shoot from midmorning to midafternoon. You can get excellent shots without flash in clear water at depths up to six or eight feet. Beyond that, flash helps considerably.

How far can you shoot? A good rule of thumb is that you can get reasonably good pictures about one-fourth as far as you can see underwater. However, leave the underwater landscape to the professionals; you'll find that your most effective pictures are close-ups. A worthwhile accessory is a close-up lens.

Depth and distance both have a bearing on the use of flash. So does the selective fall-off in colors. As light rays penetrate deeper, the water acts as a filter, selectively absorbing each of the colors of the spectrum. First to go is red (much of it disappears within 10 feet), then orange, followed by yellow and green. For your most colorful pictures, shoot within 10 feet of the surface. Fortunately, this is where a big percentage of sea life exists.

Shooting with flash

These factors mean that if you stay in relatively clear and shallow water and shoot fairly close up, you can get excellent color shots without flash. As you go deeper, flash will restore light and color, helping you shoot at greater distances.

The regular flashcube (available only in blue) gives excellent results for close-ups at medium depths. Beyond that, you'll need the larger No. 5 bulbs. If you go to bigger bulbs, always use the clear instead of the blue type; the clear will restore reds and oranges absorbed by the water.

There's one additional trick you can use, even if you have a housing without any provision for flash. Take a used flashcube and rip it apart, saving only the black plastic base. Snap this base into position atop the camera before sealing the housing. Low-cost Instamatics all have a preset shutter speed of 1/90th of a second. By inserting the cube base, you slow down

shutter speed to 1/40th of a second, giving you more light on the film.

Underwater aiming, to be frank, is difficult because your eye is offset from the viewfinder by a couple of inches—the thickness of the housing and your mask. One technique is to hold the camera in both hands at full arm's length, point it at the subject and snap the shutter.

If you do get a leak, it most likely will occur within two or three feet of the surface. Below that, water pressure helps seal the housing. And a leak, we found, is far from calamitous. In most housings, the camera rests on ribs or pads, so a few drops of water won't even touch it. Just tip the housing toward one corner, surface, reseal the housing, and then head below again.

If you want to give underwater photography a try before investing in your own equipment, you can rent an Instamatic inside a housing, ready for action, at many divers' shops and marinas. Once you see your first roll of pictures, we guarantee you'll plunge right in. ★★★

MAROONED AT 12,000 FEET

(Continued from page 198)

their second night without rest or food. For Campbell it was a third night of pain. He was still conscious—so conscious that he was sometimes critical of the rescue. If this day's descents had not sent him into hysterics, the rangers were sure tomorrow's would. No man could stand this.

When dawn came there were still three scary lowers and 940 feet to go. And there was new trouble—the men marooned above were running out of rope. They could no longer rappel. Now the only way they could get down was to *slide* down 300 feet of the thin ($\frac{7}{16}$ -inch) nylon. They came inches at a time, for a small rope is hard to hold and inflicts terrible burns. It took each man an hour to slide 300 feet. It was 10:00 a. m. before all finally got down, and the group was reunited.

Night was closing in again—the rescuer's third and Campbell's fourth—when they finally roped down across the glacier and reached the helicopter, sent there to wait. Campbell, nerve still unbroken, was whisked to a hospital.

By raw courage, the rescuers had saved a life. But they'd also conquered the North Face where no one had thought rescue was possible.

As the chopper lifted them off the mountain. Ranger Tingey saw with astonishment that Rick Reese was trembling. "Tired, Rick?" he demanded. "No," said Reese. "In this thing, I'm scared!" ★★★

ROAD RACING'S BIG LEAGUE

(Continued from page 79)

proved chassis and considerably more power. Our most likely engine will be a 351 Ford, an engine we feel is excellent for this type of racing.

There's a chance that later on we'll run an enlarged aluminum version of Ford's 429 canted-valve iron engine which—in the lighter metal—may work out to as much as 494 cu. in. But this is purely speculation, perhaps even wishful thinking. Hopeful though I am, I doubt we'll see this engine until next year. In any event, regardless of what will power the Eagle effort, I assure you that as much as I like both Bruce and Denis, we have no intention of letting them walk off with all the brass as they have the past two years.

Aerodynamic wings much in evidence

Among the things I imagine we'll see a good bit of this year are the aerodynamic wings so typical of today's Formula One cars. These wings, usually attached to the rear suspension by struts and activated by controls in the cockpit, can significantly up cornering speeds, thus lowering lap times.

The McLaren team is rumored to be readying a four-wheel-drive car for the series this year, but I doubt it will show up—if at all—until much later in the season. Bruce knows he faces rugged competition as is—without dipping into what is, essentially, an unknown well. I imagine, however, we'll see a lot of four-wheel drive in the immediate future.

Another area in which we might see a good bit of innovation is tires. Goodyear supplied all the winning rubber last year with the exception of Laguna Seca (Monterey, Calif.) and had available a wide choice of types and treads. As things settled down, just about everyone found that the 14-in. tread was best for the rears, while either 9 or 10-in. treads were best up front. This year rules allow tires with a tread width of up to 20 in., but whether or not we'll see them depends upon how fast they are.

I mentioned earlier that I'd give you the full Can-Am schedule. Following Mosport and Mont Tremblant this month, remaining dates include July 13, Watkins Glen, N.Y.; July 27, Edmonton, Alta., Canada; Aug. 17, Lexington, Ohio; Aug. 31, Elkhart Lake, Wis.; Sept. 14, Bridgehampton, N.Y.; Sept. 28, Irish Hills, Mich.; Oct. 12, Monterey, Calif.; Oct. 26, Riverside, Calif.; Nov. 9, Las Vegas, Nev.

Hope you can make one or more of the races. I guarantee some of the best, most exciting auto racing you'll ever see. ★★



Intellectual.

Because it thinks before you shoot! The KODAK INSTAMATIC 814 Camera automatically computes all the exposure variables... automatically chooses the correct exposure for the picture you want.

And all instantly. Just drop in the film cartridge. The "814" adjusts to the speed of the film; computes the exposure; tells you when to use flash; adjusts automatically for flash exposure as you focus. It's so automatic, it even advances both film and flashcube for the next picture after you've clicked the shutter!

The KODAK INSTAMATIC 814 Camera teams all this advanced thinking with a precision rangefinder and a superb 4-element $f/2.8$ EKTAR Lens. So don't just think about it. See it. Less than \$145 at your Kodak dealer's.

Price subject to change without notice.

Kodak Instamatic® 814 camera

FORD'S \$4800 MOTOR HOME

(Continued from page 119)

sucked into the MiniHome through the vent over the range. We stuffed the opening with a wad of paper towels. (Later MiniHomes, we're told, will offer hinged rear windows instead of the vent.)

We emerged onto a paved crossroad, flagged down an elderly rancher in a pickup, and learned we'd made a wrong turn.

"Foller me down the road a spell," he said, and roared off at 85 mph. With the throttle floored, I managed to keep up. The MiniHome felt surprisingly stable, even on a few sweeping, 90-mph downhill curves, and Jim and I could converse without shouting. After 30 such death-defying miles, we got back on course and continued at a saner pace.

Soon a pair of low stone pillars marked our entry into Big Bend. The desert had become green with exotic cactuses, and we began seeing more and more wild life, including deer, coyotes, hoglike javelinas and even an eagle.

Past the low, modern park headquarters building the road snaked upward into the bleak, majestic Chisos peaks. Then came a long descent into the Basin, a mile-deep valley with a spacious, well-designed campground (as well as a lodge and cabins for pantywaists).

Outdoor 'shower' available

After selecting a campsite, we toyed with the idea of using our outdoor "shower"—actually a sink dish sprayer with an extra-long hose. You open the MiniHome's rear doors to form a partial stall—if you're alone in the wilderness. We weren't, so we splurged 50 cents each on enclosed public showers. (The MiniHome shower would be handy for rinsing off saltwater or sand on the beach.) By nightfall we had our T-bones sizzling.

Next morning we breakfasted on bacon and eggs again. Then Jim pulled the hand choke and hit the starter. Nothing happened; dead battery.

The MiniHome people had assured us the refrigerator could run up to 15 hours without draining the battery; but we'd also given the water pump some heavy use the night before, and we'd left the galley light and high-intensity reading light on for hours. And that morning, before sun up, I had cleverly left the high beams on for 20 minutes while snapping time exposures of the rig. We were rescued within minutes by a ranger with jumper cables.

We drove across the purple-cactus-studded desert to Santa Elena Canyon with its 1500-foot limestone walls; then

we took a 25-cent rowboat ride across the swift Rio Grande to the sun-baked adobe houses of Santa Elena, Mexico (no passport needed); then headed east again to Boquillas Canyon, longest of Big Bend's gorges.

That night we reached the Boquillas campground too late; it was full. That's when we really began to appreciate our MiniHome's versatility. We drove to an adjoining trailer park where, for \$1.50, we made use of our a.c. current box and extra-cost outside water connection. If we hadn't been self-contained, we would have had a 50-mile drive to the nearest campground, in the Basin.

In our hurry to start our trip, we had forgotten to pick up an electrical extension cord, water hose or sink-drain hose. The trailer park manager lent us the first two items, but didn't have a drain hose or adapter to fit our odd-size connection. We used a pail to catch our dishwasher.

On our last day in the park, we awoke to find ourselves surrounded by campers. Throughout our trip we were reminded that with an eye-catching rig such as the MiniHome you can expect visitors. After an hour of providing free guided tours, we got underway and again spent the day sightseeing. We left the park that evening and camped overnight in a truck stop in Del Rio. The refrigerator ran all night, but we had no trouble with the battery.

The next day, just outside San Antonio, we stopped for a few minutes to tidy up the vehicle. The Formica and plastic surfaces proved easy to clean with a damp rag and detergent. Even the toilet is easy to empty. The holding tank, once detached from the seat, resembles a five-gallon jerry can; it can be carried easily (and inconspicuously) into a public washroom.

That afternoon we regretfully returned the MiniHome. Driving hard throughout, we had averaged 11.1 mpg—quite respectable for a new engine that wasn't tuned for mountain driving. We tallied our best mileage, 14.1 mpg, on the 45-mph park roads; our worst, 9.5 mpg, during our mad race with the old rancher.

Who'll buy this vehicle? It's a natural for campers, hunters and fishermen. With its many comforts, it'll even find a market among people who hate camping! It's a great all-around travel vehicle that feels at home on city boulevards as well as wooded trails. It can be parked in front of a fancy hotel or in a friend's driveway without embarrassment.

It's plenty big enough for two—though not three—adults. And it doesn't depreciate like a conventional car. A couple of brothers or friends could split the cost and get 10 good seasons out of it. ★★ ★

'DAMN THE SUBMARINES!'

(Continued from page 115)

picked up the pilots and the crews."

The flight leader, "Smoke" Streaun, is today Vice Admiral Streaun, Chief of Naval Air Training. With Admiral Clark, he helped artist Ed Valigursky reconstruct the scene for the painting appearing on pages 112-113. He described the nightmare of confusion in a letter to *Popular Mechanics'* art director, Tom Dauer:

"Because of the dim, wartime lights, it was difficult to get positioned to make a landing. One thing that was visible was the wake of the ship which was somewhat phosphorescent. You could use this to orient yourself and start the approach. There were as many as 15 to 30 aircraft at a time approaching a given carrier. All this caused a certain amount of panic in the minds of the pilots. They feared having to land in the water due to the shortage of fuel, and they were attempting to get aboard at all cost. This resulted in several crackups on deck. I must have made 30 approaches to different carriers. I even made an approach on a battleship. Fortunately, I recognized that it was a battleship far enough away and made no attempt to land, but that battleship got pretty excited on the radio circuits and fired several flares.

"Planes were running out of gas, and I saw three or four go in just short of the carrier. The signal officers were throwing flares into the water to locate the downed aviators; these flares would go off on contact with the water and show a light and smoke. So far as I know, very few of the downed aviators were picked up that evening. They were almost all picked up the next day when the task force came back through the area.

"When the lights were turned on, a searchlight was directed up on the *Yorktown*, which was my home, and several more were turned on in the fleet. The landing lights, outlining the landing part of the deck, were turned up, and this straightened out the situation considerably."

Of the 216 American planes that had gone after Ozawa, 20 were shot down. Eighty more either ditched or were pushed overboard in the frantic efforts to land. Sixteen pilots and 33 aircrewmembers were lost, plus two ship's officers and four enlisted men presumably knocked overboard. Fifty-one pilots and 50 crewmen were fished out of the ocean that night and the next morning. Thirty-six pilots and 26 crewmen were rescued the next day as Task Force 58 futilely pursued the fleeing enemy. ★ ★ ★

Briggs & Stratton — Clinton New Gas Engine Sale

Never before and perhaps never again—this offer of brand new genuine Clinton and Briggs & Stratton engines including 1 yr. factory warranty at less than cost. Perfect power for go-carts, scooters, tractors, mowers, generators, pumps, sprayers, etc. We hauled out 3 big factories who needed cash and the savings are yours while quantities last. Act fast.



Clinton 2 1/2 hp. Md. 500—Re-coil starter Std. 5/8 shaft w. keyway—ready to go. Reg. price \$59.50 Special (item 1002)

\$34.95

2 for \$64.50
6 for \$190.00



Briggs & Stratton 2 1/2 hp. Md. 81105 ratchet start, 3/4 shaft. Sturdy 4 cycle engine. Reg. price \$69.50 Spec Item = 1518

\$34.50

2 for \$67.50
6 for \$199.50

\$69.95
5 3/4 hp.
Briggs & Stratton



Same engine with 12 v. elec. start and battery charging.

(Item = 1571) **\$94.50**

Briggs & Stratton 5 3/4 hp. Md. 143402. Recoil start. Std. 1" shaft w. keyway, and adjustable governor—a rugged big engine ready to tackle any job.

Regular price... \$92.60
Special (item 1050) ... **\$69.95**
2 for \$135.00 6 for \$375.00

2 3/4 h.p. Clinton—34.95

Model 400, rugged 4 cycle model. Alum. Block, castiron cylinder Rope start—5/8" std. shaft. Item 1107 **34.95**
2 For **69.95**

3 1/2 h.p. Clinton—39.95

A big engine with big power. Model 404, 4 cycle, rope start, 3/4" std. shaft, industrial ball bearing engine. Item 404 **39.95**
2 for **77.50**

Remember these engines are absolutely perfect and standard and under factory warranty. Money back guarantee. Order now while stocks are complete. Factories—we buy new engines.



STANDARD DIAL PHONES WITH BELL

Bell System late model dial phones same as used by all telephone companies. Ideal as extensions on any system. Easy to connect. Several may be connected on one line. Easily modified for private inter-com system. Cost \$40.00 new—guaranteed excellent condition.



ITEM 855 NC. Wt. 8 lbs. **\$8.95**



TRUCK OR BOAT WINCH 2000

A powerful, compact winch which installs easily even in limited space. Works with any 12, 24 or 32 volt system. Reverses under power—positive brake holds load. Drip proof cover. Remote control if desired. Drum holds 100 ft. of 3/4" cable. Speed 30 ft. per minute. A terrific winch at an economy price. Item 1263 **\$69.50**
Wt. 55#

RECHARGE ALL BATTERIES

Only Everlite

- Charges 6 batteries
- Charges 3 times faster
- Charges all batteries

Including hearing aid, flashlight, lantern, radio, in fact any battery up to 12V. Save Money and have the convenience of fresh batteries always. Simple and 100% Safe. Plugs into any 115V. outlet. Guar. for one year. Send \$6.95 plus \$6.65 for shipping **695**



Model 75

Send 10c for 100 page Catalog FREE with order. Prices f.o.b. factory—Send check or MO

MASTER MECHANIC MFG. CO., Dept. A-69, Burlington, Wis.
Southern Customers write Dept. A-69, Box 65, Sarasota, Florida



BUILD THIS MINI-BIKE—YOURSELF NO WELDING NEEDED

Lightweight, Rugged. Compares with the finest mini-bike you can purchase. Simple, inexpensive construction allows you to assemble your mini-bike with ordinary hobby shop tools. Illustrated plans, instructions and suppliers parts list **\$200** Satisfaction Guaranteed. Plans Only

WESTATE ENTERPRISES
Dept. P-6, Box 9216, San Jose, Cal. 95117

REAL ESTATE BE A BROKER

PAYS BIG! SEND FOR BIG FREE CATALOG NOW! Graduates report making substantial incomes. Operate your own business quickly. Men, Women, all ages, learn easily. Course covers Sales, Appraising, Loans, Mortgages, & related subjects. **STUDY AT HOME** or in classrooms in leading cities. **Diploma Awarded. Write Today for FREE Book!** Accredited Member National Home Study Council. (Est. 1936) G. I. Approved.

**FREE
BOOK
TELLS
HOW**

WEAVER SCHOOL OF REAL ESTATE
3521-P Broadway Kansas City, Mo. 64111

HEAVY DUTY BALL-BEARING PUMP

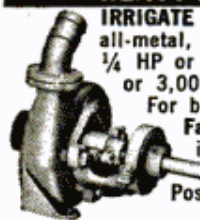

IRRIGATE • DRAIN • SPRAY • CIRCULATE • Famous all-metal, rust-proof XB pump with stainless shaft. Use 1/4 HP or larger. 1 HP for up to 5,200 GPH 60' high or 3,000 GPH from 25' well. 1 1/4" inlet. 1" outlet. For belt or direct drives. Only **\$12.95** Famous Type P won't rust or clog. Bronze bearing. Hundreds of thousands in use. Up to 2,400 GPH. 1" inlet. 3/4" outlet. Only **\$8.95** Postpaid cash with order. Money Back Guarantee. **LABAWCO, Box 2, Belle Mead, N. J. 08502**

Print Your Own

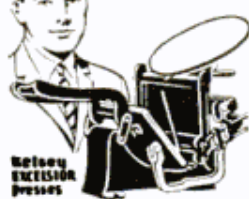

Cards, Stationery, Advertising, Circulars, labels, photo and movie titles, church work, tags, greeting, sympathy, prayer cards, etc Save money. Pays for itself in a short time.

Own a Printing Business

Good Profit. Raised printing like engraving too. Have home shop. We supply everything. Direct from factory, only. Easily followed rules. Write now for free details. **KELSEY PRESSES E-37 Meriden, Conn. 06450**

STOCK SIGNS

WEATHERPROOF ENAMEL. VIVID COLORS
also **HAND LETTERED SIGNS** at \$1.00 & up
SEND \$1. (DEDUCTIBLE FROM FIRST ORDER) FOR ILLUSTRATED LIST
DEALER INQUIRIES INVITED

**\$1 EACH
POST-PAID**

FOOTHILL SIGN Co. STUDIO K F
9009 SANTA MONICA BLVD. LOS ANGELES, CA. 90069

BUILD YOUR OWN CAMPER SAVE UP TO 50%



Complete, easy to follow plans, instructions, materials list.

Camper Plans \$3.95
Travel Trailer \$3.95
Pickup Cover \$2.00
CONVERSION PLANS:
Econoline Type Van... \$2.95
Passenger Bus or
Delivery Van..... \$2.95
Satisfaction Guaranteed

VIKING CAMPER SUPPLY, INC.
99-8P Glenwood Ave.,
Minneapolis, Minn. 55403

Please send _____ for
which I enclose \$ _____
NAME _____
ADDRESS _____
CITY _____
STATE _____ ZIP _____

EQUIPMENT CATALOG \$1.00
Refundable on First Order.
Send Dime for Details.
Save 50% on Camper Kit.
All items from catalog to
build \$1,795. Camper, 8',
10', 10'6" or Chassis Unit.

VIKING

THE 1970 CARS

(Continued from page 95)

concealed and side windows ventless. Radio antennas will be hidden in the windshield, just like the '69 Grand Prix. An antiskid brake system option will be available for the Lincoln as well as the Mark III. The Mark III itself will remain much as is.

● **Mercury**—The Montego and Cyclone will feature all-new sheet metal, extensive restyling, particularly up front. Headlights and windshield wipers will be concealed. Wheelbase will be up an inch, but length remains the same. The X-100, however, will be about 4 inches longer. It'll feature a unique "gunsight" grille insert and airscoop on the hood. A power option will be Ford's new 429-in. V8, making the car a red-hot performer.

The Cougar was redone last year, so changes will be minor. Grille bars will be vertical instead of horizontal and the front center of the hood will feature a small splash of vertical chrome. Gone is the slight side crease.

The full-size Mercurys will be just about what they are now. The Monterey will get a new grille, making it look more like the higher-priced Mercs. Don't be surprised if the intermediate Mercs bow with no convertible.

● **Oldsmobile**—Olds may or may not pop with a new car based on GM's G-body. If it does, rumor has it the car will be named the Cutlass Supreme and presumably will be a luxurious echo of the Grand Prix. The big Olds will get new front treatment and revamped taillights. The Toronado will get new front fenders. Biggest changes here will be on the F-85 intermediate line—all-new sheet metal, new grille, new rear styling. Olds will probably drop its intermediate station wagon.

● **Pontiac**—The GTO will feature a new grille, extensive sheet-metal changes, and the big Pontiacs will go all-out on the massive center grille theme, again, much like the present Grand Prix. The Grand Prix itself gets only minor ornamentation changes. The Firebird will get the same minor styling changes as the Camaro, but like the Camaro, will be all-new next spring, again with emphasis on a fastback.

● **Plymouth**—An all-new, neat, trim Barracuda will hit the market this fall. It'll be a semi-fastback, low, and stress the long-hood, short-rear-deck look of the other Mustang-ish pony cars. Inner door handles will be recessed, will house door-lock toggles. Standard power will probably be the 440, meaning it'll go like a bat. Valiant will drop its two-door sedan, replace it with a new sport coupe featuring a new roof line. Other Valiants will get new

grilles, new taillight treatment and trim changes. The Belvedere will get new front-end styling, including fenders and hood. The Fury line will probably bow with only minor ornamentation changes.

● **In general**—Fewer convertibles and station wagons, more hardtops. Ford's impact-absorbing S-frame will be more widely used throughout the corporate lines of cars, as will GM's side door safety rails. All AMC cars will have a new type of safety glass. There'll be more disc brakes, a few more antiskid braking options. Hopefully, there'll be some new seat-belt arrangements. Finally, all cars will bear a sticker Big Brother has said is supposed to advise potential buyers as to tire loads, acceleration and braking performance. ★★★

KNOW THE LAY OF THE LAND

(Continued from page 133)

made or revised is shown in the lower right-hand corner under the map name. If you buy your maps by mail from the Survey, you'll get the latest ones.

Ordering the maps by mail is simple. Send a card or letter to: U.S. Geological Survey, Washington, D.C. 20242 or U.S. Geological Survey, Federal Center, Denver, Colo. 80225. Ask for an index map of the state that interests you. At no cost to you, you'll receive a state map squared off in numbered sections. From this you can tell which section maps you'll need.

Along with the keyed state map, you'll receive an order blank and price list. You'll also get a list of special USGS maps available, such as those of river basins and cities. You'll have to allow anything from two to six weeks for the maps to come.

If you're in a hurry, you can purchase USGS maps at most large map stores and some bookstores and hobby shops. Large-scale maps, 1 to 24,000 to 1 to 125,000, are priced at 50 cents each by the Survey; smaller-scale state and regional maps are 75 cents. Shaded relief maps run about the same except that large ones for entire states are priced around \$2. The same maps, bought in a store, will usually run 25 cents or so above the Survey prices.

Even if you never use a USGS map in the field, you'll find them among the handsomest wall decorations going.

The USGS has a lot of them, including such outsize ones as a New York State shaded relief map that runs 42 by 58 inches and a big U.S. map in two sheets that, when joined, come out 54 by 80 inches. City maps, like Wichita's (49 by 62 inches), are also decorative. ★★★

GOVT. SURPLUS AND OTHER BARGAINS SAVE UP TO 90%

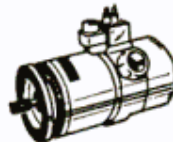

DUAL-PURPOSE NAVY GEN.
Two gen. in one. DC side rates 200 AMP @ 24 to 28 V. AC side produces 1200 Watts @ 115 V. Exc. for making your own arc welder or for lights, hot plates, radio, etc. 14" L x 6" dia. Tested prior to shipment. GOV'T COST \$350. **\$17.50** (Stk. #26)

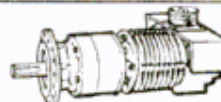

ELECTRIC GEAR MOTOR
Heavy duty, all ball bearing const. Rated approx. 3 H.P. @ 24 V.D.C. Turns 400 RPM no load on 12 V.D.C. 750 RPM on 24 V.D.C. Contains magnetic clutch, 1 1/8" shaft free wheels with power off. Reversible. 16 1/2" L x 5 1/2" dia. Like NEW. Tested prior to shpg. Approx. GOV'T COST \$250. Shpg. wt. 40 lbs. **\$27.50** (Stk. #2410)



ELECTRIC UTILITY PUMP Output up to 360 gal. per hr. @ 18 PSI. Exc. for water, fuel, insecticides, etc. Aluminum construction. Runs on 12 or 24 V.D.C. Explosion-proof motor. Inlet & Outlet ports are 1/2" pipe. Draws 5.2 amps, 9 3/4" H x 6" W. Approx. GOV'T COST \$150. Shpg. wt. 8 lbs. NEW. **\$14.50** (Stk. #2486A)



NEW! BIG! 1969 CATALOG

Send 25c for amazing catalog with 1000's of bargains in hydraulics; electrical, marine, automotive items, etc. Order from ad. All prices FOB Culver City. 50% deposit required for COD. Cal. res. add 5% sales tax. Include zip. Satisfying world-wide customers since 1945.

AIRBORNE SALES CO. Dept. PM-669
8501 Stellar Dr., Box 2727 • Culver City, Calif. 90230

Carpenters' Secret Makes Hinge Screw Holes Vanish

(Mr. W. C. B., Norristown, Pa.)

Fill unsightly hinge screw holes like professional carpenters do with **PLASTIC WOOD**. Handles like putty. Hardens like wood. Plane it. Sandpaper it. Varnish or paint it for perfect finish. Get **PLASTIC WOOD** in tube or can. Walnut, oak, mahogany or natural color. At all hardware outlets.

GENUINE
**PLASTIC
WOOD®**

CELLULOSE FIBRE FILLER



\$\$ TREASURE \$\$



New revolutionary analytical transistorized metal detector will distinguish a gold bar from a tin can. No more unnecessary digging for tin cans, nails, bottle caps, etc. Also features push button tuning, automatic tuning, loudspeaker. Negligible ground pickup. Greatest detection range, etc. Many models — free catalog.

GARDINER ELECTRONICS CO.
Dept. 8, 4729 No. 7th Ave., Phoenix, Ariz. 85013

(Continued from page 137)

neers still stick with traditional principles. KLH, one of the best-known manufacturers of top-grade speakers, explains why: "It is true that high frequencies used to radiate from the speaker in a narrow beam. But that's no longer so. Tweeters have been improved and today nearly every good speaker scatters the whole sound spectrum over a broad angle. This makes it unnecessary to rely on rearward sound projection and wall reflections for a realistic sound spread."

Such conflict of opinions is typical in the trade. Even engineers can't agree on just what makes a speaker sound good. One designer may favor a richer, more mellow sound, while another stresses brilliance and crispness. This lets you choose among various models with different tonal coloration, picking the one that best meets your personal preference.

How to pick a good speaker

Still there are some objective standards for judging a speaker. A good one must meet four basic requirements:

1. It must cover the whole tonal range from top to bottom—at least from 15,000 cycles down to 50. Within this range, its response must be "flat." This means every note, regardless of pitch, must be reproduced just as it sounded in the studio—neither emphasized nor swallowed up.

2. Tone color must remain true. Poor speakers add their own "coloration" to the music, changing the character of the various instruments. Listening to music on such a speaker is like looking at a great painting through sunglasses.

3. The speaker mustn't blur the sound or make it shrill and harsh.

4. It must spread the sound evenly over a broad angle.

Unfortunately, published specifications don't always tell the whole story. You may find a \$40 speaker boasting the same frequency response as a \$500 model. The specs may be true as stated, but this doesn't mean the \$40 speaker actually sounds like the \$500 one. Suppose the specs say a speaker has a frequency response of 30 to 18,000 cycles. All this tells you is that the speaker goes up to 18,000 and down to 30. It doesn't tell you anything about the quality of the sound at or between the upper and lower limits. The bottom bass may be just a hoarse rattle instead of a deep, rich tone. The top treble may screech like chalk on a blackboard.

Because frequency range alone is not the last word, you have to look for other

clues to quality. Here are factors affecting speaker quality you usually can check:

Cone resonance. Like every vibrating body, a speaker cone has natural resonances of its own that may emphasize certain musical frequencies and suppress others. Also, speakers don't work efficiently below their resonant frequencies. While new plastic cone materials are helping to minimize the problem, the important thing to be sure of is that the point of resonance is below the lowest note the speaker has to play. This point varies all the way from 15 or 20 cycles in some speakers up to 70 or 80 cycles in others. Anything below 35 cycles will permit good bass well down in the musical range.

Cone size: Most speakers come in standard cone diameters of 8, 10 and 12 inches. Given equal quality, the bigger cone generally produces more powerful bass because it pushes more air. A good small speaker can sound better than a poor big one, however, so consider size only along with other factors.

Power rating. This tells how many watts of amplifier output a speaker can take. If your amplifier puts out 30 watts per channel and your speaker is rated at only 20 watts, the result will be overloading and possible speaker blowout at top volume. So pick speakers with a power rating equal to or greater than the per-channel output of your amplifier.

Power requirement. This is the minimum power in watts that the speaker needs from the amplifier to produce full volume. Be sure to buy speakers that your amplifier is capable of driving. To some extent, the power requirement is an indication of speaker efficiency. Other things being equal, a 5-watt speaker is more efficient than a 15-watt model of the same size because it takes less power to drive it.

Speaker impedance. This is the load or resistance, expressed in ohms, that a speaker represents to the amplifier. It must match the amplifier's output impedance for good sound reproduction. Typical speaker impedances are 4, 8 and 16 ohms.

In choosing a speaker, be sure you know the amplifier's true output impedance. Some amplifiers offer several taps for speakers of different impedances, but only one of these represents the natural output impedance. Where there are both 4 and 8-ohm outputs, for instance, the 4-ohm tap is generally just a 4-ohm resistor connected in series with the speaker terminals to provide an 8-ohm load with a 4-ohm speaker. Since half of your am-

(Please turn to page 208)

adjustable TROLL BRACKET

inboards, outboards
stern drive, sailers



Raised position:
Motor stored with-
out creating "drag".



Operating position: Motor
quickly lowered to correct
height for full power.

For trolling or auxiliary motors on pleasure craft, particularly for salmon and steelhead fishing. Motor and mount board are winter-stored without dismantling rails remain on transom. Full sideways swing for positive steering.

No. 516 (to 10 hp) 18" rails.....\$26.00
No. 516A (to 10 hp) 24" rails.....\$30.00
No. 530 (to 20 hp) 18" rails.....\$40.00
No. 530A (to 20 hp) 24" rails.....\$45.00

See your Michigan dealer or contact: Michigan Wheel Company, Grand Rapids, Michigan 49502

MICHIGAN

9-11 Michigan Wheel Co., Grand Rapids, Mich. 49502

How To Hold FALSE TEETH More Firmly in Place

Do your false teeth embarrass you by slipping, dropping or wobbling when you laugh, talk or eat? Then sprinkle a little FASTEETH on your plates. FASTEETH holds dentures more firmly, more comfortably. This alkaline powder doesn't sour. No gooey, pasty taste. Helps check denture odor. Dentures that fit are essential to health. See your dentist regularly. Get FASTEETH today at all drug counters.

PROFIT IN YOUR SPARE TIME



SMALL ENGINE REPAIR PAYS BIG!

Outboard • Powermower • Chain Saw • Tractor
MAKE EXTRA MONEY — or fix your own engines and SAVE! Illustrated, easy-to-learn Home Study Course qualifies you as expert. Approved for Veterans. Write today!

LINCOLN TECHNICAL INSTITUTE
SUITE 6-E, 427 MARKET ST., NEWARK, N.J. 07105

WRIST ROCKET

AMERICA'S Pat.
HARDEST U.S.
HITTING SLING

Range 225 yd. - 232 fps

Matched spare rubbers
and pouch assembly, \$1.00.

Write WRIST ROCKET®
2654 44th Ave.
Columbus, Nebr. 68601 PM

\$3.00 Post Pd.
No C.O.D.'s



MAKE MONEY!

**REPAIR
HYDRAULIC
JACKS**



Earn while you learn at home. Millions of jacks in gas and auto service stations, trucking firms, body shops, riggers, factories and farms need servicing... most of which you can learn to repair. We show you HOW. Start spare time in your basement or garage. Big opportunity for mechanics. ACT NOW!

Write for Folder PMG and Free Bonus Offer

Hydraulic Jack Repair Manual Co., Inc.

G.P.O. BOX 3 • STATE ISLAND, N.Y. 10314

TUNE UP ELECTRONICALLY

ANY CAR EVER MADE!

- ✓ COMPACT or LIMOUSINE
- ✓ DOMESTIC or FOREIGN
- ✓ POSITIVE or NEGATIVE GROUND
- ✓ 4, 6 or 8 CYLINDER
- ✓ 6 VOLT or 12 VOLT

With New Improved Model BT-162

DWELL TACHOMETER

ASSURE EASY STARTS, OPTIMUM PERFORMANCE and MAXIMUM GAS ECONOMY with MODEL BT-162

MADE ORIGINALLY FOR THE PROFESSIONAL AUTOMOTIVE TECHNICIAN, MODEL BT-162 WILL PAY FOR ITSELF MANY TIMES OVER FOR THE AUTOMOTIVE HOBBYIST AND EXPERIMENTER.



The Model BT-162 will perform the services specified below in addition to many other tasks too numerous to mention.

It is no longer necessary to file points to smoothness when using the Model BT-162. The instrument will automatically make allowance for any existing "pitting" or "wear." • Indicate the most effective point setting without removing the distributor cap. • Indicate the correct settings for external adjustment type distributors. • Car manufacturers' dwell angle recommendations are included in the manual provided with the Model BT-162. • To adjust for mathematically correct carburetor adjustment and thus insure maximum gas economy and quiet engine running, simply use

the Tachometer section of the Model BT-162. • To locate a "miss" you need only disconnect or "short" the spark plugs one at a time with the Model BT-162 switched to the Tachometer position. You will be able to instantly identify which particular plug (or frequently its wire lead) is responsible for the malfunction. • Cars with automatic transmissions function efficiently only if the fluid pressures are correctly maintained. Manufacturer's instructions always refer to RPM recommendations.

Operating manual includes manufacturer's dwell angle recommendations for all cars. The manual is yours to keep even if you decide to return the instrument. **\$29.95**

SEND NO MONEY WITH ORDER PAY POSTMAN NOTHING ON DELIVERY

Try it for 10 days before you buy. If completely satisfied then send \$5.00 and pay the balance at the rate of \$5.00 per month until the total price of \$29.95 (plus P.P., handling and budget charge) is paid. If not completely satisfied, return to us, no explanation necessary.

ACCURATE INSTRUMENT CO., INC.

2435 White Plains Road, Bronx, N.Y. 10467

DEPT 657

Please rush me one Model BT-162. If satisfactory I agree to pay \$5.00 within 10 days and balance at rate of \$5.00 per month until total price of \$29.95 (plus P.P., handling and budget charge) is paid. If not satisfactory, I may return for cancellation of account.

Name _____

Address _____

City _____

Zone _____

State _____

Save money! Check here and enclose \$29.95 with this coupon and we will pay all shipping charges. You still retain the privilege of returning after 10 day trial for full refund.

.. take your pick as a ..

DIESEL TRUCK DRIVER

Learn curbing, backing, over-the-road runs, terminal parking and much more on GREER'S gigantic concourse. Jobs in demand!



.. and become SUCCESSFUL as thousands of others!

Train on GREER'S 1,700 acres, operating bulldozers, end loaders, scrapers, graders, and cranes on actual field assignments for jobs with future security.



.. take your pick as a ..

HEAVY EQUIPMENT OPERATOR

VETERAN APPROVED

Both courses also available in Home Training.

GREER TECHNICAL INSTITUTE, INC.

BOX 368

BRAIDWOOD, ILLINOIS 60408

GREER TECHNICAL INSTITUTE, INC. HOME PRE TRAINING
BOX 368 RESIDENTIAL
BRAIDWOOD, ILLINOIS 60408 VETERAN

Gentlemen: Please send more information about above trades.

COURSE _____ AGE _____

NAME _____

ADDRESS _____

CITY _____ STATE _____ P669M

MODERN HI-FI SPEAKERS

(Continued from page 206)

plifier's power will be wasted in the resistor, this is a poor arrangement unless the amplifier has plenty of extra output capacity.

Magnet weight. A speaker cone is moved back and forth by a coil oscillating inside a magnetic field. The heavier the magnet, the better it controls the movement of the cone. Bigger cones need bigger magnets. This is why a 12-inch speaker must have a heavier magnet than an 8-inch model to attain comparable performance.

Flux density. This measures the magnetic force acting on the moving coil—the voice coil, as it's called—that pushes the speaker cone. It is expressed in number of lines of magnetic flux. The higher the number, the more accurately cone motion keeps in step with sound signals.

Some speaker qualities are best determined by actual listening tests. One of these is transient response. In the hotel business, a transient is someone who stays only a short time. In audio, the term has a similar meaning. It refers to sounds that start fast and are quickly gone—like a drumbeat, a cymbal crash or the plucking of a string.

Poor speakers can't handle such sudden sound bursts. Their cones have too much inertia. They are slow to respond and keep on jiggling after the sound has stopped. Result: The music sounds blurred and soggy. The sharpness and excitement are missing.

Good transient response in a speaker depends on a strong magnet and a light cone. The magnet keeps tight control over cone motion, preventing the cone from overshooting its mark. The light cone gets moving faster and is easier to control during sudden starts and stops.

A big problem in speaker design is covering the whole range of audible tones from the lowest thud of the kettledrum to the silver tinkle of the triangle. This is hard to do with a single speaker. Most speaker systems nowadays use separate units for different parts of the tonal range. Woofers specialize in bass, tweeters in treble. Some systems also have separate mid-range units to tackle the middle frequencies from about 800 to 10,000 cycles. In some models, the tweeter nestles right inside the woofer frame. This is called a coaxial speaker.

Woofers feature a heavy cone whose mass gives it a low resonance. This makes them efficient bass producers. Around the rim, most woofers have "high-compliance" cone suspensions to let the cone

travel back and forth freely without resistance. This lets the cone push out heavy bass thrusts without distortion.

Tweeters, by contrast, have tiny cones of stiff, lightweight materials that can vibrate rapidly without buckling. Some tweeters project the highs through flared metal horns. These are called horn tweeters or compression tweeters. The point in the tonal range at which the woofer leaves off and the tweeter takes over is called the crossover frequency. It is determined by a small circuit, called the crossover network, hooked up between woofer and tweeter.

Today, most speakers are sold as complete "systems," combining woofer, tweeter, and often a mid-range unit in a matched enclosure. Far from being just a box, the enclosure is an active partner in sound reproduction. It interacts with the cone in the same way that the body of a violin interacts with the strings, giving strength, depth and fullness to the sound. Without a proper enclosure, even the best speaker would sound as tinny as a pocket radio.

Many factors enter into the calculations of an enclosure—cone resonance, length of cone travel in loud passages, enclosed air volume and back pressure. By juggling these acoustic factors to a mathematical optimum, engineers have been able to shrink the size of the enclosure. Today's bookshelf speakers, for example, pump out as much bass as bulky floor models did several years ago. Standout speakers of this type include the Acoustic Research AR-5 and AR-2X, the KLH-6 and KLH-17, the Electro-Voice E-V 4A, the ADC-400 and Lafayette Criterion 3X.

Even bantam speakers, hardly bigger than a shoebox, pour out well-balanced sound, skimping only on the very lowest notes. Granted, these little speakers won't let you shake the walls with orchestral thunder, but they give you fine performance at normal volume levels. The best models in this class (priced from \$40 to \$80) include the Acoustic Research AR-4X, KLH Model 22, Bogen LS-20, Fisher XP-60 and the Electro-Voice E-V 7A.

These advances in speaker design not only save you space; they also save you money. Smaller units, requiring less material, are cheaper to make. Not long ago, you had to fork over at least \$200 for a pair of quality speakers. Today you can pick speakers of good musical fidelity for roughly half the price.

In testing a speaker by ear, be sure to use a good stereo recording to judge by. Avoid pop records. They are so gimmicked up that the instruments don't

(Please turn to page 210)

"Get my new Signature Kit...a \$5.50 value for only \$3.00."

By Dick Kotis, President, Fred Arbogast Company, Inc.



The Jitterbug®...for surface fishing The Hawaiian Wiggler®...for middepths The Arbogaster®...for bottom fishing

Also included:

New Bait Equipment Selector
Colorful 1969 Arbogast Catalog
Handy plastic utility box

Value: \$5.50; yours for only \$3.00. Specify casting or spinning size.
Send check or money order to Fred Arbogast Co., Inc.,
1806 W. North St., Akron, Ohio 44303. Order today!

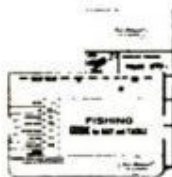

BILL PROBLEMS?

WE CAN HELP YOU — TODAY

NOBODY REFUSED UP TO \$18,000.00

Bad Credit No Problem ■ Not a Loan Co.

Send Your Name and Address
For FREE Application To Nearest Office

INTERNATIONAL ACCEPTANCE, dept. M-8

5133 N. Central Ave., Phoenix, Ariz. 85012

711 - 14th St. N.W. Washington, D.C. 20005

507 Carondelet St., New Orleans, La. 70130

I-N-V-E-N-T-O-R-S

WE NEED INVENTIONS

Sell your invention for cash—need money for Patent?—Are technical problems holding you back? Universal Inventions has helped inventors all over the world—just like yourself—why not you? Inventions provide the magic spring-board to sudden riches. REMEMBER, we either sell your invention or pay you a cash bonus. Write for details.

UNIVERSAL INVENTIONS, Dept. 13, Marion, Ohio

"\$33,000 LAST YEAR" OPERATING AUTO RADIATOR SHOP

—Mercier Bros., Lowell, Mass.

START SHOP OR ADD TO BUSINESS.

Market growing. More cars each year. Packaged radiator shop incl.: equipment, training, 98-page manual, initial supplies. Proven merchandising attracts business. Pay-as-you-profit plan. Write.



NEW 1-PIECE SHOP
Tests • Cleans • Repairs

INLAND MFG. CO., PM-6

1108 Jackson St., Omaha, Neb. 68102



110-120 VOLT A.C. LIGHT PLANTS—60 CYCLES

Fanbelt driven from pickup or small gas engine. Operates saws, drills, pumps, freezers, T.V. X1000 Watts—Needs No Battery. Now \$62.50. 1500 Watts—6 and 12 volt vehicles. Now \$52.50. 3000 Watts—12 volt vehicles only. Now \$99.50. Guaranteed. Check or Money Order.

VIRDEN PERMA-BILT, Box 7066 P.M., Amarillo, Texas 79109



LEARN MEAT CUTTING

Train quickly in 8 short weeks at Toledo for a bright future with security in vital meat business. Big pay full-time jobs — HAVE A PROFITABLE MARKET OF YOUR OWN! Time payment plan available. Diploma given. Job help. Thousands of successful graduates. OUR 46th YEAR! Send now for big new illustrated FREE

catalog. No obligation. G.I. Approved.
NATIONAL SCHOOL OF MEAT CUTTING
Dept. 50V, Toledo, Ohio 43604

POWERFUL NEW INVENTION, ONLY 2" LONG SHOTS THRU 100 PAGES—THIS BOOK!

'B-B SHOT'



MAKE THIS TEST... Load your 'BB Shot' and fire against this magazine. Notice that it drives BB's through more than 100 pages. Though only 2" long x 1" in diameter, this pocket-size device has amazing power and accuracy. Use it for targets, pests and hunting. Scientifically designed for high power, operating ease and safety.

FREE! Get the 'BB Shot' now—we'll include an extra Velocity Cone and FREE Target. BB's and Automatic BB Dispenser... all for only \$1.98 ppd. 3 for \$5.00 ppd. Money Back Guarantee. Not sold to N. Y. C. residents or minors

GRAYSON • Dept. F-35, 210 Fifth Ave., N. Y. 10010

MONEY-BACK GUARANTEE

Name.....
Address.....
City..... State.....

\$1.98
ppd.

Get FREE Booklet on New Andersen Perma-Shield® Windows

Andersen Corporation
Bayport, Minnesota 55003

Name.....
Address.....
City.....
State..... Zip.....

Andersen Windowalls®



Only the rich can afford poor windows

PM-69

LEARN TO EARN!



**NO HOME STUDY
CONTRACTOR OWNED
VA APPROVED**

- Live at school • Train on actual machines / qualified instructors
- Graduates readily accepted for construction employment

WESTERN SCHOOL OF HEAVY EQUIPMENT OPERATION

BOX 510 • WEISER, IDAHO 83672

SEND TODAY FOR FREE SCHOOL CATALOG
DEPT. M-3

NAME _____

ADDRESS _____

CITY _____ STATE _____



SPEEDY RIVETS

"JUST SWAT with Hammer"



- Works like a charm . . . holds firm!
- Look for NEW red and yellow Skin-Pack Cards!
- Look for Colorful NEW Display Carton, too!
- Available in two sizes; nickel, gilt, black and brown colors!
- Sold at hardware stores.

**COLUMBIA
FASTENER**

DIVISION OF UNITED-CARR
3229 S. Ashland Av., Chicago, Ill. 60608

Every home should have Speedy Rivets . . . "The Fix-it Man's Best Friend"!

Doctors Find Way To Shrink Hemorrhoids

**And Promptly Stop Itching,
Relieve Pain In Most Cases.**

Science has found a medication with the ability, in most cases — to stop burning itch, relieve pain and actually shrink hemorrhoids.

In case after case doctors proved, while gently relieving pain and itching, actual reduction (shrinkage) took place.

The answer is *Preparation H*® — there is no other formula like it for hemorrhoids. Preparation H also soothes inflamed, irritated tissues and helps prevent further infection. In ointment or suppository form.

MODERN HI-FI SPEAKERS

(Continued from page 208)

sound natural. Symphonic music is the toughest test for a speaker because it features large numbers of different instruments: massed strings, brass, woodwinds and percussion. As you listen, watch for these telltale clues:

1. Do the violins have a silky sheen of sound without harshness? (This shows if the speaker has smooth treble response.)

2. Is there solid weight in the sound of cello and contrabass? (This is a test for bass projection.)

3. Do drums, other percussion instruments and plucked strings sound sharp and crisp? Can you sense the impact of the sticks on the drumskins? (This is a test for transient response.)

4. Does the sound stay clear and unblurred even in loud passages scored for full symphony orchestra? (This test shows up distortion.)

One important rule for comparing speakers: Play them all at the same volume. If one speaker is louder than another, the ear fools you and invariably makes the louder speaker seem better. If a salesman, for reasons of his own, wants to push a certain speaker on you, he always plays it a little louder than the others. It's an old trick of the trade. Don't let him get away with it. ★★★

SMALL ARC WELDERS

(Continued from page 186)

precautions. Be sure your house wiring will carry the load. Weld in a fire-safe, ventilated area. The arc torch's carbons carry 110 v. and will shock you if you touch them. Since the arc is an intense source of ultraviolet rays, never view it except through the helmet's dark-green filter, and wear a long-sleeved shirt to protect your arms from sunburn.

Make sure that work you plan to weld with coated electrodes isn't grounded—if it is, connecting the welder's lead to the work can cause a direct short (since the welder's plug isn't polarized) and blow the circuit's fuse. *Don't weld grounded appliances, in-place plumbing or anything wet.*

Never try to weld or braze tanks or other closed containers—it's so hazardous it isn't worth the risk. It's impossible to clean the last traces of explosive vapor from containers that have held gasoline, oil, paint or other combustibles, and welding such a container can literally blow off the roof. The safe rule is *never* to use any kind of welding equipment on or near *any* tank. ★★★

FIXTURE TO SET BORING BARS

(Continued from page 173)

in the end of the clamp so the pointer will just touch the edge of the wheel. Drill a 1/8-in.-deep hole with a No. 76 drill and insert a 3/4-in. length of 25-ga. (0.020 in.) spring-steel wire.

Make the thumbscrew from brass so it won't mar the bar surface.

Using the adjuster

Since you must know the exact diameter of your boring bar, measure it with a micrometer. A typical example in setting the adjuster is one where the bar has an 0.486-in. diameter and is to be set to bore an 0.532-in.-dia. hole. Clamp the bar in the adjuster with its cutter under the adjusting screw as shown at the bottom of page 172. With the cutter withdrawn into the body of the bar, run the adjusting screw down until the foot contacts the body of the bar. The reading on the index wheel is the basic one for the bar which corresponds to its radius. In the example, this is 0.243 in. We want to set the cutter to a radius of 0.266 in. to bore the desired hole of 0.532-in. diameter. Thus, to obtain the setting you subtract the radius of the bar from the desired radius:

$$0.266'' - 0.243'' = 0.023'' = 23 \text{ scale divisions}$$

Back off the adjusting screw 23 divisions on the wheel. Loosen the setscrew in the bar, gently move the cutter out until its point just touches the foot of the adjusting screw, lock cutter in place and your bar is all set to bore the hole. ★★

WINDOW SCREENS

(Continued from page 165)

pick aluminum screening so it will eventually weather to match the rest.

There's nothing to replacing screening in such windows should a ball be thrown through one. All you need is an inexpensive tool made for the purpose. It has a roller at each end, one for pushing the screening into the groove around the metal frame, the other for seating a spline which holds the screening in the groove. The spline is a gray vinyl tubing which comes in four different diameters. The tool costs about \$1, the spline about 50 cents for 25 ft. The screening is cut about 3/8-in. oversize all around, which amount is tucked into the groove. Once you have the spline in place along one side of the frame, pressing it into the groove on the opposite side will pull the screening taut. To remove the old wire, just grab the end of the spline and yank it out. ★★

SECRETS ENTRUSTED TO A FEW

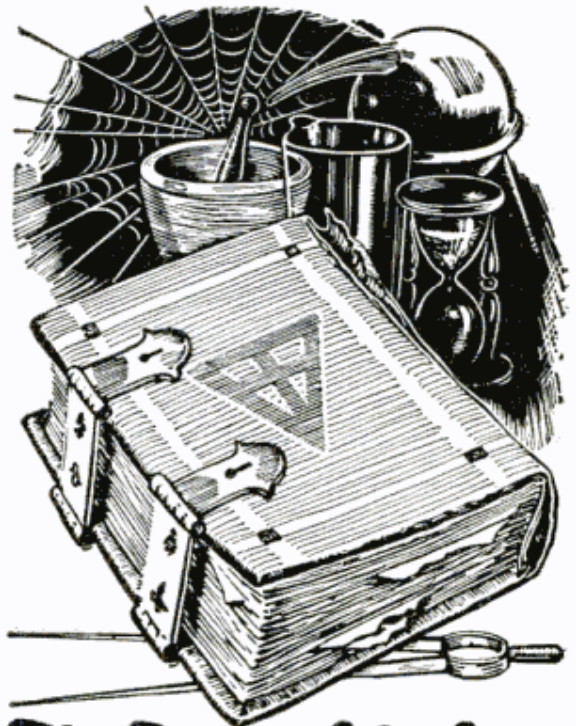

The Unpublished Facts of Life

THERE are some things that can not be generally told—*things you ought to know*. Great truths are dangerous to some—but factors for *personal power and accomplishment* in the hands of those who understand them. Behind the tales of the miracles and mysteries of the ancients, lie centuries of their secret probing into nature's laws—their amazing discoveries of *the hidden processes of man's mind, and the mastery of life's problems*. Once shrouded in mystery to avoid their destruction by mass fear and ignorance, these facts remain a useful heritage for the thousands of men and women who privately use them in their homes today.

THIS FREE BOOK

The Rosicrucians (not a religious organization), an age-old brotherhood of learning, have preserved this secret wisdom in their archives for centuries. *They now invite you to share the practical helpfulness of their teachings*. Write today for a free copy of the book, "The Mastery of Life." Within its pages may lie a new life of opportunity for you. Address Scribe D.T.G.

The ROSICRUCIANS

(AMORC)

San Jose

California 95114 U.S.A.

Please Include Your Zip Code



NOW...END BATTERY FAILURES *due to corrosion*

Sure Start Battery Kit: not a coating, but a fully vulcanized, *sealed jacket* for battery clamps and terminals. Protects new or used batteries. Auto, boat, aircraft. Easily applied; permanent, but strips cleanly if clamps need to be removed. (Pat. Pend.). In U.S.A. send \$1.88 plus 25¢ postage & handlg.

Energy Products Corp.
P. O. Box 1339, San Mateo, Calif. 94401
Enclosed find my \$2.13 for the
EPCO* Sure Start Battery Kit.

NAME _____

ADDRESS _____

CITY _____ STATE _____ ZIP _____

*Trademark

Unimat

Convertible precision lathe is vertical miller, drill press, surface grinder, polisher too! \$139.50, incl. motor & parts. Request free catalog, or send \$1 for 40 pg. detailed handbook.

AMERICAN EDELSTAAL, INC.
BF-9 / 350 Broadway / NYC 10013

Fox Mini Bike

DO IT YOURSELF
OR FULLY ASSEMBLED

FROM

\$79⁵⁰



12 MODELS
3 TO 5 HP

SEND \$1 FOR BIG CATALOG

Shows new 1969 line of the world's finest **MINI-BIKES** (most are licensable for street use), plus parts, accessories and plans. Big selection! Amazingly low prices! There's a Fox **MINI-BIKE** for everyone — from age 10 to adults.

EXTRA BONUS— Catalog shows radios, watches, walki-talkies, cameras, musical instruments, tools, appliances and many other items you can buy at practically wholesale prices. Free \$1 coupon.

FOX CORP., Box 797 PM Janesville, Wis. 53545

Don't change your address without notifying us!

To insure uninterrupted service on your **Popular Mechanics** subscription, please notify us at least six weeks before you move.

1. Attach your address label from a recent issue in the space provided below... (If label not available, be sure to give us your old address, including **Zip Code**)
2. Print your name and new address below (be sure to include your **Zip Code**).

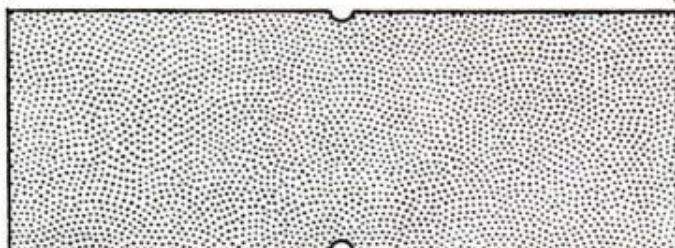

3. Mail entire notice to: **Subscription Service Dept.**
Box No. 646
New York, N. Y. 10019

Name _____

Please Print

New Address _____

City _____

State _____ Zip Code _____

SMALL BUSINESS MONEY

1000 Sources. \$500 to \$2 Million.
Business Capital, Loans, Grants,
Cash to start a Business.

WRITE TODAY
SEND NO MONEY
FREE DETAILS

NATIONAL COUNSELOR REPORTS
Div. 57E. Harlingen, Texas 78550

Tear Out & Mail. No Letter Needed

Free New Catalog 2000 Novelties

Send for world famous catalog of novelties, live animals, scientific supplies, hobbies, funmakers, planes & boats, looms, magic tricks, joke articles, unusual seeds, gadget timesavers, cameras, optical goods, projectors, movies, lucky jewelry, religious novelties, disguises, musical instruments, stamps, coins, puzzles, fortune tellers, radios, auto & bike accessories, telescopes, magnifiers, compasses, banks, smokers' gadgets, artists supplies, printing sets, engines, motors, shockers, knives, billfolds, fireworks, guns, rifles, sports, books, games, plants, etc. Send postcard or this ad. No letter needed!

CHECK YES—I want FREE Catalog. My Name & Address Attached or on Envelope

Johnson Smith Co., Dept. 513, Detroit, Mich. 48224



Exclusive Flex-O-Matic rear suspension automatically adjusts spring stiffness to loads.

Works like a truck. Rides like a car.

Know why more people pick Ford than any other pickup? Better ideas—like road-smoothing Twin-I-Beam suspension. Two forged steel I-beam axles give it strength, coil springs supply the easy going. Now add Ford's comfortable cab, roomiest of them all—the choice of smooth Sixes or V-8's big as 390 cu. in.—optional SelectAire conditioning, power front disc brakes. You have every reason to ride with Ford's better ideas. It's a smooth track all the way.



A better idea
for smooth riding:
Twin-I-Beam
Suspension—
only Ford has it!

That's why Ford's No.1. (by a comfortable margin)

Farm & Ranch, Contractor, Heavy-Duty and Camper Special models available.



FORD PICKUPS



“Me and my Winstons”

we got a real good thing...

***'cause my Winstons taste good
like a cigarette should.***