

Tips From a Trucker: How to Protect Yourself on the Road

POPULAR MECHANICS

MAY 1969
50 CENTS

Build This 4-Place Cabin Plane for \$3500

Page 112



INDIANAPOLIS PREVIEW:

Can the Eagles Do It Again?

How to Add a Screen
Porch

ON-THE-GO

CAMPING '69

 **SPECIAL
32-Page Keep-It
SECTION**

5 Easy-to- Make Garden Paths

Dan Gurney's Answers on Racing and Driving

THE REDWOODS: Exploring Our Newest National Park by Camper
10 Ways to Save Wear and Tear on Your House



When your fish runs, your Chrysler stays clear

Chrysler Lo-Profiles are perfect fishing companions—and there are eight to choose from. OBC-rated at 5, 7 and 9.9 hp.—all designed to sit low on the transom for over-the-stern fishing. They're completely portable, too. Below, you can see Chrysler's Depth-Minder Drive in action—just tilt the prop up and run in as little as 6 inches of water.

Weedless leg design prevents snags. As for power, there's our 9.9 pulling an adult skier. And the 9.9 Auto-lectric, with key-switch starting, even has a dome light for night fishing.

Let a Lo-Profile take *you* fishing. For the name of your nearest Chrysler Crew outboard dealer, call 800-243-1890. It's free. (In Connecticut, call collect: 325-4336.)

MARINE PRODUCTS



CHRYSLER
CORPORATION



Better boating begins with **CHRYSLER**

POPULAR MECHANICS

SPECIAL SECTION



- How to Handle 12 Camping Emergencies
- How to Camp Anywhere
- Pre-Trip Checkout
- What You Really Need in Camping Gear



ON-THE-GO

CAMPING

By DAN FALES, Outdoors Editor

'69



This One



60RU-H9Z-ZUOK

TEAR OUT along perforated line—keep in glove compartment



**Go where
standard
width tires
fear to tread.**

**Firestone
Wide Oval
truck tires.**

Wide Oval truck tires blaze new trails into the backwoods. Carry campers over ground where narrow tires bog down.

Up front, the Transport Wide Oval tire. Wide tread carries your camper through mush, gives a smooth, stable ride on the road. Out back, the Town & Country Wide Oval tire. Rugged tread takes hold. Gets you through.

Wide Oval truck tires. Sold and serviced by 60,000 Firestone Dealers and Stores nationwide.

Transport Wide  Oval, Town & Country Wide  Oval—
Firestone TMs. Transport® Town & Country®



The Town & Country Wide Oval truck tire—the drive-wheel tire for all-season traction.



The Transport Wide Oval truck tire—for all wheel positions. White walls available.



Firestone

DuPont announces the one fishing line that beats Stren.[®]

Improved Stren.



STREN* monofilament already had a unique blue fluorescent glow that made it easier for you to see, harder for fish to see.

STREN already had a great balance of high tensile strength, low stretch, limpness, impact and abrasion resistance and knot strength.

How do you beat a line like that?

We beat it by making STREN up to 50% stronger in basic knot strength. Now, even the simplest knot will be a stronger knot.

*Du Pont registered trademark.

Pick up improved STREN in a range of 2- to 40-lb. test at leading sporting-goods and tackle stores.

Improved STREN. Up to 50% higher basic knot strength.

When you hook 'em, we want you to hold 'em.

E. I. du Pont de Nemours & Co. (Inc.),
Plastics Department, Wilmington, Delaware 19898.

DU PONT STREN.[®]
REG. U.S. PAT. OFF.



Fleetside Pickup



Suburban



Sportvan



Chassis-Cab

Design Your Holiday Home at Your Chevrolet Dealer's.

The biggest choice of recreational vehicles is at your Chevrolet dealer's.

If you want a pickup camper, he'll suggest a Longhorn — designed specially for camper duty. He'll show you a variety of chassis-cabs. And the compact Sportvan — or a Suburban for cargo, people and

towing a camping trailer.

Pick your kind of Chevrolet and customize any way you please. Bucket seats. Air conditioning. Special auxiliary battery and much more. For just what you want, see your Chevrolet dealer. . . . Chevrolet Division of General Motors, Detroit, Michigan.



**Chevrolet is more truck
...day in, day out, day off!**

Don't Wait

for Father's Day... Buy yourself
a New Homelite® XL-102
Automatic chain saw

NOW!

The very next time your family watches you cut wood, it could be with your new Homelite XL-102 Automatic. This lightweight, powerful chain saw has automatic oiling – dependable crankshaft-driven oiler lubricates cutting chain, bar and sprocket; reduces wear and makes cutting easier than ever. Has separate manual oiler for extra lubrication.

Other important features: *Larger fuel*

tank for fewer refueling stops – *Rim-drive sprocket* provides smoother, more efficient power delivery from engine to cutting chain. – *Cutting power* to zip through a 15" hardwood log in 12 seconds, fell trees up to 4 feet thick.

Whether you cut firewood, fell trees, clear storm damage or cut rough lumber for do-it-yourself projects, you'll find the XL-102 Automatic does any job.



HOMELITE®

10205 RIVERDALE AVE., PORT CHESTER, N.Y.

Atextron
DIVISION



3,783 m.p.d.

with Gulfpride® Formula G! Mickey Thompson put his boot in it at Bonneville and blasted his Class C Mustang to a new world record: 3,783 miles in a day. He beat the old 24-hour record by 405 miles. His *average* was 157.633 m.p.h.—a big 17 m.p.h. faster. And he smashed more than 100 other records along the way.

There's only one oil for that kind of driving—Gulfpride Formula G.

It's gone through two years of the toughest kind of road racing without a single lubrication problem.

It's won the World Manufacturers Championship at Le Mans and the Can-Am series.

On track, dragstrip, or in the hottest engine Detroit puts under a hood, Formula G is the best protection against wear and overheating you can buy.

Buy it now from any Gulf dealer.



GULF OIL CO.—U.S.

POPULAR MECHANICS

The new Norelco. (Sorry, blades.)

You've probably noticed that blades have been trying to change.

They've been single-edged, double-edged, banded, injected, plastic-coated, and now even electro-coated.

We think it's because of us. And our new Norelco Triple-header.

It has round floating heads that follow your face. They go in and out as your face goes in and out. Without any pulls, nicks or cuts.

They give you a very comfortable, very close shave.

Close enough to shave you as close or closer than a blade in 2 out of 3 shaves. As found by an independent lab test.

And our Norelco has a new



hidden pop-out trimmer to let you see what you're trimming, and new push-button cleaning. It also comes in a rechargeable model that gives you almost twice as many shaves per charge as any other rechargeable.

Try the new Norelco. You won't be sorry.

Norelco®
you can't get any closer

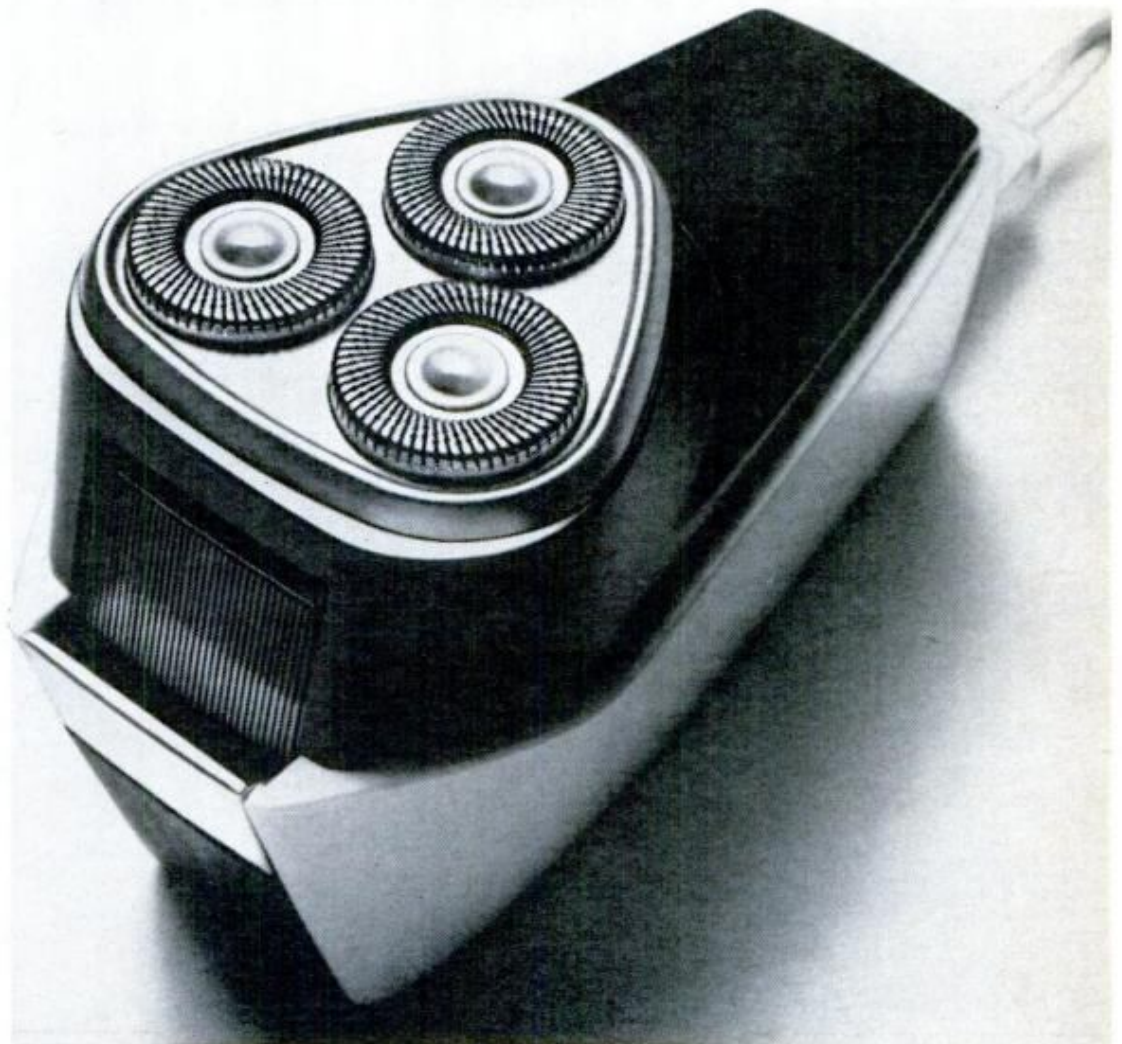

©1969 North American Philips Corporation, 100 East 42nd Street, New York, N.Y. 10017

POPULAR MECHANICS[®]

INTERNATIONAL EDITIONS: AUSTRALIA, BRAZIL, CARIBBEAN, DENMARK, FRANCE, MEXICO, SOUTHERN HEMISPHERE, SWEDEN

AUTOMOBILES AND DRIVING

- 10 Detroit Listening Post
- 24 Drivin' With Dan
- 74 Automobile Clinic
- 90 International's New Aristocrat
- 93 How You Look to a Truck Driver
- 102 PM Owners Report: Buick's Le Sabre
- 124 PM Tests a Rugged New Camper . . .
a Controversial New Park
- 132 Indianapolis Preview: Will the Eagles
Scream Again?
- 152 Saturday Mechanic: How to Check
Distributor Vacuum Advance

SHOP AND CRAFTS

- 156 Weekend Projects You Can Build
- 161 Hints From Readers
- 175 Hints From Readers
- 180 Hints From Readers
- 188 High-Speed Duplicating Machine
Makes You an Expert Woodcarver
- 190 New Tools You Should Know About
- 192 How to Choose and Use Small Vernier
Calipers
- 196 Hints From Readers

BOATING, OUTDOOR RECREATION

- 88 On-the-Go Camping
- 124 PM Tests a Rugged New Camper . . .
a Controversial New Park
- 138 New Camp Rigs for '69

PHOTOGRAPHY

- 148 Dry-Mount Your Favorite Photos
for Display
- 150 New in Photography

AEROSPACE, AVIATION, MILITARY

- 112 Build This New 4-Place Cabin Plane
for \$3500

ON-THE-GO CAMPING, '69

S1—Special 32-page tear-out section that tells you how to handle emergencies, how to camp anywhere, what gear you need, plus pretrip checkout. (*Inside the front cover.*)

HOME AND YARD

- 72 Homeowners' Clinic
- 142 They're Awful Mean to Those
Little Tractors!
- 156 Weekend Projects You Can Build
- 162 Handsome Garden Paths and Walkways
- 168 Exciting New Products
- 170 Solve the Patio Problem:
Add a Screened Porch
- 176 Save Wear and Tear on Your Home
- 181 Keep Trim With This Dual-Action
Exerciser
- 182 Solving Home Problems
- 184 6 Ways to Make Bad Water Good

SCIENCE AND INVENTIONS

- 20 Science Worldwide
- 98 Those Fast New Trains in U.S. and
Canada . . . They'd Never Make It
in Japan!
- 108 Just Patented
- 118 How to Build a Whale
- 120 New Tools for Mending Hearts
- 128 From Florida to Cape Cod—
Without Moving

ELECTRONICS, RADIO AND TV

- 146 Simple Checker for Semiconductors

REGULAR FEATURES

- 6 Letters

Cover Photo by Don Pratt

The BD-4, a four-place cabin plane you can build for \$3500.

NEXT MONTH IN POPULAR MECHANICS

The 1970 Cars: How New Will They Really Be? A sneak preview with photos.
Build PM's '\$100' Jogger for \$30. Keep fit at home or in the office.
Can-Am—the New Big League in Auto Racing. Special report by Dan Gurney.
The Night Jocko Clark Broke the Blackout: A great World War II painting.

ROBERT P. CROSSLEY

Editor

JAMES M. LISTON

Executive Editor

JOHN A. LINKLETTER

Managing Editor

WAYNE C. LECKEY

Home and Shop
Editor

SHELDON M. GALLAGER

Assistant Executive
Editor

THOMAS G. DAUER

Art Director

Published by The Hearst Corporation

RICHARD E. BERLIN, PRESIDENT

RICHARD E. DEEMS

President, Magazines Division

JOSEPH F. KERN

Publisher

WILLIAM KILPATRICK _____ Automotive
DANIEL C. FALES _____ Boating and Outdoors
SHELDON GALLAGER _____ Electronics and Photography
JOHN F. PEARSON _____ Science
BILL HARTFORD _____ Associate Automotive
LEONARD E. SABAL _____ Home Workshop
GARRY WINTER _____ Copy and Production
RICHARD H. FUNK _____ Associate Copy and Production
JOHN ADKINS _____ Assistant Copy and Production
ALVIN KIETZ _____ Assistant Art Director
DON EVANS _____ Assistant Art Director
FRED A. LEERS _____ Assistant Art Director
GEORGE W. BLOW _____ Technical Art Director
CLIFFORD B. HICKS _____ Special Projects
SOPHIE GRONOWICZ _____ Director, Bureau of Information
EVERETT JOHNSON _____ Cabinetmaker

ADDRESS ALL EDITORIAL COMMUNICATIONS TO: 575 Lexington Ave., New York, N.Y. 10022. For additional sources of information on the articles and products in this issue, write to Bureau of Information, Popular Mechanics, for free "Where-to-Find-It" list.

DANIEL J. COLEMAN

Director of Advertising

ADVERTISING OFFICES: New York: 575 Lexington Ave., Murray Hill 8-8500; Chicago: 520 N. Michigan Ave., 527-2400; Detroit: General Motors Bldg., TRinity 5-8711; Cleveland: Hanna Bldg., 1422 Euclid Ave., PRospect 1-0456; Los Angeles: 601 North Vermont Ave., 666-6263; San Francisco: 1101 Hearst Bldg., YUkon 2-0823.

SUBSCRIPTION SERVICE: Mail all subscription orders, changes of address, correspondence concerning subscriptions, and Postmaster notices of undeliverable copies to Popular Mechanics, Box 646, New York, N.Y. 10019. Please enclose your latest address label for quickest service when writing about your subscription.

POPULAR MECHANICS IS PUBLISHED MONTHLY by The Hearst Corporation, 57th St. at 8th Ave., New York, N.Y. 10019, U.S.A. Richard E. Berlin, President; George Hearst, V-Pres.; Richard E. Deems, President of Magazines; John R. Miller, Executive V-Pres. of Magazines; Raymond J. Petersen, Senior V-Pres. of Magazines; William S. Campbell, V-Pres. of Magazines; Albert A. Rachol, V-Pres. and Director of Circulation; Joseph F. Kern, V-Pres. for Popular Mechanics; Frank Massi, Executive V-Pres. and Treasurer; Harvey L. Lipton, Secy. Single copy in the United States and Canada, 50 cents; Subscription prices: United States and Possessions, \$4.00 for one year; \$7.00 for two years; \$10.00 for three years. Canada, add \$0.75 for each year. Pan American Postal Union countries, add \$1.00 for each year. All other countries, add \$2.00 for each year. When changing address, give old address as well as the new, with postal-zone number, if any, and allow six weeks for change to become effective. Second-class postage paid at New York, N.Y., and at additional mailing offices. Authorized as second-class mail by the Post Office Department, Ottawa, and for payment of postage in cash. Registered as second-class matter at the Post Office at Mexico D.F., Mexico, June 20, 1950. © 1969 by The Hearst Corporation. All rights reserved. Printed in U.S.A.

MAY 1969

*Offer valid only where legal—for a limited time only



86 PROOF • EARLY TIMES DISTILLERY CO., LOUISVILLE, KY. © ETDC 1969

I thought I saw a Pussycat

You did. You did. The Pussycat is a delightful new orange-sweet sour that mixes up about as quick as a cat. This national prize winning drink can be made with a packet of "Instant Pussycat Mix," water and Early Times. Have some fun with The Pussycat. It's playful.



To get a set of 4-10½ oz. Pussycat glasses and 4 packets of Instant Pussycat Mix, send \$2.95 to:
EARLY TIMES PUSSYCAT GLASSES
P. O. BOX 377, MAPLE PLAIN, MINNESOTA 55359

5

If your wife says she
doesn't go for the
great autumn day
aroma of Field
& Stream...

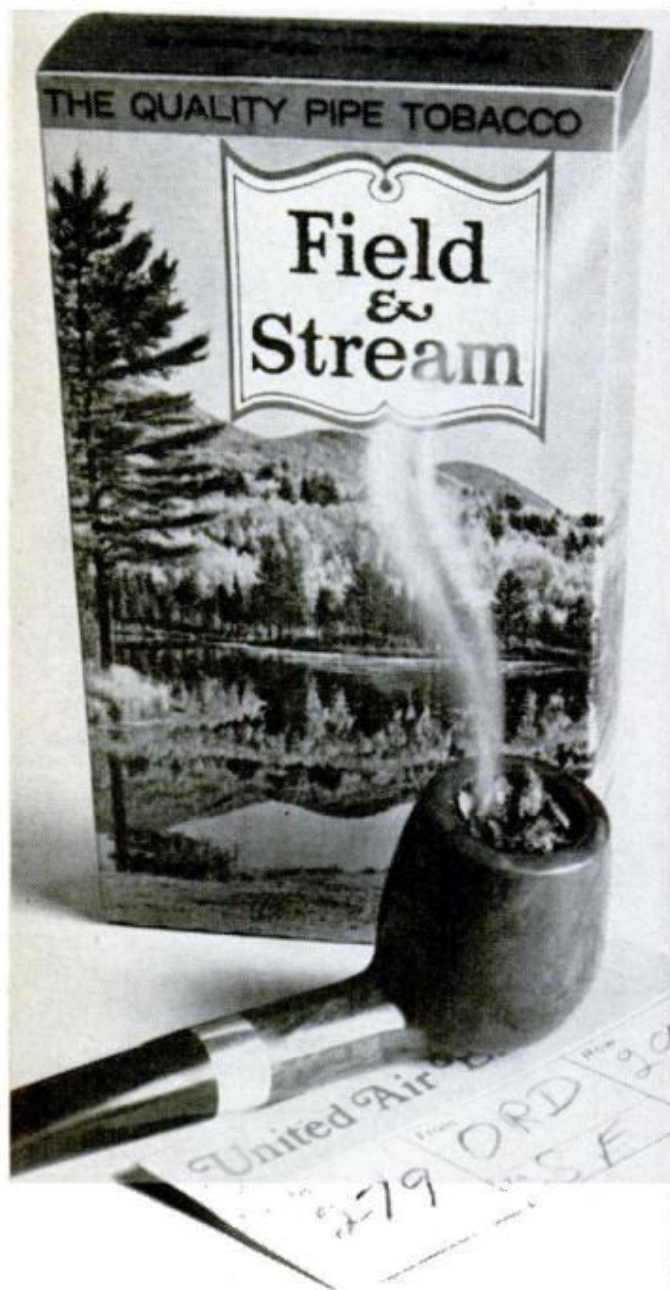

send her
home to
Mother.

A quality product of Philip Morris U.S.A.

LETTERS

TO THE EDITOR

Better prepared for tornadoes

As Boone County Civil Defense Director, I found *Now You Can 'See' Tornadoes on TV* (page 93, March PM) of extreme interest.

On April 21, 1967, the city of Belvidere was hit by a tornado. Of the 24 people killed, 22 were school children. Scores of others were injured.

The tornado season is again approaching. I feel that the information in this article would be of great interest to the people of this area. I am sure that the residents could be better prepared in the event of another tornado.

I am asking permission to reprint the article for distribution at no cost to the residents of the area.

BELVIDERE, ILL.

CHARLES E. GRAVES

In our safety promotion effort here at NASA/MSFC/Michoud Assembly Facility, we are always alert to new and timely topics of interest and distribute such information to our employees.

Your permission to reprint this excellent article for our employees will be greatly appreciated.

NASA MICHOU D ASSEMBLY FACILITY
NEW ORLEANS, LA.

W.W. MOORE
SAFETY OFFICER

Permission granted.

Anyone for wild boating?

Come on now! Your *The Wildest Boat Trip in the World* (page 122, March PM) tells it like it is, and the pictures are good—but wooden boats have been carrying paying passengers through Grand Canyon since 1938. They still are; I've been running them for the last 12 years. This summer we're using them to retrace all of Major Powell's 1869 route from Wyoming to Nevada.

Martin Litton and I are the only wooden boat holdouts in an otherwise pontoon activity, but he sometimes forgets I'm around. Please tell your audience that I am.

MEXICAN HAT, UTAH
MEXICAN HAT EXPEDITIONS

Okay, we've told 'em—and now everybody who is anybody (that's our audience) knows you're there in Mexican Hat.

Those were the good old days

I'm an old-time auto nut, and I enjoyed

(Please turn to page 8)

"Look who's smiling now!"

"The department head's job had just been left vacant. When the boys in the office learned I was gunning for it, they gave me their widest grins. One thing they didn't know: I had made up my mind sometime back to take LaSalle training that would prepare me for a better job. My study paid off so fast it surprised even me—I was picked for that shiny promotion over everyone's head. Who wouldn't be smiling with a neat new \$1,500 increase!"

LA SALLE'S files are filled with letters from graduates who have rapidly climbed the ladder of success. You, too, can qualify for the job opportunity of your choice through LaSalle home study—without interfering with your present work—and by devoting only a little of your spare time.

LaSalle has been leader in home education for more than half a century and has enrolled more than 1,000,000 ambitious men and women. Its faculty includes some of the country's foremost practicing specialists and instructors. Your training is in good, experienced hands.

Mailing the LaSalle coupon below may be the first step in getting a better job, higher pay, and all of the good things that go with success. Simply check the program in which you are most interested, and we will send you a valuable free booklet describing the opportunities in that field. Mail to LaSalle, 417 Dearborn, Chicago, Illinois 60605.

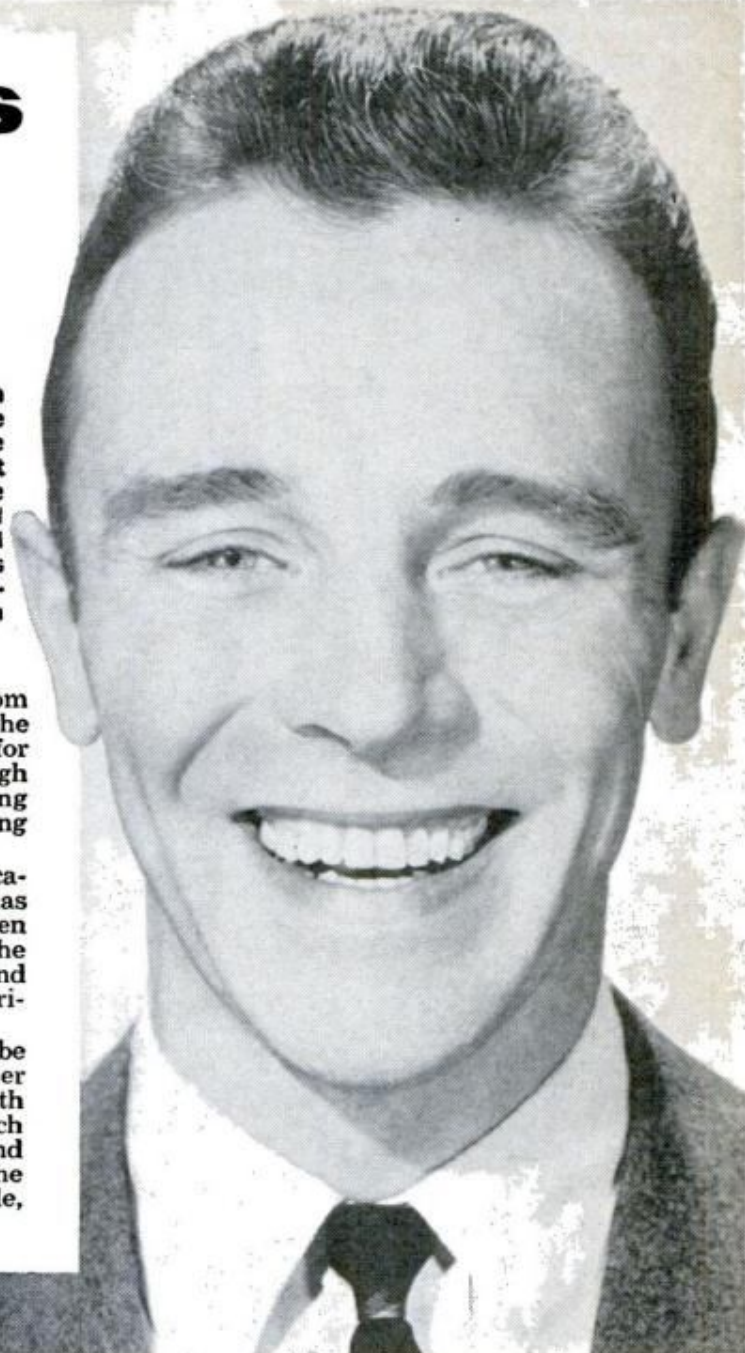

LA SALLE EXTENSION UNIVERSITY

A Correspondence Institution • 417 South Dearborn, Dept. 89-080, Chicago, Illinois 60605

Please send me, without cost or obligation, FREE booklet and full information on the field I have checked below:

ACCOUNTING

- Complete Accounting
- Income Tax
- Accounting Fundamentals
- CPA Training
- Modern Bookkeeping

BUSINESS MANAGEMENT

- Complete Business Management
- Credit and Collections
- Office Management
- Personnel Management
- Sales Management

REAL ESTATE

- Complete Real Estate
- Real Estate Brokerage
- Real Estate Management

Interested in a career not listed? Write here: _____

COMPUTER PROGRAMMING

- Complete Training

LAW COURSES

- Bachelor of Laws Degree
- Business Law
- Insurance Law
- Claim Adjusting Law
- Law for Police Officers

STENOTYPE

- Machine Shorthand

TECHNICAL COURSES

- Air Conditioning, Refrigeration, Heating
- Diesel

TRAFFIC & TRANSPORTATION

- Complete Traffic Mgt. Truck, Air, Rail, Sea

DRAFTING

- Complete Drafting

INTERIOR DECORATION

- Professional Training

ART TRAINING

- Commercial Art
- Oil, Water Color Painting
- Complete Training

HIGH SCHOOL

- High School Diploma

LANGUAGE INSTRUCTION

- French
- Spanish

MUSIC INSTRUCTION

- Piano
- Guitar
- Other: _____

CAREERS FOR WOMEN

- Accounting
- Bookkeeping
- Commercial Art
- Computer Programming
- Dental Assistant
- Interior Decorator
- Real Estate
- Secretarial
- Stenotype

Name Age Apt. No.
Please print carefully

Address County

City & State Zip No.

Occupation Working Hours A.M. P.M.

A pruner without a Nicholson blade



is like a wrench without a jaw.

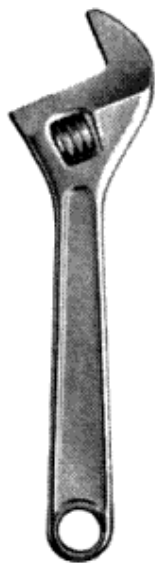

Tree pruning is free-and easy when you use any Nicholson pruning saw with Dupont Teflon-S® coating on the blade.

You nip through the greenest branches without binding. You zip through years of pruning without rust problems. Also available in bright silver-steel finish.

There's never a dull moment with

Nicholson

Nicholson File Co., Providence, R.I.



LETTERS

(Continued from page 6)

John Bentley's article, *So What Else Is New?* (page 114, Feb. PM).

I note a minor error—that Cadillac brought out its V8 engine in 1916. The 1914 Cadillac was the first to have a V8 engine; I remember it well.

I learned to drive in my father's 1911 Cadillac. Each of the four cylinders on its 30-hp motor was cast separately and had a copper water jacket. Kettering put his first electric starter on this model to try it out, and the starter was standard equipment on all 1912 Cadillacs. The 1913 Cadillac had a two-speed rear axle, but this had been patented by someone who sued General Motors and won because of their using this axle.

Many thanks to *Popular Mechanics* for helping make my retirement enjoyable.
LEXINGTON, KY. DON B. HARDING, MD

I can remember some of the old things they called autos. They may have had a lot of gadgets then, but the catch was they didn't work.

MANSFIELD, OHIO C. B. BRUMELLE

It's okay, girls

I know *PM* isn't exactly a woman's magazine, but I just had to comment on one article. *How to Spot a Bad House That Looks Good* (page 144, Feb. PM) was very helpful. Shall tear it out and save it for when I do buy a house.

Congratulations on a needed publication!
PEORIA, ILL. JACKI LEWIS

It's okay for girls to read PM. In fact, we even encourage it if you promise not to tear it up before your husband reads it. Otherwise, you foul up all our readership statistics.

Give us an inch . . .

I was amazed that the engines of *Those Small Sporty Sedans* (page 106, Jan. PM) with displacements of from 87.75 cubic feet to 121.4 cubic feet (see chart, page 109) should develop so little horsepower. I should think such burly motors would be real bombs!

NEW ALBANY, IND. W. H. McALLISTER

We bombed that time. A foot in the mouth, so to speak. And while we're wearing the uncomfortable hair shirt, we'll confess that in the April PM we said in Build PM's 'Ground Hugger' (page 192) that the bike has a 90-inch frame. That's really the overall length of the bike. The frame itself is only 64 inches long.

★★★

take a giant step forward.

In college, take the step that puts you out in front. Take Army ROTC. Gives you a running start on whatever you decide to do. In the Army. Or in a civilian career.

Why? Simply because ROTC is a course in leadership. Broadens judgment. Builds acceptance for responsibility and develops maturity. You learn to motivate others, take charge of situations. When you graduate, you can fulfill your military obligation as an officer. You've taken command of your future . . . before someone else does it for you.

Maybe you won't care to make the Army your career. Even so, you'll still come out ahead. With ROTC training and the leadership and management experience you have as an Army officer, you'll be able to offer assets many employers pay extra to get. And it all starts with that first day in Army ROTC.

Take command of your future . . . take Army ROTC.

Army ROTC
P.O. Box 12703
Philadelphia, Pa. 19134
PM 5-69
Tell me how Army ROTC
can put me out in front,
in college, in the Army,
or in a civilian career.

Name _____ Age _____
Address _____
City _____ Zip _____
State _____

DETROIT LISTENING POST

BY BILL KILPATRICK

MID-ENGINE CARS are more than mere exercises on design boards. Ford is said to have one ready for its 1971 model line-up—a sporty two-seater reminiscent of the Le Mans-winning GT-40. Car reportedly will feature a radically new engine, details of which include a new metal mix stressing high aluminum content, pistons in a novel arrangement, mounting at a 45°-plus angle.

American Motors recently sent out photos of a sporty mid-engine prototype tabbed “a design study car.” Don’t believe it; if the “ohs” and “ahs” of auto-show audiences and others who see the car have the proper ring (i.e., they sound like money panting to be spent), AMC has a “go” button ready to be pushed. Car could bow as a ’71 or ’72.

Chrysler and GM also have mid-engine designs in the works, are said to be looking towards ’72 or ’73. In any event, the concept seems the way to go for sporty cars in the 1970s.

A MAJOR BATTLE is shaping up between automakers and oil companies, the big issue at stake being just who, and to what extent, is going to invest the millions necessary to bring about dramatic reductions of car-caused air pollution. The auto companies claim great strides in air pollution reduction could be brought about with the marketing of low-volatility gasoline. But the oil companies say more efficient engine design and antismog add-ons by automakers is the way to go. Both are right, yet both are reluctant to go bucks-up for the necessary engineering and production-line changes, or changeover of present refining processes. Squabble could get noisy as sides trade “holier than thou” allegations. Then both will express “shock, surprise” when Big Daddy (the government) steps in and tells ’em what they’re going to have to do.

FIRST UNITS of Dodge’s new Challenger are due off the production line this month. The car, a GT-ish affair with pronounced European accents, will bow with the early fall introduction of the 1970 models, will be aimed at the upper range of the Mustang/Camaro/Firebird market. Car is Chrysler’s “about time” answer to the Mustang, will have to fight to first grab and then maintain a foothold in an admittedly highly competitive market arena. Some observers say car is too little, too late, others that it’s an eye-popper certain to attract buyer attention, carve a market niche for itself.

DRIVING WITH YOUR PARKING LIGHTS ON could considerably enhance your overall driving safety. A recent test involving vehicles operated by the Port of New York Authority indicated that running with the parking lights *on* seemingly reduced accidents, particularly rear-end collisions. Not only that, but what accidents *did* occur were less severe than those befalling the Authority’s unlighted vehicles. Louis Bender, Authority traffic engineering chief, said he thought the experiment proved existing cars need better daylight definition, particularly when—as in a major metropolitan area—vehicle colors can blend easily into the background. Bender also said he thought running with parking lights on improved the depth perception of other motorists. Upshot of the test is that the Authority is modifying all its vehicles so that parking lights will go on whenever the ignition is turned on.

During a recent trip to Sweden, in the course of which we drove many miles over both major and minor roads, we noted the Swedes tend to run with their parking lights on, something we found a positive aid to our driving in that it increased our awareness of other vehicles on the road, made it easier to determine suitable distances between ourselves, others.

A NEW IDEA IN TIRES is being marketed by Uniroyal—tires designed differently
(Please turn to page 14)

More power for the money with new Skilsaw Chain Saws

Up to 25% more power to get the job done faster. Pretty nice thing to have when you're cutting firewood. Or trimming limbs. Or clearing land. After all, how much time do you want to spend on woodcutting chores? Make it short. Get a new gasoline-powered Skilsaw Chain Saw with up to 25% more power. At the same price you'd pay for saws that work slower.



FREE
accessory kit, too!

Chain guard, file, work gloves, gasoline can, wedge, special lubricant—almost \$15 worth of accessories. All free with the new, more powerful Skilsaw Chain Saw. It's another good reason to see your Skil dealer soon.



SKIL[®]
*makes it
easy*

Goodyear introduces tire for pickups

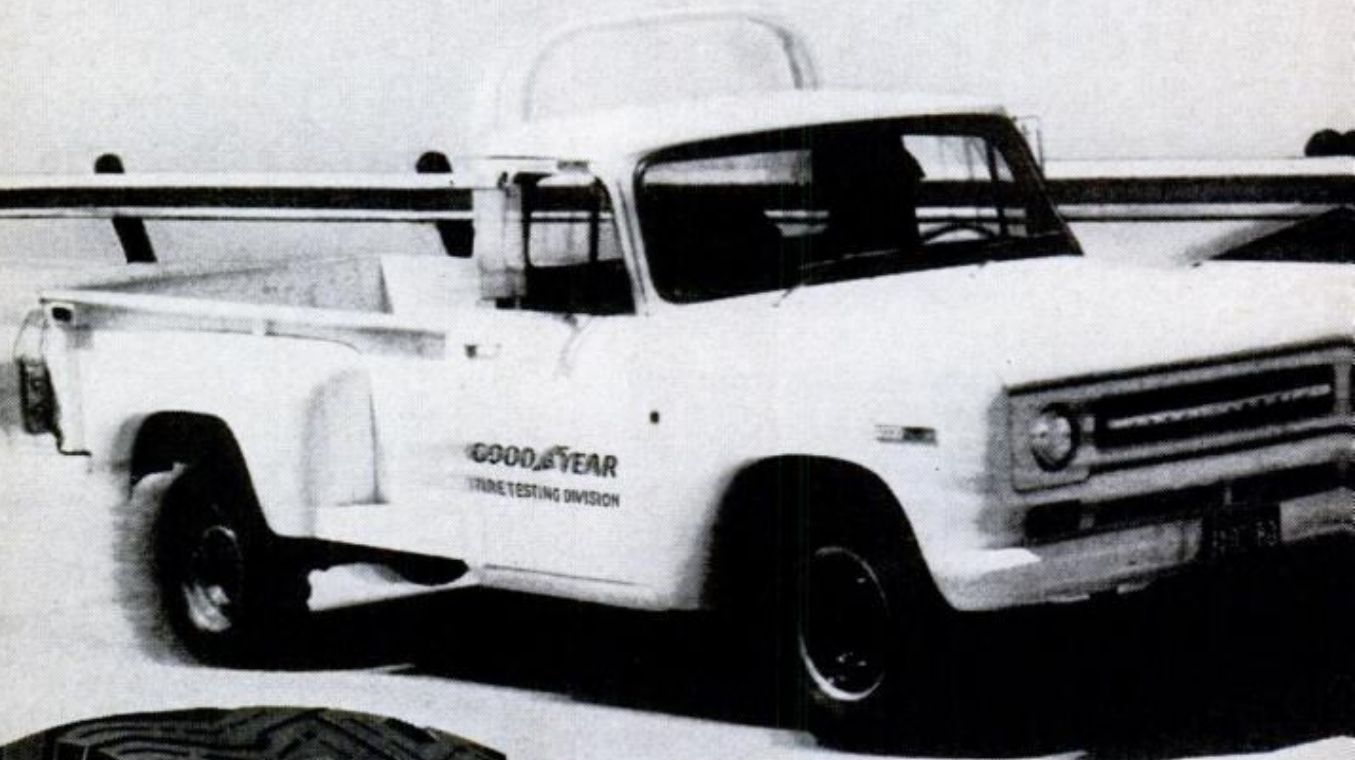

We gave it the name Custom Xtra Grip—Wide Tred. It earned the “high-performance” tag for itself...in this endurance run at Goodyear’s San Angelo test track.

a high-performance and panels



What does "high-performance" mean?

It means enough strength to run 4000 miles at 85 mph with an overload of up to 15%.

Something you wouldn't normally do in your own pickup.

But we did it to test the new Custom Xtra Grip—Wide Tred* at the Goodyear proving ground in San Angelo, Texas.

It has a wider, flatter tread designed to

wear longer. 56 deep cleats designed to claw their way through mud and snow. And a nylon tire body that shrugs off bruises and bumps.

That's what high-performance is built on.

You demand high-performance from your pickup, now get it from your tires, too.

Ask for the Custom Xtra Grip—Wide Tred at your Goodyear Dealer or Goodyear Service Store.

*8.00-16.5 size

GOODYEAR

If you change your oil every 6,000 miles, we have bad news for you.

At three or four thousand miles, if you drive like most people, your engine has made more sludge than the detergent in the oil can handle.

So instead of going into the oil filter, the stuff starts to settle inside your engine. You could change your oil sooner.

Or you could put in a can of CD-2 for low mileage cars. Add it when the oil's changed. Or at 3,000 miles, if you'd rather.

This CD-2 is a concentrated detergent, not a thick "additive." It'll keep your engine clean, like a new one.

So it'll act like a new one longer.

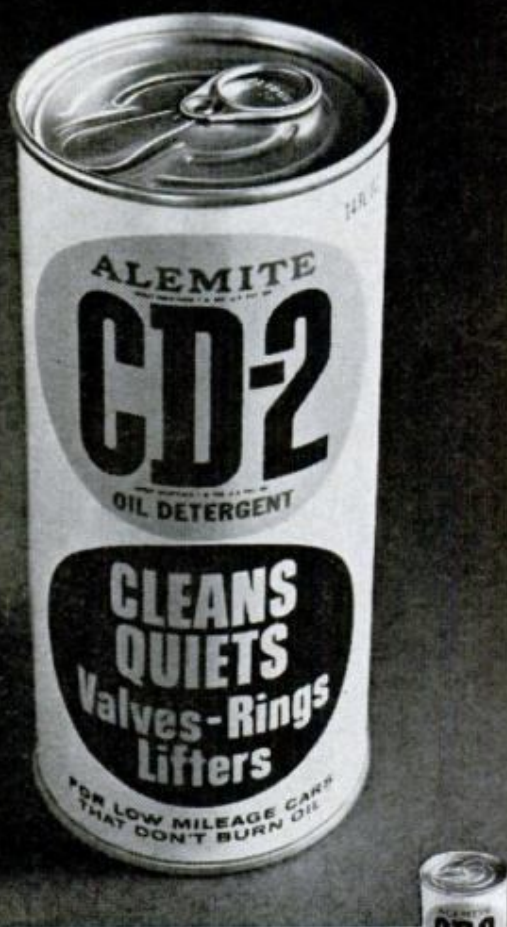

The other CD-2. We also make a CD-2 that stops oil burning in older cars. So be sure and get the right one. It may be confusing, but one kind couldn't do both jobs.



DETROIT LISTENING POST

(Continued from page 10)

and specifically for the front and rear wheel of the same car. Called Uniroyal Masters, the tires are designed to perform different functions—the fronts to steer, the rears to propel the car. The uniform-tread front tires are the new 78 series (left in photo), nearly one inch wider than conventional boots. The rear tires are the lower, wider series 70 shape (right)—almost two inches wider than conventional tires—and feature an asymmetrical tread. On the inside of the rear tire tread



are three rows of a special high-traction lug design, on the outside five rows of regular all-weather rib pattern. Uniroyal says the tread wear of the matched sets is so good it's offering Masters with a 40,000-mile guarantee.

What do you do with, say, a Toronado? You put front Masters all around.

NEW TRAFFIC HAZARD SIMULATOR is being championed in the U.S. by Renault. Designed and developed by California Automotive Research, of Newport Beach, the new device features three pylon-defined traffic lanes, each monitored by a conventional red/yellow/green traffic light. When an approaching driver crosses a trip line, a predetermined light pattern flashes to simulate unexpected hazards, indicate an escape route. For example, one lane may flash red, one yellow, one green. Driving down the red lane is the equivalent of hitting an obstacle head-on, the yellow lane dangerous, the green lane safe. Should all three lanes flash red, a driver is required to come to a complete stop before reaching the front line of pylons. Purpose of the device, which can be set up in big parking lots, drag strips—any wide stretch of road—is to test and improve driver reaction time to unexpected, yet typical, traffic situations. ★★

START YOUR NEW CAREER NOW! WITHOUT OVERHEAD! ANY PLACE! ANY AGE!

UPHOLSTERING JUST ONE

you don't even have to quit your present job!!!

CHAIR can pay you as much as your present weekly paycheck!

Start learning now. At home, or in the garage, in your spare time — no outside classes to attend. If you can tie a knot and drive a tack, you can learn this business, quickly, easily. You start learning the basics right away through the proven MUI Home Training Plan. And before you're barely into it, you can start doing the simple upholstering jobs that are all around you waiting to be done. Chairs, cushions, seats, footstools. Even before MUI students finish their training, people start bringing upholstering jobs to them, and remember—the world is full of furniture that needs fixing and re-upholstering and more is wearing out all the time!



"What started as a hobby, now pays me \$10 an hour"

Yes, many MUI graduates make better than \$10 an hour turning old wornout furniture into bright new decorator pieces! Stack it up against what you're doing now! Are you making \$150 a week? \$200? \$250? Do you put in long hours of dull work, with small raises? Is that the way you want to spend the rest of your life? Just imagine, you can make \$150, \$200, \$250 upholstering just one chair or sofa these days! And if you're the kind of person who likes to work and earn, you can sometimes finish a job like this in a day. That's pay, ... and it beats what most college graduates make!

AS YOU LEARN, YOU JUST SLIP INTO THE IMMENSE FLOW OF UPHOLSTERY WORK! Think of all there is! . . . Sofas, lounging chairs finished in beautiful fabrics, which MUI tells you how to get at the right price — even leather and all the new vinyls. And then you have built-ins and breakfast nooks, boats, trailers and all the millions of automobiles in America. Yes, you learn all this and more! When we finish teaching you, (in your own home in your spare time) and when you get our California state approved diploma, you know this business . . . as a real professional! You will then have one of the most fantastic moneymaking skills in America built into your head and hands! No one can ever take this skill away from you . . . and no one can ever fire you, because you're the boss of a business that you can take with you . . . You can make big money from then on . . . any time, anyplace you want to put out your shingle!

When you read the papers you see there's a strike here, a lockout there, Detroit lays off 150,000 men. A plant is shut down and moved out of state. A new automated machine eliminates 5,000 jobs. They talk about dislocated workers and try to do something about it. What pays the bills if you get caught up in one of these situations? When you know upholstering, life gets very simple and lots of fun. It's simple because where there are people, there are upholstering jobs and lots of them. It's fun because life is fun when the bills are paid and there's money in the bank, even enough to buy those things you've always wanted for yourself.



YOU GET SIX BIG FURNITURE KITS FREE



YOU GET THIS AUTHORIZED DIPLOMA WHEN YOU GRADUATE

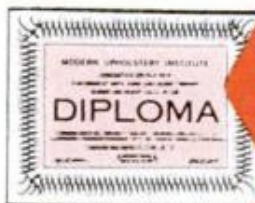

MUI IS APPROVED BY THE CALIFORNIA SUPER-INTENDENT OF PUBLIC INSTRUCTION AND IS AUTHORIZED TO ISSUE A DIPLOMA IN UPHOLSTERY.

MODERN UPHOLSTERY INSTITUTE
Box 899-BTC, Orange, Calif. 92669

WORK THE HOURS YOU LIKE TO WORK!!

If you favor a regular 35 hours a week, upholstery lets you do it and make a really fine living. On the other hand, if you're really ambitious and want to work 60 or 70 hours a week, you are starting to talk about some big, big money! The important thing is that the choice is yours, not somebody else's! (Not like when you're working for someone else.) Many students of retirement age just do a few pieces now and then just to keep things nice and comfortable.

TO GET STARTED, JUST GET THE COUPON IN THE MAIL . . . TODAY!

It costs you nothing to get the information and there's no obligation. No salesman is going to call you. This much and this much only, every successful MUI graduate must do for himself — send the coupon today!

YOU'LL GET A BIG ILLUSTRATED 32 PAGE BOOK ON UPHOLSTERY

and the upholstery business, and an actual free sample lesson showing how the fabulously successful MUI system is taught. For your sake and the sake of your future, do it now. Cut out the coupon, fill it out, put it in an envelope and mail it now. Air mail reaches MUI about two days sooner!

ALL THE SPECIAL "TOOLS OF THE TRADE" ARE YOURS . . . FREE

THIS FREE UPHOLSTERY BOOK may be the most important information you ever read.

MAIL COUPON NOW!

MODERN UPHOLSTERY INSTITUTE, Box 899-BTC Orange, Calif. 92669

Please send the FREE UPHOLSTERY CAREER BOOK, the FREE SAMPLE LESSON. I understand I am under no obligation whatever and am just sending for the free facts on job and career opportunities in Upholstering and the MUI home training program. I understand that no salesman will call.



APPROVED FOR VETERANS

Name _____ Age _____
Address _____
City _____ State _____ Zip _____

If you like to work on cars, why not get paid for it?

Home study training makes the difference between a hobby and a big money job. Trained auto mechanics are in greater demand than ever before. And when you're in demand, you do the choosing. You choose where you work and what you work on.

You can have the same choice. Our program lets you prepare to become a mechanic at home, in your spare time. This program gets you ready for the big money. Write today.

ITT Technical Institute

1340 S. Michigan Avenue, Chicago, Ill. 60650 • Dept. 163-59

Please send FREE information on your program for Automotive Training.

Name _____ Age _____

Address _____ Married Single

City _____ State _____ Zip _____

ITT TECHNICAL INSTITUTE

An educational service of International Telephone & Telegraph Corporation



UNVEIL hidden beauty



A fine veil of varnish or paint can hide the beauty of superb carvings on old furniture or antiques. Savogran's H₂OFF water rinsing paint remover does a thorough but gentle job of stripping away unsightly finishes... restoring wooden pieces to their natural state without damaging decorations or beautifully grained wood.



"AVAILABLE WHERE PAINT IS SOLD"

SAVOGRAN

NORWOOD, MASSACHUSETTS 02062

ARROW AUTOMATIC T-50 STAPLE GUN TACKER

SHOOTS A STAPLE WHEREVER YOU'D DRIVE A NAIL!
Faster .. Easier .. Better!

HEAVY DUTY Model T-50

Powerful automatic gun tacking tool for ceiling tile, insulation, screening, upholstery, roofing—1001 professional home fix-it & improvement fastening jobs.



Uses 6 staple sizes:
1/4", 5/16", 3/8", 1/2", 9/16" and CEILTILE.

ARROW LIMITED TIME SPRING SPECIALS!

\$7.70 VALUE Only \$5.95

Includes JT-21C Light Duty GUN TACKER and JT-21 Screen/Wire Attachment
YOU SAVE \$1.75



\$14.95 VALUE Only \$12.95

Includes T-50 Heavy Duty GUN TACKER with Stretcher and Wiring Attachments
YOU SAVE \$2.00



At Hardware, Building Supply, Variety, and other retail outlets.

ARROW FASTENER COMPANY, INC.

271 Mayhill Street, Saddle Brook, N. J. 07663

locksmithing and key making

PRACTICAL UP-TO-DATE COURSE — ONLY \$6.95

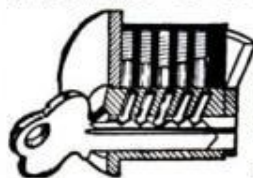

Teaches you how to pick locks, de-code, make master keys, repair, install, service, etc. New self-instruction lessons for every handyman, homeowner, carpenter, mechanic, service station operator, fix-it shop, hardware dealer, gunsmith. 53 easy illustrated lessons. Full price only \$6.95, post-paid. Satisfaction or refund guaranteed. Mail order today!

NELSON-HALL CO., Dept. ER-2
325 W. Jackson Blvd., Chicago 60606

LEARN

ELECTRONICS

MAIL COUPON FOR FREE BOOK

Coyne Electronics Institute Dept. 59-C3
1501 W. Congress Pkwy., Chicago, Ill. 60607

Send Information as checked below

- HOME TRAINING in TV, Radio and Color TV Servicing.
- RESIDENT SCHOOL COURSES in Electronics, Electricity, Engineering Technology, Television, Refrigeration, and Air Conditioning.

Name Age

Address

City State Zip

APPROVED FOR VETERANS

Accredited Member: National Association Trade and Technical Schools.



WHERE DO YOU GO FROM HERE?



Cars are your way of life. You've built 'em from the ground up. You know how to get that last horse.

All right. Where do you go from here?

Do you want your own service shop? Maybe you'd like to be sitting in Detroit designing the cars of tomorrow. Or, you want to be an automotive or aeronautical engineer.

Wishing won't make it so.

These jobs take special training. You have to know the mathematics behind the mechanics, the geometry of design, the structure of a successful business.

How do you get this training?

You can do it through the success-proven I.C.S. method of home study.

I.C.S. Courses are prepared by automotive and mechanical experts, who know what you need to know to go places. Everything you learn you can use to win quick recognition and climb to better jobs.

You study at home in your spare time. Your lessons are job related—packed with exciting new facts and ideas. Personalized guidance helps you through each step. Chances are, by the time you earn the coveted I.C.S. Diploma, you'll be well on your way to the life you want.

If you know where you want to go from here, your first step is to send coupon for free I.C.S. Career Kit.

ICS[®] International Correspondence Schools Division of Intext

ICS, Scranton, Pa. 18515
Canadian residents use this address for service from ICS Canadian, Ltd. In Hawaii: P.O. Box 418, Honolulu.

Take your first step . . . mail this coupon today . . . ICS, Scranton, Pa. 18515.

I'm interested in a program of independent study. Send me your free 3-booklet Success Kit: (1) "How to Succeed," 30 pages of valuable job tips, (2) Sample text demonstrating famous ICS method, (3) Catalog for subject checked below . . .

Miss _____
Mrs. _____
Mr. (Please print) _____ Age _____

Address _____

City _____ State _____ Zip Code _____

Occupation _____ Employed by _____ Working Hours _____ A.M. to _____ P.M.

ACCOUNTING

- Accounting (U.S. or Can.)
- Cost Accounting
- General Accounting
- Practical Accounting
- Public Accounting

ARCHITECTURE and BUILDING TRADES

- Air Conditioning
- Air Conditioning Maint.
- Architecture
- Arch. Drawing & Design
- Building Contractor
- Carpenter-Builder
- Carpentry & Millwork
- Heating & Air Conditioning with Drawing
- House Planning, Int. Design
- Plumbing
- Plumbing & Heating
- Reading Arch. Blueprints
- Refrigeration

ART and DESIGN

- Commercial Art
- Commercial Cartooning

- Interior Decorating
- Sign Painting & Design
- Sketching & Painting

AUTOMOTIVE

- Auto Body Rebuilding & Refinishing
- Auto Mechanic-Techn.
- Diesel-Gas-Motor Vehicle Engines
- Auto. Electrical Techn.
- Engine Tune-Up
- Transmission Specialist

BUSINESS

- Advertising
- Business Administration
- Industrial Psychology
- Managing a Small Store
- Personnel-Lab. Rel'ns
- Purchasing Agent
- Retail Business Mgmt.
- Traffic Management

BUSINESS: SALES

- Creative Salesmanship
- Real Estate Sales
- Sales & Sales Mgmt.

CHEMICAL

- Analytical Chemistry
- Chemical Engineering
- Chem. Lab. Technician
- General Chemistry
- Plastics Technician

CIVIL ENGINEERING

- Civil Engineering
- Highway Eng. Tech.
- Sewer Plant Operator
- Surveying & Mapping
- Water-Works Operator

COLLEGE COURSES

- American History
- Calculus
- Economics

COMPUTERS

- COBOL Programming
- Fortran Programming
- Programming for Digital Computers
- Programming the 360
- Programming the 1401

DRAFTING

- Aircraft Drafting
- Architectural Drafting

- Blueprint Reading
- Design Drafting
- Drafting Technology
- Electrical and Electronic
- Mechanical
- Structural

ELECTRICAL

- Electrical Engineering
- Appliance Servicing
- Elec. Eng. Technician
- Industrial Elec. Technician
- Motor Repairman
- Practical Electrician
- Practical Lineman

ENGINEERING (Refresher Courses for Graduate Engineers)

- Chemical
- Civil
- Electrical
- Industrial
- Mechanical
- Sanitary
- Structural

HIGH SCHOOL

- High School Business
- High School General

- High School Math.
- High School Secretarial
- High School Vocational
- College Preparatory
- Preparatory Course for H.S. Equivalency Test

MACH. SHOP PRACTICE

- Machine Shop Practice
- Maintenance Mechanic
- Reading Shop Prints
- Tool & Die Maker
- Welding, Gas & Elec.

MECHANICAL

- Mechanical Engineering
- Aircraft Mechanic
- Hydraulic, Pneumatic Power
- Industrial Engineering
- Industrial Instrumentation
- Machine Design
- Power Plant Engineering
- Quality Control
- Refrig., Air Conditioning
- Tool Design

- Vibration Analysis and Control

SECRETARIAL

- Clerk-Typist
- Secretary, Legal
- Secretary, Medical
- Secretary, Professional
- Shorthand
- Stenographic
- Typist

TV-RADIO-ELECTRONICS

- Color TV Servicing
- Electronics Fundamentals
- Electronic Technician
- General Electronics
- Indust. Electronics Tech.
- Practical Telephony
- Radio Telephone License
- TV and Radio Servicing with Equip. Training

WRITING

- English and Writing
- Free-Lance Writing
- Other (Please specify)

B4569D

Approved for veterans.

Accredited member, Nat'l Home Study Council. Convenient payment plan. Special rates to members U.S. Armed Forces.

New way to prevent cavities is with a laser beam. The technique involves coating a tooth with a sodium solution, then glazing it with a laser blast of 20-billionths of a second duration. Result: The tooth's enamel is permanently hardened and sealed by the almost instantaneous laser heat, making it highly resistant to decay. The technique has already been used on human patients, according to Dr. Fred M. Johnson of Electro-Optical Systems, Pasadena. There is no pain and no injury to tooth pulp or to the patient's mouth. Within two years, predicts Dr. Johnson, "glazers" will appear in some dental offices.

Omega, called the world's first global, all-weather navigation system, is being set up by the Navy. It uses eight transmitting stations spotted around the earth so that a ship, no matter where it is, can always pick up signals from three towers and get a fix. Said to be accurate within one mile, Omega outperforms other systems because its low-frequency signals travel up to 6000 miles without much distortion, even through bad weather. Omega already is in use in the North Atlantic and parts of the Pacific. By 1972 it should be in worldwide operation. Omega is being made available to ships and aircraft of all nations.

A rare weed that poses a threat to western ranges is under study by Department of Agriculture scientists. It's identified as a fertile hybrid of two common range weeds—halogeton and Russian thistle—and was first discovered six years ago near Patter Spring, Utah. The original patch spread so that the weed now is found in a 7 by 30-mile area. The hybrid is a harsh, thorny plant that contains poisonous oxalic acid. Livestock generally will not eat it, though they find Russian thistle partially palatable.

"Moon mud" may be the next cure-all peddled by quacks once our Apollo astronauts return from a lunar landing. That warning comes from an Arthritis Foundation spokesman who notes that health charlatans usually try to capitalize on well-known accomplishments of scientists.

Quick recognition of friendly ground troops is a problem for combat pilots. The Army and RCA's radar division are working on a lightweight interrogator-transponder system that might do the trick. Here's how it's designed to work: The airborne interrogator transmits a coded signal to the ground, where a companion transponder, small enough to be hand-held by a soldier, recognizes the signal and answers by automatically sending back a coded signal of its own. The system would be a boon to helicopter pilots looking for safe drop zones and landing areas.

For the first time, a pulsar has been put on film. That feat was accomplished recently when astronomers at the Lick Observatory, near San Jose, Calif., turned their 120-inch reflector telescope on the Crab Nebula. Equipped with a light-amplifying TV camera, the 'scope was zeroed-in on a spot associated with strong, 33-times-a-second radio pulsations. The videotape revealed a blinking light source (33 blinks per second) that had been associated with an observable star. The blinking had not been detected before because it is too fast for the human eye, causing the star to appear as a steady light source. Using special gadgetry, the astronomers succeeded in "slowing" the pulsations on the tape. The discovery adds to the picture but doesn't explain the nature of the mysterious pulsars.

The "pill" is still a controversial method of contraception. Two recent unpublished studies, according to *Medical World News*, a professional publication, indicate that among women who have taken the pill for several years there is a significantly higher incidence of cervical cancer than among women who use a diaphragm. However, two other investigations don't implicate the pill, according to the magazine. So far, all of the evidence is sketchy and inconclusive. ★ ★ ★



"FISH" WITH A MAGNET

Go treasure hunting on the bottom! Great idea! Fascinating fun and sometimes tremendously profitable! Tie a line to this powerful, but lightweight Magnet—drop it overboard in bay, river, lake or ocean. Troll along the bottom—your "treasure" haul can be outboard motors, anchors, fishing tackle—all kinds of metal valuables. Specially designed plastic coated horse-shoe-shaped with $3\frac{1}{8}$ " sq. gripping surface. Tremendous lifting power—over 150 lbs. on land, much more under water. **NO. 71,135H .150 LB. PULL...\$12.50 Ppd.**
NO. 71,150H...75 LB. PULL...\$8.75 Ppd.

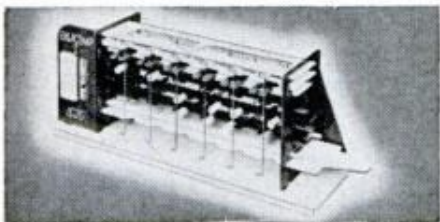

MODEL DIGITAL COMPUTER

Solve problems, teach logic, play games with miniature version of giant electronic brains! Adds, subtracts, multiplies, shifts, complements, carries, memorizes, counts, compares, sequences. Colored plastic parts easily assembled. $12" \times 3\frac{1}{2}" \times 4\frac{3}{4}"$. Incl. step-by-step assembly diagrams, 32-page instruction book covering operation, computer language (binary system) programming, problems and 15 experiments.

Stock No. 70,683H\$5.98 Ppd.
BIG NEW DIGICOMP III!
Stock No. 70,946H\$16.00 Ppd.

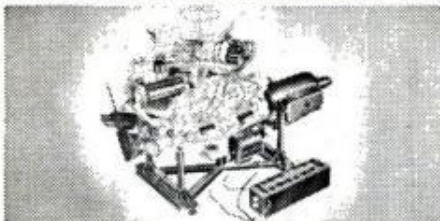

PLASTIC MODEL V-8 ENGINE

Hours of fun! Get thrill of building your own easily assembled engine from over 350 parts. Then push starter and watch it run. Crankshaft revolves, pistons move, valves open and close in sequence with spark plugs. Does everything but burn oil. $\frac{1}{4}$ scale molded in 4 colors. Same motor used in many auto-mechanic courses. Excellent, easy-to-understand "tech manual".

Stock No. 70,448H\$12.95 Ppd.



AMER. MADE OPAQUE PROJECTOR

Projects illustrations up to $3" \times 3\frac{1}{2}"$ —enlarges them to $35" \times 30"$ if screen is $6\frac{1}{2}$ ft. from projector, larger if screen farther away. No film or negatives needed. Projects charts, diagrams, color, black-and-white. 115 V A.C. Operates on 60 W bulb, not incl. $12" \times 8" \times 4\frac{1}{2}"$. 1 lb. 2 ozs. Plastic case.

Stock No. 70,199H\$7.95 Ppd.

MAY 1969



Music Vision Dramatic Breakthrough in Audio-Visual Enjoyment

SEE MUSIC IN DAZZLING ACTION

Actually see favorite musical selections translated into fantastic patterns of beautiful color—each individual note creating its own unique, twisting, radiating shape . . . each shape dancing and prancing, whirling and swirling in perfect time with the music. Attach to stereo, radio, tape recorder. Send 25c for booklet #9096H. **WALNUT CABINET MODEL**
Stock No. 85,181H\$99.50 FOB 8" SET
Stock No. 71,030H\$45.00 Ppd.
8" DO-IT-YOURSELF KIT
Stock No. 71,009H\$22.50 Ppd.



KEEP PACE WITH THE SPACE AGE!

AMAZING BARGAINS

for Fun • Study • Profit

from
EDMUND SCIENTIFIC CO.
300 Edscorp Building
Barrington, N. J. 08007



DIAGNOSE MECHANICAL TROUBLE

Professional Stethoscope. Designed for use by physicians, this super-sensitive Stethoscope is ideally suited for detecting faults in machines and engines, and in fluid, air and gas leakage. Dozens of uses in auto repair shops, labs and for hobby and educational applications.

Stock No. 50,270H\$7.50 Ppd.
BARGAIN PRICE STETHOSCOPE

Stock No. 50,223H\$3.25 Ppd.



AMERICAN-MADE 7x50 BINOCULARS

Big savings! Brand new! Crystal-clear viewing—7 power. Every optical element is coated. An excellent night glass—the size recommended for satellite viewing. Individual eye focus. Exit pupil 7 mm. Approx. field at 1,000 yds. is 376 ft. Carrying Case included. American 7 x 50's normally cost \$274.50. Our war surplus price saves you real money.

Stock No. 1544H\$74.80 Ppd.

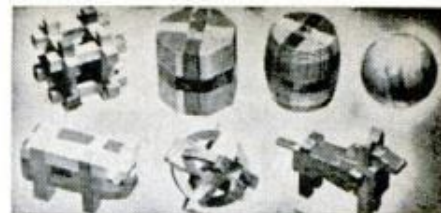

WOODEN SOLID PUZZLES

Here's a fascinating assortment of 12 different puzzles to provide hours of pleasure and stimulate ability to think and reason. Animals and geometric forms. Take them apart and reassemble them. Lots of fun for the whole family—young and old. Will test skill, patience and ability to solve problems. Order yours now. **Stock No. 70,205H\$4.00 Ppd.**



FLY 9-FT. HOT AIR BALLOON

9 Ft. tall. Rises to amazing heights on just hot air. Tether attached, can be used repeatedly. Easy to make, launch, fly, loads of fun. Great for celebrations, science fairs, plain fun. Will lift model gliders, parachutes, instruments, etc.—anything up to $\frac{1}{2}$ lb. Approx. 5 ft. diam. when fully inflated. Kit contains 10 pre-cut red & white gores (No. 1 model paper), 6 ft. 14-gauge wire for bottom ring, top, "tie-off" cord, complete instructions.

Stock No. 60,691H\$2.00 Ppd.



GIANT WEATHER BALLOONS

"Balls of fun" for kids, traffic stoppers for stores, terrific for amateur meteorologists. Create a neighborhood sensation. Great backyard fun. Exciting beach attraction. Amateur meteorologists use to measure cloud heights, wind speed and temp. Heavy duty neoprene. Inflate with vacuum cleaner or auto air hose; or locally available helium for high rise.

Stock No. 60,568H8'\$2.00 Ppd.
Stock No. 60,632H16'\$7.00 Ppd.

MONEY-BACK GUARANTEE

Order by Stock No.—Send Check or M.O.

GIANT FREE CATALOG

148 Pages! More than 4,000

UNUSUAL BARGAINS

Completely new Catalog. Packed with huge selection of telescopes, microscopes, binoculars, magnets, magnifiers, prisms, photo components, parts, kits, accessories—many hard-to-get surplus bargains. 100's of charts, illustrations. For hobbyists, experimenters, schools, industry. Mail coupon for FREE Catalog "H".

EDMUND SCIENTIFIC CO., 300 Edscorp Building, Barrington, N. J. 08007.

NAME _____
ADDRESS _____
CITY _____
STATE _____ ZIP _____

DISSTON

He just bought a \$5.60 saw for a penny!

And he got two Disston rules for the price of one . . . and saved over a dollar on a Teflon coated pruning saw. You can, too. Now at participating hardware stores. H. K. Porter Company, Inc.



1¢ SAW SALE
Buy a famous Disston Professional D-23 cross-cut saw for \$10.99. Get our \$5.60 finishing saw for only a penny more.

TEFLON-S* COATED PRUNING SAW
Bind-free sawing. No sticky sap buildup, no rust. Double-edge blade. Regularly \$6.00. Now only \$4.99. *Du Pont TM

SABRE SAW BLADES
69¢ a pack

16-FT. RULE WITH FREE REPLACEMENT BLADE OR POCKET RULE
Now only \$4.79
Prices shown are mfr's sug. retail

REMINGTON ROD SAW...THE TOOTHLESS WONDER.



Our new Rod Saw has no teeth. Instead, it has thousands of permanently bonded tungsten carbide cutting edges.

The rod itself fits any standard 10" hack saw frame. But the similarity ends there. Because the Rod Saw cuts through things a regular hack saw blade won't even scratch.

It cuts through spring steel, hardened bolts, welds and cast iron with ease. And because of the tool design, the cutting edges go all the way around the rod. So it not only cuts straight, but also cuts in any direction on brick, glass, flagstone, ceramics, fiber glass, laminates and other hard-to-cut materials. (And does it faster, because it cuts on both forward and backward strokes).

Originally developed for industry, now packaged for home use, the Remington Rod Saw is available at most hardware stores.

You should not have any trouble recognizing it. Just look for the saw without any teeth.

Remington

Made in U.S.A. U.S. Patent 3,023,490. Applications pending. Remington is a trademark of Remington Arms Company, Inc., and is a trademark of E. I. du Pont de Nemours & Co. (Inc.)

Big jobs to do? Use your electric drill and power-boosting

Versamatic

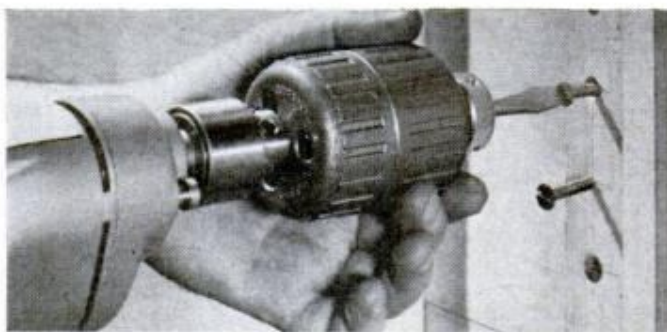

- Screw Driving
- Screw Removal
- Driving Nuts
- Removing nuts
- Heavy-duty drilling
- Tapping

Lots of big screws to drive or remove? Nuts to put on? Or take off? Need to drill in concrete or hard steel? Use power. Attach a reversible Versamatic to your portable drill for seven-fold power increase and 7 to 1 speed reduction. Versamatic more than doubles power drill usefulness. Send for free folder — "How to double the value of your power drill."

RIDGID
Supreme

Power Tool Equipment

The Ridge Tool Company, Dept. D, Elyria, Ohio 44035

POPULAR MECHANICS

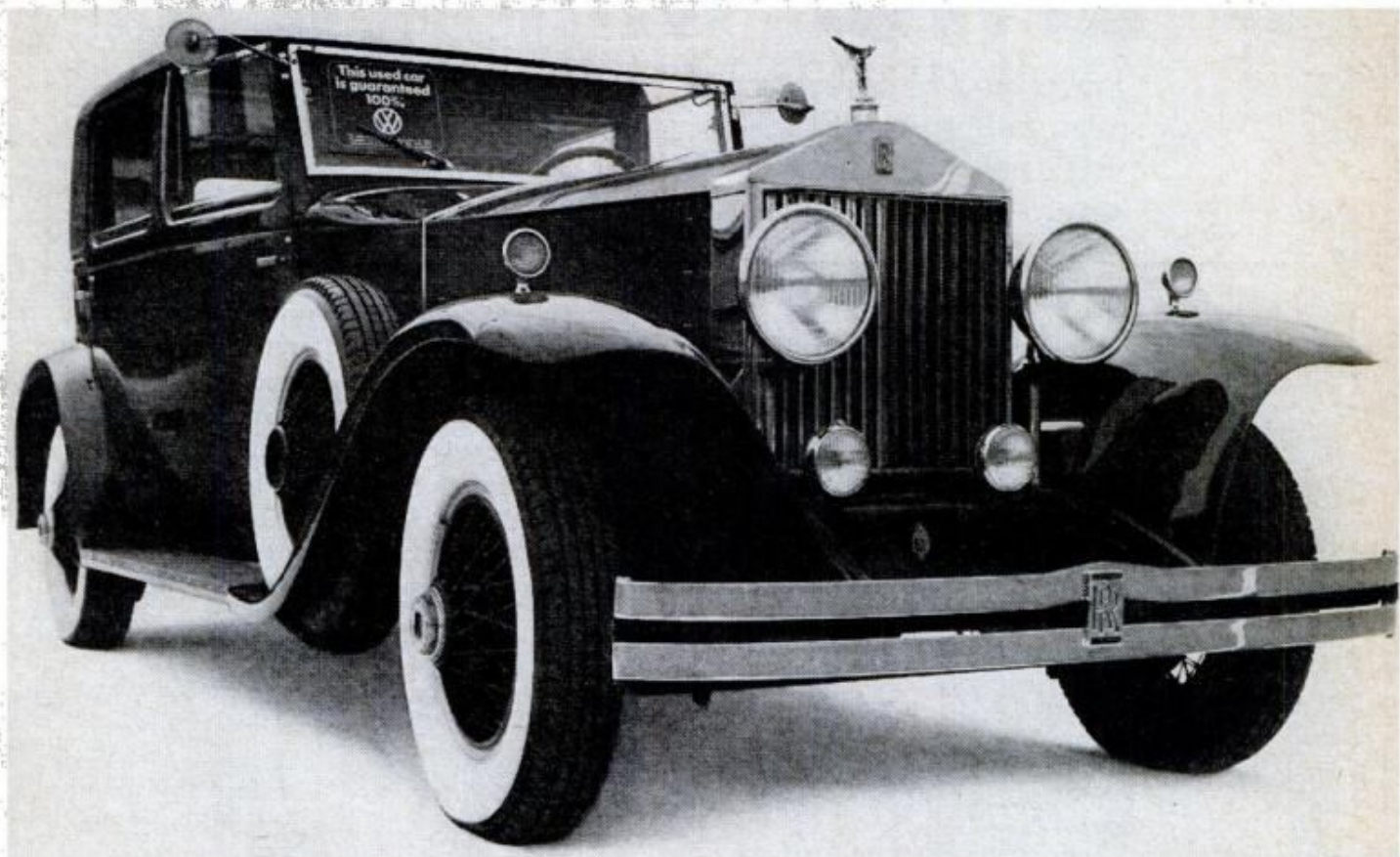

Pick up a good second car from Volkswagen.

Somebody traded in a Rolls-Royce for a Volkswagen?

Yes, somebody traded in a Rolls-Royce for a Volkswagen.

It happened in Texas, of course.

But even in average states some pretty fancy cars show up on a VW dealer's used car lot.

And some not so fancy cars. And some quite practical cars. Like Volkswagens.

But no car, Rolls or VW, gets that guarantee on the windshield automatically.

First it goes through a rigorous 16-point in-

spection.

If anything needs fixing, it gets fixed.

Only then does the dealer guarantee the free repair or replacement of every major working part* for thirty days or a thousand miles.

Whichever comes first.

So when a Volkswagen dealer says that a used car is as good on the inside as it looks on the outside, you don't have to trust him.

He'll put it all down in writing for you.

*engine, transmission, rear axle, front axle assemblies, brake system, electrical system.



Drivin' with Dan

Why did you withdraw from F-1 racing? How is average speed figured for a race course? Will accelerating on curves help make them? What helmet do you wear? Dan Gurney answers these and other automotive questions



A FAMILIAR SCENE for Dan—being interviewed at Indianapolis. It'll be more of the same this month as Dan and his crew gird for the annual 500-mile grind

Q. Have you ever tested the Shelby Cobra? What did it do?—John Fevola, Brooklyn, N.Y.

A. I drove the original roadster prototype at Riverside, and I've raced them at Sebring, Le Mans, the Targa Florio in Sicily and Daytona. In fact, I assisted in the development of the car. I raced the coupe at Sebring, Daytona, Le Mans (where Bob Bondurant and I won the GT category in 1964), finishing fourth overall. They were great fun to drive, but rough as the devil and very noisy.

Q. Why did you withdraw from Formula 1 racing? Do you plan to return?—Steve Murray, Garden Grove, Calif.

A. Frankly, the financial and man-hour burdens were so great that we had to stop either Indy, Can-Am or F-1 racing. Economically, F-1 is the lowest-paying, most expensive of the three, and, because of the increased international participation in Can-Am and Indy, the prestige of F-1 is no longer as great as it used to be. The choice was pretty easy to make. I wish that there was more money in F-1 racing.

Q. What was your first stock-car race, and how did you do?—Steve Ford, Des Moines, Iowa.

A. My first stock-car race was in 1958 on a road course at Meadowdale, Ill. Most of the big names of the day were there. I drove a '58 Ford. The deal was arranged by Jerry Unser (Louie, Bobby and Al's older brother) through our mutual friendship with former Indy winner Troy Ruttman. Bob Rose and Lou Sipolt were the mechanics (their first road race, too). I went from 28th to second, right behind the eventual winner—Fred Lorenzen—before the center of the clutch dropped out.

Q. Do you plan to stick with the pushrod stock-block Ford at Indy this year, or will you use the DOHC Turbo-Ford? Also, have you ever raced on the dirt?—Bill Chester, Oak Park, Ill.

A. I plan to stay with our pushrod stock-block Ford, but we also expect to have a car ready with a turbo DOHC. I expect our new pushrod to be quite a bit faster, as our development department has found a significant increase in hp over last year's version. No, I haven't raced on the dirt, though I love to drive or ride a motorcycle on it.

Q. On a race course, how is the average speed figured?—Mike Whitsitt, Lufkin, Tex.

A. First, you must know the distance traveled
(Please turn to page 28)

All new 'Jeep' Gladiator. First 4-wheel drive truck specially built for campers.



Route 1.



Route fun.

This new 4-wheel drive 'Jeep' Gladiator takes any make or model camper up to 2,500 lbs. . . . and takes it practically anywhere! Bigger, longer, with 132" wheelbase, 8,000 lbs. GVW, full floating axles front and rear. And a 350 C.I.D. V-8 engine with 4-speed transmission lets you carry a payload of nearly 4,000 lbs. easily and smoothly. . . on or off the highway. But you're not riding rough,

'Jeep'
The 2-Car
Cars.

with options like bucket seats, power steering and brakes, automatic transmission, air conditioning. Take your camper off. . . you've got a real workhorse. One that holds its value, too. See your 'Jeep' dealer. Test drive the 2-Car Cars. 'Jeep' 4-wheel drive.



*You've got to drive it
to believe it.*

KAISER Jeep CORPORATION
10,100 010 4301

When your
lights
don't work
you
know it



Insist on an AC Oil Filter
—available for *all* cars wherever
you have your car serviced.

Let AC

...but how
can you
be sure your
oil filter
is working?



There's one sure way. Change your oil filter regularly. And make certain the man who changes your oil installs the best—the one that's original equipment on all GM cars—an AC Oil Filter. AC builds more parts for more cars than anyone else in the world.

keep your car in action!

SAVE UP TO \$200 OR MORE ON AUTO AIR CONDITIONING!

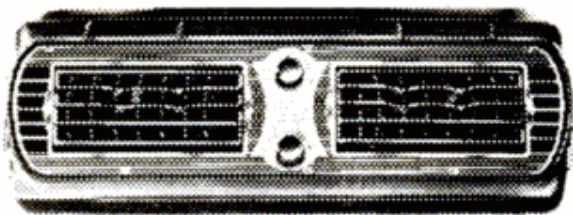

SUPER AIR



SUPREME

New prices—just \$133 on the Standard (not pictured)—\$148 on the Super Air—and new Supreme only \$165.

The new Supreme takes up no usable space. Installs quick and easy just like the other Comfy-Kit units.

Comfy-Kit performance is unsurpassed. Cooling power is greater than that of other brands costing two or three times as much.

Installation is simple—a matter of four to six hours. It's just like being paid up to \$50 an hour for your time. Everything is furnished—including the loan of special tools if you need them.

Let someone else pay big prices for air conditioning.

Mail in the coupon today—and enjoy cool, comfortable, windows-up driving all summer long.

COMFY-KIT

P. O. Box 8585, Dept. PM5 • Dallas, Texas 75216

- Enclosed is \$133* for Standard Unit.
- Enclosed is \$148* for Super Unit.
- Enclosed is \$165* for Supreme Unit.
- Enclosed is \$30 deposit on a Super Standard Supreme Unit. I will pay the balance, plus C.O.D. charges when delivered.
- Enclosed is \$8.00 deposit for a set of four tools, which will be returned to me when I return the tools.
- I would like to see the instruction book before I order. I enclose \$1.00 for the instruction book only. I understand this will apply on any future Comfy-Kit order.
- I would like information on a Comfy-Kit dealership.

Name.....

Address.....

City..... State..... Zip.....

My car is a.....(year).....(model)

Engine displacement.....Horsepower.....

Power Steering.....yes.....no

Floor shift.....Steering column shift.....

Smog pump.....yes.....no

*plus state tax where applicable

DRIVIN' WITH DAN

(Continued from page 24)

in making one lap. It doesn't matter whether it's a road circuit or an oval. Then, with a timing device, it is a matter of simple arithmetic. For example, a lap run in one minute around a two-mile circuit equals an average speed of 120 mph; in 45 seconds, 160 mph; in 40 seconds, 180 mph; in 30 seconds, 240 mph, and so on.

Q. In an Indy race, which block can live the longest in the heat—aluminum or cast iron?—Thomas Butchor, Albany, Calif.

A. That's a real tough one. I think it really depends on the design rather than the material. Iron is less expensive and slower, aluminum more expensive and faster. Both should have adequate life if designed properly.

Q. Do you think the Ford Cosworth F-1 engine is the ultimate in three-liter engines?—Kevin Cowley, New Zealand.

A. I'd say it was the best one in racing in 1968. But to call it the "ultimate" would be going too far.

Q. Will you be running the Indy championship trail or the NASCAR trail in 1969?—Ken Burbeck, Huntington Beach, Calif.

A. Indy, championship road races and Can-Am.

Q. What is the difference in driving techniques for a turbine as opposed to a piston engine?—Randy Ziemann, Fairmount, Minn.

A. Driving a turbine, you must plan ahead much more. You get very little help in slowing the car down by letting off on the throttle. So brakes play a much more important part in driving technique. The throttle response still has a lag which is longer than a piston engine, though not much different than a turbocharged piston engine. In all, it requires an entirely different technique.

Q. What is this new-type crash helmet you're wearing?—Don Stevens, Milwaukee, Wis.

A. It's called the Bell "Track Star" or "Star." It's stronger, gives you much more face protection. Dirt, stones or pebbles don't bother

(Please turn to page 32)

**NOW
READY**

Amazing RED FLOWERING GROUND COVER

Grows in poorest soil—Thrives in sun or shade!

Sub-zero hardy

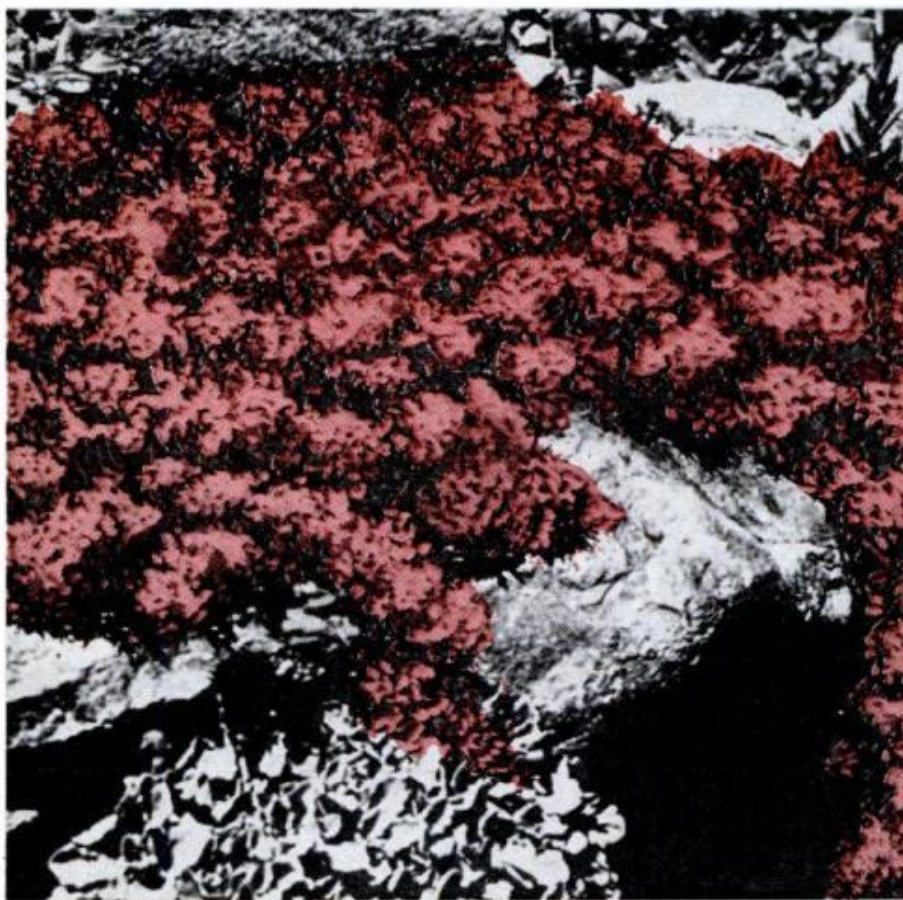

Stern's DRAGON'S BLOOD CREEPING SEDUM

(Sedum Spurium, Dragon's Blood)

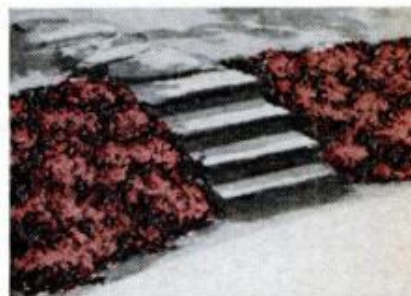

Brilliant Red Flowers in Summer, Green Foliage in Winter—Lasts a Lifetime! Here's the nearest thing to a maintenance-free planting. Never overruns itself, never needs pruning, is disease and insect-free, scoffs at worst winter conditions, ignores summer heat and drought, and is among the longest-lived plants known. Brilliant red clusters of star-shaped flowers bloom June to fall; semi-ever-green foliage completely covers the ground even when not in bloom.

Never Grows Taller Than 4"! Perfect For A Hundred Landscape Uses!

Now cover poor and sandy waste places where almost nothing else will grow: under trees, in rock gardens, banks or borders, any area of your garden. Spreads rapidly, thrives in full sun or partial shade. Beautiful in front of flower borders. For a luxuriant ground cover, plant one foot apart.

MONEY-BACK GUARANTEE (SEE COUPON)

Order now! Plant now!

Sturdy Plants Shipped in 2 1/4" Pots.
Easy Planting Directions Enclosed.
3 for \$2.25; 6 for \$4.00; 12 for \$7.50;
24 for \$14.00; 48 for \$25.00; 96 for \$45.00;
240 for \$110.00; 480 for \$200.00

Catalog #00850 (specify on order)

Stern's Nurseries

Field 82, Geneva, N.Y. 14456

Specialists in Rare and Choice
Trees, Plants and Flowers

ONLY LIMITED QUANTITY OF THIS SPECIAL. MAIL THIS COUPON TODAY!

STERN'S NURSERIES, Field 82, Geneva, New York 14456

Please send me Stern's Creeping Sedum (No. 00850) in the quantities indicated:

- | | |
|---|---|
| <input type="checkbox"/> 3 for \$ 2.25 | <input type="checkbox"/> 48 for \$ 25.00 |
| <input type="checkbox"/> 6 for \$ 4.00 | <input type="checkbox"/> 96 for \$ 45.00 |
| <input type="checkbox"/> 12 for \$ 7.50 | <input type="checkbox"/> 240 for \$110.00 |
| <input type="checkbox"/> 24 for \$14.00 | <input type="checkbox"/> 480 for \$200.00 |

Add 10% postage & packaging (70c minimum). N.Y.S. Residents add 2% (plus local) Sales Tax.

- My check or money order enclosed. Charge to my account with: Diners Club; Uni-card; American Express; Carte Blanche; Midland

Specify Card number _____

SATISFACTION GUARANTEED! You must be delighted or notify us within 2 weeks after you receive plants and we'll send a refund or free replacement for any unsatisfactory plants. No need to return plants, ever!



Name _____

Address _____

City _____ State _____ Zip _____

DEPENDABLE
CHAMPION
SPARK PLUGS

J-17 LM



NEW
FITS OVER 90%
OF ALL POWER MOWERS



14 mm thread • $\frac{13}{16}$ hex

Now—a sure way to get fast power mower starts!

Fast, sure starts all season long!

Delivers maximum cutting power!

Fits over 90% of all power mowers!

Start the season with Champion's all-new J-17LM. This unique spark plug was created by Champion engineers to spark both 2-cycle and 4-cycle engines. So, it's exactly right for 9 out of every 10 power mowers in use—including *all* popular makes! Look for the J-17LM in the distinctive green and black package at hardwares, garden centers, service stations, and home and auto accessory shops everywhere.

CHAMPION SPARK PLUG COMPANY
TOLEDO, OHIO 43601

Introducing: Elmer's kitchen and bathroom repair kit.



The first half of our kit is Elmer's® Clear Cement. It's made especially for repairing china and pottery.

It dries fast. And is so strong, it's even dishwasher-proof.

(You can use it outside of the kitchen, too. On ceramics, wood, metal, glass, plastic, leather or paper.)

Elmer's new Flexite® Tub Caulk is a live rubber sealant for waterproofing around bathtubs, showers and sinks. On porcelain, tile, ceramic, glass, metal or wood.

It's easy to apply and guaranteed not to crack, chip, peel or become mildewed for ten years.

The entire kit is brought to you by the makers of Elmer's Glue-All, America's favorite glue.

Free. A guide to gluing, taping and spray painting. Mail a stamped, self-addressed envelope to: Borden Inc./Chemical Division, Dept. B-2, 350 Madison Ave., N.Y., N.Y. 10017.



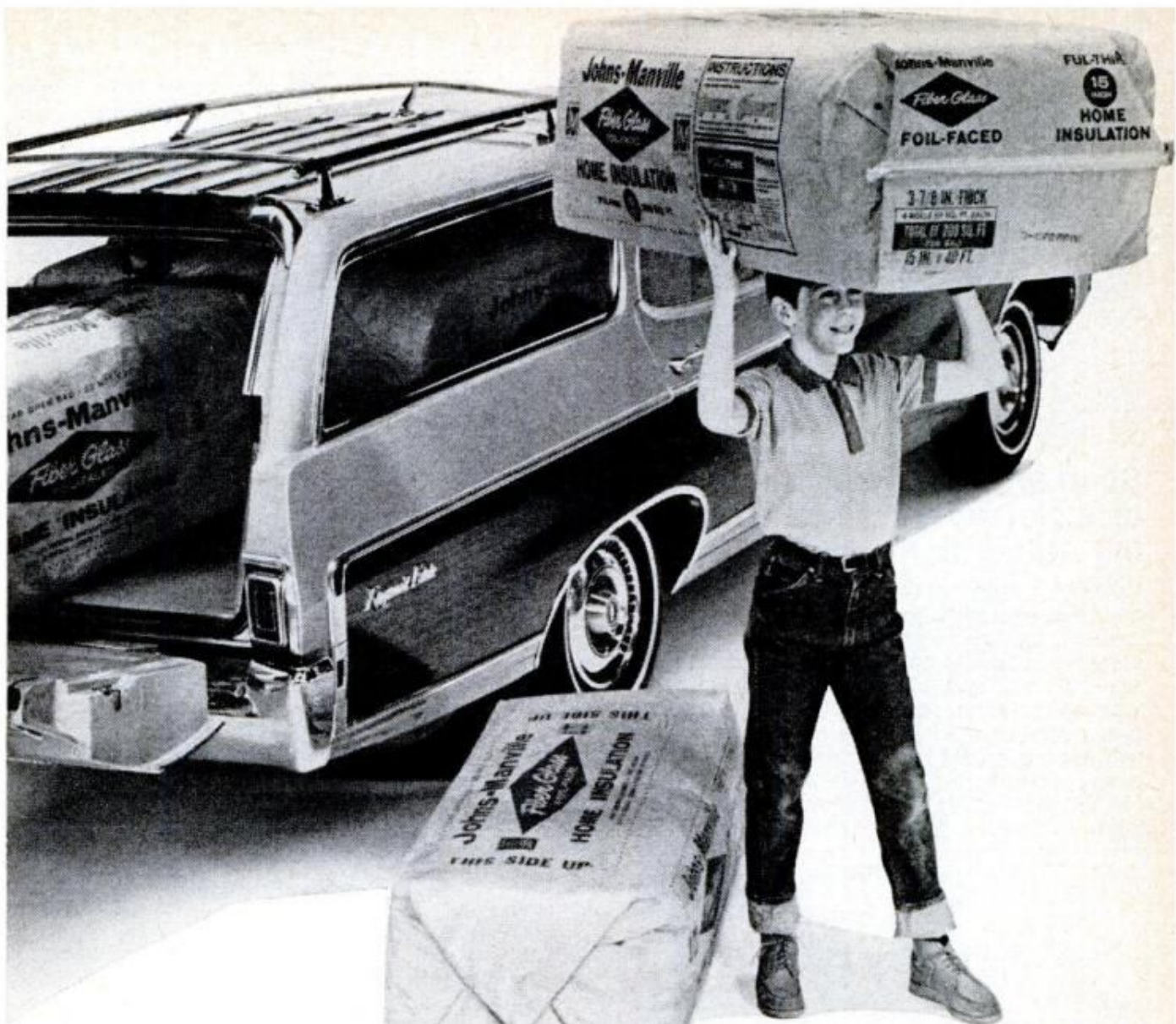

**This rugged workman
can deliver all the insulation
his father needs
for their whole house.**

J-M Foil-Faced Fiber Glass insulation cuts big jobs down to size. It's lighter. More compact. Easy to do it yourself. Finer glass fibers trap that escaping heat . . . or cool . . . more effectively. And the foil facing is a superior vapor guard and shield against summer sun.

Just follow the R/Value chart for the kind of Foil-Faced insulation recommended by J-M engineers. Complete details are at your nearest J-M dealer. Or write Johns-Manville, Box 290-BA, New York, N.Y. 10016.



Johns-Manville

Installation	J-M Foil-Faced Fiber Glass Insulation Recommended	Recommended R/Value
Ceiling	Super-Thick Ful-Thick	R-19 R-13
Wall	Medium	R-10
Floor	Ful-Thick	R-15

The higher the R/Value, the better the insulating value. So, for economy of operation with electric heat and/or air conditioning—use higher R/Value products.

Dents? Rust-outs?



Send for this free booklet, or pick it up where you buy 3M Auto-Pak Products

Now 3M brings you the methods and materials you need to make minor body damage repairs on your car. Shows you in easy steps how to get rid of minor dents, rust-outs and scratches. Plus tips on attaching weatherstripping, sealing leaks and repairing trim materials. Pick up your free booklet where you see 3M Auto-Pak Products displayed or write: Auto-Pak Booklet, 3M Company, 3M Center, Bldg. 3M, 220-6W, St. Paul, Minn. 55101 **3M** COMPANY

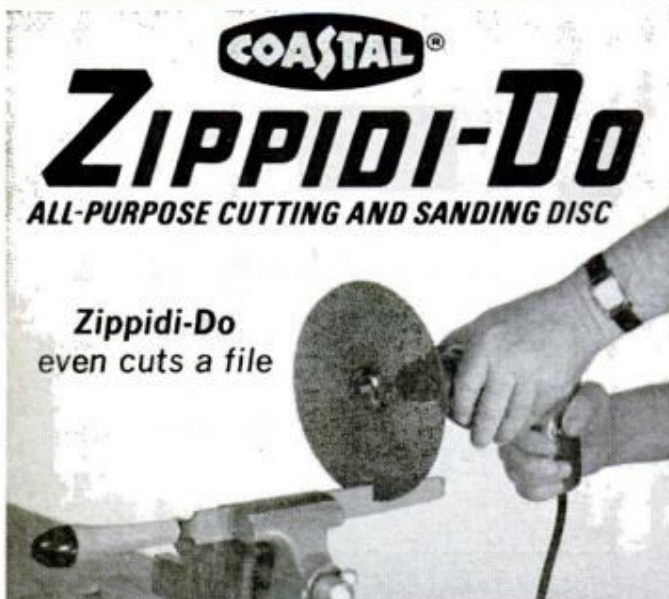

The most versatile power tool accessory... ever!

You can cut through ceramic tile, fiberglass, brick, slate, stone, all metals... even a hard file in minutes with the Zippidi-Do cutting and sanding disc. Silicon carbide grains embedded in nylon mesh give it amazing cutting ability. And the Zippidi-Do makes a great sanding and shaping disc for use on old paint, rust, wood, tile, all metals. The Zippidi-Do can be used with any electric drill or flexible shaft. It wears and wears and never clogs.

Complete kit contains Zippidi-Do disc, molded backing disc, arbor and flanges... only \$4.00 at hardware stores and depts. Coastal Abrasive and Tool Co., Inc., Trumbull, Conn. 06611.

DRIVIN' WITH DAN

(Continued from page 28)

you as much. It's like driving a very small coupe. It was first used on motorcycle dirt tracks. I like it very much.

Q. Is power steering used on race cars?—Mike Mileski, Akron, Ohio.

A. Not very often. There have been examples of power steering on championship dirt-track cars, but it's not very common.

Q. How do you think an American Motors Rebel would stand up as a racing stock car?—Ricky Mariano, West Chester, Pa.

A. Probably it would be fine by the time the car was modified to fit stock-car racing rules. Most of the cars are running with special components, anyway.

Q. What condition was your winning car in at the end of last year's Rex Mays 300? Did you still have brakes and gas?—Lee Godfrey, Tonawanda, N.Y.

A. Engine okay, brakes bad, rear suspension broken, gas down to four gallons, everything very dirty, but crew and driver very happy.

Q. I've been wondering if your height has ever had any effect on your driving or has caused you any trouble.—James Doucett, Hudson, Ohio.

A. Yes, it has caused a lot of hassles. I never seem to be able to get into someone else's car without going through the rigmarole of seat changes, windshield changes and pedal changes. Some mechanics get mad at me, and generally it is just some added work for everyone. But, where there's a will, there's a way.

Q. I would like to build a go-kart with a V8. What problems would I run into?—Mike Layden, Franklin, Pa.

A. Mainly, staying alive. ★ ★ ★

If you have questions on racing, high-performance and everyday driving techniques, send them to "Drivin' with Dan," c/o Popular Mechanics, 575 Lexington Ave., New York, N.Y. 10022. Questions cannot be answered by individual letters. Questions on maintenance and repair should be addressed to the Auto Clinic (see page 74).



When we teach a skill, the career comes with it.

Grab a handful of opportunity. Set yourself up in a technical, administrative or industrial job with a secure future. Right now there are over 300 job training courses you can pick from.

And when you finish our training, you've got a job. The rest is up to you. That's what we mean by a career. We supply training and jobs. You supply the initiative.

So get the skill you need. The chance to make it on your own. Get in touch with your Army Recruiter. Who else?

Your future, your decision . . . choose **ARMY**.

Army Opportunities
Department 200
Hampton, Va. 23369

PM 5-69

Send me more information on jobs with a future.

Name _____ Age _____

Address _____

City _____ County _____

State _____ Zip _____

Education _____

START A MONEY-MAKING BUSINESS FOR LESS THAN \$50!



You can have your own lifetime business right at home . . . work in spare time . . . and make up to \$200 a month CASH! My FREE PLAN gives you all the facts: How to start, how to grow. You don't need previous experience. You don't have to sell. I'll even finance you. People bring you the work and pay cash. Over 90¢ of every dollar you collect is clear cash profit. And you work when you want to. Let me prove you can't find a more certain, lower cost, higher paying business of your own.

Just Mail Coupon—No Salesman Will Call
BELSAW SHARP-ALL CO., Stan Field, Pres.
 719B Field Bldg., Kansas City, Mo. 64111

FREE BOOK

Name _____

Address _____

City _____ State _____ Zip _____

THE WINDOW FIXER®

BEST WAY TO REPLACE BROKEN GLASS. DAP '33' GLAZING IS EASY TO USE. STAYS FLEXIBLE FOR AIRTIGHT, WATERTIGHT SEALS. OUTLASTS ORDINARY PUTTY BY YEARS.



DAP®

'33' GLAZING

DAP Inc., Dayton, Ohio 45401 / SUBSIDIARY OF Plough, Inc.

Also available in Canada

How good a tire did you have in mind?



That's the kind we make.

To last through vacation trips. And the rest of the year. Several times over.

To give you that "all's well" feeling despite a full load of family, tents, canoe and dog. To stand the guff of all day at Interstate speeds.

Start your trip right, at your Dunlop dealer's. He's a pro. Check the Yellow Pages.

He'll show you your choice of Dunlops. And put you on the ones right for your car and driving.

And if he goes on like Dunlop invented the tire, be patient. We did.



DUNLOP

... means quality in tires, tennis and golf. Buffalo, N.Y. 14240

what gives?

Nothing gives. When it's stuck with Holdol, it's stuck for good. Use Holdol glues and adhesives for all your household jobs.

Fix broken furniture legs. White Glue is ideal for wood, paper and other porous materials. Sets fast, dries clear.

Neoprene Adhesive is stronger yet. Especially useful for bonding two coated surfaces. Any composition materials such as cork, leather, linoleum, and it is non-flammable for safe household usage.

And strongest of all, Epoxy Cement. Use it for bonding and repairing metals, ceramics, china. The strongest known all-purpose cement.

Panel a wall with stronger-than-nails Masonite Panel Adhesives. Masonite general-purpose, extra-strength adhesive and Masonite Panelhold adhesive. Both in easy-to-use cartridges.

Masonite serves all your gluing needs. Try some on your next job. See what doesn't give. Write Masonite Corp., 29 N. Wacker Dr., Chicago, Ill. 60606 for informative "Holdol" brochure.



Masonite and Royalcote are registered trademarks of Masonite Corporation.



4 Place easy TO BUILD

NOW AVAILABLE! Complete Material Packages for the new flight-proven BD-4. . . . With improved ground handling. . . . Roomy, quieter cabin . . . and folding wings for economical at-home storage. Same fast, easy Panel-Rib wing and bolt-together fuselage construction. Build this modern plane as a two-place now and upgrade it to four-place later . . . or go four-place right from the start. Either way, you get the same rugged design, cruising speeds of up to 170 M.P.H. and a family-sized airplane at rock-bottom price. All supplies now in stock and pre-packaged for immediate shipment. Get your materials one section at a time or order all seven now and save \$406.00!

MATERIAL PACKAGES

- | | |
|-------------------------------|--|
| 1. Fuselage \$474. | 5. Fuselage Controls . \$178. |
| 2. Wings \$626. | 6. Elec. System & Instruments \$514. |
| 3. Control Surface . . \$429. | |
| 4. Landing Gear . . . \$593. | 7. Power Plant System \$532. |

All Seven Packages
(everything less engine) \$2940.
Engines and optional equipment also available.

bede homebuilts

Dept. PM-59

355 Richmond Road/Cuyahoga County Airport
Cleveland, Ohio 44143/(216) 731-6474

REAL ESTATE

BE A BROKER

PAYS BIG! SEND FOR BIG FREE CATALOG NOW! Graduates report making substantial incomes. Operate your own business quickly. Men, Women, all ages, learn easily. Course covers Sales, Appraising, Loans, Mortgages, & related subjects. **STUDY AT HOME** or in classrooms in leading cities. **Diploma Awarded. Write Today for FREE Book!** Accredited Member National Home Study Council. (Est. 1936) G. I. Approved.

FREE BOOK TELLS HOW

WEAVER SCHOOL OF REAL ESTATE
3521-P Broadway Kansas City, Mo. 64111

STOCK SIGNS

WEATHERPROOF ENAMEL. VIVID COLORS
also HAND LETTERED SIGNS at \$1.00 & UP
SEND \$1. (DEDUCTIBLE FROM FIRST ORDER) FOR ILLUSTRATED LIST
DEALER INQUIRIES INVITED

EACH POST-PAID

FOOTHILL SIGN CO. STUDIO M
9009 SANTA MONICA BLVD. LOS ANGELES, CA. 90069

HOW MISERY MAY RUPTURE DISAPPEAR

FREE Sample, Send for It Today
FREE. Get this Amazing TREATISE. You may never need wear your old truss again. For *restless rupture*. Accented by Medicare. See this Pneumatic Invention. Positively costs you nothing. No obligation. Do not wait. Just 500 Free Sample copies. Supply limited. Send for yours today. Hurry, come in or write to: Dept. 22-E. **PORTNOW-53 Delancey Street, New York, N. Y. 10002**
Famous Surgical Manufacturer Since 1898

TREASURE

Find buried gold, silver, coins, treasures.
5 Powerful models.
Write for free catalog



RELCO DEPT. D-3 \$19⁹⁵ UP
BOX 10839, HOUSTON, TEX. 77018

Yesterday, John Bieniek had his state auto inspection.

But his state doesn't inspect shock absorbers. Yet.

Be your own safety council.

Have your shocks checked.

If you need new ones, get Monroe®.

The shock absorbers for people who'd rather be safer than the law allows.



MONROE AUTO EQUIPMENT COMPANY
Monroe, Michigan 48161



New Discovery Makes Stuck Windows Slide At Fingertip Touch -Without Oil.

No mess. No waiting. No oily fingers. One sw-o-o-sh! And tight stuck windows, drawers and zippers slide easy when you spray new 3-IN-ONE® DRY LUBE. Eliminates friction without oil. The secret is a new spray lubricant so clean it won't soil your best clothes. Get 3-IN-ONE DRY LUBE at all hardware outlets.



3-IN-ONE® DRY LUBE

Trail Grabber...

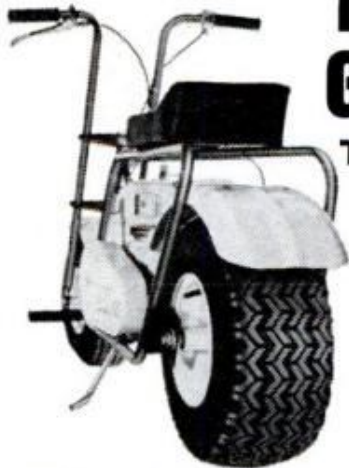

**The Biggest Wheel
In Trail Bikes
Is The Heathkit
GT-18
"Boonie-Bike"
The All-Season
Trail And
Snow Bike ...
Only \$199.95**

• Reliable, low cost transportation over almost any terrain, any condition • Easy starting, dependable 5 HP, 4-cycle Briggs & Stratton engine • Giant 18" x 8.50-8 rear tire for amazing traction on virtually any surface • 2-speed chain drive transmission for high torque & 30-mph top speed • 5" hand-operated Bendix drum-type rear brake • Safe spring-return throttle • Heavy duty welded tubular steel frame • Welded steel skid pan & 6 1/2" ground clearance • Large, comfortable seat • Spring loaded front suspension • 400 lb. load capacity — ideal for "packing-in" • Weighs just 116 lbs., only 24 1/2" wide — easy to load in cars, etc. • Optional ski accessory for going in snow — snaps on in seconds without tools • Easy assembly — motor assembled & mounted on frame, tires mounted on wheels & inflated • Accessory lights & horn kit available April

Kit GT-18, 140 lbs. \$199.95*
Model GTA-18-1, ski accessory, 12 lbs. \$16.95*

HEATH COMPANY, Dept. 17-5
Benton Harbor, Michigan 49022

Rush my FREE Heathkit Catalog.

Enclosed is \$ _____ including shipping.

Please send model(s) _____

Name _____

Address _____

City _____ State _____ Zip _____

Prices & specifications subject to change without notice.

*Mail order prices; F.O.B. factory.

GX-180

SURVEYOR & MAP MAKER

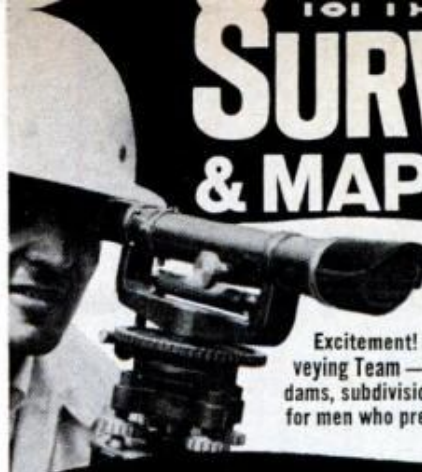

PREPARE NOW AT HOME

in spare time for rewarding Career in Surveying & Mapping. Prestige! Excitement! Fun! Imagine yourself as part of Surveying Team — in on planning of highways, bridges, dams, subdivisions, airfields, etc. Wonderful Career for men who prefer outdoor work ... ideal for those who like to work with hands.

We'll GIVE YOU this BIG 68-Piece Kit
... when you train at home with us
for a **PRESTIGE SALARY CAREER IN SURVEYING & MAPPING**



Kit includes 33-piece **SURVEYING KIT** (Training Transit, Tripod, Hand Level, 100-ft. Steel Retractable Tape, Solid Brass Plumb Bob, Slide Rule, etc.), 35-piece **MAPPING KIT** (Precision Stainless Steel Drawing Instruments, Drawing Board, T-Square, Triangles, French Curve, Rulers, etc.) plus exciting **AERIAL STEREO 3-D MAPPING KIT**.

GOVERNMENT PREDICTS HUGE NATIONWIDE SHORTAGE!

U.S. Bureau of Labor Statistics predicts shortage of 50,000 civil engineering technicians (Surveyors, etc.) by 1975. You need no previous experience, no technical ability to qualify for one of these rewarding Career Opportunities! North American's "Learn-by-Doing" home-study plan has trained 1000s men to step into good paying outdoor-technician positions in every State. Our staff of Professional Surveyors and Educators guide you step by step ... give you all the professional equipment & help you'll need to use the transit, stretch the tapes and work at practical field problems in all phases of Surveying & Mapping. This valuable equipment is yours to keep and use during your training and throughout your Career as a Professional Surveyor. Your training is fun — exciting new lessons reveal secrets of aerial, underground, & underwater mapping and even mapping of outer space! Your training is so thorough that many North American students report good earnings part time while still learning! Thousands of men who are Surveyors today got their training through home-study. You can too!

Rush Coupon for FREE Facts!

Take your pick of
**4 EXCITING
SURVEYING
& MAPPING
CAREER
Opportunities!**

- career with **GOVERNMENT** (half of all U.S. Surveyors are employed by Government)
- career with **CONSTRUCTION CO.** (or engineering or architectural firm as member of Surveying Crew)
- career with **SURVEYING CO.** (that conducts surveys for others on fee or contract basis)
- **SURVEYING BUSINESS OF YOUR OWN** (as "free lance" Surveyor. Or, start your own Surveying Co.)

Rush Coupon for FREE "SURVEYING CAREER KIT"

... including 20-Page Book, "Your Future in Surveying & Mapping," Sample Lesson & Self-Scoring Surveying Aptitude Test which will let you determine for yourself—in advance—whether you can qualify for a rewarding Career in Surveying. No cost or obligation, now or ever. No salesman will call. Rush coupon today.



**NORTH AMERICAN SCHOOL OF
SURVEYING & MAPPING** Dept. 4175

4500 Campus Drive • University Plaza, Newport, Calif. 92660

Rush "SURVEYING CAREER KIT" including Book, Sample Lesson & Aptitude Test — ALL FREE!

NAME _____ AGE _____

ADDRESS _____

CITY _____ STATE _____ ZIP _____



Unmistakable.

If you would rather shoot great pictures than worry about exposure settings, you're all set with the Kodak Instamatic 814 camera. It's the most automatic Kodak Instamatic camera of them all.

While you have the fun, it does the work.

Just drop in the film cartridge. The "814" automatically adjusts to the speed of the film. Aim it at the subject. It automatically computes and sets the proper exposure. Even warns you when to use a flashcube if the light is low. Snap the picture; a spring motor automatically advances both film and flashcube for the next picture.

So make no mistake. See the Kodak Instamatic 814 camera with its precision rangefinder and superb 4-element $f/2.8$ Ektar lens—less than \$145—at your Kodak dealer's.

Price subject to change without notice.

Kodak Instamatic® 814 camera



This Dremel Electric Engraver Permanently Marks Any Material—

metals, glass, wood, plastic. Ideal for identifying tools, engraving jewelry, coding industrial tooling. Weighs only 7 oz. Calibrated stroke regulates depth of engraving. Only \$14.95 with solid carbide point and storage case. Diamond points available. See your dealer or write for literature.

DREMEL MFG. CO.
Dept. 89-E, Racine, Wis. 53401

RAZOSHARP

PRECISION TOOL HANDLE FOR INJECTOR TYPE RAZOR BLADES



IDEAL POCKET KNIFE—EXCELLENT HOUSEHOLD UTILITY TOOL—Only holder to use standard injector type razor blades. Only holder allowing for varying blade length exposure. Only holder allowing blade to be completely protected. Only razor blade holder to give precision tool feel.

ALWAYS RAZOR SHARP—When blade dulls—pop in new blade. Re-use injector type razor blades. **SHAVE and SAVE.** Inexpensive injector type razor blades always available. Expose new sharp edge—reverse blade or clip dull edge. Excellent for cutting clippings, cardboard, trimming, etc. Excellent for opening packages, cartons, etc. Use for carving, whittling, sharpening, erasing, etc. Shape blade to suit use—snip edge or break with pliers. Nothing to break or wear out.

RAZOSHARP 421 Stockholm Street; Brooklyn, New York 11237

300 POWER.....

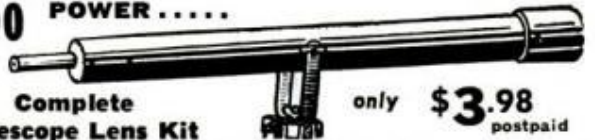

Complete Telescope Lens Kit

Conquer Space. Explore the Universe. Planets, Moon craters, New Stars etc. Complete Lens Kit consists of 80 inch focal length ground and polished objective lens, eyepiece lenses for 50 POWER, 100 POWER, 150 POWER, 200 POWER, 250 POWER, 300 POWER, and all necessary lens fittings. Easy to make from simple step by step instructions. (Tripod and mount not included.) Money back guarantee.

BUSSE SALES, Dept. PM12, Hartford, Conn. 06101

HOW TO GET RICH

Secret Mail Order business brings cash by mail. Pyramid profits. No investment. Start at home in spare time. Write for full details and Free Book.

MAIL ORDER ASSOCIATES, INC.

Dept. 2, Montvale, New Jersey 07645

SAILBOAT KITS

Save \$ \$ \$ building your own Penguin, Snipe, Windmill, Blue Jay, O K Dinghy, or Lightning sailboat. Send for free color catalog of kits and accessories.

TAFT MARINE WOODCRAFT
Dept. PM-12-8, 636 39th Avenue N.E.
Minneapolis, Minnesota 55421



HERE'S WHY A SHARPENING BUSINESS BUILT ON FOLEY Equipment Earns More Money FOR YOU!

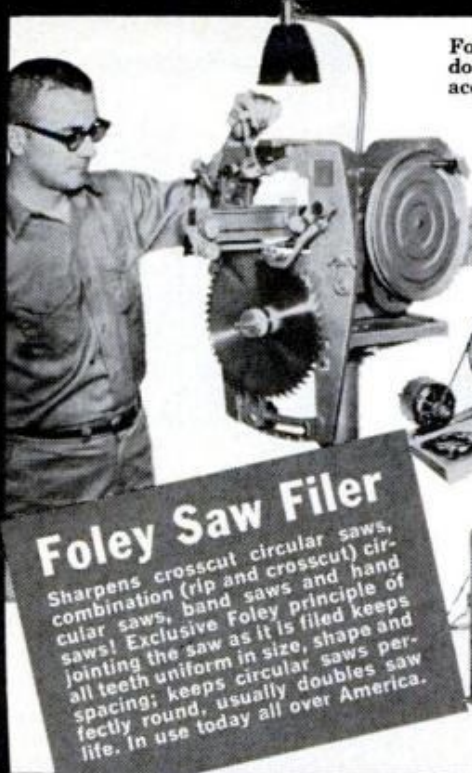

Foley Saw Filer

Sharpens crosscut circular saws, combination (rip and crosscut) circular saws, band saws and hand saws! Exclusive Foley principle of jointing the saw as it is filed keeps all teeth uniform in size, shape and spacing; keeps circular saws perfectly round, usually doubles saw life. In use today all over America.

Foley precision sharpening equipment has the built in skill to do a perfect job every time. No experience is necessary to accomplish a professional job—and you work better, faster, make more money with Foley quality equipment. The "Foley Plan" for success in the sharpening business has been developed through years of experience. Mail coupon for your free copy of "Money Making Facts" and see how Foley equipment can earn extra cash for you.

GRINDER ▶
Sharpens all types of circular saw blades—will handle any size from 5" to 44" in diameter. Attachments available for a variety of other sharpening jobs.

RETOOTHER
Cuts a full set of new teeth, either rip or crosscut, in less than a minute. Can be operated by either motor or by hand crank.

POWER SETTER ▶
Automatically sets band saw teeth up to 1 1/2" in width as well as all carpenter hand saws, either rip or crosscut. Available in two models.

MODERN LAWN MOWER SHARPENER — No need to remove reel with this money-making Foley Sharpener. Gives all year cash profits.

CARBIDE SAW GRINDER ▶
New precision machine grinds face, top, sides of carbide blades. Sharpens old teeth and replacement tips.



Foley Manufacturing Co. 516-9 Foley Bldg. • Minneapolis, Minn. 55418

Please send me FREE booklets checked below:

- A "Money Making Facts" Filer
- B Automatic Saw Filer
- C Automatic Retooler
- D Automatic Power Setter
- E Automatic Grinder
- F Modern Lawn Mower Sharpener
- G Foley Carbide Saw Grinder

Name _____

Address _____

City _____ State _____ Zip _____

SEND FOR FREE BOOKLET TODAY...



"I Earn Two Incomes Now"

Says JOHN BENNIE, Pittsburgh, Pennsylvania
"Thanks to your wonderful training, I have been able to earn \$20 to \$25 extra each and every week doing little locksmith jobs at home and after work at my regular job. This is the best trade a man can take up."

Be a LOCKSMITH

Train at HOME—Earn While You Learn. Add 50%-100% to YOUR INCOME with easy spare time earnings. Cash in on the nation-wide shortage—trained locksmiths in great demand! Quickly step into a big pay opportunity job or start a high-profit shop of your own.

Earn Extra Money RIGHT AWAY! All Master Locksmiths Special Tools, Equipment and Supplies Furnished FREE for use with course.

Age, education, minor physical handicaps don't matter in this growing trade. You can quickly qualify as a skilled locksmith. It's like a fascinating hobby. Study at home as little as one hour a week. Gain practical experience through complete well-illustrated lessons. Do real jobs on car locks, house locks, padlocks and safe locks, under the guidance of experts. FREE Illustrated Book, write now.

LOCKSMITHING INSTITUTE,
(Div. Tech. Home Study Schools)

Dept. 1110-059 • Little Falls, New Jersey 07424

MAY 1969

306 pieces of professional equipment
FREE for use with course.

Professional Equipment includes
**LOCKS—PICKS—PARTS—KEYS
SPECIAL TOOLS & SUPPLIES**
all FREE for use with course.

MAIL COUPON for FREE ILLUSTRATED BOOK

For a future as your own boss or in a high-pay job, write now for FREE Illustrated Book. Only school of its kind. Licensed by State of New Jersey. Approved for Veterans.

Accredited, Nat'l Home Study Council.

MAIL COUPON NOW

**LOCKSMITHING INSTITUTE, Dept. 1110-059
Little Falls, New Jersey 07424**

Please send FREE Illustrated Book—"Your Big Opportunities in Locksmithing," complete Equipment folder and sample lesson pages—FREE of all obligation—(no salesman will call).

Name _____
Address _____
City _____ State _____ Zip _____





more
SOCK
less shock

with the
PLUMB®
FA57

A "Proven Performer"

Swings easy and hits hard.

Dura-Cushion Grip absorbs shock.

And Plumb Fiber-Glass Handles are guaranteed not to break, bend or collapse in normal use.

They have been for over 13 years!

FAYETTE R. PLUMB, INC. •

PHILADELPHIA, PA. 19137

Advertised
Price
\$6.49

PUBLICATIONS **WORTH**
WRITING FOR

HANDY MAINTENANCE TIPS is the title of an informative booklet filled with tips, safety measures and shortcuts on cleaning and fixing more than 100 things in and around your home. Send \$1.25 to American Institute of Maintenance, 710 W. Wilson Ave., Glendale, Calif. 91209.

SHORT COURSE in natural wood finishing—an informative 24-page booklet—is filled with tips on staining, priming, filling, surface preparation and other essentials of wood finishing. Send 25 cents to Pierce & Stevens Chemical Corp., Box 1092, Buffalo, N.Y. 14240.

ADEQUATE VENTILATION and how to avoid the damaging effects of insufficient air circulation in new and existing homes are discussed in a four-page brochure entitled *The Ventilating Story*. For a free copy write for Brochure 500, George M. Stephenson & Co., 15752 Industrial Parkway, Cleveland, Ohio 44135.

HOW TO SAIL is a booklet designed to encourage the novice sailor by taking the mystery out of sailing. Written in simple terms, it explains the basic elements of sailing, as well as the most common sailing terms nomenclature. Free from Nordex Industries, P.O. Box 7, Zenda, Wis.

IF YOU'RE THINKING of beautifying your home with aluminum railings and columns, you'll be interested in the booklet called *Four Seasons Brochure*. For a free copy write Bel-Met, Inc., 439 S. Maple Ave., Greensburg, Pa. 15601.

3 WAYS to a profitable business of your own

— and only —

VON SCHRADER HAS ALL 3

Von Schrader is the oldest and largest company making Detergers of this type. For over 30 years our FREE ENTERPRISE PLAN has been fashioned with your future in mind. Start with the Deterger that most appeals to you. We have thousands of Associates who have built successful businesses with just one Deterger. Naturally, bigger and more profitable businesses can be built when you are able to offer two or all three cleaning services.

For example, let's say you start with the

VON SCHRADER WALL DETERGER

(LOWEST PRICE OF ALL THREE)

1 • Associate G. H. Jones made \$1200.00 on one job. Associate R. G. Fullmer says contracts this year will gross about \$18,000.00. And no wonder...this machine washes walls 6 times faster than by hand...with no mess...no drop cloths needed. Washing is so easy...no tiresome scrubbing...special glider wipes walls clean with little effort. You can start part-time and by working week-ends add hundreds of dollars to your income while still employed.

Then you can double your profit by adding the

VON SCHRADER UPHOLSTERY DETERGER

2 • Associate Charles Lemmin averaged \$100.00 a day during his first year. Associate Peter Young took in \$960.00 last week. You clean upholstered furniture on customers' premises—homes, hotels, motels, etc....even auto upholstery. No hauling...operate from your home. Watch business grow as customers tell their friends.

And, finally, you can more than triple your profits by adding the

VON SCHRADER RUG DETERGER

because each service helps to sell the other two

3 • Associate C. E. Nevin reports he averaged \$1000.00 a month for 12 months. An Associate father-son team grossed \$33,000.00 their first year. Von Schrader's FREE ENTERPRISE PLAN is not a lease arrangement. You sign no contract. You own the equipment. You pay no fees, dues or royalties to anyone. Every dollar you take in is yours to keep.

Full Operating Instructions come with each Deterger... you need no special skill or training. And our Business Manual tells everything you need to know about getting business, suggested sales letters, tips on keeping books and tax records, suggested ads and radio announcements, etc. Our assistance is always at your service. Training and consulting with experts is also available...and without charge.

Don't Delay...it costs nothing to get the details. Return the coupon TODAY for informative FREE booklet. Be sure to check the Deterger you are most interested in starting with.

VON SCHRADER MFG. CO.

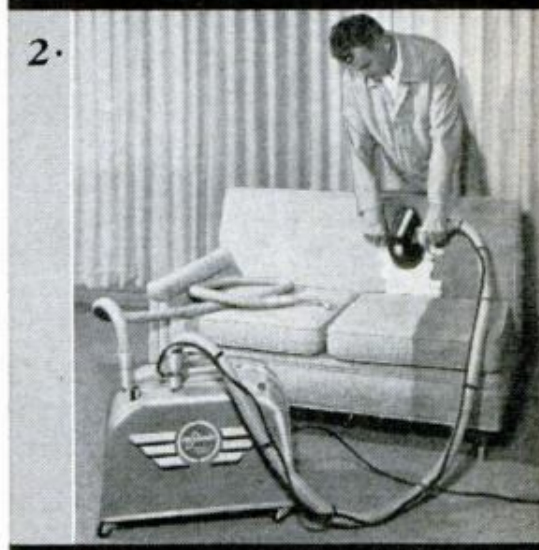

SEND FOR THE FACTS TODAY

VON SCHRADER MFG. CO.

9510 "A" Place, Racine, Wis. 53403

Please rush information about your

_____ DETERGER(S)

(Write in name of detergent(s))

and how I can start my own profitable business.

Name _____

Address _____

City _____ State _____ Zip _____

An oil for cars that don't get enough exercise.



If you do a lot of stop and go driving, your car needs extra protection. It's the kind of driving that causes harmful deposits to build up in your engine.

Quaker State Motor Oil has a natural ability to resist engine wear that's caused by these deposits.

Every drop is refined from

100% Pure Pennsylvania Grade Crude Oil. This oil is free from many impurities, like tars and asphalts, even before it's refined.

We start with the world's finest oil. And then we improve it even more. So if you can't give your car enough exercise, why not give it Quaker State Motor Oil.



Quaker State your car to keep it running young.

A Treasury of HARD-TO-FIND TOOLS NEW CATALOG

Unique collection of hard-to-find versatile hand tools and small power tools rarely found in stores or other catalogs. Large selection of unusual knives, precision tweezers, jewelers' and electronics pliers, flexible shaft machines, endless hacksaw, diamond glass cutter, soldering jigs, carbide hacksaw blades, silver solder, micro-miniature tools and scores of other fascinating items to make projects easier, more fun. All are top quality tools. Used extensively by woodworkers, machinists, craftsmen. Money back guarantee. Send 25¢.

BROOKSTONE CO.

5924 RIVER ROAD, WORTHINGTON, MASS. 01098



INVENTORS

**INVENTIONS—NEW PRODUCTS—IDEAS
DEVELOPED & PREPARED**

For Commercial Appeal & Sales

DESIGN—MARKETING—PATENT SEARCHES—DRAWINGS

*United States Patent Office former Patent Examiner
United States Dept. of Army former Patent Adviser
Member: United States Chamber of Commerce
Second Decade of Reliable Service to*

INVENTORS—MANUFACTURERS—ATTORNEYS

— — — — — FREE CONSULTATION — — — — —

THE RAYMOND LEE ORGANIZATION

230-Z Park Ave., New York 10017 (212-MU 6-8500)

SEND FREE "INVENTION RECORD" Form & "IMPORTANT PATENT INFORMATION"

Name _____

Address _____

City _____ State _____ Zip _____

Join "THE TROUBLESHOOTERS"

who get paid top salaries for keeping today's electronic world running

Suddenly the whole world is going electronic! And behind the microwave towers, push-button phones, computers, mobile radio, television equipment, guided missiles, etc., stand THE TROUBLESHOOTERS—the men urgently needed to inspect, install, and service these modern miracles. They enjoy their work, and get well paid for it. Here's how you can join their privileged ranks—without having to quit your job or go to college to get the necessary training.

JUST THINK how much in demand you would be if you could prevent a TV station from going off the air by repairing a transmitter...keep a whole assembly line moving by fixing automated production controls...prevent a bank, an airline, or your government from making serious mistakes by servicing a computer.

Today, whole industries depend on electronics. When breakdowns or emergencies occur, someone has got to move in, take over, keep things

running. That calls for a new breed of technicians—The Troubleshooters.

Because they prevent expensive mistakes or delays, they get top pay—and a title to match. At Xerox and Philco, they're called Technical Representatives. At IBM they're Customer Engineers. In radio or TV, they're the Broadcast Engineers.

What do you need to break into the ranks of The Troubleshooters? You might think you need a college degree, but you don't. What you need is know-how—the kind a good TV service technician has—only lots more.

What You Need to Know

As one of The Troubleshooters, you'll have to be ready to tackle a wide variety of electronic problems. You may not be able to dismantle what you're working on—you must be able to take it apart "in your head." You'll have to know enough electronics to understand the engineering specs, read the wiring diagrams, and calculate how the circuits should test at any point.

Learning all this can be much simpler than you think. In fact, you can master it without setting foot in a classroom or giving up your job!

For over 30 years, the Cleveland Institute of Electronics has specialized in teaching electronics at home.

We've developed special techniques that make learning easy, even if you've had trouble studying before. Our AUTO-PROGRAMMED® lessons build your knowledge as easily and solidly as you'd build a brick wall—one brick at a time. And our instruction is personal. Your teacher not only grades your work, he analyzes it to make sure you are thinking correctly. And he returns it the same day received.

Get FCC License or Money Back

Two-way mobile work and many other types of troubleshooting call for a Government FCC License. Even if your work doesn't require a license, it's a good idea to get one. It will be accepted anywhere as proof of good electronics training.

The licensing exam is so tough that two out of three non-CIE men who take it fail. But 9 out of 10 CIE graduates pass. That's why we can offer this warranty. If you complete one of our license preparation courses, you will be able to get your FCC License—or your money back.

Mail Card for 2 Free Books

Want to know more? Mail bound-in postpaid card for our 44-page catalog on CIE courses, and book on how to get an FCC License. If card is missing, use coupon below.

ENROLL UNDER NEW G.I. BILL

All CIE courses are available under the new G.I. Bill. If you served on active duty since Jan. 31, 1955, or are in service now, check box in card for G.I. Bill information.

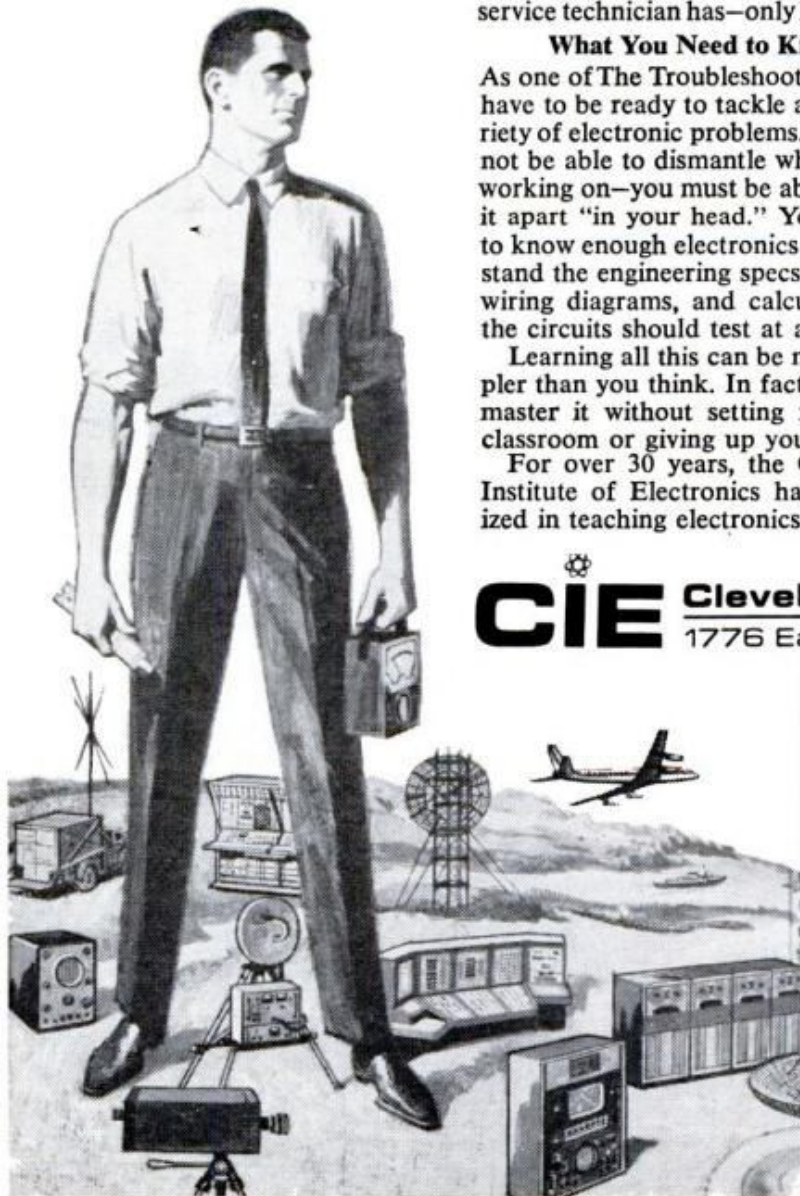

CIE Cleveland Institute of Electronics
1776 East 17th Street, Cleveland, Ohio 44114

Cleveland Institute of Electronics
1776 E. 17th St., Cleveland, Ohio 44114

Please send me without cost or obligation:

1. Your 44-page book "How To Succeed In Electronics" describing the job opportunities in electronics today, and how your courses can prepare me for them.
2. Your book on "How To Get A Commercial FCC License."

Name _____ (Please Print)

Address _____

City _____

State _____ Zip _____

Occupation _____ Age _____

Check here for G.I. Bill information

Accredited Member National Home Study Council **PM24**



ACCORDIONS and AMPLIFIERS

BIG SAVINGS up to 1/2 or more on famous make accordions. Over 40 models. Standard and new electronic models. Buy direct at low discount prices. Get five-day home trial. Small down payment, easy terms. Free gifts. Trade in allowance. Money back guarantee. Rush coupon for color catalogs, discount price list. Accordion Corp. of America, Dept. R-59, 5535 W. Belmont Ave., Chicago, Illinois 60641

COUPON BRINGS FREE COLOR CATALOG & DISCOUNT PRICES	ACCORDION CORP. of AMERICA—Dept. R-59 5535 W. Belmont Ave., Chicago, Illinois 60641 Send FREE Color catalogs and discount prices. Include special information checked:
	<input type="checkbox"/> Amplifiers <input type="checkbox"/> Button Type Accordions
	Name _____
	Address _____
	City _____ State _____ Zip _____



Transistor Radio with Battery \$1.70
Calendar Watch \$2.44
Derringer Pistol \$5.99

HOME-IMPORT BUSINESS—Make Big Profits

New Drop Ship Plan offers you first day profits! Deal direct with overseas sources at prices shown. Dazzling bargains with no investment. Full or spare time. Write for FREE BOOK today to...
MELLINGER, Dept. C2255, 1554 S. Sepulveda, Los Angeles, Calif. 90025

LEARN DRAFTING AT HOME <small>Your FUTURE in DRAFTING</small> <small>APPTITUDE TEST</small> <small>SAMPLE LESSON</small> ALL 3 FREE	U.S. Labor Dept. says "42% more Draftsmen needed next 10 years." Send for FREE "DRAFTING CAREER KIT." No salesman will call.
	NAME _____ AGE _____
	ADDRESS _____
	CITY _____ STATE _____ ZIP _____
	NORTH AMERICAN SCHOOL OF DRAFTING, Dept. 4175 Accredited National Home Study Council 4500 Campus Drive, Newport, California 92660

LAW FREE BOOK THE LAW TRAINED MAN

Write today for a FREE copy of illustrated law book, "THE LAW TRAINED MAN," which shows how to earn the professional Bachelor of Laws (LL.B.) degree through home study of the famous Blackstone Law Course. All necessary books and lessons provided. Moderate cost; convenient monthly terms. Write for FREE law training book today.
Blackstone School of Law, 307 N. Michigan Ave. Dept. 55, Chicago, Illinois 60601
Founded 1890

EVERLITE • World's THRIFTIEST Light Plants



The Champion—1200 watts 115 volts AC for only \$149.50
Unbelievable but true—Brand new production methods now make possible world's finest design in a service free alternator light plant at this unprecedented price. Plant puts out a steady 1200 watts of 115 volt AC power to run power tools, oil burners, pumps, TV, or anything that requires up to 1200 watts. Powered by a rugged 3 HP, 4 cycle, easy start gas engine with 1 year factory warranty. Complete with carry handle and shock mounts. Why fool with short life 2 cycle plants when you can buy this rugged top quality machine at our factory price.
Item # 1265 \$149.50
wt. 65 lbs.

MASTER MECHANIC MFG. CO., Dept. A-59 Burlington, Wis.
Southern Customers write Dept. A-59, Box 65, Sarasota, Florida

Now you can "Turn on the table" and hear your hi-fi!

Revolutionary, super-thin, super hi-fi speakers let you get sound from the smallest spaces! Doors, chairs, tables, even from auto sun-visors. Easy to install. See your audio or parts dealer or write for full data on these new hi-fi space savers.

The Magitran Company
311 E. Park St., Moonachie, N. J. 07074



	ALL-PURPOSE ONE PIECE JUMP SUITS Guar. Permanent Press-Machine Washable
	Perfect for camping, fishing, boating, hunting, golfing, and leisure wear. Available in Gold, Blue, Brown, Avocado, Sky Blue, Rust, and Black.
	Men Sizes: S-M-L-XL. Women Sizes: 8 to 18. Children Sizes: 6 to 18.
	ADULTS—\$14.95 CHILDREN—\$12.95 Prepaid
	CREATIVE SPORTSWEAR, P.O. Box 712, Marion, S.C. 29571

ALL TV-RADIO RECEIVING TUBES \$1.50

• ALL BRAND-NEW, First Quality. All Types Available • Orders Shipped First Class Same Day Rec'd. • Unconditionally Guaranteed. • 24 Month Warranty.
Send \$1.50 for ea. tube + 50¢ postage & handling of entire order. FREE: Write for TV Test Chart and Tube List to Dep't PM-59



UNIVERSAL TUBE CO. Cape May, N.J. 08204



NOW...END BATTERY FAILURES due to corrosion

Sure Start Battery Kit: not a coating, but a fully vulcanized, sealed jacket for battery clamps and terminals. Protects new or used batteries. Auto, boat, aircraft. Easily applied; permanent, but strips cleanly if clamps need to be removed. (Pat. Pend.). In U.S.A. send \$1.88 plus 25¢ postage.

Energy Products Co., Inc. P.O. Box 1339, San Mateo, Calif. 94401 Enclosed find my money order of \$2.13 for the Sure Start Battery Kit.			
NAME _____			
ADDRESS _____			
CITY _____	STATE _____	ZIP _____	

TOM McCAHILL SAYS:

"There's no mystery to making money if you can repair these things"

The greatest detectives in history would be hard pressed to track down somebody to fix a bum toaster or dishwasher these days. It's funny: you have no trouble finding any number of so-called experts who'll fix a leaky pipe or a home run through the picture window. But electrical appliance repairmen are still as scarce as hippies in bathtubs.

If you're lucky enough to get a repairman to come from across town, he'll eventually have your bum dishwasher humming again like bees at a picnic. He'll also present you with an oversized bill. That's where the picnic ends.

If you're in the market for more money you don't need to be a super-sleuth to find it. Look for clues in your own hacienda. If you're typical, you own a couple dozen appliances, counting your wife's hair dryer, power tools and usual plug-ins like air conditioners, toasters, refrigerators, freezers, fry pans, and on and on. A lot of men like yourself have built rewarding full-time businesses after starting part-time earning \$5 and more an hour fixing broken appliances. Others have found full-time jobs as Service Technicians. And when you hit Social Security years, think how great it would be to pick up a little extra cash doing as much Appliance Repair as you cared to do.

The Appliance Division of the National Radio Institute in Washington, D.C., has a great low-cost, home-study course covering every type of Appliance repair in detail—from toasters and irons to air conditioners, refrigeration equipment and one-lung gas engines. There's a section on farm and commercial appliances, too, if you're interested in a big payoff, for when major appliances go kaput, they're as useful as moose antlers on a mouse.

To get technical know-how, NRI starts you with basic principles of electricity. You can gain ex-



perience through actual practice, using an Appliance Tester included in the low cost of training. It's the same kind of tester a professional would use while charging you six bucks an hour. With the tester and a few basic hand tools, you can be repairing Appliances long before you finish the course. All you need for a shop is a corner of your basement or a card table left up between poker games.

You'll be amazed at how easy NRI has made this course. Lessons are bite-size and loaded with photos and drawings so you see how each appliance comes apart—and goes together again. Men who felt they were as handy as icemen in the Arctic have nothing but praise for this great training.

The coupon below will get you a free NRI catalog with all the facts. There on it's up to you. No salesman is going to bother you. Do yourself a favor and mail the coupon today . . . tomorrow morning, for sure.

Tom McCahill

TOM McCAHILL

NATIONAL RADIO INSTITUTE, APPLIANCE DIVISION
3939 Wisconsin Avenue, Washington, D.C. 20016

APPROVED UNDER NEW GI BILL
If you served since January 31, 1955 or
are in service, check GI line below.

600-059

OK—I want to see for myself. Send me the free book on Professional Appliance Servicing. No salesman will call.

Name.....Age.....

Address.....

City..... State..... Zip Code.....

Accredited Member National Home Study Council.

Check for facts on new GI Bill.

The bargain hunter

AMERICA'S ORIGINAL LOW-COST ARC WELDER AND ELECTRIC TORCH

10 DAY
TRIAL

LIFETIME
GUARANTEE



New Improved HEAVY DUTY FOUR-WAY

Only \$18⁹⁵ Prepaid Complete Ready To Use
WELD, BRAZE, SOLDER, CUT
All Metals Including Aluminum

Every home, shop, and hobbyist needs this quality metal working machine. Anyone can use. No experience needed. Use up to 1/8" welding rods and 1/4" carbons to make or repair 1001 items including furniture, garden tools, toys, auto bodies, fenders, trailers, boats, farm equipment. Operates on 110 V. line for pennies—replaces gas torches—no tanks or refills to buy — produces to 11,000° heat. Twin Carbon Arc Torch easily controls heat for each job **YOU CAN PAY MORE BUT YOU CAN'T GET A BETTER LOW COST WELDER.** Over 500,000 in use. Manufacturers of welders for over 30 years. **LIFETIME UNCONDITIONAL GUARANTEE.** Simply return. We will repair or replace and ship **FREE** of charge. **YOU GET:** heavy duty welder in rugged metal cabinet, ground clamp, cables, combination torch and rod holder, welding manual and helmet, plus Free \$2 pack "TOUCH WELD" rods for instant and automatic arc, brazing rods, 1/4" carbons, solder and flux.

ORDER TODAY ON 10-DAY UNCONDITIONAL MONEY BACK TRIAL.

MAIL THIS ORDER COUPON NOW!

Four-Way Welder Co., Dept. R2-E,
1810 S. Federal St., Chicago, 60616

Please send welder as indicated below and include **FREE** gift of
 Wrench Kit or, Wire Tool or, Welding Rod Pack.

Enclosed \$18.95. Ship Enclosed \$2.00. I will pay \$16.95
postpaid in U.S.A. plus C.O.D. and delivery charges.

NAME _____

ADDRESS _____

CITY _____ STATE _____ ZIP _____

FREE EXTRA BONUS GIFT with your order. Choice of:

1. 10-piece wrench, plier and screw driver kit in case, or,
2. Wire forming tool. Forms wire to weld valuable items, or
3. Big pack welding & brazing rods, carbons, flux & solder.

SPECIFY CHOICE OF FREE GIFT WITH YOUR ORDER

SEND ONLY \$2.00 and pay \$16.95 plus C.O.D. and
delivery charges, or send only
\$18.95 and we pay delivery in Continental U.S.A.

FOUR-WAY WELDER CO.

1810 S. Federal St., Dept. R2-E, Chicago, 60616



EVERY HANDYMAN NEEDS HANDY DANDYS

Handy Dandys are sturdy, plastic caps that snap into 1/4" pegboard and hold quarter twist baby food jars. They're ideal for storing all kinds of supplies, parts and small tools. "Try-'Em-Out Package" of 8 only \$1 ** 36 for \$3.50 ** 72 for \$6 ** 500 for \$36.50. Shipped USA postage prepaid—no C.O.D.'s.
WICKLIFFE INDUSTRIES, INC., P.O. Box 286, Dept. PM-5, Wickliffe, Ohio 44092.

GUITARISTS: SELF-HELP HERE!



Study cards for beginners to learn fingerboard rapidly \$1.25. Self-Help manual of Classical & Folk Technique \$1.25. Manual of over 90 Folk Strums \$1.25. All three for \$3. Unrestricted money back guarantee. Other items available. Send check or M.O. Now to—

Bob Noll's Guitar Service Station
349 Lincoln Avenue, San Jose, California 95126

LOCK BLADE MILITARY-KNIFE \$1.50 OVERALL LENGTH 7 3/4"



Incredibly Sharp—Top Quality—Rust-proof Military Lock Blade Knife. Made of solid stainless steel for very rugged use. An all purpose knife you'll be pleased to own. Only \$1.50 plus 25¢ for postage and handling. Supply Limited, Order Now. Satisfaction Guaranteed or Money Back.

WESTBURY SALES, Dept. M-58
P.O. Box 434, Westbury, N.Y. 11590



FREE!!! POWERFUL MUSCLES FAST!

Fantastic New Discoveries in the science of bodybuilding. Now, in the privacy of your bedroom, our method will add inches of powerful muscles to arms, chest, shoulders & legs. Learn secrets on trimming the waist with ultra-modern methods—fast! Results Guaranteed! Send for free brochure, Universal Bodybuilding, Box 5327, M-15, Northeastern, Dearborn, Mich. 48126.

TAX SALE - \$1 ACRE

Properties now being sold for municipal tax arrears. Hundreds of cottages, farms, hunt-camps, timberlands, homes from coast to coast along Canadian Border. Purchase direct from Tax authorities—NON PROFIT! For lists, pictures, regulations, write: Register, Room 22, 110 Church Street, Toronto, Canada.

WHEN
ANSWERING ADS
GIVE YOUR
ZIP CODE

The bargain hunter



GRIND-EZE

GRINDING WHEEL DRESSING BEATS THE HEAT!

GRIND-EZE is a brand new product that beats the old dulling agent... it beats the heat generated that ruins the temper in tools when they are being sharpened or otherwise ground.

- KEEPS METAL COOL
- NO TEMPER LOSS
- SELF-LUBRICATING
- GRIND WHEEL LASTS LONGER

1.5 oz. Tube \$2.00 • Money-Back Guarantee

ANDERSON-LAKEY CO. P 1
P.O. Box 2342 • Paseo, Washington 99301

BULL FIGHTER
Lock Blade

STILETTO KNIFE

5 1/4" Overall Length
3" Blade

ONLY \$1.25

- Tough and Sharp
- Opens Instantly
- Stainless Steel
- Folding Finger Guard
- Blade Locks

Flips open instantly and locks automatically to prevent accidental closing. Razor sharp tough stainless steel blade for reliable use and hard, long service. Money back in 5 days if not satisfied. Send \$1.25 plus 25c to cover postage & handling. Please state age.

WESTBURY SALES CO., DEPT. B M54B
P. O. BOX 415, WESTBURY, N. Y.

GLEN

.....boat plans full size patterns frame kits.....

catalog 50¢

BOAT PLANS—PATTERNS—FRAME KITS
Send 50¢ for Glen L's new catalog offering a complete selection of build-it-yourself designs with step-by-step instructions. Inboards & outboards, jets, 16' to 36' cruisers, 8' to 21' sailboats, houseboats, hot boats, boat trailers and camper trailer. Books: Inboard Motor Installations in Small Boats \$8.00 ppd.; Boat Building With Plywood \$7.50 ppd.; How To Build Boat Trailers \$3.00 ppd. Glen L. 9152T Rosecrans, Bellflower, Calif. 90706.

START YOUR NEW CAREER NOW!
without overhead, any place, any age!

UPHOLSTERING JUST ONE CHAIR can pay you as much as your present weekly paycheck!
you don't even have to quit your present job!

Start Learning NOW!
At home, or in the garage, in your spare time.

SEND FOR FREE UPHOLSTERY CAREER BOOK

Start as a part-time hobby... then, as you learn you just slip into the immense flow of upholstery work! Earnings to \$10 an hour! Learn to re-upholster sofas, lounging chairs, ottomans, built-ins, trailers, boats, campers, autos. Once you learn, you will have one of the most fantastic, money-making skills in America which no one can ever take away from you! Work the hours you choose—in any location you choose—big city, small town, farm, beach, mountains, anywhere. Six big furniture kits included FREE! Send for free UPHOLSTERY CAREER BOOK today—plus free sample lesson. M.U.I. approved by Calif. Superintendent of Public Instruction. Send for free information and free career book now!

APPROVED FOR VETERANS
MODERN UPHOLSTERY INSTITUTE, Box 899-BRC
Orange, Calif. 92669

FREE FEL-PRO GASKET MANUAL
... for top performance in all gasket applications
Learn about the latest gasket materials and trouble-free gasket installation techniques from Fel-Pro... for 50 years a leader in gasketing improvements. Improve engine... transmission... and rear end performance with these helpful tips. 36 fact-filled pages.

Write: FEL-PRO, INC.
7452 N. McCormick Blvd. Dept. 5PM
Skokie, Illinois 60076

FREE FEL-PRO GASKET MANUAL
... for top performance in all gasket applications
Learn about the latest gasket materials and trouble-free gasket installation techniques from Fel-Pro... for 50 years a leader in gasketing improvements. Improve engine... transmission... and rear end performance with these helpful tips. 36 fact-filled pages.

Write: FEL-PRO, INC.
7452 N. McCormick Blvd. Dept. 5PM
Skokie, Illinois 60076

- Increase Your Car's Power and Gas Mileage
- Reduce Engine Maintenance
- Instant Starting in All Climates!

CAPACITIVE DISCHARGE IGNITION SYSTEM

ONLY \$29.95 ppd

Completely wired, ready-to-install (not a kit)

- Easy installation (use original coil)
- Solid state reliability
- G-10 type spacecraft circuit board
- Distributor points last lifetime of car
- Spark plugs last 3 to 10 times longer
- No changes required on timing or dwell
- Switch built-in for instant change from CD unit to original ignition system
- For 12-volt negative ground systems only
- 1-year written guarantee

ORDER NOW!

Bay PRODUCTS, INC. P-5
P.O. Box 9562, Houston, Texas 77011

Enclosed is \$29.95 for Model SW100 Capacitive Discharge Ignition System ready for installation.

Name _____
Address _____
City _____ State _____ Zip _____

NEW SLIM-GARD Trims inches off your middle, waist, hips & lower back without dieting—without exercising! All you do is wear it. Stretches approx. 6". Made of finest, most resistant neoprene rubber. Easy to slip off & on. Sizes: S, M, L. \$9.98. Slim-Gard Co., 531-32nd St., Dept. 38-59SG, Union City, N.J. 07087.

You can't miss in **CARTOONING & COMMERCIAL ART!**
ANYONE can learn to draw...

Some people waste natural talent. Others develop theirs into richer, fuller, more rewarding careers. New easier methods and personal instructions show you how. Or get our self-teaching manuals. FREE brochure. Your Satisfaction Guaranteed.

Famous American Studios
Dept. P2 SPRING PARK, MINNESOTA 55384

The bargain hunter

FOLLOW APOLLO!



Like NASA's moon rockets,
VASHON ROCKETS
are **LIQUID FUELED!**

Altitudes over 1,000 feet • Polished aluminum body • Electrically fired • Parachute recovery • Safe — not explosive or flammable • Available anywhere in the U.S.A.
INFO-PACKED CATALOG Complete Vashon liquid rocket line and accessories—[25¢

VASHON INDUSTRIES, INC.
Box 309-MP, Vashon, Washington 98070

invest in waterfront

10-40 ACRES \$700-\$2000
\$50 down \$25 mo.

Choose green forests, hills on streams or lakes near towns in Idaho, Mont., Wash. Great fishing, abundant game. Invest now. Value increases as land taken. Clear insured titles, road access. Most tracts have water frontage or access. FREE color photos, description maps. Our foresters will show any tract. Write today!

TIMBERLAND RESOURCES
Dept. P-3, Bx 4246, Spokane, Wa. 99204



Secrets of teaching yourself music

Play familiar tunes right away. Learn real music at home with clear text, big pictures, remarkable notefinder (above). Join 1,300,000 students. Play guitar, organ, piano, sax, etc. For free 36-page booklet, send name, address, zip and name of instrument to: U.S. School of Music, Studio A305, Port Washington, N.Y. 11050. Approved by N.Y. State Education Dept. A305.

WHEN
ANSWERING ADS
GIVE YOUR
ZIP CODE

Closed: A practical all-purpose hunting knife with a four inch blade. Open: A flick of the wrist extends the blade to 8 full inches of cold steel, razor sharp and ready for anything. Commando tasks, skinning deer, throwing, or just plain whittling. High carbon steel blade, tempered and honed to a fine unyielding edge. Handle of bone and brass. Blade locks in place at 4" and 8" position, yet flicks easily from one to the other. Special locking mechanism prevents accidental closure. The Cobra is eager and bursting to work, too big a friend to be contained. Quality and satisfaction guaranteed. Leather sheath with metal tip included.

\$6.95 Post-paid, (sorry no C.O.D.'s)

NELSON BRAND
P.O. Box 1023
Dept. P Fort Lee,
N.J. 07024



THE COBRA
A double action buddy!



Thousands of exciting tool values!

SILVO (BRAND NAME) TOOL CATALOG

Thousands of Exciting Tool Values! Stanley, Millers Falls, Skil, Thor, Wen, Disston, Wiss, Wellsaw, Dremel, Speedy Sprayers, Plumb, Huot, Kennedy, Channellock, Porter-Cable, Rockwell, Helios, Vise-Grip, Crescent, Ridgid, Pony Clamps, Unimat, Foredom and many other Nationally Advertised brands of Tools & Supplies. We ship Coast to Coast at prices Hard to Beat. Send 25¢ for our big 132-page tool catalog, today. Silvo Hardware Co., PH-5, 107 Walnut St., Philadelphia, Pa. 19106.



FREE MUSCLE COURSE!

Want a new Jet-Charged body? In 15 minutes I'll prove you can slap on 4" of muscle to your chest—3" to each arm—give you life-guard shoulders, trim your waist to athletic size—give you speedy athletic legs. I don't care if you're short or tall (skinny or fat) young or not so young, expect a muscle building miracle when you send for my free course. Send only 25¢ to cover postage and handling to Joe Weider, Dept. 38-59D2, 531 32nd St., Union City, N.J.

FREE CATALOG—Popular Mechanics 16 page illustrated catalog of publications and projects. Lists hundreds of items for the home and shop. Covers tools and machines, hobbies, boating, home repair and maintenance, hundreds of others. You name it, we have it! For your free copy write to Popular Mechanics, Dept. HL, 575 Lexington Ave., New York, N.Y. 10022

The bargain hunter

**LESS THAN 15¢ PER OIL
FILTER CHANGE WITH
AMAZING**

STILKO



**ETERNAL
OIL CLEANER**

Full-flow oil filtering system uses the best-known filtering material available anywhere—toilet tissue—already proven in thousands of automobiles. Recommended for all types of cars and trucks. Keeps oil cleaner sludge-free and carbon-free. No costly installation or maintenance—simply spins on in place of regular throw-away filter! Each filter change costs less than 15¢ and oil lasts longer (some users report never changing oil). Fully guaranteed. Send check or MO for \$24.95. Or send \$5.00 and pay balance COD. Include Make, Model & Year of car, engine type and no. of cylinders.

STILKO ETERNAL OIL CLEANER
7445 Convoy Court
San Diego, Calif. 92111

TREASURE & COIN DETECTOR

10-DAY FREE TRIAL

New electronic circuit guarantees at least **TWICE THE DETECTION ABILITY** of any detector in this price range or your money back. Find gold, silver, coins, old weapons, etc. Works through earth, beach sand, water, wood, rock, etc. New circuit gives more power, more depth. Not a "probe" type but a fully electronic, 1969 model detector never offered before and available only from **VIKING**. Only detector in this price range sold on **unconditional MONEY BACK GUARANTEE!** You must



29⁹⁵
POST PAID

agree it will outperform any detector costing **TWICE** this low price or refund in 10 days for refund of cost. Only **VIKING** dares make this offer.

Fully transistorized, uses ordinary 9V battery, weighs 2 pounds. Gives loud, clear signal when object is detected. **NOTHING ELSE TO BUY.** Complete, ready to operate. Send \$29.95, check, cash or M.O. for postpaid shipment or \$3.00 and pay postman \$26.95 plus small C.O.D. when delivered.

VIKING DETECTORS
Dept. V-2, Box 10880
Houston, Texas 77018

**Mechanics, Hobbyists, Homeowners!
NEVER AGAIN RUIN YOUR WORK
OR RISK COSTLY TOOL BREAKAGE**



DRILL 'n TAP GUIDE
FOR PROFESSIONAL RESULTS EVERY TIME!

Drill straight every time with portable power drills, up to 1/2". Tap holes without breakage. Cross drill tubes, rods dead center. Thread rods evenly. Set rivets true. Drive pins with no effort. Use in place of drill jig bushings, as V-block, parallel or mounting block. Check the size of pins, rivets, screws. Simple directions and valuable Selector Chart included **FREE**.

American made of hardened steel.
MONEY BACK GUARANTEE \$6.98
Add 75¢ postage and handling

AMEDEN CORP. 94-40 158 St., Dept. M5
Jamaica, N.Y. 11433



STRATFORD TRAILER KIT

Build your own camper trailer from kit or plans. Included in kit is completed tent, welded steel work & special hardware. Camper opens to 6 1/2' x 16' long, also 7' x 16'. Features double beds, dinette, cabinets. Sleeps 6 or more. Kit \$324. Or parts sold separately. Complete building plans with 15 photos—\$3.00 or send 15¢ for circular.

STRATFORD FABRICATING CO.
P.O. Box 376-P, Newfield Sta.,
Stony Creek, Conn. 06405

**When you see
this mark**

**POPULAR
MECHANICS
PRODUCT FEATURE**

**you've seen
the product in
Popular
Mechanics**

GET YOUR FREE Sharpening Catalog

New **TREYCO** Catalog shows how to start your full or part time sharpening business. Make as much as \$6.00 an hour, enjoy extra cash now and safeguard your future and security. Everybody wants sharpening service—neighbors, hobbyists, barbers, beauty shops, markets, restaurants, contractors, farmers, rental shops. **TREYCO 6-in-1** machines hollow-grind knives, tools, scissors, pinking shears, rotary mower blades, garden tools, hand and circular saws, etc. Thousands of users since 1946. **ACT NOW**, write for your **FREE CATALOG** and Low Factory-to-You Prices.



**TREYCO
Products, Inc.**

381 Niagara St.
N. Tonawanda,
N.Y. 14120

NEW! PROTECTS HOME! KEEPS RATS OUT!



DON'T SIT ON A "TIMEBOMB"! NOW, protection YOU CAN AFFORD! New patented **RATGARD (TM)** STOPS RATS COLD . . . BARS ENTRY THRU TOILET BOWL PLUMBING . . . a proven danger to EVERY home! Made of stain and corrosion-resistant, milk-white Delrin and stainless steel. Slips quickly into place from top of toilet. Clamps securely to top edge of exit hole **IN SECONDS**, with screwdriver. Entirely under water, hinged tonque bars rats . . . rides up readily for free flushing action. **SIMPLE, ATTRACTIVE, EASY-TO-INSTALL . . . AND IT WORKS!** 1-UNIT just \$3.00 ppd., 2 or MORE just \$2.50 ea. ppd.

ORDER TODAY! BY MAIL ONLY! SATISFACTION GUARANTEED!
HOMGARD, INC. P. O. Box 4155 Omaha, Nebr. 68104

SEND ME _____ RATGARD (TM) UNITS

NAME _____

STREET _____

CITY _____ STATE _____ ZIP _____

CLASSIFIED ADVERTISEMENTS

Rate: \$1.85 per word payable in advance each insertion. Capitalized words—75¢ per word additional. Minimum insertion ten words. To be inserted under the proper classification, copy must be in our office by the 15th of the second month preceding date of issue. The next available issue to place an advertisement in America's No. 1 Classified Section is July. The closing date is May 15th. Send remittance and order to C. A. Martin, Popular Mechanics, 575 Lexington Avenue, New York, New York 10022. Please make remittance payable to Popular Mechanics.

AUTOMOBILES,

WARRANTEE TROUBLES? Don't purchase any new car or truck until you have our **COPYRIGHTED** instructions advising important steps to take before taking delivery. Will force prompt and satisfactory warrantee work. Also advice on your vehicle now under warrantee. Save yourself frustration, mental strain, ulcers. **COPYRIGHTED INSTRUCTIONS \$5.00.** N. Lee Phillips, 5725 West 5th Avenue, Denver, Colorado 80226.

MIDGET CARS

YOUR Ad in this space will be read by more than 1,662,961 active mail order buyers. Join the march to greater profits, place your products and services in front of them today with a small low cost classified ad. For further details, write: C. A. Martin, Dept. 1R, Popular Mechanics, 575 Lexington Avenue, New York, New York 10022.

AUTO SUPPLIES AND EQUIPMENT

CROSLEY And foreign car parts. Box 7, Elmont, N.Y. 11003.

JEEP Owners—V8 conversions. Read Jeep Owners, ad, page 206.

TRANSMISSION OVERHEATING—90% of automatic transmission failures are due to excessive heat buildup. \$1.00 (refundable) brings heat range chart and info. Bill Tugend, P.O. Box 4293, Panorama City, Ca. 91412.

CARBURETOR Runs Engines on Fumes. Best mileage possible. Guaranteed. Details \$1.50. Illustrated Plans rushed \$5.95. Surf, 113 Walnut, Port Clinton, Ohio 43452.

GAS-OIL HOG??? . . . Smoking?? . . . No Pep?? . . . Hard Starting?? (Save \$150-\$250) with Motaloy Ring-Valve Job While driving (\$6.50 postpaid) Advertised here every month for years! Continues saving money on repairs, gas, oil for 100,000 miles! Absolutely true! (new engines too) Nothing compares! . . . Money-back guarantee. You can't lose! Motaloy, Grantham, Penna. 17027.

REDUCE Road Noise. Plymouth, Dodge, Chrysler. Simple, inexpensive. Instructions \$3.00. C. Howlett, 1002 Calvert St., Nashville, Tenn. 37216.

HYDRAULIC Jack repair kits, parts and supplies. Catalog 50¢ (in coin). Hydraulic Jack Packing & Tool Co., Inc., General, P.O. Box 3, Staten Island, N.Y. 10314.

JEEP Conversion components catalog. Send 50¢. Lloyd Novak, Box 1324, Dept. A, Whittier, California 90603.

AUTO Parts for old cars and new. All makes. Catalogue \$1.10. Antique Auto, Milwaukee, Wisconsin 53240.

WHAT? SUPERIOR RACING Pistons 327-283 High. Camp. \$61.60 set. E. Hoppe, Box 2386, Phoenix, Ariz. 65002, Phone (602) 273-1715.

AUTO TRAILERS

BUILD Your Pickup Camper. Precut Kits, Blueprints, Supplies, Literature 10¢. Comstock Trailers, Dept. 664, Parsons, Kansas 67357.

CAMPER Plans. Compact buses, Vans—Volkswagens, Econoline, Dodges. Build yourself—Save! Details—Dot Campers, Box 2115M, Culver City, California 90230.

LOWEST Prices! Catalog of 19 pre-cut Camper Kits, send 25¢. Trailer and Camper Parts and Accessories Catalog, send \$1.00 (refundable). Snowy Mountain Campers, Dept. PMC, Lewistown, Montana 59457.

SPRING Special—Save money! Easy! Fun! Build your own camper or trailer. Complete blueprints and easy to follow instructions for the amateur. Regular price \$3.95. Buy today, only \$3.50. Five different styles: Trailers: 13 foot and 15 foot; Camper: 8 foot; Cabover Camper: 12 foot, 15 foot. State model desired. Leo Henry, Box 445, Highland Park, Ill. 60035.

BUILD Truck — Camping-Trailers — Blueprints, Manual, Supply catalog \$2.00. Catalog 50¢. Kamcraft, Box 1153, Milwaukee, Wis. 53201.

PLANS, Parts, Campers, Travel-Trailers, Vans, Tent-Trailers, Literature 10¢. Custom-Craft, Box 572, Temple City, Calif. 91780.

PICKUP Camper, Trailer or Pickup-Cover . . . Build yourself, Save! Complete plans \$3.95 each. Cover plans \$2.00. Conversion Plans—economy type van \$2.95; passenger bus or delivery van \$2.95. Satisfaction Guaranteed. Equipment catalog \$1.00 (refundable). Details 10¢. Viking Camper Supply, 99-F Glenwood, Minneapolis, Minn. 55403

MOTORCYCLES, BICYCLES, MOTORSCOOTERS AND SUPPLIES

SNOW VEHICLE & KART CATALOG. Hop up accessories—speed and performance equipment—manifolds, engine mounts, exhaust systems. Send 25¢. G.E.M. PRODUCTS, 494 E. St. Charles Rd., Carol Stream, Ill. 60187.

HARLEY-Davidsons — Used bargains. New, used parts, accessories, all models. Bulletin 35¢. Knuth's (Factory Dealer), 1753 Muskego, Milwaukee, Wis. 53204.

MOTORCYCLE TURN SIGNALS. Accessories, Catalog 25¢. Houston, PM Lockport, Illinois 60441.

AKRONT Alloy Rims Mavrick Shock Absorbers. Buy the Best. Free Literature. North American Imports, P.O. Box 621, Garden Grove, Calif. 92642.

BUILD Your own minibike! NO WELDING REQUIRED! Plans \$2.00. Westate Enterprises, Dept. PM-5, Box 9216, San Jose, California 95117.

RECONDITIONED Motorcycle motors. Indian, Mustang, Royal Enfield, Suzuki. Parts, Accessories, "Minibikes." Indian Motorcycle Sales, Kansas City, Missouri 64127.

HONDA 50-90-160 Speed Equipment. Cams—Big-Bore-Stroker. Columbia Engineering, 2105 E. 37 St., Los Angeles, Calif. 90058.

BUILD Motorbike From Bicycle! Plans . . . \$2; Go-Cart Plans . . . \$2; Snowmobile Plans . . . \$5; Go-Byk Industries, Rothsay, Minn. 56579.

EVERY PART for Kart or Mini-bike. Bargain prices. Giant catalog \$1.00. Brown's Motorsports, 19 Central St., Worcester, Mass. 01608.

BUILD "Popular Mechanics" MINI-BIKE featured June 1967 issue. Detail plans, photographs \$2.50 refundable. Kits, parts, engines; factory discount prices. Catalog 25¢. Gilliom Mfg.; PMC; St. Charles, Missouri 63301.

MINI-BIKES, Go-Carts, Engines. Wholesale Catalog, 25¢. Loren Products, Danville, Illinois 61832.

MOTORCYCLES At wholesale price. Valley Imports, 14114 Mack, Detroit, Mich. 48215. Send 25¢.

MOTORIZED Your bicycle with lawn mower engine. No welding. Easy plans \$2.00. MOTOR'S, Box 415, Baraboo, Wisconsin 53913.



AVIATION

BE A Government licensed aviation mechanic. Practical training. Free information. Aero Mechanics School, Municipal Airport, Kansas City, Missouri 64116.

TREMENDOUS OPPORTUNITIES IN AVIATION. Learn Aerosciences at home: Navigation, Aerodynamics, Communications, Weather. Free Information: United Aerosciences, P.O. Box 4106, Torrance California 90503.

HOMEBUILT. Real enclosed helicopter, 24 pages ideas, information, \$2.50. Build "executive" helicopter, drawings, specifications, \$2.00. Helicopter Development, Box PM147, Washington, New Jersey 07882.

AERO-CAR. Amazing Hovercraft built easily with ordinary tools. Lawnmower engine power. Carries one man plus. Hovers, flies forward, backward, sideways over land/snow/water. Complete construction plans and brochure, \$5.25. Aero-Projects, Box 5118, Clinton, N.J. 08809.

BARTLETT FLYING SAUCER. Amazing machine hovers 200 lb. man over land/water, powered by ordinary lawn mower engine. Easy to build. Fun to fly. Complete Plans, Kit Brochure and Photo Review \$3.00. Write: Herb Bartlett, Box 3234-C, Scottsdale, Arizona 85257.

NEW Surplus Aircraft type Continental 7 cylinder air cooled 240-HP engines. Lightweight. Ideal for Airboats, Snowsleds. Auxiliary power, etc. Ready to run. \$395.00. Brochure 25¢. Chris Stoltzfus, Coatesville, Penna. 19320.

AIRBOAT, Propellers, Engines, Plans, Kits, Supplies. Complete Airboats, Outboard Airdrives. Catalog \$1.00. Banks-Maxwell, Box 3301E, Ft. Worth, Texas 76105.

HELICOPTER. One-man. Portable. Information 10¢. Kit information 10¢. Photos 25¢. Three-view drawings 25¢. Plans \$1.00. Compco, Box 1267, Redwood City, California 94064.

TIKUAPE Manpowered Aircraft Club Membership \$1. P.O. Box 533, New York, N.Y. 10025.

ANYONE Can fly Bat-Glider. no License required. Real Man Carrying glider soars with 200lb Pilot. Build for \$20.00. Plans, Photos, Flying Instructions \$5.00. Bat-Glider, Box 7115, Amarillo, Texas 79109.

FREE Catalog. 1000 Aviation Space Books. Aero Publishers, 329 Aviation, Fallbrook, Calif. 92028.

JEANIES Teenie homebuilt airplane. All aluminum, Volkswagen powered. Photos—Specifications—Material lists—Flight reports \$5.00. Money order only. Calvin Parker, Box 727, Daphne, Alabama 36526.

APOLLO 8—Eight full color 8 X 10 photographs. \$2.50. "Twenty Years of Space"—208 page history of rocketry at America's Spaceport, through Apollo program. Regular binding, \$4.25. Deluxe hard binding, \$7.95. SPACE—320 North Atlantic Avenue, Cocoa Beach, Florida 32931.



BOATS

CANOES! Kayaks! Factory-direct quality kits, from \$20.00. Many different models. Canvas hulls. Strongest construction materials. Free literature. Sportsraft, Box 8393-PM, Columbus, Ohio 43201.

BOAT PLANS, FRAME KITS, BOAT KITS. World's largest catalog—Over 200 top design for the amateur builders. New catalog includes Cruisers, Runabouts, Deep vee's, Catamarans, Trimarans, Houseboats, Sailboats from small sail fish to 34 ft. motor sailers, large selection of inboard and outboard Hydroplanes. Send \$1.00 for large new plan & kit catalog or \$2.00 for catalog plus Boat Builder's Guide. Clark Craft Boat Company, 16-P Aqua Lane, Tonawanda, New York 14150.

PLANS, Full Size Patterns, Frame Kits with step-by-step instructions specially for amateurs. New "Glen L" Boats 8' to 36' Sail, Jets, Inboards, Outboards, Cruisers, Houseboats, Hot Boats, Catamarans, Hydros "plus" boat trailers and a camper. Send 50¢ for complete catalog. New "How To Build Boat Trailers" Book \$3.00 ppd. Glen Designs, 9152 Rosecrans, Bellflower, Calif. 90706.

BUILD Your own boat from our large-scale blueprints. Books of plans give how-to-build help. Hundreds of professional designs—motor, sail or auxiliary—for amateur builders. Free catalog. MoToR Boating, 959 Eight Ave., Dept. PM-RS, New York, N.Y. 10019.

NEW 1968 McCulloch and other outboards. 4 H.P. \$108.00. . . . 7½ \$224.00. . . . 9 Electric Start \$288.00. . . . 18 \$316.00. . . . 40 Electric \$514.00. . . . 65 Electric \$698.00. . . . All sizes. Literature 50¢. Electra Marine 1427 Broadway, Brooklyn, N. Y. 11221.

FIBERGLASS Cloth and resin. World's finest cloth and non-run resin, at direct mill prices. Flotation foam. Complete line of plastics, silicon bronze and brass screws, save 60%. No Sales tax. Boat Plans, Catalog 25¢. Freight prepaid. Stiles Boat Supply, Box 11P, Linden Ave., Mantua Hts., N.J. 08051.

FREE Catalog—plans for canoes, kayaks, accessories. Quicksilver, 115 McGavock Pike, Nashville, Tenn. 37214.

BOAT BAILER, for SMALL CRAFT, COMPLETELY AUTOMATIC. A check ball does it! And it won't forget! Only \$4.95. More information. Write De Persia AUTOMATIC BAILER, INC., Grand Haven, Michigan 49417.

KAYAKS—One-man \$19.50; two-man \$24.50; Sailboat \$44.00. Exciting Sitka Kayak Kits known world wide for speed and safety. Assemble in one afternoon. Free pictorial literature. Box 582-P, Willoughby, Ohio 44094.

FIBERGLASS CANOES. Four Exciting Models. Easily Assembled Kits. \$39.95 up. Factory Direct. Free Literature. Riverside Canoes, Box 5595-BE, Riverside, California 92507.

BOAT KITS. Molded Fiberglass. Save money—assemble yourself. Factory molded sections bond into one-piece craft. 30 models—14' to 33'. Cruisers, Runabouts, Houseboats, Sailboats. Big line accessories, motors, trailers. Easy terms. Free 88 page catalog. Luger, Dept. BC-69, 9200 Interstate 35 W South, Minneapolis, Minnesota 55431.

FREE Catalog! Camping, Boating, Sailing Supplies; Gadgets, Hardware and Gifts. Laacke and Joys, 1439 N. Water St., Milwaukee, Wisconsin 53202.

WATERSKIBOARD Now Pre-school Children can join in family sport. Build for under \$5.00. Plans \$2.25. MAJCO, A59—219 West California Street, Glendale, California 91203.

AMATEUR Boat Building Magazine—instructions, plans, kits, discounts, books. Sample 50¢. 111-B Woodcrest, White Plains, N.Y. 10604.

OUTBOARD RACING BOAT PLANS. Latest designs, Hydros, Cabovers, Runabouts. Designed by World Famous Outboard Driver. For new Catalog send 35¢ to Hal Kelly's Tested Plans: P.O. Box M1767: Fort Pierce, Fla. 33450.

SAILBOAT, tough plastic coated 12-ft. hull, 65 sq. ft. nylon sail, \$164.95 complete. Free brochure. ADECO, Painters Run Road, Pittsburgh, Penna. 15241.

BRITISH BOAT PLANS—full range of designs for amateurs, in wood, fibreglass, ferro-concrete, by leading designers (Fareham, Yachting Monthly, Simpson). Catalogues, \$2, applied to purchases, from Wood Marine (PM369) Box 141, Agincourt, Ontario, Canada.

KAYAK Boat kits, Nylon covering never needs paint or dope, assembles in one day. Fast & easy to handle. Circular with photos 15¢. Stratford Trailers, 376p Stony Creek, Conn. 06405.

250 PLANS, some Kits. Catalogs: Powerboat, Large \$1.00. Condensed, 50¢. Sailboat 40¢. Marinecraft, Box 161-M, Brighton, Mass. 02135.

START A magazine subscription business. Earn generous commissions on Popular Mechanics, Good Housekeeping and all others. Best commissions, bonus, all material sent free. No experience needed. Write Popular Mechanics, Room 5P, 250 West 55th St., New York, N.Y. 10019.

PLANS, Kits, hulls, 24-page 20th Anniversary catalog. All class racing boats. Flatbottom to drag Hydros. Midget to 7 Litre, 50¢. Champion Boats, Box 9215A, Long Beach, Calif. 90810.

MARINE EQUIPMENT AND SERVICES

NEW, Used, rebuilt marine motors. Marine conversions, fittings. Free catalog. Stokes Marine Supply, Dept. 24, Coldwater, Michigan 49036.

CONVERT Auto engines to marine. 68 Page Catalog, 50¢. Lehman Manufacturing Company, 800 Elizabeth Avenue, Linden 4, New Jersey 07036.

PROFESSIONAL Marine engines from Star Marine Kits. Engines—Gears—Props—Everything necessary for your boat propulsion. Write for free brochure. Star Marine Engine Works, Berkeley, California 94710.

FREE 1969 Catalog—Gray inboard, inboard-outboard marine engines, gasoline and diesel. Graymarine Corporation, Coldwater, Michigan 49036.

FREE Pontoon Boat Catalog, Dock Brackets, Float Brackets, Mooring Bars, Dock Ladders. Perma—D Marine Products, Dept. 35, 2308 Central Ave., Minneapolis, Minn. 55418.

ATHLETIC AND BODY BUILDING COURSES

"GIANT Arms." Dr. Young's, D.C. revolutionary discovery. \$2. Satisfaction or refund. Gaucho, Box 9309-S7, Chicago 60690.

BUILD Revolutionary New Home Weight Lifting, Gym for whole family. Drawings, Exercise Course \$1. Safeway, Box 323, Union Springs, Alabama 36089.

BIG Muscles fast, complete course \$5.00. Olympus Bodybuilding, Box 431, Garden City, Michigan 48135.

NOW! Illustrated Judo-Karate Techniques against common assaults. \$1.00. "Realistic Self Defense". Box 131-E, Auburn, New York 13021.

POWERFUL Muscles fast! Free brochure! Universal Bodybuilding. Box 4327-C, Dearborn, Michigan 48126.

11 BARBELL, Dumbbell Courses. Regular \$6.25 for \$3.00. Good Barbell, B-1495, Hendersonville, N. Car. 28739.

FEAR No bully! Master authentic Chinese Kungfu unbeatable techniques! Defeat within seconds any attacker including giant Judo-Karate experts. Free details by air write Asia's Greatest Master, Leongfu (MI-39) 119, Anderson Road, Ipoh, Malaysia.

SPORTING GOODS AND EQUIPMENT

FREE 1969 Catalog. Guaranteed Lowest Prices! Rods Reels, Lures, Accessories—Thousands of Items. Cabela's Inc., Dept S, Sidney, Nebraska 69162.

FREE . . . Wholesale Catalog, Arrow Shafts, Broadheads, Fletchings, Fisharrow Parts, Tools, Bows, Finnyports, (22G). Toledo, Ohio 43614.

THE Amazing Long Play Golf Ball is Guaranteed against splitting. Conforms with U.S.G.A. Rules \$6.95 per Doz. Send Check or Money Order To Tenute Supply Co., Dept. =40, Lisle, Ill. 60532.

BIG Money raising crickets and 12 inch African fishworms. Free literature. Carter Ranch, Plains, Georgia 31780.



FISHING, TACKLE, LURES

MOLDS—For casting your own fishing sinkers. Free illustrated booklet. Reading Instrument Co., Box P78, Reading, Pa. 19603.

MOLDS For fisherman's sinkers, jigs, squids, casting and spinning lures. Free catalog. Sweets Molds, Tonawanda 1, New York 14150.

BIG Discount "1969" Bargain Catalog Fishing Tackle, Reels, Rods, Clothes, Boots, Scopes. Prices you never dreamed possible. Don't buy until you get Catalog =116-50¢. Lombard's, Rte 59, Nanuet, New York.

SEND for FREE Wholesale Catalog. The most complete and fully illustrated catalog of reels, rods, beads, spinners, jigs, bodies and parts, sinker molds, feathers, tools, hooks, rod blanks, rod parts, swivels, wire, etc. FINNYSPOrts, ME Sports Bldg., Toledo, Ohio 43614.

SURFCASTERS, Trollers. Most amazing fishing lure ever invented. \$3.98 postpaid. Guaranteed. Free Brochure. Grotech, 380 Main St. Hackensack, N.J. 07601.

SAVE 60% Monofilament Line 500 YARD SPOOLS 6, 8, 10, or 12 Test. Postpaid \$1.25 each. 3 Spools \$3.50. **GOLDEN EAGLE Enterprises,** Box 7186-W, Miami, Florida 33155.

EARTHWORMS, LIVE BAIT

BIG Money growing fishworms, giant African Crawlers, crickets. Free Literature. Fain's Hatchery-31, Edison, Georgia 31846.

EARN Money raising fishworms for us! Exciting details free! Oakhaven-56, Cedar Hill, Texas 75104.

HYBRID Redworms—3,000—\$5.75, 5,000—\$8.00, 10,000—\$14.00. Bedruns 20,000—\$18.00, postpaid with raising instructions. Brazos Bait Farms, R-9, Waco, Tex. 76705.

SUCCESS For You! Raise Carter's Pure-bred hybrid red wiggler fishworms, crickets, and 12 inch African worms. Write for Free Literature and our Success Story in Life Magazine. Carter Redworms, Plains, Georgia 31780.

AFRICAN Nightcrawlers. Wholesales, shipped prepaid. **BONANZA WORM RANCH, LODA, ILLINOIS 60948** Phone: 217-386-2111

FROGS, FISH, REPTILES

YOUNG Frogs and Giant Breeders. Stock your lakes and ponds. Nu-Tex Frog Farm, Box 4029, Corpus Christi, Texas.



HUNTING, GUNS, DECOYS

EXTRA Income at home in Spare Time! Booklet shows you how to start your own business with Classified Advertising. Only \$1.00. Refundable with first order. C. A. Martin, Popular Mechanics Dept. PM, 575 Lexington Ave., New York 10022.



DOGS AND KENNELS

EXTRA Income at home in Spare Time! Booklet shows you how to start your own business with Classified Advertising. Only \$1.00. Refundable with first insertion order. C. A. Martin, Popular Mechanics Dept. PM, 575 Lexington Ave., New York 10022.



GAME BIRDS

FREE Big quail color catalog. Marsh, 14216 Brookhurst, Garden Grove, Calif. 92640.

HAWKS, FALCONS

HAWKS, Eagles, Falcons, Owls for hunting. Send \$1.00 for complete price list. Slocum, Box 30-13, Grove, Oklahoma 74344—Telephone 918 786-2201.

EXTRA Income at home in Spare Time! Booklet shows you how to start your own business with Classified Advertising. Only \$1.00. Refundable with first insertion order. C. A. Martin, Popular Mechanics Dept. PM, 575 Lexington Ave., New York 10022.

RABBITS—FUR BEARING ANIMALS

RAISE Rabbits for us on \$500 month plan. Free details. White's Rabbitry, Mt. Vernon, Ohio 43050.

RAISE Rabbits successfully by knowing facts. 48 page illustrated book describing 25 breeds. Housing, breeding, feeding, marketing etc. 25 cents. American Rabbit Association, 36 Arba Building, Pittsburgh, Penn. 15217.

MAKE Big Money raising chinchillas, rabbits, guinea pigs for us. Catalog—25¢. Keeney Brothers, New Freedom, Pa. 17349.

\$500—\$800 MONTHLY Raise small laboratory-breeding stock for us. We supply equipment, breeders, instructions. Illinois Research Farms, Dept. MPB-5, McHenry, Illinois 60050.

EARN \$10,000 Yearly raising angora rabbit wool, and breeding stock for us. Information 25¢ coin. American Angora Company, Malta 12, Montana 59538.

TAXIDERMY

EXTRA Income at home in Spare Time! Booklet shows you how to start your own business with Classified Advertising. Only \$1.00. C. A. Martin, Popular Mechanics Dept. PM, 575 Lexington Ave., New York 10022.

PETS—BIRDS, CATS, HAMSTERS, ETC.

LIVE SEAHORSES, marine specimens, aquarium supplies. Illustrated catalog 15¢. Marine, Box 248-210, Dania, Florida 33004.

LIVE Traps, all sizes, mouse to dog. Collapsible or rigid. Carrying Cages. Free literature. National Live Traps, Tomahawk, Wisconsin 54487.

HAWKS, Reptiles, raccoons, skunks, squirrels. Catalogue 25¢. Trails End Zoo, St. Stephens, S.C. 29479.

950 PICTURE—Pet—Hobby Book 50¢. "EVERYTHING—you name it". Stromberg's Pets Unlimited, Fort Dodge 25, Iowa 50501.

HORSES, LIVESTOCK

"HOW To Train Horses"—Everyone who likes horses or ponies should have this book: Free. Write Beery School, 1105 Pleasant Hill, Ohio 45359.

CAMPING EQUIPMENT AND TENTS

SAVINGS Plus dividends! Campers-fishermen-outdoorsmen cooperative. Free 68-page catalog. Recreational Equipment, Inc., 1525-P 11th, Seattle, Washington 98122.

CAMPING Equipment, Tents, Sleeping Bags. World's largest selection. Free giant catalogue. Morsan, 810-R Route 17, Paramus, New Jersey 07652 or 1999 Route 110, Farmingdale, New York 11735.

FREE Catalog! Camping, Boating, Sailing Supplies; Gadgets, Hardware and Gifts. Laacke and Joys, 1439 N. Water St. Milwaukee, Wisconsin 53202.

CAMPING

OVERWEIGHT CAMP Boys, ages 6-17, diet, sports, work program. Brochure. Camp Shane, Ferndale, N.Y. 12734.

"101 CAMPING Tips"—\$1. Camping Questions Answered—\$2. Free list of Guides. Lazy Camper (PM), Box 85, Winthrop, Massachusetts 02152

VISITING Vagabonds, Unique Guest Book. \$2.00. Box 452, Mt. Vernon, Ill. 62864.

TRAVEL AND RESORTS

WILDERNESS CANOE TRIPS. Free brochure. Bill Rom's Outfitting, Ely, Minnesota 55731.

HP 20 T "AMERICA By Car" Names Best Places to Eat and Stay. Scenic Routes, Parks, Historic Sights, 170,000 Word Book. Only \$2.50. W. M. Walker, 5302 First Street, N.W. Washington, D.C. 20011.

ELECTRICAL SUPPLIES

METERS—Surplus, new, used, panel and portable. Send for list. Hanchett, Box 5577, Riverside, Calif. 92507.

UNUSUAL Electrical and Lamp Specialties. Free Catalog. Homecrafters, 4605 State, Drexel Hill, Pa. 19026.

LAMP Parts. Catalog, prices, wiring instructions, 50¢. Refunded first order. Gyro, 5218P N.W. 35 Ave., Miami 42, Fla. 33133.

LAMP parts for building, repairing, converting. Catalog 40 cents. Refunded with first order. Brown Lamp Co., Box 11305, Clayton, Mo. 63105.

RECONDITIONED ELECTRONIC and Laboratory Equipment. Guaranteed. International listings. ISIS, Box 622, Ogdensburg, N.Y. 13669 or Box 1180, Prescott, Ont.

APPLIANCE—Lamp parts. Wholesale catalogue 25¢. SECO, 109 South 20th Street, Birmingham, Alabama 35233.

BATTERIES, GENERATORS

BATTERY Reconditioning Kit, includes molds, material, instructions. Battery Shop, 878, Palm Desert, California 92260.

CAMPERS, Trailerities, Boaters—New device isolates second battery. Have accessories plus starting power! Charge automatically. \$9.95 postpaid. Guaranteed. State make, model. Free brochure. Power-Saver, Box 158, Lomita, Calif. 90717.

ENGINES, MOTORS

WINDING Data, 275 motors. \$1.20. Data Company, 512 Kensington, Kansas City, Mo. 64124.

BIG Steam Engines, Kits, Catalog 50¢. Reliable Industries, New Baltimore, Mich. 48047.

LIVE Steam powered backyard railroads! All sizes. Complete "bolt-together-kits," and rough castings. Excellent drawings. 100 page catalog \$1.00. Little Engines, Lomita, Calif. 90717.

OPERATE Three phase motors from single phase. Three ways \$2.00. Donald Howell, Barnesville, Ohio, 43713.

MOTORS! Generators! Batteries! Electroplaters! Illustrated Plans! Free Catalog! "Electrical Projects". Box 10225, Kansas City, Mo. 64111.

MACHINERY, TOOLS AND SUPPLIES

SMALL Foundry furnaces, Supplies. Free literature. Pyramid Products, 3736 South 7th Avenue, Phoenix, Arizona 85041.

MICROMETERS—Indicators—Small lathes. Direct Supply, 1424 Barclay, Springfield, Ohio 45505.

MACHINISTS Build This Hydraulic Tracer Valve For Your Lathe Standard Shop Materials and Skill Precision Shop Proven Information \$1.00. Complete Plans and Instructions \$20.00. Master Designs, Box 20292, Phoenix, Arizona 85036.

NEW Portable Keyway Cutter, real money maker for Machine Shops, Maintenance Depts. Free Literature. Ball Machine, Wellington, Ontario, Canada.

8 WITTY, Humorous 7x9" shop safety signs. \$1.00. Morris Dollens, 4372 Coolidge Ave., Los Angeles, Calif. 90066.

STATIONARY power tools. Catalog \$1.00 (refundable) Low Prices. Steeves Machinery, Inc. 625 Culver Road, Rochester New York, 14609

END Mills, 1/4" Shank, High Speed, 2-Flute, Used; Excellent condition. \$3.50 Dozen Postpaid. Lillian's, Box 17165, Chicago, Illinois 60617.

SPRINGLOADED POST DRIVERS Put down posts with no effort. Free Literature. \$24.95. Agents Wanted. Corsicana Grader Machine, Box 1699, Corsicana, Texas 75110.

WELDING, SOLDERING, PLATING

CHROME Plating equipment, supplies. All other finishes. Home workshop and production sizes. Send \$2.00 (refundable) for formulas, operating data, equipment guide and catalog. HBS Equipment Division L50, 3543 East 16th, Los Angeles, Calif. 90023.

WELDERS—110/220, 150 Amperes, \$53.50. Morris, 1070 Inner, Schenectady, New York, 12303.

GOVERNMENT SURPLUS

1969 SURPLUS Army, Navy store illustrated catalog. Send 25¢ (refundable with first \$5.00 order). Ruvel, 707 Junior Terrace, Dept. 9-J, Chicago, Illinois 60613.

JEEPS Typically From \$53.90 Trucks From \$78.40 . . . Airplanes, Typewriters, Boats, Clothing, Camping, Sporting, Photographic, Electronics Equipment, Wide Variety, Condition, 100,000 Bid Bargains Direct From Government Nationwide, Complete Sales Directory and Surplus Catalog \$1.00 (Deductible First \$10.00 Order). Surplus Service, Box 820-A, Holland, Michigan 49423.

JEEP and Government Surplus Buying Manual (Jeeps pictured) 50¢. Surplus Bargain Catalogue 50¢. Both \$1. Bargain Surplus, Box 1TTP, Spring Grove, Pennsylvania 17362.

GOV'T Surplus. How and where to buy in your area. Send \$1.00. Surplus information. Headquarters Building, P.M., Washington, D.C. 20036.

JEEPS From—\$52.50: Typewriters from \$4.15; Cars from \$31.50. Walkie-talkies, motorcycles, airplanes, boats. Typical "As Is" bid bargains from Uncle Sam. Tremendous variety. Exciting free list. Write: Enterprises, Box 402X46, Jamaica, New York 11430.

HOBBIES AND COLLECTIONS

50 **GORGEOUS** Jungle butterflies \$2.50. Collectors Wonderland, Box 1170, New York, 10008.

FREE: German Regulation Medal: Send 50¢ postage, handling, get catalog: Iron Cross \$1.50; S. S. Pin 50¢; Insignia Club, Box 71, Rockaway Park, N. Y. 11694.

LEGION OF HONOUR, France's highest award \$40. Croix de Guerre \$35. Originals with ribbons. C.W.O. please. Sent Airmail Free. Refund guaranteed. Lists. VALETORM LIMITED, 47 CHURCH ROAD, BURTON JOYCE, NOTTINGHAM, ENGLAND.

"**UNIQUE**" ITEM FOR COLLECTORS! \$2.00 - \$50. HORSE RACE-TRACK TICKETS. 40 different: \$2.00; 15 different \$1.00; Sample (5) 35¢! Bell: 928 University Bay: Madison, Wisconsin, 53705.

OUR FIRST 19 IN SPACE. This limited edition lithograph has been created as a tribute to Americas Gallant Astronauts. 12 X 18 inch chart ready for framing. Only 75 cents. Popular Mechanics, Dept. GWP, 575 Lexington Avenue, New York, New York 10022.



STAMP COLLECTING

PENNY! Approvals! Regardless catalogue! Kloster, 4164 52nd St., San Diego 5, Calif. 92105.

500 **DIFFERENT** Stamps, \$1.00. Smith, 508-A Brooks, College Station, Texas 77840.

UNITED States commemorative collection containing 33 different—10¢. Approvals. White, 516-A Avenue L, Brooklyn 30, New York.

50 **YEARS** Old, fifteen different United States, over fifty years old—10¢ with approvals. Jaxon, Box 145-P, Brooklyn, New York 11230.

GIANT Stamp Collection including: Astronauts, Satellites, Moonrocks, Boy Scout issue, Complete U.N. Set, recent Olympic and Sport issues from many countries, etc., Plus Big Stamp Dictionary and approvals. Everything, 10¢! Stampex, Box 47-RM, White Plains, N.Y.

ABSOLUTELY Free 25 different United States Commemoratives when requesting United States Approvals. K & B, Box 70, Brooklyn, N.Y. 11223.

1500 **FOREIGN** \$1.00; 5000 \$3.00. 5000 USA commemoratives, revenues, airs, presidentials, 19th Century, high values \$3.00. 300 pre-1939 USA commemoratives \$2.00. 1000 foreign pre-1940 \$3.00; 5000 \$12.00. No approvals. Meyers, 5321 Fleming, Richmond, California. Zip code 94804.

50 **DIFFERENT** United States, only 10¢, with Approvals. Shelron, Box 547C, North Miami, Florida 33161.

"**AFRICA**," 25 beauties, 10¢. Approvals. Gorliz, Box 1915PM, Naples, Florida 33940.

PAINTINGS 20 Different giant multi-colored beauties 25¢. Beautiful paintings sets on approval. Roger Williams Stamp Co., Box 1281-P, Pawtucket, Rhode Island 02862.

WOW! 1,000 Different worldwide—valued over \$20.00 only \$1.00 with quality approvals. Universal, Box 6, Kenosha 5, Wisconsin 53141.

CLOSEOUTS! Grab Bags 50¢ each! Ross, Box 152, Wayne, Pa. 19087.

CLOSEOUT Sale! Unbelievable low Prices. Generous lots 30 cts.. Assortments \$1.. High Value Packets \$2.. Persile, 436 New York Ave., Brooklyn, N.Y. 11225.

FREE 50 Worldwide. Approvals. University Stamps, P.O. Box 1471, Lake Worth, Florida 33460.

U.S. Seconds, Bargain Prices, Karl Swartz, Box 373, Venice, Fla. 33595.

MILLIONS Foreign Stamps! 2¢ each! Send for gigantic approvals! ABC, Box 6000-MB, San Francisco, California 94101.

100 **OLD** United States between 1861 and 1935, \$1.00. Roush Stamps, 51 Chestnut, Mansfield, Ohio 44903.

FREE Surprise collection sent with approvals. Gould, 1784 Union, San Francisco 94123.

"**INVERTED ERROR**" Dag Hammarskjold, 6¢ with approvals. Belmont Stamps, Washington, D. C. 20015.

U.S. Approvals Low prices. Eagle, 2221 Romine Ave., Pittsburgh, Pa. 15226.

FREE—Mammoth Collection, \$10,000 Airmail, Scott's International, Master Global Albums when you buy our Approvals. Bargain Stamps, Tustin, California 92680.

RUSSIA Space, 3 sets complete, 25¢. Approvals. Continental, 271 Pinecove, Burlington, Ontario, Canada.

255 **DIFFERENT** Worldwide: 15¢. Approvals. Tibbets, 8675 Meadow, Downey, Calif. 90242.

50 **DIFFERENT** Old U.S. Revenue stamps 50¢. Winchester Stamps, Box 1592, Mansfield, Ohio 44907.

U.S. Mint specials! Flag set, complete \$1.00, 1¢, 2¢, 3¢ famous Americans (21 different) \$1.00. Frecc list, Brooks, 2601 Avenue "U," Brooklyn, N.Y. 11229.

ONE Pound value Geo. VI Bermuda, plus 100 worldwide 10¢. approvals. Stevens, Box 105A, Homecrest Sta., Brooklyn, N.Y. 11229.

NEW Issues—Free weekly illustrated list, Brooks, 2601N Avenue "U," Brooklyn, N.Y. 11229.

PENNY Stamps! 1000 Mounted in book at 1¢ each. Trust Stamp Company, P.O.B. 132-P, Jamaica, N.Y. 11435.

FREE! Triangles, Scout, 25 others. Approvals. Cambridge, Box 411, Cambridge, Ohio 43725.

RUSSIAN Space set 10¢. Russian approvals. Snedco, Box 68-P, Waldwick, N.J.

14,000 **DIFFERENT!** AMAZING new plan builds your collection systematically, country by country. Only 50¢ weekly. Ware, Monroe, Conn. 06468.

225 **STAMPS** for only 10¢! Airmails, Pictorials: stamps from strange countries cataloging up to 25¢ each! Plus unusual stamps to examine. Buy any or none return balance, cancel service anytime. Mystic Stamp Co., Camden 80, New York 13316.

FREE!! Two Beautiful Multi-Colored Complete Mint Sets. Approvals. Hamilton, 1246 Pratt, Chicago OE-5, Illinois 60626.

VIETNAM 25 Different 10¢ approval. Sam Chazen, Box 95, Ozone Park, N.Y. 11417.

50 **DIFFERENT** AFRICA plus **SOUVENIR SHEET** 25¢—Approvals accompany. Quynn's, Scotland, Penn. 17254.

"**DINOSAURS**" And Giant Cryptocleidus. Set 10¢. Zielski, Box 364, Morton Grove, Illinois 60053.

701 **U.S.A.** (PLENTY Commemoratives)—25¢. Approval purchase required, Horace Gatewood, Winston-Salem, North Carolina 27102.

ICELAND—Mint specials, 7 different \$1.00 15 different \$2.00 21-different \$3.50. EILERS, Box 26, Fleet Post Office, New York 09571.

50 **POLAND** Large Pictorials 25¢. Approvals accompany. World, 1784 Union, San Francisco 94123.

210 **DIFFERENT** U.S. Commemoratives \$1.00. Stamps, 7607 Larchview Drive, Dallas, Texas 75240.

FREE Catalogue. Rockets, Paintings, others beauties: 10¢. Approvals. Tiquet, Box 1496 Denver, Colorado 80201.

U.S. Bargain, 50 different 10¢, with beautiful worldwide approvals. Stamp Center, Kennebunk, Maine 04043.

HOW To start collecting profitably. Offers, free premiums, 25 outer space, weird countries. Everything 25¢. RoCo Stamps, Box 9523-PM3, Phoenix, Arizona, 85020.

ANNUAL Spring Sale. Excellent Values. Mounted Approvals. Preview Stamps. Box 9809M, San Diego, Calif. 92109.

121 **DIFFERENT** Flag stamps free. Approvals. W-B Stamps, Wilkes-Barre, Pa. 18703.

SURPRISE COLLECTION! Exotic mint British Colonials, absolutely free with approvals. VIKING, Great Neck 8, N.Y.

BEAUTIFUL Typical Collection—Includes Olympic sports stamps, wild animals, bicolor triangles, colorful birds, outer space stamps, Poland kitten stamp, and others. 10¢ with approvals. Clark Stamps, Dept. 57A, Muskegon, Mich. 49444.

I **PAY** \$250 EACH for 1924 1¢ green Franklin stamps rotary perforated 11 (\$2,500 unused). Send 25¢ for illustrated folders showing amazing prices paid for old stamps, coins, collections. Vincent, 85 PM, Bronx, New York 10458.

120 **YEAR** old Bavarian stamp 20¢ with approvals. Hickok, Box 2590, Napa, Calif. 94558.

TERRIFIC Stamp Bargain—125 Different! Includes beautiful Germany and Asiatic Pictorials plus colorful and exciting space Typical. Only 10¢ with Request for Approvals. Send Today! Shaw, Drawer E-14, Montevallo, Alabama 35115.

50 DIFFERENT U.S. Commemoratives, 10¢. Approvals, Cambridge, Box 411, Cambridge, Ohio 43725.

FREE! 50 Stamps—Includes 3 Triangles—Approvals—Moumblow, 12542-5T Keel, Garden Grove, California 92640.

100 DIFFERENT! Free 1/4¢ upward British Commonwealth or world approvals. Bush, 1677 Wimborne Road, Bournemouth, England.

FREE Mint Set. Approvals accompany. Stamps, Box 22092, Memphis, Tenn. 38122.

FREE! 55 Triangles, Space, others! Really nice low cost Approvals. L. Baird, PM-22, Box 8128, Portland, Oregon 97207.

2,000,000 STAMPS, 150 Countries, 2¢ each. Belden, Box 4175, Dearborn, Mich. 48126.

THOUSANDS Worldwide 2¢ each, on approval. King Penny Stamps, 4517 Ticker, Canton, Ohio 44708.

511 DIFFERENT WORLDWIDE, a \$12.50 value only \$1. Philatelic Mart, Box 252M, McGregor, Texas 76657.

HAWAII AIRMAIL (=C46) ONLY 25¢, to adult collectors of U.S. stamps requesting our better approval service. Engle, Box 8P, Lowell, Michigan 49331.

RUSSIAN PICTORIALS 25 diff. 10¢. Approvals and free U.S. list. Bridgoco, 7200P University, La Mesa, Calif. 92041.

FREE! Four Unusual Japan—Eleven more Surprise Stamps, Approvals. Postmark, Great Neck 7, New York 11022.

WOW! 110 All Different Germany 10¢ Commemoratives, Airmails, High Values, Big Catalog, bargain lists also, fine stamps from our approval service, which you may return without purchases and cancel service at any time. Jamestown Stamp, Dept. A59 PM, Jamestown, N. Y. 14701.

RUSSIA High-Value Collection, 32 different Russia—some over 50 years old! Commemoratives, Czarist Issues, Airmails, Catalog price \$2.50. Special Get-Acquainted Offer—all for only 10¢! H. E. Harris, Dept. GG-49, Boston, Mass. 02117.

TEN Different Nudes 2¢. Approvals, Stamp Farm, 2M6, Oxford, Wis. 53952.

GIGANTIC "Bicolored Drgs" Poland's latest 1969 Commemoratives—Free! Approvals plus 101 Bonus Sets. William Deems, 226a Race, Ravenswood, West Virginia 26164.

RARE stamp free. Also new packet Aden to Urundl with Kennedy, triangles, space, sports, ships, dogs, cats, reptiles plus others. All free. Send 10¢ for mailing. Empire Stamp Co., Toronto, Canada.

PRESIDENT Kennedy stamps from Uruguay, Togo, Colombia, etc. plus big illustrated catalog sent Free! Littleton Stamp Co., Littleton, JF1, N. H. 03561.

50 ASIAN Beauties, 10¢. Approvals, Louis Arpin, Philipsburg, Quebec, Canada.

TWO CENT APPROVALS THE BEST. Scotty Stamp Co., Box 155, Staten Island, N.Y. 10301.

GORGEOUS Sets free! Request approvals. Martell, Box 421, Westerly, Rhode Island 02891.

FREE! Big Bargain Catalog—New Edition listing thousands of bargains including U.S. & B.N.A. stamps, packets, albums, accessories and supplies. Also, fine stamps from our approval service which you may return without purchases and cancel service at any time. Jamestown Stamp, Dept. E59PM, Jamestown, N. Y. 14701.

U.S. USED Approvals. Reasonable Prices. Mint special: U.S. = 575-9, \$6.00; List Free. Dunruth, 248-A Hickory, Bergenfield, New Jersey 07621.

TOPICALS—Three Colorful Sets, 10¢! Approvals. COLE, Box 223-A, Buffalo, N.Y. 14221.

EXCHANGE CLUB, DETAILS 10¢. BOHNS, 72 Breton, Laval des Rapides, Quebec, Canada.

COINS, TOKENS, CURRENCY

100 INDIAN, Lincoln Cents, 1920's and older, \$5.00. Wesley Road, West Union, Iowa 52175.

SEVEN Different liberty nickels—\$2.00—Bargain listing—Dime—Huber—200 Baker Building, Minneapolis 55402.

UNCIRCULATED Dollars, 1880-81-82 S, 1883-84-85-1899-1900 01-02 O mint, \$3.50 ea. Catalogue 50¢. Shultz, Salt Lake City, Utah 84110.

OLD Coins Bought. Illustrated Catalog 25¢. Hutchinson's, Box 6256, Philadelphia, Pa. 19136.

PRICE List. Send 10¢. Village Coin Shop, Dept. P, Plaistow, N.H. 03865.

30 DIFFERENT Worldwide Coins \$1.00, Newcomers, Box 24, North Quincy, Mass. 02171.

LINCOLNS: 30 Different Brilliant Uncirculated 1954PDS-1968PDS complete (Regularly \$5.95)—Special \$2.95. Silver Dollars \$2.45 each. BONANZA, Box 4491P, San Jose, California 95126.

22 "S" LINCOLN Cents, including rare 1955S, \$1.60, 26 1909-1939, \$1.60, 10 "S" Jeffersons, \$1.60. All different. All three \$4.50. Bargain pricelists included with order. HARRIS, 2373 P Pruneridge, Santa Clara, California 95050.

SILVER And Coins bought—Buyers List \$1.00. Infocoin, Box 117, Getzville, N.Y. 14068.

BARGAINS \$1.00 EACH—ALL DIFFERENT. Fourteen (S) Lincolns, two Liberty quarters, two Barber quarters, three Barber dimes, six War nickels, six Mercury's, six Roosevelt's, nine Buffalo's, four Indians, four Liberty nickels. SPECIALS:—Large cent, two cent piece, three cent nickel \$2.00 each. U.S. list plus 1969S cent 25¢. Schultheis, Box 151M, New Hyde Park, N.Y. 11040.

SILVER Dollar with terrific list \$2.75. Nelson, 346-P, Rye, New York 10580.

COINS Wanted! Immediate cash! Fairway Company, Box 121-P, Rye, New York 10580.

BARGAINS—Latest coin price list, 10¢. Ron Farley, Metamora, Ill. 61548.

50 BUFFALO Nickels, full dates, includes early, Special \$7.95. Three different Silver Dollars, \$6.95. New type 1969S Cents, 30 for \$2.00. SERENDIPITY, Box 820P, Cupertino, California 95014.

OLD Liberty Head Nickel, Bargain Coin List, 30¢. Economy Sales, Mansfield, Mass. 02048.

TRUNKFUL 25,000 INDIAN-Lincoln cents from 1920's & older, mixed "grab-bag" style, 150-\$10; sample bag of 20-\$2. Mrs. A. Fischer, Box 743-B, Encino, Calif. 91316.

SILVER Dollar Only \$1.50. Approvals. Swenson, RFD, Box 145A, Murfreesboro, Arkansas 71958.

BARBER Dime, Quarter, Half, \$2.00. Doktor, Box 8915, Oak Park, Mich. 48237.

KENNEDY Halves: All Dates 75¢ each. Stevens, Box 546F, North Miami, Florida 33161.

RARE Lincolns: 1909VDB, 1915PD 1916PDS, 1917PDS, etc. to 1939PDS: Thirty Different \$2.50; Sixty Different All Included \$7.95. Roger's, 3531-M West 29th, Minneapolis, Minnesota 55416.

LAST Mintage before decimal currency. British 1967 uncirculated half penny plus listings, \$1.00. Schwab, 5 Holmbrook Drive, London NW4, England.

BARGAINS—1961, 1962, 1963 Proof Sets, each \$5.75. New \$2.00 Bill \$3.45. Bargain Lists 25¢. Bebee's, Incorp. Omaha, Nebraska 68111.

BEGINNERS, collect coins for profit! How to begin, where to sell. Lists of money-making coins. \$1.00 brings booklet. Banner House, 2002 Belmar Boulevard, Belmar, New Jersey 07719.

1969S CENTS Uncirculated, 17 \$1.20. McCrehead, 208B Houston, Thousand Oaks, Calif. 91360.

UNITED STATES Specials: Half Dime before 1873, \$3.00; Large Cent before 1857, \$3.00; 1893 Columbian World's Fair Half Dollar, \$3.00; Old style Large \$5.00 bill, \$12.00; All four offers \$20.00. Moneyback Guarantee. Rarcoa, 31-A, North Clark, Chicago 60602.

ANTIQUES, RELICS, INDIAN GOODS AND CURIOS

LIST Indian relics, 10 Arrowheads \$3.00. Hyde's, Box 2304, Santa Fe, New Mexico 87501.

TONS Of antique gun parts and supplies. All reproduction muzzle loading guns. Send \$1.00 for enlarged illustrated catalog No. 118-A. Dixie Gun Works, Union City 12, Tennessee.

RELIC Identification! "Wishbook 1865". 1200 items all illustrated, described, 144 pages, \$3.75 postpaid. Cleveland, 320 BZ Main, San Angelo, Texas 76910.

INDIAN Relics. Arrows, \$4.00 doz. Bird-points, \$7.50 doz. Folsom or Sandia \$5.00. List. C. Secrist, Muscatine, Iowa 52761.

RARE SIKH WAR SWORDS ANTIQUE, over 100 years old, from remote India arsenal, \$19.50. Pair \$35.00. 75¢ each postage. CENTURY St. Albans, Vermont. 05478.

MODELS—SHIPS, TRAINS, PLANES, ETC.

SHIP Models catalog 25¢. Scientific, Inc., 100 Monroe, Newark, N.J. 07105.

ROCKETS: Real flying models—flights up to 2500 ft. New illustrated catalog 25¢. Single and multistage kits, cones, engines, launchers, trackers, rocket aerial cameras, technical information. Fast service. Estes Industries, Penrose 2, Colorado 81240.

SHIP And yacht model fittings: Pine construction hull kits: blueprints. Send 50¢ for illustrated catalog. A. J. Fisher, Inc., 1002 Etowah Avenue, Royal Oak, Michigan 48067.

SHIP Model kits and fittings: clippers, frigates, etc. Catalog paint-tool list, 1969 catalog 50¢. Models Shipways, Box 65, Bogota, N.J. 07603.

SHIP Models, Kits, fittings, plans, books, tools, engines, motors. Big illustrated catalog 50¢. Mass. residents add 3% tax. James Bliss & Co., Dept. SM, Route 128, Dedham, Mass. 02026.

CANNONS, Flying Saucers, Hot Air Balloons, Rockets, Etc. Free Catalog. Zeller, Box 69, Hudson, Mich. 49247.

SOLAR Flying Saucer Lifts Animals—See Spacetratics Ad Under Science-Chemistry Column.

LOCOMOTIVES, Gasoline Engines, Tools. Catalog \$2.00. Caldwell Industries, Luling, Texas. 78648.

SCALE STRUCTURAL SHAPES in quality ABS plastic. Beams, channels, columns, tubing, strip, and sheet. Hundreds of accessory items. In all railroad, other scales. Send 50¢ in coin for big catalog. Plastruct, Inc., 1621 N. Indiana St., Dept. PM, Los Angeles, Calif. 90063.

GAMES, TOYS, PUZZLES, NOVELTIES

"ROULETTE DICE" . . . a pair of dice that have a range of thirty-six different numbers. Free information, write D. E. Products & Co., Box 488, Worcester, Mass. 01601.

KITES, Kits, Plans! Delightful booklet, 10¢. Kite Tales, Box 145C, Richardson, Texas 75080.

CARIBBEAN Checker Game with rules, \$2.00. C. Ljohn, 5118 S. Dorchester, Chicago, Illinois 60615.

BLAST off July 4th! Toy rocket soars 600'. No chemicals, batteries, explosives. Nose cone separates from body. Both parachute back for relaunch. \$3.98. Pier House, Room 8, Commonwealth Pier 5, Boston, Mass. 02210.

MOSQUITOES, Ants, Roaches. Unique way to rid them. Results Guaranteed. Kit, Instructions, \$3.00. Mcanroc, Box 368, Botsford, Conn. 06404.

MAGIC TRICKS, JOKES, VENTRILOQUISM

COMPLETELY Illustrated catalog. 84 pages, 25¢. Manhattan Magic, Box 334-M, N.Y.C. 10011.

WORLD'S Finest professional magic tricks. Joker's Novelties. Giant illustrated catalog 10¢. Top Hat, Evanston, Illinois.

HOUDINI'S Original Magic Shop. Established 1856. Send 25 cents for Illustrated Catalog containing 5000 Tricks, Mindreading, Puzzles, Hypnotism and Jokes. Flossing-Hornmann, 304 West 34th St., N.Y. 10001.

HOUDINI Magic Catalog!! Giant Professional Deluxe Edition!! 1000 World's Greatest Tricks!! 25¢ with Free Gift Certificate!! House of 1000 Mysteries. Dept. PM9C, Northeast Fifth Ave., Ft. Lauderdale, Florida 33308.

MAGIC Catalog. World's finest 3000 tricks. (340) pages \$2.50. Beginners, amateurs, professionals. Kanter's, A-200 South 13th St., Philadelphia, Pa. 19107.

500 TRICKS Catalog. 1969 Edition, showing latest magic for pocket, parlor, stage. Only 10¢. Fastest mail service for 45 years. Douglas Magicland, Dept. 11, Dallas, Texas 75221.

AMATEUR and PROFESSIONAL MAGICIANS all new magic tricks and gags catalog 25¢. Our specialty same day service. Fabulous Trick and Magic, 3319 E. Charleston, Las Vegas, Nevada 89104.

MAGIC MAGAZINE—Monthly since 1936. 44 pages. All phases. 3 month trial \$1.00. Genl. P.O. Box 36068, Los Angeles, CA 90036.

FREE Trick. New Magic Catalog. Send 25¢. Ace Magic, Box 329, Evanston, Ill. 60204.

BE A Magician! Two booklets explaining sixty-eight tricks plus large professional catalog. \$1.00. Magic, Inc., 5082 Lincoln, Chicago, Illinois 60625.

CATALOG #26, 175 pages, 25¢ (1,500,399 tricks, jokes, novelties). Elbee, 7408-P, San Antonio, Texas 78207.

PEACE Button. 250 Novelty Buttons. 10¢ Catalogue. Novelty Mart, Box 233P, Bethpage, N.Y. 11714.

VENTRILOQUISM! Information free! Dummy catalog. 25¢. State age. Maher, Studio E, Box 8356, Kensington Station, Detroit, Michigan 48224.

BOOKS, CATALOGS, NEWSPAPERS

NATIONAL Geographic Magazines. 1888-1967, any issue. Buxbaum, Box 465-PM, Wilmington, Delaware 19899.

PROPHET Elijah coming before Christ. Wonderful book free. E. Megiddo Mission, 481 Thurston Rd., Rochester, New York 14619.

BACK Date Magazines! Send needs. Midtown, Box 917-PM, Maywood, N. J. 07607.

FREE Catalog. Self-help books. Write Wilshire, 12015 Sherman Road, North Hollywood, Calif. 91605.

NEW 24 Page Catalog. guns, Guerrilla Warfare, Police Science.—10¢. Variety, Box 395-PM, McDonald, Ohio 44437.

BUSINESS Books and Directories. List 10¢. Cricket, Box 527, Ardmore, Penna. 19003.

PAPERBACK Catalogue. 270 pages. 15000 titles, subject indexed. \$2.00 credited toward order New York Book, 4 P West 43 Street, N.Y.C. 10036.

WHY Wait until Someday? Make Plans Today To Own your Liesure Home. Design Catalog \$1.00. Wm. Simkulet Jr., Skaneateles Falls, New York 13153.

USED BOOKS. Send subjects wanted. Brown's Bookshop, 7001 Bancroft, Toledo, Ohio 43617

WHERE TO RETIRE OR Vacation. Where costs are low. Book "Off the Beaten Path" covers hundreds of inexpensive Paradises. Only \$2.00. A. Connolly, 22 North Market St. Shamokin, Pa. 17872

AMAZING "Self Improvement" Books. "Free Catalog" Kindell, 2216 Fairbanks, Medford, Oregon 97501.

IMPROVE Your Personality! Fascinating 110 page book, reveals the technique of using your subconscious mind, to make a new personality for yourself! Be one of the lively ones. Begin to live! Read how. \$1.00. Vista House, Route 1, Box 6, Coeur d'Alene, Idaho 83814

FREE List of practical books For Self improvement. McAllister Sales, Box 13128 St. Louis, Mo. 63119.

PLAYS, STORIES, MANUSCRIPTS

WANT Your book published? Learn how we publish, advertise, promote, distribute. Many successes. Free booklet PM, Vantage, 120 West 31, New York City.

HOW To Sell Everything you write! Aubrey, Box 3124, Industry, California 91744.

BUSINESS OPPORTUNITIES

HUGE Profits! Mail order importing. Free information. ITIS, PM-5, Box 454, Hollywood, Calif. 90028.

BOOKKEEPERS Earn \$1000.00 month. Operate simplified Bookkeeping tax service. Universal, Box 664-M, Springfield, Missouri 65801.

WANT To make big money at home? \$10.00 profit in an hour possible with invisible mending. Make tears, holes disappear from clothing, fabrics. Steady year-round demand from cleaners, laundries, homes. Details free. Fabricon, 1585 Howard, Chicago 60626.

I MADE \$40,000.00 Year by Mailorder! Helped others make money! Start with \$10.00—Free proof! Torrey, Box 318-Y, Ypsilanti, Michigan 48197.

CONCRETE FACTS: Highly profitable home business. Experience unnecessary. Unlimited unique pottery designs easily made without moulds. Birdbaths, fountains, wishing-wells, benches, etc. Chemical coloring formulas, marblizing. FREE illustrated brochure. Hollywood Cementcraft, 602 Athens Street, Altadena, California 91001.

WORLD'S Largest supply. Merchandise 25% to 40% under wholesale. Bankrupts, closeouts 10¢ on dollar. Imports. Hong-kong clothes. Automobile discounts. Free details. International Buyers, Box 4633-MM, Colorado Springs, Colo. 80909.

RAISE Rabbits for us on \$500 month plan. Free details. White's Rabbitry, Mt. Vernon, Ohio 43050.

MAIL Baby Catalogs imprinted with your address to New Mothers for Big Profits! Details 25¢. Volz-PM, Ypsilanti, Michigan 48197.

UP To \$5.00 each for newspaper clippings! Free details. Philip, Box 368-S, Southfield, Michigan 48075.

FREE Catalogs. Repair air conditioning refrigeration. Tools, supplies, full instructions. Doolin, 2016 Canton, Dallas, Texas 75201.

FREE "Franchise Profit Letter" tells how unique NFR service is helping thousands seeking profitable businesses. Write today. National Franchise Reports, W-526, 333 North Michigan, Chicago 60601.

VENDING Machine big catalog. Rake, 523 A Spring Garden, Philadelphia, Pa. 19123.

56 ACTIVE Franchise opportunities available all over USA. Brochure details 56 franchise chances for you to have your own business tied with successful national companies. Send name, address to P. Stewart, 1085 Walnut, Des Plaines, Illinois 60016.

\$400.00 MONTHLY Raising giant fishworms. Soilless method. Charlie Morgan, Bushnell, Florida 33513.

EARN Money raising fishworms for us! Write: Oakhaven-38, Cedar Hill, Texas 75104.

400,000 BARGAINS Below wholesale! Many free. Liquidations . . . closeouts . . . job lots . . . single samples. Free details. Bargainhunters Opportunities, Box 730A, Holland, Michigan 49423.

\$200.00 DAILY In your mailbox! Your opportunity to do what mailorder experts do. Free details. Associates, Box 136-A, Holland, Michigan 49423.

CLIP Newspaper items. \$1.60-\$5.00 each. Details free. Walter, Box 1360-PA, Erie, Pa. 16512.

SELL Lifetime, Metal, Social Security Plates. Big Profits! Sample and Sales Kit Free. Russell, Box 286-PM, Pulaski, Tennessee 38478.

MAKE 2 to 3 times your cost wholesaling 1001 products. Gifts, Mail Order Specialties, Toys, Novelties, Carded Merchandise . . . Guaranteed lowest below wholesale prices. Free home business details SMC 7630 SPE, Gloria Ave., Van Nuys, Calif. 91406.

MAILORDER Book publisher wants dealers. Wonderful "drop-ship" proposition. Sample imprint circulars free. Neil H. Tasker, Shamokin, Pennsylvania 17872.

BIG Profits—Operating your own plastic laminating business with low cost equipment and supplies, money making methods included. Money back guarantee. Jiffy—Box 23485P, Los Angeles, Calif. 90023.

BUILD Custom Cases at home for profit. Get orders by mail. We supply materials, instruction—everything. Free home business details. Custom Case Supply Co., 7630-CPE, Gloria Ave., Van Nuys, Calif. 91406.

VENDING Machines. No selling. Operate a route of coin machines and earn amazing profits. 32-page catalogue free. Parkway Machine Corporation, 715 PMB Ensor Street, Baltimore, Maryland 21202.

PIANO Tuning Learned quickly at Home. Tremendous field. Musical knowledge unnecessary. GI approved. Information free. Empire School, Miami, Florida 33145.

INSTALL Burglar alarms without previous experience or costly equipment. Big profit. Free details. Nasco, 11071 Massachusetts, Dept. C-2705, Los Angeles 90025.

ADDRESSERS And mailers needed. Send stamp for information. Lindbloom, 3636 West Peterson, Chicago 60645.

FREE Book "990 Successful, Little-Known Businesses." Work Home! Plymouth-372-Y, Brooklyn, New York 11218.

MAKE \$75.00 daily distributing tools to service stations. Free Plan. INKA, 2401 Crocker, Houston, Texas 77006.

SPARE Time Cash—Sell Advertising Book Matches—every business a prospect—no investment—no experience needed to build steady repeat business. Daily Cash commission in advance. Write today—We'll send your sure-fire selling kit by return mail. Dept. MX 569, Superior Match Co., 7530 S. Greenwood, Chicago, Illinois 60619

AMAZING Automatic Fishhook. Free details. Sample \$1.00 Refundable. Aron, Post-b x 61-PM, Mastic Beach, New York 11951.

EARN \$60.00 DAILY manufacturing Concrete Fence Posts. Practically no investment. Free information. Send stamp. American, Excelsior Springs, Mo. 64024.

I GROSSED \$112,000.00 year, mailorder. Can help you make money. Free proof. Write: Williams, 44646A, Los Angeles 90044.

\$75.00 THOUSAND. Home Addressing! Longhand, Typewriter. Information, send stamped self-addressed envelope. Brewster, Box 1348-TF, Clearwater, Florida 33517.

DRAFTSMEN! Operate own **DRAFTING SERVICE!** Full, Part Time; Experience unnecessary; Details: Roberts Drafting, 1741 Circle Road, Baltimore, Maryland 21204.

1000% PROFIT BRONZING baby shoes literature Nichols, Box 11069, Kansas City, Mo. 64119.

ESTABLISH Profitable Catalog Mailorder Business! Vikari's, Box 1312PME, Salt Lake City, Utah 84110.

STOP Throwing Away Those Boxtops! They're worth money, some 25¢ each! Write: Boxtops—BO, Cedar Hill, Texas 75104.

\$500—\$800 MONTHLY Raise small laboratory-breeding stock for us. We supply equipment, breeders, instructions, Illinois Research Farms, Dept. MPD-5, McHenry, Illinois 60050.

MAKE BIG MONEY GROWING GINSENG! \$3,000-\$30,000 annually. We buy your crop. \$2.00 brings seed sample and information Glass' Ginseng Exchange, Box 1969, Springfield, Mass. 01101.

ADVERTISING BUSINESS—YOU own it. \$350 First Week or Money Back. Electric Neon Action Ad Clock, 229 W. Illinois, Chicago 60610.

HOW TO PREPARE YOUR OWN MAIL-ORDER CATALOG for pennies. . . Including All Popular Merchandise! Free Catalog-Proof! Obie, 5711-MY-14TH, Brooklyn, New York 11219.

SELL Books by mail. 400% profit. Royal, Box 450-X, Cleveland, Ohio 44127.

PLASTERCRAFT Molds, liquid rubber, plasters, flocks, candle supplies. Catalog and manual free. Blue Rapids Supply, Blue Rapids, Kansas 66411.

\$60.00 DAY. Manufacturing concrete Posts, Blocks, Mold Equipment Catalog \$1.00 refundable. Carlayne, 1803 Fremont, Rapid City, South Dakota 57701.

EARN more than many Professional men! \$1000.00 monthly operating Mail Order Collection Agency. Continental, Box 2023-A, Des Moines, Iowa 50310.

MAKE \$46 from square foot plywood: jigsaw or bandsaw necessary. Free details. Woodar, Bridgewater, Mass. 02324.

MAKE \$32 from 49¢ piece vinyl. M-1834 Edgeland, Louisville, Ky. 40204.

BIG PROFITS selling Books, Manuscripts by Mail. Free information. Belville, 1123 Reym, Saint Louis, Missouri 63132.

MAKE Money Operating Home Mailorder Business. No Inventory. Write Purple Enterprises, Box 1629AE, Jacksonville, Fla. 32216.

OPERATE Home mailorder business! Free info. Vosacek Printing, Box 1217A, Garden Grove, California 92640.

OVER \$16.50 an hour. Spare time at home! Rubber Stamp industry needs small manufacturers. We furnish all equipment and know-how! Particulars free! Write Roberts, 1512 Jarvis, Room CR-2-B, Chicago, Ill. 60626.

JOIN "MONEY GETTER'S GUILD". Receive hundreds money-making, Business Building Propositions. Year's membership only 25¢. Write: Fourstars, Box 839, Long Beach, New York 11561.

MAKE Durable Building Plastic Easily. Waterproof, Fireproof. Economical. Bays Laboratory, Cedaredge, Colorado 81413.

CALIFORNIA MANUFACTURER NEEDS man to assemble our product and be local agent, experience unnecessary. May start while presently employed. Five-figure income for responsible applicant. Information free, or sample for evaluation \$3.00 S.K.R.M. Manufacturers, 2540 Olive Avenue, Long Beach, California 90806.

OPERATE A Business of your own from home. Everything furnished. Royce, Box 204-G Dolton, Illinois 60419.

\$21.00 HOUR Profit—From Home Picture Framing Business. (Clampless Assembly Method) Write: Japs, 126-PM Seventh North, Hopkins, Minnesota 55343.

MAILORDER — Profitable products; dropshipped. No merchandise investment. Everything supplied—catalogs, ads, mailing lists. Gif-Guide, 3408½ Motor, Dept. 148, Los Angeles 90034.

MAKE MONEY Writing Short Articles at home. Report reveals How! \$1.00, Dundee Studios, 546 Lincoln, W. Dundee, Illinois 60118.

SUCCESS Can be yours. Enlightening book shows how. Free details. Shamrock Sales, Dept. C Box 65, London, Ontario, Canada.

I MAKE \$1,200 month in Accounting. You start, 50¢ lesson, 10 lessons. Certificate awarded. Try your first lesson 50¢, Jenkins, Box 571, Taft, California 93268.

FREE! 60 Lazy Ways To Strike It Rich! Stamped, Self-addressed envelope. Finderhood, (PM-26) 15 West 38th, N.Y. 10018.

UNLOCK Your Future. Become professional Locksmith with spare time home-study. Make up to \$6 per hour. All tools, equipment incl. Facts free. Send name. Locksmithing Inst., Dept. 1310-059, Little Falls, New Jersey 07424.

OPERATE Your own Record Club. We Supply Everything. Send \$2.00 for sample album, catalog, instructions. Hollyreco, 1719 Bank Street, Baltimore, Md. 21231.

PLEXIGLAS SIGN MAKING Simple instructions and supplies lets you make **PROFESSIONAL PLEXIGLAS SIGNS.** Starting kit \$12.50 for over 120 Acrylic letters and Acrylic background. Unlimited uses, great profit. Daytona Plastic, Dept. M., Box 6161, Daytona Beach, Florida 32022.

COPUBLISH "Mail Sale Advertiser," leading mailorder paper. Copy and details 25¢: U.S.A. only. Vanroy Shirk, Lebanon, Pa. 17042.

MAILORDER Records help get Increased Business! Complete 32 page Record Book shows your inquiries, orders, advertising expense, etc. Only \$1.00. Martin, Popular Mechanics, Dept. PM, 575 Lexington, New York 10022.

\$70.00 WEEKLY—home, spare time. Simplified mail bookkeeping. Immediate income easy. Auditax, 34741A, Los Angeles 90034.

MAKE Money from old tires. Operators clearing \$800, weekly. Equipment costs \$1500. Get facts. S & S Patents, Inc., 3752 N. Damen, Chicago 60618.

FREE FRANCHISE JOURNAL MAGAZINE with over 100 business opportunities. Franchise Journal, 892-G West 16th St., Newport Beach, California 92660.

LOCAL NEWSPAPER AD WILL BRING ALL THE BUSINESS YOU CAN HANDLE. Information Free. Engineered Ideas. Write 5359, Clinton St., Los Angeles, Calif. 90004.

HOMEWORKERS! \$85 weekly addressing mail for firms. Start immediately! Details, send stamped self addressed envelope. Enterprises, Box 16143-PM, Phoenix, Arizona 85011.

IMPORT Export opportunity, profitable world-wide, mail-order business from home, without capital; or travel abroad. We ship proven plan for no risk examination. Experience unnecessary. Free details Mellinger, Dept. C2705, Los Angeles, 90025.

SECRETS! Mail Order Success. Internationally famous expert reveals how to make home business fortunes. Beginners; Get free copy "Make Money By Mail." Discloses free advertising. Profitable products. Mailco, 1554 Sepulveda, Dept. C2705, Los Angeles 90025.

SUPPLY Fried chicken dinners on \$500 Week Home Plan. Free Information. White's Chicken Dinners-PM, Mt. Vernon, Ohio 43050.

HIGH Profit home Art Sales Business. \$20.00 Refundable Investment Offer. Details Free. Paintings, Box F-202, Fairborn, Ohio, 45324.

MAILORDER Business for Sale. Information Free. J & J Enterprises, 417 West 64th St., Inglewood, California 90302.

PREPARE For solid high paying career in electrical repair. Experimental kits included. Free fact pack. I.T.I. Dept. 65160, 815 E. Rosecrans, Los Angeles 90059.

PROFITABLE WATCH REPAIR. Sample lesson free. No obligation. Watchmaking. YRB, Fox River Grove, Illinois 60021.

OPERATE Restaurant. Free booklet reveals profitable plan. Write Restaurant Business School, Dept. EC59, 1920 Sunny-side, Chicago, Illinois 60640.

DATA-CRAFT Agency. One-Man Business. Prepare data for merchants: 24 other services. Get \$5 to \$25 checks monthly. Free details. Datacraft-71A, Harlingen, Texas 78550.

HOW And Where To Get Capital. 1000 sources. Free details. Counselor-17, Harlingen, Texas.

MAILORDER—Free details. 990 Successful little known Businesses. New. 1403G Athens, Mesquite, Texas. 75149.

BECOME Tax consultant. Our students earn \$1,000—\$3,000 every tax season preparing returns evenings. State approved. National Tax School, Monsey, 2DB, New York 10952.

WHY WORRY ABOUT WORK! READ HOW to acquire adequate income for life. Details free. Bine, Roca, Nebraska 68430.

MAILORDER Business. Free circulars. Harry Andrews, 160 Bleecker, New York, N.Y. 10012-PM.

PROVEN Import & Mailorder Procedures. Revealing—Profitable—Practical. Write: N.D.B.R., Box 13011-F, Kansas City, Missouri 64199

BIG Money raising fishworms and crickets. Free literature. Carter Farms, Plains, Georgia 31780.

MAIL ORDER COURSE \$2.00 Many publications of interest to beginners. Free literature Snells Box 682-A Bath, N. Y. 14810

INFORMATION! IT Cost Me \$3000. Yours For \$3.30 Wright, 4507 Cole, Dallas Texas, 75205

RESILVER MIRRORS. Instructions \$2.00. Mark Plating Co., Box 8307, W. Palm Beach, Fla. 33407.

TIN-CANS, Sawdust, Newspapers, Rubber, Rags, Glass, 324 Uses. Instructions \$3.00 Satisfaction guaranteed. Charles Company, 42-GWM, Norwood, Ohio. 45212

GET World's Largest Wholesale IMPORT Merchandise Catalog. Free details. Northwest, Medina, Washington 98039.

MAILORDER IMPORTS. Report Reveals Foreign Drop-Ship Sources, World Trader's Digest. Ideal Mailorder Items. Send \$1.00 W. W. Churchill 5915 Wellesley, Pittsburgh Pa. 15206

FREEWAY Mutual Franchise; Motels, Service Stations, Box 1041, Waterloo, Iowa 50704

NEW CRYOGENERATOR. Partner with Capital Wanted, develop breakthrough novel High efficiency Cryogenerator. Professor's Report Available. Roos, 5 Virginia, Bellerose, N.Y. 11426.

FREE Advertising? 500 Publications. Write: Dee, 10639-PM Riverside, North Hollywood, Calif. 91602.

DONUTS Earn high profits for your business, organizations, or church. Complete information, Stork-Ville Donut Co. Inc., G-4402 Calkins Rd., Flint, Mich. 48504.

EXTRA INCOME. Big profits in mail-order. FREE details how to start your own home business part-time. No investment or experience necessary. Dealers Supply, 102-A5 So. 5th St., Millard, Nebr. 68137.

BECOME PROFESSIONAL DRIVING INSTRUCTOR. Earn \$10.00 Hour, \$300 Week. Part Time—Full Time business for yourself. Free details. Howard David, 1818 Everts St., Phila., Pa. 19152.

AUSTRALIA!!! AUSTRALIA!!! AUSTRALIA!!! Opportunities Galore! Government Assisted Transportation. 1969 **HANDBOOK** \$1.00 Satisfaction Guaranteed! Associated, Box 17B5B, Lafayette, California.

SWIMMING Pools! High Profits! Highest Quality, in and on Ground Steel Wall Pool Pack. Short season. Fastest Growing Industry Nationally. Pal Pools, Inc., Mech. Div., Nesconset, N. Y. 11767.

CATALOG Of Opportunity. Unlimited opportunities, write Mavis Associates, 2205-A So. Troost, Tulsa, Oklahoma 74114.

AIR MAIL Importing. Details. 6¢ Baker's, 313 Harrison, Sullivan, Illinois 61951.

BIG Money in Manufacturing new Miracle Plastic Paints. Six formulas and complete manufacturing instructions only \$3.00. Willfors, 61 Friendly Lane, Levittown, Pa. 19055.

\$25.00—\$100.00 WEEKLY; your own Home Typing Business. Tested helps. Methods. Send stamped, addressed envelope. National, Box 1975-MMA, Little Rock, Ark. 72203.

IMPORT Merchandise at unbelievable prices. Write: Imports, 2815-P5 Grand River, Detroit 48201.

AUCTIONEERING Home Study Course —\$15.00—Diploma—American Auctioneer College, Box 316, Terra Ceia, Florida.

LIQUID Molding rubber also liquid plastic. Free information. Chaney's, 5415-A San Jose Blvd., Jacksonville, Fla. 32207.

YOUR Name Wanted. Get Homework offers, Samples, Magazines. Year \$1.00. Seals, 1109 Kimel, Salinas, Calif. 93901.

MONEYMAKING OPPORTUNITIES

\$200.00 FROM Sheet 1/4" plywood (scrap). Details 25¢. Novelties, 610 So. 24th, Elwood, Indiana 46036.

EARN \$240.00 a month at home, spare time, doing only two \$5.00 invisible mending jobs a day. Big money paid for service that makes cuts, tears disappear from fabrics. Steady demand. Details free. Fabricon, 1532 Howard, Chicago 60626.

RAISE Rabbits and fishworms on \$500 month plan. Free details. White's Rabbitry, Mt. Vernon, Ohio 43050.

MAKE Statuettes, novelties, imitation marble. Sell to stores or start gift shop. Free details. Marbleizing, 41 Waverton, St. Louis, Mo. 63124.

HOW To Make money writing short paragraphs. Information free. Barrett, Dept. C-27-R1, 6216 N. Clark, Chicago 60626.

CLIP Newspaper items. \$1.00—\$5.00 each. Details free. Walter, Box 1360-P, Erie, Pa. 16512.

VENDING Machines. No selling. Operate a route of coin machines and earn amazing profits 32-page catalogue, free. Parkway Machine Corporation, 715 P.M.M. Ensor Street, Baltimore, Maryland 21202.

WHEELER-DEALERS! Free. Little-known opportunities; foxy-smart angles. Stamped, self-addressed envelope. Wheeler-Dealer Association, (PM-36), 15 West 38th., New York 10018.

FREE Copy of world's leading contest magazine! Write Prizewinner, Box 11569, St. Petersburg, Fla. 33733.

\$800.00 WEEKLY. My net profit, year. Magic Method Mail Selling. Free proof with samples, send stamped, addressed envelope. C. Brewster, Clearwater, Florida 33517.

\$500—\$800 MONTHLY Raise small laboratory-breeding stock for us. We supply equipment, breeders, instructions. Illinois Research Farms, Dept. MP-5, McHenry, Illinois 60050.

SPARE Time Cash—Sell Advertising Book Matches—every business a prospect—no investment—no experience needed to build steady repeat business. Daily Cash commission in advance. Write today—We'll send your sure-fire selling kit by return mail. Dept. MA-569, Superior Match Co., 7530 S. Greenwood, Chicago, Illinois 60619.

CASH/Royalties for romantic songpoems! Castle's, 203-M West 46th, New York City 10036.

MONEY—Become a Finance Broker. Full or part time. RMP & Co., P.O. Box 901, Desk 10, El Reno, Oklahoma 73036.

LEARN The secrets of repairing junk batteries. "Fabulous Profits" at home. Batteryman, 878, Palm Desert, California 92260.

TYPING Pays! Unbelievable \$30.00 thousand addressing envelopes from lists. Typewriter, longhand. Immediate earnings. Instructions \$1.00. Florida Service, P.O. Box 1017CC, Hialeah, Fla. 33011.

EXTRA Earnings; take advantage newest money-making ideas; free details; write now. Hyltin Company, Box 1385, Austin, Texas 78767.

HIGHLY Profitable spare-time business. Bronzing & PearlKoting baby shoes. Complete set-up on credit available. 31 year old company. Send 25¢ for brochure. Kik-tavi, Box 4187PM, Compton, Calif. 90224.

HOMEWORKERS! 200 companies—48 page Directory. FREE details. Quest Enterprises, Box 6629, Dept. 15, San Jose, California 95150.

MEN—Women! Start money-making Plastic Laminating business at home in spare time. Material that costs 11¢ brings back \$2.58. No canvassing or selling but mail orders bring in \$20 a day. Write for full particulars free. Rush name on postcard to: Warner, Room CL-2-B, 1512 Jarvis, Chgo., Ill. 60626.

HOMEWORK. Mailing circulars. Free details! Cam Company, Dept. 155-KP, Verona, N.J. 07044.

FREE. 206 Easy Ways to make money taking orders for exciting new products—spare time. Send name, age for 5 months free subscription. Opportunity Magazine, 1460 Hancock Center, Dept. 17-EM, Chicago 60611.

LYRIC WRITERS write songs with writers who write hits for top Nashville artists. Globe, 420 Broad, Dept. PM, Nashville, Tenn. 37203.

MAIL Order Operators make \$1,000.00 on every \$80.00 invested. Free ads. Regular \$10.00 Bulletin Special. Send \$1.95 to Consultants, Box 298, Bradenton, Fla. 33505.

\$1.00 Each possible assembling Belts. Details 6¢. Redikut's 40, Richland Center, Wisconsin.

MECHANICALLY inclined? Learn profitable WATCH REPAIRING. Free sample lesson. Watchmaking, YRA, Fox River Grove, Illinois 60021.

BECOME Notary Public! Free particulars. Stationers, 405-PM Richardt, Evansville, Indiana 47711.

EARN \$\$\$. Be independent. Eight page opportunities FREE. Rees, 258 W. Kyger, #7, Frankfort, Ind. 46041.

EVERYTHING Goes big by "THINKING BIG". 256 interesting pages. Send \$2.00 now. Wynn, 21 West Third Street, Dept. 5PM, Tulsa, Okla. 74103.

MONEY—SPARETIME OPPORTUNITY PANELISTS AT HOME WANTED BY NEW YORK RESEARCHER. Leading research firm seeking people to furnish honest opinions by mail from home. Pays cash for all opinions rendered. Clients' products supplied at no cost. For information write: Research 669 Mineola, N.Y. 11501, Dept. PM-24.

\$2.40 HOURLY Making simple wood novelties. Free details! Gene's, 55 Boxwood, Falmouth, Mass. 02540.

CASH For your photos. Information \$1.00. Lin-z, 2606 E. Pontiac, Fresno, Calif. 93726.

BIG Money raising fishworms and crickets. Free literature. Carter Hatchery, Plains, Georgia 31780.

FREE MONEYMAKING CATALOG. Write Fitz, 275 Main Street, Freeville, New York 13068

PLASTER CRAFT HANDBOOK for making figurines, painting and making molds. For details write Wolfe Specialties, Box 561B, Melbourne Beach, Florida 32951

USE YOUR TABLE SAW—Make big Money from scrap lumber with New Patented Attachment—no competition—unlimited market—free details—Booth Manufacturing—15133 Wayside—Phila., Pa. 19116.

Turn Newspaper Engagement Clippings into cash. Denbarr, Box 147, Pearl River, New York 10965

MAILBOXES!!! \$200.00 WEEKLY in your Mailbox! Follow expert advice. Free Details. Associated, Box 17R5, Lafayette, California.

SWEEPSTAKES Contests. How to Win. Write for free particulars. General Contests, 1609-18 East Fifth, Duluth, Minnesota 55812.

RAISE Hard to get colored Canaries. Budgies. Exciting profitable hobby or business. Big profits. We furnish everything. Details free. Glenmere Aviaries, Box 402, Grahamsville, New York 12740.

\$350 MONTH Addressing! Companies furnish everything. Details. List \$2.00. Satisfaction GUARANTEED. D-Happy, Box 1161, Battle Creek, Michigan 49016.

MAKE MONEY with your CAMERA. How and Where. Booklet MO-54P. \$1.00. House of Values, 1395 Dawn, Montgomery, Ill. 60538.

EARN \$5.00 Hourly and more! Operate your own Lawn Mowing Service. Ideal money-maker for Students. "Moonlighters." and Retired. Also full-time Unique new book, written by successful gardener, reveals professional secrets and proven methods. Contains complete instructions. Only \$2.00. Denco Publications, 3636 Brayton Ave., Long Beach, Calif. 90807.

CASH OK?? Try our Advertising Specialty, start: \$1.00 P.O. Box 4840 San Jose, California 95126.

HOW TO make money spare time at home. New proven chemicals used in industry and homes. Amazing reorder record. Easy new marketing method. Fast advancement. Be a distributor. Start now. Send \$2.00 for information. Anderson, Box 178, Bloomfield, Nebraska 68718.

FREE Catalog! Unique Money-making opportunities, self-improvement books, folios—also distinctive gifts. Seven Seas Treasures, 6210PM Hampton Boulevard, Norfolk, Virginia 23508.

100% PROFIT Selling Lifetime Social Security Plates. Starter Kit Including Sample Free! Specialties, Box 66, Crestline, Ohio 44827.

SILK Screen Artistic Artwork. Home full, part time. Instructions \$1.00. Screenco, Box 862, Waukesha, Wis. 53186.

COLLECT Coins for profit! How to start. Where to sell. Pamphlet only \$1.00. Rea's, Box 116, Hamlin, West Virginia 25523.

PROFITABLE OCCUPATIONS

BECOME A mortgage broker, earn \$10,000 to \$50,000 a year. Details free. United, Box 6284A, Marietta, Georgia 30060.

RAISE Rabbits for us on \$500 month plan. Free details. White's Rabbitry, Mt. Vernon, Ohio 43050.

YOUR Own Sign shop. Signs, 410-S So. Western, Springfield, Ohio 45506.

HOW To Make Money Writing Short Paragraphs. Information Free. Barrett, Dept. C-27-R2, 6216 N. Clark, Chicago 60626.

CHROME Plating. Instructions, equipment and supplies. Platers' Supply, P.O. Box 565, Lugo Station, Los Angeles, Calif. 90023.

FT. SMITH Auction School, Ft. Smith, Ark. Residents & Home study. Veteran approved.

FREE Book "990 Successful, Little-Known Businesses." Work Home! Plymouth-37-Y, Brooklyn, New York 11218.

EARN \$240.00 A month at home, spare time, doing only two \$5.00 invisible mending jobs a day. Big money paid for service that makes cuts, tears disappear from fabrics. Steady demand. Details free. Fabricron, 1586 Howard, Chicago 60026.

SHARPEN Scissors, Pinkers, Inexpensive equipment, tools, supplies. Blackhawk's, Sheldahl, Iowa 50243.

INVESTIGATE ACCIDENTS: Earn \$750 to \$1000 monthly. Car furnished. Expenses paid. No selling. No college education necessary. Pick own job location. Investigate full time or earn to \$8 hour spare time. Men urgently needed Write for FREE information. No obligation. Universal Schools, CPM-5, Hillcrest, Dallas, Texas 75205.

\$500-\$800 MONTHLY Raise small laboratory-breeding stock for us. We supply equipment, breeders, instructions. Illinois Research Farm, Dept. MPA-5, McHenry, Illinois 60050.

RECEIVE Profitable Business Offers from 100 Companies. We contact them for you. Guaranteed service. Only 50¢. Campos Business Communications, 35 Exeter Avenue, Pawtucket, Rhode Island 02860.

BIG Money raising fishworms and crickets. Free literature. Carter Wormery, Plains, Georgia 31780.

EARN \$15,000 Yearly as Insurance Adjuster or Professional Damage Appraiser. Write for aptitude test today. National Adjusters Institute, Satellite Beach, Fla. 32935.

\$1,000.00 MONTHLY Operating Collection Agency. Master, Drawer 77009-A, Atlanta, Georgia 30309.

SALESMAN—DISTRIBUTORS

EARN Terrific commissions listing delinquent accounts. General Finance Company, 304-A Pickwick Building, Kansas City, Mo. 64106.

100% PROFIT—Sweet Georgia Brown Cosmetics sell fast. Write for Sample Case offer. Valmor, Dept. H, 2411 Prairie, Chicago 60616.

DO You wish to use or sell a plant food that is field proven, shows the greatest results at lowest cost? Something different in sales and use. Big monthly income or get your fertilizer FREE. Campbell's Gro-Green, Rochelle 274, Illinois.

EARN Big Commission Full or Part Time. Show America's largest line Low Priced Business Printing and Advertising Specialties Plus calendars in season. No experience. No investment. No collections or deliveries. On-the-spot commissions. Big Free Sales Kit samples hundred items used daily by businessmen. Merchandise bonuses for you. Build profitable repeat business. Start now. National Press, Dept. 91F, North Chicago, Ill. 60064.

SELL Advertising book matches. Write us today. We put you in business by return mail, handling complete line ad book matches in demand by every business right in your town! No investment; everything furnished free! Top commissions daily: Superior Match, Dept. M569, 7530 S. Greenwood, Chicago, Illinois 60619.

SELL BIBLES—24 Editions—DIRECT from PUBLISHER! Wholesale discounts! Highest profits! Free Circulars, sales course, write: Bible Publishers, Dept. PM-5, Box 5065, San Antonio, Texas 78201.

30,000 CAR Dealers desperately need good salesmen! Thousands of jobs furnishing a NEW CAR over \$1,000 per month, many fringe benefits. Our exclusive home study course will train you! Free Catalog Automotive Sales Institute, Box 746, Dept. 1B Kenosha, Wisconsin 53140.

FREE. 206 Easy Ways to make money taking orders for exciting new products—spare time. Send name, age for 5 months free subscription. Opportunity Magazine, 1460 Hancock Center, Dept. 17-ES, Chicago 60611.

MAKE Extra \$25 to \$75 spare time! Take orders for double air cushion Bronson Shoes. Amazing comfort. Terrific men's, women's line for dress, work, play. Highest commissions. Shoes for yourself. Big outfit FREE. Write Bronson, Dept. 164, Minneapolis, Minnesota 55408.

BIG Profits Selling Revolutionary Laundry Aid Discovery. Details Free. Thompson, 1018 South Waugh, Kokomo, Indiana 46901.

SELL Hertel Bibles—Part Time. Finest reference Bible available. Demonstrator and supplies furnished. Excellent commissions. Write International Book, Dept. PM, Box 118, Wichita, Kansas 67201.

LONG Needed invention. Man to contact service stations. Huge profits. Write, Cyclo Mfg., 3816 Dahlia, Dept. 144, Denver, Colorado.

TO Establish own Credit Brokerage Business. No investment. To help you get started, we guarantee \$150 weekly to men meeting our requirements. Age no handicap. Write Manager, Drawer 437, Mentor, Ohio 44060.

FREE! Money Making Opportunities! Send name, address, zip. Bradley, Box 509-D, Mt. Kisco, New York 10549

BIG Profits displaying keepsakes in glass. Nichols, Box 11069-AA, Kansas City 64119.

AGENTS WANTED

PRINTING, Advertising Salesmen—Excellent moneymaking sideline selling Decalcomania Name Plates, small quantities. Advertising Specialties, sign letters. Free Samples. Ralco XL, Boston, Mass. 02119.

YOUR Own business—Used suits \$1.50; overcoats 65¢; mackinaws 35¢; shoes 12½¢; ladies coats 30¢; dresses 15¢. Enormous profits. Catalog free. Nathan Portnoy Associates, 2109-AA Roosevelt Road, Chicago Ill. 60608.

LIFETIME Income. Business Loan Representative. Write: Financial 28 E. Jackson, Suite 1204-X3, Chicago 60604.

ESTABLISH Your own business. Low prices on used clothing, shoes, household goods. Unlimited profits. Free catalog. Northwestern Distributors, 2129 No. Western Avenue, Chicago, Illinois 60647.

EVERY Man a prospect. Refundable sales kit offer showing line belt buckles, tie clasps, money clips, cuff links, lapels, identification badges, individualized with customer's name and emblems. Cap badges for trucking, bus, taxi, police, firemen, also postal, letter carriers and heavy construction emblems. Choice 3000 emblems. Hook-Fast, Box 1088PM, Providence, R.I. 02901.

FREE. 206 Easy Ways to make money taking orders for exciting new products—spare time. Send name, age for 5 months free subscription. Opportunity Magazine, 1460 Hancock Center, Dept. 17-EA, Chicago 60611.

FASCINATING Sideline! \$50.00 Week! Sensational Free Sample Offer! Nationwide. Box 3522, Los Angeles 90054.

EMPLOYMENT INFORMATION

AUSTRALIA Wants You! Government assisted passage. Unlimited Opportunities. Latest Government Information and Forms \$1.00 Austco, Box 3623-E, Long Beach, California 90803.

FOREIGN And USA job opportunities available now. Construction, all trades. Earnings to \$3,000.00 monthly. Paid overtime, travel, bonuses. Write: Universal Employment, Woodbridge, Conn. 06525.

HIGH Paying overseas jobs. Construction, other projects. Bonuses, Travel Expenses, Extras. International Information, 124, Cortez, Florida 33522.

CHICAGO, Suburbs, and National Accelerator areas. Sunday newspaper ads. Employment, \$2.00; Housing, \$2.00; Both, \$3.00. George H. Tincknell, Limited; P.O. Box 392, Batavia, Illinois 60510.

AUSTRALIA NEEDS YOU! 1969 Handbook with latest Wages, Jobs, Opportunities, sent airmail, \$1.00. R. Miller, Box 3726, Anaheim, Calif. 92803.

BOOMING AUSTRALIA wants You! Good jobs. Adventure. Forms and Australian Handbook (1969) describing Australian assisted passage, passport-visa, advantages, opportunities \$1.00. Buckeye, Box 1032ML, Fairborn, Ohio 45324

AUSTRALIA Opportunities Handbook! Assisted passage. 1969 report: \$1.00. Stewart, Box 13262, Kansas City, Mo. 64199.

TREMENDOUS Opportunities U.S.A. Overseas. Choose Jobs—Locations, Transportation. Free Details. Occupations, International Airport, Box 100-C18, Jamaica, N.Y. 11430

AUSTRALIA!!! AUSTRALIA!!! AUSTRALIA!!! Jobs Galore! Government assisted transportation. 1969 HANDBOOK \$1.00. Satisfaction Guaranteed! Associated, Box 17B5, Lafayette, California.

HELP WANTED

OVERSEAS Jobs—Europe, South America, Australia, Far East, etc. 2000 openings all trades. Construction, Office, Engineering Sales, etc. \$400 to \$2,500 month. Expenses paid. Free Information. Write Overseas Jobs, International Airport, Box 536-M, Miami, Florida 33148.

GAS APPLIANCE SERVICEMEN: No experience necessary. Will train. 52 weeks work guaranteed annually including paid vacations and holidays; insurance; opportunities for promotion; most managers started as servicemen. Apply manager, Baltimore, Boston, Chicago, Cleveland, Detroit, Los Angeles, Philadelphia, Pittsburgh, St. Louis, San Francisco, Washington, D.C., Dallas offices (we're in phone book). GAS CONSUMER SERVICE.

OVERSEAS jobs—Australia, Europe, South America, Far East, etc. Openings in all trades and professions, \$400. to \$2,500 monthly. free information write: Foreign Employment Mart, Box 2235 A.M.P. Miami, Florida 33159

WORK home, mailing our catalogs! Free details! Cam Company, Dept. 155-LB, Verona, N.J. 07044

AUSTRALIA!!! AUSTRALIA!!! AUSTRALIA!!! Jobs Galore! Government assisted transportation. 1969 HANDBOOK \$1.00. Satisfaction Guaranteed!! Associated, Box 17B5A, Lafayette, California.

JOB HUNTING. Think Booming AUSTRALIA. Every Skill needed. Handbook and official applications. Only One Dollar. International Publications, Box 123-M, Milwaukee, Wisconsin 53201.

REAL ESTATE & FARMS

CANADIAN Vacation lands: Full price \$385.00. 40 acres. \$10 month. Suitable cottage sites, hunting, fishing, investment. Free Information. Land Corporation, 3768-C Bathurst, Downsview, Ontario, Canada.

\$1 ACRE—Canadian Border—hundreds campsites, islands, farmlands, directly from tax authorities. (Non-profit). Lists, photographs mailed. Register, Room 10, 110 Church Street, Toronto 1, Canada.

CENTRAL Ontario—Choice 640 acre Sportsmen's paradises still available—\$20.00 plus \$6.50 taxes yearly. Maps, pictures. \$2.00 (Refundable). Information Bureau, Norval 4, Ontario, Canada.

GOVERNMENT LANDS . . . Low, as \$1.00 acre. Millions acres. For exclusive copyrighted report . . . plus "Land Opportunity Digest" listing lands available throughout U.S., send \$1.00. Satisfaction guaranteed. Land Disposal, Box 9091-PE, Washington, D.C. 20003.

VACATION Lands, Canada. \$1.00 acre. Free information. Tax Corp., 206-F Bloor W., Toronto 5, Canada.

CANADIAN Lands, seized and sold for taxes. Our 52nd annual series of lists, describe many choice properties, situated from coast to coast, acquired by us through Tax Sale. Priced as low as five dollars per acre, guaranteed perfect title, small monthly payments, no mortgage. Beautifully situated hunting and fishing camps, where there is real sport; summer cottage sites, heavily wooded acreages. Now is the time to invest in Canada's minerals, forests and farms. Write to-day for free booklet with full explanation. Tax Sale Service, Room 301-D, 85 Bloor St., East, Toronto 5, Canada.

NORTHWEST WOODED WILDLANDS AS LOW AS \$950. TOTAL PRICE \$50 DOWN \$25 MONTH. 5-10-20-40 acres for people who love the land. . . . A piece of wilderness to preserve for your own forever. In Northern Idaho, Northeastern Washington, and Western Montana. In the heart of lakes and big game country. All covered with growing timber. Access, Title insurance with each tract. This is select land with natural beauty, recreational and investment values. We have tracts of many types and sizes from which to choose, including beautiful Northwest Waterfront property on the Pend Oreille, Priest and Kettle Rivers; and property on Pend Oreille Lake. Your inspection welcomed. Write us for free list, maps and complete information. Write to: Dept. PE, Reforestation, Inc., P.O. Box 8146, Spokane, Wash. 99203.

LESS Than 1 mile to Disney property. Lake living, 1/4 acre. Private ramp, beach, 11 mi. to Orlando. \$24 mo., \$50 down. BLOCH BROS., 1 North Rosalind, Orlando 26, Florida. AD65LS169-L

CANADA'S Finest lands. \$4.00 an acre and up. Acquired through estate liquidations. Suitable for hunting, fishing, camps, cottages, farming, timber, minerals, investment. Small monthly payments. Free descriptive booklet. Canadian Estate Land, Dept. 20, 194 Wilson Ave., Suite 101, Toronto, 12, Canada.

BUY Without risk for Retirement. Vacation, or Investment—under America's only "No-Risk Purchase Plan"—in Carolina Coast multi-million dollar, 14,000-acre development. 10 year money-back guarantee. 1/4-acre homesites as low as \$695.00; \$8.00 down, \$7.65 monthly. Motel, hunting, fishing, golf, country club, right on property. Private ocean beach, 50 fresh water lakes. Write for free literature. (Not offered to residents of California, Florida, New York.) Boiling Spring Lakes, Southport 1-J, North Carolina 28461.

FREE CATALOG! Spring Edition. Farms, Ranches, Business, Recreational and Investment Property. 17 States. Pictures Galore! Note State desired. Banner Adv., Box 3333, 19-A, Springfield, Mo. 65804 "Real Estate Our Specialty".

NEW!—FREE CATALOG! Giant SUMMER edition! Over 4,000 properties described, pictured—Land, Farms, Homes, Businesses—Recreation, Retirement. Selected Best thruout the U.S.! 69 Years' service, 515 Offices, 40 states Coast to Coast. Mailed FREE from the World's Largest! STROUT REALTY, 60-RX E. 24th St., N.Y., N.Y. 10017; 7-RX S. Dearborn, Chicago, Ill. 60603; 521-RX E. Green, Pasadena, Cal. 90013

FREE 232-Page Real Estate Catalog. All types property, coast to coast. UNITED FARM AGENCY, 612-PM West 47th Street Kansas City, Mo. 64112.

FARM & GARDEN EQUIPMENT

BUILD Your own Lawn and Garden carts with our heavy duty bicycle type wheels with 1/4" spokes 20" and 26" any type bearings, with or without pneumatic or semi-pneumatic tires. Steel rim spoke wheels also available. Also small differentials to build your own motorized carts. Also ornamental Windmills. Cizek Mfg. Co., Clutier, Iowa 52217.



FLOWERS, PLANTS & NURSERY SUPPLIES

BIG MONEY growing selling Jamaican Rose exotic flowering shrub, edible petals Salads, preserves, refreshments, medicinal. Seedlings sell over 25¢, plants \$3. Hand picked selected seeds: 100 \$1.75/ 500 \$7.85/ 1000 \$14.25/ 5000 \$64.25. Instructions. Sales Know-How Airmailed post-paid. Airmail Money Order: Kurt Meyer, PO Box 684, Guatemala, Central America.



DRINKING WATER—PURIFIER

EXTRA Income at home in Spare Time! Booklet shows you how to start your own business with Classified Advertising. Only \$1.00. Refundable with first insertion order. C. A. Martin, Popular Mechanics Dept. PM, 575 Lexington Ave., New York 10022.

HOME CRAFTSMEN

CABINETMAKING MADE EASY and "How to Make Formica Counter Tops," two excellent guides let you build kitchen cabinets and counter tops like professionals. Extraordinary guides bring master craftsmen's shortcut methods. Satisfaction guaranteed. Write: Japs, 126-P Seventh North, Hopkins, Minn. 55343.

PLANS, Bird houses. Send 15¢ for brochure and free feeder plan. Yeager, 1665 Linden, Homewood, Ill. 60430.

WALNUT And Cherry tapered legs, lumber, gunstock blanks, picture frame moulding. Midland Lumber Company, Box 262, Savannah, Missouri 64485.

FULL SIZE FURNITURE PLANS. Traditional, Early American, Danish Modern. Catalog 50¢. Furniture Designs, Dept. P-5, 1425 Sherman, Evanston, Illinois 60201.

FREE Popular Mechanics 16 page illustrated catalog of publications, plans and projects. Booklet covers an extremely wide variety of do-it-yourself data on home remodeling, shop tools and machines, car repair, hobbies, crafts, boating, games, lawn and garden and hundreds of others. For your free copy write to Service Bureau, Dept. PE, Popular Mechanics, 575 Lexington Ave., New York, N.Y. 10022.

PLANS For pool table with extra two-face top for table tennis and model railroad. Blueprints B1209 and building instructions \$3.50. Popular Mechanics Service Bureau, 575-M Lexington Ave., New York, N.Y. 10022.

NO NAILS SCREWS or GLUE. Amazing. Strong. Sturdy Childs Chair, Cut From 3/4" Plywood Full Size Pattern \$1.00. Werts-Wood-Products, Box 41097, Cincinnati, Ohio 45241.

MAKE FASCINATING WINDWHIRL from discarded bikewheel, plastic jugs, etc. Patterns, illustrations \$1.00. Tim's Handycraft, Washburn, Mo. 65772.

FOUNDRYETTE 2400 F. 1 1/2 to 48 lb. capacity. Circular 10¢. Kansas City Specialties, Box 193-P-5, Middleton, Wisconsin 53562.

"CIGARETTE Lighter Mechanisms." Mount into shopcrafted Bases. Write: Craftmark, Station A, Box 113-PA-1, Flushing, N.Y. 11358.

INEXPENSIVE RETAILING SERVICE. Consign anything saleable. New or used in any amount. Also orders taken from sample. Send list. Details: Box 42668, Evergreen Park, Illinois 60642

Picnic Table—Disassembles for storage—Plans \$2.00—Geebee Engineering, Route 4, Box 721-A1, Ledyard, Connecticut 06339

101 PATTERNS of smart Gifts, Novelties, Shelves, Action Windmills, plus "Make Money Jig Sawing" \$1.00. Mastercraft, 55M, 7041 Olcott, Chicago 60631

SPANISH FURNITURE PLANS. Send stamped, addressed envelope for circular. R. S. Plans, Box 12091, Parkville, Mo. 64152.

UPHOLSTERY

MAILORDER Records help get Increased Business! Complete 32 Page Record Book shows your inquiries, orders, advertising, expense, etc. Only \$1.00. C. A. Martin, Popular Mechanics, Dept. PM, 575 Lexington Ave., New York 10022.

DO-IT-YOURSELF

WATER!! Drill your own well the easy, economical way with Amazing New Invention. Save 75%. Free information. Deep-Rock Drilling Company, Opelika, Alabama 36801.

SECRET Plans revealed. Free Brochure. Audiotronix PM-5, 156 Fifth Ave., New York, N.Y. 10010.

BURGLAR-FIRE Alarm supplies and information. Free Catalog. Protecto Alarm Sales, Box 357, Birch Run, Michigan 48415.

DO-IT-YOURSELF simplified Central Air Conditioning. Approximately \$400 for homes with forced air furnace. Write for step-by-step brochure. McGraw-Edison Company, 705 N. Clark St., Albion, Michigan 49224.

CONVERT Refrigerators Into Freezers Inexpensively. Easily. Instructions, Schematics \$2.00. Silin's Enterprises, 62 Lorraine, Island Park, N.Y. 11558.

HOME PROTECTION. Combination fire-burglar alarm. Diagram and Instructions, \$2.00. McCann, 3249 E. Yale, Phoenix, Arizona 85008.

STEAM Powered lawn mower, with flash boiler. Pictures discriptions. Also fire tube boiler burners, small steam engines all parts numbered, several sheets. \$2.00 Postpaid. Travis Tool Company, Box 118, Sidney, Iowa 51652.

REFRIGERATOR Door gaskets—ELECTRIC RANGE parts. Send make and model for cost. Box 5465, Hamden, Conn. 06518.

EXERCISE At home on build-it-yourself physical fitness equipment, including bicycle exerciser, rowing machine, belt massager, and abdominal board. Send \$2.50 for blueprints B1208 and instructions. Popular Mechanics Service Bureau, 575-K Lexington Ave., New York, N.Y. 10022.

BURGLAR-Fire Alarms. Automatic Police Telephoning, Gas, Bells, Supplies. Free Catalog. Specify: business-residence. Alarm Supply, 7294 Glenview, Fort Worth, Texas 76118.

REPAIR Manuals, automatic washers, dryers, dishwashers. 20 different manuals, \$2.75 each Ppd. Send make and model number. Major Appliances, 13106 Caine Ave., Cleveland, Ohio 44105.

BREW Beer. No crocks. New method. \$2.00. Donham, Box 14683, Houston Texas 77021

SAVE \$\$\$. Tells how to service, repair your own power mower and air-cooled engines in minutes. Send \$1.00. Power Mower Tune-up, Box 910, Lancaster, Ohio 43130.

BUILD Your own VACATION HOME no money down. Small monthly payments. Send \$1.00 for catalog. FIRESTONE HOMES COMPANY, P.O. BOX 125, NEW-TOWN, CONN. 06470.

ARTS AND CRAFTS

MAKE Figurines, plaques, lawn ornaments. Molds, plastercraft kits, liquid rubber. Sample and catalogue 10¢. Wooley Company, Box 29-B, Peoria, Illinois 61601.

FREE Catalog—over 10,000 handicraft items. Supreme Handicrafts, Box 395-PM, Sioux Falls, S. Dak. 57101.

FREE! World's largest leathercraft catalog. Hundreds of Make-it Ideas. Tandy Leather Co., Dept. I-67, Fort Worth, Texas 76107.

JEWELRYCRAFT—It's easy! Big profits! Catalog, 25¢. Modern Crafts, 12790 US 19, Clearwater, Florida 33516.

MYRTLE Wood Lumber, For Gifts & Novelties. Send \$1.00 for Sample for a fast growing Business. Dundee Lumber Co., Box 12, Dundee, Oregon 97115.

SPACE AGE NEW. Your photographs, artwork, awards, permanently fused into metal. Guaranteed. Free illustrated catalog. Alexander Topper, 6087 Sunset Boulevard, Suite 210-9, Hollywood, Calif. 90028

BINOCULARS, TELESCOPES, MICROSCOPES, MAGNIFIERS

BINOCULARS Direct from manufacturer. Finest quality, tremendous savings! Request catalog. Koyu, 3860 Crenshaw Blvd., Los Angeles, Calif. 90008.

SCIENCE Bargains! Lenses, telescopes, binoculars, microscopes, kits, parts, war surplus. Send \$1.50 for beginner's 10-lens kit with instruction booklet. Order Stock 2-CH. Request free 148 page Catalog CH. Edmund Scientific Co., Barrington, New Jersey 08007.

BINOCULAR Sale! Free color catalog 100 models \$9.95-\$250.00. Write, United, 9043 So. Western, BCAT-108, Chicago 60620.

WORLD Famous "Dyroscope" Telescope. Build your own reflector telescope, mirrors, eyepieces, tripods, accessories. Request free brochures. Criterion Manufacturing, Dept PP 31, Hartford, Connecticut 06101.



CAMERAS AND EQUIPMENT

WORLD'S Largest Buying Guide—800 Illustrations—50¢—Deductible With Your Order—Olden Camera—1265 Broadway, New York, N.Y. 10001.

POLAROID Owners Make Extra Copies. Free Brochure. Rhedon Electronics, Box 42PM, Bridgeport, Conn. 06601.

FREE! FREE!—Photographic and optical bargain book. Jimco, Dept. 1AE1, 9006 Waukegan Road, Morton Grove, Ill. 60053.

PHOTO SUPPLIES

ATTENTION: WEEKEND PROFESSIONAL PHOTOGRAPHERS. Photo-mounts, albums, mailers—all your home portrait, candid and wedding presentation needs from one source. **WHOLESALE PRICES. SHIPPED POSTPAID.** Catalog 25¢. **CROWN PRODUCTS**, 2150 Superior, Cleveland, Ohio 44114.

SELL YOUR PHOTOS. Report tells how, includes directory where to sell, only \$1.00 John Fogg, Warner St., Groton, Conn. 06340

PHOTO FINISHING

CAMERA Fans! Expert photofinishing and fresh Kodak film returned: 8MM Kodachrome \$3.45; 8 exp. Kodacolor \$3.40; 35MM Kodachrome, 20 slides, \$3.15; 8 exp. black & white 99¢. We give you free photo stamps to redeem for gifts. Satisfaction guaranteed. Send exposed film or request mailers and complete price list. Direct Mail Photo, Box 8352-PM, Pittsburgh, Pa. 15218.

A FREE Kodak roll returned with each black and white or Kodacolor developed and printed, fast service, lowest prices, guaranteed quality send for free mailers. Economy Photo Service, Dept. P.M., Box 1111, Albany, N.Y. 12201.

KODACOLOR—With this advertisement only—8-12 exposure, \$1.19. Astro Photo Service, Box 166M, Waterloo, New York 13165.

LOOK—Save Money On Pictures! Jumbo Size Prints from your Kodacolor Rolls, \$1.98. Black & White, 69¢. Huge Discounts on Supplies, Enclose Advertisement. Wisconsin Film Service, La Crosse, Wisconsin 54601.

INTRODUCTORY Special—12-Exposure Kodacolor Developed for \$2.00 with this ad. **FREE GIFT.** Expires November 1, 1969. Paul Bunyan Photo, Box 309L30, Brainerd, Minnesota 56401.

COLOR SLIDES

KENNEDY SPACE CENTER, FLORIDA Apollo Missile, World's largest building, Launch Complex 39 and others. Four sets of four slides \$2.00 or 50¢ each. List with order. Cape News Company, P.O. 3466, Cocoa, Florida 32922.

ASTRONOMICAL Painting color slides: fully illustrated catalog, sample, 50¢. Morris Dollens, 4372 Coolidge Ave., Los Angeles, Calif. 90066.

MOTION PICTURES AND SOUND EQUIPMENT

FREE! 64-page catalog, 8-16mm film, supplies, processing equipment. Superior, 448 N. Wells, Chicago 60610.

5,000 8-16MM MOVIE Films. Free catalogues. International, Greenvale, L.I., N.Y. 11548.

UNUSUAL Movie supplies. Free circular. Esor, 47th Holly, Kansas City, Missouri 64112.

ELECT-BUTT-WELD 8M.M. Film. Eliminate cement splicing. For particulars write: Strang Elec. & Eng. Co., Box 555, Hawthorne, Calif. 90250.

35MM. COLOR SLIDE SAMPLER . . . 20 "best" 2" x 2" . . . \$1.00. Free catalog. Hundreds of sets . . . travel, circus, wildlife, flowers, railroads, wars, etc. Order today. Blackhawk Films, 862 Eastin-Phelan Bldg., Davenport, Iowa 52808.

175-FOOT 8MM. PREVUE MOVIE . . . ONLY \$1.99. See Laurel & Hardy, Chaplin, Fairbanks, Keystone Cops, Gish, Pickford, Chaney . . . comedy, drama, adventure, history from the silents! Taste the fun of great movies right at home! Order today . . . specify standard or Super 8. Free catalog. Blackhawk Films, 861 Eastin-Phelan Bldg., Davenport, Iowa 52808.

16MM Sound Features, Shorts, New, used for Sale. Free Catalog. National Cinema, 333 W. 57th St.-N.Y.C., N.Y. 10019.

8-16 MM. Used! Listings, 6¢ stamp. Hilton, 52 Columbia, Albany, New York 12207.

RADIO, TELEVISION AND HAM EQUIPMENT

33¢ RADIO & TV tubes. Free list. Cornell, 4213-17 University, San Diego, California 92105.

TUBES—Lowest prices in the world. Hard to get British, German, Foreign and American obsolete and present day special purpose transmitting tubes. Send for giant tube and parts catalog. United Radio Company, Dept. Z-56 Ferry St., Newark, N.J. 07105.

KITS GALORE! Free catalog subscription ALSYNCO, PM-59 171 S. Main Natick, Mass. 01760.

UNDERSTAND Transistors, Diodes, Meters, basic principles of Electronics. All ages. For circuit board, meter, and all parts with ten experiments written by team of electronic engineers and professors, send \$9.95 to Differential Electronics, Box 47322, Atlanta, Ga. 30340.

EXCITING Values In Sonar Fire and Police Portable Monitor Receivers, Transmitters, Tuners, Accessories. Details, Free Antenna Offer: Griffin's, 322-M West State, Ithaca N.Y. 14850

HIFI, RECORDS AND ELECTRONICS

FREE Catalogues, 2000 hard to find unusual records. Rose's, 300 Chelsea, Louisville, Ky. 40207.

TAPE Recorders, hi-fi components. Sleep learning equipment, tapes. Unusual values. Free catalog. Dressner, 1523C Jericho Tpke., New Hyde Park, N.Y. 11040.

RECORDS! Discounts on all LP's. Free details. Citadel Record Club, Symphonette Sq., Dept. 2, Larchmont, N.Y. 10538.

SCOTCH Cassettes, C-60 \$1.85. C-90 \$2.79. C-120 \$3.20. Tower, Lafayette Hill, Pa. 19444.

FREE 40 PAGE CATALOG offers hundreds of recordings of rare Renaissance, Baroque and Classical music. Some records priced as low as \$1.00 each! All late recordings in stereo only. **MHS RECORDS**, Box 932 PM, New York, New York 10023.

PSYCHEDELIC Color-Sound & other Electronics projects. Information 10¢. SSSD, Box 7098, San Diego, Calif. 92107.

STEREO TAPES: Cartridges, cassettes, reels. 33% discount. Largest selections, unavailable elsewhere. Mail 20¢—catalogs. **STAR RECORDINGS**, Box 1055, El Paso, Texas 79946.

HOME Electronics Course only \$26.95. Free literature. Edu-Kits, Department 713B, Hewlett, New York 11557.



MUSIC AND MUSICAL INSTRUMENTS

PLAYER Piano Rebuilding—get details from: Vestal Press, Vestal 11, N.Y. 13850.

GUITAR, Banjo Making books Plans, woods, necks, tools. List 25¢. Satinwood, 510 East 11th Street, New York, N.Y. 10009.

ACCORDION Manufacturing, 6846-P North Avenue, Chicago, Illinois 60635. Concertinas, Hohners, Chromatics, Guitars, Drums, New, Used, Tuning, Repairing, Wholesale Catalogs Free.

POEMS. Songs wanted for new song hits and recordings by America's most popular studio. Tin Pan Alley, 1650-PM Broadway, New York 10019.

VIOLIN and Guitar makers—send for latest Free Catalogue of woods & accessories. International Violin, PM8, 414 East Baltimore St., Baltimore, Md. 21202.

ELECTRIFY Player pianos, pump organs quickly, inexpensively with Lee Silent Suction Units. Write Lee Music, Box 595F, Tujunga, California 91042.

LEARN Banjo 5-String Bluegrass. No music to learn. \$3.95 complete. Details free. Blaylock, Box 25-M, Marietta, Georgia, 30060.

ACCORDION Top brands. Buy direct. Tremendous discounts. Trade accepted. Free brochure PM. Accordion-O-Rama, 874 Broadway, N.Y.C. 10003.

DRUMS, Electric guitars, amps, organs. Free catalog M: A.L.A.S. Import Company, 31 East 18th Street, NYC. 10003.

GUITARS, MANDOLINS, BANJOS. Complete stock of Gibson Martin Vega guitars. Free 100 page catalog, parts and accessories. Big Savings, New York discount prices. Send 50¢ postage handling. Eddie Bell Guitar, 201 West 49, New York 10019.

POEMS Set to music. Songs recorded. Send poems, songs. Crown Music, 49-C West 32, New York 10001.

POEMS Wanted For Songs. Nashville Music Productions, Box 9001-P, Nashville, Tennessee 37204.

POEMS Wanted for new songs and records by America's largest song studio. Send poems. Free examination. Five Star Music, 6M Beacon, Boston, Mass. 02108.

GUITARS, Accessories—Guitar maker's tools, materials, supplies. Free catalog. Guitar Center, Box 15444, Tulsa, Oklahoma 74115.

30% DISCOUNT Any Name Brand musical instruments. Write for low price. Freeport Music, 127 W. Sunrise Highway, Freeport, New York 11520.

SONGPOEMS Wanted! Write with Professional Songwriters. Share Royalties. Songwriters Contact, 888-8th Avenue, New York 10019.

FREE Circular Country Records. Uncle Jim O'Neal, Box A, Arcadia, Calif. 91006.

PLAY Organ easily. Amazing Method. Free information. Kegley, 1016 Kelly, Joliet, Illinois 60435.

ELECTRIC Guitars, amplifiers, wholesale. Catalog 25¢. Carvin, PMM, Valley Center, Calif. 92082.

SONG Writers—Send Poems, Songs to: Weiss Music Company, 1472 Broadway, New York, New York 10036.

SWISS Musical Movements. Tunes to Order! Spielman, 131 West 42nd., New York 10036.

SONGS, Poems wanted! Accepted songs published, recorded at our expense! Talent, 17-PM, Longwood Road, Quincy, Mass. 02169.

ACCORDIONS, Guitars, Band Instruments! Save to 50%. Famous makes. Easiest terms. Trades accepted. Free home trial. Free discount catalog. Mention instrument. International Music Mart, 5535-R Belmont, Chicago, 60641.

EDUCATION AND INSTRUCTION

LEARN Auctioneering. Term soon. Free catalog. Reisch Auction College, Box 850, Mason City, Iowa 50401.

PIANO Tuning quickly learned with home study course. Diploma granted. American Tuning School, Gilroy, Calif. 95020.

PIANO Tuning pays. Big money in spare time. Learn at home. No musical knowledge necessary. Phonograph, records, tools and instructions furnished. Electronic tuning also taught. Free catalog. Capital Tuning School, 3160 S.W. 16th Court, Ft. Lauderdale, Fla.

DETECTIVE Course. Free information. Universal Detectives, Box 8180-F, Universal City, California 91608.

BOOKKEEPERS. Operate your own "Dollar-A-Week" system. Ellis, Box 200, Cedar Grove, North Carolina.

PENMANSHIP Corrector. Improve poor penmanship quickly. Details free. Ozment, Box 665-34, St. Louis, Mo. 63188.

LEARN To Sing Beautifully! Free Particulars. Publisher, Box 118-P, Brooklyn 11203.

AUCTIONEERING Free Catalog Resident or Home Study Course. Nashville Auction School, 2004 West End, Nashville, Tenn. 37203. Veteran approved.

OWN Collection agency. "Little Gold Mine!" Franklin Credit, Roanoke, Virginia 24004.

EARN \$125 A week and up. Learn a trade with a future. Learn auto diesel mechanics in our shops. You learn with tools on real equipment. Earn while you learn. Many of our graduates earn \$125 a week and up. Write for free bulletin: Dept. 256, Auto Diesel College, Nashville, Tennessee 37219.

SWEDISH Massage and physical culture pays big profits. Learn at home. Diploma. Free catalog. National Institute, Dept. E-59, 307 North Michigan, Chicago 60601.

HIGH School diploma at home. Licensed teachers. Send age, highest grade completed for free details. No salesman will call. Southern States Academy, Westbury Square Professional Bldg., Dept. 16, Houston, Texas 77035.

USED CORRESPONDENCE Courses and Books sold and rented. Money back guarantee. Catalog free. (Courses bought). Lee Mountain, Pisgah, Alabama 35765.

MISSOURI Auction School. GI Approved. Free Catalog: 424-03 Nichols Road, Kansas City, Mo. 64112.

GET A British degree. Divinity, Philosophy, Radionics, 35 courses. Prospectus free. Brantridge Forest School, "Lodge" Brantridge Forest, Balcombe, Sussex, England.

TEACHERS, Elementary and secondary. TEACH the 390 BASIC ARITHMETIC FACTS with records dictating them 6, 4½ and 3 seconds apart, respectively. Particulars CADDY, Box 251, Canoga Park, Calif. 91305.

USED Courses! Books! List 10¢. Smith's, 124 Marlborough, Salem, Mass. 01970.

PHOTOGRAPHIC RETOUCHING. Good spare-time income at home. Interesting, artistic career. Free information. Hamilton Studios, Dept. PR-39, Claymont, Del. 19703.

LEARN Landscaping and the growing of plants. Start a profitable business part or full time. Free information without obligation. Lifetime Career Schools, Dept. A-601, 2251 Barry Avenue, Los Angeles, California 90064.

LEARN Asleep or awake! Records, tapes, equipment! Free catalog! Drawer, PM-400, Ruidoso, New Mexico 88345.

SUPERIOR Auction School. Nation's top Auctioneers own and instruct. 120 East Cerrogorro, Decatur, Ill. 62523.

DETECTIVE TRAINING—Booklet on auto surveillance plus full particulars. Send \$1.00 to P.S., 4425 W. Irving Park Road, Chicago, Illinois 60641.

FCC First Class License in six weeks—Nations highest success rate—Approved for Veteran's Training. Schools in Dallas, Atlanta, Chicago, New Orleans, Minneapolis and Houston. Write Elkins Institute, 2603D Inwood Road, Dallas, Texas 75235.

PIANO Technology—Electronic organ servicing, learned easily at home. G.I. Approved. Free booklet. Niles Bryant School, Dept. P, 3631 Stockton, Sacramento, California 95820.

EASY. Pass Civil Service Examinations. Free Details. Darenburg, 12220 Glynn, Downey, Calif. 90242.

BE A POLICEMAN. Complete Course and Diploma, only \$10.00 Southern Police Academy, P.O. Box 306 Fairfield, Alabama 35064.

COMPUTER PROGRAMMING—The big opportunity career. New recognised correspondence course. No maths needed. FREE brochure. Canadian Institute of Science & Technology, 263M, Adelaide St. W., Toronto.

MILLIONS Of sewing machines need repair. New book shows how. \$8.95. Sincere Press, Box 10422, Phoenix, Arizona 85018.

DIAMOND CUTTING. Eligible Federal Student Loans. GI approved. American School Diamond Cutting, Gardnerville, Nevada 89410.

LEARN Civil and criminal investigation at home. Earn steady, good pay. State age. Institute Applied Science, 1920 Sunnyside, Department 165, Chicago, Illinois 60640.

AUTOSUGGESTION. Sleep-learning headquarters! Tapes, records, books. Gigantic catalog free. Research Association, Box 24-PM, Olympia, Washington.

WATCH REPAIRING. Unique course develops skills at home. Free sample lesson. Chicago School, YR, Fox River Grove, Illinois 60021.

FREE! List of low cost popular self-improvement books. Write Dixie Gift Mart, 1384-C Monroe Drive, N.E., Atlanta, Georgia 30324.

COMPLETE YOUR HIGH SCHOOL at home in spare time with 72-year-old school. Texts furnished. No classes. Diploma. Information booklet free. American School, Dept. X545, Drexel at 58th., Chicago, Illinois 60637.

CHEMISTRY Laboratory course using Programed instruction High School Level. Results guaranteed. Certified Instructor. Details. Lee, 2741 Fremont Ave. #8, Alhambra, California 91803.

REAL Estate Course. Economical Home-study: Literature Free. Howard Schools, Box 8585-A, Kansas City, Missouri 64114.

ACCIDENT INVESTIGATION career training. Learn at home to earn up to \$8 an hour. Car furnished. Expenses paid. No selling. Free placement service. Men urgently needed. No college or experience required to train. Write for FREE information. No obligation. Universal Schools, CPM-5, 6801 Hillcrest, Dallas, Texas 75205

PREACH Your Own Ideas! Free Details. Rev. John Moore, Box 48, Berkeley, Calif. 94701.

FINISH High School—10 weeks—low cost—State Approved Diploma. EPI—Box 176-PM, Gustine, California

INFORMATIVE, Inspirational Books. Free Brochure. John A. Womsey Company, 15024-C Joy Road, Detroit, Michigan 48228

USED Courses, books, bought, sold Catalog 10¢. Bayles, 78B Courtright, Wilkes-Barre, Pa. 18702.

SINGING, 3 Page lesson \$1.00. Nelson, Box 190, Hobart, Ind. 46342

BIBLE—COLLEGE correspondence degree courses, CATALOG! BOX 647PM, MORGANTOWN, KENTUCKY 42261.

START A profitable subscription business in spare time! We need men and women (young and old) as representatives for all leading national magazines. Liberal commissions on all subscriptions. Supplies free. No experience needed. Send this ad with your name and address to Popular Mechanics, Room 5-O, 250 W. 55th St., New York, N.Y. 10010.

FOR INVENTORS

PATENT Searches complete and thorough. Related copies Air Mailed with maximum speed \$6.00. Free "Protection Forms" and "Patent Information." Write American Patent Search Company, Dept. 27, 711 14th St., N.W. Washington, D.C. 20005.

PATENT Application Financing. Free patent search plan. Global Patent Division, 2420 77th, Oakland, Calif. 94605.

PATENT And invention development by licensed professional patent engineer and U.S. Patent Office former examiner, and engineering specialists. Your inventions and ideas engineered for patent protection and commercial value. Inventions developed by us negotiated for cash or royalties with our nationwide contacts. Send for free protection "Invention Certificates" and further interesting, valuable patent information. George Spector, Licensed Professional Patent Engineer, Woolworth Building, New York.

U.S. Patent Office Searches. 234 Broadway, Room 3615, New York. Free invention certificates.

IMMEDIATE Cash, for patent applications. Free patent searches. Write for details. Universal Patents, 184-D, Marion, Ohio.

INVENTORS: Your ideas and inventions (patented; unpatented) expertly searched, royalty sales to manufacturers by professional Invention Developer with excellent record of experience, B.S., Industrial Engineering; United States Patent Office former Patent Examiner, United States Government former Patent Advisor. Second decade reliable service! Member: United States Chamber Commerce. Free "Invention Record" and "Recommended Protection Procedure." Airmailed! Write: Raymond Lee, Invention Developer, 230-P Park Ave., New York City 10017.

PATENT Searches, including copies of related U.S. patents. Inventors attorneys, manufacturers use our "worldwide" airmail service! "Invention Record" form and "Information Every Inventor Needs," sent free! Hayward Company, 1029P Vermont, Washington 5, D.C.

INVENTIONS Needed immediately for manufacturers. For additional information write Kessler Corporation, C-55-FI, Fremont, Ohio.

MANUFACTURERS NEED New Products! FREE Literature explains "How To Submit Your Invention". Congress Invention Company, 911-C Warner Building, Washington, D.C. 20004.

FREE PAMPHLET: "Tips On Safeguarding Your Invention". Write: United States Inventors Service Company, 501P Thirteenth Street N.W., Washington, D.C. 20004.

INVENTIONS WANTED

INVENTIONS Wanted. Patented: unpatented. Tremendous manufacturers lists. Global Marketing Service, 2420G 77th, Oakland, California 94605.

INVENTORS! Outright cash sale or royalties for your inventions. Patented. Unpatented. Active demand from our client manufacturers. Financial assistance available. Write Dept. 36, United States Invention Brokerage, 78 Wall Street, New York, N.Y. 10005.

INVENTORS! Don't sell your invention, patented or unpatented, until you receive our offer. Eagle Development Company, Dept. H, 79 Wall Street, New York 5, N.Y.

INVENTORS! Sell your invention for cash or royalties! Our client manufacturers eagerly seek new items. Patented. Unpatented. Financial assistance if needed. 25 Years proven performance. For free information, write Dept. 15, Gilbert Adams, Invention Broker, 80 Wall St., New York, N.Y. 10005.

INVENTORS! We will develop, sell your idea or invention patented or unpatented. Our national manufacturer-clients are urgently seeking new items for highest outright cash sale or royalties. Financial assistance available. 10 years proven performance. For free information write Dept. 47, Wall Street Invention Brokerage, 79 Wall Street, New York, N.Y. 10005.

WE Either sell your invention or pay cash bonus. Write for details, Universal Inventions, 298-E. Marion, Ohio.

FREE "Directory of 500 Corporations Seeking new Products." For information regarding development, sale, licensing of your patented/unpatented invention. Write: Raymond Lee Organization, 230-N Park Avenue, New York City 10017.

INVENTORS! Protect your ideas! Free "Recommended Procedure." Washington Inventors Service, 422F, Washington Building, District of Columbia 5.

INVENTORS—If you have an invention for sale, patented or unpatented. Wire for free brochure outlining manufacturer's requirements. Royalty rates. Kessler Corporation, C-55-IW, Fremont, Ohio.

PATENTS FOR SALE

EXTRA Income at home in Spare Time! Becket shows you how to start your own business with Classified Advertising. Only \$1.00. Refundable with first insertion order. C. A. Martin, Popular Mechanics Dept. PM, 575 Lexington Ave., New York 10022.

MANUFACTURING

INVENTORS Ideas developed. Research. Models. Manufacturing. Sales. Free brochure. William Parker, 32 Westminster, Worcester, Mass. 01605.

MODELS — small lot manufacturing. Metals, plastics, etc. Milburn, Burlington, Kentucky 41005.

BUY IT WHOLESALE

500,000 BARGAINS BELOW WHOLESALE. New, name brand merchandise. Buy at 10¢ on the dollar. Closeouts, surplus, bankrupts, liquidations, imports. Free details. International Buyers, Box 4633-M, Colorado Springs, Colo. 80909.

BARGAINS! Buy wholesale and below. Name brands. Appliances, furniture, sports equipment, televisions, cameras, watches, jewelry, thousands more. Huge discounts to \$1,000.00 on new automobiles. All makes. Free details. Write today: Worldwide Bargainhunters, Box 730-A, Holland, Michigan 49423.

20 WHOLESALE Catalogs!! List \$1.00. Zashop, 216 PM-5, West Jackson, Chicago 60606.

CAMERAS, Projectors, Typewriters, Adders, Blades, Best Buys, Simms, Warwick, N.Y. 10990.

DRAFTING Equipment, Templates . . . 5MM pencils, Catalog 30¢ Stamps, Amtech, Inc., Box 122, Mt. Holly, N.J. 08060.

ELECTRIC Guitars, amplifiers, wholesale. Catalog 25¢. Carvin PMW, Valley Center, Calif. 92082.

FREE! Illustrated Catalog of low cost Watches, Telephones, Telescopes, Wedding Gifts, Chess Sets, Thermometers, Wall Plaques. Write: Robert Carman, Dept. 6, 4609 Shoalwood, Austin, Texas 78756.

BURGLAR ALARM EQUIPMENT WHOLESALE Ultrasonic motion detectors \$79.50 to \$110.00. Automatic dialers \$110.00 to \$149.00. Simulated closed circuit TV cameras \$35.00. Send for catalogue No 110. DEHART ELECTRONICS, P.O. Box 5232, SARASOTA, FLORIDA 33579.

1000 SUPPLIERS—165,000 Products, wholesale and below. Free details, Bartlett's, 8636 East Windsor, Scottsdale, Arizona 85257

EXPORT-IMPORT

JAPAN: 1200 Products Directory, Illustrated Manufacturers' names, addresses, \$3.00. Send cash. Yamagata Office, 814 Togin Bldg., Marunouchi, Tokyo.

KNIVES—101 imported. Novelty knives—catalogue (50¢). Friedmar Imports, Box (533-PM), Montebello, Calif. 90640.

FOR THE HOME

ENZYME Septic tank Cleaner. Reduces Sludge, helps prevent Odors, 6 Treatments per box. \$2.98. Robert Bongiorno, Atlasburg, Pa. 15004.

FIRE ALARM \$5.75. **BURGLAR ALARM** \$3.75. Poolproof, guaranteed, self contained. Free literature. ALARMS, 492 E. Main, Williamsburg, Ohio 45176.

PATIO Easy ceramic granule coating. Free information, Gateway, 6851 Plainfield, Cincinnati, Ohio 45236

FOR PARENTS

OUR FIRST 19 IN SPACE. This limited edition lithograph has been created as a tribute to Americas Gallant Astronauts. 12 X 18 inch chart ready for framing. Only 75 cents. Popular Mechanics, Dept. GWP, 575 Lexington Avenue, New York, New York 10022.

OF INTEREST TO WOMEN

WOMEN! Make big money at home. \$10.00 profit in an hour possible with invisible mending. Make holes, tears disappear from clothing, fabrics. Steady year-round demand from cleaners, laundries, homes. Details free. Fabricon, 1533 Howard, Chicago 60626.

HOW To make money writing short paragraphs. Information free. Barrett, Dept. C-27-R3, 6216 N. Clark, Chicago 60626.

WANTED! Addressers—Commission Makers. Stamp required. Ooton Distributors, 122-P Duke Drive, Portsmouth, Virginia 23703.

\$500 MONTHLY POSSIBLE—clipping news at home. No experience. Free information—send stamp. American, Excelsior Springs, Mo. 64024.

NEWSPAPER Clippings Urgently Needed. Highest prices paid. Send stamped, addressed envelope, free details. Brewster, Box 1348-NCWL, Clearwater, Florida 33517.

\$500—\$800 MONTHLY Raise small laboratory-breeding stock for us. We supply equipment, breeders, instructions. Illinois Research Farms, Dept. MPC-5, McHenry, Illinois 60050.

\$100 WEEKLY POSSIBLE. HOME TYPING. Instructions, employers' list, \$1.00. Satisfaction or refund. Summithouse, Box 377-PMO, Corte Madera, California 94925.

\$75.00 THOUSAND, Home addressing! Longhand, typewriter. Information, send stamped self-addressed envelope. Brewster, Box 1348-YL, Clearwater, Florida 33517.

TYPING Pays! Unbelievable \$30.00 thousand addressing envelopes from lists. Typewriter, longhand. Immediate earnings. Instructions \$1.00. Florida Service, P.O. Box 1017C, Hialeah, Fla. 33011.

EARN \$100.00 Fast Lacing and Assembling our beautiful products! Cuties, Warsaw 9, Indiana 46580.

MAKE Money from home. Information \$1.25. Decker, 12 Fallbrook Street, Geneva, New York 14456.

HOMEWORKERS \$2.00. Hour Possible Sewing Babywear Aprons. KutieKay, Box 9194-PM, Ft. Worth, Texas 76107.

DRIVE New car, wear new clothes, buy color TV. Get daily cash income. Put spare hours to work. Write for 5 months free subscription Opportunity Magazine, see hundreds easy ways to make money. Opportunity, 1460 Hancock Center, Dept. 17-EO, Chicago 60611.

MAKE Gorgeous original candles for all holidays and special occasions. Learn expert Candle decorating, candlemaking, use of professional molds. Free details on home instruction method. Candle Institute, Dept. VL, 1600 Cabrillo, Torrance, Calif. 90501.

WOMEN: Big Money! Studio Girl Cosmetics needs women in all States including Hawaii, Alaska, Puerto Rico and American Samoa. Full or part time. No experience required. No territory restrictions. Take orders anywhere. Highest profits. 500 Good Housekeeping approved cosmetics. Everything furnished. Credit extended. No stock to carry. No franchise fees. No stock investment. For full information by mail, plus 3 free samples, write Harry Taylor, Chairman, Studio Girl Cosmetics, Dept. BC266, 11461 Hart Street, No. Hollywood, Calif. 91605. Also immediate big profit earnings for experienced City and State managers and former party plan operators.

Turn Your Leisure Hours into Dollars at Home. Assemble our products. Supplies Furnished. United Box 55392D, Indianapolis, Indiana 46205.

HOMEWORKERS! Make money mailing postcards. Particulars 10¢. Wesley, Western Springs, Illinois 60558.

\$100 WEEKLY Possible—Home Typing. Immediate earnings! Employers list, complete instructions. Details 25 cents. Typing, Box 593, PM5, Bettendorf, Iowa 52722.

EXTRA Cash: 21 Home Spare time projects; tested; workable. Send stamped, addressed envelope. National, Box 1975-ECA, Little Rock, Ark. 72203.

HILLBILLY Recipes Cookbook. Only \$1.00 Postpaid. Vidmars Sales, Freeburg, Illinois 62243.

END WORKBENCH CLUTTER. Keep your bolts, nails, screws, in baby food jars. PEG-O-CLIP holders can be used on pegboard, shelf edges or walls. 10 for \$1.30 for \$2.50, Postpaid, No COD's, McGregor Enterprises, Box 98A, Alba, Mich. 49611.

GIFT SHOPPING

FREE 140 page mailorder catalog. Farmington, 71 Farmington, Providence, Rhode Island 02909.

FREE Catalog of distinctive unusual Gifts, and money making opportunities. Palmer Place, 6901 Langston, Austin, Texas 78723.

ANNODIZED Aluminum Key Tab. Print Social Security Number and Name \$1.00 Postpaid. Mountain Mart, 1123A West Eighth, Cedar Falls, Iowa 50613

WATCHES, OLD GOLD, JEWELRY

WATCH And clock repairing books. Free catalog. North American, Box-77-AE, Fox River Grove, Illinois 60021.

USED Wrist, pocket watches—\$3.00 up. Free list. Southern Watches, 5-PM South Wabash, Chicago 60603.

CASH Immediately for old gold, jewelry, gold teeth, watches, diamonds, silverware, spectacles, platinum, mercury. Free information. Rose Industries, 29-A East Madison, Chicago 60602.

HIGHEST CASH for Gold, Jewelry, Gold Teeth, Rings, Diamonds, Watches, Silver, Platinum. Mail Articles Today. Free gift with information. Chicago Gold & Precious Metals, 6 E. Monroe, Dept. 458, Chicago, 60603.

WATCHMAKERS'—Jewelers' Catalog: Surprise; \$1.00. Watchmaking Course; Tools; \$35.00. Bengal's, 17942 Ventura, Encino, California 91316.

WEARING APPAREL

CUSTOM Made Suits! Direct from Hong Kong. Save! Free Catalog. Quality Imports, D502, 425 Camino Colinas, Redondo Beach, Calif. 90277.

HEARING AIDS

HEARING AIDS—Batteries Wholesale! Brochures—Hearing Center, Box 211, St. Petersburg, Florida.

HEARING Aids, Batteries, wholesale. Catalog 25¢. Fiston, Box 1444 New Preston, Conn. 06777.

HEARING Aids below wholesale. Regular, eyeglass, completely hidden models. Smallest, most powerful. Free home trial. No Salesman will call. Free details. Write Prestige-C6, Box 10880, Houston, Texas 77018.



SCIENCE AND CHEMISTRY

ROCKETS: Real flying models—flights up to 2500 ft. New illustrated catalog 25¢. Single and multistage kit, cones, engines, launchers, trackers, rocket aerial cameras, technical information. Fast service. Estes Industries, Penrose 7, Colorado 81240.

CHEMICALS And apparatus for industrial, analytical, and private laboratories. Catalog 50¢. Dept. M-50, Biological Supply Co., 1176 Mt. Hope Ave., Rochester, N.Y. 14620.

ROCKETS!! Real flying models—2500 feet altitude with powerful motors. Terrific Science Projects. Tubes—Cones—Parachutes—Launchers—Igniters. Gigantic catalog—rocket data—diagrams—25¢. Fast Delivery. Centuri Rockets, Box 1988, Phoenix, Arizona 55001.

CHEMICALS, Apparatus, Microscopes. Biological Supplies, 1969 Catalog 35¢. Sheard Science Supplies, Inc., Columbus, Wisconsin 53925.

ROCKETS. Single, multi-stage kits, parts amazing Accelerometer, Illustrated catalogue 25¢. Rocket Supply, Box 51B, Tappan, New York 10983.

UNDERWATER Fuse 3 3/2" Diameter. 25 feet \$1.00—125 feet \$4.00 Postpaid. Free Catalog. Zeller, Box 646, Hudson, Mich. 49247.

LABORATORY chemicals supplies 1969 catalogs has over 400 listings many scientific publications catalogues \$25 Casco, Dept. M P.O. Box 77 Riverdale, New Jersey 07457.

LASER PISTOL—\$1.00. How to build. PHASER PISTOL—\$1.00. (Add 25¢ postage.) New catalogue—10¢. Roy Davis Laboratories, Dept. PM, 118 West Adams St., Jacksonville, Florida 32202.

SEARCHING For economically priced Laboratory Supplies? Gifts with catalogue—25¢. Hagenow Laboratories; Manitowoc, Wisconsin 54220.

SEARCHING For Economically Priced Chemicals And Apparatus? Gifts With Catalogue—35¢. Starr Scientific, Manitowoc, Wisconsin 54220.

CHEMICALS Thousands of Items \$1.00 each postpaid—Pricelist \$1.00—deductable from 1st Order Spectro-chem 1354 Ellison, Louisville, Ky. 40204.

FREE Periodic classification of elements and conversion tables with catalog 35¢. Chemicals, apparatus, biology, Mid-States Scientific, 7053 N. Clark, Chicago, Ill. 60626.

CHEMICALS, laboratory supplies, fuse, casings, LOWEST prices, FASTEST service anywhere! Illustrated catalogue plus formulas, instructions—50¢. Pyrocenter, Box 9591, Arlington, Virginia 22209.

PROFESSIONAL Model rocket ignition fuse, burns underwater, 75 feet, \$1.00. Edcolabs, Box 99, Berlin, New Jersey 08009.

SAVE On casings, endcaps. Underwater fuse 70 feet \$1.00. Professional Red Fuse 50 feet \$1.00. Catalog 25¢, with samples 50¢. Bilton, Box 399, Hasbrouck Heights, New Jersey 07604.

GIRANDOLE. Petard casings. Lowest prices. Underwater fuse 75' \$1.00 PROFESSIONAL "Red Devil" Fuse 50' \$1.00. Samples 50¢. Arwel, 252 Park Ave., East Rutherford, New Jersey 07073.

SOLAR Flying Saucers. (Brand New-Solid State Engine-Fantastic Performance-Flies Miles on Sun's Power-lifts animals-sends messages-parachutes-Build Many-Easily Inexpensively with Everyday Materials. Complete plans, descriptions, drawings, plus Free Spacetratics Catalog -\$. Single Catalog -25¢. Spacetratics, Box 31043-PMS, San Francisco, California 94131

LABORATORY Supplies At Discount Prices. Catalog—35¢. Deluxe Scientific; Manitowoc, Wisconsin 54220.

SCIENTIFIC CURIOSITY: A device that produces color when none is present. Fascinate friends; party starter; ideal for school science projects. \$3.00. P.O. 15323, San Diego, Calif. 92115.

CASINGS, Stars, devices of all types. Send 50¢ for samples. Ecco, Box 189, Northvale, New Jersey 07647.

LASERS: 192 page course \$2.45. Satisfaction guaranteed. Catalog 25¢. Franks Scientific Co., P.O. Box 156, Martelle, Iowa 52305.

FORMULAS, PLANS, ETC.

ANY Formula \$3.00. Catalog—Treatise 10¢. Belfort, 192 N. Clark, Chicago 60601.

PLASTIC, LAMINATING

NEW LIQUID PLASTICS for creating unusual gifts with real flower embeddings, photographs, special collections. Reproducing originals. Hundreds of other profitable ideas. New Manual 25¢. Castolite, Dept. 9C1E; Woodstock, Ill. 60098.

PLASTIC, DECALS

SELF-ADHESIVE Company, Club or Product Decals to your design. Vinyls, Mylars, Metallics, Scotchlite and MAGNETICS for off-and-on use! Make Cars, Trucks, Airplanes and Equipment your Permanent Traveling Advertisement! Low Cost! PLASTIC DECAL COMPANY, Box 602B, Janesville, Wisconsin 53545.

TREASURE FINDERS

FIND Buried treasure with new revolutionary analytical metal detector. Features push button tuning, automatic tuning, loudspeaker, negligible ground pickup, greatest range. Free catalog. Gardiner Electronics, Dept. 9, 4729 N. 7th Ave., Phoenix, Ariz. 85013.

URECON Metal finder. 8" head, transistorized. \$40.00 delivered. Urpa 6304 Beechwood, Sarasota, Fla. 33581.

TREASURE Hunters! Prospectors! Relco's new instruments detect buried gold, silver, coins, minerals, historical relics. Transistorized. Weighs 3 pounds. \$19.95 up. Free catalog. Relco-A40, Box 10839, Houston, Texas 77018.

POWERFUL Metrotech locators detect gold, silver, coins, relics. Moneyback guarantee. Free information. Underground Explorations, Dept. A, Box 793, Menlo Park, California 94025.

TREASURE LOCATORS, MOST COMPLETE LINE. FREE INFORMATION. TESOROS, APARTADO 7-948, MEXICO 7, MEXICO.

LOCATE—Underground streams Water, Tile Lines, Sewer Pipes Etc. Make Locator 5 minutes. Few cents Hardware. Full instructions \$1.00. FAR, Box 141, Watertown, Wisconsin 53094.

"METAL Locators—Accessories. Write: Detectors, Inc., Box 101-D, Springfield, Va. 22150."

TREASURE BOOKLET. Excellent information on treasure hunting and metal detectors. Send 25¢. BOOKLET, Dept. 5-PM, Box 243, San Gabriel, California 91778.

TREASURE. Gold, silver, relics. New 1969 detectors now available. Free information. Rayscope, Box 715, North Hollywood, California 91603.

ULTRA-SENSITIVE AND POWERFUL METAL DETECTORS—join the many who are finding buried coins, minerals, relics and artifacts. Don't buy till you see our FREE catalog of new models. Write Jetco—Box 132, FM-3-Huntsville, Texas 77340.

FREE 128 Page detector catalog. General Electronic Detection Co., Box 67, Bellflower, California 90706.

TREASUREPROBE Metal detector as kit (\$12.88) assembled (\$18.88), with powerful built-in speaker (\$24.88) a schematic, parts list, and instructions (\$1.00). Money back guarantee. Free catalog. TREASURE-PROBE Dept. PG-J, P.O. Box 64, Lakewood, N.J. 08701.

METAL Locators, Kits and Assembled. Free Literature. Electronic Applications, Box 6095, Alexandria, Virginia 22306

Professionals - "Selectmatic" - world's newest treasure detection discovery; finds money on every hunt. Virtually eliminates useless digging. Worldwide patents pending. Kits available. Information \$1.00. Treasure Pro Electronics, Plain Dealing, La. 71064.

FISHER DETECTORS! Treasure fun and profit with new professional quality solid-state models. Unsurpassed sensitivity, reliability. Guaranteed. Free literature. **FISHER RESEARCH**, Dept. PM-5, Palo Alto, California 94303.

PRECIOUS STONES AND MINERALS

EARTH Science Rockhound Magazine. Subscription \$2.50. Sample 35¢. Box-550-PM, Downers Grove, Ill. 60515.

GET Free catalog no serious rockhound, gem cutter, jewelry maker, hobbyist or craftsman can be without. Full of bargains, exclusive items, low prices from largest suppliers and authorities in the field. Free new catalog just off the press, yours for the asking. Write **Grieger's**, Dept. C-12, 1633 E. Walnut, Pasadena, California 91106.

WORLDWIDE Crystal specimens, Gems. Free lists. Sering, 1705 E. Michigan, Indianapolis, Indiana 46201.

SEMI-Precious uncut gems. Ten different for \$1.00. Request list 35¢. Prospectors Shop, 201 San Francisco, Santa Fe, New Mexico 87501.

500 BEAUTIFUL POLISHED GEM-STONES \$1.50. Floodstones, P.O. 1673 Fremont, California 94538.

CARTOONING, COMMERCIAL ARTS, SHOWCARD & SIGN PAINTING

SIGN Painting, Fascinating System—Straley, 410 So. Western, Springfield, Ohio 45506.

COMPACT 23 lesson Cartoon Course and Cartoonist's Magazine, \$2.00. Hartman, Box 30367, Lincoln, Nebraska 68510.

"HOW TO MAKE MONEY WITH SIMPLE CARTOONS"—Everyone who likes to draw should have this book: **FREE**. Write Cartoonists' Exchange, 95 Pleasant Hill, Ohio 45359.

LEARN Sign painting at home. Free talent test. Ben Kerns, Box 812-PM, Greenville, S.C. 29601.

LEARN Profitable tattooing. Illustrated information and instruction \$3.00. Zels, 2220-P Delcy Dr., Rockford, Illinois 61107.

SIGN Painting - Free Catalogue. Instructions, Equipment, Kaufmann Signs, Centertown, Missouri. 65023.

ADVERTISING AGENCIES, ADV. SERVICE, MAILING LISTS

MAILING Lists most all kinds 1000 \$5.00. Free folder. Your circulars mailed \$4.00 1000. Dixie Mailers, King, N.C. 27021.

ADVERTISING Ratebook leading newspapers, magazines, 25¢. Chicago Advertising Agency, 28-E Jackson, Chicago 60604.

10,000 **RECENT** mailorder buyers from our magazine advertising. \$15.00 M one-time rental on gummed labels. Terry's, Box 2027-PM5, Downey, Calif. 90242.

TYPEWRITERS, DUPLICATORS, OFFICE EQUIPMENT

FREE Plan. Start printing, lettershop. Offset Presses, Mimeograph Copy machines, DixieGraph, King, N. Car. 27021.

RUBBER STAMPS AND OFFICE SUPPLIES

NAMEPLATES Doorplates, Signs, \$1.00. Brochure. Morris, 410 West Oakland, Lake Charles, Louisiana 70601.

STOCK SIGNS, \$1.00. Bargain list, \$1.00 (refundable). Foothill Sign Co., 9009-P Santa Monica Blvd., Los Angeles, Calif. 90069.

RUBBER Stamps 50% Discount. Free Catalog. Contessa, 1955A-S Bonsall, Philadelphia, Penna. 19145.

TYPE Catalog No. 11. 96 pages. Send One Dollar. Deductible First Order. Acme Type, 732 Federal, Chicago, Illinois 60605.

RUBBER Stamps 4 Lines \$1.25. Catalog. Bilmar, 10024 Oxborough Road, Minneapolis, Minnesota 55431.

SAME Day shipment on rubber stamp supplies. Revised wholesale price list No. 6 free. Star Stamp Supply, 732 Federal, Chicago, Ill. 60605.

FREE 48 Page catalog. Signature \$2.80. Carol's, McLoud, Okla. 74851.

RUBBER STAMP 3 Lines \$1.00. L&M Discount, 507 Fifth Ave., New York, N.Y. 10017.

FREE 40 Page catalog. Rubber stamps, office supplies. Youngers Stamp Shop, Princeton, Iowa 52768.

MAKE Your own self-molding rubber stamps and printing cuts. Plexirubber, Argyle 1, Wisconsin 53504.

RUBBER Stamp outfits, supplies. Kiewiet, 2025 Barney Road, Kalamazoo, Mich. 49007.

PRINTING PRESSES, RUBBER STAMP OUTFITS

PRINTING Presses, type, supplies. Lists, 5¢. Turnbaugh Service, Mechanicsburg, Pennsylvania 17055.

LOW Priced Rubber Stamp manufacturing supplies, starting outfits. Martin, 1432 Major, Jefferson City, Mo. 65101.

SIMPLE-X RUBBER STAMP PRESSES, hydraulic operated, electrically heated. Sizes 5"x8", 8"x12", 10"x15". Starting outfits. Orders for presses, supplies shipped day received. Free catalog low supply prices. Custom Manufacturers, 406-P East Elm, Springfield, Mo. 65801.

PRINTING AND SUPPLIES

PRINTING Free catalog with samples. Rosie, Box 901, Waycross, Georgia 31501.

PRINTING, Samples Free! Write: National, 1511 Pine Avenue, Niagara Falls, New York 14301.

TOP QUALITY OFFSET. 1000 8½x11. 20 lbs. bond. \$6.75 postpaid. Special handling. Biscayne, Box 346 Wall Street, New York, New York 10005. Write for catalog.

8 HOUR PRINTING-Free Booklet "Secrets of Cutting Printing Cost" Nationwide Printing, Atlanta, Ill. 61723.

FREE Literature, Address Labels, Business Cards, Printing, Rubber Stamps. Jordan's, 552 West O'Connor, Lima, Ohio 45801.

AMAZING business printing values. Quotations, Print Shop, Box 576, Greenville, R.I. 02828.

DO Your own printing. Save money. Simple rules. We supply everything. Print for others; good profit. Raised printing like engraving too. Have home shop. Details free. Kelsey Presses, V-11, Meriden, Connecticut 06450.

PRINTING—8 hour service. Any Quantity. Lowest prices. Free catalog "Cut Printing Costs". Allstate Press, 120-PM South LaSalle, Chicago 60603.

250 8½x11 **LETTERHEADS** \$3.50—250 Envelopes \$3.50. Davis—7609 Spruce, Baltimore, Maryland 21222.

MULTIGRAPH, MIMEOGRAPH

EXTRA Income at home in Spare Time! Booklet shows you how to start your own business with Classified Advertising. Only \$1.00. Refundable with first order. C. A. Martin, Popular Mechanics Dept. PM, 575 Lexington Ave., New York 10022.

GUMMED LABELS

1,000 **RETURN** Address Labels 75¢. Satisfaction Guaranteed. Maxwell's, 7359—24th N. W. Seattle, Wash. 98107.

1,000 **GUMMED** Address labels \$1.00. Walt's, Box 966A, South Bend, Indiana 46624.

REMAILING SERVICE

RECEIVING-Forwarding, \$3 Monthly. Hedgpeth, 406-M South Second, Alhambra, Calif. 91802.

CONVENTION City Remails 25¢. Colorful Postcards. Schoen, Box 1963-P, Chicago, Illinois 60690.

MIAMI Remails 25¢. Monthly rates. Marle, Box 1266, Coral Gables, Fla. 33134.

KANSAS CITY Remails 25¢. Receiving—Forwarding. Midway 3115-F South 45th, Kansas City, Kansas 66106.

DICK'S Confidential—Fast Excellent Rates. Box 6171, San Jose, California 95150.

CONNECTICUT, New Canaan, Westport, Rowayton, Darien, Greenwich Remails 25¢ each. \$3.00 monthly. Box 929, Darien, Conn. 06820.

SECRET Receiving and remailing. Discreet and confidential. Remail 25¢ single. 8050 S. Main, Houston, Texas 77025.

PHOENIX, Receiving, forwarding, remailing. Confidential. Troen, Box 2386, Phoenix, Arizona 85002.

MILWAUKEE Receiving-Forwarding 25¢. \$3.00 Monthly. Box 90036, Milwaukee, Wisc. 53202.

FLORIDA 25¢. \$3.00 Monthly. Harold Dalton, Daytona Beach, Fla. 32015.

BALTIMORE, WASHINGTON, ANNAPOLIS Remails, Colorful Postcards, Bowie Business Services, 12312 Winding Lane, Bowie, Maryland 20715.

BERKELEY, OAKLAND, 25¢ each, \$3 monthly. Box 2073M, Berkeley, Calif. 94702.

RECEIVING Forwarding \$3 Monthly. Additional Confidential Services. Redjack, 2401 Banner, Dearborn, Michigan 48124.

REMAILS, Prompt, Confidential, 25¢ Singles; \$3.00 Monthly. Mickens, Box 94-C Pasadena, California 91104.

WASHINGTON Remails 25¢. \$3.00 Monthly. Confidential, 410 King, Yakima, Wash. 98902.

SPAIN Your Mailing Address Abroad. \$1.00 **APARTADO** 39, Benalmadena-Costa, Malaya, Spain.

MONTGOMERY Remails—25¢. \$3.00 monthly. Kidde, Box 11124, Montgomery, Alabama 36111.

EUROPE Reairmails \$1.00 from anywhere. Confidential. Europe, Box 96, Lambertseter, Oslo 11, Norway.

PALM SPRINGS Remails .50¢ & Post Cards. P.O. Box 4008, Palm Springs, Cal. 92262.

CALIFORNIA Remailing. Prompt, dependable. 25¢ each. Ellis, Box 726, Fresno, California 93712.

NEW YORK 25¢. \$3.00 monthly. Reliable. Snow, 458 Vermont Street, Brooklyn 11207.

MIAMI 25¢ Appear here, 3/60¢ Magic City Services, Box 27, Olympia Br., Miami, Florida 33165

THE NATION'S CAPITAL—WASHINGTON, D.C. Secret receiving and remailing. Remail 25¢ single. Five - Jay, Box 19304, Washington, D.C. 20036

REMAILS 25¢. Receiving-Forwarding. EC Mailway, Drawer 9037PM22, San Jose, CALIFORNIA 95117

RECEIVING-Forwarding. \$3. Monthly. Remails 25¢. Romae, 6641-A Bo-Peep, Jacksonville, Fla. 33210.

BOSTON Confidential-Request Special Receiving-Forwarding Rates-Remails 25¢. D A D PM, Box 651, Waltham, Massachusetts 02154.

TEXAS Remails 25¢, forwarding \$3.00 monthly. Delk, P.O. Box 8224, Corpus Christi, Texas 78412.

SPECIAL SERVICES

INFORMATION On anything. Ferguson Research Specialists, 83-45 Vietor Ave., Eimhurst, N.Y. 11373.

AUTHORITATIVE INFORMATION On Anything! \$2.00 (deductible). Metzler Research, P. O. Box 2206PE, Long Island City, New York 11102.

EXTRA Income at home in Spare Time! Booklet shows you how to start your own business with Classified Advertising. Only \$1.00. Refundable with first order. C. A. Martin, Popular Mechanics Dept. PM, 575 Lexington Ave., New York 10022.

AUSTRALIA Remailing. Souvenirs. Coins, Magazines, Special Assignments. Professional Services, Box 38, Northbridge, NSW, 2063, Australia.

TOBACCO

LARGE Samples Smoking-Chewing 10¢. Jolley Farms, Dresden, Tenn. 38225.

RAZORS

SLIGHTLY Used Single Edge Razor Blades \$1.00 Per Hundred. New Blades \$3.00 Per Hundred. J. Penninger, 1744 N. 19th., Melrose Park, Ill.

PERSONAL

RUPTURED. Relief and comfort. No understraps, elastic or steel. Write Hand-Lock Products. Preston 4, Ont., Canada.

BIBLE Questions answered. Stamped envelope. Bylon, 17167 Bentler, Detroit, Michigan 48219.

INVESTIGATORS. Latest Electronic Aids. Free Literature. Clifton, 11500-P NW 7th Ave. Miami Florida 33168.

SUBCONSCIOUS Conditioning remakes personality while you sleep. Free details. Sleep-Learning, Box 24N, Olympia, Washington 98551.

PENMANSHIP Improver: Improve Penmanship Quickly! Details free. Tevis, Chillicothe, Mo. 64601.

SECRET Plans revealed. Free Brochure. Audiotronix, PP-5, 156 Fifth Ave., New York, N.Y. 10010.

BORROW \$100 to \$1,500 by Mail. Quick. Easy. Private. No Co-Signers. Repay in 36 small monthly payments. For the amount you want write today to Dial Finance Co., 410 Kilpatrick Bldg., Dept. E-214, Omaha, Nebraska 68102.

BE A winner! "Twelve Steps to a Real Life" \$10.00, guaranteed. Gift, details \$1.00. Now! Box 2013R, Atlanta 30301.

WIN MONEY EVERY MONTH working contests and puzzles. Free details. . . . NO MINORS. International Contest Club, Box 10153, Dept. PM-6, Kansas City, Missouri 64111.

POSSIBLE To make \$1,000.00 Per Week. Mail \$1.00 To Morris Cornblith, 1603 Sherman Place, Long Beach, California 90804.

READ Drugless Therapy By Dr. Joseph H. Greer M.D. 250 Pages and Illustrations. \$2.50 Postpaid. Chester Lodge, Jefferson, New Hampshire 03583.

PAY Bills! Have cash left over. \$39.65 repays \$1000 in 36 months. Write for details. American Loan Plan, Dept. EA-010B, City National Bldg., Omaha, Nebraska 68102.

BORROW \$1,205 AIRMAIL! Repay \$47 for 36 months. State licensed. Postal Finance, Dept. 17-E, 200 Keeline Building, Omaha, Nebraska 68102.

DEBT LOANS. 1000 easy sources. Immediate relief. Helped thousands-Free details. Counselor-7, Harlingen, Texas.

HYPNOTIZE! Frustrated with self-taught hypnotism courses? Learn rapidly with personal, step-by-step coaching! Careful lesson guidance, newest teaching methods. Educational specialist with University Degree. Comprehensive semester course by mail only \$40! Free information no obligation. Accelerated Learning Associates, Department 106, Box 1634, Atlanta, Georgia 30301.

"WILLS". Prepare own. Four standard forms; instructions, \$1.00. Willforms, Box 8585-A, Kansas City, Missouri 64114.

MAKE NEW FRIENDS. . . . Worldwide! Meet marriage minded Girls through our illustrated Catalog. \$2.00. I.C.B., Box 12, Toronto 16, Ontario, Canada.

FREE list books reports folios describing money making opportunities, self-improvement vacations and retirement. Hartwell Associates, RD 1, Middletown, NY 10940

NAGGING Bills? Accounts serviced up to \$20,000. You can't borrow your way out of debt. We are not a lending institution. Write for free details. Nationwide Budget Systems, Dept. PM 1227 Plainfield St., Johnston, R. I. 02919

IMPROVE Your PERSONALITY! Be popular! 110 page book-"Dynamic thinking" shows how. Send \$1.00 AL; P. Fields, 708 S. Peter St. Garrett, Ind. 46738

CANCER! You May Be Next! Stop Smoking! New Book reveals medical and psychological method. Money back guarantee. =WB 106 only \$2.00. A. Kay's Gifts, R.F.D. Redfield, Iowa 50233.

MARRIAGE, Birth Certificates, Diplomas, Wills-3 Blank Forms \$1.00. Free Samples. Form Distributors, Box 893, League City, Texas 77573.

GET OUT OF DEBT in 90 minutes, legally without borrowing or bankruptcy, facts so explosive, international credit firm tried to suppress them, details free, Anderson 8873E Kenwood, Cincinnati, Ohio, 45242.

LITTLE KNOWN HEALTH FORMULAS For everyday use, \$2.00. Duffy Family, P. O. Box 447, El Toro, California 92630.

HOROSCOPE Cards by Zolar. Lets you Tell Fortunes! Only \$3.00. Glenwood Galleries, 8512 Glenwood Circle West, Louisville, Ky. 40219.

WANTED-MISCELLANEOUS

MERCURY. Gold, Silver, Platinum; Ores assayed. Wholesale Terminal, Norwood, Mass. 02062.

MISCELLANEOUS

ORNAMENTAL Iron designs. Book of 1600 beautiful, practical designs for railings, columns, etc. Free literature. Cunningham, 3881 South 3200 West, Salt Lake City, Utah 84119.

SILENCERS For pistols and rifles. Complete details for construction and operation, \$1.00. Gunsmith, Box 185, Fairfield, Alabama 35064.

YOUR Name sent to 1000 importers, publishers, mailers, wholesalers, etc. on our mailing list. Year \$1.00, Dixie Mailers, King, N. Car. 27021.

HEARING Aid batteries wholesale. Free list. Habs, Box 51, York, Penna. 17405.

WINEMAKERS-Free catalog and recipes. Kraus, Box 451-L, Nevada, Missouri 64772.

QUART Oregon Hops with 101 recipes -Homebrewing, Winemaking, Hoppreads, Catalogue, \$1. Nichols Hops, 1190 North, Albany, Oregon 97321.

KILL Mosquitoes, Insects, electrically. Free information. US Insect Control, Box P374, Royal Oak, Michigan 48068.

CIGARETTES 12¢ a pack. Improved roller makes 20 filtertip, plain, king or regular for 12¢. Facts Free. Moberly, Box 954, Owensboro, Kentucky 42301.

WINEMAKERS. Free illustrated catalog of yeasts, equipment, Semplex, Box 7208, Minneapolis, Minn. 55412.

WANT Greatest Cash Crop working for you? Write, Ginseng, Asheville 53, N.C.

WINEMAKING . . . Grape, Elderberry, Dandelion, Frozen Juices, etc. Brewmasters' secrets revealed! Powerful Methods! Instructions, Recipes, and Supplies Catalog. \$1.00. Continental, Box 11071-PE, Indianapolis, Indiana 46201.

BOOKS On antiques and their prices. Free circular! P. Warman Publishers, Uniontown, Penna. 15401.

BIRTH Certificates, Marriage Certificates, Diplomas! 2 blank forms \$1.00. Sample 10¢. Standard Forms, Box 482-M, Washington, D.C. 20044.

HOMEOWNERS SMALL BUSINESSES: PROTECT YOURSELF from fraudulent improvement-repair agreements. Send for copy of agreement contractor signs when you sign his. Mail \$2.00 to: Industrial Research Corp. P.O. Box 7086, Phila., Penna. 19149.

GAMBLING At last the true facts about dice and 21 Send \$5 for this sensational booklet HOW TO WALK AWAY A WINNER. Forsmark, 2107 Emerson, Monroe, Louisiana 71201.

KEYS BY MAIL. Only \$1.25. Bill's Lock Shop, 4 Spring, Ossining, New York 10562.

MAGNETS. All types. Specials-20 disc magnets, or 2 stick magnets, or 10 small bar magnets, or 8 assorted magnets, \$1.00. Maryland Magnet Company, 5412-A Gist, Baltimore, Maryland 21215.

RECEIVE Magazines-Samples-Catalogues-Agency-Home-work Offers. Get listed -35¢. Roricke, Mailers-Pleasant Plain-Ohio-45162

"315 FREE Magazines". Details 25¢. (Refundable), Kirkman, 1-PM Ann Street, Woodbridge, Virginia 22191.

SLOT MACHINES, Pinball Machines, etc. Catalog 50¢. Coffco Distributors, Dept. 101, Lake Zurich, Illinois 60047

PIMPLES Disappear like magic. Guaranteed. Instructions \$1.00. Ducharme, P.O. Box 13526, Orlando, Florida 32809.

"PERPETUAL" CALENDAR-Post card size-Fits shirt pocket or purse-Any month from 1880 to 2004-\$1.00 post paid -Satisfaction or refund, Sweeney Enterprises, PO Box 7493, Arlington, California 92503.

SEE AMERICA FREE. World's first guide to free vacation. 286 page necessity for every traveler. \$1.00. Booktown, Box 8224M, Fort Worth, Texas 76112.

SNUGEEZ Correct loose-fitting glasses instantly, permanently, gently. Fit regular and sunglasses. 3 Pairs \$1. Snugeez, Box 313, Oklahoma City 73101.

BENJAMIN INTRODUCES A FABULOUS NEW AIR RIFLE

... that takes up where
the O' Reliable Super
Single Shot leaves off.

You Can **DEPEND** on BENJAMIN

Push-Pull Safety on top
of Stock behind Breech.



A no-nonsense gun that means business every time you fire, this New Benjamin combines all the superb Quality and Performance features of its famous Predecessor with extra improvements for your shooting pleasure. Foremost, is a Thumb Operated Top Safety. The only pneu-

BENJAMIN AIR RIFLE COMPANY, 896 Marion St., St. Louis, Mo. 63104

\$35.95 MODEL 348 CAL. .88
MODEL 342 CAL. 22
PELLET—MODEL 347
CAL. 177 PELLET.

matic to offer this Advanced feature for more efficient fire control, it also includes a new Ramp Front Sight and adjustable Stepped Leaf Rear Sight to bring out the full Accuracy potential of the New Model. Shoot target, small game. This Benjamin stands alone for its Power — Convenience — Safety — Reliability. At your Benjamin Dealer's.

Use Benjamin H-C Pellets—Sized & Lubricated.

FREE CATALOG! Write



PLANER · MOLDER · SAW!

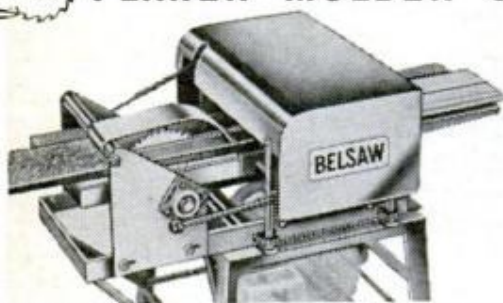

Now you can use this ONE power-feed shop to turn rough lumber into moldings, trim, flooring, furniture... ALL popular patterns. RIP... PLANE... MOLD... separately or all at once with a one HP motor. Use 3 to 5 HP for high speed output. Low Cost... You can own this power tool for only \$30.00 down.

Send Postcard Today... No Salesman Will Call

BELSAW POWER TOOLS, 909B Field Bldg., Kansas City, Mo. 64111

The best wrench to
have in a tight spot.

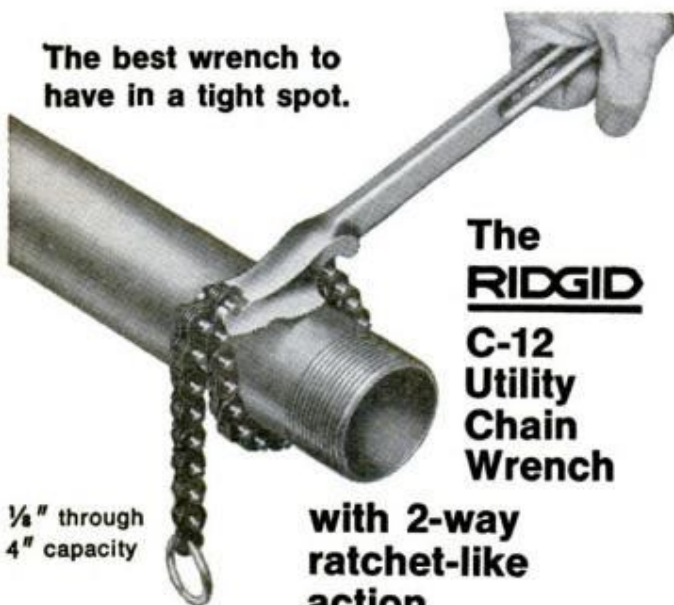

The
RIDGID
C-12
Utility
Chain
Wrench

1/8" through
4" capacity

with 2-way
ratchet-like
action.

Nothing equals this light and easy-to-use RIDGID Utility Chain Wrench for fast action in close quarters. Strong, flexible chain grips all shapes without crushing, is easy to lock and release. Double jaw turns pipe in either direction.

Buy a time-saving RIDGID Utility Wrench at your Dealer's. He has a complete stock of RIDGID Work Saver Tools from The Ridge Tool Company, Elyria, Ohio 44035.

RIDGID

MINI-BIKES



TACO TRAIL 100 — New, rugged, big-wheel performer — \$219.50. Other models as low as \$119.95. Kits less engine, clutch, chain at \$49.95. Send 25c for brochure, free decal. 130-p. catalog — \$1

STEEN'S
BOX 2276 - W
ALHAMBRA, CA. 91803

HEAVY DUTY WELDER 18⁹⁵ POST PAID WELD · BRAZE · SOLDER · CUT



10-DAY FREE TRIAL · LIFETIME GUARANTEE
110 Volt · Not One—But 3 welding heats

Weld, braze, solder or cut any metal — even aluminum. No experience necessary. Follow simple instructions to make repairs on cars, trailers, farm and lawn equipment, bicycles, appliances, etc. Make campers, boats, furniture, hundreds of valuable items. NOTHING ELSE TO BUY! Comes complete with full face shield, \$2.00 pack of welding and brazing rods, heavy duty power cables, special electric torch attachment, ground clamp, flux, easy-to-follow illustrated instructions, rod holder, etc. Uses standard 1/8" rods and 1/4" carbons to weld iron, steel, brass, bronze, aluminum, other metals. New improved HEAVY DUTY circuit gives more welding power. Gives 4 times the heat needed to melt toughest iron. Plugs into ordinary 110V outlet. 3 WELDING HEATS... Not just one as with other low cost models. Use "high" for tough jobs, "medium" or "regular" for lighter work. This important feature saves you money and time. Makes it possible for even beginners to start welding professionally the very first day. Pays for itself quickly. 10 day MONEY BACK GUARANTEE. You must be satisfied or return for refund.

FREE automatic arc striker. Weld with push-button ease. SEND ONLY \$2.00. Pay postman \$16.95 plus postage when delivered, or send \$18.95 cash, c.k., M.O., for fast postpaid shipment. WEL-DEX MFG. CO. Dept. W103, Box 10776, Houston, Texas 77018

OVER 100,000 MEN CAN TELL US:

NTS HOME-TRAINING REALLY WORKS!

AND PUTS YOU WHERE THE BIG MONEY IS!



If you think you can't learn a new technical skill with NTS Home-Training, you're wrong. Over 100,000 men have done it in the past half-century since the school was established.

And so can you.

NTS Project Method makes learning fast, easy and exciting. Takes only a few hours a week. Hours any man can fit into his life.

So, stop wasting time. Pick from these big money-making fields. We'll send you all you need to know to get started towards a new, better job. It's a sure thing!

ELECTRONICS DIVISION (New 25" Color TV Kits)

Train with the biggest, most exciting package of electronics kits ever offered! Beautiful new 25" Color TV kits included in color TV courses. No kit deposits — no extra cost. All-new Communications and Industrial Electronics Kits & Courses — put you two steps ahead of tomorrow. Check coupon for choice of Project Method Courses and New Free Color Catalog.

MECHANICS DIVISION (New Test Equipment)

NTS makes you a skilled Mechanic — Diagnostic Technician in a hurry! You get professional engine analysis test instruments at no extra cost! Special Engine Diagnostic and High Performance lessons included — everything you need to be a pro. Four fields from which to choose. Service your own car — earn while you learn. Check the coupon for new catalog.

AIR-CONDITIONING, REFRIGERATION DIV. (New Kits)

A wide-open field. NTS opens it up for you — fast and easy! Trains you to handle the big jobs. Start your own business with either of the two courses in this division. We give you the tools, tester, and instruments you need at no extra cost. No kit deposits! Check the coupon below and get rolling!

HOME APPLIANCES DIV. (New Circuit-Trainer)

Dig deep into the Major Home Appliance repair field for the big money! NEW, EXCLUSIVE! THE NTS CIRCUIT-TRAINER! Shows you the ins and outs of major appliance circuitry. Makes training a snap. Puts you in line for a piece of the billion-dollar appliance repair field. New Kits! New Catalog. Check coupon for earn-while-you-learn courses.

HIGH SCHOOL AT HOME

National offers accredited High School programs. Take only subjects you need. Study at your own pace. Everything included at one low tuition. Check special High School box in coupon for full information and FREE catalog.

CLASSROOM TRAINING

You can take classroom training at Los Angeles in Sunny Southern California. NTS occupies a city block worth over a million dollars in training facilities.

NATIONAL TECHNICAL SCHOOLS

WORLD-WIDE TRAINING SINCE 1905
4000 So. Figueroa St.
Los Angeles, Calif. 90037
No obligation.
No salesman will call.

SEND POSTCARD OR FREE BOOK AND SAMPLE LESSON

TEAR OUT AND MAIL THIS CARD TODAY. CHECK ONE ONLY.

ELECTRONICS DIVISION

- MASTER COURSE IN COLOR TV SERVICING
- COLOR TV SERVICING
- MASTER COURSE IN TV & RADIO SERVICING
- PRACTICAL TV & RADIO SERVICING
- MASTER COURSE IN ELECTRONIC COMMUNICATIONS
- FCC LICENSE COURSE
- MASTER COURSE IN ELECTRONICS TECHNOLOGY
- INDUSTRIAL AND AUTOMATION ELECTRONICS
- COMPUTER ELECTRONICS
- BASIC ELECTRONICS

HOME APPLIANCES DIVISION

- HOME APPLIANCES MASTER TECHNICIAN'S COURSE
- HOME APPLIANCES SERVICING
- HANDYMAN APPLIANCE REPAIR

AUTO-MECHANICS DIVISION

- MASTER COURSE IN AUTO & TRUCK MECHANICS
- AUTOMOTIVE MECHANICS
- TRUCK & HEAVY DUTY MECHANICS
- ENGINE TUNE-UP & ELECTRICITY

AIR CONDITIONING-REFRIGERATION DIVISION

- AIR CONDITIONING, REFRIGERATION & ELECTRICAL APPLIANCES MASTER COURSE
- AIR CONDITIONING-REFRIGERATION SERVICING COURSE

HIGH SCHOOL DEPARTMENT

- HIGH SCHOOL AT HOME Dept. 201-59



NAME _____ AGE _____

ADDRESS _____

CITY _____ STATE _____

Please fill in Zip Code for fast service _____

- Check if interested in veteran training under the new GI Bill.
- Check if interested ONLY in classroom training at Los Angeles.

Материал, защищенный авторским правом

GET OFF THE DIME. HERE'S 4 WAYS TO BOOST YOUR INCOME!



ELECTRONICS DIVISION

New color catalog

NTS Project-Method home training makes it easy for you to make your mark in Electronics. To get the big-paying job you want. Learn more, faster, with exciting kit equipment included at no extra cost. There's no better time than right now to do it! Send the coupon!



MECHANICS DIVISION

NTS gives you professional engine analyzing equipment. And top mechanics' know-how in diagnosis... speed... performance. Industry needs over 200,000 trained mechanics right now. And you can be one of them. Mail the coupon for our new catalog today!



AIR CONDITIONING, REFRIGERATION DIV.

We give you the tools, tester, instruments. Show you how to service giant industrial cooling systems and commercial refrigeration installations. There's a big job waiting for you here. All it takes to get it is the skill we give you. Don't wait any longer.



HOME APPLIANCES DIVISION

Learn to service major home appliances. Get the new, exclusive NTS CIRCUIT-TRAINER! It helps train you faster for the big jobs. Learn troubleshooting, open your own business, be your own boss. So get off the dime. Mail the coupon. We'll send you all the facts in our new catalog.



 **FILL OUT AND MAIL CARD TODAY**

GET FULL COURSE DETAILS AND LEARN ABOUT THESE NTS EXTRAS:

1. BONUS CLASSROOM TRAINING
2. JOB PLACEMENT CONSULTATION
3. BUSINESS CONSULTATION

NO OBLIGATION. NO SALESMAN WILL CALL.

APPROVED FOR VETERANS

 Accredited Member National Home Study Council

 Accredited Member National Association of Trade and Technical Schools

FIRST CLASS
Permit No. 3087
Los Angeles, Calif.

VIA AIR MAIL

BUSINESS REPLY MAIL
No Postage Stamp Necessary if Mailed in the United States

POSTAGE WILL BE PAID BY
NATIONAL TECHNICAL SCHOOLS
4000 South Figueroa Street
Los Angeles, California 90037

NAME _____

ADDRESS _____

CITY _____

STATE _____

ZIP _____

TELEPHONE _____

DATE _____

Материал, защищенный авторским правом



TUNE UP ELECTRONICALLY ANY CAR EVER MADE!

- ✓ COMPACT or LIMOUSINE
- ✓ DOMESTIC or FOREIGN
- ✓ 4, 6 or 8 CYLINDER
- ✓ 6 VOLT or 12 VOLT
- ✓ POSITIVE or NEGATIVE GROUND

With New Improved Model BT-162

DWELL TACHOMETER

**ASSURE: EASY STARTS, OPTIMUM PERFORMANCE and
MAXIMUM GAS ECONOMY with MODEL BT-162**

MADE ORIGINALLY FOR THE PROFESSIONAL AUTOMOTIVE TECHNICIAN, MODEL BT-162 WILL PAY FOR ITSELF MANY TIMES OVER FOR THE AUTOMOTIVE HOBBYIST AND EXPERIMENTER.

**The Model BT-162 will perform the services specified below
in addition to many other tasks too numerous to mention:**

- ✓ Assure precise adjustment of points that are slightly worn or pitted.
- ✓ Indicate the most effective point setting **without removing the distributor cap.**
- ✓ Read the average dwell of dual breaker points as well as individual dwell of each individual set of points.
- ✓ Indicate the correct settings for **external adjustment type** distributors.
- ✓ Car manufacturers' dwell angle recommendations are included in the manual provided with the Model BT-162 for all cars including the external adjustment type distributors specified above.
- ✓ It is no longer necessary to file points to smoothness when using the Model BT-162. The instrument will automatically make allowance for any existing "pitting" or "wear."
- ✓ To adjust for mathematically correct carburetor adjustment and thus insure maximum gas economy and quiet engine running, simply use the Tachometer section of the Model BT-162. Read the exact RPM while the engine is in neutral position. Then adjust the carburetor in conformity with the car manufacturer's recommendations as specified in the manual provided with the Model BT-162.
- ✓ To locate a "miss" you need only disconnect or "short" the spark plugs one at a time with the Model BT-162 switched to the Tachometer position. You will be able to instantly identify which particular plug (or frequently its wire lead) is responsible for the malfunction.
- ✓ Cars with automatic transmissions function efficiently only if the fluid pressures are correctly maintained and since manufacturer's instructions always refer to RPM the Model BT-162 (or an equivalent tachometer) is required to properly service automatic transmissions. Incidentally, the 5,000 RPM maximum range of the Model BT-162 is adequate for all car engines without any exceptions.

Comes complete, ready to use. Operating manual includes manufacturer's dwell angle recommendations for all cars. The manual is yours to keep even if you decide to return the instrument.

\$29⁹⁵

**SEND NO MONEY WITH ORDER
PAY POSTMAN NOTHING ON DELIVERY**

Try it for 10 days before you buy. If completely satisfied then send \$5.00 and pay the balance at the rate of \$5.00 per month until the total price of \$29.95 (plus P.P., handling and budget charge) is paid. If not completely satisfied, return to us, no explanation necessary.

ACCURATE INSTRUMENT CO., INC.

Dept. 650, 2435 White Plains Road, Bronx, N. Y. 10467

Please rush me one Model BT-162. If satisfactory I agree to pay \$5.00 within 10 days and balance at rate of \$5.00 per month until total price of \$29.95 (plus P.P., handling and budget charge) is paid. If not satisfactory, I may return for cancellation of account.

Name _____

Address _____

City _____

Zone _____

State _____

Save Money! Check here and enclose \$29.95 with this coupon and we will pay all shipping charges. You still retain the privilege of returning after 10 day trial for full refund.

HOMEOWNERS' CLINIC

BY W. CLYDE LAMMEY

Crack patch

My patio floor is of natural stone laid in a concrete bed. Only 10x12 ft., it's cracked diagonally all the way across, right through the stones. The crack is a hair-line part of the way and not more than 1/4 in. at the widest. Do I fill it as is, chisel it wider or what?—C.E., N.J.

By "laid in a concrete bed," I assume you mean the stones were originally bedded in concrete over a gravel fill, and that the openings between the stones were concrete-mortared flush with the surface. Settling of whatever the builder used as fill has undoubtedly caused the crack. There's a possibility that the crack may open farther, but I'd try filling it "as is." Several types of concrete crack fillers are available, some of which come in a cartridge for use in a caulking gun. The main problem is to clean the crack thoroughly, removing all dirt and loose debris. Usually you can do this with a strong stream of water from a hose while using a small screwdriver or other pointed tool to loosen any embedded dirt. Thoroughness of the cleaning will determine the success of the repair patch.

A thin mix of concrete patcher will probably run deeper into the fine crack than most other patchers. Fill the crack a little over flush and then brush off lightly. Cover it with wet sacks or cloths and keep them damp for at least 36 hours.

Lumpy lawn

Why is my lawn so rough and bumpy under trees? I have a wide curb shaded by large trees and under these the lawn surface is so rough it is difficult to hang onto my power-mower handle. Is there any way it can be made smoother?—I.H., Ill.

If you look closely during a heavy rain you will see water falling in streams from the tree limbs. This forces the soil into alternate depressions and hummocks that make mowing unpleasant, if not difficult. There isn't much you can do except to spread a thin dressing of black soil over the surface each season and then rake and roll it smooth. When spreading the dressing care must be taken not to cover the crowns of the grass plants. Also, be very careful when raking the dressing not to

damage the plants or pull them loose. If the black soil is damp when spread and raked, let it dry sufficiently to prevent it from sticking to the roller. On sloping curbs or lawns it is often best to use a light top dressing of peat moss, cocoa-bean hulls or some similar lawn dressing rather than black soil which may wash away in a heavy rain.

Any of these dressings will help to "cushion" the bumps and depressions and make your mower more tractable. Of course, it may be possible to trim the trees in such a way as to break and disperse the streams that are causing the trouble, but this may be costly and difficult to carry out effectively.

New finish 'blooms'

After I refinished a chest of drawers with stain, an undercoat of sealer and a top coat of brushing lacquer, the lacquer turned grayish-white. I removed the finish, did the job over and again discovered this grayish color. The materials I used were all new, right off the store shelves. Did I do something wrong?—D.T., Ga.

I suspect you did do something wrong—such as refinishing the chest in your basement where it was nice and cool and the humidity was very high. Or, you may have taken the chest outside and completed the refinishing in the shade when the humidity was also very high. Under these conditions, new finishings sometimes turn grayish-white. This is known as "blooming" and, although not common, it may happen under these conditions, especially with shellac and lacquer.

In your case there is no practical corrective measure except to start all over again. Make sure you get *all* the old finish off, right down to the bare wood. Sand the surfaces and begin—and finish—the job in a well-ventilated room or do it outside when the humidity is low and natural drying conditions are at their very best.

Hide-a-fence planting

What plants can I use to conceal a chain-link fence? The fence is about 50 ft. long and, although quite new, I'd like to conceal it entirely.—J.L., Mich.

If the fence is located where the sun shines most of the day, a flowering vine such as clematis or climbing honeysuckle will do it in a season or two. However, you should consider that it also will contribute to the deterioration of the fence by opening the way to rust. Also, the weight of the vine eventually may cause the linkage to sag between posts. ★ ★ ★

Stop. Back up.
Speed forward—
without clutching
or shifting.
One lever
Hydra Speed
Drive does it all.

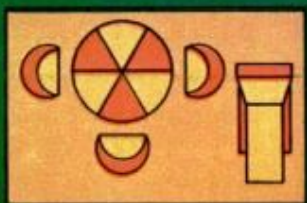

Steer with ease. Get in
close to trees and shrubs
with 42" mower.

Discover **LAWNMOTORING**
on an MF 12. Zip through lawn
work at an acre an hour.

Do your gardening, plowing,
planting, weeding, fertilizing.
The MF 12 makes
all these jobs easier.

Go **LAWNMOTORING** all year.
Clear leaves in the fall,
snow in winter.

Lawnmotoring: A great new outdoor sport from Massey-Ferguson

We'll help you
find your nearest
MF Dealer.
Call any time,
any day, toll free,
(800) 243-1890.
(In Conn.,
325-2244
collect.)



Massey-Ferguson has turned the job of lawn mowing into the sport of **LAWNMOTORING** with machines like the MF 12. Its no-shift, no-clutch Hydra Speed Drive makes any lawn work fun.

MF builds three other **LAWNMOTORING** machines, too. The MF 10 with big 10 hp work capacity and a Variable Speed transmission. The Hydra Speed MF 7 hp and the Standard MF 7 hp (at under \$560*, including 34" mower). See your MF Dealer for a test drive. Bring the sport of **LAWNMOTORING** to your backyard today.



Massey-Ferguson Inc., Des Moines, Iowa
World's Largest Tractor Manufacturer

*Manufacturer's suggested retail price is \$559.00 (34" mower included), F.O.B. Algoma, Wisc. Massey-Ferguson reserves the right to change prices or specifications without notice.

SOLUTIONS FOR MECHANICAL HEADACHES

AUTOMOBILE CLINIC

BY MORT SCHULTZ

Freeze-up

What can be done to stop the remote control side-view mirror of my 1965 Pontiac from binding, especially during cold weather?—Jack Rayburn, Memphis.

The problem begins when water enters the plastic sleeve around the cable and freezes when the temperature drops. To correct it, after the ice thaws, remove the mirror and cable enough to insert the nozzle of an air hose into the sleeve. Blow the water out. To stop water from getting back in, seal the upper end of the sleeve with a windshield sealer compound.

Wacky wipers

My 1967 Ford LTD has intermittent windshield-wiper action. The blades work awhile—rest awhile—work again—rest again, making driving in the rain a problem, to say the least. Ford has replaced the wiper motor and switch, and now says there's nothing more it can do. Have you any idea why these wipers are acting so fatigued?—Virgil Redlin, Jasper, Mich.

Possibly, but I have to give credit to a Ford serviceman buddy of mine who had a similar problem with a car. It took him five hours of troubleshooting to find the cause. In this setup, female connectors mate with male connectors on the back end of the windshield wiper switch. If your problem is like my friend's, one or more of these wire terminals are damaged and making only intermittent contact with the switch. I suggest you make this possibility known at your Ford shop, and let a troubleshooter take a long, hard look at this.

Clutching clutch

Why should the standard transmission of my 1964 Dodge 330 be hard to handle? When I first start the engine, it's tough to shift into neutral. Once I force it in, there's no problem thereafter. The transmission's been apart and everything looks okay.—Wally Hardin, Richmond, Va.

More than likely, the shifting linkage is slipping, worn or misadjusted. Check the linkage at the transmission and also at the lower base of the steering column. That should do it.

Persistent overheating

All attempts to solve an overheating problem with my 1963 Renault Dauphine have failed. Hoses, water pump, radiator cap and thermostat have been replaced. The radiator core has been rodded and cleaned, as have the block and head water passages. By use of partition boards at the front end of the side louvers, I've diverted as much air as possible through the radiator. What else is there to do?—Terry Roberson, Roxboro, N.C.

I can think of three possibilities. At times, the face of the radiator on these cars has become covered with an oil slick that restricts cooling. Just a possibility, but I think you'd want to remove the radiator and wash it by hand with kerosene. Other than this, the problem is probably a bad head gasket or cylinder sleeves that have dropped, which results in a loss of compression and restricted circulation in the cooling system.

Noisy rear

Here's a cute one. I've always used the recommended grease in the limited slip differential. Suddenly, I began to get noise and my mechanic is suggesting expensive overhaul. Anything I can do before I go into this?—Nathan Peck, New York.

You don't mention under what conditions the noise started, but if it began after you put new tires on the rear wheels, here lies a possible cause. If the two tires are of different circumference, although marked the same for type and size, you'll get noise. I'd measure them. One man I know who did this found a two-inch difference. Matching tires with the same circumference got rid of his "limited slip rear end noise."

Sin of omission

I have a real puzzler for you on my 1967 Chevrolet. The service manual's ignition switch section on page 6-10 says that when testing with a voltmeter I should get a voltage drop of from 12 volts to 5 to 7 volts. If voltage doesn't drop, the ignition switch isn't functioning properly. Sometimes I get the voltage drop—other times

(Please turn to page 76)

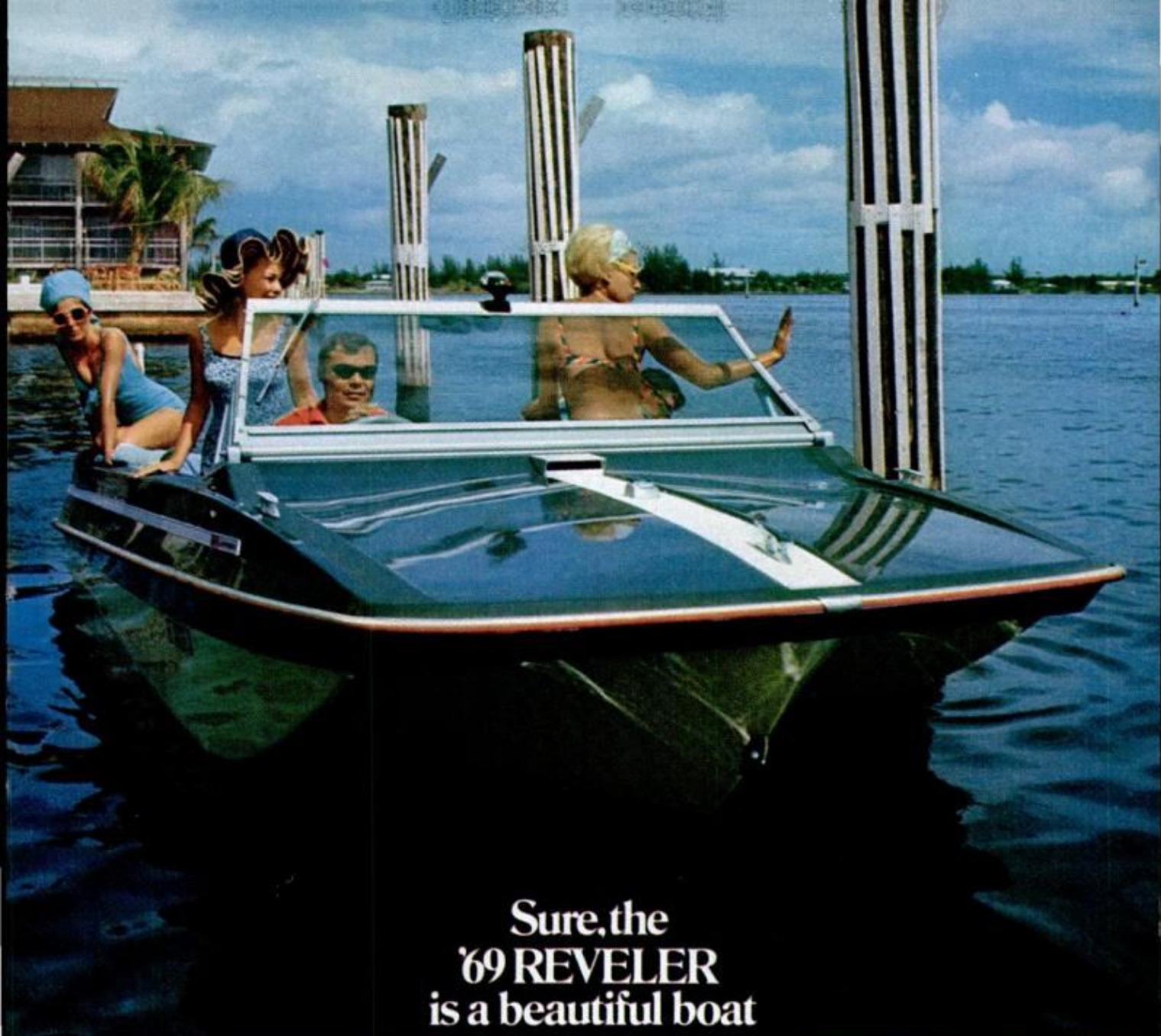

Sure, the
'69 REVELER
is a beautiful boat

Look at our new hull. Four inches deeper all along the keel make it faster, softer, dryer. Twin arches channel water to cushion your ride . . . stabilize turns . . . keep spray away from passengers.

Look at our construction. Fiberglass reinforced plastic, lab-controlled for strength plus resilience . . . oven-cured for maximum durability. Permanently bonded hull, deck and marine plywood floor for maximum tightness.

Look at our flotation . . . more than enough to keep 6 passengers and Reveler afloat and upright. Drill a hole anywhere in Reveler's floor; you'll hit non-absorbent flotation. (Unless you hit one of those big, beefy stringers that underpin the engine.) Flotation is foamed in place to fill every void . . . adds to structural strength.

Look at our hardware. All of Reveler's "comes with"—not optional-at-added-cost. It's not just screwed

but the deeper
you look...
the better
it looks



on; it's bolted through. And the bolts go through glassed-in backup plates. If that doesn't grab you, wait 'til you have to grab it. Also corrosion resistant—for skippers who'd rather spend time polishing their seamanship than their metalwork.

Look in our cockpit. Where you'll find 4 back-to-back 3-position lounge seats and two jump seats for comfortable 6 passenger capacity. Full instrumentation. Lights. Convertible top. Storage in padded side and glove compartments. A portable insulated storage chest under the starboard jump seat. 155 hp V-6 stern drive.

Johnson pioneered the concept of "quality in depth" boats with everything. So see for yourself (four models, 16'2" to 19'1") at your Johnson Boat dealer's, or write for free catalog to Johnson Motors, Waukegan, Ill. 60085, Dept. PM-B95. Division Outboard Marine Corporation

New 16-ft. Reveler is a

FIRST IN DEPENDABILITY
Johnson Boat

(That means quality in depth)

AUTOMOBILE CLINIC

(Continued from page 74)

I don't. Is my switch good or bad?—Marv Lorenz, Los Angeles.

Your switch may be good because an important detail was omitted in the manual. The voltage drop will take place only if the distributor's breaker points are closed. If the points happen to be open as you're testing, the path through the ignition resistance wire won't be completed and you won't get the drop. I wonder how many ignition switches have been replaced because the points were open?

Resolving rough idle

Although he's really been swell about it, my dealer hasn't been able to correct a rough-idle problem with my 1967 Plymouth with 383-cu.-in. engine. Do you think this is an inherent condition?—Mark Forest, Springfield, Mass.

There's a chance that the camshaft in your car may be at fault. Ask the dealer to perform a shaft base-circle runout test according to the instructions in service bulletin 68-9-8 (8/13/68). The problem has also been recognized as occurring with the 318 and 440-cu.-in. Chrysler engines.

Buyer beware

What can the public do to protect itself against new-car dealers who don't care about you once they have your money? We bought a new truck which didn't have a spare tire when delivered. It took the dealer nine months to get us one, and then he billed me \$50 although the price of the spare was included in the original price of the truck. When I refused to pay, the dealer threatened to turn the account over to a credit bureau. I took the problem to the manufacturer's district sales office. Then the dealer got mad and told me that he wouldn't service my truck. He's still after the \$50. I think there's too much of this "public be damned" attitude.—Dean Parmenter, Salmon, Idaho.

Of course, I haven't heard the dealer's side of the story, Dean, but I do agree there are some dealers who should be tarred and feathered. When you run across a guy like this, my advice is to write a detailed account of what's going on and mail it immediately to the manu-

facturer's director of customer relations. Don't wait for months to slip away. It's been my experience that pressure put on the errant dealer from the top works wonders.

Service Tips

● **Mark III owners:** If your car overheats after idling for awhile, it's probably because of an inadequate water pump impeller. Pumps designed with larger-diameter impellers are now at dealers as part No. C9VZ—8501-A. Tell your dealer that service bulletin 15 (1/6/69) authorizes replacement.

● **1969 Plymouth Furys, Chryslers or Imperials with 383 or 440-cu.-in. engines and airconditioning** should be checked to see if the liquid line that goes between the air-conditioner's receiver-drier and evaporator is being held to the fender brace by a nylon strap. If it isn't, better do something about it before vibration creates a noise and eventual condenser failure. Secure the line to the fender brace with tape or by fabricating a metal strap. The dealer can do this for you under the provisions of service bulletin 69-24-4 (11/8/68).

● **Rambler** reminds us to check the rear-axle lubricant level. The lube level should be no higher than the bottom edge of the filler opening when the differential is at operating temperature. If higher, it'll run out, of course. However, if you check the rear axle when it's cold, the lubricant should be 1/4 inch below the bottom edge of the opening. This is okay. Don't add more lubricant, because an over-fill condition will exist once the part heats up.

● **Corvette owners:** Because of space limitations in the Corvette with 427-cu.-in. engine, power steering and airconditioning, you have to remove the alternator from its mount and tip it to get the fan belt off. All other Corvette belts can be replaced in the usual manner.

● **A loose drive belt** can cause a problem, as you know, but one that's too tight can also lead to complications. Oldsmobile tells us that a number of power-steering pump failures have resulted lately from overtightening of the pump belt. A tight belt will damage the pump bushing and cause oil to leak past the pump seal. That's bad news, so be sure to check your manual for the correct spec before you tighten that belt. ★ ★ ★

GOT A PROBLEM WITH YOUR CAR? Ask Mort about it. Send your question to Auto Clinic, Popular Mechanics, 575 Lexington Ave., New York, N.Y. 10022. Letters cannot be answered individually, but problems of general interest will be published in the column.



The Sears Lawn and Garden Tractors for 1969.

Single Lever Control makes tractoring easier than driving the family car.

Touch our Hydro-Trac 12 Single Lever Control and go forward, backward, stop, or change speeds. There's no clutching or gear shifting.

In all, Sears has seven different tractors. Three different horsepowers (7, 10, and 12). Sears tractors have these "Shortcut to Leisure" features: Fingertip controls. Electric start-

ing. Solid-state ignition. Extra-wide, turf-saver tires. Craftsman® engine with patented super start. Spring mounted bucket seat. Over 40 attachments and accessories available. Rotary mowers meet A. S. A.

safety standards.

And, when you start talking money, Sears, Roebuck and Co. talks your language. No money down on Sears Easy Payment Plan. Come to Sears today. Let us demonstrate the features of these proven "Shortcut to Leisure" tractors.

Sears



Throw snow, push, pull, plant, rake, till. You name it. It does it.



Cockpit has grouped instrument panel: Single Lever Control for no-effort tractoring, visual gas gauge, and cigarette lighter.



Put the cart after the horse. Our hauling cart makes dumping easy from driver's seat.

FREE—Popular Mechanics Catalog of Publications and Projects



This FREE Booklet From Popular Mechanics Can Save You Hundreds of Dollars, And Bring You A Lifetime of Enjoyment!

Now You Can Have Your Own Sail Boat, Motor Boat, Swimming Pool, Built-in-Furniture—Almost Anything For The Home Or Week-end Fun—At A Fraction Of The Usual Cost.

Just imagine a fun-filled week-end like this! You can relax and enjoy playing the host, entertaining your friends on the patio or recreation room, have a cook-out, then a swim in the pool.

Or, perhaps you've been putting off that week-end project—building shelves and furniture . . . paneling a room . . . fixing a leaking faucet . . . or odd jobs that require repairing and painting.

Let the experts show you how you can have all these things and more. We'll show you how easy it is! All you need are these step-by-step instructions from the experts—the editors of POPULAR MECHANICS.

Easy-to-follow plans are available for many wonderful additions and improvements for your home, from a simple bookcase to a complete house—projects you can do yourself in your own shop in your spare time. And think of the money you'll save—up to hundreds of dollars—by doing them yourself. In addition, you save on expensive contractors

and long-term loans. Hundreds of practical, money-saving ideas—you'll find a goldmine of hard-to-locate information—literally hundreds of practical ideas, booklets and plans to enrich and beautify your home on such subjects as:

Boats and boating equipment/bookcases, shelves, cabinets, tables/clocks—early American, grand-fathers/camping trailers and equipment/working with glass/electric wiring/furniture; woodworking projects/hydroplane/models: ships, airplanes, sports cars, steam engine, etc./gardening equipment, planters, lawn and tree care/houses—complete architectural plans/painting, interior and exterior; wallpapering/TV, hi-fi and stereo equipment; cabinets/plastic molding/playhouses/how to do your own plumbing/repairing your roof/car repairs and tune up/swimming pools; filters/workshop projects/famous Popular Mechanics wall charts.

This is only a sampling of a multitude of moneysaving ideas and information that can bring you many hours of pleasure—something all the family can enjoy for many years to come.

Order Your Free Price-List Catalog Today

Just fill out and mail the coupon for your copy of the POPULAR MECHANICS CATALOG OF PUBLICATIONS AND PROJECTS. Please enclose a self-addressed stamped envelope, or 10¢ in coin to cover postage and handling. Your 16-page catalog will be sent by return mail listing hundreds of plans, books, projects and wall charts for your enjoyment and better living.

Popular Mechanics, Dept. BI-CA 575 Lexington Avenue • New York, N.Y. 10022

I am enclosing a self-addressed envelope (or 10¢ in coin). Please send me a copy of the Popular Mechanics CATALOG OF PUBLICATIONS AND PROJECTS. (If outside USA, please enclose 25¢ USA currency.)

Name _____ (please print)

Address _____ (please print)

City _____ State _____ Zip code _____

EMC/A

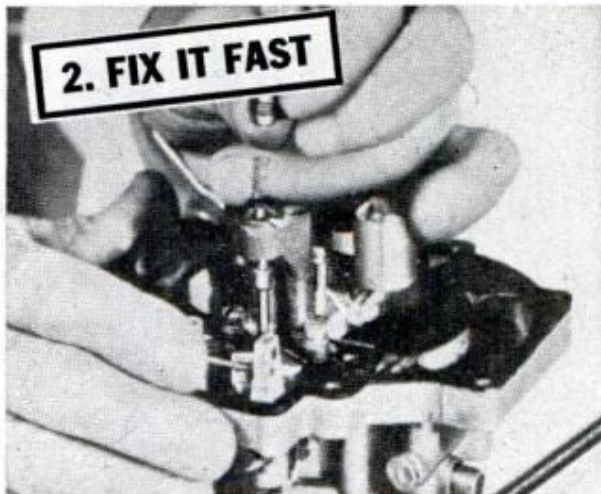

MOTOR'S easy "2-step" repair method helps you

Fix almost any part of any car...FAST

So clear, you'll breeze through tune-ups, air conditioning, brake jobs, engine overhauls — practically any repairs on cars listed.

You just can't make mistakes with the "2-step" method in MOTOR'S New 1969 AUTO REPAIR MANUAL. First, the special "Trouble Shooter" section helps pinpoint in a flash the cause of trouble. Next, 3,000 "How-To-Fix-It" close-up pictures (and plain-talk directions) show how to lick repair problems — fast and right! Even green beginner mechanics find the Manual so clear and easy to follow, they speed through the toughest jobs like real pros!

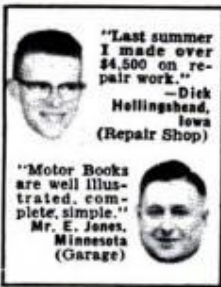

the auto repairman's indispensable "Bible." It's no wonder that more than 5,000,000 copies of the manual have been purchased by repairmen, service station operators, the U.S. Armed Forces, schools and students all over the world. Here is the help every beginner or "pro" needs to fix almost any part of any car right the very first time. And save time, work, money!

SEND NO MONEY

The Manual costs \$9.95, but we'll send it to you for 10 days FREE trial, so you can see for yourself how it makes auto repairs go quick and easy. Use it for 10 days. If it doesn't give you complete satisfaction, return it and owe nothing. Mail the coupon today.

Auto Repairman's "Bible"

Here's the real "meat" of facts and data distilled from over 300 official factory manuals and hundreds of service bulletins. Every job, from installing distributor points to front end jobs, is covered in minute detail for 2,300 car models of 45 series of American-made cars plus Volkswagen, from 1963 through 1969. There are over 1,100 oversize pages in this giant Manual containing 55,000 essential service specifications and adjustments. It's no wonder MOTOR'S is called

ALSO! FREE 10-DAY TRIAL on AUTO ENGINES & ELECTRICAL SYSTEMS



1,300 big pictures. Clear text explains how parts work; principles involved; design; construction; maintenance. Covers all parts of engines & entire electrical system. For FREE trial, check box in coupon.

Mail coupon now for
FREE
10-DAY TRIAL

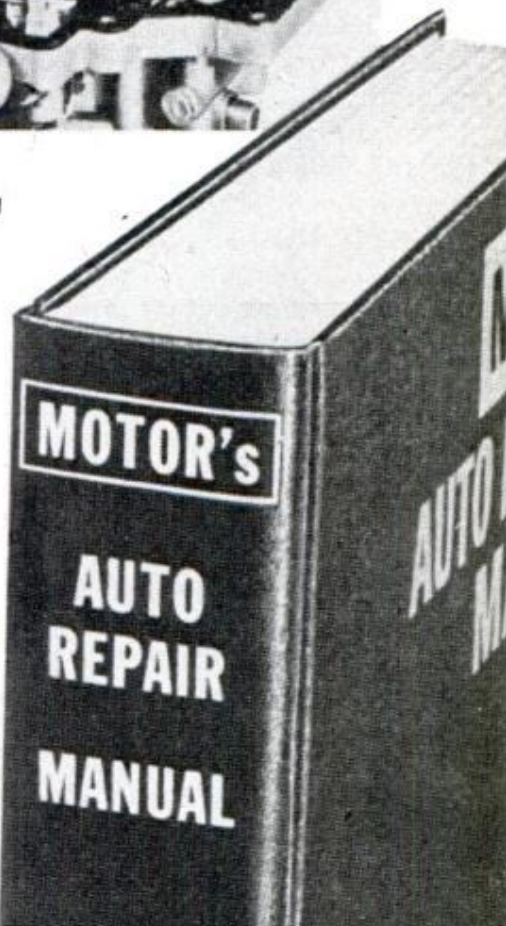

COVERS ALL THESE CARS 1963-1969

Ambassador	Nobel	Fairlane
Volkswagen	Comarc	Lancer
Mustang	Scout	Tempest
Barracuda	Chrysler	Corvette
Jag	Plymouth	Valiant
Chevy II	Rambler	Cougar
Pontiac	Dodge	Toronado
Thunderbird	Oldsmobile	Lincoln
Buick	Ford Bronco	Front Drive
Imperial	Buick	Cadillac
Cadillac	Special	Mark III-AMX
Continental	Comet	Javelin
Dart	Mercury	Montego
Mercury	Corvaire	Torino
Ford	American	
Chevelle	Olds F-85	
Chevrolet	Falcon	

MOTOR BOOK DEPT., Desk 915
250 W. 55th St., New York, N. Y. 10019

Rush to me at once (check appropriate box):
 MOTOR'S NEW COMPLETE 1969 AUTO REPAIR MANUAL. It's mine by paying \$2.00 in 10 days, \$3.00 a month for 2 months, and a final payment of \$1.95 plus delivery charge and sales tax, if any. Otherwise, I will return book postpaid in 10 days.

MOTOR'S NEW REVISED AUTO ENGINES & ELECTRICAL SYSTEMS. It's mine by paying \$8.95 plus delivery charge and sales tax, if any, in 10 days. Otherwise, I will return book postpaid in 10 days.

Print Name.....Age.....

Address.....

City & State..... Zip.....

I WANT TO SAVE DELIVERY CHARGE by enclosing \$9.95 for AUTO MANUAL and/or \$8.95 for AUTO ENGINES, plus sales tax if any. 10-day return-for-refund guaranteed.

ON-THE-GO

CAMPING

BY WADE MITCHELL

MASTER CONTROL PANELS THAT MONITOR ALL COACH COMPONENTS are new and long overdue—and highly desirable for all camping vehicles. One new control panel made by the Elton Corp. is not much larger than a paper plate. It can be mounted where most convenient for the coach owner. Each panel monitors all this information: water-tank level, battery strength, ammeter reading, holding-tank level and polarity indicator and has an a.c./d.c. light indicating which power source is in use, a water-pump indicator light and a battery protector. (Seems like the only thing missing is the LP-gas tank capacity.)

ESCAPE DOORS AND POP-OUT WINDOWS FINALLY APPEAR. Kamp-King Coaches, Streamline Travel Trailers, Coachmen Industries and other manufacturers now install new safety doors or pop-out windows as an option. In the event of fire or accidental upset (by wind or collision) passengers merely kick out the door or window and crawl to safety. A metal coach is extremely difficult to break into—or out of. New safety doors should be a great boon to campers and really be of help in emergency situations.

AIRSTREAM TRAILERS WILL BUILD AND MARKET NEW BRAND COACH. Airstream, perhaps the most widely recognized brand-name trailer in the world, features aluminum skin stretched over airframe construction. (In dollar volume, Airstream is one of the two largest RV producers in the United States.) Now Airstream plans to build a new factory in the Midwest, as rumor has it, where its new “economy brand” with fiberglass and aluminum construction will be launched. For a company basing its reputation on all-riveted aluminum coaches, this is news.

DID YOU KNOW THAT all springs on Ford chassis have been selected by a computer for the last six years? Factors of vehicle weight, tire size, center of gravity and other vital facts are fed into the computer, which “thinks” about the problem and then spits out the correct spring type. The day is fast approaching when virtually all chassis components will be computer-selected. This should make for more rugged and better balanced camping vehicles.

ALASKAN CAMPERS SWITCH TO ALL-FIBERGLASS EXTERIORS. In a surprise move, the famed Alaskan telescoping camper coaches are suddenly appearing in all-fiberglass, sleekly contoured, beautifully finished exteriors. According to a company official, the new fiberglass models, featuring vista-type windows along the roof-edge radius, weigh about 100 pounds less per model and will cost about \$200 more per model, over the old aluminum series.

SPECIAL TRAIL-BIKE COMPARTMENT OFFERED IN NEW TRAILER. The continued popularity of trail bikes has led one company to provide a rectangular storage compartment at the right rear of the trailer coach, with ramp, for trail-bike or mini-bike storage. The popularity of these off-the-trail bikes is spreading like wildfire.

WATCH OUT FOR SOFT, SQUEAKY FLOORS! At the largest recreational vehicle show this spring, I inspected many new, beautifully designed coach models that appeared to be of high quality, with one notable exception: *The floors squeaked.* Whenever a coach floor feels spongy underfoot, or whenever it squeaks and groans as passengers walk across it, you can immediately suspect insufficient bracing and low-cost construction.

★★★

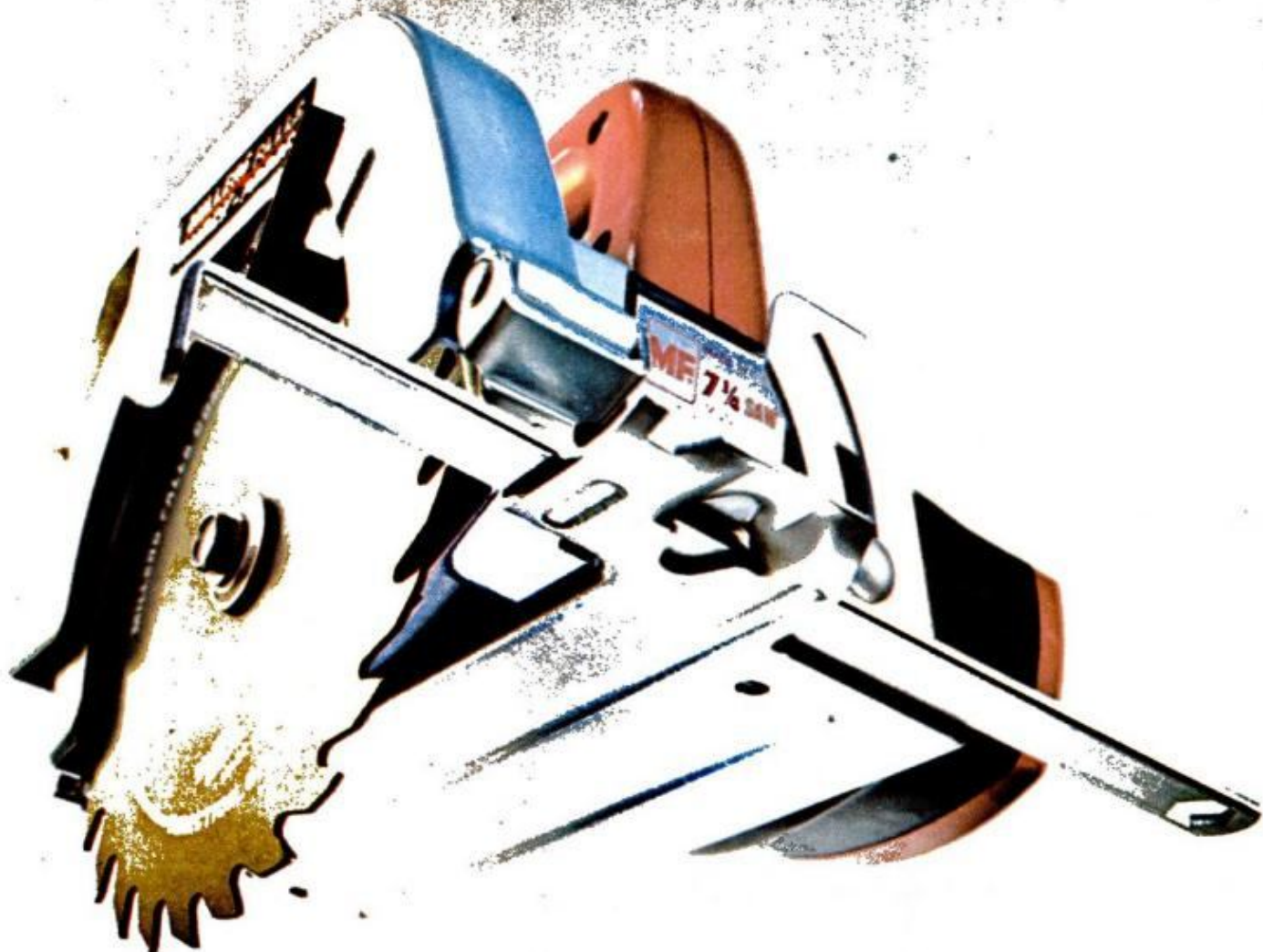

JACK THE RIPPER

The jack? \$39.88... that's all.

This is the one they thought we'd never make.

A high quality circular saw at a hot low price.

Here's what you get: Famous Millers Falls Shock-Proof safety. The kind of safety that does away with the nuisance of grounding wires, 3-prong plugs and clumsy adapters.

An unbreakable handle. A stall proof motor that just can't burn out.

New design features that make changing blades easier than you thought possible.

A sawdust chute to clear chips instantly, a depth adjustor and angle tilting.

The strongest guarantee in the game.

That's a lot of ripper for a little jack.

(The cost of embarrassment to our "giant" competitors is considerably higher.)

Millers Falls Greenfield, Mass.

The safest name in tools

It Separates The Ranchers From The Cowboys

New from International is a fancy 4x4 that'll make 'em flip on Saturday night in San Jose—and dust 'em on back-country trails.

By JIM LISTON, Executive Editor

“A VEHICLE for four-wheel-drive competition and other rugged outdoor driving assignments where power and performance are required,” is the way International pegs its new line of 4x4 Scout “recreational vehicles.”

“Scout's honor?” we asked. “Then what's this cute confection that looks like a custom job for the Bahamian police?”

At International's Fort Wayne plant, I was eyeing a Scout topped with a chrome luggage rack with bars that extended down the rear to the tailgate.

“That's a deluxe Scout we'll call the Aristocrat. Goes into limited production in April; we'll make only 2500. This is



the hand-made prototype, the only one we have. But, please, you wouldn't . . .”

“I would. Which way to the test track?”

The Aristocrat is a Scout 800A and as such can be powered with the new 304-cu.-in. V8 that develops 193 hp, or with a new Six or a Four. There's a new three-speed automatic (called the T-39) that can be shifted automatically or manually.

Unlike other Scouts, the Aristocrat will be available only with all-wheel drive. The package that makes it aristocratic includes: dark blue metallic hood and top with silver metallic body; travel top with sliding windows; chrome bumpers; chrome luggage rack with “grab bars” to the lift gate; low-profile, glass-belted tires on 7x15-inch chrome rims (for the mag wheel look); color-matched head liner, seats, carpeting, wheelwell seat pads and armrests; and dual outside rear-views.

This was just a preview of a prototype (equipped with a three-speed stick shift) so I scared but spared the engineers, who needed their baby for further work, by taking an easy spin. In second she climbed to 45 at 4000 rpm without a whimper. In the big gear she jumped from 50 to 70 to prove she could pass. In panic stops her 4200 pounds braked with authority.

Wide ovals make the Aristocrat a smooth-riding road vehicle, but how about back-trail mud? A turn to the right locks the front hubs for all-wheel drive. Then set the single-lever control on the transfer box and do the usual with your automatic or stick shift. Traveling on all four, the Aristocrat sloshed out of water-filled ditches that would be better taken with cleats or knobbies. But the 4x4 off-road capability was there—reassuring when you're towing a trailer.

The Aristocrat will separate the well-heeled rancher from the cowhand—at about \$3800 for the 4-cylinder stick shift. He can fringe his survey to \$5000. ★★ ★

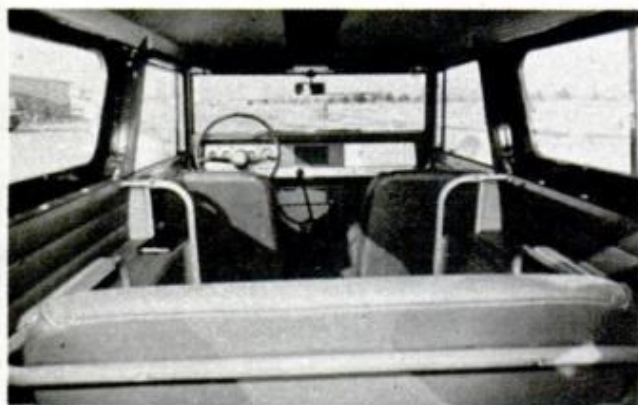

INSIDE AND OUTSIDE of International's Aristocrat



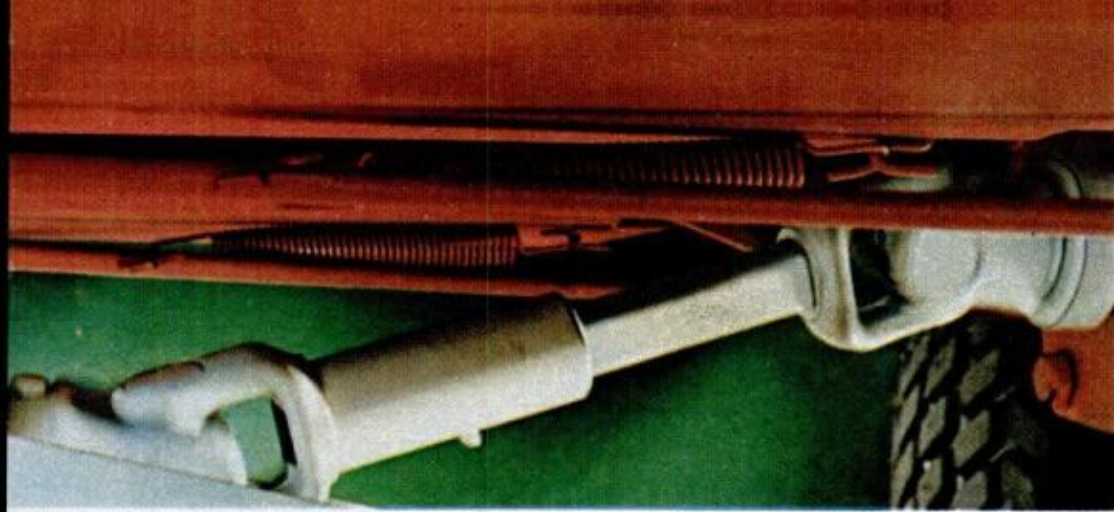

The reliability of unique all-gear drive—no belts to slip, break or adjust



Rear-mounted engine traction



The choice of front or center-mounted mowers



The feel of quality performance

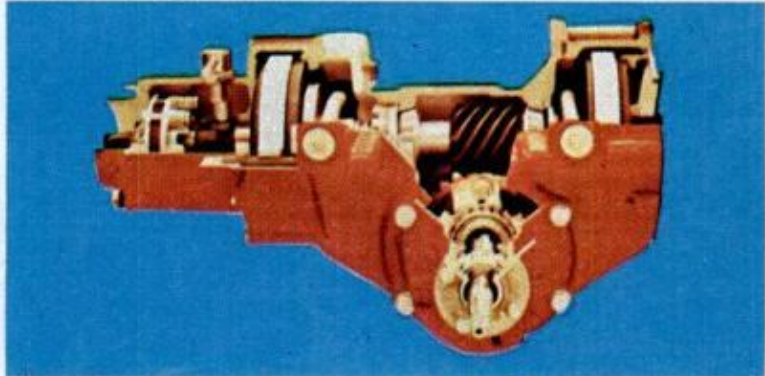

The traditional ruggedness of Gravelly all-gear transmission . . . with a choice of 10, 12 or 14 horsepower engines—instant forward and reverse



The variety of quick-change attachments

PERFORMANCE IS WHAT YOU BUY!

. . . and features like these enable Gravelly to outperform any other compact tractor on the market. At Gravelly, mechanical excellence is a tradition and leadership a serious responsibility. Ask any owner why he bought Gravelly—we'll stake our reputation on his answer. Then see your Gravelly dealer. For free, full color catalog, write Gravelly, 5705 Gravelly Lane, Clemmons, North Carolina 27012.



GRAVELLY
CORPORATION

A SUBSIDIARY OF
STANLEY-BRADCO WORKS CORPORATION, INC.

Материал, защищенный авторским правом

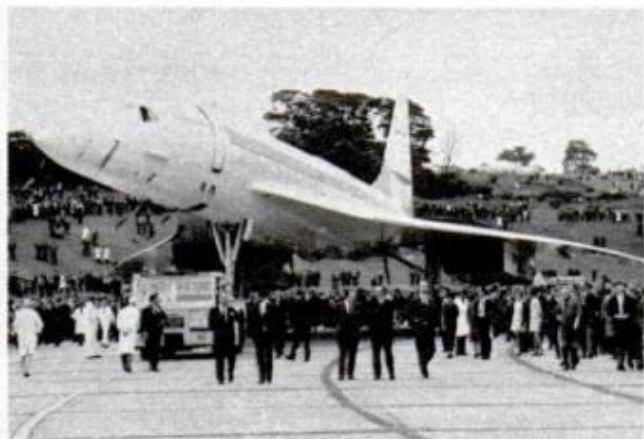

Britain's Concorde

Shown at its roll-out at Bristol is Britain's Concorde, sister of the French-built supersonic transport that flew for the first time early this year. (See *You, Too, Can Break the Sound Barrier*, page 111, March '68 PM.) Russia's SST flew on Dec. 31.

Look out below!

Spectacular air-to-air photo (left) shows British naval aircraft in a simulated attack. Planes, from Squadrons 809 and 892, are Sea Vixens (twin boom) and Buccaneer WKII.

GREER TECHNICAL INSTITUTE, INC.

OFFERS TRADES THAT PAY



Become Successful as Thousands of Others!

- DIESEL TRUCK DRIVER*
- WELDING: GAS, ARC, HELIARC*
- AUTOMOTIVE SPECIALISTS*
- BODY AND FENDER
- MACHINIST—TOOL AND DIE
- DIESEL SPECIALIST*
- REFRIGERATION - AIR CONDITIONING*
- HEAVY EQUIPMENT OPERATOR OR MECHANIC*
- 2 YEAR AUTOMOTIVE & DIESEL TECHNOLOGY



Founded 1908

*Courses also Available in Home Pre Training
VETERAN APPROVED

**2233 SO. MICHIGAN AVENUE
CHICAGO, ILLINOIS 60616**

GREER TECHNICAL INSTITUTE, INC. PRE TRAINING
2233 SO. MICHIGAN AVENUE RESIDENTIAL
CHICAGO, ILLINOIS 60616 VETERAN

Gentlemen: Please send more information about above trades.

COURSE _____ AGE _____

NAME _____

ADDRESS _____

CITY _____ STATE _____ P569M



NEW PREVAL*

SPRAYMAKER

*SPRAYS ANY COLOR,
ANY FINISH!*

With this disposable power sprayer you can spray paint, varnish, stain, lacquer—custom-mixed or right-off-the-shelf. Use the same paint you use with brush or roller. No mess, no bother. It even sprays itself clean! Then fill with lubricant or rust-protecter and protect tools and equipment. Sprays any household liquid. Better buy several. You'll find dozens of uses for them. Available at paint, hardware and hobby counters—wherever quality do-it-yourself products are sold.

ONLY \$149

Complete Suggested retail price

One Power Unit Sprays up to 16 oz.
Extra Power Units available

*Reg. Trademark of Precision Valve Corp., Yonkers, N.Y.

With the World Championship at stake, Graham Hill wasn't about to take chances on his spark plugs.

He used Autolite plugs. Like you buy.



This Ford-powered Lotus is the 1968 World Champion of Formula I Grand Prix racing.

It had to beat names like Ferrari, BRM, and Honda.

Never did spark plugs have to perform in a more competitive situation. What kind were they? They were Autolite plugs. Like the ones you can buy for your car.

Autolite spark plugs can stand up to the pressure of competition. They have a special zero leakage design that will prevent compression loss

under all operating conditions.

Why Autolite plugs in a World Championship car? Because there are no finer. Use them in your car. They're built to go the distance.

Autolite 



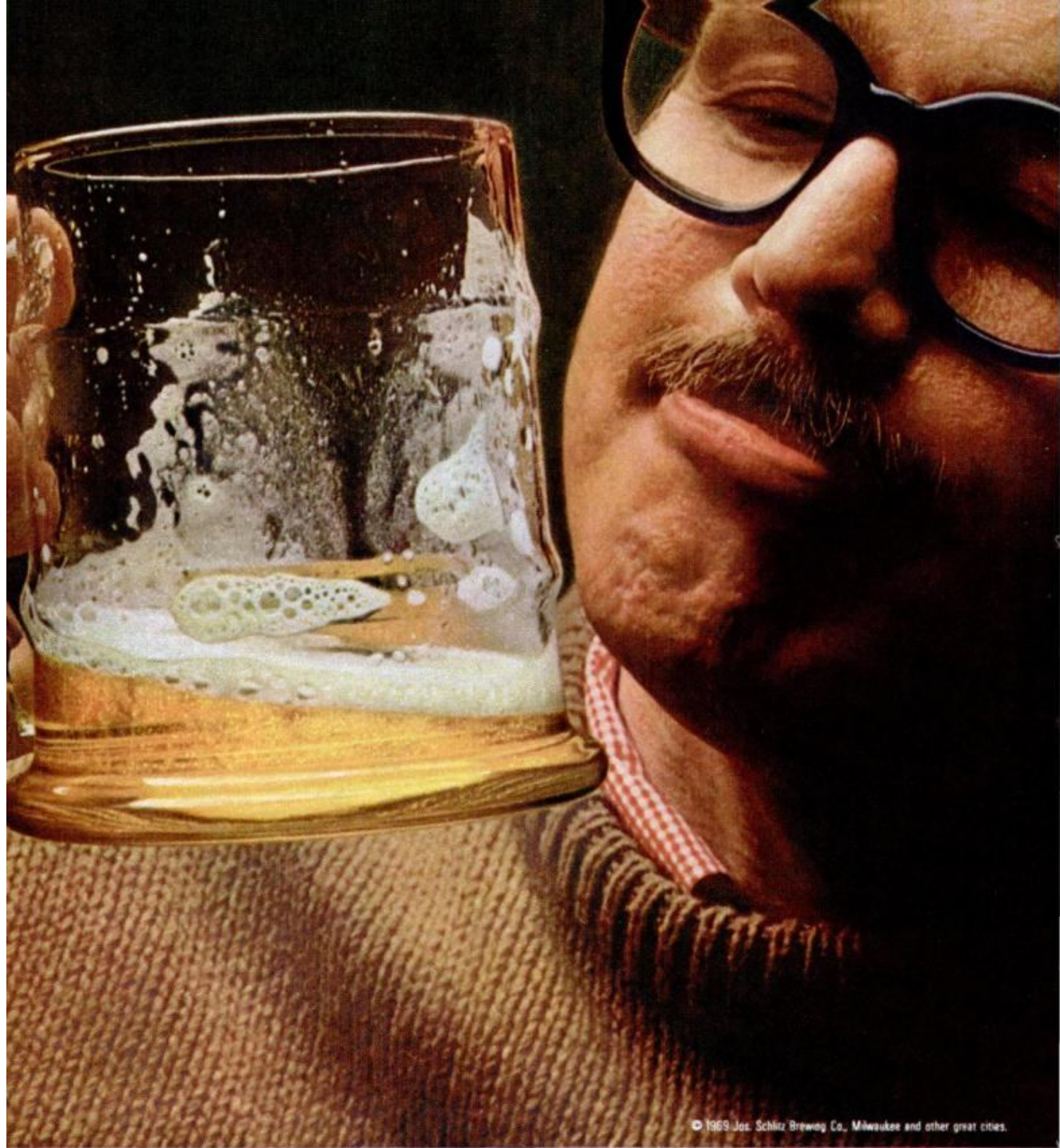

© 1969 Jos. Schlitz Brewing Co., Milwaukee and other great cities.

Taste the golden age of Schlitz

120 years ago, it took Joseph Schlitz months to brew and age his golden mellow beer. It still takes us months. The golden age is what makes Schlitz America's choicest premium beer.



“When you're out of Schlitz, you're out of beer.”

Материал, защищенный авторским правом

How You Look to a Truck Driver

By E. D. FALES JR.

Photos by Paul Lemmons

He's a pro. Too often, you look to him like you're not taking your driving as seriously as he does his

THE TRUCK CAME UP FAST behind the car; the car didn't yield; the truck pushed closer; then the car slowed down. When I passed and last saw the two they were still jousting—at 65 mph and on an unlighted highway in the black of night.

I had just witnessed a dangerous situation because the driver of the car was probably dreaming, wasn't aware of traffic conditions *behind* him, didn't see the truck until it was already tailgating and then got sore because it was. He probably slowed down for spite and muttered something like, "Damn trucks'll run you off the road if you don't fight back." I wondered about the truck driver; what was he muttering?

To find out, I hopped a ride on a big over-the-roader, one of the Carolina Line's, on the busy "Florida Run." Carolina Line, based in Cherryville, N. C., is one of the world's best-run truck lines. It handles freight from 30 states from Oregon to Maine. After the freight funnels into Cherryville, the Florida Run takes it. Of the 700 drivers with Carolina, 104 work the "Run." They're sharp and clean, and they know things about your driving that you might not know yourself.

The "Run" starts at "Dispatch Central" where phones jangle and administrative types lean over charts pinpointing the location of



STEP ON IT if you're passing. Get through turbulence quickly, but don't let truck behind (from which picture was shot) scare you into lane too fast



LAY BACK FARTHER on exit ramp even though you're where you belong: If truck decides to make last-minute exit he won't see you; you're in his blind spot



some 2000 of Carolina's rigs. The double-header run of two White twin-screws with 250-hp Cummins diesels that I am to ride gets clearance for Jacksonville, 400 miles south, and I head out in the predawn darkness to where the tractors are warming.

There are six of us in all: two drivers; two copilots; photographer Paul Lemmons, and this reporter. We swing up into the two sleeper cabs. I ride in No. 1914, the lead, with driver Yates Webb and copilot Hillard Wise. We're towing a 45-foot box full of Vermont gravestones and assorted tools. Right behind us throbs No. 1916 with a rag-top trailer and, I suppose, more gravestones.

Webb beeps the horn and bangs the lever into low. No. 1914 bucks, takes hold, creeps. And right off I get lesson No. 1. Just as we start out the gate we see headlights coming slow on NC 150. When the driver sees us he suddenly remembers that he's in a hurry and speeds up just enough to block us. We come to a shuddering halt. Webb has to get started all over again.

"Now watch," says Webb. The guy who was in such a hurry to beat us goes two blocks and turns down a side street.

"They'll do it every time," Webb grins. "On the trucks we've got a saying: The guy who's in an awful hurry isn't going very

YOU'RE GETTING PUSHED probably for good reason. Don't dawdle, else pull over to let truck pass. Downhill, truck has to build up speed for the next hill

Too close —
Increase
distance

Safe distance —
Keep up
your speed

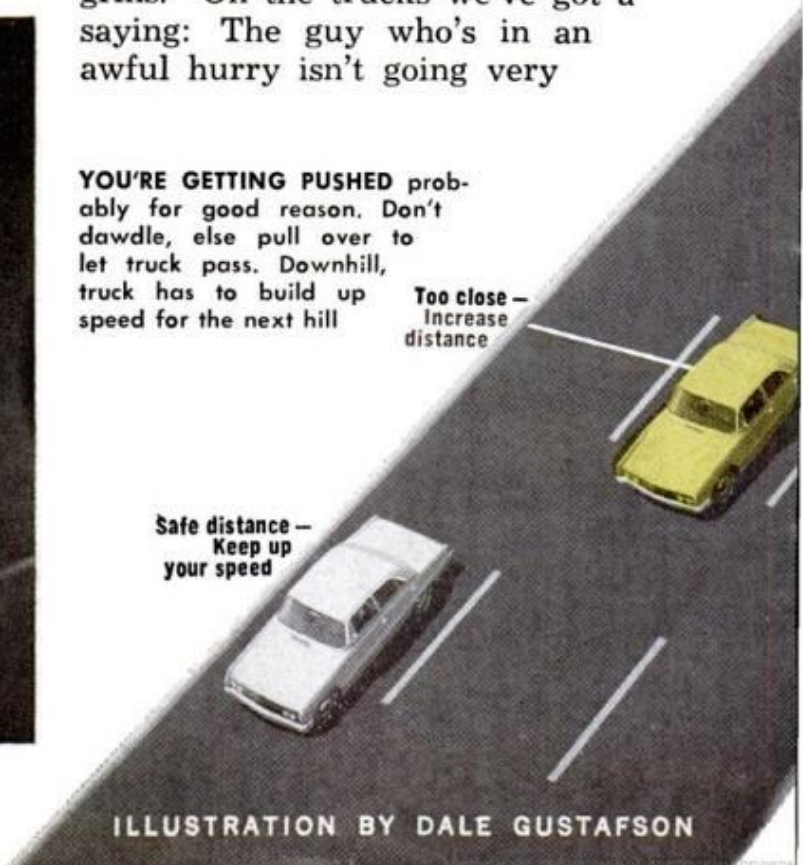

ILLUSTRATION BY DALE GUSTAFSON

far. You'll see." Webb, a big, quiet man, looks like an airline pilot in his gray uniform. "It helps," he says. "Other people respect a uniform."

He works this big twin-screw ship (four of its six are driving wheels) up through five gears, 1 to 5. In my big side mirror I see No. 1916, with drivers Crosson Padgett and Jim Davidson, right behind us. Clear of town, Webb lifts the lever to high. Now he works the same five gears. "However, this

Trucker may not see you here

Wind-buffeting again — Bad spot

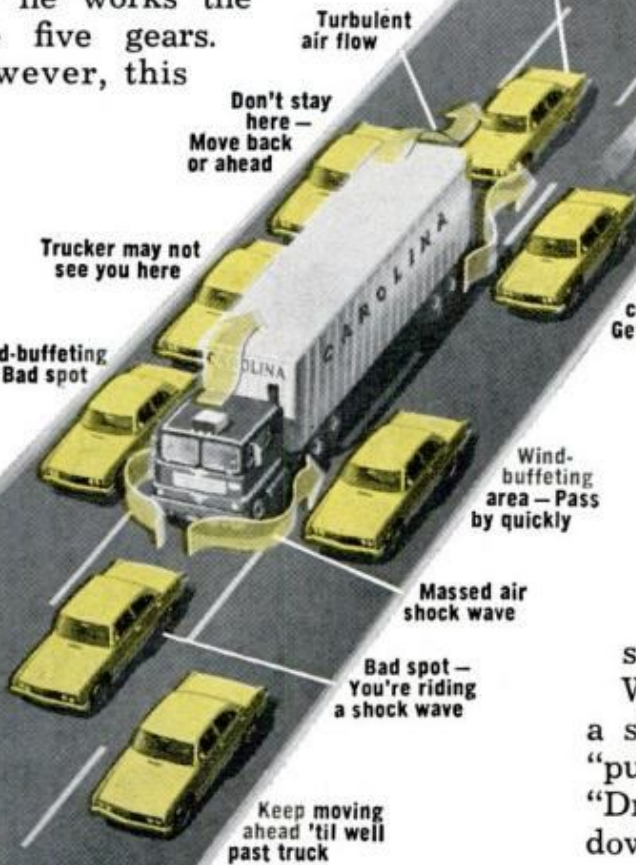

Don't stay here — Move back or ahead

Turbulent air flow

Poison — don't tailgate

Okay here — Stay 300 feet back

Too close — Move right or left

Flick lights — Get trucker's eye — He can't hear your horn

You're committed — Get on with it

Wind-buffeting area — Pass by quickly

Massed air shock wave

Bad spot — You're riding a shock wave

Keep moving ahead 'til well past truck

LOOK OUT if you find yourself in one of the positions around a truck as indicated in color on drawing at left. Callouts on the ten positions indicate potential danger for each

front of everybody at slow hilltop speed he stops and waits. A dozen grateful drivers clear.

"I've never seen a truck do that," I say. "Do you do it often?"

"About once every trip. People sure appreciate it."

We go charging downgrade—toward a slow car ahead. Webb, who rarely "pushes" a driver, has to brake down. "Drivers don't like it when we come downhill fast, then go up slow," he says. "I don't blame them, but we can't help it sometimes. A heavy truck needs momentum or it'll go up the next grade at 15 mph and block everybody. When you can, always pick up speed on a hill if you see a truck trying to make the grade. You help everybody."

"Sure," I say, "that's fine. But what about the trucks that push you on the Interstates, because they want to go faster than traffic goes?"

Webb goes to 10th. Speed 50. "Let me tell you something," he says. "We're no different from you. Car drivers have trouble with other car drivers. We have trouble with some truck drivers, too."

He explains: "We figure there are four kinds of truck drivers: line driv-

time," he says, "they're running 6-7-8-9-10." It's slow work but now we are doing 45 in 9th. "We're pulling 35 shipments," he says. "Truck's total weight: 68,900."

About 8:00 a.m. we encounter our first hill. The Cummins yammers. Downshift to 7, speed 32. We're holding up a line. Webb takes a creeper lane. But when we get to the end there's still quite a line of cars coming. Rather than pull out in



DOUBLE MIRROR ARRANGEMENT on right side of Carolina Line tractor minimizes blind spots—standard and convex mirrors give close, distant vision



PASSING ON THE RIGHT can get you into big trouble in any case, and especially if you pull back into center lane when fast truck on left starts same move

ers who are well-trained and proud of their records; nonline drivers, some good, some poor; gypsies, who sometimes don't know much about driving, and often run with poor rigs; and, worst of all, goofballs. The goofball is the guy who is trying to stay awake with a stomach full of pills. Sometimes he actually doesn't know where he is. Any guy who deliberately bugs you on an Interstate is apt to be on pills. A goofball is worse than a drunk. Stay away from him."

Every word Webb is saying he's shouting. I shout back. Already I'm hoarse. I'm learning something else: A truck cab is a noisy place.

By 9:00 a.m. we're southbound on fast I-26 in South Carolina. Copilot Hillard Wise sits in the middle. I'm in the right seat. In all the noise I hear a faint sound at my elbow. I look out. A guy is passing on the right whacking his horn. "There's a car down there," I say. "Can you hear him?" "I've been watching him," Webb says.

People think truck drivers can hear horns. Some can, some can't. When passing a truck never rely on your horn. "If you want to be sure a truck knows you're there give him a light flash, and watch his eyes in the mirror."

"Stay away from the right door," Webb shouts. "I can see cars down

there because we use 'diminishing mirror.' But many trucks don't have those." The little round convex mirror brings in close cars the big mirrors can't see.

A good trucker, Webb tells me, has great respect for motorists who vary their speed for conditions. "It's the one-speed driver who causes trouble for us," he says. We shortcut on a small road that doesn't even show on my map. Everybody ahead takes a hill fast—all except a gray Buick. He's dreaming along at 38. For the next half mile we creep: 4th gear. We lose minutes. "He doesn't realize what he's doing to us," Webb says.

We're on a narrow, old road, but a busy one. "How much clearance between your side and the stripe?" I ask. "One foot," Webb says. I glance in the mirror. My wheels are running close to the farm mail boxes, on the edge-stripe itself. It takes a heap of aiming to send these 34 tons down a chute like this between ditch and traffic. Crossroads ahead.

Suddenly our air hisses. Brakes take, release and take. I hump forward. A Mustang lurches out behind a country store and stops with bumper right on the edge stripe. "Damn!" It's the only time I heard Webb lose his cool. He misses the Mustang neatly. "Why do

guys do things like that?" he demands. "Just suppose his brakes hadn't held?"

What monumental skill it takes, I reflect, to run a ship like this day after day with mistakes all around! Webb has never had a crash in 15 years with Carolina.

About noon, Webb mentions the guy tailing us. He moves in tight behind the box and disappears from both mirrors. "That's a bad place to be," Webb says. "The suction back there is so great that a car is unstable. In fact, slow trucks sometimes move in close to hitch 'an air ride' behind more powerful trucks. It actually pulls them along.

"But even worse, you may get clobbered in the side by a guy waiting at a crossroad—like the Mustang we passed. When the truck goes by he shoots out—doesn't see the tailgater—and hits him.

There's a third danger. The truck may suddenly change lanes to miss an object in the road. Then the tailgater finds himself unable to escape to either lane, and he hits the obstruction.

Then a funny thing happens. Nervous Nellie old Merc pulls alongside and stays there for a couple of miles. Suddenly a fast Chevy belts up behind, gets on his tail and scares him out of the way. The Merc jumps like a rabbit, then pulls right in front of our bumper.

"Please, mister!" Webb pleads as if the other guy could hear him. He feathers his brakes. But it isn't a mister. As she pulls ahead we see a little old lady.

"Old folks—young guys, too—do that all the time," Webb says. "Other drivers push them into trouble. If you see a timid driver trying to pass a truck, never rush up and scare him. It isn't fair." Big trucks shove a bow wave of air. On windy days this can be quite violent. A car too close in front rides this air and is in danger. Alongside the cab the wind shoves back powerfully.

"Stay away from the saddle tanks," Webb explains. "A side wave also pulls inward behind the saddle tanks. Cars sometimes get nudged off narrow roads by the bow wave or sucked in against a truck by the side wave. When you get

to the saddle tanks, keep coming strong. Don't lay there for miles, like some do. That's where the inflow is worst."

Our two trucks go glittering toward Georgia. "Poorest driver we see," Webb says, "is the in-and-outer. He's always an amateur. We know because we see him make other mistakes, too. A good driver is steady. Next, there's the blind passer. Half the time he doesn't realize the danger. Up here we can see cars coming around blind curves and over blind hills long before he sees them."

The "good guys" in a truck driver's book, he says, are those who:

- Give an "all-clear" flash of light when the truck driver is trying to pull in ahead.
- Slow down to help him pull in from a tight spot.
- Tuck their tails in quickly when they turn off the highway. Poor drivers

'If you see a timid driver trying to pass a truck, never rush up and scare him. It isn't fair.'

make slow, lazy turns; risk getting hit.

- Adjust speed to help the truck take hills.
- Take time to say "thanks" when helped—as when a truck takes the shoulder on a slow hill. To thank a truck, Webb says, flash your rear lights, or give your turn signals a right-left-right sequence. If he can see you, wave.

I leave Webb and Hillard Wise for a while and switch back to No. 1916 with Padgett and Davidson. Davidson is driving when a fast tanker whirls toward us. Its driver grins and whirls his fist in a fast windup. Davidson grins back. "That's a 'Go!' signal. He's saying the road is clear, no wrecks, no cops."

Davidson leans forward, doubles his right fist, smacks it hard into his left palm between windshield and wheel. "If a trucker gives you *that* sign, "look out," he says. "It means 'wreck ahead!'"

Oncoming lights now bug us. Truck

(Please turn to page 206)

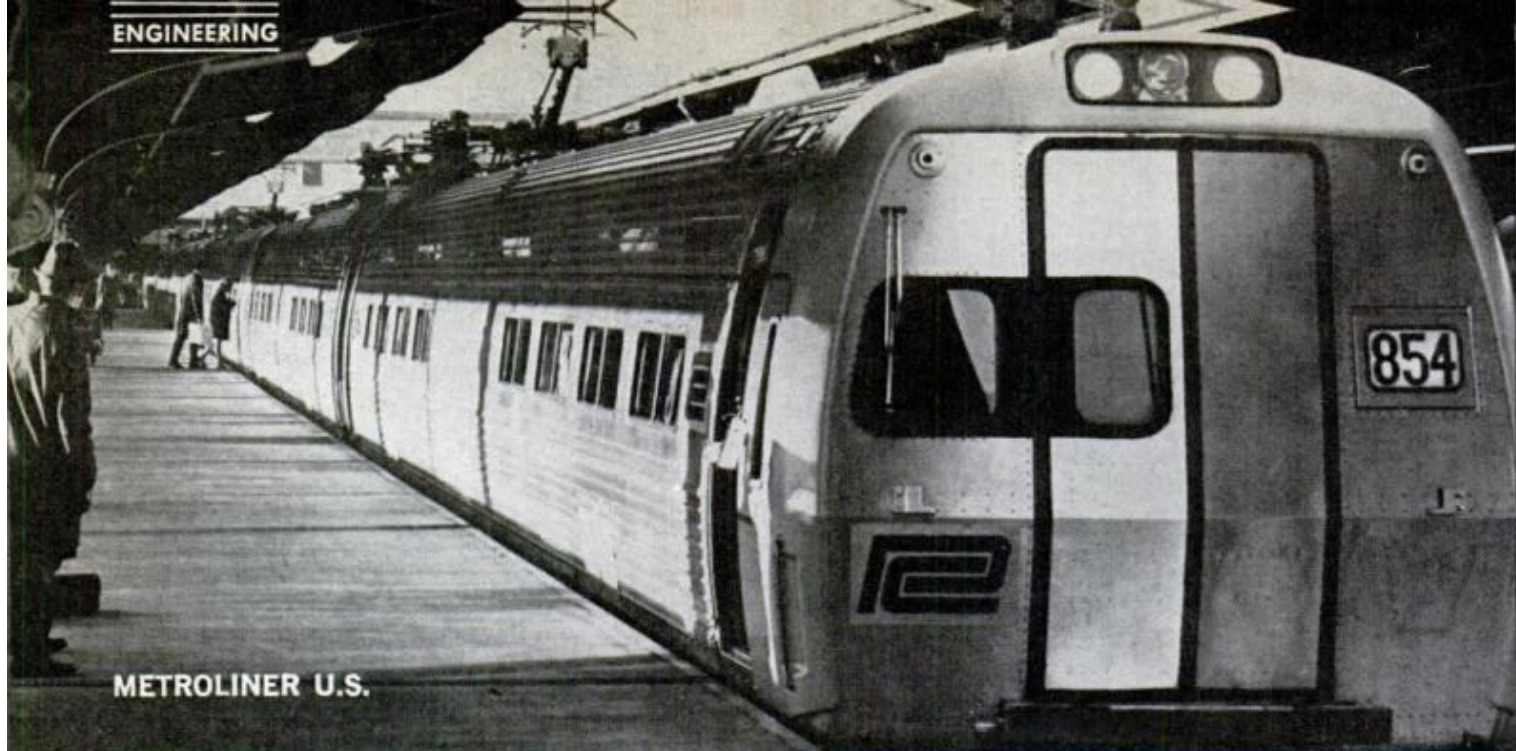

METROLINER U.S.

NEW YORK TIMES PHOTO

Those Fast, New Trains in U.S. and Canada

By ROBERT P. CROSSLEY, Editor

THE BULLET-NOSED YELLOW Streamliner streaked down the long, straight track. When it pulled into Omaha it had averaged 84.45 mph on its 507-mile run from Cheyenne.

The flat-ended shiny Metroliner pulled into New York's Penn Station. It had just averaged 75 mph on its 226-mile trip from Washington.

The former was in October, 1934. The latter was in January, 1969.

That's progress?

A month before the Metroliner's

debut, a self-propelled TurboTrain, starting daily runs between Montreal and Toronto, had done a little better. It averaged 84 mph for 325 miles—when on time. But it was late so often that the Canadian National withdrew it from service to work the bugs out of it.

I rode on the inaugural run of both new trains. I wanted to compare them with Japan's phenomenally successful New Tokaido Line, on which I had traveled a little more than a year ago (see *The Train That Gives the Jets*

COMPARISON OF HIGH-SPEED TRAINS

	<u>Metroliner U.S.</u>	<u>TurboTrain Canada</u>	<u>NTL Japan</u>
Top Speed in Trials	160	170	160
Top Speed on Run	110	95	132
Average Speed on Run	75	84	102
(Including Stops)			
Distance of Run	226 miles	335 miles	320 miles
Time of Run	2 hrs. 59 min.	3 hrs. 59 min.	3 hrs. 10 min.
Power Source	Overhead electric	Turbines	Overhead electric
Motors	24	4 ST6 gas turbines	48
Power Output	15,360 hp (640 per axle)	1600 hp (4 x 400)	8880 KW (185 per axle)
Controls	Manual with speed con- trol set by engineer	Manual by engineer (dual)	Automatic braking and speed control
Number of Trains per Day (one-way)	2	2	66
Number of Cars per Train	6	7	12
Capacity of Train	308	300	1000



**TURBOTRAIN
CANADA**

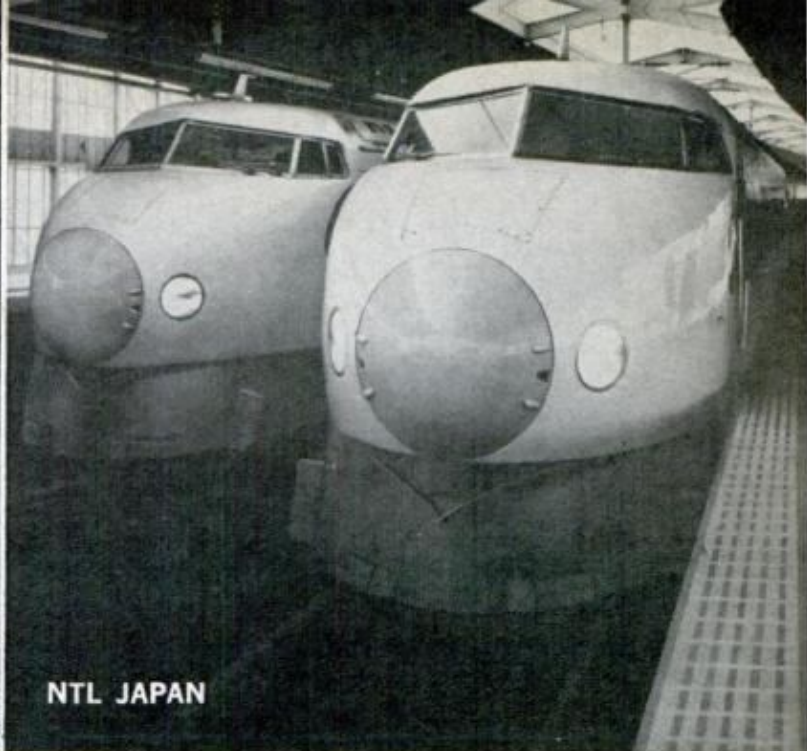

NTL JAPAN

BRUCE MOSS PHOTO

...They'd Never Make it in Japan!

the Jitters, page 94, April '68 PM).

A newspaper story described the Metroliner as "almost as fast as the NTL," and a University of Pennsylvania professor described it "as much the same."

Now I'll tell one.

The NTL, with 66 12-car trains a day in each direction and its 102-mph average over the 320-mile Tokyo-Osaka route, is the pride of Japan.

I can't see either the Metroliner or the Turbo, when a three-car version

finally starts running as a shuttle between New York and Boston, ever becoming the pride of the U.S.A.

True, we have other things to be proud of—Apollo spacecraft, for example, and tremendous airplanes like the C5-A. But even Robert A. Nelson, director of the Transportation Department's Office of High-Speed Ground Transportation, admits the Metro is "not high-speed transportation."

Despite all the brave talk by the Penn

(Please turn to page 205)

PRETTY STEWARDESS serves lunch airline-style in "Turboclub." Seconds later, wine bottle tipped over



UNLIKE JAPANESE TRAIN, Turbo is controlled entirely by engineer. You can watch track over his shoulder





Garage goes to customers

All it takes is a phone call to the dispatcher (upper left), and a completely equipped garage-on-wheels comes to your home or company parking lot to service your car . . . that is, if you live around Guilford, England. The inside of the mobile garage (left) is loaded with equipment, including electronic gear, so the mechanic can do everything from tuneup to oil change to wheel alignment (above).



New underwater team

A pair of deep-diving Navy research subs, the *Sea Cliff* (left) and the *Turtle* were launched simultaneously by the Electric Boat Div. of General Dynamics. The 21-ton submarines can dive more than a mile deep.



Chariot for beginners

The Colliday Chariot, designed by Briton R. G. Collier as a commuter and shopper car, can be driven by a novice. Controls consist of a starter switch, steering wheel and two pedals marked "stop" and "go."

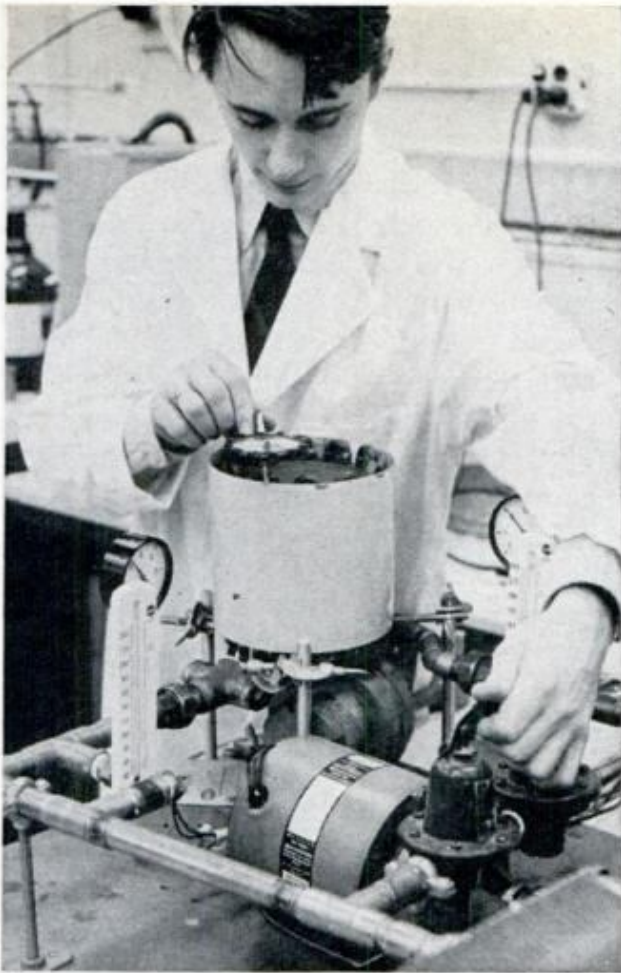

This is a home furnace?

Not much bigger than a two-pound coffee can, this experimental furnace is so efficient it can heat a nine-room house while fitting in a kitchen cupboard. Developed by Raytheon, the bantam boiler burns gas at a super-high combustion rate to heat circulating water.

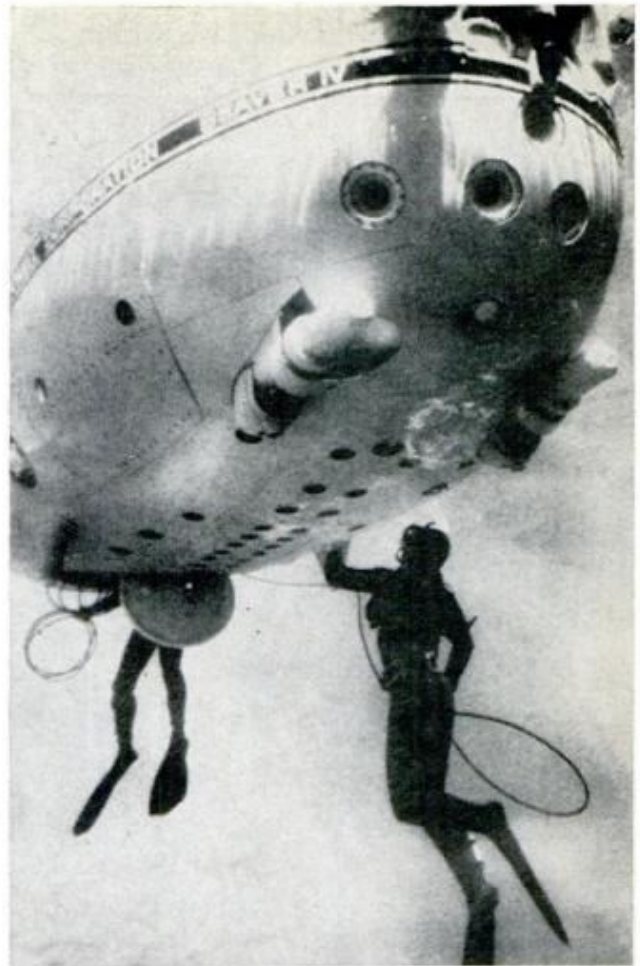

Testing an underwater door

Slithering out a small hydraulic hatch, North American Rockwell divers make the first actual undersea test of the lockout system on the Navy's deep research submarine *Beaver*. The system will let divers leave and re-enter the sub in future deep-ocean experiments.



130 mph—on two wheels

Hottest motorcycle import from England is this BSA Rocket 3, said to hit 100 mph in 14 seconds. The three-cylinder bike has a top speed of 130 mph, will sell here for \$1700.

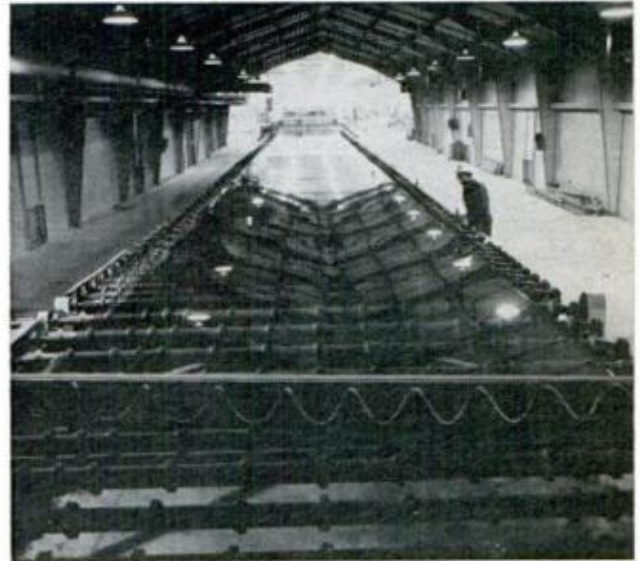

World's longest 'window'

A continuous ribbon of glass rolls through a new half-mile-long PPG float-glass plant near Meadville, Pa. The glass is floated on molten tin to make it supersmooth.

PM OWNERS REPORT
BUICK LE SABRE

A Nationwide Survey Based on
1,150,000 Owner-Driven Miles

Heavenly Ride, but the Devil to Pay For Fuel!

By **BILL HARTFORD**
Technical Auto Editor

Photos by Irving Dolin

PUMPING A GALLON of premium petrol through a 350-cu.-in. V8 every 12 miles to push two tons of Buick Le Sabre around town doesn't seem too unreasonable, but owners seem reluctant to accept the price of big car luxury and comfort.

"Poor gas mileage" is the major complaint of a North Carolina real estate salesman, who nevertheless finds "riding comfort" the best attribute of his Le Sabre. For even more comfort and steady ride, presumably, he says, "I hope to go to the Wildcat; it's just a little heavier." What'll he say about fuel mileage then? Now, he gets 10 and 15 mpg from his four-barrel carburetion for local and distance driving, respectively.

An owner in Ohio, a public school science department head, dislikes getting 11 and 12.5 mpg. He, too,





likes "comfort of ride" best, and he, too, "wanted a heavy car."

The Le Sabre weighs in at about 4200 pounds, and in one objective test that might serve as a yardstick of fuel economy, averaged 16.162 mpg. That's the result obtained by the recent Union/Pure Oil Performance Trials (*What Price Power?*, page 120, April PM). The Le Sabre ran in Class III, medium eight-cylinder, two-door sedan or hardtop. Winner in this class, running with a 318-cu.-incher, averaged 18.589 mpg; economy of Le Sabre, packing a 350, was about the same as more similarly powered competitors.

This won't make owners any happier about fuel economy. Nor will it affect their aspirations for a still larger, more luxurious car: A North Carolina salesman wants "a bigger, longer, more expensive looking car." Several owners indicated that the Electra was the car they really wanted, and the one they hoped to swing next time around. The Electra, incidentally, ran in Class I at the Performance Trials and got 14.737 mpg. How's that, folks?

One joy of owning a Buick that lightens the financial burden of operation is that, as an Iowa farm machinery zone manager says, it's "troublefree." It "doesn't dollar me to death," he adds. A retired Illinois man also likes his car's reliability: "Freedom from repairs," he says, "keeps me away from service stations." Indeed, when questioned on mechanical troubles, 71 percent say they've had none—quite a respectable figure considering that 50-50

HANDSOME AND CLEAN as the car is, owners say first consideration in buying was past experience



SMOOTH RIDE AND COMFORT were high on owners' list of likes. Some found that lowered head restraint rubs spinal column; many still find it hard to accept

LE SABRE FUEL MILEAGE CHART

350-cu.-in. V8

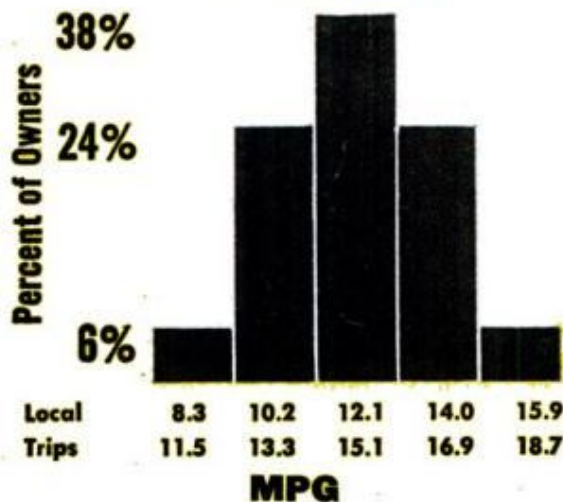

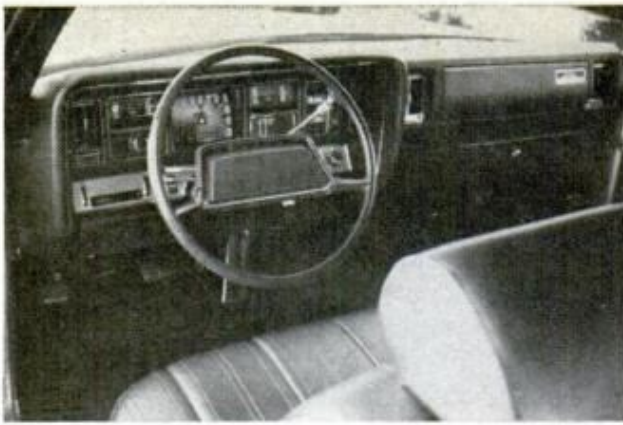

CONTROLS ARE CONVENIENT, but ashtray isn't; design of steering wheel confuses its upright position



GLOVE BOX is big enough for one pair of gloves; that's about all, say owners who want bigger one



REAR VISIBILITY was one of owners' biggest complaints. It goes for all models, not just the convert

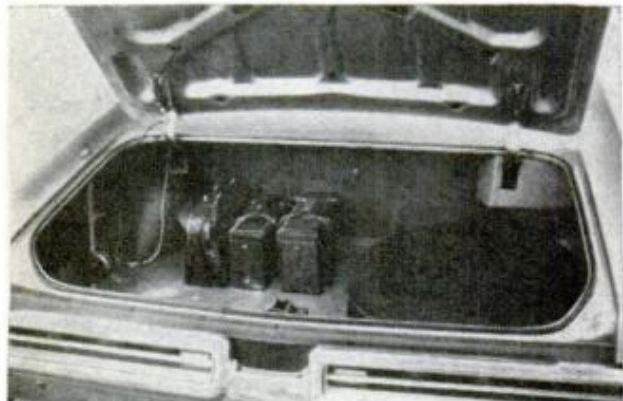

TRUNK SPACE is ample for most, but not for few who think it's too small for car of Le Sabre's size

is roughly the yes-no figure we're used to seeing.

If owners are happy about reliability, they're overjoyed about what for them is the Big Three—handling, ride and comfort. A Minnesota farmer gets carried away: "I think it's the most comfortable riding, steering, handling of any car on the road; there's absolutely no road noise." "Quietest car I've owned," confides a New Hampshire maintenance supervisor.

An industrial electrician from Ohio also likes ride and handling and the "solid feel" of his Le Sabre, but does, however, complain about "road and wind noise." Wind noise, specifically, was disturbing to other owners; to as many, in fact, as found fuel economy their biggest bugaboo. "Wind noise around the doors," complains a North Carolina stock broker (who bought a Le Sabre because "the dealer donated \$1000 to the golf tournament which is held at my club"). For other owners, part of the wind-noise problem is due to leaks around the ventless side glass.

"Give us back vent windows!" yells a 1000-mile-a-week Illinois salesman, and "Put the wing windows back in," echoes a Minnesota teacher.

A change in design to include vent windows was mentioned often—second only to the call for improved rear visibility. Across the board (28 percent, two-door coupes; 30.6 percent, four-door hardtops; 40.4 percent, four-door sedans), owners found Le Sabre models difficult to park and maneuver from



RUBBER BUMPER INSERTS are universally liked. "It's about time," says one bumper-denting owner

POPULAR MECHANICS



HANDLING AND RIDE mean smoothness and ease of control to most owners; roll in corners isn't disturbing

lack of rear visibility. "Can't see rear fenders when backing," says an Illinois engineering consultant.

Aside from a few traumatic experiences like that related by a Minnesota salesman ("an apparent short in the wiring; car caught fire and dash burned out before fire department arrived"), Le Sabre owners' miscellaneous criticisms—good and bad—are not very serious. A Nebraska salesman finds his car "a little hard to start at low temperatures—10 to 20 below zero." A North Dakota manager wants his passengers to be able to see the clock and

adjust the radio (both placed in front of the driver in a cluster of instruments and controls). He says, "The isolated 'control center' is for 707s, not cars!"

Owners are able to criticize rather minor aspects of design and slight inconveniences like ashtray location and size of the glove box, *because* there really is nothing terribly wrong with the car. Their Le Sabre gives them a soothing ride; it provides almost complete isolation from the ripples and ruts out there on the road. It is, says an Ohio barber, for better or worse, "The Modern Car of Today!" ★★★

Summary of 1969 Buick Le Sabre Owners Reports*

Total miles driven1,153,975

Average miles per gallon:
350-cu.-in. V8, local driving 12.1
long trips ...15.1

Specific likes:
Handling43.1%
Ride42.4
Comfort28.2
Style25.8
Performance18.9
Economy13.9
Roadability6.0

Specific dislikes:
Economy10.4%
Wind noise10.4
Rear visibility9.4
Workmanship5.7
No vent windows4.7
Finish4.4
Rattles3.7

What changes would you like?
Rear visibility12.0%
Vent windows10.8
Legroom8.4
Ashtray location6.4
Glove compartment size6.4
Headroom5.6
Trunk room4.8

Body style:
2-door coupe28.0%
4-door hardtop30.6
4-door sedan40.4
Convertible1.0

Transmission:
Automatic98.7%
3-speed manual1.3

Had any mechanical trouble?
No71.0%
Yes29.0

What kind of trouble?
Transmission12.5%
Cold starts11.4
Choke10.2
Windshield wiper/washer8.0
Electrical6.8

Dealer repair satisfactory?
Yes75.9%
No20.7

Why the Le Sabre?
Past experience43.0%
Economy14.9
Style12.7
Reputation8.5
Size7.3
Performance6.3

Is the Le Sabre your only car?
No50.2%
Yes49.8

Other cars owned:
Chevrolet30.9%
Buick25.9
Ford13.6
Oldsmobile5.6
Dodge4.9
Volkswagen4.3
Pontiac4.3

What options/accessories?
Power steering and power
brakes89.1%
Airconditioning56.8
Radio45.6
Tinted glass16.7
Vinyl top15.3
Remote side-view mirror13.6
Rear defroster12.9
Whitewall tires11.9
Power steering10.3
Power antenna3.5
Power windows2.9

Age distribution of owners:
15-299.5%
30-4946.0
50 plus44.5

*Where applicable percentages may not equal 100 percent due to rounding and/or insufficient sample.

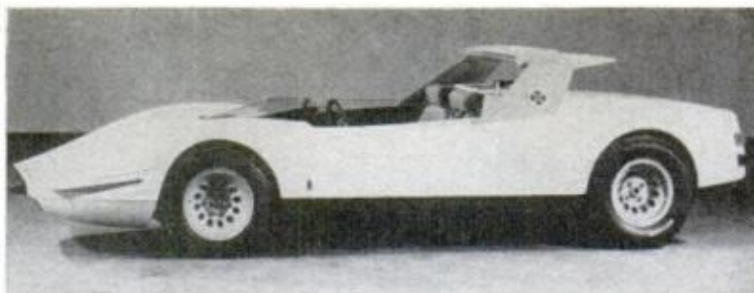
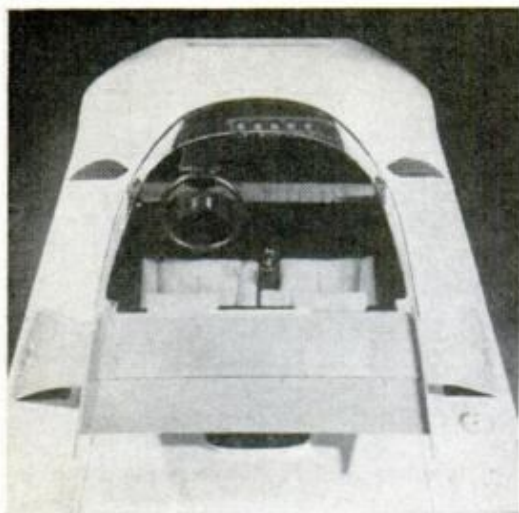

Alfa Romeo sprouts wing

The wing that's been appearing on racing cars in recent years has been designed into the sleek, new Alfa Romeo P33 Roadster. In addition to stabilizing the car at high speeds (its inclination adjusts automatically), the wing serves as a rollbar.



Old-timer with a new look and more speed

North American's World War II fighter, the P-51 Mustang, has acquired, among other things, a new engine and longer nose in an updating by Cavalier Aircraft Corp., Sarasota, Fla. The firm hopes to produce 2000 of the craft, principally as tactical fighters for the Air Force. With a Rolls-Royce Dart turboprop engine, top speed of the Mustang 3 is 470 knots.

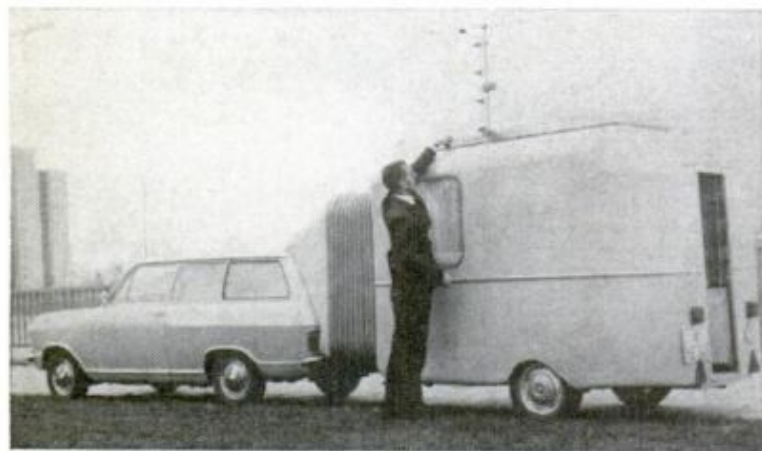

Accordion hitch for a trailer

An accordion hitch between a new travel trailer and its tow vehicle enables passengers to get from their station-wagon "bedroom" to trailer living room (right) without going out. A Munich doctor invented the hitch.



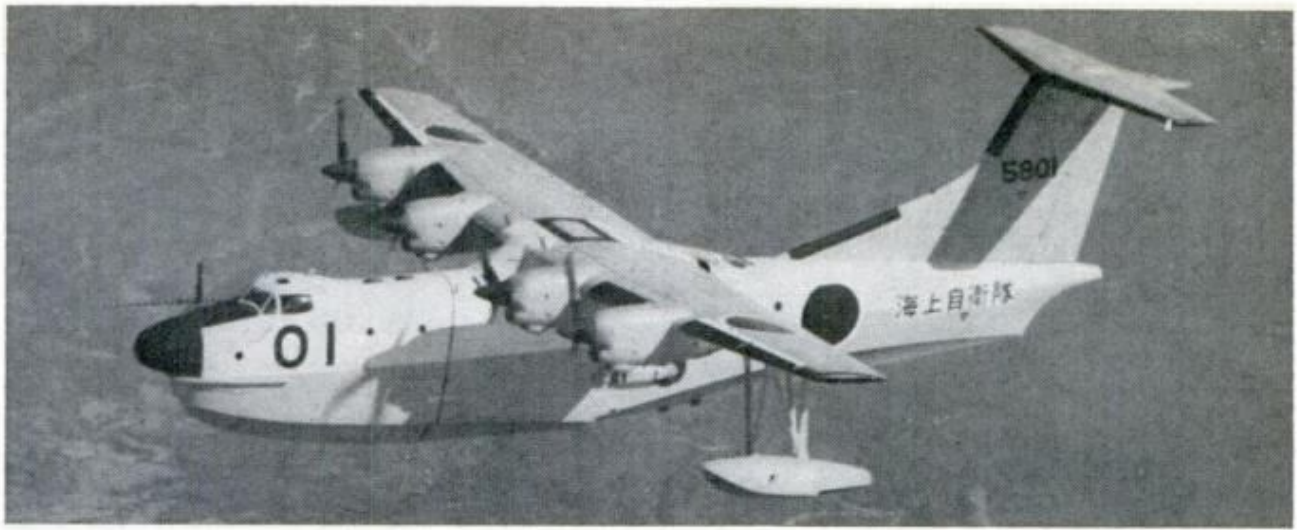

New Japanese STOL seaplane is unusually seaworthy

A new Japanese seaplane, the SS-2 built by Shin Meiwa Industry Co., could revolutionize search and rescue work. It can land and take off in 10-foot waves; with a 28-mph headwind, takeoff distance is only 260 feet. Top speed is 345 mph and range, 3000 miles.

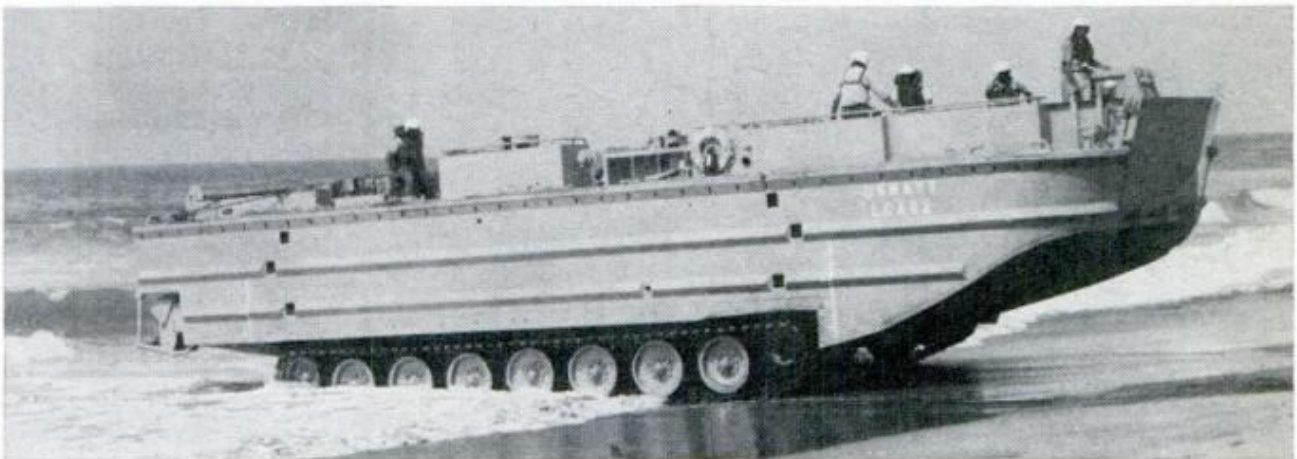

Navy tests new assault landing craft

An experimental landing craft recently tested by Navy amphibious forces could significantly improve the landing of troops and cargo. The craft, the LCA-X2, can carry 30 tons of cargo or 275 troops over water, up 60° grades or sideways along a 30° grade.

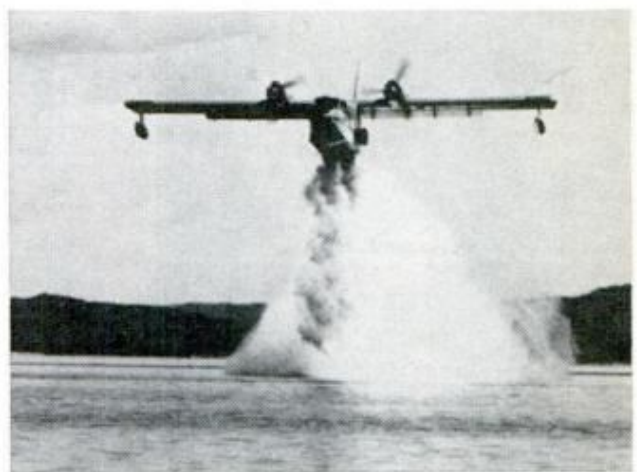

Flying fire engine loads water at 70 mph

Skimming across water at 70 mph (left), the Canadair CL-215 can scoop up a load of 12,000 pounds of water in 12 seconds and be off immediately to release the load on a forest fire (photo at right shows a water drop). It's the first plane designed for this job.

Just patented

PM'S PICK OF THE NEW INVENTIONS

Prepared in cooperation with Roger S. Shashoua, Director, International Inventors Assn., Inc.

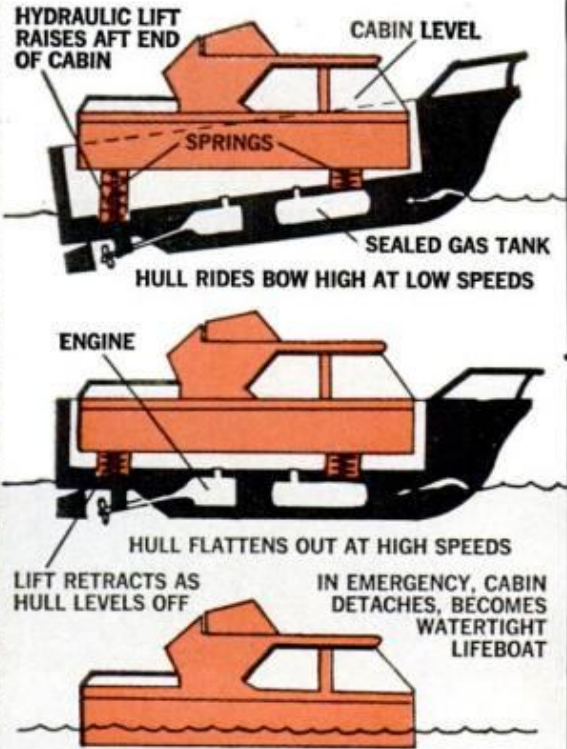
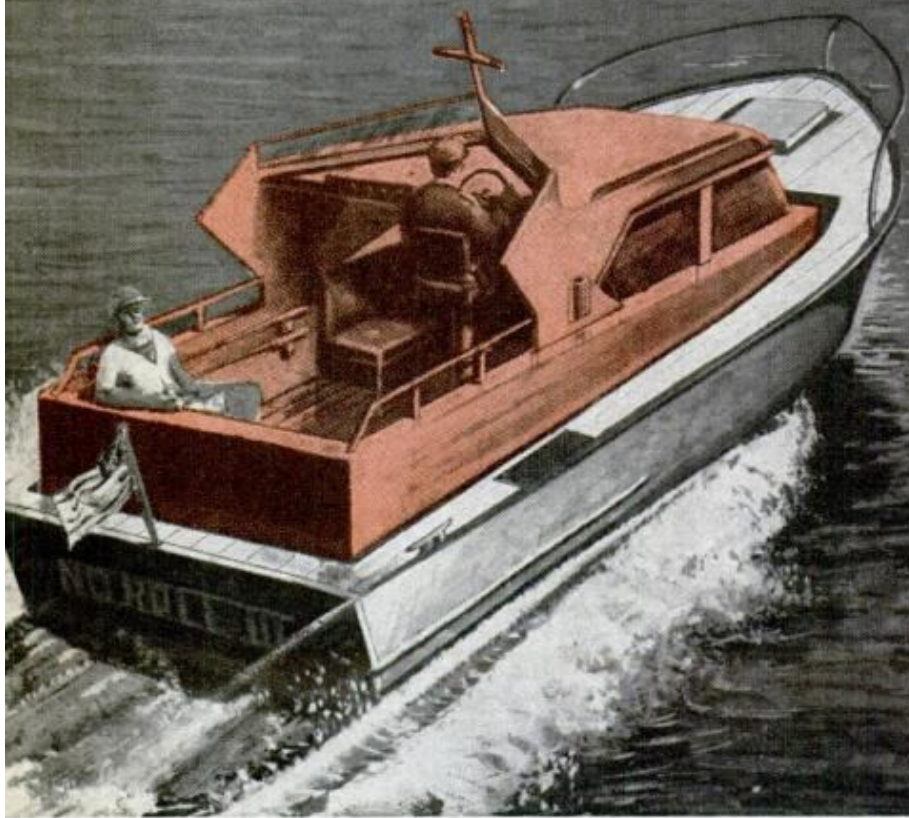

1. YOU RIDE ON AN EVEN KEEL at all times with this clever self-leveling cabin for cruisers. The compartment is a sealed unit completely separate from the hull. Hydraulic jacks raise the after end at low speeds so you can see over the up-tilted

bow. At planing speeds, the jacks retract. When it's rough, springs help to cushion hull shocks. The sealed cabin also lessens the danger of fire and explosion from fumes. In an emergency, it can be detached from the hull and will float by itself

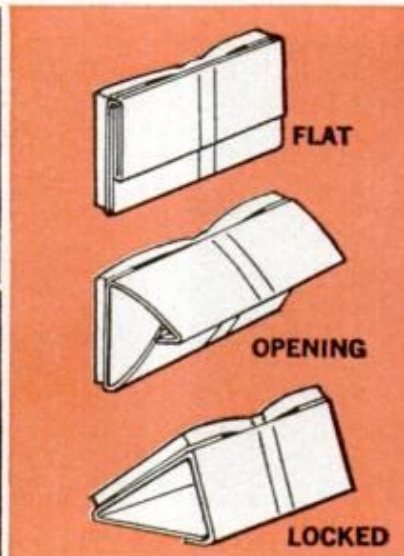
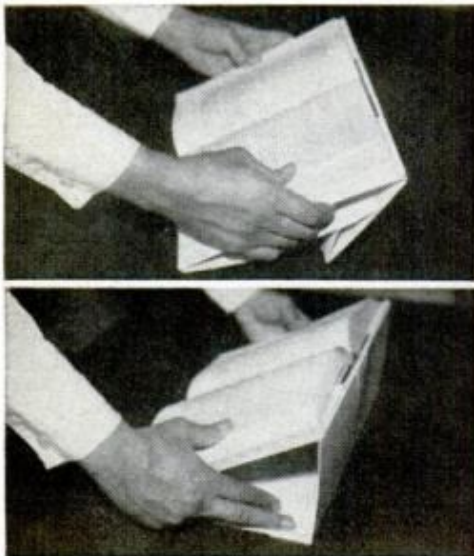

2. "INSTANT" BOOK STAND slips over a book's regular cover and folds out to form a sloping rack. Made of a stiff fiberboard, it's handy for reading in bed, studying, following cookbook recipes or checking shop plans. The book's cover slips into a pocket at each side of the rack to hold it in place. Two panels at the back swing out and interlock to make a triangular support. When not in use, the rack can be collapsed flat and left on the book until needed again. Flexible, reinforced seams in the fiberboard allow it to bend with the book's cover without tearing

Inventors of the items shown on these pages are as follows: 1. Antonio Cuesta, 2155 S. W. 5th St., Miami, Fla.; 2. Bertram Slanhoff, 1243 Post Rd., Scarsdale, N.Y.; 3. Thomas F. Henebry, Hawleyville Rd., Bethel, Conn.; 4. Frank W. Cooksey, 508 Baker Dr., Birmingham, Ala.; 5. Tentomatic, London. Roger S. Shashoua can be reached at the Inter-

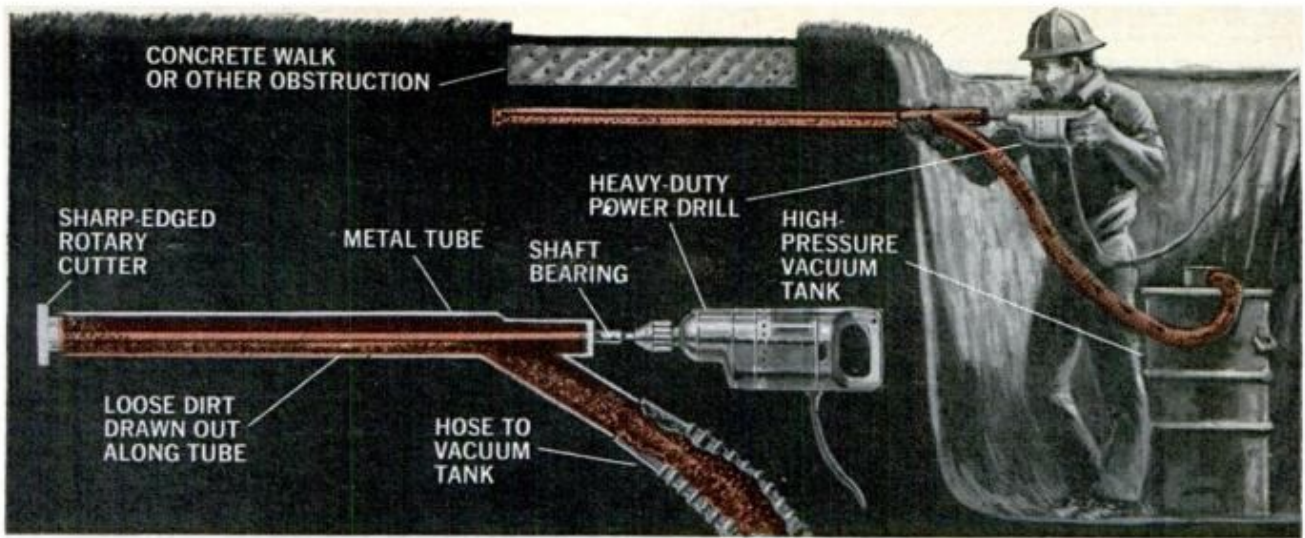

3. RUNNING PIPES AND ELECTRICAL CONDUIT under walls, concrete walks and other obstructions is no problem with this vacuum earth drill. Powered by a conventional electric drill, it consists of a rotary cutter at the end of a long metal tube. The

tube's other end is connected by a flexible hose to a high-pressure vacuum tank. As the tube is pushed under an obstruction, the spinning cutter chops away the dirt and the loose debris is drawn into the vacuum tank. This keeps the cutter from jamming

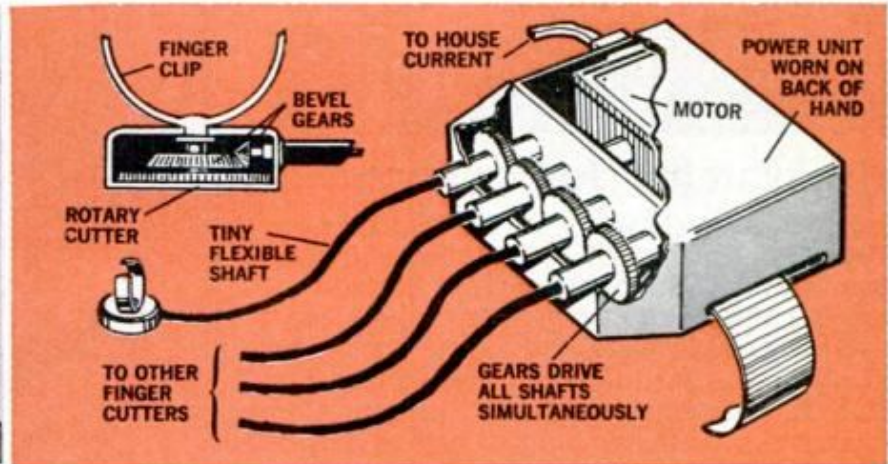

4. SMOOTHER SHAVES would be possible with this unusual fingertip electric razor. Four small rotary cutters, one for each finger, are designed to follow the contours of the face and get more easily into hard-to-reach spots. The cutters are driven

by tiny flexible shafts geared together so that they're turned simultaneously by a motor worn on the back of the hand. In its present form, the shaver is powered by house current. For use away from home, a battery version might also be possible

5. PUT THIS TENT DOWN instead of up. The ingenious cartop camping rig eliminates the hardest part of setting up a tent—erecting the frame. With the frame mounted on the roof, the car serves as a temporary support. You just drive up to the campsite and attach telescoping legs to the corners of the frame. Then you release the frame from the car and drive out from under it. All that's left to be done is to pull canvas down around the sides and peg it to the ground. The setup time is only three minutes



national Inventors Assn., Inc.,
680 Fifth Ave., New York, N. Y.
10019.

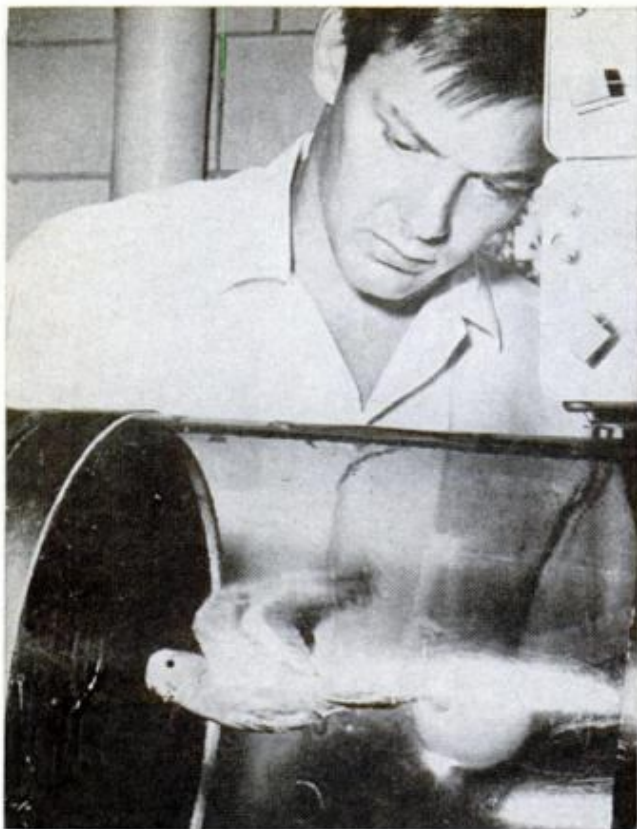

Birdwatcher for science

To observe how birds fly, Prof. Vance Tucker, a biologist at Duke University, puts them in the 30-mph airstream of a wind tunnel and studies the flying—but “motionless”—birds close at hand. By means of a plastic mask on the test subjects, the professor is able to determine how much oxygen they consume, plus the amount of carbon dioxide they breathe out. One finding: Budgerigars use only 1 percent of their weight in the effort of flying.



Catapult's foxhole

Catapult officers on the new USS *Nimitz* will direct operations from two flush-deck observation stations that raise 18 inches during launches. A station has been built at Lakehurst, N.J., for tests (above).

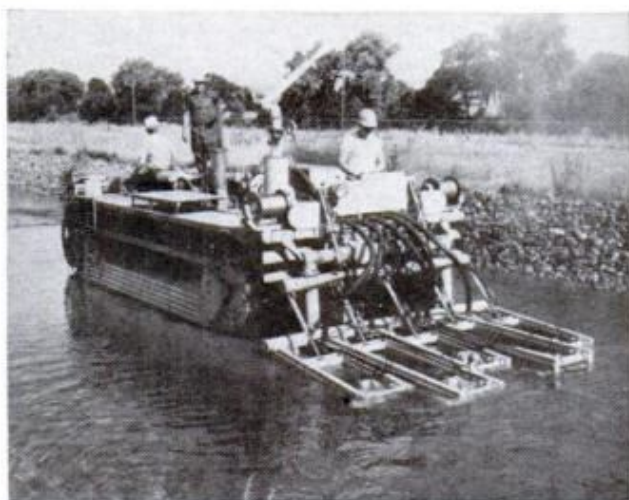

It's a riffle sifter

Newly developed by the U.S. Forest Service, the riffle sifter is a machine that travels along the salmon spawning grounds of Western rivers, cleaning the silt from the gravel to increase the production of young salmon.

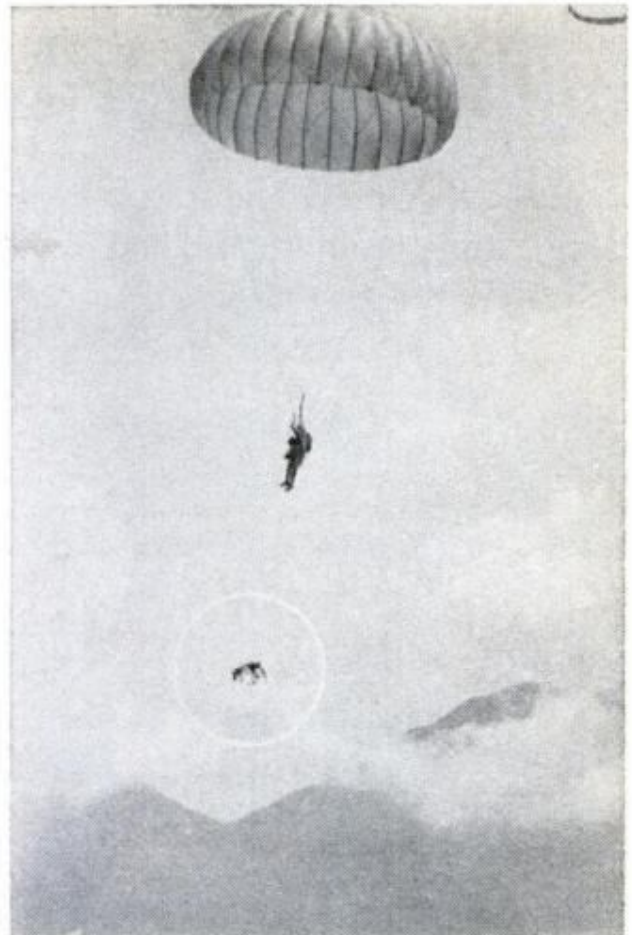

On-the-double descent

When Marine Sgt. Frank Spano parachutes into the Vietnam jungle on a reconnaissance mission, he doesn't go alone. A special harness attached to his parachute enables him to take Lobo, his scout dog, along. During the descent, Sgt. Spano lowers the dog away from him on a rope so neither is hurt when they hit the ground.

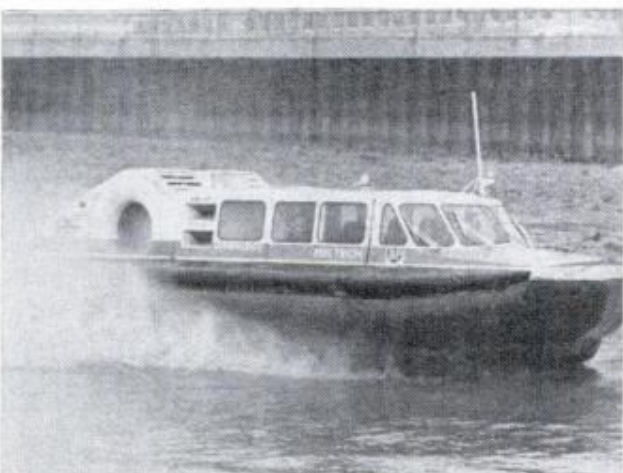

Another one from England

A new British air-cushion vehicle appeared on the Thames recently, undergoing tests by the British Ministry of Technology. The CC-7, a nine-seat vehicle, was built by Britten-Norman Customcraft. The craft may be put to use on river patrol or as a customs launch.

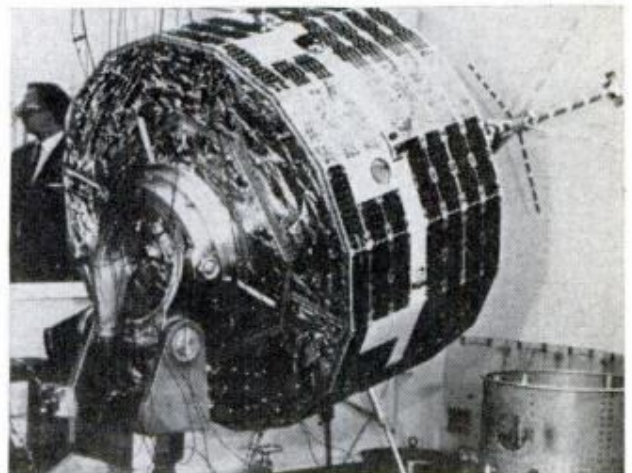

First from Germany

The first research satellite built by the Germans is Heos (highly eccentric orbiting satellite), which takes an elliptical orbit around the Earth while measuring interplanetary magnetic fields. The vehicle is shown before launch in the Junkers plant.

Build This New 4-Place Cabin Plane

Jim Bede's first homebuilt may be the easiest to construct yet. The wings come ready-made, and most of the fuselage just bolts together



By KEVIN V. BROWN

IT'S JIM BEDE TIME AGAIN. Almost annually the young Clevelander startles the aviation world with a new—and sometimes wild—creation. This year, it's a do-it-yourself airplane that may be the closest thing yet to an Erector Set homebuilt.

It features a newly designed plastic wing that you can buy almost ready-made, an all-metal fuselage with bolt-together construction (most of the parts already formed), skin that attaches with Pop Rivets and an assortment of all the other necessary parts and supplies that can be purchased from Bede, who says, "I can furnish almost everything but the paint." Complete plans—and they may be the best ever produced for an amateur aircraft—can be purchased from Popular Mechanics for \$30.

In order, Bede's other exotic aviation productions have been:

- A twin-engine business aircraft, with both engines buried in the fuselage behind the cabin pushing one propeller enclosed in a shroud. The buried engines, the ducted prop and boundary-layer-control wing pushed cruising speeds to around 300 mph. Bede built the plane, flew it—made his point—then donated it to the Experimental Aircraft Assn.'s museum in Hales Corners, Wis., and moved on to other things. He now calls it the BD-3, but you needn't pay too much attention to his numbering system.

- Next came the BD-1 (see!), a two-place low-wing monoplane that rocked the aviation world as few have ever done. Reason: Bede's announced price of \$2500 (cover story, Feb. '64 *PM*). He planned to do it with bonded construction (no rivets), interchangeable parts (lower production costs) and

for \$3500



Technical Art by Fred Wolff

honeycomb metal (higher strength-to-weight ratio). He built two, and that was it. Certification problems ran up the cost (and the price), so new money had to be brought in and eventually Jim lost control of the project. The plane was redesigned, certified, and eventually produced as the Yankee and is selling at around \$6500. Even today Jim has mixed emotions about it. "I'm not too mad. They had a lot more money than I could afford. I still own a piece of the business and, if they make money, I'll make money. I'll just use it to try some of my other ideas."

• Meanwhile, back at the Bede drawing board, he dreamed up what must have been the most-minimum homebuilt since the Kitty Hawk Flyer. He called it the Demoiselle, after a French plane of the Wright Brothers' era, and it would have been the closest thing to a



BD-4 with 150-hp engine cruises at 166 mph



Cabin seats up to four persons



Cantilever wing comes ready-made



Wing is removable for trailering



Bolt-together construction eases building

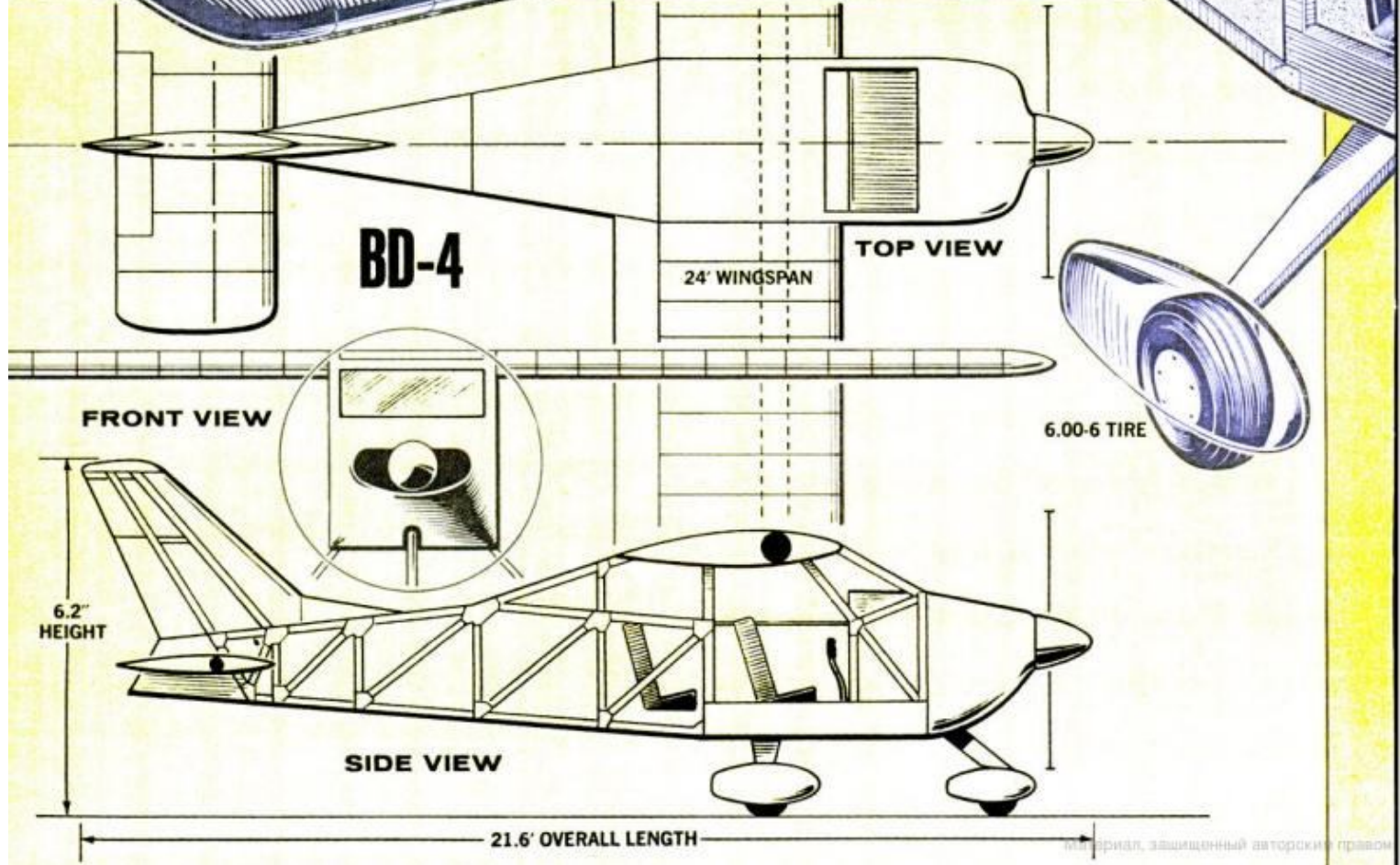
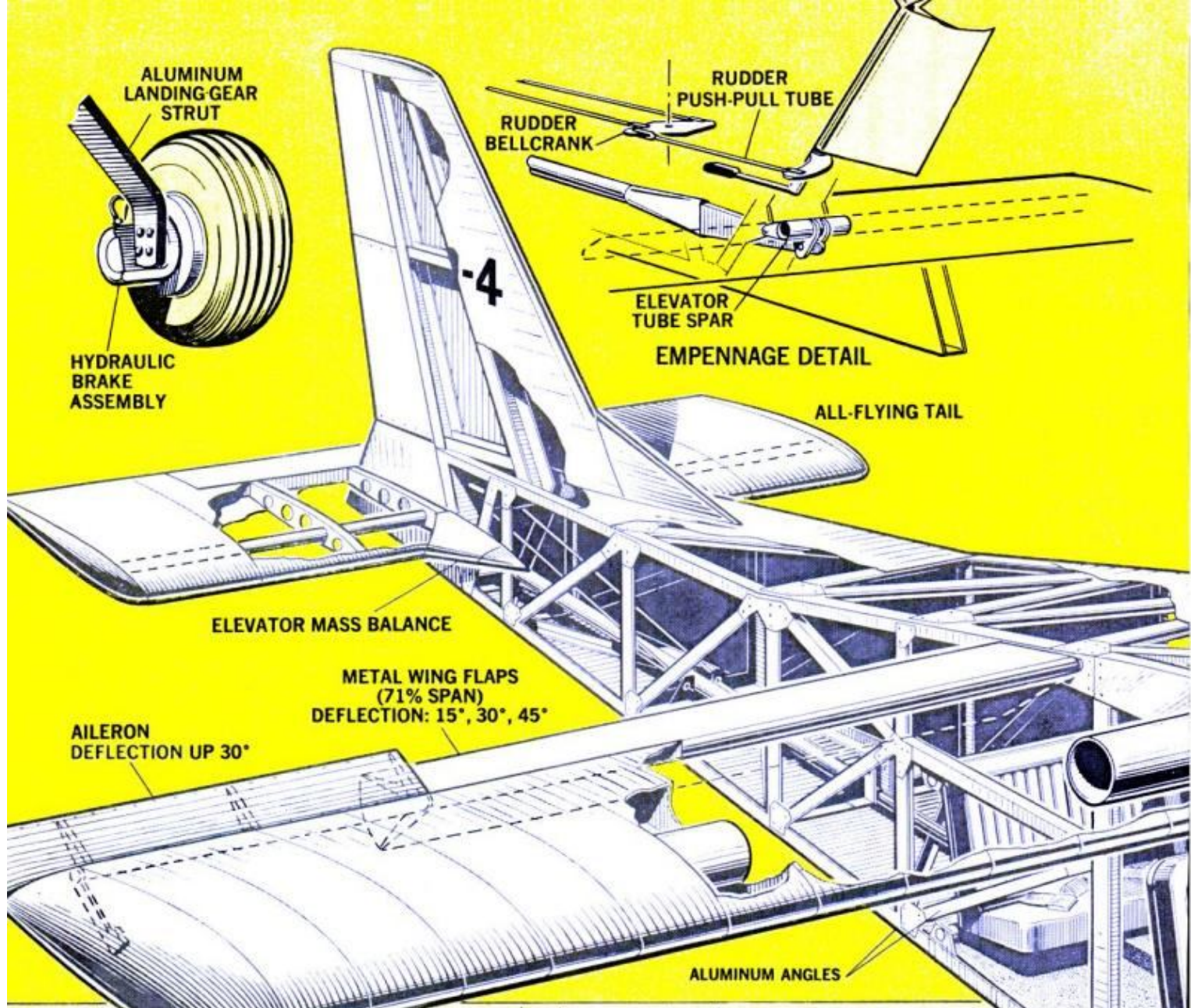

For complete plans and detailed instructions on how to build the BD-4, send \$30.00 to:

Bureau of Information (Dept. KV)
POPULAR MECHANICS
575 Lexington Avenue
New York, N. Y. 10022

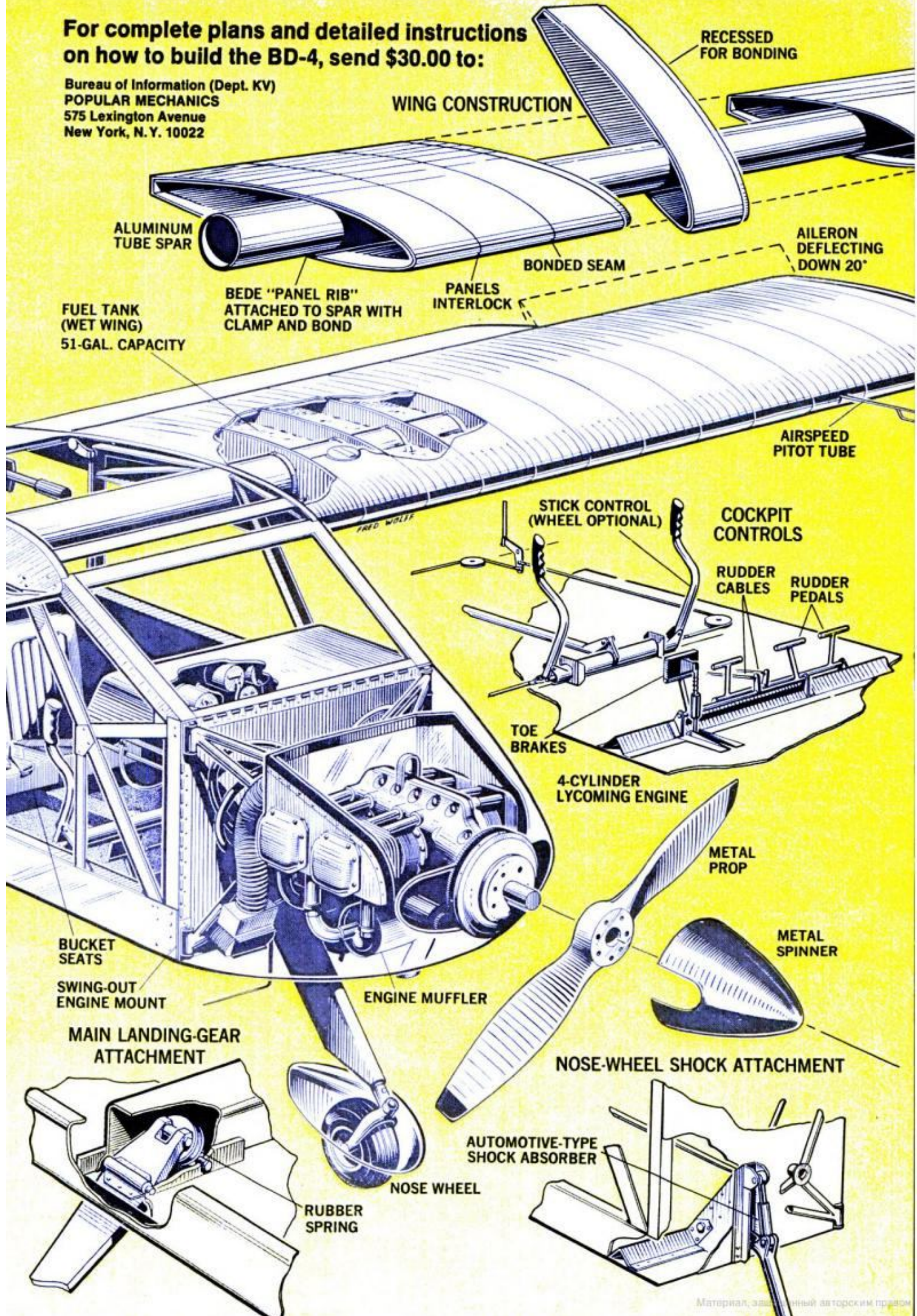

WING CONSTRUCTION

RECESSED FOR BONDING

ALUMINUM TUBE SPAR

BONDED SEAM

AILERON DEFLECTING DOWN 20°

FUEL TANK (WET WING) 51-GAL. CAPACITY

BEDE "PANEL RIB" ATTACHED TO SPAR WITH CLAMP AND BOND

PANELS INTERLOCK

AIRSPEED PITOT TUBE

STICK CONTROL (WHEEL OPTIONAL)

COCKPIT CONTROLS

RUDDER CABLES

RUDDER PEDALS

TOE BRAKES

4-CYLINDER LYCOMING ENGINE

METAL PROP

METAL SPINNER

BUCKET SEATS

SWING-OUT ENGINE MOUNT

ENGINE MUFFLER

MAIN LANDING-GEAR ATTACHMENT

NOSE-WHEEL SHOCK ATTACHMENT

AUTOMOTIVE-TYPE SHOCK ABSORBER

NOSE WHEEL

RUBBER SPRING

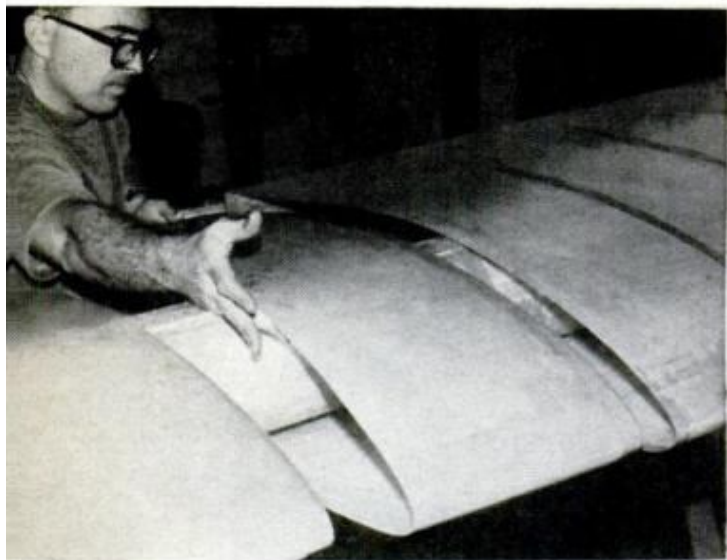

PAUL GRIFFIN, project engineer for BD-4, slips plastic wing panels over main spar onto one another

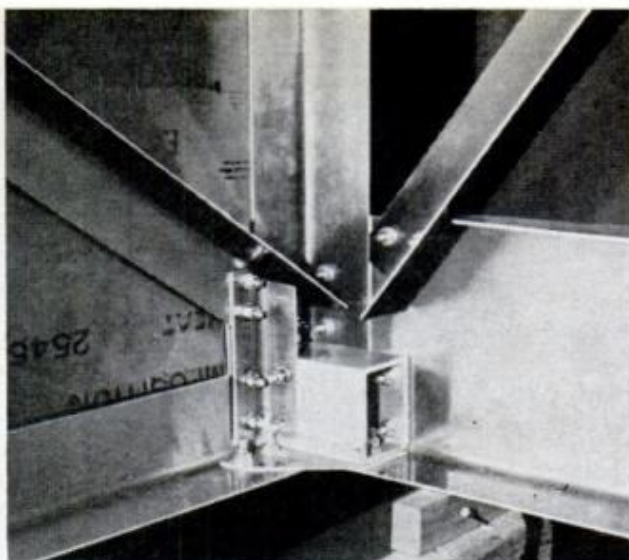

ALL NECESSARY WELDING is shown here. Still to do are some forming and drilling, but no machining

flying go-cart. It had an open-air cockpit and an open-air fuselage, a framework boom back to the tail section—and the newest Bede innovation, a plastic wing made of small, identical panels fitted together and slipped over the main spar. The spar was an extruded metal beam that first showed up in the BD-1. Bede assembled some of the parts, but the plane never flew.

• Bede's latest project—and the subject of this article—is the BD-4, a high-wing, cabin airplane that you can build at home. It draws on some of his previous projects, but, as usual with Bede, offers some innovations as well.

As mentioned, it may be the closest thing yet to a kit airplane. The Federal Aviation Administration, which certifies aircraft, has never approved a kit (exception: some Schweizer sailplanes). It insists that “more than 50

percent” of the work on amateur-built aircraft be done by the amateur.

Bede has got around this by offering some of the parts ready-made, and the rest as raw materials, uncut but with some of the difficult parts already formed. He also offers supplies right on down to the necessary number of nuts and bolts to put it together. The builder, says Bede, “will still have to do 80 percent of the work, but he'll have everything he needs to do it with.”

But before you think about building the plane, you'll want the answer to one question: How does it fly?

I flew the prototype, and I would say, “Better than most.” Forget sporty routines. It isn't built for that. It's definitely a cross-country type, and a good one. Stick the golf clubs in back, the wife up front, and go, man!

Takeoff, after a normal roll, was at

Photos by Don Pratt

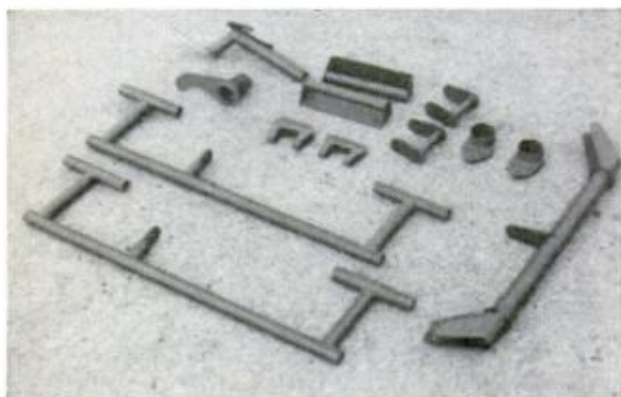

BOLT-TOGETHER CONSTRUCTION of fuselage frame allows easier building and lighter empty weight

PERFORMANCE ESTIMATES		
	Two-place	Four-place
Engine size	108 hp	150 hp
Gross weight	1400 lbs.	1700 lbs.
Empty weight	805 lbs.	830 lbs.
Max. speed (sea level).....	156 mph	186 mph
Cruising speed (65% power)	142 mph	166 mph
Stalling speed (flaps down) ..	54 mph	61 mph
Stalling speed (flaps up)....	60 mph	66 mph
Maximum rate of climb.....	900 fpm	1200 fpm
Takeoff run	600 ft.	650 ft.
Landing roll	500 ft.	600 ft.
Maximum range	1200 mi.	1200 mi.

70 mph. (The prototype, incidentally, had a 160-hp Lycoming). Climb-out started at 500 f.p.m. and eventually settled at 1200 f.p.m., at about 115 mph, 25 inches of manifold pressure and 2600 rpm. The roll, before we got complete control on the surfaces, was as skittish as most homebuilts, certainly no better.

Once at cruise, however, it really settled down, almost rock-steady. I had to hold slight left, yes left, rudder (Bede claimed some difficulty with spring tension) to prevent yaw, but the stick was a joy. I took my hand off it, tentatively at first, then rested both hands on my knees. Nothing. Straight and level all the way.

Turns were easy enough, nothing sensational, but no chore either.

The cabin, let's face it, was a bit breezy, more than a bit noisy, and so a bit much. Even on short flights it's aggravating, and on long flights it might be a real nuisance, unless you're wearing thermal underwear and ear plugs.

The noise breeze level is probably the BD-4's major fault, and could stand correcting—or caulking.

Minor faults included some sun glare from the engine cowling, and the main spar running across the center of the cabin just where my head prefers to rest. I hit it, but Bede, who is shorter, didn't. (Bede later raised it two inches, without—he says—sacrificing any performance.)

Descent was smooth, with settings at 10 inches, 2200 rpm, 120 mph and 1000 f.p.m. The landing approach (at 95 mph), like the takeoff, was a bit skittish, with the stick working overtime. But this is characteristic of homebuilts. Because of their size, they begin to act like kites at slow speeds. It didn't bother me too much. The touchdown (at 75 mph) was smooth enough.

For the rest, visibility was quite good, the seats comfortable, and, except for the noise and the awkwardness of holding the left rudder, it was an enjoyable flight. I think the plane will wear well on long cross-countries.

On the ground, Jim worked out our true airspeed at 162 mph from an indicated 138 mph at 64 percent power. This compares to 166 mph for a 150-hp engine in his announced performance estimates.

For those who need more detail, complete specifications, performance estimates, a bill of materials and price list are included with the plans.

Here's what is available in plans and ready-made parts:

- **Plans.** These can be ordered directly from *Popular Mechanics* (see page 115). The plans, which run to 40 sheets, are among the most clearly detailed ever printed. Each part—nut, bolt, whatever—is number-coded from sheet to sheet so there can be no possible misunderstanding about what goes

'Once at cruise, it really settled down, almost rock steady.'

where, and all cutting jobs have full-sized templates. Price: \$30.

- **Packages.** Bede has broken down the airplane into seven basic packages of raw materials, which can be ordered separately, or en masse, or even one part at a time. For a complete aircraft (minus engine) the seven packages cost \$2940.

The seven separate packages are:

1. **Wings.** The package includes extruded metal-beam spar and plastic panels that slip over the beam and overlap one another. The inboard panels double as gas tanks. The beam originated in the low-wing BD-1, and the plastic panels were first designed for the Demoiselle. The wing is the most complete of all the parts offered by Bede—just put it together—and it is *PM's* suggestion that if you buy the plans, and are serious about building the BD-4, you should at least buy the wings from Bede. You'd have considerable trouble—unless you're an expert—duplicating the extruded beam and plas-

(Please turn to page 208)

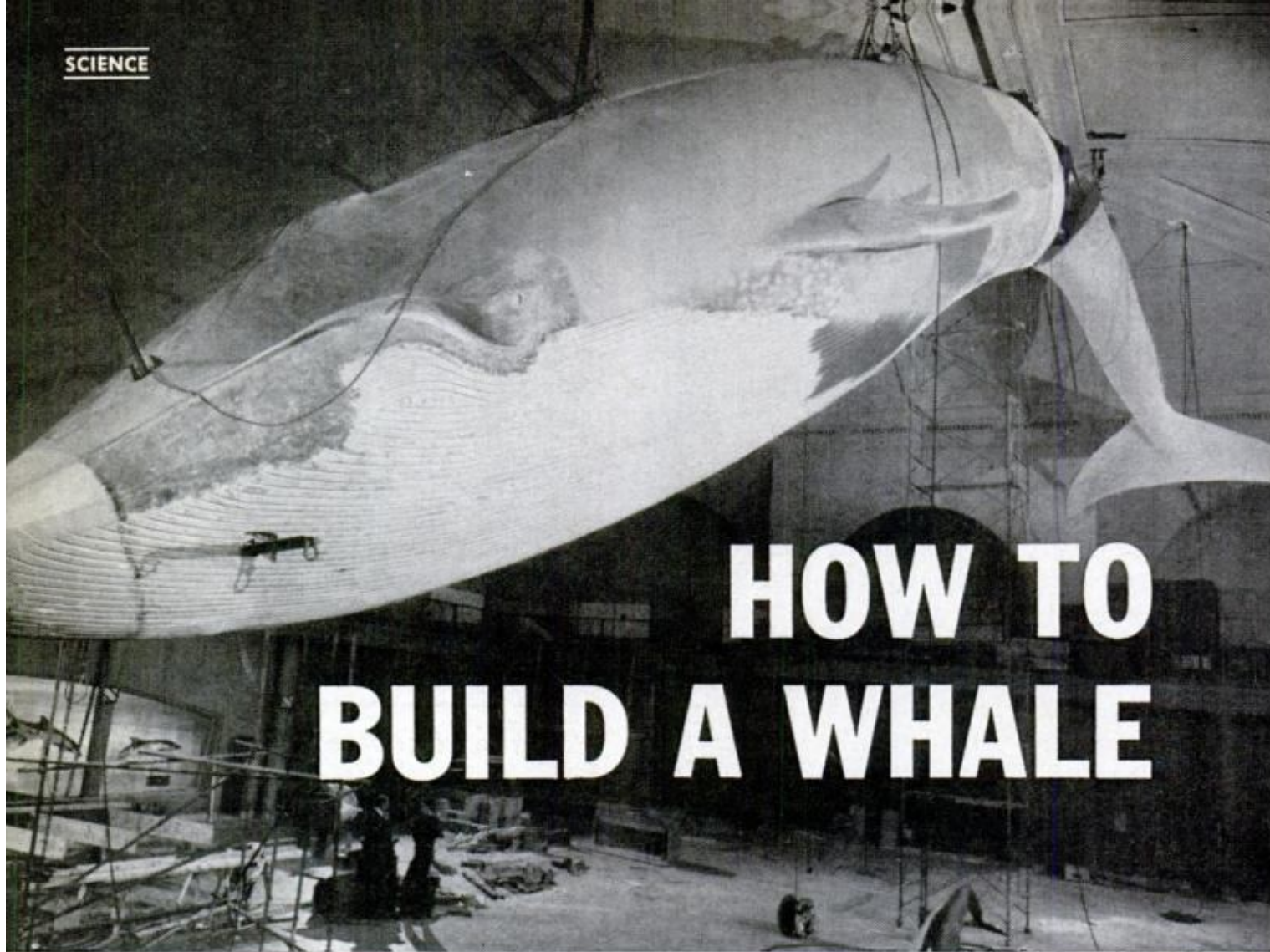

HOW TO BUILD A WHALE

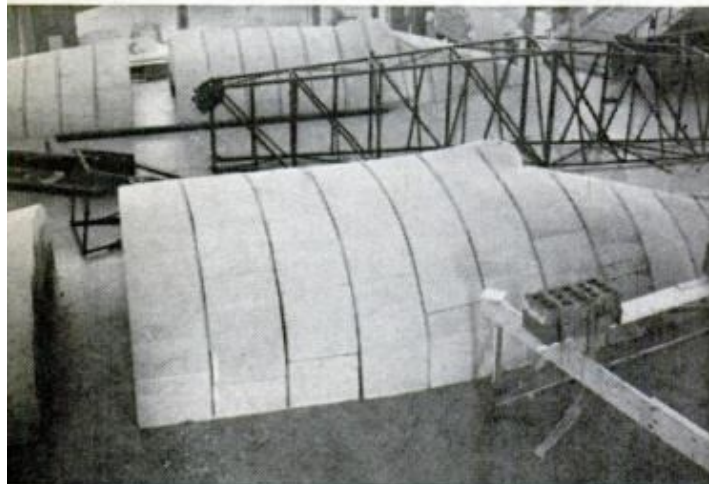

It takes \$200,000, 21,000 pounds of polyurethane, fiberglass and steel, plus two years' work, according to New York's Museum of Natural History

BLUE WHALES are the biggest animals that ever lived—and the new “Blue” in the American Museum of Natural History is the biggest single exhibit in its 100-year history. The 94-foot, 10.5-ton replica, on the drawing board seven years, required over two years to build. Suspended at a single point (creating a floating effect), the whale is in diving position. It replaces a plaster 76-footer first shown in 1908. Knowledge gained since then doomed that animal: Its body didn't bulge right and its eyes weren't protuberant. ★★

- 1 **MAN-MADE WHALE** called for careful handwork. The animal was built in a Macon, Ga., factory
- 2 **WHALE ARRIVED** at museum in pieces. Assembly is checked on floor of the new Hall of Ocean Life

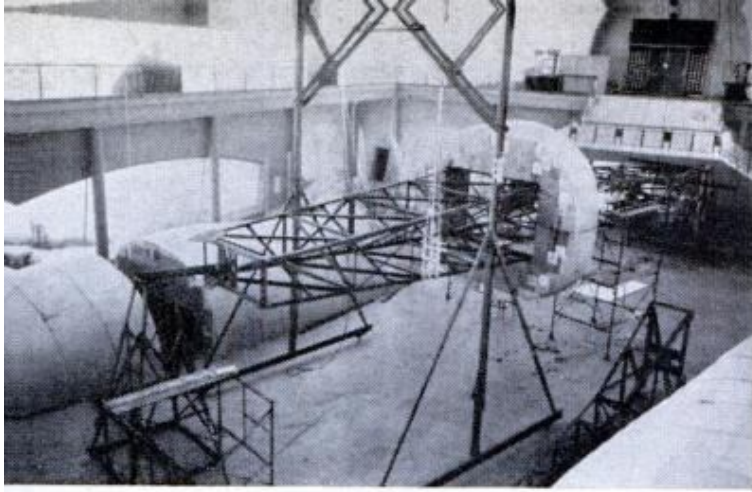

3 POLYURETHANE BODY "SLICES" are carefully placed in position over steel skeleton held in a jig. Body was built in two large sections

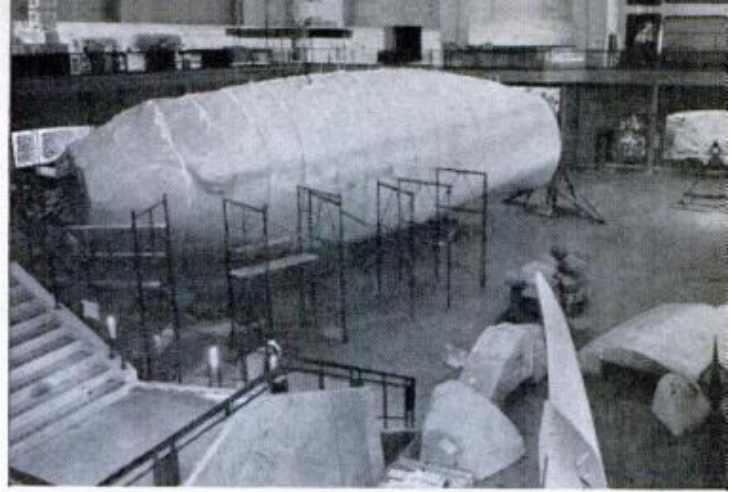

4 LOOKING LIKE HUGE LOAF of bread, completed main section awaits finishing touches. Polyurethane foam forms a firm bond between slices

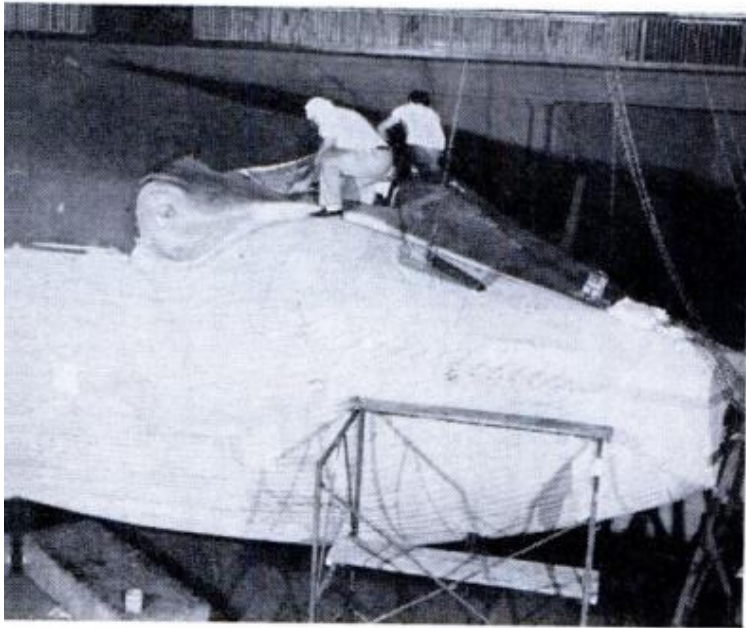

5 FIBERGLASS is applied over polyurethane to provide a smooth, strong base for paint. "Blues" look blue in water, really are black and gray



6 LOCKING DEVICE is used to bring together 28-foot tail and 66-foot body. Mechanism connects to steel pipe anchored in reinforced ceiling

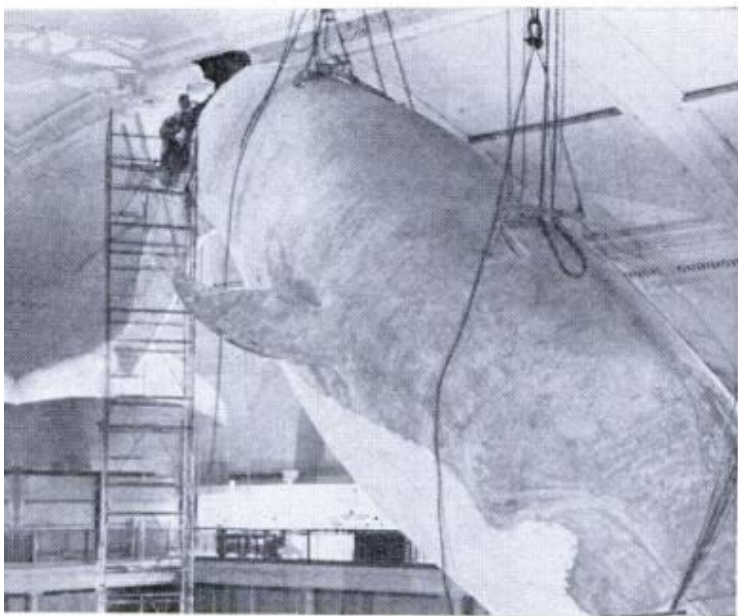

7 TRICKY MOUNTING JOB required the know-how of steelworkers. Body sections were raised to the ceiling by muscle power and chain hoists

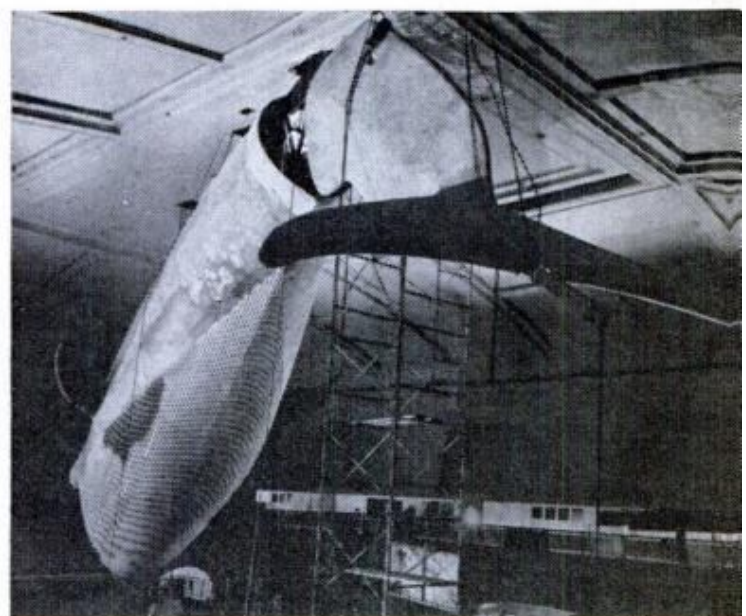

8 HUGE SIZE OF MODEL is not as great as real thing. Females, larger than males, may grow to 100 feet in length and a weight of 175 tons

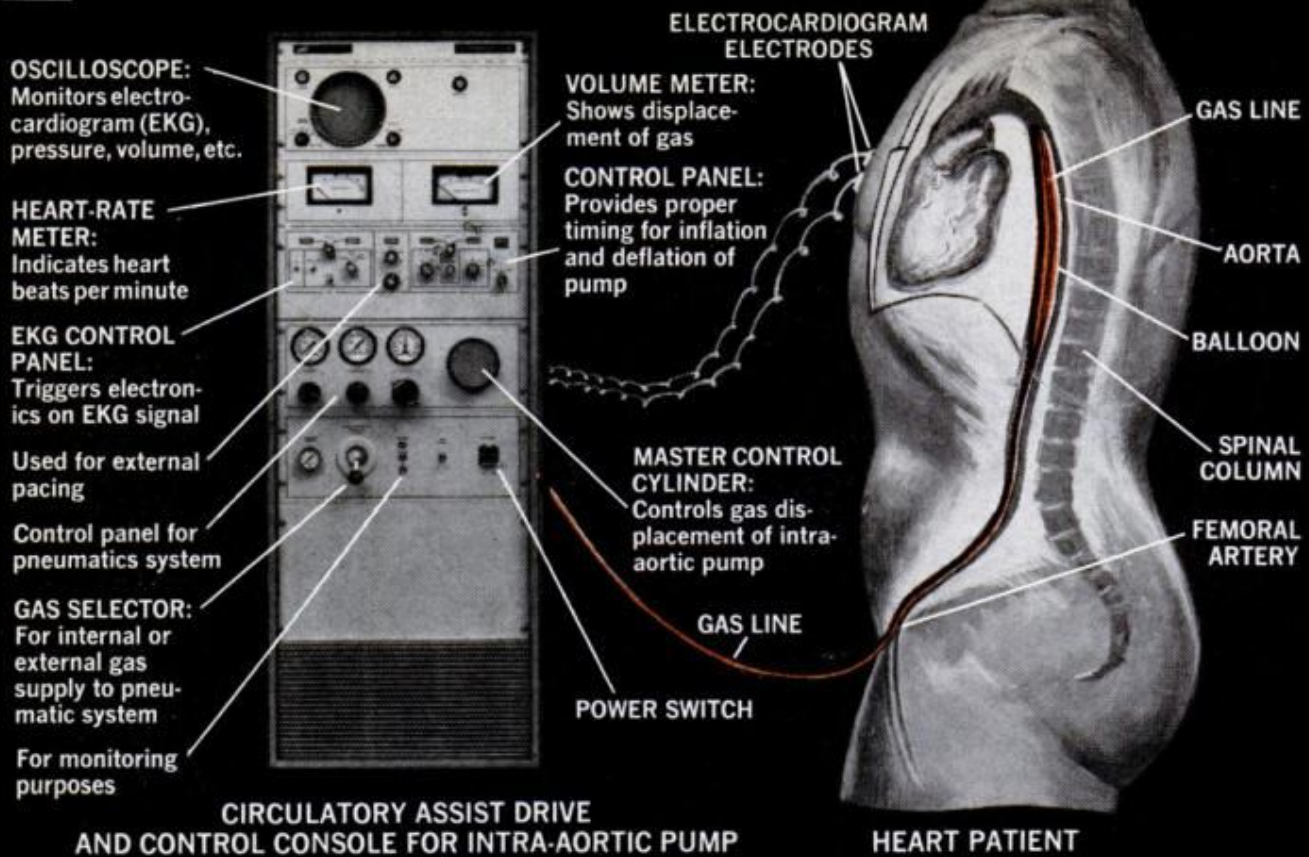

MECHANICS OF MEDICINE:

MECHANICAL DEVICES and artificial organ parts to extend the period of usefulness of worn or damaged human hearts are being developed and tested in leading laboratories.

Artificial hearts and auxiliary aids still offer the best hope for saving the lives of heart patients in the future, according to many medical scientists. The age-old medical dream of transplanting a human heart from one individual to another has been achieved, first by Dr. Christian N. Barnard, and later by other surgeons throughout the world. But it is not a feasible solution to the problems of an estimated 20 million heart-disease patients and a half-million fatal heart attacks each year—the current record in America.

In its normal condition, the human heart is one of the most efficient machines known. It converts 50 percent of its available fuel into work; an automobile engine or a steam turbine, by comparison, may have a mechanical efficiency of only 25 percent. The heart

New Tools

By **KENNETH N. ANDERSON**

expands and contracts 100,000 times a day in order to move 32,000 pounds of blood through its chambers. The only rest it gets is during a fraction of a second pause between beats. And the heart receives no direct nourishment from the thousands of gallons of blood that it handles each day. It is sustained only by tiny coronary arteries on the outside of the fist-sized bundle of muscles. And the coronary arteries depend upon a sort of backflow of blood from one of the large arteries near the heart.

By the time you reach the age of 35, your heart will have gone through its pumping action almost one and a half billion times and, usually, will have begun to show some signs of wear. When failure occurs, it usually is due

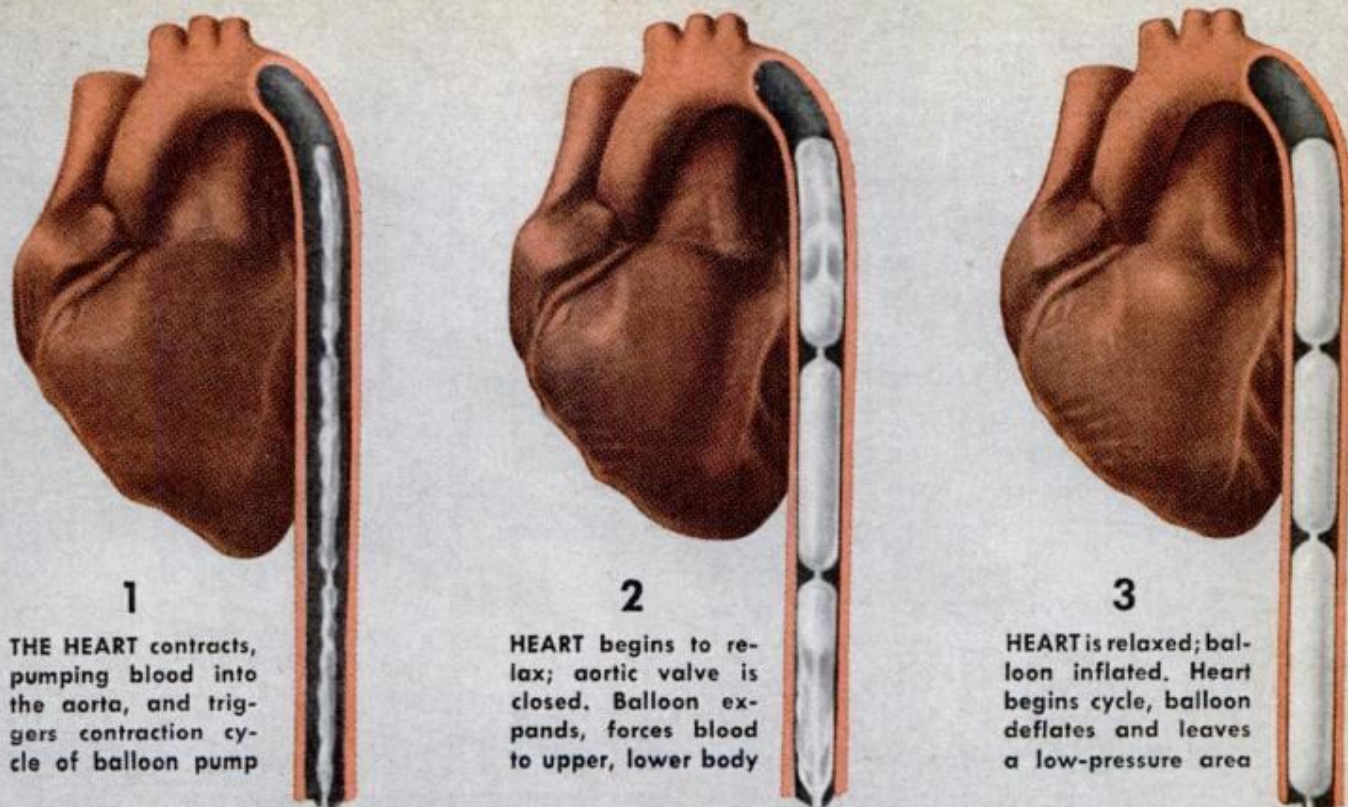

1
THE HEART contracts, pumping blood into the aorta, and triggers contraction cycle of balloon pump

2
HEART begins to relax; aortic valve is closed. Balloon expands, forces blood to upper, lower body

3
HEART is relaxed; balloon inflated. Heart begins cycle, balloon deflates and leaves a low-pressure area

Successful heart transplants have brought us closer to the ultimate answer—the artificial heart. Meanwhile, researchers are coming up with ingenious solutions that point the way to the completely mechanical heart

for Mending Hearts

Illustrations by Jack Mitchell

to blockage of a coronary artery. The bore of the tiny arteries gradually narrows because of an accumulation of fatty and calcified material, making it easy for a blood clot to form and block the flow of nutrient-enriched blood to the heart muscles.

When a coronary artery is blocked, the heart usually continues to beat but a portion of the heart muscle is deprived of blood and is weakened. If the patient is placed in a condition of complete rest, his heart does not have to carry its normally heavy load and will gradually recover. Over several weeks, new coronary artery channels will develop to compensate for the loss of blood supply.

A gas-driven balloon pump, devel-

oped by the Avco Everett Research Laboratory, was designed to reduce the heart's workload while the organ goes through its normal healing processes. Known as an IAP (for intra-aortic pump), it consists of a 10-inch-long balloon, $\frac{3}{4}$ of an inch in diameter, with a thin gas tube running down its center. It is connected to an external drive and control unit synchronized to the heartbeat.

The balloon is threaded into the femoral artery through an incision in the upper thigh and then pushed into the aorta, the major trunk artery leading from the heart. Electrodes are attached to the patient's skin to transmit electrocardiogram signals to the control unit. The signals, caused by tiny elec-

trical pulses emitted when the heart muscles contract, activate the contraction-expansion cycles of the balloon pump.

After the heart empties into the aorta and begins to relax, gas fills the balloon, causing it to expand and push the blood into arteries connected to the aorta. At the same time, some blood is forced back into the coronary arteries. When the heart begins to contract again, the balloon deflates, creating a low-pressure channel into which the heart can empty its blood load.

The IAP was developed by Dr. Arthur Kantrowitz, director of the Avco Everett Research Laboratory, in collaboration with Dr. W. Gerald Austen and Dr. Mortimer J. Buckley of the Harvard Medical School and Massachusetts General Hospital. According to Dr. Kantrowitz, a brother of the noted heart surgeon, Dr. Adrian Kantrowitz of Maimonides Hospital in Brooklyn, N.Y., the IAP can reduce the workload of a damaged heart by up to 50 percent. Not only does the heart work less during its period of recuperation, but it gets more blood itself through the back-pressure effect that fills the coronary arteries.

Installation of the IAP devices requires only a local anesthetic that can be inserted in a few minutes and easily removed when the heart has recovered sufficiently to resume its normal workload.

The main problem facing medical scientists before the balloon pump can be made available for general use is finding a plastic balloon material that does not cause blood clotting. The device has been used in animals for periods of a month or so and the researchers have discovered that materials tested thus far cause clots in humans and pigs, but not in dogs.

The National Institutes of Health, which provided money for developing the IAP, now is financing a study of what makes blood clot. The present balloon pump material causes human blood to clot in about one hour, com-

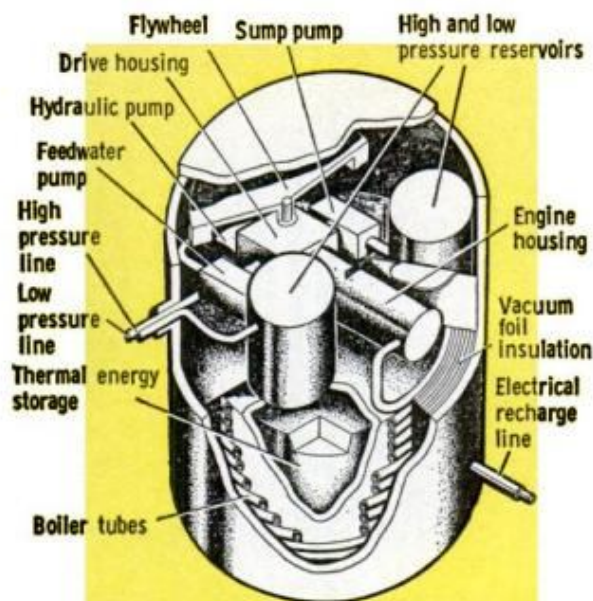

POWER SOURCE FOR IMPLANTABLE CIRCULATORY ASSIST DEVICE

NUCLEAR-POWERED HEART (a conceptual design) would function as a tiny steam engine implanted in pelvis where it would be connected to an artery and vein and function as a self-sufficient mechanical heart

pared to 30 minutes for polyurethane and five minutes for glass.

Dacron-coated ball valve

Meanwhile, NIH has solved a blood-clotting problem that has interfered with the effectiveness of artificial heart valves. The metal frames of Star-Edwards ball valves tend to collect blood clots when the bare metal is exposed;

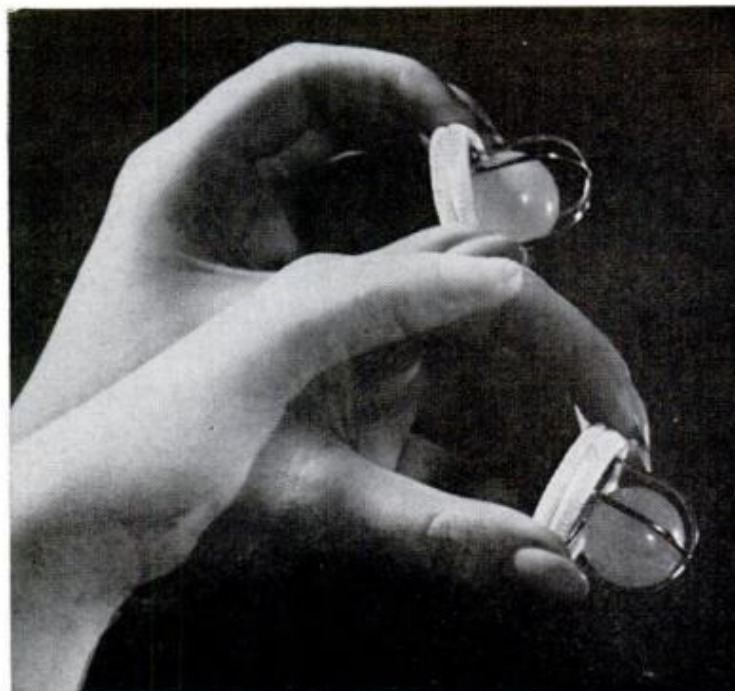

there's danger that clots will break free and flow into a small artery, thus blocking it.

Now, Dr. Andrew G. Morrow and Dr. Nina S. Braunwald of NIH have achieved success in preventing such clotting by coating the valve frames with Dacron fabric. The coating, thin enough so it will not affect clearances, is applied to all nonmoving parts. So far, 22 patients have worn the fabric-coated frames up to 12 months with no signs of clot formation.

Nuclear-powered heart

Further progress has been reported, meanwhile, in the efforts of NIH, the Atomic Energy Commission, and private industry to develop a nuclear-powered heart pump. A hazard to be overcome, in addition to radiation exposure itself, is that of heat produced by decay of the isotope, plutonium 238, which would be the energy source.

The nuclear-powered heart would function as a tiny steam engine, including a miniature boiler, with pumps attached to the arterial and venous parts of the blood system. Blood pump models, powered by external sources, have been tested in six cows in previous experiments. But the nuclear device would be implanted in the pelvis of a

human, where it would be connected to an artery and vein, and it would function as a self-sufficient mechanical heart.

The heart problem, similar to that experienced by nuclear-powered electric generators with resultant thermal pollution, occurs because of the difficulty in converting all energy of radiation energy into mechanical work. Heat output may be 10 times that derived from the atom. The Thermo Electronic Corp. of Waltham, Mass., claims it has now developed an effective heat exchanger which dumps the excess heat into the aorta. Blood flowing through the main artery would dissipate the heat throughout the body.

An experimental heat exchanger has been implanted in a test animal for studies that will lead eventually to modifications for use in humans. It contains a cavity $1\frac{5}{8}$ inches in diameter into which a 16-watt disc of plutonium 238 is inserted. The exchanger is coated with layers of thermal insulation and other materials to protect body tissues. A titanium alloy tube through which the blood flows is coated with a graphite-heparin complex to reduce the possibility of clotting. After eight months' testing in an animal, the exchanger has been declared successful. ★★ ★

ARTIFICIAL HEART VALVES tend to collect blood clots that reduce their effectiveness. If clots break free, they may block small artery and endanger patient's life. Ball valve with metal frame (far left) is shown clotted with blood (below) after implantation. No clots have formed on the heart valve frame that is coated with Dacron fabric. Technique was developed by National Institutes of Health researchers

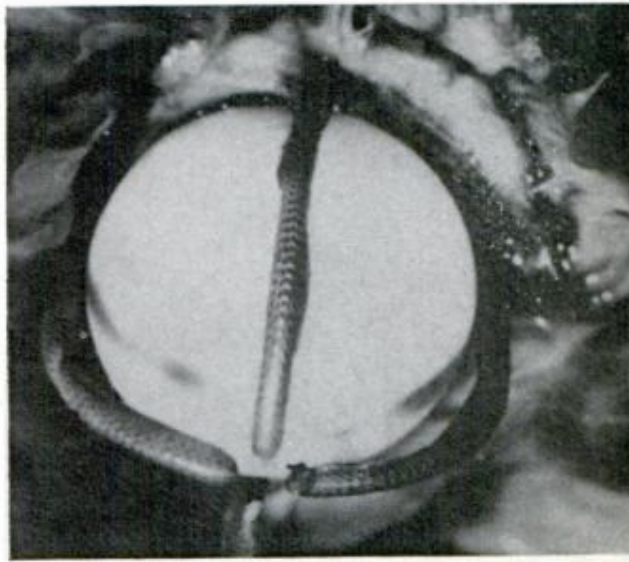

PM TESTS

A Rugged New Camper... A Controversial New Park

Redwood National Park, newest big-timber camping spot, is a natural proving ground for El Dorado's new camper and Ford's new pickup truck.

By V. LEE OERTLE



LOGGING ROADS can provide more punishment for a vehicle than any other kind of road. I'm finding that out in the brand-new, controversial Redwood National Park while testing Ford's 1969 Camper Special pickup with a new nine-foot El Dorado coach aboard. My guides are National Park Ranger Powell White and California State Ranger Terry Adams.

We are driving in the undeveloped part of the 58,000 acres tagged by Congress as Redwood National Park. Though Congress has approved the park concept, it will be some time before all the land comes under National Park Service control. At present, 27,468 acres belong to the California State Park System. This land, which has three popular camping areas, eventually will be turned over to the Park Service. The remaining acreage is under direct park service administration, but undeveloped. Until Congress acted, it was lumber-company owned—about 10,000 acres of it containing old-growth redwoods. It's in this section that we are testing equipment.

At this time of year (November) Redwood National Park is a rain forest. Rainfall in this region averages about 100 inches a year. The best and driest season is from spring to late fall, but to avoid crowds, pick the winter months. Right now,

LOCATION of brand-new Redwood National Park





TALLEST REDWOOD, left, is a 367-foot giant compared to people shown in foreground

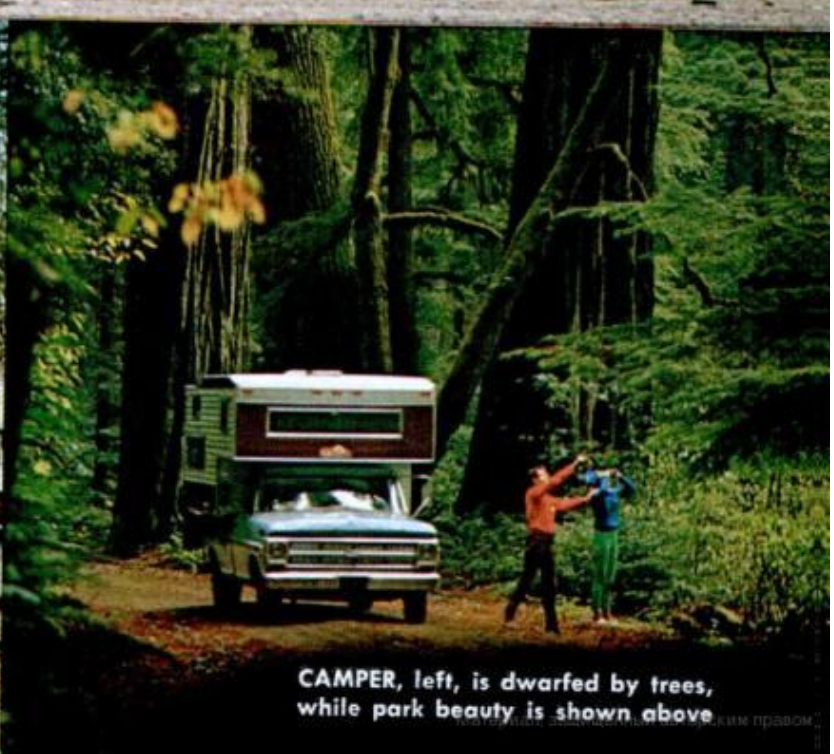

CAMPER, left, is dwarfed by trees, while park beauty is shown above

the new section of the National Park is accessible only over lumber-company roads. In some cases, you need special permission to use the logging trails, so check with park rangers before entering unused regions.

Up ahead in a four-wheel-drive patrol vehicle, my guides slip and bump over the muddy logging road which twists through the perpetual twilight. The redwoods here are so thick and big around at the base—up to 20 feet—you can hardly see where you're going.

We are heading for the boundary between new park and what is still private land. The $\frac{3}{4}$ -ton Ford pickup with 1500 pounds of coach aboard is able to keep up with the more maneuverable patrol vehicle. The Twin-I-Beam front suspension and Flex-O-Matic rear suspension are made for off-level travel.

Though the total weight of truck and coach is 7000 pounds, the extra-wide 10x16.5-in. super single tires give great flotation on the rough roads. The tires are not standard with the Ford 250 Camper Special. But it's a good idea to get them if you plan any driving along logging roads or in rain forests.

Logging trucks can loom up out of nowhere in this back country. Barreling around corners at high speeds, sliding on a dozen or more tires, they

throw up a solid wall of mud-spray as they come charging down the mountain. If you do find yourself on a logging road, keep well to one side. If you hear something coming that sounds like a wall of water from a busted dam—get off the trail fast!

As one old-timer told us, "Log haulers don't slam on the brakes for anything until they hit the bottom of the valley. All that weight would just send the brake linings up in a puff of smoke!"

At this point, Ranger Adams pulls off the road to the right, skids around in a full circle on deep red mud, and waves frantically at me to stop. He sticks his head out the window and yells, "Hold it! Road's washed out ahead."

We park and walk a little way out onto a bluff. On the left, 300-foot trees march solidly up to a stump-dotted ravine. It appears as though some giant claw had slashed through the ancient redwood groves. On the one side, dense forest. On the other, barren hills and fire-blackened stumps. No one says anything for awhile. It gets to you. Finally, I point at the line of demarcation between trees and no trees, "Is that where the National Park boundary begins?" I ask.

Lowell White nods silently.

White's job is to help plan the devel-

DEVELOPMENT of Redwood National Park is now in planning stage. Eventually, the park will include 58,000 acres of prime land for outdoor recreation

TIRE CHAINS are always good to have for back-country travel. Sudden rains can turn a hard-dirt road into a muddy bog. Note the oversized tires

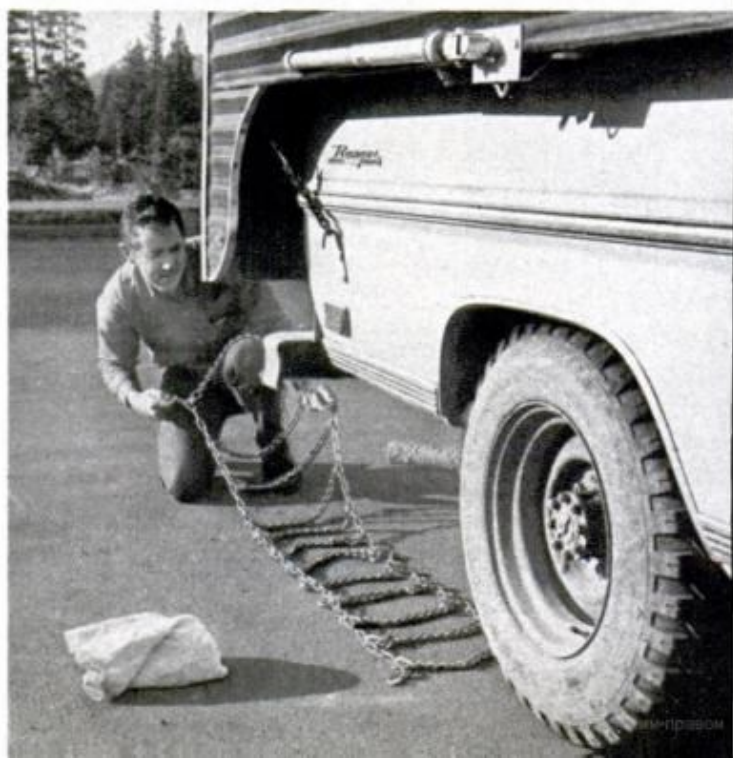
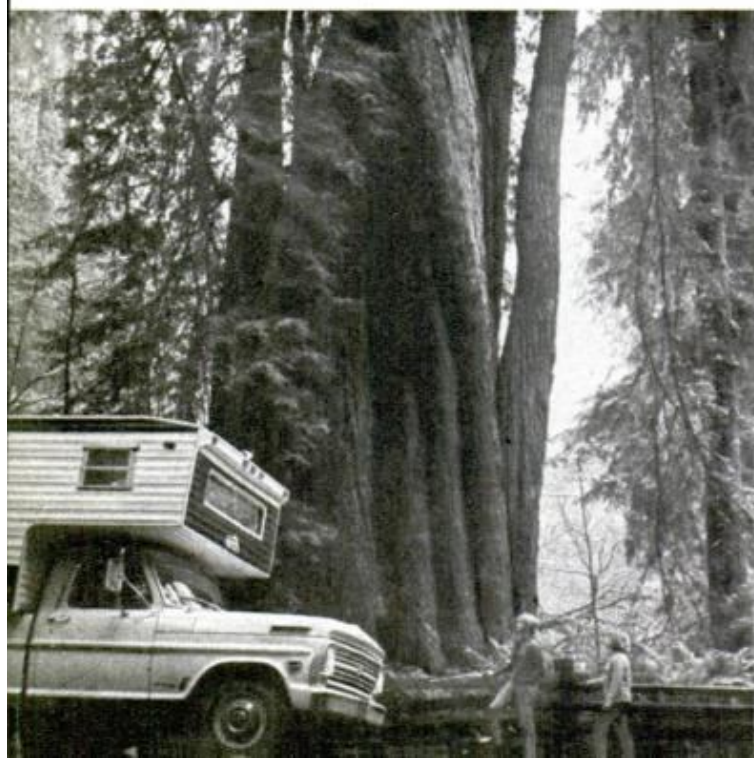

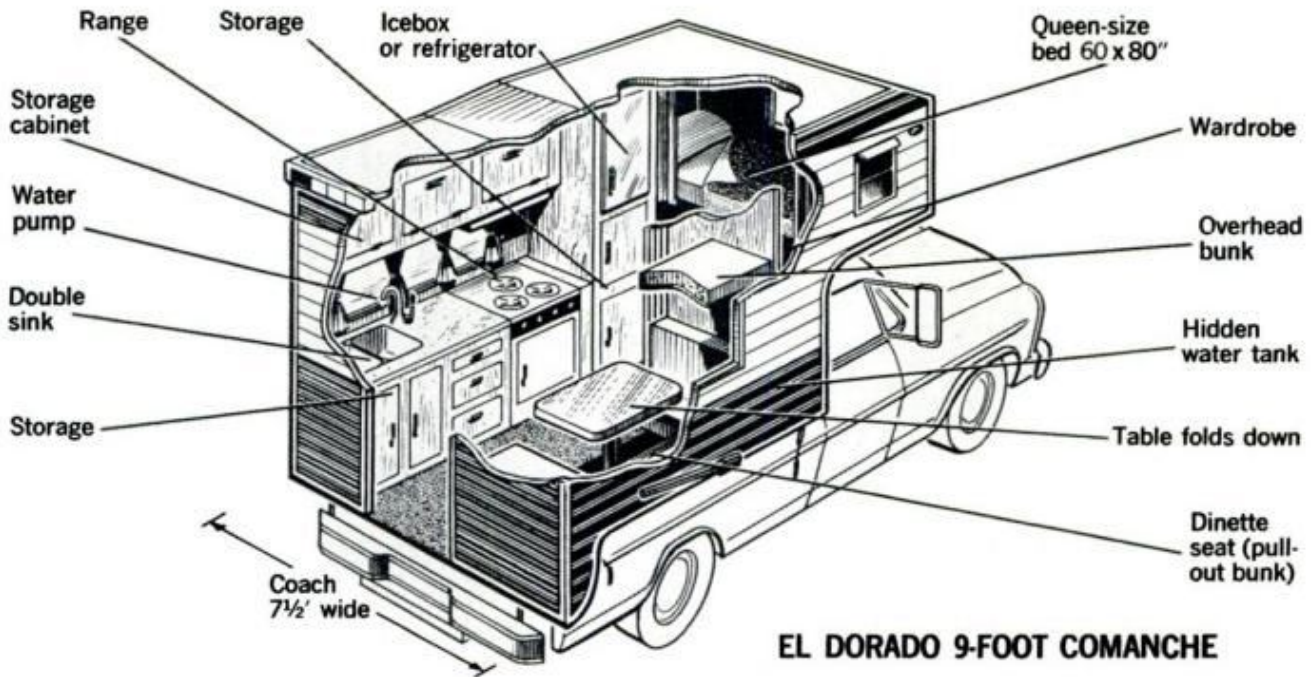

EL DORADO 9-FOOT COMANCHE

opment of the newly acquired redwood lands and the California parks. Should the complete park be operated like Yellowstone and Yosemite with vast campground complexes and large permanent staffs? Or should it be sectioned off into many smaller segments in an attempt to retain its primitive atmosphere? These are only some questions facing Ranger White in the field and Nelson Murdock, the first superintendent of Redwood National Park.

What does this mean to the average camper? For the moment not much has

SANITARY DUMPING STATIONS are available in the parks operated by the State of California. These parks soon will be added to the federal lands

changed. California will continue to operate the three extremely popular campgrounds within the Redwood National Park region: Jedediah Smith State Park, Del Norte Coast Redwoods State Park and Prairie Creek Redwoods State Park. Facilities at those locations are excellent.

Up here in the new park, I spend each night listening to rain dripping off branches hundreds of feet over the camper roof. Every morning, as I ready our gear for the day, I see the subtle changes wrought by rain forests. Shoes

(Please turn to page 210)

STARK CONTRAST between the federal park land and privately owned lumber territory. The new Redwood National Park starts with the treed area

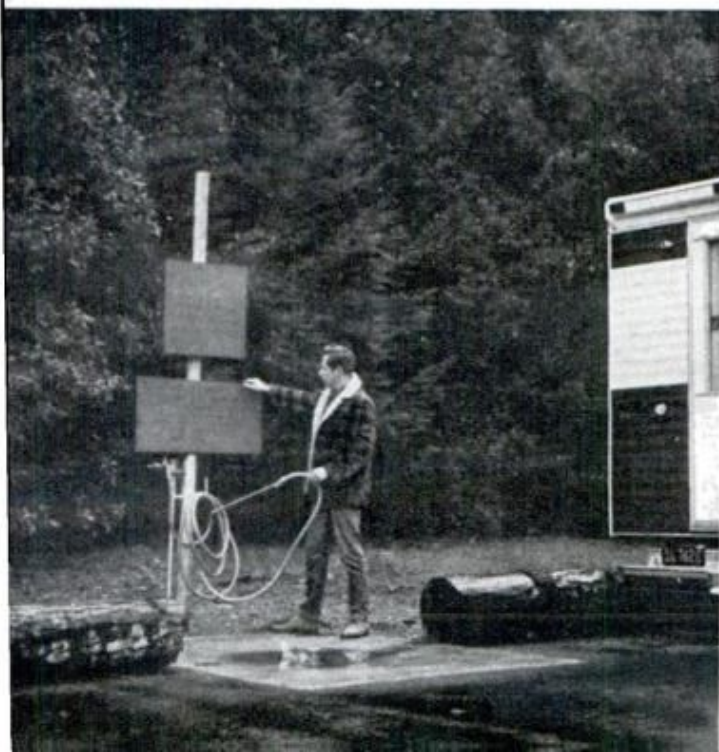

From Florida to Cape Cod— Without Moving

Hitchhiking a ride on the Gulf Stream, Dr. Jacques Piccard will turn off the motors of his unique submarine and drift on an amazing underwater voyage.

By WALLACE CLOUD

WHEN I CLIMBED UP THE SLOPING DECK of the submarine from a rubber boat, she was in the last stages of fitting out at West Palm Beach. (It seems awkward to call a sub named *Ben Franklin* "she," but there's no way around it.) By now test dives have taken place, and soon she'll be towed out to sea, with Jacques Piccard, a Grumman skipper, and Navy scientists aboard. The *Franklin* will sink and remain submerged for a month or more, slowly drifting some 1500 miles up the Gulf Stream like an undersea *Kon-Tiki*.

Throughout the voyage, Dr. Piccard told me, the sub may remain in the same cubic mile of seawater as it moves from Florida to the vicinity of Cape Cod. In the

Artist's concept of the *Ben Franklin* as it leaves the Blake Plateau (background) and begins descent to 2000 feet. Band of light blue is deep-scattering layer of plankton (shrimp and small fish) around which tuna swim. Strippers feed at the edge of the Plateau and giant sea squid lurk in the depths.

BEN FRANKLIN IN PREVIOUS POSITIONS

BLAKE PLATEAU

MAGNETOMETER

PROPULSION MOTOR

Illustration created exclusively for Popular Mechanics by renowned oceanographic artist, Ed Valigursky



SUPPORT VESSEL

SUPPORT VESSEL

6-INCH FILM CANISTER

SURFACE RADIO ANTENNA

TRACKING PINGER

TV CAMERA

SURFACE LOOKOUT

MEASURING DEVICES FOR TEMPERATURE, SALINITY, DEPTH, SOUND, VELOCITY

SONAR

TRANSMISSOMETER

AMBIENT LIGHT METER

CURRENT METER

SENSOR

35-MM STILL CAMERA

SIDE-SEEING SONAR

70-MM CAMERA

TELEPHONE

SUB-BOTTOM PROFILER

TURBULENCE METER



DR. JACQUES PICCARD, designer of the *Trieste*, in conning tower of the *Franklin* at port of Palm Beach

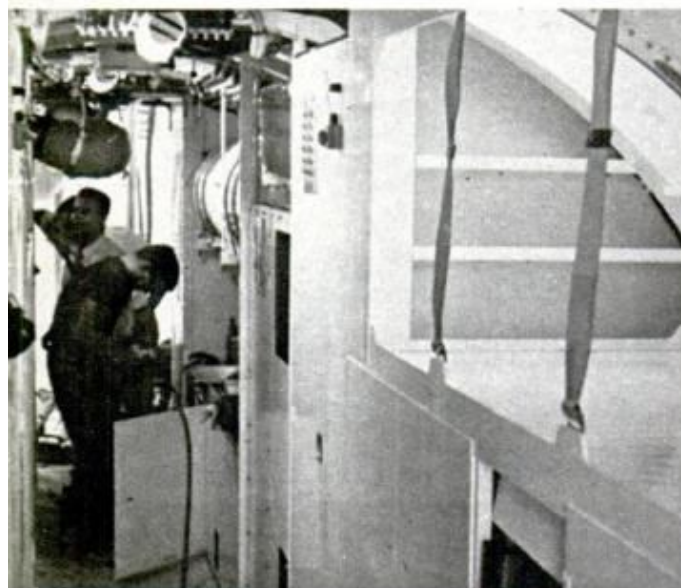

ENGINEERS CHECK WIRING in control area of the *Franklin* prior to test dives. Wardroom is beyond

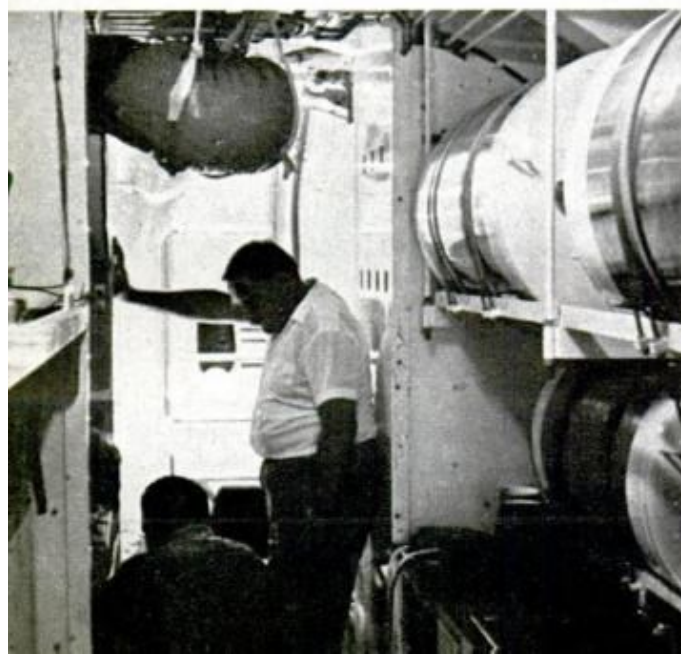

gloom 300 to 2000 feet below the surface, the six men aboard will get to know that volume of water intimately. They will monitor its changes in temperature, observe the intrusion and diffusion of surrounding water, and watch the marine creatures that enter and leave their moving cell of fluid. In a submarine that floats soundlessly at any depth down to 2000 feet, they will become a part of the Gulf Stream, that river in the sea that carries 22 times as much water as all the land rivers of the world. Under tons of pressure, they must trust the Gulf Stream to take them for a ride; they will trust their vessel, designed by Grumman Aircraft Engineering Corp. and Dr. Piccard, to bring them safely through it.

A man of enormous drive, Piccard has already been to the deepest spot in the ocean, the bottom of the Marianas Trench, 35,800 feet down in the Pacific. He went there for the U.S. Navy in the bathyscaphe *Trieste*, which he designed with his father, Prof. Auguste Piccard, the famous stratosphere balloonist.

Before christening, the *Ben Franklin* was designated PX-15—the 15th Piccard experimental design. The numbers start from the world's first bathyscaphe, FNRS-3, which the Piccards built for the French Navy. *Trieste* was their next bathyscaphe. Another vessel, the *Auguste Piccard*, built in 1963, carried 30,000 sightseers into the depths of Lake Geneva.

In September, 1964, Piccard announced plans for the Gulf Stream drift. He didn't know where the funds might come from—but then along came Grumman Aircraft Engineering Corp. Construction of the PX-15 began in March, 1967, at Monthey, Switzerland. Grumman has spent \$2.5 million on the project so far, owns the *Ben Franklin*, and employs Piccard as a full-time consultant.

The Naval Oceanographic Office, which is participating in the Gulf Stream mission, is the first "customer"

VACUUM-JACKETED TANKS (left) will hold water (to prepare freeze-dried food) at 210° F. for month

POPULAR MECHANICS

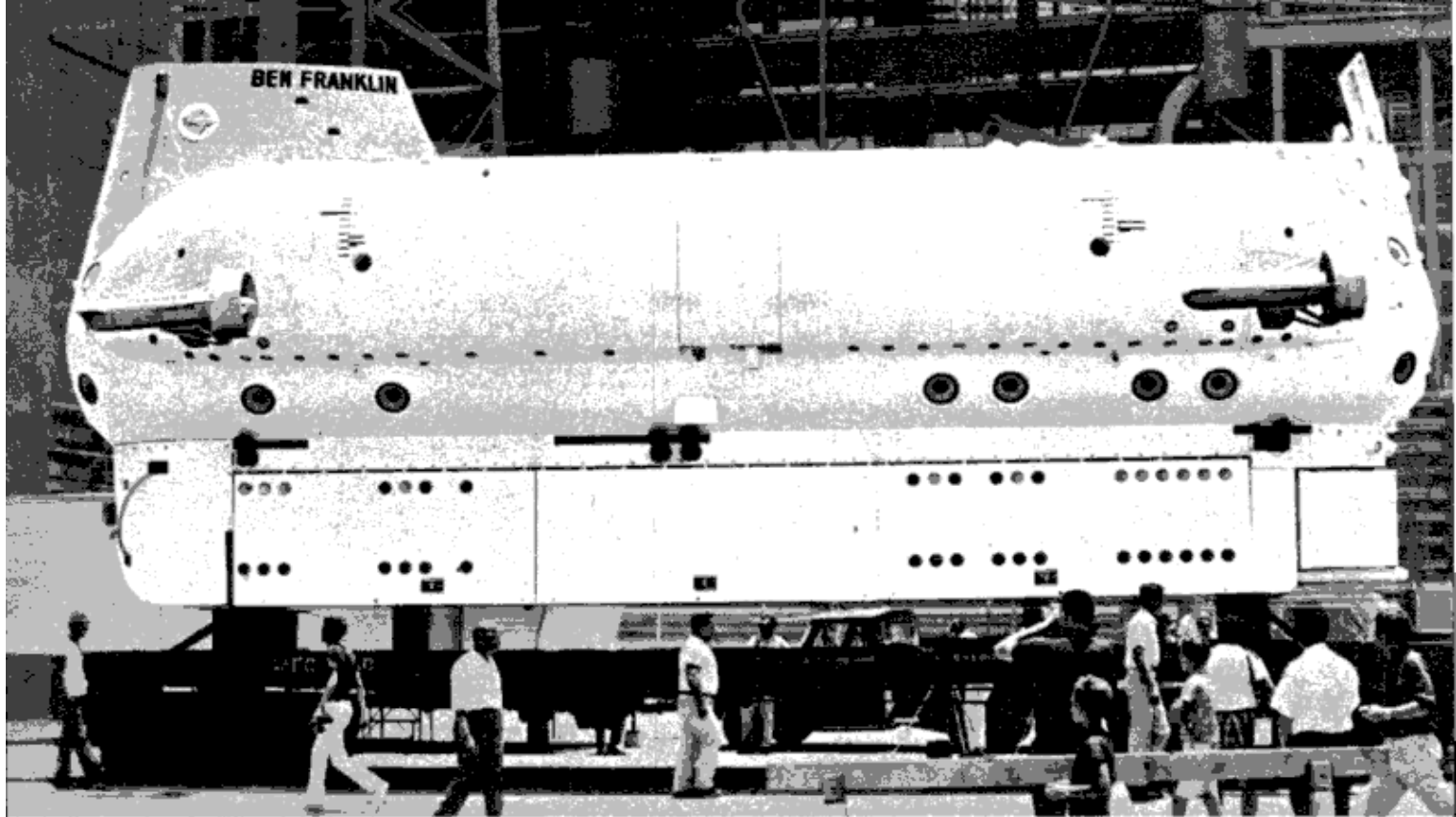

BEN FRANKLIN is simple in basic design. Hull is 10 feet in diameter and capped with hemispherical ends. Length overall is 48 feet 9 inches. Four swiveling 25-hp electric motors jut from the hull, two at each end

to use the *Franklin*—a “mesoscaphe” or submarine designed for middle depths. Her maximum cruising depth is 2000 feet.

When I visited the sub at Palm Beach, engineers were busy making sure the boat will do everything required of her. Mooring lines held the yellow-and-white sub well out from the concrete bulkheads of her slip. She rolled a surprising amount, and that was the simplest way to avoid damage to the fiberglass ballast tanks and the motors, which project at the sides, said her skipper, Don Kazimir, a former Navy submariner.

The *Ben Franklin*, although a highly sophisticated research vessel, is surprisingly simple in design. Her pressure hull is a cylinder 10 feet in diameter, stiffened with 16 rings inside and capped with hemispherical ends, all welded of 1 $\frac{3}{8}$ -inch high-strength steel. Total length is 48 feet 9 inches. Slung beneath the hull is a “keel” consisting mainly of 26 tons of lead-acid storage batteries in an aluminum framework. Above the hull is a narrow metal deck, with a small conning tower forward. Bulging below the sides of the deck

are ballast tanks. Four swiveling 25-hp electric motors jut from the sides of the hull at each end.

Inside, the sub was like a long corridor lined with bunks, workbenches and electrical gear. A portable air conditioner on the dock was blowing cold air into the forward hatch. Florida sunshine penetrated the clear water outside to pour through the three-inch-thick plexiglass windows in the ends of the hull (there are 29 viewports in all). Kazimir said a community of barnacles had already adopted the *Franklin*, some living comfortably on antifouling paint around the portholes. With no way to get out and wipe the windows, it's a question how good visibility will be by the end of the trip.

In the cockpit, engineers were checking out motor controls and power circuits. Divers beneath the hull were spotting faulty electrical connectors which had to be replaced before test dives could begin. Using electrical equipment in saltwater is the biggest operational difficulty facing the crew, Piccard told me.

Going through the hatch, I noticed a

(Please turn to page 212)

Will the Eagles



DAN GURNEY dices with three-time winner A.J. Foyt (right) and Carl Williams (left) at early point in last year's race. Gurney completed the full 200 laps, finished second. Williams drove 163 laps for 15th spot, Foyt 89 laps for 20th

CHECKING A CAP SEAL on his Coyote before start of '68 race is A.J. Foyt, who this year entered two new cars, both powered by turbo-charged Ford engines. Foyt has his heart set on becoming only man to win Indy "500" four times

Photo by Robert P. Crossley

THE OLSONITE EAGLE Gurney drove to second place last year later went on to win events at Mosport and Riverside. Throughout campaign, car was powered by stock-block pushrod Ford, same engine Dan may use for this year's Indy classic



Scream Again?

All-American Racers' Eagles finished 1-2-4 at Indianapolis last year. This year's hot flock by Gurney & Co. will be even thicker

By **BILL KILPATRICK**, Auto Editor /Photos by Stanley Rosenthal

THE MOMENT you walk in the door of Dan Gurney's "store" in Santa Ana, Calif., you know right off the bat what the principal activity is. The framed photographs and plaques hanging on the walls, the glistening trophies, the publications scattered on the waiting room tables all spell one thing—auto racing, and lots of it.

In fact, keeping an ear tuned to the conversation between the steady flow of vendors, suppliers, friends, well-wishers and Gurney personnel darting in and out will tell you specifically what race—or type of racing—is on everybody's mind at the moment.

You can bet the chatter at All-American Racers these past few months has been all Indianapolis and the annual 500-mile race. For AAR, through Gurney himself as a driver, and through the Eagle cars his organization designs and builds, has a big stake in Indy.

Last year, '68 USAC champion Bobby Unser won the race in an Eagle. Second in another Eagle was Gurney. Fourth in yet another Eagle was '68 Can-Am king Denis Hulme.

Bend the arm of anyone involved in fielding a race car and they may allow that finishing first is better than a poke in the eye. But when cars upon which a dedicated team has lavished its time, talents, energies, hopes and enthusiasms finish 1-2-4 in the world's richest, most prestigious auto race . . . well, it all

seems somehow worthwhile.

"The only trouble with that sort of success," Gurney will say with a wry smile, "is that nothing less than repeating in kind—perhaps even more so—will seem entirely satisfactory."

But considering the number of Eagles slated to see action at Indy this month, Gurney and his organization stand a pretty good chance of doing just that—repeating in kind, perhaps even more so.

Leading the assault of new aerodynamic Eagles will be Gurney himself. He'll drive one of two cars earmarked for his use; the second will serve as a backup. A third new car will be driven by Hulme as a member of the AAR team. A fourth new Eagle is in the hands of engine whiz Smokey Yunick, who—as this is being written, in mid-February—has yet to name a driver.

"Vintage" Eagles (all '68s) on hand for practice this month probably will be piloted by such stars as Bobby Unser, Gordon Johncock, Roger McCluskey, Jerry Grant and Ronnie Bucknum. Just how many Eagles will be on the grid following time trials May 17-18 and May 24-25 is, of course, up for grabs. But it's safe to say that come race day, May 30, All-American Racers will be able to see a fair sampling of its handiwork in action.

"Our '69 Eagle car building program was held up for a couple of reasons," Gurney explains. "For one thing, we

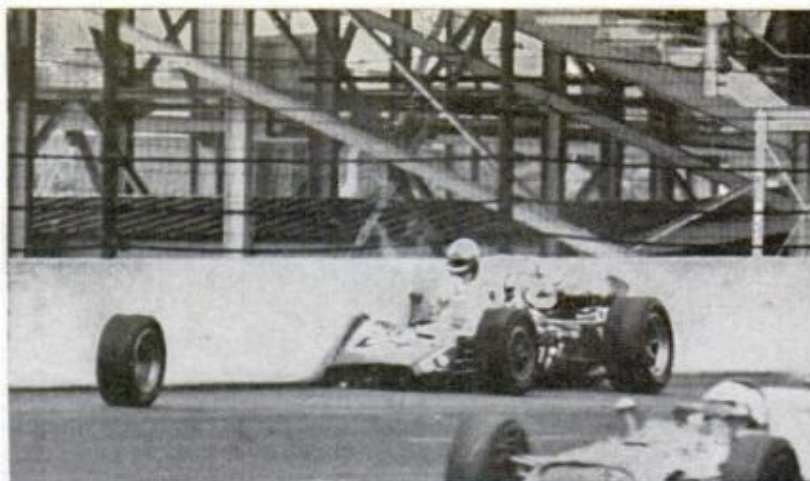
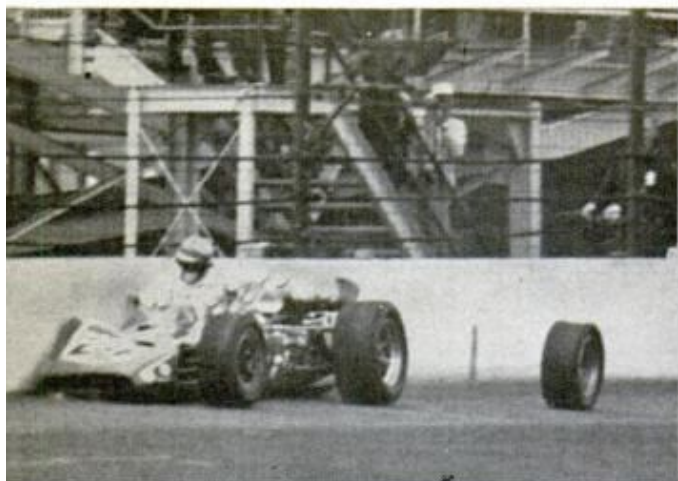

AL UNSER hit the wall last year when the right front spindle of his car let go during the 41st lap. He man-

wanted to wait and see what rule changes USAC would issue pertaining to Indy. For another, some of our engine-development work was behind schedule a bit, and that delayed some of our final decisions.

"And then, of course, there's the fact this is a bucks-up business and we just didn't get firm orders in time to build as many new cars as we would have liked to. As it is, I think we'll be going to Indy with the finest two-wheel-drive cars ever seen out there."

Gurney plans to field his Eagles powered by one of three special Ford engines: 161-cu.-in. turbocharger, 320-cu.-in. pushrod or 305-cu.-in. pushrod, the latter two with Gurney Eagle heads.

"The turbocharger is said to crank

out about 700 horsepower," Gurney said, "but we've never gone to Indy with more than 550. Even considering how well we did last year with the 305 engine over the season, it's hard to ignore all that turbocharged power, so we'll look them all over pretty carefully."

Even if Gurney decides against the turbocharged Ford, the engine will have several proponents this year. Three-time Indy winner A. J. Foyt will use it in his new Coyote, Parnelli Jones plans to install one in the Lotus chassis Joe Leonard put on the pole last year when the car was turbine-powered, Mario Andretti will use the engine in his new four-wheel-drive Lotus, and Al Unser (brother of Bob) will have one in a new four-wheel-drive

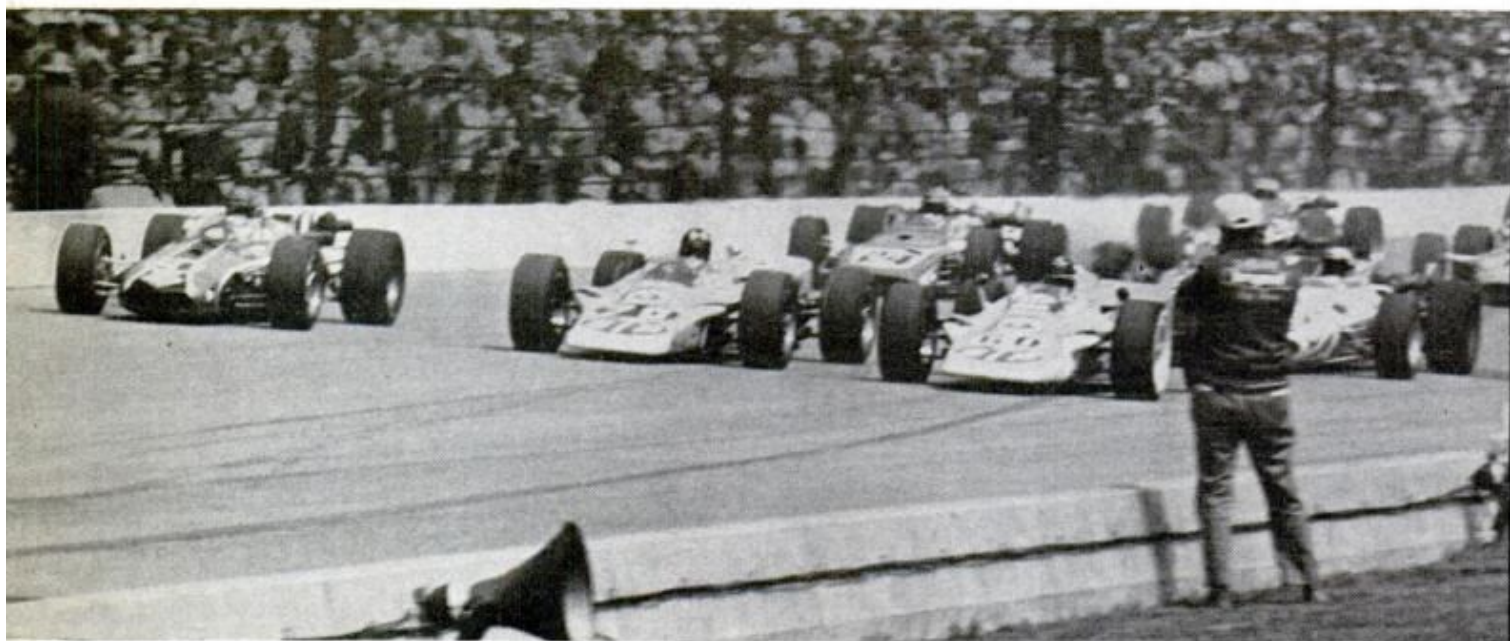

TURBOCARS of Hill (70) and Leonard (60) battle with Bobby Unser for first-turn honors at start of '68 race

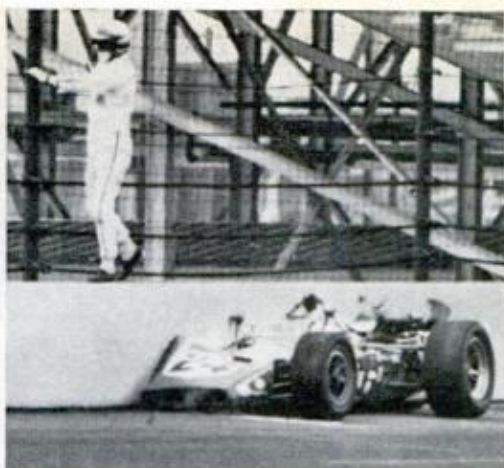
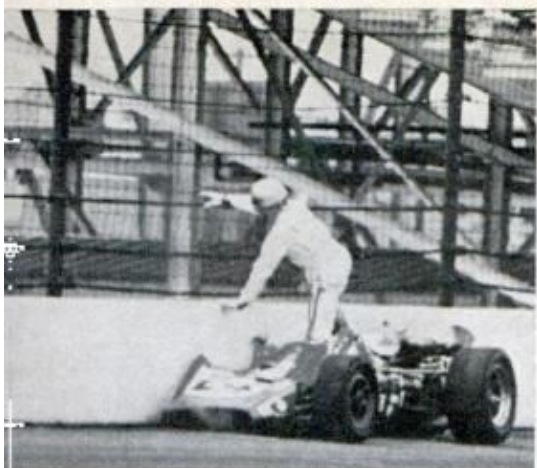

aged to scramble clear, but debris from the crash eliminated both Arnie Knepper and Gary Bettenhausen

Lola being masterminded by Indy veteran George Bignotti. This last one could be a red-hot car in that Bignotti did much of the development work on the turbocharger and presumably knows its whims and whams.

Not without its advocates, of course, is the tried-and-true turbocharged Offy, the engine that powered Unser to victory last year. He'll use it again, possibly in an Eagle or in a new four-wheel-drive Lola, as will '68 third-place finisher Mel Kenyon and the veteran Lloyd Ruby. The latter's new car was built by Dave Laycock, is owned by Gene White and sponsored by Wynn Oil. Also slated to use the Offy are such stars as Johncock, McCluskey, Gary Bettenhausen, Bill Vukovich and several others.

Something new at the Speedway this year will be at least two Chevrolet engines, one a 320-cu.-in. pushrod that may wind up in a four-wheel-drive Lola being prepared by Roger Penske for road-racing star Mark Donohue. At last word, Penske was also flirting with the idea of using the Offy, but his ties to Chevy have always been right out there for all to see. The other Chevy could be a 203-cu.-in. turbocharger in Jerry Eisert's new car, or in the '68 Eagle Weinberger Homes bought from Penske for Ronnie Bucknum. Driver of the Eisert car will probably be Jerry Grant.

No one is too sure what Colin Chapman's annual Lotus invasion will con-

(Please turn to page 219)



LIKE SO MANY BEES, Bobby Unser's pit crew swarms all over his winning steed at midpoint in the race



HOW SWEET IT IS! A weary Unser and his relieved wife accept the crowd's tribute after his big win.

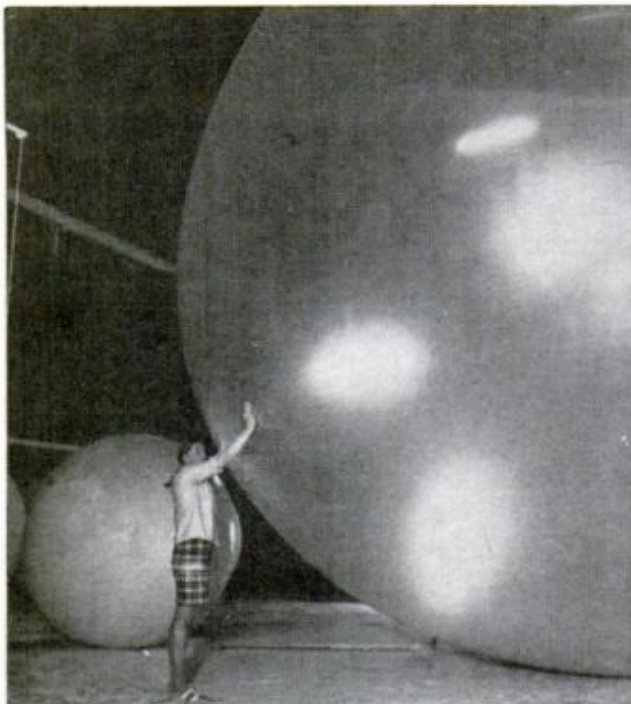

Assembly-line inflation

Weather balloons, undergoing inflation tests, give the appearance of a big circus at the Guide Bridge Rubber Co. in Britain. The firm exports 200,000 units per year.

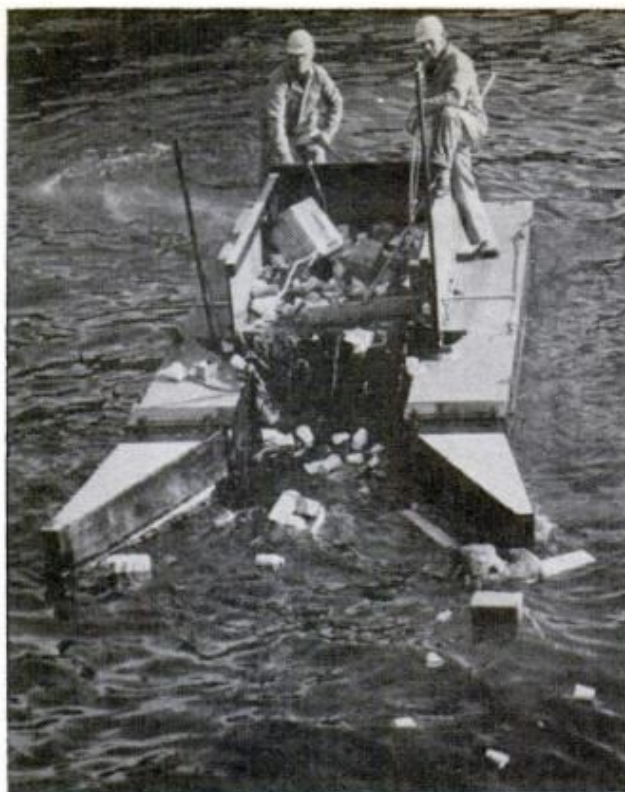

Rubbish 'eater' cleans bay

Floating rubbish is "gobbled up" in San Diego Bay by this 20-foot, outboard-powered craft. The trash is lifted by a hopper, deposited on the boat, then carried away.



Olympic tower in Munich

The Olympia Tower is already standing in Munich where the 1972 Olympic Games will take place. The 900-foot tower, built for television, will be a symbol of the games.



Fresh air for ground crew

This Bendix cryogenic backpack converts liquid air to breathing air for personnel loading toxic propellants aboard the LM spacecraft. It carries a two-hour supply.



Matsushita honors scientists

Eleven pioneers in science and industry are honored in a new display placed on the square in front of the Central Research Laboratory of Matsushita Electric in Japan. Ten bronze busts are grouped around a statue (above) of Thomas Edison. The bust shown closeup at left is of Sakichi Toyoda, Japanese inventor of the automatic loom and circular loom. In all, there are five Japanese pioneers and six from the United States and Europe.



New money transporter in Cologne

A firm that transports money and other valuables in Cologne has designed a new kind of armored car. The valuable items are carried in separate containers—like so many safety deposit boxes—and can be removed only when an authorized person unlocks the elaborate system of electrical and mechanical safeguards.



FIRST JEEP CAMPER UNIT should be available this spring. The rig is an 8-ft. El Dorado coach with wheels hooked to 81-in.-wheelbase Jeep Universal. Passengers ride inside coach. Jeep plans unit price under \$5000

New Camp Rigs for '69

Sharp-eyed quality control, new ideas and lots of models are all yours in a booming year for recreation vehicles

BY DAN FALES, *Outdoors Editor*

FIRST THING you'll spot in recreation vehicles this year is better workmanship. There's been a concerted effort within the industry for better quality control. Interiors are now being put together with an eye to smoothing out rough edges.

Workmanship has been a problem in the past—especially in the various types of conversions. When a van-maker finishes a vehicle, he turns it over to another company to add equipment to make it a camping van

FORD'S NEW MINIHOME is 123½-in.-wheelbase Econoline Super Van with camper conversion. Price: \$4800 as standard with 205-hp V8 engine

138

POPULAR MECHANICS





STARCRAFT'S new camper coach is arranged to allow additional interior space. Note the top and back design

APACHE'S NEW SCOUT is designed for the lower-priced market. This 7½-ft. tent trailer sells for \$495 plus freight. It has full, 7-ft. headroom when raised, and is 40 in. high when closed. Scout is the low end of the Apache line, which is topped by the 13-ft. Ramada for \$1675 plus freight



COLEMAN'S NEW CT 360 is a 7-ft. tent trailer which opens to a width of 15 ft. 11 in. This four-sleeper sells for \$695 plus freight. Coleman's line runs from the CT 360 up through the 11-ft. hardtop camper trailer called CT 390 which has a galley, sleeps eight adults and sells for \$1665 plus freight



NIMROD'S CAMELOT is a hardtop camper trailer which shows company's new "tent" design with wide, screened openings. The Camelot is designed to let you equip your own interior. Standard are zip-in screen door, linoleum, under-coating, high-impact thermoplastic hardtop. At \$1269 plus freight, it's the middle-range Nimrod model





AVION'S FUTURA 31 is experimental travel trailer which has aluminum exterior transformed into a gold color. From this super-luxury model, Avion plans to take features and incorporate them in the company's four production models running from the 22-ft. Tourist to 31-ft. Imperial. Avion has two camper coaches, too



GLASTRON'S new motor home is just entering the market this year. The 21-ft. vehicle is a one-piece fiberglass body mounted on Dodge M-300 chassis with 212-hp. 318-cu.-in. engine. Beds for six fold into lounges for daytime travel. There's a shower stall, bathroom, dinette, galley, heater. Glastron is pricing standard model at \$10,500 plus freight



WINNEBAGO'S motor homes come in variety of sizes from the D-27 model to the F-17. Equipped as standard, the 27-ft. model goes for \$10,420 plus freight; the 17-ft. unit for \$5,705 plus freight. Winnebago has also announced a 22-ft. traveling man's motor home that he can custom fit. Company also makes travel trailers in sizes 17½ to 23 ft.

or the like. In some cases, the conversion results in rough and sharp edges where a roof has been "elephantized" or a window added. In some camper coaches, you would get splinters in your hands from rough-cut wood. Weatherstripping in many vehicles didn't do the job.

But now the producers are taking note of the complaints by cracking down on poor quality. You'll see the results this year. You'll also see model after model of a particular make. RV manufacturers are giving you almost as many choices this year as the automakers. Some RV companies are adding two or three low-priced models to their lines as well as new superluxury rigs. Others are not only adding at both ends, but expanding in the middle, to give you a rig for just what you want to pay.

It's true that prices on some makes are higher this year—perhaps \$100 or more on each unit. Many justify this increase by making some features standard instead of "extra."

On the other hand, it's also true that there's a definite trend to make spacious RVs that will sell for under \$5000. These rigs are aimed at the "second-car" market. Now you can buy a van, or pickup truck or four-wheel-drive vehicle designed as a rig for camping, but easily transformed to an alternate means of transportation around town.

Another trend is one that hit full force last year—self-containment. This year, a new RV will let you travel almost anywhere without causing worry about facilities at stopping spots. There are better galleys in the '69 RVs; better, more permanent heads, and better decor, plus improved water pressure, heaters and a bit more space in which to move around.

The RV industry estimates that 500,000 units will be sold this year. Next year should do even better. The wheel-camping boom is really on. ★★★

MAY 1969



SIESTA'S TELESCOPING CAB-OVER is for the sleek Ranchero pickup. Roof of the unit is 6 ft. from ground in the lowered position, offers 6-ft. headroom when it's raised. A single hand crank is used to operate the roof

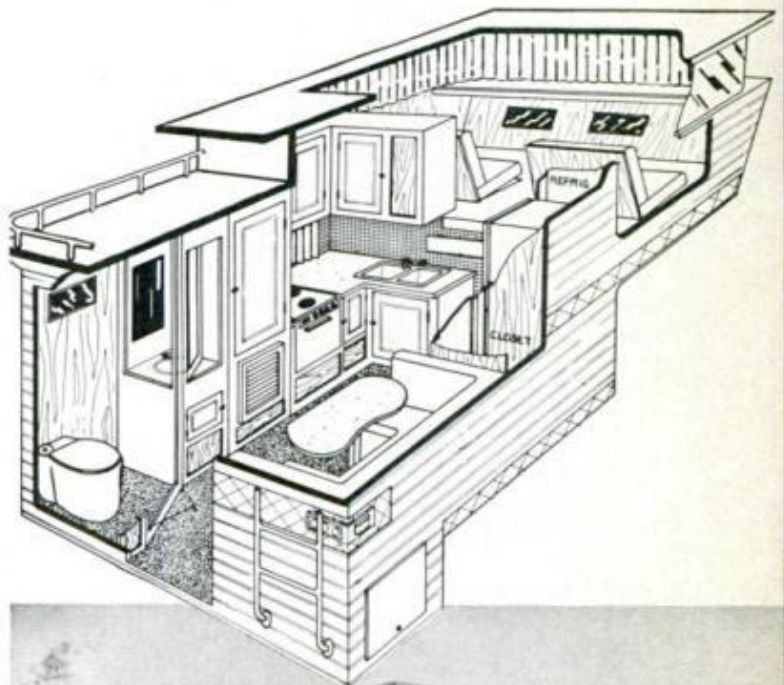

DEL REY'S IMPERIAL SKYLOUNGE is a cab-over coach designed to match crew-cab pickup trucks. The Skylounge (photo above and cutaway) comes in three different interior layouts. It's planned for big-family use

141

They're Awful Mean To Those Little Tractors!

By JAMES M. LISTON, Executive Editor

TORTURE TRACK used for large tractors is also used to test International Harvester Cadets. Treadmill, controlled from console (below), gives drawbar, cooling, temperature readings

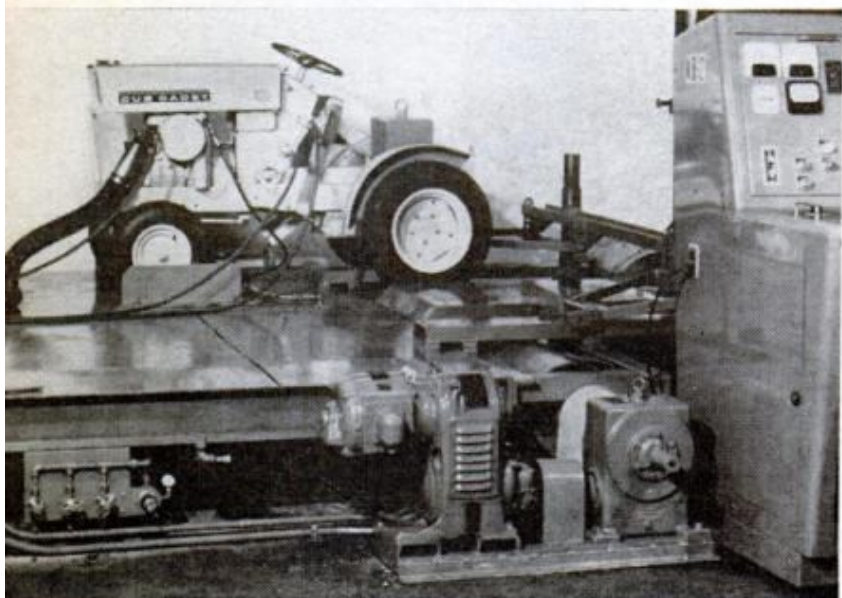

HOW GOOD are today's garden tractors? They look rugged—but are they built to stand rugged use? Have the “bugs” been worked out of them? What about parts and service?

To get answers to these and other questions about the testing and development that goes into compact tractors, I traveled to seven states and interviewed 12 major manufacturers.

This comparatively new industry—it had its start in the late '50s—is highly competitive. Most makers who have survived are old-line companies



ABANDONED RAILROAD SIDING next to Case plant (left) is used to bump-test tractors. A Gravely 424 with standard mower chews its way through tall weeds in test of shock loads expected when customers mow overgrown vacant lots



BOLENS' chief engineer, Dave Phillips (left), checks new 7-hp hydrostatic after field test

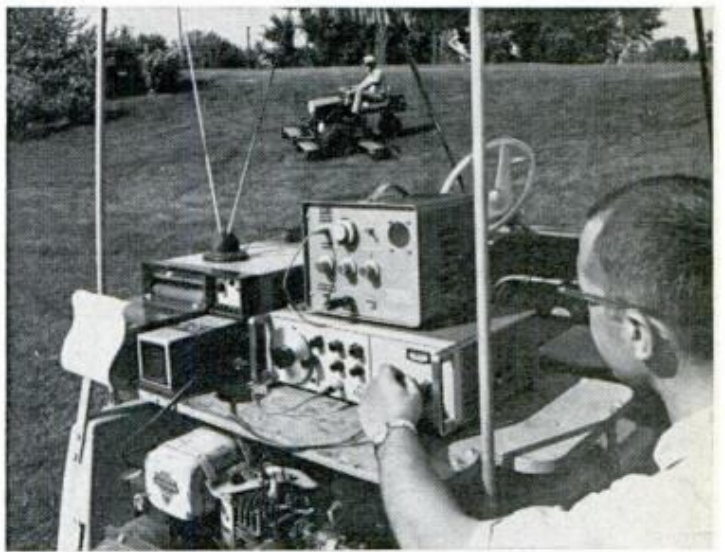

TELEMETRIC EQUIPMENT is used in the field to check the horsepower rating under load of Toro tractors and mowers

that are jealously protecting reputations for quality. Most have highly sophisticated laboratory facilities, but all conduct field tests in which a tractor and its attachments are put through "torture tests" that far exceed the sort of use you'll give it.

Take the Gravely 424 we watched in West Virginia. It had over 300 hours recorded use on a rough pasture. The pasture had been plowed and was now three feet high in weeds. Ruts and high spots had been left that caused frequent scalping by the 50-inch mower and threw sudden, heavy shock loads on the belts. The test was to see if belts from a supplier were up to Gravely specs.

"A lot of our customers are commercial-maintenance people," said Cecil Brake, Gravely's merchandising manager. "If we don't test like this, our equipment won't measure up, and our reputation will be gone. You can't build something and take an engineer's word it will last, say, 500 hours. No matter how good the engineer, he'll never test the way a man will who's actually using it. The inexperienced guy will ram the throttle to it when an engineer would ease back."

"It takes the average owner three years to put 300 hours on his mower," said John Clark, vice-president, engineering. "When you compare an average lawn with this test plot, you can at



TETHERED with a cable, Deere tractor runs in circles day and night, quickly accumulating hours of use. Cart it tows contains test equipment and gasoline

least double that figure. If a machine can handle conditions like this, it will handle ordinary jobs without trouble.

"We're increasing our laboratory testing to be sure that we have the prototype of a new model as right as possible before we start field-testing. We then see what the new product can do under actual field conditions. We make changes, then start our pilot-model runs. When production starts, we pull random samples off the line and put them through their paces in the field. We work them to death. But if there are any bugs in them, we've determined through breakage whether the failure was caused by a

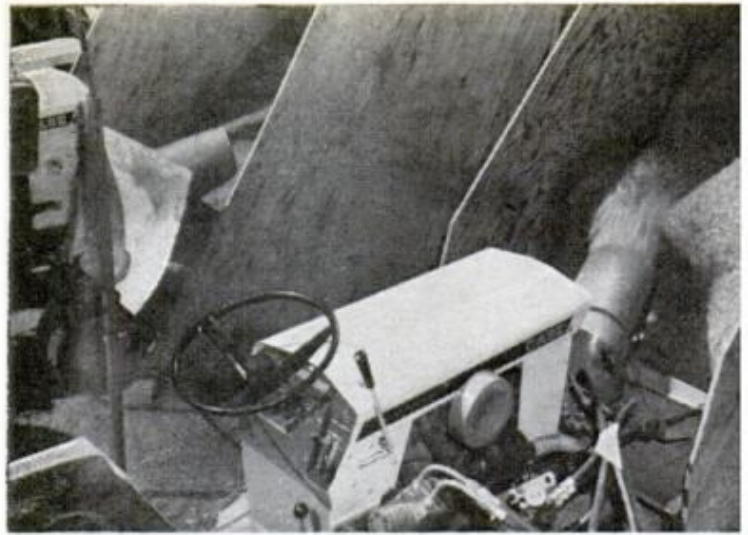

ENDURANCE LIFE of snowblower is tested by feeding the auger a damp mixture of sawdust and sand, and recirculating it. Spout is repeatedly swiveled

malfitting part or defective material and we correct it in production."

Rain was pelting the test track behind the John Deere engineering building at Horicon, Wis., but the driverless tractor, towing a trailer and fuel, continued to go around and around on a tether. It had been running at full throttle for days. Nearby, three other tractors on test stands roared into life, shifted gears, were run under load on a dynamometer, shut down, repeating the cycle endlessly. All were connected to a control panel by air lines, and the panel was set to cycle them 24 hours a day.

Vilho Mutka, test supervisor, had to



LOAD TESTING a Simplicity tractor; lead tractor must work against compression of towed unit. Instruments give drawbar and temperature readings. Control panel (right) is programmed to run Deere tractor on automated start, full load and stop cycle

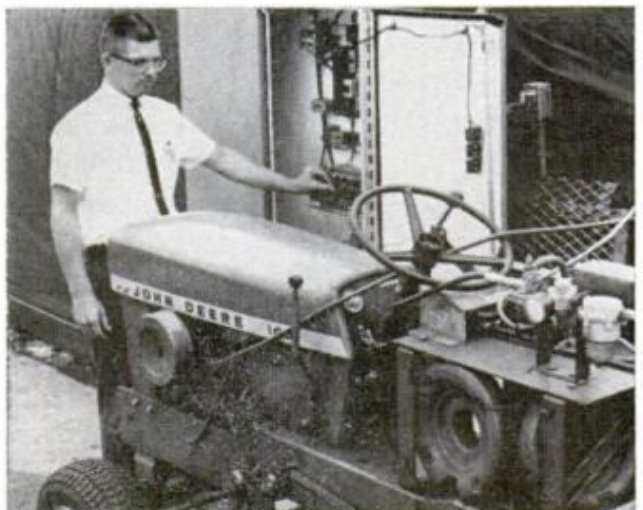



KARTING TRACK near Wheelhorse plant offers ideal condition for scuff-testing tires. Concrete is preferred to turf because it gives quick test results



LADY DRIVERS are employed by Gilson to test tractors and mowers on the theory that if there is a wrong way to operate machinery, women will find it

shout to be heard: "When a failure is reported by our dealers, many hours of use must be piled up in a short time. Field tests are limited by an eight-hour shift, but when the proper tests are set up, we can run continuously until the problem is solved."

"Like the auto industry," says Deere division engineer Jack Hoffman, "we do have 'callbacks.' For years the farm-equipment industry has had 'field changeovers' or 'improvement campaigns.' When a chronic problem becomes apparent, a field kit is issued—particularly if safety is involved—and it is the responsibility of the branch houses and service organizations to see that every machine gets changed. We haven't received as much publicity as the auto industry, but our industry has done this many times. Every reputable manufacturer has a program for correcting problems that were not apparent in prototypes."

Wayne McClellan, service manager, points out that Deere is putting increased emphasis on engineering safety into the product. A four-man board checks prototypes in use for "knuckle-skinners, knee-knockers and upset hazards." The stability of the tractor gets intensive testing, as do seat design and standardization of controls. Test drivers' reports on fatigue include details on backache and legache. Tests determine how hard a woman can de-

press a clutch, how far she can reach for a lever, how much she can lift.

Gilson's field test crew at Plymouth, Wis., includes two female mower pilots on the theory that if there's a wrong way to operate machinery women will find it. A male driver accompanies the girls as they mow, but each must start the engine herself, refuel, and make all adjustments for mowing. If the lady drivers have trouble starting the engine, operating the controls, or experience unusual fatigue, Gilson engineers want to know it. Today, with more women mowing, the company believes that if it designs with them in mind the product will be simpler and safer.

Gilson's test crew occasionally mows the shoulders of a road bordering the plant. Here they find the toughest kind of going—steep embankments, ditches and high, tough grass. I checked their reports after several days of it and the crew proudly pointed to a failure they uncovered. Cracks had developed on two footrests. The cause was apparent: the metal had been bent on too tight a radius. Although the failure had developed after 300 hours (six years of average use) and was the first of its kind, the footrest will be redesigned.

At Port Washington, Wis., Simplicity, like other manufacturers, has found the small tractor is gaining wide acceptance by commercial groundkeepers

(Please turn to page 200)

SIMPLE CHECKER FOR SEMICONDUCTORS

Want to know if a diode is good? Whether you've got the right transistor? This easy-to-make tester will tell you

By JAMES A. FRED

MODERN SEMICONDUCTORS come in a variety of confusing types, often unmarked and untested. If you keep a junkbox full of unknown parts or like to browse for secondhand bargains, this handy checker for semiconductors—I call it a Semi-Check for short—will save you a lot of grief. It will detect opens and shorts in diodes and transistors, determine PNP and NPN polarity, test for leakage and check the triggering of SCRs.

Powered by two 5.4-volt Mallory mercury batteries, the device consists of a No. 49 2-volt test lamp and a double-pole, double-throw slide switch that reverses current polarity for determining transistor types. A single-pole switch lets you check for leakage between the emitter and collector with the base open or with the base connected to the emitter.

The E, B and C test leads terminate in small alligator clips. A 200-ohm variable resistor (Mallory MTC 22L4) is connected in series with the test lamp. Start with this in maximum clockwise position, then connect the C and E leads together. With a 0 to 10-volt d.c. voltmeter across the lamp bulb, adjust the resistor until you read 1.9 volts. This protects the 2-volt bulb from excessive voltage.

Everything fits into a tiny chassis box

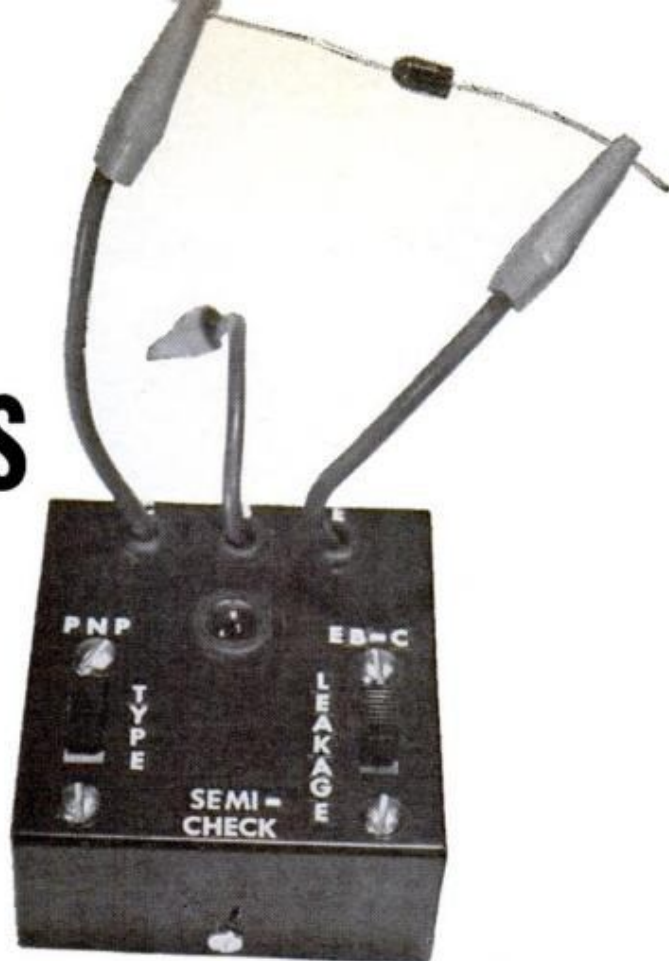

smaller than a pack of cigarets. Use a rubber grommet to form a protective collar for the lamp. The parts are readily available at radio stores or electronics supply houses such as Allied Radio in Chicago and Lafayette Radio in Syosset, N.Y. Here's how you use the checker:

To check a diode: Connect the anode to the E clip and the cathode to the C clip. With the polarity switch in the PNP position, the lamp will light if the diode is good. With the switch in the NPN position, the lamp should not light. If the lamp lights in both positions, the diode is shorted. If it doesn't light in either position, the diode is open.

To check an SCR: Connect the anode to the E clip and the cathode to the C clip with the polarity switch at PNP. The lamp should not light until the gate is connected to the B clip with the other switch in the EB-C position. The lamp should stay lit until C is disconnected.

To check a transistor: First, determine the type—PNP or NPN. Connect the emitter, base and collector terminals to the corresponding E, B and C test clips. The accompanying diagrams show the terminal arrangements for five common transistors. Slide the polarity switch to the PNP position. If the bulb doesn't light, slide the switch to the NPN position;

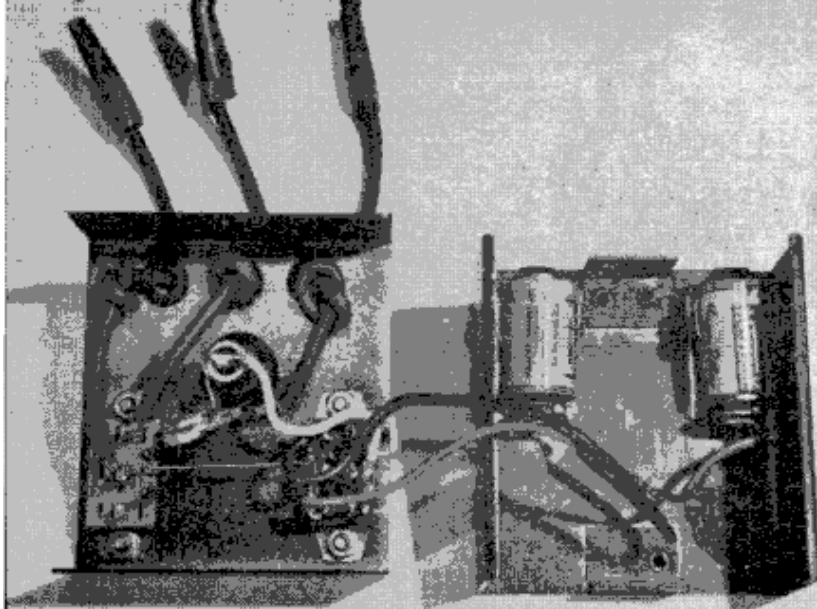

BASE DIAGRAMS OF COMMON TRANSISTORS

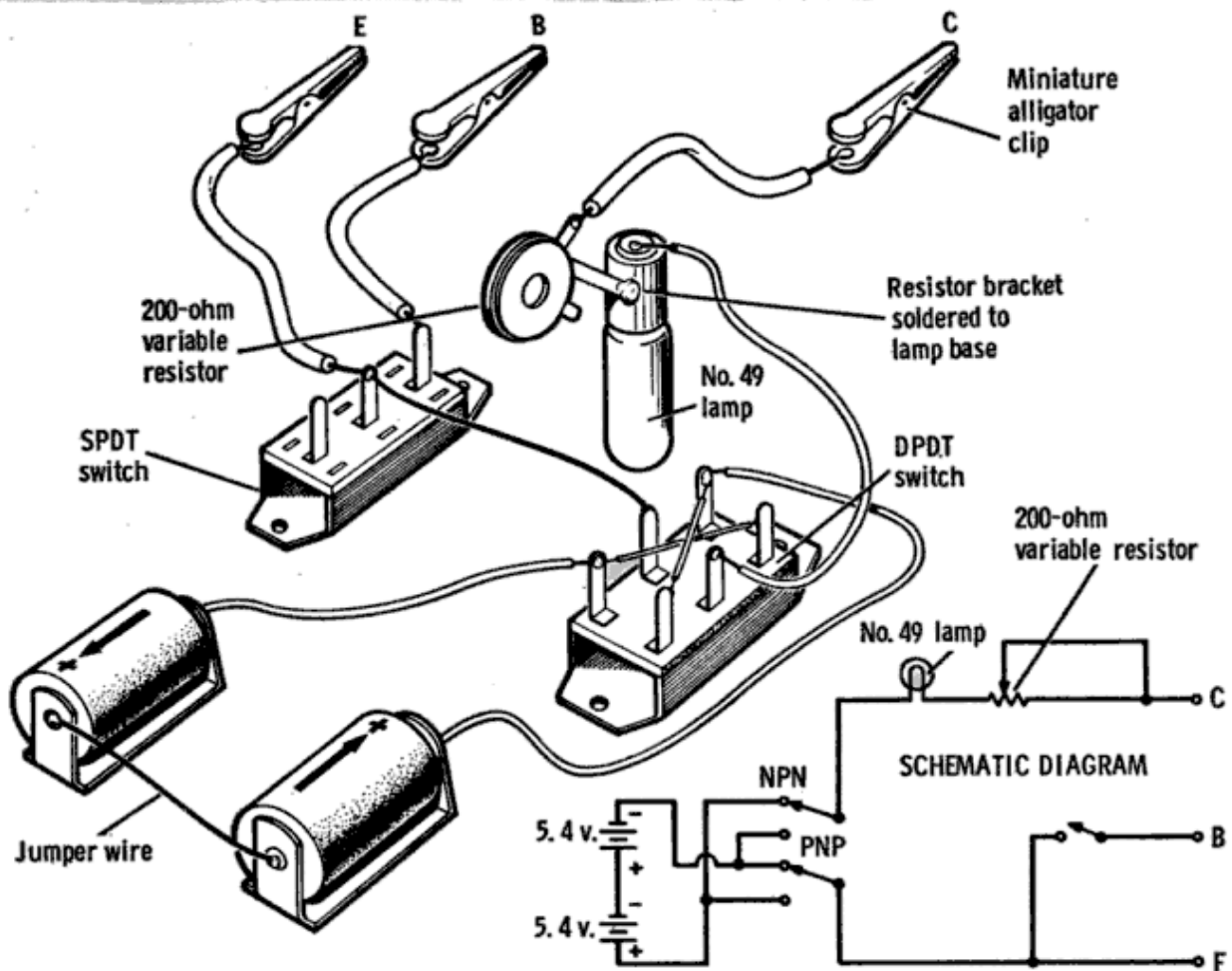
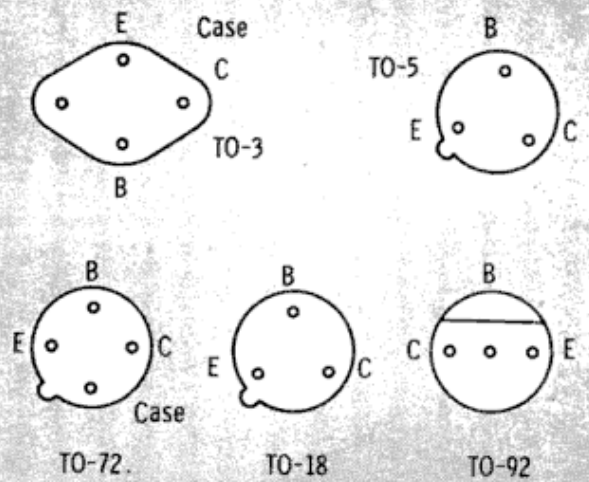

it should light in one position or the other. The position in which the bulb *doesn't* light indicates the type. If the bulb doesn't light in either position, the transistor is open. If it lights in both positions, the transistor is shorted.

Next, check for leakage. With the polarity switch set to indicate the type of transistor under test, slide the other switch away from the EB-C side. This checks leakage from C to E with the base open. The degree of light will indicate the amount of leakage. An ideal transistor

will show no light. Now slide the switch to the EB-C position. This connects the base to the emitter. Ideally, there should be no increase in light intensity. A power transistor will usually show leakage; a small signal transistor should show none.

One final caution: Be sure to install the batteries as indicated for proper polarity. Reversed polarity will cause the checker to give opposite indications from those described. If this should happen accidentally, reverse the batteries before continuing. ★ ★ ★

Dry-Mount Your Favorite Photos For Display

Simple adhesive tissue you iron on, some white mounting board and a dramatic black backdrop make a slick way to show off prized pictures

By BOB CORLEY

IT'S AMAZING what some plain white mounting board and a contrasting backdrop will do for photographic blow-ups. By displaying your best shots on a background panel, you can create a striking wall decoration for a living room or playroom and at the same time enjoy pictures that otherwise get stored away in a bureau drawer for no one to see.

You don't need an expensive mounting

MOUNTING MATERIALS ARE SIMPLE. All you need is dry-mount tissue, white mounting board, a razor blade or scissors and your wife's pressing iron. Prints look best with borders trimmed off flush

press, either. The secret lies in readily available dry-mount tissue. This is a special adhesive sheet that, when heated, melts and bonds a print smoothly and firmly to mounting board. The tissue is sold at photo shops and artists' supply stores in several sizes.

Mounting board is a heavy white cardboard, also available in various sizes at photo and artists' shops. For 8x10 prints,

LAY MOUNTING TISSUE over back of print and touch the center briefly with tip of iron. This tacks tissue in place temporarily. Trim off the excess tissue at edges with a razor blade or scissors

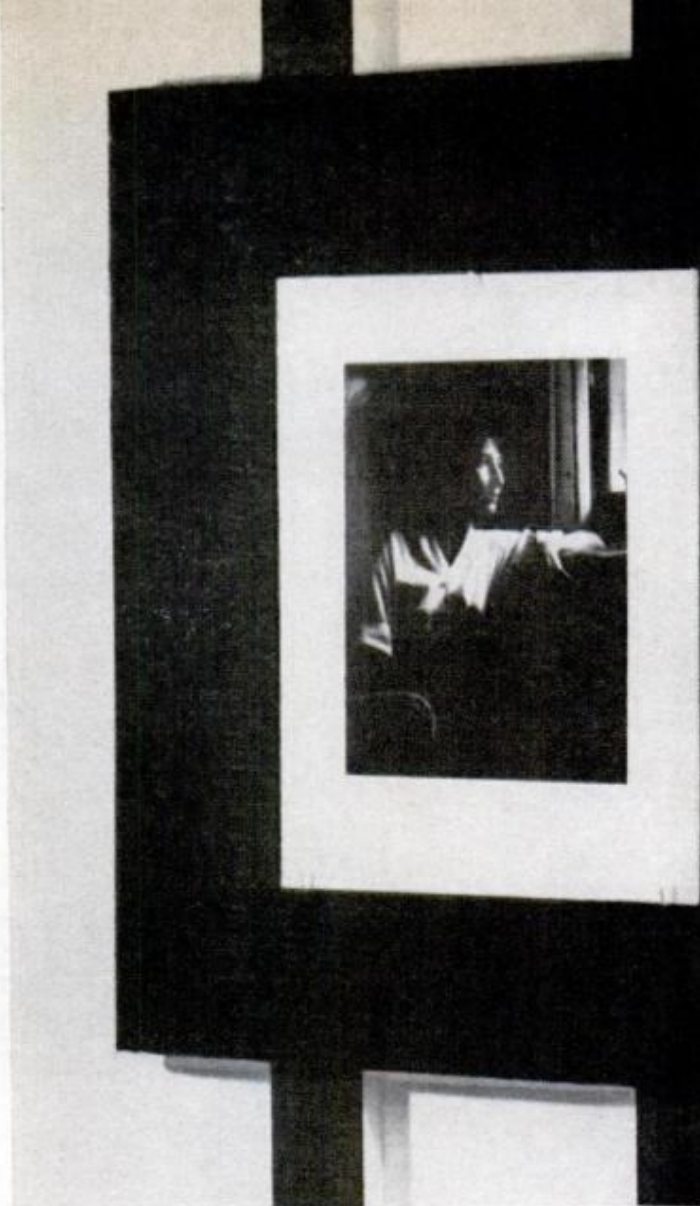



it's usually best to use an 11x14 mounting board. This creates an attractive border effect and makes your prints look larger, as well as providing a smooth, stiff protective backing.

All you need to mount a print is a pressing iron. The dry-mount tissue is slipped between the print and the mounting board and the sandwich ironed until the adhesive melts and forms a tough,

PLACE PRINT FACE UP on mounting board so that the tissue is in between. When it's properly positioned, gently lift each corner, one at a time, and tack the tissue to mounting board with iron's tip

permanent bond. To help you position the print accurately, the accompanying photos show how the tissue can be temporarily tacked in place. This keeps the parts from slipping during the ironing.

The final ironing is done over the face of the print, but not directly on it. Place down a piece of heavy brown wrapping paper or a manila envelope and iron over this to protect the print. Set the iron on

COVER PRINT with heavy paper and run iron over entire area until tissue thoroughly bonds both together. Do half of print at a time, working the iron from center outward to be sure of smooth results

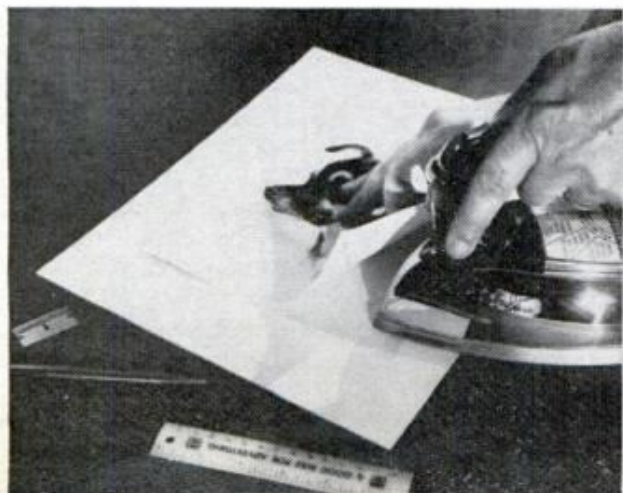

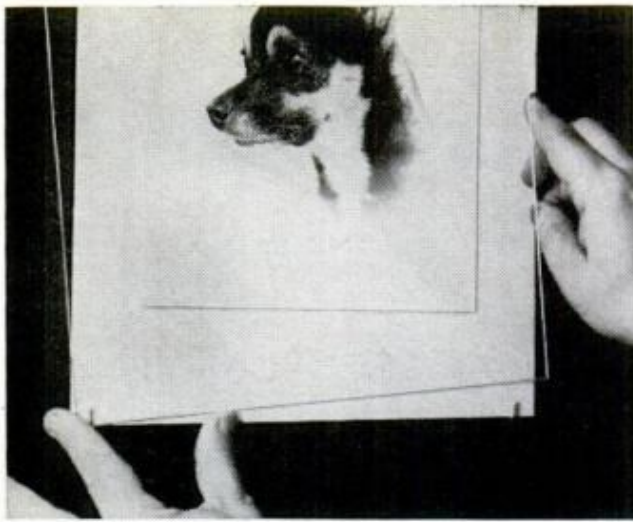

MOUNTED PHOTOS are covered with glass and held in simple L-type screw hooks—two at the bottom and one at top. This eliminates the need for frames and makes it easy to change pictures from time to time

moderate heat—too much may damage the print or cause the adhesive to over-melt and not stick.

An eye-catching display panel for your mounted prints can easily be made by covering a piece of 1/4-inch hardboard or similar material with a coarse, textured fabric. Black corduroy was used for the panel shown here. A 2x4-foot panel is just right for displaying three 8x10 prints on 11x14 mounting board.

Inexpensive window glass can be cut to fit over your pictures by a glazier or hardware store. The glass and pictures are held on the display panel by small L-type screw hooks that appear almost invisible at a distance. The panel itself can be mounted on a wall with a couple of heavy-duty picture hangers or wood screws in wall anchors. ★★★

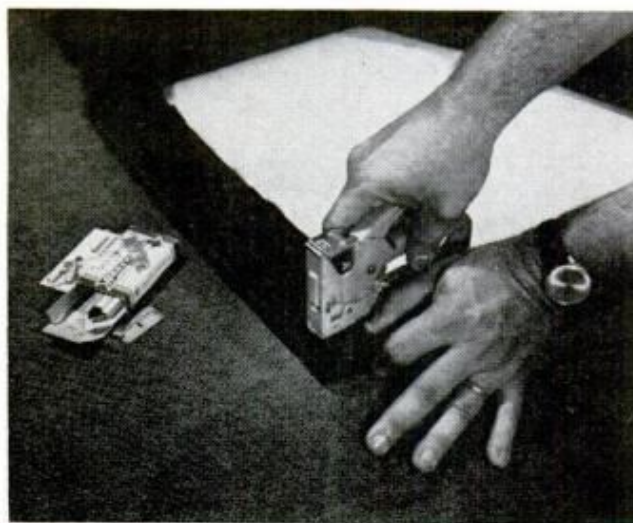

TO MAKE DISPLAY PANEL, cover a piece of hardboard or similar material with fabric. Cut fabric slightly larger than the board all around, fold over the edges and tack or staple them to the back

NEW IN

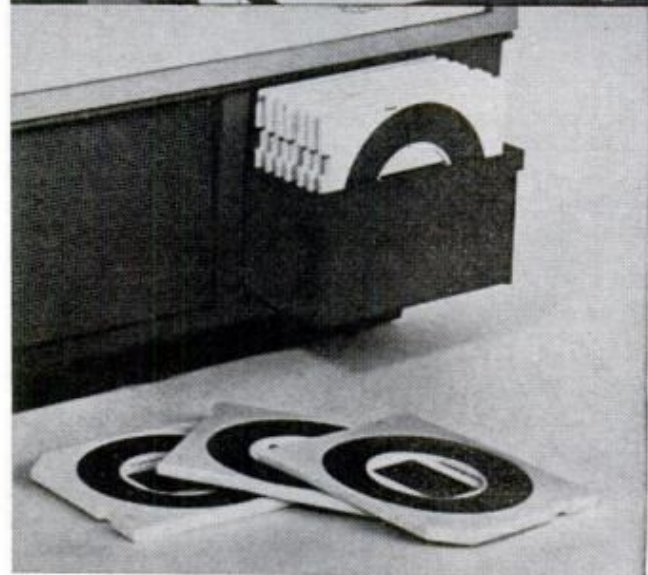

LIKE TO ADD SOUND to your slides? You can do it right on the slides with this combined projector-recorder by 3M. Each slide holder has a circular magnetic sound track running around the slide. You just project a slide and talk into a microphone to add your commentary. When the slide is shown again later, its sound track plays back automatically for your audience to hear. Each slide takes up to 35 seconds of commentary. The sound tracks can be erased and rerecorded or replaced with new ones. The machine, priced at \$645, is designed mainly for business and educational uses. A home version may come later.

PHOTOGRAPHY

YOU CAN VIEW SLIDES and movies in a brightly lighted room with this new projection screen developed by Kodak—there's no need to pull down shades or switch off lamps. Slightly curved, the screen funnels light from the projector back toward viewers in a narrow cone, instead of dispersing it as flat screens do. It also reflects stray window and overhead light out of viewing range, keeping the image sharp and intense. Photo at right shows how an image appears on the new screen in bright light, but not on a piece of ordinary screen held in front. Ektalite screen, of aluminum foil backed by fiberglass, is available in a 40 by 40-inch size for \$65.

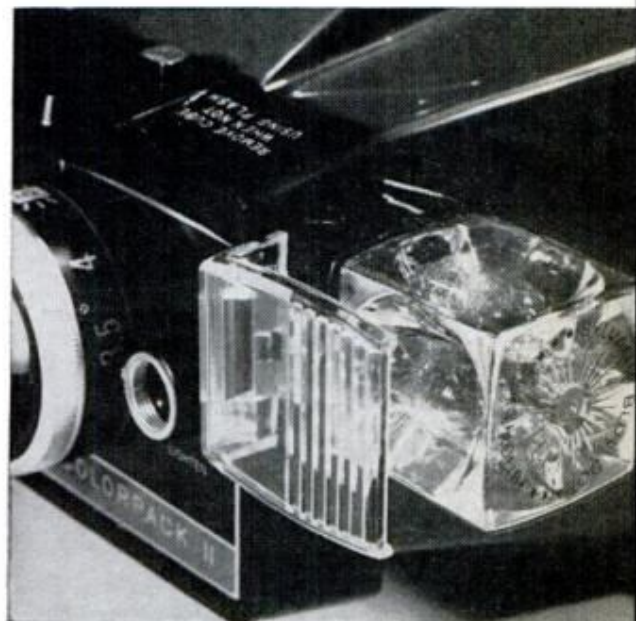
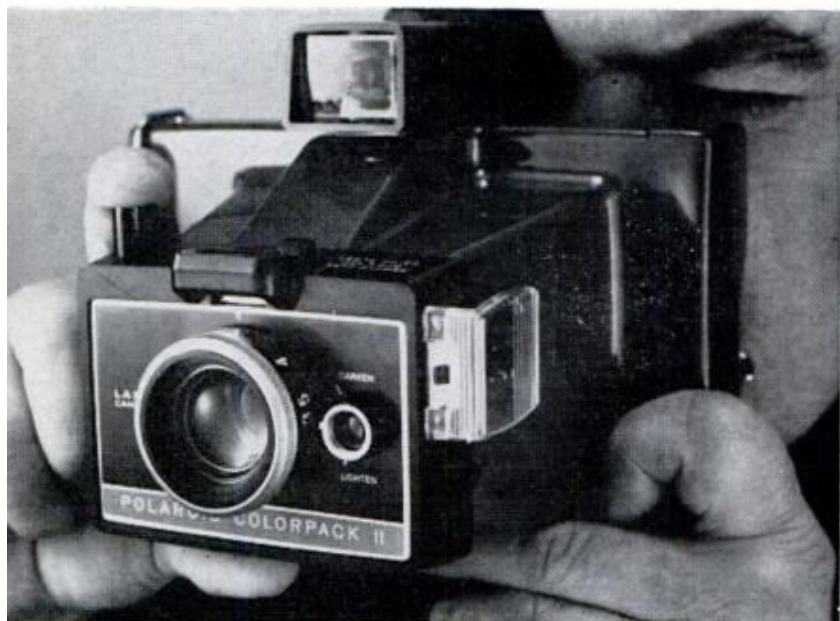
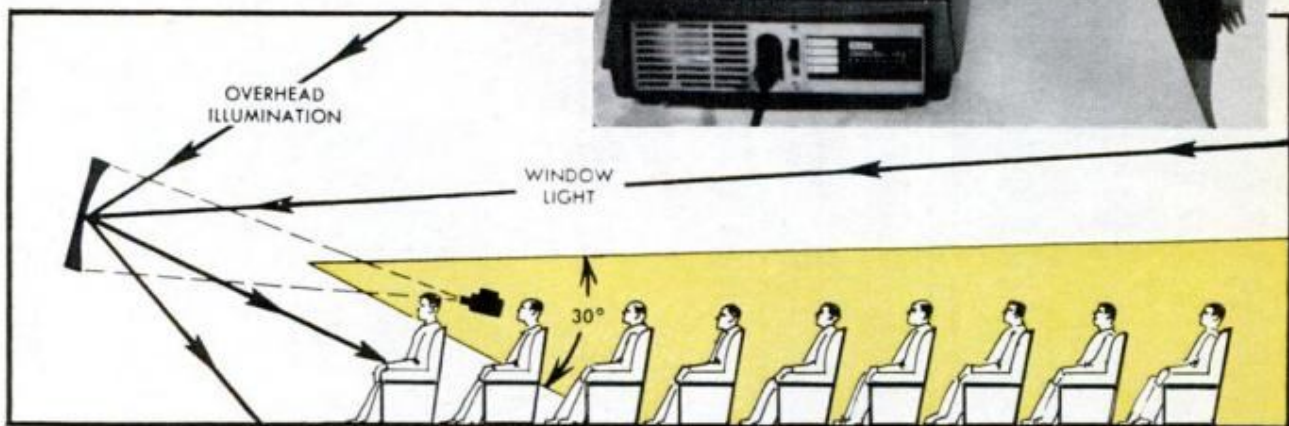

NEWEST INSTANT-PRINT CAMERA is the Polaroid Colorpack II above—the first model to take color for under \$30. One of a new line of cameras, it's also the first to incorporate a socket for flash cubes. Now all you do is flip open a hinged plastic shield, plug in a cube and shoot. The cube rotates automatically as each shot is made, ready for the next. The camera has a self-adjusting electric-eye exposure system and takes black-and-white film packs as well as color.

How to Check Distributor

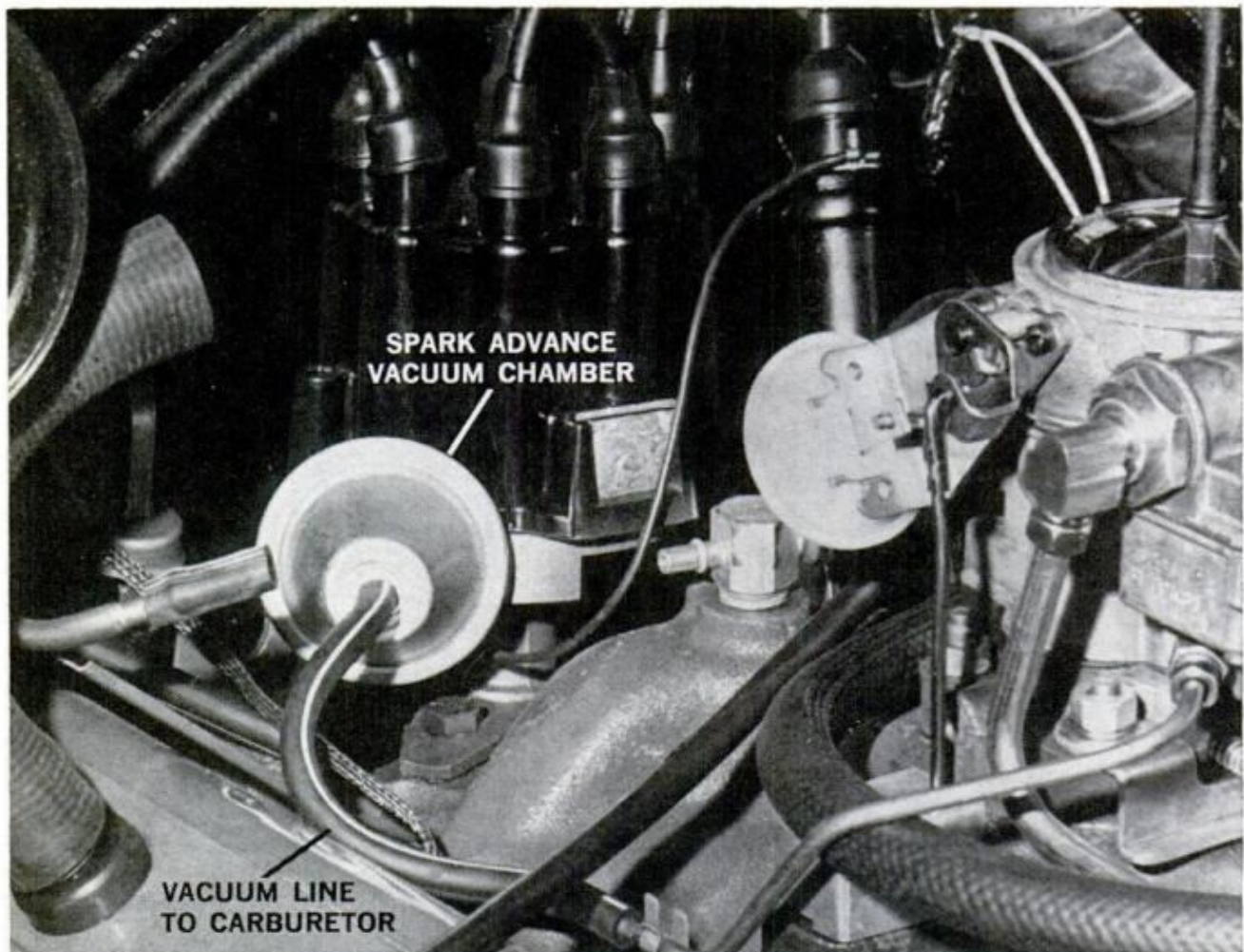

Old-timers had to advance and retard ignition spark by hand while driving; on your car it's automatic, as long as the vacuum unit is doing its job

DISTRIBUTOR VACUUM ADVANCE is variously known as vacuum advance, distributor advance, distributor spark control, automatic spark advance, distributor vacuum advance, and advance timing mechanism. Another term using the word "retard" would also be appropriate—because once the spark advance unit advances the spark, it must eventually retard the spark from the advance position.

Advance means that the spark occurs earlier than specified ignition timing, and retard means that the spark occurs later. Each term refers to the point of piston

travel at which the spark occurs to ignite the fuel mixture in the cylinders.

If the spark advance unit fails to function, your engine will act sluggish and fuel economy will suffer. These symptoms should cause you to check the advance unit, although very often it is overlooked during troubleshooting. Knowing how the unit works is the best way to appreciate its importance in engine operation.

If you operated your car at the same speed and always on a straight, flat road, the distributor's job would be relatively simple. It would just have to deliver a pulse to each sparkplug at the same time

Vacuum Advance

By MORT SCHULTZ

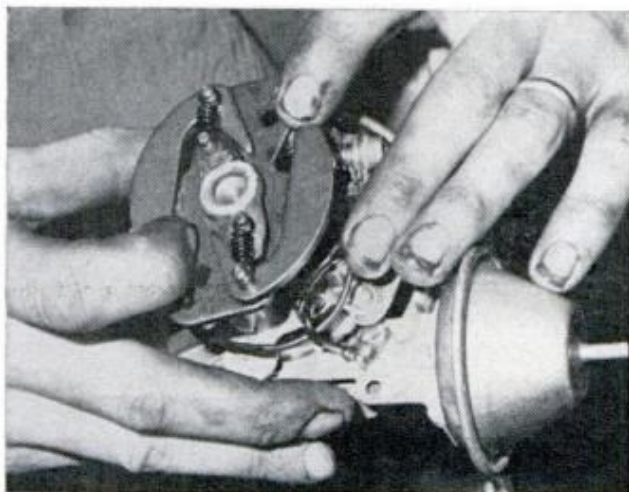

CENTRIFUGAL ADVANCE consisting of weights and springs is located above or below the breaker plate

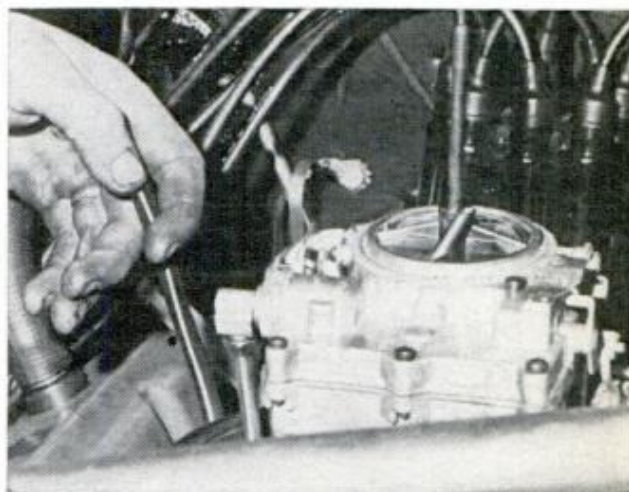

CHECKING FOR VACUUM at spark advance unit is done by removing the hose and feeling for suction

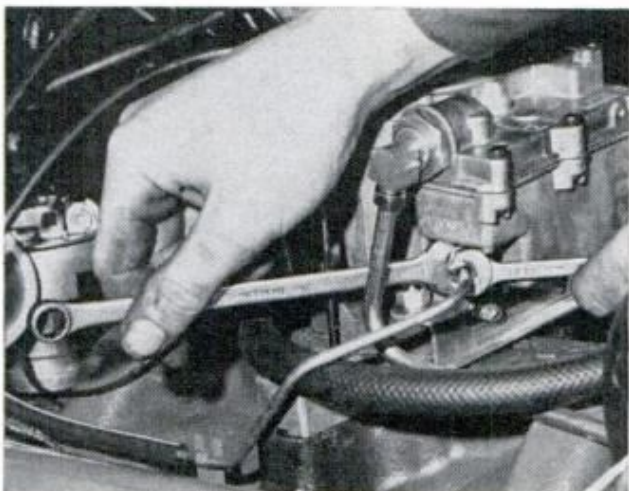

VACUUM HOSE that is damaged or clogged can be removed and replaced. Disconnect from carb fitting

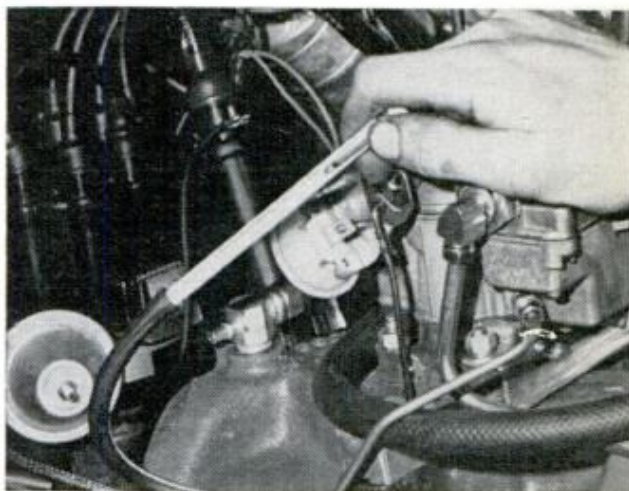

PLUG VACUUM HOSE with any improvised plug when specs call for timing ignition without advance

every time the piston reached a predetermined spot in its compression stroke.

But you don't drive that way. Your engine must operate alternately with and without a load on it, and at varying speeds. As speed and load vary, the time when the spark occurs to ignite the fuel mixture must also change—for two good reasons.

First, as speed varies, each piston travels at a slower or faster rate, and the fuel in the cylinders has more or less time to burn, respectively.

Second, as engine load varies, each cylinder receives a richer or leaner fuel

mixture that requires less or more time to burn, respectively.

The spark advance unit does *not* control the timing of the spark with engine speed. This is the job of another unit in your car's control center called the centrifugal advance.

The centrifugal advance consists of two counterweights inside the distributor which are joined together by two small springs. They are positioned to move in relation to distributor rotation. In other words, as engine rpm increases, the distributor shaft moves faster and faster. This spins the counterweights around, al-

lowing them to overcome the tension of the springs and move outward.

As they move, the counterweights activate the distributor cam assembly, allowing the cam lobes to open and close the distributor breaker points earlier in the piston's compression stroke. This advances the spark to give fuel the time it needs to ignite and burn completely before the piston starts on its power stroke. In that way, the maximum use of the fuel's full energy is made to drive the engine.

So much for advancing the spark with engine *speed*. When engine *load* varies, the vacuum unit must be ready to do its job. A rich fuel mixture requires less time to burn than a lean mixture. When the engine's put under an increased load, you are packing a richer fuel mixture into the cylinders, by depressing the accelerator pedal.

Conversely, when the engine is under a light or no load, the fuel mixture is leaner—16 to 1 or 17 to 1 as compared to a 12 to 1 or 13 to 1 ratio when the engine's under load. Since this lean fuel mixture takes more time to burn, spark has to occur earlier in the compression stroke to allow full burning.

Happily, engine vacuum varies with engine load and can be utilized to change timing automatically. As load varies and you press down or let up on the accelerator, you open or close the carburetor throttle plate which causes the intake manifold vacuum to change.

The spark advance unit is nothing more than a chamber in which vacuum is created. Inside is a diaphragm and a diaphragm spring. One side of the unit is connected by a vacuum hose to the carburetor—the other side is linked to the distributor breaker plate.

When there's little load on the engine, manifold vacuum is high (the carburetor throttle plate is partially closed, which creates more vacuum). This vacuum is strong enough to allow the diaphragm to overcome the tension of the spring. This moves the linkage to rotate the distributor breaker plate, causing distributor points to open earlier in the compression stroke. The spark is advanced and full burning of the leaner fuel is accomplished to give the piston maximum power on the power stroke.

When there's a heavy load on the en-



TIMING LIGHT is aimed at timing mark on pulley; if adjustment is necessary, turn distributor body to advance or retard the ignition timing (see text)

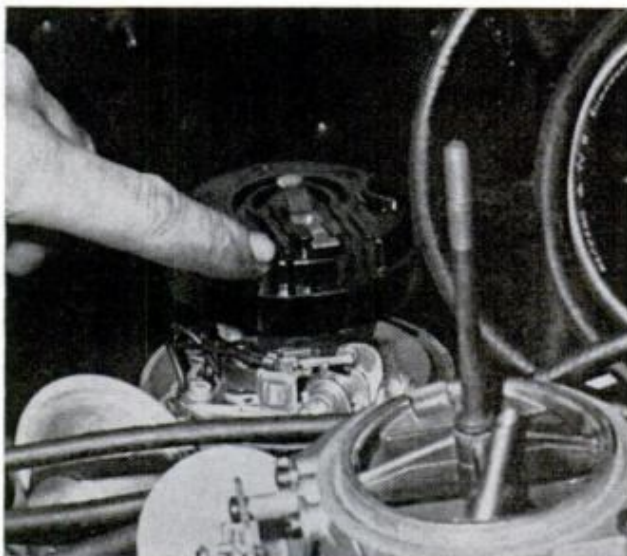

ROTOR CONTACT POSITION should be noted before removing distributor so drive gear on the shaft meshes with the camshaft gear when unit is replaced

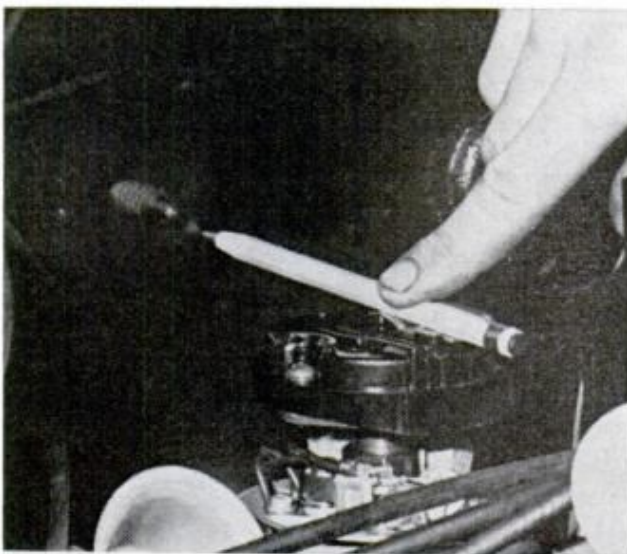

A REMINDER of distributor rotor contact position can be made by scribing a mark on an adjacent surface. It saves a lot of twisting and turning later

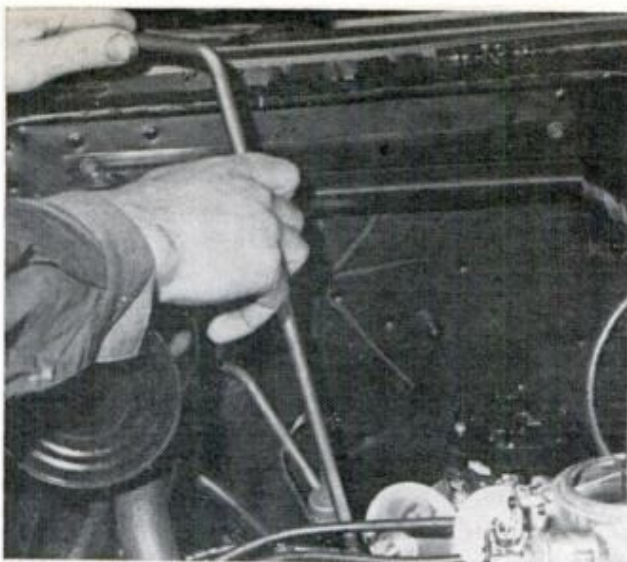

SPECIAL WRENCH with long shank is inexpensive (about \$3) and will make it a lot easier for you to reach the distributor hold-down bolt on the block

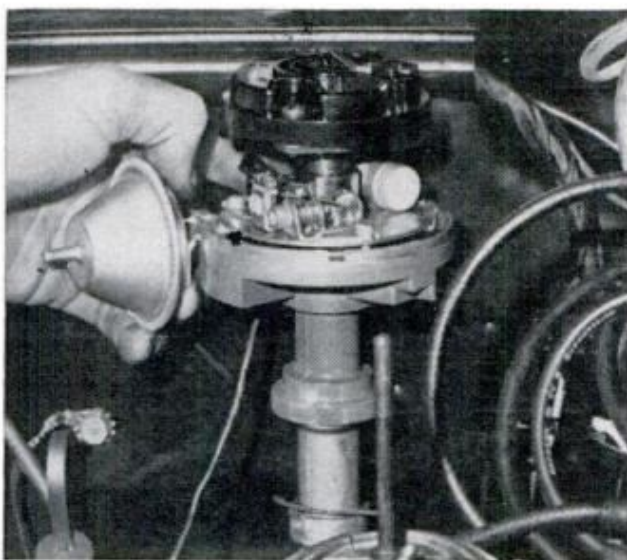

TO REMOVE DISTRIBUTOR from the engine, twist to free from cam gear and pull up carefully, keeping the shaft lined up with the hole in the engine block



FAULTY VACUUM ADVANCE UNIT is easily removed from distributor body after body is taken off engine. Replace only with a new unit specified for your car

engine, manifold vacuum is low (the carburetor throttle plate is open). This allows spring tension to govern control of the distributor breaker plate, which is now kept in retard position to cause the breaker points to open later in the compression stroke.

There isn't too much that can go wrong with the spark advance unit other than rupture of the diaphragm, which will cause the spark to occur late under all engine load conditions. This will cut down on engine power and result in a waste of fuel since not all the fuel will be burned under lighter load conditions.

It's possible, but not likely, for the vacuum hose to get plugged or develop a kink. To find out, start the engine, pull the hose from the spark advance and flick your finger back and forth over the opening. If you feel suction, there's nothing wrong with the hose. If there is no suction, disconnect the hose at the carburetor and replace it.

How can you tell if there's something wrong with the spark advance unit? There are three ways: by "feel," by using a stroboscopic timing light, and by using a distributorscope. Since you're not likely to have a scope, we'll forget about that. If you don't have a timing light, either, you might be able to tell if the spark advance is working by jockeying the vacuum hose off and on the nipple where the hose attaches to the unit with the engine running. If the unit's working, you may hear the diaphragm as it pulsates with a *thump, thump* sound.

Of course, the best way to check on spark advance is through the use of a timing light. The first thing to do, though, is to make sure the engine's timed according to spec.

With most cars you have to disconnect the vacuum line from the spark advance before you can time the ignition. The line has to be plugged in order to prevent a vacuum loss which will cause the engine to idle roughly while timing is performed.

To time the engine, hook the timing light to No. 1 sparkplug terminal and start the engine. Aim the timing light at the timing mark on the crankshaft pulley. Look straight down the beam to the timing mark and pointer. If timing is accurately set, the timed pulses of the light

(Please turn to page 216)

Weekend Projects

Rolling-Pin Catchall

AT HOME in a kitchen or dining room, this spinning catchall is easily made from a wooden rolling pin. Often you can obtain slightly used rolling pins at a flea market sale or a used-merchandise store for as little as a dime each (that was the cost of the one illustrated).

The tips of the rolling-pin handles rest in cup-shaped recesses cut in two wooden arms extending from a $\frac{3}{4}$ -in. back panel. The panel usually is mounted on a wall with roundhead screws but, if provided with a sufficiently heavy base, it also could be used on a table or desk.

The two arms can be made by gluing together two pieces of $\frac{3}{4}$ -in. stock. The cup-like recesses for the rolling-pin handles are about $\frac{1}{2}$ -in. deep and are made by first boring a hole with a regular bit, then reaming, filing or carving the resulting recess to shape.—Walter E. Burton

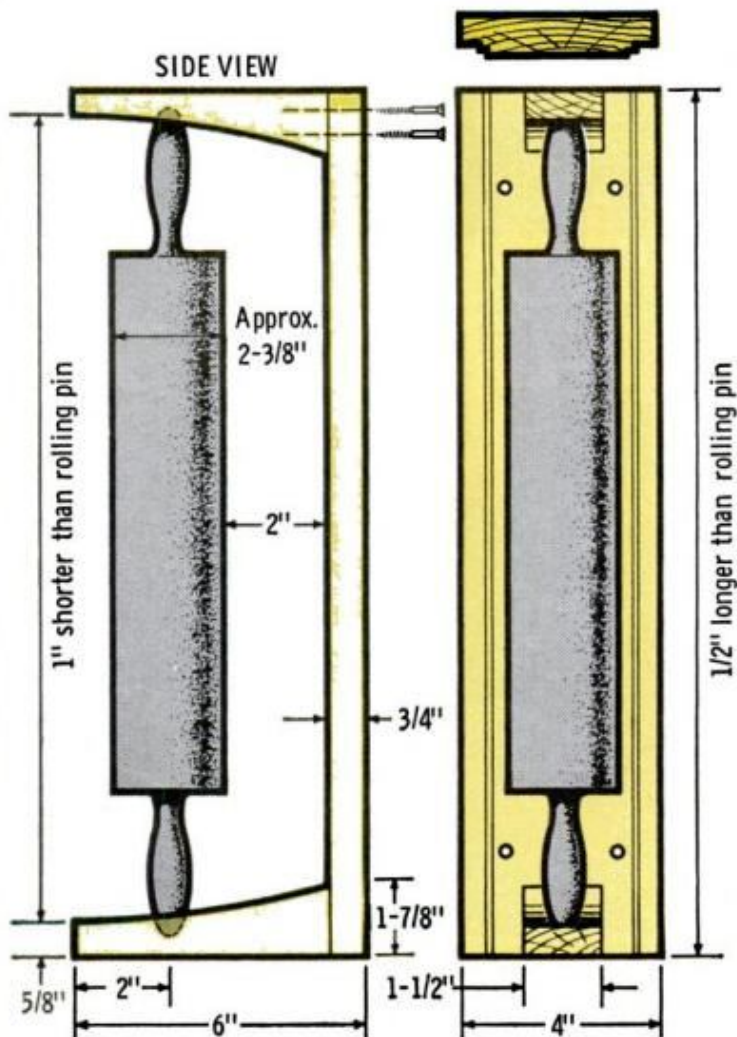
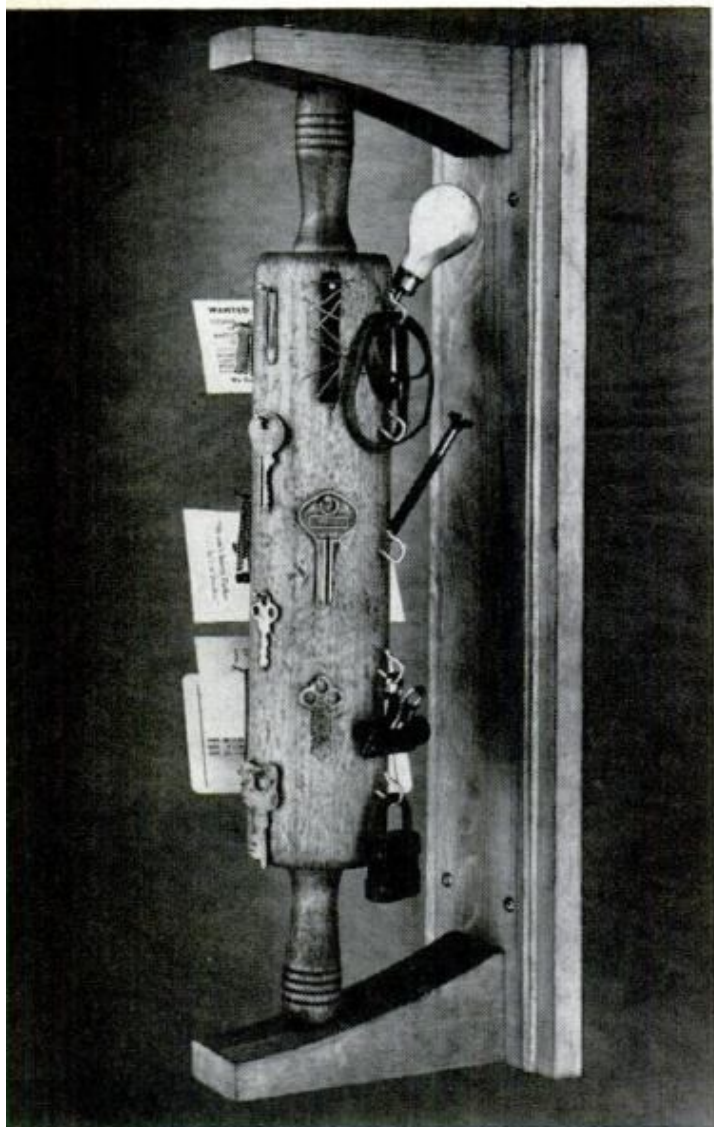

FINE SAW KERFS will hold messages, business cards and other reminders. Cup hooks keep keys handy

You Can Build

Technical Art by John Lind

Living With Lally Columns

IF UNATTRACTIVE lally columns or jack posts mar the basement you'd like to turn into a big, roomy recreation area, you can use these ideas to disguise the necessary evils.

In the case of a jack post, remove the rod (at the top of the post) that normally is used to turn the screw. This is no longer necessary since the posts are jacked up to their required height.

Next, measure the posts at the widest point where the pin goes through the center to support the top section, then measure the diameter of the post itself. It then becomes a matter of cutting spacers, as shown in the drawing below, to clear the widest point and provide nailing when the post is to be used to support a paneled partition.

Another solution to the problem is to build a square bench around the bottom

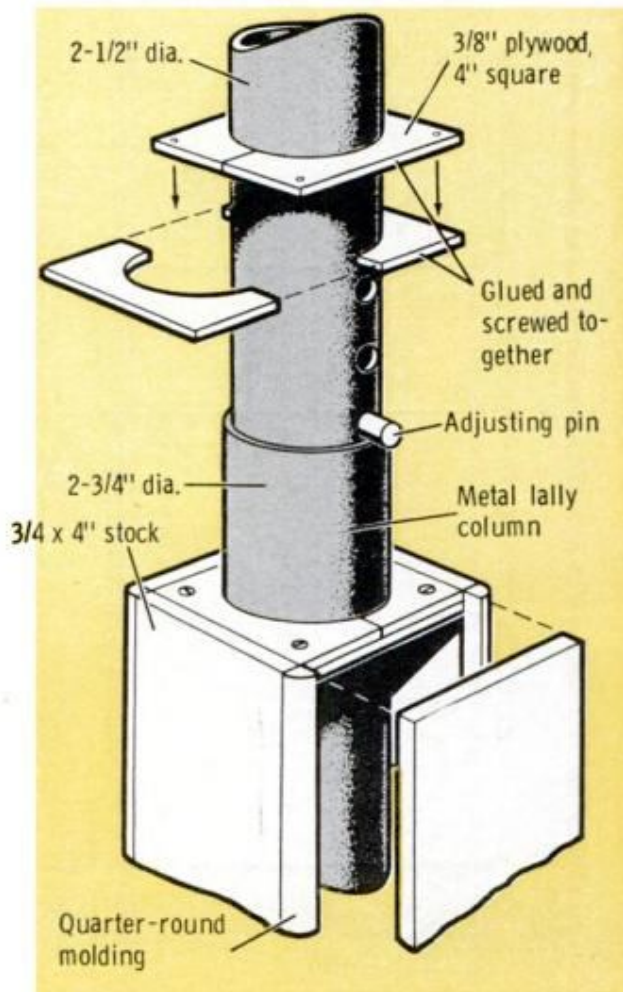

of the boxed-in post and add a wall lamp on one side. The wiring for the lamp, of course, must be put in before the post is completely finished.

Finally, fit colorful cushions on the square bench, which, incidentally, can be built as four triangles held together with small hooks at the back so as to gain added storage space beneath the bench.

—M. Sheppard



BUILT IN A CORNER, the bookcase closet takes little space, yet provides shelves, hidden storage

Walk-In Bookcase Closet

IF YOUR LIVING AREA seems to shrink before your eyes, it's no illusion—you've just become short of storage space. This is especially true if you're renting an apartment, since your rental contract likely prevents you from making any permanent changes.

A novel solution to such a storage shortage is this free-standing, combination walk-in bookcase closet which fits in a corner. Construction is easier than it looks, and although the unit takes up only 9 sq. ft. of floor space and costs under \$20 to build, it can store quite a few items of clothing and several hundred volumes from your library.

What's more, you can increase its portability by fitting small casters on the bottom. With these, you could move it from wall to wall or from room to room depending on your need.—*James Plake*

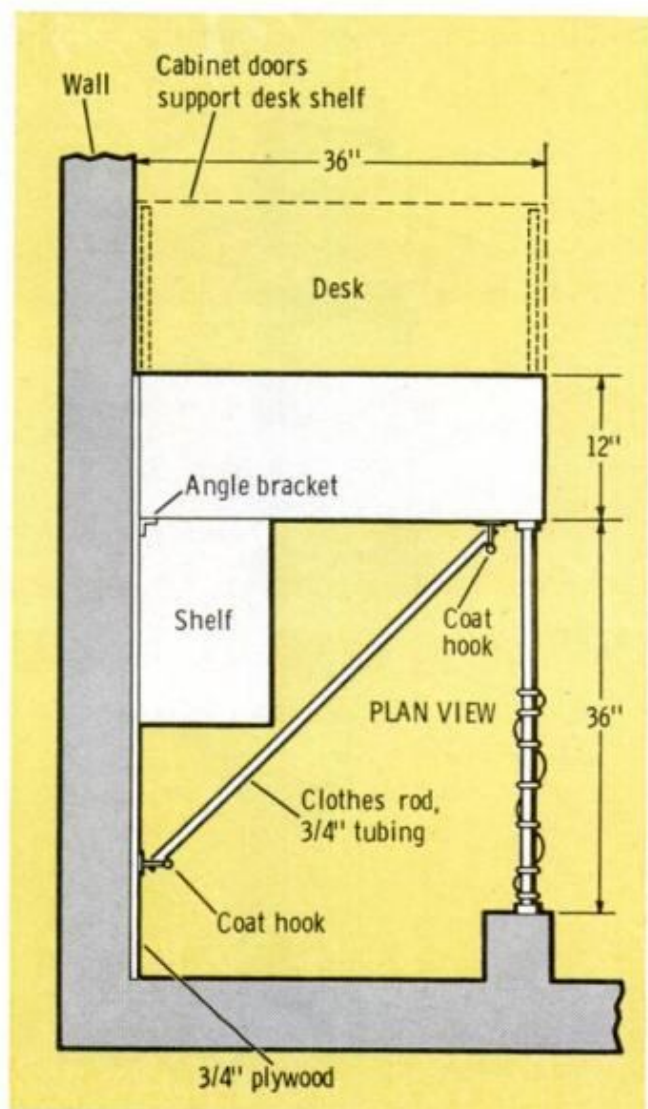



Baby Bathing Center

WITH JUST A BIT of thoughtful planning, you should be able to adapt this built-in bathinette to fit most any bathroom.

As shown in the photos, this infant's bathing center consists of a small plastic tub that's been securely fitted in a sturdy fold-down panel. The bottom of the tub, of course, is drilled for a drain hose that's opened by using a press-to-open clip like the one photographers use for chemical-dispensing hoses.

The water sprayer, on the other hand, is normally found on the newer types of kitchen sinks and can be hooked up to a wash-basin faucet without too much trouble. Thus, Mom can gently spray the baby with clean water before drying, and then she can easily drain the water into the toilet by pressing the drain clip.—*James Pickerell*



STURDY FOLDING BRACKETS must be used for short table-like support, could be permanently-installed, right-angle brackets if space allows

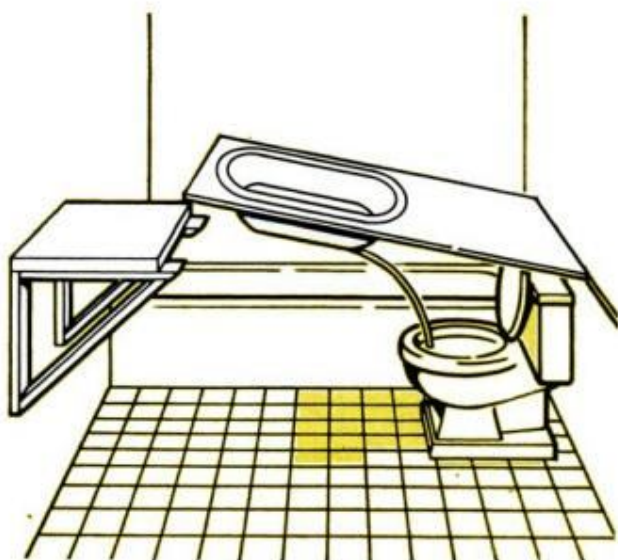



Sandbox and Play Table

THIS CUTE SANDBOX and table will keep youngsters happy while outdoors, yet it can be disassembled easily for storage during the colder months.

The unit is composed of a seat frame, a sandbox with tabletop cover, a roof unit and the roof supports, all of which are detailed in the drawing below. You can use pine lumber or $\frac{3}{4}$ -in. exterior plywood.

The bottom of the box is raised 2 in. to clear the notches that allow the box to fit over the side rails of the seat frame. Don't try to do without the spacer blocks since they keep the box from sliding.

Painting the unit with bright colors makes it eye-catching, especially if the roof is striped. Use two coats of weather-proof enamel for a lasting finish.

—Victor H. Lamoy

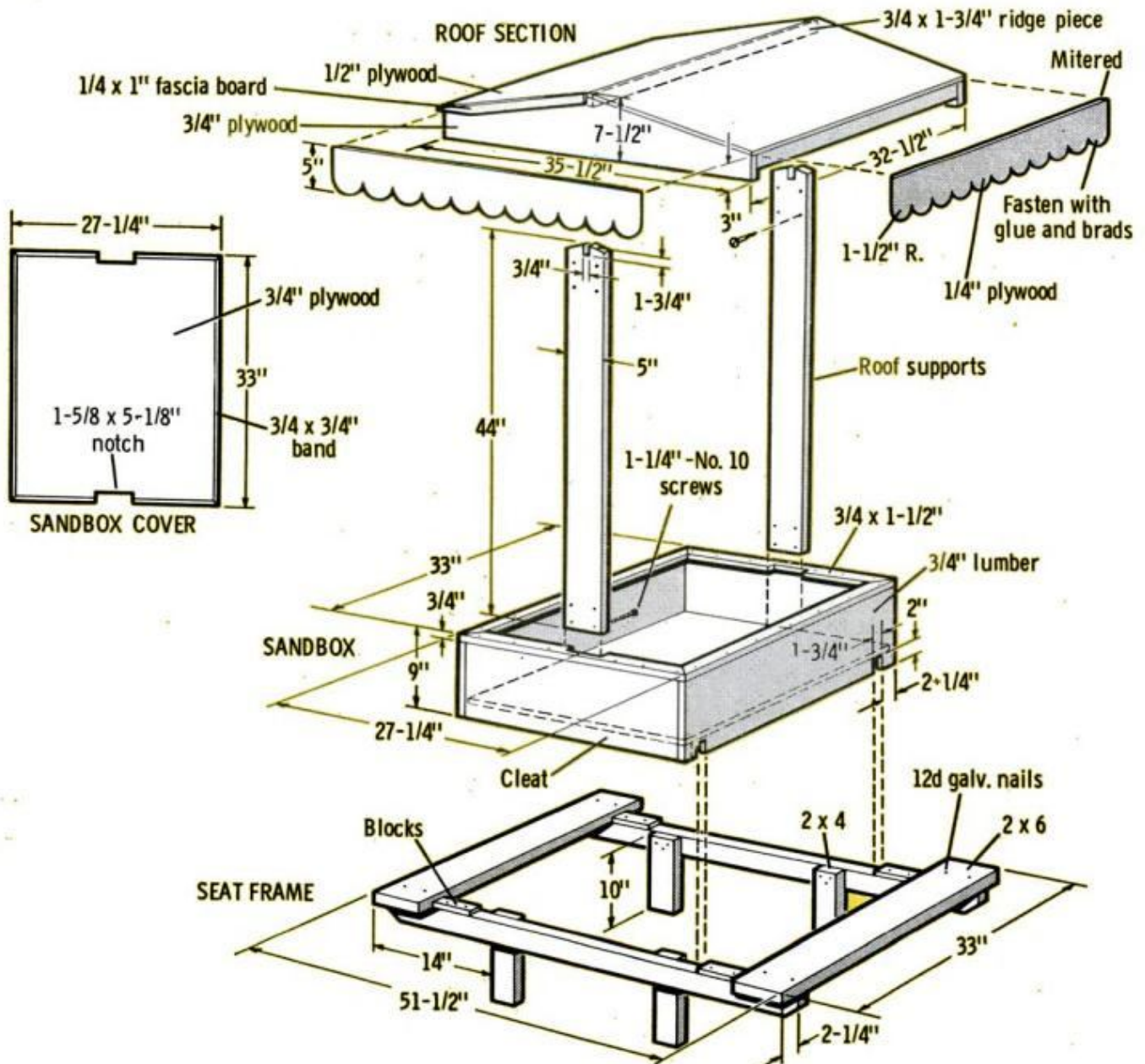

HINTS FROM READERS

Tightening handsaw screws

When it becomes necessary either to tighten or remove screws holding the wooden handle to the blade of a handsaw, try using a file to keep the flat medallion and thimble nuts from turning. Position the file so its teeth bear against the round portion and clamp both file and handle in a bench vise. This makes an often-frustrating task easy.—*H. Josephs*



Sticky tape cleans magnet

Iron and steel particles often are very difficult to remove from the poles of a magnet—try to brush them away and you'll find that the particles merely move from one section to another. You can do the job effectively, however, with the help of a few pieces of adhesive tape. Simply press the tape over the particles and strip it off. In certain cases, it may be necessary to repeat this procedure to remove all of the fine particles of metallic dust. Almost any type of tape will do the job.

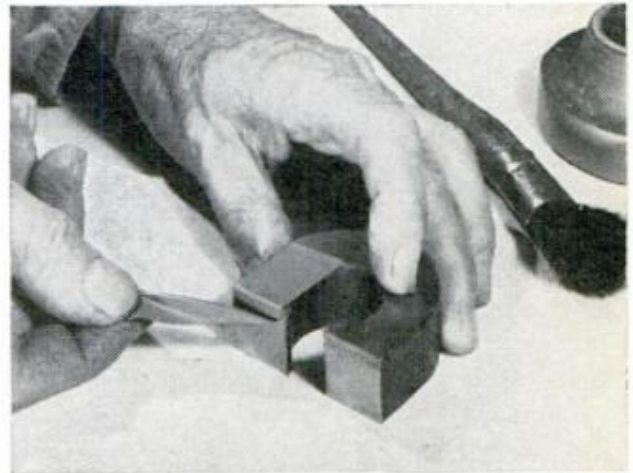

Brush-sand uneven surfaces

Sanding irregular or contoured surfaces is tricky at best—but a scrub brush can work in your favor. Simply wrap a sheet of sandpaper around the scrub brush as shown at right, secure the sandpaper to the wooden handle of the brush with a strong rubber band, and then use the brush as you would a sanding block. The stiff bristles of the brush will be flexible enough to follow the curves of the surface, yet firm enough to apply uniform pressure to the entire surface.



Trimming a miter cut

When the cut you've just made on a piece of molding proves to be a hair too long, trimming that cut can be quite exasperating—the saw will keep slipping off. The solution—place the two pieces just cut so they butt against each other, then position the molding where the new cut is desired, and clamp the pieces securely to the miterbox. Using the second piece will prevent the saw from slipping into the first cut and reduce the chances of a ragged edge in the final cut.

—*Michael Ligocki*

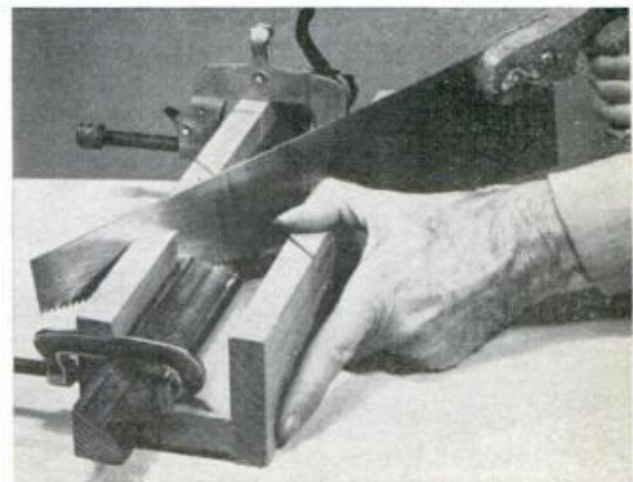

Handsome Garden Paths and Walkways

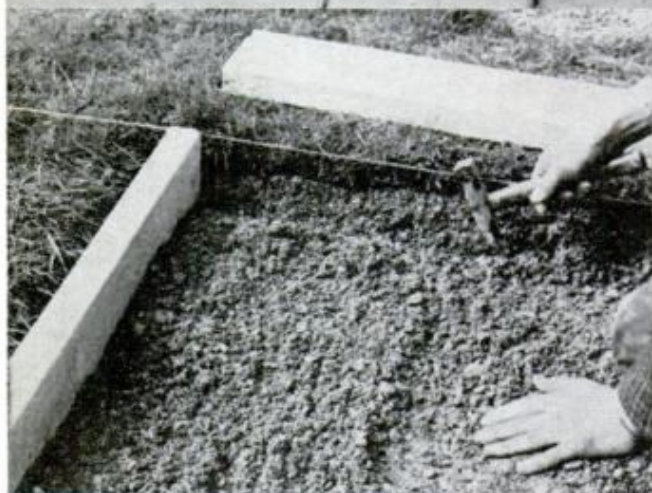

BREAK UP TOPSOIL and scoop out narrow trenches for wooden curbs treated with a good preservative

By **PETER OLDALE**

A GARDEN PATH made from blocks of stone or concrete is strong, durable, easy to lay (apart from the actual labor of carrying the slabs) and can be done in colors, materials or patterns to blend with almost any style of house or garden.

Yard for yard, slabs of concrete are on the low-cost side, but stone is a different matter. Dressed York Stone slabs are



CAREFULLY POSITION SLABS over loose soil. It's a worthwhile idea to first chart your layout of slabs



TAMP THE SLAB firmly into place by using the handle of a hammer—never pound it with hammer's head

Inlay Stones in a Concrete Bed



POUR A BED OF CONCRETE and beat the mix down with a length of lumber. Make sure the form is level



USE A TROWEL in pounding fashion to bring fuzzy finish to surface. Smooth walks can be dangerous



WHILE CONCRETE IS STILL SETTING, scoop out portions and inlay stones, slabs or other material



TAMP DOWN until level. The cement will be forced up between the joints to be flush with the surface

one of the most expensive materials obtainable (besides being one of the finest in appearance). However, before choosing the material, check as many samples of slabs and stones as possible.

These can be plain gray concrete (the cheapest), colored concrete, textured concrete cast to imitate the irregularities of natural stone, or concrete that's topped with inlaid pebbles or stone chips. Common shapes are square, rectangular, hexagonal or octagonal, all suited for layout in many patterns. Great care must be taken with the colored slabs, however, or unnaturally garish effects may be produced. A single slab, viewed in a building supply yard, may seem subdued in shade, but a whole path or drive in this same material could appear impossibly bright.

Before ordering, lay a few slabs together on the ground and, if possible, wet them down—the color of wet slabs is markedly deeper than that of dry ones, and a path that looks restrained in summer may darken unpleasantly in winter rains.

Slabs are usually sold by the piece, thus

the actual cost *per square yard* will be greater for small slabs than for larger ones. Paths and drives should be planned for widths that can use standard-sized slabs, thus eliminating a need for cutting.

Where a pattern of various-sized slabs is desired, work out beforehand the exact number of each size needed. Suggested patterns are shown, but, of course, the variations possible are innumerable. In general, avoid patterns using large numbers of small pieces. These are hard to lay, susceptible to wear and expensive.

Octagonal and hexagonal slabs will not make a straight-edged path by themselves, so halves (for edges) and quarters (for corners) are needed. Again, detailed planning will give the required number of each kind. Paths laid out with these slabs should have only parallel edges and right-angled or 45° corners. Other angles are very difficult to lay satisfactorily.

Stone paving can be *random-squared* (various irregular squares or rectangles fitted together in patterns), or it can be *crazy paving*—broken flat stones fitted to-

(Text continues on page 166)

Lay a Path With Built-In Greenery



POSITION EACH STONE carefully on a bed of soil and sand. It's best to start with the edge stones



STAND ON THE STONE and pound the soil under its edges to consolidate soil and level the stone



BE VERY CAREFUL when tamping stones around small plants. Otherwise you can damage roots



CORNER STONES should be as square as possible to maintain clean lines of the path or walkway



Use Hexagonal Slabs for a Truly Distinctive Touch

CONCRETE BLOCKS OF THIS SIZE require a high standard bed of pure sand or sand/cement dry mix. It's important to smooth the bed carefully for every concrete slab, making sure that it's perfectly level



INSERT CREEPING PLANTS, such as thyme, or small plants, such as rosemary, as work progresses



IF NECESSARY, you can chip stone to fit awkward-shaped areas, but always wear safety goggles



SPREAD FINE SOIL over the completed walkway. It often is advisable to sift all the topsoil first



BRUSH THE SOIL into all the cracks and crevices at butt joints to produce a well-defined walkway



WHERE A BLOCK MUST BE CUT, make a pair of guide lines, each about $\frac{1}{4}$ -in. off desired cutline



USE A MASONRY SAW to cut between the drawn lines, applying water liberally to lubricate the saw



LOWER THE CUT BLOCK gingerly into place on the bed, making sure that the smooth bed isn't disturbed



FINE, SIFTED SAND is then brushed into all cracks until every joint in the walk is completely filled

Laying an Asphalt Path



POUR A GENEROUS AMOUNT of gravel on top of a firm foundation and rake it until it's spread evenly



BREAK OPEN the bags of asphalt and pour this on top of gravel bed. Asphalt comes in several colors



RAKE OUT ASPHALT AT ONCE. Heating the head of the rake over a low flame makes raking task easier



A SPRINKLING OF COLORED CHIPS will break the solid color and improve appearance. Then roll path

gether in the manner of a jigsaw puzzle.

Squared slabs can be bought by the square yard, but most stone is bought by the ton. The area a ton of stone will cover depends on its average thickness and its type. Sandstone, in particular, varies somewhat in its weight per cubic foot. The most direct method of finding out the amount to order is to telephone the materials dealer and ask how much of his particular stone will be needed for the area you wish to cover.

Delivery costs can account for a large part of the price since most quarries will not deliver less than a full truckload—say five tons. If this quantity is not needed, it may pay to seek a neighbor who also is thinking of laying a stone path, and share the load.

Small orders can be collected direct from quarries at a comparatively low price—and if a truck can be borrowed, this is the most economical method of purchase. Do not be tempted, however, to overload a small truck with great heaps of stone. Five or six hundredweight of crazy paving doesn't look very heavy, but it is better to make extra trips than to ruin the suspension or springs.

Garden centers, on the other hand, will deliver almost any amount, however small, but the cost per ton is high. The cheapest solid material is broken concrete slabs, often available from public works authorities, and these can be laid down as "crazy paving" in the same way as stone. They have the additional advantage of being even in thickness, which greatly simplifies the layout work.

Unquestionably the simplest of all paths to make is the plain gravel type, which consists essentially of a layer of gravel spread between some sort of curbing. The actual gravel may be either shingle (pebbles) or stone chips; both are available in various sizes and colors. There are also a number of gravels (known as *self-setting*) containing coarse clean stones and a high proportion of finer material. This causes a well-rolled layer of this material to set much like soft concrete.

Loose gravel can be rolled to consolidate it, but it will never become truly firm. However, this has its advantages, for even paths in a very poor state can be vigorously reraked to look almost new. Loose gravel should be about 2 in. deep for chips, less for shingle. ★ ★ ★



PORTLAND CEMENT ASSN. PHOTOS

Tool Flagstone Joints in Concrete

USING A LONG PIECE OF $\frac{1}{2}$ OR $\frac{3}{4}$ -IN. COPPER TUBING in an S-shape, score a random flagstone pattern in the still-wet concrete (above left). After water sheen has completely disappeared, float and trowel the surface (center), and finally, use a soft bristle brush to touch up all of the joints (above right)

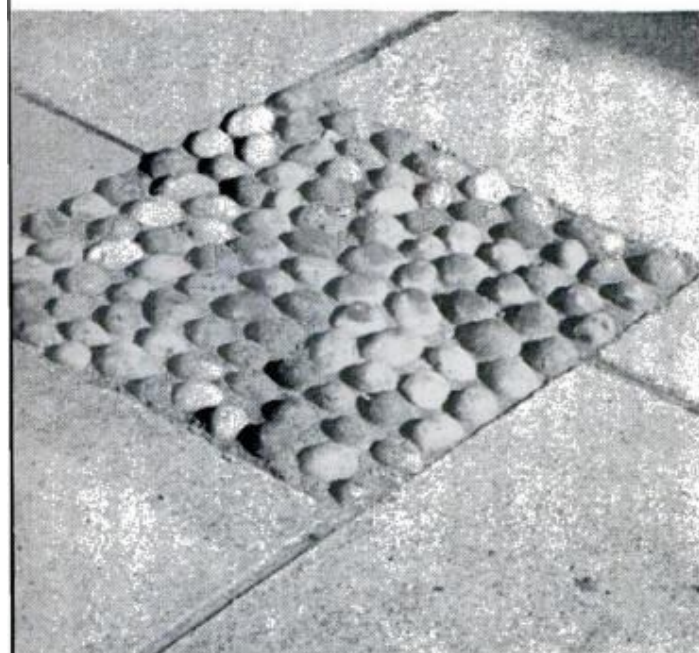

Decorative Effects Cost Little, Add Much

STONES SET INTO SQUARE OF CONCRETE will create a novel pattern to offset a path otherwise made of gray-colored concrete blocks or plain-looking slabs

SIMPLE CIRCLES can be made to add life to a walkway made of cement. After the surface has been troweled smooth, use a can to make the impressions

EXCITING NEW PRODUCTS

By CATHERINE BILSKI



MAIL INDICATOR is a step-saving device that eliminates unnecessary trips to the mailbox. Mounted on the top of the box, it has a flag that raises when mail is inserted. When you pick up the mail, you push the flag down to remake magnetic contact and reset it. The Mag-Na-Tel mail indicator is attached with two screws and fits all standard rural mailboxes. Priced at \$3.98 from Mag-Na-Tel Products, P.O. Box 833, Quincy, Ill.

METAL HOLDER converts any beer can into a handsome beer stein. Made of 21-ga. cutlery steel, the holder is brass-plated and individually boxed. When not in use as steins they can be used as decorative holders for flowers, pens, pencils, pipes, and so forth. Coasters are not needed since the base of the steins serve as insulators. Priced at \$3.98 a pair postpaid, from C. A. Bittner, Dept. P-5, Box 4732, Inglewood, Calif. 90302.



168

POPULAR MECHANICS



ANTIQUING AND WOOD GRAINING is made easy with this two-step kit. Both latex base and glaze are easy to apply and the entire process can be completed in only four hours. The finish is ideal for wood or metal and is safe for children's furniture. The Grain N Tique kit retails at \$4.49 and is available in fourteen decorator colors. Manufactured by Luminal Paints, Inc., 2750 S. Garfield Ave., Los Angeles, Calif. 90022.

HOT WATER at the touch of a finger is possible with the pushbutton dispenser built into the Ready Hot Water kitchen range. The 180°F. water for dehydrated soups, instant oatmeal or coffee is drawn from an insulated two-quart tank with a sealed, immersion-type heating element. Since the water tap is located on the range control it reduces sink-to-range trips. Manufactured by Frigidaire Div., General Motors Corp., Dayton, Ohio.



Manufactured and distributed by Frigidaire Div., General Motors Corp., Dayton, Ohio.



CARTOP CAMPER is designed to be carried on the family car, thereby eliminating towing problems. The unit sleeps four people on the top of the car and the box at the back of the sleeper converts to a combination stove, sink and table that seats six. The bathroom has running water from a 5-gal. tank, shower, basin, mirror and portable toilet. About \$300 basic (\$400 with accessories) from Camp'otel Corp, 2822 W. Lancaster, Fort Worth, Tex.

STOVE-TOP BROILER for gourmet broiled cooking at home, or when camping or boating, is a simple device that sits over the flame of a gas-stove burner. You control the flame that cooks your meat by adjusting the stove burner. The Char Broiler is priced at \$9.90 postpaid from Pelton Products, Dept. 1163, 13350 Poway Road, Poway, Calif. 92064.



MAY 1969



STOP UNAUTHORIZED USE of electric appliances or tools with the Lock-A-Plug. It locks the prongs of an electric plug to keep it from being inserted into a power outlet. The plug is freed by setting the built-in dials to the correct combination and pressing the release button. \$2.50 from Efston Mfg. Co., Ltd., 400 Prairie Ave., Wilmette, Ill.

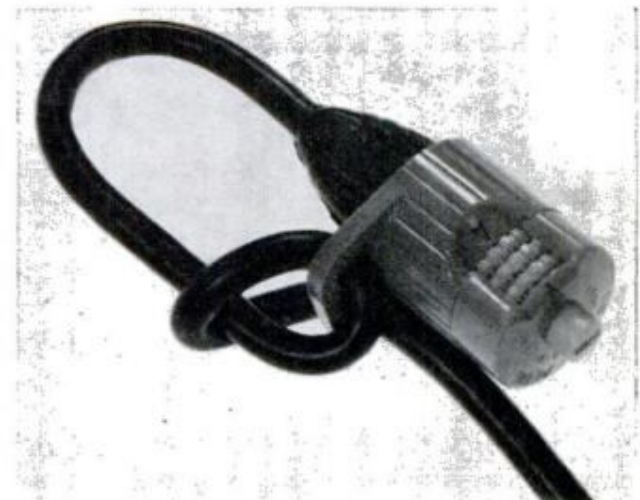

169



Solve the patio problem ADD A SCREENED PORCH

If bugs and rain send you scurrying indoors from a patio cookout, it may be time to consider adding a screened porch.

By DON SHINER

Technical Art by Fred Wolff

WHEN IT COMES to practical outdoor living, you just can't beat a screened porch. Open patios are fine when there are no bugs or sudden showers, but one or the other can ruin a cookout. When you're safe from both within the shelter of a screened porch, summer entertaining and living become twice the fun for family and guests alike.

Adding such a porch is not the major job you may think. It's a project that can be completed in stages to suit both your spare time and wallet. And even before you have it fully screened in, you'll find it

usable for a cookout without worrying about getting wet.

The best spot for your porch is at the back of the house where you have the most privacy, but more important, where it will be accessible from the kitchen. If you are able to build it on the north side of the house, it will be shaded from the hot afternoon sun.

Three-stage project

You can tackle the job in three easy stages: 1. Pouring the slab; 2. Framing the roof; 3. Adding the screens, all of which

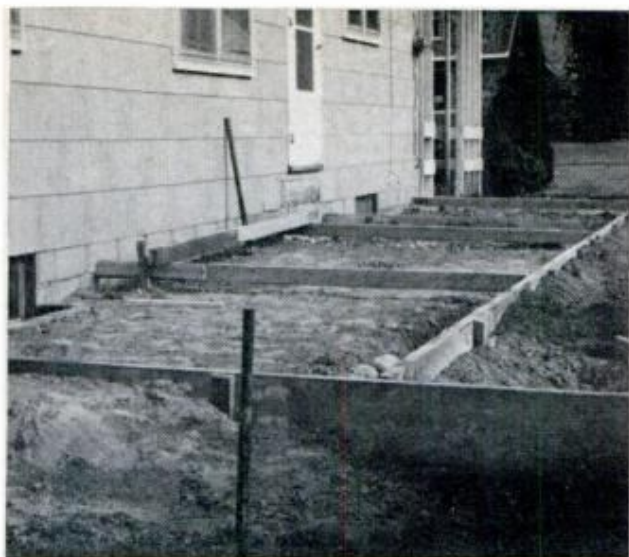

SLOPE THE FORM 2 in. at front to assure proper drainage. Then divide form in sections for pouring

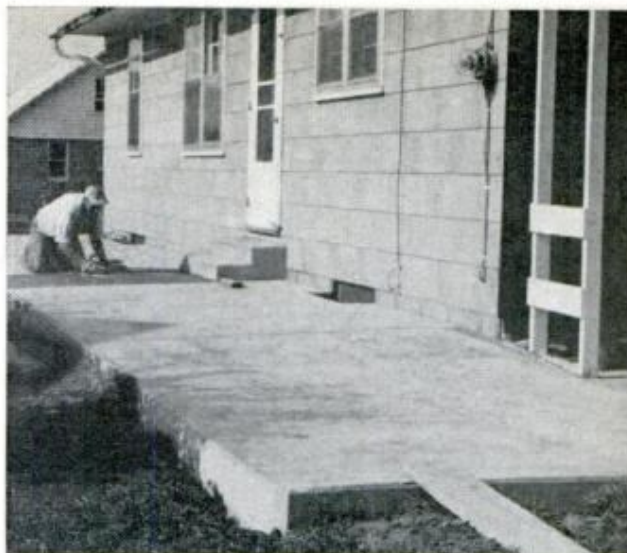

AFTER EACH SECTION is poured, smooth it with a steel trowel, then cover with burlap and keep moist



CEILING JOISTS are toenailed to a 2x6 nailer which is first nailed to the house at ceiling height

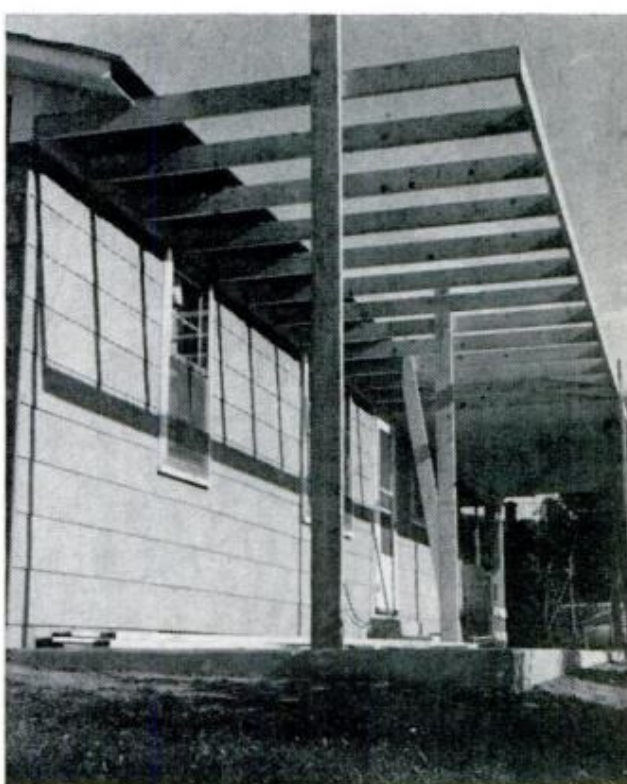

CEILING FRAMING is temporarily supported in level position by scrap props which rest on the slab

you can do yourself with help now and then from a friend. In most cases you'll be ahead if you have the slab poured. In time saved, you can have your porch completed over a two-week vacation.

If you take on the slab yourself, stake it out to suit and remove 5 or 6 in. of topsoil. Dig down 18 in. along the outer edges to form a trench to provide extra support for the roof. Erect form boards so the slab will pitch slightly away from the house ($\frac{1}{4}$ -in. per ft.) and are level with foundation.

Regardless of size, it's best to pour the slab in sections, a day apart. This mini-

mizes cracking and makes it possible, when working alone, to trowel the concrete before it sets. As each divider is pulled out, a $\frac{1}{2}$ x4-in. strip of expansion felt is tacked to the green section before pouring the next. When the slab is finished, cover it with building paper or burlap and keep it wet for four or five days, allowing the concrete to cure fully.

Framing the roof

Before you start the roof, study the framing drawing on the next two pages. Each rafter is paired with a ceiling joist



TAPERED ENDS OF RAFTERS rest on house roof to which they're nailed 24 in. o.c. Plywood covers rafters

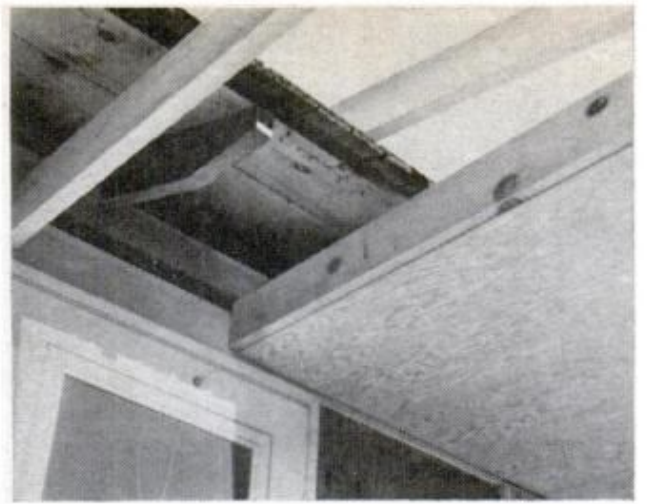

WHEN WIRING IS IN, underside of joists is covered with $\frac{3}{8}$ -in. plywood, butting joints on joists

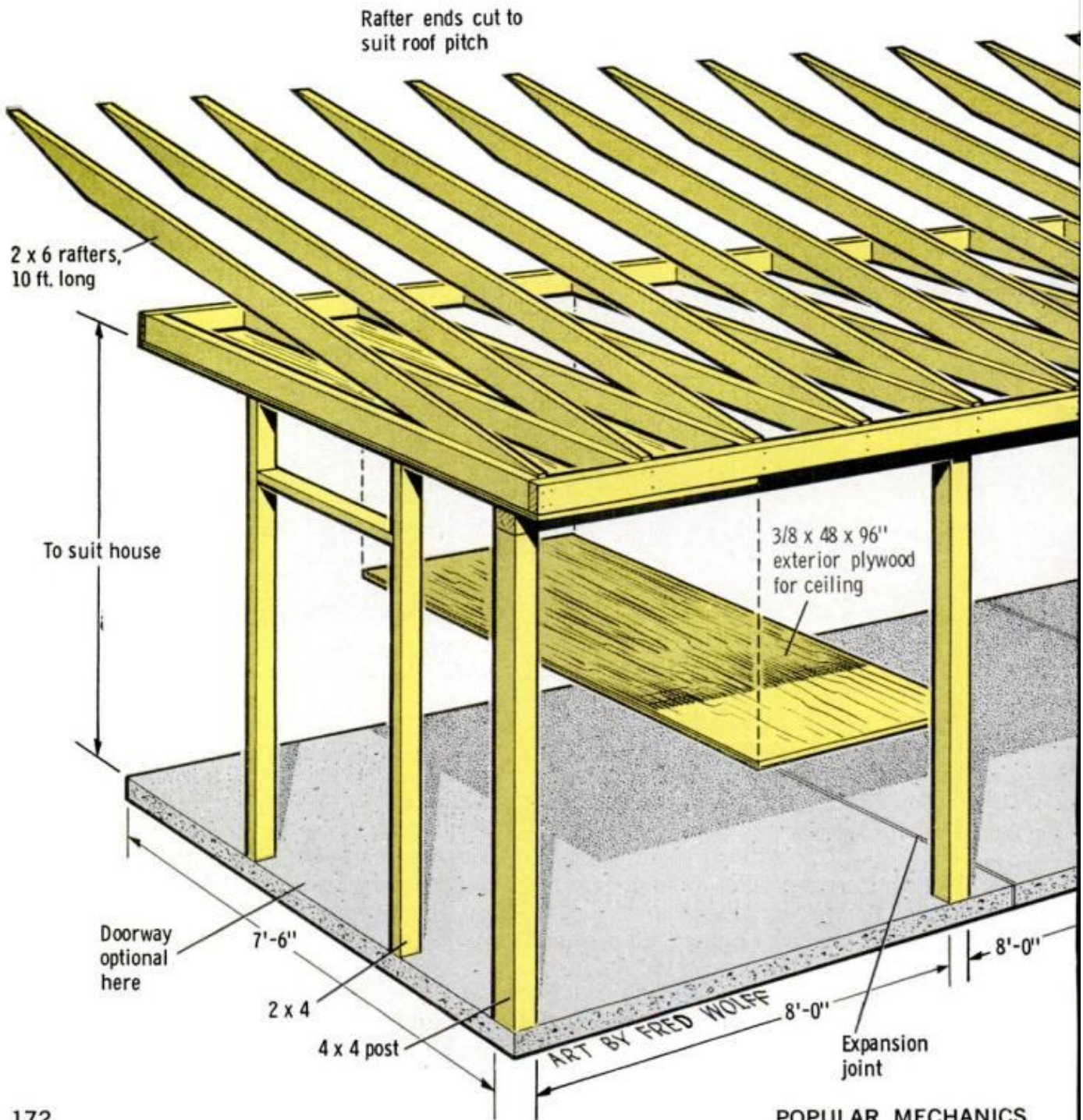



PERMANENT 4x4 POSTS are anchored to slab with angle brackets, then a 4x4 lintel is placed on top

AFTER ADDING FLASHING, roof sheathing is covered with building felt and matching shingles are applied

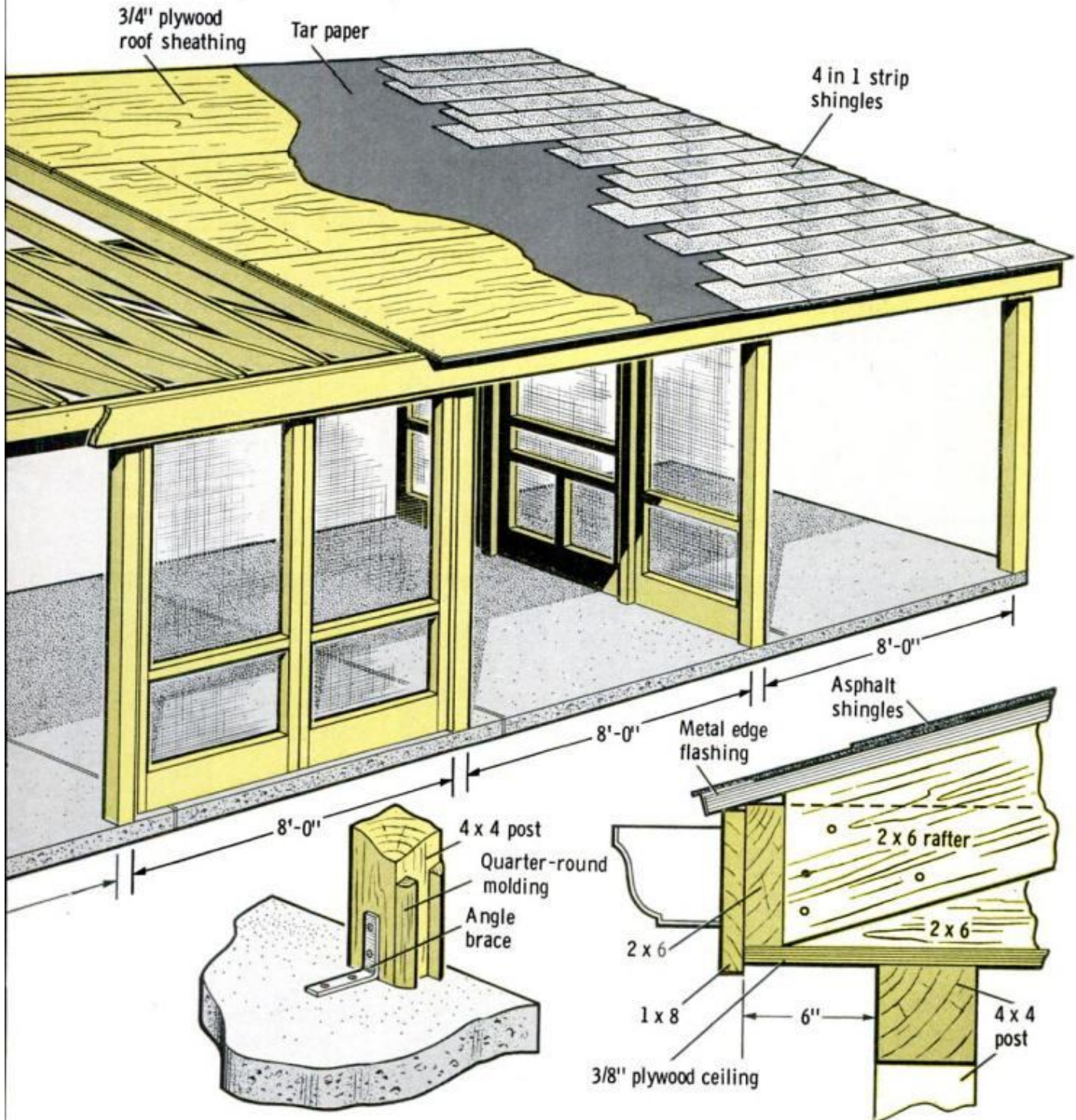

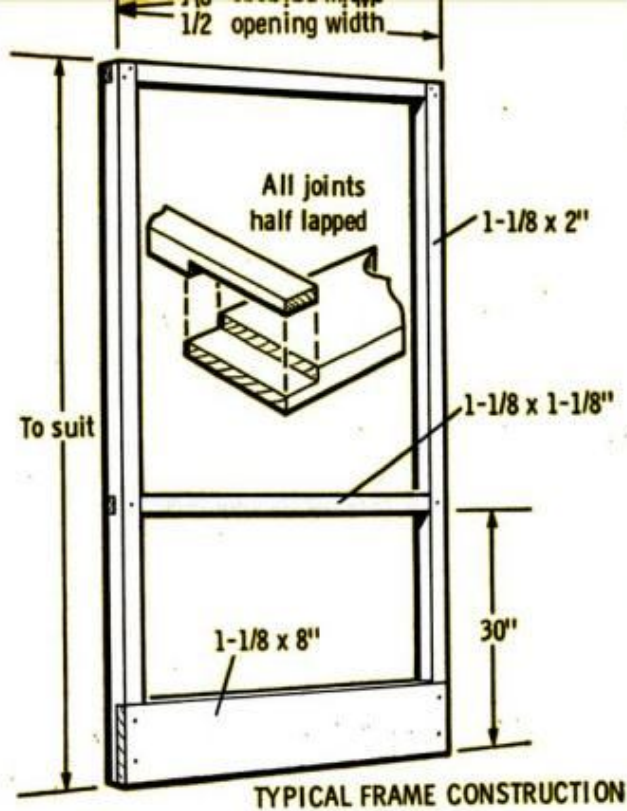

SCREEN FRAMES ARE BUILT with half-lap joints for strength. Make two frames for each 8-ft. opening

and the joists are faced on the underside with $\frac{3}{8}$ -in. plywood before a lintel, supported by 4x4 posts, is placed under it.

Start by spiking a 2x6 nailer to the side of the house at ceiling height. This runs the full length of the porch. Next erect a box-like frame around three sides and prop it up temporarily in a level position. Now install the ceiling joists, 24 in. center to center, and toenail them to the nailer.

QUARTER-ROUND MOLDING, tacked to posts and lintel, provides neat rabbets in which screens rest

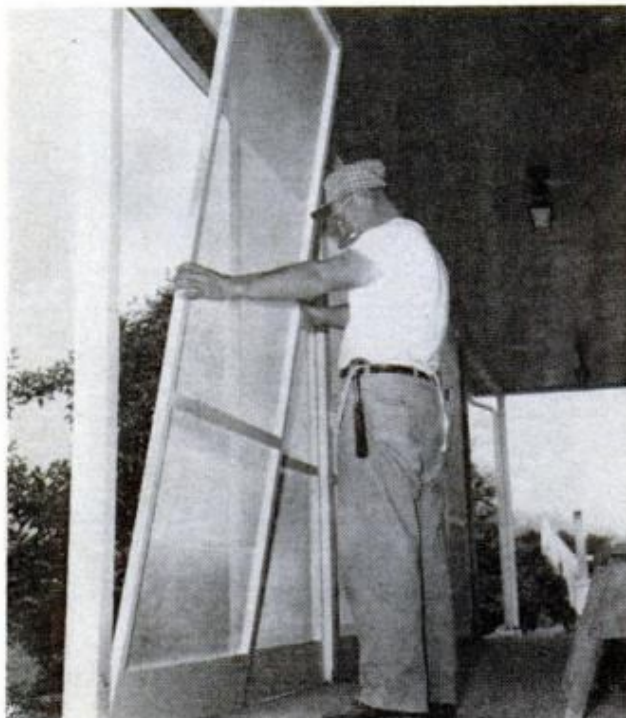

174

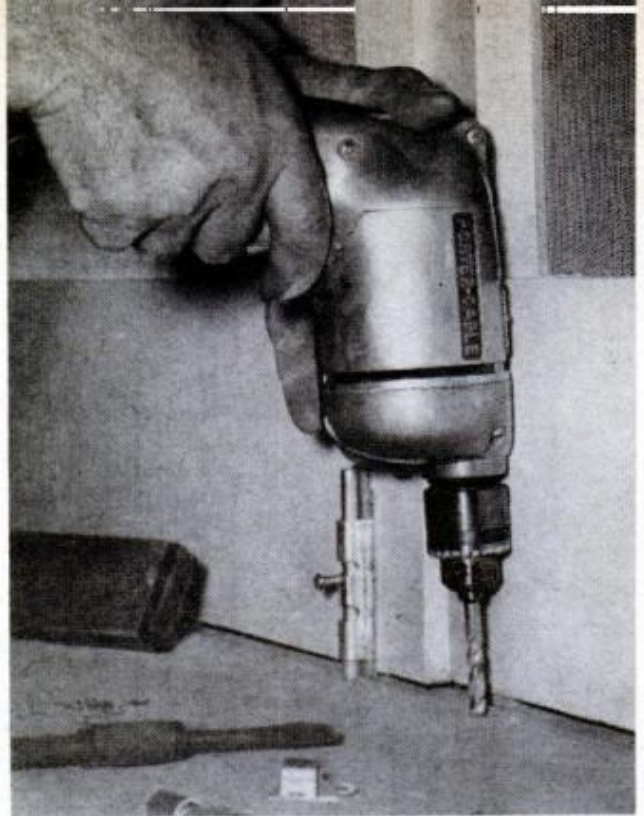

SLIDING-DOOR BOLTS lock screens to slab. Use masonry bit to drill holes in slab for sliding bolts

Spike them through at the front. After this, figure how many rafters are needed (two more than joists if you double up the end ones to make a flush surface) and cut one for a pattern. Taper the end to match the pitch of the house roof. Nail rafters to the roof, right on top of the existing shingles, and spike them to the joists.

Next, you close in the framing by nail-

(Please turn to page 202)

DOORWAY IS FRAMED in end with 2x4s for stock screen door. Openings around the door are screened



POPULAR MECHANICS

HINTS FROM READERS

Magnet for duplicate lengths

If your next woodworking project calls for cutting a number of pieces of wood to the same length, try this handy trick. Set a suitable magnet on the metal table of the saw and use this as a measuring guide. It's important, of course, not to hit the magnet with the end of the work, as pressing the work against it too much will cause it to slide somewhat.—*H. E. Roberts*

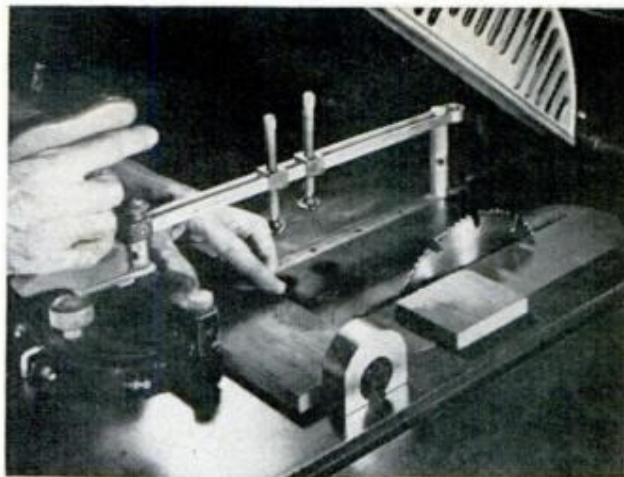

Vise removes scissor screw

When it's time to tighten or remove the screw holding the two sections of a pair of scissors or shears, the screw usually is extremely difficult to turn. Try drilling a shallow hole in one jaw face of a sturdy shop vise, then insert the end of a short, stubby screwdriver bit into the hole. Using the vise as a press to hold the screwdriver bit in the screw slot, you'll find that a wrench slipped over the flat end of the screwdriver will provide enough leverage to turn the screw.—*H. Josephs*



Candy box for small parts

The next time you decide to buy your wife a box of candy, make sure the inside of the box has the one-piece plastic divider that holds the candy in place. Then, after helping to empty the box, snap up the remains and carry them off to your workshop. There, you'll discover, the box is the right size to fit inconspicuously on a shelf—and the dividers in the box make ideal storage compartments for such workshop miscellany as screws, nails, nuts and washers.—*Joseph Braunstein*



Keep a roofing brush soft

These few steps take only minutes, yet they allow you to keep a roofing brush soft for days, even weeks, between tarring sessions. First moisten the brush in kerosene, then work out the excess by brushing over old newspapers or over an area to be tarred later. Next wrap the brush with a few layers of newspaper, enclose it in a plastic bag and bind the bag tightly around the handle with a cord. Be sure the seal is airtight, or the brush soon will dry out.—*Walter E. Burton*



How to Save Wear

By WAYNE C. LECKEY, Home and Shop Editor

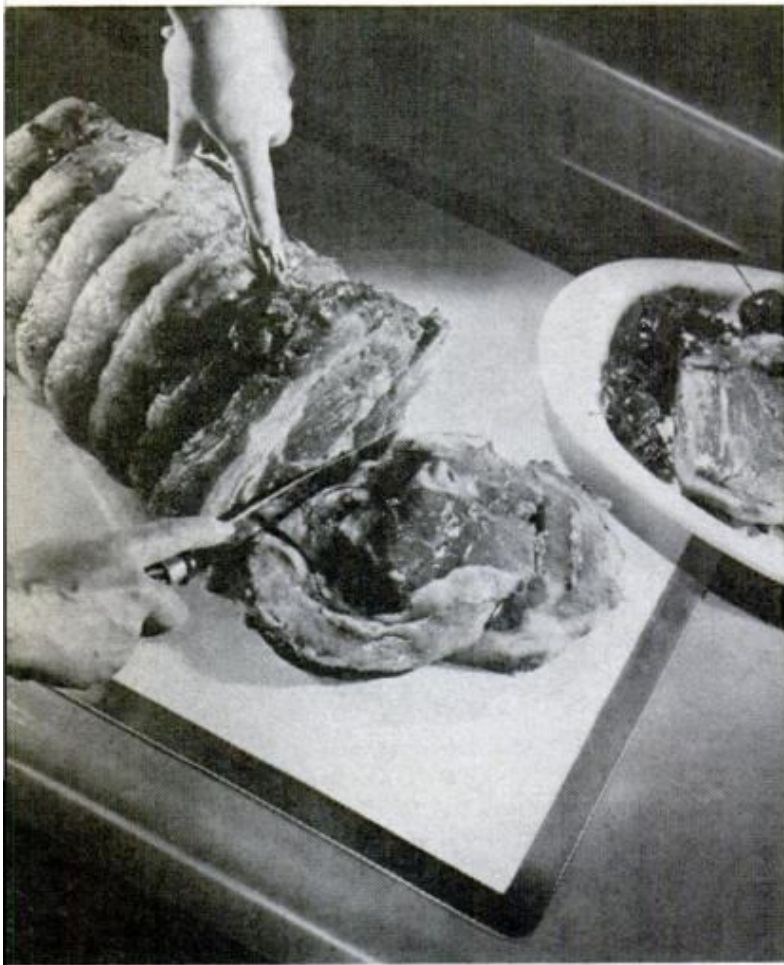

T IRED OF BEING A SLAVE keeping your home from looking old before its time? Just keeping pace with normal everyday wear is a never-ending job.

You can do a number of things to keep up with this daily wear and tear. For example, you can keep walls free of fingermarks around switch plates by adding protectors. Made of clear plastic, they simply fit under the plate. All you have to do to install one is to back out the two plate screws, remove the plate, place the protector over the toggle and screw the plate back on. Such protectors are invaluable in the case of a papered wall where soil marks are difficult, if not impossible, to remove.

Preventing doorknobs from bashing dents in the walls will help keep your home from looking beat up. In addition to the common, shin-bruising baseboard doorstop, there are a couple of new types on the market. One, made by Stanley, is designed to fit on the upper door hinge. It not only keeps the door from swinging back and hitting the wall, but also limits the distance the door can open. To install it you simply drive out the hinge pin, insert the pin through a hole in the stop and drive the pin back into the hinge. It costs about 50 cents.

A new 2½-in. rubber stop made by the H. B. Ives Co. comes in a choice of solid and concave shapes, and provides a non-marring cushion for the knob. Called a

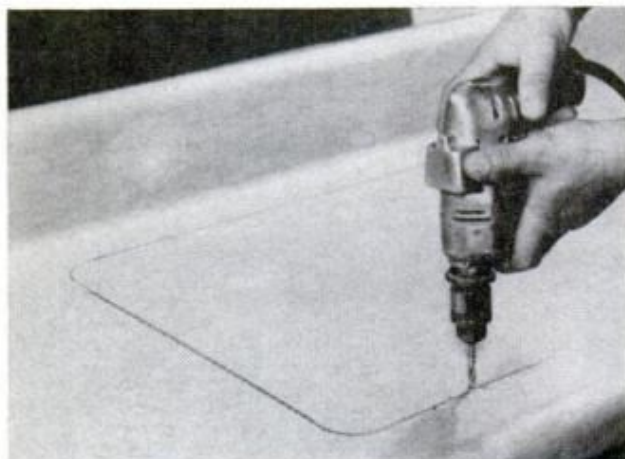
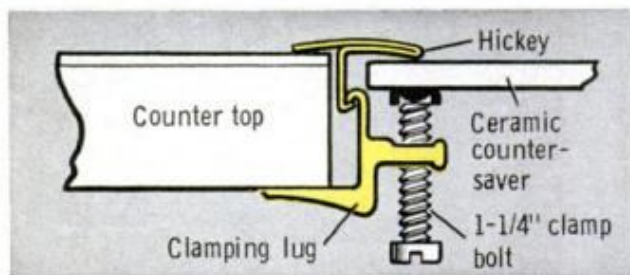

AFTER TRACING PATTERN on counter, hole is made for blade of sabre saw which is used to cut opening

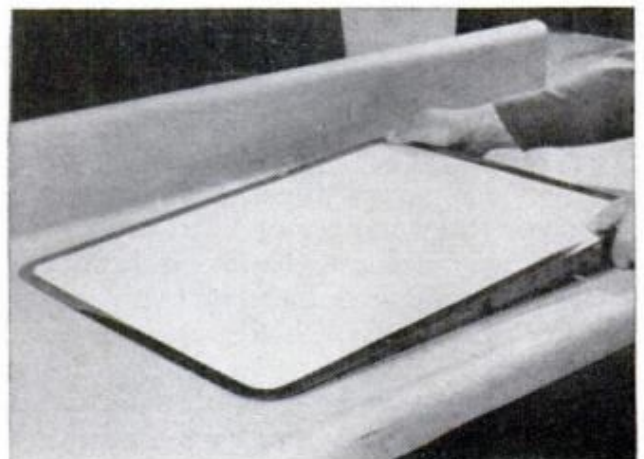

THEN CAULKING IS APPLIED to rim and Counter-Saver is positioned. Hook clamps lock it from below

and Tear on Your Home

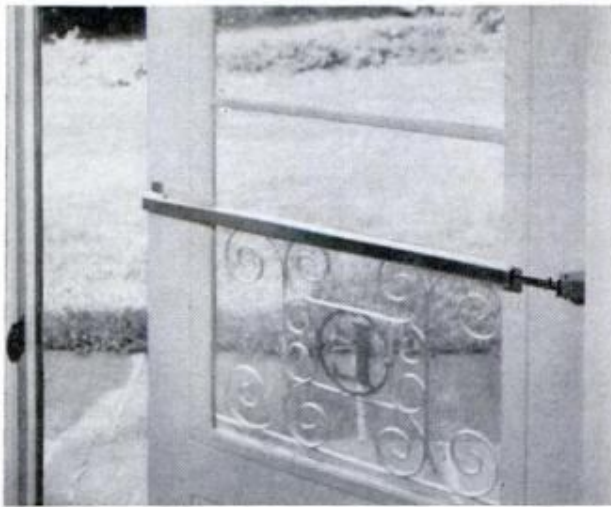

TOUCH-BAR LATCH has closer inside to ease door shut. Bar "handle" opens the latch at a simple touch

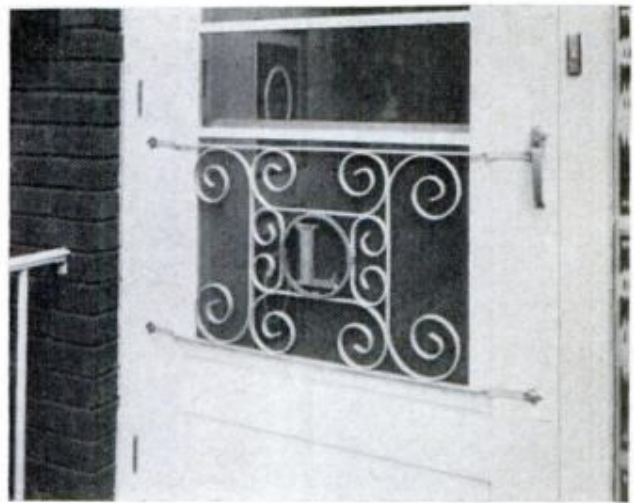

SCREEN-DOOR GRILLE is not only decorative but guards against bellied wire when pushed by kids

wrought wall bumper, it's mounted on any type of wall at a point where the knob would normally strike. It's priced from \$1.98 to \$2.75 depending on finish.

You can add metal kickplates to the front and back doors. This pays off handsomely, particularly when, because of weatherstripping, a door is hard for youngsters to open without an assist from their feet. Such brass or aluminum

guards will prevent scuff marks and a beat-up look. An aluminum one costs \$5.50.

Metal nosing applied to basement stairs will prevent wear and tear, even when the steps are not tiled. When unprotected, bare wood steps are subject to splintering along the edge, and tiled steps soon show signs of chipping—to give them a shop-worn look.

Among more extensive things you can

ALUMINUM GUTTER COVER prolongs life of galvanized troughs and eliminates messy chore of cleaning

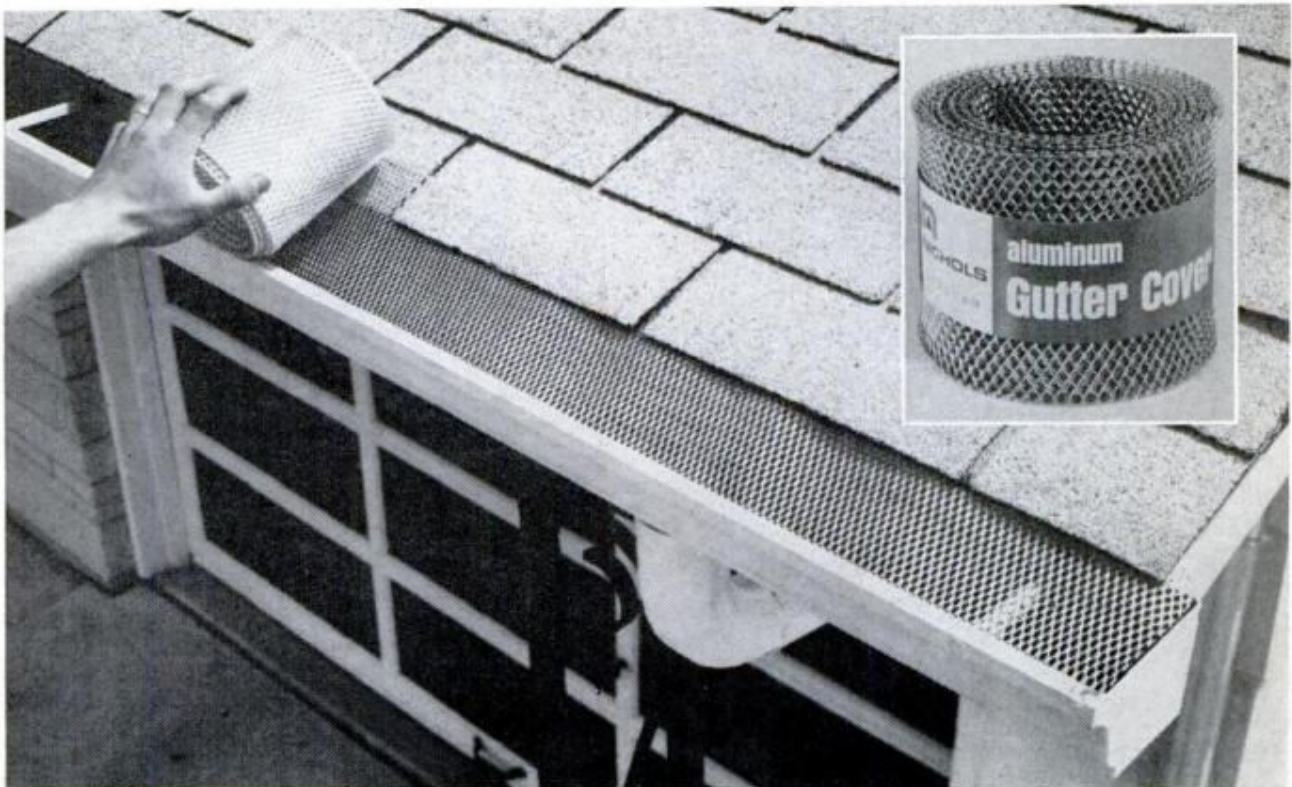

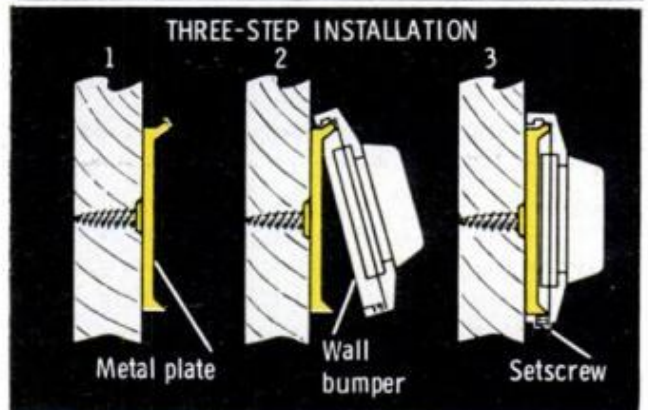
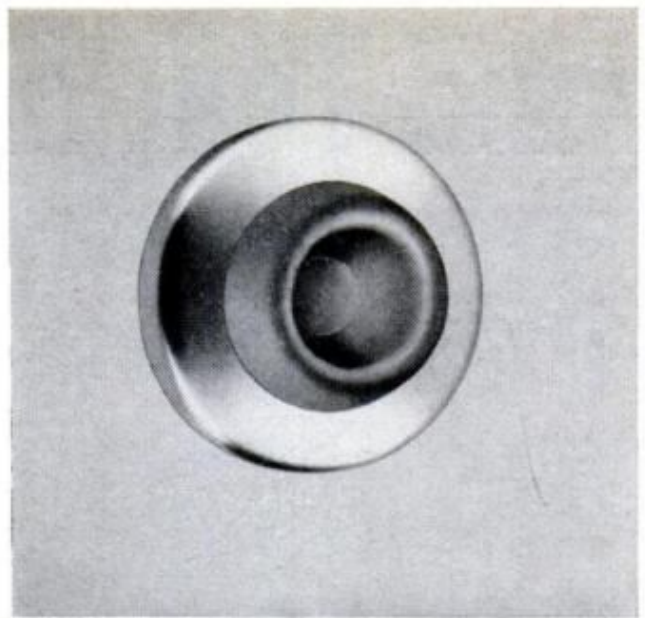
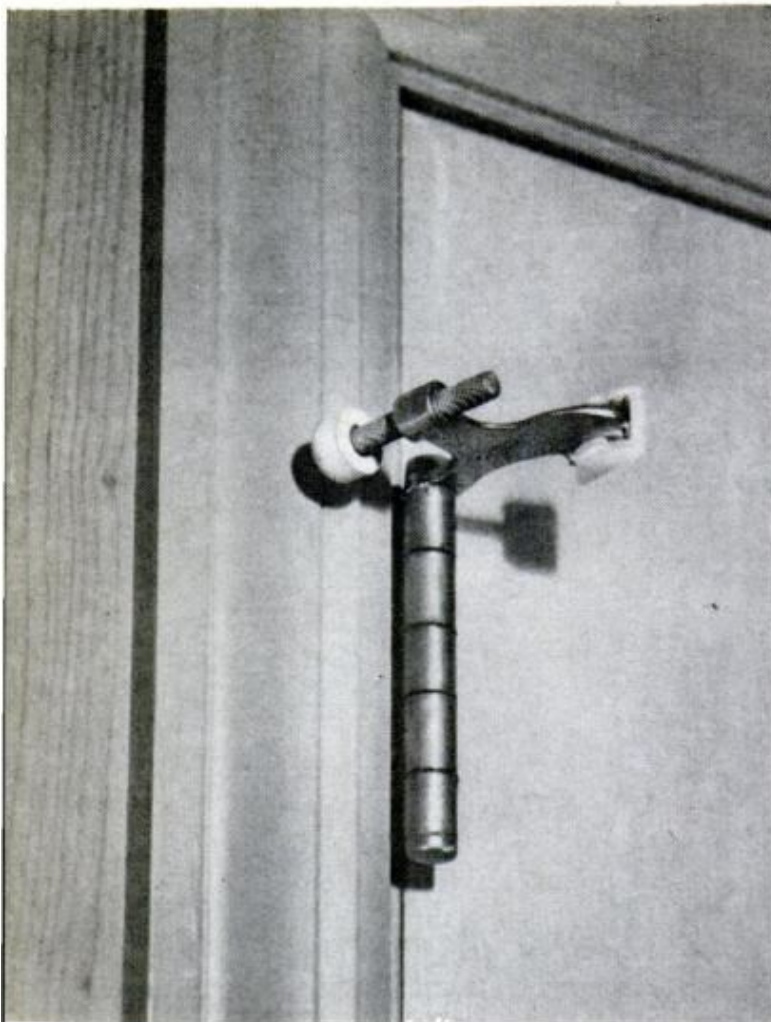

STOPS SUCH AS THESE will prevent knobs from damaging walls. Adjustable hinge-pin type limits door swing. Rubber bumper mounted where knob strikes wall, lets door swing open all the way but cushions knob

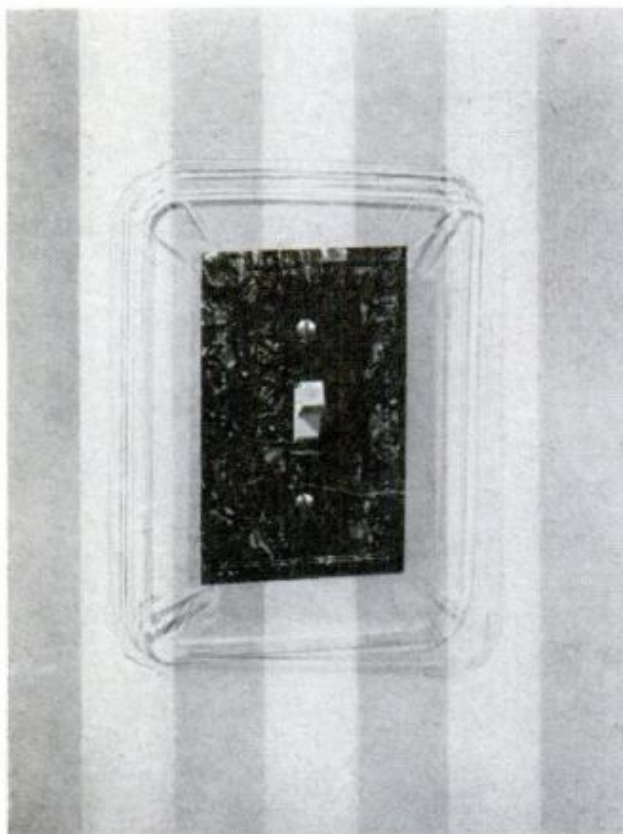

CLEAR PLASTIC PROTECTORS over switch plates save painted and papered walls from unsightly soil marks

add to save wear and tear is a drop-in Counter-Saver made by Corning Glass Works. You know what happens when, unwittingly, you place a hot pan on a kitchen counter. The plastic top is marred for good with an ugly imprint. However, with an insert of Pyroceram in the counter, you can set the hottest skillet or casserole on it without worrying. It costs about \$25—less than the cost of replacing a whole damaged counter.

Installation of this protective ceramic requires the cutting of an opening in the counter. A cardboard template comes with the kit which you trace on the counter before drilling a hole for starting a sabre-saw cutout of the opening. A stainless-steel rim (bezel), like the one around your sink, is provided to cover the rough opening. Caulking is applied to the rim before it is pressed gently in the opening and locked in place with clamps applied from below. You can get complete kits in 16x20 and 18x24-in. sizes.

Combination storm and screen doors take a beating, and not from kids alone;

without some type of chain or spring check, the wind can tear such a door from its hinges, or it can wreck itself slamming shut. Here is where a pneumatic door closer is a good investment. A new dual-purpose closer by Ideal Security Hardware Corp. is housed inside a touch-bar latch. You can unlatch the door from the inside merely by bumping the bar with your arm, knee or body. In being inside the bar, the closer is at midpoint on the door, where it works best. This latch sells for \$9.95, can be tailored to fit any width door and comes with complete instructions for installing.

Screen inserts of combination doors are



METAL KICKPLATES will prevent scuff marks when kid's toe is used to help open tight-fitting door

not free from wear and tear. Let a small child or pet push against the wire and you'll have a belly in it you can't remove. Before this happens, it will pay you to add decorative push grilles to both sides of the door. Macklanburg-Duncan sells the attractive grille shown on page 177 for \$6.75 but you can get less fancy ones in various finishes and designs.

What's a bigger headache than roof gutters! Let them fill up with leaves and muck and you'll wind up with clogged downspouts and blocked sewers. Gutter covers not only will save you the messy chore of cleaning gutters, but will prolong their life. The weight alone of clogged gutters will cause them to droop and sag. When water can flow freely, there are no standing pools that can cause galvanized gutters to rust, deteriorate and leak. Made of expanded aluminum mesh 6 in. wide, the gutter cover comes in 25-ft. rolls and in 36-in. straight lengths. A roll of Nichols Aluminum Co. gutter cover costs \$2.99, while a package of

(Please turn to page 218)



OUTSIDE DRINKING FOUNTAIN will curtail extra trips inside. This one screws onto regular sill cock



METAL STAIR NOSING will save basement steps from scuffing and chipping of tile along front edge

PERFORATED SPRINKLER CAP over downspout will prevent gushing, puddling of water near foundation

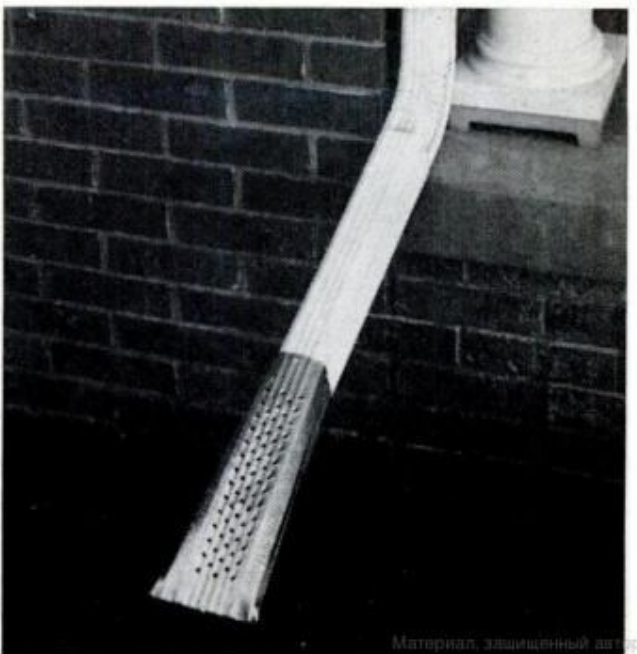

Stressed-skin doors for storage cabinet

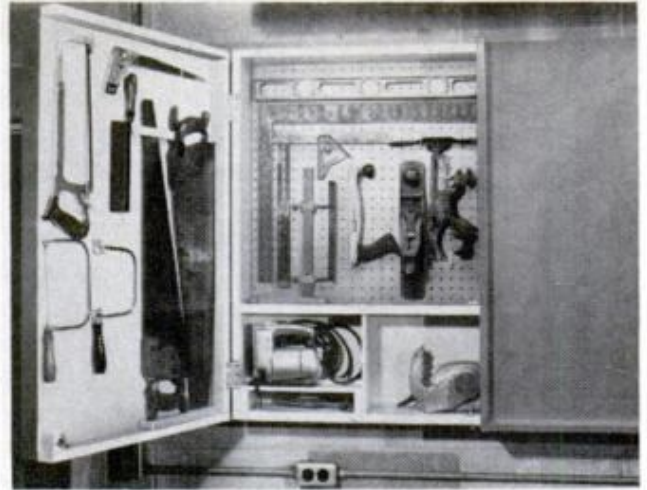
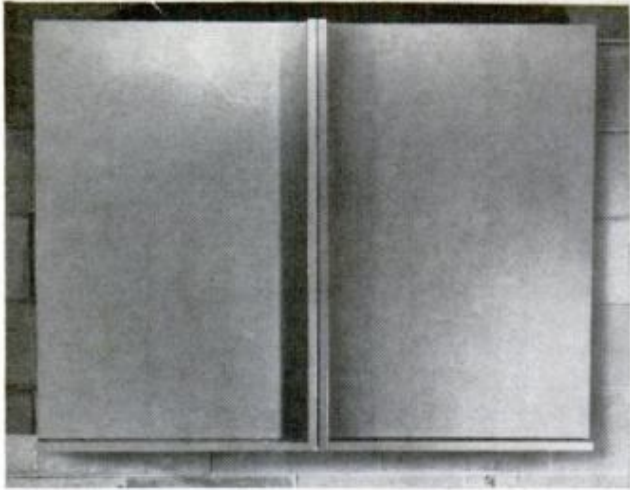

Doors for a workshop cabinet, laundry room or basement storage unit are easy to make and twice as easy to hang if you use a stressed-skin construction technique similar to that in aircraft (the load—weight of the door—is borne by the plywood skin, while the strips serve only as stiffeners). The door weighs so little that pivot-type hinges are adequate even for large doors. Hardware costs are further reduced since the protruding stiffeners act as handles.—*Charles H. Welch*

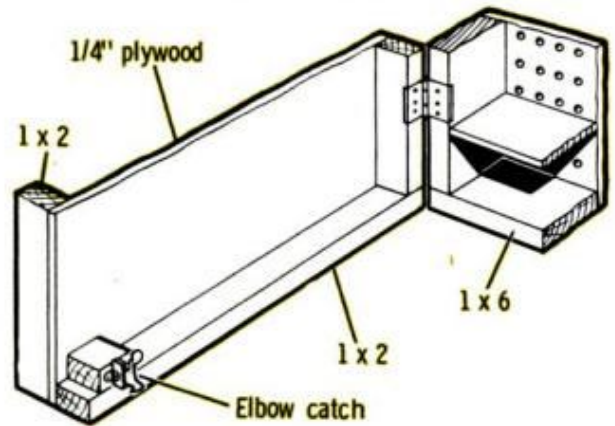

Vise improvised from C-clamp

You can convert a C-clamp into a bench vise with a simple modification costing but a few minutes' time and possibly a few cents for screws. As shown at right, this method offers the additional advantage of providing a flush work surface so you can clamp a long board anywhere along its length. To mount the clamp, first drill its frame for a pair of suitable wood screws to hold it against the end of the work table. When positioning, make sure the clamp's adjusting screw clears the table.

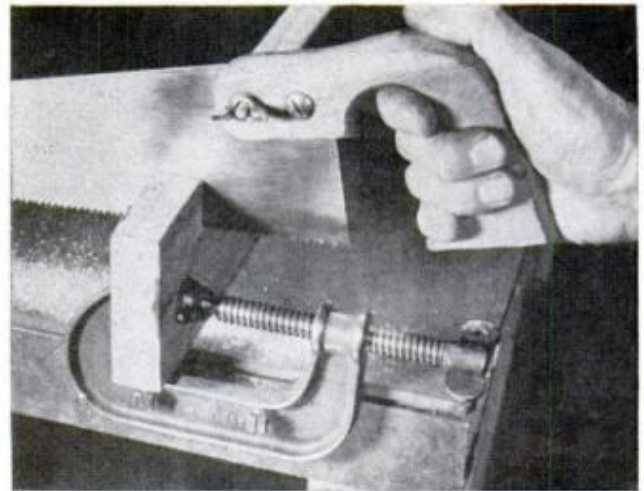

Turn can opener into staple puller

You won't need to risk broken fingernails if you make a handy staple and tack puller from a discarded can opener. Simply bevel the underside of the pointed end to reduce its thickness so it will slide under staples. Also grind the other end until it's quite thin; then file a V-like notch in the center of the slightly rounded edge. To pull thumbtacks, simply slide the round edge under the head of the tack, and position the notch so it clears the pointed shaft of the thumbtack.—*William Swallow*



Keep Trim With This Dual-Action Exerciser

THAT OLD BICYCLE rusting away in your garage can be put to work as a dual-action exerciser to help you to keep in good physical shape. While you pedal in bicycle-fashion and simultaneously pull against a spring-loaded handle, your leg, back, arm and even your neck muscles are rhythmically put into action.

To begin construction, strip the bicycle of all parts except the seat, crank and pedals. Disassemble the crank, remove the sprocket and replace the sprocket with a suitable washer. Next, reassemble the crank and tighten the cones to obtain the force desired for turning the pedals.

The stand is made of 1-in. chrome tubing bent as shown. If the tubing is hard to buy in your area, substitute 1-in. electrical conduit. The handle and the long front arm also are bent to the shapes shown. The bottom of the front arm is connected to a 14-in. long coil spring, the other end of which is attached to a hole drilled through the rear fork.—John A. McKee

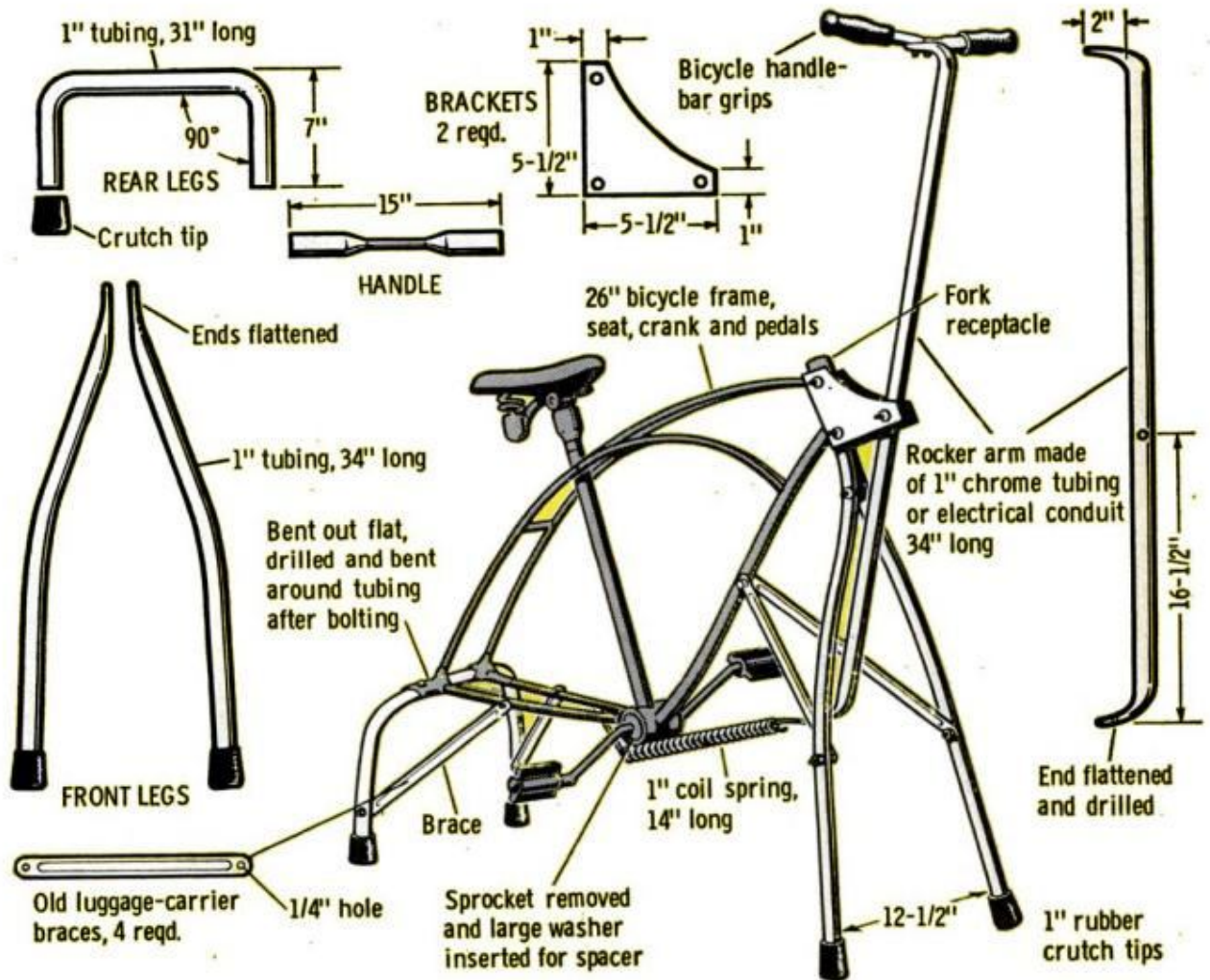

Solving home problems

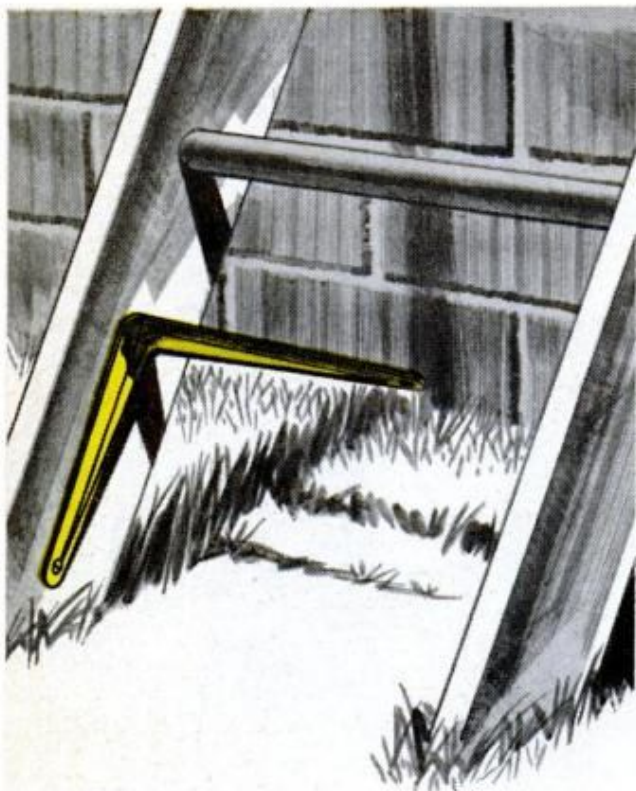

MUD CARRIED ONTO LADDER RUNGS is not only a mess, but also dangerous since it can cause you to slip off. A simple solution is to attach a sturdy shelf bracket to the ladder for use as a convenient scraper

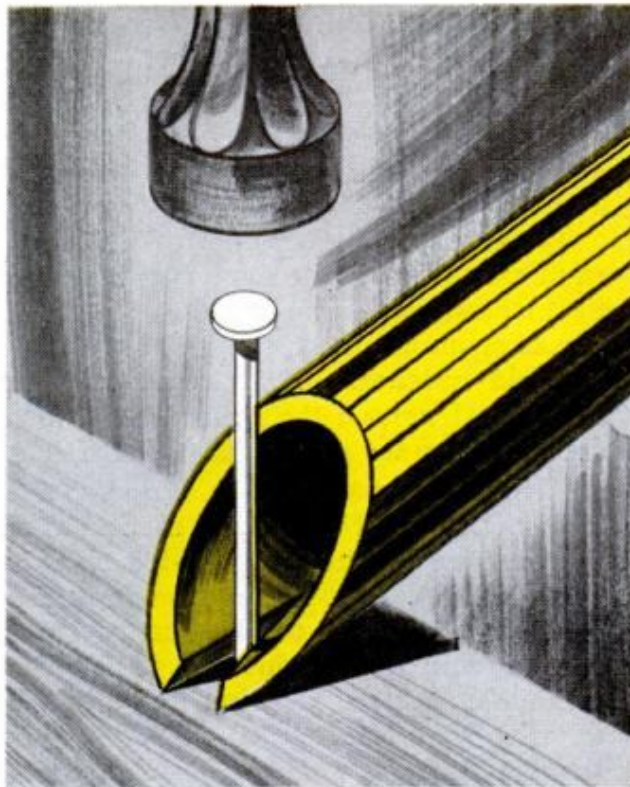

MOST EVERY PROJECT calls for driving a nail in a spot that's awkward—especially when it comes to starting the nail. You can use a piece of scrap garden hose, slotted as shown, to hold the nail in place

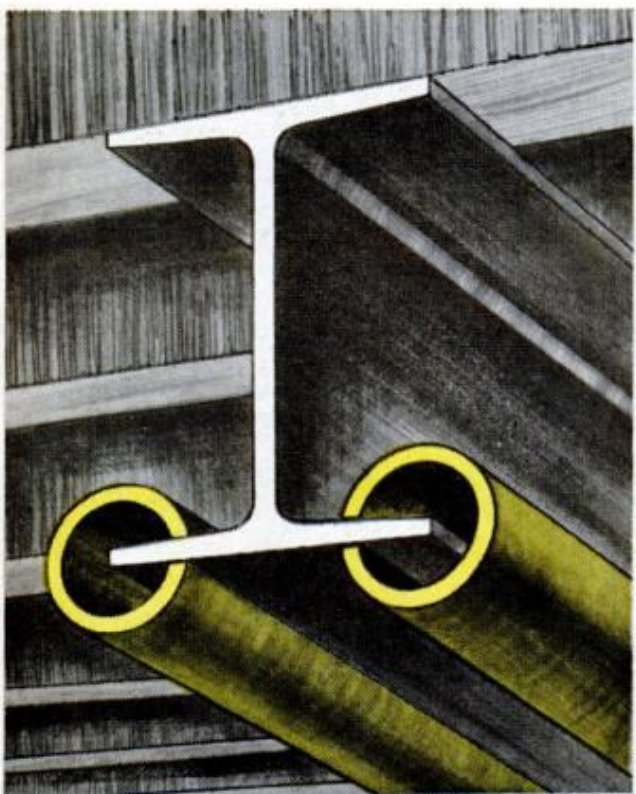

STEEL I-BEAMS present a headroom problem in many older homes, especially those with storage cellars later converted into livable basements. To protect heads, use 2-in.-dia. cardboard tubes as shown



DON'T THROW AWAY those old "peat" plastic bags. Make good use of them when laying stones in a rock garden by laying down opened bags, then placing the rocks. This keeps weeds from growing around rocks



MAKE A HANDY TACKPULLER from an old double-edge razor by filing a notch in one edge. Discard the underpiece that normally seats the blade and you'll find that the notched curve top does the job nicely

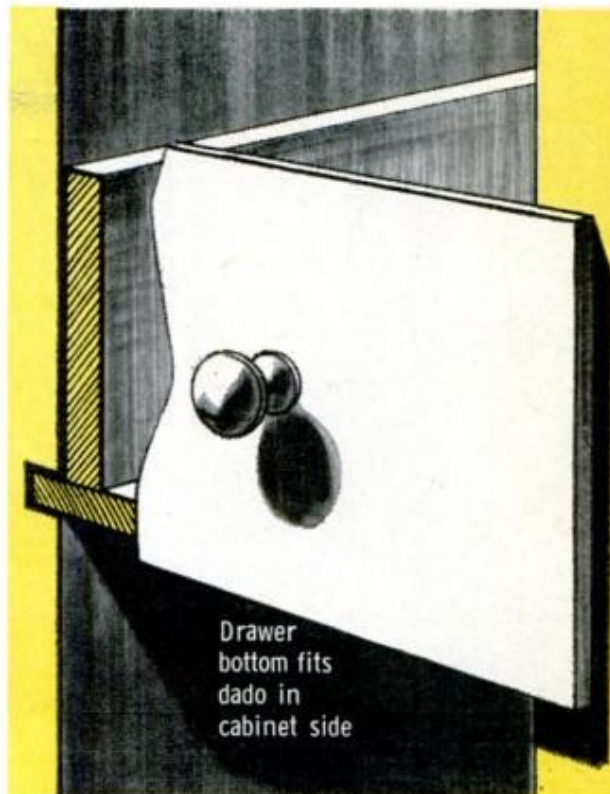

WHEN MAKING SMALL DRAWERS for a workbench or cabinet, eliminate the need for elaborate hardware by using the drawer bottom as a slide. The simple slide needs only a bit of wax for smooth operation



STRONG WINDS can't lift the covers of your trash cans if they're fitted with a pair of 16-penny nails as illustrated. The nails should be positioned 180° apart and held to the cover with short lengths of chain

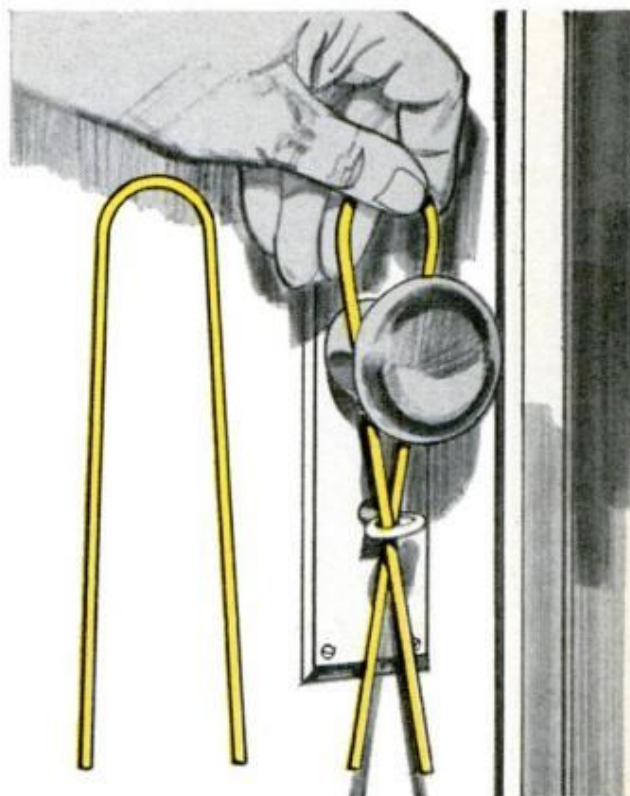

OLD-FASHIONED DOOR LATCHES can be burglar-proofed by fitting them with a length of coathanger wire as shown. The wire prevents the key from being pushed out of keyhole, then slid under the door

6 Ways to Make

By DAVID X. MANNERS

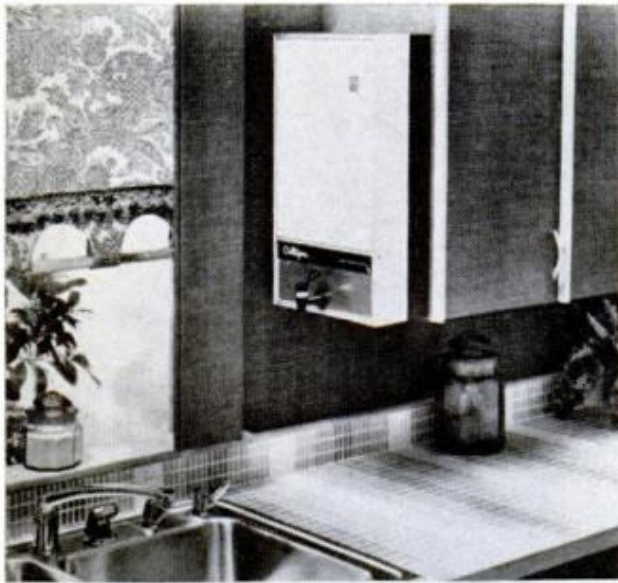

CULLIGAN'S AQUA I PURIFIER is made for mounting vertically as shown or horizontally under cabinet

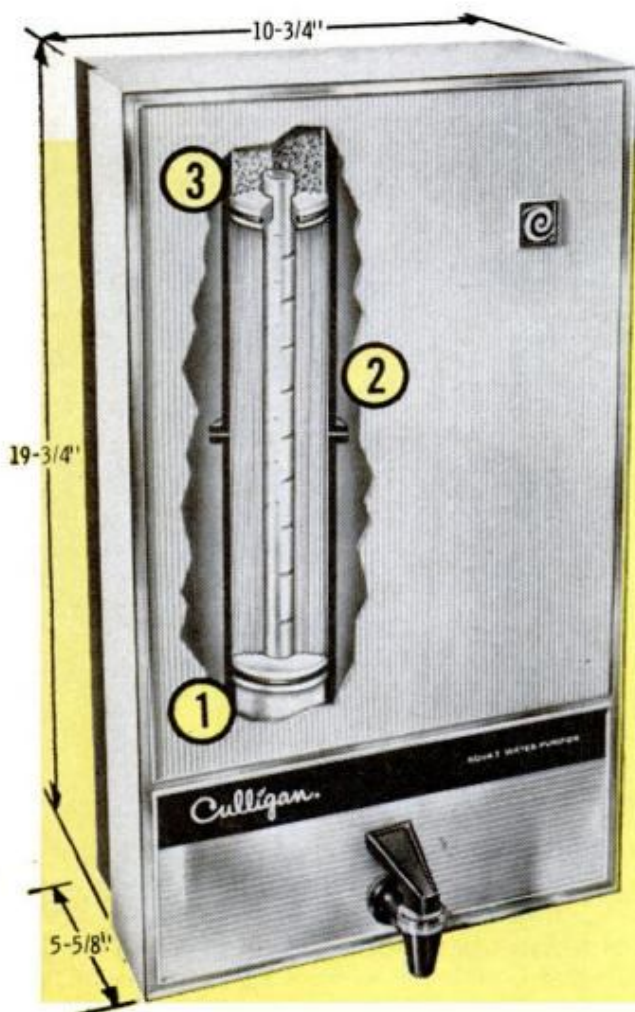

DON'T BLAME the waterworks if your water tastes bad. Or if it stains your sink and corrodes your plumbing. Or if it won't lather. At eight tons for a dollar, delivered, what do you expect?

If you have your own well, as one in four do, you already know what many people using public water are beginning to learn. Quality water isn't free and a public system can't be expected to provide it.

Here's why: Less than one percent of all water goes for drinking. Less than 10 percent of it goes for household uses. More than 90 percent of it goes for such other things as cleaning streets, fighting fires, cooling buildings, watering lawns and carrying away sewage—who needs soft, sparkling, delicious water for that?

The people who run our water systems produce the safest water in the world and the price is incredibly low. So if you want

HOW WATER PURIFIER WORKS

- 1 PREFILTER.** Water first passes through a porous cellulose filter to prevent foreign matter from clogging the membrane surface.
- 2 REVERSE OSMOSIS MEMBRANE.** This special semipermeable membrane, of cellulose acetate wound spirally on a central core, has 5 square feet of surface which rejects dissolved minerals and organic matter from water, while allowing purified water to pass through. Operates with normal water pressure.
- 3 FINAL FILTER.** Activated carbon filter adds a final "polish" to the purified water. Molded plastic case serves as 3-gallon water reservoir.

Bad Water Good

better water for drinking, laundering or bathing, it's up to *you* to provide it. The only economical way to get quality water is by point-of-use treatment using purifiers, filters, softeners or conditioners.

● *That terrible taste.* Many people solve the problem of bad drinking water by buying bottled water. It's a good way to get acquainted with how much better water can taste, but it may cost you 55 cents a gallon—and you have to lug it home. A better way is to make your own. A new purifier, born of the space age, now makes it possible to produce bottle-quality water right in your own kitchen for as little as 6 cents a gallon.

The purifier, employing a cellophane-like membrane and a process called "reverse osmosis," turns back almost every insult water can hand you. It stops chlorine, detergents, organic matter, undesirable minerals and salt. It is the first economical way to purify brackish, gypsum or alkaline water. Under some circumstances it will even stop bacteria and virus. It requires no electrical connection since it works on water pressure alone.

About the size of an attaché case, Culligan's Aqua 1 purifier, shown at the left, can be installed on or under a kitchen wall cabinet or wherever you have free wall space. A $\frac{3}{8}$ or $\frac{1}{4}$ -in. copper line supplies water to the unit. A tiny capillary tube carries away removed contaminants. By restricting water flow, the capillary tube helps maintain pressure on the membrane. Result—about 3 gallons a day of the finest water anywhere. The reservoir is right in the unit. Lindsay and Presto make a membrane-type purifier, too.

It's water that is crystal clear, excellent for drinking, beverages, cooking—including the making of juices, soups and gelatine desserts. It is recommended for infant formulas, low salt diets and ice-cube connoisseurs. People who have used it say it makes for happier tropical fish, more luxuriant potted plants and spotproof photo processing. They use it in steam irons, vaporizers and automobile batteries.

The purifier that can do this rents for

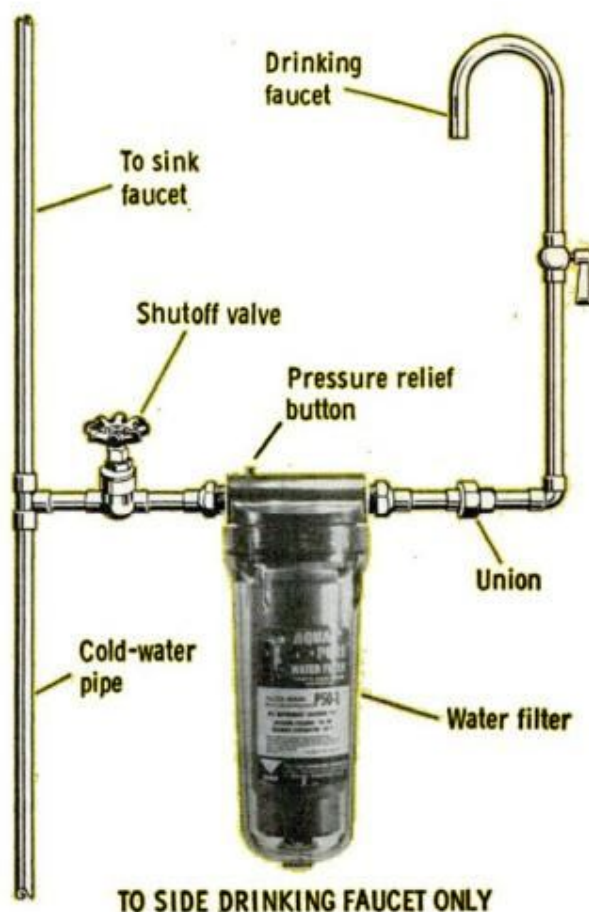

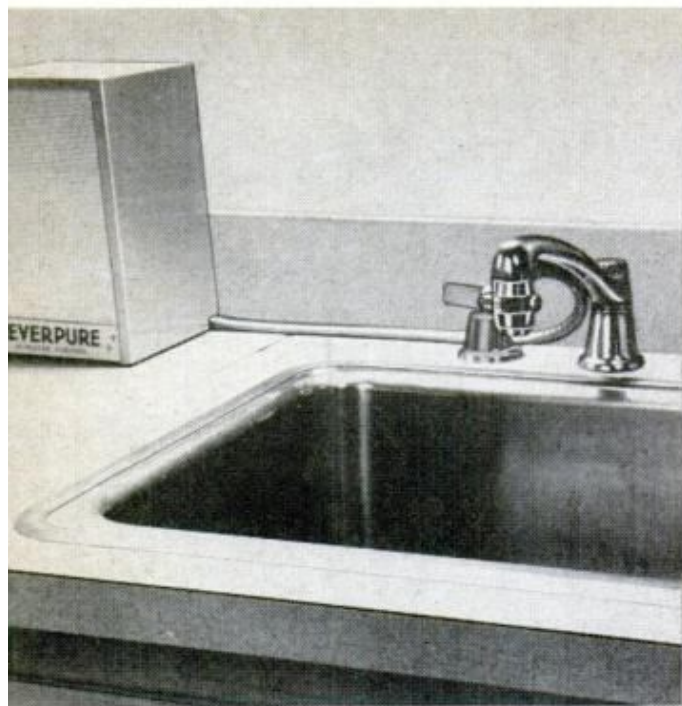

THIS COUNTERTOP FILTER, which needs no plumbing, attaches to faucet, bypasses nonfiltered water



THIS PLUG-IN FILTER, called Aqua Spring, is hand filled, works by distillation rather than filtration



about \$6.50 a month, which includes service. But there is an installation tab of from \$12 to \$20. If you want to buy one outright, the suggested price is \$195.50. The membrane requires replacement (about \$40) every two years or so.

Want something less expensive? Highly effective in improving water where taste and odor problems are not severe are small cellulose and/or activated carbon filters, such as Cuno's Aqua-Pure shown on page 185. These sell for about \$30 to \$40 each, with replacement cartridges that range from \$2.50 to \$13.

Usually, both a cellulose type and an activated charcoal cartridge are used in combination. The cellulose type removes suspended matter and makes murky water clear. The activated carbon one removes tastes and odors.

Typically, these filters are of clear plastic or stainless steel and are attached to the cold-water line under the sink.

If the area under the sink is not accessible, the filter can be installed in the basement beneath the sink. Only one shutoff valve is required, on the inlet side of the filter. A pressure-relief button on the inlet side of the filter head is used to relieve the pressure for easy sump removal and replacement. While you can run the filtered water to your regular cold-water

good filtered water for just drinking and cooking purposes.

Under-the-sink filters like these are made by Cuno Engineering Corp., Pall Corp., Everpure Inc., and others. Everpure recently introduced a filter that combines purifying and taste-and-odor removal in a single cylinder. It uses diatomaceous earth instead of cellulose, blends it with activated charcoal. Cartridges last about a year, cost \$9. The same company also makes a filtered water faucet kit for \$18.

You want to avoid plumbing? Then get a filter that goes on the sink counter instead of under it. It has lines that attach to the end of the sink faucet, but you can still use the faucet to run nonfiltered water. Eaton has a plastic one of this variety for about \$25. Everpure has one in stainless steel that will filter cold water for

drinking, hot water for tea or coffee. It costs \$98.

Bargain filters, where the complete unit screws onto the faucet, are too small to be effective. They also are easy targets for unsanitary sink splashes.

Still another type of water purifier works by distillation rather than filtration. Called the "Aqua Spring," it's a \$70 plug-in device that the manufacturer (New Medical Techniques) claims will produce safe water from any source, salt or fresh. It produces two quarts at a filling. There is no plumbing since it's filled by hand.

Another hand-filled, nonplumbing filter is Crystalab's Water Freshener. Here you simply fill a 32-oz. squeeze bottle with cold tap water and place it inverted over a special activated charcoal. In minutes you have a decanter full of freshened water, free of odor, discoloration and taste. It will freshen 600 or more quarts of water

(Please turn to page 218)

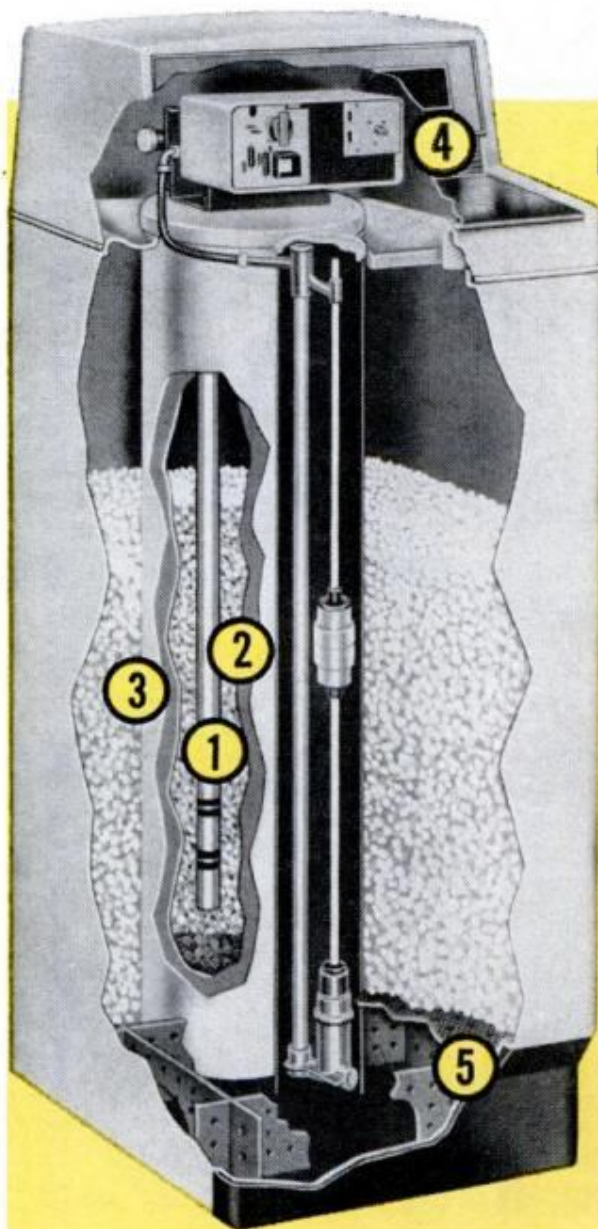

HOW A WATER SOFTENER WORKS

- 1 AQUA-SENSOR.** Two sensors located at bottom of the ion-exchange resin bed electronically detect the difference in water hardness and signal the solid-state controller. When hard water reaches the upper sensor, the lower sensor is still immersed in softened water. At proper time, unit automatically recharges.
- 2 RESIN SOFTENING BED.** Long-life resinous mineral of high softening capacity.
- 3 RESIN BED TANK.** Resinous mineral is held in rugged steel cylinder which has an inner and outer liner of heavy plastic.
- 4 SALT BED PLATE.** Plate allows any insoluble matter in the salt to settle out, preventing clogging of the brining system.
- 5 BRINE SYSTEM.** An electrically operated valve, plus a mechanical float valve, prevents overflowing or overflowing.

High-Speed Duplicating Machine Makes You an Expert Woodcarver

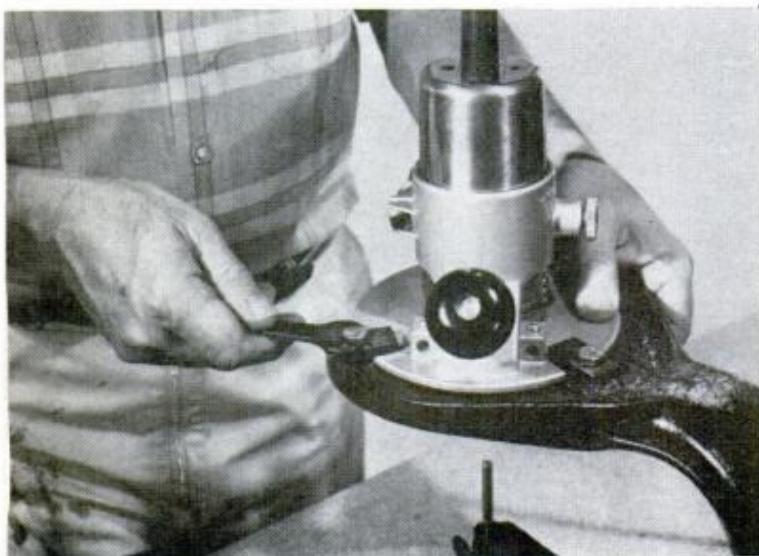
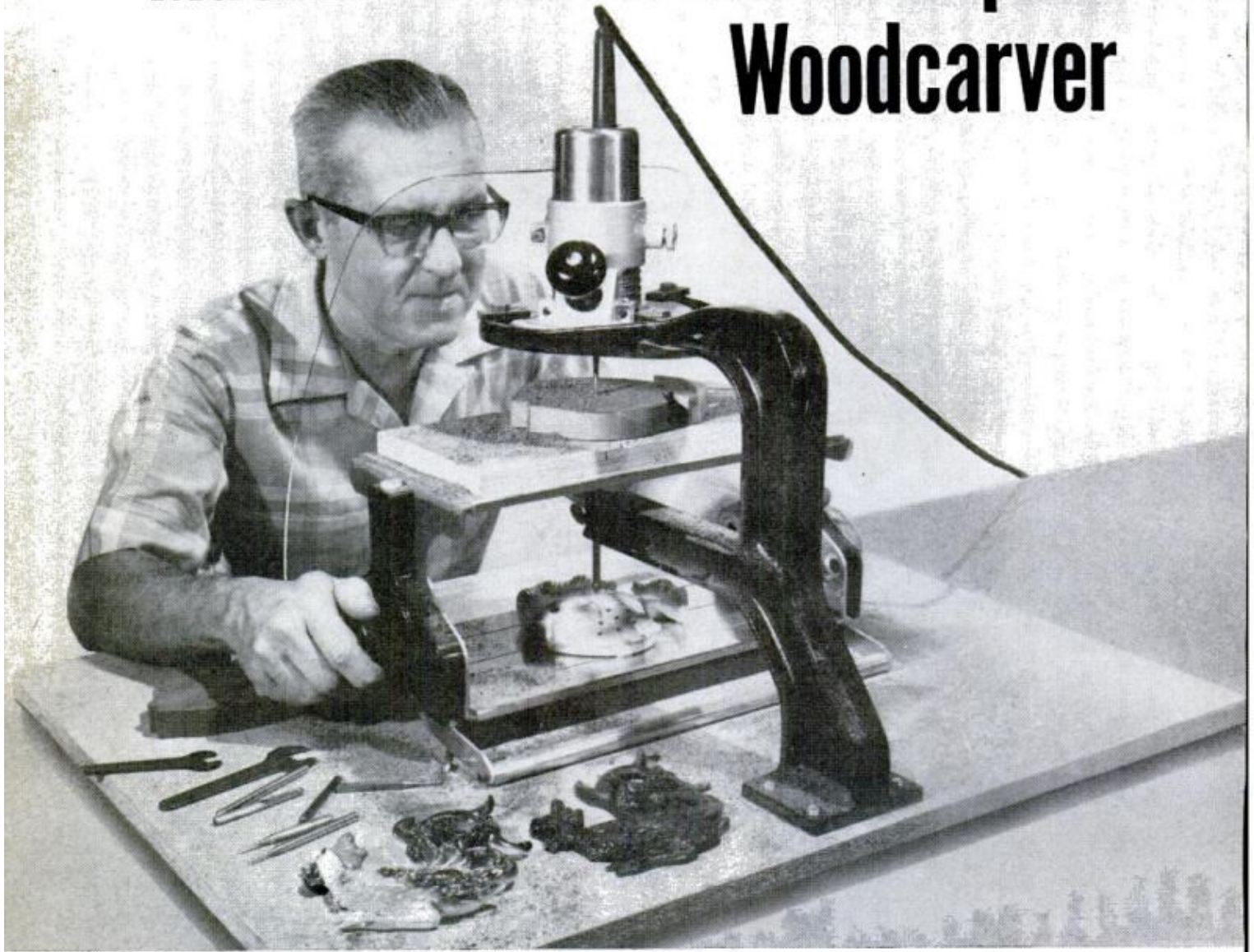

ANY STANDARD ROUTER up to 1 hp can be used. Three clamps anchor it to heavy cast-iron frame, bolted to large wood base

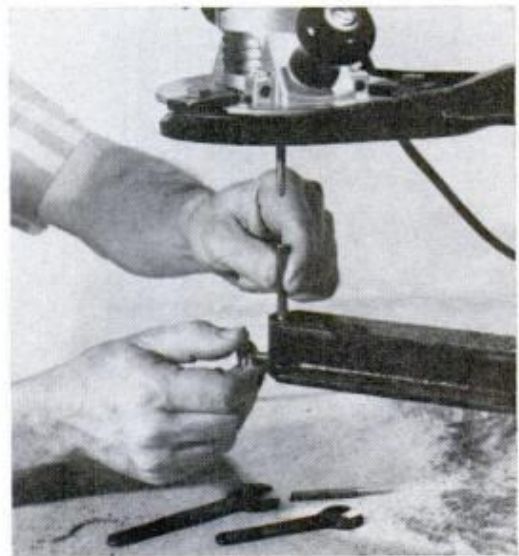

CUTTER AND STYLUS are aligned using tool with hole in bottom to accept stylus

POPULAR MECHANICS

By **WAYNE C. LECKEY**
Home and Shop Editor

IF YOU ALREADY HAVE a portable router and can plunk down \$75, there's a new carving machine waiting for you at your hardware store which will make you an expert woodcarver overnight.

It's called Hobbi-Carve and with it you can carve exact replicas in 3-D of any master pattern you follow. The finished carving becomes a perfect same-size copy down to the original chisel strokes.

I just gave this precision machine a whirl and found it to be a lot of fun. But I should warn you, like all routers it makes a lot of noise.

It works something like a pantograph in that it has a stylus which follows the master pattern. As the stylus moves over the "hills and valleys" of the pattern, the router carves the very same contours in a wood or plastic blank mounted under it. You can't goof because the stylus won't let you. The router will carve only as deep as the stylus dictates.

Differing from earlier carving machines in which the cutter and stylus moved over the pattern and blank, here it's just the reverse. The cutter and stylus are fixed; it's the blank and pattern that move. This is accomplished by a two-level "free-wheeling" table. The pattern is mounted in the lower level and the blank on top. Because the table is spring-loaded, it keeps the stylus bearing constantly against the pattern and the cutter against the blank. To move the floating table freely around under the stylus and cutter,

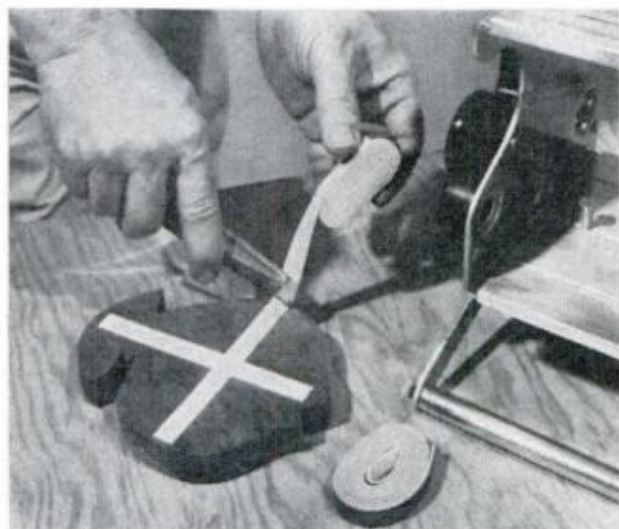

DOUBLE-BACK TAPE is used to attach pattern as well as the blank to the "floating" spring-loaded table

MAY 1969



FINAL FINE-LINE CARVING is done with a pointed cutter after roughing-down blank with large cutter

you simply push down on two convenient hand knobs.

The master pattern can be made of anything (wood, plastic, plaster, metal or stone) as long as it's flat on the back and has no undercuts. Your carving blank, however, should be hardwood, such as walnut or ash, to produce crisp, clean-cut outlines. Pine doesn't work well. Blanks are bandsawed to rough size $\frac{1}{8}$ -in. larger overall than that of the master pattern. Alignment of both pattern and blank is important.

The machine comes with two styli and two matching cutters (a large one for the initial roughing-down operation, and a fine one for final carving) and a plastic see-through workshield. You can order the machine complete with router if you wish. Hobbi-Carve is made by Saint Paul Machinery Mfg. Co., Southwest Fourth St., Osseo, Minn. 55369. ★★★



BLANK IS STUCK to top of table, pattern to bottom. Protective wood carving surface is added to top

189

New Tools You Should Know About

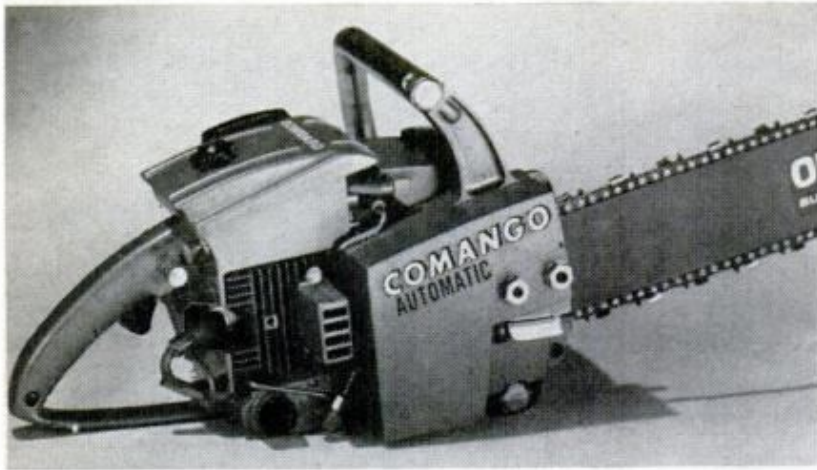

LOW-PRICE CHAIN SAW called the Comango, with 4.2-cu.-in. displacement features "guardian" oiling system which is throttle-controlled so chain gets more oil automatically as speed increases. It has a 12-in. bar and chain powered by a two-cycle engine with an all-position diaphragm carburetor. Manufactured by American-Lincoln, 518 South St. Clair St., Toledo, Ohio 43601.

CURVED JAW of Channellock's tongue-and-groove pliers provides greater grip and more positive leverage on curved or round objects. The 9½-in. size has five-jaw adjustment, 1½-in. capacity; 12-in. size, seven adjustments, 2¼-in. capacity. Channellock, Inc., Meadville, Pa.

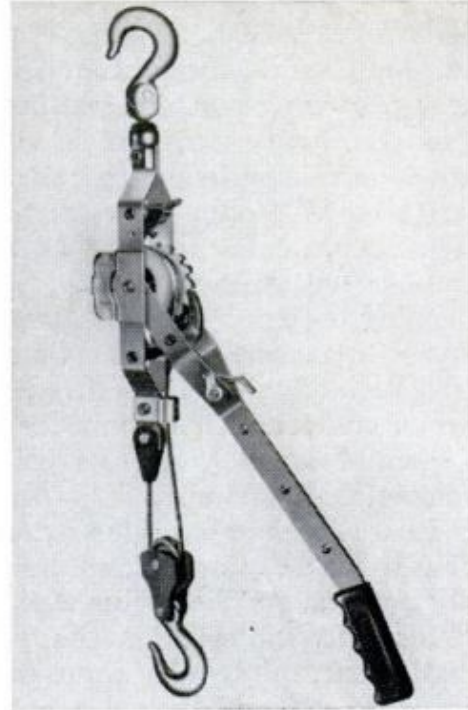
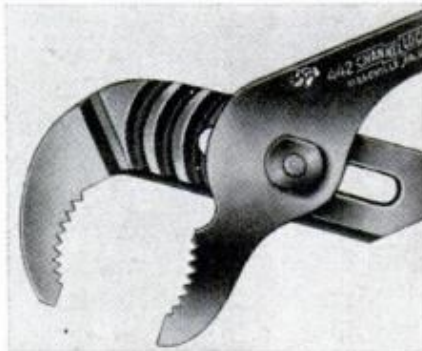

HOIST-WINCH-PULLER all in one is the Pow'r Pull, which has a 15 to 1 ratio and a rated capacity of two tons. Operates in any position, has no ropes or chains to tangle, weighs only 8 lbs. Useful in fence building, garage work and machine-tool moving. Two-ton model sells for \$38.50 from Massdan Pow'r-Pull Inc., 3130 North Hollywood Way, Burbank, Calif.



HEAVY-DUTY ENGRAVER provides a fast permanent method of marking all types of materials from hardened steel to glass. Works as easily as writing with a pencil. Calibrated stroke adjustment regulates depth of engraving from delicate fine lines to deep marks. High-speed reciprocating motor delivers 7200 strokes per minute. Comes complete in molded plastic case, and with extra points. Made by Dremel Mfg. Co., Racine, Wis. 53401.



PROFESSIONAL two-speed, 9-in. polisher/buffer virtually eliminates chance of "burning" any auto finish. Free-wheeling rotary action retards speed when user applies too much pressure. "Oscillating" head has powerful ½-in.-throw, orbital motion to eliminate swirl marks. Oversize 10-in. polishing wool bonnet is cushioned by Ethafoam pad. Has ½-hp motor, weighs 9 lbs., sells for \$59.95. Wen Products, 5812 Northwest Hwy., Chicago 60631.

HINTS FROM READERS

C-clamp as a bench vise

Peen a length of pipe or heavy rod at right angles to a C-clamp frame and you have a handy workbench vise. Simply drop the stud projection in a hole drilled in the top of the bench, insert the work and tighten the clamp. You could also drill and tap a hole in the end of the rod, drill a hole through the clamp and attach the rod with a screw.—*Clarence Preitenfeldt*

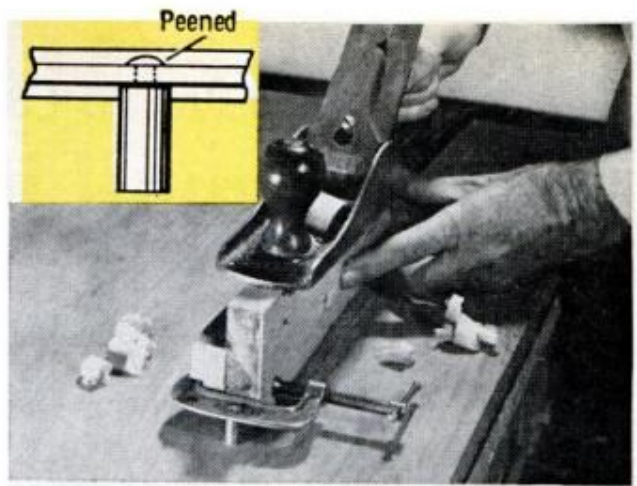

Tape holds hose clamp open

Without special pliers, spring-steel hose clamps can be the hardest things to hold open when they're being installed. Invariably they'll twist and fly off the jaws of common pliers. After having this happen several times, I hit upon the idea of using tape to hold them open. This made it easy to place the clamps over the hose and to release them by simply cutting the tape. As a safety precaution, a wire yoke (see photo) will keep the clamp in tow while it's bound with tape.—*Daniel Boucha*

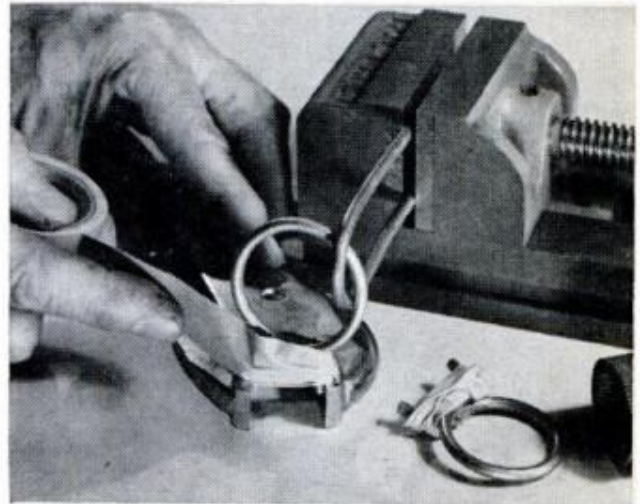

Foil keeps can rim clean

There are any number of ways to keep the rim of a paint can free of paint, including the stunt of making nail holes in it for the paint to drain back into the can. However, perhaps the simplest way of all is to crowd aluminum foil into the can rim as soon as the cover is removed. Then, no matter how much paint spills over the rim, you simply pull out the foil when you're ready to quit. The rim will be clean as a whistle and the cover will fit as tight as it did originally.—*Ken Patterson*



Custom extensions for wrenches

A useful accessory for a 1/2-in. socket wrench is a 1/2-in.-square steel bar that's been cut into six or seven various lengths. When you need to tighten or remove a bolt in a cramped or awkward-to-reach area, just insert a suitable bar in the socket and use an open-end box wrench to turn the bar, socket and bolt. It's practically the only way to get into tight quarters where a ratchet, crossbar or universal-type extension won't fit (e.g., removing a VW fuel pump).—*H. G. Bennett*

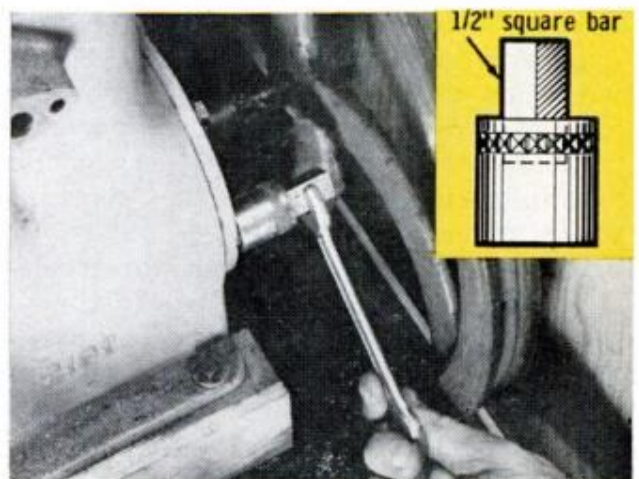

How to choose and use Small Vernier Calipers

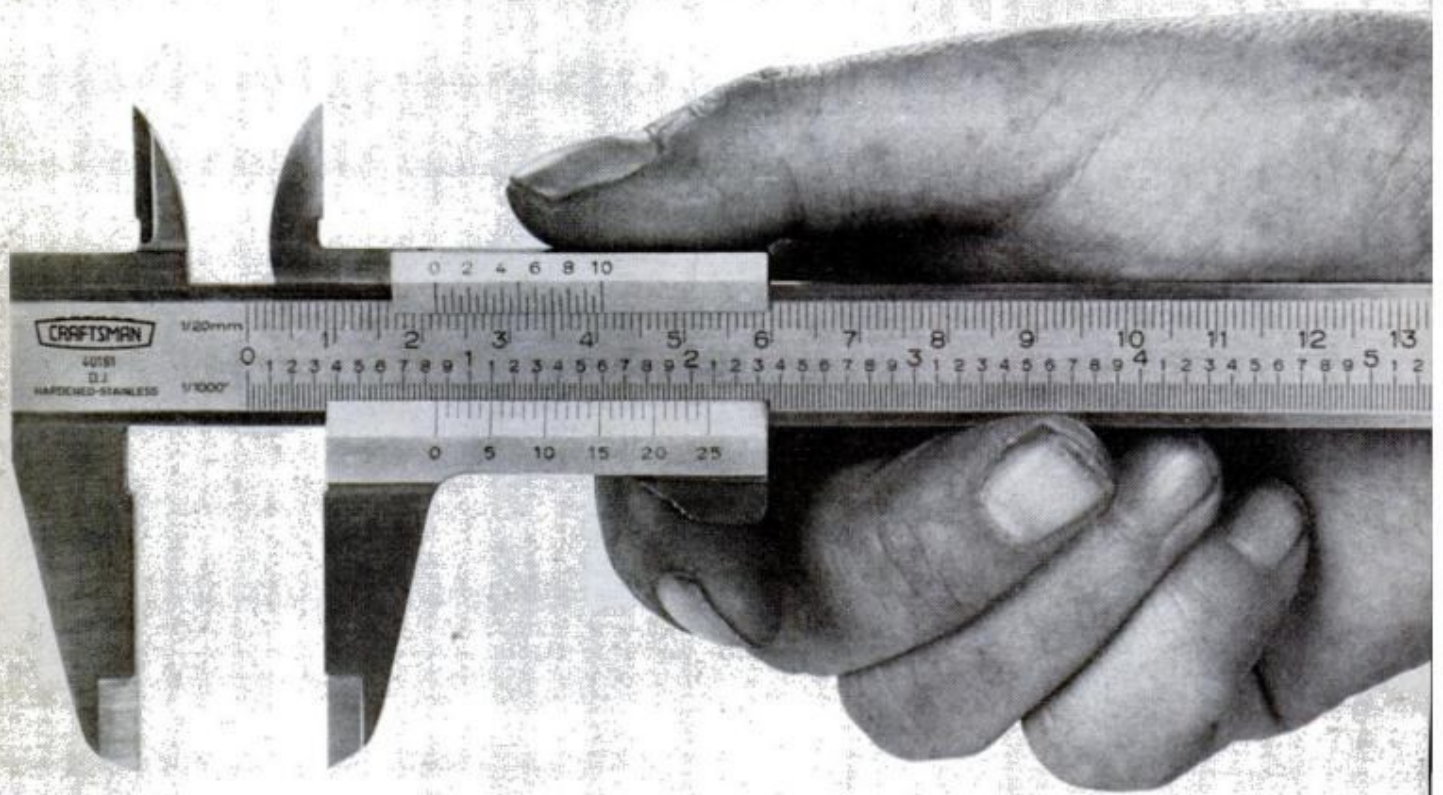

For real value in an all-purpose measuring tool for precision metalworking, it's hard to beat a 6-in. vernier caliper. What's more, they no longer are extremely expensive

By JOHN BURROUGHS

ALTHOUGH MACHINISTS have used them for years, precision vernier calipers have until recently been far too expensive to be known as popular home-workshop tools. But now there's a new class of vernier calipers that is appearing on the commercial market—serviceable 6-in. precision calipers that are competitively priced.

Made in Europe and Japan, these relatively inexpensive calipers are universal-pattern models with scissors-like inside jaws integral with the outside jaws. Selling in the \$14-to-\$20 price range, they're beautifully-finished instruments—hardened stainless steel throughout, with nice-

ly-fitted slides, accurately-lapped jaws and legible satin-chromed photoengraved scales.

The photoengraved scales account for the tools' relatively low prices. Best-quality 6-in. vernier calipers, which cost around \$70, have machine-divided scales engraved on pantograph engraving machines. Photoengraved scales are made by a process similar to that used to make printing plates; that is, they're printed from glass master negatives and then etched. While the etched graduations aren't quite as crisp as the machine-cut graduations, you'd need a magnifying glass to tell the difference. Indeed, for general

SHORT 25-division scale often found on older types of calipers is seldom used on newer models. The bar's scale is divided into tenths of inches, with each tenth divided into four parts or fortieths. The vernier subdivides these 1/40-in. graduations into 25 parts, each part being a thousandth

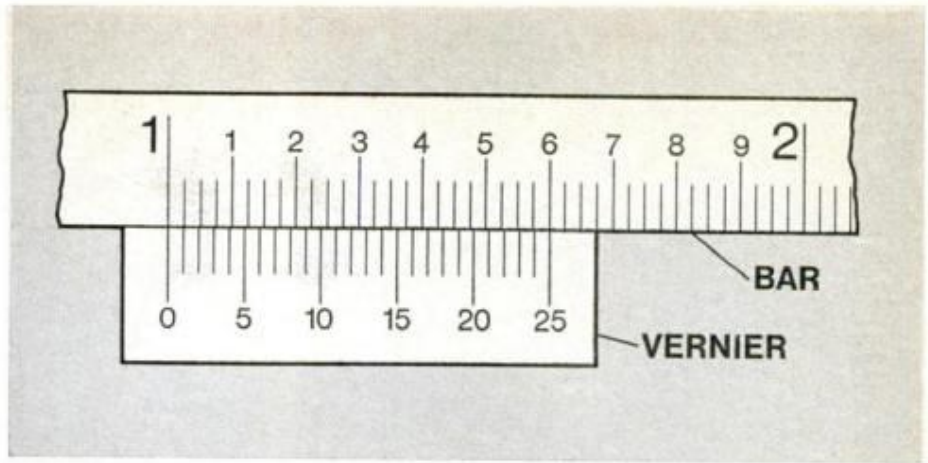

LONG 25-division vernier found on most of the new calipers is similar to short vernier, but the vernier graduations are double-spaced to make it easier to take accurate measurements. On the thousandths vernier, reading is .317 in. The top vernier, indicating millimeters, divides metric scale's millimeter into twenty parts. Can you make the equivalent reading in millimeters?

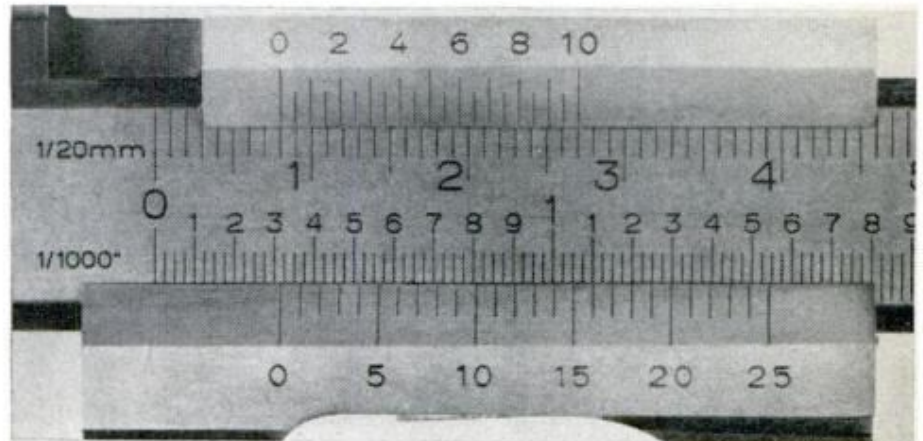

EXTRA-LONG 50-division vernier is featured on some newer makes of calipers. The bar scale has numbered tenths, each of which is divided into two parts, or twentieths. The vernier subdivides these 1/20th graduations into 50 parts, or thousandths. The reading shown is .265 inches. The top vernier scale divides the fractional-inch scale divisions (1/16ths.) into eight parts or 1/128ths. What is equivalent fractional reading?

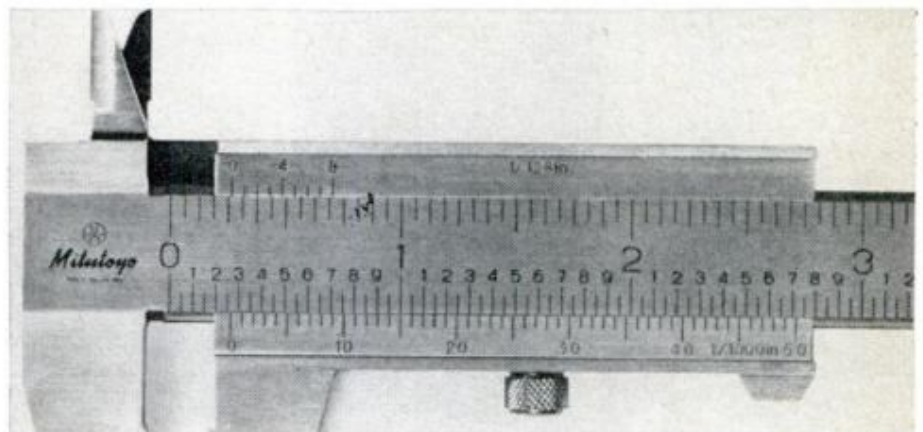

shopwork a photoengraved caliper is completely satisfactory.

Actually it's about the handiest pocket-sized measuring tool imaginable for home-workshop wood and metalworking. When you want a precision measurement, you can use the caliper's vernier to get a reading within a thousandth of an inch. When gnat-whisker accuracy isn't really required—when you're measuring the thickness of lumber, for example—you can forget the vernier and use the tool as a plain slide caliper.

A precision reading takes a little mental arithmetic, but this soon becomes second nature. All verniers are alike in principle.

They're simply auxiliary scales used to subdivide the smallest graduations on the caliper bar's scale into as many parts as there are graduations on the vernier. Thus, you could consider a vernier as just a system of offsets.

How to use the vernier

The 25-division verniers used with the decimal-inch scales are 25 thousandths of an inch shorter in total length than the equivalent graduations on the bar scale. This means that with the caliper closed, the vernier's zero-line is aligned with the bar's zero-line, but the vernier's first graduation is offset one thousandth from

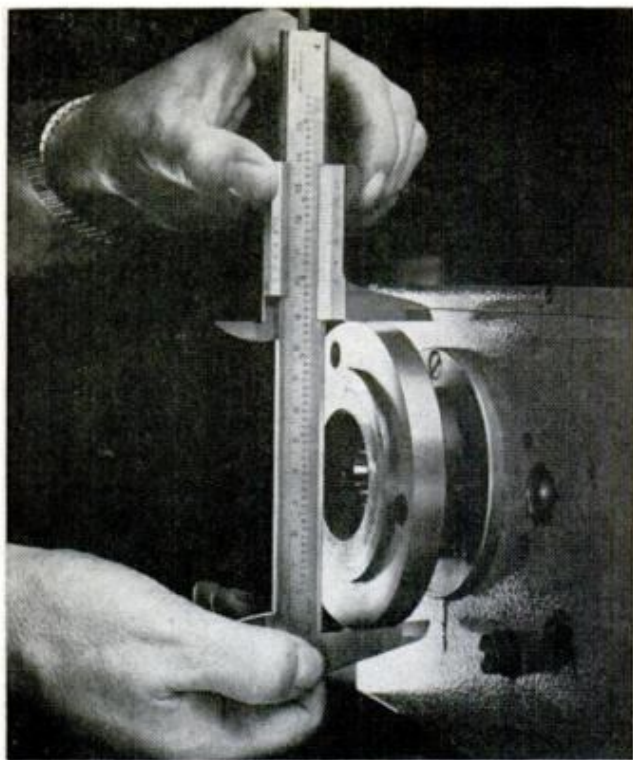

CALIPERS ORDINARILY are accurate to within one thousandth, more than sufficient for most work

TO MEASURE DIAMETERS, hold caliper square with work, take more than one reading for minimal error

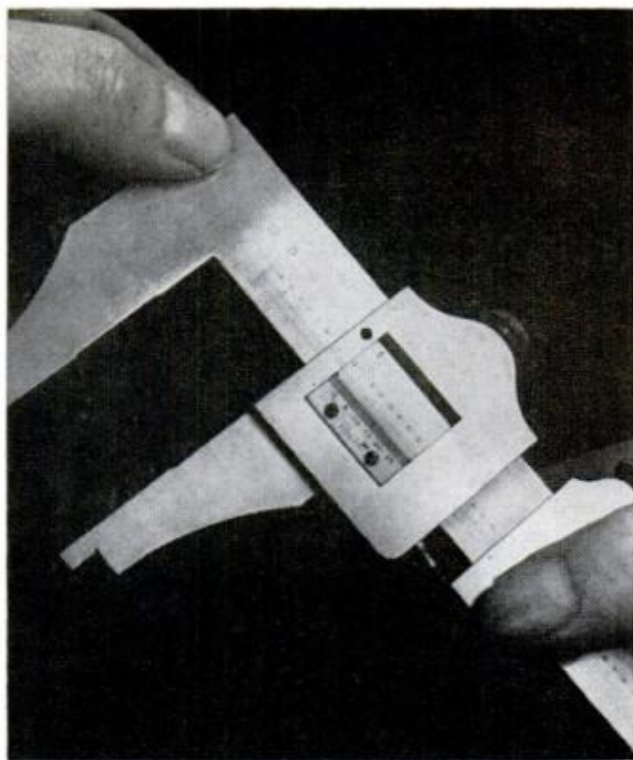

OLDER STYLE CALIPERS have 25-division verniers only .6 inches long, require use of a magnifying glass

its corresponding line on the scale above; the second graduation is offset two thousandths; the third three thousandths; and so on.

With the caliper opened, the vernier zero-line indicates the measurement to be read. Thus, to read the bar scale, first note the number of whole inches (to the left of this line), then add the tenths of an inch, which are numbered. Next, count the smallest graduations, which are fortieths of an inch, or 25 thousandths each, and add them. Finally, using the vernier, measure and add any fraction of a small graduation remaining.

Measuring this extra fraction is simply a matter of running your eye along the vernier scale to see which graduation matches a graduation of the bar scale. For example, if the vernier's 17th line matches a line above, the vernier's zero-line is offset 17/25ths of a graduation, or 17 thousandths past the last graduation on the bar scale.

Simply stated, if you think in terms of "whole inches plus 100-thousandths plus 25 thousandths plus thousandths," it's easy to quickly make any reading in thousandths mentally.

Special features

Universal-pattern vernier calipers have two bar scales, upper and lower. The deci-

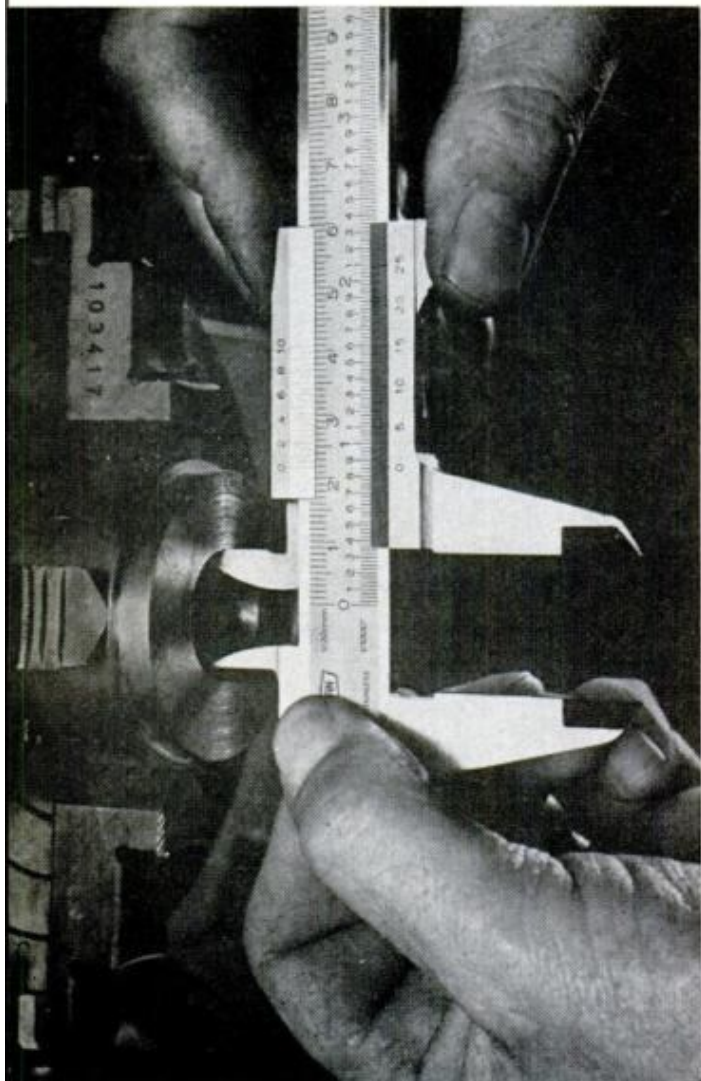



DEPTHS CAN BE MEASURED with the sliding jaw or rod on end of caliper beam. Vernier indicates reading



USE SPECIAL CARE when measuring hardened-steel cutting tools to prevent damage to the caliper's jaws

mal-inch scale (inches graduated in tenths) is the more frequently used. The other scale may be either metric (centimeters and millimeters) or ordinary fractional-inch (inches graduated in sixteenths).

A metric scale's vernier subdivides the bar scale's millimeters into twentieths or fiftieths. A fractional-inch scale's vernier subdivides the bar scale's sixteenths into eight parts, or 128ths of an inch. On most calipers the two scales have a common zero-line, which permits reading equivalents—thousandths of an inch to millimeters for example.

The slides of some 6-in. models have thumbscrew locks, while others have thumb-released friction locks. Some tools have fixed vernier plates—others have plates that can be adjusted to compensate for jaw wear. There are models with carbide-tipped jaws or fine-adjusting micro-screws.

While a micro-screw caliper is considered preferable for machinework, a tool with a friction lock

CALIPER JAWS are lapped until exactly parallel, so they can be used to check if work planes are parallel

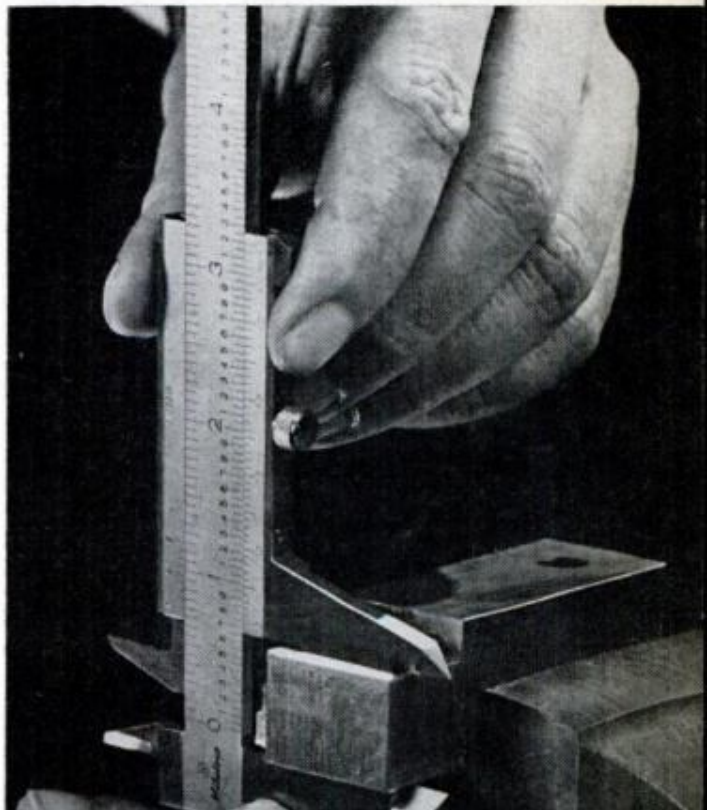

HINTS FROM READERS



Lock for hook and eye

Screen doors fitted with a hook and eye often can be opened from the outside by slipping a piece of cel- luloid between the door and jamb, or a wire through the screw. An easy way to prevent this is to use a turnbutton which will keep the hook in place when turned to a vertical position. This idea also can be used for storm doors and window screens. Just be sure that the turnbutton is screwed down tightly so that it can't slip.

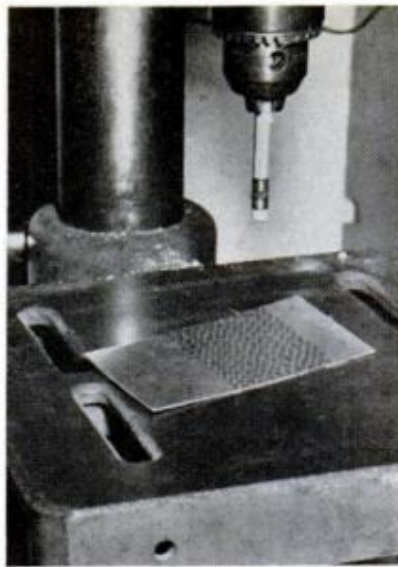

Eraser finishes metals

The next time you'd like an attractive engine finish on a metal project, chuck a ballpoint pen into the drill press. Its abrasive rubber ink eraser will score neat circular marks in the metal and can be replaced easily when fully worn. Since the body of the pen usually is plastic, be careful not to tighten the chuck excessively or the body will crack. Square off eraser tip first—otherwise it will wear and produce circles with different diameters.



Lathe chuck on press

Small, finely finished pieces of work sometimes pose a problem when they're to be secured on a drill-press table—they're either too small or too delicate to be clamped in the regular drill-press vise. The solution is a two-piece wooden clamp that holds a lathe chuck on the table. As shown, this clamp has two holes in its sides (for long clamping bolts) and four holes drilled through the top (to fit the slots in the drill press table).

NEXT MONTH IN SHOP AND CRAFTS

PM BUILDS A JOGGING MACHINE. Keeping fit nowadays usually takes the form of jogging—and with *PM*'s jogger/walker, you won't have to forego a daily session because of inclement weather. To see this neat-looking unit in color, and to learn how you can build one like it for about \$30, don't miss the June issue.

ARE LOW-COST WELDERS ANY GOOD? In response to a number of inquiries about the performance of low-cost, 110-v.a.c. welders, *PM* turned the assignment over to John Burroughs, top shop contributor. For the results of his tests—and some noteworthy tips on how to use one of these induction-type welders—watch your newsstand for the June *PM*.

HOW TO COLOR CONCRETE. Your next concrete project can be as colorful as you want, now that a number of materials and methods can be used to avoid a vast expanse of drab gray. For the complete story on how to use which material, next month's story is required reading.

BUILD THIS ONE-MAN GOLF CART. This nifty little three-wheel vehicle beats lugging a heavy bag. A quick take-apart design lets you tote it to the golf course in the trunk of your car. An oversize muffler keeps its 3-hp gas engine purring quietly, and it can be built from easily obtainable parts. Look for it in the June issue.

With an option list like ours
we ought to have taller windows



But we'd rather give you more choices than anybody else in the business

If you need a V-8 engine in your SCOUT®, you aren't going to settle for a four. We offer you both . . . and a brand new high-output six, to boot.

If you want a smooth automatic transmission, a three-speed stickshift won't do. So we offer you both . . . plus a four-on-the-floor with a super low "granny gear" for the really heavy going.

You can have a cab top or a full length wagon top, five seating arrangements including buckets,

7 colors (some metallic), color-keyed interiors, flotation tires, hub caps or fancy wheel discs, painted or chrome bumpers.

Plain or fancy . . . dolled up or calmed down . . . pleasure or performance, the most exciting do-it-yourself project you ever tackled is waiting for you at your INTERNATIONAL® SCOUT Dealer.

 **INTERNATIONAL HARVESTER COMPANY**
CHICAGO, ILLINOIS 60611

The do-it-yourself Scout.

WE'D LIKE TO MAKE VARMINT SHOOTERS.

Here's a guide to picking precisely the right Remington rifle in the right caliber for your kind of varminting.

This year Remington offers you a choice of thirty-one rifle and caliber variations that are specially geared to varmint shooting.

Why so many? Because it's a big country. With different kinds of varmints, different kinds of terrain, different shooting conditions.

Another thing, not everybody is ready to invest the same amount of money in a varmint rifle. So our prices start way down at \$89.95* for the Model 788 and wind up at \$334.95 for the Model 700 Custom... with plenty of prices in between.

Where and how will you shoot?

Your first consideration is the type of country your varmint safari will cover. If there's room to reach out 500 yards, then you'll want one of the hotter cartridges. However, if your varmint haven is broken up with stone fences or hedgerows about 100 yards apart, a milder cartridge should be ample.

For shots up to 250 yards, the 222 Rem. is a very good choice. If you

want to reach out to about 400 yards, we recommend the 22-250 Rem. Two other good long-range choices are the 6mm Rem. and the 243, which, with heavier bullets, are also suitable for bigger game such as white-tailed deer. (Our tests with varmint loads give the 6mm a slight edge in accuracy over the 243.)

Also important is how far you plan to carry your rifle on foot. If you're in a location where you can practically (and legally) stalk your varmints on gasoline-powered wheels, the weight of your rifle doesn't make too much difference. But if you have to hoof it and you're not as young as you used to be, then you might think twice about acquiring a rifle-and-scope combination that might scale ten pounds.

Here's the rundown.

We thought you'd like a complete rundown of the 1969 Remington varmint entries as a sort of guide. Of course, you don't have to agree with us 100%. There's always a degree of personal preference involved. However, so many of our Remington people are such ardent varminters, we can give you a majority opinion.

Model 788—top accuracy and power, near bottom price. This Rem-

ington series was introduced last year, mostly in big-game calibers. Now it is available in four varmint calibers—222 Rem., 22-250 Rem., 243 and 6mm Rem. (Left-hand version available in 6mm Rem. or 308.) Outstanding feature of the 788 is pinpoint accuracy that puts many an expensive target rifle to shame. Nine heavy locking lugs for solid breeching and the fastest lock time on a center fire rifle. Weight runs about 7½ lbs. A wonderful way to get into varmint shooting with a top-drawer rifle at moderate cost... from \$89.95.

Model 660 Varmint Carbine. There's no reason why you can't shoot an eastern chuck with this 20" barreled carbine. But it really comes into its own in a western saddle scabbard or car rack. On the other hand, its light weight is making it popular with field hunters from



Model 660 Carbine



LIFE SIMPLER FOR



Model 788

coast to coast. Available in three basic varmint calibers—222 Rem., 6mm Rem. and 243.

The 660 is a good choice in any caliber if you do any reloading. The bolt is the strongest made, and when it is closed, the cartridge is surrounded by three rings of steel. And there's a special barrel bracket for rugged 'scope mounting. Prices start at \$119.95.

Remington Model 700—the old reliable of the Remington varmint line... designed and built for minimum target, maximum range, precision shooting. The barrel is longer—up to 24". So the weight goes up a bit to around 7 pounds. But here's a rifle that's not too heavy for field carrying and that a rifleman can really hold on target. (Actually, in the big-game calibers, it's considered as a light- or moderate-weight arm.) Available in varmint calibers: 222 Rem., 22-250 Rem., 243 and 6mm Rem.



Model 700 Varmint Special

Model 700

We can't think of a place in the entire country where a varmint shooter carrying a Model 700 wouldn't be instantly tagged as a guy who knew his varmints—and his rifles. (It's a top choice among handloaders.) The finish, both metal and wood, on a 700 is something to make you want to stroke it like a Persian cat. Everything on it looks and feels expensive except the price. In varmint calibers from \$134.95.

The Model 700 Varmint Special.

This king of varmint rifles comes equipped with a 24" heavy barrel, which raises both its weight and its price. Nine pounds and \$169.95. However, that straight, solid barrel is less affected by heat, stock pressures and sling tension. It puts shot after shot right into the kind of groups that make rifleman drool. We don't bother to put iron sights on the Special. Simply because we know you'll equip it with the biggest, highest-powered, sassiest 'scope this side of Mount Palomar Observatory. Same varmint calibers as the regular 700 except we added the 223 Rem. It's been said that a rifle is only as good as its ammo. So we've developed...

Varmint bullets for varmint accuracy. Remington-Peters cartridges in varmint calibers from 222 Rem. up through 6mm Rem. are loaded with a very special bullet. A unique process of manufacturing produces a perfectly balanced concentric bullet that just doesn't stray off course. Shooters tell us that this accuracy actually cuts group sizes in half. The bullet has a hollow point and nose cuts to insure devastating expansion on varmint targets. Look for the name "Power-Lokt"® on the Remington-Peters boxes. (Yes, handloaders, you can get "Power-Lokt"® bullets to top off your pet handloads.)

We do hope that this information about Remington varmint rifles and ammo has helped you. We would also like to send you our catalog which shows more pictures and gives detailed information for which there just isn't room here. Write Remington Arms Company, Inc., Bridgeport, Conn. 06602—Dept. E5



"Power-Lokt" varmint bullet

Remington DU PONT PETERS

Remington, Peters and "Power-Lokt" are Reg. U.S. Pat. Off.
*Fair Trade prices in states having Fair Trade laws.

THOSE LITTLE TRACTORS!

(Continued from page 145)

who may put on 1000 hours a year.

"We must try to strike the balance that will give the improvements needed for commercial use," says Igor Kamlukin, Simplicity's chief engineer, "while keeping the tractor priced for the average buyer. The result is a vastly different machine than we had eight years ago. And the average buyer reaps the benefit. If the tractor is equal to commercial applications, it's a wonderful unit for the homeowner."

We asked Kamlukin for an example of how testing influenced design.

"Take our hydrostatic tractor. We built a prototype unit using the elements our competitors were using. We were told that if we had a cooling fan of the same proportion we'd be all right. We ran our unit under load, and our temperatures were running high. We compared our results with what competitors considered satisfactory and decided we couldn't live with them. We didn't want to tell a customer who bought our most expensive machine that he could use it for mowing but not for heavy work. We cooled the transmission in such a way that we could absorb the full power of the engine through the rear wheels.

"We tested our unit with a drawbar pull of 850 pounds at full engine speed without overheating. We increased the load until the engine lugged down and stalled. Still we did not overheat. We had accomplished what we wanted to do. Our reason for demanding more is that our tractors get into the hands of contractors. We have to build for the roughest use and still stay competitive."

At Bolens, Port Washington, Wis., a project manager is given full responsibility for the development of a new tractor.

"We keep the same project engineer on a new model for its entire life," says Dave Phillips, chief engineer. "He has a personal stake and pride in it. He designs and tests it, follows it through production and makes modifications."

How much time goes into development testing?

"About three years went into developing the hydrostatic transmission for our new 7-hp model," Phillips says. "Our 12-hp hydrostatic went through four-and-a-half years of testing before it went into production. One of the most challenging problems was developing a foot control for the hydrostatic. By driving cars people have been educated to think with their feet, so we wanted a responsive toe-and-heel control—*toe down for forward;*

heel down for reverse. This would leave the operator's hands free for steering and handling attachment controls. We tested and abused these controls until we were satisfied that they were dependable and safe and took full advantage of what hydrostatic offers—quick maneuvering in tight quarters."

At the 400-acre International Harvester Research and Engineering center, Hinsdale, Ill., Cub Cadets run the same obstacle course used by International's 140-hp giants and are tested in the same labs.

"We build garden tractors," says test engineer Dick Coleman, "to do the jobs for which they were designed for the length of time we have established in our original goal. That means in the neighborhood of 150 hours of continuous heavy-duty use before any major repairs should be necessary. Even then we don't mean complete failure. You may expect a bearing to deteriorate, but not all bearings or gear teeth to fail. We might expect what we call 'class three' parts—those that should be replaced on inspection because they show deterioration. But 150 hours of our continuous full-load running is the equivalent of 5 to 10 years of use by the average owner."

"We don't qualify our 12-month warranty," says Jim Reed, specialist on lawn and garden equipment. "It's 12 months whether it's homeowner or commercial usage. Some of our seven-year-old tractors need only a minor tune-up and a new mower to put them back in shape."

Because it was first in the industry to offer a two-year warranty on tractors and mowing equipment, Wheelhorse, South Bend, Ind., believes that this attests to the thoroughness of its field testing.

"The average customer realizes that there's always the possibility of some minor failure of a machine, no matter how good it is," says Jim Barnes, manager of testing. "As important as quality is quick service on parts and repairs. Our testing minimizes failures, but it also minimizes delay in correcting problems because we have isolated the cause and can speed replacements to customers."

"Despite careful checks, occasionally something gets past us that stumps us for a while," says Jack Rose, chief project engineer of Massey-Ferguson at Detroit, Mich. "We once had a rash of battery problems. After some digging we discovered that the supplier had one worker on his line who was doing things his own way and every battery he made was bad. Until we found the cause, we couldn't risk shipping defective replacements.

"We have a rectification program to *(Please turn to page 202)*



It takes a big glass to measure up to America's Number One beer.

Our brewmaster brews Bud. to kick up a healthy head of foam. He says,
"The bigger the glass, the better the Bud. Shorty up there just won't do."

Budweiser is the King of Beers.

(But you know that.)

THOSE LITTLE TRACTORS!

(Continued from page 200)

correct any major problems in the field. If it's a serious problem, we go out to the customer. If necessary, we'll send a mechanic to correct every machine."

We're careful to fight company patriotism—the idea that if it's painted our color it's perfect," said William Schlapman, president of the Winneconne, Wis., division of J. I. Case. "Like everyone else, we goof occasionally, but we make good. In '66 the kingpins on our front axles weren't hardened. Engineers believed that the cold-rolled steel that was used with the cast-iron front-axle housing and the lubricant would function properly. It didn't. As soon as we discovered this, we heat-treated the kingpins; this prevented the galling of the cast iron. We had a field campaign to replace this part. We instructed dealers to make the repair and we underwrote the entire cost. However, only 0.65 percent of all our tractors sold in the last 12 months had claims filed against them for warranty service or replacements. Only \$3.85 per tractor was paid in claims. This includes parts at dealer's cost and labor at local rates."

At Ariens, Brillion, Wis., as each tractor reaches the end of the production line it is load-tested and tuned on a dynamometer.

"We don't sample the line; every tractor is run in," emphasizes Ariens' Jim Youngworth. "Our engine supplier has already run every engine; we dynamometer-test it again and tune it under load."

"Field-testing gets the emphasis at Ariens. What a customer can do to a machine and what you can do to it in the lab are two different things!" says Youngworth.

"We do a lot of laboratory testing," says Kenneth Finden, chief engineer at Toro, Minneapolis, "but our evaluation and long-term durability testing is done in the field. Our units are mowing 13 hours a day—and in California in the winter. We test snowthrower attachments in the Canadian Rockies where we get altitude and wide variations of temperature. In the cold room of our lab we can simulate temperatures, but we can't as yet duplicate all snow conditions."

"It's how the product performs in actual operation that counts. We could spend thousands more on fancy lab equipment, but if a little old lady in Dubuque uses your product and finds some glaring error you didn't catch in the lab, it can be very embarrassing. That's why we put most of our effort on field testing."

At Lexington, S.C., we asked the man-

ager of engineering for the Outdoor Products Division of Allis Chalmers, L. R. McGrath, why tractor makers are continually testing mower attachments.

"Every new mower model is different," he said. "It may have a different length of blade, or operate at a slightly different speed, or the clearance between the blade and the housing may have been changed. All these factors affect performance. And every new model must be tested to meet American Standards Assn. safety specifications. We won't release a mower that won't do a quality job. That requires constant testing." ★★★

ADD A SCREENED PORCH

(Continued from page 174)

ing 3/4-in. plywood to the rafters and 3/8-in. plywood to the joists. Follow this by covering the roof with tar paper, then with a metal flashing where the new roof meets the old and, finally, with shingles to match the house. All that's left is to install the 4x4 lintel and its supporting 4x4 posts before filling in the ends of the porch roof and adding a 1x8 fascia board across the front and up the ends.

Making the screens

The number and size of frames you need to enclose your porch is determined from the porch itself. If you've planned for 8 ft. between posts, then all screens across the front can be made 48 in. wide. The drawing on page 174 shows how the screen frames are made from common 1 1/8-in. screen stock. Note how members are half-lapped for extra strength.

You have a choice of installing the frames permanently in place or fitting them so they can be lifted out and stored for the winter. In the latter case, door bolts are added to the bottom rails to engage holes drilled in the slab. Quarter-round molding nailed to the posts and lintel makes the screens fit bug-tight. Drain notches should be provided along the bottoms of the screens, and if screens are permanently installed, pick copper wire or aluminum, or one of the new plastic screening materials, to cover them.

The door opening in the end of the porch is framed with 2x4s which are anchored to the slab and the joist with angle brackets. You can buy a stock door as cheaply as you can make one. The area which surrounds the doorway is fitted with individual screens.

As the summer goes by you'll enjoy your porch more and more. You'll find it one of the best investments you can make for a small home. ★★★

Take away the old-style carburetor and the primer and what have you got?

This new Sears Craftsman. Most eager-to-start mower that ever manicured a lawn.



The quicker the mowing gets going, the quicker it's over. So get the Craftsman StrongMower push rotary. Ask for Sears Model No. 9155.

One pull, maybe half a pull, gets the new Craftsman StrongMowers cutting. It took a completely different kind of engine to make them so eager.

Instead of the old-style carburetor, there's a no-adjust fuel system. No priming. Nothing to fiddle with or goof-up. And an automatic compression release ends the tug of war between you and the starter cord.

Easy, sure starts aren't all the new Craftsman StrongMowers give

you. There's enough power to give the toughest grass a neat, smooth look. A magnesium housing that's a third lighter than aluminum: An extra blade that keeps the housing clean.

You can get a 20-inch push-type Craftsman StrongMower at Sears. Or a 22-inch Self-Propelled Strong-Mower. Both come complete with grass catcher. We also have other rotaries from 2½ hp on up. Buy any of them for No

Money Down on Sears Easy Payment Plan.

Sears, Roebuck and Co. guarantees* the Craftsman StrongMowers from their parts to their performance. Good reason right there to get started to Sears.

*Craftsman Mowers are guaranteed for one full year from date of sale. If repairs or repair parts are required for proper performance, they will be furnished at no cost. Normal maintenance tuneups, blade sharpening, cleaning, and failures which are a result of abuse are not included in this coverage.



No adjusting or fiddling.
Just one pull, and you're mowing.

Sears

These great minds were Rosicrucians . . .



Francis Bacon Benjamin Franklin Isaac Newton

WHAT SECRET POWER DID THEY POSSESS?

Why were these men great?

How does anyone—man or woman—achieve greatness? Is it not by mastery of the powers within ourselves?

Know the mysterious world within you! Attune yourself to the wisdom of the ages! Grasp the inner power of your mind! Learn the secrets of a full and peaceful life!

Benjamin Franklin, statesman and inventor . . . Isaac Newton, discoverer of the Law of Gravitation . . . Francis Bacon, philosopher and scientist . . . like many other learned and great men and women . . . were Rosicrucians. The Rosicrucians (NOT a religious organization) have been in existence for centuries. Today, headquarters of the Rosicrucians send over seven million pieces of mail annually to all parts of the world. Address: Scribe W.H.A.

THIS BOOK FREE

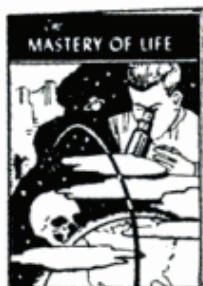

The ROSICRUCIANS

San Jose (AMORC) California, 95114, U.S.A.

SEND THIS COUPON

Scribe W.H.A.

The ROSICRUCIANS
(AMORC)

San Jose, California, 95114 U.S.A.

Please send me the *free* book, *The Mastery of Life*, which explains how I may learn to use my faculties and powers of mind.

Name _____

Address _____

City _____

State _____ Zip Code _____

Please Include
Your Zip Code

FALSE TEETH

**Chewing Efficiency
Increased up to 35%**

Tests prove you can now chew better—make dentures average up to 35% more effective—if you just sprinkle a little FASTEETH on your plates. FASTEETH Powder is alkaline. It holds false teeth firmer, more comfortably. No gummy, gooey, pasty taste. Doesn't sour. Helps check dental plate odor. Dentures that fit are essential to health. See your dentist regularly. Get FASTEETH at all drug counters.

"For myself, OUTWARD BOUND has presented an ideal challenge and adventure . . . an education: a true, real lesson in life."

OUTWARD BOUND

26-day wilderness courses

Accept the challenge — write

OUTWARD BOUND

Four Wheeler St., Andover, Mass. 01810.

Don't change your address without notifying us!

To insure uninterrupted service on your **Popular Mechanics** subscription, please notify us at least six weeks before you move.

1. Attach your address label from a recent issue in the space provided below. . . (If label not available, be sure to give us your old address, including Zip Code)
2. Print your name and new address below (be sure to include your Zip Code).

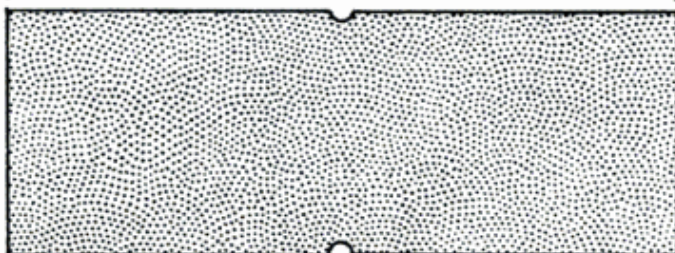

3. Mail entire notice to: **Subscription Service Dept.
Box No. 646
New York, N. Y. 10019**

Name _____ *Please Print*

New Address _____

City _____

State _____ Zip Code _____

THOSE FAST, NEW TRAINS

(Continued from page 99)

Central (whose first move after the merger of the Pennsylvania and New York Central was to try to buy into the clothing business) and the U. S. Government, we don't care enough any more to have a first-class, passenger-hauling railroad. Maybe it's like building a streamlined stage coach after the Golden Spike was driven—100 years ago this very month. For 80 years after that, passenger trains in this country got faster and faster, cleaner and cleaner, more and more luxurious. Then with the advent of jet airplanes and interstate turnpikes they went to pot. The Pennsylvania, which carried 130,000 passengers a day between Washington and New York in 1946, carried less than a third that many last year. Obviously, it wasn't all the railroads' fault.

With the highways filling up and the airlines becoming more and more congested and unreliable on short runs, putting more people back on the rails seems like a logical, almost imperative move.

Rails make the difference

The stumbling block that neither the government nor the railroads has been willing to face is, "Can you put them back on the same old rails?"

The Canadian National tried it and had to limit its Turbo trains, capable of 170 mph, to a maximum of 95. The Penn Central which laid 312 miles of welded rail (on 452 miles of double track), lets its 160-mph Metroliners out to 110 mph for short distances.

In Japan, the NTL goes 132 mph nearly all of the way, because it runs on an all-new railroad. The welded rails are nearly a mile long. The ties are concrete. There are no freight trains to beat down the roadbed, and there is not a single grade crossing between Tokyo and Osaka. There are still 20 on the Metroliner's route and 300 on the CN between Montreal and Toronto. Sure enough, the Turbo train hit a truck on one of them the first day. The Metroliner fared better. All it did was suck the windows out of an old train as it passed.

The Penn Central has put \$43 million into launching the Metroliner, with another \$12 million contributed by the U. S. Department of Transportation. Japan spent a cool billion on the NTL.

United Aircraft, which wanted to diversify as well as find more uses for its versatile little ST6 turbine (the same one Andy Granatelli used in his Indianapolis racing cars last year), designed and built

the Turbo as a train that could run at high speeds on existing roadbeds. To accomplish this, the cars are suspended to swing inward on curves and the wheels are "steered" instead of depending entirely on flanges to get them through the curves.

The Turbo makes it around the curves, but on some of them at 95 mph the passengers are hanging on.

On the NTL I placed a cup of coffee on the window sill. At 132 mph it didn't slosh a drop. On the Turbo, a pretty hostess serving lunch, airline style, poured me a glass of wine and set the bottle on my tray. Before she turned her back it was all over my lap.

Turbo has 'dome-car' viewing

Both the Turbo and the Metroliner are designed to be comfortable. Coach seats in each are like those in airliners and are only two abreast. First-class seats on the Metroliner swivel and are only one-abreast. On the Turbo there is a "dome-car" section over the turbines at each end. One is for coach passengers, the other for first class. From either, depending on which direction the double-ended train is going, you can look over the shoulders of the two enginemen at the track ahead. The Metroliner operates with only one man in the cab, like the New York subway, and is not much of a sightseeing vehicle.

On the opening day a TV interviewer asked E. B. Selover, the Metro's sport-jacketed engineer, "How do you think these trains will stack up?"

Maybe it was a rehearsed answer, but I'd like to think it was fast thinking by Selover. He replied: "That's one thing we aren't going to do—stack up."

By the time this appears there could be more Metroliners in service, CN's Turbo should be back on the rails, and the three-car Turbos should be running between New York and Boston. If they're not, you can kiss the dream of high-speed trains goodbye. ★★★

From PM's How-to-Do-It Library:

Choosing and Using THE RIGHT PAINT

A reliable guide, this 32-page booklet tells all about house paints, protecting metal from rust, spray techniques, handling the new epoxies and cures for moisture problems. Profusely illustrated and detailed.

Get your copy now by sending 50¢ for How-to-Do-It Library Booklet No. H101 to

Popular Mechanics Bureau of Information,
575 Lexington Ave., New York, N.Y. 10022

Swiss Watchmakers Break-through!

Now available after years of development

100% ACCURATE

WORLD'S VERY FIRST

DIGITAL



ONLY \$24.98 p.p.d.

WRIST WATCH

Flashes time and date directly in numerals

This is new! This is good! Know the time exactly to the second by a quick glance at this strikingly designed Swiss jewelled-movement wrist watch.

Flashes hour, minute, and date in large, clear numbers. Gold or silver-tone case (specify), tarnishproof stainless steel back, satin-brushed dial. Sweep-second hand, black leather strap. Shock-resistant, unbreakable mainspring.

Have the time of your life for only \$24.98 p.p.d. 10-day money-back guarantee. 1-year warranty.

Satisfaction guaranteed. Prompt shipment. Send check or money order—no C.O.D.'s

HOBIC Dept. PX-59

7 Delaware Drive
Lake Success, N.Y. 11040

HOW YOU LOOK TO A TRUCKER

(Continued from page 97)

drivers, sitting much higher, get blinded by your brights long before car drivers do. "You don't get the glare as soon," says Padgett. "It helps to lower your beams even when a truck's a mile away."

We have a hot dinner at a Jesup, Ga., gas stop, then get in No. 1914 with Yates Webb. Copilot Hillard Wise is snoring in the bunk, curtains pulled. We're on two-way US 1 in dark pinewoods when we begin having trouble with a driver ahead. Our speed drops to 48. In our headlights is the rear of a great, shabby truck. No name. "Must be an illegal load. He's taking no chances on a ticket," Webb says.

At last there's a place to pass. Webb boosts speed and pulls out. The other truck speeds up. Then comes a long no-pass zone. And the guy ahead slows down!

We try again. Same story. "He isn't giving me a break," says Webb. For awhile he watches the other truck. One of its taillights keeps going out. Webb tries again, coaxing the needle up to 58.

"He's sure giving me a hard time," says Webb. "He must have three pills under his belt. That's your goofball driver."

Cars from Kansas, Maine, New York whirl by us. They pass but we can't. It's 9:37 before we come to a safe two-mile straight and Webb at last commits our 34 tons to another attempt. Our speed is 55. The goofball goes to 56. Webb goes to 56. The goof goes to 57. Webb puts us at 57, then coaxes the new engine to 58.

Suddenly we're neck and neck. And the Cummins diesel is roaring. A fast-over-taking truck always pushes wind ahead. But on the sides it pushes a back-blast—a strong drag force. In the next lane it's like a hand pushing you back. And now our back-blast seems to take hold of the goofball. Slowly we push ahead.

He keeps trying hard. But our new Cummins, feeling its oats, is actually dragging him back. Our speed goes to 59. Headlights appear far ahead. Now we've got to get back in. Webb gives the engine everything. We pull ahead—at 60 mph!

And suddenly, we're back in line with plenty to spare. Webb shakes his head. "You see, we have trouble with some drivers, too. That guy sure was on pills. But most of us don't act like that. After all, we're all car drivers, too!"

Fourteen minutes before midnight we throb into Jacksonville terminal. Webb, uniform still fresh, swings down for coffee, and No. 1916 rolls in. I take leave of them here. By midnight Yates Webb and pals thunder out for Miami, another 350 miles, with all those Yankee gravestones. ★★ ★

SAW SHARPENING IS EASY

Super Filer No. 11 joints and sharpens circular saws 6" to 10" with all teeth correct in height, depth, pitch, bevel. When file hits steel roller, teeth are finished. \$10.95 P.P.D. Saw runs true with no side pull. Includes 8" file.

FREE LITERATURE

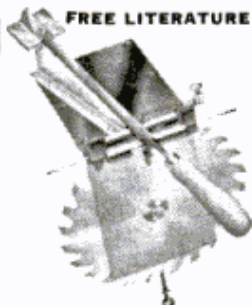

"TRU-CIRCLE" saw set automatically sets teeth at 10" \$2.95 or more. P.P.D.

MONEY BACK GUARANTEE

A. D. MCBURNEY, 1610 Victory Blvd., Glendale, Calif. 91201, Dept. A58

Two or four-wheel drive
JEEP OR SCOUT OWNERS

REPOWER with a 6 or V-8. H.D. ADAPTORS for using Car, Compact and some Truck engines. "State year & model, Jeep or Scout." Want fast action? Give us **FULL INFORMATION**. Send \$25.00 Dep. and we will ship correct kit, bal. COD. Send full amount for prepaid shipment. Wire, phone or write today. Details **FREE**

HOOSIER MACHINE PRODUCTS CO.

312 S. E. 6th St., Phone 276-3442, Pendleton, Oregon 97801



HAND CRANKED GENERATOR

\$6.95 plus 50c pstg.

Turn the crank and this gov't surplus Generator will drive fish worms out of the ground, charge areas of land or water, light electric bulbs, perform

scores of other experiments. Generates 75 to 100 volts AC. Size 2 3/4" dia. x 3 3/4".

P & S SALES Dept. P-5, Box 155
155 W. First Tulsa, Okla. 74102

WRITE FOR
FREE CATALOG

THOSE FAST, NEW TRAINS

(Continued from page 99)

Central (whose first move after the merger of the Pennsylvania and New York Central was to try to buy into the clothing business) and the U. S. Government, we don't care enough any more to have a first-class, passenger-hauling railroad. Maybe it's like building a streamlined stage coach after the Golden Spike was driven—100 years ago this very month. For 80 years after that, passenger trains in this country got faster and faster, cleaner and cleaner, more and more luxurious. Then with the advent of jet airplanes and interstate turnpikes they went to pot. The Pennsylvania, which carried 130,000 passengers a day between Washington and New York in 1946, carried less than a third that many last year. Obviously, it wasn't all the railroads' fault.

With the highways filling up and the airlines becoming more and more congested and unreliable on short runs, putting more people back on the rails seems like a logical, almost imperative move.

Rails make the difference

The stumbling block that neither the government nor the railroads has been willing to face is, "Can you put them back on the same old rails?"

The Canadian National tried it and had to limit its Turbo trains, capable of 170 mph, to a maximum of 95. The Penn Central which laid 312 miles of welded rail (on 452 miles of double track), lets its 160-mph Metroliners out to 110 mph for short distances.

In Japan, the NTL goes 132 mph nearly all of the way, because it runs on an all-new railroad. The welded rails are nearly a mile long. The ties are concrete. There are no freight trains to beat down the roadbed, and there is not a single grade crossing between Tokyo and Osaka. There are still 20 on the Metroliner's route and 300 on the CN between Montreal and Toronto. Sure enough, the Turbo train hit a truck on one of them the first day. The Metroliner fared better. All it did was suck the windows out of an old train as it passed.

The Penn Central has put \$43 million into launching the Metroliner, with another \$12 million contributed by the U. S. Department of Transportation. Japan spent a cool billion on the NTL.

United Aircraft, which wanted to diversify as well as find more uses for its versatile little ST6 turbine (the same one Andy Granatelli used in his Indianapolis racing cars last year), designed and built

the Turbo as a train that could run at high speeds on existing roadbeds. To accomplish this, the cars are suspended to swing inward on curves and the wheels are "steered" instead of depending entirely on flanges to get them through the curves.

The Turbo makes it around the curves, but on some of them at 95 mph the passengers are hanging on.

On the NTL I placed a cup of coffee on the window sill. At 132 mph it didn't slosh a drop. On the Turbo, a pretty hostess serving lunch, airline style, poured me a glass of wine and set the bottle on my tray. Before she turned her back it was all over my lap.

Turbo has 'dome-car' viewing

Both the Turbo and the Metroliner are designed to be comfortable. Coach seats in each are like those in airliners and are only two abreast. First-class seats on the Metroliner swivel and are only one-abreast. On the Turbo there is a "dome-car" section over the turbines at each end. One is for coach passengers, the other for first class. From either, depending on which direction the double-ended train is going, you can look over the shoulders of the two enginemen at the track ahead. The Metroliner operates with only one man in the cab, like the New York subway, and is not much of a sightseeing vehicle.

On the opening day a TV interviewer asked E. B. Selover, the Metro's sport-jacketed engineer, "How do you think these trains will stack up?"

Maybe it was a rehearsed answer, but I'd like to think it was fast thinking by Selover. He replied: "That's one thing we aren't going to do—stack up."

By the time this appears there could be more Metroliners in service, CN's Turbo should be back on the rails, and the three-car Turbos should be running between New York and Boston. If they're not, you can kiss the dream of high-speed trains goodbye. ★★★

From PM's How-to-Do-It Library:

Choosing and Using THE RIGHT PAINT

A reliable guide, this 32-page booklet tells all about house paints, protecting metal from rust, spray techniques, handling the new epoxies and cures for moisture problems. Profusely illustrated and detailed.

Get your copy now by sending 50¢ for How-to-Do-It Library Booklet No. H101 to

Popular Mechanics Bureau of Information,
575 Lexington Ave., New York, N.Y. 10022



We've taken the "bite" out of pipe smoking

Your favorite blend never had it so smooth, right from the very first puff because: the world's only pre-smoked pipe needs no breaking-in! What curing does for tobacco, pre-smoking does for your Dr. Grabow.

WORLD'S FINEST IMPORTED BRIAR

Starfire.....\$5.95
Viscount.....\$6.95
Commodore...\$7.95
Eldorado.....\$10.00

For FREE informative booklet, write
Dr. Grabow pre-smoked pipes
Box 21888, Greensboro, N. C. 27420

Dr. Grabow

the World's only Pre-Smoked Pipes

EARN \$20.00/HOUR

By Assembling These Unique Lawn & Garden Tractors



MINI-DOZER®

Heavy-duty, high performance track vehicle. Smooth lawn or cleared dozer tracks. Highly maneuverable — turns 360° in own length. Full line of attachments including dozer blade, mowers, plow, etc.

Two popular models are offered at low, factory-direct prices in easy-to-assemble Kit form. Just assemble, then resell locally to make Big Money in your spare time! Keep one to enjoy and demonstrate. "Build-it-yourself" PLANS and 16 pg. CATALOG available for either Tractor. (Cost deducted from Kit purchase price.) Either Catalog 50c, both 75c. Either Plans \$5.00, both \$7.50.



MINI-BEEP®

Full 4-wheel drive compact Lawn Tractor. Also makes a fine lightweight cross country vehicle. Maneuverability and traction unequalled by any other lawn and garden tractor. Complete line of lawn attachments.

C. F. STRUCK CORP., Dept. PM-59, Cedarburg, Wis. 53012

Train for top jobs, top earnings, in PHOTOGRAPHY

NYI trains you for the best jobs—or your own successful business. Learn by doing at home, quickly, easily the individualized NYI way. Low cost. No experience or expensive equipment needed. Earn while you learn. Easy pay plan. Approved for Veterans, Student Loans. Approved by N.Y. State Ed. Dept. Accredited member Natl. Home Study Council. FREE color career book. No salesman will call. RESIDENT TRAINING in all profitable phases of photography and Creative Motion Picture Course. Our 59th year. NEW YORK INSTITUTE OF PHOTOGRAPHY • 10 West 33 St., New York, N.Y. 10001, Dept. 49-5



"\$7,108.50 First Year
SERVICING RADIATORS!"

— Hank Konter, Newcastle, Wyo.
Make good money servicing auto-truck-tractor radiators with new Inland 1-Piece Radiator Shop. Easy to test-clean-repair radiators. Inland, world's largest radiator equip. mfr., trains you free. Small down payment starts you. Easy-pay plan lets you pay from profits. Proved merchandising assures volume. Profitable dept. for garage or service station. WRITE for Free Book. INLAND MFG. CO., Dept. PM51108 Jackson St., Omaha 2, Nebr.



NEW!

HEAVY DUTY BALL-BEARING PUMP

IRRIGATE • DRAIN • SPRAY • CIRCULATE • Famous all-metal, rust-proof XB pump with stainless shaft. Use ¼ HP or larger. 1 HP for up to 5,200 GPH 60' high or 3,000 GPH from 25' well. 1¼" inlet, 1" outlet. For belt or direct drives. Only \$12.95



Famous Type P won't rust or clog. Bronze bearing. Hundreds of thousands in use. Up to 2,400 GPH. 1" inlet, ¾" outlet. Only \$8.95

Postpaid cash with order. Money Back Guarantee. LABAWCO, Box 2, Belle Mead, N. J. 08502

A BUSINESS OF YOUR OWN REPAIR HYDRAULIC JACKS

Earn while you learn at home. Millions of jacks in gas and auto service stations, trucking firms, body shops, riggers, factories and farms need servicing . . . most of which you can learn to repair. We show you HOW. Start spare time in your basement or garage. Big opportunity for mechanics. ACT NOW! Write for folder PM-5, and free bonus offer

HYDRAULIC JACK REPAIR MANUAL CO., INC.
G. P. O. BOX 3 • STATEN ISLAND, N. Y. 10314



Career in ELECTRONICS?

Career training at home the new easy way with RCA Institutes. Lab work with first lesson. Pay as you go. Send for free 64-page book.

RCA Institutes, Inc. Dept. PM-59
320 W. 31 St., N. Y., N. Y. 10001



POLICE - FIRE - EMERGENCY - CAR RADIO \$9.99

Works with regular CAR RADIO and ANTENNA! NO special wiring or installation. Mounts UNDER DASH in 5 minutes in ANY CAR OR TRUCK. Panel switches INSTANTLY from REGULAR to POLICE-FIRE-EMERGENCY radio CALLS—Receives ALL stations in your AREA within range. Size only 2"x3 1/2"—Two tone steel cabinet. (Cash, Ck, M.O.) and pay **SEND ONLY \$2.00** postman \$7.95 plus COD pstg or send \$9.99 for ppd Del in USA. COMPLETE ready to clip in your CAR with all parts and instructions. One year parts and service Warranty—10 day money back trial (if retrnd). **AMAZING OFFER** good only by mail and from: **WESTERN RADIO Dept. BPM-5 Kearney, Nebr. 68847**



knows what's
best for camping!

Now available, a new 32-page booklet of **CAMPING TENTS AND CAMPING TIPS**. Send 10¢ to cover handling cost to **HETRICK**.

Dept. PM, Box 5110, Statesville, N. C. 28678

The Swingline Tacker Gun can finish off every room in your house...



for only \$8.95

Use the Model 800 Heavy-Duty Tacker Gun to install ceiling tile... repair screens... lay carpet... insulate... weather-strip... upholster... you-name-it! Takes 5 staple sizes, from $\frac{1}{4}$ " to $\frac{5}{16}$ " — plus special Loktile® staples for ceiling tile installation. Easy to load — easy to operate.



Model 800

Write for
free booklet,
TIPS ON TACKING
Dept. PM-59

Also available:

Model 101 Tacker Gun. Only \$5.95.
Takes 2 Staple Sizes $\frac{4}{16}$ " and $\frac{5}{16}$ "

Swingline®

Consumer Products Division, 32-00 Skillman Ave.,
Long Island City, N.Y. 11101.

NEW CABIN PLANE FOR \$3500

(Continued from page 117)

tic panels elsewhere. Package price: \$626.

2. *Fuselage.* A bolt-together frame that absorbs most of the stress, and aluminum skin that Pop-Rivets to the frame. Most of the difficult angles are preformed. Price: \$474.

3. *Control surfaces.* Most of the difficult bending—rudder, elevator, ailerons—is completed. Price: \$429.

4. *Landing gear.* Includes struts, wheels, brakes, tires, everything. Price: \$593.

5. *Control systems.* Includes control stick, rudder pedals, push-pull rods, all connecting systems. Price: \$178.

6. *Fuel, electrical, and instrument systems.* Price: \$514.

7. *Powerplant system* (not including engine), prop, spinner, exhaust, cowling, and so on. Price: \$532.

Bede will also have new engines available of 108 to 200 hp, but these are not included in the basic price of \$2940 for the complete airplane package. So the final price will probably average about \$3500.

Many parts are stock items

Obviously, most of these parts—except the wings—are readily available as stock items, and many builders would prefer to scrounge for them on their own. However, Bede claims he can save them 15 percent on the seven complete packages over what the items, purchased individually, would cost. And he is quite willing to sell you the individual items—at regular prices—without packaging them. The packages are not only a convenience and a savings, but Bede's way of saying, "Here is all you need for this section of the airplane."

There are few "family size" experimental planes around, and, if you've been looking for something more than a one-seat, weekend runabout, this may be it. Bede recommends two seats for engines of from 108 to 140 hp, and four seats for engines from 150 to 200 hp.

Also, it may be one of the sturdiest and safest of all the homebuilts. In spite of its respectable cruising speeds, it would win few pylon races or aerobatic contests.

Finally, and probably most important, it is surely one of the easiest to build of all homebuilts—almost foolproof, in fact. From the instructions—written by Bede himself—and crystal-clear plans, plus the easy availability of every nut and bolt necessary from Bede himself, it could be as simple as number painting.

What's the sum-up? I think it's one of the most professional of all amateur aircraft, and one that will wear better as you and it grow old together. ★★

HEARING AIDS

2/3 OFF DEALER PRICES

LARGEST SELECTION of tiny, all-in-the-ear, behind the ear, eyeglass and pocket models. FREE HOME TRIAL. No obligation. Money back guarantee. No down payment. Easy terms. No salesmen or dealers. Order direct and save 65%. Write for free catalog. PRESTIGE, Dept. D-34, Box 10947, Houston, Tex. 77018



Free Catalog!

For **TOOLMAKERS** who use the **FINEST**

GERSTNER TOOL CHESTS
Dept. C-9, 20 Cincinnati Street
Dayton, Ohio 45407



LEARN MEAT CUTTING

Train quickly in 8 short weeks at Toledo for a bright future with security in vital meat business. Big pay, full-time jobs — **HAVE A PROFITABLE MARKET OF YOUR OWN!** Time payment plan available. Diploma given. Job help. Thousands of successful graduates. **OUR 46th YEAR!** Send now for big new illustrated **FREE**

catalog. No obligation. G.I. Approved. **NATIONAL SCHOOL OF MEAT CUTTING**
Dept. 50U, Toledo, Ohio 43604

GET INTO ELECTRONICS

V.T.I. training leads to success as technicians, field engineers, specialists in communications, guided missiles, computers, radar, automation. Basic & advanced courses. Electronic Engineering Technology and Electronic Technology curricula both available. Assoc. degree in 29 mos. B.S. obtainable. G.I. approved. Start Sept., Feb. Dorms, campus. High School Graduate or equivalent. Catalog.

VALPARAISO TECHNICAL INSTITUTE
DEPARTMENT D, VALPARAISO, INDIANA 46383



110-120 VOLT A.C. LIGHT PLANTS—60 CYCLES

Fanbelt driven from pickup or small gas engine. Operates saws, drills, pumps, freezers, T.V. X1000 Watts—Needs No Battery. Reg. \$99.50. Now \$62.50. 1500 Watts—6 and 12 volt vehicles. Reg. \$89.50. Now \$52.50. 3000 Watts—12 volt vehicles only. Reg. \$179.50. Now \$99.50. *Guaranteed.* Check or Money Order.

VIRDEN PERMA-BILT, Box 7066 P.M., Amarillo, Texas 79109



Solves Repair Problems

Durham's fills cracks and holes in plaster, wood and tile. Won't shrink or fall out. Economical, easy to use. Big 4-lb. can, only 1.60 at lumber, paint, and hardware dealers, or shipped direct postpaid in U. S. for \$2.00. Money-back guarantee. Order now. Donald Durham Co., Box 804-T, Des Moines, Iowa.

MFR'S. AUCTION!

AUTO TOPS, were \$69	NOW \$25
CARPETS, were \$38	NOW \$ 8
SEAT COVERS, were \$36	NOW \$15
TONNEAU COVERS, were \$39	NOW \$12

R & Y CO. 2334 First Ave.,
New York, N. Y. 10035. (212) 722-9603

New way to glue permanently in just 60 seconds



World's first automatic feed Electric Glue Gun

Grab hold of Swingline's contour molded handle. Squeeze the **exclusive** automatic feed trigger—you'll **one-hand** the toughest possible gluing job. Permanently bond any combination of wood, tile, leather, fabrics, crockery—in **just one minute**. Set the precision-engineered fingertip control thermostat for any one of three heat cycles—another Swingline first. Loads fast, starts fast, handles easy. It's the new hot-melt way to glue and caulk.



Special Introductory Offer—get the new Swingline Automatic Feed Electric Glue Gun for only \$8.95. 14 sticks of Glue and Sealer **FREE!**

Model 968

Ask for it for Father's Day!

Swingline®

Consumer Products Division, 32-00 Skillman Ave.,
Long Island City, N.Y. 11101.

Learn To Be A LOCKSMITH

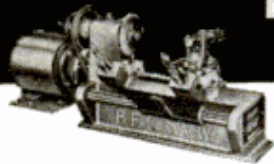

**PROFESSIONAL
KEY MACHINE
YOURS TO KEEP!**

Big demand for skilled Locksmiths! Earn big money spare time in your own home. Be your own boss: earn steady, year 'round income with no layoffs. BELSAW INSTITUTE training, approved by master locksmiths, teaches you to make keys, open and repair locks on homes, cars and buildings. Easy, illustrated lessons complete with ALL tools and supplies, including the \$125 Key Machine which is yours to keep. Shows you how to get jobs, how to charge, how to earn while you learn and how to build a lifetime, cash-profit business.

Read These Reports from Belsaw Graduates:

Oscar Larson, Long Beach, Calif.: "I have all the locksmith work I can handle in spare time. I give hearty thanks for your wonderful training."

Herbert Bernard, Point Pleasant, N. J.: "I recommend your course highly. Locksmithing gives me real enjoyment and extra money."

J. Marko, Ferndale, Mich.: "With me locksmithing is full time. I sincerely thank you for giving me this chance to better myself."

J. W. Cookman, Lakeland, Fla.: "I've been in full time locksmithing for three months. Thanks for your fine cooperation."

Accredited Member National Home Study Council. Approved for Veterans. Mail coupon today... no salesman will call.

BELSAW INSTITUTE
109B Field Bldg., Kansas City, Mo. 64111

Send FREE book, "Keys To Your Future!"

**FREE
BOOK**

Name _____

Address _____

City _____

State _____

Zip _____

NOW... from the Editors of the

**Universally Accepted
SMALL ENGINES
SERVICE MANUAL**

Snowmobile Service Manual



2nd Edition
4 95
Covers almost every machine built through 1968 and many '69 models! ... Engine section includes Hirth, JLO, Kohler, MAG, Sachs, Chrysler, OMC, Rotax, Lloyd, Yamaha and Wankel.

Motorcycle Service Manual



Volume 1
2-Stroke
2nd Edition
4 95
208 pages devoted to over 75 models of 18 manufacturers. Includes nearly every 2-stroke "popper" thru 1967 and many '68 cycles.

Motorcycle Service Manual



Volume 2
4-Stroke
2nd Edition
4 95
A total of 16 manufacturers represented. Complete instructions on everything... from brake adjustment to engine tear-down and reassembly. 232 big pages.

Small Engines Service Manual



8th Edition
4 95
Complete repair information on over 1,300 models of foreign and domestic small engines that power lawn mowers, tillers, go-karts, etc. ... 320 pages factory "Know-How"!

Money Back Guarantee. Send check or Money order and we pay postage.

Outboard Motor Service Manual



Volume 1
Motors under 30 HP
4th Edition
4 95
Covers outboard motors built from 1955 to 1967! Every repair procedure from power head to prop. Over 35 different makes included. 239 pages.

Outboard Motor Service Manual



Volume 2
Motors 30 HP and Up
4th Edition
4 95
Contains all pertinent service data on motors from 30 to 110 H.P. Same thorough model and year coverage as in Volume one. 208 pages.

Small Tractor Service Manual



2nd Edition
4 95
Universal service manual for popular "compact" garden utility tractors. Covers models ranging from 6 to 12 1/2 HP.

Complete! Comprehensive! Each book concisely written. Heavily illustrated. Each contains hundreds of diagrams, exploded view drawings, photographs. Lets you see exactly how work should be performed. Used and acclaimed by professional mechanics, do-it-yourselfers, classroom instructors. The most accurate and easy to understand universal repair manuals available anywhere.

TECHNICAL PUBLICATIONS DIV., Dept. PM-569
1014 Wyandotte, Kansas City, Mo. 64105

NEW CAMPER . . . NEW PARK

(Continued from page 127)

will not dry out overnight. Bedding feels clammy. Coats, suspended from hangers, still aren't dry. A tent wouldn't have a chance, except in summer.

But I am using a coach. I like the way the El Dorado coach handles on the highway. Pitch and yaw over chuckholes is missing. Nor does it sway, rock or wobble in hard winds. Careful loading of our gear keeps the center of balance nearly unchanged. The El Dorado earns very high ratings for overall highway stability. No tail-end sag is visible during any highway test. The interior is adequately insulated, bright and attractive, and convenient for dining, sleeping, or relaxing. I picked the nine-foot Comanche because it seems to condense all the features of big coaches into one of modest weight and somewhat shorter overall length. It is ideal for a family of three to five persons.

Though the coach design is good, there are some new-unit problems which plague us for several days. The roof leaks badly, allowing water to pour in through a forgotten seal around one top-mounted vent. It is repaired easily and quickly. The rear door will not stay in adjustment and frequently pops open during rough-road travel. The icebox drain hose will not stay in place. As soon as the ice melts, water fills the icebox floor pan then runs down the walls when the box door is opened.

Our 3/4-ton Ford pickup is equipped just the way I like it for carrying a camper coach. The heavy-duty camper-package equipment provides about 3500 pounds of payload capacity. Since our total coach, gear and passenger load brings the street-weight up to 7000 pounds, there's a comfortable 500 to 600 pounds of safety factor at all times. Yet, despite this load, the big 390-cu.-in. V8 handles the situation without problems. Load-starting power is excellent. Acceleration is good, considering the weight involved. And even at 55 to 65-mph cruising speeds the Cruise-O-Matic kicks into passing gear without hesitation. There's no engine overheating at any time. The big engine runs smoothly, without pinging, on the cheapest grades of regular gasoline. Average fuel consumption with our 7000-pound load is about 10 mpg on the flats and about 9 mpg in the hills.

On the truck itself, I find the lack of a night light on the shift-panel bothersome. And the two-way switchover valve for the reserve fuel tank is in an awkward position to turn the valve rapidly.

The new Redwood National Park may be the last great act of conservation of our time. Go see it. ★ ★ ★

Fox Mini Bike

DO IT YOURSELF
OR FULLY ASSEMBLED

FROM

\$79⁵⁰



12 MODELS
3 TO 5 HP

SEND \$1 FOR BIG CATALOG

Shows new 1969 line of the world's finest **MINI-BIKES** (most are licensable for street use), plus parts, accessories and plans. Big selection! Amazingly low prices! There's a Fox **MINI-BIKE** for everyone — from age 10 to adults.

EXTRA BONUS — Catalog shows radios, watches, walki-talkies, cameras, musical instruments, tools, appliances and many other items you can buy at practically wholesale prices. Free \$1 coupon.

FOX CORP., Box 797 PM Janesville, Wis. 53545

5000° OXYGEN WELDING TORCH
\$34.95 New portable SOLIDOX welding torch goes anywhere. Only 4 lbs. Burns amazing solid oxygen pellets & propane. Flame exceeds 5000°F. Braze weld, silver solder, melt 1/4" steel. Complete kit: torch, pellets, propane, glasses, braze rods, lighter, etc. Ideal for shops, hobby, metal repair. Professional results. Low-cost SOLIDOX pellets available by mail. SOLIDOX is simple and safe. Money-back guarantee. Only \$34.95 ppd.

SEND ONLY \$5.00

Write for free brochure.
pay postman \$29.95 plus postage on delivery.
Cleanweld Products Co., PMS, Box 1061, South Gate, Calif. 90280

YOU CAN FIND HIDDEN TREASURE AND RELICS

WITH THE AMAZING "GOLDSTAR"
MORE POWER • MORE DEPTH
DETECTS COINS, GOLD,
METALS, RELICS, ORE, ETC. •
OUT-PERFORMS PROBE TYPE
IMPORTED MODELS

ULTRA-SENSITIVE AND POWERFUL
Detects through earth, wood, rock,
sand, water, etc. Comes with batteries
and ready to use. Send check, cash,
money order today! 5% deposit on
COD orders. Immediate shipment.
SATISFACTION GUARANTEED

**JETCO P. O. BOX 132, PM1
HUNTSVILLE, TEXAS 77340**

**2 YEAR
GUARANTEE
\$29⁹⁵
P.P.D.**

MAN-SIZE TRACTOR



... PRICED
WITH THE
COMPACTS!

Mows up to
60" swath

No week-end toy — this garden tractor has *real work power!* 14 hp, plus extra size, weight, and traction gives you added pull-power. All-gear drive saves horsepower... puts more into larger attachments. You can mow 2 to 3 acres per hour; clear 16" snow in one pass; plow, roto-till, move dirt. So well built, you actually get over \$100 *more value*. Send for catalog, prices, name of dealer.

NAME _____

ADDRESS _____

CITY, STATE, ZIP _____ C-16

SEND TO **ECONOMY TRACTOR**

1005 K-5 Anoka Ave., Waukesha, Wisconsin

FREE!

Learn how you can buy used engines \$15 up, new engines \$30 with FREE confidential list and coupons when you order your plans

- **BUILD THIS MINI-BIKE!**
Plans reveal step by step details!
- **BUILD A RACING KART!**
Build frame for less than \$10!

RUSH \$2 for plans (indicate type) or send 25¢ for circular describing plans
PLANS, Box 517, Omaha, Nebr. 68101

GUNK

ENGINE BRITE

ENGINE CLEANER and DEGREASER

Just spray it on... hose it off!

GUNK LABORATORIES, INC.
5625 N. 66TH, CHICAGO, ILL. 60638

SOLID STATE MOBILE DUAL POWER

Mobile Power operates all power tools. Universal Motors. Camping equipment. Flood Lights. Charges Batteries, etc. Mounts on dash board of any car, truck or tractor. 30 ampere continuous power. One Year Warranty.

Regular \$149.50. Now \$89.50. Send check or Money order.
Copy Star Electronics, Pembina, N.D.
Dealers inquiries invited.

(Continued from page 130)

reminding technicians that all objects placed aboard or removed had to be weighed. Later, I mentioned this to Dr. Piccard. "We must have an exact record," he said, "of the boat's weight, in order to calculate the ballast. If the submarine is one pound too light, we will never be able to sink. If we are one pound too heavy, we will never come up."

He explained that the submarine is designed to "float" at any depth down to its 2000-foot limit without pumping water in or out of the ballast tanks. This is because the submarine's pressure hull is less compressible than water.

All conventional submarines, including nuclear subs, are more compressible than water. That means that as the sub descends, its hull is squeezed to slightly smaller volume by sea pressure. Not much can be done about this in a military submarine, Dr. Piccard said, because the weight of equipment and armament limits the weight, and therefore the rigidity, of the pressure hull. Of course a nuclear sub, with virtually unlimited power, can "hover" by pumping ballast, or use its motor to "fly" at a desired depth. But in a research submarine weight can be carefully regulated in relation to the size and stiffness of the hull to create a design that can be balanced to neutral density at a wide range of depths. (A pound of water added or subtracted makes the *Ben Franklin* descend or rise exactly 10 feet.) This is what makes the Gulf Stream drift possible; otherwise the power available would limit how long the sub could stay down.

Hull construction remarkable

The *Franklin's* pressure hull alone is a wondrous job of engineering. It was fabricated by bending and welding together 20 massive pieces of steel—six cylindrical sections and the two hemispheres, each made of seven segments. These were reinforced with 16 welded stiffening rings. Cast-steel reinforcement plates were added wherever there were portholes or penetrations for electrical cables or piping. A variety of clips, brackets and attachment points, designed to support equipment inside and outside, were welded in place. In all, 1000 items were welded into the hull.

All that welding introduced stresses. These were relieved by cooking the entire hull in a giant electric oven at almost 1000°F. for several days and letting it cool slowly. Then all the welds were X-rayed and tested ultrasonically, and the hull was measured all over to make sure

nothing was out of line more than about $\frac{3}{8}$ inch. So careful was the work that no imperfections were found by an American Bureau of Shipping inspector. The hull's collapse depth is 4000 feet.

The hull is in two pieces bolted together at a flange joint aft of amidships. The forward section contains all controls, electrical gear, galley, head and shower. The after section contains five of the six bunks, workbenches and space for scientific equipment. It can be removed and a new one bolted in place for a different sort of mission. This might be, for example, a lock-out diving chamber that can be pressurized while the forward section remains at sea-level pressure.

Aside from the hull, electrical equipment constitutes the heaviest part of the *Ben Franklin*. The 378 batteries make up close to 25 percent of the sub's weight. It was logical to place them in the keel, where their weight keeps the sub upright. In this free-flooding section, the batteries must be sealed against seawater, yet able to release hydrogen gas given off during operation. That's done in smaller research subs by encasing the batteries in an oil bath. To save weight, the *Franklin's* batteries are vented through a manifold of oil-filled tubes leading to a single duckbill valve.

Battery power, totaling 756 kilowatt-hours, is available in four different voltages: 168 volts for the motors that swivel the main propulsion motors, 336 volts for the main motors, 112 volts for the lamps that light up the sea around the *Franklin*—70 powerful searchlights—and 28 volts for on-board equipment. The sub's motors, running on a.c. for better control, require inverters and switching gear that take up a good deal of space.

The four motors provide a top speed of five knots, but are intended for maneuverability, rather than speed. Since they can be pointed forward or back, up or down, the sub can turn or tilt every which way. During the mission the motors will be used mostly to get back into the mainstream if the *Franklin* should drift into one of the Gulf Stream's branches. Here's what the mission will be like, as far as Dr. Piccard can visualize it beforehand.

The *Ben Franklin* will be towed out to sea with her crew aboard, said Dr. Piccard. The western edge of the great current is only a mile offshore near Palm Beach, so the tow will be short—fortunately, since the sub's surface behavior is less than ideal. Aboard will be Piccard, Kazimir and Erwin Aebersold, a Swiss associate of Piccard's, as pilot. Three U.S. Navy scientists will be headed by Frank

(Please turn to page 214)

KLEPPER

3 Boats-in-1 Foldaway

Easy to Carry . . .
(bags fit any car)
Speedy Assembly
(no tools, no strain)
Most Economical
(low cost, low upkeep)
Unsinkable
(perfect family boat)
Many New Models
(kayaks to sloops)
FREE Catalog PM9



Sail
Motor
Row

KLEPPER, 35 Union Sq. W • N.Y.C. 10003

NOT TO BE CONFUSED WITH IMITATION
PLASTIC MODELS SELLING FOR LESS!! **\$5.95**

Not Sold
to Calif.
or N.Y.
res.

22 Cal. Blank Cart. 8 Shot Revolver
No Permit Required
Imported from ITALY



"BLACK VENETTA"

Latest model, not a toy. Gun is of solid steel construction. Lightweight and perfectly balanced. Fires 8 rounds in 2 seconds! Double or single action. Precision crafted. 5 1/2 inches long. Ideal for stage, sporting events, boating, protection. Revolver \$5.95, deluxe leather holster \$2.25. Send cash, check or M.O. and save C.O.D. charges. \$1.00 deposit with C.O.D. orders.

BIG THREE ENT., INC. 1109 Sixth Ave., Dept. PM-569, N.Y., N.Y. 10036

At Last a New Amazingly Simple

GAS TURBINE JET ENGINE

Build from easy to follow plans. Length 15",
Dia. 8 1/2", Wt. 15 lbs. Fuel: Gasoline or Kero.



"Screamin Demon" develops 20 H.P. Ideal project for serious-minded hobbyists, students; scientific and industrial arts classes. Make on 9" metal cutting lathe with milling attachment. For use on small racing boats, midget cars, etc. Full size assembly drawings with critical dimensions, bill of materials and photos. Price \$5.00. No C.O.D.

SAVOY SCIENTIFIC, BOX 1398, SANTA MONICA, CALIF. 90406

Travel the **SHORT** way

avoid wrong turns —
save time, money
and frustration with



... at
leading
stores
everywhere!

AIRWAY COMPASS, Mexico, Indiana 46958

NEW PORTABLE MACHINE STAMPS BIG PROFITS!



"ENGRAVE" Social Security Plates, Identification Plates, Fraternal, Religious, Door/Name Plates, Medical Plates & Tags, Dog Tags, Key Protectors, etc.

WE SUPPLY EVERYTHING! Print name, address, zip code and Social Security Number; enclose 50c for your personal Social Security Plate with Carrying Case, plus 24 page booklet "Big Money In Home Business" Supply Catalog (in color with pictures) Social Security Earnings (your personal record)

FREE

**PERMA-PRODUCTS, INC. 16511 N.E. 6th Ave., Dept. M-8
North Miami Beach, Fla. 33162**

EARN HIGH WAGES as a HEAVY EQUIPMENT OPERATOR



Train your way to high pay in the booming construction industry! Learn the skills you need to qualify, by actual field training on machines like the ones used by the industry. Huge training grounds in North Carolina, a million dollars worth of school-owned diesel-engined machines, experienced instructors, full 220-hour and 440-hour courses. National, the original school of heavy equipment operation, is a recognized leader. Member American Road Builders Assn., Services and Supply Division. Associate Member A.G.C. Full-time Job Advisory and Counseling Director on staff. VA approved. For men ages 17 to 56. Train Now-Pay Later plan . . . other payment plans also available. Write TODAY for FREE catalog and FREE copy of school newspaper reporting news of National School graduates. Accredited member NATTS.

**NATIONAL SCHOOL
OF HEAVY EQUIPMENT OPERATION, Dept. D-27
P. O. Box 1686, Moores Chapel Road, Charlotte, N. C. 28201**

Please send me FREE illustrated school catalog and complete information. I understand there's no obligation.

Name _____ Age _____

Address _____ Phone _____

City _____ State _____ Zip Code _____

BASEMENT TOILET FLUSHES UP



TO OVERHEAD SEWER OR SEPTIC TANK.
NO DIGGING UP FLOORS. INSTALLS EASY. Write
McPHERSON, INC., BOX 15133, TAMPA, FLORIDA 33614

LAFAYETTE RADIO ELECTRONICS

FREE!



1969 Catalog 690

Over 500 Pages

BETTER THAN EVER

Stereo Hi-Fi • Citizens Band • Ham Gear • Tape Recorders • Test Equipment • TV and Radio Tubes and Parts • Cameras • Auto Accessories • Musical Instruments • Tools • Books

**LAFAYETTE Radio ELECTRONICS
Dept. 15108 P.O. Box 10
Syosset, L.I., N.Y. 11791**

Send me the FREE 1969 catalog 690. 15059

Name _____

Address _____

City _____

State _____ Zip _____

FROM FLORIDA TO CAPE COD

(Continued from page 212)

Busby of the Naval Oceanographic Office.

After hatches have been sealed and final checkout performed, the sub will submerge. First will come complete flooding of the "soft" fiberglass ballast tanks, which provide surface flotation. Next, a carefully calculated amount of water will be let into the two "hard" (pressure-resistant) ballast tanks in the keel which hold about 100 gallons.

The dive will be slow. After a gradual descent, during which ballast will probably be pumped to arrive at approximately the right depth, an even slower settling will take place as the sub cools off to the temperature of the water. It's expected that 24 hours will elapse before the *Franklin* finishes contracting as it cools and reaches a state of neutral buoyancy.

Since the water here is of continental-shelf depth—a few hundred feet offshore, gently sloping out to sea—during the first half of the mission the sub will be drifting at fairly shallow depths—300 to 600 feet. Several excursions to the bottom will be made to take pictures of undersea topography. The sub will be equipped for 35-mm movie-making and still photography. The excursions will take place during the first half of the trip, because north of Cape Hatteras the Gulf Stream veers off over a bottom more than 10,000 feet deep.

Piccard plans to stay close to the west wall of the Gulf Stream. Since the water temperature in the current increases to the east, he could conceivably navigate by monitoring the temperature and periodically adjusting position to the desired temperature line. But this would not provide position data accurate enough for scientific measurements. For that data, the sub will rely on two surface ships supplied by the Navy, and contact them by means of a sound-powered underwater telephone.

The men aboard the sub will be able to deliver items to the surface. A small airlock in the top of the hull is designed for release of five-inch aluminum spheres in which rolls of film, tape cartridges, written notes or small specimens of marine life can pop to the surface.

Daily drift 36 to 48 miles

Drifting with the current, the *Franklin* will average 1.5 to 2 knots, and make 36 to 48 nautical miles a day. At the surface, the Gulf Stream has an average speed of 4 knots. This means that the surface ships, in order to remain above the sub, will travel 1500 miles northward by steaming south.

"Our life on board will be relatively comfortable," says Piccard. "Each man has his own bunk. There is a roomy wardroom forward, where a game of gin rummy can be enjoyed. And we will have a fresh-water shower, washing and toilet facilities." Considerable intelligence has been devoted to life-support systems that are foolproof and use practically no electric power.

Cooking water stored near boiling

Food will be the freeze-dried variety, "cooked" by adding hot water. To avoid using power to heat it, the hot water—some 190 gallons—is carried in "super-insulated" tanks designed to keep it just below boiling for the whole month. The superinsulation—a vacuum jacket surrounded by layers of aluminized mylar film—was developed originally for the Apollo lunar spacecraft.

Another 380 gallons of water is aboard for drinking, washing and toilet-flushing—over two gallons per man per day. Waste water cannot be pumped overboard. That would reduce the sub's weight and make it rise. So well-sealed waste tanks are provided.

Due to the long duration of the voyage, unusual attention had to be paid to control of odors and poisonous fumes from electrical and lab equipment as well as from humans. Forty different gas-detector tubes will identify contaminants in the atmosphere, and a catalytic burner will dispose of what activated charcoal won't remove. Breathing atmosphere is supplied by a surprisingly simple system—two standard industrial Thermos-bottle-type tanks of liquid oxygen, to be vaporized and metered automatically, plus trays of lithium hydroxide for carbon-dioxide removal.

Heating is not expected to be necessary. Since the surrounding water temperature will be about 61°F., heat generated by machinery and crew will keep the cabin temperature between 63° and 81°.

Barring any emergency, the scientists should have ample opportunity to study the marine scene through the portholes. Unlike many research subs, the *Franklin* is not equipped with a claw for taking samples. It does have one unique sampling device, a quartz tube connecting two of the rear portholes. Equipped with valves, it permits small quantities of water to be brought inside the sub, where small marine life can be studied under the microscope at depth pressure. They can then be allowed to swim out or be added to the biologist's collection.

A form of marine life Piccard hopes to study, he said, is what is known to ocean-

ographers as the "deep scattering layer." This shows up on sonar scopes as a false bottom at depths down to several thousand feet. The DSL is thought to consist of shrimplike creatures or small fish; it moves up toward the surface at night, presumably in response to darkness. Many attempts have been made to sample the organisms, with confusing results. Piccard believes the *Franklin* is the ideal tool for study of the DSL—it can spot the layer on sonar from below or above, place itself right in the layer, and follow the slow rise and fall of the layer through its 24-hour cycle.

The submarine is also ideally suited to study ocean sounds, since most of the time she will be drifting with motors and noise-making gear shut down. Tape recorders will capture the grunts, chirps and clicks that fish make, and the dull grating of the water over the sandy bottom. The sub will also study underwater sound transmission, a fascinating subject for the Navy.

If all goes well, the mission will be terminated when about 80 percent of battery power has been used. The *Franklin* should then be 100 to 250 miles off Cape Cod. The procedure for coming up, if nobody's in a rush, is the opposite of going down: Blow water out of the ballast tanks with compressed air.

Steel shot speeds surfacing

The sub also carries over six tons of steel shot that can be dumped to bring her to the surface in a hurry. The shot is held in two hoppers by electromagnetic "valves." A steel ring at the mouth of each hopper is permanently magnetized, so it takes no electric power to keep the shot in place; a pulse of current through a coil can demagnetize the ring and let the shot pour out. A second ring of soft iron can be variably magnetized to meter out shot if desired. A total power loss is the worst emergency that could occur, says Piccard. If that happened, the shot could be released through a hydraulic gate pumped by hand.

Piccard is confident no serious emergency will arise. It's certain that one exciting moment will be the end of the trip, when the sub surfaces in the rough North Atlantic. The *Ben Franklin* will be heaving, rolling, and pitching as a small boat comes over from one of the escort ships. After the towline has been secured, Piccard and his companions will transfer to the small boat.

The sub and the boat are going up and down," says Piccard, demonstrating with his hands. "There comes a moment when the two are together—that's when you jump." ★ ★ ★

MAY 1969

GOVT. SURPLUS AND OTHER BARGAINS SAVE UP TO 90%



STAINLESS STEEL TANK Exc. for fuel, water, oil, acids, etc. 4 gal. cap. Pressure-tested to 35 lbs. 2" filler neck, 22" L. x 10 3/4" H. x 5 1/2" W. Purchased at special price less cap & drain boss. A \$36 value. Shpg. wt. 9 lbs. NEW. \$12.50 (Stk. #2480)

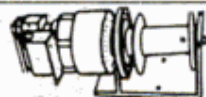

HEAVY DUTY BATTERY WINCH

Rugged, deluxe winch. Ball bearing construction thruout motor & gear train. High gear reduction. Rated cap 3000 lb. pull. Reversing switch. Rugged 3/4" plate steel mounting base with outrigger support. 22" L. x 9" W x 8" H. Handles 250' of 1/4" cable. Built for 12 V battery operation; also operates on 6 V at reduced cap. & speed. For Scouts, Jeeps, Trucks, Boat loading trailers, etc. Shpg. wt. 80 lbs. Approx. GOVT COST \$490. NEW. 90-day guarantee. Model E-D. \$89.50 (Stk. #692)

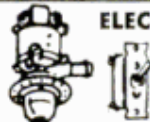

ELECTRIC PUMP WITH CONTROL SWITCH

For boats, campers & trailers. Output 300 GPH. Can be used in fuel or water. 1/2" pipe bronze inlet. 12 or 24 V.D.C. Explosion-proof motor. Shpg. wt. 9 lbs. Complete with wiring diagram. Approx. GOVT COST \$200. \$12.95 (Stk. #1164)



NEW! BIG! 1969 CATALOG

Send 25c for amazing catalog with 1000's of bargains in hydraulics; electrical, marine, automotive items, etc. Order from ad. All prices FOB Culver City. 50% deposit required for COD. Cal. res. add 5% sales tax. Include zip. Satisfying world-wide customers since 1945.

AIRBORNE SALES CO. Dept. PM569
8501 Stellar Dr., Box 2727 • Culver City, Calif. 90230

Tear Out & Mail. No Letter Needed

Free New Catalog 2000 Novelties

Send for world famous catalog of novelties, live animals, scientific supplies, hobbies, funmakers, planes & boats, toms, magic tricks, joke articles, unusual seeds, gadget timesavers, cameras, optical goods, projectors, movies, lucky jewelry, religious novelties, disguises, musical instruments, stamps, coins, puzzles, fortune tellers, radios, auto & bike accessories, telescopes, magnifiers, compasses, banks, smokers' gadgets, artists supplies, printing sets, engines, motors, shockers, knives, billfolds, fireworks, guns, rifles, sports, books, games, plants, etc. Send postcard or this ad. No letter needed!

CHECK HERE YES—I want FREE Catalog. My Name & Address Attached or on Envelope

Johnson Smith Co., Dept. 511, Detroit, Mich. 48224

Make Rubber Stamps for BIG PAY



Need more money? Earn \$60-\$75 a week, spare time, at home making rubber stamps for offices, factories, individuals. Hundreds of uses. Hundreds of prospects—everywhere. Right in your own community. Turn out special stamps for names, addresses, notices, prices, etc., in minutes with table-top machine. We furnish everything and help finance you, at less than bank rates. Write for free facts. No salesman will call.

Rubber Stamp Div., 1512 Jarvis, Dept. R-2-ES, Chicago 60626

BUILD YOUR OWN CAMPER SAVE UP TO 50%



Complete, easy to follow plans, instructions, materials list.

Camper Plans\$3.95
Travel Trailer\$3.95
Pickup Cover\$2.00
CONVERSION PLANS:
Econoline Type Van..\$2.95
Passenger Type Van
Delivery Van.....\$2.95
Satisfaction Guaranteed

VIKING CAMPER SUPPLY, INC.
99-BP Glenwood Ave.,
Minneapolis, Minn. 55403
Please send _____ for
which I enclose \$ _____
NAME _____
ADDRESS _____
CITY _____
STATE _____ ZIP _____

EQUIPMENT CATALOG \$1.00

Refundable on First Order. Send Dime for Details. Save 50% on Camper Kit. All items from catalog to build \$1,795. Camper 8', 10', 10'6" or Chassis Unit.





This **COUPON** entitles you to years of trouble-free grass cutting with famous

Devere-Locke ROTARY MOWERS

Send me **FREE Literature** on **Devere-Locke Rotaries**

and also on Locke reel and Manco-Locke high-wheel mowers. I'd like name of closest dealer too.

(name) (street)

(city) (state) (ZIP)

Locke Mfg. Cos., Inc. 5675-Y MaeCorkle Ave. SW S. Charleston, W. Va.

Bazooka hub

Outboard Props

2 to 3 mph speed increases common. Patented hub design combines with other Michigan features. Many thru-hub-exhaust props have flares or flanges that create drag. Exhaust sucking action provided in Michigan's Bazooka Hub by inside flare or venturi shape. Outside surface is clean, straight... no drag. See your dealer or contact:

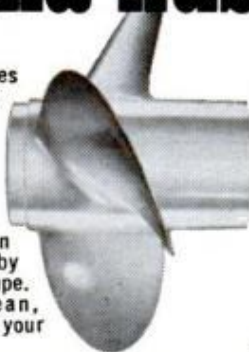

MICHIGAN WHEEL CO., GRAND RAPIDS, MICH. 49502

EVINRUDE-JOHNSON	YEAR	PART NO.	DIA. & PITCH	PRICE
55-85-115-HP Thru-Hub Exhaust	68-69	PR290	14 x11	29.00
		PR288	14 x13	29.00
		PR286	13½ x15	29.00
		PR284	13½ x17	29.00
		PR282	13½ x19	29.00
		PR280	13½ x21	29.00
		AJC321	13¾ x23	31.00
		AJC323	13¾ x25	31.00

These propellers also available in Michalloy-K Bronze



Repair any watch

... SWISS OR AMERICAN

Unique, modern Sweazey System starts you making repairs right away. Develops skill step by step at home in spare time. Diploma awarded. Free sample lesson. No obligation.

CHICAGO SCHOOL OF WATCHMAKING
Dept. 159, Fox River Grove, Ill. 60021

PROFIT IN YOUR SPARE TIME

SMALL ENGINE REPAIR PAYS BIG!

Outboard • Powermower • Chain Saw • Tractor
MAKE EXTRA MONEY — or fix your own engines and **SAVE!** Illustrated, easy-to-learn Home Study Course qualifies you as expert. Approved for Veterans. Write today!

LINCOLN TECHNICAL INSTITUTE
SUITE 5-E, 427 MARKET ST., NEWARK, N.J. 07105

DISTRIBUTOR VACUUM ADVANCE

(Continued from page 155)

will make the timing mark appear stationary.

If there is flutter, however, timing has to be reset. Loosen the distributor housing, and turn the housing *against* rotor rotation to advance timing—with rotor rotation to retard timing. With the pointer aligned with the timing mark, retighten the distributor and recheck the setting.

Timing light tests

Before checking on the functioning of the advance unit, disconnect the timing light from No. 1 cylinder and connect it to the sparkplug of the alternately firing cylinder. On V8 engines, this will be No. 5 cylinder in the firing order. On in-line engines, it's No. 4 cylinder in the firing order.

Check timing. There should be little or no variation in timing between the two cylinders. If you find there is more than a 3° variation, a problem with the distributor cam is indicated. It's probably worn.

Reconnect the vacuum line to the spark advance, and reconnect the timing light to No. 1 cylinder. Gradually increase the speed of the engine as you watch the timing mark, which should advance smoothly by action of the centrifugal advance.

To check whether the vacuum advance unit is working, pull and push the vacuum hose off and on the unit as you watch the timing mark. If the spark advance is working properly, the timing mark will shift rapidly.

If this test indicates that the spark advance unit is not working, it will have to be replaced. First step is remove the distributor from the engine. Note the position of the rotor contact. When the distributor goes back in the engine the rotor will have to be in this position. As an aid, lay a pen or sharp pointed tool along the rotor contact and scribe a line, if possible, on a suitable adjacent surface. Rotor and scribe line should line up when the distributor is reinstalled.

Unbolt the distributor. (You may require a special wrenching tool). After lifting the distributor from the engine, you'll find two bolts which secure the spark advance unit. One attaches the distributor ground wire to the link between the spark advance and breaker plate. The other bolt attaches the link to the breaker plate. Remove both and slide off the spark advance unit. Be very sure that you replace the vacuum advance unit with one specified for your car. ★ ★ ★

RADIAL ARM SAW KIT... for under \$100

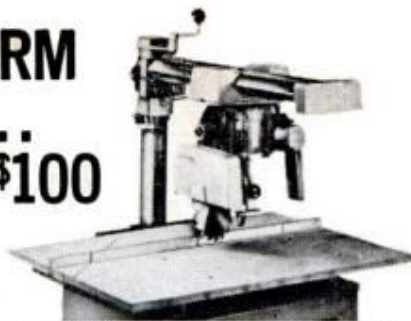

Buy direct from factory, assemble yourself. Incl. 1/2 h.p. G.E. motor, easy to follow instructions, all parts, nuts and bolts. Guar. for life pat. pend. radial arm track; twice the usual bearings for extra rigidity, greater precision. Rips 24", crosscuts 12"; belt brake. \$99. complete, freight col. Kit less motor (any stand. 1/2 h.p. or larger will do) \$84.85. With optional G.E. motor developing 1 h.p. \$108.65. Money back guaranteed by one of world's largest manufacturers of bench power tools. Write for brochure. Terms if desired or check or M.O. to American Machine & Tool Co., Dept. PM59, Royersford, Pa. 19468

WHAT'S HE DOING?

Making a Concrete Flower Pot! ... and SO CAN YOU!



Make and sell your own Ornamental Concrete items. Rush \$2.00 for book about Aluminum Molds with prices and production trade secrets direct from world's largest mold manufacturer. Over 350 designs to select from.

Send \$2.00 CONCRETE MACHINERY COMPANY

Today To → P. O. BOX 99 • HICKORY 2, N. C. 28601

DRAINS collars, cisterns, wash tubs; \$8.95



IRRIGATES - CIRCULATES - SPRAYS
1,001 uses. Stainless shaft. Won't rust or clog! Use 1/8 HP motor or larger... 3/4 HP for up to 2,400 GPH; 450 GPH 80' high; or 1,800 GPH from 25' well. 1" inlet; 3/4" outlet. Coupling included free. \$8.95.
HEAVY DUTY BALL-BEARING PUMP. Up to 5,200 GPH; or 3,000 GPH from 25' well. 1 1/4" inlet; 1" outlet. \$12.95
Postpaid if cash with order. MONEY BACK GUARANTEE

Centrifugal and Gear Pumps in All Sizes
LABAWCO, Box 7, Belle Mead, N. J. 08502

Print Your Own



Cards, Stationery, Advertising, Circulars, labels, photo and movie titles, church work, tags, greeting, sympathy, prayer cards, etc Save money. Pays for itself in a short time.

Own a Printing Business

Good Profit. Raised printing like engraving too. Have home shop. We supply everything. Direct from factory, only. Easily followed rules. Write now for free details. **KELSEY PRESSES E-37 Meriden, Conn. 06450**

1000 Sources. \$500 to \$2 Million.
Business Capital, Loans, Grants,
Cash to start a Business.
SMALL BUSINESS MONEY WRITE TODAY
SEND NO MONEY FREE DETAILS
NATIONAL COUNSELOR REPORTS
Div. 57E, Harlingen, Texas 78550



Get more
GETUPANDGO
from every engine with
GUMOUT

enjoy

a real wood-burning fireplace without expensive masonry



So Easy To Install You Can Do It Yourself



Save time, labor and money. No masonry or footings needed. Use ordinary tools. Complete Package, base to chimney top. Choice of contemporary or simulated brick chimney top — single or double.

Any room location. It's as easy to locate in an old or new house as a sofa. Finished with any mantel materials or trims. Corner or front styles. Choice of size. Listed by U/L. Built-in clearances permit butting against wood studs, floors, or walls. Thousands in use — nationwide.

For 1, 2, or 3 STORY HOUSES

Majestic® thulman® FACTORY-BUILT WOOD-BURNING FIREPLACES

Write Today for Details — also other Majestic Fireplaces

The Majestic Co., Inc., 723 Erie St., Huntington, Ind. 46750



WORLD'S MOST POPULAR HOMEBUILT AIRCRAFT

Now you can afford your own personal Copter! More than 3000 Bensens have been built by people like you, in this country and abroad. The Gyrocopter costs no more to operate than a car. Stores in the garage, requires little space for take-offs and landings. Interchange floats with wheels for extra fun. Fly slow as 20 mph or zip along fast and high. Flying instructions come with complete plans. Kits and parts available. Send \$3 for 3-View Drawings, specs, photo.

SEND \$3 NOW BENSEN AIRCRAFT CORP., Dept. PM-59
Raleigh-Durham Airport, Raleigh, N. C. 27602
NAME _____
ADDRESS _____

HOW TO MAKE BAD WATER GOOD

(Continued from page 187)

before exhaustion, works anywhere and sells for \$13.95.

● *Hard water into soft.* There's an old wives' tale that water is purified by going through the ground. True, it may lose a few bacteria, but it picks up other troublesome materials. Water that trickles through limestone dissolves calcium and magnesium minerals. This dissolved rock, or hardness, makes shaving difficult and shampooing futile. It combines with soaps and detergents to create insoluble scum instead of dirt-suspending lather. This scum can't be rinsed completely from hair or skin, and after bathing, it shows up as a sticky ring around the tub. It makes laundry gray and rough, instead of refreshingly clean and soft.

Heat hard water, and some of the hardness minerals are forced out. They clog your water heater with an insulating layer that runs up your bills.

Back in 1905, a German professor discovered a way of removing calcium and magnesium, the two hardness minerals, from water. He did it by exchanging them for the sodium contained in "zeolite," and the water-softening industry was born. The zeolite is recharged periodically with common salt, and the hardness minerals are flushed down the drain.

The result is "softened" water rather than soft water. Naturally soft water, like that in sections of the Northwest and New England, is low in minerals and usually acid in character. Typical softened water retains its original alkaline character and original concentration of minerals. But it has the wonderful cleansing ability of naturally soft water.

● *Three ways to get soft water.* You can buy the equipment, rent it or subscribe to a soft-water service.

The service arrangement is the simplest. The softener service company merely installs some valves in your water line and hooks up a portable softener unit. Since a softener requires recharging periodically, a freshly charged portable unit is installed and the exhausted unit is taken back for the recharging process. At the plant, the portable softener is thoroughly cleaned and restored to full softening capacity by flushing with a solution of common salt. It may cost as little as \$4.50 per month.

If you buy a softener, it may cost you \$300 to \$500, but if your water is very hard, or if you use large amounts of water, you'll come out ahead. Modern softeners are completely automatic. They recharge themselves, using salt from a storage container. Even salt delivery is available on a

definite schedule in most areas. And the latest softeners are more efficient and economical. Here's why:

Until recently, automatic water-softener recharge cycles were controlled by "calendar clocks." Every few days, on a preset schedule and at a preset time, the clock would initiate a recharge cycle. This system had drawbacks. If you were away and used no water, the softener would still recharge itself on schedule. But, if you had a number of guests and used more water than usual, the softener could become exhausted.

Now an "Aqua-Sensor" has been introduced which detects the need for recharging in much the same way that a thermostat detects the need for a furnace start-up. This efficient system may save 40 percent of the salt and 50 percent of the water needed for recharging. Most important, you don't ever run out of softened water. The drawing on page 187 shows how the sensor works.

● *Combination water conditioners.* Culligan recently introduced a new group of all-purpose water conditioners. Called "Ultra-Clear," they will handle several combinations of special water problems.

One model treats hardness and acidity. Another treats iron, sulfur and hardness, while a third treats iron, sulfur, acidity and hardness. These all-purpose units sell for about \$500, plus installation, or can be rented for about \$10 a month, plus the cost of salt and treatment materials. ★★

SAVING HOME WEAR AND TEAR

(Continued from page 179)

seven straight lengths costs \$4.97. The latter lock in place, while the roll type fits under the shingles.

Another point of wear and tear is where water gushes from a downspout near the foundation. If allowed to form a puddle, the water not only will undermine and wash out foundation plantings, but also find its way into the basement through cracks in the wall. A downspout extension such as Scatter Rain will prevent puddling. It simply caps the end of the pipe, causing the water to sprinkle. It sells for \$1 and is made by Nichols.

Any time you can keep youngsters from making numerous trips into the house during the summer saves wear and tear. Here is where an outside drinking fountain will help. A clever one by Camco Manufacturing Co. screws onto any standard outside sill cock and has the added feature of not interfering with the use of a garden hose. It comes in two models at \$4.95 and \$6.95. ★★

WILL EAGLES SCREAM AGAIN?

(Continued from page 135)

sist of. The guess is that the cars will be reworked wedge designs powered by variations on a theme by Ford. Drivers will be '68 Grand Prix champion Graham Hill (who won at Indy in '66) and F/1 star Jochen Rindt.

Turbines still trying

Despite rule changes that STP bossman Andy Granatelli claims knocked turbines out of contention at Indy, at least one such car will try to make the race—the Jack Adams car Glenn Bryant built last year but couldn't get ready in time for qualifying. The turbine being used is the Allison 250, a lightweight (139 lbs.) engine Bryant says will move his ultralight chassis at more than competitive speeds. The driver has not as yet been announced.

Speaking of Granatelli, he'll be on hand with two cars for Art Pollard, one a backup. Power will be a 318-cu.-in. Plymouth passenger-car engine Granatelli claims can be modified to put out 525 hp. Chassis will be the '68 four-wheel-drive turbocars he campaigned last season.

Regardless of what chassis/engine combinations make the race, they'll have to be mighty quick about it. Leonard won the pole last year in one of Granatelli's Turbocars with a four-lap record speed of 171.559. Just making the race in 33rd position was Larry Dickson with a speed of 161.124. This year, prerace guesses peg the pole speed at close to 175, with about 168 being needed to make the grid. For an idea of just how fast that is and what's happening at Indy, in 1965—four short years ago—A. J. Foyt won the pole and set a qualifying record speed of 161.233.

Series began in 1911

In all, this year's race ought to be a dilly. Indy always is, being rich and colorful and crusty in tradition. The '69 race will be the 53rd in a series dating back to 1911, the only exceptions in this string being the war years of 1917-18 and 1942-45.

The race never fails to bring out racing's Establishment and hundreds of thousands of its die-hard fans, all of whom gather as if they were attending an annual rite to pay homage to and thrill to the skill and daring of the men who literally "lay it on the line" with every lap they make.

This year, more so than ever before, Indy is no place for strokes; the only conceivable strategy for the race calls for a driver to put his right foot all the way down—hard—and steer left. ★★

Carpenters' Secret Makes Ugly Nail Holes Vanish.

Repair ugly nail holes like professional carpenters do with PLASTIC WOOD. Handles like putty. Hardens like wood. Plane it. Sandpaper it. Varnish or paint it for perfect finish. Get PLASTIC WOOD in tube or can. Walnut, oak, mahogany or natural color. At all hardware outlets.

GENUINE
**PLASTIC
WOOD**[®]



CELLULOSE FIBRE FILLER

BILL PROBLEMS?

WE CAN HELP YOU — TODAY



NOBODY REFUSED UP TO \$18,000.00

Bad Credit No Problem ■ Not a Loan Co.

Send Your Name and Address
For FREE Application To Nearest Office

INTERNATIONAL ACCEPTANCE, dept. M-8

★ 5133 N. Central Ave., Phoenix, Ariz. 85012, ★
★ 711 - 14th St. N.W. Washington, D.C. 20005 ★
★ 507 Carondelet St., New Orleans, La. 70130 ★



Unimat

Convertible precision lathe is vertical miller, drill press, surface grinder, polisher too! \$139.50, incs. motor & parts. Request free catalog, or send \$1 for 40 pg. detailed handbook.

AMERICAN EDELSTAAL, INC.
BE-9 / 350 Broadway / NYC 10013

I-N-V-E-N-T-O-R-S WE NEED INVENTIONS

Sell your invention for cash—need money for Patent?—Are technical problems holding you back? Universal Inventions has helped inventors all over the world—just like yourself—why not you? Inventions provide the magic spring-board to sudden riches. REMEMBER, we either sell your invention or pay you a cash bonus. Write for details.
UNIVERSAL INVENTIONS, Dept. 13, Marion, Ohio

WOOD
VENEERS • TOOLS
Shop Equipment • Supplies
POWER TOOLS
at Lowest
Discount Prices!

SAVE MONEY on finest domestic and imported hardwoods... all dimensions. Over 1500 items for the home craftsman and woodworking hobbyist. Lamp parts, upholstery supplies, tile, power tools at discounts.
NEW CATALOG READY
132 pages. Full Color. Send name, address and 35¢ to cover handling, and postage. Write...

CRAFTSMAN Wood Service Co
Dept. A-59
2729 S. Mary, Chicago, Ill. 60608

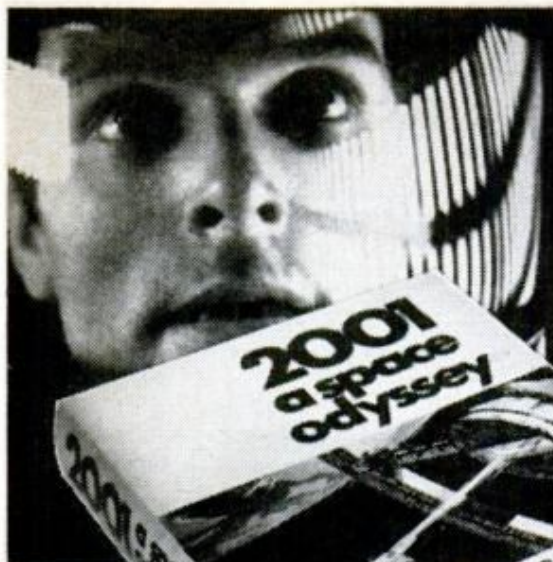

The Science Fiction Book Club invites you to take

Any 3 books only \$1

with trial membership

Including, if you wish,

2001: A Space Odyssey

best-selling novel and
award-winning cinema spectacular

2001: A SPACE ODYSSEY by Arthur C. Clarke
Hunting an alien "presence" in the universe, 5 men and a computer-gone-psycho-tic stumble upon the incredible secret of mankind's birth — only to trigger the cosmic "booby-trap" that could spell its death. A controversial best-seller by the most acclaimed science fiction writer of our era.

PHOTOGRAPH COURTESY OF MGM FROM THE FILM 2001: A SPACE ODYSSEY, A STANLEY KUBRICK PRODUCTION.

Science Fiction has grown up.
Have you kept up?

A new literary genre has come of age—your age. Mature. Sophisticated. Provocative. *And respected.* You are invited to explore it now under an amazing trial offer. Take any 3 volumes on this page (worth up to \$23.40 in original publishers' editions) for only \$1 with membership. * New club selections will be described to you in advance each month. Choose from new works of fiction—and fact—by such acclaimed authors as Ray Bradbury, Rod Serling, Isaac Asimov, Arthur Clarke, Robert Heinlein and others. All volumes are full-length, hard-bound—and uncut. Though they sell for as much as \$4.95, \$5.95 and more in their original publishers' editions, club members pay only \$1.49 plus shipping. (You may choose an optional extra-value selection at a slightly higher price.) Your sole obligation is to accept as few as four books during the coming year. Cancel any time thereafter. Science Fiction Book Club, Garden City, N.Y. 11530.

SCIENCE FICTION BOOK CLUB Dept. 95-PTX, Garden City, N.Y. 11530

Please accept my application for membership and rush me the 3 books whose numbers I have circled below. Bill me only \$1.00, plus shipping and handling, for all 3. Then, every month, send me the Club's free bulletin, "Things to Come", which describes coming selections. For each book I accept, I will pay only \$1.49, plus shipping and handling, unless I take an extra-value selection at a higher price. I need take only four books within the coming year and may resign at any time thereafter.

NO-RISK GUARANTEE: If not delighted with my introductory package, I may return it in 10 days to cancel membership.

Circle the numbers of
the 3 books you want.

600	606	610
616	618	619
622	623	627
628	632	643
644		

Print Name _____

Address _____

City _____ State _____ Zip _____

22-S79

If under 18, parent must sign here. (Offer good in U.S.A. only)



610. Three Novels by Damon Knight. Rule Golden, The Dying Man & Natural State—all complete. Pub. ed. \$3.95

619. Asimov's Mysteries by Isaac Asimov. 13 love-and-larceny spiced whodunits of the future — puzzlers all! Pub. ed. \$4.50

622. The Foundation Trilogy, by Isaac Asimov. The ends of the galaxy revert to barbarism. Pub. ed. \$10.50

627. Last Starship From Earth by John Boyd. Young lovers flee loveless society ruled by computer "god" Pub. ed. \$4.95.



643. The Past Through Tomorrow: "Future History" Stories, by Robert A. Heinlein. Pub. ed. \$5.95

616. Twice 22 by Ray Bradbury. Forty-four stories by the Grand Master of science fiction. Pub. ed. \$4.95

632. Chocky by John Wyndham. Alien powers "possess" small boy in shocker from author of "Day of the Triffids"

628. From The Twilight Zone by Rod Serling. 14 spine-tingling stories that breach the gap between science and superstition.



606. Killer Thing by Kate Wilhelm. A scientist in the 23rd century develops a robot with a laser eye. Pub. ed. \$3.95

600. A Treasury of Great Science Fiction, 2-volume set. 1,000 pages. Counts as one book. Pub. ed. \$5.95

644. October the First is Too Late, by Fred Hoyle. Solar beams play havoc with time on earth. Pub. ed. \$3.95

618. Dangerous Visions. Anthology of 33 original stories never before in print by Sturgeon, Anderson, others. Pub. ed. \$6.95

Amazing 200th Anniversary Celebration
Limited Time Offer on Heirloom Edition
BEST DISCOUNT EVER
on this magnificent new edition of
ENCYCLOPAEDIA BRITANNICA

You get all 24 volumes now . . . direct from the publisher . . . pay later on easy Book a Month Payment Plan

Yes, the response to our 200th Anniversary Celebration last year was so favorable that Encyclopaedia Britannica has decided to extend the Celebration —by making available to you now—a completely new offer. Under this new offer you may obtain this magnificent new Heirloom edition —at the best discount ever—for this year only! This latest edition of Britannica—the greatest treasury of knowledge ever published—is being offered on a remarkable direct-from-the-publisher plan.

Benefits Passed on to You. You may wonder how we're able to make this truly dramatic discount offer. First, because we hope for great demand on this magnificent Heirloom edition, we would expect to materially reduce our costs. And, because we would like every youngster to have the advantages of this great encyclopaedia—to help with homework and to answer questions—we pass these benefits on to you. All 24 volumes of the new Encyclopaedia Britannica will be placed in your home NOW. . . you pay later on convenient budget terms. It's as easy as buying a book a month.

Thousands of Subjects and Illustrations For Homework and Household Help. In the new edition of Britannica, you will find thousands of subjects that you and your family will refer to in the course of your normal day-to-day affairs. For example, you'll find special articles on household budgets, interior decorating, medicine and health, home remodeling, and child care. For students, Britannica is indispensable. And the new edition is the most readable, interesting and easy to use in our entire history. It develops the active, alert minds that bring success in school and later life. The latest edition offers more than 22,000 magnificent illustrations—thousands in vivid color. The atlas section contains the finest, most current maps available. With 36,000,000 words—the work of some 10,200 of the world's great authorities—Britannica is the largest, most complete reference work published in America. Also, may we send you our special new 200th Anniversary Preview Booklet which pictures and describes the latest edition? For your free copy and complete information about this dramatic discount offer on the magnificent Heirloom edition—available only during this year—simply mail the attached postage-free card now.

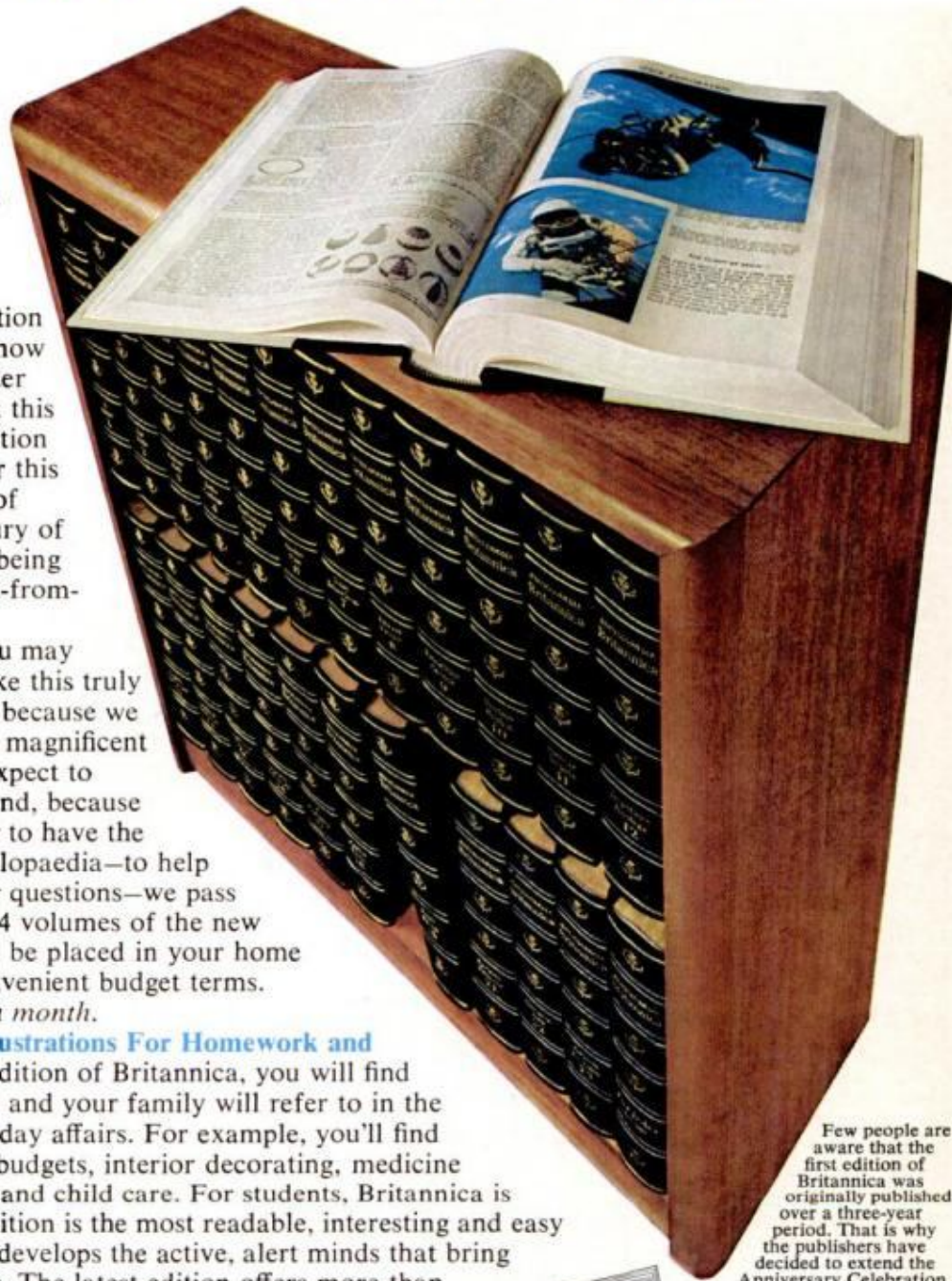

Few people are aware that the first edition of Britannica was originally published over a three-year period. That is why the publishers have decided to extend the Anniversary Celebration.

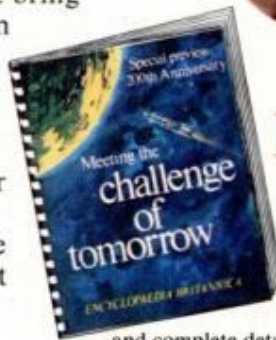

FREE!
Mail attached card now for Special New Preview Booklet

and complete details on this remarkable offer.

If card is detached, write to Encyclopaedia Britannica, Dept. 324-Z, 425 N. Michigan Ave., Chicago, Ill. 60611.