

# POPULAR MECHANICS

FEB. 1969  
50 CENTS

## WINTER DRIVING TIPS

How to Keep Going on Icy Turnpikes  
And Mountain Roads Page 96

## DAYTONA '500' PREVIEW

Can Chrysler Put the Crunch on Cale?

**BUILD THESE:** Tent Camper •  
Model Brass Cannon •  
Colonial Desk •  
Plus 5 Weekend  
Projects!

**Boat-Camping  
On Lake Powell in  
Glastron's New Vagabond**

**Bright Ideas for a Beautiful Bar • New Fire Alarms for Your Home  
What's New in Station Wagons • How to Do More on a Circular Saw  
Saturday Mechanic: Rebuilding Your Carburetor • Drivin' With Dan Gurney • Auto Clinic**

**FIRST  
REPORT  
From  
AMX  
Owners  
Page 140**

FOR BUYER REGISTER ADJUSTMENTS  
USE ONLY  
Run Copy.



We brew every bottle of Miller High Life as if it were the only one



Miller  
makes it  
right...

The Champagne of Bottle Beer

# Important! Don't skip over the next seven pages.

Unless, by chance,  
you married into money,  
or know it all,  
or can't stand praise,  
or don't want your pay to escalate,  
or figure you're too old to learn,  
or refuse help,  
or can never be fired,  
or have no urge to succeed,  
or don't like to read anyway.

**This One**



548L-P1Y-AA85

# How to boost the payload you carry between your ears.

## The importance of NOW!

You couldn't pick a better time to begin a course of specialized training.

Business is on dead center. There's no real prosperity, no real recession.

It's a wait-and-see period, a time for companies to size up employees in preparation for the predicted boom.

Get yourself ready—through home study. It offers important advantages:

Your time is your own when you study at home. You waste none of it commuting to and from class.

You set your own schedule, your own pace.

You learn while you earn, pay as you go.

You learn quickly. Nobody holds you back.

Rewards can come quickly, too. Many students get the promotions and pay raises they want even before they complete their course.

But the time to act is NOW.

## Here's HOW:

I. C. S. is your best bet.

Not just because it's the oldest, largest, most respected of the home study schools.

But because it offers exactly what you want. With 253 programs, you have a much wider selection than from any other school . . . anywhere. (Each program is prepared by a recognized authority, edited by home study experts, guided step-by-step by a personal instructor.)

And because I. C. S. training pays off.

One recent survey showed that the average I.C.S. graduate increased his income by \$1000 within two years.

Another revealed that one out of every fourteen company presidents (men who made it all the way to the top) studied with I. C. S. at one time in their careers.

A magazine writer once called I. C. S. "The Harvard of home study institutions."

Find out why.

---

### Free I. C. S. Success Kits

In addition to a special catalog describing the courses in your field of interest, I. C. S. will send you free the helpful 28-page handbook, "How to Succeed," together with an actual lesson demonstrating the I. C. S. method.

Mark and mail the coupon at the bottom of any of the following pages or the postage-paid card you'll find at the end of this section.

# To excel in Electronics, Radio-TV, specialize.

## A wise choice!

If you've selected Electronics-Radio-TV as the field in which you want to make good, you've chosen wisely.

No other field has a greater demand for skilled specialists, or a bigger shortage.

There are more good jobs than there are qualified men and women to fill them.

General training is essential. But, more and more, you're going to need specialized training in specific areas.

You're going to need the kind of training in depth that I. C. S. can give you, with 26 courses—far more than you can get from other leading schools.

But you owe it to yourself to compare schools, to select the right one for you.

That's just what the catalog (below) will help you do.

## A wide choice:

1. Color Television Principles & Servicing
2. Communications Technology

3. Electronic Fundamentals
4. Electronic Fundamentals Programmed Course
5. Electronic Instrumentation & Servo Fundamentals
6. Electronic Principles for Automation
7. Electronics & Applied Calculus
8. Electronics Technician
9. First Class Radiotelephone License
10. Fundamentals of Electronic Computers
11. General Electronics
12. Hi-Fi Stereo & Sound Systems Servicing
13. Industrial Electronics
14. Industrial Electronics Engineering
15. Industrial Electronics Engineering Technician
16. Numerical Control Electronics & Maintenance
17. Practical Radio & TV Engineering
18. Practical Telephony
19. Principles of Radio-Electronic Telemetry
20. Principles of Semiconductor-Transistor Circuits
21. Radio & Television Servicing
22. Second Class Radiotelephone License
23. Sound Systems Specialist
24. Telephony, Electronics & Radio Communications
25. Television Receiver Servicing
26. Television Technician

Send this coupon or postage-paid card at end of this section



I. C. S. Dept. G0569A, Scranton, Penna. 18515

Please send me "ELECTRONICS," your free 68-page catalog listing all 26 Electronics, Radio and TV courses with complete details. Also send "How to Succeed" and sample lesson.

Mr. \_\_\_\_\_ Age \_\_\_\_\_ Address \_\_\_\_\_  
Miss \_\_\_\_\_  
Mrs. \_\_\_\_\_  
City \_\_\_\_\_ State \_\_\_\_\_ Zip Code \_\_\_\_\_ Working Hours \_\_\_\_\_ A.M. to \_\_\_\_\_ P.M.  
Occupation \_\_\_\_\_ Employed by \_\_\_\_\_  
Low rates to members of U. S. Armed Forces.  
Approved for veterans under New G. I. Bill.

# Sixty-seven ways to succeed in Business.

## ... with or without a computer.

Take a look at the want ads in today's newspaper. Note the many openings in all phases of Business.

Now check the list of courses on this page.

You'll see a similarity, because I. C. S. accurately anticipates and meets the needs of Business, stays on top of the times.

Take computer training, for example. There are four programming courses for business people, as up-to-date as you'll find anywhere.

There's an I. C. S. course for just about anyone in Business. For clerks, stenographers and typists who want to move up. For foremen and supervisors. For junior executives. For those now in business for themselves... and those who'd like to be.

Select a program of training that meets your specific needs. The catalogs below can help you.

### Choose yours:

#### Accounting

1. Accounting for Business Programmers
2. Auditing
3. Business Law
4. Cost Accounting
5. C.P.A. Review

6. Estate & Trust Acc't'g
7. Executive Accounting
8. Federal Tax
9. General Accounting
10. Industrial Accounting
11. Junior Accounting
12. Legal Accounting

13. Office Accounting
14. Practical Accounting
15. Public Accounting
16. Small Business Acc't'g
17. Starting & Managing a Bookkeeping Service

#### Business

18. Advertising
19. Basic Inventory Control
20. Basic Supervision
21. Business Administration
22. Business Management & Production
23. Clerk-Typist
24. Commercial
25. Cond. Business Practice
26. Condensed Marketing
27. Creative Salesmanship
28. Direct Mail & Mail Order Advertising
29. Engineering Secretary
30. Industrial Foremanship
31. Industrial Psychology
32. Industrial Supervision
33. Legal Secretary
34. Mag. & Newspaper Adv.
35. Man'g't & Marketing
36. Managing a Small Store
37. Marketing
38. Marketing Research
39. Medical Secretary
40. Modern Exec. Man'g't
41. Modern Woman as a Supervisor

42. Motor-Traffic Man'g't
43. Office Automation
44. Office Management
45. Personal Income Tax Procedure
46. Personnel-Labor Rel't'n
47. Professional Secretary
48. Purchasing Agent
49. Railway Rate Clerk
50. Real Estate Salesmanship
51. Retail and Local Adv.
52. Retail Bus. Man'g't
53. Retail Merchandising
54. Retail Selling
55. Sales Management
56. Salesmanship
57. Salesmanship & Sales Management
58. Shorthand
59. Stenographic
60. Supervision
61. Systems & Procedures Analysis
62. Traffic Management
63. Typewriting

#### COMPUTER COURSES

64. COBOL Programming
65. Programming for Digital Computers
66. Programming for IBM 1401 Computer
67. Programming IBM System/360 Computer

Send this coupon or postage-paid card at end of this section



I. C. S. Dept. G1569A, Scranton, Penna. 18515

Please send me the free catalog I have checked, plus the 28-page handbook, "How to Succeed," and sample lesson.

Accounting  Business

Mr. \_\_\_\_\_ Age \_\_\_\_\_ Address \_\_\_\_\_

Miss \_\_\_\_\_

Mrs. \_\_\_\_\_

City \_\_\_\_\_ State \_\_\_\_\_ Zip Code \_\_\_\_\_ Working Hours \_\_\_\_\_ A.M. to \_\_\_\_\_ P.M.

Low rates to members of U. S. Armed Forces.  
Approved for veterans under New G. I. Bill.

Occupation \_\_\_\_\_ Employed by \_\_\_\_\_

# Power up for big pay. Get technical.

## Where there's a will . . .

Industry is desperate for men with technical training. Colleges and trade schools can't begin to fill the need.

Become an I. C. S.-trained technician or engineer and you'll be on your way.

With good reason: I. C. S. has the largest home study School of Technology in the world, offers the most complete and comprehensive curriculum.

Courses start at operator levels, go up to Chemical, Civil, Electrical, Mechanical and Power Engineering.

There are special refresher courses for the graduate engineer who wants to keep up to date. Also special courses for management men who must make engineering decisions—and vice versa.

Make a decision now to get the facts.

## . . . there are 68 ways:

### Chemical

1. Analytical Chemistry
2. Chemical Engineering
3. Chemical Engineering Unit Operations

### 4. Chemical Laboratory Technician

5. Chemical Process Oper.
6. Elements of Nuclear Energy

7. General Chemistry
8. Instrumental Laboratory Analysis
9. Natural Gas Prod. & Transmission
10. Oil Field Technology
11. Paper Machine Operator
12. Paper Making
13. Petroleum Production
14. Petroleum Prod. Eng'r'g
15. Petroleum Ref. Oper.
16. Pipeline Engineering Technology
17. Plastic Technician
18. Pulp & Paper Eng'r'g Technology
19. Pulp & Paper Making
20. Pulp Making

### Civil

21. Civil Engineering
22. Construction Eng'r'g
23. Highway Engineering
24. Math & Mech. for Eng'rs
25. Principles of Surveying
26. Reading Structural Blueprints
27. Reading Hwy. Blueprints
28. Sanitary Engineering
29. Sewage-Plant Operator
30. Structural Drafting
31. Structural Engineering
32. Surveying & Mapping
33. Water-Works Operator

### Electrical

34. Elec. Appliance Ser.
35. Electrical Contractor
36. Electrical Engineering
37. Elec. Eng'r'g Tech.

38. Elec. Instrument Tech.
39. Elec. Motor Repairman
40. Industrial Elec. Tech.
41. Power Line Design & Construction
42. Power Plant Operator
43. Practical Electrician
44. Practical Lineman
45. Reading Elec. Blueprints

### Mechanical

46. Aircraft & Power Plant Mechanic
47. Domestic Refrigeration
48. Fortran Prog. for Eng'rs
49. Hydraulic & Pneumatic Power
50. Industrial Engineering
51. Ind. Eng'r'g Tech.
52. Industrial Management for Engineers
53. Machine Design
54. Mechanical Engineering
55. Quality Control
56. Refrigeration
57. Refrigeration & Air Cond.
58. Safety Eng'r'g Tec'l'gy
59. Tool Design
60. Value Analysis
61. Vibration Analysis & Control

### Power

62. Boiler Inspector
63. Industrial Bldg. Eng'r'g
64. Industrial Inst.
65. Power Plant Eng'r'g
66. Stationary Diesel Eng's.
67. Stationary Fireman
68. Stationary Steam Eng'r'g

Send this coupon or postage-paid card at end of this section

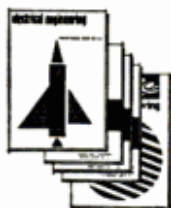

I. C. S. Dept. G2569A, Scranton, Penna. 18515

Please send me the free catalog which I have checked below, plus 28-page handbook, "How to Succeed," and sample lesson.  Chemical  Civil  Electrical  Mechanical  Power

Mr. \_\_\_\_\_ Age \_\_\_\_\_ Address \_\_\_\_\_  
Miss \_\_\_\_\_

Mrs. \_\_\_\_\_  
City \_\_\_\_\_ State \_\_\_\_\_ Zip Code \_\_\_\_\_ Working Hours \_\_\_\_\_ A.M. to \_\_\_\_\_ P.M.

Occupation \_\_\_\_\_ Employed by \_\_\_\_\_  
Low rates to members of U. S. Armed Forces. Approved for veterans under New G. I. Bill.

# There's real Jack in all trades. Master one.

## It takes a real man!

Mastering a trade . . . going into business for yourself . . . these are among the most satisfying and rewarding of careers—with base pay up to \$7 an hour.

But it takes guts. And sound training.

With I. C. S. you have the advantage of guidance by experts in your field.

Texts are easy to follow. You learn from pictures, tables, step-by-step diagrams and from doing practical projects.

Your instructor takes a personal interest in your progress, gives you encouragement and suggestions, helps you move ahead fast.

The toughest part is making up your mind to mail the coupon (or card on the next page).

The rest comes easy!

## And it takes real training!

### Automotive Trades

1. Automatic Trans. Spe'll'st
2. Automobile Body Rebuilding & Refinish'g
3. Automobile Elec. Tech.
4. Auto. Eng. Tune-Up
5. Automobile Technician
6. Automotive Mechanic
7. Diesel-Gas Motor-Vehicle Engines

### Building Trades

8. Air Conditioning
9. Air Cond. Maintenance
10. Building Contractor
11. Building Estimator
12. Building Inspector
13. Building Maintenance
14. Carpenter-Builder
15. Carpentry & Millwork
16. Domestic Heating with Oil & Gas
17. Heating & Air Cond.
18. Industrial Heating
19. House Planning & Interior Design

20. Indust. Air Conditioning
21. Mason
22. Painting Contractor
23. Pipe Fitting
24. Plumbing
25. Plumbing & Heating
26. Practical Plumbing

### Shop Practice

27. Drill Operator
28. Foundry Practice
29. Industrial Metallurgy
30. Lathe Operator
31. Machine Shop Practice
32. Machine Shop Inspection
33. Metallurgical Eng. Tech.
34. Milling Machine Oper.
35. Multicraft Maint. Mech.
36. Practical Millwrighting
37. Rigging
38. Tool Eng. Technology
39. Tool Grinder
40. Toolmaking
41. Turret Lathe Operator
42. Welding Eng. Technology
43. Welding Processes

Send this coupon or postage-paid card at end of this section



**I. C. S.** Dept. G3569A, Scranton, Penna. 18515

Please send me the free catalog I have checked below, plus the 28-page handbook, "How to Succeed," and sample lesson.  Automotive  Building Trades  Shop Practice

Mr. \_\_\_\_\_ Age \_\_\_\_\_ Address \_\_\_\_\_  
Miss \_\_\_\_\_

Mrs. \_\_\_\_\_  
City \_\_\_\_\_ State \_\_\_\_\_ Zip Code \_\_\_\_\_ Working Hours \_\_\_\_\_ A.M. to \_\_\_\_\_ P.M.

Occupation \_\_\_\_\_ Employed by \_\_\_\_\_ Low rates to members of U. S. Armed Forces.  
Approved for veterans under New G. I. Bill.



# Make your mark in Drawing, Drafting or Architecture.

## Make your talents pay off!

The combination of a trained mind and a skilled hand commands universal respect—and a great deal of money.

Your ability to visualize, to create, to communicate through line and detail, opens up unusual career opportunities.

Some people start with talent. Others develop it. But talent alone is not enough.

You need to train it, refine it, make it pay off in money and satisfaction.

This is where I. C. S. can help you.

You learn by doing. You submit drawings and designs with each assignment. And you get back professional critiques.

Start by making your mark below.

## Your choice of 24 ways:

### Architecture

1. Arch. Drawing & Des'g'ng
2. Design of Plastic Prod.
3. House Planning & Interior Design
4. Review in Arch. Design & Practice
5. Review of Mechanical Systems in Buildings
6. Reading Architect's Blueprints

### Art

7. Amateur Artist
8. Commercial Art
9. Commercial Cartooning
10. Illustrating
11. Interior Decorating

12. Oil Painting for Pleasure
13. Show Card & Sign Prod.
14. Show Card Writing
15. Sign Painting & Designing
16. Sketching & Painting

### Engineering Drawing

17. Aircraft Drafting
18. Architectural Drafting
19. Design Drafting
20. Drafting Technology
21. Electronic Drafting
22. Pressure-Vessel & Tank Print Reading
23. Sheet-Metal Layout for Air Conditioning
24. Structural Drafting

Send this coupon or postage-paid card at end of this section



**I. C. S.** Dept. G4569A, Scranton, Penna. 18515

Please send me the free catalog I have checked, plus the 28-page handbook, "How to Succeed," and sample lesson.  Architecture  Art  Engineering Drawing

Mr. \_\_\_\_\_ Age \_\_\_\_\_ Address \_\_\_\_\_  
 Mrs. \_\_\_\_\_  
 City \_\_\_\_\_ State \_\_\_\_\_ Zip Code \_\_\_\_\_ Working Hours \_\_\_\_\_ A.M. to \_\_\_\_\_ P.M.  
 Occupation \_\_\_\_\_ Employed by \_\_\_\_\_  
 Low rates to members of U. S. Armed Forces.  
 Approved for veterans under New G. I. Bill.

# 68,000 reasons to finish High School.

## It's never too late, BUT . . .

There's a \$68,000 difference between the lifetime earnings of the average High School graduate and that of the dropout.\*

That's money you and your family could use—if you had a High School education.

Government facts show other differences:

- you're more likely to lose your job.
- you stand twice the chance of being out of work for 15 weeks or more.
- the few jobs open to you are almost sure to be the lowest-pay ones.

But—no matter how old you may be—it's not too late to get help the I. C. S. way.

With I. C. S., you take only those subjects you need, with personalized guidance.

You can earn an I. C. S. High School diploma, respected by business and industry.

In short, you can overcome the awful handicap of an incomplete education—now!

\*Source: H. E. W. Dept. figures, 1965

## Pick only the subjects you need:

1. High School Business
2. High School College Preparatory (Arts)
3. High School College Preparatory (Engineering & Science)
4. High School General
5. High School Secretarial
6. High School Vocational
7. Special High School Courses (These include a selection of some 50 Elementary, High School and Advanced subjects you may elect to round out your education.)
8. Advanced Mathematics
9. High School Mathematics

Send this coupon or postage-paid card.



I. C. S. Dept. G5569A, Scranton, Penna. 18515

Please send me a free copy of "High School," your new 40-page catalog detailing the I. C. S. High School Program. Also send 28-page handbook "How to Succeed" and sample lesson.

Mr. \_\_\_\_\_ Age \_\_\_\_\_ Address \_\_\_\_\_  
Miss \_\_\_\_\_  
Mrs. \_\_\_\_\_  
City \_\_\_\_\_ State \_\_\_\_\_ Zip Code \_\_\_\_\_ Working Hours \_\_\_\_\_ A.M. to \_\_\_\_\_ P.M.  
Occupation \_\_\_\_\_ Employed by \_\_\_\_\_  
Low rates to members of U. S. Armed Forces.  
Approved for veterans under New G. I. Bill.

# The principle behind and in front of Renault automobiles.



THE FRONT ENGINE, FRONT-WHEEL DRIVE RENAULT 16.



THE REAR ENGINE, REAR-WHEEL DRIVE RENAULT 10.

The basic principle behind the Renault 10 and in front of the Renault 16 is exactly the same: The engine has weight. Put it where it'll do the most good. Over the drive wheels.

It's only common sense. When you have the weight of the engine bearing down on the drive wheels, they get a much better grip on the road. We learned long ago that you can't expect the very best traction when you put an empty trunk over the drive wheels.

When we make a car with rear-wheel drive, we put the engine in the rear. When we make a car with front-wheel drive, we put the engine up front.

And since we don't put the

engine and drive wheels on opposite ends of the car, we don't have to connect them with a bulging, heavy drive shaft. So there's no dead weight to steal

power (and gas). And no extra bulk to steal leg room.

Despite a difference in price (the Renault 10 is \$1775,\* and the Renault 16 is \$2445\*), they

both have many other things in common.

Both cars are gas scrimpers. The Renault 10 can get 35 m.p.g. The Renault 16 can get 30.

Both come with sealed liquid cooling systems, virtually eliminating the bother of anti-freeze.

Both come with wet cylinder sleeves, 4 doors, 4-wheel independent suspension, and a 5 main-bearing engine.

In short, both come with very much the same kind of thinking. Behind. In front. Inside and out.

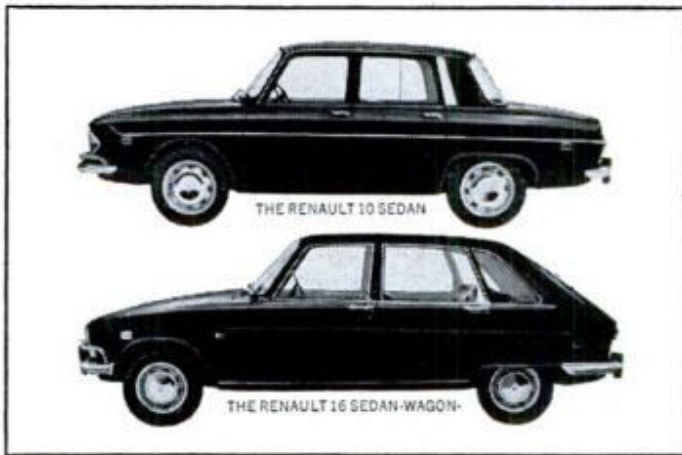

THE RENAULT 10 SEDAN

THE RENAULT 16 SEDAN-WAGON



FOR MORE INFORMATION SEE NEAREST DEALER OR WRITE RENAULT INC., 100 SYLVAN AVENUE, BOX 38 ENGLEWOOD CLIFFS, NEW JERSEY 07632.



The Transport Wide Oval truck tire—for all wheel positions. Available with white sidewall.



The Town & Country Wide Oval truck tire—new drive-wheel tire for all-season traction.

## Wide Oval truck tires—built extra wide for that extra weight.



Two broad-shouldered nylon cord truck tires. Built to cut a wide trail into camping country. On and off the beaten path.

First: The Transport Wide Oval truck tire. Now original equipment on new pickup campers. With wider tread—for more traction, more flotation, less sway than regular truck tires.

Second: The Town & Country Wide Oval truck tire. A new drive-wheel tire. With a hungry tread design that bulls its way. Through soft gravel. Through mud. Through the roughest camping country anywhere.

Added Wide Oval advantages: Sure starts and safe stops. Softer rides. Heavier loads.

Get Wide Oval truck tires at your Firestone Safe Tire Center. Or... specify them on your new camper.

Transport WIDE  OVAL. Town & Country WIDE  OVAL  
—Firestone TMs, Transport®, Town & Country®

# Firestone

Life insurance  
for you, your wife,  
all the kids...  
\$20,000 worth  
for \$17<sup>30</sup> a month.



When he was 25, Gene Taylor wanted life insurance a young father could build on. So he covered the whole family with a single policy. \$10,000 permanent insurance on himself, \$4,000 term on his wife, and \$2,000 term on each of the 3 children. Talk to the "good hands" people about the Family Plan.

Allstate—  
the company that  
makes life a lot easier  
for the young  
family man.

You're in good hands with Allstate®

Allstate Life Insurance Company, Northbrook, Illinois



# POPULAR MECHANICS®

INTERNATIONAL EDITIONS: AUSTRALIA, BRAZIL, CARIBBEAN, DENMARK, FRANCE, MEXICO, SOUTHERN HEMISPHERE, SWEDEN

## AUTOMOBILES AND DRIVING

- [12 Detroit Listening Post](#)
- [46 Drivin' With Dan](#)
- [84 Automobile Clinic](#)
- [87 Can Chrysler Put the Crunch on Cale?](#)
- [96 How to Buck a Blizzard](#)
- [104 'Sizing Up' the 1969 Station Wagons](#)
- [114 So What Else Is New?](#)
- [140 PM Owners Report: American Motors AMX](#)
- [160 Saturday Mechanic: Put Life Back in Your Carburetor](#)

## HOME AND YARD

- [76 Homeowners' Clinic](#)
- [130 Bar Full of Bright Ideas](#)
- [132 Build This Colonial Cabinet-Top Desk](#)
- [144 How to Spot a Bad House That Looks Good](#)
- [154 Five Weekend Projects to Build](#)
- [170 Exciting New Products](#)
- [172 Now: Smaller Tractors That Shift for Themselves](#)
- [176 What You Should Know About Fire Warning Systems](#)
- [181 All-Purpose Alarm You Can Build From a Kit](#)
- [184 Solving Home Problems](#)

## BOATING, OUTDOOR RECREATION

- [126 Lake Powell: A Spectacular Test Ground for Glastron's Vagabond](#)
- [164 We Built This Tent Trailer for \\$250](#)

## JOBS AND CAREERS

- [25 How to Be Your Own Boss: The \\$50-Billion Boom in Franchising](#)

## SPACE, AVIATION, MILITARY

- [121 The Moon Bug Learns to Mate](#)

## SHOP AND CRAFTS

- [132 Build This Colonial Cabinet-Top Desk](#)
- [134 Model This 24-Pounder](#)
- [154 Five Weekend Projects to Build](#)
- [164 We Built This Tent Trailer for \\$250](#)
- [169 Hints From Readers](#)
- [175 Hints From Readers](#)
- [186 Hints From Readers](#)
- [187 Unique Piggyback Speed Reducer](#)
- [188 The Circular Saw: A Worksaver for All Workshops](#)
- [192 Hints From Readers](#)
- [193 New Tools You Should Know About](#)
- [194 Make a King-Size Toolpost for Hefty Turning Bits](#)
- [197 Bench Grinder](#)
- [198 Hints From Readers](#)

## SCIENCE AND INVENTIONS

- [20 Science Worldwide](#)
- [92 How Deep Will Divers Work?](#)
- [100 Queen Elizabeth 2](#)
- [108 They're Mining Oil With Buckets](#)
- [152 Just Patented: PM's Pick of the New Inventions](#)

## ELECTRONICS, RADIO AND TV

- [58 New in Electronics](#)
- [181 All-Purpose Alarm You Can Build From a Kit](#)

## PHOTOGRAPHY

- [42 Picture This](#)
- [148 The Drop-In Film Cartridge Has Come to Stay](#)
- [159 Photo Hints](#)

## REGULAR FEATURES

- [6 Letters](#)

Cover Illustration by Ed Valigursky  
*How to keep going on icy turnpikes and mountain roads.*

## NEXT MONTH IN POPULAR MECHANICS

What's the Truth About Your Auto Warranty? What all that small print really means.  
Amazing New Way to "See" a Tornado Coming on Your TV. It may save your life.  
The Boston Arm: The wonderful artificial limb that obeys commands.  
What Owners Say About Dodge Coronet. Another exclusive PM Owners Report.

**ROBERT P. CROSSLEY**

Editor

**JAMES M. LISTON**  
Executive Editor

**JOHN A. LINKLETTER**  
Managing Editor

**WAYNE C. LECKEY**  
Home and Shop  
Editor

**SHELDON M. GALLAGER**  
Assistant Executive  
Editor

**THOMAS G. DAUER**  
Art Director

Published by The Hearst Corporation  
**RICHARD E. BERLIN, PRESIDENT**

**RICHARD E. DEEMS**  
President, Magazines Division

**JOSEPH F. KERN**  
Publisher

- WILLIAM KILPATRICK** \_\_\_\_\_ Automotive
- KEVIN V. BROWN** \_\_\_\_\_ Aviation
- DANIEL C. FALES** \_\_\_\_\_ Boating and Outdoors
- SHELDON GALLAGER** \_\_\_\_\_ Electronics and Photography
- BILL HARTFORD** \_\_\_\_\_ Associate Automotive
- LEONARD E. SABAL** \_\_\_\_\_ Home Workshop
- GARRY WINTER** \_\_\_\_\_ Copy and Production
- RICHARD H. FUNK** \_\_\_\_\_ Associate Copy and Production
- KATHY GARAVUSO** \_\_\_\_\_ Assistant Copy and Production
- ALVIN KIETZ** \_\_\_\_\_ Assistant Art Director
- DON EVANS** \_\_\_\_\_ Assistant Art Director
- FRED A. LEERS** \_\_\_\_\_ Assistant Art Director
- GEORGE W. BLOW** \_\_\_\_\_ Technical Art Director
- CLIFFORD B. HICKS** \_\_\_\_\_ Special Projects
- SOPHIE GRONOWICZ** \_\_\_\_\_ Director, Bureau of Information
- EVERETT JOHNSON** \_\_\_\_\_ Cabinetmaker

**ADDRESS ALL EDITORIAL COMMUNICATIONS TO:** 575 Lexington Ave., New York, N.Y. 10022. For additional sources of information on the articles and products in this issue, write to Bureau of Information, Popular Mechanics, for free "Where-to-Find-It" list.

**DANIEL J. COLEMAN**  
Director of Advertising

**ADVERTISING OFFICES:** New York: 575 Lexington Ave., Murray Hill 8-8500; Chicago: 520 N. Michigan Ave., 527-2400; Detroit: General Motors Bldg., TRinity 5-8711; Cleveland: Hanna Bldg., 1-422 Euclid Ave., PROspect 1-0156; Los Angeles: 601 North Vermont Ave., 666-6263; San Francisco: 1101 Hearst Bldg., YUkon 2-0823.

**SUBSCRIPTION SERVICE:** Mail all subscription orders, changes of address, correspondence concerning subscriptions, and Postmaster notices of undeliverable copies to Popular Mechanics, Box 646, New York, N.Y. 10019. Please enclose your latest address label for quickest service when writing about your subscription.

**POPULAR MECHANICS IS PUBLISHED MONTHLY** by The Hearst Corporation, 57th St. at 8th Ave., New York, N.Y. 10019, U.S.A. Richard E. Berlin, President; George Hearst, V-Pres.; Richard E. Deems, President of Magazines; John R. Miller, Executive V-Pres. of Magazines; Raymond J. Petersen, Senior V-Pres. of Magazines; William S. Campbell, V-Pres. of Magazines; Albert A. Raehol, V-Pres. and Director of Circulation; Joseph F. Kern, V-Pres. for Popular Mechanics; Frank Massi, Executive V-Pres. and Treasurer; Harvey L. Lipton, Secy. Single copy in the United States and Canada, 50 cents. Subscription prices: United States and Possessions, \$4.00 for one year; \$7.00 for two years; \$10.00 for three years. Canada, add \$0.50 for each year. Pan American Postal Union countries, add \$1.00 for each year. All other countries, add \$2.00 for each year. When changing address, give old address as well as the new, with postal-zone number, if any, and allow six weeks for change to become effective. Second-class postage paid at New York, N.Y., and at additional mailing offices. Authorized as second-class mail by the Post Office Department, Ottawa, and for payment of postage in cash. Registered as second-class matter at the Post Office at Mexico D.F., Mexico, June 20, 1950. © 1969 by The Hearst Corporation. All rights reserved. Printed in U.S.A.

**It's true. The aroma of Field & Stream will remind you of a great autumn day in the woods.**



**But don't cancel your vacation.**

A product of Philip Morris Inc.

# Soup for nuts

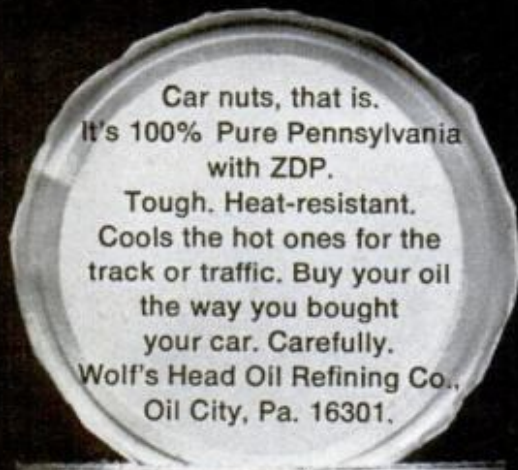

Car nuts, that is.  
It's 100% Pure Pennsylvania  
with ZDP.

Tough. Heat-resistant.  
Cools the hot ones for the  
track or traffic. Buy your oil  
the way you bought  
your car. Carefully.

Wolf's Head Oil Refining Co.,  
Oil City, Pa. 16301.

WOLF'S  
HEAD

**RACING**  
MOTOR OIL  
with  
ZDP

NET CONTENTS 1 U.S. QUART

the uncommon motor oil

## LETTERS TO THE EDITOR

### Missed the target

Some significant facts were omitted or blurred in the editing of my article on hypervelocity impact (*Faster Than a Speeding Bullet*, page 130, Dec. PM).

The research described was done by Prof. Ray Kinslow, chairman of the engineering science faculty at Tennessee Tech, under contract from the Air Force. Prof. Kinslow's studies have received international attention. He used the facilities of Arnold Engineering Development Center at Tullahoma, Tenn., for the actual firing of pellets into target materials at high speeds.

COOKEVILLE, TENN.      DOUGLAS NORMAN

### Another money-saver

Congratulations on *How to Save Money When You Finance a Car* (page 94, Dec. PM). Here's another tip you might like to pass on:

I borrowed money against my insurance policy at 5% true interest rate, and then I paid cash for the car. I made monthly payments to a savings account (5% annual, compounded daily, paid quarterly). I repaid the insurance company 13 months later. No, you don't eliminate the interest, but it sure reduces it!

SUNNYVALE, CALIF.      DAVID D. DELINE

### Don't crank that engine

In *Prepare Your Car to Beat the Cold* (page 136, Dec. PM) you make the statement on page 138 that the ohmmeter "should read no more than 1/2 ohm as the engine is being cranked."

If there is ever a no-no that should be followed in electronics, it's this: Never put an ohmmeter in a circuit that has current flowing through it. If you do you will have a mess of shunt resistors and meter movements in your meter that will be burned out.

OWOSSO, MICH.      DENNIS TOMLINSON

"Yipes . . . he's right," agrees author Mort Schultz. "That sentence should read 'no more than 1/2 ohm—period.' An ohmmeter is never connected in a live circuit."

### Best lesson

Congratulations on the fine article by A. R. Roalman (*'Grounded' for 90 Days*, [Please turn to page 8](#))



# "Look who's smiling now!"

"The department head's job had just been left vacant. When the boys in the office learned I was gunning for it, they gave me their widest grins. One thing they didn't know: I had made up my mind sometime back to take LaSalle training that would prepare me for a better job. My study paid off so fast it surprised even me—I was picked for that shiny promotion over everyone's head. Who wouldn't be smiling with a neat new \$1,500 increase!"

LA SALLE'S files are filled with letters from graduates who have rapidly climbed the ladder of success. You, too, can qualify for the job opportunity of your choice through LaSalle home study—without interfering with your present work—and by devoting only a little of your spare time.

LaSalle has been leader in home education for more than half a century and has enrolled more than 1,000,000 ambitious men and women. Its faculty includes some of the country's foremost practicing specialists and instructors. Your training is in good, experienced hands.

Mailing the LaSalle coupon below may be the first step in getting a better job, higher pay, and all of the good things that go with success. Simply check the program in which you are most interested, and we will send you a valuable free booklet describing the opportunities in that field. Mail to LaSalle, 417 Dearborn, Chicago, Illinois 60605.



## LA SALLE EXTENSION UNIVERSITY

A Correspondence Institution • 417 South Dearborn, Dept. 86-100, Chicago, Illinois 60605

Please send me, without cost or obligation, FREE booklet and full information on the field I have checked below:

### ACCOUNTING

- Complete Accounting
- Income Tax
- Accounting Fundamentals
- CPA Training
- Modern Bookkeeping

### BUSINESS MANAGEMENT

- Complete Business Management
- Credit and Collections
- Office Management
- Personnel Management
- Sales Management

### REAL ESTATE

- Complete Real Estate
- Real Estate Brokerage
- Real Estate Management

Interested in a career not listed? Write here: \_\_\_\_\_

### COMPUTER PROGRAMMING

- Complete Training

### LAW COURSES

- Bachelor of Laws Degree
- Business Law
- Insurance Law
- Claim Adjusting Law
- Law for Police Officers

### STENOTYPE

- Machine Shorthand

### TECHNICAL COURSES

- Air Conditioning, Refrigeration, Heating
- Diesel

### TRAFFIC & TRANSPORTATION

- Complete Traffic Mgt. Truck, Air, Rail, Sea

### DRAFTING

- Complete Drafting

### INTERIOR DECORATION

- Professional Training

### ART TRAINING

- Commercial Art
- Oil, Water Color Painting
- Complete Training

### HIGH SCHOOL

- High School Diploma

### LANGUAGE INSTRUCTION

- French
- Spanish

### MUSIC INSTRUCTION

- Piano
- Guitar
- Other: \_\_\_\_\_

### CAREERS FOR WOMEN

- Accounting
- Bookkeeping
- Commercial Art
- Computer Programming
- Dental Assistant
- Interior Decorator
- Real Estate
- Secretarial
- Stenotype

Name ..... Age ..... Apt. No. ....  
*Please print carefully*

Address ..... County .....

City & State ..... Zip No. ....

Occupation ..... Working Hours ..... A.M. .... P.M.

## LETTERS

(Continued from page 6)

page 61, Nov. PM). If more persons would take the attitude shown by Mr. Roalman, there would be only a small percentage of suspensions shown today. The author's obedience to the law in not driving during this 90-day period apparently gave him more of a lesson than anything in the way of fines or other penalties could do.

It might be interesting to note that in the State of Oregon, as well as other states, if you do drive while under suspension, not only do you pay a stiff fine and spend a minimum of two days in jail, your automobile is impounded up to 120 days—which means in most cases that you cannot have your wife chauffeur you around because you no longer have wheels.

BAKER, ORE.

JOHN V. BRENNAN  
MUNICIPAL JUDGE

### River pilots

My friend and I must have read *We Took a Houseboat Vacation* (page 100, Nov. PM) at least four times apiece.

For the past couple of years, we have been trying to find something out of the ordinary to do on our next summer va-

cation. When we read of the Linkletter family excursion, we decided we would like to try it ourselves. Our parents have consented to let us go if we get some navigation lessons first, but we do not know where these lessons are given.

CHICAGO

STEVEN JACOBS

*"Characteristically, I did things backwards," comments author John Linkletter. "I took the houseboat cruise in the summer and then decided to take the Power Squadron piloting course in the fall. I'd have felt much less a novice if I'd had the piloting course first."*

*"The piloting course is excellent—and it's free. You can find the location nearest your home by querying Headquarters, United States Power Squadrons, P.O. Box 510, Englewood, N.J. 07361."*

*"As for the houseboat, you can buy one, build one (see *Build This Houseboat for Under \$1000*, page 158, Jan. PM), or rent one (see page 10 of the January Letters for leads on where to find the houseboat rentals)."* ★ ★ ★

ADDRESS LETTERS to Letters to the Editor, Popular Mechanics, 575 Lexington Ave., New York, N.Y. 10022. Please keep them short as possible, and be sure to include your name and address.

## Copenhagen<sup>®</sup> Tobacco isn't for smoking. It isn't lit, puffed or inhaled. It's too good to smoke.

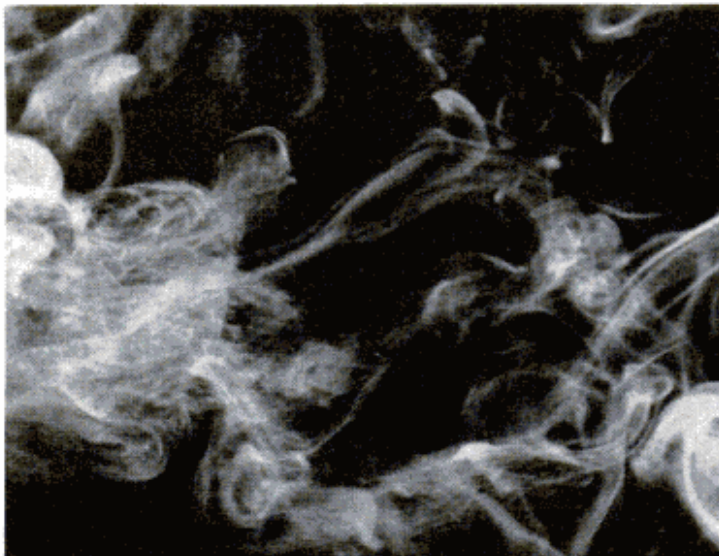

Put a pinch between gum and cheek, and enjoy it. Without even chewing. It's too good to smoke. Copenhagen gives you all the satisfaction of prime aged tobaccos. It costs less, too. Sure beats smoking!



For information on how to use Copenhagen, please write:  
United States Tobacco Company, 630 Fifth Ave., New York, N.Y. 10020

Copenhagen's partners: Skoal<sup>®</sup> Wintergreen Happy Days<sup>®</sup> Raspberry Tobacco

# THIS CAN BE YOUR "BIG BREAK"

if you're a man who's ever said...

**"I'm sick and tired of my Job!"**

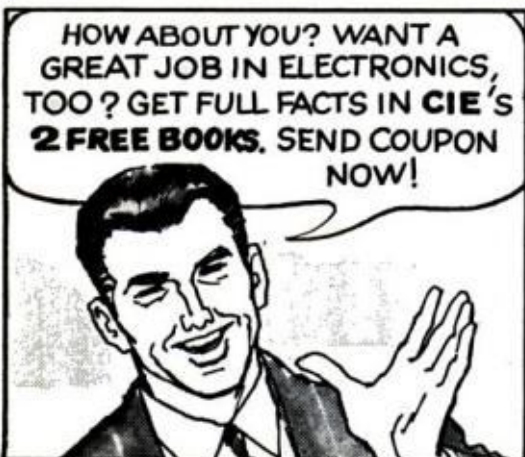

**CIE** Cleveland Institute of Electronics  
1776 E. 17th St., Cleveland, Ohio 44114

Please send me 2 FREE books describing opportunities in Electronics and how to prepare for them.

Name \_\_\_\_\_ Age \_\_\_\_\_  
(please print)

Address \_\_\_\_\_

City, State, Zip \_\_\_\_\_

Veterans & Servicemen: check here for G.I. Bill information  
Accredited Member National Home Study Council

PM-21



# I'd like to give this to my fellow men... while I am still able to help!

I was young once, as you may be—today I am older. Not too old to enjoy the fruits of my work, but older in the sense of being wiser. And once I was poor, desperately poor. Today almost any man can stretch his income to make ends meet. Today, there are few who hunger for bread and shelter. But in my youth I knew the pinch of poverty; the emptiness of hunger; the cold stare of the creditor who would not take excuses for money. Today, all that is past. And behind my city house, my

summer home, my Cadillacs, my winter-long vacations and my sense of independence—behind all the wealth of cash and deep inner satisfaction that I enjoy—there is one simple secret. It is this secret that I would like to impart to you. If you are satisfied with a humdrum life of service to another master, turn this page now—read no more. If you are interested in a fuller life, free from bosses, free from worries, free from fears, read further. This message may be meant for you.

By Victor B. Mason

I am printing my message in a magazine. It may come to the attention of thousands of eyes. But of all those thousands, only a few will have the vision to understand. Many may read; but of a thousand only you may have the intuition, the sensitivity, to understand that what I am writing may be intended for you—may be the tide that shapes your destiny, which, taken at the crest, carries you to levels of independence beyond the dreams of avarice.

Don't misunderstand me. There is no mysticism in this. I am not speaking of occult things, of innumerable laws of nature that will sweep you to success without effort on your part. That sort of talk is *rubbish!* And anyone who tries to tell you that you can *think* your way to riches without effort is a false friend. I am too much of a realist for that. And I hope you are.

I hope you are the kind of man—if you have read this far—who knows that anything worthwhile has to be *earned!* I hope you have learned that there is no reward without effort. If you have learned this, then you may be ready to take the next step in the development of your karma—you may be ready to learn and use the secret I have to impart.

## I Have All The Money I Need

In my own life I have gone beyond the need of money. I have it. I have gone beyond the need of gain. I have two businesses that pay me an income well above any amount I have need for. And, in addition, I have the satisfaction—the deep satisfaction—of knowing that I have put more than three hundred other men in businesses of their own. Since I have no need for money, the greatest satisfaction I get from life is sharing my secret of personal independence with others—seeing them achieve the same heights of happiness that have come into my own life.

Please don't misunderstand this statement. I am not a philanthropist. I believe that charity is something that no proud man will accept. I have never seen a man who was worth his salt who would accept something for nothing. I have never met a highly successful man whom the world respected who did not sacrifice something to

gain his position. And, unless you are willing to make at least half the effort, I'm not interested in giving you a "leg up" to the achievement of your goal. Frankly, I'm going to charge you something for the secret I give you. Not a lot—but enough to make me believe that you are a little above the fellows who merely "wish" for success and are not willing to sacrifice something to get it.

## A Fascinating and Peculiar Business

I have a business that is peculiar—one of my businesses. The unusual thing about it is that it is needed in every little community throughout this country. But it is a business that will never be invaded by the "big fellows." It has to be handled on a local basis. No giant octopus can ever gobble up the whole thing. No big combine is ever going to destroy it. It is essentially a "one man" business that can be operated without outside help. It is a business that is good summer and winter. It is a business that is growing each year. And, it is a business that can be started on an investment so small that it is within the reach of anyone who has a television set. But it has nothing to do with television.

This business has another peculiarity. It can be started at home in spare time. No risk to present job. No risk to present income. And no need to let anyone else know you are "on your own." It can be run as a spare time business for extra money. Or, as it grows to the point where it is paying more than your present salary, it can be expanded into a full time business—overnight. It can give you a sense of personal independence that will free you forever from the fear of lay-off, loss of job, depressions, or economic reverses.

## Are You Mechanically Inclined?

While the operation of this business is partly automatic, it won't run itself. If you are to use it as a stepping stone to independence, you must be able to work with your hands, use such tools as hammer and screw driver, and enjoy getting into a pair of blue jeans and rolling up your sleeves. But two hours a day of manual work will keep your "factory" running 24 hours turning out a product that has a steady and

ready sale in every community. A half dollar spent for raw materials can bring you six dollars in cash—six times a day.

In this message I'm not going to try to tell you the entire story. There is not enough space on this page. And, I am not going to ask you to spend a penny now to learn the secret. I'll send you all the information, free. If you are interested in becoming independent, in becoming your own boss, in knowing the sweet fruits of success as I know them, send me your name. That's all. Just your name. I won't ask you for a penny. I'll send you all the information about one of the most fascinating businesses you can imagine. With these facts, you will make your own investigation. You will check up on conditions in your neighborhood. You will weigh and analyze the whole proposition. Then, and then only, if you decide to take the next step, I'll allow you to invest \$15.00. And even then, if you decide that your fifteen dollars has been badly invested I'll return it to you. Don't hesitate to send your name. I have no salesmen. I will merely write you a long letter and send you complete facts about the business I have found to be so successful. After that, you make the decisions.

## Does Happiness Hang on Your Decision?

Don't put this off. It may be a coincidence that you are reading these words right now. Or, it may be a matter that is more deeply connected with your destiny than either of us can say. There is only one thing certain: If you have read this far you are interested in the kind of independence I enjoy. And if that is true, then you must take the next step. No coupon on this advertisement. If you don't think enough of your future happiness and prosperity to write your name on a postcard and mail it to me, forget the whole thing. But if you think there is a destiny that shapes men's lives, send your name now. What I send you may convince you of the truth of this proverb. And what I send you will not cost a penny, now or at any other time.

**VICTOR B. MASON**  
1512 Jarvis Ave., Suite M-2-B5  
CHICAGO, ILLINOIS 60626

# FANTASTIC VALUES WITH THIS COUPON

AMERICAN MACHINE & TOOL CO., Dept. PM29 Royersford, Pa. 19468

Please send me the units checked. Payment in full enclosed \$..... or \$3 deposit each item enclosed, balance C.O.D.  I MUST BE FULLY SATISFIED OR WILL RETURN UNIT WITHIN 10 DAYS FOR FULL REFUND. No questions asked.

- |                                                       |                                                           |
|-------------------------------------------------------|-----------------------------------------------------------|
| <input type="checkbox"/> 8" Power Saw at \$14.95      | <input type="checkbox"/> Belt Sander at \$14.95           |
| <input type="checkbox"/> Standard Rip Fence at \$3.50 | <input type="checkbox"/> Disc sander attach. at \$7.95    |
| <input type="checkbox"/> Long Rip Fence at \$4.50     | <input type="checkbox"/> Mitre Gauge for sander at \$1.95 |
| <input type="checkbox"/> Lathe at \$9.85              | <input type="checkbox"/> Jointer Planer at \$19.95        |
| <input type="checkbox"/> Face Plate at \$2.50         | <input type="checkbox"/> Drill Press at \$29.95           |
| <input type="checkbox"/> Turning Chisels at \$4.95    |                                                           |

G.E. Motor  \$18.80 (with other item)  \$24.85 (purchased separately)

NAME .....  
ADDRESS .....  
CITY ..... STATE ..... ZIP .....

SAVE AS MUCH AS...  
**80%** WITH  
QUALITY   
POWER TOOLS

**DIRECT FACTORY OFFER AND REVOLUTIONARY PATENTS** decrease costs, increase efficiency. Full scale power tools of heavy duty 100% cast iron and steel. Streamlined design reduces weight, cuts material and production costs. Special patents provide added efficiency, accuracy, savings. Parts made, assembled, tested, packed right in our own factories shipped direct... save store profits.

**ENDORSED BY AMERICA'S TOP MAGAZINES...** Here is what the editors say:

"A good bit of sound—imaginative—engineering." Popular Science; "(saw) boasts many features of bigger brothers." Popular Mechanics; "Amazingly versatile." Workbench; "Highly substantial construction, sturdy enough for production line use." Industrial Woodworking. And Workbench awarded these tools their coveted "Work Tested" Seal.

**OVER A MILLION USERS** confirm their precision, versatility and rugged performance.

**\*10-YEAR FULL SERVICE GUARANTEE...** Any part or parts of any AMCO power tool (except motor) which may become inoperative for any reason within ten years after the purchase date will be repaired or replaced by the factory without cost to the purchaser. Your only cost: for postage.

**UNCONDITIONAL  
10-DAY MONEY  
BACK  
GUARANTEE**

You must be fully satisfied. If not, return in 10 days, freight collect. Money promptly refunded in full.

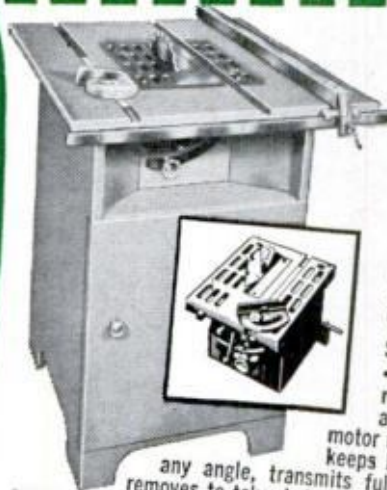

## 8" TILT ARBOR POWER SAW

**DOES WORK OF \$75 BENCH SAW** as is. Converts easily to equal any \$300 floor model cabinet units! Crosscuts, rips, mitres, cuts compound angles, dados, makes coves and mouldings.

**\$14.95** f.o.b. factory. Wt. 25 lbs. Includes completely assembled cast iron and steel 8" saw with ground cast iron table... less blade. **RIP FENCE**, if desired, for easier work alignment, \$3.50 add'l.

**SAW BLADE TILTS... TABLE STAYS LEVEL**

Locks securely at any angle up to 50°, raises, lowers 0"-2 1/4". Patented tilt mechanism, accurate etched scale. Patented motor mount takes std. 1/4 h.p. or larger motor, keeps belt tight, assures perfect alignment at any angle, transmits full power. Takes std. blade, saw insert removes to take dadoe heads, cutters, etc. (not incl.). Accurate mitre gauge assembly. Ground spindle. Enclosed steel base. "Compo" bearings. Accessories available at factory prices. **RIP FENCE**, if desired for easier work alignment: Std. size (for bench saw) \$3.50; larger fence (for cabinet base, as ill'd.) \$4.50.

**FREE CABINET BASE PLANS** Use as portable bench saw as received (inset photo) ... or transform easily and inexpensively into floor model (as shown) guar. to do work of floor models costing \$300. **FREE plans...** all you'll need are a sheet of 3/4" plywood and 3-4 hours. Use your AMCO saw for cutting. Plans provide 27" x 24" work surface, 33" height, tool storage compartment.

**10-YEAR FULL SERVICE GUARANTEE\***

## 6" SWING 3-FOOT LATHE



Optional faceplate for turning bowls, trays, lamp bases, rosettes, etc. \$2.50. **\$9.85** f.o.b. factory Wt. 14 lbs.

Set of 3 high speed turning chisels, \$4.95 add'l.

**DOES THE WORK OF \$40 UNITS...** with same precision and speed. Turns wood, plastic. Sturdy cast iron with tubular steel bed. Ball thrust cup center, spur center, T-rest assembly, lever action tail stock, 2-speed pulley. Fits any motor.

**10-YEAR FULL SERVICE GUARANTEE\***

## PRECISION 4" x 36" BELT SANDER

f.o.b. factory. Wt. 15 lbs.

**\$14.95** †Disc Sander attachment incl. disc bracket, ground cast table (tilts 0-45°): \$7.95 add'l.

**DOES WORK OF \$50 SANDERS...** The world's most talented belt sander. Heavy cast sander incl. 4" x 36" sanding belt, V-pulley drive, multi-purpose drive spindle. Changes from horizontal to vertical sanding in secs. Uses 1/2 hp or larger motor.

**10-YEAR FULL SERVICE GUARANTEE\***



Mitre gauge: \$1.95 add'l.

## FULL 22" LONG, 4 1/8" JOINTER-PLANER

**\$19.95**

f.o.b. factory. Wt.: 19 lbs. Complete as shown.



100% precision ground cast iron and steel.

**DOES THE WORK OF \$60 UNITS...** Professional power planing at a hand tool price. Make faster, more accurate joints, rabbetts, bevells for windows, doors, drawers, square tapered legs—Adjustable precision ground cast iron tables. Patent-pending design holds knife to table clearances at any depth. Rabbett depth 3/8". Fence adjustable 0°-50°. Hardened, ground hi-speed steel knives. Dual cutter guards. Balanced cutter head.

**10-YEAR FULL SERVICE GUARANTEE\***

## 32" RADIAL DRILL PRESS

All cast iron and steel f.o.b. factory **\$29.95** Wt. 30 lbs. 1/2" cap.

Jacob's chuck incl. **DOES WORK OF \$90 UNITS...** and much more. Industrial quality precision unit with all standard features, many extras. Head raises, lowers. Depth of throat up to 16". Pre-set to any angle for on-or-off table drilling, even horizontal drilling. **10-YEAR FULL SERVICE GUARANTEE.\***

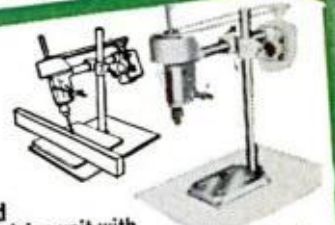

**BRAND NEW MOTOR** DEVELOPING FULL 1 HP... **\$18.80** F.O.B. FACTORY / FOR ANY OF ABOVE MACHINES. WT. 17 LBS. PURCHASED SEPARATELY, \$24.85

DETROIT

# LISTENING POST

BY BILL KILPATRICK

**YOU CAN COUNT ON** significant styling changes in certain of the 1970 cars. Due for the most extensive restyling are the so-called "personal" cars, particularly those at the premium end of the price range, and one or two of the out-and-out luxury cars, the Lincoln Continental being the best bet to get a thorough going-over. Buick's Riviera and Oldsmobile's Toronado, which share the same basic shell, will debut with all-new bodies, promised to be entirely different from the current (and new this year) Pontiac Grand Prix. Also rumored to be an extensively restyled car is the '70 Thunderbird. So, what with all the all-new cars—the subcompacts, the Dodge Challenger, a new Plymouth Barracuda, and so on—plus the usual face-liftings, 1970 could turn out to be a bonanza styling year.

**AUTO EXECUTIVES ARE TAKING A SECOND LOOK** at auto shows, the thought being they don't generate enough business to offset their high cost. Shows are becoming more and more elaborate, require increasingly expensive displays, extensive personnel to man them. Shows seem to attract mainly coin-shy youngsters, have heretofore been rationalized on the theory of building brand loyalty. Random interviews of typical "kid" spectators, however, indicate brand loyalty is formed long before they ever get around to visiting an auto show, leading some execs to think maybe the industry—by supporting the big, flashy shows—is merely taking in its own laundry. Asked what it cost his organization to exhibit its wares at the recent Detroit Auto Show, Dodge headman Bob McCurry replied, in a flat voice, "A fortune."

**MAVERICK** will be the name of Ford's new subcompact, due to bow April 1. Car all along has been called Delta, one of several names Ford "leaked" to the industry's rumor mills. Company paid a substantial price for exclusive use of the name, had to buy it from a Canadian manufacturer who used "Maverick" for a line of auto accessories.

**FORD STATION WAGONS**, which at one time seemed like the only game in town, will make a strong bid next year to become again synonymous with the wagon concept. Due are a heavy ad and promotion campaign aimed to push several styling features, the most eye-catching to be a swivel front seat on the passenger side. The seat can be locked to face forward or turned about and locked to face to the rear. The idea, an old one, appeared most recently on Chrysler's LeBaron Imperial.

**A NEW VERSION OF MERCURY'S COUGAR** may be offered later on this year. Called "Eliminator," the car will feature a unique, pearlescent, one-color-only (radiant sun gold, no less) finish, front and rear spoilers, a blocked-out grille, Ford's big 428-cu.-in., 335-hp engine. The front spoiler is attached to the valance panel under the bumper, the adjustable rear spoiler to the backs of the rear fenders, forming a winglike structure over the back edge of the trunk lid. At speeds of over 100 mph (ye gods!) the spoilers are said to reduce drag by as much as 10 percent.

**THE MIDNIGHT OIL** is being burned at American Motors as last-minute changes are being made on the company's all-new subcompact. The car originally was going to be an extensively redone Rambler, but when AMC brass got wind of what was in the works at Ford and GM, it ordered all hands back to the drawing boards. The result is said to be a smaller car than the original, much more stylish, more competitive in price. More stylish, however, doesn't mean more geegaws and chrome. In fact, all the new subcompacts will go easy on bangles and baubles. Instead, automakers look to paste-on stripes, special paint schemes to impart customary new-car flash.

*(Please turn to page 16)*

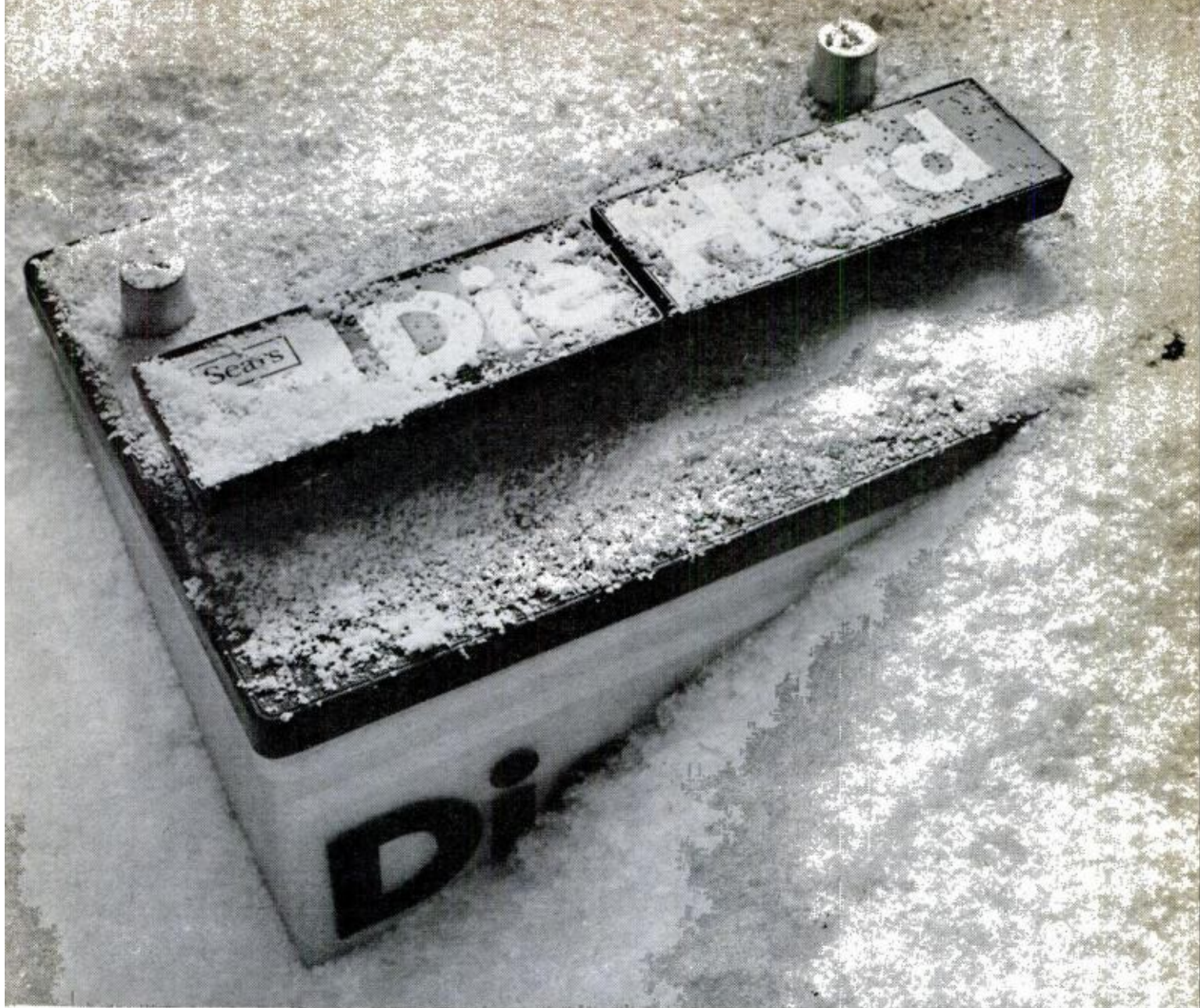

# The DieHard won't get you away from it all, but it'll get you started

**Size for size, it's America's most powerful car battery—by 35%.**

Lying on a sun-drenched beach would be nice. But, at freezing temperatures in a blizzard, it's amazing what you'll settle for. Like getting to the drugstore or getting to work, or just getting home.

The DieHard was invented for just such swell times. It's got 35% more usable starting power than any other battery around.

Polypropylene made that possible. That's the name of the thin plastic case of the DieHard. This case is the same size on the outside but roomier on the inside. For bigger plates and more acid. You couldn't have squeezed all this extra power

into a rubber case, and yet this battery case is 6 times stronger than those used for conventional batteries.

If you just have to put up with bad winters, the DieHard will make good company. It's guaranteed for five long years. That's probably longer than you'll keep your car. So why wait? And remember, when Sears guarantees . . . Sears guarantees.

There are over 2500 places to buy the DieHard. They're all Sears, Roebuck and Co. stores. You can Charge It of course on your Sears Revolving Charge.

So maybe the DieHard can't get you to a warmer climate, but if it gets you to work on time, you can bask in the warmth of your boss's smile.

**The Sears 5-year guarantee:** "Free replacement within 90 days of purchase if battery proves defective. After 90 days we replace the battery, if defective and charge you only for the period of ownership, based on the regular price less trade-in at the time of return, prorated over number of months of guarantee."

The DieHard. Sold only at Sears. \$29.95 with trade-in. In Canada, at Simpsons-Sears at slightly higher prices.

**Sears**

ALLSTATE

You can't do better than Sears.

DieHard batteries now fit 97% of the cars on the road. Sears carries a complete line of other fine batteries as well, in a wide range of prices.

Материал, защищенный авторским правом

# How to get rich

How can you get rich some day? Make a hit record . . . a killing on the stock market . . . or invent a gadget like the hula hoop?

For most of us, these are just dreams. But have you ever stopped to think that there is a way to get rich—possibly only one sure way? Most fortunes, as you know, are made by people who own their own business.

Perhaps you've thought of starting a small business of your own . . . a franchised drive-in, or maybe a service business. Trouble is, you need \$10,000 to \$15,000 to get started and even then it's a gamble—with slim chances of ever making really big money.

But there is *one* business which could make you rich—almost overnight! And the beauty of it is, you can start on a shoestring during your spare time, even while holding your regular job.

## Cash by Mail

The business is Mail Order—and it's fabulous! Come up with a 'hot' new item . . . and WHAM!

It strikes like a bolt of lightning! Suddenly, you are deluged with cash orders from all over the country . . . MORE MONEY than you could ever make in a lifetime!

Like the Vermont dealer who ran one ad in Sports Afield Magazine. His ad pulled 22,000 orders—over A HALF MILLION DOLLARS IN CASH!

There is no other business where you can make a fortune so quickly!

● A beginner from Newark, N.J., ran his first small ad in House Beautiful—offering an auto clothes rack. Business Week reported that his ad brought in \$5,000 in orders. By the end of his first year in Mail Order, he had grossed over \$100,000!

● Another beginner—a lawyer from the midwest, sold an idea by mail to fishermen. Specialty Salesman Magazine reveals, "he made \$70,000 the first three months!"

## Proof

It's a fascinating business! Running ads in newspapers and magazines . . . mailing gift catalogs . . . getting cash orders in your daily mail—steady as clockwork.

There is no other business where you can start on a shoestring and pyramid your profits—without investing in merchandise! One husband and wife mail order team took in \$40,000 selling one item. They obtained FREE ads in national magazines . . . didn't invest a cent in merchandise, and even got the supplier to ship all orders for them!

These exceptional cases are absolute proof that *you can get rich* in your own Mail Order business. Very rich. Even a U.S. Gov. Report stated: "A number of

one-man Mail Order enterprises make up to \$50,000!"

Pick up any magazine. Notice how the same mail order ads are repeated . . . month after month? That's concrete proof! You know those ads wouldn't be repeated over and over again—*unless* they were bringing in big cash profits to their owners.

## The Secret

The secret of getting rich in Mail Order lies in *financial leverage*. It's a little-known, almost secret method—using other people's capital to make money for you!

You can get thousands of dollars worth of advertising in big national magazines—without investing your own money! And you don't have to write a single ad. Tested and proven ads are prepared for you by experts. Reinvest the profits from your first successful ad—to get more, larger ads, and the profits begin to snowball! It's like building a chain of stores . . . each new store puts more money in *your* pocket.

You mail out beautiful catalogs which offer hundreds of dollars worth of fine, quality gifts—yet you don't invest one



The thrill of receiving money in your mail is one you'll never tire of!

cent of *your* own money in merchandise! Your catalogs are printed with your name and address, so all orders come to you. Everything is "drop-shipped" for you, and there's up to 100% mark-up! You pocket the cash profits immediately—even before the orders are shipped to your customers!

Repeat orders alone, just from mailing catalogs, could bring you a steady income for the rest of your life!

Yes, Mail Order is the fastest-growing, most profitable business in America! And now, with more people moving to the suburbs . . . the population explosion . . . and the expanding teenage market . . . we are on the verge of the BIGGEST BOOM in Mail Order history!

Now, with the help and backing of Mail Order Associates, Inc., of Montvale, N.J., you can follow the same proven steps to Mail Order success—using the 'secret' of financial leverage!

## Start Now

We supply you with beautiful gift catalogs throughout the year. All products are dropshipped for you, with up to 100% mark-up! You get free samples of top-selling mail order items, plus monthly trade reports on 'hot' new products . . . tested, successful ads are sent to you monthly. You get advertising directories, postal laws, complete courses, expert guidance—EVERYTHING you need to practically guarantee YOUR SUCCESS. Why? Because *our* business depends upon your success. It's mutually profitable!

A recent feature article in Income Opportunities Magazine stated, "Mail Order Associates Inc., offers the most comprehensive Mail Order program ever offered to beginners." They go on to say, "This could be the opportunity you've been looking for. A chance to get in on the ground floor in a little-known business which we believe is on the verge of a new boom."

## Free

We are now accepting a limited number of charter members in our new Mail Order Program. No previous experience is required but you must be over 21.

If you are sincerely interested in starting a profitable business of your own . . . if you can see the tremendous advantages which Mail Order offers . . . then ACT NOW!

Mail the coupon today, or simply send your name and address on a postcard. No salesman will call. We will send you a free book—gift catalog, reprints of feature articles, plus complete facts about our program. Write to:

Mail Order Associates, Inc., Dept. 141  
Montvale, New Jersey 07645

Rush Coupon for  
**FREE BOOK!**

plus reprints of  
Mail Order  
articles

Mail Order Associates, Inc., Dept. 141  
Montvale, New Jersey 07645

Please rush complete details on your Mail Order Program. I understand everything is free and there is absolutely no obligation. I am over 21.

Name.....

Address.....

City.....State.....Zip.....

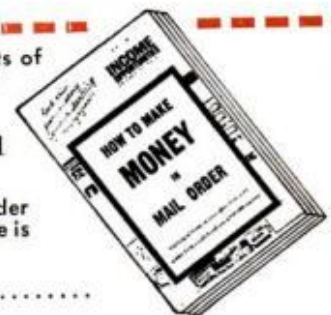

POPULAR MECHANICS



# My Wife and I started our own Anti-poverty program with this beat-up davenport— picked up for \$5—sold for \$300! Now that MUI taught us the secret, we'll never be poor or dependent again!

Better than \$10  
an hour for our time!

"I hate to think how many years I put in, slaving away at a dull, dead-end job. My wife and family were doing without the good things in life, while right at hand were opportunities for making money I never dreamed about. Now that we know upholstery, we know that every second-hand furniture store or thrift store—where they practically give away old, beat-up furniture—is a gold mine for us!"



## UPHOLSTERY IS ON THE MOVE WITH AMERICA!

**JOIN THE GROUP—AND PROSPER!** Just open your eyes and look around you! Never in all American history has there been a boom to equal this one. New freeways, new buildings, new real estate developments, new homes, hotels, motels, restaurants, bars. Can you imagine how much **UPHOLSTERED FURNITURE** is required for all this? And can you imagine how much of it will be *worn out and need reupholstering!* America is on the move with campers, trailers, mobile homes, boats—and even these constantly need upholstery and re-upholstery! Autos—26 million of them on the road, millions in need of new re-upholstered seats, headliners, door panels! All this spells opportunity, security, independence, good hard cash in your pocket if you have the know-how to take advantage of this greatest of all booms. Don't let it pass you by!



**BUSINESS OF YOUR OWN! TOP PAY,  
AUTOMATION-PROOF JOB OPPORTUNITIES!**  
M.U.I. Step-by-step training qualifies you  
for jobs, or your own business, or both!  
Husband-wife teams ideal!

One of the great features about upholstery is that it takes so little capital to start. Many begin in their garage, doing small jobs for friends and neighbors. Then the word gets around and your own private "boom" begins. Many have far more work than they can handle in a few short months. To get started easily, the husband often stays on his job while the wife learns the easy MUI way. Or if you don't want your own business, check the Sunday classified ads. Industry is **CRYING** for skilled upholsterers **right now**. Top wages are offered. And the jobs are **AUTOMATION-PROOF!** Computers will never learn upholstery—but **YOU** can—quickly, easily, the practical, step-by-step, tried and proven MUI way!

**THIS FREE UPHOLSTERY CAREER  
BOOK & SAMPLE LESSON  
MAY BE THE MOST IMPORTANT  
LITERATURE YOU'LL EVER READ.**



This free, illustrated 32-page upholstery career book may change your life in ways you can't even imagine! It has done so for others, thousands! It has taken low-pay men and women, all ages, regardless of education or experience, and has brought them up out of their workaday ruts and exposed them to the ways of prosperity, pleasure, independence, security, through **UPHOLSTERY**, the great boom business that is eager to share its **BILLIONS** with **YOU!** Send for **FREE BOOK & SAMPLE LESSON** today!

**UPHOLSTERY NEEDS YOU—YOU NEED  
UPHOLSTERY! AT LEAST SEND FOR THE FREE  
FACTS—YOU CAN'T LOSE—YOU MUST GAIN!**

A simple act—just clipping and mailing the coupon in this ad—brings you the MUI 32-page illustrated career book, the free sample lesson and all free information about **UPHOLSTERY**, the automation-proof industry that has more to offer ambitious men and women today than ever before in history. Clip the coupon and mail it now! Start your own anti-poverty program!

MODERN UPHOLSTERY INSTITUTE, Box 899-BMM Orange, Calif. 92669

**IF YOU CAN'T BE A COLLEGE GRAD—AT LEAST  
EARN LIKE ONE.** Get this diploma—your passport to prosperity. We can't all go to college—but now, thanks to the progressive MUI training program, you can earn as much—**AND MORE**—than many college graduates. MUI is authorized by the California Superintendent of Public Instruction to issue a **DIPLOMA** in upholstery.



**AIRMAIL  
COUPON  
TODAY**

**BUILD A  
ROOMFUL OF FURNITURE  
WITH MUI'S 6 BIG KITS.  
KEEP IT—SELL IT.  
—PROFIT BY IT.**



**YOU LEARN AT HOME, IN SPARE TIME...  
YOU GET SIX TOP-QUALITY FURNITURE KITS  
AND FREE HAND TOOLS FOR PRACTICAL  
"LEARNING-BY-DOING" TRAINING.**



MODERN UPHOLSTERY INSTITUTE, Box 899-BMM Orange, Calif. 92669

Please send the **FREE UPHOLSTERY CAREER BOOK**, the **FREE SAMPLE LESSON**. I understand I am under no obligation whatever and am just sending for the free facts on job and career opportunities in Upholstery and the MUI home training program.

Name \_\_\_\_\_ Age \_\_\_\_\_  
Address \_\_\_\_\_  
City \_\_\_\_\_ State \_\_\_\_\_ Zip \_\_\_\_\_

**APPROVED FOR VETERANS**

## DETROIT LISTENING POST

(Continued from page 14)

**A SKID-RESISTANT ROAD SURFACE** that stands up to the wear and "polishing" caused by heavy traffic—long a goal of highway engineers—has been developed and tested in Britain. Nearly two years ago small chips of calcined bauxite were bonded with epoxy resin to conventional concrete and asphalt surfaces of seven of London's busiest intersections. Results indicate that bauxite resists "polishing," retains its skid-resistant qualities. More importantly, accidents at these particular junctions were reduced 70 percent in less than two years.

**AMERICAN MOTORS** brass reported pleased and proud of the record established by its Javelin in its first year of major-league racing competition. Entered in 12 of the 13-race Trans-American series run by the Sports Car Club of America (SCCA), one or the other of the two-car Javelin team finished second six times, third twice, fourth twice, and fifth four times. At least one Javelin finished all 12 of the races entered. Two-car team ran entire season with only seven engine blocks, a remarkable achievement when compared to the series' many Mustang and

Camaro entries, most of which seem to eat engines like salted peanuts. Principal Javelin drivers this past year were Peter Revson and George Follmer, both of whom are said to be signed up for the coming season.

**FRANCE'S RECENT MONEY CRISIS**, and the steps taken by international monetary authorities to resolve it, has—among other things—boosted list prices of Volkswagens in the U.S. In shoring up the sagging franc, the West German government slapped a four percent tax on exports in an effort to cut its highly favorable trade balance. The result is that the popular "Beetle" sedan, for example, is now \$1799 at East and Gulf Coast ports of entry, an increase of \$50. Other increases throughout the VW line range upward to a maximum of \$71 for the "Squareback" sedan. All this, of course, points to an interesting and possibly lively situation: Here's VW, forced to jack the price of its cars, particularly the Beetle, just as Detroit is launching an all-out competitive effort, the opening round of which will be April's introduction of Ford's Maverick. That \$1799 list price is perilously close to \$1800, and in view of Ford's intention to price the Maverick "well under \$2,000," the sales battle could be intense. ★★★



What's the Gilson S-12 got that other tractors haven't?

# Plenty!

That's because the S-12 was designed and built from scratch to lead the field.

No souped up last year's model, this one. Rugged 12 hp design starts with a specially contoured frame that's high in the back for good visibility and nipped in at the middle so you practically ride in it, not on it. More, the

frame cradles the engine to form a single, rock-solid unit. There's direct drive from the engine to the transaxle. And a new variable speed control that keeps engine torque high so implements run at peak efficiency in any one of four speed ranges. Plus one convenient PTO point for all attachments. Of course, you also get grouped controls, big, fat, turf-saving tires, padded bucket seat, hydraulic implement lift, full-fledged auto battery and much more. Both 12 hp and 10 hp models team up with a full line of attachments. See your Gilson dealer for a demonstration, or write direct for catalog and your *free* copy of "Gilson Tips for Lawn & Garden Care."

**Gilson**<sup>®</sup> BROTHERS COMPANY, BOX 152, PLYMOUTH, WIS. 53073



**Transistorized  
TWO STATION INTERCOM**  
Switch on and talk! No complicated connections. With 66 feet connecting wire. **SET \$285**



**8mm  
MOVIE  
CAMERA**  
Electric powered—no winding! Detachable pistol grip. Loads in seconds. Adjustable lens. Black and white or color. **\$550**

**Transistor  
TAPE  
RECORDER**

Records—Plays Back—Erases—Rewinds. Includes dynamic speaker, microphone, tape, reels, etc.

**\$495**



**ELECTRIC RAZOR**

Product of Swiss Craftsmanship, Shaped to shave heaviest beard. Maker guarantees for one full year. With cord, head guard and brush. **\$170**

**Buy Below  
Wholesale**

**JEEP**

Great surplus buys available also. Austin Jeep with Rolls-Royce engine.

**\$346<sup>00</sup>**



**DUTCH  
MOTOR-  
CYCLE**

**\$113<sup>00</sup>**



Double tubular racing frame. Complete with buddy seat, chrome panels, lock, claxon, tools, speedometer. Deluxe Sprintmaster model for sporty appeal.

**Start your own BIG PROFIT  
Home Import Business...**

Import bargains by the thousands give you profit opportunities beyond your wildest dreams. Men—women start now in your own Home Import Business, full or part time. Cash in now without previous experience or capital investment. You can make your first import order 10 minutes after you get my proven drop ship plan. These bargains and thousands more go quick to stores, mail order operators, premium users, friends, others.



**CALENDAR  
WATCH**

Swiss movement. Beautiful styling. Tells time and date. Sweep second hand, gift case, stainless steel back, water resistant, antimagnetic. METAL EXPANSION BAND 11¢.

**\$2<sup>33</sup>**

**FIELD  
GLASSES**

7x35 G.C.F.



7 x 35 G.C.F. Clear and powerful. Beautifully balanced. Very lightweight, protective lens cover, center focusing. **\$240**

**DISCOVER SECRETS OF IMPORT  
The Profits are All Yours!**

Plan reveals everything to start you importing immediately. Gives you free membership in International Traders—famous world wide organization that puts you in direct contact with suppliers abroad. It's easy to buy below wholesale when we show you how. Rush coupon today for my FREE BOOK, "How to Import and Export"—get details about thousands of amazing buys. Airmail reaches me overnight.

**REAL SAPPHIRE  
RING**

Hand set Sapphire Stone in Sterling Silver mounting. Smart design. Ladies styles also available.



**3<sup>50</sup>**

**VOLKSWAGEN S955** Good used buys too. 1 yr. old Volkswagen \$1080 2 yr. old \$955 others low as \$400. Guaranteed.



B. L. MELLINGER, JR.  
Famous world trader...  
President of The Mellinger Co.

**Send No Money!**

Do Not Order From Us. I show you how to get these bargains and hundreds of others. Prices shown are direct from suppliers abroad.

**Put coupon  
in mail today!**



**HUMAN  
HAIR WIG**

Exciting new craze! Glamour high fashion wigs. Popular hair colors. Skillfully made. Luxuriously soft; fine textured.

**\$910**

**Get details on 8 FREE Imports**

**MAIL THIS COUPON TODAY**

**FREE BOOK TELLS HOW  
TO MAKE MONEY IN IMPORT**

**How to  
IMPORT  
AND  
EXPORT**

More examples of thousands of import bargains you can get to make fantastic profits up to 200% and more.

- FISHING ROD . . . . .50
- FM HI-FI RADIO . . . . .8.80
- RIFLE SCOPE . . . . .1.85
- MOVIE TITLE KIT . . . . .1.00
- BEADED HANDBAG . . . . .1.01
- FLASHLIGHT . . . . .1.10
- TRANSISTOR RADIO . . . . .1.70
- CARDIGAN SWEATER . . . . .2.00
- SPINNING REEL . . . . .96
- STOP WATCH . . . . .1.12
- WRIST RADIO . . . . .2.90
- MODEL BOAT KIT . . . . .65
- WATER PISTOL . . . . .05

Prices subject to availability, price fluctuation.

**THE MELLINGER CO., Dept. C-2252**  
1554 S. Sepulveda  
Los Angeles, Calif. 90025

**30-POWER  
TELESCOPE  
& TRIPOD**

Sturdy Metal Construction



3 section Telescope lets you see farther. Extends for razor-sharp focus.

**\$194**

The Mellinger Co., Dept. C-2252  
1554 S. Sepulveda, Los Angeles, Calif. 90025

Send Free Book showing how I can start a business of my own and make big profits. Show me how I can get bargains like these, how to buy below wholesale. (If under 21, state age.)

Name \_\_\_\_\_ Age \_\_\_\_\_  
Address \_\_\_\_\_  
City \_\_\_\_\_  
State \_\_\_\_\_ Zip Code \_\_\_\_\_

Save 3 days . . . Give Zip No. for fastest reply.

IF POST CARD HAS BEEN REMOVED, PLEASE RUSH COUPON

# Science Worldwide

BY JOHN F. PEARSON

Best treatment for some cases of ulcers, hypertension, migraine headaches, asthma and other so-called psychosomatic ailments is a regular pattern of sound sleep. So says University of Southern California's Dr. Leon Marder, who successfully treated 12 patients suffering from various ills. Drugs were used to keep the patients asleep 18 to 20 hours a day for two weeks. They were awakened three times a day for meals, light exercise and psychiatric consultations. But it's the quality, not the quantity, of sleep that counts, says Dr. Marder. The patients had been getting little or no "stage four" sleep, the deepest phase, before they became ill. It has been established that a lack of stage-four sleep can eventually cause humans to become psychotic.

A computer is helping drivers in the Houston, Tex., area by letting them know when it's safe to enter the flow of traffic on the Gulf Freeway. Detectors along a 6½-mile section of the freeway report the speed and distance of an oncoming car to a computer. The machine compares this information with factors relating to a car about to enter highway traffic—its acceleration capability and the length of the access ramp. If the computer finds that the safety gap between the two cars is adequate, it actuates a green light for the car waiting on the ramp.

Savor every mouthful if you get the chance to munch a Spijon or a Jonagold. They're new varieties of apple and their development took more than 20 years at the New York State Agricultural Experiment Station at Geneva. The Spijon, 3¼ inches in diameter and dark crimson in color, was developed from a Red Spy and a Monroe; the Jonagold, 3½ inches around the middle with red striping over a yellow background, has the Golden Delicious and the Jonathan as its progenitors. Researchers say the new apples are firm, juicy and delicious. Footnote: 57 varieties of apple have been developed by the Experiment Station since it was opened in 1882.

Factories in space are being considered by NASA theoreticians, according to Dr. George E. Mueller, associate administrator for Manned Space Flight. Weightlessness would make possible the manufacture of nearly perfect ball bearings, according to Dr. Mueller, because "liquid floating in a weightless environment takes the shape of a perfect sphere. It is conceivable that metal ball bearings could be manufactured in space to tolerances impossible on earth." In machinery, perfect ball bearings would reduce friction and noise levels almost to the vanishing point. Other improved products might include flawless optical blanks for telescopes and foamed structural steels almost as light as balsa wood.

Camelot, legendary court of King Arthur, is the object of a search by archeologists at a site in South Cadbury, England. Because the area has been occupied for about 4000 years, it is confusingly rich in ancient remains, requiring the use of a computer and other hardware to help sort out clues. Sensing instruments—proton magnetometers—act like modern witching rods as they read out underground shapes in the form of dot density patterns. (A proton magnetometer measures the earth's magnetic field, which is modified by buried pits, ditches, kilns, hearths and the like. So far, it seems, Camelot still is located only in the realm of legend.

A rabbit has been turned into a living battery by researchers at a General Electric lab. Two dissimilar metallic electrodes were implanted in the 3-pound rabbit's body. Galvanic action produced electricity (much as it does in an ordinary battery) sufficient to power an implanted transmitter that broadcasts the rabbit's heartbeats. One application in humans would be the operation of implanted artificial organs and devices for long periods of time. The tiny batteries now used to power heart pacemakers have a limited life and have to be replaced under surgery.

★★★

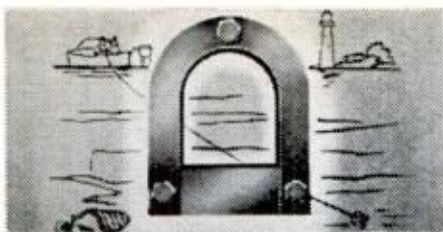

### "FISH" WITH A MAGNET

Go treasure hunting on the bottom! Great idea! Fascinating fun and sometimes tremendously profitable! Tie a line to this powerful, but lightweight Magnet—drop it overboard in bay, river, lake or ocean. Troll along the bottom—your "treasure" haul can be outboard motors, anchors, fishing tackle—all kinds of metal valuables. Specially designed horseshoe-shaped with 3 1/8" sq. gripping surface. Tremendous lifting power—over 150 lbs. on land, much more under water.

NO. 71,135H...150 LB. PULL...\$12.50 PPD.  
NO. 71,134H...75 LB. PULL...\$6.50 PPD.

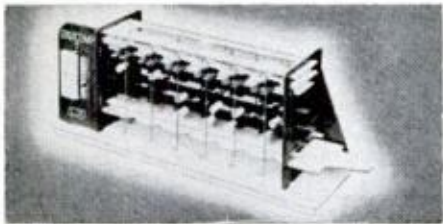

### MODEL DIGITAL COMPUTER

Solve problems, teach logic, play games with miniature version of giant electronic brains! Adds, subtracts, multiplies, shifts, complements, carries, memorizes, counts, compares, sequences. Colored plastic parts easily assembled. 12" x 3 1/2" x 4 3/4". Incl. step-by-step assembly diagrams, 32-page instruction book covering operation, computer language (binary system) programming, problems and 15 experiments.

Stock No. 70,683H .....\$5.98 Ppd.  
**BIG NEW DIGICOMP II!**  
Stock No. 70,946H.....\$16.00 Ppd.



### PLASTIC MODEL V-8 ENGINE

Hours of fun! Get thrill of building your own easily assembled engine from over 350 parts. Then push starter and watch it run. Crankshaft revolves, pistons move, valves open and close in sequence with spark plugs. Does everything but burn oil. 1/4 scale molded in 4 colors. Same motor used in many auto-mechanic courses. Excellent, easy-to-understand "tech manual".

Stock No. 70,448H .....\$12.95 Ppd.



### AMER. MADE OPAQUE PROJECTOR

Projects illustrations up to 3" x 3 1/2"—enlarges them to 35" x 30" if screen is 6 1/2 ft. from projector, larger if screen further away. No film or negatives needed. Projects charts, diagrams, color, black-and-white. 115 V A.C. Operates on 60 W bulb, not incl. 12" x 8" x 4 1/2". 1 lb. 2 ozs. Plastic case.

Stock No. 70,199H .....\$7.95 Ppd.



### NEW! PROJECTION KALEIDOSCOPE

At last—a low-cost unit complete with 9" diam. liquid wheel. Projects infinite variety of brilliant color patterns which **do not repeat**. Specially designed wheel, 3" projection lens and Edmund Visual Special Effects Projector make it all possible. Easily operated. Large screen image at short projection distance perfect for photo backgrounds, light shows, parties, dances, etc. Front or rear projection. Incl: 1 RPM 115V Motor, motor bracket, instructions.

Stock No. 71,121H .....\$94.50 Postpaid  
**SOLID MULTI-COLORED GLASS ACCESSORY WHEEL**  
Stock No. 71,122H.(9" Diam.).\$15.00 Ppd.

**KEEP PACE WITH THE SPACE AGE!**

# AMAZING BARGAINS

for Fun • Study • Profit  
from  
**EDMUND SCIENTIFIC CO.**  
300 Edscorp Building  
Barrington, N. J. 08007



### 3" ASTRONOMICAL TELESCOPE

See the stars, moon, phases of Venus, planets close up. 60 to 180 power. Aluminized and overcoated 3" diameter f/10 primary mirror, ventilated cell. Equatorial mount with locks on both axes. Equipped with 60X eyepiece and mounted Barlow lens. 3X finder telescope, hardwood tripod. Includes "STAR CHART"; 272-page "HANDBOOK"; "HOW TO USE TELESCOPE" book.

Stock No. 85,050H.....\$29.95 Ppd.  
Stock No. 85,105H..4 1/4"....\$84.50 f.o.b.  
Stock No. 85,086H..(6")...\$199.50 f.o.b.

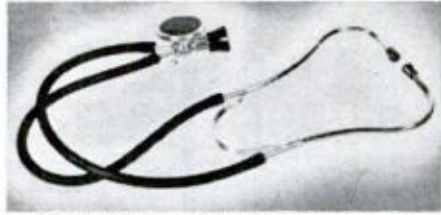

### DIAGNOSE MECHANICAL TROUBLE

Professional Stethoscope. Designed for use by physicians, this super-sensitive Stethoscope is ideally suited for detecting faults in machines and engines, and in fluid, air and gas leakage. Dozens of uses in auto repair shops, labs and for hobby and educational applications.

Stock No. 50,270H .....\$7.50 Ppd.  
**BARGAIN PRICE STETHOSCOPE**  
Stock No. 50,223H .....\$3.25 Ppd.

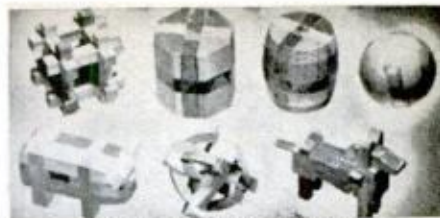

### WOODEN SOLID PUZZLES

Here's a fascinating assortment of 12 different puzzles to provide hours of pleasure and stimulate ability to think and reason. Animals and geometric forms. Take them apart and reassemble them. Lots of fun for the whole family—young and old. Will test skill, patience and ability to solve problems. Order yours now.

Stock No. 70,205H.....\$4.00 Ppd.



### FLY 9-FT. HOT AIR BALLOON

9 Ft. tall. Rises to amazing heights on just hot air. Tether attached, can be used repeatedly. Easy to make, launch, fly, loads of fun. Great for celebrations, science fairs, plain fun. Will lift model gliders, parachutes, instruments, etc.—anything up to 1/2 lb. Approx. 5 ft. diam. when fully inflated. Kit contains 10 pre-cut red & white gores (No. 1 model paper), 6 ft. 14-gauge wire for bottom ring, top, "tie-off" cord, complete instructions.

Stock No. 60,691H.....\$2.00 Ppd.



### GIANT WEATHER BALLOONS

"Balls of fun" for kids, traffic stoppers for stores, terrific for amateur meteorologists. Create a neighborhood sensation. Great backyard fun. Exciting beach attraction. Amateur meteorologists use to measure cloud heights, wind speed and temp. Heavy duty neoprene. Inflate with vacuum cleaner or auto air hose; or locally available helium for high rise.

Stock No. 60,568H....8'.....\$2.00 Ppd.  
Stock No. 60,632H....16'.....\$7.00 Ppd.

### MONEY-BACK GUARANTEE

Order by Stock No.—Send Check or M.O.

## GIANT FREE CATALOG

148 Pages! More than 4,000 UNUSUAL BARGAINS

Completely new Catalog. Packed with huge selection of telescopes, microscopes, binoculars, magnets, magnifiers, prisms, photo components, parts, kits, accessories—many hard-to-get surplus bargains. 100's of charts, illustrations. For hobbyists, experimenters, schools, industry. Mail coupon for FREE Catalog "H".

**EDMUND SCIENTIFIC CO., 300 Edscorp Building, Barrington, N. J. 08007.**

NAME \_\_\_\_\_  
ADDRESS \_\_\_\_\_  
CITY \_\_\_\_\_  
STATE \_\_\_\_\_ ZIP \_\_\_\_\_

discover the lure of

# Ski Barge

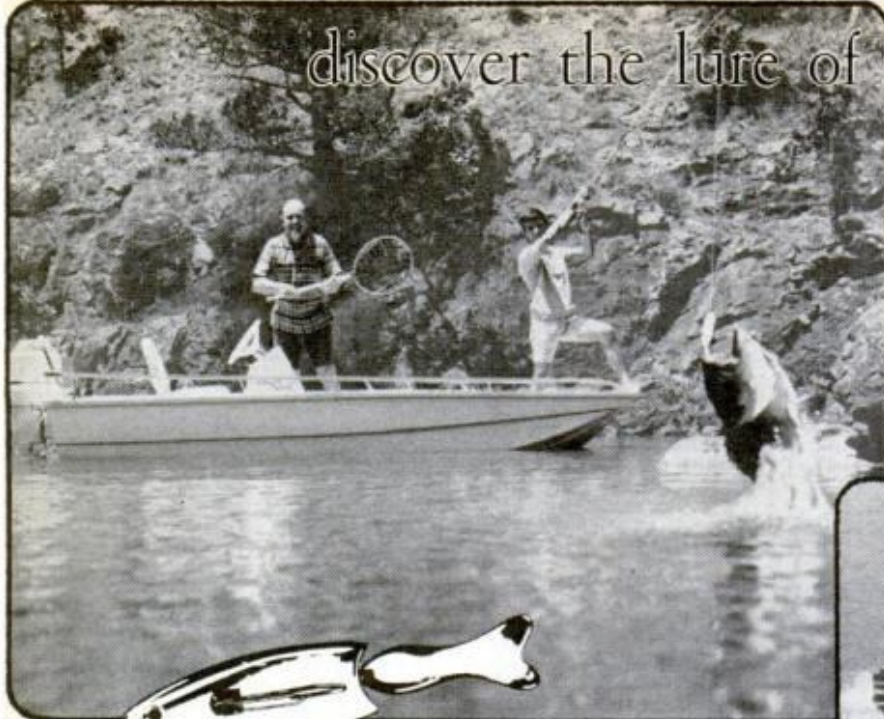

The ideal fishing boat would be a casting platform with plenty of speed to move from spot to spot and a shallow draft to put you where the lunkers lie—and that's a Ski Barge. Uncluttered deck is fly casters dream, seating and rigging is infinitely variable to suit an angler's needs. Three hulls, seven models.

Just for the HULL of it  
TEST DRIVE Ski Barge



Discover the lure of Ski Barge and discover a new Heddon Commando—the lure that strikes and runs—absolutely FREE.

Please send me a Ski Barge Catalog and a coupon for my FREE HEDDON Commando, redeemable at my participating Ski Barge dealer, along with my dealer's name and address.

Name .....

Address .....

City ..... State ..... Zip.....

**KENNER BOAT CO.**  
A division of A. J. Industries, Inc.

P. O. Box 16, Knoxville, Arkansas 72845

## ARROW

HEAVY DUTY T-50

# STAPLE GUN

Uses 6 staple sizes from 1/4" to 9/16", including CEILTILE



**\$12.95**

### A HANDY CHECKLIST OF HOUSEHOLD FASTENING USES

<ul style="list-style-type: none"> <li>• Install ceiling tile</li> <li>• Apply insulation</li> <li>• Fasten weatherstripping</li> <li>• Reupholster chairs</li> <li>• Fasten fence wire to posts</li> <li>• Repair window screens</li> <li>• Secure antenna wiring</li> <li>• Tack down stair treads</li> <li>• Replace worn window shades</li> <li>• Attach vines to trellises</li> <li>• Tack carpet underpadding</li> </ul>	<ul style="list-style-type: none"> <li>• Apply polyethylene vapor barriers</li> <li>• Make window boxes</li> <li>• Trim kitchen shelves</li> <li>• Line closets</li> <li>• Fasten burlap around tree trunks</li> <li>• Cover valances</li> <li>• Hang drapes</li> <li>• Affix wall decorations</li> <li>• Install plastic wall brick</li> </ul>
--------------------------------------------------------------------------------------------------------------------------------------------------------------------------------------------------------------------------------------------------------------------------------------------------------------------------------------------------------------------------------------------------------------------------------	-------------------------------------------------------------------------------------------------------------------------------------------------------------------------------------------------------------------------------------------------------------------------------------------------------------------------------------------------

**SHOOT A STAPLE WHEREVER YOU'D DRIVE A NAIL!**  
**FASTER . . . BETTER . . . CHEAPER . . .**

At Hardware, Lumber and Building Supply, Stationery and other retail outlets

ARROW FASTENER COMPANY, INC., Saddle Brook, N. J. 07663

## SAVE \$200 ON AUTO AIR CONDITIONING

Now save even more on NEW, LOWER PRICES on Comfy-Kit—world's leading install-it-yourself auto air conditioner. Standard Unit is now just \$133—Super is still just \$148—and Supreme still only \$165.

Easily installed with simple tools (we'll loan you the tools if desired). Comfy-Kit has been proven to exceed the performance of air conditioning units costing hundreds of dollars more.

Join the thousands of satisfied Comfy-Kit owners. Mail coupon today, and get the jump on summer.

### COMFY-KIT®

P.O. Box 8585, Dept. PM 2  
Dallas, Texas 75216

Enclosed is \$133 for Standard Unit.

Enclosed is \$148\* for Super Unit.

Enclosed is \$165\* for Supreme Unit.

Enclosed is \$30 deposit on a Super /Standard  Supreme Unit. I will pay the balance, plus C.O.D. charges when delivered.

Enclosed is \$8.00 deposit for a set of four tools, which will be returned to me when I return the tools.

I would like to see the instruction book before I order. I enclose \$1.00 for the instruction book only. I understand this will apply on any future Comfy-Kit order.

I would like information on a Comfy-Kit dealership.

Name \_\_\_\_\_

Address \_\_\_\_\_

City \_\_\_\_\_ State \_\_\_\_\_ Zip \_\_\_\_\_

My car is a \_\_\_\_\_ (year) \_\_\_\_\_ (model)

Engine displacement \_\_\_\_\_ Horsepower \_\_\_\_\_

Power Steering \_\_\_\_\_ yes \_\_\_\_\_ no

Floor shift \_\_\_\_\_ Steering column shift \_\_\_\_\_

Smog pump \_\_\_\_\_ yes \_\_\_\_\_ no

\*plus state tax where applicable



# TUNE UP ELECTRONICALLY ANY CAR EVER MADE!

- ✓ COMPACT or LIMOUSINE
- ✓ DOMESTIC or FOREIGN
- ✓ 4, 6 or 8 CYLINDER
- ✓ 6 VOLT or 12 VOLT
- ✓ POSITIVE or NEGATIVE GROUND

With New Improved Model BT-162

## DWELL TACHOMETER

**ASSURE** - EASY STARTS, OPTIMUM PERFORMANCE and  
MAXIMUM GAS ECONOMY with MODEL BT-162

MADE ORIGINALLY FOR THE PROFESSIONAL AUTOMOTIVE TECHNICIAN, MODEL BT-162 WILL PAY FOR ITSELF MANY TIMES OVER FOR THE AUTOMOTIVE HOBBYIST AND EXPERIMENTER.

**The Model BT-162 will perform the services specified below in addition to many other tasks too numerous to mention:**

- ✓ Assure precise adjustment of points that are slightly worn or pitted.
- ✓ Indicate the most effective point setting **without removing the distributor cap.**
- ✓ Read the average dwell of dual breaker points as well as individual dwell of each individual set of points.
- ✓ Indicate the correct settings for **external adjustment type** distributors.
- ✓ Car manufacturers' dwell angle recommendations are included in the manual provided with the Model BT-162 for all cars including the external adjustment type distributors specified above.
- ✓ It is no longer necessary to file points to smoothness when using the Model BT-162. The instrument will automatically make allowance for any existing "pitting" or "wear."
- ✓ To adjust for mathematically correct carburetor adjustment and thus insure maximum gas economy and quiet engine running, simply use the Tachometer section of the Model BT-162. Read the exact RPM while the engine is in neutral position. Then adjust the carburetor in conformity with the car manufacturer's recommendations as specified in the manual provided with the Model BT-162.
- ✓ To locate a "miss" you need only disconnect or "short" the spark plugs one at a time with the Model BT-162 switched to the Tachometer position. You will be able to instantly identify which particular plug (or frequently its wire lead) is responsible for the malfunction.
- ✓ Cars with automatic transmissions function efficiently only if the fluid pressures are correctly maintained and since manufacturer's instructions always refer to RPM the Model BT-162 (or an equivalent tachometer) is required to properly service automatic transmissions. Incidentally, the 5,000 RPM maximum range of the Model BT-162 is adequate for all car engines without any exceptions.

Comes complete, ready to use. Operating manual includes manufacturer's dwell angle recommendations for all cars. The manual is yours to keep even if you decide to return the instrument.

**\$29<sup>95</sup>**

**SEND NO MONEY WITH ORDER**  
**PAY POSTMAN NOTHING ON DELIVERY**

Try it for 10 days before you buy. If completely satisfied then send \$5.00 and pay the balance at the rate of \$5.00 per month until the total price of \$29.95 (plus P.P., handling and budget charge) is paid. If not completely satisfied, return to us, no explanation necessary.

ACCURATE INSTRUMENT CO., INC.  
Dept. 624 2435 White Plains Road, Bronx, N. Y. 10467

Please rush me one Model BT-162. If satisfactory I agree to pay \$5.00 within 10 days and balance at rate of \$5.00 per month until total price of \$29.95 (plus P.P., handling and budget charge) is paid. If not satisfactory, I may return for cancellation of account.

Name \_\_\_\_\_

Address \_\_\_\_\_

City \_\_\_\_\_

Zone \_\_\_\_\_

State \_\_\_\_\_

Save Money! Check here and enclose \$29.95 with this coupon and we will pay all shipping charges. You still retain the privilege of returning after 10 day trial for full refund.

## **MARTIN SALES**

2005 Ross Ave., Dept. PM-269  
Cincinnati, Ohio 45212



I can meet initial cash requirement of \$12,000 and a good credit rating for a franchised One Hour Martinizing store. Please send me full particulars on the franchise program. Without obligation, of course.

Name \_\_\_\_\_

Street \_\_\_\_\_

City \_\_\_\_\_ State \_\_\_\_\_

Phone \_\_\_\_\_ Occupation \_\_\_\_\_

# This coupon will bring you the full story of a business described by many as "Dollar-for-Dollar, the best franchise opportunity today."

You'll learn about ONE HOUR MARTINIZING—the best known name in dry cleaning—and a unique business system that's brought INDEPENDENCE and outstanding FINANCIAL GAIN to the owners of nearly 3000 stores. It can do the same for you!

The MARTINIZING story shows how you can share in a business where the American Public spends nearly 1½ BILLION DOLLARS ANNUALLY on dry cleaning alone. This figure grows each year, regardless of business conditions. So does MARTINIZING!

You'll see how MARTINIZING offers you a stable business that is built on the principles of CASH & CARRY, NO CREDIT, NO INVENTORY, NO DELIVERY. Requires only a minimum number of employees. Here's simplicity itself. Isn't that what you want?

EXCELLENT INCOME POTENTIAL! You'll also get an insight to the exceptionally good income that can be realized with ONE HOUR MARTINIZING. Following recommended procedures, owners should gross about 20% to 25% profit on sales. (We don't take a percentage of your sales or profits—or force you to buy supplies from us). Many people expand to profitable ownership of several stores in just a few years.

RUN THE BUSINESS? NOT ME. If you are interested in absentee management only, your Martin sales dealer will assist you in finding good managers. You'll come to agree with one Martinizing owner who says, "It's the best franchised business today as far as earnings potential versus initial investment."

WATCH TV, HEAR RADIO, SEE MAGAZINES? Then you've probably seen one of our ads—part of dry cleaning's largest year 'round program of CONSUMER ADVERTISING that has made MARTINIZING the best known name in dry cleaning. This sales building program can work for you.

WHAT'S THE HITCH? We don't think you'll find one. We have 20 years experience putting people into business (and keeping them there). Our parent company, McGraw-Edison, is one of the nation's top corporations. If you have a good credit rating and about \$12,000 as an initial cash requirement (covering down payment, installation and estimated starting expenses) then we have something to offer you right now that may well be your "Key To Success." Find out!

MARTIN SALES, 2005 Ross Ave., Dept. PM-269, Cincinnati, Ohio 45212.

**ONE HOUR**  
**"MARTINIZING"**  
CERTIFIES  
**THE MOST IN DRY CLEANING**

©Certification Mark, Reg. U.S. Pat. and Canadian Trade Marks Off.



**W**HEN Milton Aronoff turns around from the battery of 12 big deep-frying machines in his Chicken Delight shop in Fair Lawn, N. J., he can see them matched by rows of nearly as many smart-looking delivery trucks parked outside, waiting to carry orders right to customers' doors. Physically, Milt's shop is small—just big enough for the machines, himself, and a couple of helpers. What isn't small about this bustling franchised business is that it nets him around \$30,000 a year.

When he graduated from high school in nearby Paterson about 10 years ago, Milt went to work in a linen supply business, making about \$6000 a year. Then he heard about Chicken Delight. At that time, a franchise to sell these fresh-cooked, carry-out foods cost \$15,000, half of which had to be in cash. Milt borrowed what he needed and the Chicken Delight people did the rest. They built him a shop on busy Route 4, supplied him with cooking equipment, and even trained him. Within a couple of years, he repaid all he owed on his franchise, and he and his family moved into a handsome new home.

Today, Milt's business is really rolling—and so is Chicken Delight. The company now has about 1000 outlets coast-to-coast, and the cost of a franchise is up to \$30,000. The operation has been streamlined for maximum efficiency. Milt's suppliers send him chicken, shrimp, fish, loin ribs and potatoes all cut up ready for frying. This saves valuable preparation time since most of Milt's business comes in the hectic time between 4:30 and 7:30 in the evening. His stable of delivery trucks is equipped with heaters to keep customers' orders hot en route.

The big thing about a franchised business, aside from making you your own boss, is that you are buying into a going operation with an advertised name and a respected reputation. Right away, you become a member of an estab-

# How to Be Your Own Boss:

## The \$80-Billion Boom In Franchising

Every year, thousands who dreamed of running their own businesses are finding that dream coming true. From ice-cream stands to auto-service shops, opportunities in owner-managed franchises are almost endless—and so are the profits for anyone really eager

By CREIGHTON PEET

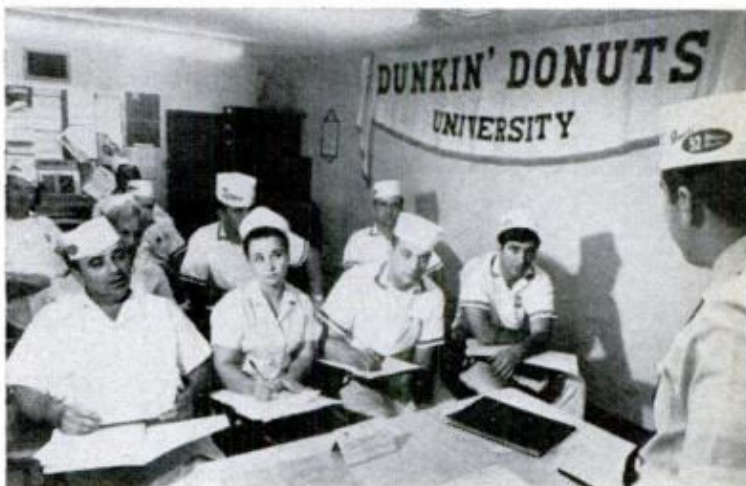

**FUTURE PROPRIETORS** of Dunkin' Donuts shops go to school at Newton, Mass., to learn proper cooking and business practices. Graduates earn as much as \$25,000 to \$35,000 a year





**KEEPING THINGS RUNNING** is vital to the success of an equipment-rental shop. Here, trainees for an A to Z Rental franchise, one of the biggest in the country, are taught proper power-mower maintenance



**YOU DON'T HAVE TO BE A MECHANIC** to apply for a Rayco Auto Center. Franchise includes training in all phases of auto service. Typical cash investment: \$30,000. Profits range up to \$66,000 a year

lished, experienced team. The parent company is just as anxious to have you be successful as you are—it won't make any money unless you do.

In most cases, the "franchisor"—the company that grants the franchise—helps you decide where to locate, gives you an exclusive right to sell his product in that area, trains you in good business practices and helps you get started. If you get into a jam, he's in a position to give you wise advice based on the experiences of thousands of others handling the same product or service.

This special relationship between the franchisor and you as the franchisee gives you an edge in starting a business. Proponents of the system take pride in pointing out that failure rates for franchised businesses are as low as three to five percent.

Failure rates for nonfranchised businesses range from an average of 20 percent to as high as 27 percent for food-serving operations. Moreover, if you *should* fail or want to get out of the business for some reason, a franchisor will often help you find a new owner to take over so you don't get stuck with a total loss.

The franchise business is booming. What started mainly as an aid to job-hungry GIs returning from World War II has now mushroomed into a major American industry. An estimated \$80 billion worth of goods and services are sold through franchises every year—approximately 10 percent of the country's total economic output.

A lot of the smaller family-owned franchises are in food-serving businesses of one type or another—places like Milt's

**FRANCHISED CAMPSITES**, one of newest ideas, provide tents, platforms and recreational facilities for campers. Safari Camps of Columbia, Mo., estimates a seasonal profit of \$21,830 for typical 100-site camp

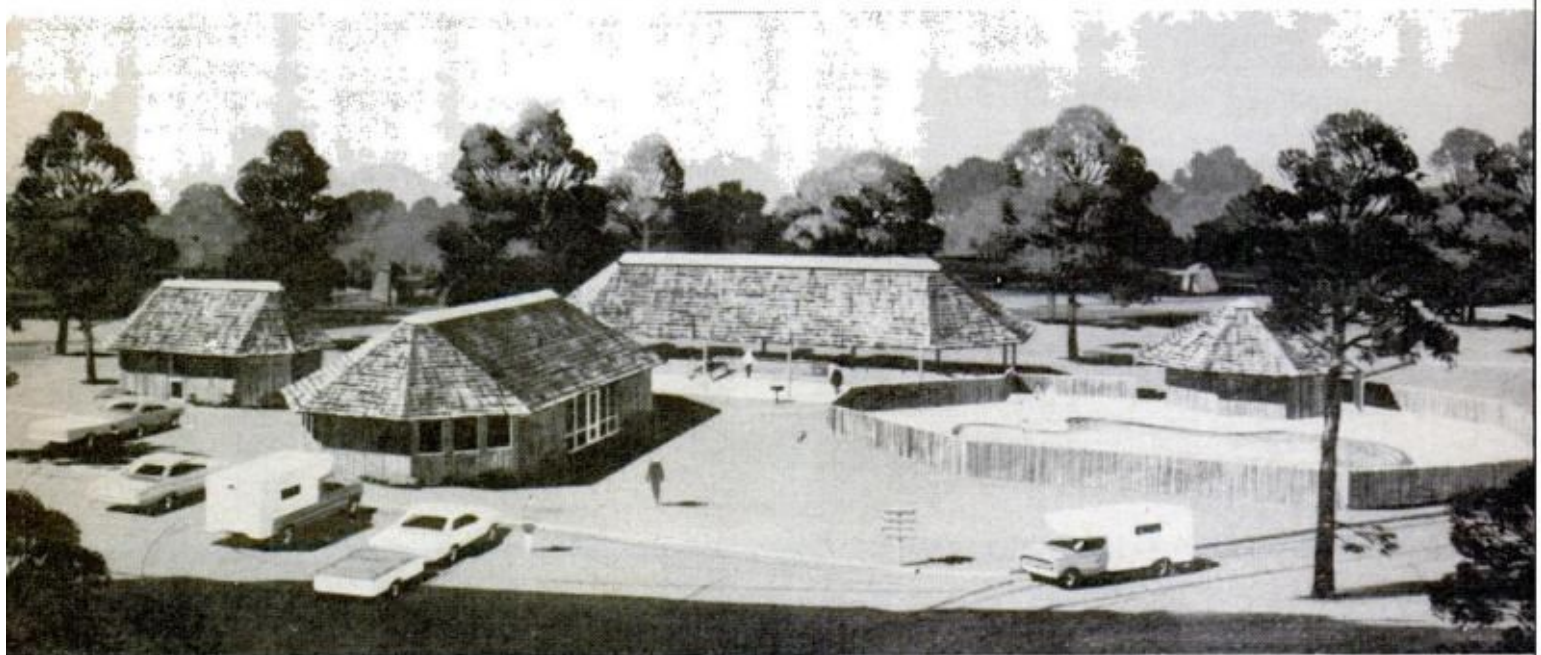

# The \$675 chain saw.

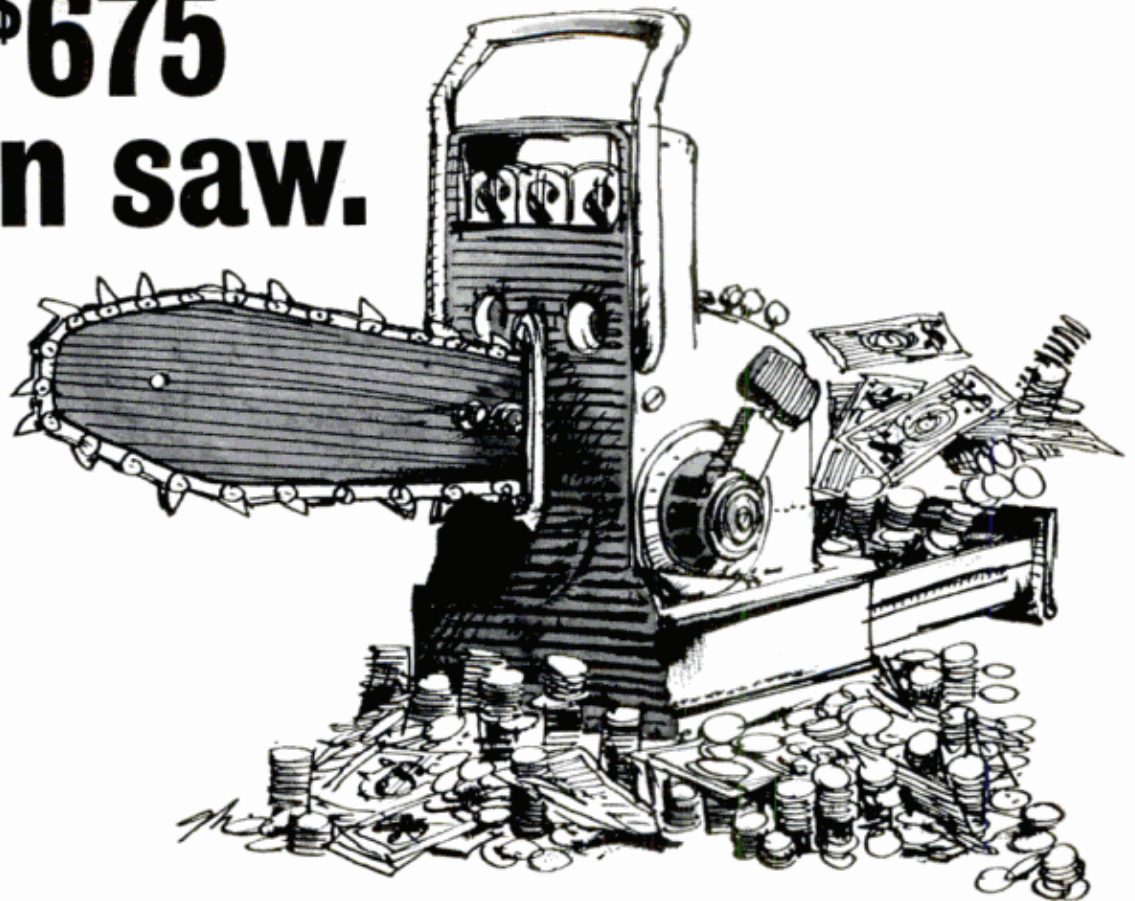

Cut yourself in. Of all service businesses, the rental business will be the real growth one in the 1970's and beyond. Every business publication predicts this. Americans nowadays are more affluent, more mobile, less tied to possessions. They can afford to rent things, and they prefer to. Party goods, exercise machines, baby furniture, gardening equipment, power tools, sickroom items, you name it. Every item is high-profit...makes money for you even when your rental mart is closed for the night. Example: In a typical mart, a chain saw is rented 37 times a year, yielding \$675 in rentals.

## United Rent-All is Number One

in the rental business, with some 400 rental marts coast to coast. We are a member of International Industries, which is listed on the New York Stock Exchange and operates other highly successful franchise operations.



**A good choice of  
prime locations nationwide.**

## All it takes is \$15,000.

You retain \$5,000 of this as operating capital. We back you with a prime location in a high-traffic area, a distinctive, air-conditioned building with a large, lighted sign and adjacent parking lot. The complete program includes an intensive training course, five in-store promotions a year, NBC network advertising, accounting and inventory help, and a computerized Rental Research Center.

You're in business for yourself but not by yourself.

If you feel we are right for you, and vice-versa, get in touch with us. For the in-depth facts about our complete program we invite you to send in this coupon or call us collect at (213) 836-4900.

Robert Feinstein, Franchise Director  
United Rent-All, Inc.  
10131 National Boulevard, Dept. PM-2  
Los Angeles, California 90034

Name \_\_\_\_\_

Address \_\_\_\_\_

City \_\_\_\_\_ State \_\_\_\_\_

Zip \_\_\_\_\_ Phone \_\_\_\_\_



**FAMILIAR** Midas Muffler shops are seen in many areas and offer a number of franchise possibilities. Like Rayco, they provide variety of automotive services but do not require that a prospective franchisee be an automotive expert. Similar opportunities can be found in the well-known Lee Myles chain—a system of franchised shops that specialize in overhauling and rebuilding automotive transmissions. Actual in-shop training is provided for all franchisees in auto service

Chicken Delight, hamburger drive-ins, pancake houses, doughnut shops, ice-cream stands and the like. In addition to these, there is a staggering variety of nonfood operations ranging from equipment rental centers and auto-service shops to golf driving ranges, franchised campsites and coin-operated laundry services. You can even start a nightclub on a franchise.

How much you need to start a franchised business of your own may vary all the way from \$50 to \$50,000 depending on the type of operation, the location, whether you work out of your own home or need a separate building, and other factors. For a typical roadside establishment, you'd probably need from \$8000 to \$25,000 in cash. Many franchises, however, run to considerably less where all you do is buy or lease certain equipment.

Take Ronald J. Bonomo of Traverse City, Mich., for example. He's making a very good thing out of a Duraclean franchise for cleaning upholstery and carpets. Bonomo found himself pushed into the business when the factory where he was working for \$90 a week laid off all hands for an indefinite period. Reluctantly, he borrowed \$1500, bought the cleaning franchise, and right away it worked magic. Within a couple of days, he landed a job cleaning carpets for a motel for \$384. Now he's netting around \$12,000 a year, mainly on large commercial cleaning jobs.

For Harris Eisner, the big change in his life came when a cousin told him about something called Lawn-A-Mat, a tractor-like machine that sprays, seeds and rolls lawns all at once, doing a day's work for 10 men in 15 minutes. With loans from relatives and savings, Eisner bought a Lawn-A-Mat franchise for \$9500 and went into business in Mount Vernon, N.Y. He can service 10 to 12 lawns a day with the machine and is netting \$15,000 to \$20,000 a year.

Here are the prices for a few other typi-

cal franchises: Grout Lock, a new cinder-block construction material is \$5500. Roto-Rooter, a device for cleaning drains and cesspools, is \$6000. A Western Auto Supplies outlet goes for \$14,000; a Mary Carter paint store for \$15,000. Car-washing installations are a big thing this year and come in all sizes from Washmobile's coin-operated self-service setups for \$1695 to much more elaborate Wash & Waxmobile setups with wrap-around rotary brushes



**THIS ONE-HOUR DRY CLEANING SERVICE**, known as "Martinizing," is based on a franchised process. While exact profits aren't made public, yearly incomes in five figures are said to be common

costing \$20,000, with a cash outlay of \$10,000.

Franchising provides a manufacturer with direct consumer outlets, entirely bypassing the middleman. Some of this reduced operating cost is passed on to the franchisee. Since the franchisor buys in tremendous quantities and has no middleman expense, he can afford to give you the benefit of lower prices on the supplies you buy from him.

Don't, however, get the idea that a franchise is an easy way to get rich quick. It isn't. Developing a franchised business, like any new venture, requires long hours,

## Be a Yamaha Dealer for all seasons



In the spring and summer handle Yamaha Motorcycles — the complete line of top-selling sportcycles in America.

In the fall and winter handle the new, dependable Yamaha Snowmobiles — the snow machines with the features people ask for.

Send this coupon in to:

Yamaha International Corp. Motorized Products Division  
P.O. Box 54540 • Los Angeles, California 90054

I'm interested in Motorcycles \_\_\_\_\_ Snowmobiles \_\_\_\_\_  
Both \_\_\_\_\_.

- Have your district sales manager contact me as soon as possible.
- Rather than have your representative contact me, please mail all available brochures, including franchise information.

NAME \_\_\_\_\_ POSITION \_\_\_\_\_

COMPANY \_\_\_\_\_

ADDRESS \_\_\_\_\_

CITY \_\_\_\_\_ STATE \_\_\_\_\_ ZIP \_\_\_\_\_

**YAMAHA** 

INTERNATIONAL CORPORATION • SINCE 1887

## YOU TOO CAN BE SUCCESSFUL as a Franchise Paint Dealer with MARY CARTER'S PROVEN AID

Fill in coupon and mail today!

A Mary Carter Paint Franchise will get you started on the path to profits in excess of \$15,000 annually. And your investment in stock is GUARANTEED REPURCHASABLE by Mary Carter Paint Co. should you elect to terminate your franchise at any time. There are no franchise or royalty fees to pay, either. From \$7,500 to \$10,000 for inventory sets you up in business, ready to start making profits! Free weekly paint deliveries to your store, liberal co-op advertising, free advertising materials and a complete training program assure you of success as one of more than 1300 franchised Mary Carter Paint Dealers across the U.S.A.

**MARY CARTER PAINT CO.  
FRANCHISE SALES DEPT.**

**P. O. BOX 15335  
TAMPA, FLORIDA 33614**

PLEASE SEND COMPLETE  
DETAILS ON MARY CARTER  
FRANCHISE AVAILABILITIES.

NAME \_\_\_\_\_

ADDRESS \_\_\_\_\_ PHONE \_\_\_\_\_

CITY \_\_\_\_\_ STATE \_\_\_\_\_



**TWO MILLION HAMBURGERS A DAY** are consumed by hungry motorists who stop at McDonald's roadside stands across the country. One of the best-known franchised food chains, it insists on careful pre-training and stiff quality controls. Average net income before taxes: between \$50,000 and \$60,000



hard work, initiative and self-sacrifice. Milton Aronoff still puts in an 11-hour day at his Chicken Delight shop, working from noon until almost midnight. In the early years, he worked even longer hours and his wife helped out, too, taking orders and keeping the books.

There are generally no hours in a small family-run business—you work as long as there is work to do. The more time and effort you're willing to put in, the more profit you usually get out. Also, you must

be willing to accept the identity of your franchisor and abide by his rules and policies. In this respect, you are not entirely your own boss.

You cannot, for instance, handle a competing product, and you will usually have to purchase all or most of your supplies from your parent company. Prices, quantities, even the architectural design and decorative motif of your shop, will be established by the franchisor. In most cases, you will be expected to pay back to the franchisor a royalty charge of three to five percent or more off your gross revenue every year.

The easily recognizable identity, the established reputation and the rigid controls all work to your ultimate benefit, but you have to have the right personality to fit into a franchised operation. Not everybody can. Here are some other helpful tips to bear in mind when you're looking for franchise opportunities:

Don't take on an operation involving more money than you have or can borrow comfortably. It may be a while before your project gets rolling and if you are



**COMMERCIAL CLEANING BUSINESS** requires relatively small investment in rug and upholstery shampoo machines. You buy the equipment outright and keep all you earn in Von Schrader system of Racine, Wis.



**SPECIAL VAN** travels around spray-washing buildings, statues—anything needing cleaning. The Instant Mobile Powerwash Service is franchise offered by Franchises International, White Plains, N. Y.

# 3 WAYS to a profitable business of your own

— and only —

## VON SCHRADER HAS ALL 3

Von Schrader is the oldest and largest company making Detergers of this type. For over 30 years our FREE ENTERPRISE PLAN has been fashioned with your future in mind. Start with the Deterger that most appeals to you. We have thousands of Associates who have built successful businesses with just one Deterger. Naturally, bigger and more profitable businesses can be built when you are able to offer two or all three cleaning services.

For example, let's say you start with the

### VON SCHRADER WALL DETERGER (LOWEST PRICE OF ALL THREE)

1 • Associate G. H. Jones made \$1200.00 on one job. Associate R. G. Fullmer says contracts this year will gross about \$18,000.00. And no wonder...this machine washes walls 6 times faster than by hand...with no mess...no drop cloths needed. Washing is so easy...no tiresome scrubbing...special glider wipes walls clean with little effort. You can start part-time and by working week-ends add hundreds of dollars to your income while still employed.

Then you can double your profit by adding the

### VON SCHRADER UPHOLSTERY DETERGER

2 • Associate Charles Lemmin averaged \$100.00 a day during his first year. Associate Peter Young took in \$960.00 last week. You clean upholstered furniture on customers' premises—homes, hotels, motels, etc....even auto upholstery. No hauling...operate from your home. Watch business grow as customers tell their friends.

And, finally, you can more than triple your profits by adding the

### VON SCHRADER RUG DETERGER

because each service helps to sell the other two

3 • Associate C. E. Nevin reports he averaged \$1000.00 a month for 12 months. An Associate father-son team grossed \$33,000.00 their first year. Von Schrader's FREE ENTERPRISE PLAN is not a lease arrangement. You sign no contract. You own the equipment. You pay no fees, dues or royalties to anyone. Every dollar you take in is yours to keep.

Full Operating Instructions come with each Deterger... you need no special skill or training. And our Business Manual tells everything you need to know about getting business, suggested sales letters, tips on keeping books and tax records, suggested ads and radio announcements, etc. Our assistance is always at your service. Training and consulting with experts is also available...and without charge.

**Don't Delay...** it costs nothing to get the details. Return the coupon TODAY for informative FREE booklet. Be sure to check the Deterger you are most interested in starting with.

**VON SCHRADER MFG. CO.**

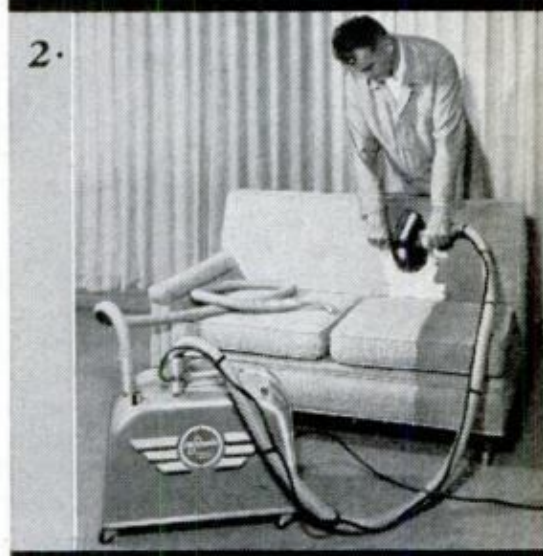

**SEND FOR THE FACTS TODAY**

VON SCHRADER MFG. CO.  
9210 "A" Place, Racine, Wis. 53403

Please rush information about your

\_\_\_\_\_ DETERGER(S)

(Write in name of detergent(s))

and how I can start my own profitable business.

Name \_\_\_\_\_

Address \_\_\_\_\_

City \_\_\_\_\_ State \_\_\_\_\_ Zip \_\_\_\_\_

saddled with excessive payments, you may fail before you're really started. You should have enough capital to operate for at least five to six weeks without much money coming in.

Investigate the local franchise you are considering thoroughly. Check it out with the local Better Business Bureau, Chamber of Commerce and any businessmen you know.

Check over, on your own, what the company representative has told you about his franchise. Has he exaggerated or perhaps painted too rosy a picture? Visit other holders of franchises for this same product in nearby towns. Talk to them. How do they seem to be making out? Have they any gripes? Do customers seem to like this product or service?

Visit the store or office location you are considering. If you are going to rely on drop-in customers, clock the number of people passing at different times of the day and days of the week. Do they look prosperous?

From your prospective franchisor get a clear picture of your financial obligations. When he says you need only so much cash, is this really all or are there unexpected extras? Are they counting on your using your own car or truck for deliveries or pickups? This may be all right, but be sure you understand all the details before you sign up. And when you do, get a lawyer to check over your agreement.

Think a long time before you get into a field you know nothing about. This doesn't mean you shouldn't try something entirely new to you. But if you do, be

**AN INSTANT SUCCESS**, Henry Vierra made a profit of \$18,000 in his first year of operating a Mister Donut shop in Waltham, Mass. Franchises cost \$25,000 to \$30,000, but to encourage expansion, company will permit a successful operator to start a second shop for as little as half

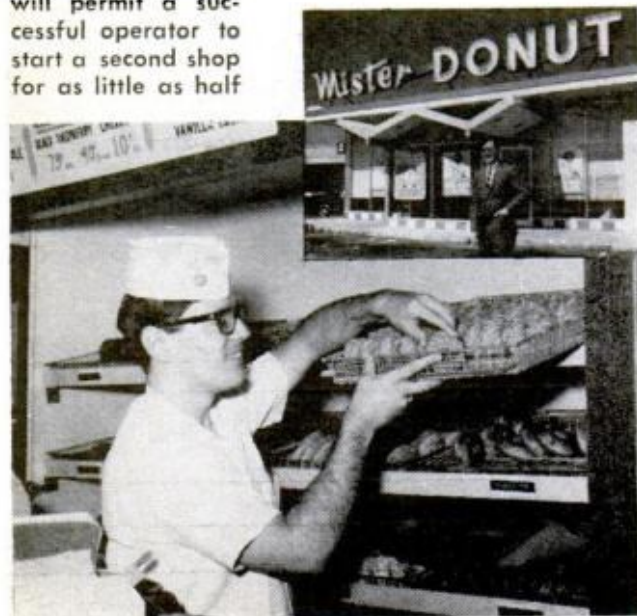

**FRANCHISED DEALERS** for Beltone hearing aids can work out of an office or their own homes. Using a portable electronic audiometer, they often visit customers' homes in person to test hearing acuity

**ROLLING GRASS FACTORY** seeds, fertilizers, rolls, aerates and kills weeds and bugs in one operation. Available on a franchise from Auto-Lawn, Matawan, N.J., it gives owner nine-month lawn-care business

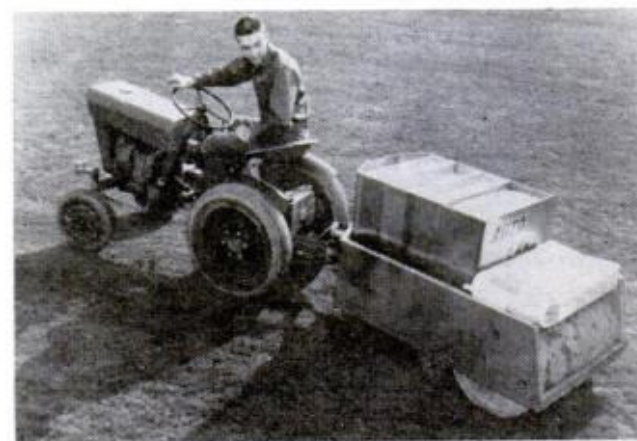

sure you have talents that can be adapted to this new work. Everything is so specialized today that only a fairly young man can switch very easily.

Another thing to consider when you are buying a franchise is how your wife feels about it. She probably will have to help you man the telephone and keep the records. The business of bookkeeping is extremely important, not only because you want to keep track of your business, but because your franchisor will require periodic financial statements. Some companies insist that their franchisees hire a bookkeeping service if they are weak in this



## In What Business of Your Own Can You MAKE BACK YOUR INITIAL INVESTMENT in as little as TWO WEEKS?

### You Can Do It When You're a Successful MERLITE PRESTO SHINE DEALER!

The initial investment in a Merlite Presto Shine Dealership is so modest, and the earnings you can make are so surprisingly high, that it's possible for you to earn back your initial investment in as little as 2 to 4 weeks! How many other business opportunities permit you to recoup so quickly?

### Imagine! You Offer a Genuine SIMONIZ PASTE WAX JOB FOR ONLY \$5.95

When you're a Merlite Presto Shine Dealer, the equipment which we supply you and the system which we teach you, enable you to clean, wax and polish a car with genuine Simoniz Paste Wax in as little as 20 minutes! You charge only \$5.95 for this genuine Simoniz wax job—about 1/3 the usual professional charge. Yet you make up to \$5.75 gross profit on every car! Weekly gross profit up to \$500.00 and more is possible—as much as \$25,000-\$30,000 in a year!

### NOW, HERE'S WHAT WE OFFER YOU:

#### 1. REMARKABLE PATENTED INVENTION.

You get authorized use of patented HM Polishing Machine (U.S. Patent No. 2,967,315), which amazingly duplicates the motion of the human hand, enables you to start with a dirty car and bring it to a lustrous, gleaming, protected Simoniz Wax finish within as little as 20 minutes!

#### 2. PERSONAL TRAINING IN YOUR AREA WITHOUT A PENNY OF RISK!

Even before you decide to become a Merlite Presto Shine Dealer, we will send one of our skilled instructors to train you in the use of the HM Polishing Machine and the astonishing Merlite Presto Shine speed method. So easy, even a child can do it, after a little training! After your personal instruction, if you decide not to become a Merlite Presto Shine Dealer, you're not out a penny! You take no risk!

#### 3. PRACTICALLY NO OVERHEAD . . . YOU CAN WORK FROM YOUR HOME.

The HM Polishing Machine operates on ordinary house current, so you can do all the work right at your home, if you wish, and save overhead expenses. Supplies and materials cost you about 20¢ per car, so your gross profit on a \$5.95 Simoniz Wax job is approximately \$5.75!

#### 4. START IN YOUR SPARE TIME.

Many of our most successful Merlite Presto Shine Dealers held on to their full-time jobs, started out in spare time—evenings and weekends. Then, when they saw how much more money per hour they were making with Merlite Presto Shine, they went into full-time business of their own, and stopped punching the timeclock. You can do it, too!

#### 5. TREMENDOUS DEMAND EVERYWHERE.

Your astounding low \$5.95 price draws a steady stream of motorist-customers. You also get big commercial accounts: new and used car dealers, fleet operators such as taxicabs, rent-a-cars, etc., plus service stations, garages and car washes. You need never run out of customers!

**COMPLETE PROSPECTUS—FREE . . .  
MAIL THIS COUPON TODAY . . .**

**MERLITE PRESTO SHINE CORP.**

114 East 32nd St., Dept.

New York, N.Y. 10016



"Above you see one of our Merlite Presto Shine Dealerships, operated in conjunction with a parking lot. You can set up your own Merlite Presto Shine Dealership in practically any location—even at home."

### Read What Merlite Presto Shine Dealers Say About This Great Opportunity:

**Larry Drain of Illinois:** "Within 13 days of getting started, profits from the business paid for the initial investment—and that includes my TV and radio advertising. Since then I have been averaging between \$1,000 and \$1,300 a week! Because I cannot handle the business myself, I now have 3 employees who work full time."

**Peter J. Strikwerda of New York State:** "Yesterday I did a 60' x 12' 1-year-old trailer. I hope this is a good beginning in this area, because it was accomplished with ease and resulted in a great sense of satisfaction when I saw the trailer glistening. You can imagine the dirt, grime and film that had accumulated in one year. Now I would like to get 3 more machines."

**David J. Paradise of Massachusetts:** "Just two years ago my wife and I returned to Mass. from Arizona. We were broke. I got a job in a factory and then read about Merlite Presto Shine. Then presto, I got my dealership and started making money as they said. Today I have a steady flow of customers, and we now own our own home with an acre of land."

**Pedro Ramirez of Puerto Rico:** "As a Merlite-Presto Shine Dealer, I do Simoniz wax jobs on aircraft on a contract basis. Already I have steady business contracts totaling \$500.00 a month. Recently a domestic airline signed a contract for me to do their 12-passenger Beechcrafts at \$75.00 per plane per month, and a plane takes me only 5 hours to do."

**Steven Schorr of Long Island, N.Y.:** "I am 15 years old and in junior high school. My dad will let me do only 10 cars on a weekend, although I could do a lot more, if I didn't have to do homework. Even so, I make about \$50.00 a weekend, which will go to my college education. This summer I've lined up 2 beach clubs, and 2 of my friends to do the work for me."

Merlite Presto Shine Corp., Dept. Y-15K

114 East 32nd St., New York, N.Y. 00000

Rush me complete Prospectus of my opportunity to make big profits in a business of my own as a Merlite Presto Shine Dealer. Everything comes to me by mail, prepaid, absolutely FREE, and entirely without obligation.

NAME \_\_\_\_\_

ADDRESS \_\_\_\_\_

CITY \_\_\_\_\_ STATE \_\_\_\_\_ ZIP \_\_\_\_\_

In Canada: Merlite Presto Shine  
675 King St. W., Toronto, Ont.

department. Some wives also attend to direct mail advertising to special lists of prospects and even take charge when their husbands are ill or away.

Some people turn to an agency for advice on selecting a franchise. Such an agency is Franchising Developments, with headquarters in New York and representatives in most large cities. David Seltz, who runs this operation and has written a number of books on franchising, says he has turned down 80 percent of the firms that have approached him for recommendations because they did not have enough to offer. Consulting such a specialist does not cost you anything—the franchisor pays the fee.

Two good sources of basic facts about franchises and listings of available opportunities are the International Franchise Association at 333 North Michigan Ave., Chicago, Ill. 60601, and National Franchise Reports at 115 East Ontario St., also in Chicago. Both of these organizations offer advice to prospective franchisees and publish helpful guidebooks that can be obtained for a nominal charge.

While you are deciding what type of franchise you might do best in, you can also write to the Government Printing Office in Washington for some of their Small Business Administration pamphlets, most of which sell for less than \$1 each. They are filled with advice on all kinds of franchises.

One man who hit the right business right off was Richard E. Hubel, who bought a United Rent-All franchise in Saddle River, N.J., for \$8000 in cash, some of which he was able to borrow. The franchise costs \$10,000, half of which must be paid in cash, and the franchisee must also buy \$20,000 worth of merchandise to start off, of which \$3000 must be in cash.

A United Rent-All mart supplies everything homeowners have occasional use for—garden equipment, power tools, floor Sanders and waxers, ladders, paint sprayers, and so on, as well as large quantities of party china, glass and silver, and tents for outdoor affairs.

Hubel's first year netted him around \$7,000 and his second around \$10,000. This year, his sixth in business, he expects to clear about \$18,000. The increase is due not only to hard work but also to the additional stock he has purchased. The more items you have to rent, the more customers you can satisfy—an important factor in this type of business.

Another interesting opportunity for those who are mechanically inclined is the growing chain of "Mr. Sharp" Sharpening Centers—the only operation of its kind in the country. These centers are

equipped for every conceivable type of sharpening job from scissors, knives and power mowers to saw blades, pruning shears and ice skates.

You buy the equipment as part of the franchise and are trained in its use. A completely outfitted center costs \$15,500, of which only \$6000 has to be in cash. Basic annual income is estimated at \$11,000 with the possibility of doubling or tripling this. The Mr. Sharp company, based in Lansing, Mich., helps you plan advertising and sales campaigns, contributes part of the cost, and offers a continuing consultation service to insure that you maintain a healthy business. For this, the company charges an annual fee of four percent.

Some franchise stories leave you bug-eyed. When Charles Gauchet, 23, of St. Louis got out of college a year ago, his father gave him an Oli's of Hong Kong franchise costing \$13,500. This is one of those outfits that has suits and dresses made for you in Hong Kong from fine fabrics.

For the cost of the franchise, Gauchet received a small tailor shop completely equipped with samples of fabrics and suits and dresses and instruction in measuring customers and in preparing the necessary forms. He employs an experienced tailor who is paid \$200 a week. The very first day, they took in \$2200. Today, a year later, Gauchet is taking out \$400 a week in personal salary and has had an offer of \$50,000 for the franchise. Admittedly, this was an extraordinary franchise situation—but it shows what can happen. ★★

*Place for everything? If not, you need . . .*

## **OUTDOOR STORAGE SPACE**

*A PM How-to-Do-It Library Booklet*

If things are spilling out of your garage, basement or attic, here are a number of practical ways to put them in their place. You get full information for construction of a classy, free-standing storeroom, a play fort with separate toolshed area, simple lean-tos, structural additions, shed and shelter combination, patio lounge and firewood box, even a collapsible shed that's especially desirable if you rent or plan to move—plus some clever ideas for hiding those unsightly storage tanks in the yard. For your copy, send 35¢ for Booklet H104 to:

Popular Mechanics Bureau of Information  
517 Lexington Ave., New York, N.Y. 10022

# PARKING

COMPANY OF AMERICA

## OFFERS AN OUTSTANDING FRANCHISE

### OPPORTUNITY IN THE OPERATION OF YOUR OWN PARKING LOTS

*Any city of 50,000 population or more can afford you excellent profits*

**How  
Excellent?**

Albuquerque, New Mexico — 19 Lots — 37,000 Net Yearly (1967)

El Paso, Texas — 9 Lots — 2,000 Net Monthly

Honolulu, Hawaii — 1 Lot — 1,750 Net Monthly

5,000 Minimum Investment Required—Company Training at Home Office and in the Field

**PARKING COMPANY OF AMERICA**

Please Send Me Complete Information on Parking Company of America

MAIL TO:  
W. G. RADFORD,  
DIRECTOR OF  
FRANCHISING

Name \_\_\_\_\_

Address \_\_\_\_\_ Phone \_\_\_\_\_

City \_\_\_\_\_ State \_\_\_\_\_ Zip \_\_\_\_\_

**PARKING COMPANY OF AMERICA**

6500 Wilshire Boulevard, Los Angeles, California 90048

## If you have enough money for one restaurant, or transmission shop, or similar franchise, you can open two LAUNDROMAT® Stores...

**Laundromat**  
FORMERLY  
WESTINGHOUSE



That's right! Your total cost in a LAUNDROMAT Self-service Laundry and Drycleaning Store is half what is required for most franchises. And whether you open two, or just one LAUNDROMAT Store, you'll get your money back faster than with most other franchises.

**Laundromat**  
FORMERLY  
WESTINGHOUSE



There are a number of reasons for this happy situation. Self-service laundry and drycleaning is a growing industry ... over \$800,000,000 now ... \$1 billion before 1970 ... and it serves a basic, expanding consumer need. Labor requirements are minimum. No credit, inventories, or deliveries.

There are also a number of reasons for the superiority of a LAUNDROMAT Store over all other self-service laundries. The LAUNDROMAT Store name is the best-known in the industry. LAUNDROMAT equipment ... by Westinghouse ... is the most advanced coin laundry and drycleaning equipment made. The LAUNDROMAT Store Franchise gives you experienced assistance in everything from site location and store design to personnel and promotion.

So, if the other franchises are too much for you to handle

financially, get all the facts on the great LAUNDROMAT Store Franchise Plan. Of course, if you wish, we'll be glad to help you with two or more Stores. Just think, you might start out with a chain!

### **Econo Sales**

Dept. PM-2-69

American Laundry Machinery Ind.

Division of McGraw-Edison Co.

5010 Section Avenue, Cincinnati, Ohio 45212

Econo Sales is the national distributor of Westinghouse LAUNDROMAT Equipment & Stores

 You can be sure if it's Westinghouse

ECONO SALES, Dept. PM-2-69  
5010 Section Ave., Cincinnati, Ohio 45212  
Please send me full information on the  
LAUNDROMAT Store Franchise Plan.

Name \_\_\_\_\_

Address \_\_\_\_\_

City \_\_\_\_\_ State \_\_\_\_\_

Zip \_\_\_\_\_ Phone \_\_\_\_\_

Present Business \_\_\_\_\_

# HOT DOG

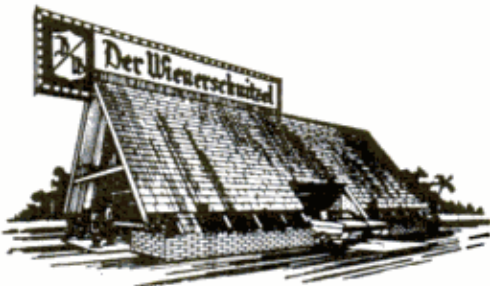

## COAST-TO-COAST

**CHICAGO:** 7101 W. Higgins  
Chicago, Ill. 60656  
312/692-4167

**HOUSTON:** 3110 Southwest Freeway  
Houston, Texas 77002  
713/529-5931

**TORRANCE:** P.O. Box 3788  
Torrance, Calif. 90502  
213/320-7500

Not just any old hot dogs. Der Wienerschnitzel hot dogs, der best dogs anywhere.

High returns! Selling D/W hot dogs is where der big money comes in! The average Der Wienerschnitzel franchise owner takes home, yearly, almost as much as his total initial investment . . . some, of course, take a lot more, some a little less. Many recoup the original cash investment of \$20,000 within the first year!

Safe Investment. D/W franchise operations have been meticulously planned to eliminate every possible element of risk and locations are carefully selected for maximum volume.

# Der Wienerschnitzel

\$20,000,000 business! Der Wienerschnitzel has grown in just seven years from one stand in Los Angeles to a nationwide business grossing nearly \$20,000,000 annually. While this growth is spectacular, it is also carefully planned.

How to join the D/W movement. Acquiring a D/W franchise requires two things: willingness to work hard and a cash investment of \$20,000. (That may sound like a lot of money to put together, but it's amazing the way it can be done if you really want to.) If you qualify on both counts, act right now. Write or phone—we will send you the complete story of a Der Wienerschnitzel franchise.



# WESTERN AUTO

## ONE franchise that gets you off to a running start

What happens when you open your new store with the famous red and white Western Auto sign? You step onto a fast moving express that is speeding down the tracks toward profits. There is no "warm up" period, no time lost in "making your name known."

Powerful national advertising has built immediate acceptance of the name "Western Auto".

**OWN YOUR OWN WESTERN AUTO STORE.** Yours is a family store selling household appliances of all kinds; yard and garden products; paint; hardware; TV, radio and Hi-Fi; sporting goods; plus more than 17,000 items customers can order from your catalog.

**NO FRANCHISE FEE—NO MONTHLY ROYALTY!** Unlike other franchises you pay no franchise fee—training is free. No starting up charges—we help you select store location; supply fixtures and store layout; advise on inventory. No Monthly Royalty—all the profits are yours to keep. But, we back you up constantly with personal guidance, advertising, financing, and a time-pay plan for your customers that gets your money at once.

**WE FINANCE HALF THE COST.** The total investment for opening your Western Auto Store is \$20,000, but

for qualified men we finance half—so your cash need is only \$10,000—of which \$2,000 remains with you for operating capital. How much can you make? There is no limit.

Hundreds of pre-selected locations are ready for your choice right now. You can grow rapidly with the help of the top marketing men. Send for complete information. It's free. No obligation.

**C. R. Hobbs, V.P., Western Auto Supply Co.**  
Room 52, 2107 Grand Ave., Kansas City, Missouri 64108

**C. R. Hobbs, V.P., Western Auto Supply Co.**

Room 52, 2107 Grand Ave., Kansas City, Missouri 64108

Please mail all facts free showing how you can help me succeed in a business of my own.

Name \_\_\_\_\_

Address \_\_\_\_\_

City \_\_\_\_\_

State \_\_\_\_\_

& Zip \_\_\_\_\_ Phone: \_\_\_\_\_

In keeping with our policy of offering the most advanced and most dependable in chain saws — we have incorporated solid state ignition into the STIHL 041 AV Electronic Saw. Other than eliminating the need for points and providing a molded circuit that is impervious to moisture, dirt, and temperature extremes — this model offers big 5½ horsepower performance

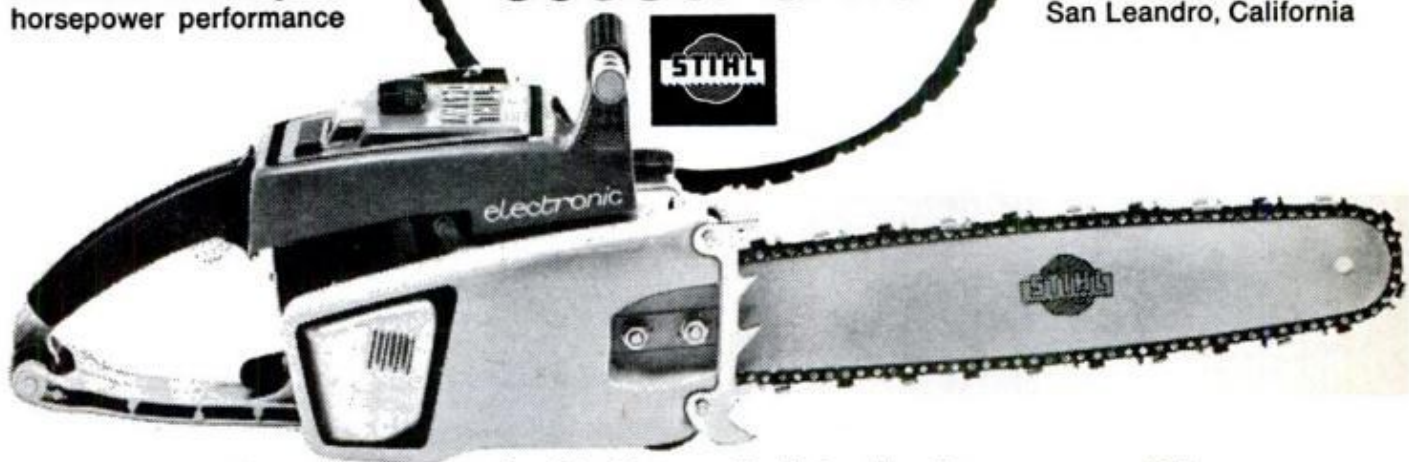

coupled with a light 15½ pound weight and the fabulous new vibration absorbing AV handle.

**STIHL American, Inc.**  
194 Greenwood Ave.,  
Midland Park, N. J.  
Phone 201-445-0890  
7364 Lee Industrial Blvd.,  
Mableton (Atlanta), Georgia  
2468 Teagarden Street,  
San Leandro, California

**first and only lightweight chain saw with built-in shock absorbers plus solid state ignition**

DON'T GO INTO A BUSINESS OF YOUR OWN UNTIL YOU...

## read this book

Hundreds of A to Z Rental Center owners have followed our guided program to success. They've invested from \$15,000 to \$50,000 in community rental centers that supply everything needed in the home or business... centers that are meeting the demands of the booming rental business with over 300 items for camping, lawn and garden care, home improvement, floor and carpet care, parties and health care. Our full-support program has helped them build growing, profitable businesses.

Before you go into business, send for our free book. Return the coupon below.



A NATIONWIDE FULL-SUPPORT FRANCHISE

**A to Z Rental, Inc.**

Nationwide Industries Building  
201 North Wells Street, Suite 000  
Chicago, Illinois 60606  
Phone: (312) 263-5200

I'm thinking of going into my own business. Please send my free copy of your Guided Program brochure.

Name \_\_\_\_\_

Address \_\_\_\_\_

Phone No. \_\_\_\_\_

City \_\_\_\_\_

State \_\_\_\_\_

Zip \_\_\_\_\_

A SUBSIDIARY OF NATIONWIDE INDUSTRIES, INC. Canadian franchises also available



## NOW... from the Editors of the Universally Accepted SMALL ENGINES SERVICE MANUAL

### Snowmobile Service Manual

2nd Edition Covers almost every machine built through 1968 and many '69 models! Engine section includes Hirth, JLO, Kohler, MAG, Sachs, Chrysler, OMC, Rotax, Lloyd, Yamaha and Wankel.



4.95

### Motorcycle Service Manual

2-Stroke 208 pages devoted to over 75 models of 18 manufacturers. Includes nearly every 2-stroke "popper" thru 1967 and many '68 cycles.



4.95

### Motorcycle Service Manual

Volume 2 4-Stroke A total of 16 manufacturers represented. Complete instructions on everything... from brake adjustment to engine tear-down and reassembly. 232 big pages.



4.95

### Small Engines Service Manual

8th Edition Complete repair information on over 1,300 models of foreign and domestic small engines that power lawn mowers, tillers, go-karts, etc. . . . 320 pages factory "Know-How"!



4.95

### Outboard Motor Service Manual

Volume 1 Covers outboard motors built from 1955 to 1967! Every re-4th Edition pair procedure from power head to prep. Over 35 different makes included. 239 pages.



4.95

### Outboard Motor Service Manual

Volume 2 Contains all pertinent service data on motors from 30 to 110 H.P. Same thorough model and year coverage as in Volume one. 208 pages.



4.95

### Small Tractor Service Manual

2nd Edition Universal service manual for popular "compact" garden/utility tractors. Covers models ranging from 6 to 12½ HP.



4.95

Complete! Comprehensive! Each book concisely written. Heavily illustrated. Each contains hundreds of diagrams, exploded view drawings, photographs. Lets you see exactly how work should be performed. Used and acclaimed by professional mechanics, do-it-yourselfers, classroom instructors. The most accurate and easy to understand universal repair manuals available anywhere.

Money Back Guarantee. Send check or money order and we pay postage.

TECHNICAL PUBLICATIONS DIV., Dept. PM-269  
1014 Wyandotte, Kansas City, Mo. 64105



## 5000° OXYGEN WELDING TORCH

**\$34.95**

New portable SOLIDOX welding torch goes anywhere. Only 4 lbs. Burns amazing solid oxygen pellets and standard 14 oz. propane. Flame exceeds 5000°F. Braze weld, silver solder, melt 1/4" steel. Complete kit contains: Torch, pellets, propane, protective glasses, nickel-silver braze rods, spark lighter, tip cleaner, instruction in welding techniques. Ideal for shops, hobby, metal repair. Professional results. Low-cost SOLIDOX pellets available by mail. SOLIDOX is simple and safe. Money back guarantee. Only \$34.95 ppd. Write for free brochure.

**SEND ONLY \$5.00**

pay postman \$29.95 plus postage on delivery.

Name \_\_\_\_\_  
 Address \_\_\_\_\_  
 City \_\_\_\_\_  
 State \_\_\_\_\_ Zip \_\_\_\_\_

Cleanweld Products Co., Box 1061, South Gate, Calif. 90280

## Let a GBS area director TELL IT LIKE IT REALLY IS!

Our Area Directors have facts and figures to show how a GBS franchise paid off for them! Let them tell you how high income and prestige can be yours, servicing small business in your exclusive franchise area with needed business control services. Thorough training and continuing support. \$7,500 investment required . . . write for

**FREE** booklet \_\_\_\_\_

Mr. C. E. Gaw, Executive Vice Pres.

**GENERAL BUSINESS SERVICES, INC.**

7401 Wisconsin Ave., N.W.  
 Washington, D.C. 20014



**BUY GOV'T SURPLUS SAVE TO 85%**

### FISH/WORM SHOCKER



**\$7.95**

FOB

Cost Gov't Over \$11.00

• (ITEM #670) - Harvest worms without digging, clear private ponds of coarse fish. Hand cranked unit puts out 110-VAC. Creates powerful electrical field in ground or water. Ideal for experiments, shocking fun at parties, etc. SAFE. 2" x 3" x 4". Shpg. wt. 3 lbs.

### BATTERY GEAR MOTOR



**\$25.95**

FOB

• (ITEM #571-A) - Powerful, ball bearing unit. Use with worm gear winches, build hoists, electric cars, etc. Operates on 6 to 12 volts DC. 20 to 1 gear ratio, fully reversible. 130 270 RPM. 6-12 VDC. Shaft 5/8" d. x 1-1/2" l. 6" diam x 15". Shpg. wt. 30 lbs.

### WALL TYPE TELEPHONE



Orig. Cost Over \$27.50

**\$7.95**

FOB

• (ITEM #715-W) - Genuine Automatic Electric dial telephones. Ideal for use as extension phones, for use on private systems, etc. Work on any commercial telephone system. Reconditioned, tested, guaranteed. Excellent condition, work like new. Shipping weight 9 lbs.



Send 25¢ (Coin or Stamp) For BIG BARGAIN CATALOG

1000's Of Bargains; Surplus, Excess Inventory, Brand Name Equipment  
 Hydraulics • Power Plants  
 Winches • Gear Motors • Surveying Instruments • Pumps • Welders  
 Compressors • Telephones • Binoculars • Electronics • Many Others  
**"SATISFACTION OR MONEY BACK GUARANTEE"**

**SURPLUS CENTER**

**PM-209**

Lincoln, Nebraska  
 Zip Code 68501

## NEW WESTERN HAIG

**.12 CALIBER  
 SPECIAL FACTORY  
 OFFER!**



**\$3.00**  
 post-paid

**USES POWDER CHARGE**

This small bore gun shoots .12 cal. (steel) bullets fired by small 4.4 mg. powder charge. Not a CO<sub>2</sub> gun! You'll like the handsome lines, grip, and balance. Western in style, but patented ball and cap action allows this low price. 9 3/4" steel barrel cased in knurled styrene stock, overall 13 1/2". Develop pistol form, accuracy at a fraction of cost of large caliber pistols. Comes with 50 steel bullets. Satisfaction guaranteed. Send \$3 to: Haig Mfg. Co., P.O. B-24, Alhambra, Calif. 91802

## INVENTORS

**INVENTIONS—NEW PRODUCTS—IDEAS DEVELOPED & PREPARED**

*For Commercial Appeal & Sales*

**DESIGN—MARKETING—PATENT SEARCHES—DRAWINGS**

*United States Patent Office former Patent Examiner*

*United States Dept. of Army former Patent Adviser*

*Member: United States Chamber of Commerce*

*second Decade of Reliable Service to*

**INVENTORS—MANUFACTURERS—ATTORNEYS**

**FREE CONSULTATION**

**THE RAYMOND LEE ORGANIZATION**

230-Z Park Ave., New York 10017 (212-MU 6-8500)

**SEND FREE "INVENTION RECORD" Form & "IMPORTANT PATENT INFORMATION"**

Name \_\_\_\_\_

Address \_\_\_\_\_

City \_\_\_\_\_ State \_\_\_\_\_ Zip \_\_\_\_\_

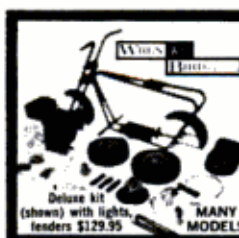

**FACTORY DIRECT!**

**MINI-BIKE KIT! \$109.95**

Build your own mini-bike in about 2 hours! No welding! Speeds to 30 mph. You get:  
 • 2 1/2 hp 4 cycle engine  
 • Precision welded frame  
 • Complete instructions

**\$10 Down  
 \$7 Month**  
 Assembled \$119.95

**RUSH 25¢ for brochure to:**

BIRD engineering, Box 427, Dept. PM2, Omaha, Nebr. 68101

# AUDEL

## SKILL-BUILDING PRACTICAL GUIDES

**LEARN MORE—  
EARN MORE!**

### Electric Motors

Covers hookups, control, maintenance and trouble shooting of all types of motors. Completely illus. 432 pages. \$5.95  
Circle No. 27 in Coupon

### Truck and Tractor Guide

A guide for mechanics, drivers and maintenance men. Gas & Diesel repair, service and operation. Illus. 1366 pages. \$6.95  
Circle No. 5 in Coupon

### Diesel Engine Manual

Complete practical guide to modern Diesel engines. Explains principles & how to maintain & oper. Illus. 544 p. \$6.95  
Circle No. 9 in Coupon

### Sheet Metal Pattern Layouts

Modern guide to all phases of sheet metal work, including pattern development. 350 layouts. Illus. 1152 p. \$11.95  
Circle No. 29 in Coupon

### Masons and Builders Guides

4 practical volumes for bricklayers, masons, cement workers, plasterers. 2000 illus. 1488 pages. 4-Vol. Set \$14.95  
Circle No. 26 in Coupon

### Plumbers and Pipefitters Guides

3 vols. of ready reference for plumbers, pipe & gas fitters, sheet metal workers. 540 illustrations. 960 pages. 3-Vol. Set \$12.50  
Circle No. 6 in Coupon

### Blueprint Reading

For mechanics & construction men. Step-by-step explanation how to read all types of prints. 416 pages. \$5.25  
Circle No. 25 in Coupon

### Welders Guide

Practical guide to theory; operation; maintenance all types—electric, oxy-acetylene & Thermit. 626 pages. \$5.50  
Circle No. 10 in Coupon

### Outboard Motor & Boating Guide

Practical details on all phases of outboard motor repair, maintenance and operation. Up-to-date. Illus. 446 pages. \$4.95  
Circle No. 49 in Coupon

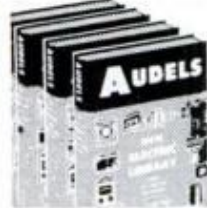

### ELECTRIC LIBRARY

A complete 10-volume electrical encyclopedia. Covers basic principles & applications of applied electricity. Answers thousands of problems. Ill. 5600 pgs. Set \$35.00  
Circle No. 15A in Coupon

### Millwrights & Mechanics Guide

Practical information on plant installation; operation and maintenance data for foremen & workers. Illus. 1236 pgs. \$7.95  
Circle No. 42 in Coupon

### MONEY BACK GUARANTEE

You must be COMPLETELY satisfied with the Audel Guides you order, or you may return them within 10 days and get your money back.



**THEODORE AUDEL & CO.**  
division of HOWARD W. SAMS & CO., INC.  
Indianapolis • New York

FEBRUARY 1969

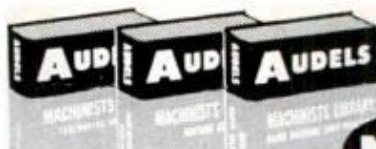

### MACHINISTS LIBRARY

Three volumes of ready reference on all the latest shop practices for machinists and toolmakers. Vol. 1—Practical Fundamentals of Basic Machine Shop Operations. Vol. 2—Setup and Operation of all the widely used, important shop machines. Vol. 3—Toolmakers Handbook with down-to-earth data on layouts, specifications, jigs and fixtures, gear forming, cams, etc. Illus. 1310 pages. 3-Vol. Set \$15.50  
Circle No. 12N in Coupon



### CARPENTERS & BUILDERS GUIDES

Four all-inclusive volumes provide latest inside trade information on modern construction. Vol. 1—Tools, Steel Square, Joinery. Vol. 2—Builders Math, Drawings, Specs. Vol. 3—Layouts, Foundations, Framing. Vol. 4—Millwork, Power Tools, Windows, Doors, Roofing, Flooring. Most practical guide available. Thousands of diagrams, charts, graphs and photos. 1616 pages. 4-Vol. Set \$16.95  
Circle No. 8 in Coupon

## AUTO GUIDE ALL-NEW

biggest value!



**\$7.95**

## FIX ANY CAR FAST!

STEP-BY-STEP REPAIR GUIDE COVERS EVERYTHING: Troubleshooting—unique symptoms-and-causes charts • Spark Plugs • Batteries • Tune-up • Distributors • Ignition Testing • Starters & Generators • Lighting • Tire Servicing • Brakes • Power Brakes • Front Suspension • Steering Systems • Wheel Alignment • Chassis, Springs & Shocks • Fuel Pumps • Carburetors • Cooling Systems • Lubricating Systems • Pistons & Rings • Crankshafts and Connecting Rods • Camshafts • Valves • Clutches • Automatic & Manual Transmissions • Drive Shafts & Universal Joints • Rear Axle Assemblies—ABSOLUTELY EVERYTHING YOU SHOULD KNOW TO FIX ANY CAR! Hundreds of illus. 736 pages. \$7.95  
Circle No. 1 in Coupon

### HOME APPLIANCE SERVICING

How to test, service, and repair all modern gas & electric appliances such as refrigerators, washers, dryers, ranges, irons, hot water heaters. Gives up-to-date methods, wiring diagrams, complete servicing data. Fully illustrated. 608 pages. \$6.95  
Circle No. 2 in Coupon

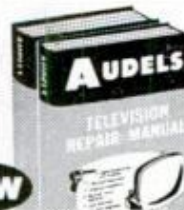
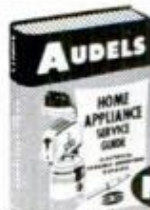

### TV-RADIO LIBRARY

Two vols. of practical and theoretical knowledge including basic electronics, basic radio and radio receiver repair. Complete from basics through transistors. Covers entire subject of television, both black & white and color, from theory thru testing & repair. Illustrated. 960 pages. 2-Vol. Set \$10.95  
Circle No. 3 in Coupon

### Foreign Auto Repair Manual

Up-to-date service data for all popular imports: English, French, German, Italian, Swedish. Illus. 592 pages. \$5.95  
Circle No. 53 in Coupon

### Mathematics for Mechanics

A complete guide to the mastery of practical math. Simplified method makes learning fast and easy. Ill. 704 pgs. \$5.50  
Circle No. 11 in Coupon

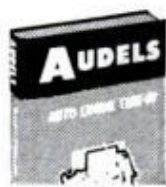

### Auto Engine Tune-up

Complete tune-up procedures for all types of auto engines. Full adjustment data for carburetors, ignition, valves, etc. For mechanics & owners. Illus. 416 pages. \$5.95  
Circle No. 58 in Coupon



### Practical Electricity

Get your start in the electrical industry with this complete handbook of practical, simplified ready reference on all electrical subjects. 1300 illus. 1088 pages. \$6.95  
Circle No. 4 in Coupon



### Home Refrigeration & Air Conditioning

Complete information on installing, servicing, and repairing all types of home and auto air conditioners and gas & electric refrigerators. Illus. 576 pages. \$6.95  
Circle No. 14A in Coupon

## MAIL THIS NO-RISK COUPON TODAY!

THEODORE AUDEL & CO.—Self Improvement Publishers Since 1879—  
4300 W. 62nd Street, Indianapolis, Indiana 46268

Please mail me books circled at right. Enclosed is down payment of \$\_\_\_\_\_ (3 down payment for purchase amounting to less than \$9; 1/2 of total if purchase price is over \$9). I agree to pay balance, including shipping costs, within 30 days. If I am not completely satisfied with my Audel Guides I may return them for refund.

### SAVE SHIPPING COSTS—Send full payment with order!

Check here if you enclose full payment with order (plus sales tax, if any). We pay postage charges. You have same return privilege.

Name \_\_\_\_\_  
PLEASE PRINT  
Address \_\_\_\_\_  
City \_\_\_\_\_ State \_\_\_\_\_ Zip \_\_\_\_\_

P-29	1	2	3	4
	5	6	8	9
	10	11	12N	14A
	15A	25	26	27
	29	42	49	53
	58			

I have bought Audel books before

# FRANCHISES IS OUR FIRST NAME

WRITE FOR PORTFOLIO

Before you make a move toward going into any business for yourself, it makes sense to contact the people who are First in Franchising.

This portfolio tells what the world's largest franchise organization has to say about 3 types of restaurants, beauty salons, the service business, a weight control franchise, and major franchise marketing itself.

Must reading for the person with \$10,000 to \$50,000 to start his own business.

It's free for the asking. No obligation, of course.



write for this portfolio to:  
**FRANCHISES INTERNATIONAL**  
 Dept. P, 285 Central Ave.  
 White Plains, N.Y. 10606  
 Phone (914) 949-5107

A SUBSIDIARY OF CITY INVESTING COMPANY

## LAW FREE BOOK THE LAW TRAINED MAN

Write today for a FREE copy of illustrated law book, "THE LAW-TRAINED MAN," which shows how to earn the professional Bachelor of Laws (LL.B.) degree through home study of the famous Blackstone Law Course. All necessary books and lessons provided. Moderate cost; convenient monthly terms. Write for FREE law training book today.

**Blackstone School of Law, 307 N. Michigan Ave.**  
 Founded 1890 Dept. 52, Chicago, Illinois 60601

## A Treasury of HARD-TO-FIND TOOLS

NEW CATALOG

Unique collection of hard-to-find versatile hand tools and small power tools rarely found in stores or other catalogs. Large selection of unusual knives, precision tweezers, jewelers' and electronics pliers, flexible shaft machines, endless hacksaw, diamond glass cutter, soldering jigs, carbide hacksaw blades, silver solder, micro-miniature tools and scores of other fascinating items to make projects easier, more fun. All are top quality tools. Used extensively by woodworkers, machinists, craftsmen. Money back guarantee. Send 25¢.

## BROOKSTONE CO.

2924 RIVER ROAD, WORTHINGTON, MASS. 01098

### FREE FACTS

on how to become a

## GAME WARDEN

Fish-Wildlife Mgr. • Forester,  
 Gov't Hunter or Aid or Assistant  
 Type Positions that require  
 Less Formal Education



• PROTECT FORESTS & WILDLIFE  
 • ARREST VIOLATORS

Don't be chained to desk, machine or store counter. Easy home-study plan prepares you for exciting career in Conservation. Many Forestry & Wildlife men hunt mountain lions, parachute from planes to help marooned animals or save injured campers. Live the outdoor life you love. Sleep under pines. Catch breakfast from icy streams. Feel and look like a million.

### OPPORTUNITIES IN YOUR STATE?

We show you how to seek out job openings in your state and others Coast-to-Coast. Good pay, low living costs, no layoffs. Age 17-45, sometimes older on private game farms and hunt clubs. Live a life of thrills and adventure. **G. I. Bill Approved.** Accredited Member National Home Study Council. No salesman will call.

**FREE:** 20-pg Conservation Career Book, "JOBS FOR SPORTSMEN—How & Where to Get Them" & 3-mo. subscription to Conservation Magazine. Rush name today! State your age.

**NORTH AMERICAN SCHOOL OF CONSERVATION**  
 4500 Campus Dr., Dept 4172, Newport, Calif. 92660

### HEAVY DUTY BALL-BEARING PUMP

IRRIGATE • DRAIN • SPRAY • CIRCULATE • Famous all-metal, rust-proof XB pump with stainless shaft. Use 1/4 HP or larger. 1 HP for up to 5,200 GPH 60" high or 3,000 GPH from 25' well. 1 1/4" inlet. 1" outlet. For belt or direct drives. Only \$12.95  
 Famous Type P won't rust or clog. Bronze bearing. Hundreds of thousands in use. Up to 2,400 GPH. 1" inlet. 3/4" outlet. Only \$8.95  
 Postpaid cash with order. Money Back Guarantee.  
**LABAWCO, Box 2, Belle Mead, N. J. 08502**

### Fantastic NEW Swiss Measuring Tools

Dial Caliper 5 1/2" RANGE ONLY 7.95 + 25¢ POSTAGE  
 3 for \$23.00  
 12 for \$85.00  
 Measures inside, outside, depth & step readings. Dial graduated in .001" unbreakable, rust proof, patented construction of Borg-Warner Cyclocac®. Verniers 1/16" - 1/10 mm, illustrated instructions included. SEND 25¢ FOR CATALOG

**A.O.K. TOOL CORPORATION 82-27 SUTTER AVE. OZONE PARK, N.Y. 11417**

## New Way to Big Pay!

### LEARN AIR CONDITIONING REFRIGERATION & HEATING

Want big money? A better job or a business of your own? Learn Air Conditioning, Refrigeration & Heating. Over 20,000 new mechanics needed yearly. CTI sends 25 kits. You build a refrigeration system (see picture at right). Many students earn as they learn. Mail coupon now for valuable FREE booklet.



**COMMERCIAL TRADES INSTITUTE Dept. PM-269**  
 1400 Greenleaf Avenue • Chicago, Illinois 60626

Name \_\_\_\_\_ Age \_\_\_\_\_  
 Address \_\_\_\_\_ Zip Code \_\_\_\_\_  
 City \_\_\_\_\_ County \_\_\_\_\_ State \_\_\_\_\_

Check for facts on GI Bill



# 10 Reasons why RCA Home Training is

# your best investment for a rewarding career in electronics:

Transistor experiments  
on programmed breadboard —  
using oscilloscope.



## 1 LEADER IN ELECTRONICS TRAINING

RCA stands for dependability, integrity and pioneering scientific advances. For over a half century, RCA Institutes, Inc., has been a leader in technical training.

## 2 RCA AUTOTEXT TEACHES ELECTRONICS FASTER, EASIER

Beginner or refresher — AUTOTEXT, RCA Institutes' own method of Home Training will help you learn electronics faster, easier, almost automatically.

## 3 THOUSANDS OF WELL PAID JOBS ARE OPEN NOW

RCA Institutes can help you qualify for a rewarding career if you have an interest in electronics. Every year, thousands of well paid electronics jobs go unfilled just because not enough men take the opportunity to train themselves for these openings.

## 4 WIDE CHOICE OF CAREER PROGRAMS

Select from a wide choice of courses and career programs ranging from basic Electronics Fundamentals to advanced training including Computer Programming and Electronics Drafting. Each

Career Program begins with the amazing AUTOTEXT method.

## 5 SPECIALIZED ADVANCED TRAINING

For those working in electronics or with previous training, RCA Institutes offers advanced courses. Start on a higher level. No wasted time on material you already know.

## 6 PERSONAL SUPERVISION THROUGHOUT

All during your program of home study, your training is supervised by RCA Institutes experts who become personally involved in your efforts and help you over any "rough spots" that may develop.

## 7 VARIETY OF KITS, YOURS TO KEEP

At no extra cost, a variety of valuable specially engineered kits come with your program—yours to keep and use on the job.

## 8 TRANSISTORIZED TV KIT AND VALUABLE OSCILLOSCOPE

You will receive in most career programs a valuable oscilloscope. Those enrolled in the TV Program or courses receive the all-new Transistorized TV Receiver—exclusive with RCA. Both are at no extra cost.

## 9 TWO CONVENIENT PAYMENT PLANS

Pay for lessons as you order them. No contract obligating you to continue the course. Or, you can take advantage of RCA's convenient monthly payment plan.

## 10 RCA GRADUATES GET TOP RECOGNITION

Thousands of graduates of RCA Institutes are now working for leaders in the electronics field; many others have their own profitable businesses... proof of the high quality of RCA Institutes training.

**RCA INSTITUTES, INC.** Dept. PM-29  
320 West 31st St., N.Y., N.Y. 10001

**Canadians:** These same RCA courses are available to you in Canada. No postage. No customs. No delay. Your inquiry will be referred to our school in Canada.

All courses and programs approved for veterans under new G.I. Bill.

**CLASSROOM TRAINING ALSO AVAILABLE. FREE CATALOG ON REQUEST.**

ACCREDITED MEMBER National Home Study Council

Construction of Oscilloscope.

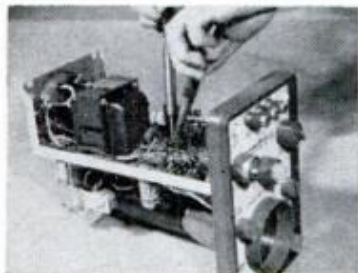

Construction of Multimeter.



# RCA

Send Coupon Today for Free Descriptive Book.

## RCA INSTITUTES, INC.

Home Study Dept. PM-29  
320 West 31st Street  
New York, N.Y. 10001

Name \_\_\_\_\_

Address \_\_\_\_\_

City \_\_\_\_\_

State \_\_\_\_\_

Zip \_\_\_\_\_

Check here if interested in Classroom Training

# PICTURE THIS

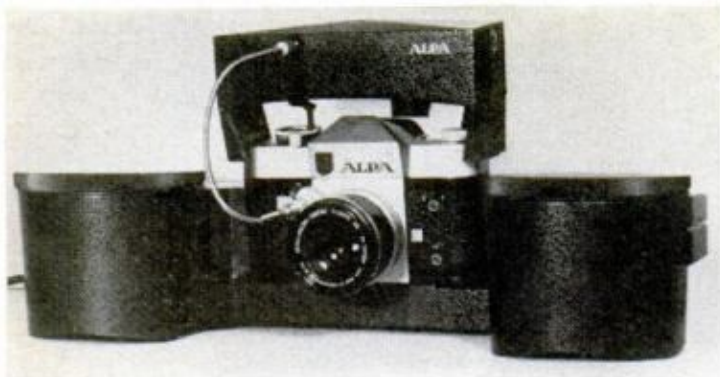

**NEWEST CAMERA** to join the growing list of precision single-lens reflexes is this swank Alpa—a supersophisticated example of Swiss craftsmanship. Anticipating the use of faster and faster films, the camera's built-in exposure-control system has settings for ASA speeds up to 6400. Shutter speeds go up to 1/1000th of a second and include synchronization for all types of flash. More than 30 inter-



changeable lenses are available from a 1.9-mm ultrawide-angle to a 5000-mm super telephoto. An accessory bulk-film magazine and electric motor drive, shown at left above, turn the rig into a high-speed sequence camera capable of shooting up to 800 35-mm exposures nonstop. Basic price for the camera with a standard 50-mm Xenon f/1.9 lens is \$499. Karl Heitz, Inc., 979 Third Ave., New York, N. Y.

**YOU CAN'T CUT YOUR FINGER** on this new type of paper cutter developed by Honeywell. Instead of the usual guillotineline blade that swings down, a small, sharp-edged wheel rolls along a guide bar to do the cutting. You just position the paper and pull the wheel toward you over the surface. The wheel is geared to cut smoothly without tearing. The cutter will handle plastic, rubber and other such materials in addition to paper. Four sizes—12, 16, 20 and 24 inches—are available. Prices range from \$24.95 to about \$60. Honeywell Photographic Div., 4800 E. Dry Creek Rd., Denver, Colo. 80217

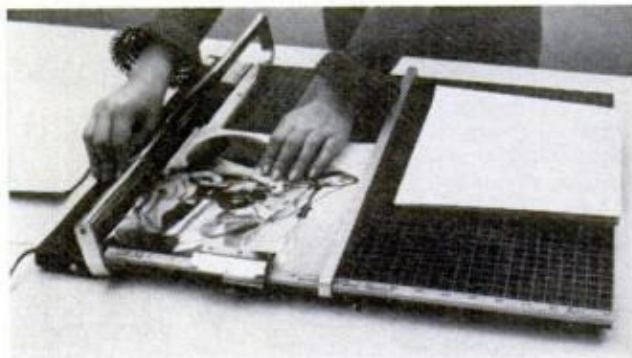

Out of focus



In focus

**YOU'RE ALWAYS IN PERFECT FOCUS** with this new Keystone slide projector. It has a built-in optical rangefinder that works like the split-image finders used on cameras. At the start, you project a split test target on the screen and adjust the focus until the two halves line up. All slides are then kept automatically in sharp focus. Price: \$159.95

OVER 100,000 MEN CAN TELL YOU:

# “NTS HOME-TRAINING REALLY WORKS!”

AND PUTS YOU WHERE THE BIG MONEY IS!



If you think you can't learn a new technical skill with NTS Home-Training, you're wrong. Over 100,000 men have done it in the past half-century since the school was established.

And so can you.

NTS Project Method makes learning fast, easy and exciting. Takes only a few hours a week. Hours any man can fit into his life.

So, stop wasting time. Pick from these big money-making fields. We'll send you all you need to know to get started towards a new, better job. It's a sure thing!

### ELECTRONICS DIVISION (New 25" Color TV Kits)

Train with the biggest, most exciting package of electronics kits ever offered! Beautiful new 25" Color TV kits included in color TV courses. No kit deposits — no extra cost. All-new Communications and Industrial Electronics Kits & Courses — put you two steps ahead of tomorrow. Check coupon for choice of Project Method Courses and New Free Color Catalog.

### MECHANICS DIVISION (New Test Equipment)

NTS makes you a skilled Mechanic — Diagnostic Technician in a hurry! You get professional engine analysis test instruments at no extra cost! Special Engine Diagnostic and High Performance lessons included — everything you need to be a pro. Four fields from which to choose. Service your own car — earn while you learn. Check the coupon for new catalog.

### AIR-CONDITIONING, REFRIGERATION DIV. (New Kits)

A wide-open field. NTS opens it up for you — fast and easy! Trains you to handle the big jobs. Start your own business with either of the two courses in this division. We give you the tools, tester, and instruments you need at no extra cost. No kit deposits! Check the coupon below and get rolling!

### HOME APPLIANCES DIV. (New Circuit-Trainer)

Dig deep into the Major Home Appliance repair field for the big money! NEW, EXCLUSIVE! THE NTS CIRCUIT-TRAINER! Shows you the ins and outs of major appliance circuitry. Makes training a snap. Puts you in line for a piece of the billion-dollar appliance repair field. New Kits! New Catalog. Check coupon for earn-while-you-learn courses.

### HIGH SCHOOL AT HOME

National offers accredited High School programs. Take only subjects you need. Study at your own pace. Everything included at one low tuition. Check special High School box in coupon for full information and FREE catalog.

### CLASSROOM TRAINING AT LOS ANGELES.

You can take classroom training at Los Angeles in Sunny Southern California. NTS occupies a city block with over a million dollars in training facilities.

### NATIONAL TECHNICAL SCHOOLS

4000 So. Figueroa St.  
Los Angeles, Calif. 90037  
No obligation.  
No salesman will call.

SEND POSTCARD FOR FREE BOOK AND SAMPLE LESSON

### TEAR OUT AND MAIL THIS CARD TODAY. CHECK ONE ONLY.

#### ELECTRONICS DIVISION

- MASTER COURSE IN COLOR TV SERVICING
- COLOR TV SERVICING
- MASTER COURSE IN TV & RADIO SERVICING
- PRACTICAL TV & RADIO SERVICING
- MASTER COURSE IN ELECTRONIC COMMUNICATIONS
- FCC LICENSE COURSE
- MASTER COURSE IN ELECTRONICS TECHNOLOGY
- INDUSTRIAL AND AUTOMATION ELECTRONICS
- COMPUTER ELECTRONICS
- BASIC ELECTRONICS

#### HOME APPLIANCES DIVISION

- HOME APPLIANCES MASTER TECHNICIAN'S COURSE
- HOME APPLIANCES SERVICING
- HANDYMAN APPLIANCE REPAIR

#### AUTO-MECHANICS DIVISION

- MASTER COURSE IN AUTO & TRUCK MECHANICS
- AUTOMOTIVE MECHANICS
- TRUCK & HEAVY DUTY MECHANICS
- ENGINE TUNE-UP & ELECTRICITY

#### AIR CONDITIONING-REFRIGERATION DIVISION

- AIR CONDITIONING, REFRIGERATION & ELECTRICAL APPLIANCES MASTER COURSE
- AIR CONDITIONING-REFRIGERATION SERVICING COURSE

#### HIGH SCHOOL DEPARTMENT

- HIGH SCHOOL AT HOME Dept. 201-29



NAME \_\_\_\_\_ AGE \_\_\_\_\_

ADDRESS \_\_\_\_\_

CITY \_\_\_\_\_ STATE \_\_\_\_\_

Please fill in Zip Code for fast service \_\_\_\_\_

- Check if interested in veteran training under the new GI Bill.
- Check if interested ONLY in classroom training at Los Angeles.

# GET OFF THE DIME. HERE'S 4 WAYS TO BOOST YOUR INCOME!



## ELECTRONICS DIVISION

New color catalog

NTS Project-Method home training makes it easy for you to make your mark in Electronics. To get the big-paying job you want. Learn more, faster, with exciting kit equipment included at no extra cost. There's no better time than right now to do it! Send the coupon!



## MECHANICS DIVISION

NTS gives you professional engine analyzing equipment. And top mechanics' know-how in diagnosis... speed... performance. Industry needs over 200,000 trained mechanics right now. And you can be one of them. Mail the coupon for our new catalog today!

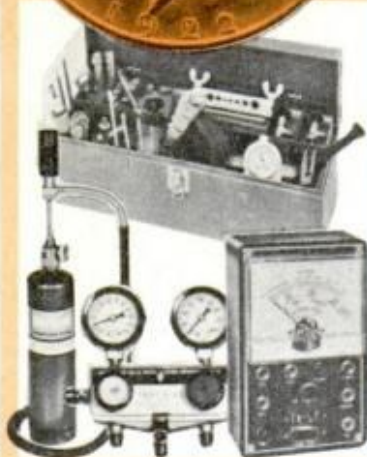

## AIR CONDITIONING, REFRIGERATION DIV.

We give you the tools, tester, instruments. Show you how to service giant industrial cooling systems and commercial refrigeration installations. There's a big job waiting for you here. All it takes to get it is the skill we give you. Don't wait any longer.



## HOME APPLIANCES DIVISION

Learn to service major home appliances. Get the new, exclusive NTS CIRCUIT-TRAINER! It helps train you faster for the big jobs. Learn troubleshooting, open your own business, be your own boss. So get off the dime. Mail the coupon. We'll send you all the facts in our new catalog.



### BUSINESS REPLY MAIL

No Postage Stamp Necessary if Mailed in the United States

POSTAGE WILL BE PAID BY

**NATIONAL TECHNICAL SCHOOLS**

4000 South Figueroa Street

Los Angeles, California 90037

FIRST CLASS  
Permit No. 3087  
Los Angeles,  
Calif.

VIA AIR MAIL



FILL OUT  
AND MAIL  
CARD TODAY

GET FULL COURSE  
DETAILS AND  
LEARN ABOUT THESE  
NTS EXTRAS:

1. BONUS CLASSROOM TRAINING
2. JOB PLACEMENT CONSULTATION
3. BUSINESS CONSULTATION

NO OBLIGATION.  
NO SALESMAN WILL CALL.

APPROVED FOR VETERANS



Accredited Member  
National Home  
Study Council



Accredited Member  
National  
Association  
of Trade and  
Technical Schools

# MOW AN ACRE IN 30 MINUTES!



MAN  
SIZE!

Handles 48" and 60" mowers . . . bigger implements for gardening, dozing, removing snow. Here's why: Big 14 hp . . . extra size and traction . . . all-gear-drive with automatic clutch, transmission and differential. More for your money! Send for free catalog.

## ECONOMY TRACTOR

1005 K-2 Anoka Ave.  
Waukesha, Wisconsin

World  
Famous  
WITCH  
Automatic  
Needle  
Threader



## 25c SAMPLE (\$1 Retail)

Make up to \$10 an hour in your spare time just showing this amazing little invention that threads a needle simply by pressing a button. Show it to women (men, too) and watch them grab it out of your hands for only \$1.00. No sales experience needed. **INTRODUCTORY OFFER:** Rush 25¢ for sample or \$3 for 1 doz. in 3-color store display carton, and money making facts, plus other self-selling moneymakers.

UNIQUE PRODUCTS, Dept. T-1492  
216 W. Jackson Blvd., Chicago, Ill. 60606

## SURE SQUARE



Sturdy aluminum, locates 90° cuts to your mark as it clamps instantly to stock up to 12" wide, eliminating creep under vibration. Free Literature —10 day trial privilege ONLY \$12.50 + \$1 pstg. & ins. (Pa. + 75c S.T.)

Saw Guide as shown in Dec. & Feb. ('69) Popular Mechanics  
INDEPENDENCE SPECIALTIES, Box 2987, Phila., Pa. 19126

## EARN HIGH WAGES as a HEAVY EQUIPMENT OPERATOR



Train your way to high pay in the booming construction industry! Learn the skills you need to qualify, by actual field training on machines like the ones used by the industry. Huge training grounds in North Carolina, a million dollars worth of school-owned diesel-engined machines, experienced instructors, full 220-hour and 440-hour courses. National, the original school of heavy equipment operation, is a recognized leader. Member American Road Builders Assn., Services and Supply Division. Associate Member A.G.C. Full-time Job Advisory and Counseling Director on staff. VA approved. For men ages 17 to 56. Train Now-Pay Later plan . . . other payment plans also available. Write TODAY for FREE catalog and FREE copy of school newspaper reporting news of National School graduates. Accredited member NATTS.

NATIONAL SCHOOL  
OF HEAVY EQUIPMENT OPERATION, Dept. D-24  
P. O. Box 1686, Moores Chapel Road, Charlotte, N. C. 28201  
Please send me FREE illustrated school catalog and complete information. I understand there's no obligation.

Name \_\_\_\_\_ Age \_\_\_\_\_  
Address \_\_\_\_\_ Phone \_\_\_\_\_  
City \_\_\_\_\_ State \_\_\_\_\_ Zip Code \_\_\_\_\_

FEBRUARY 1969

# ACCORDIONS

## SAVE 1/2 Big Discounts

off retail prices of comparable accordions



## BUY DIRECT

IMPORTER-TO-YOU PRICES

**E-Z TERMS** LOW DOWN  
PAYMENT  
Low as \$7.95 a month

**NO RISK 5 DAY  
HOME TRIAL!**

## 42 "NEW SOUND" Electronic and Standard Models

Choose your "new sound" accordion from world's biggest selection of Famous Imported Italian Makes . . . for beginners, hobby players, professionals. Totally new styling and startling new features—plus an exciting new sound! Buy direct from world's largest dealer at fantastic Importer-to-You savings of 1/2 or even more. Easy terms . . . low down payment, up to 3 years to pay. **NO RISK PLAN—5 Day No Obligation Home Playing Trial.** Lifetime performance policy. Satisfaction guaranteed or money back.

**TRY BEFORE  
YOU BUY!**

## FREE BONUS GIFTS

for promptness in ordering  
E-Z LESSONS • MUSIC PORTFOLIO  
• MUSIC STAND • DELUXE CASE  
YEAR'S SUPPLY OF MUSIC Many More



NOW—Popular "Button Type" Accordions! Full line at discount prices. Check coupon below.



Big discounts on  
Accordion Amplifiers  
and Reverb Units.  
Finest makes—  
custom designed  
for Accordions.

**FREE! Color Catalogs  
Selection Guide  
Discount Prices. Beautiful  
New Color Swatches**

Rush coupon today. Get full details, pictures and low discount prices on over 40 models . . . plus big savings on Amplifiers and accessories. All FREE. No obligation. Write:

## MONEY BACK GUARANTEE

**TRADE-INS!** BIG ALLOW-  
ANCE on any-  
thing of value!

**ACCORDION CORP. of AMERICA, Dept. R-29**  
5535 West Belmont, Chicago, Illinois 60641

**FREE  
Color  
Catalogs  
Discount  
Prices  
Rush  
Coupon**

Accordion Corp. of America, Dept. R-29  
5535 West Belmont, Chicago, Illinois 60641

Send FREE Color Catalogs and Discount prices. Includes special information checked.

Amplifiers  Button Type Accordions

Name \_\_\_\_\_

Address \_\_\_\_\_

City \_\_\_\_\_ State \_\_\_\_\_ Zip \_\_\_\_\_

I have a trade-in

# Drivin' with Dan

Are any race drivers color blind? Should I get power or manual steering on my new street/strip GTX? How is AMA horsepower measured; what does it mean? Dan Gurney answers these and other provocative questions

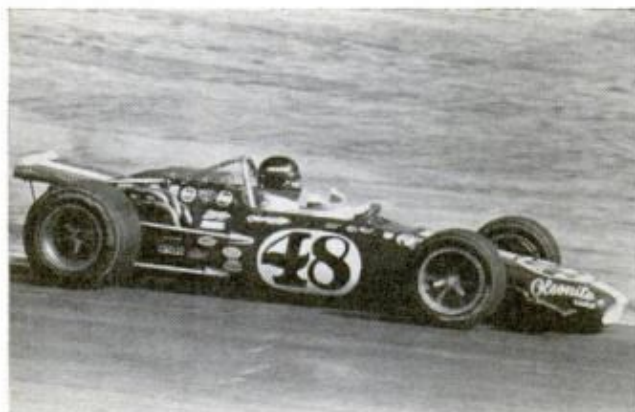

**REPEAT PERFORMANCE** was turned in by our Dan'l as he won his second straight Rex Mays 300 at Riverside last December. His average speed was a record 111.69

**Q.** What is meant by "AMA horsepower?" How is it measured?—*Wm. Domenici, Albuquerque, N. M.*

**A.** I'm not certain of this, but I think the "AMA" stands for Automobile Manufacturers Association. As I understand it, AMA horsepower is brake horsepower measured on a dynamometer and then corrected to compensate for the theoretical frictional loss of operating, say, the alternator, or certain accessories. It can, I think, vary widely in extremes and seldom relates to the average power really available at the clutch.

**Q.** We're running a limited sportsman with a Chevy 302 engine on a one-half-mile dirt oval. We want to convert to alcohol or alcohol/nitro. How do we set a four-barrel Holley carburetor to run this fuel?—*Lewis Merwine, Levittown, Pa.*

**A.** I can't really answer your question since I've never tried it. However, your methanol mileage will be about 60 percent of what it is on gasoline. A mixture of 20 percent nitro with 80 percent methanol cuts mileage even further to about 40 percent of what it is on

gas. I would use an air pressure tank system to feed the carb and I think I'd increase all jets and passages to meet the fuel delivery requirements based on the mileage approximations mentioned above.

**Q.** I saw a photograph of a car being pitted during a race. The head pit man was pointing at the car with two fingers. What does this sign mean?—*Janet Harper, Plains, Ga.*

**A.** It could mean anything—the car's position in the race, the number of pit stops remaining, the number made, the tires to be changed, the number of shopping days 'til Christmas . . . anything.

**Q.** Could you tell me exactly what the Can-Am series of races is?—*Larry Frost, Cottonwood, Minn.*

**A.** The series is comprised of six professional races for Group Seven sports cars powered by engines that must be over two liters (or 122 cu. in.). The races are held in both the United States and Canada and the purses are attractive. Richest race in the series is Riverside, which pays the winner about \$20,000. In addition to purse money, last year's high point car and driver received about \$70,000 in supplementary prizes. There will be 10 races in the series this year. The cars, by the way, are the fastest road racing cars in history.

**Q.** I have Goodyear Polyglas F-70s on my '68 Torino. Cornering and handling are fine, but I get wheel hop and bounce over small irregularities and bumps in the road. Would heavy-duty shocks help?—*Leon Gross, Philadelphia.*

**A.** First, make sure your wheels are round and true and properly balanced. By all means

*(Please turn to page 52)*

# Ed Crouch Never Dreamed He'd Earn Up To \$2,000 A Month When He Mailed The Coupon



**But he does . . . And his car and business expenses are paid, too. Read how he moved up fast to an exciting, top pay career**

For 10 long years Ed Crouch worked in a drive-in theater in California. He saw a lot of movies, but he didn't see much in the pay envelope. A bright future just wasn't in the coming attractions.

So Ed became dissatisfied, restless for change. He wanted a fresh start in a real pay-off business. But what do you do when you've got 10 years of your life invested in one job?

If you're at all like Ed Crouch, you start looking around for a better opportunity. And that's what Ed was doing when he mailed the coupon that changed his life.

That coupon, the same one that's on this page you're reading right now, brought Ed a free book of facts on the booming Accident Investigation field. And it was an eye-opener!

## 30 MINUTES THAT CHANGED THE FUTURE FOR ED CROUCH

Ed learned that Accident Investigation is part of the *biggest business in the world today* — a \$20 billion industry of wide-open opportunities.

He learned that more than 22 million accidents and losses must be investigated and settled every year in this country. He learned that more and more trained men are urgently needed now, everywhere, to handle this huge workload — in cities, towns and rural areas.

It took Ed Crouch just 30 minutes to skim through that free book of facts. But that half-hour changed everything. He knew he had found the opportunity of a lifetime.

## EARNS UP TO \$2,000 A MONTH, EXPENSES PAID

Today Ed is a professional Accident Investigator with an independent firm in California. His income ranges from \$1,200 a month up to \$2,000 a month! He has car and all business expenses paid. He's on top and set for life.

Ed Crouch has the kind of life and income now that he never even dreamed of when he mailed the coupon on this page. But how did he do it? How did he make such a success when he had absolutely no experience in the field?

It was simple. Ed just followed the path hundreds of others have taken to new careers in Accident Investigation.

He trained at home in his spare time. He read lessons-by-mail from Universal Schools of Dallas, Texas.

## HE DIDN'T MISS A PAYCHECK

Ed learned that Universal is the oldest, largest, most successful correspondence training school in the field. He learned that Universal has trained and placed more men in Accident Investigation careers than any other organization — 80% of them men with no experience, no college.

So Ed enrolled. He studied Universal's famous 50-lesson course in his spare time at home. He kept right on with his old job while he trained. He didn't miss a single paycheck.

In brief, clear, interesting lessons, Ed learned exactly how to step in and start making money quickly in Accident Investigation. And that's what he did.

"The training I received from Universal Schools put me where I am today." Ed writes. "There are not words to thank them enough. Universal is the top school in the field."

Ed Crouch's income is unusually high and not typical of the field. But it shows what an inexperienced man can do with the help of Universal training and placement service.

Here, for example are just a few reports from other recent Universal graduates:

"My income has more than doubled." — James T. Woodruff, Louisiana.

"An immediate 40% increase in wages." — Bill Ruhnke, Missouri.

"A raise every three months for the next two years, plus new car and expense account." — Oscar Singletary, Georgia.

"My salary has increased by 63%." — Marcel Roy, Canada.

## SEND FOR FREE BOOK TODAY

Send for your free book of facts on this remarkable field — the same book that put Ed Crouch and so many others on the road to bigger opportunities.

Remember, more trained men are urgently needed right now, everywhere — in cities, towns and rural areas. There's opportunity wherever you live or wherever you want to live.

Simply mail the coupon below and we'll send your free book immediately. Or, write to Universal Schools, 6801 Hillcrest Ave., Dallas, Texas 75205.

When Ed Crouch mailed this coupon, he didn't dream he'd someday be making up to \$2,000 a month. But he does!

APPROVED FOR VETERANS' TRAINING

### FREE PLACEMENT SERVICE

Universal Schools provides prompt, effective job placement help in any part of the United States and Canada. More than 1,000 companies have requested and receive our monthly list of graduates. Universal trains and places more men in the Accident Investigation field than any other school. Or, if you would prefer to start your own full or part time business, we will show you exactly how to do it.

## SEND FOR YOUR FREE BOOK OF FACTS

UNIVERSAL SCHOOLS, Dept. PM-2  
6801 Hillcrest, Dallas, Texas 75205

Gentlemen: Please rush free book on opportunities and earnings in the booming Accident Investigation field. No obligation. No salesman will call.

Name \_\_\_\_\_ Age \_\_\_\_\_  
Address \_\_\_\_\_  
City \_\_\_\_\_ State \_\_\_\_\_ Zip Code \_\_\_\_\_



# The bargain hunter

## AMERICA'S ORIGINAL LOW-COST ARC WELDER AND ELECTRIC TORCH

10 DAY  
TRIAL

LIFETIME  
GUARANTEE



## New Improved HEAVY DUTY *FOUR-WAY*

Only \$18<sup>95</sup> Prepaid Complete Ready To Use  
**WELD, BRAZE, SOLDER, CUT**  
All Metals Including Aluminum

Every home, shop, and hobbyist needs this quality metal working machine. Anyone can use. No experience needed. Use up to 1/8" welding rods and 3/4" carbons to make or repair 1001 items including furniture, garden tools, toys, auto bodies, fenders, trailers, boats, farm equipment. Operates on 110 V. line for pennies—replaces gas torches—no tanks or refills to buy—produces to 11,000° heat. Twin Carbon Arc Torch easily controls heat for each job YOU CAN PAY MORE BUT YOU CAN'T GET A BETTER LOW COST WELDER. Over 500,000 in use. Manufacturers of welders for over 30 years. LIFETIME UNCONDITIONAL GUARANTEE. Simply return. We will repair or replace and ship FREE of charge. YOU GET: heavy duty welder in rugged metal cabinet, ground clamp, cables, combination torch and rod holder, welding manual and helmet, plus Free \$2 pack "TOUCH WELD" rods for instant and automatic arc, brazing rods, 3/4" carbons, solder and flux.

ORDER TODAY ON 10-DAY UNCONDITIONAL MONEY BACK TRIAL.

### MAIL THIS ORDER COUPON NOW!

Four-Way Welder Co., Dept. R-2-B  
1810 S. Federal St., Chicago, 60616

Please send welder as indicated below and include FREE gift of  
 Wrench Kit or,  Wire Tool or,  Welding Rod Pack.

Enclosed \$18.95. Ship  Enclosed \$2.00. I will pay \$16.95  
postpaid in U.S.A. plus C.O.D. and delivery charges.

NAME \_\_\_\_\_

ADDRESS \_\_\_\_\_

CITY \_\_\_\_\_ STATE \_\_\_\_\_ ZIP \_\_\_\_\_

### FREE EXTRA BONUS GIFT with your order. Choice of:

1. 10-piece wrench, plier and screw driver kit in case, or,
2. Wire forming tool. Forms wire to weld valuable items, or
3. Big pack welding & brazing rods, carbons, flux & solder.

SEND ONLY \$2.00 and pay \$16.95 plus C.O.D. and  
delivery charges, or send only  
\$18.95 and we pay delivery in U.S.A. Specify gift.

**FOUR-WAY WELDER CO.**

1810 S. Federal St., Dept. R-2-B, Chicago, 60616



### EVERY HANDYMAN NEEDS HANDY DANDYS

Handy Dandys are sturdy, plastic caps that snap into 1/4" pegboard and hold quarter twist baby food jars. They're ideal for storing all kinds of supplies, parts and small tools. "Try-Em-Out Package" of 8 only \$1.00 for \$3.50 or 72 for \$6.50 for \$36.50. Shipped USA postage prepaid—no C.O.D.'s.

WICKLIFFE INDUSTRIES, INC., P.O. Box 286,  
Dept. PM-2, Wickliffe, Ohio 44092

### HOLD EVERYTHING!

With handy Magnagrip magnetized holders.  
Mount easily on any surface.



only  
**\$2.95**  
p.p.

**TOOLS** are orderly, safe when hung on MAGNABAR. Hardwood natural finish. Holds any metal tools. 1" wide by 12" long. Other lengths available.



only  
**\$3.95**  
p.p.

**KITCHEN KNIVES** always handy on styled white MAGNAGRIP MARK X. Gift-boxed.



Only  
**\$1.98**  
p.p.  
SOAP hangs in air wherever you want, dries fast with **MAGNAGRIP SOAP HOLDER** Easy to install.

Write for complete line folder. Magnagrip guaranteed or money back. Send check to Dept. B

PHELON MAGNAGRIP COMPANY, INC.  
East Longmeadow, Mass. 01028



Thousands of  
exciting tool  
values!

### SILVO (BRAND NAME) TOOL CATALOG

Thousands of Exciting Tool Values! Stanley, Millers Falls, Skil, Thor, Wen, Diacon, Wiss, Wellsaw, Dremel, Speedy Sprayers, Plumb, Huot, Kennedy, Channellock, Porter-Cable, Rockwell, Helios, Vise-Grip, Crescent, Ridgid, Pony Clamps, Unimat, Foredom and many other Nationally Advertised brands of Tools & Supplies. We ship Coast to Coast at prices Hard to Beat. Send 25¢ for our big 132-page tool catalog, today! Silvo Hardware Co., PM-2, 107 Walnut St., Philadelphia, Pa. 19106.

## TAX SALE - \$1 ACRE

Properties now being sold for municipal tax arrears. Hundreds of cottages, farms, hunt-camps, timberlands, homes from coast to coast along Canadian Border. Purchase direct from Tax authorities—NON PROFIT! For lists, pictures, regulations, write: Register, Room 19, 110 Church Street, Toronto, Canada.

### THE GEARED MOTOR

You've been looking for!



30 lb. Torque. 5/16" Shaft, 1 1/2" long. 58 or 28 RPM. Please specify RPM. 8/32" Tapped Mounting Holes. AC 115 Volt, 60 cycle. \$8.95 postpaid  
**CANAL ELECTRIC MOTOR, inc.**

310 Canal St., New York, N.Y. 10014

AMERICA'S NO. 1  
CLASSIFIED SECTION  
CAN BE FOUND  
ON PAGE 60  
IN THIS ISSUE



# The bargain hunter

## JUMBO CLOTH BAG OF FOREIGN STAMPS



**Only \$1.00 PPD.**

**BIG CLOTH BAG** is packed to the brim with more than 500 genuine postage stamps from over 30 strange countries in far-away Asia, Africa, Europe, South Seas. Unpicked, unsorted stamps — just as received from foreign natives, banks, missionaries. It's an exciting treasure hunt, for nobody knows what's inside! Only \$1.00 ppd. Also, selections of unusual stamps to examine free. Buy any or none, return balance, cancel service anytime. EXTRA: "How to Get Valuable Stamps FREE." Send \$1.00 today!

H. E. HARRIS & CO., Dept. B-71, Boston, Mass. 02117



**SAVE \$240! FINAL CLOSEOUT ON UNDERWOOD FORUM ELECTRIC OFFICE TYPEWRITERS**—These demonstrators use both carbon and fabric ribbon, have all the latest repeat features and will be shipped F.O.B. N.J. in factory cartons with guarantee, cover and instruction book. Originally sold for \$470.00, now for the first time we are offering these machines to the general public for only \$229.50. Send check or money order payable to **ALLISON BUSINESS EQUIPMENT CO., P.O. BOX 641, WESTWOOD, N.J. 07675.**

## OVERTIME PAY You Can Depend On

Why be at the mercy of overtime cut-backs? Turn your own spare time into regular overtime pay. Get sharp and start your sharpening shop. Housewives, hobbyists, barbers, beauty and pet shops, sportsmen, markets, restaurants, contractors, rental shops, farmers—everybody is your cash customer. **TREYCO 6-in-1 Machine** hollow-grinds knives, saws, tools, scissors, pinking shears, clippers, garden tools, rotary mowers, skates, etc.! Make as much as \$6 an hour. Learn how **TREYCO** gives you **6 MACHINES IN 1** for low price of one. Quality guaranteed. Thousands of users since 1946. Write for big **FREE CATALOG** and **LOW Factory-To-You Prices.**

**TREYCO Products, Inc.** 381 Niagara St. N. Tonawanda, N.Y. 14120



**IMPROVE YOUR GARDEN**

Mobile **KEMP Shredders** turn garden wastes and other organic matter into the rich compost, humus, mulch you need to make the good earth better. Mulched gardens always look neat, produce healthier, more vigorous plants. Guaranteed **KEMP Shredders**, priced from \$96.50. Write for free folders, easy terms, **KEMP Shredder Co., 519 Kemp Bldg., Erie, Pa. 16512**



**FREE MUSCLE COURSE!**

Want a new Jet-Charged body? In 15 minutes I'll prove you can slap on 4" of muscles to your chest—3" to each arm—give you life-guard shoulders, trim your waist to athletic size—give you speedy athletic legs. I don't care if you're short or tall (skinny or fat) young or not so young, expect a muscle building miracle when you send for my free course. Send only 25¢ to cover postage and handling to **Joe Weider, Dept. 38-29D, 531 32nd St., Union City, N.J.**

## SECRETS of Teaching Yourself MUSIC

revealed in your own home this money-saving way



**YES!** Teach yourself Piano, Guitar, Accordion, Violin, ANY instrument—even if you don't know a single note now! No special "talent," no previous training needed. Famous low-cost **U.S. School of Music Course**, with step-by-step pictured lessons, makes it simple as A-B-C. Everything is in print and pictures. First you are told what to do. Then a picture shows you how. It's as easy as cutting a soft cake. You start by playing actual pieces. Sooner than you may imagine you'll amaze friends by playing your favorite music—popular, classical, jazz, country music, dance tunes, etc. Over 1,250,000 students all over the world.



### Stop Cheating Yourself of These Joys

Popularity. New friends. Gay parties. Musical career. Extra money. Banish worries, frustrations. Satisfy self-expression, creative urge. Gain self-confidence.

Write today for our new Illustrated **FREE** booklet, **U.S. SCHOOL OF MUSIC, Studio A302, Port Washington, N.Y. 11050.** (Est. 1898. Approved by N.Y. State Education Dept.)



Print Name.....  
 Address.....  
 City.....  
 State..... Zip Code.....

## Searching?

Should you wait years to meet your match?? Take the opportunity to establish new friendships NOW! The computer has smashed the social time barrier . . .

Request free questionnaire \$10.00 fee payable when you return questionnaire.



**COM/PAIR SYSTEMS, Inc., PM-7**  
 194 Nassau St., Princeton, N.J. 08540

Name.....  
 Address.....  
 City..... State.....

© Copyright 1966 COM/PAIR Systems Inc.

## STUDY ART In Spare Time

as a way to a richer life

**DO YOU** find yourself doodling interesting designs? Wanting to sketch and capture on canvas a sunny lake among the trees, or paint a likeness of a loved one? Then you should know more about the renowned **Washington School of Art's** completely new home study Course. In your spare time you can learn to draw; paint in oils, water color and other media . . . all under the personal supervision of instructors who will become your "friends by mail." Big artist's outfit and professional case, at no extra cost, will help develop your hidden talents. Learn advertising art, painting, illustrating, cartooning, fashion drawing, TV graphic art at remarkably low cost. Send name, age and zip for our **FREE** helpful booklet. Write

to **WASHINGTON SCHOOL OF ART, Studio 14-008, Port Washington, L.I., New York 11050** (Est. 1914.) Accredited Member, National Home Study Council.





### HENLEY'S

**20th Century Book of 10,000 Recipes, Formulas & Processes**

Here is a wealth of practical, accurate and clear information and instruction that can save you thousands, or make you a fortune! Housewives, manufacturers, farmers, handymen, home experimenters, electricians, chemists, people in every walk of life, refer to Henley's daily. In this gold-mine of a book, you too will find formulas and recipes for almost everything used in the home, farm, workshop

or industry. Discover the trade secrets of thousands of commercial products—learn new money-savings and exciting way of doing things. As indispensable as a dictionary. Satisfaction guaranteed. 900 pages hard cover-cloth binding. Only \$5.95 postpaid.

**EMBASSY SALES, Dept. PM-5  
Box 67, East Elmhurst, N.Y. 11369**



Today let these **AMAZING SHOES** ADD INCHES TO YOUR HEIGHT!

Nothing like a pair of "ELEVATORS" to help you get up in the world! In seconds, these miraculous height-increasing shoes make you almost 2 inches taller! And no one will suspect that you're wearing them because "ELEVATORS" look just as smart and feel just as comfortable as any other fine shoes.

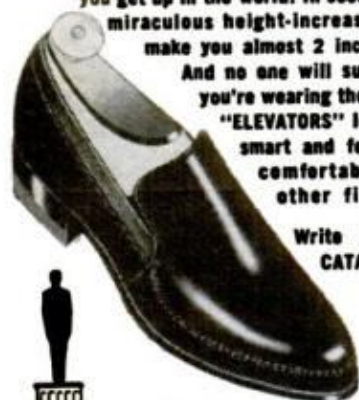

Write for **FREE CATALOG** today.



### **ELEVATORS®** HEIGHT-INCREASING SHOES

Brockton Footwear, Inc.  
Dept. 5102K, Brockton, Mass. 02403  
Please send free catalog

Name \_\_\_\_\_  
Street \_\_\_\_\_  
City \_\_\_\_\_ State \_\_\_\_\_

CLIP AND MAIL COUPON NOW

AMERICA'S NO. 1  
CLASSIFIED SECTION  
CAN BE FOUND  
ON PAGE 160  
IN THIS ISSUE

### FIND BURIED TREASURE

10-DAY MONEY BACK GUARANTEE  
**TREASURE PROBE**  
**14.88 Ppd.**  
DEALER INQUIRES INVITED  
**3 MODELS AVAILABLE**  
**ALL TRANSISTORIZED**

All models find buried metal objects and signal location thru earphone with loud sound. Detect gold, silver, metallic ore, and nuggets of all kinds. Find lost coins, jewelry, Indian artifacts, civil war souvenirs. All models guaranteed to equal instruments selling for much more or your money back. Each model includes sensitive earphone, battery, and instruction booklet. Send for **FREE** pamphlet on the exciting new hobby of electronic treasure finding.

- **NEW TREASURE PROBE KIT**—only \$14.88 Ppd. a complete do it yourself instrument that we guarantee to work when completed.
- **ORIGINAL TREASUREPROBE**—only \$18.88 Ppd. completely assembled and ready to use.
- **NEW TREASUREPROBE MKII**—only \$24.88 Ppd. an advanced model that includes a powerful built in speaker that automatically is disconnected when earphone is in use. completely assembled.

**TO ORDER**—send cash, check, or money order. \$3.00 deposit for C.O.D. in N.J. add 4% sales tax  
**TREASURE PROBE DEPT PAO**  
PO Box 64 LAKEWOOD N.J. 08701

### 100 STYLES FOR **WIDE FEET**

and **HIGH INSTEPS**  
EE to EEEEE Only  
Sizes 5 to 13

Men only. Casual, dress, work shoes that really fit. Top quality, popular prices. Money-back guarantee.



Not sold in stores

Write Today for **FREE CATALOG**  
**HITCHCOCK SHOES, INC.**  
Hingham 28-A, Mass. 02043

### **BULL FIGHTER** Lock Blade **STILETTO KNIFE**

5 1/4" Overall Length  
3" Blade

ONLY  
**\$1.25**

- Tough and Sharp
- Opens Instantly
- Stainless Steel
- Folding Finger Guard
- Blade Locks



Flips open instantly and locks automatically to prevent accidental closing. Razor sharp tough stainless steel blade for reliable use and hard, long service. Money back in 5 days if not satisfied. Send \$1.25 plus 25c to cover postage & handling. Please state age.  
**WESTBURY SALES CO., DEPT. B M 54A**  
P. O. BOX 415, WESTBURY, N. Y.

WHEN  
ANSWERING ADS  
GIVE YOUR  
ZIP CODE

### SPARK GENERATOR

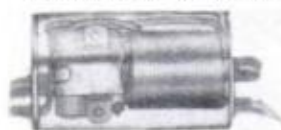

New Army  
Surplus  
**\$3.00**  
Ppd.

Adaptable to scores of uses. Designed as igniter for Army's portable flame thrower. Works on 1 1/2 to 6 volts DC or AC. Generates sparks up to 1/4" long. Moisture-proof clear plastic case is 3" long x 1 1/4" dia. Weighs 6 oz.

### G. I. PIN PUNCHES

12 for **\$1.00 Ppd.**

New Govt. Surplus. Made of finest tool steel. Point size, .08". Overall length, 3". Priced at a fraction of actual cost!

**P & S SALES, Dept. P-2**  
Box 155, Tulsa, Okla. 74102

WRITE FOR  
**FREE CATALOG**

### **BOAT** plans & kits



### PLANS - FRAME KITS - HULL KITS BOAT KITS

Over 200 tested designs for the amateur builder. Conventional or deep vee, inboard or outboard, cruisers, runabouts 10-36 ft. Sailboats, 8-34 ft. conventional—trimarans—catamarans. New 33-36 ft. cement sailboats. Large selection inboard or outboard hydroplanes, ski boats, house boats, fishing boats.

Send \$1.00 for New Plan Kit Catalog or \$2.00 for Catalog Plus Boat Builders' Guide.

New Book on Complete Boat Building includes photos, step by step information.—Send \$5.00.

**CLARK CRAFT BOAT CO.**  
16 PP Aqua Lane, Tonawanda, N. Y. 14150



**FREE!!! POWERFUL MUSCLES FAST!**  
Fantastic New Discoveries in the science of bodybuilding. Now, in the privacy of your bedroom, our method will add inches of powerful muscles to arms, chest, shoulders & legs. Learn secrets on trimming the waist with ultra-modern methods—fast! Results Guaranteed! Send for free brochure, Universal Bodybuilding, Box 5327, M-11, Northeastern, Dearborn, Mich. 48126.

**JOBS IN EUROPE—  
MARRIED OR SINGLE**

Just think—within months you could actually be living in London, Paris, Dublin or Rome! American companies in Europe desperately need all skills and talents. Wages to \$1,800.00 per month and over. Many jobs pay complete transportation for you and your family. American Gov't schools for the kids. If you're single it's a Bachelor's Paradise!

My wife and I have lived in Europe for over 3 years. We've just finished our 1969 European Employment Directory. It's crammed with hundreds of high-paying jobs—Who to write to—salaries—skills or semi-skills needed. Our directory is unconditionally guaranteed to please you or your money back. The supply is limited. Only \$3.98.

European Employment Directory (Box 5157)  
1800 Hazelwood Drive  
Fort Wayne, Indiana 46805

**INVENTORS  
MAKE  
MONEY**

Don't waste time and money with unsuccessful conventional methods. Revolutionary plan shortens road to riches. Unique inventors club will research, protect, and market your idea. 30-day full-privileged trial membership \$1.00. Satisfaction guaranteed. **IDEA DEVELOPMENT CLUB OF AMERICA**, Dept. P1, P. O. Box 5159, Fort Worth, Texas 76108.

**When you see  
this mark**



**you've seen  
the product in  
Popular  
Mechanics**

# Build Your Own Guitar



**• NO SPECIAL TOOLS REQUIRED!**  
You can build this beautifully toned instrument in only a few nights. Kit contains all necessary materials, pre-cut and formed parts, glue, strings, everything. Just assemble, sand and finish. When finished your guitar will compare with expensive imported instruments. Complete kit only \$18.00 plus \$2 handling and shipping charges. (Texas residents add \$.54 sales tax.) Clip and send the coupon below to SPANISH GUITARS LTD., P.O. Box 1377, San Antonio, Texas 78206.

Send me \_\_\_ kits at \$18 plus \$2 shpg. chgs.  
Check or money order is enclosed.

Name \_\_\_\_\_  
Address \_\_\_\_\_  
City \_\_\_\_\_ (zip) \_\_\_\_\_

**SPANISH GUITARS LTD., P.O. BOX 1377  
SAN ANTONIO, TEXAS 78206**

**GLLEN**

.....boat plans  
full size patterns  
frame kits.....

catalog  
50¢

**BOAT PLANS—PATTERNS—FRAME KITS**  
Send 50¢ for Glen L.'s new catalog offering a complete selection of build-it-yourself designs with step-by-step instructions. Inboards & outboards, jets, 16' to 36' cruisers, 8' to 21' sailboats, houseboats, hot boats, boat trailers and camper trailer. Books: Inboard Motor Installations In Small Boats \$6.00 ppd.; Boat Building With Plywood \$7.50 ppd.; How To Build Boat Trailers \$3.00 ppd. **Glen L.** 9152T Rosecrans, Bellflower, Calif. 90706.

**AMAZING NEW PLANS  
REVEAL "SECRETS"...**

**HOW YOU CAN  
BUILD YOUR OWN  
KART or MINI CYCLE  
FRAME for less than \$10!**

**SAVE UP TO \$50 IN COSTS**  
New proven plans with complete parts list show how to use inexpensive materials to build your own professional Kart or Mini Cycle at home! Easy to build! Step by step procedures! Requires only a few hand tools and very little welding. **Plans only \$1 Both \$2.**

**MONEY BACK GUARANTEE** Send check, cash or money order to:  
**GO CYCLE Dept. PM-12  
915 NORTH HOLLYWOOD WAY  
BURBANK, CALIFORNIA 91505**

**PLANS \$1  
ONLY**

Print Name \_\_\_\_\_  
Street \_\_\_\_\_  
City \_\_\_\_\_ State \_\_\_\_\_ Zip \_\_\_\_\_

**PUBLICATIONS WORTH  
WRITING FOR**  
BY EILEEN MORAN

**STORAGE SPACE** is a problem with most families. Where to put the 101 items of outdoor equipment that must be stored can be solved by sending for an excellent booklet No. H104 on how to build an outdoor storage room. Send 35 cents plus 15 cents for postage and handling to Bureau of Information, Popular Mechanics, 575 Lexington Ave., New York, N.Y. 10022.

**THOSE MOON SHOTS** are zipping into space on the Saturn V. Get your 19x25-

inch full-color print of the space vehicle for \$1.25 from PM's Bureau (address above).

**GARDEN PROJECT BOOKLET** has step-by-step instructions on how to build planters, decorative screen block walls, flower bed edging, patio floors, seating walls, barbecue, pools, steps and walks with Sakrete Concrete and Mortar Mixes. Nineteen different projects in all. Send 15 cents to Sakrete, Inc., P.O. Box 873, Dept. PM, Dayton, Ohio 45401.

**CLOCK AND CABINET MAKERS**—send for your free catalog containing a listing of clock movements, both mechanical and battery operated, dials, escapements, chains and the like by writing to Modern Technical Tools & Supply Co., 211 Nevada Street, Hicksville, N.Y. 11801. ★★★

## DRIVIN' WITH DAN

*(Continued from page 46)*

**add heavy-duty shocks. Finally, make certain tire pressures are correct.**

**Q.** *I plan to buy a new GTX for both street and strip use. Should I get manual or power steering?—Ira Stein, Bronx, N. Y.*

**A. Power.**

**Q.** *Is riding a motorcycle more dangerous than car-racing? Can a 13-year-old race karts or midgets?—Ronnie McElroy, Olive Branch, Miss.*

**A. No, it isn't. Motorcycle riding requires good judgment more than anything else. If a driver has that, it can be quite safe and a lot of fun. To answer your other question, a 13-year-old can race a kart, but not a midget.**

**Q.** *Are any race drivers color blind? Do any wear glasses?—Creed Dew, Boxford, Mass.*

**A. I know of several top drivers who are color blind to a degree, but I'm not sure how much. A driver should be able to distinguish between red, green, yellow, blue, and so on. The easiest "colors" to recognize (also the ones drivers see the least of) are the black-and-white of the checkered flag. Yes, many top drivers wear glasses.**

**Q.** *What is Stirling Moss doing these days?—Mark Parus, Mt. Calvary, Wis.*

**A. Among many other things, Stirling is an important part of the Johnson Wax public relations and promotion staffs, particularly in relation to the Can-Am series. Also, he's a racing broadcaster, has several product endorsement contracts, and serves as consultant to racing circuits throughout the world.**

**Q.** *In what recent years did Ford engines win at Indianapolis? I say from 1965 to 1968, but my buddy says only 1967 and 1968.—Tom Glusyk, Westland, Mich.*

**A. Ford power was used by winners Jim Clark in 1965, Graham Hill in 1966, and A. J. Foyt in 1967. Bob Unser's winning car last year was powered by an Offy engine.**

**Q.** *What make is the 396-cu.-in. engine David Pearson used in his 1968 Torino on the smaller tracks?—Bob Carver, Spring Lake Heights, N. J.*

**A. It's a Ford all the way, Bob. The 396 engine is a de-stroked 427.**

**Q.** *If Cadillac has the biggest V8 engine in a production passenger car, why isn't it used in stock-car racing? Why aren't there any front-wheel-drive cars in stock-car races? If headers give a car 40 hp more, why aren't they standard equipment?—Dave Jonas, Bay Village, Ohio.*

**A. Stock-car racing rules limit maximum displacement to 428 cu. in., plus or minus an inch. Front-wheel drive is not as good as rear-wheel drive when it comes to full acceleration, because under full power, weight tends to shift to the rear wheels. Headers do not last as long, nor are they as trouble-free as conventional equipment. They cost more to make and are slightly more noisy.**

**Q.** *How did you get started in racing?—Philip Berry, Olathe, Kans.*

**A. I began with the California Sports Car Club, a group that no longer exists. I raced a Triumph TR-2 and a Porsche 1600-S in amateur road races. I gradually managed to drive cars owned by other people in amateur road races, and finally graduated to professional road-racing after building a favorable reputation as a driver.**

**Q.** *Innes Ireland drove a turbine and said he had never experienced such powerful acceleration. Joe Leonard said after Indy that the turbine did not have enough acceleration on straightaways. Who's right?—Jack Fowler, Toledo, Ohio.*

**A. I'm not sure they drove the same turbine, but both are excellent drivers and I think you can say both are right. Again, it boils down to hp and torque and mass.**

**Q.** *I recently saw a TV special about you in which you were pictured on a bike. What kind was it, and how many cc?—Dave Dougherty, Ludington, Mich.*

**A. A Montesa 250-cc scrambler. I ride a Montesa 360-cc scrambler now when I get the chance.** ★ ★ ★

---

*If you have questions on racing, high-performance and everyday driving techniques, send them to "Drivin' with Dan," c/o Popular Mechanics, 575 Lexington Ave., New York, N.Y. 10022. Questions cannot be answered by individual letters. Questions on maintenance and repair should be addressed to the Auto Clinic (see page 84).*

---

# FREE! World's Largest Electronic Kit Catalog

● **Deluxe Color TV** . . . the sets you've read about that give better performance yet cost no more; three models: 295, 227 & 180 sq. in. rectangular; exclusive built-in self-servicing aids. Custom, wall, or cabinet installation. New optional wireless remote controls, and new Heathkit antenna line.

● **Transistor Organs** . . . deluxe 19-voice and low cost 10-voice Thomas models in kit form — save up to \$500. Also VOX "Jaguar" combo organ at \$200 savings.

● **Electric Guitar Amplifiers and accessories**...amps, "fuzz" booster, microphones and speakers.

● **Portable and Table Radios and Phonographs** . . . AM, FM, short-wave radios . . . mono or stereo phonographs.

● **Stereo/Hi-Fi Components** . . . stereo receivers (including the famous Heathkit AR-15), amplifiers, tuners, speakers, turntables.

● **Amateur Radio Gear** . . . world's most popular line . . . SSB transceivers, transmitters, receivers, accessories.

● **Citizen's Band Radio** . . . fixed and mobile transceivers, walkie-talkies.

● **Test and Lab Instruments** . . . a complete line for home & hobby, shop, educational and industrial use. Newly designed and styled.

● **Scientific and Educational** . . . Berkeley Physics Lab, Malmstadt-Enke instrumentation including Analog/Digital equipment, kits for home & classroom study.

● **Marine Electronics** . . . radiophones, RDF, depth sounder, fuel vapor detector.

● **Photographic Aids** . . . Heath/Mitchell Fotoval® and Colorval® darkroom computers for perfect B&W and color printing; electronic photo timer.

**New . . . Over 300 Kits  
For Every Interest . . .  
Save Up To 50%**



## MAIL COUPON NOW!

- **Biggest Selection . . . Over 300 Kits**
- **Up to 50% Savings**
- **Easiest To Build**
- **World Famous Easy-To-Understand Construction Manuals**
- **Highest Quality Components**
- **Best Performance**
- **Unique Creative Satisfaction**
- **Pride Of Achievement**
- **Free Technical Consultation**
- **Easy Credit Terms**

**HEATH COMPANY, Dept. 17-2**  
Benton Harbor, Michigan 49022

Please send FREE Heathkit Catalog

Name \_\_\_\_\_  
(please print)

Address \_\_\_\_\_

City \_\_\_\_\_ State \_\_\_\_\_ Zip \_\_\_\_\_

CL-339

# THE WALL FIXER®

BEST HELP YOU CAN FIND FOR FAST PATCHING JOBS. READY-MIXED. WHITE. SMOOTH SANDING, **DAP** SPACKLING SPREADS EASILY, FILLS CRACKS, HOLES, JOINTS IN PLASTER, WOOD AND WALLBOARD.



**DAP**®

vinyl-paste  
**SPACKLING**

DAP Inc., Dayton, Ohio 45401 / SUBSIDIARY OF Plough, Inc.  
In Canada: DAP-DURATITE LTD., Toronto 10, Ontario



## Painting the town

Wielding his paintbrush on the Rose and Crown pub is one of the maintenance men who take care of the model village on the grounds of the Redoubt, Eastbourne, England.

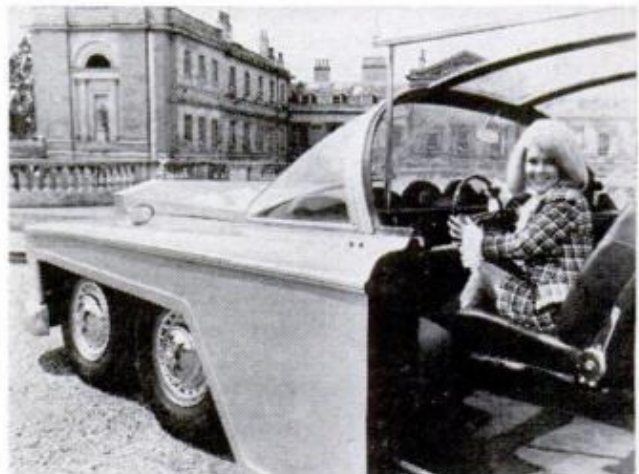
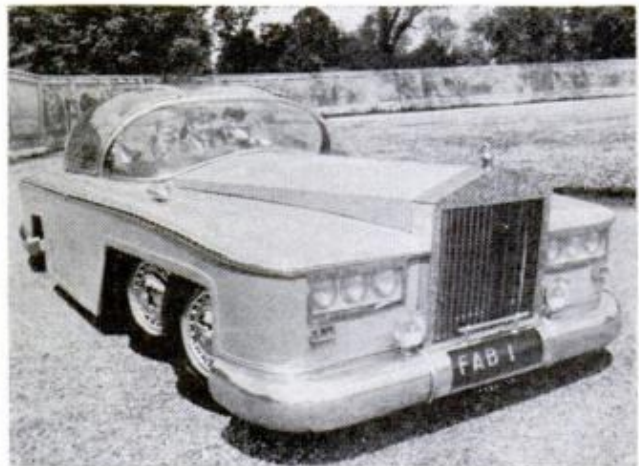

## Yeah, but what's the mileage?

Fab 1 is a three-ton car with dual front wheels, its own computer, a closed-circuit TV system and a remote-controlled machine gun that fires through the radiator grille. It goes fast, too—something like 150 mph. All of this is by way of promoting a TV series, *Thunderbirds*, and movie, *Thunderbirds Six*.



## BUILD YOUR OWN

ALCORT

**Sailfish**®

(Standard Model) Only \$224  
F.O.B. Waterbury, Conn.

Kits are also available for popular Super Sailfish and Sunfish models. Sails and all fittings included.

FOR DETAILS WRITE:

AMF ALCORT, PM-29 P.O. BOX 1345, WATERBURY, CONN. 06720

WORLD'S SMALLEST

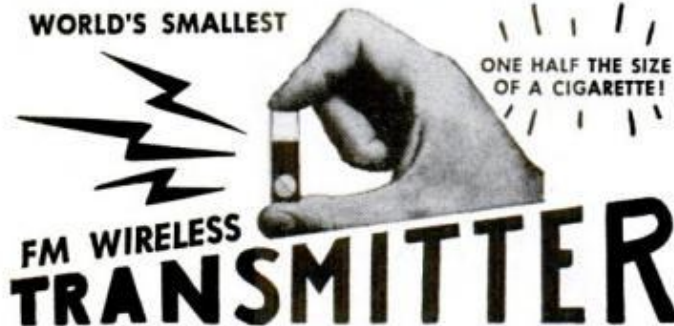

ONE HALF THE SIZE OF A CIGARETTE!

# FM WIRELESS TRANSMITTER

## "LISTEN-IN" ON ANY FM RADIO!

This miniature electronic marvel picks up the slightest sounds and clearly transmits them to any standard FM radio up to 150 feet away! Latest engineering advances in micro-miniaturization have reduced this unit to ONE HALF THE SIZE OF A REGULAR LENGTH CIGARETTE! Completely self contained unit including sensitive sub-miniature mike and battery!

Many uses include: Portable public address system, burglar alarm, improve sales talks, personal baby sitter, guitar amplifier, etc. Comes complete including battery and plastic screw-driver for changing frequency (88-108mcs).

ORDER NOW! ALL ORDERS RUSHED BY RETURN MAIL! **29<sup>95</sup>**  
MONEY BACK GUARANTEE! Dealer inquiries invited!

Save COD fee and send Check or Money Order to: © 1968  
SONIC DEVICES, 69-29 Queens Blvd., N. Y. C. 11377

# TOM McCAHILL SAYS:

## "Good Appliance Repairmen are Scarce as Edsel Dealers!"

I don't think anything disturbs me as much as trying to find an appliance repairman . . . and finding out I'll have to wait my turn because he has more business than he can handle.

With over 400 million Appliances now in use, and more coming every year, there just are not enough repairmen around to take care of every Mrs. Jones who wants a broken Appliance mended in a hurry! And that's why a smart guy could really clean up in the Appliance repair field.

Some years back, almost anyone could do a fast repair on an iron or toaster with a bit of fancy tinkering. But today's complicated Appliances call for a special brand of know-how the average Joe doesn't have without training. Appliances are loaded with thermostat controls, solenoids, and special devices. Unless a repairman has a working knowledge of these parts, he won't even get to first base.

That's why I want you to take a good look at the home study course offered by the Appliance Division of the National Radio Institute. They show you all about repairing home and commercial Appliances—even farm Appliances and small gasoline engines. If you're interested, they also include a special package covering air-conditioning and refrigeration repairs. The cost is surprisingly low, and even includes a special Appliance Tester.

NRI is one of the biggest and best schools in the field, and has been around since 1914. They have a staff of 150 people in Washington, D.C., who are



equipped to guide you through the easy course with expert and personal instruction.

Take it from Tom . . . this is one of the easiest and most rewarding fields a guy can enter today. You don't need a college education, you don't even need to know the first thing about Electrical Appliances when you begin your training.

There's nothing to lose . . . except the price of a stamp on your letter or postcard. Fill out the coupon below *now*, before you turn the page. Get the full rundown on the training that can increase your spare time income or provide you with a business of your own a lot sooner than you think. In just a few short months you could be ready to take the first profitable step towards a new and rewarding career. Do it!

*Tom McCahill*

TOM McCAHILL

APPLIANCE DIVISION, NATIONAL RADIO INSTITUTE  
3939 Wisconsin Avenue, Washington, D. C. 20016

AVAILABLE UNDER NEW GI BILL.  
If you served since January 31, 1955  
or are in service, check GI line below.

600-029

OK—I want to see for myself. Send me the free book on Professional Appliance Servicing. No salesman will call.

Name \_\_\_\_\_ Age \_\_\_\_\_

Address \_\_\_\_\_

City \_\_\_\_\_ State \_\_\_\_\_ Zip Code \_\_\_\_\_

Accredited Member National Home Study Council.

Check for facts on new GI Bill.

# NEW IN ELECTRONICS



▲ **A KNOB IN THE HANDGRIP** lets you hold and tune this lightweight treasure finder with one hand as you walk along. Weighing only 3½ pounds, the induction-balance detector spots metal objects up to five feet deep. Price is \$158.50. Fisher Research Lab, 1890 Embarcadero Rd., Palo Alto, Calif.

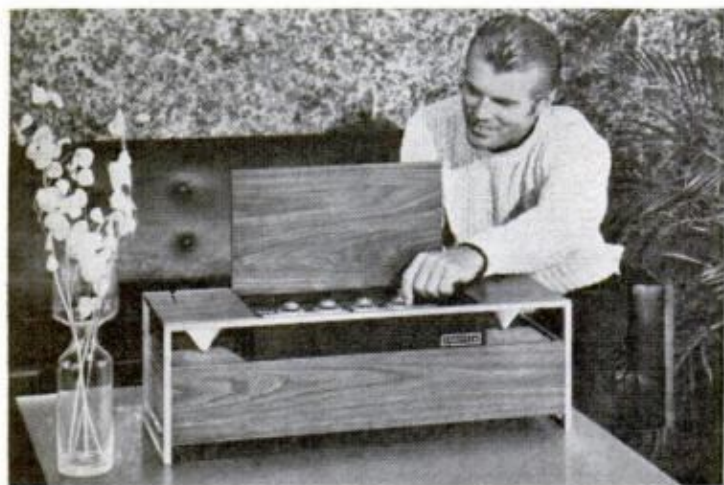

**THIS SWANK TABLE-MODEL RADIO** is said to be the first to incorporate full 360°-dispersion speakers. Two 4½-in. speakers, instead of facing outward, direct their sound upward against two cones (visible at the ends). The cones reflect the sound outward in all directions. The walnut-finished AM/FM/FM stereo receiver is priced at \$169.95. Zenith Sales Corp., 1900 N. Austin Ave., Chicago, Ill. 60639



**DISPOSABLE THERMOMETERS** may soon be used to take patients' temperatures in hospitals. Each one consists of a plastic probe with a small ball of wax at one end. The wax absorbs heat, holding the patient's temperature long enough for the probe to be inserted in an electronic instrument that registers the number of degrees on a dial. The throwaway thermometers, developed by 3M Co., end risk of breakage and cross-infection



**A HANDY CHARGER** has been developed for use with Mallory's new line of Duracell rechargeable alkaline batteries. Operating on 115-volt house current, it will recharge either two or four batteries simultaneously in any of the popular sizes—the standard D, smaller C or penlight AA





# CLASSIFIED ADVERTISEMENTS

Rate: \$1.85 per word payable in advance each insertion. Capitalized words—75¢ per word additional. Minimum insertion ten words. To be inserted under the proper classification, copy must be in our office by the 15th of the second month preceding date of issue. The next available issue to place an advertisement in America's No. 1 Classified Section is April. The closing date is February 15th. Send remittance and order to C. A. Martin, Popular Mechanics, 575 Lexington Avenue, New York, New York 10022. Please make remittance payable to Popular Mechanics.

## POPULAR MECHANICS

## AUTOMOBILES, MIDGET CARS

**YOUR Ad in this space will be read by more than 1,662,961 active mail order buyers. Join the march to greater profits, place your products and services in front of them today with a small low cost classified ad. For further details, write: C. A. Martin, Dept. 1R, Popular Mechanics, 575 Lexington Avenue, New York, New York 10022.**

## AUTO SUPPLIES AND EQUIPMENT

**CROSLEY And foreign car parts. Box 7. Elmont, N.Y.**

**ANTIQUE Car pistons, gaskets, gears, valves, etc. Catalogue \$1.10. Antiques Auto. Milwaukee, Wisconsin 53204.**

**JEEP Owners—V8 conversions. Read Jeep Owners, ad, page 223.**

**PERMA-BALANCE CAR WHEEL BALANCERS, automatic adjusting centrifugal force, permanent. Longer tire life. Better braking, handling and stability. Guaranteed. Satisfaction or money back. Set of four \$29.95. Free Brochure. P. G. Distributing Co., P. O. Box 211, Pratt, Kansas, 67124.**

**3-D MAGNETIC Signs. Quick change from car to truck. 10"X20" \$25.00 pair. 4 for \$45.00 other sizes, discounts. Send copy and colors desired. Doty Signs, 12168 Woodside, Lakeside, California 92040.**

**GAS-OIL HOG??? . . . Smoking?? . . . No Pep?? . . . Hard Starting?? (Save \$150-\$250) with Motaloy Ring-Valve Job While driving (\$6.50 postpaid) Advertised here every month for years! Continues saving money on repairs, gas, oil for 100,000 miles! Absolutely true! (new engines too) Nothing compares! . . . Money-back guarantee. You can't lose! Motaloy, Grantham, Penna. 17027.**

**PARTS: Army jeep and truck parts. Spare Parts & Equipment Co., P. O. Box 751, Lexington, Ky. 40502.**

**AUTOMOBILE Mini Folding Umbrella: Keep one in Your Automobile compartment For Rainy Day; Colors: Red, Black. \$7.00. Yamagata Office, 814 Togin Bldg., Marunouchi, Tokyo, Japan.**

**SNOW PLOWS: Kits—weld parts yourself with 6'6" blades completely pre-fabricated. \$115. DYNAMIC, Slocum, R.I. 02877.**

## SNOWMOBILES

**SNOWMOBILE Kits \$25. Plans and photos \$1.00. Information 10¢. Compop, Box 1267, Redwood City, California 94064.**

**BUILD Racing Type Snowmobile! Plans \$5.00; Go-Byk, Industries, Rothsay, Minn. 56579.**

## AUTO TRAILERS

**CAMPER Plans. Compact buses, Vans—Volkswagens, Econoline, Dodges. Build yourself—Save! Details—Dot Campers, Box 2115M, Culver City, California 90230.**

**BUILD Your Pickup Camper. Precut Kits. Blueprints. Supplies. Literature 10¢. Comstock Trailers, Dept. 664, Parsons, Kansas 67357.**

**PICKUP Camper, Trailer or Pickup-Cover . . . Build yourself. Save! Complete plans \$3.95 each. Cover plans \$2.00. Econoline Bus or Van, Bus Conversion drawings, \$2.95 each. Satisfaction Guaranteed. Equipment catalog \$1.00 (refundable). Details 10¢. Viking Camper Supply, 94-F Glenwood, Minneapolis, Minn. 55403.**

**LOWEST Prices! Catalog of 19 pre-cut Camper Kits, send 25¢. Trailer and Camper Parts and Accessories Catalog, send \$1.00 (refundable). Snowy Mountain Campers, Dept. PMC, Lewistown, Montana 59457.**

## MOTORCYCLES, BICYCLES, MOTORSCOOTERS AND SUPPLIES

**HONDA 50-90-160 Speed Equipment. Cams—Big-Bore-Stroker. Columbia Engineering, 2105 E. 37 St., Los Angeles, Calif. 90058.**

**SNOW VEHICLE & KART CATALOG. Hop up accessories—speed and performance equipment—manifolds, engine mounts, exhaust systems. Send 25¢. G.E.M. PRODUCTIONS, 494 E. St. Charles Rd., Carol Stream, Ill. 60187.**

**HARLEY-Davidsons — Used bargains. New, used parts, accessories, all models. Bulletin 35¢. Knuth's (Factory Dealer). 1753 Muskego, Milwaukee, Wis. 53204.**

**MOTORCYCLE TURN SIGNALS. Accessories. Catalog 25¢. Houston, PM Lockport, Illinois 60441.**

**BUILD "Popular Mechanics" MINI-BIKE featured June 1967 issue. Detail plans, photographs \$2.50 refundable. Kits, parts, engines; factory discount prices. Catalog 25¢. Gilliom Mfg., PMC, St. Charles, Missouri 63301.**

**BUILD Your own minibike! NO WELDING REQUIRED! Plans \$1.50. Westate Enterprises, Dept. PM-2, Box 9216, San Jose, California 95117.**

**RECONDITIONED Motorcycle motors. Indian, Mustang, Royal Enfield, Suzuki. Parts, Accessories. "Minibikes." Indian Motorcycle Sales, Kansas City, Missouri 64127.**

**MINI-BIKES. Chain saws. Wholesale catalog, 25¢. Loren Products, Danville, Illinois 61832.**

**AKRONT Alloy Rims Mavrick Shock Absorbers. Buy the Best. Free Literature. North American Imports, P.O. Box 621. Garden Grove, Calif. 92642.**

**BUILD Motorbike From Bicycle! Plans . . . \$2; Go-Cart Plans . . . \$2; Snowmobile Plans . . . \$5; Go-Byk Industries, Rothsay, Minn. 56579.**

**NEW Motorcycles at Wholesale Price. Valley Imports, 14114 Mack, Detroit 48215.**

**SEND US NAMES, addresses two motorcycle owners or prospective owners, and stamps. We then send you book "HOW TEACH NEW RIDER, I LIKE MOTORCYCLES" pin, catalog 400 books, catalog INDIAN MAMMOTH MOTORCYCLES, DECAL. Floyd Clymer, Dept. PM, Los Angeles, Calif. 90004.**

**NEW 1969 INDIANS. 50 MPH big minibikes, \$295. PAPOOSE 4-speed, \$345. INDIAN ROADSTER 500, \$1,450. MAMMOTH 125MPH 4-cyl. world's most unique cycle, \$4,000, or \$3,200 at factory in GERMANY. Dealers wanted. Open territory. Send stamps for catalog INDIAN-MAMMOTH MOTORCYCLES, CATALOG 400 CYCLE, Automobile Books, Floyd Clymer, Dept. PM, Los Angeles, Calif. 90004.**



## AVIATION

**HELICOPTER One-man. Portable Kits Plans. Information 25¢. Photos and three-view drawings \$1.00. Compop, Box 1267, Redwood City, California 94064.**

**HOMEBUILT. Real enclosed helicopter, 24 pages ideas, information, \$2.50. Build "executive" helicopter, drawings, specifications, \$2.00. Helicopter Development, Box PM147, Washington, New Jersey 07882.**

**BE A Government licensed aviation mechanic. Practical training. Free information. Aero Mechanics School, Municipal Airport, Kansas City, Missouri 64116.**

**AERO-CAR. Amazing Hovercraft built easily with ordinary tools. Lawnmower engine power. Carries one man plus. Hovers, flies forward, backward, sideways over land/snow/water. Complete construction plans and brochure, \$4.25. Aero-Projects, Box 5118, Clinton, N.J. 08809.**

**AIRCRAFT Classified. Thousands everywhere. Subscription \$2. Aero-Shopper, Henrietta, Texas 76365.**

**DOBSON Famous, Proven Air Cushion Amphibians, Single and Two Place. Brochure \$1.00. Plans \$30.00. Locke Enterprises, 4887 Pointe Tremble, Algonac, Michigan 48001.**

**AVIATION SURPLUS Big Catalogue 50¢ (refundable). Box 52PM3, Thomasville Penna. 17364.**

**BARTLETT FLYING SAUCER. Amazing machine hovers 200 lb. man over land/water, powered by ordinary lawn mower engine. Easy to build. Fun to fly. Complete Plans, Kit Brochure and Photo Review \$3.00. Write: Herb Bartlett, Box 3234-C, Scottsdale, Arizona 85257.**

**AIRBOAT. Snowplane, Gyrocopter, Hovercraft propellers. Complete airboats, Kits, Plans, Mounts, Engines, Supplies. Corvair, Volkswagen Conversions. Outboard air-drives. Catalog \$1.00. Banks-Maxwell, Box 3301E, Ft. Worth, Texas 76105.**

**TREMENDOUS OPPORTUNITIES IN AVIATION. Learn Aerosciences at home: Navigation, Aerodynamics, Communications, Weather. Free Information: United Aerosciences, P.O. Box 4106, Torrance California 90503.**



## BOATS

**CANOE! Kayaks!** Factory-direct quality kits, from \$20.00. Many different models. Canvas hulls. Strongest construction materials. Free literature. Sportsraft, Box 8393-PM, Columbus, Ohio 43201.

**BOAT PLANS, FRAME KITS, BOAT KITS.** World's largest catalog—Over 200 top design for the amateur builders. New catalog includes Cruisers, Runabouts, Deep vee's, Catamarans, Trimarans, Houseboats, Sailboats from small sail fish to 34 ft. motor sailers, large selection of inboard and outboard Hydroplanes. Send \$1.00 for large new plan & kit catalog or \$2.00 for catalog plus Boat Builder's Guide. Clark Craft Boat Company, 16-P Aqua Lane, Tonawanda, New York 14150.

**KAYAKS**—One-man \$19.50; two-man \$24.50; Sailboat \$44.00. Exciting Sitka Kayak Kits known world wide for speed and safety. Assemble in one afternoon. Free pictorial literature. Box 582-P, Willoughby, Ohio 44094.

**PLANS, Full Size Patterns, Frame Kits** with step-by-step instructions specially for amateurs. New "Glen L" Boats 8' to 36' Sail, Jets, Inboards, Outboards, Cruisers, Houseboats, Hot Boats, Catamarans, Hydros "plus" boat trailers and a camper. Send 50¢ for complete catalog. New "How To Build Boat Trailers" Book \$3.00 ppd. Glen Designs, 9152 Rosecrans, Bellflower, Calif. 90706.

**BUILD** Your own boat from our large-scale blueprints. Books of plans give how-to-build help. Hundreds of professional designs—motor, sail or auxiliary—for amateur builders. Free catalog. MoToR Boating, 959 Eight Ave., Dept. PM-RS, New York, N.Y. 10019.

**NEW 1968 McCulloch** and other outboards. 4 H.P. \$108.00. . . . 7½ \$224.00. . . . 9 Electric Start \$288.00. . . . 18 \$316.00. . . . 40 Electric \$514.00. . . . 65 Electric \$698.00. . . . All sizes. Literature 50¢. Electra Marine 1427 Broadway, Brooklyn, N. Y. 11221.

**FREE Catalogue**—plans for canoes, kayaks, accessories. Clark, 115 McGavock Pike, Nashville, Tenn. 37214.

**FIBERGLASS Cloth and resin.** World's finest cloth and non-run resin, at direct mill prices. Flotation foam. Complete line of plastics, silicon bronze and brass screws, save 60%. No Sales tax. Boat Plans, Catalog 25¢. Freight prepaid. Stiles Boat Supply, Box 11P, Linden Ave., Mantua Hts., N.J. 08051.

**BOAT Kits, Molded Fiberglass.** Save money—assemble yourself. Factory molded sections bond into one-piece craft. 30 models—14' to 33'. Cruisers, Runabouts, Houseboats, Sailboats. Big line accessories, motors, trailers, Easy terms. Free 88 page catalog. Luger, Dept. BC-69, 9200 Interstate 35W South, Minneapolis, Minnesota 55431.

**FULL Size, cut-to-shape boat patterns,** blueprints. Send 60¢ for big new illustrated "Build a Boat" catalog includes fishing boats, garvies, cruisers, catamarans, houseboats—7½ to 38'. 20% Winter discount. "How to Build a Boat" booklet, \$2.50. Cleveland Boat Blueprint Co., Box 18250, Cleveland, Ohio.

**FIBERGLASS Canoes.** Four exciting models. Easily assembled Kits, \$39.95 up. (Factory Direct) Free Literature. Riverside Canoes, Box 5595B, Riverside, Calif. 92587.

**AMATEUR Boat Building Society, 111-B Woodcrest Ave., White Plains, N.Y. 10604;** Plans, kits, discounts, books, technical help, local building clubs, instructions, monthly magazine. Free information.

**RUBBER BOATS.** One Man Pararaff 27 Twelve man Rubberized Nylon raft \$20.00. Catalogue 50¢. Surplus, Box 8MB, Thcmasville, Penna. 17364.

**SPEEDOMETER** For boat. Accurate, portable, no installation, \$5. Satisfaction guaranteed or refund. Free brochure included. Leonard, Box 264-M Dedham, Massachusetts 02026.

**FIBERGLASS Cloth, matt, polyester,** epoxy and foam resins. Lowest prices. Seifert's, Box 1206-M, Green Bay, Wis. 54305.

## MARINE EQUIPMENT AND SERVICES

**NEW, Used, rebuilt marine motors.** Marine conversions, fittings. Free catalog. Stokes Marine Supply, Dept. 24, Coldwater, Michigan 49036.

**CONVERT** Auto engines to marine. 68 Page Catalog, 50¢. Lehman Manufacturing Company, 800 Elizabeth Avenue, Linden 4. New Jersey 07036.

**PROFESSIONAL** Marine engines from Star Marine Kits, Engines—Gears—Props—Everything necessary for your boat propulsion. Write for free brochure. Star Marine Engine Works, Berkeley, California 94710.

**MARINE Conversion Kits** for all Chevrolets, Chrome plated crankshaft kits and cylinder head kits. Write for catalog. Mack Boring & Parts Co., Engine City, Rt. 22, Union, New Jersey.

## ATHLETIC AND BODY BUILDING COURSES

**"GIANT Arms."** Dr. Young's, D.C. revolutionary discovery. \$2. Satisfaction or refund. Gaucho, Box 9309-S7, Chicago 60690.

**POWERFUL** Muscles fast! Free brochure! Universal Bodybuilding, Box 4327-C, Northeastern, Dearborn, Michigan 48126.

## SPORTING GOODS AND EQUIPMENT

**FREE . . . Wholesale catalog.** Arrow shafts, broadheads, fletchings, fisharrow parts, tools, bows, FinnySports (22G), Toledo, Ohio 43614.

**FREE 1969 Catalogues!** Guaranteed lowest prices. Fishing Tackle, Archery, Hunting and Camping Equipment. Thousands of items. Cabela's Inc., Sidney, Nebraska 69162.

## FISHING, TACKLE, LURES

**MOLDS** For fisherman's sinkers, jigs, spoons, casting and spinning lures. Free catalog. Sweets Molds, Tonawanda 1, New York 14150.

**MOLDS**—For casting your own fishing sinkers. Free illustrated booklet. Reading Instrument Co., Box P78, Reading, Pa. 19603.

**FREE . . . Wholesale catalog.** Beads, Spinners, Lure parts, Sinkers molds, Jigs, Reels, FinnySports (ME), Toledo, Ohio 43614.

**FISH Traps,** collapsible. Pond-lake types. Animal, bird traps. Free catalog and trapping secrets. Sensitronix, 2225-F27 Lou Ellen, Houston, Texas 77018.

**USE** Your power tools to manufacture and sell patented fishing lure. Sample lure and details \$1.00. Sherman Bryant Lures, Lewisport, Ky. 42351.

**LIVE-CATCH** Animal traps. A size for every purpose. Also fish, sparrow, turtle, and other traps. World's largest selection. Free catalog. Sensitronix, 2225-MC36 Lou Ellen, Houston, Texas 77018.

**SURFCASTERS,** Trollers. Most amazing fishing lure ever invented. \$3.98 postpaid. Guaranteed. Free Brochure. Grotech, 380 Main St., Hackensack, N.J. 07601.

**"FREE Fly Tying instructions.** Gene's Tackle Shop, Box 7701, Rochester, N.Y. 14622."

## EARTHWORMS, LIVE BAIT

**BIG** Money growing fishworms, giant African Crawlers, crickets. Free Literature. Pain's Hatchery-31, Edison, Georgia 31846.

**EARN** Money raising fishworms for us! Exciting details free! Oakhaven—56, Cedar Hill, Texas 75104.

**HYBRID** Redworms—3,000—\$5.75. 5,000—\$8.00. 10,000—\$14.00. Bedruns 20,000—\$18.00. postpaid with raising instructions. Brazos Bait Farms, R-9, Waco, Tex. 76705.

**REDWORMS,** Bedrun. Postpaid: 10,000, \$9.00; 30,000, \$20.00 with instructions. Worms, Box 4185, Bellmead, Texas 76705.

## FROGS, FISH, REPTILES

**MAILORDER** Records help get Increased Business! Complete 32 Page Record Book shows your inquiries, orders, advertising, expense, etc. Only \$1.00. C. A. Martin, Popular Mechanics, Dept. PM, 575 Lexington Ave., New York 10022.



## HUNTING, GUNS, DECOYS

**FREE** Gun & Ammo Bargain Lists. Century Arms, St. Albans, Vermont.



## DOGS AND KENNELS

**EXTRA** Income at home in Spare Time! Booklet shows you how to start your own business with Classified Advertising. Only \$1.00. C. A. Martin, Popular Mechanics Dept. PM, 575 Lexington Ave., New York 10022.



## GAME BIRDS

**FREE** Big quail color catalog. Marsh, 14216 Brookhurst, Garden Grove, Calif. 92640.

## HAWKS—FALCONS

**MAILORDER** Records help get Increased Business! Complete 32 Page Record Book shows your inquiries, orders, advertising, expense, etc. Only \$1.00. C. A. Martin, Popular Mechanics, Dept. PM, 575 Lexington Ave., New York 10022.

## RABBITS—FUR BEARING ANIMALS

**EARN \$10,000** Yearly raising angora rabbit wool, and breeding stock for us. Information 25¢ coin. American Angora Company, Malta 12, Montana 59538.

**RAISE** Rabbits for us on \$500 month plan. Free details. White's Rabbitry, Mt. Vernon, Ohio 43050.

**RAISE** Rabbits successfully by knowing facts. 48 page illustrated book describing 25 breeds, housing, breeding, feeding, markets, marketing etc. 25 cents. American Rabbit Association, 36 Arba Building, Pittsburgh, Penn. 15217.

**MAKE** Big Money raising chinchillas, rabbits, guinea pigs for us, Catalog—25¢. Keeney Brothers, New Freedom, Pa. 17349.

**\$500-\$800 MONTHLY.** Raise small laboratory-breeding stock for us. We supply equipment, breeders, instructions. Illinois Research Farms, Dept. MP-2B, McHenry, Illinois 60050.

## TAXIDERMISTRY

**EXTRA** Income at home in Spare Time! Booklet shows you how to start your own business with Classified Advertising. Only \$1.00. C. A. Martin, Popular Mechanics Dept. PM, 575 Lexington Ave., New York 10022.

## PETS—BIRDS, CATS, HAMSTERS, ETC.

**LIVE SEAHORSES,** marine specimens, aquarium supplies. Illustrated catalog 10¢. Marine, Box 248-210, Dania, Florida 33004.

**HAWKS,** Reptiles, raccoons, skunks, squirrels. Catalogue 25¢. Tralls End Zoo, St. Stephens, S.C. 29479.

**FLYING** Squirrels, Chipmonks, Wonderful Pets. Literature 10¢. Pets, Neches, Texas 75779.

**LIVE** Traps, all sizes, mouse to dog. Collapsible or rigid. Carrying Cages. Free literature. National Live Traps, Tomahawk, Wisconsin 54487.

## HORSES & LIVESTOCK

"HOW To Train Horses"—Everyone who likes horses or ponies should have this book: Free. Write Beery School, 1102 Pleasant Hill, Ohio 45359.

## CAMPING EQUIPMENT AND TENTS

SAVINGS Plus dividends! Campers-fishermen-outdoorsmen cooperative. Free 68-page catalog. Recreational Equipment, Inc., 1525-P 11th, Seattle, Washington 98122.

CAMPING Equipment, Tents, Sleeping Bags. World's largest selection. Free giant catalogue. Morsan, 810-R Route 17, Paramus, New Jersey 07652 or 1999 Route 110, Farmingdale, New York 11735.

FREE Catalog! Camping, Boating, Sailing Supplies; Gadgets, Hardware and Gifts, Laacke and Joys, 1439 N. Water St. Milwaukee, Wisconsin 53202.

CAMPING Trailer kit tent top 16" size \$33.00 complete plans and instructions \$3.00, circular 10¢. Stratford Trailers, Stony Creek, Conn. 06405.

## EMBLEMS, BRASSARDS, PATCHES

EXTRA Income at home in Spare Time! Booklet shows you how to start your own business with Classified Advertising. Only \$1.00. C. A. Martin, Popular Mechanics Dept. PM, 575 Lexington Ave., New York 10022.

## TRAVEL & RESORTS

PLAN Your Camping Trips NOW! New Listing Reveals 500 Choice Campgrounds across America. Send 50¢ Today! Values. Dept. 6A, 3804 Thornton, Cincinnati, Ohio 45236.

## ELECTRICAL SUPPLIES

METERS—Surplus, new, used, panel and portable. Send for list. Hanchett, Box 5577, Riverside, Calif. 92507.

LAMP Parts. Catalog, prices, wiring instructions, 50¢. Refunded first order. Gyro, 5218P N.W. 35 Ave., Miami 42, Fla. 33133.

LAMP parts for building, repairing, converting. Catalog 40 cents. Refunded with first order. Brown Lamp Co., Box 11305, Clayton, Mo. 63105.

## BATTERIES, GENERATORS

BATTERY Reconditioning Kit, includes molds, material, instructions. Battery Shop, 878, Palm Desert, California 92260.

## ENGINES, MOTORS, DYNAMOS

LIVE Steam powered backyard railroads! All sizes. Complete "bolt-together-kits," and rough castings. Excellent drawings. 100 page catalog \$1.00. Little Engines, Lomita, Calif. 90717.

WINDING Data, 275 motors, \$1.20. Data Company, 512 Kensington, Kansas City, Mo. 64124.

OPERATE Three phase motors from single phase. Three ways \$2.00. Donald Howell, Barnesville, Ohio, 43713.

BIG Steam Engines, Kits, Catalog 50¢. Reliable Industries, New Baltimore, Mich. 48047.

MOTORS! Generators! Batteries! Electrolaters! Testers! Plans! Diagrams! Catalog! Modetrip, Box 10025, Kansas City, Mo. 64111.

## MACHINERY, TOOLS AND SUPPLIES

GERSTNER Tool chests new SECONDS. Free catalog. Gerstner & Sons, Dayton, Ohio 45407.

SMALL Foundry furnaces, Supplies. Free literature. Pyramid Products, 3736 South 7th Avenue, Phoenix, Arizona 85041.

MICROMETERS—Indicators—Small lathes. Direct Supply, 1424 Barclay, Springfield, Ohio 45505.

GRANITE Surface Plate, 8"x12"x2". Certificate of Traceability, \$14.95 plus postage. Precision Granite, 11550 Larch, Mpls., Minn. 55433.

BEAM Compass with plated 30" split beam \$5.95. Dealers Wanted. Haro Industries Ltd. Box 263, Station K, Montreal 427.

## WELDING, SOLDERING, PLATING

CHROME Plating equipment, supplies. All other finishes. Home workshop and production sizes. Send \$1.00 (refundable) for formulas, operating data, equipment guide and catalog. HBS Equipment Division L50, 3543 East 16th, Los Angeles, Calif. 90023.

WELDERS—110/220, 150 Amperes, \$49.50. Morris, 1070 Inner, Schenectady, New York, 12303.

FREE BUFFING AND POLISHING COMPLETE INSTRUCTION MANUAL. Schaffner Manufacturing Co., Inc. Dept. PM-1, Schaffner Center, Pittsburgh, Pennsylvania 15202.

BUFF AND POLISH METALS AND PLASTICS. DO IT YOURSELF LIKE A PRO. Complete Schaffner building and polishing wheel compound Starter Kit =4. Instruction manual included. Send \$3.00 plus 75¢ postage today. Schaffner Manufacturing Co. Inc., Dept. PM-2, Schaffner Center, Pittsburgh, Pennsylvania 15202.

## GOVERNMENT SURPLUS

FREE Jeep Buying Information when you send 50¢ for 1969 Gov't. Surplus Bargain Catalogue. Surplus, Box 1P4, Spring Grove, Penna. 17362.

1969 SURPLUS Army, Navy store illustrated catalog. Send 25¢ (refundable with first \$5.00 order). Ruvel, 707 Junior Terrace, Dept. 9-J, Chicago, Illinois 60613.

JEEP And Gov't. Surplus Buying Manual (Jeeps Pictured) 50¢. Surplus Bargain Catalogue 50¢. Both \$1. Bargain Surplus, Box 1PM3, Spring Grove, Penna. 17362.

GOVERNMENT LANDS . . . Low as \$1.00 Acre. Millions Acres! For Exclusive Copyrighted Report . . . plus "Land Opportunity Digest" listing lands available throughout U.S., send \$1.00. Satisfaction Guaranteed! Land Disposal, Box 9091 RN, Washington, D.C. 20003.

GOV'T Surplus. How and where to buy in your Area. Send \$1.00. Surplus Information, Surplus Headquarters Building, PM. Washington, D.C. 20036.

JEeps From—\$52.50; Typewriters from—\$4.15; Cars from—\$31.50. Walkie-talkies, motorcycles, airplanes, boats. Typical "As Is" bid bargains from Uncle Sam. Tremendous variety. Exciting free list. Write: Enterprises, Box 402X43 Jamaica, New York 11430.

SURPLUS BARGAINS—War, Government, Industrial surplus at savings to 80%. Clothes, boots, coats, tents—bargains for farm, home, outdoors. SEND FOR FREE CATALOG—must give zip code. Surplus Store, Dept. 24B, Sioux Falls, S.D. 57102.

JEeps Typically From \$53.90 Trucks From \$78.40 . . . Airplanes, Typewriters, Boats, Clothing, Camping, Sporting, Photographic, Electronics Equipment. Wide Variety, Condition, 100,000 Bid Bargains Direct From Government Nationwide, Complete Sales Directory and Surplus Catalog \$1.00 (Deductible First \$10.00 Order). Surplus Service, Box 820-A, Holland, Michigan 49423.

## HOBBIES AND COLLECTIONS

50 GORGEOUS Junjungle butterflies \$2.50 Collectors Wonderland, Box 1170, New York, 10008.

U.S. ARMY SHOULDER PATCHES. Great for collectors. Official patches, all major Army and Air Corps Units, 10 asst'd patches, price list and catalog, \$2.00. Catalog of unusual gift items, 25¢. SPRINGER'S-PM, P.O. Box 577, El Paso, Texas 79944.

CAMERA Owners! Sell your photos. Booklet tells how, where. Color slide markets. Hurry \$1.00 Empire Gifts, Desk 129, 305 East 24th Street, Suite 15J, New York, 10010.



## STAMP COLLECTING

PENNY! Approvals! Regardless catalogue! Kloster, 4164 52nd St., San Diego 5, Calif. 92105.

500 DIFFERENT Stamps, \$1.00. Smith, 508-A Brooks, College Station, Texas 77840.

PENNY Stamps! 1000 Mounted in book at 1¢ each. Trust Stamp Company, P.O.B. 132-P, Jamaica, N.Y. 11435.

100 OLD United States between 1861 and 1935, \$1.00. Roush Stamps, 51 Chestnut, Mansfield, Ohio 44903.

50 DIFFERENT Old U.S. Revenue stamps 50¢. Winchester Stamps, Box 1592, Mansfield, Ohio 44907.

FREE Surprise collection sent with approvals. Gould, 1784 Union, San Francisco 94123.

U.S. Mint specials! Flag set, complete \$1.00, 1¢, 2¢, 3¢ famous Americans (21 different) \$1.00. Free list. Brooks, 2601 Avenue "U," Brooklyn, N.Y. 11229.

FREE! Triangles, Scout, 25 others. Approvals. Cambridge, Box 411, Cambridge, Ohio 43725.

FREE! Big Bargain Catalog—New Edition listing thousands of bargains including U.S. & B.N.A. stamps, packets, albums, accessories and supplies. Also, fine stamps from our approval service which you may return without purchases and cancel service at any time. Jamestown Stamp, Dept. E29PM, Jamestown, N.Y. 14701.

U.S. Bargain, 50 different 10¢, with beautiful worldwide approvals. Stamp Center, Kennebunk, Maine 04043.

RUSSIAN Space set 10¢. Russian approvals. Snedco, Box 68-P, Waldwick, N.J.

ONE Pound value Geo. VI Bermuda, plus 100 worldwide 10¢, approvals. Stevens, Box 105A, Homecrest Sta., Brooklyn, N.Y. 11229.

WOW! 110 all different Germany 10¢ Commemoratives, Airmails, High Values, Big catalog, bargain lists also, fine stamps from our approval service, which you may return without purchases and cancel service at any time. Jamestown Stamp, Dept. A29PM, Jamestown, N.Y. 14701.

FREE 50 Worldwide. Approvals. University Stamps. P.O. Box 1471, Lake Worth, Florida 33460.

INTRODUCING Our better United States approvals we offer 15 United States stamps including Columbian, Bi-Centennials, famous American, airs, others; only 10¢. Ocean Stamps, Box 64-PM, Brooklyn, New York 11229.

UNITED States commemorative collection containing 33 different—10¢. Approvals. White, 516-A Avenue L, Brooklyn 30, New York.

50 YEARS Old, fifteen different United States, over fifty years old—10¢ with approvals. Jaxon, Box 145-P, Brooklyn, New York 11230.

GIANT Stamp Collection including: Astronauts, Satellites, Moonrocks, Boy Scout issue. Complete U.N. Set. recent Olympic and Sport issues from many countries, etc., Plus Big Stamp Dictionary and approvals. Everything, 10¢! Stampex, Box 47-RM, White Plains, N.Y.

ABSOLUTE'Y Free 25 different United States Commemorative when requesting United States Approvals. K & B, Box 70, Brooklyn, N.Y. 11223.

**QUALITY And price. Mounted approvals 2¢ up. Preview Stamps, P.O.B. 9809M, San Diego, Calif. 92109.**

701 U.S.A. (Plenty Commemoratives)—25¢. Request approvals. Horace Gatewood, Winston-Salem, N. C. 27102.

1045 DIFFERENT—\$1.50. Foreign approvals. KayKaye, Box 452, Harrisburg, Ill. 62946.

U.S. Seconds, Bargain Prices, Karl Swartz, Box 373, Venice, Fla. 33595.

ONE Cent a stamp. Write for a jumbo book of foreign stamps at 1¢ each, mounted in Scott order, Bulloet Approvals, 6815 Bay Parkway, Bklyn., N.Y. 11204.

SENSATIONAL Free offer; 20 outer space stamps; selected approvals; Louis Morrison, 1027 Maryland, Cape May, N.J. 08204.

CANADA: Outdoor recreation set 40¢ value only 15¢, approvals. Rheume, 6591 11th Ave., Montreal 36, Canada.

2,000,000 STAMPS, 150 Countries, 2¢ each. Belden, Box 175, Dearborn, Michigan 48121.

251 DIFFERENT U.S. commemoratives with approvals \$1.00. Carstamps, 12 Mockingbird Lane, Fort Smith, Arkansas 72901.

FREE Twenty different worldwide stamps When you request our approvals. Fairplay Stamps, 1411 Marion Way, Santa Ana, California 92706.

14,000 DIFFERENT! AMAZING new plan builds your collection systematically, country by country. Only 50¢ weekly. Ware, Monroe, Conn. 06468.

CANADA Sports complete. 10¢. Canada approvals. Valley Stamps, Little Valley, New York 14755.

U.S. Worldwide price list . . . 10¢ handling. No approvals Dept. P. 5001 Eastern, Hyattsville, Md. 20782.

500 FINE Mixed Canada. 25¢. Continental, 271 Fine Cove, Burlington, Ontario, Canada.

"INVERTED ERROR" Dag Hammarskjöld. 6¢ with approvals. Belmont Stamps, Washington, D. C. 20015.

1500 FOREIGN \$1.00; 5000 \$3.00. 5000 USA commemoratives, revenues, airmails, presidentials, 19th Century, high values \$3.00. 300 pre-1939 USA commemoratives \$2.00. 1000 foreign pre-1940 \$3.00; 5000 \$12.00. No approvals. Meyers, 5321 Fleming, Richmond, California. Zip code 94804.

FREE—World's Greatest Premium—5000 all different stamps, actual Catalogue value over \$100.00 given approval buyers. Thrifty Stamps, Grossmont, California 92041.

IRAQ, Iran, Turkey 75 Stamps 10¢ with approvals. Berchtold Stamps, Troy, Ohio 45373.

50 DIFFERENT United States, only 10¢. with Approvals. Shelton, Box 547C, North Miami, Florida 33161.

INVEST IN STAMPS. Details of systematic investment plan and current investment newsletter \$1.00 refundable. Jeffrey Needleman, 2367 East 18th Street, Brooklyn, New York 11229.

FREE—Mammoth Collection, \$10.00 Airmail, Scott's International. Master Global Albums when you buy our Approvals. Bargain Stamps, Tustin, California 92680.

TRIANGLES Galore! Terrific Stamp Bargain! Three beautiful sets of triangles plus 105 different, including colorful Asiatic pictorials. Only 10¢ with request for approvals. Send today! Shaw, Drawer E-4, Montevallo, Alabama 35115.

PAINTINGS. 10 Different beauties. 5¢. Approvals. Mayers, 37 Dawson, Belleville, New Jersey 07109.

PENNY Approvals. Premiums with purchases. Large selections. Penny Stamps, Orange, California 92669.

U.S. Approvals Low prices. Eagle, 2221 Romine Ave., Pittsburgh, Pa. 15226.

**MILLIONS Foreign Stamps! 2¢ each! Send for gigantic approvals! ABC, Box 6000-MB, San Francisco, California 94101.**

225 STAMPS for only 10¢! Airmails. Pictorials; stamps from strange countries cataloging up to 25¢ each! Plus unusual stamps to examine. Buy any or none return balance, cancel service anytime. Mystic Stamp Co., Camden 80, New York 13316.

69 DIFFERENT Free with approvals. Collier, Box 265, Folkston, Georgia 31537.

PRESIDENT Nixon inauguration cover—addressed to you on special cacheted envelope carrying official historic-date postmark from Washington. 35¢ each—3 for \$1. K. M. Walsh, Box 308, Tuckahoe, N.Y. 10707.

TOPICALS—Three Colorfull Sets, 10¢! Approvals. COLE, Box 223-A, Buffalo, N.Y. 14221.

FREE!! Two Complete Mint Sets. Approvals. Hamilton, 1246 Pratt, Chicago OE-2, Illinois 60626.

RUSSIA High-Value Collection. 32 different Russia—some over 50 years old! Commemoratives, Czarist Issues, Airmails. Catalog price \$2.99. Special Get-Acquainted Offer—all for only 10¢! H. E. Harris, Dept. GG-5, Boston, Mass. 02117.

UNITED STATES LISTS—15¢. (Refunded) Livingston, 21 View, Holyoke, Mass. 01040.

FREE Mint set. Approvals accompany. Stamps, Box 22092, Memphis, Tenn. 38122.

SENSATIONAL Clearance. Ten different packets 25¢. No Approvals. Norge, Ho-Ho-Kus N.J. 07423.

FREE—50 Stamps includes Ryukyus, Greenland, Iceland, Macao—Approvals—Moublow, 12542-5R Keel, Garden Grove, California 92640.

SIPEX Souvenir Sheet (1311) mint, plus illustrated U.S. price sheets, 25¢. Eric Nemejer, 8211C Forest Hills Drive, Elkins Park, Pennsylvania, 19117.

10 FAMOUS PAINTING 10¢ with Approvals. Gerlach, 3851 Kingswood Drive, Dayton, Ohio 45429.

FREE STAMPS! Birds, Animals, Triangles, Approvals. Eddy, Box 2122, Waterbury, Connecticut 06720.

"ATTRACTIVE" European Set 10¢. Approvals. Kenneth Zielski, Box 364, Morton Grove, Illinois 60053.

I PAY \$250 each for 1924 1¢ green Franklin stamps, rotary perforated eleven (\$2.500 unused). Send 25¢ for illustrated folders showing amazing prices paid for old stamps, coins, collections. Vincent, 85PM, Bronx, New York 10458.

"AFRICA." 25 beauties. 10¢. Approvals. Gorriz, Box 1915PM, Naples, Florida 33940.

DISCOUNT—United States, Foreign. Richard Kehrle, 274 Balcom Ave., Bronx, N.Y. 10465.

LARGE PICTORIALS 100 Different 25¢ with approvals. Arlo Bones, Box 5995, San Jose, California 95150.

50 DIFFERENT Foreign, guaranteed \$5.00 catalogue value, \$1.00. 125 different, guaranteed \$12.00 value, \$2.00. Lakeshore, Box 162-PM, Concord, Tennessee 37720.

POLAND—25 Different Beauties, 10¢ Approvals, Tarheel Philatelics, Siler City, North Carolina 27344.

25 DIFFERENT U.S. Air Mails 25¢. 45 diff. \$1.00. Free price list. EBERLING, 105 Franklin Ave., Staten Island, N.Y. 10301.

RUSSIA—15 Beauties. 10¢. All Complete Sets! Approvals. Postmark, Great Neck, 4. N.Y.

PAINTINGS 20 Different giant multi-colored beauties 25¢. Beautiful paintings sets on approval. Rger Williams Stamp Co., Box 1281-P, Pawtucket, Rhode Island 02892.

BREATHTAKING. 50 Mint Monaco, \$1.00. Approvals Accompany. World, 1784 Uni. n, San Francisco 94123.

**"WHOLESALE" Pricelist and catalog free! Everything guaranteed. Schneider Co., Holland, Mich. 49423.**

ATTRACTIVE Topical Collection 10¢ with Worldwide approvals. Roderick, Hampden, Massachusetts 01036.

FREE—Mint British Colonials from Sabah, Seychelles, Tristan Cunha, Sarawak, Negri Sembilan, Caymans, South Georgia. Free with approvals. Viking, Great Neck 8, N.Y.

WOW! 1,000 Different worldwide—valued over \$20.00 only \$1.00 with quality approvals. Universal, Box 6, Kenosha 5, Wisconsin 53141.

FREE Stamp Wallet with approvals. Wide choice collections by countries. Clark, Box 28-P, Wilmette, Ill. 60091.

WHILE They last! \$5.00 Hamilton fine used 30¢ with approvals to advanced collectors. Borgen, Box 502, Paso Robles, Calif. 93446.

100 DIFFERENT Stamps 12¢ (stamps). Bargain approvals. Sigmam, Box 231 Agnew, Santa Clara, Calif. 95054.

5000 U.S. FOREIGN Pictorials Free with purchases. Approvals. Stamp Farm, YM3, Oxford, Wis. 53952.

PAINTINGS 25 different. 10¢. Artistic approvals. James Shaw, Box 431, Allapattah Station, Miami, Florida 33142.

SPAIN. 50 different, 5¢. approvals. Hljop, Box 505, Norristown, Pa. 19401.

"50 INTERESTING India" 10¢! With "Approvals." Myakka, Box 278-J, Miami, Florida 33165.

NEW Issues—Free weekly illustrated list. Brooks, 2601N Avenue "U," Brooklyn, N.Y. 11229.

FAR East Assortment—Stamps from Viet Nam, Japan, Korea, Formosa and others only 10¢ with world-wide approvals. Clark Stamps, Dept. 57V, Muskegon, Mich. 49444.

STAMPS Free! New issues, new countries, triangles, rockets, Olympics, Scouts, birds, flowers, animals. Also old Canadian and U.S. Stamps. Plus complete illustrated Canadian stamps catalog. Send 10¢ for mailing. Gray Stamp Co., Toronto, Canada.

CANADA, 100 DIFFERENT, \$2.00. A. F. Lee, Placentia, Newfoundland.

50 DIFFERENT AFRICA plus SOUVENIR SHEET 25¢.—Approvals accompany. Quynn's, Scotland, Penna. 17254.

MINI-SKIRTED "Playmates". Rwanda's latest native Women Costumes—Free! Approvals plus 101 Bonus Sets. William Deems, 226 Race, Ravenswood, West Virginia 26164.

## COINS, TOKENS, CURRENCY

MERCURY DIMES, 20 different, \$3.95. "S" ROOSEVELTS, 10 different (1946S-1955S complete), \$2.95. Uncirculated 1955S Cent, 2 for \$1.00. 1943PDS STEEL Cents, 2 sets \$1.00. SERENDIPITY, Box 820P, Cupertino, California 95014.

40 GENUINE Coins from 40 countries. Mostly uncirculated. Beautiful, \$2.00. Hindley, Box 708, Aurora, Illinois 60507.

100 INDIAN, Lincoln Cents, 1920's and older. \$5.00. Wesley Road, West Union, Iowa 52175.

"SEVEN Different liberty nickels—\$2.00—Bargain listing—Dime—Huber—200 Baker Building, Minneapolis 55402.

UNCIRCULATED Dollars, 1880-81-82 S, 1883-84-85-1899-1900 01-02 O mint. \$3.50 ea. Catalogue 50¢. Shultz, Salt Lake City, Utah 84110.

U.S. Large Cent before 1857, \$2.00; Civil War 3¢ piece, \$2.00; Five different Indian Cents, \$1.00; Lincolns, ten different "S" mints before 1955, \$1.00. RARCOA, 31-A North Clark, Chicago 60602.

LIBERTY Nickel, 60 years old. Coin list, 30¢. Economy Sales, Mansfield, Mass. 02048.

**LINCOLNS:** 30 Different Brilliant Uncirculated 1954PDS-1968PDS complete (Regularly \$5.95)—Special \$2.95. Silver Dollars \$2.45 each. BONANZA, Box 4491P, San Jose, California 95126.

**COINS Discounted!** Catalogue 25¢. Buying Catalogue 50¢. Sullivan's = 3330-AC St. Paul, Minnesota 55101.

**PRICE List.** Send 10¢. Village Coin Shop, Dept. P, Plaistow, N.H. 03865.

**BARGAINS GALORE:**—\$1.00 Specials! nine different Buffalo's, four different Indians, four different Liberty nickels, six different War nickels, fourteen (S) Lincoln cents, EXTRA special:—Seated dime \$2.35. SENSATIONAL U.S. coin list 10¢. Schultheis, 214M Devonshire, New Hyde Park, N.Y. 11040.

**SCARCE** Date Jefferson nickels. All V.G. Satisfaction Guaranteed. 1942D—1949S—1950—50¢ each. 1943D—1951S—1955—75¢ each. 1939S—\$1.25. 1938D—\$1.65. 1938S—\$3.25. 1939D—\$5.00. 1950D—\$14.50. Dates not listed 20¢ each. Bryson Inc., 612A White, Toledo, Ohio 43605.

**CIVIL** War token \$2.00. Doktor, Box 8915, Oak Park, Mich. 48237.

**SILVER** Wartime Nickels, 4 Different, 50¢. Stevens, Box 546F, North Miami, Florida 33161.

**OLD** Coins Bought. Illustrated Catalog 25¢. Hutchinson's, Box 6256, Philadelphia, Pa. 19136.

22 "S" LINCOLN Cents, including rare 1955S, \$1.60. 26 1909-1939, \$1.60. 10 "S" Jeffersons, \$1.60. All different. All three \$4.50. Bargain pricelists included with order. HARRIS, 2373 P Pruneridge, Santa Clara, California 95050.

**LINCOLNS:** 1909VDB Through 1939DS; 1915PD, 1916DS, 1921S, 1932D, 1938DS 59¢ each; Thirty Different \$2.50; Sixty Different All Included \$7.95. Roger's, 3531M West 29th, Minneapolis, Minnesota 55416.

"7 COUNTRIES" Coins—25¢ 7 Countries' bills—25¢. JOLIE, BOX 50E, BROOKLYN, N.Y. 11224."

**BEAUTIFUL** Large Bronze "Official" Inaugural Medals—Kennedy \$13.75. Johnson \$6.75. Nixon \$6.75. All Three \$24.75. Bargain Lists 25¢. Bebec's, Inc., Omaha, Nebraska 68111.

**COLLECT** Coins for PROFIT! How to Start, Where to Sell Lists of Valuable Coins. Check your change. Send \$1.00 to: Family House, 280 Dowe Avenue, Carle Place, New York 11514.

**BAGS** (100) Old Lincoln Unsorted \$5.75. "Coins", 7A Broad, Lynn, Mass. 01902.

**INDIAN** Cents 4 different 97¢. Coins, Box 8541, Minneapolis, Minnesota 55435.

**COINS** Cheap. Catalog 10¢. Buying Catalog 25¢. Winters, Box 7055BD, Minneapolis, Minnesota 55411.

**SALE!** 1863 Cent \$1.65. List 10¢ Fairway 121- P, Rye, New York 10580.

1968S CENTS Uncirculated, 21—\$1.00. 1968S Nickels 6—\$1.25. Both \$2.00. Morehead, 208B, Houston, Thousand Oaks, Calif. 91360.

**SPECIAL!** Eagle Cent \$3.00! Terrific Bargains! Nelson 346-P, Rye, New York 10580.

**GOLD** COINS of the World. Beautiful low prices. Plus thousands of United States Coins. Free price list. Please send long, airmail envelope, self-addressed stamped, Silver Center, Box 22171-M, San Francisco, California 94122.

**THREE** Mexican Silver Dollars \$1.00. Donald M. Petermeier, RR #1, Box 288A Anoka, Minnesota 55303.

"S" ROOSEVELT Dimes, 10 different (1946S-1955S Complete!), \$2.65. Mercury Dimes, 23 different, \$3.95. 10 different Jefferson Nickels, \$2.00. 50 Buffalo Nickels, Includes Many Early Dates! Only \$8.95! Kennedy's, Box 9425, San Jose, California 95117.

**QUEBEC**—Famous Carnaval—50¢—And All Years. Fernand Brousseau, 241 Aberdeen, Quebec 6, Que., Canada.

**CHINA** Dollar (nickel silver) for 50th year of Free China only 10¢ with big catalog and approvals. Littleton Coin Co., Littleton KC1, N.H. 03561.

**LOWEST** Prices anywhere quoted on request. Special listings, gift, 15¢. WKS, Box 705, Port Orange, Fla. 32019.

### ANTIQUES, RELICS, INDIAN GOODS AND CURIOS

**LIST** Indian relics, 10 Arrowheads \$3.00. Hyde's, Box 2304, Santa Fe, New Mexico 87501.

**TONS** Of antique gun parts and supplies. All reproduction muzzle loading guns. Send \$1.00 for enlarged illustrated catalog No. 117-A. Dixie Gun Works, Union City 12, Tennessee.

**ONE** Dozen perfect arrowheads \$4.00. George Smith, 9825 Conway Drive, Indianapolis, Indiana 46236.

**BURR** Relative Wants etchings, watercolors. Seeber, 506 Ballantine Road, Bloomington, Indiana 47401.

**AUTHENTIC** Apache Pima Zuni etc. Indian Artifacts. Trade buy sell. List 50¢. Bowers, 1015 Florence Blvd., Casa Grande, Arizona 85222.

**WANTED** Old Clocks. W. Harding Collector, 9314 Walden, Silver Spring, Maryland 20901.

**INDIAN** Relics. Arrows, \$4.00 doz. Bird-points, \$7.50 doz. Folsom or Sandia \$5.00. List. C. Sechrist, Muscatine, Iowa 52761.

### MODELS—SHIPS, TRAINS, PLANES, ETC.

**SHIP** Models, Kits, fittings, plans, books, tools, engines, motors. Big illustrated catalog 50¢. Mass. residents add 3% tax. James Bliss & Co., Dept. SM, Route 128, Dedham, Mass. 02026.

**SHIP** Models catalog 25¢. Scientific, Inc., 100 Monroe, Newark, N.J. 07105.

**ROCKETS:** Real flying models—flights up to 2500 ft. New illustrated catalog 25¢. Single and multistage kits, cones, engines, launchers, trackers, rocket aerial cameras, technical information. Fast service. Estes Industries, Penrose 2, Colorado 81240.

**SHIP** And yacht model fittings; Pine construction hull kits; blueprints. Send 50¢ for illustrated catalog. A. J. Fisher, Inc., 1002 Etowah Avenue, Royal Oak, Michigan 48067.

**SCALE** Building materials, 1/4" & 1/8" scale. Windows, doors, siding, roofing, lumber and structural shapes. Send 50¢ for catalog. Small Sales Co., P.O. Box 177, Shawnee Mission, Kansas 66201.

**SHIP** Model kits and fittings: clippers, frigates, etc. Catalog paint-tool list, 1969 catalog 50¢. Models Shipways, Box 65, Bogota, N.J. 07603.

**ROCKETS!** Flying models, Engines. Beginning through advanced. Catalog 25¢. Rocket Development Corporation, Route 3-M, Seymour, Indiana 47274.

**LIVE** Steam Engine Kits. Fascinating Hobby For Model Mechanics. Boilers, Fittings, Accessories. Pictured Catalog \$1.00. H.P.K. Models, Centuck 34, Yonkers N, New York 10710.

"PUFFER" Patented inflatable kite. Wild orange. No sticks, \$1.00 P.P. Box 253, Pacific Palisades, Calif. 90272.

### GAMES, TOYS, PUZZLES & NOVELTIES

"COME Seven or twenty-seven!" "EMO", played with 36 numbered "ROULETTE DICE". Send \$2.00 to D. E. Products & Co., P.O. Box 488, Worcester, Mass. 01601.

**KITES.** Kits, plans. Delightful booklet, 25¢. Kyte Tales, Box 145C, Richardson, Texas 75080.

"PUFFER" Patented inflatable kite. No sticks, \$1.00 P.P. Box 253, Pacific Palisades, Calif. 90272.

**PEACE** Button, 250 Novelty Buttons Free Catalogue. Dealers Inquire. Harrison, Box 233, Bethpage, New York 11714.

### MAGIC TRICKS, JOKERS & VENTRILOQUISM

**AMATEUR** and **PROFESSIONAL** MAGICIANS all new magic tricks and gags catalog 25¢. Our specialty same day service. Fabulous Trick and Magic, 3319 E. Charleston, Las Vegas, Nevada 89104.

**MAGIC** MAGAZINE—Monthly since 1936. 44 pages. All phases. 3 month trial \$1.00. Genii, P.O. Box 36068, Los Angeles, CA 90036.

**COMPLETELY** Illustrated catalog, 84 pages, 25¢. Manhattan Magic, Box 334-M, N.Y.C. 10011.

**WORLD'S** Finest professional magic tricks. Joker's Novelties. Giant illustrated catalog 10¢. Top Hat, Evanston, Illinois.

**FREE!** World's Leading Catalog 2000 Novelties, Jokes, Tricks, Scientific Gadgets, Hobbies, Johnson-Smith, D-356, Detroit, Michigan 48224.

**HOUDINI'S** Original Magic Shop. Established 1856. Send 25 cents for Illustrated Catalog containing 5000 Tricks, Mindreading, Puzzles, Hypnotism and Jokes. Flossie-Hornmann, 304 West 34th St., N.Y. 10001.

**FREE** Trick with Magic Catalog. Send 10¢ Ace Magic, Box 329, Evanston, Illinois 60204.

**VENTRILOQUISM!** Information free! Dummy catalog, 25¢. State age. Maher, Studio L, Box 8356, Kensington Station, Detroit, Michigan 48224.

**CATALOG** 10¢ (1,500, 399 tricks, jokes, novelties) Elbee, 7408-P, San Antonio, Texas 78207.

**HOUDINI** Magic Catalog!! Giant Professional Deluxe Edition!! 1000 World's Greatest Tricks!! 25¢ with Free Gift Certificate!! House of 1000 Mysteries. Dept. PM9C, Northeast Fifth Ave., Ft. Lauderdale, Florida 33308.

**MAGIC** Catalog. World's finest 3000 tricks. (340) pages \$2.50. Beginners, amateurs, professionals. Kanter's, A-200 South 13th St., Philadelphia, Pa. 19107.

**500** TRICKS Catalog. 1969 Edition, showing latest magic for pocket, parlor, stage. Only 10¢. Fastest mail service for 45 years. Douglas Magicland, Dept. 11, Dallas, Texas 75221.

**FREE** Ventriloquism information. Dummies, Books, Records, Mouthpiece, 25¢. STAVDRY, Whitestone, New York.

**35,000** COMEDY Lines—Complete catalog plus jokebook, \$1.00. John Rain Assoc., Inc., Dept. M, 232 Madison Ave., N.Y., N.Y. 10016.

**BE A** Magician! Two booklets explaining sixty-eight tricks plus large professional catalog, \$1.00. Magic, Inc., 5082 Lincoln, Chicago, Illinois 60625.

### BOOKS, PERIODICALS, NEWSPAPERS

**NATIONAL** Geographic Magazines, 1888-1967, any issue. Buxbaum, Box 465-PM, Wilmington, Delaware 19899.

**PROPHET** Elijah coming before Christ. Wonderful book free. E. Megiddo Mission, 481 Thurston Rd., Rochester, New York 14619.

**FREE** Catalog. Self-help books. Write Wilshire, 8721 Sunset, Los Angeles 90069.

**PAPERBACK** Catalogue, 270 pages, 15,000 titles, indexed, \$2.00 credited toward order. New York Book, 4 P West 43 Street, N.Y.C. 10036.

**PAPERBACK** Catalogue, 270 pages, 15,000 titles, indexed, \$2.00 credited toward order. New York Book, 4 P West 43 Street, NYC 10036.

**ASTONISHING!** Astounding! Scarce! Adult books, magazines. Giant discounts! Free illustrated catalog. Crossland, 11126 Corbett, Detroit, Michigan 48213.

**BACK** Date Magazines! Send needs. Midtown, Box 917-PM, Maywood, N. J. 07607.

**ANTIQUE Dealers Handbook.** New 9th Edition. Now available to public. \$7.95 or write for free catalog. Eastwood, Dept. M2 1209 22nd St., Logansport, Ind. 46947.

**BOOKS** Used and new. Crafts, courses, trades, hobbies, educational, science. Free catalog. George Brown, Box 7146, Toledo, Ohio 43615.

**CO-Publish** your own magazines. We pay 50% commission. Details 25¢. Martins Service, Rives Rd. Martinsville, Va. 24113.

**FREE Catalog.** Self-Help books. Henry, 1500 Joliet, Plainview, Texas 79072.

**"HARD-To-find"** Adult books. Free catalog. C&S (PM12), 2224 D. Box 4-701, Anchorage, Alaska 99503.

**ADULT.** Self Improvement Books. Free catalog. AJ Enterprises, Box 5, Mt. Ranier, Md. 20822.

**DISTINCTIVE GIFTS:** Low cost Books and Booklets, \$1.00 and \$2.00 each. Success, Wealth, Happiness. Health and other personal problems. Write for Catalog. W. H. Wear Co., 4436 A Florida Short Route, Birmingham, Alabama 35243.

### PLAYS, STORIES, MANUSCRIPTS

**WANT** Your book published? Learn how we publish, advertise, promote, distribute. Many successes. Free booklet PM, Vantage, 120 West 31, New York City.

### BUSINESS OPPORTUNITIES

**HUGE Profits!** Mail order importing. Free information. ITIS, PM-2, Box 454, Hollywood, Calif. 90028.

**\$15.00 HOURLY PROFIT—OWN** Business with one serviceman. Quickly learned. Easy to do. Operate from home. Few hundred dollars builds your own nationally advertised business while continuing present job. Investigate immediately. . . . before your territory is taken. Free booklet explains everything. Send Today. Then decide. Duraclean, C9-161, Duraclean Building, Deerfield, Illinois.

**BOOKKEEPERS** Earn \$1000.00 month. Operate simplified Bookkeeping tax service. Universal, Box 664-M, Springfield, Missouri.

**WANT** To make big money at home? \$10.00 profit in an hour possible with invisible mending. Make tears, holes disappear from clothing, fabrics. Steady year-round demand from cleaners, laundries, homes. Details free. Fabricon, 1585 Howard, Chicago 60626.

**I MADE \$40,000.00** Year by Mailorder! Helped others make money! Start with \$10.00—Free proof! Torrey, Box 318-Y, Ypsilanti, Michigan 48197.

**CONCRETE FACTS:** Highly profitable home business. Experience unnecessary. Unlimited unique pottery designs easily made without moulds. Birdbaths, fountains, wishing-wells, benches, etc. Chemical coloring formulas, marbled glazing. FREE illustrated brochure. Hollywood Cementcraft, 602 Athens Street, Altadena, California 91001.

**MAKE \$46** from square foot plywood: jigsaw or bandsaw necessary. Free details. Woodard, Bridgewater, Mass. 02324.

**SELL** Books by mail. 400% profit. Royal, Box 450-X, Cleveland, Ohio 44127.

**WORLD'S Largest** supply. Merchandise 25% to 40% under wholesale. Bankrupts, closeouts 10¢ on dollar. Imports. Hong-kong clothes. Automobile discounts. Free details. International Buyers, Box 4633-MM, Colorado Springs, Colo. 80909.

**RAISE** Rabbits for us on \$500 month plan. Free details. White's Rabbitry, Mt. Vernon, Ohio 43050.

**MAIL** Baby Catalogs imprinted with your address to New Mothers for Big Profits! Details 25¢. Volz-PM, Ypsilanti, Michigan 48197.

**UP** To \$5.00 each for newspaper clippings! Free details. Philip, Box 368-S, Southfield, Michigan 48075.

**FREE Catalogs.** Repair air conditioning refrigeration. Tools, supplies, full instructions. Doolin, 2016 Canton, Dallas, Texas 75201.

**FREE "Franchise Profit Letter"** tells how unique NFR service is helping thousands seeking profitable businesses. Write today. National Franchise Reports, W-528, 333 North Michigan, Chicago 60601.

**VENDING** Machine big catalog. Rake, 523 A Spring Garden, Philadelphia, Pa. 19123.

**56 ACTIVE** Franchise opportunities available all over USA. Brochure details 56 franchise chances for you to have your own business tied with successful national companies. Send name, address to P. Stewart, 1085 Walnut, Des Plaines, Illinois 60016.

**\$400.00 MONTHLY** Raising giant fishworms. Soilless method. Charlie Morgan, Bushnell, Florida 33513.

**EARN** Money raising fishworms for us! Write: Oakhaven-38, Cedar Hill, Texas 75104.

**400,000 BARGAINS** Below wholesale! Many free. Liquidations . . . closeouts . . . job lots . . . single samples. Free details. Bargainhunters Opportunities, Box 730A, Holland, Michigan 49423.

**\$200.00 DAILY** In your mailbox! Your opportunity to do what mailorder experts do. Free details. Associates, Box 136-A, Holland, Michigan 49423.

**CLIP** Newspaper items. \$1.60-\$5.00 each. Details free. Walter, Box 1360-PA, Erie, Pa. 16512.

**PLASTERCRAFT** Molds, liquid rubber, plasters, flocks, candle supplies. Catalog and manual free. Blue Rapids Supply, Blue Rapids, Kansas 66411.

**BIG** Money—making new greaseless donuts in kitchen. Everything furnished. Sell stores. Free receipts. Montgomery Ray, Waseca, Minn. 56093.

**SELL** Lifetime. Metal. Social Security Plates. Big Profits! Sample and Sales Kit Free. Russell, Box 286-PM, Pulaski, Tennessee 38478.

**MAKE** 2 to 3 times your cost wholesaling 1001 products. Gifts, Mail Order Specialties, Toys, Novelties, Carded Merchandise . . . Guaranteed lowest below wholesale prices. Free home business details SMC 7630 SPB, Gloria Ave., Van Nuys, Calif. 91406.

**HOW TO PREPARE YOUR OWN MAIL-ORDER CATALOG** for pennies. . . . Including All Popular Merchandise! Free Catalog-Proof! Ohle, 5711-MF-14th, Brooklyn, New York 11219.

**MAILORDER** Book publisher wants dealers. Wonderful "drop-ship" proposition. Sample imprint circulars free. Neil H. Tasker, Shamokin, Pennsylvania 17872.

**BIG Profits—**Operating your own plastic laminating business with low cost equipment and supplies. Money making methods included. Money back guarantee. Jiffy—Box 23485P, Los Angeles, Calif. 90023.

**BUILD** Custom Cases at home for profit. Get orders by mail. We supply materials, instruction—everything. Free home business details. Custom Case Supply Co., 7630-CPB; Gloria Ave., Van Nuys, Calif. 91406.

**MERCHANTS** Police career! Patrol local business buildings nights. National, Box 327, Springfield-5, Oregon 97477.

**\$70.00 WEEKLY—**home, spare time. Simplified mail bookkeeping. Immediate income easy. Auditax, 34741A, Los Angeles 90034.

**VENDING** Machines. No selling. Operate a route of coin machines and earn amazing profits. 32-page catalogue free. Parkway Machine Corporation, 715 PMB Ensor Street, Baltimore, Maryland 21202.

**PIANO** Tuning Learned quickly at Home. Tremendous field. Musical knowledge unnecessary. GI approved. Information free. Empire School, Miami, Florida 33145.

**INSTALL** Burglar alarms without previous experience or costly equipment. Big profit. Free details. Nasco, 11071 Massachusetts, Dept. C-2702, Los Angeles 90025.

**ADDRESSERS** And mailers needed. Send stamp for information. Lindbloom, 3636 West Peterson, Chicago 60645.

**FREE** Book "990 Successful, Little-Known Businesses." Work Home! Plymouth-372T, Brooklyn, New York 11218.

**IMMEDIATE** Profits with no capital or experience. Take orders for all magazine subscriptions. Friends and neighbors are your prospects. Write now for complete, free kit. McGregor Magazine Agency, Dept. GB9, Mount Morris, Illinois 61054.

**\$75.00 THOUSAND.** Home Addressing! Longhand, Typewriter. Information, send stamped self-addressed envelope. Brewster, Box 1348-TF, Clearwater, Florida 33517.

**SET** Your own income just talking to boat dealers! Sound fantastic? Many of us are. \$30,000 and up per year. How about you? Experience not mandatory! \$5.00 gets you the How, Who and Why of a fine exciting business. Counselor Services, P. O. Box 67, Dayton View Station, Dayton, Ohio 45406.

**SUPPLY** Fried Chicken Dinners on \$500 week home plan. Free information. White's Chicken Dinners—PM, Mt. Vernon, Ohio 43050.

**BE** DATACRAFTER At Home. Sell hometown merchants, doctors, banks. I train you what, where, how to sell. Free particulars. Datacraft-71A, Harlingen, Texas.

**MAKE** \$75.00 daily distributing tools to service stations. Free Plan. INKA, 2401 Crocker, Houston, Texas 77006.

**EASY-To-start** rubber stamp business at home in spare time. Make up to \$16.50 an hour without experience. Facts free. Write to: Roberts, 1512 Jarvis, Room CR-2-A, Chicago, Ill. 60626.

**FREE FRANCHISE JOURNAL** MAGAZINE with over 100 business opportunities. Franchise Journal, 892-G West 16th St., Newport Beach, California 92660.

**BIG MONEY MAKER!** Custom Furniture Upholstery plus Auto Trim, Slip Covers, Drapes. Tremendous spare-full time earnings. Men, women, all ages. No experience required. We furnish everything: Easy Home Instruction. Tools, Supplies to build roomful of beautiful furniture . . . yours to keep—sell! Approved for Veterans. Send for Big FREE Illustrated Book. Modern Upholstery Institute, Box 899 BM5, Orange, California 92669.

**SPEEDYMAIL** Can help you start Profitable. Private, Mail Delivery System from your local Post Office. Free Information! Speedymail, Box 4543A, Miami Beach, Fla. 33141.

**FREE!** 60 Lazy Ways To Strike It Rich! Stamped, self-addressed envelope. Funderhood. (PM-23), 15 West 38th, N.Y. 10018.

**BECOME** PROFESSIONAL DRIVING INSTRUCTOR. Big demand. Earn \$10.00 hour. \$300 week. Part time. Full time. Business for yourself. Free details. Write Howard David, 1818 Everts St. Phila., Pa. 19152.

**PLEXIGLAS SIGN MAKING** Simple instructions and supplies lets you make PROFESSIONAL PLEXIGLAS SIGNS. Starting kit \$12.50 for over 120 Acrylic letters and Acrylic background. Unlimited uses. great profit. Daytona Plastic, Dept. M., Box 6161, Daytona Beach, Florida 32022.

**OPERATE** Home mailorder business! Free info: Vosacek Printing, Box 1217A, Garden Grove, California 92640.

**MAKE** \$32 from 49¢ piece vinyl. M-1834 Edgeland, Louisville, Ky. 40204.

**MAKE** Gorgeous original candles for all holidays and special occasions. Learn expert Candle decorating, candlemaking, use of professional molds. Free details on home instruction method. Candle Institute, Dept. SS, 1600 Cabrillo, Torrance, Calif. 90501.

**DRAFTSMEN!** Operate own DRAFTING SERVICE! Full, Part Time; Experience unnecessary! Details: Roberts Drafting, 1741 Circle Road, Baltimore, Maryland 21204.

**COPUBLISH "Mail Sale Advertiser,"** leading mailorder paper. Copy and details 25¢. U.S.A. only. Vanroy Shirk, Lebanon, Pa. 17042.

**MAILORDER Records help get Increased Business!** Complete 32 page Record Book shows your inquiries, orders, advertising expense, etc. Only \$1.00. Martin, Popular Mechanics, Dept. PM, 575 Lexington, New York 10022.

**BIG Profits Wholesale gifts items** novelties toys carded merchandise in full or spare time. Goldman, Dept. A98, 931 N. Ditman Ave., Los Angeles, Calif. 90063.

**MAKE Money from old tires.** Operators clearing \$800, weekly. Equipment costs \$1250. Get facts. S & S Patents, Inc., 3752 N. Damen, Chicago 60618.

**COLORGLAZED Concrete pottery** made without molds. Patented method. Cementery products, novelties, tiles. Basement leak-sealing. Money-making projects. Booklet, details free. Men only. National Potteries Company, Grand Rapids, Minnesota 55744.

**TIN-CANS 63 USES.** Sawdust 112. Newspapers 27. Rubber 67. Glass 20. Rags 35. Instructions \$1.00 each. Any three \$2.00. All six \$3.00. Satisfaction guaranteed. Charles Company, 42-GWH, Norwood, Ohio 45212.

**MAKE Money Operating Home Mailorder Business.** No inventory. Write Purple Enterprises, Box 16291AB, Jacksonville, Fla. 32216.

**SUCCESSFUL Home business opportunities.** Details Free. Cassill, Box 1535, Eugene, Oregon 97401.

**AUCTIONEERING Home Study Course—\$15.00—Diploma—American ( ) Auctioneer College,** Box 316, Terra Ceia, Florida.

**PROFITABLE WATCH REPAIR.** Sample lesson free. No obligation. Watchmaking, YOB, Fox River Grove, Illinois 60021.

**SPARE Time Cash—Sell Advertising Book Matches—every business a prospect—no investment—no experience needed to build steady repeat business.** Daily Cash commission in advance. Write today—We'll send you sure-fire selling kit by return mail. Dept. MX 269, Superior Match Co., 7530 S. Greenwood, Chicago, Illinois 60619

**HOW AND WHERE TO GET CAPITAL.** Sources of \$500 to \$2,000,000. Free details—\$10 helps you. Counselor-17, Harlingen, Texas.

**SECRETS! Mail Order Success.** Internationally famous expert reveals how to make home business fortunes. Beginners: Get free copy "Make Money By Mail." Discloses free advertising, profitable products. Mailco, 1554 Sepulveda, Dept. C2702, Los Angeles 90025.

**WHY WORRY ABOUT WORK! READ HOW TO acquire adequate income for life.** Details free. Bine, Rocca, Nebraska 68430.

**BOOKKEEPERS.** Operate profitable bookkeeping service. R. I. Systems, 1645 Warwick Avenue, Warwick, R. I. 02889.

**DATA-CRAFT Tax Plan.** 24 other services. Work home. Banks, merchants, doctors, shops use your reports. \$65 establishes you. Write: Datacraft-71A, Harlingen, Texas.

**\$500—\$800 MONTHLY Raise Small laboratory-breeding stock for us.** We supply equipment, breeders, instructions. Illinois Research Farms, Dept. MP-2D, McHenry, Illinois 60050.

**OPERATE Restaurant.** Free booklet reveals profitable plan. Write Restaurant Business School, Dept. EC 29, 1920 Sunnyside, Chicago, Illinois 60640.

**MAKE MONEY IN MAIL ORDER.** Practical book gives complete instructions. Details free. Martyn, 475 Fifth Avenue, Dept. DM29, New York, N.Y. 10017.

**SAILBOAT Rental business.** Unusual program. Write: Nordex, Box 7, Zenda, Wis. 53195.

**\$1,000 MONTHLY Apartment Income!** No Investment. Free Newsletter Reveals How. Dodd, 1014-M Woodhaven, Lynchburg, Virginia 24502.

**NEW Plan! Pays up to \$25.00 an hour!** Little as 4 hours weekly. Place Thriftie self-service displays in stores. No cost to merchants. No experience needed. Free details. Lux Company Incorporated, Dept. 1110, Elkhart, Indiana 46514.

**SELL Gifts And Household Items—Make extra money.** Toys, Jewelry, Stationery, Wrappings, All Occasion, Easter Card Assortments. Salable Samples on Approval. Free color catalog. Bonus Plan. Write Hedenkamp, 361 Broadway, Dept. CD-8, New York 10013.

**IMPORT Export opportunity, profitable world-wide, mail-order business** from home, without capital; or travel abroad. We ship proven plan for no risk examination. Experience unnecessary. Free details. Mellinger, Dept. C2072, Los Angeles 90025.

**MAILORDER Little Encyclopedia.** "Wholesale by Mail." "315 free magazines." Foreign trade, marking, sources. 1,000 Names. Address. Details 10¢. Brown, PM2, Postbox 40, Westminster, Calif. 92683.

**HOW YOU CAN ESTABLISH YOUR OWN SMALL BUSINESS.** Details Free. Mervin Balb, Route 2-A, Portageville, Mo. 63873.

**AMAZING Automatic Fishhook.** Free details. Sample \$1.00 Refundable. Aron, Postbox 61-PM, Mastic Beach, New York 11951.

**EARN \$60.00 DAILY manufacturing Concrete Fence Posts.** Practically no investment. Free information. Send stamp. American, Excelsior Springs, Mo. 64024.

**100 NEW PHONO RECORDS \$9.95.** Send cash, Check, or Money Order to Records: Box 852, Sedalia Mo. 65301.

**JEWELRYCRAFT—It's easy! Big profits!** Catalog, 25¢. Modern Craft, 12790P Highway 19, Clearwater, Florida 33516.

**OPERATE Profitable Home Sign Shop.** Free Details. Write: Northland Products, S.R. 32C Rockland, Maine 04841.

**SECOND Income . . . Mailing Baby gift catalog to new mothers . . . No inventory . . . Everything Supplied . . . Free Sample, details, Babyland, 1605-p 79 Street, Brooklyn, New York 11214.**

**\$2,500 GUARANTEED within six months in your own spare time mailorder business.** Free details. Enterprise Books, (PMI), Box 188, Seabrook, Texas 77586.

**PREPARE Tax Returns—Housewife Jo Ann Netzley made \$5,500 last season.** Train at home. VA Approved. National Tax School, Monsey, 2AB, New York 10952.

**We Will buy your product or parts, package it, ship from our facilities, and collect for it.** M & M, 215 Main, Marion, Ohio 43302.

**CALIFORNIA MANUFACTURER NEEDS man to assemble our product and be local agent, experience unnecessary.** May start while presently employed. Five-figure income for responsible applicant. Information free, or sample for evaluation \$3.00. S.K.R.M. Manufacturers, 2540 Olive Avenue, Long Beach, California 90806.

**MAILORDER Business. Dime. Experience unnecessary.** Harry Andrews, 160 Blecker Street, New York, New York PM 10012.

**\$600 PROFIT—Mailing 100 Unique Catalogs! Receive sample "315 Free Magazines", Catalog, Details. Send \$2.98 (REFUNDABLE). Kirkman, 1-PM Ann Street, Woodbridge Virginia, 22191.**

**BUY No Plan Before This Information.** Details. Wright, 3115 Gus Thomasson, Dallas, Texas 75228, D269.

**ARE You Interested in joining a group where you can meet individuals who want to go into different businesses?** Business Contacts, 2836 North 76th Court, Elmwood Park, Illinois 60635.

**"GIANT-SAVINGS Buying Program."** Leading below-wholesale suppliers. Fantastic bargains, profits. Free summary. Vault International, 868 East High, Lexington, Kentucky 40502.

**MAIL Baby Catalogs, your imprint, to New Mothers. Big Profits! Details 25¢.** Krefski, 609 Lee, Plymouth, Penna. 18651.

**MAKE Money on Government Surplus.** 1969 information on opportunities, sales methods, terms and where to buy in your area \$1.00. Surplus Disposal, Box 1032HG, Fairborn, Ohio 45324.

**\$60.00 DAY. Manufacturing concrete Posts, Blocks. Mold Equipment Catalog \$1.00 refundable.** Carlayne, 1803 Fremont, Rapid City, South Dakota 57701.

**PROVEN Professional Mailorder Course (copyrighted) only \$2.98.** Free brochure. National Laboratories Box 1531, St. Petersburg, Florida 33731.

**EARN more than many Professional men! \$1000.00 monthly operating Mail Order Collection Agency.** Continental, Box 2023-A, Des Moines, Iowa 50310.

**I GROSSED \$112,000.00 year, mailorder.** Can help you make money. Free proof. Write: Williams, 44646A, Los Angeles 90044.

**1000% PROFIT BRONZING baby shoes** literature Nichols, Box 11069, Kansas City, Mo. 64119.

**FASTEST Growing! Most completely trained and equipped! Unlimited growth in your own professional cleaning services business.** Moderate investment. For full information, write world's leading system—Servicemaster, Dept. 112A, Downers Grove, Illinois 60515.

**LOCAL NEWSPAPER AD WILL BRING ALL THE BUSINESS YOU CAN HANDLE.** Information Free. Engineered Ideas. Write 5359, Clinton St., Los Angeles, Calif. 90004.

## MONEYMAKING OPPORTUNITIES

**\$200.00 FROM Sheet 1/4" plywood (scrap).** Details 25¢. Novelties, 610 So. 24th, Elwood, Indiana 46036.

**EARN \$240.00 a month at home, spare time, doing only two \$5.00 invisible mending jobs a day.** Big money paid for service that makes cuts, tears disappear from fabrics. Steady demand. Details free. Fabricon, 1532 Howard, Chicago 60626.

**RAISE Rabbits and fishworms on \$500 month plan.** Free details. White's Rabbitry, Mt. Vernon, Ohio 43050.

**MAKE Statuettes, novelties, imitation marble.** Sell to stores or start gift shop. Free details. Marbleizing, 41 Waverton, St. Louis, Mo. 63124.

**FREE, 206 Easy ways to make money** taking orders for exciting new products—spare time. Send name, age, for 5 months free subscription. Opportunity Magazine, 850 N. Dearborn, Dept. 17-BM, Chicago 60610.

**HOW To Make money writing short paragraphs.** Information free. Barrett, Dept. C-27-M1, 6216 N. Clark, Chicago 60626.

**CLIP Newspaper items. \$1.00—\$5.00 each.** Details free. Walter, Box 1360-P, Erie, Pa. 16512.

**\$15.00 HOURLY Profit—Own Business with one serviceman. Quickly learned. Easy to do.** Operate from home. Few hundred dollars builds your own nationally advertised business while continuing present job. Investigate immediately . . . before your territory is taken. Free booklet explains everything. Send Today. Then decide. Duraclean, C9-161B, Duraclean Building, Deerfield, Illinois.

**VENDING Machines. No selling. Operate a route of coin machines and earn amazing profits 32-page catalogue, free.** Parkway Machine Corporation, 715 PMM Ensor Street, Baltimore, Maryland 21202.

**"MONEY Quick", written for those that need extra cash quick.** Explains the simple trick of making an extra \$100.00 to pay doctor or hospital bills. Don't delay, order now. Pamphlet \$1.00. Advisors, Box 773, San Bernardino, California 92402.



**HOMEWORK PAYS!** 75 Companies begging for sparetime workers. . . Complete Instructions, List, \$1.00. Opportunities, Box 11071-PB, Indianapolis, Indiana 46201.

**MAKE \$5,000 yearly, sparetime, raising mink, chinchilla, nutria, etc.** Free booklet reveals proven plan. Write: Furs, Dept. R, Bewdley, Ont, Canada.

**MONEY—SPARETIME OPPORTUNITY PANELISTS AT HOME WANTED BY NEW YORK RESEARCHER.** Leading research firm seeking people to furnish honest opinions by mail from home. Pays cash for all opinions rendered. Clients' products supplied at no cost. For information write: Research 669 Mineola, N.Y. 11501. Dept. PM-24.

**\$800.00 WEEKLY.** My net profit, year. Magic Method Mail Selling. Free proof with samples, send stamped, addressed envelope. C. Brewster, Clearwater, Florida 33517.

**INSTANT Money!** Plastics are the wave of the future. Big profits now! At home! Spare time! Materials costing 11¢ bring \$2.58 profits immediately! Free information! Rush name on postcard to: Warner, 1512 Jarvis, Dept. CL-2-A, Chicago, Ill. 60626.

**MAKE Big Easy Profits** making costume jewelry at home, spare time! Quick, easy to make; easier to sell! Details FREE! Donbar, 2934 Fullerton, Dept. A209, Chicago, Illinois 60647.

**TYPING Pays!** Unbelievable \$30.00 thousand addressing envelopes from lists. Typewriter, longhand, immediate earnings. Instructions \$1.00. Florida Service, P.O. Box 1017CC, Hialeah, Fla. 33011.

**HOMEWORK.** Mailing circulars. Free details! Cam Company, Dept. 155-KP, Verona, N.J. 07044.

**CHURCHES, Clubs, Organizations;** are you faced with the problem of raising money? We can help you. Howard, Box 1647-PM, Sumter, South Carolina 29150.

**WHEELER-DEALERS!** Free. Little-known opportunities; foxy-smart angles. Stamped, self-addressed envelope. Wheeler-Dealer Association, (PM-33), 15 West 38th., New York 10018.

**SCIENTIFIC MESSAGE: BIG EARNINGS** uncrowded profession. Learn spare time at home. Diploma awarded. Free catalog. Write: Anderson School, Dept. B-I-C, Princeton, Illinois 61356.

**BECOME Notary Public!** Free particulars. Stationers Exchange, 405-PM Richardt, Evansville, Indiana 47711.

**SPARE Time cash.** Sell Famous Hanover Shoes. Actual samples and sales kit free. No experience needed. No age limit. Lowest prices for high quality makes selling easy. Every man a prospect. Big daily commissions. For full details, write Hanover Shoe, 445 Carlisle, Hanover, Penna. 17331.

**HOMEWORKERS!** 200 companies—48 page Directory. FREE details. Quest Enterprises, Box 6029, Dept. 12, San Jose, California 95150.

**START Home Mailorder Business.** No Inventory. Purple Enterprises, Box 16291-A2, Jacksonville, Fla. 32216.

**SIGN Painting!** Profitable! Fascinating! Easy with letter patterns. Paulow, 1935 Stardust, Waukesha, Wis. 53186.

**SELL Advertising Book Matches—**every business a prospect—no investment—no experience needed to build steady repeat business. Daily Cash commission in advance. Write today—We'll send your sure-fire selling kit by return mail. Dept. MA269, Superior Match Co., 7530 S. Greenwood, Chicago, Illinois 60619.

**COINS For Investment and Profit.** How to Start. Where to Sell. Booklet #M053C Only \$1.00. Harbor Lights, Charlotte Harbor, Florida 33950.

**25 FREE Moneymaking books** Where? Moneymaker-BBB, Box 6359, Los Angeles, California 90055.

**GOLDMINE!** 100 Firms offering Home Businesses Directory \$1.00. Marthaller Enterprises, Box 917D, Auburn, Washington 98002.

**SELL Beautifully Colored Social Security Plates.** Big Profits! Free Sample! Roy Wright, Box 3053, Paterson, N.J. 07509.

**MAILERS WANTED.** Send 12¢ Stamps For Details. Smyre's, 953-P, Newark, N. J. 07101.

**GUARANTEED Moneymaker.** \$1.00 for details. Don Miller, 130 Lancaster, Brookline, Mass. 02146.

**MECHANICALLY Inclined?** Learn profitable WATCH REPAIRING. Free sample lesson. Watchmaking, YOA, Fox River Grove, Illinois 60021.

**UP To \$200 or more weekly.** List accounts for collection. No collecting, selling or investment. Everything furnished. No experience needed. Full or parttime. United Financial Service, Merchandise Bldg., Dept. 368, Minneapolis, Minn. 55403.

**\$500—\$800 MONTHLY** Raise small laboratory-breeding stock for us. We supply equipment, breeders, instructions. Illinois Research Farms, Dept. MP-2, McHenry, Illinois 60050.

**SHARP \$\$\$ opportunity!** One low-cost machine sharpens-serrates knives, scissors, pinking shears. Earn \$6-\$9 hourly in spare time. Professional results without experience. Free details, Beaver Grinder, 329C Nielsen Building, Eugene, Oregon 97402.

**MAKE Money** with your camera. Sell your photos and color slides. Booklet tells How, Where, \$1.00. Only Kansas residents pay sales tax. Ken-Rae Sales, Dept. 1-PM, 4812 East Sixth, Topeka, Kansas 66607.

**KOOKIE Kar . . . 20 Samples \$1.00.** Free Information: Box 157-A, Madison, Ohio 44057.

**MAIL Order imports.** Report reveals foreign drop ship sources. World Trader's Digest. Ideal mail order items. \$1.00. Harrison Enterprises, 655 Smith Ave., Elba, Ala. 36323.

**WIN CONTESTS** New Book Reveals Inner Secrets. Write Gainey, 1324 Auduson Dr., Cocoa, Fla. 32922.

**MAKE Up to \$5000 a month.** No investment required. Guaranteed to work. Send only \$10.00 for complete plan. Explorations Unlimited 2801 Atkinson Square, Cincinnati, Ohio 45246.

**PALSTER CRAFT** "(How To)" Handbook for Figurines. Completely Illustrated \$3.00. V-Cee Enterprises, 1332 Moulin, Madison Ht., Michigan 48071.

**LEARN The secrets** of repairing junk batteries. "Fabulous Profits" at home. Batteryman, 878, Palm Desert, California 92260.

**GOOD Money in Home Shop.** Write, "Instruction" Box 2775, Pomona, Calif. 91766.

**HOME, Sweet home.** That's the place to make money. Startling details, Hamilton, Astoria, New York 11105.

**MAKE Money** writing short articles collecting coins your camera other opportunities available. Free Catalogue. Al P. Fields, 706 S. Peter St., Garrett Indiana 46738.

**HIGHER Income.** 256 page book "Thinking Big" reveals secrets that make men Rich. Send \$2.00, Fitz Mail Order House, Freeville, N.Y. 13068.

**LOCKSMITHING—Fit keys** By sight National Locksmithing, Glenstone 3127, Springfield, Missouri 65804.

**\$1.00 Each** possible assembling Belts. Details 6¢. Redikut's, 462-PM North Park, Richland Center, Wisconsin.

**CASH For Newspaper Items.** Send Stamp For Details Gillette, P.O. Box 30154, Cincinnati, Ohio 45230.

**LEARN HOW to Make Money—**Writing Fillers (MO51F)—In mail order (MO521)—On Government Surplus (MO50S) Booklets, \$1.00 each. Harbar House, 138 Greenbelt Lane, Levittown, N.Y. 11756.

**COMPLETE Training!** New services added, new profits coming as you grow! Own your own business as leader in professional cleaning services. Moderate investment. Write world's leading system—Service Master, Dept. 112B Downers Grove, Illinois 60515.

**FREE Copy** of world's leading contest magazine! Write Prizewinner, Box 11569, St. Petersburg, Fla. 33733.

**EXTRA Earnings;** take advantage newest money-making ideas; free details; write now. Hytlin Company, Box 1385, Austin, Texas 78767.

**\$18 EXTRA** daily collecting names. 10¢ brings first requirements. Thornton, PM, Logan, Ala. 35098.

**NOW!** You can make Money collecting Coins for profit. Report reveals how. Send \$1.00 today! C. P. Flag, 25890 Five Mile, Detroit, 48239.

**COMPILE And sell Name Lists.** Free Details. Albe Box 279, N.Y.C. 10008.

**50,000 ITEMS** at Rock Bottom Wholesale Prices plus dozens of free and hard-to-get items. THE BARGAIN ENCYCLOPEDIA is a Treasure House of Money-Making information. Send \$2.00 to Sunny, PM 2-9, 1076 St. Johns Place, B'klyn, N.Y. 11213.

**NEW NIGHT FISHING PRODUCT!** "Bite-Lite"—unfailingly signals night fisherman fish is biting. Unlike anything on market. Fits on rod; doesn't interfere with casting, reeling, setting hook. Lifetime guarantee! Sells on sight to fishermen, retailers, resorts, etc. Big profit. Start own business now—part or full time. Send \$2.00 (refundable) for sample, details. Lakenwood Industries, 155 East Ohio, Chicago, Illinois 60611.

**"TAX TIP CODE."** UNIQUE—simple. Whoever does your return (1040 only)—Before mailing—Deductions, Adjustments, Credits, Nontaxable Incomes checked quickly. Save many times \$2.00 Code Cost. Copywritten—Box 1791, Hartford, Conn. 06101.

**HOMEWORKERS** Get cash for newspaper clippings. Up to \$5.00 each. Free details. Kim-Craft Specialties, Box 595 Main, P.O. Niagara Falls, N.Y. 14302.

**\$\$\$\$MAKING Opportunities!** FREE, Unique Catalog, Lists—16 Low Cost Informative Books—Booklets, Gifts for Car, Home, Games. Write: Eastend Sales, 608 Fairwood Rd., Dept. BH67, Troutdale, Virginia 24378.

**\$140.00 DAY'S Homework!** Haines, 86 Great Hill Rd., Seymour, Conn. 06483.

**START A profitable** subscription business in spare time! We need men and women (young and old) as representatives for all leading national magazines. Liberal commissions on all subscriptions. Supplies free. No experience needed. Send this ad with your name and address to Popular Mechanics, Room 20, 250 W. 55th St., New York, N.Y. 10010.

## PROFITABLE OCCUPATIONS

**BECOME A mortgage broker,** earn \$10,000 to \$50,000 a year. Details free. United, Box 6284A, Marietta, Georgia 30060.

**RAISE Rabbits** for us on \$500 month plan. Free details. White's Rabbitry, Mt. Vernon, Ohio 43050.

**YOUR Own Sign shop.** Signs, 410-S So. Western, Springfield, Ohio 45506.

**HOW To Make Money** Writing Short Paragraphs. Information Free. Barrett, Dept. C-27-M2, 6216 N. Clark, Chicago 60626.

**CHROME Plating.** Instructions, equipment and supplies. Platers' Supply, P.O. Box 565, Lugo Station, Los Angeles, Calif. 90023.

**BAKE New greaseless doughnuts** in kitchen. Sell stores. Free recipes. Michael Ray, Waseca, Minn. 56093.

**FT. SMITH Auction School,** Ft. Smith, Ark. Residents & Home study. Veteran approved.

**INVESTIGATE ACCIDENTS:** Earn \$750 to \$1000 monthly. Car furnished. Expenses paid. No selling. No college education necessary. Pick own job location. Investigate full time or earn to \$8 hour spare time. Men urgently needed Write for FREE information. No obligation. Universal Schools. CPM-2 Hillcrest, Dallas, Texas 75205.

**FREE Book "990 Successful, Little-Known Businesses."** Work Home! Plymouth-37T, Brooklyn, New York 11218.

**EARN \$240.00 A month** at home, spare time, doing only two \$5.00 invisible mending jobs a day. Big money paid for service that makes cuts, tears disappear from fabrics. Steady demand. Details free. Fabricon, 1586 Howard, Chicago 60026.

**SHARPEN Scissors, Pinkers, Inexpensive equipment, tools, supplies.** Blackhawk's, Sheldahl, Iowa 50243.

**JANITORS—Cleaners—Custodians.** Get A Better Job—Make More Money. Become a maintenance Supervisor. Homestudy details; free: Maintenance Training, 907 Beachpoint, Fairport Beach, Ontario.

**\$500-\$800 MONTHLY.** Raise small laboratory-breeding stock for us. We supply equipment, breeders, instructions. Illinois Research Farms, Dept. MP-2A, McHenry, Illinois 60050.

**NEW "Operate Own 'Stain Doctor' Service"**—Copyrighted Manuscript Reveals Methods Which Increase Income. FREE Details!! Valuable Formulas Included—Eddie Long, 1212 First Avenue, EauClaire, Wisconsin 54701.

**MONEY—Become a Finance Broker.** Full or part time. RMP & Co., P.O. Box 901, Desk 10, El Reno, Oklahoma, 73036.

**SPRING Cleanup, \$150-\$350/week, part-time.** Send \$3.00 for information. S-W Company, Box 8653, Albany, N.Y. 12208.

**\$20,000 ANNUALLY** You can make in Auto Sales: \$3.00. Mar-Lo Products, 8150 Roselawn, Dept. 5, Detroit, Mich. 48204.

**START A magazine subscription business.** Earn generous commissions on Popular Mechanics, Good Housekeeping and all others. Best commissions, bonus, all material sent free. No experience needed. Write Popular Mechanics, Room 2P, 250 West 55th St., New York, N.Y. 10019.

### SALESMEN—DISTRIBUTORS

**FREE, 206 Easy Ways to make money** taking orders for exciting new products—spare time. Send name, age for 5 months free subscription. Opportunity Magazine, 850 N. Dearborn, Dept. 17-BS, Chicago 60610.

**FREE Selling outfit, Office supplies, furniture & equipment.** Osco, 15-PM North Jefferson, Chicago, Ill. 60606.

**EARN Terrific commissions listing delinquent accounts.** General Finance Company, 304-A Pickwick Building, Kansas City, Mo. 64106.

**100% PROFIT—Sweet Georgia Brown Cosmetics** sell fast. Write for Sample Case offer. Valmor, Dept. H, 2411 Prairie, Chicago 60616.

**DO You wish to use or sell a plant food** that is field proven, shows the greatest results at lowest cost? Something different in sales and use. Big monthly income or get your fertilizer FREE. Campbell's Gro-Green, Rochelle 274, Illinois.

**EARN Big Commission Full or Part Time.** Show America's largest line Low Priced Business Printing and Advertising Specialties Plus calendars in season. No experience. No investment. No collections or deliveries. On-the-spot commissions. Big Free Sales Kit samples hundred items used daily by businessmen. Merchandise bonuses for you. Build profitable repeat business. Start now. National Press, Dept. 91F, North Chicago, Ill. 60064.

**MAKE Extra \$25 to \$75 spare time!** Take orders for double air cushion Bronson Shoes. Amazing comfort. Terrific men's, women's line for dress, work, play. Highest commissions. Shoes for yourself. Big outfit Free. Write: Bronson, Dept. 161, Minneapolis, Minnesota 55408.

**NEW Car Thief signal.** Lightning seller. Samples for trial. NORTHWEST ELECTRIC, Ave. 510, Mitchell, S. Dak. 57301.

**30,000 CAR Dealers** desperately need good salesmen! Thousands of jobs furnishing a NEW CAR over \$1,000 per month, many fringe benefits. Our exclusive home study course will train you! Free Catalog Automotive Sales Institute, Box 746, Dept. 1B Kenosha, Wisconsin 53140.

**SELL Advertising book matches.** Write us today. We put you in business by return mail; handling complete line ad book matches in demand by every business right in your town! No investment; everything furnished free! Top commissions daily: Superior Match, Dept. M269, 7530 S. Greenwood, Chicago, Illinois 60619.

**BIG Earnings** selling Hertel Bibles. New 3-dimension cover, finest reference edition sells fast. Demonstrator furnished. Big commissions. International Book, Dept. PM Box 118, Wichita, Kansas 67201.

**EXCITING New product.** Big profits! Exclusive! Test it yourself Sample offer. Send no money. Just your name. KRISTEE, 131A Akron, Ohio 44308.

**SELL America's biggest value wedding line!** Big 40% profit showing wedding invitations and over 50 exciting accessory items. Sideline for printing. Christmas card salesmen. Free display album. Elmcraft, 7201 S. Cicero, Dept. EW-168, Chicago, Illinois 60629.

**PERSONAL Protective Devices** Now in Big Demand due to increased crime rate. Proven. Sell easy to Drive-Ins, Stores, Nurses, Night Workers, Motorists. Sales experience unnecessary. Get Profit details now. Hagen Supply, Dept. CL2A, St. Paul, Minn. 55107.

**GOOD Man.** Mature. Short trips around county. Part time. Excellent earnings. Write Cyclo Mfg., 3816 Dahlia, Dept. 119, Denver, Colorado 80201.

**GET New shirt outfit free!** \$90 weekly on 5 average orders a day. Famous quality made-to-measure dress and sport shirts at \$4.95 up, sell to all men. No experience needed. Full or part time. Write: Packard Shirt Co., Dept. 116, Terre Haute, Indiana 47808.

**BIBLES DIRECT FROM PUBLISHER.** Write: Bible Publishers, Box 5065, San Antonio, Texas 78201.

### AGENTS WANTED

**FREE, 206 Easy Ways to make money** taking orders for exciting new products—spare time. Send name, age, for 5 months free subscription. Opportunity Magazine, 850 Dearborn, Dept. 17-BA, Chicago 60610.

**EVERY Man** a prospect. Refundable sales kit offer showing line belt buckles, tie clasps, money clips, cuff links, lapels, identification badges, individualized with customer's name and emblems. Cap badges for trucking, bus, taxi, police, firemen, also postal, letter carriers and heavy construction emblems. Choice 3000 emblems. Hook-Fast, Box 1088PM, Providence, R.I. 02901.

**PRINTING, Advertising Salesmen—Excellent moneymaking sideline** selling Decalcomania Name Plates, small quantities. Advertising Specialties, sign letters. Free Samples. Raico XL, Boston, Mass. 02119.

**YOUR Own business—Used suits \$1.50; overcoats 65¢; mackinaws 35¢; shoes 12½¢; ladies coats 30¢; dresses 15¢.** Enormous profits. Catalog free. Nathan Portnoy Associates, 2109-AA Roosevelt Road, Chicago Ill. 60608.

**LIFETIME Income.** Business Loan Representative Write: Financial 28 E. Jackson, Suite 1204-X3, Chicago 60604.

**WANT TO MAKE UP TO \$100 A WEEK** Spare time, and get free shoes for life, too? No investment. Rush card for free details. Mason Shoes, K-647, Chippewa Falls, Wisconsin 54729.

**INDIAN MOTORCYCLE DEALERS WANTED.** Opening for rider agents in small towns, Rural districts. Small investment only for two 1969 demonstrators. \$295. small 50MPH motorcycles (large minibike) up to fantastic 4-cyl. MAM-MOTH. Write Clymer, Indian Sales Division, Dept. PM, Los Angeles, Calif. 90004.

**SELL Gifts and Household Items—Make extra money.** Toys, Jewelry, Stationery, Wrappings, All Occasion, Easter Card Assortments. Salable Samples on Approval. Free color catalog. Bonus Plan. Write Hedekamp, 361 Broadway, Dept. CD-8, New York 10013.

**WILL You test new items in your home?** Surprisingly big pay. Latest conveniences for home, car. Send no money. Just your name. Kristee, 159, Akron, Ohio 44308.

### EMPLOYMENT INFORMATION

**AUSTRALIA Wants You!** Government assisted passage. Unlimited Opportunities. Latest Government Information and Forms \$1.00 Austco, Box 3623-E, Long Beach, California 90803.

**FOREIGN And USA job opportunities** available now. Construction, all trades. Earnings to \$3,000.00 monthly. Paid overtime, travel, bonuses. Write: Universal Employment, Woodbridge, Conn. 06525.

**JOBS On Ships, Wages To \$25,000.00.** Four Month Vacations. No Experience Needed. Free Information. Commander, Box 1354-PM, Plainfield, New Jersey 07060.

**HIGH Paying overseas jobs.** Construction, other projects. Bonuses, Travel Expenses, Extras. International Information, 124, Cortez, Florida 33522.

**AUSTRALIA WANTS YOU!** Good Pay. Adventure, Government Paid Transportation! Send \$1.00 for "Australian Opportunities Handbook." Satisfaction Guaranteed! International Services, Box 12-A2, Greenfield, Indiana 46140.

**I MADE \$185,752.50** in twelve years working for American companies overseas! My story plus foreign employment tips—\$1.25 Airmailed. Paul Smith, Casilla 11612-PM, Santiago 9, Chile.

**BOOMING AUSTRALIA** Needs you now!! Government paid transportation allowance. Unlimited opportunity, 1969 HANDBOOK \$1.00. Guaranteed. Associated. Box 17B2, Lafayette, California 94549.

**TREMENDOUS opportunities U.S.A.** overseas, choose jobs-locations, transportation. Free details. Occupations, International Airport, Box 100-C15, Jamaica, N.Y. 11430.

**THE Secret to getting a better job** is a well-prepared Resumé. Our famous "Rapid Resumé Guide" helps you prepare your own in easy step-by-step manner. Gives complete instructions, examples, worksheets, recommended forms, etc. Only \$2.00 postpaid. Satisfaction guaranteed. Emerald Publishers, Dept. M, Box 545, Dallas, Texas 75221.

### HELP WANTED

**OVERSEAS Jobs—Europe, South America, Australia, Far East, etc.** 2000 openings all trades. Construction, Office, Engineering Sales, etc. \$400 to \$2,500 month. Expenses paid. Free Information. Write Overseas Jobs, International Airport, Box 536-M, Miami, Florida 33148.

**BOOMING Australia** wants You! Good jobs, Adventure, Forms and Australian Handbook (1969) describing Australian assisted passage, passport-visa, advantages, opportunities \$1.00. Buckeye, Box 1032MH, Fairborn, Ohio 45324.

**GAS APPLIANCE SERVICEMEN:** No experience necessary, will train. 52 weeks work guaranteed annually including paid vacations and holidays; insurance; opportunities for promotion; most managers started as servicemen. Apply manager, Baltimore, Boston, Chicago, Cleveland, Detroit, Los Angeles, Philadelphia, Pittsburgh, St. Louis, San Francisco, Washington, D.C., Dallas offices (we're in phone book). GAS CONSUMER SERVICE.

**OVERSEAS Jobs—Australia, Europe, South America, Far East, Etc.** Openings in all trades and professions. \$400 to \$2,500 monthly, free information write: Foreign Employment Mart, Box 2235 A.M.F. Miami, Florida 33159.

## REAL ESTATE—FARMS

**CANADIAN Vacation lands:** Full price \$385.00. 40 acres, \$10 month. Suitable cottage sites, hunting, fishing, investment. Free information. Land Corporation, 3768-C Bathurst, Downsview, Ontario, Canada.

**\$1 ACRE—Canadian Border—hundreds campsites, islands, farmlands,** directly from tax authorities. (Non-profit). Lists, photographs mailed. Register, Room 10, 110 Church Street, Toronto 1, Canada.

**CENTRAL Ontario—Choice 640 acre Sportsmen's paradises still available—\$20.00 plus \$6.50 taxes yearly.** Maps, pictures, \$2.00 (Refundable). Information Bureau, Norval 4, Ontario, Canada.

**40 TIMBERED Acres \$1650.00 Total Price.** Wash.—Idaho—Mont. \$50.00 Down—\$25.00 month, in Northern Idaho, North-eastern Washington, and Western Montana. In the heart of lakes and big game country. All covered with growing timber. Access, title insurance with each tract. This is select land with natural beauty, recreational and investment values. We have tracts of many types and sizes from which to choose, including Waterfront property on Pend Oreille, Priest, Kettle and the St. Joe Rivers and in Pend Oreille Lake area. Your inspection welcomed. Write us for free list, maps and complete information. Write to: Dept. PB, Refor-estation, Inc., P.O. Box 8146, Spokane, Wash. 99203.

**GOVERNMENT LANDS . . . Low, as \$1.00 acre.** Millions acres. For exclusive copyrighted report . . . plus "Land Opportunity Digest" listing lands available throughout U.S., send \$1.00. Satisfaction guaranteed. Land Disposal, Box 9091-PB, Washington, D.C. 20003.

**CANADIAN LANDS, seized and sold for taxes.** Our 52nd annual series of lists, describe many choice properties, situated from coast to coast, acquired by us through Tax Sale. Priced as low as five dollars per acre, guaranteed perfect title, small monthly payments, no mortgage. Beautifully situated hunting and fishing camps, where there is real sport; summer cottage sites, heavily wooded acreages. Now is the time to invest in Canada's minerals, forests and farms. Write to-day for free booklet with full explanation. **TAX SALE SERVICE,** Room 301-D, 85 Bloor St., East, Toronto 5, Canada.

**ARIZONA—Fine hunting area north of Lake Havasu City.** Investment acreage—2½ acres \$895. \$25 down, \$20 monthly. Mrs. Anne Young, 2233 N. 7th St., Phoenix 85006.

**NEW!—FREE CATALOG! Big SPRING edition!** Over 4,000 properties described, pictured—Land, Farms, Homes, Businesses—Recreation, Retirement. Selected Best throughout the U.S.! 69 Years' service, 512 Offices, 39 states Coast to Coast. Mailed FREE from the World's Largest! **STROUT REALTY,** 60-RX E. 42nd St., N.Y., N.Y.; 7-RX S. Dearborn, Chicago, Ill.; 521-RX E. Green, Pasadena, Cal.

**THE Only "No-Risk Land Purchase Plan" in America—10 year money-back guarantee on any Vacation, Retirement or Investment homesite in Boiling Spring Lakes—the multi-million dollar, 14,000-acre development on the Carolina Coast.** All facilities, electricity, roads, motel, golf course, country club, already in. Private ocean beach, 50 fresh water lakes, ½-acre homesites as low as \$645.00; \$7.00 down, \$7.10 month. Write for free literature. (Not offered to residents of California, Florida, New York.) Boiling Spring Lakes, Southport 1-F, North Carolina 28461.

**FREE! Real Estate Catalog,** spring edition. Farms, Ranches, Business, Recreational and Investment Property. Please note state desired. **BANNER Adv.,** P.O. Box 3333 GS, 19A, Springfield, Mo. 65804. "Real Estate Our Specialty."

**FLORIDA 2½-Acre Lakeside Estates,** surrounding two sparkling lakes in famous Panama City Gulf area. Popular developed Community. Maps, Photos, Color Brochure. Owen B. Wood, Fountain, Florida 32438. (AD66LS152-B).

**CANADA'S Finest lands, \$4.00 an acre and up.** Acquired through estate liquidations. Suitable for hunting, fishing, camps, cottages, farming, timber, minerals, investment. Small monthly payments. Free descriptive booklet. Canadian Estate Land, Dept. 20, 194 Wilson Ave., Suite 101, Toronto, 12, Canada.

**VACATION Lands, Canada, \$1.00 acre.** Free information, Tax Corp., 206-F Bloor W., Toronto 5, Canada.

**CANADIAN Fishing and hunting lands** with substantial water frontage at low prices. Heavily wooded. Well situated. Great investment potential. Free booklet. Northern Corporation, Dept. 41, 194 Wilson Ave., Suite 101, Toronto 12, Canada.

**FREE . . . 232-page Spring 1969 CATALOG!** Describes and pictures hundreds of farms, ranches, town and country homes, businesses coast to coast! Specify type property and location preferred. Zip code, please. **UNITED FARM AGENCY,** 612-PM West 47th St., Kansas City, Mo. 64112.

## FARM AND GARDEN EQUIPMENT

**EXTRA Income at home in Spare Time!** Profit Booklet shows you how to start your own business with Classified Advertising. Only \$1.00. C. A. Martin, Popular Mechanics Dept. PM, 575 Lexington Ave., New York 10022.



## FLOWERS, PLANTS and NURSERY SUPPLIES

**600 ASSORTED Sweet Onion Plants** with free planting guide, \$3.60 postpaid. **TONCO,** "Home of the Sweet Onion," Farmersville, Texas 75031.

**SHADE Trees, Extremely Fast Growing.** Beautiful. Guaranteed. Write: Caryb Nursery, Inverness, Florida 32650.



## DRINKING WATER-PURIFIERS

**MAILORDER Records help get Increased Business!** Complete 32 Page Record Book shows your inquiries, orders, advertising, expense, etc. Only \$1.00. C. A. Martin, Popular Mechanics, Dept. PM, 575 Lexington Ave., New York 10022.

## HOME CRAFTSMEN

**CABINETMAKING MADE EASY and "How to Make Formica Counter Tops,"** two excellent guides let you build kitchen cabinets and counter tops like professionals. Extraordinary guides bring master craftsmen's shortcut methods. Satisfaction guaranteed. Write: Japs, 126-P Seventh North, Hopkins, Minn. 55343.

**EXOTIC And domestic hardwoods catalog, 10¢.** Wood Product Specialties, 30 Bartholomew Ave., Hartford, Conn. 06106 Dept. B-17.

**PLANS, Bird houses.** Send 15¢ for brochure and free feeder plan. Yeager, 1665 Linden, Homewood, Ill. 60430.

**WOOD For the Craftsman and Hobbyist.** Catalog 25¢. Creative Wood Products, Box 388, Gladstone, Mich. 49837.

**WOODWORKING Catalog and Manual 25¢.** Plus free "101 Project Ideas." World's most beautiful veneers, lumber, plywood! Wood finishing, upholstery supplies. Cane Lamp parts. Furniture hardware. Animal whittling blocks. 2,000 workshop products. Constantine, 2051-B, Eastchester Road, Bronx 10461.

**FREE Popular Mechanics 16 page illustrated catalog** of publications, plans and projects. Booklet covers an extremely wide variety of do-it-yourself data on home remodeling, shop tools and machines, car repair, hobbies, crafts, boating, games, lawn and garden and hundreds of others. For your free copy write to Service Bureau, Dept. PE, Popular Mechanics, 575 Lexington Ave., New York, N.Y. 10022.

**FASCINATING Stained glass hobby Details free.** Whittemore Durgin, Box 206SY, Hanover, Mass. 02339.

**PLANS For pool table with extra two-face top for table tennis and model railroad.** Blueprints B1209 and building instructions \$3.50. Popular Mechanics Service Bureau, 575-M Lexington Ave., New York, N.Y. 10022.

**WALNUT And Cherry tapered legs, lumber, gunstock blanks, picture frame moulding.** Midland Lumber Company, Box 262, Savannah, Missouri 64485.

**101 PATTERNS Of smart Gifts, Novelties, Action Windmills, plus "Make Money Jig Sawing", \$1.00.** Mastercraft, 25M, 7041 Olcott, Chicago 60631.

**SPANISH Octagonal lamp table plans.** Specify 100P. \$1.00. Missouri add 3%. R S Plans, Box 12091, Parkville, Missouri 64152.

**FULL SIZE FURNITURE PLANS.** Traditional, Early American, Danish Modern. Catalog 25¢. Furniture Designs, Dept. P-2, 1425 Sherman, Evanston, Illinois 60201.

**FIBERGLASS Molding.** Illustrated book. Send \$2.00. Johnson's, 4132 Lomita, Dallas, Texas 75220.

## UPHOLSTERY

**MAILORDER Records help get Increased Business!** Complete 32 Page Record Book shows your inquiries, orders, advertising, expense, etc. Only \$1.00. C. A. Martin, Popular Mechanics, Dept. PM, 575 Lexington Ave., New York 10022.

**ONE-Way.** See through Mirrors. . . . Convert any glass! Easy instructions—\$1.00. Laner, Box 1347-PX, Studio City Calif. 91604.

## DO-IT-YOURSELF

**WATER!! Drill your own well the easy, economical way with Amazing New Invention.** Save 75%. Free information. Deep-Rock Drilling Company, Opelika, Alabama 36801.

**SECRET Plans revealed, Free Brochure.** Audiotronix, PM-2, 156 Fifth Ave., New York, N.Y. 10010.

**BURGLAR-FIRE Alarm supplies and information.** Free Catalog. Protecto Alarm Sales, Box 357, Birch Run, Michigan 48415.

**BUILD Your own Swimming Pool,** complete plans \$5.00, (refundable) or catalog \$1.00. Pool, Dept. PM269, Box 7, Cohasset, Mass 02025.

**EXERCISE At home on build-it-yourself physical fitness equipment,** including bicycle exerciser, rowing machine, belt massager, and abdominal board. Send \$2.50 for blueprints B1208 and instructions. Popular Mechanics Service Bureau, 575-K Lexington Ave., New York, N.Y. 10022.

**OPERATE Any size overhead door with unusual quietness and ease.** Exclusive new cadmium plated nylon rollers with ball bearing center. Outwears any roller. 10 roller set \$19.95 ppd. Additional rollers \$1.90 each. Catalogue free with order. No C.O.D. Money back guarantee. C&S Sales Corp., 2015 Utica Ave., Brooklyn, N.Y. 11234.

**SAUNA, Build your own complete plans \$2.50.** Saunatown, Cohasset, Mass. 02025.

**MIRACLE EXPANDING CEMENT repairs China, Utensils; Sets tiles and Fixtures; Anchors Bolts, nuts, brackets.** Send \$1 for sample. Literature Free. X-PANDO 43-15 36th St., Long Island City, NY 11101.

**SAVE TAXFREE \$\$! Complete Unique Income Tax Working Kit.** Federal Long Form with Deductions Schedule. Samples, etc. New Easy Step by Step guidance. Legal Tax-savings Opportunities! AVOID audit with Confidential Schedule! Mail \$2.—"Taxkit," Box 94, Glendale, Calif. 91209.

**FLUORESCENT Tubes** rejuvenated at no cost. Instructions \$1.00. Rejuvenators, 172 Bolton St., Portland, Me. 04102.

**REPAIR Manuals**, automatic washers, dryers, dishwashers, 20 different manuals, \$2.75 each Ppd. Send make and model number. Major Appliances, 13106 Caine Ave., Cleveland, Ohio 44105.

## ARTS AND CRAFTS

**MAKE Figurines**, plaques, lawn ornaments, Molds, plastercraft kits, liquid rubber, Sample and catalogue 10¢. Wooley Company, Box 29-B, Peoria, Illinois 61601.

**FREE Catalog**—over 10,000 handicraft items. Supreme Handicrafts, Box 395-PM, Sioux Falls, S. Dak. 57101.

**MAKE MONEY IN ARTS AND CRAFTS.** No tools or talent needed. Start your own business, or hobby! Free information on new home study course. Lifetime Career Schools, Dept. E-294, 2251 Barry Avenue, Los Angeles, California 90064.

**FREE!** World's largest leathercraft catalog. Hundreds of Make-it Ideas. Tandy Leather Co., Dept. I-67, Fort Worth, Texas.

**STAINED Glass** for beginners. Whittemore, Box L2065, Hanover, Mass. 02339.

## BINOCULARS, TELESCOPES, MICROSCOPES, MAGNIFIERS

**BINOCULAR Sale!** Free color catalog 100 models \$9.95-\$250.00. Write, United, 9043 So. Western. BCAT-9308, Chicago 60620.

**BINOCULARS Direct** from manufacturer. Finest quality, tremendous savings! Request catalog. Koyu, 3860 Crenshaw Blvd., Los Angeles, Calif. 90008.

**SCIENCE Bargains!** Lenses, telescopes, binoculars, microscopes, kits, parts, war surplus. Send \$1.50 for beginner's 10-lens kit with instruction booklet. Order Stock 2-CH. Request free 148 page Catalog CH. Edmund Scientific Co., Barrington, New Jersey 08007.

**FREE! FREE!**—Optical and Photographic Bargain Book, JIMSCO, Dept. 4B1, 9006 Waukegan Road, Morton Grove, Ill. 60053.

**WORLD Famous "Dyroscope" Telescope.** Build your own reflector telescope, mirrors, eyepieces, tripods, accessories. Request free brochures. Criterion Manufacturing, Dept. PP 28, Hartford, Connecticut 06101.



## CAMERAS AND EQUIPMENT

**WORLD'S Largest Buying Guide**—800 Illustrations—50¢—Deductible With Your Order—Olden Camera—1265 Broadway, New York, N.Y. 10001.

**EXAKTA VX 1000, 50/2 Auto Pancolor** \$119.50. Free Wall St. Camera News. Wall Street Camera 120 Wall Street NYC 10005.

**TURN Your Travel pictures into CASH!** Booklet \$1.00 Cherry House, 166 Cherry, Long Branch, New Jersey 07740.

**FREE! FREE!**—Photographic and Optical Bargain Book, JIMSCO, Dept. 41B, 9006 Waukegan Road, Morton Grove, Ill. 60053.

## PHOTO SUPPLIES

**ATTENTION: WEEKEND PROFESSIONAL PHOTOGRAPHERS** Photo-mounts, albums, mailers—all your home portrait, candid and wedding presentation needs from one source. **WHOLESALE PRICES, SHIPPED POSTPAID.** Catalog, 25¢. CROWN PRODUCTS, 2150 Superior, Cleveland, Ohio 44114.

## PHOTO FINISHING

**CAMERA Fans!** Expert photofinishing and fresh Kodak film returned: **8MM Kodachrome \$3.45; 8 exp. Kodacolor \$3.40; 35MM Kodachrome, 20 slides, \$3.15; 8 exp. black & white 99¢.** We give you free photo stamps to redeem for gifts. Satisfaction guaranteed. Send exposed film or request mailers and complete price list. Direct Mail Photo, Box 8352-PM, Pittsburgh, Pa. 15218.

**SPECIAL WITH THIS AD**—Kodacolor developed 12 prints \$2.25. Black & White developed 2 prints each Jumbo size—12 exposure 70¢. **LENS PHOTOS**, Dept. J-4, Janesville, Wis. 53545.

**A FREE Kodak roll** returned with each black and white or Kodacolor developed and printed, fast service, lowest prices, guaranteed quality send for free mailers. Economy Photo Service, Dept. P.M., Box 1111, Albany, N.Y. 12201.

**PHOTOGRAPHY For Pleasure or Profit.** Learn at home. Practical basic training. Long established school. Free booklet. American School of Photography, 835 Di-versey Parkway, Dept. 674-022, Chicago, Illinois 60614.

**SPECIAL:** Black-white, 8-45¢; 12-55¢. Kodacolor, 8-\$1.89; 12-\$2.09. Astro Photo Service, Box 166M, Waterloo, New York 13165.

**8X10 COLOR Enlargements 80¢ each**—Special Trial offer from 120 color negatives, professionals only send business card with order. Professional, Box 1873, New Haven, Connecticut.

## COLOR SLIDES

**YOUR Ad in Popular Mechanics** will be seen by more than 5,000,000 active buyers for your products and services. It costs only \$1.85 per word. And, if you wish to run all or part of your ad in capital letters—you can do so for as little as 75¢ per word additional. Act now! Place your classified ad in Popular Mechanics today.

## MOTION PICTURES AND SOUND EQUIPMENT

**35MM. COLOR SLIDE SAMPLER . . .** 20 "best" 2" x 2" . . . \$1.00. Free catalog. Hundreds of sets . . . travel, circus, wildlife, flowers, railroads, wars, etc. Order today. Blackhawk Films, 862 Eastin-Phelan Bldg., Davenport, Iowa 52808.

**16MM sound-projectors, films, new, used** for sale. Free catalog. National Cinema, 333 W. 57 Street, New York City, N.Y. 10019.

**5,000 8-16MM MOVIE Films.** Free catalogues. International, Greenvale, L.I., N.Y.

**FREE!** 64-page catalog. 8-16mm film, supplies, processing equipment. Superior, 448 N. Wells, Chicago 60610.

**16mm. FILMS—Projector Parts.** Gordon 28-53 Steinway Street, Astoria, Long Island, New York, 11103. . . .

**175-FOOT 8MM. PREVUE MOVIE . . . ONLY \$1.99.** See Laurel & Hardy, Chaplin, Fairbanks, Keystone Cops, Gish, Pickford, Chaney . . . comedy, drama, adventure, history from the silents! Taste the fun of great movies right at home! Order today . . . specify standard or Super 8. Free catalog. Blackhawk Films, 861 Eastin-Phelan Bldg., Davenport, Iowa 52808.

## RADIO, TELEVISION AND HAM EQUIPMENT

**33¢ RADIO & TV tubes.** Free list. Cornell, 4213-17 University, San Diego, California 92105.

**CB—POLICE—FIRE—VHF—calls on** broadcast radio! Brochure. TUNAVERTER, Woodsboro PM23, Texas 78393.

**GOVERNMENT Surplus receivers, transmitters, snooperscopes, parts.** Catalog. 25¢. Meshna, Nahant, Mass. 09108.

**EXCITING Values In Fire And Police** Portable Monitor Receivers, Converters, Accessories, Details, Free Antenna Offer: Griffin's, 322-M West State, Ithaca, N.Y. 14850.

**POWERFUL Wrist Watch Shape Radio.** Satisfaction Guaranteed, Free Details, Alexander Topper, 6087 Sunset Boulevard, Suite 210-1, Hollywood, Calif. 90028.

**TUBES—Lowest prices in the world.** Hard to get British, German, Foreign and American obsolete and present day special purpose transmitting tubes. Send for giant tube and parts catalog. United Radio Company, Dept. Z-56 Ferry St., Newark, N.J. 07105.

## HIFI, RECORDS AND ELECTRONICS

**FREE Catalogues, 2000 hard to find un-**usual records. Rose's, 300 Chelsea, Louisville, Ky. 40207.

**TAPE Recorders, hi-fi components, Sleep** learning equipment, tapes. Unusual values. Free catalog. Dressner, 1523C Jericho Tpke., New Hyde Park, N.Y. 11040.

**RECORDS! Discounts on all LP's.** Free details. Citadel Record Club, Symphonette Sq., Dept. 2, Larchmont, N.Y. 10538.

**FREE—FREE—FREE FREE—FREE—**FREE—FREE Send in for your FREE one year subscription to Olson Electronics' fantastic value packed catalog—unheard of low, low prices on brand name speakers, changers, tubes, tools, stereo amplifiers, turners, CB and other values. Credit plan available. If you have a friend interested in electronics, send his name and address for a FREE subscription also. Olson Electronics, 325 S. Forge St., Akron, Ohio 44302.

**SCOTCH Cassettes, C-60 \$1.85, C-90** \$2.79. C-120 \$3.20. Tower, Lafayette Hill, Pa. 19444.

**"LITTLE GEM" protector for reel re-**corders saves tape and recordings, helps prevent loss of equipment by theft. \$1.00 P.P. Crosstown Alarms, 372 McArthur Dr., North Little Rock, Ark. 72118.

**HOME Electronics Course only \$26.95.** Free literature. Edu-Kits, Department 710B, Hewlett, New York 11557.

**STEREO TAPE CLUB.** Average cost \$3.78 to \$4.20. Cartridges, cassettes, reels. No minimum purchases. Enclose 10¢ for catalog. STAR RECORDINGS-PM, Box 1055, El Paso, Texas 79946.

## MUSIC AND MUSICAL INSTRUMENTS

**PLAYER Piano Rebuilding—get details** from: Vestal Press, Vestal 11, N.Y. 13850.

**GUITAR, Banjo Making books Plans,** woods, necks, tools. List 20¢. Satinwood, 510 East 11th Street, New York, N.Y. 10009.

**ELECTRIFY Player pianos, pump or-**gans quickly, inexpensively with Lee Silent Suction Units. Write Lee Music, Box 595F, Tujunga, California 91042.

**POEMS Wanted for new songs and re-**ords by America's largest song studio. Send poems. Free examination. Five Star Music, 6M Beacon, Boston, Mass. 02108.

**ACCORDION Manufacturing, 6846-P** North Avenue, Chicago, Illinois 60635. Concertinas, Hohners, Chromatics, Guitars, Drums, New, Used, Tuning, Repairing. Wholesale Catalogs Free.

**POEMS, Songs wanted for new song hits** and recordings by America's most popular studio. Tin Pan Alley, 1650-PM Broadway, New York 10019.

**PLAYER PIANO ROLLS, books, electric** pumps! Big catalog free! Golden Rule, Box 28-PM, Prospect Heights, Illinois 60070.

**LEARN Musical instrument of your** choice—easy! New home study tape course. Write for free brochure. Carver School, 7 West 1st, Dept. E, Hinsdale, Illinois 60521.

**ACCORDION** Top brands. Buy direct. Tremendous discounts. Trade accepted. Free brochure **PM**. Accordion-O-Rama, 874 Broadway, N.Y.C. 10003.

**DRUMS**, Electric guitars, amps, organs. Free catalog **M**: A.L.A.S. Import Company, 31 East 18th Street, NYC. 10003.

**ACCORDIONS**, Guitars, Band Instruments! Save to 50%. Famous makes. Easiest terms. Trades accepted. Free home trial. Free discount catalog. Mention instrument. International Music Mart, 5535-R Belmont, Chicago, 60641.

**GUITARS**, Accessories—Guitar maker's books, materials, supplies. Free catalog. Guitar Center, Box 15444, Tulsa, Oklahoma 74115.

**DO-IT-YOURSELF** Piano-organ **CHORD** Method. 2-12" L.P. records, \$3.98. Box 12283, Oklahoma City, Okla. 73112.

**ELECTRIC** Guitars, amplifiers, wholesale. Catalog 25¢. Carvin, PMM, Valley Center, Calif. 92082.

**GUITARS**, **MANDOLINS**, **BANJOS**. Complete stock of Gibson Martin guitars. Free 100 page catalogue, parts and accessories. Big Savings New York discount prices. Send 50¢ postage handling. Eddie Bell Guitar, 201 West 49, New York 10019.

**AMPICO** Pianos, Rolls, Wanted. 2510 Kenmore Court, Austin, Texas 78703.

**WE** Pay all recording costs on accepted material! Need new song material for immediate recording! Free examination! Grand Recording, 835-PM Dorchester Ave., Dorchester, Mass. 02125.

**PSYCHEDELIC LIGHTING MANUAL**—includes complete instructions for building Strobes, Color Organs, Light Machines, etc. Send \$2.00 to: Music, Box 8127-PM, Boston, Mass. 02114.

**LEARN** Banjo 5-String Bluegrass. No music to learn, \$3.95 complete. Details free. Blaylock, Box 25-M, Marietta, Georgia, 30060.

**EXCELSIOR** Accordions and Amplifiers. Save 50%. Buy Direct. Factory Distributor. Terms. Trades. Free Catalog. Excelsior, 3147 North Luna, Chicago 60641.

**FREE**. Song Selling Information. Peerless Music Publications, Box 193-A Bloomfield, Conn. 06002.

**POEMS** Set to music. Songs recorded. Send poems, songs. Crown Music, 49-C West 32, New York 10001.

**SONG** Writers—Send Poems, Songs to: Weiss Music Company, 1472 Broadway, New York, New York 10036.

**GUITARS**, **MANDOLINS**, **BANJOS**. Complete stock of Gibson Martin guitars. Free 100 page catalogue, parts and accessories. Big Savings New York discount prices. Send 50¢ postage handling. Eddie Bell Guitar, 201 West 49, New York 10019.

**VIOLIN** and Guitar makers—send for latest Free Catalogue of woods & accessories. International Violin, PM8, 414 East Baltimore St., Baltimore, Md. 21202.

**SING**, Dance, enjoy new patriotic record. Great for any occasion—sheet music included \$2.00 Ramrecords, P.O. Box 494, G.P.O. Bronx, New York 10451.

## EDUCATION AND INSTRUCTION

**EARN** College degree at home. All subjects. Ohio Christian College, 1156 Striebel Road, Columbus, Ohio 43227.

**FCC** First Class License in six weeks—nation's highest success rate—approved for Veterans Training. Write Elkins Institute, 2603D Inwood Road, Dallas, Texas 75235.

**LEARN** Auctioneering. Term soon. Free catalog. Reisch Auction College, Box 850, Mason City, Iowa 50401.

**LEARN** Asleep or awake! Records, tapes, equipment! Free catalog! Drawer, PM-400, Ruidoso, New Mexico 88345.

**EARN** Your degree in electronics engineering. Highly effective home study courses in electronics engineering technology and electronics engineering mathematics. Free literature. Cook's Institute of Electronics Engineering, P. O. Box 36185, Houston, Texas 77036 (Established 1945).

**DETECTIVE** Training—for free information write to: 1917M, North Kenneth Ave., Chicago, Illinois 60639.

**PIANO** Tuning quickly learned with home study course. Diploma granted. American Tuning School, Gilroy, Calif. 95020.

**PIANO** Tuning pays. Big money in spare time. Learn at home. No musical knowledge necessary. Phonograph, records, tools and instructions furnished. Electronic tuning also taught. Free catalog. Capital Tuning School, 3160 S.W. 16th Court, Ft. Lauderdale, Fla.

**DETECTIVE** Course. Free information. Universal Detectives, Box 8180-F, Universal City, California 91608.

**GAME WARDEN**, Government Hunter, Forestry, Park and Wildlife Services announce job openings regularly. Prepare at home for outdoor work, good pay, security. Complete information Free! Write North American School of Conservation-AZW, Newport, California 92660.

**BOOKKEEPERS**. Operate your own "Dollar-A-Week" system. Ellis, Box 200, Cedar Grove, North Carolina.

**PENMANSHIP** Corrector. Improve poor penmanship quickly. Details free. Ozment, Box 665-34, St. Louis, Mo. 63188.

**LEARN** To Sing Beautifully! Free Particulars. Publisher, Box 118-P, Brooklyn 11203.

**COMPUTER PROGRAMMING**—The big opportunity career. New recognised correspondence course. No maths needed. FREE brochure. Canadian Institute of Science & Technology, 263M, Adelaide St. W., Toronto.

**AUCTIONEERING** Free Catalog Resident or Home Study Course. Nashville Auction School, 2004 West End, Nashville, Tenn. 37203. Veteran approved.

**PROFITABLE** National Camera Repair School training at home! PM2, Englewood, Colorado.

**OWN** Collection agency. "Little Gold Mine!" Franklin Credit, Roanoke, Virginia 24004.

**EARN** \$125 A week and up. Learn a trade with a future. Learn auto diesel mechanics in our shops. You learn with tools on real equipment. Earn while you learn. Many of our graduates earn \$125 a week and up. Write for free bulletin: Dept. 256, Auto Diesel College, Nashville, Tennessee 37219.

**SWEDISH** Massage and physical culture pays big profits. Learn at home. Diploma. Free catalog. National Institute, Dept. E-29, 307 North Michigan, Chicago 60601.

**DETECTIVE** Course. Free information. Criminology Institute, Box 201, Geronimo, Oklahoma 73534.

**HIGH** School diploma at home. Licensed teachers. Send age, highest grade completed for free details. No salesman will call. Southern States Academy, Westbury Square Professional Bldg., Dept. 16, Houston, Texas 77035.

**COMPLETE YOUR HIGH SCHOOL** at home in spare time with 72-year-old school. Texts furnished. No classes. Diploma. Information brochure free. American School, Dept. X245, Drexel at 58th, Chicago, Illinois 60637.

**TRAVEL** Agents make \$\$\$\$\$. Exciting. Booming Careers! Easy Home-Study Plan. Free! "Travel Career Kit." Write—North American School of Travel-AZW, Newport, California 92660.

**DRAFTING**—Learn at Home! U.S. Government reports "42% more Draftsmen needed next 10 years." Send for Free "Drafting Career Kit." No Salesman Will Call. G.I. Bill Approved. North American School of Drafting-AZW, Newport, California 92660.

**USED** CORRESPONDENCE Courses and Books sold and rented. Money back guarantee. Catalog free. (Courses bought). Lee Mountain, Pisgah, Alabama 35765.

**GRAPHOANALYSIS**—Learn scientific handwriting analysis for profit, pleasure. Free sample lesson, catalog, reveals plan. Write: Teas, Inc. 325 Jackson, Dept. 2-AR2, Chicago 60606.

**LEARN** Bartending home study course 300 East Armour, #517D, Kansas City, Missouri.

**LEARN** Landscaping and the growing of plants. Start a profitable business part or full time. Free information without obligation. Lifetime Career Schools, Dept. A-598, 11826 San Vicente Blvd., Los Angeles, Calif. 90049.

**MISSOURI** Auction School. GI Approved. Free Catalog! 424-03 Nichols Road, Kansas City, Mo. 64112.

**MATHEMATICAL** Topics for Businessman, Tradesmen Improve your ability. Lee's Service, 1224 Shakespeare Avenue, Bronx, N.Y. 10452.

"**STAMMER**—Stutter—no more." (Dr. Young.) Write: Gaucho, Box 9309-S7, Chicago 60690.

**BE** A Real Estate Broker. Big earnings. Prepare quickly, easily. GI approved. Free Catalog. Weaver School, 3519-P Broadway, Kansas City, Missouri 64111.

**AUTOSUGGESTION**. Sleep-learning headquarters! Tapes, records, books. Gigantic catalog free. Research Association, Box 24-PM, Olympia, Washington.

**GET** A British degree. Divinity, Philosophy, Radionics, 35 courses. Prospectus free. Brantridge Forest School, "Lodge" Brantridge Forest, Balcombe, Sussex, England.

**\$1,000,000** MEMORY. Yours overnight. Free details. Box 444MJ, Maywood, CA. 90270.

**WATCH** REPAIRING. Unique course develops skills at home. Free sample lesson. Chicago School, YO, Fox River Grove, Illinois 60021.

**LEARN** Civil and criminal investigation at home. Earn steady, good pay. State age. Institute Applied Science, 1920 Sunnyside, Department 162, Chicago, Illinois 60640.

**PHOTOGRAPHIC** RETOUCHING. Good spare-time income at home. Interesting, artistic career. Free information. Hamilton Studios, Dept. PR-39, Claymont, Del. 19703.

**TEACHERS**, Elementary and secondary. **TEACH** the 390 BASIC ARITHMETIC FACTS with records dictating them 6, 4½ and 3 seconds apart, respectively. Particulars, CADDY, Box 251, Canoga Park, Calif. 91305.

**HIGH SCHOOL** DIPLOMA FAST! Free information. Educational Service, Box 514, Dept. PM, Jackson Heights, N.Y. 11372.

**HAM** RADIO COURSE—Always wanted to be a ham? Complete course, theory, code and operating procedure. At home. Ham Radio Course, 4109A North 39th Street, Phoenix, Arizona 85018.

"**DO YOU KNOW**" The Automobile Salesman earns from \$7,000 to \$20,000 yearly. 90% of all Automobile Salesmen have no more than a High School Education of which 20% are Dropouts. From 18 to 55 years qualifies you. "NOW YOU DO KNOW" Age and Education is no block. \$2.50 per correspondence instruction. Pay as you Learn, progress as you wish. For enrollment particulars, write—MVAAS, Box 308, Botsford, Conn. 06404.

**DRAFTING**—Home Courses \$25.00. Send \$2.00 First Lesson. Prior, Inc. 23-09 169th Street, Whitestone, New York 11357.

**ADVERTISING** ART, home study spare time. Send for FREE trial lesson, to be corrected, by artists of an advertising agency—not a school. Learn from the "pros"—actual art assignments. Earn while you learn. Write: ALVIN EPSTEIN ADVERTISING, 1737 F St., N. W., Dept. 401, Washington, D. C. 20006.

**USED** Courses! Books! List 10¢, Smith's, 124 Marlborough, Salem, Mass. 01970.

**MINISTERIAL** Bible College Degrees Granted Correspondence Courses. Residential, Approved for Veterans. Soms, 887 West Spruce, Ravenna, Ohio 44266.

MILLIONS Of sewing machines need repair. New book shows how. \$7.95. Sincere Press, Box 10422, Phoenix, Arizona 85018.

PIANO Technology — Electronic organ servicing, learned easily at home. G.I. Approved. Free booklet. Niles Bryant School, Dept. P. 363 Stockton, Sacramento, California 95820.

## FOR INVENTORS

PATENT Searches complete and thorough. Related copies Air Mailed with maximum speed \$6.00. Free "Protection Forms" and "Patent Information." Write American Patent Search Company, Dept. 27, 711 14th St., N.W. Washington, D.C. 20005.

PATENT Application Financing. Free patent search plan. Global Patent Division, 2420 77th, Oakland, Calif. 94605.

PATENT And invention development by licensed professional patent engineer and U.S. Patent Office former examiner, and engineering specialists. Your inventions and ideas engineered for patent protection and commercial value. Inventions developed by us negotiated for cash or royalties with our nationwide contacts. Send for free protection "Invention Certificates" and further interesting, valuable patent information. George Spector, Licensed Professional Patent Engineer, Woolworth Building, New York.

U.S. Patent Office Searches, 234 Broadway, Room 3615, New York. Free invention certificates.

IMMEDIATE Cash, for patent applications. Free patent searches. Write for details. Universal Patents, 184-D, Marion, Ohio.

INVENTORS Wanted immediately for promoting on cash or royalty. Patented, unpatented. Free booklet outlines royalty rates, requirements. Write Kessler Corporation, C-52-FI, Fremont, Ohio.

PATENT Searches, including copies of related U.S. patents. Inventors attorneys, manufacturers use our "worldwide" airmail service! "Invention Record" form and "Information Every Inventor Needs," sent free! Hayward Company, 1029P Vermont, Washington 5, D.C.

PATENT SEARCH SERVICE! For Lawyers, Companies, Inventors. "Confidential report" including copies of related United States patents rushed "Certified Airmail" Free! "Patent Search Information." Write: Congress Patent Search Company, 911-C Warner Building, Washington, D.C. 20004.

INVENTORS: Your ideas and inventions (patented; unpatented) expertly searched, royalty sales to manufacturers by professional Invention Developer with excellent record of experience. B.S., Industrial Engineering; United States Patent Office former Patent Examiner. United States Government former Patent Advisor. Second decade reliable service! Member: United States Chamber Commerce. Free "Invention Record" and "Recommended Protection Procedure." Airmailed! Write: Raymond Lee, Invention Developer, 230-P Park Ave., New York City 10017.

QUALITY Patent Searches! Preferred by Professional Inventors. Lawyers, Manufacturers. "Confidential Report" including related United States patent copies "Airmailed Certified." FREE Information! United States Inventors Service Company, 501-P Thirteenth Street, N.W. Washington, D.C. 20005.

## INVENTIONS WANTED

INVENTIONS Wanted. Patented; unpatented. Tremendous manufacturers lists. Global Marketing Service, 2420G 77th, Oakland, California 94605.

INVENTORS! Outright cash sale or royalties for your inventions. Patented, Unpatented. Active demand from our client manufacturers. Financial assistance available. Write Dept. 36, United States Invention Brokerage, 78 Wall Street, New York, N.Y. 10005.

INVENTORS! Don't sell your invention, patented or unpatented, until you receive our offer. Eagle Development Company, Dept. H, 79 Wall Street, New York 5, N.Y.

INVENTORS! Sell your invention for cash or royalties! Our client manufacturers eagerly seek new items. Patented, Unpatented. Financial assistance if needed. 25 Years proven performance. For free information, write Dept. 15, Gilbert Adams, Invention Broker, 80 Wall St., New York, N.Y. 10005.

INVENTORS! We will develop, sell your idea or invention patented or unpatented. Our national manufacturer-clients are urgently seeking new items for highest outright cash sale or royalties. Financial assistance available. 10 years proven performance. For free information write Dept. 47, Wall Street Invention Brokerage, 79 Wall Street, New York, N.Y. 10005.

WE Either sell your invention or pay cash bonus. Write for details, Universal Inventions, 298-E, Marion, Ohio.

INVENTIONS Wanted immediately for promoting on cash or royalty. Patented, unpatented. Free booklet outlines royalty rates, requirements. Write Kessler Corporation, C-52-IW, Fremont, Ohio.

INVENTORS! Protect your ideas! Free "Recommended Procedure." Washington Inventors Service, 422F, Washington Building, District of Columbia 5.

FREE "Directory of 500 Corporations Seeking new Products." For information regarding development, sale, licensing of your patented/unpatented invention. Write: Raymond Lee Organization, 230-N Park Avenue, New York City 10017.

## PATENTS FOR SALE

A CYLINDRICAL ELECTRIC AIR HEATER, JUST PATENTED -3,407,284 can be used many ways. Specially for diesel air intake. Contact John Prata, 17615 Orleans, Detroit, Michigan 48203.

## MANUFACTURING

MODELS — small lot manufacturing. Metals, plastics, etc. Milburn, Burlington, Kentucky 41005.

INVENTORS Ideas developed. Research. Models. Manufacturing. Sales. Free brochure. William Parker, 32 Westminster, Worcester, Mass. 01605.

HOMEWORKERS! Make money mailing postcards. Particulars 10¢. Wesley, Western Springs, Illinois.

## BUY IT WHOLESALE

500,000 BARGAINS BELOW WHOLESALE. New, name brand merchandise. Buy at 10¢ on the dollar. Closeouts, surplus, bankrupts, liquidations, imports. Free details. International Buyers, Box 4633-M, Colorado Springs, Colo. 80909.

BARGAINS! Buy wholesale and below. Name brands. Appliances, furniture, sports equipment, televisions, cameras, watches, jewelry, thousands more. Huge discounts to \$1,000.00 on new automobiles. All makes. Free details. Write today: Worldwide Bargainhunters, Box 730-A, Holland, Michigan 49423.

20 WHOLESALE Catalogs!! List \$1.00. Zashop, 216 PM-2, West Jackson, Chicago 60606.

ELECTRIC Guitars, amplifiers, wholesale. Catalog 25¢. Carvin PMW, Valley Center, Calif. 92082.

SAVE Money! Fascinating list. Over 800 foreign manufacturers. Cameras, Radios, Watches, China, Binoculars, Camping Equipment, Cars, and much more. Refund guaranteed. \$2.00. Rockford Manor, 200 Center, Monroe, Utah 84754.

WHOLESALE Buying Guide: Five section directory. U.S. and foreign sources \$3.00. Charlecta, P.O. Box 155, Port Richey, Florida 33568.

## EXPORT-IMPORT

JAPAN: 1200 Products Directory, Illustrated Manufacturers' names, addresses, \$3.00. Send cash. Yamagata Office, 814 Togin Bldg., Marunouchi, Tokyo.

## FOR THE HOME

MAILORDER Records help get Increased Profit Business! Complete 32 Page Record Book shows your inquiries, orders, advertising, expense, etc. Only \$1.00. C. A. Martin, Popular Mechanics, Dept. PM, 575 Lexington Ave, New York 10022.

## FOR PARENTS

EXTRA Income at home in Spare Time! Profit Booklet shows you how to start your own business with Classified Advertising. Only \$1.00. C. A. Martin, Popular Mechanics, Dept. PM, 575 Lexington Ave., New York 10022.

## OF INTEREST TO WOMEN

WOMEN! Make big money at home. \$10.00 profit in an hour possible with invisible mending. Make holes, tears disappear from clothing, fabrics. Steady year-round demand from cleaners, laundries, homes. Details free. Fabricon, 1533 Howard, Chicago 60626.

TYPING Pays! Unbelievable \$30.00 thousand addressing envelopes from lists. Typewriter, longhand. Immediate earnings. Instructions \$1.00. Florida Service, P.O. Box 1017C, Hialeah, Fla. 33011.

RAISE Rabbits for us on \$500 month plan. Free details. White's Rabbitry, Mt. Vernon, Ohio 43050.

DRIVE New car, wear new clothes, buy color TV. Get daily cash income. Put spare hours to work. Write for 5 months free subscription Opportunity Magazine; see hundreds easy ways to make money. Opportunity, Dept. 17-BO, 850 N. Dearborn, Chicago 60610.

HOW To make money writing short paragraphs. Information free. Barrett, Dept. C-27-M3, 6216 N. Clark, Chicago 60626.

\$500 MONTHLY Possible—Clipping news at home. No experience needed. Free information. Send stamp. American, Box 11056, Kansas City, Kansas 66111.

HOME Typing. Earn up to \$100 weekly. Instructions, employers' list, \$1.00. Satisfaction or refund. Summithouse, Box 377-PM, Corte Madera, California 94925.

HAVE Profitable Sparetime Hobby Lacing and Assembling our beautiful products! Cuties, Warsaw 9, Indiana 46580.

HOMEWORKERS \$2.00. Hour Possible Sewing Babywear Aprons. KutieKay, Box 9194-PM, Ft. Worth, Texas 76107.

DOLLS MAKE BIG MONEY! Start your own hobby-business dressing, making, repairing and selling dolls. Send for FREE booklet describing the excellent opportunities open to you. Doll Hospital School, Dept. D-552, 2251 Barry Avenue, Los Angeles, California 90064.

NEWSPAPER Clippings Urgently Needed. Highest prices paid. Send stamped, addressed envelope, free details. Brewster, Box 1348-NCWL, Clearwater, Florida 33517.

\$400.00 MONTHLY POSSIBLE Home Typing! Guaranteed Profitable Methods, Instructions, \$1.00. Pulse, Box 11211-PB, Indianapolis, Indiana 46201.

EARN Up to \$2.40 hourly. Assemble our Products. Supplies Furnished. United, Box 55392D, Indianapolis, Indiana 46205.

WANTED! Addressers — Commission Mailers. Stamp required. Ooton Distributors, 122-P Duke Drive, Portsmouth, Virginia 23703.

\$500—\$800 MONTHLY Raise small laboratory-breeding stock for us. We supply equipment, breeders, instructions. Illinois Research Farms, Dept. MP-2C, McHenry, Illinois 60050.

EXTRA Money Easily! Free Sample \$2.00 DeLux 24-card Everyday Assortment. Pays \$1.00 cash profit per box. 250 fast selling cards, stationery, gift novelties boost your income. Experience unnecessary. Money-making samples on approval. Cardinal, 1400 State, Dept. 49-T, Cincinnati 45214.

**\$50-\$100 WEEKLY!** List of firms wanting home addressers—Commission mailers! Mail \$1.25. Smiths', Box 2469-PM, Newark, New Jersey 07114.

**FREE HOME DECORATING-CUSTOM DRAPERY BOOK** tells how to get started learning & earning Big \$\$\$ at home doing interior decorating, custom drapes, slip-covers, bedspread ensembles. Turn sewing machine into money making machine—supply HUGE endless demand. Delightful hobby too! Learn, earn, work right at home. No experience needed, **WE SHOW YOU HOW!** Fabrics wholesale—save big money on your own decorating & drapes. Write for **FREE** four color book today! Custom Drapery Institute, Box 555-F7, Orange, Calif. 92669.

**SELL Greeting Cards**—Make extra money. All Occasion Assortments, Easter, Stationery, Wrappings, Gifts, Toys, Jewelry Experience unnecessary. Salable Samples on Approval. Free color catalog, Bonus Plan. Write Hedenkamp, 361 Broadway, Dept. CD-9, New York 10013.

**TIRED** Of cracked boiled eggs? Use the Egg Piercer before boiling. Easy to use. 89¢ ppd. Carver Company, Box 1501, Ft. Pierce, Florida 33450.

**EXPOSED**—Successful home typing methods—Trade secrets. Complete exclusive manual, \$1.00 postpaid. Satisfaction guaranteed. Details for stamp. Arrow Typing Services, Box 3015-A, Milwaukee, Wisconsin 53218.

**\$500 MONTHLY POSSIBLE**—clipping news at home. No experience. Free information—send stamp. American, Excelsior Springs, Mo. 64024.

**SPARE** Time profits—report reveals 25 fascinating methods. Actual experiences. \$2.00. Satisfaction guaranteed! Chang, Box 5628-BB, Vancouver 12, C., Canada.

**SELL** Gifts and Household Items. Make extra money. Toys, Jewelry, Stationery, Wrappings, All Occasion, Easter Card Assortments. Salable Samples on Approval. Free color catalog, Bonus Plan. Write Hedenkamp, 361 Broadway, Dept. CD-8, New York 10013.

## GIFT SHOPPING

**FREE** Distinctive Catalog. Mountain Mart, 1123P West Eighth, Cedar Falls, Iowa 50613.

**FREE:** Catalog of Distinctive Gifts. The Medallion Co. P.O. Box 61246, Los Angeles, Calif. 90061.

## WATCHES, OLD GOLD, JEWELRY

**WATCH** And clock repairing books. Free catalog, North American, Box 77-AB, Fox River Grove, Illinois 60021.

**USED** Wrist, pocket watches—\$3.00 up. Free list. Southern Watches, 5-PM South Wabash, Chicago 60603.

**CASH** Immediately for old gold, jewelry, gold teeth, watches, diamonds, silverware, spectacles, platinum, mercury. Free information. Rose Industries, 29-A East Madison, Chicago 60602.

**WANTED**—Gold, silver, platinum (any form), mercury. Information free. Wilmot's, 1067 Bridge St., Grand Rapids, Mich. 49504.

**HIGHEST CASH** for Gold, Jewelry, Gold Teeth, Rings, Diamonds, Watches, Silver, Platinum. Mail Articles Today. Free gift with information. Chicago Gold & Precious Metals, 6 E. Monroe, Dept. 158, Chicago, 60603.

## WEARING APPAREL

**MAILORDER** Records help get Increased Business! Complete 32 Page Record Book shows your inquiries orders, advertising, expense, etc. Only \$1.00. C.A. Martin, Popular Mechanics, Dept. PM, 575 Lexington Ave., New York 10022.

## HEARING AIDS

**HEARING AIDS**—Batteries Wholesale! Brochures—Hearing Center, Box 211, St. Petersburg, Florida.

**HEARING Aids.** Batteries, wholesale. Catalog 25¢. Fiston, Box 1444 New Preston, Conn. 06777.



## SCIENCE AND CHEMISTRY

**CHEMICALS.** Apparatus, Microscopes, Mineralogy Sets, Telescopes. Catalog 35¢. Sheard Science Supplies, Inc. Columbus, Wisconsin 53925.

**CHEMICALS** And apparatus for industrial, analytical, and private laboratories. Catalog 50¢. Dept. M-50, Biological Supply Co., 1176 Mt. Hope Ave., Rochester, N.Y. 14620.

**UNDERWATER** Fuse 3/32". Diameter, 25 Feet \$1.00—125 feet \$4.00. Postpaid. Free Catalog. Zeller, Box 646, Hudson, Mich. 49247.

**ROCKETS:** Real flying models—flights up to 2500 ft. New illustrated catalog 25¢. Single and multistage kit, cones, engines, launchers, trackers, rocket aerial cameras, technical information. Fast service. Estes Industries, Penrose 7, Colorado 81240.

**LABORATORY** chemicals supplies 1969 catalog has over 400 listings many scientific publications catalog \$2.25 Caseco, Dept. M P.O. Box 77 Riverdale, New Jersey 07457.

**ROCKETS!!** Real flying models—2500 feet altitude with powerful motors. Terrific Science Projects. Tubes—Cones—Parachutes—Launchers—Igniters. Gigantic catalog—rocket data—diagrams—25¢. Fast Delivery. Centuri Rockets, Box 1988, Phoenix, Arizona 55001.

**SEARCHING** For economically priced Laboratory Supplies? Gifts with catalogue—25¢. Hagenow Laboratories; Manitowoc, Wisconsin 54220.

**FREE** Gift and discount lists with Laboratory Supplies. Catalogue—35¢. Deluxe Scientific, Manitowoc, Wisconsin 54220.

**SEARCHING** For economically priced chemicals and apparatus? Gifts with catalog. 25¢. Starr Scientific, Manitowoc, Wisconsin 54220.

**ILLUSTRATED** Catalog: Chemistry, mineralogy, biology 25¢. Tracey Laboratories, Evanston, Illinois 60204.

**FREE** Periodic classification of elements and conversion tables with catalog 35¢. Chemicals, apparatus, biology. Mid-States Scientific, 7053 N. Clark, Chicago, Ill. 60626.

**SOLAR** Flying Saucers. (Brand New—Solid State Engine—Fantastic Performance—Flies for Miles on Sun's Power—lifts animals—send messages—parachutes—Build Easily for next to nothing with Everyday Materials—Many sizes—many designs) Complete plans, descriptions, drawings, \$1. Spacetratics, Box 31043-D, San Francisco, Calif. 94131.

**GIANT** Science Catalog 35¢. 100 feet fuse \$1.49. Plans for UFO Detector \$1.00. Chemistry Experiment Book \$1.00. Xercon, 8542 Oglesby, Chicago, Illinois 60617.

**FREE** 2 Feet Fuse, with catalogue 20¢. Scientific, 8886 Melvin, Livonia, Michigan 48154.

**FLEXIBLE** Magnets! Bend them into circle! Tie into knot! Unique! \$1.00 per foot. Catalog 25¢. Franks Scientific Co., P.O. Box 156, Martelle, Iowa 52305.

**SAVE** On casings, endcaps. Underwater fuse 70 feet \$1.00. Professional green fuse 56 feet \$1.00. atalog 25¢, with samples 50¢. Bilton, Box 399, Hasbrouck Heights, New Jersey 07604.

**GIRANDOLE,** Petard casings. Lowest prices. Underwater fuse 75' \$1.00. PROFESSIONAL green fuse 50' \$1.00. Samples 50¢. Arwel, 252 Park Ave., East Rutherford, New Jersey 07073.

**CHEMICALS** Thousands of Items \$1.00 each postpaid—Pricelist \$1.00—deductable from 1st Order Spectro-chem 1354 Ellison, Louisville, Ky. 40204.

**20 LACHRYMATOR** formulas! (Catalog too!) \$1.00. Kenrus-F, 42 Crocus, Woodbridge, New Jersey 07095.

**100 ONE** Minute time delay fuses! \$1.00 240—\$2.00. 700—\$5.00. Use with rockets, experiments, etc. Kenrus-F, 42 Crocus, Woodbridge, New Jersey 07095.

**CATALOG** Of Ver-ry Interesting Products—25¢. (Free with any purchase—see our other Kenrus ads!) Kenrus-F, 42 Crocus, Woodbridge, New Jersey 07395.

**PROFESSIONAL** Model rocket ignition fuse, burns underwater, 75 feet, \$1.00. Ed-colabs, Box 99, Berlin, New Jersey 08009.

**LASER PISTOL**—\$1.00. How to build. **PHASER PISTOL**—\$1.00. (Add 25¢ postage.) New catalogue—10¢. Roy Davis Laboratories, Dept. PM, 118 West Adams St., Jacksonville, Florida 32202.

## FORMULAS, PLANS, ETC.

**FOR** Proof of what you can do in specialty manufacturing get our literature. It's free! Miller, Chemist, 1517-P, Tampa, Florida 33601.

**ANY** Formula \$3.00. Catalog—Treatise 10¢. Belfort, 192 N. Clark, Chicago 60601.

## PLASTICS

**PLASTIC** Embedders, jewelry workers. We have everything. Findings, moulds. New catalog 25¢. David Co., 861 Broad St., Dept. M, Providence, R.I. 02907.

**NEW LIQUID** PLASTICS for creating unusual gifts with real flower embedments, photographs, special collections. Reproducing originals. Hundreds of other profitable ideas. Illustrated information free. Castolite, Dept. 9C1B, Woodstock, Ill. 60098.

**"YOU** can build a Vacuum Forming Machine from: Blueprints. Box 205, Woodbridge, Virginia 22191."

## TREASURE FINDERS

**FIND** Buried treasure with new revolutionary analytical metal detector. Features push button tuning, automatic tuning, loudspeaker, negligible ground pickup, greatest range. Free catalog. Gardiner Electronics, Dept. 9, 4729 N. 7th Ave., Phoenix, Ariz. 85013.

**URECON** Metal finder. 8" head, transistorized, \$40.00 delivered. Urpa 6304 Beechwood, Sarasota, Fla. 33581.

**TREASURE** Hunters! Prospectors! Relco's new instruments detect buried gold, silver, coins, minerals, historical relics. Transistorized. Weighs 3 pounds. \$19.95 up. Free catalog. Relco-A40, Box 10839, Houston, Texas 77018.

**LOCATE**—Underground streams Water, Tile Lines, Sewer Pipes Etc. Make Locator 5 minutes, Few cents Hardware. Full instructions \$1.00. FAR, Box 141, Watertown, Wisconsin 53094.

**"METAL** Locators—Accessories. Write: Detectors, Inc., Box 101-D, Springfield, Va. 22150."

**FISHER** "METALERT" award-winning Model 70. Brand new treasure and metal detector for exciting results! Unsurpassed sensitivity. Use anywhere, even beaches and streams. For Free literature write: Fisher Research, Dept. PM-2, Palo Alto, California 94303.

**POWERFUL** Metrotech locators detect gold, silver, coins, relics. Moneyback guarantee, terms. Free information. Underground Explorations, Dept. A, Box 793, Menlo Park, California 94025.

**TREASURE** BOOKLET. Excellent information on treasure hunting and metal detectors. Send 25¢. BOOKLET, Dept. 2-PM, Box 246, San Gabriel, California 91778.

FREE 128 Page detector catalog. General Electronic Detection Co., Box 67, Bellflower, California 90706.

**GOLDAK Treasure Locators**—New for '69! A hobby you'll enjoy for fun and profit. Find coins, gold, silver. Goldak, Dept. PMC, 1101A Airway, Glendale, California 91201.

**AMAZING Performance! Newest Models**—Treasure Detectors. Sensational low prices! Complete models and kits from \$14.95 to \$129.50. Let us prove it. Free catalog. Jetco Electronics, Box 132-PM, Huntsville, Texas 77340.

**TREASURE LOCATORS, MOST COMPLETE LINE. FREE INFORMATION.** TESOROS, APARTADO 7-948, MEXICO 7, MEXICO.

**FIND BURIED TREASURE** with the most popular transistorized metal detector in the country. Treasure Probe available as kit (\$14.88), assembled (\$18.88), with powerful built in speaker (\$24.88), schematic, parts list, and step by step instructions \$1.00. Ten Day money back guarantee. Free catalog available. Treasure Probe Dept. PGG, P.O. Box 64, Lakewood, New Jersey 08701.

**GOLD.** Valuable Maps to Mines and Diggings. Send 50¢ to Prospectors, 2513 Lansing, Fresno 93726.

### PRECIOUS STONES AND MINERALS

**EARTH Science Rockhound Magazine.** Subscription \$2.50. Sample 35¢. Box-550-PM, Downers Grove, Ill. 60515.

**100 COLORFUL, Polished gemstones,** \$1.00. Tumblecraft, 5401 James North, Minneapolis, Minnesota 55431.

**GET Free catalog no serious rockhound,** gem cutter, jewelry maker, hobbyist or craftsman can be without. Full of bargains, exclusive items, low prices from largest suppliers and authorities in the field. Free new catalog just off the press, yours for the asking. Write Grieger's, Dept. C-12, 1633 E. Walnut, Pasadena, California 91106.

**SEMI-Precious uncut gems.** Ten different for \$1.00. Request list 30. Prospectors Shop, 201 San Francisco, Santa Fe, New Mexico 87501.

**WORLDWIDE Crystal specimens, Gems.** Free lists. Sering, 1705 E. Michigan, Indianapolis, Indiana.

**500 POLISHED GEMSTONES \$1.50.** Cabochons, slabs. Floodstones P.O. 1673 Fremont, California 94538.

**GOLD.** Native Sample, \$2.00. Moneyback Guarantee. Lea, Box 237, Mt. Shasta, California 96067.

**GOLD 10 Small nuggets panned from Oregon Streams \$1.00.** Robert Brandt, Sweethome, Oregon 97386.

### CARTOONING, COMMERCIAL ART, SHOWCARD & SIGN PAINTING, TATTOOING

**SIGN Painting, Fascinating System**—Straley, 410 So. Western, Springfield, Ohio 45506.

**COMPACT 23 Lesson Cartoon Course and Cartoonist's Magazine,** \$2.00. Hartman, Box 30367, Lincoln, Nebraska 68510.

**"HOW TO MAKE MONEY WITH SIMPLE CARTOONS"**—Everyone who likes to draw should have this book: **FREE.** Write Cartoonists' Exchange, 92 Pleasant Hill, Ohio 45359.

**LEARN Sign painting at home.** Free talent test. Ben Kerns, Box 812-PM, Greenville, S.C. 29601.

**LIKE To draw? Splendid opportunities in professional cartooning.** Write for free catalogue. National School of Cartooning, Studio-H, Box 8958, Cleveland 44136, Ohio.

**LEARN Profitable tattooing.** Illustrated information and instruction \$3.00. Zeis, 2220-P Delcy Dr., Rockford, Illinois 61107.

**SIGN Painting**—Instructions, brushes, equipment. Free catalog. Kaufman Supply, Centertown, Missouri 65023.

**"SIGN Painting, Lettering Tricks"** (Deluxe Edition Airmailed \$1.25). Harris, Box 1567-AB, Portland, Oregon 97207.

**YOU Can entertain with chalk talks.** Catalog 10¢. Balda the Cartoonist, Oshkosh, Wis. 54901.

**SIGN PAINTING COURSE** Best ever offered. Earn big. **FREE** Information. Midwestern, 1924 Salisbury, St. Louis, Mo. 63107.

### ADVERTISING AGENCIES, ADV. SERVICE, MAILING LISTS

**MAILING Lists** most all kinds 1000 \$5.00. Free folder. Your circulars mailed \$4.00 1000. Dixie Mailers, King, N.C. 27021.

**ADVERTISING Ratebook** leading newspapers, magazines, 25¢. Chicago Advertising Agency, 28-E Jackson, Chicago 60604.

**"ADVERTISE 70 Countries!!"** 25¢ Word. Excelsior, 312-PM Shepard, Englewood, New Jersey 07631.

### TYPEWRITERS, DUPLICATORS, OFFICE EQUIPMENT

**FREE Plan.** Start printing, lettershop. Offset Presses, Mimeograph Copy machines. DixieGraph, King, N. Car. 27021.

### RUBBER STAMPS AND OFFICE SUPPLIES

**ADDRESS Stamp \$1.50 Signature \$2.80** Catalog. Carol's, McLoyd, Okla. 74851.

**FREE 40 Page catalog.** Rubber stamps, office supplies. Youngers Stamp Shop, Princeton, Iowa 52768.

**RUBBER Stamps 4 Lines \$1.25.** Catalog. Bilmar, 10024 Oxborough Road, Minneapolis, Minnesota 55431.

**LARGE Selection Stock Stamps.** Low as 3 for \$1.00. For shipping and office use. Made to order address, signature stamps. Catalog 10¢. Wesco., Huntsville, Mo. 65259.

**NAMEPLATES, Doorplates, Directional Signs, Brochure.** Morris, 410 West Oaklane, Lake Charles, Louisiana 70601.

### PRINTING, MULTIGRAPHING, MIMEOGRAPHING, GUMMED LABELS

**OFFSET PRINTING—8 HOUR SERVICE** 25 to 5,000 copies. Free booklet "Secrets of Cutting Printing Cost." Nationwide Printing, Atlanta, Illinois 61723.

**AMAZING Business printing values.** Quotations. Print Shop, Box 576, Greenville R.I. 02828.

**1,000 GUMMED Address labels \$1.00.** Walt's, Box 966A, South Bend, Indiana 46624.

**BOOKLET Specialist on Hi Speed Web.** Free Price List 20M 16pg 8 1/2 x 11 2 color booklets at 2¢ each. Copen Press, 337p Butler St., Brooklyn, N.Y. 11217.

**FREE Literature: Address Labels, Business Cards, Printing, Rubber Stamps.** Jordan's, 552 West O'Connor, Lima, Ohio 45801.

**1000 QUALITY Gummed labels 4 lines \$1.00,** self inking Pocket Rubber Stamp, 3 lines \$1.00 Postpaid. Quick Service, send check, cash or stamps. Printing, Novelty catalog 25¢ refunded. Seal, Box 505P, Elgin, Ill. 60120.

**QUALITY Letterheads, Cards, Envelopes, Invoices, Samples, Printer,** Box 659, Venice, Calif. 90291.

**1000 BUSINESS Cards, \$4.50 . . . Postpaid!!!** "Raised Lettering" . . . Samples! . . . NOBLE PM2, 505 Briggs, Bellmore, New York 11710.

**"FREE" Circular! Labels, Personalized Items, Stationery, Longwood, D-4729,** Fort Johnson, New York 12070.

**BEAUTIFULLY "embossed" business cards,** \$5.75—1000. Samples, P. E. Parks, Old York Road, New Cumberland, Pa. 17070.

**250 8 1/2 x 11 Hammermill Letterheads \$3.50** 250 Envelopes \$3.50. 1,000 Business cards \$4.95. Davis, 7609 Spruce, Baltimore, Maryland 21222.

**PEACE, POWER & PLENTY is your heritage.** Possess it now. Details free. Cothran, Box 277-PM, Aberdeen, North Carolina 28315.

### PRINTING & RUBBER STAMP OUTFITS—SUPPLIES

**TYPE Catalog No. 11, 96 Pages.** Send One Dollar, Deductible First Order. Acme Type, 732 Federal, Chicago, Illinois 60605.

**SAME Day shipment on rubber stamp supplies.** Revised wholesale price list No. 5 free. Star Stamp Supply, 732 Federal, Chicago, Ill. 60605.

**DO Your own printing. Save money.** Simple rules. We supply everything. Print for others; good profit. Raised printing like engraving too. Have home shop. Details free. Kelsey Presses, V-11, Meriden, Connecticut 06450.

**PRINTING Presses, type, supplies, Lists.** 5¢. Turnbaugh Service, Mechanicsburg, Pennsylvania 17055.

**RUBBER Stamp outfits, supplies, Kiewiet.** 2025 Barney Road, Kalamazoo, Mich. 49007.

**LOW Priced Rubber Stamp manufacturing supplies,** starting outfits, Martin, 1432 Major, Jefferson City, Mo. 65101.

**NEW 1968-69 Printers Supply Catalog** 264 page 9" x 12" book. Hundreds of new items. Rubber stamp presses and supplies, hot stamping equipment, hand and power printing presses, proof presses, paper cutters, folding machines, composing room equipment, offset equipment, drawing equipment, thousands of items. The most complete Graphic Arts book published. All items illustrated. Postpaid. \$5.00 American Printing Equipment & Supply Co., Dept. PM, 42-25 Ninth St., Long Island City, N.Y. 11101.

**MAKE your own self-molding rubber stamps and printing cuts.** Plexirubber, Argyle 1, Wisconsin.

**SIMPLE X STAMP PRESSES,** hydraulic operated, electrically heated. Sizes 5" x 8", 8" x 12", 10" x 15". Starting outfit's. Orders for presses, supplies shipped day received. Free catalog low supply prices. Custom Manufacturers, 46-P East Elm, Springfield, Mo. 65801.

### REMAILING SERVICE

**RECEIVING-Forwarding, \$3 Monthly.** Hedgpeh, 406-M South Second, Alhambra, Calif. 91802.

**SO. AMERICA Registered re-airmails \$1.00.** Confidential. Genaro, Box 360, Guayaquil, Ecuador.

**CONVENTION City Remails 25¢.** Colorful Postcards. Schoen, Box 1963-P, Chicago, Illinois 60690.

**ENTERSULL.** Your secret address. Prompt. Reliable. Box 1882-M, Forsyth, Ga. 31029.

**SECRET Receiving and remailing.** Discreet and confidential. Remail 25¢ single. 8050 S. Main, Houston, Texas 77025.

**MIAMI Remails 25¢.** Monthly rates. Marle, Box 1266, Coral Gables, Fla. 33134.

**KANSAS CITY Remails 25¢.** Receiving-Forwarding. Midway 3115-F South 45th. Kansas City, Kansas 66106.

**PHOENIX, Receiving, forwarding, re-mailing.** Confidential. Troen, Box 2386, Phoenix, Arizona 85002.

**ALASKA Re-airmails, Singles 50¢** monthly \$5.00. KARMS, Box 2463-A, Kodiak, Alaska 99615.

**FT. LAUDERDALE, Fla. Remail 25¢.** Monthly Rates \$3.00. A. Cunningham, P.O. Box 319, Ft. Lauderdale, Fla. 33302.



**MUSIC CITY U.S.A.** Remails 25¢ \$3.00 monthly, Confidential, M. Huffine, P. O. Box 12332, Nashville, Tennessee 37212.

**NEW YORK & Northern New Jersey** 25¢ each. \$3.00 monthly. Colorful Postcards Info. MJM, Box 3028, N.Y., N.Y., 10008.

**BOSTON** Remails 25¢ \$3 monthly. Ideal. Box 694, Boston, Mass. 02102.

**LAS VEGAS**—Best re-mail address. 25¢ single, \$3.00 monthly, instant service. Business remail specialty. 1145 June Avenue, Las Vegas, Nevada 89104.

**SAN ANTONIO** Texas Remails 25¢. 1005 Division, San Antonio, Texas, 78225.

**HAVE** Your letters mailed from Quaint Old Heidelberg, only \$1.00 each. J. A. Wilson, 6900 Heidelberg, Karpfengasse 8, West Germany.

**CANADA** Montreal Receiving & Remailing Service. Discreet confidential. 0.25¢ or \$3.00 monthly. Allan Moisan, 4865 Lucerne Street, Pierrefonds, Quebec.

**MICHIGAN**, Wisconsin Remails 30¢. Strategic Dispatch, Box 122, Iron Mountain, Michigan 49801.

**FORT LAUDERDALE** Remails. 25¢. Monthly \$3.00. Strictly Confidential. Dixie, Box 22598, Ft. Lauderdale, Fla. 33315.

## REPAIRS AND SERVICING

**EXTRA** Income at home in Spare Time! Booklet shows you how to start your own business with Classified Advertising. Only \$1.00. C. A. Martin, Popular Mechanics Dept. PM, 575 Lexington Ave., New York 10022.

## SPECIAL SERVICES

**INFORMATION** On anything. Ferguson Research Specialists, 83-45 Vietor Ave., Elmhurst, N.Y. 11373.

**PAYING INCOME TAX ON PENSION?** Retirement Income Credit can save \$228, send one dollar for details. Route 3, Box 30, Ellensburg, Wa. 98926.

**LOCATING** Service! Any item, product. Jake Barraco, 478 Gardner, South Beloit, Illinois 61080.

## TOBACCO

**YOUR** Ad in Popular Mechanics will be seen by more than 5,000,000 active buyers for your products and services. It costs only \$1.85 per word. And, if you wish to run all or part of your ad in capital letters—you can do so for as little as 75¢ per word additional. Act now! Place your classified ad in Popular Mechanics today.

## RAZORS

**MAILORDER** Records help get Increased Business Complete 32 Page Record Book shows your inquiries orders, advertising, expense, etc. Only \$1.00. C. A. Martin, Popular Mechanics, Dept. PM, 575 Lexington Ave., New York 10022.

## WANTED—MISCELLANEOUS

**MERCURY**, Gold, Silver, Platinum; Ores assayed. Wholesale Terminal, Norwood, Mass. 02062.

## PERSONAL

**WIN MONEY EVERY MONTH** working contests and puzzles. Free details. . . . NO MINORS. International Contest Club, Box 10153, Dept. PM-6, Kansas City, Missouri 64111.

**RUPTURED**. Relief and comfort. No understraps, elastic or steel. Write Hand-Lock Products, Preston 4, Ont., Canada.

**RAISE** Money, consolidate bills. Free amazing details. Write Interstate, 28 E. Jackson, Suite 1204-PM, Chicago 4.

**BORROW** \$100 to \$1,500 by Mail. Quick Easy. Private. No Co-Signers. Repay in 36 small monthly payments. For the amount you want write today to Dial Finance Co., 410 Kilpatrick Bldg., Dept. B214, Omaha, Nebraska, 68102.

**BORROW** \$1,205 Airmail! Repay \$47 for 36 months. State licensed. Postal Finance, Dept. 17-A, 200 Keeline Building, Omaha, Nebraska 68102.

**PENMANSHIP** Improver: Improve quickly! Complete information free. Tevis, Chillicothe, Mo. 64601.

**BIBLE** Questions answered. Stamped envelope. Bylon, 17167 Bentler, Detroit, Michigan 48219.

**INVESTIGATORS**, Latest Electronic Aids. Free Literature. Clifton, 11500-P NW 7th Ave, Miami Florida 33168.

**"MAKE FRIENDS"** send your description and a stamp for bulletin "INTRODUCTIONS" P.O. Box 2471, Detroit, Mich. 48231.

**SUBCONSCIOUS** Conditioning remakes personality while you sleep. Free details. Sleep-Learning, Box 24N, Olympia, Washington 98511.

**LITTLE-KNOWN** Law Wipes Out Debts. Free details—get help fast. Counselor-7, Harlingen, Texas.

**PAY** Bills! Have cash left over. \$39.39 repays \$1000 in 36 months. Write for details. World Finance Company, Dept. AWC-O10B, 620 Symes Bldg., Denver Colorado 80202.

**DISCOVER YOURSELF—DISCOVER A GOLD MINE!** "Creativity" is man's supreme expression and experience. Small wonder it produces success, money, and personal satisfaction! Thus, our lives will adjust in accordance with this ability. The ultimate in creative technique is revealed in "How to Solve Problems by the Scientific Method". A single concept solves Mathematical, Literary, and Inventive problems. An innovation! 163 pages; \$1.60. Ten-day satisfaction guarantee, or money back. JAICO, Box 3262D, Saginaw, Michigan 48605.

**BORROW** \$1,205 Airmail! Repay \$47 for 36 months. State licensed. Postal Finance, Dept. 17-A, 200 Keeline Building, Omaha, Nebraska 68102.

**HELP** Him! Is someone you know entering the service soon or eligible? Send for vital survival information. \$3.00 Jasm Corp. Box 20894, Dallas, Tex. 75220.

**TATTOO** Removing Do-it-Yourself-kit. \$14.00. Information Free. Atlanta Co., 907 Lekcrest, Fairport Beach, Ontario.

**DIVORCE** Information—most complete book available. 300 pages. Covers every state. Canada, Mexico. Saves on lawyers fees. Send \$2.00. Money back guarantee. Sent in plain wrapper. Sheridan Publishing Co., Box 90-A, Kingsville, Texas 78363.

**DELUXE SOCIAL SECURITY CARDS**. Beautiful 3-Color Plastic. Your Name and Number Embossed. Signature Panel. Completely Personalized! Status Symbol! Manufactured Processed National Corporation Listed N.Y. Stock Exchange. Only \$1.50 PPD. Evergreen Enterprises, Box 441, Sequim, Wash. 98382.

**RESTORE** Your hair for only Pennies. Send \$1.00 For Complete Information. Chester Lodge, Jefferson, New Hampshire 03583.

**STOP SMOKING! MONEY-BACK GUARANTEE, NO MEDICATION**. Each kit \$1.00 postpaid. Wentworth's, Box 2572, Paterson, New Jersey 07509.

**INCOME TAX SAVINGS**: Simplified fill-in forms with simple instructions, developed by experienced tax consultant—\$2.00. Ronald Hall, 555 E. Williams, Ann Arbor, Michigan 48108.

## FANCY ORNAMENTAL POULTRY

**MAILORDER** Records help get Increased Business! Complete 32 Page Record Book shows your inquiries, orders, advertising, expense, etc. Only \$1.00. C. A. Martin, Popular Mechanics, Dept. PM, 575 Lexington Ave., New York 10022.

## MISCELLANEOUS

**ORNAMENTAL** Iron designs. Book of 1600 beautiful, practical designs for railings, columns, etc. Free literature. Cunningham, 3881 South 3200 West, Salt Lake City, Utah 84119.

**SILENCERS** For pistols and rifles. Complete details for construction and operation. \$1.00. Gunsmith, Box 185, Fairfield, Alabama 35064.

**YOUR** Name sent to 1000 importers, publishers, mailers, wholesalers, etc. on our mailing list. Year \$1.00, Dixie Mailers, King, N. Car. 27021.

**HEARING** Aid batteries wholesale. Free list. Habs, Box 51, York, Penna. 17405.

**WINEMAKERS**—Free catalog and recipes. Kraus, Box 451-L, Nevada, Missouri 64772.

**QUART** Oregon Hops with 101 recipes—Homebrewing, Winemaking, Hopbreads, Catalogue, \$1. Nichols Hops, 1190 North, Albany, Oregon 97321.

**BIRTH** Certificates, Marriage Certificates, Diplomas! 2 blank forms \$1.00. Sample 10¢. Standard Forms, Box 462-M, Washington, D.C. 20044.

**KILL** Mosquitoes, Insects, electrically. Free information. US Insect Control, Box P374, Royal Oak, Michigan 48068.

**CIGARETTES** 12¢ a pack. Improved roller makes 20 filtertip, plain, king or regular for 12¢. Facts Free. Moberly, Box 954, Owensboro, Kentucky 42301.

**WINEMAKERS**. Free illustrated catalog of yeasts, equipment, Semplex, Box 7208, Minneapolis, Minn. 55412.

**WANT** Greatest Cash Crop working for you? Write, Ginseng, Asheville 53, N.C.

**RECEIVE** Magazines, Samples, Catalogues, Agency. Homework offers—Get listed—35¢. Roricke Mailer, Pleasant Plains, Ohio 45162.

**GOVERNMENT LANDS** . . . Low as \$1.00 Acre! Millions Acres throughout U.S. Details 10¢. Land Digest, Box 11071-PB, Indianapolis, Indiana 46201.

**WINEMAKING** . . . Grape, Elderberry, Dandelion, Frozen Juices, etc. Brewmasters' secrets revealed! Powerful Methods! Instructions, Recipes, and Supplies Catalog. \$1.00. Continental, Box 11071-PB, Indianapolis, Indiana 46201.

**AMAZING** Books, jewelry-sweaters-watches. Lynn's, Box 1573 Waco, Texas 76703.

**BRAND** Name Tool and Hardware Catalog. \$2.00 (refundable) Mid-Michigan Supply, Box 601K, East Lansing, Michigan 48823.

**BREWS**, Wines, Peach Brandy—Strongest Formulas, \$2.25. (complete brew supplies-hydrometers catalog included)—Research Enterprises, 29-SN35 Samoset, Woburn, Mass. 01801.

**FLYING SAUCERS**. 38 photos \$1.00. Catalog 35¢. P. O. Box 552, Detroit, Mich. 48232.

**PHANTOM PROTECTOR** billy club for automobile \$2.98. New York City police stick for home protection \$3.50. Both defenders \$6.00. Instructions with purchase. Free circular. United Enterprises, Dept. 1, Gardner, Massachusetts 01440.

**BOOKS** On antiques and their prices. Free circular! P. Warman Publishers, Uniontown, Penna. 15401.

**PSYCHEDELIC** Catalog send 25¢. Hole, 6055 Lankershim, North Hollywood, Calif. 91606.

**COMPLETE HOME BREWERY** using kitchen equipment—beer, ale, apple brandy. Detailed instructions, recipes, \$1.00. Brewmeister, 16 Nicholson, Marblehead, Mass. 01945.

**FREE** Sample cigarettes and information on revolutionary new cigarette making machine—Save 25¢ a pack (plain or filtertip.) Write E. M. S. Products, Dept. 11, 902 Filbert St., Phila., Pa. 19107.

**HARD** To find imported Italian Stilettoes and other interesting items. Free Catalogue—write: Westbury Sales Co., P.O. Box 434, Westbury, New York 11590, Dept. CA-1

# HOMEOWNERS' CLINIC

BY W. CLYDE LAMMEY

## 'Rusty' basement walls

*My cinder-block basement walls are coated with light yellow and pale blue masonry paint. What look like rust spots are appearing on sections below ground level. There are no leaks. What is this and what is the remedy?—A.T., W.Va.*

I'd guess the "rust" spots are actually rust or, perhaps more properly, the result of oxidation of metallic substances in the blocks. Many cinder-block makers use slags and other aggregates containing metal particles. Slow oxidation of the metal in the presence of moisture causes rust, or inner-wall surface discoloration.

There's no simple remedy. Some masonry paints seal better than others against such discolorations, but even these are not entirely dependable. Perhaps the surest remedy is to cover the walls with a cement plaster troweled on  $\frac{3}{4}$  in. thick or more. The oxides are unlikely to bleed through such a coat. If you are sure the present coating is a masonry paint (not an oil-base or other types), the cement plaster will bond to the wall without the aid of any other preparation.

## Stain or paint?

*I've just purchased a summer home with walls of stained shingles. I was told that originally the walls were stained with creosote. Now tips of the wood shingles are turning gray and, in two areas back of shrubbery, there's marked discoloration. Here and there the shingles are roughened—weathered, I suppose. Can these walls be painted?—S.S., Mich.*

Some paints can be applied over creosoted shingles, but I recommend you stick with the original stain. It provides good protection, measurable proof against insect invasion and it's long lasting. If the weather-roughened shingles are not curled or cupped appreciably, a light sanding should prepare them adequately for restaining. Cupped, cracked or badly curled shingles should be replaced.

When applying new stain, work it well into the wood and into openings between the shingles. Remove any shrubbery brushing the walls and trim low-growing trees nearby to gain better air circulation.

## Pinpointing roof leak

*Shingles on my home are laid over a low-pitch plywood deck. I've just discovered a leak and don't know how to locate it. About halfway down the ridge, it shows as a discoloration at a joint in the deck. How can I pinpoint it?—D.W., Nev.*

It's going to take some rather blind sleuthing. You're reasonably certain that water is coming through at a point more or less directly above the discoloration at the joint in the plywood deck. You also know this point can't be more than 4 ft. above the stain. So, drive back the projecting ends of the roofing nails across the width of the plywood sheet directly above where the stain appears. Then go up on the roof and gently lift the loosened shingles until you locate the cause of the leak.

This may turn out to be a split or broken shingle tab, a bent nail hammered inadvertently through a shingle, a not-fully-seated nail, permitting rain to creep under a shingle, or other damage. Once you've found the cause, the remedy should be quite simple: replace a defective shingle or seal a break with roofing cement. Drive all nails back in place.

## Unsticking old glue

*I have an old, rather battered and wobbly rocking chair that I'd like to take apart, rework and refinish fit for use again. But how do I unstick the glued joints, some of which appear solid and others a bit loose?—P.H., Tenn.*

Perhaps you should visit a local antique shop or furniture repair man and watch an expert reduce an old chair to individual pieces in minutes, using a wooden mallet or a soft hammer. He'll likely do it without breaking or even damaging a single part. That's your clue to procedure. As a rule a light tap with a soft hammer will break old glued joints without damage. You can then scrape the glue from the tenon and ream it out of round holes with a twist drill of the same size as the hole. On some old glues ordinary vinegar acts as a softener if you can get it where the glue is, but be careful—this may darken some woods.

You may not need to disassemble the old chair. Consider using a glue injector to tighten the loose joints and do the rest of the cleanup with a scraper and sandpaper. The injector, simple and inexpensive, has a container you fill with glue and a plunger you operate by hand or the light tap of a mallet. Drill a small hole into the joint, insert the injector nozzle, then just press or tap the plunger. ★★★

Need More Money? Want to Be Your Own Boss?

# START SAW SHARPENING BUSINESS

Of Your Own - in Your Sparetime



Turn your spare hours in the evening or week-ends into extra dollars, this proven practical way—start your own money-making sharpening business—No selling or canvassing—No experience required. You can do it automatically with the Foley Saw Filer or Lawn Mower Sharpener.

## Beginners Earn \$3 to \$6 an Hour

People, just like yourself, all over the United States are making extra cash—\$20 to \$30 a week—right now in their spare time. "My sparetime saw filing business has made me \$952 these first ten months," says R. T. Chapman. Many start part-time, find it so profitable that they build year-round service business. You can, too, simply by following easy Foley plan.

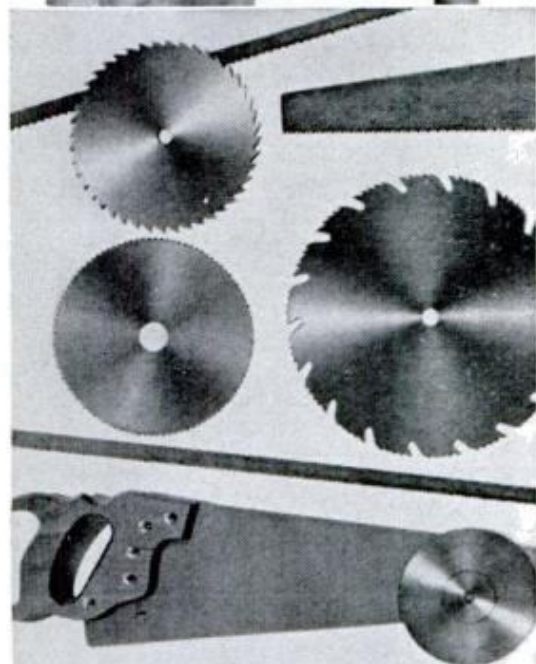

## Town of 150 Supports Profitable Business

Here's the story from Dick and Jo Ann Koester after being in business less than a year. "We have acquired another Foley Saw Filer and for the past two months we have been in full-time operation. As we live in a small town of 150 population in farm area we use our truck to pick up saws in five nearby towns. With a family to support and plans for building to our house we had to pick up a business fast and already sharpen an average of 15-20 saws a day. Business for the future looks even better as good machine filing is our best advertising."

## CASH for Sharpening Mowers

Every neighbor with a lawn needs his lawn mower sharpened at least once a year. No experience is needed to start—anyone can operate and turn out professional jobs. All operations are handled quickly, easily and accurately.



Sharpen These Professionally  
with amazing

## Foley Saw Filer

You can sharpen combination (rip and crosscut) circular saws, band saws, hand saws, crosscut circular saws—and do a perfect job every time without experience or special training. The precision Foley Filer does it for you automatically! A complete repair shop in one machine! Set up in basement or garage, work your own hours in your own way and earn big sparetime profits.



# FREE

**BOOKLET TELLS HOW!** Free Book "Money Making Facts" shows just how you can start at home in spare time. Small investment—time payments if desired. Get this booklet—study it! Send coupon today. No salesman will call on you.

Foley Manufacturing Co., 216-9 Foley Bldg.  
Minneapolis, Minnesota 55418

Send Free Booklet on  Saw Sharpening Business  Lawn Mower Sharpening

Name \_\_\_\_\_

Address \_\_\_\_\_

City \_\_\_\_\_ State \_\_\_\_\_ Zipcode \_\_\_\_\_

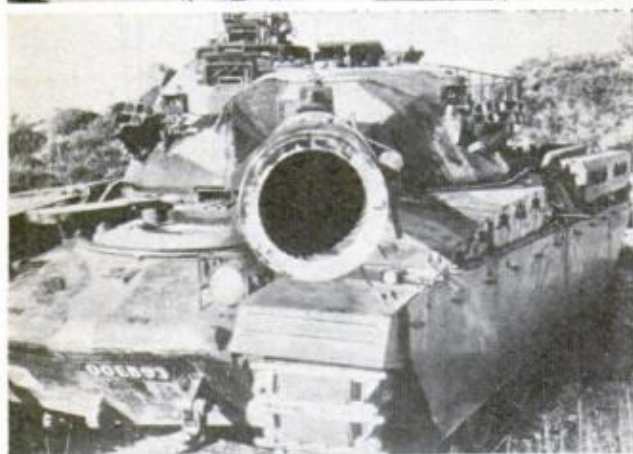
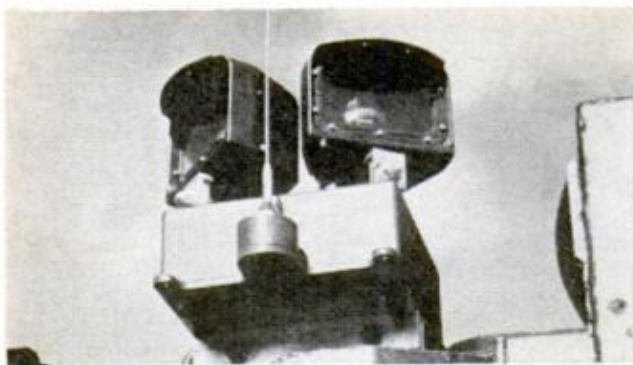

### **British conduct mock tank battles with lasers**

Armies can now conduct realistic tank battles safely with a British gunnery simulator that fires electronic "shells" from a laser projector fitted on the gun barrel (upper right). When detectors on the target tank (upper left) are hit by the low-powered infrared laser rays, the tank "burns" (lower right). At lower left is a completely equipped Chieftain tank.

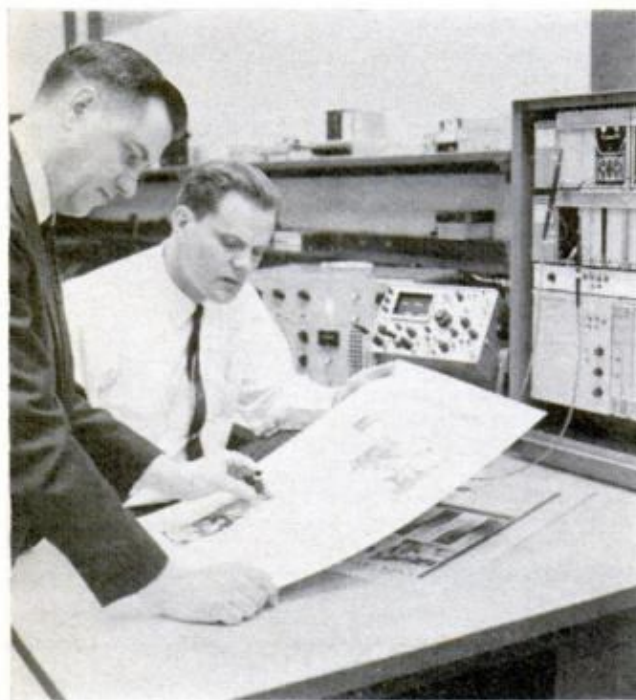

### **Newspaper by telephone**

Whole newspaper pages are sent as electrically encoded pulses over telephone lines with Bell's new data conversion terminal (right). It transmits a page in six minutes.

### **Clean teeth for killer whale**

Brushing the teeth of the killer whale in the Coney Island Aquarium takes a deft hand for she could snap a man's wrist with her jaws. The brushing removes algae from her teeth.

# Look what happens when you power a Chrysler with a Chrysler!



Nobody else engineers a boat-outboard combo like this one... because only Chrysler makes both the outboards and the boats they power.

So, get your family a boat and a motor that were planned to go together. A matched set—in weight, balance, power and load capacity; a matched rig that handles easily, corners smoothly, performs

the way a boat *should* perform. Fishing, skiing, cruising—you'll get your kind of safe family fun.

There are lots of Chrysler combos. There are 44 Chrysler boats—from 12 to 24 feet—all B.I.A. certified for safety. There are 39 Chrysler outboards—3.5 to 105 hp.—including lightweight Lo-Profiles, economical Mid-Rangers, and mighty Magnapowers, with the

industry's most dependable ignition system. Or, if you want Chrysler inboard, inboard-outdrive or V-Drive power—there are 27 choices from 80 to 335 hp.!

A smart choice? ... absolutely. For the name of your dealer, call 800 243-1890. It's free! (In Connecticut, call collect: 325-4336.)

MARINE PRODUCTS



CHRYSLER  
CORPORATION



Better boating begins with **CHRYSLER**

# SOLUTIONS FOR MECHANICAL HEADACHES

# AUTOMOBILE CLINIC

BY MORT SCHULTZ

## Pooped spring

*I recently bought a 1965 Dodge Monaco with one of those crazy-tilt steering columns. All's well except for one minor problem. When the wheel is in the down position, the turn-signal switch won't cancel of its own accord. Is there anything I can do about it?—Ken Boyle, Portland, Ore.*

A Dodge service bulletin points out that this car has a detent spring in the switch that's too light to handle the load. You can get rid of your problem by installing a new detent spring. Get part No. 2467807 from a Dodge dealer.

## Stained rear glass

*What's the best way to clean stains and discoloration from the back glass of my convertible so I can get better vision?—Len Turner, Baltimore.*

Oldsmobile offers a good solution. Use a clean polishing pad on a medium-speed polisher with Dry Cleaner. You can get this Oldsmobile product from a dealer (ask for part No. 982066). The deeper the abrasion or the darker the stain, the more pressure you'll have to apply to the polishing wheel. Really deep scratches and some stains can't be removed entirely, but all can be cleaned to some degree.

## Floating on air

*My 1966 Chevelle station wagon has a vary scary medium to high-speed floating effect when the brakes are applied. I've been told this is a built-in condition. Adjustments and linings are okay. Is there a cure?—William Hyde, Warren, Mich.*

Delayed braking action can be scary, but as you say, your braking system is okay. Putting in a power-brake unit (a relatively inexpensive option) will take the delay out.

## Wiggly wheel?

*My 1966 Pontiac vibrates at 60/75 mph. Tires have been trued and balanced, new heavy-duty shocks installed, new ball joints installed, front end adjusted, drive line checked, and so on. Vibration seems to come from the left rear section of the*

*vehicle, and I've noticed that the tire on the left rear wheel has ripples on the outer tread. What now?—Donald D. Prawl, Hixson, Tenn.*

Go to work on the problem at the point of origin. Obviously, the source is in that left rear wheel area, probably with a bad wheel bearing or perhaps a bent axle shaft.

## Axle arbitration

*My 1968 Plymouth Sport Satellite seems to have too much slack in the rear. When I push on the gas and let up or when I stop quickly, I can hear and feel slack taking up. My dealer says this is normal, and there's nothing to do for it. I don't buy that. Please help.—Kenneth Moore, Memphis, Tenn.*

All cars have a certain amount of rear-end backlash. This is normal clearance between the rear end and transmission. However, if backlash is excessive, there could be too much clearance between the pinion and ring gear in the rear, or too much slack in the rear end spider gears. I suggest you ask the dealer to call in a factory-trained field representative to let him make the determination.

## Thar she blows

*The engine of my 1963 Ford Fairlane throws oil through the oil filler, which points to trouble with the PCV. Right? Wrong! The valve's been replaced, the mesh filter in the block under the PCV flange fitting cleaned, and a new oil filler cap installed. I still get oil all over the place. Have you a solution?—William E. Pilgermayer, Glenside, Pa.*

Yes, Sir. Take off the intake manifold. There you'll find a piece of screen mesh. Remove it and throw it away. Then, remove the oil separator and screen, and throw that away, too. This hardware was put on the car during this model year, which was the first year they started experimenting with devices to cut down on air pollution. The screening which is probably plugged, is not necessary and may well be building up a great deal of internal pressure that's forcing out oil. Unfortunately, this pressure may have already

*(Please turn to page 86B)*



## For You Who Know Good Tools . . . And Won't Buy Any Other Kind

If you're one of those discriminating hand tool users who know and demand only the best, chances are you're already a Channellock customer. You know the beauty of full-polished, drop-forged steel, the smooth working precision-made working parts, the fine, hand honed cutting edges that distinguish hand

tools by Channellock. What you may not know is the wide choice of Channellock quality tools available to you. You can treat yourself to an arm-chair visit with the entire Channellock family in our color catalog. Let us send you a copy, no charge.

TOOLS BY  
**CHAN NEL LOCK**  
 MEADVILLE, PA.

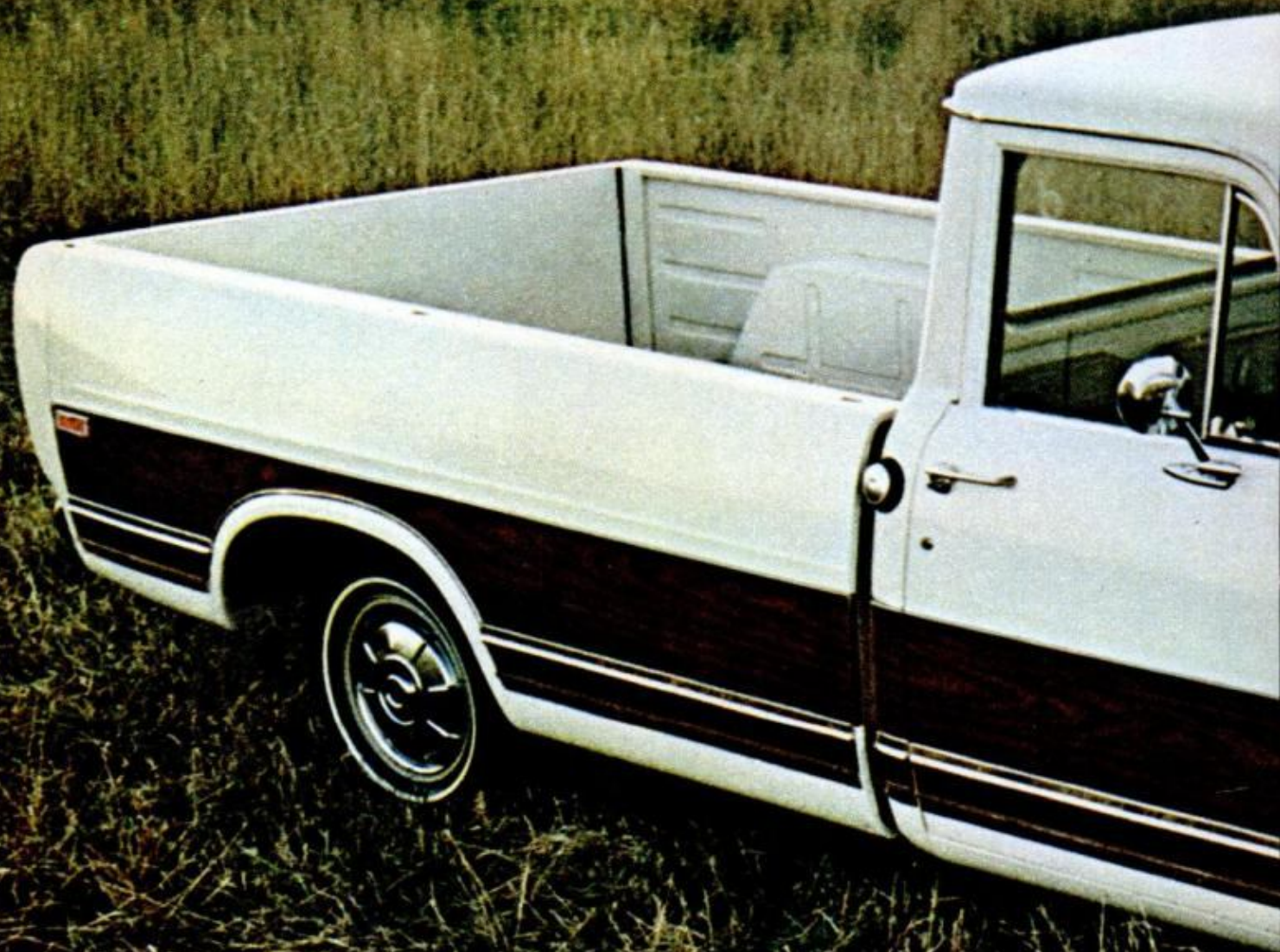

# THE REINVENTION OF THE PICKUP. THE INTERNATIONAL.

Here is everything you never thought a pickup was.

With 83 advancements that make it the first complete pickup.

Here's a smooth new ride you might expect from a car. Here's handling ease you'd

only expect from power extras. Responsive steering, the finest in any pickup. More effortless shifting. And the strongest, surest pickup brakes available.

Here's the pickup with all new style, new color, inside and out. With greater new vis-

ibility, roomier cab, comforts you never expected.

Here's sure, smooth power from INTERNATIONAL's four great engines. Including three big V-8's and the new Power Thrift Six with 10% greater gas mileage.

**83 ADVANCEMENTS IN RIDE, HANDLING, PERFORMANCE, AND STYLE.** INTERNATIONAL АВТОРСКИМ ПРОВОМ



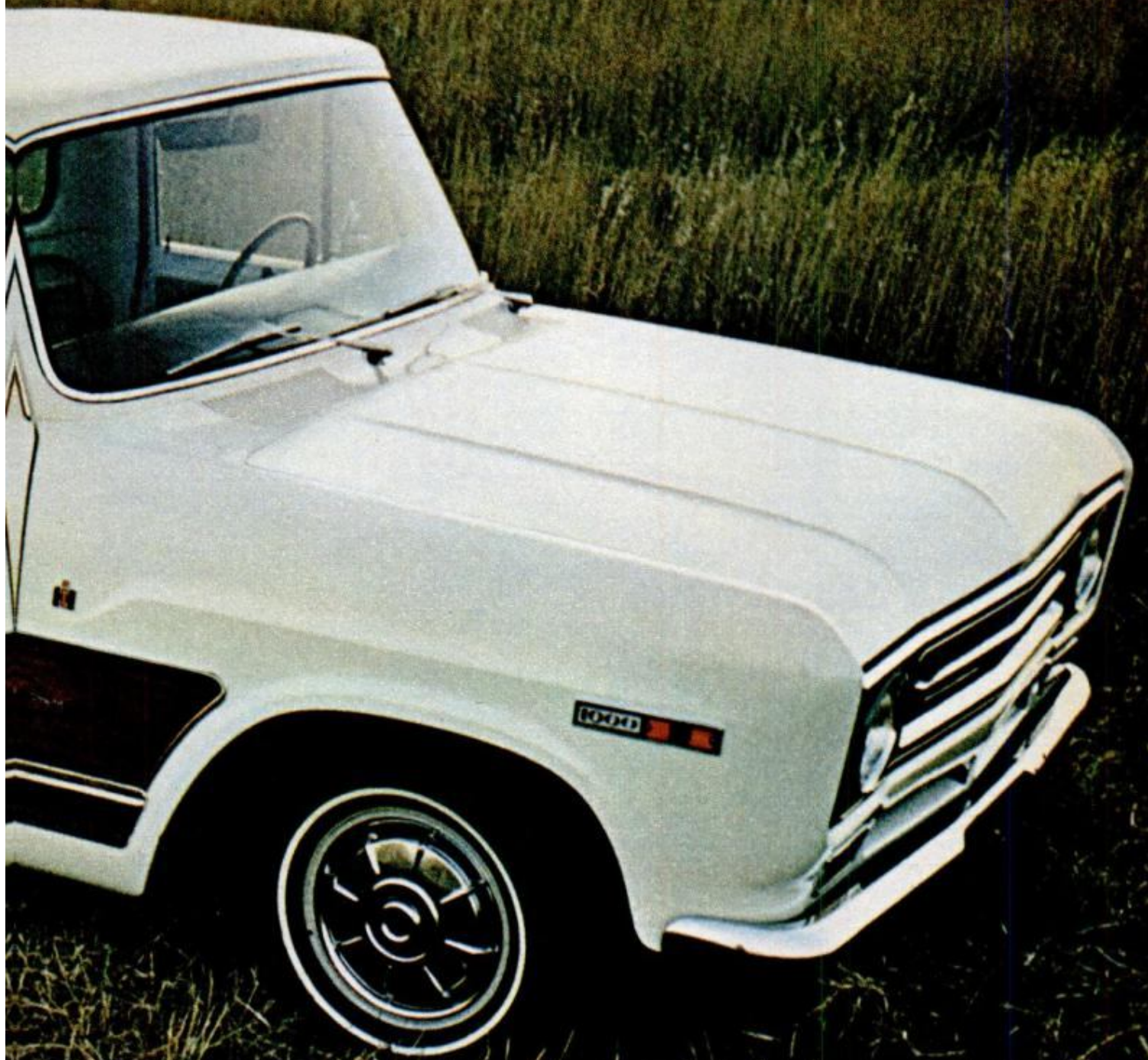

Here's the pickup with the widest choice of new features and options, from wheelbases to air conditioning to trailer hitches. For serving the widest needs. Business, personal transportation, recreation.



We've reinvented the pickup. It's still the strongest, most durable of all. But now it's everything else too.

 **INTERNATIONAL HARVESTER COMPANY**  
CHICAGO, ILLINOIS 60611

## AUTOMOBILE CLINIC

(Continued from page 84)

ruined the valve seals, and new ones may be needed before you can cap that gusher from the oil filler tube.

### Driving a diesel

*My wife's 1967 Camaro dieselized the first week we took it from the showroom, and it hasn't stopped. Tune-ups don't help, long trips at 65 mph don't help, premium gas doesn't help and a new transistorized ignition system hasn't helped. What do I do now?—Bill Schulz, Wenonah, N.J.*

Get back to basics. The No. 1 cause for a car's dieseling—running after the ignition is shut off—is red hot carbon particles in the engine. Excessive engine idle speed may be another reason. Ask your dealer to check these possibilities. And if your car is still under warranty, use it.

### Concealed condensation

*It happened the first rain after I bought my 1968 Chrysler Newport, with vinyl roof. The front windshield, I thought, started to leak. It was replaced twice by the dealer, yet the inside top of the car is always sticky, and when it rains it gets damp all over. My dealer assures me there's no leak. What can cause this?—Andrew Callahan, Coeur d'Alene, Idaho.*

Water leaking or condensation can cause dampness. Try driving with the windows open to see if the problem continues. If not, condensation is the trouble and the cure is more ventilation inside the car. Otherwise, there's a leak somewhere that the dealer may need help in finding. Ask him to call in a factory field rep.

### Spotty service

*My 1968 Plymouth Sport Fury (383-cu-in. engine with four-barrel carburetor) has run rough since the day I took delivery. Every now and then it fires back through the carburetor. My dealer says there's no cure for this problem. Is he right?—Bob Rittelman, Forestville, Md.*

No. This carburetor is obviously running on the lean side. It takes a lot of work to set it up right if correct idle cannot be

achieved normally. The plugs over the idle-mixture screws of 1968 (and 1969) cars must come off, and idle set with an exhaust gas analyzer. These plugs, which prevent the owner from adjusting the mixture too rich, are antipollution devices required by federal law. As outlined in the service manual, the work involved in removing the plugs and setting up the carburetor is considerable. But that's no reason to offer such a lame excuse and slough off the problem as your dealer seems to be doing, even though, in your case, the warranty assures that the work will be done at no cost to you.

## SERVICE TIPS

● **Chrysler owners** who have airconditioning systems in cars made prior to the 1968 models have had a problem with windshields fogging when the defrosters are operating. The factory says that the trouble can be minimized by operating the airconditioner for at least two minutes before turning on the heater or defroster. This removes the excess moisture from the air, which is the chief cause of fogging.

● **1968 Corvair owners** who have been doing their own ignition timing, using specifications on page 44 of the owner's manual, have been getting the wrong time. The specs have been changed by Chevy as follows: 95-hp engine—6° BTDC with manual transmission, 14° BTDC with automatic; 110-hp engine 4° BTDC with manual transmission, 12° BTDC with automatic; 140-hp engine—4° BTDC with manual or automatic transmission.

● **1969 Ford or Mercury owners** who have airconditioning may find the edge of the fan belt frayed or fuzzed soon after taking delivery. Don't worry about it. It's normal, won't affect the wearability or life of the belt, and should wear off within the first 150 to 250 miles of operation. The condition is the result of the edge construction of the so-called Nomex cord fiber belt that's used on some models.

● **Chevy tells us** that too many air-injector reactor pumps have been damaged by prying against the pump housing to adjust the belt drive. This housing is made of cast aluminum and easily deformed. If necessary to adjust the belt with a pry bar, apply pressure against the pump's cast-iron end cover. ★ ★ ★

---

**GOT A PROBLEM WITH YOUR CAR?** Ask Mort about it. Send your question to Auto Clinic Popular Mechanics, 575 Lexington Ave., New York, N.Y. 10022. Letters cannot be answered individually, but problems of general interest will be published in the column.

## A fast new way to blast carbon out of your car's engine.

Sure, you know what happens when carbon deposits build up in an engine. You know how power drops. How pickup slackens off. How you start burning more gas and oil. How knocks and pings creep in.

You know all this. But sometimes it takes the jolting cost of an overhaul to make you really aware of the damage carbon deposits can do.

**Carbon plus lead equals trouble.** You get carbon deposits with everything you burn—logs in your fireplace or gasoline in your engine. But why can't the deposits in your engine be brushed away as easily as the soot that collects in a fireplace? Because gasoline contains lead compounds and other non-combustible elements. These additives, under enormous heat of combustion, combine with carbon particles to form tough, flinty deposits that build up, layer by layer, on pistons, valves and cylinder heads.

You sometimes see products that promise to dissolve the carbon in your engine. Don't be taken in. This kind of carbon is almost indestructible. Nothing on earth can dissolve it. You can't *dissolve* carbon deposits any more than you can dissolve diamonds.

But, with remarkable new Fuel Mix Tune-up Concentrate, you can rid your engine of carbon deposits, quickly and easily. As easily as pouring a can of it into your fuel tank. Fuel Mix doesn't do a thing to carbon. But it's murder on the lead compounds that "cement" the carbon particles together. It reacts chemically with these compounds, breaks them down so effectively that carbon deposits magically flake off—and are blasted out through your exhaust system.



In the combustion chamber, hard, crusty carbon deposits build up on pistons, cylinder heads and valves to cause knock, ping, fuel waste.

Good for engine break-in, too. Fuel Mix also protects your engine by lubricating the hot, oil-starved upper cylinder area to improve valve and ring action. Add a can to each tank of gas during the first 1,000 miles you drive a new car or rebuilt engine. It'll help prevent excess wear during those first critical miles of driving.

Use Fuel Mix regularly every 1,000 miles. You'll notice a big difference in engine performance almost immediately. Smoother, quieter running. Eager response. And power you forgot you had. But please don't take our word for it. Look for Fuel Mix wherever fine automotive products are sold, and give it a try. Prove to yourself that it really works.



Before Fuel Mix is added to the fuel tank, cylinder heads are encrusted with layer upon layer of deposits of carbon and lead compounds.

After 4½ hours of driving, Fuel Mix has already removed most of the deposits, to improve engine performance and fuel economy.

**GUMOUT** Pennsylvania Refining Company  
Cleveland, Ohio 44104

A fast new way to  
**BLAST CARBON**  
out of your car's engine.

And it really works.

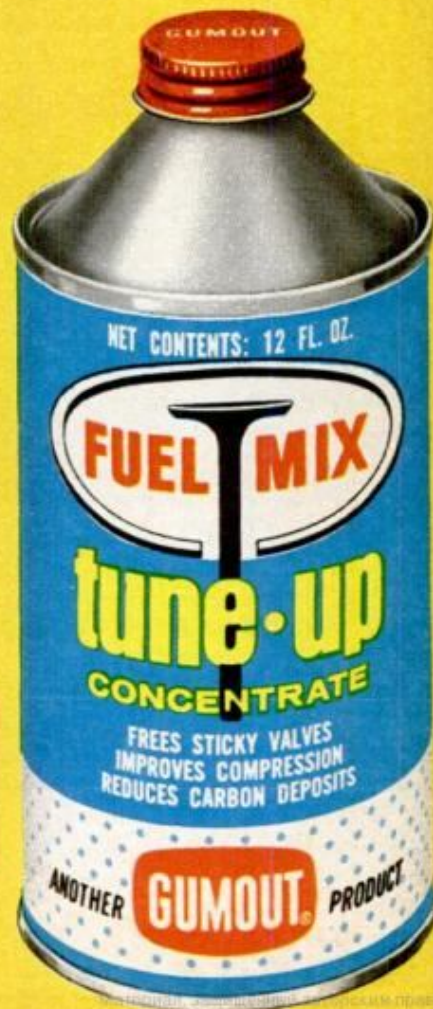

# We'd like to put in a good word for hoods.



Why not? We've got the toughest looking in the business.

Take that sweep of metal on the '69 Pontiac Grand Prix. You won't find a longer stretch from Sing Sing to Alcatraz.

The two bulges on Firebird 400 and GTO are pretty unsubtle, too. They're air scoops. Functional air scoops when you order Ram Air.

Now, you can order an externally mounted tach for each of these hoods. And they'll look tougher. But let's face it. No hood's complete without a persuader.

Pontiac has them.

Grand Prix's is a standard 350-horse, 400-cubic-inch V-8. Or specify a 370- or 390-horse 428-cube V-8.

Firebird 400 has a 330-horse, 400-cubic-inch V-8 standard. You get even more impressive statistics when you order the H.O. or Ram Air IV version.

GTO started it all. Remember? A 350-horse, 400-cubic-inch V-8 is standard. A 366-hp V-8 and a 370-hp Ram Air IV await your order.

Obviously, this is no year to go around bad-mouthing Pontiac's hoods.



MARK OF EXCELLENCE  
Pontiac Motor Division

4 individual color pictures of our '69 Break Away Squad, specs, book jackets and decals are yours for 30¢ (50¢ outside U.S.A.). Write to: '69 Wide-Tracks, P.O. Box 88H, 196 Wide-Track Blvd., Pontiac, Mich. 48056.

# Can Chrysler Put The Crunch On Cale?

Photo by Stanley Rosenthal

## DAYTONA PREVIEW:

The Chargers and Road Runners know the guys to beat—the 'pilots' of Torinos and Cyclones

By BILL KILPATRICK,  
Auto Editor

**H**E DOESN'T LOOK like a winner. Not in this photograph, anyway. But Cale Yarborough—an amiable, engaging leadfoot from a South Carolina whistlestop—is stock car racing's official all-time moneybags.

In fact, the photo shows an exhausted Yarborough minutes after he drove his '68 Wood Brothers Mercury to second place in last season's Old Dominion 500 at the Martinsville (Va.) Speedway—the race that earned him \$2700 and boosted him \$431 over Richard Petty's 1967 record earnings of \$130,275.

Following Martinsville, Yarborough ran his 1968 prize money up to \$136,786, a juicy target at which the rest of "them good ol' boys"—plus a now-and-then sprinkling of such USAC stars as A. J. Foyt, Mario Andretti, Dan Gurney and others—are aiming as NASCAR's 1969 Grand National season hits full stride.

Richest and most prestigious stock car racing bauble for drivers, car owners and



**DODGE CHARGERS** will be Chrysler's trumps in effort to dominate big-league stock-car racing this year. Here Charlie Glotzbach leads Buddy Baker out of a turn during last year's National 500, won by Glotzbach

auto manufacturers is this month's Daytona 500. Because it's the fastest, most grueling event on the NASCAR calendar, the winner gains—in addition to upward of \$50,000 in prize money—a psychological “leg up” on the competition; the fact he even *exists* is a formidable force with which others must contend for the rest of the season.

Yarborough's win last year kicked off an unprecedented superspeedway win streak. Following Daytona, he won the Atlanta 500, Firecracker 400 (which he had won in '67—this made it three in a row at Daytona), and Southern 500 at Darlington. Ford Motor Co. was so delighted it named Yarborough its Man of the Year.

Ford had other reasons to cheer, too. When the 1968 NASCAR season ended, Ford had the manufacturers' championship again, and David Pearson in a Holman-Moody Ford Torino

won the Grand National drivers' point championship.

Watching the Fords go by in most of the big, headline-grabbing events was, of course, Chrysler. It's true that Richard Petty, in 1967 the nearest thing to Superman this side of comic books, drove a Plymouth to 16 Grand National victories in '68. It's true that Bobby Isaac, in a Dodge Charger, went right to the wire with Pearson for the point championship. And it's true that the season's superspeedway finale—the National 500 at Charlotte—was won by Charlie Glotzbach in a Dodge Charger, leaving Chrysler with a pleasant aftertaste. But that isn't what Chrysler has in mind; despite operating on a smaller racing budget than Ford, it wants to drive the Dearborn Demon right into the ground as it did in 1964. That will be tougher than ever in '69, for Ford will have even the Pettys on its side



**CALE YARBOROUGH** leads Lee Roy Yarbrough through a turn at 1968 Daytona 500, one of the closest, most exciting races ever run. Neck-and-neck most of the way, Yarbrough managed to win by a one-second margin

this year. Their switch, after ten years with Plymouth, really shook up pit row.

The most formidable weapon left in the Chrysler arsenal is the new Dodge Charger 500, a car frankly designed for racing. Featuring a flush-mounted grille and a more slanted, also flush-mounted rear window, it reportedly affords better aerodynamic characteristics than the '68s. Spearheading Chrysler's effort will be Buddy Baker, driving for Ray Fox, Glotzbach for Cotton Owens, Isaac for K&K Insurance, and 1968 Grand National Rookie-of-the-Year Pete Hamilton for A. J. King, all of whom will be at Daytona this month.

About the fastest Plymouths in sight at this writing (late November) will be driven by Bobby Allison and Darel Dieringer. Allison will drive for Tom Friedkin, Dieringer for Mario Rossi.

Arrayed against this small, valiant

band is a horde of Fords and Mercurys driven by some of the biggest names in racing. Carrying the Dearborn banner at Daytona and throughout the year will be Yarbrough, driving for the Wood Brothers, Pearson for Holman-Moody, Lee Roy Yarbrough for Junior Johnson, Donnie Allison for Banjo Matthews, Tiny Lund for Bud Moore, and all-time NASCAR winner Richard Petty for Petty Engineering. Master mechanic and car builder Henry "Smokey" Yunick, now in the Ford fold, possibly may field a car, the driver of which could be Paul Goldsmith, who won the last "beach race" for Smokey in 1958.

Supplementing this all-star lineup at Daytona and certain other FIA-approved superspeedway events will be the likes—some likes!—of Foyt, Gurney and Andretti, all in one way or another tied to Ford. Foyt will drive for Jack



**THINK DETROIT'S RANK AND FILE DOESN'T CARE** what happens on the major stock-car circuits? This header, dispatched from the Dodge factory, plainly bears the competitive sentiments of the men who made it

Bowsher, Andretti for Holman-Moody. If and when Gurney appears in a stock-car race outside of his annual Riverside 500 outing, chances are it will be in a Wood Brothers car.

In addition to having what seems like all the cars and drivers, Ford this year will campaign its big, new 429-cu.-in. engine. You can be sure nobody's doing much talking, but the word is that the engine in racing trim cranks out well over 600 hp, power that can be put to fruitful use on Daytona's long, booming straights. Chrysler hopes to equal Ford's power advantage via carburetion modifications on its famed and formidable 426-cu.-in. Hemi. Last year, NASCAR let the Hemi run with two four-barrel carburetors, a combination few Dodge or Plymouth crews got running to their complete satisfaction. But this year the Hemi is single again, a setup the crews know how to handle. Also in effect this year is a uniform overall car weight requirement of 3900 lbs.

All this added horsepower, plus spoilers and more sleek aerodynamic

body design, will probably push this month's qualifying speeds at Daytona up to around 195 mph. Yarborough gained the pole last year by qualifying at 189.22.

Race speeds will go up, too. Last year, the leaders hit speeds of 182-183 at various points. This year, they could go as high as 187-188.

If these eye-popping qualifying and race speeds aren't reached at Daytona this year, it won't be because Firestone and Goodyear don't have tires that'll take the punishment. They do. The drawback, if any, will be that drivers are groping toward the unknown; at the higher speeds on a track like Daytona, they're not sure at exactly what point the car ceases to be a car and becomes a projectile. Despite jack screws, spoilers, weight distribution gimmickry, and an admittedly liberal interpretation of what is "stock" in a stock-car front end, that front end starts to get pretty light as speeds approach 180.

As a result, drivers going that fast

*(Please turn to page 220)*



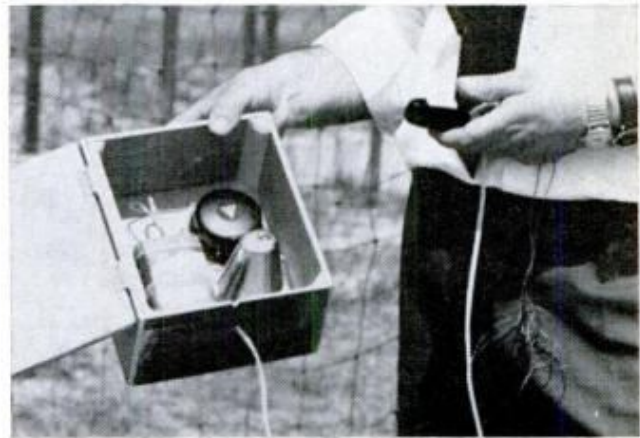

## Blind ballplayers keep their ears on the bell

The blind soccer players above can't see the ball—they hear it. A small bell attached to the ball (left) allows the players to follow its general direction. Behind each goal is a battery-powered bell (right) to indicate the location of each net. The system was devised by an organization for the blind in Milan, Italy, which hopes to establish international matches.



## It's only a model—the real thing's even bigger

Carrying a crew of two, this 37-foot "baby" VT-1 hovercraft is a working model of a bigger design to come. Built to a 40-percent scale by British firm, Vosper Thornycroft, it uses two 70-hp VW engines for lift, two 130-hp Porsche engines for forward propulsion.

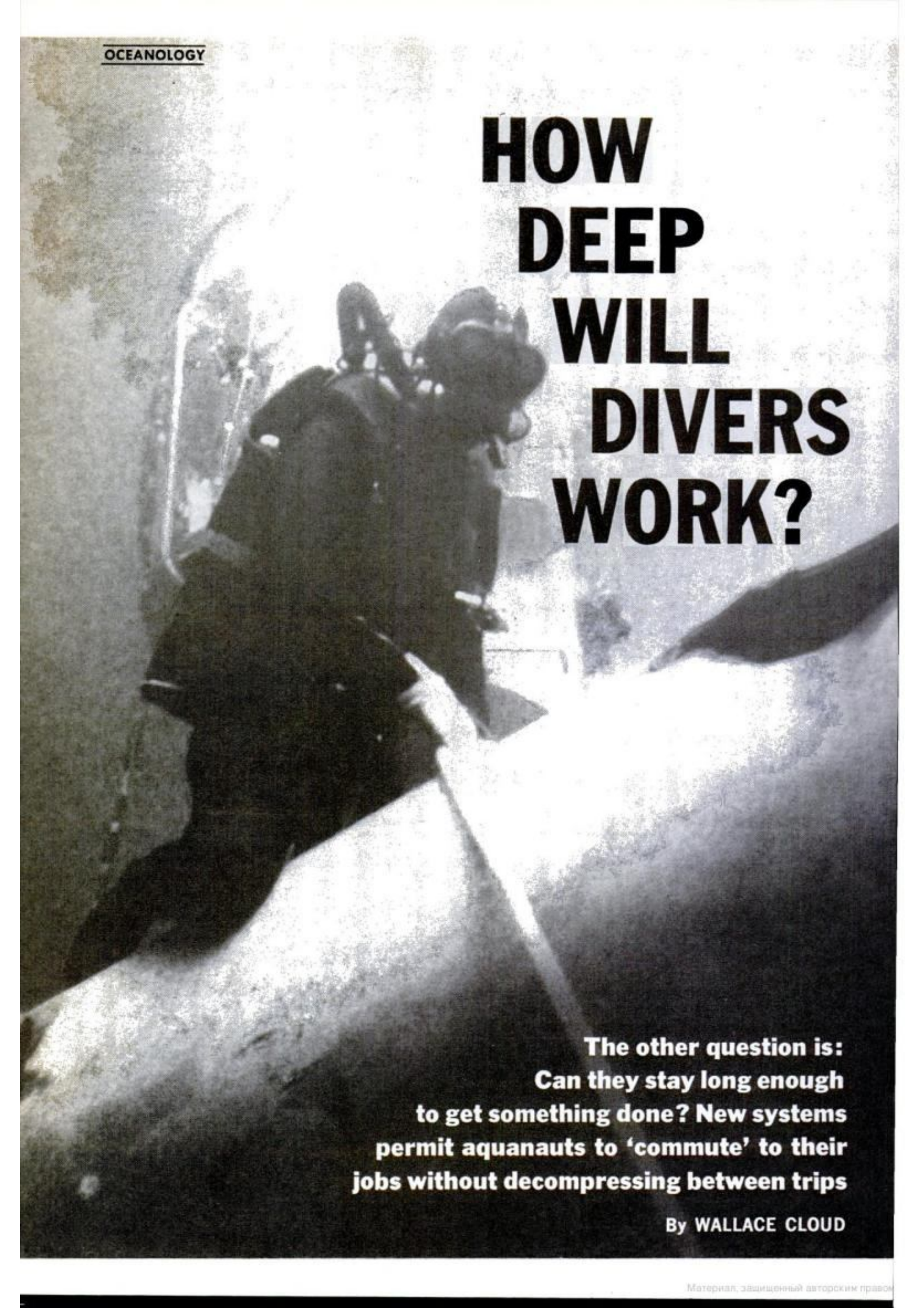

# HOW DEEP WILL DIVERS WORK?

**The other question is:  
Can they stay long enough  
to get something done? New systems  
permit aquanauts to 'commute' to their  
jobs without decompressing between trips**

By WALLACE CLOUD

**I**S THERE A "DEPTH BARRIER" beyond which divers cannot work exposed to the pressure of the sea?

Diving physiologists—medically trained scientists who specialize in studying the body's responses to undersea stress—are now beginning to discover that there is, indeed, a mysterious barrier to human survival at a depth somewhere below 1000 feet.

Until recently, only one man had lived through a dive to 1000 feet. The Swiss diver, Hannes Keller, made it off Catalina Island in December, 1962. A companion died on that dive.

Keller's record was surpassed by Dr. Ralph W. Brauer, a North Carolina scientist, and French engineer Andre Veyrone, who "descended" to the equivalent of 1190 feet in a pressure chamber on land, in Marseilles last June. Both men experienced tremors, starting around the 900-foot level, and were drifting in and out of sleep. "I had trouble distinguishing right from left," said Dr. Brauer. "I had trouble reading my watch. I recognized the danger, but it didn't really seem to matter."

In the test, both Brauer and Veyrone

**DEEP DIVING** has barrier, too. Men in backpacks, at this state of art, can go to about 1000 feet. One backpack, developed by Alan Krasberg (below, left), is shown in front and rear views (right). A diver uses two lunglike bags, exhaling into one, inhaling from other, reusing original gases. Krasberg relaxes in deck chamber, pressurized to depth of intended dive, eliminating decompression

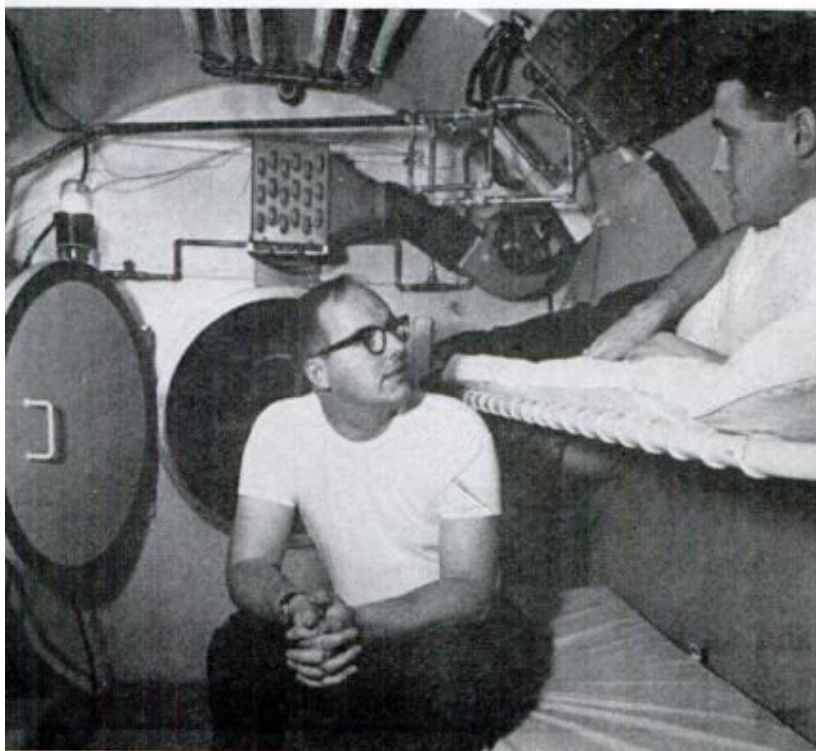
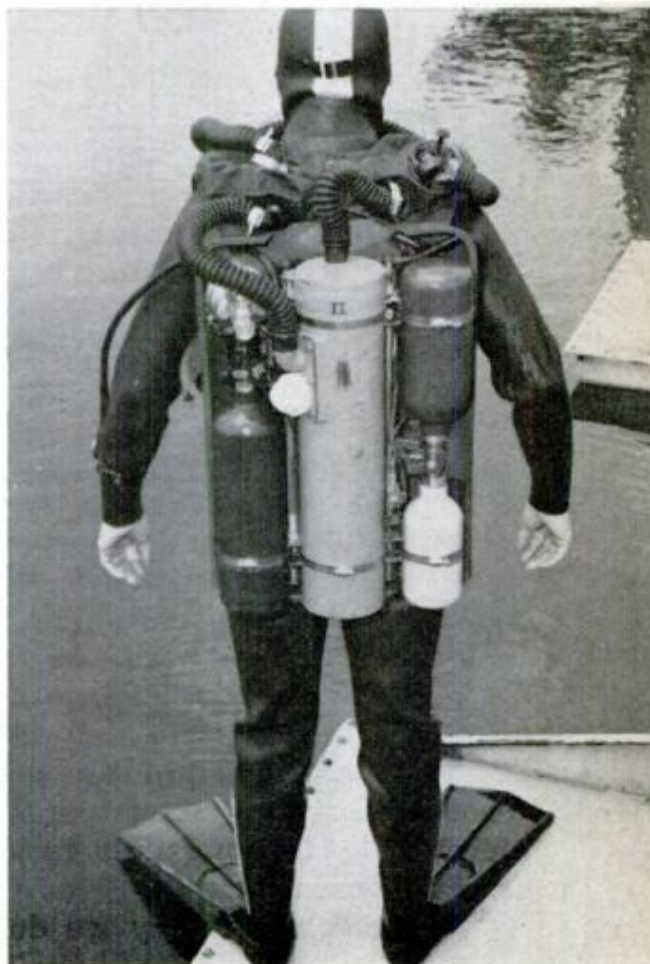

were breathing the mixture of helium and oxygen that is now standard for deep dives. Brauer believes hydrogen is the key to reaching depths below 1000 feet. No more than two-percent oxygen is needed at such depths, he says, and helium would replace the hydrogen at depths shallower than 600 feet.

The question of the depth barrier has become important because working divers now have equipment enabling them to spend long periods at depths approaching 1000 feet. This was demonstrated, even before the Navy's Sealab III project, by teams of industrial divers from two competing undersea-engineering firms who made little-publicized dives in the 600-to-700-foot range, living at deep-sea pressures for many days at a stretch.

Those successes led to confidence, in the undersea business, that divers can now work freely at least to 1000 feet, perhaps deeper. That meant all the world's offshore continental shelves, with a total area as big as Africa and a 1000-foot maximum depth, were suddenly open to exploration and commercial exploitation.

Westinghouse was the first to carry out a 600-foot working dive in the Gulf of Mexico, in the summer of 1967. Next came a similar dive to a slightly greater depth, 636 feet, by divers of Ocean Systems, Inc., a firm owned jointly by Union Carbide Corp. and General Precision, Inc. Last March, Ocean Systems divers made a dive to 700 feet in the Bahamas, using a little submarine to "lock out" and "lock in" at the working depth.

Unlike the Sealab divers, the men using the Westinghouse and Ocean System techniques do not live on the bottom of the sea. Between working periods, they remain under deep-sea pressure in a compression chamber aboard ship. A second chamber—a sophisticated diving bell—is used like an elevator to transport divers to and from the working depth.

"We think that's why we don't see

the fatigue problems they encountered in Sealab," said Alan Krasberg. "Sealab divers were constantly exposed to the undersea environment, and had to do all their own housekeeping. We provide the men with comfortable ship-board quarters and support facilities, and they can put in a six-hour working day, the same as divers working at shallower depths."

Perhaps they have other incentives—such as their \$3000 to \$4000 a week pay.

Both companies use essentially the same approach. The combination of deck-compression chamber and smaller elevator chamber was developed originally by Edwin A. Link, inventor

**DIVERS DESCEND** inside small chamber, already pressurized to programmed depth. At that depth, they will emerge for preplanned activity outside chamber

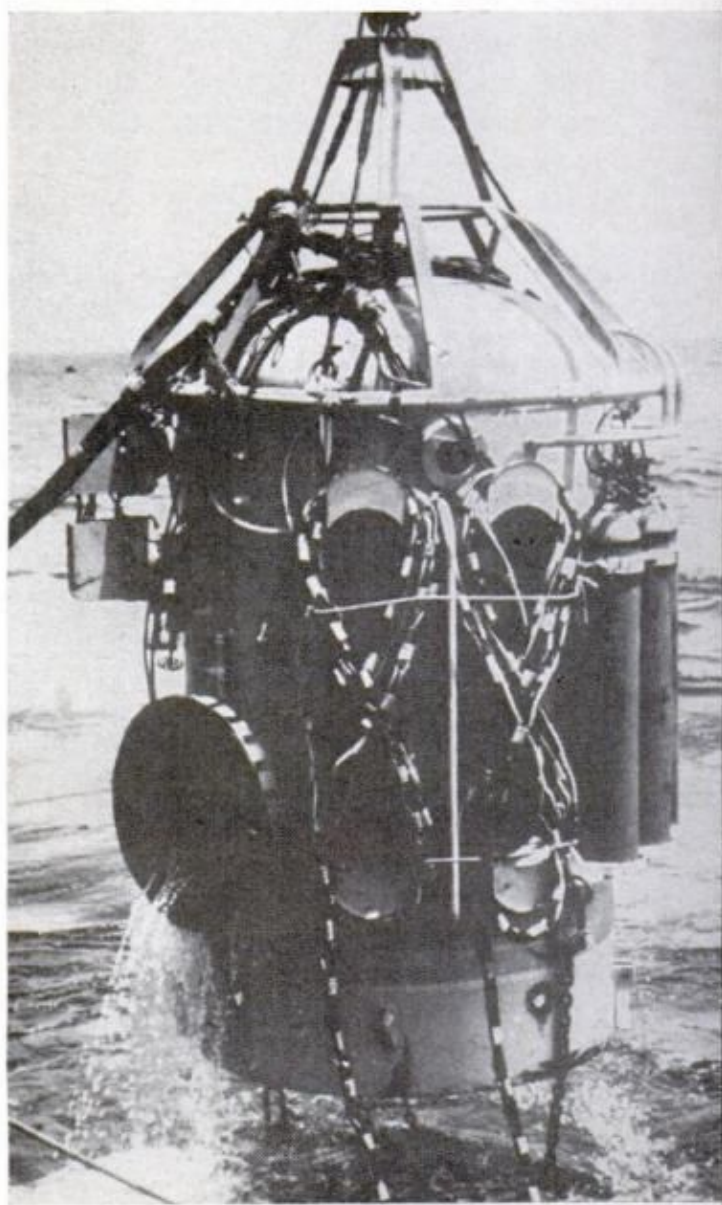

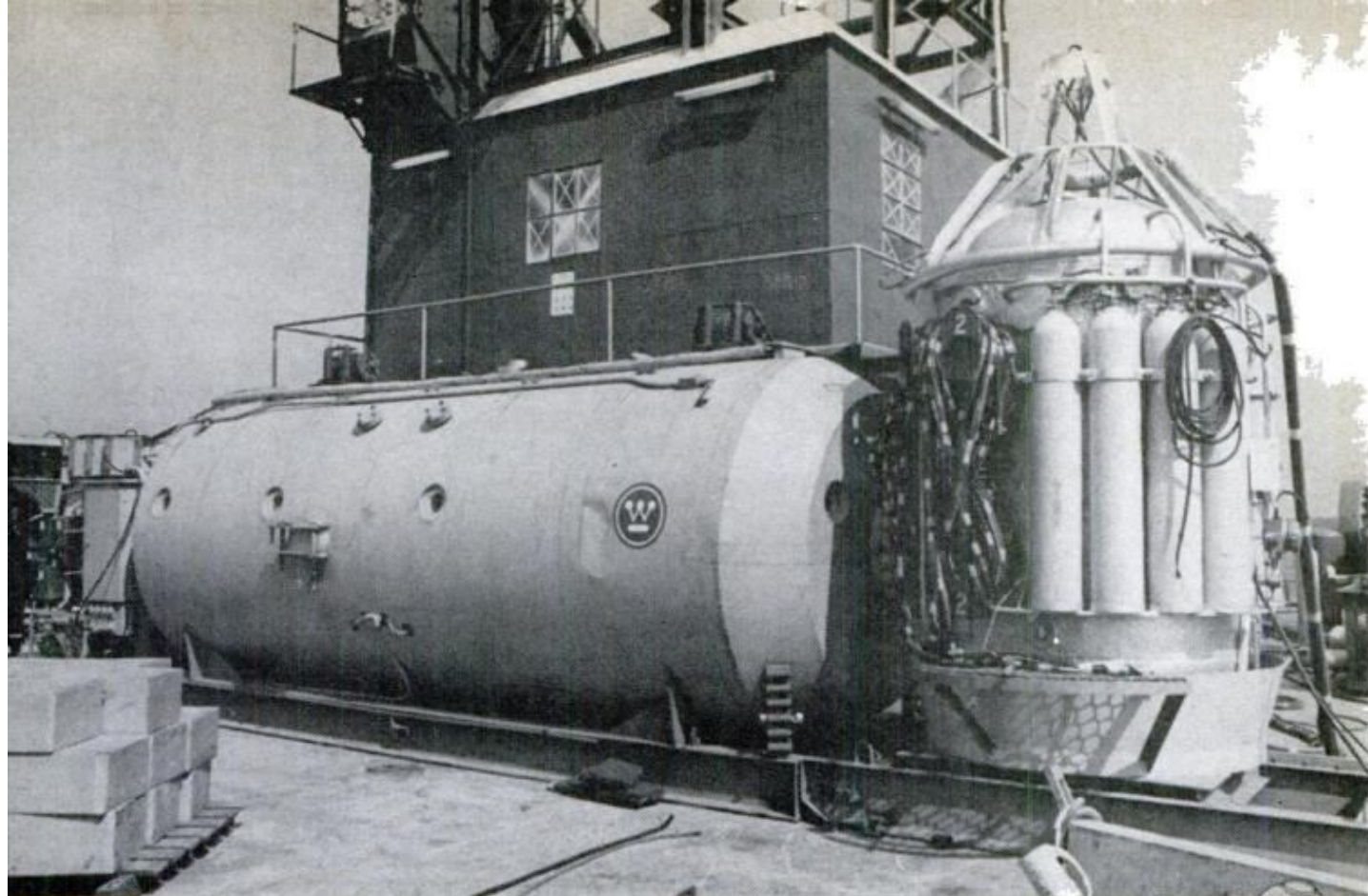

**BETWEEN DIVES** divers ascend inside small chamber which is attached to large deck chamber. Without decompressing, they can relax inside large chamber in comfort, extending total time they can spend working

of the Link aviation trainer and mastermind of Ocean Systems. Westinghouse developed equipment along similar lines, calling it the Cachalot system (named after the French word for whale, what the deck chamber looks like to some people).

Such advanced diving systems are designed for the technique of "saturation diving." That means the divers continuously live in an atmosphere pressurized to the equivalent of a specific depth in the sea, so that their blood and tissues become saturated with dissolved gases at that pressure. They decompress only after completing days or weeks on the job.

How an advanced diving system works can be seen in the Westinghouse dive to a 600-foot depth in the Gulf of Mexico.

The operation began when six divers entered the compression chamber on the deck of a barge anchored 45 miles off Grand Isle, La. In the chamber they breathed a mixture of oxygen and helium instead of air. This atmosphere was

pressurized to a "storage depth" of 350 feet.

Through an airlock, diving teams of two or three men at a time entered the elevator chamber, also pressurized to the equivalent of 350 feet. This chamber has a side hatch that mates with the deck chamber, and a bottom hatch for use in the water. With both hatches sealed, the diving chamber was lowered over the side trailing an umbilical of cables and hoses.

At 350 feet the pressure of the water outside equaled the pressure inside the chamber, and the bottom hatch popped open. The men donned their rubber suits. Warm water, fed through a hose from the surface barge, flowed into the suits near the waist and out at the ankles and wrists. The chamber continued to descend. Water was kept from rising through the hatch by increasing the pressure of the atmosphere inside.

At the working depth, divers left the chamber to perform assigned one-hour  
*(Please turn to page 210)*



# How to Buck

These tips from experts who make their living fighting snowstorms on Colorado's highest highways may save your life in the lonely terror of a whiteout

By E. D. FALES JR.

Illustrations by Dale Gustafson

**D**RIVING IN SNOWSTORMS has never been a picnic. But it is becoming more dangerous as traffic gets thicker and speeds go up. In one eastern storm last winter, 300 cars were smashed in 50 pile-ups. Some involved 10 cars. At Syracuse, N.Y., 29 cars collided in one pile. Near Ottumwa, Iowa, eight motorists were killed in a single snowdrift crash.

Can you cope with a sudden storm that swamps your defrosters, freezes your windshield? Can you keep going when other cars slither? Do you know what to do when the road vanishes in a "whiteout"?

In the high country above Idaho Spring, Colo., there are a few snow-driving experts who can keep going

when just about everyone else can't. How do they do it? To find out, I drove the high Rockies last winter with some of the best drivers in the Colorado Highway Dept.'s winter-maintenance and plow patrols. These men—supervisors, patrolmen and plowmen—*have* to keep going, even in terrific storms.

One is a slim, weatherbeaten road boss named Pat Murray, dean of the department's snowdrivers. His eyes are edged by wrinkles from hundreds of storms on the dizzy, sheer, 11,000-foot Berthoud and Loveland Pass routes. Another is Burr Hartman, a 19-year snow-buster up top. Besides riding with Pat and Burr, I rode with plow crews in whiteouts so thick we couldn't see the edge of the road. And below

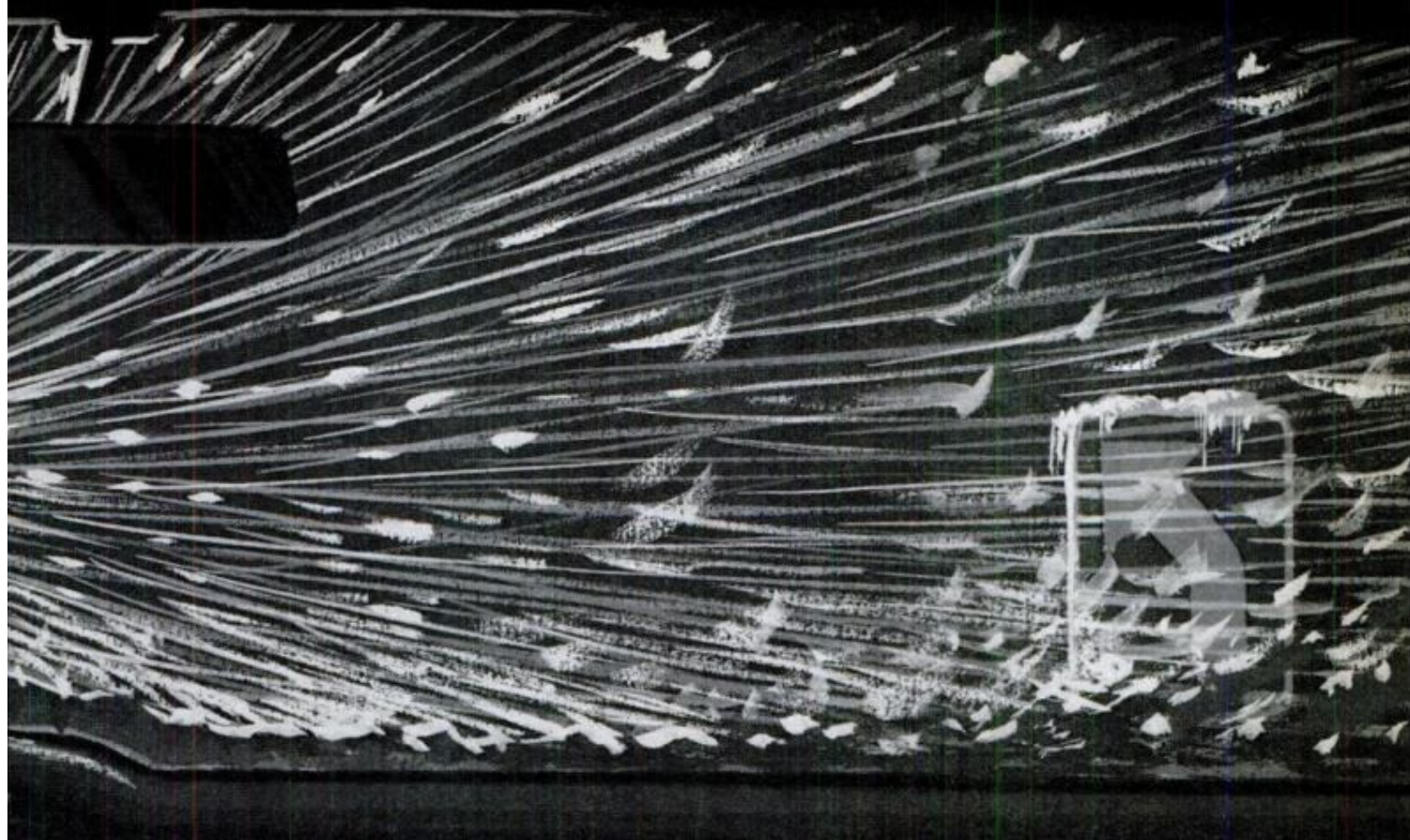

# a Blizzard

that edge lay a mile of nothing. These men *have* to know all the tricks. Here are a few that see them through.

● *Cold storm, cold windshields:* One mistake that gets drivers in trouble, Pat Murray says, is running with defrosters turned on in cold storms. To Pat a "cold storm" is when the mercury drops below 25° F. (Anything else is a "warm storm.") "If you leave cold snow alone," Murray says, "it bounces off your windshield. But if you use defrosters, it melts, then forms ice. It soon becomes a solid mass that creeps under wipers and takes over."

When it's below 25, Pat and Burr never warm up a car or its engine before starting. They want everything as cold as possible. "Sometimes we even leave a window open in zero weather to cool all the glass," they say. Even with defrosters off, they lay cloth pads over closed defroster vents to kill the trickle of warmth that leaks through.

● *Warm storm, warm windshield:* But when the mercury is 25 or over, they keep windshields *hot*. Then they warm up for some time before starting, use full heat and blower. "We even try to get the windows warm," Pat says. "In a storm you've not only got to see ahead, you have to see on both sides and to the rear."

● *If you do ice up:* "The guys we find in the ditch," Burr Hartman says, "are peephole drivers. When defrosters can't keep up with the storm, they scrape a hole in the windshield ice. No one can drive that way. You lose all sense of feel. To keep control in a snowstorm, you need wide-track vision."

When a windshield ices up, a careful driver stops and scrapes it. But this can be dangerous. Where do you stop on a fast, slushy superhighway when escape shoulders are piled high with plowed snow, and there's no exit for 20 miles? Even if you *do* find a place,

## HOW TO REVERSE DIRECTION ON A STRAIGHT, LEVEL ROAD

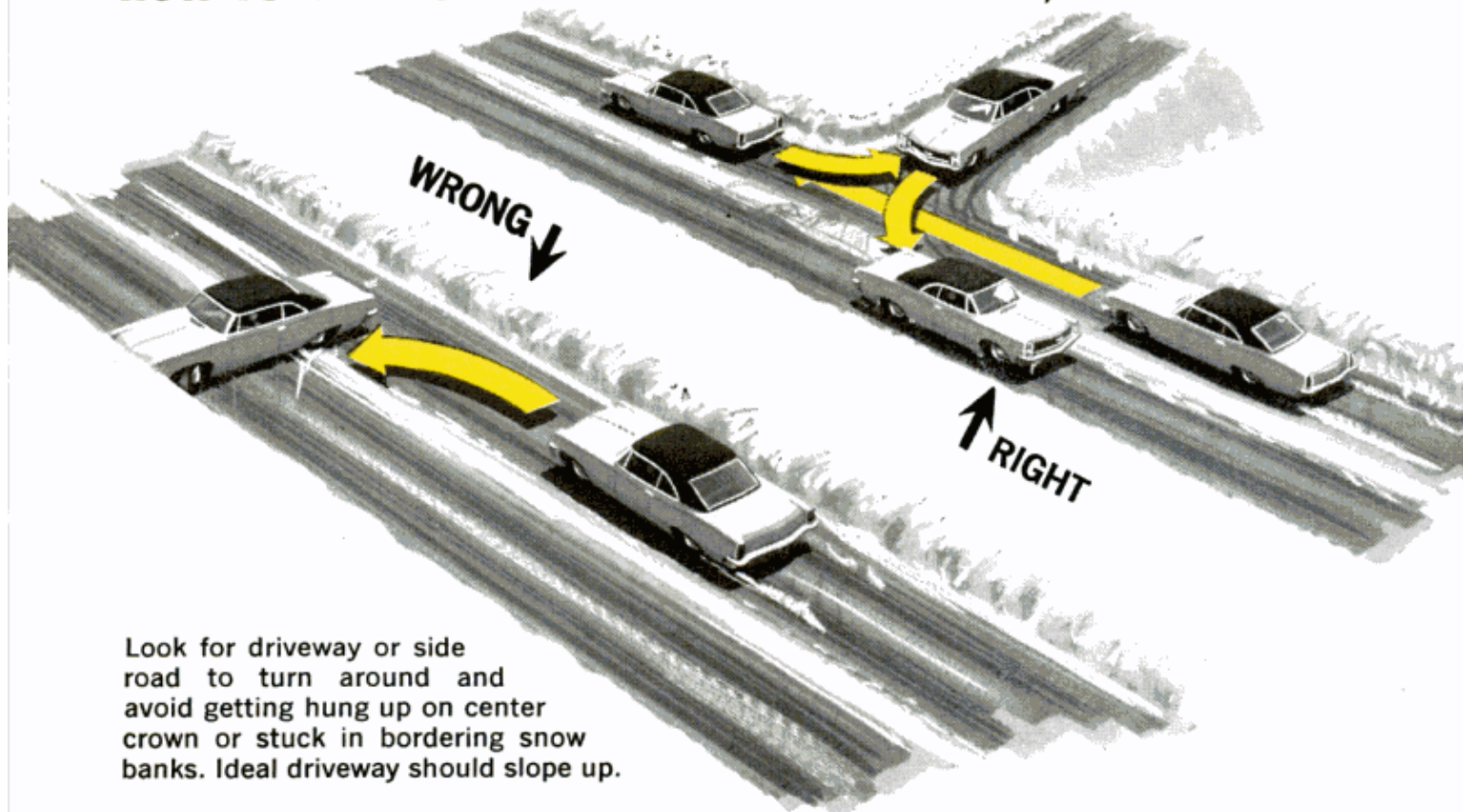

Look for driveway or side road to turn around and avoid getting hung up on center crown or stuck in bordering snow banks. Ideal driveway should slope up.

what happens if your windshield immediately ices up again because there's freezing rain in the snow? To cope with this problem, Pat Murray has his own trick. Choosing a safe stretch of road, he slows down, sets hazard flashers going, then opens the window. Steering carefully with one hand, he reaches out around the windshield frame with a small plastic scraper and chips away at the ice.

It's not as hard as it sounds. The trick is to loosen the build-up of thick ice that forms at the left edge of the wiper sweep area—where blades are ineffective and defroster heat seldom reaches. Luckily, it's right next to the frame and within easy reach. Between each blade sweep, Pat gets in one or two quick digs at this "key ice." That's usually all it takes. Suddenly the ice floats free, the blades break it up, and the windshield is clear.

Dangerous? Sure, but you're in far more danger if you stop on a highway, or try to drive half-blind.

But suppose the blade also ices up? Pat's trick is to reach around the corner post, press two or three fingers tight to the windshield and let the end

of the blade run right over them. His fingers flex the blade, break away the lumps. In a few seconds, most of the blade is clear. If small lumps remain frozen to the back of the blade, it's important to remove them. If you don't, new ice will form and spread. "Frisk" the blade lightly, on each sweep, between thumb and fingers. It's easily done, but be careful not to hold the blade still or dislodge it.

Burr Hartman showed me another trick that helps. On many cars, four wires lead to the wiper motor. One is the "return" wire that parks your blades at the bottom of the windshield whenever you turn off the switch. If you disconnect the return wire, you can use the switch to stop the blade in any position. If you stop it at the left side, it's more easily "frisked."

● *The match trick:* When defrosters can't cope with ice, open the engine hood slightly, stuff one or two folded matchbooks under the trailing edge, then close the hood. This opens a crack about a foot long and a half-inch wide between hood and cowl. The engine fan will blow a steady stream of heat through

*(Please turn to page 214)*



## HOW TO REVERSE DIRECTION ON A BANKED CURVE

### WRONG

Here's where many highway jams develop during snowstorms. Driver entering a banked curve sees tie-up ahead, stops, then tries to make 180° turn by backing to lower side of the road slope. Once his drive wheels are lower than front wheels and momentum stops, he loses traction, can easily slew into a roadside snowbank. Road is now blocked from both directions. A good snow driver carefully considers each move he plans, anticipates its consequences to his own car, other cars on the road.

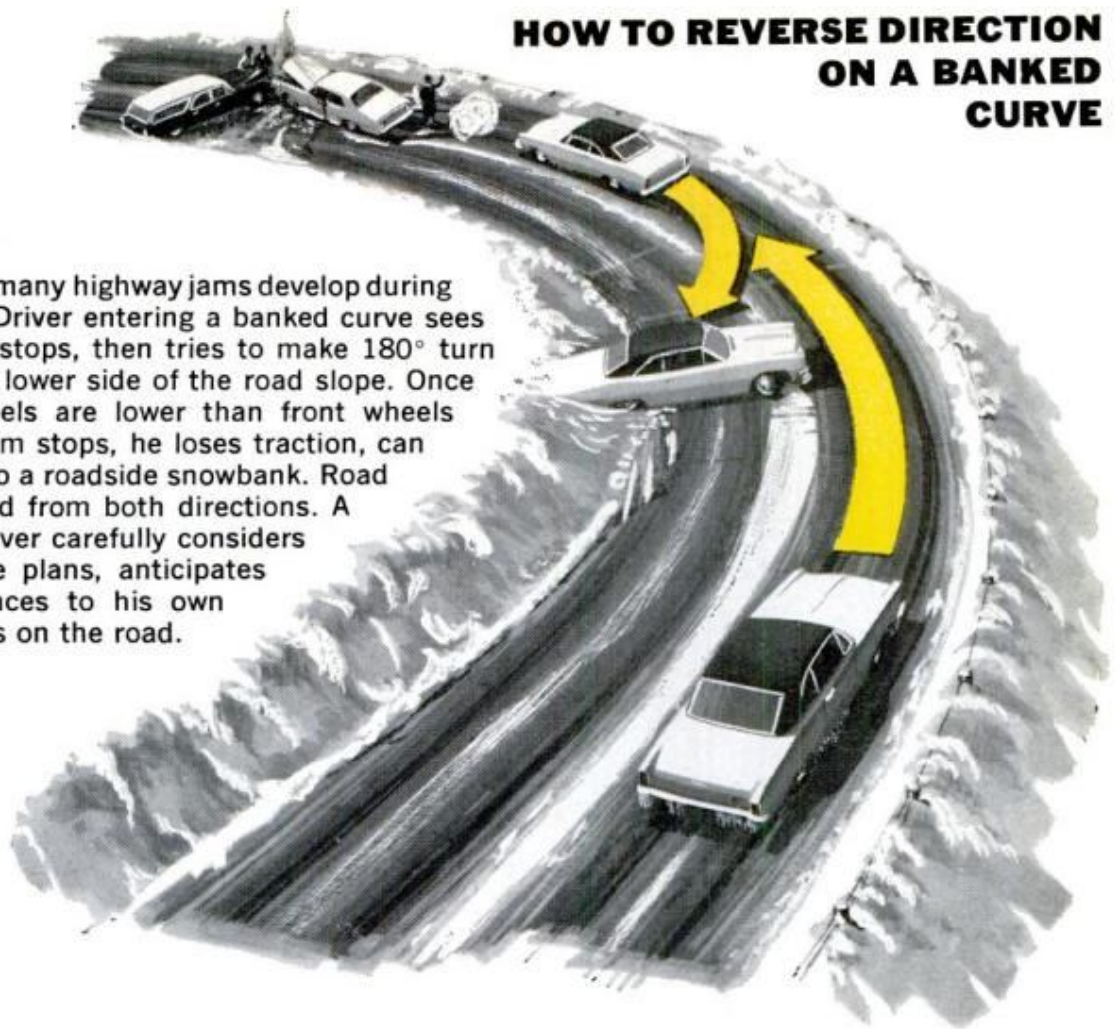

### RIGHT

To reverse direction on a banked curve in the situation shown above, back up slowly, gradually build up speed, then turn front wheels slightly to steer toward lower—or opposite—side of road. Immediately reverse steering, take your foot off the gas, let your momentum carry drive wheels to high side of the road. In this position it's easy to roll forward, turn your car in the direction you want to go. It's most important to make all moves smoothly, let momentum do most work.

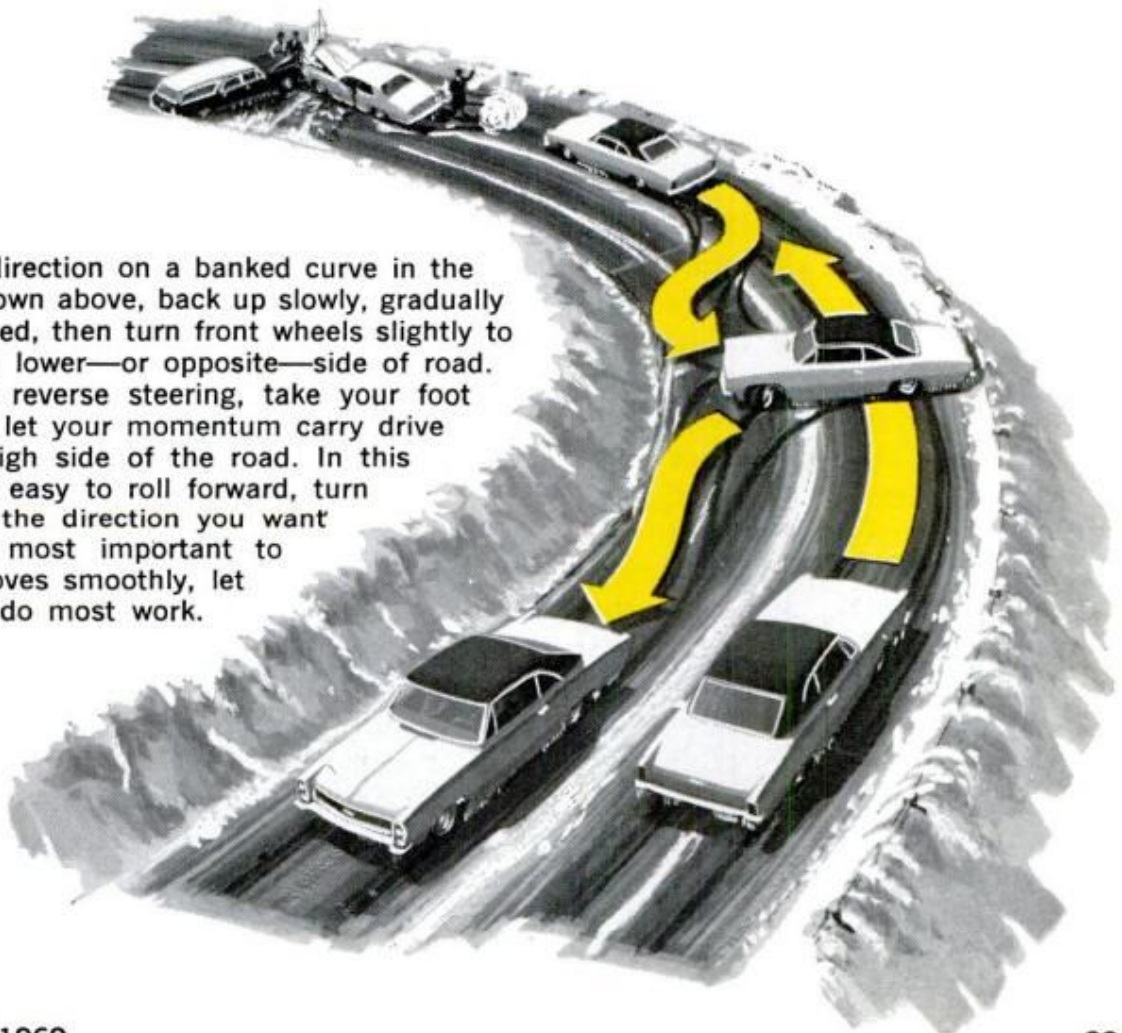

# Queen Elizabeth 2

From her 67-foot funnel and computerized bridge to her twin six-blade screws, the QE2 is different. Gone are the dowagers and potted palms—the Queen is now a swinging seagoing resort city

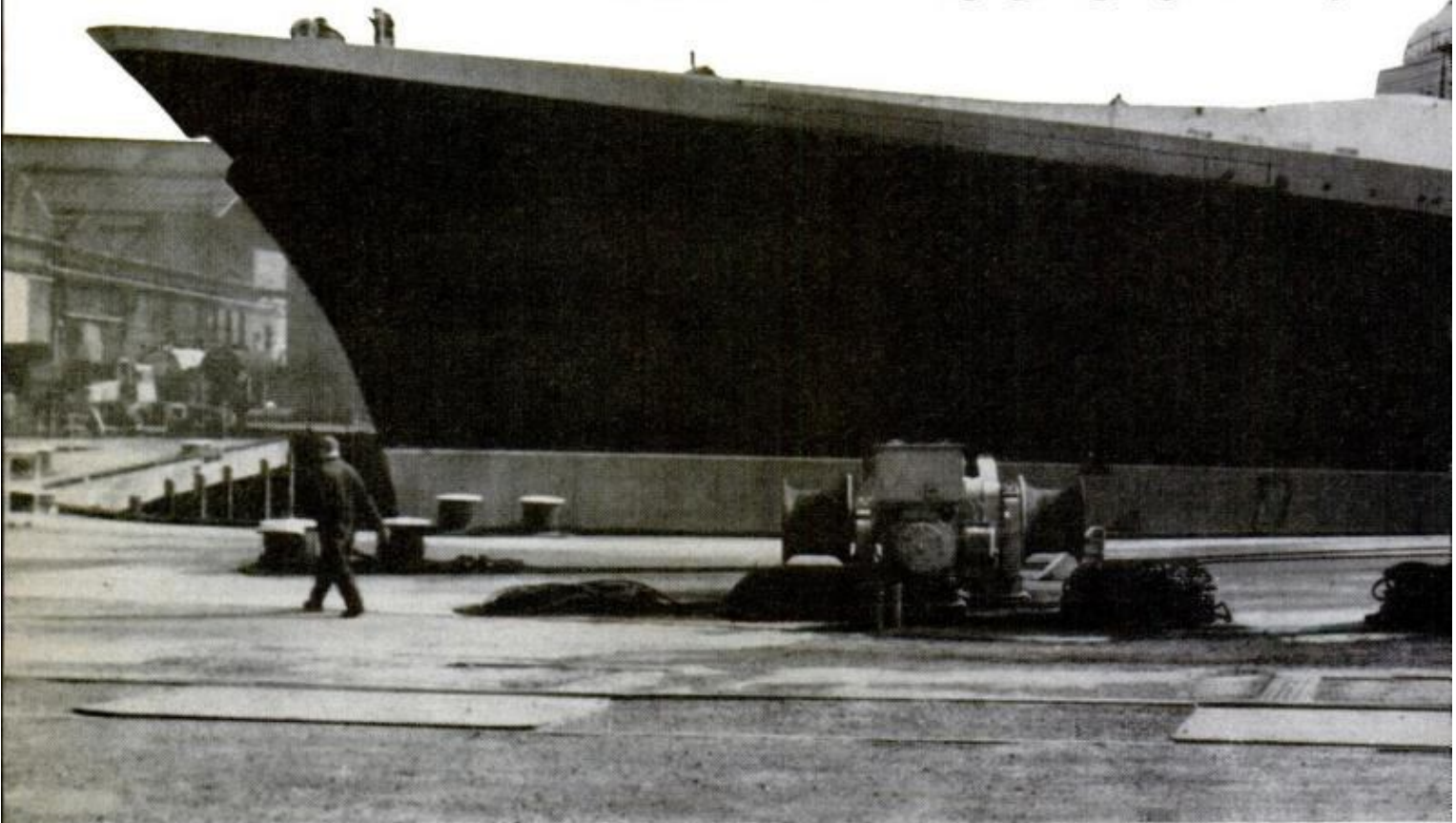

**S**HE'S NOT THE BIGGEST or the fastest, but in this age of air-travel she's causing a lot of excitement. She's Cunard's latest: the *Queen Elizabeth 2*, heralded as the ultimate deterrent against boredom at sea.

On Jan. 30, Americans will catch their first glimpse of the *QE 2* as she sails up the Hudson. Above a slim, sleek hull, the superstructure appears dangerously high, but from the quarterdeck upwards, all structural work is in aluminum, saving over 1000 tons of top weight. The 963 feet of hull are painted black and white: the white superstructure is accented with pale green. Topping the whole is the single 67-foot black-and-white funnel, a drastic change from the four, three and two stacks of the *Mauretania*, *Queen Mary* and *Queen Elizabeth*.

At first sight, it may seem extravagant to replace the *Elizabeth*—sold for \$7,800,000—with a vessel 80 feet shorter and costing nine times as much. Can the \$72-million *QE 2* make money? The answer, Cunard hopes, is yes, lots.

With 30 years' technological advance since the building of the *Elizabeth*, it's now possible to get the same performance out of far less massive machinery. The *QE 2* carries the same number of passengers (about 2000) as *Elizabeth* and *Mary*. And she steams at Cunard's traditional 28½ knots.

But her gross tonnage is only 65,000 tons, instead of 84,000. Her two engines need develop only 110,000 shaft horsepower, instead of 160,000. Engineering staff number only 103—compared with 230 on the *Mary*. The three-boiler steam turbine setup demands

## By J. A. MAXTONE-GRAHAM



**QUEEN ELIZABETH 2**, which is two-thirds the tonnage of the original Queen, will carry the same number of passengers at the same speeds, but will do it on 600 tons of oil a day as against 1,300 tons for *Mary*

600 tons of fuel a day. The *Mary* had 27 boilers, and a greedy thirst for 1300 tons of oil. The fuel saving alone amounts to \$12,000 a day.

Throughout the vessel, every conceivable modern device has been used to increase economy, comfort and safety. The use of 1000 tons of aluminum meant sending 80 welders to school to learn a special welding technique. Much of the metal was prefabricated ashore and hoisted aboard, like the 13½-ton, twin-staircased structure of the ballroom.

The ship's hull is studded with thousands of electrodes, flush with the welded steel plates. A small current confines corrosion to replaceable electrodes—while the hull stays unpitted

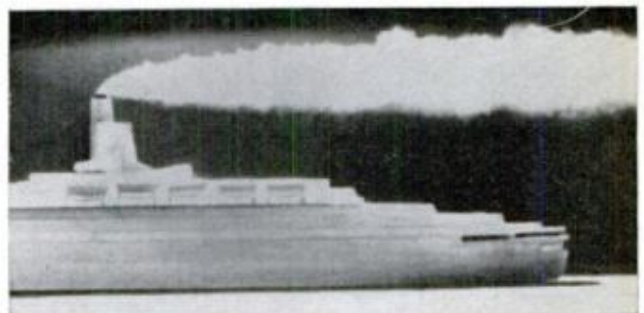

**SINGLE FUNNEL** of new QE 2 (below) thrusts smoke far above passenger deck, unlike earlier Queen, whose smoke often dipped to annoyingly low levels. Other vents in funnel discharge below-deck odors



**MAIN CONTROL ROOM** features pushbutton consoles that direct electrical distribution, power supply, air conditioning, stabilizers and other major mechanical operations

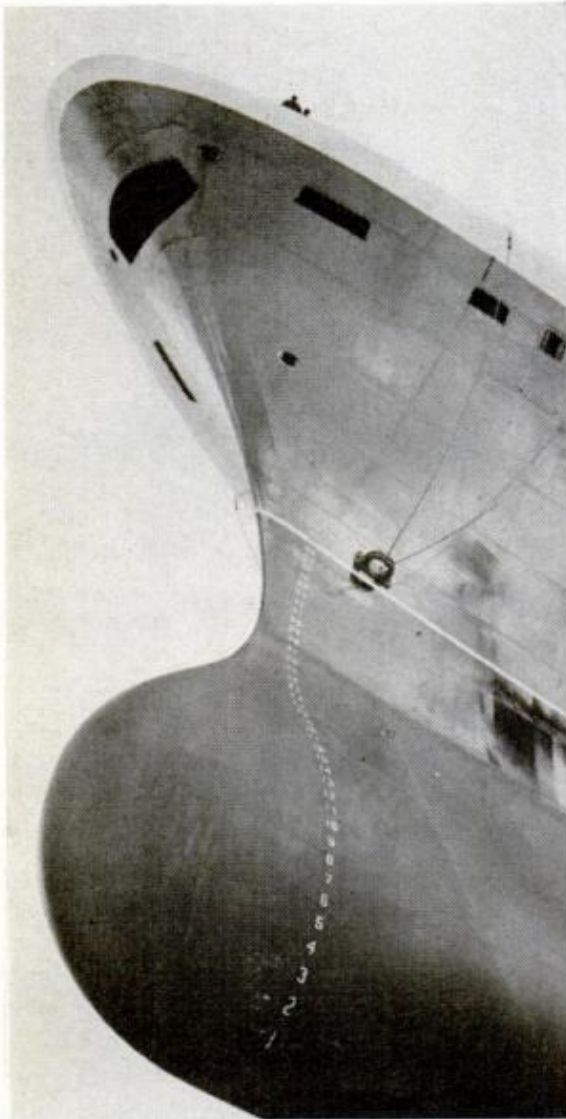

**BULBOUS BOW** on QE 2 will be another first on new 65,000-ton passenger ship. It helps make luxury liner the fastest twin-screw liner in world. Inside the bow are 27 vats containing ship's supply of draft beer—13,000 gallons

by rust and free from unnecessary drag. Stabilizers—with the optional use of two fins or four—cut a 20° roll to 3°, and give the smooth ride that a first-class passenger should expect for \$500 or \$1000. And the six blades of the two propellers will cut vibration to a minimum. The nut to secure one of these 19-foot-diameter giants itself weighs a ton and a half.

The QE 2 should be the safest ship afloat. One new department, permanently staffed by two men, is the safety control room. From two gleaming consoles they can operate all 58 watertight and 359 fireproof doors (all of which can also be worked locally).

Should smoke be detected in any part of the holds, a touch of a button squirts carbon dioxide at the right spot. A vast panel covered with hundreds of blue, red, yellow and green telltale lights gives instant checks on the working of every safety device on each of the 13 decks. Safety control can also put into operation an elaborate pumping system in case the hull should be punctured: Water can be quickly pumped across to empty tanks to give a maximum list of only 7°.

Twenty fiberglass lifeboats will let all 3000 persons aboard get clear within half

**MAIN-GEAR TEETH** get some last-minute "dental" work at the factory before wheel's installation on the QE 2 at Scottish shipyard. Main-gear wheel weighs 50 tons, has a diameter of 15 feet

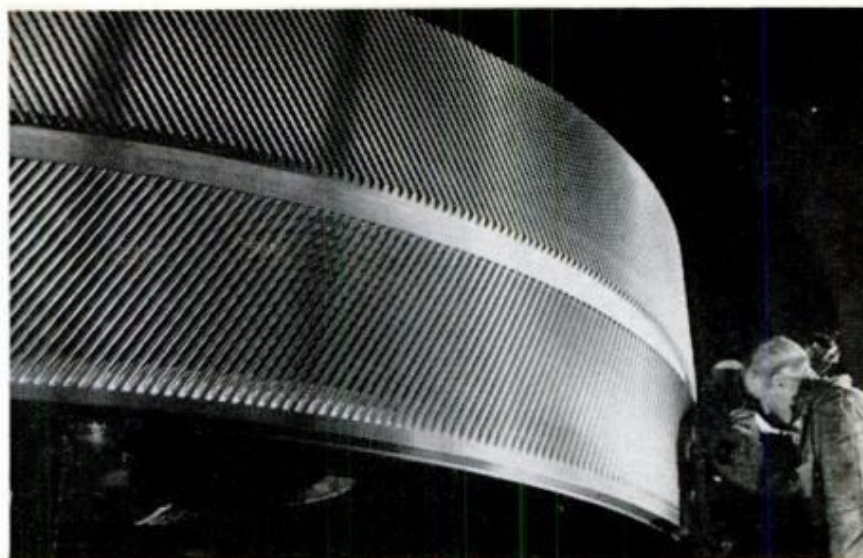

an hour. Two of these—painted red—are specially designed for "ambulance work" in mid-ocean; for example, to take a sick man off a doctorless merchantman. For delicate maneuverability in high seas, they're propelled by water-jets.

The perils of docking without tugs (in time of strike, for instance) have been reduced by two powerful bow thrusters—nicknamed the "Frothblowers"—controlled from the bridge. At the touch of a button, the skipper can turn on a 1000-hp motor driving a four-bladed, 6½-foot-diameter propeller that shoots out a powerful jet of water 20 feet below the waterline and forces the bow sideways towards her berth with all the power of a medium-sized tugboat.

No longer need a ship carry several massive funnels to prove her power and majesty. The QE 2's single stack is functional, not ornamental, and the result of 20 different attempts to get the right answer. Rigorous wind-tunnel tests revealed the perfect design, one that would take exhaust gases up and clear of the decks—whatever the wind direction. The tall stack contains three tubes to handle engine-room smoke; the white attachment behind is an outlet for used air from the rest of the ship. (Ugly exhaust cowls no longer disfigure the decks.) Two ramps curve up to the funnel; when the ship travels at speed, these guide a strong draft of

*(Please turn to page 232)*

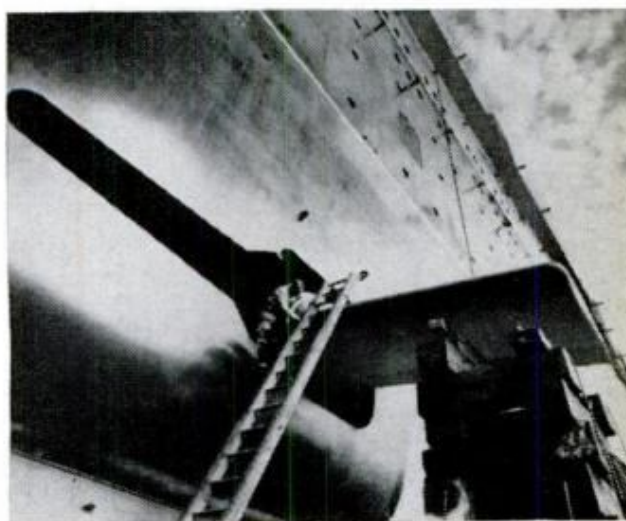

**QE 2 STABILIZERS** are also new, swinging forward into hull when not in use, instead of retracting, thus cutting down necessary storage space inside hull

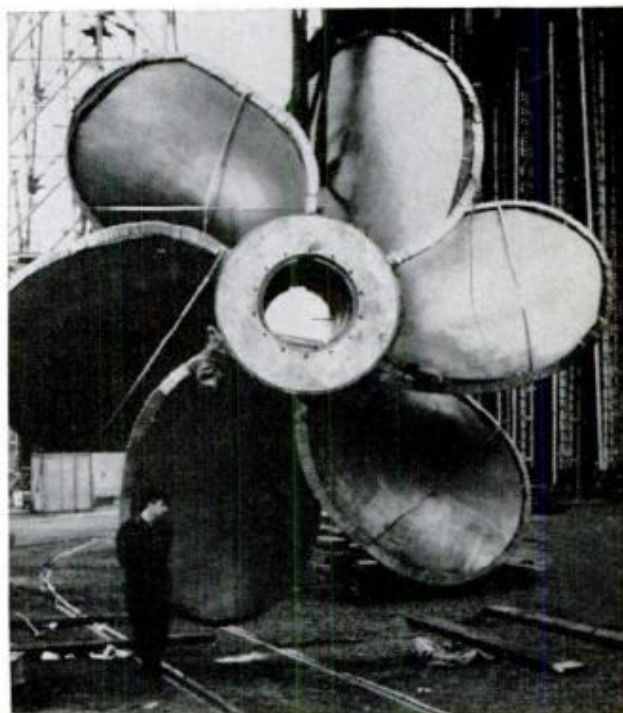

**SIX-BLADED SCREW** is one of two on new liner, and largest ever fitted on twin-screw ship. Four were made, with two held in reserve as emergency spares

# 'Sizing Up' The 1969 Station Wagons

It's easier than ever to pick the perfect wagon to fit the family, lug packages and pets, and still get sports appeal

By **BILL HARTFORD**,  
Associate Auto Editor

*Photos by Irving Dolin*

**W**HAT MAN could possibly get enthused about buying a "school bus" for the kids, a "shopping cart" for the wife, a square box on wheels? It's impossible—until you discover it's also impossible to squeeze *your* 125-hp outboard into the fastback's "trunk"; or until you find yourself fearing for the kids' spinal columns as they bounce along bent over in the back of *your* sporty little car; or until you take a close look at some of the latest station wagons from Detroit.

First glance at the extremely sophisticated, simulated wood-paneling job on these machines should conjure up all the romance of the wood-bodied sporting wagonettes of yore. Once



**SMALL** In class of its own, Rambler 440 wagon has 106-inch wheelbase, a true compact, yet with size advantage over imports

known as a "shooting brake" (brake being a carriage chassis that was harnessed to spirited horses to "break" them), the turn-of-the-century wagon was an open carriage with bench seats that carried shooting parties on large estates. As it became an all-purpose vehicle for conveying master and servant alike, the wagon became an "estate car" and that is still the British terminology for the station wagon.

Here at home, a lot of cars rolled off the line before the 1923 wood-paneled Durant became America's first production station wagon—and many more have rolled off since 1940 when the almost-classic, wood-sided wagon was the only one among every 100 cars pro-



**MEDIUM** Representing intermediate-size wagons is Pontiac Le Mans with 116-inch wheelbase. Bumper cutout step is new

**BIG** Full-size family wagons are represented by 121-inch-wheelbase Ford LTD Country Squire. Air deflector is part of the luggage rack

**WAGON LINEUP**—Rambler 440, Pontiac Le Mans and Ford Country Squire—illustrates size jump from Rambler's 66 cu. ft. of cargo volume to Pontiac's 83.1 cu. ft. to Ford's 96.2 cu. ft., the last two volume figures typical of intermediate and full-size wagons. As size goes up, so does the availability of comfort, convenience and trim options—and so does the price. (See chart, p. 106)



# 1969 STATION WAGONS

MAKE	MODEL	WHEEL-BASE (in.)	CARGO AREA DIMENSIONS				3RD SEAT	2-WAY TAIL GATE	MFR'S PRICES START:
			max. length (in.) <sup>o</sup>	min. width (in.) <sup>†</sup>	max. ht. (in.)	vol. (cu. ft.) <sup>‡</sup>			
<b>SMALL</b>	American Motors Rambler 440	106	76.78	41.8	29.69	66	No	No	\$2478
<b>MEDIUM</b>	American Motors Rebel, SST	114	92.63	45.08	31.72	91.12	Yes	Yes	\$2817
	Buick Special Deluxe	116	90.9	44.5	31.5	83.6	No	Yes	\$3075
	Chevrolet Chevelle Nomad, Greenbrier, Concours Estate	116	90.9	44.5	31.6	84.0	Yes	Yes	\$2651
	Dodge Coronet Deluxe, 440, 500	117	91.7	45.3	31.2	84.9	Yes	Yes	\$2905
	Ford Falcon, Futura Fairlane, 500, Torino	113	89.0	42.6	32.7	85.2	No	Yes	\$2643 \$2824
	Mercury Montego MX	113	89.0	42.6	32.7	85.2	Yes	Yes	\$2962
	Olds F-85 Cutlass	116	90.9	44.5	31.6	86.1	No	Yes	\$3038
	Plymouth Belvedere Satellite	117	91.7	45.3	31.2	84.9	Yes	No Yes	\$2862
	Pontiac Custom S, Le Mans	116	90.9	44.5	31.3	83.1	No	Yes	\$2939
<b>BIG</b>	American Motors Ambassador DPL, SST	122	92.63	45.08	31.72	91.12	Yes	Yes	\$3504 <sup>§</sup>
	Chevrolet Brookwood, Townsman, Kingswood, Kingswood Estate	119	96.0	49.7	30.7	100.2	Yes	Yes	\$3047
	Buick Sportwagon	121	96.1	44.5	34.1	96.3	Yes	Yes	\$3448
	Chrysler Town & Country	122	98.98	48.5	29.04	93.1	Yes	Yes	\$4566
	Dodge Polara, Monaco	122	98.98	48.5	29.04	93.1	Yes	Yes	\$3505
	Ford Custom 500 Ranch Wagon, Galaxie 500 Country Sedan, LTD, Country Squire	121	92.4	48.7	31.6	96.2	Yes	Yes	\$3074
	Mercury Monterey, Monterey Custom, Marquis Colony Park	121	92.4	48.7	31.6	96.2	Yes	Yes	\$3519
	Olds Custom Vista Cruiser	121	96.1	44.5	34.5	100.5	Yes	Yes	\$3440
	Plymouth Fury Suburban, Custom Suburban, Sport Suburban	122	98.98	48.5	29.04	93.1	Yes	Yes	\$3214
	Pontiac Catalina, Executive Bonneville	122	93.7 93.5	48.9	30.6 30.3	91.7 90.8	Yes	Yes	\$3502

<sup>o</sup>Measured at floor with tailgate closed.  
<sup>†</sup>Measured between wheel housings.

<sup>‡</sup>Does not include underfloor storage where available.  
<sup>§</sup>Airconditioning standard; automatic transmission standard on SST.

duced. It was hardly a popular body style at that time, but the traditional use of wood or wood-grain applique has been popular ever since.

Today, roughly one of 10 cars off the line is a station wagon. These wagons won't fill your nostrils with the tang of rich leather or real rubbed wood, and they won't excite you as would a GT, but they will be to the family man or sportsman, the best *Gran Turismo* of all—offering Grand Traveling in comfort, convenience and style.

Station-wagon style, as is quickly evident, follows that of the production sedan of which it is the counterpart. Most are on the same wheelbase, offer the same engine and transmission options, and the same comfort and convenience options, plus those unique to wagons.

If you select the "usual" options—

automatic transmission, power brakes and steering, larger engine than standard, maybe a radio, and some extra trim, tinted glass and some other irresistible—plus the wagon options—two-way tailgate with power window, third seat, optional tires, heavy-duty suspension, factory rack, maybe some "yacht-deck" wood trim—you can figure on going \$500 to \$1000 over suggested retail for the manufacturer's bottom-priced wagon in the intermediate line and an easy \$1000 over in the family wagons.

With an intermediate-size wagon, don't expect to lay out 4x8-foot panels. Width between wheelhouses is less than 46 inches. Passenger seating for eight, however, is possible in those wagons offering a third seat option. Figure paying about \$100 extra.

Cargo space in the Rebel wagons is





**TWO-WAY TAILGATE** hinging at side or bottom is standard on many wagons. Ford's Magic Doorgate, shown here, is the only "fifth door" that is operable with the rear window fully up



**FACTORY RACKS**, some adjustable to secure various size loads quickly, may seem to be an expensive option, but are sturdy, streamlined—a must for full use of a wagon



**UNDERFLOOR STORAGE** offers bonus cargo-carrying capacity. The hatch on some wagons can be locked. Handle is recessed for flat floor

impressive, but it is the same in the longer-wheelbased Ambassador. Falcon and Fairlane wagons, too, have the same cargo area dimensions and, both on a 113-inch wheelbase, are medium-size wagons.

In the family-size wagons, Buick and Oldsmobile continue to offer tinted-glass roof panels for Vista Cruising. Dual-action tailgate, Drop-or-Swing, call it what you will, is available across the board; standard on some models, about \$50 when optional. Power tailgate window, a very desirable option, is usually \$40 to \$50 extra.

The Ford Magic Doorgate is the only tailgate that can be opened as a door with the window up—a bonus feature. On medium and large GM wagons a new cutout in the rear bumper forms a convenient step for passengers.

Dodge and Plymouth wagons include as standard on some models, an integral air deflector which is exceedingly effective in keeping the tailgate window clean. Passenger handles on either side of the tailgate opening give a long overdue helping hand. The Chrysler Town and Country sizes up as the most powerful (440-cu.-in.V8 option), luxurious and expensive of all. And at 224.9 inches, it's the longest.

Long or short, the '69 wagons have a lot more than just size to meet the eye. Take a look. ★ ★ ★

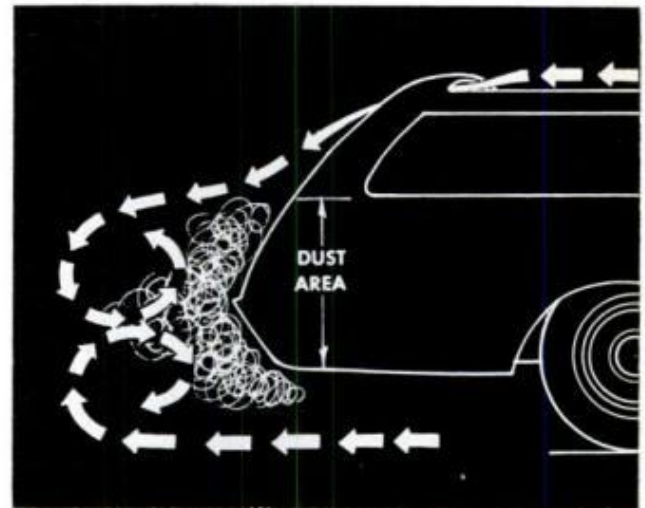

**AIR DEFLECTOR**, built into roof line of Chrysler, Plymouth and Dodge models, aerodynamically lowers dusty low pressure area to keep rear window clean. Cars also offer hidden wiper-washer in tailgate



**THIRD SEAT**, whether it faces forward, aft or is actually a pair of facing seats, as shown here, is available on all large wagons, some intermediates

THE WHEEL is about 30 feet in diameter and has 10 sand-scooping buckets and 10 bottomless "bows"

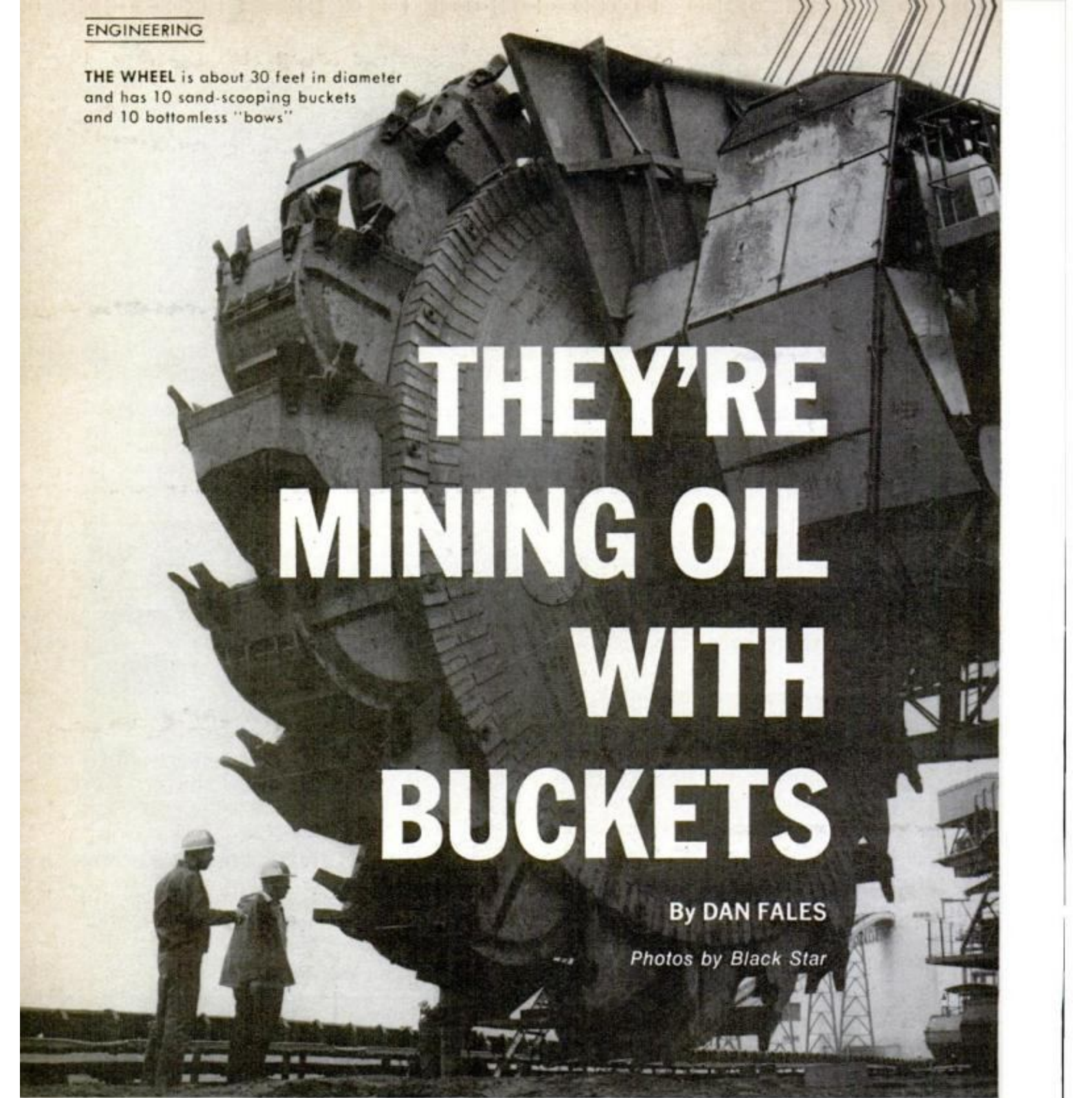
A large, dark, industrial machine, 'The Wheel', dominates the background. It has a complex, multi-tiered structure with various mechanical components. In the foreground, two men wearing hard hats and work clothes stand on a platform, looking towards the machine. The scene is set outdoors, possibly at a construction or industrial site, with a clear sky and some structures visible in the distance.

# THEY'RE MINING OIL WITH BUCKETS

By DAN FALES

*Photos by Black Star*

**T**HE WHEEL is what they call it. The machine stands 100 feet high, 200 feet long, weighs 1600 tons, handles 50,000 tons of sand a day, travels 23 feet a minute, and is being used to mine oil.

Actually, the wheel is one of two being used by Great Canadian Oil Sands, Ltd., to process 100,000 tons of oily sand a day. It's all happening 600 miles south of the Arctic Circle in the Athabasca area of Alberta, Canada. In this spot, nature deposited an oily "beach" which,

if man-made, would be a pollution problem. But here G.C.O.S. will get 45,000 barrels of oil a day. Also from the oily sand will come coke, sulphur, naphtha, gas and clean fine-grained sand.

This type of oil operation is really strip mining. But there's one big difference. Once the oil has been washed from the sand, the sand is replaced, then planted leaving no gigantic scars in the earth.

Great Canadian Oil Sands, connected

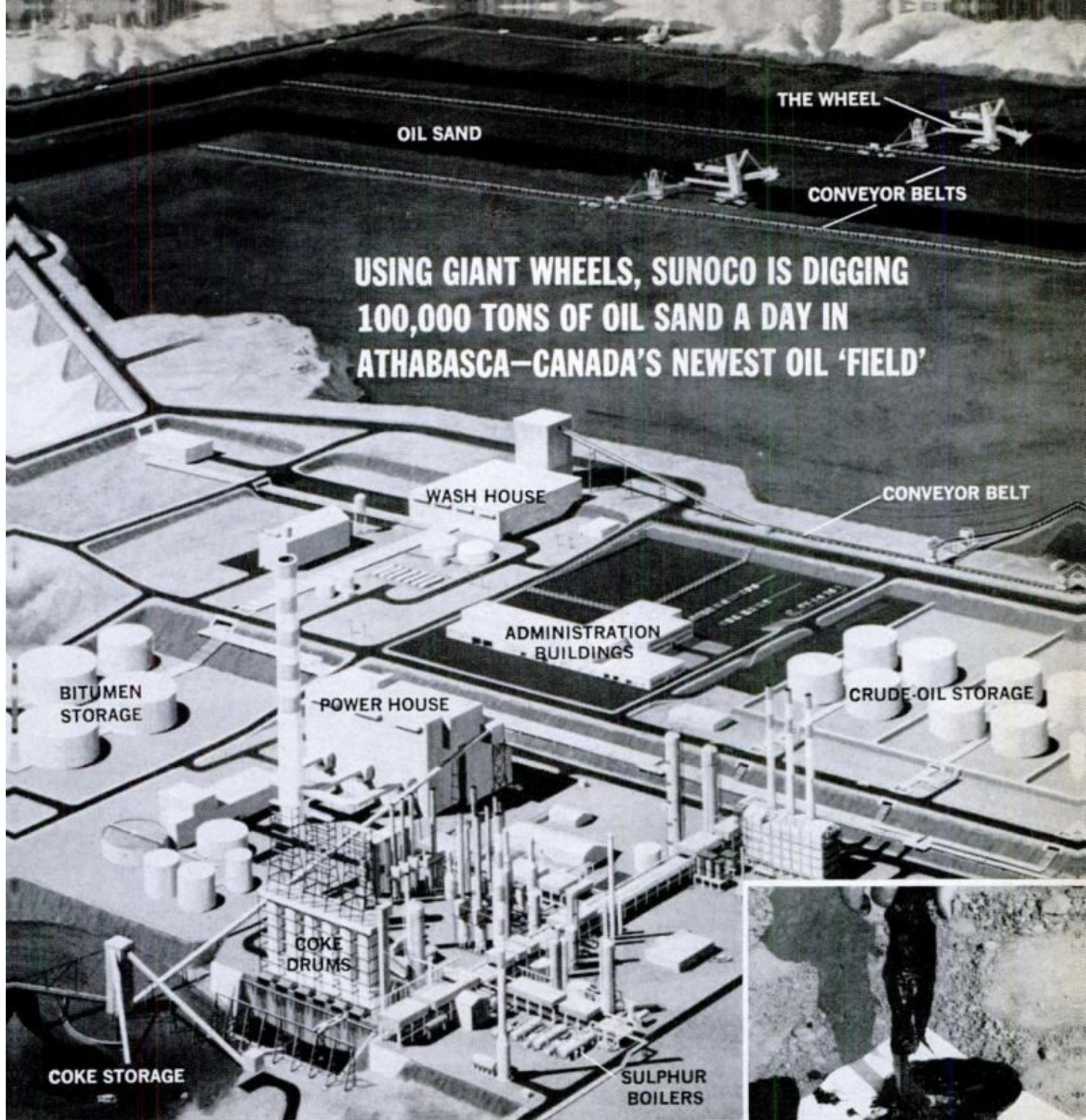

**USING GIANT WHEELS, SUNOCO IS DIGGING 100,000 TONS OF OIL SAND A DAY IN ATHABASCA—CANADA'S NEWEST OIL 'FIELD'**

**IN PROCESSING PLANT**, oily sand is conveyed to wash house where bitumen is floated from sand and processed. Coke, a byproduct, fuels powerplant

with Sun Oil Co. of Philadelphia, Pa., is mining the oil under a lease from the Canadian government.

Here's how the mining operation works. The giant machines scoop up oily sand—about 9000 tons an hour. Three men ride each of the two—one operator, one belt man, one observer. The wheel, about 30 feet in diameter, has 10 buckets that hold sand and 10 "bows"—bottomless buckets that break the sand loose. Sand is dumped on conveyor belts running to a washing area.

Here, the gunky oil called bitumen is floated free of the sand in hot water and then sent through an initial cracking process producing fine crude oil. Byproducts



**OILY SAND** (left) yields a tar substance called bitumen (center) and clean sand (right). The bitumen is treated to produce crude oil, coke, sulphur. Crude oil is pumped 250 miles to refinery, while clean sand is used to fill the excavation

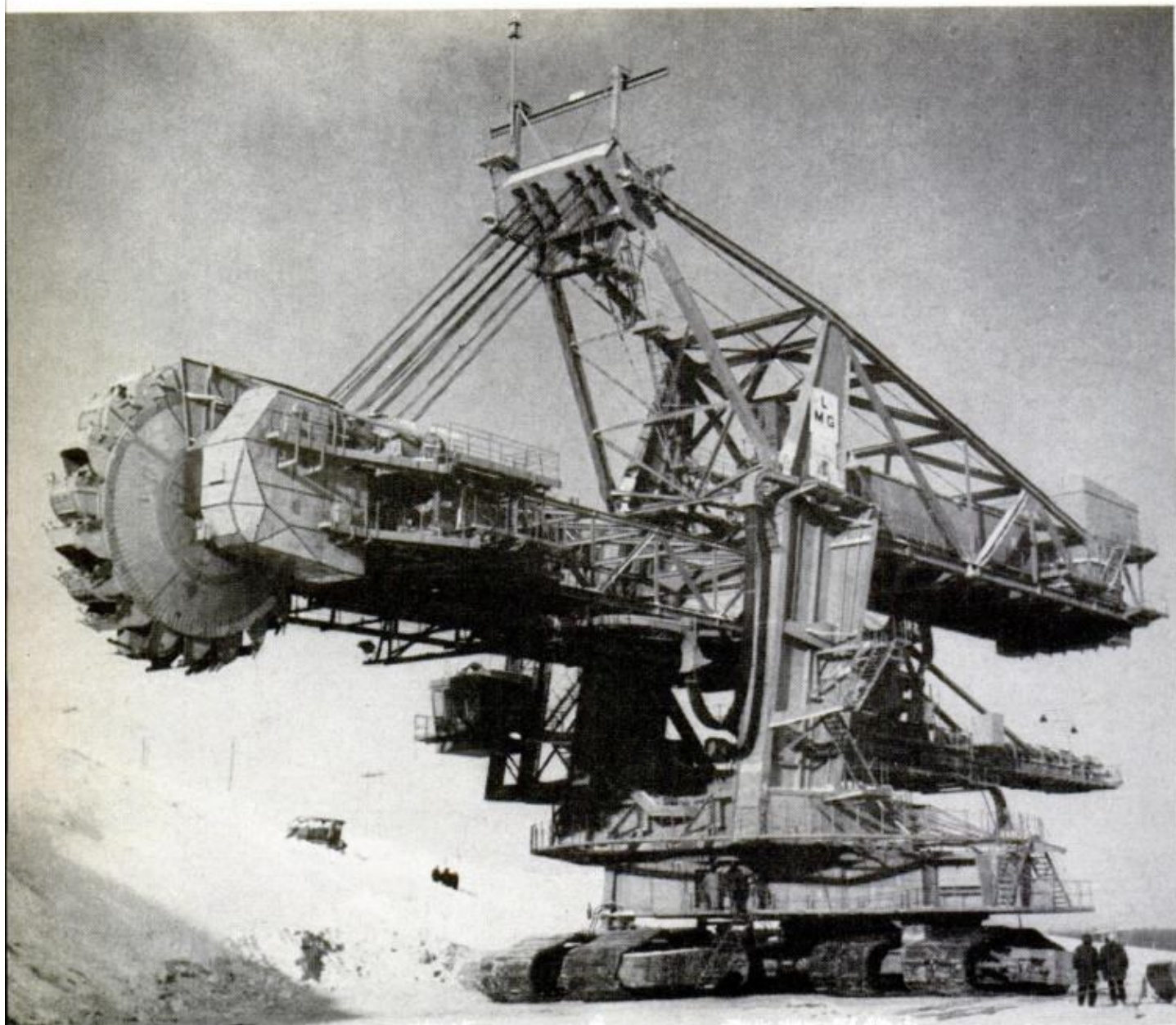

**THE WHEEL'S CONTROLS** are in operator's box below front arm. Anemometer warns of belt-flapping winds



**OPERATOR** can swing, raise or lower the wheel. Wheel works in semicircle as entire machine moves

are then tapped off the oil. One important one is coke. The coke is used to fire the boilers in the electric generation and heat plant. This power is used to run the entire mining operation.

The final crude oil is pumped through pipes for 250 miles to central cracking plants in southern Alberta.

Saturated in the Athabasca area is enough recoverable oil to equal the total amount of oil known to be located in natural reservoirs in the Free World. That's about 300 billion barrels.

Why there's oil in the Athabasca sands is a mystery. Some say it leaked from a deep subterranean reservoir following massive earthquakes.

Others feel the oil was created in the area. In any event, there's enough oil in this area to last a long time. ★★★



## Matchless match models

German engineer Fritz Forster of Nuremberg has used up 60,000 wood matchsticks in the past eight years producing scale models of vintage cars and locomotives as a hobby. Unlike many matchwork models, all of his 69 intricately detailed creations have wheels that turn and other moving parts.

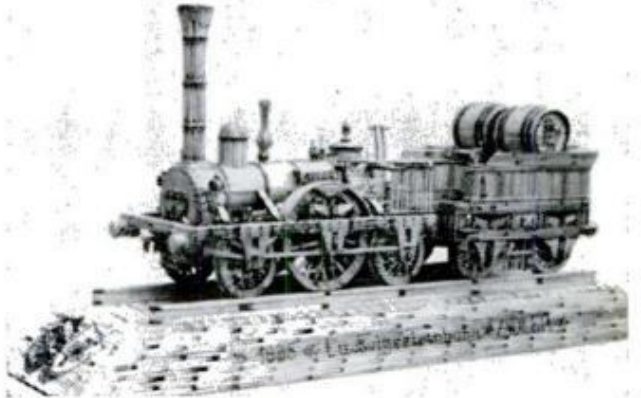
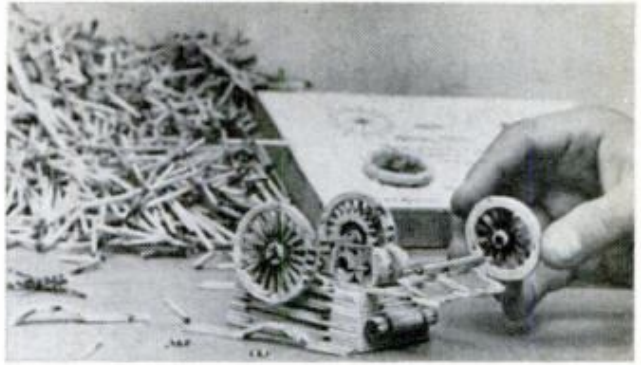

FEBRUARY 1969



## No pitter-patter here

Looking vaguely like a beached whale, Chicago's new Center for the Performing Arts wears an outer skin of sheet lead, chosen to deaden the sound of rain and hail. The unusual saddle-roofed structure houses a 600-seat theater and TV station WFLD, making good soundproofing a must. Detail photo (above) shows standing seam between panels.



## Swiss summer job: Building protection against avalanches

Years ago, only a few daring farmers could be seen on the steep slopes of Swiss mountains, harvesting fodder for their animals. Now, workmen may be found on those slopes in the summer operating air drills and making giant barriers from reinforced concrete to hold or to divert avalanches. The work is difficult and dangerous. Often the materials—and even the men—must be brought to the barrier sites by helicopters. After holes have been dug and steel set in concrete, the barriers (far right) stand, protecting the valleys below.



## Pilot develops city car

This is the rear of a new "city car" developed by Mike Forrest, a former RAF pilot. The rear-facing back seat of the four-passenger car is one of several features he's designed to make the car his answer to city traffic problems. The front and back of the car are doors, so passengers can step directly out. A 750-cc engine propels the vehicle. The body is made of fiberglass, and the entire machine weighs 900 pounds. Main controls are incorporated in a single tiller.



## Aerobatic Nipper

The Nipper is a fully aerobatic British single-seater that comes in a do-it-yourself kit.



## Phantom for British fleet

Here's McDonnell-Douglas's F-4K Phantom dressed up for service with the Royal Navy.

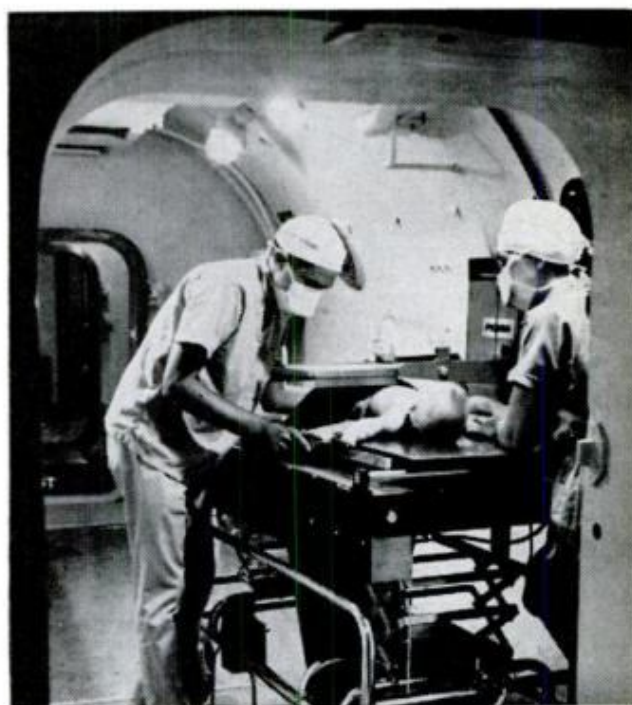

## Department store railroad

One Tokyo department store has found a way to keep the customers' kids amused when they accompany their parents on a shopping tour. The youngsters are given rides on an electrically-driven scooter that runs the full length of the store. An engineer controls the speed of the toy.

## Help for 'blue babies'

High-pressure oxygen in a hyperbaric chamber sustains the life of a "blue baby," giving doctors precious extra time to work under a fluoroscope that guides them in inserting a catheter into the newborn infant's heart to correct a valve defect. (See *High-Pressure Medicine*, page 99, Dec. PM.)



**1908** | **CHRISTIE FRONT-WHEEL DRIVE**

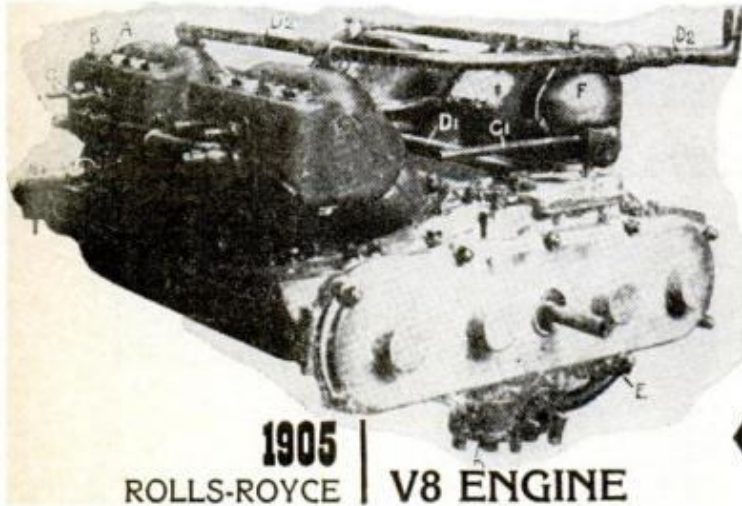

**1905** | **ROLLS-ROYCE V8 ENGINE**

# SO WHAT

▲ **RACING MACHINE** of J. Walter Christie design had front wheels driven by transversely mounted engine

◀ **ROLLS V8** was shown at London auto show—believe it or not—in 1905; its 3½ liters put out 20 hp

▼ **GREAT ROADABILITY** from low center of gravity was early-recognized boon of chassis hung from springs

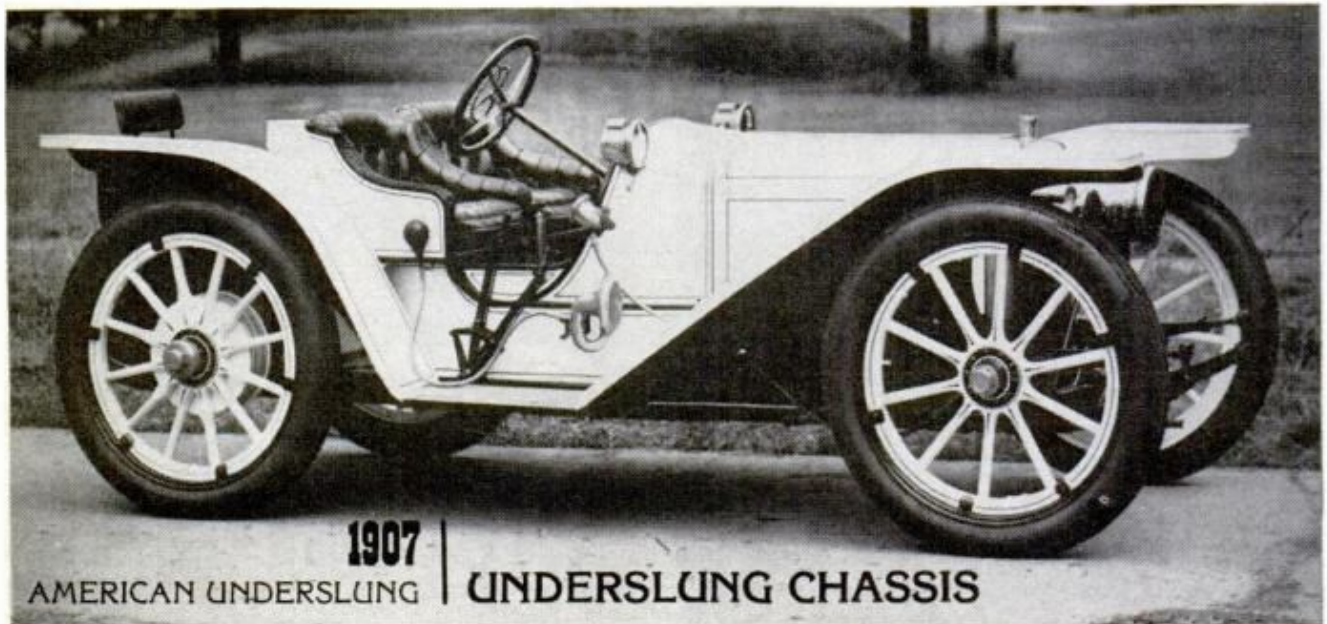

**1907** | **AMERICAN UNDERSLUNG CHASSIS**



The old cars  
had everything...  
an automatic  
transmission in  
1895, coil springs  
on a 1907 model,  
a V8 engine in  
1905.  
Your '69 model  
is 60 years  
old if it's  
a day!

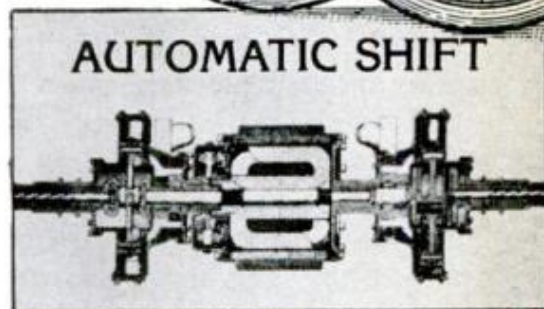
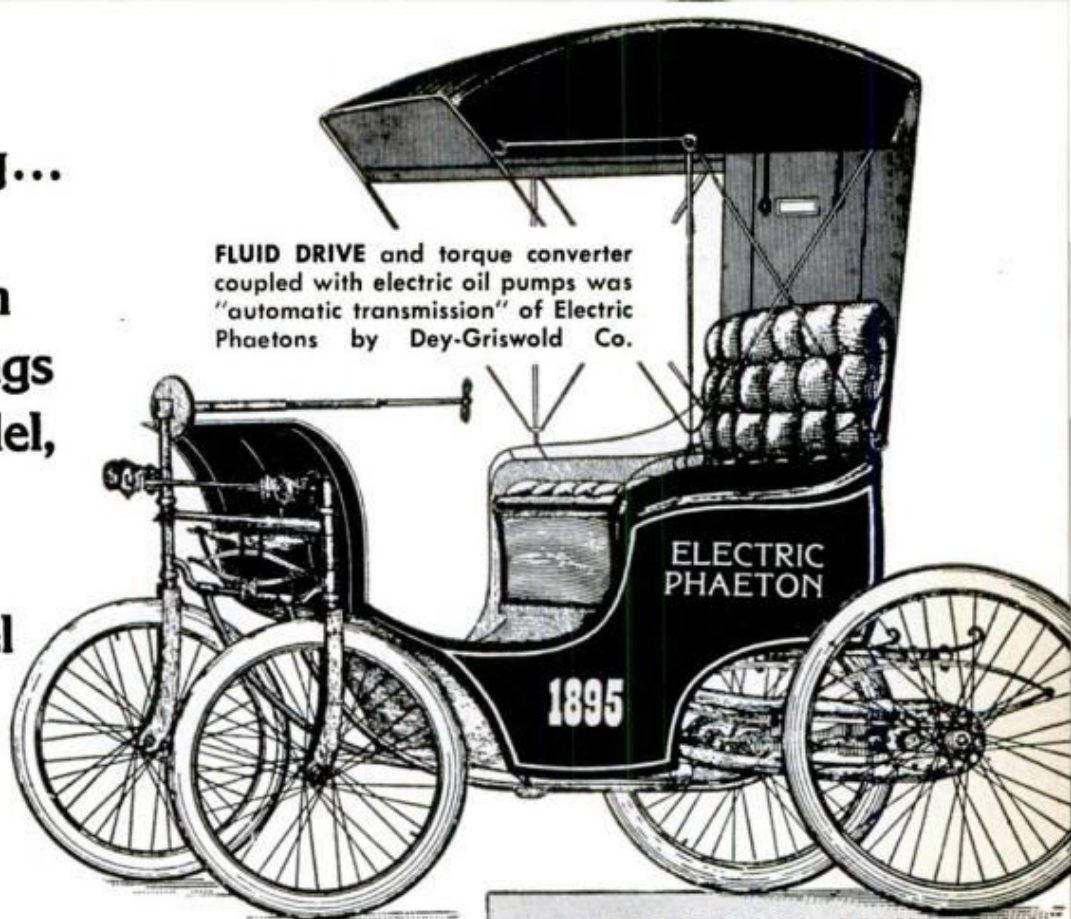

# ELSE IS NEW?

By JOHN BENTLEY

**N**EW CARS AREN'T VERY NEW. Old-timers who witnessed the birth of this country's third largest industry and watched it grow from a handful of back-yard enterprises to a multibillion-dollar road transportation system, can tell you that. They smile at some of the advertising claims of today's automakers. Features described as "sensational," "entirely new," and even "years ahead of present design," all appeared at one time or another on some of the earliest models.

They appeared but usually didn't "make it." Most were dropped because of technical bugs, production problems and the like, or for the sound financial reason that the public was not yet "ready" to accept—or pay for—them.

Torque converters (automatic transmissions), the overhead camshaft engine, front-wheel drive and four-wheel

drive, the V8 engine, interaxial seating, coil suspension, underslung chassis, four-wheel brakes, the extensive use of aluminum in bodies and engines—you name it—all go back to the beginning of the century or even earlier.

● *Automatic transmissions.* The modern torque converter—or automatic transmission—provides a means of varying the ratio between engine and road-wheel speeds by utilizing a fluid coupling or turbine.

This idea was actually tried out in November 1895. That year, Harry E. Dey, president of the Dey-Griswold Co. of New York, worked out a "system for propelling streetcars and wagons." The Dey-Griswold Electric Phaeton had an electric motor with a revolving field and armature, each driving a shaft on which was fitted a radial oil pump with single-acting pistons. A special battery (Dey High Potential



**4-WHEEL DRIVE**

**DEEP SNOW** was no problem for Badger, made by Four Wheel Drive Auto Co. of Wisconsin. Not many cars were made, but those that were became first successful vehicles with four-wheel-drive design

Series Battery) supplied the current to the motor. When the current was switched on and the shafts began rotating, twin oil pumps forced oil along lines to miniature fluid gear turbines located on each rear wheel. Here is a contemporary description:

“If we come to a gentle grade, the motor automatically takes a little more current. If the grade gets heavier, more current comes. On a downgrade, the motor (now driven by the oil pumps on the overrun) changes to a dynamo and puts back current into the battery. The steeper the hill, the more the return, and at the same time the generator is acting as a brake. This is accomplished without once changing the handle . . .”

In today’s torque converter, the turbine is not located on the driven wheels, but the fundamental idea remains unchanged.

To what extent the Dey-Griswold torque converter underwent practical tests has not been recorded, though

several models were actually built. Among other things, problems of heat dissipation almost certainly defeated the idea in its infancy, but the idea was there.

● *Front-wheel drive* in an automobile did not arrive with the Olds Toronado. In fact, it’s more than 60 years old. In 1908, Walter Christie, founder and owner of the Christie Iron Works in New York, built a front-drive race car on the so-called modern “sidewinder” principle, with the engine transversely across the front. The car’s name was Big Bear, and its huge four-cylinder, V-shaped power unit displaced 1220 cubic inches.

“If I succeed,” Christie promised, “I’ll have some front-drive cabs plying for hire on the streets of New York within a year. It’s the toughest testing ground you could find.”

He was true to his word. In 1909, a number of Christie front-drive cabs (with smaller engines but operating on

**1910** | **ISOTTA-FRASCHINI** | **4-WHEEL BRAKES**

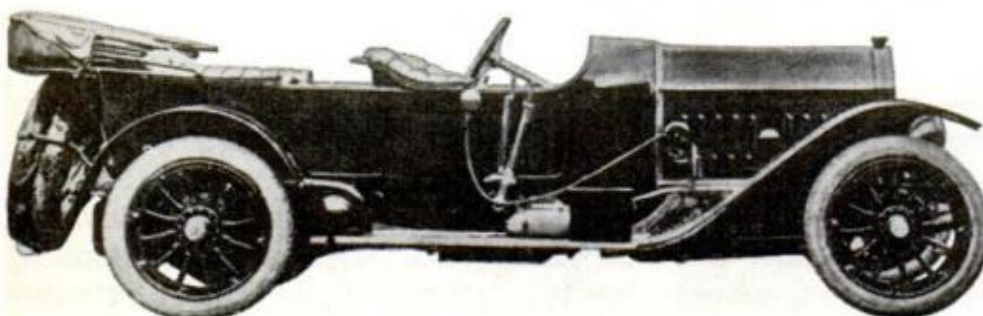

**BRAKES ALL ROUND** were pioneered in Europe during first years of the century; and successful ones on the Isotta-Fraschini predated the wide-scale use of four-wheel brakes by years

exactly the same principle) appeared on the streets of Manhattan. Their reliability was, unfortunately, not equal to the appalling strain of cab work with its endless stops and starts; but the idea was considered good enough by fire departments of several cities which were persuaded to replace their antiquated horse-drawn fire engines with Christie front-drive units.

● *Overhead camshaft engines.* It is generally believed that Augie Duesenberg first put into production the overhead-cam engine when he offered his sensational new straight-eight Tourist Model (which included hydraulic four-wheel brakes) at the 1921 New York Show. In fact, the Duesenberg was at least 15 years behind the Ariel Automobile Co., Bridgeport, Conn., whose 1906 brochure contained some startling information. The actual photo of the Ariel's engine is a collector's item. It shows four separate, liquid-cooled cylinders with an overhead camshaft operating in the open, directly on the valves. No casing or protective cover. But under the photo we read: "The entire valve mechanism of the Ariel, being on top of the motor, is very accessible; all of which makes for reliability, as in two minutes one can inspect every piece of the mechanism on the motor without removing one's gloves."

The Ariel's 30-hp engine not only had a gear-driven overhead camshaft which put it "in a unique field of design," but also offered *interchangeable* valves, inclined at an angle of 30°. "No other manufacturer has so far come forward with so daring a design." Ariel

long ago went broke. Today, Pontiac is the only make which offers a production overhead camshaft engine in the United States, priced within reach of the average buyer.

● *V8 engine.* Cadillac is proud of pioneering the V8 engine in 1916, even though the mass-produced Ford V8 of 1932 really popularized the design. But, Rolls-Royce was way ahead of both when it exhibited a V8 engine at the London Olympia Automobile Show of 1905. This was a side-valve design with the cylinders set at 45°. Bore and stroke were 3.24-in. and the output was 20 hp at 2000 rpm. Ignition was by synchronized trembler coils. The cylinders were cast in pairs and mounted on a common crankcase.

A contemporary show report described the design as "most original. The impulses and compressions must necessarily overlap each other in a much more regular manner than is even possible with a six-cylinder motor, which type has been regarded as coming pretty close to perfection in this respect. Furthermore, an absence of noise is had from all cylinders because the moving parts are *very light*. The exhaust volume per cylinder is small and the almost continuous discharge is in itself an aid to muffling."

● *Coil suspension.* Coil springs up front were reintroduced to the American public as a "radical" innovation—a wonderful new idea, back in 1934. What people didn't know (and many still don't) was that this principle already was so old it was new again. Back in 1906—over 62 years ago—the

**1933**

**PIERCE-ARROW**

**AHEAD OF ITS TIME**  
is one way to describe the 1933 Silver Arrow. For the year, built-in headlights, no running boards, hidden spare wheels, recessed door handles, were big innovations.

**STREAMLINING**

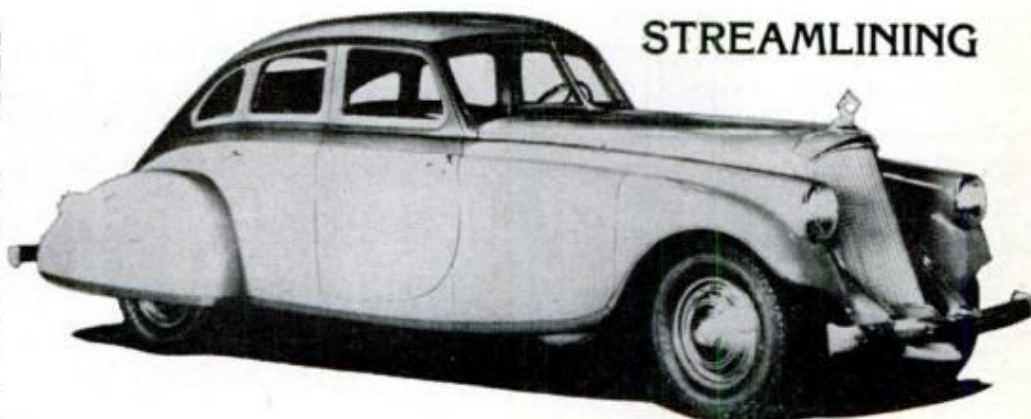

Brush Runabout had coil springs *on all four wheels*. The Brush, it is true, did not have *independent* coil suspension on all four wheels, but it embodied an ingenious combination of radius rod and friction-type shock absorber, decades ahead of its time.

Alanson P. Brush, versatile auto designer, used a chassis frame and axles made of wood for his Runabout. The wood—hickory, maple or oak—was oil-treated and air-dried before painting. With metallurgy still in its infancy, Brush claimed that wood combined lightness with great strength and the resiliency of steel. He proved correct. Some 3000 Brush Runabouts were built and sold for \$500 before the public's fancy latched on to something else. The Brush, however, featured many ingenious details. For instance, the coil springs had the additional advantage of operating under tension and closing up on the rebound, instead of working under compression as they do today.

Brush also had some practical ideas about engine balance. The Runabout's single-cylinder, seven-hp engine could turn a smooth 2200 rpm—an exceptional speed for that time. This performance was possible not only because of the usual crankshaft counterweights, but by an extra loaded system of weights driven from the crankshaft and rotating *in the opposite direction*. This arrangement was claimed to “remove all vibration due to reciprocating weight and, in addition, most of the torque vibration.”

Incidentally, the coil springs gave the Brush a much shorter turning radius than the average car of its day, and this, combined with a short wheelbase, made it very maneuverable.

● *Underslung chassis*. Many modern automobiles no longer have a separate chassis frame. The floor pan and body are welded in one piece, but the principle used for getting a lowered center of gravity (with superior roadability) goes back to 1907. The basic idea is to suspend the mass *below* the springs, and not perch it on top of them. Harry

C. Stutz, then with the American Motor Car Co., designed this idea into the famous Underslung, soon to be copied by other American makes such as Regal. By giving the front axle a steep upward curve at either end and using upswept frame members so that the front springs were carried high, both axles could be suspended at the same level.

“In swinging this frame,” the car catalog read, “the center of gravity is lowered, throwing the weight near the ground. This system affords great safety in turning corners, for the reason that the springs are so nearly in line with the horizontal center of the mass of weight that, instead of being deflected vertically, the load is applied to the side of the springs. As the spring cannot be deflected laterally, the frame is retained in a horizontal position and the unpleasant swing-out feeling at a corner is quite obviated.”

Other advantages claimed were “a straight-line drive for the propeller shaft and the conservation of engine energy ordinarily lost by an angle joint.” Skidding was eliminated and the driver could see both front fenders, yet the American used “selected hickory” wheels of 12 spokes and 40-inch diameter. Tire size was 40 x 4-inch and small diameter, low-profile, extra-wide-tread tires had not even been thought of.

● *Interaxial seating*. Today, cradling the passengers between the front and rear wheels of a modern sedan is standard, but don't imagine for a moment it's a new idea. Many people regard this design as an “innovation of the '30s.” In fact, it goes back to 1913. Then, the Austin Automobile Co. of Grand Rapids, Mich., (no connection with the British Austin) patented a system of

*(Please turn to page 220)*

## 1907 | BRUSH | COIL SUSPENSION

BRUSH RUNABOUT, a popular two-seater, had coil springs all around way back before the Great War

Color Photo by Tom Burnside

POPULAR MECHANICS



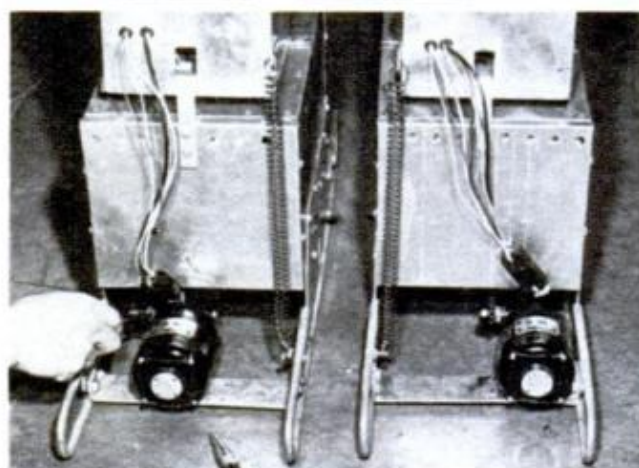
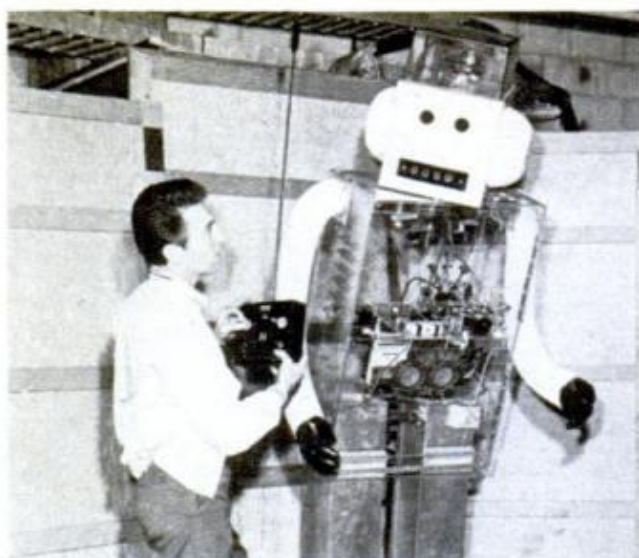
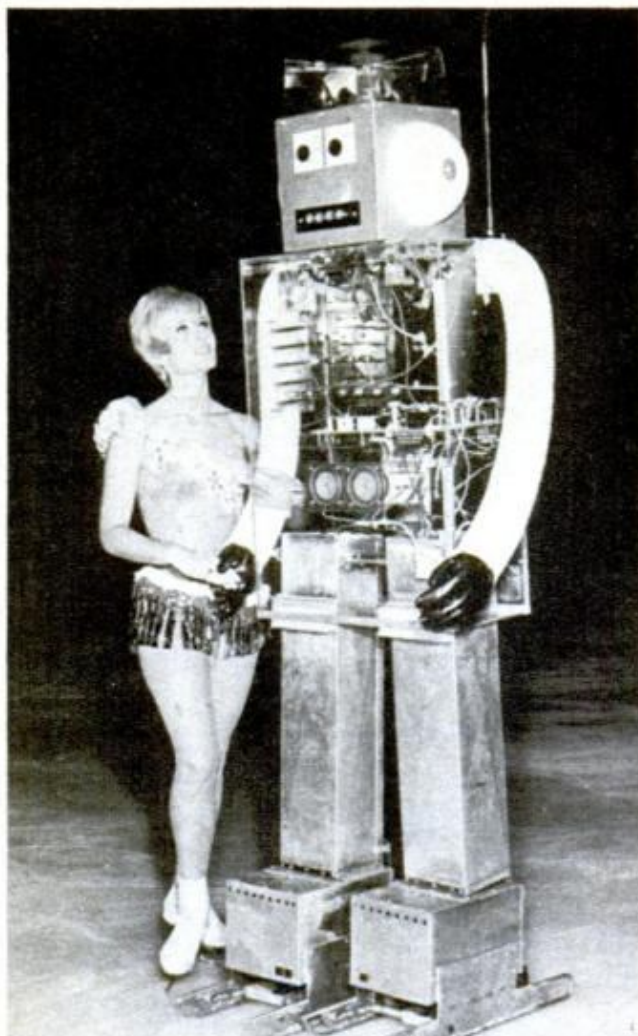

## First year of skating—and he's in the Follies!

Commander Robot is a 7-foot, 4-inch aluminum and plexiglass creation whose skating skill rates him a featured spot in Shipstads and Johnson Ice Follies of 1969—as well as an admiring glance from another skater (left) who obviously is *not* a robot. The robot's creator, Dave Colman (upper right), demonstrates the radio gear that transmits to the robot's 14-channel receiver to activate seven motors and control movement. In the robot are 50 pounds of batteries, clusters of servo switches, tape recorder, assorted lights and two 1/50th-hp motors (lower right) that drive sprockets that bite into the ice to make him move.



## Supersonic Blowpipe

Britain's new infantry weapon, the Blowpipe, is a supersonic missile that's fired from a hand-held canister against surface targets or aircraft within a four-mile range. The entire unit, including one round of ammunition, weighs 40 pounds. Incorporated into the firing canister is a sight and control that guides the missile to its target.



**APOLLO SPACECRAFT CREW** for first flight with lunar module (from left): Russell Schweikart, LM pilot; Lt. Col. David Scott, CSM pilot, and Lt. Col. James McDivitt, commander

**Hopefully, before the month is out, ungainly LEM will burst out of its shroud and unite with a free-maneuvering Apollo. On the success of this union hang our chances of planting men on the moon this year**

By WALLACE CLOUD



## The Moon Bug Learns to Mate

**O**UR FIRST TRUE SPACESHIP, Ray Pratt calls the Apollo Lunar Module. "It can't even be tested satisfactorily in the atmosphere. We won't be sure about it until the astronauts fly it into orbit."

Pratt, a mission-support expert at Grumman Aircraft Engineering Corp., was steering me through the complex LM construction and testing facilities. Climbing in and out of spacecraft in various stages of completion, we discussed what will happen during the first manned flight of the gawky-looking moon bug.

(Formerly called LEM, for lunar-excursion module, the vehicle is now officially called the LM, for lunar module. But in conversation among space engineers, the familiar LEM sticks.)

Even though Apollo 8 was more exciting, this mission, Apollo 9, is the key to actually *landing* on the moon.

At launch, the basic configuration

goes like this. The Saturn V rests on the launching pad. The LM is stowed in the third stage, with its legs folded and within a protective shroud. The Saturn is topped off by a service module and command module, both exposed and collectively known as the Command/Service Module (CSM). The astronauts take the initial ride into space in the command module, often identified as the Apollo, although it's more correct to refer to the entire configuration, including the LM and CSM as the Apollo Spacecraft.

In orbit, the three-man crew in the command module will detach the CSM, pitch over 180°, dock hatch-to-hatch with the LM, then detach the mated pair from the Saturn's third stage and pull away.

Only then—for the first time in the space age—will astronauts move from one spacecraft to another, crawling

*(Text continues on page 124)*

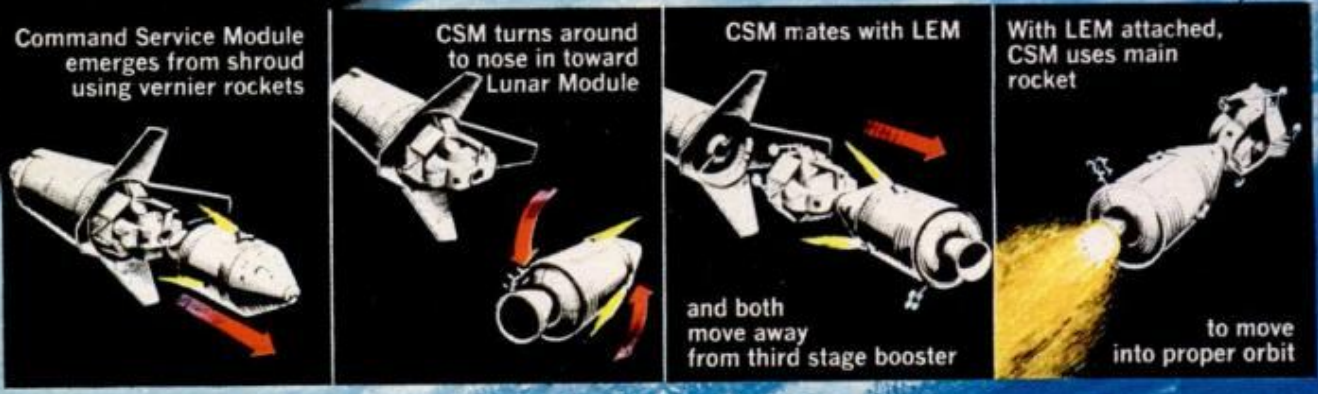
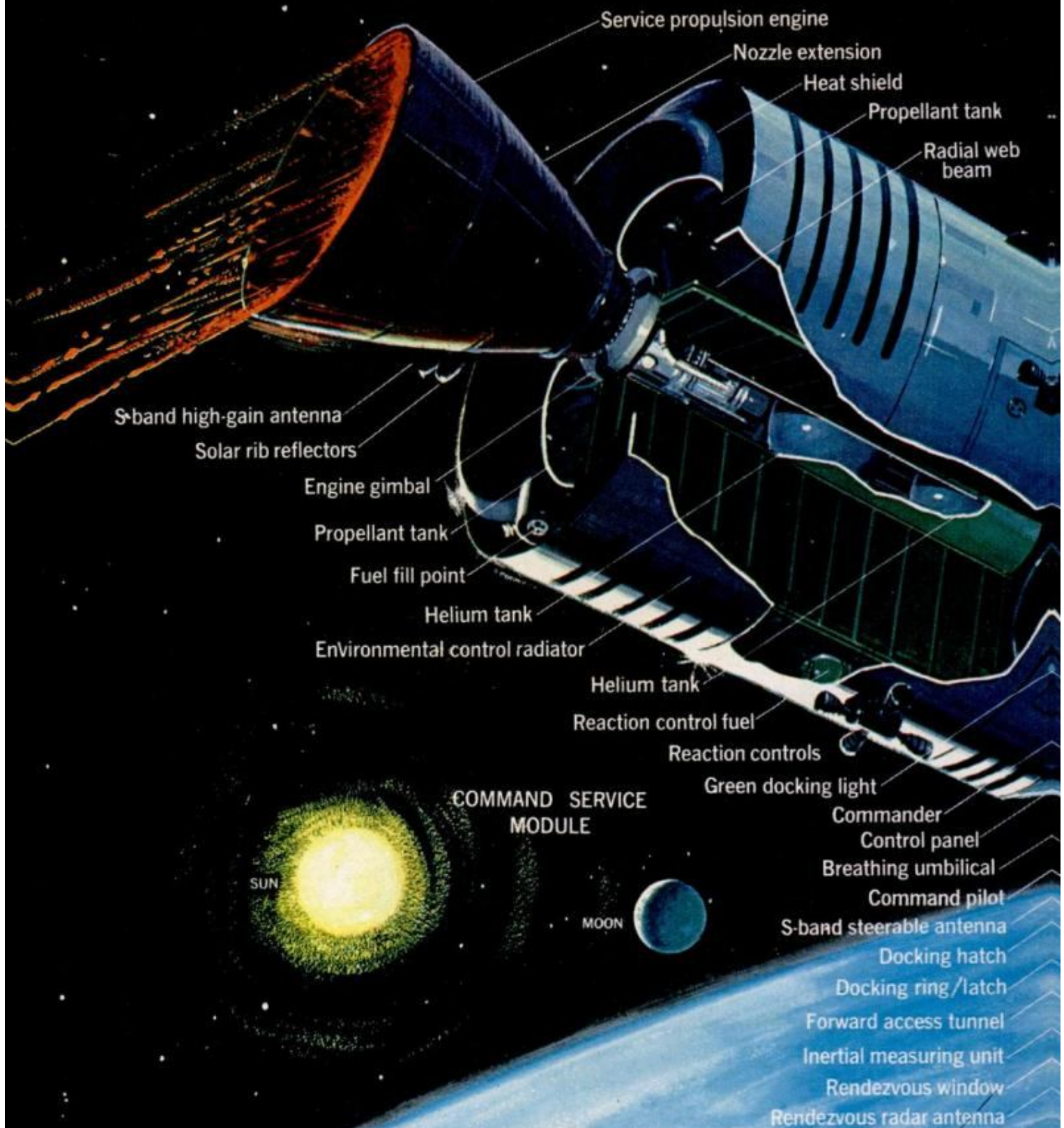



# APOLLO SPACECRAFT

Astronauts in first transfer from Command Module to Lunar Module in test flight while in Earth orbit.

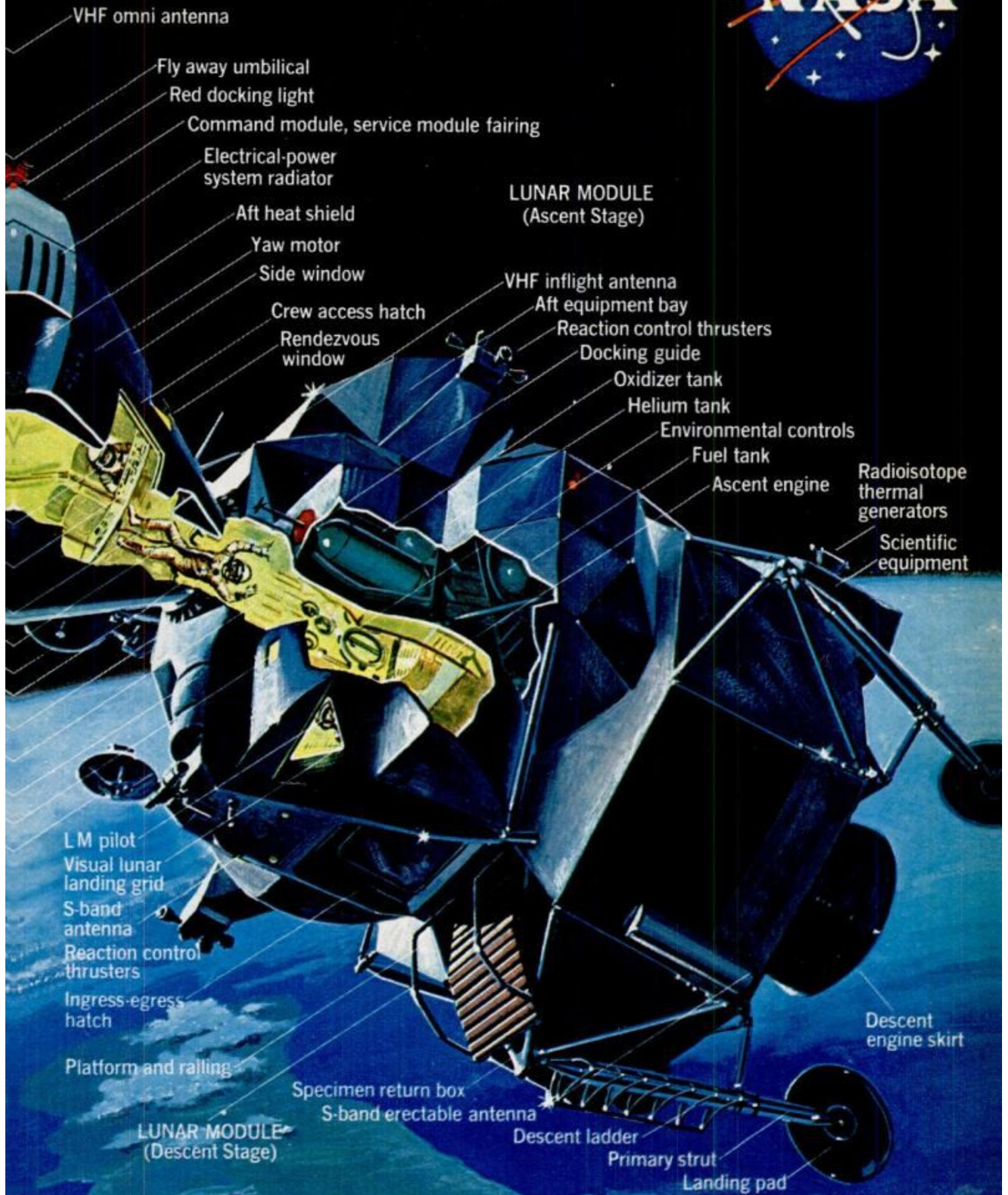

VHF omni antenna

Fly away umbilical

Red docking light

Command module, service module fairing

Electrical-power system radiator

Aft heat shield

Yaw motor

Side window

Crew access hatch

Rendezvous window

LUNAR MODULE (Ascent Stage)

VHF inflight antenna

Aft equipment bay

Reaction control thrusters

Docking guide

Oxidizer tank

Helium tank

Environmental controls

Fuel tank

Ascent engine

Radioisotope thermal generators

Scientific equipment

LM pilot

Visual lunar landing grid

S-band antenna

Reaction control thrusters

Ingress-egress hatch

Platform and railing

Specimen return box

S-band erectable antenna

LUNAR MODULE (Descent Stage)

Descent ladder

Primary strut

Landing pad

Descent engine skirt

Illustration created especially for Popular Mechanics by Fred Wottt, Ed Valigursky and Marian Mantredi

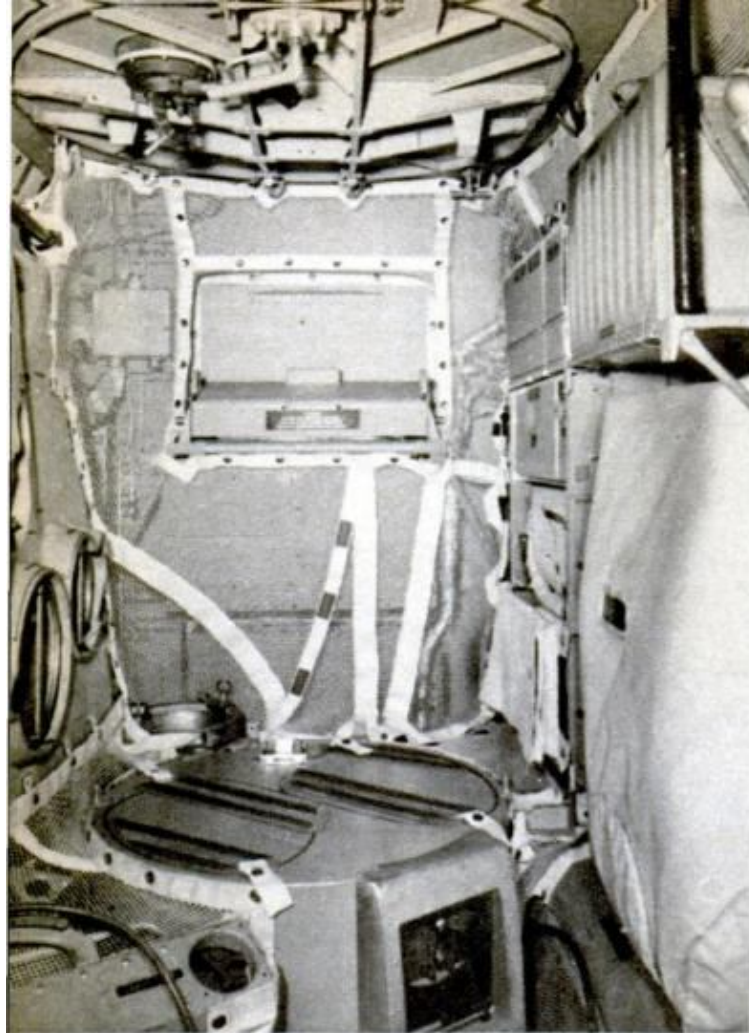

LM CABIN, behind astronauts, shows hatch (top) to CSM crawlway, ascent-stage engine housing (bottom)

from the CSM to the LM. Next they will rehearse, while in Earth orbit, what other astronauts must do in a later mission to land on the moon. They will detach the LM, simulate a moon landing and moon takeoff, rendezvous with the CSM, and return to Earth. How are they going to manage such an intricate series of operations?

To find out, I put on a surgical cap and gown and followed Pratt into the dust-free LM construction area, and got my first surprise. The LM is *big*, two stories tall (22 feet) and 16 tons heavy. I thought, "They're going to land *that* on the moon!"

The LM looks like a gargantuan bug, a scowling face with triangular eyes in a lumpy head that rests on a squat, octagonal body that is supported by four crouching legs. Actually, the "face" is a two-man cabin with windows.

The LM is a two-stage rocket ship. The octagonal base houses fuel and oxidizer tanks surrounding a rocket en-

gine; this is the "descent stage," which produces the thrust on which the LM will balance as it descends to the lunar surface. The legs contain crushable aluminum honeycomb material to cushion the landing impact. The descent stage will also serve as a disposable launching pad when the LM lifts off the moon. The upper section is a detachable "ascent stage," its cabin and equipment clustered around a rocket engine normally concealed from view.

The entire ship looks strange because it's designed to function only in space, and has been stripped of all nonessentials that would add weight and waste fuel. Because the LM is also designed as a disposable craft, to be jettisoned in space, with a life span of only 48 hours once its systems are turned on, a lot of checkout must be crammed into the few earth-orbiting test flights that will take place before the actual lunar trip.

On the first orbital flight, the scheduled crew will consist of Air Force Lt. Col. James McDivitt, commander; Russell L. (Rusty) Schweikart, a civilian, LM pilot; and Air Force Lt. Col. David Scott, CSM pilot.

Their first job, once in orbit, is to "extract" the LM from the housing called the spacecraft-LM adapter, or SLA (pronounced "slaw"), behind the CSM at the tip of the Saturn booster.

Firing a shaped explosive charge will cut loose the joined modules and release the "petals" of the SLA shroud, pulled open by a spring-cable system.

Next comes a maneuver called transposition and docking. The CSM pilot fires the small rocket jets of the reaction-control system to move the CSM 50 to 100 feet away from the LM. Using the same jets, he brakes, flips the ship end-for-end, and moves back in to dock. This is done by means of "probe and drogue" gear. A probe projecting from the command module's docking tunnel is poked into a funnel-shaped drogue in the LM's hatchway. Hooks on the probe engage the drogue. Then a gas-powered piston in the probe is retracted, firmly pulling the two craft

together, and latches are then fastened.

During close docking maneuvers, the pilots control their spacecraft manually, and line up the target visually. Other maneuvers will be controlled through computers, but the delicate management required for docking can be entrusted only to human judgment.

Now the command module's hatch is opened and a crew member reaches into the docking tunnel to plug in a short umbilical cable. This enables the CSM pilot to fire explosive bolts that hold the LM to the third stage of the booster. The docked spaceships will then be free in space.

The LM crew, McDivitt and Schweikart, will enter their lunar ship on the third day of the flight. When it's time, the LM pilot reaches into the hatch tunnel and demounts the probe and drogue, which are stowed in the command module. Then both men crawl through the tunnel into the LM cabin. There are no seats, so the astronauts "stand" weightless—buckled into restraining harnesses before the triangular viewports and instrument panels.

During various tests, the LM will be

activated and deactivated several times. By turning on and off the life-support system and other systems that consume power, the LM can be left dormant for long periods, stretching its 48-hour life.

The fifth day should provide the most spectacular space acrobatics—separation of the LM from the CSM, maneuvering up to 90 miles from the mother ship and in another orbit, then simulating a climb from the moon to the CSM.

To begin, McDivitt and Schweikart will enter the LM, activate its systems and check them out. Then they will reinstall the probe and drogue in the tunnel and seal the tunnel's end hatches. Scott, who stays in the command module, throws switches retracting the probe hooks and tunnel latches. The LM pilot, Schweikart, fires his reaction-control jets to move the LM.

Now, for a first time, men will fly the lunar module. After a runthrough of the attitude-control and station-keeping systems, they fire the descent engine to brake the spacecraft, simulating descent to the moon. The LM falls toward

*(Please turn to page 222)*

**LM INSTRUMENT PANEL.** One astronaut will stand at each window, strapped in, during free-flight maneuvers. Below panel in center is front hatch where astronauts will emerge for ultimate landing on moon

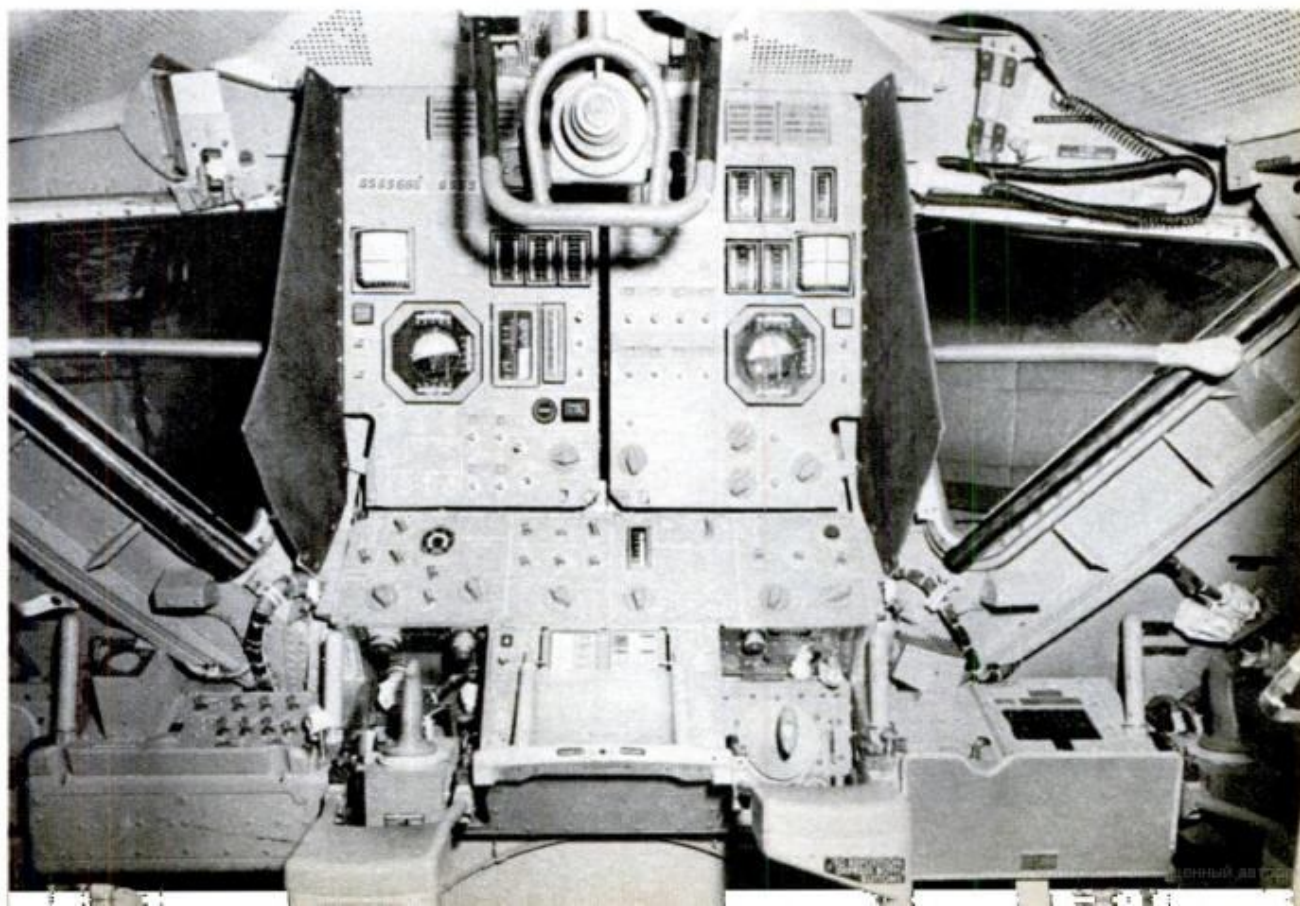

# LAKE

## *A Spectacular Test Ground*

**PM reports on how you can use this 21-foot bow-rider as a camp trailer on land—as a camp boat afloat**

By DAN FALES, Boating and Outdoors Editor

Photos by Joe Munroe

**W**ILDERNESS BUFFS AND RIVER RUNNERS liked Glen Canyon better the way it used to be—when the savage Colorado meandered quietly through its awesome, but surprisingly placid, gorge. Now there's no river, but a lake—a big one—and perhaps the most scenic and spectacular water in the world for ordinary powerboats.

The boat I am testing between Lake Powell's red-walled cliffs and amphitheaters is no ordinary powerboat, but a luxury stern drive with a 160-hp engine. Instead of drifting, I move along at 35 mph.

Canyon after canyon along the shore calls for exploration. I stop at some and listen for the echoes of history: mules struggling



# **POWELL:** *for Glastron's Vagabond*

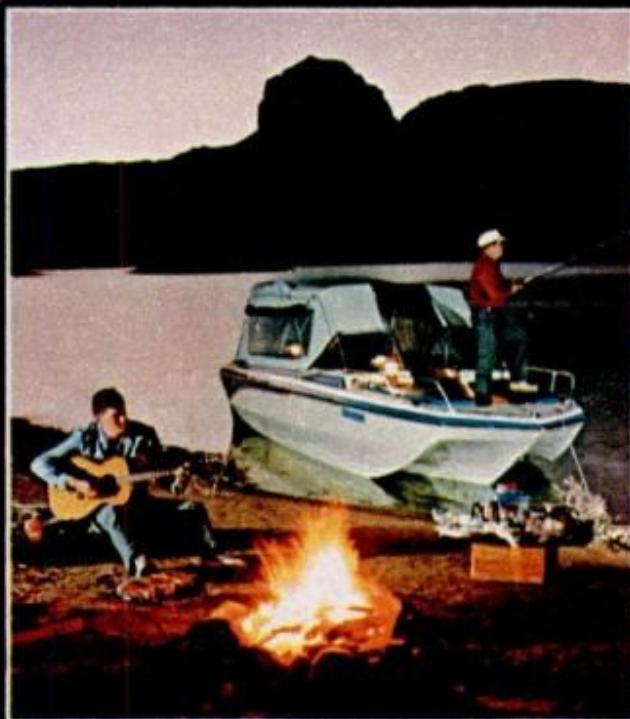



**A GREAT FEATURE** on Vagabond is the stern steps. Not only is it easy to climb aboard from the water, but it's easy to climb aboard from dry land when the boat is high on a trailer. The steps fold into the stern neatly (see photo at bottom of the page)



**SNORKELING** or scuba diving are only two of the many boat-fun activities made easy by Vagabond's design. Ranger Lynn Pattan has been trained for underwater work. This is part of his exciting job. On a trailer, Vagabond (right), can easily be made into a camping rig by setting up the "tent" as shown on the next page. Rigging the tent is a simple matter once you get the hang of it

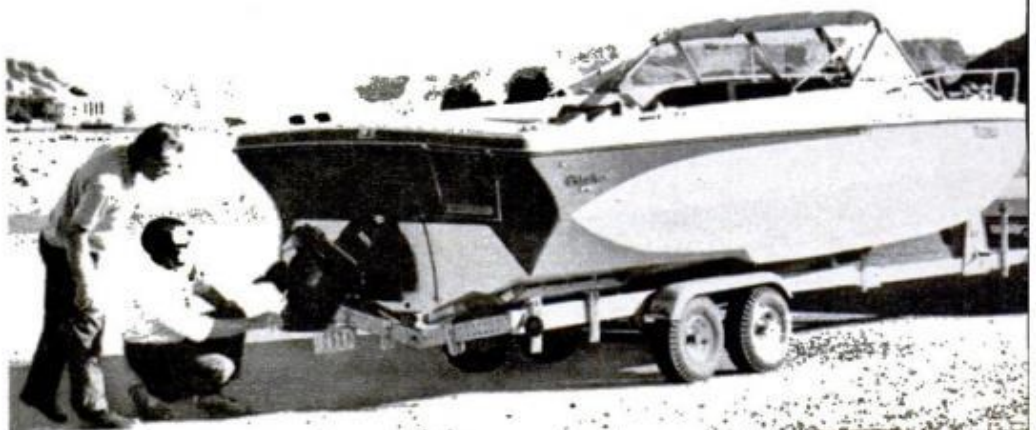

to hold Mormon wagons back as they descend through Hole in the Rocks; lingering echoes of those who camped at Cathedral in the Desert; Teddy Roosevelt astride a horse gazing at Rainbow Bridge—sights that men spent days reaching, risking life and limb. They were worn and tired and angry and hurt and awed. I'm comfortable and fully equipped.

All this you can do, too. You can see it, feel it, hear it, live it. I am testing a camping boat; you can come in your own boat.

Eight years ago, men built a barrier across the Colorado River. They called it Glen Canyon Dam. It's enormous. And it's the cork in a 183-mile bottle that's shaped like a lightning bolt. It's Lake Powell starting at Page, Ariz., and spearing deep into Southeastern Utah. The lake is named for Maj. John W. Powell, who was the first to explore this glenlike section of the Colorado just 100 years ago.

Right now, I'm 400 feet above the level that Powell rode 100 years ago. The water behind the dam is that deep. I'm in a 21-foot Glastron boat called the Vagabond because it's a camper, too. With me is Joe Munroe, an experienced river runner and expert photographer, and Lynn Pattan—a young, energetic ranger for the National Park Service.

Our purpose—see Lake Powell and try out the camper boat.

At 9:05 a.m., the three of us leave our base at Wahweap, Ariz. This is Park Service headquarters for the Glen Canyon National Recreation Area

which includes Lake Powell. It's also one of four major boat-launching sites on the lake. Gas, food, fishing licenses and boat supplies are available here.

A cold wind, threatening sky and a light rain force me to raise the navy top on the Vagabond. This is an easy task, taking not more than two minutes. With the top up and the window/door to the bow-riding section closed, I am out of the elements. But there's no windshield wiper on the Vagabond so during rain showers, I find my eyes straining to see Lynn's boat ahead.

We are taking two boats along—the Glastron and a high-powered craft used by the Park Service to patrol the lake. By the way, the Park Service does a tremendous job of keeping track of people on the lake. They use boats with big "RANGER" signs on the sides. You can spot them a mile away. The Service also marks the main channels and anchors information signs at entrances to the most important and scenic side canyons.

But my first meeting with Lake Powell is not in a side canyon but right out in the main channel. We are not 15 minutes from Wahweap when we enter the Narrows. This is a 10-mile section that's only 200 yards wide.

Boat wakes are the big problem in the Narrows. There's no place for the

energy developed in the wakes to dissipate. A wake will bounce back and forth across the channel for 20 minutes. You couple this one wake with hundreds and you can see the situation—especially bad on weekends when there's heavy boat traffic.

This is the first chance to test the Vagabond. At three-quarter throttle, I hop these ricocheting wakes. Vagabond with its cathedral hull is stable, dry, easy to handle. When she comes off a wake top and hits "bottom" her weight

*(Please turn to page 224)*

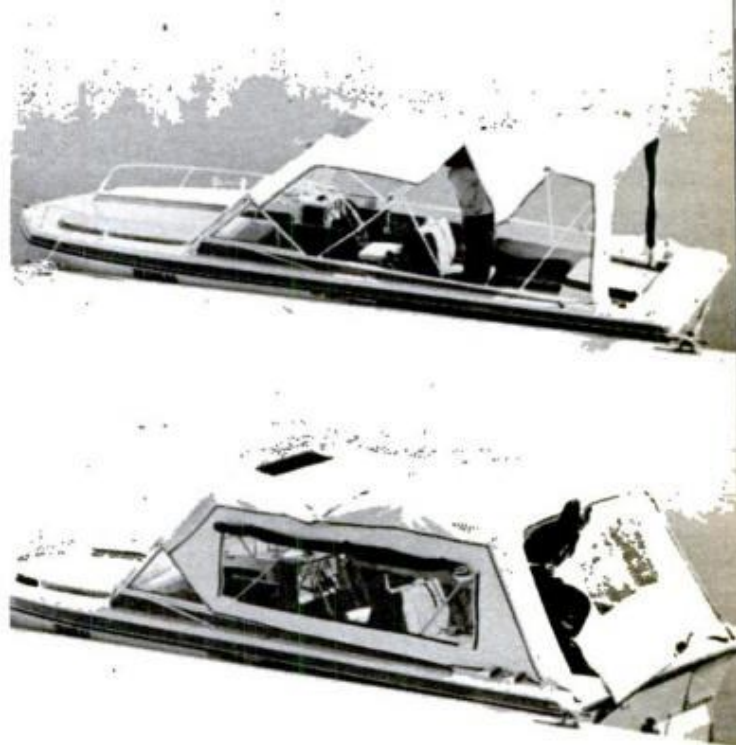

**ERECTING THE TENT** (upper right) means zipping together navy top and stern top, adding the two side curtains, zipping on the stern curtain. All curtains snap down on hull. With tent up (right) there's plenty of room inside. (The Vagabond has a storage area amidships between the two lounge seats.) Up under deck are two bunks (bottom) which sleep two six-foot people. Cushion between bunks covers head



# Bar Full of Bright

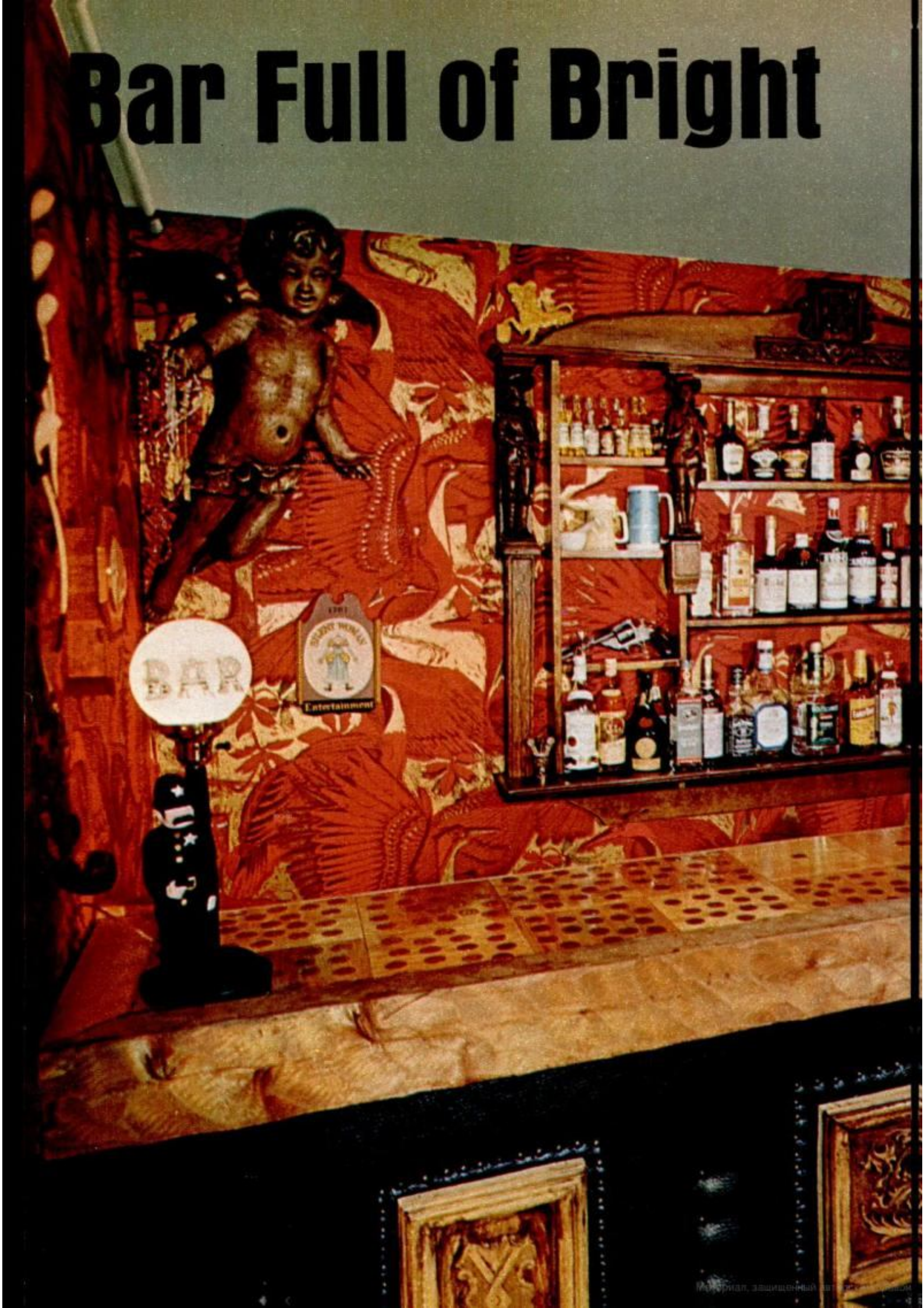



# Ideas

**Y**OU CAN ALMOST SEE Diamond Jim Brady hoisting a few at this nostalgic "Silver Dollar Bar." Yet the coins embedded in the bartop are not silver, but shiny British pennies fitted into holes drilled in parquet flooring blocks.

The figures on the liquor shelves look like expensive custom carvings, but they came off the legs of an old dining table.

Paul Bruckman, a General Electric sales executive, ordered the pennies through his bank and covered them with marine varnish. (Clear casting resin would provide a more durable surface.) He salvaged the table legs from the basement of a house his family was renting before moving into their new home in Stamford, Conn. Carved panels on the bar front came from an old chest; carving at the top of the shelves from an old headboard.

What all this proves is that ingenuity is more important than money, and that you can do a lot with a little imagination.

The Bruckmans admit they splurged a little on the handsome red wallpaper in this tiny space off their family room. The 25-in.-high baroque cherub is a plastic reproduction that costs about \$16 from Artistic Latex Form Co., 1216 Brook Ave., Bronx, N.Y. 10456.

If you'd like to try the casting resin for your next bar project, you can order it from Polk's, 314 Fifth Ave., New York, N. Y. 10001. A gallon, with catalyst, costs \$8.50, postpaid. ★★★

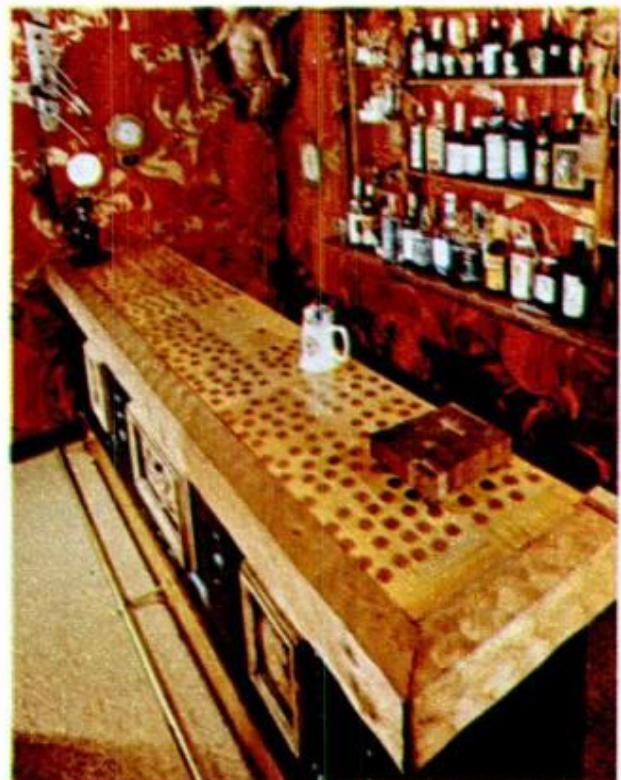
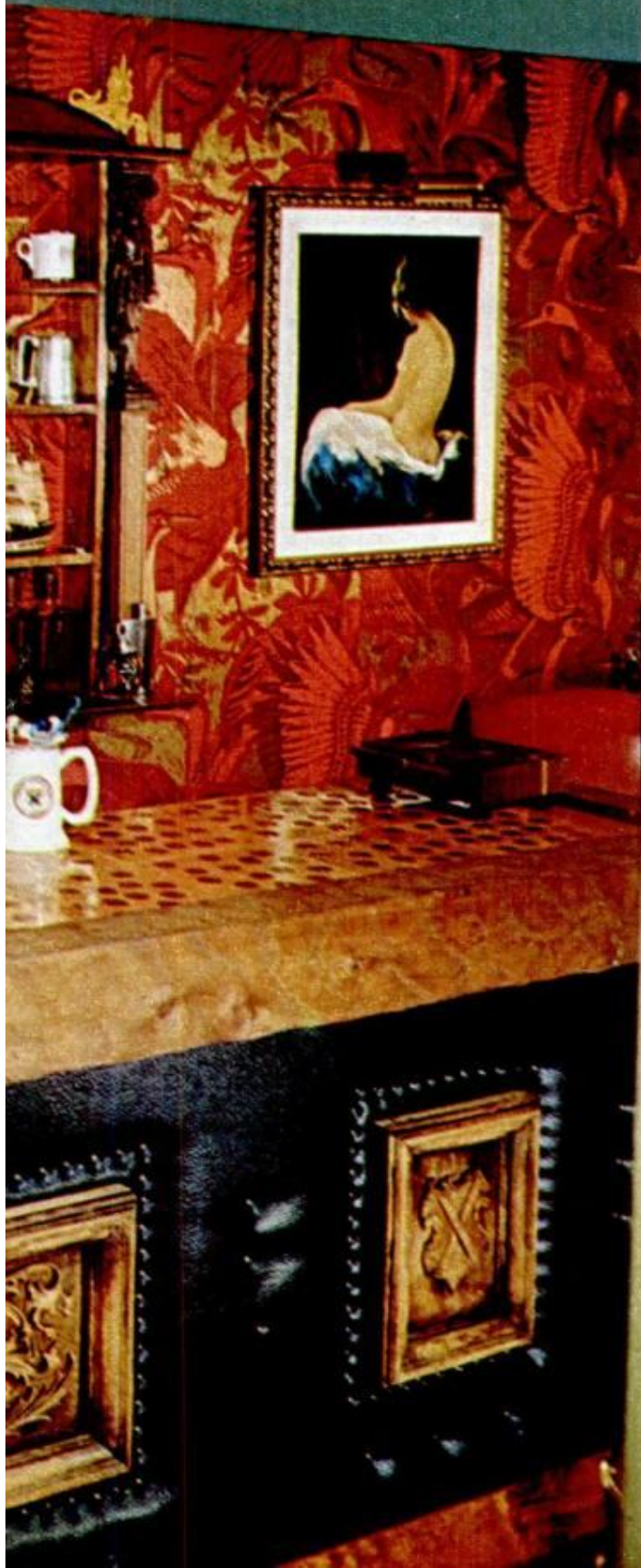

Photos by Robert Borst

# BUILD THIS Colonial Cabinet-Top Desk

By PATRICK K. SNOOK



**L**ARGE COLONIAL DESKS have become as rare as the wide pine boards used to build them. However, a little digging around at local lumberyards will usually turn up the necessary wide clear-pine planks. Once you have the material, making the desk is easy.

Lay out and cut the two sides from  $\frac{3}{4}$  x 22 x 122-in. planks. Cut the center divider, five shelves, bottom for the top cabinet, writing table and lower cabinet shelf.

Cut the  $\frac{1}{4}$ -in.-deep rabbets for the shelves, writing table and bottom of the top cabinet. Remember that the bottom shelf runs only from the right side to the center divider.

Glue and nail the shelves to the center divider, then fit the assembly to one of the sides. Nail it in place from the outside and use plenty of glue. If you want an authentic look, you first can flatten the heads of the nails to give them the appearance of old hand-wrought nails.

Assemble the drawer support and nail it to the bottom of the upper cabinet base. Now fit the entire assembly to the desk side, glue and nail it in place, then assemble the remaining desk side.

Fit the upper front crosspiece and center divider front strip, then assemble the

lid support housings and clamp in place before gluing to be sure that the lid supports have enough clearance to slide freely. If the fit is correct, glue and clamp the housings in place, making sure that you leave enough clearance so the door-frame pieces will fit flush with the sides. Allow sufficient time for the glue to set, then frame in the lower cabinet door. The top door-frame strip is nailed, from the front, into the ends of the lid support housings. The rest of the framing is glued and nailed, from the outside, to the sides.

Cut the desk lid and upper cabinet doors and fit the end pieces by tongue and grooving. These three pieces are hung with a pair of 2-in. wrought-iron "H" hinges. In order to achieve a good flush fit on the desk lid, it may be necessary to chisel the sections under the hinge pins. Then round the lateral edges of the lid.

Several coats of Minwax Early American oil stain, mixed with a bit of dark oak stain and black paint, will give the rich, warm tobacco color of aged pine. Sand lightly and finish with three or four coats of well-thinned shellac or Waterlox, followed by a thick coat of paste wax. When the finishing is completed, the back panel can be fitted in place. ★★★

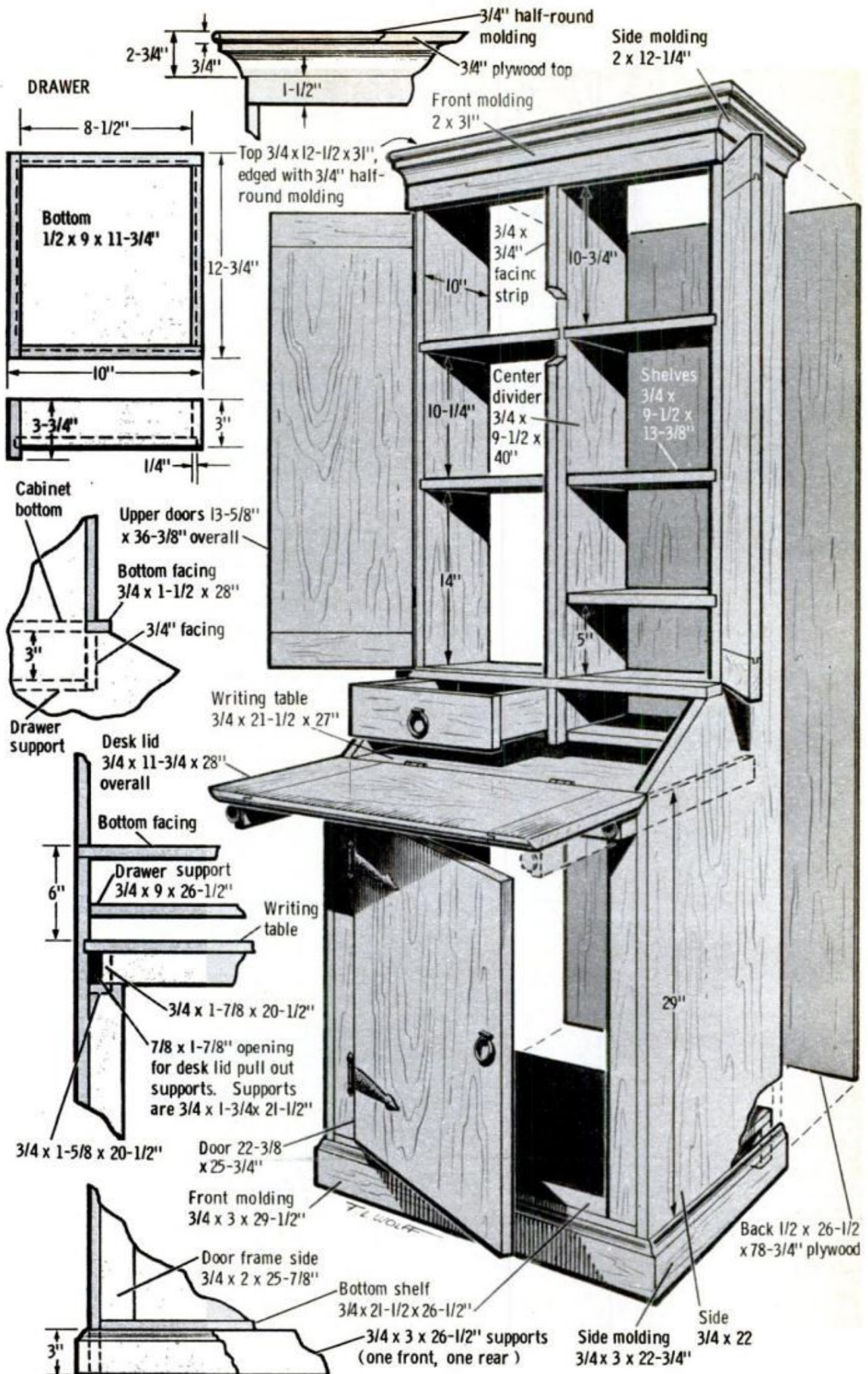

# *Model This*



# 24-Pounder

1/20th actual size of a gun from the main battery of the U.S. frigate *Constitution*, this gleaming replica makes an attractive ornament for desk or bookshelf.

By WALTER E. BURTON

**I**F YOU ARE a dyed-in-the-wool model-maker, you know that plastic models can't begin to give you the satisfaction and pride of accomplishment you get from building an authentic replica from scratch. You'll get such a charge from modeling and displaying this 24-pounder from the main battery of the U. S. frigate *Constitution*.

While both English and American types of 24-pounders were in *Old Ironside's* complement of guns, this model, in gleaming brass and contrasting walnut, is patterned after the 12 American-type guns which were deployed at the forward and after ports. It's based on original shipyard plans which were followed in the 1927-1931 restoration of the *Constitution*. The vessel is still a commissioned ship in the United States Navy.

The original guns measured 9 ft., 5 $\frac{3}{4}$  in. in length and were of gray cast iron. The wooden carriages were of white oak, and most of the fittings were steel. The barrel of our model is brass and is approximately 5 $\frac{1}{2}$  in. long, which makes it about 1/20th actual size.

Carriages for the guns in the main battery varied in size according to the gun deck, and the heights of the carriage bed blocks, which were used for elevating the barrel, were determined by trial during firing missions.

All the metal parts of the model are brass; the wooden parts are walnut. Clear lacquer is used to keep the

polished brass from tarnishing; the walnut carriage is finished natural.

Most of the dimensions are given in decimals. This is particularly true in the case of the gun barrel since the tool feed of a lathe on which it is turned is measured in thousandths of an inch. If you prefer to work in fractions, you can convert the measurements with the aid of a decimal-equivalent table. To increase the scale and size of the model, merely multiply each dimension by a suitable factor—such as 1.5 for a gun 8 $\frac{1}{4}$  in. long.

## The gun barrel

The gun-barrel blank is a 1-in. brass rod about 7 in. long. This length was selected as a convenient size for the Unimat lathe which I used in making the complete pilot model. Because a 3-jaw chuck would cut down on the usable length, the rod was center-drilled and mounted between centers, and driven by a dog made from the outer ring of

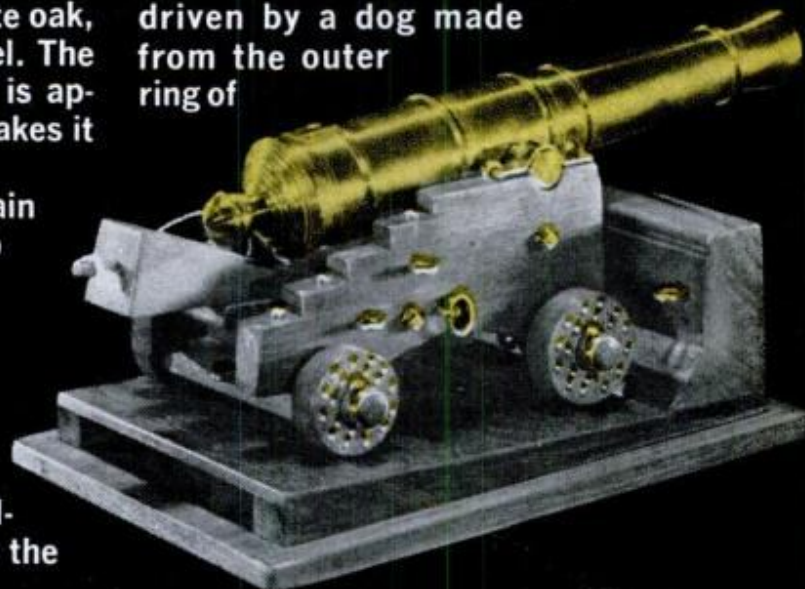

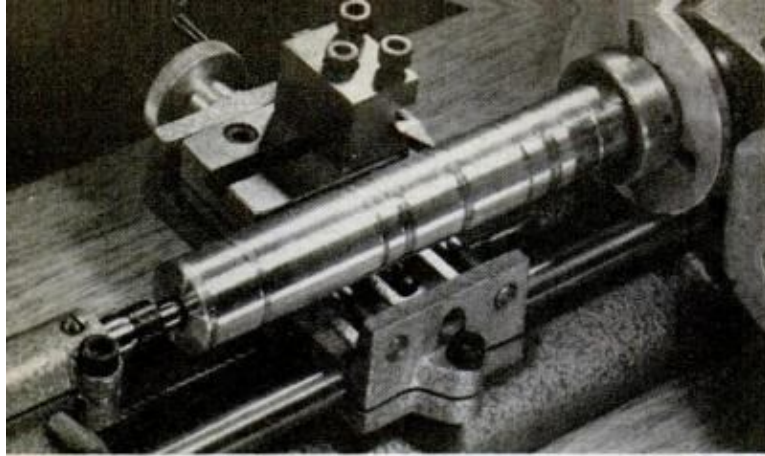

**BARREL BLANK**, mounted between centers, is driven by special faceplate dog made from ball-bearing ring

**AFTER RIDGES** are machined square they're rounded with Swiss-type file as done here at gun's muzzle end

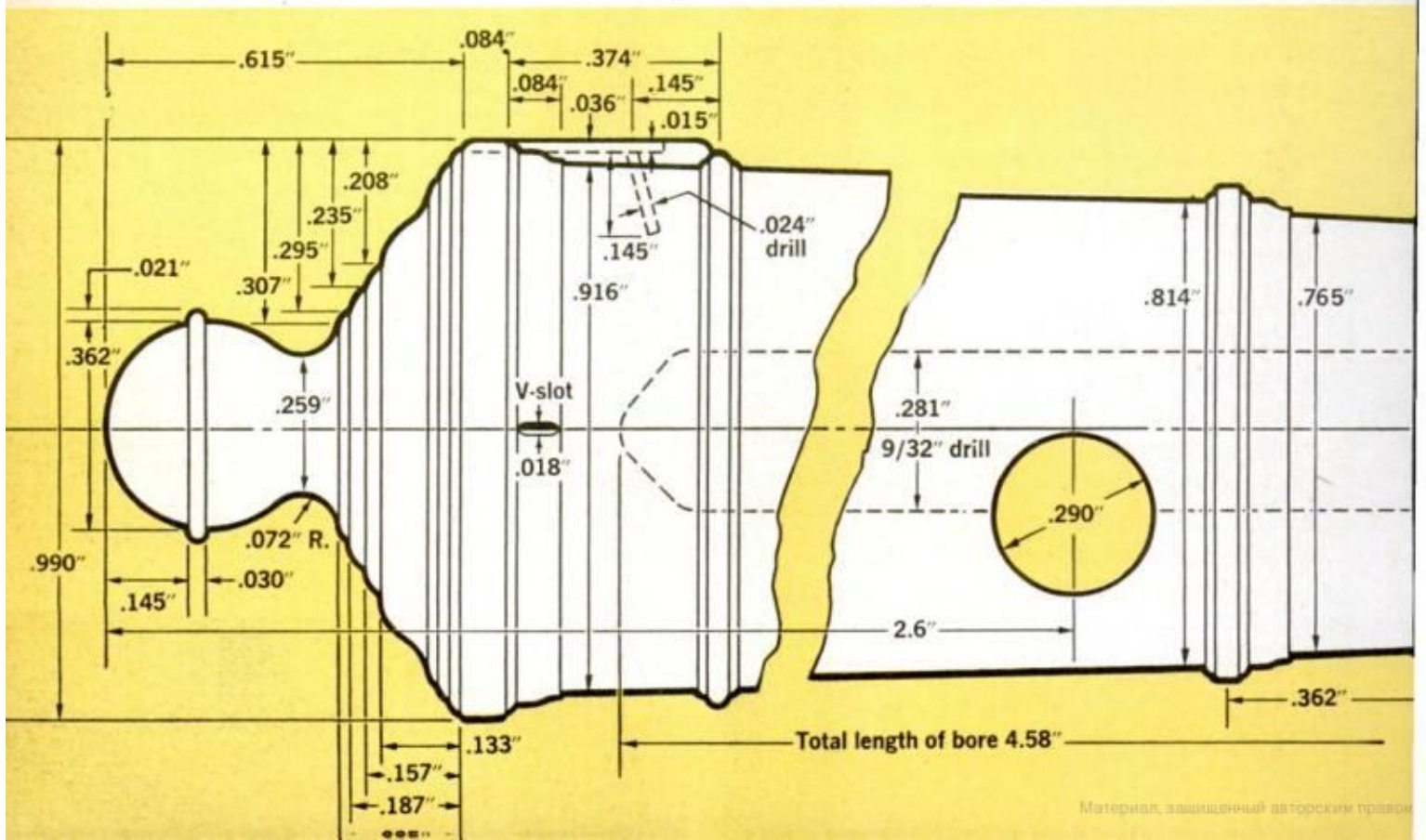
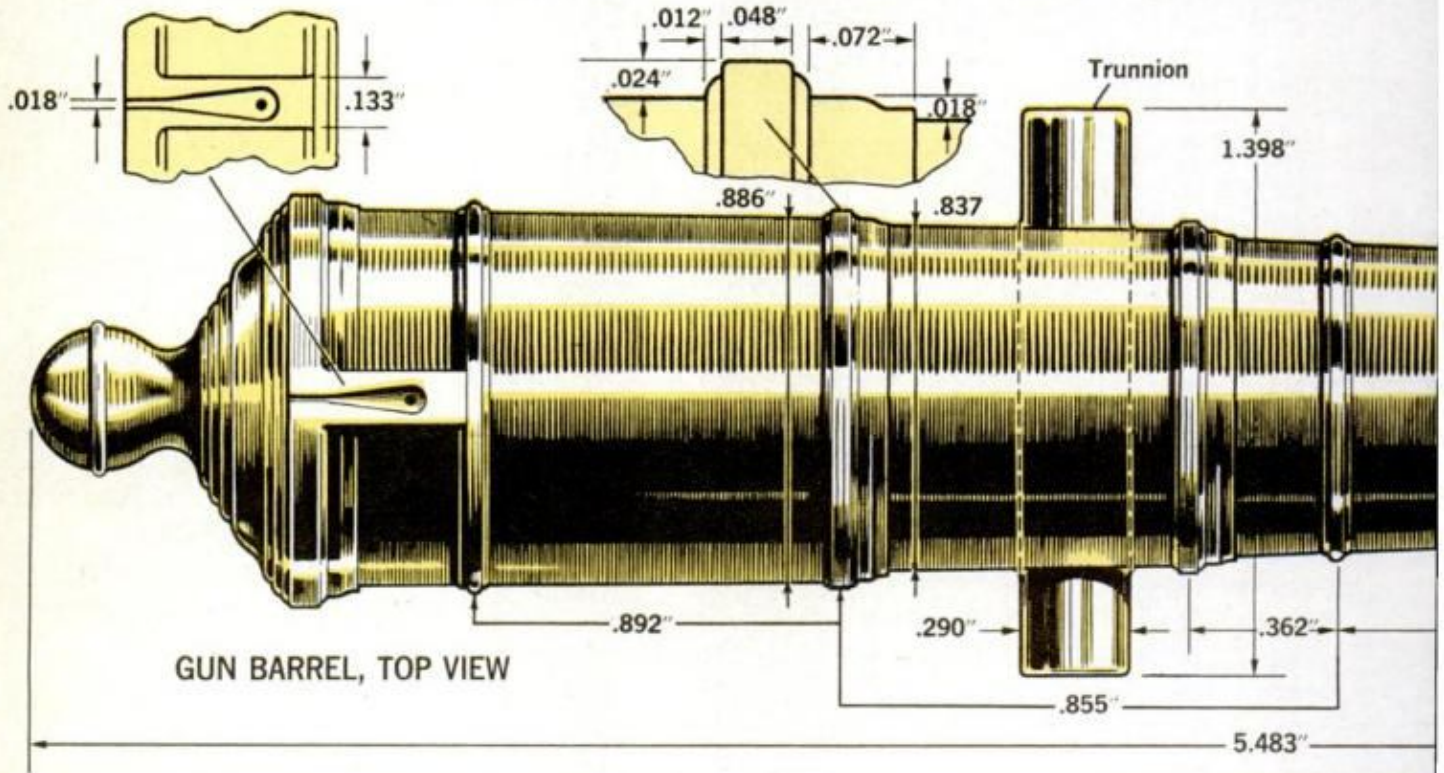

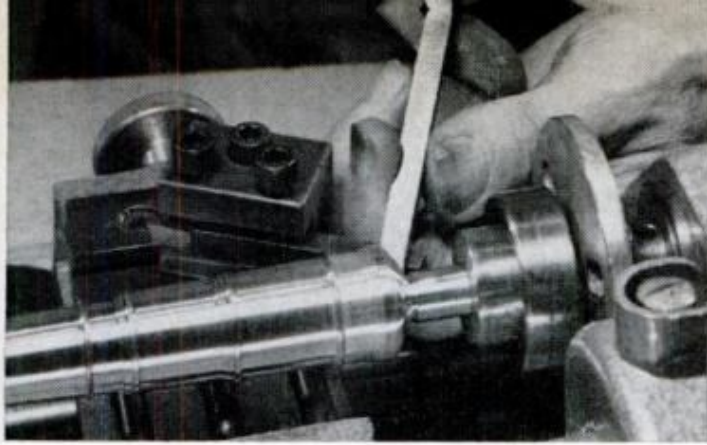

**HAND-HELD CHISEL** resting on blank bit clamped in toolholder is used to shape final breech contours



**COMPLETED BARREL** is polished in the lathe with a brass polish; the ball end is hand-finished later

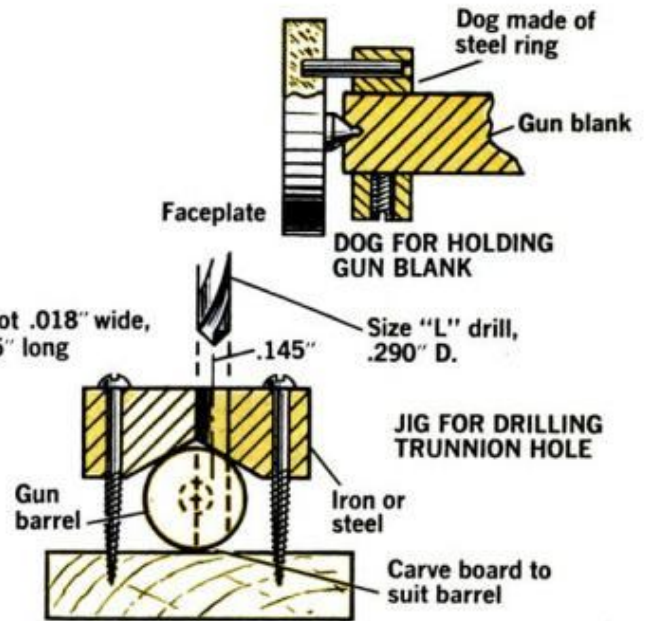
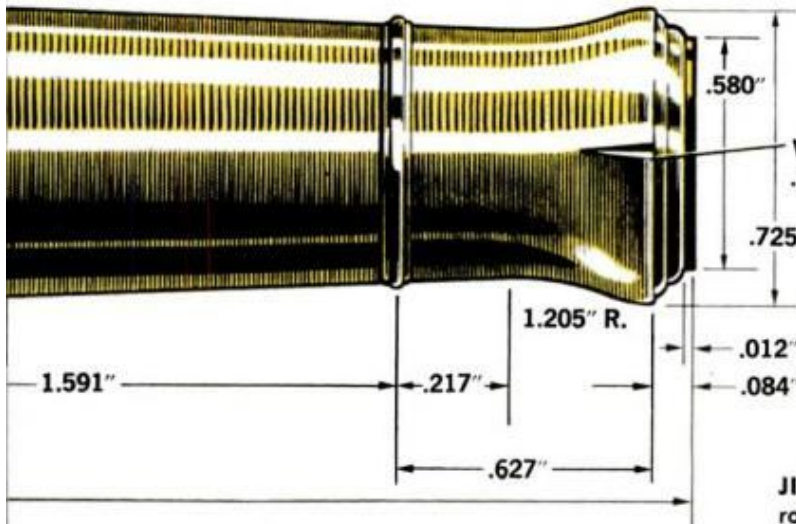
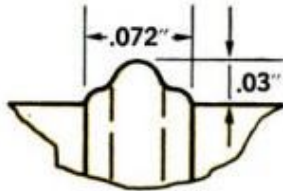

**JIG IS USED** to drill hole through barrel for trunnion rod. Note how barrel is protected with masking tape

a ball bearing having a 1-in. bore. However, any similar ring will do. If your lathe lacks bed length to drill the center holes with a bit in a tailstock chuck, lay out centers carefully and use a center drill in a drill press.

When machining the barrel, follow the drawings on these pages. To form the rounded bands and contours, machine them with square edges, then round them with a fine file or a hand-held chisel.

Trunnions are usually an integral part of a real cannon. In the model barrel, however, they are cut from brass rod. To drill the hole in the barrel for this rod, use the jig detailed above, right. If you lack an L-size drill (.290-in. dia.), you can make a  $\frac{3}{32}$  or  $\frac{19}{64}$ -in. hole and match the trunnion notches in the carriage. The rod forming the trunnions can be a drive fit or held with a setscrew on the underside of the barrel.

To bore out the barrel, use a  $\frac{3}{32}$ -in.

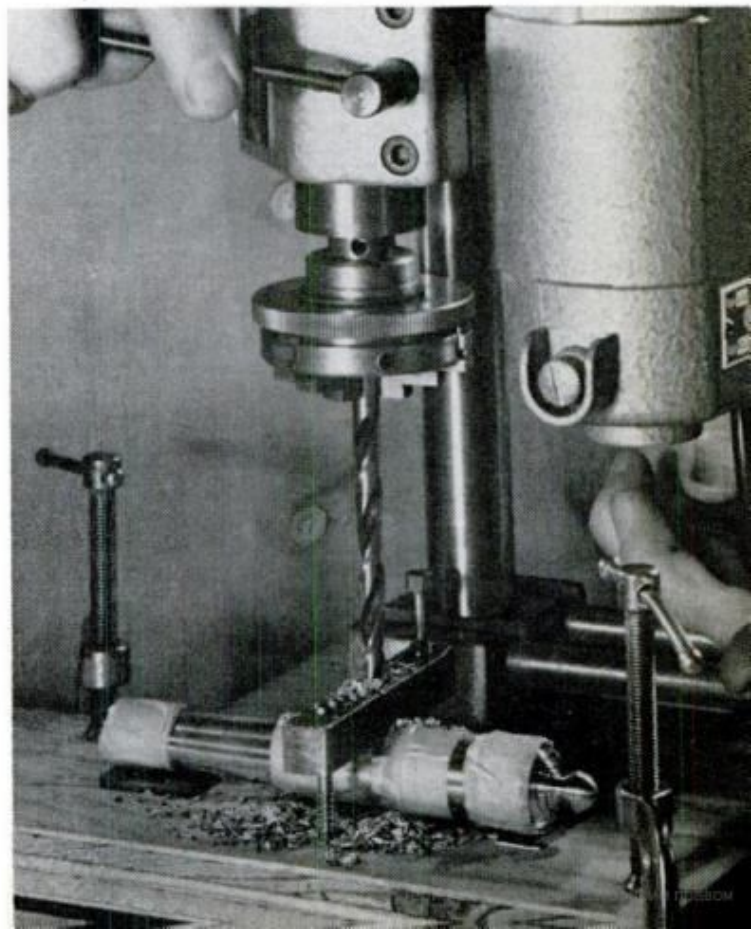

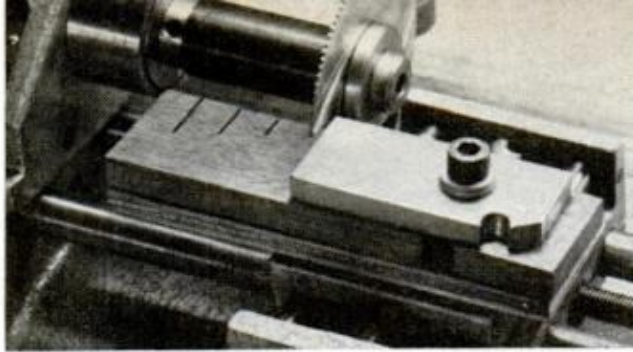

**THIN MILLING CUTTER**, on head spindle arbor, is used to cut walnut side members of gun carriage

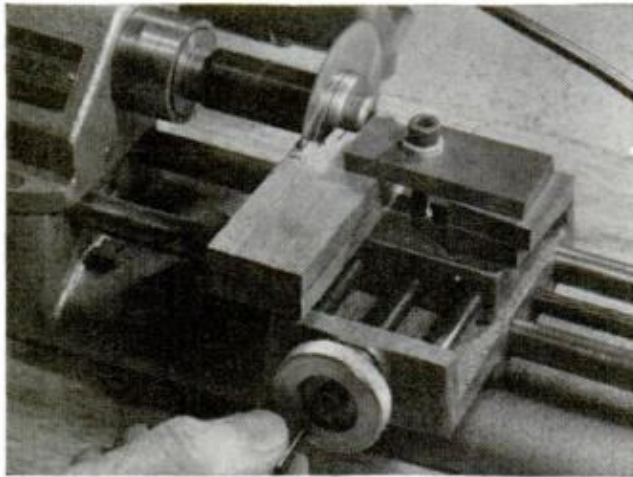

**CUTS AT RIGHT ANGLE** to first ones are made in both side pieces at same time, require hand finishing

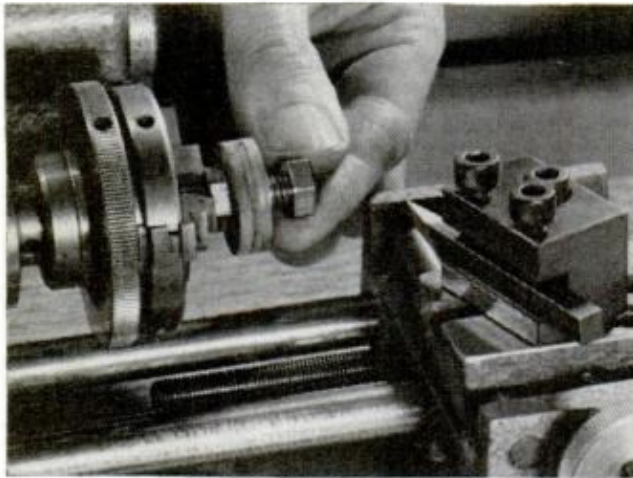

**CARRIAGE TRUCKS** are turned to final diameter by mounting discs on arbor of  $\frac{5}{16}$ -in. bolt and two nuts

**HOMEMADE "PLUG CUTTER"** from  $\frac{1}{8}$ -in. pipe is used in drill press to round ends of wooden axle-tree parts

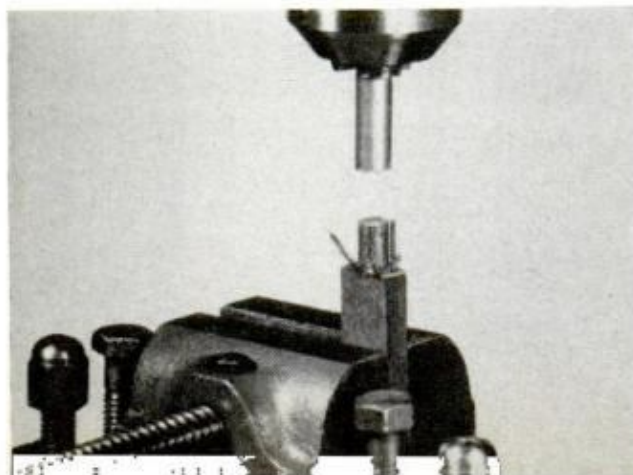

twist drill, starting at the center hole in the muzzle end. The drawing shows the bore full length, as in the original cannon, but in the model it need extend only to the trunnion hole, enough to keep the barrel from being muzzle-heavy.

The powder-igniting arrangement on top of the breech is formed as shown. The teardrop recess is a separate piece of brass soldered or cemented with epoxy to the barrel. V-shaped sighting notches on top and each side of the barrel can be hand-filed or scribed while the barrel is in the lathe. To do this, move the lathe carriage back and forth and feed a pointed tool so it shaves a notch .018-in. wide.

Before removing the barrel, polish it with very fine abrasive cloth. Then use a brass polish for a final luster. After cutting scrap from the breech, carefully smooth and polish the rounded end. If

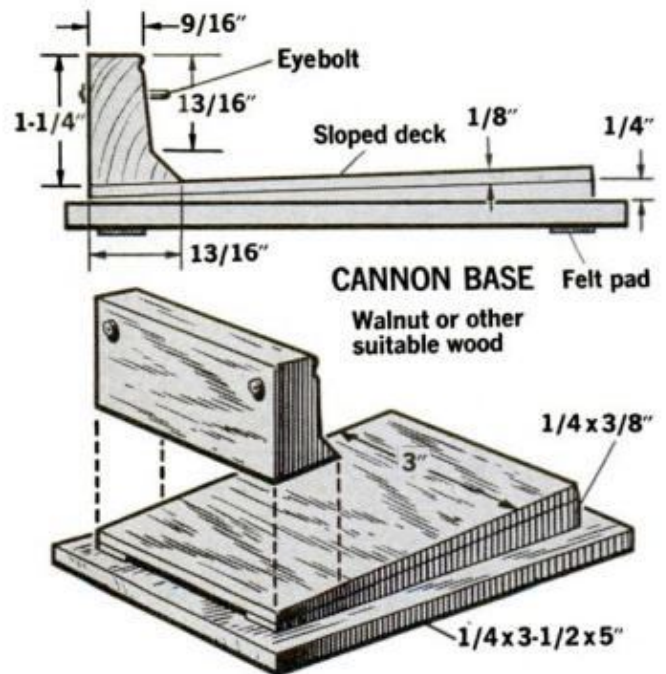

you solder the powder "pan" to the barrel, repolish the metal to remove heat discoloration. Spray the polished brass with clear lacquer.

### The gun carriage

Full-size patterns for wooden parts on the gun carriage are shown at the right. As for the sides, made in pairs, you'll find it helpful to make a master pattern from aluminum or cardboard, then drill the ring and tie-bolt holes in it. Saw both sides at one time, tape the template to them, then drill the holes slightly smaller than the eyebolts. Note that the sides

*(Please turn to page 204)*



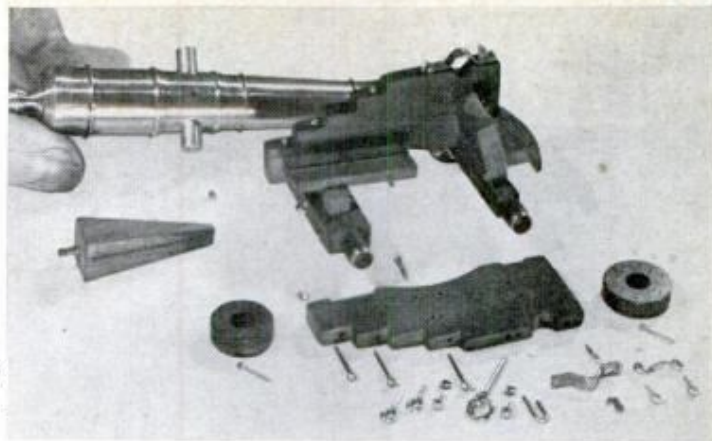
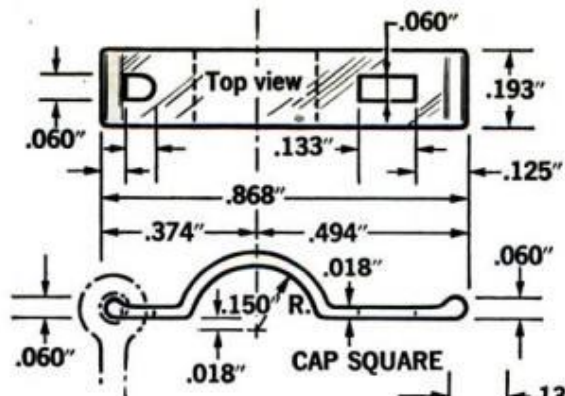

**PARTLY ASSEMBLED CARRIAGE.** Eyebolts and other parts are half-length to simulate bolts passing clear through

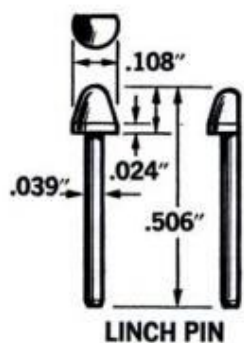

**LINCH PIN**

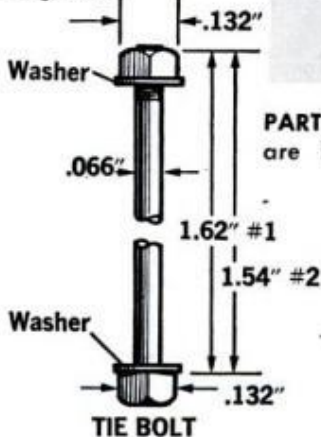

**TIE BOLT**

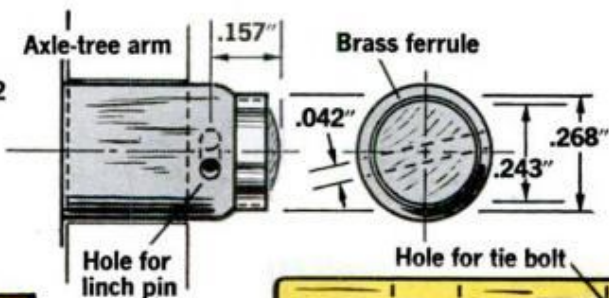

**Axle-tree arm**

**Brass ferrule**

**Eyebolt**

**Bed block**



**Ferrule**

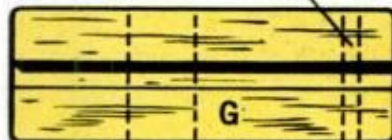

**BED** 3/16" stock

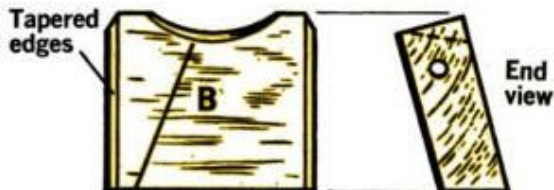
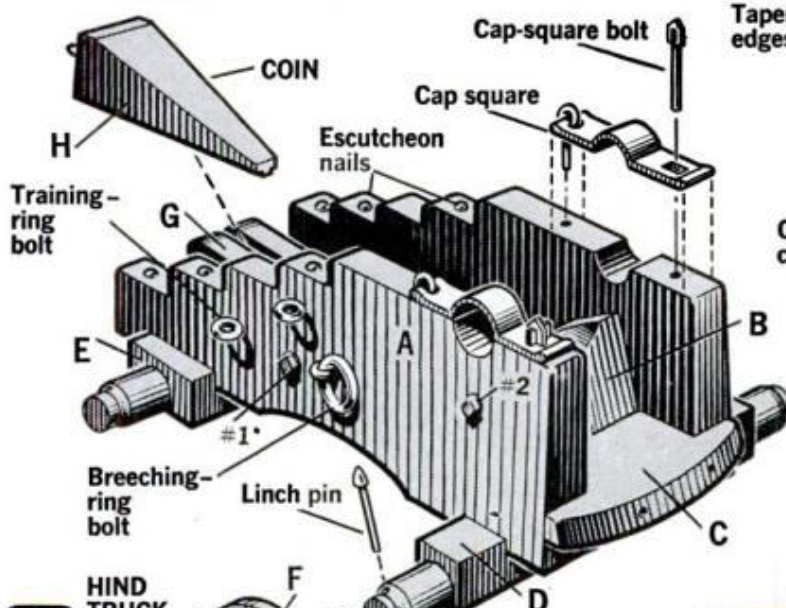

**TRANSOM**

Cut away to clear gun barrel

**GUN CARRIAGE**

**NOTE TO READERS**  
 All parts in color shown actual size for tracing direct from magazine



**FORE AXLE TREE**



**5/16" stock**



**FORE TRUCK**

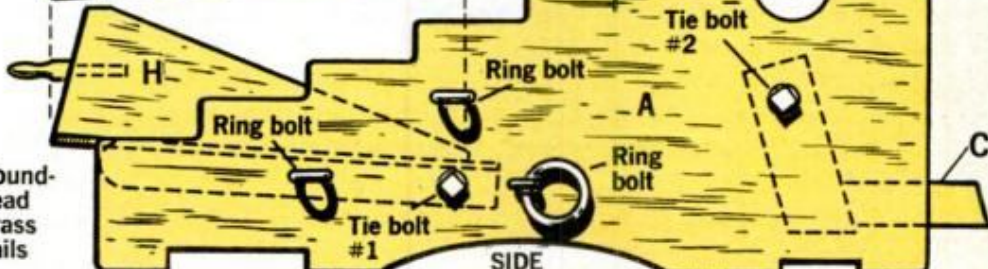
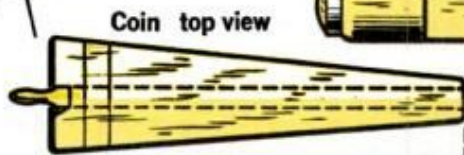

# A Beauty Outside; Some Bugs Inside



By **BILL HARTFORD**, Associate Auto Editor

Photos by Irving Dolin

**I**T'S BEEN A LONG WAIT for AMX owners: "I drove a VW for eight years waiting for a car like this; three cheers for American Motors for the AMX," exclaims an Indiana dentist. And "it's about time," says a North Carolina accountant, "that American manufacturers gave us a choice in cars so we all don't have to ride around in Detroit bathtubs."

► **He said it, I didn't.**

AMX owners aren't subtle about giving it to the insolent chariots right between their quadruple, chrome-encased eyeballs. While America's biggest industry evolved and perfected the art of producing a superhighway, cruise-command capsule, some citizens awakened to the fact that piloting a "bathtub" may not be the ultimate driving experience.

Enthusiasts have been waiting—for the AMX: "We looked at foreign cars as the only comparison to the AMX. We bought the AMX even though I owned a Porsche," states an Illinois bank officer. A steamfitter from the same state "wanted a sports car—American made." He would probably

agree with a Massachusetts advertising man: "It's got the appeal of a Ferrari or Lamborghini!" "Just sitting on the street it looks like it's doing 100 mph . . . handles like a European job," brags a Texas aircraft mechanic.

A young computer clerk in Ohio and her husband share four cars: a Fiat, Volvo and Renault—and the AMX (no explanation for the collection). She likes the "continental lines" of their only American car. A computer analyst in Florida says, "I wanted a unique two-seater sports car with guts—I got it." And a building contractor from Florida articulates what many owners referred to: the fact that AMX's only domestic competitor is the Corvette. But "the AMX," as he says, "has the size, comfort, far better storage and, last but not least, price."

Indeed, the waiting is over for AMX owners. They are almost unanimous in saying that they've finally got the car that is their idea of what a car should be. "Hug-the-road handling," top praise of a Georgia-based, Army helicopter pilot,

**INTERIOR BUGS** cited by AMX owners include several elements of both design and workmanship. Ventless side windows, certain to be on cars from now on, as a glance at any futuristic, streamlined design will confirm, still bug owners who want that slight breath of fresh air they got with a vent. Wind noise around window is another complaint. Owners wish to express their individual taste on dash layout. No complaints on automatic gear shift lever, shown here, but some owners find throw excessive with a four-speed manual. Workmanship complaints are almost all for the interior of an otherwise well-built car. Photos of specific problems are on page 142



and "tough looks," words of a New York secretary, are samples of how owners express what they like best. Over three-quarters of them would buy another AMX. When it comes to criticism, one happy owner is careful to point out that his remarks are "suggestions," not complaints.

Whether mildly or strongly worded, criticism of, or "suggestions" for, improving the AMX are most numerous when owners discuss the interior. Their dissatisfaction runs all the way from the floor to, in one instance, the droopy headliner. Owners appreciate the fact that the carpeting covers almost all of the lower interior of the car and goes all the way up to the

rear window in the area behind the seats, but there's a big "but."

As a New Jersey pipefitter says mildly, "good quality rugs, but very poor fit." His remark would contribute much to a Ralph Nader quality-control investigation, but that spurted out by a Washington aircraft research mechanic would blow the whole thing with both Management and Labor: "The interior rug must have been bought at the Salvation Army and installed by three-fingered deranged monkeys."

Getting down to particulars, an Illinois attorney speaks for several owners when he says the "rug doesn't fit the passenger

## Summary of 1969 AMX Owners Reports\*

Total miles driven: .....1,370,324

### Average miles per gallon:

290-cu.-in. V8, local driving 14.1  
long trips 16.9  
343-cu.-in. V8, local driving 13.2  
long trips 15.9  
390-cu.-in. V8, local driving 12.5  
long trips 15.5

### Specific likes:

Handling .....57.7%  
Style .....53.1  
Performance .....26.5  
Power .....24.0  
Comfort .....19.4  
Economy .....14.8

### Specific dislikes:

Workmanship .....22.7%  
Wind noise .....18.6  
Interior styling .....15.0  
Rear visibility .....10.8  
Transmission .....8.9  
Comfort .....7.7

### What changes would you like?

Better workmanship .....22.5%  
Better dash layout .....22.0  
Rear seats added .....11.5  
Vent windows added .....11.5  
Style .....7.3  
Bigger engine option .....5.2

### Engine:

290-cu.-in. ....17.9%  
343-cu.-in. ....21.4  
390-cu.-in. ....60.7

### Transmission:

4-speed manual .....72.2%  
Automatic .....27.8

### Had any mechanical trouble?

Yes .....70.9%  
No .....29.1

### What kind of trouble?

Tachometer .....18.5%  
Transmission .....16.3  
Shifting .....15.2  
Clutch .....15.2  
Brakes .....10.9  
Carburetor .....8.7  
Window action .....8.7

### Dealer repair satisfactory?

Yes .....66.1%  
No .....32.1

### Why the AMX?

Style .....76.7%  
Price .....16.8  
Performance .....15.7  
Handling .....13.2

### Is the AMX your only car?

No .....53.6%  
Yes .....46.4

### Other cars owned:

Ford .....24.7%  
Chevrolet .....20.8  
Rambler .....14.9  
Oldsmobile .....14.9  
Cadillac .....8.9  
Buick .....7.9  
Pontiac .....6.9  
Dodge .....5.9

### What options/accessories?

Power steering and brakes 57.8%  
Radio .....43.5  
"Go" package .....22.3  
Power steering only .....17.3  
Wide oval tires .....17.1  
Airconditioning .....17.1  
Tinted glass .....17.1  
Disc brakes .....16.1  
Power brakes only .....15.6  
Mag wheels .....15.5  
Stereo tape .....11.9  
Light package .....10.9

### Age distribution of owners:

15-29 .....77.0%  
30-49 .....18.9  
50 plus .....4.0

\*Where applicable percentages may not equal 100 percent due to rounding and/or insufficient sample.



**MOLDING FIT** falls short in some owners' cars; a few found it not secured tightly



**WINDSHIELD SEALER**, squeezed out and not trimmed smartly, is minor complaint

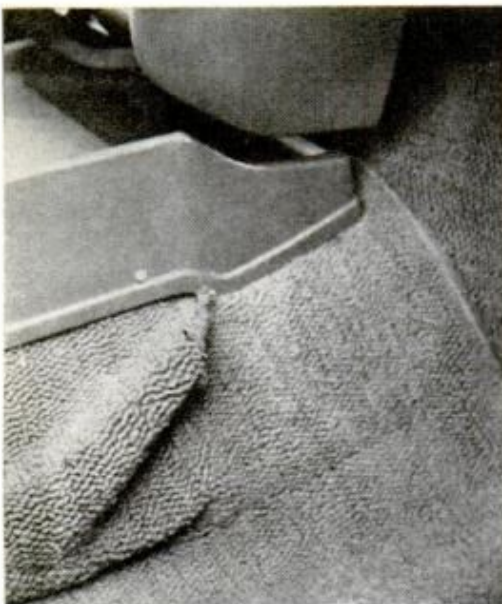

**SLOPPY CARPET INSTALLATION** is big beef, but owners like copious use, quality

**AMX FUEL-MILEAGE CHART**  
390-cu.-in. V8

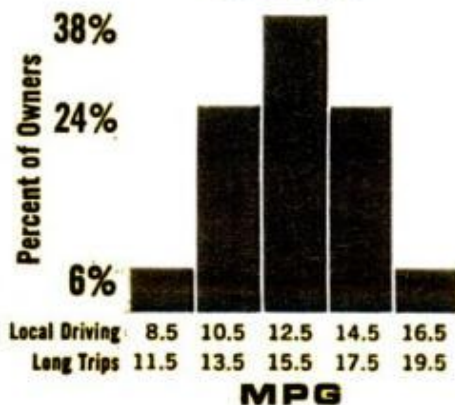

side. It was cut too short." "Carpeting looks like it was thrown in the car," complains a New Jersey serviceman. And a New York steel company employee is unhappy that the "interior is put together quite sloppily; I found numerous screws loose or stripped."

"Rug comes loose and unravels under the seats," continues a Connecticut key punch operator. "Carpeting seams are buckled and split, adds a Minnesota papermaker. The calm voice of a Massachusetts mechanic appraises the problem with a comparison: "My major dislike is that for a \$4300 car it looks cheap inside compared to other cars in its class."

► **AMX prices start at \$3297. That's with the standard 290-cu.-in. V8 and four-speed manual transmission.**

A substantial number of owners suggested modifications in the interiors of their 1968 AMXs (PM's survey was made before names became available for owners with '69 models). Many of these modifications have been made on the '69 cars. Among the suggestions is the use of wood: "I would like to see a wood dash offered. I redid mine in wood myself," says a Pennsylvania stockroom manager. "Needs a sporty grab handle," declares an Ohio draftsman. "Leather seats!" demands a Texas music teacher.

► **Wood-grain applique is now on center panel of dash, on door panels and armrests. Passenger grab handle is above glovebox. Leather seat option includes headrests.**

One modification some owners would like to see is not factory-available: "Milking stools could be used in the back for passengers," quips a Pennsylvania editor. Small, fold-down seats is the more practical suggestion of owners who are nevertheless happy with the omission of a built-in "ha-ha" seat, as a New York engineer calls it. The space behind the seats is "just right" for a variety of uses. It's perfect for carrying "drums and other instruments" for the musical moonlighting of a New Jersey hand glassblower; it's a car crib for the small baby of a New York computer operator; it's a playpen for the 20-month-old son of a West Virginia printer who says his boy is "as much at home in the AMX on a trip as in a station wagon"; it's great for the three children of a fun-loving Tennessee physician who says "they ride better and happier than in the old '63 Chevy"; it's fine for a pair of Irish setters of a Colorado lawyer; it's a perfect spot for the German shepherd dog of a West Virginia mechanic who says his dog "rides in it all the time and loves it"; and it's okay with other assorted animals, kids and sports.

As an enthusiast's automobile, it's natural that the car is bought by people who are concerned with every element of design that mates driver with vehicle, fuses man and machine. Handling for such owners means more than just how easily the

steering wheel turns. As an airline employee muses: "For me, handling always rates first, since performance can be had from most anything, but what happens when you meet that hard turn or otherwise need precise control of your car? So far, I've had a '61 Austin Healy 3000, '61 Porsche Super, '63 Corvair Monza, '65 Plymouth Sport Fury and '66 Mustang. Except for the Porsche, the AMX handles best."

Having this approach to driving, AMX owners are demanding of everything in their automobile's drive train from stick to slicks. The stock box in the AMX does not measure up to the standards of some owners: "Could be quicker and smoother," says a Maryland engineer. "Throw on the four-speed is too long and clumsy," complains a U.S. Air Force lieutenant. "Sloppy linkage in four-speed," says a California salesman. A Wisconsin computer technician complains about the "sloppy stick shifter and slight mismatch in gear ratios. He replaced the stock unit with a Hurst shifter. Other owners indicate the desire to do the same.

►All AMXs, as of last December, now have Hurst shifters as standard equipment.

Another minor complaint logged in this PM survey has also been remedied in a "running change" (one made during a model year). The problem was with the engine bonnet. Insufficiently reinforced, the leading edge of the hood would dent if it was pushed down too hard in closing it. A reinforcement has been added.

Owners who found that their hoods were acting like trampolines, even to the extent of denting, are not soured on the AMX by the experience. They seem to have learned to live with it and they just lower the lid with a little more care. Like the Pennsylvania technician who says, "I knew I wouldn't like not having a vent window before I bought the car," most of the owners adjust to the fact that their cars are not perfect.

Aside from any personal wows and woes, owners seem to appreciate that the AMX offers buyers something unique in sporty American cars. With all the sameness among them, that in itself is a good thing. Now that he has the car he has waited for, the Wisconsin computer technician we've already heard from concludes: "I expect to keep my AMX for a long, long time." ★★★



AMX STYLE sold the car to overwhelming percentage of owners who compare it to European designs



BACK-SEAT AREA is praised as perfect for babies and young travelers, even 80-pound German shepherds

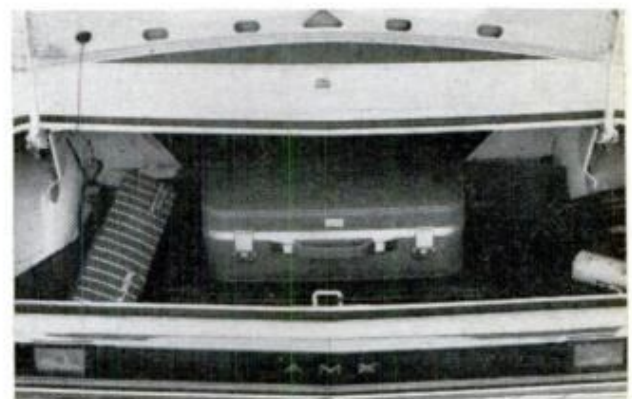

TRUNK SIZE is okay, but some owners prefer a full-size spare, even if it's larger than fold-up type



Good, solid construction features are the mark of real quality



## HOME BUYING

**OUTWARD SIGNS** can sometimes fool you. Top-grade materials, like the hardwood parquet flooring at left, are usually a genuine indication of long-lasting, quality construction. But eye-catching features, like the breakfast bar, kitchen pass-through and luminous bathroom ceiling shown on the opposite page, are sometimes used as a "come on" to divert your attention from low-grade materials, shoddy workmanship or a poor house plan. Some important factors, like adequate insulation and roofing quality, cannot be judged readily by eye—you have to ask about them. Asphalt shingles, for instance, should have a minimum weight of 235 pounds per square and be either interlocking or self-sealing to stay down well in high winds. Don't accept less

*Published by permission of Meredith Press. From HOW TO AVOID THE 10 BIGGEST HOME-BUYING TRAPS by A. M. Watkins. Copyright 1968 by A. M. Watkins.*

# How to Spot a Bad

By A. M. WATKINS, author of the new book, *How to Avoid the 10 Biggest Home-Buying Traps*



Often gimmicked up to catch your eye, the marginal home can seem like a great buy—until you've lived in it for a while. Here, an expert tells you why good construction and top-grade building materials pay off and how to be sure of getting them

POPULAR MECHANICS

Материал, защищенный авторским правом

**T**HE MARGINAL HOUSE is one that just squeaks by. Its construction and the parts that went into it are of minimum quality, just good enough to get by minimum standards. It's not necessarily a sub-standard house. The house very likely came up to the local building code, sometimes even to the Federal Housing Administration's minimum standards, but nevertheless it's a marginal house.

One couple knows well the trouble, irritation and extra expense a marginal house represents. There was the summer vacation that went down the drain because money was needed for a new paint job, though at the time the house was a mere three years old. There were the chilly children's bedrooms that were impossible to heat during cold weather, in addition to high fuel bills. There were the paper-thin walls and the cheap paneling that looked deceptively handsome when they first moved in but soon began to wear thin and look tawdry. And there was also the low-grade flooring, especially in the kitchen and bathroom, which was impossible to keep clean and good-looking.

The lowest-grade economy materials are used widely in house construction to keep down costs. They actually cost you money in the long run. In time, their performance tails off. More and more upkeep and maintenance are required. They add up to a marginal house that becomes a

Fancy extras are nice to have but shouldn't mask poor workmanship



# House That Looks Good

growing source of nagging annoyance and bother.

Moreover, really good, if not topnotch, quality building products often cost only a little more than the lowest-grade ones. The very best quality house paint, for example, costs only a dollar or two more per gallon than the minimal grade usually used on houses. Using that best paint on a typical \$25,000 house will increase total paint cost by a mere \$15 to \$20.

High-quality flooring, paneling, wiring, heating and many other products similarly cost only a little more, by and large, than the same products in marginal quality. Studies show that the initial price of a house built with high-quality materials will run no more than 8 to 10 percent more





**EXTRA-THICK INSULATION**, like these 6-in. batts between ceiling joists, indicates good construction

than the price of an identical house built of marginal quality. You will get that extra cost back plus a dividend each month after you move in. The studies show that the high-quality house will save you, on the average, about \$250 to \$300 a year on upkeep, maintenance and inevitable repairs.

A young couple bought a \$24,500 house in a new development we'll call Highway Acres. They bought it principally because of a luminous Japanese ceiling in the downstairs bathroom. It was a distinctive, eye-catching feature, a suspended light screen indirectly illuminated by recessed lights above. It turned out later that more than half the buyers of the 80 houses in Highway Acres also bought largely because of the luminous ceiling feature.

Surveys show that houses are often bought because of one or more distinctive features that trigger the buying impulse. The trouble is that such features are often gimmicks, put there deliberately to catch the eye of buyers. The houses in Highway Acres are marginal house-traps. Measured against any standards, they are of miserable design. The interior floor plans,



**IN WET AREAS**, foundation drain tiles can make all the difference between a dry or flooded basement

by and large, are nightmares for living. The kitchens are singularly small and ill-planned. And the construction is marginal, if not of downright shoddy quality. Yet the irresistible appeal of the Japanese ceiling so overshadowed the implicit flaws that the builder sold some \$2 million worth of marginal houses at an extra cost of about \$65 per house (the estimated cost of the glamor ceiling).

The gimmicks used to sell houses take a variety of shapes and forms. They include fancy kitchen trappings like a dining

*(Please turn to page 228)*

**CHECK THE PLANS** for items not visible to the eye, such as an adequate underground waterproofing system

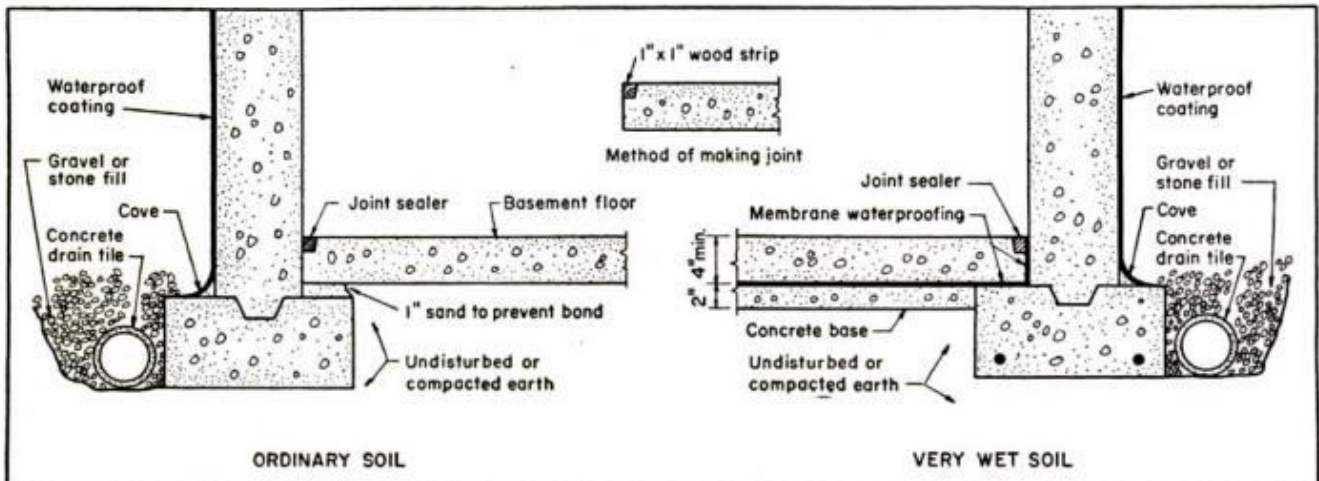



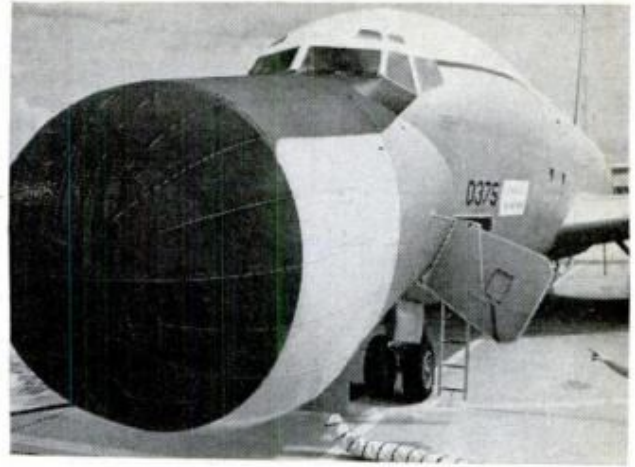
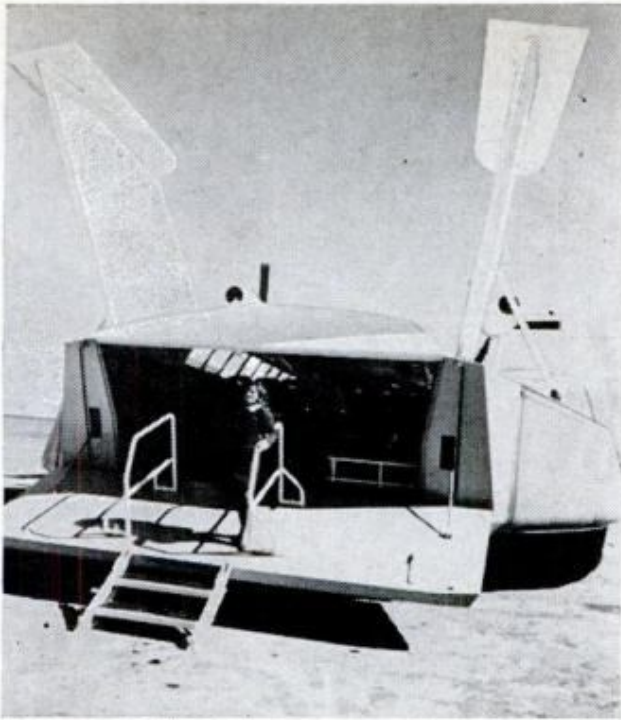

### Nose job for KC-135

Huge noses have been added to eight KC-135 jets to house parabolic antennas. These and other special gear enable the planes to be a link in ground-to-Apollo communications.



### Now they whisper

Engine noise from training planes has been reduced by about 30 percent by Lufthansa engineers at the airline's flying school in Bremen. The noise suppressors are simply extensions fitted to the exhaust stacks. They call the trainers "whispering airplanes."

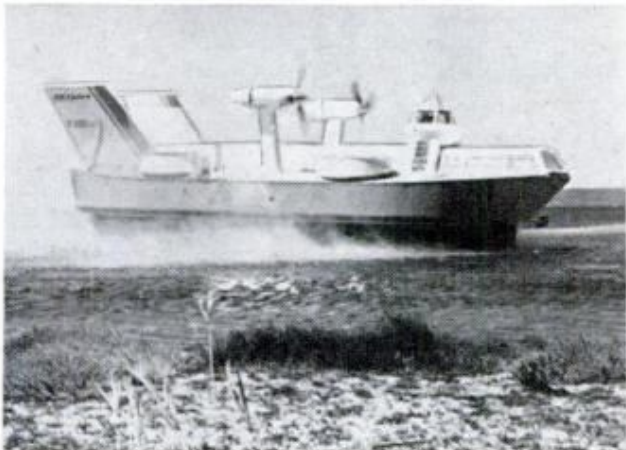

### French air-cushion vehicle

The French are testing an air-cushion vehicle, the Naviplane, that they intend to put into use as a passenger ferry. The machine is currently capable of carrying 90 passengers at a speed of about 60 mph. Speed will later be pushed up above 70 mph.

### Skyservants for America

The Dornier aircraft plant near Munich is turning out 52 Sky servant planes for the U.S. firm, Butler Aviation. Each Sky servant can carry 12 passengers.



## THE DROP-IN FILM CARTRIDGE HAS COME TO STAY

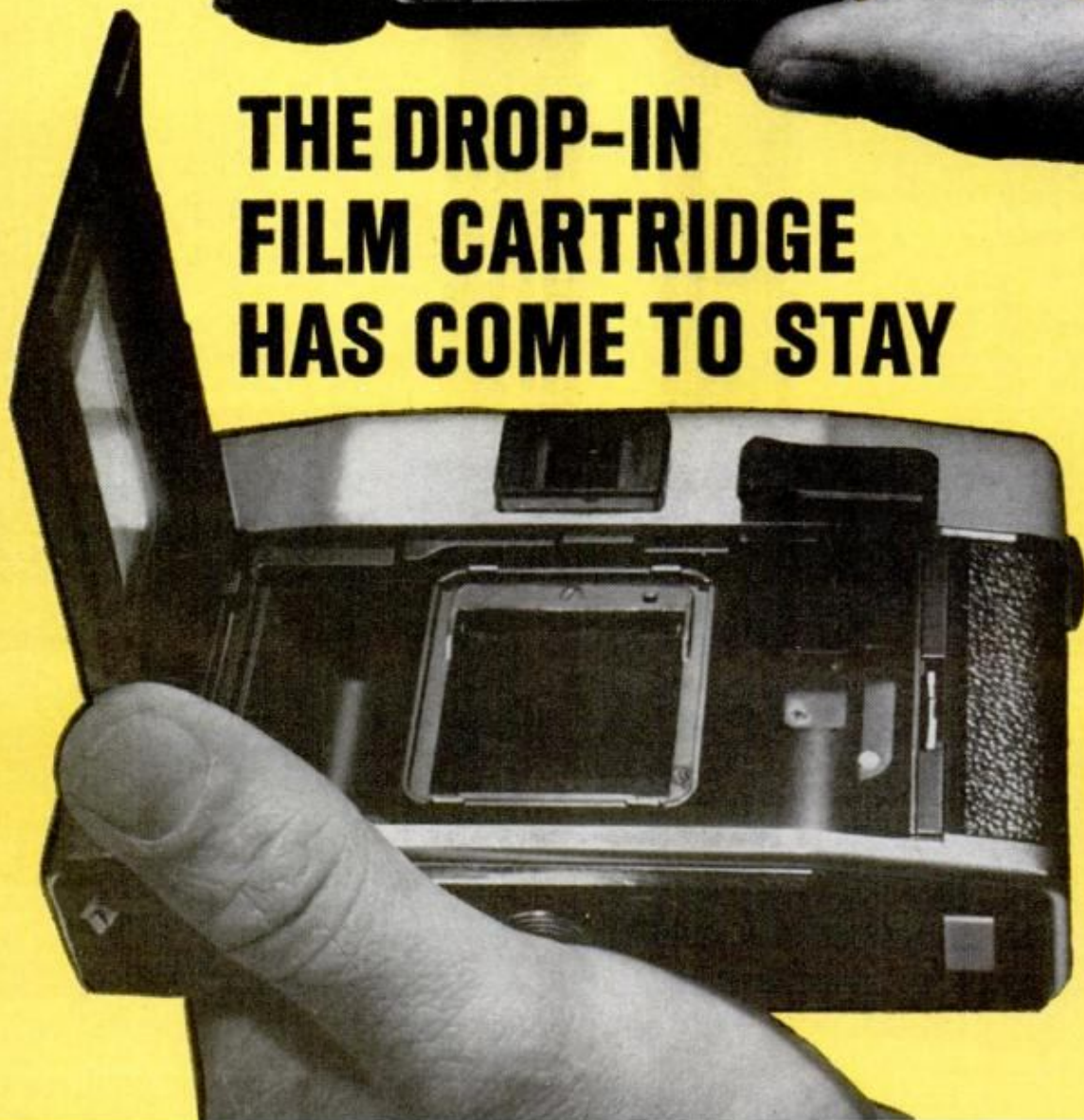

The handy instant-load cassette, widely used in simple cameras, is now showing up in shiny new single-lens-reflex models, combining convenience with advanced features for the serious amateur

By SHELDON M. GALLAGER

**T**WO GREAT DEVELOPMENTS in photography have finally gotten together. The result is a brand-new breed of camera that combines the simplicity of the instant-load film cartridge with the versatility of the long-proven single-lens reflex.

The new cartridge-loading SLRs look

and work much like the trim, popular 35-mm single-lens reflex. They use the same mirror and prism arrangement that lets you see what you're shooting through the actual lens that takes the picture. The difference is that there's no threading of film to do, no spools to fuss with and no rewinding. All you do is open the back,



**YOU CAN USE FLASH CUBES** or electronic flash with this Ricoh 26C-Flex—it has sockets for both. Like other cameras shown here, it takes drop-in cartridges, gives you choice of interchangeable lenses



**MODELED AFTER** traditional 35-mm SLRs, the Contaflex has a focal-plane shutter, behind-the-lens exposure meter and accessory flash shoe on top. Four lenses from 32 mm to 135 mm are available for it



**SMALLEST OF THE FOUR**, the Rolleiflex SL26 is less than four inches wide and weighs only 19¾ ounces. Available lenses include a 40-mm normal, a 28-mm wide-angle, and an 80-mm moderate telephoto



**KODAK'S INSTAMATIC REFLEX**, like the Ricoh, has provision for both flash cubes and electronic flash. You can get seven different lenses for it, from a 28-mm wide-angle to telephotos of 135 and 200 mm

drop in a cartridge (they all take the 126 cassette) and start shooting.

To date, four well-known makers have brought out instant-loading SLRs, and it's a safe bet that others will follow suit. Kodak, which pioneered the cartridge idea for simple cameras, now has its own Instamatic Reflex, a sophisticated SLR designed especially for cartridge use. Other new SLR cameras using the instant-load principle are the Rolleiflex SL26, the Contaflex 126 and the Ricoh 126C-Flex.

All of the cameras offer interchangeable lenses ranging from wide-angle types to long-focus telephotos. All have modern behind-the-lens light meters and a full range of adjustable exposure settings. On

most, the exposure is set automatically for you, but can be overridden if you want to create special effects.

In line with the move to the simpler film cartridge, two of the cameras have provision for using handy, disposable flash cubes as well as electronic flash. These are the Kodak and the Ricoh. The Contaflex and Rolleiflex have accessory shoes that take external flashguns.

Cartridge films are multiplying almost as fast as the cameras that take them. Already, there are half a dozen on the market in a variety of types and speeds. Kodak offers a medium-speed black-and-white, two color-transparency films in medium and high-speed types, and a negative

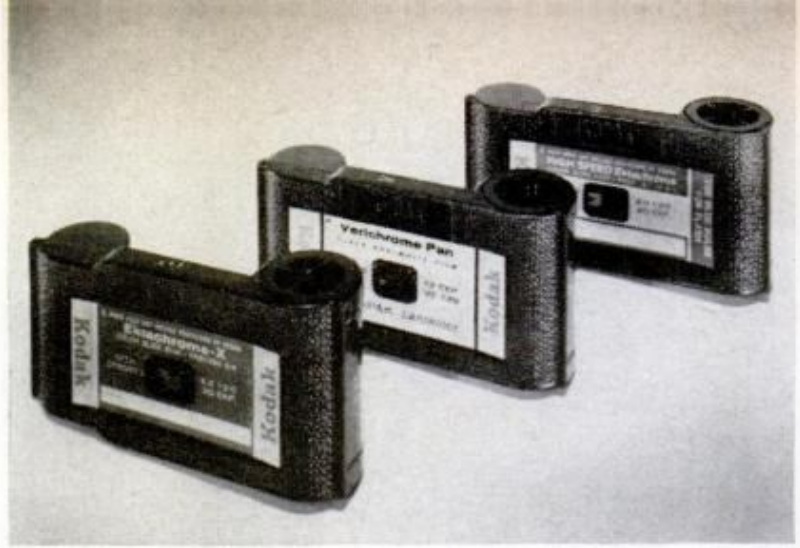

**JUST OPEN THE BACK** and plop the cartridge in—it's that simple. This Rollei has a "hot" flash shoe on top that takes a flashgun without a cord

**SOME OF THE MANY CARTRIDGE FILMS** now available are these from Kodak. They include a black-and-white and two color-transparency types, one medium-speed and one high-speed. Anscochrome and 3M's new Dynachrome also come in cartridges in several types

film for color prints. Anscochrome and 3M's new Dynachrome also come in cartridge form in several different types.

The cartridges are designed so you can't accidentally put them in the wrong way. An identifying notch in the side tells the camera what film you're using and automatically sets the exposure for the correct film-speed index.

Prices for the new cameras vary, as do some individual features. Kodak's Instamatic Reflex goes for just under \$200 with a normal-focus 45-mm, f/2.8 lens. Rollei's SL26 reflex lists for \$299.50 with a 40-mm, f/2.8 lens. The Contaflex 126 sells for about \$160 and the Ricoh 126C-Flex for about \$120, both with standard-length lenses. ★★★

**ONE BIG ADVANTAGE** of the cartridge system is that the camera's exposure meter is set to the correct film-speed index automatically—you don't have to bother with it. Each cartridge has a small notch

that indicates the film speed by its position. As the cartridge is inserted, the notch engages a lever, that adjusts the meter to the proper setting, as shown in this cutaway of Kodak's Instamatic Reflex

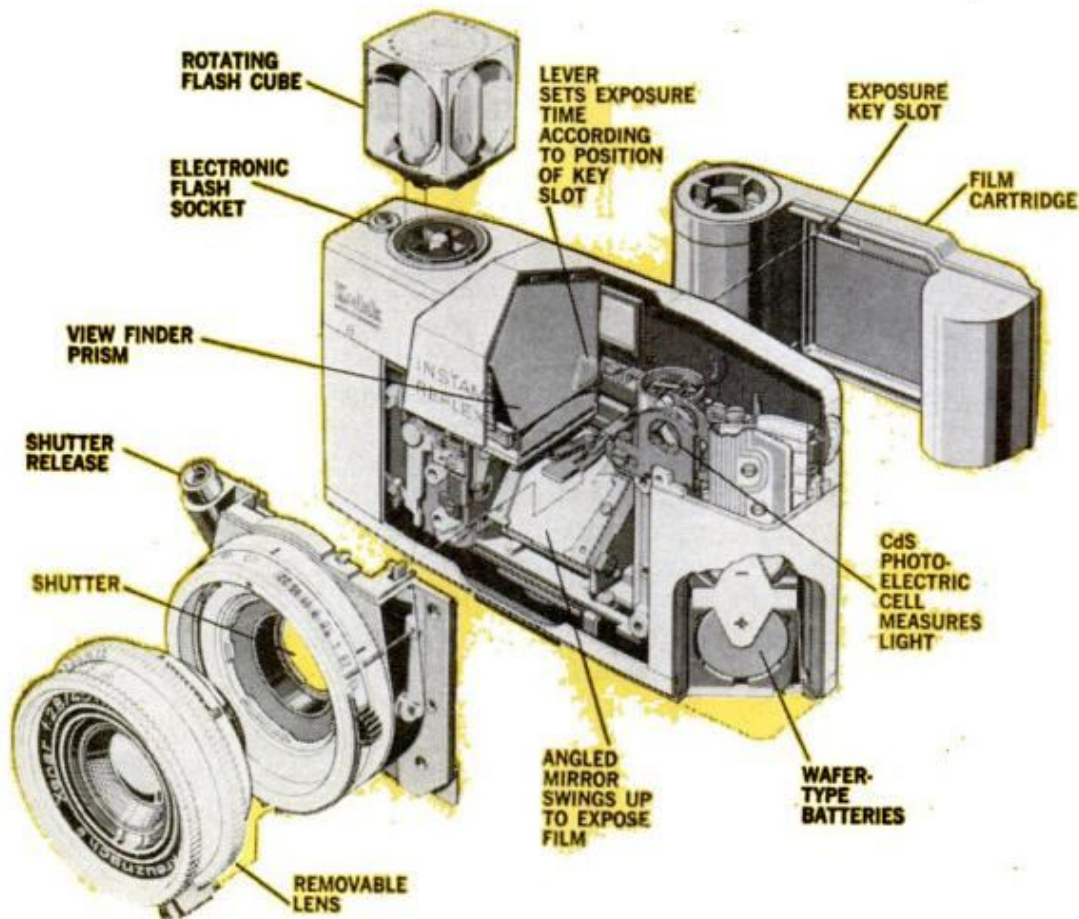

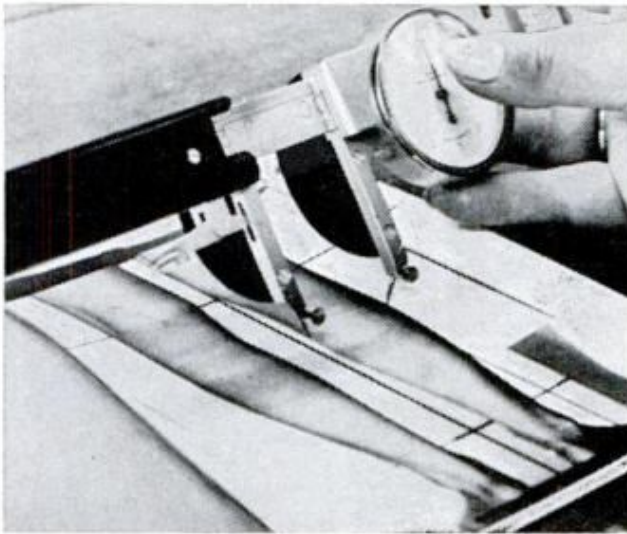
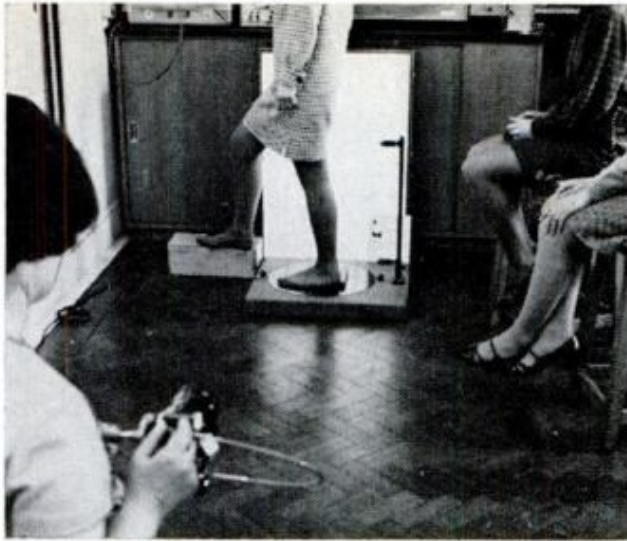

## Scientific leg show

Citing evidence that body build can be informative, a team of researchers at Aston University in England is photographing the legs of 1000 girls (above) to learn if the legs will reveal personality, social status and place of birth. Measurements are made on each photo (directly above); samples at right.

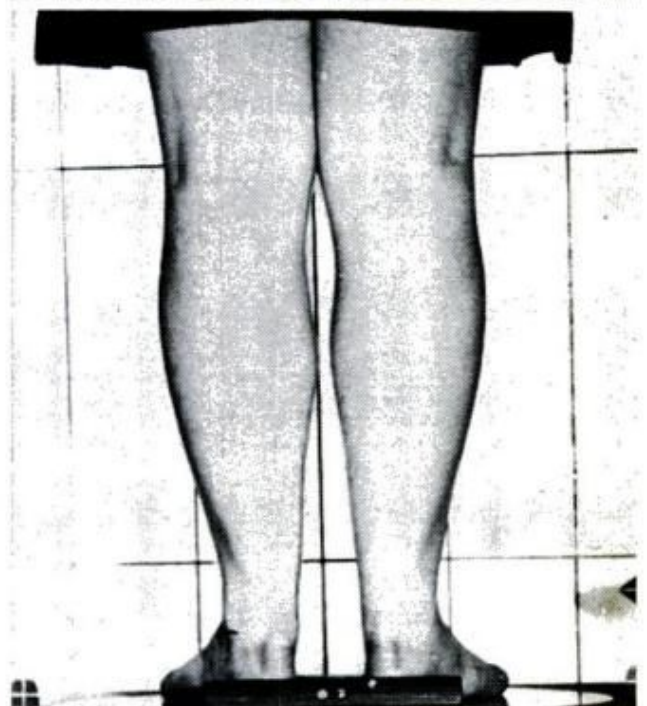
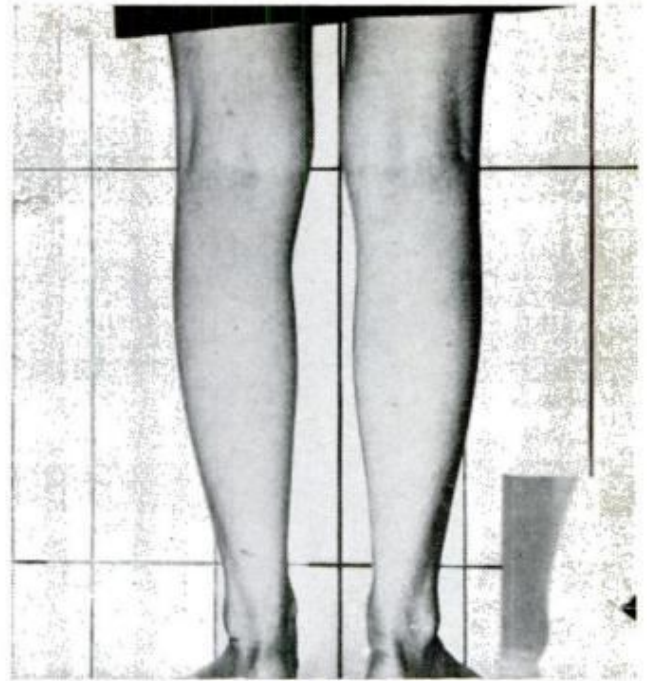

## Contractor's office building has wings

Two 300-ton wings, cantilevered from a rectangular center section, create an unusual office building for the W.J. Megin contracting firm in Naugatuck, Conn.

# Just patented

PM'S PICK OF THE NEW INVENTIONS

Prepared in cooperation with Roger S. Shashoua, Director, International Inventors Association, Inc.

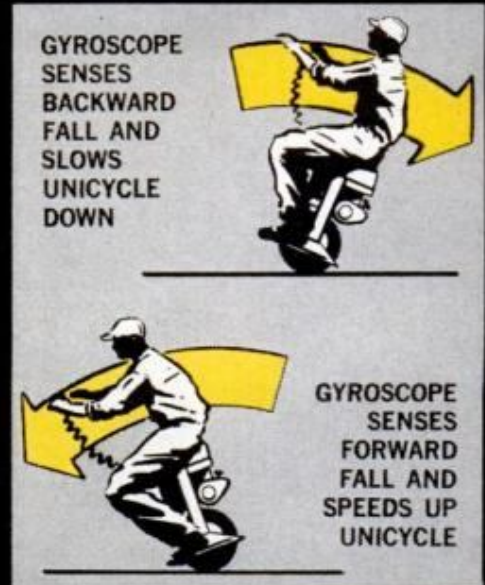
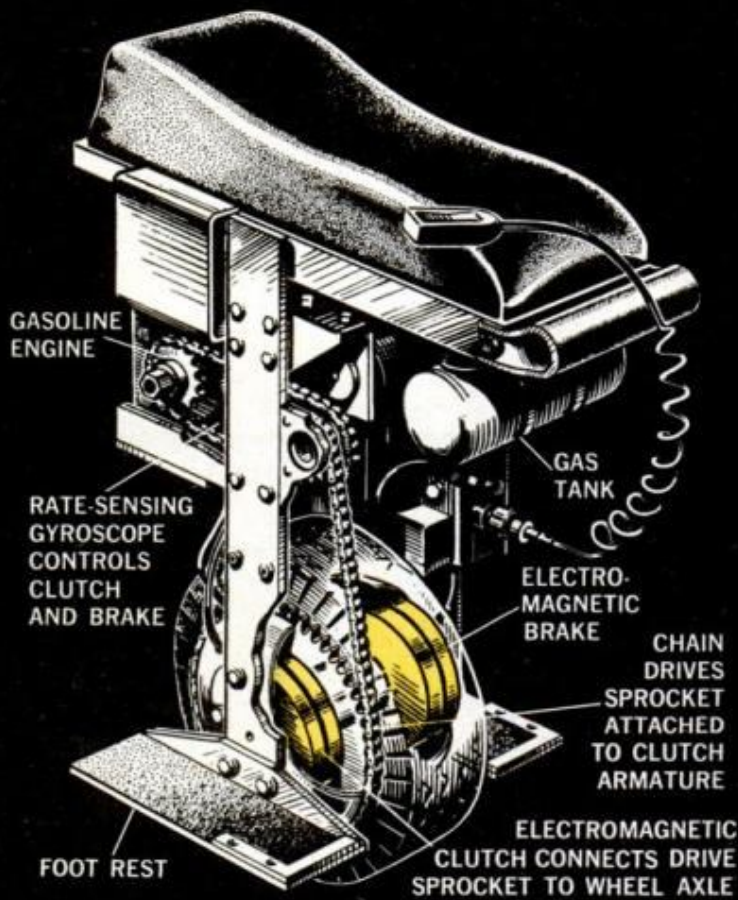

**1. WHAT COULD BECOME A NEW SPORT THRILL** is this gas-powered unicycle that can do twists, turns, panic stops and other acrobatic maneuvers without falling. Earlier unicycles attempted to use gyroscopes to keep upright, but weren't successful. This new design uses a gyroscope, but not to stabilize the machine itself—merely to sense which way it is falling. If it tips forward, the gyroscope automatically increases speed to counteract the fall. If it tips backward, the brakes go on to force it forward. It can also be operated by a hand control without the gyroscope, requiring more skill. An electromagnetic clutch and brake provide smooth, precise control

**2. THE RUNNERS TILT** instead of turn to steer this unusual sled. Each one is controlled separately by a handle at the side. Pulling on the left-hand handle causes the left runner to tilt inward, forcing the sled to the right. Pulling the right-hand handle steers the sled to the left. The system provides more steering action than the fixed runners on a child's sled, yet costs less than the pivoted runners used on bobsleds. Also, tilting both runners together produces a snowplow-like braking action for good control

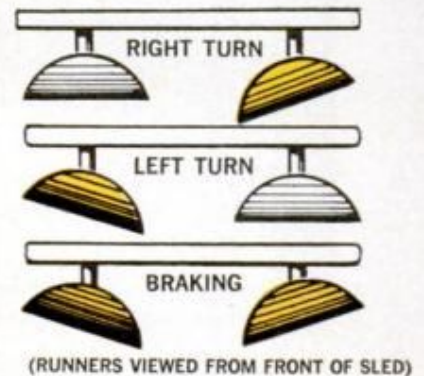

Inventors of the items shown on these pages are as follows: 1. Frank Malick, Franklin Control Co., 518 Greenleaf Drive, Monroeville, Pa. 15146; 2. Josef Schroll, Bad Tolz, Germany; 3. Ronald C. Gdanski, Montreal, Canada; 4. Lichtenfeld & Co.,

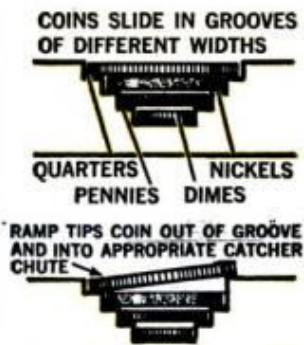
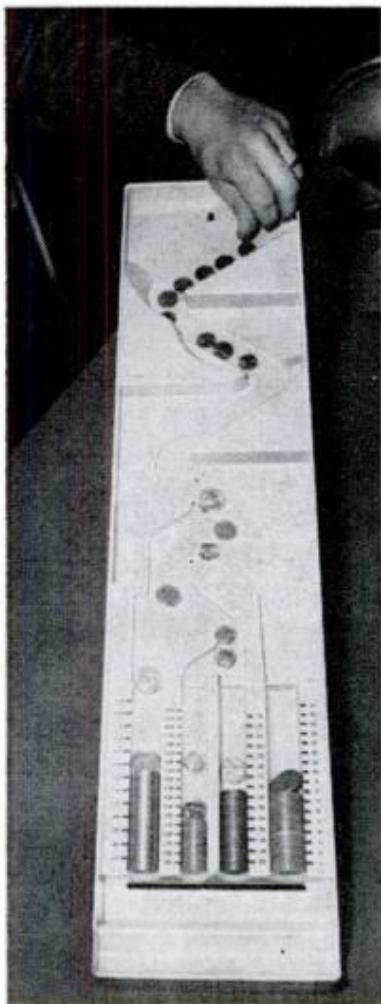

OTHER COINS CONTINUE ON INTO DIFFERENT CHUTES

**3. DROP A HANDFUL** of mixed coins into the top of this plastic slide and they automatically end up at the bottom in four neat stacks, one for nickels, one for dimes, one for pennies and one for quarters. The ingenious sorter uses a system of shallow grooves—one for each size of coin—to catch the different denominations and guide them in different directions. Near the bottom, tiny ramps tip the coins out of the grooves and into each one's appropriate collector slot

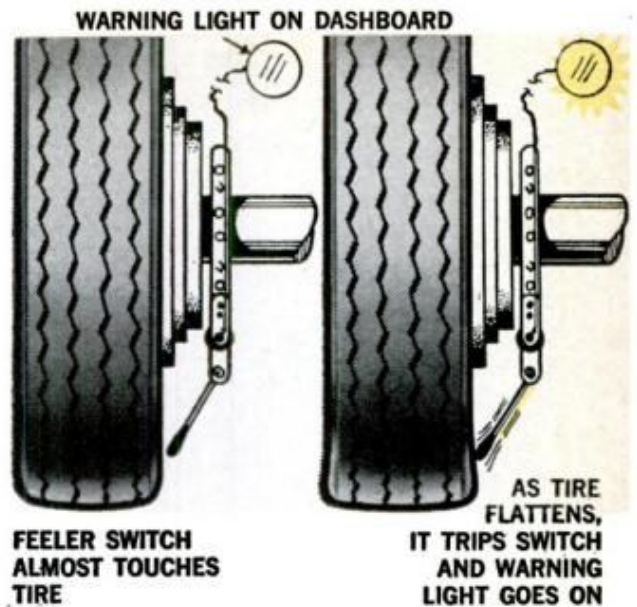

**4. A FLAT TIRE** wouldn't catch you off-guard with this warning device. At the first sign of a leak, a red light on your dashboard flashes on, giving you time to find a service station or get safely off the road before the tire goes completely flat. A tiny feeler wire is mounted inside each wheel so that it almost touches the tire in normal driving. If the tire starts to lose air, the feeler senses the increased bulge in the casing, closing a switch that turns on the warning light. By using four separate warning lights, it's possible for you to pinpoint which of the tires is at fault before you even get out of the car

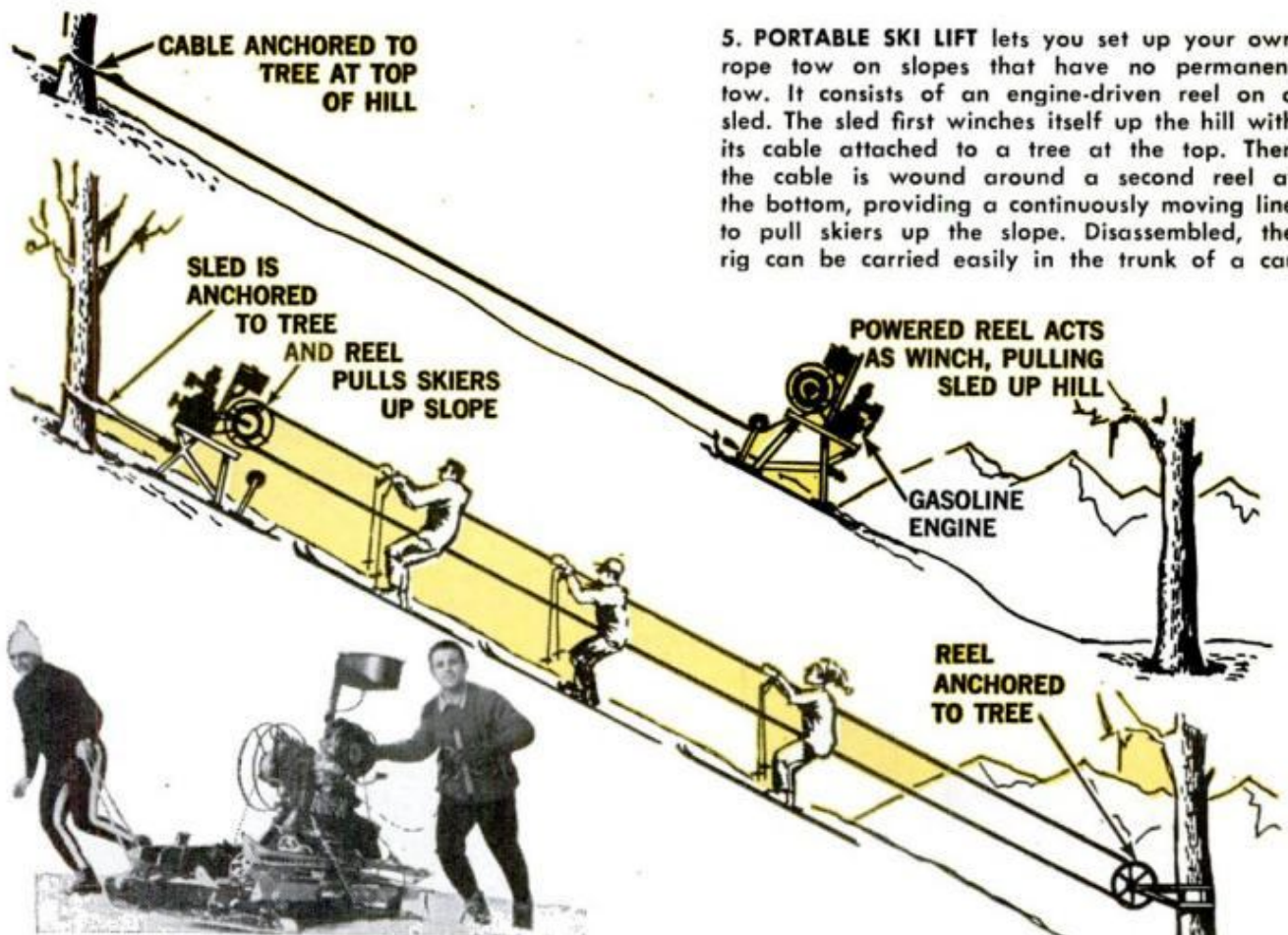

**5. PORTABLE SKI LIFT** lets you set up your own rope tow on slopes that have no permanent tow. It consists of an engine-driven reel on a sled. The sled first winches itself up the hill with its cable attached to a tree at the top. Then the cable is wound around a second reel at the bottom, providing a continuously moving line to pull skiers up the slope. Disassembled, the rig can be carried easily in the trunk of a car

Hamburg, West Germany; 5. Arturo Panetta, Reggio Calabria, Italy. Anyone interested in bringing new inventions to the attention of Roger Shashoua can reach him at the International Inventors Assn., Inc., 680 Fifth Ave., New York, N.Y. 10019.

# Five Weekend

## Counter Knife Holder

**W**HAT DO YOU DO when you have an electric carving knife that's designed to hang on a wall and there's no wall to hang it on? You chuck it in a drawer where it's out of sight and soon out of mind. That's what happened at our house until I made this neat little holder which let us store the knife right on the kitchen counter. There's a place in the front for the cord and separate stalls for blade and handle.

I cut it out and put it together one night and stained and finished it the next—it's that simple to make. I made the whole thing from 1/4-in.-thick pine, but plywood will do just as well. Both sides are alike. The back fits between the sides, the front laps the sides and the bottom projects 1/4 in. all around. "Holes" in the fixed shelf are made to suit the blade and handle of your particular knife. Tiny brass hinges are used to hinge the lid, one leaf being applied to the inside. A brass knob completes it.—Lynn R. Mortensen

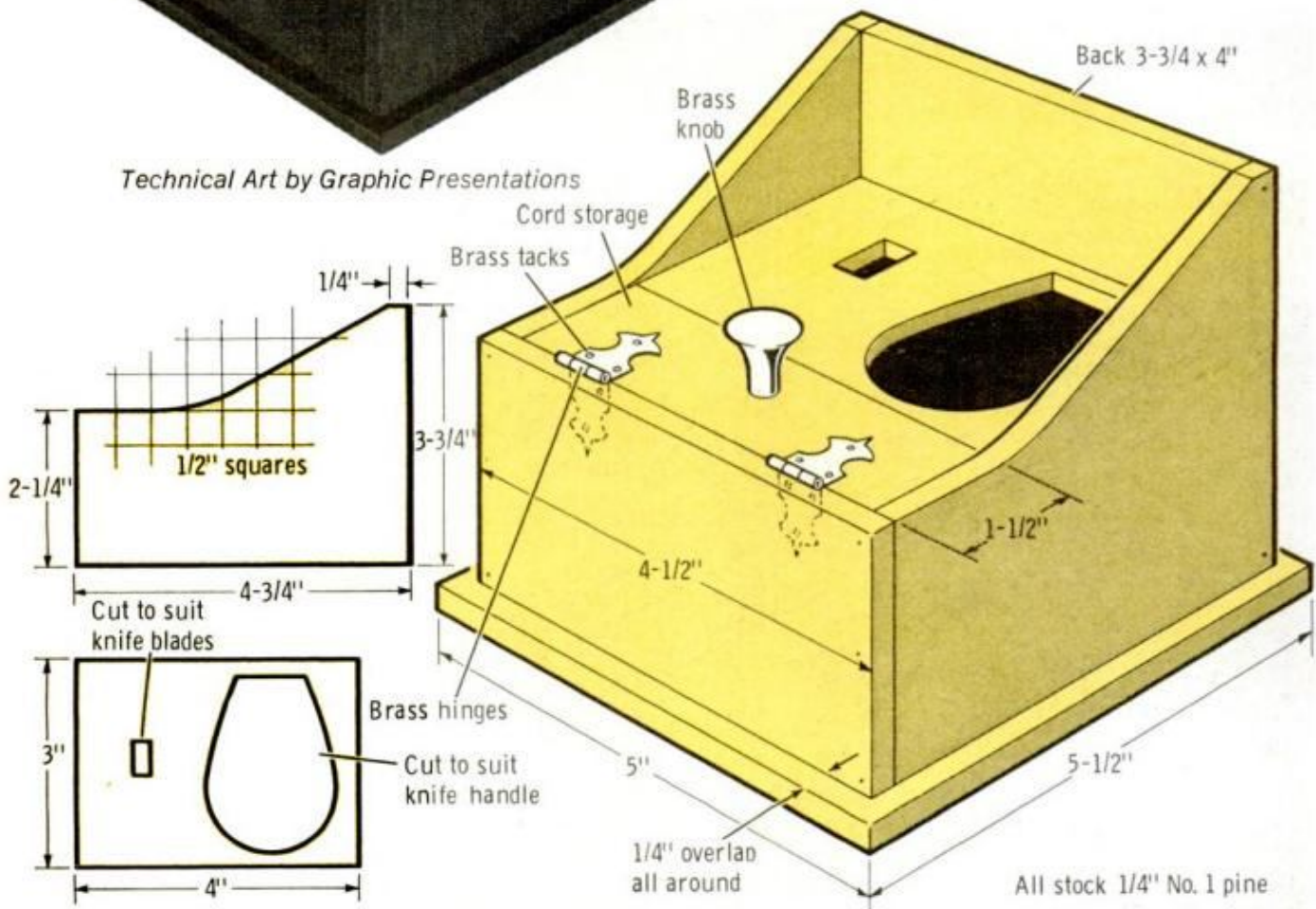



# Projects to Build

## Glass-Top Coffee Table

IF YOU'VE PRICED them lately, you know that glass-top coffee tables are not cheap. In New York City you'll pay up to \$45 for the top alone. You couldn't find this elegant table in a store for less than twice as much.

The cost is all in the top, really, for the base of 1x2s can be pine and painted black, or hardwood and varnished. Post legs are double-thick and notched to house the crossrails. Five rails across the bottom provide a magazine shelf. Any Libbey-Owens-Ford glass distributor can provide the  $\frac{3}{4}$ -in.-thick ground-edge top.

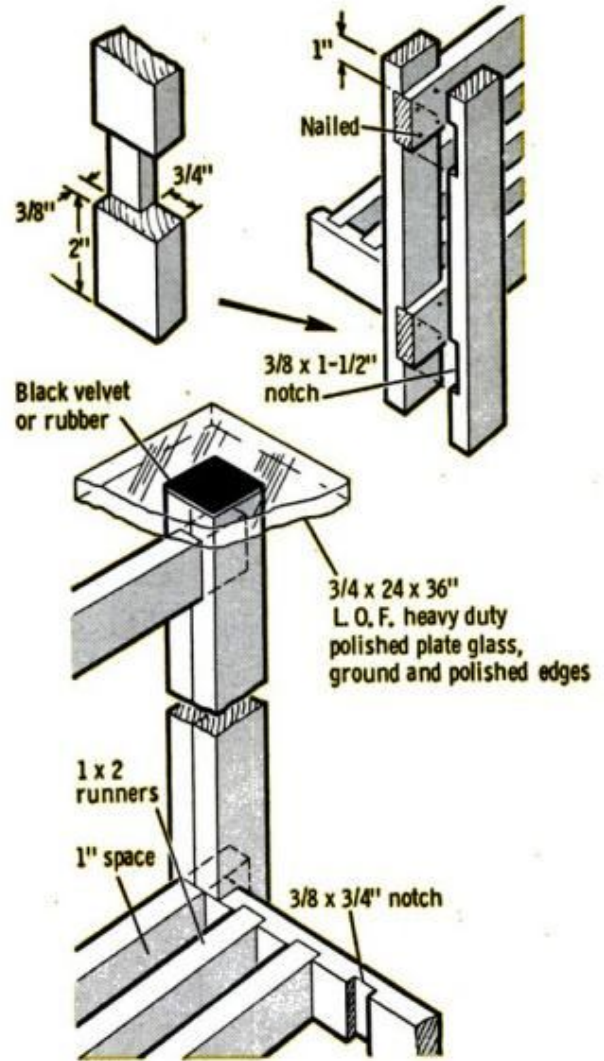
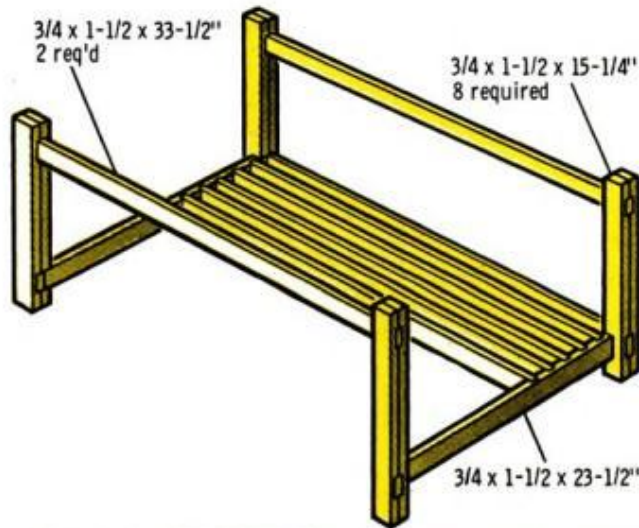



## Twin-Bed Night Table

TALL ENOUGH to let one bed slide under it when not in use, this clever corner table not only provides a handy night table for two beds, but saves space in a small room shared by brothers or sisters.

Built something like a card table, except that the legs don't fold, the table has aprons only on three sides. It's made from stock lumber, 2x2s for the legs, 1x6s for the aprons, 1x2s for the cleats, plywood for the top, and ready-made molding for the edges. Metal corner braces anchor the legs. Wood screw plugs hide screwheads in the legs, while plastic laminate hides screwheads in the plywood. The molding around the top is neatly mitered at the corners.—Robert L. Hoppough

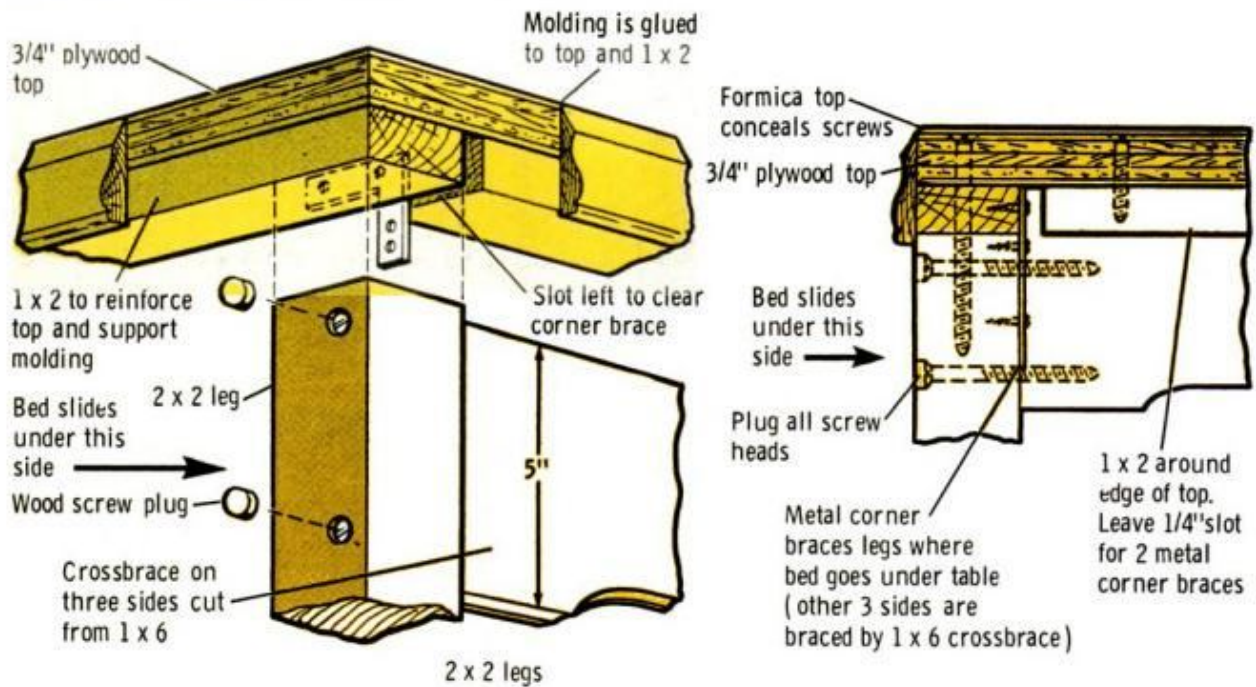

## Circus-Wagon Toy Box

LOOKING LIKE A TOY ITSELF, this roomy caster-fitted "animal wagon" adds a circus touch to Junior's room and, more important, goes a long way in corralling toys galore. Except for the frame which holds the dowel bars, 1/2-in. plywood is used throughout. For the most part the wagon is nothing more than a four-sided box with a lift-off cover.

I mitered all the corners to obtain the neatest joints for finishing, but if miters are a problem, you can simply butt the corners. This goes for the top also. Any tin can having a 9-in. diameter can be used to lay out the scallops.

Swivel-type plate casters screwed to blocks are partly concealed by dummy wagon wheels which clear the floor by about 1/8 in. A colorful animal picture is pasted in place before bars are fastened with screws from inside.—*Marilyn Cann*

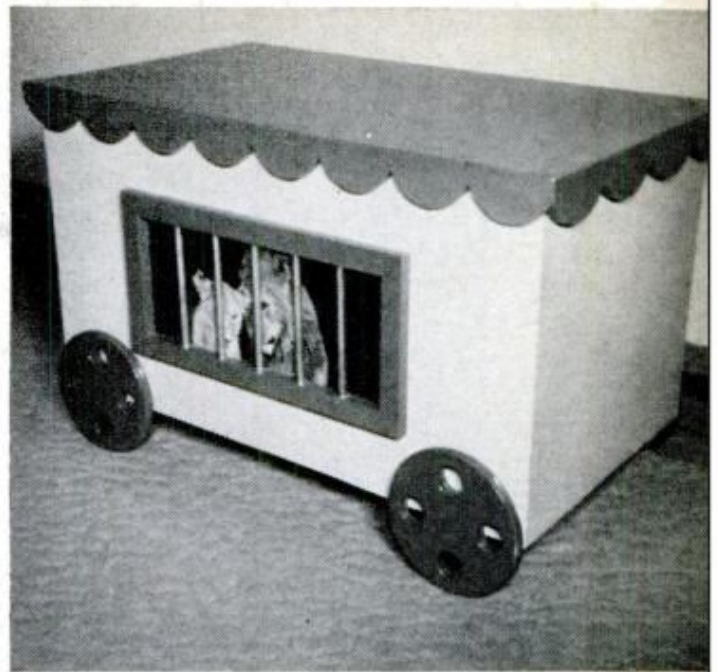

**PAINTED IN LIVELY COLORS**, this novel toy box will add a gay touch to any youngster's room. The top could be made to hinge open rather than lift off

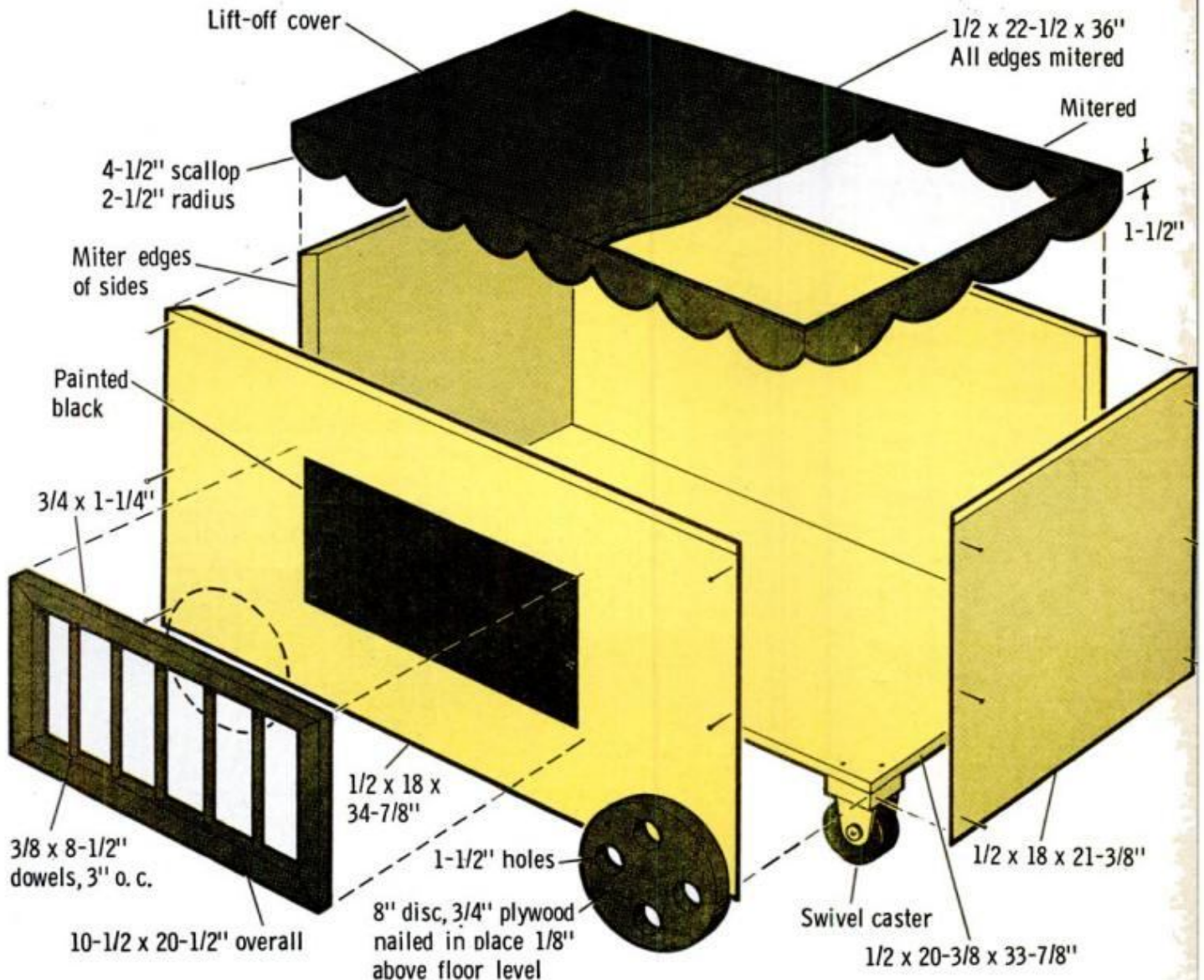

## Clock and Cup Shelf

A SPARE ALARM CLOCK, or any electric movement for that matter, will make this handsome Early American wall shelf do double duty. It's just the thing for those narrow wall spaces in your kitchen and perfect for displaying decorative shaving mugs or other prized bric-a-brac.

I used old, wormy cherry salvaged from a chest of drawers to make it. As you see, both sides are duplicates which I bandsawed together. All shelves are the same width, but some are made deeper than others. The hole in the door to the clock compartment is jigsawed to suit the clock face and is made for a press fit. Appropriate strap hinges are selected to hinge the door. A small knob opens it and a magnetic catch holds it shut. You can preserve the natural finish of the wood by applying a sealer, stain or wax.

—Don Shiner

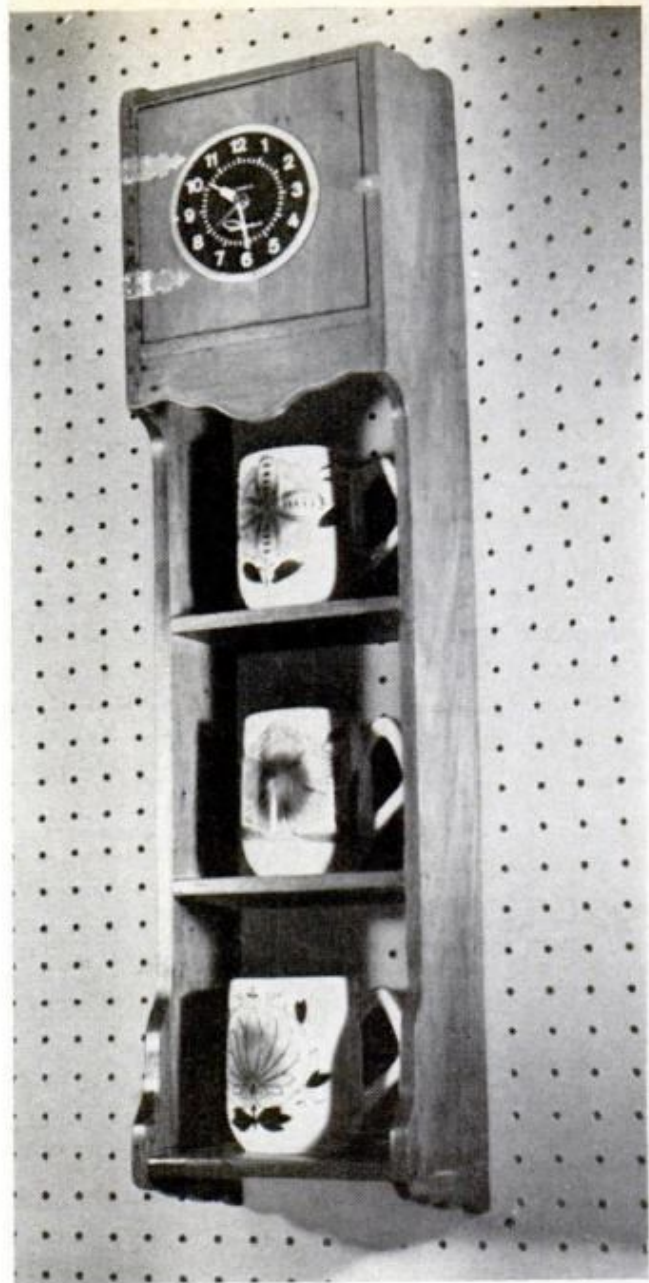

**YOU'LL BE GLANCING** at this charming shelf for two reasons: It's just plain pretty and it tells the time

**WHILE I MERELY BUTTED** the shelves between the sides and clamped them, they could be set in dados

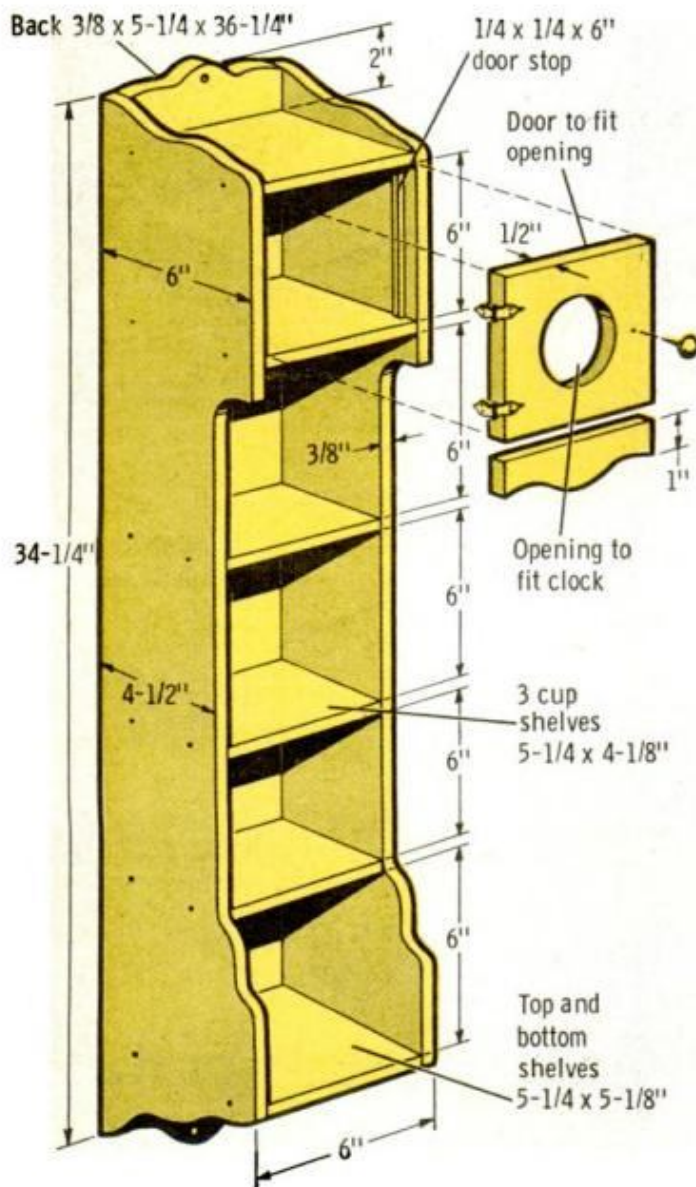

# PHOTO HINTS

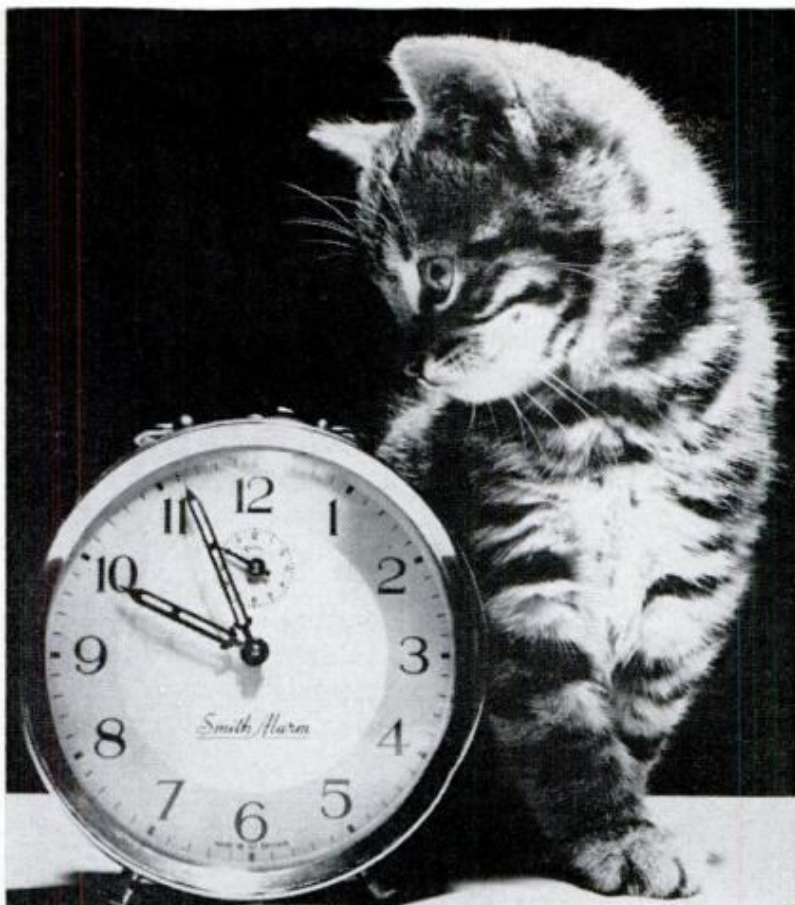

**GETTING PETS TO POSE** is exasperating. This trick with an alarm clock works well with cats and may be useful for other animals. Set the alarm to go off in a few minutes. The ticking will attract and hold the cat's attention. When the alarm sounds, the cat will react with surprise or anger, perhaps even attacking the clock, as did the one shown here. It's usually possible to get several good action shots during this period. The louder the clock, the better—you'll find the old-fashioned wind-up type is ideal



Cat eyes clock, intrigued by ticking



As bell sounds, he attacks. Take that!



**EVER PUT YOUR CAMERA AWAY** with a half-finished roll of film in it and then forget what film you were using? This handy tag not only identifies the film for you, but it also supplies useful data on exposure settings and flash guide numbers. Use a plastic sleeve of the type sold for identification cards and wallet photos. Punch a hole in one corner for a small key chain. Slip the data sheet from the film box into the sleeve and fasten the chain to a strap ring on the camera. Make one up for each type of film you use and you'll always have the right information at your fingertips.—Ken Patterson

**SMALL CAMERA ACCESSORIES** rattle around a gadget bag unless you store them in individual holders. If your bag didn't come fitted with pockets, you can add them easily this way. Cut perforated hardboard into small pieces and thread elasticized ribbon through the holes to form loops, as shown at right. By varying the spacing of the loops, you can make them wide or narrow to take the different accessories. One board can be made to fit inside the bag's lid, and others can be slipped down along the sides. Elasticized ribbon is sold at sewing counters in department stores and variety shops.—Arthur L. Ramos

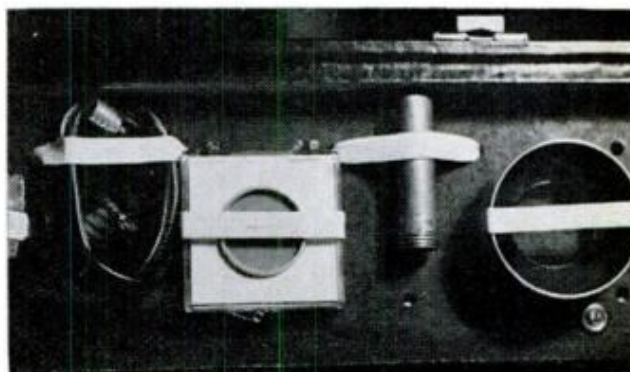

**How to install  
a rebuild kit and**

# **PUT LIFE BACK IN YOUR CARBURETOR**

**By MORT SCHULTZ**

**T**EARING APART a carburetor for cleaning and rebuilding isn't easy—especially if you're working with four barrels. But if you keep your cool, you can do as good a job as any professional in a couple of hours, and the outcome is certainly rewarding.

Illustrating the job is the overhaul of one of the most complex carburetors ever made—a Rochester 4GC (four barrel), which was taken from a 1964 Oldsmobile Cutlass. If you think you can do the work on this carburetor, you can certainly overhaul a much simpler one or two-barrel carburetor that you may have on your car. The procedure is generally the same as that outlined here, except that you'll have fewer parts to fool with on a single or dual-barrel job.

Professional mechanics, incidentally, get up to \$40 for overhauling a four-barrel carburetor, approximately \$30 for a two-barrel carburetor, and \$20 to \$25 for single-barrel jobs. Your cost if you do the work yourself is about \$15—\$6.50 for a parts kit and the remainder for a jug of carburetor cleaning solvent. Let's discuss this equipment, because you could easily end up with less-than-adequate stuff that will give you less-than-adequate results.

There are two types of parts (or rebuild) kits sold for every carburetor—a minor kit and a major kit. The minor kit contains needle(s) and seat(s), accelerator pump and gaskets. I suggest that you *not* buy this one, although it's about \$2 less in price.

The major carburetor overhaul kit contains all of the aforementioned parts, plus all others that you will need in order to do a *complete* carburetor overhaul. These additional parts include a fuel filter, idle

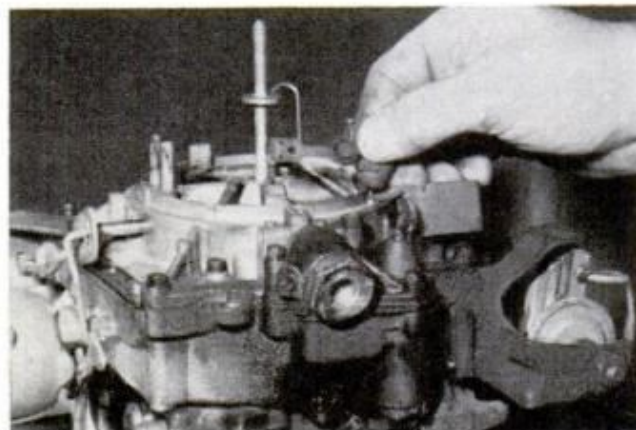

**REBUILD KIT** for major overhaul has everything from a manifold gasket to a rubber idle vent (above)

screws, main metering jet, idle vent and check valves.

Surprisingly, the work of replacing all of these parts is no greater than if you do the job with a minor kit. You have to tear down the carburetor thoroughly in both cases if you expect all parts to be thoroughly cleaned.

When you turn a carburetor over to a mechanic for overhaul, you're never sure whether you're going to get a "minor" or "major" rebuild.

By the way, the best place to buy a major carburetor rebuild kit is the parts department of a dealer who sells your make of car. Just make sure you get the parts kit for your model carburetor.

Carburetor cleaning solvent represents the major expense, because you get more than solvent if you buy a carburetor solvent kit, which you should. The solvent comes in one and five-gallon cans (one gallon is sufficient for your needs), but included in that can is a basket. As you take parts from the carburetor, place them in the basket, which is immersed into the solvent after tear-down is completed.

A solvent kit costs about \$9 in one-gallon size, but you can use it over and over for cleaning any metal parts on your car. The best place to buy it is from a local supplier of auto parts. Auto dealers' parts departments sell it, but usually in larger quantities.

You need one other piece of equipment for carburetor overhaul, and here's where you might hit a snag. After carburetor parts have soaked in solvent for a couple of hours and are then washed in water to remove solvent, they must be given a blast of compressed air inside and out. This is done primarily to remove specks of dirt loosened by the solvent that could be left in orifices and passages. Use of the compressed-air blast will also expedite drying.

Naturally, if you have a compressor, you have compressed air at hand. If you don't, I hope you're chummy with your local gas station operator. Ask

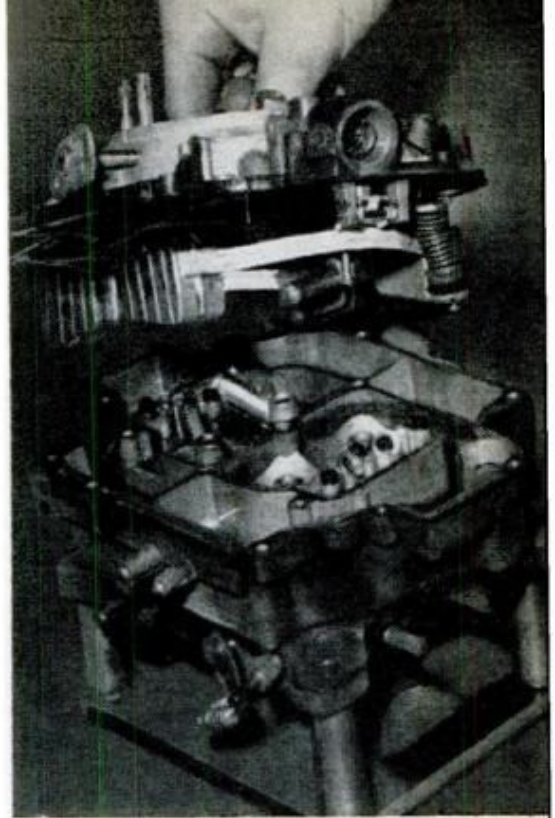

**TWO HALVES** of carburetor casting are separated for access to the internal parts. Note the four floats that are suspended from the top half

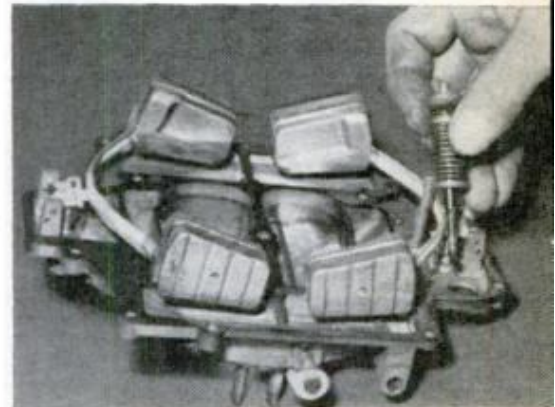

**TOP HALF** of carburetor body is inverted to reveal the accelerator pump. All rebuild kits contain a new pump, so discard old one when you remove it

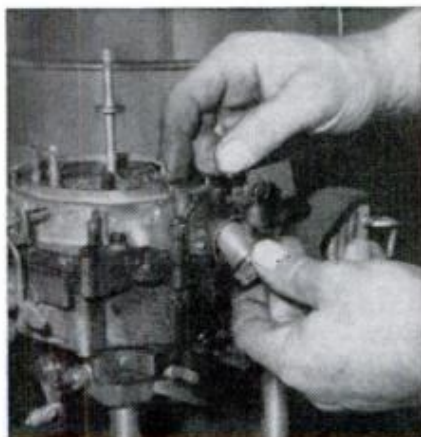

**FUEL STRAINER** is removed and discarded; new one's in rebuild kit

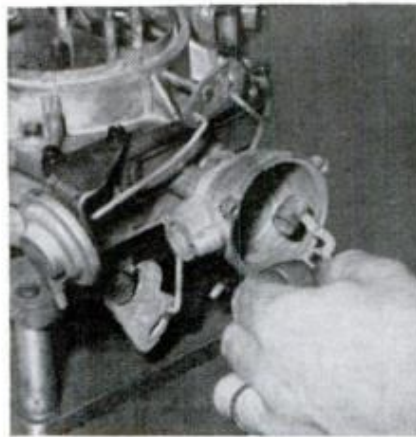

**AUTOMATIC CHOKE** is removed for access to piston on this carb

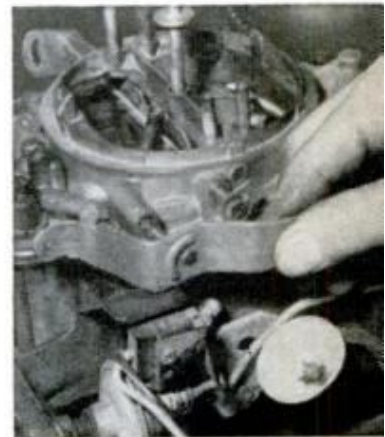

**ACCELERATOR PUMP** lever is removed from the carb

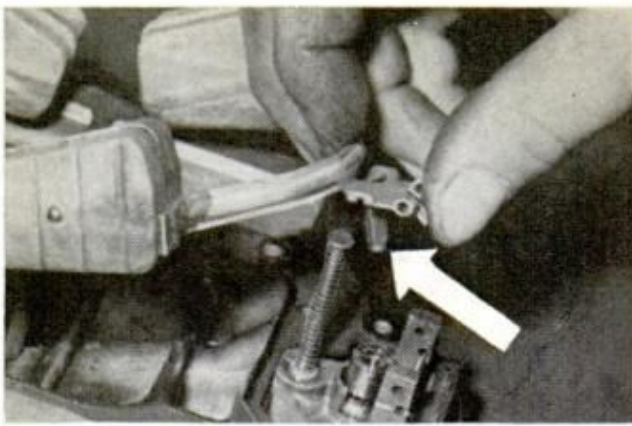

**FLOAT ASSEMBLY** is removed and the needle valve (arrow pointing to tip) is replaced with a new one

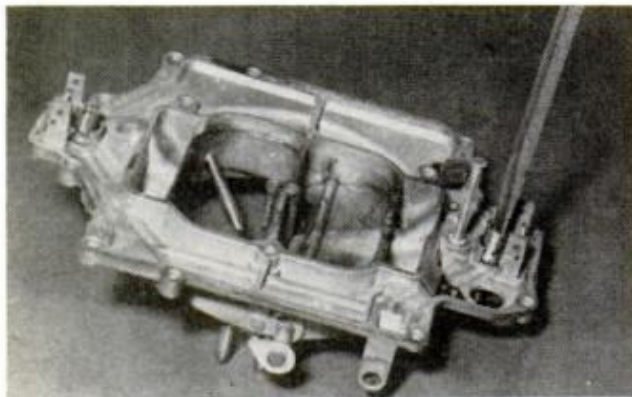

**NEEDLE VALVE SEATS** are removed and discarded. Minor and major rebuild kits have new ones included

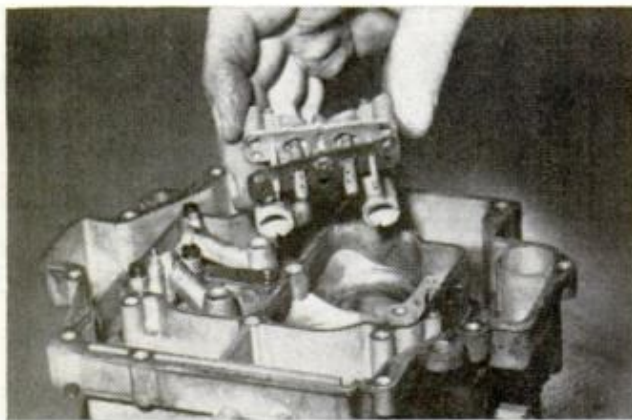

**VENTURI CLUSTER** is removed and main metering jet is unscrewed. Check for a new gasket in rebuild kit



**IDLE SCREWS** are removed and checked. If damaged, and rebuild kit has no replacements, buy separately

him to let you use his air setup—you'll tie it up only for two or three minutes.

Be careful how you handle carburetor parts in transporting them back and forth to the gas station. They could get dirt on them, so use a clean receptacle with a cover.

Another question that's probably on your mind is when or how often to overhaul a carburetor. This is not an easy question to answer, because the symptoms a dirty carburetor can exhibit are those that are created by faulty parts in other areas of the car.

However, once a carburetor reaches the 30,000-mile-mark in operation without its ever having been rebuilt, it's time to do an overhaul job. Let this be a hard-and-fast rule!

Suppose, though, that the engine suddenly becomes hard to start, begins to flood, starts to run or idle rough, begins to hesitate on acceleration, starts to eat gas, backfires, fouls sparkplugs or begins to stall. Each of these faults could be caused by a dirty carburetor or worn carburetor parts—or by other problems not related in any way to the carburetor.

You can handle the situation in one of two ways. First, you can plunge right ahead and do a carburetor overhaul, especially if dirt is visible in the carburetor throat or if it's actually leaking gasoline. If the car has been driven a considerable number of miles, an overhaul won't hurt and will probably do much good although it still might not clear up the problem. Or, you can do a tune-up and see if the condition disappears. If it doesn't, start the rebuilding.

Okay, let's get to work.

With the Rochester 4GC you can proceed as follows:

1. Unscrew the fuel line, choke tube and all vacuum hoses.

2. Disconnect solenoid connections, if there are any, and remove the throttle linkage from the throttle lever.

3. Unscrew the carburetor retaining nuts and lockwashers, and lift the carburetor mounting gasket. As with all other gaskets you take off, throw this away. You'll find that new ones are included in the rebuild kit.

4. Place the carburetor on a workbench and unscrew the idle vent. The small vent part itself is made of rubber, so push that piece out and place the idle vent metal



retainer in your cleaning basket. Discard the rubber part; a replacement should be in the rebuild kit.

**Caution:** Before discarding any part, such as the idle vent, *make sure* there's a replacement in the kit. Each kit varies as to the parts it contains, so it's wise to take an inventory of your kit before starting the job.

5. Remove the fuel strainer and throw it away—there's a new one in the kit.

6. Unscrew the choke cover, which contains the thermostatic spring. Do not put this plastic cover in the cleaning basket, but lay it aside.

7. Reach into the choke housing and unscrew the choke piston. Now, unscrew the choke housing.

8. Unscrew the accelerator-pump lever and remove the air cleaner stud by lifting it out—that's the part that holds the air cleaner.

9. Unscrew the air-horn retaining screws and separate the air horn from the bowl. Now, remove the accelerator pump. This is the part that provides the spurt of extra gas needed by an engine to compensate for sudden engine load changes. Throw this part away—there's a new one in your rebuild kit. Remove the accelerator-pump spring, which is also usually replaced.

10. Take off the float assembly and discard the needle. One and two-barrel carburetors have one float. Simple four-barrel

carburetors have two floats, but complex four-barrel carburetors, like this Rochester, have four.

Each float must go back into the carburetor in the same manner it was removed, so note positions. If a float is dented or you hear sloshing inside, indicating that the float is leaking, replace it with a new one. Do not put floats into the cleaning basket. Although metal, they are fragile and could be crushed by other heavier parts.

11. Unscrew seats and discard them.

12. Remove the venturi clusters, which are held by screws, and remove their gaskets. Unscrew the main metering jet. Some kits have new ones—others don't, so make sure before discarding.

13. Remove the idle mixture screws. Again, check your rebuild kit before discarding.

14. Finally, unscrew the carburetor base.

Now, let the parts soak in solvent for two hours or so. Then, wash each and dry them with compressed air before reassembling.

When the carburetor is reassembled, there are several adjustments that have to be made. Adjustments for simple carburetors are few in number. Those for four-barrel carburetors number as many as 12. Adjusting your newly rebuilt carburetor will be discussed in the March *Saturday Mechanic*. ★★★

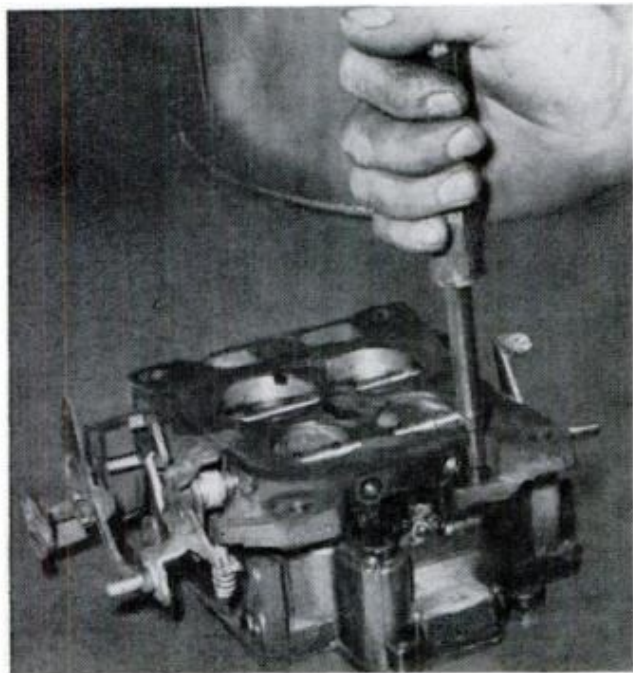

**CARBURETOR BASE** is disassembled for access to the throttle valves. Keep sketch for reassembling parts

FEBRUARY 1969



**BEST CLEANING** is by placing parts in solvent for couple of hours, then blasting with compressed air

163

# We Built This Tent Trailer

Using common tools, with an assist from my wife, I built this four-sleeper tent trailer in my garage

By JAMES L. BENNETT



**B**ECAUSE WE THINK CAMPING is the best and least expensive way to take vacations, my wife and I decided to put together this tent trailer.

With an 8½-foot trailer, we thought we could take our two children and dog on fun trips for less money.

So with my wife's help, I built our first tent trailer. It took me four weekends and it cost \$335.

I purchased the open A-frame chassis for \$145. You can build the whole tent

trailer for about \$250 if you make the chassis yourself. I decided to purchase the chassis because I am not that experienced in metalwork. But I do know woodworking.

I found that building the trailer box was simple once the plywood and lumber are cut to size. The plywood sections are so designed that you can use every bit of eight 4x8-ft. pieces of plywood. This means that you don't have extra bits and pieces left over after construction. It also

# for \$250



TENT unfolds easily at campsite. With one wing open (upper right), mattress straps are visible. Tent is up in center photo, and an optional canopy added in lower photo.

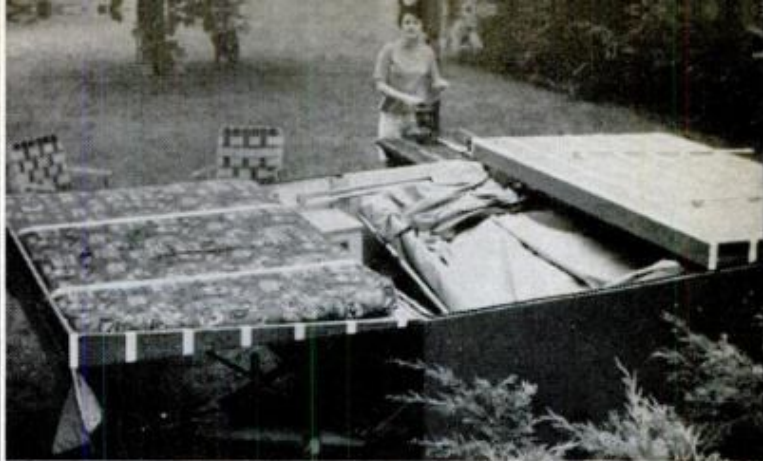

means that you will not have the expense of extra sheets of plywood.

To start, you need the trailer chassis. You can get this from a number of commercial metal works. Better still, you can scavenge it from an old beat-up trailer. Or you can build it from scratch—but you will need metalworking equipment. I purchased the frame from Stratford Fabricating Co.

Should you want to build the chassis, the materials you'll need include two

10½-foot sections of 2½-inch pipe. The trailer bed is 8 feet long, but you'll need an additional 2½ feet of length for the trailer tongue. Next, you need six 6½-foot pieces of angle-iron stringers. These must be welded to the piping. Suspension springs, brackets, axle and wheels come next. (See diagram, page 167.) Positioning of the axle is critical. You want the completed trailer to tow straight behind the car, and be so balanced that only 50 to 60 pounds of weight rests on the hitch. The

## PLYWOOD PATTERNS

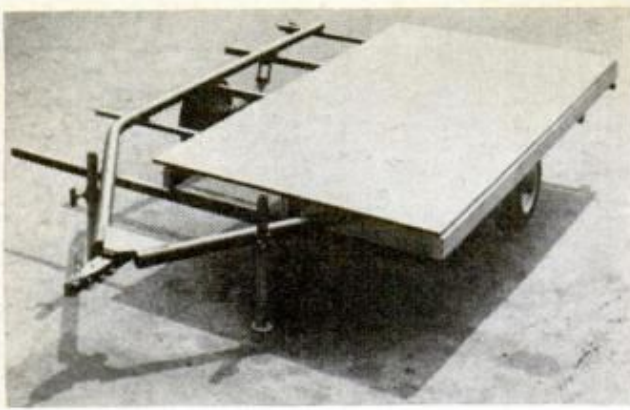

**BUILD CHASSIS**, then attach floor pieces. Trailer stands are attached to forward portion of chassis

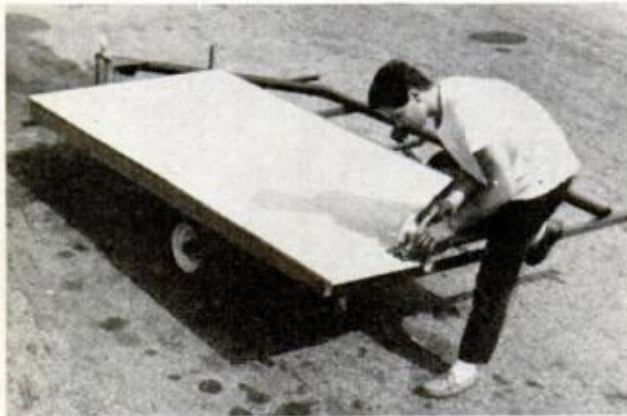

**PLYWOOD FLOORING** is laid on joists. Attach floor and joists to angle iron with bolts or wood screws



**PREFABING SIDES** is a good idea. Note position of the structural supports for cabinets at box ends

trailer tires should be 4.80/4.00 x 8-in., which are rated to carry 1200-pound loads at 60 mph. You want to try to keep away from large tires as they call for wheel wells in the camper box for wheel clearance.

The trailer body is basically a box made of plywood with 2x4-in. lumber used as joists under the floor.

The floor should be of 5/8-in. plywood,

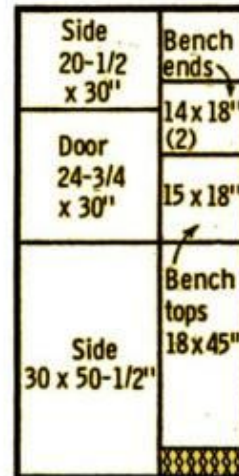
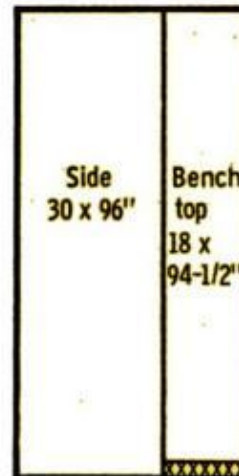
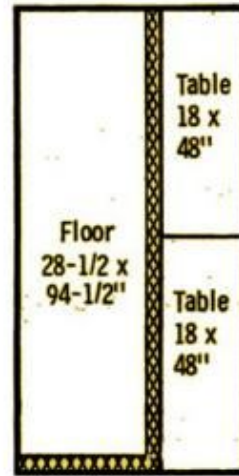

xxxxxx denotes scrap

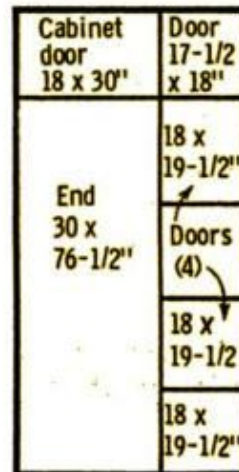
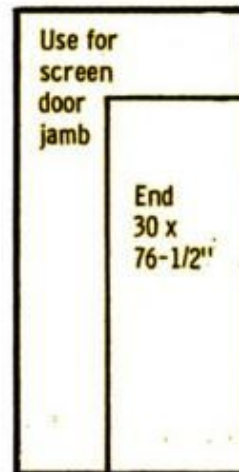
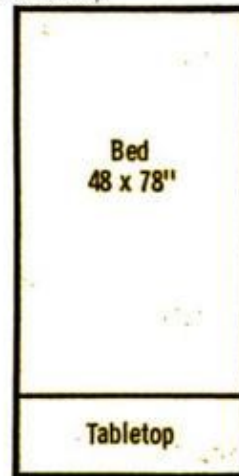
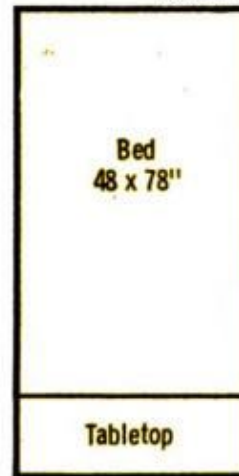

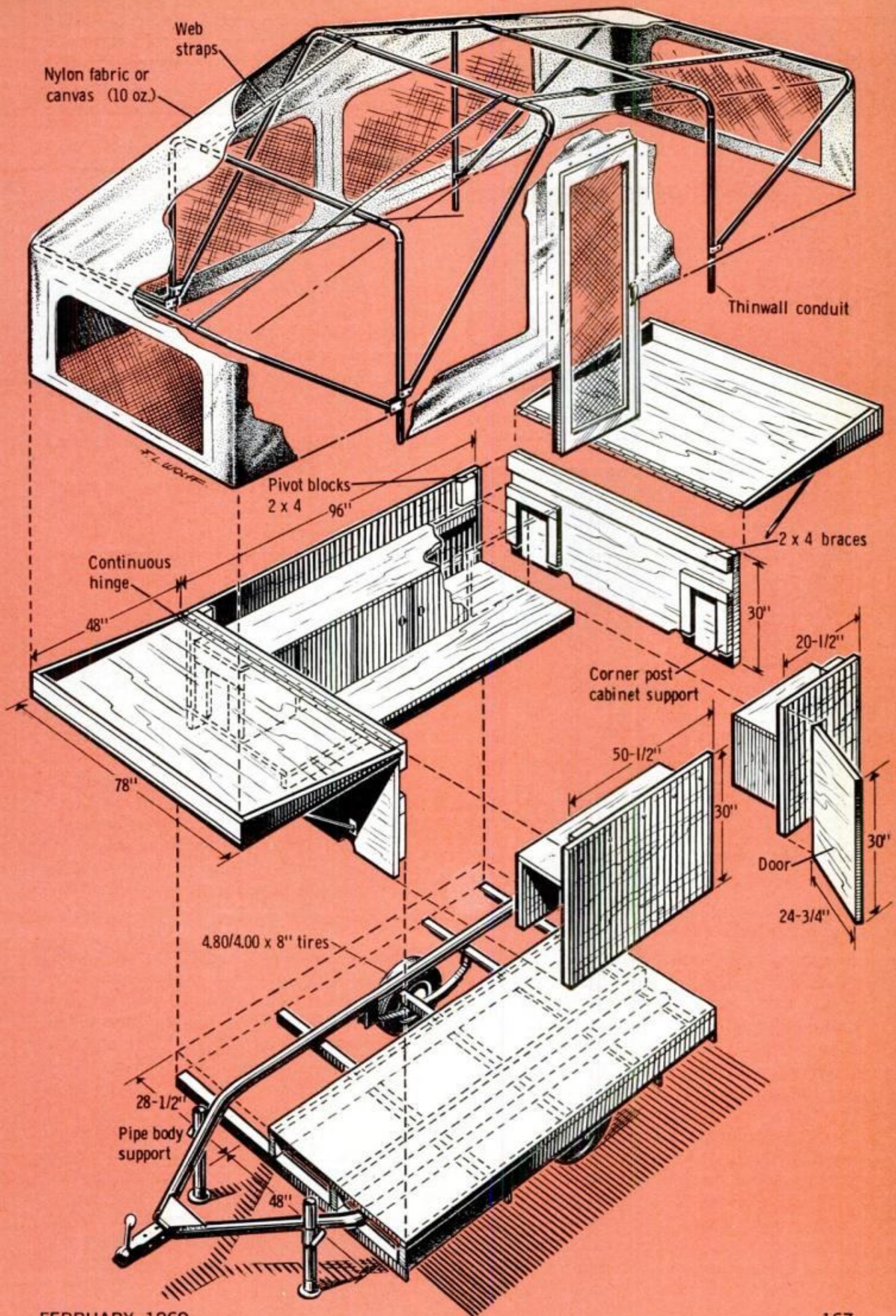



**SCREEN DOOR** can be mounted. This door is removed and laid on the floor when you collapse the trailer

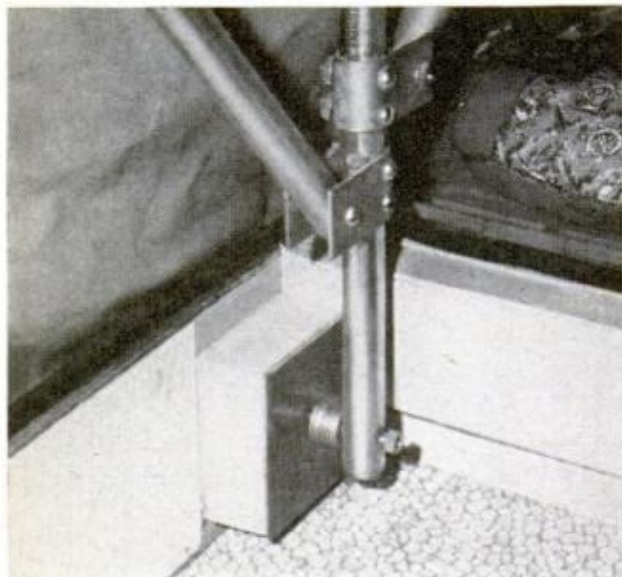

**PIVOT BLOCKS** and bolts are necessary for tent pole. Note the steel straps used to attach oblique pole

while the trailer sides, top and cabinets can be of  $\frac{5}{8}$ -in. or  $\frac{1}{2}$ -in. Once you've cut all your wood, start by laying floors on joists and drilling through floor, joist and angle iron. Bolt together securely. Remember, this trailer will take a lot of bouncing.

To finish off the floor, it's a good idea to lay tile. Remember to arrange the tile so the joint between the two plywood floor sheets is covered. Also lay the tile before adding cabinets. This avoids intricate tile cutting and assures proper fit.

For the cabinets, use strips of 1x3-in. lumber as supports and lengths of 2x2-in. as structural supports in the corners and at the ends. Cabinet doors can be covered with vinyl to spruce up the trailer interior.

For extra sleeping space, make the table so the support leg can be folded under and the table can be detached from trailer bracket. Then lay the tabletop across the cabinet tops or benches. This can make up into another bed.

Here are some other trailer building tips:

Remember to keep the door handle low enough so there is enough space for collapsed tent poles and canvas.

Use heavy  $2\frac{1}{2}$ -in. continuous piano-type hinges to secure bedwings to the trailer box.

Use awning brackets as sockets for bedwing support rods.

Use pivot blocks in corners so tent poles fall within the trailer box. Use pivot bolts to secure poles.

Cement sponge-rubber weatherstripping around the top edge of the trailer box. When the trailer is closed in the travel position, this stripping will absorb shock and help keep road dust out.

Paint the chassis so it will not rust and so it can be hosed off after long, muddy trips.

Now you're ready for the tough part—the tent canvas.

It is very possible that you may want some professional help on this important section. Few people have sewing machines capable of double stitching 10-oz. canvas. Rug-binding and hand awls may also present a problem to the average builder. A good awning and tentmaker can turn out a first-rate job for you when given the dimensions of your trailer. Remember, the tent poles, from pivot to peak, cannot be longer than the interior dimensions of the trailer box.

Electrician's thinwall conduit—about 9 cents a foot—can be used for tent poles and ribs. This material can be bent with a plumber's bending tool. Or you can have formed corners of  $1\frac{3}{16}$ -in. bar inserted in saw-cut tubing ends. Wrap all joints with tape to prevent wear on canvas. Web luggage straps can serve to hold poles in the correct standing position.

There is a helpful source for those of you who might have trouble building the chassis and sewing the canvas. It's the Stratford Fabricating Co. in Bridgeport, Conn. This firm manufactures the open A-frame chassis and the tent. Prices run about \$145 for the chassis and \$146 for the tent.

★★★

# HINTS FROM READERS

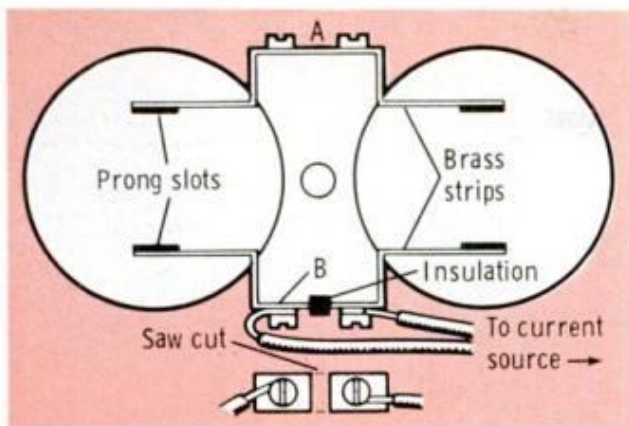

## Circuit tester from duplex receptacle has own safety fuse

A simple change converts any electric receptacle in your workshop to a separately fused safety circuit.

To convert the receptacle you must wire the two pairs of outlet slots (normally connected in parallel) in series. With a hacksaw cut one of the brass strips between its two wire-holding screws. Make the slot as wide as possible, and fill it with insulating fiber. Apply insulating varnish

or shellac to this wedge. Now connect each wire of the current-supply cord to one of the two screws shown at B in the drawing. No connections are required at point A.

Mount the outlet in a standard box. Insert a lamp socket adapter into a receptacle and install a fuse of lower rating than the circuit fuse. Plug a suspected appliance in the other receptacle, and see if the fuse blows.—*Henry R. Rosenblatt*

## Extension rule is handy depth gauge

When it comes to taking an inside measurement with a zigzag rule which has sliding extension, you already know how handy such a rule can be. But do you know that this same sliding brass extension can be handy too for checking the depth of dowel holes? Since the extension is narrower than the rule itself, the end of the rule provides a shoulder. Thus all you have to do is insert the extension in the hole and press forward until the rule touches the work.—*Richard K. Rogers*

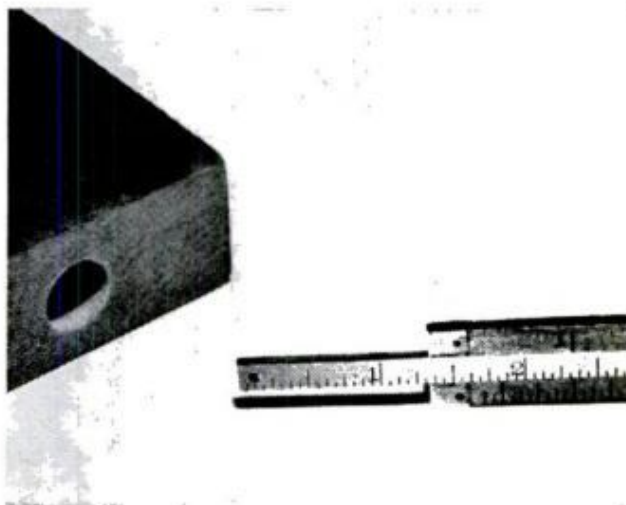

## Improvised spoke tightener

A bicycle-spoke tightener is a tool you seldom need. Even if you have one, chances are you can't lay your hands on it right away. But when you need one, it's hard to find another tool that will do. Here's a perfect substitute you probably can find in your drawer of miscellaneous hardware: Select a castellated nut with slots that are  $\frac{1}{8}$  in. wide. You'll find the slots fit the spoke nipples perfectly, and you can easily tighten or loosen them with this makeshift wrench.—*Joe Dettling*

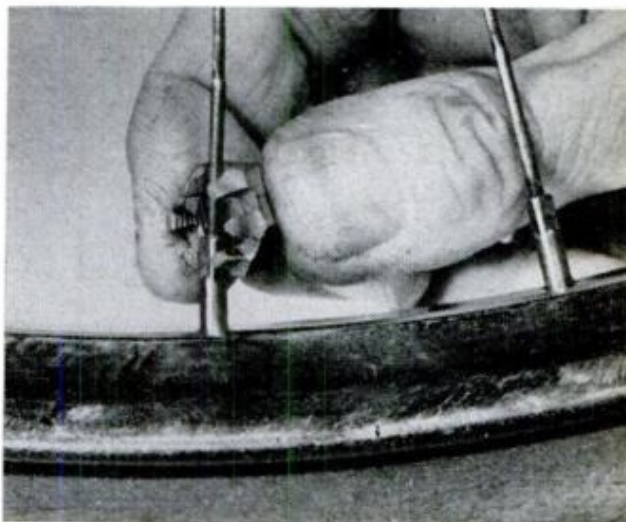

# EXCITING NEW PRODUCTS

By CATHERINE BILSKI

**TORCH-LITE GLASSES** have built-in, battery-powered lights that illuminate your work while leaving your hands free. Uses include emergency work in unlit basements and lighting awkward work areas. At retail outlets or for \$5.95 ppd. from C. & A. Imports, P.O. Box 87, Ocotillo, Calif. 92259.

**GRID RISERS** placed on top of the runners of an existing suspended ceiling recess the ceiling panels to give a framed effect (below). At lumber dealers and building supply stores, they sell for about 7 cents a lineal foot. The ceiling panels shown are named Sahara (also made by Armstrong Cork) and have a woven-grass-mat effect. Available for about 22 cents a square foot.

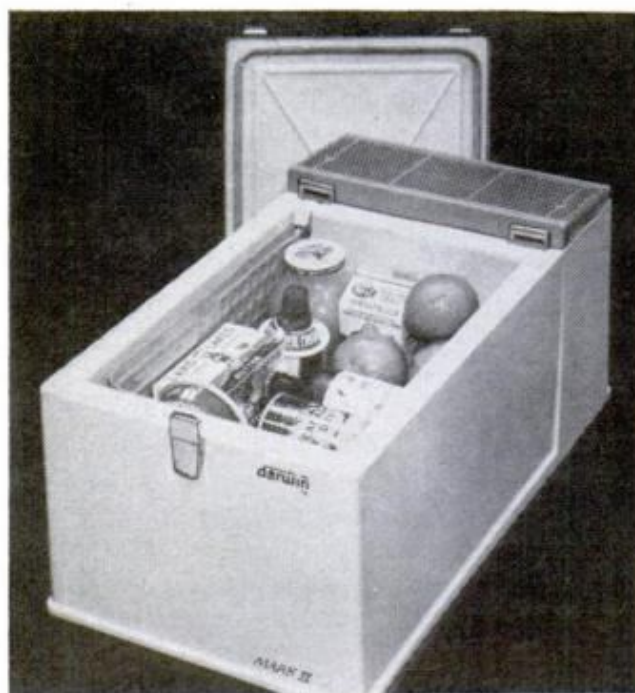
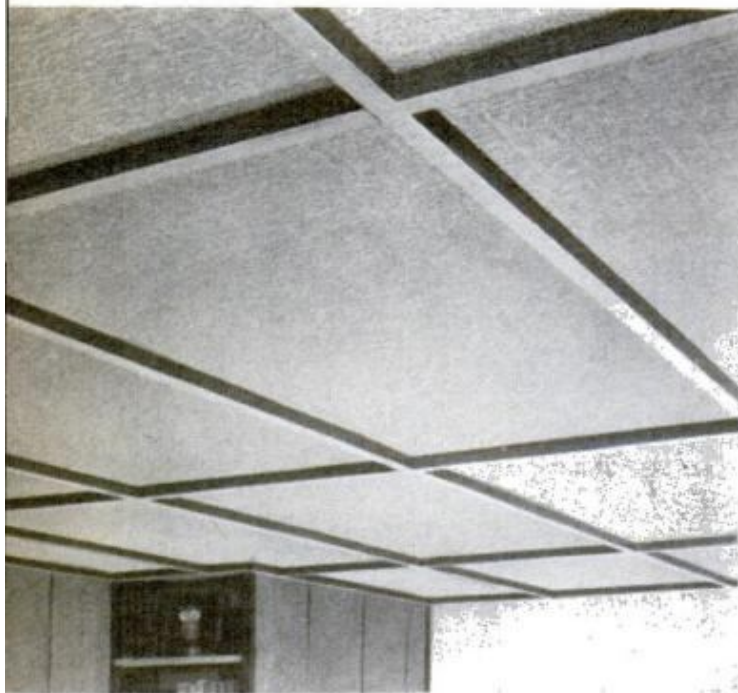
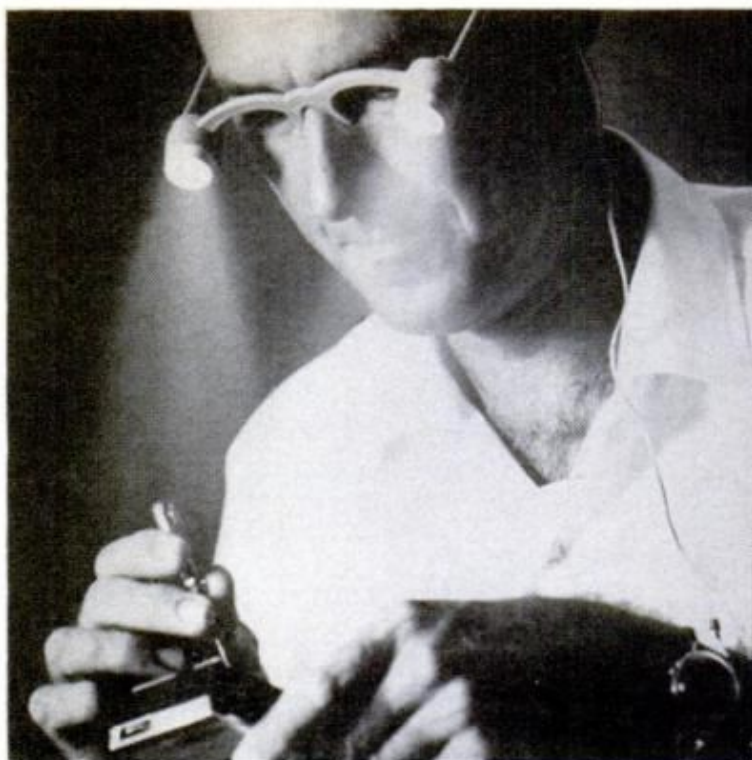

**PORTABLE REFRIGERATOR** (above) operates on car cigaret lighter or direct from 6, 12 or 24-v. battery. Called the Darwin Mark II, it comes complete with a 15-ft. lighter attachment cord. It sells for \$77 and is available from Darwin Industries, Inc., P.O. Box 745, Orange, Conn.



**HAGARON PEEL** is the solution to a complex of sticky problems such as dissolving pastes, gums and glues. It is odorless, colorless, non-toxic and nonvolatile. Priced at 49 cents (1 fluid ounce), it's sold at most stationery and retail outlets. In handy plastic squeeze container, it's distributed by Yasutomo & Co., 24 California St., San Francisco, Calif.



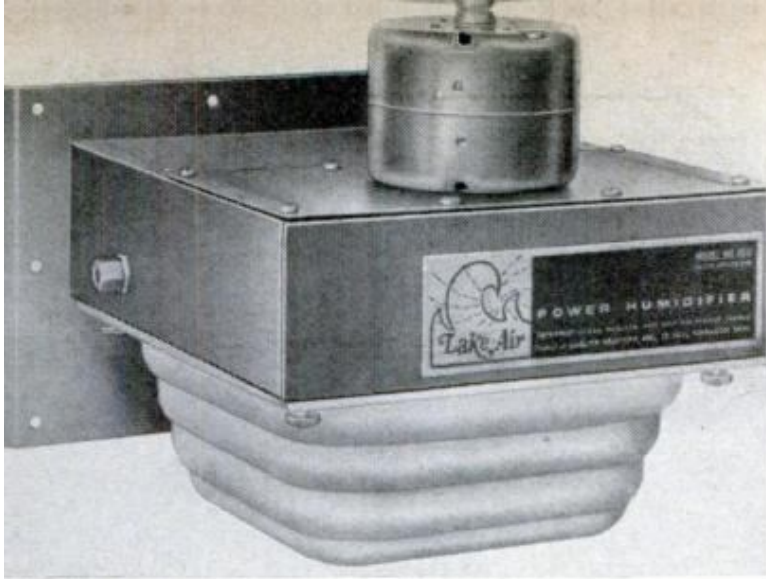

**HIGH-CAPACITY HUMIDIFIER** operates through forced-air furnace to add moisture to the air in a home. Heated air is bypassed to the unit, and a fan forces the humidified air through the duct system. Made by Quality Krafters, Inc., 700 W. Country Road B., St. Paul, Minn., Lake-Air unit retails for \$89.95.



**ONE-COAT ANTIQUING KIT** now lets you prime, grain and seal in just one application. Covers practically any surface from furniture to walls and dries to a satin finish. Price is \$5.95 a pint and \$8.95 a quart at department and paint stores. Distributed by Krisler Corp., 60 Bowne St., Brooklyn, N.Y. 11231.

**TAP-N-HOLD BRACKETS** eliminate need for conventional standards or wall strips when used with drywall or plywood paneling,  $\frac{1}{4}$ ,  $\frac{3}{8}$ ,  $\frac{1}{2}$  or  $\frac{5}{8}$ -in. thick. They are quickly installed with just a hammer and without screws or toggle bolts. Available in 6, 8 or 10-in. lengths, the brackets sell for \$1.77 to \$2.33 per pair. Timber Engineering Co., 1619 Massachusetts Ave. N.W., Washington, D.C. 20036.

**ATTIC ROOF FAN** prevents excessive heat buildup under the roof and keeps lower and better balanced temperatures in living areas. Model RF-68 can be installed easily on a pitched or flat roof. Priced at \$99.95, it's made by NuTone, Madison and Red Bank Rds., Cincinnati, Ohio.

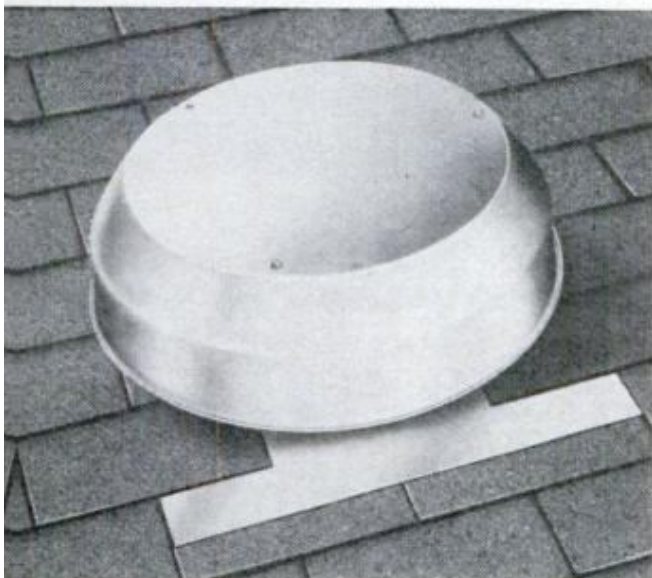
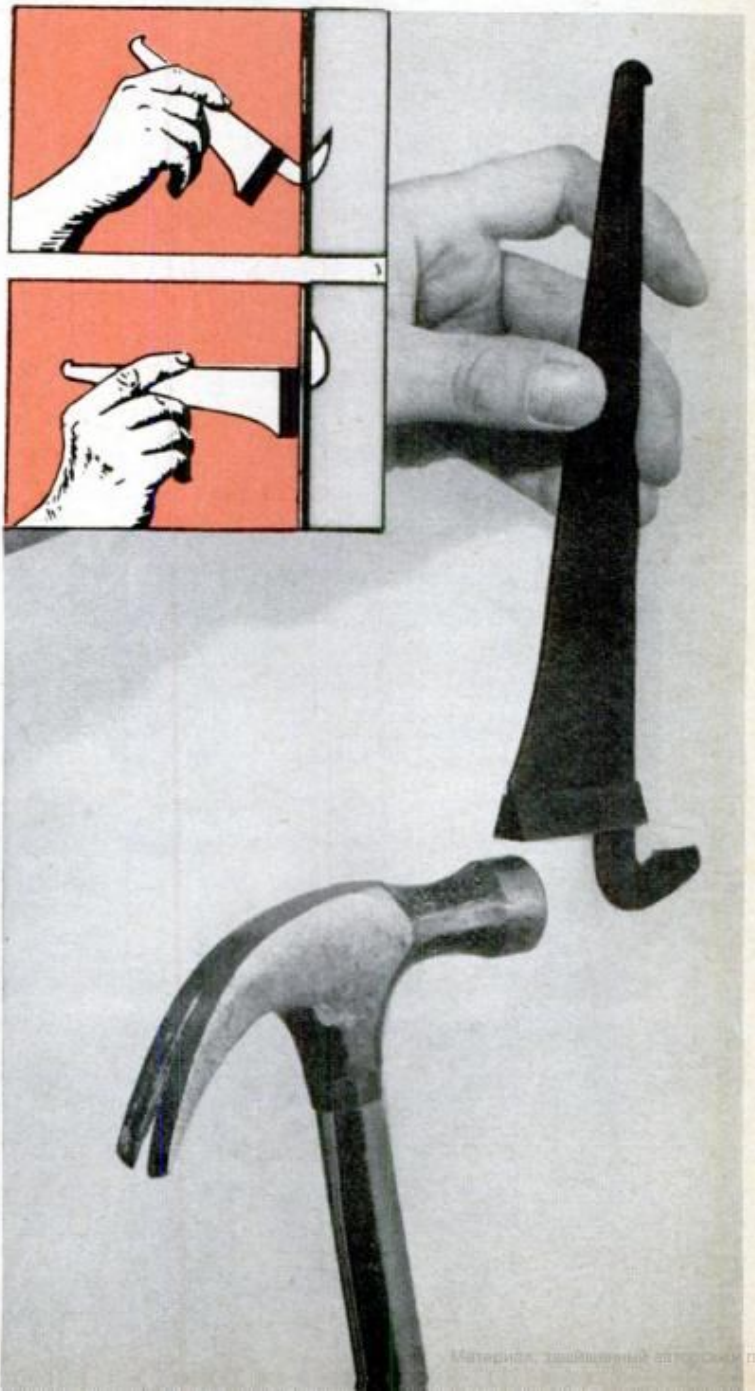

# NOW: Smaller Tractors That Shift for Themselves

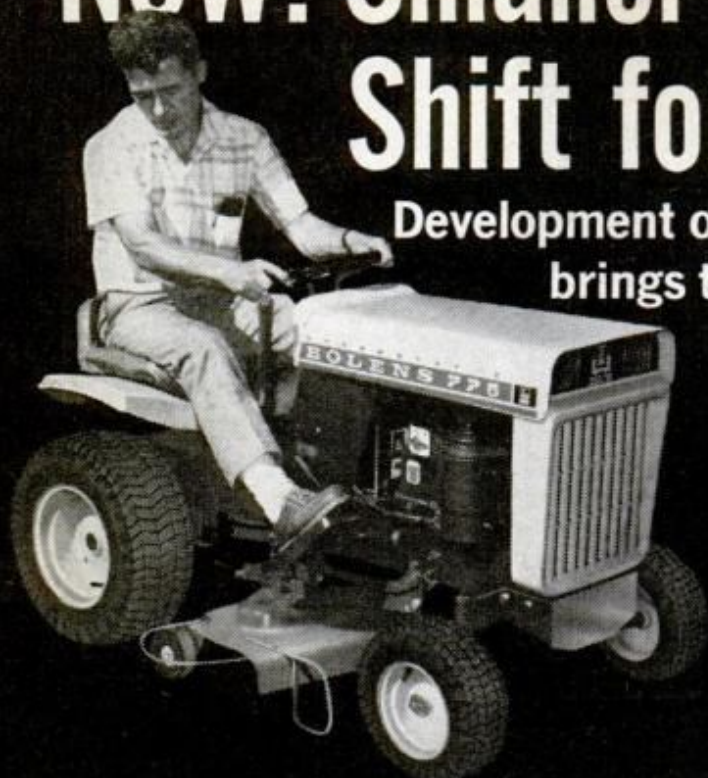

Development of a smaller, low-cost unit now brings the convenience and efficiency of hydrostatic transmission to five new small-frame garden tractors

By JIM LISTON  
Executive Editor

**G**OOD NEWS for prospective buyers of '69 compact tractors is that four leading manufacturers—Bolens, Massey-Ferguson, Toro and Wheelhorse—have introduced seven-hp hydrostatic models for well under the \$1000 it had previously taken to eliminate clutching and shifting. Prices range from \$695 to \$800. The higher price includes a 36-inch mower, electric starting and headlights. The new sevens will be welcomed by many homeowners who didn't need the wheelbase and weight of a 10 or 12 hp for their two main jobs: mowing and snow removal.

The four new tractors have plenty of power for their big mowers. (We've tested all of them.) All four manufacturers offer snow-thruster attachments, and

one—Wheelhorse—has found its seven can handle an 8-inch plow for light garden work.

The new hydrostatic sevens resulted from the development by Eaton Yale & Towne of a simplified, compact hydrostatic transmission that can be coupled to a seven-hp engine. The new transmission offers all the advantages of the 12-hp "automatics": smooth speed changes from full forward to full reverse, perfect matching of speed to load, and elimination of clutching and throttle changing.

The transmission has three major parts: a variable displacement radial-piston pump; a fixed displacement ball piston motor, and a system of valves between the pump and motor. The pump

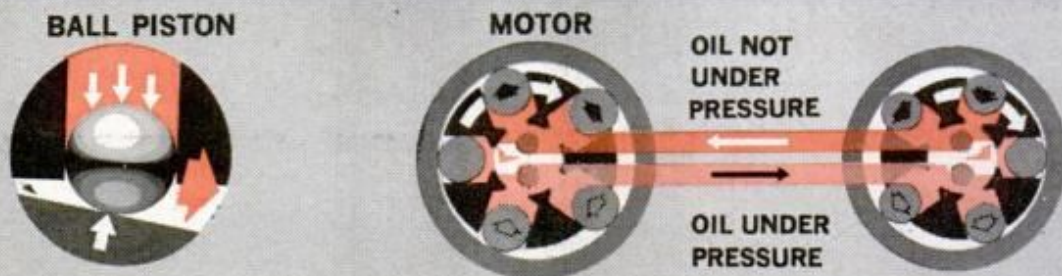

Combination of forces—the result of oil pressure on ball and off-center control ring—make pump

rotate. Pump converts mechanical energy (input) to pressure energy; reconverts it to mechanical (out-

put). Conversion makes possible varied output torque, speed and direction with constant input.

# RADIAL BALL PISTON HYDROSTATIC TRANSMISSION

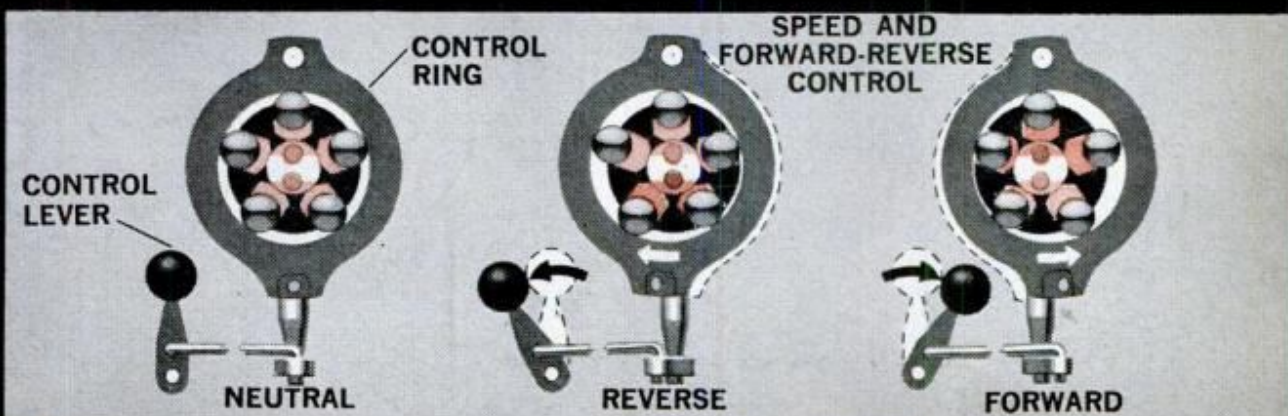
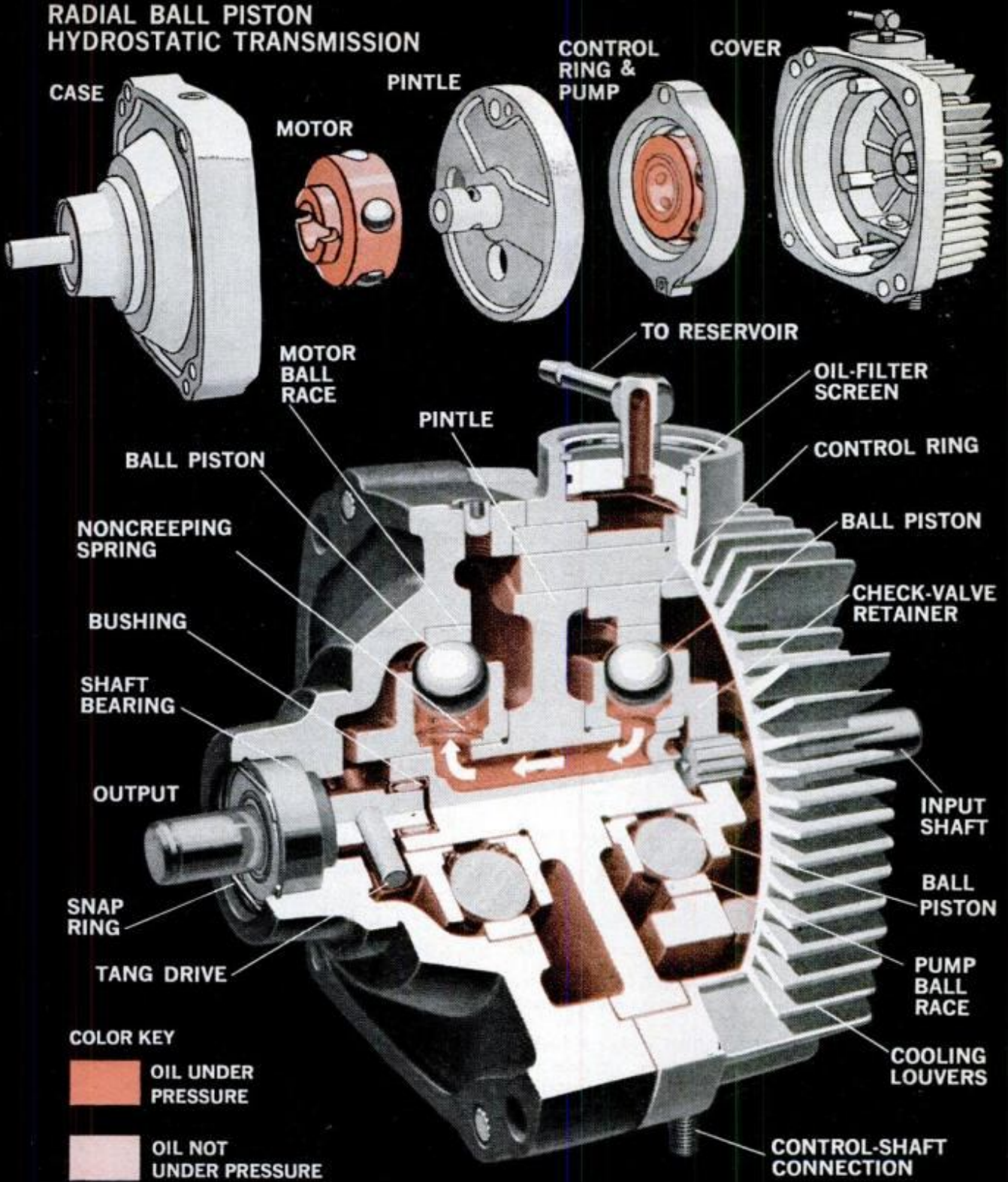

ART CREATED EXCLUSIVELY FOR POPULAR MECHANICS BY DALE GUSTAFSON



**WHEELHORSE CHARGER V7** (electric-starting standard) takes 36-inch mower, pulls 8-inch plow, costs \$780



**MASSEY-FERGUSON** costs \$695; with 34-inch mower, \$100 more. Electric starting is standard equipment

**TORO'S 25-INCH TURNING RADIUS** makes it highly maneuverable. The \$800 price includes as standard a 36-inch mower, headlights, electric starting



produces a flow of oil under pressure, through internal channeling, between pump and motor. The speed of the tractor is regulated by changing the amount of oil delivered by the pump. When the speed control is moved forward, the cam ring of the variable displacement pump is moved off center and oil flows through the circuit. Moving the lever varies the flow of oil—which varies the speed of the tractor. Since the circuit is a closed loop—and oil is relatively incompressible—whatever flow reaches the motor is transformed into speed, depending on volume and direction of flow. Maintenance is limited to checking the dipstick every 25 hours. ★★

**BOLENS HUSKY 775** has foot-pedal control for hydrostatic: toe down for forward, heel down for reverse. Standard: electric starting, headlights at \$750



# HINTS FROM READERS

## Protection for new flooring

When nailing strips of tongue-and-groove flooring, protect them from denting hammer blows with this simple shield. It's just a 3 or 4-in.-long section of angle iron with one leg cut to the height of the tongue to the face. The center of this shortened leg then is notched for the nail. Even if you should miss the nailhead, the angle will absorb the force of the blow.



## Handy ink marker for crates

When filled with ink or paint, a spreader-type glue bottle will make it easy to address shipping crates or cartons. Just press the rubber cap of the bottle down against the crate so ink begins to flow, then draw the cap through the ink to form the necessary letters or numerals. Just be sure to apply only light pressure to avoid covering the surface of the crate with unsightly and unreadable blobs of ink. Show this trick to your children—it will help them make school posters.



## Odd parts from ball pens

Old ballpoint pens can be made into useful items for your workshop supply. Remove the ink cartridge and all metal fittings, then slice the body, cap and even the ink cartridge into segments of assorted lengths. The result is a collection of plastic washers and spacers useful for building or repairing different projects. Some of the rings and spacers shown at the right were cut from the body or cap using the saw shown, while others were cut off on a lathe.—Walter E. Burton

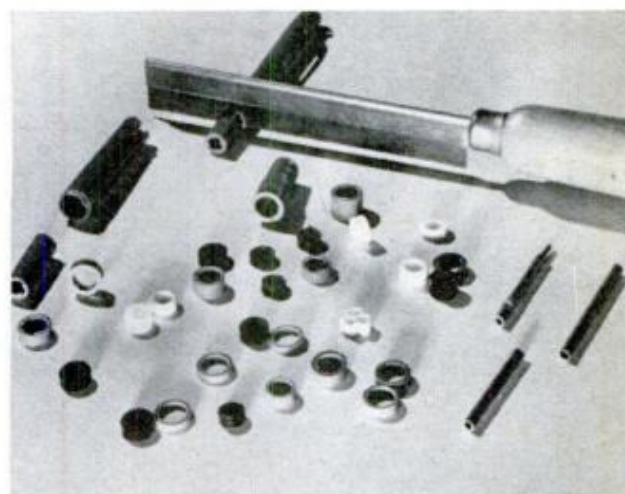

## Cutting tubing neatly

To squarely cut sections of small-diameter tubes or thin, limber rods, clamp a suitable length of tongue-and-groove flooring in a bench vise so that the groove side faces upward. Cut a fine kerf across the lips of the groove, much like the slots in a miterbox. Then just position the tube or rod in the groove so the cutoff point is aligned with the fine kerf and saw through the work with a hacksaw. Supporting the work this way also prevents it from becoming marred in the vise jaws.

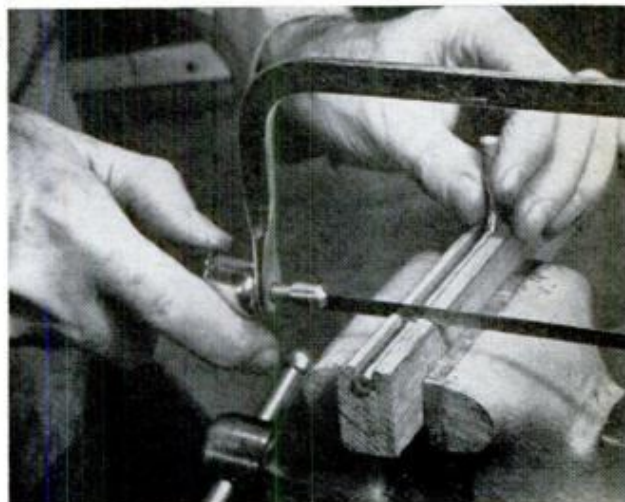

# WHAT YOU SHOULD KNOW ABOUT

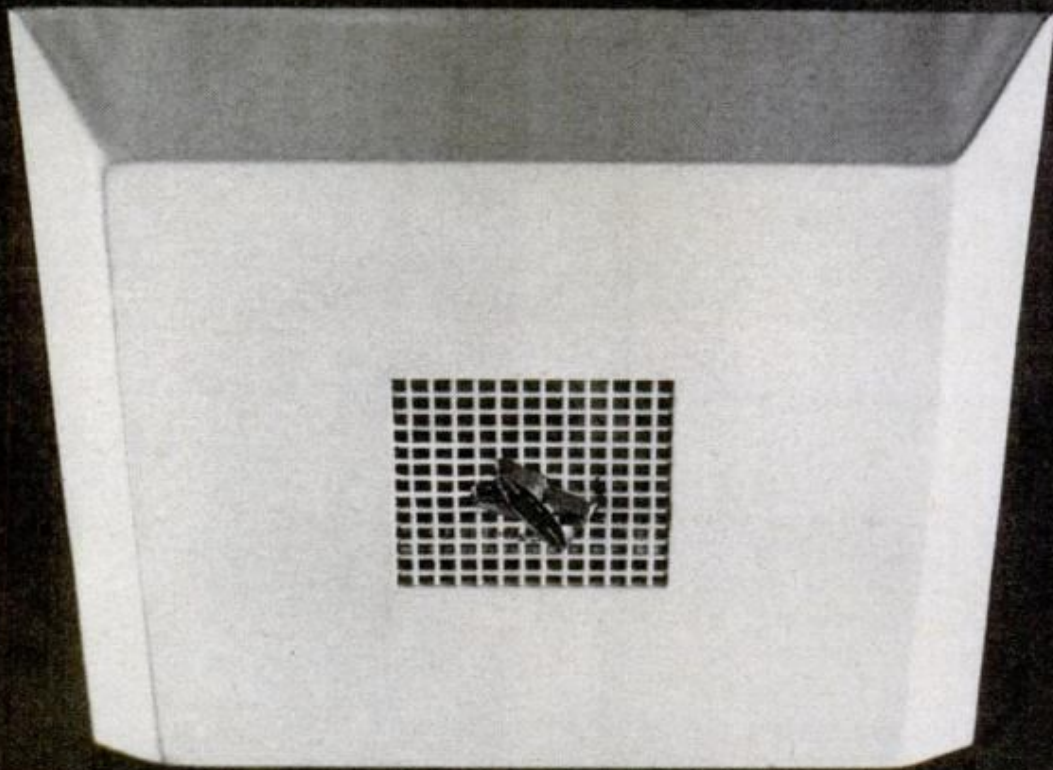

# FIRE WARNING SYSTEMS

**This single piece of equipment can protect more than your living-room furniture—it could one day save the lives of those in your family**

By **JAMES P. SCHENLEY**

Technical Art  
By Fred Wolff

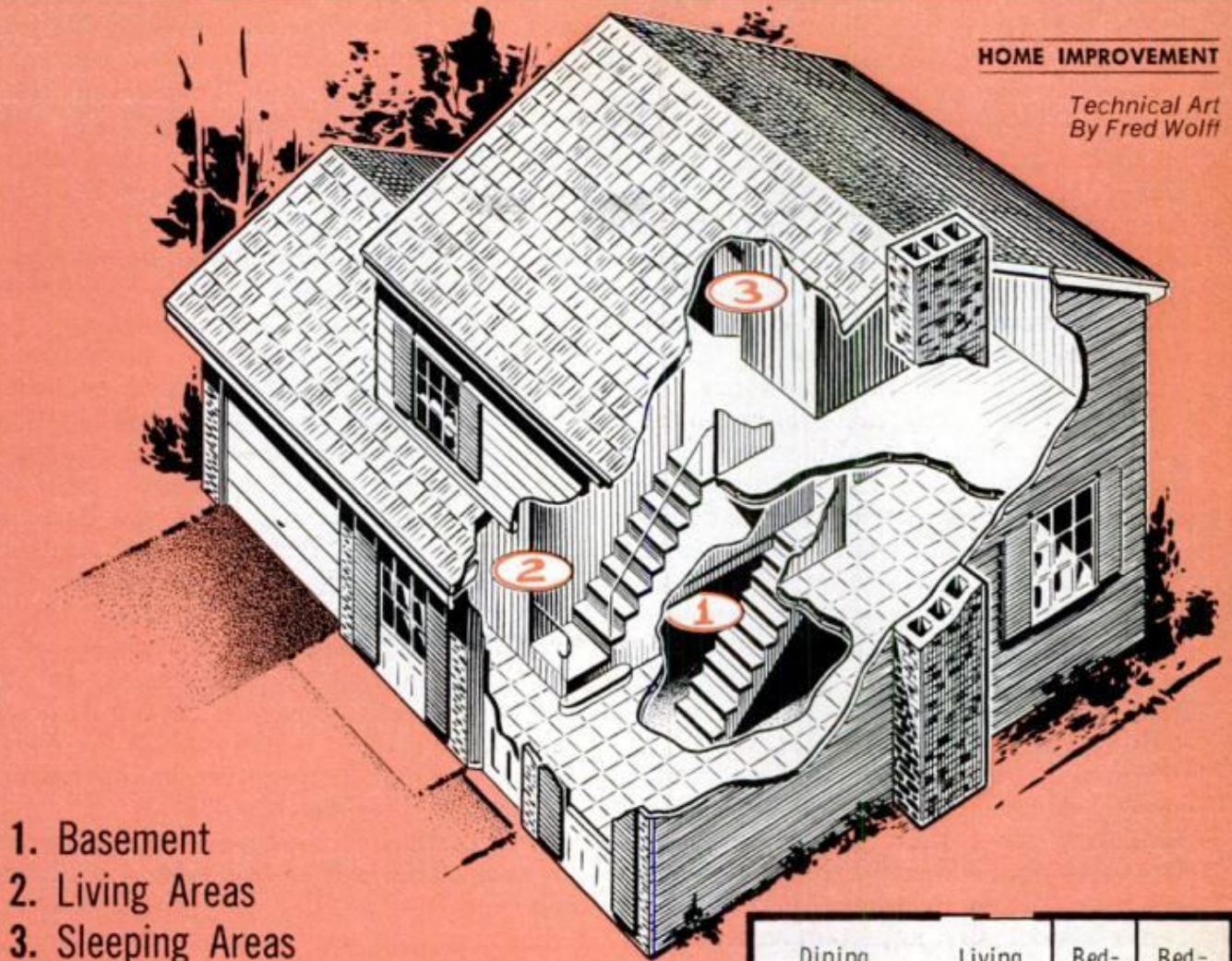

1. Basement
2. Living Areas
3. Sleeping Areas

IDEAL LOCATIONS FOR SMOKE AND FIRE DETECTORS are shown in cutaway. In plan below, bedrooms are protected

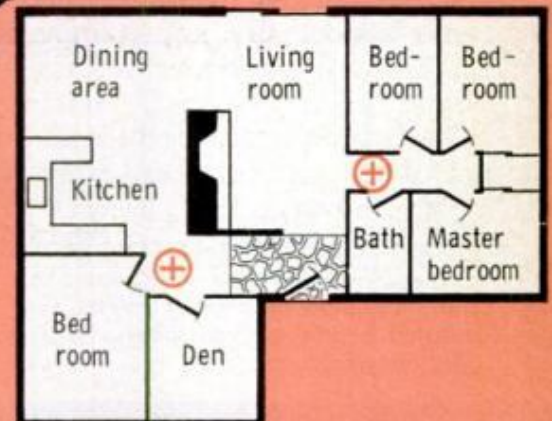
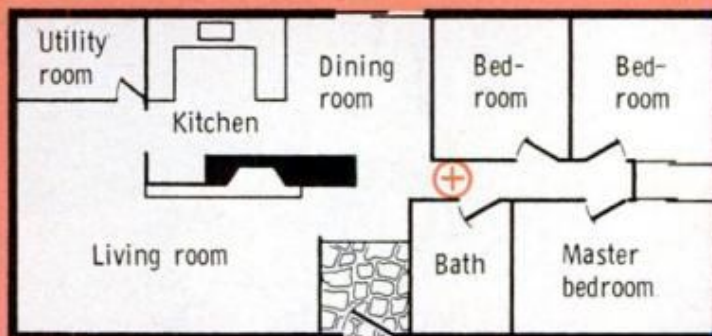

MORE THAN ONE SLEEPING AREA in a home calls for a minimum fire-protection arrangement that includes a separate detector for each area as indicated above

**W**HAT REALLY CONSTITUTES a reliable and adequate fire warning system for your home? Is it the can of compressed gas with a whistle that sells in hardware stores and supermarkets for \$3.95? Or is it a sensitive ionization system that costs \$1500 to install in a six-room house?

The fire-warning system for your home is probably neither, unless, of course, you can afford an ionization system. This system employs minute particles of radium to

detect a difference in air current—a difference created by a fire in its incipient stage when neither smoke nor flame is visible.

The right system, however, should detect both heat and visible smoke or, if this will strain your budget, at least detect smoke. Fire officials claim that approximately 75 percent of home fires begin as smoldering types that produce dense smoke in advance of flame. This smoke kills by asphyxiation, especially when the

victims are sleeping, unaware of their plight.

But before I describe the ideal and compromise systems, there is one most important fact to remember. Never buy detection equipment which doesn't carry the label of the Underwriters' Laboratories (UL) or the Factory Mutual Engineering Corp. (FM). This label is your assurance that the equipment has been thoroughly tested and will give dependable performance. In Canada, the label of Underwriters' Laboratories of Canada (ULC) provides the same assurance.

To help you find the system to meet your needs, a list of manufacturers is provided on page 179. Write to them for information, including price, before deciding which system you want. Ask them for names of their distributors in your area. Do not buy equipment from a door-to-door salesman, even though he may be selling UL or FM-tested devices. His price is usually inflated and he's not able to provide service if it's ever needed.

Warning devices for the home are smoke or heat detectors or both. Smoke detectors, other than the ionization system, use photoelectric cells to detect the products of combustion. Heat detectors sense abnormally high temperature or a rapid rate-of-temperature rise and usually are electrically or gas operated.

Each type must produce an alarm signal that can be heard throughout the

house. It must be rated at not less than 85 decibels at 10 ft. Each detector should also have a trouble signal to warn you of a failure in the system. This could be a different tone than that of the alarm signal, a light which flashes there's a failure or, in the case of a gas-operated heat detector, a sight glass.

**A typical UL-listed smoke detector** is a single-station device with a light-tight enclosure open to the atmosphere. (A "single station" assembly incorporates both the detector and the alarm sounding device into one unit.) A sharp beam of light is focused in the darkened enclosure of the smoke detector. Smoke particles entering the enclosure cause the beam to reflect light to a photoelectric cell, causing a decrease in the resistance of the cell. This sets off the alarm.

Although the primary purpose of a smoke detector is to detect smoke in advance of heat, many also contain a heat-detecting element which sets off the alarm if the ambient temperature in the vicinity of the detector reaches 135° F.

Installation of a single-station detector is easy. The unit is hung on a wall and plugged into a 115-v.a.c. outlet. The top should not be less than 6 nor more than 12 inches from the ceiling. Also, it should not be placed in a corner.

Heat detectors will switch on the alarm when exposed to a fire producing heat but

**CHECK FIRE WARNING SYSTEMS REGULARLY.** Smoke detectors, such as the one below, can be checked simply by blowing cigaret smoke into grille. Gas-operated heat detectors, such as that shown on the right, incorporate a sight glass to check gas level

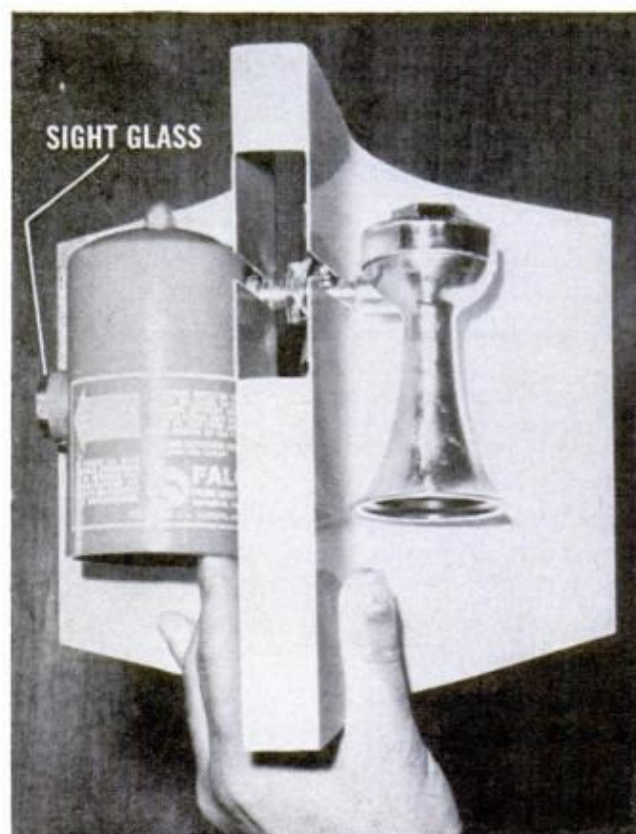
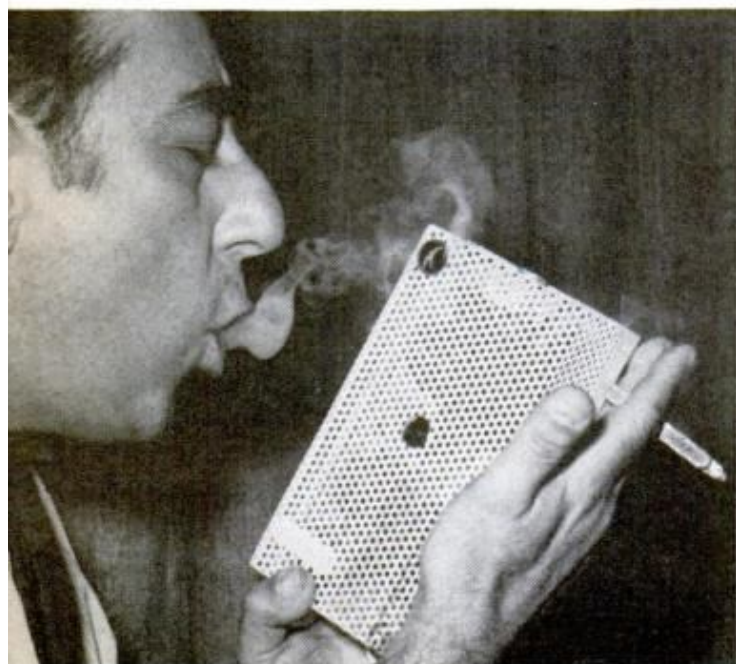



little smoke. Electrically operated heat detectors have a thermostat that makes or breaks an electrical circuit to set off the warning alarm. Although electric systems are plugged into 115-v.a.c. outlets, they then transform and rectify the a.c. to not more than 30 v.d.c.

An electrical heat-detection system must be equipped with a reserve power supply of batteries in the event of a power failure. The batteries present a maintenance task since they should be checked or recharged yearly.

An electrically operated system should also have a means to test the system (usually a switch). The average cost of such a heat-detection system for a typical house is about \$750.

**Gas-operated heat detectors** are normally single-station devices that sell for about \$45 each. You can install these yourself, since all you do is screw a bracket into place to hold the unit.

The gas unit is a cylinder of Freon with a heat-sensing element. As temperature rises, gas pressure builds up until a valve opens to let the Freon pass to the alarm. Units for living quarters are set to go off at 136° F. while units rated at 174° F. are for attics or near a furnace.

In an average house, heat detectors

### LIST OF MANUFACTURERS

- Alarm Device Mfg. Co., 100 Voice Rd., Carle Place, N.Y. 11514.  
 Bliss-Gamewell, 209 W. Central St., Natick, Mass. 01760.  
 BRK Electronics, Skokie, Ill. 60076.  
 Casady Engineering Associates, 13626 S. Normandie Ave., Gardena, Calif. 92047.  
 Chicago Fire & Burglar Detection, 646 Roosevelt Ave., Glen Ellyn, Ill. 66137.  
 S. H. Couch, Inc., 3 Arlington St., North Quincy, Mass. 02171.  
 Dictograph Security Systems, 733 Mountain Ave., Springfield, N.J. 07081.  
 Edwards Co., Inc., Norwalk, Conn. 06854.  
 Electronic Locator Corp., 343 W. 37th St., New York, N.Y. 10018.  
 Emerson Electric, 8100 Florissant, St. Louis, Mo. 63136.  
 Evergard Fire Alarm Co., Inc., 601 W. Susquehanna Ave., Philadelphia, Pa. 19122.  
 Falcon Alarm Co., 20 Stern Ave., Springfield, N.J. 07081.  
 Faraday Div., Gray Mfg. Co., Tecumseh, Mich. 49286.  
 Fenwal, Inc., Ashland, Mass. 01721.  
 Fire Alert Co., 505 W. 40th Ave., Denver, Colo. 80216.  
 Fire Control Co., 703 Thorton St., Wilmington, Del. 19801.  
 Fire Device Co., 414 Rolyn Pl., Arcadia, Calif. 91006.  
 Fire-Lite Alarms, Inc., 190 Fulton Terrace, New Haven, Conn. 06502.  
 FSI Security Systems, 223 Arch St., Philadelphia, Pa. 19106.  
 Honeywell, Inc., 2701 Fourth Ave. S., Minneapolis, Minn. 55408.  
 Interstate Engineering Corp., 522 E. Vermont Ave., Anaheim, Calif. 92805.  
 Walter Kidde & Co., Inc., Belleville, N.J. 07109.  
 Notifier Corp., 3700 N. 56th St., Lincoln, Neb. 68501.  
 NuTone, Inc., Madison and Red Bank Rds., Cincinnati, Ohio 45227.  
 Protectowire Co., Hanover, Mass. 02339.  
 Pyrotector, Inc., 349 Lincoln St., Hingham, Mass. 02043.  
 Pyrotronics, Inc., 2343 Morris Ave., Union, N.J. 07083.  
 Signals Systems, Inc., 650 Arch St., New Britain, Conn. 06051.

FEBRUARY 1969

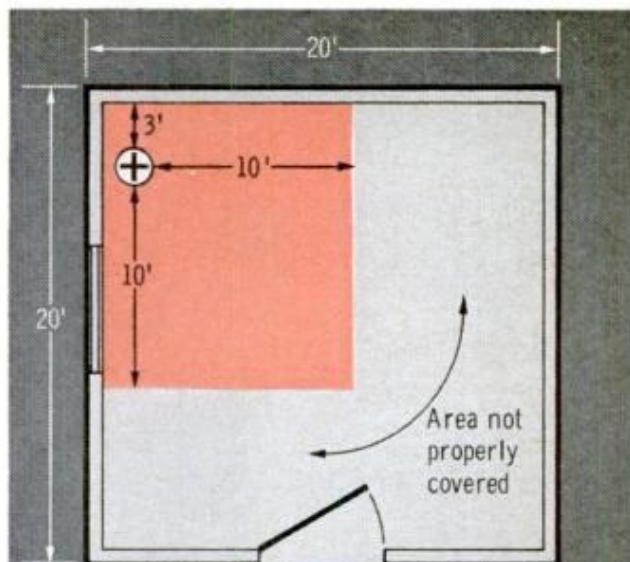

AN IMPROPERLY LOCATED DETECTOR is hardly better than none at all. As shown above, a detector with a sensing distance of 10 ft., for example, will cover only a portion of a 20x20-ft. room when placed in a corner. Placed in the center of the room, however, it covers the full area (below)

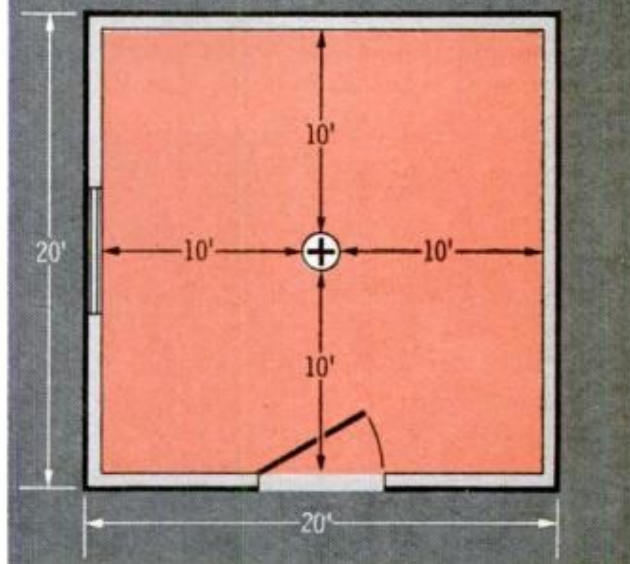

**IONIZATION DETECTOR** sets off alarm in initial stage of fire, even though no smoke or fire is visible



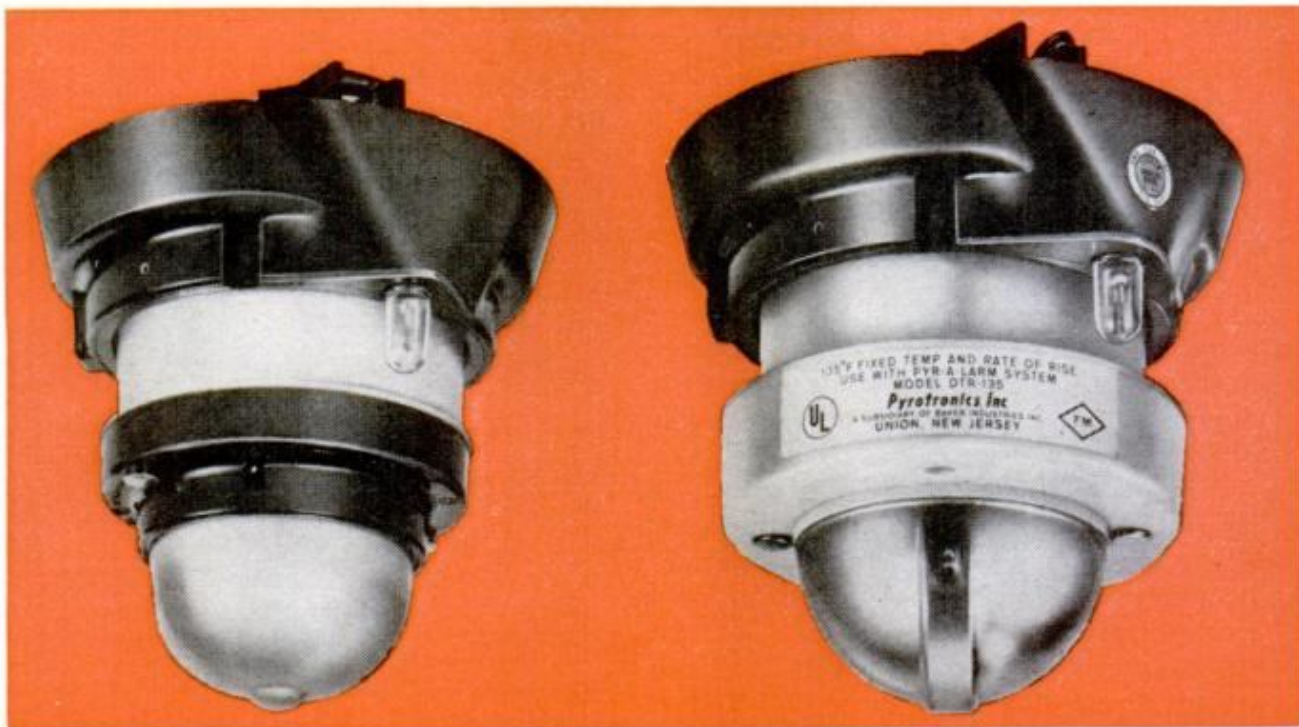

**ELECTRICALLY OPERATED HEAT DETECTORS** may be activated by temperature increase or rapid rate of temperature increase. The latter type (above, left) signals when the room temperature rises 15° F. per minute

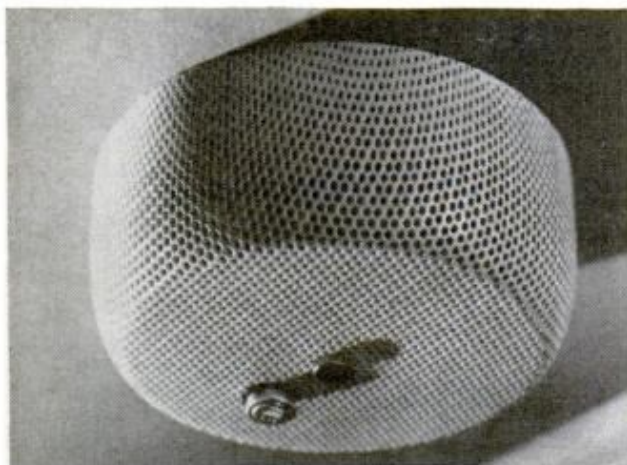

**LATEST INNOVATION** in home security systems is a combined fire-burglar alarm. Such systems package 135° F. heat detectors, door and window switches, plus different sirens or horns as signals. Smoke detector is shown above and control panel below

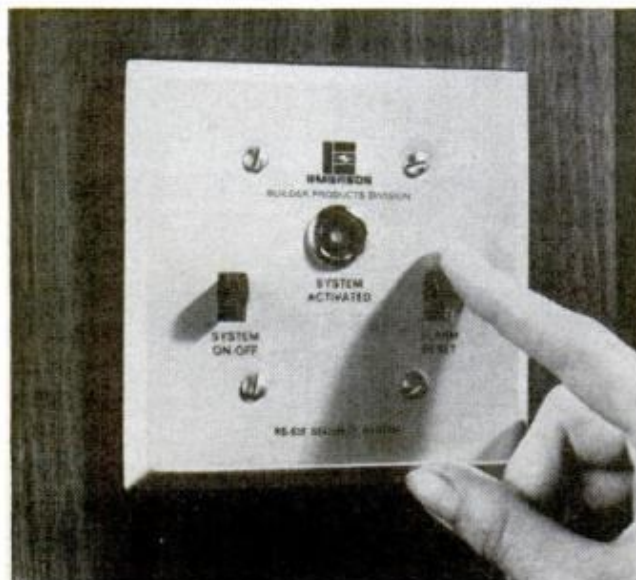

should be hung in the basement (on the underside of joists—not between them); on the basement side of the door leading to the living quarters; in the kitchen, living and dining areas, halls outside bedrooms, garage and in the attic.

Since gas units can't be tested without ruining them, an important part is a sight glass that allows you to see the level of the Freon. If the cylinder leaks, the unit should be replaced.

Both electric and gas-operated heat detectors are rated according to the distance (D) they cover—measured from the detector to the side of the largest square that can be effectively sampled by the detector. Distances covered vary from 5 to 25 ft.—thus, it's important to know the distance rating of a unit to position it properly.

For example, a single detector with a D of 10 ft. mounted on a smooth ceiling in the middle of a 20x20-ft. room will cover the entire room. However, if the detector is moved to a point near the wall, the coverage is reduced to approximately 10x13 ft. Thus, more than one detector would be needed in this room for full coverage.

If you're now thinking about installing a fire warning system in your home, I suggest you read "Household Fire Warning Systems." You can get this free pamphlet (NFPA No. 74) by writing the National Fire Protection Assn., 60 Batterymarch St., Boston, Mass. 02110. ★★★



# All-Purpose Alarm You Can Build From a Kit

This versatile new Heathkit home-protection system can sense smoke, fire, burglars, a flood in your basement, even a freezing water pipe. Its warning signals are transmitted through your house wiring

By **SHELDON M. GALLAGER**

*Photos by Robert D. Borst*

**Y**OU CAN WIRE this new electronic alarm to warn yourself of just about anything that can happen around a home. In addition to providing fire protection, it will sound an alert if your cellar starts to flood, your food freezer goes off, or a prowler tries to break in. Designed to be fail-safe, it will also squawk if the power goes off or if one of its own components starts to act up.

Made by Heath, the ingenious system is sold in kit form and you put the parts together yourself. There are three basic units—a smoke-heat sensor to detect fire, a general-purpose utility sensor that can be wired to a variety of detection devices (such as basement flood detectors), and a remote alarm station that sounds a warning if any of the

**ALARM SYSTEM** requires no wires between units. You merely plug them into wall outlets and signals are transmitted anywhere in the house over existing wiring. Three basic units are attractive tabletop alarm station (upper left), smoke-heat detector (above) and multi-purpose detector (below)

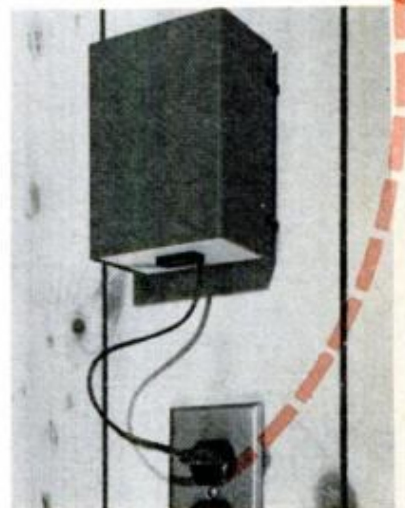

**ALARM UNIT** is easy to assemble because main wiring is all done on a predrilled and labeled printed-circuit board, shown at near right. You just insert the leads through the holes and solder them to foil backing on the opposite side. Large round object at far right is the audible alarm sounder that gives out a loud, high-pitched screech when one of remote sensors is tripped

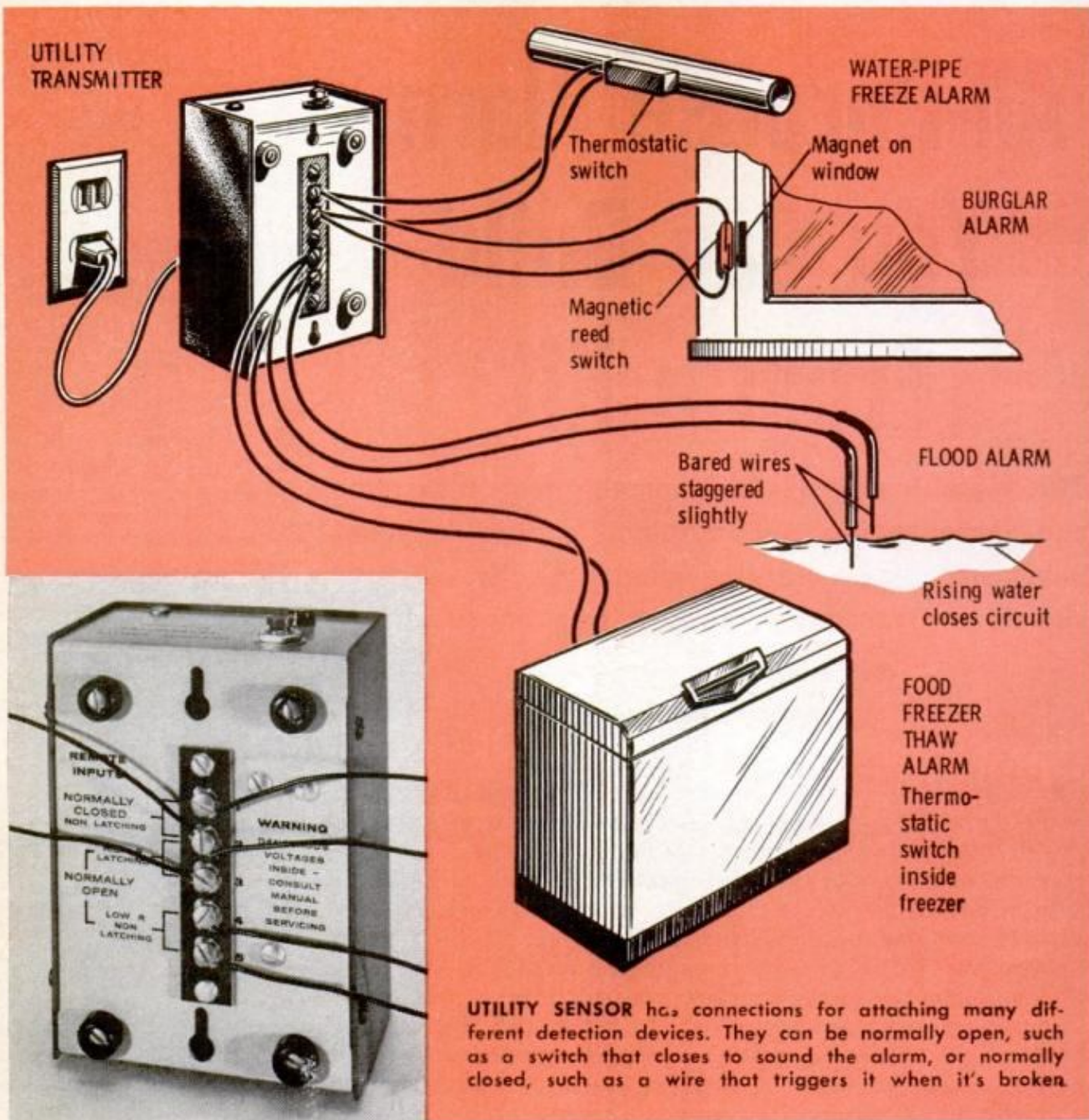

**UTILITY SENSOR** has connections for attaching many different detection devices. They can be normally open, such as a switch that closes to sound the alarm, or normally closed, such as a wire that triggers it when it's broken.

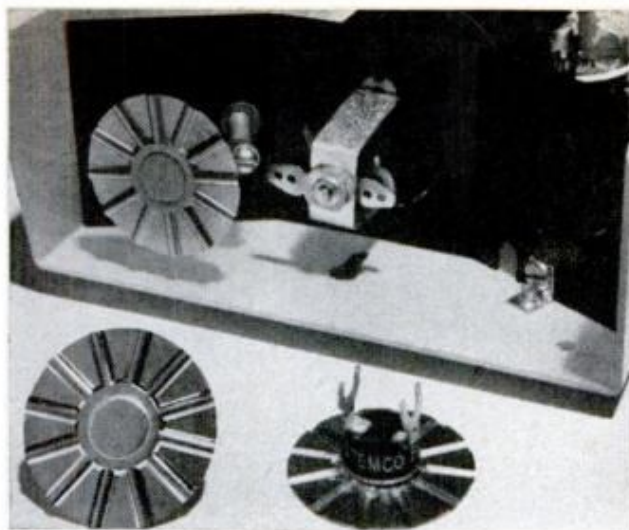

**FIRE-WARNING UNIT** contains a small, round heat sensor that sounds alarm if temperature goes above about 133° F. Extra sensors (shown in foreground) can be wired in series with the one in the unit to give you additional protection in other locations

sensors are triggered. There aren't any wires to string between the units. You just plug each one into the nearest wall outlet. The two sensing units are actually small transmitters. When triggered, they send out a 50-kHz signal over the house wiring to the alarm unit. The alarm picks up the signal and sounds a high-pitched warning screech.

You can place the sensing units anywhere you want—down in the basement, up in the attic, out in the garage, and so on. The alarm, a trim-looking little unit resembling a small radio, can be kept on a bedside table or bookshelf. Any number of sensor units can be combined with any number of alarm units. For the average-size house, one alarm is probably sufficient since the warning squawk is loud enough to be heard for some distance.

The advantage of this remote-controlled system over the single-unit, self-contained type is that the alarm sounds not where the fire is, but where *you* are. This is important if you're asleep at one end of the house and a fire breaks out at the other end.

Should the power go off or the alarm become accidentally disconnected, batteries automatically take over to sound a warning. In addition to the built-in squawker, there's also an outlet for connecting an external bell, buzzer, siren, light or other remote warning device.

The fire-warning unit incorporates two separate sensors—one for smoke and one for heat. This way, a smoldering fire that gives off smoke without much heat will

trigger the alarm through the smoke detector before it gets big enough to set off the heat sensor. If the temperature goes above about 133° F., the alarm will sound whether there's any smoke or not.

The smoke detector represents a bit of electronic ingenuity. There's a tiny light bulb shining into a dark chamber, with a light-dependent resistor off to one side out of the way of the beam. So long as the chamber is clear, no light reaches the resistor and its resistance remains high. When smoke trickles into the chamber, it reflects some of the light onto the resistor. The resistance drops, passing current to a transmitter that sends out the warning.

Handiest unit in the system is the utility sensor. It can be wired to send out a signal from various homemade sensors as well as from many commercial devices. A couple of bare wires will function as a simple flood detector, as shown in the accompanying drawing. Thermostatic switches available from heating and refrigeration dealers can be hooked up to warn you if a pipe is in danger of freezing or your food freezer starts to thaw. Different types of pressure and magnetic switches can be rigged to set off the alarm if a door or window is opened.

The units will send and receive over a considerable distance—even between two houses if there's no line transformer in the way. This raises the interesting possibility that your next-door neighbor might "house sit" for you when you're away. You'd simply give him your alarm unit to keep for you, and anything that triggered a sensor in your house would automatically sound the alarm in his house.

In the present version, there's no way of telling just which sensor has set off the alarm—you have to make a fast check to determine the cause. Heath is exploring the possibility of devising a system that would pinpoint the source of the trouble—such as fire, flood, intruders—but this would raise the cost.

The three units are available separately. Prices are \$39.95 for the alarm kit, \$49.95 for the fire detector kit, and \$34.95 for the utility sensor kit. The kits are relatively simple and can be put together in a few hours. Included with the assembly instructions are suggestions for various sensors you can make yourself. The Heathkit system is sold by Heath Co., Benton Harbor, Mich. 49022. ★★★

# Solving home problems

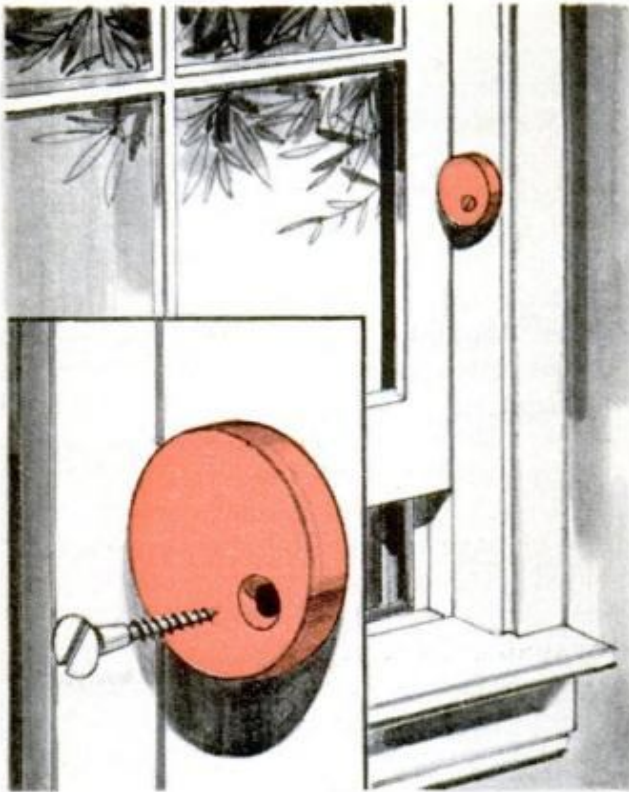

**LOCKING CAM FOR WINDOWS** will allow you to raise a window as much as necessary, without risking its slamming shut accidentally. As shown in the detail, the cam is a simple wooden disc that's drilled offcenter



**AN IRONING BOARD** can serve as a convalescent's tray and make him more comfortable while he's fighting the flu. The board is easy to move as necessary and will also act as a reading table or a hobby bench

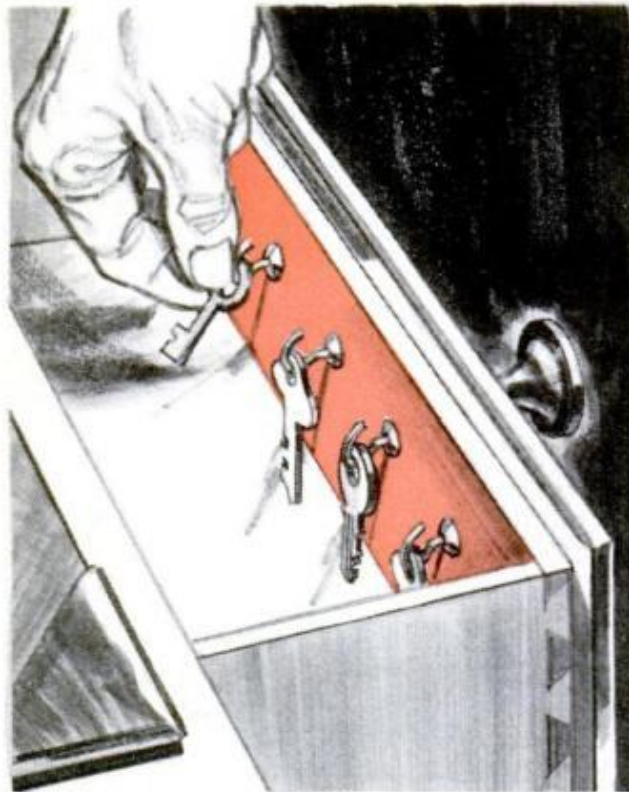

**SELDOM-USED, BUT OFTEN MISLAID, KEYS** can be kept handy by screwing ordinary cup hooks into the inner face of a drawer. Slip the keys over the hooks and you'll no longer spend hours searching for one key

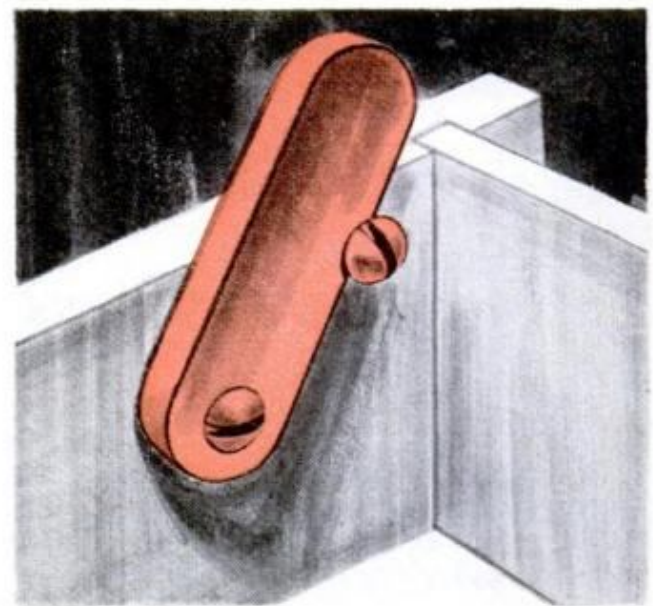

**DRAWERS WITHOUT STOPS** can be fitted with this type of pivoting drawer stop, yet removed when necessary. Simply remove the drawer, install the stop, flip it down and reinstall drawer. Then flip the stop up



**IN AN EMERGENCY**, a small oil can may easily be converted into an alcohol lamp. Clean the can and fill with alcohol. Then enlarge the opening of the tip and feed through a long cotton cord to act as the wick

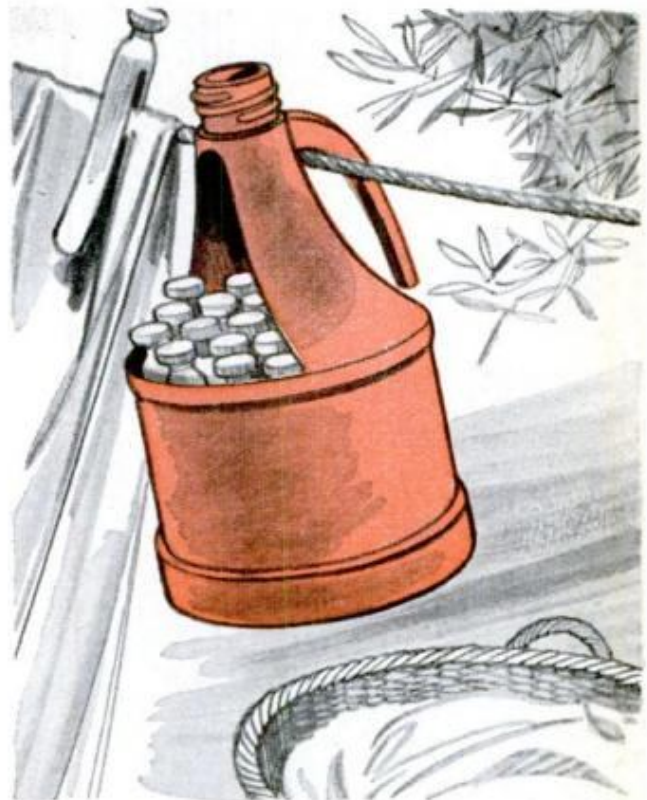

**MAKE YOUR WIFE'S WASHDAY EASIER** by presenting her with this simple clothespin container. It's just a plastic bottle with a section removed for access. Feed it on the line and it's easy to slide it along



**TACK A TIN STRIP** around the top of a tree stump and you have a convenient planter for vines that will hide the stump. In only a few years, the hidden stump will rot and then be much easier to remove

FEBRUARY 1969

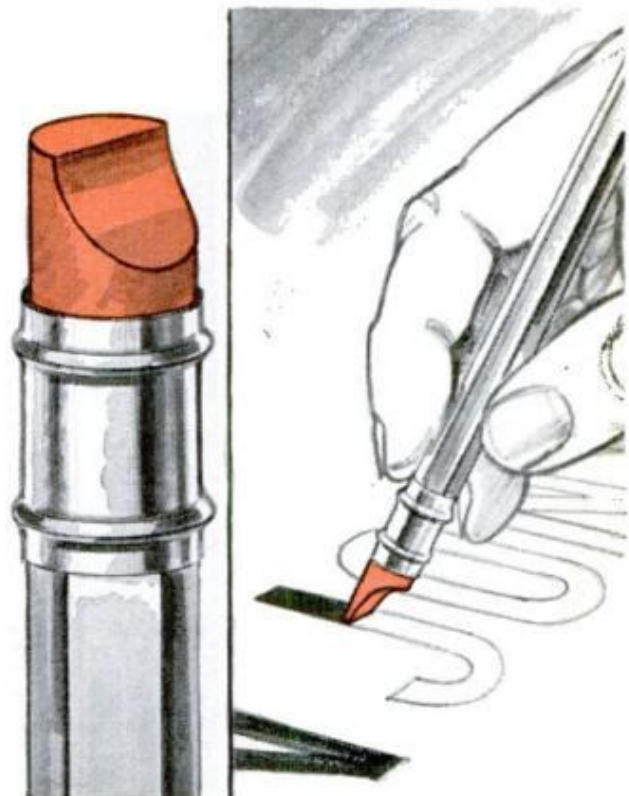

**NEAT LETTERING** for signs, placards and posters is a cinch with this easy-to-make lettering tool. It's simply a pencil eraser, cut at a slight curve. Use with India ink or writing ink for a neat job

185

# HINTS FROM READERS

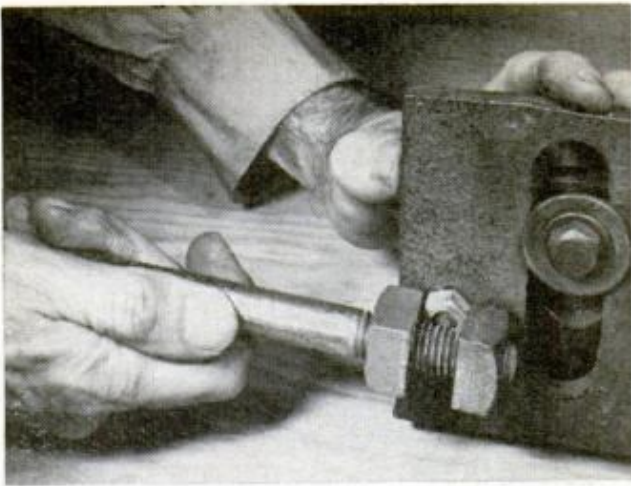

## Emergency wrench

When you need an adjustable wrench but are unable to find one, try improvising with this trick. Just thread two square nuts on a long bolt, the longer the better. Turn down the nuts so they slip tightly over the nut to be removed (or tightened); apply leverage as needed. For small nuts you likely can make do with hex nuts on the bolt instead of square nuts (as shown).

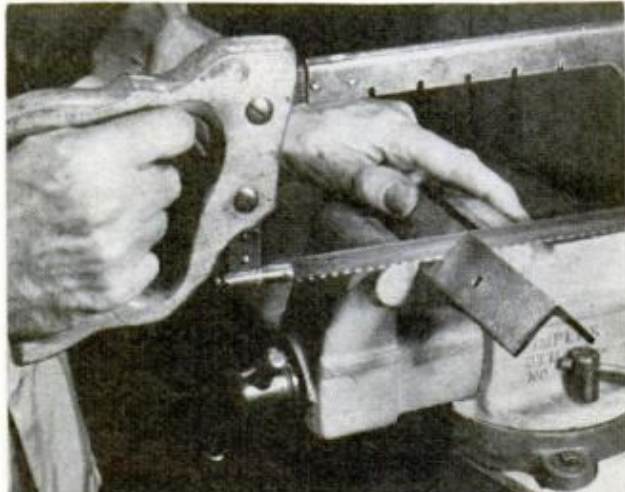

## Cutting angle the right way

Save time by starting a hacksaw at the corner of a piece of angle iron instead of sawing down one leg and across the other. Obviously, fewer strokes of the saw are required to completely cut through the angle, thus saving time and labor. Another advantage, although not as obvious, is that the saw will cut more smoothly because more of the teeth will be engaged in cutting through both legs of the angle at the same time. Be sure, however, that the angle is firmly secured in a vise.

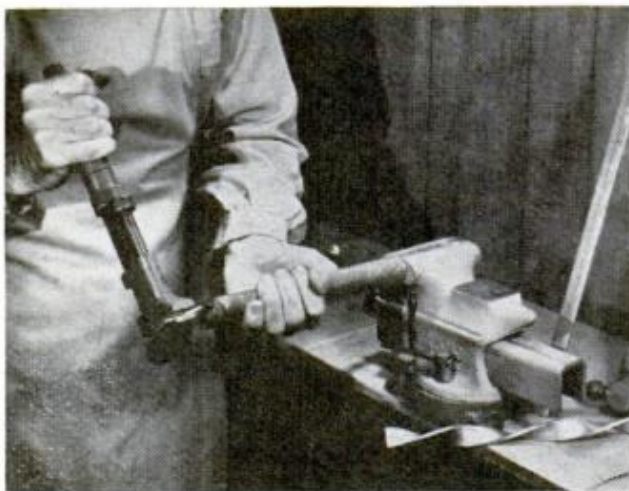

## Twisting flat iron uniformly

To keep from producing undesired bends while twisting a piece of flat iron, slip it in a piece of pipe with a diameter slightly larger than the width of the strip of flat iron. Secure one end of the strip in a bench vise and grip the other end with a large monkey wrench. Twist slowly to spiral, but not kink, the strip. If the strip wedges inside the pipe, gently tap it out with a hammer. Alternatively, you could leave one end secured in the vise and tap off the pipe, instead of forcing the strip.



## Polishing attachment for small jobs

For delicate polishing tasks, especially those involving a small, intricately shaped area, try using this highly effective shortcut. Dip a cotton swab into polish, then chuck the swab in an electric drill or hand grinder. With very light pressure, feed the spinning swab against the work until all tiny recesses have been covered. Then clean off the excess polish, chuck a clean swab into the drill and buff the work, again using only light pressure to avoid breakage of the wood shaft.



# Unique Piggyback Speed Reducer

LIFT YOURSELF by your bootstraps?

At first glance that's what this novel piggyback speed reducer appears to do, for it cuts your 1725 rpm double-shaft motor to under 200 rpm, and with only *one* shaft. The secret is that it uses the motor shaft itself as another jackshaft.

The heart of the speed reducer is the 6-in. free-running pulley to which the drive pulley is bolted. It revolves freely about the motor shaft and is driven through speed-reducing pulleys from the other end of the motor. To use the motor at normal speed, you just slip one belt and turn a setscrew to fasten the free-wheeling pulley to the motor shaft.

To construct the piggyback, replace the top motor-housing bolts and replace with longer bolts. Sections of angle iron (the size depends on your particular motor), shimmed out with spacers of  $\frac{1}{8}$ -in. pipe, provide support for the hangers.

Many  $\frac{1}{2}$ -in. motor shafts have a flat ground on the shaft, and provide insufficient bearing surface for a free-running pulley. In this case epoxy a  $\frac{1}{2}$ -in. bronze bushing over the shaft and use a  $\frac{5}{8}$ -in. arbor pulley. If your motor shaft is  $\frac{5}{8}$  in., it probably has a key slot, and no bushing will be required.

—William Waggoner

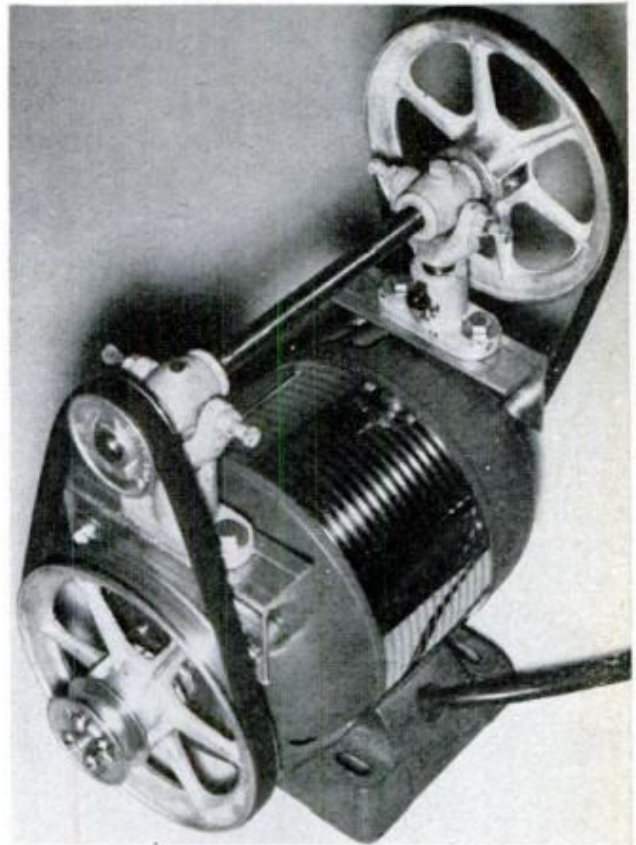

**SECRET** of the unique setup is that the large pulley (lower left) is free-running on the motor shaft

**BRONZE BUSHING** (below left) is epoxied to a  $\frac{1}{2}$ -in. motor shaft to enlarge bearing surface for pulley

**PIGGYBACK SETUP** (below) is ideal for cramped quarters, such as making your bandsaw a metalcutter

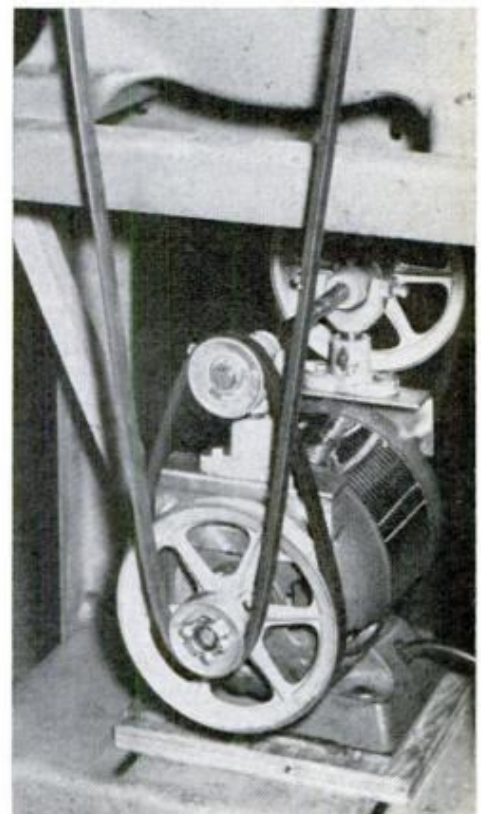
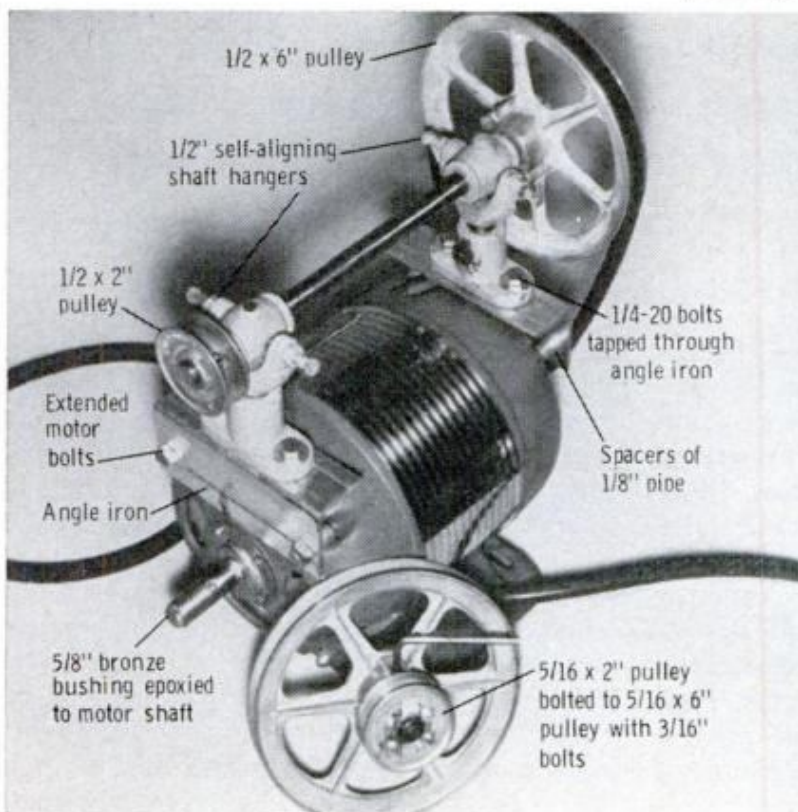

# The Circular Saw: A Worksaver For All Workshops

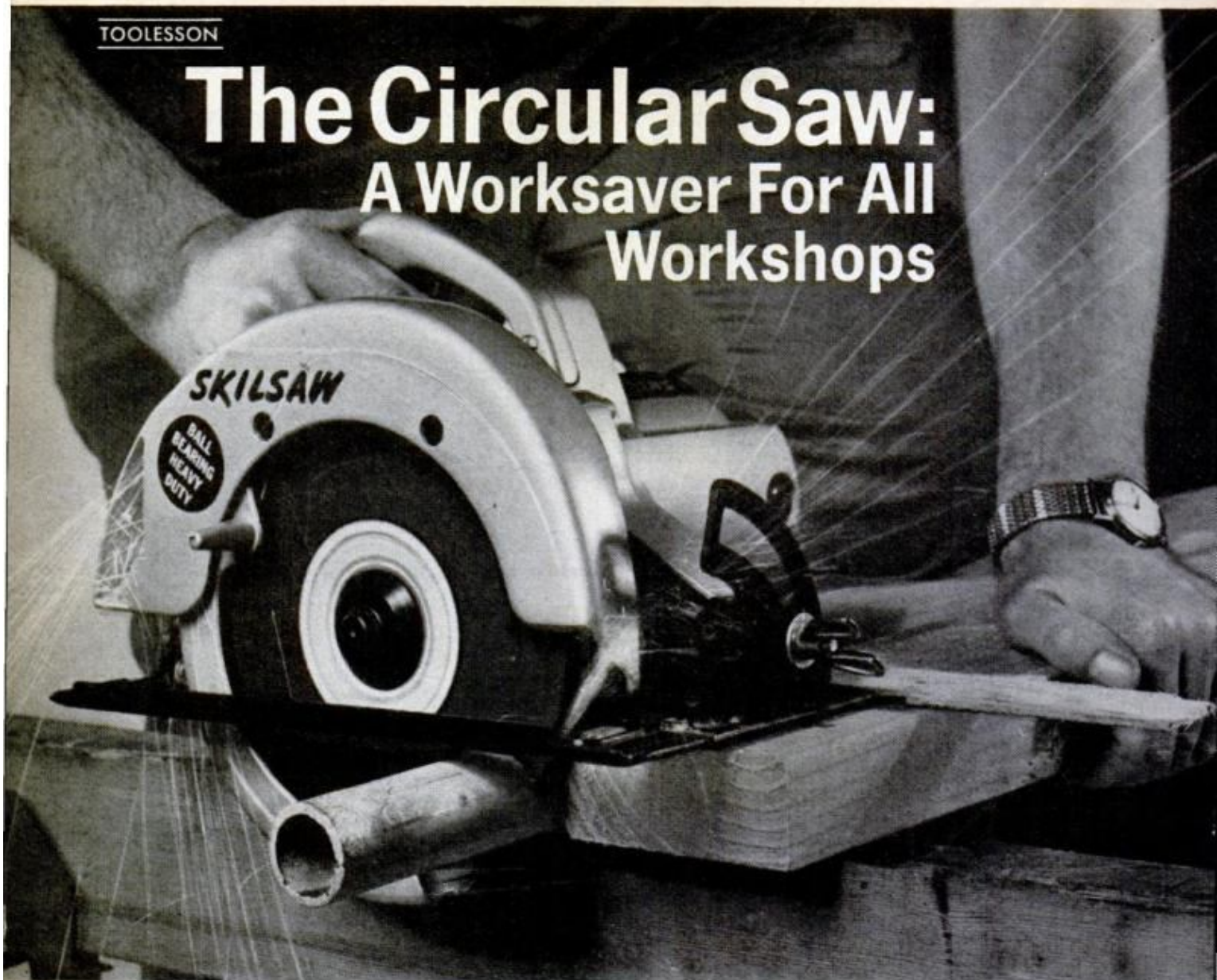

**This little workhorse will not only cut wood, but can also cut your working time and effort, if you know how to use it properly**

By JOHN BURROUGHS

**B**ELIEVE IT OR NOT, portable circular saws have higher power ratings than motors used on table saws. Shop-model portable saws with 6½ to 7½-in.-dia. blades draw around 10 amperes and develop 1 to 1½ hp. Builders' portable saws with 8 to 10-in. blades draw 13 to 14 amps. and develop more than 2 hp—power enough to drive a blade through hard-grained and knotty 2-in.-thick planks almost as fast as you can guide it.

To develop this high power output the saw's universal motor revs to very high speed. The motor armature turns too fast to drive the blade directly, so the end of the armature has a pinion that gear-

drives a short stub shaft. This geared-down shaft turns the blade at the required 4500 to 5500-rpm operating speed.

Two saw blades to handle all ordinary shop sawing are a chisel-tooth combination blade (for general ripping and cross-cutting) and a hollow-ground miter (or planer) blade for fine cabinetwork.

A chisel-tooth blade's special advantage is the ease with which it can be resharpened, since the teeth are ground square-across rather than beveled. This blade can be sharpened quickly on a ¼-in.-thick, round-faced saw-gumming wheel rigged on a bench grinder. If you grind the chisel teeth lightly only on their faces,

they can be resharpened many times before they need jointing or resetting. Blades with hardened teeth are reground until the teeth lose their set, then discarded.

Save the hollow-ground miter blade, which cuts slowly but very cleanly, for your most careful work. Never force a miter blade in the cut, and keep it knife-sharp. When teeth begin to dull, joint and file them lightly with a slim taper file.

Other blades such as sanding discs, sheet-metal slicing wheels and abrasive cutoff wheels also can be used in portable saws. Some makers offer accessory sheet-metal bench stands in which the saw mounts bottom-up. When using such a stand, however, make sure it's fastened securely on a solid bench.

Although you can make surprisingly straight cuts freehand, for really accurate

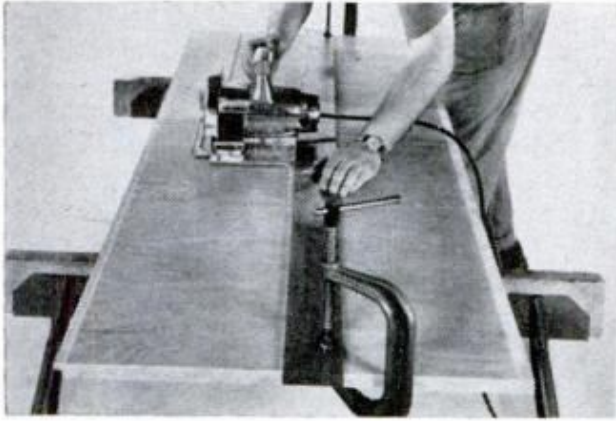

**TRUE STRAIGHTEDGE** is a necessity for accurate cuts. Keep length of steel stock for this purpose

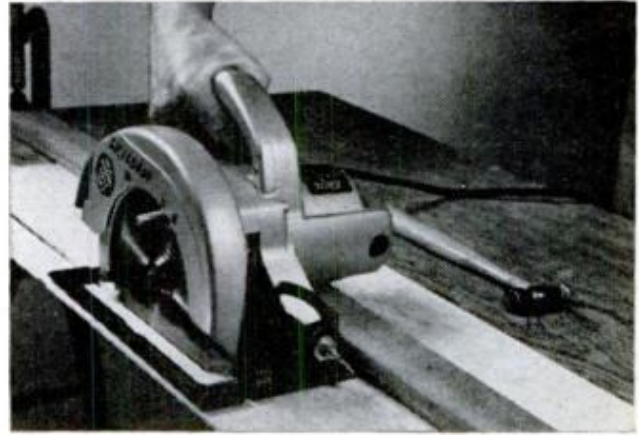

**WHEN CUTTING SMALL PIECES** of panel stock, the work can be secured by tacking it to a larger piece

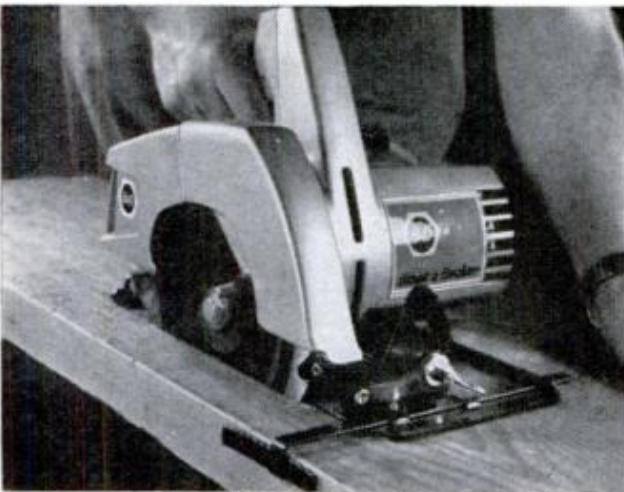

**USING A RIP GUIDE** requires lateral pressure to keep the guide bearing squarely along edge of work

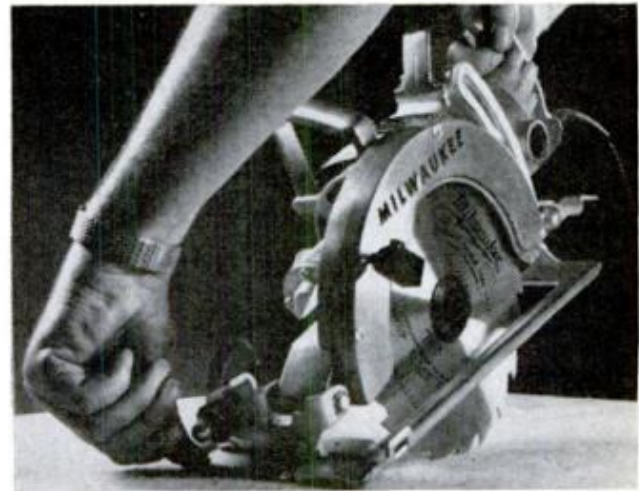

**TO MAKE POCKET CUTS** in panels, tie back the blade guard, tilt saw forward and rock it into the panel

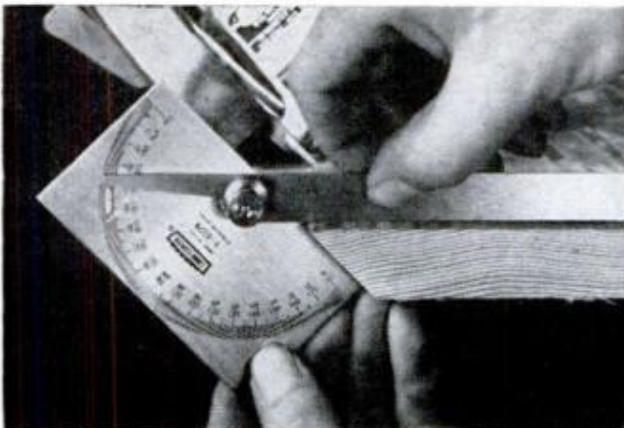

**TO CHECK BLADE-ANGLE SETTINGS**, make trial cut, then measure angle of cut with a bevel protractor

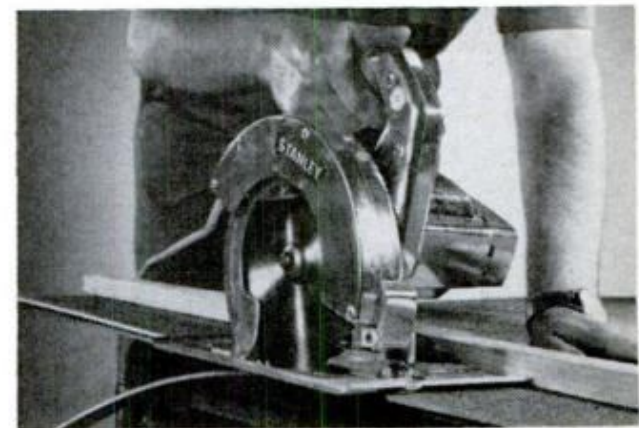

**FOR SMOOTHEST CUT**, set blade depth  $\frac{1}{4}$ -in. below bottom of work. Always cut with good side down

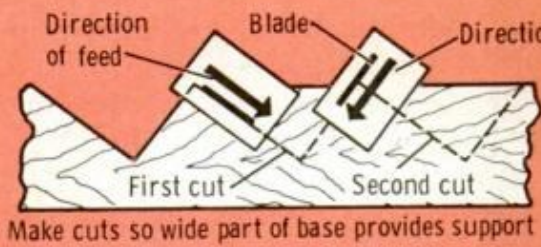

Make cuts so wide part of base provides support

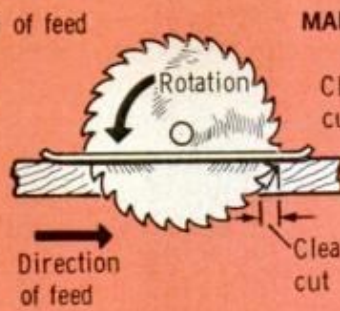

**MAKING 90° CUTS**

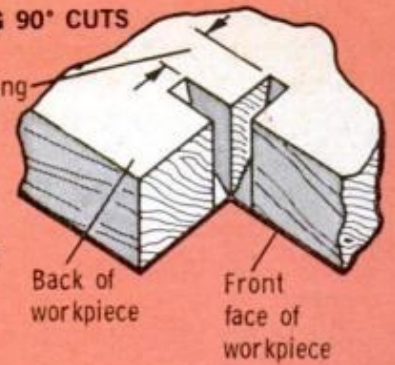

For a minimum cleaning cut, set saw for maximum depth

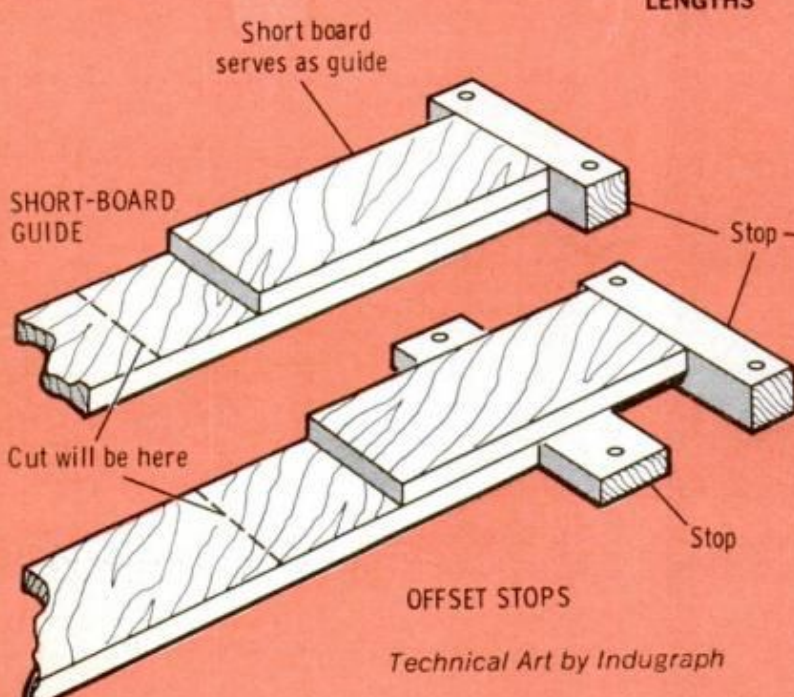
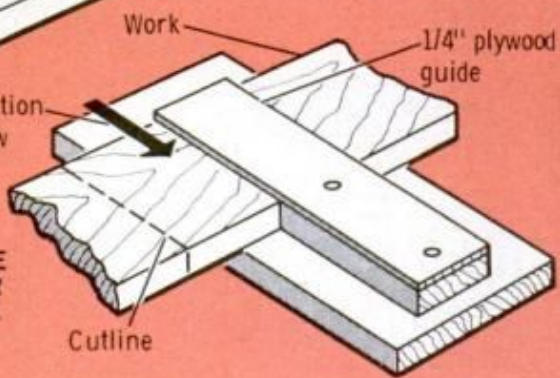
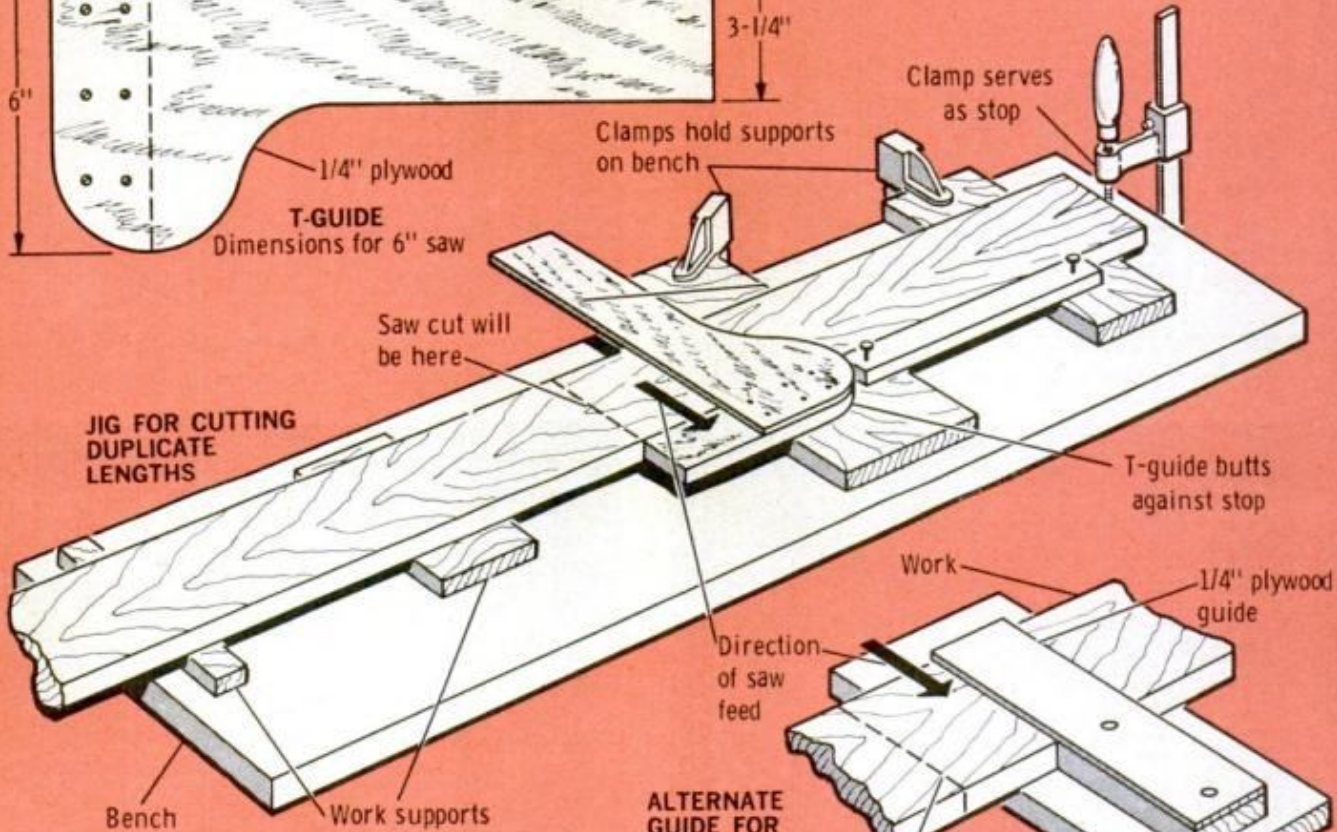
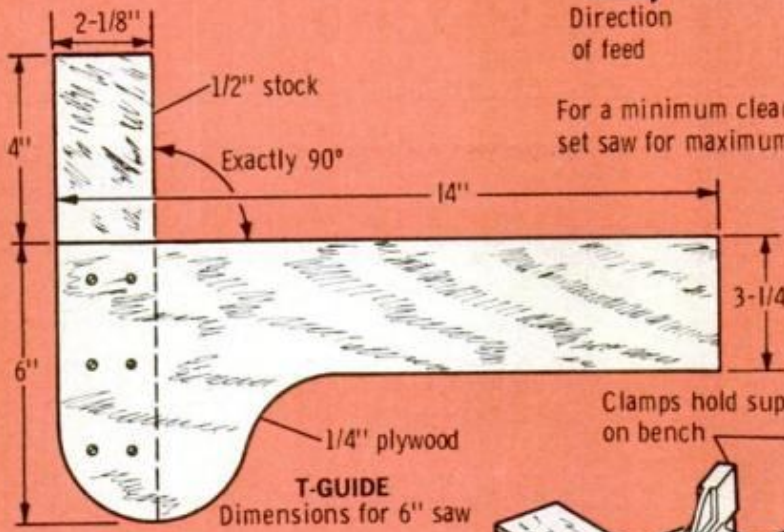

**CUTTING MULTIPLE DUPLICATE LENGTHS**

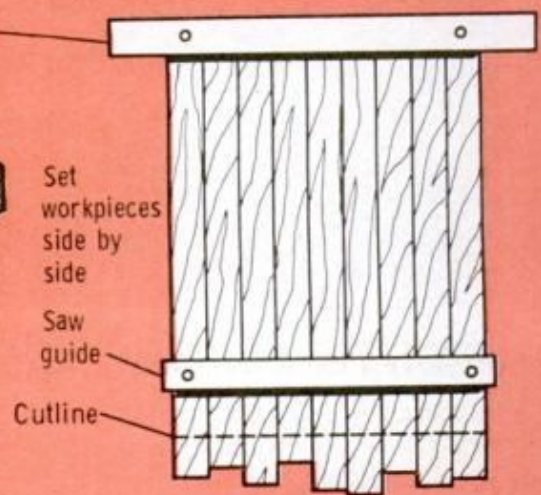

Technical Art by Indugraph



**CLAMP-ON CUTOFF GUIDE** won't sideslip; squeeze-type handle will clamp lumber up to 12-in. wide

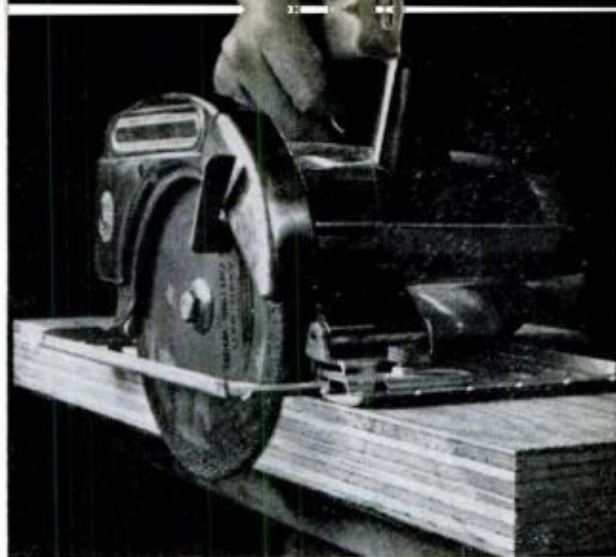

**RIM-CUTTING, CARBIDE-GRIT WHEEL** can be used for edge sanding, notching or grooving. Take light cuts

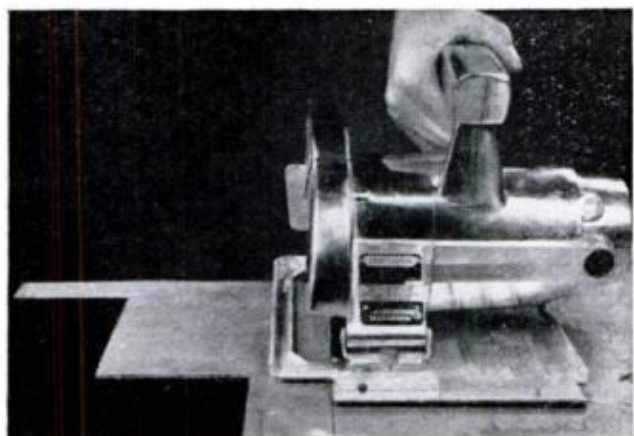

**FINE-TOOTH, METAL-CUTTING BLADES** will slice through soft brass and sheet aluminum, but not steel



**BLADE CLEANING SOLVENT** makes it easy to remove pitch from saw blades, carbide-grit sanding wheels



**CHECK CARBON BRUSHES REGULARLY.** When they wear to half their original length, install replacements

work the saw shoe should be guided along a clamped straightedge. Using a straight-edge several inches longer than the work makes it easier to start the cut. With either a simple straightedge or one of the worksaving jigs shown opposite, always advance the saw with a slow, even feed and avoid heavy lateral pressure.

Other than checking the motor's carbon

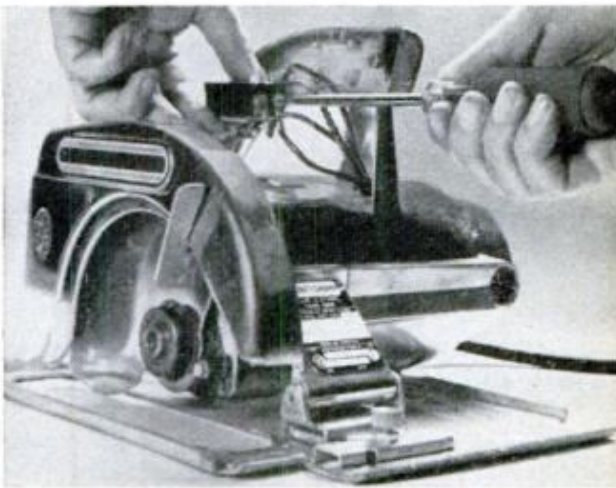

**TRIGGER SWITCHES** can be replaced, but for long switch life, always avoid starting motor under load

brushes occasionally, a portable saw needs little maintenance. Nearly all models have sealed, lubed-for-life bearings, and several have sealed, permanently-lubed gearcases. If your tool's gearcase requires periodic relubrication, use the special grease specified by the manufacturer. Since grease expands as it heats, avoid filling the gearcase more than half full. ★★★

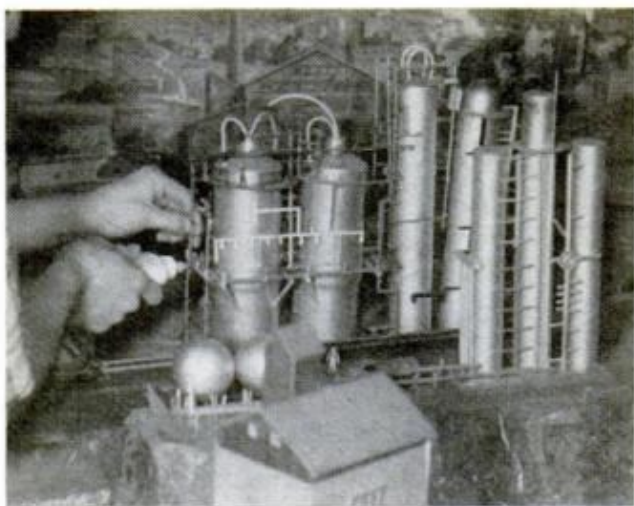

# HINTS FROM READERS

## Modeler's refinery

A surprisingly realistic refinery for an HO-ga. model-train layout can be fabricated of empty cylinders of butane or propane gas and the plastic remnants of a model car or airplane kit. Simply save the "trees" on which the kit parts are attached and cement them to the tanks or round mailing tubes. When sprayed with aluminum paint, they look like the real thing.

—Hank Clark

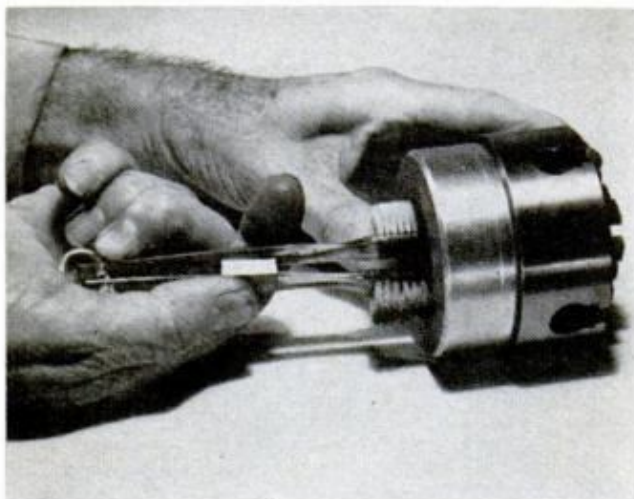

## Double-duty lathe brush

This novel cleaning tool will help you to keep the chuck and leadscrew on your metal-turning lathe free of troublesome chips. It's made of two old toothbrushes fed back-to-back on a suitable ring, with a pad of rubber taped to the back of one of the brushes. To clean the chuck, squeeze the handles together and feed the brushes into the chuck. They will spread apart and clean the inside threads. For cleaning a leadscrew, flip the brushes so they face each other.—Peter Legon

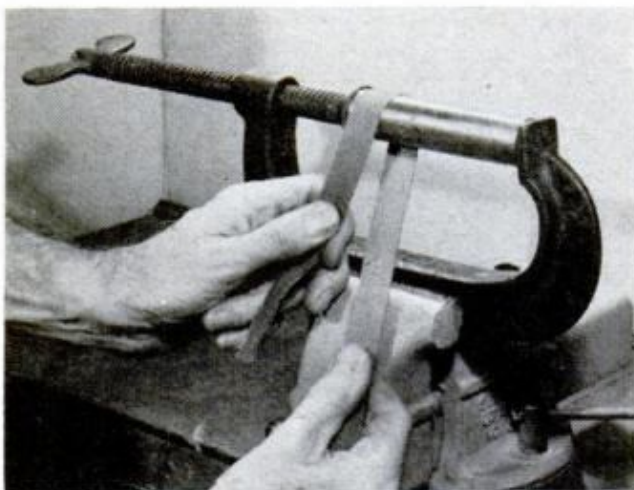

## Clamp instead of vise

The next time you're faced with the problem of how to mount an irregularly shaped piece of work that won't fit the normal jaw opening of a conventional vise, try this simple trick. Mount the work in a C-clamp of the proper size for the job, and then mount the C-clamp in a vise. This shortcut is especially useful when you're working with a soft or highly finished piece of metal that could be damaged in the vise jaws. It will also avoid possible flattening of thin wall tubes or pipes.

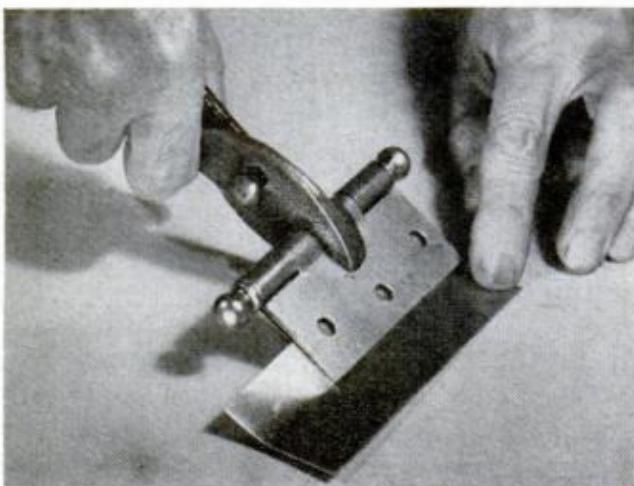

## Hinge makes king-size pliers

A large hinge should be kept handy for the occasional odd job that requires a wide-gripping pair of jaws. Just slip the hinge over the work and clamp a pair of pliers over the joint of the hinge leaves. As shown in the photo at left, this tip makes easy work of bending light-gauge sheet metal. It will also come in handy whenever you find it necessary to break off scored strips of glass from a large section and want to be sure of a clean break every time.—Albert Pippi

# New Tools You Should Know About



## Multipurpose wrench

Nine tools in one, it functions as a socket wrench, monkey wrench, open-end wrench, pipe wrench, slip-joint pliers, lineman's pliers, small vise, wire cutter and clamp. The jaws, which grip like a vise, remain parallel in all positions, and grip any shape—round, hex or square. Plierench is available in two sizes for \$6.25 and \$7.95. Vaco Products Co., 510 N. Dearborn St., Chicago, Ill. 60610.

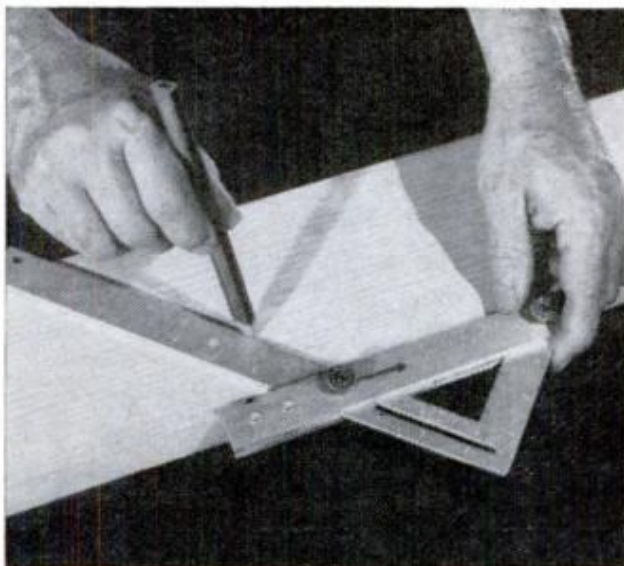

## Adjustable square and angle

While it's a square, protractor, level, saw guide, T-square, sight-plumb, straightedge, layout jig, pitch finder and rule all in one, you can do 18 different jobs with this unique tool called Squangle. It assembles in four different positions by loosening two nuts and bolts, then sliding the arm and blade, as necessary. Attached to fully illustrated folder, it sells for \$3.35 by Great Neck Saw Manufacturers, Inc., Mineola, N. Y.

FEBRUARY 1969

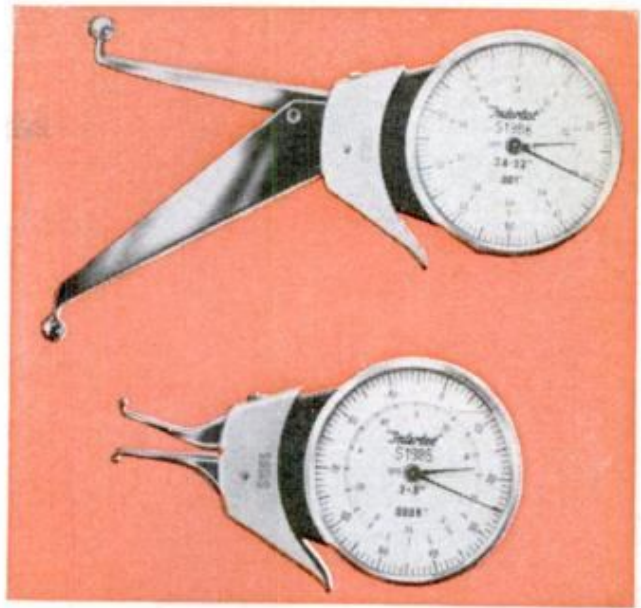

## Ball-tip internal gauges

Internal gauges with ball contact points have a jeweled movement which operates on a unique "scissors" action. They're designed for measuring the inside diameters of ball races, O-ring grooves and similar applications. Direct-dial readings are in .001 in. Gauges, in 12 models, range from .2 in. to 4.8 in. Other contact points are available. The Dyer Co., Oberlin, Ohio 44074.

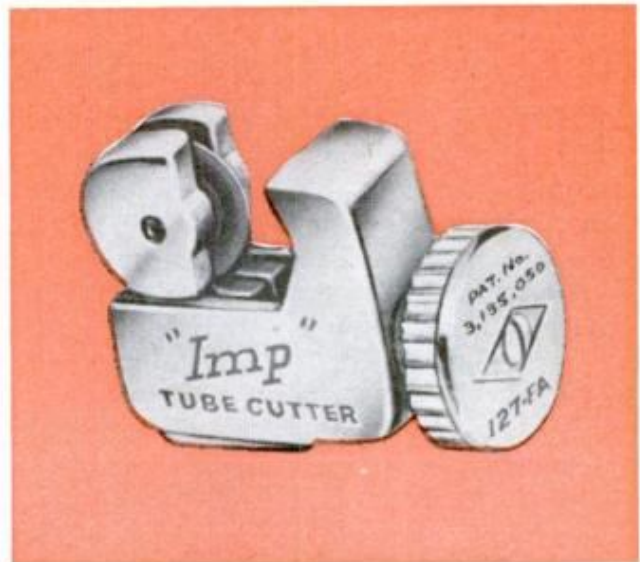

## Compact tube cutter

This tiny tube cutter is designed for use in tight quarters such as refrigeration systems and instrument panels. It requires a swing radius of only 1 1/4 in. to cut tubes up to 1/2 in. in diameter. The cutting wheel is easy to adjust for tube diameters from 1/8 to 5/8 in., and will cut copper, aluminum, brass, thin-wall steel and titanium tubing. Imperial-Eastman Corp., 6300 W. Howard St., Chicago, Ill. 60648.

193

# MAKE A KING-SIZE TOOLPOST FOR HEFTY TURNING BITS



By WALTER E. BURTON

**H**EFTY, HIGH-SPEED steel or carbide bits are more rigid and in other ways superior to the toolholder-bit combination widely used on small lathes—but a conventional toolpost has too narrow a slot to accommodate them. Even if the slot were wide enough, some sort of

**OVERSIZE POST** starts out as a 1 $\frac{1}{8}$ -in. steel rod. Bottom hole is drilled and tapped for mounting stud

block or shim system would have to be improvised to position cutting edges at the proper height.

Not so with the toolpost shown, however, since it was specifically designed to accommodate bits up to  $\frac{1}{2}$ -in. wide. It has an easily set height-adjustment feature

**TOP HOLE** should be drilled and tapped for a  $\frac{3}{8}$ -16 clamping bolt, preferably one with a square head

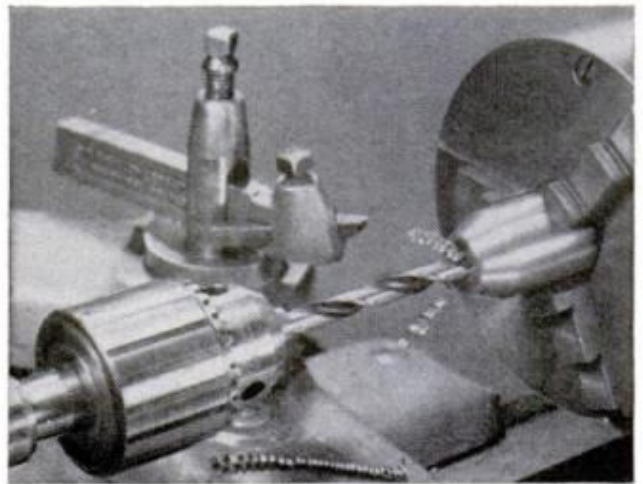
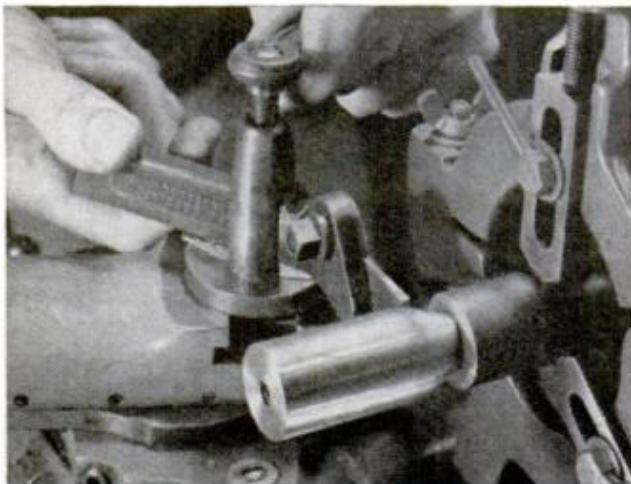



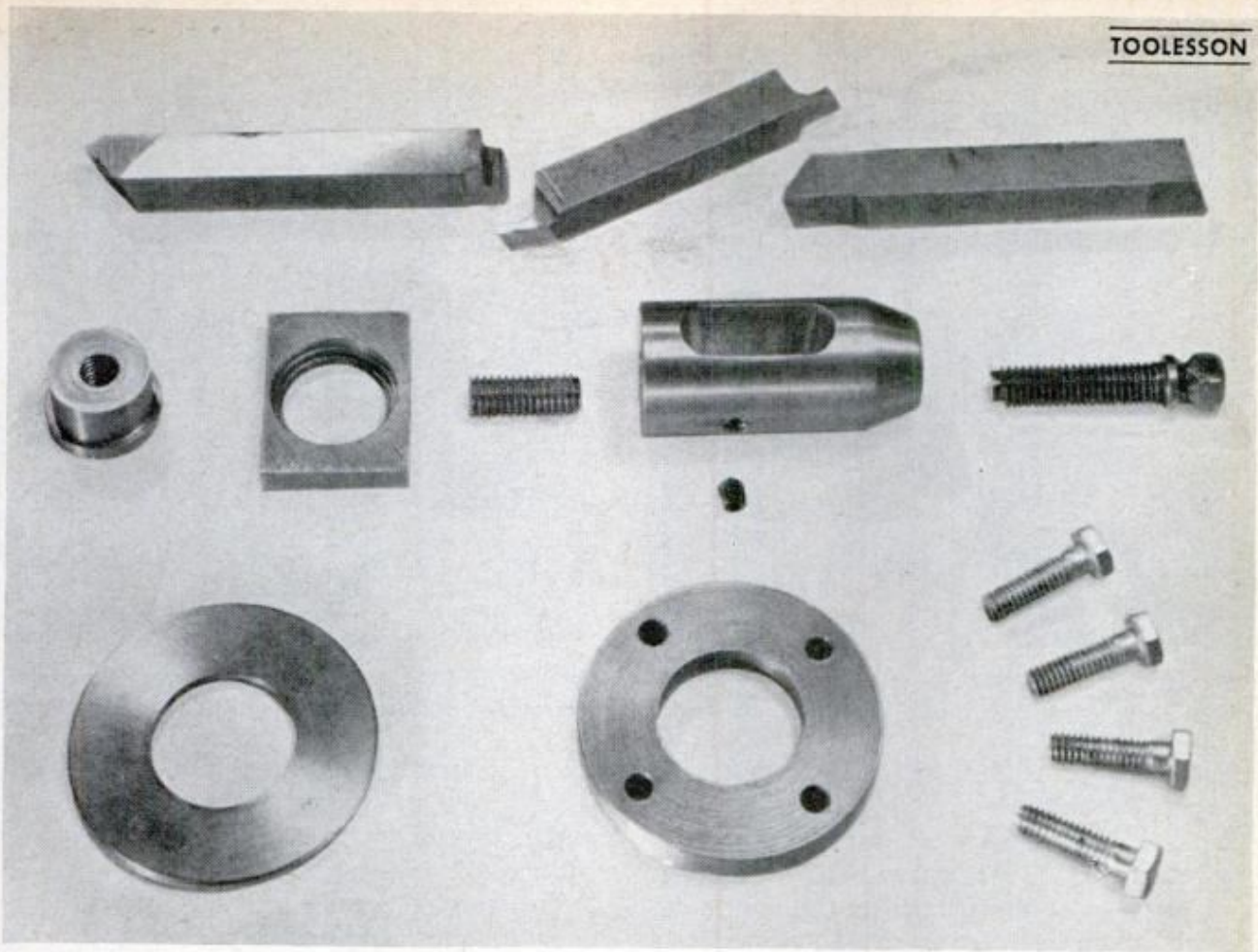

EASY-TO-SHAPE PARTS go together as shown in the exploded view below. Two setscrews may be needed

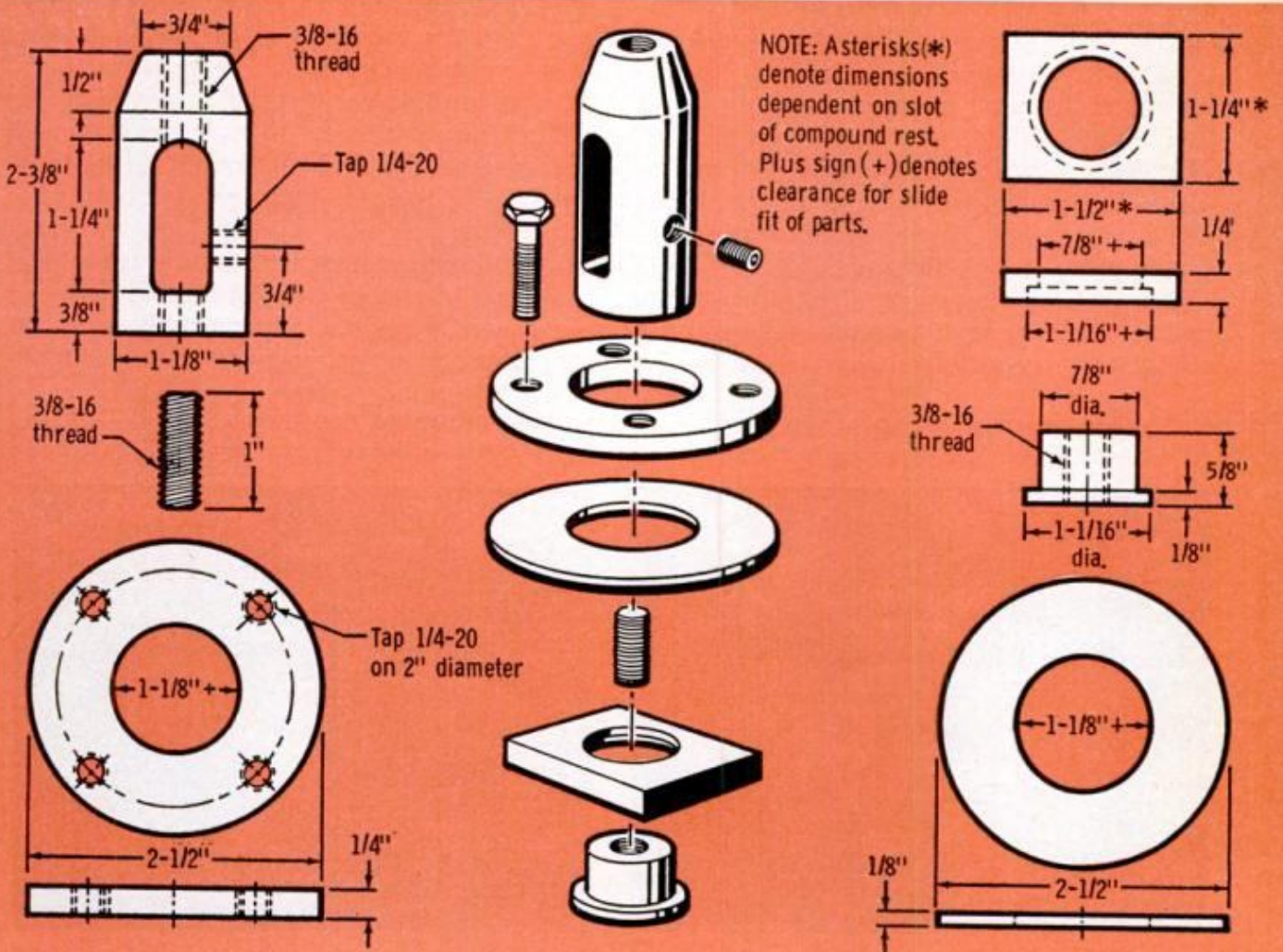

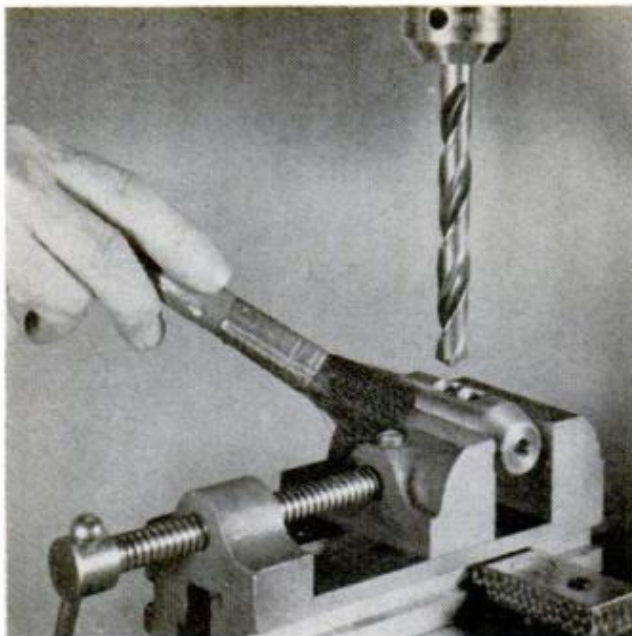

**TO CUT SLOT IN POST**, first drill two  $\frac{1}{2}$ -in. holes about  $\frac{3}{4}$ -in. apart (measured from center to center)

consisting of a steel ring supported by a quartet of bolts. It also provides firm support for boring bars or large bits ground as boring tools. All parts can be made of ordinary or tool steel, although for maximum durability, parts subjected to wear should be hardened.

Because of the wide tool slot, the diameter of the post is greater than that of the conventional post—yet the button and the block forming the base of the post assembly must be kept small enough to enter the toolpost T-slot on the compound rest. Therefore, the post assembly must be made in two sections so that the block can be installed (these sections are held together by the  $\frac{3}{8}$ -16 stud).

The  $\frac{1}{4}$ -20 setscrew in the side of the holder will prevent possible side shifting of the bit, especially when it does not

**BUTTON ON BOTTOM OF POST ASSEMBLY** is machined to fit T-slot, then fitted on  $\frac{3}{8}$ -16-thread stud

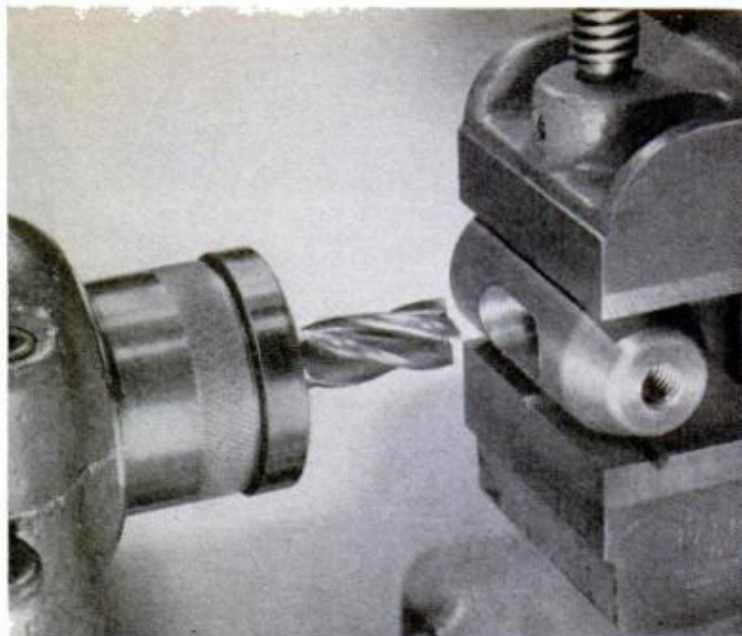
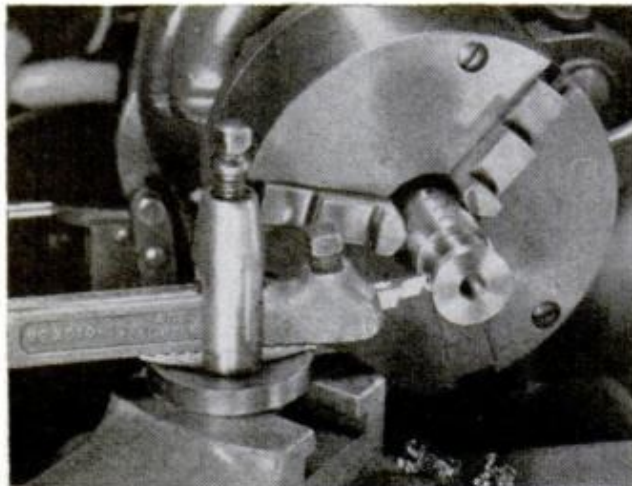

**MILLING IS BEST WAY** to remove rest of material. Alternately, excess metal could be sawn and filed

completely fill the wide slot. You could install two or more screws, if required, which would be most effective when the bit is making heavy side cuts.

The tool bit rests on a ring assembly consisting of a thick upper ring through which four  $\frac{1}{4}$ -20 bolts extend to rest on the thinner ring. By adjusting the 1-in.-long bolts to control the height of the upper ring, it's possible to set the bit at the proper cutting height. It's also possible to tilt the bit and vary the effective rake.

The top bolt used to exert downward pressure on the tool bit should be a standard  $\frac{3}{8}$ -16, square-head toolpost bolt. The dimensions in the drawing are for the holder shown, which will handle up to  $\frac{1}{2}$ -in.-thick bits on a 9-in. lathe. Of course, for other lathes or different bit sizes, it may be necessary to vary dimensions. ★★★

**BUTTON SHOULD BE LOOSE FIT** in shouldered block. Check clearance before removing block from lathe

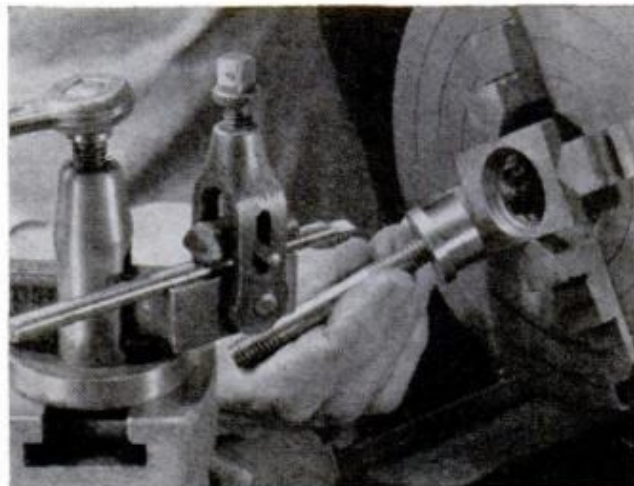

# BENCH GRINDER

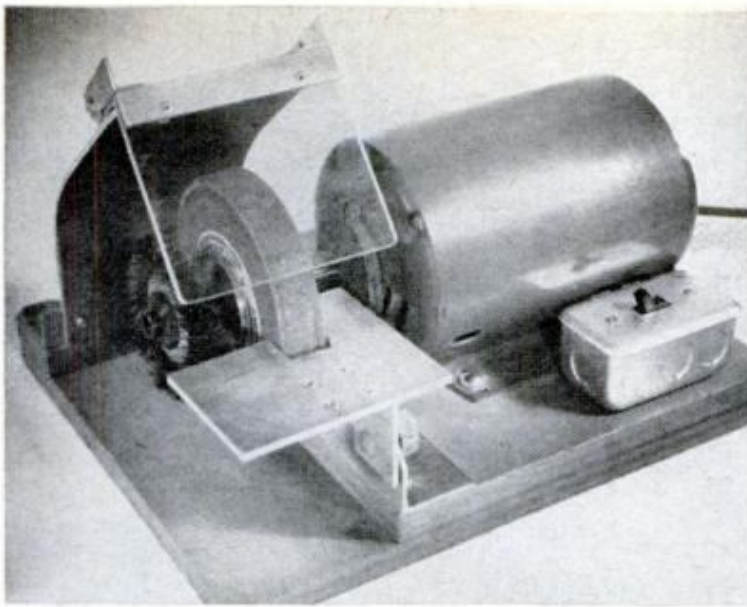

IT SHOULDN'T COST you more than \$6 or \$7 to make this bench grinder since you likely have a suitable motor that's been salvaged from an old tool or appliance. In fact, you might even look around for a double-shaft motor and, using the same construction details shown, produce a two-wheel grinder. Remember, most motors are reversible by switching connections.—*James Johnson*

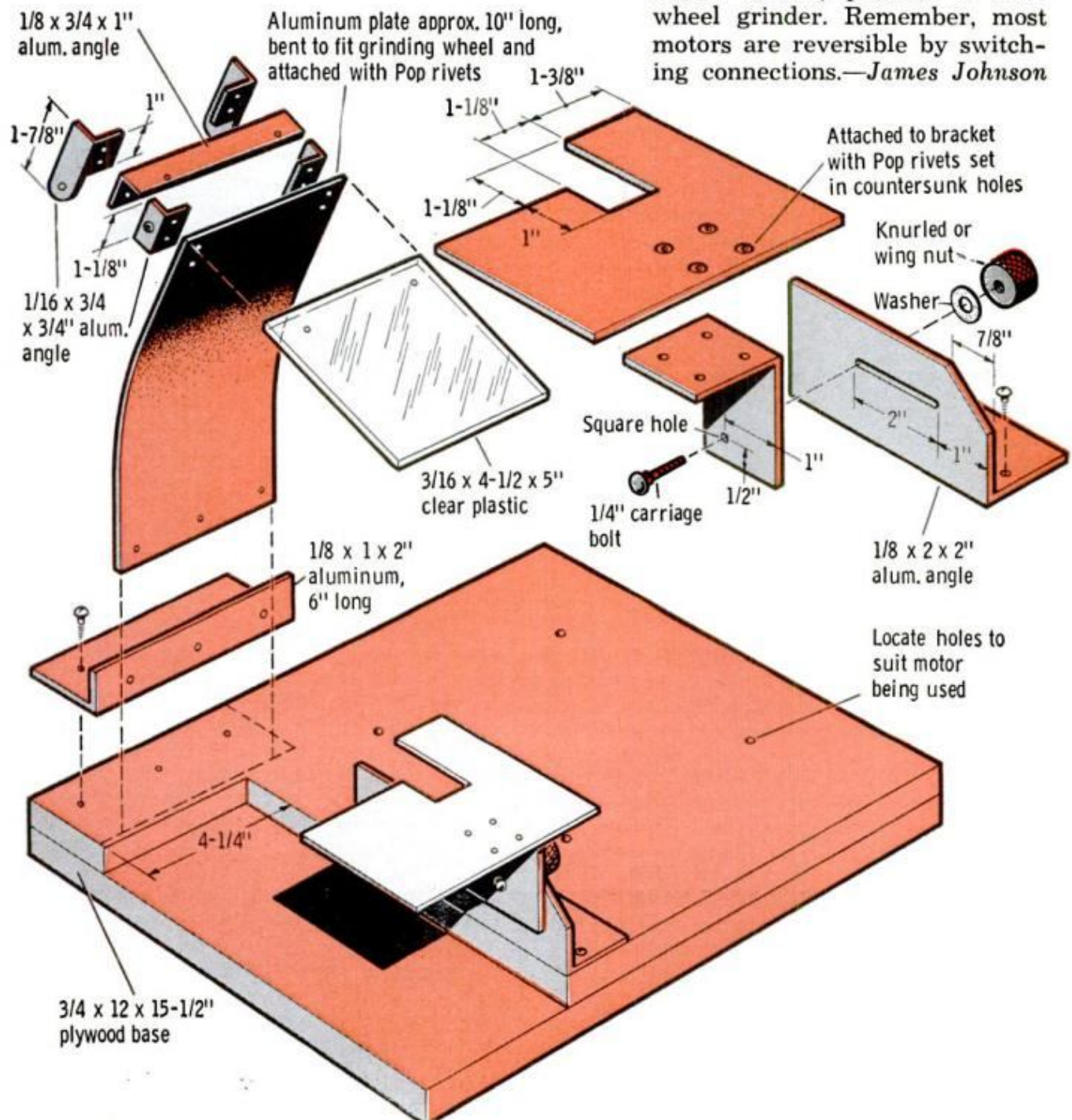

# HINTS FROM READERS



## Cross-drilling bolts

It's easy to drill accurately through the center of a bolt with this method. Simply run a suitable nut on the bolt and use this as a flat which you can centerpunch and drill. It may be worthwhile to drill the nut first.

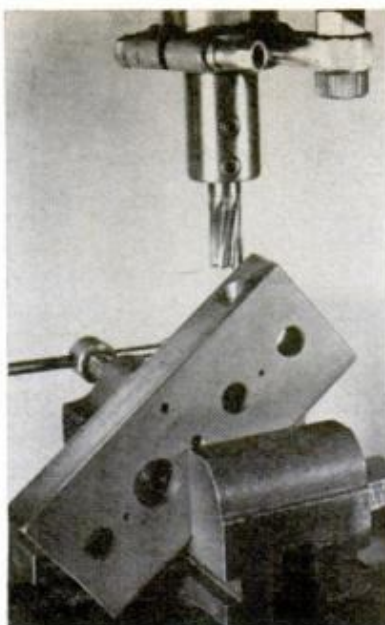

## Drilling angled holes

When it's necessary to drill into a piece of work at an angle, it will pay first to mill a small flat on the work. When centerpunched, the flat will prevent runoff of the bit and keep it from bending and possibly breaking.



## Substitute chuck key

Here's a fine old trick worth remembering—you can tighten or loosen a chuck on a drill press or portable drill by using a rod and screwdriver. Just insert the rod into side of chuck and use the screwdriver as a lever.

## Replace worn cartop carrier straps with rubber bands cut from inner tube

When the web straps on your cartop luggage carrier become badly worn and frayed, replace them with 1½-in.-wide rubber bands cut from an inner tube.

Loop the band around the leg of the carrier, then feed the other end through the slotted clamp and over a dowel to keep it from slipping out.—*G. K. Hawk*

## NEXT MONTH IN SHOP AND CRAFTS

**HOW TO SOLVE YOUR PARKING PROBLEMS.** Widening your driveway is the obvious solution to a parking problem, but for a number of other practical alternatives, next month's story is required reading. All, however, will let you and your guests park off the street. Among the eight solutions you should find one that suits your home.

**HOW TO BUILD A COLD FRAME.** Basically a simple version of a greenhouse, this cold-frame shelter will let you grow seedlings throughout the spring months. Presented in color, this simple project will pay off handsomely in healthy plants ready for transplanting. It's made of fiberglass and comes apart in sections for summer storage.

**\$16 KIT MAKES YOU A WHIZ IN MODEL ROCKETRY.** This easy-to-put-together kit uses a safe liquid propellant to send a rocket to heights of 1000 ft. Among the components of the kit is a working parachute that will bring both engine and nose cone safely back to earth. It fires electrically by battery. It's ideal for getting started in model rocketry.

**HOW TO USE A STEADY REST.** Lathe-turning long rods, tubes and pipes require that you know how to use either a steady rest or a follower rest for a specific job. For the complete story, be sure to read the March issue of *PM*.

# Mercury '69: The outboards that take care of themselves

## like no others can.

Everybody talks about saltwater corrosion (it can happen in polluted fresh water, too). Mercury does something more about it this year. Every new Mercury outboard is built of a special new aluminum alloy, "XK." It's more corrosion-resistant than other aluminum alloys used in outboard motors—and it's 40% stronger. Everybody talks about paint scuffing and peeling. Mercury does something about that, too. A new 4-coat baked enamel finish goes farther to prevent paint failure than anyone's ever gone before.

Corrosion resistance and a new finish that's tough as nails.  
Two more reasons to choose Mercury (if you needed any more).



LEADERS IN MARINE PROPULSION  
FOR 30 YEARS: 1939-1969

# MERCURY

# Special Invitation to Inventors

If you have an invention (whether patented or unpatented) that you believe has commercial value, our Free Booklet entitled "How to Go About Selling Your Invention" may help you save time and money.

We are specialists in representing inventors and submitting their inventions to manufacturers. We work with scores of manufacturers who are seeking new products or new product ideas, and we therefore know which firms may be interested in your particular invention. Our service is designed to do all those things the average inventor lacks the knowledge or facilities for doing, or does not have time to do. We prepare your sales letters, folios, duplicate drawings, handle correspondence, select the firms.

We charge the standard commission (on sales) and a modest fee for the submitting service. This fee is refunded if a manufacturer buys your invention through our efforts. We are a nationally known concern with an impeccable reputation for ethics and integrity.

The Free Booklet we have prepared especially for inventors contains such information as current royalty rates being paid by manufacturers, discusses many types of inventions, the possible market for them, tells the effective methods of presenting your invention for sale, whether you employ us or do it yourself, and outlines how we may be able to help you.

You can obtain this booklet "How to Go About Selling Your Invention" by mailing the coupon below. And if you wish to write us for comments on your invention, please do so. We make no charge for consultation. But please do NOT send drawings or models. Just describe the purpose and nature of your invention. Mail the coupon to K. O. Kessler, Pres., Kessler Sales Corporation, Dept. D-52, Fremont, Ohio 43420.

You are welcome to ask your lawyer, local Bank, Chamber of Commerce to carefully check on our reputation for honesty and fair-dealing.

## MAIL THIS COUPON

Mr. K. O. Kessler, President, Dept. D-52  
Kessler Sales Corp., Fremont, Ohio 43420

Please mail me a copy of your Free Booklet "How to Go About Selling Your Invention." It is understood that this does not obligate me in any way to use your Service.

My Name .....  
Street Address.....  
City ..... State..... Zip.....

## Do FALSE TEETH Rock, Slide or Slip?

Many wearers of false teeth suffer embarrassment because their plates drop, slip or wobble at just the wrong time. Don't live in fear of this happening to you. Just sprinkle a little FASTEETH, the alkaline powder, on your plates. FASTEETH holds false teeth firmer so they feel more comfortable. Helps check denture breath. Dentures that fit are essential to health. See your dentist regularly. Get FASTEETH today at all drug counters.

## CERTIFIED AIRCRAFT BIRCH PLYWOOD

FOB per 48x48" sheet. 1 to 3 sheets \$2.50 extra. 20% dealers discount 100 sheets. Cut in half or quarter for parcel post with faster delivery. Also industrial and cabinet birch plywood, all thicknesses, sheets and cut to any size and shape.

1/32" \$5.90	1/8" \$10.50
1/16" 6.90	3/16" 14.50
3/32" 8.90	1/4" 17.50

Violette Plywood Corp., Box 141-A Lunenburg, Mass.

## Don't change your address without notifying us!

To insure uninterrupted service on your **Popular Mechanics** subscription, please notify us at least six weeks before you move.

1. Attach your address label from a recent issue in the space provided below... (If label not available, be sure to give us your old address, including Zip Code)
2. Print your name and new address below (be sure to include your Zip Code).

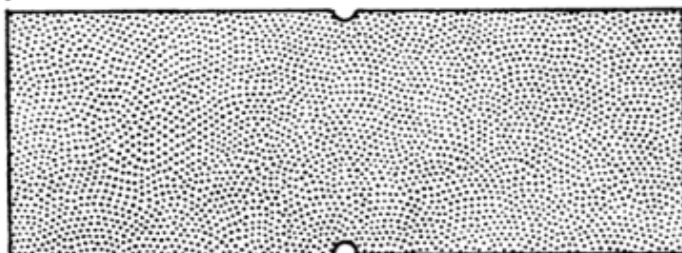

3. Mail entire notice to: **Subscription Service Dept.  
Box No. 646  
New York, N. Y. 10019**

Name \_\_\_\_\_ *Please Print*

New Address \_\_\_\_\_

City \_\_\_\_\_

State \_\_\_\_\_ Zip Code \_\_\_\_\_

# It's Like Having Auto Factory Experts Right Beside You...

when you use this famous illustrated step-by-step guide that shows you

## HOW TO FIX ALMOST ANY PART OF ANY CAR

Now—Whether You're a Beginner or Pro Mechanic—You Can "Breeze Through" Almost ANY Repair Job on Any Popular-Make Car—1963-1969!

**M**OTOR'S AUTO REPAIR MANUAL shows you in step-by-step words and pictures all the factory-approved repair procedures you'll ever need for fixing practically ANY part of ANY car listed here—1963-1969.

**1,000 BIG PAGES—  
3,000 PICTURES!**

This GIANT NEW, 1969 Edition covers everything you need to know to fix almost any car model from 1963 thru 1969. 1,000 giant pages. 3,000 pictures. 365 "Quick-Check" charts. 55,000 essential repair specifications. Over 225,000 service and repair facts.

PLUS Adjustment Tables, Tune-Up Charts, Tables of Measurements and Clearances, Overhauling and Replacement Facts, Carburetor Adjustment, etc. Special Trouble-Shooter Section and detailed trouble-shooting information thruout help pinpoint the cause of any of 4,200 car troubles in a jiffy.

### Same Offer on MOTOR'S AUTO ENGINES & ELECTRICAL SYSTEMS

1,300 big pictures. Clear text explains how parts work; principles involved; design; construction; maintenance. Covers all parts of engines & entire electrical system. For FREE trial, check coupon.



No guesswork! Even a green beginner mechanic can do a good job with this giant manual before him. And if you're a top-notch mechanic, you'll profit from the time-saving and work-cutting procedures you'll find. MOTOR'S MANUAL makes almost every operation on any car—from Volkswagen to Cadillac—as easy as A-B-C! Eliminates trial and error—saves you time, work and money.

**OVER 5  
MILLION  
COPIES SOLD**

**SEND NO MONEY  
Try Manual at OUR  
Risk—FREE**

See for yourself why U.S. Armed Forces, Schools, and garages everywhere "swear" by MOTOR. Just mail the coupon. TRY Manual for 10 full days—FREE! If it doesn't pay for itself in those 10 days, just return it and pay nothing, owe nothing. Mail the coupon AT ONCE to MOTOR Book Dept., 250 West 55th Street, New York, N.Y. 10019 (SCHOOLS, BOOKSTORES: Write for Discounts.)

**TRY BOOK  
FOR TEN DAYS  
FREE**

#### FIX ALL THESE CARS

Volkswagen	Ford Bronco
Mustang	Buick
Barracuda	Special
Jeep	Comet
Chevy II	Corvair
Pontiac	American
Thunderbird	Olds F-85
Buick	Falcon
Imperial	Fairlane
Cadillac	Lancer
Continental	Tempest
Dart	Corvette
Mercury	Valiant
Ford	Cougar
Chevelle	Toronado
Chevrolet	Lincoln
Camaro	Front Drive
Scout	Cadillac
Chrysler	Mark III-
Plymouth	AMX
Rambler	Javelin
Dodge	Montego
Oldsmobile	Torino



**MOTOR'S**

**AUTO  
REPAIR  
MANUAL**

**TROUBLE-SHOOTER Section  
Helps Spot 4,200 Car Troubles**  
Trouble-Shooter section & detailed trouble-shooting info thruout help pinpoint 4,200 causes of car trouble: transmissions, brakes, engines, electrical systems, much more!

#### MAIL COUPON NOW FOR 10-DAY FREE TRIAL

**MOTOR BOOK DEPT., Desk 912  
250 W. 55th St., New York, N. Y. 10019**

Rush to me at once MOTOR's New AUTO REPAIR MANUAL. If O.K., I will remit \$2 in 10 days, \$3 monthly for 2 months and a final payment of \$1.95 (plus delivery charges and sales tax, if any) one month after that. Otherwise I will return the book postpaid in 10 days.

Print Name..... Age.....

Address.....

City & State.....

ZIP CODE ZONE NO.  
[ ] [ ] [ ] [ ] [ ] [ ] [ ] [ ] [ ] [ ]

Also send me for 10-day Free Trial MOTOR'S AUTO ENGINES and ELECTRICAL SYSTEMS. If O.K., I will remit \$8.95, plus delivery charges and sales tax, if any, in 10 days. Otherwise I will return book postpaid in 10 days.

Check box and save shipping charge by enclosing WITH coupon in envelope entire payment of \$9.95 for AUTO REPAIR MANUAL (or \$8.95 for AUTO ENGINES and ELECTRICAL SYSTEMS) plus sales tax, if any. Same 10-day return-for-refund privilege applies.

# 1969 • FOUR NEW FIRSTS\* IN DEPENDABILITY



\*\*\* **New Sea-Horse low profile Vees — 115 and 85-hp. Everything new but the shape of the engine block. V-115: 15 more hp, weighs 20 lbs. less than last year's V-100.**

Johnson's V-115 is lower, leaner, lighter than other motors in its hp class—makes your boat look, ride and handle better. New high in performance, new lows in fuel consumption, vibration and sound. Computer-designed lower unit reduces drag.

\*\*\* **Our "total performer" — the new Johnson Sea-Horse 25. Fast it is, but heavy it isn't.**

You can ski it, fish, cruise it, race, work it . . . and still lift it! New computer designed prop, large bore carb, stainless steel reed valves, new pistons with super-slim, high rpm rings are a few reasons why we've clocked it at 30-plus mph on a 14-footer.

\*\*\* **All new Sea-Horse 4 feels like a 5. Weedless Angle-Matic**



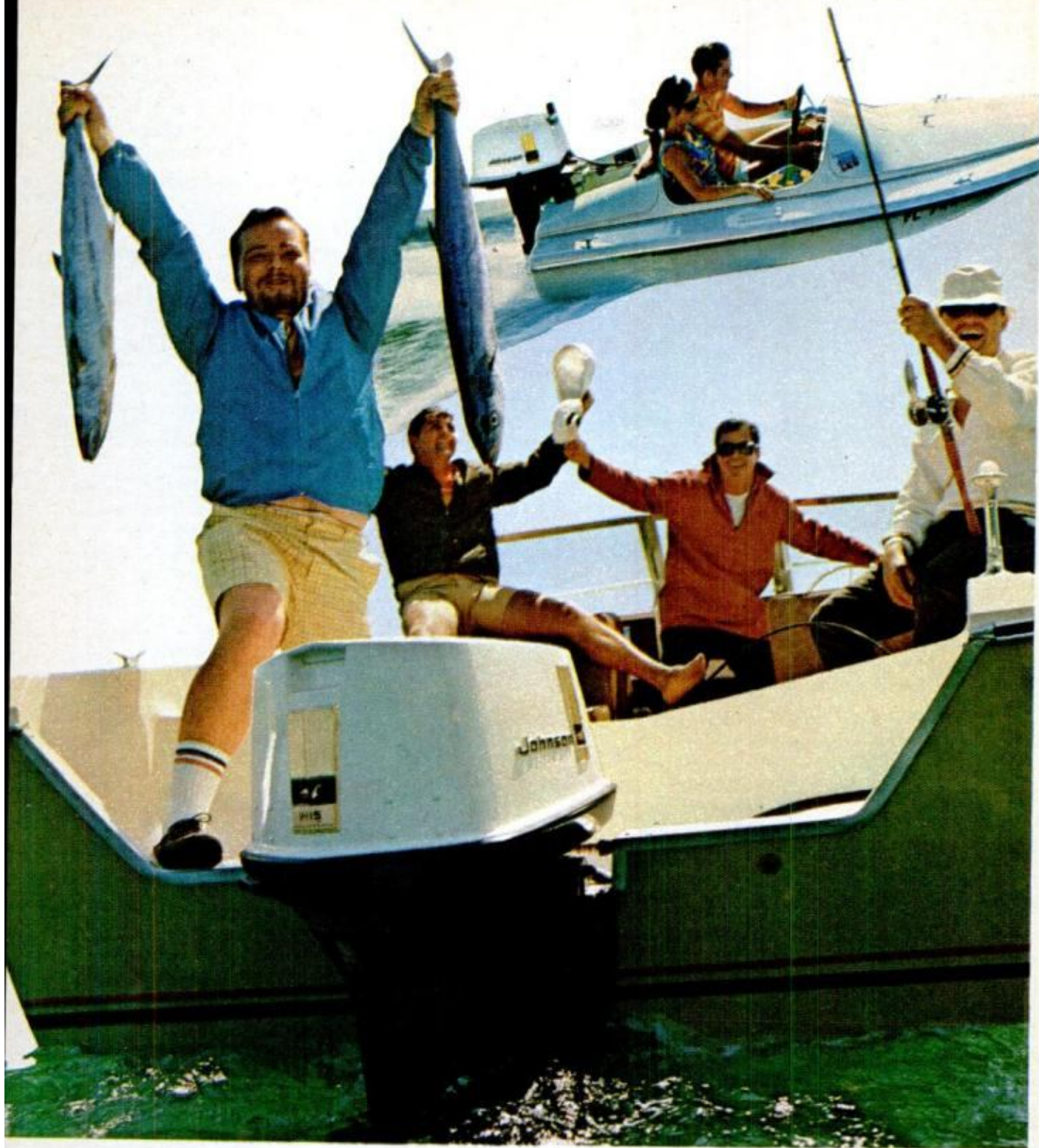

**prop now delivers 25% more open water thrust.**

A high-efficiency combustion chamber design with wide-open fuel intake system, twice as many reed valves, a new high-capacity carburetor increased the horsepower but added only 1 lb. over our old 3. Silencing is improved, vibration dampened with a new isolation system.

**Choose from 16 models (1½ to 115-hp) all new or improved... all with the dependability we**

**never stop Improving. Backed by our 2-yr. warranty.\***

To see the most 1969 firsts, see your Johnson dealer first—he's in the Yellow Pages. Write for free 36-page catalog. Johnson Motors, Waukegan, Ill. 60085, Dept. PM-92.

**Johnson**

FIRST IN DEPENDABILITY

Division Outboard Marine Corporation

\*For 24 months after purchase, Johnson Motors will replace or repair without cost to the original purchaser any part of its manufacture which, upon inspection, proves to have failed in normal pleasure use due to faulty material or workmanship.

## MODEL THIS 24-POUNDER

(Continued from page 138)

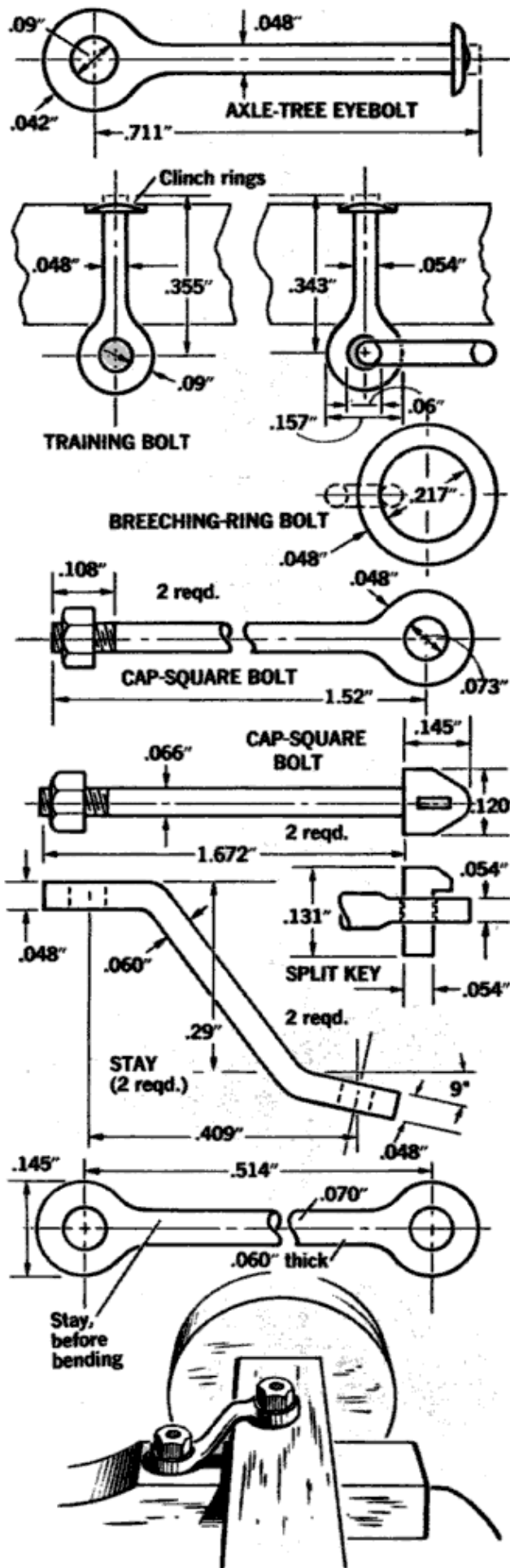

taper upward slightly from the base to top.

Carriage parts are shaped from black walnut and glued in the order shown. The trucks of the original cannon were built up in layers, as detailed for the model, but you can cut them from 1/4-in. stock and represent the joints with knife cuts. Note that hind trucks are smaller than the fore trucks. Use tiny brass escutcheon pins for rivets—a paper pattern will help spot them around the face of the wheels.

Round ends of the fore and hind axle trees can be "turned" to fit the trucks with a homemade plug cutter chucked in the drill press. It's made from 1/8-in. pipe reamed with a 3/16-in. twist drill. Form teeth around one end with a file. Axle-tree ferrules are turned from brass rod and bored to form a press-fit ring.

Tie bolts and cap-square bolts are shown full length, but you can simulate them merely by inserting the "heads" of the bolts in shallow undersize holes. Likewise, the eyes of the eyebolts need not be solid rings, as shown. Simply form an eye with needle-nose pliers and force it into the wood so you can't see the open end. If you can find actual bolts and nuts from junked timepieces, your model will look more authentic.

Cut stays for the fore axle tree from .060-in. brass sheet, then file, drill and bend to shape. Shape the linch pins from fair-size brass escutcheon pins, filing a flat on their heads to clear the axle trucks.

Cap squares that clamp over the trunnions can be shaped from .060-in. brass. File away the middle portion to .024-in. thick, then cut the piece in half lengthwise to form the two cap squares. Round the thick ends remaining as shown and form the slots by drilling and filing. Brass should be soft enough to bend easily around the trunnions. Note that one end of the cap squares pivots on an eyebolt while the slot in the opposite end engages a bolt with a slotted "head." A brass split key fits the slot and locks the cap square around the trunnion.

The base detailed on page 138 represents a section of sloping deck and ship rail. Make it of walnut to match the carriage or of lighter, contrasting wood. For a darker tone than you get with clear lacquer, rub in boiled linseed oil and let dry a day or two. Or, seal the first or second application with thinned shellac (after oil has dried), sand lightly and apply a final lacquer coat.

Take your time finishing your model. Many otherwise fine models are made less perfect by careless finishing. ★★★



Exclusive Flex-O-Matic rear suspension automatically adjusts spring stiffness to loads.

## Works like a truck. Rides like a car.

Ford's great road show has twin stars . . . the two front axles in Twin-I-Beam suspension. Forged steel I-beams for strength. Coil springs for easy ride. And what a cast! Roomiest, quietest cab of any pickup . . . Six or V-8 power up to 390 cubic inches . . . optional SelectAire conditioning, front power disc brakes, power steering and SelectShift Cruise-O-Matic transmission. Your Ford Dealer's reserved the best seat in the house for you. Guess where!



A better idea  
for smooth riding:  
Twin-I-Beam  
Suspension—  
only Ford has it!

## Best double-feature now running.

Farm & Ranch, Contractor, Heavy-Duty and Camper Special models available.

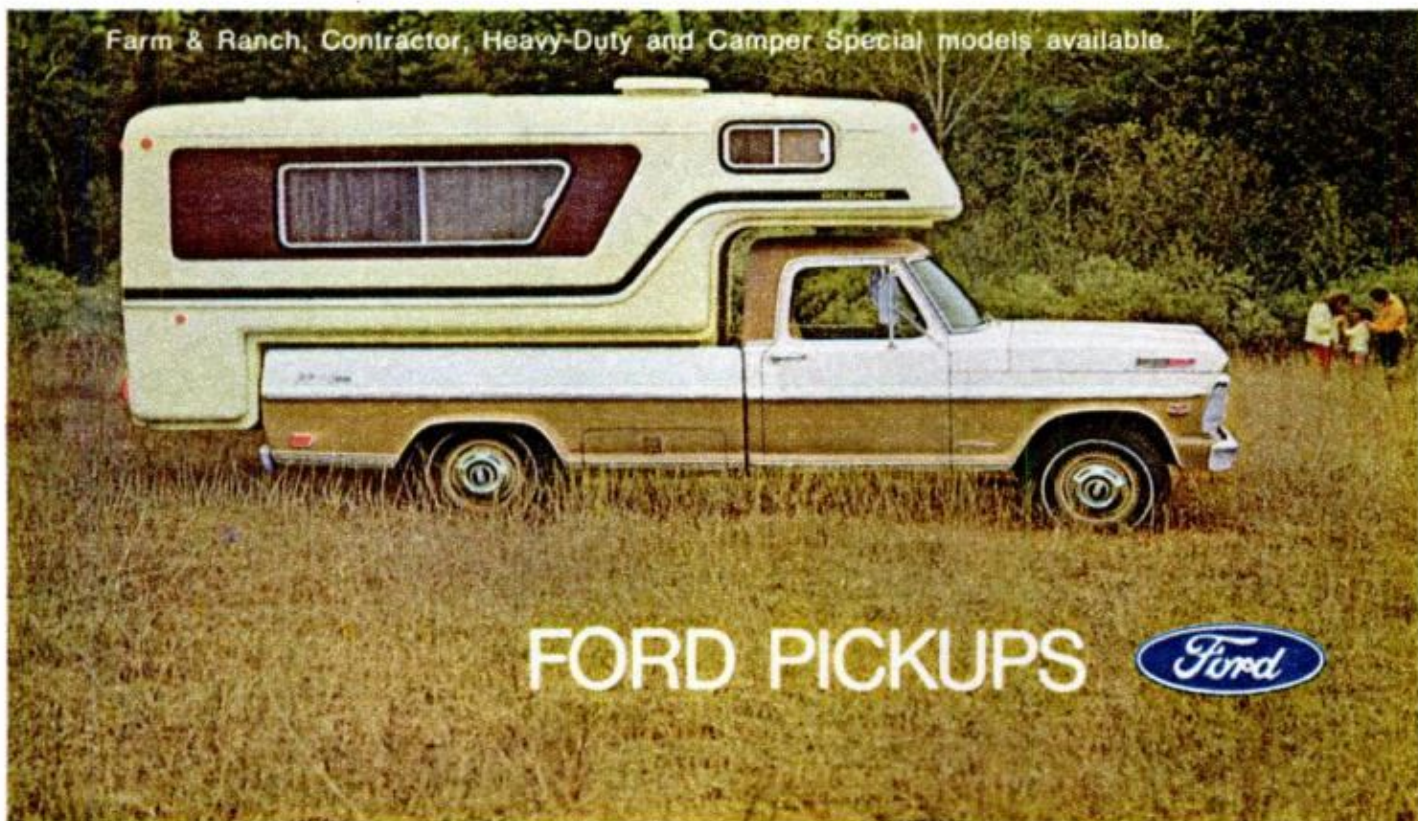

FORD PICKUPS





A whisker under thirteen bucks.  
\$12.88 to be precise.  
With Shock-Proof safety to boot.  
No other drill can touch it for the price.

Shock-Proof drills are double-insulated.  
Each live part is encased in a double  
wall of thick insulation. Just for you.  
To prevent against electric shocks.

No grounding necessary, either. No three prong  
plug nuisance with adaptors. It drills, buffs,  
mixes paint. It might even beat eggs.  
And it comes with a housing so tough you can  
drive your car over it.

Besides that, we tuck in the strongest  
guarantee in the game.

# World beater.

Get ready to take on the world. Beat it  
down to your Millers Falls dealer.

**Millers Falls**

The safest name in tools

Greenfield, Mass

## CASH IN ON THE BOOM IN COLOR TELEVISION

The NRI TV-Radio Servicing course includes your choice of black and white or color TV training equipment. Color TV needs thousands of trained men to keep pace with millions of sets being sold every year. NRI prepares you quickly. Cash in on the boom.

IF  
CARD IS  
MISSING  
MAIL  
THIS  
COUPON

NATIONAL RADIO INSTITUTE  
Washington, D.C. 20016

100-029



Name \_\_\_\_\_  
Address \_\_\_\_\_ Age \_\_\_\_\_  
City \_\_\_\_\_ State \_\_\_\_\_ Zip \_\_\_\_\_  
 Check for facts on GI Bill

# You get more for your money from NRI

NRI pioneered the idea of supplying home-study students with custom designed training kits to give practical on-the-job experience as you learn. Today, NRI's "3-Dimensional" training can't be equalled. You get more *value* — from the exclusive Achievement Kit sent the day you enroll, to "bite-size" texts and custom training equipment. Learning TV-Radio, Electronics or Communications at home is easy, exciting, the NRI simplified, dramatized way.

## BE A SKILLED TECHNICIAN IN AMERICA'S FASTEST GROWING INDUSTRY

Regardless of your educational background, you can learn the Electronics field of your choice the practical NRI way. The NRI color catalog, sent to you *free* and without obligation, tells you how you can qualify quickly to be a part of the fast growing Electronic Age; about engineering jobs in business, industry, broadcasting, government, now offered to men without college degrees. It will open your eyes to the great number of success opportunities available right now in the high-pay world of TV-Radio Servicing, Broadcasting-Communications and Industrial-Military Electronics. With NRI technical training, you can take your choice of a wide variety of career

openings or have a business of your own. And if you choose one of five NRI courses that include FCC License preparation, *you must earn your FCC License or NRI refunds your tuition!*

## MAKE \$4 TO \$6 AN HOUR EXTRA IN SPARE TIME STARTING SOON

Tens of thousands of NRI graduates are proof it is practical to train at home in your spare time. Keep your present job while preparing for a better one, and earn \$4 to \$6 an hour extra in spare time while you train, fixing sets for friends and neighbors. NRI shows you how. Equipment you build and keep becomes useful in your work.

## STEP UP TO BETTER PAY, A BRIGHTER FUTURE

NRI can help you, but the decision to act must come from you. Decide *now* to move ahead . . . mail the postage-free card. If missing, use coupon above for FREE NRI color catalog. No salesman will call. NATIONAL RADIO INSTITUTE, Electronics Division, Washington, D.C. 20016.

### APPROVED UNDER GI BILL

If you served since January 31, 1955, or are in service, check GI line on postage-free card or in coupon.

# NRI Programmed Equipment Gives You Priceless Confidence, Makes Learning TV-Radio, Electronics Fast and Fascinating

**BUILD • TEST • EXPLORE** All this is yours — from Achievement Kit, to solid state Radio, to training-engineered Color TV set — when you enroll for NRI's TV-Radio Servicing course. Other courses equally complete. Unique training methods, "bite-size" texts, many personal services have made NRI the leader in its field for over 50 years.

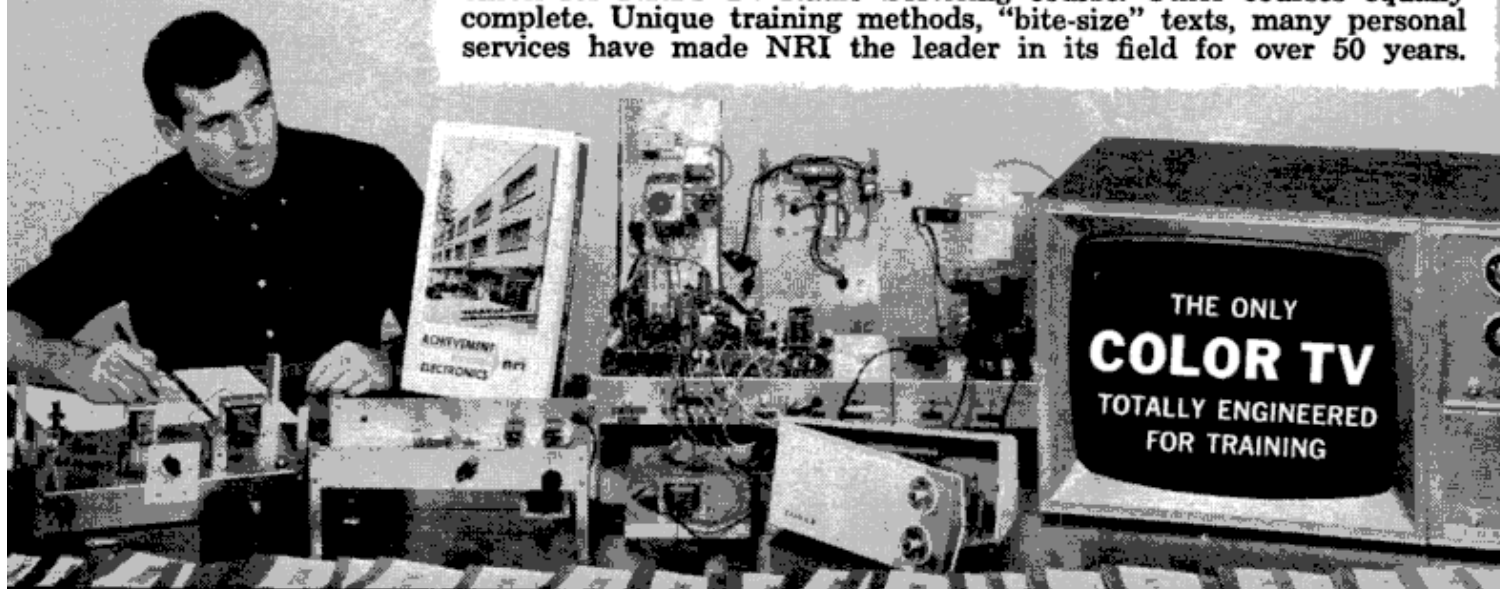

## HOW DEEP WILL DIVERS WORK?

*(Continued from page 95)*

tasks in the water, each man still linked to the chamber by his own umbilical of cables and hoses, including a hot-water hose. Through a special face mask, he breathed oxygen and helium from a backpack, to which the exhaled gas was also returned for removal of carbon dioxide and replenishment of oxygen.

All six divers lived in the deck chamber, at the 350-foot storage pressure, during three days of diving. Then they spent two-and-a-half more days in the chamber, slowly decompressing under the control of a fail-safe analog computer regulating the supply of gases, before they could come out.

The Ocean Systems dive, sponsored by Esso Production Research Co. in August, 1967, took place in almost the same location in the Gulf of Mexico, and also demonstrated maintenance work on an offshore wellhead. Two divers made a series of three dives to 636 feet, spending a total of 48 hours at the 600-foot pressure, including six hours in the water.

In March, 1968, Ocean Systems divers made an even deeper plunge—to 700 feet off Great Stirrup Cay, in the Bahamas. They used Ed Link's submarine *Deep Diver*, the world's first "lock-out" sub. (It's a true free-diving sub with a lock chamber from which divers can operate at deep-sea pressure, while the submarine crew remains at surface pressure in a separate compartment.) The divers reported they didn't experience pressure effects any different from those at 200 to 300 feet.

Man-in-the-Sea has become almost as complex as Man-in-Space. The array of sophisticated hardware effectively protects divers against the four major hazards of the depths: the bends, caused by the pressure of the sea; nitrogen narcosis, the "rapture of the deep"; poisoning by life-giving oxygen itself; and the near-freezing temperature almost always encountered in deep water.

### **Quick relief from the bends**

Saturation diving, pioneered by Capt. George F. Bond, head of the Navy's Experimental Diving Unit and the moving spirit of Sealab, takes care of the bends.

This risk exists because a diver must breathe air or a gas mixture at the same pressure as the water around him, to avoid being crushed by sea pressure. Some of the breathing gas dissolves in his blood and tissues. When he decompresses, the gas comes out of solution. If decompression is too fast, bubbles trapped in

joints or the nervous system can cause excruciating pain, paralysis, or death.

Capt. Bond realized that the solution was simple: Don't decompress between dives. Once a diver has become "saturated" at a specific depth, no more gas can go into solution as long as he remains at the same pressure. Thus, the time required for decompression does not increase.

With a system like Cachalot, if a diver gets the bends, it's easy to recompress him, since he's already in a chamber. This provides quick relief, then decompression is resumed, more cautiously.

Like the bends, nitrogen narcosis and oxygen poisoning result from increased concentrations of dissolved gases in the diver's body. Nitrogen becomes an intoxicant when a diver breathes air below about 165 feet. Oxygen becomes poisonous if the concentration in the bloodstream is too high, causing convulsions and unconsciousness.

These problems are handled by substituting helium for nitrogen and carefully regulating the percentage of oxygen. Helium is expensive, so it's desirable to recirculate the diver's exhaled breath through a purification system and re-use the helium, instead of wasting it into the water. Such a system must be highly reliable—the diver's life depends on it.

### **Backpack rebreather**

Westinghouse divers use a backpack rebreather commonly known as the Krasberg rig (it was developed by Alan Krasberg). It combines two flexible breathing bags, which come over the diver's shoulders like a life vest, with a backpack containing a canister of CO<sub>2</sub>-absorbing chemical, oxygen and helium cylinders, and—all-important—an electronically controlled oxygen-regulating device.

The diver's exhaled breath goes into one breathing bag and through the CO<sub>2</sub> canister, then has oxygen added to it, then flows into the second breathing bag, from which he inhales. The oxygen content is monitored by means of a fuel cell that uses a tiny bit of oxygen to generate electricity. Power output is proportional to the amount of oxygen, and this signal is amplified to control the oxygen valve.

The briefcase-size backpack can supply a diver with oxygen for about six hours, and uses only a thousandth as much helium as would be required by a diver exhaling into the water. The diver breathes about two-percent oxygen at 600 feet, and Krasberg says regulation is highly accurate.

Cold is a severe problem for deep divers. The temperature is usually around

*(Please turn to page 212)*



## "I Earn Two Incomes Now"

Says **JOHN BENNIE, Pittsburgh, Pennsylvania**

"Thanks to your wonderful training, I have been able to earn \$20 to \$25 extra each and every week doing little locksmith jobs at home and after work at my regular job. This is the best trade a man can take up."

# Be a LOCKSMITH

Train at HOME—Earn While You Learn. Add 50%-100% to YOUR INCOME with easy spare time earnings. Cash in on the nation-wide shortage—trained locksmiths in great demand! Quickly step into a big pay opportunity job or start a high-profit shop of your own.

**Earn Extra Money RIGHT AWAY!** All Master Locksmiths Special Tools, Equipment and Supplies Furnished FREE for use with course.

Age, education, minor physical handicaps don't matter in this growing trade. You can quickly qualify as a skilled locksmith. It's like a fascinating hobby. Study at home as little as one hour a week. Gain practical experience through complete well-illustrated lessons. Do real jobs on car locks, house locks, padlocks and safe locks, under the guidance of experts. FREE Illustrated Book, write now.

**LOCKSMITHING INSTITUTE,**  
(Div. Tech. Home Study Schools)

Dept. 1110-029 • Little Falls, New Jersey 07424

**306** pieces of professional equipment  
**FREE** for use with course.

Professional Equipment includes  
**LOCKS—PICKS—PARTS—KEYS**  
**SPECIAL TOOLS & SUPPLIES**  
all FREE for use with course.

MAIL  
COUPON  
for FREE  
ILLUSTRATED  
BOOK

For a future as your own boss or in a high-pay job, write now for FREE Illustrated Book.

Only school of its kind. Licensed by State of New Jersey. Approved for Veterans.

Accredited. Nat'l Home Study Council.

---MAIL COUPON NOW---

**LOCKSMITHING INSTITUTE, Dept. 1110-029**  
**Little Falls, New Jersey 07424**

Please send FREE Illustrated Book—"Your Big Opportunities in Locksmithing," complete Equipment folder and sample lesson pages—FREE of all obligation—(no salesman will call).

Name \_\_\_\_\_  
Address \_\_\_\_\_  
City \_\_\_\_\_ State \_\_\_\_\_ Zip \_\_\_\_\_



## Save Money on WOOD

Hardwood Veneers . . . Hardware . . .  
Wood Shop Supplies and Equipment  
. . . Power Tools



Hardwoods, Fine Plywoods, Inlays, Mouldings, Mosaic Tile, Tools, Lamp Parts, Upholstery Supplies

Your new MONEY SAVING wood and workshop buying guide now ready! 140 page. Full color! Your best "one stop" source for finest kiln dried domestic and imported hardwoods, veneers, plywoods, modern and traditional legs . . . over 1500 items.

**STANLEY TOOLS at Discounts**  
Startling savings on top name power tools, hard to find cabinet hardware, lamp and upholstery supplies. New projects and kits. Enclose 35¢ to help pay mailing and handling costs. Mail coupon.

**New Catalog**  
over 1500 items  
**Now Ready!**

**CRAFTSMAN**  
**WOOD SERVICE COMPANY**

2729 South Mary, Chicago, Illinois 60608. Dept. A-29

Rush new Craftsman WOOD Catalog. I enclose 35¢ to help pay mailing cost.

NAME \_\_\_\_\_  
ADDRESS \_\_\_\_\_  
CITY \_\_\_\_\_ STATE \_\_\_\_\_ ZIP CODE \_\_\_\_\_

**This point lets you bore holes up to 1 1/2" with small electric drill**

**IT'S HOLLOW GROUND to bore cleaner, faster at any angle**

Now step-up the boring range of your small electric drill or drill press to 1 1/2" with Irwin Speedbor "88" wood bits. 1/4" shank chucks perfectly. No wobble. No run-out. Sharp cutting edges on exclusive hollow ground point start holes faster, let spade type cutters bore up to 5 times faster. You get clean, accurate holes in any wood at any cutting angle.

Each Irwin Speedbor "88" forged from single bar of finest tool steel. Each machine-sharpened and heat tempered full length for long life. 17 sizes, 1/4" to 1 1/2", and sets. See your Irwin hardware or building supply dealer soon.

\$ .85 each	\$ .95 each	\$ 1.50 each
1/4" to 3/8"	3/8" to 1"	1 1/4" to 1 1/2"

**IRWIN SPEEDBOR "88" WOOD BITS**

at Wilmington, Ohio, Since 1885



# LEARN TO BE A SKILLED LOCKSMITH



Change combination of pin tumbler cylinder—EARN \$1.50 in 15 MIN.

**TYPICAL JOBS EARN YOU \$271 PART TIME (in only 53 hours!)**

Owner loses key; pick car trunk—EARN \$5.50 in 10 or 20 MIN.



Install new knob door lock—EARN \$15.00 in 30 MIN.



After-hour emergency opening—EARN \$2.50 to \$5.50 in 20 MIN.

## Hundreds have succeeded like these Belsaw Graduates:

**R. W. Davis, St. Louis, Mo.:** "I am doing a wonderful business thanks to your course in locksmithing. Last Saturday I took in \$110.00."

**Pierson Crook, Los Angeles, Calif.:** "I am making \$200 a month extra income with the Belsaw Locksmith Course. I would recommend your course to anyone."

Big demand for skilled Locksmiths! Earn big money spare time in your own home. Be your own boss. No layoffs. Steady year 'round income. Age and schooling are no handicap.

**BELSAW INSTITUTE** training...approved by master locksmiths...helps you start faster with easy picture lessons guided by your own mail instructor.

Get thorough job training on all types of locks. We supply tools, equipment and business help: how to start, how to charge, how to get jobs, how to earn while you learn and build a lifetime cash-profit business. Accredited Member National Home Study Council. Approved by State Board of Education. Approved for Veterans.



**This \$125 key machine is yours to keep!**

**MAIL COUPON—NO SALESMAN WILL CALL**

**BELSAW INSTITUTE, 109F Field Bldg.  
Kansas City, Mo. 64111**

Send FREE book, "Keys To Your Future!"



Name \_\_\_\_\_

Address \_\_\_\_\_

City \_\_\_\_\_ State \_\_\_\_\_ Zip \_\_\_\_\_

## HOW DEEP WILL DIVERS WORK?

(Continued from page 210)

40°F. at 600 feet and below, and helium is more conductive than air, carrying away body heat rapidly. Divers for both companies use the same kind of water-heated suit.

But problems loom at the 1000-foot level. One is simply the mechanical difficulty of breathing. As a gas is compressed, it becomes more dense. Deep divers say that air at 200 feet becomes viscous, almost like breathing a fluid. Helium is less dense than the nitrogen in normal air, so the helium-oxygen mixture is easier to breathe, but it becomes almost fluidlike below 600 feet.

### Diver's undersea limit 1000 feet?

More important, research indicates that helium narcosis becomes a problem around 1000 feet. This has nothing to do with the chemical properties of the gas, but is a physical effect on the nervous system that results from an increased concentration of dissolved helium in the blood.

That's why Dr. Brauer and Andre Veyrune were sleepy and disoriented in the simulated dive to 1190 feet. "From a scientific standpoint, this was our most important achievement," says Brauer. "We demonstrated that there is a real physiological barrier beyond which man cannot go with the standard breathing mixture of helium and oxygen."

Brauer doesn't think that any gas mixture will enable man to function very far below 1000 feet.

At Ocean Systems, physiologist Dr. Heinz Schreiner found that human cells stop growing, become distorted, and disintegrate at a simulated depth of 2000 feet in a helium-oxygen atmosphere.

Nevertheless, Schreiner is optimistic and hopes to see a depth limit of 2000 feet for working dives within the next 20 years. He thinks 1500 feet will be well within the state of the art by the mid-1970s.

Whatever the exact figure, it appears that there is a limit below which men will never be able to survive, breathing gas mixtures and exposed to the pressure of the sea. At that depth submarines with clawlike manipulator arms will have to take over from divers. But the undersea work they can do is performed much more awkwardly than by a diver working with his hands in the water.

Will ways to penetrate the depth barrier be devised? Perhaps, since the ingenuity of deep-sea scientists constantly strains at limits imposed by nature. ★ ★ ★



# It only tastes expensive



Popular price

EARN SPARE TIME MONEY...

## Buy Lowest - Below Wholesale!

SELL AT TOP PROFITS... Up to 600% Profit on Top Selling Specialties, Novelties, Gift Items, Mail Order Products, Toys—1000 Bargains!

EARN EXTRA INCOME—up to \$10,000-\$20,000 and more. Start your own Wholesale or Mail-Order Business in the booming specialty merchandise field. No experience needed. No franchise to "buy." No canvassing. Work at home part time or full time. Revolutionary marketing program brings you automatic orders. Make big money right from the start.

SPECIALTY MERCHANDISE CORP.

7630 Gloria Avenue, Dept. S-2, Van Nuys, Cal. 91406

WRITE FOR AMAZING FREE BOOK!



# BUILD

REFINISH RESTORE  
...anything of wood

LET Constantine's picture-packed Catalog-Manual help you build new furniture—help you restore and refinish beat-up cabinets, chairs, chests, tables. Find instantly whatever you need. Newest materials plus plans, instructions. Largest selection of beautiful woods. Specialty tools. Products not found in stores or by mail elsewhere. *Unsurpassed values.* Send for vast, illus. catalog NOW!



2,000

CRAFTSMAN PRODUCTS  
Woods—Veneers—Inlays  
Newest Workshop Tools  
Wood Finishes—Moldings  
Carving Woods & Patterns  
Cane Kits—Lamp Parts  
Hard-to-find Hardware

Tear out ad. Mail with 25¢  
for vast new CATALOG  
Plus New "101 Project Ideas"



CONSTANTINE

2050 Eastchester Rd., Bronx N.Y. 10481 Dept. B-5

# INTRODUCING... the NEW WARNER SUCCESS PROGRAM that is

## PROGRAMMED FOR PROFIT

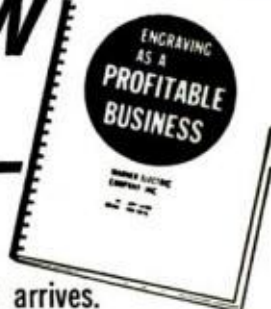

This amazing Warner Success Program shows you, in step-by-step instructions, how you can establish your own business—in your spare time at home. AND, without any experience because we provide everything.

### HERE'S WHAT OTHERS HAVE TO SAY . . .

MR. J. C. — "I wish to take this opportunity to say thank you for all the help and encouragement which you offered. The Warner Success Program is absolutely invaluable. I have never had an aptitude for anything mechanical, but after reading your instructions I had no difficulty. I cannot praise this Success Program highly enough."

Yes, the Warner Success Program, "Engraving as a Profitable Business," is complete in every detail. It shows you 8 different ways to get business . . . it illustrates how to get orders without canvassing or house-to-house selling. It shows you how to get others to work for you, how to expand and how to make a market survey locally, before you invest any money. The Success Program enables you to get business before you invest one penny . . . and be in business

the very day your Warner Shop arrives.

C. W. B. — "I picked up my Warner Home Business at 8:30 this morning and on the way home to set up my shop I stopped at the local stationery store and he had 75 orders waiting for me. My profit from my first order was \$64.20 for less than three hours work . . . and that's \$21.40 AN HOUR! All from following the Warner Success Program."

Don't make any decision now. Just send me your name and address on the coupon, or on a postcard. I'll see that complete information is sent to you by return mail, postpaid. No salesman will call.

Warner Electric Co., Dept. E-2-BS  
1512 Jarvis Ave., Chicago, Ill. 60626

Engraving Division, Dept. E-2-BS SEND NO MONEY  
1512 Jarvis Ave., Chicago, Ill. 60626

Please rush your free illustrated brochure to:

Name \_\_\_\_\_

Address \_\_\_\_\_

City, State, Zip \_\_\_\_\_

## HOW TO BUCK A BLIZZARD

(Continued from page 98)

the crack and up against the windshield. This can help prevent ice buildup.

● **“Arctic blades”:** Some experienced snow drivers use “Arctic blades.” The trouble with ordinary blades is that their exposed metal surfaces get wet and freeze. “Arctic blades,” which cost slightly more than ordinary blades, are entirely cased in rubber. I have used them for years, and under certain conditions they work quite well. On some windshields I have found them less effective—perhaps because of the windshield’s shape. Pat Murray uses them, and while he finds them less apt to ice up, they, too, get coated occasionally and need to be “frisked.”

● **Bust the snowpile:** “We can always tell a poor snowdriver,” Pat says. “He starts off with a pile of snow on his roof. At slow speed in a storm, a wet pile traps more snow.” Then, a few miles down the road, the driver hits his brakes. Instantly, the whole fluid mass slides forward over his windshield like a carpet, blinding him and swamping his wipers. In real trouble, he can’t even see to stop. “That’s why we always knock a snowpile off the roof before starting,” Murray says.

Snow, he adds, should also be removed from the hood. If you don’t do it, your slipstream, at speeds over 25 mph, erodes the pile and feeds a steady stream of fine snow to the windshield. In a moderate storm this may go on for ten miles.

● **Before you start:** 1. Kick off the frozen lumps that hang from fenders. When snow gets deep, these lumps drag, help lift tires, reduce traction. And if you get stuck in a snowdrift they make it difficult to get a shovel in near your tires.

2. Clean all windows. The inward slope of car windows nowadays lets snow pile deep on the glass during stops. If you fail to clean this snow away, it trickles down, freezes, may lock windows shut.

3. Besides filling your windshield-washer reservoir, add *plenty* of antifreeze to its contents. On snowy days, windshields get spattered and opaqued. And in today’s fast traffic, if you suddenly need your washers but find them empty—or the jets frozen—you’re in trouble. After adding antifreeze, Pat suggests running the blades until the antifreeze is pumped through the system. If jets *do* freeze, some drivers suggest stopping and thawing them with warm water. But be careful not to pour hot water on the cold glass.

● **If a “whiteout” begins:** If you’ve never driven in a real whiteout, you have an experience coming. Snow closes around you in a blanket. The road vanishes, posts dis-

appear. All you see is a glare of wind-blown snow. You know other cars are out there but you can’t see them. Sometimes you don’t know where to steer because the thick horizontal flow of snow across the road destroys all sense of direction.

For whiteouts, Pat keeps skiers’ yellow-filter glasses on his car’s dashboard. With these on, the edge of the road is visible. If you lack filters, try ordinary sunglasses.

● **How to “control” a snowstorm:** When a windblown storm gets *really* dangerous, one trick is so simple few drivers think of it, Pat says. Simply turn around, when you can do so safely, and go the other way. I tried this technique not long ago in a vicious night whiteout. I was headed into a snowstorm that was blowing in 30-mile gusts. When vision became almost impossible, I turned around and started back. Instantly, I could see! The storm was as bad as ever, but now I was moving east at 30 mph, the same speed as the wind. Soon I found a motel, stopped, then continued the next morning.

● **If you have to turn around:** There’s a right and wrong way in a snowstorm. Let’s say you’re on a conventional two-way road. Snow is getting deep. If you try to turn in the roadway itself, your rear wheels may spin and refuse to climb the high center crown. You may get stuck. The best bet is to slow down, watch for a clear driveway (or side road) that slopes *up* from the highway. Stop just beyond it, then make a backing turn with enough momentum to carry your wheels *up onto the driveway (or side road)*. Now it’s easy to roll forward and turn the opposite way.

● **To turn around on a curve:** Here’s where many highway jams develop. A driver sees a car stuck on a curve ahead, stops, tries to make a 180° turn on the same curve and slews across the road.

“The mistake most drivers make,” Pat says, “is getting trapped on the lower side of the curve. They either back, or advance, *down* the slope. Once they have one pair of wheels lower than the others, they can never complete the turn. The right way is to back in an S-curve. *Start* backing down the slope, but immediately reverse your steering and let momentum carry your rear wheels to the high side of the road. Now it’s easy to roll forward. The slope will help you complete the turn.”

● **When the going gets rough:** Put extra weight in your trunk! I know some experts advise against this. They worry that heavy weight in back can help spin you out on fast turns. And, of course, it can come forward and wrap around your neck if you hit something. But you don’t go racing around fast turns in snowstorms. Nor

[\(Please turn to page 216\)](#)

## DEFENDER OF WOMEN!



**Instantly Stops Attacker**

Assailants run screaming when sprayed in face with DEFENDER. When you're in danger, simply press top. Temporarily leaves attackers helpless. Dyes skin identifying attacker for police. Effective up to 15 ft. Lip-Stick size—hides easily in palm of hand. Women buy on sight. Amazing profit!

**SAMPLES for TRIAL** Sample offer sent to all who send name at once. Postcard will do. **SEND NO MONEY.** Just your name.

**KRISTEE CO., Dept. 672, Akron, Ohio 44308**

Learn how to become a **TRAVEL AGENT**



Thousands big money career opportunities open for qualified men, women in travel. Travel is booming... increasing at rate of 15% each year! Easy home-study program trains you now for a rewarding job with travel agency, airline, resort hotel, etc. . . . shows how you may become travel agent in your own area . . . reveals how you can escort guided tours. Send now for big "TRAVEL CAREER KIT"—ALL FREE!

**NORTH AMERICAN SCHOOL OF TRAVEL**  
4500 Campus Dr., Dept. 4172, Newport, Calif. 92660

### POLICE - FIRE - EMERGENCY - CAR RADIO \$9.99



Works with regular CAR RADIO and ANTENNA! NO special wiring or installation. Mounts UNDER DASH in 5 minutes in ANY CAR OR TRUCK. Panel switches INSTANTLY from REGULAR to POLICE-FIRE-EMERGENCY radio CALLS—Receives ALL stations in your AREA within range. Size only 2"x1 1/2"—Two tone steel cabinet. (Cash, Ck, M.O.) and pay postman \$7.95 plus COD pstg or send \$9.99 for ppd Del in USA. COMPLETE ready to clip in your CAR with all parts and instructions. One year parts and service Warranty—10 day money back trial (if retrnd). AMAZING OFFER good only by mail and from:

**WESTERN RADIO Dept. BPM-2 Kearney, Nebr. 68847**

## I-N-V-E-N-T-O-R-S WE NEED INVENTIONS

Sell your invention for cash—need money for Patent?—Are technical problems holding you back? Universal Inventions has helped inventors all over the world—just like yourself—why not you? Inventions provide the magic spring-board to sudden riches. REMEMBER, we either sell your invention or pay you a cash bonus. Write for details.

**UNIVERSAL INVENTIONS, Dept. 13, Marion, Ohio**

### TRAIL-BREAKER® Goes anywhere



**Outdoorsmen:** Ride where you had to walk before. Revolutionary two-wheel drive vehicle climbs mountains, fords streams, hauls man-sized loads. Runs all day on a tank of gas.

Write Rokon, Inc., Dept. A  
Wilmington, Vt. 05363

### MAKE MONEY! REPAIR HYDRAULIC JACKS



Earn while you learn at home. Millions of jacks in gas and auto service stations, trucking firms, body shops, riggers, factories and farms need servicing . . . most of which you can learn to repair. We show you HOW. Start spare time in your basement or garage. Big opportunity for mechanics. ACT NOW!

Write for Folder PM2 and Free Bonus Offer

**Hydraulic Jack Repair Manual Co., Inc.**  
G. P. O. BOX 3 • STATEN ISLAND, N. Y. 10314



## The Dunk Test.

Dunk an unopened Kentucky Club pouch into a tank full of water and what happens? Nothing. Absolutely nothing. Because the pouch is sealed! Water can't seep in. So obviously air can't get in, either. And freshness can't leak out. Now you know how we can guarantee you fresh tobacco: 48% fresher than any brand in ordinary pouches. Because we're the only ones who seal a pouch. Try a free package of ours and see for yourself. Just send us the coupon and an empty pouch of what you're now smoking (any brand but ours). We think you'll agree your taste never had it so fresh.

FREE OFFER TO PIPE SMOKERS

Mail to: Fresh Tobacco, Box H  
Wheeling, W. Va. 26003

Gentlemen: Here's my ordinary pouch. Now I'd like to try a full-sized package with that sealed-in freshness you promised me.

Name \_\_\_\_\_

Address \_\_\_\_\_

City \_\_\_\_\_

State \_\_\_\_\_ Zip \_\_\_\_\_



Offer good in U.S.A. only. Sorry, only one to a customer.

## HOW TO BUCK A BLIZZARD

*(Continued from page 214)*

do you, if you're even "average-good," run into things!

What some experts overlook is that when the going gets tough and the snow is deep, you're a menace to everybody if you don't have plenty of traction weight. It's mainly weight over the driving wheels that keeps big cars moving smoothly. And it's weight that keeps trucks moving when many cars are sliding around. Also, the best snow tires in the world won't help if snow is pushing up underneath your car.

Often passengers in back are all the extra weight you need—or a shift in baggage and a full load of gas. If not enough, many snow drivers add sand. Burr Hartman says he never goes into a storm without 100 pounds of sand over or just behind the rear wheels. Pat insists on 300.

After the storm, of course, it's only sensible to get rid of excess weight. Many drivers on long snowstorm climbs up here put rocks in the trunk for traction. Rocks are dangerous things to have in a car, but, again, it's a question of what is *least* dangerous in a temporary emergency.

● *If you start snow-busting:* When snow gets so deep they must buck their way, many drivers plug ahead, losing speed until the rear tires spin. Then they're stuck.

Never force a car into snow. Ease it into heavy stuff as far as it will roll. Catch it instantly when it stops and roll back a few yards—before it can settle in. And be careful to back out in the same track. Now get a new start, without wheel spinning, and bust a few more yards. Keep doing this until you get through the drift area.

After getting past deep drifts, some drivers find their engines boiling. The trouble is that in drift-busting, snow can clog your radiator. So, it is important to stop in a safe place, open the hood and inspect the radiator and grille. If clogged, close the hood and let the engine idle. If the radiator tends to boil, turn the engine off—its heat will melt the blockage, often within ten minutes.

However, in heavy going, Pat Murray says, you may also find large quantities of snow packed solid around the engine itself. When this happens, he scoops it out.

● *If you spin out:* Many drivers spin and get stuck needlessly. "Seems they never heard of the simple art of backing," Pat says. "Nor do they know about straightening their front wheels."

A car that spins usually stops with wheels turned right or left. And this is like dropping anchor—in deep snow it's all but impossible to move. "Unless they're down in a ditch," Pat says, "we get most

cars out by merely unwinding their front wheels, then backing a little."

Here is where many drivers go wrong. They try to ram the car out and get stuck deeper. They don't take time, Pat says, to discover the pressure-points that need to be broken down. Before you back, get out and look things over. Look under each section of the car. Know exactly where "pressure snow" needs to be loosened and pulled out. A garden rake or hoe is a good tool to have along, as well as a shovel.

Before straightening your wheels, also remove snow that is pushing against your sidewalls. Otherwise, the wheels will pack this snow solid when you straighten them. Heat of compression melts snow, enabling it to freeze into a hard wall.

Next clear a "backing track" behind each wheel—a good yard or two—and a "starting track" in front of each wheel. If there's any slope or crown to the road surface, note in advance which way the rear wheels will shift. Put sand or salt on that side. (While doing all this, you have also been helping yourself in another way. By *not* trying to blast your way out immediately, you've let your tires cool. And cool tires bite best.)

● *Use those flares!* While trying to get unstuck, place flares out in both directions. Being stuck in a snowstorm, Pat says, is like being stuck in fog. You may get run over before anyone sees you.

Don't skimp on flares. Use plenty—the worse the storm, the more flares. "We never go into a storm without a good supply," adds Burr Hartman.

● *A "skylight" at night:* One danger in snowstorms is being overtaken while moving. You're feeling your way. Your taillights are frosted over. Even if clear, they couldn't be seen because of falling snow. Suddenly, a faster vehicle looms up behind you, not seeing your snow-sheathed car, and hits you. To guard against this, experienced snow drivers aim spotlights up into a storm and back—about 15° from vertical. The loom of such a "skylight" often can be seen long before taillights become visible. (Even some big trucks run with this protection.)

In a snowstorm, you can't have too much rear protection. In a recent bad storm, I saw a red flare sputtering in the dark. I got ready to stop, then realized the flare was on a big truck I was overtaking. Its alert driver, knowing his trailer was sheathed in ice and all but invisible, had lighted a big 30-minute flare and jammed it into the tailgate on the left side. This had its dangers. A flare in the wrong place could start a fire. But in this storm it was the one light bright enough to be seen—one that certainly wouldn't ice over! ★★



**Bert Stern** is one of America's most versatile photographers. He made \$50,000 a year before he reached 30, and his camera won him 6 Art Director awards.

## We want to test your talent for photography

**We'll send you our Aptitude Test free and without obligation — to help you find out if you can be trained for success as a photographer**

**By Bert Stern**  
Guiding Faculty Member,  
Famous Photographers School

If you enjoy taking pictures, we want to test your aptitude for photography. We'll help you find out if you can be trained for a money-making career in the exciting field of photography, either part-time or full-time. Many men and women have photographic talent but have no reliable way of finding out if it's worth developing. Others, who are surer of their ability, simply can't get top-notch professional training without leaving their homes or jobs.

### How to take the test

You don't need a camera or even any technical knowledge to take this Aptitude Test. All you need is a pencil and a half-hour of your time. You will be asked to put down your immediate, instinctive answers to a number of visual questions. In this way, you'll be revealing your sensitivity and your natural reactions to photographic situations.

### What the test covers

Our test measures your ability to judge photographs from several different standpoints. For example, you are shown ten sets of similar photographs, asked to compare them and decide which you feel is more effective. This is a test of your visual taste and judgment. In an-

other category, you judge five pairs of photographs — each pair designated with a descriptive word — and you are asked to check the photograph that best illustrates the meaning of each word. There are also pictures of an identical scene cropped differently. You are asked to pick which is the better composition.

### Your test is graded free

When you return your completed test, it will be graded by a member of our staff and returned to you. If you do well on the test, you will be eligible to enroll for the professional training offered by the Famous Photographers School. However, you are under no obligation.

### A new way to learn photography

The nine distinguished photographers who joined with me in starting the Famous Photographers School are among the best-known, highest-paid professionals in the field. They include Alfred Eisenstaedt, Irving Penn, Philippe Halsman, Joseph Costa, Richard Avedon, Ezra Stoller, Arthur d'Arazién, Harry Garfield and Richard Beattie. We spent three years pouring into a series of comprehensive lessons all the know-how it had taken each of us many years to acquire. We contributed or made over 2,000 "teaching photographs" so that each lesson would be like an actual studio or field demonstration. Then we developed a series of practical assignments — which you can carry out with your own camera, in your own home or neighborhood, on your own time schedule.

### Almost like private studio tutoring

When you send an assignment to the Famous Photographers School, a professional photographer spends up to two hours on it — giving it his complete and undivided attention. He makes special

overlays, drawings and diagrams to show you exactly how to improve your photographs. Then he writes you a detailed personal letter giving you further suggestions and advice. It's like having a master photographer at your side passing along his most valuable secrets and techniques. Yet you learn at home — on your own time — and at your own pace.

### Students earn while they learn

This method of training is so effective that many of our students are starting to make money with their cameras. "My last prize-winning picture got me a job as full-time staff photographer on our local paper," writes Robert Coyle, Dubuque, Iowa.

Mrs. Gerhard R. Schade, Jr. of Glastonbury, Conn. says, "Since starting the Course, I've had photos published in seven magazines and newspapers. The Chicago American ran one of my photos for the front cover of its magazine section. All in my spare time!"

George Godfrey of Forest, Ill., reports, "I sold photos to a Michigan ad agency, which resulted in four-color ads and direct mail pieces. This one assignment more than paid for my Course and allowed me to buy more equipment."

### Take the first step to success

If you want to find out whether you have the aptitude for success in photography, send for our test. You will also receive an interesting brochure about the School and its revolutionary method of instruction. To get the Aptitude Test and brochure — both free of any obligation — why not fill in the postpaid card attached to this page and mail it in right now? (If card is missing, send your name, address and age to Famous Photographers School, Studio P515, Westport, Conn. 06880.)

## SO WHAT ELSE IS NEW?

*(Continued from page 118)*

double-cantilever rear suspension that carried along with it many advantages.

"We particularly want you to note," said the catalog, "the advantages of the *close-coupled* body and long wheelbase (141 inches) where all the passengers are placed so far forward of the rear axle and in the most desirable position for easy riding." Passengers in this Austin got what for them was a safe, easy ride.

● *Four-on-the-floor.* With wood-rimmed steering wheels, legible instruments and manual transmissions that can be adapted to all kinds of ratios, the automotive fraternity appears to have turned the full circle in a little over two generations. But the *close-ratio*, sports-type manual transmission is more than 66 years old. Back in 1902, Mercedes was importing into the United States a four-cylinder, 60-hp sporting model of 563-cu.-in. displacement that transmitted power to the rear wheels through a standard equipment *close-ratio*, four-speed box. Shift action was described by the manufacturers (and by enthusiastic owners) as "akin to a good knife slicing through the best butter!" Not bad, during an era when even the term *synchromesh* was unknown. And you didn't have to pay extra for this option as you do today.

● *Four-wheel drive.* The four-wheel drive system, popularized by thousands of Jeeps during World War II and now appearing on racing cars for greatly improved stability and cornering, is around 60 years old. Back in 1908 a handsome and costly (\$4500) automobile called the Badger appeared on the market. Its designers were Otto Zachow and William Besserdich who devised a four-wheel drive system which could propel the car "through deep snow." The Badger, produced by the FWD Automobile Co. of Clintonville, Wis., had a four-cylinder, 60-hp engine and was built in limited numbers.

● *Superchargers.* The history of the automobile, both here and in Europe, is underscored by many attempts to introduce the supercharger (or forced-induction system) as an assembly-line feature, available to any buyer. Other than in racing, these attempts have not been successful. Alvis tried it in England, Mercedes in Germany, Alfa-Romeo in Italy and so on, but the idea never really caught on.

There are, of course, three types of superchargers, each with its own advantages and weaknesses. The oldest is the centrifugal blower, next is the positive displacement type and the newest is the so-called turbocharger adapted to Offy engines at

the racetracks. In this one, the exhaust gases are used to compress the air which is rammed into the cylinders for combustion.

Although most people know the supercharger is not new, they have no real notion how old it is. The Chadwick Co. of Pennsylvania produced a model that had a three-stage centrifugal supercharger—and that was in 1905!

● *Front-wheel brakes.* It is probably fair to credit Duesenberg with the first production automobile featuring four-wheel brakes; and that was back in 1921. But brakes up front in an automobile go back a lot farther than that. The oldest known patent on four-wheel brakes was taken out by an English firm back in 1906. But, after three years of trying to iron out bugs caused by steering lock, the firm gave up.

The Italian firm of Isotta-Fraschini, however, made a design work. The Isotta-Fraschini car can be said to have predated the wide-scale adoption of four-wheel mechanical brakes by some 15 years. This magnificent automobile, (chassis price tag alone was \$9000!) had *three* sets of mechanical brakes, all of the contracting type. Separate pedals operated the pair on the rear wheels and the water-cooled differential brake. The front brakes were actuated by a hand lever, so the driver must have been pretty busy when making a panic stop.

The Isotta could not claim that its four-wheel brakes were coupled as an integral system. The Duesenberg could. So could the Argyle and Perrot. The Isotta boasted 628-cu.-in. for its four-cylinder engine and developed 120 hp. It obviously needed all those brakes! ★ ★ ★

## CAN CHRYSLER CRUNCH CALE?

*(Continued from page 90)*

cross over into a sort of never-never land wherein control of the car becomes pretty marginal. This, naturally, creates a tendency to back off, particularly in the corners, something that can't (never has, anyway) win races at Daytona, strictly a "flat out" track.

How the drivers and their crews will cope with these problems created by the sharp boost in speed over the past year is, of course, what makes racing. For the solo runs of qualifying, suspensions will be "loose" to allow drifting and maximum speeds through the corners. But on race day itself, when traffic is fast and thick, suspensions will be snubbed down. Still, with all that power, speeds will be higher than ever, the race more exciting than ever.

# NEW RUBBER STAMP BUSINESS PAYS BEGINNERS UP TO \$16.50 AN HR. START AT HOME IN SPARE TIME

THIS LITTLE TABLE TOP MACHINE  
MAKES EVERYTHING SIMPLE & EASY

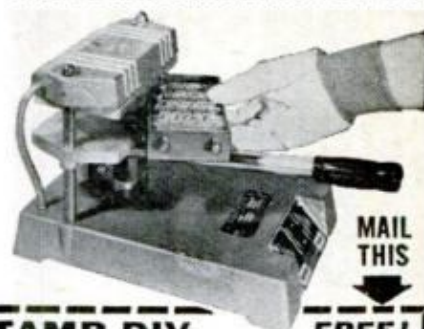

MAIL  
THIS

The multi-million dollar Rubber Stamp business—once controlled by a few big companies—is now being taken over by small operators—one in each community throughout the United States. Men and Women who have this inexpensive machine can turn out huge quantities of Rubber Stamps with special wording that buyers once were forced to buy from big cities. Material costing only 27c makes a stamp that sells for \$2.75. The machine that does the work is simple and easy to operate and it turns out as many as six Rubber Stamps at a time, each with different wording such as names, addresses, notices, stock numbers, prices and other "copy" needed by offices, factories and individuals. Working full capacity, it can earn as much as \$33.00 an hour for the operator! Now you can get into the big-pay business yourself, with your own home as headquarters. You don't need experience. We supply everything, including complete instructions and eight ways to get business coming in fast. We even help finance your start. Start making up to \$16.50 an hour from the very beginning. Cash in on the profitable Rubber Stamp business in your community, right away. We'll mail full particulars FREE and no salesman will call. Be first in your locality. Rush coupon or send your name on postcard now to:

**RUBBER STAMP DIV., Dept. R-2-BS**  
1512 Jarvis Ave. • Chicago, Illinois 60626

## RUBBER STAMP DIV. FREE!

1512 Jarvis Avenue Dept. R-2-BS Chicago, Ill. 60626

Please rush full particulars about your financing plan and the little machine that can get me started in the profitable Rubber Stamp business at home in spare time. Everything you send me is FREE and no salesman will call.

Name \_\_\_\_\_  
Address \_\_\_\_\_  
City \_\_\_\_\_  
State \_\_\_\_\_ Zip Code \_\_\_\_\_

## DON'T QUIT SMOKING before giving my pipe a 30 Day Trial

New principle that contradicts every idea you've ever had about pipe smoking. I guarantee it to smoke cool and mild hour after hour, day after day, without rest, without bite, bitterness or sludge. To prove it, I'll let you try a new Carey Pipe. Send your name and address today for my free complete trial offer. Write:

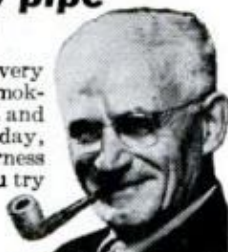

E. A. CAREY, 1920 Sunnyside Ave., Dept. 252B, Chicago 40

## BELSAW PLANER · MOLDER · SAW!

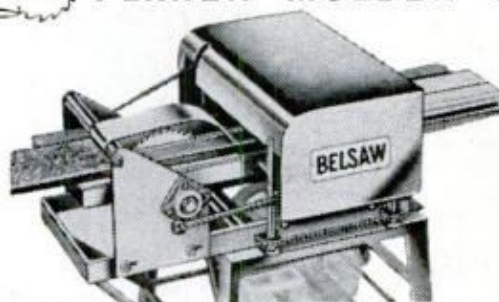

Now you can use this ONE power-feed shop to turn rough lumber into moldings, trim, flooring, furniture... ALL popular patterns. RIP... PLANE... MOLD... separately or all at once with a one HP motor. Use 3 to 5 HP for high speed output. Low Cost... You can own this power tool for only \$30.00 down.

Send Postcard Today... No Salesman Will Call  
BELSAW POWER TOOLS, 909 F Field Bldg., Kansas City, Mo. 64111

## GET INTO ELECTRONICS

V.T.I. training leads to success as technicians, field engineers, specialists in communications, guided missiles, computers, radar, automation. Basic & advanced courses. Electronic Engineering Technology and Electronic Technology curricula both available. Assoc. degree in 29 mos. B.S. obtainable. G.I. approved. Start Feb., Sept. Dorms, campus. High School Graduate or equivalent. Catalog.

**VALPARAISO TECHNICAL INSTITUTE**  
DEPARTMENT D, VALPARAISO, INDIANA 46383



You can't miss in **CARTOONING & COMMERCIAL ART!**  
ANYONE can learn to draw...  
Cartooning is simple exaggeration. Learn by proven methods. Easy step-by-step instructions. Draw figures the very first day. You have to begin someplace... so send for our FREE brochure today! Guaranteed.

**Famous American Studios**  
Dept. 10 SPRING PARK, MINNESOTA 55284

The Easy Way to Build

**BEAUTIFUL CLOCKS**

Send 25¢ for 48-page catalog of easy patterns, fine clock movements, dials and hardwood kits.

**CRAFT PRODUCTS**  
ELMHURST (1) ILL. 60126

## PROFIT IN YOUR SPARE TIME



**SMALL ENGINE REPAIR PAYS BIG!**  
Outboard · Powermower · Chain Saw · Tractor  
**MAKE EXTRA MONEY** — or fix your own engines and SAVE! Illustrated, easy-to-learn Home Study Course qualifies you as expert. Approved for Veterans. Write today!

**LINCOLN TECHNICAL INSTITUTE**  
SUITE 2-E, 427 MARKET ST., NEWARK, N.J. 07105

ALL FAMOUS BRANDS!  
**TIRES!** FARM TRUCK AUTO  
AT LESS THAN WHOLESALE  
SAVINGS NEVER LESS THAN 50% up to 70% OFF REG. PRICE!  
HEADQUARTERS for ALL SPORT CAR TIRE SIZES  
FREE - SEND FOR YOUR FREE CATALOG - FREE!

**RELIABLE TIRE DIST.**, 1111 Chestnut St., Camden, N. J.

# My Spare Time Hobby Makes Me

**\$500 AN  
HOUR**

**CASH  
PROFIT**

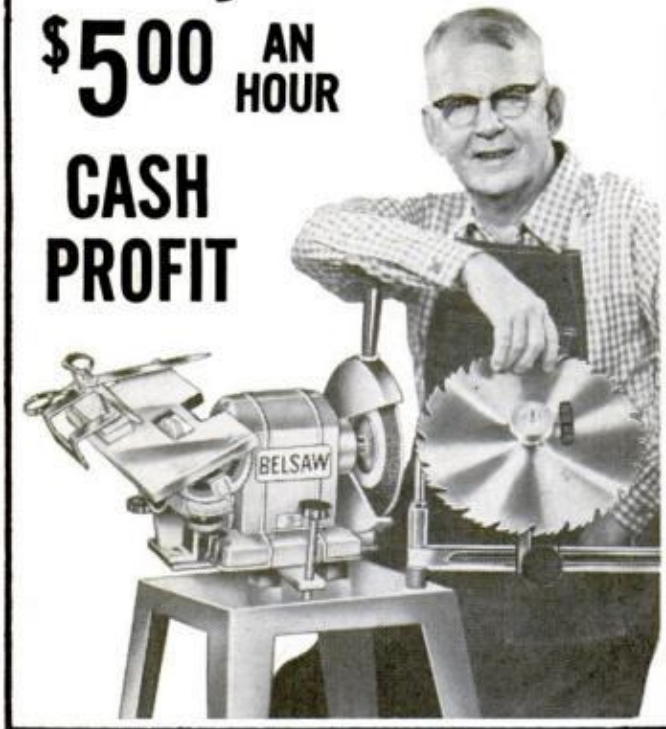

## Here's How You Can Start Your Own Spare Time Business!

You can turn your spare time into Big Cash Profits with your COMPLETE SHARPENING SHOP! Grind Saws, knives, scissors, skates, lawn mower blades... all cutting edges. Your own CASH BUSINESS with no inventory...no selling...no experience needed...and you work the hours you want!

**FREE BOOK** tells how you can start while you are still working at your regular job. Low cost—time payments only \$15.00 a month. *Send coupon today!*



No Obligation... No Salesman Will Call

**BELSAW SHARP-ALL CO.**  
Stan Field, President  
719F Field Bldg., Kansas City, Mo. 64111

Send Free Book "LIFETIME SECURITY"

Name \_\_\_\_\_

Address \_\_\_\_\_

City \_\_\_\_\_ State \_\_\_\_\_ Zip \_\_\_\_\_

## MOON BUG LEARNS TO MATE

*(Continued from page 125)*

the Earth into an elliptical orbit behind the command module and lower in altitude. The LM will remain in this orbit until considerably separated from the CSM.

Next, the LM must climb back up, simulating ascent from the moon. Actually, the descent-stage engine will be used for the first part of this trip, then this stage will be jettisoned, using an explosive-driven "guillotine" to chop electric cables connecting the two sections. The ascent engine will then, for the first time, be used and LM will close with the CSM.

The maneuvers can be executed automatically by a guidance computer. The pilot inserts a program code by pressing buttons on a keyboard; the numbers show up on a lighted display panel so he can make sure he has dialed the right code. He then pushes an "enter" button to feed the code to the computer, which selects the designated set of instructions from its memory. When the pilot is ready, he pushes a "start" button. Watching the attitude display and other instruments, and the view through the ports, the astronauts can monitor the maneuver and take over from the computer whenever necessary.

As the LM approaches the CSM, the spacecraft will be flipped over so its engine can be used for braking. The reaction-control jets are used for docking. At a distance of about 50 feet, once the two spacecraft are aligned, the pilot can't see through the front viewports and then uses a tiny window above his head for final positioning. As the tricky maneuver is completed, the probe and drogue engage, and the Command Module pilot triggers the probe piston, drawing the two ships together. Tunnel latches are fastened and hatches are opened between the space cabins. The probe and drogue are demounted and left in the LM cabin. Its crew crawls back into the command module and closes the hatches. The CSM pilot fires an explosive charge that severs the docking tunnel, and the LM is set adrift. After the CSM is clear, the LM's ascent engine, under ground control, is fired for the last time to monitor its burnout characteristics.

And that's what will take place during the LM's first manned test in space.

Grumman's \$1.6-billion order calls for 15 complete LMs for test and lunar missions, and 10 incomplete LM "test articles."

"That's LM-5," Ray Pratt said, pointing to a finished moon bug ready for delivery to the National Aeronautics and Space Administration. "It could be the first manned vehicle to land on the moon."

It looked ready.

★★★



Two or four-wheel drive  
**JEEP OR SCOUT OWNERS**

**REPOWER** with a 6 or V-8. H.D. ADAPTORS for using Car, Compact and some Truck engines. Conversion Kits \$45.35 to \$56.90. Want fast action? Give us **FULL INFORMATION**. Send \$15.00 Dep. and we will ship correct kit, bal. COD. Send full amount for prepaid shipment. Wire, phone or write today. Details **FREE**

**HOOSIER MACHINE PRODUCTS CO.**

312 S. E. 6th St., Phone 276-3442, Pendleton, Oregon 97801

*Secrets of* **VENTRILOQUISM**  
*Now Revealed!*



Easy to learn in 60 to 90 days with our Home Study Course. **RESULTS GUARANTEED** Make Money! Be Popular! Have Fun! Big Opportunity! Radio, Television, Stage Appearances! For **FREE** information regarding price and terms **WRITE**. You must state your age. Dummy Catalog 25c.  
**MAHER HOME COURSE OF VENTRILOQUISM**  
Box 8536, Studio PM-2, Kensington Station  
Detroit, Michigan 48224

**BLAST FURNACE 2400 F**



Since 1937  
**Hobbyists • Schools • Inventors, etc.**  
Make your own castings of any metal from cast iron, down to lead and zinc. Available in 6 sizes, 1/2 to 50 lbs. Complete units from \$50.40 to \$162. Send 25¢ for circular—refundable.

**KANSAS CITY SPECIALTIES CO.**  
Dept. P-2  
P.O. Box 193  
Middleton, Wisc. 53562

At Last a New Amazingly Simple

**GAS TURBINE JET ENGINE**



Build from easy to follow plans. Length 15", Dia. 8 1/2", Wt. 15 lbs. Fuel: Gasoline or Kero.

"Screamin' Demon" develops 20 H.P. Ideal project for serious-minded hobbyists, students; scientific and industrial arts classes. Make on 9" metal cutting lathe with milling attachment. For use on small racing boats, midget cars, etc. Full size assembly drawings with critical dimensions, bill of materials and photos. Price \$5.00. No C.O.D.

**SAVOY SCIENTIFIC, BOX 1398, SANTA MONICA, CALIF. 90406**

**EARLY TIMES**

**Kentucky Straight Bourbon Whisky**

86 PROOF • EARLY TIMES DISTILLERY CO., LOUISVILLE, KY. © ETDC 1968

**BASEMENT TOILET FLUSHES UP**



TO OVERHEAD SEWER OR SEPTIC TANK. NO DIGGING UP FLOORS. INSTALLS EASY. Write

**McPHERSON, INC., BOX 15133, TAMPA, FLORIDA 33614**



**WARNING**

U.S. Surplus High Speed Milling Files going fast. New, in G.I. Packs. Hardened steel, for filing, milling, routing, drilling—any work in metal or wood. Use in 1/4 in. drill, etc. Big tools, from 1/4 to 1 inch wide. Get these most useful tools now.

16 tool set—government cost \$109. . . . . \$ 9.00 to you!  
36 tool set—government cost \$265. . . . . \$15.00 to you!  
100% GUARANTEED. WE PAY POSTAGE. A LIFETIME BUY!!

**THE SURPLUS CENTER**  
LANCASTER, TEXAS 75146

The original "Wedge-Type" screwdriver

**QUICK-WEDGE**  
SCREW HOLDING SCREWDRIVER

Just **ONE** Screwdriver does all the job!

**HOLDS STARTS DRIVES AND SETS THE SCREW** to normal tightness!  
Only **QUICK-WEDGE** does the whole job —  
**GET A SET TODAY!**



© 1968 by Kedman Co.

At Your Dealers or Write

**KEDMAN COMPANY**

P. O. Box 267 Salt Lake City, Utah 84110

**Check the Kind of Body You Want**

Charles Atlas

... and I'll Show You How **EASILY** You Can Have It!



Just tell me, in coupon below, the kind of body you want and I'll give it to you **SO FAST** your friends will be amazed. "Dynamic-Tension," my easy, 15-minute-a-day method, will make your chest and shoulders bulge . . . arms and legs surge with power . . . you: whole body feel "alive!"

**FREE BOOK** Learn how I became "World's Most Perfectly Developed Man"—Mail coupon! **CHARLES ATLAS**, Dept. 82, 115 East 23rd Street, New York City, N. Y. 10010

**CHARLES ATLAS, Dept. 82**  
115 East 23rd St., New York, N. Y. 10010

Dear Charles Atlas: Here's the Kind of Body I want:

(Check as many as you like)

- Broader Chest, Shoulders
- More weight—Solid—in the Right Places
- Powerful Arms, Legs, Grip
- Slimmer Waist, Hips
- Better Sleep, More Energy

Send me absolutely **FREE** a copy of your famous book showing how "Dynamic-Tension" can make me a new man—32 pages, crammed with photographs, answers to vital questions, and valuable advice. No obligation.

PRINT NAME . . . . . AGE . . . . .

ADDRESS . . . . .

CITY . . . . . ZIP . . . . .

STATE . . . . . ZIP CODE . . . . .

In England send to: Charles Atlas, Chitty St., London, W. 1



**BAIT WELL** is located in the stern. On a three-day trip, I was able to keep a dozen waterdogs alive

## LAKE POWELL

*(Continued from page 129)*

(1850 pounds) and length soften the blow.

Once out of the Narrows, Lake Powell opens to a half mile in width. This is one of the widest stretches along the whole lake. It's also one of the most panoramic. Huge buttes stick straight up from the desert shore. High, wind-carved walls line the opposite shore. Deep color in the red rocks appears to change with every turn.

In this calm-water section, I test Vagabond at just under full throttle. At 4000 rpm the speedometer registers 32 mph. Again, she handles well though the steering is a little heavy. An adjustment of the power tilt and power trim on the Mercruiser stern-drive unit corrects this.

Rounding the point at Gun Sight Butte, I try some turns. Vagabond holds well on wide come-arounds, but she tends to slip just a bit on wheel-hard-over turns. This is not serious, and is more than compensated by the stability of the cathedral hull.

We're 50 miles from Wahweap when we turn into Rainbow Canyon. At canyon's end the Park Service has built a dock. You tie up here and walk a mile and a half to an incredible sight—Rainbow Bridge—the largest known natural bridge in the world. More people saw this arch last year than the total number of people who have ever seen it before. Lake Powell is responsible. You get here only by boat, unless you want to walk 14 miles from the nearest road through the Navajo Indian Reservation. But today, you can boat for three hours, walk for 15 minutes, then stand and wonder at the arch which is 309 feet high and 278 feet wide.

Heading from Rainbow Bridge to the

main channel, we stop at a unique marina. The Park Service has anchored a dozen floating docks in a sheltered basin.

You can buy gas and supplies here. We stop to gas. I find that Vagabond takes 13.9 gallons after a 50-mile trip. The boat has an 18-gallon tank that is considered standard equipment. I would suggest, though, that anyone cruising Lake Powell have extra fuel tanks installed.

After overnighting at Rainbow, we cruise to Bullfrog—about 50 miles up-lake. On the way, we take a side trip up the Escalante River, about 15 miles from Rainbow. It's off the Escalante that we photographed the Vagabond blasting through Davis Arch. (See photo on page 126.) If the lake ever reaches "full pool," this arch will be submerged. Right now, there's only six-inch clearance for a boat on plane. I do not recommend that you charge through this opening at top speed, but I do suggest you see it. It's up Fifty Mile Canyon.

We spend the last night on the lake camped on a beautiful beach. Actually, I wanted to camp in the Vagabond.

The "tent," covering the main cockpit, is good. You have full headroom when all the curtains are in place. With a small heater inside you can be very snug on cool nights. The two bunks under the forward bow-riding deck are quite comfortable. Each of the two lounge-seat bunks in the cockpit will hold a good-size sleeping bag.

But there is one problem—zipping up the curtains. You have to manipulate 20 zippers to get the "tent" up. I'm sure that after raising and lowering the tent several times, the canvas will stretch a bit making the job easier. But this time, it takes me 45 minutes of tugging and pulling to get all the zippers zipped. There are advantages to zippers, but I have long disliked them especially around water. They corrode and break apart. The zippers used in Vagabond are heavy-duty and will probably hold up, but I did have one pull apart on the first "tent raising." Snaps are better, though harder to work.

Not only is Vagabond good for all-around boating fun, but you can camp on it 100 miles from any water.

When trailering the boat, you can pull off the road, raise the tent, and presto—a camping rig. The fold-out steps in the stern let you climb aboard easily. Glas-tron, as an option, will equip Vagabond with a small galley on the motor hood.

Vagabond's specifications: length, 21 ft., 5 in.; transom width, 85 in.; weight, 1850 lbs.; mechanical steering; stern-drive power options up to 210 hp; suggested price, \$5595 with the 160-hp engine. ★★

**SET YOUR SITE**  
*Under This*  
**VACATION HOME . . .**

*or one of over*  
**80 great designs.**

PRICES START AS  
LOW AS \$615



Lindal, world's largest manufacturer of cedar homes, offers you custom quality, kiln-dried Canadian Cedar homes. All pre-cut, ready for quick, easy assembly on your favorite site. Save hundreds of hours—and dollars. Our all-new, full color Home Planning Kit includes more than 80 exciting designs—Chalets, A-Frames, Lodges, Year-Around Homes. Dealer Inquiries Invited.

**LINDAL CEDAR HOMES**  
9004 So. 19th  
Tacoma, Wash. 98465

- Write for information on Lindal contest that anyone can enter to win a Lindal Cedar Home FREE.
- Enclosed is \$1.00 for my complete Lindal Cedar Homes Planning Kit.

Name \_\_\_\_\_

Address \_\_\_\_\_

City \_\_\_\_\_

State \_\_\_\_\_ Zip \_\_\_\_\_

PM-2-69

**Train for top jobs, top earnings, in PHOTOGRAPHY**

NYI trains you for the best jobs—or your own successful business. Learn by doing at home, quickly, easily the individualized NYI way. Low cost. No experience or expensive equipment needed. Earn while you learn. Easy pay plan. Approved for Veterans, Student Loans. Approved by N.Y. State Ed. Dept. Accredited member Natl. Home Study Council. FREE color career book. No salesman will call. RESIDENT TRAINING in all profitable phases of photography and Creative Motion Picture Course. Our 59th year.

**NEW YORK INSTITUTE OF PHOTOGRAPHY** • 10 West 33 St., New York, N.Y. 10001, Dept. 49-2

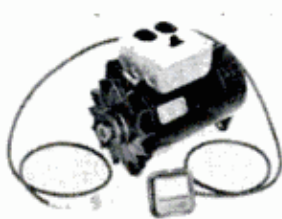

**110-120 VOLT A.C. LIGHT PLANTS—60 CYCLES**  
Fanbelt driven from pickup or small gas engine. Operates saws, drills, pumps, freezers, T.V. X1000 Watts—Needs No Battery. Reg. \$99.50. Now \$62.50. 1500 Watts—6 and 12 volt vehicles. Reg. \$89.50. Now \$52.50. 3000 Watts—12 volt vehicles only. Reg. \$179.50. Now \$99.50. *Guaranteed.* Check or Money Order.

**VIRDEN PERMA-BILT, Box 7066 P.M., Amarillo, Texas 79109**

**locksmithing and key making**

**PRACTICAL UP-TO-DATE COURSE — ONLY \$6.95**

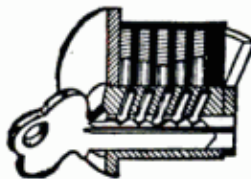

Teaches you how to pick locks, de-code, make master keys, repair, install, service, etc. New self-instruction lessons for every handyman, homeowner, carpenter, mechanic, service station operator, fix-it shop, hardware dealer, gunsmith. 53 easy illustrated lessons. Full price only \$6.95, postpaid. Satisfaction or refund guaranteed. Mail order today!

**NELSON-HALL CO., Dept. BR2**  
325 W. Jackson Blvd., Chicago 60606

**BIG MONEY** ~~\$188.00~~  
**in BURGLAR ALARMS** ~~\$225.00~~ ~~\$415.00~~

Secret for years—now I reveal inside facts! Beginners discover how to start spare time without mechanical experience or costly equipment. My step-by-step plan starts you to prestige career installing burglar alarms. Huge market—factories, homes, stores, Steady income business. Get your \$12,000 profit story. **NASCO, 11071 Massachusetts Dept. C2252, Los Angeles 25, Calif.**

**FREE** Plan now!

**FREE!**

Learn how you can buy used engines \$15 up, new engines \$30 with FREE confidential list and coupons when you order your plans

- **BUILD THIS MINI-BIKE!** Plans reveal step by step details!
- **BUILD A RACING KART!** Complete frame for less than \$10!



**RUSH \$2 for plans (indicate type) or end 25¢ for circular describing plans**  
PLANS, Box 517, Omaha, Nebr. 68101

**Bean's Free Spring Catalog**

Ready February 15



Fully illustrated 104 pages of camping specialties, fishing tackle, clothing and footwear for men and women. Featuring practical outdoor items, many of our own manufacture.

**L. L. Bean, Inc.**

248 Main St., Freeport, Maine 04032

*Fishing, Camping and Hunting Specialties*

**BUILD CUSTOM CASES AT HOME FOR PROFIT . . .  
GET ORDERS BY MAIL!**



Here is a spare time or full time Home Business so extensive that you will almost catch your breath when you see it for the first time. Learn how you can make Custom Cases in your home to tap a waiting, rich market—to make yourself financially independent for life. We supply materials, instructions, everything. No canvassing; No house to house selling; No salesmanship needed: Send for the full story of this amazing opportunity.



**CUSTOM CASE SUPPLY CO.**

Dept. C-202

7630 Gloria Avenue, Van Nuys, Cal. 91406

# BILL PROBLEMS?

**WE CAN HELP YOU — TODAY**  
NOBODY REFUSED UP TO \$18,000.00

Bad Credit No Problem ■ Not a Loan Co.

Send Your Name and Address  
For FREE Application To Nearest Office

**INTERNATIONAL ACCEPTANCE, dept. M-8**

★ 5133 N. Central Ave., Phoenix, Ariz. 85012, ★  
★ 711 - 14th St. N.W. Washington, D.C. 20005 ★  
★ 507 Carondelet St., New Orleans, La. 70130 ★

## LIVE-CATCH ALL-PURPOSE TRAPS

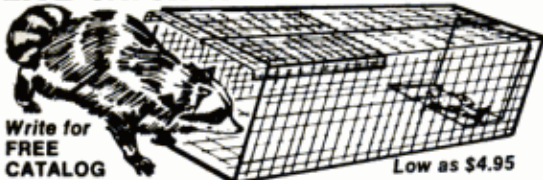

Write for  
**FREE  
CATALOG**

Low as \$4.95

Trap without injury squirrels, chipmunks, rabbits, mink, fox, raccoons, stray animals, pests, etc. Sizes for every need. Also traps for fish, sparrows, pigeons, crabs, turtles, quail, etc. Save 40% on low factory prices. Send no money. Free catalog and trapping secrets.

**TRAP FACTORY, Dept. M14 Box 10880, Houston, Texas 77018**



## Excitement! Security! Good Pay! CRIME DETECTION

**LEARN AT HOME IN SPARE TIME—START NOW!**

Crime everywhere is on the rise! Learn now, in your own home, the profitable profession that enables you to track down criminals and bring them to justice! Hundreds of Identification Bureaus employ I. A. S. graduates . . . trained in finger printing, police photography, handwriting identification, firearms and investigation. Our 44th year! FREE "Blue Book of Crime" . . . packed with crime facts and the full story of famous I. A. S. training. State exact age. No salesman will call. Rush Coupon!  
*A Correspondence School Founded in 1916.*

**FREE**  
Blue Book of Crime  
**MAIL**  
COUPON

**INSTITUTE OF APPLIED SCIENCE, Dept. 1352**  
1920 Sunnyside Avenue, Chicago, Ill. 60640  
Rush Blue Book of Crime . . . FREE!

NAME . . . . . Age . . . . .  
ADDRESS . . . . .  
TOWN . . . . . STATE . . . . . ZIP CODE . . . . .

## REAL ESTATE BE A BROKER

**PAYS BIG! SEND FOR BIG FREE CATALOG NOW!**  
Graduates report making substantial incomes. Operate your own business quickly. Men, Women, all ages, learn easily. Course covers Sales, Appraising, Loans, Mortgages, & related subjects. **STUDY AT HOME** or in classrooms in leading cities. **Diploma Awarded. Write Today for FREE Book!**  
Accredited Member National Home Study Council. (Est. 1936) G. I. Approved.

**WEAVER SCHOOL OF REAL ESTATE**  
3521-P Broadway Kansas City, Mo. 64111

## Build Your CAMPER

**SAVE UP TO 50%  
TO**

Complete, easy to follow Camper or Trailer Plans. **\$3.95** ea.  
Instructions, Material List.  
**SATISFACTION GUARANTEED**  
Pickup Cover Plans \$2.00  
Econoline Van or Bus Conversion Plans—indicate choice . . . . .ea. \$2.95



**EQUIPMENT CATALOG \$1.00**

Refundable on first order.  
**SEND DIME FOR DETAILS**  
**SAVE 50% ON CAMPER KIT**  
All items from our catalog to build a \$1,795 camper. 8', 10', 10'6" or Chassis Unit.



**VIKING CAMPER SUPPLY, INC.**  
99-BP Glenwood Ave.,  
Minneapolis, Minn. 55403  
Please send \_\_\_\_\_ for  
which I enclose \$\_\_\_\_\_  
NAME \_\_\_\_\_  
ADDRESS \_\_\_\_\_  
CITY \_\_\_\_\_  
STATE \_\_\_\_\_ ZIP \_\_\_\_\_

## NEW Improved Accurate Scope-Shot

**SCOPE-SHOT COMPLETE WITH 50 DISINTEGRATING PELLETS**  
They crack like a rifle when they hit—leave mark—puff of smoke!

World's Finest Precision **SLINGSHOT**  
Scope-type sight!

**ROUITS PESTS!**

Price without pellets **\$150 P.P.**

Big Bag of **250 EXTRA Pellets**  
98c P.P.

Pure gum rubber slings. Beautifully polished cast aluminum stock. Pistol grip. So powerful it kills small game. Fits pocket perfectly! Guaranteed. **FREE** shooting manual.

**EXTRA RUBBER SLINGS**, 4 pairs \$1.00 p.p. Leather Pouch & Sling assembly only 40c p.p. Order NOW from:

**GENERAL SPORTS**

4184-M2 Apple Street, Cincinnati, Ohio 45223



## Print Your Own

Cards, Stationery, Advertising, Circulars, labels, photo and movie titles, church work, tags, greeting, sympathy, prayer cards, etc. Save money. Pays for itself in a short time.

### Own a Printing Business

Good Profit. Raised printing like engraving too. Have home shop. We supply everything. Direct from factory, only. Easily followed rules. Write now for free details. **KELSEY PRESSES E-37 Meriden, Conn. 06450**

## MAKE BIG MONEY

**MAKING COSTUME JEWELRY AT HOME!**

Thrilling spare-time, **MONEY-MAKING** hobby! Make newest, beautiful jeweled earrings, necklaces, bracelets, pins, pendants, cuff links, tie clips! Quick, easy to make—easier to sell to friends, neighbors, stores, at big profit! Details FREE!

**DON-BAR CO., Dept. B-199**

2934 W. Fullerton Ave., Chicago, Ill. 60647



## BE A LANDSCAPE CONTRACTOR

**LEARN MODERN LANDSCAPING** for exciting hobby or profit. Thousands of spare or full time money making opportunities. Start a profitable business—we show you how. Study and earn your certificate at home.

Write today for Free Book.

**LIFETIME CAREER SCHOOLS**

Dept. A-622  
2251 Barry Ave.  
Los Angeles, Calif. 90064

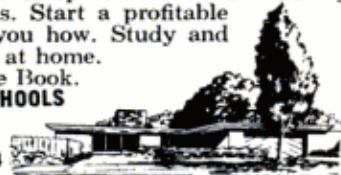

## ENROLL—EARN YOUR DEGREE

of Bachelor of Bible Philosophy (B.Ph.B.), Master of Bible Philosophy (M.Ph.B.), Graduate of Bible Philosophy (G.Ph.B.), Doctor of Metaphysics (Ms.D.), or Doctor of Divinity (D.D.). Chartered by State, Correspondence Courses only. Please write for **FREE BOOKLET**.

**AMERICAN BIBLE INSTITUTE**

Dept. PM, Post Office Box 8748, Kansas City, Missouri 64114

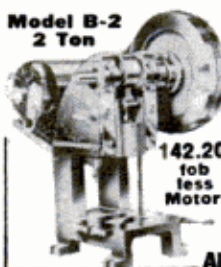

## ALVA ALLEN Power Punch Presses

**1 to 100 Ton Capacity**

Complete line of Punch Presses in hundreds of different style and model combinations. Write for **FREE** literature on presses and complete line of punch Press accessories as—Feeds, Punch Units, Dies, etc.

Alv a Allen Industries, Dept. PM, Clinton, Mo. 64735

## BUILD YOUR OWN POWER TOOLS



FREE CATALOG  
GILLIOM MFG. CO. Dept. PM-2 St. Charles, Mo. 63301

**METAL PARTS KITS AT LOW FACTORY DISCOUNT PRICES FOR: \$50 OR MORE**

- 10-IN. TILT ARBOR SAW
- COMB. DRILL PRESS-LATHE
- 12-IN. BAND SAW
- 18-IN. BAND SAW
- 6-IN. BELT SANDER
- SPINDLE SHAPER

**PLANS \$1.00 EACH DEDUCTIBLE**  
Full Size Patterns

Kits from \$16.99 to \$42.99. Satisfaction guaranteed. Built and sold for 22 years. 50,000 units in use. Send for Plans today!

## BE YOUR OWN BOSS!

A SPACE AS SMALL AS 10" X 13" CAN MAKE YOU INDEPENDENT

in the high profit (low investment) rubber stamp field. Increase your income; full or part time basis. Deal direct with manufacturer offering lowest prices on professional SIMPLE-X presses & supplies, plus valuable aid. For FREE full facts write

**CUSTOM MFRS.**  
406PM E. Elm, Springfield, Mo. 65801



## CROSSBOW Outfit

# \$29.95



**USE 30 DAYS AT OUR RISK!**

**CROSSBOW SHOOTING**—the exciting modern sport. Kill game, do backyard target shooting, even crossbow fishing! Powerful 80 lb. thrust shoots arrows "like bullets". Easy pull. Aims like a rifle, has adjustable open and peep sights.

**POWERFUL—SILENT—ACCURATE**

Handsome, polished hardwood stock. Steel trigger. Aluminum bow. Automatic safety lock. Simple instructions. Ready to use. **Crossbow plus leather quiver, 1 hunting, 2 target arrows and fishing harpoon.** Only \$29.95. Add \$1.75 for shipping. COD's require \$3 deposit. **SHOOT 30 DAYS IF NOT SATISFIED RETURN FOR A FULL REFUND! ORDER TODAY!** Midwest Crossbow Co., Dept. XB-9908, 9043 S. Western Ave., Chicago, Ill. 60620. Established 1936.

## SAW SHARPENING IS EASY

Super Filer No. 11 joints and sharpens circular saws 6" to 10" with all teeth correct in height, depth, pitch, bevel. When file hits steel roller, teeth are finished. **\$10.95** Saw runs true with no side pull. Includes 8" file. **PPD.**

**"TRU-CIRCLE"** saw set automatically sets teeth at 10° **\$2.95** or more. **PPD.**

**MONEY BACK GUARANTEE**

A. D. McBURNEY, 1610 Victory Blvd., Glendale, Calif. 91201, A-28

**FREE LITERATURE**



## LEARN MEAT CUTTING



Train quickly in 8 short weeks at Toledo for a bright future with security in vital meat business. Big pay, full-time jobs — **HAVE A PROFITABLE MARKET OF YOUR OWN!** Time payment plan available. Diploma given. Job help. Thousands of successful graduates. **OUR 45th YEAR!** Send now for big new illustrated FREE catalog. No obligation. G.I. Approved.

**NATIONAL SCHOOL OF MEAT CUTTING**  
Dept. 50-R, Toledo, Ohio 43604

*You can make money in*

# WATCH REPAIR

### Learn at home the low cost Sweazey Way

Watch repairing pays up to \$6 an hour, part time watch makers report on survey. Unique and modern Sweazey home study System starts you making repairs right away on Swiss and American watches. Professionally prepared training. No previous experience needed. Special tools provided for practice. Diploma Awarded. Free sample lesson and opportunity book give all facts. Write today. No obligation.

**CHICAGO SCHOOL OF WATCHMAKING**  
Dept. 129 Fox River Grove, Illinois 60021

### FREE BOOK and SAMPLE LESSON

**CHICAGO SCHOOL OF WATCHMAKING**  
Dept. 129, Fox River Grove, Illinois 60021  
Please rush **FREE BOOK** and Sample Home Study Lesson.

Name \_\_\_\_\_ Age \_\_\_\_\_

Address \_\_\_\_\_

City \_\_\_\_\_ State \_\_\_\_\_ Zip \_\_\_\_\_

## HEAVY DUTY WELDER

Does work of \$85.00 welder yet costs only **1895** POST PAID

Fits ordinary 110V outlet Not one - but 3 welding heats



Weld, braze, solder or cut most anything made of metal. No experience necessary. Follow simple instructions. Uses standard 1/8" rods to weld iron, steel, brass, bronze, aluminum, other metals. Repair cars, farm implements, appliances, toys. Make campers, trailers boats. Pays for itself quickly. Comes complete with mask, \$2.00 pack of rods, flux, etc. **NOTHING ELSE TO BUY.**

**3 WELDING HEATS** . . . Not just one as with other low cost models. "High" for tough jobs, "Medium" or "Regular" for lighter work. 3 heat feature saves you money. New HEAVY DUTY circuit gives more welding potential than ever before. Approved for homes, garages, factories, shops. Has power boost circuit for industrial uses. Raises heat to 4 TIMES that needed to melt toughest iron. No other welder has all three fine features.

**FREE!** Automatic arc striker now makes welding easy, even for beginners. Just plug welder into ordinary 110V outlet, touch automatic arc striker and start welding. You can't buy this important new Wel-Dex invention but it's yours free if you order from this ad.

10 day **MONEY BACK TRIAL.** Guaranteed against burnout.

SEND \$2.00 and pay \$16.95 plus small C.O.D. when delivered or \$18.95 for postpaid shipment. Phone (713) 682-5811 for C.O.D.

**WEL-DEX MFG. CO., Dept. W-10, Box 10776, Houston, Texas 77018**

# MAGIC MAIL PLAN

*that comes with this Little Machine*

## CAN MAKE YOU \$1200 AN HOUR

**The machine is turning out a job that will bring operator \$2.58, by mail. Material cost, only 11c**



Write today for free facts about the newest and most fascinating of all new home operated businesses. For the first time, a simplified machine brings the fabulous profits of Plastic Sealing and Plastic Laminating within reach of the small operator. Anyone can learn to operate it with a few minutes practice. Then—with our **MAGIC MAIL PLAN**—can get mail orders pouring in daily with cash in every envelope.

**No Canvassing or Selling**

Fill orders at home in spare time to start. Then expand to full time business. We even supply circulars to bring back cash and orders. Rush name for all the facts you need to start. A postcard will do. No charge.

**WARNER ELECTRIC CO., Dept L-2-BS**  
1512 Jarvis, Chicago, Ill. 60626

## HOW TO SPOT A BAD HOUSE

*(Continued from page 146)*

room pass-through wall, a shiny new wall oven or appliance plug-in center, intercom systems, showy fireplaces, wrought-iron balcony rails, roof pagodas.

To be sure, "gimmicks" sometimes can be perfectly functional and nice to have. The gimmick house is a trap to avoid, however, when one or two eye-catching features propel an unsuspecting couple into buying a house that they otherwise would not touch with a 10-foot pole. Is the house and its overall design and construction good, really good for you and your family? That's the key question.

How do you tell the difference between the marginal house and a really good house? It comes down to knowing the distinguishing traits of good-quality products and materials.

Buying a new FHA-insured house is a big step in the right direction. It means the house is built according to FHA's Minimum Property Standards. By and large, these building standards are stiffer than any others in effect for houses today. But they do not mean that you will get uniformly high quality throughout the house. You therefore must go a step further to avoid marginal quality even in an FHA house.

### Eleven quality checks

Here is a summary of high-quality features to look for when you buy a house.

1. *Foundation walls* of poured concrete are usually better than concrete or cinder block walls. Poured walls offer better natural waterproofing and are more durable.

Concrete-block walls should be parged (plastered) with a half-inch of cement mortar on the outside. Much extra strength is gained if they are reinforced with steel mesh or rods. These would be placed in mortar beds between courses of block—generally every few courses.

Whichever type of foundation, ask for troweled-on waterproofing instead of the usual brush-on or spray-on type. If local water conditions are bad, this can be further improved with a film of polyethylene or asphalt-impregnated membrane.

A system of tile drain pipe should be put in the ground around the house at the base of the foundation walls, except in dry areas. This gets rid of ground water that would otherwise get into the basement.

2. *Termite protection* should be there with either soil chemicals, chemical-treated timber or termite shields. A poured concrete foundation will provide additional protection.

3. *Exterior walls* obviously should be

rugged and durable with a long-lasting finish. Prefinished wall siding is highly recommended to reduce repainting. It includes prefinished hardboard or wood, aluminum siding, galvanized steel, plywood and mineral fiber sidings.

If the walls are painted, insist on top-of-the-line paint, the very best. It should be a well-known brand. Get a three-coat job—primer and two finish coats. Make sure the siding is applied with double-galvanized, aluminum, or other rustproof nails.

4. *Interior walls* are usually made of half-inch plasterboard today, which is better than the  $\frac{3}{8}$ -inch plasterboard sometimes used. Even better is the  $\frac{5}{8}$ -inch thickness. The builder should use three layers of compound over joints and nail-heads.

### Are walls well finished?

On paneled walls, prefinished materials give easier cleaning, plus resistance to soiling, marring and stains. Wood paneling gains fire resistance if applied over plasterboard or asbestos-cement board instead of directly to the framing members. With plaster, two coats over metal lath is good, three coats better, though rarely done today.

5. *Flooring* should be closely fitted and display no wide gaps and no high edges. No squeaks should be heard when you walk over it slowly. Resilient flooring starts with asphalt tile, the cheapest and lowest quality; it's good for a concrete basement floor, but that's about all. Vinyl is best for most uses. Rubber has only fair resistance to oil and grease. Cork can look exceedingly rich and handsome but will soon look worn in heavily traveled areas. There's also sheet linoleum, the granddaddy of composition flooring, which is cheap. Get the heaviest gauge available.

6. *Windows and doors* should be a well-known national brand, such as Andersen, Malta and Pella. They should fit tightly, open and close easily, and be easy to clean from inside. Weatherstripping should be built into the frames; you should see it. Aluminum windows should contain plastic fittings which prevent a direct connection (thus no cold flow) between the movable parts and the frame.

7. *The kitchen countertop surfaces* should be a plastic laminate (such as Formica, Micarta, Panelite) or possibly ceramic tile, which is even tougher though it's hard on dropped chinaware. Best kitchen cabinets are those of a brand-name manufacturer with a rugged factory-applied finish.

There should be enough electric outlets

*(Please turn to page 230)*

# Doctors Find Way To Shrink Hemorrhoids



And Promptly Stop Itching,  
Relieve Pain In Most Cases.

Science has found a medication with the ability, in most cases—to stop burning itch, relieve pain and actually shrink hemorrhoids.

In case after case doctors proved, while gently relieving pain and itching, actual reduction (shrinkage) took place.

The answer is *Preparation H*\*—there is no other formula like it for hemorrhoids. Preparation H also soothes inflamed, irritated tissues and helps prevent further infection. In ointment or suppository form.



In  
Squirt  
or  
Spray  
Cans

## LIQUID WRENCH

The super-penetrating rust solvent that loosens rusted nuts, bolts, screws, parts . . . in seconds! Powerful, yet safe on all metals...use it on your watch or farm tractor.



Radiator Specialty Co.  
Charlotte, N. C. 28201



**DRAINS** cellars, cisterns, wash tubs; **\$ 8.95**  
**IRRIGATES - CIRCULATES - SPRAYS**

1,001 uses. Stainless shaft. Won't rust or clog! Use 1/8 HP motor or larger . . . 3/4 HP for up to 2,400 GPH; 450 GPH 80' high; or 1,800 GPH from 25' well. 1" inlet; 3/4" outlet. Coupling included free. **\$8.95.**  
**HEAVY DUTY BALL-BEARING PUMP.** Up to 5,200 GPH; or 3,000 GPH from 25' well. 1 1/4" inlet; 1" outlet. **\$12.95**  
Postpaid if cash with order. **MONEY BACK GUARANTEE**

**Centrifugal and Gear Pumps in All Sizes**  
**LABAWCO, Box 7, Belle Mead, N. J. 08502**



**Learn Profitable Profession**  
**in few months at Home**

**MEN AND WOMEN, 18 TO 60**

\$4.00 to \$5.00 for 1-hour treatment is the established charge for a skilled operator. Easy to learn and do. Diploma awarded. Open your own office or earn good income from Doctors, Hospitals, Clubs, and other health or recreational centers. Wonderful part-time profession. Low monthly payments. Write today for free Anatomy Charts and catalog. No obligation.

**ANDERSON SCHOOL OF SCIENTIFIC MASSAGE**  
Dept. B-1, Princeton, Illinois

**LEARN TAX PREPARATION  
WITH H&R BLOCK**

**EARN UP TO  
\$700  
PER MONTH**

Here's your opportunity to learn tax preparation in your spare time from H & R Block, America's largest tax service. Join the ranks of successful H & R Block graduates who occupy a respected position in the tax preparation field. Earn up to \$700 a month as a tax preparer during tax season. No previous training or education required. Ideal for retired people and/or men and women seeking full or part time income. Job opportunities available for qualified graduates. Low tuition costs includes all supplies you need for this complete home study course. Send for full information today.

**H & R BLOCK INC.**

**TAX TRAINING INSTITUTE**

4412 Main Street Kansas City, Mo. 64111

Yes, please send me without obligation full details on your home study course for income tax preparation.

Name \_\_\_\_\_

Address \_\_\_\_\_

City \_\_\_\_\_ State \_\_\_\_\_ Zip \_\_\_\_\_

**RIDGID**  
the toughest  
pipe wrench  
in the  
joint.



Choice of 10 sizes 6" through 60"

Certainly RIDGID Heavy-Duty Pipe Wrenches are tough. That's the way we build them. Then we work test them just to be doubly sure that they'll outperform and outlast all others.

Tool steel hook jaw has patented spring suspension that gives instant, slip-proof grip. Jaws can't lock . . . always release fast. Handy pipe scale, always easy adjustment and comfort-grip I-beam handle all help make a genuine RIDGID your best pipe wrench buy. Try one.

**Buy a time-saving RIDGID Pipe Wrench at your Dealer's. He has a complete stock of RIDGID Work Saver Tools from The Ridge Tool Company, Elyria, Ohio 44035.**

**RIDGID**

## HOW TO SPOT A BAD HOUSE

(Continued from page 228)

behind the countertop for plugging in small appliances, and one or two double outlets where the kitchen table will go. Overhead lighting should flood the length of the countertop; one light in the middle of the room is not enough.

### Special attention to bathrooms

8. *Each bathroom fixture* should show the imprint of a national manufacturer (Standard, Briggs, Eljer and Richmond are some). This is important because manufacturers do not stamp their imprint on their lowest-quality fixtures. An enameled cast-iron tub has the edge over the enameled-steel kind. Cast iron is less apt to chip or wear and comes in more styles and sizes. Tall people in a family who like to take tub baths should be sure the tub is long enough. They range in length from six feet long down to pygmy length.

Flushing action is the key to toilet quality. Cheapest of all is a washdown model which is poorest and the least sanitary. Next steps up in quality are: the reverse-trap action unit, siphon jet, which is quite good, and the siphon jet vortex, best of all and the kind used for luxury one-piece, quiet-flush toilets. The one-piece wall-mounted toilet makes cleaning the bathroom easier, though it has a luxury price tag. Whatever the toilet model, test it for noise by flushing it.

The best lavatory bowls are made of gleaming vitreous china. They are only slightly more expensive than enameled cast iron, which is next best. There are also enameled-steel bowls, third in quality and more susceptible to chipping and wear.

Good faucets are made of solid brass with a tough coat of chrome, nickel, or brushed or polished brass. The marginal kind are usually made of lightweight zinc or aluminum castings, which tarnish quickly, drip and look dreadful within a short time.

An "automatic diverter control" should come with a combination shower-tub. It automatically diverts the water back to the tub faucets after one has showered. That prevents the next person in the tub from being pelted with hot or cold water. Omission of the diverter, an inexpensive item, can cause accidental scalding of children.

Waterproof floors and walls, particularly around the tub and shower, are also essential. Ceramic tile is the old proven wall and floor material, and you can hardly go wrong with it. There are also rugged new plastic wall tiles and materials, such as

melamine-coated hardboard, which are very good.

As for flooring, avoid linoleum and asphalt tile in the bathroom. They quickly fall prey to water rot, as well as being hard to keep clean and attractive. The flooring should be a tough pure vinyl or comparable material, ceramic tile, or, say, marble or terrazzo.

Also check the bathroom for safety features such as grab bars in the shower (to prevent falls), a waterproof shower light, electric outlets well out of reach of the shower, tub and lavatory water (to prevent being electrocuted), and good-quality soap holders and towel racks.

9. *Good plumbing* starts even before the water meter. The water-supply pipe from the street to the meter should be at least one inch in diameter, rather than the usual half or three-quarter inch. That insures ample water and water pressure to the house. Shutoff valves at every fixture are a must, allowing the water to be turned off by hand in case of repairs.

10. *The water heater* for gas or oil ordinarily should have a tank capacity of 40 to 50 gallons—at least 80 gallons if electric. In a new house, the kind of guarantee is the tip-off to quality. It should be guaranteed for at least 10 years.

If the water heater is an integral part of the hot-water heating boiler used for heating the house, minimum rating for a one-bath house is 2.75 gpm (gallons per minute of hot water); at least 3.25 gpm for two baths, more for a large family and large house. The rating will be on the boiler, which also should have an IWH seal for good quality. That stands for an approved Indirect Water Heater. If there's no IWH seal on the boiler, the quality is probably poor.

11. *A septic tank* should have a capacity of at least 900 gallons for a three-bedroom house, 1000 gallons with four bedrooms or a large family. It's best when the tank and its pipe system (leaching field) are located in front of the house. That will facilitate the lowest-cost, most direct connection to the street sewer later.

*Additional features:* The heavier asphalt roofing is, the longer it will last. Asphalt roof shingles of 235 pounds in weight are considered the least to accept. They also should be either the seal-down or glue-tab kind to stay put on a roof in an area where violent windstorms or hurricanes occur.

The attic should be fitted with large air vent louvers, not the small kind. These not only help cool the house in summer, but also provide essential attic ventilation the year around (to prevent condensation and wood rot problems under the roof). ★★ ★





**Hearing test for newborns**

The hearing of newborn infants can be tested with a new instrument, the Zenith Neo-Meter, so that problems can be diagnosed early. Pushing each of four buttons causes the instrument to make sounds of increasing loudness. The newborn responds by blinking.



**Street vacuum cleaner**

Undergoing recent tests in New York City is a street-cleaning vehicle that works like a giant vacuum cleaner. The British-built device picked up such litter as bricks, broken glass, tin cans and the contents of litter baskets.

**GOVT. SURPLUS AND OTHER BARGAINS SAVE UP TO 90%**

**ELECTRIC GEAR MOTOR**  
 Heavy duty, all ball bearing const. Rated approx. 3 H.P. @ 24 V.D.C. Turns 400 RPM no load on 12 V.D.C. 750 RPM on 24 V.D.C. Contains magnetic clutch. 1 1/2" shaft free wheels with power off. Reversible. 16 1/2" L x 5 1/2" dia. Like NEW. Tested prior to shpg. Approx. GOVT COST \$250. Shpg. wt. 40 lbs. **\$27.50** (Stk. #2410)

**ELECTRIC UTILITY PUMP**  
 Output up to 360 gal. per hr. @ 18 PSI. Exc. for water, fuel, insecticides, etc. Aluminum construction. Runs on 12 or 24 V.D.C. Explosion-proof motor. Inlet & Outlet ports are 1 1/2" pipe. Draws 5.2 amps. 9 3/4" H x 6" W. Approx. GOVT COST \$150. Shpg. wt. 8 lbs. NEW **\$14.50** (Stk. #2468)

**DC JET GENERATOR ARC WELDING KIT** Mfr. by G.E. 400 AMP DC continuous duty @ 3700 RPM @ 43 V.D.C. Capable of up to 600 AMP intermittent. Kit contains Gen., Volt. Reg., Electrode Holder, Welder's Helmet, Toggle switch, 1/8" welding Rods & Welder's Gloves & 2 Rheostats. All units guaranteed pre-tested. Shpg. Wt. 110 lbs. Approx. GOVT COST \$700. Complete Kit **\$64.50** (Stk. #75) Incl. wiring diagram.

**NEW! BIG! 1969 CATALOG**  
 Send 25c for amazing catalog with 1000's of bargains in hydraulics; electrical, marine, automotive items, etc. Order from ad. All prices FOB Culver City. 50% deposit required for COD. Cal. res. add 5% sales tax. Include zip. Satisfying world-wide customers since 1945.

**AIRBORNE SALES CO.** Dept. PM269  
 8501 Stellar Dr., Box 2727 • Culver City, Calif. 90230

**ELECTRIC ARC WELDER \$14.95!**

**LIFETIME BURN-OUT GUARANTEE**—10 day money back (if ret'n'd) trial! Works on 110-volt plug in **10 WAYS!** WELDS, BRAZES, SOLDERS, CUTS, METALS, most ALL metals! HEATS, SOFTENS, THAWS, LOSENS, BENDS. COMPLETE READY TO USE WITH face mask, clamps, arc torch, rod holder cables—and supply of welding, brazing carbon, solder rods. **ARC WELDING INSTRUCTION BOOK**—Tells how YOU can use for CARS-HOME-FARM-SHOP—NO EXPERIENCE NEEDED! DOES AND HAS EVERYTHING others claim! SEND ONLY \$2.00 (cash, ck, M.O.) and pay postman \$12.95 plus COD postage or send \$14.95 for PP del. in USA. Best Welder—Best Price! Midway Welder, Dept. SPM-2, Kearney, Nebr. 68847

**FREE!**

**ALLIED ELECTRONICS FOR EVERYONE 1969**

**1969 ALLIED CATALOG**

**SAVE ON:**

- Electronic & Hobby Kits
- Stereo Hi-Fi
- Tape Recorders, Tape
- CB 2-Way Radios
- Walkie-Talkies
- FM-AM & AM Radios
- Shortwave Receivers
- Portable TV
- Phonographs
- Amateur Gear
- Intercoms & PA
- Automotive Electronics
- Test Instruments
- TV Antennas & Tubes
- Power Tools, Hardware
- Tubes, Transistors
- Parts, Batteries, Books

536 PAGES

Shop by mail and save at Allied, world's largest electronics headquarters. Hundreds of money-saving values. NO MONEY DOWN. Up to 2 years to pay!

**MAIL COUPON BELOW**

**ALLIED RADIO, Dept. 078**  
 P.O. Box 4398, Chicago, Ill. 60680 (Please Print)

NAME \_\_\_\_\_  
 First Middle Last

ADDRESS \_\_\_\_\_

CITY \_\_\_\_\_

STATE \_\_\_\_\_ ZIP \_\_\_\_\_

## QUEEN ELIZABETH 2

(Continued from page 103)

air upward and carry the exhausts clear of the quarterdeck.

Well forward of the funnel, there's what appears to be a mast. Its hollow center carries the exhaust air from the galleys. At the top is a special antenna for navigation by satellite, and by which her position may be fixed at any time of day or night to the fantastic accuracy of 300 feet.

On the bridge, Capt. William Warwick is aided by science like no other merchant skipper. A miracle, quarter-million-dollar, one-cu.-ft. computer system lined to 400 vital shipboard points takes over much of his drudgery: collecting and analyzing weather reports and advising on suitable courses; writing the engine-room log; watching for the slightest overheating or other malfunction in the works; controlling the intricate machinery in the interest of economical running; predicting fresh-water needs for optimum operation of the desalinization plant; listing the food, drink and domestic necessities—3000 items—to be loaded at the next port.

---

**At press time, Cunard announced that it refused to accept the *Queen Elizabeth 2* from the builder because of uncompleted interiors and faulty turbines. It was feared that corrective work would delay the Queen's maiden voyage to New York.**

---

At the wheel—a toy of a thing only 14 inches across—Capt. Warwick has an immediate choice of two manual steering systems—or he can change to automatic at the flick of a lever. Behind, on a 12-foot control panel, he can read at a glance every detail of the performance of watertight doors, lighting arrangements, tachometer indicator, rudder indicator—every single thing aboard his ship, except who's dancing with whom in the 736 Nightclub.

Meanwhile, on the 10 decks available to passengers, as many as 2025 people are exposed to a luxury that reflects the 1½-million man-hours that were spent designing this ship. In the cabins—three-quarters of them have a sea view—only 178 passengers in a chock-full ship will have to sleep on upper berths. Even the dog kennels offer a vista of the ocean.

In the bow-facing "Lookout" lounge, children of ages up to 80 will enjoy the shiny red Chart Reader installed for their amusement. Linked to the bridge, it's a mini-TV screen; by pressing buttons on its side, the chart of the day lights up within the frame; gamblers on the Ship's Run sweepstakes will doubtless spend many calculating hours gazing at it.

The range of facilities stretches far beyond normal shipboard expectations. The three do-it-yourself laundrettes cut out the need to use expensive laundry services. All four swimming pools are heated; the two outside ones are carefully sited near the stern out of the breeze. There are both Turkish and sauna baths; and every cabin of each class has a private bathroom.

For the first time, a shipping line has admitted that many passengers want to bring their cars—but don't like seeing them handled by cranes. Huge doors in the hull allow your car to drive on, drive off at high tide or low. An elevator whisks 40 cars an hour down to the hold; a built-in turntable allows for quick maneuvering into the 80-car capacity garage. At a round-trip cost of \$500 for a compact, taking your car may prove as cheap as renting one for six weeks in Europe.

Built in an astonishing 40 months, the *QE 2* now starts on a hectic program of Atlantic crossings and luxury cruises: In an average year, she'll make a dozen spring and summer round trips between New York and LeHavre/Southampton. Then, in fall and winter, she'll follow the sun through the Caribbean, Bermuda, the Canary Islands and the Mediterranean. Forget the idea of getting from A to B, says Cunard: Treat us as hoteliers.

Back in the early 1950s, the *Mary* and the *Elizabeth* were aging rapidly. At first, there were tentative plans for a third vessel of the same type, provisionally termed *Q3*. But *Q3* was never built, for Cunard realized in time that the pattern of travel had changed dramatically.

So, the new ship—Job No. 736 to John Browns, the Scottish shipbuilders—had to cultivate an appeal of her own. (See *Successor to the Queens*, page 106, Sept. '67 PM.) and, she had to be readily adaptable from the trans-Atlantic run to the more leisurely requirements of winter cruising. The use of aluminum on a scale unparalleled in shipbuilding has given a seven-foot reduction in draft compared with the *Queens*: She can now berth at Southampton at all tides, and can pass through the canals of Suez—when and if reopened—and Panama, the latter with only 30 inches to spare either side. There's now no effort by Cunard to compete with the airlines.

"Ships have been boring for long enough," admitted C.N. (Nick) Anderson, president in America of Cunard Line. There should be little opportunity for boredom on the *QE 3*; there is every luxury and facility that you could find at a first-rate Florida resort hotel, except actual beach; although there's even some of that in the children's sandpit. ★★

# Secret Agent 10W-40.



Assignment: protecting the life of your car's engine. It's an under-the-hood job in a very complex case: the crankcase of your engine. The motor oil you use isn't up to the job, you seldom know it until it's too late. But if it's Quaker State Del Luxe Motor Oil 10W-40, you can drive with peace of mind.

Quaker State is refined from 100% Pure Pennsylvania Grade Crude Oil. And it's fortified to provide even greater protection than your car owner's manual demands.

You may not see the job it's doing. But you'll know by the way your engine performs year after trouble-free year.



Quaker State your car to keep it running young.

**ALDS**

al Concrete

Aluminum  
Molds... prices and  
products... secrets  
direct from... world's large-  
est mold manufacturer.



SEND  
\$2.00

CONCRETE MACHINERY COMPANY, INC.

P. O. BOX 99 • HICKORY 2, N. C. 28601

**POWERFUL NEW INVENTION, ONLY 2" LONG  
SHOOTS THRU 100  
PAGES-THIS BOOK!  
'B-B SHOT'**



**MAKE THIS TEST...** Load your 'BB Shot' and fire against this magazine. Notice that it drives BB's through more than 100 pages. Though only 2" long x 1" in diameter, this pocket-size device has amazing power and accuracy. Use it for targets, pests and hunting. Scientifically designed for high power, operating ease and safety.

**FREE!** Get the 'BB Shot' now—we'll include an extra Velocity Cone and FREE Target, BB's and Automatic BB Dispenser... all for only \$1.98 ppd. 3 for \$5.00 ppd. Money Back Guarantee. Not sold to N. Y. C. residents or minors

**GRAYSON CO. • Dept. F-30, Fifth Ave., N. Y. 10**

**MONEY-BACK  
GUARANTEE**

Name.....  
Address.....  
City..... State.....

**\$1.98**  
ppd.

# Get your own full-color print of the **SATURN V**

THE WORLD'S  
BIGGEST ROCKET

Beautifully printed on heavy  
paper suitable for framing.  
(Size: 19 by 25 inches)  
**\$1.25 postpaid**

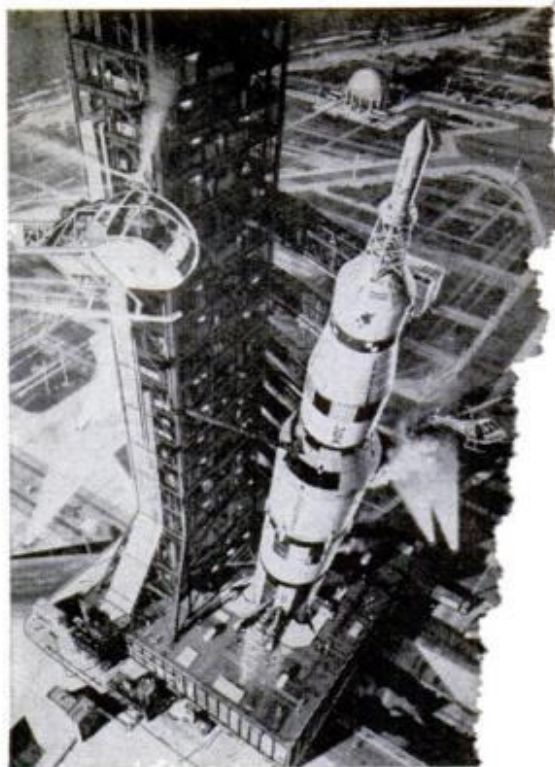

-----  
**Saturn V, Popular Mechanics, 575 Lexington Ave., New York, New York**

Please send me \_\_\_\_\_  
copies of PM's Saturn V  
painting. Enclosed find  
\$1.25 for each.

Name \_\_\_\_\_  
Street \_\_\_\_\_  
City \_\_\_\_\_ State \_\_\_\_\_

## EVERLITE® World's THRIFTIEST Light Plants



THE CHAMPION \$149.95

**The Champion—1200 watts  
115 volts AC for only \$149.95**  
Unbelievable but true—Brand new  
production methods now make possible  
world's finest design in a service  
free alternator light plant at  
this unprecedented price. Plant  
puts out a steady 1200 watts of  
115 volt AC power to run power  
tools, oil burners, pumps, TV, or  
anything that requires up to 1200  
watts. Powered by a rugged 3 HP,  
4 cycle, easy start gas engine with  
1 year factory warranty. Complete  
with carry handle and shock  
mounts. Why fool with short life  
2 cycle plants when you can buy  
this rugged top quality machine at  
our factory price.  
Item # 1265 ..... \$149.95  
Wt. 65 lbs.

### 2¾ h.p. Clinton—34.95

Model 400, rugged 4 cycle model.  
Alum. Bl'ck, castiron cylinder  
Rope start—¾" std. shaft.  
Item 1107 ..... 34.95  
2 For ..... 69.95

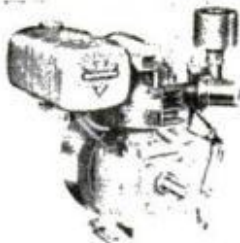

### 3½ h.p. Clinton—39.95

A big engine with big power. Model  
404, 4 cycle, rope start, ¾" std. shaft,  
industrial ball bearing engine.  
Item 404 ..... 39.95  
2 for ..... 77.50

Remember these engines are absolutely perfect and standard and  
under factory warranty. Money back guarantee. Order now while  
stocks are complete. Factories—we buy new engines.

### STANDARD DIAL PHONES WITH BELL

Bell System late model dial phones same  
as used by all telephone companies. Ideal as ex-  
tensions on any system. Easy to connect. Several  
may be connected on one line. Easily modified  
for private inter-com system. Cost \$10.00 new—  
guaranteed excellent condition.



ITEM 855 NC. Wt. 8 lbs. .... **\$7.45**

All Prices FOB Factory—10 Day Money-Back Guarantee

## Briggs & Stratton New Gas



Clear  
50  
er  
k

**\$69.95**

**5¼ hp.**

**Briggs**

**&**

**Stratton**

Same with  
Electric  
Starter  
(Item 1571)  
\$94.50

Remember these engines are  
factory warranty. Money back  
complete. Factories—we buy new

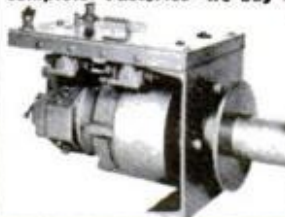

**MASTER MECHANIC MFG. CO.** Dept. A-29 Box A, Burlington, Wis. 53105  
Box 65, Sarasota, Fla. 33578

Send orders to nearest office.

your  
cover  
the cr  
If th  
to the  
until it's  
State De  
you can  
MO  
for makin  
Ornaments  
Items...  
ook about  
s with  
tion tr  
des  
cabin  
0 ft. per minute. A  
terrific  
at an economy price.  
Item  
Wt. 8 1/2 lbs. .... **\$69.50**

# BIG

**YACHT-SMART**  
Sail Rig  
DACRON  
from  
**\$112**



# WINTER SAVINGS NOW

# FOLBOT

**TRAVEL CRAFT**  
fits in every  
home or car

**FOR YOUR SPORT AND FAMILY FUN**

and  
**RECORD FISHING**

GENUINE Folbot RECREATION for just ONE small investment, WITHOUT the continuous burdens of complicated 'big rig' operation. You GO CAREFREE anytime with COMPACT Folbot . . . rocky streams, lakes, marsh, surf & open sea. Superior non-sinkable designs provide SAFEST low gravity center, balanced low & high seating, substantial construction, protective decks & EXCLUSIVE swivel-back COMFORT. ALL within your reach. In handy Folbot YOU GLIDE smoother, faster & NOISELESS with paddles, oars, or sails and ride softly w. 1 to 10 HP. motors. Many styles & sizes from 1 to 4 seaters, FOLDING or rigid PORTABLE come in PREFAB KIT, or expertly FACTORY BUILT

Just a few Dollars start  
YOU right away. From

**ONLY \$19 NOW**

for BASIC KIT

16 feet long

'CAYAT'  
car top  
YACHT.

**NEW**  
Fabulous  
16 foot  
**\$109**

Factory BUILT

**FREE**  
ACTION CATALOG

**STARTLING**  
**FACTS & FIGURES**  
Mail coupon or address

to: FOLBOT CORP.  
Dept. PM2 Charleston, S. C. 29405

Name \_\_\_\_\_

Address \_\_\_\_\_

City \_\_\_\_\_ State \_\_\_\_\_

## 75 POWER TELESCOPE \$498

**NEW** 3 in one telescopes, 3 variable 25X 45X-75X magnification. Brass bound. 25 power for ultra bright images 45 & 75 power for long range. Guaranteed to bring distant stars, moons, objects, sports 75 times closer.

Most powerful scope anywhere at this amazing-low price. 5 sections. Opens 36" closes 1 ft.; contains 4 ground & polished lenses. Can also be used as powerful microscope. American made, Mass production enables us to offer telescope complete including case \$4.98 post paid. Money back guarantee.

CRITERION CO., Dept. PBM-51, 331 Church St., Hartford, Conn. 06101



**IF YOU CAN SING, WHISTLE, OR HUM A TUNE . . .**

you can play the Musical Saw. No notes to read, no musical knowledge required. Since 1921 we have furnished the entire world this unusual, sweet-toned instrument. If you are 10 or 70, you play or no pay. Musical Saw, soft hammer, bow, resin and lessons mailed on 5 days' trial. Write today for details and free copy of "Sawing News of the World," picturing successful saw musicians. MUSSEHL & WESTPHAL, 107 Fort St., Fort Atkinson, Wisconsin, 53538.

## A REFRESHER COURSE IN MATHEMATICS

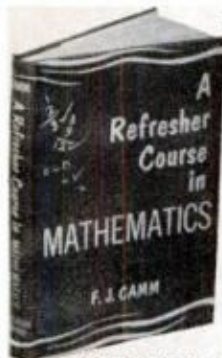

BY F. J. CAMM—Basic course, from arithmetic to the calculus; in order of difficulty. Explanations of principles followed by worked examples.

Includes treatment of fractions, decimals, square root and cube root, logarithms, interest, algebra, equations, graphs, plane and solid geometry, trigonometry, differential and integral calculus; summary of mathematical formulas; etc., etc.

Will be of enormous help to those who have forgotten their math; also to those now acquiring it. 195 illustrations.

\$3.95 Postfree • 10-Day Money-Back Guarantee

**EMERSON BOOKS, Inc., Dept. 6-S**  
251 West 19th Street, New York, 10011

**TO YOUR OWN DOCTOR'S PRESCRIPTION**



**EYEGLASSES BY MAIL AT GREAT SAVINGS!**

Mail orders filled by **\$9.95**  
licensed optician from

(Including single vision lenses, frame and case).

Doctor's prescription will be filled by a skilled, approved and licensed optician or your own prescription duplicated. Lenses are ground and manufactured to U.S. optical standards. Choose from complete catalog of men's, women's and children's glasses. Bifocals, trifocals, sunglasses or SAFETY HARDENED LENSES at low additional cost. We guarantee accuracy, perfect fit.

SEND FOR YOUR FREE CATALOG TODAY

**PRISM OPTICAL INC.**

Dept. PM-2 136 Liberty St., New York 6, N. Y.

**A handful of  
compact power  
30,000 rpm!**



**NEW!**  
**DREMEL MOTO-TOOL**  
with constant-torque  
permanent-magnet motor

Now all Dremel Moto-Tools belt out twice the torque of previous models! They're virtually stall-proof, even when you're really bearing down. Compact — lightweight — and now super-powered for grinding, drilling, polishing, carving, deburring, and sanding. Shock-proof Lexan housing. See your dealer for a demonstration.

- No. 260 super-compact . . . . . \$22.95
- No. 270 with bronze bearings . . . \$29.95
- No. 280 ball bearing construction . \$39.95

**New Moto-Tool Kits**  
Complete with Moto-Tool  
and 34 accessories

- No. 261 . . . . . \$32.95
- No. 271 . . . . . \$39.95
- No. 281 . . . . . \$49.95



**DREMEL MFG. CO., Dept. 119B, Racine, Wis. 53401**

New 160-page "Dremel Handbook of Hobbies, Crafts, and Projects", only \$1.45.

- Please send book. I enclose \$1.45.
- Send free power tool literature.



Name.....  
Address.....  
City..... State..... Zip.....

**When you  
see this mark  
you've seen  
the product in  
Popular Mechanics.**



**Tear Out & Mail. No Letter Needed!**

**Free  
New Catalog 2000 Novelties**

Send for world famous catalog of novelties, live animals, scientific supplies, hobbies, funmakers, planes & boats, looms, magic tricks, joke articles, unusual seeds, gadget timesavers, cameras, optical goods, projectors, movies, lucky jewelry, religious novelties, disguises, musical instruments, stamps, coins, puzzles, fortune tellers, radios, auto & bike accessories, telescopes, magnifiers, compasses, banks, smokers' gadgets, artists supplies, printing sets, engines, motors, shockers, knives, billfolds, fireworks, guns, rifles, sports, books, games, plants, etc. Send postcard or this ad. No letter needed!

CHECK HERE  YES—I want FREE Catalog. My Name & Address Attached or on Envelope

**Johnson Smith Co., Dept. 504, Detroit, Mich. 48224**

**"\$33,000 LAST YEAR"  
OPERATING AUTO  
RADIATOR SHOP**



— Mercier Bros., Lowell, Mass. Make big money repairing radiators — servicing cooling systems. Inland's Proven Program includes: training, equipment, "How-to-Operate" Manual, advertising aids and "Pay-As-You-Profit" purchase plan. **START YOUR OWN SHOP OR ADD TO PRESENT BUSINESS.** Market Growing — More vehicles on road each year. Small modern cooling systems and air conditioning are adding extra stress on radiators—demanding frequent service. Cash in now!

**FREE!** INLAND MFG. CO., Dept. PM-2  
1108 Jackson Street, Omaha, Nebr. 68102

42-page booklet "Make Money Repairing Radiators" shows equip. prices, owner letters—complete program. Send free 42-page booklet and money-making plan.  
Print Name.....  
Address.....  
City..... State.....

# ENJOY AN EXCITING, ROMANTIC, IMPRESSIVE LOOK ANYTIME!

HAVE THE LOOK MEN ENVY, AND WOMEN  
ADMIRE WHENEVER YOU CHOOSE!

Now at last you can have the experience of wearing sideburns, mustache, or Van Dyke that is so real looking your friends will think it is your very own! Competition tough... want to impress your employer or girl friend... want to look older or younger or different... cool or sharp??? Do you miss the attention you should be getting?? Try a Masculiner Van Dyke, Sideburns and/or Mustache... all three, separately or in different combinations... and see the amazing difference... in your NEW LOOK you can have in seconds! Don't miss out on all the fun that so easily can be yours! Send for your Mustache, Sideburns and Van Dyke at once! Simply check the color you want in the coupon or send a sample of your hair and leave the matching to our expert. Your hair sample is color matched at no extra cost... or order in the color you choose. MAIL COUPON NOW!

Adheres securely... off and on in seconds... can be worn as is or trimmed to just the style you want... wear it confidently whenever you can to have the LOOK you want for yourself!

**FREE:** Complete instructions on how best to wear your Van Dyke, Mustache or Sideburns... sent in plain wrapper with order.

**SOLD ON MONEY BACK GUARANTEE:** You must be 100% satisfied, you must see an exciting new LOOK in your appearance, it must be everything you want it to be or your money back!

## ALL THREE \$6

Wear All Three or Any Combination

**VAN DYKE \$3** **MUSTACHE \$2**  
Try it alone or with any combination. Try it... see the difference.

**SIDEBURNS \$3**  
Try it alone or with either Van Dyke, mustache or both.



VAN DYKE \$3



MUSTACHE \$2



SIDEBURNS \$3

### MAIL COUPON NOW!

MASCULINER CO., Dept. 98, P.O. Box 802  
160 Amherst St., East Orange, New Jersey

O.K. I WANT TO SEE THE MANY DIFFERENT CHANGES IN MY APPEARANCE. SEND THE ONES CHECKED ON A MONEY BACK GUARANTEE. PAYMENT IS ENCLOSED. I MUST be 100% Satisfied or I may return everything for full refund. Send color checked or  please match sample of my hair enclosed.

Rush the Following:

- Mustache \$2.  
 Van Dyke \$3.  
 Sideburns \$3.

Please Send Order in Color Checked:

- Blonde  Black  Dark Brown  
 Light Brown  Grey - Silver  
 Medium Brown  Dark Auburn  
 Light Auburn

I enclose \$6. send all 3 (I save \$2.) cash, check or money order.

Name .....  
Address .....  
City ..... State ..... Zip .....

Entire Contents Copyrighted 1968  
SOLD ON MONEY BACK GUARANTEE

## Fox Mini Bike

DO IT YOURSELF  
OR FULLY ASSEMBLED

FROM

# \$79<sup>50</sup>



12 MODELS  
3 TO 5 HP

### SEND \$1 FOR BIG CATALOG

Shows new 1969 line of the world's finest MINI-BIKES (most are licensable for street use), plus parts, accessories and plans. Big selection! Amazingly low prices! There's a Fox MINI-BIKE for everyone — from age 10 to adults.

**EXTRA BONUS** — Catalog shows radios, watches, walki-talkies, cameras, musical instruments, tools, appliances and many other items you can buy at practically wholesale prices. Free \$1 coupon.

**FOX CORP.,** Box 797 PM Janesville, Wis. 53545

## NOW! DO ALL MACHINE OPERATIONS ON ONE TOOL.

Wonderful for hobbyists. Work with metal, wood and plastics. UNIMAT is lathe, vertical miller, drill press, tool grinder and polisher—all in one compact unit. Change from one machine to another in seconds. No machine shop experience necessary. With precision UNIMAT anyone can turn out perfect parts by following simple instructions. Make all kinds of hobby, experimental or repair parts. Motorized UNIMAT is portable and ready to use. Also available in Canada. Write for free color folder, or send \$1 for "Miniature Machining Techniques" handbook.

# UNIMAT

COSTS ONLY \$139<sup>50</sup>



DRILL PRESS

**AMERICAN EDELSTAAL, INC.**  
Dept. 88-9, 350 BROADWAY, N.Y., N.Y. 10013

Get more  
for your \$\$



### with ATLAS 12" lathes

Quick change gear box with 54 threads and feeds. 16 spindle speeds—V-belt drive. Power cross feed—power longitudinal feed. Timken tapered roller bearings. 12 1/4" swing—big capacity. And more—from only \$525 f.o.b. factory.

Write for free catalog.  
**ATLAS PRESS CO.**

2-25 N. Pitcher St. • Kalamazoo, Mich. 49001

537

At last!  
A new Miter Table  
lets you cut even  
compound angles  
with ease!

If mitering wood, masonry or metal has been a headache for you, relax. Now, Baldwin Tool makes a new patented Miter Table that cuts any angle with ease. It's so accurate you'll make repeat cuts and be right on the money every time. Most every power hand saw fits this remarkable device. Best of all, it's yours for \$19.95 postpaid from Baldwin Tool, Inc., P. O. Box A428, Independence, Ore. 97351. (Dealer inquiries invited)

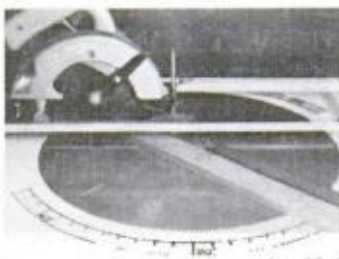

Send me a miter table. My check/money order is enclosed.

Name \_\_\_\_\_

Address \_\_\_\_\_

City, State \_\_\_\_\_ Zip \_\_\_\_\_

## FREE OUTFIT STARTS YOU IN BIG MONEY SHOE BUSINESS!



Run your own profitable 'shoe store' business from home in spare or full time. We give you—FREE—complete Starting Outfit that makes you \$217.00 EXTRA each month for just 2 easy orders a day. You feature 275 fast-selling dress, sport, work shoe styles for men and women. Air-cushion shoes, many other special features! Sizes to 16—widths AAAA to EEEE. Draw on 300,000 pair stock. Your own shoes FREE. Discounts to your family. Prizes, bonuses—even a new car—at no cost to you. Rush postcard for your FREE Starting Outfit today... Now! **MASON SHOE, H-377 CHIPPEWA FALLS, WIS.**

**\$5.95**

less bell



### DIAL TELEPHONES

With bell \$8.95. If plug is required add \$2.00. Factory reconditioned, Guaranteed. Many other phones available, write for free list.

All shipments FOB Waymart, Pa.

### SURPLUS SAVING CENTER

Dept. PM-9, Waymart, Penna. 18472

### BUILD A LOW COST PONTOON BOAT WITH THIS KIT...



### FREE CATALOG

It's fun, it's easy too! You can build a rugged pontoon boat that will provide years of fun for your family at an amazingly low cost.

WRITE: PERMA-D MARINE PRODUCTS DIV.  
DEPT. 35, CENTRAL MACHINE WORKS CO.  
2308 Central Ave. N.E. • Mpls., Minn. 55418



### BUILD THESE BEAUTIFUL CLOCKS

Now at big savings! Send just \$1 for plans & instructions to build choice of: (A) Grandfather (B) Steeple (C) Grandmother, plus information-packed catalog of movements, dials, parts & kits to build these & 16 other fine clocks. All 3 plans \$2.50. Catalog alone—25¢.

### MASON & SULLIVAN CO.

Dept. PM2, Osterville, Mass. 02655



# sports cabinet plans



Easy-to-build plywood cabinet stores all kinds of sports gear. Vary the shelves for canned goods, linens. Great in the garage for garden tools. For plans send 10c to American Plywood Assn., Dept. PM, Tacoma, Wash. 98401.



# SPECIAL OFFER!

Two PM Wall Charts (\$2 value)  
For \$1.50



THE SATURN V  
EARLIEST ROCKET IN THE WORLD  
AS DESCRIBED IN  
POPULAR MECHANICS  
BY FAMOUS AERONAUTIC ARTIST DONALD SCHWAB

**SATURN V**, the world's largest rocket, printed in full color on heavy stock. Size: 19x25 inches. (Regular price: \$1.25)



OUR FIRST 19 IN SPACE  
PHOTOGRAPH BY DONALD SCHWAB FOR POPULAR MECHANICS

**OUR FIRST 19 IN SPACE.** Photographs of the first 19 U.S. astronauts on heavy stock. Size: 12x18 inches. (Regular price: 75 cents)

### Use This Coupon

Dept. ES, Popular Mechanics, 575 Lexington Ave., New York, N.Y. 10022.

Name \_\_\_\_\_

Street \_\_\_\_\_

City \_\_\_\_\_ State \_\_\_\_\_ Zip \_\_\_\_\_

# Scorpion

FULL-FLIGHT HELICOPTER



**BUILD IT  
FLY IT**

Your dream of a backyard helicopter built with small shop tools can now come true! Plans and components are available for the amazing, vertical take-off Scorpion. Paul Brehm, Cedarburg, Wisconsin, is building his Scorpion for under \$1,000. Introduction package includes pilot licensing and flight instruction information, scale drawings, flight photos, price lists and full particulars. Take the first step today!

SEND  
**\$3**  
NOW

**RotorWay Inc.**

P.O. Box #1096 • Mesa, Arizona 85201

NAME \_\_\_\_\_

ADDRESS \_\_\_\_\_



**BRAND NEW!**

### Solid-state lamp dimmer socket.

Amazing new Varolite™ dimmer socket converts 1-way and 3-way lamps into full-range, variable intensity lights. Varolite eliminates need for costly 3-way bulbs. Instead, using an inexpensive 150-watt bulb, you can dial a brilliant light for reading, or a low glow for watching TV. Varolite makes a perfect night light, too. Simple installation instructions included with order. Money-back guarantee.

ONLY  
**6.25**   
POSTPAID  
SEND CHECK  
OR M. O.

**POWER CONTROLS DIVISION, VARO, INC.**

DEPT. PM-2

725 EAST WALNUT STREET, GARLAND, TEXAS 75040

# FREE—Popular Mechanics Catalog of Publications and Projects



This FREE Booklet From Popular Mechanics Can Save You Hundreds of Dollars, And Bring You A Lifetime of Enjoyment!

Now You Can Have Your Own Sail Boat, Motor Boat, Swimming Pool, Built-in-Furniture—Almost Anything For The Home Or Week-end Fun—At A Fraction Of The Usual Cost.



Just imagine a fun-filled week-end like this! You can relax and enjoy playing the host, entertaining your friends on the patio or recreation room, have a cook-out, then a swim in the pool.

Or, perhaps you've been putting off that week-end project—building shelves and furniture . . . paneling a room . . . fixing a leaking faucet . . . or odd jobs that require repairing and painting.

**Let the experts show you how** you can have all these things and more. We'll show you how easy it is! All you need are these step-by-step instructions from the experts—the editors of POPULAR MECHANICS.



Easy-to-follow plans are available for many wonderful additions and improvements for your home, from a simple bookcase to a complete house—projects you can do yourself in your own shop in your spare time. And think of the money you'll save—up to hundreds of dollars—by doing them yourself.

In addition, you save on expensive contractors and long-term loans. Hundreds of practical, money-saving ideas—you'll find a goldmine of hard-to-locate information—literally hundreds of practical ideas, booklets and plans to enrich and beautify your home on such subjects as:

Boats and boating equipment/bookcases, shelves, cabinets, tables/clocks—early American, grand-fathers/camping trailers and equipment/working with glass/electric wiring/furniture; woodworking projects/hydroplane/models: ships, airplanes, sports cars, steam engine, etc./gardening equipment, planters, lawn and tree care/houses—complete architectural plans/painting, interior and exterior; wallpapering/TV, hi-fi and stereo equipment; cabinets/plastic molding/playhouses/how to do your own plumbing/repairing your roof/car repairs and tune up/swimming pools; filters/workshop projects/famous Popular Mechanics wall charts.

This is only a sampling of a multitude of moneysaving ideas and information that can bring you many hours of pleasure—something all the family can enjoy for many years to come.

## Order Your Free Price-List Catalog Today

Just fill out and mail the coupon for your copy of the POPULAR MECHANICS CATALOG OF PUBLICATIONS AND PROJECTS. Please enclose a self-addressed stamped envelope, or 10¢ in coin to cover postage and handling. Your 16-page catalog will be sent by return mail listing hundreds of plans, books, projects and wall charts for your enjoyment and better living.

Popular Mechanics, Dept. BI-CA 575 Lexington Avenue • New York, N.Y. 10022

I am enclosing a self-addressed envelope (or 10¢ in coin). Please send me a copy of the Popular Mechanics CATALOG OF PUBLICATIONS AND PROJECTS. (If outside USA, please enclose 25¢ USA currency.)

Name \_\_\_\_\_ (please print)

Address \_\_\_\_\_ (please print)

City \_\_\_\_\_ State \_\_\_\_\_ Zip code \_\_\_\_\_

EMC/A

# 40" FLEXIBLE SHAFT

with 1/4" Jacobs Chuck

Use with any 1/4" drill to drive

- DRILL BITS
- WIRE WHEELS
- GRINDING WHEELS
- ROTARY FILES-RASPS

Buy a Coastal Flexible Shaft at your favorite tool store. Only \$11.98. And while you're there, be sure to see all the work-saving Coastal power tool accessories. Coastal Abrasive and Tool Company, Inc., Trumbull, Conn. 06611.

**COASTAL**

Mention **POPULAR MECHANICS** when writing to advertisers.

## LEARN TO EARN!



**NO HOME STUDY  
CONTRACTOR OWNED  
VA APPROVED**

- Live at school • Train on actual machines / qualified instructors
- Graduates readily accepted for construction employment

**WESTERN SCHOOL  
OF HEAVY EQUIPMENT OPERATION**

BOX 510 • WEISER, IDAHO 83672

SEND TODAY FOR FREE SCHOOL CATALOG  
DEPT. M-1

NAME \_\_\_\_\_  
ADDRESS \_\_\_\_\_  
CITY \_\_\_\_\_ STATE \_\_\_\_\_

FEBRUARY 1969

# THE LOOK YOU WANT- WHEN YOU WANT IT!

**Be Amazed at the Exciting Change in your Personal Appearance!**

Now You can actually select the way you want to look, Older, Younger, Distinguished, Cool, Suave — you name it! Wear each one independently or combine them for the effect you desire.

All items made to exacting professional standards. Firmly self-adhering. Can be worn with self confidence anywhere, anytime. They are so life-like you will have to remind yourself that they can be removed!

**FREE** with each order, a complete guide that tells how to naturally wear your sideburns, mustache and van dyke.

When ordering state hair color — light, medium, or dark brown, black or off-black, blonde, auburn (red), or silver (grey). If not sure of your hair shade enclose hair sample. 100% Money Back Guarantee. Mustache \$2, Sideburns \$3, Van Dyke \$3. Order all 3 items for only \$5. ( Save \$3 )

Send to:  
MAN INTERNATIONAL,  
6311 Yucca Street, Dept. 540  
Hollywood, California 90028.

Sideburns \$3

Mustache \$2

Van Dyke \$3

Wear Any Combination

## FIND BURIED TREASURE!

**\$17<sup>88</sup>**

Plus \$1.00 Shipping  
**10-DAY MONEY  
BACK GUARANTEE**  
SEND ONLY \$3.00.

Pay \$14.88 plus postage and C.O.D. when delivered, or send \$18.88 for postpaid shipment to

**TREASURE ENTERPRISES**

Dept. , Box 10947, Houston, Texas 77018

Find buried gold, silver, coins, war relics with new sensitive detector. Works for days on a common 60¢ 9-V battery. Fully transistorized. 1969 model. Ideal for beach combing, treasure and coin hunting, prospecting for gold. So sensitive it will detect a single coin or gold nugget. NOT A KIT. Complete, ready to operate. Nothing else to buy. Gives loud, clear signal, when metal is detected. Sensitive earphone included for treasure hunting in secrecy. Weighs 2 pounds.



# THESE 3 BIG DRAFTING KITS\* GIVEN TO YOU!

...when you train at home with NASD for a

# HIGH PAY JOB IN DRAFTING!

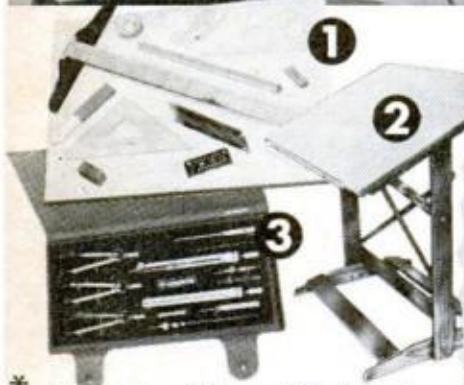

\* Precision Drawing Instrument Set, Professional Drafting Board Outfit and Fingertip Tilting Drafting Table are given to you with your complete North American Course in Drafting.

## U. S. LABOR DEPT. REPORTS SERIOUS SHORTAGE OF DRAFTSMEN

(The following quotes from U. S. Labor Dept. point out nationwide shortage for Draftsmen):

"The dearth of qualified applicants has resulted in increasing calls for trainees, as employers in many areas relaxed hiring specifications. Experience requirements have been virtually eliminated, along with age barriers."

"Steadily growing employer requirements...were accompanied by marked reductions in the supply of draftsmen available."

### TOP AMERICAN EMPLOYERS WELCOME NASD GRADUATES

"We would be interested in interviewing your grads as potential employees." **REMINGTON**

"At the present time we have several openings available for qualified Draftsmen. I look forward to considering graduates of your institution." **WESTINGHOUSE**

"We have immediate openings for designers and Draftsmen and have a definite interest in interviewing candidates immediately." **AMERICAN MACHINE & FOUNDRY**

## (3) High School Draftsmen

\$90-\$120 PER MONTH  
NO EXPERIENCE  
Single ability with training and a year's schooling, you need not get on the ground floor. We accept all professional research men and those of the military.

### NO EXPERIENCE REQUIRED!

Trainees who satisfactorily pass a basic test and accept employment will receive:

- ✓ FULL SALARY
  - ✓ AUTOMATIC SALARY ADJUSTMENTS
  - ✓ FULL EMPLOYEE BENEFITS
- Call immediately to arrange interview appointment  
**JOE PASMORE**  
363-4111

### Design Draftsmen

Positive experience in design and drafting of civil, mechanical or electrical.

CALL OR APPLY  
**AERQUIET-GENERAL CORP.**  
11711 Woodruff Ave.

**DRAFTSMAN**  
Architectural

**WESTERN GEAR**

## Take Your Pick of 2 EXCITING FIELDS

### 1 Architectural Drafting

Today's population explosion guarantees boom in building of homes, churches, schools, factories, office buildings & warehouses is just starting. Thousands Architectural Draftsmen needed NOW because drawings must be made of every part of every building before ground can be broken.



### 2 Mechanical Drafting

SkYROCKETING U.S. mass production requires millions of drawings & thousands of Mechanical Draftsmen all along the way. Drawings must be made of every PART of every product used in the U. S. (as well as of the machines that make these parts) before production can be started.



### HERE'S WHAT STUDENTS SAY

**Earns \$820 Month!**  
"My first position after completing your course jumped my income from \$350 to \$820 per month."  
—G. W., Tenn.

**Big Promotion!**  
"I was promoted from the production line ahead of 4 others and got a good pay raise."  
—W. A., Wisc.

**Gets 50% Raise!**  
"Shortly after I completed your course I was made shop foreman. My pay was increased by half."  
—W. R., New York

**No Layoffs!**  
"Strikes and layoffs are nightmares of the past. Your training has opened the door to a wonderful future for me."  
—H. O., Ohio

**RUSH ABOVE POSTPAID CARD NOW**

**NO SALESMAN WILL CALL**

Veterans! Servicemen! you may be eligible for Gov't educational benefits

**FREE Drafting "Career Kit"—Rush Postpaid Card Now**  
NO SALESMAN WILL CALL

**Your FUTURE in DRAFTING**

**APTITUDE TEST SAMPLE LESSON**

1 Intriguing new 5-Way Drafting Instrument which will give you the "feel" of using Drafting tools. Yours to keep as a FREE GIFT without cost or obligation.

3 20-page Drafting Career Fact Book, "Your Future in Drafting," jam-packed with detailed information about Drafting Career Opportunities, including requirements, job locations, salaries, etc.

2 Self-scoring Drafting Aptitude Test which will help you rate yourself in advance on how well you may be suited for a high pay Career in Drafting.

4 Comprehensive Sample Lesson of North American's Drafting Course. A "sneak preview" of exciting things to come.

**ALL 4 FREE**

(A home-study program in association with Cleveland Engineering Institute)

**NORTH AMERICAN SCHOOL OF DRAFTING, 4500 Campus Dr., Dept. 4172, University Plaza, Newport, Calif. 92660**

Accredited Member, Nat'l Home Study Council. Authorized to issue diplomas by California Supt. of Public Instruction.

**This \$100,000 car was built to break the world land speed record. They didn't scrimp on anything. They used Autolite spark plugs. Like you buy. About \$1 each.**



This wheeled projectile is 30 feet long and 37 inches high. It looks a lot like a bullet. And it goes like one, too. On one of the early runs it topped 400 miles per hour easily. And it was just warming up then.

It has two 427-SOHC Ford engines. A conventionally aspirated one producing 810 horses up front. And a supercharged one producing 1260 horses in the rear. These engines cost over \$6,000 apiece.

The spark plugs? About a dollar a throw. They're Autolite plugs. The same kind you buy.

Autolite plugs are specially constructed to keep performing at the highest peak regardless of how rough the going gets. The hermetic glass seal is designed to stay intact despite extremes in heat, pressure, or stress. That means that compression can't leak off just when you need it most.

Why \$1 spark plugs in a \$100,000 car? Because there are no better plugs. Not at any price. So put Autolite spark plugs in your car. Whatever kind of car you drive.

Autolite is the only name you need to know for spark plugs, batteries, filters, shock absorbers, and complete ignition systems.

**Autolite** 



# The Evinrude Triumph is unfair



Triumph's aimed intake passages "loop" the fuel charge up and away from the exhaust ports. Deflectors and all their problems are eliminated. Note the flat-top automotive-type pistons, the fuel passages molded into the cast iron cylinder sleeves, the fuel delivery "window" in the piston skirt, and the efficiently shaped hemispherical combustion chamber.

## It has a built-in \$5,000,000 advantage.

The advantage is "loop charging"—a new, dramatically more efficient way of fueling a modern outboard engine.

Loop charging delivers an *aimed* fuel charge *directly* to the top of the combustion dome. It eliminates need for the deflector "hump" on the piston and the deflector-shaped "bulge" in the combustion chamber.

With the deflector gone, pistons are lighter, compression can be higher, and the combustion chamber can be shaped the way it ought to be shaped.

The loop principle isn't new. But because of the problems of building precision fuel passages into the spaces between cylinders — it has never before been possible to build a true loop system into a modern water-cooled multi-cylinder aluminum outboard engine.

A year ago, Evinrude engineering broke through the design barrier.

The method was ingenious (see diagram), and the results were spectacular. One result of our \$5,000,000

research and tooling investment was an immediate saving of as much as a gallon of fuel an hour in the top speed range (where fuel savings really count).

Fuel economy is exceptional. But so is performance. The Triumph "55" actually equals our workhorse "65" in pulling power, and surpasses it in speed and quiet and push-button elegance. The Evinrude "55" *eliminated* the Evinrude "65".

We hadn't planned on being quite that unfair.

CATALOG FREE, Write Evinrude Motors,  
4280 N. 27th St., Milwaukee, Wis. 53216

**EVINRUDE**  
Div. of Outboard Marine Corporation

**first  
in  
outboards**