

Build Our 25-Foot Houseboat for \$1000 Page 158

POPULAR MECHANICS

JAN. 1969
50 CENTS

Has the
Gasoline
Engine
Had it?
Page 95

SPECIAL
MIDWINTER

CAR ISSUE 36 Pages

The Wood Bros: Can They Win Again at Riverside?

Comparing Those Sporty Small Sedans:

Datsun, BMW, Cortina, Saab, Fiat 124

Luxurious New
Pickups

Styling:
Why U.S.
Cars Look
Alike

Dan Gurney's
Column
Auto Clinic



STARLIGHT SCOPE

The Story Behind Our New
See-in-the-Dark Gunsight

HOW TO: Build Game Storage Under a Pool Table ■

Hop Up a Snowmobile ■ Install Trim Tabs to Make Your Boat Ride Better ■ Amplify Your Telephone ■ Adjust Garage Doors ■ Give Your Wife More Storage in the Kitchen ■ Build an 'Antique' Clock ■ Put a Sink in Your Darkroom ■ Mill on a Drill Press ■ Make a Stand for Your Shop Tools ■ Replace Ignition Wiring (Saturday Mechanic)

Best seat in the boat



Reserved for the man who owns the most versatile fishing motor ever built.



The motor is the Evinrude Sportwin — 9½ "horses" strong, 60 lbs. light, and just 34 inches long.

It hides down low on the boat, out of the way. You fish over it, not around it. Outside, it's short, and small, and light. Inside, it's a 15 cu. in. powerhouse — biggest in its class. Powerful enough to plane three fishermen and all their gear. Fast enough to be first where the fishing is best. Smooth enough to chuckle along by the hour at tick-over trolling speed. Economical enough to run all day on a tank of fuel.

Sportwin is an all-round fishing motor. With efficient 90° drive for 20 mph speeds where the water is deep and

clear. With eight special tilt-out running positions for shedding weeds and sliding over shallows and shoals. It has a thermostat to keep the motor warm when the water is cold. And the same sealed powerhood that keeps the sound in, keeps the rain and spray and sea out.

Sportwin has full gearshift, plug-in fuel tank with built-in fuel gauge. Twist grip throttle. Finger-pull starting. Shock-mounted semi-weedless propeller. And a speed adjustment that lets you pre-set trolling speed and return to it, automatically.

It's the largest selling fishing Evinrude ever made. Five minutes in the driver's seat and you'll know why.

CATALOG FREE. Write Evinrude Motors,
4205 N. 27th St., Milwaukee, Wis. 53216

EVINRUDE  **first
in
outboards**
Div. of Outboard Marine Corporation

Instant firewood

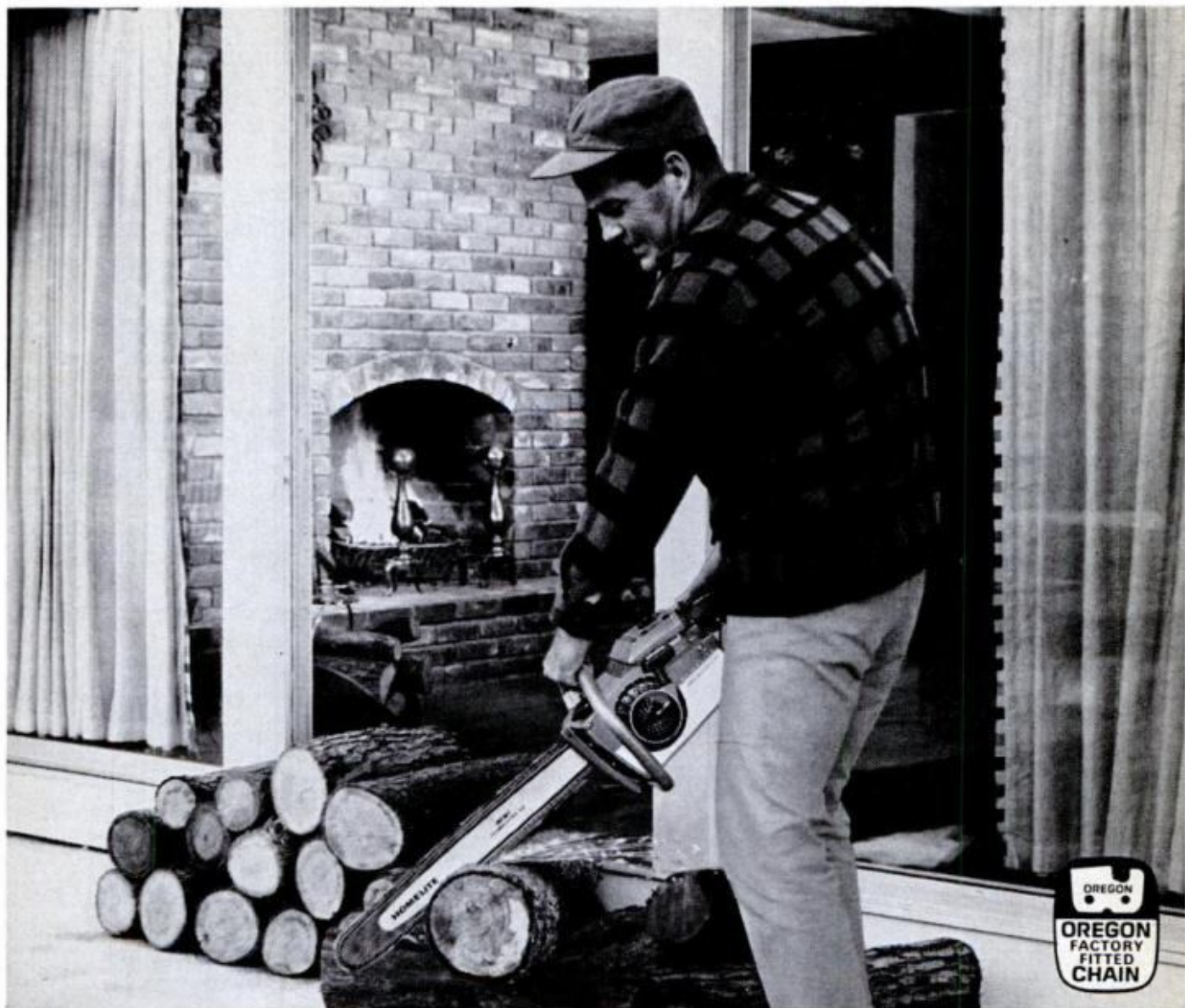

There's nothing like a warm, crackling wood fire at the end of a winter's day. Thanks to Homelite, it's easier and quicker than ever to enjoy.

Homelite XL chain saws make fast firewood for you. They're easy to handle and loaded with power, cutting through 12-inch logs in mere seconds and felling trees up to four

feet thick. You'll be surprised at their light weight, smooth running and fast cutting.

You'll enjoy the winter more when you own a chain saw, and you'll enjoy your chain saw more if it's a Homelite XL, the fastest-selling chain saw line in the world. See one now, at your Homelite dealer. He's listed in the Yellow Pages.

Other Homelite chain saws are priced as low as \$129.95

HOMELITE®

10201 RIVERDALE AVE., PORT CHESTER, N.Y.

A **Textron**
DIVISION

This One



LRC5-QSH-5XG8

4-121

JANUARY 1969

1

FREE—Popular Mechanics Catalog of Publications and Projects



This FREE Booklet From Popular Mechanics Can Save You Hundreds of Dollars, And Bring You A Lifetime of Enjoyment!

Now You Can Have Your Own Sail Boat, Motor Boat, Swimming Pool, Built-in-Furniture—Almost Anything For The Home Or Week-end Fun—At A Fraction Of The Usual Cost.



Just imagine a fun-filled week-end like this! You can relax and enjoy playing the host, entertaining your friends on the patio or recreation room, have a cook-out, then a swim in the pool.

Or, perhaps you've been putting off that week-end project—building shelves and furniture . . . paneling a room . . . fixing a leaking faucet . . . or odd jobs that require repairing and painting.

Let the experts show you how you can have all these things and more. We'll



show you how easy it is! All you need are these step-by-step instructions from the experts — the editors of POPULAR MECHANICS.

Easy-to-follow plans are available for many wonderful additions and improvements for your home, from a simple bookcase to a complete house —projects you can do yourself in your own shop in your spare time. And think of the money you'll save —up to hundreds of dollars—by doing them yourself.

In addition, you save on expensive contractors

and long-term loans. Hundreds of practical, money-saving ideas—you'll find a goldmine of hard-to-locate information—literally hundreds of practical ideas, booklets and plans to enrich and beautify your home on such subjects as:

Boats and boating equipment/bookcases, shelves, cabinets, tables/clocks—early American, grand-fathers/camping trailers and equipment/working with glass/electric wiring/furniture; woodworking projects/hydroplane/models: ships, airplanes, sports cars, steam engine, etc./gardening equipment, planters, lawn and tree care/houses—complete architectural plans/painting, interior and exterior; wallpapering/TV, hi-fi and stereo equipment; cabinets/plastic molding/playhouses/how to do your own plumbing/repairing your roof/car repairs and tune up/swimming pools; filters/workshop projects/famous Popular Mechanics wall charts.

This is only a sampling of a multitude of moneysaving ideas and information that can bring you many hours of pleasure—something all the family can enjoy for many years to come.

Order Your Free Price-List Catalog Today

Just fill out and mail the coupon for your copy of the POPULAR MECHANICS CATALOG OF PUBLICATIONS AND PROJECTS. Please enclose a self-addressed stamped envelope, or 10¢ in coin to cover postage and handling. Your 16-page catalog will be sent by return mail listing hundreds of plans, books, projects and wall charts for your enjoyment and better living.

Popular Mechanics, Dept. BI-CA 575 Lexington Avenue • New York, N.Y. 10022

I am enclosing a self-addressed envelope (or 10¢ in coin). Please send me a copy of the Popular Mechanics CATALOG OF PUBLICATIONS AND PROJECTS. (If outside USA, please enclose 25¢ USA currency.)

Name _____ (please print)

Address _____ (please print)

City _____ State _____ Zip code _____

EMC/A



Put your walls to work!

With Royalcote Living Wall, you just plug in the brackets and it's instant shelves—wherever you want them. Masonite's Living Wall is just like Royalcote: handsome 4 x 8-foot hardboard panels in Teak, Sable Walnut or Honeytone Cherry. The difference is in the grooves. That's where we've hidden the tiny slots that take the brackets. We've got the brackets, even picture hooks.

We've also got the shelves. Reinforced hollow core shelves for lightness and strength, or solid wood shelves in contemporary or traditional styling; both factory prefinished in walnut. Stains and fingermarks wipe off with a damp cloth. Panels, brackets, hooks, shelves: the whole works is available through your lumber dealer. He's in the Yellow Pages. Or use the coupon. Just don't shelve the idea.

Masonite and Royalcote are registered trademarks of Masonite Corporation



Concealed slots support shelf brackets and picture hooks.

MASONITE CORPORATION Dept. PM-1
Box 777, Chicago, Illinois 60690
In Canada, Masonite Company of Canada,
Quebec

Please send me your booklets on Living Wall and Masonite Shelves.

Name _____

Address _____

City _____ County _____

State _____ ZIP _____

POPULAR MECHANICS®

INTERNATIONAL EDITIONS: AUSTRALIA, BRAZIL, CARIBBEAN, DENMARK, FRANCE, MEXICO, SOUTHERN HEMISPHERE, SWEDEN

AUTOMOBILES AND DRIVING

- [24 Detroit Listening Post](#)
- [30 Drivin' With Dan](#)
- [72 Automobile Clinic](#)
- [84 Your Second Car May Be a Truck!](#)
- [88 Why Your Car Looks the Way It Does](#)
- [95 How Far Can We Go With the Piston Engine?](#)
- [106 Those Small Sporty Sedans](#)
- [110 When Radiators Were Regal](#)
- [119 Those Wonderful Brothers Wood](#)
- [134 Saturday Mechanic: How to Replace Your Car's Ignition Wiring](#)

SPACE, AVIATION, MILITARY

- [46 The Army's Attic of Antique Arms](#)
- [79 How the Army Learned to See in the Dark](#)
- [92 They're Putting the Old Birds Back Into Battle](#)
- [122 The Flying Belt Stretches Its Wings](#)

BOATING, OUTDOOR RECREATION

- [28 What's New Outdoors](#)
- [36 Ice-Fishing Gadgets](#)
- [124 Trim Tabs: Do They Really Make a Difference?](#)
- [138 8 Ways to Hop Up a Snowmobile Engine](#)
- [158 Build This Houseboat for Under \\$1000](#)

SCIENCE AND INVENTIONS

- [20 Science Worldwide](#)
- [100 Just Patented: PM Picks the New Inventions](#)
- [102 Flying the English Channel: Altitude 7 Feet](#)
- [114 His Office Is Under the Sea](#)
- [142 Unique Idea in Link Roller Chain](#)

SHOP AND CRAFTS

- [150 Build This Connecticut Shelf Clock](#)
- [154 Build This Storage Into Your Pool Table](#)
- [168 Keep the Swing in an Overhead-Type Garage Door](#)
- [172 New Tools You Should Know About](#)
- [173 Hints From Readers](#)
- [174 How to Squeeze More Storage Space out of Your Kitchen](#)
- [178 Build This Box-Leg Power-Tool Stand](#)
- [179 Hints From Readers](#)
- [180 How to Mill on a Drill Press](#)
- [185 Hints From Readers](#)
- [186 Turning Rings on a Lathe](#)

HOME AND YARD

- [76 Homeowners' Clinic](#)
- [150 Build This Connecticut Shelf Clock](#)
- [154 Build This Storage Into Your Pool Table](#)
- [164 Solving Home Problems](#)
- [166 Exciting New Products](#)
- [168 Keep the Swing in an Overhead-Type Garage Door](#)
- [174 How to Squeeze More Storage Space out of Your Kitchen](#)

ELECTRONICS, RADIO AND TV

- [143 Electronic Kinks](#)
- [144 No-Hands Amplifier for Your Telephone](#)
- [148 New in Electronics](#)

PHOTOGRAPHY

- [40 Biggest Tele?](#)
- [130 Darkroom Sink With a Built-In Washer](#)
- [133 Photo Hints](#)

REGULAR FEATURES

- [6 Letters](#)

Cover Illustration by Ed Valigursky:
Army's rifle-mounted Starlight Scope, now in use in Vietnam

NEXT MONTH IN POPULAR MECHANICS

- Daytona "500" Preview: Can Chrysler put the crunch on Cale?
- Boat Camping on Lake Powell in Glastron's New Vagabond. A PM editor reports.
- Winter Driving Tips. How to keep going on icy turnpikes and mountain roads.
- PM Owners Report on American Motors' AMX. Owners tell what's good and bad.

ROBERT P. CROSSLEY

Editor

JAMES M. LISTON
Executive Editor

JOHN A. LINKLETTER
Managing Editor

WAYNE C. LECKEY **SHELDON M. GALLAGER**
Home and Shop Editor Assistant Executive Editor

THOMAS G. DAUER
Art Director

Published by The Hearst Corporation
RICHARD E. BERLIN, PRESIDENT

RICHARD E. DEEMS
President, Magazines Division

JOSEPH F. KERN
Publisher

WILLIAM KILPATRICK _____ Automotive
KEVIN V. BROWN _____ Aviation
DANIEL C. FALES _____ Boating and Outdoors
SHELDON GALLAGER _____ Electronics and Photography
BILL HARTFORD _____ Associate Automotive
LEONARD E. SABAL _____ Home Workshop
GARRY WINTER _____ Copy and Production
RICHARD H. FUNK _____ Associate Copy and Production
KATHY GARAVUSO _____ Assistant Copy and Production
ALVIN KIETZ _____ Assistant Art Director
DON EVANS _____ Assistant Art Director
FRED A. LEERS _____ Assistant Art Director
GEORGE W. BLOW _____ Technical Art Director
SOPHIE GRONOWICZ _____ Director, Bureau of Information
EVERETT JOHNSON _____ Cabinetmaker

ADDRESS ALL EDITORIAL COMMUNICATIONS TO: 575 Lexington Ave., New York, N.Y. 10022. For additional sources of information on the articles and products in this issue, write to Bureau of Information, Popular Mechanics, for free "Where-to-Find-It" list.

DANIEL J. COLEMAN
Director of Advertising

ADVERTISING OFFICES: New York: 575 Lexington Ave., Murray Hill 8-8500; Chicago: 520 N. Michigan Ave., 527-2400; Detroit: General Motors Bldg., TRinity 5-8711; Cleveland: Hanna Bldg., 1422 Euclid Ave., PRospect 1-0456; Los Angeles: 601 North Vermont Ave., 666-6263; San Francisco: 1101 Hearst Bldg., YUkon 2-0823.

SUBSCRIPTION SERVICE: Mail all subscription orders, changes of address, correspondence concerning subscriptions, and Postmaster notices of undeliverable copies to Popular Mechanics, Box 646, New York, N.Y. 10019. Please enclose your latest address label for quickest service when writing about your subscription.

POPULAR MECHANICS IS PUBLISHED MONTHLY by The Hearst Corporation, 57th St. at 8th Ave., New York, N.Y. 10019, U.S.A. Richard E. Berlin, President; George Hearst, V-Pres.; Richard E. Deems, President of Magazines; John R. Miller, Executive V-Pres. of Magazines; Raymond J. Petersen, Senior V-Pres. of Magazines; William S. Campbell, V-Pres. of Magazines; Albert A. Rachol, V-Pres. and Director of Circulation; Joseph F. Kern, V-Pres. for Popular Mechanics; Frank Massi, Executive V-Pres. and Treasurer; Harvey L. Lipton, Secy. Single copy in the United States and Canada, 50 cents. Subscription prices: United States and Possessions, \$4.00 for one year; \$7.00 for two years; \$10.00 for three years. Canada, add \$0.50 for each year. Pan American Postal Union countries, add \$1.00 for each year. All other countries, add \$2.00 for each year. When changing address, give old address as well as the new, with postal-zone number, if any, and allow six weeks for change to become effective. Second-class postage paid at New York, N.Y., and at additional mailing offices. Authorized as second-class mail by the Post Office Department, Ottawa, and for payment of postage in cash. Registered as second-class matter at the Post Office at Mexico D.F., Mexico, June 20, 1950. © 1968 by The Hearst Corporation. All rights reserved. Printed in U.S.A.

JANUARY 1969

**A handsaw
without
Nicholson
bite**



**is like
a brush
without
bristles.**



Get yourself a bristling-sharp Nicholson handsaw with Du Pont Teflon-S® coating on the blade.

You'll breeze through woodcutting — and have a rust-free blade for years. Don't be without one of these biting beauties.

There's never a dull moment with

Nicholson

Nicholson File Co., Providence, R.I.



LETTERS

TO THE EDITOR

Grizzly bear mystery

The article *Glacier Park's Grizzly Bear Mystery* (page 82, Nov. PM) seemed quite fair concerning the events and author E. D. Fales Jr. avoided some of the sensationalism of other writers.

Mr. Fales mentions the hope of having some kind of defensive protection for the people who hike in the back country of the national parks. Most people recognize that the national parks are for protection of the ecology and animal life and that human visitors are just that—visitors.

The Park Service has enforced an excellent policy to keep the back country clean as one means to avoid encounters with bears. But more is needed.

Friends of Glacier National Park has sought just such a chemical spray as Mr. Fales mentions. Possibly some reader might have some advice. If so, he may write Friends of Glacier National Park, Box 322, West Glacier, Mont. 59936.

WEST GLACIER, MONT. THOMAS R. BEST
PRESIDENT

I was shocked because people are not allowed to carry guns in our park system to defend themselves. In a free country people should have the right to protect themselves; a gun should be the right of any person leaving the tourist centers to backpack or hike into the interior of a park. The way to self-protection is not to exterminate the "enemy" (we must remember that a demented bear is the exception just as a demented person is), but to be allowed to defend yourself adequately. A gun is as basic a survival tool as matches for those who pack in.

MERRIMAC, WIS. LINDA VLAHOS

A recounting of these tragic events should not have been published out of consideration for the families of the girls who lost their lives. Reporting of the event by news media at the time it happened was sufficient. Surely if families or close friends have the misfortune to read the current story, it will renew grief which had perhaps begun to heal.

LEWISTON, N.Y. THOMAS E. GUENTER

No bargaining power

That book excerpt, *How to Bargain With a Car Dealer* (page 76, Nov. PM) was enlightening, but of little or no real help.

The whole article could have been nice-

ly summed up by stating the cold, hard fact that you can never beat the car dealer at his own game. He has a product you desire very much—and knows it. You can buy it only on his terms or not at all. The buyer has absolutely no bargaining power.

CHICAGO

KEN GREENBERG

Author Merle Dowd states a retail sticker price of \$3660 with a 25-percent markup would give a dealer a markup of \$915.

A new automobile that costs a dealer \$2928 from the factory with a 25-percent markup would have a list price of \$3660. The 25-percent markup would be \$732. You must take 20 percent of the retail price of an article with a 25-percent markup to arrive at the correct dealer's cost.

YOUNT FORD SALES

ROBERT YOUNT

BARRINGTON, ILL.

Strictly speaking, Mr. Yount is correct. The National Assn. of Automobile Dealers explains the semantics of the situation this way:

The dealer buys the car from the manufacturer at its retail (sticker) price, less a discount fixed by the manufacturer. The amount the dealer pays is the invoice price. Whatever the dealer sells the car for—above invoice price—is the markup.

Thus, if the dealer buys a \$4000 (sticker price) car from the manufacturer at a discount of 25 percent, he pays a \$3000 invoice price. If he sells it to you at a markup of 25 percent, the price is \$3750.

(There are, of course, other cost factors—such as shipping—that the dealer has to pay and pass on to the buyer.)

Lightweight is load-bearing

With the article *How to Lay Concrete Blocks Like an Amateur* (page 166, Oct. PM) you printed *A Thumbnail Guide to Concrete Blocks* (page 171) in which you made the statement: "Never use lightweight blocks for load-bearing walls."

This is a blatant misstatement of fact. Not only is it possible to use lightweight block for load-bearing walls, the majority of walls built for load-bearing masonry construction—even in those areas subject to the severe stresses of earthquakes—are built of lightweight blocks.

An example of load-bearing masonry is the Sportsmen's Lodge Hotel, built several years ago in North Hollywood. Another

(Please turn to page 8)

START YOUR NEW CAREER NOW! WITHOUT OVERHEAD! ANY PLACE! ANY AGE!

UPHOLSTERING JUST ONE

you don't even have to quit your present job!!!

CHAIR can pay you as much as your present weekly paycheck!

Start learning now. At home, or in the garage, in your spare time — no outside classes to attend. If you can tie a knot and drive a tack, you can learn this business, quickly, easily. You start learning the basics **right away** through the proven MUI Home Training Plan. And before you're barely into it, you can start doing the simple upholstering jobs that are all around you waiting to be done. Chairs, cushions, seats, footstools. Even before MUI students finish their training, people start bringing upholstering jobs to them, and remember—the world is full of furniture that needs fixing and re-upholstering and more is wearing out all the time!

"What started as a hobby, now pays me \$10 an hour"

Yes, many MUI graduates make better than \$10 an hour turning old wornout furniture into bright new decorator pieces! **Stack it up against what you're doing now!** Are you making \$150 a week? \$200? \$250? Do you put in long hours of dull work, with small raises? Is that the way you want to spend the rest of your life? Just imagine, you can make \$150, \$200, \$250 upholstering just **one** chair or sofa these days! And if you're the kind of person who likes to work and earn, you can sometimes finish a job like this in a day. That's pay, ... and it beats what most college graduates make!

AS YOU LEARN, YOU JUST SLIP INTO THE IMMENSE FLOW OF UPHOLSTERY WORK! Think of all there is! ... Sofas, lounging chairs finished in beautiful fabrics, which MUI tells you how to get at the right price — even leather and all the new vinyls. And then you have built-ins and breakfast nooks, boats, trailers and all the millions of automobiles in America. Yes, you learn all this and more! When we finish teaching you, (in your own home in your spare time) and when you get our California state approved diploma, you **know** this business ... as a **real professional!** You will then have one of the most fantastic moneymaking skills in America built into your head and hands! No one can ever take this skill away from you ... and no one can ever fire you, because **you're the boss** of a business that you can take with you ... You can make big money from then on ... any time, **anyplace** you want to put out your shingle!

When you read the papers you see there's a strike here, a lockout there. Detroit lays off 150,000 men. A plant is shut down and moved out of state. A new automated machine eliminates 5,000 jobs. They talk about dislocated workers and try to do something about it. What pays the bills if you get caught up in one of these situations? When you know upholstering, life gets very simple and lots of fun. It's simple because where there are people, there are upholstery jobs and lots of them. It's fun because life is fun when the bills are paid and there's money in the bank, even enough to buy those things you've always wanted for yourself.

MUI IS APPROVED BY THE CALIFORNIA SUPER-INTENDENT OF PUBLIC INSTRUCTION AND IS AUTHORIZED TO ISSUE A DIPLOMA IN UPHOLSTERY.

**MODERN UPHOLSTERY INSTITUTE
Box 899-BGA, Orange, Calif. 92669**



YOU GET SIX BIG FURNITURE KITS FREE



YOU GET THIS AUTHORIZED DIPLOMA WHEN YOU GRADUATE

Name _____ Age _____
 Address _____
 City _____ State _____ Zip _____

WORK THE HOURS YOU LIKE TO WORK!!

If you favor a regular 35 hours a week, upholstery lets you do it and make a really fine living. On the other hand, if you're really ambitious and want to work 60 or 70 hours a week, **you are starting to talk about some big, big money!** The important thing is that the choice is **yours**, not somebody else's! (Not like when you're working for someone else.) Many students of retirement age just do a few pieces now and then just to keep things nice and comfortable.

TO GET STARTED, JUST GET THE COUPON IN THE MAIL... TODAY!

It costs you nothing to get the information and there's no obligation. No salesman is going to call you. This much and this much only, every successful MUI graduate must do for himself — **send the coupon today!**

YOU'LL GET A BIG ILLUSTRATED 32 PAGE BOOK ON UPHOLSTERY and the upholstery business, and an actual free sample lesson showing how the fabulously successful MUI system is taught. For your sake and the sake of your future, do it now. Cut out the coupon, fill it out, put it in an envelope and mail it now. Air mail reaches MUI about two days sooner!

ALL THE SPECIAL "TOOLS OF THE TRADE" ARE YOURS... FREE

THIS FREE UPHOLSTERY BOOK may be the most important information you ever read.

MAIL COUPON NOW!

MODERN UPHOLSTERY INSTITUTE, Box 899-BGA Orange, Calif. 92669

Please send the **FREE UPHOLSTERY CAREER BOOK**, the **FREE SAMPLE LESSON**. I understand I am under no obligation whatever and am just sending for the free facts on job and career opportunities in Upholstering and the MUI home training program. I understand that no salesman will call.



APPROVED FOR VETERANS

The Lazy Pipe Tobacco



Bond Street is for the man who gets a lot out of pipe smoking. He likes to stretch out the pleasure with a pipeful that lasts him awhile. Bond Street does, because it's a combination of plugs and flakes, for smooth and steady burning.

Just to give you an idea: you can watch about half of an old Charlie Chan movie on one filling of Bond Street. You'll be quite happy with the good Bond Street flavor (and unless you're alone, someone will surely say something nice about the aroma).



Lights easy—
takes its own
good time about burning.



LETTERS

(Continued from page 6)

larger example is the eight-story Hanalei Hotel addition in San Diego. An even more striking example is the 13-story Catamaran Motor Hotel in San Diego.

If lightweight concrete blocks are used in such critical load-bearing structures, they would certainly be adequate for whatever use might be made of your recommendations.

LOS ANGELES

WALTER L. DICKEY
CONSULTING STRUCTURAL ENGINEER

There is no technical foundation for your statement. The American Society for Testing and Materials has specifications for lightweight aggregates for concrete masonry units as well as specifications for load-bearing concrete masonry units. Units made with aggregates of our members always exceed the 1000 p.s.i. minimum compressive strength requirements (gross area) stipulated for load-bearing units.

EXPANDED SHALE CLAY AND SLATE INST. WASHINGTON, D.C.
FRANK G. FRISKINE
MANAGING DIRECTOR

Responds author Richard Day: "I am wrong, wrong, wrong. I don't know where the statement came from."

"Henry Toennies, director of engineering of the National Concrete Masonry Assn., says: 'Absolutely no difference is made in the use of lightweight-aggregate concrete masonry units and the units made with normal or heavyweight materials.'"

Why the New Jersey?

After reading *A Battlewagon Returns From Mothballs* (page 88, Oct. PM), I have two questions:

Why was the *New Jersey* chosen as opposed to one of her other three sister ships—specifically the more famous *Missouri*?

Where does author Bob Zimmerman get the 58,000-ton figure he quotes in the article? As I remember, the *Iowa*-class battleships were officially rated at 45,000 tons displacement.

PITTSBURGH, PA.

W. J. KOPP

"The main consideration in choosing the *New Jersey* for reactivation instead of one of the others was the time and investment needed to get it back in shape," writes Mr. Zimmerman. "There was more stainless steel used in the construction of the *New Jersey* than in the other three, and therefore it had weathered its years

(Please turn to page 10)

 **CIE Cleveland Institute of Electronics**
1776 E. 17th St., Cleveland, Ohio 44114

Please send me 2 FREE books describing opportunities in Electronics and how to prepare for them.

Name _____ Age _____
(please print)

Address _____

City _____

State _____ Zip _____

Veterans & Servicemen: check here for G.I. Bill information

Accredited Member National Home Study Council

PM-20



Are you stuck in dull, low pay work? The coupon above can change your life

Mail it right now for 2 FREE BOOKS about today's fantastic Electronics boom, and how you can earn up to \$12,000 a year by cashing in on it.

IF YOU'RE TRAPPED in a job with no future—plugging away at dull, routine work for penny-ante pay—here is your chance to do something about it.

Just mail the coupon above and we'll send you, FREE, two books that can start you on the road to a rewarding new career. A career you can be proud of. One where you'll do exciting work. And one that can pay you the kind of money that many men only dream of.

Thousands of career openings like this

exist right now in America's hottest growth industry—Electronics. It's an industry where you can take your pick of literally scores of different "glamor jobs"—in broadcasting, automation, the aerospace program, and many other areas. And it's an industry where, once you have some experience under your belt, you can earn up to \$5, \$6, \$7 an hour... \$200, \$225, \$250 a week... \$10,000, \$11,000, \$12,000 a year.

You don't need college training to break in. Our free books will show you how you can prepare right at home in your spare time. And they'll show you, too, how we can help you land the "dream job" of your choice.

So why delay? Mail the coupon above for your two FREE books today.

Sure, you can buy welders for less money
... and for even more money ... but ...

YOU CAN'T GET A BETTER WELDER VALUE THAN A LINCOLN!

Lincoln Electric, the world's largest manufacturer of arc welding equipment, builds welders to industrial quality standards in high volume. You get these unbeatable values:

- **Longer life** ... some Lincolns over 50 years old are still going strong.
- **Rugged, reliable** ... just push the button and get the job done, fast, every time!
- **Easy to operate** ... no spit, no sputter. Easy to start, easy to set controls.
- **Versatile** ... weld all metals, cut, solder, braze. Ample amps.
- **Safe** ... built to conservative, industrial ratings. Underwriters approved standards.

Compare these values ...

(Prices subject to change without notice.)

Only \$93 (Zone 1 list) for this 225-amp shop welder. Complete with accessories, electrode kit, power cord, instruction books. ▼



Air-cooled engine-driven Weldanpower®. Goes anywhere, welds anything. 130 amps AC for welding, plus auxiliary power for tools. Zone 1 list price \$355.



Versatile, heavy-duty Idealarc® AC or AC/DC welder. Range 30-300 amps. Single phase. Zone 1 list price (AC/DC) \$287.

MAIL COUPON FOR FREE LITERATURE

The Lincoln Electric Company
Cleveland, Ohio 44117

**LINCOLN
ELECTRIC**

I am interested in Weldanpower 130
 225 AC shop welder Idealarc 250

Send full details without obligation.

Name _____

Address _____

City _____ State _____ Zip _____

LETTERS

(Continued from page 8)

in storage in better shape. Also, the New Jersey had been in active service more recently than the others, and having spent less time in mothballs it needed less refurbishing.

"Mr. Kopp is correct in that the Iowa-class battleships have an official 'standard displacement' rating of 45,000 tons. The 58,000-ton figure is the New Jersey's full-load displacement—carrying fuel, ammunition, stores, and so on. Neither figure is any more accurate than the other, as long as you understand what type of displacement you mean. Jane's Fighting Ships and other directories usually list both."

Doesn't feel sorry

The police forgot to fine A. R. Roalman for driving with a broken speedometer ('Grounded' for 90 Days, page 61, Nov. PM). With a broken speedometer, he could have been going 20 mph over the speed limit.

Your windshield wipers, speedometer, horn, lights, brakes, and so on are to be in working order at all times. Driving with his speedometer broken was a violation in itself. I don't feel sorry for this man.

BINGHAMTON, N.Y. ANTHONY J. MILDICE

We suspect that after three months afoot, Mr. Roalman has the best-maintained and most law-abiding car on the block. However, he writes so well that we're trying to get him into some other trouble with the police.

'Turned on' about houseboats

We Took a Houseboat Vacation (page 100, Nov. PM) by John Linkletter has "turned us on." Now supply us with the "stuff." The article has us wanting to rent a boat for a vacation as soon as possible.

Where can we find out who rents houseboats and where? Is there a directory or other source of information?

MOUNTAINSIDE, N.J. ERNEST SCHMID

There's no national association of houseboat renters, thus no "official" list. The most complete list we've seen is the Coast-to-Coast Houseboat Rental Directory published by Family Houseboating, P.O. Box 2081, Toluca Lake, Calif. 91602. Send them 50 cents and your name and address for a copy.

There's also a special houseboat section (including rental list) in the Dec. 1967 issue of Sports Afield that a neophyte would find extremely valuable. Look in your local library. ★★★

BIG

YACHT-SMART
Sail Rig
DACRON
from
\$112



WINTER SAVINGS NOW

FOLBOT

TRAVEL CRAFT
fits in every
home or car

FOR YOUR SPORT AND FAMILY FUN

and RECORD FISHING

GENUINE Folbot RECREATION for just ONE small investment, WITHOUT the continuous burdens of complicated 'big rig' operation. You GO CAREFREE anytime with COMPACT Folbot . . . rocky streams, lakes, marsh, surf & open sea. Superior non-sinkable designs provide SAFEST low gravity center, balanced low & high seating, substantial construction, protective decks & EXCLUSIVE swivel-back COMFORT. ALL within your reach. In handy Folbot YOU GLIDE smoother, faster & NOISELESS with paddles, oars, or sails and ride softly w. 1 to 10 HP. motors. Many styles & sizes from 1 to 4 seaters, FOLDING or rigid PORTABLE come in PREFAB KIT, or expertly FACTORY BUILT

Just a few Dollars start
YOU right away. From

ONLY \$19 NOW

for BASIC KIT

16 feet long

'CAYAT'
car top
YACHT.

NEW
Fabulous
16 foot
\$109

Factory BUILT

FREE
ACTION CATALOG

**STARTLING
FACTS & FIGURES**
Mail coupon or address

to: FOLBOT CORP.
Dept. PM-1 Charleston, S. C. 29405

Name _____

Address _____

City _____

State _____



Get more
GETUPANDGO
from every engine with
GUMOUT



Transistor
Radio with
Battery
\$1.70

Calendar
Watch \$2.44



Derringer
Pistol \$5.99

HOME-IMPORT

BUSINESS-Make Big Profits

New Drop Ship Plan offers you first day profits! Deal direct with overseas sources at prices shown. Dazzling bargains with no investment. Full or spare time. Write for FREE BOOK today to...

MELLINGER, Dept. c2251, 1554 S. Sepulveda, Los Angeles, Calif. 90025

CUT-TO-FIT HOMES SAVE LABOR COSTS UP TO 100%

Save labor cost up to 100%, reducing completed home cost. You can assemble any of 57 designs from easy-to-follow plans. No measuring or cutting . . . every piece precision machine pre-cut and marked. **BUY DIRECT FROM MILL.** Eliminate all between overhead, profit and labor

PRICED FROM \$2295 UP

Prices do not include carpentry labor, heating, lighting, plumbing and masonry materials.
FIVE EASY-PAYMENT PLANS,

THIS
HOME
\$6535

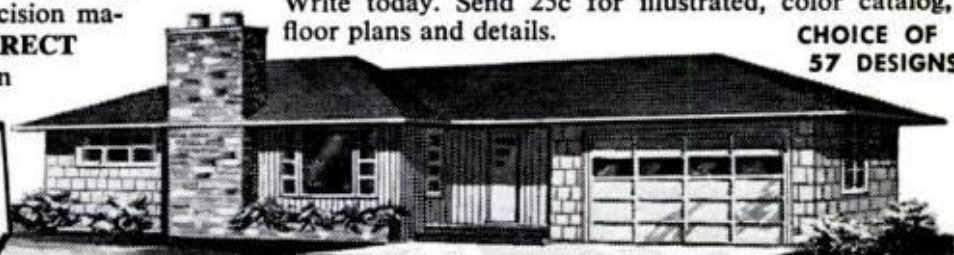

costs. Nothing to plan or figure. Complete with all lumber, hardware, paint, nails, glass, roofing, etc. Sterling Home quality material throughout. Freight paid most areas.

Write today. Send 25c for illustrated, color catalog, floor plans and details.

CHOICE OF
57 DESIGNS

INTERNATIONAL MILL & TIMBER CO. Bay City, Michigan, DEPT. PM-19

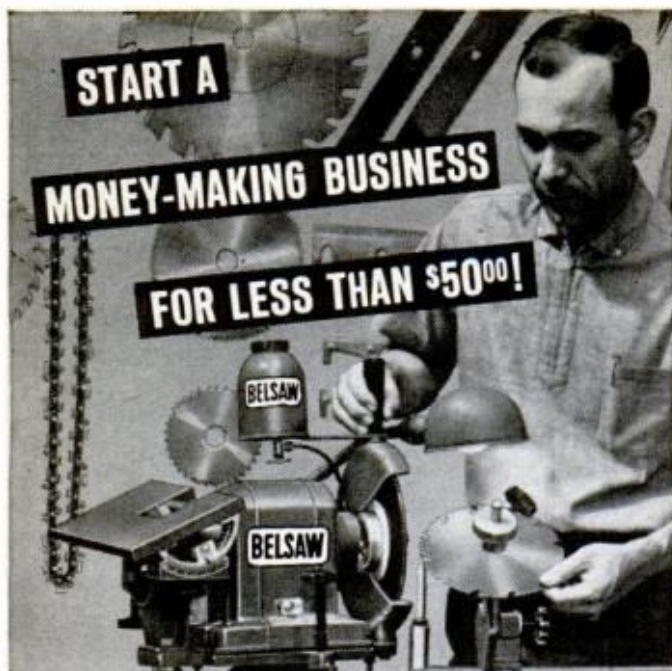

No Selling, No Inventory... All Cash Profits and YOU Set The Hours!

You can have your own lifetime business right at home... work in spare time... and make up to \$200 a month CASH! My FREE PLAN gives you all the facts: How to start, how to grow. You don't need previous experience. You don't have to sell. I'll even finance you. People bring you the work and pay cash. Over 90¢ of every dollar you collect is clear cash profit. And you work when you want to. Let me prove you can't find a more certain, lower cost, higher paying business of your own.

**Does The Belsaw Pay?
YOU BET!**

W. R., Maryland

"My BELSAW is working fine and business is increasing by 20 to 30 customers a month. I've added one employee and am looking for a night man to handle rush jobs."

C. S., Minnesota

"The sharpening business has helped me buy two homes and three motor cars. The nice thing about the Sharp-All is that you get some cash every day."

RUSH COUPON TODAY!

Just Mail Coupon — No Salesman Will Call

BELSAW SHARP-ALL CO.

Stan Field, President
719J Field Bldg., Kansas City, Mo. 64111

Name _____

Address _____

City _____ State _____ Zip _____

**FREE
BOOK**

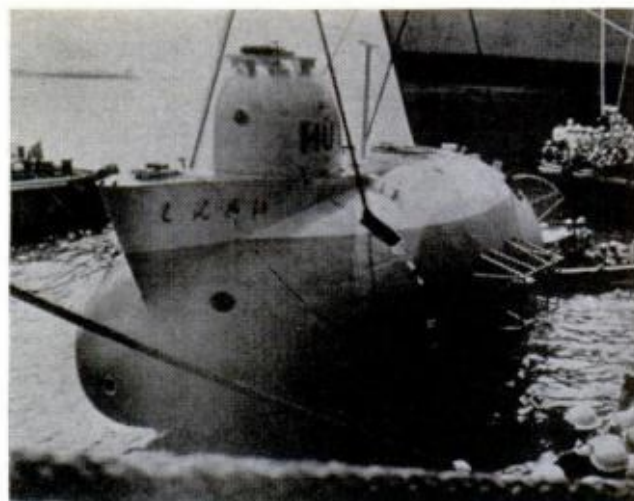

First for Japan

The *Shinkai*, Japan's first bathyscaph, can submerge to a depth of 1980 feet, carrying a crew of four. It'll be used for research.

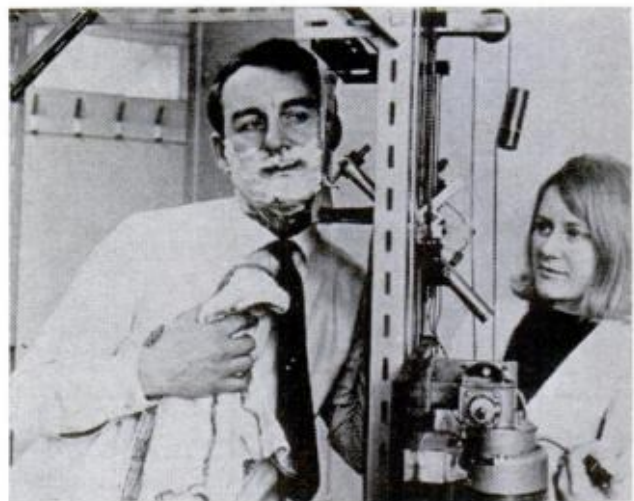

Haircut, too?

Gillette researchers in Reading, England, come to work unshaven so the "Scaffold" can shave one square inch of skin and record the pressure required in shaving.

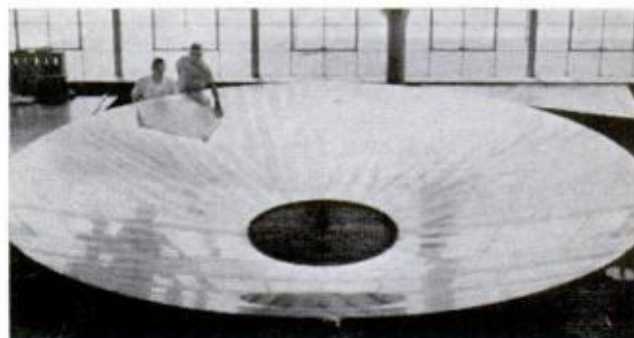

Giant mirror

A 20-foot magnesium mirror, built by GE for NASA, is coated with metallized aluminum that was evaporated off tungsten metallizing filaments in a vacuum chamber.

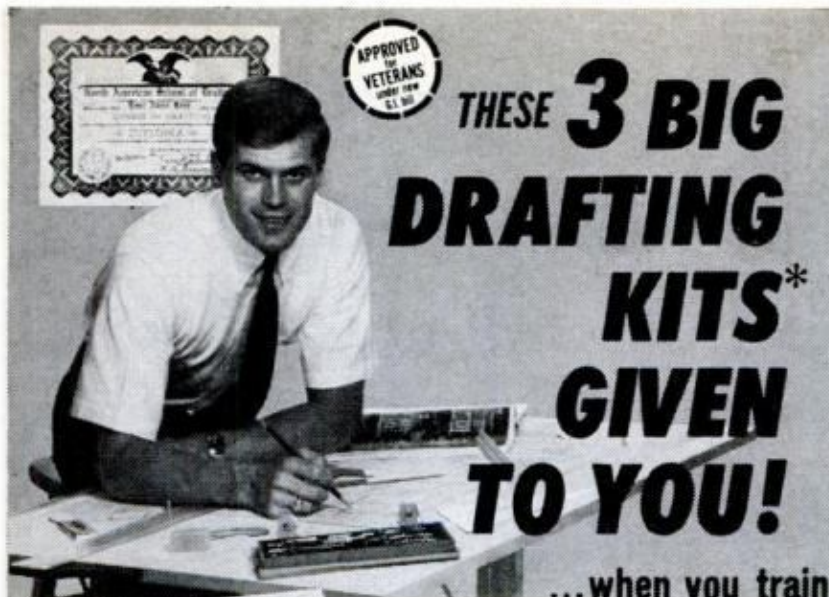

THESE 3 BIG DRAFTING KITS* GIVEN TO YOU!

...when you train at home with NASD for a

HIGH PAY JOB IN DRAFTING!

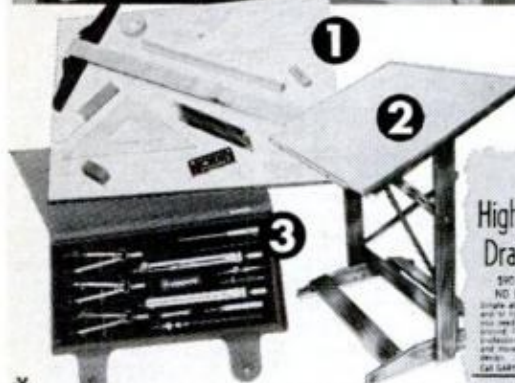

*Precision Drawing Instrument Set, Professional Drafting Board Outfit and Fingertip Tilting Drafting Table are given to you with your complete North American Course in Drafting.

U. S. LABOR DEPT. REPORTS SERIOUS SHORTAGE OF DRAFTSMEN

(The following quotes from U. S. Labor Dept. point out nationwide shortage for Draftsmen):

"The dearth of qualified applicants has resulted in increasing calls for trainees, as employers in many areas relaxed hiring specifications. Experience requirements have been virtually eliminated, along with age barriers."

"Steadily growing employer requirements... were accompanied by marked reductions in the supply of draftsmen available."

TOP AMERICAN EMPLOYERS WELCOME NASD GRADUATES

"We would be interested in interviewing your grads as potential employees." **REMINGTON**

"At the present time we have several openings available for qualified Draftsmen. I look forward to considering graduates of your institution." **WESTINGHOUSE**

"We have immediate openings for designers and Draftsmen and have a definite interest in interviewing candidates immediately." **AMERICAN MACHINE & FOUNDRY**

(3) High School Draftsmen

\$50-\$120 PER MONTH
NO EXPERIENCE
Simple plans with training
and a basic tool and instrument
set. You need to get on the
ground. You get the job of
drafting. Research, train
and work for the whole
year.

Call 8487-0702, 300-4422

NO EXPERIENCE REQUIRED!

Trains who satisfactorily
pass a basic quiz and attend
employment and receive
FULL SALARY
AUTOMATIC SALARY
INCREASES
FULL EMPLOYEE BENEFITS

Call immediately to
arrange interview
equipment

JOE PASKOWSKI

204-4113

THE FLUOR

Corporation, Ltd.
INTERNATIONAL
ENGINEERING-CONSTRUCTORS
2200 S. ALHAMBRA BLVD.
LOS ANGELES, CALIF. 90022

Design Draftsmen

Requires experience in
design and drafting of
small mechanical
devices.

CALL OR APPLY

ADRIANT-GENERAL CORP.

17711 Woodruff Ave.

DRAFTSMAN

Architectural

WESTERN GEAR

Take Your Pick of 2 EXCITING FIELDS

1 Architectural Drafting

Today's population explosion guarantees boom in building of homes, churches, schools, factories, office buildings & warehouses is just starting. Thousands Architectural Draftsmen needed NOW because drawings must be made of every part of every building before ground can be broken.



2 Mechanical Drafting

Skyrocketing U.S. mass production requires millions of drawings & thousands of Mechanical Draftsmen all along the way. Drawings must be made of every PART of every product used in the U. S. (as well as of the machines that make these parts) before production can be started.



HERE'S WHAT STUDENTS SAY



Earns \$820 Month!
"My first position after completing your course jumped my income from \$350 to \$820 per month." —G. W., Tenn.



Big Promotion!
"I was promoted from the production line ahead of 4 others and got a good pay raise." —W. A., Wisc.

Gets 50% Raise!
"Shortly after I completed your course I was made shop foreman. My pay was increased by half." —W. R., New York

No Layoffs!
"Strikes and layoffs are nightmares of the past. Your training has opened the door to a wonderful future for me." —H. O., Ohio

Authorized to issue diplomas by California Superintendent of Public Instruction.
Accredited Member, National Home Study Council.

Veterans, Servicemen you may be eligible for Gov't education benefits in association with Cleveland Engineering Institute.

ALL 4 FREE!
Rush Coupon Today!

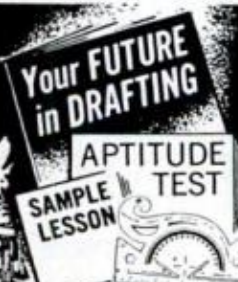

- 1 5-Way Drafting Instrument—yours to keep as a FREE GIFT without obligation.
- 2 20-Pg. Drafting Career Fact Book — packed with details about career opportunities.
- 3 Self-Scoring Drafting Aptitude Test — tells if you are suited for high-pay Drafting Career.
- 4 Sample Lesson — a "sneak preview" of things to come.

NORTH AMERICAN SCHOOL OF DRAFTING
4500 Campus Dr., Dept. 4171 University Plaza, Newport, Calif. 92660

NORTH AMERICAN SCHOOL OF DRAFTING, Dept. 4171
4500 Campus Dr., University Plaza, Newport, Calif. 92660
Rush "DRAFTING CAREER KIT" including Book, Sample Lesson, Aptitude Test & Drafting Instrument — ALL FREE! No salesman will call.

NAME _____ AGE _____

ADDRESS _____

CITY _____ STATE _____ ZIP _____



I'd like to give this to my fellow men... while I am still able to help!

I was young once, as you may be—today I am older. Not too old to enjoy the fruits of my work, but older in the sense of being wiser. And once I was poor, desperately poor. Today almost any man can stretch his income to make ends meet. Today, there are few who hunger for bread and shelter. But in my youth I knew the pinch of poverty; the emptiness of hunger; the cold stare of the creditor who would not take excuses for money. Today, all that is past. And behind my city house, my

summer home, my Cadillacs, my winter-long vacations and my sense of independence—behind all the wealth of cash and deep inner satisfaction that I enjoy—there is one simple secret. It is this secret that I would like to impart to you. If you are satisfied with a humdrum life of service to another master, turn this page now—read no more. If you are interested in a fuller life, free from bosses, free from worries, free from fears, read further. This message may be meant for you.

By Victor B. Mason

I am printing my message in a magazine. It may come to the attention of thousands of eyes. But of all those thousands, only a few will have the vision to understand. Many may read; but of a thousand only you may have the intuition, the sensitivity, to understand that what I am writing may be intended for you—may be the tide that shapes your destiny, which, taken at the crest, carries you to levels of independence beyond the dreams of avarice.

Don't misunderstand me. There is no mysticism in this. I am not speaking of occult things, of innumerable laws of nature that will sweep you to success without effort on your part. That sort of talk is *rubbish!* And anyone who tries to tell you that you can *think* your way to riches without effort is a false friend. I am too much of a realist for that. And I hope you are.

I hope you are the kind of man—if you have read this far—who knows that anything worthwhile has to be *earned!* I hope you have learned that there is no reward without effort. If you have learned this, then you may be ready to take the next step in the development of your karma—you may be ready to learn and use the secret I have to impart.

I Have All The Money I Need

In my own life I have gone beyond the need of money. I have it. I have gone beyond the need of gain. I have two businesses that pay me an income well above any amount I have need for. And, in addition, I have the satisfaction—the deep satisfaction—of knowing that I have put more than three hundred other men in businesses of their own. Since I have no need for money, the greatest satisfaction I get from life is sharing my secret of personal independence with others—seeing them achieve the same heights of happiness that have come into my own life.

Please don't misunderstand this statement. I am not a philanthropist. I believe that charity is something that no proud man will accept. I have never seen a man who was worth his salt who would accept something for nothing. I have never met a highly successful man whom the world respected who did not sacrifice something to

gain his position. And, unless you are willing to make at least half the effort, I'm not interested in giving you a "leg up" to the achievement of your goal. Frankly, I'm going to charge you something for the secret I give you. Not a lot—but enough to make me believe that you are a little above the fellows who merely "wish" for success and are not willing to sacrifice something to get it.

A Fascinating and Peculiar Business

I have a business that is peculiar—one of my businesses. The unusual thing about it is that it is needed in every little community throughout this country. But it is a business that will never be invaded by the "big fellows." It has to be handled on a local basis. No giant octopus can ever gobble up the whole thing. No big combine is ever going to destroy it. It is essentially a "one man" business that can be operated without outside help. It is a business that is good summer and winter. It is a business that is growing each year. And, it is a business that can be started on an investment so small that it is within the reach of anyone who has a television set. But it has nothing to do with television.

This business has another peculiarity. It can be started at home in spare time. No risk to present job. No risk to present income. And no need to let anyone else know you are "on your own." It can be run as a spare time business for extra money. Or, as it grows to the point where it is paying more than your present salary, it can be expanded into a full time business—overnight. It can give you a sense of personal independence that will free you forever from the fear of lay-off, loss of job, depressions, or economic reverses.

Are You Mechanically Inclined?

While the operation of this business is partly automatic, it won't run itself. If you are to use it as a stepping stone to independence, you must be able to work with your hands, use such tools as hammer and screw driver, and enjoy getting into a pair of blue jeans and rolling up your sleeves. But two hours a day of manual work will keep your "factory" running 24 hours turning out a product that has a steady and

ready sale in every community. A half dollar spent for raw materials can bring you six dollars in cash—six times a day.

In this message I'm not going to try to tell you the entire story. There is not enough space on this page. And, I am not going to ask you to spend a penny now to learn the secret. I'll send you all the information, free. If you are interested in becoming independent, in becoming your own boss, in knowing the sweet fruits of success as I know them, send me your name. That's all. Just your name. I won't ask you for a penny. I'll send you all the information about one of the most fascinating businesses you can imagine. With these facts, you will make your own investigation. You will check up on conditions in your neighborhood. You will weigh and analyze the whole proposition. Then, and then only, if you decide to take the next step, I'll allow you to invest \$15.00. And even then, if you decide that your fifteen dollars has been badly invested I'll return it to you. Don't hesitate to send your name. I have no salesmen. I will merely write you a long letter and send you complete facts about the business I have found to be so successful. After that, you make the decisions.

Does Happiness Hang on Your Decision?

Don't put this off. It may be a coincidence that you are reading these words right now. Or, it may be a matter that is more deeply connected with your destiny than either of us can say. There is only one thing certain: If you have read this far you are interested in the kind of independence I enjoy. And if that is true, then you must take the next step. No coupon on this advertisement. If you don't think enough of your future happiness and prosperity to write your name on a postcard and mail it to me, forget the whole thing. But if you think there is a destiny that shapes men's lives, send your name now. What I send you may convince you of the truth of this proverb. And what I send you will not cost a penny, now or at any other time.

VICTOR B. MASON
1512 Jarvis Ave., Suite M-2-AS
CHICAGO, ILLINOIS 60626



TUNE UP ELECTRONICALLY ANY CAR EVER MADE!

- ✓ COMPACT or LIMOUSINE
- ✓ DOMESTIC or FOREIGN
- ✓ 4, 6 or 8 CYLINDER
- ✓ 6 VOLT or 12 VOLT
- ✓ POSITIVE or NEGATIVE GROUND

With New Improved Model BT-162

DWELL TACHOMETER

ASSURE - EASY STARTS, OPTIMUM PERFORMANCE and
MAXIMUM GAS ECONOMY with MODEL BT-162

MADE ORIGINALLY FOR THE PROFESSIONAL AUTOMOTIVE TECHNICIAN, MODEL BT-162 WILL PAY FOR ITSELF MANY TIMES OVER FOR THE AUTOMOTIVE HOBBYIST AND EXPERIMENTER.

The Model BT-162 will perform the services specified below in addition to many other tasks too numerous to mention:

- ✓ Assure precise adjustment of points that are slightly worn or pitted.
- ✓ Indicate the most effective point setting **without removing the distributor cap.**
- ✓ Read the average dwell of dual breaker points as well as individual dwell of each individual set of points.
- ✓ Indicate the correct settings for **external adjustment type distributors.**
- ✓ Car manufacturers' dwell angle recommendations are included in the manual provided with the Model BT-162 for all cars including the external adjustment type distributors specified above.
- ✓ It is no longer necessary to file points to smoothness when using the Model BT-162. The instrument will automatically make allowance for any existing "pitting" or "wear."
- ✓ To adjust for mathematically correct carburetor adjustment and thus insure maximum gas economy and quiet engine running, simply use the Tachometer section of the Model BT-162. Read the exact RPM while the engine is in neutral position. Then adjust the carburetor in conformity with the car manufacturer's recommendations as specified in the manual provided with the Model BT-162.
- ✓ To locate a "miss" you need only disconnect or "short" the spark plugs one at a time with the Model BT-162 switched to the Tachometer position. You will be able to instantly identify which particular plug (or frequently its wire lead) is responsible for the malfunction.
- ✓ Cars with automatic transmissions function efficiently only if the fluid pressures are correctly maintained and since manufacturer's instructions always refer to RPM the Model BT-162 (or an equivalent tachometer) is required to properly service automatic transmissions. Incidentally, the 5,000 RPM maximum range of the Model BT-162 is adequate for all car engines without any exceptions.

Comes complete, ready to use. Operating manual includes manufacturer's dwell angle recommendations for all cars. The manual is yours to keep even if you decide to return the instrument.

\$29⁹⁵

SEND NO MONEY WITH ORDER
PAY POSTMAN NOTHING ON DELIVERY

Try it for 10 days before you buy. If completely satisfied then send \$5.00 and pay the balance at the rate of \$5.00 per month until the total price of \$29.95 (plus P.P., handling and budget charge) is paid. If not completely satisfied, return to us, no explanation necessary.

ACCURATE INSTRUMENT CO., INC.

Dept. 613, 2435 White Plains Road, Bronx, N. Y. 10467

Please rush me one Model BT-162. If satisfactory I agree to pay \$5.00 within 10 days and balance at rate of \$5.00 per month until total price of \$29.95 (plus P.P., handling and budget charge) is paid. If not satisfactory, I may return for cancellation of account.

Name _____

Address _____

City _____

Zone _____

State _____

Save Money! Check here and enclose \$29.95 with this coupon and we will pay all shipping charges. You still retain the privilege of returning after 10 day trial for full refund.

FANTASTIC VALUES WITH THIS COUPON

AMERICAN MACHINE & TOOL CO., Dept. PM-19, Royersford, Pa. 19468
Please send me the units checked. Payment in full enclosed \$.....
or \$3 deposit each item enclosed, balance C.O.D. I MUST BE FULLY
SATISFIED OR WILL RETURN UNIT WITHIN 10 DAYS FOR FULL REFUND.
No questions asked.

<input type="checkbox"/> 8" Power Saw at \$14.95	<input type="checkbox"/> Jointer-Planer at \$19.95
<input type="checkbox"/> Standard Rip Fence #354 at \$3.50	<input type="checkbox"/> Lathe at \$9.85
<input type="checkbox"/> Long Rip Fence #354C at \$4.50	<input type="checkbox"/> Set of 3 High Speed Turning Chisels at \$4.95
<input type="checkbox"/> Belt Sander at \$14.95	<input type="checkbox"/> Drill Press at \$29.95
<input type="checkbox"/> Mitre gage for Sander at \$1.95	<input type="checkbox"/> Disc Sander at \$7.95†

GE Motor \$18.80 (purchased with other item)
 \$24.85 (if purchased separately)

NAME

ADDRESS

CITY ZONE/ZIP STATE

SAVE AS MUCH AS... 80% WITH QUALITY **Amco** POWER TOOLS

DIRECT FACTORY OFFER AND REVOLUTIONARY PATENTS decrease costs, increase efficiency. Full scale power tools of heavy duty 100% cast iron and steel. Streamlined design reduces weight, cuts material and production costs. Special patents provide added efficiency, accuracy, savings. Parts made, assembled, tested, packed right in our own factories shipped direct... save store profits.

ENDORSED BY AMERICA'S TOP MAGAZINES... Here is what the editors say:

"A good bit of sound—imaginative—engineering." Popular Science; "(saw) boasts many features of bigger brothers." Popular Mechanics; "Amazingly versatile." Workbench; "Highly substantial construction, sturdy enough for production line use."

Industrial Woodworking. And Workbench awarded these tools their coveted "Work Tested" Seal.

OVER A MILLION USERS confirm their precision, versatility and rugged performance.

***10-YEAR FULL SERVICE GUARANTEE...** Any part or parts of any AMCO power tool (except motor) which may become inoperative for any reason within ten years after the purchase date will be repaired or replaced by the factory without cost to the purchaser. Your only cost: for postage.

**UNCONDITIONAL
10-DAY MONEY
BACK
GUARANTEE**

You must be fully satisfied. If not, return in 10 days, freight collect. Money promptly refunded in full.



8" TILT ARBOR POWER SAW

DOES WORK OF \$75 BENCH SAW as is. Converts easily to equal any \$300 floor model cabinet units! Crosscuts, rips, mitres, cuts compound angles, dadoes, makes coves and mouldings.

\$14.95 f.o.b. factory. Wt. 25 lbs. Includes completely assembled cast iron and steel 8" saw with ground cast iron table... less blade. **RIP FENCE**, if desired, for easier work alignment, \$3.50 add'l.

SAW BLADE TILTS... TABLE STAYS LEVEL

Locks securely at any angle up to 50°, raises, lowers 0"-2 1/4". Patented tilt mechanism, accurate etched scale. Patented motor mount takes std. 1/4 h.p. or larger motor, keeps belt tight, assures perfect alignment at any angle, transmits full power. Takes std. blade, saw insert removes to take dadoe heads, cutters, etc. (not incl.). Accurate mitre gauge assembly. Ground spindle. Enclosed steel base. "Compo" bearings. Access. Std. size (for bench saw) \$3.50; larger fence (for cabinet base, as ill'd.) \$4.50.

FREE CABINET BASE PLANS Use as portable bench saw as received (inset photo) or transform easily and inexpensively into floor model (as shown) guar. to do work of floor models costing \$300. **FREE plans...** all you'll need are a sheet of 3/4" plywood and 3-4 hours. Use your AMCO saw for cutting. Plans provide 27" x 24" work surface, 33" height, tool storage compartment.

10-YEAR FULL SERVICE GUARANTEE*

6" SWING 3-FOOT LATHE



Optional faceplate for turning bowls, trays, lamp bases, rosettes, etc. \$2.50. **\$9.85** f.o.b. factory Wt. 14 lbs.

Set of 3 high speed turning chisels, \$4.95 add'l.

DOES THE WORK OF \$40 UNITS... with same precision and speed. Turns wood, plastic. Sturdy cast iron with tubular steel bed. Ball thrust cup center, spur center, T-rest assembly, lever action tail stock, 2-speed pulley. Fits any motor.

10-YEAR FULL SERVICE GUARANTEE*

PRECISION 4" x 36" BELT SANDER



f.o.b. factory. Wt. 15 lbs.

\$14.95 † Disc Sander attachment incl. disc bracket, ground cast table (tilts 0-45°): \$7.95 add'l.

DOES WORK OF \$50 SANDERS... The world's most talented belt sander. Heavy cast sander incl. 4" x 36" sanding belt, V-pulley drive, multi-purpose drive spindle. Changes from horizontal to vertical sanding in secs. Uses 1/2 hp or larger motor.

10-YEAR FULL SERVICE GUARANTEE*

Mitre gage: \$1.95 add'l.

FULL 22" LONG, 4 1/8" JOINTER-PLANER

\$19.95



f.o.b. factory. Wt.: 19 lbs. Complete as shown.

100% precision ground cast iron and steel.

DOES THE WORK OF \$60 UNITS... Professional power planing at a hand tool price. Make faster, more accurate joints, rabbetts, bevells for windows, doors, drawers, square tapered legs—Adjustable precision ground cast iron tables. Patent-pending design holds knife to table clearances at any depth. Rabbett depth 3/8". Fence adjustable 0°-50°. Hardened, ground hi-speed steel knives. Dual cutter guards. Balanced cutter head.

10-YEAR FULL SERVICE GUARANTEE*

32" RADIAL DRILL PRESS

All cast iron and steel
f.o.b. factory **\$29.95**
Wt. 30 lbs.
1/2" cap.
Jacob's chuck incl.

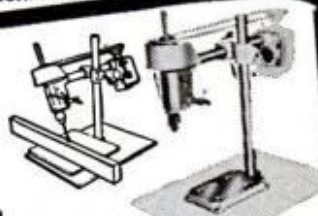

DOES WORK OF \$90 UNITS... and much more. Industrial quality precision unit with all standard features, many extras. Head raises, lowers. Depth of throat up to 16". Pre-set to any angle for on-or-off table drilling, even horizontal drilling. **10-YEAR FULL SERVICE GUARANTEE.***

BRAND NEW MOTOR

DEVELOPING FULL 1 HP... **\$18.80**

F.O.B. FACTORY / FOR ANY OF ABOVE MACHINES. WT. 17 LBS. PURCHASED SEPARATELY, \$24.85

This free booklet will tell you how you can become a Computer Programmer

50,000 more programmers needed now! 500,000 more will be needed in a few years!

...and how you can train at home for big earnings in the world's newest, most exciting profession.

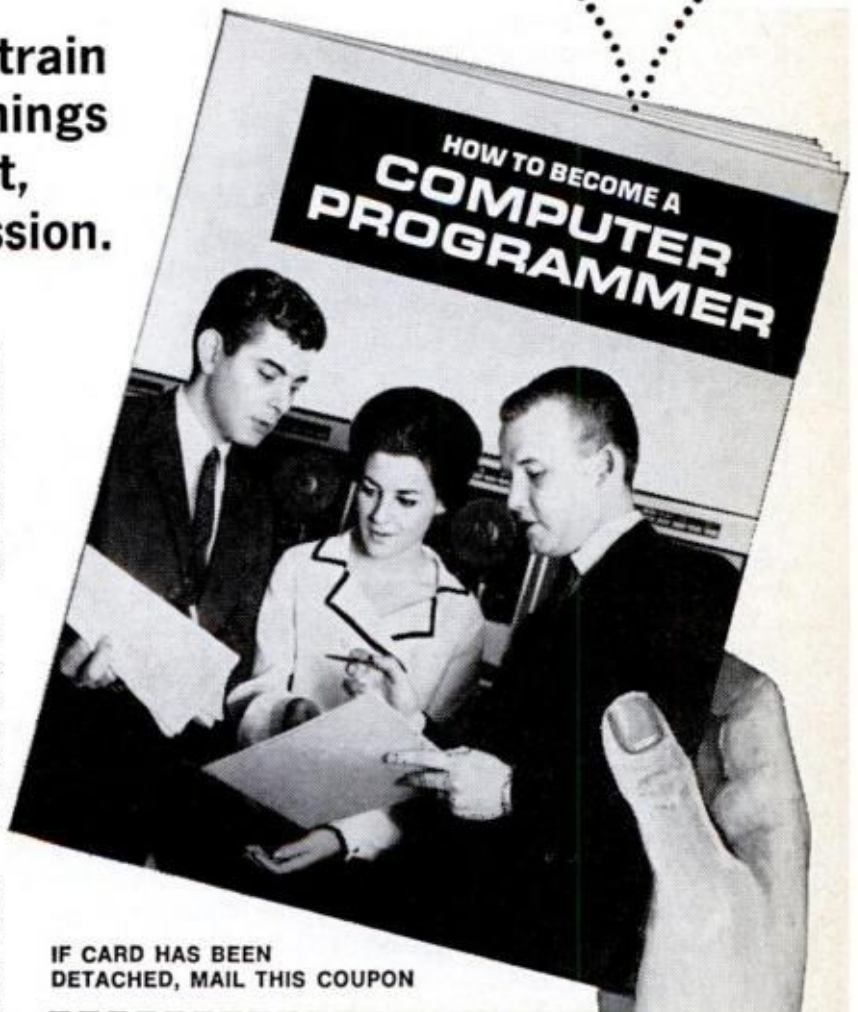

IF YOU'RE dissatisfied with your present job, why don't you become a programmer? So great is the demand for programmers, you'll have your choice of openings, with a growing future ahead.

For the vast majority of good positions, a high school education, a logical mind and the right preparation are all that are required. LaSalle, world leader in home education, will train you as a programmer in your spare time.

Why not plan for bigger success in the field where employers are looking for you? *Authorities agree that for many years to come there will be more openings in computer programming than people to fill them!* Even beginners are paid well; and with experience, programmers can fill major supervisory positions at salaries of \$12,000 to \$15,000 a year — often as much as \$20,000.

Without leaving your present position, you can start your training now — at very low cost. You can study at home, in hours of your own choosing. Experienced LaSalle instructors will guide you by mail every step of the way. Industry experts say this is the most thorough course of its kind that they have seen. The ease and rapidity with which you learn will surprise you.

LaSalle has just published a fascinating booklet "How To Become a Computer Programmer." In simple, non-technical language this booklet tells you what computer programming is; what the programmer does; how you can train by mail through the school that has enrolled more than 1,500,000 people in its many success courses. Mail attached card now for your free copy or write to LaSalle, South Dearborn, Chicago, Illinois 60605.

© 1968 LaSalle Extension University

IF CARD HAS BEEN DETACHED, MAIL THIS COUPON

LA SALLE EXTENSION UNIVERSITY
A Correspondence Institution
 417 S. Dearborn Street, Dept. 85-081, Chicago, Illinois 60605

Please mail to me the free illustrated booklet "How To Become a Computer Programmer."

Print Name..... Age.....
 Address..... Apt. No.....
 City.....
 State..... Zip No.....

A flexible contact lens, more comfortable than the hard plastic lenses now in use, has been developed by Bausch & Lomb, Inc. Because of its softness, the new lens conforms to the curvature of the eye and rarely pops out, a characteristic that should recommend it to athletes. The lens is made of hydroxyethyl methacrylate, a water-absorbent material that becomes soft when wet.

Voyages to nearby stars will be possible 200 years from now, according to Prof. Freeman Dyson of the Institute for Advanced Study in Princeton, N.J. Method of propulsion may be the fusion reaction that takes place in hydrogen bombs. Chemical rockets, says Prof. Dyson, have just about reached their practical limit. Their ratio of take-off weight to final "flying" weight is too high. But a fusion rocket could carry a payload that would be a reasonable fraction of its total weight. Since the nearest neighboring star is 4.3 light-years away, the trip would take several centuries. It would be necessary to send colonies of people rather than individuals.

Which pig or steer to slaughter for its lean meat? A new device—an ultrasonic animal scanner—makes it easy to tell. The scanner shoots ultra-high-frequency sound signals into an animal and then picks up the echoes from layers of fat and muscle, which differ in density. The echoes show up on an oscilloscope as blips of light. The blips are recorded on film to produce a composite picture of the animal's tissues. The device was developed by Dr. James R. Stouffer of the New York State College of Agriculture at Cornell University. One valuable use: to pick out animals for breeding that have particularly good meat characteristics.

The job of reassembling 30,000 pieces of an ancient Egyptian temple at Karnak is being given an assist by an IBM computer. Fortunately, each piece is decorated with scenes and hieroglyphic inscriptions, giving archeologists clues to work with. The pieces are coded and photographed, and the photos matched with the help of the computer. The temple was devoted to Aten, the sun god, and was built during a period of monotheism. But it was destroyed in about 1350 B.C. when a new pharaoh re-established polytheism. Its blocks were scattered and used as fill for new buildings.

Insomniacs can be helped by electrosleep treatments. That report comes from Israel's Hadassah-Hebrew University Medical Center where physicians have treated patients suffering from chronic insomnia by passing a mild electrical current through the brain. After 10 to 20 such treatments, 15 out of 20 patients regained normal sleeping habits, which they continue to maintain a year later. All patients were resistant to conventional therapies and most were addicted to sleeping pills. Though electrosleep has not gained much scientific attention in the United States, it is said to be used in the Soviet Union.

Newly announced plans by NASA call for the construction of an X-ray spectrographic telescope that will fly in the 1970s as part of a "giant Apollo telescope mount which is to be attached to a spent Saturn rocket stage." The spent stage, according to NASA, will be converted into a space workshop in which men will stay for prolonged periods and perform various experiments. The spectrographic telescope will be used to accumulate data on X-ray emissions from the quiet and active regions of the sun.

Electricity-producing fuel cells for use in the home, factory and office will be available within a year, according to a spokesman for the American Gas Assn. The fuel cells will combine natural gas and air electrochemically to produce energy that should be competitive in price with conventionally generated electricity within two or three years. The fuel cells probably will be leased to users.

★★★



Music Vision Dramatic Breakthrough in Audio-Visual Enjoyment
SEE MUSIC IN DAZZLING ACTION

Actually see favorite musical selections translated into fantastic patterns of beautiful color—each individual note creating its own unique, twisting, radiating shape... each shape dancing and prancing, whirling and swirling in perfect time with the music. Easily attached to stereo, radio, tape recorder. Send 25¢ in coin for 16-page booklet #9096H.

WALNUT CABINET MODEL
 Stock No. 85,181H\$99.50 FOB
8" SET—Stock No. 71,030H..\$45.00 Ppd.
8" DO-IT-YOURSELF KIT
 Stock No. 71,009H\$22.50 Ppd.

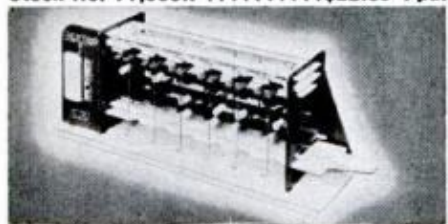

MODEL DIGITAL COMPUTER

Solve problems, teach logic, play games with miniature version of giant electronic brains! Adds, subtracts, multiplies, shifts, complements, carries, memorizes, counts, compares, sequences. Colored plastic parts easily assembled. 12" x 3 1/2" x 4 3/4". Incl. step-by-step assembly diagrams, 32-page instruction book covering operation, computer language (binary system) programming, problems and 15 experiments.

Stock No. 70,683H\$5.98 Ppd.
BIG NEW DIGICOMP II!
 Stock No. 70,946H.....\$16.00 Ppd.

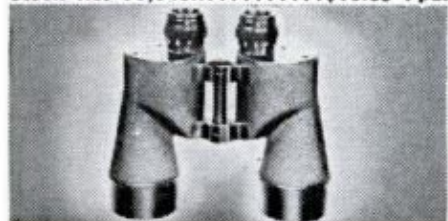

AMER. MADE 7 x 50 BINOCULARS

Big savings! Brand new! Crystal-clear viewing—7 power. Every optical element is coated. An excellent night glass—the size recommended for satellite viewing. Individual eye focus. Exit pupil 7 mm. Approx. field at 1,000 yds. is 376 ft. Carrying Case included. American 7x50's normally cost \$274.50.

Stock No. 1544H.....\$74.80 Ppd.
 Stock No. 963H (6x30).....\$40.00 Ppd.



AMER. MADE OPAQUE PROJECTOR

Projects illustrations up to 3" x 3 1/2"—enlarges them to 35" x 30" if screen is 6 1/2 ft. from projector, larger if screen further away. No film or negatives needed. Projects charts, diagrams, color, black-and-white. 115 V A.C. Operates on 60 W bulb, not incl. 12" x 8" x 4 1/2". 1 lb. 2 ozs. Plastic case.

Stock No. 70,199H\$7.95 Ppd.



WFF'N PROOF—GAMES OF LOGIC

Practice abstract thinking and math logic. Developed by Yale prof. If you think learning should be fun, try WFF'N PROOF brain-to-brain combat! 21 games of progressive difficulty. Starts with simple games mastered by 6-year-olds, ends with subtle logic to challenge professional logicians. 8 1/2" x 5 3/4" case contains logic cubes, playing mats, timer & 224-p. book.
 Stock No. 60,525H\$6.00 Ppd.

KEEP PACE WITH THE SPACE AGE!

AMAZING BARGAINS

for Fun • Study • Profit

from

EDMUND SCIENTIFIC CO.

300 Edscorp Building
 Barrington, N. J. 08007

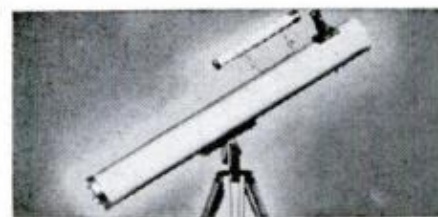

3" ASTRONOMICAL TELESCOPE

See the stars, moon, phases of Venus, planets close up. 60 to 180 power. Aluminized and overcoated 3" diameter f/10 primary mirror, ventilated cell. Equatorial mount with locks on both axes. Equipped with 60X eyepiece and mounted Barlow lens. 3X finder telescope, hardwood tripod. Includes "STAR CHART"; 272-page "HANDBOOK"; "HOW TO USE TELESCOPE" book.
 Stock No. 85,050H.....\$29.95 Ppd.
 Stock No. 85,105H..4 1/4"....\$84.50 f.o.b.
 Stock No. 85,086H..(6")...\$199.50 f.o.b.



DIAGNOSE MECHANICAL TROUBLE

Professional Stethoscope. Designed for use by physicians, this super-sensitive Stethoscope is ideally suited for detecting faults in machines and engines, and in fluid, air and gas leakage. Dozens of uses in auto repair shops, labs and for hobby and educational applications.

Stock No. 50,270H\$7.50 Ppd.
BARGAIN PRICE STETHOSCOPE
 Stock No. 50,223H\$3.25 Ppd.

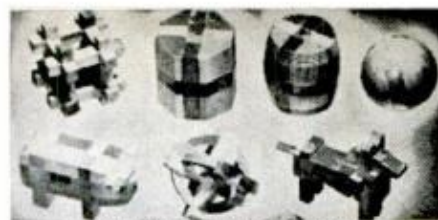

WOODEN SOLID PUZZLES

Here's a fascinating assortment of 12 different puzzles to provide hours of pleasure and stimulate ability to think and reason. Animals and geometric forms. Take them apart and reassemble them. Lots of fun for the whole family—young and old. Will test skill, patience and ability to solve problems. Order yours now.
 Stock No. 70,205H.....\$4.00 Ppd.



FLY 9-FT. HOT AIR BALLOON

9 Ft. tall. Rises to amazing heights on just hot air. Tether attached, can be used repeatedly. Easy to make, launch, fly, loads of fun. Great for celebrations, science fairs, plain fun. Will lift model gliders, parachutes, instruments, etc.—anything up to 1/2 lb. Approx. 5 ft. diam. when fully inflated. Kit contains 10 pre-cut red & white gores (No. 1 model paper), 6 ft. 14-gage wire for bottom ring, top, "tie-off" cord, complete instructions.

Stock No. 60,691H.....\$2.00 Ppd.



GIANT WEATHER BALLOONS

"Balls of fun" for kids, traffic stoppers for stores, terrific for amateur meteorologists. Create a neighborhood sensation. Great backyard fun. Exciting beach attraction. Amateur meteorologists use to measure cloud heights, wind speed and temp. Heavy duty neoprene. Inflate with vacuum cleaner or auto air hose; or locally available helium for high rise.

Stock No. 60,568H....8'.....\$2.00 Ppd.
 Stock No. 60,632H....16'....\$7.00 Ppd.

MONEY-BACK GUARANTEE
 Order by Stock No.—Send Check or M.O.
GIANT FREE CATALOG

148 Pages! More than 4,000 UNUSUAL BARGAINS
 Completely new Catalog. Packed with huge selection of telescopes, microscopes, binoculars, magnifiers, prisms, photo components, parts, kits, accessories—many hard-to-get surplus bargains. 100's of charts, illustrations. For hobbyists, experimenters, schools, industry. Mail coupon for FREE Catalog "H".

EDMUND SCIENTIFIC CO., 300 Edscorp Building, Barrington, N. J. 08007.

NAME _____
 ADDRESS _____
 CITY _____
 STATE _____ ZIP _____

CHARLES ATLAS Says: MY FREE BODY-BUILDING BOOK

Shows How YOU Can Become A REAL HE-MAN

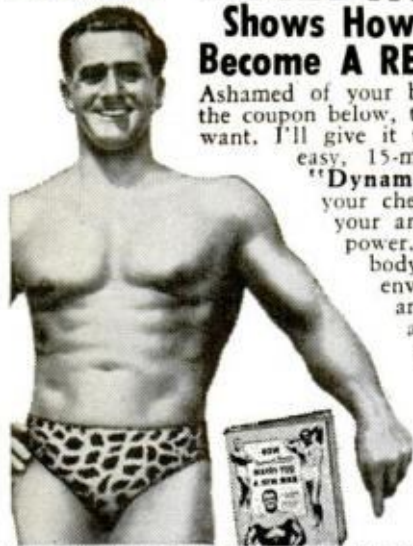

Ashamed of your body? Then tell me, in the coupon below, the kind of body you *do* want. I'll give it to you FAST—with my easy, 15-minutes-a-day method of "Dynamic-Tension." I'll make your chest and shoulders bulge, your arms and legs surge with power. I'll give you the kind of body women admire and men envy. *Your friends* will be amazed. *You* will feel like a tiger!

FREE BOOK. Learn how "Dynamic-Tension" made me "World's Most Perfectly Developed Man"—and how I can change YOU. Mail coupon to me: CHARLES ATLAS, Dept. 81, 115 E. 23rd St., N. Y. 10010.

**CHARLES ATLAS, Dept. 81
115 East 23rd St., New York, N. Y. 10010**

Dear Charles Atlas, Here's the Kind of Body I Want:

(Check as many as you like)

Broader Chest, Shoulders Powerful Arms, Legs
 Iron-Hard Biceps, Grip More Solid Weight

Show me how "Dynamic-Tension" can make me a new man. Send your famous 32-page FREE book, full of pictures, valuable advice. No obligation.

PRINT NAME..... AGE.....

ADDRESS.....
CITY & STATE..... ZIP CODE.....

In England: Atlas, Chitty St., London, W.1

The most versatile power tool accessory...ever!

You can cut through ceramic tile, fiberglass, brick, slate, stone, all metals...even a hard file in minutes with the Zippidi-Do cutting and sanding disc. Silicon carbide grains embedded in nylon mesh give it amazing cutting ability. And the Zippidi-Do makes a great sanding and shaping disc for use on old paint, rust, wood, tile, all metals. The Zippidi-Do can be used with any electric drill or flexible shaft. It wears and wears and never clogs.

Complete kit contains Zippidi-Do disc, molded backing disc, arbor and flanges...only \$4.00 at hardware stores and depts. Coastal Abrasive and Tool Co., Inc., Trumbull, Conn. 06611.

WHAT'S HE DOING?

Making a Concrete Flower Pot! ... and SO CAN YOU!



Make and sell your own Ornamental Concrete items. Rush \$2.00 for book about Aluminum Molds with prices and production trade secrets direct from world's largest mold manufacturer. Over 350 designs to select from.

Send \$2.00 CONCRETE MACHINERY COMPANY
Today To → P. O. BOX 99 • HICKORY 2, N. C. 28601

EARN SPARE TIME MONEY... Buy Lowest - Below Wholesale!

SELL AT TOP PROFITS...Up to 600% Profit on Top Selling Specialties, Novelties, Gift Items, Mail Order Products, Toys—1000 Bargains!

EARN EXTRA INCOME—up to \$10,000-\$20,000 and more. Start your own Wholesale or Mail-Order Business in the booming specialty merchandise field. No experience needed. No franchise to "buy." No canvassing. Work at home part time or full time. Revolutionary marketing program brings you automatic orders. Make big money right from the start.

SPECIALTY MERCHANDISE CORP.

7630 Gloria Avenue, Dept. S-1, Van Nuys, Cal. 91406

WRITE FOR AMAZING FREE BOOK!



BUILD CUSTOM CASES AT HOME FOR PROFIT... GET ORDERS BY MAIL!



Here is a spare time or full time Home Business so extensive that you will almost catch your breath when you see it for the first time. Learn how you can make Custom Cases in your home to tap a waiting, rich market—to make yourself financially independent for life. We supply materials, instructions, everything. No canvassing; No house to house selling; No salesmanship needed: Send for the full story of this amazing opportunity.

CUSTOM CASE SUPPLY CO.

Dept. C-201

7630 Gloria Avenue, Van Nuys, Cal. 91406



Be a LOCKSMITH



EARN'S BACK TUITION, PLUS

Joe E. Warren, Overland Park, Kansas, says,

"The lessons were so arranged that I could start earning almost at once. Before completing the course I earned enough money to pay for the entire course and purchase some \$800 worth of equipment and supplies."

**"I EARNED
\$1138.75
DURING
TRAINING!"**



Says Joel Daigle, Fort Kent, Me.,

"I wanted a complete change in work. Something more enjoyable and less tiring. Now that I've learned Locksmithing I average \$20 a week more. During my training period I earned \$1138.75 from Locksmithing. I have an established lock opener position in our town."

**"\$642
WHILE
LEARNING**



and used the money to outfit a complete shop. Now I'm able to average \$3.25 an hour in spare-time. With the help of your fine instructors, anyone can master the course with ease."

*R. Ted Gifford
506 East Main St.
Robinson, Ill.*

TRAIN AT HOME — EARN WHILE YOU LEARN

Add to YOUR INCOME—even double it with easy spare time earnings. Cash in on the nation-wide shortage that demands hundreds more trained locksmiths. Quickly step into a big pay opportunity, full- or part-time job, or start a high-profit shop of your own!

EARN EXTRA MONEY RIGHT AWAY!

You can quickly qualify as a skilled locksmith. Age, education, even minor physical handicaps don't matter in this ever-growing trade. So easy to learn—it's easy, it's fun, it's just like a fascinating new hobby!

Study at home as little as one hour a week. All special professional tools, supplies, including files, calipers, tweezers, cylinders, door handles, assemblies, gages, pins, springs, extractors, picks wrenches, and different kinds of locks and keys—supplied FREE! Gain practical experience by doing real jobs on car locks, house locks, padlocks, safe locks, etc. Just follow well-illustrated lessons under the guidance of experts.

For a future as your own boss or in a high-pay job, get all the facts, complete details. Write today for FREE Illustrated Book, FREE Sample Lesson Pages Give Exciting Facts.

No cost, no obligation, no salesman will call.

*Only school of its kind: Licensed by State of New Jersey,
Accredited Member National Home Study Council.*

LOCKSMITHING INSTITUTE Dept. 1110-019

A Division of Technical Home Study Schools • Little Falls, New Jersey 07424

APPROVED FOR VETERANS



**SEND TODAY FOR
FREE FACT-BOOK**



ESTABLISHED
1948

MAIL THE COUPON AT ONCE!

LOCKSMITHING INSTITUTE,
A Division of Technical Home Study Schools
Dept. 1110-019 Little Falls, New Jersey 07424

Please send without obligation the FREE illustrated book, "Your Opportunities in Locksmithing." I understand no salesman will call.

NAME _____

ADDRESS _____

CITY _____ STATE _____ ZIP _____

Check here if eligible for Vet Benefits.

LISTENING POST

BY BILL KILPATRICK

FORD WILL OFFER TWO SUBCOMPACTS, first a Ford, to be followed by a similar—but presumably plusher—car to be sold by Lincoln-Mercury dealers. The Ford version is due to be introduced in another few months, the Mercury not 'til fall, possibly even later. The subcompact concept at Ford started out as a strictly bread 'n' butter affair aimed at grabbing off a little (or a lot!) of VW-type business. But now Dearborn is said to be fiddling with vinyl roofs, sporty trim options . . . even a hop-up kit. It figures. An affluent buying market wants cars that reflect its affluence, particularly when it comes to domestics. The imports have going for them a sort of "mystique" that plainly indicates their buyers have exercised an "informed" freedom of choice. But when it comes to "Made in U.S.A." cars, American buyers want candy and more candy. Catering to this desire on one hand, and holding the price below (or very near) \$2000 on the other, is going to be the big hurdle for all the new subcompacts.

CAR REPAIR COSTS are being probed by the Senate's Anti-Trust and Monopoly Subcommittee. Under the chairmanship of Sen. Philip A. Hart (D., Mich.), the subcommittee is reportedly anxious to learn why repair parts and labor costs have risen over 50 percent in less than 10 years. This one could be a beaut, could be a prime mover in needed overhaul of the entire service/repair business. Under the subcommittee gun? Auto manufacturers, who will be urged to make more of their products more repairable, and the many middlemen—wholesalers, jobbers, distributors and so on—between a part and its ultimate consumer. Also scheduled for Senate scrutiny are current flat-rate manuals, the thought being they're an unsatisfactory means of determining labor repair-cost guidelines.

CHEVROLET WILL DROP the Corvair name when the car goes out of production at the end of the current model year. Some industry observers thought GM might dub its new subcompact—due as a 1971 model—a Corvair, but the auto giant is said to feel the name is a loser, mostly as a result of the present car's well-publicized troubles in court. The car has been soft-pedaled by Chevy the past three years, was offered in the '69 line as a sop to GM's pride. Sales of '68 Corvairs were down 50 percent from '67 (in peak year '61, sales topped 300,000), are down even more so far in the '69 model year. Car wasn't exactly a standout when introduced, has since been evolved into a trim, nimble package worthy of more buyer attention than it gets. But "the word" is out, and that's that. The name being bandied about for the new subcompact is Chevette.

CONVENTIONAL SNOW TIRES provide only a small improvement in pulling power over regular tires, a study by the National Safety Council's Committee on Winter Driving Hazards indicates. In tests conducted on glare ice at Stevens Point, Wis., the committee determined that conventional snow tires improve pulling power only 28 percent. Used studded snow tires are reported as being 183 percent better in pulling power than regular tires, new studs over 218 percent better. Best of all, the committee reports, are reinforced tire chains, said to improve pulling power over 600 percent.

SAFETY CRITICS are quietly mustering forces for an all-out attack this year on so-called "performance" cars. They aren't as unhappy with the cars per se as they are with the way they're promoted. Specifically, the attack will be focused on "hot car" ads pointedly aimed at youngsters—ads that stress speed, imply that aggressive cars, driving are "in." Supposedly shocked at plethora of muscle-car promotion, self-appointed consumer champion Ralph Nader—no stranger here—has said he plans to squawk long and loud before the President's National Commission on Causes and

(Please turn to page 26)

AUDEL

SKILL-BUILDING PRACTICAL GUIDES

LEARN MORE—
EARN MORE!

Electric Motors

Covers hookups, control, maintenance and trouble shooting of all types of motors. Completely illus. 432 pages. \$5.95
Circle No. 27 in Coupon

Truck and Tractor Guide

A guide for mechanics, drivers and maintenance men. Gas & Diesel repair, service and operation. Illus. 1366 pages. \$6.95
Circle No. 5 in Coupon

Diesel Engine Manual

Complete practical guide to modern Diesel engines. Explains principles & how to maintain & oper. Illus. 544 p. \$6.95
Circle No. 9 in Coupon

Sheet Metal Pattern Layouts

Modern guide to all phases of sheet metal work, including pattern development. 350 layouts. Illus. 1152 p. \$11.95
Circle No. 29 in Coupon

Masons and Builders Guides

4 practical volumes for bricklayers, masons, cement workers, plasterers. 2000 illus. 1488 pages. 4-Vol. Set \$14.95
Circle No. 26 in Coupon

Plumbers and Pipefitters Guides

3 vols. of ready reference for plumbers, pipe & gas fitters, sheet metal workers. 540 illustrations. 960 pages. 3-Vol. Set \$12.50
Circle No. 6 in Coupon

Blueprint Reading

For mechanics & construction men. Step-by-step explanation how to read all types of prints. 416 pages. \$5.25
Circle No. 25 in Coupon

Welders Guide

Practical guide to theory; operation; maintenance all types—electric, oxy-acetylene & Thermit. 626 pages. \$5.50
Circle No. 10 in Coupon

Outboard Motor & Boating Guide

Practical details on all phases of outboard motor repair, maintenance and operation. Up-to-date. Illus. 446 pages. \$4.95
Circle No. 49 in Coupon

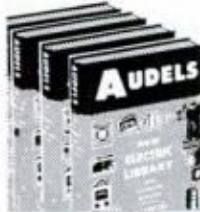

ELECTRIC LIBRARY

A complete 10-volume electrical encyclopedia. Covers basic principles & applications of applied electricity. Answers thousands of problems. Ill. 5600 pgs. Set \$35.00
Circle No. 15A in Coupon

Millwrights & Mechanics Guide

Practical information on plant installation; operation and maintenance data for foremen & workers. Illus. 1236 pgs. \$7.95
Circle No. 42 in Coupon

MONEY BACK GUARANTEE

You must be COMPLETELY satisfied with the AuDel Guides you order, or you may return them within 10 days and get your money back.



THEODORE AUDEL & CO.
division of HOWARD W. SAMS & CO., INC.
Indianapolis • New York

JANUARY 1969

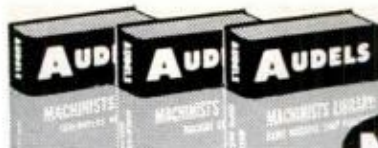

MACHINISTS LIBRARY

Three volumes of ready reference on all the latest shop practices for machinists and toolmakers. Vol. 1—Practical Fundamentals of Basic Machine Shop Operations. Vol. 2—Setup and Operation of all the widely used, important shop machines. Vol. 3—Toolmakers Handybook with down-to-earth data on layouts, specifications, jigs and fixtures, gear forming, cams, etc. Illus. 1310 pages. 3-Vol. Set \$15.50
Circle No. 12N in Coupon



CARPENTERS & BUILDERS GUIDES

Four all-inclusive volumes provide latest inside trade information on modern construction. Vol. 1—Tools, Steel Square, Joinery. Vol. 2—Builders Math, Drawings, Specs. Vol. 3—Layouts, Foundations, Framing. Vol. 4—Millwork, Power Tools, Windows, Doors, Roofing, Flooring. Most practical guide available. Thousands of diagrams, charts, graphs and photos. 1616 pages. 4-Vol. Set \$16.95
Circle No. 8 in Coupon

AUTO GUIDE

ALL-NEW

biggest value!



\$7.95

FIX ANY CAR FAST!

STEP-BY-STEP REPAIR GUIDE COVERS EVERYTHING: Troubleshooting—unique symptoms-and-causes charts • Spark Plugs • Batteries • Tune-up • Distributors • Ignition Testing • Starters & Generators • Lighting • Tire Servicing • Brakes • Power Brakes • Front Suspension • Steering Systems • Wheel Alignment • Chassis, Springs & Shocks • Fuel Pumps • Carburetors • Cooling Systems • Lubricating Systems • Pistons & Rings • Crankshafts and Connecting Rods • Camshafts • Valves • Clutches • Automatic & Manual Transmissions • Drive Shafts & Universal Joints • Rear Axle Assemblies—ABSOLUTELY EVERYTHING YOU SHOULD KNOW TO FIX ANY CAR! Hundreds of illus. 736 pages. \$7.95
Circle No. 1 in Coupon

HOME APPLIANCE SERVICING

How to test, service, and repair all modern gas & electric appliances such as refrigerators, washers, dryers, ranges, irons, hot water heaters. Gives up-to-date methods, wiring diagrams, complete servicing data. Fully illustrated. 608 pages. \$6.95
Circle No. 2 in Coupon

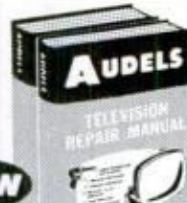

TV-RADIO LIBRARY

Two vols. of practical and theoretical knowledge including basic electronics, basic radio and radio receiver repair. Complete from basics through transistors. Covers entire subject of television, both black & white and color, from theory thru testing & repair. Illustrated. 960 pages. 2-Vol. Set \$10.95
Circle No. 3 in Coupon

Foreign Auto Repair Manual

Up-to-date service data for all popular imports: English, French, German, Italian, Swedish. Illus. 592 pages. \$5.95
Circle No. 53 in Coupon

Mathematics for Mechanics

A complete guide to the mastery of practical math. Simplified method makes learning fast and easy. Ill. 704 pgs. \$5.50
Circle No. 11 in Coupon

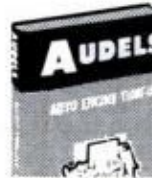

Auto Engine Tune-up

Complete tune-up procedures for all types of auto engines. Full adjustment data for carburetors, ignition, valves, etc. For mechanics & owners. Illus. 416 pages. \$5.95
Circle No. 58 in Coupon

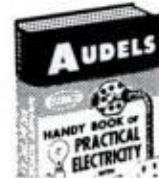

Practical Electricity

Get your start in the electrical industry with this complete handbook of practical, simplified ready reference on all electrical subjects. 1300 illus. 1088 pages. \$6.95
Circle No. 4 in Coupon



Home Refrigeration & Air Conditioning

Complete information on installing, servicing, and repairing all types of home and auto air conditioners and gas & electric refrigerators. Illus. 576 pages. \$6.95
Circle No. 14A in Coupon

MAIL THIS NO-RISK COUPON TODAY!

THEODORE AUDEL & CO.—Self Improvement Publishers Since 1879—
4300 W. 62nd Street, Indianapolis, Indiana 46268

Please mail me books circled at right. Enclosed is down payment of \$_____ (\$3 down payment for purchase amounting to less than \$9; 1/3 of total if purchase price is over \$9). I agree to pay balance, including shipping costs, within 30 days. If I am not completely satisfied with my AuDel Guides I may return them for refund.

SAVE SHIPPING COSTS—Send full payment with order!

Check here if you enclose full payment with order (plus sales tax, if any). We pay postage charges. You have same return privilege.

Name _____
PLEASE PRINT

Address _____

City _____ State _____ Zip _____

P-19	1	2	3	4
	5	6	8	9
	10	11	12N	14A
	15A	25	26	27
	29	42	49	53
	58			

I have bought AuDel books before



The Home Team. Takes a cue from Brunswick.

When the name of the game is billiards, everyone wants to make the scene. And everyone can (mom, dad and kids, too), because this is one fun game with no age limit.

Brunswick gives you ten tables to choose from (plus a bumper pool table for those billiard buffs a bit short on space).

Take a cue from the Home Team. Put a little togetherness in your house from Brunswick.



Brunswick



THE NO. 1 NAME IN BILLIARDS
CONSUMER DIVISION / BRUNSWICK CORPORATION

DETROIT LISTENING POST

(Continued from page 24)

Prevention of Violence, says he wants the commission to take into account "the emphasis by the auto industry on aggression, power and speed in selling a product involved in the deaths of 53,000 people a year." Industry, which cooled the horsepower race slightly over the past three years, counters that it has to pour it on to attract young buyers, remain competitive. "If we don't peddle performance," one highly placed auto man told DLP privately, "the competition will. It's what the kids want and are buying."

WORKING UP STEAM is inventor/industrialist William P. Lear, who recently announced he's working on a "complete automotive system" built around what he describes as a "small, reliable" steam engine utilizing space-age technology and materials. Lear says his new engine will fire up in 20 seconds or less in temperatures as low as minus 20° F., will get 20-22 miles to a gallon of kerosene while powering a 4000-lb. car 60 mph, will be the basis of a business that in three years will grow to annual sales of \$150 million. Lear also said he'll deliver ten steam-driven busses to "a major American city" this spring, that he plans to build two steam race cars for this year's Indianapolis 500. Founder of Lear Jet Industries and Lear, Inc., he holds more than 100 aviation and electronic product patents, has an impressive business record, also has cash, facilities and enthusiasm to give his steam-car project a good run.



OFF ON A NEW JAG is newly-formed British Leyland Motors with the recent introduction in the United States of the Jaguar XJ Luxury Sedan. Tagged at just under \$6500 (East Coast P.O.E.), new car features four-wheel disc brakes, four-wheel independent suspension, manual or automatic transmissions and Jag's by-now-traditional 246-hp, 4.2-liter Six, said to be capable of moving things along at 127 mph maximum. Car is a very comfortable, posh four-seater (five in a literal pinch); replaces the Jaguar 420. ★★★

TOM McCAHILL SAYS:

"A Smart Guy Can Really Clean Up in the Appliance Repair Field"

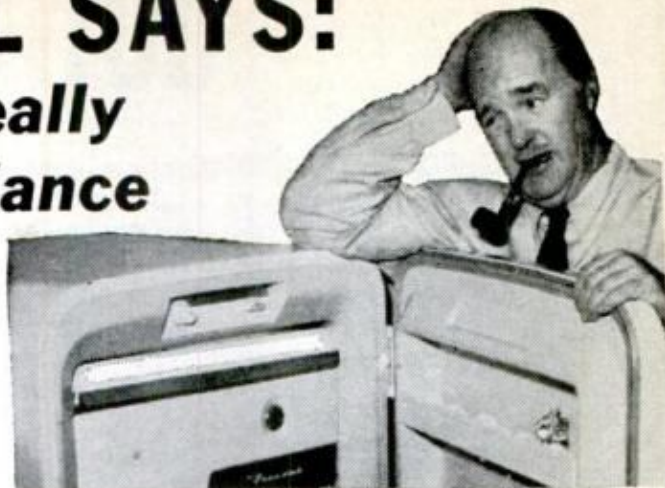

Those electrical gadgets you have around your house are great on convenience, but if you're like a lot of do-it-tomorrow Johnnies, you don't know where to turn when one breaks down. So you call one of the busy Appliance Servicemen in your town, then drink instant until that fancy automatic coffee pot is perking again.

People have so many electrical appliances, it's no wonder Appliance Repairmen are busy as a bear in a bee nest. Count yours. The average home has at least a dozen, maybe more. There are better than 800 million appliances in the U.S.A. right now. No wonder the man who knows how to service appliances properly is pocketing \$4 to \$6 an hour, for as many hours as he cares to work!

If you're interested in making money (and who isn't), here is a job field crying for good men. And it's no sweat at all to get the training you need. Thousands have trained with National Radio Institute's Appliance Division. NRI has a great, low-cost home-study program covering every type of Appliance repair in detail. You study at home, in your spare time, learning through actual practice how to fix home, commercial and farm appliances. And not just the little stuff, either. Besides cantankerous coffee pots and toasters, you can learn how to repair air conditioners, refrigeration equipment, even small gasoline engines—and that's where the big bucks are, in the major appliances you'll fix.

NRI is one of the biggest and best schools in the home-study field. They have this Appliance Servicing course worked out to the most nit-picking detail. Yet, you'll be amazed at how little it costs. You even get a 25-buck professional Appliance Tester without extra cost. With your Tester and a few basic tools you probably have in your house, you'll be doing repair work long before you finish the course. And you can work anywhere—

in a corner of your basement, in the garage, even on the kitchen table.

NRI has been in home-study education since 1914. Experienced, well-trained instructors on the staff of 150 in Washington, D. C., give you all the personal attention a man could ask. You don't even need a high school diploma. Take it from Uncle Tom . . . this can be one of the easiest and most rewarding businesses you'll find today, either full-time or in spare hours. As a matter of fact, knowing how to service Electrical Appliances can pay off even if you don't want to strike out on your own. That coffee pot on the fritz probably needed ten minutes of a repairman's time to be perking again like the mudpots in Yellowstone Park. You can do it yourself with the training NRI gives you. And if you're thinking about Social Security years, this is a great way to pick up some money and keep yourself busy at the same time.

There's nothing to lose except a postage stamp and the energy it takes to walk to the mailbox. What you'll get for your efforts is the newest NRI Appliance Servicing catalog. Nobody is going to ring your doorbell to pressure you into signing an enrollment blank. NRI doesn't employ salesmen.

Do yourself a favor and mail the coupon now—before you turn this page.

Tom McCahill

NATIONAL RADIO INSTITUTE, APPLIANCE DIVISION
3939 Wisconsin Avenue, Washington, D. C. 20016

APPROVED UNDER NEW GI BILL
If you served since January 31, 1955
or are in service, check GI line below.

600-019

OK—I want to see for myself. Send me the free book on Professional Appliance Servicing. No salesman will call.

Name Age.....

Address

City State Zip Code

Accredited Member National Home Study Council.

Check for facts on new GI Bill.

WHAT'S NEW OUTDOORS

BY DAN FALES

CLOSING TO THE PUBLIC some areas in our national parks and limiting visitor hours in other areas can only be termed a tragedy.

Last year, Congress ordered manpower restrictions within the National Park Service. This order means that NPS can no longer give total service to the 270 areas under its jurisdiction.

This may not sound like much, but the urbanization of our society means that the people have to "get outside more." This need is becoming a necessity. "Getting out" can no longer be called a luxury.

This fact is obvious when park visitation figures are cited. In the past five years, there's been a 48 percent increase in the number of visits to our national parks—from 103 million in 1963 to an expected 152 million in 1968! During this period, too, management responsibilities for 46 new areas were added to NPS. With only a 13 percent rise in NPS manpower, it's not hard to see the problem.

Now Congress steps in and says that NPS must cut back from 7575 employees to the June 30, 1966, level of 5998. That's going the wrong way.

NPS has never been at full strength, but at least it had hold of the situation. If this year's Congress doesn't reverse the decision of last year's group, you'll see restricted use of our public lands.

This doesn't mean that the 90th Congress was all bad. Passed late in the session were bills creating the Redwood National Park, the North Cascades Park, Scenic Rivers and the Great Swamps National Wildlife Refuge.

A SNOWMOBILE SERVICE MANUAL is now on the market. This 144-page book gives a complete rundown on 22 makes of snowmobiles.

There's also a section on engines which covers 30 models including the new two-cycle Kohler, Yamaha, Chrysler 820 series and the Wankel rotating combustion engine. Full explanations of engine design and principles are included in the manual.

There are sec-

tions on transmissions and tracks. The book is available for \$5 from J. C. Whitney & Co., 1917 Archer Ave., Dept. 406, Chicago, Ill. 60616.

A KIT to help your car's transmission keep its cool is available for those who use their cars to pull heavy trailers.

Towing travel trailers or heavy boats on trailers can cause additional heat-con-



trol problems which the towing car's factory-installed cooling system is not designed to cope with.

According to automotive engineers, the normal temperature of transmission oil ranges from 200° to 280° F. Under load, the temperature can go to 350°. Transmission oil begins to break down at 200° and deteriorates faster as temperature rises.

With excessive heat, shifting becomes sloppy and transmission seals begin to bake out and leak.

The Hayden Trans-Cooler, developed by Valley Tow-Rite, is a kit that you can install. It bypasses the car's factory-installed cooler or it can be installed in parallel to the factory system.

The kit consists of hoses, hose clamps, fittings, brackets for mounting the unit and installation instructions.

It takes about half an hour to rig. The installation can be removed at will, and the original factory system reconnected.

It costs about \$30 for a unit that will provide effective transmission cooling for trailer loads up to 2000 pounds. For more information, contact Valley Tow-Rite, Inc., 27 E. Vine St., Lodi, Calif. 95241.

IN ONE YEAR, 8¼ million saltwater fishermen caught 737 million fish weighing 1.47 billion pounds. That's no fish story.

This happened three years ago, according to a survey conducted by the U.S. Bureau of Sport Fisheries and Wildlife, U.S. Department of Interior. ★★★



3 WAYS

TO A PROFITABLE BUSINESS of your own with small investment

**YOU CAN START WITH ONE DETERGER...
ANY TWO...OR ALL THREE
FULL OR PART TIME!**



■ Von Schrader offers you these three tried and proven money-making businesses. You can start with one Deterger and, by working week-ends, add hundreds of dollars to your monthly income while still employed.

■ Or, you can start your business with any two, or all three Detergers, and build rapidly to a point where helpers and even additional Detergers are necessary. All three Detergers are reasonably priced...and many Associates make more than the price they paid in the first few weeks and from the supplies that came with their original order.

■ You need no shop because all work is done in customers' homes or on their premises. And you have no overhead because you work out of your own home.

■ Full operating instructions come with the Detergers and you need no special skill or training. You can grow as fast as you want to with the assurance that Von Schrader will help you every step of the way. Our Business Manual tells everything you need know, including how to go about getting business, suggested sales letters, tips on keeping books and tax records, suggested ads and radio announcements, etc. Von Schrader assistance is always at your service. Training and consulting with experts is also available... and without charge.

■ Von Schrader is the oldest and largest company manufacturing machines of this type and we are keenly interested in the success of each of our Associates. Our FREE ENTERPRISE PLAN has been developed and fashioned with your future in mind. Your business always belongs to you...no one can ever take it away. You pay no dues or fees or royalties to anyone. All the money you take in belongs to you...you are truly your own boss in your own business.

VON SCHRADER MFG. CO.

READ BELOW what a few of our many Associates have to say about the success of Von Schrader's FREE ENTERPRISE PLAN. Then return the coupon or write today. It costs nothing to get the details. Be sure to check the Deterger you are most interested in starting with.

E. L. McLAINE • New York • Wall—"I'm over 60 years old. In my spare time I make \$125 to \$175 per week."

F. LOTMAN • Canada • Wall—"Our machines have grossed us over \$50,000 for the past 12 months."

R. MORTON • Michigan • Wall—"This last month just working Saturdays and occasional evenings I cleared around \$600."

G. WINTER • Wyoming • Upholstery—"Last year I did \$10,000. This is a one-man operation. Many weeks are now \$250-\$300."

E. ACTON • Oregon • Upholstery—"I don't work very hard at this but in one day my boy and I made \$170."

S. RALLINGS • California • Upholstery—"I'm averaging about \$200 a week...one month went up to \$1000."

T. NORTHRUP • New Jersey • Rug—" \$2000 in two weeks...several weeks over \$1000."

J. THORNTON • Illinois • Rug—" \$90 and \$100 a day is common with your wonderful detergent."

C. LEONARD • Ohio • Rug—"My largest week so far brought me \$1568."

SEND FOR THE FACTS TODAY

VON SCHRADER MFG. CO.
9110 "A" Place, Racine, Wis. 53403
Please rush information about your

_____ DETERGER(S)
(Write in name of detergent(s))
and how I can start my own profitable business.

Name _____

Address _____

City _____ State _____ Zip _____

Drivin' with Dan

How do you measure engine displacement? Is four-wheel drive safer than two-wheel drive? What would happen to racing if the big companies pulled out? Dan Gurney answers these and other provocative questions



DAN GURNEY leads Jack McCoy through turn during last year's Riverside 500-mile stock-car race. This month Dan'll be seeking his sixth Riverside 500 win

Q. When you were starting your racing career, how much "rough stuff" were you subjected to on the track by older, more established drivers?
—Clint Beatty, Albany, N. Y.

A. That is a very good question. "Rough stuff" is cloaked in different clothing on different circuits. Things that would be considered rough stuff on a half-mile dirt track in a stock car would be suicide at Daytona. Things that would be considered rough stuff at Daytona in a stock car would again be suicide in an Indy car on the same track. Rough stuff in an open-wheel Grand Prix car would be child's play in a stock car or a trans-Am car on a road circuit. There is always a certain amount of testing of one's courage or spirit even among established drivers. As a rule I found the best drivers on road circuits were those who engaged in rough stuff the least. The beginning driver usually is tested by the rough-stuff drivers until they find out where each stands. Each driver has a "track personality" and the "pecking order" must be established. I doubt if I received any more rough stuff in the beginning than I have since.

Q. In measuring engine displacement, is the combustion chamber included, or only the cylinder area from the top of the block to the top of the piston at the bottom point in its stroke?—Cyrus Hayes, Erie, Pa.

A. Engine displacement concerns only the bore, stroke and number of cylinders. The combustion chamber volume at top dead center is what governs the compression ratio, not the displacement.

Q. Do you think four-wheel drive is safer than two-wheel drive? If so, what was USAC's reason for outlawing it?—David Kronoshek, Indianapolis.

A. No, I don't. There are more things to break in a four-wheel-drive car. On the other hand they seem faster under slippery conditions. I think USAC was concerned about the expense of racing. It is very difficult to find enough money to purchase and operate an Indy car these days. It takes over \$100,000 to be serious about going to the Indy 500.

Q. What would happen if the big car, tire and sparkplug companies pulled out of big-time racing? Where would that leave you, for example?
—Harold Johnson, Baton Rouge, La.

A. It would be a severe blow. However, I think that one or two would sneak back in when the others weren't looking, because it is a great way to sell a product. The performance image is important to the man on the street.

Q. Now and then, we read or hear of a "stuck throttle" causing a race accident. Why does this happen?—Elwood Abernathy, Des Moines.

A. It sounds ridiculous, but racing seems to bring out failures like this. Stresses on all the
(Please turn to page 34)



SECRETS of Teaching Yourself MUSIC



You can learn any instrument in your home . . . in spare time

TEACH *yourself* music? Yes, you can — and you'll be amazed how easy it is! Piano, guitar, accordion, saxophone — any popular instrument — you can teach yourself to play it *right away*. It's all possible thanks to the remarkable home-study Course offered to you now by the famous U.S. School of Music.

You Learn Quickly, Easily

This superb Course shows you how to play your favorite music *by note*. You read and play actual sheet music. There are no "gimmicks" at all. And the incredible thing is that you learn so *quickly and easily*.

The secret of this rapid success is in the Course's unique, proven method of instruction. Simple, easy-to-understand instructions tell you what to do. Then, wonderfully clear pictures *show* you just how to do it. These lessons are so well-developed and effective, you actually *teach yourself!* It's so easy that even children can learn. And you don't need any special talent, or previous experience, or even special knowledge of music!

From the very first lesson you start playing actual tunes from sheet music. As you progress, you'll be playing more and more advanced pieces. Before you know it you'll be playing your favorite music as though you've known how all your life!

Convenient and Economical

You'll also be delighted to discover how *convenient* and *economical* this wonderful Course is. You learn at

home, in your spare time. You go as fast or as slowly as you wish. There's no expensive private teacher to pay. You get valuable sheet music at no extra cost. And you learn for just pennies a day!

Start Enjoying a New Way of Life

Just imagine yourself playing your favorite instrument, and playing it *well*. What a thrill and sense of accomplishment you'll feel as you skillfully and confidently play popular hits . . . classical pieces . . . folk and country music . . . dance tunes — any kind of music you like! You'll enjoy a wonderful escape from the tensions and problems of everyday life. You'll win *new* friends and *new* popularity. Best of all, you'll have that warm, deep-down sense of satisfaction and self-fulfillment that comes with going ahead and really doing something you've always wanted to do!

MAIL COUPON TODAY

Don't go on missing the pleasures that playing music can bring into your life. Mail the coupon below right now for our **FREE** new booklet that tells you all about the Course and shows you how *fast* and *easy* this unique instruction really is. We'll also send you a **FREE** Piano "Notefinder." No obligation. Just mail the coupon **TODAY** to:

U.S. SCHOOL OF MUSIC, Studio A301, Port Washington, N. Y. 11050. *Estab. 1898. Licensed by the New York State Education Department.*



Here's How Others Learned to Play This Fast, Easy Way!

EXCITED — DELIGHTED — "I'm so excited, thrilled and delighted with this magnificent Course that it's difficult to 'go slowly.' Instructions are easily understood. And I enjoy the fact that I can practice and study at my own time and speed."

Clara J. Napoleon
Trenton, N. J.

PLAYS FOLK MUSIC — "I have finished college, and my ability to play the guitar really paid off there, especially since folk music has become so popular. I have played both as lead guitarist and accompanist guitarist."

Dwight Bullard
Concord, Ark.

FRIENDS ARE ASTONISHED — "Ever since I signed up for the Piano Course, I have been reaping happiness. My friends are astonished and my family happy. I will never forget all the fun I've had."

Linda Kurtz
Alrville, Pa.

Accredited Member National Home Study Council

U.S. SCHOOL OF MUSIC, Studio A301
Port Washington, New York 11050

Yes! I want to learn to play the instrument checked below. Please send me, **FREE**, your new illustrated booklet "Now You Can Learn To Play Music in Your Own Home"—plus your free Piano "Notefinder." I am under no obligation.

Check the instrument you would like to play (check one only):

- | | | |
|---------------------------------------|--------------------------------------|-----------------------------------|
| <input type="checkbox"/> Piano | <input type="checkbox"/> Saxophone | <input type="checkbox"/> Cornet |
| <input type="checkbox"/> Guitar | <input type="checkbox"/> Violin | <input type="checkbox"/> Clarinet |
| <input type="checkbox"/> Accordion | <input type="checkbox"/> Tenor Banjo | <input type="checkbox"/> Ukulele |
| <input type="checkbox"/> Organ | <input type="checkbox"/> Mandolin | <input type="checkbox"/> Trombone |
| <input type="checkbox"/> Steel Guitar | <input type="checkbox"/> Trumpet | |

Do you have instrument? Yes No State.....

222

Instruments, if needed, supplied to our students at reduced rates.

Name.....Age.....
(Please Print Clearly)

Address.....

City.....

ZIP CODE ZONE NO
[] [] [] [] [] [] [] []

INTRODUCING . . . the NEW WARNER SUCCESS PROGRAM that is

**P R O G R A M M E D
F O R P R O F I T**

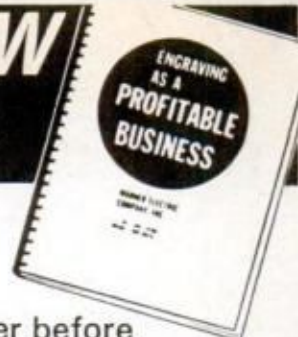

THIS IS IT! The new Warner Success Program "Engraving as a Profitable Business" is now ready for you. It contains twenty chapters of pertinent information. It instructs you, step-by-step, in the actual craft of engraving; it shows you how you can check the advantages of your own Engraving business in your community, your neighborhood; it tells you how to get the right price for your engravings, both made-to-order and stock engravings. The chapter on Marketing gives you eight plans . . . any one plan of which will bring you the increased income you desire.

SEND FOR FREE BROCHURE

There is absolutely NO RISK to this offer. You send no money, just your name and address. Never before has such an opportunity presented itself to the small

home-operator . . . never before could so much profit be realized on so small an investment. Don't delay. Get the facts today! Use the coupon or send your name and address on a postcard.

**Warner Electric Co., Dept. E-2-AS
1512 Jarvis Ave., Chicago, Ill. 60626**

Engraving Division, Dept. E-2-AS
1512 Jarvis Ave., Chicago, Ill. 60626

SEND NO MONEY

Please rush full particulars about your new Success Program, "Engraving as a Profitable Business." Tell me about your less-than-bank-rate credit plan that will help me get started in this profitable business in my spare time, at home. Everything you send me is FREE . . . no salesman will call.

Name _____

Address _____

City, State, Zip _____



POUR A NEW COUNTER TOP

with your DAP®
Seamless Decorating Kit

Create an entirely new look to counter tops, table tops and scores of other surfaces by *seamless decorating*. You pour the surfaces, adding colorful chips. Tough, resilient surfaces that never need wax. Kit has all you need to start with . . . even work gloves! Experiment with kit then graduate to large floor areas. Ask about this colorful, new hobby at better hardware, paint and building supply stores.

DAP INC., Dayton, Ohio 45401 • Subsidiary of *Plough, Inc.*

**When you
see this mark
you've seen
the product in
Popular Mechanics.**





SAVE 1/2 ON "NEW SOUND" ELECTRONIC ACCORDIONS*

BIG DISCOUNTS!
Importer-to-you
Prices

42 STANDARD AND
ELECTRONIC MODELS
for Students, Teachers
and Professionals

FREE GIFTS
E-Z Lesson Course,
Year's Music Supply,
Music Stand, Straps,
and Case... Many More!

Rush Coupon
Free Color Catalog
Discount Price List

Easy Terms • Low as \$7.95 a Month

★Rush coupon for **proof** you save up to 50% off retail prices of comparable accordions! **BUY DIRECT**—Low Importer-to-You prices. World's largest accordion dealer. All famous makes. 42 New **Electronic** & Standard models, Amplifiers. Popular "Button type" accordions, too! Lifetime Performance Policy. Money Back Guarantee. Easy terms. Big Trade-In. Color Catalogs, Selection Guide and Discount Prices—**FREE!**

ACCORDION CORP. OF AMERICA
Dept. R-19, 5535 W. Belmont Ave., Chicago, Ill. 60641

5 Day Home Trial

Accordion Corp. of America, Dept. R-19
5535 W. Belmont, Chicago, Ill. 60641
Send **FREE** Catalog of Accordions, Amplifiers
—Selection Guide, Color Chart, Discount Prices.

NAME _____
ADDRESS _____
CITY _____ STATE _____
 Check here if you have a Trade-in.



The Easy
Way to
Build



BEAUTIFUL CLOCKS

Send 25¢ for 48-page catalog of easy patterns, fine clock movements, dials and hardwood kits.

CRAFT PRODUCTS
ELMHURST (1) ILL. 60126

INVENTORS

INVENTIONS—NEW PRODUCTS—IDEAS DEVELOPED & PREPARED

For Commercial Appeal & Sales

DESIGN—MARKETING—PATENT SEARCHES—DRAWINGS

United States Patent Office former Patent Examiner

United States Government former Patent Adviser

Member: United States Chamber of Commerce

Second Decade of Reliable Service to

INVENTORS—MANUFACTURERS—ATTORNEYS

THE RAYMOND LEE ORGANIZATION

230-Z Park Ave., New York 10017 (212-MU 6-8500)

SEND FREE "INVENTION RECORD" Form & "IMPORTANT PATENT INFORMATION"

Name _____
Address _____
City _____ State _____ Zip _____

How Ed Crouch Zoomed His Pay Up To \$2,000 A Month

Ed Crouch was a drive-in theater man. He had 10 years in the business, but it wasn't paying off. He wanted more money . . . action . . . opportunity. And he got all three.



Because Ed just dumped all that past experience and stepped into a new career. Today he's making \$1,200 to \$2,000 a month as a professional Accident Investigator with an independent company in California.

His car mileage is paid. His expenses are paid. He does no selling. He's on top, enjoying more income, more action, more security than ever before.

FREE BOOK STARTED IT ALL

Ed made this dramatic change in his life because he sent away for a free book of facts from Universal Schools of Dallas.

He learned that Accident Investigation is part of the *biggest business in the world*.

That more trained men are urgently needed now, everywhere, to investigate more than 22 million accidents and losses every year.

That Universal Schools, oldest and largest in the field, has trained and placed more men in this booming business than any other—80% of them men with no experience, no college.

TRAIN AT HOME, IN SPARE TIME

Ed enrolled for Universal training. He simply read lessons-by-mail at home in his spare time. And he didn't miss a paycheck, because he kept right on with his old job while he trained.

Today, with earnings up to \$2,000 a month in Accident Investigation, Ed says this: "Universal put me where I am today. There are not words to thank them enough."

Ed's income is above average and not typical of the field. But it shows what a Universal-trained man can do starting from scratch in this business.

SEND FOR FREE BOOK NOW

Discover your opportunities in this amazing profession. Mail the coupon today for your free book of facts—the same book that started Ed Crouch and so many others on the road to profitable new careers.

Mail the coupon or write to Universal, 6801 Hillcrest, Dallas, Texas 75205. No obligation. No salesman will call.



Plus Mileage Paid
Expenses Paid
No Selling

GET FREE BOOK OF FACTS

APPROVED FOR
VETERANS' TRAINING

UNIVERSAL SCHOOLS, Dept. PM-1
6801 Hillcrest, Dallas, Texas 75205

Please rush free book on Accident Investigation
No obligation. No salesman.

Name _____ Age _____

Address _____

City _____

State _____ Zip Code _____

DRIVIN' WITH DAN

(Continued from page 30)

linkages are much more severe than one would imagine. If you were to take an absolutely standard automobile and race it, all sorts of silly and dangerous things would happen. A stuck throttle still boils down to poor engineering and maintenance.

Q. *Why is the color green never used on American race cars, or even seen around racetracks?—Willard Moraghan, El Paso, Tex.*

A. It is an old superstition, but there are many exceptions these days. I really don't know how it started in the United States, but, on the other hand, I don't know how 13 was chosen as an unlucky number either. Peanuts in the shell are also taboo around USAC races. On the world scene, of course, the English have British Racing Green as their national color and they manage to get by.

Q. *Why don't you drive in more stock-car races?—Jay Hanigan, Mountainside, N.J.*

A. Because I am primarily a road racer. Stock cars race mostly on ovals. There are only 52 weekends per year, and most stock-car race schedules conflict with my other commitments.

Q. *I read where Lincoln-Mercury is seriously considering a power effort with you in next year's Can-Am series. Is this so?—James Gilmore, Santa Barbara, Calif.*

A. So far, Lincoln-Mercury has helped me with engine parts for the Can-Am series.

Q. *After a car has become obsolete, especially one very specialized like a Group 7 or Formula 1, what is done with it?—Jim Martin, Cincinnati.*

A. Most such cars usually are gobbled up quickly by the swelling ranks of amateur racers. Others are turned into show cars, cannibalized and converted to up-to-date versions, go to museums, or just rust in junk piles.

Q. *I hear you're getting out of Formula 1. Is it true?—Jerry Matthews, Sarasota, Fla.*

A. Yes, it is. We've taken a long, hard look at the entire F1 picture as it pertains to All-American Racers and have decided to abandon ship. F1 racing, particularly in the development of a competitive car, is becoming in-

creasingly expensive. Needed sponsor support is dwindling and I just don't see how we can hack it financially any longer. So, regretfully, we're pulling out. Personally, I have no definite F1 plans for the coming season.

Q. *Why do service stations insist on installing the newest and best tires on the front of the car? In my opinion, they belong on the rear. Am I right?—Noel Martin, Cynthia, Ky.*

A. I'd say you should have good ones on all four corners, because it is just about impossible to say which end is most important.

Q. *What are the advantages of the V12 engine used in your Eagles over other Grand Prix cars with a V8?—Chris Kennedy, Kensington, Md.*

A. In theory it can produce more power. However, in practice we have not achieved this in the form of usable racing power. Our engine also seems to require more oil and water cooling, and maintenance is more difficult. At the moment, the V8 seems to be the best compromise all around.

Q. *I've heard a lot about Hemis. What is the difference between a Hemi and a regular engine?—Dex Simanton, Auburn, Ind.*

A. The word "hemi" refers to the hemispherical shape of the combustion chamber in the cylinder head. It is an old standby in racing-engine design. Other head shapes are "wedge," "pent roof" and "Semi-Hemi." The difference is in the shape, location and number of the valves. The "pent roof" four-valve seems best for power.

Q. *What's going to be the next type of engine at Indy?—Phil Nash, Summitville, Ind.*

A. Turbocharged engines look good. So do standard-block, pushrod-operated valve engines. Pure turbines may still have a chance. There are rumors of steam engines. I think the conventional engine will remain competitive for another decade. Do you know anything about atoms?

If you have questions on racing, high-performance and everyday driving techniques, send them to "Drivin' with Dan," c/o Popular Mechanics, 575 Lexington Ave., New York, N.Y. 10022. Questions cannot be answered by individual letters. Questions on maintenance and repair should be addressed to the Auto Clinic (see page 72).

NEW PRICE SHOES

SAY
"the END"
to
\$15 to \$30
SHOES

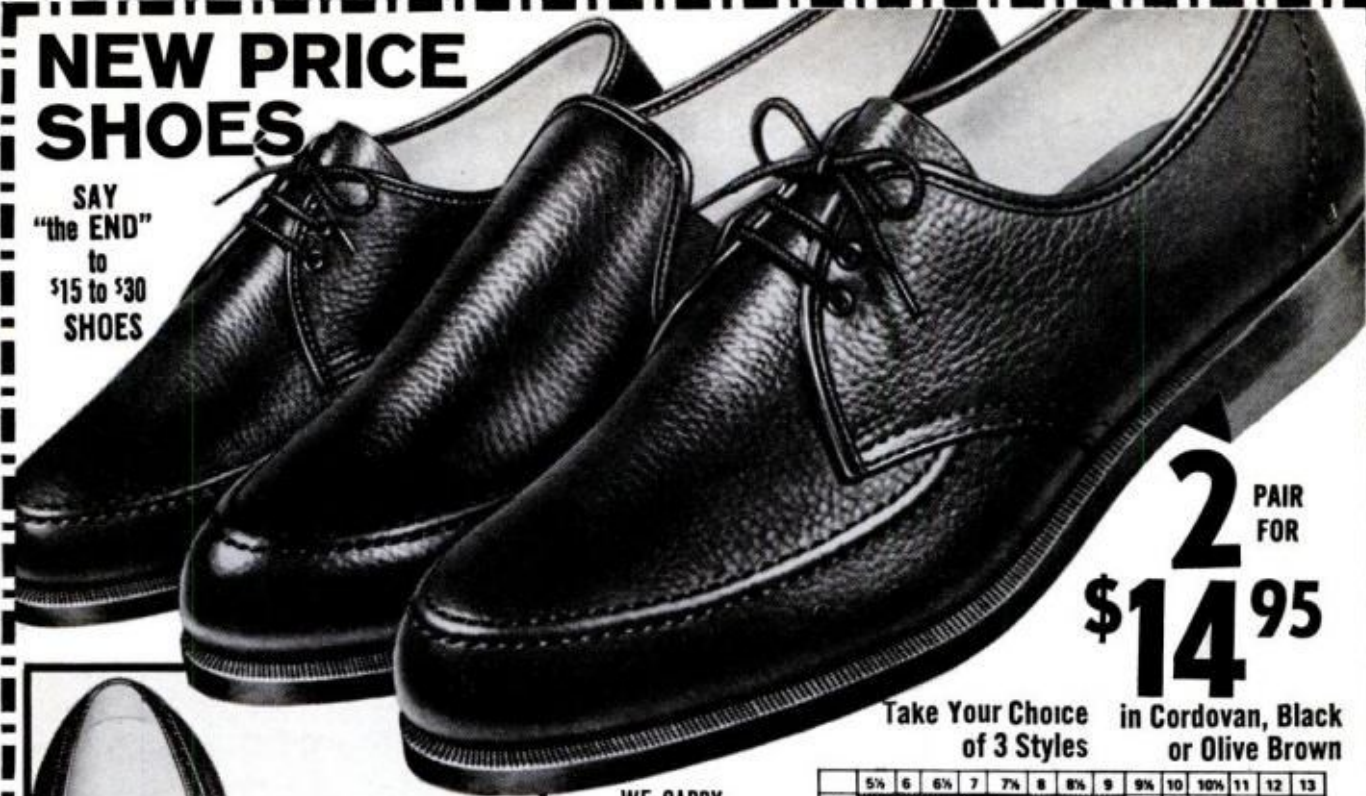

2 PAIR
FOR
\$14⁹⁵

Take Your Choice of 3 Styles in Cordovan, Black or Olive Brown



NEW!
WING TIP
BROGUES

SAME
miraculous
LOW
PRICE

Black
or
Brown

Check Choice
on
Order Form

WE CARRY
ALL THESE SIZES →
OXFORDS, LOAFERS,
WING TIP BROGUES

	5%	6	6%	7	7%	8	8%	9	9%	10	10%	11	12	13
A														
B														
C														
D														
E														
EEE														

You'll be shocked when you see our shoes

After what you've paid for shoes, you'll wonder how any such price as ours can be. Well, you get top quality uppers, good lifetime laces, life-of-the-shoe PVC sole and heels, flexible support shank in the arch, gentle foam heel cushions, superior gentleman's detailing. The works! Even the new luxury linings.

SOONER OR LATER you'll be wearing The New Price Shoes

Today's new man-made shoe materials beat the price out of

leather, scoff at scuffs, keep better shape. Why spend even one dollar more for shoes? Here's something NEW. Here's something PROVEN.

Please note. At the price we sell shoes, we are not allowed to mention the famous brand name of this new shoe material. Suffice it to say it looks like top grain leather, performs even better. Why pay higher and higher prices? Get in on this astounding low price. Send in now:

TWO PAIRS FOR \$14.95

CASH IN NOW on these Extraordinary Savings! The day of the high priced shoe is over. Folks are paying many dollars less than ever before, thanks to the miracle new "polymeric" shoe materials. This is no "cheap imitation" shoe. It's the real thing: the New Price Shoe that looks and feels and wears as well as any shoe you have ever worn and yet costs a fraction of the price.

We will be proud to send them to you for ON APPROVAL AT HOME INSPECTION

Haband Company
Paterson, N. J. 07508

operating by U.S. MAIL since 1925

SEE IT YOURSELF USE THIS COUPON

HABAND—265 No. 9th St., Paterson, N. J. 07508
SPECIAL SERVICE Dept. P M

Gentlemen: Please send me, ON APPROVAL, the.....pairs of New Price Shoes specified below, for which my remittance of \$.....is enclosed.

color	OXFORD		LOAFERS		WING TIP	
	HOW MANY	SIZE	HOW MANY	SIZE	HOW MANY	SIZE
Cordovan						
Black						
Brown						

Name _____
Street _____
City & State _____

FULL SATISFACTION GUARANTEED OR YOUR REMITTANCE REFUNDED

ICE-FISHING GADGETS

TWO QUICK PROJECTS FOR WINTER-FISHING BUFFS

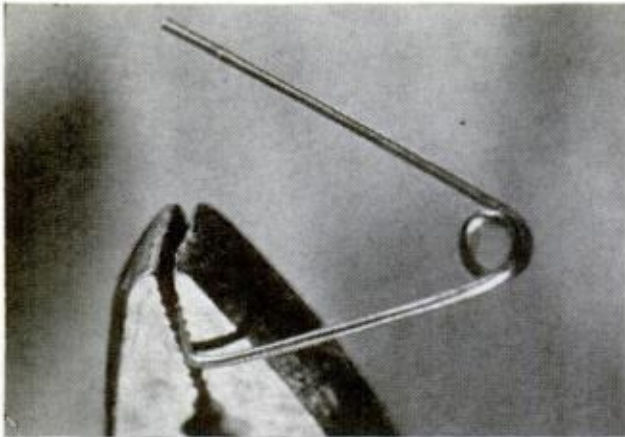

STEP 1. Trim ends off a safety pin; bend remaining tips

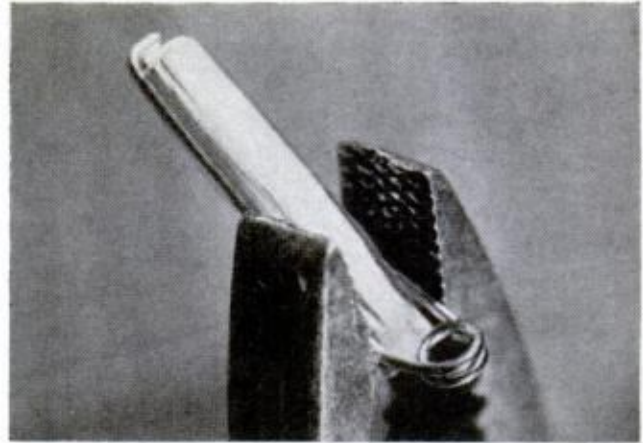

STEP 2. Shape a dowel; bend pin over tapered wood

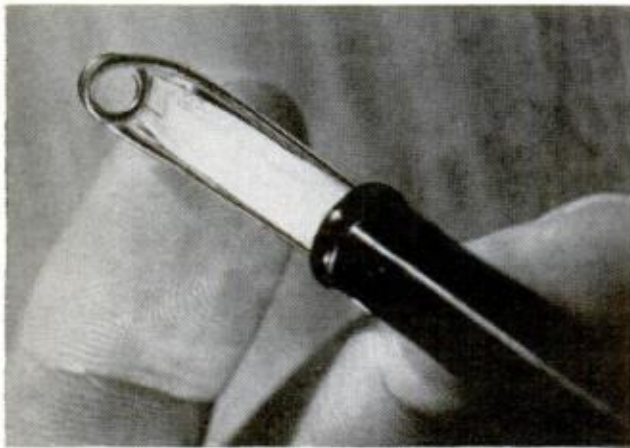

STEP 3. Shape until dowel and pin fit into rod ferrule

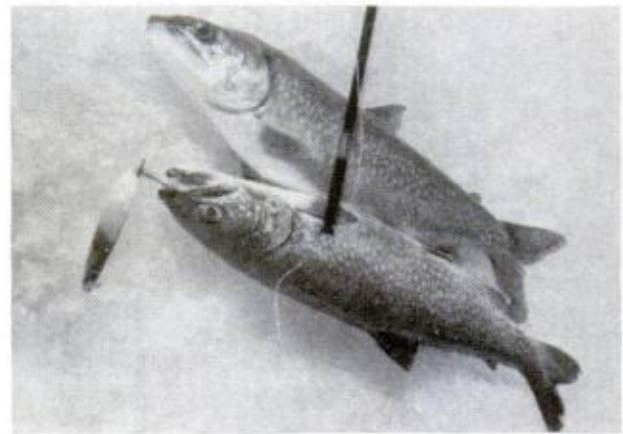

STEP 4. Reeve line through safety-pin eye. Catch fish

A HANDY ICE-FISHING ROD can be made from the butt end of any spinning rod. All you need is a dowel, safety pin, knife and pliers. After clipping the ends off the pin, bend the two open ends (Step 1) so they'll clamp over a dowel. Bend the pin loop at a right angle, then shape the

dowel so it fits firmly in the ferrule opening. Now clamp the pin onto the dowel (Step 2). Keep whittling the dowel so the pin and wood slip almost all the way into the ferrule (Step 3). Only a small part of the dowel extends from the ferrule when the fit is a correct one.

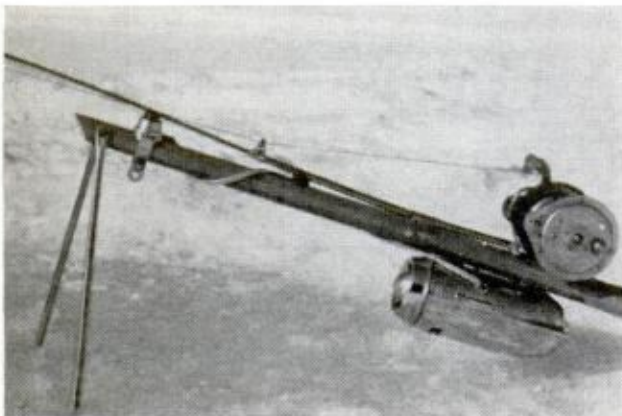

A BICYCLE HORN lets the fisherman know there's action when he uses this rig. He no longer needs the red tip-up flag.

To make it, all you need is the tip of an old steel rod, an inexpensive reel, a broomstick and a battery-operated bicycle horn with button. Attach the horn button at the end of the broomstick. Run insulated wire back to the horn. Position the rod and reel so the slightest wiggle of the rod activates the button. Attach folding tripod legs.—Rod Cochran

**New Way
to
Paint!
Fastest! Easiest!**



Speed Demon®

Nylon fibres make quick work of painting large areas, indoors or out! No brush marks! No orange peel effect! 3 sizes: 9", 7", 5". Adjustable trim guide. Threaded handle. At hardware, paint stores.



Red Devil inc
UNION, N. J. 07083, U.S.A.

Tear Out & Mail. No Letter Needed!

Free New Catalog 2000 Novelties



Send for world famous catalog of novelties, live animals, scientific supplies, hobbies, funmakers, planes & boats, looms, magic tricks, joke articles, unusual seeds, gadget timesavers, cameras, optical goods, projectors, movies, lucky jewelry, religious novelties, disguises, musical instruments, stamps, coins, puzzles, fortune tellers, radios, auto & bike accs, toys, telescopes, magnifiers, compasses, banks, smokers' gadgets, artists supplies, printing sets, engines, motors, shockers, knives, billfolds, fireworks, guns, rifles, sports, books, games, plants, etc. Send postcard or this ad. No letter needed!

CHECK HERE → YES—I want FREE Catalog. My Name & Address Attached or on Envelope

Johnson Smith Co., Dept. 502, Detroit, Mich. 48224

Save Money on WOOD

Hardwood Veneers . . . Hardware . . .
Wood Shop Supplies and Equipment
. . . Power Tools



Hardwoods, Fine Plywoods, Inlays, Mouldings, Mosaic Tile, Tools, Lamp Parts, Upholstery Supplies

Your new MONEY SAVING wood and workshop buying guide now ready! 140 page. Full color! Your best "one stop" source for finest kiln dried domestic and imported hardwoods, veneers, plywoods, modern and traditional legs . . . over 1500 items.

STANLEY TOOLS at Discounts
Startling savings on top name power tools, hard to find cabinet hardware, lamp and upholstery supplies. New projects and kits. Enclose 35¢ to help pay mailing and handling costs. Mail coupon.

**New Catalog
over 1500 items
Now Ready!**

CRAFTSMAN WOOD SERVICE COMPANY

2729 South Mary, Chicago, Illinois 60608. Dept. A-19

Rush new Craftsman WOOD Catalog. I enclose 35¢ to help pay mailing cost.

NAME _____
ADDRESS _____
CITY _____ STATE _____ ZIP CODE _____

BE A TRAVEL AGENT OR TOUR GUIDE



... I'LL GIVE YOU this
Rand-McNally World Globe
and exciting 86-Volume
Travel Library!



World Globe, 12-Volume Rand-McNally World Atlas, PanAm 2-Volume "World Horizons," 12-Volume Vacation Guide Encyclopedia, Travel Agents' Manual, 500-page Travel Industry Personnel Directory, Official Airlines Guides, International Shipline Guide, Hotel & Travel Index, 52-issue subscription to Travel Agent Magazine and dozens travel folders, maps & posters given to you with your complete 50-Lesson North American Course in Travel.

... When you train at home with N.A.S.T. for a BIG MONEY CAREER IN TRAVEL

(as Travel Agent, Tour Guide or in one of 100's Big Money Career Positions in Travel)

There's excitement, big money, fun, prestige in Travel. Thousands big money career opportunities open to qualified men & women. Travel is booming—increasing 15% each year. Easy home-study plan trains you for well-paid job with travel agency, airline, resort, etc.—shows you how



to become Travel Agent—reveals how to make big profits escorting tours—discloses how to roam the world at reduced rates. Send for big "TRAVEL CAREER KIT"—20-Page Book "Opportunities in Travel," giant full color World Wall Map & Sample Lesson—ALL FREE! No salesman will call. Mail coupon today!

J. Russell Calvert / Executive Director
North American School of Travel, Dept. 4171
4500 Campus Dr., University Plaza, Newport, Calif. 92660

Mail "TRAVEL CAREER KIT"—20-Page Book, Giant Wall Map & Sample Lesson—ALL FREE!

NAME _____ AGE _____
ADDRESS _____
CITY _____ STATE _____ ZIP _____



WE BROUGHT YOU the SUPER-HACK

(and everybody imitated us)

Now We Bring You the **SUPER-FILE™**

Tungsten Carbide (cousin of the diamond) is permanently fused to a steel file. Now you can file the "unfilables" . . . materials like glass, tough plastics, fiberglass, any kind of metal including the hardest tool steel . . . wood, paint, ceramics (the only file that will smooth pottery and porcelain rough spots) . . . brick, stone, etc. Even on wood Super-File™ is twice as fast, lasts much longer, cuts forwards, backwards and circularly so it saves time. Use for finishing, shaping, notching, any material. You'll enjoy using this gleaming golden beauty with its soft leathery handle. One side of file is for fine work, the other is for coarse filing. File those rough spots of metal objects with this de-luxe product, only \$3.00, we pay postage.

Combination Offer—One Super-Hack . . . One Super-File™ . . . \$4.00 we pay postage.

MEREDITH, Dept. PM-1, 310 West 9th Street, Kansas City, Mo. 64105

Big jobs to do? Use your electric drill and power-boosting

Versamatic



- Screw Driving
- Screw Removal
- Driving Nuts
- Removing nuts
- Heavy-duty drilling
- Tapping

RIDGID Supreme

Power Tool Equipment

Lots of big screws to drive or remove? Nuts to put on? Or take off? Need to drill in concrete or hard steel? Use power. Attach a reversible Versamatic to your portable drill for seven-fold power increase and 7 to 1 speed reduction. Versamatic more than doubles power drill usefulness. Send for free folder—"How to double the value of your power drill."

The Ridge Tool Company, Dept. D, Elyria, Ohio 44035

BE YOUR OWN BOSS!

A SPACE AS SMALL AS 10" X 13" CAN MAKE YOU INDEPENDENT in the high profit (low investment) rubber stamp field. Increase your income; full or part time basis. Deal direct with manufacturer offering lowest prices on professional SIMPLE-X presses & supplies, plus valuable aid. For FREE full facts write

CUSTOM MFRS.

406PM E. Elm, Springfield, Mo. 65801



DON'T QUIT SMOKING

before giving my pipe a 30 Day Trial

New principle that contradicts every idea you've ever had about pipe smoking. I guarantee it to smoke cool and mild hour after hour, day after day, without rest, without bite, bitterness or sludge. To prove it, I'll let you try a new Carey Pipe. Send your name and address today for my free complete trial offer. Write:

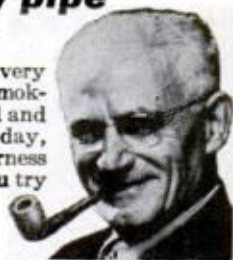

E. A. CAREY, 1920 Sunnyside Ave., Dept. 252A, Chicago 40

SATURDAY MORNING INCOME PLAN!



Earn \$5 to \$20 extra in spare weekend or evening hours, accepting orders from friends and neighbors for our nationally famous shoes. Just show our beautiful full color catalog of over 275 exciting styles, many exclusive comfort features! No experience needed to make extra money, earn prizes, bonuses—even FREE SHOES for life! Rush name & address for FREE Starting Outfit today. **MASON SHOE, Dept. H-376, Chippewa Falls, Wis. 54729**

DEFENDER OF WOMEN!



Instantly Stops Attacker

Assailants run screaming when sprayed in face with DEFENDER. When you're in danger, simply press top. Temporarily leaves attackers helpless. Dyes skin identifying attacker for police. Effective up to 15 ft. Lip-Stick size—hides easily in palm of hand. Women buy on sight. Amazing profit! **SAMPLES for TRIAL** Sample offer sent to all who send name at once. Postcard will do. **SEND NO MONEY.** Just your name. **KRISTEE CO., Dept. 671, Akron, Ohio 44308**

PROFIT IN YOUR SPARE TIME

SMALL ENGINE REPAIR PAYS BIG!

Outboard • Powermower • Chain Saw • Tractor

MAKE EXTRA MONEY — or fix your own engines and **SAVE!** Illustrated, easy-to-learn Home Study Course qualifies you as expert. Approved for Veterans. Write today!



LINCOLN TECHNICAL INSTITUTE
SUITE 1-E, 427 MARKET ST., NEWARK 5, N.J.

POPULAR MECHANICS

NEW RUBBER STAMP BUSINESS PAYS BEGINNERS UP TO \$16.50 AN HR. START AT HOME IN SPARE TIME

The multi-million dollar Rubber Stamp business—once controlled by a few big companies—is now being taken over by small operators—one in each community throughout the United States. Men and Women who have this inexpensive machine can turn out huge quantities of Rubber Stamps with special wording that buyers once were forced to buy from big cities. Material costing only 27c makes a stamp that sells for \$2.75. The machine that does the work is simple and easy to operate and it turns out as many as six Rubber Stamps at a time, each with different wording such as names, addresses, notices, stock numbers, prices and other "copy" needed by offices, factories and individuals. Working full capacity, it can earn as much as \$33.00 an hour for the operator! Now you can get into the big-pay business yourself, with your own home as headquarters. You don't need experience. We supply everything, including complete instructions and eight ways to get business coming in fast. We even help finance your start. Start making up to \$16.50 an hour from the very beginning. Cash in on the profitable Rubber Stamp business in your community, right away. We'll mail full particulars FREE and no salesman will call. Be first in your locality. Rush coupon or send your name on postcard now to:

RUBBER STAMP DIV., Dept. R-2-AS
1512 Jarvis Ave. • Chicago, Illinois 60626

THIS LITTLE TABLE TOP MACHINE
MAKES EVERYTHING SIMPLE & EASY



MAIL
THIS

RUBBER STAMP DIV. FREE!

1512 Jarvis Avenue Dept. R-2-AS, Chicago, Ill. 60626

Please rush full particulars about your financing plan and the little machine that can get me started in the profitable Rubber Stamp business at home in spare time. Everything you send me is FREE and no salesman will call.

Name _____
Address _____
City _____
State _____ Zip Code _____

EARN \$20.00 / HOUR

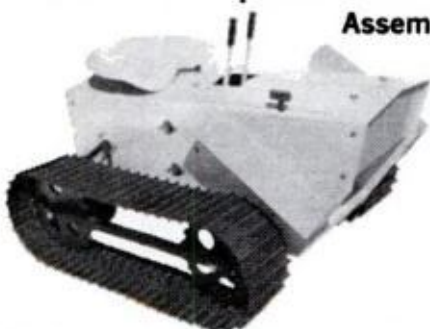

Assemble MINI-DOZERS

for resale and make big money in your spare time! It's easy. Just order this unique garden-tractor kit at our low, factory-direct price, assemble (in 6 hrs. avg.) and resell profitably to local customers. Keep one to enjoy and demonstrate. Order complete kit or any parts desired. Full line of

attachments. To see how Dozer works, send for Plans and Parts Price List — only \$5.00. Cost deducted from kit purchase price. 16 page illustrated Catalog — 50c. Order now!

C.F. STRUCK CORP., Dept. PM-19, Cedarburg, Wis. 53012

WORTH \$50 Powermaster hunting CROSSBOW

Special \$35
POST PAID

KILLS DEER, BEAR, Etc.
RABBITS, SQUIRRELS,
ALL SMALL GAME
COLLECTOR'S
ITEM

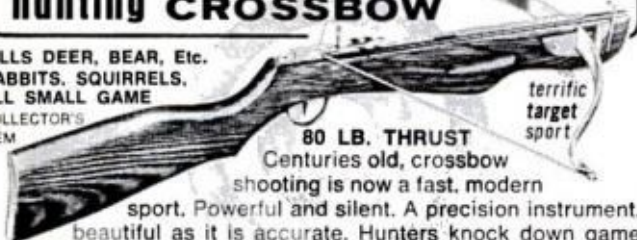

terrific target sport
80 LB. THRUST
Centuries old, crossbow shooting is now a fast, modern

sport. Powerful and silent. A precision instrument, beautiful as it is accurate. Hunters knock down game at 200 ft. Two-way sights—open and peep—windage and elevation. Anyone can target-shoot right in their own backyard. Harpoon fish with free line attachment. 34" hardwood stock, 33" bow. Handsome den display. Possession is legal in all states... Money back if not completely satisfied. Target arrows 80¢ each. Hunting and fishing arrows \$1.25. Send to: S & R RESEARCH, Box 20-K, San Gabriel, California 91778

Build Your CAMPER

SAVE UP TO 50% OFF

Complete, easy to follow Camper or Trailer Plans. \$3.95 ea.
Instructions, Material List. ea. SATISFACTION GUARANTEED
Pickup Cover Plans \$2.00
Econoline Van or Bus Conversion Plans—indicate choiceea. \$2.95

EQUIPMENT CATALOG \$1.90
Refundable on first order. SEND DIME FOR DETAILS
SAVE 50% ON CAMPER KIT
All items from our catalog to build a \$1,795 camper. 8', 10', 10'6" or Chassis Unit.

VIKING CAMPER SUPPLY, INC.
99-BP Glenwood Ave., Minneapolis, Minn. 55403
Please send _____ for which I enclose \$ _____
NAME _____
ADDRESS _____
CITY _____
STATE _____ ZIP _____

VIKING

You can make money in

WATCH REPAIR

Learn at home the low cost Sweazey Way

Watch repairing pays up to \$6 an hour, part time watch makers report on survey. Unique and modern Sweazey home study System starts you making repairs right away on Swiss and American watches. Professionally prepared training. No previous experience needed. Special tools provided for practice. Diploma Awarded. Free sample lesson and opportunity book give all facts. Write today. No obligation.

CHICAGO SCHOOL OF WATCHMAKING
Dept. 119 Fox River Grove, Illinois 60021

FREE BOOK and SAMPLE LESSON

CHICAGO SCHOOL OF WATCHMAKING
Dept. 119, Fox River Grove, Illinois 60021
Please rush FREE BOOK and Sample Home Study Lesson.

Name _____ Age _____
Address _____
City _____ State _____ Zip _____

JANUARY 1969

39

BUILD YOUR OWN POWER TOOLS

METAL PARTS KITS AT LOW FACTORY DISCOUNT PRICES FOR: **SAVE \$50 OR MORE**

- 10-IN. TILT/ARBOR SAW
- COMB. DRILL PRESS-LATHE
- 12-IN. BAND SAW
- 18-IN. BAND SAW
- 6-IN. BELT SANDER
- SPINDLE SHAPER

PLANS \$1.00 EACH
Full Size Patterns DEDUCTIBLE

Kits from \$16.99 to \$42.99. Satisfaction guaranteed. Built and sold for 22 years. 50,000 units in use. Send for Plans today!

GILLIOM MFG. CO. Dept. PM-1 St. Charles, Mo. 63301

FREE CATALOG

BIGGEST TELE?

By SHELDON M. GALLAGER

A new spotting scope designed to double as a long photo lens lets you really get up close



CAN YOU USE a spotting scope as a supertelephoto camera lens? Intriguing idea. Spotting scopes are generally used for bird watching, checking targets in sharpshooting, and so on. What happens when you hook one of these big eyes to a camera?

The Swift people, noted makers of spotting scopes, recently answered the question by bringing out a model designed especially for camera buffs. Called the Telemaster, it's a zoom-type scope that gives magnifications from 15 to 60 times at the turn of a knob. Threaded adapter rings permit it to be fitted to just about any popular single-lens reflex—Exakta, Miranda, Minolta, Nikon, Canon, Konica, Yashica, and others.

At maximum magnification, the scope is equivalent to a whopping 4000-mm telephoto. We decided to give it a try ourselves. The telephone pole at right, 100 yards away, pops into a startlingly close view with the scope at only 15X. At 30X, you can zero in on a single insulator. At extreme magnifications, atmospheric haze begins to cause some blurring, but at low to medium powers you can have a ball zooming in on distant objects barely visible to the naked eye. The Telemaster is \$135 by itself, \$165.50 with tripod. Instructions for determining exposures are included. Swift Instruments, 954 Dorchester Ave., Boston, Mass. 02125.



POLE IS TINY SPECK with regular lens

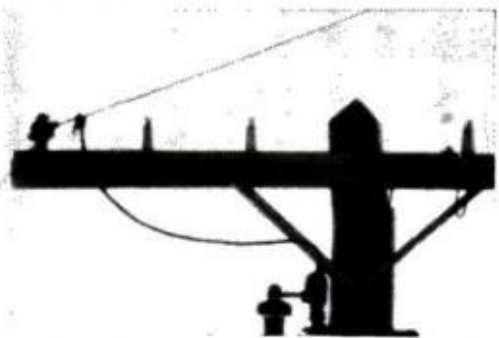

SAME POLE with spotting scope at 15X

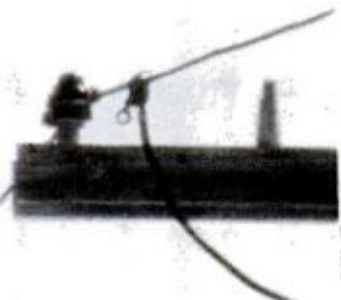

YOU'RE REALLY THERE with scope at 30X



POPULAR MECHANICS



It's no picnic. Never has been.

**Valley Forge, Meuse-Argonne, Monte Cassino,
Pork Chop Hill—they were dirty jobs.**

And not without sacrifice. But freedom lived.

**American soldiers have never ducked
the dirty job. And free men everywhere are
grateful. But it's never been done for thanks.
Or gain. Or even glory.**

**When freedom cries help, men who have
known freedom hear the call. And they go.
It's no fun. But they go. Every time.**

Your future, your decision...choose ARMY.

Army Opportunities
Department 200
Hampton, Va. 23369

PM 1-69

Tell me about soldiering and service
to my Country.

Name _____ Age _____

Address _____

City _____ County _____

State _____ Zip _____

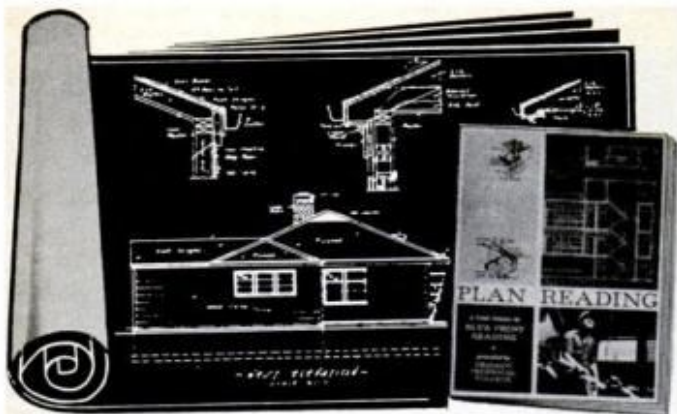

These FREE BLUEPRINTS CAN START YOU TO BIG SUCCESS IN BUILDING CONSTRUCTION

In all fifty states, men who have sent for these free blue prints are today enjoying big success as foremen, estimators, or building contractors, and so can you. Learn to read blueprints; master all the practical details of construction in your spare time, at home. Prepare for a big-pay job in building, or start your own profitable contracting business. Mail the coupon today and cash in on the booming building business. Approved for veterans. Accredited member, N.H.S.C.

CHICAGO TECHNICAL COLLEGE

A207 Tech Bldg., 2000 S. Michigan
Chicago, Illinois 60616

Please mail me FREE trial lesson, blueprints.

Name _____ Age _____

Address _____

City _____ State _____ Zip _____

Occupation _____

New G.I. Bill! Veterans check here

FREE Trial Lesson in DRAFTING

Learn Drafting at home, in your spare time. Just a few hours weekly can prepare you for a good job and better pay. Send for FREE Trial Lesson today.

Dept. DH, 2000 S. Michigan Ave., Chicago, Ill. 60616

CHICAGO TECHNICAL COLLEGE

BELSAW. PLANER · MOLDER · SAW!

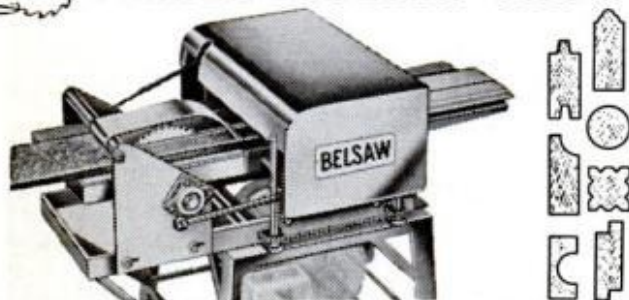

Now you can use this ONE power-feed shop to turn rough lumber into moldings, trim, flooring, furniture . . . ALL popular patterns. RIP . . . PLANE . . . MOLD . . . separately or all at once with a one HP motor. Use 3 to 5 HP for high speed output. Low Cost . . . You can own this power tool for only \$30.00 down.

Send Postcard Today . . . No Salesman Will Call

BELSAW POWER TOOLS, 909 J Field Bldg., Kansas City, Mo. 64111

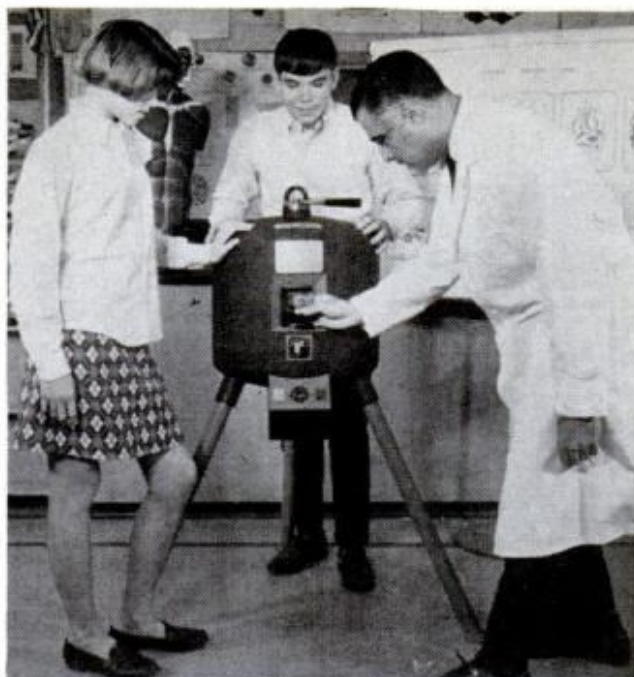

School was never like this

If your youngster comes home from school and says he's been experimenting with nuclear radiation, he probably has. This miniature radiation chamber, the size of a beach ball, is designed to be cheap enough for use in high-school science classes. Specimens placed on a turntable are exposed to powerful gamma rays to study the effects on cell growth and bacteria. Radiation Machinery Corp. says the Gammator 50 will sell to schools for \$3875.

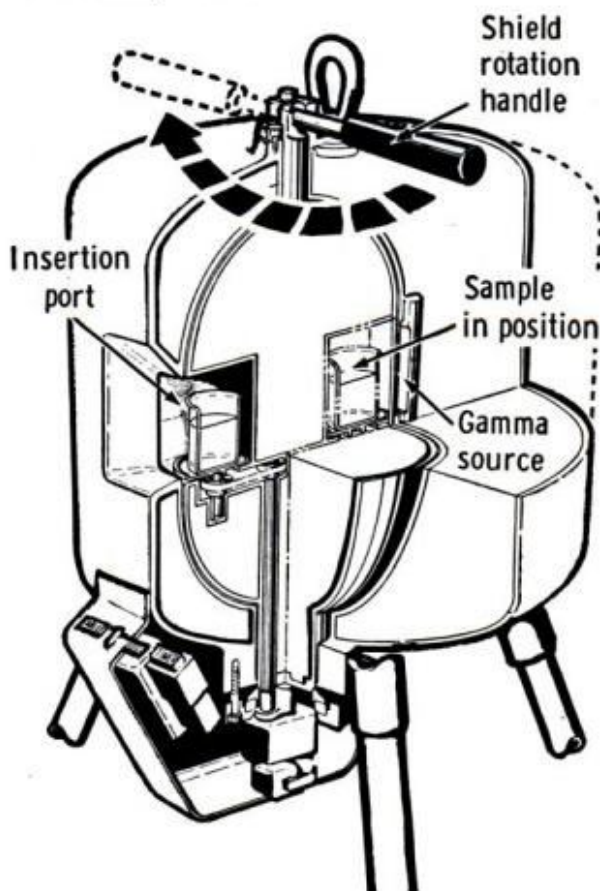

POPULAR MECHANICS

CASH IN ON THE BOOM IN COLOR TELEVISION

The NRI TV-Radio Servicing course includes your choice of black and white or color TV training equipment. Color TV needs thousands of trained men to keep pace with millions of sets being sold every year. NRI prepares you quickly. Cash in on the boom.

IF
CARD IS
MISSING
MAIL
THIS
COUPON

NATIONAL RADIO INSTITUTE
Washington, D.C. 20016

100-019



Name _____
Address _____ Age _____
City _____ State _____ Zip _____
 Check for facts on GI Bill

You get more for your money from NRI

NRI pioneered the idea of supplying home-study students with custom designed training kits to give practical on-the-job experience as you learn. Today, NRI's "3-Dimensional" training can't be equalled. You get more *value* — from the exclusive Achievement Kit sent the day you enroll, to "bite-size" texts and custom training equipment. Learning TV-Radio, Electronics or Communications at home is easy, exciting, the NRI simplified, dramatized way.

BE A SKILLED TECHNICIAN IN AMERICA'S FASTEST GROWING INDUSTRY

Regardless of your educational background, you can learn the Electronics field of your choice the practical NRI way. The NRI color catalog, sent to you *free* and without obligation, tells you how you can qualify quickly to be a part of the fast growing Electronic Age; about engineering jobs in business, industry, broadcasting, government, now offered to men without college degrees. It will open your eyes to the great number of success opportunities available right now in the high-pay world of TV-Radio Servicing, Broadcasting-Communications and Industrial-Military Electronics. With NRI technical training, you can take your choice of a wide variety of career

openings or have a business of your own. And if you choose one of five NRI courses that include FCC License preparation, *you must earn your FCC License or NRI refunds your tuition!*

MAKE \$4 TO \$6 AN HOUR EXTRA IN SPARE TIME STARTING SOON

Tens of thousands of NRI graduates are proof it is practical to train at home in your spare time. Keep your present job while preparing for a better one, and earn \$4 to \$6 an hour extra in spare time while you train, fixing sets for friends and neighbors. NRI shows you how. Equipment you build and keep becomes useful in your work.

STEP UP TO BETTER PAY, A BRIGHTER FUTURE

NRI can help you, but the decision to act must come from you. Decide *now* to move ahead . . . mail the postage-free card. If missing, use coupon above for FREE NRI color catalog. No salesman will call. NATIONAL RADIO INSTITUTE, Electronics Division, Washington, D.C. 20016.

APPROVED UNDER GI BILL

If you served since January 31, 1955, or are in service, check GI line on postage-free card or in coupon.

NRI Programmed Equipment Gives You Priceless Confidence, Makes Learning TV-Radio, Electronics Fast and Fascinating

BUILD • TEST • EXPLORE All this is yours — from Achievement Kit, to solid state Radio, to training-engineered Color TV set — when you enroll for NRI's TV-Radio Servicing course. Other courses equally complete. Unique training methods, "bite-size" texts, many personal services have made NRI the leader in its field for over 50 years.

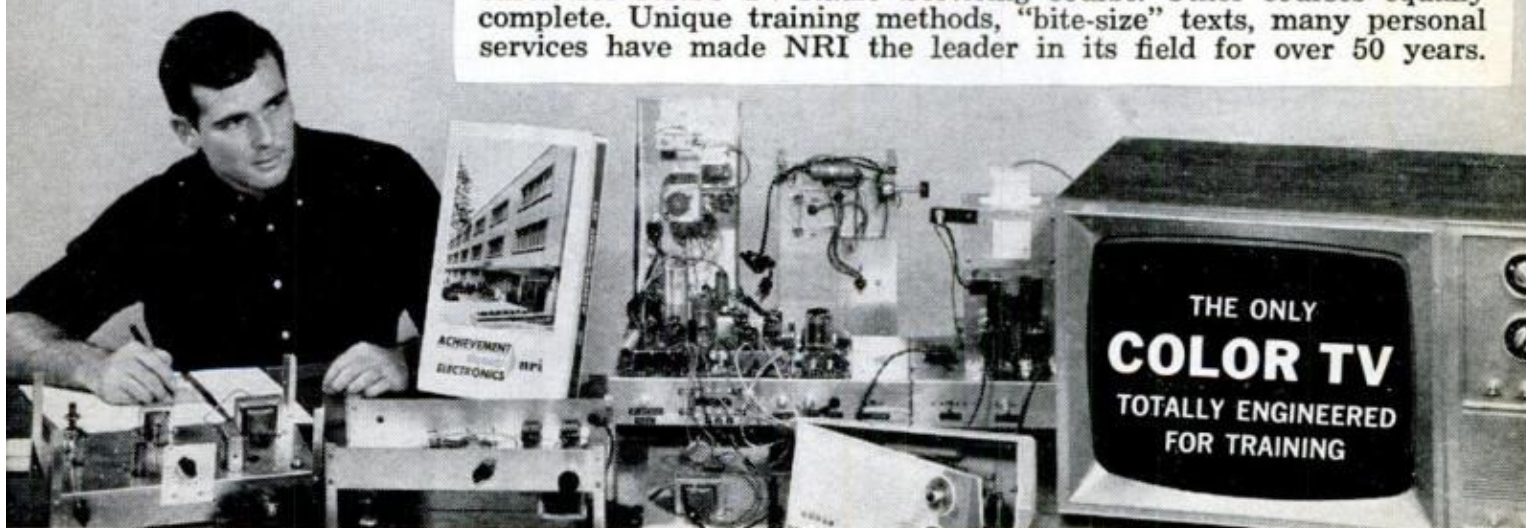

THE ARMY'S ATTIC OF ANTIQUÉ ARMS

MUSEUM CURATOR, Col. G. Burling Jarrett, stands beside "Anzio Annie," German railroad gun, too large to display inside

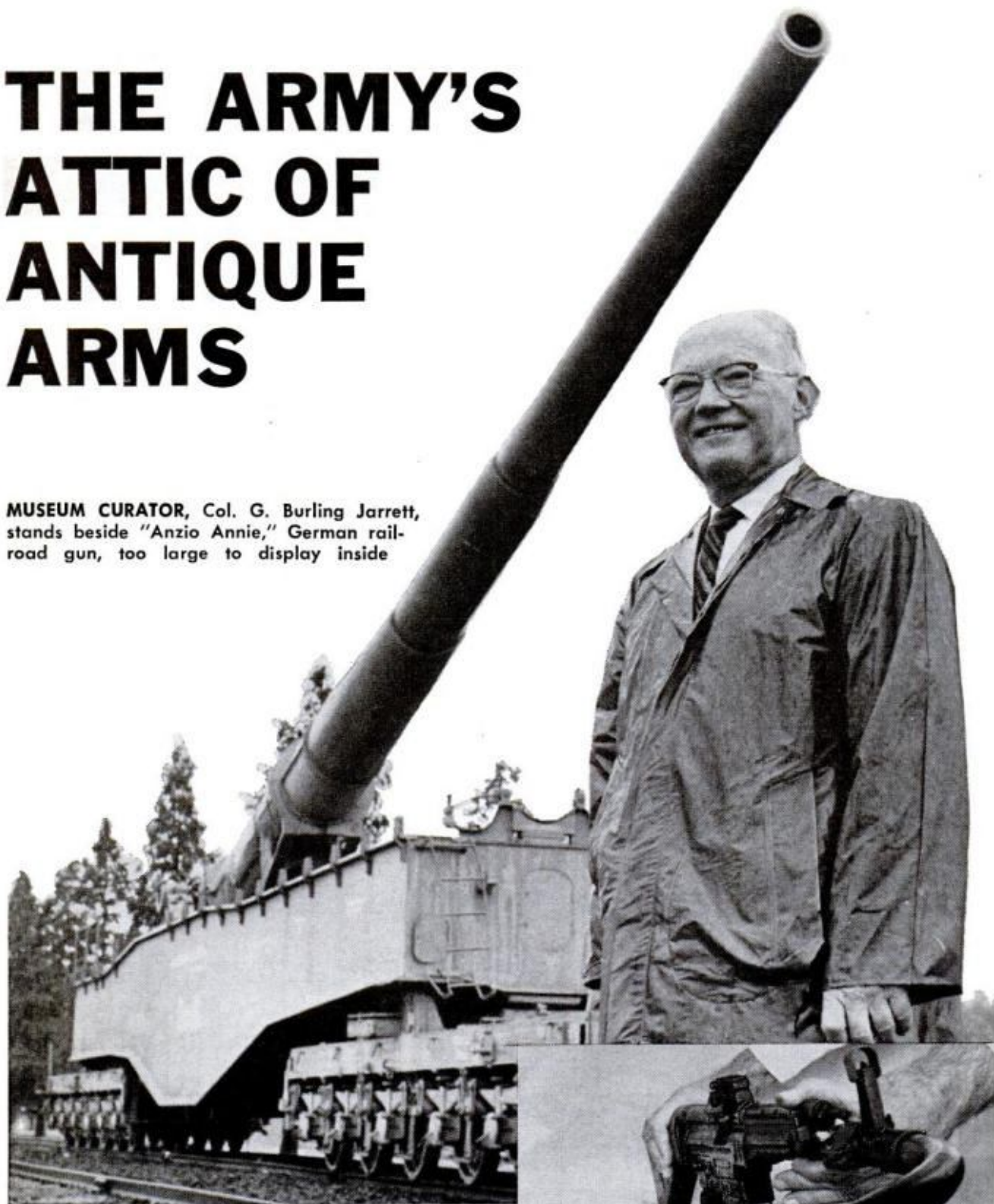

MUSEUMS are for study, including the U.S. Army's arsenal of vintage weapons at its Aberdeen Proving Ground in Maryland. So, while the Army's future weapons are tested within earshot, its new recruits and old dogfaces alike study those used in former wars by both friend and foe. The bigness, the smallness and the cleverness of some weapons may yield ideas that can be used again.

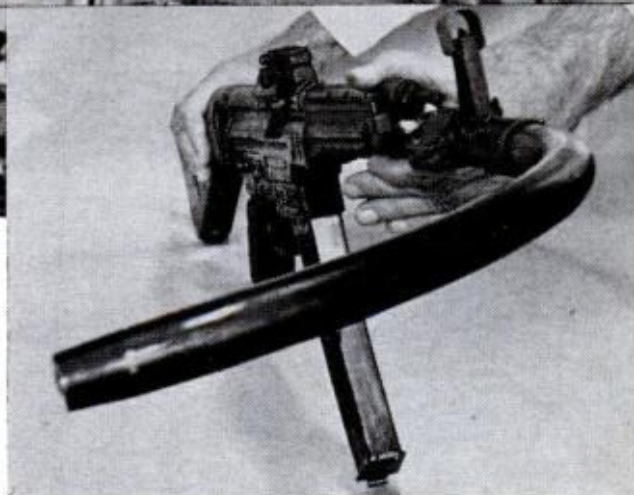

CURVED BARREL of German machine gun was designed to shoot around corners during World War II, but there is no record of whether it was actually used

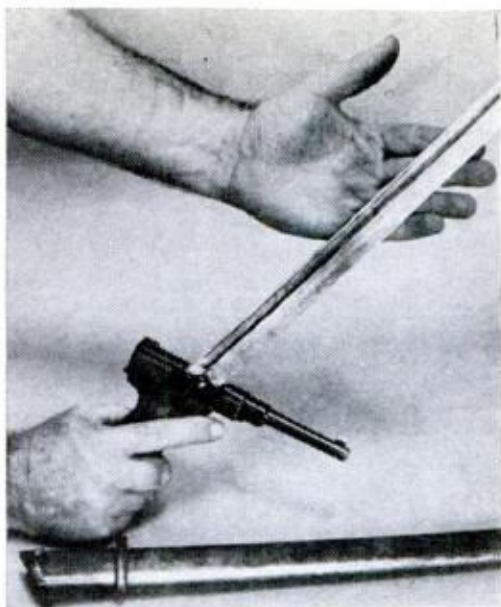

MOST EXOTIC weapon in museum is this World War II Japanese combination: a sword that uses automatic pistol as handle



CHINESE PISTOL (right, top) is copy of famous German Mauser automatic. Chinese gun, however, fires only single shots

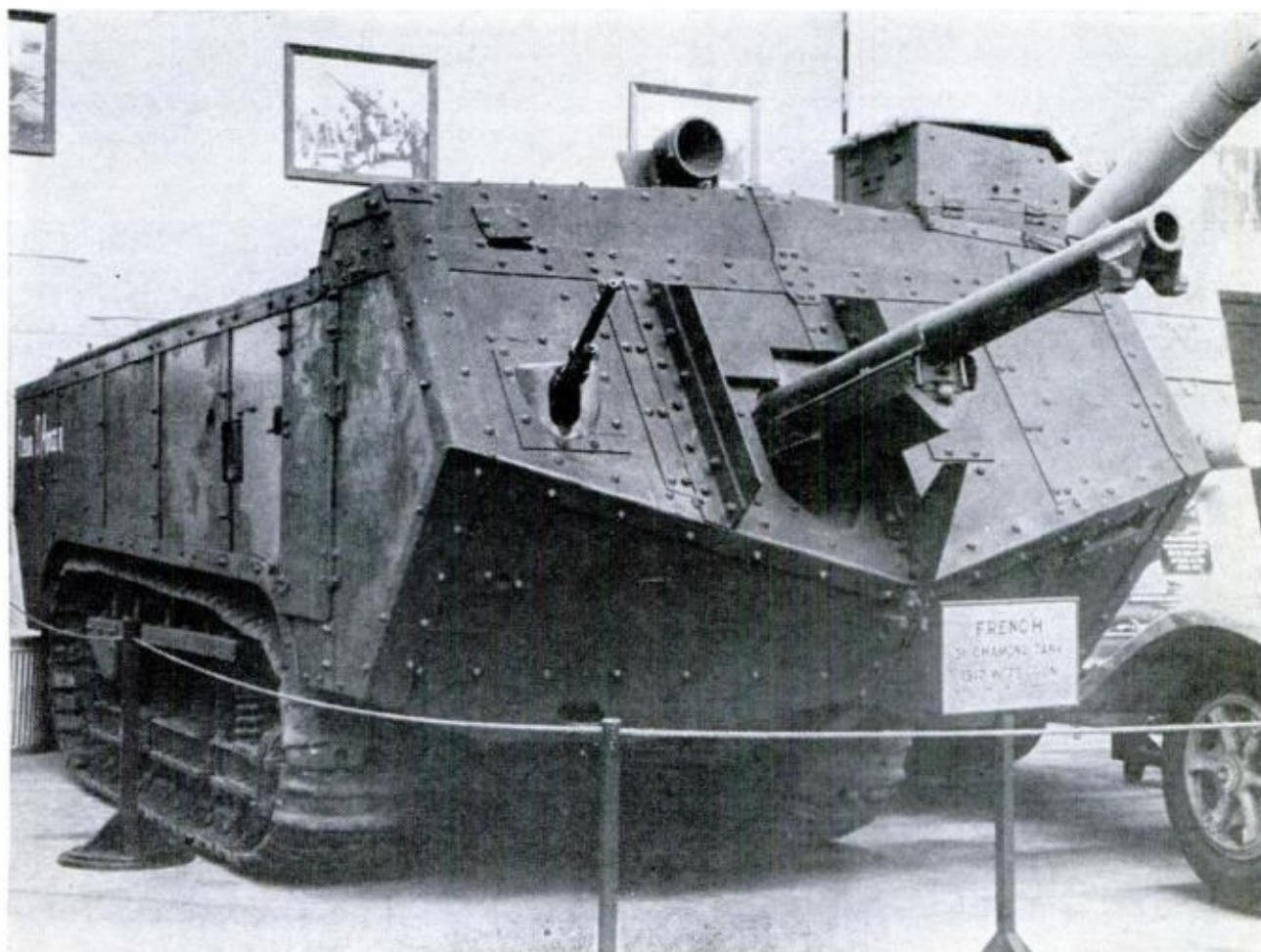

WORLD WAR I French tank, the St. Chamond, is odd-looking by modern standards, but saw service. Its principal armament is 75-mm cannon and machine gun. Other weapons displayed include Vietcong equipment

The bargain hunter

AMERICA'S ORIGINAL LOW-COST
ARC WELDER
AND ELECTRIC TORCH

10 DAY
TRIAL

LIFETIME
GUARANTEE



New Improved HEAVY DUTY
FOUR-WAY

Only \$18⁹⁵ Prepaid Complete Ready To Use
WELD, BRAZE, SOLDER, CUT
All Metals Including Aluminum

Every home, shop, and hobbyist needs this quality metal working machine. Anyone can use. No experience needed. Use up to 3/8" welding rods and 1/4" carbons to make or repair 1001 items including furniture, garden tools, toys, auto bodies, fenders, trailers, boats, farm equipment. Operates on 110 V. line for pennies—replaces gas torches—no tanks or refills to buy — produces to 11,000° heat. Twin Carbon Arc Torch easily controls heat for each job YOU CAN PAY MORE BUT YOU CAN'T GET A BETTER LOW COST WELDER. Over 500,000 in use. Manufacturers of welders for over 30 years. LIFETIME UNCONDITIONAL GUARANTEE. Simply return. We will repair or replace and ship FREE of charge. YOU GET: heavy duty welder in rugged metal cabinet, ground clamp, cables, combination torch and rod holder, welding manual and helmet, plus Free \$2 pack "TOUCH WELD" rods for instant and automatic arc, brazing rods, 1/4" carbons, solder and flux.

ORDER TODAY ON 10-DAY UNCONDITIONAL MONEY BACK TRIAL.

MAIL THIS ORDER COUPON NOW!

Four-Way Welder Co., Dept. R2-A
1810 S. Federal St., Chicago, 60616
Please send welder as indicated below and include FREE gift of
 Wrench Kit or, Wire Tool or, Welding Rod Pack.
 Enclosed \$18.95. Ship Enclosed \$2.00. I will pay \$16.95
postpaid in U.S.A. plus C.O.D. and delivery charges.

NAME _____

ADDRESS _____

CITY _____ STATE _____ ZIP _____

FREE EXTRA BONUS GIFT
with your order. Choice of:

1. 10-piece wrench, plier and screw driver kit in case, or
2. Wire forming tool. Forms wire to weld valuable items, or
3. Big pack welding & brazing rods, carbons, flux & solder.

SEND ONLY \$2.00 and pay \$16.95 plus C.O.D. and
delivery charges, or send only
\$18.95 and we pay delivery in U.S.A. Specify gift.

FOUR-WAY WELDER CO.

1810 S. Federal St., Dept. R2-A, Chicago, 60616

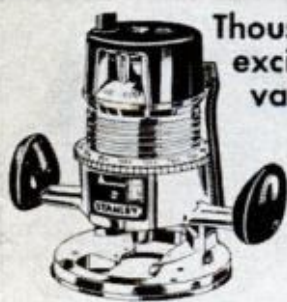

Thousands of
exciting tool
values!

SILVO (BRAND NAME) TOOL CATALOG

Thousands of Exciting Tool Values! Stanley, Millers Falls, Skil, Thor, Wen, Disston, Wiss Wellsaw, Dremel, Speedy Sprayers, Plumb, Huot, Kennedy, Channellock, Porter-Cable, Rockwell, Helios, Vise-Grip, Crescent, Ridgid, Pony Clamps, Unimat, Foredom and many other Nationally Advertised brands of Tools & Supplies. We ship Coast to Coast at prices Hard to Beat. Send 25¢ for our big 132-page tool catalog today. Silvo Hardware Co., PM-1, 107 Walnut St., Philadelphia, Pa. 19106.

OVERTIME PAY You Can Depend On

Why be at the mercy of overtime cut-backs? Turn your own spare time into regular overtime pay. Get sharp and start your sharpening shop. Housewives, hobbyists, bars, beauty and markets, restaurants, contractors, rental shops, farmers—everybody is your cash customer. TREYCO 6-in-1 Machine hollow-grinds knives, saws, tools, scissors, pinking shears, clippers, garden tools, rotary mowers, skates, etc.! Make as much as \$6 an hour. Learn how TREYCO gives you 6 MACHINES IN 1 for low price of one. Quality guaranteed. Thousands of users since 1946. Write for big FREE CATALOG and LOW Factory-To-You Prices.

TREYCO
Products, Inc.



381 Niagara St.
N. Tonawanda,
N.Y. 14120



FREE!!! POWERFUL MUSCLES FAST!

Fantastic New Discoveries in the science of bodybuilding. Now, in the privacy of your bedroom, our method will add inches of powerful muscles to arms, chest, shoulders & legs. Learn secrets on trimming the waist with ultra-modern methods—fast! Results Guaranteed! Send for free brochure. Universal Bodybuilding, Box 5327, M-11, Northeastern, Dearborn, Mich. 48126.

TESTS CIRCUIT WITH POWER OFF Electrical CONTINUITY TESTER



GIVE TESTERS FOR CHRISTMAS

Alternators and Diodes repaired. \$2⁹⁸

Order from your Dealer or send check to
BURNWORTH TESTER CO.
Box 65 El Cerrito, Calif. 94530

SELF POWERED

WANTED:

Rotary Tiller Owners!
We Will Pay You \$1.00 Cash for the brand name and year you purchased your tiller. Why? We haven't room to explain all about this survey here, but will when we send you \$1.00. So, please clip this and mail with the brand name and year you purchased your tiller to GARDEN WAY MFG. CO., Dept. 1911, Troy, N.Y. 12182. Thank you.

AMERICA'S NO. 1
CLASSIFIED SECTION
CAN BE FOUND
ON PAGE 52
IN THIS ISSUE



BOAT plans & kits

4 Ways To Build Your Own Boat by CLARK CRAFT

PLANS - FRAME KITS - HULL KITS BOAT KITS

Over 200 tested designs for the amateur builder. Conventional or deep vee, in-board or outboard, cruisers, runabouts 10-36 ft. Sailboats, 8-34 ft. conventional—trimarans—catamarans. New 33-36 ft. cement sailboats. Large selection inboard or outboard hydroplanes, ski boats, house boats, fishing boats.

Send \$1.00 for New Plan Kit Catalog or \$2.00 for Catalog Plus Boat Builders' Guide.

New Book on Complete Boat Building includes photos, step by step information.—Send \$5.00.

CLARK CRAFT BOAT CO.

16 PP Aqua Lane, Tonawanda, N. Y. 14150



FREE MUSCLE COURSE!

Want a new Jet-Charged body? In 15 minutes I'll prove you can slap on 4" of muscles to your chest—3" to each arm—give you life-guard shoulders, trim your waist to athletic size—give you speedy athletic legs. I don't care if you're short or tall (skinny or fat) young or not so young, expect a muscle building miracle when you send for my free course. Send only 25¢ to cover postage and handling to Joe Weider, Dept. 38-19D, 531 32nd St., Union City, N.J.

BERNARD WIRE CUTTERS



\$2.00

plus 35¢ pstg.

New Army Surplus. Reg. \$3.50 value. Side cutters will cut wire up to 3/16". Powerful jaws for gripping and wire stripping. 6 1/2" overall length.

G. I. PIN PUNCHES

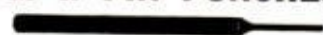

12 for \$1.00 Ppd.

New Gov't Surplus. Made of finest tool steel. Point size, .08". Overall length, 3". Priced at a fraction of actual cost!

P & S SALES, Dept. P-1
Box 155, Tulsa, Okla. 74102

WRITE FOR
FREE
CATALOG



MAKE GERMAN BEER FOR ONLY

6¢ AT HOME

A BOTTLE

You can make 1-10 cases of delicious German. Canadian or American beer—at home in one evening—using standard kitchen equipment. Borrowed from German Brewmasters during the 1930's. Tastes better than commercial brands. Guaranteed to completely satisfy or money back. Complete, easy-to-follow MANUAL—ONLY \$3.98

BIERHAUS BOOK CO. (Box 5157-B), 1800 Hazlewood Dr., Ft. Wayne, Ind. 46805

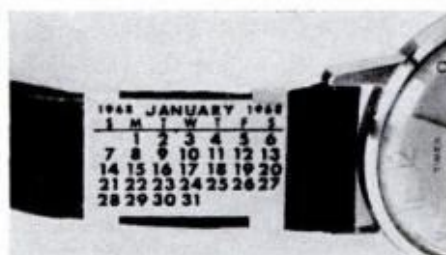

WATCH BAND CALENDARS

See the date instantly on your wrist! These handy metal calendars fasten to the band of your wristwatch; fits either metal or leather bands. Printed on both sides (gold & chrome) to match watch. Set of 12 contains a new calendar for each month: Starts with month order is received. Gift-boxed. Also available at quantity prices with imprint. Send \$1.50 for each set or \$7.50 for 6 sets to: YOSHIDA CO., Box 26878-D1 Los Angeles, Calif. 90026

FREE FEL-PRO GASKET MANUAL

... for top performance in all gasket applications
Learn about the latest gasket materials and trouble-free gasket installation techniques from Fel-Pro... for 50 years a leader in gasketing improvements. Improve engine... transmission... and rear end performance with these helpful tips. 36 fact-filled pages.

Write: FEL-PRO, INC.
7452 N. McCormick Blvd. Dept. 1PM
Skokie, Illinois 60076

WHEN ANSWERING ADS GIVE YOUR ZIP CODE



STUDY ART

In Spare Time

as a way to a richer life

WSA Collection

Do YOU find yourself doodling interesting designs? Wanting to sketch and capture on canvas a sunny lake among the trees, or paint a likeness of a loved one? Then you should know more about the renowned Washington School of Art's completely new home study course. In your spare time you can learn to draw; paint in oils, water color and other media... all under the personal supervision of instructors who will become your "friends by mail." Big artist's outfit and professional case, at no extra cost, will help develop your hidden talents. Learn advertising art, painting, illustrating, cartooning, fashion drawing, TV graphic art at remarkably low cost. Send for our FREE helpful booklet and find out how little ART costs, how much it brings you. Write to WASHINGTON SCHOOL OF ART, Studio 13-015, Port Washington, L.I., New York 11050 (Est. 1914.) Accredited Member, National Home Study Council.



Print Name..... Age.....

Address..... Apt. No.....

City & State..... Zip Code.....

NEW MONOGRAM DIE TOOL

\$5.75 ppd.

Permanently stamps your initials in classic script as shown:

Hardened tool steel. Lasts a lifetime. Comparable to a \$15 die tool. Permanently stamps up to 3 initials on almost anything you own with a single blow. Made only by Henry Evers, makers of quality marking devices since 1898.

R.W.D.

actual size



HENRY A. EVERS CO., INC.
Dept. PM, 72 Oxford St., Prov., R.I. 02905
Enclosed is \$5.75 for my Die Tool.

Please print
Name _____
Street _____
City _____
State _____ Zip _____

For more information on articles and products, write to the PM Bureau of Information for "Where-to-Find It" list.

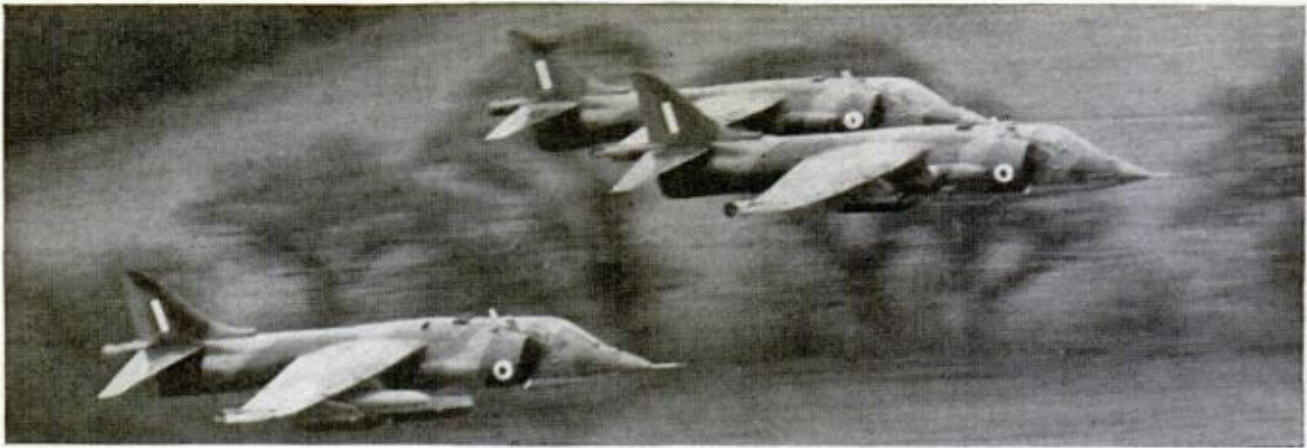

Harriers for the RAF

Now in production for the Royal Air Force are 60 Hawker Siddeley Harriers, VTOL aircraft that can operate from a 50-square-foot grass field or other firm surface. Powered by a Rolls-Royce Bristol Pegasus vectored thrust turbofan, the Harrier will go into service with an initial warload capacity of 5000 pounds and ferry range of 2000 miles. Its speed is described as "transonic."

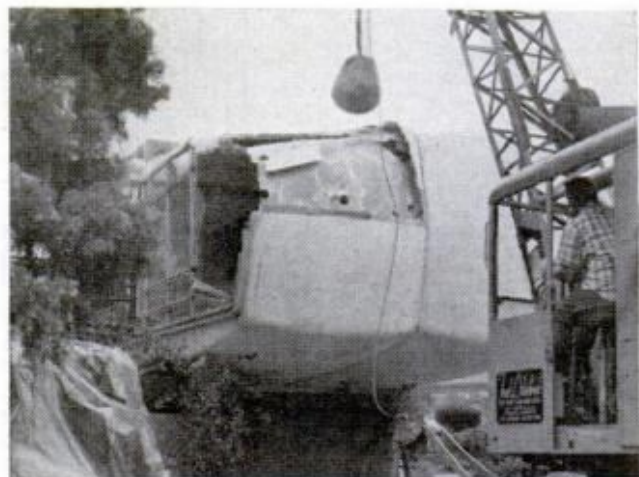

Home-wrecking turns out to be a tough job

When wreckers started the "two-day" task of dismantling the 10-year-old Monsanto "Home of the Future," they found the plastic shell was still tough. It took them two weeks.



Up and over

The six-wheel drive of U.S. Steel's experimental military truck enables it to go over rough terrain that stops conventional trucks.



Tape antenna

Stainless-steel tape that spirals into a three-foot, self-supporting tube is under test by the Army as a combat radio antenna.



AIR LIFT AUTO LEVELERS

These tough, inflatable butyl cylinders raise the rear of your vacation-loaded car to safe, normal riding level. Air Lift Auto Levelers literally lift excess weight from overworked springs . . . also minimize sway on turns and absorb impact of bumps. Simple to install—no parts to remove from car. Ideal for camping, a "must" for trailering. Low as \$33.95 per set—tell us model of car. Free literature.

AIR LIFT COMPANY

Dept. PM, 2710 Snow Road, Lansing, Mich.

IMPORTED STILETTO POCKET KNIFE

9" Overall Length
5" When Closed

- Opens instantly
- Sharp and Tough
- Stainless Steel Blade



ONLY \$1.75

WESTBURY SALES CO., DEPT. S56
P. O. BOX 415, WESTBURY, N. Y.

Earn \$10 Hourly With a J.B. Saw Shop

Set and sharpen saws 3 to 40" Bevel and hook 0 to 45 powered and ready to go. Experience Not Needed. Write for Details.



BURNS, INC.
165 Rodman Street
Fall River, Mass. 02721



EVERY HANDYMAN NEEDS HANDY DANDYS

Handy Dandys are sturdy, plastic caps that snap into 1/8" pegboard and hold quarter twist baby food jars. They're ideal for storing all kinds of supplies, parts and small tools. "Try-'Em-Out Package" of 8 only \$1 ** 36 for \$3.50 ** 72 for \$6 ** 500 for \$36.50. Shipped USA postage prepaid—no C.O.D.'s. **WICKLIFFE INDUSTRIES, INC., P.O. Box 286, Dept. PM-1, Wickliffe, Ohio 44092**

FIND BURIED TREASURE!

10-DAY MONEY BACK GUARANTEE

TREASURE PROBE

\$18.88 ppd

ALL TRANSISTORIZED

3 ft. portable detector finds buried metal objects. Signals location with loud audible sound. Detects gold, silver, metallic ore and nuggets of all kinds. Find lost coins, jewelry, Indian artifacts, civil war souvenirs. Treasureprobe guaranteed to equal detectors selling to \$150 or your money back. Absolutely complete, sensitive earphone, 9v battery, nothing else to buy. **TO ORDER:** Send check, cash or money order, \$5.00 deposit for COD in N.J. add 57¢ tax.

TREASUREPROBE Dept. PAN, P.O. Box 228 Toms River, N.J. 08753



Metal Piercing Throwing knife

Great for hunting game. Weighted, balanced for sure throwing accuracy. Hits with a hard smack. **FAST, EASY TO THROW.** Use for self defense, hunting, thrills, targets. Razor sharp cutlery steel, 16" long—Double edge. Wrapped leather handle. **\$1.00 (2 for \$1.85) (3 for \$2.75).** Knife-throwing instructions **FREE.** Order Now. **WORLD CO., Dept. 1PM, 1 Park Ave., New York City.**

IMPORTED LOCK-BLADE KNIFE

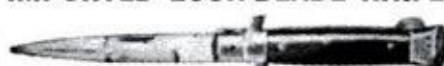

OPENS WITH FLICK OF FINGER, and locks with a click into position. Blade can't shut when in use. **PUSH BUTTON** release. Handy pocket size, yet rugged. Fine quality, polished stainless steel razor-sharp blade. **PIERCES METAL.** Narrow tapered stiletto blade with thick rigid backbone for heavy duty trouble-free use. Fine outdoor knife for sportsmen and emergencies. Comfortable handle. Safety guards. Don't be fooled by imitations. **WORLD CO., Dept. 1PM, 1 Park Ave., N.Y.C.**

\$1.88

Free Postage

Order now.

FREE SAMPLE LESSON in Advertising ART, DESIGN & LAYOUT

Your free sample lesson proves you can learn high-pay ADVERTISING ART in half the time! For the first time you're taught by the Art Department of a 22 year old Advertising Agency—not a school! Actual art studio "assignments" are given you as a "trainee", not a student, to prepare you for a great art career with a Newspaper, Magazine, TV Station, Movie Studio, Gov't Agency, Printer, Advertising Agency or to operate your own "free lance" art studio. No more "dry as dust" lessons but actual art, graphics and layout problems from "pros" who teach you all the money making tricks of the trade even while learning.

THIS MAY BE THE MOST IMPORTANT COUPON IN YOUR LIFE!

Mr. Ed Hopper, Art Director
ALVIN EPSTEIN ADVERTISING AGENCY
1737 F St., N.W.
Washington, D. C. 20006

Rush FREE trial lesson in Advertising Art which I may complete and return to you for your Art Dept. corrections and analysis, at no cost or obligation.

Name _____ Age _____
Address _____
City _____ State _____ Zip Code _____

.....boat plans
full size patterns
frame kits.....

catalog
50¢

BOAT PLANS—PATTERNS—FRAME KITS

Send 50¢ for Glen L's new catalog offering a complete selection of build-it-yourself designs with step-by-step instructions. Inboards & outboards, jets, 16' to 36' cruisers, 8' to 21' sailboats, houseboats, hot boats, boat trailers and camper trailer. Books: Inboard Motor Installations In Small Boats \$6.00 ppd.; Boat Building With Plywood \$7.50 ppd.; How To Build Boat Trailers \$3.00 ppd. **Glen L, 9152T Rosecrans, Bellflower, Calif. 90706.**

WHEN ANSWERING ADS GIVE YOUR ZIP CODE

FREE CATALOG—Popular Mechanics 16 page illustrated catalog of publications and projects. Lists hundreds of items for the home and shop. Covers tools and machines, hobbies, boating, home repair and maintenance, hundreds of others. You name it, we have it! For your free copy write to Popular Mechanics, Dept. CM, 575 Lexington Ave., New York, N.Y. 10022

CLASSIFIED ADVERTISEMENTS

Rate: \$1.85 per word payable in advance each insertion. Capitalized words—75¢ per word additional. Minimum insertion ten words. To be inserted under the proper classification, copy must be in our office by the 15th of the second month preceding date of issue. The next available issue to place an advertisement in America's No. 1 Classified Section is March. The closing date is January 15th. Send remittance and order to C. A. Martin, Popular Mechanics, 575 Lexington Avenue, New York, New York 10022. Please make remittance payable to Popular Mechanics.

POPULAR MECHANICS

AUTOMOBILES, MIDGET CARS

YOUR Ad in this space will be read by more than 1,662,961 active mail order buyers. Join the march to greater profits, place your products and services in front of them today with a small low cost classified ad. For further details, write: C. A. Martin, Dept. 1R, Popular Mechanics, 575 Lexington Avenue, New York, New York 10022.

AUTO SUPPLIES AND EQUIPMENT

CROSLY And foreign car parts. Box 7. Elmont, N.Y.

ANTIQUE Car pistons, gaskets, gears, valves, etc. Catalogue \$1.10. Antiques Auto. Milwaukee, Wisconsin 53204.

JEEP Owners—V8 conversions. Read Jeep Owners. ad, page 195.

PERMA-BALANCE CAR WHEEL BALANCERS, automatic adjusting centrifugal force, permanent. Longer tire life. Better braking, handling and stability. Guaranteed. Satisfaction or money back. Set of four \$29.95. Free Brochure. P. G. Distributing Co., P. O. Box 211, Pratt, Kansas, 67124.

HIGH PERFORMANCE silver-plated rotors for increased performance and cold-starts. All makes and models. (state which) \$3.50 (postpaid) T. G. Electronics, 171 Eglinton E., Fleet 305, Toronto, Ont., Canada.

CHEVROLET Owners: Join NCOC—Newsletters, discounts on accessories, free catalogs, technical help, membership cards. Send \$5.00 for annual membership to: NCOC, Dept. 3, Box 5701, San Jose, Calif. 95150.

FORD Owners: Join, GTF—newsletters, discounts on accessories, free catalogs, technical help, membership cards. Send \$5.00 for annual membership to: GTF, Dept. 4, Saratoga, Calif. 95070.

JEEP OWNERS: New Cast Iron Generator pulleys for M-38 & M38-A1 Military Jeeps. \$8.50 each. R. Trostel, 614 Austin Drive, Huntsville, Alabama 35805.

VOLKSWAGEN Owners. Appearance and protection **RUBBER BUMPER GUARDS** 1958-1969 Sedans \$29.95. Gilmore, P.O. Box 8200, Rochester, 14617.

HYDRAULIC Jack repair kits, parts and supplies. Catalog 50¢ (in coin). Hydraulic Jack Packing & Tool Co., Inc. General, P.O. Box 3, Staten Island, N.Y. 10314.

NEW, THEFT-PROOF, AUTOCARE and **HOOD LOCK** Electronic anti-theft car device. Easily installed, completely automatic, absolutely safe. Small and compact. Fits all cars, foreign, Domestic, U/L-CSA approved. **LIFETIME GUARANTEE.** Only \$20.00 plus \$1.00 handling. California residents add 5% sales tax. **BURGLE-BUNGLE.** 401 West Manchester Blvd., Inglewood, Calif. 90301.

CAR Expense Record Book! For Private, Salesmen, Trucks, Boats. One Dollar, Lasts Several Years. Edelmann, 3910 Virginia, St. Louis, Missouri 63118.

AUTO ALARM, with ten year manufacturers guarantee, \$8.00. Diljberto, 79 Himrod Street, Brooklyn, New York 11221.

3-D MAGNETIC Signs. Quick change from car to truck. 10"X20" \$25.00 pair. 4 for \$45.00 other sizes, discounts. Send copy and colors desired. Doty Signs, 12168 Woodside, Lakeside, California 92040.

GAS-OIL HOG??? . . . Smoking?? . . . No Pep?? . . . Hard Starting?? (Save \$150-\$250) with Motaloy Ring-Valve Job While driving (\$6.50 postpaid) Advertised here every month for years! Continues saving money on repairs, gas, oil for 100,000 miles! Absolutely true! (new engines too) Nothing compares! . . . Money-back guarantee. You can't lose! Motaloy, Grantham, Penna. 17027.

NEW POLYGLAS Wide Ovals from Good-year. We pay freight-fantastic savings. Wide Trac Discount Center, 1119 N. Las Palmas Ave., Los Angeles, Cal. 90038.

KEEP It turned with IGLIT. Free details. Q-arc, Box 47876, Los Angeles, Calif. 90047.

SNOWMOBILES

SNOWMOBILES—Factory Direct Prices. Save 30%. Five latest 1969 models. 5—18 HP. Easy Terms. Driving trial. Money back guarantee. Free catalog. Luger, Dept. SB-68, 9200 Bloomington Freeway, Minneapolis, Minnesota 55431.

SNOWMOBILE Kits \$25. Plans and photos \$1.00. Information 10¢. Compop, Box 1267, Redwood City, California 94064.

AUTO TRAILERS

CAMPER Plans. Compact buses, Vans—Volkswagens, Econoliner, Dodges. Build yourself—Save! Details—Dot Campers, Box 2115M, Culver City, California 90230.

BUILD Your Pickup Camper. Precut Kits. Blueprints. Supplies. Literature 10¢. Comstock Trailers, Dept. 664, Parsons, Kansas 67357.

PICKUP Camper, Trailer or Pickup-Cover . . . Build yourself. Save! Complete plans \$3.95 each. Cover plans \$2.00. Econoline Bus or Van, Bus Conversion drawings, \$2.95 each. Satisfaction Guaranteed. Equipment catalog \$1.00 (refundable). Details 10¢. Viking Camper Supply, 94-F Glenwood, Minneapolis, Minn. 55403.

MOTORCYCLES, BICYCLES, MOTORSCOOTERS AND SUPPLIES

HONDA 50-90-160 Speed Equipment. Cams—Big-Bore-Stroker, Columbia Engineering, 2105 E. 37 St., Los Angeles, Calif. 90058.

BUILD Motorbike from Bicycle! Plans —\$2.00; Go-cart plans—\$2.00; Snowmobile plans—\$3.00; Go-byk Industries, Rothsay, Minn. 56579.

SNOW VEHICLE & KART CATALOG. Hop up accessories—speed and performance equipment—manifolds, engine mounts, exhaust systems. Send 25¢. G.E.M. PRODUCTS, 494 E. St. Charles Rd., Carol Stream, Ill. 60187.

HARLEY-Davidsons — Used bargains. New, used parts, accessories, all models. Bulletin 35¢. Knuth's (Factory Dealer). 1753 Muskego, Milwaukee, Wis. 53204.

MOTORCYCLE TURN SIGNALS. Accessories. Catalog 25¢. Houston, PM Lockport, Illinois 60441.

BUILD "Popular Mechanics" MINI-BIKE featured June 1967 issue. Detail plans, photographs \$2.50 refundable. Kits, parts, engines; factory discount prices. Catalog 25¢. Gilliom Mfg., PMC, St. Charles, Missouri 63301.

MINI-BIKES. Chain saws. Wholesale catalog, 25¢. Loren Products, Danville, Illinois 61832.

BUILD Your own minibike! NO WELDING REQUIRED! Plans \$1.50. Westate Enterprises, Dept. PM-1, Box 9216, San Jose, California 95117.

RECONDITIONED Motorcycle motors. Indian, Mustang, Royal Enfield, Suzuki. Parts, Accessories, "Minibikes." Indian Motorcycle Sales, Kansas City, Missouri 64127.

MOTORSCOOTER, \$110. Minibike complete with engine \$50. Mo-ped \$15. Briggs and Stratton engine \$12. (Mail order only) send 35¢ for the Midget Motors Directory listing these and other bargains individuals have listed with us for sale. Midget Motors Directory, Athens, Ohio 45701.



AVIATION

HELICOPTER One-man. Portable Kits Plans. Information 25¢. Photos and three-view drawings \$1.00. Compop, Box 1267, Redwood City, California 94064.

HOMEBUILT. Real enclosed helicopter, 24 pages ideas, information, \$2.50. Build "executive" helicopter, drawings, specifications, \$2.00. Helicopter Development, Box PM147, Washington, New Jersey 07882.

BARTLETT FLYING SAUCER. Amazing machine hovers 200 lb. man over land/water, powered by ordinary lawn mower engine. Easy to build. Fun to fly. Complete Plans, Kit Brochure and Photo Review \$3.00. Write: Herb Bartlett, Box 3234-C, Scottsdale, Arizona 85257.

BE A Government licensed aviation mechanic. Practical training. Free information. Aero Mechanics School, Municipal Airport, Kansas City, Missouri 64116.

AIRBOAT, Snowplane, Gyrocopter, Hovercraft propellers. Complete airboats, Kits, Plans, Mounts, Engines, Supplies. Corvair, Volkswagen Conversions. Outboard air-drives. Catalog \$1.00. Banks-Maxwell, Box 3301E, Ft. Worth, Texas 76105.

AERO-CAR. Amazing Hovercraft built easily with ordinary tools. Lawnmower engine power. Carries one man plus. Hovers, flies forward, backward, sideways over land/snow/water. Complete construction plans and brochure, \$4.25. Aero-Projects, Box 5118, Clinton, N.J. 08809.

AIRCRAFT Classified. Thousands everywhere. Subscription \$2. Aero-Shopper, Henrietta, Texas 76365.

LEARN AVIATION AT HOME. Navigation, aerodynamics, communications, weather taught in your home. Unique method. Free information. United Aero-Sciences Institute, Dept. C, P.O. Box 4106, Torrance, California 90503.

DOBSON Famous, Proven Air Cushion Amphibians, Single and Two Place. Brochure \$1.00. Plans \$30.00. Locke Enterprises, 4887 Pointe Tremble, Algona, Michigan 48001.

AVIATION SURPLUS Big Catalogue 50¢ (refundable). Box 52PM3, Thomasville Penna. 17364.

FREE Catalog, 1000 Aviation Space Books. Aero Publishers, 329 Aviation, Fallbrook, Calif. 92028.



BOATS

CANOEES! Kayaks! Factory-direct quality kits, from \$20.00. Many different models. Canvas hulls. Strongest construction materials. Free literature. Sportsraft, Box 8393-PM, Columbus, Ohio 43201.

BOAT PLANS, FRAME KITS, BOAT KITS. World's largest catalog—Over 200 top design for the amateur builders. New catalog includes Cruisers, Runabouts, Deep vee's, Catamarans, Trimarans, Houseboats, Sailboats from small sail fish to 34 ft. motor sailers, large selection of inboard and outboard Hydroplanes. Send \$1.00 for large new plan & kit catalog or \$2.00 for catalog plus Boat Builder's Guide. Clark Craft Boat Company, 16-P Aqua Lane, Tonawanda, New York 14160.

KAYAKS—One-man \$19.50; two-man \$24.50; Sailboat \$44.00. Exciting Sitka Kayak Kits known world wide for speed and safety. Assemble in one afternoon. Free pictorial literature. Box 582-P, Willoughby, Ohio 44094.

PLANS, Full Size Patterns, Frame Kits with step-by-step instructions specially for amateurs. New "Glen L" Boats 8' to 36' Sail, Jets, Inboards, Outboards, Cruisers, Houseboats, Hot Boats, Catamarans, Hydros "plus" boat trailers and a camper. Send 50¢ for complete catalog. New "How To Build Boat Trailers" Book \$3.00 ppd. Glen Designs, 9152 Rosecrans, Bellflower, Calif. 90706.

BUILD Your own boat from our large-scale blueprints. Books of plans give how-to-build help. Hundreds of professional designs—motor, sail or auxiliary—for amateur builders. Free catalog. MoToR Boat-ing, 959 Eight Ave., Dept. PM-RS, New York, N.Y. 10019.

NEW 1968 McCulloch and other outboards. 4 H.P. \$108.00. . . . 7½ \$224.00. . . . 9 Electric Start \$288.00. . . . 18 \$316.00. . . . 40 Electric \$514.00. . . . 65 Electric \$698.00. . . . All sizes. Literature 50¢. Electra Marine 1427 Broadway, Brooklyn, N. Y. 11221.

FREE Catalogue—plans for canoes, kayaks, accessories. Clark, 115 McGavock Pike, Nashville, Tenn. 37214.

FIBERGLASS Cloth and resin. World's finest cloth and non-run resin, at direct mill prices. Flotation foam. Complete line of plastics, silicon bronze and brass screws, save 60%. No Sales tax. Boat Plans, Catalog 25¢. Freight prepaid. Stiles Boat Supply, Box 11P, Linden Ave., Mantua Hts., N.J. 08051.

AMATEUR Boat Building Society, 111-B Woodcrest Ave., White Plains, N.Y. 10604; Plans, kits, discounts, books, technical help, local building clubs, instructions, monthly magazine. Free information.

BOAT Kits. Molded Fiberglass. Save money—assemble yourself. Factory molded sections bond into one-piece craft. 30 models—14' to 33'. Cruisers, Runabouts, Houseboats, Sailboats. Big line accessories, motors, trailers. Easy terms. Free 88 page catalog. Luger, Dept. BC-69, 9200 Interstate 35W South, Minneapolis, Minnesota 55431.

PLANS, Kits, hulls, 24-page 20th Anniversary catalog. All class racing boats. Flatbottom to drag Hydros. Midget to 7 Litre, 50¢. Champion Boats, Box 9215A, Long Beach, Calif. 90810.

FULL Size, cut-to-shape boat patterns, blueprints. Send 60¢ for big new illustrated "Build a Boat" catalog includes fishing boats, garvies, cruisers, catamarans, houseboats—7½ to 38'. 20% Winter discount. "How to Build a Boat" booklet, \$2.50. Cleveland Boat Blueprint Co., Box 18250, Cleveland, Ohio.

FIBERGLASS Canoes. Four exciting models. Easily assembled Kits, \$39.95 up. (Factory Direct) Free Literature. Riverside Canoes, Box 5595B, Riverside, Calif. 92587.

MARINE EQUIPMENT AND SERVICES

NEW. Used, rebuilt marine motors. Marine conversions, fittings. Free catalog. Stokes Marine Supply, Dept. 24, Coldwater, Michigan 49036.

CONVERT Auto engines to marine. 68 Page Catalog, 50¢. Lehman Manufacturing Company, 800 Elizabeth Avenue, Linden 4, New Jersey 07036.

PROFESSIONAL Marine engines from Star Marine Kits. Engines—Gears—Props—Everything necessary for your boat propulsion. Write for free brochure. Star Marine Engine Works, Berkeley, California 94710.

ATHLETIC AND BODY BUILDING COURSES

"GIANT Arms." Dr. Young's, D.C. revolutionary discovery. \$2. Satisfaction or refund. Gaucho, Box 9309-S7, Chicago 60690.

POWERFUL Muscles fast! Free brochure! Universal Bodybuilding, Box 4327-C, Northeastern, Dearborn, Michigan 48126.

DEADLY As Karate, but much simpler. Amazing new gimmicks and techniques developed for POLICE, BODYGUARDS, etc. **GUARANTEED UNBEATABLE**. Simple, clear instructions show you how. Photo illustrated. Written by an expert. \$1.00. R. J. Graham, 171 East Bank, Fond du Lac, Wisconsin 54935.

11 BARBELL, Dumbbell Courses. Regular \$6.25 for \$3.00. Good Barbell, B-1495, Hendersonville, N. Car. 28739.

FEAR No bully! Master authentic Chinese Kungfu unbeatable techniques! Defeat within seconds any attacker including giant Judo-Karate experts. Free details by air write: Asia's Greatest Master, Leongfu (MI/37) 119, Anderson Road, Ipoh, Malaysia.

SPORTING GOODS AND EQUIPMENT

FREE . . . Wholesale catalog. Arrow shafts, broadheads, fletchings, fisharrow parts, tools, bows. Finnsports (22G), Toledo, Ohio 43614.

HUNDREDS Of Army-Navy surplus items, camping, hunting, fishing equipment, gun accessories, etc. Write for free catalog. P&S Sales, Box 155, Tulsa, Oklahoma.

FREE 1969 Catalogues! Guaranteed lowest prices. Fishing Tackle, Archery, Hunting and Camping Equipment. Thousands of items. Cabela's Inc., Sidney, Nebraska 69162.

PERMANENT Match—can't get wet—A must for hunters, campers, fishermen. \$1.00 postpaid. Apex Products, 4931 Northwest Eleventh Street, Fort Lauderdale, Florida 33313.

BIG Money raising crickets and 12 inch African fishworms. Free literature. Carter Ranch, Plains, Georgia 31780.



FISHING, TACKLE, LURES

MOLDS For fisherman's sinkers, jigs, squids, casting and spinning lures. Free catalog. Sweets Molds, Tonawanda 1, New York 14150.

MOLDS—For casting your own fishing sinkers. Free illustrated booklet. Reading Instrument Co., Box P78, Reading, Pa. 19603.

FREE . . . Wholesale catalog. Beads, Spinners, Lure parts, Sinkers molds, Jigs, Reels, Finnsports (ME), Toledo, Ohio 43614.

FISH Traps, collapsible. Pond-lake types. Animal, bird traps. Free catalog and trapping secrets. Sensitronix, 2225-F27 Lou Ellen, Houston, Texas 77018.

USE Your power tools to manufacture and sell patented fishing lure. Sample lure and details \$1.00. Sherman Bryant Lures, Lewisport, Ky. 42351.

FREE FISHIN' CATALOG—170 Pages, Pocket Size. A real "Dream Book" with all the latest in "Do-it-Yourself" Kits, Rods, Reels, Lures and gadgets galore. Write: NETCRAFT Co., Toledo, Ohio 43613.

EARTHWORMS, LIVE BAIT

BIG Money growing fishworms, giant African Crawlers, crickets. Free Literature. Fain's Hatchery-31, Edison, Georgia 31846.

EARN Money raising fishworms for us! Exciting details free! Oakhaven—56, Cedar Hill, Texas 75104.

HYBRID Redworms—3,000—\$5.75, 5,000—\$8.00, 10,000—\$14.00. Bedrun 20,000—\$18.00, postpaid with raising instructions. Brazos Bait Farms, R-9, Waco, Tex. 76705.

REDWORMS, Bedrun, Postpaid: 10,000, \$9.00; 30,000, \$20.00 with instructions. Worms, Box 4185, Belmead, Texas 76705.

BIG Profits raising worms. Instructions 25¢. Three Oaks, Dresden, Tennessee 38225.

SUCCESS For You! Raise Carter's Pure-bred hybrid red wiggler fishworms, crickets, and 12 inch African worms. Write for Free Literature and our Success Story in Life Magazine. Carter Redworms, Plains, Georgia 31780.

\$5.00 STARTS Your Fishworm Business 800% profit. Free literature. Lee's Worms, 2554 Park, Pixley, Calif. 93256.

FROGS, FISH, REPTILES

MAILORDER Records help get Increased Business! Complete 32 Page Record Book shows your inquiries, orders, advertising, expense, etc. Only \$1.00. C. A. Martin, Popular Mechanics, Dept. PM, 575 Lexington Ave., New York 10022.

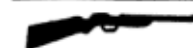

HUNTING, GUNS, DECOYS

FREE Gun & Ammo Bargain Lists. Century Arms, St. Albans, Vermont.



DOGS AND KENNELS

EXTRA Income at home in Spare Time! Booklet shows you how to start your own business with Classified Advertising. Only \$1.00. C. A. Martin, Popular Mechanics Dept. PM, 575 Lexington Ave., New York 10022.



GAME BIRDS

FREE Big quail color catalog. Marsh, 14216 Brookhurst, Garden Grove, Calif. 92640.

RAISE Rainbow Trout, Ringneck Pheasants, Wild Turkeys on Profit/Pleasure plan. Free information, Jumping Rainbow Ranch, Box 848J11, Livingston, Montana 59047.

HAWKS—FALCONS

MAILORDER Records help get Increased Business! Complete 32 Page Record Book shows your inquiries, orders, advertising, expense, etc. Only \$1.00. C. A. Martin, Popular Mechanics, Dept. PM, 575 Lexington Ave., New York 10022.

RABBITS—FUR BEARING ANIMALS

EARN \$10,000 Yearly raising angora rabbit wool, and breeding stock for us. Information 25¢ coin. American Angora Company, Malta 12, Montana 59538.

RAISE Rabbits for us on \$500 month plan. Free details. White's Rabbitry, Mt. Vernon, Ohio 43050.

RAISE Rabbits successfully by knowing facts. 48 page illustrated book describing 25 breeds. Housing, breeding, feeding, markets, marketing etc. 25 cents. American Rabbit Association, 36 Arba Building, Pittsburgh, Penn. 15217.

MAKE Big Money raising chinchillas, rabbits, guinea pigs for us. Catalog—25¢. Keene Brothers, New Freedom, Pa. 17349.

\$500-\$800 MONTHLY. Raise small laboratory-breeding stock for us. We supply equipment, breeders, instructions. Illinois Research Farms, Dept. MP-1B, McHenry, Illinois 60050.

TAXIDERMY

EXTRA Income at home in Spare Time! Booklet shows you how to start your own business with Classified Advertising. Only \$1.00. C. A. Martin, Popular Mechanics Dept. PM, 575 Lexington Ave., New York 10022.

PETS—BIRDS, CATS, HAMSTERS, ETC.

LIVE Traps, all sizes, mouse to dog. Collapsible or rigid. Carrying Cages. Free literature. National Live Traps, Tomahawk, Wisconsin 54487.

LIVE SEAHORSES, marine specimens, aquarium supplies. Illustrated catalog 15¢. Marine, Box 248-210, Dania, Florida 33004.

HAWKS, Reptiles, raccoons, skunks, squirrels. Catalogue 25¢. Trails End Zoo, St. Stephens, S.C. 29479.

FLYING Squirrels, Chipmunks, Wonderful Pets, Literature 10¢. Pets, Neches, Texas 75779.

HORSES & LIVESTOCK

"HOW To Train Horses"—Everyone who likes horses or ponies should have this book: Free. Write Beery School, 1101 Pleasant Hill, Ohio 45359.

CAMPING EQUIPMENT AND TENTS

SAVINGS Plus dividends! Campers-fishermen-outdoorsmen cooperative. Free 68-page catalog. Recreational Equipment, Inc., 1525-P 11th, Seattle, Washington 98122.

SURPLUS Arctic Clothing, Special Survival Gear and Trail Equipment. Free, Catalog. Yergers Supplies, Box 8138, Anchorage, Alaska 99504.

CAMPING Equipment, Tents, Sleeping Bags. World's largest selection. Free giant catalogue. Morsan, 810-R Route 17, Paramus, New Jersey 07652 or 1999 Route 110, Farmingdale, New York 11735.

EMBLEMS, BRASSARDS, PATCHES

EXTRA Income at home in Spare Time! Booklet shows you how to start your own business with Classified Advertising. Only \$1.00. C. A. Martin, Popular Mechanics Dept. PM, 575 Lexington Ave., New York 10022.

TRAVEL & RESORTS

MOVING TO CALIFORNIA. Read factual booklet first \$1.00. Jim Mitchell, 227 W. DeLaGuerra, Santa Barbara, Calif. 93101.

NOW! You can see Europe for as little as \$5.00 a day. "Europe on a Shoestring" tells you where to eat, sleep, what to see, also customs, money, ships—Plus much more. Supply limited. \$2.00 Empire Gifts, Desk 119, 305 East 24th Street, Suite 15J, New York, New York 10010.

WHERE TO RETIRE OR VACATION. Where Costs are Low! Norman Ford's 100,000 Word Book, "Off-the-Beaten Path". Covers Hundreds of World Paradises. Only \$2.00. Kenneth Connor, 153-25 Hillside Avenue, Jamaica, New York 11432.

ELECTRICAL SUPPLIES

METERS—Surplus, new, used, panel and portable. Send for list. Hanchett, Box 5577, Riverside, Calif. 92507.

LAMP Parts. Catalog, prices, wiring instructions, 50¢. Refunded first order. Gyro, 5218P N.W. 35 Ave., Miami 42, Fla. 33133.

LAMP parts for building, repairing, converting. Catalog 40 cents. Refunded with first order. Brown Lamp Co., Box 11305, Clayton, Mo. 63105.

BATTERIES, GENERATORS

BATTERY Reconditioning kit, includes molds, material, instructions. Battery Shop, Palm Desert, California 92260.

ENGINES, MOTORS, DYNAMOS

LIVE Steam powered backyard railroads! All sizes. Complete "bolt-together-kits," and rough castings. Excellent drawings. 100 page catalog \$1.00. Little Engines, Lomita, Calif. 90717.

WINDING Data, 275 motors, \$1.20. Data Company, 512 Kensington, Kansas City, Mo. 64124.

OPERATE Three phase motors from single phase. Three ways \$2.00. Donald Howell, Barnesville, Ohio, 43713.

BIG Steam Engines. Kits, Catalog 50¢. Reliable Industries, New Baltimore, Mich. 48047.

MOTORS! Generators! Batteries! Electrolaters! Testers! Plans! Diagrams! Catalog! Modequip, Box 10025, Kansas City, Mo. 64111.

MACHINERY, TOOLS AND SUPPLIES

GERSTNER Tool chests new SECONDS. Free catalog. Gerstner & Sons, Dayton, Ohio 45407.

SMALL Foundry furnaces, Supplies. Free literature. Pyramid Products, 3736 South 7th Avenue, Phoenix, Arizona 85041.

ROUTER Bits, 1/4" Shank, hi-speed, used; excellent condition, \$2.50 Dozen Postpaid. Lillian's, Box 17165, Chicago, Illinois 60617.

MICROMETERS—Indicators—Small lathes. Direct Supply, 1424 Barclay, Springfield, Ohio 45505.

WELDING, SOLDERING, PLATING

CHROME Plating equipment, supplies. All other finishes. Home workshop and production sizes. Send \$1.00 (refundable) for formulas, operating data, equipment guide and catalog. HBS Equipment Division L50, 3543 East 16th, Los Angeles, Calif. 90023.

WELDERS—110/220, 150 Amperes, \$49.50. Morris, 1070 Inner, Schenectady, New York, 12303.

SILVER PLATING—No equipment necessary. Instant plating, copper-brass. Silverware-jewelry refinishing, printed circuits. \$4.95 Postpaid. Box 943, Goleta, California 93017.

WELDORS TEST GUIDE. How to pass Industrial Code Arc Welding Tests. \$2.75 Postpaid. Satisfaction guaranteed. Everett Smith, Box 191, New Castle, Delaware 19720.

GOVERNMENT SURPLUS

JEEPS Typically From \$53.90 Trucks From \$78.40 . . . Airplanes, Typewriters, Boats, Clothing, Camping, Sporting, Photographic, Electronics Equipment, Used, 100,000 Bid Bargains Direct From Government Nationwide. Surplus Catalog. Directory and Sales Bulletins Application \$1.00 (Deductible First \$10.00 Order). Surplus Service, Box 820-A, Holland, Michigan 49423.

JEEPS From—\$52.50; Typewriters from—\$4.15; Cars from—\$31.50. Walkie-talkies, motorcycles, airplanes, boats. Typical "As Is" bid bargains from Uncle Sam. Tremendous variety. Exciting free list. Write: Enterprises, Box 402X42 Jamaica, New York 11430.

FREE Jeep Buying Information when you send 50¢ for 1969 Gov't. Surplus Bargain Catalogue. Surplus, Box 1P4, Spring Grove, Penna. 17362.

1969 SURPLUS Army, Navy store illustrated catalog. Send 25¢ (refundable with first \$5.00 order). Ruvel, 707 Junior Terrace, Dept. 9-J, Chicago, Illinois 60613.

JEOP And Gov't. Surplus Buying Manual (Jeeps Pictured) 50¢. Surplus Bargain Catalogue 50¢. Both \$1. Bargain Surplus, Box 1PM3, Spring Grove, Penna. 17362.

GOVERNMENT LANDS . . . Low as \$1.00 Acre. Millions Acres! For Exclusive Copyrighted Report . . . plus "Land Opportunity Digest" listing lands available throughout U.S., send \$1.00. Satisfaction Guaranteed! Land Disposal, Box 9091-RM, Washington, D.C. 20003.

GOV'T Surplus. How and where to buy in your Area. Send \$1.00. Surplus Information, Surplus Headquarters Building, PM, Washington, D.C. 20036.

HOBBIES AND COLLECTIONS

50 GORGEOUS Junjungle butterflies \$2.50. Collectors Wonderland, Box 1170, New York, 10008.

U.S. ARMY SHOULDER PATCHES. Great for collectors. Official patches, all major Army and Air Corps Units. 10 asst'd patches, price list and catalog, \$2.00. Catalog of unusual gift items. 25¢. SPRINGER'S-PM, P.O. Box 577, El Paso, Texas 79944.



STAMP COLLECTING

PENNY! Approvals! Regardless catalogue! Kloster, 4164 52nd St., San Diego 5, Calif. 92105.

500 DIFFERENT Stamps, \$1.00. Smith, 508-A Brooks, College Station, Texas 77840.

PENNY Stamps! 1000 Mounted in book at 1¢ each. Trust Stamp Company, P.O.B. 132-P, Jamaica, N.Y. 11435.

100 OLD United States between 1861 and 1935, \$1.00. Roush Stamps, 51 Chestnut, Mansfield, Ohio 44903.

50 DIFFERENT Old U.S. Revenue stamps 50¢. Winchester Stamps, Box 1592, Mansfield, Ohio 44907.

FREE Surprise collection sent with approvals. Gould, 1784 Union, San Francisco 94123.

U.S. Mint specials! Flag set, complete \$1.00. 1¢, 2¢, 3¢ famous Americans (21 different) \$1.00. Free list. Brooks, 2601 Avenue "U," Brooklyn, N.Y. 11229.

FREE! Triangles, Scout, 25 others. Approvals. Cambridge, Box 411, Cambridge, Ohio 43725.

FREE! Big Bargain Catalog—New Edition listing thousands of bargains including U.S. & B.N.A. stamps, packets, albums, accessories and supplies. Also, fine stamps from our approval service which you may return without purchases and cancel service at any time. Jamestown Stamp, Dept. E19-PM, Jamestown, N.Y. 14701.

U.S. Bargain, 50 different 10¢, with beautiful worldwide approvals. Stamp Center, Kennebunk, Maine 04043.

RUSSIAN Space set 10¢. Russian approvals. Snedco, Box 68-P, Waldwick, N.J.

ONE Pound value Geo. VI Bermuda, plus 100 worldwide 10¢, approvals. Stevens, Box 105A, Homecrest Sta., Brooklyn, N.Y. 11229.

U.S. Approvals Low prices. Eagle, 2221 Romine Ave., Pittsburgh, Pa. 15226.

WOW! 110 all different Germany 10¢ Commemoratives, Airmails, High Values. Big catalog, bargain lists also, fine stamps from our approval service, which you may return without purchases and cancel service at any time. Jamestown Stamp, Dept. A19PM, Jamestown, N.Y. 14701.

MILLIONS Foreign Stamps! 2¢ each! Send for gigantic approvals! ABC, Box 6000-MB, San Francisco, California 94101.

FREE 50 Worldwide. Approvals. University Stamps, P.O. Box 1471, Lake Worth, Florida 33460.

INTRODUCING Our better United States approvals we offer 15 United States stamps including Columbian, Bi-Centennials, famous American, airs, others; only 10¢. Ocean Stamps, Box 64-PM, Brooklyn, New York 11229.

UNITED States commemorative collection containing 33 different—10¢. Approvals. White, 516-A Avenue L, Brooklyn 30, New York.

50 YEARS Old, fifteen different United States, over fifty years old—10¢ with approvals. Jaxon, Box 145-P, Brooklyn, New York 11230.

GIANT Stamp Collection including: Astronauts, Satellites, Moonrocks, Boy Scout issue, Complete U.N. Set, recent Olympic and Sport issues from many countries, etc., Plus Big Stamp Dictionary and approvals. Everything, 10¢! Stampex, Box 47-RM, White Plains, N.Y.

"ATTRACTIVE" Set free! Request Approvals. Gorliz, Box 1915PM, Naples, Florida 33940.

EXPLOSIVE Near East always in the news. We are offering a nice collection of stamps from Israel, Egypt, Jordan, Syria, Iraq, etc. for only 10¢ to approval applicants. Clark Stamps, Dept. 57C, Muskegon, Mich. 49444.

ABSOLUTELY Free 25 different United States Commemoratives when requesting United States Approvals. K & B, Box 70, Brooklyn, N.Y. 11223.

QUALITY And price. Mounted approvals 2¢ up. Preview Stamps, P.O.B. 9809M, San Diego, Calif. 92109.

701 U.S.A. (Plenty Commemoratives)—25¢. Request approvals. Horace Gatewood, Winston-Salem, N. C. 27102.

1045 DIFFERENT—\$1.50. Foreign approvals. KayKaye, Box 452, Harrisburg, Ill. 62946.

U.S. Seconds, Bargain Prices. Karl Swartz, Box 373, Venice, Fla. 33595.

ONE Cent a stamp. Write for a jumbo book of foreign stamps at 1¢ each, mounted in Scott order. Bullot Approvals, 6815 Bay Parkway, Bklyn., N.Y. 11204.

SENSATIONAL Free offer; 20 outer space stamps; selected approvals; Louis Morrison, 1027 Maryland, Cape May, N.J. 08204.

CANADA: Outdoor recreation set 40¢ value only 15¢, approvals. Rheume, 6591 11th Ave., Montreal 36, Canada.

SENSATIONAL Offer. Forty Different Packets \$1.00. No approvals. Norge, Ho-Ho-kus, N.J. 07423.

"WHOLESALE" Pricelist and catalog free! Everything guaranteed. Schneider Co., Holland, Mich. 49423.

FREE 50 stamps with approvals. Martus, Box 158 Centuck, Yonkers, New York 10710.

2,000,000 STAMPS, 150 Countries, 2¢ each. Belden, Box 175, Dearborn, Michigan 48121.

251 DIFFERENT U.S. commemoratives with approvals \$1.00. Carstamps, 12 Mockingbird Lane, Fort Smith, Arkansas 72901.

FREE Twenty different worldwide stamps When you request our approvals. Fairplay Stamps, 1411 Marion Way, Santa Ana, California 92706.

14,000 DIFFERENT! AMAZING new plan builds your collection systematically, country by country. Only 50¢ weekly. Ware, Monroe, Conn. 06468.

CANADA Sports complete. 10¢. Canada approvals. Valley Stamps, Little Valley, New York 14755.

U.S., Worldwide price list . . . 10¢ handling. No approvals Dept. P. 5001 Eastern, Hyattsville, Md. 20782.

14 DIFFERENT Confederate facsimiles 10¢. 7 different 3¢ commemorative plate books \$1.00. Approvals . . . Gordon Davison, Henniker, New Hamp. 03242.

ILLUSTRATED New Issue List—Five weeks 50¢. Brooks, 2601-N Avenue "U", Brooklyn, N. Y. 11229.

500 FINE Mixed Canada, 25¢. Continental, 271 Pine Cove, Burlington, Ontario, Canada.

"INVERTED ERROR" Dag Hammarskjöld, 6¢ with approvals. Belmont Stamps, Washington, D. C. 20015.

225 STAMPS for only 10¢! Airmails, Pictorials; stamps from strange countries cataloging up to 25¢ each! Plus unusual stamps to examine. Buy any or none return balance, cancel service anytime. Mystic Stamp Co., Camden 80, New York 13316.

1500 FOREIGN \$1.00; 5000 \$3.00. 5000 USA commemoratives, revenues, airs, presidentials, 19th Century, high values \$3.00. 300 pre-1939 USA commemoratives \$2.00. 1000 foreign pre-1940 \$3.00; 5000 \$12.00. No approvals. Meyers, 5321 Fleming, Richmond, California. Zip code 94804.

FREE—World's Greatest Premium—5000 all different stamps, actual Catalogue value over \$100.00 given approval buyers. Thrifty Stamps, Grossmont, California 92041.

PAINTINGS 20 different giant multi-colored beauties 25¢. BEAUTIFUL paintings sets on approval. Roger Williams Stamp Co. Box 1281-M, Pawtucket, Rhode Island 02862.

WORLDWIDE Sets on Approvals. Humphrey, 805 24th Ave, Santa Cruz, Calif. 95060.

FREE 400 Genuine postage stamps! Worth \$10.00 at catalogue prices. Africa, Europe, Asia, British Emp—a fascinating valuable mixture from foreign convents, banks, etc. Who knows what you will find. Also free valuable booklet. Adults only. Approvals enclosed. Frasek Co., PM-1, White Plains, N.Y.

100 DIFFERENT! Free 1/4¢ upward British Commonwealth or world approvals. Bush, 1677 Wimborne Road, Bournemouth, England.

2¢, 3¢ APPROVALS. Other bargains. Pam, Box 22092, Memphis, Tenn. 38122.

IRAQ, Iran, Turkey 75 Stamps 10¢ with approvals. Berchtold Stamps, Troy, Ohio 45373.

FREE! 55 Different Triangles, Space, others. Really nice approvals. L. Baird, PM-21, Box 8128, Portland, Oregon 97207.

25 LARGE Poland Stamps. 10¢ No approvals. Jack Field, 2109 N. Argonaut, Stockton, Calif. 95204.

50 DIFFERENT United States, only 10¢. with Approvals. Shelton, Box 547C, North Miami, Florida 33161.

121 DIFFERENT Flag stamps free. Approvals. W-B Stamps, Wilkes-Barre, Pa. 18703.

INVEST IN STAMPS. Details of systematic investment plan and current investment newsletter \$1.00 refundable. Jeffrey Needleman, 2367 East 18th Street, Brooklyn, New York 11229.

8 CANAL ZONE 25¢. Approvals! Merkel, 30 Grandview, South Hadley Falls, Mass. 01075.

FREE—Mammoth Collection, \$10,000 Airmail, Scott's International, Master Global Albums when you buy our Approvals. Bargain Stamps, Tustin, California 92680.

SURPRISE COLLECTION! Exotic mint British Colonials, absolutely free with approvals VIKING, Great Neck 8, N.Y.

EXOTIC Worldwide pictorials free when buying approvals. Stamp Farm, IMI, Oxford, Wis. 53952.

TRIANGLES Galore! Terrific Stamp Bargain! Three beautiful sets of triangles plus 105 different, including colorful Asiatic pictorials. Only 10¢ with request for approvals. Send today! Shaw, Drawer E-4, Montevallo, Alabama 35115.

FREE! 50 Stamps includes Saints Kitts, Lucia, Vincent—Approvals—Moumbou, 12542-5V Keel, Garden Grove, California 92640.

69 DIFFERENT Free with approvals. Collier, Box 265, Folkston, Georgia 31539.

PAINTINGS, 10 Different beauties, 5¢. Approvals. Mayers, 37 Dawson, Belleville, New Jersey 07109.

OLYMPICS! SPORTS! 29 Different Action Packed Thrillers—10¢. Illustrated Bargain lists and Bonus, Approvals included. Barton, Box 441-E, Elizabeth, N.J. 07207.

15 U.S. Commemoratives 10¢ with U.S. of interest approvals; Salsman, P.O. Drawer 109, Fairfield, Calif. 94533.

TWO Cent Approvals. The Best. Scotty Stamp Co., Box 155, Staten Island, N. Y. 10301.

RUSSIA, 15 Different Beauties—10¢. Colorful Approvals. Postmark, Great Neck 1, N.Y. 11022.

CLOSEOUT Sale! Unbelievable Low Prices. Generous Assortment 30 cts. High Value Packet \$1.00. No Approvals. Persil, 436 N. Y. Ave. Brooklyn, N. Y. 11225.

GIANTIC "Garden Flowers" Hungary's latest 1968 Commemoratives—Free! Approvals plus 101 Bonus Sets, William Deems, 226 Race, Ravenswood, West Virginia 26164.

BREATHAKING, 50 Mint Monaco, \$1.00. Approvals accompany. World, 1784 Union, San Francisco 94123.

RARE Stamp free. Also new packet Aden to Urundl with Kennedy, triangles, space, sports, ships, dogs, cats, reptiles plus others. All free. Send 10¢ for mailing, Empire Stamp Co., Toronto, Canada.

ROCKETS, Flags, Diamonds, Triangles, 55 others 5¢. With Approvals. Dealing, Box 185, Long Lake, Minnesota 55356.

ENGLAND-Remails. \$3.00 Monthly. Moore, 38 Crawford Street, London W. 1.

500 DIFFERENT Worldwide, pictorials included, \$1.00. Anderson, 149 Campbell Road, Buffalo, New York 14215.

VIETNAM 25 Different 10¢ approval. Sam Chazen, Box 95, Ozone Park, N.Y. 11417.

PERSIA 20 Different, 25¢. Approvals. Lamar Gant, 3010 Hoyte Dr., Shreveport, Louisiana 71108.

PRESIDENT Nixon inauguration cover—addressed to you on special cacheted envelope carrying official historic-date postmark from Washington, 35¢ each—3 for \$1. K. M. Walsh, Box 308, Tuckahoe, N.Y. 10707.

BOSTON—Singles 25¢. Monthly \$3.00. Unlimited—Dad-PM, Box 651, Waltham, Massachusetts 02154.

SEND 10¢ For Stamp Grab Bag. Over 100 unsorted old and new Asia, Africa, Europe, South Seas, etc. Approvals, illustrated catalog included. Littleton Stamp Co., Littleton GB1, N.H. 03561.

TOPICALS—Three Colorfull Sets, 10¢! Approvals. COLE, Box 223-A, Buffalo, N.Y. 14221.

FREE!! Two Complete Mint Sets. Approvals. Hamilton, 1246 Pratt, Chicago OE-1, Illinois 60626.

PENNY Approvals. Premiums with purchases. Large selections. Penny Stamps, Orange, California 92669.

RUSSIA High-Value Collection. 32 different Russia—some over 50 years old! Commemoratives, Czarist Issues, Airmails. Catalog price \$2.99. Special Get-Acquainted Offer—all for only 10¢! H. E. Harris, Dept. GG-5, Boston, Mass. 02117.

FREE! 25 Egypt. 15¢ handling. Approvals. Bellet, Mapledale, Hazel Park, Michigan 48030.

COINS, TOKENS, CURRENCY

MERCURY DIMES, 20 different, \$3.95. "S" ROOSEVELTS, 10 different (1946S-1955S complete), \$2.95. Uncirculated 1955S Cent, 2 for \$1.00. 1943PDS STEEL Cents, 2 sets \$1.00. SERENDIPITY, Box 820P, Cupertino, California 95014.

40 GENUINE Coins from 40 countries. Mostly uncirculated. Beautiful, \$2.00. Hindley, Box 708, Aurora, Illinois 60507.

100 INDIAN, Lincoln Cents, 1920's and older, \$5.00. Wesley Rood, West Union, Iowa 52175.

"SEVEN Different liberty nickels—\$2.00 —Bargain listing—Dime—Huber—200 Baker Building, Minneapolis 55402.

SCARCE Date Jefferson nickels. All V.G. Satisfaction Guaranteed. 1942D—1949S—1950—50¢ each. 1943D—1951S—1955—75¢ each. 1939S—\$1.25, 1938D—\$1.65, 1938S—\$3.25, 1939D—\$5.00, 1950D—\$14.50. Dates not listed 20¢ each. Bryson Inc., 612A White, Toledo, Ohio 43605.

UNCIRCULATED Dollars, 1880-81-82 S, 1883-84-85-1899-1900 01-02 O mint. \$3.50 ea. Catalogue 50¢. Shultz, Salt Lake City, Utah 84110.

U.S. Large Cent before 1857, \$2.00; Civil War 3¢ piece, \$2.00; Five different Indian Cents, \$1.00; Lincolns, ten different "S" mints before 1955, \$1.00. RARCOA, 31-A North Clark, Chicago 60602.

20 UNCIRCULATED Foreign Coins \$1.00. Coins, Box 8541, Minneapolis, Minnesota 55435.

LINCOLNS: Rare Uncirculated 1955S—Exciting new 1968S. Both included with 50 mixed "S" cents, only \$2.00! 1968S nickels, 9 for \$2.00. Silver Dollars \$2.45 each. HARRIS, 4535P Stevenscreek, Santa Clara, California 95050.

GOLD Coins of the world. Beautiful. Low prices. Plus thousands of United States Coins. Free Price List. Please send long, airmail, envelope, self-addressed, stamped. Silver Center, Box 22171-M, San Francisco, California 94122.

LIBERTY Nickel, 60 years old, Coin list, 30¢. Economy Sales, Mansfield, Mass. 02048.

LINCOLNS: 30 Different Brilliant Uncirculated 1954PDS-1968PDS complete (Regularly \$5.95)—Special \$2.95. Silver Dollars \$2.45 each. BONANZA, Box 4491P, San Jose, California 95126.

LINCOLN'S: 1919, 1920, 1926. Only 10¢. Stevens, Box 546 F, North Miami, Florida 33161.

UNCIRCULATED Silver Dollar with list \$3.50. Fairway, 121-P Rye, New York 10580.

MORGAN Quarter with terrific list \$1.00. Nelson, 346-P Rye, New York 10580.

1968-S UNCIRCULATED Roll, Cents, \$1.50 Nickels, \$5.25 Proof Set, \$21.50. PPD Universal, P.O. Box 403, Salinas, Cal. 93901.

COINS Discounted! Catalogue 25¢. Buying Catalogue 50¢. Sullivan's, #3330-AA St. Paul, Minnesota 55101.

BARGAINS—Brilliant Uncirculated Silver Dollars: 1881-0, 1882-0, 1883-0, 1884-0, 1885-0, 1898-0, 1899-0, 1902-0 each \$3.50. All Eight \$25.85. Rare 1885-CC \$59.50. Bargain lists 25¢. Bebee's, Incorp., Omaha, Nebraska 68111.

1968 PROOF Sets, \$16.00 Each. Mint Sealed. Excellent Investment. Cort Headland, 3150 Ebano Drive, Walnut Creek, California, 94598.

FREE 1968-S Cent, Three 1955-S Cents \$1.00. Edel's, Carlyle, Illinois 62231.

140 DIFFERENT Lincolns! Good—Uncirculated! \$12.50! Satisfaction Guaranteed! Charles Wheatley, Hartford City, Indiana 47348.

PRICE List. Send 10¢. Village Coin Shop, Dept. P, Plaistow, N.H. 03865.

ALWAYS Know what Coins to save, Wallet Card makes you an Expert \$1.00—Quality House, Dept. J, 6900 Stockton, El Cerrito, California 94530.

BARGAINS GALORE:—\$1.00 Specials! nine different Buffalo's, four different Indians, four different Liberty nickels, six different War nickels, fourteen (S) Lincoln cents, EXTRA special:—Seated dime \$2.35. SENSATIONAL U.S. coin list 10¢. Schultheis, 214M Devonshire, New Hyde Park, N.Y. 11040.

WANTED Silver certificates. Best price paid. Aaron, 2634 North 40th Street, Milwaukee, Wisconsin 53210.

SILVER Sassanian Coins, 1000 years old \$6.00; 1968-S Proof sets \$18.50; 40 Silver Quarters, \$14.50. Thomas Miller, Franklin, Georgia 30217.

40 PAGE Illustrated United States and Canadian coin list 10¢. Stoney, 260 Washington, Boston 8, Mass.

BARGAINS—Latest coin price list, 10¢. Ron Farley, Metamora, Ill. 61548.

TRUNKFUL 25,000 Indian-Lincoln cents from the 1920's and older, mixed 'grab-bag' style, 150—\$10; sample bag of 20—\$2. Mrs. B. Fischer, Box 743-B, Encino, Cal. 91316.

ANTIQUES, RELICS, INDIAN GOODS AND CURIOS

LIST Indian relics, 10 Arrowheads \$3.00. Hyde's, Box 2304, Santa Fe, New Mexico 87501.

TONS Of antique gun parts and supplies. All reproduction muzzle loading guns. Send \$1.00 for enlarged illustrated catalog No. 117-A. Dixie Gun Works, Union City 12, Tennessee.

ONE Dozen perfect arrowheads \$4.00. George Smith, 9825 Conway Drive, Indianapolis, Indiana 46236.

MODELS—SHIPS, TRAINS, PLANES, ETC.

SHIP Models, Kits, fittings, plans, books, tools, engines, motors. Big illustrated catalog 50¢. Mass. residents add 3% tax. James Bliss & Co., Dept. SM, Route 128, Dedham, Mass. 02026.

SHIP Models catalog 25¢. Scientific, Inc., 100 Monroe, Newark, N.J. 07105.

ROCKETS: Real flying models—flights up to 2500 ft. New illustrated catalog 25¢. Single and multistage kits, cones, engines, launchers, trackers, rocket aerial cameras, technical information. Fast service. Estes Industries, Penrose 2, Colorado 81240.

SHIP And yacht model fittings; Pine construction hull kits: blueprints; Send 50¢ for illustrated catalog. A. J. Fisher, Inc., 1002 Etowah Avenue, Royal Oak, Michigan 48067.

SCALE Building materials, 1/4" & 1/8" scale. Windows, doors, siding, roofing, lumber and structural shapes. Send 50¢ for catalog. Small Sales Co., P.O. Box 177, Shawnee Mission, Kansas 66201.

SHIP Model kits and fittings: clippers, frigates, etc. Catalog paint-tool list, 1969 catalog 50¢. Models Shipways, Box 65, Bogota, N.J. 07603.

ROCKETS! Flying models, Engines. Beginning through advanced. Catalog 25¢. Rocket Development Corporation, Route 3-M, Seymour, Indiana 47274.

LIVE Steam Engine kits. Fascinating hobby for model mechanics. Boilers, fittings, accessories. Pictured catalog \$1.00. H.P.K. Models, Centuck 34, Yonkers M, New York 10710.

GAMES, TOYS, PUZZLES & NOVELTIES

"COME Seven or twenty-seven!" "EMO", played with 36 numbered "ROULETTE DICE". Send \$2.00 to D. E. Products & Co., P.O. Box 488, Worcester, Mass. 01601.

SAMPLES! Hundreds Free Just for asking! Details. Mailord, 862 E. 65th St. Chicago 60637.

PLAYING CARDS, 2 decks, monogramed in Gold on Red and Blue, plastic coated, \$2.95. SOLITAIRE! Styrofoam board to hold cards. Booklet shows 150 ways to play. \$2.98. Free catalog. W. H. Wear Company, 4436 Fla. Short Rt., Birmingham, Alabama 35243.

KITES, Kits, Plans. Delightful Booklet, KYTE TALES, 25¢. Kyte House, Box 145C, Richardson, Texas 75080.

MAGIC TRICKS, JOKERS & VENTRILOQUISM

AMATEUR and PROFESSIONAL MAGICIANS all new magic tricks and gags catalog 25¢. Our specialty same day service. Fabulous Trick and Magic, 3319 E. Charleston, Las Vegas, Nevada 89104.

MAGIC MAGAZINE—Monthly since 1936. 44 pages. All phases. 3 month trial \$1.00. Genii, P.O. Box 36068, Los Angeles, CA 90036.

COMPLETELY Illustrated catalog, 84 pages, 25¢. Manhattan Magic, Box 334-M, N.Y.C. 10011.

WORLD'S Finest professional magic tricks. Joker's Novelities. Giant illustrated catalog 10¢. Top Hat, Evanston, Illinois.

FREE! World's Leading Catalog 2000 Novelities, Jokes, Tricks, Scientific Gadgets, Hobbies. Johnson-Smith, D-356, Detroit, Michigan 48224.

HOUDINI'S Original Magic Shop. Established 1856. Send 25 cents for Illustrated Catalog containing 5000 Tricks, Mindreading, Puzzles, Hypnotism and Jokes. Flosshornmann, 304 West 34th St., N.Y. 10001.

BE A Magician! Two booklets explaining sixty-eight tricks plus large professional catalog, \$1.00. Magic, Inc., 5082 Lincoln, Chicago, Illinois 60625.

NEW 1969 Catalog, 500 Tricks, now ready! Visit our store, or send 10¢ for Catalog showing latest magic for pocket, parlor, stage. Fastest mail service for 54 years. Douglas Magicland, Dept. 11, Dallas, Texas 75221.

FREE Trick with Magic Catalog. Send 10¢ Ace Magic, Box 329, Evanston, Illinois 60204.

VENTRILOQUISM! Information free! Dummy catalog, 25¢. State age. Maher, Studio K, Box 8356, Kensington Station, Detroit, Michigan 48224.

42 PAGE Illustrated joke—novelty catalog 25¢. Joke, Box 7212E, Chicago 60680.

CATALOG 10¢ (1,500, 399 tricks, jokes, novelties) Elbee, 7408-P, San Antonio, Texas 78207.

MAGIC Catalog. World's finest 3000 tricks. (340) pages \$2.50. Beginners, amateurs, professionals. Kanter's, A-200 South 13th St., Philadelphia, Pa. 19107.

HOUDINI Magic Catalog!! Giant Professional Deluxe Edition!! 1000 World's Greatest Tricks!! 25¢ with Free Gift Certificate!! House of 1000 Mysteries. Dept. PM9C, Northeast Fifth Ave., Ft. Lauderdale, Florida 33308.

MAGIC Tricks and novelties. Free catalog. Aladdin's, 630 Commercial Place, New Orleans, La. 70130.

BOOKS, PERIODICALS, NEWSPAPERS

NATIONAL Geographic Magazines, 1888-1967, any issue. Buxbaum, Box 465-PM, Wilmington, Delaware 19899.

PROPHET Elijah coming before Christ. Wonderful book free. E. Megiddo Mission, 481 Thurston Rd., Rochester, New York 14619.

FREE Catalog. Self-help books. Write Wilshire, 8721 Sunset, Los Angeles 90069.

PAPERBACK Catalogue, 270 pages, 15,000 titles, indexed, \$2.00 credited toward order. New York Book, 4 P West 43 Street, N.Y.C. 10036.

BOOKS New and used. Crafts, courses, hobbies, science, vocational. Free catalog. George Brown, Box 7146, Toledo, Ohio, 43615.

FREE! List of low cost popular books. Success, happiness, personality, wealth, personal problems. Hilltop House, Dept. 11, Clive, Iowa 50053.

PAPERBACK EXCHANGE—Send Five And \$1.50—Receive Five. Same Category. Coastal, Box 5601, Pensacola, Fla. 32505.

BOOKS—1000's of Titles! Free Lists. Midwest Mail Sales, Box 44R2-DS, Shawano, Wisconsin 54166.

SKYWAYS. . . \$2.00. What UFO's really are. Beaconsfields, 1370 N. Rowell, Fresno, Calif. 93703.

CO-PUBLISH Your own magazine. 50% Commission. Full details 25¢. Martin's Service, Rives Road, Martinsville, Va. 24113.

COMBAT Pilot Hero Authors Sequel to World War II Best-Seller—"God is still My Co-Pilot". Warm, easy to read inspirational work of personal anecdotes, exciting fighter combat experiences and about our 'No-Win War' in Vietnam. Cloth cover \$7.50. Augury Press, Box 848, Phoenix, Arizona 85001.

FREE Book catalog. Adult reading. Catalog, 2217 Lackland, St. Louis, Missouri 63114.

PLAYS, STORIES, MANUSCRIPTS

WANT Your book published? Learn how we publish, advertise, promote, distribute. Many successes. Free booklet PM. Vantage, 120 West 31, New York City.

BUSINESS OPPORTUNITIES

HUGE Profits! Mail order importing. Free information. ITIS, PM-1, Box 454, Hollywood, Calif. 90028.

\$15.00 HOURLY PROFIT—OWN Business with one serviceman. Quickly learned. Easy to do. Operate from home. Few hundred dollars builds your own nationally advertised business while continuing present job. Investigate immediately. . . before your territory is taken. Free booklet explains everything. Send Today. Then decide. Duraclean, C9-161. Duraclean Building, Deerfield, Illinois.

BOOKKEEPERS Earn \$1000.00 month. Operate simplified Bookkeeping tax service. Universal, Box 664-M, Springfield, Missouri.

WANT To make big money at home? \$10.00 profit in an hour possible with invisible mending. Make tears, holes disappear from clothing, fabrics. Steady year-round demand from cleaners, laundries, homes. Details free. Fabricon, 1585 Howard, Chicago 60626.

I MADE \$40,000.00 Year by Mailorder! Helped others make money! Start with \$10.00—Free proof! Torrey, Box 318-Y, Ypsilanti, Michigan 48197.

CONCRETE FACTS: Highly profitable home business. Experience unnecessary. Unlimited unique pottery designs easily made without moulds. Birdbaths, fountains, wishing-wells, benches, etc. Chemical coloring formulas, marbled glazing. FREE illustrated brochure. Hollywood Cementcraft, 602 Athens Street, Altadena, California 91001.

DRAFTSMEN! Operate own DRAFTING SERVICE! Full, Part Time; Experience unnecessary; Details: Roberts Drafting, 1741 Circle Road, Baltimore, Maryland 21204.

MAKE \$46 from square foot plywood: jigsaw or bandsaw necessary. Free details. Woodar, Bridgewater, Mass. 02324.

SELL Books by mail. 400% profit. Royal, Box 450-X, Cleveland, Ohio 44127.

\$60.00 DAY. Manufacturing concrete posts, blocks, etc. Carlayne, 1803 Fremont, Rapid City, South Dakota 57701.

WORLD'S Largest supply. Merchandise 25% to 40% under wholesale. Bankrupts, closeouts 10¢ under dollar. Imports. Hong-kong clothes. Automobile discounts. Free details. International Buyers, Box 4633-MM, Colorado Springs, Colo. 80909.

RAISE Rabbits for us on \$500 month plan. Free details. White's Rabbitry, Mt. Vernon, Ohio 43050.

MAIL Baby Catalogs imprinted with your address to New Mothers for Big Profits! Details 25¢. Volz-PM, Ypsilanti, Michigan 48197.

UP To \$5.00 each for newspaper clippings! Free details. Philip, Box 368-S, Southfield, Michigan 48075.

FREE Catalogs. Repair air conditioning refrigeration. Tools, supplies, full instructions. Doolin, 2016 Canton, Dallas, Texas 75201.

FREE "Franchise Profit Letter" tells how unique NFR service is helping thousands seeking profitable businesses. Write today. National Franchise Reports, W-528, 333 North Michigan, Chicago 60601.

VENDING Machine big catalog. Rake, 523 A Spring Garden, Philadelphia, Pa. 19123.

56 ACTIVE Franchise opportunities available all over USA. Brochure details 56 franchise chances for you to have your own business tied with successful national companies. Send name, address to P. Stewart, 1085 Walnut, Des Plaines, Illinois 60016.

\$400.00 MONTHLY Raising giant fishworms. Soilless method. Charlie Morgan, Bushnell, Florida 33513.

EARN Money raising fishworms for us! Write: Oakhaven-38, Cedar Hill, Texas 75104.

400,000 BARGAINS Below wholesale! Many free. Liquidations . . . closeouts . . . job lots . . . single samples. Free details. Bargainhunters Opportunities, Box 730A, Holland, Michigan 49423.

\$200.00 DAILY In your mailbox! Your opportunity to do what mailorder experts do. Free details. Associates, Box 136-A, Holland, Michigan 49423.

CLIP Newspaper items. \$1.60-\$5.00 each. Details free. Walter, Box 1360-PA, Erie, Pa. 16512.

PLASTERCRAFT Molds, liquid rubber, plasters, flocks, candle supplies. Catalog and manual free. Blue Rapids Supply, Blue Rapids, Kansas 66411.

BIG Money—making new greaseless donuts in kitchen. Everything furnished. Sell stores. Free receipts. Montgomery Ray, Waseca, Minn. 56093.

SELL Lifetime, Metal, Social Security Plates, Big Profits! Sample and Sales Kit Free. Russell, Box 286-PM, Pulaski, Tennessee 38478.

COPUBLISH "Mail Sale Advertiser," leading mailorder paper. Copy and details 25¢: U.S.A. only. Vanroy Shirk, Lebanon, Pa. 17042.

MAILORDER Records help get Increased Business! Complete 32 page Record Book shows your inquiries, orders, advertising expense, etc. Only \$1.00. Martin, Popular Mechanics, Dept. PM, 575 Lexington, New York 10022.

MAKE 2 to 3 times your cost wholesaling 1001 products. Gifts, Mail Order Specialties, Toys, Novelties, Carded Merchandise . . . Guaranteed lowest below wholesale prices. Free home business details SMC 7630 SPA, Gloria Ave., Van Nuys, Calif. 91406.

BIG Profits Wholesale gifts items novelties toys carded merchandise in full or spare time. Goldman, Dept. A98, 931 N. Ditman Ave., Los Angeles, Calif. 90063.

HOW TO PREPARE YOUR OWN MAIL-ORDER CATALOG for pennies. . . Including All Popular Merchandise! Free Catalog-Proof! Obie, 5711-MJ-14th, Brooklyn, New York 11219.

MAILORDER Book publisher wants dealers. Wonderful "drop-ship" proposition. Sample imprint circulars free. Neil H. Tasker, Shamokin, Pennsylvania 17872.

BIG Profits—Operating your own plastic laminating business with low cost equipment and supplies, money making methods included. Money back guarantee. Jiffy—Box 23485P, Los Angeles, Calif. 90023.

BUILD Custom Cases at home for profit. Get orders by mail. We supply materials, instruction—everything. Free home business details. Custom Case Supply Co., 7630-CPA, Gloria Ave., Van Nuys, Calif. 91406.

MERCHANTS Police career! Patrol local business buildings nights. National, Box 327, Springfield-5, Oregon 97477.

SAVE 'Lost' money! Inside "know-how" reveals how to select the one right franchise for you. Free details: write today! Allas, Box 3793, Charlotte, North Carolina 28203.

\$70.00 WEEKLY—home, spare time. Simplified mail bookkeeping. Immediate income easy. Auditax, 34741A, Los Angeles 90034.

VENDING Machines. No selling. Operate a route of coin machines and earn amazing profits. 32-page catalogue free. Parkway Machine Corporation, 715 PMB Ensor Street, Baltimore, Maryland 21202.

PIANO Tuning Learned quickly at Home. Tremendous field. Musical knowledge unnecessary. GI approved. Information free. Empire School, Miami, Florida 33145.

INSTALL Burglar alarms without previous experience or costly equipment. Big profit. Free details. Nasco, 11071 Massachusetts, Dept. C-2701, Los Angeles 90025.

ADDRESSERS And mailers needed. Send stamp for information. Lindbloom, 3636 West Peterson, Chicago 60645.

BUY No moneymaking plan before reading this information. For \$3.00, you will be grateful. Wright, 3115 Gus Thomasson, Dallas, Texas 75228.

I GROSSED \$112,000.00 year, mailorder. Can help you make money. Free proof. Write: Williams, 44646A, Los Angeles 90044.

ESTABLISH Profitable Catalog Mailorder Business! Vikari's, Box 1312PMA, Salt Lake City, Utah 84103.

MAKE Money from old tires. Operators clearing \$800, weekly. Equipment costs \$1250. Get facts. S & S Patents, Inc., 3752 N. Damen, Chicago 60618.

FREE Book "990 Successful, Little-Known Businesses." Work Home! Plymouth-372R, Brooklyn, New York 11218.

HOW And Where To Get Capital. 1000 sources. Free details. Counselor-17, Harlingen, Texas.

NEW Plan! Pays up to \$25.00 an hour! Little as 4 hours weekly. Place Thriftie self-service displays in stores. No cost to merchants. No experience needed. Free details. Lux Company Incorporated, Dept. 1109, Elkhart, Indiana 46514.

DEVELOP THAT HUNCH—convert that occasional intuitive impression into a real business opportunity. Your secret partner is your unused mental potential. Write today for a free copy of *The Mastery of Life*. It explains how thousands have learned to use this undeveloped power as you can! Address: Scribe S.J.D. The Rosicrucians, AMORC, San Jose, California 95114. Please include Zip Code if part of your address.

IMMEDIATE Profits with no capital or experience. Take orders for all magazine subscriptions. Friends and neighbors are your prospects. Write now for complete, free kit. McGregor Magazine Agency, Dept. GB9, Mount Morris, Illinois 61054.

\$75.00 THOUSAND. Home Addressing! Longhand, Typewriter. Information, send stamped self-addressed envelope. Brewster, Box 1348-TF, Clearwater, Florida 33517.

SECRETS: Mail order success. Internationally famous expert reveals how to make home business fortunes. Beginners: Get free copy "Make Money By Mail." Discloses free advertising, profitable products. Mailco, 1554 Sepulveda, Dept. C2701, Los Angeles 90025.

SET Your own income just talking to boat dealers! Sound fantastic? Many of us are. \$30,000 and up per year. How about you? Experience not mandatory! \$5.00 gets you the How, Who and Why of a fine exciting business. Counselor Services, P. O. Box 67, Dayton View Station, Dayton, Ohio 45406.

OPERATE Restaurant. Free booklet reveals profitable plan. Write Restaurant Business School, Dept. EC 19, 1920 Sunny-side, Chicago, Illinois 60640.

FREE! Catalog, mailorder success letter. Sullins, Box 1881 M Forsyth, Georgia 31029.

EARN More than many Professional men! \$1000 monthly operating mail order Collection Agency. Continental, Box 2023-A, Des Moines, Iowa 50310.

SUPPLY Fried Chicken Dinners on \$500 week home plan. Free information. White's Chicken Dinners—PM, Mt. Vernon, Ohio 43050.

COLORGLAZED Concrete pottery made without molds. Patented method. Cemetery products, novelties, tiles. Basement leak-sealing. Money-making projects. Booklet, details free. Men only. National Potteries Company, Grand Rapids, Minnesota 55744.

BE DATACRAFTER At Home. Sell hometown merchants, doctors, banks. I train you what, where, how to sell. Free particulars. Datacraft-71A, Harlingen, Texas.

MAKE MONEY IN MAIL ORDER. Practical book gives complete instructions. Details free. Martyn, 475 Fifth Avenue, Dept. PM19, New York, N.Y. 10017.

FREE Advertising? 500 Publications. Write: Dee, 10639-PM Riverside, North Hollywood Calif. 91602.

EASY Home Business! Amazing mail-order book shows how. \$2.00. Satisfaction guaranteed. Pioneer, Box 44, Somerville, Mass. 02145.

BIG MONEY MAKER! Custom Drapery making plus Interior Planning and Slip Covers. Tremendous spare-full time earnings. Women, Men all ages. No experience required. We furnish everything: Easy Home Instruction, Tools, supplies to create valances, drapes and window coverings of all kinds . . . yours to keep! Send for beautiful, colorful brochure. CUSTOM DRAPERY INSTITUTE, Box 555-D5, Orange, California 92669.

MAKE \$75.00 daily distributing tools to service stations. Free Plan. INKA, 2401 Crocker, Houston, Texas 77006.

IMPORT Export opportunity, profitable world-wide, mail-order business from home, without capital; or travel abroad. We ship proven plan, for no risk examination. Experience unnecessary. Free details. Melinger, Dept. C2703, Los Angeles, 90025.

EASY-To-start rubber stamp business at home in spare time. Make up to \$16.50 an hour without experience. Facts free. Write to: Roberts, 1512 Jarvis, Room CR-2-A, Chicago, Ill. 60626.

TIN-CANS 63 USES. Sawdust 112. Newspapers 27. Rubber 67. Glass 20. Rags 35. Instructions \$1.00 each. Any three \$2.00. All six \$3.00. Satisfaction guaranteed. Charles Company, 42-GWG, Norwood, Ohio 45212.

REAL Live Moneymaking Sparetime Mailorder Opportunity. Exciting details: sample subscription to fascinating hoyists Magazines \$1.00. Hobby World, Oakton-PM, Virginia 22124.

BOOKKEEPERS Operate simplified bookkeeping tax service in your locality as representative of North America's fastest growing chain, Dutot Business Records and Tax Service Centres, Hensall, Ontario, Canada.

FREE FRANCHISE JOURNAL MAGAZINE with over 100 business opportunities. Franchise Journal, 892-G West 16th St., Newport Beach, California 92660.

BIG MONEY MAKER! Custom Furniture Upholstery plus Auto Trim, Slip Covers, Drapes. Tremendous spare-full time earnings. Men, women, all ages. No experience required. We furnish everything: Easy Home Instruction, Tools, Supplies to build roomful of beautiful furniture . . . yours to keep-sell! Approved for Veterans. Send for Big FREE Illustrated Book. Modern Upholstery Institute, Box 899 BGX Orange, California 92669.

MAKE Money Operating Home Mailorder Business. No Inventory. Write Purple Enterprises, Box 16291AA, Jacksonville, Fla. 32216.

BECOME A mailorder millionaire. Amazing success secrets revealed. Free details! Williams Company, Dept. PM-1, 4249 Carona, Springfield, Ohio 45503.

\$500—\$800 MONTHLY. Raise small laboratory-breeding stock for us. We supply equipment, breeders, instructions. Illinois Research Farms, Dept. MP-1D, McHenry, Illinois 60050.

BIG Money raising fishworms and crickets. Free literature. Carter Farms, Plains, Georgia 31780.

MEDICARE-Social Security. Earn top fees assisting clients obtain maximum benefits. National Tax School, Monsey, 302ZB, New York 10052.

WATCH REPAIRING piles up extra cash fast. Free sample lesson. Watchmaking, YNB, Fox River Grove, Illinois 60021.

SPEEDYMAIL Can help you start Profitable, Private, Mail Delivery System from your local Post Office. Free Information! Speedymail, Box 4543A, Miami Beach, Fla. 33141.

SPARE Time Cash—Sell Advertising Book Matches—every business a prospect—no investment—no experience needed to build steady repeat business. Daily Cash commission in advance. Write today—We'll send your sure-fire selling kit by return mail. Dept. MX169 Superior Match Co., 7530 S. Greenwood, Chicago, Illinois 60619.

WORLD'S Largest wholesale Import Catalog. Free details. Northwest, Medina, Washington 98039.

REPAIR Hydraulic Jacks—Free details. Hydraulic Parts Supply, Box 295, Port Isabel, Texas, 78578.

PREPARE Tax Returns—Policeman Albert Myers made \$2000 his very first season. Train at home. VA Approved. National Tax School, Monsey, 2ZB, New York 10952.

FREE! 60 Lazy Ways To Strike It Rich! Stamped, self-addressed envelope. Funderhood, (PM-22), 15 West 38th, N.Y. 10018.

HOW To get Ads in National Magazines—Absolutely Free! Details in "Mail Order Imports" booklet. Send \$1.00. Cherry House, 166 Cherry, Long Branch, New Jersey 07740.

TRAVEL For Pay—Amazing Plan!!! Information free. Noalco, Box 486, Torrance, California 90508.

MAKE BIG MONEY GROWING GINSENG! \$3,000-\$30,000 annually. We buy your crop. \$2.00 brings seed sample and information Glass Ginseng Exchange, Box 1969, Springfield, Mass. 01101.

BECOME PROFESSIONAL DRIVING INSTRUCTOR. Big demand. Earn \$10.00 hour. \$300 week. Part time. Full time. Business for yourself. Free details. Write Howard David, 1818 Everts St. Phila., Pa. 19152.

SPARE Time earnings. With your table-saw, bandsaw or jigsaw. Write: Workshop, A3800 Harney, Vancouver, Washington 98660.

\$1500.00 IN 15 DAYS. Spin-Art business. Free information. 1581 Ramillo Ave., Long Beach, California 90815.

PLEXIGLAS SIGN MAKING Simple instructions and supplies lets you make PROFESSIONAL PLEXIGLAS SIGNS. Starting kit \$12.50 for over 120 Acrylic letters and Acrylic background. Unlimited uses, great profit. Daytona Plastic, Dept. M., Box 6161, Daytona Beach, Florida 32022.

SUCCESSFUL Home business opportunities. Details Free. Cassill, Box 1535, Eugene, Oregon 97401.

OPERATE Home mailorder business! Free info: Vosacek Printing, Box 1217A, Garden Grove, California 92640.

MAKE \$32 from 49¢ piece vinyl. M-1834 Edgeland, Louisville, Ky. 40204.

27 MILLION Homes and apartments need fantastic new DUR-A-FLEX Do-it-Yourself seamless floors. Install brilliant colored vinyl floor; make big profits. Send for free literature on how you can become a DEALER-INSTALLER. Be part of a great new growth industry. Write Dur-A-Flex, Inc., Dept. PM3 269 Franklin Ave., Hartford, Conn. 06114.

MAKE Gorgeous original candles for all holidays and special occasions. Learn expert Candle decorating, candlemaking, use of professional molds. Free details on home instruction method. Candle Institute, Dept. SR, 1600 Cabrillo, Torrance, Calif. 90501.

AUCTIONEERING Home Study Course—\$15.00—Diploma—American Auctioneer College, Box 316, Terra Ceia, Florida.

MONEYMAKING OPPORTUNITIES

\$200.00 FROM Sheet 1/4" plywood (scrap). Details 25¢. Novelties, 610 So. 24th, Elwood, Indiana 46036.

EARN \$240.00 a month at home, spare time, doing only two \$5.00 invisible mending jobs a day. Big money paid for service that makes cuts, tears disappear from fabrics. Steady demand. Details free. Fabricon, 1532 Howard, Chicago 60626.

RAISE Rabbits and fishworms on \$500 month plan. Free details. White's Rabbitry, Mt. Vernon, Ohio 43050.

MAKE Statuettes, novelties, imitation marble. Sell to stores or start gift shop. Free details. Marbleizing, 41 Waverton, St. Louis, Mo. 63124.

FREE, 206 Easy ways to make money taking orders for exciting new products—spare time. Send name, age, for 5 months free subscription. Opportunity Magazine, 850 N. Dearborn, Dept. 17-AM, Chicago 60610.

HOW To Make money writing short paragraphs. Information free. Barrett, Dept. C-27-M1, 6216 N. Clark, Chicago 60626.

SELL Advertising book matches. Write us today; we put you in business by return mail, handling complete line ad book matches in demand by every business right in your town! No investment; everything furnished free! Top commissions daily! Superior Match, Dept. MA-169, 7530 S. Greenwood, Chicago, Ill. 60619.

MAKE \$12.00 Profit each dozen assembling Belts. Details: Send Stamp. Redikut's, Loganville 40, Wisconsin.

WANT To win a contest? Write Prize-winner, Box 11569, St. Petersburg, Fla. 33733.

HOMEWORKERS! 200 companies—48 page Directory. FREE details. Quest Enterprises, Box 6029, Dept. 11, San Jose, California 95150.

CLIP Newspaper items. \$1.00-\$5.00 each. Details free. Walter, Box 1360-P, Erie, Pa. 16512.

LEARN The secrets of repairing junk batteries. "Fabulous Profits" at home. Batteryman, Palm Desert, California 92260.

\$15.00 HOURLY Profit—Own Business with one serviceman. Quickly learned. Easy to do. Operate from home. Few hundred dollars builds your own nationally advertised business while continuing present job. Investigate immediately . . . before your territory is taken. Free booklet explains everything. Send Today. Then decide. Duraclean, C9-161B, Duraclean Building, Deerfield, Illinois.

SPARE TIME PROFITS: Invisible re-weaving. Complete instructions and kit at lowest cost. Vaught, Box 321, Royal Oak, Mich. 48068.

VENDING Machines. No selling. Operate a route of coin machines and earn amazing profits 32-page catalogue, free. Parkway Machine Corporation, 715 PMM Ensor Street, Baltimore, Maryland 21202.

"MONEY Quick", written for those that need extra cash quick. Explains the simple trick of making an extra \$100.00 to pay doctor or hospital bills. Don't delay, order now. Pamphlet \$1.00. Advisors, Box 773, San Bernardino, California 92402.

HOMEWORK PAYS! 75 Companies begging for sparetime workers . . . Complete Instructions, List, \$1.00. Opportunities, Box 11071-PA, Indianapolis, Indiana 46201.

WIN At Poker. Booklet reveals winning secrets, professional strategy. Only \$2. Banner House, 16121 Del Norte, Poway, California 92064.

MAKE \$5,000 yearly, sparetime, raising mink, chinchilla, nutria, etc. Free booklet reveals proven plan. Write: Furs, Dept. R, Bewdley, Ont. Canada.

EXTRA Income at home in Spare Time! Booklet shows you how to start your own business with Classified Advertising. Only \$1.00. C. A. Martin, Popular Mechanics Dept. PM, 575 Lexington Ave., New York 10022.

MONEY—SPARETIME OPPORTUNITY PANELISTS AT HOME WANTED BY NEW YORK RESEARCHER. Leading research firm seeking people to furnish honest opinions by mail from home. Pays cash for all opinions rendered. Clients' products supplied at no cost. For information write: Research 669 Mineola, N.Y. 11501. Dept. PM-24.

PLASTER Craft "(How To)" Handbook for Figures, Completely illustrated. Three Dollars. V-Cee Enterprises, 1332 Moulin, Madison Hts., Mich. 48071.

25 FREE Moneymaking Books . . . Where? Moneymaker—Bab, Box 6359, Los Angeles, California 90055.

HIGHLY Profitable spare-time business. Bronzing & PearlKoting baby shoes. Complete set-up on credit available. 31 year old company. Send 25. for brochure. Kiktavi, Box 4187, Compton, Calif. 90224.

\$800.00 WEEKLY. My net profit, year. Magic Method Mail Selling. Free proof with samples, send stamped, addressed envelope. C. Brewster, Clearwater, Florida 33517.

CASH For newspaper items. Free details. Gillette, P.O. Box 30154, Cincinnati, Ohio 45230.

INSTANT Money! Plastics are the wave of the future. Big profits now! At home! Spare time! Materials costing 11¢ bring \$2.58 profits immediately! Free information! Rush name on postcard to: Warner, 1512 Jarvis, Dept. CL-2-A, Chicago, Ill. 60626.

MAKE Big Easy Profits making costume jewelry at home, spare time! Quick, easy to make; easier to sell! Details FREE! Donbar, 2934 Fullerton, Dept. A209, Chicago, Illinois 60647.

\$140.00 DAY'S Homework! How? IGY-Ensenat, Box 223, Hillsdale, New Jersey 07642.

SMOKEALARMS Build for Profit. Details \$1.00. Lectromek, Box 824, Warwick, R.I. 02888.

GENEROUS Supply of moneymaking opportunities, magazines, wholesale catalog. 25¢ Galaxy 21, 2428 S. Hamlin, Chicago, Ill. 60623.

BIG Money raising fishworms and crickets. Free literature. Carter Hatchery, Plains, Georgia 31780.

TYPING Pays! Unbelievable \$30.00 thousand addressing envelopes from lists. Typewriter, longhand, Immediate earnings. Instructions \$1.00. Florida Service, P.O. Box 1017CC, Hialeah, Fla. 33011.

HOMEWORKERS! \$85 weekly addressing, mailing circulars for firms. Everything furnished. Details, send stamped self addressed envelope. Enterprises, Box 16143-M, Phoenix, Arizona 85011.

\$500-\$800 MONTHLY. Raise small laboratory-breeding stock for us. We supply equipment, breeders, instructions. Illinois Research Farms, Dept. MP-1, McHenry, Illinois 60050.

START Home Mailorder Business. No Inventory. Purple Enterprises, Box 16291-A1, Jacksonville, Fla. 32216.

WATCH REPAIRING makes every day a payday. Learn at home. Free details. Watchmaking, YNA, Fox River Grove, Illinois 60021.

SIGN Painting! Profitable! Fascinating! Easy with letter patterns. Paulow, 1935 Stardust, Waukesha, Wis. 53186.

HOMEWORK. Mailing circulars. Free details! Cam Company, Dept. 155-KP, Verona, N.J. 07044.

"609 UNUSUAL, Profitable, Businesses!" Write, Risden, 6005 Rohns, Detroit, Mich. 48213-PM.

CHURCHES, Clubs, Organizations; are you faced with the problem of raising money? We can help you. Howard, Box 1647-PM, Sumter, South Carolina 29150.

NOW! You can make money writing short articles at home. Report reveals how. Send \$1.00 today! W. P. Flag, 25890 Five Mile, Detroit 48239.

\$18 EXTRA Daily supplying us names. Details 10¢. Thorton, 24PM, Logan, Ala. 35098.

WHEELER-DEALERS! Free. Little-known opportunities; foxy-smart angles. Stamped, self-addressed envelope. Wheeler-Dealer Association, (PM-32), 15 West 38th., New York 10018.

\$20,000 ANNUALLY You can make in Auto Sales. \$3.00, Mar-Lo Products, 8150 Roselawn, Dept. #5, Detroit, Michigan 48204.

SCIENTIFIC MASSAGE: BIG EARNINGS uncrowded profession. Learn spare time at home. Diploma awarded. Free catalog. Write: Anderson School, Dept. A-1-C, Princeton, Illinois 61356.

INSTALL BURGLAR ALARMS. Send \$5.00 for installation instructions. Dealership information and alarm equipment manufacturers addresses or write for free details. SANTIAGO, Box 215, Boulevard Station, Bronx, N.Y. 10459.

BECOME Notary Public! Free particulars. Stationers Exchange, 405-PM Richardt, Evansville, Indiana 47711.

SELL Advertising Pens. Samples \$1.00. Columbus, 717 East Pike, Seattle 98122.

EASIEST Mailorder Business! Profitable? You bet! Instructions \$1.00. Howland, S6971 Catalina, Hales Corners, Wis. 53130.

MAIL TRADE, oldest in field. Tells how to sell by mail. Extra sparetime income. Stories from experts, dropship, sources, opportunities. \$2.50 year, sample 50¢ None free. Mail Trade, Box 1302, Springfield, Ill. 62705.

\$50,000 PER YEAR *TAX FREE* Franchises are booming! New report—2 years research—tells how to put them to work for you. Money back guarantee! Send \$3.00. ADCO, Associates, 1741 S. Post Oak, Houston, Tex. 77027.

SPARE Time cash. Sell Famous Hanover Shoes. Actual samples and sales kit Free. No experience needed. No age limit. Lowest prices for high quality makes selling easy. Every man a prospect. Big daily commissions. For full details, write Hanover Shoe, 445 Carlisle, Hanover, Penna. 17331.

PROFITABLE OCCUPATIONS

BECOME A mortgage broker, earn \$10,000 to \$50,000 a year. Details free. United, Box 6284A, Marietta, Georgia 30060.

RAISE Rabbits for us on \$500 month plan. Free details. White's Rabbitry, Mt. Vernon, Ohio 43050.

YOUR Own Sign shop. Signs. 410-S So. Western, Springfield, Ohio 45506.

HOW To Make Money Writing Short Paragraphs. Information Free. Barrett, Dept. C-27-M2, 6216 N. Clark, Chicago 60626.

CHROME Plating. Instructions, equipment and supplies. Platers' Supply, P.O. Box 565, Lugo Station, Los Angeles, Calif. 90023.

BAKE New greaseless doughnuts in kitchen. Sell stores. Free recipes. Michael Ray, Waseca, Minn. 56093.

SHARPEN Scissors, Pinkers. Inexpensive equipment, tools, supplies. Blackhawk's, Sheldahl, Iowa 50243.

FT. SMITH Auction School, Ft. Smith, Ark. Residents & Home study. Veteran approved.

INVESTIGATE ACCIDENTS: Earn \$750 to \$1000 monthly. Car furnished. Expenses paid. No selling. No college education necessary. Pick own job location. Investigate full time or earn to \$8 hour spare time. Men urgently needed Write for FREE information. No obligation. Universal Schools, CPM-1 Hillcrest, Dallas, Texas 75205.

FREE Book "990 Successful, Little-Known Businesses." Work Home! Plymouth-37R, Brooklyn, New York 11218.

EARN \$240.00 A month at home, spare time, doing only two \$5.00 invisible mending jobs a day. Big money paid for service that makes cuts, tears disappear from fabrics. Steady demand. Details free. Fabricon, 1586 Howard, Chicago 60026.

MONEY! Importing! Report, \$1.00. Packwell Associates, 1015 Geary, San Francisco, California, 94109.

BIG Money raising fishworms and crickets. Free literature. Carter Wormery, Plains, Georgia 31780.

\$500-\$800 MONTHLY. Raise small laboratory-breeding stock for us. We supply equipment, breeders, instructions. Illinois Research Farms, Dept. MP-1A, McHenry, Illinois 60050.

"MORTGAGE BROKERAGE" Lucrative!! Huge Commissions! (Free particulars.) Chase, Uleta, Florida 33164.

SALESMEN—DISTRIBUTORS

FREE, 206 Easy Ways to make money taking orders for exciting new products—spare time. Send name, age for 5 months free subscription. Opportunity Magazine, 850 N. Dearborn, Dept. 17-AS, Chicago 60610.

FREE Selling outfit. Office supplies, furniture & equipment. Oseco, 15-PM North Jefferson, Chicago, Ill. 60606.

SELL Advertising book matches. Write us today, we put you in business by return mail; handling complete line ad book matches in demand by every business right in your town! No investment; everything furnished free! Top commissions daily. Superior Match, Dept. M-169, 7530 S. Greenwood, Chicago, Illinois 60619.

EARN Terrific commissions listing delinquent accounts. General Finance Company, 304-A Pickwick Building, Kansas City, Mo. 64106.

100% PROFIT—Sweet Georgia Brown Cosmetics sell fast. Write for Sample Case offer. Valmor, Dept. H, 2411 Prairie, Chicago 60616.

DO You wish to use or sell a plant food that is field proven, shows the greatest results at lowest cost? Something different in sales and use. Big monthly income or get your fertilizer FREE. Campbell's Gro-Green, Rochelle 274, Illinois.

SELL Hertel Bibles—Part Time. Finest reference Bible available. Demonstrator and supplies furnished. Excellent commissions. Write International Book, Dept. PM, Box 118, Wichita, Kansas 67201.

LONG Needed Invention. Man to contact service stations. Huge profits. Cyclo Manufacturing, 3816 Dahlia, Dept. 100, Denver, Colorado 80201.

PROFITABLE Sideline. Sell popular plastic advertising signs. Free kit. Banner House, 16121 Del Norte, Poway, California 92064.

EARN Big Commission Full or Part Time. Show America's largest line Low Priced Business Printing and Advertising Specialties Plus calendars in season. No experience. No investment. No collections or deliveries. On-the-spot commissions. Big Free Sales Kit samples hundred items used daily by businessmen. Merchandise bonuses for you. Build profitable repeat business. Start now. National Press, Dept. 91F, North Chicago, Ill. 60664.

\$732.51 PROFIT In two weeks. Michael P. made that much with new "Instant" Photo Album. Sells itself. Has self adhesive pages. Details, sample, Free. Keating, PM-19 Brighton, Pittsburgh, Pa. 15212.

MAKE Extra \$25 to \$75 spare time! Take orders for double air cushion Bronson Shoes. Amazing comfort. Terrific men's, women's line for dress, work, play. Highest commissions. Shoes for yourself. Big outfit Free. Write: Bronson, Dept. 160, Minneapolis, Minnesota 55408.

EXCITING New Product. Big profits! Exclusive! Test it yourself. Sample offer. Send no money. Just your name. Kristee, 158 Akron, Ohio 44308.

NEW Car Thief signal. Lightning seller. Samples for trial. NORTHWEST ELECTRIC, Ave. 509, Mitchell, S. Dak. 57301.

DISTRIBUTORS WANTED. Handle new Portable Air cleaner unit, Removes Dust, Pollen, Smoke, assorted fumes, oxides, acids and gasses. Every office, hotel, motel, restaurant, bar and home a Potential Customer. No Franchise Fee. Money back guarantee. Write—Aire Products Corp., P. O. Box 969, Nokomis, Fla. 33355.

30,000 CAR Dealers desperately need good salesmen! Thousands of jobs furnishing a NEW CAR over \$1,000 per month, many fringe benefits. Our exclusive home study course will train you! Free Catalog Automotive Sales Institute, Box 746, Dept. 1B Kenosha, Wisconsin 53140.

AGENTS WANTED

FREE, 206 Easy Ways to make money taking orders for exciting new products—spare time. Send name age, for 5 months free subscription. Opportunity Magazine, 850 Dearborn, Dept. 17-AA, Chicago 60610.

EVERY Man a prospect. Refundable sales kit offer showing line belt buckles, tie clasps, money clips, cuff links, lapels, identification badges, individualized with customer's name and emblems. Cap badges for trucking, bus, taxi, police, firemen, also postal, letter carriers and heavy construction emblems. Choice 3000 emblems. Hook-Fast, Box 1088PM, Providence, R.I. 02901.

PRINTING, Advertising Salesmen—Excellent moneymaking sideline selling Decalcomania Name Plates, small quantities. Advertising Specialties, sign letters. Free Samples. Raico XL, Boston, Mass. 02119.

YOUR Own business—Used suits \$1.50; overcoats 65¢; mackinaws 35¢; shoes 12½¢; ladies coats 30¢; dresses 15¢. Enormous profits. Catalog free. Nathan Portnoy Associates, 2109-AA Roosevelt Road, Chicago Ill. 60608.

LIFETIME Income. Business Loan Representative Write: Financial 28 E. Jackson, Suite 1204-X3, Chicago 60604.

WILL You test new items in your home? Surprisingly big pay. Latest convenience for home, car. Send no money. Just your name. Kristee, 130-A, Akron, Ohio 44308.

WANT TO MAKE UP TO \$100 A WEEK Spare time, and get free shoes for life, too? No investment. Rush card for free details. Mason Shoes, K-646, Chippewa Falls, Wisconsin 54729.

BE The Popular Mechanics representative in your neighborhood and earn big profits in your spare time. Write Popular Mechanics, Room 10A, 250 West 55th St., New York 19, N.Y.

EMPLOYMENT INFORMATION

AUSTRALIA Wants You! Government assisted passage. Unlimited Opportunities. Latest Government Information and Forms \$1.00 Austco, Box 3623-E, Long Beach, California 90803.

TREMENDOUS Opportunities U.S.A. overseas, choose jobs-locations, transportation. Free details. Occupations. International Airport, Box 100-C14, Jamaica, N.Y. 11430.

FOREIGN And USA job opportunities available now. Construction, all trades. Earnings to \$3,000.00 monthly. Paid overtime, travel, bonuses. Write: Universal Employment, Woodbridge, Conn. 06525.

JOBS On Ships, Wages To \$25,000.00. Four Month Vacations. No Experience Needed. Free Information. Commander, Box 1354-PM, Plainfield, New Jersey 07060.

HIGH Paying overseas jobs. Construction, other projects. Bonuses. Travel Expenses, Extras. International Information, 124, Cortez, Florida 33522.

AUSTRALIAN OPPORTUNITIES BI-WEEKLY Airmail lists selected current opportunities. Australian (a) employment, (b) business and property investment. (a) or (b) \$20 year, both \$25. Samples, together with "Americans in Australia", describing moving costs, taxation, what to take/leave behind/expect, only \$4. W. D. Craig, G.P.O. Box 1248-M, Hobart, Tasmania, Australia.

AUSTRALIA WANTS YOU! Good Pay, Adventure, Government Paid Transportation! Send \$1.00 for "Australian Opportunities Handbook." Satisfaction Guaranteed! International Services, Box 12-A1, Greenfield, Indiana 46140.

I MADE \$185,752.50 in twelve years working for American companies overseas! My story plus foreign employment tips—\$1.25 Airmail. Paul Smith, Casilla 11612-PM, Santiago 9, Chile.

FLORIDA: Statewide list of employment firms, addresses and phones. \$2.00, Airmail \$2.50. Charleeta, P.O.B. 155, Port Richey, Florida 33568.

BOOMING AUSTRALIA Needs you now!! Government paid transportation allowance. Unlimited opportunity, 1969 HANDBOOK \$1.00. Guaranteed. Associated, Box 17B1, Lafayette, California 94549.

CONSTRUCTION! California wage scales, all Trades, \$1.00 Box 1125, Gretna, Louisiana 70053.

HELP WANTED

OVERSEAS Jobs—Australia, Europe, South America, Far East, etc. Openings in all trades and Professions. \$400 to \$2,500 monthly. Free Information write National Employment Service (Foreign Division), Box 2235 P.M.F., Miami, Florida 33159.

OVERSEAS Jobs—Europe, South America, Australia, Far East, etc. 2000 openings all trades. Construction, Office, Engineering Sales, etc. \$400 to \$2,500 month. Expenses paid. Free Information. Write Overseas Jobs, International Airport, Box 536-M, Miami, Florida 33148.

REAL ESTATE—FARMS

CANADIAN Vacation lands: Full price \$385.00. 40 acres, \$10 month. Suitable cottage sites, hunting, fishing, investment. Free information. Land Corporation, 3768-C Bathurst, Downsview, Ontario, Canada.

\$1 ACRE—Canadian Border—hundreds campsites, islands, farmlands, directly from tax authorities. (Non-profit). Lists, photographs mailed. Register, Room 10, 110 Church Street, Toronto 1, Canada.

CENTRAL Ontario—Choice 640 acre Sportsmen's paradises still available—\$20.00 plus \$6.50 taxes yearly. Maps, pictures. \$2.00 (Refundable). Information Bureau, Norval 4, Ontario, Canada.

40 TIMBERED Acres \$1650.00 Total Price. Wash.—Idaho—Mont. \$50.00 Down—\$25.00 month, in Northern Idaho, North-eastern Washington, and Western Montana. In the heart of lakes and big game country. All covered with growing timber. Access, title insurance with each tract. This is select land with natural beauty, recreational and investment values. We have tracts of many types and sizes from which to choose, including Waterfront property on Pend Oreille, Priest, Kettle and the St. Joe Rivers and in Pend Oreille Lake area. Your inspection welcomed. Write us for free list, maps and complete information. Write to: Dept. PA, Reforestation, Inc., P.O. Box 8146, Spokane, Wash. 99203.

GOVERNMENT Lands One Cent An Acre. For exclusive report send \$1.00 to: National Lands, Box 241-E, Massapequa, N. Y. 11758.

GOVERNMENT LANDS . . . Low, as \$1.00 acre. Millions acres. For exclusive copyrighted report . . . plus "Land Opportunity Digest" listing lands available throughout U.S., send \$1.00. Satisfaction guaranteed. Land Disposal, Box 9091-PA, Washington, D.C. 20003.

FLORIDA CAMPSITES—Deep in the heart of the great Ocala National Forest—where few individuals have the privilege of owning land. Isolated yet accessible, with electricity. Good fishing, hunting. Warranty Deed. Pitch tent, park trailer, build lodge. Free maps and photos. Howard Vernor, DeLand, Florida, 32720. AD66LS149

FREE CATALOG! Big 196 page FALL-HOLIDAYS edition! Thousands of properties described, pictured—Land, Farms, Homes, Businesses—Recreation, Retirement. Selected Best thruout the U.S.! 68 Years' service, over 500 Offices, 39 states Coast to Coast. Mailed FREE from the World's Largest! STROUT REALTY, 60-RX E. 42nd St., N.Y., N.Y.; 7-RX S. Dearborn, Chicago, Ill.; 521-RX E. Green, Pasadena, Cal.

VACATION LANDS; CANADIAN Suitable camping, cottages, hunting, fishing, investment. Full Price \$285.00, 40 acres, \$10.00 a month. Free information, Land Sales Corp., 206-F Bloor West, Toronto 5, Canada.

FREE REAL ESTATE CATALOG: Land is the best investment on Earth; get details from our NEW SPRING issue. **SAFE-BUY REAL ESTATE,** P.O. Box 589-PM, Little Rock, Ark. 72203.

CANADIAN LANDS, seized and sold for taxes. Our 52nd annual series of lists, describe many choice properties, situated from coast to coast, acquired by us through Tax Sale. Priced as low as five dollars per acre, guaranteed perfect title, small monthly payments, no mortgage. Beautifully situated hunting and fishing camps, where there is real sport; summer cottage sites, heavily wooded acreages. Now is the time to invest in Canada's minerals, forests and farms. Write to-day for free booklet with full explanation. **TAX SALE SERVICE,** Room 301-D, 85 Bloor St., East, Toronto 5, Canada.

FREE REAL ESTATE CATALOG. Real Estate bargains know no season with us; everyday is bargain day. Write for your NEW SPRING copy of our famous catalog! **SAFE-BUY REAL ESTATE,** P.O. Box 589-PM, Little Rock, Ark. 72203.

BUY Without risk for Retirement, Vacation, or Investment—under America's only "No-Risk Purchase Plan"—in Carolina Coast multi-million dollar, 14,000-acre development, 10 year money-back guarantee. 1/2-acre homesites as low as \$645.00; \$7.00 down, \$7.10 month. Motel, hunting, fishing, golf, country club, right on property. Private ocean beach, 50 fresh water lakes. Write for free literature. (Not offered to residents of California, Florida, New York.) Boiling Spring Lakes, Southport 1-E, North Carolina 28461.

CANADA'S Finest lands. \$4.00 an acre and up. Acquired through estate liquidations. Suitable for hunting, fishing, camps, cottages, farming, timber, minerals, investment. Small monthly payments. Free descriptive booklet. **Canadian Estate Land,** Dept. 20, 194 Wilson Ave., Suite 101, Toronto, 12, Canada.

ARIZONA—Fine hunting area north of Lake Havasu City. Investment acreage—2 1/2 acres \$895. \$25 down, \$20 monthly. Mrs. Anne Young, 2233 N. 7th St., Phoenix 85006.

CANADIAN Fishing and hunting lands with substantial water frontage at low prices. Heavily wooded. Well situated. Great investment potential. Free booklet. **Northern Corporation,** Dept. 41, 194 Wilson Ave., Suite 101, Toronto 12, Canada.

FREE! Real Estate Catalog! Farms, Ranches, Business, Recreational and Investment Property. Please note state desired. **BANNER Adv.,** P.O. Box 3333 GS, 19A, Springfield, Mo. 65804. "Real Estate Our Specialty."

FREE . . . New Spring 1969 CATALOG! Describes and pictures hundreds of farms, ranches, town and country homes, businesses coast to coast! Specify type property and location preferred. Zip code, please. **UNITED FARM AGENCY,** 612-PM West 47th St., Kansas City, Mo. 64112.

SURPLUS GOVERNMENT LAND—Million Acres sold dirt cheap. Official Information \$1.00. Gov't. Land, Box 769PM, York, Penna. 17405.

FISHING Boat and Motor included with our beautiful wooded 1 acre Ranchette in Central Florida's lake section. No money down. \$20 a month. Will send plat and color photos. Write Gary Morse, Rainbow Acres, P.O. Box 369, Miami, Florida 33162. AD64LS126 (A-1A).

FARM AND GARDEN EQUIPMENT

EXTRA Income at home in Spare Time! Profit Booklet shows you how to start your own business with Classified Advertising. Only \$1.00. C. A. Martin, Popular Mechanics Dept. PM, 575 Lexington Ave., New York 10022.



FLOWERS, PLANTS and NURSERY SUPPLIES

600 ASSORTED Sweet Onion Plants with free planting guide, \$3.60 postpaid. **TONCO,** "Home of the Sweet Onion," Farmersville, Texas 75031.

RAYNER'S FREE 1969 Strawberry Book. Grow bigger, tastier berries for table, freezing market. Book describes 31 virus-free varieties including new *Raritan* and *Redchief*. Illustrates best for your area. Gives instructions for planting in simple terms. All plants certified, guaranteed. Lists blueberries, raspberries, grapes, fruit trees, etc. Write today for free copy. **Rayner Bros., Inc.,** Dept. 64, Salisbury, Md. 21801.



DRINKING WATER-PURIFIERS

MAILORDER Records help get Increased Business! Complete 32 Page Record Book shows your inquiries, orders, advertising, expense, etc. Only \$1.00. C. A. Martin, Popular Mechanics, Dept. PM, 575 Lexington Ave., New York 10022.

HOME CRAFTSMEN

CABINETMAKING MADE EASY and "How to Make Formica Counter Tops," two excellent guides let you build kitchen cabinets and counter tops like professionals. Extraordinary guides bring master craftsmen's shortcut methods. Satisfaction guaranteed. Write: **Japs, 126-P Seventh North, Hopkins, Minn. 55343.**

FREE Popular Mechanics 16 page illustrated catalog of publications, plans and projects. Booklet covers an extremely wide variety of do-it-yourself data on home remodeling, shop tools and machines, car repair, hobbies, crafts, boating, games, lawn and garden and hundreds of others. For your free copy write to Service Bureau, Dept. PE, Popular Mechanics, 575 Lexington Ave., New York, N.Y. 10022.

EXOTIC And domestic hardwoods catalog, 10¢. **Wood Product Specialties,** 30 Bartholomew Ave., Hartford, Conn. 06106 Dept. R-16.

FASCINATING Stained glass hobby Details free. **Whittemore Durgin,** Box 2065Y, Hanover, Mass. 02339.

PLANS For pool table with extra two-face top for table tennis and model railroad. Blueprints B1209 and building instructions \$3.50. **Popular Mechanics Service Bureau,** 575-M Lexington Ave., New York, N.Y. 10022.

WALNUT And Cherry tapered legs, lumber, gunstock blanks, picture frame moulding. **Midland Lumber Company,** Box 262, Savannah, Missouri 64485.

PLANS, Bird houses. Send 15¢ for brochure and free feeder plan. **Yeager,** 1665 Linden, Homewood, Ill. 60430.

WOOD For the Craftsman and Hobbyist. Catalog 25¢. **Creative Wood Products,** Box 388, Gladstone, Mich. 49837.

INDUSTRIAL—Homecraft, Supplies and equipment Reducing large inventory, catalog \$0.25. **McKillingan Supply,** Maine, N.Y. 13802.

101 PATTERNS Of smart Gifts, Novelties, Shelves, Action Windmills, plus "Make Money Jig Sawing". \$1.00. **Mastercraft, J5M, 7041 Olcott, Chicago 60631.**

FREE HEAT! The equivalent of one to three extra registers for your basement, without increasing your fuel bill! For details, send \$2.00 to P. O. Box 1785, Sta. A, Canton, Ohio 44705.

WOODWORKING Catalog and Manual 25¢. Plus free "101 Project Ideas." World's most beautiful veneers, lumber, plywood! Wood finishing, upholstery supplies, Cane Lamp parts. Furniture hardware. Animal whittling blocks. 2,000 workshop products. **Constantine, 2051-M, Eastchester Road, Bronx 10461.**

UPHOLSTERY

MAILORDER Records help get Increased Business! Complete 32 Page Record Book shows your inquiries, orders, advertising, expense, etc. Only \$1.00. C. A. Martin, Popular Mechanics, Dept. PM, 575 Lexington Ave., New York 10022.

DO-IT-YOURSELF

EXERCISE At home on build-it-yourself physical fitness equipment, including bicycle exerciser, rowing machine, belt massager, and abdominal board. Send \$2.50 for blueprints B1208 and instructions. **Popular Mechanics Service Bureau,** 575-K Lexington Ave., New York, N.Y. 10022.

WATER!! Drill your own well the easy, economical way with **Amazing New Invention.** Save 75%. Free information. **Deep-Rock Drilling Company, Opelika, Alabama 36801.**

TRANSISTOR Stereo, Color Organs, Kits, Workshop, Box 393PM Bethpage, New York 11714.

CONVERT Old REFRIGERATORS into FREEZERS inexpensively. Instructions, plans \$2.00. **Silin's Enterprises,** 62 Lorraine, Island Park New York 11558.

SECRET Plans revealed. Free Brochure. **Audiotronix, PM1, 156 Fifth Ave., New York, N.Y. 10010.**

REFRIGERATOR Door gaskets—ELECTRIC RANGE parts. Send make and model for cost. Box 5465, Hamden, Conn. 06518.

BURGLAR-FIRE Alarm supplies and information. Free Catalog. **Protecto Alarm Sales,** Box 357, Birch Run, Michigan 48415.

BUILD Your own Swimming Pool, complete plans \$5.00, (refundable) or catalog \$1.00. Pool, Dept PM169, Box 7, Cohasset, Mass 02025.

OPERATE Any size overhead door with unusual quietness and ease. Exclusive new cadmium plated nylon rollers with ball bearing center. Outwears any roller. 10 roller set \$19.95 ppd. Additional rollers \$1.90 each. Catalogue free with order. No C.O.D. Money back guarantee. **C&S Sales Corp.,** 2015 Utica Ave., Brooklyn, N.Y. 11234.

SAVE Your old Vacuum Cleaner with amazing new hose. Write Pat's, Box 2311, Los Angeles 90028.

FREE Popular Mechanics 16 page illustrated catalog of publications, plans and projects. Booklet covers an extremely wide variety of do-it-yourself data on home remodeling, shop tools and machines, car repair, hobbies, crafts, boating, games, lawn and garden and hundreds of others. For your free copy write to Service Bureau, Dept. PE, Popular Mechanics, 575 Lexington Ave., New York, N.Y. 10022.

REPAIR Manuals, automatic washers, dryers, dishwashers, 20 different manuals, \$2.75 each Ppd. Send make and model number. **Major Appliances,** 13106 Caine Ave., Cleveland, Ohio 44405.

ARTS AND CRAFTS

MAKE Figurines, plaques, lawn ornaments. Molds, plastercraft kits, liquid rubber. Sample and catalogue 10¢. **Wooley Company,** Box 29-B, Peoria, Illinois 61601.

FREE Catalog—over 10,000 handicraft items. **Supreme Handicrafts,** Box 395-PM, Sioux Falls, S. Dak. 57101.

STAINED Glass for beginners. **Whittemore,** Box L2065, Hanover, Mass. 02339.

CAST Plaques, Picture Frames, Novelties. **Monroe Molds, RR-3, Winchester, Indiana 47394.**

JEWELRYCRAFT for Fun or Profit! Catalog, 25¢. **Modern Craft,** 12790 US 19, Clearwater, Fla. 33516.

MAKE MONEY IN ARTS AND CRAFTS. No tools or talent needed. Start your own business, or hobby! Free information on new home study course. Lifetime Career Schools, Dept. E-293, 2251 Barry Avenue, Los Angeles, California 90064.

FREE! World's largest leathercraft catalog. Hundreds of Make-it Ideas. Tandy Leather Co., Dept. I-67, Fort Worth, Texas.

BINOCULARS, TELESCOPES, MICROSCOPES, MAGNIFIERS

MANON Binoculars. Buy direct from importer. Best quality and prices. Write: Manon, Dept. M, Box 1386, Huntington Beach, California 92647.

BINOCULARS Direct from manufacturer. Finest quality, tremendous savings! Request catalog. Koyu, 3860 Crenshaw Blvd., Los Angeles, Calif. 90008.

BINOCULAR Sale! Free color catalog 100 models \$9.95-\$250.00. Write, United, 9043 So. Western, BCAT-9208, Chicago 60620.

SCIENCE Bargains! Lenses, telescopes, binoculars, microscopes, kits, parts, war surplus. Send \$1.50 for beginner's 10-lens kit with instruction booklet. Order Stock 2-CH. Request free 148 page Catalog CH. Edmund Scientific Co., Barrington, New Jersey 08007.

WORLD Famous "DynaScope" Telescope. Build your own reflector telescope, mirrors, eyepieces, tripods, accessories. Request free brochures. Criterion Manufacturing, Dept. PP 27, Hartford, Connecticut. 06101.



CAMERAS AND EQUIPMENT

WORLD'S Largest Buying Guide—800 Illustrations—50¢—Deductible With Your Order—Olden Camera—1265 Broadway, New York, N.Y. 10001.

PHOTO SUPPLIES

EXTRA Income at home in Spare Time! Booklet shows you how to start your own business with Classified Advertising. Only \$1.00. C. A. Martin, Popular Mechanics Dept. PM, 575 Lexington Ave., New York 10022.

ATTENTION: WEEKEND PROFESSIONAL PHOTOGRAPHERS Photo-mounts, albums, mappers—all your home portrait, candid and wedding presentation needs from one source. **WHOLESALE PRICES. SHIPPED POSTPAID.** Catalog. 25¢. **CROWN PRODUCTS**, 2150 Superior, Cleveland, Ohio 44114.

PHOTO FINISHING

CAMERA Fans! Expert photofinishing and fresh Kodak film returned: 8MM Kodachrome \$3.45; 8 exp. Kodachrome \$3.40; 35MM Kodachrome, 20 slides, \$3.15; 8 exp. black & white 99¢. We give you free photo stamps to redeem for gifts. Satisfaction guaranteed. Send exposed film or request mappers and complete price list. Direct Mail Photo, Box 8352-PM, Pittsburgh, Pa. 15218.

SPECIAL WITH THIS AD—Kodacolor developed 12 prints \$2.25. Black & White developed 2 prints each Jumbo size—12 exposure 70¢. **LENS PHOTOS**, Dept. J-4, Janesville, Wis. 53545.

A **FREE** Kodak roll returned with each black and white or Kodacolor developed and printed, fast service, lowest prices, guaranteed quality send for free mappers. Economy Photo Service, Dept. P.M., Box 1111, Albany, N.Y. 12201.

PHOTOGRAPHY For Pleasure or Profit. Learn at home. Practical basic training. Long established school. Free booklet. American School of Photography, 835 Diversey Parkway, Dept. 674-021, Chicago, Illinois 60614.

SPECIAL: Black-white, 8-45¢; 12-55¢. Kodacolor, 8-\$1.89; 12-\$2.09. Astro Photo Service, Box 166M, Waterloo, New York 13165.

8X10 COLOR Enlargements 80¢ each—Special Trial offer from 120 color negatives, professionals only send business card with order. Professional, Box 1873, New Haven, Connecticut.

COLOR SLIDES

SPACE—Nature—Underwater slides. Catalog. Roberts, Box 608, Dana Point, California 92629.

MOTION PICTURES AND SOUND EQUIPMENT

UNUSUAL Movie supplies. Free circular. Esor, 47th Holly, Kansas City, Missouri 64112.

35MM. COLOR SLIDE SAMPLER . . . 20 "best" 2" x 2" . . . \$1.00. Free catalog. Hundreds of sets . . . travel, circus, wildlife, flowers, railroads, wars, etc. Order today. Blackhawk Films, 862 Eastin-Phelan Bldg., Davenport, Iowa 52808.

16MM sound-projectors, films, new, used for sale. Free catalog. National Cinema, 333 W. 57 Street, New York City, N.Y. 10019.

5,000 8-16MM MOVIE Films. Free catalogues. International, Greenvale, L.I., N.Y.

FREE! 64-page catalog. 8-16mm film, supplies, processing equipment. Superior, 448 N. Wells, Chicago 60610.

16mm. FILMS—Projector Parts. Gordon 28-53 Steinway Street, Astoria, Long Island, New York, 11103. . . .

175-FOOT 8MM. PREVUE MOVIE . . . ONLY \$1.99. See Laurel & Hardy, Chaplin, Fairbanks, Keystone Cops, Gish, Pickford, Chaney . . . comedy, drama, adventure, history from the silents! Taste the fun of great movies right at home! Order today . . . specify standard or Super 8. Free catalog. Blackhawk Films, 861 Eastin-Phelan Bldg., Davenport, Iowa 52808.

RADIO, TELEVISION AND HAM EQUIPMENT

33¢ RADIO & TV tubes. Free list. Cornell, 4213-17 University, San Diego, California 92105.

BRAND New tubes. World's lowest prices on radio, TV-industrial, special purpose tubes. Write for free parts catalog. United Radio, Newark, N.J.

CB—POLICE—FIRE—VHF— calls on broadcast radio! Brochure. TUNAVERTER, Woodsboro PM23, Texas 78393.

GOVERNMENT Surplus receivers, transmitters, sniperscopes, parts. Catalog. 25¢. Meshna, Nahant, Mass. 09108.

POLICE-FIRE DEPARTMENT RADIO STATION DIRECTORIES. Callsigns: All dispatcher frequencies. Nationwide. Catalogs for stamp. Communications, Box 56-PM, Commack, N.Y. 11725.

EXCITING Values In Fire And Police Portable Monitor Receivers, Converters, Accessories, Details, Free Antenna Offer: Griffin's, 322-M West State, Ithaca, N.Y. 14850.

MONITOR Fire and Police Emergency Calls with Miniverter II. Free Brochure. Scientific Associates Corporation, Department MX, Box 276, South Glastonbury, Connecticut 06073.

RCA COLOR T V—20% or more off retail. Catalog and prices sent on request. T V, Box 412, Muscatine, Iowa 52761.

HIFI, RECORDS AND ELECTRONICS

FREE Catalogues, 2000 hard to find unusual records. Rose's, 300 Chelsea, Louisville, Ky. 40207.

TAPE Recorders, hi-fi components. Sleep learning equipment, tapes. Unusual values. Free catalog. Dressner, 1523C Jericho Tpke., New Hyde Park, N.Y. 11040.

RECORDS! Discounts on all LP's. Free details. Citadel Record Club, Symphonette Sq., Dept. 2, Larchmont, N.Y. 10538.

HOME Electronics Course only \$26.95. Free literature. Edu-kits, Department 709 B, Hewlett, New York 11557.

FREE - FREE - FREE - FREE - FREE - FREE - FREE. Send in for your FREE one year subscription to Olson Electronics' fantastic value packed catalog - unheard of low, low prices on brand name speakers, changers, tubes, tools, stereo amplifiers, tuners, CB and other values. Credit plan available. If you have a friend interested in electronics, send his name and address for a FREE subscription also. Olson Electronics, 309 S. Forge St., Akron, Ohio 44308.

STEREO TAPE CLUB. Average cost \$3.78 (4 track), \$4.20 (8 track). Cartridges, cassettes, reels. No minimum purchases. Enclose 10¢ for catalog. STAR RECORDINGS-PM, Box 1055, El Paso, Texas 79946.

MUSIC AND MUSICAL INSTRUMENTS

PLAYER Piano Rebuilding—get details from: Vestal Press, Vestal 11, N.Y. 13850.

GUITAR, Banjo Making books Plans, woods, necks, tools. List 20¢. Satinwood, 510 East 11th Street, New York, N.Y. 10009.

ELECTRIFY Player pianos, pump organs quickly, inexpensively with Lee Silent Suction Units. Write Lee Music, Box 595F, Tujunga, California 91042.

POEMS Wanted for new songs and records by America's largest song studio. Send poems. Free examination. Five Star Music, 6M Beacon, Boston, Mass. 02108.

SWISS Musical Movements. Mechanical-Electrical. Spielman, 131 West 42nd, New York 10036.

ACCORDION Manufacturing. 6846-P North Avenue, Chicago, Illinois 60635. Concertinas, Hohners, Chromatics, Guitars, Drums, New, Used, Tuning, Repairing. Wholesale Catalogs Free.

POEMS, Songs wanted for new song hits and recordings by America's most popular studio. Tin Pan Alley, 1650-PM Broadway, New York 10019.

PLAYER PIANO ROLLS, books, electric pumps! Big catalog free! Golden Rule, Box 28-PM, Prospect Heights, Illinois 60070.

BANJO Kits parts list. Sweeney Parts, Box 5104, Long Beach, Cal. 90805.

WHOLESALE Guitar drums amps tapes catalog. Allied, 406 E 189, Bronx, N.Y. 10458.

ELECTRIC Guitars, amplifiers, wholesale. Catalog 25¢. Carvin, PMM, Valley Center, Calif. 92082.

LEARN Musical instrument of your choice—easy! New home study tape course. Write for free brochure. Carver School, 7 West 1st, Dept. D, Hinsdale, Illinois 60521.

GUITARS, MANDOLINS, BANJOS. Complete stock of Gibson Martin Fender guitars. Free 100 page catalogue, parts and accessories. Big Savings New York discount prices. Send 50¢ postage handling. Eddie Bell Guitar, 201 West 49, New York 10019.

ACCORDION Top brands. Buy direct. Tremendous discounts. Trade accepted. Free brochure PM. Accordion-O-Rama, 874 Broadway, N.Y.C. 10003.

DRUMS, Electric guitars, amps, organs. Free catalog M: A.L.A.S. Import Company, 31 East 18th Street, NYC. 10003.

30% DISCOUNT Any Name Brand musical instruments. Write for low price. Freeport Music, 127 W. Sunrise Highway Freeport, New Ycrk 11520.

ACCORDIONS, Guitars, Band Instruments! Save to 50%. Famous makes. Easiest terms. Trades accepted. Free home trial. Free discount catalog. Mention instrument. International Music Mart, 5535-R Belmont, Chicago, 60641.

EXCELSIOR Accordions and Amplifiers. Save 50%. Buy Direct. Factory Distributor. Terms. Trades. Free Catalog. Excelsior 3147 North Luna, Chicago. 60641.

GUITARS, Accessories—Guitar maker's books, materials, supplies. Free catalog. Guitar Center, Box 15444, Tulsa, Oklahoma 74115.

SONG Writers—Send Poems, Songs to: Weiss Music Company, 1472 Broadway, New York, New York 10036, or 147 West 42nd Street, New York, New York, 10036.

SONGS, Poems wanted! Accepted songs published, recorded at our expense! Talent, 17-PM, Longwood Road, Quincy, Mass. 02169.

PIANISTS, Modern intros, endings, \$1.00. Triad, Box 44, Bethel Park, Pa. 15102.

VIOLIN And guitar makers, send for latest Free catalogue of woods & accessories. International Violin, PM-2, 414 East Baltimore St., Baltimore 2, Md.

LEARN Guitar with Records! Write Dixie's, 326PM Bidney, Burlington, N. C. 27215.

SONGPOEMS Wanted! Write with active professional songwriters. Share royalties. Songwriters Contact, 1619-D Broadway, New York 10019.

DO-IT-YOURSELF Piano-organ CHORD Method, 2-12" L.P. records, \$3.98. Box 12283, Oklahoma City, Okla. 73112.

EDUCATION AND INSTRUCTION

EARN College degree at home. All subjects. Ohio Christian College, 1156 Striebel Road, Columbus, Ohio 43227.

FCC First Class License in six weeks—nation's highest success rate—approved for Veterans Training. Write Elkins Institute, 2603D Inwood Road, Dallas, Texas 75235.

LEARN Auctioneering. Term soon. Free catalog. Reisch Auction College, Box 850, Mason City, Iowa 50401.

SECOND Chance for high school drop-outs. Get diploma at home in spare time. Full credit for previous schooling. No classes. Given Free: Booklet on finishing high school at home, Government advice for drop-outs, aptitude test. Write: Academy for Home Study, 425 S. Dearborn, Dept. 85-910, Chicago, Illinois 60605.

LEARN Asleep or awake! Records, tapes, equipment! Free catalog! Drawer, PM-400, Ruidoso, New Mexico 88345.

EARN College Degree through experience. Send dollar for program. All subjects. Illinois Christian College, 537-PM South Dearborn, Chicago, Illinois 60605.

AUTOSUGGESTION, Sleep-learning headquarters! Tapes, records, books. Gigantic catalog free. Research Association, Box 24-PM, Olympia, Washington.

GET A British degree. Divinity, Philosophy, Radionics, 35 courses. Prospectus free. Brantridge Forest School, "Lodge" Brantridge Forest, Balcombe, Sussex, England.

EARN Your degree in electronics engineering. Highly effective home study courses in electronics engineering technology and electronics engineering mathematics. Free literature. Cook's Institute of Electronics Engineering, P. O. Box 36185, Houston, Texas 77036 (Established 1945).

DETECTIVE Training—for free information write to: 1917M, North Kenneth Ave., Chicago, Illinois 60639.

PIANO Tuning quickly learned with home study course. Diploma granted. American Tuning School, Gilroy, Calif. 95020.

PIANO Tuning pays. Big money in spare time. Learn at home. No musical knowledge necessary. Phonograph, records, tools and instructions furnished. Electronic tuning also taught. Free catalog. Capital Tuning School, 3160 S.W. 16th Court, Ft. Lauderdale, Fla.

DETECTIVE Course. Free information. Universal Detectives, Box 8180-F, Universal City, California 91608.

GAME WARDEN. Government Hunter, Forestry, Park and Wildlife Services announce job openings regularly. Prepare at home for outdoor work, good pay, security. Complete information Free! Write North American School of Conservation-AZW, Newport, California 92660.

BOOKKEEPERS. Operate your own "Dollar-A-Week" system. Ellis, Box 200, Cedar Grove, North Carolina.

PENMANSHIP Corrector. Improve poor penmanship quickly. Details free. Ozment, Box 665-34, St. Louis, Mo. 63188.

LEARN To Sing Beautifully! Free Particulars. Publisher, Box 118-P, Brooklyn 11203.

COMPUTER PROGRAMMING—The big opportunity career. New recognized correspondence course. No maths needed. FREE brochure. Canadian Institute of Science & Technology, 263M, Adelaide St. W., Toronto.

USED Courses! Books! List 10¢. Smith's, 124 Marborough, Salem, Mass. 01970.

AUCTIONEERING Free Catalog Resident or Home Study Course. Nashville Auction School, 2004 West End, Nashville, Tenn. 37203. Veteran approved.

PROFITABLE National Camera Repair School training at home! PM1, Englewood, Colorado.

OWN Collection agency. "Little Gold Mine!" Franklin Credit, Roanoke, Virginia 24004.

EARN \$125 A week and up. Learn a trade with a future. Learn auto diesel mechanics in our shops. You learn with tools on real equipment. Earn while you learn. Many of our graduates earn \$125 a week and up. Write for free bulletin: Dept. 256, Auto Diesel College, Nashville, Tennessee 37219.

SWEDISH Massage and physical culture pays big profits. Learn at home. Diploma. Free catalog. National Institute, Dept. E-19, 307 North Michigan, Chicago 60601.

BRICKLAYERS Latest literature opportunities lay-off plans. Retirement information. Send six-cents. Details. The Pretlo Services, P. O. Box 114, Durham, N. Car. 27702.

DETECTIVE Course. Free information. Criminology Institute, Box 201, Geronimo, Oklahoma 73534.

EXTRA Income at home in Spare Time! Booklet shows you how to start your own business with Classified Advertising. Only \$1.00. C. A. Martin, Popular Mechanics Dept. PM, 575 Lexington Ave., New York 10022.

HIGH School diploma at home. Licensed teachers. Send age, highest grade completed for free details. No salesman will call. Southern States Academy, Westbury Square Professional Bldg., Dept. 16, Houston, Texas 77035.

COMPLETE YOUR HIGH SCHOOL at home in spare time with 72-year-old school. Texts furnished. No classes. Diploma. Information brochure free. American School, Dept. X145, Drexel at 58th, Chicago, Illinois 60637.

TRAVEL Agents make \$\$\$\$. Exciting, Booming Careers! Easy Home-Study Plan. Free! "Travel Career Kit." Write—North American School of Travel-AZW, Newport, California 92660.

DRAFTING—Learn at Home! U.S. Government reports "42% more Draftsmen needed next 10 years." Send for Free "Drafting Career Kit." No Salesman Will Call. G.I. Bill Approved. North American School of Drafting-AZW, Newport, California 92660.

USED CORRESPONDENCE Courses and Books sold and rented. Money back guarantee. Catalog free. (Courses bought.) Lee Mountain, Pisgah, Alabama 35765.

GRAPHOANALYSIS—Learn scientific handwriting analysis for profit, pleasure. Free sample lesson, catalog, reveals plan. Write: Igas, Inc., 325 Jackson, Dept. 2-AR2, Chicago 60606.

LEARN Bartending home study course 300 East Armour, #517D, Kansas City, Missouri.

LEARN Landscaping and the growing of plants. Start a profitable business part or full time. Free information without obligation. Lifetime Career Schools, Dept. A-597, 11826 San Vicente Blvd., Los Angeles, Calif. 90049.

LEARN Civil and criminal investigation at home. Earn steady, good pay. State age. Institute Applied Science, 920 Sunnyside, Department 161, Chicago, Illinois 60640.

MISSOURI Auction School. GI Approved. Free Catalog! 424-03 Nichols Road, Kansas City, Mo. 64112.

MATHEMATICAL Topics for Businessman, Tradesmen Improve your ability. Lee's Service, 1224 Shakespeare Avenue, Bronx, N.Y. 10452.

"STAMMER—Stutter—no more." (Dr. Young.) Write: Gaucho, Box 9309-S7, Chicago 60690.

USED Courses, books, bought, sold. Catalog 10¢. Bayles, 78B Courtright, Wilkes-Barre, Pa. 18702.

PEACE, POWER & PLENTY is your heritage. Possess it now. Details free. Cothran, Box 277-PM, Aberdeen, North Carolina 28315.

COMPLETE Home training in lucrative Watch Repair. Free sample lesson. Chicago School, YN, Fox River Grove, Illinois 60021.

\$1,000,000 MEMORY. Yours overnight. Free details. Box 444MJ, Maywood, CA. 90270.

BE A Real Estate Broker. Big earnings. Prepare quickly, easily. GI approved. Free Catalog. Weaver School, 3519-P Broadway, Kansas City, Missouri 64111.

DIAMOND CUTTING TRAINING Inquire American School Diamond Cutting, Gardnerville, Nevada 89410.

ART Production. Study this profitable occupation at home. Drawing ability unnecessary. Free information. Box 122, New Canaan, Connecticut 06840.

PLAY ORGAN Easily. Amazing Method. Free Information. Kegley, Dept. PM-11, 1016 Kelly, Joliet, Illinois 60435.

FOR INVENTORS

PATENT Searches complete and thorough. Related copies Air Mailed with maximum speed \$6.00. Free "Protection Forms" and "Patent Information." Write American Patent Search Company, Dept. 27, 711 14th St., N.W. Washington, D.C. 20005.

PATENT Application Financing. Free patent search plan. Global Patent Division, 2420 77th, Oakland, Calif. 94605.

PATENT And invention development by licensed professional patent engineer and U.S. Patent Office former examiner, and engineering specialists. Your inventions and ideas engineered for patent protection and commercial value. Inventions developed by us negotiated for cash or royalties with our nationwide contacts. Send for free protection "Invention Certificates" and further interesting, valuable patent information. George Spector, Licensed Professional Patent Engineer, Woolworth Building, New York.

U.S. Patent Office Searches. 234 Broadway, Room 3615, New York. Free invention certificates.

IMMEDIATE Cash, for patent applications. Free patent searches. Write for details. Universal Patents. 184-D, Marlon, Ohio.

FORMING American Amateur Inventors Club. Charter membership free. William J. Lawson, Potet, Texas 78065.

INVENTORS—Do you want to sell or license your invention on cash or royalty basis? Write: Kessler Corporation, C-51-FI, Fremont, Ohio.

INVENTORS: Your ideas and inventions (patented; unpatented) expertly searched, royalty sales to manufacturers by professional Invention Developer with excellent record of experience. B.S., Industrial Engineering; United States Patent Office former Patent Examiner. United States Government former Patent Advisor. Second decade reliable service! Member: United States Chamber Commerce. Free "Invention Record" and "Recommended Protection Procedure." Airmailed! Write: Raymond Lee, Invention Developer, 230-P Park Ave., New York City 10017.

PATENT Drafting. Booklet "Inventions" Free. Pen-Ink, 50 East 42, New York 10017.

PATENT SEARCH SERVICE! For Lawyers, Companies, Inventors. "Confidential report" including copies of related United States patents rushed "Certified Airmail" Free! "Patent Search Information." Write: Congress Patent Search Company, 911-C Warner Building, Washington, D.C. 20004.

QUALITY Patent Searches! Preferred by Professional Inventors, Lawyers, Manufacturers. "Confidential Report" including related United States patent copies "Airmailed Certified." FREE Information! United States Inventors Service Company, 501-P Thirteenth Street, N.W. Washington, D.C. 20005.

PATENT Searches, including copies of related U.S. patents. Inventors attorneys, manufacturers use our "worldwide" airmail service! "Invention Record" form and "Information Every Inventor Needs," sent free! Hayward Company, 1029P Vermont, Washington 5, D.C.

INVENTIONS WANTED

INVENTIONS Wanted. Patented: unpatented. Tremendous manufacturers lists. Global Marketing Service, 2420G 77th, Oakland, California 94605.

INVENTORS! Outright cash sale or royalties for your inventions. Patented. Unpatented. Active demand from our client manufacturers. Financial assistance available. Write Dept. 36, United States Invention Brokerage, 78 Wall Street, New York, N.Y. 10005.

INVENTORS! Don't sell your invention, patented or unpatented, until you receive our offer. Eagle Development Company, Dept. H, 79 Wall Street, New York 5, N.Y.

INVENTORS! Sell your invention for cash or royalties! Our client manufacturers eagerly seek new items. Patented. Unpatented. Financial assistance if needed. 25 Years proven performance. For free information, write Dept. 15, Gilbert Adams, Invention Broker, 80 Wall St., New York, N.Y. 10005.

INVENTORS! We will develop, sell your idea or invention patented or unpatented. Our national manufacturer-clients are urgently seeking new items for highest outright cash sale or royalties. Financial assistance available. 10 years proven performance. For free information write Dept. 47, Wall Street Invention Brokerage, 79 Wall Street, New York, N.Y. 10005.

WE Either sell your invention or pay cash bonus. Write for details. Universal Inventions. 298-E. Marlon, Ohio.

IF Your invention is adaptable to promoting we will contract for selling on cash or royalty. Free booklet outlines royalty rates, requirements. Kessler Corporation, C-51-IW, Fremont, Ohio.

FREE "Directory of 500 Corporations Seeking new Products". For information regarding development, sale, licensing of your patented/unpatented invention. Write: Raymond Lee Organization, 230-N Park Avenue, New York City 10017.

INVENTORS! Protect your ideas! Free "Recommended Procedure." Washington Inventors Service, 422F, Washington Building, District of Columbia 5.

INVENTORS TOYS, GAMES AND PUZZLES Toy and Game Division of prominent Leisure-Time Products manufacturer seeks submission of your new product ideas. Write for our "Product Submission Folder." P. O. Box 25309, Los Angeles, California 90025.

PATENTS FOR SALE

EXTRA Income at home in Spare Time! Booklet shows you how to start your own business with Classified Advertising. Only \$1.00. C. A. Martin, Popular Mechanics Dept. PM, 575 Lexington Ave., New York 10022.

MANUFACTURING

MODELS — small lot manufacturing. Metals, plastics, etc. Milburn, Burlington, Kentucky 41005.

INVENTORS Ideas developed. Research. Models. Manufacturing. Sales. Free brochure. William Parker, 32 Westminster, Worcester, Mass. 01605.

BUY IT WHOLESALE

500,000 BARGAINS BELOW WHOLESALE. New, name brand merchandise. Buy at 10¢ on the dollar. Closeouts, surplus, bankrupts, liquidations, imports. Free details. International Buyers, Box 4633-M, Colorado Springs, Colo. 80909.

BARGAINS! Buy wholesale and below. Name brands. Appliances, furniture, sports equipment, televisions, cameras, watches, jewelry, thousands more. Huge discounts to \$1,000.00 on new automobiles. All makes. Free details. Write today: Worldwide Bargainhunters, Box 730-A, Holland, Michigan 49423.

ELECTRIC Guitars, amplifiers, wholesale. Catalog 25¢. Carvin PMW, Valley Center, Calif. 92082.

20 WHOLESALE Catalogs!! List \$1.00. Zashop, 216 PM 1 West Jackson, Chicago 60606.

DRAFTING EQUIPMENT, Templates, Slide Rules. Catalog 30¢. AMTECH, INC., Box 122, Mt. Holly, N.J. 08060.

WHOLESALE PRICES: jewelry, sports equipment, appliances, typewriters, cameras etc. . . . details FREE . . . International Bargainfinders, Box 1693, Kansas City, Missouri 64141.

EXPORT-IMPORT

JAPAN: 1200 Products Directory. Illustrated. Manufacturers' names, addresses: \$3.00. Mail-Order Catalog. Novelties, \$1.00. Send Cash. Yamagata Office, 814 Togin Bldg., Marunouchi, Tokyo.

FOR THE HOME

MAILORDER Records help get Increased Profit Business! Complete 32 Page Record Book shows your inquiries, orders, advertising, expense, etc. Only \$1.00. C. A. Martin, Popular Mechanics, Dept. PM, 575 Lexington Ave, New York 10022.

FOR PARENTS

EXTRA Income at home in Spare Time! Profit Booklet shows you how to start your own business with Classified Advertising. Only \$1.00. C. A. Martin, Popular Mechanics, Dept. PM, 575 Lexington Ave., New York 10022.

OF INTEREST TO WOMEN

WOMEN! Make big money at home. \$10.00 profit in an hour possible with invisible mending. Make holes, tears disappear from clothing, fabrics. Steady year-round demand from cleaners, laundries, homes. Details free. Fabricon, 1533 Howard, Chicago 60626.

TYPING Pays! Unbelievable \$30.00 thousand addressing envelopes from lists. Typewriter, longhand. Immediate earnings. Instructions \$1.00. Florida Service, P.O. Box 1017C, Hialeah, Fla. 33011.

RAISE Rabbits for us on \$500 month plan. Free details. White's Rabbitry, Mt. Vernon, Ohio 43050.

DRIVE New car, wear new clothes, buy color TV. Get daily cash income. Put spare hours to work. Write for 5 months free subscription Opportunity Magazine; see hundreds easy ways to make money. Opportunity, Dept. 17-AO, 850 N. Dearborn, Chicago 60610.

HOW To make money writing short paragraphs. Information free. Barrett, Dept. C-27-M3, 6216 N. Clark, Chicago 60626.

\$500 MONTHLY Possible—Clipping news at home. No experience needed. Free information. Send stamp. American, Box 11056, Kansas City, Kansas 66111.

HOME Typing. Earn up to \$100 weekly. Instructions, employers' list, \$1.00. Satisfaction or refund. Summhouse, Box 377-PM, Corte Madera, California 94925.

HAVE Profitable Sparetime Hobby Lacing and Assembling our beautiful products! Cuties, Warsaw 9, Indiana 46580.

HOMEWORKERS \$2.00. Hour Possible Sewing Babywear Aprons. KutieKay, Box 9194-PM, Ft. Worth, Texas 76107.

\$15-\$30 PER day home addressing long-hand typewriter. Information, send stamped self addressed envelope, Box 2815-P, Abilene, Texas, 76604.

DOLLS MAKE BIG MONEY! Start your own hobby-business dressing, making, repairing and selling dolls. Send for FREE booklet describing the excellent opportunities open to you. Doll Hospital School, Dept. D-551, 2251 Barry Avenue, Los Angeles, California 90064.

HOME-TYPING: \$75 week possible! Full or part time. Ten money-making plans. Mail \$1. Typist, P.O. Box 549, Fresno, Calif.

NEWSPAPER Clippings Urgently Needed. Highest prices paid. Send stamped, addressed envelope, free details. Brewster, Box 1348-NCWL, Clearwater, Florida 33517.

\$500—\$800 MONTHLY. Raise small laboratory-breeding stock for us. We supply equipment, breeders, instructions. Illinois Research Farms, Dept. MP-1C, McHenry, Illinois 60050.

AUSTRALIA WANTS YOU! Government assisted passage. Unlimited opportunities. Latest Government Information and forms, \$1.00. Guaranteed, Associated, Box 17B1B, Lafayette, California 94549.

\$400.00 MONTHLY POSSIBLE Home Typing! Guaranteed Profitable Methods, Instructions, \$1.00. Pulse, Box 11211-PA, Indianapolis, Indiana 46201.

EARN Up to \$2.40 hourly. Assemble our Products. Supplies Furnished. United, Box 55392D, Indianapolis, Indiana 46205.

WANTED! Addressers — Commission Mailers. Stamp required. Ooton Distributors, 122-P Duke Drive, Portsmouth, Virginia 23703.

HOMEWORKERS! Make money mailing postcards. Particulars 10¢. Westley, Western Springs, Illinois 60558.

GIFT SHOPPING

FREE Gift Catalog, Selective and Distinctive. True Values, PM-4, Box 903, Salt Lake City, Utah 84110.

FREE COLOR CATALOG. over 200 distinctive items, free bonus gifts, satisfaction guaranteed. C. E. Enterprises, 1305-B. Redondo, Killeen, Texas 76541.

FREE Catalog. Useful, unusual gifts. All occasions. D. W. Bahr, PM-169, 5860 Lilac Lane, Hales Corners, Wisconsin 53130.

FREE Catalog black forest novelty clocks. Prentzas, 406 Crestland, Greensboro, N.C. 27401.

WATCHES, OLD GOLD, JEWELRY

WATCH And clock repairing books. Free catalog. North American, Box 77-AA, Fox River Grove, Illinois 60021.

USED Wrist, pocket watches—\$3.00 up. Free list. Southern Watches, 5-PM South Wabash, Chicago 60603.

CASH Immediately for old gold, jewelry, gold teeth, watches, diamonds, silverware, spectacles, platinum, mercury. Free information. Rose Industries, 29-A East Madison, Chicago 60602.

WANTED—Gold, silver, platinum (any form), mercury. Information free. Wilmot's, 1067 Bridge St., Grand Rapids, Mich. 49504.

HIGHEST CASH for Gold, Jewelry, Gold Teeth, Rings, Diamonds, Watches, Silver, Platinum. Mail Articles Today. Free gift with information. Chicago Gold & Precious Metals, 6 E. Monroe, Dept. 1258, Chicago 60603.

WATCHMAKERS'—Jewelers' catalog. surprise. \$1.00. Watchmaking Course, Tools \$35.00. Bengal's, 17942 Ventura, Encino, California 91316.

WANTED—Gold, Silver, Mercury, etc. Aaron, 2634 North 40th Street, Milwaukee, Wisconsin 53210.

WEARING APPAREL

MAILORDER Records help get Increased Business! Complete 32 Page Record Book shows your inquiries orders, advertising, expense, etc. Only \$1.00. C.A. Martin, Popular Mechanics, Dept. PM, 575 Lexington Ave., New York 10022.

MEN—Buy your Outerwear Coats and Jackets WHOLESALE directly from manufacturer. Write now for free illustrated booklet showing styles for Fall 1968. Sharob Corp. Carbondale, Penna. 18407.

HEARING AIDS

HEARING AIDS—Batteries Wholesale! Brochures—Hearing Center, Box 211, St. Petersburg, Florida.

HEARING Aids, Batteries, wholesale. Catalog 25¢. Fiston, Box 1444 New Preston, Conn. 06777.



SCIENCE AND CHEMISTRY

CHEMICALS. Apparatus, Microscopes, Mineralogy Sets, Telescopes. Catalog 35¢. Sheard Science Supplies, Inc. Columbus, Wisconsin 53925.

CHEMICALS And apparatus for industrial, analytical, and private laboratories. Catalog 50¢. Dept. M-50, Biological Supply Co., 1176 Mt. Hope Ave., Rochester, N.Y. 14620.

ROCKETS!! Real flying models—2500 feet altitude with powerful motors. Terrific Science Projects. Tubes—Cones—Parachutes—Launchers—Igniters. Gigantic catalog—rocket data—diagrams—25¢. Fast Delivery. Centuri Rockets, Box 1988, Phoenix, Arizona 55001.

UNDERWATER Fuse 3/32". Diameter. 25 Feet \$1.00—125 feet \$4.00. Postpaid. Free Catalog. Zeller, Box 646, Hudson, Mich. 49247.

ROCKETS: Real flying models—flights up to 2500 ft. New illustrated catalog 25¢. Single and multistage kit, cones, engines, launchers, trackers, rocket aerial cameras, technical information. Fast service. Estes Industries, Penrose 7, Colorado 81240.

SEARCHING For economically priced Laboratory Supplies? Gifts with catalogue—25¢. Hagenow Laboratories; Manitowoc, Wisconsin 54220.

FREE Gift and discount lists with Laboratory Supplies. Catalogue—35¢. Deluxe Scientific, Manitowoc, Wisconsin 54220.

SEARCHING For economically priced chemicals and apparatus? Gifts with catalogue, 25¢. Starr Scientific, Manitowoc, Wisconsin 54220.

ILLUSTRATED Catalog: Chemistry, mineralogy, biology 25¢. Tracey Laboratories, Evanston, Illinois 60204.

ROCKETS. Single, multi-stage kits, parts amazing Accelerometer. Illustrated catalogue 25¢. Rocket Supply, Box 51B, Tappan, New York 10983.

FREE Periodic classification of elements and conversion tables with catalog 35¢. Chemicals, apparatus, biology. Mid-States Scientific, 7053 N. Clark, Chicago, Ill. 60626.

PYROTECHNICAL Chemicals, casings, tools, supplies, literature. **LOWEST** prices, **FASTEST** service anywhere!! Catalogue with samples, instructions, formulas—50¢. Pyrocenter, Box 9591, Arlington, Virginia 22209.

20 TEAR Gas formulas! (Catalog too!) \$1.00. PMJ, B-723, Metuchen, New Jersey 08840.

GROW Large crystals! Instruction book—\$2.00. (Teachers: quantity discounts for you and your students! Please inquire.) PMJ, B-723, Metuchen, New Jersey 08840.

100 ONE Minute time delay fuses! \$1.00 240—\$2.00. 700—\$5.00. PMJ, B-723, Metuchen, New Jersey 08840.

CATALOG Of Ver-ry Interesting Products—25¢. (Free with any purchase—see our other PMJ ads! B-723, Metuchen, New Jersey 08840.

LABORATORY chemicals supplies 1969 catalogs has over 400 listings many scientific publications catalogs \$.25 Casaco, Dept. M P.O. Box 77 Riverdale, New Jersey 07457.

SOLAR Flying Saucers. (Brand New—Solid State Engine—Fantastic Performance—Flies for Miles on Sun's Power—lifts animals—send messages—parachutes—Build Easily for next to nothing with Everyday Materials—Many sizes—many designs) Complete plans, descriptions, drawings. \$1. Spacetronics, Box 31043-D, San Francisco, Calif. 94131.

FLYING Saucer Detector—automatically alerts you when UFO is near. Gives general direction. Send 10¢ for information. Sin/Dec Company, 6202H Vine St., Elmwood Place, Ohio 45216.

FANTASTIC Superscience products of the 21st Century, available now! **CHEMISTRY, ELECTRONICS, BIONICS,** etc. Amazing catalog and gift—50¢ R. J. Graham, 171 East Bank, Fond du Lac, Wisconsin 54935.

PROFESSIONAL Model rocket ignition fuse, burns underwater, 75 feet, \$1.00. Edcolabs, Box 99, Berlin, New Jersey 08009.

POWERFUL Converging Stellar Radiations Cause Gravitation \$1.00 Refundable. Carnahan, 2007 Eaton, Austin, Texas 78723.

PYROTECHNIC Chemicals, casings, supplies. List 10¢. Pyrochem, Box 169, Berlin, New Jersey 08009.

1200 VOLT shock module \$5.95. Fun, pranks, property protection. Uses flashlight batteries. Effective. Non-lethal. Catalog 20¢. Franks Scientific Co., P.O. Box 156, Martelle, Iowa 52305.

PYROTECHNIC Instruction manual. Reveals formulas, preparations, uses. Only \$2.00. Free with order. \$1.95 bonus Kit. Edco, Box 99, Berlin, New Jersey 08009.

FREE 4' Balloon with \$1.00 Booklet. "Hydrogen Balloons." Hydroflight, Box 3914, Centredale, R.I. 02911.

LASER PISTOL, \$1.00. How to Build. PHASER PISTOL, \$1.00. You have seen it on TV, now Build Your Own—Safe, Loads of Fun. Add 25¢ postage. Complete catalogue of PRIZE-WINNING Science Projects. 35¢. Roy Davis Laboratories, Dept. PM, 118 West Adams St., Jacksonville, Florida 32202.

WANTED. Salesmen to sell giant 3' sparklers, excellent profits, for information send 25¢ to: Sparkle Plenty, Box 85, Bergenfield, New Jersey 07621.

PYROTECHNIC Casings. Low, low prices. Underwater fuse 70 feet \$1.00. Professional green fuse 50 feet \$1.00. Weingart's book, "Pyrotechnics" \$8.50. Catalog 25¢, with samples 50¢. Bilton Box 399, Hasbrouck Heights, N.J. 07604.

PYROTECHNIC Casings, stars, devices of all types. Send 50¢ for samples. Ecco, Box 189, Northvale, New Jersey 07647.

FORMULAS, PLANS, ETC.

FOR Proof of what you can do in specialty manufacturing get our literature. It's free! Miller, Chemist, 1517-P, Tampa, Florida 33601.

ANY Formula \$3.00. Catalog—Treatise 10¢. Belfort, 192 N. Clark, Chicago 60601.

10,000 SECRET Formulas, 882 Pages, \$5.95 Post Paid. Formulas, 420 Holden Ave., Lockport, Ill. 60441.

HORSE TRAILER Plans \$7.50 completely detailed—P.M. Plans, Box 9227, So. Denver, Colo.

PLASTICS

PLASTIC Embedders, jewelry workers. We have everything. Findings, moulds. New catalog 25¢. David Co., 861 Broad St., Dept. M, Providence, R.I. 02907.

TREASURE FINDERS

FIND Buried treasure with new revolutionary analytical metal detector. Features push button tuning, automatic tuning, loudspeaker, negligible ground pickup, greatest range. Free catalog. Gardiner Electronics, Dept. 9, 4729 N. 7th Ave., Phoenix, Ariz. 85013.

URECON Metal finder. 8" head, transistorized. \$37.50 delivered. Urpa, 6304 Beechwood, Sarasota, Fla. 33581.

TREASURE Hunters! Prospectors! Relco's new instruments detect buried gold, silver, coins, minerals, historical relics. Transistorized. Weighs 3 pounds. \$19.95 up. Free catalog. Relco-A40, Box 10839, Houston, Texas 77018.

NEW Sensitive Treasure Metal Detectors. New low prices. Professional models from \$29.95 to \$129.50. Write for free catalog today. Jetco Electronics, Box 132-PM, Huntsville, Texas 77340.

LOCATE—Underground streams Water, Tile Lines, Sewer Pipes Etc. Make Locator 5 minutes, Few cents Hardware. Full Instructions \$1.00. FAR, Box 141, Watertown, Wisconsin 53094.

"METAL Locators—Accessories. Write: Detectors, Inc., Box 101-D, Springfield, Va. 22150."

FISHER "METALERT" award-winning Model 70. Brand new treasure and metal detector for exciting results! Unsurpassed sensitivity. Use anywhere, even beaches and streams. For Free literature write: Fisher Research, Dept. PM1, Palo Alto, California 94303.

POWERFUL Metrotech locators detect gold, silver, coins, relics. Moneyback guarantee. terms. Free information. Underground Explorations, Dept. A, Box 793, Menlo Park, California 94025.

FREE 128 Page detector catalog. General Electronic Detection Co., Box 67. Bellflower, California 90706.

TREASURE, Gold, silver, relics. New 1969 detector now available. Free information. Rayscope, Box 715, North Hollywood, California 91603.

TREASURETRON High-Sensitivity metal detectors. EDI 611M Park Drive. Bradenton, Florida 33505.

GOLDAK Treasure Locators—New for '69! A hobby you'll enjoy for fun and profit. Find coins, gold, silver. Goldak, Dept. PMC, 1101A Airway, Glendale, California 91201.

TREASURE BOOKLET. Excellent information on treasure hunting and metal detectors. Send 25¢. BOOKLET, Dept. 1-PM, Box 243, San Gabriel, California 91778.

PRECIOUS STONES AND MINERALS

EARTH Science Rockhound Magazine. Subscription \$2.50. Sample 35¢. Box-550-PM, Downers Grove, Ill. 60515.

100 COLORFUL, Polished gemstones, \$1.00. Tumblecraft, 5401 James North, Minneapolis, Minnesota 55431.

GET Free catalog no serious rockhound, gem cutter, jewelry maker, hobbyist or craftsman can be without. Full of bargains, exclusive items, low prices from largest suppliers and authorities in the field. Free new catalog just off the press, yours for the asking. Write Grieger's, Dept. C-12, 1633 E. Walnut, Pasadena, California 91106.

SEMI-Precious uncut gems. Ten different for \$1.00. Request list 30. Prospectors Shop, 201 San Francisco, Santa Fe, New Mexico 87501.

WORLDWIDE Crystal specimens, Gems. Free lists. Sering, 1705 E. Michigan, Indianapolis, Indiana.

500 POLISHED GEMSTONES \$1.50. Cabochons, slabs. Floodstones P.O. 1673 Fremont, California 94538.

GOLD! 10 Small Nuggets Panned from Oregon Streams, \$1.00. Robert Brandt, Sweet Home, Oregon 97386.

CARTOONING, COMMERCIAL ART, SHOWCARD & SIGN PAINTING, TATTOOING

SIGN Painting, Fascinating System—Straley, 410 So. Western, Springfield, Ohio 45506.

COMPACT 23 lesson Cartoon Course and Cartoonist's Magazine, \$2.00. Hartman, Box 30367, Lincoln, Nebraska 68510.

"HOW TO MAKE MONEY WITH SIMPLE CARTOONS"—Everyone who likes to draw should have this book: FREE. Write Cartoonists' Exchange, 91 Pleasant Hill, Ohio 45359.

LEARN Sign painting at home. Free talent test. Ben Kerns, Box 812-PM, Greenville, S.C. 29601.

SIGN PAINTING COURSE Best ever offered. Earn big. FREE Information. Tetton, 1924 Salisbury, St. Louis, Mo. 63107.

LIKE To draw? Splendid opportunities in professional cartooning. Write for free catalogue. National School of Cartooning, Studio-H, Box 8958, Cleveland 44136, Ohio.

COMPACT 23 lesson Cartoon Course and Cartoonist's Magazine, \$2.00. Hartman, Box 30367, Lincoln, Nebraska 68510.

ADVERTISING AGENCIES, ADV. SERVICE, MAILING LISTS

MAILING Lists most all kinds 1000 \$5.00. Free folder. Your circulars mailed \$4.00 1000. Dixie Mailers, King, N.C. 27021.

ADVERTISING Ratebook leading newspapers, magazines, 25¢. Chicago Advertising Agency, 28-E Jackson, Chicago 60604.

TYPEWRITERS, DUPLICATORS, OFFICE EQUIPMENT

FREE Plan. Start printing, lettershop. Offset Presses, Mimeograph Copy machines. DixieGraph, King, N. Car. 27021.

RUBBER STAMPS AND OFFICE SUPPLIES

ADDRESS Stamp \$1.50 Signature \$2.80 Catalog. Carol's, McLoyd, Okla. 74851.

FREE 40 Page catalog. Rubber stamps, office supplies. Youngers Stamp Shop, Princeton, Iowa 52768.

POCKET Rubber Stamp, Your Name, Address. 89¢. B. Ormiston, Stockport, Ohio 43787.

RUBBER Stamps 4 Lines \$1.25. Catalog. Bilmar, 10024 Oxborough Road, Minneapolis, Minnesota 55431.

PRINTING, MULTIGRAPHING, MIMEOGRAPHING, GUMMED LABELS

OFFSET PRINTING—8 HOUR SERVICE 25 to 5,000 copies. Free booklet "Secrets of Cutting Printing Cost." National Printing, Atlanta, Illinois 61723.

AMAZING Business printing values. Quotations. Print Shop, Box 576, Greenville R.I. 02828.

1,000 GUMMED Address labels \$1.00. Walt's, Box 966A, South Bend, Indiana 46624.

FREE Literature: Address Labels, Business Cards, Printing, Rubber Stamps. Jordan's, 552 West O'Connor, Lima, Ohio 45801.

BOOKLET Specialist on Hi Speed Web. Free Price List 20M 16pg 8½x11 2 color booklets at 2¢ each. Copen Press, 337p Butler St., Brooklyn, N.Y. 11217.

REPEAT Business—Pressure Sensitive Labels Stick Anywhere. Samples, Ad-Label, 1747 Selby, Saint Paul, Minnesota 55104.

250 8½x11 HAMMERMILL Letterheads \$2.95. 250 Envelopes \$2.95. Davis, 7609 Spruce, Baltimore, Maryland 21222.

BIRTH, Marriage Certificates, wills, diplomas. 3 blank forms \$1.00. Free Samples. Form Distributors, Box 893 League City, Texas 77573.

DELUXE Business Cards Samples. Scott Company, 603 Sixth Lincoln, Illinois 62656.

"FREE" Circular. Labels, Personalized Items, Stationery. Longwood, D-4719, Fort Johnson, New York 12070.

1000 BUSINESS Cards, "Raised Lettering" \$4.50 Postpaid!!! Samples... Noble PM1, 505 Briggs, Baltimore, New York 11710.

500 QUALITY Gummed Labels, 4 lines printing. 50¢. Postpaid. Prompt, Pomseal, Box 505, Elgin, Ill. 60120.

1,000 ZIP CODED GUMMED address labels \$1.00. L&M Discount, 507 Fifth Ave., New York, N.Y. 10017. SPECIAL 3,000 \$2.00.

PRINTING & RUBBER STAMP OUTFITS—SUPPLIES

TYPE Catalog No. 11, 96 Pages. Send One Dollar. Deductible First Order. Acme Type, 732 Federal, Chicago, Illinois 60605.

SAME Day shipment on rubber stamp supplies. Revised wholesale price list No. 5 free. Star Stamp Supply, 732 Federal, Chicago, Ill. 60605.

DO Your own printing. Save money. Simple rules. We supply everything. Print for others; good profit. Raised printing like engraving too. Have home shop. Details free. Kelsey Presses, V-11, Meriden, Connecticut 06450.

PRINTING Presses, type, supplies, Lists. 5¢. Turnbaugh Service, Mechanicsburg, Pennsylvania 17055.

RUBBER Stamp outfits, supplies. Kiewiet, 2025 Barney Road, Kalamazoo, Mich. 49007.

LOW Priced Rubber Stamp manufacturing supplies, starting outfits. Martin, 1425 Major, Jefferson City, Mo. 65101.

REMAILING SERVICE

RECEIVING-Forwarding, \$3 Monthly. Hedgpeh, 406-M South Second, Alhambra, Calif. 91802.

SO. AMERICA Registered re-airmails \$1.00. Confidential. Genaro, Box 360, Guayaquil, Ecuador.

CONVENTION City Remails 25¢. Colorful Postcards. Schoen, Box 1963-P, Chicago, Illinois 60690.

ENTERSULL. Your secret address. Prompt. Reliable. Box 1881-M, Forsyth, Ga. 31029.

LAS VEGAS Remails 25¢. \$3.00 monthly. Confidential, free details. Bmec, Box 1186, Las Vegas, Nevada 89101.

SECRET Receiving and remailing. Discreet and confidential. Remail 25¢ single. 8050 S. Main, Houston, Texas 77025.

BURBANK Home of television. 25¢, six for dollar. Belwood, Box 4494, Glendale, California 91202.

NEW ORLEANS, BATON ROUGE Remails 25¢. \$3.00 monthly. Mac, Box 51474, New Orleans, La. 70150.

ALASKA Re-airmails, Singles 50¢ monthly \$5.00. KARMS, Box 2463-A, Kodiak, Alaska 99615.

REMAIL From New England, Singles 25¢, 6 for \$1.00. Faulkner, P. O. Box 1327, Hartford, Connecticut 06101.

"BEAUTIFUL Downtown Burbank" 25¢. (\$3.00 monthly. Free N.B.C. Studios color postcard included.) Nugget, 10532-PA, Lanark, Sun Valley, Calif. 91352.

CALIFORNIA Remails 25¢ \$3.00 monthly. Cardinal, Box 655, Carlsbad, California 92008.

FT. LAUDERDALE, Fla. Remail 25¢. Monthly Rates \$3.00. A. Cunningham, P.O. Box 319, Ft. Lauderdale, Fla. 33302.

MIAMI Remails 25¢. Monthly rates. Marle, Box 1266, Coral Gables, Fla. 33134.

KANSAS CITY Remails 25¢. Receiving—Forwarding. Midway 3115-F South 45th. Kansas City, Kansas 66106.

FORT LAUDERDALE Remails, 25¢, monthly \$3.00. Strictly confidential. Dixie, 2275 S.W. 31 Street, Apt. 4, Fort Lauderdale, Florida 33312.

SOUTH African Airmails. One dollar. Box 39, Maydon Wharf, Durban.

AIRPLANE Capitol Remails 25¢. \$3.00 Monthly. P.O. Box 302, Wichita, Kansas 67102.

HOUSTON Remails, 25¢. Singles. Secret! Confidential! Reliable! Box 5202-x, Houston, Texas 77012.

RECEIVING, Forwarding \$3 Monthly. Bob White, 2298 Claiborne, Clearwater, Florida 33516.

REMAILING—Receiving 25¢. \$3.00 Monthly. Confidential, Box 90036 Milwaukee, Wis. 53202.

PHOENIX, Receiving, forwarding, remailing. Confidential. Troen, Box 2386, Phoenix, Arizona 85002.

REMAILS, Single 25¢; Monthly \$3.00. Aaron, 2634 North 40th Street, Milwaukee, Wisconsin 53210.

JUL FRICK, 1126 BUSH, SAN FRANCISCO, CALIFORNIA 94109. REMAILS, 25¢.

REPAIRS AND SERVICING

EXTRA Income at home in Spare Time! Booklet shows you how to start your own business with Classified Advertising. Only \$1.00. C. A. Martin, Popular Mechanics Dept. PM, 575 Lexington Ave., New York 10022.

SPECIAL SERVICES

INFORMATION On anything. Ferguson Research Specialists, 83-45 Vietor Ave., Elmhurst, N.Y. 11373.

COMPLETE Weather, climatic information. Any area. \$2.00. Weather, Box 6537, Asheville, N.C. 28806.

PAYING INCOME TAX ON PENSION? Retirement Income Credit can save \$228, send one dollar for details, Route 3, Box 30, Ellensburg, Wa. 98926.

TOBACCO

LARGE Samples Smoking — Chewing 10¢. Jolley Farms, Dresden, Tenn. 38225.

RAZORS

MAILORDER Records help get Increased Business Complete 32 Page Record Book shows your inquiries orders, advertising, expense, etc. Only \$1.00. C. A. Martin, Popular Mechanics, Dept. PM, 575 Lexington Ave., New York 10022.

WANTED—MISCELLANEOUS

MERCURY, Gold, Silver, Platinum; Ores assayed. Wholesale Terminal, Norwood, Mass. 02062.

PERSONAL

SUBCONSCIOUS Conditioning remakes personality while you sleep. Free details. Sleep-Learning, Box 24N, Olympia, Washington 9851.

WIN MONEY EVERY MONTH working contests and puzzles. Free details. . . . NO MINORS. International Contest Club, Box 10153, Dept. PM-6, Kansas City, Missouri 64111.

RUPTURED. Relief and comfort. No understraps, elastic or steel. Write Hand-Lock Products, Preston 4, Ont., Canada.

RAISE Money, consolidate bills. Free amazing details. Write Interstate, 28 E. Jackson, Suite 1204-PM, Chicago 4.

'BUG' Detectors, Surveillance TV, Conference Recorders, Telephone Accessories, Intrusion Alarms. Free Details: Security Electronics-PM, 13 East 43rd Street, New York City 10017.

BORROW \$100 to \$1,500 by Mail. Quick Easy, Private, No Co-Signers. Repay in 36 small monthly payments. For the amount you want write today to Dial Finance Co., 410 Kilpatrick Bldg., Dept. A-214, Omaha, Nebraska, 68102.

PAY Bills! Have cash left over. \$39.39 repays \$1000 in 36 months. Write for details. World Finance Company, Dept. TW-010B, 620 Symes Bldg., Denver, Colorado 80202.

DEBTS Wiped Out By Little-Known Law. Free details—Used by thousands. Counselor-7, Harlingen, Texas.

BORROW \$1,205 Airmail! Repay \$47 for 36 months. State licensed. Postal Finance, Dept. 17-A, 200 Keeline Building, Omaha, Nebraska 68102.

PENMANSHIP Improver: Improve quickly! Complete information free. Tevis, Chillicothe, Mo. 64601.

TATTOO Removing Do-It-Yourself Kit \$14.00. Information Free: Atlanta Co., 907 Beachpoint, Fairport Beach, Ontario.

NOW Scientific Poker Playing Rules can make you a Winner. Money Back Guarantee. Complete rules \$2. Mid-West Sales Co., P.O. Box 1025, Temple, Texas 76501.

WASTE NOT your time in small thought. "Thinking Big", 256 page book reveals secrets of higher income, security, power and prestige. Only \$2.00. WB-123. Amber & Co., 5911 Fair Oaks Blvd., Carmichael, Ca. 95608.

BIBLE Questions answered. Stamped envelope. Bylon, 17167 Bentler, Detroit, Michigan 48219.

INVESTIGATORS. Latest Electronic Aids. Free Literature. Clifton, 11500-P NW 7th Ave. Miami Florida 33168.

PENFRIENDS. Singapore, Worldwide, Copy, send 4IRC. Mafe International, P.O. Box, 78, Singapore-14.

"MAKE FRIENDS" send your description and a stamp for bulletin "INTRODUCTIONS" P.O. Box 2471, Detroit, Mich. 48231.

"WILLS". Prepare own. Four standard forms; instructions, \$1.00. Willforms, Box 8585-A, Kansas City, Missouri 64114.

HIGHER INCOME! Gain Financial Security. Learn the Secrets that make men Rich. Fascinating book, a "MUST" for any one who wants to get ahead. Send \$2.00. W. H. Wear Company, 4436 Fla. Short Rt., Birmingham, Alabama 35243.

STOP SMOKING within 10 days or money back. No pills, no medication. Send \$1.00 for each kit. Wentworth's, Dept. 41, Box 2711, Paterson, N. J. 07521.

HIGHER INCOME, Security and Power. 256 page Book "Thinking Big" reveals secrets that make men Rich! Send \$2.00. ARNOLD'S ACRES, Dept. PM-1, 1101 N. Waukegan Rd., Lake Bluff, Ill. 60044.

FANCY ORNAMENTAL POULTRY

MAILORDER Records help get Increased Business! Complete 32 Page Record Book shows your inquiries, orders, advertising, expense, etc. Only \$1.00. C. A. Martin, Popular Mechanics, Dept. PM, 575 Lexington Ave., New York 10022.

MISCELLANEOUS

ORNAMENTAL Iron designs. Book of 1600 beautiful, practical designs for railings, columns, etc. Free literature. Cunningham, 3881 South 3200 West, Salt Lake City, Utah 84119.

SILENCERS For pistols and rifles. Complete details for construction and operation. \$1.00. Gunsmith, Box 185, Fairfield, Alabama 35064.

YOUR Name sent to 1000 importers, publishers, mailers, wholesalers, etc. on our mailing list. Year \$1.00, Dixie Mailers, King, N. Car. 27021.

HEARING Aid batteries wholesale. Free list. Habs, Box 51, York, Penna. 17405.

WINEMAKERS—Free catalog and recipes. Kraus, Box 451-L, Nevada, Missouri 64772.

QUART Oregon Hops with 101 recipes—Homebrewing, Winemaking, Hoppreads, Catalogue, \$1. Nichols Hops, 1190 North, Albany, Oregon 97321.

BIRTH Certificates, Marriage Certificates, Diplomas! 2 blank forms \$1.00. Sample 10¢. Standard Forms, Box 482-M, Washington, D.C. 20044.

KILL Mosquitoes, Insects, electrically. Free information. US Insect Control, Box P374, Royal Oak, Michigan 48068.

CIGARETTES 12¢ a pack. Improved roller makes 20 filtertip, plain, king or regular for 12¢. Facts Free. Moberly, Box 954, Owensboro, Kentucky 42301.

WINEMAKERS. Free illustrated catalog of yeasts, equipment. Semplex, Box 7208, Minneapolis, Minn. 55412.

AMAZING Books, jewelry-sweaters-watches. Lynn's, Box 1573 Waco, Texas 76703.

AMAZING ROOT KILLER. Keep your sewer flowing freely, chemically. Will not harm plumbing or cesspool. Successful since 1940. Box of 6 Postpaid, Send \$3.95 to M Q Co., Dept. 10, Hugo, Minn. 55038.

BOOKS On antiques and their prices Free circular! P. Warman Publishers, Uniontown, Penna. 15401.

MAGNETS. All types. Specials—20 disc magnets, or 2 stick magnets, or 10 small bar magnets, or 8 assorted Magnets, \$1.00. Maryland Magnet Company, 5412-A Gist, Baltimore, Maryland 21215.

OLD Fashion Homebrewing recipe send \$1.00. "Formulas", Camargo, Ill. 61919.

WANT Greatest Cash Crop working for you? Write, Ginseng, Asheville 53, N.C.

BREWS, Wines, Peach Brandy—Strongest Formulas, \$3.00. (complete brew supplies, hydrometers catalogue included)—Research Enterprises, 29-SN35 Samoset, Woburn, Mass. 01801.

GAMBLING Book learn the systems and odds on all phases of gambling. Be a winner instead of a loser. Send \$3.25 Artcraft, 128 Holt, Ontario, Calif.

MINATURE REPRODUCTIONS of your SOCIAL SECURITY NUMBER to carry on your KEY CHAIN for handy reference. GLEAMING gold letters and numbers on jet black anodized aluminum plastic coated for long life, \$1.00 each. SATISFACTION guaranteed or your money back. ALLOW 3 weeks for delivery. Diane Lane of Camarillo, 1919 East Granger, Drawer 744, Camarillo, California 93010.

RECEIVE Magazines, Samples, Catalogues, Agency, Homework offers—Get listed—35¢. Roricke Mailer, Pleasant Plains, Ohio 45162.

SELL Books by mail! No inventory. Receive "315 Free Magazines" sample and details. Rush \$2.00 (Refundable). Kirkman, 1 Ann Street, Woodbridge, Virginia 22191.

GOVERNMENT LANDS . . . Low as \$1.00 Acre! Millions Acres throughout U.S. Details 10¢. Land Digest, Box 11071-PA, Indianapolis, Indiana 46201.

WINEMAKING . . . Grape, Elderberry, Dandelion, Frozen Juices, etc. Brewmasters' secrets revealed! Powerful Methods! Instructions, Recipes, and Supplies Catalog, \$1.00. Continental, Box 11071-PA, Indianapolis, Indiana 46201.

FREE BREW-MEASURING HYDROMETER!! Make Gallons, Powerful Beer for Pennies! Complete Instructions, Prohibition Recipe! Plus: Free Hydrometer (\$5.00 value!) . . . WINEMAKING—Stilling Methods, Catalog! All—\$1.00. Williams, 2121 Conger, Olympia, Washington 98501.

MEN! Free Catalog, "unusual" novelties. Trix, Box 2012-M1, Miami Beach, Florida 33140.

THE LOCK of the future today! The first important difference in locks in 4,000 years. Swedish designed Punchlock, the first padlock to offer a lifetime guarantee and absolutely Theft-proof. Dealer inquiries invited. \$9.75. COBRA Imports, Santa Barbara, Cal. 93105.

IDENTIFICATION Letters—Iron on Color Fast. 432 Letters—three colors—two styles \$1.00. Lakeview Industries Inc., P. O. Box 3609, Milwaukee, Wisc. 53217.

HOW To Cash in on the Silver Bonanza! Thousands to be made! Details \$1.00. American Silver, Box 3976-H, Long Beach, California 90803.

FREE FACTS
mail coupon

on how to become a
GAME WARDEN
Fish-Wildlife Manager
Forester, Gov't Hunter
or Aid or Assistant Type
Positions that require
Less Formal Education



• PROTECT
FORESTS &
WILDLIFE
• ARREST
VIOLATORS

Don't be chained to office desk, store counter or factory machine. Easy home-study plan prepares you now for outdoor man's dream job in Forestry & Wildlife Conservation. Get the facts: Live the life you love. Mail coupon today!

OPPORTUNITIES FOR YOU IN YOUR STATE?
We show you how to seek out job openings in your own state and other states Coast-to-Coast. Age limits 17 to 45, sometimes older on private game farms and hunt clubs. We are not connected with the Government.

DIPLOMA AUTHORIZED
Authorized by Calif. Dept. of Education to grant diplomas. Accredited Member Nat'l Home Study Council.

FREE! 3 GUIDES!
Each jam-packed with exciting Conservation Career Facts! Rush coupon today!

THRILLS AND ADVENTURE
Many Forestry & Wildlife men hunt mountain lions — parachute from planes to help marooned animals or save life of injured campers — protect forests — arrest game violators. Adventure, public service, good pay. Rush coupon today!

SECURITY-RETIREMENT
LOW LIVING COSTS—GOOD PAY
Most conservation careers are permanent. No layoffs. No worry about your paycheck. Living costs are low, too — and a pension may assure you a good income for life when you retire.

HEALTHFUL OUTDOOR LIFE Hard muscles, bronzed skin and vibrant good health are extra rewards of outdoor living. Sleep under pines. Catch breakfast from icy streams. Feel and look like a million!



VACATION JOBS FOR STUDENTS
No experience or preparation needed for vacation jobs in Parks, Forests, Vacation Resorts. Many accepting Applications now. Rush coupon today!

G. I. BILL APPROVED

ALL 3 FREE MAIL COUPON

North American School of Conservation, Dept. 4171
4500 Campus Dr., University Plaza, Newport, Calif. 92660
Rush 20-page Fact Book on exciting Conservation Career, "JOBS FOR SPORTSMEN—How & Where to get Them" & 3-mo. subscription to Conservation Magazine — ALL FREE! No salesman will call.

NAME _____ AGE _____
STREET _____
TOWN _____ STATE _____ ZIP _____

FIX CLOCKS, WATCHES—

FOR FUN & PROFIT! Fascinating new Handbook by master craftsman H. G. Harris gives you the kind of knowledge skilled watchmakers learn. **OVER 200 ILLUSTRATIONS** show how to install hands, dials, crystals, mainsprings, stems rehouse old movements in modern cases . . . speedily cure many troubles by demagnetizing or cleaning, etc. **INSTRUCTIONS COVER** every popular watch and clock, chimes, grandfathers, cuckoo, everyday alarm and electric clocks. Handbook tells you where to buy parts . . . where to send "overflow" work for repairs at wholesale prices as business expands!
FRIENDS GLADLY PAY \$5 to \$50 for restoring cherished timepieces. Try the **HANDBOOK OF WATCH AND CLOCK REPAIRS** seven days! Rush only \$4.95 on money-back guarantee to:
EMERSON BOOKS, INC.
Dept. 956-E, 251 West 19 Street, New York, N. Y. 10011

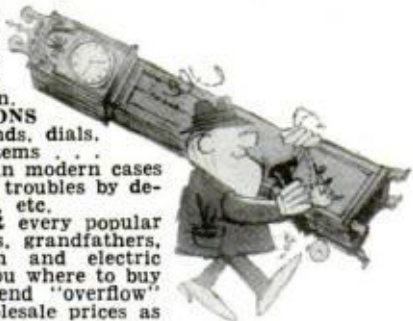

NEWS BRIEFS



Deep-sea demitasse

These Styrofoam cups were once the same size. The one at left, though, was taken 8310 feet underwater in the Lockheed *Deep Quest's* free-flooding outer hull, where pressure is 3700 pounds per square inch.

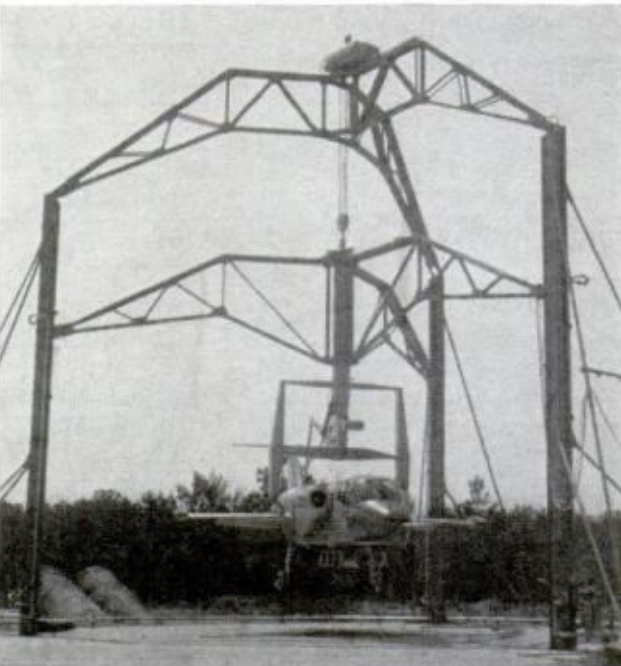

Tethered Hummingbird

Before it actually took to the air, the Air Force's XV-4B Hummingbird II was given captive flight tests in an "inverted telescope." The Hummingbird is a VTOL craft.

10 Reasons why RCA Home Training is

your best investment for a rewarding career in electronics:

Transistor experiments
on programmed breadboard—
using oscilloscope.



1 LEADER IN ELECTRONICS TRAINING

RCA stands for dependability, integrity and pioneering scientific advances. For over a half century, RCA Institutes, Inc., has been a leader in technical training.

2 RCA AUTOTEXT TEACHES ELECTRONICS FASTER, EASIER

Beginner or refresher — AUTOTEXT, RCA Institutes' own method of Home Training will help you learn electronics faster, easier, almost automatically.

3 THOUSANDS OF WELL PAID JOBS ARE OPEN NOW

RCA Institutes can help you qualify for a rewarding career if you have an interest in electronics. Every year, thousands of well paid electronics jobs go unfilled just because not enough men take the opportunity to train themselves for these openings.

4 WIDE CHOICE OF CAREER PROGRAMS

Select from a wide choice of courses and career programs ranging from basic Electronics Fundamentals to advanced training including Computer Programming and Electronics Drafting. Each

Career Program begins with the amazing AUTOTEXT method.

5 SPECIALIZED ADVANCED TRAINING

For those working in electronics or with previous training, RCA Institutes offers advanced courses. Start on a higher level. No wasted time on material you already know.

6 PERSONAL SUPERVISION THROUGHOUT

All during your program of home study, your training is supervised by RCA Institutes experts who become personally involved in your efforts and help you over any "rough spots" that may develop.

7 VARIETY OF KITS, YOURS TO KEEP

At no extra cost, a variety of valuable specially engineered kits come with your program—yours to keep and use on the job.

8 TRANSISTORIZED TV KIT AND VALUABLE OSCILLOSCOPE

You will receive in most career programs a valuable oscilloscope. Those enrolled in the TV Program or courses receive the all-new Transistorized TV Receiver—exclusive with RCA. Both are at no extra cost.

9 TWO CONVENIENT PAYMENT PLANS

Pay for lessons as you order them. No contract obligating you to continue the course. Or, you can take advantage of RCA's convenient monthly payment plan.

10 RCA GRADUATES GET TOP RECOGNITION

Thousands of graduates of RCA Institutes are now working for leaders in the electronics field; many others have their own profitable businesses... proof of the high quality of RCA Institutes training.

RCA INSTITUTES, INC. Dept. PMQ-19
320 West 31st St., N.Y., N.Y. 10001

Canadians: These same RCA courses are available to you in Canada. No postage. No customs. No delay. Your inquiry will be referred to our school in Canada.

All courses and programs approved for veterans under new G.I. Bill.

CLASSROOM TRAINING ALSO AVAILABLE. FREE CATALOG ON REQUEST.

ACCREDITED MEMBER National Home Study Council

Construction of Oscilloscope.

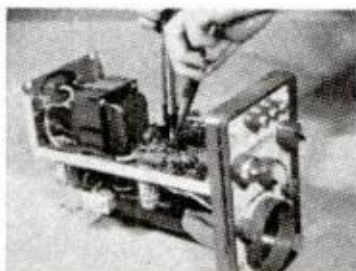

Construction of Multimeter.

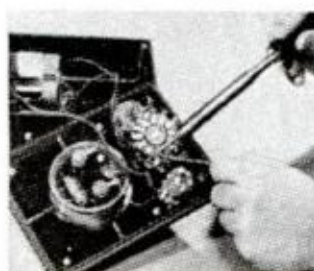

RCA

If Reply Card Is Detached—Send This Coupon Today

RCA INSTITUTES, INC.

Home Study Dept. PMQ-19
320 West 31st Street
New York, N.Y. 10001

Name _____

Address _____

City _____

State _____

Zip _____

Check here if interested in Classroom Training

SOLUTIONS FOR MECHANICAL HEADACHES

AUTOMOBILE CLINIC

BY MORT SCHULTZ

Foul play

Even after tune-ups, my six-cylinder 1966 Mustang quickly fouls sparkplugs. Other Mustang owners I've spoken to seem to be having the same trouble. Have you heard about this?—Dennis Hunt, Warren, Ohio.

Yes, and there seem to be two primary reasons behind it. The trouble could be faulty valve-guide seals or it could be with valves that flap around inside the valve guides. In the first case, a set of new valve-guide seals will solve the problem. But in the second situation, the cylinder head will have to come off and the valve guides trued up. In that case, I would switch to a valve that is no more than .003 in. oversize in order to firm things up.

Small torque

A few weeks after having motor work done on my 1966 (Canadian) Studebaker, I noticed that my engine was covered with oil. Though I cleaned it off, it reappeared after several more miles of driving. What has the mechanic done wrong?—Edward Lee, Lexington, Ky.

I can take a guess. This car takes a neoprene-covered cork gasket for the rocker arm, and this gasket takes less torquing than plain cork gaskets. It is likely that the mechanic simply over-torqued the rocker-arm screws, which resulted in distortion of the gasket. I'd have a new gasket installed and, if it happens to be neoprene, remind the mechanic that the correct torque is 40 to 55 in./lbs.

Getting the rap

Despite new hydraulic valve lifters, a reground crankshaft, and new main and rod bearings, I still get a loud rap for three to four seconds when starting my 1963 Chevy. There seems to be an oil-pressure delay. Could it be due to the oil filter filling with oil and is this something to worry about?—Norman G. Ziesse, Pittsburgh.

No, the oil filter has nothing to do with it. Yes, it's something to worry about. That rapping you hear indicates that your

bearings are operating without oil. If they continue to do so, they'll soon be ruined. Apparently you have an oil leakdown problem. More than likely, you'll find that the trouble's in the oil pump, which could have a bad check valve that isn't holding properly and is allowing oil to drain out of the lines. As an alternate possibility, there could be an internal leak.

Speedometer seminar

Auto Clinic has been receiving an increasing number of letters that describe speedometer troubles. To try to answer all in one clip, here's a diagnosis chart. As you road-test your car, watch and listen for the following defects, then tackle the probable causes, taking the easiest one first. For example, tighten a cable nut to see if that helps before replacing a cable.

Defect	Probable Cause
Slight needle flutter (no noise)	<ul style="list-style-type: none"> Loose cable nut Defective drive and driven gear
Severe needle flutter (no noise)	<ul style="list-style-type: none"> Loose cable nut Bent cable core Kinked or pinched cable housing Excessive grease in the speedometer head
Speedometer not working	<ul style="list-style-type: none"> Broken cable core Defective drive and driven gear Defective speedometer head
Clicking or ticking noise	<ul style="list-style-type: none"> Loose cable nut Defective drive and driven gear
Grinding noise	<ul style="list-style-type: none"> No lube on cable core Defective drive and driven gear
Ringing noise	<ul style="list-style-type: none"> Defective speedometer head

Two-timer

I have a 1968 Ford with 302 V8 engine. In only 6000 miles I've had to have the ignition timing set three different times. On each occasion, the mechanic said it was way off and he didn't know why. What's wrong? Why doesn't the timing
(Please turn to page 74)

Now! Do car repairs this quick, easy way

You can "breeze through" engine jobs, tune-ups, front end jobs, brake repairs, steering adjustments, carburetor adjustments, alternator servicing — almost ANY car service or repair job **ON THE VERY FIRST TRY!**



1 FIND THE TROUBLE!
MOTOR'S AUTO REPAIR MANUAL features Trouble-Shooter Section and detailed trouble-shooting info thruout, to help you spot 4,200 car troubles and find the repair needed. No guesswork!



2 FIX THE TROUBLE!
Step-by-step instructions, photos, diagrams show you where to start, what tools to use. Factory experts practically guide your hands through every move. You can't go wrong!

1,196-PAGE ILLUSTRATED GUIDE SHOWS YOU

How to Fix Almost Any Part of Any Car

YES! MOTOR's giant new **AUTO REPAIR MANUAL** is the answer to practically all your car repair problems. Almost every car repair on popular-make cars built since 1962 is explained and illustrated in fool-proof detail. You will develop new speed and confidence on any repair job you tackle.

Try it FREE for 10 Days

Words can't possibly describe the vast contents . . . the thousands of photos and diagrams . . . the easy-as-pie instructions . . . the wonderful feeling when you know you've got that car running like new again!

You've got to see it, use it for yourself! That's why we offer to send it to you, at our risk, for **FREE** ten-day trial. Try it. See how it makes even the toughest jobs seem like child's play. If you're not 100% satisfied, just send it back and you won't owe a penny!

are guided by the men who actually build the cars, for this book "boils down" the time-cutting and work-saving methods from 300 official factory shop manuals.

This **NEW, REVISED EDITION** gives you just about everything you need to know to service or repair engines, transmissions, brakes, ignition systems, automatic level controls, exhaust emission controls, speed controls, air conditioning, concealed headlamps, steering, alternators, etc., etc.—practically every part of the car makes listed below.

1,196 double-size pages include 3,200 drawings and photographs, 365 Quick-Check charts, 55,000 essential specifications — more than 225,000 service and repair facts! It includes all the new 1968 models.

No wonder you'll see copies of MOTOR's Manual on almost every garage workbench in the country. No wonder it's used by schools, factories, the U.S. Army & Navy. Over 5,000,000 copies sold.

MOTOR'S AUTO REPAIR MANUAL

Nearly **1 FOOT HIGH**
3,200 Illustrations
Over 1,196 Pages

5,000,000 COPIES SOLD
PRAISED BY BEGINNER AND EXPERT MECHANICS ALIKE . . .



"I am a racing 'bug' and expect the most out of my cars. Your Manual has been of excellent help to me."—Duane Davis, Indiana (Racing Advisor)

"I always rely on my Motor Books. They're well illustrated—and complete and simple."—Mr. Erv Jones, Minnesota (Garage Owner)

"Motor's Auto Repair Manual is invaluable to me. I depend on it for all makes and models."—Mr. W. W. Farlines, Virginia (Mechanic)

Same Offer on MOTOR'S AUTO ENGINES & ELECTRICAL SYSTEMS
1,300 pics. how-to text on principles, design, upkeep of engine & electrical systems. Check box in coupon.

Almost Everything You Need to Know to Fix Cars Like a Crack Mechanic
The instructions and pictures are so complete, so clear, you just can't go wrong. Your hands

SEND NO MONEY
Just mail the coupon. Use the Manual for 10 whole days **FREE**. If it doesn't pay for itself in time and money saved within 10 days, return it and owe nothing. But act now! **MOTOR BOOK DEPT., 250 W. 55th Street, New York, New York 10019.** (Schools Bookstores: Write for Discounts.)

- FIX ALL THESE CARS**
- | | | |
|-------------|-----------|-------------|
| Volkswagen | Dart | Tempst |
| Mustang | Mercury | Oldsmobile |
| Barracuda | Ford | Corvette |
| Jean | Chevle | Ford Bronco |
| Chevy II | Chevrolet | Buick |
| Pontiac | Comet | Cougar |
| Thunderbird | Corva | Teronado |
| Scout | American | Riviera |
| Buick | Olds F-85 | Firebird |
| Imperial | Falco | Eldorado |
| Cadillac | Fairlane | Marlin |
| Continental | Lancer | Javelin |
| | | Montego |
| | | Torino |

FREE 10-DAY TRIAL
Return and Pay Nothing if Not Satisfied

MAIL COUPON NOW FOR 10-DAY FREE TRIAL

MOTOR BOOK DEPT., Desk 911
250 W. 55th St., New York, N. Y. 10019

Rush to me at once **MOTOR'S New AUTO REPAIR MANUAL**. If O.K., I will remit \$2 in 10 days, \$3 monthly for 2 months and a final payment of \$1.95 plus delivery charge and sales tax, if any, one month after that. Otherwise I will return the book postpaid in 10 days.

Print Name..... Age.....

Address.....

City & State.....

Also send me for 10-day Free Trial **MOTOR'S AUTO ENGINES & ELECTRICAL SYSTEMS**. If O.K., I will remit \$8.95, plus delivery charge and sales tax, if any, in 10 days. Otherwise I will return book postpaid in 10 days.

Check box and save shipping charge by enclosing WITH coupon payment of \$9.95 for **AUTO MANUAL** (or \$8.95 for **AUTO ENGINES**) plus sales tax, if any. Same return privilege.

AUTOMOBILE CLINIC

(Continued from page 72)

stay put?—Glen E. Wright, Broken Bow, Neb.

It's possible that the distributor isn't being locked up tight, but I doubt it. The distributor in this car and in many other 1968 Ford models is of the dual-diaphragm type. This setup is supposed to allow for surer and better spark advance. Anyway, there's a knack to timing a car with this kind of distributor. It's a lengthy procedure, so tell your mechanic, tactfully, to consult the service manual and make sure the ignition is timed twice—once when the engine's cold and again when it's warmed up. A conventional timing procedure just won't work.

Wind song

Maybe you can tell what's causing a noise in my 1965 Pontiac. This low-pitched whistle occurs only when the windshield wipers are operating, and then only when the wipers are in an up position. Any ideas?—Jack Gibson, Kansas City, Mo.

It's a long shot, but maybe air is being swept by those windshield-wiper arms into an opening in the upper windshield reveal molding. If I'm right, you can get rid of the noise by getting some nonhardening windshield sealing caulk from an auto supply store and spreading it beneath the molding to close up any opening.

Voices of experience

Three readers writing about items previously covered in *Auto Clinic* offer these tips from their own experiences:

Spec. 5 Jim Garthwaite writes from Vietnam that the VW 1300 choke problem noted in the April '68 column "can be caused by the carburetor throat being squeezed just enough by tightening the air filter too much. This binds up the butterfly valve on the choke." Thanks, Jim.

Larry Zink of Morgantown, Ind., comments on the banging noise Fred Wolff of Paterson, N.J., wrote about (July '68). "I had the same noise with my Ford," Larry says. "I thought it was the exhaust system until I raised the car up and down and took hold of the rear shock absorbers. I could actually feel the noise right in

the shocks. I replaced the shocks and the noise went with them."

Dick Willman of Philadelphia discusses "A Matter of Lubrication" (July '68), which covered the groans and vibration noise from a '64 Chevy. He says: "Differential companion spline noise often sounds like a U-joint clank. Since the driveshaft is torqued in forward motion (clockwise) most of the time, the companion flange will change direction when the car's put into reverse and accelerated slowly. Twist on the pinion shaft sometimes gives noise similar to a bad U-joint. This can be corrected by removing the companion flange and lining the splines with white lead."

Service Tips

● **1968 Toronado headlight grilles** may be heard popping open while you're driving down the highway in broad daylight with your lights off. It's normal. This system is designed to provide an extra air flow through the radiator when coolant temperature exceeds 220° F. To get that added air flow, a remote control valve is put into the system to open the hide-away headlight doors.

● **Chrysler Corp.** reminds owners of its cars that premature rear-brake lining failure can result if the parking brake cable isn't properly adjusted.

● **1968 Ford and Mercury owners** would do well to double check the routing of power-steering hoses following the servicing of their cars. Sometimes these hoses are moved from their original position by a serviceman who is trying to get more room in which to work. If the hoses are accidentally left in contact with the exhaust manifold, they can start to burn through. A glance will tell you if a hose is touching the manifold.

● **1968 Chevys with V8 engines** should have their oil filters more than hand tight. Unless they are torqued to 25 ft./lbs., leaks can result. You can approximate the proper torque by bringing the filter up snug to the base, then giving it one to one and a third additional turns.

● **1968 Ford Fairlane owners** may have a problem with a front fender contacting or being "grounded" to the bumper. The trouble is loose front-fender brace attachments. Your dealer is authorized to correct it by item 1300, service bulletin 86. ★ ★ ★

GOT A PROBLEM WITH YOUR CAR? Ask Mort about it. Send your question to Auto Clinic, *Popular Mechanics*, 575 Lexington Ave., New York, N.Y. 10022. Letters cannot be answered individually, but problems of general interest will be published in the column.



Exclusive Flex-O-Matic rear suspension automatically adjusts spring stiffness to loads.

Works like a truck. Rides like a car.

Know why more people pick Ford than any other pickup? Better ideas—like road-smoothing Twin-I-Beam suspension. Two forged steel I-beam axles give it strength, coil springs supply the easy going. Now add Ford's comfortable cab, roomiest of them all—the choice of smooth Sixes or V-8's big as 390 cu. in.—optional SelectAire conditioning, power front disc brakes. You have every reason to ride with Ford's better ideas. It's a smooth track all the way.



A better idea for smooth riding: Twin-I-Beam Suspension—only Ford has it!

That's why Ford's No.1. (by a comfortable margin)

Farm & Ranch, Contractor, Heavy-Duty and Camper Special models available.



FORD PICKUPS



HOMEOWNERS' CLINIC

BY W. CLYDE LAMMEY

Painting brick house

I have an old two-story home with boxed cornices, dentil molding—all the trimmings of years gone by. But the walls are brick and I don't like their pale, reddish color. I'd like to paint the walls this summer but can't decide on the color. The trim will be white or, perhaps, off-white. Any suggestions?—J.R., Tenn.

I hesitate to agree with the painting of brick walls of homes—brickwork just doesn't look like brickwork once it's painted. Also, if you change the color of the bricks and cover the mortar joints you may change the appearance of the house—making it look larger or smaller. Moreover, you add the periodic maintenance chore of repainting the entire structure instead of just the trim, a cost factor that should be considered. If the brickwork is still in good condition I'd strongly recommend that you let well enough alone, especially if your home blends well with its surroundings. If you *must* paint, a light gray often goes well with white trim—however, the selection often depends much on the architecture of the structure. White also seems acceptable to some owners of brick houses. Sometimes a tile red is used.

Renewing gilt

I have an old rectangular picture frame with a liner which I'm sure is gold leaf. The liner is shaped with two beads and a flat portion. On the latter the gold leaf has become dull and pitted, but the beads are still bright and smooth. Is there some way to renew these surfaces without applying gold paint which eventually will tarnish?—T.D., Mo.

As a rule, liners are softwoods. Thus, it could be that the leaf has been cracked or broken by shrinkage and expansion of the wood through the years. This and an accumulation of dust could give the dull appearance. I would try a very mild, but soapy, wash, taking care not to wet the surface excessively. Apply the mild solution with a dampened ball of cotton and rub very lightly. This should remove the accumulated dirt and quite possibly will brighten the gilding appreciably, but it is

not likely to hide the pits. Dry burnishing with a ball of clean cotton may also help to bring up the glow of the gilding. But, judging from your description, you'll either have to live with the pits, have a new liner fitted and gilded, or resort to a gold wax on the affected flat portions. The gold wax, or "wax gilt" as it is sometimes called, is quite effective for restoration projects. It's applied with a fingertip and then burnished, but doesn't tarnish as do most gold paints. (See *Antique Gilt Goes on Like Wax*, page 128, Aug. '68 PM.)

Squeak hunt

An annoying squeak has developed in my forced-air furnace. I've tried every way I can think of to locate it but I still have the squeak. The noise can be heard upstairs when the blower is operating. It sounds like a metal-to-metal squeak, but where?—D.P., Mich.

If you're sure it isn't the V-belt (assuming you have a belt-driven blower), the search should center first, on sheet-metal screws which may have loosened and, second, on parts of the fan and motor mounting. Turn the thermostat up until the furnace starts cycling. Then begin the hunt by pressing with a finger at various points over the outside of the sheet-metal jacket. If this doesn't pinpoint the squeak, open the blower compartment and repeat the procedure. Touch all the sheet metal, especially the wall between the blower and exchanger compartments and also the motor mount. Be extremely careful when pressing on parts of the mounting when the unit is running; don't get a shirt sleeve or finger caught in the machinery.

This procedure may take some time, but if you persist, sooner or later you are almost certain to touch the part causing the squeak. The rest is easy; tightening a screw or spraying the troublesome sheet-metal joint lightly with a nonflammable silicone compound usually stops the noise.

Patio chair stains

I have an aluminum patio chair that leaves a black stain on clothing. A grayish coating covers the metal. What is this, and how can I prevent it?—W.W., Tex.

An oxide coating forms on many metals exposed to the air, especially aluminum. The only thing you can do about it—and it's only a stopgap cure—is clean the metal and coat the "wear" surfaces with a metal lacquer. Any clear finishing material will do, but genuine metal lacquer will do the best possible job. ★★★

ORDER THESE PM PAINTINGS!

Four outstanding PM illustrations printed in full color on heavy paper suitable for framing.

RACING CARS

The finest painting ever made of racing cars. 32 types in 8 major classes—Championship, Stock, Sports, Formula, GT, Drag, etc. Includes summary of specifications. A great argument settler.

Size: 35 x 23 inches.

\$1.50 each postpaid

SATURN V

The world's biggest rocket.

Size: 19 x 25 inches.

\$1.25 postpaid

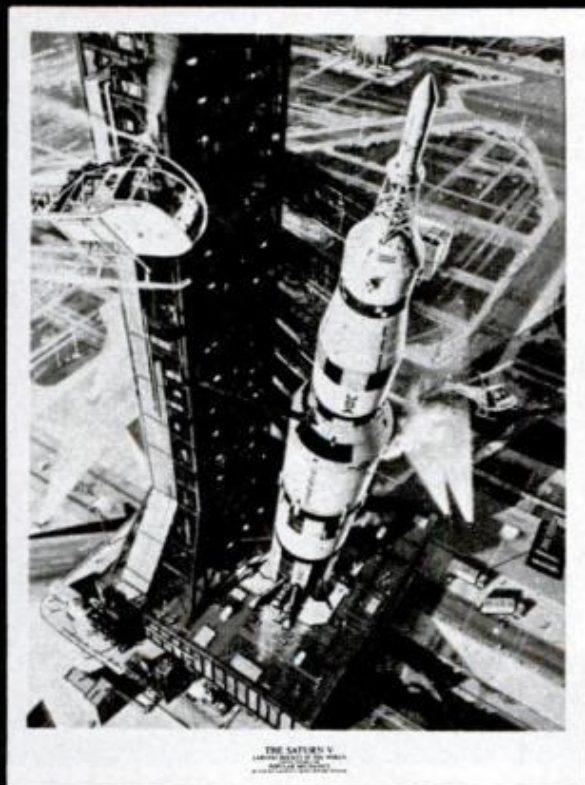
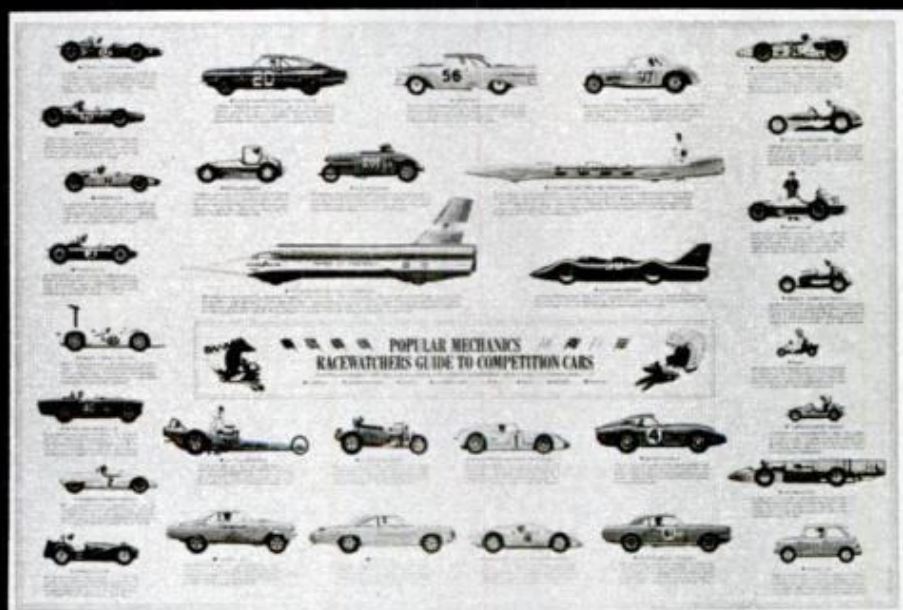

VIETNAM COMBAT PAINTINGS

U. S. Planes in Vietnam and U. S. Helicopters in Vietnam. All latest models shown in blazing action.

Each 18 x 24
Both for \$1.95

Use the coupon below to order your paintings.

Pictures, Popular Mechanics, 575 Lexington Ave., New York, N. Y. 10022

Please mail PM paintings as indicated below:

Racing Cars _____ Copies @ \$1.50 ea.

Saturn V _____ Copies @ \$1.25 ea.

Planes and Helicopters _____ Copies @ \$1.95 set

Enclosed find _____

Name _____

Street _____

City _____ State _____ Zip Code _____



When Ford spent \$150,000 creating this experimental car, you can be sure they didn't scrimp on the oil filter.

They used an Autolite filter. Like you buy. About \$4.

This is the experimental Ford Mach II. It is a one-of-a-kind two-passenger sports car for possible street and competition use.

The hand-built Fiberglas body stands only 47 inches high. The unusual midship-mounted engine gives the car near-perfect balance. Performance and handling are like a foreign racing machine's.

And the oil filter? A standard Autolite filter. Like you buy.

Why a standard \$4 Autolite

oil filter in a \$150,000 experimental car? Because there is no better oil filter. Not at any price.

The Autolite filter is a two-stage depth filter that can actually *double the life* of your oil. It removes up to ten times more dirt and sludge than ordinary filters. And it has an up-front bypass valve that prevents trapped dirt from washing back into your engine.

Put this kind of filter in your car. Whatever kind you drive.

Autolite...filters, spark plugs, batteries, shock absorbers, and complete ignition systems.

Autolite 



This car is permanently rustproof, soundproof, dustproof.



Here's the proof.

See your Ziebart Rust Specialist.



For total rustproofing, see the Ziebart Rust Specialist. He uses patented tools and methods to apply Ziebart rust preventive to every rust-prone section of your car . . . **from within.** Ziebart innercoating seals even welded seams; locks out rust, dust and road sound. And the little yellow Ziebart plugs that close innercoating access points prove it! Ziebart guarantees your new car rustproof for 5 years/50,000 miles. Your nearby Ziebart Dealer is in the phone book. Or write Ziebart, 16135 Harper, Detroit, Mich. 48224 for his address. (Certain choice franchise territories still available.)

® Reg. U.S. Pat. Office



You can give her hope.



Your fair share gift works many wonders
THE UNITED WAY



27 million families benefit by child care, family service, youth guidance, health programs, disaster relief and services for the Armed Forces from 31,000 United Way agencies.

Kimmimik pikagungitchuk*

when you own an *Ariens*



Ask any Eskimo. Nothing breaks trail like an Ariens Sno-Thro. It's as rugged as an Arctic blizzard . . . a real drift buster. Check this winter sports model: *four-speed stick shift/two-tone paint job/7 H.P. modified engine with brute power/snow tires that hold their own on ice and snow/differential with lock-out hub/wide swing discharge chute/all-synchro Disc-O-Matic drive/other models with engine options up to 15 cubes of thoroughbred power.*

*All this is translated into something important at your nearby Ariens dealer's igloo.

New, from Ariens. The Manorway 7 H.P. riding tractor with a 32" two-stage Sno-Thro. Maneuvers easily and safely with low center of gravity. Many attachments available for year 'round use.

Drive it today.



Ariens COMPANY • 655 W. RYAN STREET • BRILLION, WISCONSIN



How the Army Learned to See In the Dark

Here's the inside story of the Army's supersecret gun scope that intensifies images up to 50,000 times and gives gunners daylight vision in pitch-black darkness.

By MORT SCHULTZ

PICTURES of Russian tanks squashing the Hungarian revolution in 1956 revealed that the giant turret-mounted searchlights those tanks had been carrying were missing. How were the tankers able to see at night?

Maybe the Soviets didn't need lights for this operation and had removed them. But was it possible they had developed a system, now mounted inside the tanks, which would let



HERB
MOTT

WITHOUT SCOPE
GIs can see only a few feet

WITH SCOPE
Scene is 50,000 times brighter

STARLIGHT SCOPE intensifies dimmest light, even fluorescence of rotting vegetation in Vietnam, up to 50,000

them see in the dark with the nighttime sky as their only light source? This could be disastrous for U.S. troops if war ever came.

At the time, our most effective night surveillance equipment was the famous, but obsolete, infrared Sniperscope of World War II. Infrared can't be seen by the naked eye, but viewing devices can convert this invisible beam to visible light. A soldier using one of these detection devices can see the infrared beam as if it were a searchlight and can trace it back to its source.

THREE VERSIONS of Starlight Scope include small scope mounted on infantryman's rifle, large tripod-mounted scope and medium-sized scope (shown below) mounted on machine guns or recoilless rifles

Supporting the possibility of a Soviet breakthrough in the critical night-vision field was the fact that Germany had been on the verge of developing such a system, called passive image intensification, when World War II ended. Several of Hitler's key optical scientists who had worked on the program were in Russia.

According to some nonofficial sources, the U. S. Army couldn't take any chances and assume that the absence of searchlights was of minor importance. Immediately, they contend, our own basic research in the field, which had started in 1952, increased.

This work was given a meteoric boost in 1961 when Dr. Louis Alvarez told President Kennedy that our Army was unprepared to fight at night. Alvarez was head of a committee investigating the ability of U. S. forces to engage in limited war.

Suddenly, the 30 scientists of the Night Vision Laboratory at Fort Belvoir, Va., found themselves with millions of dollars and an order: Use your research to develop a

POPULAR MECHANICS



times. It robs enemy like Vietcong of one of their favorite weapons—sneak attacks in pitch-black darkness

piece of hardware that would take the blindfold off our troops as soon as possible. The laboratory, whose ranks swelled (there are now 300 assigned to the group), had that equipment, called Starlight Scope, ready for use in 1965.

Naturally, as the first scopes were sent to Vietnam, the development remained a secret to keep the Vietcong from knowing that we had something that would let our troops operate as efficiently in the dark as in daytime. However, several scopes have been captured; security is no longer necessary.

What makes this device work? That's what I wanted to know about this most fascinating piece of military equipment I have ever used.

According to Dr. Martin Rome, the scope consists of three main components: an intensifier tube, an optical system and a power supply. Rome did initial development work on image intensifier tubes as a member of Machlett Laboratories in Stamford, Conn. He is now a vice-president of Electro-Mechanical Research, Inc., Princeton, N. J.

The three components literally absorb the dimmest nighttime illumination (starlight, the moon shining through the clouds or, as in the jungles of Vietnam, the fluorescence of rotting vegetation) and amplify it into bright light, allowing you to see everything

around you. Hard to believe? Let me describe my experience in a cornfield at 10 o'clock on a cloudy night.

What had been utter blackness—I couldn't see my hand smack to my face—transformed to a scene of razor-sharp clearness when I held Starlight Scope to my eye. It was as if a hundred spotlights had suddenly been switched on. The only difference between the light I was seeing by and daylight was an eerie pale-green aura emitted by phosphor in the tube. It bathed the scene. Charles D. Jackson of the Machlett

NIGHT-OBSERVATION DEVICE is largest of scopes, weighing 38 pounds. It has range of 1300 yards and is generally used by night observation teams



Laboratories described what my Starlight Scope had done this way: "About 50,000 times more light came out the back end of that scope and into your eye than went in the front."

The key to this tremendous amount of intensification is the intensifier tube. Each end of the tube contains a fiber-optic lens, which traps light. The lens in the front is coated with a photo-emissive substance. This photo-cathode coating, like that of a TV camera tube, gives off electrons when struck by light.

Photo cathodes used in commercial television couldn't be used for Starlight Scope. They aren't sensitive enough to excite electrons under low-level illumination. In 1955, though, Dr. Al Sommer of RCA found a photo cathode which far surpassed in sensitivity those used for TV. This coating, consisting of cesium, antimony, sodium and potassium, was adopted for Starlight Scope.

Once the photo cathode begins emitting electrons, the intensifier tube steps up their speed and controls their direction. Amplification is accomplished by 15,000 volts of direct current. Control is the job of a concentric electron optical system which, like a camera lens, directs the image to a piece of "film." In Starlight Scope, the "film" is a phosphor coating on the rear fiber-optic lens.

According to Mike Klein, associate director of the Night Vision Lab, "the concentric optical system is a lens for electrons that's made from the metal,

kovar. Part of the configuration is shaped into an anode cone. Voltage applied across the metal pushes electrons through the small aperture of the cone. It's the job of the metal electron lens to shape and focus the electron image."

Kovar, an alloy of nickel, cobalt, iron and manganese, is highly conductive and is the one metal which fuses best to the glass of the intensifier tube. The metal is also nonmagnetic and highly resistant to weathering and corrosion.

The electron lens was developed by Peter Schagen in the late 1940s when he was a member of Philips Laboratory in Eindhoven, Netherlands. It's accepted worldwide as the electron optical system for tubes.

When the electrons are given the voltage jolt and push through the small aperture of the anode cone, they slam into the thin phosphor coating of the rear fiber-optic lens. A phosphor emits light when excited by electrons. Thus, the impact of the electrons on the phosphor produces an image that's 30 to 50 times brighter than what comes into the front of the tube.

But one little intensifier tube will not produce a bright enough image for field troops. Nor two tubes. But three will. So, for maximum amplification, three tubes are butted together, the rear fiber-optic lens of one in contact with the front lens of the other.

Each tube amplifies brightness 30 to

(Please turn to page 224)

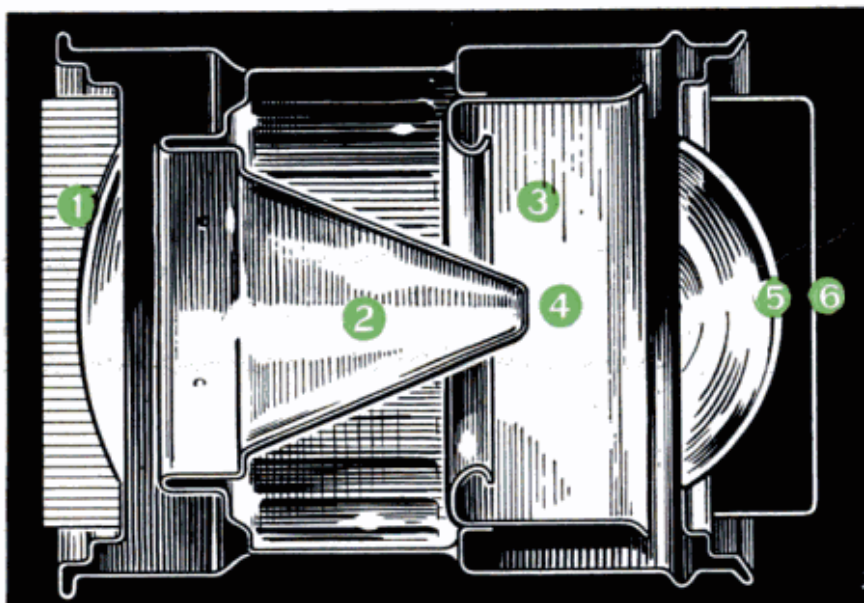

HERE'S HOW scope works. Light hits fiber-optic lens (1). It is coated with photo emissive substance which gives off electrons when struck by light. 15,000 volts are applied, forcing electrons through anode cone (2). Cone and adjacent configuration (3), made of special metal comprise optical system, shaping image as electrons speed through cone's aperture (4) and slam into phosphor coating (5) of fiber optic lens (6). Coating is like film in camera, receiving the image for viewing



Just listening—they say

When Munich policemen hear an unusually loud motorcycle, they take it to their "listening station" and actually measure its decibel output. Too much noise means a ticket—even for a pretty girl in a miniskirt.



Fizzy well

Max Blekeman, an Australian farmer, has tapped an underground supply of water that's charged with pure carbon dioxide. It's even shipped 250 miles to Sydney for bottling.



Super traffic jam

Though it looks like Times Square at 5:00 p.m., it's a display of 10,000 miniature cars by a model-car club in Tokyo.



Out for a spin

Alan Howitt of England borrowed an idea from the railroads in order to make his way safely onto a busy street in front of his home. He built a turntable in his driveway so he never has to back out into the road.

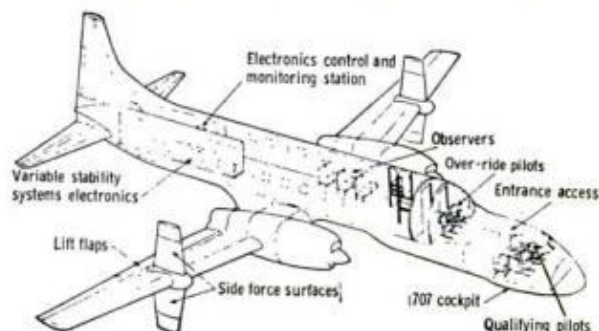

Pinocchio plane for training

Air Force and airlines pilots will begin training this year in a Convair 580 that has an extended nose containing a second cockpit that simulates anything from a commercial jet to a supersonic transport. The plane, called a Total In-Flight Simulator (TIFS), has a computer aboard that creates the flight characteristics of the plane that the trainees will later fly. Tex Johnston, Inc., makes the TIFS.

Your Second Car May Be

The classic half-tonner, once the workhorse of rural America, is pushing to be suburbia's all-purpose fun car, and the '69 pickups are here in red, white and blue to prove it.

Photos by Jeannie Weaver



By **BILL HARTFORD**
Associate Auto Editor

CAN A 100-POUND WISP of a woman jockey around a "half-ton" truck and still preserve her femininity? In a new 1969 pink pickup she can—and you can bet your eight-foot cargo box on that.

Don't think that the new pickups have been emasculated just because they've gone soft on that old, hard ride and are sporting woman-pleasing, deep-pile, color-keyed and coordinated carpeting. Of course, *you* don't need airconditioning, power steering and brakes, two-tone paint with wood-grain trim, vinyl roof and stereo tape—not for loading hay you don't. But the pickup is becoming almost—but not quite—too uppety to work. As its sales

soar for use as a recreational vehicle, the compliant pickup is being engineered, fashioned and outfitted to be comfortable and stylish to all the members of the second sex sliding behind the wheel.

"Built to be womanhandled," advertises one manufacturer; "his and her transmission," brag a couple of others who have a manual/automatic transmission; and even Auntie Martha is out loading up antiques as another advertisement pictures the typical "work" situation.

So be forewarned, men, while you're mentally juggling average job loads and sizes and deciding on the best suspension, wheelbase, transmission and engines for

a Truck!

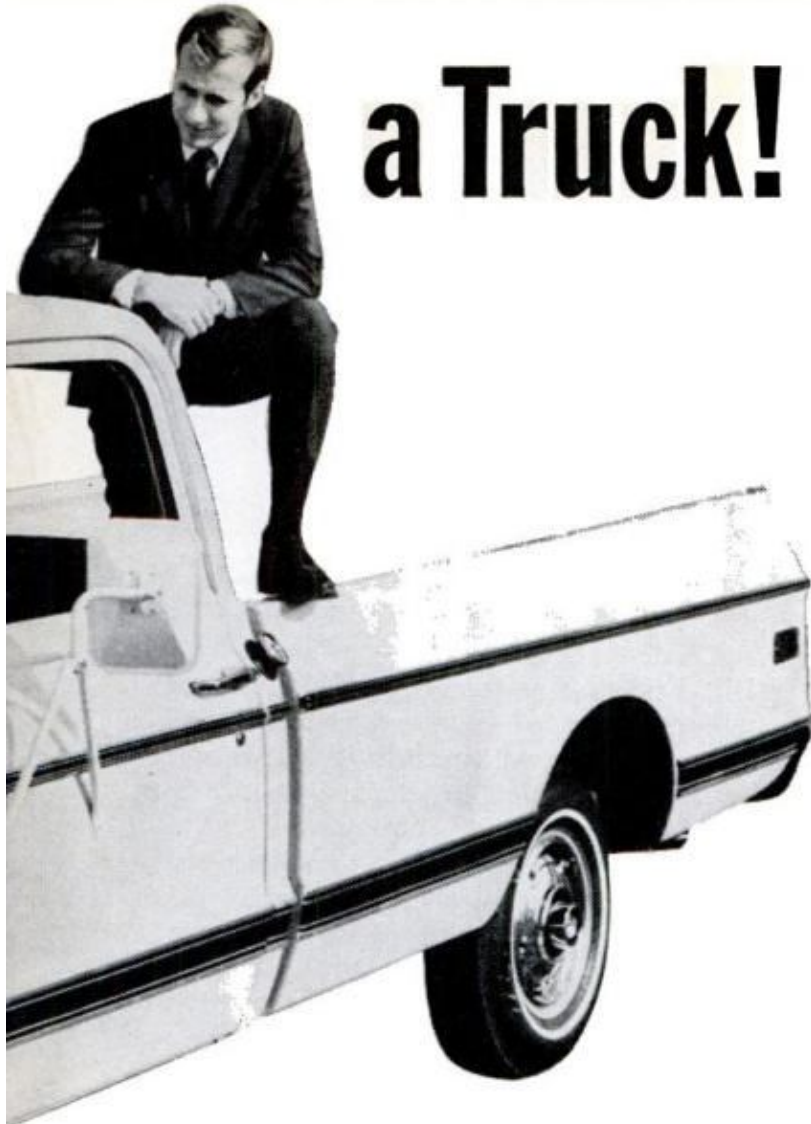

THE BIG SIX of light trucking are out in force for 1969. Chevy's CST/10 (above) has new front-end styling, 350-cu.-in. V8. Ford's F-100 with 131-in. wheelbase offers Contractor and Farm & Ranch work packages. International 1000D is the basic pickup in company's all-new lineup of vehicles for '69. Four-wheel-drive Jeep J-3000 Gladiator is both rugged and streamlined. Dodge Adventurer's vinyl roof typifies "sports truck" trend. GMC Sierra Grande model comes loaded with luxury

your pickup, or rather, the family's second car, the woman in the family will already have decided that she'd look chic in a pickup painted 1969's sweet new hue: prairie gold. Or should it be lime? Plum? Spruce tip? Maybe Bahama blue metallic?

Well, at least the Mack truck bulldog is still head-high on the hoods of the big rigs. Square-jawed and steadfast, he hasn't been replaced by a fluffed and ribboned poodle. *Big business is all business.*

But any lightweight that tips the scales around 5000 pounds up to 10,000 pounds GVW (gross vehicle weight) is registered, at least in part, for f-u-n! According to an executive of one of light trucking's



FORD



INTERNATIONAL



JEEP



DODGE



GMC



PICKUP INTERIORS must be seen to be believed. Standard and optional equipment and appointments like courtesy lights, carpeting, embossed bucket seats, airconditioning and stereo can make a very cozy cab



CONVENTIONAL WISHBONES and coil springs are used by GMC and Chevy in their front suspension design. On half-ton, springs are 1250-lb., 1350 optional

FOUR-WHEEL DRIVE, standard on Jeep, optional on other pickups, is a must for off-the-road operation. Semi-elliptical leaves and shocks suspend front axle



Big Six, the percentage of light trucks used strictly for business is down to 20! Of course, a good number of the pleasure-bent other 80 percent double up for both work *and* play.

It's this versatility that's really putting record numbers of pickups on the pike: Just remove the workday contractor box and slide on the camper unit. Beautiful! Leave the landscaping business in the garage and tow the boat to the lake for spring launching. Simple! Clean up the snow in the neighborhood and then unbolt the plow and go hunting. A snap! Leave the aluminum siding at the warehouse and load the lumber for the upstate cabin. Payload to payload versatility. Terrific!

Utility and good looks are what meets the eye with all the '69s, but if you're serious about pickin' a pickup from among the hundreds of models and variations, you've got to take a long, hard look. Before you get too far, you'll sort out

COMPENSATING SHACKLE of Ford's Flex-O-Matic rear suspension pivots to adjust leaf spring stiffness

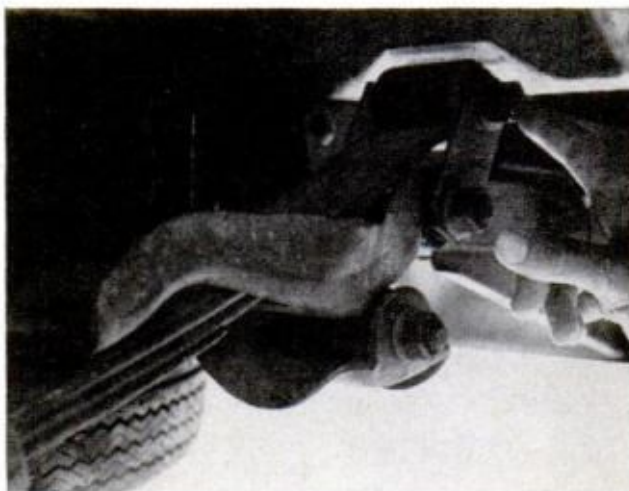

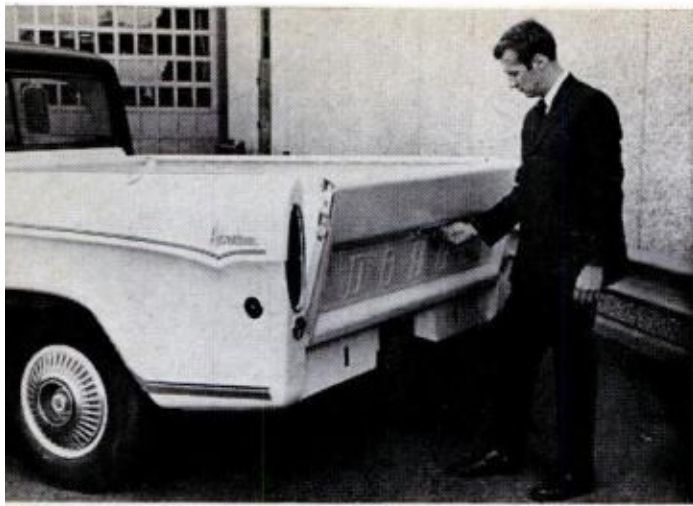

CONVENIENCE AND SAFETY FEATURES on current crop of pickups include easy one-hand tailgate operation with hinged tailgate support straps on full-width cargo boxes, and from Chevy, new Below-Eye-Line mirror

the fancy terms, all of which refer to the same thing—like Flareside, Stepside, Utiline, Thriftside and Fenderside. The last of the designations is the most descriptive; it refers to those pickups with the cargo box running between the inside of the two rear fenders; the fenders are outside the box. The Styleside, Fleetside, Sweptline, Townside and Wide-side models have—you guessed it—a cargo box flush on the outside; the fenders are inside the box. Both types have the same dimensions between wheel wells—about 49 or 50 inches—but the latter models look slick, have wide tailgates and greater cargo capacity—and price tags.

Total payload, one of the most important considerations in selecting a pickup for your own particular requirements, cannot be inferred for a specific model by the almost obsolete references to “half-ton,” “three-quarter ton,” and “one-ton.” So-called half-ton units, for example, vary

in payload, the maximum being well over three-quarters of a ton. Choice of short and long wheelbases does nothing to decrease your confusion quotient.

One manufacturer says, “We invite comparison,” and the only thing to do is to take him up on that. Drive them all. And don’t expect to find one that *really* rides like a marshmallow. You’ll still know you’re in a truck, but probably it will be the most comfortable, lowest, handsomest, most powerful pickup you’ve ever driven. Here are a few of the highlights of the ’69 lines:

● *Chevrolet.* Automatic chokes are now standard on all engines, including the new 350-cu.-in. V8, successor to the 327. Two sixes, 250 and 292 cu. in., and 307 and 396-cu.-in. V8s complete the engine availability. Wheelbases are 115 and 127 in. in the CS/CE 10 (½-ton) series, 127 and 133 in. in the CS/CE 20 (¾-ton) series

(Please turn to page 194)

I-BEAM FRONT AXLE on Dodge trucks has been improved by addition of a sway bar for better control

TRAILING ARM/COIL SPRING, standard on some rears, needs auxiliary leaf option for a top payload

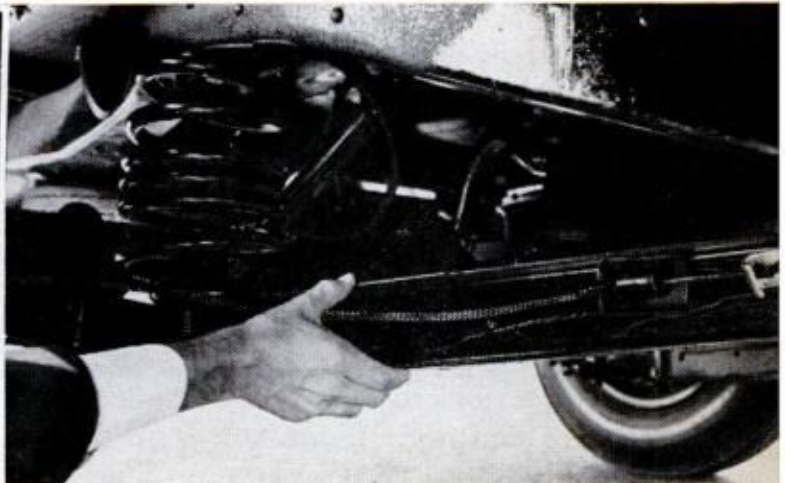
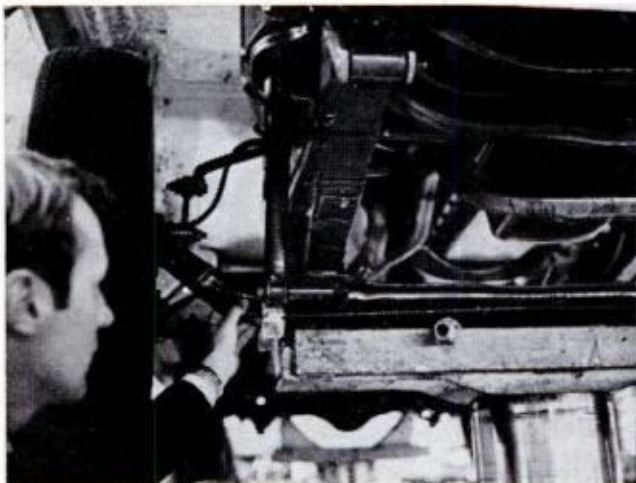



CAR STYLING is compromise between what looks well and what works, plus economics of what costs least

Why Your Car Looks The Way It Does

Those brand-new styling features may be as much as 10 years old. It can take that long to move a car from the drawing board to an assembly line

By MICHAEL LAMM

TODAY was three years ago and, with luck, tomorrow might come in 10 more. That's the way Detroit designers view their basic timetable.

Those sparkling 1969 models might look brand-new to you, but they're old hat in Detroit—two, maybe three years old. Advance stylists at General Motors, Ford, Chrysler and American Motors are doodling away at far-out drawings of cars that might be built sometime around 1978-80. In other studios, more down-to-earth designers are finishing renderings of the '72 models, and in still other locked rooms, design sculptors are putting final touches on full-sized clay models of '71 cars. The '70

models, of course, are pretty well set except for perhaps a wheel cover pattern or a few similar picky details.

All four Detroit automakers follow much the same routines and schedules in styling their cars. It's a complicated, painstaking business that involves lots of hands and brains plus plenty of compromise.

"Styling," says Dick Teague, design chief of American Motors, "may produce a car calling for an overall height

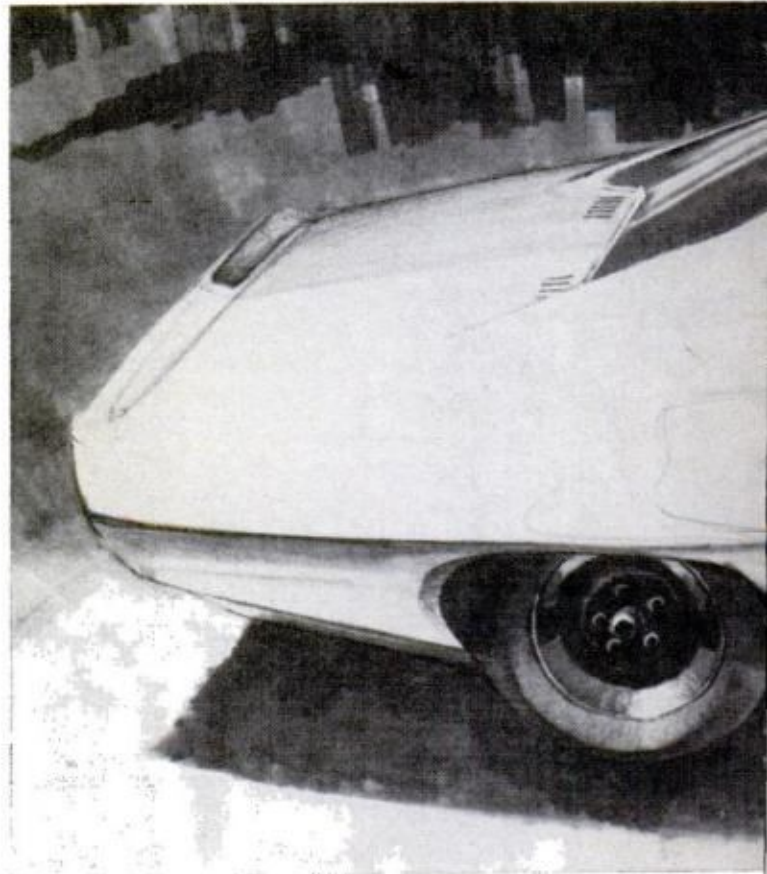

of 48 inches. Engineering may advise that the existing chassis will take a height more like 58 inches. What follows is an adjustment to a feasible design of, say, 54 inches."

Designers almost invariably try to utilize components already in production. This isn't only an economy of material but also of time, because it takes just as much manpower to design and tool for the unseen parts of a car as the exterior. If a company can keep from revising an existing model's underpinnings, it's a great saving.

For the year-after-year cars—the established industry nameplates like Chevy, Ford and Pontiac—facelifting

the next year's model might take as little as four or five months. A complete restyle, though, usually means about 36 months' hard work. And when it comes to putting a completely new car on the road (like a Toronado or a Mustang), preliminary research might stretch back 10 years or more.

With the Toronado for example, preliminary development and testing of front-drive assemblies plus body sub-frame design started as early as 1954, 12

model, let's take a look at the basic steps:

1. Management gets its collective head together to begin figuring out what sort of car will sell. What does a given market segment want three to five years hence? They work up a preliminary portfolio, then hand these basic requirements to Styling.

2. Styling takes this information (calling it a "paper car") about size, projected price, seating capacity, purpose,

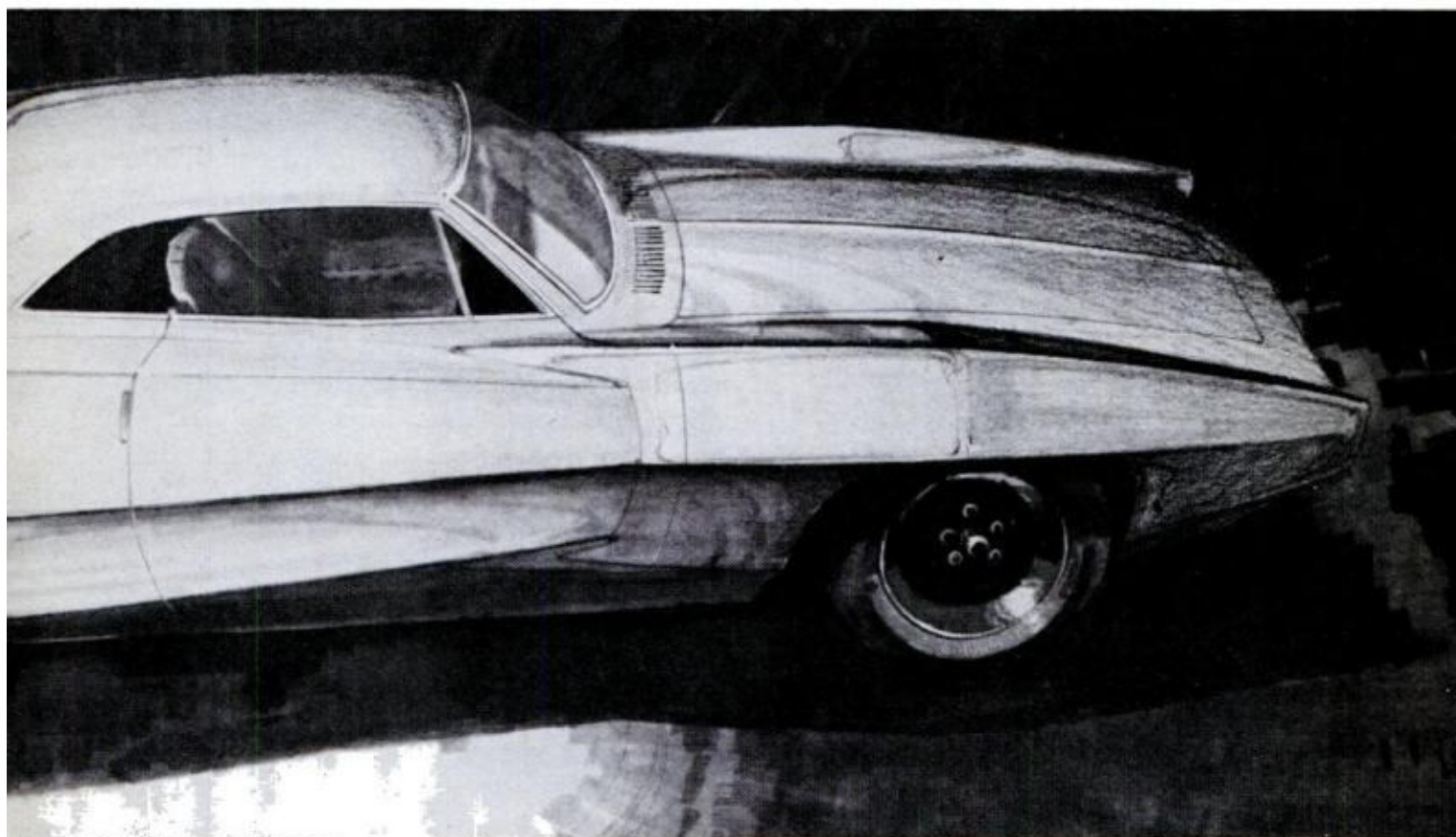

years before the car saw the light of day. The LaSalle II show car unveiled at the 1965 GM Motorama was the Toronado's grandfather. Likewise, Ford started seriously chewing on the Mustang in late 1959, and in this instance it took FoMoCo only five years to give birth to a new model (April, 1964). But then the first Mustangs used a lot of Falcon components, and that made the production job easier.

The normal styling process can't be separated from pure research, market research, product planning, engineering, tooling, and several more big-biz pastimes. But to review the hypothetical, normal evolution of a changed



INTERIOR DESIGN is just as important as exterior. Seats must be comfortable, complement styling theme

. . . ideas and sketches that look good on paper might hit File 13 . . .

and the sorts of people who will buy the vehicle, and they start drawing sketches. Styling might rough out hundreds, even thousands, of renderings within a few weeks. These quick sketches on translucent vellum consist only of basic lines, no details. The stylists keep eliminating and amalgamating designs until they boil the roughs down to a handful or two of likely candidates.

The more promising are made up as $\frac{3}{8}$ -scale clay models so they can be looked at in three dimensions. Sometimes the $\frac{3}{8}$ clays are modeled against a mirror so only one side needs to be sculpted, saving time. All the while, Management has been dropping in to the studios regularly, keeping tabs on progress and offering suggestions.

3. Interior designers, cloistered in separate but equal studios, go through the same pains as exterior stylists. At some point, when the various design processes reach a certain unspoken, but always recognized, stage, all the designers get together with Engineering and Management to begin ironing out details.

Engineering has actually been involved all along, but Styling takes the ball first, then theoretically it's up to Engineering to put running gear, seat-

ing, trunk space and so on into the package Styling presents. Here's where the business of compromise begins. Plenty of ideas and sketches that look good on paper might hit File 13 right away when Engineering starts making serious calculations.

4. A studio engineer or group of engineers begins to work out the details of making a chosen design practical—giving attention to hinge positions, making sure that optional equipment like airconditioning compressors will fit, deciding where to put mastic and sound-deadening materials, and so on.

5. Management now chooses several $\frac{3}{8}$ clay models for further development. Styling takes these and draws them up in side view, full size. These drawings are usually airbrush and watercolor on black paper.

6. At this point, too, both Interior and Exterior Styling get started on full-sized clay models. Skilled sculptors take full-sized drawings and the $\frac{3}{8}$ clays and begin work on the full clay over what's called an "armature." This armature is a wooden structure built to roll on regular car wheels. It's made of thin wood slats and sometimes Styrofoam for certain pieces, assembled in the rough shape of a car. Clay goes all over this armature. Contours and lines are smoothed to as near the final shape as possible.

It's the full-sized clays that Styling finally unveils to top Management for



CLAY MODELS are made when Styling and Engineering agree; then fiberglass molds are made from them



WOOD CHASSIS are built to hold full-size models for final changes in detail before making die molds

ultimate approval. Detail changes such as different taillights or a revised wrap to the bumpers are common at this point. But it's pretty late for major alterations in the basic body configuration.

These full-sized clays become the most crucial stage in the styling process, because it's here that most refinements are made. Sculptors work closely with stylists, Styling with Management, and small modifications are incorporated wherever necessary. The clay might be painted; windows are usually represented by black or plastic sheeting; metal foil gives the illusion

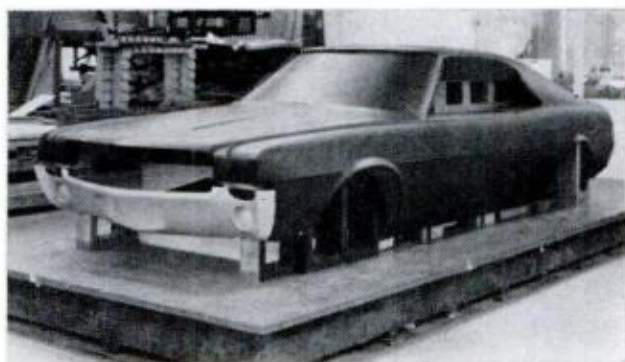

FINAL CLAY MODEL of AMC's Javelin is propped up for Management before car gets the final okay

of chrome on bumpers, door hardware, and so on.

7. Since full-sized clays aren't very stable—they're easily gouged and tend to crack after standing—the next step is to take fiberglass molds of them. This is done by first pouring a plaster fiber colloid over the clay, letting it harden, then lifting off the plaster cast with compressed air blown between the cast and the clay. The plaster then becomes the female mold for fiberglass layups. Basic clays can be changed for different body styles—wagons, convertibles, fast-backs.

The fiberglass may be cut so that doors and hoods open. Also, handmade dashboards, seats, door panels and so forth, worked up by Interior Styling, can be installed so the car becomes practically indistinguishable from a production automobile.

8. After fiberglass molds are pulled, body engineers go back to the clays for

precise measurements. The clays and styling drawings are translated into engineering drawings, very exact ones called "master drafts." These are scribed full size onto gridded aluminum plates with 12-carat gold styluses.

9. Now begins the *real* work of making the car practical. While the outer body sheet metal might have no more than 15 or 20 separate panels (doors, top, hood, trunk, rockers, fenders), the total body might incorporate as many as 4000 different pieces. It's up to the body engineers to figure out how to shape these unseen bits, how to make them go together in the most rigid, eco-



FINAL FIBERGLASS MODEL of Javelin is displayed, looking every bit as finished as production model

nomical and reliable fashion. It's just as tough to design the guts of a door or the cross section of a body side rail as the car's outer skin—tougher, usually. But it has to be done, and done precisely. Unseen supports, flanges, brackets, clips, hooks and the thousands of other details all have to be remembered and integrated into the final design.

10. The car has now gone far beyond Styling's hands. The logistics of actually building it go through another series of important steps, and these are worth reviewing quickly.

Pretest models, using newly designed underpinnings or whole chassis (if the car is entirely new), are mounted under current-year bodies to test for rigidity, possible pockets that might collect corrosives, and so forth. For the Toronado, for example, pretest cars consisted of 1963 Riviera bodies mounted on front-wheel-drive chassis. The Toronado's

(Please turn to page 196)



They're Putting the Old Birds

Once rusty and forgotten, some of World War II's most famous airplanes are taking off from the scrap heap to do jobs the jets can't handle

By **NORMAN SKLAREWITZ**

Photos by James Pickerell

IN A DESERTED CORNER of the Tucson (Ariz.) Municipal Airport stands a forlorn row of old World War II bombers that have had a reincarnation. No longer doomed to the scrap heap, they're being spruced up in combat colors for a war they were never built to fight.

Because of the spread of brush-fire warfare, once-obsolete warplanes are among the hottest items on military shopping lists. In many combat situations, a propeller-driven plane is more efficient than a much swifter jet.

It takes more than a new coat of paint to make these rusty old birds ready for action again, however, and several small aviation companies around

the country are giving the task almost custom-finishing attention.

In some cases the planes are being put back into better shape than they were originally. The A-26 is getting 2500-hp powerplants, replacing the original 2000-hp engines, plus larger rudders, tip tanks, antiskid brakes and reversible props. About 90 percent of the wings are new, too, permitting eight .50-cal. machine guns, and four pylons under each wing for an assortment of bomb loads.

The P-51, a great fighter in its day, may be even better today. It's a considerably more powerful aircraft than the one turned out over 25 years ago by North American. The new version



Back Into Battle

can pack 4000 pounds of ordnance, including six .50-cal. machine guns. Some of these conversions are actually reconversions. Many of the P-51s had been outfitted as racing planes.

The T-28, originally a Navy trainer, will have a 1425-hp engine instead of the original 800-hp plant. Other modifications include armor plating for the cockpit area, self-sealing fuel tanks, and strengthening of the landing gear and wing positions for machine gun rocket pods.

The conversions are being made in most cases by shops which specialized in converting American planes for foreign air forces, principally in South America, or, in the case of the P-51, for racing purposes or air shows.

Hamilton Engineering Co. in Tucson, Ariz., is overhauling old A-26s, as is On Mark Engineering Co. in Van Nuys,

T-28 TRAINERS are being refitted for combat duty on assembly line at North American-Rockwell plant

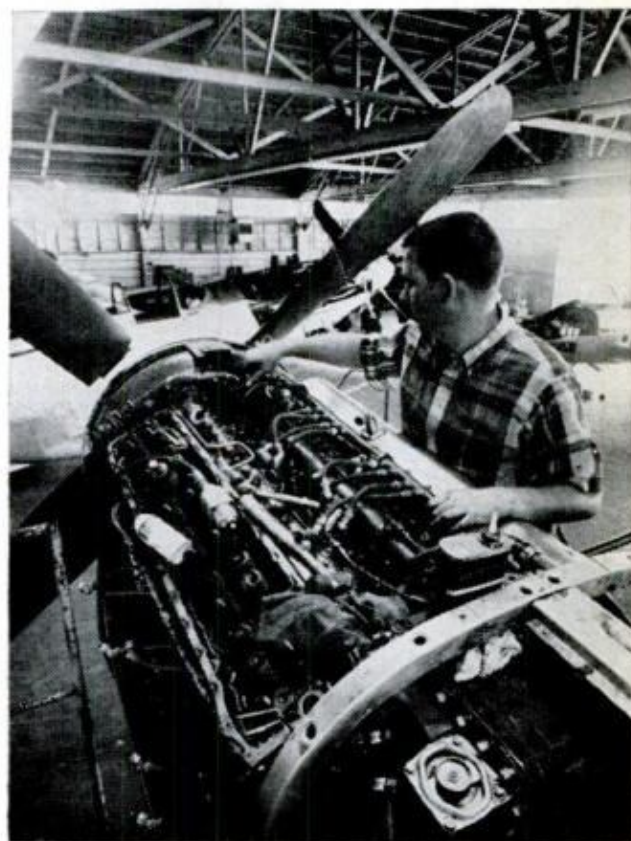

P-51 MUSTANGS, World War II vets, are beefed up (above) and put in combat colors (above, left)

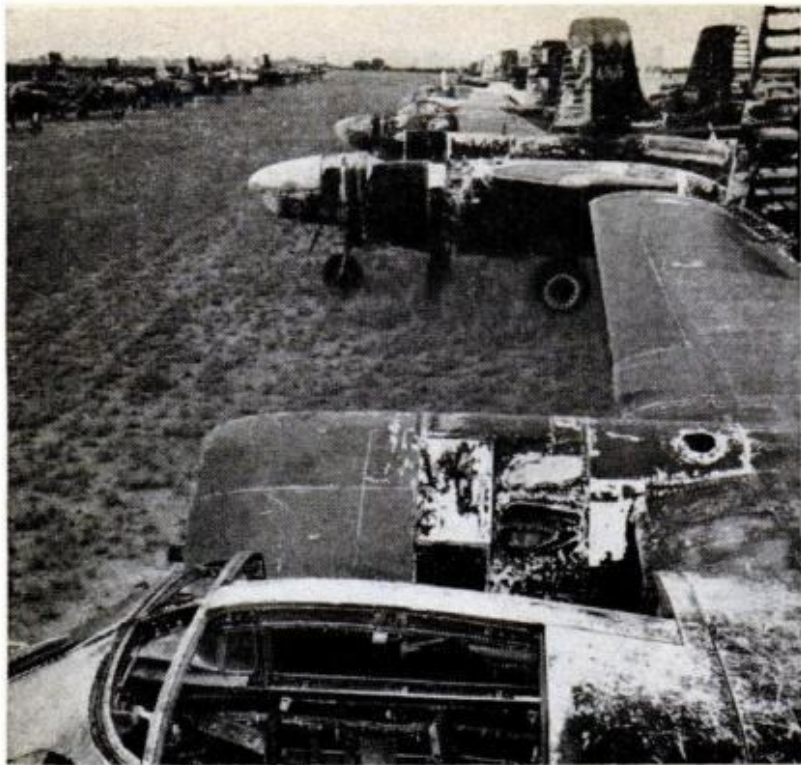

BEFORE: A-26 Marauders, forlorn and partially dismantled, await shipment to factory for conversion. Some will be used for parts

BIGGER ENGINES are major changes on most of the reconverted airplanes

Calif. Cavalier Aircraft Corp. of Sarasota, Fla., which is known for its civilian versions of the P-51s, is also reconverting some of those World War II favorites for combat. In addition, Aero Sport at San Bernardino, Calif., is redoing the Mustang. The T-28, unlike the others, is being redone by its original maker, North American (now North American-Rockwell) at Columbus, Ohio, on what is probably the largest assembly line for this sort of rebirth.

The North American assembly lines may become even busier if a new ver-

sion of the P-51, the Mustang 3, is accepted by the Air Force. Cavalier Aircraft, which recently demonstrated a prototype before USAF officers, proposes construction of 2000 new Mustang 3s. The plane, with an elongated nose housing a Rolls-Royce Dart turbo-prop engine, would have a maximum speed of 470 knots.

The general feeling among companies that are refurbishing the old birds is that business will get better. As they point out: "Half the battles of World War III are being fought with World War II aircraft." ★ ★ ★

AFTER: Reconverted A-26 Marauder, all shined up and ready to fly, rests on a ramp before its test flight



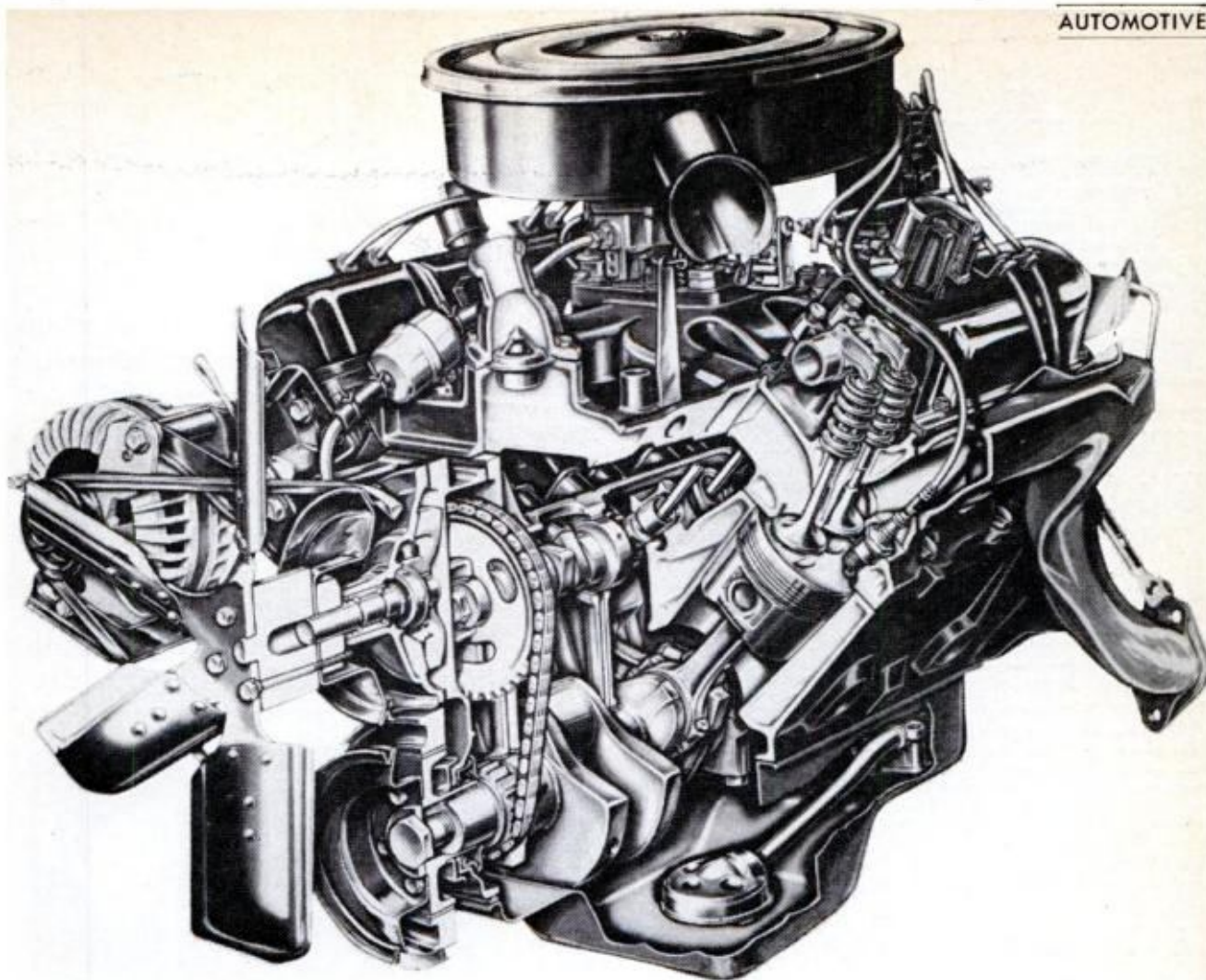

How Far Can We Go With The Piston Engine?

Slick turbine, electric and steam cars may be getting all the headlines, but lots of improvements are ahead for the internal combustion four-stroker

By ROGER HUNTINGTON

Technical Art by Fred Wolff

AN EARLY DEATH for the age-old internal combustion piston engine is the prediction of some people. They say the exhaust can't be cleaned up enough to meet future air-pollution and antismog laws and that we'll be running around with batteries, steam, fuel cells and atomic engines in another ten years.

Well, Detroit doesn't think so. Auto industry engineers are confident that exhausts *can* be cleaned up substantially. Furthermore, they feel they can

radically improve the performance, economy and durability of passenger car engines in the next ten years—within this framework of cleaner exhaust. But it will take a lot of hard work and money. The old piston engine that's been powering the world's cars and trucks for over 70 years is not dead by any means!

It's no secret that the conventional automotive piston engine as we know it today has some glaring, weak spots that need attention. The engineers know

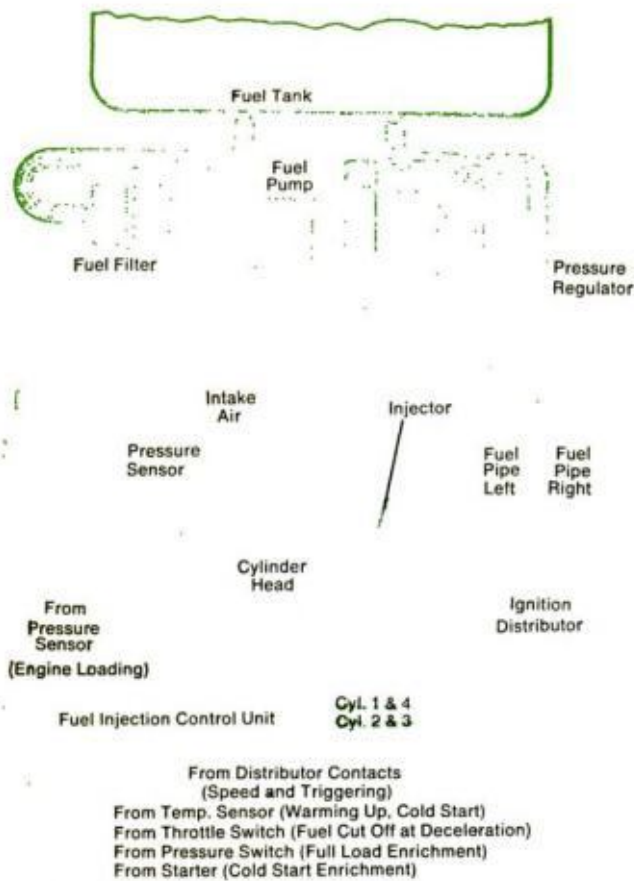

FUEL INJECTION: This setup already in use on the VW 1600 reduces fuel consumption, exhaust pollution

how to solve these problems, but in most cases they're not doing it because the solution involves hardware that costs too much money to put on millions of engines as standard equipment. However these improvements *will* gradually come in the next few years. Here are just a few of these weaknesses we have now—and solutions you can look for in the future:

● *Uneven Fuel/Air Mixture Distribution Between Cylinders.* With a carburetor setting in the center of a manifold, feeding fuel to the cylinders through long, curvy passages, it's impossible to get exactly equal amounts of fuel and air to each cylinder. Some cylinders run a little rich, while others run lean. And the worst part is that the carburetor itself must be jetted rich enough to keep the leanest cylinder from misfiring. This wastes gas, and the engine doesn't respond as quickly as it could when you punch the throttle because the extra fuel has to bounce around through 10 or 12 inches of pipe between the carb and cylinders!

All these problems can be solved

with fuel injection. Just squirt the fuel into the intake port, right next to the valve—or even directly into the cylinder. It's done with a special injector pump and a system of pipes and nozzles to each individual cylinder. There's no carburetor. Only pure air goes through the manifold. In this way you get exactly equal amounts of fuel to each cylinder. And you get it instantaneously when you punch the accelerator. You even save a little gas because the overall ratio of fuel to air can be a bit leaner without misfiring. And—very important—this leaner mix reduces exhaust pollution. All internal combustion engines will have fuel injection someday.

● *Ignition Point Wear and Timing Loss.* The breaker points in your dis-



PULSE DISTRIBUTOR triggers spark magnetically; no points and rotor to wear out, timing stays set

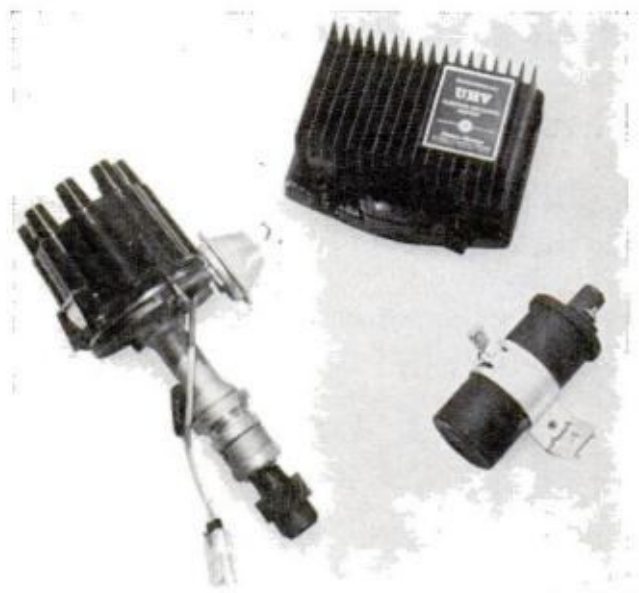

CAPACITOR DISCHARGE ignition system builds up high voltage for firing sparkplugs, prevents fouling

tributor that open and close to trigger the sparkplugs suffer fast wear and corrosion because of heat and arcing. This can cause hard starting, rough running and misfiring within 10,000 miles or less. Also, the little plastic block that rubs on the rotor cam to open and close the points will gradually wear down and cause the spark timing to slip back. Point wear and timing loss cause the engine to lose pep and power, and use more gas. And they can happen in less than a thousand miles after you

● *Fast Wear and Fouling of Sparkplugs.* Sparkplugs are about the weakest point in an engine. They pit and corrode, misfire, get fouled up with soot and lead deposits. A new set doesn't give top performance for more than 500 miles. There just isn't enough energy in a conventional ignition coil to fire the plug with all the deposits on the tip.

The best way to get that tremendous blast of spark energy is with a "capacitor discharge" circuit. Instead of feed-

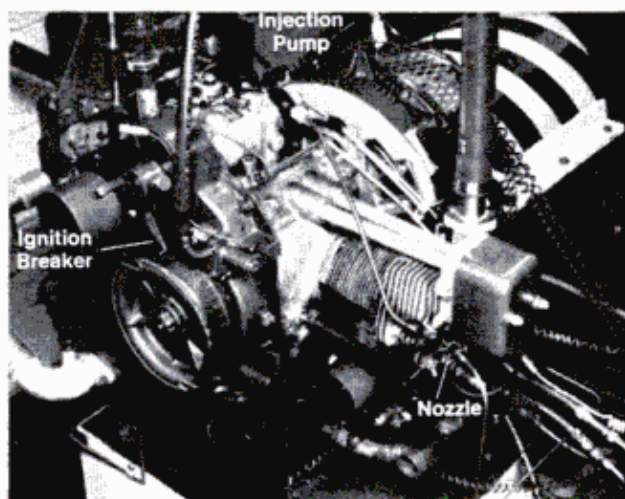

STRATIFIED-CHARGE COMBUSTION PROCESS is precision burning of fuel in a specially designed combustion chamber. Using fuel injection and a piston head configuration that induces an air swirl in the combustion chamber, fuel and air are mixed in exact proportions and the fuel charge is in the right place at the right time for the best burning. The result is greater fuel economy, less pollution and the ability to burn inexpensive low-octane fuel at high compression ratios with no knock. Texaco's adaptation of the principle is currently being researched in its experimental engine shown above. Texaco's research is only one attempt at the best stratified-charge design. Automakers are working on it, too

install new points and adjust the timing. These conditions are a chief cause of performance loss in passenger cars.

Detroit knows how to get rid of breaker points altogether: Use a little magnetic rotor and pickup in the distributor to trigger the spark by a magnetic pulse. No rubbing parts, nothing to wear out, lasts forever, timing stays where you set it. Only catch is that it takes an electronic circuit to amplify the tiny magnetic spike signal to charge the coil. Too much money now; someday the price will be right.

JANUARY 1969

TEXACO COMBUSTION PROCESS

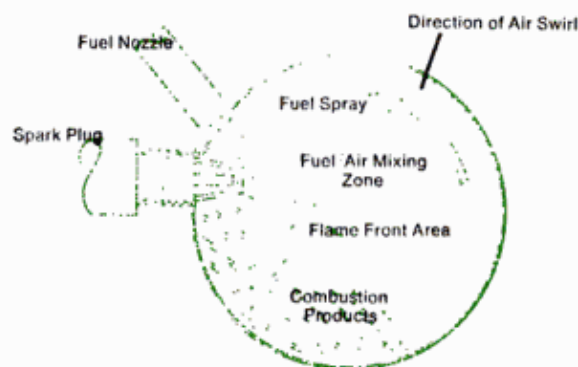

COMBUSTION CHAMBER CONFIGURATION

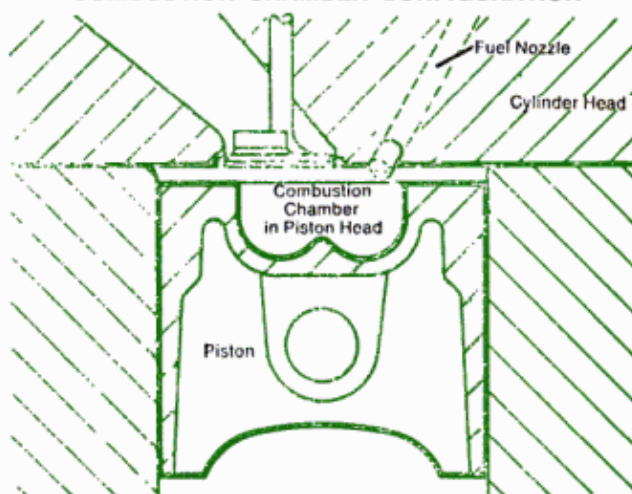

ing 12 volts of battery current into the coil, we use this current to "pump up" a capacitor or condenser—much like pumping air into a balloon. A capacitor stores electrical energy. When we trigger the capacitor it blasts up to 400 volts into the coil, and we get a quick-rising surge of up to 30,000 volts at the sparkplug. The plug can't help but fire with this kind of kick. The tip can be partially burned away, pitted, coated with deposits, even soaked with oil. The spark jumps anyway. And, of course, the plugs last and last. There's no need

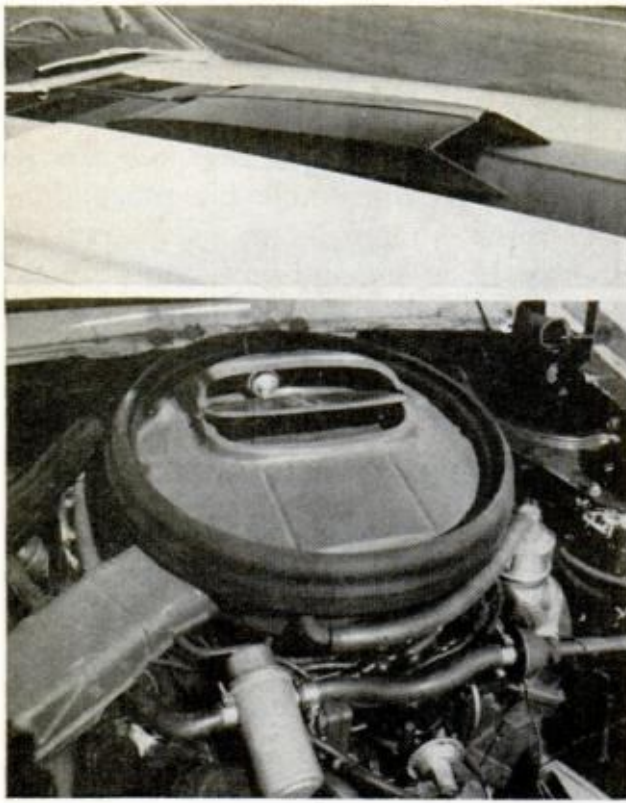

COLD-AIR SCOOPS are on some cars now. Cold air rammed into carb means more engine power output

to change them. Maybe every three years, so they don't fall apart!

● *Can't Burn a Lean Fuel Mixture.* A conventional automotive piston engine can't burn a really lean fuel/air mixture because there's not enough gasoline right around the sparkplug to ignite. We need at least one part of fuel to every 15 parts of air to get the fire going. If we could somehow cluster the bulk of the fuel around the plug just before ignition, we could burn much leaner mixtures—and maybe get

another 10 or 15 miles out of a gallon.

One answer is the "stratified charge" engine. There are various forms but the principle is to inject the fuel directly into the cylinder near the sparkplug. Then induce a swirling motion in the air in the cylinder, so the fuel is swept right to the plug. The flame rather stands still while the fuel is fed to it. Sure, the idea is complicated and expensive, but these stratified charge designs show fantastically low fuel consumption—and you can burn cheap, low-octane fuels at high-compression ratios without knock.

Detroit automakers are getting more and more interested. Ford, for one, is

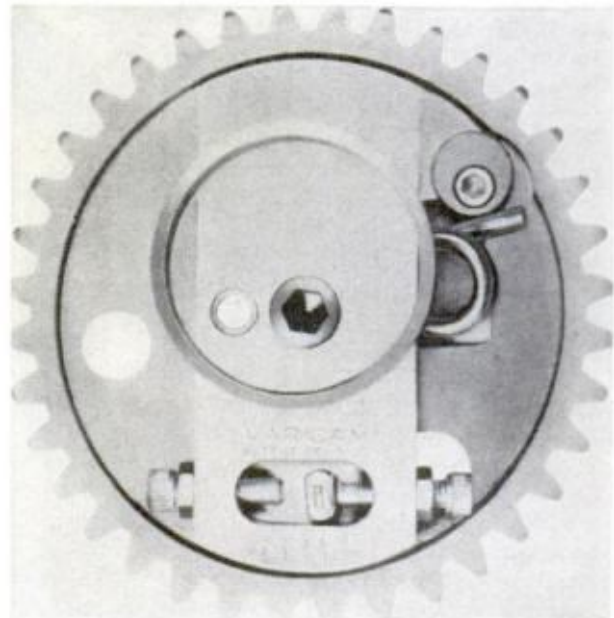

VARIABLE VALVE TIMING instead of preset. It will make possible smooth running at every rpm

refining an FCP engine (Ford Combustion Process) for eventual production.

● *Wasted Exhaust Energy.* At least one-third of the heat energy in the gasoline you burn is blown out the exhaust pipe—wasted. Engineers have been looking for a practical way to recover some of that energy for 50 years.

The best answer right now is the "turbo-supercharger." Here we have the waste exhaust gases driving a turbine, which in turn drives a tiny rotary compressor that forces the fuel/air mixture into the cylinders under pressure. It works like crazy. The "turbo-supercharger" unit weighs about 20 or

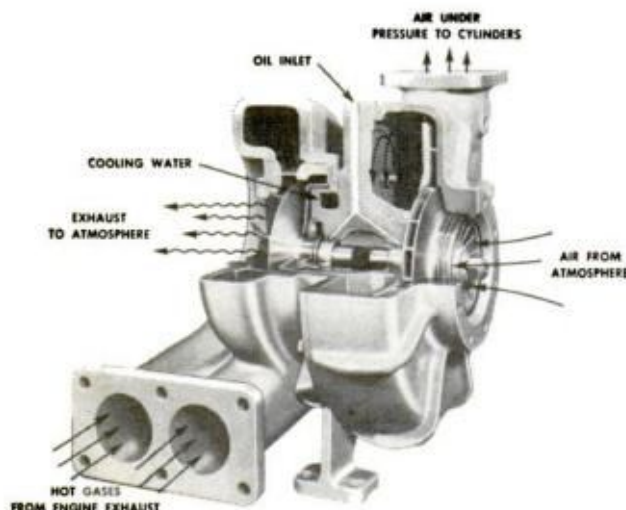

TURBOCHARGER utilizes wasted exhaust gases to drive turbine and force air into the engine cylinders

30 pounds, is the size of a watermelon and pumps up to 30 pounds per square inch pressure at 100,000 revolutions per minute or more! You can double the horsepower of a conventional engine with no trouble. In effect you're putting waste exhaust gas to work to "supercharge" the intake side. And turbochargers are not exotic laboratory curiosities these days. They're widely used on diesel trucks, tractors and trains. And, you'll recall that Bobby Unser, driving a turbocharged Offenhauser won the Indianapolis race last year to the dismay of three drivers in exotic turbine-powered cars.

It should be just a matter of time before your family car has one, especially since it's one good way to increase performance without a dirty exhaust.

● *Excessive Exhaust Restriction.* Most standard American passenger cars have excessively restrictive exhaust systems that generate a lot of "back pressure," and choke off the engine power. It's common to lose 30 to 40 hp. And it's no trick to solve the problem: Streamline exhaust manifolds and dual tailpipes and mufflers. Some of our high-performance models like the GTO and Corvette have beautiful exhaust systems. But Detroit isn't buying them for standard cars. They say streamlined manifolds cost too much and take up too much space, and dual exhausts corrode and rust out too fast. There's not enough hot exhaust gas going through

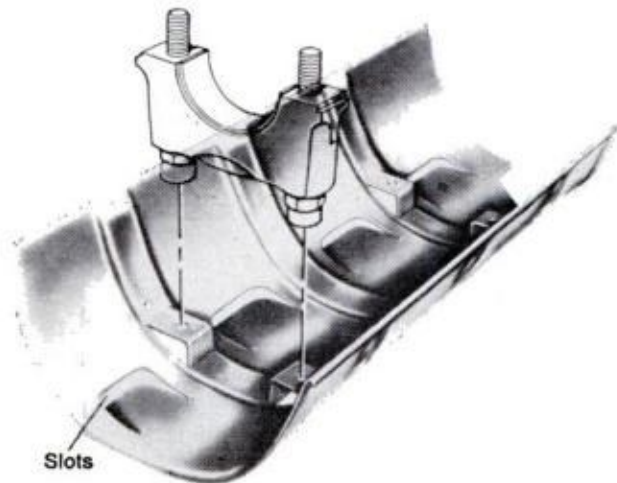

CRANKCASE Baffle fits between crankshaft and oil pan to eliminate churning. Slots let the oil run back

JANUARY 1969

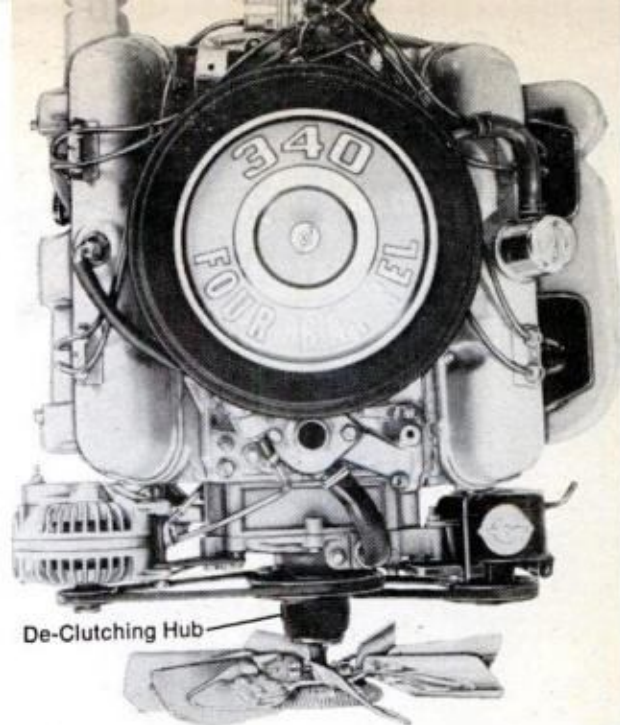

DECLUTCHING HUB disconnects fan from engine at high speeds, saving horsepower needed to drive it

them at low speeds to vaporize and carry away moisture and acids.

We think this picture will change. Engineers are doing more work on manifold design these days. And new low-cost anticorrosion coatings and steel alloys will solve the rust-out problem.

● *Power Loss From Hot Intake Air.* Your engine breathes hot air under the hood of your car. And we all know that hot air is thinner than cold air and that an engine can develop more power on the heavier cold air. In fact you can pick up 10 or 15 horses just by scooping cool outside air into your carburetor. Some of the latest high-performance models from Detroit have this new "ram-air" feature, using hood scoops or air tubes from the front. We expect to see a lot more of this. One reason is that some of the new government-required exhaust emission control systems are pumping hot air to the carburetor at low speeds. It's easy to rig a valve deflecting cold air to the carb when you punch the throttle wide open. Mild to wild in half a second!

● *Compromise Valve Timing.* Timing of intake and exhaust valves in relation to the suction and exhaust piston strokes has to be a compromise to get an engine to run smoothly over a broad

[\(Please turn to page 222\)](#)

Just patented

PM'S PICK OF THE NEW INVENTIONS

Prepared in cooperation with Roger S. Shashoua, Director, International Inventors Association, Inc.

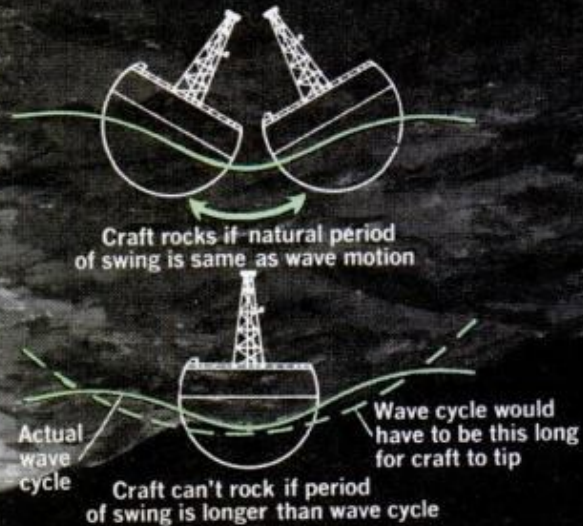

1. STORM-TOSSED WAVES can't rock this offshore oil-drilling rig no matter how rough they get. The secret is that the ball, acting like a swinging pendulum in the water, can be tuned to oscillate only at a certain frequency—just as a metronome is tuned to oscillate at a desired musical tempo. All waves have frequencies that fall within a fairly narrow range. The ball is tuned to a longer swing rate than is found in natural wave motion and thus can't be rocked by the waves. Providing a stable platform reduces drill breakage and eliminates the danger of capsizing—a serious hazard in storms. The tuning weight is placed at the bottom of the ball and is adjusted to provide the exact swing rate desired. Small motor-driven props permit the rig to maneuver under its own power. The idea can also be applied to floating factories, such as fish-canning plants.

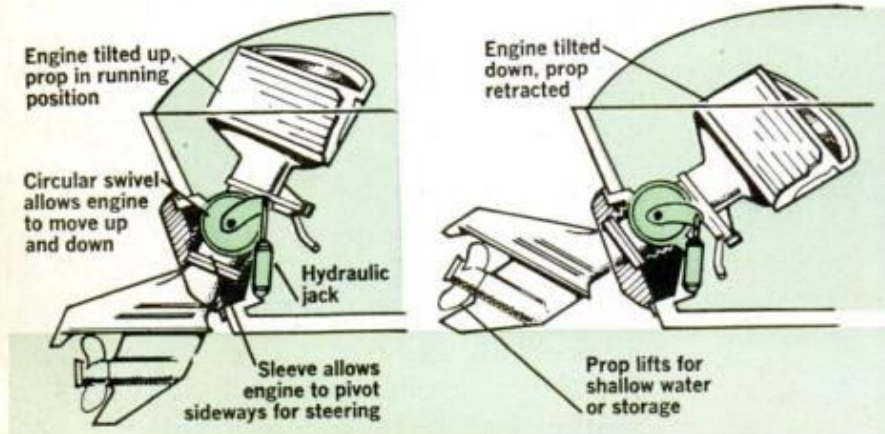

2. AN OUTBOARD ENGINE becomes an inboard powerplant with this through-the-transom pivot arrangement. The idea is to provide the advantages of an outdrive with a simpler installation. Enclosing the outboard offers greater protection in bad weather, gives the trim look of a decked-over inboard, and makes the engine easier to reach for maintenance. Like an outdrive, the two-way swivel lets the prop swing sideways for steering and tilt up and down for running in shallow water.

Inventors of the items shown on these pages are as follows: 1. John F. Holmes, Sanders Associates, Inc., 95 Canal St., Nashua, N. H.; 2. Elmer Carl Kiekhaefer, Winter Haven, Fla. (No. 3,382,839); 3. Robert H. Reno, 133 Columbia Turnpike, Rensselaer, N. Y. (No. 3,361,396); 4. Hivotronic, Ltd., Wella Rd., Basingstoke, Hampshire, England; 5. J. W. Putt,

3. SWITCHING CARGO from a trailer truck to an airplane takes only a few minutes with this system. The truck's body is actually a detachable cargo pod shaped to form the lower half of the plane's fuselage. The plane is jacked up on telescoping landing gear, the truck backs under it, and the pod is bolted on. The truck drives off empty, and the plane is ready for flight. With the system, planes could switch cargoes quickly without waiting for them to be unloaded. The pods could also be transported via railroad on flatcars and in container ships

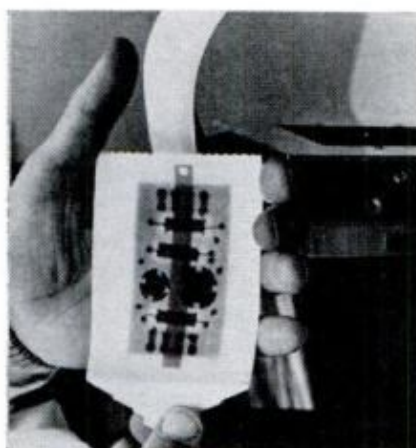
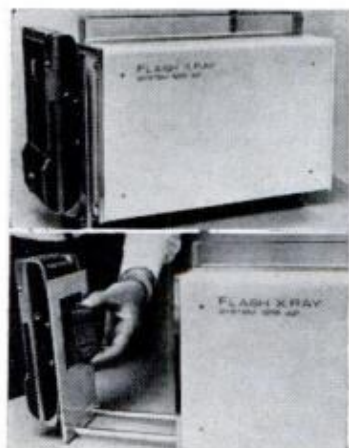
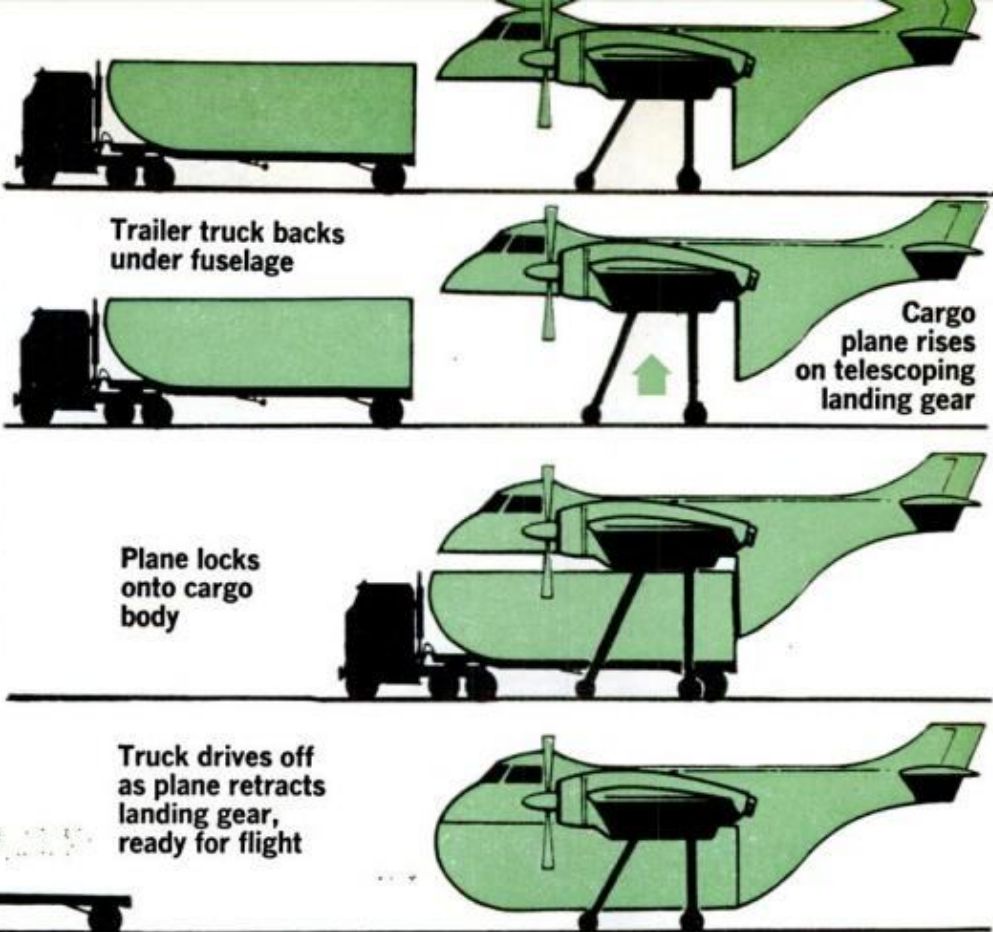

4. YOU CAN MAKE AN X-RAY as fast as you can take a Polaroid picture with the clever device at left. In fact, that's exactly how the system works. X-ray images produced inside the machine are recorded by a standard Polaroid camera held in a slide-out rack at the end. In 20 seconds, out comes a finished print of the X-ray. The sample print at near left shows the insides of a tiny electronic switch embedded in plastic and normally invisible. The small, portable unit, weighing only 25 pounds, is designed for both medical and industrial uses where there is a real demand for X-rays quickly

5. YOU DON'T EVEN HAVE TO STOP to put on the "instant" tire chains below. In good weather, spiked cross links are held above the wheel on a stationary disc. In snow, you press a button and springs force the disc against the wheel hub. Teeth on the disc catch in slots in the hub and the disc turns with the wheel. The cross links spread around the tire until they're evenly spaced, then lock to give traction

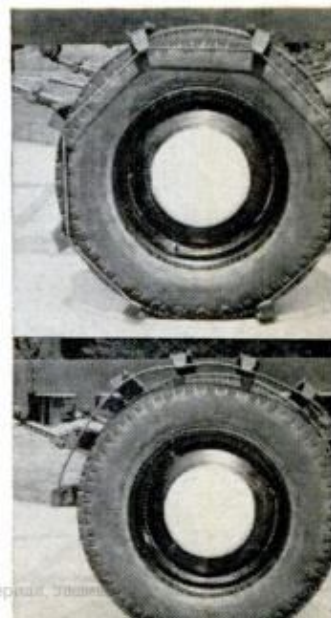
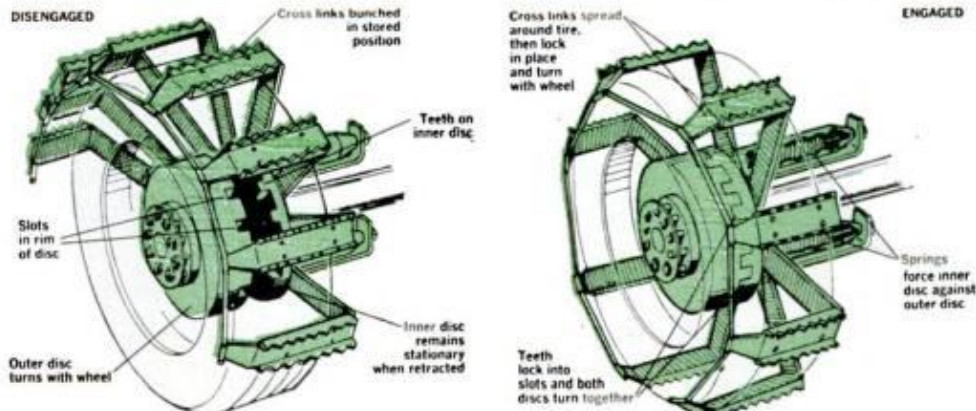

Non-Skid, Inc., 1730 Wyoming Ave., Forty Port, Pa. Readers wishing to bring new inventions to the attention of Roger S. Shashoua can reach him at the International Inventors Assn., Inc., 680 Fifth Ave., New York, N. Y. 10019.

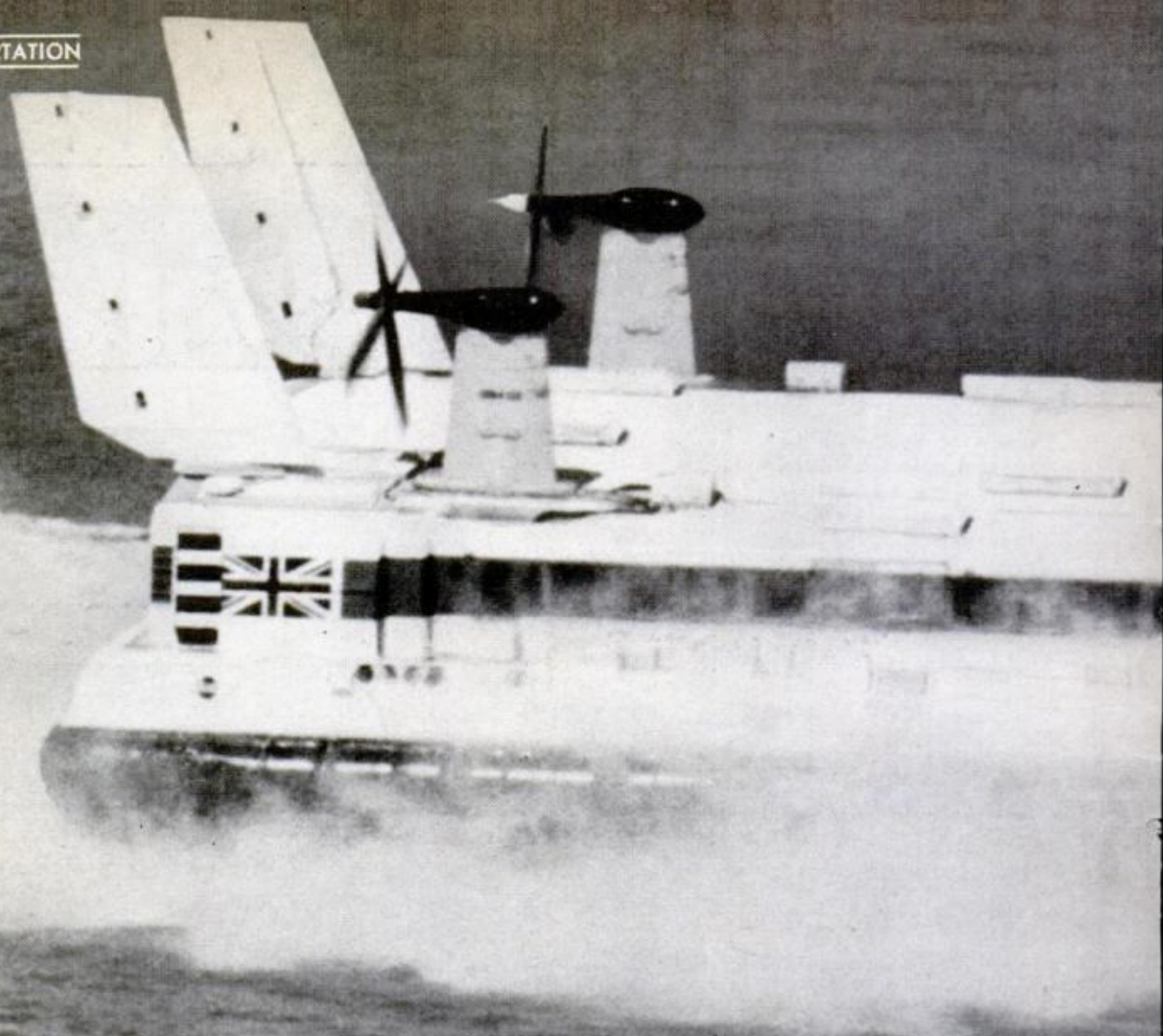

Flying the English

England's huge new Hovercraft skims smoothly above the choppy waters, carrying 30 cars and 250 passengers to France and back at up to 80 knots

By J. A. MAXTONE-GRAHAM

"THE FASTEST SHIP in the air." That's what they're calling Britain's newest over-water vehicle that whooshes cars and passengers 26 nautical miles to France at twice the speed of a destroyer.

Early in August, I stood below the white cliffs of Dover on a newly paved area beside the sea, within the harbor walls. I climbed the aircraft-style steps into an aircraft-style cabin filled with rows of aircraft-style seats. But there were no safety belts, and I could continue to smoke.

Soon, four 19-foot four-bladed propellers churned to life atop a weird, blunt-nosed hull. Then, with engines revved to full power, a great blast of air thrust downward at the beach. I felt the craft rise sedately to cruising altitude—all of seven feet! Half a minute later, she was moving seaward down a ramp at 20 knots. Once past the narrow harbor entrance, the pilot increased the pitch of the propellers; suddenly biting the air, they pushed our speed up to a dramatic 50.

Within 35 minutes, we hundred pas-



Channel: Altitude 7 Feet

sengers were stepping down to the French beach at Boulogne. A hydraulically controlled ramp lowered smoothly to the ground, and 20 cars rolled out. By normal steamship, the whole process would have taken nearly three hours.

The British Hovercraft Corp.'s SR.N4 is by far the largest, fastest and most reliable air-cushion vehicle yet made. One hundred tons of aluminum alloy and rubber, it towers 45 feet into the air, and would overflow a tennis court; its 130-foot length makes it fit to breast 12-foot waves. It's driven by four giant Marine Proteus Rolls-Royce engines, each developing 3400 horsepower—and even if two failed, the craft could still hover and travel slowly. Each of

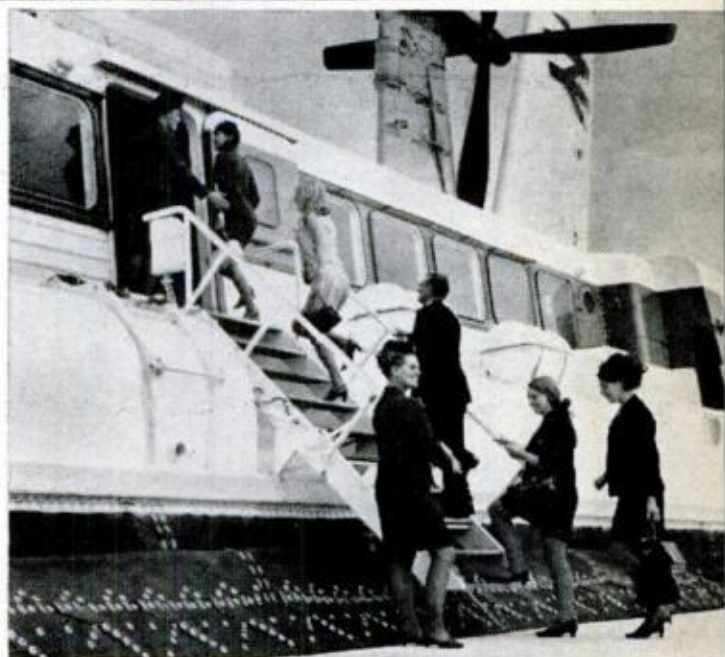

HOVERCRAFT PASSENGERS board ship from dry ramp via airline-style stairs for ferry trip to France



CARS, TOO, are loaded aboard 100-ton Hovercraft. Huge ship can carry 30 of them for each crossing



AWAY WE GO! *Princess Margaret* rises on air cushion, floats down ramp, and heads across Channel

the engines drives one of the variable-pitch propellers for propulsion, plus a 12-bladed centrifugal fan for lift. With a 200-mile range and a top speed of nearly 80 knots, it is scheduled to make 12 cross-channel trips a day with a 50-ton payload: 30 cars and 250 passengers. The SR.N4 has brought Hovercraft out of the realm of experimental playthings and into the true world of commerce.



250 PASSENGERS sit in comfort on airline-style seats. Smooth ride keeps seasickness to a minimum

Says the British Hovercraft Corp., which built it: "William the Conqueror needed 700 ships to bring his 10,000 invaders from France in two days. In that much time we could have moved them all with *one SR.N4.*"

To watch *Princess Margaret* skimming over the wavetops of the choppy English Channel, it seems hard to realize that 11 years ago not even the

PILOT, COPILOT sit in airline-style cockpit. One handles horizontal movements, the other lift and thrust

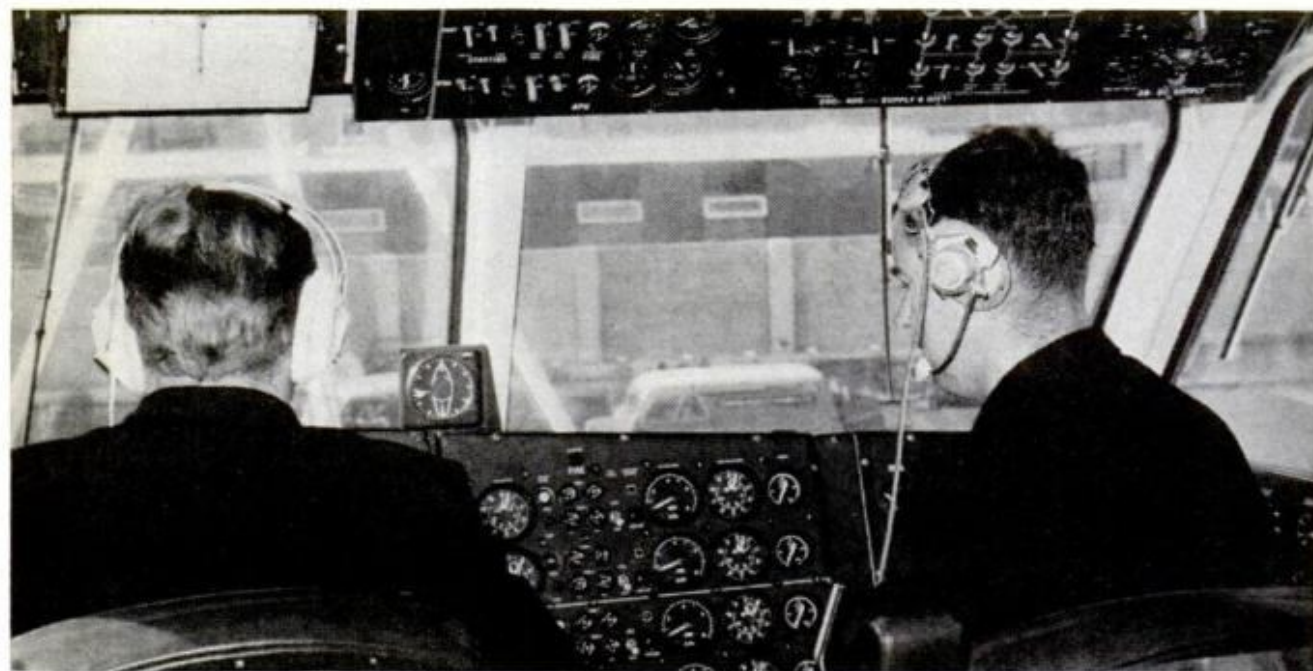



JOURNEY'S END. Hovercraft rests, slightly "squashed" on slanted ramp in France. Turnaround time, 25 minutes

smallest Hovercraft had been built. It was only in the mid-'50s that Christopher Cockerell experimented with a coffee can, a pet-food can and a hair dryer to make the first hovering device. It's as if the Model-T Ford were running a decade after the invention of the wheel. Like the iron horse, the horseless carriage and the flying machine, the Hovercraft was easily dismissed by traditionalists as a passing fad that could never have any lasting or commercial application; yet, designers are already toying with plans for colossal 5000-ton super-Hovercraft capable of taking you—and your car—across the Atlantic in 24 hours for under \$200.

On my outward trip from Dover, the Channel was no more than choppy. All the same, the six men employed as "car-lashers" put a firm strap from each car wheel to steel rings on the deck. The full 50 knots were maintained all the way. I found it gently and predictably bumpy, as if riding in an unsprung farm trailer along a dirt road, or riding at a trot on a horse. There is no bar service for this reason, although pretty "purserettes" in trim blue airline-style uniforms will sell you duty-free bottles and cigarets.

As spray hammered on the 2½ by 3-foot windows, we streaked impudently
(Please turn to page 204)

PRINCESS MARGARET is not immune to weather. Huge wave last fall tore 8-foot hole in bow, 12-foot hole in skirt. Service was suspended for repairs



MORE EXCITEMENT THAN MEETS THE EYE



Those Small

Here are five imports that remind us motoring can be fun. Lined up from left: Saab De Luxe, BMW 2002, Fiat 124 Sport Coupe, Ford Cortina GT and Datsun PL 510.

By **ALEX MARKOVICH**

Photos by Stanley Rosenthal

THE KID in the chrome-encrusted, ego-boosting V8 glances scornfully at your little foreign sedan and yawns. You pretend you're watching something else, but sneakily you ease the stubby shift lever into first.

Green light. You kick the gas, pop the clutch and smile your cocky Walter Mitty smile. Yeow-w-w—the little Four winds up tight. The kid, caught un-awares, eats dust.

That's what these hot new sports sedans from Europe and Asia are all about. Camouflaged as somewhat flabby, asthmatic economy cars, they offer the comfort, passenger room and milquetoast appearance of a sedan—plus the performance of a sports roadster.

If you've had it with the big stuff, step right up and try a gen-yoo-wine





Sporty Sedans



BMW LEANS HARD (opposite, top). Sway bars in later 2002s correct this. The carb needed adjustment; on hard left turns, engine missed. Fiat (opposite, middle) corners the flattest. Well-located live rear axle takes any kind of road. Saab (opposite, bottom) will switch from understeer to oversteer by just letting up on gas. Front-wheel drive is stable on icy, snowy road surfaces. Cortina GT (top) leans hard in corners. Suspension is soft and front-end plowing limits car's maneuverability. Datsun (above) handling is respectable but not sensational. Skimpy bucket seats give no lateral support in hard turns, making it hard to reach car's full handling potential

imported Q-ship. Absolutely guaranteed to cure everything that ails you. But beware of imitations with racy names, gaudy stripes, chicken hearts.

To separate the sheep from the wolves, we wrung out five popular sports sedans, all roughly in the \$2000 to \$3000 range. The list reads like a UN roll call: from Germany, the BMW 2002; Italy, the Fiat 124 Sport Coupe; Sweden, the Saab De Luxe; England, the Ford Cortina GT; Japan, the Datsun PL 510.

Unfortunately, a few potent sedans are missing. The Opel Rallye from Germany probably would have made a good showing, but we couldn't get one in time for our tests. And race-winning machines such as the Lotus-Cortina no longer can be sold in this country; they're victims of antipollution laws.

BMW 2002

Our most expensive test car was the BMW. Though the ads say \$2847, all cars sold here come with \$161 worth of "options," including tachometer, front and rear sway bars, reclining seats, and vinyl upholstery; these bring the bill up to \$3008.

Though not revolutionary, styling is



clean and tasteful. All body panels fit just so and the paintwork is flawless.

The interior would do credit to a car costing \$1000 more. Everything is thickly padded. The underside of the instrument panel is covered to shield your sensibilities from the sight of dangling wires. Wall-to-wall carpeting is standard.

To hold assorted clutter there's a long package tray in the instrument panel, a glovebox that shuts like the gates of Fort Knox, a large storage bin over the floor hump (full of optional radio), and map pockets in the seat backs. The trunk, while smallest of the test cars, holds a respectable 9.5 cu. ft.

Smack in front of the driver are the big, round speedometer and tachometer, plus fuel and coolant-temperature gauges. Unfortunately, warning lights replace the oil-pressure gauge and ammeter, and the temperature gauge has no numbers.

Front seats fit anyone from an orangutan to the Jolly Green Giant. Headroom is ample front and rear, but adjusting the front seat for a tall driver makes the rear impossible for long trips.

The cabin, with glass rivaling that of a window factory, gives perfect visibility in all directions. Grab handles sprout from the doors and headliner, but they're rarely needed—at least in front. The firm, comfortable bucket seats hold everyone in place when the car is flung into corners with wild abandon (a caper that's hard to resist with the BMW).

The suspension probably is the car's

(Please turn to page 206)

BRAKING TESTS for the five sporty sedans were revealing. From top to bottom, photos indicate results for the cars as follows: Braking distances for such a sporting car as the BMW 2002 were disappointing. All the stops were essentially straight, however. Brakes of Fiat's 124 Sport Coupe fared well in the fade tests. The pedal's spongy feel did not seem to affect efficiency. Saab's brakes gave good braking distances after three panic stops, but there was considerable loss of directional stability. With the Ford Cortina GT, hard braking resulted in extreme nosediving. Stopping distances and directional stability proved fair. Best brakes of all come in Japan's low-priced Datsun PL 510. Repeated panic stops caused no noticeable fading

POPULAR MECHANICS



BMW 2002



FIAT 124

SAAB DE LUXE

CORTINA GT

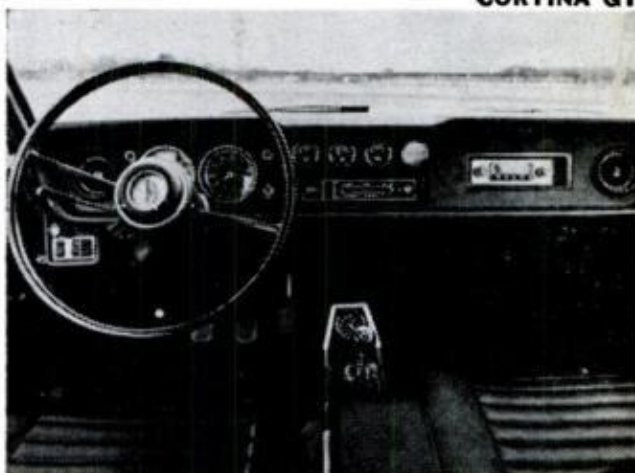
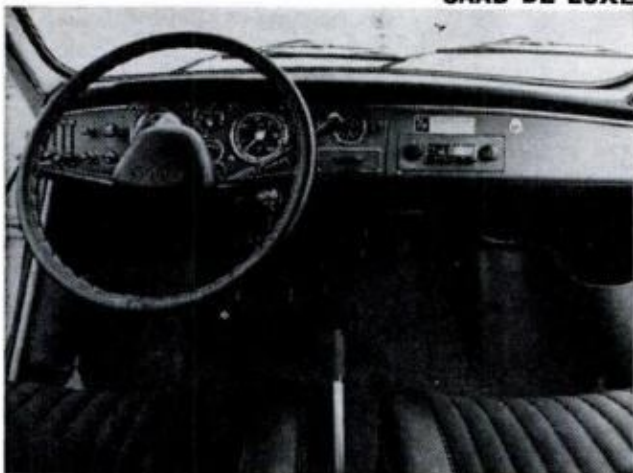

DATSUN PL 510

IMPORT'S INTERIORS all have bucket seats, but differ on many counts. BMW (top, above) has clock as center instrument, but tachometer is substituted in newer models. Steering wheel is too big and too high. Bucket seats have fully reclining feature, which is standard on BMWs coming into U.S. In the Saab (above), high cowl cuts visibility, especially for shorter drivers. Front-wheel drive gives flat floor. Fiat (top right), has immaculately designed cockpit. Gauges are set in wood-grain panel and controls are perfectly placed. Bucket seats are great. Cortina interior (right, middle), has nicely shaped bucket seats, but pedal placement is poor. Full array of round gauges is set in the handsome dash. Datsun interior (right), was executed with economy in mind. Also, gauges are hard to read: key, handbrake are inconveniently located



SMALL SPORTY SEDANS—HOW THEY COMPARE

	BMW 2002	FIAT 124 SPORT COUPE	SAAB DE LUXE	CORTINA GT	DATSUN PL 510
Price	\$3,008	\$2,878	\$2,550	\$2,243	\$1,999
Engine type/displacement (cu.ft.)	sohc 4/121.4	dohc 4/87.75	V4/91.4	4/97.5	sohc 4/97.3
Horsepower @ rpm	114 @ 5800	96 @ 6500	73 @ 5000	93 @ 5400	96 @ 5600
Length (in.)	166.5	162	164	168	162.2
Wheelbase (in.)	98.4	95.3	98.0	98.0	95.3
Curb weight (lbs.)	2068	2110	1940	2088	2127
Steering (overall ratio) /turns (lock to lock)	17.6:1/3.5	16.4:1/2.75	14.0:1/2.25	16.4:1/4.25	15.5:1/3.0
Turning circle (ft.)	34.1	36.1	35.0	30.0	31.4
Trunk capacity (cu.ft.)	9.5	9.6	13.0	12.0	11.4

When Radiators Were Regal

Text and Photos by MIKE LAMM

RADIATOR ORNAMENTS used to be to cars what faces are to people. Classic Packards, for example, were recognized by their hood statuary because Packard never stooped to emblazon its name on models of the late '20s and early '30s.

The ornaments had practical beginnings. At one time they housed stubby thermometers called motor meters, but as temperature gauges moved inside, the meters were replaced by graceful, often beautifully sculpted works of art. All but a few were gorgeously proportioned and painstakingly detailed, as these photos taken at Harrah's Auto Museum, Reno, Nev., plainly show.

Hood-ornament art reached its zenith about 40 years ago. Toward the mid-'30s abstraction began to set in and art directors rather than artists became responsible for hood ornament design. Ornaments became more clinical, less classical, reaching their nadir just after World War II. Soon, the plastic-cum-anodized aluminum lumps that became standard at the time spelled the final doom of the once magnificent radiator art.

With the recent advent of formal safety standards, the hood ornament all but disappeared. ★★★





1913 MERCER



1928 ROLLAND PILAIN



1931 BUGATTI ROYALE



1927 STUTZ BLACKHAWK



1925 MINERVA



1932 LINCOLN KB



1929 KISSEL WHITE



1927 DUESENBERG MODEL X



1928 FRANKLIN



1909 MODEL T



1930 DU PONT ROYAL



1913 COEY FLYER



1930 PACKARD



1936 HISPANO-SUIZA TYPE K6



1938 PHANTOM III



Talking doll helps analyze children's problems

Baby Belinda, a talking doll, helps therapists at Dublin Children's Hospital find causes of speech and behavior problems. While watching the child via a see-through mirror (above), a therapist talks to the child by means of an amplifier in the doll's head (far right). Therapists find that children are relaxed and more responsive when playing with toys.



Breath control

By puffing into plastic tubes, quadriplegic John Eygenraam can control his motorized wheelchair. Motors on the rear wheels are connected to sensitive switches that are, in turn, controlled by the air coming through the plastic tubes. The chair was made in the physics dept. of West Australia University.

112

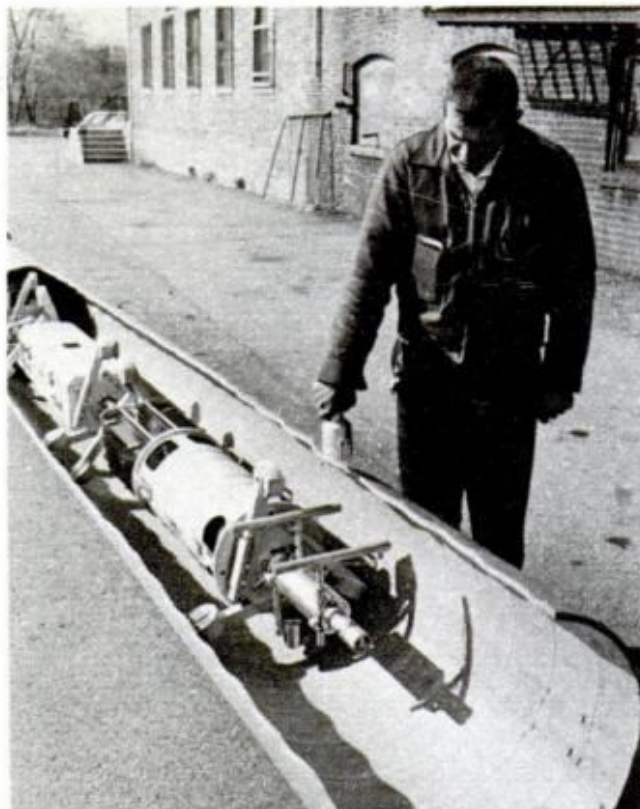

Automatic pipe inspector

This battery-powered X-ray machine can inspect the welds in a mile of pipeline before its nickel cadmium batteries need recharging. A remote-control device stops the machine at the joint to be X-rayed. It then emits a 360° beam, exposing a film strip wrapped around the weld. Flaws show up on the film.

POPULAR MECHANICS

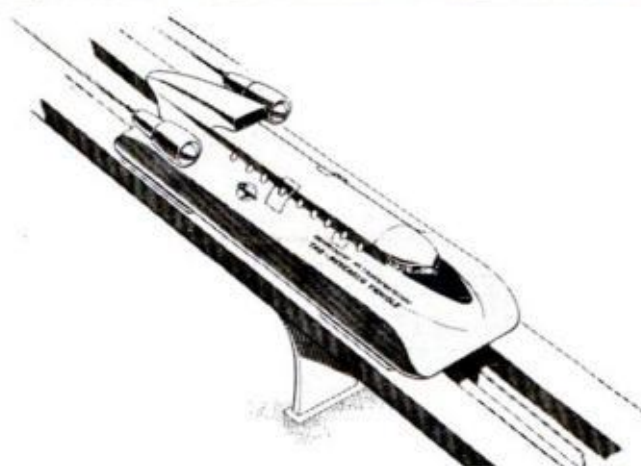

300-mph trains

A 300-mph air-cushion train might look like one of these two designs. The U.S. Dept. of Transportation has awarded contracts for a preliminary design study for a Tracked Air-Cushion Research Vehicle to General Electric (top drawing) and Grumman (bottom).

JANUARY 1969

Well done

Capt. Grant Callin leaves a research oven at Wright-Patterson Air Force Base where he and other volunteers are exposed to temperatures up to 500°F. as part of space-flight research. They wear only light flying clothes, and can tolerate 500° for about six minutes.

113

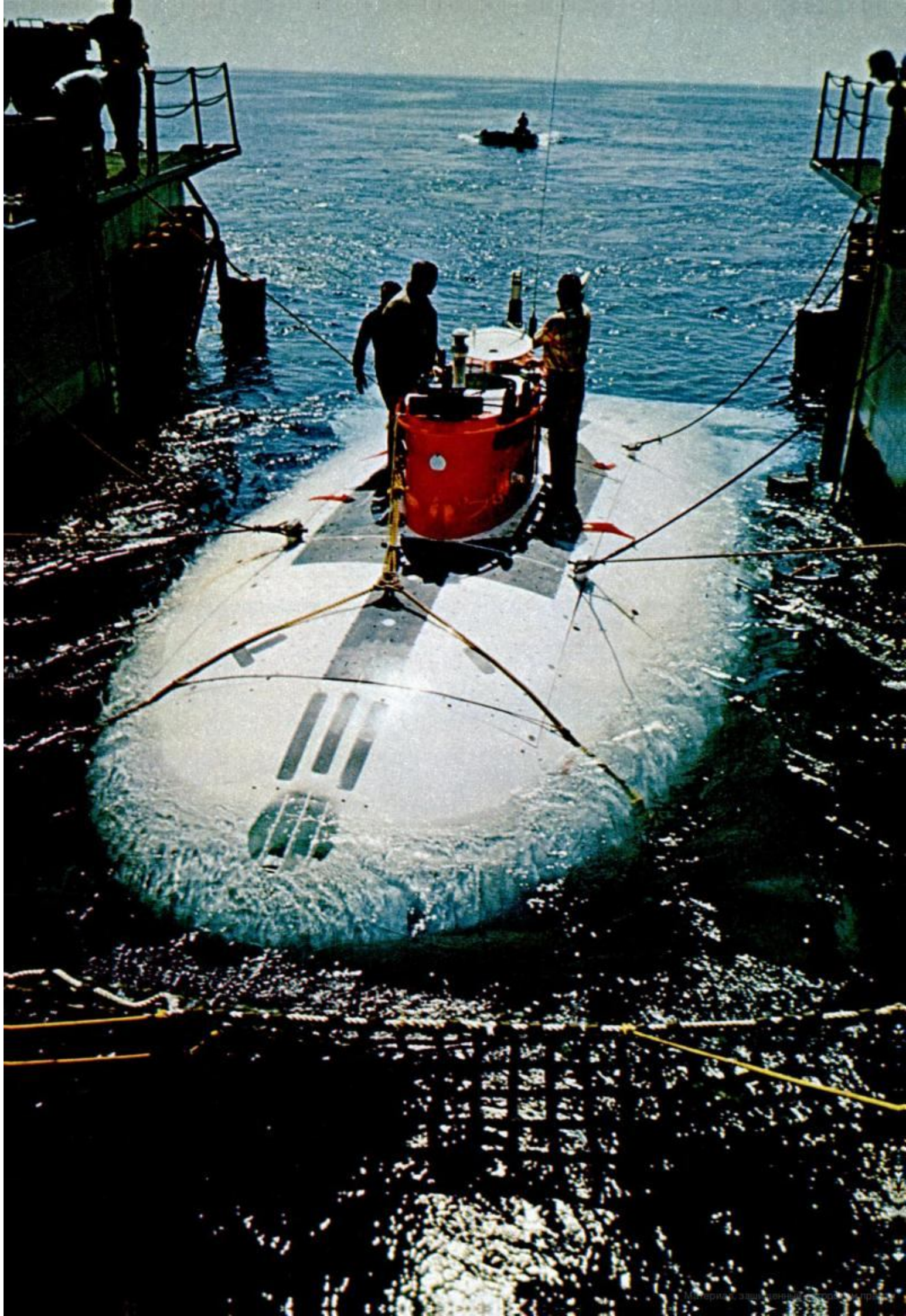

His Office Is Under the Sea

Lockheed's Donald Saner belongs to a new and select breed of submariners to whom the ocean depths are not a battleground but a frontier that should be explored and developed.

By **NORMAN SKLAREWITZ**
 Photos by James Pickerell

LIKE MANY GUYS before him, Donald Saner sweated out retirement from the Navy. He enlisted right after high school when he was just 18 and worked up through the ranks to lieutenant (j.g.).

Still, Don was a submariner—and what does a veteran of 20 years in the undersea service do in civilian life?

That's easy: He becomes a civilian submariner.

Don Saner today is a pilot with *Deep Quest*, the deep-diving submarine built by Lockheed Missiles and Space Co., and operated out of its ocean laboratory in San Diego. It's a challenging and fast-growing profession that involves exploring the secrets of the sea and paving the way for new

DON SANER (with telephone, left and right) guides *Deep Quest* as it is lowered to water level by its mother ship, *Transquest*, then floats on surface before making dive

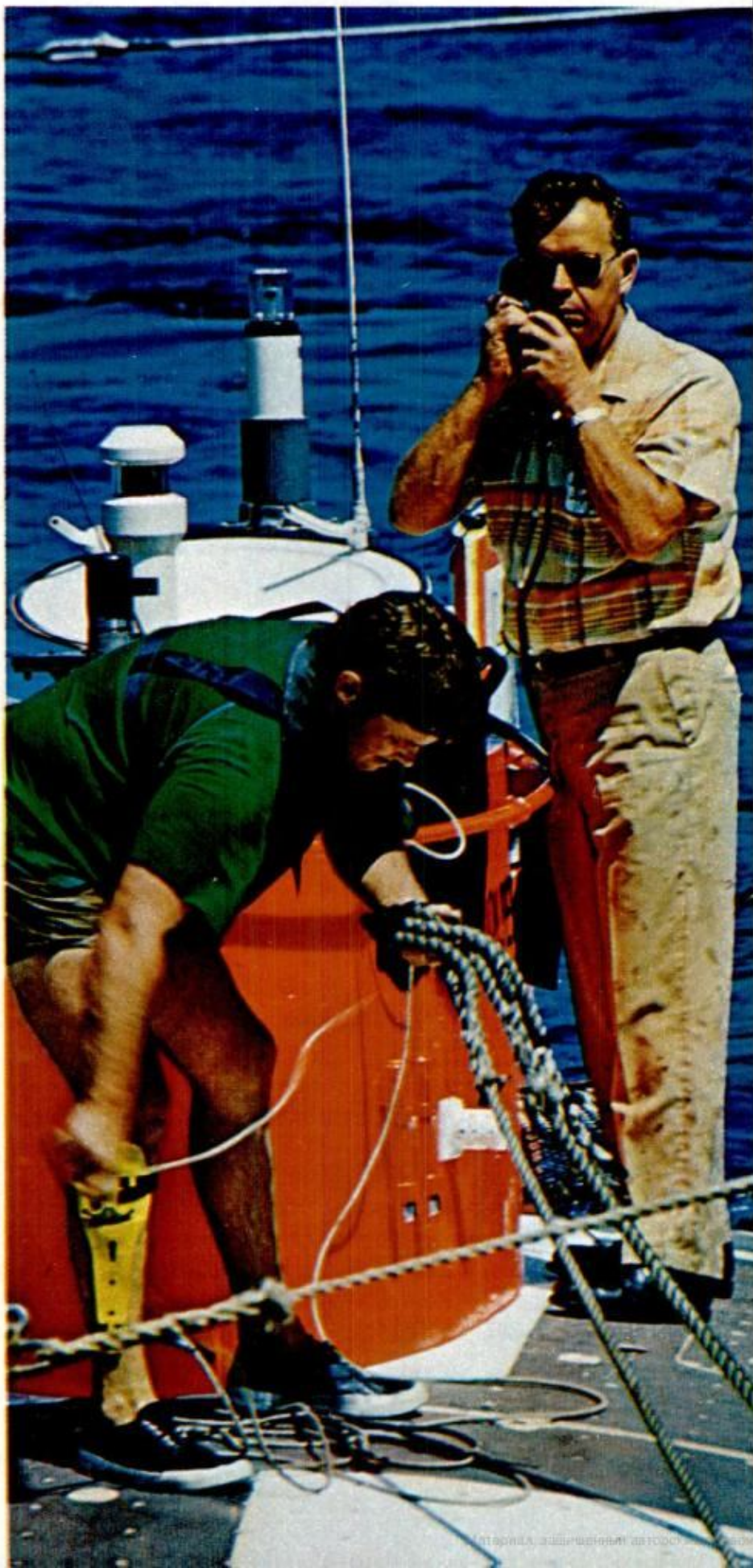

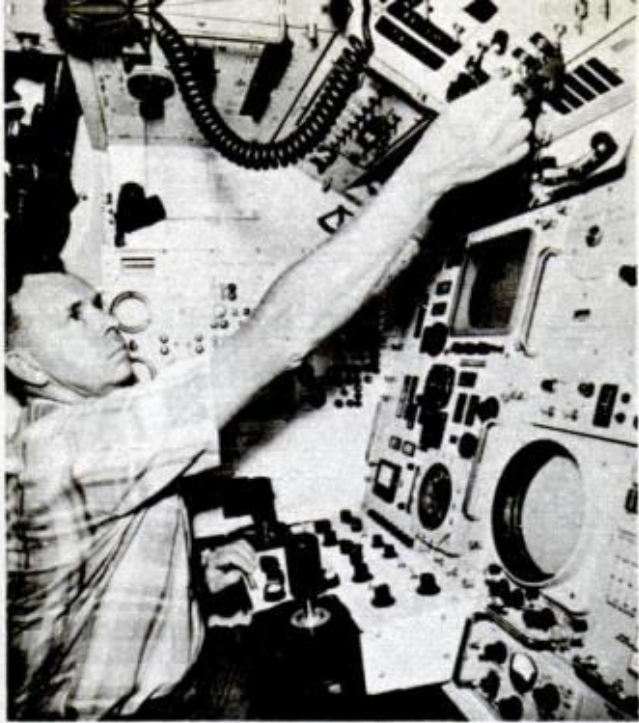

INSIDE SUB Saner checks control panel in pre-dive preparations. He was aboard during its record dive

traffic like any other Californian. By 7:30 a.m., he swings through a gate and parks in front of operational headquarters. It's the kind of spot in which an ex-Navyman feels at home. The blue waters of San Diego Bay sparkle a few steps away. Looming gray and imposing in the distance are anchored ships of the U.S. First Fleet.

Inside the two-story ops building are a half-dozen unimposing offices. Each member of the *Deep Quest* crew has two jobs, one during dives, the other ashore. Larry Shumaker, for example, has made every one of the sub's 24 shakedown dives, all as its commander. When the sub is in port, he's responsible for all its maintenance and systems repairs.

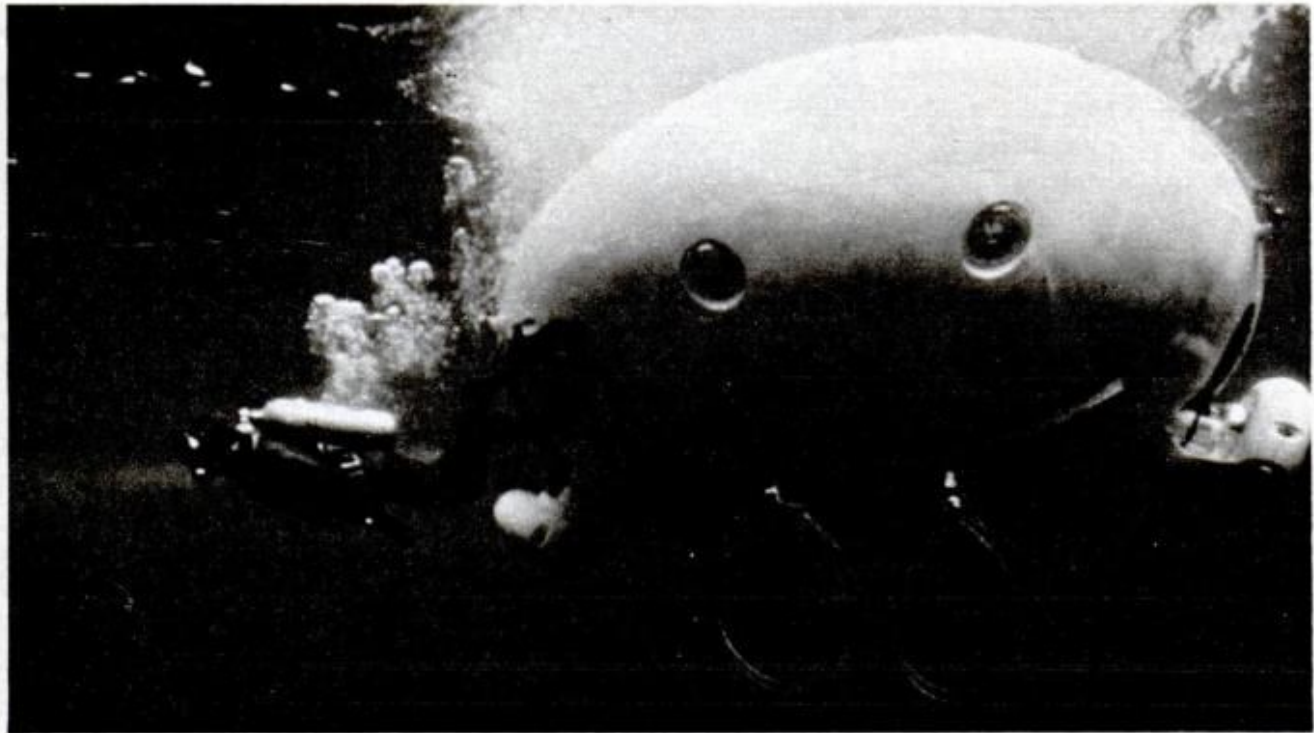

DEEP QUEST floating near surface on day it set record. Diver is making final inspection before it descends

industrial and military applications of underwater craft.

For now, though, being a civilian submariner is an exclusive thing. There are just 32 members of the Deep Submersible Pilots Assn. In the whole world, there are probably no more than 30 civilian subs.

Being part of this exciting new world, however, is still a job. So Don Saner pushes his Rambler station wagon through early morning freeway

Glenn Minard is chief pilot during dives and the man responsible for structural and mechanical operations of the sub.

Bob Worthington, a pilot, is also charged with planning and operations.

Don Saner is pilot during dives and, ashore, is the man in charge of the sub's electrical systems.

The entire staff is made up of 18 men under P. E. "Pete" Summers, program manager, and it includes Dave



DON SANER guides *Deep Quest* from above as diver checks connection around and beneath deep-diving sub

McCafferty, skipper of the 108-foot *Transquest* support ship, technicians and even a seagoing chef.

During its first series of two dozen dives, *Deep Quest* was tested to see how its motors, life-support systems and on-board equipment worked. The tests included a dive which took the sub down to 8310 feet, the deepest ever made by a commercial true submarine.

But when we visited there these trial runs had ended. It's since been made into a sub-for-hire, available on contract to industry and government, and

Lockheed sees a variety of uses for its whale-shaped craft. It can take core samples from the ocean floor for scientific or ocean mining or drilling operations. For equipment makers, it can take advanced underwater acoustic systems and equipment down for research studies or test checkouts. And the military is interested in *Deep Quest* to train aquanauts and to develop advanced underwater search and recovery techniques.

There's almost no such thing as an

(Please turn to page 215)

TRANSQUEST carries *Deep Quest* out to diving site where it will lower sub to water level on its elevator





Those Wonderful Brothers Wood



GLEN AND LEONARD WOOD time every lap of their car, work each race according to plan

Auto racing's most dedicated team has fielded the last five winners of the Riverside 500. This month Glen & Co. will be shooting for a sixth straight

By BILL KILPATRICK, Auto Editor

Photos by Stanley Rosenthal

HERE'S GLEN WOOD, race-car owner, the-man-in-charge, the head-knocker—early 40s, wiry, weathered, looking like every drover on every TV Western you've ever seen—policing his pit area.

When the chairman of the board stoops to pick up butts and stray candy wrappers, you realize you're looking at a man who takes his career seriously.

Here's Leonard Wood, race-car brood hen, top wrench, engine genius, micrometers for fingers—early 30s, also wiry, looking like a bespectacled seminarian—scrambling up under an upraised hood.

To observe his absolute concentration as he squats atop an engine and gets right down there to the serious business of carburetor adjustment is to understand you're looking at a man dedicated to his work.

These two men—Glen (“Don't know what happened to that other 'n'. Guess I dropped it when I started signing autographs.”) and Leonard Wood, from a nice little “down home” town called Stuart, Va.—are the backbone and full-time personnel of a colorful and highly successful enterprise known as the Wood Brothers, one of the winningest teams in auto-racing history. Cars prepped and crewed by the Woods have won the big 500-milers at Indianapolis (Jimmy Clark in '65), Daytona, Atlanta, Rockingham, Riverside, you-name-it. They've also fielded winners at scores of smaller tracks in the South, home and hotbed of stock-car racing.

At Riverside, their cars have won the annual 500-mile stock-car race five times in a row. This month, working a car driven by either Dan Gurney (who has won the race five times, four in a Woods Brothers car; their other winner was Parnelli Jones) or Cale Yarborough, perhaps a car for each, they'll be seeking their sixth straight. Consistency of this sort is impressive and far from a matter of chance, although the brothers gratefully acknowledge an at-least-nodding acquaintance with Lady Luck.

“The harder you work to prepare a car, the better your chances of winning,” says Leonard. “But luck has a big part in it, you can be sure of that.”

Another big part of the Woods' success is

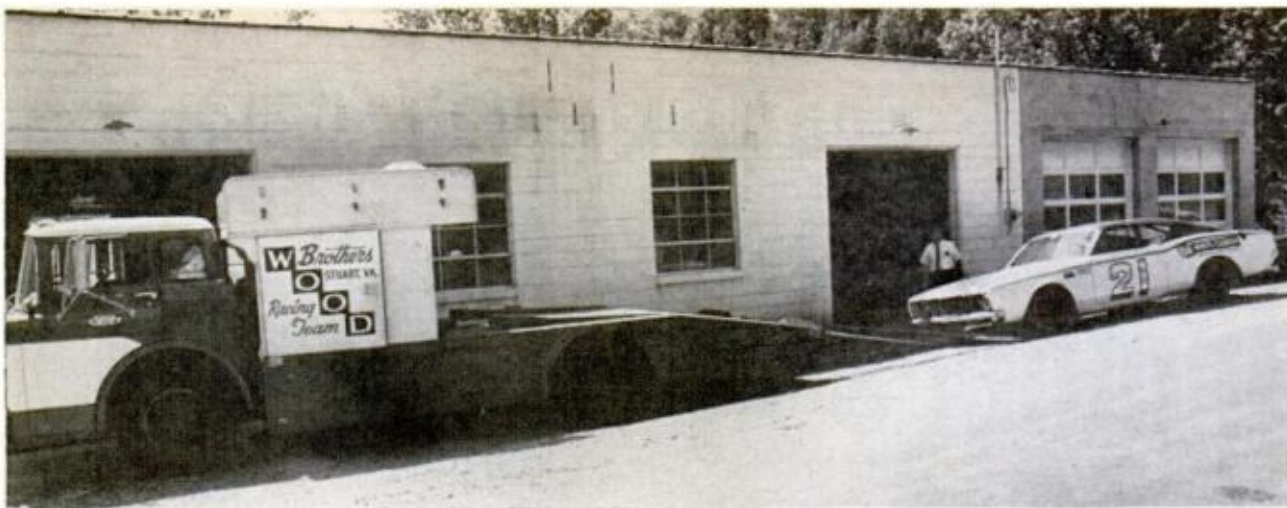

WOOD BROTHERS work out of modest garage in Stuart, Va. Race car is hauled to tracks via special truck

the great dedication and skill of the rest of the crew—brothers Clay (“He’s older,” says Glen. “He’s even 45!”) and Delano (they pronounce it De-lay-no), cousin Ralph Edwards and friend Ken Martin, all of whom are raceday regulars. From time-to-time, depending upon who can get away from his workaday job, other friends—Jim Reed, Jack Kendrick, Grover Adkins—help out.

Dressed alike in fresh, crisp uniform shirts, each of which bears the wearer’s name embroidered over the right pocket, and sparkling white ducks, they look like they mean business. To appreciate how much they mean business, you have to watch them work a race. Really watch them.

When a car they’re crewing is out on

the track, they watch over it like a mother bird watching a fledgling’s first flight. Despite the frenzy and ear-shattering noise of the race itself, they seem able to detect the slightest note change in an engine’s roar, the least variation in a car’s handling. Not a trick is missed as to what’s happening with and to their car at any point.

Glen or Leonard, often both, time each lap, shout the results to Delano, who, in a broad, graceful hand, chalks the appropriate numbers on a large, somewhat battered blackboard he then holds aloft for the driver to read as he flashes by. Ken Martin, in charge of refueling, tends to his gas cans—lining them up just so, carefully placing a protective rag and tin can over the neck of each. Clay and Ralph Edwards see that

GARAGE, neat, quiet and well-laid-out, affords Leonard a time, place to letter driver’s name on car door





WOOD BROTHERS are meticulous about small details. Delano mans broom in a pit area before start of race

the impact wrenches, new rubber, tools, jacks—whatever might be needed during a pit stop—are in place and ready to go. Jim Reed does the scoring, methodically records each lap the car makes. Jack Kendrick and Grover Adkins keep the pit area free of clutter, help position the tires and other equipment likely to be used at any given pit stop. All jobs, with the exception of those of Glen and Leonard, are interchangeable, all are performed with a relaxed informality that belies their seriousness.

When Glen passes the word and Delano flashes the driver to make a pit stop, the pace picks up in a blur of activity. Poised, the arms of their trade at-the-ready, they swarm at the car like bees. Each duty is specific and well-rehearsed.

Glen goes over the pit wall first. He darts in front of the still-braking car, heaves against the right front fender to help bring it to a halt. On his heels is Leonard, carrying an impact wrench and the 70-lb. right front wheel and tire. Poor timing on the part of either man means a sore back and a bruised rump.

In back scoot Ralph Edwards, carrying another impact wrench, and Delano, lugging a hydraulic service jack. Clay hops over the wall, twists open the fuel cap, reaches back to grab the right rear tire and wheel. He and Delano have clamped in their teeth short rods upon which are strung several new lug nuts.

Ken Martin, with a hand from Jack Kendrick (or whoever has the duty), goes over the wall hefting one of the big refueling cans. His feet dancing up and down a mile-a-minute, he slings the heavy can around and jams its neck onto the fuel intake pipe. It has to be the closest thing to in-flight refueling to be seen below 30,000 feet.

Delano sets the jack as Leonard and Edwards attack the right side wheels with the impact wrenches. He heaves the car up as the sorely-used rubber falls off. Clay, having brought the right rear tire around, drops it in position, unclamps his teeth to drop the new (and cool!) lugs into the palm of his hand. Delano, the car jacked up, steps toward the front, also releases the lugs

(Please turn to page 218)

ANOTHER RACE OVER, weary Cale Yarborough climbs out of second place car, is greeted by Leonard



The Flying Belt

The "Buck Rogers" belt now has a jet engine that gives it longer range for a whole new variety of missions. Who knows, someday it may even become a commuter's vehicle.



ROCKET BELT (above, in flight) is smaller, with shorter range, than new and bulkier jet belt

Stretches Its Wings

BUCK ROGERS suggested it and Bell Aerosystems produced it, but their rocket belt had a limited burning time and, consequently, a limited range. So Bell switched to a jet engine which now increases its time aloft from seconds to minutes, and its range from feet to miles.

Its military significance is apparent. One man in a jet belt could safely clear a path through a mine field, lay communications lines or flit about as an artillery spotter. Several of them could become airborne infantrymen, spotting and surrounding hapless guerrilla forces.

Civilian applications may be even

more spectacular. Police could use jet belts for riot control, spotting snipers or burglars, or for setting up roadblocks and chasing fleeing criminals.

And the average commuter may, at last, have the long-awaited individual commuting vehicle that would whisk him from his front porch to his office entrance in minutes.

Like the rocket belt, the jet belt is controlled by hand grips which allow the wearer to direct his flight up, down or in any other direction to a maximum of 70 mph. The specially constructed jet engine, one foot in diameter and two feet long, uses two nozzles for thrust.

★★★



JET BELT is strapped to user's harness and rests mainly on hips during flight. Stand supports it on ground. Jet engine is heart of system, giving belt more burning time and longer ranges. It burns ordinary kerosene fuel, the same kind used in airliners. The jet belt is expected to have wide application among both military and civilian users

Trim Tabs: Do They Really Make a Difference?

PM's stopwatch tests, plus a season of cruising, turn up some surprising facts about stern flaps

POWER OF TABS is indicated by wake within normal hull wake

By **ART MIKESELL**

Photos by Henry Bedlivy

IF IT WEREN'T FOR the fact that no hull is absolutely perfect, trim tabs probably would never have been invented. As it is, though, adjustable tabs provide the most efficient means of making a good hull perform better under various operating conditions. Here's why.

Any hull is a compromise shape, a combination of design factors put together to meet average requirements for that particular type of boat. A specialized design can come closer to perfection, because the performance requirements are so narrow. With an SK (high-performance ski boat), for instance, the designer can concentrate on quick getaway and speed. He doesn't worry about how the boat will handle in rough water, because nobody in his right mind would take an SK out in heavy seas.

It's the average boat that presents the problems. Survey the people who are going to buy it, and you'll find performance requirements stretching all over the lot. To satisfy everyone, it must have the speed of a three-point hydro, the stability

of a catamaran, the rough-water capability of a dory, the load-carrying ability of a barge and the appealing lines of Raquel Welch. Also, it should be priced within the reach of everyone.

Since a marine architect isn't a magician, the best he can do is mix the various design factors to produce a hull that has a little of all of the above. He may give up a little speed for increased stability, or vice versa, but the result is still a compromise.

Once you buy a boat, you're stuck with a locked-in set of performance characteristics. You can't change the hull lines to get a little more speed and alter them again an hour later to soften the ride in a chop. However, you can get about the same effect by adding adjustable trim tabs.

In case you've never seen a trim-tab installation, it consists of a pair of hinged flaps, similar to those on an airplane wing, mounted on the bottom of the stern parallel with the bottom of the hull. The best are adjustable from the helm and can be reset while under way. Those for

WITH TABS (left) bow-rise at start is minimal. Without tabs at start (center) bow-rise is quite awkward



small fishing boats, however, often have to be adjusted with a wrench while the boat is at rest.

Pushing the tabs down produces a lifting effect at the transom, the amount of lift being determined by how far the tabs are depressed. Each tab can be controlled independently to produce lift on either side of the stern.

Trim tabs have been around for a long time, but strangely enough, they aren't too well understood by many boat owners. For some odd reason, a few people still lump them with stern wedges and shingles (which are permanent additions mounted on the bottom of the boat) and dismiss them as stopgap solutions to bad design errors.

To clear up some of these misconceptions about trim tabs and find out just how well they really work for the average boat owner, *PM* mounted a set of Tempo's hydraulically controlled 18-in. tabs on Executive Editor Jim Liston's 18½-ft. cruiser and ran tests.

In this installation, all the cards were stacked against the tabs. Tempo engineers warned us that tab installations on deep-vee hulls, such as Jim's, were "touchy," and that the tabs would perform more efficiently on shallower vee or flat-bottom hulls.

Also, none of these tests were in the all-out speed end of performance, since we assume people spend more hours at cruising rpm rather than full throttle. Since tabs are dynamic mechanisms, however, they function more efficiently at higher speeds and more dramatic results probably would have been obtained from high-speed runs. We passed these up in favor of tests more closely meeting most boat owners' day-to-day requirements.

ON PLANE (right). It takes 11 seconds without trim tabs, and only 8 seconds with the tabs in operation

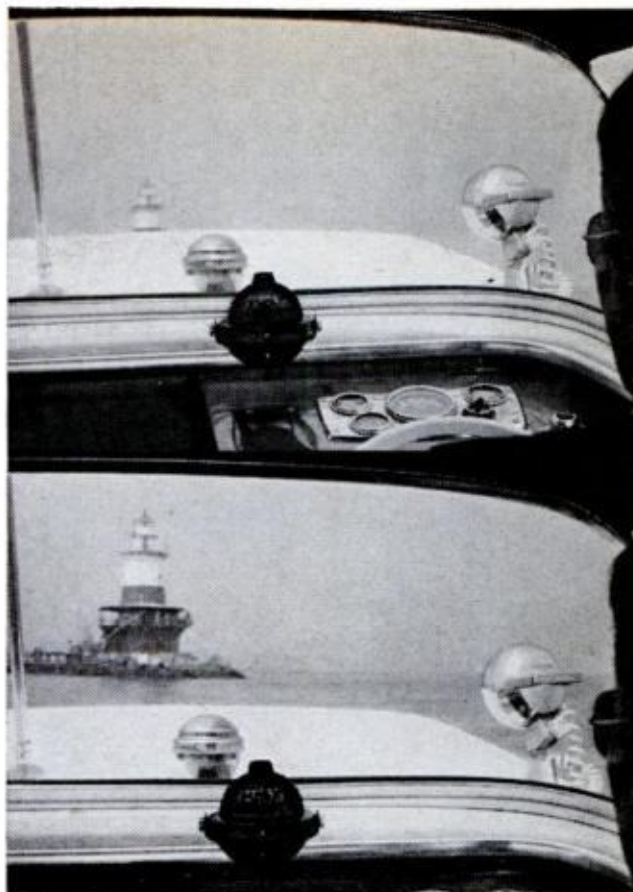

HELMSMAN'S VIEW while climbing to plane demonstrates tab's safety advantages. Top photo was taken as boat was squatting; bottom, on reaching plane

Here's a quick recap of the tests and the results we obtained:

Speed at cruising rpm

Test. Load consisted of normal equipment and full fuel tank, plus helmsman and passenger. To simulate the effect of two extra passengers, four 70-lb. concrete blocks were placed in the stern on either side of the engine box. Each test consisted of two two-way runs at 2500 rpm through a surveyed one-mile course. Results were averaged.

Results. Without tabs, the average time





through the course was 3 minutes, 50 seconds. With tabs down, average time dropped 10 seconds to 3 minutes, 40 seconds.

Conclusions. A 5 percent increase in speed was actually quite a sharp improvement in terms of this low-rpm test. However, there were other, more dramatic advantages which couldn't be measured, primarily in handling. For instance, the boat had an 18-gal. fuel tank mounted on the port side which caused the hull to lean and the steering to drag. In the tabs-down tests, the port tab was depressed fully, while the starboard tab was put down only part way. This brought the port side up, making possible hands-off steering. It also showed up in throttle control. With the tabs adjusted as described above, the helmsman could set the needle at 2500 rpm at the beginning of each run and the needle would hang right on the mark for the whole run. Without tabs, however, the boat was hypersensitive to wave conditions. The slightest wake would cause it to slow momentarily and begin to slip off plane, making the engine lug and rpm drop. When the throttle was readjusted to maintain a steady 2500 rpm, the boat would slowly climb back to a full plane, then scoot ahead. Once the load was off, the engine would stop lugging and the tach would show a sharp jump in rpm. All the no-tabs runs were marked by this continual need to readjust the throttle, a condition which completely disappeared when the tabs were used.

Low-speed cruising

Test. With the concrete blocks removed, the boat was run through an 18.2-mile course at a steady 2500 rpm, the owner's normal cruising rate. No tabs were used. Then a second run through the course was made at 2200 rpm, a minimum which would have been impossible without the use of tabs.

Results. The first run took one hour

INSTALLING TRIM TABS is a comparatively uncomplicated operation. Top photo shows the sharp deep-vee angle of our test hull. Tab location was first outlined and holes marked for drilling. The entire area under the mounting plates was then caulked to prevent leaks. Once the tabs themselves were in place, the hydraulic lines were routed through holes drilled above the waterline and up to control station at the helm. Lines were filled via the master cylinder at the control station and connected to tab cylinders

and required 5.3 gallons of fuel which cost \$2.11. The second run, at lower rpm (with tabs down), took 1½ hours, using 5.4 gallons of gas which cost \$2.17.

Conclusions. One unusual fact which came out of this is that tabs make it possible for you to get 50 percent more cruising time at no extra cost and at no sacrifice of comfort or handling. This may seem like a dubious advantage to water-skiers, but it's a big plus to the gunkholer who enjoys just cruising around at minimum rpm, enjoying being on the water. The only negative handling characteristic at lower rpm was a slightly slower recovery from waves and wakes. This was more than balanced by the decrease in engine noise.

Ability to hold a plane

Test. Concrete blocks were loaded aboard again to simulate a four-passenger load. Throttle was set at 2300 rpm.

Results. With tabs depressed, the boat held a full plane indefinitely. When tabs were raised, however, speed dropped sharply within three seconds. The boat slid quickly off plane and commenced to plow.

Conclusions. The ability of trim tabs to lower minimum cruising rpm was even more evident with a simulated full load, especially when the weight was concentrated near the stern as it is in most runabouts and small cruisers.

Climbing to plane

Test. With same simulated four-man load, the throttle was set at 1500 rpm, then jammed full-on to find how long it took to climb to plane. Three runs were made with tabs down, then three without tabs. Results were averaged.

Results. Tabs down, the boat planed in

LIST TO PORT caused by fuel tank and passengers on that side affected handling adversely without tabs



JANUARY 1969

8 seconds. Without tabs, it took 11 seconds.

Conclusions. This is a clear-cut demonstration of one strong advantage of tabs. It cut 3 seconds off that dangerous time when the boat was running bow-high with the helmsman's view almost completely blocked to nearby dangers.

General conclusions

Quick planing, low-rpm cruising, and to a certain extent, fuel economy seem to be the strongest measurable advantages that we discovered in these tests. However, the ones we couldn't measure—handling, comfort, ability to trim the boat to suit water conditions—may be even more important. Here's what Jim Liston had to say after a season of use:

"I started shopping for trim tabs after an unsatisfactory cruise one day with two heavyweight guests aboard. We had been loafing along and I gave her the throttle to get up on plane. While she labored to get up, I turned and saw my passengers looking frightened when they found themselves sitting 'way down there while I rose high above them. I cut the throttle. With those heavyweights back there, getting up on plane was a slow, sloppy operation all afternoon. Trim tabs have cured that. With fatties in the stern, I use full tab, give her the gun, and I'm up.

"It used to be that when a heavyweight traded places with someone on the port side, for example, I'd either have to ask him to move or run with a bad list. Now I compensate with a little more port tab and she trims out beautifully.

"Biggest advantage, though, is that in a chop I can keep this baby on plane at lower rpm. Instead of punishing the boat and jarring the passengers, I'm planing just fast enough to stay up there, which is where this boat belongs." ★★★

PORT TAB DOWN and starboard tab only partially depressed brought hull back up to perfect lateral trim



127



Lasers go underwater

Lasers are being used in underwater experiments to determine how useful the beam is in detecting ships, submarines and fish. Present laser equipment is expected to be able to penetrate for 1000 feet—five or six times the distance of ordinary light.



Basketball on unicycles

A new basketball league has been formed by the San Diego Unicycle Club—and the gimmick, of course, is that all players are on unicycles. One of the few rule changes for the one-wheelers: A player has only three wheel revolutions before he must dribble.



Airborne cleanup for oil spills

Detergent sprayed from two 11-foot booms suspended under a helicopter can clean up oil spills in the ocean. The spraying device is shown during a demonstration by Mobil Oil off the coast of Louisiana.



Instant replay disc

The highly polished and plated aluminum disc is used to record color television images for instant replay during sports broadcasts and to record documents in information systems. Maker is Ampex Magnetic Disc Dept.



Little Harvey is a pop-up specialist

When an umpire in the Oakland baseball stadium needs a new supply of balls, all he does is give a signal and Little Harvey rises out of the turf, lifting the baseballs on his head. Umpire Al Salerno is shown utilizing Harvey's services, while the fans watch with amusement.



Road signs for flying cops

German police are experimenting with huge arrows along the autobahns to mark control zones so helicopter-borne officers can spot traffic offenders more easily. Motorists talk of retaliating by camouflaging their cars.

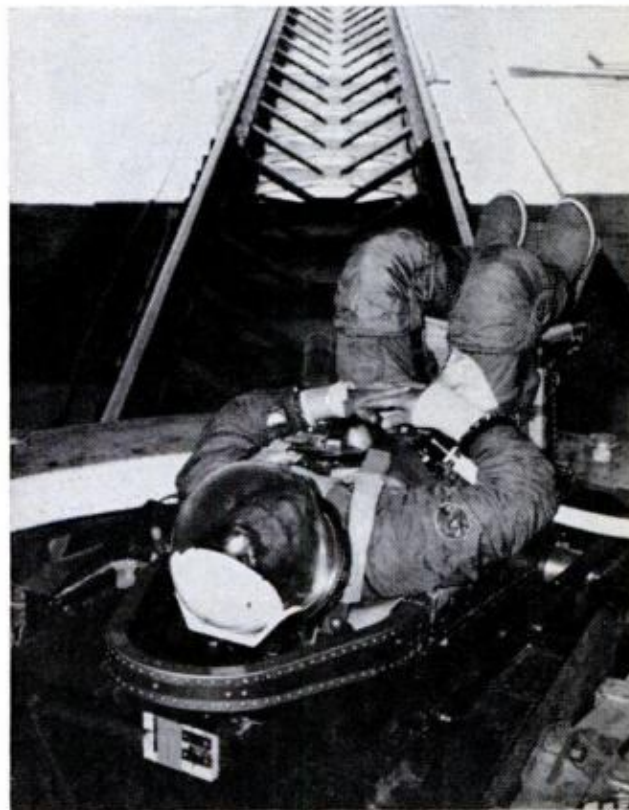

Preflight re-entry test

Among the ground tests of Apollo equipment before the astronauts went into space was this decelerator run. Air-propelled sled, stopped by water brakes, showed how Apollo couches would stand landing impact.

ANYONE CAN MAKE Darkroom Sink With a

By R. S. HEDIN



PRINTS ARE WASHED AUTOMATICALLY at one end of sink while processing is going on in trays at other end. Jet spray is made from plastic pipe and stock fittings. Partition holds in water

ANYONE who does his own photo processing usually longs to have a big, professional-type sink and an automatic print washer—items that in commercial form are far too costly for a home darkroom. This homemade wood sink gives you both features in a single unit that's easy to build.

The setup makes for a speedy assembly-line operation. The washer is right next to your processing trays. As prints come out of the trays, you plop them into the wash water without having to move. Jets of water swirl the prints and separate them, thoroughly washing both sides.

You can vary the size of the sink to suit your own needs and space. The dimensions shown here provide plenty of room for the print washer at one end and three good-sized processing trays at the other end. The trays rest on a removable drain rack that makes it easy to keep the sink clean.

The washer section is partitioned off with a slip-in gate of thin hardboard. This forms a dam, keeping water in the washer. Water is fed in through spray jets made by drilling small holes in a length of plastic pipe, as shown at left. An overflow hole in the gate allows dirty water to drain off as fresh water is added, maintaining a constant level.

The gate is held in slotted cleats and can be slipped out to drain the washer quickly after use. While it should fit fairly snugly, it doesn't matter if it leaks a bit around the edges

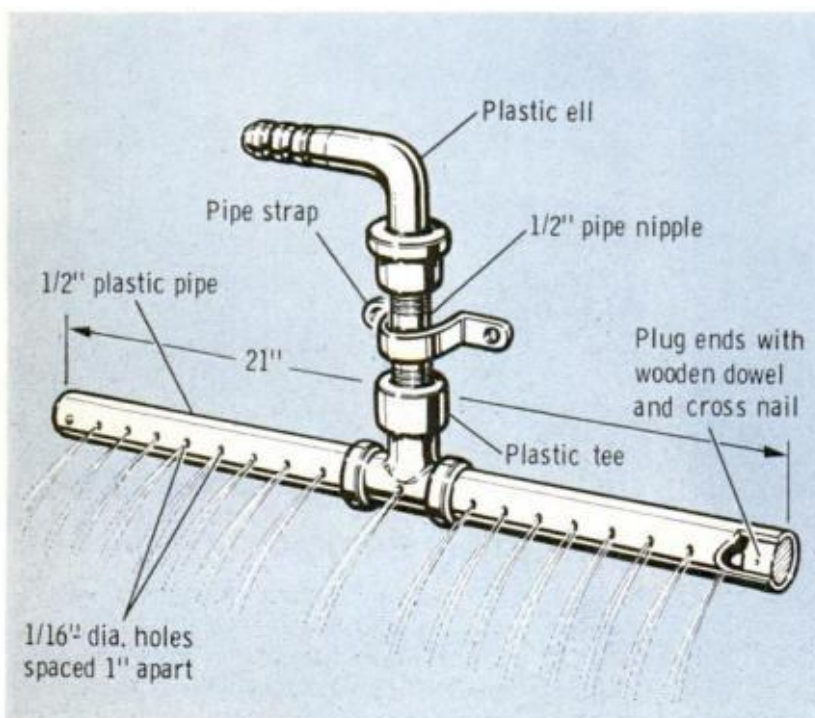

THIS SIMPLE WOOD-FRAME Built-In Print Washer

Technical Art by Indugraph



T-SHAPED INLET PIPE has two faucets, one for processing section and one for print washer. Shelf below the sink stores chemicals, as shown at right

since the washer is constantly draining anyway. To make the sink itself watertight, use waterproof glue at all seams and finish the wood with several coats of sealer and enamel.

The sink is made self-draining by dishing the tray end slightly, as shown in the drawing. A hole is drilled through the bottom at the lowermost point and a drain hose is attached. Water flows automatically from the print washer down into the dished end and out the hose. To help the draining action, also shim up the sink slightly at the washer end—about half a bubble on a spirit level.

If your darkroom should be located near a basement floor drain, it's a simple matter to run the sink hose into this, eliminating the need for permanent plumbing. If this

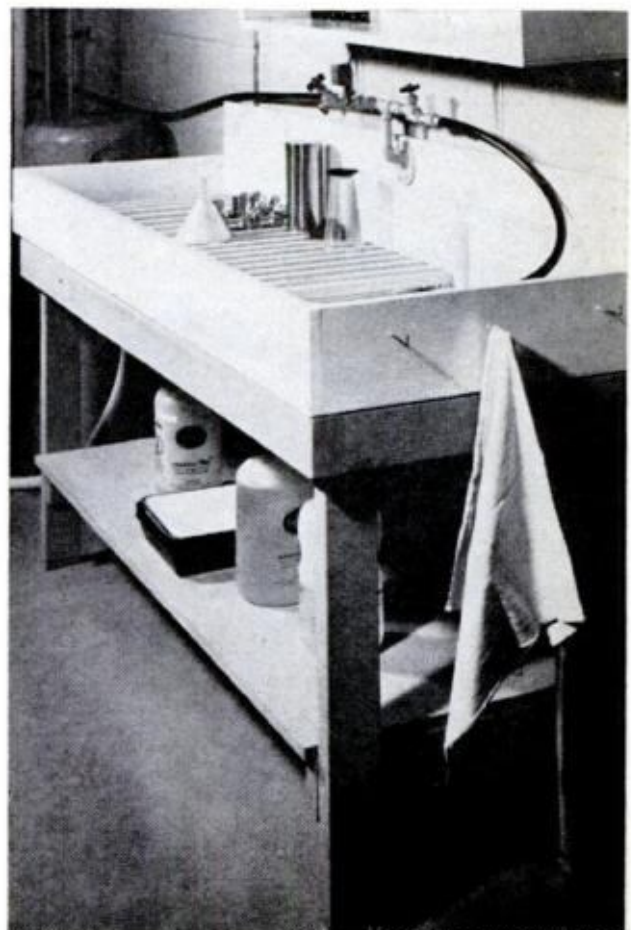

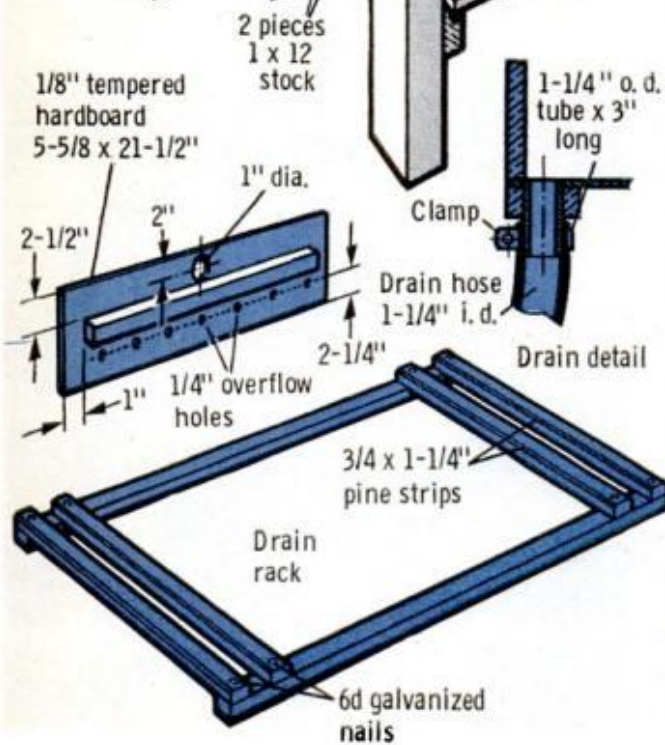
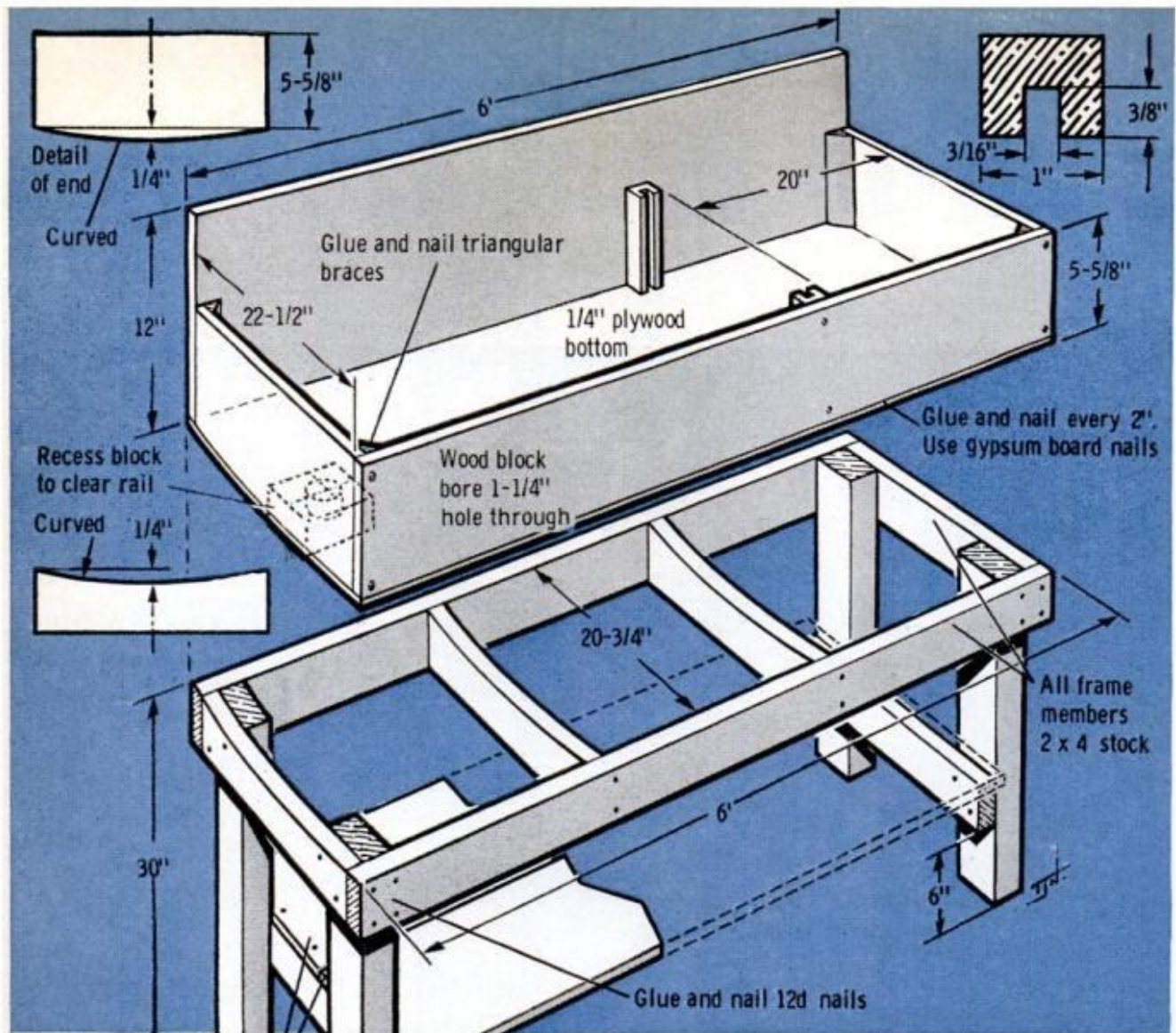

isn't possible, a connection can usually be made easily at the trap opening in your main sewer drain.

The water inlet is a T arrangement with a faucet at each end—one to control the flow to the print washer and one to provide water for the processing section. Either faucet can be operated independently of the other. The T, in turn, is connected by plastic hose to a standard mixer faucet on a nearby washtub, permitting water temperature to be adjusted as desired.

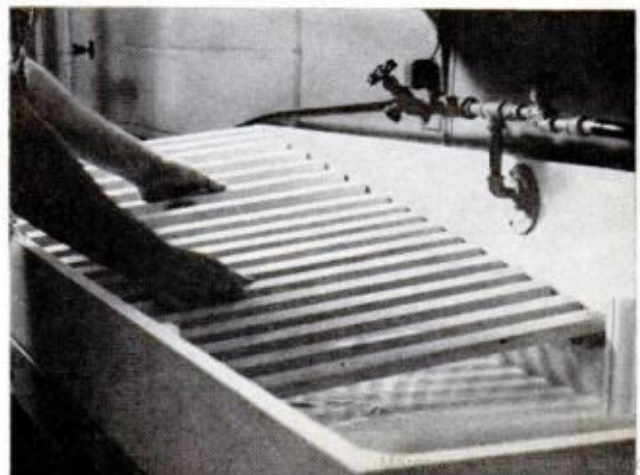

REMOVABLE DRAIN RACK supports processing trays, is lifted out for easy cleaning of sink. Drawing shows how sink bottom is rounded to drain off water

PHOTO HINTS

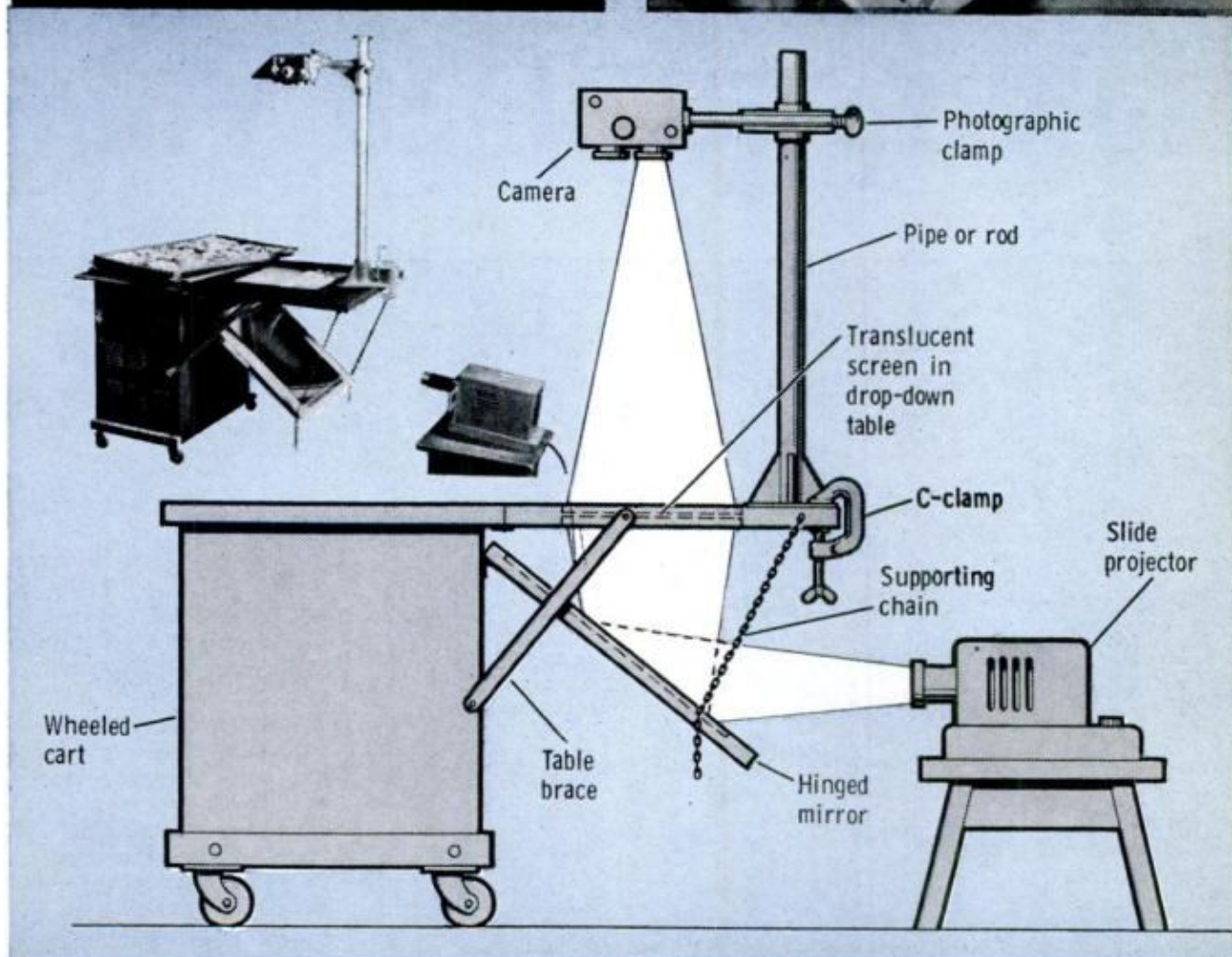

DRAMATIC TITLES FOR SLIDE SHOWS are easy to produce with this setup. You project one of your prize slides onto a translucent screen, arrange titling letters on top of the screen, then photograph both together. The result is an ingenious, Hollywood-like effect in which your title appears magically superimposed right on the picture. You'll need a piece of opal glass or white translucent plastic about 18 inches square for the screen. Below this, arrange a mirror at a 45° angle so the image from your slide projector can be directed upward onto the underside of the

screen. Movie titling letters, available in many sizes and styles at photo stores, are then laid out on the screen, as shown at upper right. Turn on the projector and measure the light at the screen with an exposure meter. Using color film with an ASA rating of 125, typical exposures are 1/50th of a second at f/8 or 1/10th of a second at f/22. With slower ASA 25 film, exposures run to 1/5 of a second at f/5.6 or half a second at f/8. To be safe, bracket a stop or two on each side. I used a small wheeled cart to mount a hinged mirror and screen, as shown.—*Frank E. Hewens*

Your ignition cables may look good, but beneath the insulation they could be damaged. Here's how to check and replace them before your engine starts to misfire

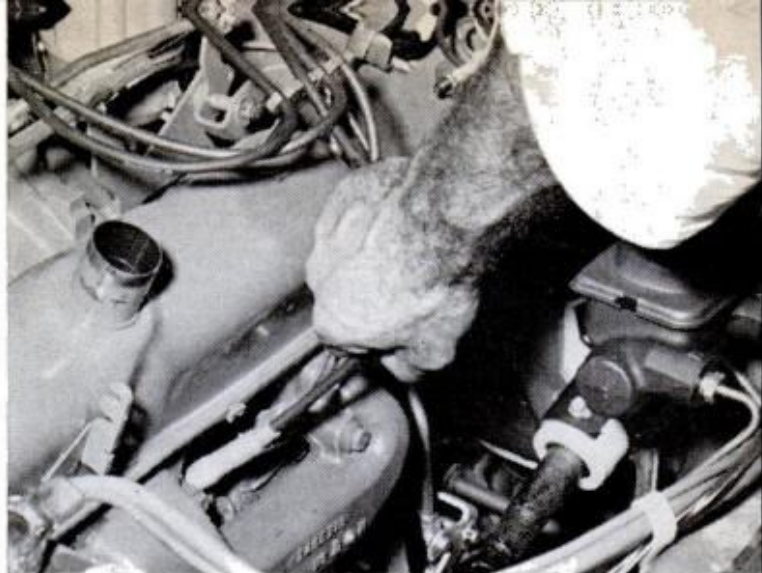

MANHANDLING can damage conductor inside ignition cable. Don't copy bad example; handle by boot

How to Replace Your

By **MORT SCHULTZ**

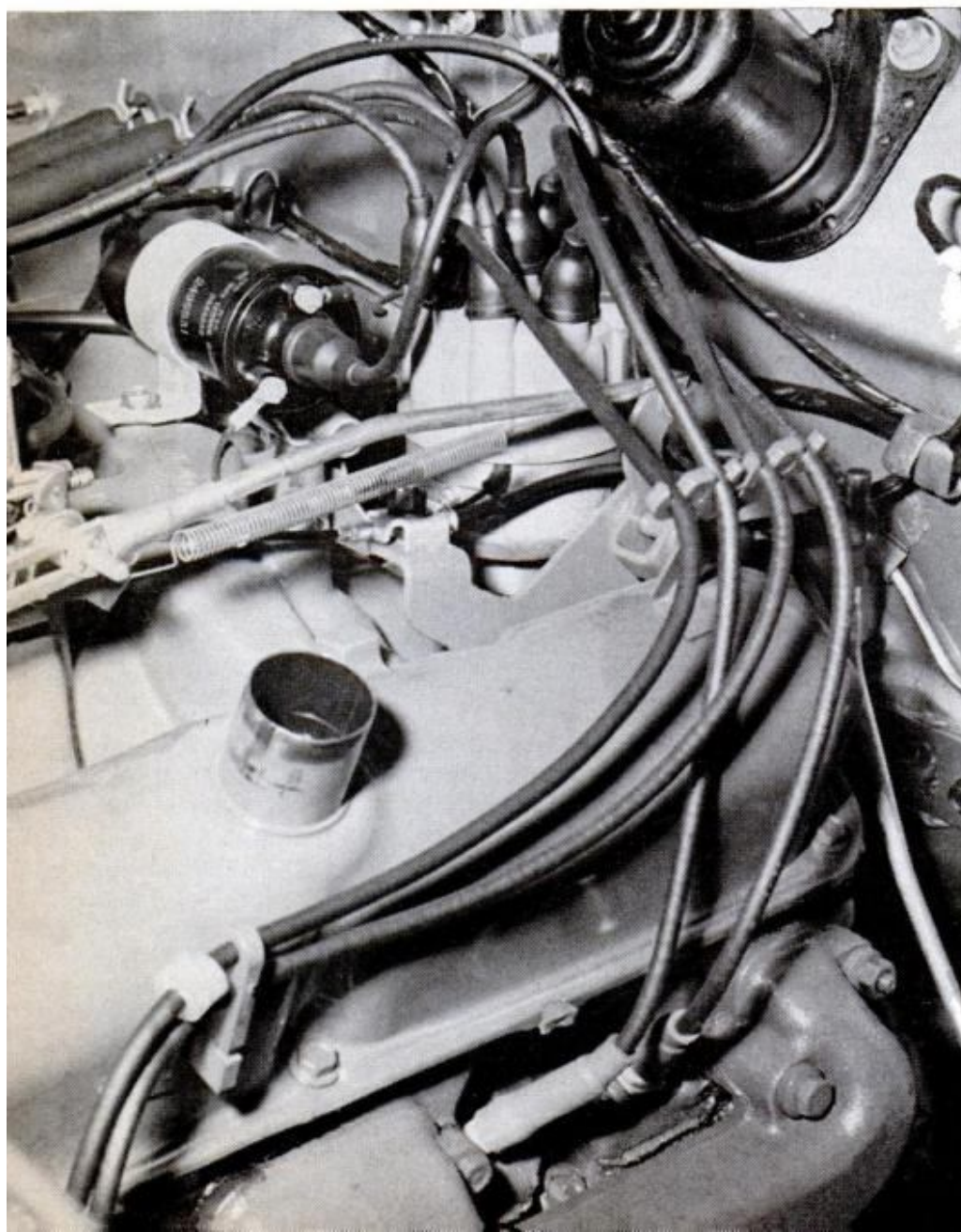

IGNITION SYSTEM secondary circuit uses TV and radio suppression (TVRS) cable to carry high voltage. At times called "resistance" cable, it suppresses the electrical pulses of the ignition system to minimize interference with surrounding radio and TV reception and reception on your car radio. Cable connects each sparkplug to distributor cap and the coil to center tower of the cap. One tipoff that cable may be damaged and need replacement is a misfiring engine

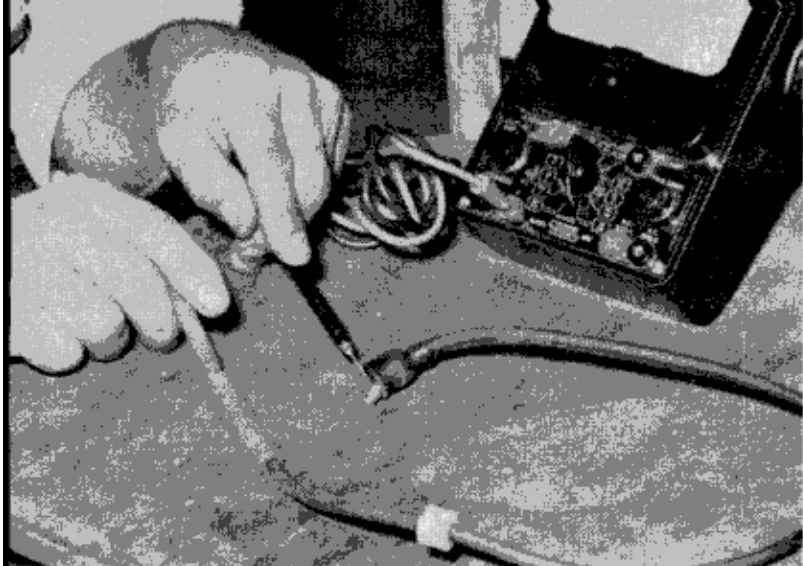

SPARKPLUG CABLE RESISTANCE, checked with ohmmeter, should meet specs, usually about 20,000 ohms



SPARK INTENSITY gives idea of cable condition. Damage results in too-high resistance, weak spark

Car's Ignition Wiring

YOU MAY HAVE WONDERED why it should ever be necessary to replace ignition wiring. If the insulation is still good and the wiring is not visibly damaged, what can be wrong with it? The answer is that ignition wiring is not conventional copper wire. It's "electronic suppression cable" often referred to as "TVRS" for television and radio suppression cable, and it can be damaged internally.

These cables, as their name indicates, reduce electrical pulses emitted by your ignition system which interfere with surrounding radio and TV reception and also with reception on your car radio.

The construction of TVRS cable is unique and has been the subject of some controversy. Actually the controversy over suppression-type secondary ignition cables has been going on for almost 20 years. Only the other day, for instance, a man wrote *Auto Clinic* that his mechanic told him, "The only reason car manufacturers use TVRS cable is to reduce costs." This man's letter is typical and points up some serious misconceptions about TVRS cable. In fact, some mechanics are going so far as to recommend that TVRS cables be replaced with the older type copper conducting cable which does not use a graphite-shrouded conducting center to provide the resistance needed for electronic suppression. This is not necessary

and I think it's time we explored the truth about the vices and virtues of TVRS cable.

As you know, the secondary cables in your car are those which connect the distributor cap to the sparkplugs, and the one that connects the center terminal of the distributor cap to the center terminal of the ignition coil. Pontiac was the first to use electronic suppression cables in 1950. Since then, every major manufacturer in the country has made the cables original equipment on new cars.

It's true that many car owners have been experiencing trouble with these cables. Most times, the conductor strands separate, causing excessive resistance and insufficient current at the sparkplugs. The result is engine misfire. However, in most cases this trouble is a direct result of shoddy handling of cables by mechanics, including many Saturday Mechanics.

What is *not* true, though, is the contention by the mechanic quoted above that TVRS cables cost less money than copper conducting cables. Actually, electronic suppression wiring costs about 50 percent more than copper cables. The additional expense results from the way in which TVRS cables are made.

The center conductor is composed of strands of linen or glass fibers around which is usually woven nylon thread. This assembly is immersed in a liquid graphite

solution which is then coated with liquid neoprene.

At this point, the assembly is tested to make sure that resistance is uniform over the entire cable. A resistance of no more than 1000 ohms per inch is typical.

Finally, the assembly is covered with rubber insulation, around which is placed an outer jacket of neoprene to protect the rubber insulation from oil and grease.

Interference is a problem created by the automotive ignition system every time a spark occurs at a sparkplug. The very-high-frequency oscillations in the secondary circuit when a plug discharges cause electromagnetic waves to radiate.

When resistor-type ignition cables are introduced into the ignition system, however, this interference is reduced by reducing the peak current that flows as the sparkplug discharges. Without resistance, this peak current may reach 200 to 500 milliamperes. With resistance, it is reduced to between 1 and 10 milliamperes.

Generally, automotive ignition systems can tolerate up to 20,000 ohms of resistance without any undesirable effects. However, the exact resistance limit of each cable depends upon the cable's length. For example, with the 1968 Plymouth, the allowable resistance is as much as 30,000 ohms. You'll need to know just how much resistance your car maker allows for cables, so check the service manual.

In testing cables to assure they have not exceeded resistance limits, the most accurate way is with an ohmmeter. The best place to get one is in an electronic supply

TO REMOVE CABLE from sparkplug, grasp the boot firmly, give a slight twist and pull off straight

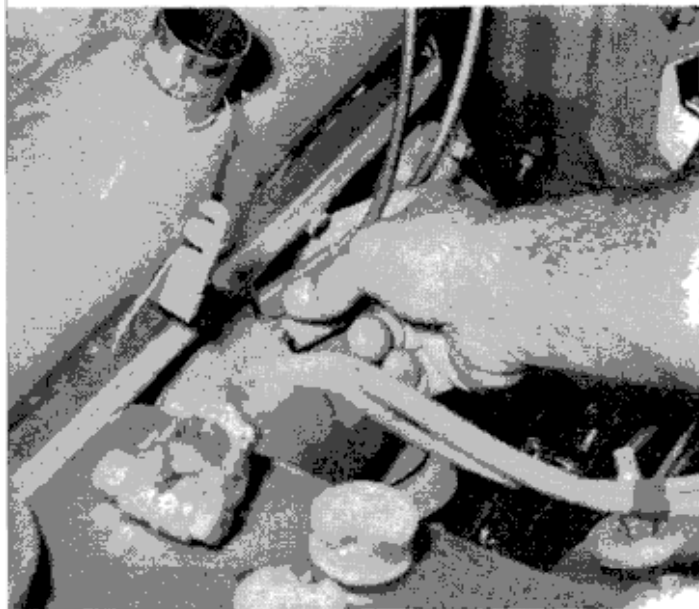

store. One that will do this job will cost you about \$10.

Remove the cable from the car, lay it on a bench and probe the cable terminals with the meter leads. The meter's reading shouldn't exceed the allowable resistance limit for the cable. If it does, the cable is damaged and should be replaced.

Don't forget to test the coil-to-distributor cap high-tension cable, too. The resistance of this cable is usually less than that of sparkplug cables. For example, as mentioned, sparkplug cables of the 1968 Plymouth are rated at no more than 30,000 ohms. The resistance of the coil-to-distributor cap high-tension lead of this car should not exceed 15,000 ohms.

If an ohmmeter isn't available, a less accurate way to find out how a cable is functioning is by the spark intensity test.

Disconnect the sparkplug cable from the plug and insert a terminal adapter in the terminal. Hold the adapter about 1/4 inch from a good ground, such as the exhaust manifold, and crank the engine. A good spark should jump the gap at regular intervals.

If the spark intensity of all wires is satisfactory, the coil, condenser, rotor, distributor cap and secondary wiring are okay. If the spark is equal at all wires, but weak and intermittent, the fault lies with the coil, distributor cap, or coil-to-distributor high-tension lead. If there is a weak or intermittent spark with some wires only, those cables are probably damaged and should be replaced.

Some Saturday mechanics will contend that when they replaced TVRS cables with copper wiring and resistor sparkplugs, their engines stopped misfiring. Sure they did, but let's look at the likely reason.

Most people in changing cables also replace or clean sparkplugs and distributor breaker points. It's quite likely that in making these other changes, they removed the *real* cause for a misfiring engine. Even the simple action of removing a cable ending from a sparkplug which has a dirty terminal can eliminate a cause of misfire. The terminal could be wiped clean by movement of the cable ending.

Certainly, changing to copper wiring and using resistor plugs will provide electronic suppression, but this is the expensive way of doing things. Not only do you have to pay for new cables, but those plugs cost about \$1.50 each. That's \$12 for

plugs alone. By comparison, replacing every cable in an eight-cylinder engine with TVRS cable costs only \$8.50.

I wouldn't recommend that you operate your car without some means of ignition system suppression. Forget the other guy's TV and radio. *Your* car's radio will be affected. So will your sparkplugs. Without some resistance in that ignition system, there's an increase in amperage across the sparkplug gap which can quickly erode the electrodes and ruin your plugs.

Cables are handled frequently—every time sparkplugs are cleaned or replaced, and whenever the ignition is timed.

If not handled correctly, a cable's thin, fragile conductor can be pulled apart. Once broken, resistance within that cable increases and engine misfiring can result.

So, never grab the cable at its center and jerk it from a plug, and never flex the cable back and forth or twist it. Don't puncture the cable with a probe either. This causes separations in the conductor. The correct way to remove sparkplug cables is to grasp the rubber boot or molded cup and twist it slightly to break its seal. Then, lift the boot (and cable) straight up with a steady, even pull.

If you really want to be safe, you can use special pliers (about \$2.50 at an automotive supply store) that allow you to remove and handle TVRS cable with little danger of damaging it.

Here are other facts about TVRS cable:

- Electronic suppression cable is sold either in packaged prefabricated sets ready for installation or in reeled bulks

SPARKPLUG CABLE PLIERS, used by pros, give good leverage for removing cables without damaging them

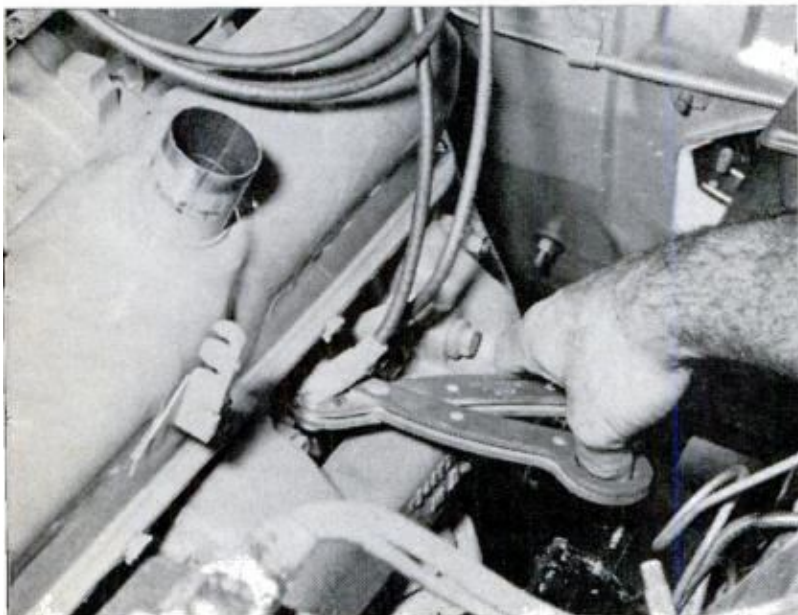

JANUARY 1969

of 100 feet. I recommend the prefabricated sets, because they come with terminals and boots and in the right lengths. Cost is about \$8.50.

A reel of wire, on the other hand, will cost you about \$14. You must measure each cable to the exact size of the old cable and cut it from the bulk. Boots and terminals must be attached, which calls for crimping terminals to the cable. You have to buy boots and terminals separately. Boots cost about 15 cents each—terminals about 10 cents each.

Electronic suppression cables, by the way, can be identified by labeling on the cable, such as "electronic suppression" or "Radio-GM TVRS."

- Any cable that is frayed, corroded at the terminals, or has cracked insulation should be replaced. Wipe cables with a kerosene-dampened cloth to check them.
- Although cables might be in good condition, they should never be allowed to operate with defective sparkplug boots. If boots are cracked, replace them. They allow carbon tracks to form on a sparkplug insulator and cause the plug to short.
- There's a knack to seating cables in the distributor cap towers. Improper seating causes a gap that allows corrosion to form. This can lead to misfire.

Install the cable and boot assembly over the tower, entering the terminal into the tower. Push lightly. Then, pinch the large diameter of the boot to release air which may be trapped between the boot and tower. Continue pushing and pinching the boot until the cable is seated. ★ ★ ★

ON DISTRIBUTOR CAP, fully seat cables by pushing down while squeezing boot to release trapped air

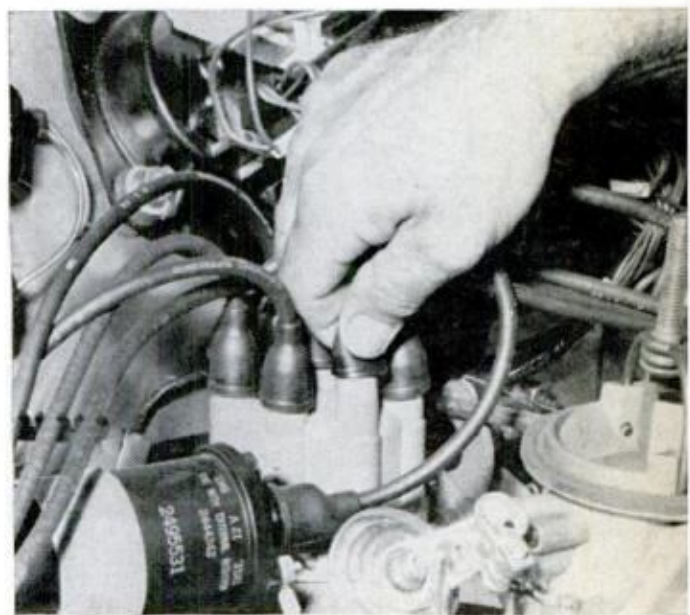

137



8 WAYS TO HOP UP

Modifying your two-cycle motor, like the racers

By HANK and VERA BRADSHAW

RIGHT NOW, you can probably do 40 to 50 mph with your snowmobile. But by hopping up its engine you can add 4½ hp, 500 rpm and get about 65 mph out of your machine.

Methods shown here were actually used by experts, including Dave Bode at Polaris Manufacturing Co. in Rouseau, Minn.

We took a German-made, 372-cc JLO two-cycle engine designed for 20 hp at 5000 rpm. The modifications shown can be done on most any two-cycle reciprocating snowmobile engine.

Engine modifications include the polishing and altering of the intake and exhaust ports; milling the head; boring the cylinder to oversize; skirting the piston, and golf-balling the piston. You may also want to increase the size of the carburetor from the normal 1⅜ in. to 1½ in. Specialty companies make an adapter block so you can mount the large carb.

Changes in exhaust system will produce the most noticeable power increases, but engine changes must be made first or the new exhaust system will not affect power.

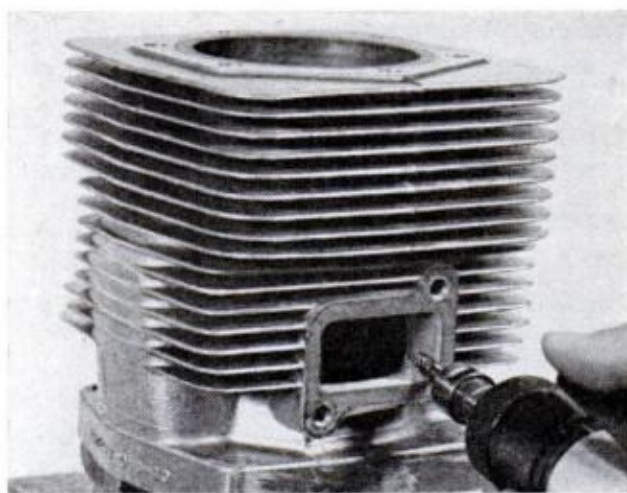

POLISHING PORTS. With a drill-file, carefully polish the bottom of the carburetor intake port and the top of the exhaust port. This cat's-whisker alteration lets more fuel vapor into engine and allows better exhausting of the cylinder. These ports are cast and rough to the touch. You want to polish them smooth—that's all. Be sure not to remove too much. Adjust the timing for engine efficiency after altering ports.

CUTAWAY OF SNOWMOBILE ENGINE shows various parts involved in a modification. Photo at right shows piston at the bottom of cycle. The transfer ports are visible behind the piston. Photo below shows piston up. Carburetor intake port can be seen beneath piston

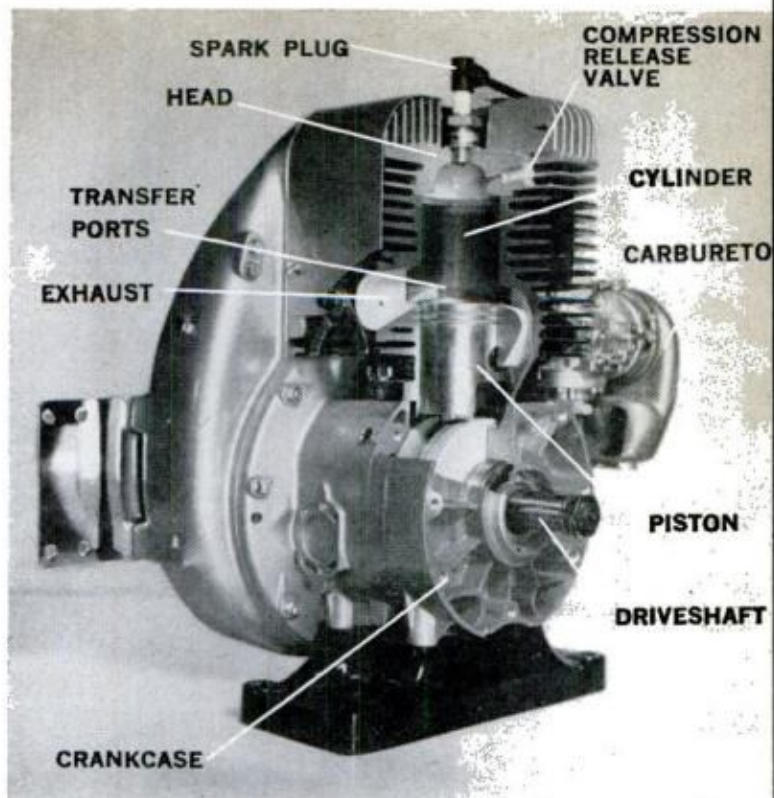
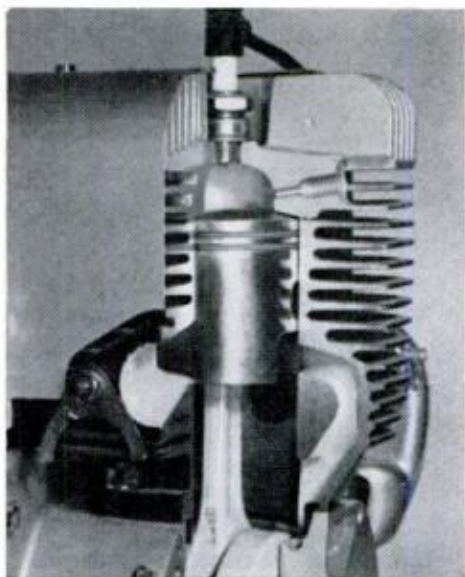

A SNOWMOBILE ENGINE

do, will add power and speed to your snowmobile

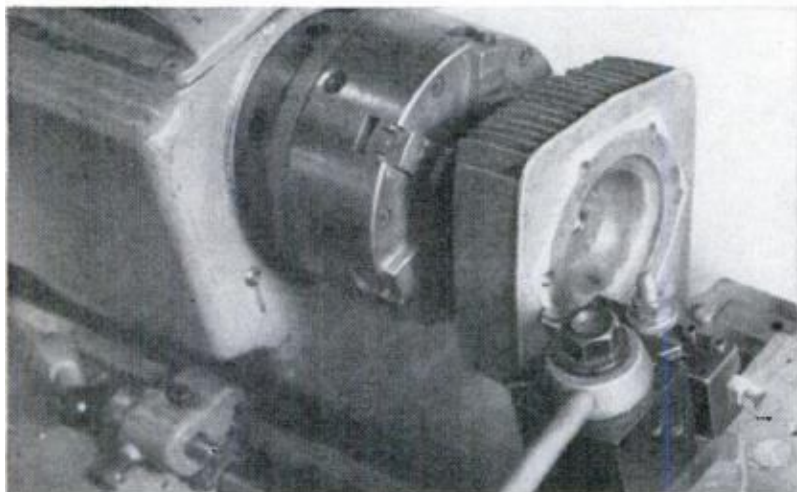

MILLING THE HEAD. With the chuck of a lathe screwed into the sparkplug hole in the head, take off about .10 inch. This is generally the depth of the lip found on many heads. Removing the lip will decrease the cylinder and dome space, thus increasing the compression for more power. Make sure that the piston does not hit the head. If it does strike the head, make a fly cut by trimming back the edge of the dome slightly.

JANUARY 1969

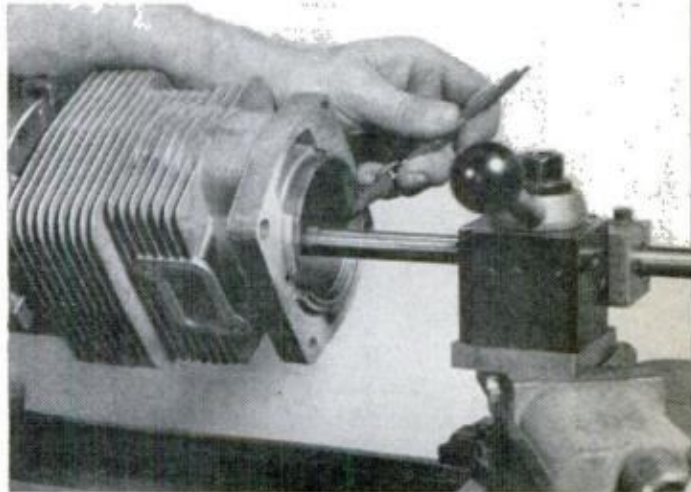

BORING CYLINDER TO OVERSIZE. Increasing the cylinder size lets in more fuel, giving more power. You can bore out the cylinder on a home lathe or have it done in a machine shop. Most mechanics cut from .080 to .100 inch. This leaves room for reboring should a broken ring scar the cylinder wall. Removing .100-inch will increase the capacity from 372 to 396 cc on this JLO. A larger piston will be needed for the cylinder.

139

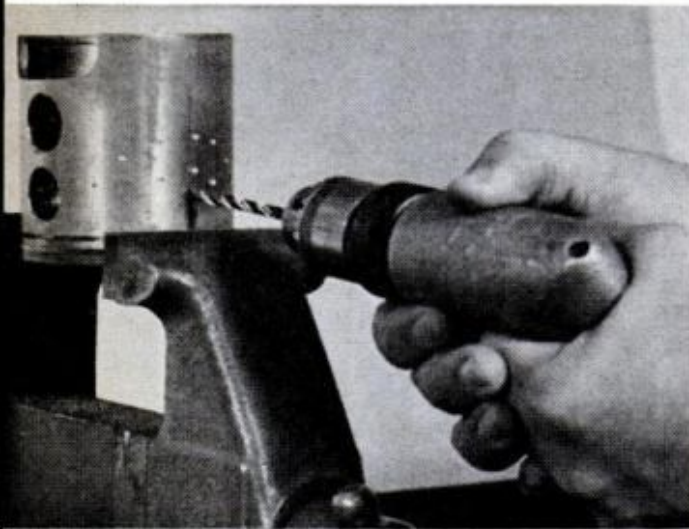
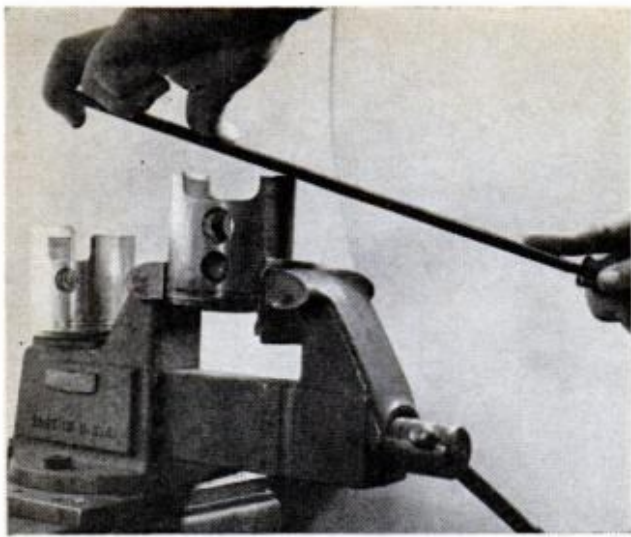

SKIRTING THE PISTON. Skirting is done to let more fuel vapor enter the crankcase before the downward-traveling piston seals off the carburetor intake port. Remove the piston from the cylinder. File off $\frac{1}{8}$ to $\frac{1}{4}$ inch from the bottom of the piston. This is done only on the side of the piston which covers the carburetor intake port. The exhaust side remains the same.

After skirting the piston, you can lightly file the piston head at the edge of the top where it passes the transfer ports. This will allow the full crankcase charge to pass to the cylinder.

With provision for increased fuel, it's a good idea to file about $\frac{1}{8}$ inch off the edge of the piston top where it passes the exhaust port.

GOLF-BALLING THE PISTON. Added fuel in the cylinder means more heat. More heat means more lubrication. Thus the need to golf-ball the piston. With a dull drill bit, pockmark the piston surface. These indentations should be about $\frac{1}{16}$ inch deep. Oil will be retained longer, lubricating the piston walls.

EXHAUST SYSTEM. With all the foregoing modifications, plus the addition of an $1\frac{1}{2}$ -inch carburetor, you're ready for exhaust-system changes. Changing the exhaust will really snap up your horsepower. You have three choices:

1. Install a straight pipe to exhaust the engine fumes downward. The straight pipe is the best dissipator of heat. Unless the heat is dissipated rapidly, the engine might seize or blow up. Normal operating temperature of a cylinder under the sparkplug when using a straight pipe is about 350° F.

2. Install a megaphone exhaust, eliminating the gases out the side of the hood instead of down. This creates more noise but gives a broader power range, although there might be some heat problems. The normal temperature when using a megaphone is about 550° F. For a 372-cc engine, megaphones should have a 12-inch bell of approximately $3\frac{1}{2}$ inches diameter at the mouth.

3. Install an expansion chamber. Only an expert knows when this can be used successfully. It can cause burn-out problems in the engine. Assuming that everything is correct, however, expansion chamber exhausts will give an engine more power in a narrower and normally higher rpm range.

"If we knew why," said the experts, "we'd be millionaires." All the experts know is that the answer lies in back pressure and resonant waves returning to the cylinder. However, your engine may run about 700° —that's just 35° below the point at which an engine will blow up.



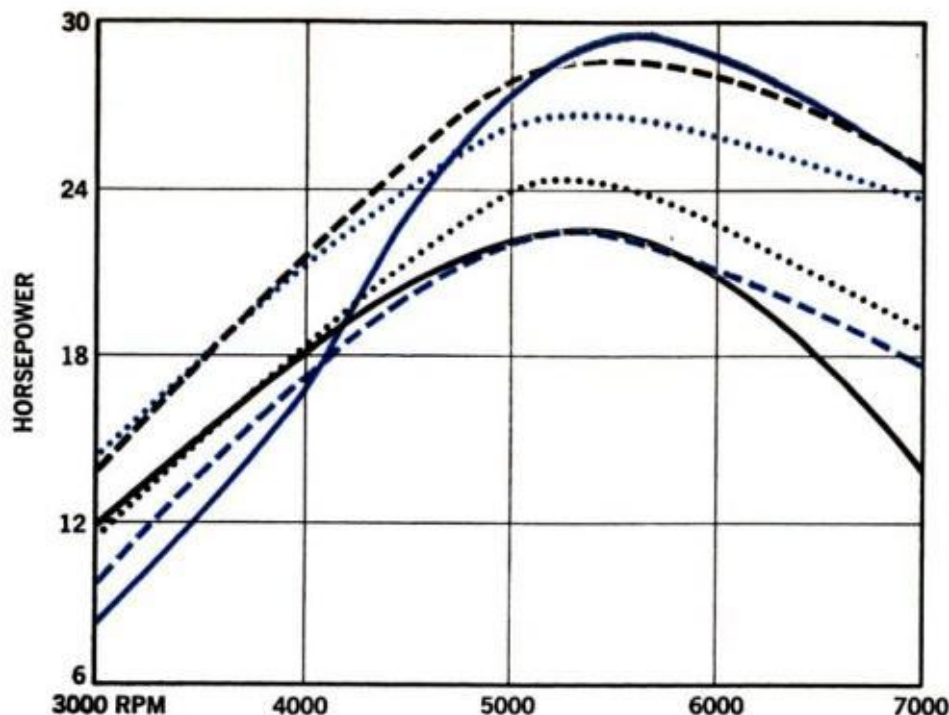

HP/RPM CHART shows the effect of each modification. Note that biggest horsepower increase occurs when expansion chamber exhaust is added, but such an increase is accomplished only after other modifications are made

- Standard
- - - Megaphone
- Head milling
- Expansion chamber
- - - Polishing ports and altering ports
- Bore oversized cylinder

MILLING THE FLYWHEEL. This modification cuts the total weight of a snowmobile. With snowmobiles generally operated in cold weather, the extra weight of cooling fins on the engine is not needed. Clipping the fins in a lathe and milling down the flywheel itself from ½ to 1 inch (depending on thickness) will cut from 4 to 10 pounds of weight. Less weight, more speed.

If you don't need the cooling fins, then you don't need the engine housing. Removing this cover will knock off another 8 to 10 pounds from the total weight of the machine.

With all these modifications you have added from 4½ to 5 hp to your machine. It should be a greater racer now.

EXTRA SPROCKETS. These are valuable for extra speed. Whether you'll use the small, medium or large gear depends on snow conditions, terrain and length. A small gear gives quick starting, is good for rough-country races where you're speeding up and slowing down. A large gear gives you slow start, but top speed. Normally, racers change the top sprocket. Another modification is changing your present clutch to a variable-speed-drive clutch. This increases torque at low rpm and speed at high rpm.

Modifying your snowmobile can be fun. But remember, it voids any warranties, and cuts down on engine life. Nevertheless, you can add snap and zing to your machine. ★★★

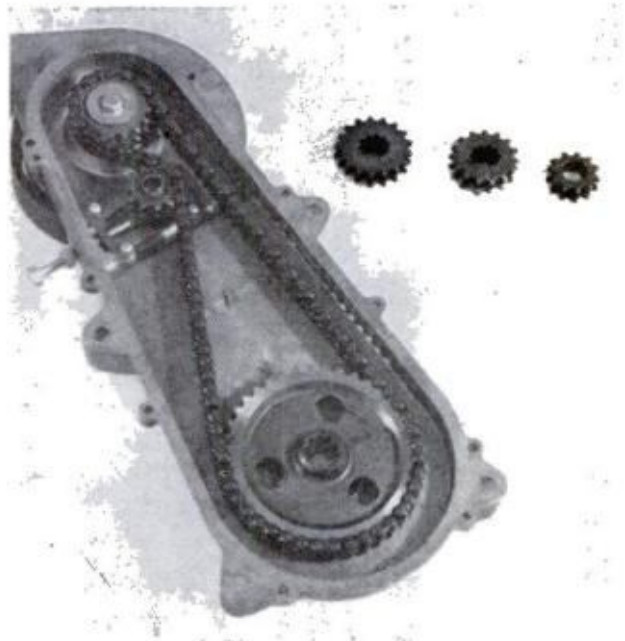
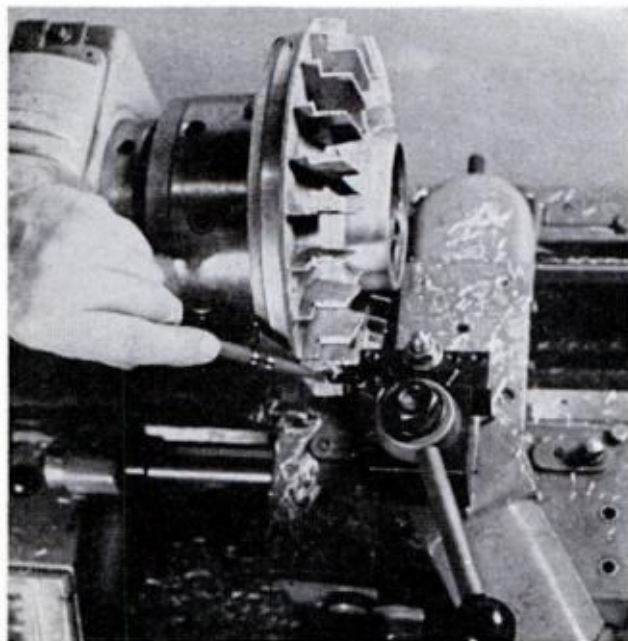

Unique Idea in Link Roller Chain



DOING THE TWIST. Double-pitch chain (above) shows how much it can flex in following a tortuous path around out-of-line sprockets. Photo at bottom of page shows how chain with a single cable is joined with a flat link connector

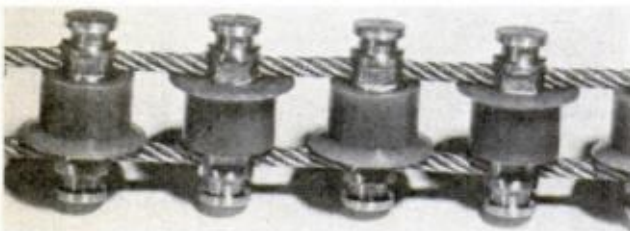

FLANGED PLASTIC ROLLERS clinched between flexible stranded cables form a single-pitch concept



THERE HAVE BEEN better mousetraps and better can openers, but in the last 50 years there has not been a better link roller chain—not until now. During these five-decades there has been little or no significant change in the conventional bicycle roller chain.

Now, however, Winfred M. Berg of East Rockaway, N. Y., has come up with something really different in a cable-and-roller drive system which could make the common link roller chain as obsolete as the horse and buggy. He calls it Pow-R-Tow.

What's better about this new chain? Several things. Molded from a tough fiberglass-filled plastic, it requires no lubrication. It's lightweight (25 percent lighter than conventional roller chain). With no metal-to-metal contact between chain and sprocket, it's smooth and quiet-running. It can be cut with wire cutters and spliced in a jiffy. Two design concepts will handle double and single sprocket drives. ★★★

ELECTRONIC KINKS

SMALL PORTABLE RADIOS have two faults—they sound tinny because of their small speakers and their reception is weak in fringe areas. This bass reflex baffle can help to cure both. It improves sound quality by boosting the bass and it incorporates an external antenna for better reception. The baffle is just a plywood box with a sloping front and a small ledge to hold the radio at an angle.

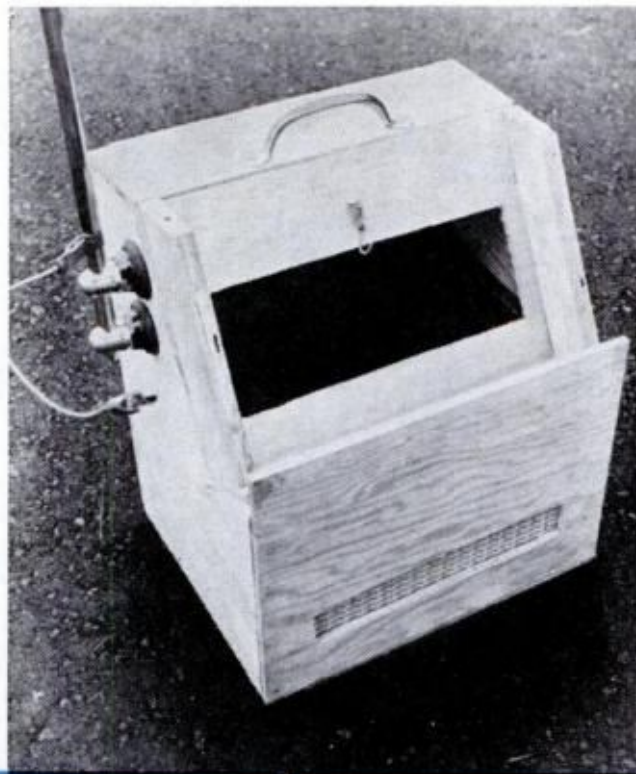

Bass notes from the back of the radio bounce around inside the box and come out a port in front greatly increased in volume. Adjust the box's dimensions to suit your own radio. The inside volume should be about one cubic foot. Make the port slot about 2 in. deep. Lining the back, bottom and one side of the box with acoustical tile or other absorbent material will greatly improve the effect.—K. R. Johnson

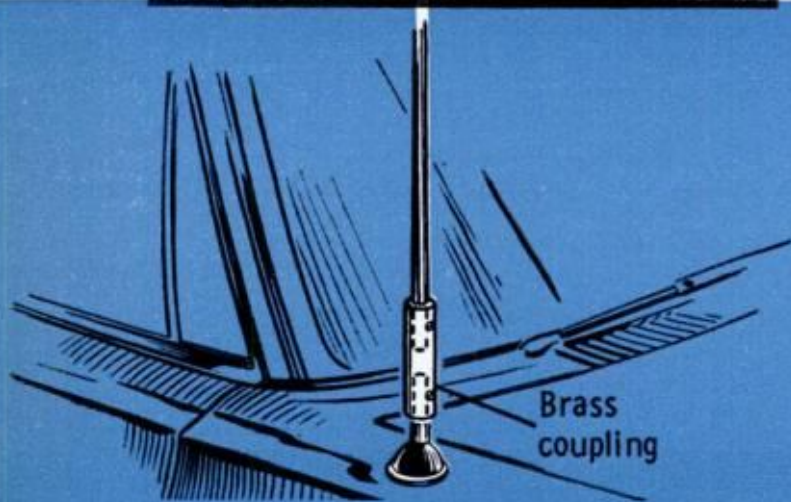

A CAR RADIO ANTENNA is often a target for pranksters when you park in a strange neighborhood. To keep mine from being broken or stolen, I hacksawed it off near the base, then reattached it with a small coupling made of brass pipe. Two setscrews in tapped holes hold the sections firmly together. Now when I park I just loosen the coupling and lock the antenna top safely in the trunk.—Wilfred Beaver

POWER CORDS on tools and appliances that are longer than you want can be shortened with a shower-curtain clip. Wind the excess into a coil and snap the clip around it. The clip looks neat and is easier to put on and take off than a rubber band



AN EMPTY PILL BOTTLE can make a handy dispenser for solder. Drill a small hole in the plastic cap near one edge. Wind the solder onto a length of wood dowel that's slightly smaller than the inside diameter of the bottle. Slip the coil into the bottle and thread the end out through the hole in the cap. The solder will pull neatly out as you need it without the usual kinking and tangling

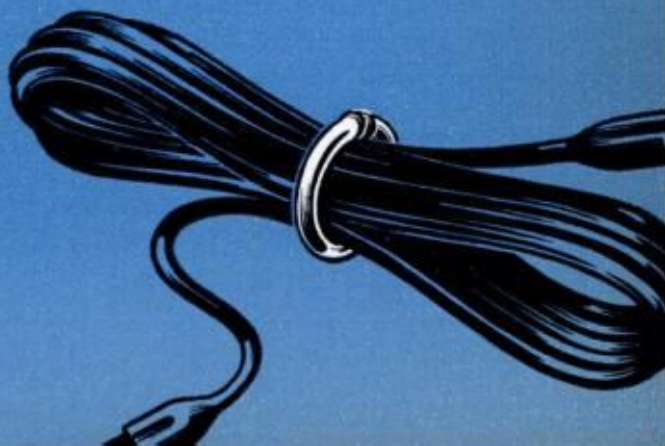

No-Hands Amplifier For Your Telephone



You can pipe two-way conversations to room speakers for the whole family to hear or feed them to a tape recorder for automatic message-taking. Construction is easy because you start with a prewired amplifier

By WALTER SALM

THERE'S SOMETHING positively luxurious about being able to pick up your telephone and hear the caller's voice boom out over a separate loudspeaker without your having to hold the receiver to your ear. It's a joy when you have a message to take down. You just put down the phone and write as the caller talks. Your wife will find it handy for copying down recipes from friends. When someone calls home from far away, it's great fun for the whole family to gather around and listen in together instead of having to take turns with the phone.

The little amplifier shown here will let you do all of these things and more. For

direct listening, it has its own miniature built-in speaker. For bigger sound, you can plug in an extension speaker or pipe the amplifier's output right into your regular hi-fi system. When someone calls, his voice will come almost magically out of your big room speakers. While the amplifier is not designed to serve as a microphone, it's possible to carry on two-way conversations without touching the telephone because the transmitter will pick up your voice from several feet away.

The amplifier also makes it possible to record telephone calls on tape. This is not easy to do with the little transistor recorders that are popular today because

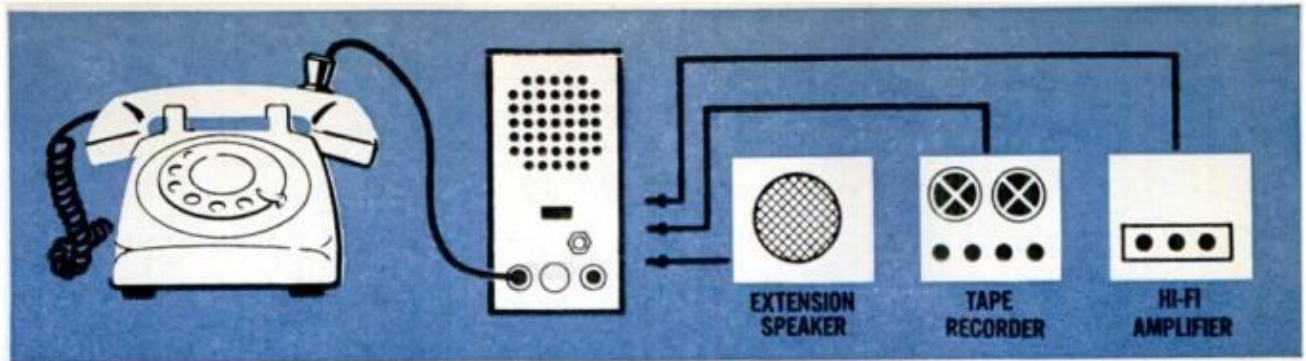

WITH MIDGET AMPLIFIER, telephone conversations can be fed easily to any type of home sound equipment

they don't have enough amplification in the early stages to handle unamplified signals directly from a phone. Also, there's a problem of improper impedance match. The typical telephone pickup coil—the kind you stick on with a rubber suction cup—operates at a high impedance, 15,000 to 50,000 ohms. The average transistor recorder has an input impedance of only a few hundred ohms or at most a thousand or so. The resulting mismatch makes for poor recordings.

The amplifier cures this by incorporating an impedance-matching transformer. It also serves as a preamplifier, giving the telephone signals a boost. The result is good, crisp, full-volume sound. When someone isn't home, you can record a message for him without having to remember it or write it down. If someone gives you complicated driving directions on the phone, you can record them on tape, then play them back right in the car.

The amplifier is a cinch to build because you start with a prewired unit—a miniature five-transistor push-pull amplifier available from Lafayette for less than \$6. Besides saving work, it costs less than

what you'd pay for the individual parts. It's so tiny it fits perfectly into a $1\frac{5}{8} \times 2\frac{5}{8} \times 5\frac{1}{8}$ -in. Bakelite box. Except for the battery, all of the other parts mount directly on the box's aluminum cover plate.

The prewired unit comes with various sets of leads already attached, making the hookup simple. The leads are color-coded and carefully identified on a sheet supplied with the amplifier. One pair goes to a tiny 2-in., 8-ohm speaker. A second pair goes to a 9-v. radio battery, the kind used in transistor portables. A third pair goes to a double-pole slide switch, and a fourth goes to the telephone input jack through the matching transformer.

A final group of three leads goes to a 10,000-ohm audio taper volume control. To make the volume control fit inside the box, remove the rear section containing the on-off switch and cut off the excess shaft length. On-off switching is handled by the slide switch instead. The reason for adding this switch is that it gives you an extra set of contacts. These are wired

TELEPHONE PICKUPS work by induction, permitting you to hear calls without actually hooking into a phone's wiring. They come in several types. Two at left below are held by suction cups to phone's receiver. Thin, flat kind at right slips underneath the phone's base, can be left in place permanently

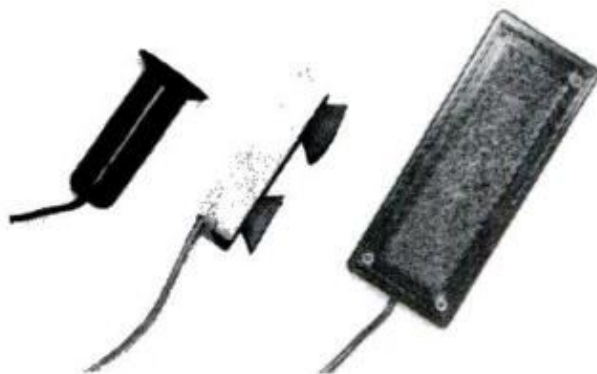

TAPING CALLS requires only two connections—one from phone pickup to amplifier and one from amplifier to recorder. Remember that taping is legal only if caller is notified and gives his permission



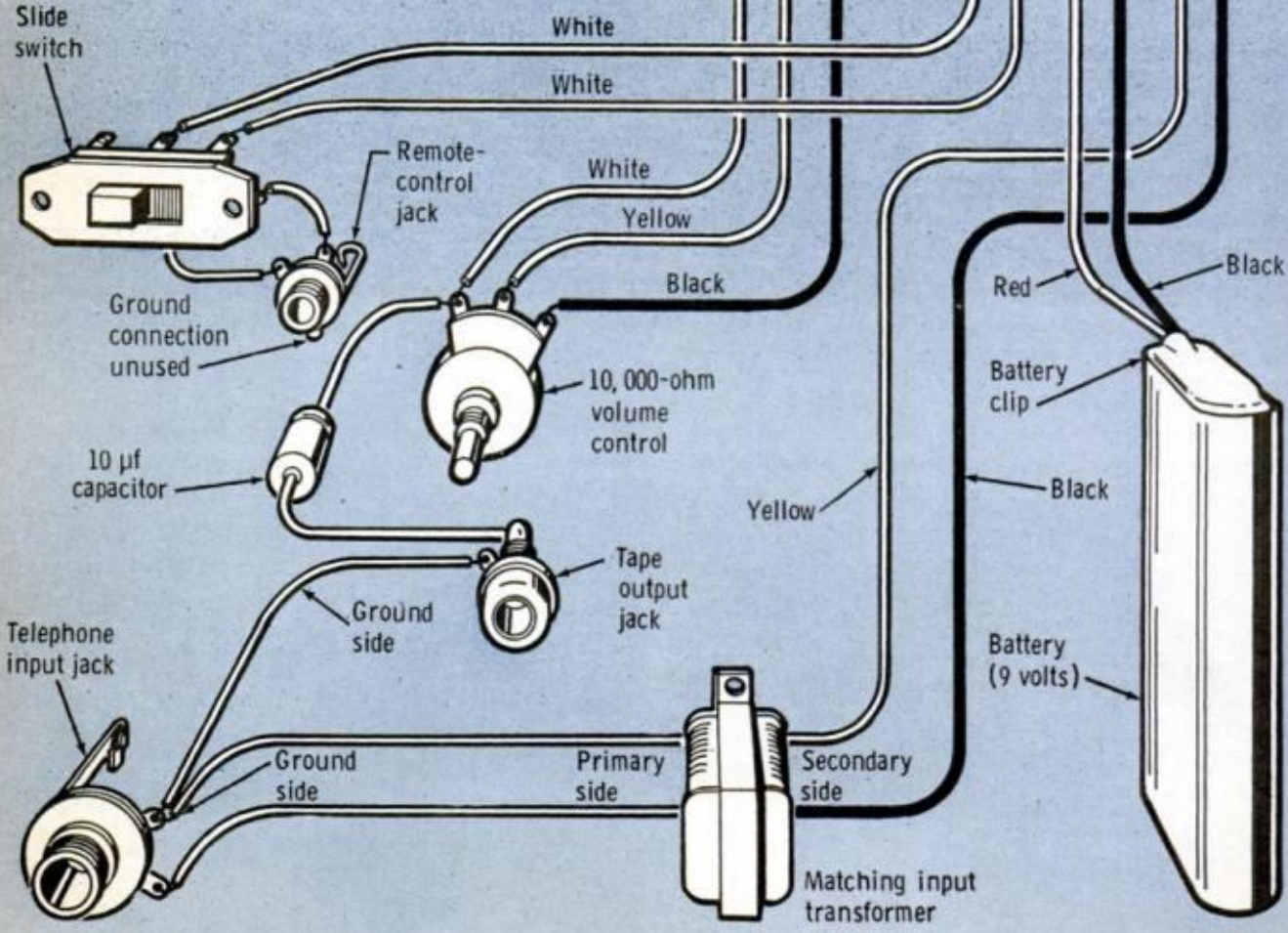
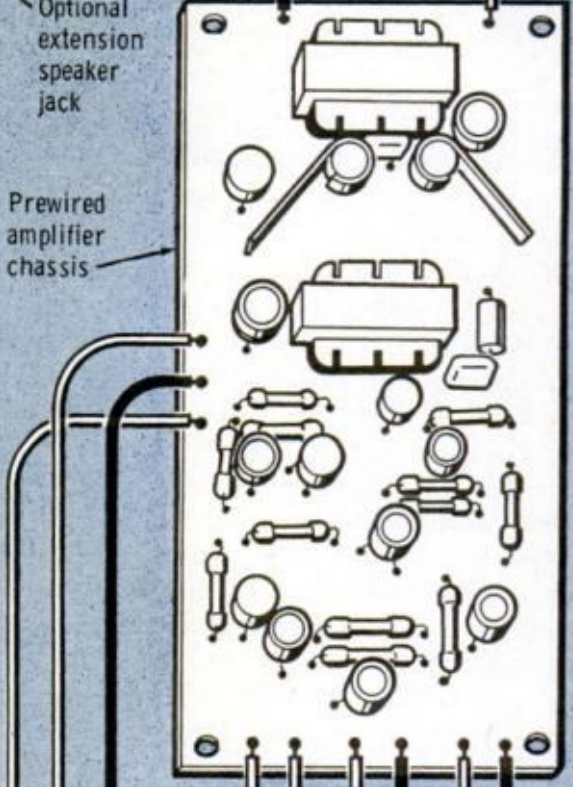
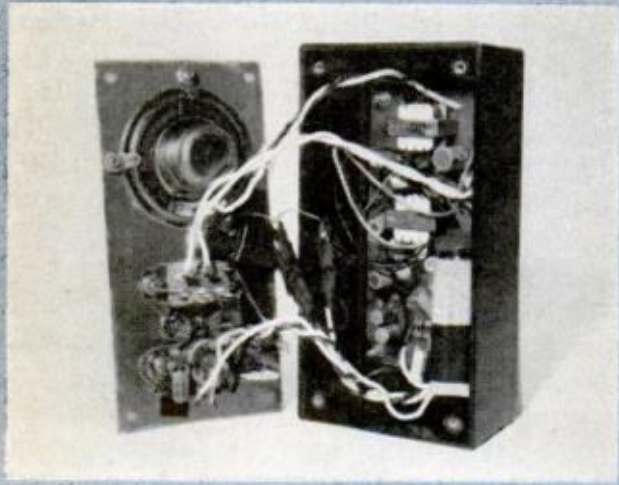
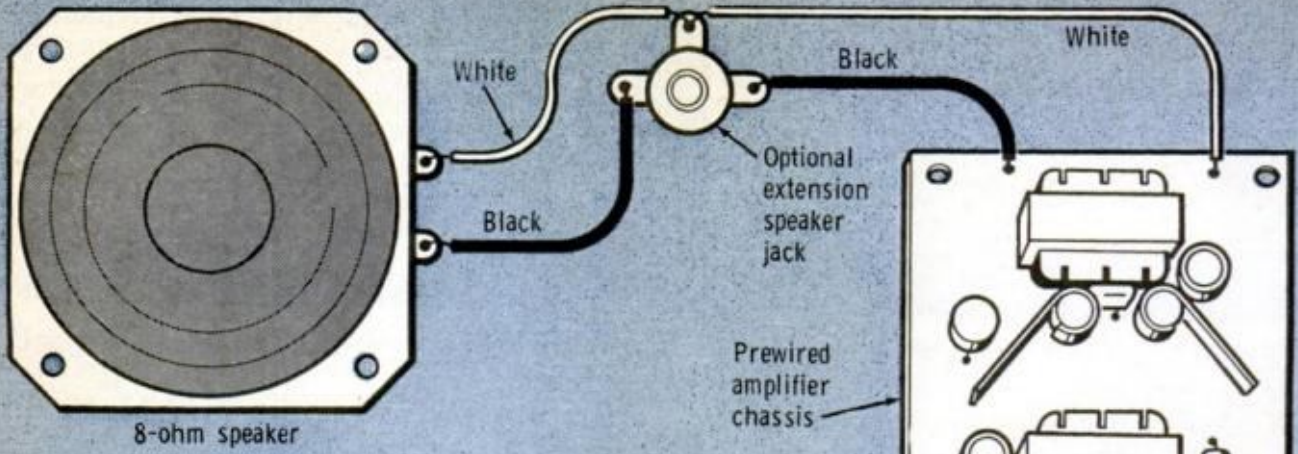

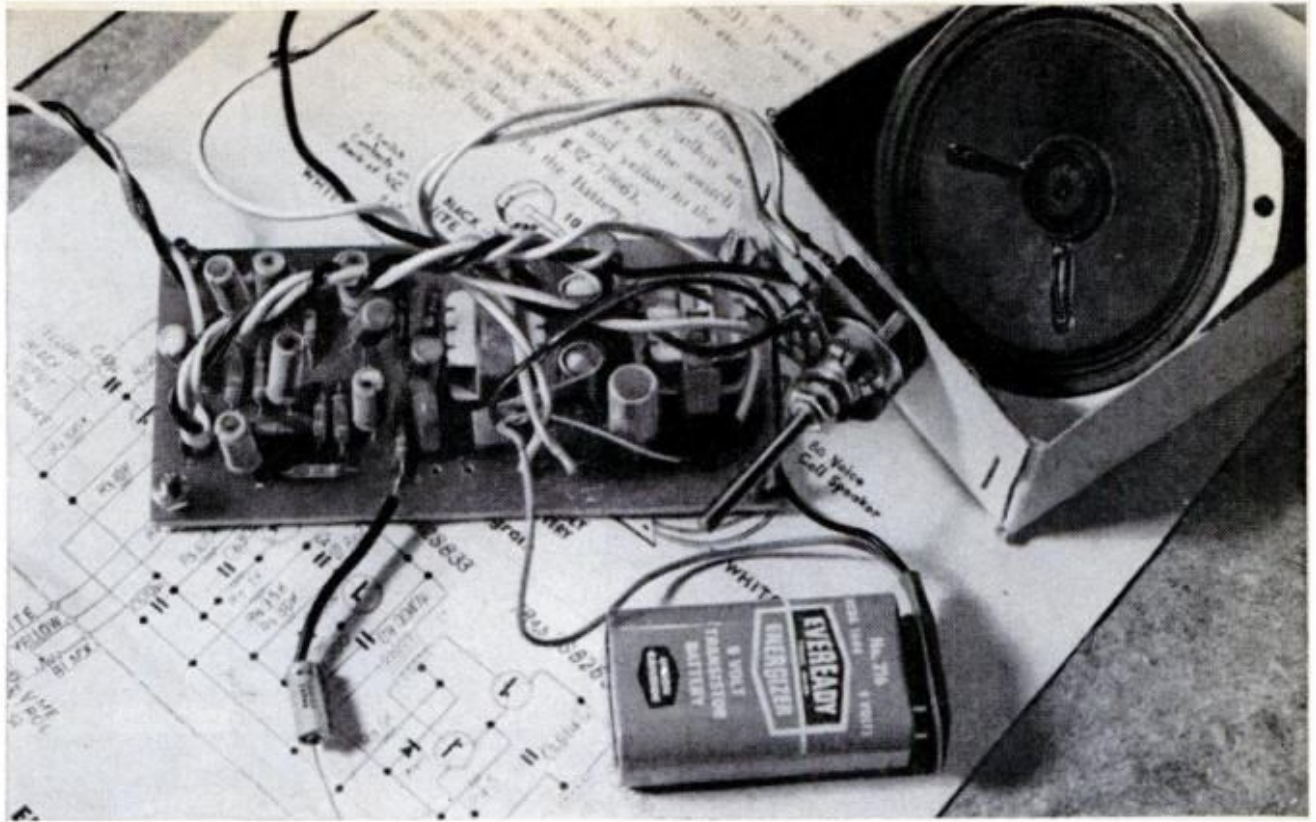

CONSTRUCTION IS MADE EASY by using this tiny preassembled audio amplifier from Lafayette. It has five transistors, costs under \$6. Speaker shown here is for testing. Actual unit uses a smaller 2-in. type

to a remote-control jack so that the jack is hot when the switch is closed. Many tape recorders have a connection for a remote-control switch to turn the machine on and off from a distance. If you run a cable from this connection to the remote-control jack on the amplifier, your recorder will go on automatically when you throw the slide switch to turn on the amplifier.

Depending on the type of connections you want to make, you may wish to use different jacks from those here. If your telephone pickup has a miniature plug on it, you can substitute a matching miniature jack for the phone jack shown. The tape output jack is a phono type. With a standard phono patch cord, you can feed the telephone signal into your hi-fi amplifier's auxiliary input jack.

To feed the signal into a transistor tape recorder of the cassette type, you will need an adapter cord with a phono plug on one end and a miniature plug on the other. Note that a capacitor is connected between the tape output jack and one of the terminals on the volume control. It's important that the *negative* side of this capacitor go to the tape jack and the *positive* side to the volume control.

The easiest way to provide a grille for the speaker is to drill a circular pattern

of small holes in the cover plate. The jack for an extension speaker is optional. If you add one, use the closed-circuit type and wire it as shown in the diagram. This way, the small built-in speaker is automatically cut off when the larger external one is plugged in.

The following parts list is based on components available from Lafayette Radio Electronics Corp., 111 Jericho Turnpike, Syosset, L. I., N.Y. 11791. Similar parts are also available from other electronics-supply houses. ★★★

PARTS LIST

- Prewired amplifier**—5-transistor, push-pull audio type (99T9037).
- Volume control**—10,000-ohm audio taper (32T7364); miniature knob (32T2401).
- Speaker**—2-in., 8-ohm (99T6036).
- Transformer**—input matching (99T6034).
- Switch**—double-pole slide (34T3911).
- Capacitor**—10-uf, 15-v. miniature electrolytic (99T6045).
- Battery**—9-v. radio type (99T6021).
- Housing**—1 $\frac{5}{8}$ x 2 $\frac{5}{8}$ x 5 $\frac{1}{8}$ " Bakelite box (99T8075).
- Phone input jack**—telephone type (99T6213).
- Tape output jack**—phono type (99T6234).
- Remote-control jack**—miniature 3-conductor plug and jack set (99T6328).

NEW IN

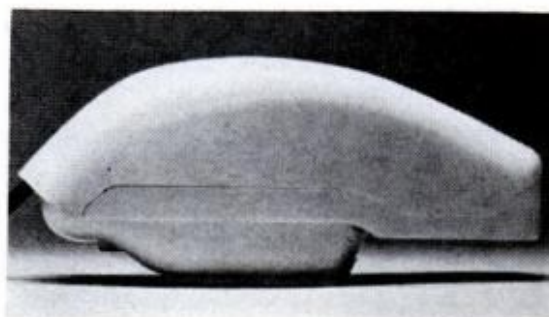

NEW LOOK IN TELEPHONES: The sleek, palm-size phone above contains transmitter, receiver and dial all in a single hinged unit. When not in use, it folds up, becoming an attractive ornament. Opening it automatically disconnects the bell and connects the voice circuit for making or receiving a call. The maker is Italtel s.p.a. in Milan, Italy. Equally compact is the pushbutton model below. Designed by Western Electric, it uses a tiny printed circuit, may eventually find its way into U.S. homes.

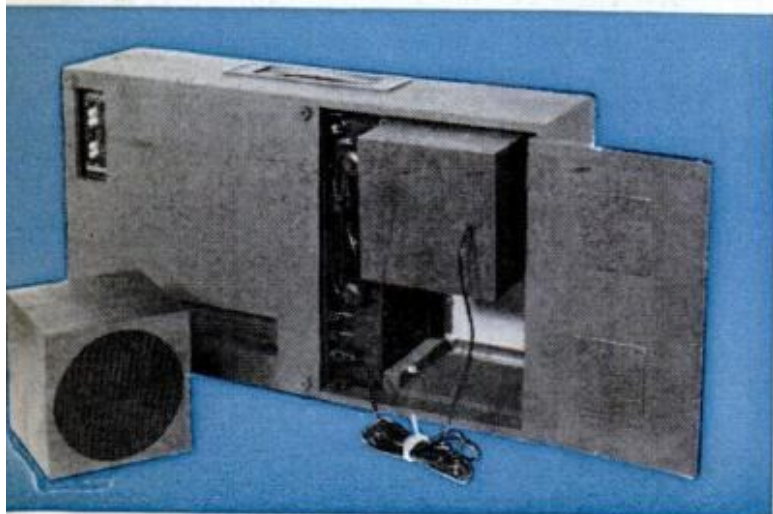

A CLEVER ARRANGEMENT OF SPEAKERS enables this new Ampex tape recorder to deliver good stereo reproduction without sacrificing a compact cabinet design. Two cube-shaped extension speakers store in the back. For monaural listening, they play through a grille cloth on the front of the cabinet—just like a built-in speaker. For stereo listening, you remove the cubes and place them up to 20 feet apart for proper separation. The recorder threads and reverses automatically, permitting the takeup reel to be hidden out of sight. Model 1461 is \$429. Ampex Corp., 205 W. Touhy Ave., Park Ridge, Ill.



ELECTRONICS

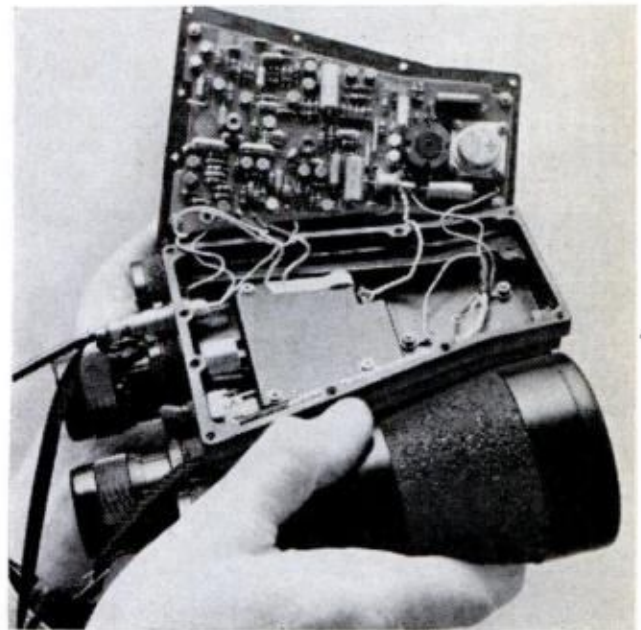
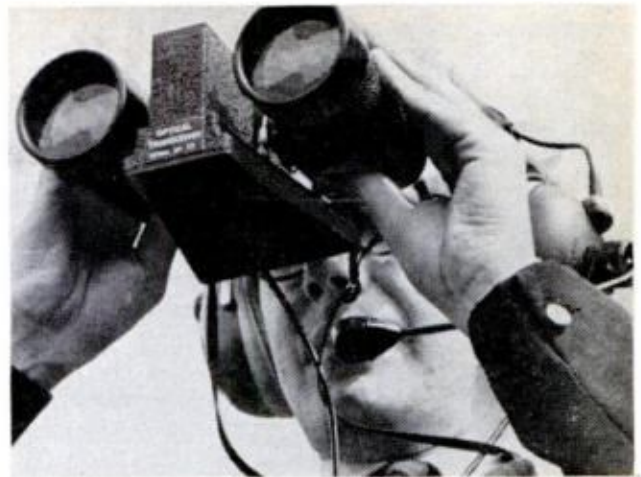

AIM THESE BINOCULARS at another person similarly equipped and you can not only see each other—you can talk back and forth, too. The binoculars send out invisible infrared pulses representing coded voice sounds. At the other end, the pulses are converted electronically back into the original sounds. Two-way conversations can be carried on over half a mile. Battery-run binoculars were designed for military use by Signals Research and Development Establishment in England.



A PIGGYBACK CLOCK perches on top of this novel bedside radio. The two parts, while styled to look like separate units, are actually interconnected. The AM/FM radio comes on at a preset time in the morning to wake you, and a slumber switch turns it off after you've gone to sleep at night. There's also a separate buzzer alarm. Price is \$42.95. Arvin Industries, 1531 13th St., Columbus, Ind.

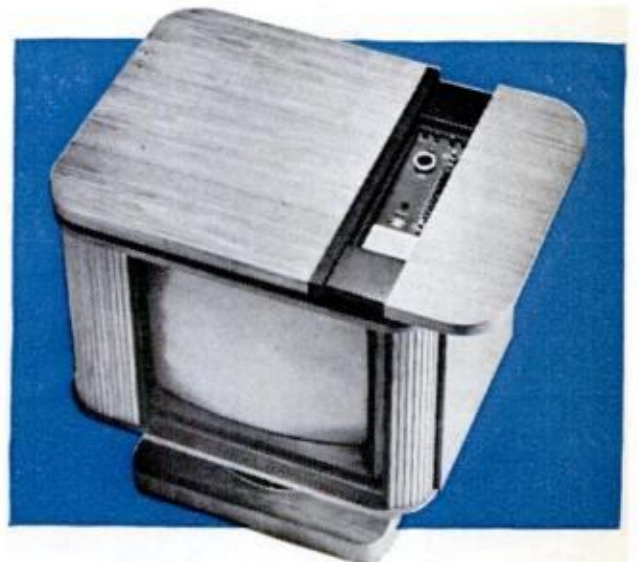

SWIVEL-MOUNTED COLOR TV above rotates 360° for viewing from any angle. Speakers in the base radiate sound in all directions regardless of which way the screen is turned. Pushbutton controls are hidden under a slide-out panel on top. \$1065, by Andrea Radio, 2701 Bridge Plaza N., Long Island City, N.Y.

BUILD THIS Connecticut

By FRANK L. GREENWALD

A fine example of Colonial design, its simple lines will blend well with either Contemporary or Early American furnishings

AS A PROJECT, this clock has just about everything to recommend it to the home craftsman. The styling is authentic, construction is simple and the cost is surprisingly low.

The clock I built, shown on the opposite page, is fitted with an eight-day short-pendulum movement and a roman-numeral dial. If you would prefer to eliminate the ticking and also the necessity of having to wind the clock once a week, a battery-powered electric movement could be substituted.

The original Connecticut shelf clocks (or "mirror clocks," as they were sometimes called) were made with a variety of different door panels. Some had a small mirror, while others used hand-painted scenes. When they were fitted with pendulum movements, however, a small oval area was always left clear so the pendulum action could be seen.

I wanted the effect of a hand-painted scene, but I'm not much of an artist. Thus, my "painting" is a piece of wall paper cut from a sample roll at the local paint store. I simply glued this to the back of a clear glass panel.



CLOCK MOVEMENT is a standard eight-day short-pendulum type which has a roman-numeral dial.



CUT BOTH RABBETS in one 30-in. board. Then cut the sides and top to length from this board.



RABBET MITER used to join sides and top is begun by making $\frac{3}{8}$ -inch cut $\frac{1}{4}$ inch from the end.



SECOND CUT more than halfway to end is then made and area between cuts is cleaned with saw.



MITER CUT at 45° should just reach the root of the first cut. Sides are then cut to length.

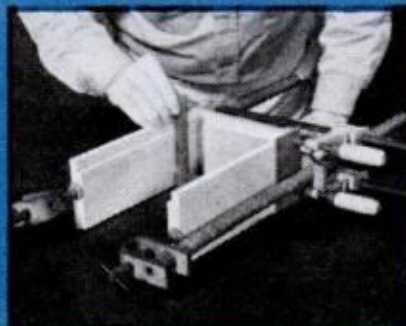

SIDES AND TOP are glued together after miter cuts have been made. Bottom piece is installed later.

Shelf Clock

Technical Art by INDUGRAPH



Shelf Clock (Continued)

I used common white pine since it is considered authentic for this type of clock, but many early New England clocks had cases of cherry, mahogany and walnut.

The sides and top of the case require a piece of wood $\frac{3}{4}$ -in. thick, 4 in. wide and approximately 30 in. long. I ran the front and rear rabbets along the sides of the piece before cutting it up into specific lengths. I even found it best to first sand it, using No. 80 grit paper and then No. 220.

The sides are joined to the top piece by a joint called a rabbet-miter which you'll find makes a strong joint and simplifies the job of clamping. To cut such a joint you first set the blade on your table saw

$\frac{3}{16}$ in. high. Then you set the fence so it's $\frac{3}{4}$ in. from the outside of the blade. Make the cut across the end of both side pieces first, then shift the fence so you can make a second cut halfway from the end of the pieces. The area between the cuts is cleaned out with two or three passes. Now set the fence $\frac{7}{16}$ in. from the outside of the blade and make a cut across both ends of the top piece. With this done, set the blade at 45° and miter each end. The miter cut should just reach the root of the first cut. Finally, make similar miter cuts at the upper ends of the side pieces. You can now trim the side pieces to $9\frac{3}{4}$ in.

The next step is to glue the miter joints and clamp them. A temporary spreader piece across the bottom of the assembly



GLUE AND NAIL the mitered joints with 6d finishing nails. I blunted the nail points to avoid splitting

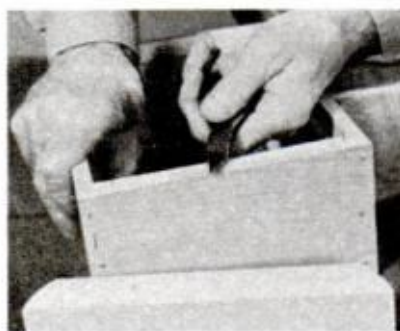

BRAD POINTS keep base pieces from shifting when gluing. Drive them part way, then cut off heads

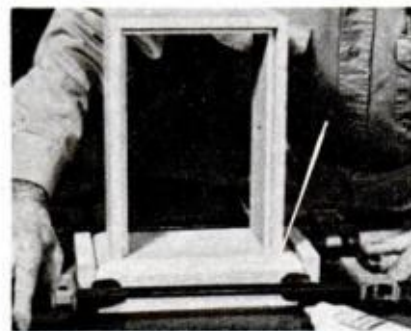

TIGHTEN CLAMPS slowly and evenly so as not to force mitered corners out of line; apply as shown

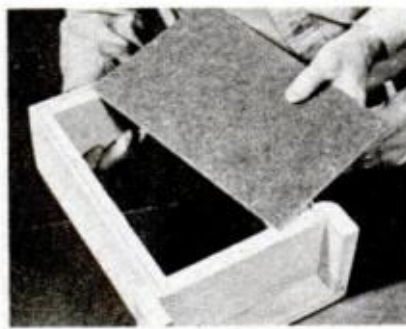

BACK OF CASE fits flush in rabbets previously cut in top and sides. Back laps bottom of case



AFTER GLUING butt corners of door frame, $\frac{1}{8}$ -in. splines are inserted, glued and trimmed flush

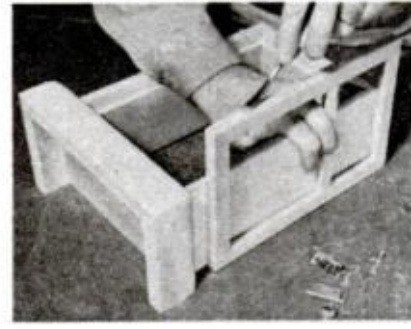

HINGE MORTISES are cut in frame only. Make approximately $\frac{1}{16}$ -in. deep to assure proper clearance



MOVEMENT IS MOUNTED on dial backing plate, then used to determine location of support cleats



MAGNETIC CATCH, stripped of its frame, is fastened to case with screw through center hole

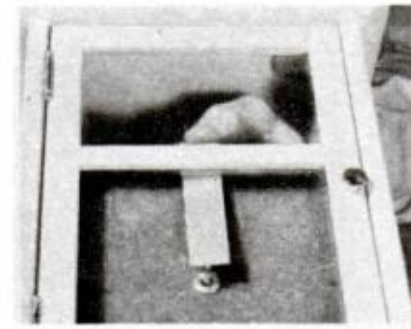

STRIP OF PAPER is used to check minimum clearance between minute-hand shaft and glass of door

will assure square corners. It's best to use just a scrap at the bottom now so that any variation in width at the top caused by clamping can be compensated for by cutting the final bottom piece. Fasten the latter with glue and 6d finishing nails.

Next, rip a 20-in.-long piece for the three base pieces. I used my molding head to round the top edge, but you can also form it with a hand plane and sandpaper. The strip is cut into three pieces and mitered to fit around three sides of the case at the bottom. In doing so, the important thing to remember is that the inner face of the front piece must extend the full width of the clock case. The side pieces of the base were left extra long for final trimming after the miters are checked for

a good fit. I drove small brads into the case at the bottom and cut the heads off so they'd impale the base and prevent shifting when gluing and clamping it.

Screwing the hardboard back to the case completes the job. Use 1/2-in. No. 6 oval or flathead screws to fasten it in the rabbets.

Simple butt joints are used to make the door. I rabbeted the members for the two pieces of glass and then glued the door together. After the glue dried, I ran saw kerfs in the joints at the corners and inserted splines. Fit the door to the case so there is 1/32-in. clearance at top and bottom and 1/16-in. at the sides. The hinges are mortised into the edge of the door

(Please turn to page 221)

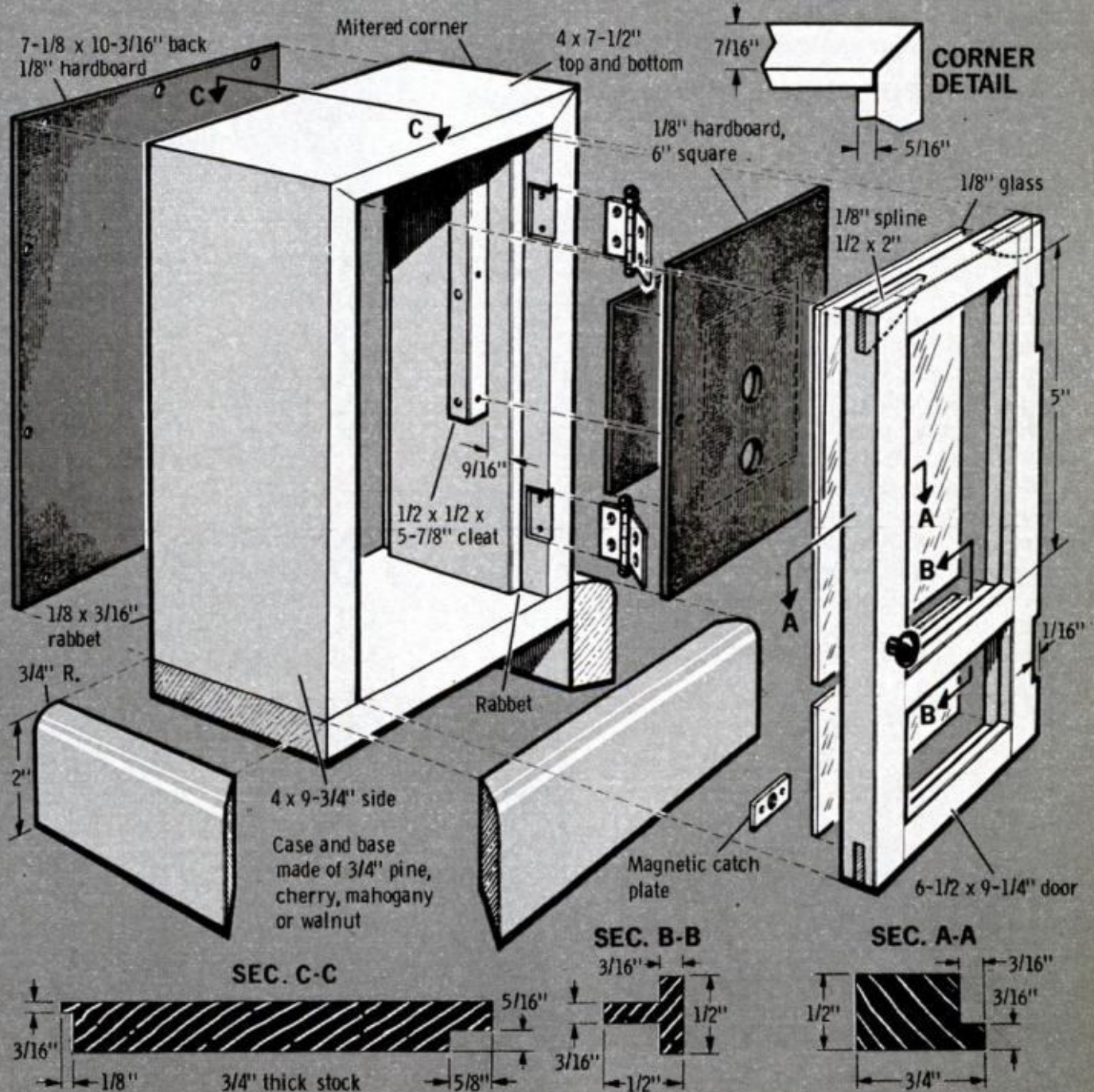

Build This Storage Into Your Pool Table

Color Photo by Robert Borst

WISH YOU HAD more room to store the dozens of games and other gear that clutters your playroom? Stop wishing! There's space aplenty going to waste right under your nose—more specifically, right under your pool table. All you have to do to put it to work is tuck a couple of roomy cabinets between its legs and you'll wind up with storage galore that's as handy as can be.

If you happen to have a Brunswick table such as the Monarch shown at the right, you can follow the cabinet dimensions given. Because of a central connecting stretcher which joins the legs of the table shown, it was necessary to build two separate cabinets. With other makes of tables you may find that a single cabinet can be built and slid in place. In each case, overall dimensions will

Sliding-door cabinet

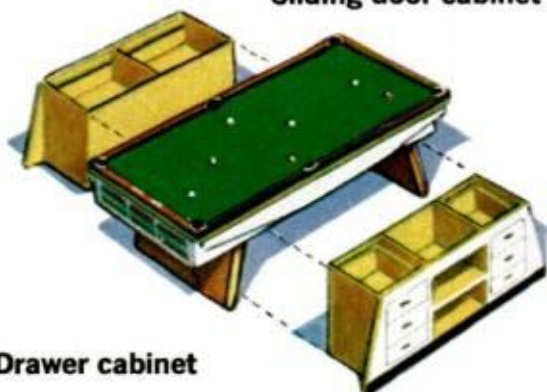

Drawer cabinet

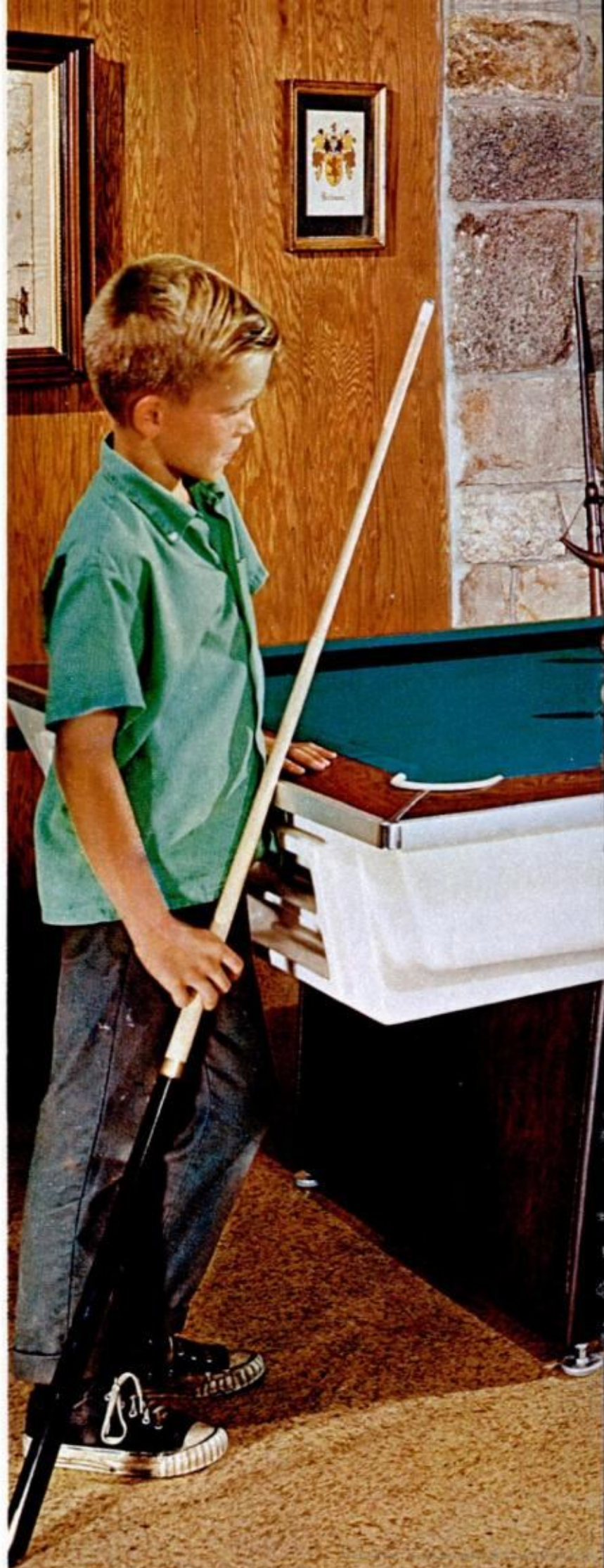



Simple plywood cabinets nest between legs of pool table to convert waste space into handy storage

Sliding-Door Cabinet

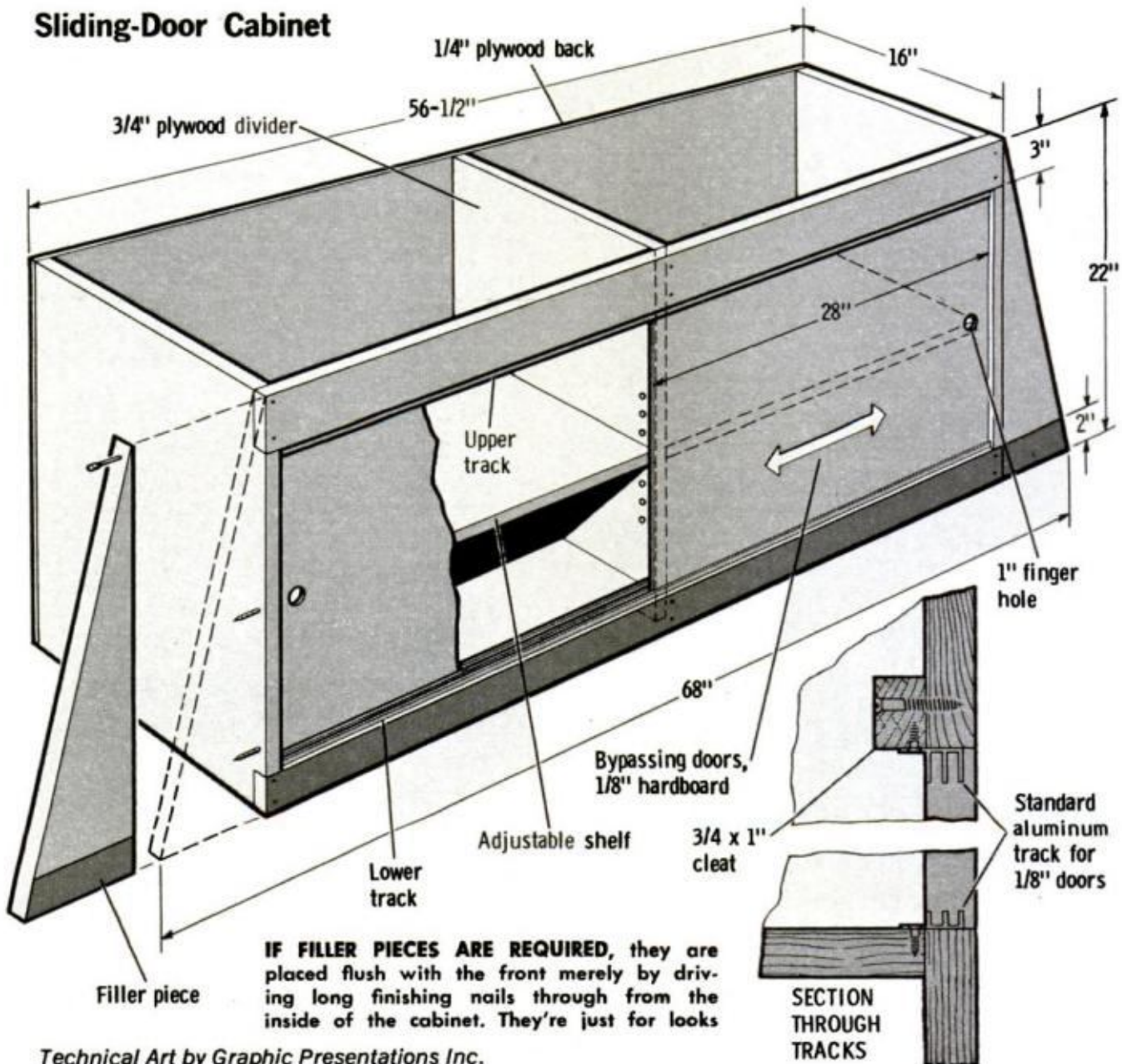

Technical Art by Graphic Presentations Inc.

vary with the particular table you own.

You have a choice of building twin cabinets, or one with sliding doors and the other with drawers. Both types are detailed on these pages. The main difference in the sliding-door cabinet detailed above is its center divider. While only one is required, you will notice it is not notched at the front for the crossrails.

In making both cabinets, cut and notch all the ends and dividers exactly alike, cutting them from 3/4-in. fir plywood. You can rip the crossrails from plywood or solid stock. Glue and nail the crossrails in the notches, then place the assembly face down on the floor and nail on the 1/4-in. plywood back. The bottom for each compartment of the door cabinet is cut to fit and tapped in place, even with the top edge of the lower crossrail. When it's level, you nail it in place through the front,

sides and back with finishing nails. Nails driven through the divider at an angle will anchor the two bottom members to it.

The shelves are loose-fitting and made adjustable for height by boring rows of holes for regular 1/4-in. shelf rests.

Standard DIY aluminum track is used for the 1/8-in. hardboard doors. Notice in the section view that the deeper of the two tracks is mounted across the top. Thus, you can insert the doors in the tracks after the latter are screwed in place. Because the tracks are set in 1/8-in. or so from the edge, cleats are required across the tops of the door openings to provide a screwing surface for the track.

As is the case with both cabinets, tapered filler pieces are required to fill the space between the cabinet ends and the slanting table legs. The particular table will determine whether these pieces are

Drawer Cabinet

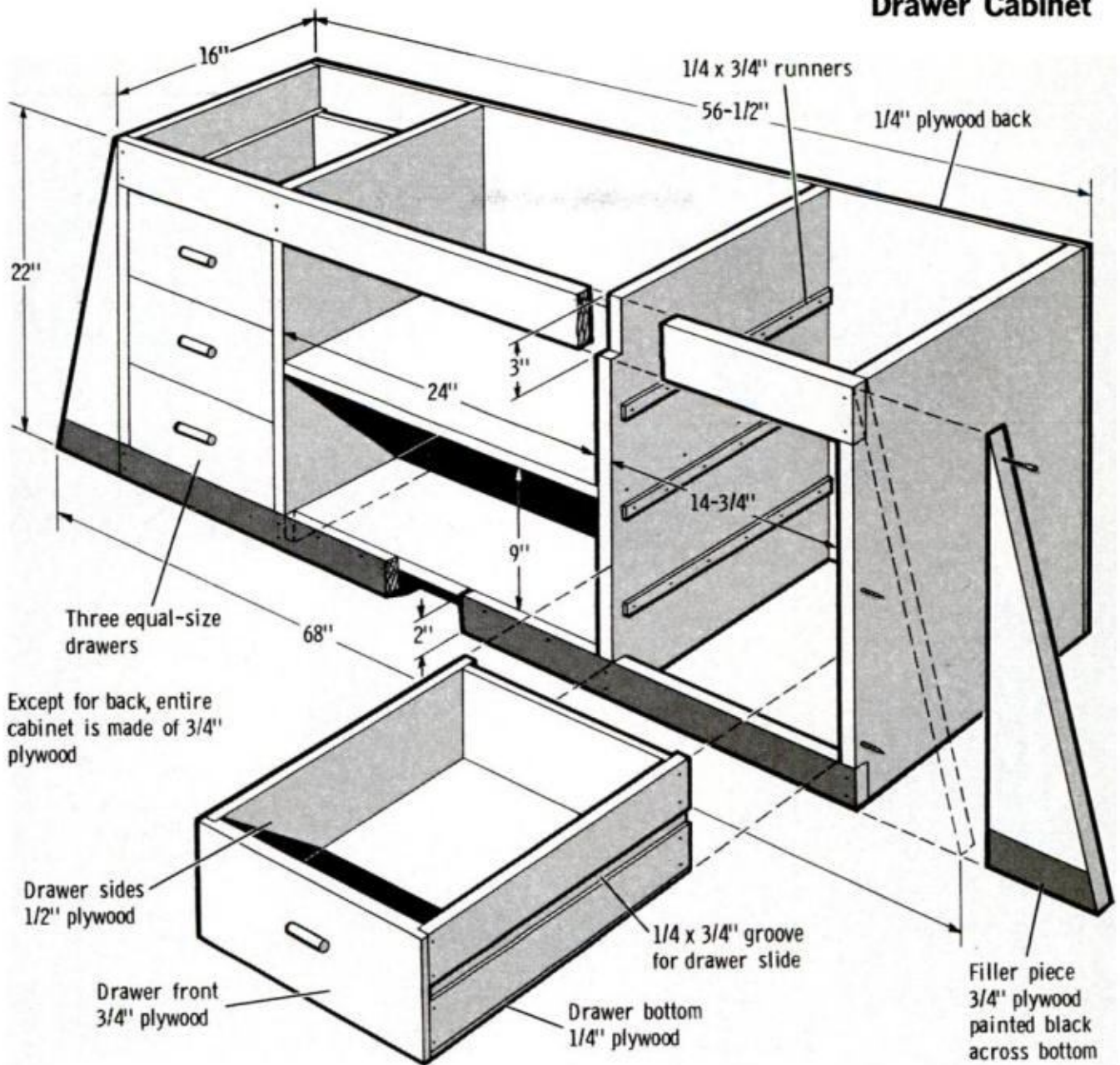

needed. The drawer cabinet has two dividers instead of one. They are notched at top and bottom for the front crossrails. Both center shelves are fixed and fastened in place with finishing nails driven in through the dividers.

All six drawers have identical flush fronts and dadoed sides. You can mass-produce the drawer parts quickly with table-saw setups which will guarantee duplicate pieces. After all fronts are cut, run the rabbets at the ends and a 1/8-in. groove 1/2-in. up from the bottom on the inside face. Similar grooves are made on the inside faces of the drawer sides for hardboard bottoms, then the work is turned over and a drawer-guide dado is run down the middle. Drawer backs are cut to fit between the sides and rest on the drawer bottoms. Allow suitable clearance on all sides so that the drawer

fronts will slide nicely in the openings.

Add the 1/4-in. runners to the sides of the dividers and end pieces. These are spaced and located by trial, after light tacking in position with small brads and then checking the sliding fit of the drawer. When it pushes in easily, without binding, nail the runners permanently. Coat dados and runners with paste wax for a nice sliding fit. Handles complete the job.

To place the cabinets between the pool-table legs, you must first lift off the top of the table. Then with both cabinets standing back to back you lift the leg-and-stretcher assembly up over the cabinets and nest the stretcher between them. The top can now be replaced. The filler pieces actually fit inside the slanting, tapered legs of the table. You can screw the cabinets to the stretcher if you wish, although it's not necessary. ★★★

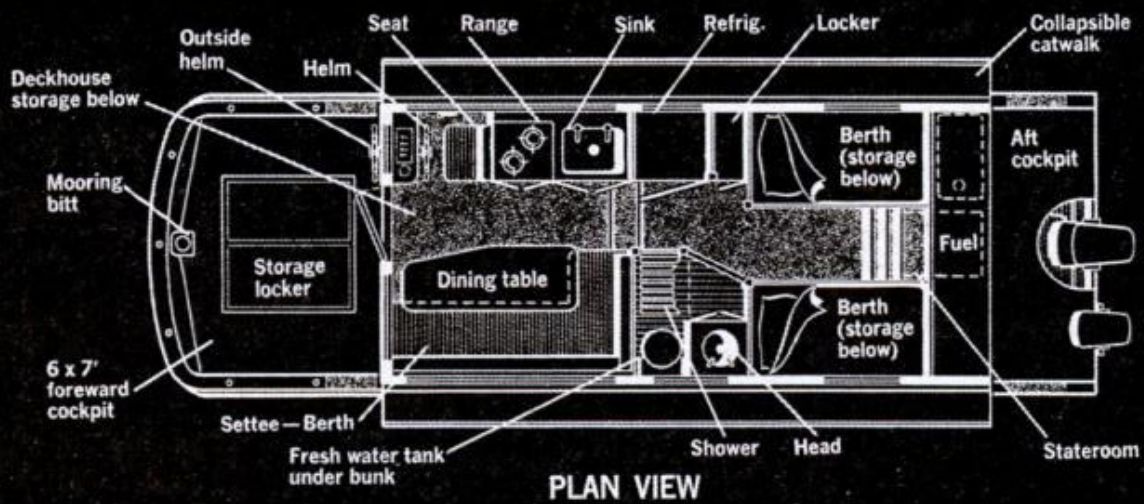

Build This Houseboat For Under \$1000

You can put together this floating home and trailer it to any place there's water

By DAN FALES, Boating Editor

Photos by Ralph Poole

I COULDN'T BELIEVE my eyes when I first spotted the houseboat. "This isn't homemade," I told myself. "It must be manufactured." But I was wrong. The boat was built at home by Byrl Graham. It took 10 months working weekends, a buddy, and less than \$1000 to construct the bare boat.

Byrl finished it a year ago, and since then he's used it almost every weekend. He takes family and friends up and down the Lake Mohave section of the Colorado River—a 67-mile stretch.

He pokes into isolated coves; trolls for large bass and trout; camps at water's edge in some of the most beautiful country in the United States. He enjoys his boat.

Designed and tested by Glen L., this houseboat has one big advantage over others—it's trailerable. You can load this 8-ft.-beam boat on a trailer and take it

anywhere you find a launching ramp.

"Anyone can build it," Byrl says. It's true that he has modified the plan some. He's changed the position of the hanging locker; put the shower outside in the stern; added steps and storage space; changed the head somewhat. But it's basically the same boat that you can build from plans.

In the past, a build-it-yourself houseboat was designed to look like a barge—with blunt bow and scowish-looking lines. But today, a houseboat is a sleek craft that parts the water with a vee bow. Graham's type of boat is no exception. It has a shaped bow. However, shaping the bow might present a construction problem.

"We molded two 3/8-in. layers of plywood planking over frame and stem," Byrl says. "I think it would be easier if others used a laminate of three layers of 1/4-in. plywood instead of two layers of 3/8-in.,

BYRL GRAHAM (center), author (right) and Howard Honaker relax aboard 25-ft. houseboat after lunch

CATWALKS ON EACH SIDE are approximately 18 in. wide, making it easy for a person to "get around"

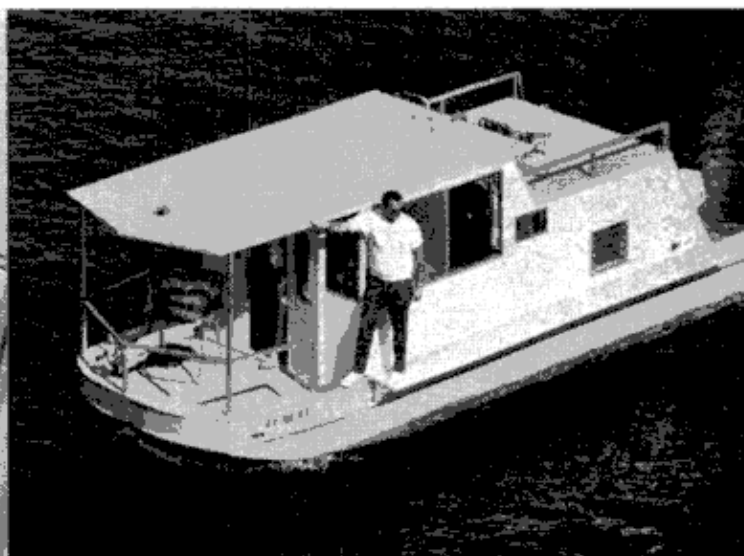

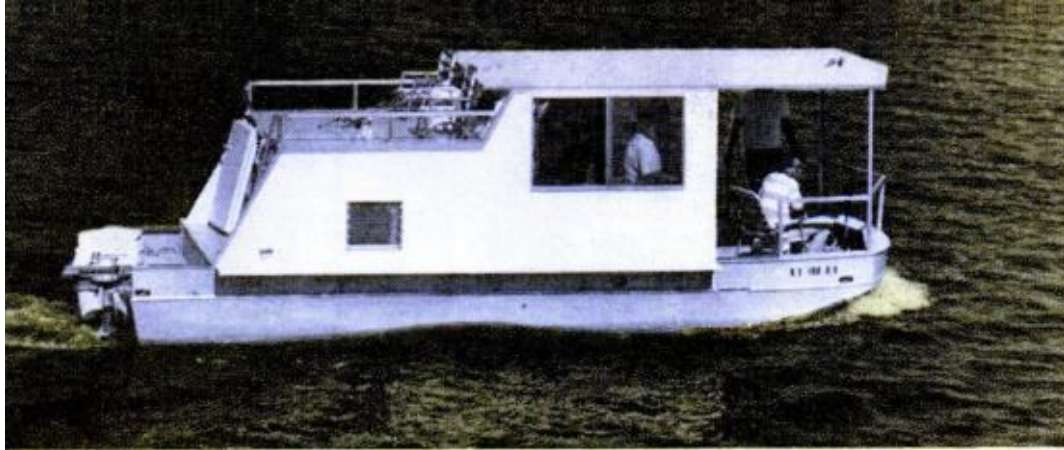

DOING ABOUT 10 KNOTS, this 25-foot houseboat rides easily. The helmsman has good visibility all around. There's plenty of fun room on the sun deck and in the bow

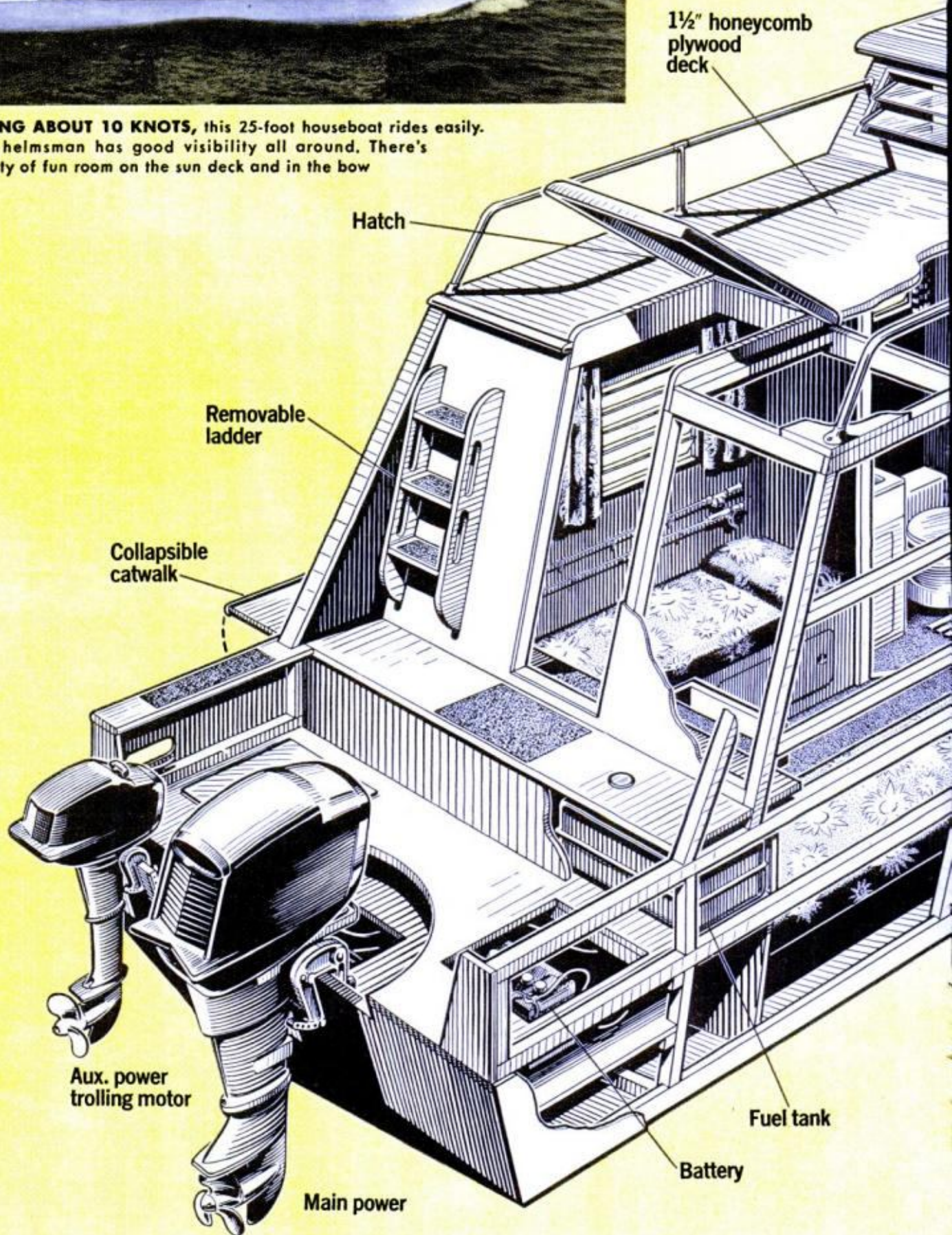

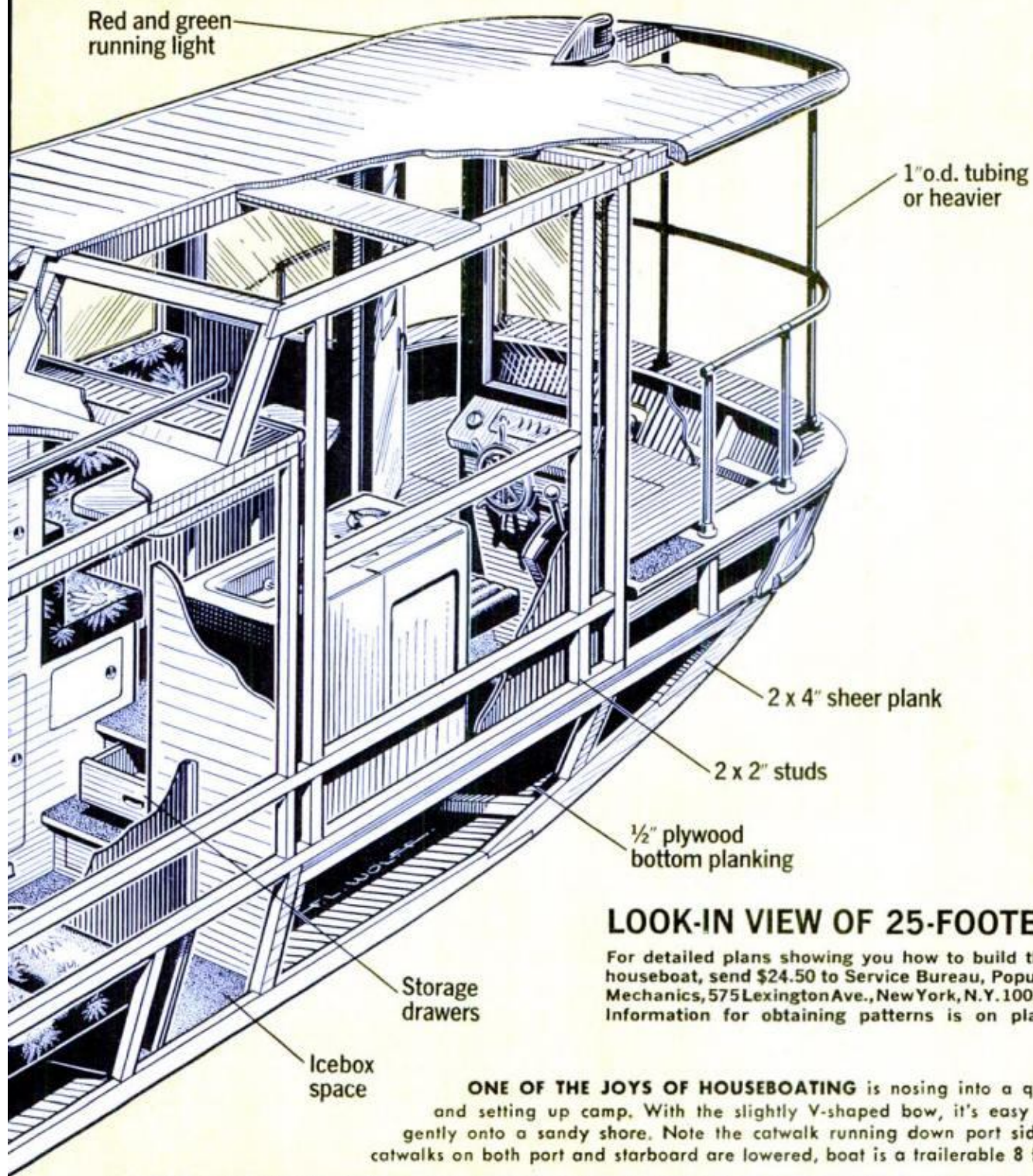

LOOK-IN VIEW OF 25-FOOTER

For detailed plans showing you how to build this houseboat, send \$24.50 to Service Bureau, Popular Mechanics, 575 Lexington Ave., New York, N.Y. 10022. Information for obtaining patterns is on plans

ONE OF THE JOYS OF HOUSEBOATING is nosing into a quiet cove and setting up camp. With the slightly V-shaped bow, it's easy to bump gently onto a sandy shore. Note the catwalk running down port side. When catwalks on both port and starboard are lowered, boat is a trailerable 8 feet wide





VIEW THROUGH DECKHOUSE: past compact galley, into the main cabin and out through the stern door

since the $\frac{3}{8}$ s are hard to bend and hold in place while gluing. I tried everything from hot towels to wetting the plywood on the lawn with a garden hose. I finally managed, but thinner stuff would surely be easier to work."

This was the only operation in which Byrl found the construction to be difficult. The rest of the project was rather easy, he says.

The finished houseboat looked as if it

CATWALKS CAN BE DROPPED when entering a tight mooring slip or preparing the boat for trailering



BUNKS FOR TWO are located in the deckhouse. The back of the settee swings in to serve as upper bunk

were a snap to put together. But like any good job, the easier it looks the more professional it is.

The boat is roomy and handles easily. For a day, I tried Byrl's boat on Lake Mohave. It was trim, roomy and neat.

The deck chairs fit perfectly on the foredeck. It's a great place just to lounge and watch the passing waters. Or better yet, lounge and troll a fishing line astern.

From the wheelhouse, the pilot has plenty of visibility all around. With louvered windows astern, there's no need for the skipper to wonder what's behind—he can turn and see.

Just behind the helmsman's seat is the galley. There's plenty of room to use the stove (propane), sink and icebox. On the port side, a table and settee can be converted into bunks for two.

Aft of the deckhouse is the main cabin. There are two large permanent bunks, along with the head and hanging locker. Below the port bunk is a 40-gallon water tank and pump for a pressurized water system. And, there's good storage space below the starboard bunk.

Byrl changed the hatch (doorway) leading out onto the rear deck. He did not add the raising hatch which shows in the plans. This means he has a bit more space on the sun deck.

The sun deck is another great place from which to troll. I sat in a deck chair and let my line drift out astern. It's like fishing from the flying bridge of a charter boat.

Tucked neatly away in the center of



UNDER LOWER BUNK are water tank, pump, good storage space



STRINGERS protect bottom when heavy gear is stored in the bow



ANCHOR is kept in hatch under companionway of the deckhouse

the sun deck is the 10-pound bottle of propane. This lasts the Grahams most of the summer—depending on the amount of stove and oven use.

Looking down from the sun deck you can see the powerplants. We are emphasizing the outboard model in the photos here. But the plans do show you how to build the hull to accommodate an in-board/outboard unit and fuel tanks of adequate capacity. The plans also list the amount of plywood, the kind of plywood, the number of regular 2x2s and 2x4s, and the number of stringers you will need.

Byrl coated the inner hull with a heavy coat of clear epoxy. This seals the inner wood, thus lessening the chance of dry rot attacking bare wood. This is especially important in fresh-water operation.

The bottom is covered with regular fiberglass, set in epoxy and coated with an outer layer of epoxy. Byrl has operated the boat a full year. "And still there are no leaks," he says.

One of the best features of this design is the provision of catwalks on either side. These walks give you the exterior space of an 11-foot beam.

All you need do to "shrink" to an 8-ft. beam is to collapse the catwalks. This is the maximum width allowed on most highways, without the need for obtaining special towing permits.

The boat weighs 5800 pounds. Once trailered to water and floated, it will cruise at 10 to 13 knots with a 55-hp outboard. Byrl uses a four-cycle Homelite on the stern.

"I don't want the boat on plane because I'm never in that much of a hurry to get anywhere," he says.

Byrl does add that the boat is not of a deep-sea design. "I've had her out in three-foot waves and that's all I want. But anything under that is okay," he says.

It's true, this is not a blue-water boat; but then few houseboats are, especially in this size.

Byrl says he built the boat for less than \$1000. This is the bare boat. This cost does not include accessories such as power, stove, icebox and head. Neither does it account for trim like drapes and bedspreads. But it does include the material to build the hull, superstructure, sun deck, plus wooden fixtures like bunks, lockers and galley.

Rough estimates call for \$500 for plywood, \$250 for lumber and \$150 for fastenings. An additional \$50 should be included for such items as epoxy glue and fiberglass materials. ★★★

FOR HOUSEBOAT PLANS, SEND THIS COUPON TODAY

Popular Mechanics Service Bureau, Dept. AF
575 Lexington Avenue
New York, N.Y. 10022

Please send me a complete set of plans, materials list, fastening schedule and step-by-step instructions for building the 25-foot trailerable houseboat described in your January, 1969, issue. Also, let me know how I can obtain full-size patterns for a slight additional charge.

I enclose my check (or money order) for \$24.50.

Name (please print) _____

Street _____

City _____ State _____ Zip Code _____

Solving home problems

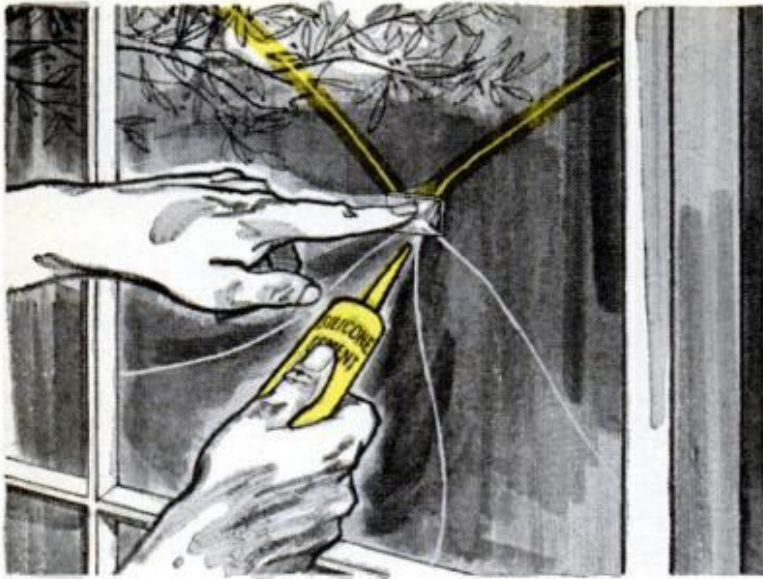

STOPGAP REPAIR for a cracked window can be made with silicone cement. If it's a sunburst crack, first mount a small piece of glass over the center to prevent movement, then seal the rays

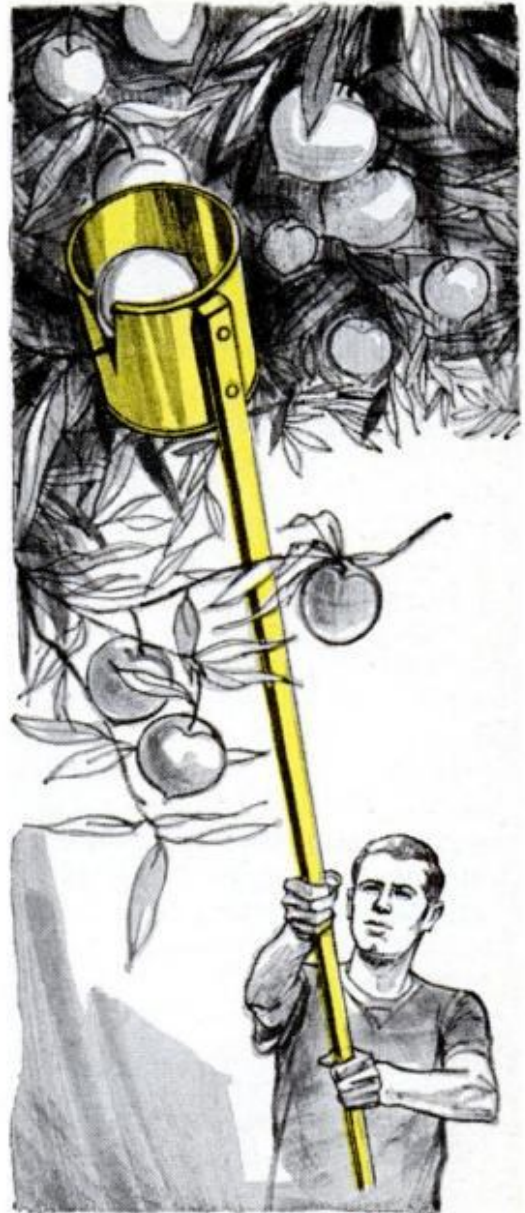

FRUIT PICKER plucks easily bruised fruit from high branches without risk of damage. Just cut a deep V-notch in one side of a 1-lb. coffee can and mount it at the top of a long pole with two screws

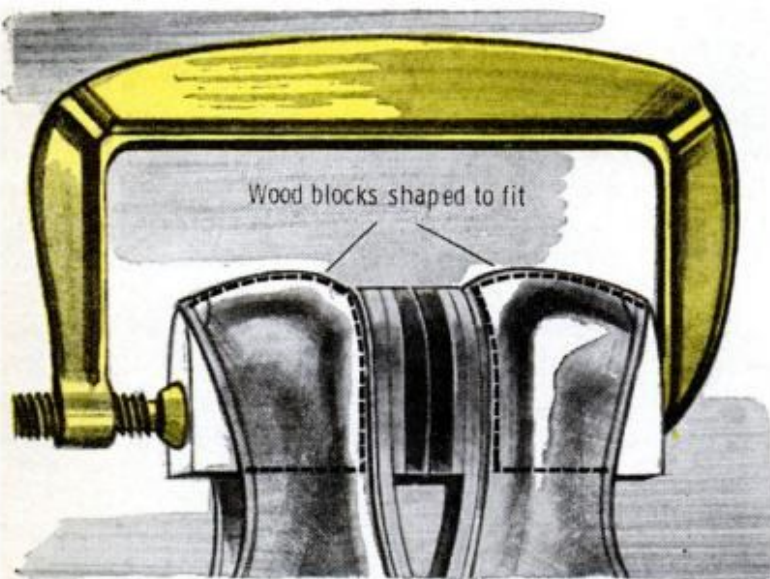

YOU WON'T NEED a last or nails to install new heels if you mount them with epoxy cement. Use 2-in. blocks to hold them in C-clamp while drying, then dress the edges with bench grinder

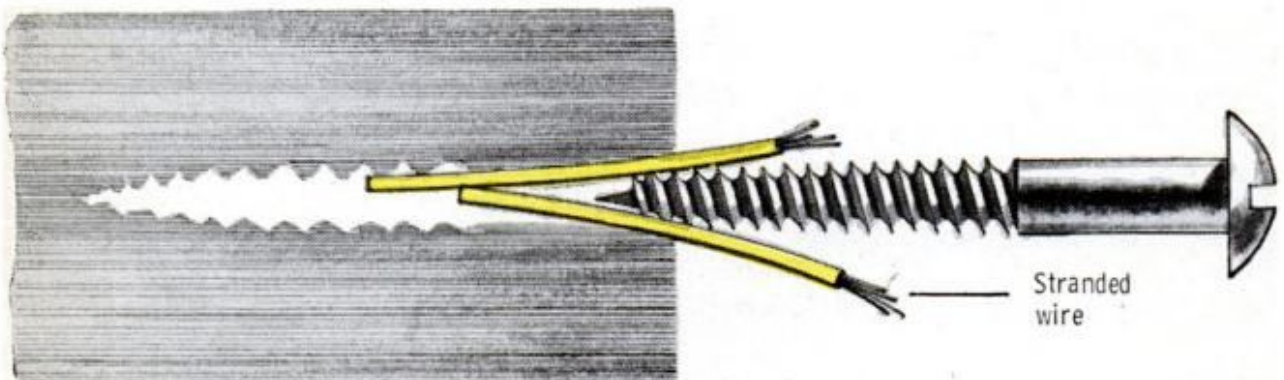

WHEN YOU HAVE TO RESET WOOD SCREWS in the same holes a number of times, they no longer hold as well. To renew the grip, insert short lengths of plastic-covered stranded wire in the threaded area of the heels



PLUMBER'S FRIEND makes a good mixing container for small batches of spackling compound. It's handy to hold, and the flexible cup is easy to clean, even if some of the plaster should become hard

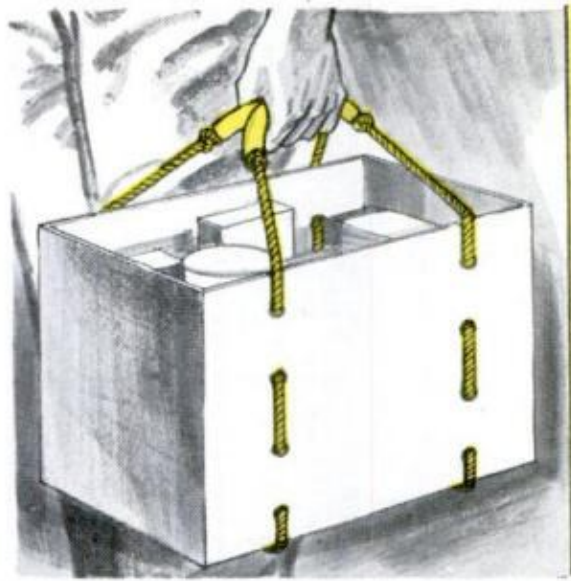

CARDBOARD CARTONS rigged with rope handles become easy-to-carry tote boxes. Punch holes for rope with $\frac{3}{8}$ -in. pipe ground to sharp edge on one end. Use garden hose for the hand grips

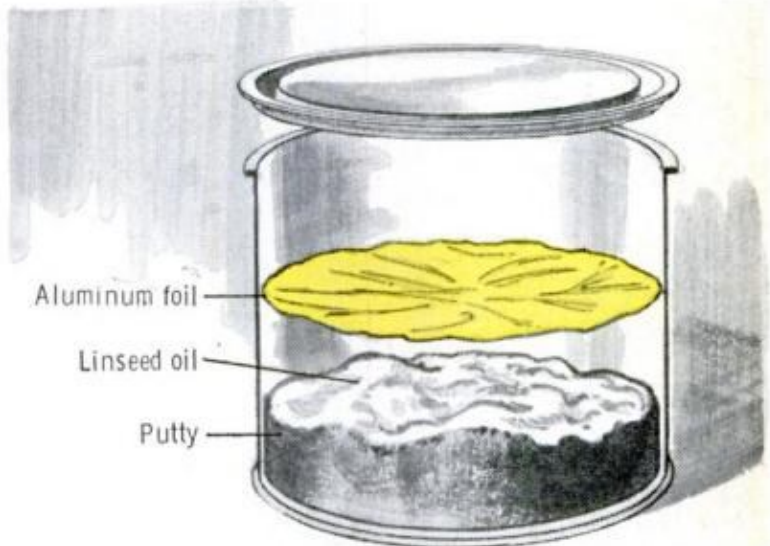

TO PREVENT glazier's putty from drying out, flatten it smooth in the can, brush on a film of linseed oil and press an aluminum foil disc over the surface to replace the original paper disc

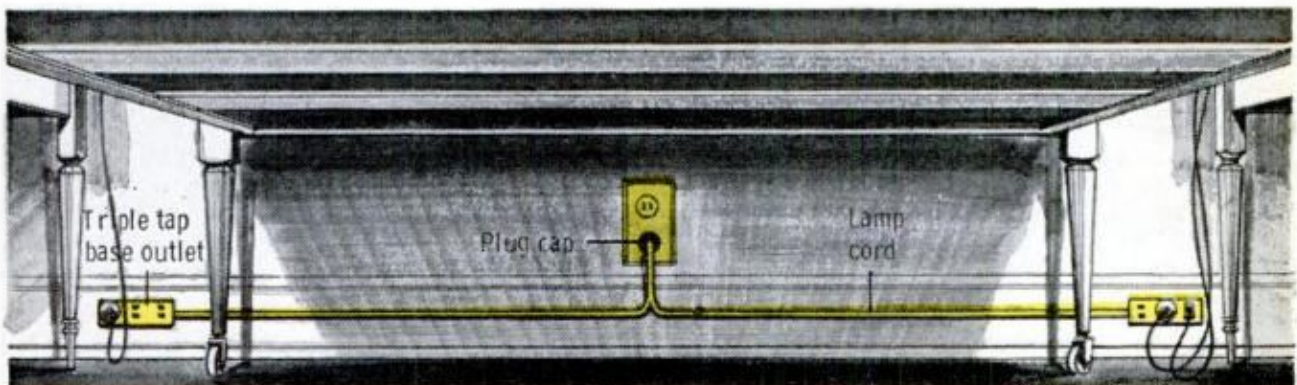

DOUBLE EXTENSION CORD provides outlets on both sides of a bed or sofa. Just cut the plugs from the ends of two triple-socket extension cords designed for baseboard mounting and connect them to single plug

EXCITING NEW PRODUCTS

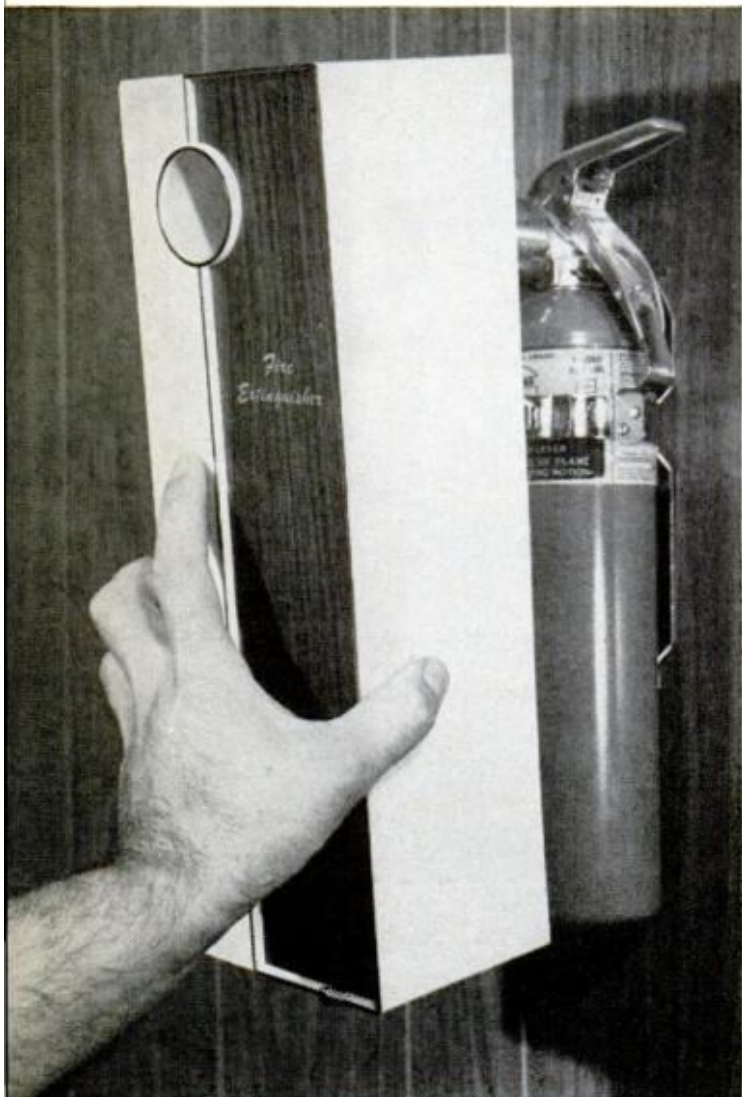

FIRE EXTINGUISHER can be hung anywhere—even on the living room wall—and not detract from your decorative scheme, when its bright red cylinder is housed in a Dec-O-Cover. Extinguisher and cover by General Fire Extinguisher Corp., Box 326, Northbrook, Ill.

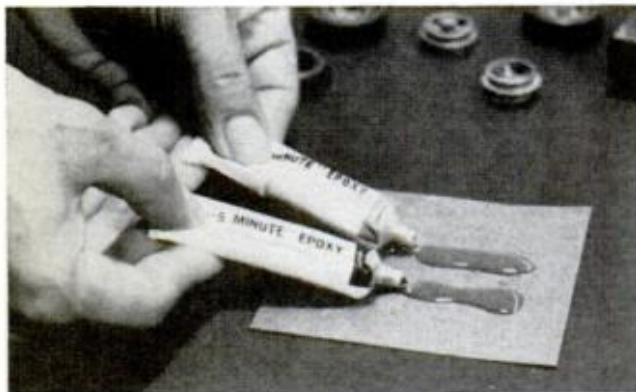

FIVE-MINUTE EPOXY really sets in that time, even at low temperature, dries clear without shrinking, can set while in water. Exact one-to-one mix of this two-part compound is key to successful use. From Devcon: \$1.25 retail.



INDOOR-OUTDOOR VACUUM CLEANER for really tough jobs has been added to the Singer line of home appliances. Model D-5 sells for \$29.95 with utility brush and wand. Five-piece accessory kit is \$10. Also added to the line are two canister and two upright cleaners. Available nationally at Singer Centers.



INDOOR-OUTDOOR CARPET with stylized patterns makes up the new Fiesta line produced by the Ozite Corp. Shown above is the pattern designated as "brick." Available at department, furniture and carpet specialty stores.



RAILROADER LIGHT combines a powerful beam, flashing warning blinker and novel design since it's a replica of an antique railroad signal lantern. It's 8 in. high and weighs $\frac{1}{2}$ lb. Price is \$2.98 postpaid, from Gemael Products, Box 228, Tallahassee, Fla. 32302.

FIRST-AID KIT FOR FABRICS lets you repair burnt holes or small stains in minutes. Called Patch-N-Match, the kit helps you to cut out a circle precisely around the damaged section, fill it with a matching circular patch (cut from a cuff or seam) and seal it in place with a small piece of Thermo-Plastic tape. Included in the kit are a backing tile disc used when cutting the circular patches, heat sensitive tape and cutter. \$5.95 from Sears.

AIR-CIRCULATING PERIMETER HEATER can be the answer to your unusually cold problem areas, since its output varies from 3413 to 4505 or to 5631 BTUs, according to the setting of its built-in automatic thermostat. Corresponding power ratings are 1000, 1320 and 1650 w. Air flow is rated at 30 c.f.m. The unit has a safety feature that will shut it off automatically if it's knocked over. \$36.95 from Arvin Industries, Noblitt St., Columbus, Ind.

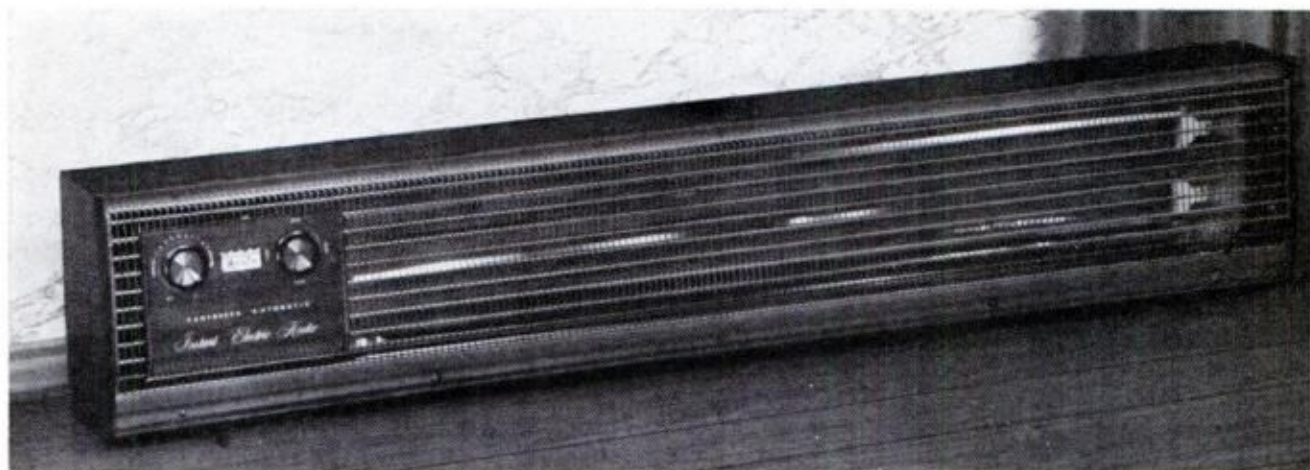

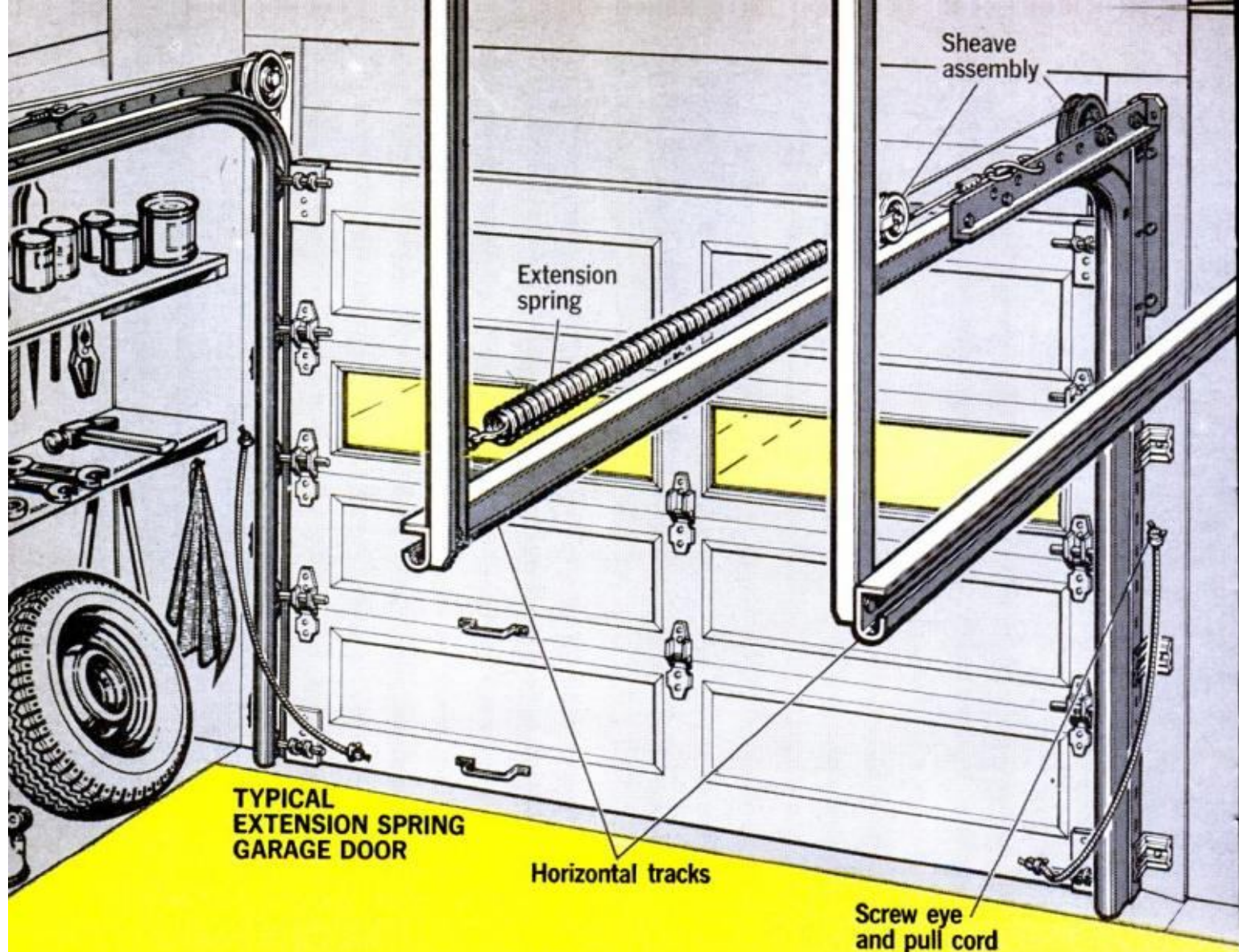

TYPICAL
EXTENSION SPRING
GARAGE DOOR

Horizontal tracks

Screw eye
and pull cord

Keep the Swing In an Overhead

By STEVEN J. HOWARD

SOME PEOPLE never have trouble with their garage doors. Others start having headaches the day the doors are installed.

Why? There are actually eight reasons.

1. Enough forces are working against a door to knock it out of adjustment.

2. Bolts, screws and lags holding hardware can loosen in time.

3. Wooden doors often absorb moisture and get too heavy for simple spring adjustment.

4. Rainy spells will also cause wooden doors and stops to swell, creating binding and friction.

5. Anything added to the door after initial adjustment and balance (such as glass, decorations, even paint) increases weight and can throw the springs out of balance.

6. Dirt in the tracks increases friction.

7. Lack of lubrication or dirty lubricant will also add to door problems.

8. Any physical damage to either the

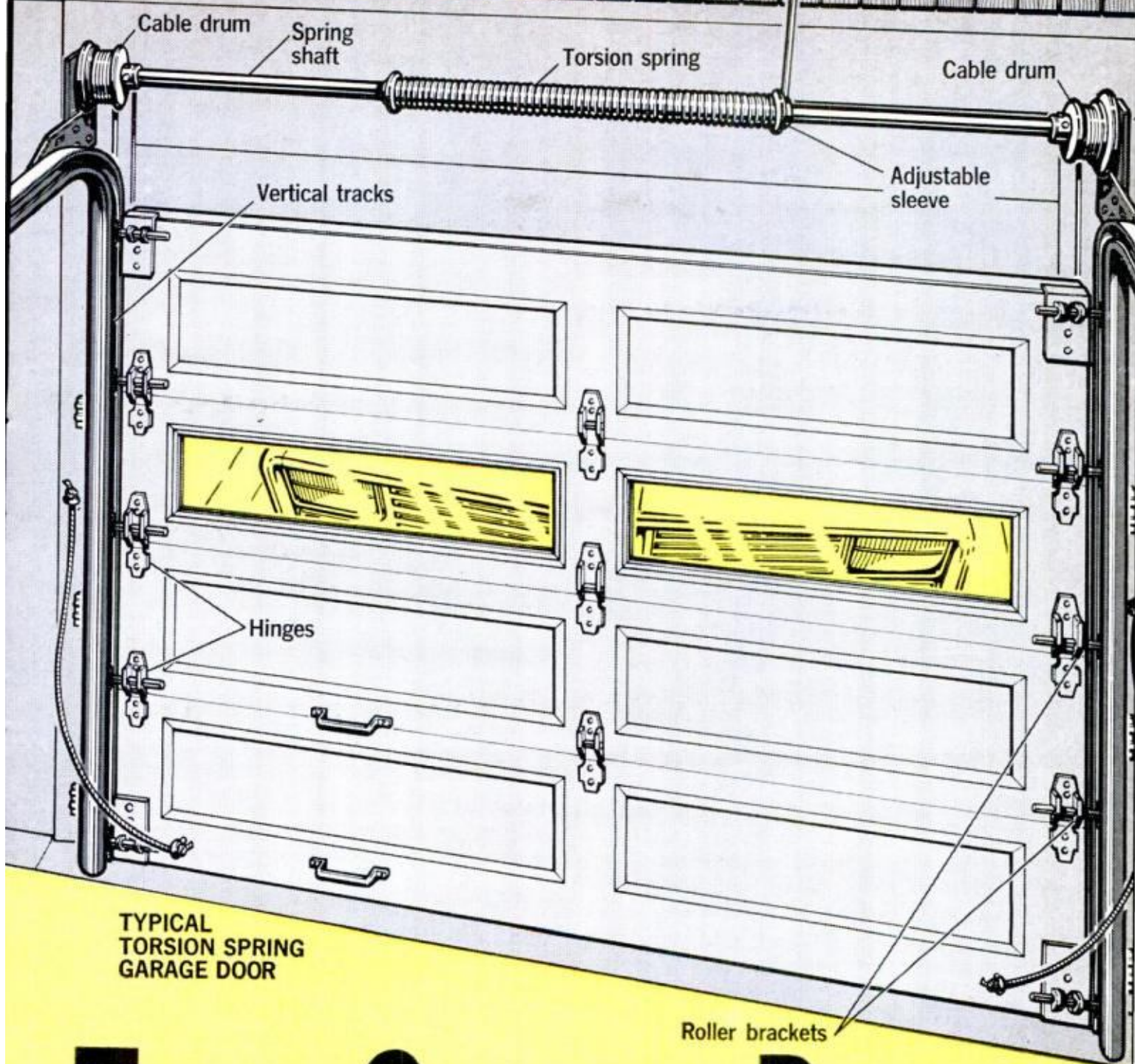

TYPICAL
TORSION SPRING
GARAGE DOOR

-Type Garage Door

Technical Art by Indugraph

doors or tracks will affect their operation.

These eight factors will affect both extension-spring and torsion-spring overhead-type doors. The extension-spring type, identified by springs along both horizontal tracks, is the easiest to work on—you can repair and adjust it yourself.

The torsion-spring door is identified by torsion springs wrapped around a shaft that can be seen across the top of the door when it is closed. Cables in a torsion-spring setup wind on winchlike drums

attached to the same shaft as the springs.

Here's the only rub—you shouldn't attempt to adjust torsion springs by yourself. According to one door manufacturer, "The only way spring force of a torsion-spring door can be increased is by winding the springs additional turns. This requires two bars to hold the winding plugs. The springs are under tremendous tension and someone who has had no experience in the job can be seriously injured. We recommend a professional if

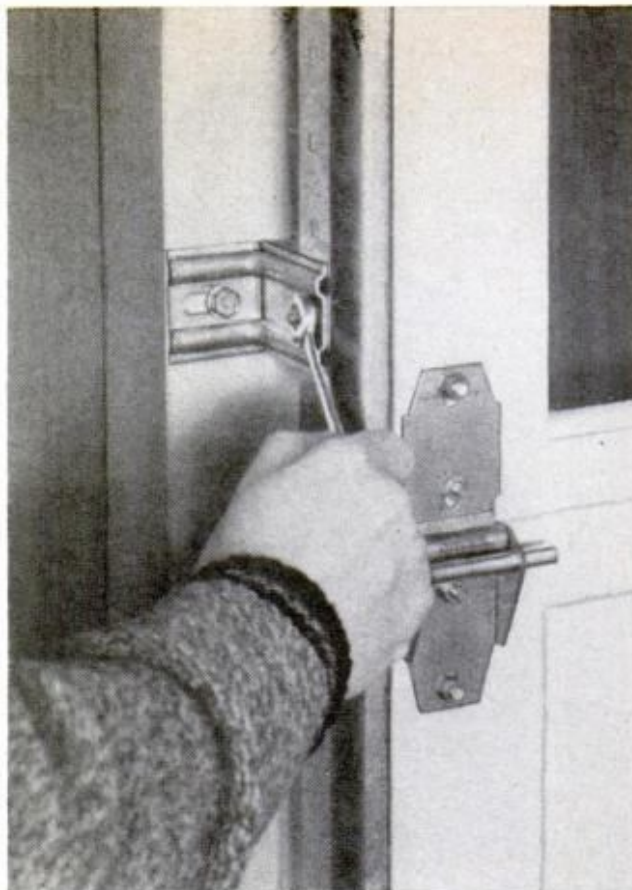
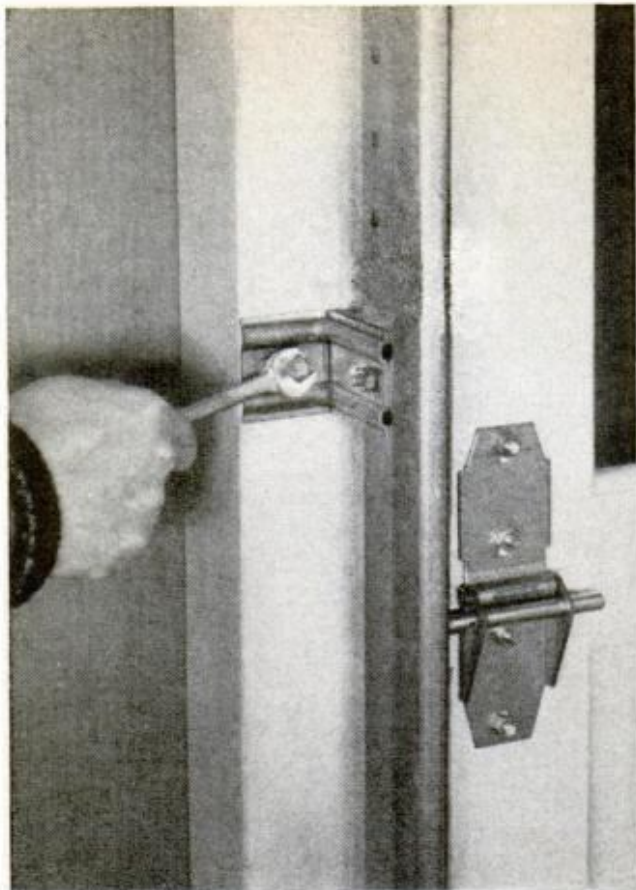

REDUCING FRICTION between the door and track (left) or door and stop (right) requires bolt adjustment

adjustment is required to any torsion-spring setup, other than oiling and adjusting of hardware."

Before getting to service information I suggest you first get a diagram calling out the specific parts of your particular door. The manufacturer of the door will usually supply it if you give him the right information. Look for a name and serial number plate near the lock. Tell the manufacturer the width and height of the door, its material (wood, fiberglass, steel), model name (if available), serial number and approximate age.

Now let's take each major door problem and see how to handle it.

Friction, for instance, is the most prevalent. To cure it, use a fairly heavy grade of oil (No. 20 is best) on pulley, ball bearings, door rollers and hinge pins. Only a few drops are needed at each point.

Roller shafts should be free to slide back and forth in the roller bracket. Many manufacturers recommend general-purpose Lubriplate, available through automotive stores, since it's waterproof and unaffected by weather changes.

Another lubrication spot you shouldn't miss is inside the track where the rollers slide, especially around curved portions.

Should lubrication fail to solve the

friction problem, check the door and door stops to see where and to what degree paint has been rubbed off. If you find evidence of excessive rubbing, you have two alternatives: You can move the stops away from the door if rubbing is localized in one or two areas, or you can move the door away from the stops if it is a general problem—that is, if rubbing occurs along most of the contact surface.

In the latter case, examine the hardware alongside of each track. Brackets holding the track away from the door may be spot-welded and not adjustable, or attached with bolts and fully adjustable.

If you have a door with adjustable brackets, loosen the bolts holding the track, pull the track toward you about $\frac{1}{8}$ in. and tighten the nuts. This will usually alleviate the problem. If you find friction localized to a few smaller areas, plane the stop to remove high spots.

It is important to have $\frac{1}{4}$ to $\frac{1}{2}$ in. of side play between door and tracks at any position, open or closed. You should be able to float the door from side to side $\frac{1}{4}$ to $\frac{1}{2}$ in. If not, the tracks may be too close to the door edge and bind the rollers.

To adjust, simply go back to the track brackets, back out the lags a few turns and move the tracks farther apart. Make

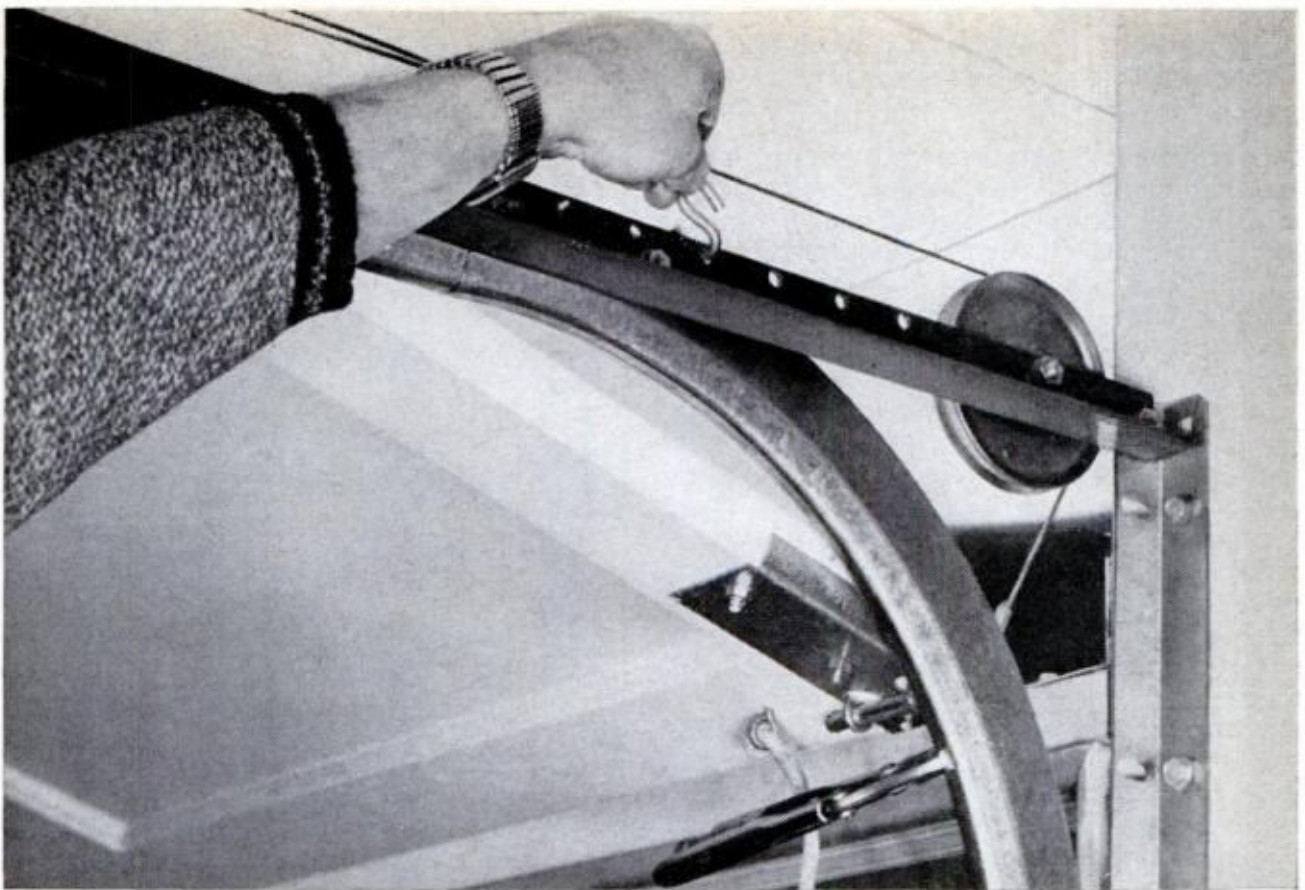

COMMON WAY to adjust spring tension is to change S-hook placement. Vise clamp keeps door from falling

sure tracks are vertical and evenly spaced by checking with a carpenter's level.

Spacing tracks too far apart is not a good idea. This could permit one side to reach higher than the other during open cycles. The condition, called "racking," wedges the door in the track and stops it.

Now we come to the overweight door. Tip-offs to a moisture problem are surface checks and small cracks in panels. Springs can be adjusted to compensate for added weight, but during a dry spell you should thoroughly sand panels and repaint *both sides* with a quality exterior paint.

Adjusting for weight is done by putting more stretch in springs. But remember—do this only on extension-spring doors.

Most extension-spring doors are adjusted from the cable's dead end fastened to the horizontal track reinforcing member near the door opening headers.

No matter how springs are adjusted, the door must be opened and propped, since springs will be detached and the door can fall. Prop the door open with clamps or by putting a strong ladder beneath it.

Many doors are anchored by S-hooks. To increase spring tension, first move one hook forward a few holes, then move the hook on the other side the same amount.

On some doors, spring adjustment is

made by moving the back end of the extension spring over a notched bar. On still others, adjustments are made with an eyebolt and nut through the rear track hanger.

Next check for the proper balance point. With the bottom of the door 1 to 2 ft. off the floor, it should neither tend to raise or fall by itself. Above this position, a well-balanced door will tend to rise slowly by itself. Below it, the door should fall by itself.

If it's no longer possible to balance the door with the present springs, they should be replaced with stronger ones. If you can identify the make of door, you can probably get them from a dealer. If not, weigh the door (detach the springs and lower the door onto a bathroom scale placed under the center of the door).

You'll probably need help. A one-car garage door weighs up to 150 pounds; two-car sizes weigh 300 pounds and more. When you know the weight, ask a dealer to get workable springs for you.

To keep a working door troublefree, lubricate all moving and turning parts once every six months. At that time, tighten all loose bolts, check the cables for fraying or wear and make sure one hasn't slipped off its sheave. ★ ★ ★

New Tools You Should Know About

CENTER-SINK for installing all types of hardware automatically centers and drills screw pilot holes accurately and in one operation. Thus, installing hinges, latches, drawer pulls, cover plates, door knobs, marine hardware and kickplates becomes a simple job, even when you're working with stubborn cross-grained hardwoods.

To use it, just place the guide tube in the hole of the plate or hinge, then start the drill and apply a light pressure so that the turning drill bit will be centered exactly. Then continue to apply this pressure to overcome the spring resistance of the center-sink tool until the drill has completely bored into the work for its full length.

Never bear down heavily on the pilot hole locator, and always withdraw it while it is still turning. Install one screw to hold the plate or hinge securely in place before drilling the other pilot holes. A set of three for No. 4 to No. 12 screws sells for \$4.45 from Norfolk Products Corp., Winsted, Conn. 06098.

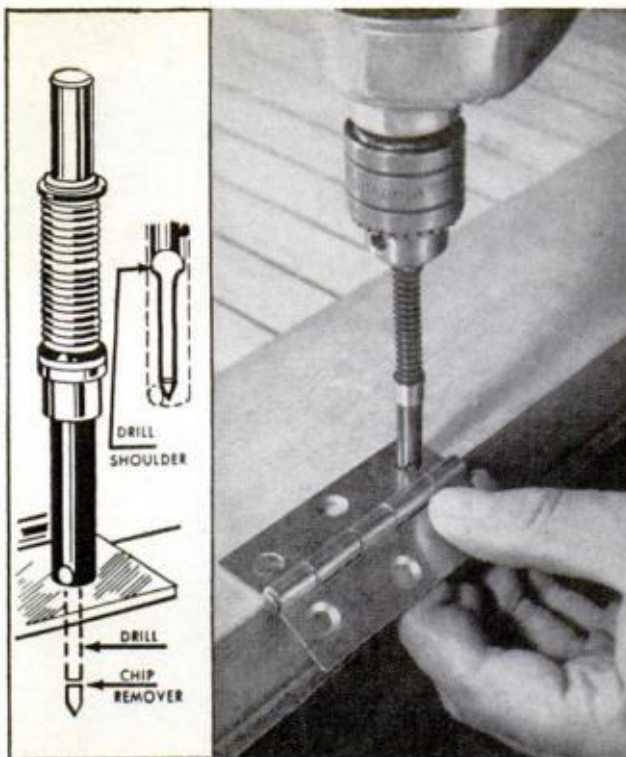

FAST-CUTTING RASPS in 3 different styles have a 10-in.-long cutting surface with over 1000 individual teeth for easy working with common workshop materials like wood, plastics and soft metals. The flat rasp is ideal for such tasks as planing, beveling, sanding and filing flat objects, while the curved rasp has a convex cutting surface especially useful for shaping concave or contoured surfaces. The hole rasp has a circular shape and can be used either for enlarging holes or for shaping sharp curves. Price for each of the first two is \$1.98, while the last costs \$1.68. All three are available at retail outlets, or for \$4.75 postpaid from Arco Tools, Inc., 421 West 203 St., New York, N.Y. 10034.

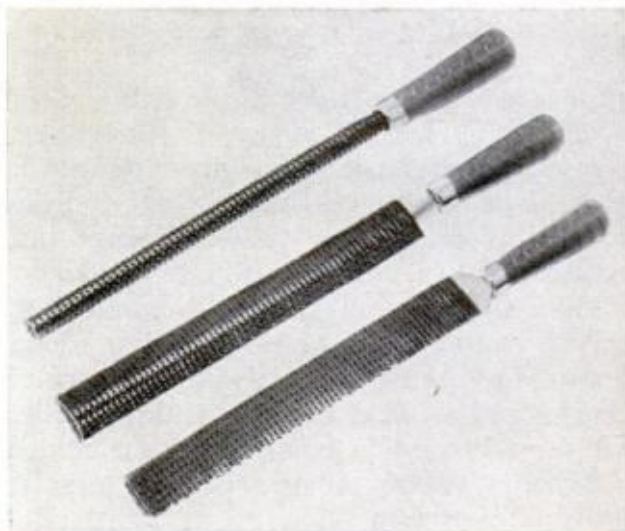

DRILL STAND for portable electric drills will let you convert most any $\frac{1}{4}$ or $\frac{3}{8}$ -in. portable drill to a handy bench motor for such indispensable operations as grinding, buffing, sanding, sharpening or wire brushing. It's constructed of sturdy polystyrene and features a stainless steel, quick-adjusting clamp that will firmly hold and lock the drill in place when mounted on a workbench.

The drill stand can be especially useful whenever a flexible shaft must be fitted to the drill. Four screws and washers are included for easy mounting of the drill stand to your workbench. Price of the No. 4511 stand (shown at right) is \$1.50. It's available at retail hardware stores or you can order it directly from the manufacturer, Coastal Abrasive and Tool Co., Inc., Box 337, Trumbull, Conn. 06611.

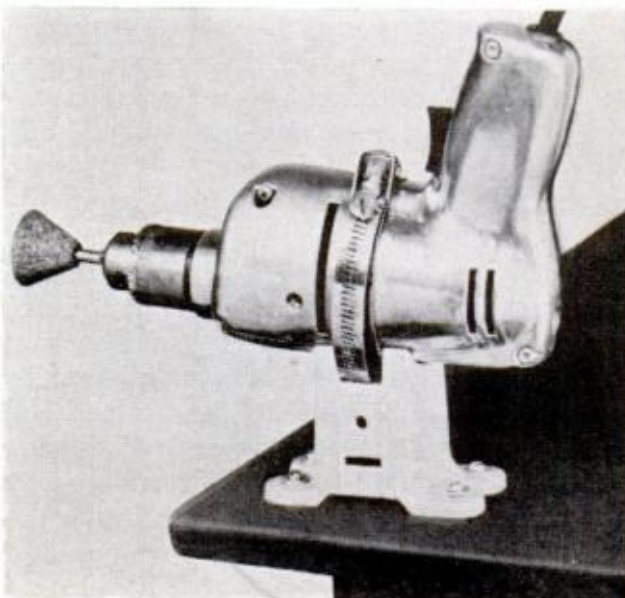

HINTS FROM READERS

Increasing sawhorse capacity

Working with 4x8-ft. sheets of plywood or paneling can be quite awkward—but not when you have a pair of these modified sawhorses. As shown, there are two hinged extension arms added to the top crossbar to increase its 24-in. width to 4 ft. The second change is the notch in the crossbar to accept a 2x2-in. stabilizing brace or stretcher running from one horse to the other.—*Dr. John A. Walker*

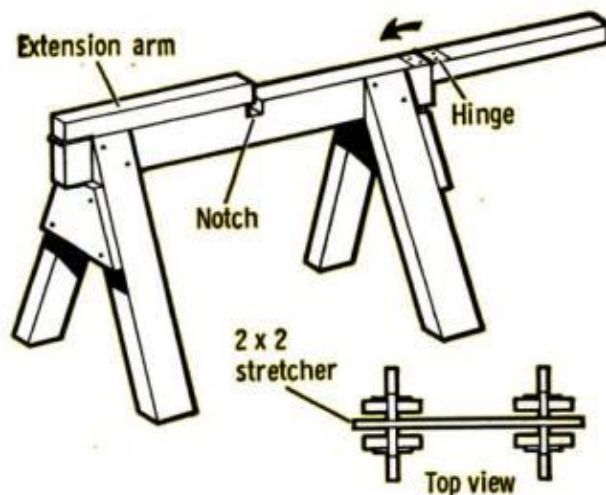

Piano muffler

If your children's piano practice is limited to those hours when no one's home simply because it's more noise than music, fit this quick-switch muffler to the piano and allow the kids to play as long as they like. As shown, the muffler is merely a 1/8-in.-thick piece of felt that's threaded to an aluminum crossbar. The felt slips behind the hammers to absorb most of the force, yet allows a full, soft tone without sacrificing tonal graduation. When the muffler isn't needed, simply pivot it upward out of the way.—*Roderick R. Hall*

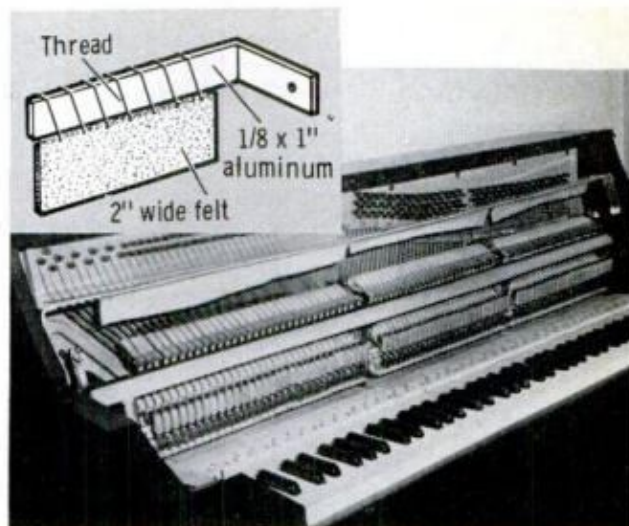

Simple lock control for electronic garage-door opener

As a long time enthusiast and owner of automatic garage-door openers, I enjoyed the article *How to Install Your Own Garage-Door Opener* (page 171, April '68 *PM*). There are few things indeed that, once used, change suddenly from the category of *luxury* to that of *absolute necessity*.

I have, however, one suggestion. I have yet to see a radio-controlled, garage-door

opener that is not occasionally subject to phantom operation; that is, a random signal may open or close the door. To reduce the chances of my door opening, I've included a switch in the 115-v.a.c. line to the operator. At night, or when I'm away on a trip, I flip the switch off—and rest secure in knowing that only a heavy crowbar and inordinate brute strength will open my garage door.—*H.L. Lynch*

Pair up horses for height

The next time you find yourself trying to manhandle a 4x8-ft. sheet of plywood or a long board on a table saw, try this trick. All you need are a pair of sawhorses, a pair of C-clamps and a minute or two of work. Place one horse on top of the other and clamp the legs together as shown in the sketch. In the event you find that the sawhorses become top-heavy and tend to tip forward, try canting the top horse so that one leg on either side contacts the lower horse; i.e., in the view at right, one clamp will be on the left and the other on the right.—*John Hilden*

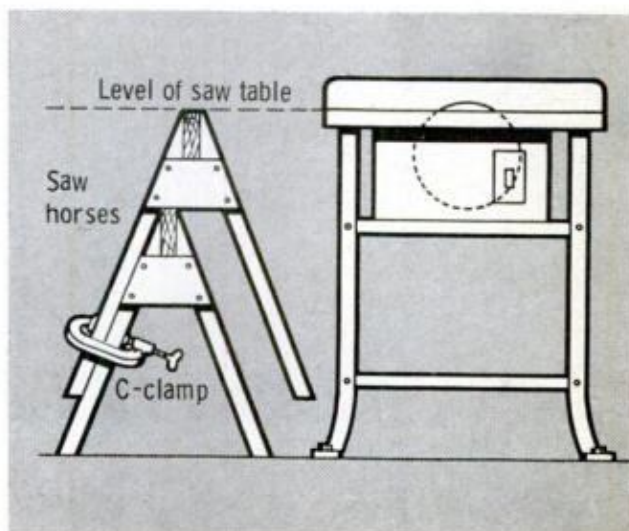

How to Squeeze More Storage

Put wasted space to work with these simple projects that make stowage a cinch

By D. SWANSON

WANT TO BE THE REAL HERO of the family? Then turn the high-traffic room of your home, the kitchen, into a comfortable, livable and highly efficient area—simply by incorporating just a few of these storage ideas in it or by building in two or three of these work-savers.

What's more, they're all uncomplicated enough to be tackled one or two at a time each winter weekend so that by the time spring rolls around, the value of your home will have increased considerably—dollar-wise as well as convenience-wise.

One such convenience feature is the storage area for rolled tablecloths (shown at the left) while another is a pair of simple drawers (below) used exclusively for pans and trays that are too awkward to store in a conventional fashion.

These and additional spacesavers (and space-makers) were found originally in the home of Mr. and Mrs. Frank Myers of Winston-Salem, N.C. Although Mr. Myers



CAREFUL SEARCH FOR HIDDEN SPACES usually will yield two or three areas that can be effectively utilized for storage of odd items. In this case, a long space was found for tablecloths wound on tubes

SIMPLE DRAWERS AND PULL-OUT RODS can be used to store pots and pans compactly within easy reach

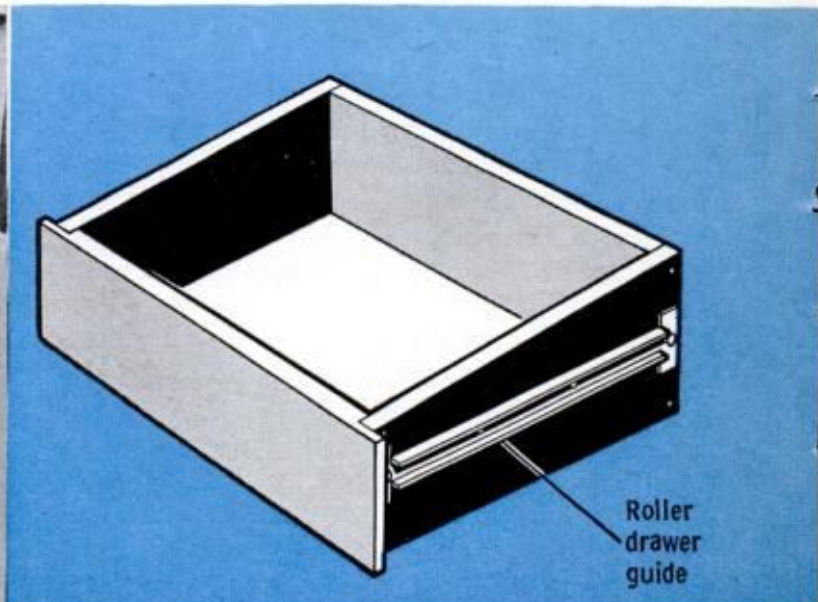

Space Out of Your Kitchen

is in the electrical supply business, the couple's specialty is finding simple solutions to big problems. Their island unit, for example, has a triple sink and stainless steel top; it could be installed easily in the wasted space in the center of an average kitchen. It also offers the bonus feature of providing enough under-the-sink space to hold trash cans and cleaning supplies. A pull-out Formica-topped shelf rests hidden in the island until needed, while a separate, but nevertheless handy, cutting board is similarly built-in next to the sink.

The cabinets around the perimeter of the 12 x 14-ft. kitchen also were designed with livability in mind. With careful planning, the Myers were able to transform a single 12-ft. wall into more than 300 ft. of shelving. To the right of their refrigerator, for example, four standard-size doors open to uncover a broom closet and shallow pantry type storage. Three of the doors are lined with shelves and three deep drawers at the bottom hold odd-sized containers, supplies and bottles.

In fact, there are drawers and shelves neatly tucked away in nearly every cabinet. In one, a linen drawer replaces the

SMALL BOTTLES OF SPICES can be neatly arranged in a simple rack fitted to inside of a door. Two or three of such racks will do for entire kitchen

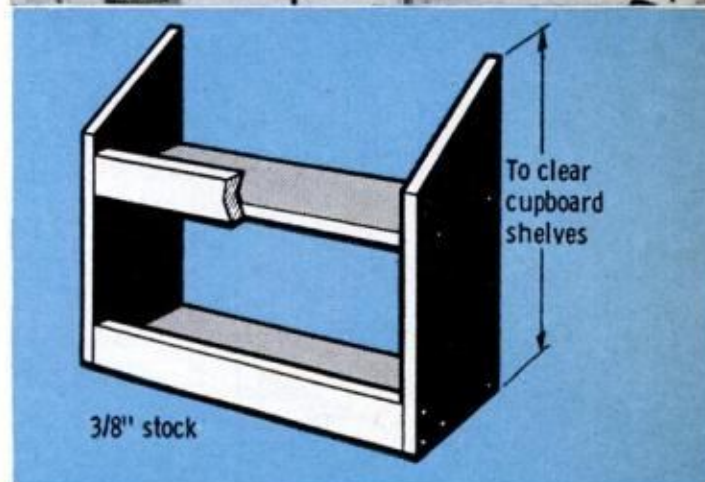

KNIFE DRAWER with two shaped cross members will stow knives out of sight, protect them from damage

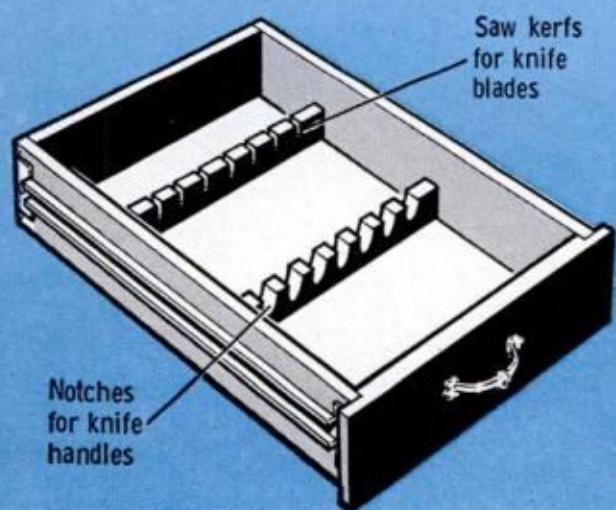



bottom shelf; in another, two drawers hold large pans and pan covers; while in a third, pull-out racks hold pans with handles in a vertical, spacesaving position. Thus, the spacemakers are also backsavers since it's possible to reach any item without resorting to kneeling or bending over for more than a few seconds.

In most kitchens, it's usually possible to find hidden or otherwise wasted space that could be put to effective use as a storage area. The Myers, for example, discovered unused space above the airconditioning unit installed between the garage and their dining room. Since the space ended at the kitchen wall, it was a relatively simple chore to cut an opening in the wall and build in a long shaftlike cabinet to hold tablecloths rolled on cardboard tubes. A careful study of the plans of your home likely will reveal a similar space between the walls of additions, at the back of deep closets or around stairways and built-in appliances.

Other special-use spacesavers that you could easily build into your kitchen take

HANDY CUTTING SURFACE is easy to build and install. It's basically just a bottomless drawer fitted with a top that will hold up under a knife blade

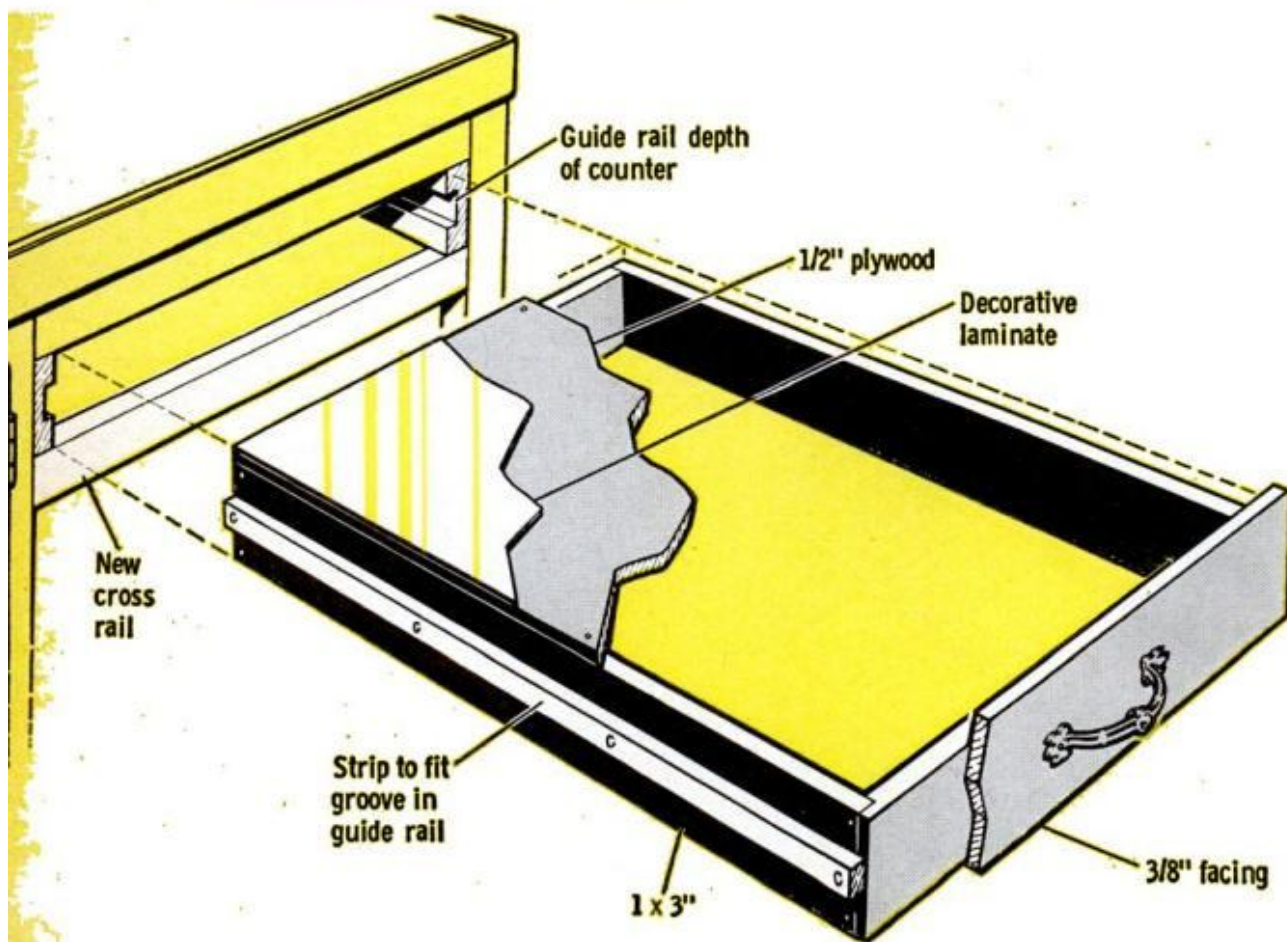

the forms of spice racks, knife drawers, bread bins and multi-shelf units used strictly for canned or bottled goods. Here again, the trick is to search out unused space and put it to work—preferably using it to solve the problem of storing awkward, bulky, shelf-robbing items such as toasters, mixers and similar appliances.

Combine these simple kitchen aids and worksavers with such conveniences as lighting fixtures concealed under the cabinets and adequate electrical outlets, and you'll find that your once-congested kitchen will be transformed into a highly organized, highly livable center your wife will be proud to show—and use efficiently.

Yet, as previously pointed out, you can make these additions and changes gradually and without great expense since you likely have enough odd pieces of lumber left over from old projects to complete five or six of these weekend projects at your leisure. Also noteworthy is the fact that it's not necessary to tear up the kitchen and disrupt its use during this modernization program. And at completion, you should look forward to the biggest, thickest steak ever. ★★★



ROLL-OUT BINS placed in bottom of cabinets are for storage of kitchen towels and cleaning supplies; eliminate need to kneel just to remove item in back

PANTRY SHELVES built on doors can provide storage space that's ideal for canned and bottled supplies

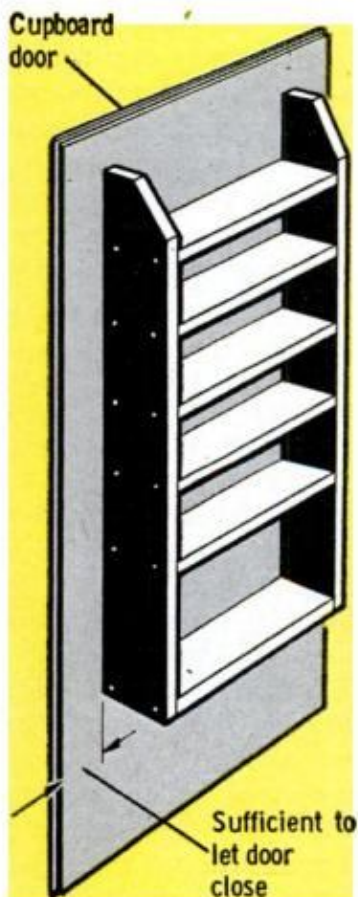

Build This Box-Leg Power-Tool Stand

By JOHN BURROUGHS

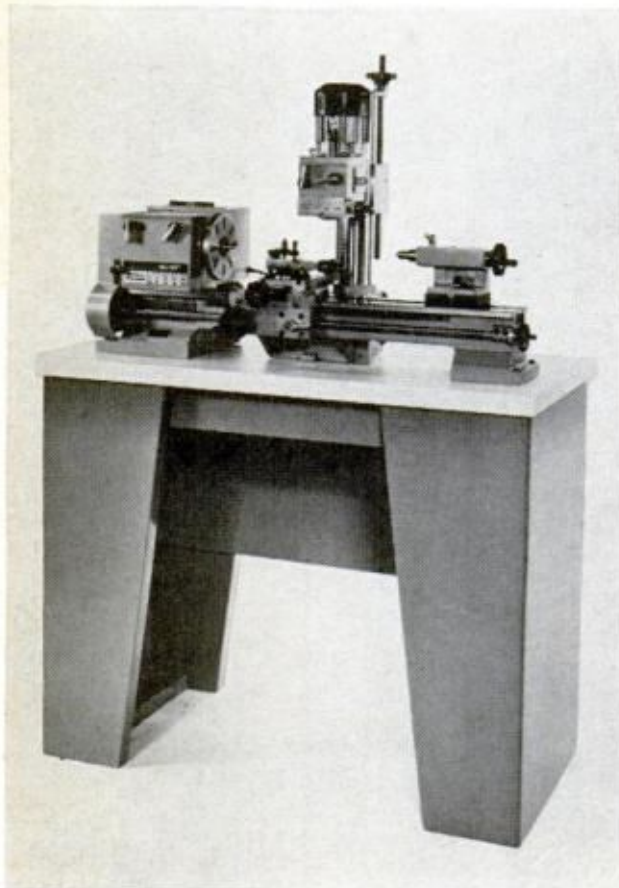
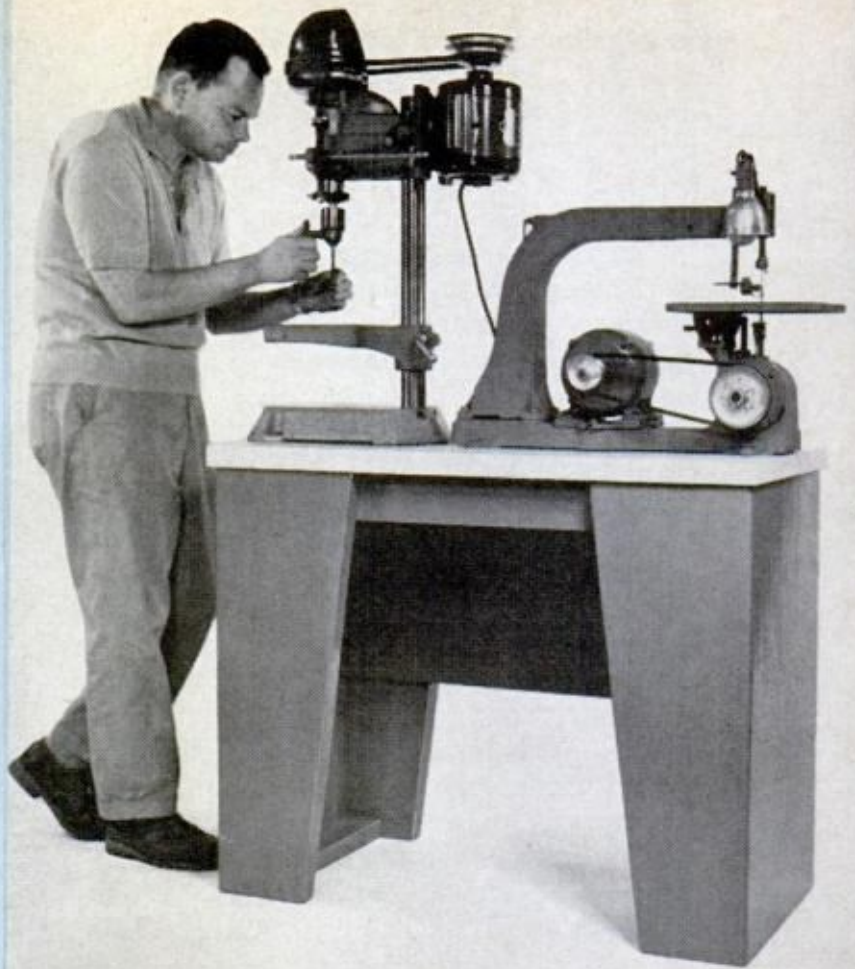

STAND IS IDEAL for a lathe. Finish the underbody with machine-gray enamel and leave top unfinished

THOUGH IT'S MADE from economical low-grade lumber, this solidly built tool stand is rugged enough structurally for the heaviest machine in your shop. With a single power tool and a vise it makes a fine combination stand-workbench. If you already have a bench, you can install two power tools side by side and turn it into an attractive double-length machine stand.

Length and width should be matched to the tool or tools you plan to install on the stand. To make the understructure, build two identical box-leg assemblies. These are joined with a 2x4 front rail and a 20-in.-deep back panel of $\frac{3}{4}$ -in. plywood. Glue and nail all joints.

The slab top can be either doubled $\frac{3}{4}$ -in. plywood edged with strips of oak flooring or 1½-in. hard maple, edge-glued and cross-bolted. Dimension it to overhang the base about $\frac{1}{4}$ in. on all sides.

When mounting a lathe, grinding head, bandsaw or other tool that should be belt-driven from underneath, hang the motor inside one of the box legs and cut slots in the top for the belt. ★★★



JOIN BOX LEGS with a 2x4 rail in front and a plywood panel in rear. Glue and nail all joints securely

BOX-LEG ASSEMBLY

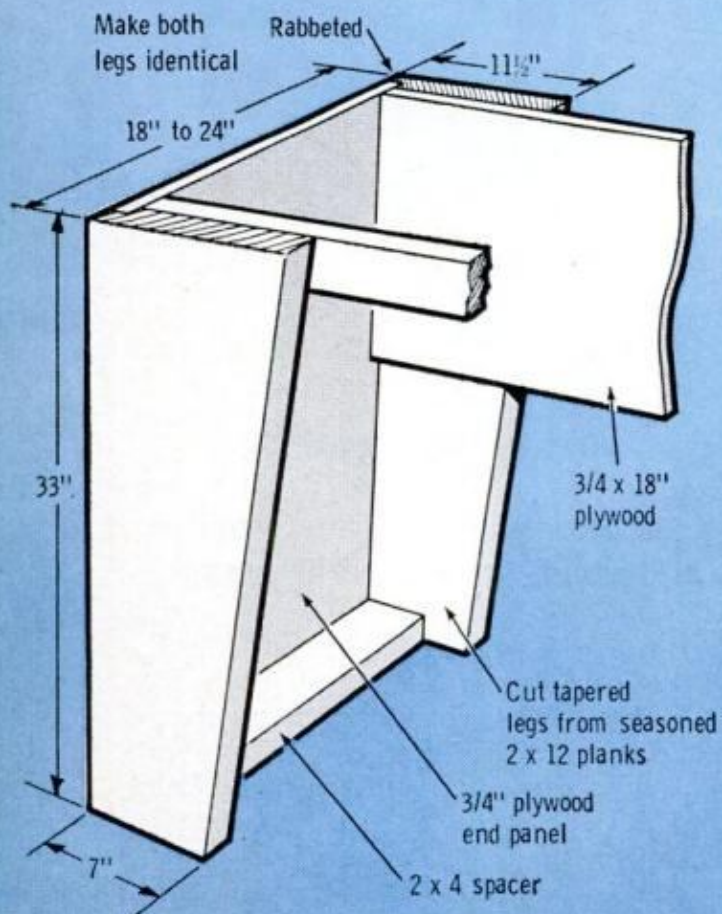

JANUARY 1969

HINTS FROM READERS

File-card contour gauge

The next time you have to copy a contour or curve, try this fast and foolproof method. Just take a stack of 3x5-in. file cards, wrap a thick rubber band around the length of the cards and force the cards down around the contoured surface. Then snap a spring-type stationery clamp over the width of the cards to hold the duplicate contour. Be sure, however, that the cards are kept tight to prevent them from spreading.

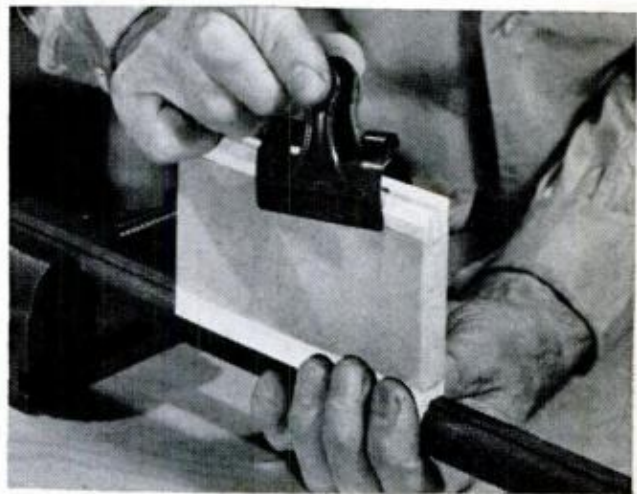

Lathe-center tester

Cut a disc from the bottom of a tin can and you have a handy tester for checking lathe-center alignment. If the centers are properly aligned, the disc will remain at right angles to the lathe axis when lightly clamped between the pointed centers. If the tailstock center is shifted, the angle will not be 90°. Of course, the disc must be flat, and the points should not contact it on an embossed letter or figure.

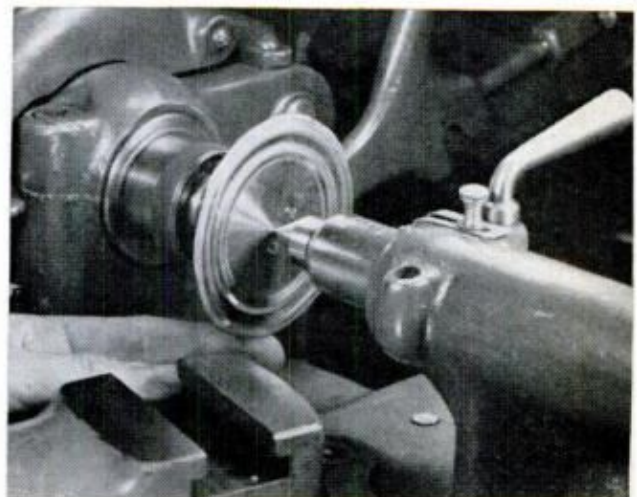

179

HOW TO MILL ON A DRILL PRESS

By **KENNETH B. LITTLEFIELD**

Technical Art by Graphic Presentations

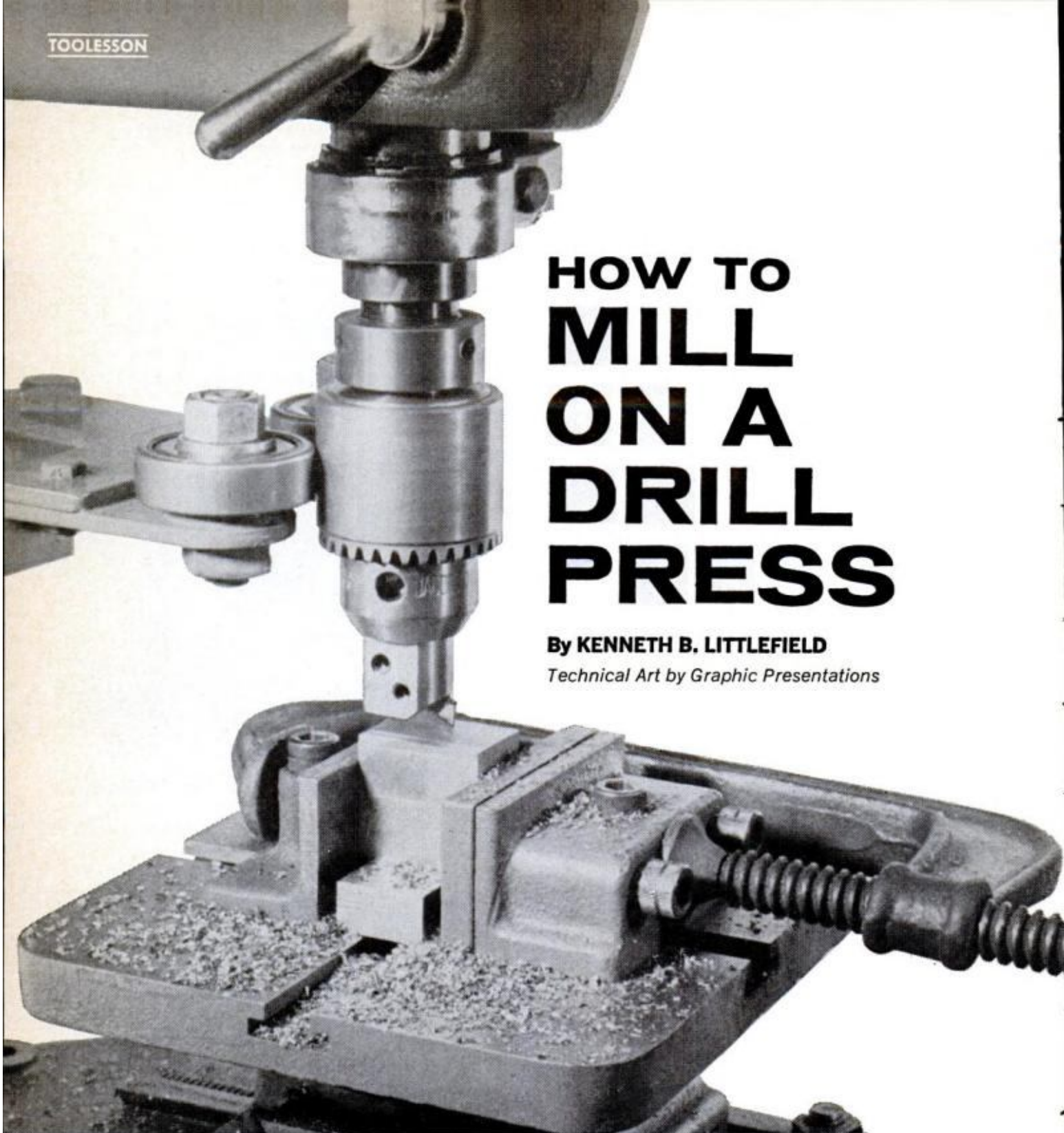

These simple cutting attachments will make it possible for you to mill metals, such as aluminum, cast iron and steel, on your drill press

COMBINE ANY MILLING VISE with the cutters and spindle support attachment shown here and you can convert your drill press into an excellent light-duty milling machine.

Use of fly cutters instead of multi-tooth commercial milling cutters makes drill-press milling practical for the home-workshop craftsman. These fly cutters are

inexpensive $\frac{3}{16}$ -in.-sq. lathe tool bits fitted in vertically mounted toolholders. You can keep them sharp without special grinding equipment and can change cutting angles readily to suit the metal being milled.

However, these fly cutters *must never be used without the spindle support attachment*. If the workpiece is advanced too

TOOL HOLDERS

Drill all tool holes 1/4"
All shanks 1/2 x 1-1/4"
All setscrews 1/4-20, 1/4" long

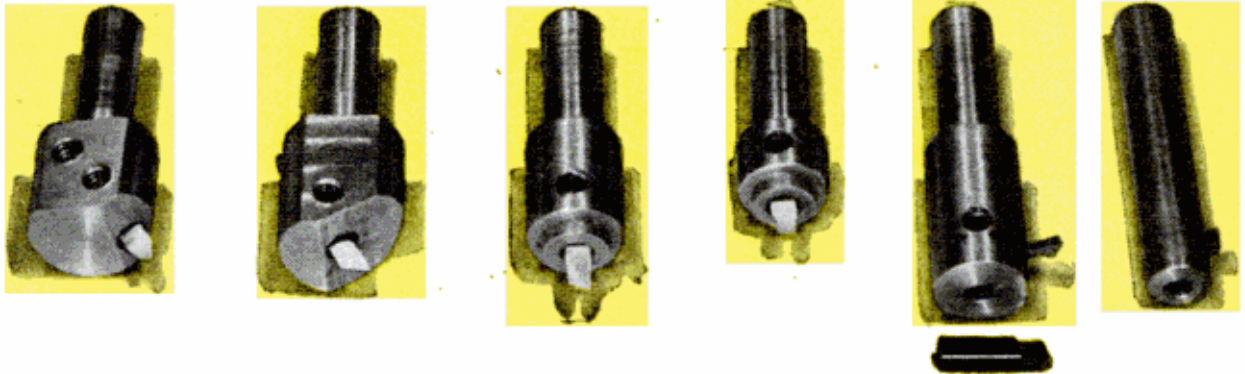
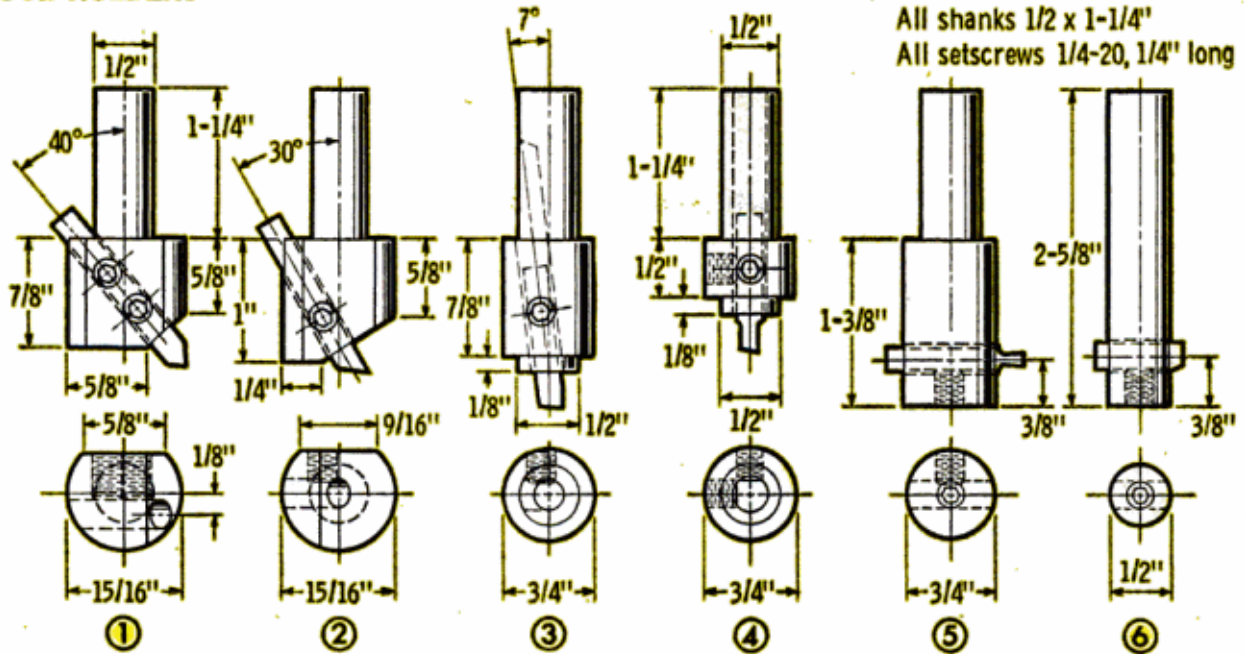

BITS FOR TOOL HOLDER NO. 1

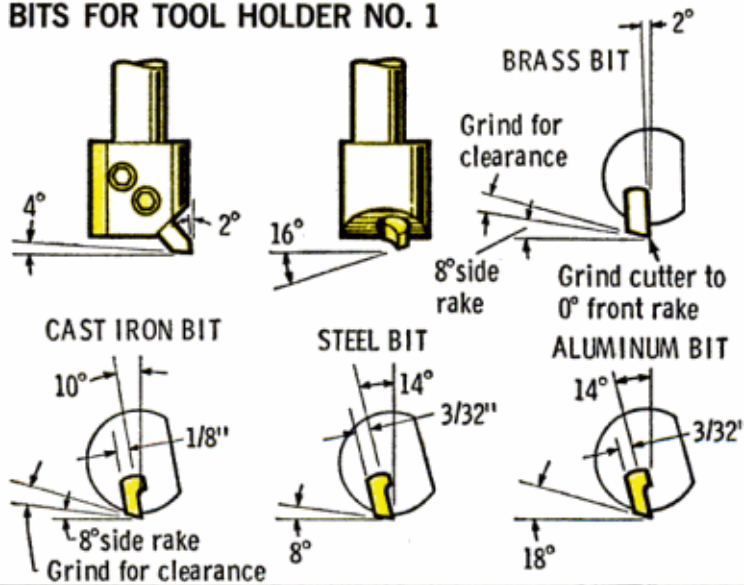

BITS FOR HOLDERS NO. 2, 3 & 4

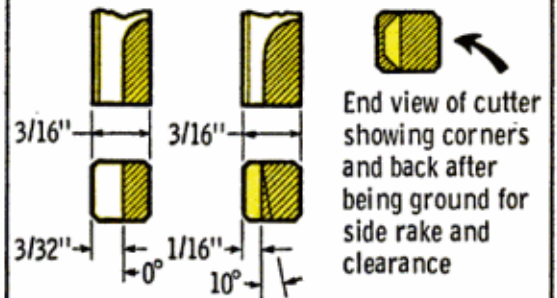

Front rake is obtained by reducing thickness of tool bit

Rake angles the same as those for Bit No. 1

KEYWAY CUTTER FOR TOOL HOLDERS NO. 5 & 6

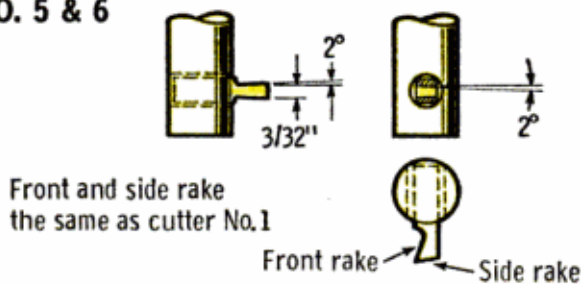

BORING BAR FOR TOOL HOLDERS NO. 5 & 6

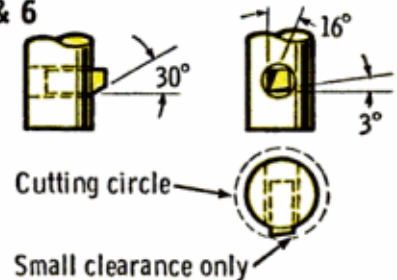

SPINDLE SUPPORT ATTACHMENT

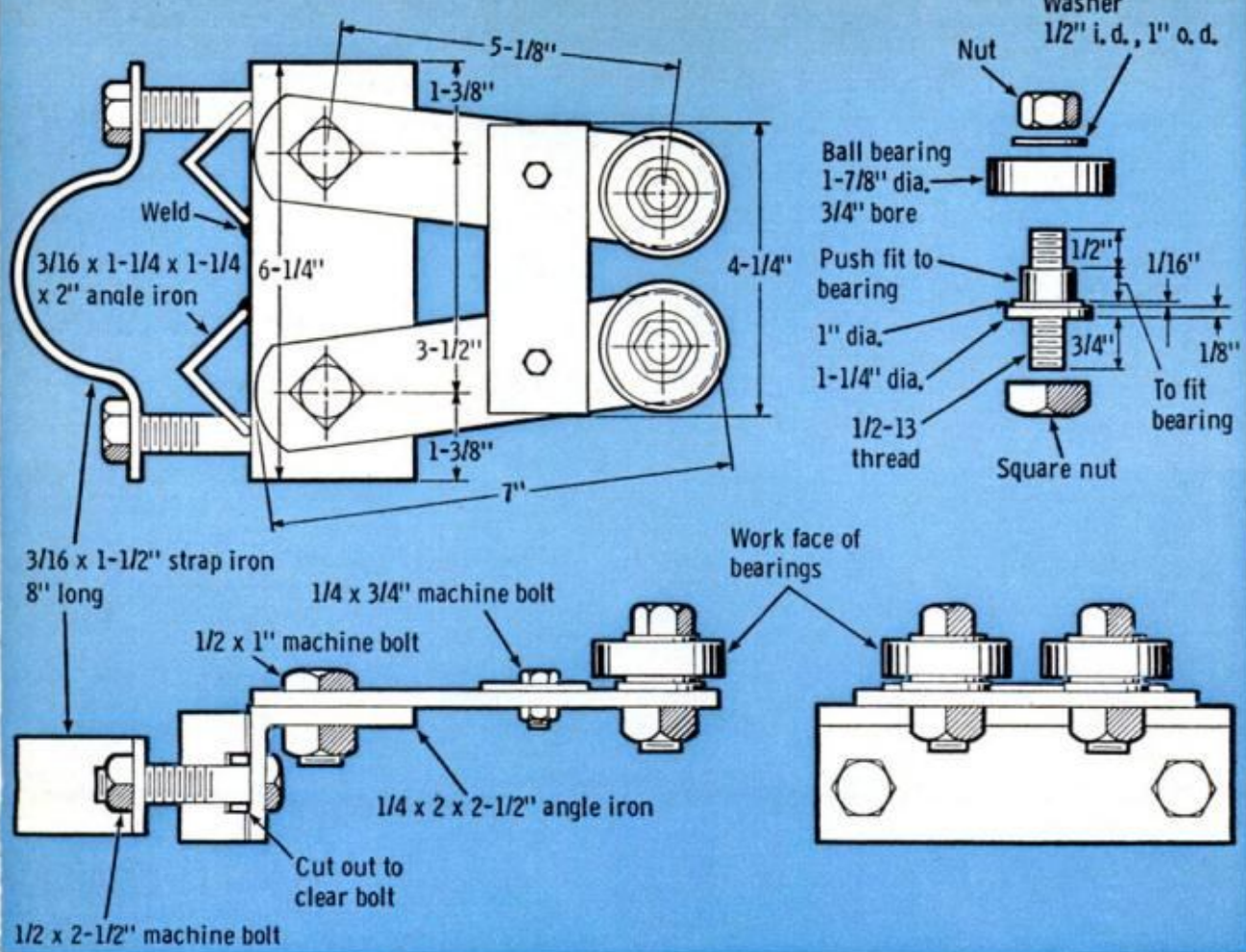

SPINDLE SUPPORT is easy to make of common workshop materials. Thicker, but not lighter, metal can be used **FITTED ON DRILL-PRESS COLUMN**, spindle support will prevent deep bites of bit from bending chuck spindle

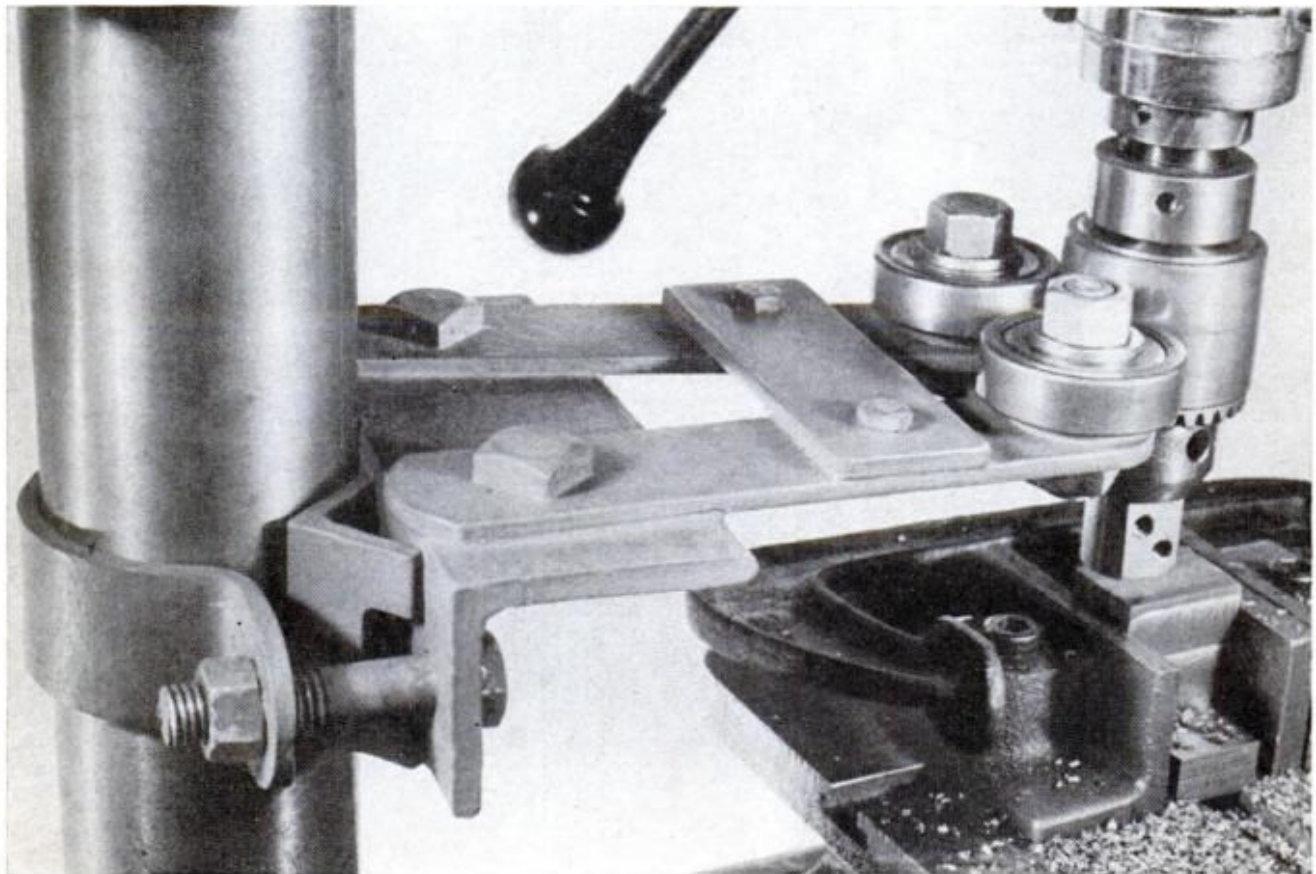

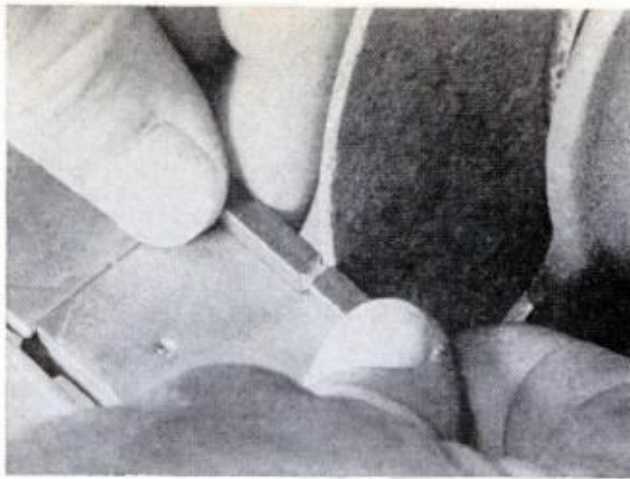

EASY WAY TO CUT BLANK TOOL BIT to the desired length is with a $\frac{1}{8}$ -in.-thick abrasive cutoff wheel

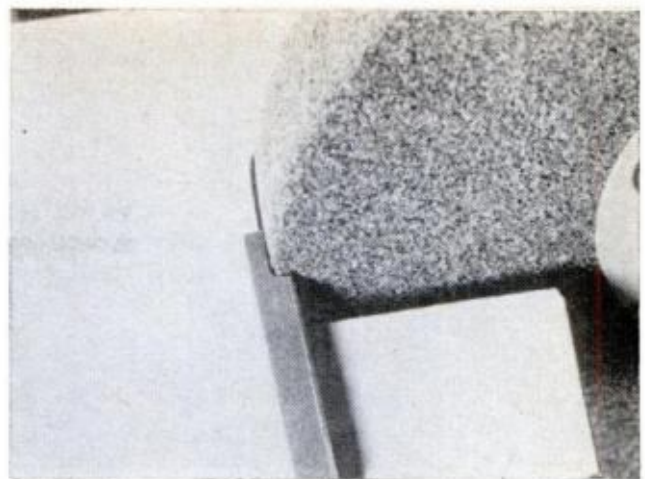

NEXT REDUCE THE THICKNESS of the blank bit on a bench grinder. Dip in water to avoid overheating

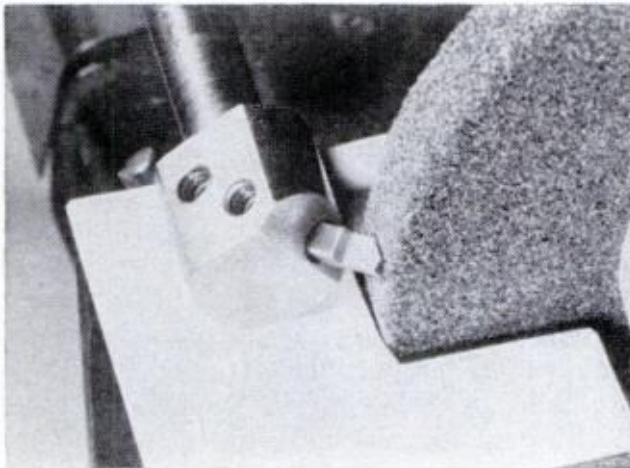

PLACE THE BIT IN ITS HOLDER and continue to grind it to approximately the correct size and shape

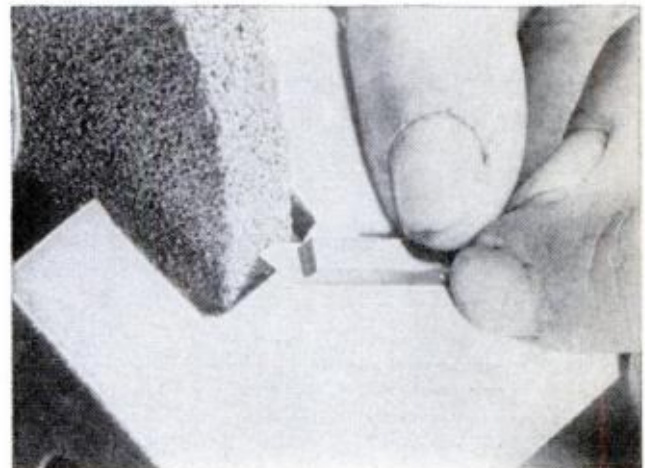

CAREFULLY FINISH GRINDING the fly-cutter bit by adjusting the grinder's toolrest to the required angle

rapidly, or it slips in the vise, the cutter will strike powerfully against the work. The spindle support absorbs the force of this blow, so no damage will result. Without it, the drill-press spindle would probably bend and be permanently damaged.

The spindle support shown is for a drill press with a $2\frac{3}{4}$ -in.-diameter column. Exact size of the two ball bearings isn't really important. Heavier steel can be substituted for that in the drawing; lighter metal definitely should not be used.

To set up the attachment, clamp the base to the drill-press column and attach both arms and bearings to the base. Swing them in until the bearings press firmly against the side of the drill-press chuck, then bolt the cross brace in position.

Turn the toolholders from mild steel and cut flats on two faces of the holders to facilitate boring holes for the cutter bits and setscrews. Later, corners of the tool bits must be beveled slightly to fit the $\frac{1}{4}$ -in. holes in the holders. The No. 1 toolholder is bored offcenter to simplify

grinding the rake angle of the bit; that is, a front rake of up to 14° can be obtained simply by reducing the thickness of the bit. Except for the keyway cutter, a front rake is obtained similarly in the other cutters by reducing the tool bit thickness. A rake of about 10° can be had without weakening the tool bit. The keyway cutter is ground like a lathe tool.

Rake and clearance angles shown in the drawings are the actual working angles of the cutters when held in the toolholders. To avoid confusion, hold the blank tool bit in its holder as you grind.

With the drill press running at its slowest speed, make a trial cut. The cutter should produce small, neatly formed chips. If not, check for sufficient side rake and regrind if necessary. If it still refuses to cut, it is because of insufficient front rake (especially when milling steel).

If the cutter seizes into the metal, accompanied by considerable vibration, reduce the side rake. With brass and to a lesser extent, gray cast iron, this effect

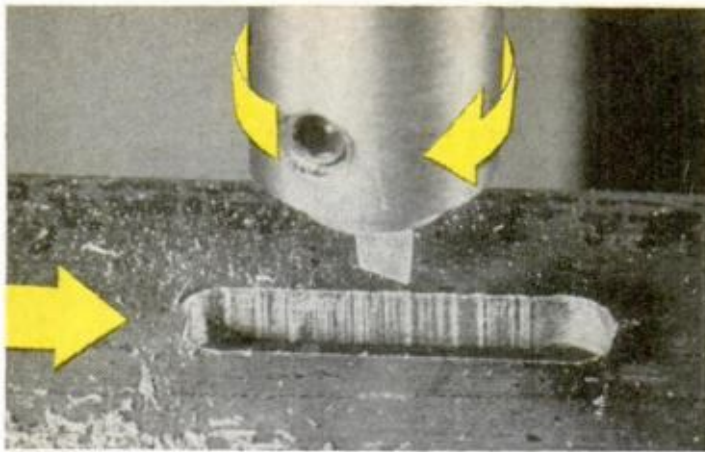

METHOD OF MAKING CUTS

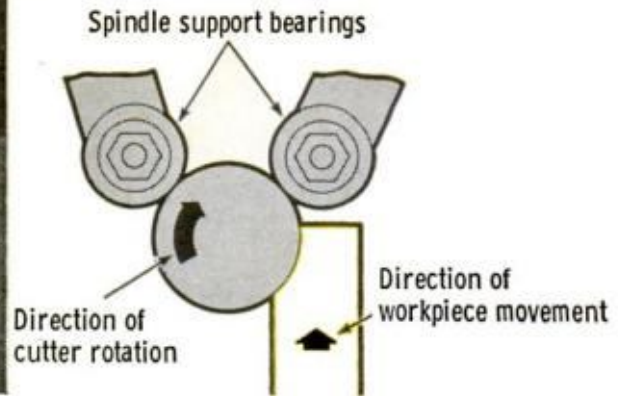

TO MAKE SLOTTED CUTS, first remove the bulk of the material with a series of drilled holes. Then fit drill press with the cutter and feed the work into the bit, in direction indicated in the drawing directly above

can also be caused by too much front rake. Bottom clearance and rake have little effect on the cutting of the bit but will affect the finish of the work.

The cutting speeds listed below are suggested only as a working basis. Too fast a speed rapidly wears away the tool's cutting edge; too slow a speed increases vibration and leaves a rough finish.

Cutter No.	1	2	3 & 4	5 & 6
Aluminum	1600	1000	2000	1000
Brass	1000	1000	1500	1000
Cast Iron	500	500	700	500
Annealed				
Alloy Steel	750	400	750	400
Mild Steel	1000	705	1000	750

The depth of cut with the large cutters should not exceed $\frac{3}{32}$ in., while the small cutters are limited to $\frac{1}{16}$ in.

Aluminum, brass and gray cast iron should be milled dry, as can be mild steel, but thread-cutting oil will help retain a sharp edge on the tool bit. Also use this oil when milling annealed alloy steel.

Cutters 1, 3 and 5 are sufficient for most milling jobs. No. 2 is useful for milling

small dovetail slides but it is suitable only for light work. No. 4 is particularly useful when working with soft metals.

Cutters 5 and 6 can be used either as keyway cutters or boring bars for enlarging existing holes. In the latter case, the optimum cut is about $\frac{1}{32}$ in., and the cutter must be fed into the work very slowly to avoid vibration. The best cutting speed will vary according to the hole diameter, but should not exceed 800 rpm for a $\frac{5}{8}$ -in. hole or 350 rpm for a $1\frac{1}{4}$ -in. hole. Cutting oil should be used.

There is considerable difference in the milling qualities of different metals. Even mild steel can vary so much that one piece may be milled at well over 1000 rpm, while 750 rpm may be the maximum for a different piece of the "same" metal.

Alloy steel is very unpredictable in this respect. It's always a good idea first to make a trial cut on the piece of steel selected for a certain job. If it appears it will be difficult to mill, a different—and more easily worked—piece of steel should be substituted. ★★★

V-BLOCKS ARE EASY TO MILL by making successive $\frac{3}{32}$ -in.-deep cuts, each approximately $\frac{1}{4}$ -in. wide

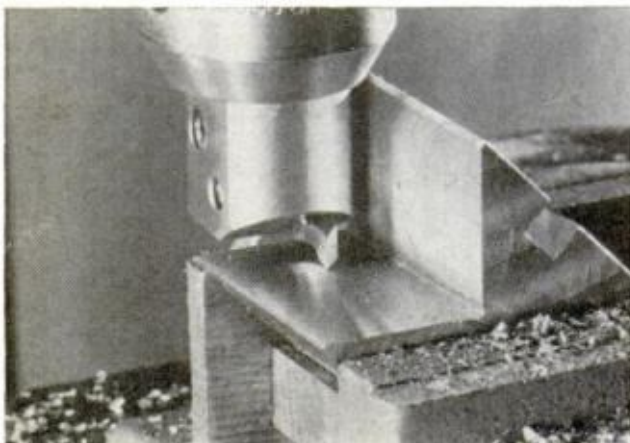

SLOTS ALSO CAN BE MADE with a number of repeat passes. Start slowly to avoid jamming bit in work

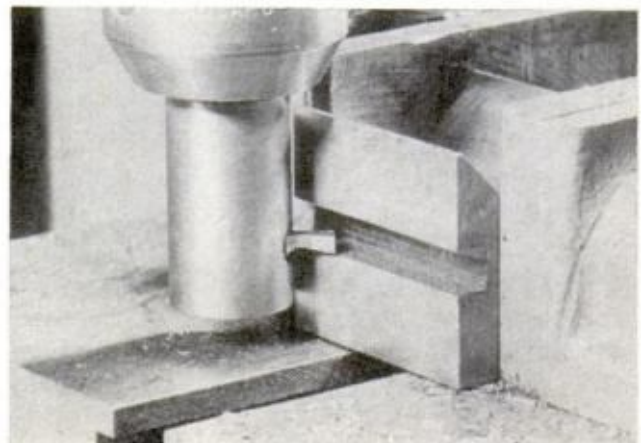

HINTS FROM READERS

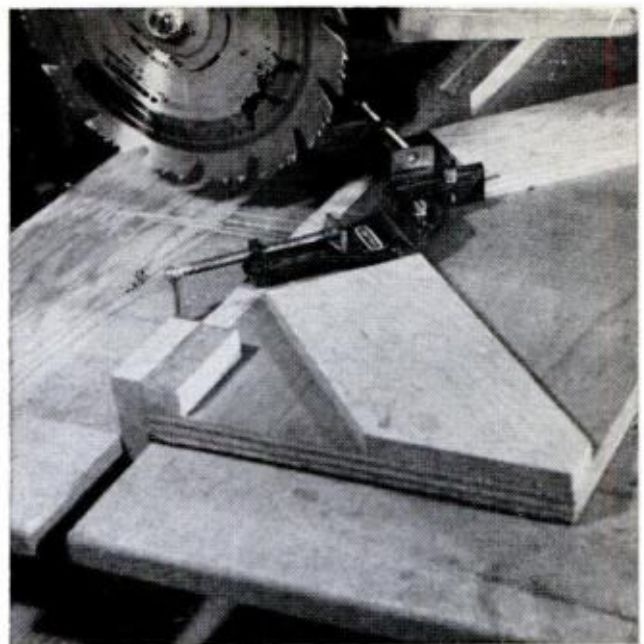
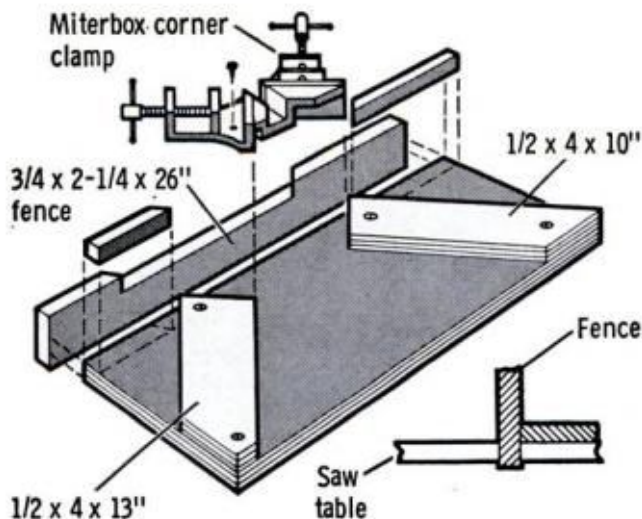

Miter jig for radial-arm saw produces perfect fitting joints

Anyone can make a fairly neat miter joint by using a miterbox, backsaw and a bit of wood putty—but with this simple jig for your radial-arm saw, you're assured of *perfect* miter joints every time. What's more, you'll be able to trim both pieces with just one pass.

The miter jig is built around a Craftsman miterbox (45° angle) corner lamp

which sells for \$2.29. Remove the backsaw guides and the rubber bumper and mount the clamp on a 3/4-in. plywood base with its own auxiliary fence. To use the jig, remove the regular fence from the saw table and lock the jig firmly in place. The two strips of scrap plywood tacked to the base will help position and support the molding or framing being cut.—*A. Joyner*

Filling cracks in concrete

I had quite a few hairline cracks in the concrete floor of my carport and was advised by "experts" to widen the cracks and fill them flush with cement. Halfway through, I gave up the chipping and filled the rest of the cracks with auto body filler. Now the cement-filled cracks have reappeared, but not those filled with the body compound.—*Stephen Stresnic*

Cool it in the washer

Every time my children have their friends in for a birthday party, I stack all the bottles of soda in the clothes washer and cover them with ice cubes. Not only does this keep the soda cold, it also saves storage space in the refrigerator for cakes, ice cream and other party favors. When the party's over, just drain out the water in the usual way.—*R. Sowa*

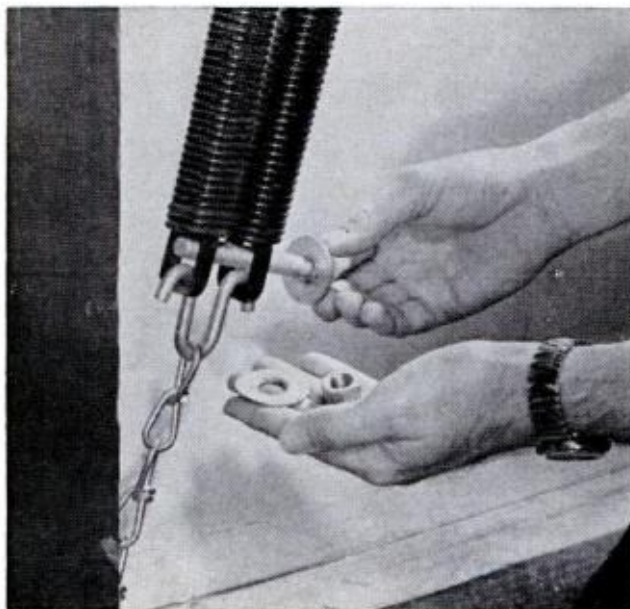

An ounce of prevention

Those heavy springs that take the work out of raising an overhead garage door can become dangerous missiles if they snap under tension. True, the possibility is rather remote, but to play it *absolutely* safe, make this simple low-cost modification that will keep broken springs from becoming airborne. For a single door, run a wire cable up through the center of the spring, loop it over the pin at top and bring it back down again. Using cable clamps, make loops in the two ends and secure them to the door jamb with heavy lagscrews. For a double door with springs (left), use a carriage bolt to join similar loops to ends of the springs.—*Clifford Lillo*

Turning Rings

On a Lathe

By WALTER E. BURTON

RINGMAKING is an exciting but often overlooked talent of the metal-working lathe. You can turn out sizes and shapes you could never buy—big, little, square, rectangular, triangular, oval, round, half-round, hexagonal, octagonal—you name it. You can make them of steel, cast iron, brass, aluminum, rigid plastic, even hardwood such as maple.

Turned rings are, of course, jointless. They have a handsome, elegant look that makes them ideal for pieces of jewelry and ornamental hardware. They can be used as decorative drawer and cabinet pulls, ladies' brooches and stands for models. Large rings can serve as bracelets or unusual picture frames.

The stock you use for making rings can be hollow tubing or pipe or solid bar material in round, hexagonal or other shapes. If you start with bar stock, you first bore out the center. Plain rings can be made simply by slicing sections off

Ever wonder how you make a ring with no joint? Slicing pipe and tubing like bologna produces perfect seamless circles in many types and sizes

PLASTIC RING, turned from a section of plastic plumbing pipe, gets a polishing below before final cut is made to separate it from remaining stock

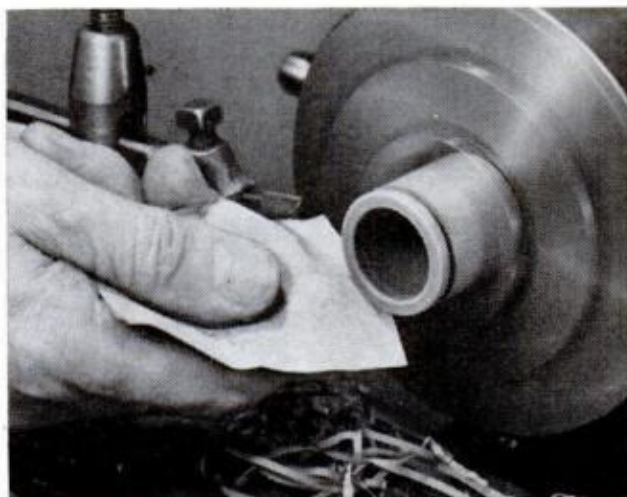

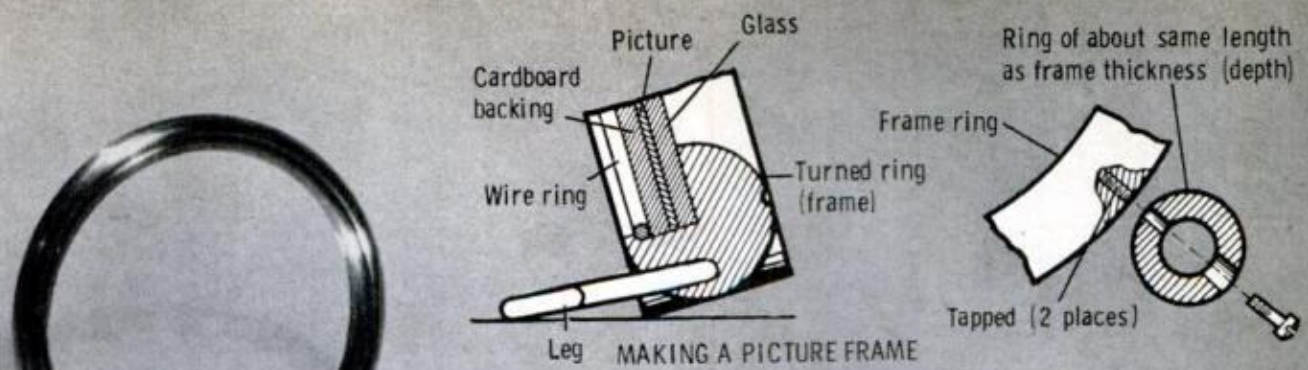

SOME OF THE MANY RINGS you can make are shown above. Oval ring to left of center was made by squeezing a round ring with pliers to flatten it slightly. At top is an example of how a large ring

can become a decorative picture frame. A recess is machined at the back to hold the picture and legs are added, as shown in the sketch. Big rings of this type could also make novel ladies' bracelets

RINGS DROP OFF one after another and slide neatly onto this automatic catcher. The simple device consists of a bent wire held in the tailstock chuck

FREEHAND TURNING enables you to shape round, oval and other curved-section rings. Tool is hand-held. Bar clamped in toolpost serves as toolrest

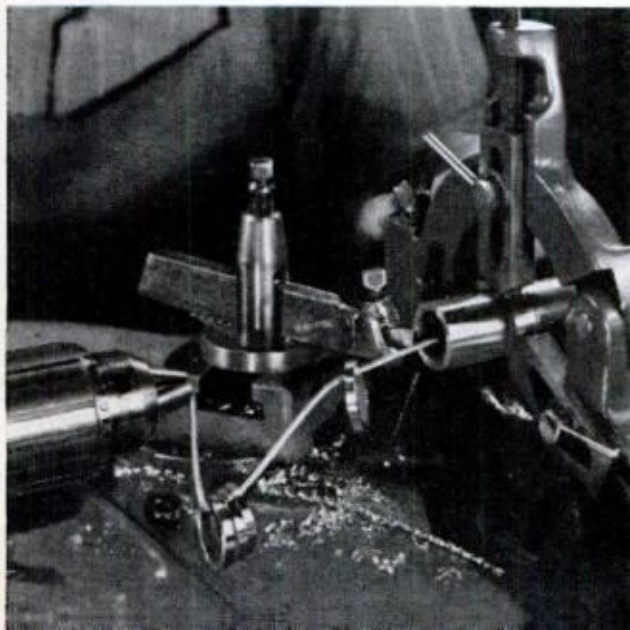

your stock like cutting a loaf of bread. If the width of the slice is the same as the wall thickness of your stock, you have a ring of square cross section. By making cuts at various angles, you end up with a ring of triangular, diamond, hexagonal or octagonal section.

As a matter of safety, it is not a good idea to let the stock project excessively beyond the chuck. The shorter the projection, the better. Chuck jaws can grip a tubular piece on either the outside or inside. Sometimes the outer end of a solid bar can be steadied on a tailstock center if you don't bore away the material at the bar's center until later.

When rings are to be cut from long stock, the piece should be supported near its outer end by a steady rest, as shown in some of the photos. The end toward the headstock should be gripped firmly by the chuck or lashed securely to the faceplate

Turning a Diamond-Shaped Ring

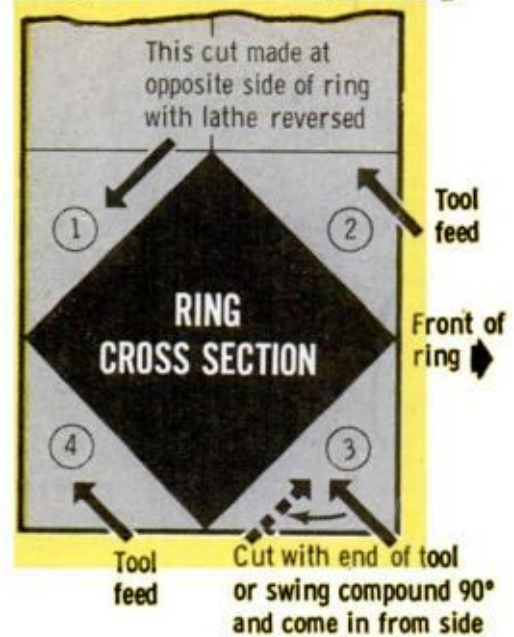

Numbers indicate sequence of cuts, compound set at 45°

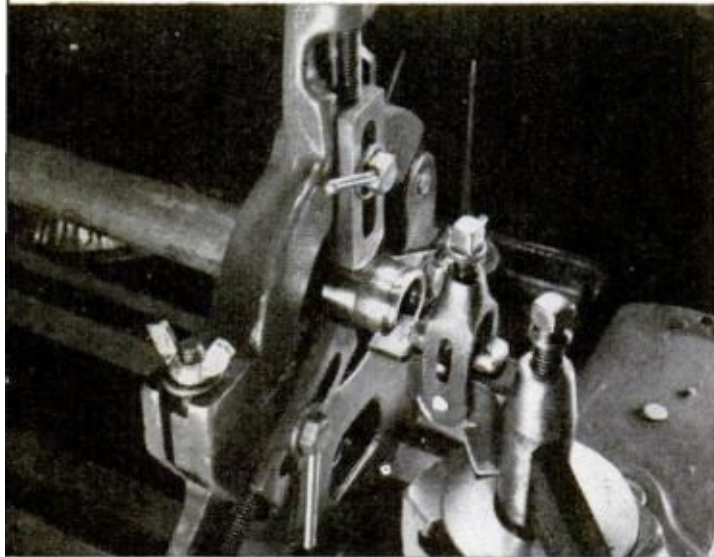
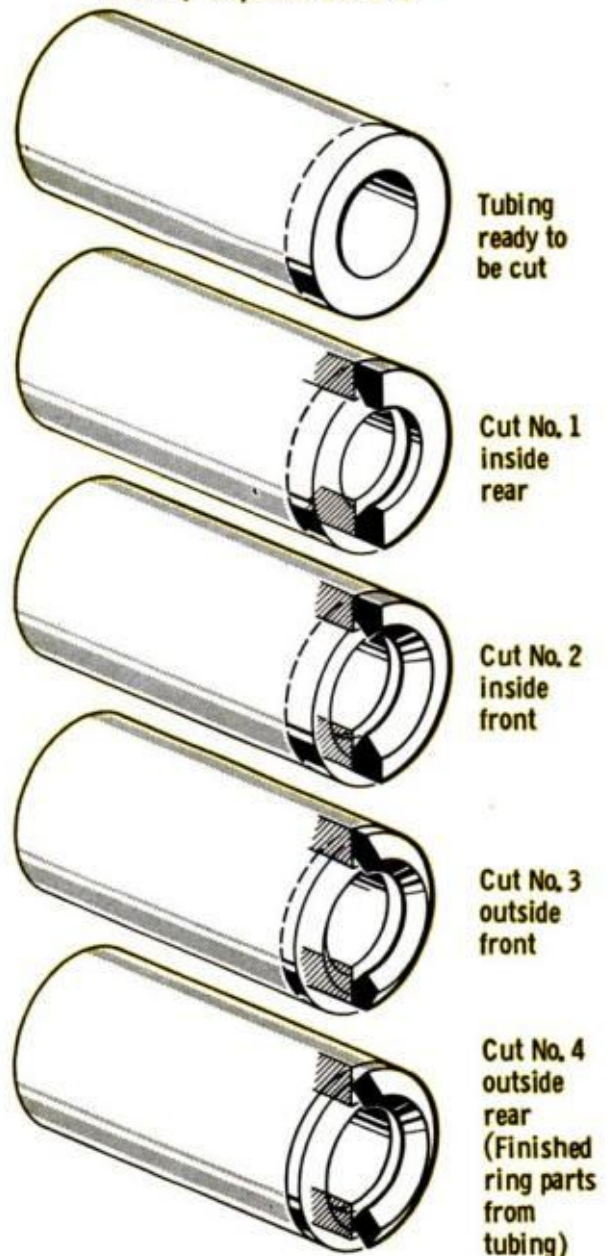

HOMEMADE BITS speed the work on special jobs, such as turning out round or oval-section rings in quantity. One below, for round-section rings, was made from old flat file. Two holes of ring diameter were drilled, the material between them removed, relief angles filed, and the tool rehardened. Bit is held in regular boring-bar holder, as above



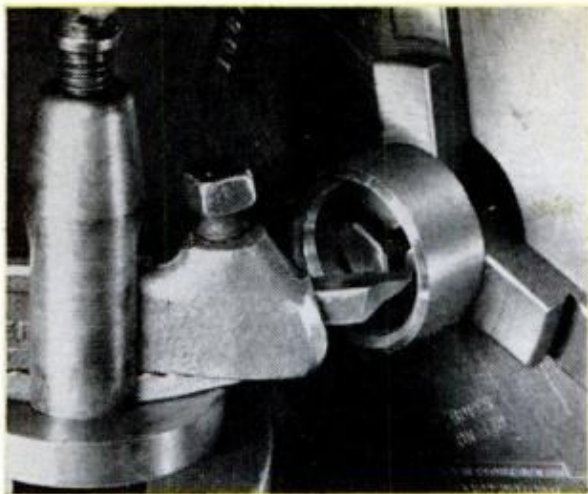

INSIDE CUT on diamond-shaped ring (cut No. 1) is made at far side of stock with lathe reversed. All other cuts are made at stock's near side with lathe running forward, as shown in diagram

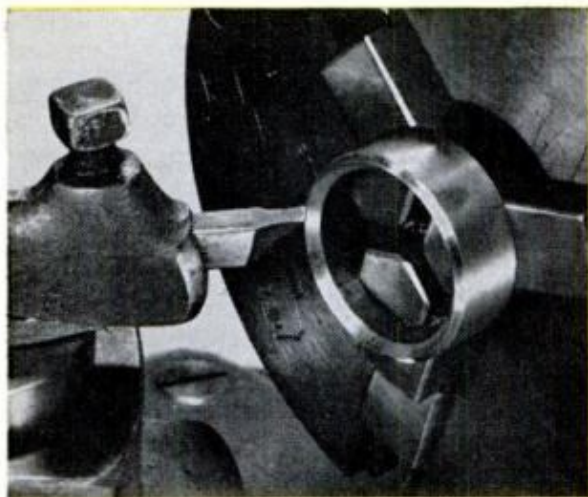

OUTER CORNER of stock can be removed in two ways. You can feed toward headstock, as here, using square end of bit to do forming, or swing compound 90° and feed from opposite direction

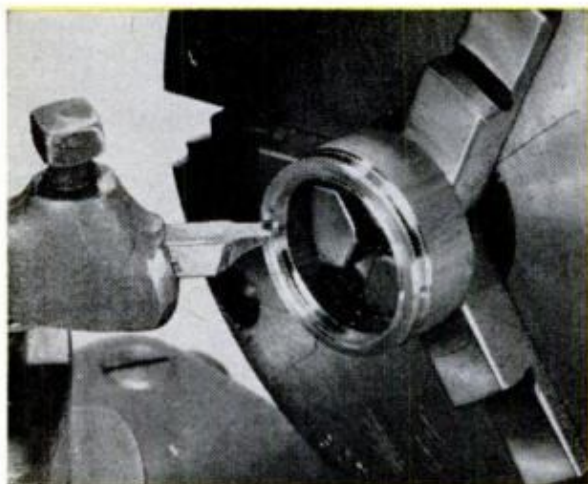

INNER LIP of stock is machined by feeding tool with compound-slide screw. Final cut (cut No. 4) has been started here, will be deepened later to part ring from stock as the last step

to prevent endwise crawl from occurring.

Single rings often are clamped in a chuck for minor finishing operations such as filing or sanding for smoothness, rounding sharp edges, or removing the "flash" left by a cut-off tool. The ring should be clamped to run true. Sometimes an independent-jaw chuck is preferable because the ring can be centered accurately with the aid of a gauge.

Remember that when you clamp a ring in a chuck, jaw pressure springs it slightly out of round. Tubular stock is similarly distorted near the chuck. A ring machined from a blank distorted in this way, will not be perfectly circular when jaw pressure is released. In most cases, this is probably not important, but it could affect ring fit in close-tolerance work, such as in making optical-instrument parts.

Metal, plastic and wood rings can be shaped freehand on a metal lathe in much the same manner as parts are formed on a wood-turning lathe, the tool being hand-held and supported by a fixed rest.

Carbide-tipped turning chisels are available for use on metal parts, or you can grind suitable ones from tool steel or high-speed-steel lathe bits. Various common wood-turning chisel shapes are useful in working metal rings. The skewer shape is particularly handy. Such tools can be manipulated to cut, rather than scrape, metal neatly from the work, with the formation of fine, thin chips. The hand-turning technique is useful in shaping rings having round, oval, or similar cross section and in making decorative grooves and ridges.

Rings having diamond-shaped, triangular, hexagonal and octagonal sections can be formed by feeding the tool with the compound rest set at the proper angle. Here is a helpful way to work out the machining sequence: Draw a scaled plan of the desired ring cross section, showing it as if you were looking down on top with the side facing you representing the side toward which the tool will feed. With this, you can easily determine the angles, dimensions of various faces, and distances the tool must travel in making different cuts. These values are then used to control the movement of the tool bit by means of the micrometer collars on the carriage screws, particularly that controlling the compound slide.

The drawings show the cross-sectional

Some of the Many Different Shapes You Can Make

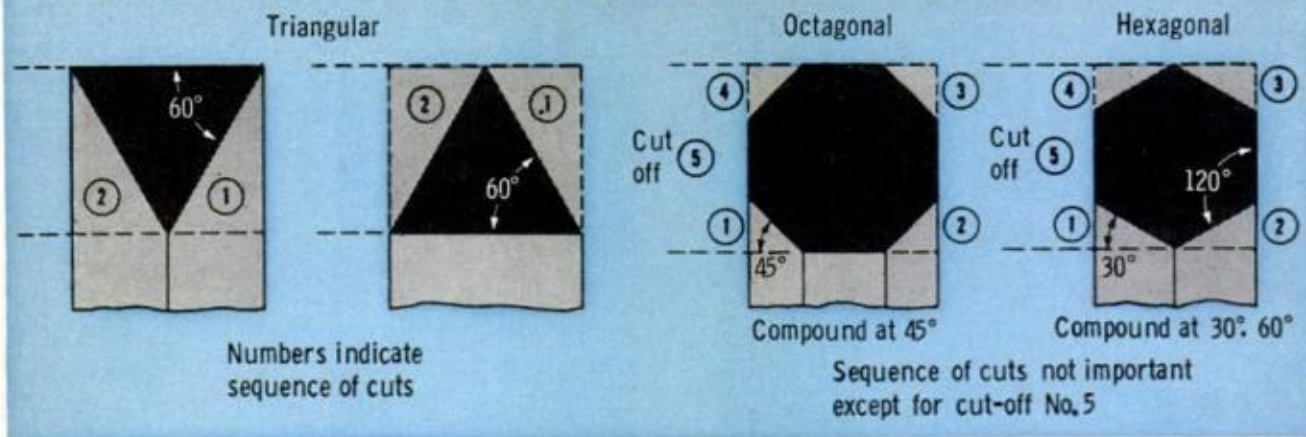

layout of rings of various sections. The numbered segments indicate waste material to be machined away. In some cases, the numbers represent a suggested cutting sequence, selected to make it easier to establish starting points for measuring tool movement.

You can make nonmetal rings from such materials as rigid PVC (polyvinyl chloride) pipe available in many stores. Such plastic material is machined much as if it were metal. It is easy to cut and requires only moderate tool pressure. Chuck-jaw pressure should be controlled according to the strength and bendability of the material.

A ring can be machined to serve as a frame for a round picture, plaque or other object. In the back of the frame, ma-

chine a recess to receive the picture, a glass or plastic cover if one is used and a piece of backing material, such as heavy cardboard. The simplest holding arrangement consists of an open ring of wire sprung into a shallow groove around the inside of the recess. Feet for the frame to stand on can be made from smaller rings attached to the main ring with screws, rivets or solder.

You can finish turned rings in the same way as other items of the same materials. Files and abrasive paper or cloth are suitable for smoothing most materials. Rings can be given various distinctive textures by knurling them while they are in the lathe, or by some other suitable treatment such as peening, engraving or stamping. ★★★

NEXT MONTH IN SHOP AND CRAFTS

WHAT YOU SHOULD KNOW ABOUT FIRE WARNING SYSTEMS. There are any number of fire warning systems that you could buy or install, but almost all of them share a common feature—they could save not only your living room furniture, but also the lives of members of your own family. For a complete rundown of these systems, read the February issue of *PM*.

MODEL A 24-POUNDER FROM THE CONSTITUTION. This gleaming replica of a cannon from the U.S. frigate *Constitution* is a wood and brass, 1/20th-scale model that's an ideal project for the winter months. Complete plans and lathe-turning tips will greatly simplify its construction.

HOW TO GET THE MOST FROM A CIRCULAR SAW. This little workhorse can do much more than just cut wood—it will also cut your working time and effort if you know how to use it efficiently. Exactly how you can gain this expertise is covered fully in next month's issue.

FIVE WEEKEND PROJECTS FOR FUN AND FUNCTIONAL USE. Next month's collection of workshop projects will include a toy box that looks like a circus wagon, a handsome glass-topped coffee table, a corner bed table, an Early American cup shelf and a handy holder for an electric knife.

OVER 100,000 MEN CAN TELL YOU:

“NTS HOME-TRAINING REALLY WORKS!”



AND PUTS YOU WHERE THE BIG MONEY IS!

If you think you can't learn a new technical skill with NTS Home-Training, you're wrong. Over 100,000 men have done it in the past half-century since the school was established.

And so can you.

NTS Project Method makes learning fast, easy and exciting. Takes only a few hours a week. Hours any man can fit into his life.

So, stop wasting time. Pick from these big money-making fields. We'll send you all you need to know to get started towards a new, better job. It's a sure thing!

ELECTRONICS DIVISION (New 25" Color TV Kits)

Train with the biggest, most exciting package of electronics kits ever offered! Beautiful new 25" Color TV kits included in color TV courses. No kit deposits — no extra cost. All-new Communications and Industrial Electronics Kits & Courses — put you two steps ahead of tomorrow. Check coupon for choice of Project Method Courses and New Free Color Catalog.

MECHANICS DIVISION (New Test Equipment)

NTS makes you a skilled Mechanic — Diagnostic Technician in a hurry! You get professional engine analysis test instruments at no extra cost! Special Engine Diagnostic and High Performance lessons included — everything you need to be a pro. Four fields from which to choose. Service your own car — earn while you learn. Check the coupon for new catalog.

AIR-CONDITIONING, REFRIGERATION DIV. (New Kits)

A wide-open field. NTS opens it up for you — fast and easy! Trains you to handle the big jobs. Start your own business with either of the two courses in this division. We give you the tools, tester, and instruments you need at no extra cost. No kit deposits! Check the coupon below and get rolling!

HOME APPLIANCES DIV. (New Circuit-Trainer)

Dig deep into the Major Home Appliance repair field for the big money! NEW, EXCLUSIVE! THE NTS CIRCUIT-TRAINER! Shows you the ins and outs of major appliance circuitry. Makes training a snap. Puts you in line for a piece of the billion-dollar appliance repair field. New Kits! New Catalog. Check coupon for earn-while-you-learn courses.

HIGH SCHOOL AT HOME

National offers accredited High School programs. Take only subjects you need. Study at your own pace. Everything included at one low tuition. Check special High School box in coupon for full information and FREE catalog.

CLASSROOM TRAINING AT LOS ANGELES.

You can take classroom training at Los Angeles in Sunny Southern California. NTS occupies a city block with over a million dollars in training facilities.

NATIONAL TECHNICAL SCHOOLS

WORLD-WIDE TRAINING SINCE 1902

4000 So. Figueroa St.
Los Angeles, Calif. 90037

No obligation.
No salesman will call.

SEND POSTCARD FOR FREE BOOK AND SAMPLE LESSON



TEAR OUT AND MAIL THIS CARD TODAY. CHECK ONE ONLY.

ELECTRONICS DIVISION

- MASTER COURSE IN COLOR TV SERVICING
- COLOR TV SERVICING
- MASTER COURSE IN TV & RADIO SERVICING
- PRACTICAL TV & RADIO SERVICING
- MASTER COURSE IN ELECTRONIC COMMUNICATIONS
- FCC LICENSE COURSE
- MASTER COURSE IN ELECTRONICS TECHNOLOGY
- INDUSTRIAL AND AUTOMATION ELECTRONICS
- COMPUTER ELECTRONICS
- BASIC ELECTRONICS

HOME APPLIANCES DIVISION

- HOME APPLIANCES MASTER TECHNICIAN'S COURSE
- HOME APPLIANCES SERVICING
- HANDYMAN APPLIANCE REPAIR

AUTO-MECHANICS DIVISION

- MASTER COURSE IN AUTO & TRUCK MECHANICS
- AUTOMOTIVE MECHANICS
- TRUCK & HEAVY DUTY MECHANICS
- ENGINE TUNE-UP & ELECTRICITY

AIR CONDITIONING-REFRIGERATION DIVISION

- AIR CONDITIONING, REFRIGERATION & ELECTRICAL APPLIANCES MASTER COURSE
- AIR CONDITIONING-REFRIGERATION SERVICING COURSE

HIGH SCHOOL DEPARTMENT

- HIGH SCHOOL AT HOME Dept. 201-19



NAME _____ AGE _____

ADDRESS _____

CITY _____ STATE _____

Please fill in Zip Code for fast service _____

- Check if interested in veteran training under the new GI Bill.
- Check if interested ONLY in classroom training at Los Angeles.

GET OFF THE DIME. HERE'S 4 WAYS TO BOOST YOUR INCOME!



ELECTRONICS DIVISION

New color catalog

NTS Project-Method home training makes it easy for you to make your mark in Electronics. To get the big-paying job you want. Learn more, faster, with exciting kit equipment included at no extra cost. There's no better time than right now to do it! Send the coupon!



MECHANICS DIVISION

NTS gives you professional engine analyzing equipment. And top mechanics' know-how in diagnosis... speed... performance. Industry needs over 200,000 trained mechanics right now. And you can be one of them. Mail the coupon for our new catalog today!



AIR CONDITIONING, REFRIGERATION DIV.

We give you the tools, tester, instruments. Show you how to service giant industrial cooling systems and commercial refrigeration installations. There's a big job waiting for you here. All it takes to get it is the skill we give you. Don't wait any longer.



HOME APPLIANCES DIVISION

Learn to service major home appliances. Get the new, exclusive NTS CIRCUIT-TRAINER! It helps train you faster for the big jobs. Learn troubleshooting, open your own business, be your own boss. So get off the dime. Mail the coupon. We'll send you all the facts in our new catalog.



FILL OUT AND MAIL CARD TODAY

GET FULL COURSE DETAILS AND LEARN ABOUT THESE NTS EXTRAS:

1. BONUS CLASSROOM TRAINING
2. JOB PLACEMENT CONSULTATION
3. BUSINESS CONSULTATION

NO OBLIGATION. NO SALESMAN WILL CALL.

APPROVED FOR VETERANS



Accredited Member National Home Study Council



Accredited Member National Association of Trade and Technical Schools

FIRST CLASS
Permit No. 3087
Los Angeles,
Calif.

VIA AIR MAIL

BUSINESS REPLY MAIL

No Postage Stamp Necessary if Mailed in the United States

POSTAGE WILL BE PAID BY

NATIONAL TECHNICAL SCHOOLS

4000 South Figueroa Street

Los Angeles, California 90037

BENJAMIN INTRODUCES A FABULOUS NEW AIR RIFLE

... that takes up where
the Ol' Reliable Super
Single Shot leaves off.

You Can **DEPEND** on **BENJAMIN**

Push-Pull Safety on top
of Stock behind Breech.



A no-nonsense gun that means business every time you fire, this New Benjamin combines all the superb Quality and Performance features of its famous Predecessor with extra improvements for your shooting pleasure. Foremost, is a Thumb Operated Top Safety. The only pneu-

matic to offer this Advanced feature for more efficient fire control, it also includes a new Ramp Front Sight and adjustable Stepped Leaf Rear Sight to bring out the full Accuracy potential of the New Model. Shoot target, small game. This Benjamin stands alone for its Power — Convenience — Safety — Reliability. At your Benjamin Dealer's.

Use Benjamin H-C Pellets—Sized & Lubricated.

BENJAMIN AIR RIFLE COMPANY, 896 Marion St., St. Louis, Mo. 63104 **FREE CATALOG! Write**

MODEL 340 CAL. .22
MODEL 342 CAL. .22
PELLET—MODEL 347
CAL. .177 PELLET.

make your own Gems 39.50 F.O.B.

The Gem Maker comes complete with all necessary equipment, including a super-charged diamond blade for sawing, and all the wheels for grinding, shaping and polishing; also complete instructions. The complete equipment as shown, less motor and belt for only \$39.50. f.o.b., Burlington, Wisconsin. Write today for information and literature.

B&I MANUFACTURING CO.
Dept. P, Burlington, Wis. 53105

BLAST FURNACE 2400 F
Since 1935
Hobbyists • Schools • Inventors, etc.

Make your own castings of any metal from cast iron, down to lead and zinc. Available in 6 sizes, 1 1/2 to 50 lbs. Complete units from \$50.40 to \$162. Send 25¢ for circular—refundable.

KANSAS CITY SPECIALTIES CO.
Dept. P-1
P.O. Box 193
Middleton, Wis. 53562

HEAVY DUTY BALL-BEARING PUMP
IRRIGATE • DRAIN • SPRAY • CIRCULATE • Famous all-metal, rust-proof XB pump with stainless shaft. Use 1/4 HP or larger. 1 HP for up to 5,200 GPH 60' high or 3,000 GPH from 25' well. 1 1/4" inlet, 1" outlet. For belt or direct drives. Only \$12.95
Famous Type P won't rust or clog. Bronze bearing. Hundreds of thousands in use. Up to 2,400 GPH. 1" inlet, 3/4" outlet. Only \$8.95
Postpaid cash with order. Money Back Guarantee.
LABAWCO, Box 2, Belle Mead, N. J. 08502

**I-N-V-E-N-T-O-R-S
WE NEED INVENTIONS**

Sell your invention for cash—need money for Patent?—Are technical problems holding you back? Universal Inventions has helped inventors all over the world—just like yourself—why not you? Inventions provide the magic spring-board to sudden riches. **REMEMBER**, we either sell your invention or pay you a cash bonus. Write for details.

UNIVERSAL INVENTIONS, Dept. 13, Marion, Ohio

Print Your Own

Cards, Stationery, Advertising, Circulars, labels, photo and movie titles, church work, tags, greeting, sympathy, prayer cards, etc. Save money. Pays for itself in a short time.

Own a Printing Business

Good Profit. Raised printing like engraving too. Have home shop. We supply everything. Direct from factory, only. Easily followed rules. Write now for free details. **KELSEY PRESSES E-37 Meriden, Conn. 06450**

WARNING

U.S. Surplus High Speed Milling Files going fast. New, in G.I. Packs. Hardened steel, for filing, milling, routing, drilling—any work in metal or wood. Use in 1/4 in. drill, etc. Big tools, from 1/4 to 1 inch wide. Get these most useful tools now.

16 tool set—government cost \$109..... \$ 9.00 to you!
36 tool set—government cost \$265..... \$15.00 to you!
100% GUARANTEED, WE PAY POSTAGE. A LIFETIME BUY!!

THE SURPLUS CENTER
LANCASTER, TEXAS 75146

**A BUSINESS OF YOUR OWN
REPAIR HYDRAULIC JACKS**

Earn while you learn at home. Millions of jacks in gas and auto service stations, trucking firms, body shops, riggers, factories and farms need servicing... most of which you can learn to repair. We show you HOW. Start spare time in your basement or garage. Big opportunity for mechanics. ACT NOW! Write for folder **PM-1**, and free bonus offer

HYDRAULIC JACK REPAIR MANUAL CO., INC.
G.P.O. BOX 3 • STATEN ISLAND, N.Y. 10314

ENROLL—EARN YOUR DEGREE

of Bachelor of Bible Philosophy (B.Ph.B.), Master of Bible Philosophy (M.Ph.B.), Graduate of Bible Philosophy (G.Ph.B.), Doctor of Metaphysics (Ms.D.), or Doctor of Divinity (D.D.). Chartered by State, Correspondence Courses only Please write for **FREE BOOKLET**.

AMERICAN BIBLE INSTITUTE
Dept. PM, Post Office Box 8748, Kansas City, Missouri 64114

**CERTIFIED AIRCRAFT
BIRCH PLYWOOD**

FOB per 48x48" sheet, 1 to 3 sheets \$2.50 extra. 20% dealers discount 100 sheets. Cut in half or quarter for parcel post with faster delivery. Also industrial and cabinet birch plywood, all thicknesses, sheets and cut to any size and shape.

1/32"	\$5.90	1/8"	\$10.50
1/16"	6.90	3/16"	14.50
3/32"	8.90	1/4"	17.50

Violette Plywood Corp., Box 141-A Lunenburg, Mass.

**At Last a New Amazingly Simple
GAS TURBINE
JET ENGINE**

Build from easy to follow plans. Length 15", Dia. 8 1/2", Wt. 15 lbs. Fuel: Gasoline or Kero.

"Screamin Demon" develops 20 H.P. Ideal project for serious-minded hobbyists, students; scientific and industrial arts classes. Make on 9" metal cutting lathe with milling attachment. For use on small racing boats, midget cars, etc. Full size assembly drawings with critical dimensions, bill of materials and photos. Price \$5.00. No C.O.D.

SAVOY SCIENTIFIC, BOX 1398, SANTA MONICA, CALIF. 90406

Solves Repair Problems

Durham's fills cracks and holes in plaster, wood and tile. Won't shrink or fall out. Economical, easy to use. Big 4-lb. can, only 1.60 at lumber, paint, and hardware dealers, or shipped direct postpaid in U. S. for \$2.00. Money-back guarantee. Order now. Donald Durham Co., Box 804-T, Des Moines, Iowa.

**SAVE \$200 OR MORE
ON AUTO AIR CONDITIONING**

Comfy-Kit is easily and quickly installed — gives you unexcelled cooling power — and costs much less than other air conditioners. For complete information write —

COMFY-KIT

P. O. Box 8585, Dept. P.M. I Dallas, Texas 75216

YOUR SECOND CAR A TRUCK?

(Continued from page 87)

and 133 in. in the CS/CE 30 (one-ton) series. Four-wheel drive is available in the 1/2-ton and 3/4-ton lines. And optional power steering is available on these four-wheel-drive models for the first time.

Good visibility is the advantage of new Below-Eye-Line outside mirrors. Low mirror mounting and elimination of upper support arms do the trick. Seatbacks are now polyurethane foam.

Half-ton and 3/4-ton panel trucks, offerings unique to Chevy since the introduction of compact vans for covered cargo space, are still available. And a special "Longhorn" pickup is for campers.

● **Dodge.** Chassis modifications on four-wheel-drive models lower overall height of these "power wagon" pickups. Four-wheel drive is available on all pickups: 1/2-ton, 100 series (114 and 128-in. wheelbases); 3/4-ton, 200 series (128-in. wheelbase) and one-ton, 300 series (133-in. wheelbase). Six-passenger, four-door "crew cabs" are available on 3/4 and one-ton models with resulting wheelbases of 146 and 159 in., respectively. Exception is wheelbase on the 3/4-ton camper special which is 160-in. The luxurious Adventurer is available in D100 and D200 (two-wheel drive) models only.

A "compact pickup," the A100 on 90-in. wheelbase, a unique Dodge offering, is best described as a van pickup—a van-type cab ahead of an open cargo box. Racing buffs probably know the A100 as the Little Red Wagon, a hemi-charged, hair-raising hot rod.

Powerplant choice is between 170 and 225-cu.-in. slant Sixes, or 318 and 383-cu.-in. V8s. Ride and handling of D100 and D200 models has been improved by the addition of a sway bar to the "cushioned beam" front suspension, lower spring rates and plastic tip liners between leaves.

● **Ford.** More "user packages" to simplify selection of a pickup enhances the '69 lineup. Pickups job-engineered for contractors, farm and ranch folks and those who need the works in the way of heavy-duty outfitting have been added to the "Camper Special" package. Ordering the camper package saves you making a long checklist of necessary equipment, heavy-duty springs, and so on, but equipment can also be ordered *a la carte*.

Half, 3/4 and one-ton pickups in the line are designated F-100, F-250 and F-350 with 115 or 131-in., 131-in., and 135 or 159-in. wheelbases, respectively. Four-wheel drive is available on 100 and 250 pickups and engine offerings are 240 and 300-cu.-in. Sixes and 360 and 390-cu.-in. V8s.

Standard front suspension on all two-wheel-drive pickups is the four-year-old Twin-I-Beam, a proven design in no need of updating. Standard on the F-250, but optional on the F-100, is the Flex-O-Matic rear suspension, a design that shortens the leaf spring's effective length with increasing load, yet allows a long, more flexible spring for a cushioned ride when the pickup is unloaded.

● **GMC.** Ditto everything said about the Chevrolet lineup, above, for the GMC line. Half, 3/4 and one-ton pickups, designated C-1500, C-2500 and C-3500, are essentially the same as their Chevy counterparts. Among few differences is an additional engine, a 305-cu.-in. V6.

The luxury-loaded GMC models are romantically branded Sierra and Sierra Grande, and the GMC equivalent of the Chevy Longhorn is the Custom Camper.

● **International.** At this writing, the International Harvester Co. is readying its new line of pickups for introduction during December. Exterior design of the 24 models is all new, as are several other features. A 232-cu.-in., 145-hp Six, new standard engine for the line, promises greater fuel mileage than the previous, similarly powered Six. Optional V8s displace 304, 345 and 392 cu. in. Gears in a new three-speed transmission can be shifted manually ("His . . .") or not shifted by leaving the lever in automatic (and Hers"). Five-speed forward transmission with or without overdrive is still available.

Several wheelbases are available in the half-ton (1000 series), 3/4-ton (1100 series) and one-ton (1200 series): Along with the 115 and 119-in. wheelbases, a 131-in. has been added to the 1000s. Same three wheelbases are available in the 1100s, with a fourth, 149-in., in the 1200s. Crew cabs (149 and 164-in. wheelbases) can be ordered in the 1200 line. And four-wheel drive is optional on 1100 and 1200. I-beam front axle is standard on heavier pickups; independent torsion bar is standard, I-beam optional, on 1/2-ton units.

● **Jeep.** Kaiser Jeep Corp. continues unchanged its line of ubiquitous Gladiator pickups, all with four-wheel drive as standard. A special camper pickup of unique design is about to be introduced and will be on the road for the 1969 season.

The J-2000 and J-3000 series have 120 and 126-in. wheelbases, respectively, with GVWs from 5000 to 7000 pounds. Six-cylinder, 232-cu.-in. engine is standard, 327 V8 is optional.

The four-wheel-drive Jeep line, however masculine, offers a full range of comfort and luxury items, and is the only brand to offer four-wheel drive paired with an automatic transmission. ★★

For Sparetime or Full Time
Income, There's Good

MONEY IN SHARPENING



Here's a proven practical way to earn extra dollars in spare time—to develop a money-making repair business of your own. Investment is small. There's no overhead, no stock of goods to carry. No experience needed, no canvassing. You do it with the famous Foley Saw Filer that automatically sharpens all kinds of saws—and the Modern Lawn Mower Sharpener that precision sharpens all types of mowers.

EARN \$3 TO \$6 AN HOUR SPARETIME

Hundreds of people like yourself are making cash like this—\$20 to \$30 a week—right now in spare time. "My spare time saw filing business has made me \$952 these first ten months"—says R. T. Chapman. Many have built a complete sharpening service with such year-around profits. You can too, simply by following the sure, easy Foley Plan.



Foley

MANUFACTURING CO.
MINNEAPOLIS, MINN.



MONEY MAKING FACTS BOOKLET FREE!!!

This valuable book shows you how to start, how to get business from home owners, factories, carpenters, etc., and how to make profits fast. Mail coupon today. No salesman will call.

FOLEY MFG. CO. 116-9 Foley Bldg., Minneapolis, Minn. 55418

Saw Filer information.

Lawn Mower Sharpener information.

Money Making Facts booklet.

NAME _____

ADDRESS _____

CITY _____

STATE _____

300 POWER

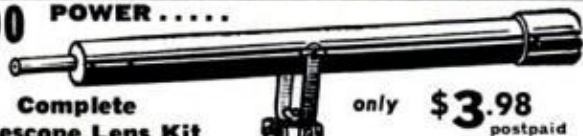

Complete Telescope Lens Kit only \$3.98 postpaid

Conquer Space, Explore the Universe, Planets, Moon craters, New Stars etc. Complete Lens Kit consists of 80 inch focal length ground and polished objective lens, eyepiece lenses for 50 POWER, 100 POWER, 150 POWER, 200 POWER, 250 POWER, 300 POWER, and all necessary lens fittings. Easy to make from simple step by step instructions. (Tripod and mount not included.) Money back guarantee.

BUSSE SALES, Dept. PM10, Hartford, Conn. 06101

Hard-to-Find TOOLS

CATALOG of exceptionally useful tools rarely found in stores or other catalogs. Industrial—professional quality only. Used by wood & metal workers, repairmen, welders, machinists, clock, watch and instrument makers, jewelers and model makers. Brookstone tools solve problems—make work easier, more fun. We ship same day. Send 25¢

1924 RIVER ROAD
BROOKSTONE CO. WORTHINGTON, MASS. 01098

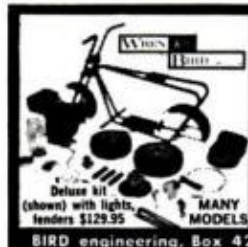

FACTORY DIRECT!

MINI-BIKE KIT! \$109⁹⁵

Build your own mini-bike in about 2 hours! No welding! Speeds to 30 mph.

You get:
• 2½ hp 4 cycle engine
• Precision welded frame
• Complete instructions

\$10 Down
\$ 7 Month
Assembled \$119.95

RUSH 25¢ for brochure to:

BIRD engineering, Box 427, Dept. PM1 Omaha, Nebr. 68101



MASONS!
Send today for free catalog of Masonic & Eastern Star books and rituals

EZRA A. COOK PUBLICATIONS, INC.

P.O. BOX 796, DEPT. A-85, CHICAGO 60690

AVOID FREEZE DAMAGE



The "LITTLE DRIPPER" is an inexpensive, precision unit designed to prevent freeze-up and damage to outside faucets or hydrants exposed to freezing conditions.

Housed in a durable plastic body, the unit is easy to operate. Just screw the unit on an exposed faucet and open the faucet to the full flow position. If the temperature is above freezing, no water will flow. When the temperature reaches freezing, a thermostatic element in the unit opens a valve allowing water to drip from the faucet to prevent freezing with subsequent pipe damage and other serious inconveniences involving expensive plumbing repairs.

When the temperature returns to above freezing, the unit shuts off automatically to prevent water waste and unsightly puddles accumulating at the faucet location.

The "LITTLE DRIPPER" eliminates the need for wrapping and insulating exposed faucets and hydrants and the inconvenience of cutting off water in freezing weather.

Price \$4.95 Postpaid
DEL MAR PRODUCTS
P.O. Box 26663
Houston, Texas 77032

Two or four-wheel drive
JEEP OR SCOUT
owners

REPOWER with a 6 or V-8 H.D. ADAPTORS for using Car, Compact and some Truck engines. Conversion Kits \$45.35 to \$56.90. Want fast action? Give us FULL INFORMATION. Send \$15.00 Dep. and we will ship correct kit, bal. COD. Send full amount for prepaid shipment. Wire, phone or write today. Details FREE

HOOSIER MACHINE PRODUCTS CO.

312 S. E. 6th St., Phone 276-3442, Pendleton, Oregon 97801

BASEMENT TOILET FLUSHES UP



TO OVERHEAD SEWER OR SEPTIC TANK. NO DIGGING UP FLOORS. INSTALLS EASY. Write

McPHERSON, INC., BOX 15133, TAMPA, FLORIDA 33614

JANUARY 1969

195



NEW PREVAL* SPRAYMAKER

**SPRAYS ANY COLOR,
ANY FINISH!**

With this disposable power sprayer you can spray paint, varnish, stain, lacquer—custom-mixed or right-off-the-shelf. Use the same paint you use with brush or roller. No mess, no bother. It even sprays itself clean! Then fill with lubricant or rust-proofer and protect tools and equipment. Sprays any household liquid. Better buy several. You'll find dozens of uses for them. Available at paint, hardware and hobby counters—wherever quality do-it-yourself products are sold.

ONLY \$129
Complete
Suggested retail price

One Power Unit sprays up to 16 oz.
Extra Power Units under \$1.

*Reg. Trademark of Precision Valve Corp., Yonkers, N.Y.



**TOOL CHESTS
of the
HIGHEST QUALITY
for your
PRECISION TOOLS..**

GERSTNER TOOL CHESTS
Dept. A-9, 20 Cincinnati Street
Dayton, Ohio 45402

Free Catalog!

**"\$7,108.50 First Year
SERVICING RADIATORS!"**

— Hank Konter, Newcastle, Wyo.



NEW!

Make good money servicing auto-truck-tractor radiators with new Inland 1-Piece Radiator Shop. Easy to test-clean-repair radiators. Inland, world's largest radiator equip. mfr., trains you free. Small down payment starts you. Easy-pay plan lets you pay from profits. Proved merchandising assures volume. Profitable dept. for garage or service station. **WRITE for Free Book.**
INLAND MFG. CO., Dept. PMI 1108 Jackson St., Omaha 2, Nebr.

TRAIL-BREAKER® **»»» Goes anywhere**



Outdoorsmen:
Ride where you had to walk before. Revolutionary two-wheel drive vehicle climbs mountains, fords streams, hauls man-sized loads. Runs all day on a tank of gas.
Write **Rokon, Inc., Dept. A**
Wilmington, Vt. 05363

You can't miss in **CARTOONING & COMMERCIAL ART!**
ANYONE can learn to draw...
Cartooning is simple exaggeration. Learn by proven methods. Easy step-by-step instructions. Draw figures the very first day. You have to begin somewhere... so send for our **FREE** brochure today! Guaranteed



Famous American Studios
Dept. 10 SPRING PARK, MINNESOTA 55384

HOW CARS ARE STYLED

(Continued from page 91)

new engine, drive train and body/sub-frame construction were tested on public roads for hundreds of thousands of miles, even before the car's final body shape became jelled.

Then, too, body dies have to be made. These begin immediately after the car's styling is set. Specialists start carving so-called "die models" from solid mahogany or carvable epoxy plastic. These die models have to be compulsively exact, because special machines feel and translate the finished die model surfaces into metal dies. Later, the metal dies are assembled in gigantic stamping presses, then accurately aligned.

This description necessarily skips hundreds of the steps involved, simply because of their number.

1600 people shape GM styling

As mentioned, all four carmakers go through more or less the same processes in styling their new models. General Motors, with the greatest number of models, employs more designers than any other company in the world. GM estimates a total of 1600 people are involved directly in their styling processes.

GM's Central Styling Studio serves the various auto divisions, plus Chevrolet and GMC trucks. It regards the divisions as clients. Yet within Central Styling, each division is assigned a number of designers who work only on that make.

Pontiac, for instance, has four designers, an assistant chief designer, and a chief designer. Those six men hold responsibility for all Pontiac car exteriors (with Styling-Management direction, of course). Same with Chevy, Olds, Buick and Cadillac.

Several separate studios

Then there's GM's Body Development Studio. This group bridges the gaps between divisions so several can share the same body shell. It's common knowledge that big Chevys and Pontiacs share one basic body. So do the GM intermediates; the big Buick, Olds and Cad; and Riviera, Toronado and Eldorado.

General Motors also maintains separate studios for Interior Styling, for Advance Design, for Styling Research. Advance Design might be working on those 10 to 15-year-ahead concepts, while Styling Research dabbles in new body architecture, methods and processes of future types of transportation.

Over at Ford, the picture looks much
(Please turn to page 198)

**When you see
this mark you've
seen the product in
Popular Mechanics.**



Very soon you'll start seeing products bearing Popular Mechanics "Product Feature" Mark appearing on many dealers shelves. This is a brand new service to our readers and will help you recognize the products that are advertised in your magazine.

Look for the mark on hang tags, stickers, counter cards and on the products themselves.

This is just another idea in a long line of new ideas from Popular Mechanics. Remember the Mark. Ask for it. Know and buy the products that wear it. They're the products advertised in your magazine.

**THERE'S ALWAYS SOMETHING
NEW AT POPULAR MECHANICS**

MAGIC MAIL PLAN

that comes with this Little Machine
CAN MAKE YOU \$1200 AN HOUR

The machine is turning out a job that will bring operator \$2.58, by mail. Material cost, only 11c



Write today for free facts about the newest and most fascinating of all new home operated businesses. For the first time, a simplified machine brings the fabulous profits of Plastic Sealing and Plastic Laminating within reach of the small operator. Anyone can learn to operate it with a few minutes practice. Then—with our MAGIC MAIL PLAN—can get mail orders pouring in daily with cash in every envelope.

No Convassing or Selling

Fill orders at home in spare time to start. Then expand to full time business. We even supply circulars to bring back cash and orders. Rush name for all the facts you need to start. A postcard will do. No charge.

WARNER ELECTRIC CO., Dept. 2-AS
1512 Jarvis, Chicago, Ill. 60626

HEAVY DUTY WELDER

Does work of \$85.00 welder
yet costs only **1895**
POST PAID

Fits ordinary 110V outlet
Not one • but 3 welding heats

Weld, braze, solder or cut most anything made of metal. No experience necessary. Follow simple instructions. Uses standard 3/8" rods to weld iron, steel, brass, bronze, aluminum, other metals. Repair cars, farm implements, appliances, toys. Make campers, trailers boats. Pays for itself quickly. Comes complete with mask, \$2.00 pack of rods, flux, etc. **NOTHING ELSE TO BUY.**

3 WELDING HEATS . . . Not just one as with other low cost models. "High" for tough jobs, "Medium" or "Regular" for lighter work. 3 heat feature saves you money. New HEAVY DUTY circuit gives more welding potential than ever before. Approved for homes, garages, factories, shops. Has power boost circuit for industrial uses. Raises heat to 4 TIMES that needed to melt toughest iron. No other welder has all three fine features.

FREE! Automatic arc striker now makes welding easy, even for beginners. Just plug welder into ordinary 110V outlet, touch automatic arc striker and start welding. You cant' buy this important new Wel-Dex invention but it's yours free if you order from this ad.

10 day MONEY BACK TRIAL. Guaranteed against burnout. SEND \$2.00 and pay \$16.95 plus small C.O.D. when delivered or \$18.95 for postpaid shipment. Phone (713) 682-5811 for C.O.D.

WEL-DEX MFG. CO., Dept. W-10, Box 10776, Houston, Texas 77018

MAKE BIG MONEY

MAKING COSTUME JEWELRY AT HOME!

Thrilling spare-time, MONEY-MAKING hobby! Make newest, beautiful jeweled earrings, necklaces, bracelets, pins, pendants, cuff links, tie clips! Quick, easy to make—easier to sell to friends, neighbors, stores, at big profit! Details **FREE!**

DON-BAR CO., Dept. A-199
2934 W. Fullerton Ave., Chicago, Ill. 60647



BRAND NEW BOOKLET REVEALS HOW TO LIVE BETTER, FOR LESS IN FLORIDA

Gives full facts on Florida mobile home living, its wonderful advantages. Learn how to enjoy the outdoors; fishing, boating, sun bathing. Shows how to save thousands of dollars, gives tips for an easier life. Send 10c to Florida Researchers, 3132 Ponce de Leon Blvd., Coral Gables, Fla. 33134, Dept. D



BIG MONEY WAITING!



- Learn to Repair—Rebuild
Resell Typewriters—All Makes—
in your spare time AT HOME!
- MAKE \$50—2 HRS. SPARE TIME
 - GET A HIGH-PAY, BIG-FUTURE JOB
 - or START YOUR OWN BUSINESS

NEVER BEFORE could you get industry-approved training at home. Now you can qualify quickly in your spare time for this big growth field. Desperate shortage of trained men. Thousands more needed at once. Earn while you learn with real typewriter, sub-assemblies, all professional tools, and step-by-step illustrated lessons prepared by industry experts for home study. Become a trained technician in six months.

SEND NAME FOR FREE BOOK

Send today for the FREE book that gives you vital government facts about the urgent need for trained typewriter repair men, the big pay, and the vast opportunities waiting. No obligation—no salesman will call.

TYPEWRITER REPAIR SCHOOL

D-3110-019, Little Falls, N.J. 07424
Licensed by State of New Jersey, Accredited Member, National Home Study Council, Official Training Center, Nat. Office Machine Dealers' Assn. V.A. Aprod.

FREE PROFESSIONAL
TOOLS, TYPEWRITER
SUPPLIED WITH COURSE



TYPEWRITER REPAIR SCHOOL, Dept. 3110-019, Little Falls, N.J. 07424

Please mail FREE book, postage prepaid, no obligation. No salesman is to call.

Check here for V.A. Information

Name.....

Address.....

City..... State & Zip.....



Enjoy the fun of building and the thrill of flying your own Bensen Gyrocopter

Fly low and slow—or high and fast, as you wish—in this easy to handle Copter. World's lowest priced one-man aircraft! Economical to operate. Designed by aeronautical engineers for easy building with hobby-shop tools. Bensen whirlybirds have brought the thrills of personal flying to thousands of amateur and professional flyers all over the world. 3-View Drawings, specs, photos of Gyrocopter \$3 or Gyroglider \$2. Order today!

SEND \$2 or \$3 BENSEN AIRCRAFT CORP., Dept. PM-19
Raleigh-Durham Airport, Raleigh, N. C. 27602

NAME.....
ADDRESS.....

HOW CARS ARE STYLED

(Continued from page 196)

the same on a slightly smaller scale. All FoMoCo cars, trucks, and tractors get styled in the new 493,000-square-foot Design Center at Dearborn. Here, five major design offices, complete with fabricating shops, engineering layout rooms, indoor and outdoor showrooms, house individual studios for Ford Div. (Ford, Fairlane, Falcon, Mustang, Thunderbird and Ford trucks), Lincoln Mercury (Continental, Lincoln, Mercury, Monterey and Cougar), Interiors, Corporate Projects and Special Development.

Divisions share body shells

This is a slightly different setup from GM, because the two big FoMoCo divisions work with a bit more independence. Yet again there's overlap and coordination in shared body shells—Mustang and Cougar, Ford and Mercury, Montego and Falcon/Fairlane.

To give some idea of Ford's styling activities, the corporation buys roughly 150 tons of clay each year. And this isn't the river-bottom variety. It's a closely guarded formula with high contents of sulphur, iron oxide and other chemicals.

Chrysler Corp.'s setup is much like Ford's, with relatively great independence between divisions.

American Motors, being the smallest Big Four automaker, has the smallest styling staff. AMC has a Senior Studio, responsible for Ambassador and Rebel; a Junior Studio for Javelin, AMX and American; an Interior Soft Trim Studio; Interior Hard Trim Studio; and an Advance Styling Studio where the far-out designs originate.

Major sales factor

The business of automotive styling—or art form, whichever it is—isn't even two generations old, yet it's already one of the most important facts of our nation's economic life. A new car's styling is its strongest single selling point. More people buy a new car on the basis of exterior and interior appearances than any other attribute. Price, engineering qualities, brand loyalty and other factors influence buying decisions, naturally, but none sways the customer so compellingly as styling.

And since the auto industry ranks so high in our nation's economy, provides one out of every seven jobs in the country, and acts as *the* bellwether of our economy, it's safe to say that styling—in helping sell so many new cars each year—constitutes much more than a vanity. It's a vital necessity. ★★★

SPECIAL OFFER!

Two PM Wall Charts (\$2 value)
For \$1.50

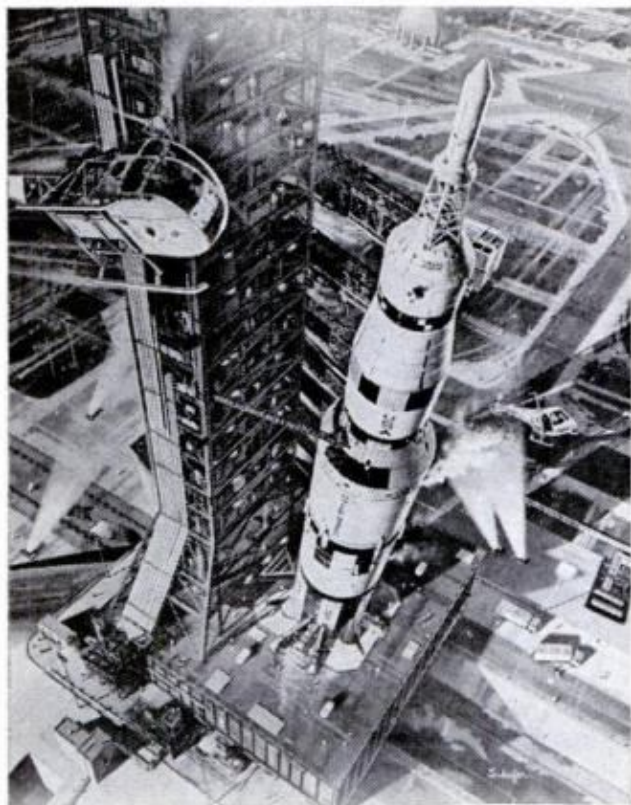

THE SATURN V
LARGEST ROCKET IN THE WORLD
POPULAR MECHANICS
BY HENRY HANCOCK ARTIST HOWARD CHAMBERLAIN

SATURN V, the world's largest rocket, printed in full color on heavy stock. Size: 19x25 inches. (Regular price: \$1.25)



OUR FIRST 19 IN SPACE. Photographs of the first 19 U.S. astronauts on heavy stock. Size: 12x18 inches. (Regular price: 75 cents)

Use This Coupon

Dept. ES, Popular Mechanics, 575 Lexington Ave., New York, N.Y. 10022.

Name _____
Street _____
City _____ State _____ Zip _____



Pipe just can't slip when it's in the steel jaws of a **RIDGID** Bench Vise.

Nothing grips pipe like a RIDGID vise. Our full width, tool-steel jaws have specially cut hardened teeth that positively anchor the work.

Malleable iron base and yoke can't break or warp. And when the work's finished, your RIDGID releases instantly. Integral bend-over and rear pipe rest make everything easy.

RIDGID Bench Yoke Vises come in 8 sizes, 1/8" through 6", can be set up for fast right or left hand opening.

See and buy one at your Dealer's. He carries a complete line of Work Saver Tools from The Ridge Tool Company, Elyria, Ohio 44035.

RIDGID

BUY GOV'T SURPLUS SAVE TO 85%

FISH/WORM SHOCKER



\$7.95
FOB

Cost Gov't Over \$11.00

• (ITEM #670) -- Harvest worms without digging, clear private ponds of coarse fish. Hand cranked unit puts out 110-VAC. Creates powerful electrical field in ground or water. Ideal for experiments, shocking fun at parties, etc. SAFE, 2 1/2" x 3" x 4". Shpg. wt. 3 lbs.

BATTERY GEAR MOTOR



Cost Gov't Over \$175.00

\$25.95
FOB

• (ITEM #571-A) -- Powerful, ball bearing unit. Use with worm gear winches, build hoists, electric cars, etc. Operates on 6 to 12 volts DC. 20 to 1 gear ratio, fully reversible. 130-270 RPM @ 6-12 VDC. Shaft 5/8" d. x 1-1/2" l. 6" diam x 15". Shpg. wt. 30 lbs.

WALL TYPE TELEPHONE



Orig. Cost Over \$27.50

\$7.95
FOB

• (ITEM #715-W) -- Genuine Automatic Electric dial telephones. Ideal for use as extension phones, for use on private systems, etc. Work on any commercial telephone system. Reconditioned, tested, guaranteed. Excellent condition, work like new. Shipping weight 9 lbs.

Send 25¢ (Coin or Stamps) For BIG BARGAIN CATALOG

1000's Of Bargains; Surplus, Excess Inventory, Brand Name Equipment
Hydraulics • Power Plants • Pumps • Welders
Winches • Gear Motors • Surveying Instruments • Compressors • Telephones • Sineoscilloscopes • Electronics • Many Others
"SATISFACTION OR MONEY BACK GUARANTEE"

SURPLUS CENTER PM-109 Lincoln, Nebraska Zip Code 68501

NEW Improved Accurate Scope-Shot

SCOPE-SHOT COMPLETE WITH 50 DISINTEGRATING PELLETS
They crack like a rifle when they hit—leave mark—puff of smoke!

World's Finest Precision SLINGSHOT
Scope-type sight!

ROUTES PESTS!
Price without pellets \$1.50 P.P.

Big Bag of 250 EXTRA Pellets 98¢ P.P.

Millions Sold! Patent No. D-178,837

Pure gum rubber slings. Beautifully polished cast aluminum stock. Pistol grip. So powerful it kills small game. Fits pocket perfectly! Guaranteed. FREE shooting manual.

EXTRA RUBBER SLINGS, 4 pairs \$1.00 p.p. Leather Pouch & Sling assembly only 40¢ p.p. Order NOW from:

GENERAL SPORTS
4184-MX Apple Street, Cincinnati, Ohio 45223

Order Now!

*the
Best
thing in
Electronics
is*

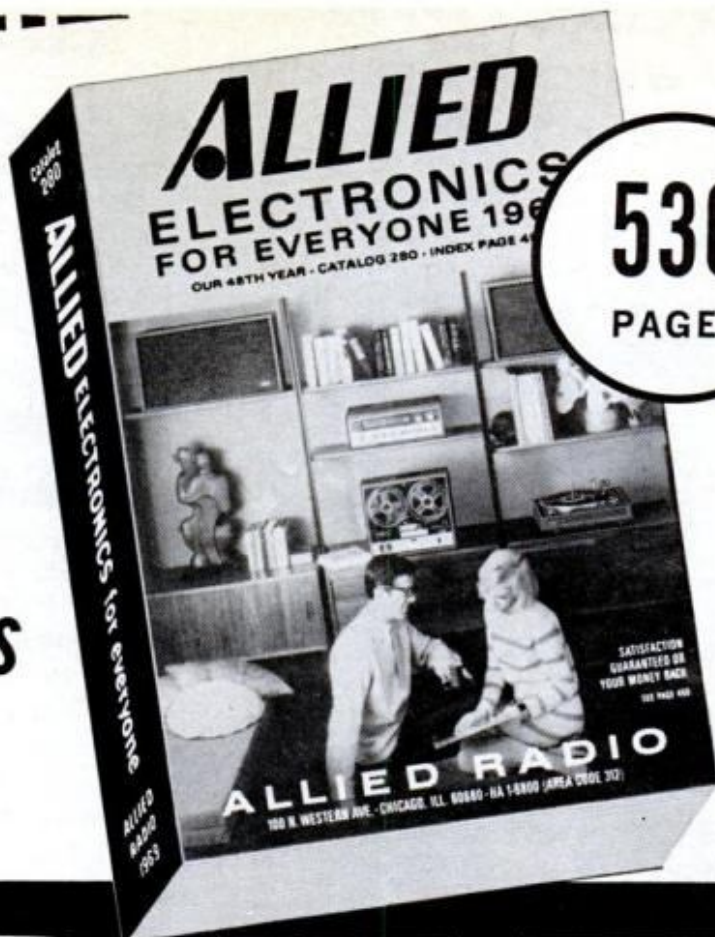

FREE

1969 *ALLIED* CATALOG

Brand new! Fresh off the press! Allied's 1969 Catalog...536 fascinating pages jam-packed with the very latest in Hi Fi, Tape Recorders, CB, Kits, Radios, Tools, Electronic Parts, Books. Probably nowhere else on earth will you find such a complete selection of everything electronic...and virtually all new as tomorrow! Literally thousands of items...many of them never shown before. Allied's all new 1969 Catalog makes wonderful reading...and it's yours absolutely FREE! Tear off the card...mail it in today...and we'll rush you your own personal copy of the newest and most complete book of what's new in electronics...Allied's 1969 Catalog!

TEAR OUT AND MAIL CARD AT RIGHT...OR WRITE

ALLIED RADIO P.O. BOX 4398
CHICAGO, ILLINOIS 60680

BIG NEED FOR SYSTEMS MEN

... LEARN AT HOME IN SPARE TIME



Every company, large & small, needs a Systems Man. As a Systems Man, you'll work with management... help them make vital decisions... make a prestige salary... and enjoy your work, too! You'll supervise CHARTING, PROCEDURE PLANNING, FORMS DESIGN, OFFICE LAYOUT, COMPUTER PROGRAMMING, DATA PROCESSING, etc. Big demand - see high salary positions in "help wanted" sections of your newspaper. You need no previous experience or special training... easy home-study plan guides you toward success, prestige, good salary in exciting, respected field. High school education required. Send for Free Booklet, "OPPORTUNITIES IN SYSTEMS."



North American Institute of Systems & Procedures
4401 BIRCH ST., DEPT. 4171, NEWPORT, CALIF. 92660

NEW WESTERN HAIG .12 CALIBER SPECIAL FACTORY OFFER!



\$300 post-paid

USES POWDER CHARGE

This small bore gun shoots .12 cal (steel) bullets fired by small 4.4 mg. powder charge. Not a CO₂ gun! You'll like the handsome lines, grip, and balance. Western in style, but patented ball and cap action allows this low price. 9 3/4" steel barrel cased in knurled styrene stock, overall 13 1/2". Develop pistol form, accuracy at a fraction of cost of large caliber pistols. Comes with 50 steel bullets. Satisfaction guaranteed. Send \$3 to: Haig Mfg. Co., P.O. J-24, Alhambra, Calif. 91802

GUNK ENGINE BRITE



ENGINE CLEANER and DEGREASER

Just spray it on... hose it off!

GUNK LABORATORIES, INC.
5829 W. 96TH, CHICAGO, ILL. 60638



PIANO TUNING MADE EASY

No tedious theory. New down-to-earth pictorial method shows you step-by-step exactly which keys to strike. Complete instructions, all necessary tools, only \$17.95. Seven-day money-back guarantee. Free details. Van Brook Co., Box 324-K, Oregon, Ill. 61061.

MONEY-MAKING MACHINES! \$130 PROFIT A RACE DAY WITH \$50

PENCLIFF the world's greatest horse-race computer predicts BIG wins—easily. Payouts up to \$79 with \$2 stakes. Level stake profits at meetings on the day up to \$688. Average outlay \$60. Full details plus our remarkable guarantee: Full refund if no level stake profits with PENCLIFF at any track.

R.H.P. CO. BOX 5715, PE-MC Carmel, Calif. 93921.
Tear out this ad NOW & mail with name, address, & zip.

RADIAL ARM SAW KIT—for under \$100...

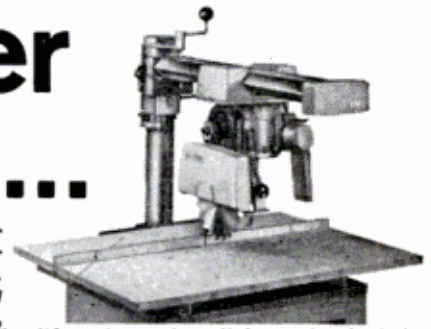

Buy direct from factory, assemble yourself. Incl. 1/2 h.p. G.E. motor, easy to follow instructions, all parts, nuts and bolts. Guar. for life pat. pend. radial arm track; twice the usual bearings for extra rigidity, greater precision. Rips 24", crosscuts 12"; belt brake. \$99. complete, freight col. Kit less motor (any standard 1/2 h.p. or larger will do) \$ 84.85. With opt'l G.E. motor developing 1 h.p. \$108.65. Money back guaranteed by one of world's largest manufacturers of bench power tools.

MAIL COUPON FOR ILLUSTRATED BROCHURE

American Machine & Tool Co.

Dept. PM-1R, Royersford, Pennsylvania 19468

Please send me without obligation your free illustrated brochure containing full information on the PermaTrak radial arm saw kit. Also send free reprints of feature articles by editors of Popular Mechanics, Workbench and Family Handyman. NO SALESMAN IS TO CALL.

NAME _____

ADDRESS _____

CITY _____ STATE _____ ZIP _____



5000° OXYGEN WELDING TORCH

\$34.95 New portable SOLIDOX welding torch goes anywhere. Only 4 lbs. Burns amazing solid oxygen pellets & propane. Flame exceeds 5000°F. Braze weld, silver solder, melt 1/4" steel. Complete kit: torch, pellets, propane, glasses, braze rods, lighter, etc. Ideal for shops, hobby, metal repair. Professional results. Low-cost SOLIDOX pellets available by mail. SOLIDOX is simple and safe. Money-back guarantee. Only \$34.95 ppd.

Write for free brochure.

SEND ONLY \$5.00

pay postman \$29.95 plus postage on delivery.
Cleanweld Products Co., PM19, Box 1061, South Gate, Calif. 90280

More Security With FALSE TEETH At Any Time

Do your false teeth embarrass you by slipping, dropping or wobbling when you laugh, talk or eat? Then sprinkle a little FASTEETH on your plates. FASTEETH holds dentures more firmly, more comfortably. This alkaline powder doesn't sour. No gooey, pasty taste. Helps check denture odor. Dentures that fit are essential to health. See your dentist regularly. Get FASTEETH today at all drug counters.

FLYING THE ENGLISH CHANNEL

(Continued from page 105)

past one of the regular cross-channel car ferries and swooped under the stern of a Brazilian cargo ship, whose astonished crew lined the rail to watch a vessel twice as fast as any they'd seen before. Once we bore down on a trio of seagulls drifting complacently in the swell. They hadn't been warned about Hovercraft, either, and they passed right under our floating hull. Yet such is the even pressure of the air blast—only 60 pounds per square foot—that they emerged at the stern surprised but only ruffled. I asked if I was allowed on deck. "Not unless you enjoy standing in a 50-knot gale," said the steward.

I had a slap-up French lunch in Boulogne. When I returned to Dover in the evening, the wind had whipped up six-foot waves, and our speed was cut down to 40. There was no sideways roll at all, but a good deal of pitching, with occasional and unexpected swoops down into the troughs. There was more seasickness than there would have been in a conventional ship, yet, on arrival, one ashen-faced woman victim told me: "I'm always sick anyway—and I'd rather it was half an hour instead of two."

Noise just a buzz

I had expected to be half deafened by the noise, a big Hovercraft bugbear in the past, both for the travelers and for the residents of the ports. The problem is the great speed of the propeller tips, which in previous craft had reached Mach 0.8, or some 600 mph. By making the N4's props a full 19 feet in diameter, the tip speed is kept to Mach 0.6; the noise is less than that of propeller aircraft. Inside the cabin, you soon get used to the steady buzz that comes through the thick roof insulation. The cabin crew don't notice it now—"although it gave me a sore throat the first day," one steward admitted.

"You know, you couldn't sink this thing if you tried," he told me later, after we'd passed lightly over a huge floating tree trunk. "There's 24 separate sealed buoyancy tanks in the deck. You could split her from stem to stern, and she'd still float." In fact, with a reserve buoyancy of 250 percent, 10 of the 24 tanks would keep the whole craft up. You can't see any of the guts of an N4: Round the base is the massive eight-foot rubber-and-neoprene skirt that contains the air blast and keeps the craft riding high. The lower half of the skirt looks like a row of giant licorice sticks; these are the "fingers" which, being separately replaceable, greatly reduce the cost of skirt maintenance; and,

being separately movable, reduce the expensive losses of air.

For a short while, I visited the control cabin of *Princess Margaret*. You reach it by a steep ladder leading up from the car deck. It looks much like the flight deck of a medium-sized airliner—except that it lacks an artificial horizon. The real horizon, topped by the glaring white of Dover's chalk cliffs, bucks disconcertingly as the craft jerks over the waves. All the crew wear headsets. The pilot sits at banks of gleaming dials that indicate airspeed and waterspeed, propeller pitch and rate of turn. He steers with his feet on a rudder bar that turns the propeller pylons and the two stern-mounted rudders. To his right is the engineer first officer, who shares the driving. At "takeoff" and "landing," one of them looks after the steering while the other controls lift and thrust.

Short stopping distance

Behind them sits the navigator, armed with Decca radar. Traveling at 70 knots across a waterway used by nearly 1000 ships a day, he has a normal stopping distance of half a mile, or 100 yards in emergency; and foreign mariners have not yet learned to allow for a crossing craft going five times their own speed.

At present, the N4 service is more expensive than a conventional steam ferry: a small car with two passengers, one way across the Channel by Hovercraft, costs about \$19—a third more than by steamer. But charges will probably come down as the service becomes better known, and the traveler in a hurry will always value a saving of an hour and a half on the sea, followed by a quick five minutes from car deck to customs.

All the crew are immensely proud of their craft and of its amazingly quick 25-minute terminal turnaround. A smart, bearded fellow in a tweed jacket next to me turned out to be John Syring, one of the regular pilots on the route. This was his day off, and he was spending it at his favorite place: aboard *Princess Margaret*.

"Fastest ship in the air," I commented.

"Yes," he replied. "Or, fastest plane on the sea." ★ ★ ★

Sonic booms like pile drivers

Scientists have recorded well-developed seismic waves generating from sonic booms of jet fighters at high altitudes.

The seismic waves, they find, are comparable to those created by a large pile driver about 200 feet away.

The experiments were conducted with acoustical and seismograph stations located at Cape Kennedy.

SET YOUR SITE

Under This

VACATION HOME . . .

or one of over
80 great designs.

PRICES START AS
LOW AS \$615



Lindal, world's largest manufacturer of cedar homes, offers you custom quality, kiln-dried Canadian Cedar homes. All pre-cut, ready for quick, easy assembly on your favorite site. Save hundreds of hours—and dollars. Our all-new, full color Home Planning Kit includes more than 80 exciting designs—Chalets, A-Frames, Lodges, Year-Around Homes. Dealer Inquiries Invited.

LINDAL CEDAR HOMES
9004 So. 19th
Tacoma, Wash. 98465

- Write for information on Lindal contest that anyone can enter to win a Lindal Cedar Home FREE.
- Enclosed is \$1.00 for my complete Lindal Cedar Homes Planning Kit.

Name _____
Address _____
City _____
State _____ Zip _____
PM-1-69

GET INTO ELECTRONICS

V.T.I. training leads to success as technicians, field engineers, specialists in communications, guided missiles, computers, radar, automation. Basic & advanced courses. Electronic Engineering Technology and Electronic Technology curricula both available. Assoc. degree in 29 mos. B.S. obtainable. G.I. approved. Start Feb., Sept. Dorms, campus. High School Graduate or equivalent. Catalog.

VALPARAISO TECHNICAL INSTITUTE
DEPARTMENT D, VALPARAISO, INDIANA 46383



TAX SALE—\$1 ACRE

Properties now being sold for municipal tax arrears. Hundreds of cottages, farms, hunt-camps, timberlands, homes from coast to coast along Canadian Border. Purchase direct from Tax authorities—NON PROFIT! For lists, pictures, regulations, write: Register, Room 18, 110 Church Street, Toronto, Canada.

MAKE MONEY AT HOME

“Inside” reports reveal 5 unusual, small businesses you can start on a “Shoestring”, run from your home. No door to door selling. Reports give facts, figures, case histories, how to start. Money back guarantee! All 5 confidential reports, Only \$2.98 ppd. Send cash, check, or money order to: Quality Gifts, Dept. PM-169, 1531 East 65th Street, Chicago, Illinois 60637.

Secrets of VENTRILOQUISM Now Revealed!



Easy to learn in 60 to 90 days with our Home Study Course. **RESULTS GUARANTEED** Make Money! Be Popular! Have Fun! Big Opportunity! Radio, Television, Stage Appearances! For FREE information regarding price and terms WRITE. You must state your age. Dummy Catalog 25c.
MAHER HOME COURSE OF VENTRILOQUISM
Box 8536, Studio PM-1, Kensington Station
Detroit, Michigan 48224

SAW SHARPENING IS EASY

Super Filer No. 11 joints and sharpens circular saws 6" to 10" with all teeth correct in height, depth, pitch, bevel. When file hits steel roller, teeth are finished. **\$10.95** Saw runs true with no side pull. Includes 8" file. PPD.



“TRU-CIRCLE”

saw set automatically sets teeth at 10° **\$2.95** or more. PPD.

MONEY BACK GUARANTEE

A. D. McBURNEY, 1610 Victory Blvd., Glendale, Calif. 91201, A-18

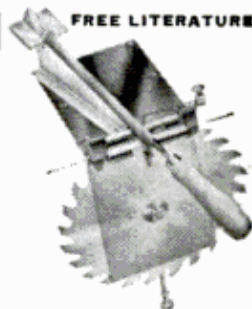

GET INTO ADVERTISING!

✓18,000 NEW JOBS EACH YEAR!

in Radio-TV, Advertising Agencies, Newspapers, Magazine Media, etc.



There's Big Money in Advertising! Train at home for a career in America's most “fun” business. Exciting, booming field. Meet fascinating people. No writing or art ability needed. G.I. Bill Approved. Send for big “ADVERTISING CAREER KIT”—ALL FREE!
NORTH AMERICAN SCHOOL OF ADVERTISING, Dept. 4171
4500 Campus Drive, Newport, California 92660

BILL PROBLEMS?

WE CAN HELP YOU—TODAY
NOBODY REFUSED UP TO \$18,000.00

Bad Credit No Problem ■ Not a Loan Co.

Send Your Name and Address
For FREE Application To Nearest Office

INTERNATIONAL ACCEPTANCE, dept. M-8

★ 5133 N. Central Ave., Phoenix, Ariz. 85012, ★
★ 711 - 14th St. N.W. Washington, D.C. 20005 ★
★ 507 Carondelet St., New Orleans, La. 70130 ★

Train for top jobs, top earnings, in PHOTOGRAPHY

NYI trains you for the best jobs—or your own successful business. Learn by doing at home, quickly, easily the individualized NYI way. Low cost. No experience or expensive equipment needed. Earn while you learn. Easy pay plan. Approved for Veterans, Student Loans. Approved by N.Y. State Ed. Dept. Accredited member Natl. Home Study Council. FREE color career book. No salesman will call. **RESIDENT TRAINING** in all profitable phases of photography and Creative Motion Picture Course. Our 59th year.

NEW YORK INSTITUTE OF PHOTOGRAPHY • 10 West 33 St., New York, N.Y. 10001, Dept. 49-1



SMALL SPORTY SEDANS

(Continued from page 108)

most appealing feature. With sophisticated independent springing front and rear, the BMW can negotiate the roughest roads without a trace of axle hop. Cornering is safe, predictable and faster than that of most all-out two-seater sports cars.

Ride is nothing short of sensational over all surfaces and at all speeds. Our test car leaned sharply on corners, but we had an early model that lacked front and rear sway bars. Later models should corner flatter, even faster.

The overhead-camshaft Four is a masterpiece of precision engineering. It starts immediately in all kinds of weather with little or no choke, runs smoothly and quietly, cranks out 0 to 60 in 10.1 seconds—fastest time of any of the five test cars. Those 114 horses are good for a top of 106 mph, matched only by Fiat.

Transmission is light, quiet, precise and beautifully synchronized. Steering is sensitive and light, with good road feel.

What's *wrong* with the BMW? Well, the steering wheel is too big and too high—and the brakes (discs front, drums rear) fade noticeably. After several consecutive panic stops from 60, pedal pressure increased markedly, along with stopping distance (longest in our tests). The brakes aren't really bad, but we expected better in such a high-performance machine.

FIAT 124 SPORT COUPE

The neatest styling package, in our opinion, is the Fiat. With crisp, modern lines, Ferrari-like grille, huge greenhouse (visibility at least as good as the BMW's) and bobbed tail, the Fiat got more attention than any other car we drove.

At \$2878, it's in the BMW's price range—a choice between them is tough. Though labeled a coupe, the Fiat has a cabin as roomy as those of our other test cars—which is why it's included here.

If the driving position in the BMW is excellent, in the Fiat it's superlative. Beautifully shaped bucket seats offer comfort, lateral support and a wide range of adjustment. The small, sporty steering wheel allows a straight-arm grip, and all controls are perfectly located.

With the front seat all the way back, rear legroom is zero, but even the tallest driver isn't likely to need all the available adjustment. The heavily upholstered rear seat is comfortable for two.

The interior is tasteful and luxurious, with full carpeting, a wood grain instrument panel that looks like the real thing, and a full complement of legible gauges, including a tachometer. Quality is out-

standing, except for an abominable harness-belt combination that rides well above its victim's beltline. The trunk is a shade larger than the BMW's, but a small load opening limits its usefulness.

The Fiat is living proof that an independent rear suspension isn't the only route to go for top handling and comfort. With its well-located live rear axle, the car can take any corner, smooth or rough, at astonishing speeds. The ride is tight, well-controlled and absolutely flat.

The BMW and Fiat go around corners extremely fast, but differently. The BMW steering feels neutral until near the point at which the tires lose their grip. Then oversteer gradually sets in; rear tires slip wider and wider until finally, after three airmail letters and a telegram to tell you what's happening, they let go. A skillful driver can use such oversteer to hang out the tail end, dirt-track style, to increase cornering speed.

The Fiat understeers all the way; the front tires slip wider and wider as cornering forces increase. If pushed beyond reason, the Fiat eventually plows straight ahead instead of following the curve of the road. But, still, we think such understeer feels more stable and imparts more confidence to the average driver.

A big plus for the Fiat is four-wheel disc brakes. They snub the car down straight and fast, with no hint of fade.

Like the BMW, the Fiat has some exquisite machinery under its front-hinged hood: a dual-overhead-camshaft Four cranking out 96 hp from 87.75 cu. in. It only starts to perform above 3500 rpm, but this is no problem if you don't mind rowing that light, precise, extra-fast shift lever to keep the revs up.

In acceleration, the Fiat was second to BMW with 11.5 seconds from 0 to 60. And the sound of that exhaust! Only the Italians could shape such a beautiful note.

SAAB DE LUXE

Most unorthodox of our test cars was the Saab De Luxe, which sells for \$2550. The De Luxe label entitles you to Pirelli radial-ply tires and a tachometer.

Before testing, we wondered whether the Saab could fairly be included in such sporting company. Our misgivings proved valid in performance: The 73-hp, 91.4-cu.-in. V4 took 15.2 seconds to reach 60. Top speed was an unglamorous 95. Nevertheless, the car has many attributes that the knowledgeable driver should like.

Unfortunately, styling isn't one of them. Originally a sleek, functional wind-tunnel design, the car has suffered at the hands of stylists. A few bulges and scoops added

(Please turn to page 208)

**Guaranteed
10 Years!**

\$1.98



The knife for hunting, fishing and all around use. Mirror polished, imported stainless steel blade honed to a razor's edge. Rugged. Opens with flick of finger. Locks into position. Blade will not close when in use. Press button in handle to close. Safety finger guard. Sure-grip handle. Balanced for target throwing. **IF BROKEN WITHIN 10 YEARS WE WILL REPLACE AT NO CHARGE!** Use 30 days. Money back if not pleased. Only \$1.98 plus \$.27 postage and handling. **ORDER NOW!** Midwest Knife Co., 9043 S. Western Ave., Dept. RC-9608, Chicago, Ill. 60620. Established 1936.



FREE FISHING

CATALOG

**170 PAGES
OVER 5,000
FISHING ITEMS**

Hard to find Fishing Specialties and Kits
Send postal card & please add ZIP

NETCRAFT CO.
Toledo, Ohio 43613

PERMANENT MATCH

AMAZING INVENTION SELLS LIKE MAD!

Lights up to 15,000 times. Pull this ingenious metal wonder out of its case, strike on side, and presto!—it's lit. Amazes everyone who sees it. **MAKE BIG PROFITS.** Show to friends, fellow-workers, in stores, offices, taverns, factories. Sells on sight for \$1.00. Order at low wholesale prices: ONLY \$4.90 per doz.; \$14.25 for 3 doz.; \$49.20 for 12 doz. (2 samples \$1.00). Display cards available for big store sales. Catalog of 100 other fast sellers included free! Lakeside Company, Dept. PP-19, 6800 N. Campbell Ave.; Chicago, Ill. 60645.



locksmithing and key making

PRACTICAL UP-TO-DATE COURSE — ONLY \$6.95

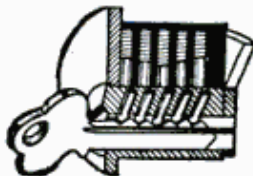

Teaches you how to pick locks, de-code, make master keys, repair, install, service, etc. New self-instruction lessons for every handyman, homeowner, carpenter, mechanic, service station operator, fix-it shop, hardware dealer, gunsmith. 53 easy illustrated lessons. Full price only \$6.95, post-paid. Satisfaction or refund guaranteed. Mail order today!

NELSON-HALL CO., Dept. AR-2
325 W. Jackson Blvd., Chicago 60606



**IF YOU CAN SING, WHISTLE,
OR HUM A TUNE...**

you can play the Musical Saw. No notes to read, no musical knowledge required. Since 1921 we have furnished the entire world this unusual, sweet-toned instrument. If you are 10 or 70, you play or no pay. Musical Saw, soft hammer, bow, resin and lessons mailed on 5 days' trial. Write today for details and free copy of "Sawing News of the World," picturing successful saw musicians. **MUSSEHL & WESTPHAL**, 107 Fort St., Fort Atkinson, Wisconsin. 53538.

**LEARN
MEAT CUTTING**



Train quickly in 8 short weeks at Toledo for a bright future with security in vital meat business. Big pay full-time jobs — **HAVE A PROFITABLE MARKET OF YOUR OWN!** Time payment plan available. Diploma given. Job help. Thousands of successful graduates. **OUR 45th YEAR!** Send now for big new illustrated **FREE** catalog. No obligation. **G.I. Approved.**
NATIONAL SCHOOL OF MEAT CUTTING
Dept. 50-Q, Toledo, Ohio 43604

**Learn To Be A
LOCKSMITH**

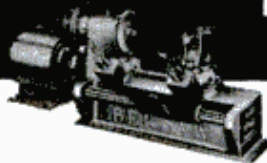

**PROFESSIONAL
KEY MACHINE
YOURS TO KEEP!**

Big demand for skilled Locksmiths! Earn big money spare time in your own home. Be your own boss: earn steady, year 'round income with no layoffs. **BELSAW INSTITUTE** training, approved by master locksmiths, teaches you to make keys, open and repair locks on homes, cars and buildings. Easy, illustrated lessons complete with **ALL** tools and supplies, including the \$125 Key Machine which is yours to keep. Shows you how to get jobs, how to charge, how to earn while you learn and how to build a lifetime, cash-profit business.

Read These Reports from Belsaw Graduates:

Oscar Larson, Long Beach, Calif.: "I have all the locksmith work I can handle in spare time. I give hearty thanks for your wonderful training."

Herbert Bernard, Point Pleasant, N. J.: "I recommend your course highly. Locksmithing gives me real enjoyment and extra money."

J. Marko, Ferndale, Mich.: "With me locksmithing is full time. I sincerely thank you for giving me this chance to better myself."

J. W. Cookman, Lakeland, Fla.: "I've been in full time locksmithing for three months. Thanks for your fine cooperation."

Accredited Member National Home Study Council. Approved for Veterans. Mail coupon today... no salesman will call.

BELSAW INSTITUTE
109J Field Bldg., Kansas City, Mo. 64111

Send **FREE** book, "Keys To Your Future!"



Name _____
Address _____
City _____ State _____ Zip _____



**NEW MIRACLE
NYLON
FASTENER**
jif-lok

Improves old hollow wall anchors.

Adjusts to various thickness in any material.
Vibration proof.

PAT. NO. 3350976

JORDAN Industries, Inc.
3030 N.W. 75th St.
Miami, Fla. 33147

At leading hardware & variety stores everywhere



LIVE-CATCH ALL-PURPOSE TRAPS

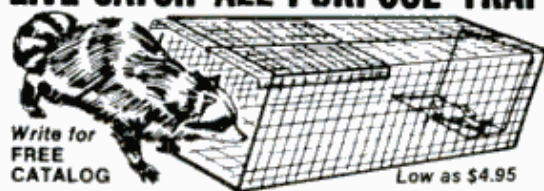

Write for **FREE CATALOG**

Low as \$4.95

Trap without injury squirrels, chipmunks, rabbits, mink, fox, raccoons, stray animals, pests, etc. Sizes for every need. Also traps for fish, sparrows, pigeons, crabs, turtles, quail, etc. Save 40% on low factory prices. Send no money. Free catalog and trapping secrets.

TRAP FACTORY, Dept. M14 Box 10880, Houston, Texas 77018

SMALL SPORTY SEDANS

(Continued from page 206)

here, a little overhang there, extra bright-work all around, and the result is best described as neo-Zeppelin.

The car is rugged. The few Saabs that have rolled over in competition invariably came through with roof and pillars intact. Panels and trim are perfectly aligned.

The interior is neat, though a bit old-fashioned and plain-Jane. There's a big, legible speedometer and tachometer, a small clock and a fuel gauge. All other functions are monitored by warning lights.

Front seats, with vinyl-trimmed cloth, adjust to fit any size driver and passenger. The rear seat holds two comfortably, three in a pinch. An optional kit, which takes about 15 minutes to assemble, converts the seats into a double bed.

The sharply slanting windshield comes uncomfortably close to the driver's forehead. We kept bumping our heads on the rear-view mirror when climbing out.

The trunk, displacing a roomy 13 cu. ft., looks like a tunnel. Unhappily, the tiny, stiff trunk-release knob—it's fiendishly blocked by the bumper overrider—offers a constant test of strength. However, it's easy to forgive such minor flaws once you drive the car. Countless wins in major European rallies attest to its cornering. With front-wheel drive, it is especially stable on icy, snowy roads. Perhaps that's why Saab is so successful in New England.

Like other front-wheel drives, the Saab tends to understeer with power on. But let up on the gas in a corner and you get a dramatic change to oversteer. A novice may find this scary, but once you get the knack, it's great fun. You actually can steer with the throttle. Ride is fairly good on normal roads, but is harsh on rough surfaces unless you drive fast.

The little V4 starts willingly, idles smoothly, and revs past its 5600 rpm red-line without protest. Our self-imposed 6000 rpm limit felt conservative.

An odd feature is the freewheeling device that automatically disengages the engine from the transmission and allows it to drop to idle speed whenever you lift off the throttle. With the old Saab two-cycle engine, freewheeling kept the engine from starving for oil on the overrun. On the V4 it cuts down on air pollution, eliminating the need for an air pump. Also, it saves fuel. And in a skid, a freewheeling car is easier to control.

Unfortunately, when you want to accelerate again, it's hard to feed just enough gas to avoid an unpleasant jerk. And we missed the absence of engine braking.

The four-speed transmission is beauti-

fully synchronized, but a sloppy, balky column linkage takes all the fun out of shifting. Steering is very fast and precise, but heavy. The brakes (discs front, drums rear) take repeated panic stops with little fade. Stopping distances compare to the Fiat's, but directional stability isn't as good.

The Saab's best selling point probably is its reputation for reliability. The new V4 shows every indication of matching the old two-cycle's ruggedness.

CORTINA GT

If you prefer Detroit styling, you'll be at home with the Cortina. It looks like an un-Sanforized Falcon that got caught in the rain. The GT interior shows a strong American influence, with a stylized instrument panel and floor-mounted console with storage bin and built-in clock.

Exterior workmanship on our test car was reasonably good, but things could have been improved inside. Cutouts in the carpeting were oversize. There were a couple of glue drippings on the upholstery, and the headliner suffered from a few odd-looking lumps.

Also, there are what we feel are designed-in boo-boos. Rear windows are sealed shut. Instead of a folding seat back, the entire front seat hinges forward for rear access. This is inconvenient and the seat also knocks the rear-view mirror out of kilter. (So do the sun visors.) The brake pedal is too close to the transmission hump and tends to snag your shoe when you lift off the accelerator.

Front buckets are attractive and comfortable. With the console, they give good lateral support. Front legroom is a bit snug, but rear legroom was the best of all our test cars. Front-seat brackets can be reversed to increase travel.

The Cortina GT is unusually well instrumented, with large, round speedometer and tachometer, and legible gauges for amps., fuel, coolant and oil. The recessed package tray actually holds small packages without obstructing vision.

The engine, a 97.5-cu.-in., 93-hp Four, boasts several unusual features. A cross-flow head allows gases to enter and exit without turning corners, increasing engine efficiency. Combustion chambers formed in the pistons instead of the head, means that chambers can be cast absolutely identical, making for a smoother engine.

Our 0-to-60 runs averaged a respectable 12.2 seconds, in spite of the high first gear. Top speed is about 96.

The beautifully synchronized transmission takes the most brutal speed shifts without complaint. Our test car, a '68, had a rather vague shift linkage, but the '69s,

(Please turn to page 214)

NOW AT BIG SAVINGS!

BUILD THESE BEAUTIFUL CLOCKS

Send just \$1 for plans & instructions to build choice of: (A) Grandfather, (B) Banjo, (C) Steeple, (D) Grandmother plus information-packed catalog of movements, dials, parts & kits to build these & 15 other fine clocks. All 4 plans \$3.50. Catalog alone—25¢.

MASON & SULLIVAN COMPANY
Dept. PM-9, Osterville, Mass. 02655

Giant Football MUMS



Proven prizewinners. Proper care assures beautiful mums of cup size. Early flowering, and dependable. Choice of yellow, bronze, white, and pink. Guaranteed merchandise. See other popular varieties of flowers, trees, shrubs, and fruits in our big colorful 60 page NURSERY CATALOG. Our 120th anniversary year.



FREE BOOK

SPRING HILL NURSERIES, 2312 Elm Street, Tipp City, Ohio 45371

BE A LANDSCAPE CONTRACTOR

LEARN MODERN LANDSCAPING for exciting hobby or profit. Thousands of spare or full time money making opportunities. Start a profitable business—we show you how. Study and earn your certificate at home.

Write today for Free Book.

LIFETIME CAREER SCHOOLS

Dept. A-576
2251 Barry Ave.
Los Angeles, Calif. 90064

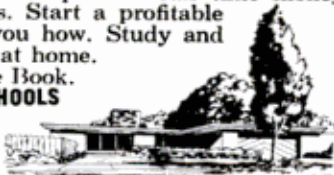

FREE!

Learn how you can buy used engines \$15 up, new engines \$30 with FREE confidential list and coupons when you order your plans

- **BUILD THIS MINI-BIKE!** Plans reveal step by step details!
- **BUILD A RACING KART!** Complete frame for less than \$10!



RUSH \$2 for plans (indicate type) or end 25¢ for circular describing plans
PLANS, Box 517, Omaha, Nebr. 68101

INSTALL ALARM SYSTEMS

BEGINNERS MAKE BIG MONEY—YOUR OWN BOSS

New plan opens multi-million dollar burglar fire alarm business to small home operators. Guides beginners step by step.



Starts you full or spare time without previous experience or big investment. See how to cash in on invisible web of protection that stops crooks cold, makes big profits. No salesman will call. Write for free details!

NASCO, 11071 Massachusetts Avenue, Dept. C2251, Los Angeles, Calif. 90025

for outdoors, indoors, home, office, farm, camping

BIG, BRAUNY, DURABLE 9 x 12 FT. TARPAILINS

... UNBELIEVABLE VALUE!

3 for \$10⁹⁵ \$5.00 each

- MILDEWPROOF
- WATERPROOF
- ROTPROOF

"Instant garage" for cars, machinery, toys . . . tent floor . . . construction and storage shield . . . a million uses. Pay for themselves in no time in property saved! One piece construction. No seams. Four heavy-duty metal, non-rusting grommet holes. Can be roped down securely. **MONEY BACK IF NOT DELIGHTED.** Send check or money order. Free catalog!

Add 50c for postage, handling and insurance for each Tarpaulin.

JAY NORRIS CORP. Dept. ME-1
31 Hanse Ave., Freeport, New York 11520

BUILD THIS BEAUTIFUL NUTS and BOLTS MAN!

- PATENT PENDING
- All Parts Moveable

Make a beautiful bookend, paper-weight, trophy, or other novelty items.

For complete instructions, bill of materials, and drawing send \$1.00 to

NUTS and BOLT MAN
P.O. Box 1081, Thomasville, N. C. 27360

LAW FREE BOOK THE LAW TRAINED MAN

Write today for a FREE copy of illustrated law book, "THE LAW TRAINED MAN," which shows how to earn the professional Bachelor of Laws (LL.B.) degree through home study of the famous Blackstone Law Course. All necessary books and lessons provided. Moderate cost; convenient monthly terms. Write for FREE law training book today.

Blackstone School of Law, 307 N. Michigan Ave. Founded 1890 Dept. 51, Chicago, Illinois 60601

ACCOUNTING

Accounting (U.S.A.)
 Accounting (Canadian)
 Accounting for Business
 Programmers
 Accounting for
 Management Decisions
 Auditing
 Business Law (U.S.A.)
 Cost Accounting
 C.P.A. Review (U.S.A.)
 General Accounting
 Income Tax (U.S.A.)
 Industrial Accounting
 Junior Accounting
 Office Accounting
 Practical Accounting
 Public Accounting
 Small Business
 Accounting (U.S.A.)
 Starting & Managing a
 Small Bookkeeping
 Service (U.S.A.)

**ARCHITECTURE
AND BUILDING**

Architectural Drawing &
 Designing
 Architecture
 Building Contractor
 Building Estimator
 Building Inspector
 Building Maintenance
 Carpenter-BUILDER
 Carpentry & Millwork
 Fundamentals of
 Urban Planning
 House Planning & Interior
 Design
 Mason
 Painting Contractor
 Reading Arch. Blueprints
 Review in Arch. Design &
 Practice
 Review of Mech. Systems
 in Buildings

ART

Amateur Artist
 Commercial Art
 Commercial Cartooning
 Illustrating with Options:
 —Magazine
 —Advertising Layout and
 Illustration
 Interior Decorating
 Oil Painting for Pleasure
 Show Card & Sign
 Production
 Show Card Writing
 Sign Painting & Designing
 Sketching & Painting

AUTOMOTIVE

Automatic Transmission
 Specialist
 Automobile Body
 Rebuilding & Refinishing
 Automobile Electrical
 Technician
 Automobile Engine Tune-Up
 Automobile Technician
 Automotive Mechanic
 Diesel-Gas Motor Vehicle
 Engines

BUSINESS

Advertising
 Business Administration
 Business Practice (Cond.)
 Canadian Business Course
 Condensed Marketing
 Direct Mail & Mail
 Order Advertising
 Industrial Psychology
 Inventory Control
 Magazine & Newspaper
 Advertising
 Managing a Retail Business
 Managing a Small Store
 Marketing Management
 Marketing Research
 Modern Executive
 Management
 Office Automation
 Office Management
 Production Management
 Purchasing Agent
 Retail & Local Advertising
 Retail Business
 Management
 Retail Merchandising
 Retail Selling
 Systems and Procedures
 Analysis

BUSINESS: SALES

Creative Salesmanship
 Real Estate Salesmanship
 Salesmanship
 Sales Management

**BUSINESS:
SUPERVISION**

Basic Supervision
 Industrial Foremanship
 Industrial Supervision
 Management,
 Salesmanship & Sales
 Modern Woman as a
 Supervisor
 Personality Development
 Personnel-Labor
 Relations (U.S.A.)
 Supervision

CHEMICAL

Chemical Engineering
 Analytical Chemistry
 Chemical Engineering Unit
 Operations
 Chemical Laboratory Tech'n
 Chemical Process Operator
 Elements of Nuclear Energy
 General Chemistry
 Instrumental Laboratory
 Analysis

CIVIL ENGINEERING

Civil Engineering
 Construction Engineering
 Technology
 Highway Engineering Tech.
 Principles of Surveying
 Reading Highway
 Blueprints
 Reading Struct. Blueprints
 Sanitary Engineering Tech.
 Sewage Plant Operator
 Structural Engineering
 Technology
 Surveying and Mapping
 Water Works Operator

COLLEGE COURSES

American History
 Calculus
 Economics

**CAST
 YOUR
 BALLOT
 FOR
 A
 SUCCESSFUL
 FUTURE!**

266 ICS

Special rates to members of U. S. Armed Forces

Approved for veterans under new G. I. Bill.



ICS is the oldest, largest school of its kind. Over 250 courses for men and women. High school, business, secretarial, interior decorating, engineering. One for **you**. Direct, job-related. Bedrock facts and theory plus practical

application. You learn from experts. Diploma to graduates.

Clip and mail the coupon **now**. You'll receive, absolutely FREE, 3 valuable booklets that have helped thousands. But don't delay. Cast **your** "ballot" today!



COMPUTERS

COBOL Programming
 Fortran Programming for Engineers
 Programming for Digital Computers
 Programming the IBM 1401 Computer
 Programming the IBM SYSTEM/360 Computer, Introduction

DRAFTING

Aircraft Drafting
 Architectural Drafting
 Design Drafting
 Drafting Technology
 Electrical Drafting
 Electrical Engineering Drafting
 Electronic Drafting
 Introductory Mechanical Drafting
 Mechanical Drafting
 Pressure-Vessel and Tank Print Reading
 Sheet Metal Layout for Air Conditioning
 Structural Drafting

ELECTRICAL

Electrical Engineering (Power option or Electronics option)
 Electrical Appliance Servicing
 Electrical Appliance Servicing with Equipment Training
 Electrical Contractor
 Electrical Engineering Tech.
 Electrical Home Maintenance
 Electrical Home Maintenance with Equipment Training
 Electrical Instrument Tech.
 Electrical Motor Repairman
 Industrial Electrical Tech.
 Power Line Design and Construction
 Power Plant Operator (Hydro or Steam Option)

ELECTRICAL (cont'd)

Practical Electrician
 Practical Electrician with Equipment Training
 Practical Lineman
 Reading Electrical Blueprints

ENGINEERING (Refresher Courses for Graduate Engineers)

Chemical
 Civil
 Electrical
 Industrial
 Mechanical
 Sanitary
 Structural

ENGLISH AND WRITING

Better Business Writing
 English for Spanish (U.S.A.)
 Free Lance Writing for Fun & Profit
 Introductory Technical Writing
 Modern Letter Writing
 Practical English
 Short Story Writing

HIGH SCHOOL

High School Business
 High School (Canadian)
 High School General
 High School Mathematics
 High School Secretarial
 High School Vocational
 High School College—Preparatory—Arts
 High School College Prep.—English & Science
 Preparatory Course for High School Equivalency Test

MACHINE SHOP PRACTICE

Drill Operator
 Foundry Practice
 Industrial Metallurgy
 Lathe Operator
 Machine Shop Inspection
 Machine Shop Practice
 Metallurgical Engineering Technology
 Milling Machine Operator
 Multicraft Maintenance Mechanic
 Practical Millwrighting
 Reading Shop Prints
 Rigging
 Tool Engineering Tech'I'gy
 Tool Grinder
 Toolmaking
 Turret Lathe Operator
 Welding Engineering Technology
 Welding Processes

MATHEMATICS

Advanced Mathematics
 Mathematics and Mechanics for Engineering Tech'ns
 Mathematics and Physics for Engineering Tech'ns

MECHANICAL

Mechanical Engineering
 Aircraft & Power Plant Mechanic
 Hydraulic & Pneumatic Power
 Industrial Engineering
 Industrial Engineering Tech.
 Industrial Instrumentation
 Machine Design
 Quality Control
 Safety Engineering Tech'I'gy
 Tool Design
 Vibration Analysis & Control

PETROLEUM

Natural Gas Production & Transmission
 Oil Field Technology
 Petroleum Production
 Petroleum Production Engineering Technology
 Petroleum Refinery Operator
 Pipeline Engineering Tech.

PLASTICS

Design of Plastic Products
 Plastics Technician

PLUMBING, HEATING AIR CONDITIONING

Air Conditioning
 Air Conditioning Maintenance
 Domestic Heating with Oil & Gas
 Domestic Refrigeration Heating
 Heating & Air Conditioning with Drawing
 Industrial Air Conditioning
 Industrial Heating
 Pipe Fitting
 Plumbing
 Plumbing & Heating
 Plumbing & Heating Estimator
 Practical Plumbing
 Refrigeration
 Refrigeration & Air Conditioning

PULP AND PAPER

Paper Machine Operator
 Paper Making
 Pulp Making
 Pulp & Paper Engineering Technician

SECRETARIAL

Clerk-Typist
 Commercial
 Secretary, Engineering
 Secretary, Legal
 Secretary, Medical
 Secretary, Professional
 Shorthand
 Stenographic
 Typewriting

STEAM AND DIESEL POWER

Boiler Inspector
 Industrial Building Engineer
 Power Plant Engineering
 Stationary Diesel Engines
 Stationary Fireman
 Stationary Steam Engineering

TEXTILES

Carding
 Carding and Spinning
 Dyeing & Finishing
 Loom Fixing
 Spinning
 Textile Designing
 Textile Mill Supervision
 Textile Technology
 Warping and Weaving

TRAFFIC

Motor Traffic Management
 Railway Rate Clerk
 Traffic Management

TV-RADIO-ELECTRONICS

Color Television Principles & Servicing
 Electronic Instrumentation & Servo Fundamentals
 Electronics Technician
 First Class Radiotelephone License
 Fundamentals of Electronic Computers
 General Electronics
 General Electronics with Equipment Training
 Hi-Fi Stereo and Sound Systems Servicing
 Industrial Electronics Technician
 Numerical Control Electronics & Maintenance
 Practical Telephony
 Principles of Semiconductor-Transistor Circuits
 Radio & TV Servicing
 Radio & TV Servicing with Equipment Training
 Second Class Radiotelephone License
 Sound Systems Specialist
 Telephony, Electronics and Radio Communications
 TV Receiver Servicing & Repair

COURSES

In Hawaii: P. O. Box 418, Honolulu
 In Canada: Mail to Scranton, Penna. Further service handled through ICS Canadian, Ltd.
 In other countries: ICS World, Ltd.

Clip coupon—and take your first big step to real success! ICS, Scranton, Penna. 18515

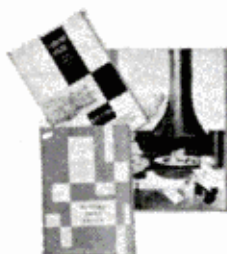

FREE! THE ICS SUCCESS KIT!
 Three valuable booklets sent to you free when you mark and mail the ICS coupon. No obligation.

1. A new, exciting booklet on the principles of success that lets you evaluate yourself and your future in an entirely different way!
2. Complete catalog outlining job opportunities and outlook in your field of interest.
3. Illustrated brochure which demonstrates the success-proved ICS method of spare-time study.

Accredited Member, National Home Study Council

ICS INTERNATIONAL CORRESPONDENCE SCHOOLS
 Dept. N7266M, Scranton, Penna. 18515

I'm interested in a program of independent study. Send me, without cost, your booklet on the principles of success, your illustrated brochure on the ICS method, and your catalog for _____ (Select from listing above)

Name _____ Age _____
 (Indicate Mr., Mrs., or Miss)

Address _____

City _____ State _____ Zip code _____

Occupation _____ Working hours _____ A.M. to _____ P.M.

Employed by _____

Special ICS booklets for women Convenient Payment Plans

FREE!

1969 Catalog 690

Over 500 Pages

BETTER THAN EVER

Stereo Hi-Fi • Citizens Band • Ham Gear • Tape Recorders • Test Equipment • TV and Radio Tubes and Parts • Cameras • Auto Accessories • Musical Instruments • Tools • Books



LAFAYETTE Radio ELECTRONICS

Dept. 15108 P.O. Box 10

Syosset, L.I., N.Y. 11791

Send me the FREE 1969 catalog 690. **15019**

Name

Address

City

State Zip

LICKITY WACO LOG SPLITTER

Splits Big Profits from toughest woods— Ends Splitting Drudgery with 18 ton hydraulic power!

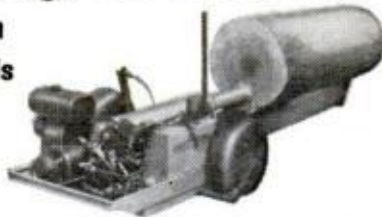

7 H.P. trailer unit squats under power to load logs without dead lift. Has 2 speeds, auto-shift, auto-stroke. 26" ram travel splits logs up to 34", any diameter — with extended frame and adjustable wedge splits up to 60". **NEW LOW COST Economy model** for farmers and small wood lots. Also ask about the 60L Series for logs up to 8½ ft. long—Details free.

Piqua Engineering Inc., Dept. P, Box 605, Piqua, Ohio

YOURS... \$100 MORE VALUE

Man-size! Does big jobs faster! Full 14 hp. All-gear drive (no belts, no fluid power loss). Bigger frame, bigger wheels, extra weight and traction. Gives you more pull-power, handles bigger tools.
 ■ Mow lawn up to 60" swath. Clear deep snow. Bulldoze, front-end-load, till, plow, cultivate. Send for free catalog, prices.



ECONOMY TRACTOR
 1005 K-1 Anoka Avenue
 Waukesha, Wisconsin

REAL ESTATE BE A BROKER

PAYS BIG! SEND FOR FREE, BIG, ILLUSTRATED CATALOG NOW! Graduates report making substantial incomes. Start and run your own business quickly. Men, Women, all ages, learn easily. Course covers Sales, Property Management, Appraising, Loans, Mortgages, & related subjects. **STUDY AT HOME** or in classrooms in leading cities. **DIPLOMA AWARDED. Write TODAY for FREE Booklet!** Accredited Member National Home Study Council. (Established 1936)
WEAVER SCHOOL OF REAL ESTATE
 3521-P Broadway Kansas City, Mo. 64111



SMALL SPORTY SEDANS

(Continued from page 208)

unchanged but for safety provisions, are said to offer a more positive linkage.

Suspension feels much softer than that of our other cars (again the Detroit influence). But if the GT's cornering isn't terribly fast, at least it's predictable—it understeers at all times. The live rear axle can take fairly rough corners without losing its composure. Brakes (discs front, drums rear) are about on a par with those of the BMW—okay, but nothing to brag about at the local pub.

DATSUN PL 510

The "cheapie" in our lineup, the \$1999 Datsun PL 510, actually offers many luxury features. The single-overhead-camshaft Four and independent rear suspension are suspiciously similar to BMW's. But, though the Datsun handles predictably in all situations (it understeers), it can't match the superb cornering and ride of the BMW. Of course, don't forget it's \$1000 cheaper.

Maybe some adjustments in the shock settings or spring rates are the answer. Radial-ply tires definitely would help; the Datsun is the only one among our test cars not to include radials as standard.

The 97.3-cu.-in. engine, producing about 96 hp, takes 14.3 seconds to reach 60. Top speed is 98.

Considering the price range, the manufacturer has to scrimp a little—front seats are small and skimpily padded, offer little lateral support. Front legroom is, we think, inadequate. There are no armrests, no cigar lighter. One key services ignition, door and trunk locks. The handbrake is hard to reach in an emergency. And, personally, we don't dig rectangular gauges.

Yet, the Datsun has many exclusives. It's the only four-door in our lineup. (At this writing, Datsun has just announced a two-door version—for \$133 less!) Rear windows roll down all the way (the other cars, except for Cortina, have hinged rear windows). A radiator fan cutout is standard, as are whitewalls and dual headlights. The built-in ventilating system is most efficient. And the disc-drum braking system consistently chalked up the shortest stopping distances, with no deviation.

What's more, Datsun alone offers an optional automatic transmission (\$165).

From a practical standpoint, the Datsun may offer the most value for the money. For dependability, we vote Saab. Cortina GT gets the nod for comfortable motoring on a budget. But if you want to go hunting at a price for wild beasts from Detroit, you can't beat BMW or Fiat. ★★★

OFFICE UNDER THE SEA

(Continued from page 117)

ordinary working day at the Lockheed Ocean Laboratory. When the boat is in its hangar, the atmosphere resembles a Navy base.

On the bulletin board in the hangar, schedules give times by military system, on the 24-hour clock. Operational orders, too, are strictly GI. They start off "To: All Hands."

In the bookcase in Don Saner's office you'll find a well-read copy of the *Boatswain's Mate* handbook as well as old Navy manuals. Fur-collared Navy flight jackets are also popular among civilian submariners, who insist the "USN" inside stands for "University of Southern Nevada."

Service atmosphere

There are admittedly times when the men themselves seem to forget they aren't back with the Fleet. Bob Worthington told this story. It happened aboard the *Transquest* as it was carrying the *Deep Quest* out for a dive.

There for the event was a Lockheed engineer who ordinarily worked in the company's home plant up in Sunnyvale, Calif. He was busy aft with some equipment when the ship's chef got Dave McCafferty out of hearing. "Say, skipper," he asked in a whisper, "who's that civilian aboard?"

If Lockheed's little San Diego naval base is a lot like a corner of some Navy yard, being at sea with the support ship and sub is, to many of the men, all the world like being back in service.

Pilot of the *Deep Quest* during dives sits in the left-hand seat in the forward sphere. Before him are instruments and controls that are a combination of those found in ships and planes. The fathometer is no different from that used on a large ship; the magnetic directional compass is, however, taken from an airplane. But the integrated control-and-display system was designed specially for *Deep Quest*.

Two handles, something like those used on a helicopter, provide the pilot with control of his two main 7½-hp a.c. motors; two similar motors are installed for vertical movement and water jet thrusters for lateral moves.

The copilot and navigator occupies the right-hand seat. Behind the two in the after sphere ride the two observers or technicians, usually Don and another observer.

Don admits he thought all his seagoing
(Please turn to page 216)

Briggs & Stratton — Clinton New Gas Engine Sale

Never before and perhaps never again—this offer of brand new genuine Clinton and Briggs & Stratton engines including 1 yr. factory warranty at less than cost. Perfect power for go-carts, scooters, tractors, mowers, generators, pumps, sprayers, etc. We hauled out 3 big factories who needed cash and the savings are yours while quantities last. Act fast.



Clinton 2½ hp. Mdl. 500—Re-coil starter Std. 5/8 shaft w. keyway—ready to go. Reg. price \$59.50 Special (item 1002)

\$34.95

2 for\$64.50
6 for\$190.00



Briggs & Stratton 2½ hp. Mdl. 81106 ratchet start. 3/4 shaft. Sturdy 4 cycle engine. Reg. price \$69.50 Spec Item = 1518

\$34.50

2 for\$67.50
6 for\$199.50

\$69.95
5¾ hp.
Briggs & Stratton

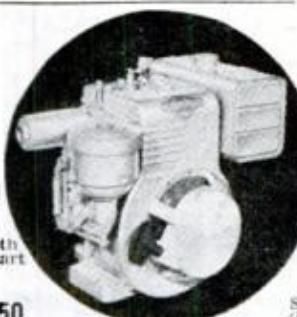

Same engine with 12 v. elec. start and battery charging. (Item = 1571) **\$94.50**

Briggs & Stratton 5¾ hp. Mdl. 143302. Recoil start. Std. 1" shaft w. keyway, and adjustable governor—a rugged big engine ready to tackle any job. Regular price . . . \$92.60 Special (item 1059) . . . **\$69.95**

2 for \$135.00 6 for \$375.00

2¾ h.p. Clinton—34.95

Model 400, rugged 4 cycle model. Alum. Block, castiron cylinder Rope start—3/8" std. shaft. Item 110734.95
2 For69.95

3½ h.p. Clinton—39.95

A big engine with big power. Model 404, 4 cycle, rope start, 3/4" std. shaft, industrial ball bearing engine. Item 40439.95
2 for77.50

Remember these engines are absolutely perfect and standard and under factory warranty. Money back guarantee. Order now while stocks are complete. Factories—we buy new engines.

STANDARD DIAL PHONES WITH BELL

Bell System late model dial phones same as used by all telephone companies. Ideal as extensions on any system. Easy to connect. Several may be connected on one line. Easily modified for private inter-com system. Cost \$40.00 new—guaranteed excellent condition.

ITEM 855 NC. Wt. 8 lbs. **\$7.45**

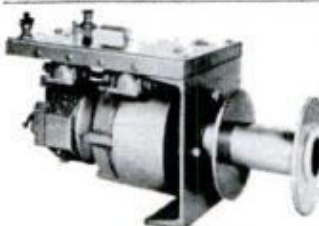

TRUCK OR BOAT WINCH 2000

A powerful, compact winch which installs easily even in limited space. Works with any 12, 24 or 32 volt system. Reverses under power—positive brake holds load. Drip proof cover. Remote control if desired. Drum holds 100 ft. of 3/4" cable. Speed 30 ft. per minute. A terrific winch at an economy price. Item 1263
Wt. 55# **\$69.50**

RECHARGE ALL BATTERIES

Only Everlite

- Charges 6 batteries
- Charges 3 times faster
- Charges all batteries

Including hearing aid, flashlight, lantern, radio, in fact any battery up to 12V. Save Money and have the convenience of fresh batteries always. Simple and 100% Safe. Plugs into any 115V. outlet. Guar. for one year. Send \$6.95 plus \$.65 for shipping

695



Model 75

Send 10¢ for 100 page Catalog FREE with order. Prices f.o.b. factory—Send check or MO

MASTER MECHANIC MFG. CO., Dept. A19, Burlington, Wis.
Southern Customers write Dept. A-19, Box 65, Sarasota, Florida

NEW 80 AMP **DYNAMIC** MARK 88
INDUSTRIAL TRANSFORMER ARC WELDER

IDEAL GIFT — EDUCATIONAL, ENJOYABLE, PROFITABLE
ANYONE CAN WELD, BRAZE,
CUT, SOLDER, HEAT
STEEL, BRASS, ALUMINUM,
AND OTHER METALS.



Build and repair anything of metal. Save time & money with this **BRAND NEW, PROFESSIONAL ARC WELDER!** Rugged metal cabinet, baked Hammerloid finish. Ideal for home, shop, farm and industrial use. Expert work on **FIRST** job. **POWERFUL** glass insulated transformer welds 1/2" metals with 3/8" rods. 4 heat settings 20 to 80 amps. Operates on 110 Volt AC line fused for 30 amps. Complete with fibre glass helmet, electrode holder, ground clamp and cables, solder, assorted rods and simplified welding manual. **DOUBLE PROTECTION GUARANTEE, 10 day money back trial plus full 5-yr. warranty.** If inoperative return prepaid, we will repair or replace without charge.

ORDER TODAY. Complete ready to weld. Only \$59.50. SEND ONLY \$6.00. Pay \$53.50 plus C.O.D. delivery charges or send \$59.50 and we will pay delivery in U.S.A. Welder and time payment details **FREE.**

DYNAMIC WELDER CO. 1808 SO. FEDERAL ST. Dept. D2-A CHICAGO, ILL. 60616

METAL WORKING MADE EASY

UNIMAT

Trained mechanic or beginners produce accurate parts in metal, plastics or wood with this combination lathe, miller, borer, drill press and grinder. Extremely accurate and simple to operate. Only **\$139.50.**

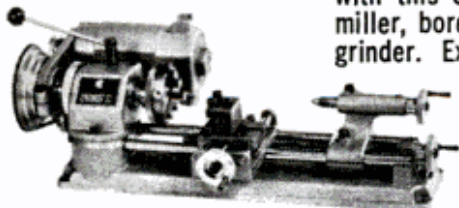

Write American Edelstaal, Inc.
Dept. BA-9, 350 Broadway, New York, N.Y.



Excitement! Security! Good Pay!
CRIME DETECTION

LEARN AT HOME IN SPARE TIME—START NOW! Crime everywhere is on the rise! Learn now, in your own home, the profitable profession that enables you to track down criminals and bring them to justice! Hundreds of Identification Bureaus employ I. A. S. graduates... trained in fingerprinting, police photography, handwriting identification, firearms and investigation. Our 44th year! **FREE "Blue Book of Crime"**... packed with crime facts and the full story of famous I. A. S. training. State exact age. No salesman will call. Rush Coupon! *A Correspondence School Founded in 1916.*

FREE
Blue Book
of Crime
MAIL
COUPON

INSTITUTE OF APPLIED SCIENCE, Dept. 1351
1920 Sunnyside Avenue, Chicago, Ill. 60640
Rush Blue Book of Crime... **FREE!**

NAME.....Age.....
ADDRESS.....
TOWN.....STATE.....ZIP CODE.....



Learn Profitable Profession
in few months at Home

MEN AND WOMEN, 18 TO 60

\$4.00 to \$5.00 for 1-hour treatment is the established charge for a skilled operator. Easy to learn and do. Diploma awarded. Open your own office or earn good income from Doctors, Hospitals, Clubs and other health or recreational centers. Wonderful part-time profession. Low monthly payments. Write today for free Anatomy Charts and catalog. No obligation.

ANDERSON SCHOOL OF SCIENTIFIC MASSAGE
Dept. A-1, Princeton, Illinois

OFFICE UNDER THE SEA

(Continued from page 215)

adventures were well behind him when he left the Navy. After all, it's tough to top 10 wartime submarine patrols in the Pacific (including six in which contact was made with enemy shipping). Then, too, after the war he served four years aboard the presidential yacht *Williamsburg* before going on to join the nuclear-powered Polaris sub *Theodore Roosevelt*. He finally closed out his career as engineering officer and qualified pilot on the bathyscaph *Trieste II*.

"When I retired, I figured I had about three job choices," says Don, ruefully. "I could work as a night watchman, sell insurance or drive a Good Humor truck." Yet less than a year after he walked away from his last day in the Navy, Don Saner was aboard *Deep Quest* 93 miles southwest of San Diego. Its mission: Go deeper than any other true sub had ever been.

Deep Quest had already been down to 6300 feet. Bugs in the design and in some parts had shown up and had been corrected. Now it was time to push the sub down to its design depths, to a level where pressure on those two seven-foot cockpit circles would be 3750 pounds per square inch, more than 230 times sea-level pressure.

Through the forward viewing port, the crew watched the strange marine life bathed in the eerie glow of the high intensity mercury-vapor flood lights. "I'd been underwater countless times in a Navy sub," recalls Don, "but had never really thought about life outside the boat."

One of Don's jobs on the record dive was to monitor strain gauges. The inner pressure hull was about 90/100ths of an inch thick yet it easily withstood pressures of 3750 pounds per square inch. The sub was down for nearly eight hours.

The compartment grew cold, but no one paid any attention. There was a heater aboard but no one thought to turn it on. "We were just too excited to think about anything but how deep we were going," says Don. "It's not every day that you dive a mile and a half," he smiles.

Deep Quest was in hydrophone contact with *Transquest* on the surface but the orders were to keep all talk to a minimum. Even inside the sub, there was almost no idle conversation.

Watching the strange sea life, Don recalls, "made it all worth while." Then the sub dove deeper, well beyond light, past areas that support vegetation, and finally into the regions where the crew became explorers.

At one point, they snapped the first

photos ever made of a long-finned cod, considered a biological rarity that lives on the ocean bottom. And until *Deep Quest* spotted it, scientists had never known it to go deeper than 6000 feet.

"Guess we extended the known depth of the fish by nearly half a mile," Don says casually.

That dive was made last year. And *Deep Quest* was now in her land hangar being readied to return to her strange and still-unexplored realm.

No nine-to-five job

Regular hours at the Ocean Lab hardly exist. Occasionally, some of the men do knock off on schedule at 4:45 p.m. But that's rare; more often, it's 6:00 or 6:30. And sometimes it's midnight before the men finish their day.

Once the lab is locked up, Don drives home to his comfortable bungalow in the San Diego suburb of Clairmont. He likes to fire up some charcoal in the back-yard barbecue pit and grill some steaks for his family. Son Gary, 17, is a senior in high school this fall; daughter Donna, 21, works in town but lives at home. Don's wife, Joyce, is from Australia. The couple met when Don's submarine was based in Perth during the war.

On weekends, the whole family likes to go out of town to picnic. On occasional free evenings, they might also go bowling together. Bowling, picnicking or tinkering in his little shop are the only parts of Don's life that are typically suburban. His neighbors, however, are hardly aware that Don is a professional submariner. In fact, when he has to list his occupation on a form of any sort, Don casually writes in "research engineer." Saying he's a "submarine pilot" sounds like he's bragging and this would be quite out of character for the quiet Mr. Saner even though his office is, indeed, under the sea. ★★★

Hot moon or cold?

Three observers from the Air Force Cambridge (Mass.) Research Laboratories have new evidence in favor of the theory that the moon has a hot interior like Earth's.

Drs. Graham R. Hunt, John W. Salisbury and Robert K. Vincent made the discovery while studying warm spots on the surface of the moon. The spots become quite prominent during eclipses as the moon's surface cools when the Earth's shadow cuts off its sunlight.

The explanation for most of these hot spots is that they represent surface features that cool more slowly than their surroundings.

GOVT. SURPLUS AND OTHER BARGAINS SAVE UP TO 90%



STAINLESS STEEL TANK Exc. for fuel, water, oil, acids, etc. 4 gal. cap. Pressure-tested to 35 lbs. 2" filler neck. 22" L. x 10 3/4" H. x 5 1/2" W. Purchased at special price less cap & drain boss. A \$36 value. Shpg. wt. 9 lbs. NEW. \$12.50 (Stk. #2480)

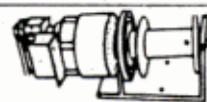

HEAVY DUTY BATTERY WINCH

Rugged, deluxe winch. Ball bearing construction thruout motor & gear train. High gear reduction. Rated cap 3000 lb. pull. Reversing switch. Rugged 3/8" plate steel mounting base with outrigger support. 22" L x 9" W x 8" H. Handles 250' of 1/4" cable. Built for 12 V battery operation; also operates on 6 V at reduced cap. & speed. For Scouts, Jeeps, Trucks, Boat loading trailers, etc. Shpg. wt. 80 lbs. Approx. GOV'T COST \$490. NEW, 90-day guarantee. Model E-D. \$89.50 (Stk. #692)

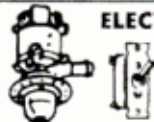

ELECTRIC PUMP WITH CONTROL SWITCH

For boats, campers & trailers. Output 300 GPH. Can be used in fuel or water. 1/2" pipe bronze inlet. 12 or 24 V.D.C. Explosion-proof motor. Shpg. wt. 9 lbs. Complete with wiring diagram. Approx. GOV'T COST \$200. \$12.95 (Stk. #1164)



NEW! BIG! 1969 CATALOG

Send 25c for amazing catalog with 1000's of bargains in hydraulics; electrical, marine, automotive items, etc. Order from ad. All prices FOB Culver City. 50% deposit required for COD. Cal. res. add 5% sales tax. Include zip. Satisfying world-wide customers since 1945.

AIRBORNE SALES CO. Dept. PM169
8501 Stellar Dr., Box 2727 • Culver City, Calif. 90230

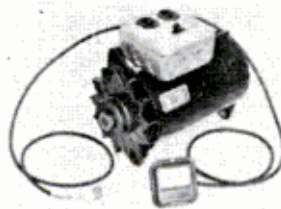

110-120 VOLT A.C. LIGHT PLANTS—60 CYCLES

Fanbelt driven from pickup or small gas engine. Operates saws, drills, pumps, freezers, T.V. X1000 Watts—Needs No Battery. Reg. \$99.50. Now \$32.50. 1500 Watts—6 and 12 volt vehicles. Reg. \$89.50. Now \$52.50. 3000 Watts—12 volt vehicles only. Reg. \$179.50. Now \$99.50. Guaranteed. Check or Money Order.

VIRDEN PERMA-BILT, Box 7066 P.M., Amarillo, Texas 79109

Fox Mini Bike

DO IT YOURSELF
OR FULLY ASSEMBLED

FROM

\$79⁵⁰



12 MODELS
3 TO 5 HP

SEND \$1 FOR BIG CATALOG

Shows new 1969 line of the world's finest **MINI-BIKES** (most are licensable for street use), plus parts, accessories and plans. Big selection! Amazingly low prices! There's a Fox **MINI-BIKE** for everyone — from age 10 to adults.

EXTRA BONUS—Catalog shows radios, watches, walki-talkies, cameras, musical instruments, tools, appliances and many other items you can buy at practically wholesale prices. Free \$1 coupon.

FOX CORP., Box 797 PM Janesville, Wis. 53545

WONDERFUL BROTHERS WOOD

(Continued from page 121)

into the palm of his hand. When Leonard and Edwards slap the new rubber in place, Clay and Delano reach down and thread on the new lugs. Back into action go the impact wrenches as Clay slips around to give Martin a hand with the refueling and Delano steps back to man the jack.

Glen, in the meantime, has given the entire right side a fast once-over for race damage—pranged sheet metal, rubbing tires, whatever. He then ducks in front, yanks out the hood locking pins, opens the hood, checks for loose wires, hoses, spewed oil, and so on, adds oil if necessary, slams the hood shut, replaces the locking pins. He then scans the left side, checks the left side rubber. If it needs replacing, he grabs another impact wrench and dives at the lugs. If not, he wipes the windshield, confers with the driver.

Kendrick or whoever, having helped Martin with the fuel can, reaches over the wall and hands the driver a drink of water. If the driver requests it, Kendrick also hands him a pressurized water hose with which he can soak himself to cool off. (Should Glen decide the left rubber needs replacing, Kendrick will man another jack from a position inside the pit wall; he'll crank up as the opposite side is cranked down.)

The right side rubber in place and ready to go, Leonard and Edwards step back as Delano dumps the car level and jerks the jack back out of the way. Martin whirls, heaves the can to the ground, twists the fuel cap on. Glen nods, Martin pounds on the roof with his fist to signal the driver the stop is completed, and the car roars back into action.

The entire process has taken about 20 seconds!

Impossible takes a bit longer

Such incredible pit times are possible, of course, only if everything goes smoothly and the car doesn't require special attention. If it does—like the impossible—it takes longer. But not much.

Early in last year's Daytona 500, when Cale Yarborough's '68 Mercury experienced ignition trouble, Leonard leaped in the car during a pit stop and replaced the floor-mounted transistorized unit in such a short time that Yarborough lost only one lap. He was able later to make up the lap and win the race.

"Leonard crawled right over me," Yarborough says, recalling the incident. "Seems he was done and out of there before I could even get focused on what he was doing. Back out on the track, with

everything going right, I was thankful for the Wood brothers. I can promise you."

Another driver who has had occasion to be thankful the brothers are what they are is Dan Gurney. During a pit stop at the Daytona 500 in 1964, Glen cross-threaded a lug nut, stripping the threads. It's a common pit goof, one that is often ignored. But not by Glen—no car and driver in his charge is going to be out on any track with only four lugs holding a wheel in place! He told Dan what had happened and advised that time be taken to make proper repairs. Dan, who had been running with the leaders, was disappointed, but very much impressed by Glen's concern for his safety. The repairs were made and Dan went back out to finish 14th.

"It was a tough break," Dan says, "but there's still no one with whom I'd rather go racing."

Made Indy history

The Woods have been racing as a crew since 1960. They hit international headlines via their astonishing performance during the 1965 Indianapolis 500. They pitted winner Jimmy Clark in 19.8 and 24.7 seconds respectively, the shortest total pit time in the race's history. They've won many pit-crew speed and accuracy competitions, but they often do even better during an actual race.

In what has become almost a cliché of successful pit crews, Glen says, "We don't do anything different than anybody else, we just work at it."

Glen himself has been working at racing since he and a few friends bought a modified stock car almost 20 years ago. He was the driver and the original thought behind the venture was to have a little fun. But the "fun" concept got shoved aside as Glen began to win more and more races.

"Glen Wood was one of the best drivers on an asphalt track I ever saw," says all-time racing great Curtis Turner. "He could read that stuff like the palm of his hand."

As Glen's driving improved and his reputation as a winner grew, he moved up into Grand National cars, the major league of stock-car racing. His driving credits include four Grand National victories, the last in 1963. He retired as a driver in 1964. As he puts it frankly, "Those big super-speedways just weren't for me."

That the transition from pilot to crew chief was smooth and rewarding is attested to by the scores of both driver and "top wrench" trophies lining the walls of his den at home in Stuart. More importantly, it is attested to by the generally

(Please turn to page 220)



\$7.50

That's all you'll pay for the PM Jet. The first do-it-yourself boat designed for turbojet propulsion. And that's one of our most expensive designs.

For three dollars you can buy the PM38, a sleek 13 foot runabout. And for \$38.00 you can build it. We don't have to tell you what a great buy that is.

And that's not all we've got to offer. We've got El Gato, a 12 foot, twin hulled catamaran. But we're not about to sell this beauty for three dollars. It will cost you four.

There are eight other models in the PM line. Some are less expensive, others will cost you more. We even sell one model that costs as much as ten dollars.

If you'd like to order the PM Jet, PM38 or El Gato just complete the coupon below and return it to us. If you want to see the rest of the fleet there's a place on the coupon for that too.

BOAT PLANS
POPULAR MECHANICS
575 LEXINGTON AVENUE
NEW YORK, NEW YORK 10022

PLEASE SEND ME THE FOLLOWING

- Plans for the PM Jet at \$7.50 a set
- Plans for El Gato at \$4.00 a set
- Plans for PM 38 at \$3.00 a set
- Please send me information about the rest of the PM fleet.

NAME _____

ADDRESS _____

CITY _____ STATE _____ ZIP _____

JANUARY 1969



EARN HIGH WAGES

as a HEAVY
EQUIPMENT
OPERATOR

Train your way to high pay in the booming construction industry! Learn the skills you need to qualify, by actual field training on machines like the ones used by the industry. Huge training grounds in North Carolina, a million dollars worth of school-owned diesel-engined machines, experienced instructors, full 220-hour and 440-hour courses. National, the original school of heavy equipment operation, is a recognized leader. Member American Road Builders Assn., Services and Supply Division. Associate Member A.G.C. Full-time Job Advisory and Counseling Director on staff. VA approved. For men ages 17 to 56. Train Now-Pay Later plan . . . other payment plans also available. Write TODAY for FREE catalog and FREE copy of school newspaper reporting news of National School graduates. Accredited member NATTS.

NATIONAL SCHOOL
OF HEAVY EQUIPMENT OPERATION, Dept. D-23
P. O. Box 1686, Moores Chapel Road, Charlotte, N. C. 28201

Please send me FREE illustrated school catalog and complete information. I understand there's no obligation.

Name _____ Age _____

Address _____ Phone _____

City _____ State _____ Zip Code _____

DISCOVER new worlds of beauty



A world of beautiful wood may be lying undiscovered under layers of unsightly old finishes on furniture and antiques. Savogran's STRYPEEZE Nonflammable paint remover has strong cutting action for fast penetration of extra-tough paints and varnishes. Works well on exterior and marine finishes, too!

"AVAILABLE WHERE PAINT IS SOLD"



SAVOGRAN
NORWOOD, MASSACHUSETTS 02062

219

SPECIAL OFFER!

**Two PM wall charts
(\$2.00 value) for \$1.50**

SATURN V, world's largest rocket printed in full color. Size 19x25 in. (Reg. price \$1.25)
OUR FIRST 19 IN SPACE. Photographs of the first U. S. astronauts in space. Size 12x18 in. (Reg. price 75¢) Hurry, get your set by sending **\$1.50** plus 20¢ to Popular Mechanics Dept. CM, 575 Lexington Ave., New York, N. Y. 10022.

Don't change your address without notifying us!

To insure uninterrupted service on your **Popular Mechanics** subscription, please notify us at least six weeks before you move.

1. Attach your address label from a recent issue in the space provided below. . . (If label not available, be sure to give us your old address, including **Zip Code**)
2. Print your name and new address below (be sure to include your **Zip Code**).

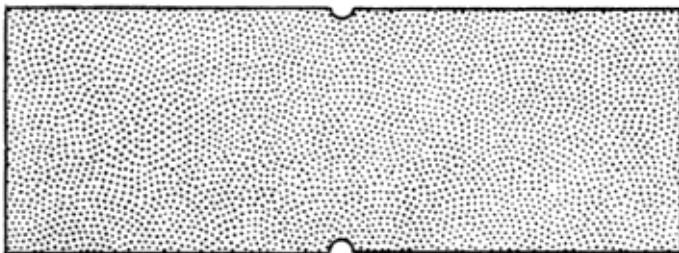

3. Mail entire notice to: **Subscription Service Dept.
Box No. 646
New York, N. Y. 10019**

Name _____
Please Print

New Address _____

City _____

State _____ Zip Code _____

WONDERFUL BROTHERS WOOD

(Continued from page 218)

good-natured envy expressed now and then by his racing peers.

On the morning of qualifying day for last September's Old Dominion 500 at the Martinsville (Va.) Speedway, the Woods were a few minutes behind schedule in arriving at the track.

"Where's Glen Wood?" someone wanted to know.

"Home," a voice answered.

"Humph!" the seeker said, kicking at a pebble. "Probably countin' all that money."

Glen is justifiably proud of his career to date, a pride shared by everyone else involved in the enterprise.

'Pride' is the key

The word "pride," in fact, may be the significant clue to the Woods' fabulous success. All of them—the brothers, the family and friends on the crew, the wives and children, even the one Wood sister (named Crystal)—devote themselves in one way or another to an ideal of perfection. The result is a quiet group self-confidence, a knowledge that because they're serious about, and dedicated to, what they do, they have no need to crank out press releases and talk beyond their abilities. They figure that by paying attention to the little things—Clay, for example, carefully recoiling an impact wrench air hose after a pit stop—the big ones will take care of themselves.

An insight as to how and why the Wood Brothers tick was overheard just before the start of a Grand National race last fall. As the cars were lined up to start their parade lap, a member of a rival crew leaned over to holler in Glen's ear, "Now when we lap y'all out there this afternoon, we want you to get your rump out of the way."

Glen eyed the man levelly, then said in a voice barely audible above the roar of the poised race cars, "You'll have to catch us first." ★ ★ ★

Choosing and Using THE RIGHT PAINT

A practical guide, this 32-page booklet tells all about house paints, protecting metal from rust, spray techniques, handling the new epoxies and cures for moisture problems. Profusely illustrated and detailed. Get your copy now by sending 50¢ for How-to-DO-It Library Booklet No. H101 to

Popular Mechanics Bureau of Information,
575 Lexington Ave., New York, N.Y. 10022

CONNECTICUT SHELF CLOCK

(Continued from page 153)

but not into the case. Use only one screw in each leaf for a trial fit. Then you can make an adjustment, if necessary.

Fasten the glass in the upper section of the door temporarily with a couple of brads. Then cut 3 and 6-in. squares of 1/8-in. hardboard. Locate the holes for the hand shaft and key stem in the 6-in. piece by using the dial plate as a pattern. Now center the 3-in. square and glue it to the rear face of the 6-in. square. This double thickness is needed since the threaded bushings supplied with most movements are designed for 1/4-in. panels.

For best visibility, the clock hands should be located as close as possible to the glass. Here is how I located the movement:

First I fastened the movement to the 6-in. square and measured the projection of the minute-hand shaft. Then I added 3/32 in. to the dimension, closed the door and measured in to locate the support cleats which are attached to each side of the case. I fastened the cleats only temporarily, placed the movement in position with the case on its back and checked the clearance between the glass and the shaft. Finally I removed the cleats, applied glue and fastened them permanently.

I used a magnetic catch to hold the door shut, after stripping off the metal frame and using just the magnet and the two pole plates.

If you'd like to finish your clock as I did, brush on pigmented wiping stain, a 50/50 mixture of walnut and French provincial. Let stand until it starts to flatten, then wipe with a cloth. Let dry 24 hours. Next apply a coat of color glaze (Martin Senour sable No. 457). Wipe off with a cloth, leaving traces in the corners, nicks and scratches. Let dry 24 to 48 hours. Follow with two coats of sanding sealer, letting them dry an hour or so between coats. Now sand *lightly* with 6/0 garnet paper and dust thoroughly. Next brush on four coats of lacquer, allowing 30 minutes between coats. Let dry 24 hours.

Wet-sand with soapy water and No. 400 wet-or-dry paper on a felt or rubber block. Use light pressure and inspect the surface frequently by wiping. Stop sanding when the surface has an even satin finish and clean up with a dry cloth.

Fasten the dial backing plate to the support cleats with 1/2-in. No. 4 flathead screws, drop the dial plate into position and install the movement with the bushings furnished. Always remember to remove the pendulum before moving the clock. ★ ★ ★



TRAINS ANY DOG INSTANTLY!

PUPPIES, DOGS OF ALL AGES. NEVER FAILS!
TEACHES STOPS

Come (at all times!)
Sit • Drop • Heel • Go
Stay • Fetch • Hold
Instant Point, etc.

House soiling • Jumping
Chewing • Barking • Biting
Digging • Gun shyness
"Busting" birds, etc.

40,000 satisfied users. Hundreds of unsolicited testimonials. Four demonstrations on Art Linkletter CBS-TV. Now prescribed by veterinarians, breeders.

Simple hand sound device controls, teaches dogs like magic. Use at home or in the field. Leashless. Train your dog anything, near or far. Achieve far better results than professional trainers!

Write, wire or phone for complete information on this new, scientific dog learning-sound discovery. Kind, not electronic. Fascinating!

HI-FIDO CANINE BEHAVIOR INSTITUTE
(213) 826-5616 11927 Montana Avenue
Dept. PM-19, Los Angeles, California 90049

CATCH ANIMAL RAIDERS!

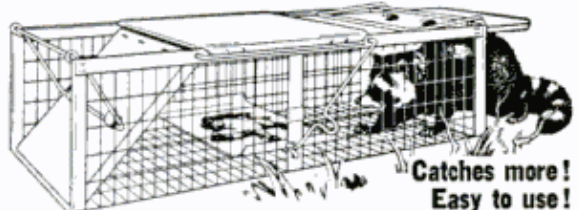

Simple, safe HAVAHART traps catch raiding rabbits, coons, squirrels, pigeons, sparrows, etc., without injury. Straying pets, poultry released unharmed. No jaws or springs to break. Galvanized; many in use 20 years. Open ends give animal confidence. Sizes for all needs. Write for valuable illustrated guide and price list.

HAVAHART, 136-J Water St., Ossining, N. Y. 10562

Please send me FREE new 48-page guide and price list.
Name _____ Zip _____
Address _____

ALL ABOUT HOUSEBOATING!

Not just boating—but truly living on the water! Explore, fish, hunt, ski or relax on an aquatic hide-away! New, first and only publication of its kind, tells you how to buy, where to rent, where to go—all to get you started. Now, special 1/2-price offer: Only \$2.75 for 2-year subscription (8 big issues!). Reg. \$5.50 value. Write "FAMILY HOUSEBOATING", Dept. PM-1 Box 2081, Toluca Lake, Calif. 91602.

TREASURE

Find buried gold, silver, coins, treasures.

5 Powerful models.

Write for free catalog



RELCO DEPT. D-3 \$19.95 UP
BOX 10839, HOUSTON, TEX. 77018

BE A RADIATOR TECHNICIAN EARN \$8,000 TO \$12,000 A YEAR



In 2 weeks or less at our Omaha school we'll make you a professional radiator repairman. This badly needed skill brings higher wages, better job opportunities. Mail this ad with name and address for free literature and letters from successful graduates.

INLAND MFG. CO., Dept. PMS1, 1108 Jackson, Omaha, Nebr. 68102

Build this "Flying Volkswagen" for less than \$600



At Last You Can Have the Thrilling Experience of Flying Your Own Plane! You Can Build *Jeanie's Teenie*—the Amazing All-metal Airplane— With These Remarkably Easy-to-follow plans.

Here is a new breakthrough in the field of homebuilt airplanes—one that even a beginner can build. Until now, homebuilts cost at least \$1,000 and up—and this for basically wood-and-fabric. This new plane costs a maximum of \$600! Its major advantages are—a Volkswagen engine . . . all-metal construction . . . easy-to-build design.

FLOWN BY POPULAR MECHANICS. The original plane was certified by the FAA and has been flown by Popular Mechanics' Aviation editor.

Designed by Calvin Parker, *Jeanie's Teenie* is the first model to be conceived with the VW engine in mind—because it's light, dependable and relatively inexpensive. Also, several conversion kits make the engine easily adaptable to airplane use.

USES STOCK PARTS AND SIMPLE TOOLS. No complicated equipment or expensive tools are necessary. The metal parts can be easily purchased as stock items in any metal-products shop. Also, they can be cut and shaped with tools as simple as a plastic-headed hammer and tin snips.

You will be thrilled with your *Jeanie's Teenie*—its sporty open-air atmosphere—helmet, goggles, silk scarf and all! This is truly a remarkable breakthrough in amateur construction.

SEND THIS COUPON TODAY FOR YOUR PLANS

Popular Mechanics, Dept. B01
575 Lexington Avenue
New York, N.Y. 10022

I am enclosing my check (or money order) for \$15.00. Please send me the complete step-by-step instruction booklet and the 7 sheets of plans for complete construction of *Jeanie's Teenie* all-metal airplane.

Name

Address

City State Zip Code

EMJT/A

PISTON ENGINE

(Continued from page 99)

range of speed and load. For high speed, you want to keep the valves open longer. But this hurts the power and response at low speeds. A low-speed engine has very short valve "duration." For years auto engineers have been looking for some way to vary the valve timing automatically while the engine is running.

Various tricks have been tried. One has the camshaft on a special hub that swivels in relation to the crankshaft, so that the valves close later and later as the speed goes up. You get more power at the top end and more low-speed torque at the same time. We fully expect to see something like this offered as an option on some Detroit models within five years.

● **Crankcase Oil Churning Loss.** When your crankcase and connecting rods spin at high speed in the crankcase, they generate tremendous air turbulence that churns and whips the oil in the oil pan. Engineers call this crankcase "windage." And the friction and churning loses horsepower—like 10 or 15 at 5000 rpm on a big engine. This is wasted power that can be recovered with a simple stamped steel pan, or baffle, that goes between the spinning crankshaft and the oil in the crankcase. The pan is slotted so the oil can run back, but can't splash up on the crankcase. It costs less than \$1 and saves 10 to 15 hp. All Detroit engines will have them soon.

● **Cooling-Fan Loss at High Speed.** The fan on the front of your engine can absorb up to 15 hp at high speeds. And yet the only time it's really needed is to pull air through the radiator when idling and at very low car speeds. The rest of the time it's just wasting power. We have the answer today in these new "declutching" fans that are being supplied as standard equipment on many high-performance engines. They have a simple fluid-drive hub that is designed to slip when the fan gets up to some medium speed (maybe around 2000 rpm). They cost extra money, but we expect to see them on all cars soon, especially with the increasing use of air-conditioning and exhaust-emission controls that throw more load on the cooling system. Tomorrow's cars will need bigger radiators and bigger fans. But the fans will still be a waste at high speed. Detroit has got to solve this one.

These are just a few of the problems with the piston engine and some of today's and tomorrow's solutions. There are other problems in areas of engine life, reliability, maintenance, engine weight, cost and performance. But lots of *potential* is what the piston engine's got today. ★★ ★

THE LOOK YOU WANT - WHEN YOU WANT IT!

You will be Amazed at the Exciting Change in your Personal Appearance!

The Natural Look of these sideburns, mustache, and van dyke actually allows you to select the way you want to look, Older, Younger, Distinguished, Cool; Suave — you name it! Wear each one independently or combine them for the effect you desire — sideburns and beard, sideburns alone, van dyke alone, van dyke and mustache. The combinations are limitless!

All items are made of simulated natural hair to exacting professional standards. Firmly self-adhering. Can be worn with self confidence anywhere, anytime. They are so life-like you will have to remind yourself that they can be removed.

FREE with each order, a complete guide that tells how to naturally wear your sideburns, mustache and van dyke.

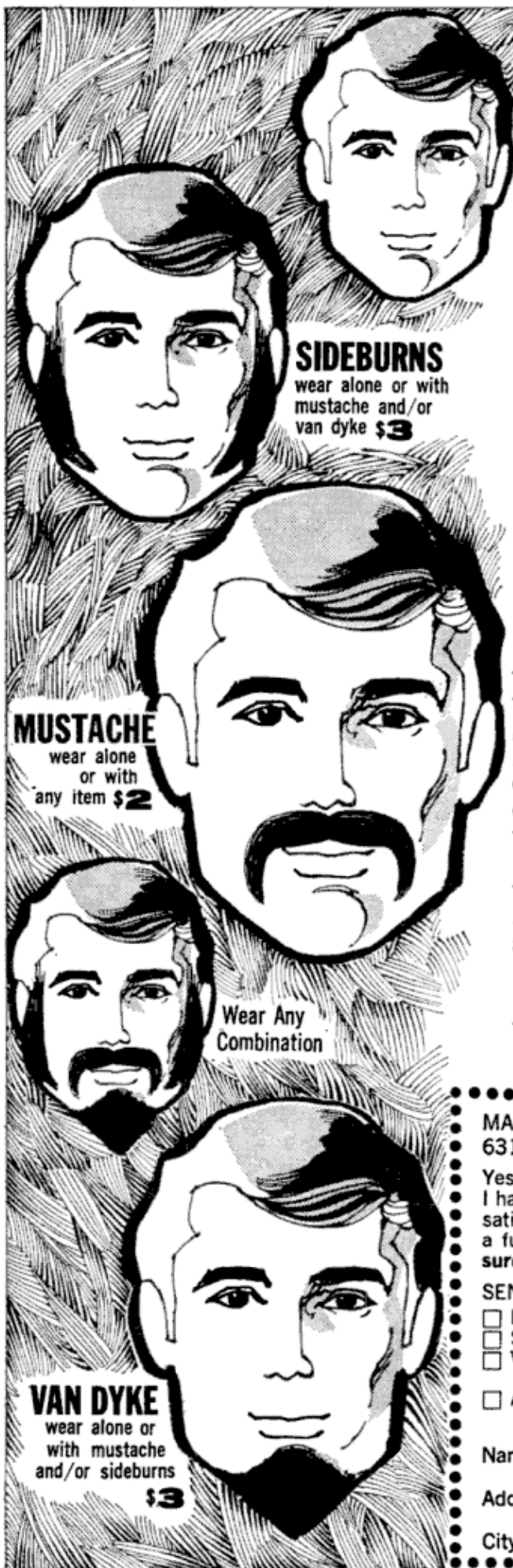

SIDEBURNS
wear alone or with mustache and/or van dyke \$3

MUSTACHE
wear alone or with any item \$2

Wear Any Combination

VAN DYKE
wear alone or with mustache and/or sideburns \$3

MAN INTERNATIONAL...Dept. 512
6311 Yucca Street, Hollywood, California 90028

Yes, I want to choose my own appearance. Rush me the items I have checked below. I understand that I must be completely satisfied or I may return the merchandise within 10 days for a full refund. Check items and color shade you want. If not sure of your hairshade, enclose hair sample with order.

SEND ME THESE ITEMS:

- Mustache \$2
- Sideburns \$3
- Van Dyke \$3

All items \$5 (Save \$3.00)

MAKE ITEMS THIS COLOR:

- Light Brown
- Medium Brown
- Dark Brown
- Black
- Blonde
- Auburn (Red)
- Silver (Grey)

Name

Address

City State & Zip

ARMY'S SUPERSECRET SCOPE

(Continued from page 82)

50 times, and amplification of one tube is multiplied by that of the others to give a picture approximately 50,000 times brighter than the scene itself.

"It's not possible to get 100 percent efficiency," Klein points out. "We lose light in transferring the image from one tube to the other. However, the brightness we do get is more than enough for troops to see."

One of the biggest problems faced in development of the Starlight Scope was to find a way of transferring the image from one tube to the next without losing too much image resolution. It was at this point in development that the Allied armies interrupted the work of the German scientists.

They had been experimenting with pieces of phosphor-coated glass .0003 inch in thickness. However, the image lost too much resolution, and the thin glass made the device too fragile.

The answer to the problem was fiber optics, the invention of Dr. A. C. S. Van Heel, of the University of Delft, in the Netherlands in 1948. Each fiber-optic lens consists of two million tiny hexagon-shaped light pipes which direct the amplified picture from the phosphor coating of one tube to the photo cathode of the other.

The uniqueness of fiber optics lies in its ability to transfer light without diffusion. In Starlight Scope, light from a particular spot on the phosphor of one tube falls in the same spot on the photo cathode of the next tube.

By comparison, conventional glass lenses would cause too much diffusion and, consequently, too much loss of light. When you're using available nighttime light to see by, any loss of that light is critical.

Each fiber optic lens (there are six to a scope—two for each tube) is carefully curved to permit every electron to travel the same distance. This gives a perfectly focused image.

The electrical system of Starlight Scope begins with a small 1.7-volt mercury battery. An oscillator steps up voltage to 2500 volts a.c., which is fed into a voltage multiplier. The result is 45,000 volts d.c.—15,000 for each tube.

An irksome problem regarding this current was to find a way of protecting the user in case of an insulation failure. "After all, a man's putting 45,000 volts to his eye," Klein states.

The eyepiece of the scope was shaped into a series of convolution rings which, if the scope did leak, would allow a long leakage path, making a shock insignificant.

There are now three versions of Star-

light Scope. The small scope is mounted on a man's rifle as a gunsight. It has a maximum range of about 450 yards and weighs 5¾ pounds.

A larger-sized scope is used on crew-served weapons, such as machine guns and recoilless rifles. Weighing 16 pounds, it has a maximum range of about 1100 yards.

The big scope, called NOD (Night Observation Device), is used by night observation teams. It's mounted on a tripod, weighs 38 pounds and has a maximum range of about 1300 yards.

The Army spent \$20 million developing Starlight Scope. Was it worth it? Only the guys who have used it in combat can tell.

On one occasion, for example, an infantry night patrol of 15 men detected a company-sized Vietcong force moving toward them. The scope had sighted them.

As the Americans prepared to open fire, the patrol leader, Lt. Robert Hibbs, of Cedar Falls, Iowa, spotted another VC force through his Starlight Scope.

Hibbs let the first unit pass, placed his patrol between the two and opened fire on the second. Each enemy unit, thinking it was being attacked by Americans, opened fire as the U.S. patrol withdrew. They blasted one another. Hibbs, killed during the withdrawal, was awarded the Congressional Medal of Honor.

In another action, an American aircraft gunship equipped with a Starlight Scope spotted 200 Vietcong in a rice paddy preparing to attack a village. The gunship zeroed in and opened fire. This stopped the attack before it got started.

Because of the tremendous tactical advantage offered an army that has passive image intensifiers, the question remains as to how long it will be before the Vietcong and North Vietnamese develop theirs. They have captured some of ours.

"It's unlikely that the VC or North Vietnamese have the degree of technical sophistication needed to make a device like Starlight Scope," says Dr. Robert S. Wiseman, head of the Night Vision Lab.

A most important and difficult operation in the production of the scope, for example, is to get a vacuum-tight fit when the three intensifier tube segments are butted together. Less than a perfect seal would allow air leaks and lead to unrestricted movement of electrons. How this aspect of the production operation is performed is still a secret.

But what about the Chinese and Russians—can they develop something like Starlight Scope?

"We must assume that the former can develop passive image intensification if they desire, and that the latter may already have it," Wiseman states. ★★

Put a little spring in your Phyfe



Duncan Phyfe or Modern, French Provincial or Contemporary; there's no reason to let beautiful furniture like this run down. Keep your furniture as lustrous and beautiful as the day you bought it, let "Popular Mechanics Home Book of Refinishing Furniture" show you how to put a little spring in it.

Including such things as finishing methods, complete finishing schedules, reupholstery instruction, sample projects and much, much more; this book is a complete

manual of spruce-up and refinishing techniques.

Whether you're a beginner or an accomplished craftsman, whether you work in the kitchen or in a completely equipped workshop, this is the book for you.

To order your copy of "The Popular Mechanics Home Book of Refinishing Furniture," send only \$4.95 plus .25 postage and handling to: Refinishing Book, Popular Mechanics, Book Department, 575 Lexington Avenue, New York, New York 10022.



FURNITURE COURTESY OF WOOD & HOGAN, INC. NEW YORK, N. Y.

Popular Mechanics, Book Department
575 Lexington Avenue, New York, New York 10022

I have enclosed \$_____ (plus .25 postage) for _____ copies of
"Popular Mechanics Home Book of Refinishing Furniture."

Name _____

Address _____

City _____ State _____ Zip Code _____

20 WOOD SAMPLES with woodworkers Catalog

ENJOY woodworking more! Let Constantine's big picture-packed Catalog-Manual help you build new furniture — refinish, restore beat-up cabinets, chairs, chests, tables, etc. Find instantly whatever you need. Buy at money-saving prices from world's largest catalog source for imported and domestic woods. Cabinet lumber, carving blocks, veneers, plywood, pipe briar, inlays and more! Newest Catalog features new tools, materials, shop devices. Fabulous all-purpose clear finish. Glue that needs no clamps. Inlay picture kits, 99¢. Needed products found nowhere else. Plus woodworking instructions, plans, patterns!



2,000
PRODUCTS FOR SHOP & HOME
Woods — Veneers — Finishes
Furn. Hardware — Lamp Parts
Cane — Upholstery — Tools
Picture Molding — Clock Kits

FREE WITH CATALOG
"101 PROJECT IDEAS"

Catalog & Wood Samples Only \$1

Dollar Fully Refunded on First Order
Accept this offer to own fascinating set of 20 2x4 specimens of world's glamorous veneers — Rosewood, Satinwood, Lacewood, Teak, etc! Compare! Then instantly identify finest woods wherever you go. Send only \$1 for Wood Samples and Woodworkers Catalog. Dollar refunded on first order.

ALBERT CONSTANTINE AND SON, INC.
2050 Eastchester Rd. Bronx N.Y. 10461 Dept. A-5

Enclosed \$1 for Wood Samples & Woodworkers Catalog. (\$1 refunded) Catalog only 25¢



Name _____

Address _____

Zip _____

22 CAL. PELLET FIRING "STINGER AUTOMATIC"



\$1.00

50 22 CAL. PELLETS FREE
Looks and Feels Like Real Pocket Automatic — Loads 15 Shots

Fires 22 cal. pellets just as fast as you can pull the trigger. Great for fast action combat-type target practice. 50 reusable 22 cal. pellets free. Free supply of targets. Money back if not satisfied. Just send \$1.00 plus 25¢ postage and handling to:

HONOR HOUSE, Dept. 96-RA-49, Lynbrook, N. Y. 11563

From PM's How-to-Do-It Library:

6 Easy-to-Build FUN BOATS

- **SAUCY SHINGLE**—Make this fast and rugged 3-point hydro from \$30 worth of materials.
- **POWER OR PEDAL WATER BIKE**—Putt-putt or puff-puff at drop of your paddle wheels.
- **RIBLESS 14-FT. CANOE**—It's fast, light and stable, just perfect for camping trips.
- **WATERBUG**—The midget hand-cranked paddle wheeler that's perfect for your small fry.
- **FEATHERWEIGHT KAYAK**—You carve it out of an 8-ft. block of foam, it's unsinkable.
- **PLATFORM BOAT**—Plans for pontoons and a deck; base for any kind of floating fun.

Construction details for all six of these fun boats are in PM's 32-page Booklet H102. For your copy send 50¢ to

Popular Mechanics Bureau of Information,
575 Lexington Ave., New York, N.Y. 10022

EARN EXTRA MONEY FOR HOBBY AND WORKSHOP EQUIPMENT



Now you can earn as much extra money as you have available sparetime. As a Popular Mechanics subscription representative working from your own home you offer the most popular magazines at the lowest rates to friends and neighbors and earn good money for equipment you need.

Today, 85% of American families read at least one magazine regularly and more people are subscribing every day. And Popular Mechanics regularly sends you free aids and brochures for your prospects that makes it easier for you to earn bigger profits.

Mail this coupon today and Popular Mechanics will send you all you need to get started at once. No obligation, no money to invest. Discover why thousands of men find this plan the easiest to start and best for earning the extra money they need for hobby and workshop equipment.



Send me complete details. **POPULAR MECHANICS Rm 1130**
250 W. 55th, N.Y., N.Y. 10019

Name _____

St. & No. _____

City _____

State _____ Zip _____

ELECTRIC ARC WELDER \$14.95!

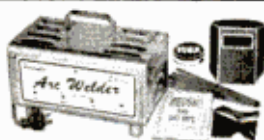

LIFETIME BURN-OUT GUARANTEE
—10 day money back (if ret'n'd) trial!
Works on 110-volt plug in 10 WAYS!
WELDS, BRAZES, SOLDERS, CUTS,
MELTS most ALL metals! HEATS,
SOFTENS, THAWS, LOOSENS, BENDS.
COMPLETE READY TO USE WITH
face mask, clamps, arc torch, rod
holder cables—and supply of welding,
brazing carbon, solder rods. ARC

WELDING INSTRUCTION BOOK—Tells how YOU can use for CARS-HOME-FARM-SHOP—NO EXPERIENCE NEEDED!

SEND ONLY \$2.00 (cash, ck, M.O.) and pay postman \$12.95 plus COD postage or send \$14.95 for PP del. in USA. Best Welder—Best Price! Midway Welder, Dept. SPM-1, Kearney, Nebr. 68847



EARLY TIMES

Kentucky Straight Bourbon Whisky

86 PROOF - EARLY TIMES DISTILLERY CO., LOUISVILLE, KY. © ETDC 1968

FINISH CORNERS • CUT MOULDING WITH ANY ELECTRIC DRILL NO \$50 ROUTER OR \$6 BITS NEEDED!

You don't have to buy an expensive Router to finish corners, moulding & trim. ARCO Corner Finishing & Moulding Cutters do the work at a fraction of the cost. Simply slip the Cutter's $\frac{1}{4}$ " shank in any drill chuck and it's ready to produce! Special Dual Guides assure accurate cuts along entire length & width of workpiece. Cuts wood, plastics, soft metals. Quality-made in U.S.A. of hardened steel.

No. 6—3 PIECE CUTTER SET CUTS $\frac{3}{16}$ " CONTOURS

\$3⁹⁵

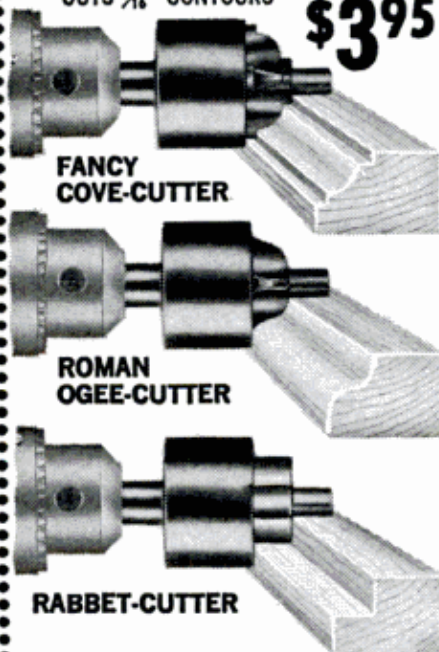

No. 7—3 PIECE CUTTER SET CUTS $\frac{3}{16}$ " CONTOURS

\$3⁹⁵

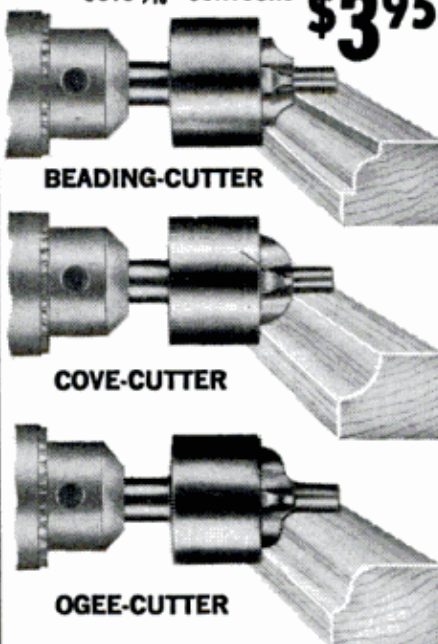

No. 15—4 PIECE RADIUS & BEVEL CUTTER SET

\$5⁷⁵

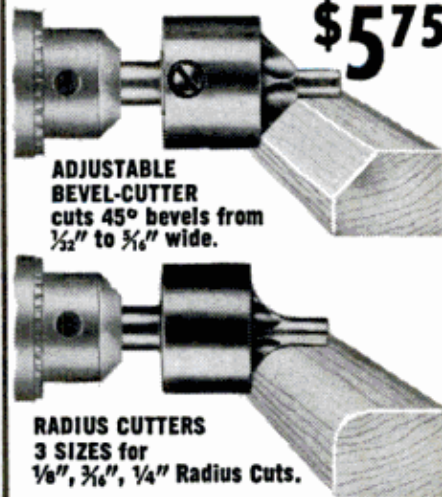

SPECIAL SAVING!

Order all of above 3 Sets at our Special Money-Saving Price. No. 6715, total **\$11⁹⁵** of 10 Cutters, only

"ARCO" Tools are available at your dealer or order direct on 20-day Money Back Guarantee.

MAIL THIS COUPON TODAY!

ARCO TOOLS, INC. Dept. PM-1,
421 West 203rd St., N.Y., N.Y. 10034

Ship on your 20-day Money Back Guarantee:

- No. 6, 3-Piece Cutter Set \$ 3.95
- No. 7, 3-Piece Cutter Set 3.95
- No. 15, 4-Piece Cutter Set ... 5.75
- No. 6715, All 10 Cutters 11.95
- I enclose Check. M.O.—SHIP PPD.
- Ship COD (\$6 or over) + post.

Name _____
Address _____
City _____ State _____ Zip _____

Easy way to keep solder from sticking where it's not wanted

WHEN SOLDERING with either a propane torch or a conventional soldering iron, it's often desirable to keep the molten solder from running on to the adjacent work surface. In such cases, I've discovered I can "mask" these areas by using a paste made of lampblack—a very black powder sold at most hardware and paint stores for 20 to 25 cents a pound. It's normally used for darkening concrete or paint, but I've found that it does a great job of repelling the molten solder and protecting adjacent surfaces.

To prepare a mixture properly, first clean an empty shoe-polish can (of the easy-open key type), then spoon in lampblack until the can is half full. Slowly mix in a half spoon or so of kerosene, thoroughly blending it with the powder. If necessary, add a few more drops of kerosene and continue mixing until the paste has a very fine and thin consistency.

Don't try to use water as the mixing agent, for the lampblack rejects the water and you wind up with an unmanageable mess. (Other solvents may do the job, but kerosene is usually available and it won't evaporate as quickly.)

To use the thin paste, first clean the joint with a wire brush or steel wool, then use a small artist's paintbrush to apply the lampblack mixture to the surfaces you want to protect. Then you can solder as usual, for the heat of the iron will dry the mixture and leave a fine masking coat to which molten solder won't stick.

After the work has cooled, wipe or wash the joint to remove the masking film and reveal a well-controlled soldering job. Tightly cover the can containing the remaining mixture, and the next time you have a soldering job that requires delicate masking, just open the can and brush on the paste.—Andrew Vena

ANNOUNCING-

Practical Handyman's Gigantic

\$99,500 GIVEAWAY

for budget-wise men and women who want to save extra \$\$\$\$ with exciting "DO-IT-YOURSELF" home projects!

Mail attached Claim Check Card to get your share of Practical Handyman's \$99,500 Giveaway! Yes, if you want to cut costly home repair bills, increase the beauty and value of your home—YOU HAVE HIT THE JACKPOT! During the next few months 35,000 copies of Volume One of the PRACTICAL HANDYMAN'S ENCYCLOPEDIA (a whopping \$99,500 value) will be given away to readers of this magazine and other home handymen and their wives ABSOLUTELY FREE!

MAIL the attached CLAIM CHECK CARD for your share of GIGANTIC \$99,500 GIVEAWAY! No stamp or addressing necessary. Yes, take FREE everything you want to know about every money-saving home handyman project!

SEND FOR YOUR FREE VOLUME

... with more than 200 giant 7 $\frac{3}{4}$ " x 10 $\frac{1}{4}$ " pages, filled to overflowing with more than 400 "how to" pictures and projects!

SEND FOR YOUR FREE VOLUME

... packed with interesting "do-it-yourself" projects such as Built-In-Closets and Drawers—Auto Tune-Ups—Air Conditioning of Home and Car—TV Adjustments—Motor Repairing—Attic Ventilation—Aluminum Projects—Garden Accessories—and many, many more.

SEND FOR YOUR FREE VOLUME

... find such "money-in-your-pocket" projects as: Appliance Repairs—TV Antennas—Emergency Car Repairs—Spray Painting—Burglar Alarms—Additional Bedrooms—Boosting Gas Mileage—and many, many more!

IDEA: Add an extra bedroom virtually for cost of materials alone. Save up to \$1,000.



SEND FOR YOUR FREE VOLUME

... discover the pleasure and sense of accomplishment in such projects as: Home Ventilation—House Framing—Window Framing—Skylights—Barbecues—Weatherproofing—and many, many more!

THOUSANDS OF DOLLARS WORTH OF EXPERT ADVICE

There is no obligation! We give you this valuable FREE VOLUME so that you may see—at our expense—just how valuable the PRACTICAL HANDYMAN'S ENCYCLOPEDIA can be for you and every member of your family! 22 Superb Volumes! 4,056 fact-filled pages. Over 7,250 Show-How Pictures! Over 1,000,000 Instructive Words! Hundreds of Expert Contributors—Thousands of Pleasure-Giving Ideas and Projects! Alphabetically Arranged! Complete Cross-Reference Index!

IDEA: Build this outdoor grill! Enjoy 1,001 other money-saving projects!



NOW YOU CAN SAVE \$\$\$\$ BY DOING IT YOURSELF!

Think of it! You can SAVE \$325 on a cedar closet—SAVE over \$1,000 by building your own garage—SAVE up to \$100 by covering your backyard patio yourself—SAVE \$50 by installing acoustical tile on playroom ceiling—SAVE \$60 by paneling a room yourself—SAVE up to \$2,000 by constructing your own vacation cabin!

18 ENCYCLOPEDIAS IN ONE HANDYMAN'S LIBRARY

Here's an Encyclopedia that thoroughly covers just about EVERY kind of Home Repair and Improvement, including: Carpentry, Plumbing, Electrical Wiring, Appliance Repair, Masonry and Cement Work, Painting, Flooring, Upholstery, Roofing, AND IT IS...

... ALSO AN ENCYCLOPEDIA OF GARDENING with hundreds of pages on Home Landscaping, Making a Perfect Lawn, Flower Raising, Roses, Cold Frames, Garden Furniture, Arbors, Walks!

... ALSO AN ENCYCLOPEDIA OF FURNITURE MAKING, including hundreds of handsome Chairs, Closets, Sofas, Beds, Desks, Tables—for Living Room, Bedroom, Nursery,

IDEA: Install a new, modern ceiling—complete with recessed lighting! Save \$50 to \$100.



Playroom, Den, Library, Patio—for every room in your house or apartment!

... ALSO A HI-FI, STEREO, AND TV ENCYCLOPEDIA, including Assembling Systems, Equipment Improvement, Tape Re-

orders, Picture-Tube Installations, Trouble-Shooting and Repairs!

... ALSO A TOYS-AND-GIFTS ENCYCLOPEDIA, with complete illustrated instructions for Swings, Happy Clown Slide, Circus Wagon, Teen-Age Hi-Fi, etc.

... ALSO A CAR OWNERS ENCYCLOPEDIA, covering Engines, Brakes, Fuel, Ignition and Cooling Systems, Trouble-Shooting, Emergency Repairs, Building a Midget Auto, a Hot-Rod, a Go-Cart!

... ALSO A WORKSHOP ENCYCLOPEDIA, covering all types of Power Tools, Hand Tools, Work Benches, Building and Equipping Workshops! PLUS... 12 others!

IDEA: How to plan a home workshop, buy, care for, and use Hand and Power Tools.



FOOLPROOF STEP-BY-STEP DIRECTIONS THAT CAN'T FAIL!

Here is a partial list of the foremost experts who created the "Can't-go-wrong" projects: Bernard Gladstone, Home Improvement Editor, New York Times; Walter Fischman, "how-to" writer, New York News and Popular Science; Robert Hertzberg, famed electronics expert; Art Margolis, who conducts TV Repair Department of Popular Science; Fred Russell, dean of car experts—and hundreds of others!

CLAIM YOUR SHARE OF \$99,500 GIVEAWAY—GIANT VOLUME ONE FREE—YOU RISK NOTHING!

Mail the attached CLAIM CHECK CARD today! Volume One of the PRACTICAL HANDYMAN'S ENCYCLOPEDIA will be sent absolutely FREE! You do not have to subscribe to anything in order to get this book.

But you may if you wish, go on to accumulate further volumes of this Encyclopedia.

Each big, new volume will come to you ENTIRELY ON APPROVAL for 7 days' FREE EXAMINATION.

Volumes 2, 3 and 4 will come to you about one a month. After that, remaining volumes will come in two shipments... all ON APPROVAL. Within 7 days' FREE EXAMINATION you may decide whether to keep the shipment or not—you may decide to return it and owe nothing, or you may remit the low price of just \$2.98 per volume plus a few cents for shipping—for only one book each month. You may buy as few volumes as you wish, even none at all if you so choose, and no volumes will be sent after your cancellation is received. \$99,500 Giveaway, Practical Handyman, Dept. PM-169 100 Sixth Avenue, New York, N. Y. 10013

Mail attached CLAIM CHECK CARD for FREE Book!

Get your free copy of Ford's Performance Buyer's Digest! 1969 Muscle Cars...Specs...Prices... Color Illustrations...Hi-Per Parts!



The 1969 Ford Performance Buyer's Digest contains full color illustrations of the hot new Cobras, Torino GT's, Mach I, Mustang GT's and Ford XL GT's. Plus engine, transmission, chassis and tire specifications and available hi-per options—all with prices. In addition, the Digest offers you color illustrations, specs and parts numbers on many of Ford's Hi-Per parts. This is the first time a Ford Performance Buyer's Digest has ever been offered, so don't miss out on this opportunity. But hurry! The supply is definitely limited—mail the coupon today!

Ever since 1903 when Henry Ford built Old 999 and won his first race, Ford has been building high performance machines. And proving them by winning... at Bonneville, Pomona, Indianapolis, Riverside and Le Mans. But there's more to Ford performance than a worldwide winning streak. The same Ford engineers who stretch their minds to win on the tracks are involved in designing performance cars and parts you can buy. And if you don't think that makes for winners on the road, look for this sign which marks your Ford Dealer's Performance Corner and let him prove it. It's the place you've got to go to see what's going on!

Mail coupon or
write to:

Performance Digest
Department C, P.O. Box 1000
Dearborn, Michigan 48121

FORD



Performance Digest
Department C, P.O. Box 1000
Dearborn, Michigan 48121

(NAME)

(AGE)

(ADDRESS)

(CITY)

(STATE)

(ZIP)

(MAKE AND YEAR OF PRESENT CAR OWNED)



You can
take Salem
out of the
country
but...



you can't take the
"country" out of Salem.

Wherever, whenever you light up, Salem gently air-softens every puff for a taste that's country soft, country fresh. Take a puff... it's springtime!