

POPULAR MECHANICS

AUGUST 1966
35 CENTS

EXCLUSIVE!

How We Found the Missing H-Bomb

Alvin Pilot Bill Rainnie's Own Story

How to Drive and Stay Alive



**3-Way Car Test:
Riviera-T-Bird-New Yorker**

**The Saturday Mechanic:
When a Tune-Up Doesn't Do It**

**12 Record-Player Headaches
You Can Cure**

**If you check the price of a GMC pickup,
you'll find it's \$49* more than others.**

**If you check the way it's built,
you'll wonder why it isn't a lot more.**

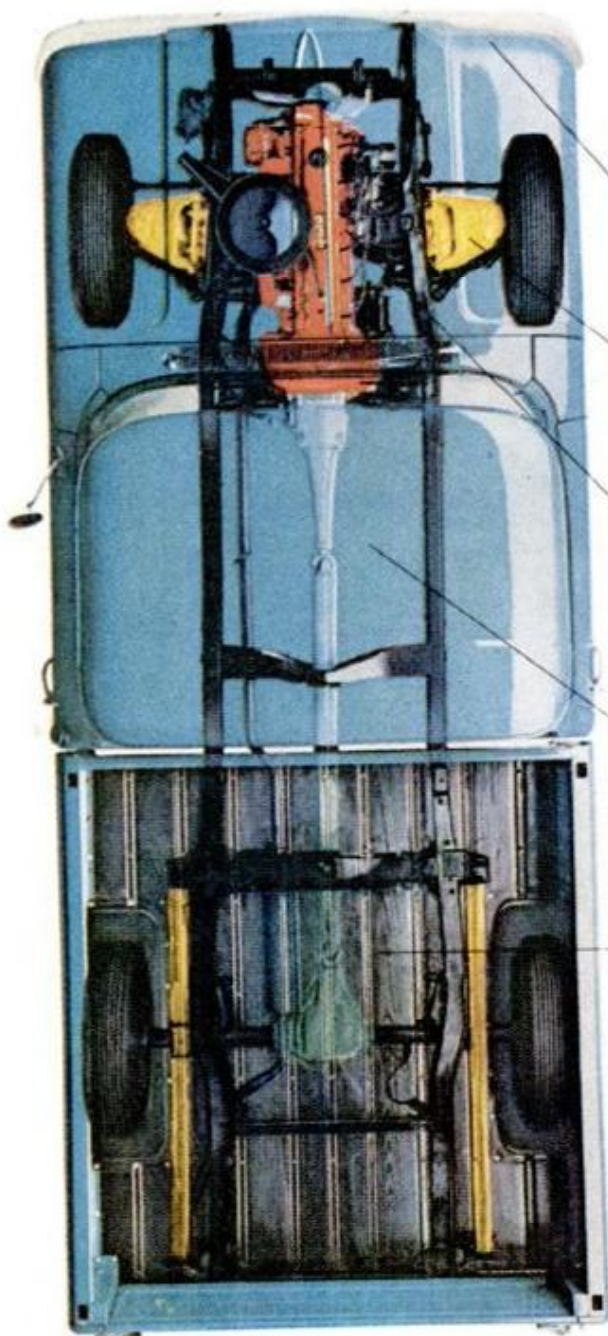

The three letters on the grille—**GMC**—stand for "built, sold and serviced by truck people." People who know how to give you a lot more truck for your money.

Four headlights.
Not two like most other pickups.

Check the way the suspension is built. The combination of independent coil front suspension and progressive leaf rear springs gives a smooth ride, even with maximum loads.

The heart of this beautiful brute—GMC's I-6 engine. More power this year—155 h.p. Also, it has more torque, more cooling and lubricating capacity than most competitive engines. Which means it can trim the fat off your maintenance budget.

The roof of the cab has two walls of steel and a thick pad of insulation. More security. More comfort. Longer cab life.

The loadbed floor is made of wood. Unlike metal, it's quiet. Can't rust or corrode. Stronger. Longer lasting.

*Based on manufacturers' suggested retail prices, the GMC I-6 model pictured above is never priced more than \$49 over comparable competitive base models. Often the difference is less.





Lucite® turns you loose

This One



U41Q-NPK-3LGG



Du Pont LUCITE® House Paint will last and last. You'll paint less often, have extra free time to enjoy life.

Du Pont LUCITE will stand between you and frequent repainting because it does something about the very things that make other paints fail.

Such as the invisible moisture vapor that's always trying to escape through the outside walls.

LUCITE lets it out. (Lots of paints form a clogging seal that makes the paint blister. And peel.)

LUCITE House Paint has also been proven to resist cracking, flaking, chalk-

ing, fading and mildewing far longer than leading oil-base paints.

LUCITE goes on easily—there's no tiresome "brush drag." And it'll dry in just 30 minutes.

Protect your house and your leisure time for the long haul.

If there's something you'd rather do than paint your house, let LUCITE turn you loose.



Better Things for Better Living
...through Chemistry

We won at Indy, the day before the race.

Every car had a Fram filter.

Of the 33 cars in the 1966 Indianapolis 500 mile race, 33 had Fram oil filters.

And Indy is just part of the Fram racing story. Fram-equipped cars ended up first at the Daytona 500. First in all classes at Sebring. First at Phoenix and Trenton.

And we put the same race-winning know-how into a new kind of filter for cars just like yours. It's the new Fram Super Wear-Guard oil filter.

With a filter medium 20% thicker
And many more extra-small pores.

It protects your car's engine like
no other filter ever could before.

So get a new Fram Super Wear-Guard oil filter for your car. Get it at your service station. **They work on the track. They work on the road.**





RALLY 'ROUND THE FUN WITH **YOUNG AMERICA**

Get on a Harley-Davidson Sportcycle and get with the In Crowd! Rally 300 swingin' miles between gas pumps. You're free as a breeze for pennies a week. Quality? We wrote the book! Dellorto carb, Pirelli tires, full lighting and brakes, easy handling. You get more for your money now, more for your bike later with Harley-Davidson's better trade-in value. Five models from 50 cc. to 250 cc. starting around \$225. Low-cost financing and insurance from your dealer. See him for the action time of your life. Now!

HARLEY-DAVIDSON



50 cc. models start around **\$225**

AUGUST 1966

3

POPULAR MECHANICS

INTERNATIONAL EDITIONS: AUSTRALIAN, SPANISH, CARIBBEAN, FRENCH, DUTCH, PORTUGUESE, DANISH, SWEDISH

AUTOMOBILES AND DRIVING

- 19 Detroit Listening Post
- 44 Auto Clinic
- 63 How to Stay Alive on the Turnpikes
- 68 Thousand-Mile Triple Comparison Test
- 86 The Best Driver in the Whole World
- 110 The Way-Out World of Wacky Insurance Claims
- 150 Big-Load Carriers for Beetles
- 154 Saturday Mechanic: Get Out from Behind This Eight Ball!
(Flagged for filing)
- 159 Shortcuts

SCIENCE AND INVENTIONS

- 10 Science Worldwide
- 23 New Inventions
- 61A Personal Car for Road and Rails
- 72 How We Found the Missing H-Bomb
- 80 North American Water Colossus
- 92 The Ship You Drive With One Finger
- 96 More Comfort for You at the Dentist's
- 116 Birth Control for Bugs

SHOP AND CRAFTS

- 24 Pint-Size Router
- 124 Build Your Own Slot-Car Track
- 138 Which Glue is Best for Wood?
- 149 Rolling Saw Stand Features Handy Bins
- 160 Band Sander for Your Bench Saw
- 168 Tips from Readers

HOME AND YARD

- 40 Homeowners' Clinic

- 114 New for Your Home
- 122 Triple-Deck Bunks
- 128 Easy but Elegant Patio Wall
- 132 Solving Home Problems
- 134 Pedal-Plane Whiz-Around

AEROSPACE, AVIATION, MILITARY

- 15 News from the Military
- 18 Aviation Jetstream

ELECTRONICS, RADIO AND TV

- 170 Twelve Record-Changer Troubles You Can Cure
- 174 New in Electronics

BOATING, OUTDOOR RECREATION

- 30 What's New Outdoors
- 102 Scuba-Diving Fire-Eaters
- 107 Crackdown on the Everglades 'gator Poachers
- 130 Tuckaway Camper Cabana
- 144 The Perfect Marine Plug
- 147 Outboard Clinic
- 148 Swing-up Stern Ladder
- 165 Up-and-Flying Model Sailboat
(Flagged for filing)

JOB AND CAREERS

- 37 Career Barometer

REGULAR FEATURES

- 6 Letters to the Editor

PHOTOGRAPHY

- 143 New for Camera Buffs

Cover painting by Howard Shafer

NEXT MONTH IN POPULAR MECHANICS

7000 Better Mousetraps! A roundup of some of the far-out gadgets that will be shown at the International Inventors Exhibition in September in New York.

Computerburgers Hit the Assembly Line. A PM staff member dines at a restaurant that's run by a computer.

Home Improvement Ideas Galore: 42 pages of helps, ranging from a bathroom remodeling to quickie tips for sprucing up your home.

Published By The Hearst Corporation
RICHARD E. BERLIN, PRESIDENT

President, Magazines Division:
RICHARD E. DEEMS

Publisher:
JOSEPH F. KERN

Editor:
ROBERT P. CROSSLEY

Executive Editor:
RICHARD F. DEMPEWOLFF

Managing Editor:
JOHN A. LINKLETTER

Shop Crafts Managing Editor:
WAYNE C. LECKEY

CLIFFORD B. HICKS	Midwest Editor
THOMAS E. STIMSON	Western Editor
WILLIAM KILPATRICK	Automotive
KEVIN V. BROWN	Aviation
ALFRED W. LEES	Home Workshop
RICHARD HOWE	Building and Landscape
ARTHUR MIKESSELL	Boating
JOHN F. PEARSON	Science
STUART JAMES	Outdoors
LARRY STECKLER	Electronics
LEONARD SAMUELS	Photography, Shop Products
JOHN J. SHEAHAN	Production
TERRY HONIGFELD	Assistant Production
MURRAY COOPER	Assistant Art Director
LEO R. WEEKS	Assistant Art Director
GEORGE W. BLOW	Staff Artist
PHILIP H. HUY	Staff Artist
HILDA SUEN	Staff Artist
FRANK P. FRITZ	Chief Photographer
EUGENE A. COLANGELO	Staff Photographer
RALPH L. CLAAR	Photographer
GARRY WINTER	PM Books
FRANKLYN JACOBY, ASID/IDI	Design Consultant
EVERETT JOHNSON	Cabinetmaker

ADDRESS ALL EDITORIAL COMMUNICATIONS TO: 575 Lexington Ave., New York, N.Y. 10022. For additional sources of information on the articles and products in this issue, write to Bureau of Information, Popular Mechanics, for free "Where-to-Find-It" list.

L. PARK BENJAMIN, Advertising Director

ADVERTISING OFFICES: New York: 575 Lexington Ave., Murray Hill 8-8500; Chicago: 520 N. Michigan Ave., 527-2400; Detroit: General Motors Bldg., TRinity 5-8711; Cleveland, Hanna Bldg., 1422 Euclid Ave., PRespect 1-0456; Los Angeles: 3460 Wilshire Blvd., DUnkirk 2-8458; San Francisco: 1101 Hearst Bldg., YUKon 2-0823.

SUBSCRIPTION SERVICE: Mail all subscription orders, changes of address, correspondence concerning subscriptions, and Postmaster notices of undeliverable copies to Popular Mechanics, Box 646, New York, N.Y. 10019.

Popular Mechanics is published monthly by The Hearst Corporation, 57th St. at 8th Ave., New York, N.Y. 10019, U.S.A. Richard E. Berlin, President; George Hearst, V-Pres.; Richard E. Deems, President of Magazines; John R. Miller, V-Pres. and Gen. Mgr. of Magazines; William S. Campbell, V-Pres. and Director of Circulation; Joseph F. Kern, V-Pres. for Popular Mechanics; Frank Massi, Treasurer; R. F. McCauley, Secy. Single copy in the United States and Canada, 35 cents. Subscription prices: United States and Possessions, \$4.00 for one year; \$7.00 for two years; \$10.00 for three years. Canada, add \$0.50 for each year. Pan American Postal Union countries, add \$1.00 for each year. All other countries, add \$2.00 for each year. When changing address, give old address as well as the new, with postal-zone number, if any, and allow six weeks for change to become effective. Second-class postage paid at New York, N.Y., and at additional mailing offices. Authorized as second-class mail by the Post Office Department, Ottawa, and for payment of postage in cash. Registered as second-class matter at the Post Office at Mexico, D.F., Mexico, June 20, 1950. © 1966 by The Hearst Corporation. All rights reserved. Printed in U.S.A.

AUGUST 1966

MAN SIZE

One wide,
dry stroke
daily
stops
perspiration
odor
24 hours!



You perspire like a man, don't you? Then protect yourself like a man with Mennen Speed Stick. That's the man-size deodorant. A fistful of it. One stroke daily stops odor up to 24 hours. And it goes on clean because it goes on dry. Never drippy, tacky, crumbly. When it comes to deodorants, nothing measures up to broad, brawny Speed Stick. New economy size also available.

All it takes is one clean stroke daily!

Test your automotive I.Q.

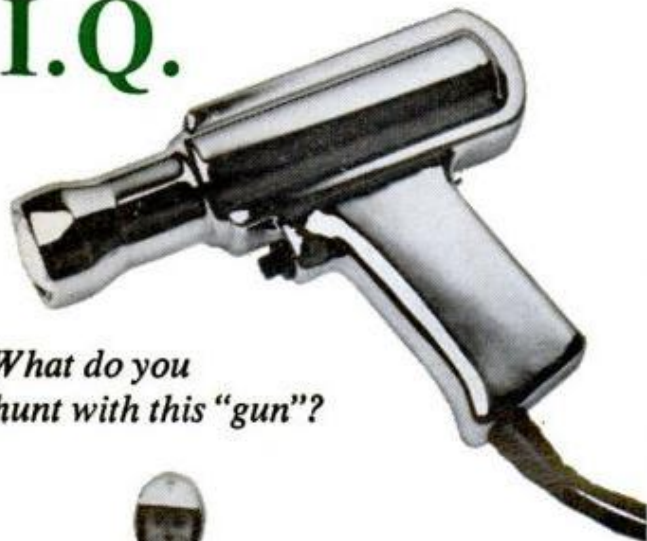

What do you
hunt with this "gun"?



What does this symbol stand for?

This pistol-shaped instrument is a modern timing light used to hunt ignition faults. The life preserver stands for Quaker State Motor Oil—because it is the best engine life preserver. Quaker State gives every car long-lasting lubrication with top protection and saves you money. It's refined from 100% Pure Pennsylvania — the choicest and most costly crude oil available. Always ask for Quaker State—to keep your car running young.



Quaker State Oil Refining Corporation
Oil City, Pennsylvania

LETTERS TO THE EDITOR

Two-stage builder

I built the *Hydro Dynamic* (page 144, March '63 *PM*) in a way which I am sure the average boat builder would consider unusual. So that I could work on it during the winter, I built it in my recreation

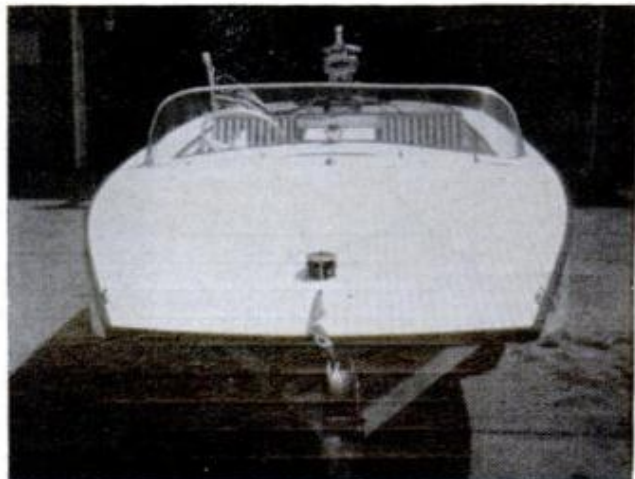

room. However, I did not glue the joints, and I put a screw every 10 inches instead of every 2 inches—but I did provide a drilled hole every 2 inches for final assembly. When the boat was over 90 percent complete and good weather returned, I disassembled and labeled each part and reassembled and completed the boat in my garage.

Utica, Mich.

EDWARD SIMEK

Auto fan

Automobile Clinic is the first thing I read in *PM* each month. There is more information in this one feature than in a lot of so-called car magazines.

Miami, Fla.

C. B. RAYMOND

Homespun spinners

I was delighted to see the spinning articles (*Reproduce This Prized Antique*, page 176, and *How to Work with a Spinning Wheel*, page 182) in your March issue.

About a year and a half ago I became so interested in this art (note to Alfred Lees: It is not a lost art!) that I wrote a 40-page booklet on the subject. I had thought that only a few museum people knew how to spin, but now I know of large groups in New Hampshire, Washington and Oregon, and there are spinners in Pennsylvania and Ontario also.

The castle type of spinning wheel, for
[\(Please turn to page 8\)](#)

This private office (with salary to match) is waiting for you

Will you give a little of your spare time to qualify for it?

MORE easily than you think, you can command a big salary—with your name on the office door—by acquiring specialized training. You can become trained in the kind of work you like — *and employers will seek you out.* For in today's vastly expanded business activity, there are more key jobs than there are trained men to fill them.

Without interfering with your present work—and by devoting only a little of your spare time — you can qualify rapidly for the position you want through LaSalle home study. The cost is remarkably low.

For more than half a century LaSalle has been an acknowledged leader in home education. LaSalle has provided training to more than 1,000,000 men and women.

Over 5,500 Certified Public Accountants have trained with LaSalle. Each year LaSalle enrolls more than 4,000 students in its Law School. LaSalle's distinguished faculty includes some of the country's foremost practicing specialists and instructors. Your training is in experienced hands. Your LaSalle diploma will be a credential respected by employers.

Mailing the coupon below may be the start of a whole new future for you . . . may be the first step in getting a more important job, higher pay, all of the good things that go with success. Simply check the program in which you are most interested, and we will send you a valuable free booklet describing the opportunities in that field. Write to LaSalle, 417 South Dearborn Street, Chicago, Illinois 60605.

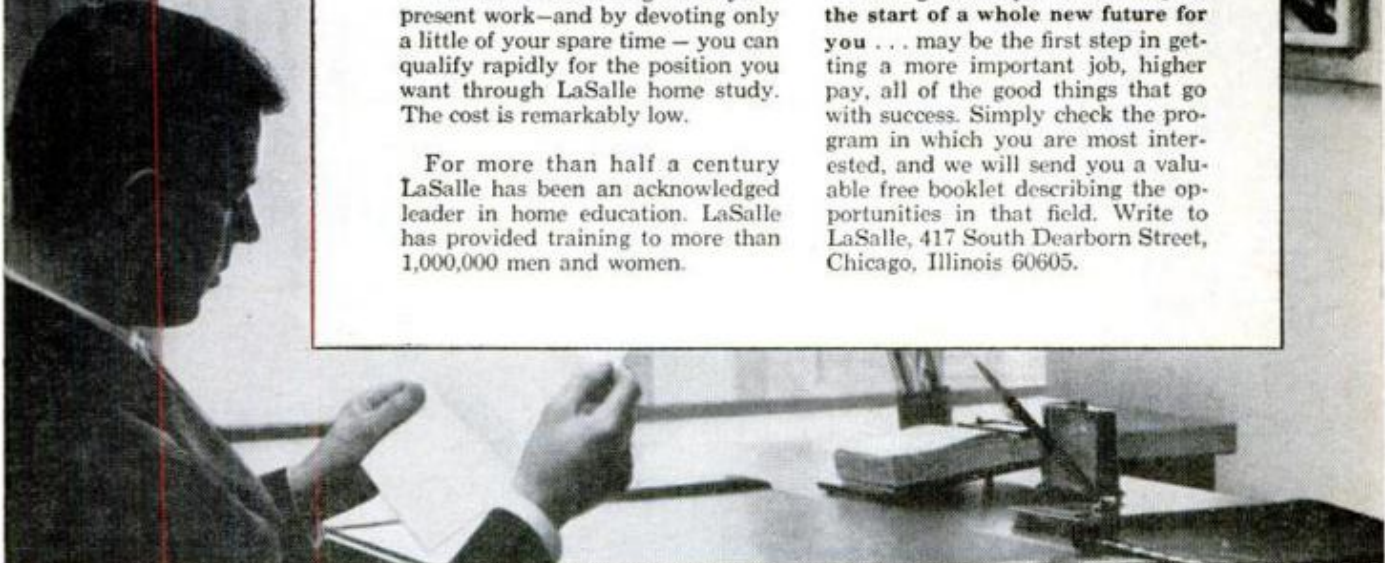

LASALLE EXTENSION UNIVERSITY

A Correspondence Institution • 417 South Dearborn, Dept. 56-110, Chicago, Illinois 60605

Please send me, without cost or obligation, FREE booklet and full information on the field I have checked below:

ACCOUNTING

- Complete Accounting with CPA Training
- General Accounting
- Income Tax
- Accounting Fundamentals
- Auditing
- Controllership
- CPA Training
- Modern Bookkeeping

BUSINESS MANAGEMENT

- Complete Business Management
- Credit and Collections
- Office Management
- Personnel Management
- Business Correspondence

LAW COURSES

- Bachelor of Laws Degree
- Business Law
- Insurance Law
- Claim Adjusting Law
- Law for Police Officers
- Law for Trust Officers

SALESMANSHIP

- Sales Management
- Complete Sales Training

DRAFTING

- Basic Drafting
- Aeronautical Drafting
- Architectural Drafting
- Electrical Drafting
- Mechanical Drafting
- Structural Drafting

REAL ESTATE

- Complete Real Estate
- Real Estate Brokerage
- Real Estate Management
- Real Estate Sales

TRAFFIC AND TRANSPORTATION

- Complete Traffic Mgt.
- Transportation Law
- Rates and Tariffs

- Agency and Services
- Motor Truck Traffic

STENOTYPE

- Machine Shorthand

TECHNICAL COURSES

- Mechanical Refrigeration
- Air Conditioning, Refrigeration and Heating
- Diesel

HIGH SCHOOL

- High School Diploma

CAREERS FOR WOMEN

- Interior Decorator
- Dental Assistant
- Secretarial
- Accounting
- Bookkeeping
- Real Estate

Name Age

Address County

City & State Zip No.

Occupation Working Hours A.M. P.M.

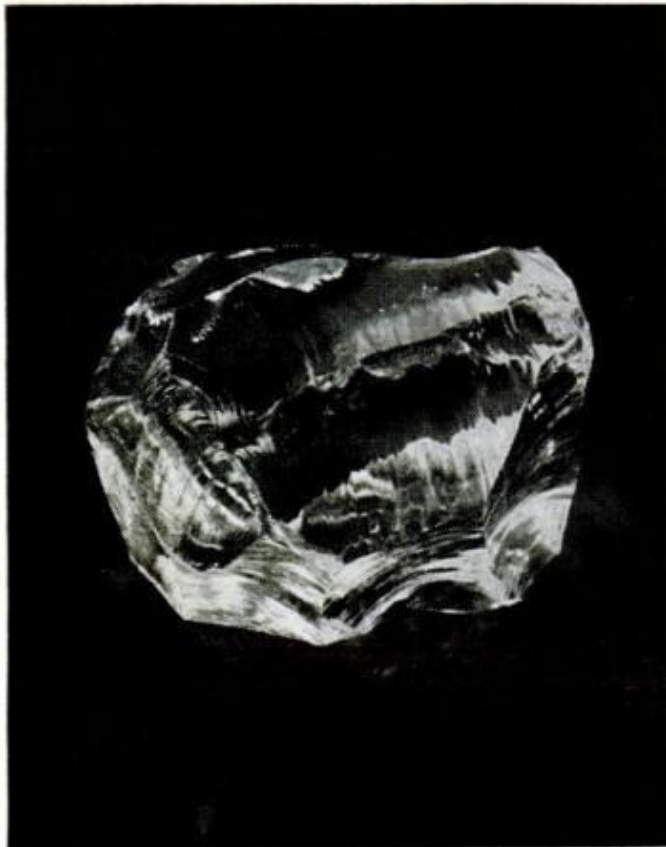

Optical glass... \$15 a pound

... but only 10%
is good enough for you!

By the time we've made a finished rifle scope lens, the glass alone is worth more than solid silver. Even at \$15 a pound, we reject most of it. Much of that might have been "good enough," but our optical inspectors wouldn't pass it. More than a century of optical research and manufacturing excellence have made us sticklers for uniquely high standards. That's why shooters who want to be sure — as well as proud — of their equipment own B&L telescopic sights. Everything you want to know about rifle scopes is in our 85-page manual, "Facts About Telescopic Sights." Send 25¢ to Bausch & Lomb, Rochester, New York 14602.



BAUSCH & LOMB 

LETTERS continued

(Continued from page 6)

which you gave plans, is of English or European origin, I strongly suspect. A wheel similar to this with two spindles was invented in Scotland (probably) around 1764, and it was a common sight there up to the 1800s.

Do tell a potential spinner not to get discouraged. It takes practice to coordinate feet and hands. Also tell her the "raw fibers" are spun *before* going into "eye" or orifice of spindle. And *don't* wax the rim of the wheel or the bobbin if you want them to go around.

Marion, Mass. MRS. WALTER E. CHANNING

Candle burners

I was glancing through my father's June PM and happened to notice an article about tin can stoves (page 30).

Come now, gentlemen, Girl Scouts have known about tin can stoves or buddy burners for heaven knows how long.

I might suggest that if your readers would like to use the stove indoors, they use Sterno; otherwise the candles blacken the ceiling.

Scotia, N.Y.

CHARMAINE BALDASARE

Most appreciated

After seeing *Build a Modern Tree House* (page 126, June '65 PM), I decided it was just what my children needed, and I built them one with a few minor changes.



I set it four feet off the ground and mounted a slide and small roller coaster on the porch of the playhouse. The children's sandbox is underneath the house in the shade. Total cost for the project was \$65—the most satisfying, appreciated and effective money I ever spent on them. Thanks for the idea.

Middletown, Ohio

CHARLES GREENE



**NEW TEFLON*
OIL RINGS DRAIN
160% FASTER,
WON'T CLOG EVEN IN
STOP/GO CITY DRIVING**

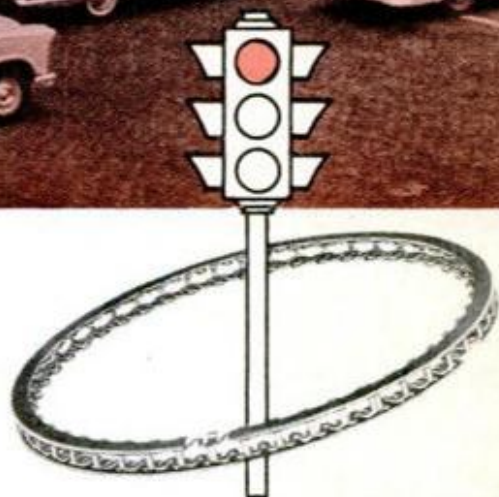

Bumper to bumper traffic and short trips can make carbon and sludge build up fast in today's high compression engines. But not in engines equipped with new PC Perflon oil rings. Why? Because Perflon rings are coated

with Teflon—a material that's so slick that carbon and sludge build-up is no problem. In addition, Perflon rings have a new wide-span slot design that speeds drainage. Ask for PC Perflon rings next time you re-ring.

*Registered trademark for Du Pont fluorocarbon resin finishes.

PERFECT CIRCLE

DANA PARTS
COMPANY



DANA CORPORATION

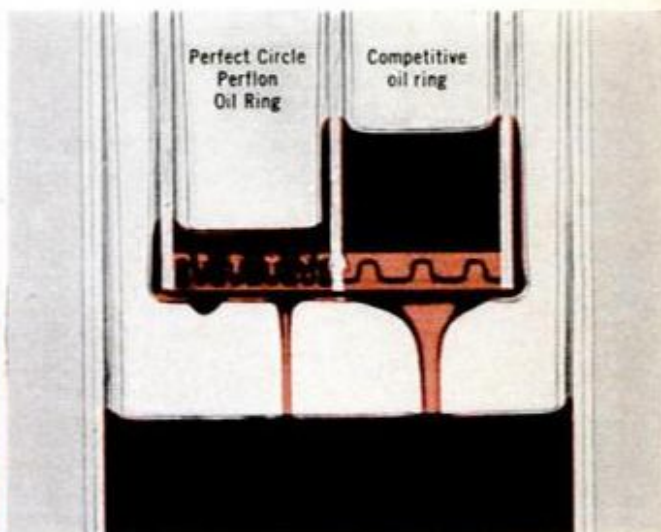

Un-retouched photo shows how much faster equal amounts of the same weight oil drain through a section of Perflon ring (left) than through a section of a competitive ring (right). Only PC Perflon rings assure this kind of free oil flow and proper lubrication.

BY JOHN F. PEARSON
SCIENCE
WORLDWIDE

Atomic heart pacer with an expected life of 10 years is under development for the Atomic Energy Commission. The tiny unit (1 by 3 by 3 inches) will be powered by plutonium-238, a man-made radioisotope; heat will be converted directly into electricity for stimulating the heart.

Present pacers are battery powered and last only two to three years. Each replacement requires additional surgery. It's expected that the atomic unit will be available to patients within three to five years.

New explosive, said to be more powerful than dynamite, nitroglycerine or any other non-nuclear type, has been developed by a West Coast company. Called Astrolite, it is an offshoot of advanced rocket technology.

Taming of the shrew. Successful colonization of the tree shrew under laboratory conditions has been achieved by veterinarians of the SEATO Medical Research Laboratory in Bangkok, Thailand. Study of the shrew, one of the lowest primates in the evolutionary scale, is expected to make an important contribution to medical research. Before this, only limited success had ever been achieved in making the species breed away from its natural habitat.

Bracing effect of a shower may not be entirely due to the cleansing action of the water. A negatively charged bathroom could have a lot to do with creating that pleasant feeling, say two scientists at California's Stanford Research Institute. In hitting your body and the tub, drops of water break up and lose negative ions to the atmosphere, creating a relatively high negative field.

Cystoscope group study. A TV camera connected to a cystoscope and using a fiber-optic illuminating system may soon enable an entire class of medical students to look together inside a functioning human organ. The cystoscope, an instrument used by surgeons to examine the interior of the bladder, is a one-man-at-a-time viewing device and not a good teaching tool. The new TV system is under development at Columbia University.

At least 20 square miles of phosphate rock, valuable in the manufacture of fer-

tilizers, detergents and baking soda, have been discovered 30 miles off the coast of North Carolina by a Duke University scientist. The deposit is on the continental shelf in water from 60 to 100 feet deep.

Asbestos in the air may someday be a new hazard of urban living. That warning comes from two medical researchers who reviewed autopsies performed on 500 residents of Miami. Writing in a professional journal, they report that asbestos fragments—presumably from auto brake linings, roofing materials, floor tiles—were found in the lungs of 30 percent of the males and 20 percent of the females.

Though none of the deaths studied was caused by a lung ailment, it is known that asbestos, if inhaled in sufficient quantities, can cause lung disease, including malignant tumors.

How to measure mountains. Field surveys by scientists of the U.S. Geological Survey are resulting in measurements of the gravitational variations in the Appalachian mountain system in northern Virginia and southern Maryland. Purpose of the project is to obtain more data on a major discontinuity in the earth's crust that underlies the mountain system from Nova Scotia to Alabama. By measuring gravity differences, scientists are able to explore the "hidden" rock structures beneath the surface.

Nuclear desalting plant—first U.S. land-based facility of its type—is producing fresh water from the ocean at the Navy's remote McMurdo Station in the Antarctic. In the past, fresh water had to be obtained by melting snow, and, although the average snowfall at McMurdo is 40 inches, it was often hard to get enough to meet water needs because the snow tends to be powdery and is blown off the volcanic rock on which the station is located. The new plant can produce 14,000 gallons of fresh water a day.

Intense sound waves at frequencies a million times higher than a man can hear are generated in a lab at M.I.T. The waves, produced by laser beams hitting quartz crystals and setting up extreme vibrations, are used for a variety of experimental purposes.

\$6.44 AN HOUR IN YOUR OWN BUSINESS



**STEP INTO THIS BOOMING
\$19 BILLION A YEAR INDUSTRY**

Hundreds of accidents and losses will happen this year in your community.

We'll show you how to investigate and adjust these losses for insurance companies, railroads, government offices. You buy NO tools or equipment. You do NO selling. You need NO prior experience or higher education. And you can operate out of your own home. *Right now independent Accident Investigators average \$6.44 an hour.* We'll train you quickly to do the same. Start part-time if now employed. Fill the need for an Accident Investigation specialist in your area. Colorful booklet explains everything. Absolutely no obligation on your part. No salesman will call. Write TODAY for FREE Booklet.

UNIVERSAL SCHOOLS, PM-8, 6801 Hillcrest, Dallas 5, Texas

Learn Profitable Profession in few months at Home

MEN AND WOMEN, 18 TO 60

\$4.00 to \$5.00 for 1-hour treatment is the established charge for a skilled operator. Easy to learn and do. Diploma awarded. Open your own office or earn good income from Doctors, Hospitals, Clubs and other health or recreational centers. Wonderful part-time profession. Low monthly payments. Write today for free Anatomy Charts and catalog. No obligation.

ANDERSON SCHOOL OF SCIENTIFIC MASSAGE
Dept. J-1, Princeton, Illinois



EARN HIGH WAGES as a HEAVY EQUIPMENT OPERATOR

Train your way to high pay in the booming construction industry! Learn the skills you need to qualify . . . NOT by correspondence, but by actual field training on machines like the ones used by the industry. Huge training grounds in North Carolina, a million dollars worth of school-owned diesel-engined machines, experienced instructors, full 220-hour and 440-hour courses. National, the original school of heavy equipment operation, is the recognized leader. Member American Road Builders Assn., Services and Supply Division. Associate Member A.G.C. Full-time Job Advisory and Counseling Director on staff. VA approved. For men ages 17 to 56. Train Now-Pay Later plan . . . other payment plans also available. Write TODAY for FREE catalog and FREE copy of school newspaper reporting news of National School graduates.

NATIONAL SCHOOL
OF HEAVY EQUIPMENT OPERATION, Dept. D-78
P.O. Drawer 1686, Charlotte, N. C.

Please send me FREE illustrated school catalog and complete information. I understand there's no obligation.

Name _____
Address _____ Phone: _____
City _____ State _____ Zip Code _____

AUGUST 1966

UNUSUAL BARGAINS

... MANY U.S. GOV'T SURPLUS

'FISH' WITH A WAR SURPLUS MAGNET Go Treasure Hunting On The Bottom

Great Idea! Fascinating fun and sometimes tremendously profitable! Tie a line to our 5-lb. Magnet—drop it overboard in bay, river, lake or ocean. Troll it along the bottom—your "treasure" haul can be outboard motors, anchors, fishing tackle, all kinds of metal valuables. 5-lb. Magnet is war surplus—Alnico V Type—Gov't. Cost—\$50. Lifts over 125 lbs. on land—much greater weights under water. Order now and try this new sport.
Stock No. 70,571-H. 5 lb. Magnet. \$12.50 Postpaid
Stock No. 70,570-H. 3 1/2 lb. Lifts 40 lbs. \$8.75 Postpaid
Stock No. 85,152-H. . . . (lifts over 350 lbs.) \$33.60 F.O.B.



OPAQUE PROJECTOR

Projects illustrations up to 3" x 3 1/2" and enlarges them to 35" x 30" if screen is 6 1/2 ft. from projector; larger pictures if screen is further away. No film or negatives needed. Projects charts, diagrams, pictures, photos, lettering in full color or black-and-white. Primarily intended for children. Operates on 115 volt. A.C. current. 6-ft. extension cord and plug included. Operates on 60 watt bulb, not included. Size 12" x 8" x 4 1/2" wide. W. 1 lb., 2 oz. Plastic case.
Stock No. 70-199-H \$7.95 Postpaid



See the Stars, Moon, Planets Close Up!

3" ASTRONOMICAL REFLECTING TELESCOPE

60 TO 180 POWER!
Famous Mt. Palomar Type!
An Unusual Buy!

See the Rings of Saturn, the fascinating planet Mars, huge craters on the Moon, phases of Venus. Equatorial Mount with lock on both axes. Aluminized and over-coated 3" diameter high-speed f/10 mirror. Telescope comes equipped with a 60X eyepiece and a mounted Barlow Lens. Optical Finder Telescope included. Hardwood, portable tripod. FREE with Scope: Valuable STAR CHART plus 272-page "HANDBOOK OF HEAVENS" plus "HOW TO USE YOUR TELESCOPE" BOOK.
Stock No. 85,050-H \$29.95 Postpaid

4 1/4" REFLECTING TELESCOPE—Up to 275 Power
Stock No. 85,105-H \$79.50 F.O.B., Barrington, N.J.

SOLVE PROBLEMS! TELL FORTUNES! PLAY GAMES! NEW WORKING MODEL DIGITAL COMPUTER

ACTUAL MINIATURE VERSION OF
GIANT ELECTRONIC BRAINS
Fascinating new see-through model computer actually solves problems, teaches computer fundamentals. Adds, subtracts, multiplies, shifts, complements, carries, memorizes, counts, compares, sequences. Attractively colored, rigid plastic parts easily assembled. 12" x 3 1/2" x 4 3/4". Incl. step-by-step assembly diagrams, 32-page instruction book covering operation, computer language (binary system), programming, problems and 15 experiments.
Stock No. 70,683-H \$5.98 Ppd.

DETAILED PROGRAMMING BOOKLET FOR EXPERIMENTS
Stock No. 9080-H . . . (50 Pages) \$1.00 Ppd.

"Balls of Fun" for Kids . . . Traffic Stoppers for Stores Terrific for Amateur Meteorologists SURPLUS GIANT WEATHER BALLOONS

At last . . . available again in big 8-ft. diameter. Create a neighborhood sensation. Great backyard fun. Exciting beach attraction. Blow up with vacuum cleaners or auto air hose. Sturdy enough for hard play; all other uses. Filled with helium (available locally) use balloons high in the sky to attract crowds, advertise store sales, announce fair openings, etc. Amateur meteorologists use balloons to measure cloud heights, wind speed, temperature, pressure, humidity at various heights. Photographers can utilize for low-cost aerial photos. Recent Gov't surplus of heavy, black, neoprene rubber.
Stock No. 60,568-H \$2.00 Ppd.

WAR SURPLUS ELECTRIC GENERATOR

Brand new Signal Corps Electric Generator for scientific experiments, electrical uses, demonstrations. Generates up to 90 volts by turning crank. Use in high impedance relays. Charge ground and bring up night crawlers for bait or study. 2 Alnico Magnets alone worth original price. Wt. 2 lbs. Cost to Govt. \$15.
Stock No. 50,225-H \$6.95 Postpd.

Same type generator, mounted, with light, as electricity demonstrator.
Stock No. 50,365-H \$11.95 Postpaid

Order by Stock No.—Send Check or M.O.—Money-Back Guarantee
EDMUND SCIENTIFIC CO., Barrington, New Jersey

MAIL COUPON FOR FREE CATALOG "H"

Completely new 1966 Edition, 148 pages
Nearly 4500 Bargains.
EDMUND SCIENTIFIC CO., Barrington, N. J.
Please rush Free Giant Catalog "H".

Name _____
Address _____
City _____ State _____ Zip _____

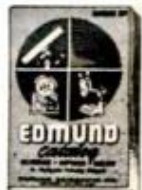

11

FREE Key Machine

Kind master locksmiths use. Sells for \$125, but yours FREE with Locksmithing Course



You Can Learn To Be A LOCKSMITH in your spare time

There's a big demand for skilled locksmiths. You can earn big money either full or part-time in your own home. Be your own boss; earn steady, year 'round income with no layoffs. The BELSAW INSTITUTE training, recommended by professional locksmiths, teaches you to make keys, open and repair locks on homes, cars and buildings. Easy, step-by-step illustrated lessons complete with all tools and supplies. We tell you how to get servicing jobs, how much to charge, how to earn while you learn and how to build a secure cash profit business.

Mail Coupon for FREE Book Today!

BELSAW INSTITUTE, 1071 Field Bldg., Kansas City, Mo. 64111
Send FREE book, "Keys To Your Future!"
No obligation. No salesman.

Name

Address

City State Zip

MAIL TODAY FOR FREE BOOKLET ...

Showing the most beautiful school in the country... elaborately equipped with the most modern, scientific testing equipment known.

Day and evening classes. Good, full & part time jobs and housing provided.



G. I. APPROVED
1645 S. Grand, Dept. P.M., St. Louis, Mo. 63104

Name _____ Age _____
Street _____
Town _____ Zip _____ State _____
Telephone _____

**WORLD FAMOUS
BAILEY TECH SCHOOL**

"\$7,108⁵⁰ First Year SERVICING RADIATORS!"

— Hank Konter, Newcastle, Wyo.
Make good money servicing auto-truck-tractor radiators with new Inland 1-Piece Radiator Shop. Easy to test-clean-repair radiators. Inland, world's largest radiator equip. mfr., trains you free. Small down payment starts you. Easy-pay plan lets you pay from profits. Proved merchandising assures volume. Profitable dept. for garage or service station. WRITE for Free Book. INLAND MFG. CO., Dept. PM-8, 1108 Jackson, Omaha 2, Neb.



REAL FLYING MODELS ROCKETS!

Flights up to 2500 ft.

BLAST OFF! ... with a flying scale model

IDEAL STARTER KIT

- WAC Corporal (shown) with 2 powerful rocket engines, all parts, instructions, design booklet and FREE illustrated catalog. ORDER NO SK-2 ... \$2.00
- Or SK-6, same as above, plus igniter-launcher ... \$6.00



25 exciting new rockets for you to build and fly

Giant illustrated catalog ... 25¢

PLEASE USE ZIP CODE WHEN ORDERING
ESTES INDUSTRIES
PENROSE 15, COLORADO

Dealer inquiries invited
Many flights - Parachute recovery

PROFIT IN YOUR SPARE TIME



SMALL ENGINE REPAIR PAYS BIG!

Outboard · Powermower · Chain Saw · Tractor
MAKE EXTRA MONEY — or fix your own engines and SAVE! Illustrated, easy-to-learn Home Study Course qualifies you as expert. Approved for Veterans. Write today!

LINCOLN TECHNICAL INSTITUTE
SUITE 8E, 427 MARKET STREET, NEWARK 5, N.J.

A flounder is born with an eye on each side of the head, but as the fish grows, one eyeball wanders around the head to join the other.

GET INTO ADVERTISING!



There's Big Money in Advertising! 18,000 new jobs each year. Train at home for a career in this exciting, growing field. Meet fascinating people! No writing or art ability needed. Diploma awarded. Send for big ADVERTISING CAREER KIT—All Free! Write today!
No. American School of Advertising, University Plaza, Campus Drive, Dept. 4178, Newport, California 92660.

GO AHEAD! Ask Your Dealer to Demonstrate this BENJAMIN

... then You'll Know Why Today's Oldest AIR RIFLE is Still the Most DEPENDABLE BB or PELLET GUN ever made!

This Single Shot Model isn't new. It's been around since 1908. In Performance and Popularity it has more than proved itself to be the Dominant Hi-Compression Air Rifle in the field. Does that surprise you? Probably if you owned one you'll find you agree it cannot be equalled, much less surpassed, in qualities which contribute to Better Shooting. A universal favorite for all uses — Indoors or Out. This gun combines such distinctive features as Genuine Bronze Barrels, Machined Brass and Steel Parts, Superior Workmanship with Modern Refinements and Styling to deliver Power, Accuracy, Dependability that rightfully put it in a class by itself. Choice of BB or 177 or 22. At Benjamin Dealers.



\$30.00 No. 310 CAL. BB—No. 312 CAL. 22 PELLET—No. 317 CAL. 177 PELLET.
BENJAMIN AIR RIFLE COMPANY
896 Marion St., St. Louis, Mo. 63104

FREE Catalog Benjamin Single Shot and Repeaters—Cal. BB or 177 or 22. Also Special Hunting Knife Offer. Write today!

You Can DEPEND on BENJAMIN

ALL-NEW AUTO GUIDE 1966 EDITION

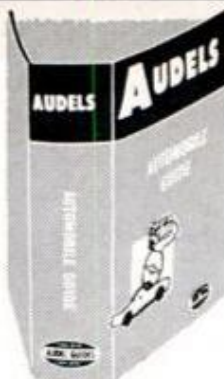

FIX ANY CAR FAST!

**NEW FROM
COVER TO COVER**

The latest, most instructive auto repair guide available today. Explains in detail how to troubleshoot and repair every part and system in any make or model car. Helps you work like a factory-trained mechanic to fix any car fast!

**ONLY
\$6.95**

biggest Auto
Guide value!

STEP-BY-STEP REPAIR GUIDE COVERS EVERYTHING:
 Troubleshooting—unique symptoms-and-causes charts •
 Engine Tune-up • Spark Plugs • Storage Batteries • Distributors •
 Ignition Testing • Starters and Generators • Lighting Systems •
 Tire Servicing • Brakes • Power Brakes • Front Suspension •
 Steering Systems • Front-Wheel Alignment • Chassis, Springs
 and Shocks • Fuel Pumps • Carburetors • Cooling Systems •
 Engine Lubricating Systems • Pistons and Rings • Crankshafts
 and Connecting Rods • Camshafts • Valves • Manual Transmission and Clutches
 • Automatic Transmissions • Drive Shafts and Universal Joints • Rear-Axle
 Assemblies—ABSOLUTELY EVERYTHING YOU SHOULD KNOW TO FIX ANY
 CAR! 736 pages. Every detail covered in hundreds of illustrations. **\$6.95**

Circle No. 1 in Coupon

Home Appliance Service Guide

How to fix refrigerators, washers, ranges, toasters, and all other electric & gas appliances. Fully illus. 608 pages. **\$6.95**

Circle No. 2 in Coupon

Home Refrigeration & Air Conditioning

Servicing, operation and repair of all systems and machines, freezers, lockers, water coolers, etc. Illus. 576 pages. **\$6.95**

Circle No. 14 in Coupon

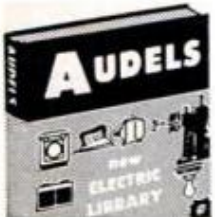

new Electric Library

10 volume electrical encyc. Answers questions on thousands of electrical problems. 9000 ill. 5558 pgs. Set **\$25.00**

Circle No. 15 in Coupon

Practical Electricity

Complete handbook; practical, simplified ready reference on all electrical subjects. 1300 illus. 1088 pages. **\$5.95**

Circle No. 4 in Coupon

TV-Radio Library

Two vols. on TV & radio circuits & how to install and repair all radio and TV including color. Illus. 960 pages. Set **\$9.50**

Circle No. 3 in Coupon

Mathematics for Mechanics

A complete guide to the mastery of practical math. Simplified method makes learning fast and easy. Ill. 704 pgs. **\$4.95**

Circle No. 11 in Coupon

Sheet Metal Pattern Layouts

Modern guide to all phases of sheet metal work, including pattern development. 350 layouts. Illus. 1152 p. **\$7.50**

Circle No. 29 in Coupon



CARPENTERS & BUILDERS GUIDES

Four all-inclusive volumes provide latest inside trade information on modern construction. Vol. 1—Tools, Steel Square, Joinery. Vol. 2—Builders Math, Drawings, Specs. Vol. 3—Layouts, Foundations, Framing. Vol. 4—Millwork, Power Tools, Windows, Doors, Roofing, Flooring. Most practical guide available. Thousands of diagrams, charts, graphs and photos. 1616 pages. 4-Vol. Set **\$16.95**

Circle No. 8 in Coupon



MACHINISTS & TOOLMAKERS GUIDES

Latest shop practices for machinists & toolmakers.

Vol. 1 Basic Machine Shop Practices. Practical fundamentals of shop operations. Illus. 416 pgs. **\$4.95**

Circle No. 12A in Coupon

Vol. 2. Setup & Operation of Machines. Covers all important shop machines. Illus. 512 pages. **\$4.95**

Circle No. 12B in Coupon

Vol. 3. Toolmakers Handybook. Practical data on layouts, jigs, dies, gears, etc. Illus. 384 pages. **\$4.95**

Circle No. 12C in Coupon

All 3 Volumes **\$13.50**—Circle No. 12N in Coupon

**AUDEL PUTS MORE
SKILL IN YOUR HANDS—
MORE MONEY IN
YOUR POCKET!**

Diesel Engine Manual

Complete practical guide to modern Diesel engines. Explains principles & how to maintain & oper. Illus. 544 p. **\$6.00**

Circle No. 9 in Coupon

Outboard Motor & Boating Guide

Practical details on all phases of outboard motor repair, maintenance and operation. Up-to-date. Illus. 414 pages. **\$4.00**

Circle No. 49 in Coupon

Truck and Tractor Guide

A guide for mechanics, drivers and maintenance men. Gas & Diesel repair, service and operation. Illus. 928 pages. **\$5.95**

Circle No. 5 in Coupon

Masons and Builders Guides

Four practical vols. for bricklayers, stone masons, cement workers, plasterers. 2000 illus. 1478 pages. Set **\$10.50**

Circle No. 26 in Coupon

Plumbers & Steam- fitters Guides

4 vols. of ready reference for plumbers, steam fitters, gas fitters, sheet metal workers. 3600 ill. 2272 pages. Set **\$10.50**

Circle No. 6 in Coupon

Welders Guide

Practical guide to theory, operation. Maintenance of all types of electric, oxy-acetylene & Thermit welding. Ill. 624 p. **\$4.95**

Circle No. 10 in Coupon

Foreign Auto Repair Manual

Up-to-date service data for all popular imports: English, French, German, Italian, Swedish. Illus. 592 pages. **\$5.00**

Circle No. 53 in Coupon

Oil Burner Guide

Latest practical book on all home and industrial oil burners. Electrical hookups and wiring data. 320 illus. 420 pgs. **\$3.95**

Circle No. 28 in Coupon

10-DAY FREE EXAMINATION

SEND NO MONEY—Pay the postman nothing! We are glad to send you any of the AuDel Guides for absolutely FREE examination in your own home. We take all the risks and leave all the decisions up to YOU. There is no obligation! If you decide to keep the books of your choice you may pay for them under our astounding easy-pay plan of only \$3 a month.

HERE IS ALL YOU DO—IT'S EASY TO ORDER: In the No-Risk Mail Order Coupon at the right just draw a circle around the number of AuDel Guides you want us to send you for FREE EXAMINATION. We will send them to you at once to help you build a brighter future by increasing your SKILL. If you are not COMPLETELY satisfied, return the books, and that will end the matter! NO STRINGS OR CATCHES TO THIS OFFER.



THEODORE AUDEL & CO.
 division of HOWARD W. SAMS & CO., INC.
 Indianapolis • New York

MAIL THIS NO-RISK COUPON TODAY!

THEODORE AUDEL & CO.—Self Improvement Publishers Since 1879—
 4300 W. 62nd Street, Indianapolis, Indiana 46206 P-86

Please mail me for 10 days' FREE EXAMINATION the books I have circled at right. I agree to mail \$3 in 10 days on each book or set ordered, and to further mail \$3 a month on each book or set ordered until I have paid the purchase price, plus shipping costs. If I am not completely satisfied with my AuDel Guides I may return them.

Name _____
PLEASE PRINT

Address _____

City _____ State _____ Zip _____

Employed By _____

SAVE SHIPPING COSTS! Check here if you enclose complete payment with order (plus sales tax, if any). We pay postage charges. You have same return privilege. I have bought AuDel books before

1	2	3	4	5
6	7	8	9	
10	11	12A	12B	
12C	12N	14A	15A	
25	26	27	28	
29	42	49	53	

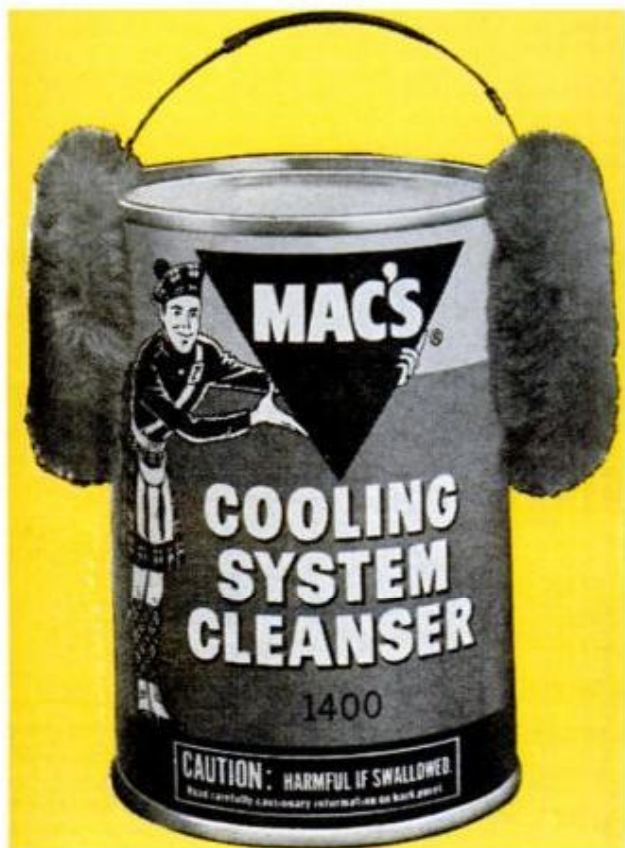

FOR COOL HEADS

MAC'S Cooling System Cleanser has a way with clogged radiators that gets right down to the "core" of the problem.

A single flush eliminates all clogging material, without the need of a neutralizer.

Result: hot heads become cool heads. Your motor's always ready to make the scene.

So why not get with a can of MAC'S Cooling System Cleanser today? And play it cool, man.

**MAC'S
SUPER GLOSS CO., INC.**
Los Angeles 90042
Cincinnati 45226

PLANER • MOLDER • SAW!

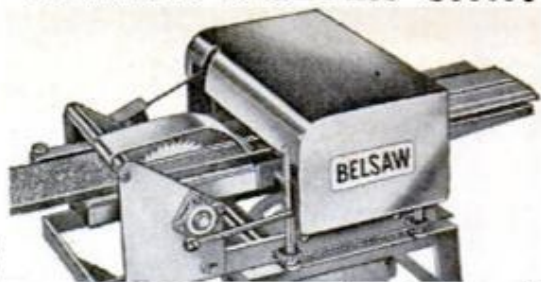

Now you can use this ONE power-feed shop to turn rough lumber into moldings, trim, flooring, furniture... ALL popular patterns. RIP... PLANE... MOLD... separately or all at once with a one HP motor. Use 3 to 5 HP for high speed output. Low Cost... You can own this power tool for only \$30.00 down payment.

Send postcard today for complete facts.
BELSAW POWER TOOLS, 9071 Field Bldg., Kansas City, Mo. 64111

I-N-V-E-N-T-O-R-S WE NEED INVENTIONS

Sell your invention for cash—need money for Patent?—Are technical problems holding you back? Universal Inventions has helped inventors all over the world—just like yourself—why not you? Inventions provide the magic spring-board to sudden riches. REMEMBER, we either sell your invention or pay you a cash bonus. Write for details.

UNIVERSAL INVENTIONS, Dept. 13, Marion, Ohio

make your own Gems 36⁵⁰

The Gem Maker comes complete with all necessary equipment, including a super-charged diamond blade for sawing, and all the wheels for grinding, shaping and polishing; also complete instructions. The complete equipment as shown, less motor and belt for only \$36.50, f.o.b. Burlington, Wisconsin. Write today for information and literature.

B&I MANUFACTURING CO.
Dept. P, Burlington, Wis.

Catalog of 2900 Novelties 10c

Send 10c for amazing catalog of novelties, live animals, scientific supplies, hobbies, funmakers, planes & boats, looms, magic tricks, joke articles, unusual seeds, gadget timesavers, cameras, optical goods, projectors, movies, lucky jewelry, religious novelties, disguises, musical instruments, stamps, coins, puzzles, fortune tellers, radios, auto & bike accessories, telescopes, magnifiers, compasses, banks, smokers' gadgets, artists' supplies, printing sets, engines, motors, shockers, knives, billfold, guns, rifles, sports, books, games, plants etc. Send 10c.

JOHNSON-SMITH CO., Dept. 111, Detroit 48207

EARN \$200 A WEEK

LEARN A TRADE YOU LIKE

After graduation you start as a mechanic in a good paying job; then advance to head mechanic or service manager. Many earn \$200 a week and up. You learn fast in our shops because you learn with tools on real equipment. Some students earn the greater part of their expenses while going to school.

Check the course in which you are interested.

- DIESEL MECHANICS AUTO MECHANICS
 WELDING BODY FENDER REPAIR

Mail to: AUTO-DIESEL COLLEGE

226 7th Avenue, North, Department 86, Nashville, Tennessee
Send me FREE catalog about course I have checked, also information about your FREE Placement Service.

Name _____
Address _____
City _____ State _____

NEWS FROM THE MILITARY

BY WILLIAM R. KREH

Prime movers. Elephants rented from a logging company in Thailand were used in a test recently to determine their usefulness to U.S. Army Signal Corps units in clearing dense jungle. The Army reports that it takes three pushes by an elephant to bowl a tree over, clearing the way for construction—and logistics people say the beasts are practical and could be an asset in future construction work in Asia.

Holy muscles! The Navy is developing a unique exoskeleton suit called "Hardiman" which can be worn like an outer garment to augment a man's ability to lift and move heavy objects. The suit, which contains its own power supply, is a jointed, load-bearing framework which enables the wearer to perform tasks beyond his normal ability or which would demand prolonged exertion.

With the aid of the exoskeleton suit, a man will be able to lift as much as 1500 pounds to a height of six feet and be able to carry the load at least 25 feet in 10 seconds. Enough joints will be included in the suit to allow the wearer to walk, bend, turn, lift, climb, push and pull with ease. The "gloves" of the suit will be flexible enough to permit the man to climb ladders, grip handles and ropes and handle objects of different sizes and shapes.

This suit-of-the-future will replace forklifts for some jobs and will probably be issued to cargo handlers. The Navy also sees potential use for the device in bomb loading, dock work, and salvage.

Simple English. Capt. George Bond, who's in charge of the Navy's Sealab experiments, tells of the difficulties in understanding speech in the underwater lab's helium-oxygen atmosphere. "Remarkably enough, however," he says, "there are some words that come through helium speech with astounding clarity . . . they're the words we don't use in polite society. This is some advantage, though, when you're working with Navy men," he adds. "At least one third of their speech fits."

Targets shoot back. Army engineers have rigged up some experimental silhouette targets that shoot back at soldiers who are slow to react. If the pop-up targets aren't hit within two seconds, a gun-fired pellet stings the soldier a good one. Masks and other equipment protect him. ★★



It's hollow ground to bore cleaner, faster at any angle

NOW YOU CAN increase the boring range of your small electric drill or drill press. New Irwin Speedbor "88" bits bore faster, cleaner holes up to 1 1/2" in any wood. 1/4" shank chucks perfectly. No wobble, no run-out. Sharp cutting edges on Irwin exclusive hollow ground point start holes faster, permit spade-type cutters to bore up to 5 times faster. All Irwin Speedbor "88" wood bits are forged from single bar of special bit steel, tempered full length and machine-sharpened for extra accuracy, longest life. 17 sizes, 1/4" to 1 1/2". Buy individually or in sets from your Irwin hardware or building supply dealer.

Only 75¢ each, sizes 1/4" to 9/16" 5/8" to 1", \$.85 ea., 1 1/8" to 1 1/2", \$1.30 ea.

IRWIN SPEEDBOR "88" WOOD BITS
at Wilmington, Ohio, since 1885

A "NEVER-BEFORE" OPPORTUNITY to Learn Quick—Earn Quick at Home



Be a TYPEWRITER REPAIRMAN

NOW, for the FIRST TIME, you can get into this booming, uncrowded, high-income field! You can easily, quickly cash in on the one skilled trade with proved industry training, never before available by home study!

- Earn up to \$50 per week in Spare Time
 - Step into well-paid jobs
 - Be the Boss of a big-profit business of your own
- Great DEMAND for trained men. Over 25 million typewriters need service and repairs. Find out how YOU can cash in FAST on this 300 million dollar market. WRITE TODAY: Typewriter Repair School, Dept. 310-056, Little Falls, New Jersey 07424. N. J. Lic'd. Acct'd. Member Nat'l. Home Study Council

Earn while you learn to fix, rebuild, resell ALL MAKES AND MODELS, you get real typewriter, sub-assemblies, professional tools all at NO EXTRA COST with course. Illustrated step-by-step instruction under guidance of industry experts. Get full facts in FREE BOOKLET from only school authorized to give you industry-approved training and State Approved Diploma.

MAIL COUPON NOW:

TYPEWRITER REPAIR SCHOOL, Dept. 310-056, Little Falls, New Jersey 07424

Send FREE BOOKLET about opportunities for Typewriter Repairmen. No obligation. No salesman will call.

Name _____

Address _____

City _____ State _____ Zip _____

Check here for Veteran Information

WE CAN'T THE ROAD



FIX UP

But we can give you a tire that takes any road in stride: The Workhorse. The tough-job tire for pickup & delivery work. Strong nylon cord body resists scrapes and bruises.

Pickup and delivery work can be pretty rough going. Over back roads. Construction sites. Cornfields. Railroad crossings. Fallen branches. Sharp rocks. Potholes. Ruts. Curbs.

That's where the Workhorse tire really comes through. The triple-tempered cord carcass shrugs off the bruises, bumps and scrapes.

**Up to 25%
more mileage.**

You can drive the Workhorse hard. Hit the brake. Step on the gas. The Workhorse is built for the stop-and-go grind of pickup and delivery.

In addition to triple-tempered nylon, the Workhorse has Tufsyn, toughest rubber Goodyear ever used in tires. And more of it—in the right places. 20% deeper tread. Thicker undertread, too. Up to 25% more rubber between

the cord and the road. The Workhorse delivers up to 25% more mileage than tires now used in most pickup and delivery work.

**Light trucks don't
always travel light.**

That's OK with the Workhorse. It's no Sunday tire. Pile on the tools, appliances, sand and gravel, camping equipment, logs or livestock. The Workhorse has stronger sidewalls for extra load-carrying strength. Helps you haul more. In fewer trips.

What's the price?

No more than an ordinary tire. Prices start at less than \$15.00.*

If you drive a pickup, panel, or light delivery truck—get the tough-job tire. The Workhorse, at your Goodyear Dealer's or Goodyear Service Store. Goodyear, Akron, Ohio 44316.



The Workhorse tire gives you a choice of two tread designs: Extra-traction design (shown above) for on and off the road. Rib type for on-highway work.

*(Size 6.00 x 16. Rib-type. Plus \$2.40 federal excise tax. At all Goodyear Stores. See your local Goodyear Dealer for his "competitive" prices.)

GOODYEAR

Tufsyn, Workhorse—T.M.'s The Goodyear Tire & Rubber Company, Akron, Ohio



Be a two-season hunter!

Want to become a better hunter? Become a bow-hunter! Bowhunting gives you an entire second hunting season in which to sharpen your hunting skills. Be one of the thousands who'll double their hunting season this year. Add a Bear bow to your gun rack (if you can handle a gun, you can handle a bow). The first step—see your nearby Bear dealer and his great new line of Bear hunting bows. See him now! And write for your free copy of the full color 1966 Bear catalog.



Bear® ARCHERY COMPANY
Dept. PM-8 • Rural Route One • Grayling, Michigan
In Canada: Canadian Bear Archery Distributors

BY KEVIN V. BROWN
AVIATION
JETSTREAM

At Edwards Air Force Base in June, I was scheduled to "fly" the XB-70 in a simulator, along with Chief Test Pilot Al White. I also hoped to see Joe Walker. Who wouldn't?

Joe Walker was the hottest airplane pilot in the world. As chief test pilot for NASA, he had flown higher (354,200 feet) and faster (4104 miles per hour) than any aviator in history. Altogether he flew dozens of times in the rocket-powered X-15,



JOE WALKER, test pilot for NASA, died at his work

setting some kind of a record on nearly every trip. Last year he spent most of his time testing the Lunar Landing Research Vehicle, a wingless contraption controlled by downward air jets that will be used to teach astronauts how to land easily on the moon. This year he was training to fly the XB-70, America's first supersonic bomber, which had achieved speeds of Mach 3.

On June 8, Joe Walker was observing one of our two B-70s in flight from an F-104 chase plane accompanying the half-billion-dollar monster. For some reason that may never be determined, the two collided. Joe Walker was killed. So was Major Carl Cross, co-pilot of the big bomber. Al White, who had been scheduled to acquaint me with the B-70 simulator, was at the B-70's controls. He managed to eject but was in a state of serious shock. Let's hope he gets better. I might still get to "fly" with him.

DETROIT

LISTENING POST

ROBERT W. IRWIN

The intermediates may be bigger yet in another year. Word is that the Ford Fairlane's overall length will increase four inches in the 1968 models. The present 197 inches will stay the same in 1967 but should go to 201 in '68. Center-pillar width may go up two inches but wheelbase will stay at 116. American Motors' Ambassador line will grow about three inches in '67, should add another three in '68, extending overall length to about 206 inches, the same as Pontiac's present Tempest. Ambassador should get some real power, too, from a bigger version of AMC's new 290-cu.-in. V8. One source mentions a 401-inch engine as a '68 possibility—in line with AMC's decision to get more zip in its cars.

Cadillac's new Eldorado is expected to sell for about \$7000 at its fall debut. The front-wheel-drive model, built off the Toronado-Riviera body, has a cost target a little under \$4000, according to industry sources who report that the engineers were only about \$150 above that a short time ago. The figures are said to reflect the 20 to 25 percent dealer's profit margin in the new-car retail price, as well as a similar markup for the manufacturer.

"Oops! Sorry about that, boss," was what a Pontiac man might have said after he inadvertently released a picture of a 1967 model. A publicity shot of the new General Motors proving grounds showed several cars on hoists. All were '66s except one—a nice rear view of a '67. Reporters at first thought it was a tease photo; later were told it was a blunder by a not too keen-eyed press agent. Because they had telephoto-lens pictures of the car being road-tested at the proving grounds, the reporters knew it was next year's model.

First U.S. auto safety chief may be Dr. William Haddon Jr. A physician and engineer now employed by the New York State Department of Health, he's been mentioned as the man in line for this most influential post and has won the praise of both the industry and its chief critic. He's highly regarded by Roy E. Haeusler, Chrysler's well-known automotive safety engineer, who says "they couldn't get a better man in terms of a sense of responsibility, balance and proportion." The selection is vital to the auto industry because whoever heads the auto safety program that Congress is expected to set up will determine the standards required for every car sold in the United States. Even auto critic Ralph Nader approves of Haddon. "It would be hard to find anyone who has been closer to the auto safety problem," Nader says. Haddon would seem to be the choice of both camps.

Rubber-lined fuel tanks, which proved their worth at the recent Indianapolis "500," may have some potential as a new safety feature in passenger cars. Henry Banks, director of competition for USAC, believes the rubber bladders "very definitely prevented a worse accident" in this year's "500" when every driver escaped a first-lap, 16-car pileup. The linings are designed to prevent a fiery explosion like that which killed Eddie Sachs and Dave MacDonald in 1964. Auto engineers have studied the devices but there are no plans to put them in passenger cars—yet.

Another new safety device, called an "essential light monitor," may have a good chance of becoming a production item on cars. It tells a driver when there is a malfunction in the car's running lights. If a brake light sticks or a headlight burns out, he'll know immediately. The device consists of three lights: red, green and amber. The green glows when everything is operating properly. If there is a malfunction

(Please turn to page 20)

EARN BIG MONEY IN AIR CONDITIONING, REFRIGERATION AND HEATING

25 KITS SENT TO BUILD THIS
COMPLETE REFRIGERATION SYSTEM



You learn by
practicing with real equipment

A better job, top pay and steady work are easily within your reach. Learn to repair and install air conditioning systems, refrigerators and freezers. Air conditioning is one of America's fastest-growing industries. Millions of autos and homes are being air-conditioned. The need for trained men is immediate and great.

Make Home Your Training Center — Learn by practicing. CTI sends 25 kits of tools and parts to build a complete refrigeration system — which you later convert into a refrigerator or freezer. The course is easy!

Earn Money As You Train — Since the CTI course includes training with real equipment, many students earn money repairing units soon after enrolling. On completing training they go into top pay jobs. Many get started in their own business.

Mail Coupon Today for free book. No obligation. Prove to yourself that the air conditioning, refrigeration and heating field is best for you — the easiest training to master and loaded with top pay opportunities.

Commercial Trades Institute, Chicago, Ill. 60626

COMMERCIAL TRADES INSTITUTE

1400 Greenleaf Avenue
Chicago, Illinois 60626 Dept. PM-866

Send book, *Be a Success in Air Conditioning, Refrigeration & Heating*. No obligation.

Name _____ Age _____

Address _____ Zip _____

City _____ County _____ State _____

Accredited Member National Home Study Council



DETROIT LISTENING POST

(Continued from page 19)

in the lighting system, the red shows. The amber light assures that the brake light is okay. Marketed by John Fitch, the semi-retired race driver from Lime Rock, Conn., the device is a standard item on his Tornado Phantom conversion and a \$29.50 option on his Corvair Sprint. As a production item it would cost about \$12. Fitch believes it's a possibility for '68 cars.

Speeder-catching planes are becoming popular with police. Newest airborne cops are in Michigan. Col. Frederick E. Davids, director of the Michigan State Police, says, "We've used aircraft for a long time to patrol the highways, but now we're going all out to use the planes to check speeders." Davids says the system is being employed in Illinois, Ohio and other states, as well as in parts of Canada. "It's a very simple operation and the accuracy is fantastic," Davids says. A quarter-mile check zone is established by painting a line at each end on the shoulder of the road. An observer in a police plane following a suspected speeder clicks on his stopwatch when the car enters the quarter-mile zone, clicks it off when the car leaves and then checks a calibration chart to get the exact speed. The pilot then radios ahead to a police car to stop the driver and give him a ticket.

Cutting collision costs is serious business at Blairsville, Pa., a village 40 miles east of Pittsburgh and home of a technical institute highly regarded by the major auto insurance companies. There, Eugene C. Vale trains insurance adjusters in appraising auto collision damage and costs, also operates a trade school for auto mechanics. As a result of one of his studies, the insurers no longer recognize a claim from one who says his engine was ruined by someone putting sugar in the gas tank. Contrary to popular belief, this won't damage the engine, Vale says. The institute also devised a way to repair hail damage to car roof and body panels. A rivet is soldered into each dent, then pulled off; the dent pops out, too.

Vale is now working on a project he thinks may cut repair bills for minor body damage. "Metal has a memory," he says. "If it's dented, it wants to go back to its original shape." This can be done, he believes, by vibrating the metal. So he's working on a portable vibrator that could be used by repair shops. "You could attach the vibrator to a piece of metal, turn a switch and the metal would return to its original shape," Vale says. ★★★

Tune-up notes from AC:

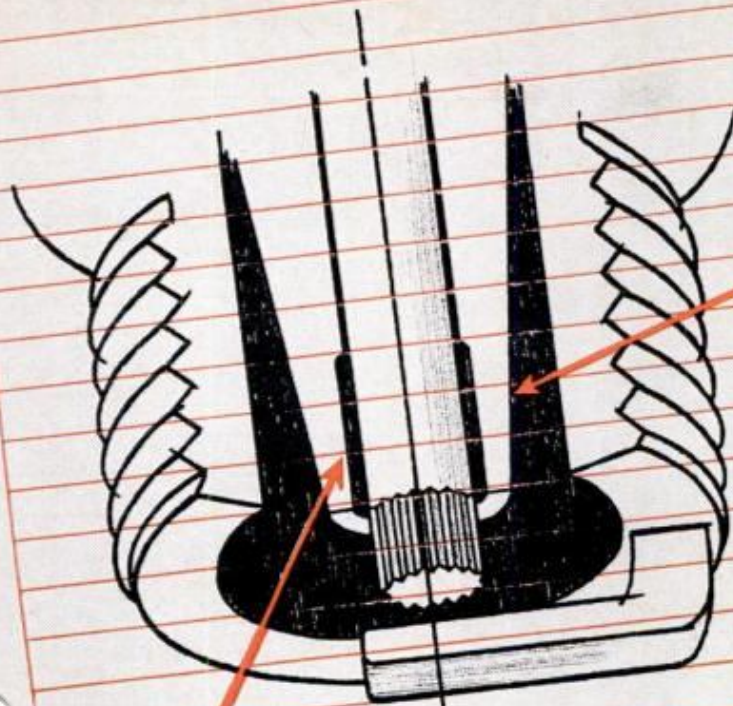

*tapered-tip
design opens up
more
scavenging area.*

*thin recessed tip
heats faster to burn
away fouling deposits.*



How AC's Self-Cleaning Hot Tip Insulator promotes peak power longer.

Because of its ultra-thin, recessed design, AC Spark Plug's Self-Cleaning Hot Tip Insulator gets hotter, faster—to stay cleaner, longer. The hot tip burns away fouling deposits and promotes more powerful, more responsive engine performance. AC's exclusive recessed tip also cools faster to minimize pre-ignition. With their faster heating and cooling properties, AC Fire-Ring Spark Plugs can be driven harder with less danger of overheating—can be used for slower speeds with less danger of fouling. Make your own tune-up note now. Promote maximum power and performance in your car's engine. Insist on AC Fire-Ring Spark Plugs next time you change.

AC SPARK PLUG DIVISION



**FIRE-RING
SPARK PLUGS**

AUGUST 1966

21

FREE!



Trial lesson in **DRAFTING & DESIGN**

LEARN AT HOME IN SPARE TIME

Check the want ads in any newspaper—SEE the big-pay opportunities open to you as a draftsman. What's more, you can learn this well-paid, prestige profession at home—quickly, easily! No special talent needed! Get complete, step-by-step Chicago Tech lessons in the mail, spend a few pleasant hours studying each week. In a short time you'll be a well-trained draftsman, ready to take your pick of many good jobs. Act now!

FREE INFORMATION—MAIL COUPON TODAY!

Get FREE TRIAL LESSON plus information about C.T.C. practical training. Learn what successful Chicago Tech graduates say about high pay and opportunities in drafting. No charge, or obligation.

Est. 1904 Accredited National Home Study Council

CHICAGO TECHNICAL COLLEGE

**K-204 Tech Bldg., 2000 So. Michigan Ave.
Chicago 16, Illinois**

Mail me FREE Lesson with information about big opportunities in DRAFTING.

Name..... Age.....
Address.....
City..... Zone..... State.....

TELLS HOW TO SELL YOUR INVENTION

If you have an invention that you believe has merit, write us at once for copy of copyrighted booklet "How to Go About Selling Your Invention." We work with manufacturers, and booklet reveals present markets, qualities of a saleable invention, current royalty rates being paid by manufacturers. Booklet is FREE, is offered to encourage new ideas we might submit to manufacturers. Just send name (no drawings, please) to Kessler Sales Corp., Dept. D-58, Fremont, Ohio 43420

BUILD YOUR OWN CAMPER AND SAVE!



Complete, easy to follow Camper Plans, Instructions and Materials List ... \$3.95

PICKUP COVER PLANS \$2.00
EQUIPMENT CATALOG \$1.00

**SAVE 50% WITH THIS
VIKING PACKAGE DEAL**
All items from our catalog to build a 10' or 10'6" Camper. Average retail \$1,795. Total Pkge. \$847.10.

Refundable on first order. SATISFACTION GUARANTEED. Also Factory Built Units.

**VIKING
CAMPER SUPPLY, INC.**
94-8P Glenwood Ave.
Minneapolis, Minn. 55403

SEND CHECK OR M.O. FOR DETAILS SEND DIME.
NAME.....
ADDRESS.....
CITY..... STATE.....

WOOD VENEERS • TOOLS Shop Equipment • Supplies **POWER TOOLS** at Lowest Discount Prices!

SAVE MONEY on finest domestic and imported hardwoods . . . all dimensions. Over 1500 items for the home craftsman and woodworking hobbyist. Lamp parts, upholstery supplies, tile, power tools at discounts. **NEW CATALOG READY** 132 pages. Full Color. Send name, address and 35¢ to cover handling, and postage. Write . . .

CRAFTSMAN Wood Service Co. Dept. A-86
2729 S. Mary, Chicago, Ill. 60608

NOW! WARN OVERDRIVE gives 'Jeeps' more Go!



New approved accessory cuts engine RPM 33% at any speed, reduces noise, vibration so you can drive your Jeep 4-w.d. comfortably at freeway speeds. Amazing synchromesh OD lets you shift up or down, on the go, anytime, in any gear, at any speed. Adds six forward speeds, two reverse. At Jeep dealers, or write us.



WARN SALES CO., Inc.
9050-A Empire Way South
Seattle, Washington 98118

Two or four-wheel drive
JEEP or SCOUT
owners

REPOWER with a 6 or V-8. H.D. ADAPTORS for using Car, Compact and some Truck engines. Conversion Kits \$45.35 to \$56.90. Want fast action? Give us FULL INFORMATION. Send \$15.00 Dep. and we will ship correct kit, bal. COD. Send full amount for prepaid shipment. Wire, phone or write today. Details FREE

HOOSIER MACHINE PRODUCTS CO.
312 S. E. 6th St., Phone 276-3442, Pendleton, Oregon

Coral polyps live in all seas, even as far north as Norway's fjords. Reef-building varieties thrive best in tropic shallows.

HYDRAULIC JACK REPAIRS



Earn While You Learn at Home

Earn while you learn at home. Trained and qualified mechanics needed NOW to service inoperative hydraulic jacks. BIG opportunity for ambitious men. We show you HOW—in your basement or garage, spare time cash income in an expanding industry. Don't wait, ACT NOW! Get the facts.

Write for folder No. PM8 and free bonus offer

HYDRAULIC JACK REPAIR MANUAL CO.
P. O. BOX 50 • BLOOMFIELD, N. J.

CATCH THEM ALIVE AND UNHURT!



Amazing HAVAHART trap captures raiding rats, rabbits, squirrels, skunks, pigeons, sparrows, etc. Takes mink, coon without injury. Straying pets, poultry released unhurt. Easy to use—open ends give animal confidence. No jaws or springs to break. Galvanized. Sizes for all needs. FREE illustrated practical guide with trapping secrets.



Catches more!
Easy to use!

HAVAHART, 136-T Water St., Ossining, N. Y. 10562
Please send me FREE new 48-page guide, price list.

Name.....
Address..... Zip.....

FROM THE PATENT OFFICE **NEW INVENTIONS**
BY M. J. PEDERSEN

Double standard on highways with one speed limit posted for daytime driving and another, lower one at night helps promote auto safety. One of the two basic methods for making these signs was awarded patent 3,247,005 for Allan D. Parry, East Freedom, Pa., and William H. Riley, Jr., Altoona, Pa. The technique is to paste or spray the night limit figure over the daytime one, relying on light from headlights to make the nighttime message visible.

Improved rust resistance—at no cost to brightness—of the chromium-stainless steel used as trim on many cars may be achieved by an electrolytic treatment which earned patent 3,247,086 for Arthur Moskowitz and David Goldstein, who assigned rights to the Crucible Steel Co. of America, Pittsburgh, Pa.

Fish flour protein—increasingly used to

nourish the world's burgeoning population—has been freed of its usual rancidity and given a longer shelf life by a method that received patent 3,252,962 for Wilson M. Whaley, Chicago, and Raymond J. Moshy, Westport, Conn. An entire fish that's high in oil content, such as menhaden, is ground up in a mill, and water is added to form a slurry. After a heat and acid treatment, the protein is extracted from the slurry with a bland solvent.

3-D X-ray suggests particular value in markedly reducing the time a patient need be exposed to the X-rays. Patent 3,244,878 was awarded Dr. Ralph R. Stevenson and Edward S. Stein, Washington, D.C.

Commissioner of Patents Edward J. Brenner told us in a recent interview that the time lapse from date of application to issuance of a patent has been reduced to an average of 2½ years—down from 3½ years; the goal is 18 months by 1970. Lag time for patents in the mechanical field averages 2 years.

For a preview of one of the entries to appear at the upcoming **Inventors and New Products Exhibition** at the New York Coliseum (Sept. 9—18), see page 61A.

NO

No dirty rifle barrels when you're shooting Remington "Hi-Speed" 22's with "golden" bullets. The only 22's with famous "Kleanbore" priming, the original non-corrosive mixture that protects barrel accuracy, lengthens barrel life. Ask for them by name at your nearest Remington dealer's.

"Kleanbore" is Reg. U.S. Pat. Off. and "Hi-Speed" is a trademark of Remington Arms Company, Inc., Bridgeport, Conn. 06602.



Remington 

GAIN PRESTIGE, BIG INCOME, JOB SECURITY



You, too, can be an Accident Investigator

Thrilling New Way To Earn Up To \$8 An Hour!

Even while you read this, more than 2,000 accidents, fires, and windstorms are occurring across the U.S.A. Insurance and transportation companies are in dire need of men trained to investigate and adjust the thousands of claims that result from these incidents. Such claims are required by law to be settled *quickly*, yet there are hundreds of cities and rural areas where there are not enough men to handle this vital work. This creates a golden opportunity for men up to 65.

We are training scores of accident investigators by mail and helping to place them in the fast-growing, highly profitable Accident Investigating Field. No previous experience is required. A car is usually furnished; expenses are paid. Many men earn while they learn. Only average education is required.

Here are just a few reports of recent earnings: Bob Durant jumped his salary to \$7500 as soon as he started. Bill Peck made \$943.00 in just 5 days, checking hurricane damage! Bob Pritchard reports companies in his area offering men \$8,000 a year to start, plus car and expenses! (Many men are earning \$8 an hour on the side in their spare time.) No wonder Art Victoria writes, "I recommend Liberty School's Home Study Course for those seeking a better life."

Keep Old Job Until Ready to Switch

Only 15 minutes reading a day puts you on the high road to success as an accident investigator. Progress as fast or as slow as you like. Many men get their diplomas in a matter of weeks! (We give you FREE Employment Help through our nation-wide PLACEMENT SERVICE—or show you how to start an investigating business of your own at home.) Dozens of big companies with job openings are making good use of our monthly graduate list.

Let us prove how easily you can quickly switch into this exciting new career that provides prestige, security, a bright future! Sending for FREE Brochure does not obligate you in any way. No salesmen will call. Mail postcard or coupon to Dept. 58, Liberty School, 1139 W. Park, Libertyville, Ill. (Liberty School is fully licensed as a Business School by the State of Illinois.)

Your Steps
to Success as an
ACCIDENT
INVESTIGATOR

Eric P. McNair, President, Dept. 58
Liberty School of Claim Investigating
1139 W. Park, Libertyville, Illinois

**FREE
BROCHURE**

Rush me your FREE BROCHURE showing how I can gain job security and prestige and make as much as \$1,000 a month by getting into the Booming Accident Investigating Field. Also include the actual names and locations of successful graduates all over the country. This does not obligate me in any way, and no salesman will call.

Name _____ Age _____

Address _____

City _____ State _____ Zip Code _____

PM TEST REPORT



This Pint-Size Router Tackles Man-Size Jobs

A LITTLE BROTHER to the standard router in muscle and size — but not in ability — is Stanley Power Tools' Job/Master Rout-about. I found that, at \$32.50 (below half its sibling's price), this ¼-hp, 25,000-rpm router can do what the big ones do, but with smaller bites and at slower speed.

Its light weight (3¼ lbs.) and large handles make it a cinch to maneuver, even for edge work on narrow stock. This ease is offset, however, by a shallow edge guide, which makes it difficult to start a blind groove with precision. While the guide is set by tightening Phillips-head screws, thumbscrews would have been better.

The upper edge of the base is spiraled and marked in 1/32-in. increments. Resting on this is the depth indicator on the motor housing. A large thumbscrew locks the setting. (Unless it's tight, don't upend the base or the motor will drop out.)

Apart from slower cutting speed and a maximum cut of 3/16 in., I found the biggest shortcoming to be in setting the cut. Depth-of-cut setting is precise, but not simple for lack of a zero-depth calibration between bit and base. The bit does not bottom in the chuck, but is inserted 1/2 to 3/4 in. You zero-adjust by aligning the bit with the base and note where the indicator points. To set the depth, you count off 1/32-in. marks from the adjusted zero.

Discounting these convenience factors, the Rout-about is an effective tool at a price that every shop should be able to afford.—Len Samuels

Cast your ballot for a successful future!

253 I.C.S. COURSES



I.C.S. is the oldest, largest correspondence school. Over 200 courses. Business, industrial, engineering, academic, high school. One for you. Direct, job-related. Bedrock facts and theory plus

practical application. Complete lesson and answer service. No skimping. Diploma to graduates.

Send for the 3 free booklets offered here and find out how I.C.S. can be your road to success.

ACCOUNTING
Accounting for Business
Accounting (Canada)
Auditing
Business Law
Cost Accounting
C.P.A. Review
Estate & Trust Accounting
Executive Accounting
Federal Tax
General Accounting
Industrial Accounting
Junior Accounting
Legal Accounting
Office Accounting
Personal Income Tax & Social Security
Practical Accounting
Public Accounting
Small Business Accounting
Starting & Managing a Small Bookkeeping Service

ARCHITECTURE AND BUILDING
Arch. Drawing & Design
Architecture
Building Contractor
Building Estimator
Building Inspector
Building Maintenance
Carpenter-Builder
Carpentry & Millwork
House Planning & Interior Design
Mason
Painting Contractor
Reading Arch. Blueprints
Review in Arch. Design & Practice
Review of Mech. Systems in Buildings

ART
Amateur Artist
Commercial Art
Commercial Cartooning
Interior Decorating
Oil Painting for Pleasure
Show Card & Sign Prod.
Show Card Writing
Sign Painting & Designing
Sketching & Painting

AUTOMOTIVE
Automatic Transmission Specialist
Automobile Body Rebuilding & Refinishing
Automobile Electrical Tech.
Automobile Engine Tune-Up

Automobile Technician
Automotive Mechanic
Diesel-Gas Motor Vehicle Engines

BUSINESS
Advertising
Basic Inventory Control
Business Administration
Business Management & Marketing
Business Management & Production
Canadian Business Courses
COBOL Programming
Condensed Business Practice
Direct Mail & Mail Order Advertising
Industrial Psychology
Magazine & Newspaper Advertising
Managing a Small Store
Marketing
Marketing Research
Modern Executive Management
Office Automation
Office Management
Programming for Digital Computers
Programming the IBM 1401 Computer
Purchasing Agent
Retail Business Management
Retail & Local Advertising
Retail Merchandising
Retail Selling
Systems and Procedures Analysis

CHEMICAL
Analytical Chemistry
Chemical Engineering
Chemical Engineering Unit Operations
Chemical Laboratory Tech.
Chemical Process Operator
Elements of Nuclear Energy
General Chemistry
Instrumental Laboratory Analysis

CIVIL ENGINEERING
Civil Engineering
Construction Engineering
Highway Engineering
Principles of Surveying
Reading Highway Blueprints
Sanitary Engineering
Sewage Plant Operator

Structural Engineering
Surveying and Mapping
Water Works Operator

DRAFTING
Architectural Drafting
Design Drafting
Drafting Technology
Electrical Drafting
Electrical Engineering Drafting
Electronic Drafting
Introductory Mechanical Drafting
Mechanical Drafting
Pressure Vessel and Tank Print Reading
Sheet Metal Layout for Air Conditioning
Structural Drafting

ELECTRICAL
Electric Motor Repairman
Electrical Appliance Servicing
Electrical Contractor
Electrical Engineering (Power option or Electronic option)
Electrical Engineering Tech.
Electrical Instrument Tech.
Industrial Electrical Tech.
Power Line Design and Construction
Power Plant Operator (Hydro or Steam Option)
Practical Electrician
Practical Lineman
Reading Electrical Blueprints

ENGINEERING (Professional)
Chemical Civil
Electrical Mechanical
Industrial Management for Engineers

ENGLISH AND WRITING
Better Business Writing
Free Lance Writing
Introductory Tech. Writing
Modern Letter Writing
Practical English
Short Story Writing

HIGH SCHOOL
High School Business
High School (Canada)
High School College Prep. (Arts)
High School College Prep. (Engineering & Science)

High School General
High School Mathematics
High School Secretarial
High School Vocational

LANGUAGES
(Edited by Berlitz)
French German
Italian Spanish

LEADERSHIP
Basic Supervision
Industrial Foremanship
Industrial Supervision
Personality Development
Personnel-Labor Relations

MATHEMATICS
Advanced Mathematics
Mathematics and Mechanics for Engineering
Mathematics and Physics for Engineering
Mathematics & Physics for Technicians
Modern Elementary Statistics

MECHANICAL
Aircraft & Power Plant Mechanic
Industrial Engineering
Industrial Instrumentation
Machine Design
Mechanical Engineering Quality Control
Safety Engineering Tech.
Tool Design
Value Analysis

PETROLEUM
Natural Gas Production & Transmission
Oil Field Technology
Petroleum Production
Petroleum Production Engineering
Petroleum Refinery Oper.
Pipeline Engineering

PLASTICS
Plastics Technician

PLUMBING, HEATING, AIR CONDITIONING
Air Conditioning
Air Conditioning Maint.
Domestic Heating with Oil & Gas
Domestic Refrigeration Heating
Heating & Air Conditioning with Drawing
Industrial Air Conditioning

Industrial Heating
Plumbing
Plumbing & Heating
Practical Plumbing
Refrigeration
Refrigeration & Air Conditioning
Steam Fitting

PULP AND PAPER
Paper Machine Operator
Paper Making
Pulp Making
Pulp & Paper Engineering
Pulp & Paper Making

SALESMANSHIP
Creative Salesmanship
Real Estate Salesmanship
Sales Management
Salesmanship

SECRETARIAL
Clerk-Typist
Commercial
Legal Secretary
Medical Secretary
Professional Secretary
Shorthand
Stenographic
Typewriting

SHOP PRACTICE
Drill Operator
Foundry Practice
Industrial Metallurgy
Lathe Operator
Machine Shop Inspection
Machine Shop Practice
Machine Shop Practice & Toolmaking
Metallurgical Engineering Technology
Milling Machine Operator
Multicraft Maintenance Mechanic
Practical Millwrighting
Reading Shop Prints
Rigging
Tool Engineering Techn'y
Tool Grinder
Toolmaking
Turret Lathe Operator
Welding Engineering Tech.

STEAM AND DIESEL POWER
Boiler Inspector
Industrial Building Engineer
Power Plant Engineering
Stationary Diesel Engines
Stationary Fireman
Stationary Steam Eng.

TEXTILES
Carding
Carding and Spinning
Dyeing & Finishing
Loom Fixing Spinning
Textile Designing
Textile Technology
Textile Mill Supervisor
Warping and Weaving

TRAFFIC
Motor Traffic Management
Railway Rate Clerk
Traffic Management

TV-RADIO-ELECTRONICS
Communications Techn'y
Electronic Fundamentals
Electronic Fundamentals (Programed)

Electronic Fundamentals with Electr. Equip. Tr'n'g
Electronic Instrumentation & Servo Fundamentals
Electronic Principles for Automation
Electronics and Applied Calculus
Electronics Technician
First Class Radiotelephone License

Fundamentals of Electronic Computers
General Electronics
General Electronics with Electronic Equip. Tr'n'g
Hi-Fi Stereo and Sound Systems Servicing
Industrial Electronics
Industrial Electronics Engineering
Industrial Electronics Engineering Technician
Practical Radio-TV Eng'r'g
Practical Television
Principles of Radio-Electronic Telemetry
Principles of Semiconductor-Transistor Circuits
Radio Servicing with Equipment Training
Radio & TV Servicing
Radio & TV Servicing with Equipment Training
Second Class Radiotelephone License
Sound Systems Specialist
Telephony, Electronics and Radio Communications
TV Receiver Servicing
TV Technician

Clip coupon—and take your first big step to real success! I.C.S., Scranton, Penna. 18515 Accredited Member, National Home Study Council

INTERNATIONAL CORRESPONDENCE SCHOOLS I C S

Dept. 2006, Scranton, Penna. 18515 (In Hawaii: P.O. Box 418, Honolulu. In Canada: I.C.S. Canadian, Ltd. In other countries: I.C.S. World, Ltd.)
Without cost or obligation, rush me "HOW to SUCCEED," the opportunity booklet about the field I have indicated below, and a sample lesson.
New! Special Package for Women! Special training programs for industry Convenient Payment Plan

Name of the course in which you are interested _____
Name _____ Age _____ Address _____
(Please indicate Mr. Miss Mrs.)
City _____ State _____ Zip Code _____ Working Hours _____ A.M. to _____ P.M.
Occupation _____ Employed by _____
 I am a member of U.S. Armed Forces.
Send me information on special low rates.

HEAVY DUTY BALL-BEARING PUMP

IRRIGATE
DRAIN SPRAY
CIRCULATE



Famous, all-metal, rust-proof XB pump with stainless shaft. Use 1/4 HP or larger. 1 HP for up to 5,200 GPH 60' high or 3,000 GPH from 25' well. 1 1/4" inlet. 1" outlet. For belt or direct drives. Only \$12.95
Famous Type P won't rust or clog. Bronze bearing. Hundreds of thousands in use. Up to 2,400 GPH. 1" inlet. 3/4" outlet. Only \$8.95

Postpaid cash with order.
Money Back Guarantee. LABAWCO PUMPS Belle Mead 104, N. J.

ACCORDIONS • Big Discounts

Buy
Direct
Importer-
to-You

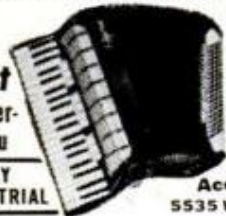

5-DAY
HOME TRIAL

NEW ELECTRONIC MODELS

SAVE 1/2 42 "New Sound" Electronic and Standard models. Amplifiers too! All Famous Makes. Try before you buy—5-Day Trial. Easy Terms. Trade-ins. Free Accessories. Money Back Guarantee. Free Color Catalogs, Handy Selection Guide, Discount Prices, Write
Accordions Corporation of America
5535 W. Belmont, Dept. R-86, Chicago 41, Ill.

BILL TROUBLES ?

NOBODY REFUSED UP TO \$15,000.00

Bad Credit • No Problem • Not a Loan Co.

Send your name and address for FREE application to nearest office for faster service

ATLANTIC ASSOCIATES, Dept. 54

146 Westminster St., Providence, R. I.

3312 N. Central Ave., Phoenix, Arizona

GET INTO ELECTRONICS

V.T.I. training leads to success as technicians, field engineers, specialists in communications, guided missiles, computers, radar, automation, Basic & advanced courses. Electronic Engineering Technology and Electronic Technology curricula both available. Assoc. degree in 29 mos. B.S. obtainable. G.I. approved. Start Sept., Feb. Dorms, campus. High School Graduate or equivalent. Catalog.

VALPARAISO TECHNICAL INSTITUTE
DEPARTMENT D. VALPARAISO, INDIANA



LEARN WELDING AT HOME

WE SEND YOU A WELDER

A trade with a future—in demand everywhere
We have trained thousands—Men who earn up to \$4.50 an hour. Learn Arc, Heli-Arc and Gas Welding. We supply equipment that lets you earn while you learn. Practical lessons on brand new, industrial rated machines. Both arc and flame welding. On completion the equipment is yours. Set up your own shop or work in any shop on any job. Send today for full information.

AMERICAN INSTITUTE OF ENGINEERING & TECHNOLOGY
1131 W. Fullerton Parkway, Chicago, Illinois

LAW FREE BOOK THE LAW TRAINED MAN

Write today for a FREE copy of illustrated law book, "THE LAW TRAINED MAN," which shows how to earn the professional Bachelor of Laws (LL.B.) degree through home study of the famous Blackstone Law Course. All necessary books and lessons provided. Moderate cost; convenient monthly terms. Write for FREE law training book today.

Blackstone School of Law, 307 N. Michigan Ave.
Founded 1890 Dept. 50-C, Chicago 51, Illinois

START YOUR OWN MONEY MAKING BUSINESS

Clean rugs on customers' floors—upholstery in their homes—even painted walls—with highly efficient electric machines which are making big money for others and giving them independence. Write today for complete information. It's FREE!

VON SCHRADER MFG. CO., Dept. 810 "R" Pl., Racine, Wis.

Good grooming
companion.

TRIM NAIL CLIPPER

Look for the full line of TRIM implements at your favorite store.

The W. E. Bassett Co., Derby, Conn.



IMPORTED LONG BLADE POCKET KNIFE

ONLY

\$1.75

9" Overall Length

5" When Closed

- Opens instantly
- Sharp and Tough
- Stainless Steel Blade



Opens instantly—folding finger guard snaps into position automatically. Razor sharp tough stainless steel blade holds its edge for years of long hard service. A knife you will be proud to own. Guaranteed. Money back in five days if not satisfied. Send \$1.75 plus 25c to cover postage and handling. NOT SOLD TO MINORS. Please state age.

WESTBURY SALES CO., DEPT. S120
P. O. BOX 415, WESTBURY, N. Y.

Build Your Own Business While Still Employed

It's true. Without giving up your regular job—without losing a single pay check—you now have an opportunity to double your income in your own business. A big 24-page book tells how other men do it—then expand to a full time operation. Gross hourly profit \$9.00—PLUS \$6.00 additional on each service man. Income unlimited.

Your service is Nationally Advertised, world-wide and endorsed by McCall's and Parents' Magazines. Carpet and upholstery cleaning. Also 5 other superior on location services. You need no experience. We show you how and finance you for all but a few hundred dollars. Easy to learn—easy to do—easy to build up to a good, steady volume because we show you 15 tested ways to get customers.

G. F. Monroe, after 12 months, sold his business for 10 times his cost. Leo Lubel sold his for \$7,116 more than he paid. L. Babbit writes, "I average \$2,600 monthly, part time." W. C. Smith earned \$650 in one week. Ed Kramsky said, "In two years I have two assistants, a home and security."

This may be the opportunity of your life. Find out today before someone else gets your location. Mail coupon now for details and 24-page illustrated free book. No obligation. No salesmen will call. Mail coupon now while territories are open.

DURACLEAN COMPANY

6-168 Duraclean Building, Deerfield, Illinois 60015

Please send me your 24-page illustrated book that tells how I can double my income in spare time, in a business of my own. Everything you send me now is free and I am under no obligation. No salesmen will call.

NAME _____

ADDRESS _____

CITY _____ STATE _____ ZIP CODE _____

QUICKER; EASIER; CHEAPER TO LEARN TO MOVE UP FASTER; MAKE MORE MONEY
PAY WITH N.T.S. HOME TRAINING the "Project Method" way.



ELECTRONICS DIVISION

1. Electronics-TV-Radio Servicing and Communications
2. Master Course in Electronics-TV-Radio Advanced TV and Industrial Electronics
3. FCC License Course
4. Radio Servicing (AM-FM-Transistors)
5. Television Servicing (Including Color)
6. Stereo, Hi-Fi and Sound Systems
7. Basic Electronics
8. Electronics Math

NO KIT DEPOSITS

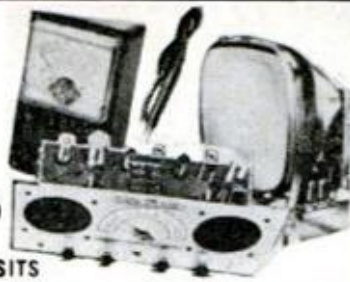

AUTO-MECHANICS DIVISION

1. Automotive-Diesel Master Course
 2. Automotive Mechanics
 3. Diesel Mechanics
 4. Engine Tune-Up and Electricity
- Eighty million cars and trucks need maintenance. Here's real opportunity! Get and keep valuable tools. No kit deposits, no extra cost.

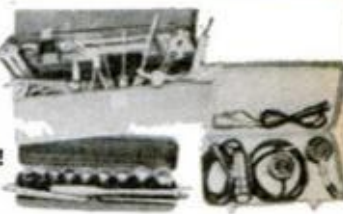

AIR CONDITIONING-REFRIGERATION DIVISION

1. Air Conditioning-Refrigeration Servicing Course
 2. Air Conditioning Refrigeration & Electrical Appliances Master Course
- Good income in servicing and installation. Big equipment kits with both courses at no extra cost. No kit deposits.



HOME APPLIANCES DIVISION

1. Home Appliances Master Technician's Course
 2. Home Appliances Servicing Course
- Prepare for full or part time career. Earn while you learn. No kit deposits. Tools included at no extra cost.



NATIONAL TECHNICAL SCHOOLS

4000 S. Figueroa St., Los Angeles, California 90037

HIGH SCHOOL AT HOME

National offers accredited high school programs. Take only subjects you need. Study at your own pace. Everything included at one low tuition. Check special High School box in coupon for complete FREE Diploma information.

CLASSROOM TRAINING AT LOS ANGELES

You can take classroom training in our famous Resident School in Los Angeles. Check Resident School box in coupon for full details.

SEND FOR FREE BOOK & SAMPLE LESSON



NATIONAL TECHNICAL SCHOOLS, DEPT. 201-86
 4000 S. Figueroa St., Los Angeles, Calif. 90037
 Please rush FREE BOOK AND SAMPLE LESSON for Division checked below. Please check one only.

- ELECTRONICS Division
 AUTO MECHANICS Division
 HIGH SCHOOL Department
- AIR CONDITIONING REFRIGERATION Division
 HOME APPLIANCES Division

Name _____ Age _____
 Address _____
 City _____ State _____ ZIP _____
 Check for Veteran Training under new G. I. Bill.
 Check here if interested only in classroom training at Los Angeles.

NATIONAL TECHNICAL SCHOOLS

WORLD-WIDE TRAINING SINCE 1905

4000 S. Figueroa St., Los Angeles, Calif. 90037
 YOU ENROLL BY MAIL. NO SALESMAN WILL CALL.



SAVE UP TO 85%

GOV'T SURPLUS and NEW EQUIP'T

Send 25c For 3 Big Catalogs

- PUMPS
 WELDERS
 WINCHES
 SURVEYING
 TELEPHONES
 HYDRAULICS
 GENERATORS**
- ELECTRONIC
 BINOCULARS
 GEAR MOTORS
 COMPRESSORS
 SPEED REDUCERS
 WEED SPRAYING
 MANY OTHERS**



SURPLUS CENTER Dept. PM-086 Lincoln, Nebraska

STOP THAT OIL DRIP



End unsightly oil stains on floor and driveway

\$3.95 at your service station or ppd SILOO INC.
 395 Seventh Ave., N.Y., N.Y. 10001



LEARN TO EARN!

NO CORRESPONDENCE • NO HOME STUDY • CONTRACTOR OWNED • VA APPROVED



- Students train on the machines they will operate
- All training by fully qualified instructors
- Students live at the school
- Western's graduate students are readily accepted for employment
- Many courses of study are offered

WRITE TODAY FOR FREE SCHOOL CATALOG

WESTERN SCHOOL

OF HEAVY EQUIPMENT OPERATION

Associate member of Associated General Contractors and A.R.B.A.

BOX 510 • WEISER, IDAHO

Dept. M-22
 NAME _____
 ADDRESS _____
 CITY _____ STATE _____

Liquid WRENCH

LOOSENS RUSTED NUTS, BOLTS, PARTS IN SECONDS
at Service Stations, Auto and Hardware Stores
RADIATOR SPECIALTY COMPANY, CHARLOTTE, N. C.



MY SPARE TIME HOBBY MAKES ME

\$500 an hour

CASH PROFIT

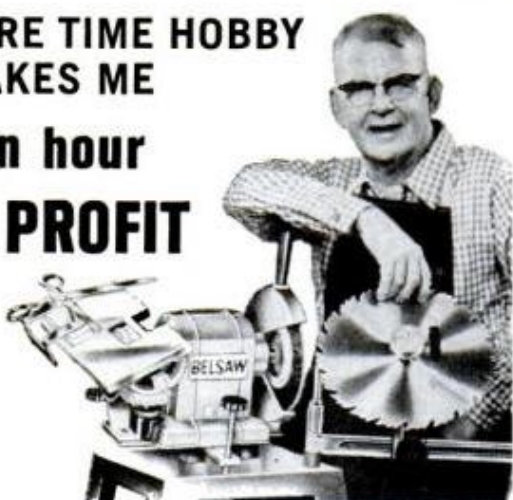

START YOUR OWN SPARE TIME BUSINESS

You can turn your spare time into Big Cash Profits with your own **COMPLETE SHARPENING SHOP**... Grind saws, knives, scissors, skates, lawn mower blades... all cutting edges. Your Own Cash Business with no inventory... right at home... no experience needed.

FREE BOOK tells how you can start your own spare time business while you are still working at your regular job. Low Cost—time payments only \$15.00 a month. Send coupon today.

**FREE
BOOK**

BELSAW SHARP-ALL CO., 7171 Field Bldg., Kansas City, Mo. 64111
Send Free Book, "LIFETIME SECURITY." No obligation.

Name _____

Address _____

City _____

State _____

Zip _____



WE'LL SEND YOU
A MONEY-MAKING
"SHOE STORE BUSINESS"
FREE

Rush postcard today for
free sales outfit

Run your own profitable shoe store at home. Sell to friends, neighbors, folks where you work. Earn \$217.00 EXTRA monthly on just 2 easy orders a day. You feature 230 styles of quality shoes for men and women. Famous Air Cushion Mason Shoes that sell themselves. Sizes 2½-15. Widths AAAA to EEEE. Many comfort features—stock of over 250,000 pair to draw from. Also horsehide jackets. Represent fast-growing million dollar shoe firm in spare or full time and big profits are yours. Everybody is a customer. You don't need to invest a cent in this wonderful sales opportunity. We'll rush you FREE a complete starting outfit that contains everything you need to begin making money. Just send us a postcard today!



MASON SHOE, Dept. G-413 Chippewa Falls, Wisc.

WHAT'S NEW OUTDOORS

BY STUART JAMES

Cram course for campers would be a good subtitle for a new booklet just published by the Coleman Co. Whether you're a novice or an expert, this 72-page "outdoors encyclopedia" will tell you what you need to know to start camping, or will jog your memory for things you've forgotten.

The by-lines on the articles in *Outdoor Holiday Fun Guide* are a veritable "who's who" in the Outdoor Writers of America. Roger Latham, outdoors editor of the Pittsburgh Press, is editorial coordinator; then there's Byron Dalrymple, Maury Delman, Hurley Campbell, George Laycock, Homer Circle and John Gartner. And for the woman's point of view there's an article by Katie McMullen, editor of *Better Camping*, one of the best magazines in the outdoor field.

Ranging from how to plan a camping trip to recipes for camp cooking and how to travel on \$5 a day, the articles are loaded with expertise. After reading it, I sent away for a dozen copies to pass along to friends. There is no charge for the booklet, and if you don't find it at a local sporting goods store you can write for a copy from the Coleman Co., Wichita, Kans.

An organization for boat owners who do not belong to a club has been established as an affiliate of the Outboard Boating Club of America. It is called Boat Owners Council of America and is headquartered at 333 North Michigan Ave., Chicago, Ill. Annual membership for an individual is \$5 and this includes a subscription to a quarterly magazine titled *Watersport*. Ted Williams is president of the group and Guy Lombardo is chairman.

Recent years have seen legislators at all levels of government with their eyes on boating—looking for tax revenue and seeking to create laws inhibiting the use of power boats. Aside from the general promotion of the overall enjoyment of boating and acting as an information center for members, a major function of this new organization will be to act as a watchdog for the interests of small-boat owners. I know how important these "watchdog" groups have been in the conservation movement, literally raising the roof when special interest groups sought to turn parks and wilderness areas into Coney Islands and industrial wastelands, and boating can use as loud and strident a voice as it can get. ★★★

Two smooth ideas from Ford solve rough driving problems!

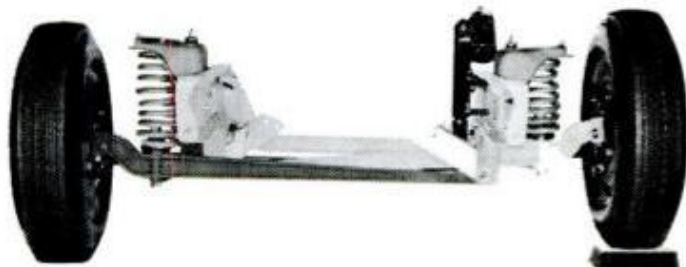

Truck operators, sportsmen and others who often find the going rugged can take comfort from Ford's latest advances in vehicle suspension systems. One bright idea, found only in Ford light-duty trucks, is a front suspension with *two* axles. These axles, forged from steel "I" beams, make each front wheel work independently to soak up road shock. Result: Ford pickups ride almost as smoothly as a passenger car!



Another Ford development: Bronco's unique Mono-Beam front-wheel suspension—one reason why this 4-wheel-drive fun car handles back roads and mountain trails with ease. Here, the driving axle is connected to the frame by forged steel radius rods through heavy-duty rubber bushings to absorb vibration. A front track bar aids stability and axle

alignment. And there are high-deflection-rate coil springs and double-acting shock absorbers to make big bumps feel like ripples in the road.

Making the road ahead of you easier and more pleasant to travel is our business—and your Ford dealer's. See him now for a '66 Ford pickup or a fun-filled Bronco. You've never had it so smooth!



MUSTANG • BRONCO • FALCON • FAIRLANE • FORD • THUNDERBIRD • COMET • MERCURY • LINCOLN CONTINENTAL

AUGUST 1966

31

\$100.00 for your thoughts

**Win Easy Money in the Schenley
"Household Hints" Contest! Mr. Joseph
Spicola Won \$100.00 With This Idea!**

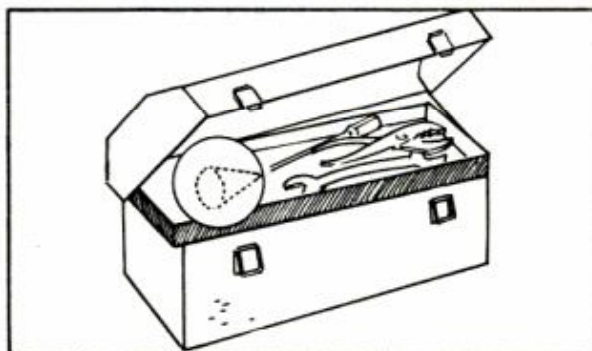

To keep tools from rusting, place a few cones of carpenter's chalk in your tool-box, and leave them there. Calcium carbonate in the cones absorbs moisture, helps prevent rust from forming.

Do you have a time, work or money-saving "do-it-yourself" suggestion of your own? Send it in to our "Household Hints" Contest, and win up to \$100 in cash for yourself!

Every month, Schenley Industries will award five prizes for the best household hint submitted by readers of Popular Mechanics. Send your hint to:

Contest Manager, Schenley "Household Hints" Contest, Room 1303A, 10 E. 40th Street, N.Y.C. Entries must



be submitted no later than midnight, August 31, 1966 to be judged in this month's contest. All ideas become property of Schenley Distillers Co., and all decisions of judges are final. Offer not made to minors or residents of states where illegal.

And Here's a Schenley Hint For You! For really cool summer drinks, place your glasses in the refrigerator about a half-hour before serving. For best drinks, use Schenley liquors straight, mixed or on the rocks.

BLENDED WHISKY, 86 PROOF. 65% GRAIN NEUTRAL SPIRITS. © SCHENLEY DIST. CO., N.Y.C.

AUGUST 1966

33

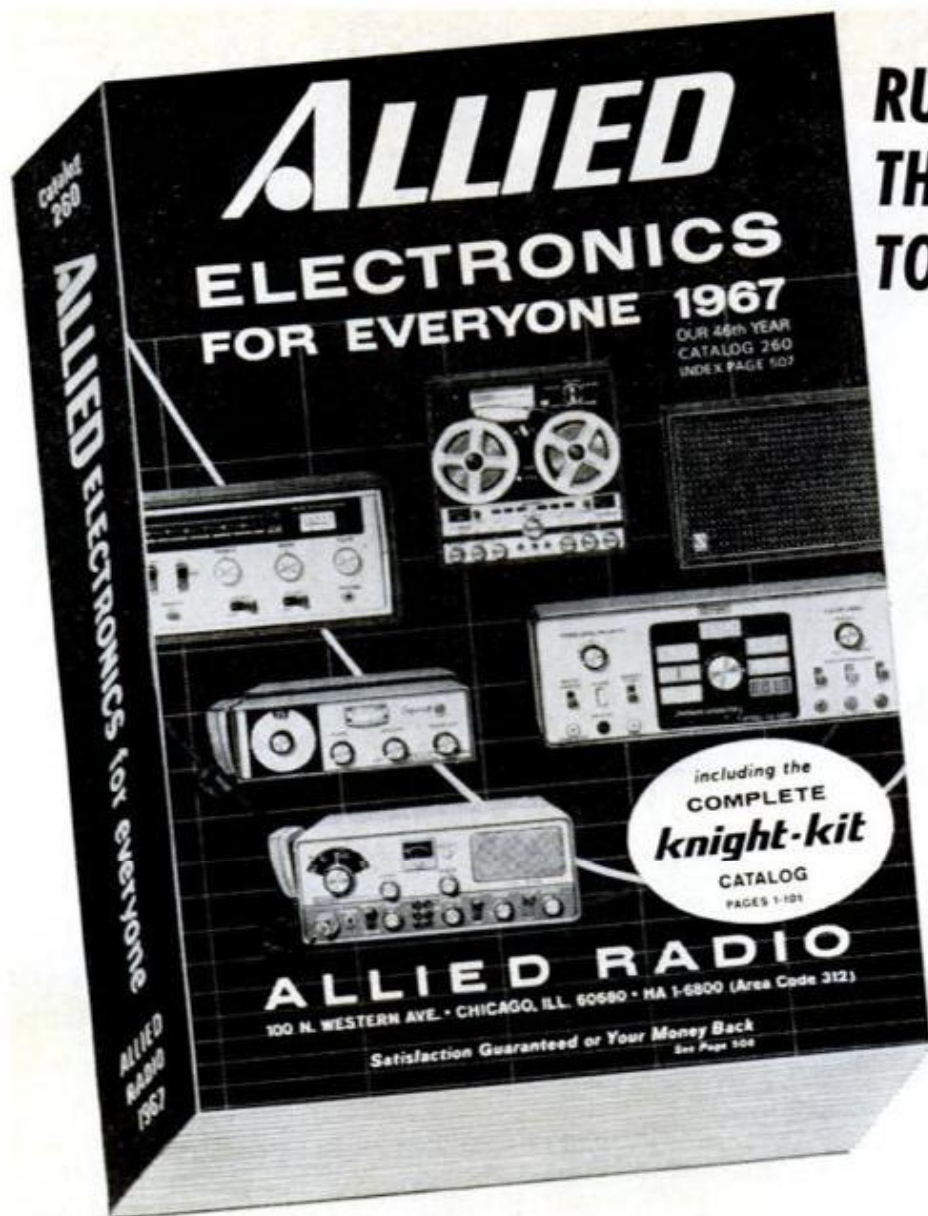

**RUSH
THIS CARD
TODAY**

FREE NEW 514-PAGE 1967 ALLIED CATALOG

TOP SAVINGS ON THE BEST IN ELECTRONICS FOR EVERYONE . . .

Famous Knight-Kits • Stereo Hi-Fi • Tape Recorders & Tape • CB 2-Way Gear • Walkie-talkies • FM-AM & AM Radios • Short Wave Radios • Portable TV • Phonographs • Amateur Gear • Intercoms & P.A. • Automotive Electronics • Test Instruments • TV Antennas & Tubes • Power Tools • Hardware • Parts • Tubes • Transistors • Batteries • Books

FREE!

Send for new 1967 ALLIED Catalog

ALLIED RADIO, Dept. 6-H
P.O. Box 4398, Chicago, Ill. 60680

Send FREE 1967 Allied Catalog

Name _____

PLEASE PRINT

Address _____

City _____ State _____ Zip _____

Plus hundreds more new and exclusive items, and scores of special Allied values!

NO MONEY DOWN! 24 MONTHS TO PAY!

Enjoy the things you want now, while you take 24 months to pay for them on the convenient, easy-on-the-budget Allied Credit Fund Plan.

ALLIED RADIO

P.O. Box 4398, Dept. 6-H
Chicago, Illinois 60680

CAREER BAROMETER

BY CREIGHTON PEET

BETWEEN MEDICARE with its 19,-100,000 eligible citizens 65 or over, and the other millions insured by municipal, company, or private hospital and medical plans, the demand for health services in this country is booming. And in addition to the work of doctors and dentists, who of course need long and expensive training, there are an increasing number of health jobs for men which require less schooling.

One of the most basic and profitable careers in the health field is that of public health sanitarian. Such jobs have a wide range of duties and, working for a big city staff, a man is soon likely to become a specialist.

The sanitarian makes sure the public is protected in every way possible. He watches for polluted air, water and food; he checks on fumes and wastes from industrial plants, supervises insect and rodent control and sewage treatment operations. He also visits milk and food

processing plants, stores, restaurants, schools, and such public gathering places as swimming pools and playgrounds.

Primarily the sanitarian is alert to the possibility of epidemics, and works closely with physicians to make sure his community stays healthy.

Four years of college with majors in the sciences provide an excellent background, but many junior colleges have two-year courses which lead to a degree in this field. Starting salaries depend on the community in which you go to work, and range from \$4500 to \$7000. With a little more experience the sanitarian can earn \$8-9000 a year.

Other health workers, usually called safety engineers, are employed by industry. They watch for dangerous machinery and processes, and order the correction of any condition which might injure an employee. For further information, contact the American Public Health Assn. at

(Please turn to page 39)

JOB TITLE	CURRENT NATIONAL		STATES WITH HIGHEST DEMAND				
	DEMAND	3-MONTH TREND					
Chemists, Biological	19	Demand steady	N.J. 3	Del. 2	Ohio 3	Wis. 2	Calif. 3
Chemists, Organic	67	Some increase	N.J. 7	N.Y. 5	Penn. 8	Ala. 6	Ill. 7
Chemists, Inorganic	19	Demand doubled	N.J. 1	Penn. 2	Ill. 9	Okla. 1	Calif. 1
Engineers, Metall.	59	Some increase	Conn. 4	N.J. 16	Penn. 4	Ohio 7	Ill. 5
Engineers, Civil	551	Good increase	D.C. 70	Penn. 26	Mich. 43	Ohio 81	Calif. 101
Engrs. Elect & Electron.	1052	Good increase	N.Y. 110	D.C. 47	Fla. 106	Ill. 44	Calif. 250
Engineers, Industrial	593	Good increase	N.Y. 48	Penn. 72	Ohio 63	Ill. 41	Calif. 82
Engineers, Mechanical	1364	Some decline	N.J. 105	Penn. 88	Fla. 74	Ohio 97	Calif. 287
Engineers, Aero.	616	Very good increase	Penn. 71	Fla. 26	Mo. 60	Calif. 231	Wash. 180
Pharmacists	91	Substantial increase	Va. 9	Ill. 5	Ind. 10	Calif. 7	Idaho 19
Natural Scientists	239	Very good increase	N.J. 20	D.C. 23	Penn. 10	Tex. 10	Wash. 144
Draftsmen, Architectural	100	Some decline	N.Y. 25	Ohio 8	Ill. 5	Calif. 16	Wash. 9
Draftsmen, Electrical	266	Demand steady	N.J. 14	N.C. 20	Penn. 26	Mo. 20	Calif. 140
Draftsmen, Mechanical	475	Good increase	N.C. 60	Ohio 56	Wis. 60	Calif. 38	Wash. 72
Draftsmen, All Other	399	Some decline	Penn. 50	Ohio 29	Mo. 54	Calif. 77	Wash. 41
Tool Designers	190	Big decline	Penn. 15	Ill. 14	Kans. 25	Calif. 51	Wash. 50
Lab. Tech. & Assistants	121	Demand steady	Penn. 16	Ga. 11	Ill. 10	Ind. 11	Kans. 9
Medical Technicians	193	Some increase	Del. 25	Md. 21	Colo. 18	Calif. 20	Wash. 18
Sports Instr. & Officials	24	Considerable decline	Conn. 2	R.I. 2	N.J. 3	Penn. 2	Fla. 2
Surveyors	10	Some decline	Mass. 1	N.C. 1	Penn. 2	Ill. 1	Iowa 1
Techs. Eng'g & Phys. Sci.	935	Big increase	Ala. 187	Fla. 52	Ohio 64	Calif. 250	Wash. 241
Tool Planners	38	Considerable decline	Ohio 12	Ind. 7	Kans. 15	Okla. 4	
Systems Engineers	40	Demand steady	N.Y. 5	Penn. 1	Kans. 10	Mo. 21	Neb. 2
Programmers	445	Big increase	N.Y. 7	Va. 12	Ohio 16	Calif. 103	Wash. 226
Systems Analysts	55	Demand steady	N.Y. 5	D.C. 7	Ind. 3	Calif. 14	Wash. 15

PM's Career Barometer Chart, above, gives the actual number of men currently needed for specific jobs. "Current Demand" figures are true as of our closing date. Check this chart each month and it will tell you where your talents are needed, and how badly. For names of actual employers represented by these listings, contact the state employment agency in the capi-

tal city of the state indicated. Mention that you saw this in **POPULAR MECHANICS**.

Today, with proper schooling, you can qualify for many of the job categories shown. For a list of accredited correspondence and residence schools, write to **POPULAR MECHANICS' Information Bureau, 575 Lexington Ave., N.Y. 10022.**

The perfect business opportunity
for readers of Popular Mechanics

With a modest investment
you can get into the nation's
fastest growing business!

Own your own

A to Z

RENTAL CENTER

Producing a gross revenue of
\$35,000 AND MORE
YEARLY



**A to Z is the community rental
center for everything
used in the home and business:**

Lawn and garden tools • Plumbing tools • Party
needs • Camping equipment • Floor care equip-
ment • Invalid and health needs • Home enter-
tainment needs • Contractors' equipment
"Do-it-Yourself" tools • Painters' equipment

Here's your opportunity to get into the profit-
able rental field—the nation's fastest growing
business. Choice, protected franchises available.

Over 125 A to Z Rental Centers now in opera-
tion by people like you. Our exclusive Full-
Support Franchise Program assures your success:
complete orientation-training program at the
A to Z Rental Owner-Management School; we
assist you in site location; set you up in busi-
ness; give you continuous operational guidance;
help you with business-building promotion.

Minimum cash investment of \$7,500 for a
\$30,000 Center to \$18,750 for a \$75,000 Center.
We make available initial and growth financing
if you qualify.



WRITE, WIRE OR PHONE TODAY.

Warren S. Claussen, Vice President
Suite 1628-AG
164 W. Jackson Blvd., Chicago, Illinois 60604
Phone: Area 312, 922-8450

A SUBSIDIARY OF NATIONWIDE INDUSTRIES, INC.

LICKITY WACO LOG SPLITTER

Splits Big Profits from
toughest woods—Ends
Splitting Drudgery
with 18 ton
hydraulic power!

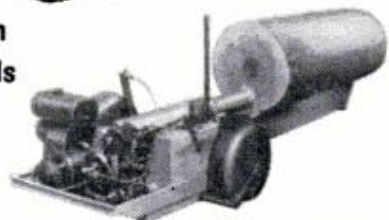

7 H.P. trailer unit squats under power to load logs without dead lift.
Has 2 speeds, auto-shift, auto-stroke. 26" ram travel splits logs up
to 34", any diameter — with extended frame and adjustable wedge
splits up to 60". **NEW LOW COST Economy model** for farmers and
small wood lots. Also ask about the 60L Series for logs up to 8½ ft.
long—Details free.

Piqua Engineering Inc., Dept. P, Box 605, Piqua, Ohio

**130,000 CANDLE POWER
FLAME THROWERS**



WARREN AUTOMOTIVE

Fits all 4 light systems—bright
sockets. American made for
American cars. 65,000 candle
power in each sealed beam
unit. Over 2½ times as bright
as the factory stock brights.
Lets you really see where you
are going.

\$995 pair

Prepaid U.S.A. No C.O.D. please.
Caution: May not be approved in
some states.
Box 563 Skokie, Illinois 60076



FOX

YOUR OWN BIKE

\$119.50 to 179.50

Even Mom'll go for this one—
costs less, runs for just pennies
(nearly 100 miles on a gallon of
gas). And it's American made!
It's the popular **CAMPUS BIKE!**

Literature **FREE** • Parts Catalog \$1.00
Box 797PM • Janesville, Wis. 53546

**This free folder
was created
from your
mistakes.**

Send for 101 tips on preserving
wood with Woodlife®, the water
repellent wood preservative that
protects against warping, swelling,
rotting, paint failure.

Write to U.S. Plywood Corp.,
Dept. P M 8-66,
2305 Superior Ave.,
Kalamazoo, Mich. 49003

Name
Address
City
State Zip Code



U.S. Plywood Corporation

CAREER BAROMETER

(Continued from page 37)

1790 Broadway, New York, N.Y. 10019.

Pharmacy is another profession which offers a good future, but graduation from a college of pharmacy, which means five years after high school, is essential. It is also necessary in most states to pass a state board examination and to have one year of practical experience under a registered pharmacist before you can be registered yourself. Most pharmacists work in drug stores, either as employees or owners, but a number have jobs in hospitals and other health installations. Salaries usually start at \$6-7000, while experienced men make \$10,000, and those who have their own stores make a great deal more. As an employee you will probably work an 8-hour day, but owners very often put in 50-hour weeks. For further information, contact the American Pharmaceutical Assn., 2215 Constitution Ave. N.W., Washington, D.C.

Still another profitable health job is that of dental laboratory technician. You do not deal with patients, but work in a laboratory manufacturing bridges, crowns and dentures, following dentists' prescriptions and specifications. This is delicate, precise work, and requires patience, manual dexterity and a high degree of craftsmanship. Some technicians work in gold or other metals, ceramics or plastics. Most jobs are in commercial laboratories with one or two men—but there are some big shops, too. Other dental technicians work in dentists' offices, or Government hospitals. Pay runs about \$80 to \$150 a week.

For more information, contact the National Assn. of Dental Laboratories, Inc., 500 Walker Building, Washington, D.C. 20005.

Radiologic technology, or the use of X-rays, provides still other health jobs. X-ray technicians usually work in hospitals or clinics, but a few are employed by doctors in their own offices. Both will take X-ray pictures and provide X-ray treatment for certain diseases, such as cancer, under a physician's direction.

X-ray technicians must have two years of special training beyond high school. Many hospitals and medical schools offer such courses. About half of all X-ray technicians are employed by agencies of the Federal Government, where starting pay is from \$4480 to \$6000 a year. Top pay in this field is about \$10,000, but many institutions throw in such fringe benefits as room and board, laundry, uniforms and free medical care.

For more information on X-ray technicians contact the American Society of Radiologic Technologists, 537 S. Main St., Fond du Lac, Wis. 54935.

Be a LOCKSMITH



JOEL DAIGLE says,
"Earned \$1138.75 while training. Now have excellent locksmith job—and enjoy every minute of the work."
Fort Kent, Me.



JOHN SCHMITZ says,
"What a happy way of life. My own successful shop—a completely outfitted mobile unit and a substantial income."
Butler, N. J.



JOE E. WARES says,
"Paid entire tuition and made \$800 besides in spare-time, even before completing training."
Overland Park, Kan.

306

Pieces of Professional Equipment. **LOCKS, PICKS & TOOLS** supplied for use with course.



TRAIN AT HOME—EARN WHILE YOU LEARN

Add to YOUR INCOME FAST—even double it with easy sparetime earnings. Cash in on the nation-wide shortage of trained locksmiths. Quickly step into a big pay job, or start a high-profit shop of your own!

EARN EXTRA MONEY RIGHT AWAY!

You can quickly qualify as a skilled locksmith. Age, education, minor physical handicaps don't matter in this ever-growing trade. So easy to learn it's like a fascinating new hobby!

Study at home as little as one hour a week. All special professional tools, supplies, including files, calipers, tweezers, cylinders, door handles, assemblies, gages, pins, springs, extractors, picks, locks and keys—supplied FREE. Gain practical experience by doing real jobs on car locks, house locks, padlocks, safe locks, etc.

Send for FREE BOOK. "Your Opportunities in Locksmithing" and FREE SAMPLE LESSON PAGES. No cost, no obligation, no salesman will call.

Only school of its kind: Licensed by State of New Jersey, Accredited Member National Home Study Council, State Approved Diploma.

APPROVED FOR VETERANS

LOCKSMITHING INSTITUTE, Dept. 110-086,

(A Division of Technical Home Study Schools)—Little Falls, New Jersey 07424

Est. 1948

MAIL THE COUPON AT ONCE

LOCKSMITHING INSTITUTE, Dept. 110-086, Little Falls, New Jersey, 07424

Please send without obligation the FREE illustrated book, "Your Opportunities in Locksmithing" and Sample Lesson pages. I understand no salesman will call.

Check here if eligible for veteran benefits.

Name _____

Address _____

City _____ State _____ Zip _____



SETS ▲ GLASS

DAP® '33' GLAZING

Gives best possible seal around window glass. Outlasts ordinary putty by years. For wood or metal sash. Remains flexible—won't harden and crack like putty. Resists heat, cold, moisture. Sold at leading hardware, building supply, paint and specialty stores.



DAP DAP INC., Dayton 31, Ohio
SUBSIDIARY OF *Plough, Inc.*

QUESTIONS ANSWERED

HOMEOWNERS' BY W. CLYDE LAMMEY CLINIC

Man the pumps!

Though my house is only three years old I have a serious basement flooding problem. After every heavy rain the floor is covered with 2 to 5 in. of water. The seepage occurs where the floor joins the walls. Apparently the grade has gradually settled and now slopes toward the wall instead of away from it. Is there any emergency waterproofing I can do until I can have the grade corrected?
—C.E., Ill.

Some time ago I encountered the same problem, though in a much older house. The first thing I did—in order to protect the furnace and hot-water heater—was to run out and buy a second-hand sump pump (electric). I placed it in the drain well, then led the discharge hose outside through a window and well away from the house. This kept the basement free of water until I was able to get to the root of the problem: a crack in one of the foundation walls. I repaired the crack, then coated all four basement walls with waterproofing compound—and haven't had any seepage since.

I suggest you take both of these steps. Furthermore, on the side or sides of the house where the grade has settled, lay down a wide length of polyethylene—half on the ground and half against the house—so that it extends beyond the house at both ends. This plastic sheet will catch and carry off most of the water that would otherwise seep through your foundation. However, get to the job of regrading the land around your foundation as soon as possible in order to solve permanently your flooding problem.

Woods for a wood lathe

I'm a greenhorn in the art of wood turning, having just bought my first lathe. I'm anxious to get going, though. Can you tell me which of the woods are best suited for wood-turning?—L.M., Ky.

All woods can be turned on a lathe—from balsa to ironwood. However, birch and black cherry are perhaps the most workable woods. Walnut, poplar and selected pine are also recommended. The

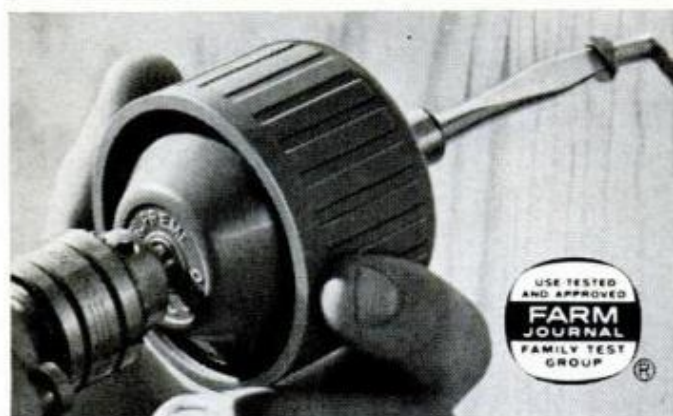

To drive screws . . . use your power drill and job-tested VERSAMATE

Versamate is a speed reducer made exclusively for the blister-building business of screw driving. The secret is 7-to-1 speed reduction that boosts power seven-fold and slows down the drill speed until it's perfect for sinking any screw—large or small. See your tool dealer for this \$5.95 beauty.

RIDGID POWER TOOL EQUIPMENT
Supreme

THE RIDGE TOOL COMPANY, ELYRIA, OHIO, U.S.A.

species of wood used are not so important as the grade of the particular piece selected. Avoid woods with knots, sap streaks and other natural defects. Choosing the correct lathe spindle speed and using razor-sharp cutting tools are probably more important to good lathe work than the wood itself. As a general rule you rough-in on stock at a relatively slow spindle speed (1200 to 1500 rpm), and then finish at a higher speed (2500 to 3000 rpm).

Late date with a lawn

I've just moved into a nice new house that boasts the crummiest lawn in the neighborhood—bare patches, spindly grass, weeds, the works. So before my neighbors start picketing me, can you give me some hints on how to improve this spotty turf?

—A.D., Kans.

Put some lawn soil in a bottle and take it over to your county agricultural agent. He'll be able to run a test on it and let you know what plant foods it needs. Get these and feed 'em to your lawn. You can kill the weeds with a good herbicide. If the surface soil is hard-packed pan, wet it down, then go over it with a spiker to loosen it up. Spot-seed the bare patches and water them regularly until the grass sprouts. Finally, seed the whole lawn with about half the seed that would normally be used on a new lawn; go over it again with the spiker and water it regularly during dry weather. With a little luck your ailing lawn will show a noticeable improvement by the time the first frost sets in.

De-shining varnish

I have a fine old carving whose beauty was cheapened—probably many years ago—when somebody coated it with a shiny varnish. Is there any way of dulling this finish without damaging the carving?—R.V., Me.

This can be tricky. You could spray it with a dull-luster varnish right over the old finish. However—especially if the carving is small—this could further detract from its clarity of line.

So try this: get one of those fine, brass-bristle brushes used to clean suede shoes. Very carefully use it to brush the gloss from the carving. The brush should prove very efficient in getting into crevices and reliefs of the carving. By gentle, steady rubbing you should be able to reduce the shine to the soft glow of an old finish. ★ ★ ★

Sure beats smoking!



Enjoy Copenhagen: Place a small pinch between cheek and gum. No chewing.

United States Tobacco Company

HOME WORKSHOP ARC WELDER!



**ELECTRIC
WELD BRAZE,
SOLDER, CUT
ALL METALS**



New 1966 Model
LIFETIME BURNOUT GUARANTEE—10 day money back
trial. Works on any 110 volt "Plug in". Welds up to 1/4" steel with 1/16" to 1/8" rods. **EXTRA** Special twin pressure type arc torch (shown) develops up to 10,000 deg. heat—**HAS A MILLION USES—** for **CARS—HOME—FARM—FACTORY**. No experience needed—**FREE** Welding book teaches **YOU**. Thousands of users. **SEND ONLY \$2.00** (cash, Ck, MO) and pay postman \$12.95 COD Pstg. or send \$14.95 for postpaid delivery in USA. **COMPLETE** ready to use with 12 ft. H.D. Cables, Arc torch rod holder, carbons, welding and brazing rods, flux solder, work clamp and full face mask. **FREE EXTRA "Dark" eye goggles**—if you order at once. **THIS BEST FOR THE MONEY** welder sold **ONLY** by **MIDWAY WELDER**, Dept. DPM-8, Kearney, Nebr.

**The
Devil
has
quite a
temper**

!



TM



15737-B



We're proud of the temper in Red Devil's high carbon steel blades . . . just one of the quality features in our full line of putty knives, wall scrapers, wood scrapers and other home patch-up tools. Buy the best! Buy Red Devil!

Red Devil inc

UNION, N. J., U.S.A.

POPULAR MECHANICS SHOPPING GUIDE

FREE Electronics Bargain Catalogs for 1 Year!



Exclusive House Brands Nationally Famous Makes Closeout Special Buys

Stereo • CB • Parts • Kits. Testers • Tubes • Tools • Tape.

Read the exciting catalogs of America's biggest nationwide electronics store chain. Get our latest issue today.

RADIO SHACK 2727 West 7th St.
Fort Worth, Texas 76107, Dept. PM

Name _____
Street _____
City _____
State _____ Zip _____

•••• Radio Shack Corp. — Division of Tandy Corp. ••••

SECRETS of Teaching Yourself MUSIC

revealed in your own home this money-saving way



YES! Teach yourself Piano, guitar, Accordion, Violin, ANY instrument—even if you don't know a single note now! No special "talent," no previous training needed. Famous low-cost U.S. School of Music Course, with step-by-step pictured lessons, make it simple as A-B-C.

Everything is in print and pictures. First you are told what to do. Then a picture shows you how. No boring exercises, no tedious scales. You start by playing actual pieces. Sooner than you may imagine you'll amaze friends by playing your favorite music—popular, classical, jazz, country music, dance tunes, etc. Over 1,250,000 students all over the world.

Stop Cheating Yourself of These Joys

Popularity. New friends. Gay parties. Musical career. Extra money. Banish worries, frustrations. Satisfy self-expressions, creative urge. Gain self-confidence.

Write today for 36-page illustrated FREE book. **U.S. SCHOOL OF MUSIC, Studio 308, Port Washington, N.Y. 11050.** (Est. 1898. Licensed by N.Y. State Education Dept.)

Print Name _____
Address _____
City _____
State _____ Zip Code _____



SAVE \$100
up to OR MORE!



AUTO AIR FOR EVERYONE!

American's new refrigerated air conditioner fits all U. S. cars and is especially designed for the do-it-yourselfer. A spare Saturday can save you up to \$100 or more. We furnish everything: air conditioner, tools, instruction and full product warranty. Nothing more to buy. Send \$149 with car make, year, model and engine horsepower and ride in cool comfort... or send \$1 for installation manual (we'll credit it against your order). **FREE LITERATURE!**

AMERICAN SALES CO.

Write Dept. PM
P. O. BOX 31216, DALLAS, TEXAS 75231

Stamp Your Name PERMANENTLY

reg. size Identify articles you own
\$3.95 ppd. **EVERSTAMP**



Hardened tool steel. Reg. Size 1/16" 15 letters max. last name only.

Names shown actual size
SMITH

Large size 3/16" \$5.25 10 letters max.

Stamp just about anything you own with one blow of a hammer. Made by the Henry A. Evers Co., Inc., makers of quality marking devices since 1898. Makes thousands of impressions. Send check or money order.

HENRY A. EVERS CO., INC.
Dept. P 72 Oxford St., Prov., R. I. 02905

- DIE TOOL**
Comparable to a \$9.00 die tool, now available at this special price.
- TOOLS
 - LUGGAGE
 - BOOKS
 - SPORTS EQT.
 - PAINT BRUSHES
 - PIPES
 - GUNS
 - FLASH-LIGHTS
 - DRAFTING TOOLS
 - PLUS HUNDREDS OF OTHER ITEMS

WHERE-TO-FIND-IT List for this issue, free on request, gives sources of supply or further information on all items for which this information is available. Send a stamped, self-addressed envelope to

READERS' SERVICE BUREAU POPULAR MECHANICS

575 Lexington Avenue
New York 22, New York



FREE GASKET MANUAL

Valuable Facts for those who value Top Performance:

- Rear End Gasket Installation Tips
- Correct Way to Install Pump Gaskets
- New Type Gaskets for Valve Covers
- Important Steps in Head Gasketing
- Metal Shim Gaskets
- How to Make Sure Gaskets Fit

32 pages of tips—hints—facts about gaskets and how to improve engine performance

Published as a service to the nation's mechanics, schools and car owners by Fel-Pro, Inc., one of the world's leading gasket manufacturers.

Write: **FEL-PRO, INC.**
7452 N. McCormick Blvd., Skokie, Illinois



Dept. PM-8
Division of Felt Products Mfg. Co.



SEND ONLY \$2.00

Money Back Guarantee

HEAVY DUTY-ARC WELDER

Life Time Guarantee

All New 110 Volt Heavy Duty Arc Welder. You cannot buy a better welder anywhere at this low price. **NO EXPERIENCE NECESSARY.** Anyone can braze, solder, cut and weld metal up to 1/4" thick. Generates heat to 10,000 degrees for cutting through steel plate, etc. **NOTHING ELSE TO BUY.** Comes complete with heavy duty power cable, twin carbon torch, helmet, instruction book, rod holder, and a supply of 1/16" and 1/8" welding and brazing rods, carbons, and flux, etc. **MONEY BACK GUARANTEE.** Try it for 10 days. If not completely satisfied, we will immediately refund your money without question. **LIFE TIME GUARANTEE.** Never a repair charge for parts or labor. Do not confuse this new improved welder with other units selling for \$14.95. This is a heavy duty deluxe model selling for \$18.95 and we have over 25,000 satisfied customers throughout the world. **SEND ONLY \$2.00** and when delivered pay postman \$16.95 plus postage, or send \$18.95 and we will ship postpaid. (For an extra supply of rods, carbons, and flux, send an additional \$2.00.)

Order Direct from factory: **NATIONAL ELECTRIC, Dept. PM-8, DELRAY, FLORIDA**

PUBLICATIONS **WORTH WRITING FOR**

BY MARION MOREY

The right propeller for your outboard makes the difference between sluggish or swift action. To select and maintain the best prop for your boat, send for a free copy of this 20-page booklet "From Horse-

power to Waterpower." Important points such as transom height, angle adjustment and proper loading are covered. Write Outboard Marine Corp., Dept. PM 1, Galesburg, Ill.



WHOLESALE SELL-OUT
Manufacturer disposing of brand-new surplus

TINY DC RACING MOTORS

COMPACT! POWERFUL! LIGHTWEIGHT!

Actual size photo. 20,000 rpm @ 12V DC. (.0027 H.P.). Weighs only 1.06 oz.

Build your own model racing cars, boats, automated toys, experiments, etc. Complete with lead wires, 8-tooth pinion.

McAldon International, Inc.
P.O. Box 2591, Hollywood, Calif. 90028

EACH **85¢**
WHILE THEY LAST
(add 15¢ to each order for postage & handling)



Honey is for bees.
(and beginning pipesmen)

Revelation is for pipe smokers who're tired of sweet, syrupy blends. You get the rich *naturally* mellow flavor of five great tobaccos. It's a taste you can stick with all day long.

Revelation is for the experienced pipe smoker.



WANT MORE MONEY? GET INTO PHOTOGRAPHY

Coast-to-coast, high-paying jobs in photography are waiting for people with the "know-how" to fill them. You can quickly, easily qualify at home with the world-famous NYI Learn-by-Doing Method. Write today for free catalog. Also resident training in New York. Our 56th Year.

NEW YORK INSTITUTE OF PHOTOGRAPHY
Dept. 49-8 10 West 33 St. New York 1, N.Y.



You can make money in

WATCH REPAIR

Learn at home the low cost Sweazey Way

Watch repairing pays up to \$6 an hour, part time watch makers report on survey. Unique and modern Sweazey home study System starts you making repairs right away on Swiss and American watches. Professionally prepared training. No previous experience needed. Special tools provided for practice. Tuition only \$5 a month. Diploma Awarded. Free sample lesson and opportunity book give all facts. Write today. No obligation.

CHICAGO SCHOOL OF WATCHMAKING
Dept. 186, Fox River Grove, Illinois 60021

FREE BOOK and SAMPLE LESSON

CHICAGO SCHOOL OF WATCHMAKING
Dept. 186, Fox River Grove, Illinois 60021
Please rush **FREE BOOK** and Sample Home Study Lesson.

Name _____ Age _____

Address _____

City _____ Zone _____ State _____

SOLUTIONS FOR MECHANICAL HEADACHES

AUTOMOBILE CLINIC

BY MORT SCHULTZ

Installing an ammeter

A great number of our favorite people—*Auto Clinic* readers—have written inquiring how to install an ammeter on cars equipped with alternators. The Stewart-Warner ammeter is the most often mentioned. Since these kits come with complete instructions, including diagrams, a do-it-yourself installation job is not too difficult. Should you get hold of a kit that lacks instructions, write to the manufacturer for 'em before attempting the installation.

There are two types available: the shunt-type ammeter with two terminals and the induction ammeter.

The shunt-type gauge is connected in series with the hot lead from the starter motor terminal; it's located beneath the dash. The tie-in of the ammeter is made by disconnecting this wire or cutting into it so that the two ammeter terminals can be installed.

An induction ammeter, on the other hand, can be installed without cutting into any wires. In this case the starter-motor wire is simply threaded through a loop on the back of the ammeter. This type of gauge records amperage by measuring the magnetic lines of force surrounding the wire, rather than by picking up the current directly.

From V8 to Model T—on washboards

My '65 Ford V8 becomes a bucking bronco on rough back roads. The dealer replaced the steering gear box at 2000 miles because of a bad bearing, but this didn't affect the problem. Front-wheel alignment has been checked twice, and front tires are wearing normally. The car performs beautifully on good roads. What do you think?—William C. Miller, New Canaan, Conn.

I think you ought to stay off those rugged washboard roads, or else readjust your front-wheel caster to compensate for 'em. My guess is that your wheels lack sufficient caster to meet the strains of rough-road driving. What is "enough"

caster is something you'll have to discover yourself by adjusting the wheels a little at a time until desired performance is reached.

A VW fix we missed

Thanks for your good try at solving my '64 Volkswagen problem. You may recall that I wrote that my VW had developed a squeak soon after I had run it over a pothole. You wrote that it could be due to a damaged wheel bearing, a bent spindle or a smashed speedometer cable.

Well, it turned out that the pothole had nothing to do with it, that the condition would have developed anyway. It seems some '64 VWs have been plagued with an off-center (factory-installed) grease seal. The seal starts to squeak when the grease behind it begins to get hot, then seeps past the seal. Centering the seal cleared up the problem.—Robert Gartelman, Bronx, N.Y.

And thanks to you, Bob, for cluing me in on a VW fault I hadn't heard of before. Chances are you've solved a squeaky mystery for more than a few 1964 Volkswagen owners.

Transmission emission

I have a '58 Dodge station wagon. Lately, when I park the car after a trip, the transmission fluid overflows from a little tube up by the engine. However, the transmission works fine—no slippage. Could you give an opinion on this one?—Lee Burnette, Tarentum, Pa.

Could be that the transmission has been overfilled with fluid. Or the torque-converter control valve might be sticking; this could be causing pressure to build up, leading to a resultant blowby condition.

The next time you park after a drive of 10 miles or more, check the overfill condition; shift into neutral and take a dip-stick reading. If the reading shows over-filling is not the problem, then check out the control valve. Any deeper involvement with the transmission should be undertaken by a professional.

(Please turn to page 46)



In James Bond Tradition:

Super-Spy Lets You 'See Through' Walls, Fences and Locked Doors!

Secret of Private Detectives and Industrial Spies Revealed!

A remarkable optical device about half the size of a cigarette now makes it possible for you to see—without being seen. Your children, for example, can play in the "privacy" of an adjoining room—unaware that you can see everything they do!

Operation of the tiny device is silent, almost impossible to detect. The eye-piece is not much bigger than the head of a pin.

If you drilled an ordinary hole that size through a wall, fence or door, you could see very little. But Super-Spy's unique optical principle, called "X-Pand," multiplies your field of vision over 42½ times, by actual test! With "X-Pand," almost no detail of a room can escape your Super-Spy sight! That gives you some idea of Super-Spy's powers! But the real surprise is the price: three dollars!

Unlimited Uses:

Super-Spy's uses are unlimited. With Super-Spy, you can keep an eye on the kids while they take their naps, even if the door to their room is closed!

With Super-Spy installed you can observe beyond walls in your home, office or factory—while you remain invisible!

Professional Uses:

Private and hotel detectives. Insurance investigators. Undercover agents. Security guards. Photographers.

Store owners—watch shoplifting suspects. Employers—get eye-witness proof of loafing or theft. Hospital staff—watch restless patients without disturbing them. Housewives—see a salesman or

stranger at the door—while you stay safely hidden!

You can even take pictures through its low-distortion lens!

Important and Profitable

What will you do with Super-Spy? If it's important, in your home, for you to know what people do when they don't know they're being watched (and there's no invasion of privacy)—get Super-Spy!

Order spares for sudden or unexpected opportunities to observe—without being observed!

Order extras for trusted friends: they might be glad to pay you a handsome profit.

Perfected in Germany

Super-Spy was perfected in Germany. Limited quantities are now available to the public

through a special division (Detection Appliances) of a reputable mail order firm. The parent firm's total sales throughout U.S. are over \$1,000,000. The owner has been a respected local businessman for 19 years.

5-Year Service Guarantee

Super-Spy is sold with this 5-year guarantee: If it fails to work due to any defect in material or workmanship, you can return it as directed and pay ONLY the postage. Without any charge, D.A. will either repair or replace it—or refund the purchase price.

All Rights Reserved

D.A. specifically reserves the right to refuse orders without explanation or liability, except for prompt return of payment.

ORDER NOW!

D.A., Dept. 4029

7471 Melrose Avenue
Los Angeles, Calif. 90046

Yes! I wish to order the vision X-panding SUPER-SPY so that I can see—without being seen! Under proper conditions and within legal limits, I would like to be able to see what goes on behind walls, fences, and closed doors. Please send me _____ Super-Spy(s) on your 5-year guarantee. Include complete, simple instructions for maximum effectiveness.

I enclose cash, check, or money order (Payable to D.A.)

1 for \$3 2 for \$5 No C.O.D.'s
3 for \$7 6 for \$13 Please!

Please RUSH! I enclose extra 50c

(Print Clearly)

Name _____

Address _____

City _____

State _____ Zip _____

AUTOMOBILE CLINIC

(Continued from page 44)

Lock buttons stuck

Once the back doors of my '61 Ford Galaxie are locked, it takes the strength of two men to lift the lock buttons. Any suggestions on how I can limber them up?—*J.R. Tusso, Westfield, N.J.*

Try shooting a little light household oil around the lock-button cylinder. If this doesn't work, try a little penetrating oil. If they still stick, you'll have to open up the doors to expose the locking mechanism for cleaning and lubricating.

. . . He jus' keeps rollin' along

When cruising along in my '62 Corvair Monza, I'll remove my foot from the accelerator pedal—and nothing happens; it just sticks there. I have to give the pedal a sharp tap to get it to kick back. What's hanging it up?—*Douglas T. Mundy, Somerville, N.J.*

Any one, or a combination of several things, Doug. Check for a sticky or improperly adjusted carburetor linkage; a sticky high-speed cam; a dashpot that's out of adjustment (if the car's equipped with automatic transmission); and/or sticky throttle plates. That ought to keep you busy for a while.

Service Tips

- **SERVICE MANUALS GOOF TOO.** Like the ones for '64 through '66 Chevy IIs state that maximum looseness for the upper control arm spherical joint (upper ball joint) should not exceed 3/32 in. Brother, if it exceeds 1/16 in. you're in trouble; it means the joint is badly worn and should be replaced. Chevrolet, catching the goof, has put out a fast communication to this effect.
- **NOTICE GAS LEAKING OUT OF THE FILLER NECK** of your '65 Pontiac or Tempest? Check the vent pipe and hose to make sure they're properly installed. On the Tempest the metal tab must be bent around the pipe to keep the pipe in the correct position. On the Pontiac the pipe is welded in place. Be sure the rubber hose is fitted so that it is free of kinks.
- **ALL YOU OWNERS OF FORDS WITH LOCKING DIFFERENTIALS**—be sure to feed those units with Locking Differential Additive (Part No. C1AA-19B546-A) to get the most from them in the way of quiet, smooth operation. Use 1 oz. of additive with each pint of hypoid-gear or F-hypoid-gear lubricant, whichever you use. SAE 90 lube is suggested for all temperatures above -25°F; SAE 80 grade for all temperatures below -25°F.
- **PLEASE CHECK THE RADIATOR INLET HOSE** if you've got a '66 Dodge Polara, Monaco or Monaco 500 equipped with a 383 or 440 CID engine and airconditioning. Two types of hose were used on these models, and some of them were mistakenly installed on the wrong cars.
A 22-in. radiator is used with the 383 engine when the car is **not** equipped with the cleaner-air package or the trailer-towing package. The proper radiator inlet hose for these cars carries Part No. 2465771. All these cars with the 383 CID engine which **are** equipped with the cleaner-air package or trailer-towing package, and all 440 CID engine cars with airconditioning have 26-in. radiators and use the inlet hose which carries Part No. 2532702.
With a 2465771 hose installed on a car having a 26-in. radiator, belt clearance will be so scant that a whipping belt can cut the hose and cause loss of coolant. So make sure you have the right hose; the belt number is stamped on it.

Each month Auto Clinic answers questions on car repair. For a personal reply, send 50 cents in coin to cover mailing and handling. Write Auto Clinic, Popular Mechanics, 575 Lexington Ave., New York, N.Y. 10022. One question per letter, please.

CLASSIFIED ADVERTISEMENTS

Rate: \$1.40 per word payable in advance each insertion. Minimum insertion ten words. To be inserted under the proper classification, copy must be in our office by the 15th of the second month preceding date of issue. The next available issue to place an advertisement in America's No. 1 Classified Section is October. The closing date is August 15. Send remittance and order to C. A. Martin, Popular Mechanics, 575 Lexington Avenue, New York, New York 10022.

AUTOMOBILES, MIDGET CARS

 YOUR Own highly profitable business—used imported auto parts. Wilco, Box 8342-M, Birmingham, Alabama 35218.

STOP The guesswork! New car buyers! Will you over pay when buying that new car? Arm yourself with Dealers costs now available. Send make, models & accessories of your choice. Plus \$1 to: New Car Buyer Guide, P.O. Box 155, Bay Station, Bklyn, N.Y. 11235.

AUTOMOBILE Literature, antique, classic, rare reprints. Non-profit hobby club. Free information. Enthusiasts, Box 451B, Mt. Clemens, Mich. 48043.

AUTO SUPPLIES AND EQUIPMENT

JEEP Parts catalog: Military and Civilian. For owners, dealers, garages, service stations. Save \$\$\$ Surplus and replacements. American Auto Parts Co., 1830 Locust, Kansas City, Missouri

FOREIGN Car parts. Discounts. Catalog. Box 7, Elmont, N.Y.

ANTIQUE Car pistons, gaskets, gears, valves, etc. Catalogue \$1.00. Antique Auto Parts, Milwaukee, Wisconsin 53204.

CROSLY. New, used, parts. Discounts. Catalog. Box 7, Elmont, N.Y.

CLASSIC Car wax apply hot or cold, surface satisfaction guaranteed, large 18 oz. can \$5.00. C. B. Kolb, Niverville, N.Y. 12130.

SICK Car engine? Ready for junkheap? Save it with Motormaster! Cleans carbon deposits and rust from valve stems and lifters, piston rings, oil lines, rocker arms. Saves oil and gas. Restores power, smooth performance, easy starting. A scientifically sound product. Send \$2.95 for bottle with instructions, to Motormaster, Dept. M, Hinsdale, Mass.

SAVE \$150! Ring-valve job while driving. \$6.00 postpaid. Safe! Guaranteed! Our 15th year! Motaloy, Grantham, Penna. 17027.

NEW And used parts savings. Complete guaranteed service all model cars and trucks. Largest in west. Jeep and Army parts specialists. Shifting hubs for all front-end drive vehicles. \$27.50 up. Foreign parts. Fast service. Pioneer, 734 W. 13th Avenue, Denver, Colorado 80217.

260/1 ELECTRONIC Ignition coils. \$3.50 postpaid. Anderson Engineering, Epsom, N.H.

HYDRAULIC Jack repair kits and supplies. Catalog 35¢ (in coin). Hydraulic Jack Packing & Tool Co., P.O. Box 50, Bloomfield, N.J.

PEEL Safe while learning to drive with a feel safe dual brake—an extra brake that "clamps on" any car quickly. Only \$4.98 post paid. Money back guarantee. Fortune Manufacturing, 89 Tremont St., Bridgeport, Conn. 06606.

BUTT Snuffer—Cigarettes extinguished like magic in seconds. New invention fits your automobile ash tray. Make money selling them to friends. \$1.00 post paid Satisfaction guaranteed or money refunded. Mechanical Research Industries, Route 3, Box 94, Gainesville, Florida 32601.

JEEP Owners—V8 conversions. Read Jeep Owners ad, page 22.

AUTO TRAILERS

WILD Life decals, full color, large. Free folder. Washington Poster Co., 16824-PMC Pacific Highway So., Seattle, Wash. 98188.

PICKUP Camper, trailer or pickup-cover—build yourself, save! Complete plans \$3.95 each. Econoline Camper, foldout trailer, bus conversion drawings. \$2.95 each. Satisfaction guaranteed. Equipment Catalog \$1.00 (refundable on first order). Details 10¢ Viking Camper Supply. 94-F Glenwood, Minneapolis, Minn. 55403.

BUILD Your pickup camper. Precut kits. Blueprints. Supplies. Literature, 10¢. Comstock Trailers, Dept. 664, Parsons, Kansas 67357.

BUILD Aluminum pickup camper over-cab, hi-boy, lo-boy, blueprints, material, list, 3 models included, \$3.00. Bennett Custom Camper, 1500 S. Dallas, Auburn, Indiana 46706.

CAMPER Units for compact buses—Volkswagens, Econoliners, Dodges—Inexpensive—Build yourself—Details. Dot Campers, P.O. Box 67M, Saugus, California.

PRE-Cut pickup camper kits. Ready to assemble. Literature, 15¢. Snowy Mountain Campers, Lewistown, Montana.

CAMPING Trailer kits. Sleep 6, basic kit, \$140.00 pickup camper kits. Circular, 10¢. Stratford Trailers, Seymour St., Stratford, Conn.

MOTORCYCLES, BICYCLES, MOTORSCOOTERS AND SUPPLIES

HARLEY-Davidsons — Used bargains. New, used parts, accessories, all models. Bulletin 35¢. Knuth's (Factory Dealer), 1753 Muskego, Milwaukee, Wis.

MINIBIKE \$10. Cushman \$10. Honda \$30, less engines. Kart complete \$10. Minibike \$20. Cushman \$25. Engines \$3.00 up. (mail order only.) Send 25¢ (35¢ for first class mailing) for directory - catalogue number 129, listing these and hundreds of similar bargains, homebuilders plans, parts, etc. Midget Motors Directory, Athens, 1 Ohio.

HONDA 50 to 90-S big bore & stroker kits. Columbia Engineering, 2105 E. 37th, Los Angeles, Calif. 90058.

NOW! Save up to 50%. Mini-Bikes, parts & assemblies at Discount Factory prices! Illustrated catalog 25¢. Mercury, Dept. PM86, 3751 West 63rd Street, Chicago 29.

BUILD Motorbike from Bicycle! Plans, \$1.00: Go-Byk Industries, Rothsay, Minnesota 56579.

AVIATION

 PROPELLERS, Plans, kits, supplies for airboats, snowplanes. Gauges, spark plugs, gas-oil hose, oil coolers, primers, wrenches, switches, propeller hubs, engine mounts. Corvair-Volkswagon conversion parts. 125-190 Lycoming engines, manuals, gaskets, parts. Catalog. \$1.00. Banks-Maxwell, Box 3301E, Ft. Worth, Texas 76105.

BE A Government licensed aviation mechanic. Practical training. Free information. Aero Mechanics School Municipal Airport, Kansas City 16, Missouri.

HOMEBUILT. Real enclosed helicopter. 24 pages ideas, information. \$2.00. Build "executive" helicopter, drawings, specifications, \$1.50. Helicopter Development, Box PM147, Washington, New Jersey.

BOATS

 BUILD Your own boat from our large-scale blueprints. Books of plans give how-to-build help. Hundreds of professional designs—motor, sail or auxiliary—for amateur builders. Free catalog. MoToR Boating, 959 Eighth Ave., Dept. RS, New York 19, N. Y.

VIKING Canoes, factory direct. Four canvas covered kit models, under \$25.00. Uncomplicated assembly. Free information. Sportsraft, Box 8393-P, Columbus, Ohio 43201.

HYDROPLANES, Runabouts, inboards, outboards. Ski and class. Plans, kits or complete. Big catalogue, 25¢. Champion Boats, Dept. 10H, Box 9215, Long Beach, California.

KAYAKS — One-man \$19.50; two-man \$24.50; Sailboat \$42.00. Exciting Sitka Kayak Kits known world wide for speed and safety. Assemble in one afternoon. Free pictorial literature. Box 78-P, Brecksville, Ohio 44141.

BOAT Kits. Factory molded fiberglass or pre-assembled plywood. 50 models. 12" to 40'. Runabouts, Cruisers, Houseboats. Free catalog. Luger, Dept. BC-66, 9200 Bloomington Freeway, Minneapolis, Minnesota 55431.

BOAT Plans, full size patterns, and frame kits especially prepared for amateur builders. Save the "Glen L" way by selecting from modern up to date designs—Deep Vee's and SK styled inboards and outboards, cruisers, houseboats, sailing catamarans. Every type from 8' to 35'. Huge new 80 page catalog. 50¢. Glen Designs, 9152 Rosecrans, Bellflower, Calif. 90707.

BOAT Plans, world's largest selection. Frame kits and full size paper patterns. Designed for the amateur. Over 200 proven designs from all over the world. Fishing boats—cruisers—sailing—inboard and outboard hydroplanes. Send \$1.50 for catalog. \$2.00 for catalog plus boat building handbook. Custom Boat Designs, 1709-P Niagara Street, Buffalo, New York 14207.

WORLD'S Finest boat kits! Frame kits! Models from 8' to 24'. Prams—Skiffs—runabouts—cruisers. All leaders in styling and performance. Send 50¢ for catalog. \$1.00 for catalog plus boat building handbook. Custom Boat Designs, 1709-P Niagara Street, Buffalo, New York 14207.

FIBERGLASS Canoes. Three exciting models. Easily assembled kits. \$34.95 up (factory direct). Free literature. Riverside Canoes, P.O. Box 5595BE, Riverside, Calif.

DC-14 CATAMARANS. We have an attractive money-saving and money-making proposition for sailors who would like to own and show off our fabulous DC-14 Phantom racing sloop in exclusive territories. Write Duncan Sutphen, Inc., 342 Madison Avenue, New York, N.Y. 10017.

FREE Catalogue—dozens of plans for kayaks, canoes, sailing rigs. Bruce Clark, PM, 115 McGavock Pike, Nashville, Tenn. 37214.

SUBMERSIBLE Platform for Scuba operations, salvage. Construction plans. \$3.00. Engineering Enterprises, Box 10445, Denver, Colorado.

FULL Size, cut-to-shape boat patterns, blueprints. Send 60¢ for big new illustrated "Build a Boat" catalog includes fishing boats, garvies, cruisers, catamarans, houseboats—outboards, inboards, sailboats—7½ to 38". "How to Build a Boat" booklet, \$2.50. Cleveland Boat Blueprint Co., Box 18250, Cleveland, Ohio.

FIBERGLASS Cloth and resin. World's finest cloth and non-run resin, at direct mill prices. Flotation foam. Complete line of plastics, silicon bronze and brass screws, save 60%. No sales tax. Boat Plans. Free catalogue. Freight prepaid. Stiles Boat Supply Box 11P, Linden Ave., Mantua Hts., N.J.

MARINE EQUIPMENT AND SERVICES

NEW. Used, rebuilt marine motors. Marine conversions, fittings. Free catalog. Stokes Marine Supply, Dept. 24, Coldwater, Michigan.

FIBERGLASS Boat covering. Wholesale prices. Free literature and sample. Selfert's, Box 1206-M, Green Bay, Wisconsin.

BUILD Your own inboard engine from Chevy, Ford V-8, etc. Complete kits—Send for catalog. Star Marine, Berkeley, California 94710.

CONVERT Auto engines to marine. Catalog, 50¢. Lehman Manufacturing Company, 800 Elizabeth Avenue, Linden 4, New Jersey.

ATHLETIC AND BODY BUILDING COURSES

POWERFUL Muscles fast! Free brochure! Universal Bodybuilding, Box 4327-C, Northeastern, Dearborn, Michigan 48126.

"GIANT Arms." Dr. Young's, D.C. revolutionary discovery, \$2. Satisfaction or refund. Gaucho, Box 9309-S7, Chicago 90.

FEAR No bully! Master authentic Chinese Kungfu unbeatable techniques! Defeat within seconds any attacker including giant Judo-Karate experts. Free details by air. Write Asia's Greatest Master, Leong Fu, (MI/15) 119 Anderson Road, Ipoh, Malaysia.

DON'T Be bullied! Protect yourself! Secret fighting methods from Army expert. Illustrated—easy to learn. \$1.98. Satisfaction or refund. Lt/Colonel Van Fleet, 3104 Lomita, Springfield, Missouri 65804.

KARATE—Complete instructions, illustrated, only \$1.25. Bales Co., Box 5050, Rt. 2-PM, Escondido, Calif. 92025.

SPORTING GOODS AND EQUIPMENT

FREE Wingshooter's handbook. New helpful facts on shotgun shooting, shotgun chokes and how to save ammunition. Write to Poly-Choke Co., Dept. 845C, Hartford, Conn. 06101.

BIG Money raising crickets and 12 inch African fishworms. Free literature. Carter Ranch, Plains, Georgia.

SEND \$2.00 For 300-page shooting supplies catalogue. Quality gunsmithing—Lowest prices. Western Gun & Supply, 3730 N. 56th, Lincoln, Nebraska.

PLAN-A-Swing—Make it yourself—helps improve golf swing at home—\$1.25 for plans and instructions. John B. Conklin, Box 237, New Bedford, Pa. 16140.

FREE Catalogs. Hunting, fishing, jewelry, gifts, photography. Brand name merchandise at Lowest Discount Prices. Charge it. Specify Catalogs Desired. Include Zip. Parker Distributors, 40 Industrial Place, (Dept. PM-86) New Rochelle, N.Y. 10805.

SILENCERS: Pistol, rifle details, diagrams, simpler, cheaper! Plus new design for .22s \$1.00. Twin, Box 192-A, Dunellen, New Jersey 08812.

FISHING, TACKLE, LURES

FREE . . . Wholesale catalog. Beads. Spinners. Lure parts. Sinker molds. Jigs. Reels. Finnyports (ME), Toledo, Ohio 43614.

MOLDS For fisherman's sinkers, jigs, squids, casting and spinning lures. Free catalog. Sweet's Molds, Tonawanda 1, New York.

EARTHWORMS, LIVE BAIT

SUCCESS For you! Raise Carter's Pure-bred hybrid red wiggler fishworms, crickets. "Known All Over the World." Write for free literature and our success story in Life Magazine. Pure-Bred Fishworms—3000—\$5.95, 5000—\$8.95, 10,000—\$16.95. Postpaid with Free Raising Instructions. Carter Redworms, Plains, Georgia.

MEN!—Women! Make money raising Bait for us at home. Wigglers, Warsaw 45, Indiana 46580.

HYBRID Redworms 1000—\$3.00, 3000—\$5.75, 5000—\$8.00, 10,000—\$14.00. Bedruns 20,000—\$19.00. Postpaid with raising instructions. Brazos Worm Farms, Route 9, Waco, Texas.

EARN Money raising fishworms for us! Exciting details free! Oakhaven—56, Cedar Hill, Texas.

FROGS, FISH, REPTILES

FROG Raising. Young frogs and giant breeders. Stock your lakes, pond. Nu-Tex Frog Farm, Box 4029, Corpus Christi, Texas.

HUNTING, GUNS, DECOYS

7MM CHILEAN German Mauser, M95, rifles—\$27.50, 7mm F.N. Mauser, M98, rifles—\$34.50, carbines—\$39.50, semi-automatic—\$69.50. Ammunition \$5.00 per 100. Elgin Arms, 1520 Vine, Cincinnati, Ohio 45210

YOUR Ad in this space will be read by more than 1,400,000 active mail order buyers. Join the march to greater profits, place your products and services in front of them today with a small low cost classified ad. For further details, write: C. A. Martin, Dept. 15N, Popular Mechanics, 575 Lexington Avenue, New York, New York 10022.



DOGS AND KENNELS

PEDIGREED White German Shepherds, no albinos. Ansonia Kennels, McHenry, N. Dak.

TELL The more than 1,400,000 avid readers of Popular Mechanics about your products and services. It costs very little to place your classified message in front of these proven mail order buyers. For further details, write: C. A. Martin, Dept. 14N, Popular Mechanics, 575 Lexington Avenue, New York, New York 10022.



GAME BIRDS

YOUR Ad in this space will be read by more than 1,400,000 active mail order buyers. Join the march to greater profits, place your products and services in front of them today with a small low cost classified ad. For further details, write: C. A. Martin, Dept. 15N, Popular Mechanics, 575 Lexington Avenue, New York, New York 10022.

RABBITS—FUR BEARING ANIMALS

EARN \$10,000 Yearly raising Angora rabbit wool for us. Particulars 25¢ coin. Angora, Malta 12, Montana.

RAISE Rabbits successfully by knowing facts, 48 page illustrated book describing 25 breeds. Housing, breeding, feeding, markets, marketing etc. 25 cents. American Rabbit Association, 36 Arba Building, Pittsburgh, Penn.

RAISE Rabbits for us on \$500 month plan. Free details, White's Rabbitry, Mt. Vernon, Ohio.

MINK Raising information free. Lake Superior Mink Farm, Inc., Superior EE1, Wisconsin.

PETS—BIRDS, CATS, HAMSTERS, ETC.

MAKE Money raising chinchillas, mink, rabbits, cavies for us. Free catalog. Keeney Brothers, New Freedom 2, Penna.

ALLIGATORS—babies, guaranteed live lots of fun. \$4.00 Prepaid. Tropical Treasures Box 735-PM, South Miami, Fla.

PIGEONS—Pure white homers, white kings, pigeon supplies—Informative booklet, price list, \$1.00. Paul Layne, 203 North Wayne, Arlington, Va.

CAMPING EQUIPMENT AND TENTS

CAMPING Equipment, tents, sleeping bags. Tremendous selections. Free 100-page Catalogue-Handbook. Morsan, 810-R Route 17, Paramus, New Jersey.

EMBLEMS, BRASSARDS, PATCHES

CLUB Emblems embroidered to your order. Ideal for club recognition. Low minimum. Send your design for free price quotation. Write for free catalog. Eastern Emblem Mfg. Corp., Dept. PM, P.O. Box 628, Union City, N.J. 07087.

AUTHORIZED Flag for Servicemen's families. \$2.00. United States Publishing Corp., Stuart, Fla. 33494.

POPULAR MECHANICS

TRAVEL AND RESORTS

YOUR AD in this space will be read by more than 1,400,000 active mail order buyers. Join the march to greater profits, place your products and services in front of them today with a small low cost classified ad. For further details, write: C. A. Martin, Dept 19N, Popular Mechanics, 575 Lexington Avenue, New York, New York 10022.

ELECTRICAL SUPPLIES

METERS—Surplus, new, used, panel and portable. Send for list. Hanchett, Box 5577, Riverside, Calif.

APPLIANCE—Lamp parts. Wholesale catalogue 35¢. SECO, 112 South 20th Street, Birmingham, Alabama 35233.

LAMP Parts. Catalog, prices, wiring instructions. 50¢. Refunded first order. Gyro, 5208P N.W. 35 Ave., Miami 42, Fla.

BATTERIES, GENERATORS

BATTERY Reconditioning kit, includes molds, material, complete instructions. The Battery Shop, P.O. Box 416, Palm Desert, Calif.

COMPLETE Rebuilding Manuals! Batteries \$3.00. Hydraulic jacks \$3.00. C.O.D. accepted. Bayer Publications, 938 Betty Avenue, Neenah, Wisconsin.

ENGINES, MOTORS, DYNAMOS

DIESEL Injector parts and fuel pumps wanted. GM51-53-71-110, Bares, 2093 East 19 Street, Cleveland 15, Ohio.

REWINDING Specifications, 300 motors \$1. Modern, Box 10025, Kansas City, Mo. 64111.

WINDING Data, 275 motors, single and three phase \$1.10. Data Company, 512 Kensington, Kansas City, Mo. 64124.

MACHINERY, TOOLS AND SUPPLIES

MAGNETIC Chuck V blocks & parallels, edge finders, center finders, thread measuring wires, sine bars. Hi-precision—first quality—low prices. Factory distributors wanted. Be the dealer in your locality. Buy for yourself and sell to others. Liberal discount, products guaranteed. Est. 1943. Write for brochures. Fisher Machine, 11704-M Inglewood, Hawthorne, Calif. 90250.

"RAFTERULE" Solves any rafter cutting problem. Free literature. Emmert, Sycamore, Illinois 60178.

MICROMETERS — Indicators, cutters, chucks, drills, rods. Campbell's, 1424 Barclay, Springfield, Ohio 45505.

SILAGE Distributors \$65.15. Zimmerman's Manufacturing, East Earl, Penna. Salesmen needed.

WELDING, SOLDERING, PLATING

A.C. WELDERS, 150 Amperes, \$49.50. Morris, 1070 Inner, Schenectady, N. Y. 12303.

FREE Catalog, Welders, kits. Build 350-ampere Welder. Plans, 25¢. Le Jay Manufacturing, Belle Plaine, Minnesota 56011.

CHROME Plating equipment, supplies. All other finishes. Home workshop and production sizes. Send \$1.00 (refundable) for formulas, operating data, equipment guide and catalog. HBS Equipment Division L50, 3543 East 16th, Los Angeles, Calif. 90023.

GOVERNMENT SURPLUS

GOV'T. Surplus. How and where to buy in your area. Send \$1.00. Surplus Information. Headquarters Building, P.M., Washington 6, D.C.

JEEPS Typically from \$53.90 . . . trucks from \$78.40 . . . boats, typewriters, airplanes, sporting equipment, used, 100,000 bargains direct from Government nationwide. Complete sales directory and surplus catalog, \$1.00. Deductible first \$10.00 order. Surplus Service, Box 820-A, Holland, Michigan 49424.

JEEPS From—\$52.50. Typewriters from—\$4.15, cars from—\$31.50. Walkie-Talkies, Guns, Airplanes, Boats, Typical "As Is" Bid Bargains From Uncle Sam. Tremendous variety. Exciting free list. Write: Enterprises, Box 402X13, Jamaica, New York 11430.

HOBBIES AND COLLECTIONS

AMERICAN Newspaper, complete, original, dated before 1880, \$1.50. 25¢ stamps brings catalogue. D. R. Spaight, Book-seller Tall Timbers 1, Maryland 20690.

50 JUNGLE Butterflies \$2.00. 65 Oriental seashells \$6.50. Giant nature hobbies catalog 25¢. Collectors Wonderland, Box 1170, New York 8.



STAMP COLLECTING

"INVERTED Error." Dag Hammarskjöld 5¢ with Approvals. Belmont Stamps, Washington, D. C. 20015.

RUSSIAN Space set 10¢. Russian approvals. Snedco, Box 68-P, Waldwick, N.J.

50 DIFFERENT Old U.S. Revenue stamps 50¢. Winchester stamps, Box 1592, Mansfield, Ohio 44907.

FREE! Congo triangle set! Boy Scout beauty! 25 others, different. Approvals, Cambridge, Box 411, Cambridge, Ohio.

100 OLD United States between 1861 and 1935, \$1.00. Roush Stamps, 51 Chestnut, Mansfield, Ohio.

225 STAMPS For only 10¢! This mammoth value includes airmails, pictorials; stamps from strange countries cataloging up to 25¢ each! Also approvals. Mystic Stamp Company, Camden 80, New York.

SELL Your surplus good grade stamps. Write, describing fully what you have. Vanroy Shirk, Lebanon, Pennsylvania.

500 DIFFERENT Stamps, \$1.00. Smith, 508-A Brooks, College Station, Texas.

PENNY Stamps! 1000 Mounted in book at 1¢ each. Trust Stamp Company, P.O.B. 132-P, Jamaica, N.Y. 11435.

ONE Pound value Geo. VI Bermuda, plus 100 worldwide 10¢, approvals. Stevens, Box 105A, Homecrest Sta., Brooklyn 29, N.Y.

60 DIFFERENT U.S. (30 commemoratives) 25¢. No approvals. Seidenberg, Salem 169, Oregon.

AMAZING OFFER! 200 United States stamps—including commemoratives, airmails, high denominations to \$1.00. Only 10¢ to approval applicants! Illustrated bargain lists free. Mystic Stamp Co., Dept. 80, Camden, New York.

PENNY! Approvals! Regardless catalogue! Kloster, 4164 52nd St., San Diego 5, Calif.

64 PAGE U.S. and U.N. catalog free. Stone, 260 Washington, Boston 8, Mass.

FREE Sample. Interesting, illustrated, informative National Stamp News, Anderson, South Carolina 29621.

INTRODUCING Our better United States approvals we offer 15 United States stamps including Columbian, Bi-Centennials, famous American, airmails, others; only 10¢. Ocean Stamps, Box 64-PM, Brooklyn 29, New York.

UNITED States commemorative collection containing 33 different—10¢. Approvals. White, 516-A Avenue L, Brooklyn 30, New York.

UNITED STATES price list, 132 pages, price 30¢. Mark Hanna, 335 Fifth Ave., Pittsburgh 22, Pa.

121 DIFFERENT Flag stamps free. Approvals. W-B Stamps, Wilkes-Barre, Pa.

U.S. Mint specials! Flag set, complete \$1.00. 1¢, 2¢, 3¢ famous Americans (21 different) \$1.00. Free list. Brooks, 2601 Avenue "U", Brooklyn 29, N.Y.

U.S. Approvals. Low prices. Eagle, 2221 Romine Ave., Pittsburgh 26, Pa.

GERMAN Commemoratives, 10¢ with approvals. Schaefer, Box 1704, Washington 13, D. C.

WOW! 110 All different Germany 10¢ Commemoratives, Airmails, high values, big catalog, bargain lists plus selections of fine stamps from our approval service, returnable without obligation. Jamestown Stamp, Dept. A86PM, Jamestown, N.Y. 14701.

FREE! Big bargain catalog—new edition listing thousands of bargains including U.S. & B.N.A. stamps, packets, albums, accessories and supplies. Plus selections of fine stamps from our approval service, returnable without obligation. Jamestown Stamp, Dept. E86PM, Jamestown, N.Y. 14701.

50 DIFFERENT U.S. Commemoratives 25¢. No approvals. Earl Mills, Box 272-K, Auburn, Mass. 01501.

FREE 1966 U. S. list, mint #704-15 \$4, #740-9 \$2.10, #859-99 \$6, #909-21 \$1. Simmy & Co., 40 Court St., Boston, Mass.

U.S. Bargain, 50 different 10¢, with beautiful worldwide approvals. Stamps, Kennebunk, Maine.

25 Different United States Commemoratives 1893 Up 10¢. Approvals. K. & B. Stamp Company, Box 70, Brooklyn 23, New York.

FIPEX—Tipex-Cipex-Ashville. Four miniature sheets used for \$1.00 if you ask for our bargain priced U.S. approvals. Triboro, 38 Park Row, New York, New York 10038.

FREE Stamp wallet with approvals. Wide selection collections by countries. Clark, Box 28-C, Wilmette, Illinois.

"COLORFUL" Set free! Worldwide approvals. Gorliz, Drawer 388PM, Park Ridge, Illinois.

MILLION Foreign stamps! 2¢ each! Send for thrilling, giant approvals! ABC Stamps, Box 6000-MB, San Francisco 1, Calif.

DEFECTIVE Old U.S. 1/5 Scott. Approvals, Swartz Stamps, Malden Bridge, New York.

NEW Issues — Free weekly illustrated list. Brooks, 2601N Avenue "U", Brooklyn 29, N.Y.

FREE Surprise collection sent with approvals. Gould, 1784 Union, San Francisco 94123.

FROM War torn Vietnam 50 scarce pictorials \$1.00. Approvals accompany. Merryman Stamps, PO Box 50, Somerville, N.J.

105 DIFFERENT U.S. Stamps, 25¢ approvals included. Shelton, Box 187, Hempstead, N.Y.

GIANT Stamp collection, including astronauts, satellites, moonrockets, boy scout issue, complete U.N. set, many Olympic and sport issues, etc., plus big stamp dictionary and approvals. Everything, 10¢ Stampex, Box 47-RM, White Plains, N.Y.

FREE Mint set. Approvals accompany. Stamps, Box 22092, Memphis, Tenn. 38122.

THOUSANDS Of worldwide sets and singles on approval. Highest quality! Cole, Box 223A, Buffalo, N.Y. 14221.

NEW Zealand triangle set. Free with approvals. Academy Stamps, P.O. Box 1747, Annapolis, Maryland 21401.

BREATHTAKING, 50 Mint Monaco pictorials, multicolors. \$1.00. Approvals. Stamp Exchange, Box 103, Fairfield, California.

FREE—Mint British Colonials from Antarctic Territory, Borneo, Brunel, St. Christopher, Nevis, Caymans, Trengganu, Pitcairns. Free with approvals. Viking, Great Neck 8, N.Y.

1500 FOREIGN \$1.00. 5000 \$3.00. 5000 USA—commemoratives, airmail, high values, revenues, 19th Century, etc. \$3.00. No approvals. Meyers, 5321 Fleming, Richmond, California.

FREE! 222 Worldwide. 25¢ handling. Penny approvals. Jung, 1601 North Stanley, Los Angeles 90046.

STAMPS Free! New issues, new countries, triangles, rockets, Olympics, Scouts, birds, flowers, animals. Also old Canadian and U.S. stamps. Plus complete illustrated Canadian stamp catalog. Send 10¢ for mailing. Gray Stamp Co., Dept. PM, Toronto, Canada.

TURKEY 50 Different, 5¢. Approvals. Hijop Box 505, Norristown, Pa.

BEAUTIFUL Topical collection includes olympic sports stamps, wild animals, bicolor triangles, colorful birds, outer space stamps. Poland kitten stamps and others. 10¢ with approvals. Sunny Stamps, Fruitport 2B, Michigan.

AMERICAN Historical collection!! Enormous airmail diamond! Pres. Kennedy & movie star Grace Kelly, 1st USA spaceman Shepard, plus midget soldier, Latin Orchid issue, old St. Pierre Fisherman, etc. 10¢ with approvals. Roseland Stamps, Spring Lake 2A, Michigan.

SCANDINAVIAN Price list free. Send your name, self addressed envelope. Karlsson, Olive Bridge, N.Y.

25 LARGE Poland stamps, 10¢. No approvals. Jack Field, NAS New York, Brooklyn, N.Y. 11234.

CANADIAN First day covers. Next three issues, \$1.00. Canstamps, 33 Montford Drive, Willowdale, Ontario, Canada.

FREE! 110 British Empire stamps (worth over \$2.50 at standard catalog prices) when you send only 10¢ for mailing costs! Get this big, valuable collection—from Antarctica to Zambia! Spectacular issues picturing Conquest of Ice Continent, Pappan Cannibal, Flying Dragon of Wales; plus many others from Tanganyika, Sharjah, Dubai, South Georgia, Christmas Island, etc. A sensational offer to introduce you to world's most rewarding hobby. 110 genuine, all-different stamps plus special Free bonus—a complete set of England's 42 Kings and Queens. Also, selections of attractive and unusual stamps from our stamps-on-approval service for free examination. You may return selections without buying and can cancel service any time. Plus free "How to Recognize Rare Stamps" booklet, and big illustrated collectors' catalog! Send 10¢ to: Kenmore, Milford QR-53, New Hamp. 03055.

ABSOLUTELY Free 50 worldwide. Request inexpensive approvals. University Stamps, P.O. Box 326, Pompano Beach, Florida 33061.

"PUT A Tiger in your collection" also Bears, Leopards, Boars.—latest gigantic Bhutan Commemoratives—Free! Approvals, plus 101 Bonus Sets. William Deems, 226a Race, Ravenswood, West Virginia. 26164.

NUDES! Ten different, 20¢. Approvals. Stamp Farm, 2M12, Oxford, Wis. 53952.

50 YEARS Old, fifteen different United States, over fifty years old—10¢ with approvals. Jaxon, Box 145-P, Brooklyn, New York 11230.

COINS, TOKENS, CURRENCY

HIGHEST Prices paid immediately for coins. Send 10¢ for 1966 buying prices. Wilmot's, 1067-F Bridge St., Grand Rapids, Mich., 49504.

CIVIL War specials: 1863 cent, \$1.75; 1863 civil war token, \$1.75; 1864 genuine confederate states of America \$10.00 bill, \$2.00. All three \$5.00. Rarcoa, 31 North Clark, Chicago 60602.

GIGANTIC Coin Clearance. Illustrated lists 10¢ (refundable). Hutchinson's, Box 6256, Philadelphia, Pa. 19136.

SPECIALS: Scarce date Lincoln cents. All good or better. Satisfaction guaranteed. 50¢ each 1916S, 1927S, 1939D, 1955S, 75¢ each 1915, 1915D, 1921S, 1924S, 1932, 1932D, 1933, \$1.00 each 1909VDB, 1913D, 1923S, \$1.50 each 1911D, 1912D, \$3.00 each 1913S, 1922D, 1931D, 1933D, \$4.50 each 1910S, 1915S, 1926S, \$5.00 each 1912S, 1914S, \$10.00 each 1911S, 1924D. Bryson Inc., 612A White, Toledo 5, Ohio.

SILVER Dollars uncirculated, 1878-79-80-81-82 S mint \$3.00 ea. Illustrated Catalogue 50¢. Shultz, Salt Lake City, Utah 84110.

OLD Time Lincoln cents, 15 different before 1931 only \$1.00. Gene Carlton, Chandler, Okla. 74834.

LARGEST Coin magazine, 200 pages, 50¢. Scrapbook, 7320-J Milwaukee, Chicago 48.

40 PAGE Illustrated United States and Canadian coin list 10¢. Stony, 260 Washington, Boston 8, Mass.

100 BUFFALO Nickels—clear dates many different (scarce), only \$10.95. Van's Coins, 168 Walworth, Wisconsin.

SILVER Dollar \$1.75; 3¢ nickel \$2.00; half-dime \$3.25; large cent \$1.80; all four \$8.40. Fairway, 121-P, Rye, New York 10580.

SILVER Dollar specials! Ten different uncirculated \$25.00, twenty different \$45.00, thirty different \$75.00. Complete set Franklin halves \$39.00, \$5.00 gold \$25.00, \$20.00 gold \$57.50. Suburban Coin, 607G Mesquite, Corpus Christi, Texas.

LINCOLNS: 22 Different "S" including rare 1955S, \$1.60. 28 different before 1940, plus odd 1960D small date, \$1.60. 10 different "S" Jefferson nickels, \$1.60. All three \$4.50. Harris, 3354-P El Camino, Santa Clara, California 95051.

REVISED Catalog now ready, 50¢ with refunding certificate. Hobby Sales, St. Paul, Minnesota 55116.

BEAUTIFUL Large Bronze Inaugural Medals: President Kennedy \$14.75, President Johnson \$5.50, 1967 Redbook \$1.75, Bluebook \$1.00, World's greatest bargain catalogue \$1.00. Bebee's, Inc., 4514 North 30th Omaha, Nebr. 68111.

FREE Details. Permanent protection for coins and stamps. Dept. A, Box 4407, Chicago, Illinois 60680.

3 LINCOLN Cents, 1929D, 1919, 1923 plus catalog only 10¢. Approvals, Littleton Coin Co., Littleton W1, New Hampshire.

LIBERTY Nickel with bargain list, 35¢. Nelson, 346-P, Rye, N.Y. 10580.

FREE Coin supplies! Giant coin list 10¢ (refundable). Economy Sales, Mansfield, Massachusetts.

ANTIQUES, RELICS, INDIAN GOODS AND CURIOS

ANTIQUES! Monthly magazine. Sample 25¢ or free circular. Antiques Journal, Uniontown, Penna. 15401.

ARROWHEADS, 10 for \$3.00. List free. Hyde's, Box 1788, Santa Fe, New Mexico.

10 ASSORTED Perfect arrowheads, \$3.00. George Smith, 9825 Conway Drive, Indianapolis, Indiana 46236.

TONS Of antique gun parts and supplies. All reproduction muzzle loading guns. Send \$1.00 for enlarged illustrated catalog No. 115. Dixie Gun Works, Union City 12, Tennessee.

1915 TITAN Tractor. Restoreable. What offers. Box 54, Kipp Alta, Canada.

SELLING 20,000 Ancient arrowheads, spearheads, etc. List free. Lear's, Glenwood, Arkansas.

MODELS—SHIPS, TRAINS, PLANES, ETC.

SHIP and yacht model fittings; Pine construction hull kits; blueprints. Send 50¢ for illustrated catalog. A. J. Fisher, Inc., 1002 Etowah Avenue, Royal Oak, Michigan 48067.

SHIP Models, Kits, fittings, plans, books, tools, engines, motors. Big illustrated catalog, 50¢. James Bliss & Co., Dept. SM, Route 128, Dedham, Mass. 02026.

BUILDING Materials, 1/4" & 1/8" scale, windows, doors, siding, roofing, lumber and structural shapes. Send 35¢ for catalog with samples. Small Sales Co., 6025 Martway, Mission, Kansas 66202.

ROCKET Or fireworks fuse 3/32" diameter, water proof, 25 feet with formulas, instructions, \$1.00 postpaid, 125 feet \$4.00. Zeller, Box 639, Hudson, Mich.

SHIP Model kits and fittings; clippers, frigates, etc. Catalog paint-tool list, book list, 40¢. Model Shipways, Box 65, Bogota, N.J.

ROCKETS: Real flying models—flights up to 2500 ft. New illustrated catalog 25¢. Single and multistage kits, cones, engines, launchers, trackers, rocket aerial cameras, technical information. Fast service. Estes Industries, Penrose 2, Colorado.

MODEL Ships just out—exciting pictorial register of great sailing ships of the historic past. Masterful authentic reproductions created in limited editions by the finest European craftsmen. The catalogue itself is a memorable collectors item. For your catalogue send \$1 to: Nautical Engineers Co., Dept. M, 1180 Ave. of the Americas, N. Y. C. 10036.

SLOT Racers! Trains! 25¢ brings 32 page bargain catalogue. Thousands of Lionel, Gilbert, Varney, Strombecker, Eldon, Aurora, Scalextrix, Revell, etc. Trains, all gauges, racers all sizes. Hobby Surplus, P.O. Box 1106M, New Britain, Conn.

GAMES, TOYS, NOVELTIES

MONACO. Anyone? Card players wanted to launch a new family of card games. Your money refunded within 30 days if you cannot make at least one word with any two cards in the 52-card deck without repeating a word! 2 deck box, including booklet of rules, \$3.00 ppd. Single deck, \$1.75. Combo Playing Cards Inc., 500 Griswold St., Detroit, Michigan 48226.

CROSSBOW: New exciting toy. Easily made child's crossbow. Instructions, detailed plans \$1.00 postpaid. Falcon Crossbows, 130 Fieldstone, Johnstown, Penna. 15904.

STRIP Tees checkers. A fascinating and tantalizing game, \$1.00 ppd. Sesame, 628 Emerson, Detroit, Mich. 48215.

NEWLY Patented holster! 4-Guns, 8-way draw. Write: Holst-R-Ama, Box 175, Roosevelt, New Jersey 08555.

MAGIC TRICKS, PUZZLES, JOKER NOVELTIES

VENTRILOQUISM! Information free! Dummy catalog, 25¢. State age. Maher, Studio H, Kensington Station, Detroit 24, Michigan.

MAGIC Catalog. World's finest. 3000 tricks. (340) pages \$2.50. Beginners, amateurs, professionals. Kanter's, A-200 South 13th St., Philadelphia, Pa. 19107.

BE A Magician! Introductory catalog with free trick, only 35¢. Ireland Magic, 5082 Lincoln, Chicago, Illinois 60625.

500 TRICKS. Douglas famous catalog No. 36, only 10¢. Contains best in magic for pocket, parlor, club, stage. Fastest service to magicians for over 50 years. Douglas Magicland, Dept. 21, Dallas, Texas 75221.

COMPLETELY Illustrated catalog. 84 pages, 25¢. Manhattan Magic, Box 334-M, N.Y.C. 11.

WORLD'S Finest professional magic tricks. Joker's Novelties, Giant illustrated catalog 10¢. Top Hat, Evanston, Illinois.

FUN'n Magic catalog. 10¢. (1,500,399 tricks, jokes, novelties, puzzles, disguises). Elbee, 7408-P, San Antonio, Texas 78207.

COMIC Cards. Funniest ever printed. 60 assorted \$1.00. Babbit, Bethel, New York 12720.

164 PAGE Giant surprise catalog! Over 1000 tricks, professional magic, jokers!! World's greatest! 800 pictures! Special only 10¢. Vick Lawton's Magic, Dept. PM6, Northeast Fifth Ave., Ft. Lauderdale, Florida 33308.

GIANT Magic Catalog and free trick only 10¢. Write today. Mailmart, M766, Box 616, White Plains, N.Y. 10602.

BOOKS, PERIODICALS

HOW To raise capital plus twenty nine self-improvement books. Free brochure. Box 725, Binghamton, N.Y. 13902.

CHALLENGING! Different! Unusual books! Free catalog. Ruby's, D-26, Paradise, Pennsylvania 17562.

BOOKS. Free general catalog, 60 pages. Text, vocational, educational, instructional subjects. Millions of volumes, new and used. Bargain prices. Books bought, Est. 1902. Long's College Book Co., Dept. PM, Columbus 1, Ohio.

OUT-Of-print books at lowest prices! You name it, we find it! Fast service. No obligation. International Bookfinders, Box 3003-PM, Beverly Hills, Calif. 90212.

FREE Catalog. Self-help books. Write Wilshire, 8721 Sunset, Los Angeles 69P.

POETS Corner: Five original editions, \$2.00. Bookways, 444-M, Fort Lee, N.J. 07024.

HIGHER Income, security and power. 256 page book "Thinking Big" reveals secrets that make men rich. Send \$2.00. Schoch's Mail Order Service, P.O. Box 267 Lynn, Mass. 01903.

PROPHET Elijah coming before Christ. Wonderful book free. E. Megiddo Mission, Rochester, New York 14619.

FREE Catalog. Self-help books. Write Wilshire, 8721 Sunset, Los Angeles 69P.

PUBLISH Your book! Join our successful authors. All subjects invited. Send for free appraisal and detailed booklet. Carlton Press, Dept. PMH, 84 Fifth Avenue, New York 10011.

FREE List. Best self-help books. Brubaker Co., Earlysville, Virginia 22936.

TREASURE Map catalog. \$1.00. United States Publishing Corp., Stuart, Florida 33494.

NEW Way of life. Send \$1.00 for "Dynamic Thinking." Free brochure of self-improvement titles. Don Hill, PM-2220 Teresa, Savannah, Georgia 31406.

BOOKFINDERS! All subjects. Send wants! Sydney Jaher, 175-45 88 Ave., Jamaica, N.Y. 11432.

PLAYS, STORIES, MANUSCRIPTS

WANTED Writers! Short stories, articles, books, plays, poetry. Will help place, sell your work. Write today, free particulars! Literary Agent Mead, Dept. C-32, 915 Broadway, New York 10, N.Y.

WANT Your book published? Learn how we publish, advertise, promote, distribute. Many successes. Free booklet PM, Vantage, 120 West 31, New York City.

BUSINESS OPPORTUNITIES

EARN Money raising fishworms for us! Write: Oakhaven-38, Cedar Hill, Texas.

IMPORT-Export opportunity, profitable world-wide, mailorder business from home, without capital; or travel abroad. We ship proven plan, for no risk examination. Experience unnecessary. Free details. Mellinger, Dept. X708, Los Angeles 90025.

MAKE Money from old tires. Operators clearing \$400 weekly. Equipment costs \$800. Get facts. S & S Patents, Inc., 3511 N. Lincoln, Chicago 13.

READ Progressive Mailtrade, the magazine that tells how to make money by mail. Quarter brings sample and special offer. Mailtrade, P.O. Box 357, Sheboygan, Wis. 53082.

MAILORDER Catalogs. No inventory required. Discounts 40% up, postpaid. Send 25¢ for 32 page sample catalog, featuring 150 unusual, fast-moving products and complete details. Satisfaction guaranteed. Gaylords, North Adams 7, Mass.

BIG Money raising fishworms and crickets. Free literature. Carter Farms, Plains, Georgia.

\$400.00 MONTHLY Raising giant fishworms. Soiless method. Charlie Morgan, Bushnell, Florida 33513.

COLORGLAZED Concrete pottery made without molds. Patented method. Cemetery products, novelties, tiles. Basement leak-sealing. Money-making projects. Booklet, details free. Men only. National Potteries Company, Grand Rapids, Minnesota.

PROFITABLE Catalog Mailorder Business! Vikari's, 835-PM, First Avenue, Salt Lake City, Utah 84103.

START Your own business on credit. Your own boss. Hundreds of dealers making \$100 to \$300 and more weekly. We supply stocks, equipment on credit. 300 home necessities. Sales experience unnecessary. Pleasant, profitable business backed by world-wide industry. Write Rawleigh, Dept. H-U-PPM, Freeport, Ill.

FREE Book "990 Successful, Little-Known Business." Work home! Plymouth-972H, Brooklyn, New York 11218.

BUILD Custom cases at home for profit. Get orders by mail. We supply materials, instructions, everything. Free home business details. Customcase, 805CPM, Sunset Los Angeles 12.

ADDRESSERS And mailers needed. Send stamp for information. Lindbloom, 1508 West Erie, Chicago, 60622.

VENDING Machines. No selling. Operate a route of coin machines and earn amazing profits. 32-page catalogue free. Parkway Machine Corporation, 715 PMB Ensor Street, Baltimore 2, Maryland.

SELL Books by mail. 400% profit. Royal, Box 450-X, Cleveland, Ohio 44127.

OPERATE Home mailorder business. Vosacek Printing, 4444AI Ute, San Diego, Calif. 92117.

DOLLS! Dolls! Dolls! We teach you to repair, make, dress, also how to operate a Doll Hospital. Study at home. Earn while you learn. Or enjoy a fascinating hobby! Free informative booklet. Lifetime Career Schools, Studio MC-86, 11824 San Vicente Blvd., Los Angeles, Calif. 90049.

\$60.00 DAY. Manufacturing concrete posts. Carlayne, 1803 Fremont, Rapid City, South Dakota 57701.

LEARN Landscaping and the growing of plants. Start a profitable business part or full time. Free information without obligation. Lifetime Career Schools, Dept. MC-86, 11826 San Vicente Blvd., Los Angeles, Calif. 90049.

HUGE Profits! Mail order importing. Free information. ITIS-PM-6, Box 454, Hollywood, Calif. 90028.

MAKE \$32 From 49¢ piece vinyl. PMA-1834 Edgeland, Louisville, Ky. 40204.

\$15.00 HOURLY Profit—Own Business with one serviceman. Quickly learned. Easy to do. Operate from home. Few hundred dollars builds your own nationally advertised business while continuing present job. Investigate immediately . . . before your territory is taken. Free booklet explains everything. Send today then decide. Duraclean, C6-168, Duraclean Building, Deerfield, Illinois.

400,000 BARGAINS Below wholesale! Many free. Liquidations . . . closeouts . . . job lots . . . single samples. Free details. Bargainhunters Opportunities, Box 730A, Holland, Michigan 49424.

VENDING Machine big catalog. Rake, 1214A West Girard, Phila., Pa. 19123.

SELL Advertising book matches. Write us today; we put you in business by return mail, handling complete line ad book matches in demand by every business right in your town! No investment; everything furnished free! Top commissions daily! Superior Match, Dept. MX-866, 7530 S. Greenwood, Chicago 19, Ill.

BECOME Tax consultant. Our students earn \$1,000-\$3,000 every tax season preparing returns evenings. Accredited State approved National Tax Training School. Monsey Q-2, New York.

BOOKKEEPING System. Substantial profit selling Start Service. Kern, Box 263, North Hollywood, California.

SECRETS! Secrets! Mail order success revealed by internationally famous expert who discovered how to make home business fortunes. Beginners: Get free copy "How to Make Money in Mail Order." Discloses free advertising, profitable products, everything! No obligation. Write Mailco, 1554 Sepulveda, Dept. X708, Los Angeles 90025.

"MAILORDER . . . Stop looking!" Get your own catalogue! Methods, 18118-FD, Lafayette Hill, Pennsylvania 19444.

I MADE \$40,000.00 Year by Mailorder! Helped others make money! Start with \$10.00—Free proof. Torrey, Box 63566-Y Oklahoma City, Oklahoma 73106.

FREE Details—Start your own plastic laminating business. We supply everything. Jiffy, Box 23485P, Los Angeles, Calif. 90023

FREE "Franchise Profit Letter" tells how unique NFR service is helping thousands seeking profitable businesses. Write today. National Franchise Reports, W-528, 333 North Michigan, Chicago 60601.

PIANO Tuning learned quickly at home. Tremendous field! Musical knowledge unnecessary. Information free. Empire School of Piano Tuning, Box 327, Shenandoah Station, Miami, Florida 33145. (Founded 1935).

MAKE Extra money — show friends, neighbors—gifts, stationery, Christmas, all occasion cards. Experience unnecessary. Salable samples on approval, free catalog, free name imprinted Christmas card album. Hedenkamp, 361 Broadway, Dept. PM-90, New York.

PACKAGE At home for profit! We supply everything. No "selling." Free home business details. HPC-807HPB, Sunset, Los Angeles 12.

LIQUID Molding rubber also liquid plastic free information. Chaney's, 5415-A San Jose Blvd., Jacksonville, Fla. 32207.

"MAIL-Order plan of the month." New service for those wanting their own Mail-Order Business. Free details. Volz-UN, Ypsilanti, Michigan.

FREE! 128 Page illustrated catalog. More than 2000 name brand items; below wholesale prices. Sell full or part time. Save hundreds of dollars on purchases for yourself! Watches, jewelry, cameras, radios, phonographs, tape recorders, appliances, housewares, cookware, hardware, power tools, luggage, musical instruments sporting goods, toys, many others. Orders shipped within 24 hours. Continuous supply. Send for free catalog now! H. B. Davis Corp., Dept. PM 1177 Main St., Hartford, Conn. 06103.

FREE Catalog! Packaging supplies, bags, display racks, etc. Write: Tadco, Lafayette, New Jersey 07848.

RADIO Mail order. \$50,000 in one month possible. No cost percentage plan. Walthay Box 53-M-8, Los Angeles 90032.

\$200.00 DAILY in your mailbox! Your opportunity to do what mailorder experts do. Free details. Associates, Box 136-A, Holland, Michigan 49423.

BOOKKEEPERS Earn \$1000.00 month. Operate simplified Bookkeeping tax service. Universal, Box 664-M, Springfield, Missouri.

HELPING Hand to avoid mistakes in mailorder. Inquire: Seben Enterprises, 220A Fifth Avenue, New York, N.Y. 10001.

\$200.00 WEEKLY. Every business and professional man has No-pay accounts. Send them to us for collection. We pay you for each name listed. No collecting. Dept. PM-12 General Finance Company, Pickwick Bldg., Kansas City, Mo. 64106.

FREE! Furnished apartment, plus \$400-\$1,000 monthly salary, if qualified as Motel Manager. Live graciously, meet VIPs. Train at home. Earn diploma from approved school. Free placement assistance. Openings for men, women, couples. If over 21, write for facts. Motel Management, Dept. 206, 2433 N. Mayfair Rd., Milwaukee, Wisc. 53226.

WANT To make big money at home? \$10.00 profit in an hour possible with invisible mending. Make tears, holes disappear from clothing, fabrics. Steady year-round demand from cleaners, laundries, homes. Details free. Fabricon, 1585 Howard, Chicago, Ill. 60626.

\$70.00 WEEKLY—home, spare time. Simplified mail bookkeeping. Immediate income, easy. Auditax, 34741a, Los Angeles 90034.

CONCRETE Facts: Cement artists make big money at home. Simple equipment. Experience unnecessary. Unlimited unique pottery designs easily made without moulds. Birdbaths, Wishing-Well, Waterfalls, Rustic Gardens, Patio items, etc. Formulated chemical coloring, marble-glazing. Free illustrated Brochure. Hollywood Cementcraft, 602 Athens, Altadena, California, 91001.

POPULATION Explosion spells profit. Mail baby catalogs to new Mothers. Details, catalog, \$1.00. Eureka Promotions, 4158 Greeby Street, Phila., Penna. 19135.

DEVELOP That Hunch—convert that occasional intuitive impression into a real business opportunity. Your secret partner is your unused mental potential. Write today for a free copy of *The Mastery of Life*. It explains how thousands have learned to use this undeveloped power as you can! Address: Scribe K.W.X., The Rosicrucians, AMORC, San Jose, California 95114. Please include Zip Code if part of your address.

ORCHIDS: Grow them at home for pleasure or profit. Illustrated book, price-list, 25¢. Presner, Box 10, Coral Gables, Florida.

RAISE Rabbits for us on \$500 month plan. Free details. White's Rabbitry, Mt. Vernon, Ohio.

WORLD'S Largest wholesale supply. Buy from 7853 American, European, Japanese wholesalers. Hong Kong tailormade suits, 123 dropship catalogs. Rockbottom prices. Automobiles. Free details. International Buyers, Post Office Box 4061, Colorado Springs, Colorado 80909.

SAVE 40%! Make your own professional rubber stamp manufacturing press! Parts list, photo-diagrams, instructions, \$1 00 (refundable). Garmac, 769 Rio Grande Bldg., Dallas, Texas 75502.

BIG Money, plastics are the wave of the future. Amazing profits, no selling, spare time, free information. Rush name on postcard. Best Plastics, Dept. PM-8, 940 Central Avenue Kansas City, Kansas.

FREE Report, "Home Business Opportunities." Profitable! Wyman, G-99, Congress, New York 10920.

LOAN Brokerage! Funds, leads, furnished. Set-up \$1.00. Brokerage. Dansville, N.Y.

MONEY Earn at home full or part time. Free details Kapco, Box 188 Elberton, Georgia 30635.

A BUSINESS of your own. Free details. Longtin, Route #1, Dept. M. Henderson, Kentucky 42420.

IMPORT-Export lucrative, two-way profitable business. Represent manufacturers, no investment. Free advertising in seven languages, 130 countries. Monthly dropship opportunities. Market Guides Japan, Hong Kong, Africa. Details 10¢. Benko, Box 188-A, New York 21, N.Y.

START—Operate easy small business. I made \$10,000 first year. Free proof. Ventures-331, Harlingen 1, Texas.

EXPLOSIVE!!! Mailorder business goldmine. Terrific! Moneymaking details free. Livingston's, Box 5332, North Charleston 1, South Carolina 29406.

GET Finance capital—Use tested sources. Loans, Grants. Free details. National Counselor, Harlingen 17, Texas.

SELL Urethane seamless floors, in do-it-yourself kits to homes, institutions, industry that save hundreds of dollars, or install it yourself and triple your profit on every sale. Anyone can brush, roll or trowel their own walls, counters, patios with Dur-A-Flex self leveling miracle glaze and chips. Be first with Space Age Floors. Write for details or send \$10.00 for a trial order. Dur-A-Flex, Inc. Dept. S, 269 Franklin Ave., Hartford, Conn.

GET Dollars in your mail! Start at home. Grow. Details free. Opportunity, Box 224-P1, Prospect Heights, Illinois 60070.

OPPORTUNITY To earn \$15,000-\$30,000 annually. Franchise protected. Guaranteed on \$15,000 basis. No merchandise to buy. Self employed. One of most exclusive and noncompetitive businesses in United States and Canada. Patent pending. Free 26-page brochure. Executives, P.O. Box 4680 APM, New Orleans, Louisiana.

STOP Wondering! Get facts about mail-order. Free information. Bentley, 122 Oakwood, San Angelo, Texas.

CO-PUBLISH Mail-order magazine earn money. 25¢ brings copy. Link, 1711 Debeney, Houston, Texas.

FREE Samples. Each merchandised for mail-order, rack-selling, franchising, or other profitable enterprise, Merritt, Box 16305-D, San Francisco, California 94116.

MAKE \$46 From square foot plywood: jigsaw necessary. Free details. Woodart, Bridgewater, Mass.

MONEYMAKING OPPORTUNITIES

EARN Money evenings, copying and duplicating comic cartoons for advertisers. Aservice, Argyle-1, Wisconsin.

\$200.00 FROM Sheet 1/4" plywood (scrap). 25¢ refundable. Novelties. 610 So. 24th. Elwood, Indiana.

MINK Raising information free. Lake Superior Mink Farm Inc., Superior, EE1, Wisconsin.

EARN Big commissions full or part time. Show America's largest line low priced business printing and advertising specialties plus big catalog union label political advertising items. Calendars in season. Big free sales kit samples hundreds items used daily by businessmen and political candidates. Merchandise bonuses for you. Free gifts for customers. Build profitable repeat business. Start now. National Press, Dept. 147, North Chicago, Ill.

EARN \$240.00 a month at home, spare time, doing only two \$5.00 invisible mending jobs a day. Big money paid for service that makes cuts, tears disappear from fabrics. Steady demand. Details free. Fabricon, 1532 Howard, Chicago, Ill. 60626.

CLIP Newspaper items. \$1.00-\$5.00 each. Details free. Walter, Box 1023-P, Erie, Pa.

BIG Money raising fishworms and crickets. Free literature. Carter Hatchery, Plains, Georgia.

NEW Instant invisible mending. Learn in one hour, repair in five minutes. Make \$150.00 week. Literature free. Henson, P.O. Box 6136-6, Philadelphia, Pa. 19115.

MAKE \$50-\$100 Fast assembling Link Belts. Free details! Redikut's, Loganville, 40 Wisc.

SHARP \$\$\$ Opportunity! One low-cost machine sharpens—serrates knives, scissors, pinking shears. Earn \$6-\$9 hourly in spare time. Professional results without experience. Free details. Beaver Machine, 836C Nielson Bldg., Eugene, Oregon.

\$400.00 MONTH Possible raising night-crawlers, redworms. Three Oaks Ranch, Dresden, Tenn.

MAIL Letters featuring real merchandise—Get \$10 orders in every mail—\$8 profit. Everything furnished. Universal, Dept. 15, 510 First National Bank Building, El Dorado, Arkansas 71730.

AMAZING Successes through franchises! Become exclusive franchise holder your territory. Information rushed. National Franchise Reports, WP-528, 333 North Michigan, Chicago 60601.

MAKE Big extra money in spare time as accident investigator. College unnecessary. Keep present job. Work from home. Salary to \$8 an hour, plus expenses. State approved correspondence course trains you quickly. For free information write Liberty School, Dept. B58, 1130 W. Park, Libertyville, Illinois.

AMAZING Mailorder profits using proven methods. Particulars free. Unicrus, Box 735-PY, Norwalk, Conn. 06852.

RAISE Rabbits and fishworms on \$500 month plan. Free details. White's Rabbitry, Mt. Vernon, Ohio.

MAKE Big money taking orders for Stark Dwarf fruit trees. Everybody can now grow Giant Size Apples, Peaches, Pears in their yards. Also Shade Trees, Shrubs, Vines, Roses, etc. Outfit free. Stark Bro's, Desk 30187, Louisiana, Missouri 63353.

EARN Extra money spare time \$5 per hour — vacuum cleaner repair — information. \$1.00. P.O. Box X922, Poughkeepsie, N.Y. 12602.

MONEYMAKING Opportunities in closed-circuit TV. Full or part time. Send 10¢ for details. ATV Research, Box 396-PMM, South Sioux City, Nebraska 68776.

"HOMEWORKERS' Opportunity Directory" lists 75 companies with spare-time work! \$1.00. Opportunities, Box 26034-PH, Indianapolis, Indiana 46226.

LEARN The secrets of repairing junk batteries. "Fabulous Profits" at home. Details. The Batteryman, P.O. Box 416, Palm Desert, Calif.

MASTER Watchmaking at home. Free sample lesson. Chicago School, Dept. YHA, Fox River Grove, Illinois 60021.

MAKE \$5,000 Yearly sparetime, raising mink, chinchilla, nutria, etc. Free booklet reveals proven plan. Write: Furs, Dept. E. Bewdley, Ontario, Canada.

JEWELRYCRAFT for fun or profit! Catalog. 25¢. Modern Craft, Box 3614-RO, Cranston, R. I. 02910.

YOU Can earn up to \$25,000 year, right from your own home! Two 5¢ stamps for information. Dickerson, Box 6236, Austin, Texas 78702.

SELL Books by mail, 400% Profit. Shalimar Enterprises, Box 772, Shalimar, Florida 32579.

FREE Catalog of forty money-making manuals. Dailey's, Box 4, East Montpelier, Vermont 05651.

MAKE Money writing short paragraphs! No tedious study! I tell you what to write, where and how to sell, and supply list of editors buying from beginners. Many small checks add up quickly. Write to sell, right away. Send for free facts. Benson Barrett, Dept. C-27-H1, 6216 No. Clark, Chicago 26.

HOW To net \$50 day in Ad Market. Sell dollar ads. Home, phone, mail. Write: Ad Market, Harlingen 4, Texas.

"DIRECTORY Of Close-Out Firms." 20,000 items at close-out prices. Complete Details \$1.00. Global, 9107 Joy Rd. Oak Ridge, Tenn.

DO You need money? 101 different ways of making easy money in your spare time. Over 50 ideas for the woman at home. \$1.00. The Angel Center, P.O. Box 5441, San Jose, California 95150.

EARN Money full or part time. Work at home or away. Write Sato, 19710 Arrowhead, Cleveland, Ohio 44119.

MAKE Money zip-coding at home. Information free. Automated Mail, Dept. 128, Stamford, Connecticut 06904.

COMEDY Writing pays! This is a wide-open market for new writers in TV, books, magazines, newspapers, advertising, etc. A unique home-study course teaches you all the professional secrets and techniques. Endorsed by top comedy stars and writers, and approved by the California Superintendent of Public Instruction. Send for free brochure: The Hollywood School of Comedy Writing, Dept. PM68, 922 North Vine Street, Hollywood, Calif. 90038.

CIGARETTES—Make 20 filtertip or plain for 10¢. Mild-tasty-satisfying. All any cigarette can give. Facts free. Moberly, Box 935, Owensboro, Kentucky.

FREE Information—sell by mail, profitable, pleasant, easy. Box 284, Lincoln, Ill. 62656.

VENDING Machines. No selling. Operate a route of coin machines and earn amazing profits. 32-page catalogue free. Parkway Machine Corporation, 715 PMM Ensor Street, Baltimore 2, Maryland.

START A profitable subscription business in spare time! We need men and women (young and old) as representatives for all leading national magazines. Liberal commissions on all subscriptions. Supplies free. No experience needed. Send this ad with your name and address to: Popular Mechanics, Room 8-O, 250 W. 55th St., New York 10, N.Y.

PROFITABLE OCCUPATIONS

EARN \$240.00 A month at home, spare time, doing only two \$5.00 invisible mending jobs a day. Big money paid for service that makes cuts, tears disappear from fabrics. Steady demand. Details free. Fabricon, 1586 Howard, Chicago, Ill. 60626.

INVESTIGATE Accidents. Earn \$750 to \$1,400 monthly. Car furnished. Expenses paid. No selling. No college education necessary. Pick own job location. Investigate full time. Or earn \$8.44 hour spare time. Men urgently needed now. Write for Free literature. No obligation. Universal, CPM-8, 6801 Hillcrest, Dallas, Texas 75205.

VENDING Machines. No selling. Operate a route of coin machines and earn amazing profits. 32-page catalogue free. Parkway Machine Corporation, 715 PMM Ensor Street, Baltimore 2, Maryland.

SHARPEN—Scissors, pinkers. Inexpensive equipment, tools, supplies. Blackhawk's, Sheldahl, Iowa.

FREE Facts and descriptive bulletin. Be an air conditioning, refrigeration, and heating serviceman. High pay, jobs open everywhere, operate your own service business, no school or correspondence necessary. Write Doolco, Trouble Shooter, 2016 Canton, Dallas, Texas.

BECOME Independent with your own franchise business. Thousands earning handsome incomes. Request interesting facts today. National Franchise Reports, PM-528, 333 North Michigan, Chicago 1.

CHROME Plating. Instructions, equipment and supplies. 'Platers' Supply, P.O. Box 565, Lugo Station, Los Angeles, Calif.

FREE Book "990 Successful, Little-Known Businesses." Work home! Plymouth-97H, Brooklyn, New York 11218.

YOUR Own sign shop—Signs, 1017 W. Mulberry, Springfield, Ohio.

FREE Catalogs. Repair air conditioning refrigeration. Tools, supplies, full instructions. Doolco, 2016 Canton, Dallas, Texas 75201.

MAKE Money at home doing telephone interview work. No selling. Ketchum's Advertising, Springfield, Illinois.

LEARN PROFESSIONAL Exterminating methods. Complete outline, \$2.00 Camco, Box 7332-A, Kansas City 16, Missouri.

SCIENTIFIC Massage: Big earnings, uncrowded profession. Learn spare time at home. Diploma awarded. Free catalog. Write: Anderson School, Dept. J-1C Princeton, Illinois.

AUCTIONEERING—Resident & home study courses. Veteran approved. Auction School, Ft. Smith, Arkansas.

RAISE Rabbits for us on \$500 month plan. Free details. White's Rabbitry, Mt. Vernon, Ohio.

MAKE Money writing short paragraphs. Information free. Barrett, Dept. C-27-H2, 6216 N. Clark, Chicago 26.

HIGHER Income, security, power. 256 page book, "Thinking Big," reveals secrets that make men rich! \$2.00. Allen House, Box 7617, Shreveport, La. 71107.

REPAIR Power tools, jacks, pullers. Diagramed instruction manuals. Samples. Tech-Aids, Box 381, Baton Rouge, Louisiana.

BIG Money raising fishworms and crickets. Free literature. Carter Wormery, Plains, Georgia.

START A magazine subscription business. Earn generous commissions on Popular Mechanics, Good Housekeeping and all others. Best commissions, bonus, all material sent free. No experience needed. Write Popular Mechanics, Room 8-P, 250 West 55th St., New York 19, N.Y.

SALESMEN—DISTRIBUTORS

\$1,000.00 a month for making dramatic 3-second demonstration of amazing Light-weight Presto Fire Extinguisher. New chemical used by Airforce snuffs out fires instantly. Only \$4.95. Terrific commissions. Millions want it. Free Kit. Merlite, 114 E. 32nd, Dept. P-66B, New York 16.

SENSATIONAL New longer-burning light bulb. Amazing free replacement guarantee—never again buy light bulbs. No competition. Multi-million dollar market yours alone. Make small fortune even spare time. Incredibly quick sales. Free sales kit. Merlite (Bulb Div.), 114 E. 32nd, Dept. C-73B, New York 16.

EARN Big commissions full or part time. Show America's largest line low priced business printing and advertising specialties plus big catalog union label political advertising items. Calendars in season. Big free sales kit samples hundreds items used daily by businessmen and political candidates. Merchandise bonuses for you. Free gifts for customers. Build profitable repeat business. Start now. National Press, Dept. 146, North Chicago, Ill.

JOIN An established firm. Over 30 years with Calendars and advertising specialties. Bonuses-prizes-free pens. Fleming, 6335-A Cottage Grove, Chicago 60637.

FREE. 206 Easy ways to make money taking orders for exciting new products—spare time. Send name, age for 5 months free subscription Opportunity Magazine, 850 N. Dearborn, Dept. 17-GS, Chicago.

SELL Advertising book matches. Write us today, we put you in business by return mail; handling complete line ad book matches in demand by every business right in your town! No investment; everything furnished free! Top commissions daily. Superior Match, Dept. M-866, 7530 S. Greenwood, Chicago 19, Illinois.

AGENTS WANTED

PRINTING. Advertising salesmen—Excellent moneymaking sideline selling decalomania name plates, small quantities. Automobile initials, sign letters. Free samples. Ralco, XL, Boston, Mass. 02119.

YOUR Own business—Used suits \$1.50; overcoats 65¢; mackinaws 35¢; shoes 12½¢; ladies coats 30¢; dresses 15¢. Enormous profits. Catalog free. Nathan Portnoy Associates, 2109-AA Roosevelt Road, Chicago 8, Ill.

CHRISTMAS Cards—business and personal. Customer's name imprinted. Earn unusually high commissions from this medium—and high-priced line. Free sample album. Process Corp. (our 45th year), 3456 S. 54th Ave., Chicago, Ill. 60650.

MAKE Extra money—show friends, neighbors—gifts, stationery, Christmas, all occasion cards. Experience unnecessary. Salable samples on approval, free catalog, free name imprinted Christmas card album. Hedenkamp, 361 Broadway, Dept. PM-90 New York.

ESTABLISH Your own business. Low prices on used clothing, shoes, household goods. Unlimited profits. Free catalog. Northwestern Distributors, 2129 No. Western Avenue, Chicago, Illinois 60647.

MAKE Extra money introducing new runless seamless nylons at amazing low direct-from-mill price, 59¢ a pair! Friends snap them up by the dozen. Write for free sample stocking and kit. American Hosiery Mills, Dept. 129, Memphis, Tennessee 38101.

MAKE \$50.00 Daily selling air operated vacuum cleaners to service stations. Free details. Inka Industries, 2401 Crocker, Houston, Texas 77006.

GET New shirt outfit free! \$90 weekly on 5 average orders a day. Famous quality made-to-measure dress and sport shirts at \$4.95 up, sell to all men. No experience needed. Full or part time. Write: Packard Shirt Co., Dept. 509, Terre Haute, Indiana 47808.

START Making money now. Earn top commissions taking orders for all magazine subscriptions. Friends and neighbors are your prospects. No experience needed. Write for free money-making kit. McGregor Magazine Agency, Dept. OAT, Mount Morris, Illinois 61054.

SEEKING New products? Get my outfit 47 money-making specialties. Latest conveniences for home, car. Send no money. Just your name. Kristee, 115 Akron, Ohio 44308.

BUSINESS Kit free! Postcard puts you in business! Complete line 275 shoe styles, jackets! New discoveries pay big commissions. No investment. Send for free kit. Mason, Chippewa Falls, K-355, Wisconsin 54729.

AGENTS—300%. Profit selling genuine gold window letters; stores and offices. Free samples. Metallic Sign Letter Co., 1217-D West Newport, Chicago.

250,000 NEW Mothers every month! Bonanza for bronzed baby shoes! \$50.00 a day profit. No investment, no inventory. Full or spare time. Exciting details free. Sentimental, 1919 Memory Lane, Dept. 8H, Columbus, Ohio 43209.

RAISE Rabbits for us on \$500 month plan. Free details. White's Rabbitry, Mt. Vernon, Ohio.

EMPLOYMENT INFORMATION

FOREIGN Employment: South America, Africa, Europe, Australia, USA. Earnings to \$2,000.00 monthly. Construction, all trades, professions, occupations. Many companies pay fare, housing, benefits, bonuses. Write: Universal, Dept. B-1, Woodbridge, Connecticut 06525.

BOOMING Australia needs your skills! Government assisted passage. Details, \$1.00. Irv Heyer, 321A S.W. Salmon, Portland, Oregon.

FOREIGN Employment. Construction, other work projects. Good paying overseas jobs with extras, travel expenses. Write only. Foreign Service Bureau, Dept. PM, Bradenton Beach, Florida.

DIRECTORY Reports. Construction, aviation, shipping, oilfields, government, manufacturing, trucking, etc. foreign—stateside. Helpful information plus job-getting tips on preparing application letters. Unconditional money-back guarantee. Only \$3.00 (\$3.25 airmail) Research Services, Box 6768-PM, St. Louis, Missouri 63144.

JOBS Passenger ships, freighters, \$100.00 week. Beginners, men, women. Information: Work At Sea, Box 52, Murray Hill Station, New York City 10016.

TREMENDOUS Opportunities U.S.A.—Overseas. Choose jobs—locations—transportation. Free details. Occupations, International Airport, Box 100-C5, Jamaica 30, N.Y.

HELP WANTED

OVERSEAS Jobs—Europe, South America, Far East, etc. 2,000 openings in all trades. Construction, Office Work, Sales, Engineers, etc. \$400 to \$2,500 month. Expenses paid. Free information, write Overseas Jobs, Box 22456, Fort Lauderdale, Florida.

FARMS—REAL ESTATE

CANADIAN Vacation lands: Full price \$385.00. 40 acres, \$10 month. Suitable cottage sites, hunting, fishing, investment. Free information. Land Corporation, 3768-O Bathurst, Downsview, Ontario, Canada.

CANADIAN Lands, seized and sold for taxes. Our 49th annual series of lists, describe many choice properties, situated from coast to coast, acquired by us through tax sale. Priced as low as five dollars per acre, guaranteed perfect title, small monthly payments, no mortgage. Beautifully situated hunting and fishing camps, where there is real sport; summer cottage sites, heavily wooded acreages. Now is the time to invest in Canada's minerals, forests and farms. Write today for free twenty page booklet with full explanation. Tax Sale Service, Room 301-D, 85 Bloor St., E., Toronto 5, Canada.

400,000,000 ACRES Government public land in 25 states. Some low as \$1.00 acre. 1966 report. Details \$1.00. Public Land, 422-PM-8, Washington Building, Washington, D.C.

FREE Summer catalog! Bargains galore! Coast-to-coast! Low prices, easy down payments! Safe-Buy Real Estate Agency, 712-PM, West Third, Little Rock, Ark. (Please include Zip Code.)

FREE! Summer catalog! Big 180-pages! Selected Best throughout the U.S. Thousands of properties described, pictured—Land, Farms, Homes, Business—Waterfront, Recreation, Retirement, 66 Years' service, 490 Offices, 36 states coast to coast. Mail Free from the World's largest! Strout Realty, 7-CJ, So. Dearborn, Chicago, Illinois 60603.

\$1 ACRE—Canadian border—hundreds campsites, islands, farmlands, directly from tax authorities. (Non-profit). Lists, photographs mailed. Register, Room 203, 92 King St., E., Toronto 1, Canada.

GOVERNMENT Lands . . . Low as \$1.00 acre! Millions acres throughout U.S. Free details! Lang Digest, Box 260-34-PH, Indianapolis, Ind. 46226.

ABANDONED Timber Leaslands! Choice 640 acre Sportsmen's paradises still available—\$20.00 plus \$6.50 Taxes yearly. Maps, pictures, \$1.00 (Refundable). Director, Erindale 4, Ontario, Canada.

"THE Only 'No-Risk Land Purchase Plan' in America"—10 year money-back guarantee on any vacation, retirement or investment homesite in Boiling Spring Lakes—the multi-million, 14,000-acre development on the Carolina Coast. All facilities, electricity, roads, shopping center, motel, golf course, country clubs, already in. Private ocean beach. ¼-acre homesites as low as \$435.00; \$5.00 down. Write for free literature. (Not offered to residents of California, Florida, New York). Boiling Spring Lakes, Southport 1-X, North Carolina 28461.

FREE!! 160-Page real estate catalog! Over 1800 pictures! Farms, ranches, homes, businesses, vacation and retirement properties in 29 states coast to coast! United Farm Agency, 612-PM West 47th St., Kansas City, Mo. 64112.

NORTH Florida lots, \$69.00 each. Casper Corporation, 3970 N.W. 177 St., Miami, Florida 33054.

FREE—Public land bulletin, listing millions of acres . . . with copyrighted booklet "How to Acquire Public Lands." Send \$1.00. Land Service, P.O. Box PM4496, Washington, D. C. 20017.

CANADA'S Finest lands. \$4.00 an acre and up. Acquired through estate liquidations. Suitable for hunting, fishing, camps, cottages, farming, timber, minerals, investment. Small monthly payments. Free descriptive booklet. Canadian Estate Land, 2788-P Bathurst Street, Toronto, Canada.

FARM AND GARDEN EQUIPMENT

DRILL Your own water well for 2¢ per foot! New high-speed drilling rig only \$145 complete. Brochure and "How to Find Water on Your Property" 25¢. DeepRock Drilling Company, 605 Trafco, Opelika, Alabama 36831.



FLOWERS, PLANTS and NURSERY SUPPLIES

WANT Greatest cash crop working for you? Write Ginseng, Asheville 53, N. C.

LUCKY Leaf. Grows anywhere without soil or water. 50¢ pair. Lesco, 1251 Palmetto Road, West Palm Beach, Florida 33406.

GINSENG Goldenseal wanted. Write for free pricelist and tags. Buying direct fifty years. Consolidated Raw Fur & Ginseng Co., Dept. PM, 157 West 29 Street, New York 10001.

HOME CRAFTSMEN

101 PATTERNS Of smart gifts, novelties, shelves, action windmills plus "Make Money Jig Sawing" \$1.00. Mastercraft, 85M, 7041 Olcott, Chicago 60631.

WALNUT And cherry tapered legs, lumber, gunstock, blanks, picture frame moulding. Midland Lumber Company, Box 262, Savannah, Missouri.

FREE! Big 80 page Leathercraft catalog. 100's of new items! MacPherson Bros., Dept. K, 730 Mission St., San Francisco, Calif. 94103.

PATTERNS Of exciting wooden souvenirs, 50¢. Fiesta, No. Conway, N.H. 03860.

PICTURE Frame moulding—Any size, style, wood. Original patterns. Write. Japs, 126-P Seventh North, Hopkins, Minn. 55343

SKIL-Crafts new '65-'66 Catalog. Largest and finest selections of leathercraft, artist, hobby-craft supplies in the world. Send 50¢ (refunded plus free gift with first \$5 minimum catalog order). Skil-Crafts, Box 105-P, Joplin, Missouri.

GLASS Cutting, edging, hole drilling; easy instructions with illustrations for the home workshop. \$1.00. Glass, Box 895, Fort Lauderdale, Florida.

WOODWORKING Catalog and manual 25¢. Plus free "101 Project Ideas." World's most beautiful veneers, lumber, plywood! Wood finishing, upholstery supplies. Furniture hardware, 2,000 needed workshop products. Constantine, 2051-M Eastchester Road, Bronx 10461.

COMPLETE Working Plans, specifications, bill of materials for attractive Barbecue Serving Cart. Send \$1.00 today. Ease-Crafts, 1819-9th Street, Rockford, Illinois. 61108.

PLANS—Detailed book, 21 homecrafted toys and games you can't buy. 75¢. S & S Enterprises, 3228 University Avenue, Madison, Wisconsin 53705.

KNOCKDOWN Cedar chests, also over fifty kits. Catalog 25¢. Giles Kendall Co., Huntsville 2, Alabama.

BURGLAR Alarm. Open door—horn sounds. Battery operated. Plans, \$1.00. Finished unit—\$4.85. Mass. residents add 3% tax. Minute Man House, Box 445, Lexington, Mass. 02173.

WORKCENTER For your homeshop. Low heavy table for landing, assembling, gluing, finishing. 9-ply top, rubber feet. \$1.00 for drawing, photograph, kit information. ordkits, 330 Grove, Glencoe, Illinois.

INDIANS Teepee pattern! Make your little Indian a life-size teepee! Instructions easily followed. \$1.00. The Angel Center, P.O. Box 5441, San Jose, Calif. 95150.

2512 PLANS. Patterns, things to make, do. Fun. Profit. World's greatest selection. Catalog 10¢. Craftplans, 18250-A Harwood, Homewood, Ill.

PLANS for pool table with extra two-face top for table tennis and model railroad. Blueprints B1209 and building instructions \$3.50. Popular Mechanics Service Bureau, 575-M Lexington Ave., New York, N.Y. 10022.

DO-IT-YOURSELF

WATER Free. Sink your own well. Easy illustrated instructions. \$1.00. Butler, Box 67, East Longmeadow, Mass.

MAKE Rotary mower into shredder and mulcher. Send \$1.50 for pattern. Minnie The Mulcher, 300 Fowler Street, Cortland, Ohio 44410.

MOUNT Fish using household materials. Instructions \$1.00. C. Thompson, Manomet, Mass. 02345.

AIR Compressors, (converted mower engines.) portable, dependable. Complete instructions. \$4.95. Showalter, Box 409P, Abilene, Kansas 67410.

NEW Idea. Build your own. Sell for big profits. Round, end, and corner tables. 3 plans in all, easy to follow, step by step instructions, guaranteed. Send \$1.00 to P. Mims, P.O. Box 217, Bonifay, Florida.

FIREPLACES, Brick. Do it yourself. Save hundreds. For complete plans send \$3.50. Don Black, Taylor, Arizona.

EXERCISE At home on build-it-yourself physical fitness equipment, including bicycle exerciser, rowing machine, belt massager, and abdominal board. Send \$2.50 for blueprints B1208 and instructions. Popular Mechanics Service Bureau, 575-K Lexington Ave., New York, N.Y. 10022.

FREE Check-list covering more than 300 classifications of projects, plans, instructions, service and repair information detailed in Popular Mechanics famous series of instructional booklets, books, patterns, and blueprints. List covers an extremely wide variety of do-it-yourself data on home remodeling, repair and improvement, hobbies, crafts, boating, games, lawn and garden, and hundreds of others. For your free copy of this helpful list, write: Service Bureau, Popular Mechanics, 575 Lexington Ave., New York 22, New York.

ARTS AND CRAFTS

MAKE Figurines, plaques, lawn ornaments. Molds, plastercraft kits, liquid rubber. Sample and catalogue 10¢. Wooley Company, Box 29-B, Peoria, Illinois.

2500 DIFFERENT plastic molds, figurines, crafts. Catalog, 25¢. Steece Bros., Box 177-PM, Sioux Falls, So. Dak. 57101.

BINOCULARS, TELESCOPES, MICROSCOPES, MAGNIFIERS

SCIENCE Bargains! Lenses, telescopes, binoculars, microscopes, kits, parts, war surplus. Send \$1.50 for beginner's 10-lens kit with instruction booklet. Order Stock 2-CH. Request free 148 page Catalog CH. Edmund Scientific Co., Barrington, New Jersey.

BINOCULARS Direct from manufacturer. Finest quality, tremendous savings! Request catalog. Koyu, 3860 Crenshaw Blvd., Los Angeles, Calif.

BUILD Your own reflector telescopes: Complete kits: mirrors, eyepiece, tripods. Free catalog F describing other accessories sent on request. Also free brochure describing amazing line, World famous "Dynascope" reflector telescopes. Criterion Manufacturing Dept. KPM41; Hartford, Connecticut.

BINOCULAR—Riflescope sale! Free color catalog, 100 models, \$9.95-\$250.00. Write: United, 9043 So. Western BCAT-6508, Chicago 60620.

AMAZING Offer, microscopes, telescopes, binoculars. Lowest prices. Free brochure. University Optics, Box 205-M, Ann Arbor, Michigan.



CAMERAS AND EQUIPMENT

TELL The more than 1,400,000 avid readers of Popular Mechanics about your products and services. It costs very little to place your classified message in front of these proven mail order buyers. For further details, write: C. A. Martin, Dept. 49N, Popular Mechanics, 575 Lexington Avenue, New York, New York 10022.

PHOTO SUPPLIES

PHOTOGRAPHY For pleasure or profit. Learn at home. Practical basic training. Long established school. Free book, American School of Photography, 835 Diversey Parkway, Dept. 345B, Chicago, Illinois 60614.

PHOTO FINISHING

KODACOLOR: 8 Exposures, \$2.00, 12 Exposures, \$2.50. Black and White: 8 Exposures, .50¢. 12 Exposures, .70¢. Our 50th year. Free mailers. Savon Photo Service, Box 110M, Watertown, Wisconsin.

CAMERA Fans! Expert photofinishing and free film returned: 8MM Kodachrome \$3.10; 8 Exp Kodachrome \$3.10; 35MM Kodachrome, 20 slides, \$2.85; 8 exp black & white 90¢. We give you free photo stamps to redeem for gifts. Satisfaction guaranteed. Send exposed film or request mailers and complete price list. Direct Mail Photo, Box 8352-PM, Pittsburgh, Pa. 15218.

A FREE Kodak roll returned with each black and white or Kodachrome developed and printed, fast service, lowest prices, guaranteed quality send for free mailers. Economy Photo Service, Dept. P. M., Box 1111, Albany 1, N.Y.

FAST, Hi-quality finishing. Kodachrome rolls: eight jumbo prints \$1.98. Twelve \$2.49. Twenty \$3.49. Reprints 15¢. Also low B&W prices. Custom Quality Studio, Box 4838-PM, Chicago 60680.

COLOR SLIDES

TRANSPARENCIES Wanted! Learn free-lancing. American Color, Box 46372, Hollywood, California.

MOTION PICTURES AND SOUND EQUIPMENT

FREE Catalog! Save on 8/mm.-16mm. film and supplies. Superior, 448 N. Wells, Chicago 10.

16MM sound-projectors, films, new, used for sale. Free catalog. National Cinema, 333 W. 57 Street, New York City, N.Y. 10019.

16MM SOUND Shorts, cartoons, features, Cinemax Films, 10134 Perry Ave., Chicago, Ill. 60628.

5,000 8-16 MM. Movie films. Free catalogues. International, Greenvale, N.Y.

24 PAGES 16MM movies. Surprise reel—1200—\$4.85. Gaines (PM), 14544 Vanowen, Van Nuys, Calif. 91405.

16MM Sound films features and shorts. Bedner, 5300 So. Talman, Chicago.

8MM MOVIES, 2"x2" Color slides—biggest selection anywhere! Hollywood classics, railroad, antique automobiles, circus, World War II, travel, wildlife, many others. 16mm films also. Big catalog free. Blackhawk Films, 24 Eastin-Phean Bldg., Davenport, Iowa 52808.

RADIO, TELEVISION AND HAM EQUIPMENT

FREE Electronics catalog. Tremendous bargain. Send postcard. Edu-Kits, Department C-649B Hewlett, New York 11557.

CONVERTERS For automobile radios, receive Marine, Police, Fire. 2-3, 30-50, 100-200 megacycles. Any kit \$5.00. Meshna, Lynn, Mass. 09104.

TV Camera kits, \$18.95 up. Catalog 10¢. ATV Research, Box 396-PM, South Sioux City, Nebraska 68776.

BRAND New tubes. World's lowest prices on radio, TV-industrial, special purpose tubes. Write for free parts catalog. United Radio, Newark, N.J.

UNBELIEVABLE Electronic bargains. Exclusive items. Catalog 50¢. San Diego Electronics Center, 700 Market, San Diego, California.

33¢ RADIO & TV tubes. Free list. Cornell, 4213-17 University, San Diego 5, California.

HIFI, RECORDS AND ELECTRONICS

EXCLUSIVE Free catalogue; extraordinary hard to find hobby party records. Record Suppliers, 300 Chelsea, Louisville, Kentucky 40207.

RECORDS! Discounts on all LP's. Free details. Citadel Record Club, 545 Fifth Ave., Dept. 2, New York 17, N.Y.

TAPE Recorders, hi-fi components. Sleep learning equipment, tapes. Unusual values. Free catalog. Dressner, 1523 Jericho Tpke., New Hyde Park 3, N.Y.

MONITOR Telephone conversations through any radio. Simplified instructions \$3.00. Electronic Devices, Box 572, Fayetteville, N. C.

LOW Quotes, fast service, everything in Audio. Dynaco our Specialty—kits or wired and handcrafted walnut Dyna Covers. Kitercraft, 738M Washington Avenue, Brooklyn 1238.



MUSIC AND MUSICAL INSTRUMENTS

ELECTRIC Guitars, amplifiers, wholesale. Free catalog. Carvin, PMM, Covina, Calif. 91722.

GUITAR. Banjo Making books. Plans, woods, necks, tools. List 20¢. Satinwood, 510 East 11th Street, New York 9, N.Y.

SONG Ideas wanted. Write with active professional songwriters with publisher contacts. Records made. Share royalties. Send ideas—free examination. Songwriters' Associates, 236 W. 55th, N.Y. 19-P.

PIANO Self-Teaching Book. Includes popular, classical, harmony, theory, chords, scales. Price \$5.00. LaPont Publishing Company, Box 606-P, Franklin, Michigan 48025.

SONGPOEMS Wanted. Send poems for offer. Nashville Music Institute, Box 532-PM, Nashville, Tennessee.

SONGS Wanted by new commercial recording company. Royalty basis. Send material to Preview Records, 6311-B Yuca, Hollywood, California 90028.

INCOME Guaranteed two years for song-poems accepted! Free public releases! Castle's, 203PM West 46th Street, New York City 10036.

GUITARS. \$11.95. Electric double pickups with tremolo bar, \$49.95. Accordions. \$125.00. Concertinas, \$350.00. Drums pearl set, \$99.00. Wind instruments \$39.95. Free catalogs. EZ, Terms, Melody Music, 4951 W. 95th St., Oaklawn, Ill.

SONGWRITERS Wanted! Send song material for recording consideration. Tin Pan Alley, 1650-P Broadway, New York 10019.

PLAYER Piano books. Free catalog. Vestal Press, Vestal 11, N.Y. 13850.

POEMS Wanted for new songs and records. Send poems. Crown Music, 49-C West 32, New York 1.

ACCORDION Top brands. Buy direct. Tremendous discounts. Trade accepted. Free brochure PM. Accordion-O-Rama, 874 Broadway, NYC.

DRUMS. Electric guitars, amps, organs. Free catalog M: A.L.A.S. Import Company, 31 East 18th Street, NYC.

SONGS, Poems, collaboration, publication. Details, Newart, Box 693, Syracuse, N.Y.

ACCORDIONS, Guitars, band instruments! Save to 50%. Famous makes. Easiest terms. Trades accepted. Free home trial. Free discount catalog. Mention instrument. International Music Mart, 5535-R Belmont, Chicago 60641.

POEMS Wanted for new songs and records. Send poems. Five Star Music, 6M Beacon, Boston 8, Mass.

SONGS, Poems wanted! Accepted songs published, recorded at our expense! Ted Rosen, 17-PM Longwood Road, Quincy, Mass.

GUITAR: Amazingly easy, illustrated ten-lesson course \$1.98. Daniel's, Apartado 1001, Mexico City.

SONG Poems Wanted! Collaborate with professional songwriters equally. Share royalties. Songwriters Contact, 1619-D, Broadway, New York 19.

ACCORDION Manufacturing, 6343-P South Ashland, Chicago Illinois 60636. Piano Accordions, Chromatics, Hohners, Concertinas. Wholesale catalogs free.

EDUCATION AND INSTRUCTION

OWN Collection agency. "Little Gold Mine!" Franklin Credit, Roanoke, Virginia.

BOOKKEEPERS. Operate your own "Dollar-A-Week" system. Ellis, Box 200, Cedar Grove, North Carolina.

PIANO Tuning pays. Big money in spare time. Learn at home. No musical knowledge necessary. Phonograph, records, tools and instructions furnished. Electronic tuning also taught. Free catalog. Capital Tuning School, 3160 S.W. 16th Court, Ft. Lauderdale, Fla.

MISSOURI Auction School. Free catalog! 1330-03 Linwood, Kansas City, Mo. 64109.

FCC License in 6 weeks. First class radio telephone. Results guaranteed. Elkins Radio School, 2603D Inwood, Dallas, Tex.

DETECTIVE Course. Free information. Universal Detectives, Box 8180-F, Universal City, California, 91608.

SWEDISH Massage and Physical culture pays big profits. Learn at home. Diploma. Free catalog. National Institute, Dept. E86, 307 North Michigan, Chicago 1.

LEARN Auctioneering. Term soon. Free catalog. The Reisch American School of Auctioneering, Inc., Box 850, Mason City 1, Iowa.

LEARN Asleep or awake! Records, tapes, equipment! Free catalog! Drawer, PM-400, Ruidoso, New Mexico 88345.

AUTOSUGGESTION. Sleep-learning headquarters! Tapes, records, books. Gigantic catalog free. Research Association, Box 24-PM, Olympia, Washington.

FREE Sleep-learning catalog. Fletcher, 2407 Catherine, Dallas, Texas 75211-PM.

PIANO Tuning quickly learned with home study course. Diploma granted. American Tuning School, Gilroy, Calif.

USED Courses! Books! List 10¢. Smith's, 124 Marlborough, Salem, Mass.

FREE Bible course. Degree, PM, 143 South Gregg, Charlotte, N.C. 28208.

BE A real estate broker. Big Earnings. Free catalog. Weaver School of Real Estate, 3519-P Broadway, Kansas City, Missouri 64111.

LEARN Civil and criminal investigation at home. Earn steady, good pay. State age. Institute Applied Science, 1920 Sunnyside, Department 168, Chicago, Illinois 60640.

GET A British degree. Divinity, Philosophy, Radionics, 35 courses. Prospectus free. Brantridge Forest School, "Lodge" Brantridge Forest, Balcombe, Sussex, England.

USED Correspondence courses and books sold and rented. Money back guarantee. Catalog free. (Courses bought.) Lee Mountain, Pisgah, Alabama.

HIGH School diploma at home. Licensed teachers. Send age, highest grade completed for free detail. No salesman will call. Southern States Academy, Professional Bldg., Dept. 16, Decatur, Ga.

MOVIE Camera and editing techniques for television and industry. Learn at home from a professional. Write Weston, Box 5216M, Madison, Wisconsin 53705.

PENMANSHIP Corrector. Improve poor penmanship quickly. Details free. Ozment, Box 665-34, St. Louis 88, Mo.

"STAMMER—Stutter—no more." (Dr. Young.) Write: Gaucho, Box 9309-S7, Chicago 90.

LEARN Special investigation. 20 Lessons, credentials, diploma, future. International Academy of Police Science, Oklahoma City, Oklahoma.

MINISTERIAL Home study course. Free qualifying examination. Soms, 5955 Powdermill Road, Kent, Ohio.

ENGINEERING And Electronics—send \$1.00 for 100 page career opportunities. C.I.S.T., Suite 804, 263 Adelaide St., West, Toronto, Canada.

PENMANSHIP Book: Improve ornamental writing and poor writing quickly. Details free. T. Tevis, Chillicothe, Mo.

DISC Jockey course write for free information. Kingston, McGehee, Ark.

COMPLETE Your high school at home in spare time with 69-year-old school. Texts furnished. No classes. Diploma. Information booklet free. American School, Dept. XC45, Drexel at 58th, Chicago, Illinois 60637.

INVESTIGATOR'S Course. Credentials, diploma. Free information. Southwestern Institute Criminology, Box 201, Geronimo, Oklahoma.

WATCH Repairing. Learn to repair American and Swiss watches in spare time at home. Tuition only \$5 monthly. Diploma awarded. Free sample lesson. No obligation. Chicago School, Dept. YH, Fox River Grove, Illinois 60021.

FREE Electronics catalog. Tremendous bargains. Send postcard. Edu-Kits, Department C-648B, Hewlett, New York 11557.

FREE List of books for self development, no obligation. P.O. Box 846, Dept. P. Ft. Wayne, Ind., 46801.

BECOME An ordained minister—Get D.D. degree and your chartered branch church. Send 25¢ today for complete information. Seminary, Box 1029-A, Glendale, California 91209.

"APARTMENT Management" Extra income or new career. Full time, or part time employment. New job opportunities everywhere. Send for free brochure. Ruth B. Krebs Associates Training School, 8155 Van Nuys Blvd., 204 P.M. Panorama City, California 91402.

SWEDISH Massage. Foot technique. Post graduate. Home study. Residential. Diploma. Dr. Swanson's Illinois Licensed School, 3809-PL Alta Vista, Chicago 13.

You Actually "learn to drive" from a specially designed picture book. (Takes 1/2 hour to read) \$1.00 Post paid. Fortune Manufacturing, 89 Tremont St., Bridgeport, Conn. 06606.

LEARN Retail meat cutting. Approved course. Retail groceries. Southwestern College of Meat Cutters, 304 S. Klein, Oklahoma City, Oklahoma 73108.

MEN Wanted. Earn \$125 a week and up. Master a trade with a future. Learn auto diesel mechanics in our shops. You learn with tools on real equipment. Earn while you learn. Many of our graduates earn \$125 a week and up. Write for free bulletin: Dept. 256, Auto Diesel College, Nashville 3, Tenn.

FOR INVENTORS

PROFESSIONAL Patent searches, \$6.00, including official U.S. Patent Office copies of related U.S. patents! Prompt, dependable service. Certified, airmailed! For free "Invention Record Folio" and important patent information every inventor should have, write: United States Inventors Service Company, 501-P Thirteenth Street NW, Washington, D.C. 20004.

IMMEDIATE Cash, for patent applications. Free patent searches. Write for details. Universal Patents, 184-D, Marlon, Ohio.

PATENT Searches, including copies of related U.S. patents, \$6.00. Inventors, attorneys, manufacturers use my "worldwide" airmail service! "Invention Record" form and "Information Every Inventor Needs," sent free! Miss Hayward, 1029P Vermont, Washington 5, D.C.

U.S. Patent Office Searches, 234 Broadway, Room 3615, New York. Free invention certificates.

PATENT Searches including Maximum speed, full airmail report and closest patent copies, \$6.00. Quality searches expertly administered. Complete secrecy guaranteed. Free Invention Protection forms and "Patent Information." Write Dept. 15, Washington Patent Office Search Bureau, 711-14th, N.W., Washington 5, D.C.

PATENT Application financing. Free patent searches. Global Patent Division, 2420 77th, Oakland 5, California.

INVENTORS: Your ideas and inventions (patented; unpatented) expertly searched and developed for commercial appeal and cash/royalty sales to manufacturers by professional Invention Developer with excellent record of experience. B.S., Industrial Engineering; U.S. Patent Office former Patent Examiner; U.S. Government former Patent Adviser. Second decade of reliable service! Free "Invention Record" and Important Information. Airmailed! Write Raymond Lee, Invention Developer 130-N West 42nd, New York City 10036.

PATENT Office drawings skillfully executed: reasonable, free engineering and booklet "How to Invent." Pen-Ink, 50 East 42 Street, New York 17.

INVENTORS—If you have an invention for sale, patented or unpatented, write for free brochure outlining manufacturer's requirements. Royalty rates. Kessler Corporation, C-558-FI, Fremont, Ohio.

PATENT And invention development, by licensed professional patent engineer and U.S. Patent Office former examiner, and engineering specialists. Your inventions and ideas engineered for patent protection and commercial value. Inventions developed by us negotiated for cash or royalties with our nationwide contacts. Send for free protection "Invention Certificates" and further interesting, valuable patent information. George Spector, Licensed Professional Patent Engineer, Woolworth Building, New York.

INVENTIONS WANTED

INVENTORS Wanted: Manufacturers need new items! Your inventions, ideas developed for cash/royalty sales. Free "Invention Record": Information. Raymond Lee, 130-P West 42nd, New York City 10036.

INVENTIONS Wanted. Patented: unpatented. Tremendous manufacturers lists. Global Marketing Service, 2420G 77th, Oakland 5, California.

INVENTIONS Wanted patented, unpatented. Put your ideas to work. Tremendous manufacturers lists. For information write: John K. Suggs, P.O. Box 204, DeKalb, Ill.

INVENTORS Needing help with any problem—financing, protection, securing manufacturer, searches. Contact the organization with "know-how." Be completely informed. Pioneer Invention Service, Dept. 83, 150 Broadway, New York, N.Y. 10038.

INVENTORS: Protect your ideas! Free "Recommended Procedure." Washington Inventors Service, 422F, Washington Building, District of Columbia 5.

WE Have markets for worthwhile inventions. Harvey Engineers, Cambridge, Maryland 21613.

INVENTORS! Don't sell your invention, patented or unpatented, until you receive our offer. Eagle Development Company, Dept. H, 79 Wall Street, New York 5, N.Y.

INVENTIONS Needed immediately for manufacturers. For additional information write Kessler Corporation, C-58-IW, Fremont, Ohio.

WE Either sell your invention or pay cash bonus. Write for details. Universal Inventions, 298-E, Marlon, Ohio.

MANUFACTURING

BIRCH Plywood—Any size, shape, specification. Violette Plywood, Lunenburg, Mass.

MODELS. Precision parts, electronic assemblies, printed circuits, etched metal nameplates. Lane Jackson Company, 645 Marshall, St. Louis, Missouri 63119.

MODELS—Small lot manufacturing. Metals, plastics, etc. Milburn, Burlington, Kentucky.

BUY IT WHOLESALE

BARGAINS! Buy wholesale! Save money! Free catalog! Norris, 273 Merrick, Dept. 215, Lynbrook, N.Y.

HEARING Aid batteries wholesale. National Wholesale Battery Company, P.O. Box 825, Wichita, Kansas 67201.

NEW 6-Color Deluxe below wholesale catalog. Automobile catalog and others. Housewares, clothing furs, furniture, rugs, appliances, refrigerators, washers, dryers, vacuum cleaners, polishers, cookware, dinnerware, strollers, cribs, radios, stereos, phonographs, records, recorders, cameras, film, projectors, musical instruments, organs, typewriters, books, binoculars, luggage, sporting goods, bowling, golf, game tables, power/rider mowers, garden tractors, boats, motors, bicycles, clocks, watches, diamonds, jewelry. Huge discounts, hundreds name-brand products. For free list (factory prices) postcard: Selbyco-5, Decatur, Illinois 62522.

BARGAINS! Buy wholesale and below. Name brands. Appliances, furniture, sports equipment, televisions, cameras, watches, jewelry, thousands more. Huge discounts to \$1,000.00 on new automobiles. All makes. Free details. Write today: Worldwide Bargainhunters, Box 730-A, Holland, Michigan.

WORLD'S Largest wholesale supply. Buy from 7853 American, European, Japanese wholesalers. Hong Kong tailored suits. 123 dropship catalogs. Rockbottom prices. Automobiles. Free details. International Buyers, Post Office Box 4061, Colorado Springs, Colorado 80909.

100,000 BARGAINS! Wholesale! Close-outs! Imports! Wholesalers. 1265-M Broadway, New York 1, N.Y.

FREE Catalog. Over 500 fantastic bargains. Send now, we'll refund stamp. International Distributing Company, 61-A Queens Ave., Atlantic Beach, New York 11509.

WHY Pay retail price when you can now buy wholesale? We are wholesale distributors for one of nation's largest manufacturers of paints. Send one dollar for color cards and prices, refundable on first order. Specify category such as house, marine, industrial or other. Our reference Dun & Bradstreet, Rech Co., Bryson City, North Carolina.

ELECTRIC Guitars, amplifiers, wholesale. Free catalog. Carvin PMW, Covina, Calif. 91722.

EXPORT-IMPORT

JAPAN: Mail-Order 26 page catalog, dolls, novelties. Manufacturers' names, addresses \$1.00; 1000 products illustrated trade directory \$3.00. Send cash. Yamagata Office, 814 Togin Bldg., Marunouchi, Tokyo.

MONEY in 'Mailorder', selling low cost foreign products, for big profits. Suppliers, procedures, techniques, revealed. Details 25¢. Garrett, Box 464, Metairie, Louisiana.

5 PIECE Sewing scissor set from West Germany, \$5.00 ppd. E. R. Bush Co., P.O. Box 5538, Los Angeles, Calif. 90055.

CATALOGS Bargains send \$1.00. Deducted first order. P.O. Box 546, Campbell, Calif. 95008.

FREE Brochures on imports from overseas. Descartes, 1105 College Ave., Bronx, New York 10456.

FOR THE HOME

AMERICA'S Best faucet sealer. Literature. Jordan's, 743 Dorrance, Philadelphia, Pa. 19146.

OF INTEREST TO WOMEN

LEARN Expert cake decorating, candy making. Free details on home instruction method. Candy & Cake, Box 54-ALN, Redondo Beach, Calif. 90277.

MAKE Extra money—show friends, neighbors—gifts, stationery, Christmas, all occasion cards. Experience unnecessary. Salable samples on approval, free catalog, free name imprinted Christmas card album. Hedenkamp, 361 Broadway, Dept. PM-91, New York.

WOMEN! Make big money at home. \$10.00 profit in an hour possible with invisible mending. Make holes, tears disappear from clothing, fabrics. Steady year-round demand from cleaners, laundries, homes. Details free. Fabricon, 1533 Howard, Chicago, Illinois 60626.

\$100 WEEKLY Possible typing at home! Instructions \$1. Bonco, 130 Cumberland, Masontown 8, Penna.

MAKE Gorgeous original candles for all holidays and special occasions. Learn expert Candle decorating, candlemaking, use of professional molds. Free details on home instruction method. Candle Institute, Box 54-HD, Redondo Beach, California 90277.

RUN Spare time greeting card-gift shop at home! Show friends samples of new 1966 Christmas, All-Occasion greeting cards, gifts! Take orders. Earn to 50% profit! No experience needed. Try without cost! Special fund-raising plans for organizations. Rush name for samples on approval. Regal Greetings, Dept. 173-P, Ferndale, Michigan 48220.

FREE Make 'em and save leathercraft idea manual. Tandy Leather Co., 1001 Poch, C57, Fort Worth, Texas.

\$200.00 MONTHLY Possible, sewing babywear! Write: Cuties, Warsaw 9, Indiana 46580.

3 OLD Southern barbecue recipes, \$1. 200 Tulane, Clinton Mississippi.

WORLD'S Easiest mail order business, \$1.00. Plastic Magic Company, 1926 Iowa, Dept. 180, Davenport, Iowa 52803.

\$45.00 THOUSAND My Way, compiling lists. Addressing from them: Longhand, typewriter, information, stamped, addressed envelope. Brewster, Box 1626-J, Clearwater, Florida 33515.

DRIVE New car, wear new clothes, buy color TV. Get daily cash income. Put spare hours to work. Write for 5 months free subscription Opportunity Magazine; see hundreds easy ways to make money. Opportunity, Dept. 17-GO, 850 N. Dearborn, Chicago.

WATCHES, OLD GOLD, JEWELRY

USED Brand name watches \$5 up. Free list. Southern Watches, 5-PM South Wabash, Chicago 60603.

CASH Immediately for old gold, jewelry, gold teeth, watches, diamonds, silverware, spectacles, platinum, mercury. Free information. Rose Industries, 29-A East Madison, Chicago 2.

HIGHEST Cash—Gold, Jewelry, Diamonds, Silver, Platinum. Mail articles. Free information. Chicago Gold & Precious Metals, 6 E. Monroe, Dept. 3458, Chicago 60603.

WATCH Repair \$5.95 reliable, 1-year guarantee. Fast coast to coast service. Official Railroad Watch inspectors. Terminal Watch Co., Union Terminal, Cleveland, Ohio 44113.

WATCH And clock repairing books. Free catalog. North American, Box 77-AV, Fox River Grove, Illinois 60021.

USED Pocket watches—as is—\$5 for \$25.00. Joseph Bros., 5 South Wabash, Chicago 60603.

WEARING APPAREL

YOUR Ad in this space will be read by more than 1,400,000 active mail order buyers. Join the march to greater profits, place your products and services in front of them today with a small low cost classified ad. For further details, write: C. A. Martin, Dept. 15N, Popular Mechanics, 575 Lexington Avenue, New York, New York 10022.



SCIENCE AND CHEMISTRY

ROCKETS! Flight kits, testing equipment. Catalog 25¢. Rocket Development Corporation, Route 3, Seymour, Indiana 47274.

AMAZING New book of science experiments, formulas, and catalogue of laboratory supplies. Only 35¢. National Scientific Co., 13 S. Park Avenue, Dept. PM-8, Lombard, Illinois.

FIREWORKS Supplies, casings, end caps, plugs, chemicals, fuse, do-it-yourself kits, send 35¢ for samples and catalogue—Ecco, Box 189, Northvale, New Jersey 07647.

CHEMICALS And apparatus for industrial, analytical, and private laboratories. Catalog 35¢. Dept. M-50, Biological Supply Co., 1176 Mt. Hope Ave., Rochester 20, N.Y.

CHEMICALS, Apparatus, Biology, Catalog 25¢. Mid-States Scientific, 7053 N. Clark, Chicago, Ill.

SEARCHING For economically priced chemicals and apparatus? Gifts with catalog, 25¢. Starr Scientific, Manitowoc, Wisconsin 54220.

CONTACT Explosive. Explodes with touch of feather. Handled safely wet. Powerful. Applies like paint. Made from household chemicals. Results guaranteed. Complete instruction for making both kinds only \$1.00. Franks Scientific Company, P.O. Box 156, Martelle, Iowa 52305.

ROCKETS, Single, multi-stage kits, parts amazing Accelerometer. Illustrated catalogue 25¢ Rocket Supply, Box 51B, Tappan, New York 10983.

GERMAN Rocket and fireworks formulas, \$1.00. Import, P.O. Box 71, Pottsville, Pa.

ILLUSTRATED Catalog: Chemistry, mineralogy, biology 25¢. Tracey Laboratories, Evanston, Illinois.

CHERRY Bomb fuse, water proof 25 feet with formulas, instructions \$1.00 Post paid, 125 feet \$4.00. Zeller, Box 640, Hudson, Mich.

UNUSUAL Chemistry courses, kits! Information booklet, 25¢. National, Box 94, Redwood City, Calif. 94064.

PROFESSIONAL Firecracker fuse, burns, underwater, 75 feet, \$1. Fireworks, explosives formulas, free information. Edcolabs, Box 99, Berlin, New Jersey 08009.

FIREWORKS—Explosives—detonators. New manual reveals formulas, preparations, only \$2. Free with order, \$2 certificate for fuse. Pyrochem, Box 169, Berlin, New Jersey 08009.

ROCKETS: Real flying models—flights up to 2500 ft. New illustrated catalog 25¢. Single and multistage kit, cones, engines, launchers, trackers, rocket aerial cameras, technical information. Fast service. Estes Industries, Penrose 7, Colorado.

FIREWORKS Explosives formulas biggest ever at price \$1.00. Thurner, 4115 Florida Court, Livermore, California 94550.

SKYROCKETS, Fireworks, easy instruction manual: 28 Types-rockets (5000' altitude), aerial displays, roman candles, fountains, fireballs, \$1.00; 75 Formulas-contact explosives, propellants, colored flare-smokes, fuses, \$1.00. Satisfaction guaranteed. Sentec, 433e Ellis, San Francisco 2.

LIQUID Rocket, Plans, \$2.98. Star Space Systems, Box 4353, Inglewood, California.

SKYROCKETS, Firecrackers, fireworks—Make your own! 60 simple formulas \$1.00; 30 smoke formulas, 15 colors \$1.00; 10 fuse formulas 50¢. Paloma Pyrotechnics, Box 247, Auburn 5, California.

FORMULAS, PLANS, ETC.

FOR Proof of what you can do in specialty manufacturing get our literature. It's free! Miller, Chemist, 1517-P, Tampa, Florida.

10,103 FORMULAS, \$1.00 shipped postpaid. Sword Publications, Box 4142-MA, Omaha, Nebr. 68104.

LATE, Modern manufacturing formulas. List free. Moon Chemical, Martville, New York.

ENCYCLOPEDIA Of formulas. Details free. Cassill, Box 1535, Eugene, Oregon 97401.

FORMULAS—All kinds. Amazing big catalog, 10¢. Kemixal, Park Ridge, Ill.

PLASTICS

PLASTICS for arts & crafts, fun & profit. See how easy it is to work with liquid plastics. Turn your plastics hobby into \$ for you. Send 50¢ for catalog to PMI, 1644 20th, Santa Monica, California.

NEW Liquid casting plastic clear colors. Embed real flowers, butterflies, photos, coins. Send 25¢ for two handbooks "How to Cast Liquid Plastics" and "How to Make Extra Money at Home." Castolite, Dept. 66-101-J, Woodstock, Illinois.

BOXES, Plastic, 200 sizes. Free list. Althor, 2260 Benson Ave., Brooklyn, N.Y.

TREASURE FINDERS

TREASURE. Find gold, silver, relics with super, powerful Detectron locators. Free information. Detectron, Dept. PM-8, P.O. Box 243, San Gabriel, California.

BEFORE Buying a metal detector, find out about Sensitronix's new "Electronic Prospectors"—the latest development in treasure and coin detection equipment. Trade-ins accepted. Free information and treasure hunting guide. Sensitronix, 2225-C Lou Ellen, Houston, Texas 77018.

NEW Revolutionary selective transistor metal detector and six other models. Free catalog. Gardiner Electronics Co., Dept. 9, 4729 N. 7th Avenue, Phoenix, Arizona 85013.

COMPLETELY New prospecting technique developed by Relco. New transistor models detect buried gold, silver, coins, treasures. \$19.95 to \$129.50. Write for free catalog and "guide for beginners". Relco-A40, Box 10563, Houston 18, Texas

POPULAR MECHANICS

TREASURE Metal detectors most complete line in U.S.A. Free catalog. Bill's Service Center, Box 1, Paramount, California.

NUCLEAR Locators! Coins, relics! write Howe, 811-C Kansas, Atchison, Kansas.

METAL Locator kits and assembled models from \$39.90. Terms, Transistorized models available. Free catalog. Electronic Applications, Dept. M, Box 6095, Alexandria, Virginia.

POWERFUL Metrotech locators detect gold, silver, coins, relics. Moneyback guarantee, terms. Free information. Underground Explorations, Dept. A, Box 793, Menlo Park, California.

EXCITING Adventure locating hidden loot, treasure, relics, etc., with powerful, electronic M-scope locator. Lightweight. Guaranteed. Very easy terms. Send for free booklet, interesting customer reports. Fisher Research, Dept. AAY, Palo Alto, Calif. 94302.

PROSPECTORS, treasure hunters — "Quality-Engineered Mineral-metal Detectors available. Detects gold, silver, coins, jewelry. Fully guaranteed. Terms. From \$39.95—Free catalog. White's Electronics, Room 351, Sweet Home, Oregon 97386.

TREASURE Wrecks, 143 pinpointed on keyed chart: Gulf of Mexico, Atlantic, Caribbean. Authentic, \$1. P.O. Box 117, Stuart, Fla.

DIMONS Gold indicators, Pamphlet free. Simpson, 18788 Cajon Blvd., San Bernardino, California.

TREASURE, Gold, silver, relics. New 1966 detectors now available. Free information. Rayscope, Box 715, North Hollywood, California.

PRECIOUS STONES AND MINERALS

SEMI-Precious uncut gems. Ten different for \$1.00. Request list 30. Prospectors Shop, 201 San Francisco, Santa Fe, New Mexico.

ROCKHOUNDS. Free brochures listing thousands of mountings, cut stones and gemstone rough from around the world, many shown in full color! Make jewelry for profit. It's easy! Gemex Co., Dept. PM, Hwy. 76, Pala, California 92059.

GET Free catalog no serious rockhound, gem cutter, jewelry maker, hobbyist or craftsman can be without. Full of bargains, exclusive items, low prices from largest suppliers and authorities in the field. Free new catalog just off the press, yours for the asking. Write Grieger's, Dept. C-12, 1633 E. Walnut, Pasadena, California.

CARTOONING, COMMERCIAL ART, SHOWCARD & SIGN PAINTING, TATTOOING

YOU Can entertain with chalk talks. Catalog 10¢. Balda the Cartoonist, Oshkosh, Wis.

LEARN Sign painting at home. Free talent test, Ben Kerns, Box 812-PM, Greenville, S.C.

LEARN Profitable magazine cartooning. Free details. Hartman, Box 3097, Lincoln 10, Nebraska.

CARTOONING And commercial art. Easy home-study drawing course. Art background not necessary. Excellent creative money making opportunities part or full time. We show you how. Low monthly tuition. Free booklet. Continental Schools, Dept. 6A-20, 1336 W. Olympic Blvd., Los Angeles, Calif. 90015.

"HOW To Make Money With Simple Cartoons"—Everyone who likes to draw should have this book: Free. Send name, zip code. Cartoonists Exchange, 98 Pleasant Hill, Ohio 45359.

SIGN Painting. Fascinating system. Straley, 410 South Western, Springfield, Ohio.

SIGN Painting and art. Instructions, brushes, equipment, everything. Free catalogue. Kaufmann Supply, Centertown, Missouri.

ADVERTISING AGENCIES, ADV. SERVICE, MAILING LISTS

ADVERTISING Ratebook leading newspapers, magazines, free. Chicago Advertising Agency, 28-E Jackson, Chicago 4.

NEWEST Mailing list. 4000 farmers ranchers directory, So. Texas. \$2.95 postpaid. Write: American Printing, 4035 Ayers, Corpus Christi, Texas 78415.

MAILING Lists most all kinds 1000 \$5.00. Free folder. Your circulars mailed \$4.00 1000. Dixie Mailers, King, N.C. 27021.

TYPEWRITERS, DUPLICATORS, OFFICE EQUIPMENT

OFFSET. Letterpresses, varitypers, typewriters, mimeograph, multigraph machines. Bargains. DixieGraph, King, North Carolina 27021.

RUBBER STAMPS AND OFFICE SUPPLIES

FREE Catalog: Rubber stamps, printing, Dowling Products, Dept. PM36, Pitts-town, N.J.

CATALOG: Rubber stamps, business cards. Martin, 1425 Major, Jefferson City, Missouri 65101.

FREE 32 Page rubber stamp catalog. Signature stamps \$3.50. Youngers Stamp Shop, Princeton, Iowa.

PRINTING, MULTIGRAPHING, MIMEOGRAPHING, GUMMED LABELS

QUALITY Printing: Lowest prices. Samples. Dowling Press, Dept. PM-36, Pitts-town, N.J.

1,000 **THERMOGRAPHED** (Raised letter) business cards, \$3.75. Free samples! Griffin, 322 West State, Ithaca, New York 14850.

PRINTING. Choose type faces. McDonald, 545 North Oakland, Pasadena, California 91106.

OFFSET Printing: 25 to 5,000 copies. 24 hour service. Cisco's Duplicating, Atlanta, Illinois 61723.

BUSINESS, Social stationery and card printing. Rubber stamps, Mimeographing. Gessels, Box 44, Bethel Park, Pa. 15102.

OFFSET! Quality—service—low prices! 24 page catalog, samples. Napco Press, 1744 Bath Avenue, Brooklyn, N.Y. 11214.

BUSINESS Cards—professional quality, 100 for \$1.00, postpaid in U.S.A. Dollar Print Shop, 417 West State, Ontario, Calif. 91761.

1000 **GUMMED** Address labels, \$1.00. Wait's, Box 966-A, South Bend, Indiana 46624.

3000 **ADDRESS** Labels—\$1.25. Free catalog. Kizer, Green Lake, Wisconsin.

1000 **EMBOSSED** Business cards \$3.90. Quality business printing. Samples. Artcraft, Box 178, Brighton, Michigan 48116.

QUALITY Business cards \$4.85 thousand, postpaid. Write for samples. Hollywood Cards, 5617 Lemon Grove, Hollywood 90038.

BUSINESS Cards, \$3.95 to \$20.00 per 1000.—See samples. Parkside Press, 4628 Park, San Diego, California 92116.

PRINTING? Write: Fifty States, Box 1253, Station C, Canton, Ohio 44708.

BUSINESS Cards: 1,000 \$4.10, postpaid. Goodall Printing, 68-N Joost, San Francisco, California. 94131.

OFFSET Free mailing envelope instructions. Penny Press, Box 565, New York 10036.

AMAZING Business printing values. Samples. Print Shop, Box 576, Greenville, R. I. 02828.

PRINTING & RUBBER STAMP OUTFITS—SUPPLIES

PRINTING Presses, type, supplies. Lists, 5¢. Turnbaugh Service, Mechanicsburg, Pennsylvania.

DO Your own printing. Save money. Simple rules. We supply everything. Print for others; good profit. Raised printing like engraving too. Have home shop. Details free. Kelsey Presses, V-11, Meriden, Connecticut.

TYPE Catalog No. 11, 96 Pages. Send One Dollar. Deductible First Order. Acme Type, 732 Federal, Chicago, Illinois.

TYPE And supplies for rubber stamp makers. New wholesale price list No. 3 free. Star Stamp Supply, 732 Federal, Chicago 5, Ill.

RUBBER Stamp presses, hydraulic operated, electrically heated. Sizes 5" x 8", 8" x 12", 10" x 15". Starting outfits, supplies. Printing presses. Orders for presses and supplies shipped same day received. Custom Manufacturing, 402-P, East Elm, Springfield, Missouri.

RUBBER Stamp outfits, supplies. Kiewiet, 2025 Barney Road, Kalamazoo, Mich. 49007.

RUBBER Stamp manufacturers supplies. New products. Low prices. Catalog. Jackson Supply, 1433 Winnemac, Chicago, Illinois 60640.

MAKE Your own self-molding rubber stamps and printing cuts. Plexirubber, Argyle 1, Wisconsin.

REMAILING SERVICE

ALASKA Remail, 25¢ single, \$3.00 monthly, confidential. Malone, 274 So. Klevin, Anchorage, Alaska 99504.

SO. AMERICA Registered re-airmails, \$1.00. Confidential, reliable. Genaro, Box 360, Guayaquil, Ecuador.

CANADA: Confidential remailing .25 per letter, \$3.00 monthly rates. Box 1135, Station B, Montreal, P.Q., Canada.

FLORIDA—Remails, forwarding, job listings, shopping. Details free. Remail, Box 895, Ft. Lauderdale, Florida.

REMAILING: Fast! Many services. Free details. Rucker, 909 Buena, Chicago, 60613.

TIMELY Remailing 25¢. Unlimited Monthly \$3.00. Confidential. Postcards. Schoen, Box 1963-P, Chicago, Illinois 60690.

LOS ANGELES, Hollywood, San Fernando Valley—25¢ single; \$3.00 monthly. Confidential. 10437 Lanark Street F, Sun Valley, California 91352.

ARABIAN Re-airmails. Receiving and forwarding. Postage, \$1.00. Sadiegie, Box 469, Al Khobar, Saudi Arabia.

SECRET Mail receiving system. Hedg-peth, 406-M South Second, Alhambra, California 91802.

HAWAII Secret Address. Remails 25¢. Receiving-forwarding \$3.00 monthly. Postcards, gifts, slides, Uppie, Box 984, Kailua, Hawaii 96734.

SECRET Mail receiving timely 25¢ \$3.00. Baker, 2542R Yellowstone, Billings, Montana 59102.

SECRET Receiving and remailing. Discreet and confidential. Remail 25¢ single. 8050 S. Main, Houston, Texas.

CONFIDENTIAL Rapid remails 25¢ single. \$3.00 MONTHLY. Details, Fesco, P.O. Box 6120, San Francisco, California.

COLO. Springs remails, 25¢. Box 6224, W. Sta., Colorado Springs, Colorado 80904.

SECRET Mail receiving system-complete business services. Harvey, 35124 Euclid Ave., Suite 202H, Willoughby, Ohio.

COMPLETE, Confidential remails, 25¢ single, \$3.00 monthly. Bill, Box 1788, Phoenix, Ariz.

MIAMI Remails 25¢. Monthly Rates, Marle, P.O.B. 1266, Coral Gables, Florida 33134.

REPAIRS AND SERVICING

YOUR Ad in this space will be read by more than 1,400,000 active mail order buyers. Join the march to greater profits, place your products and services in front of them today with a small low cost classified ad. For further details, write: C. A. Martin, Dept. 15N, Popular Mechanics, 575 Lexington Avenue, New York, New York 10022.

SPECIAL SERVICES

OVERSEAS Remailing, \$1.00, souvenirs \$2.00 up, Australian literature, coins, stamps, business representation, special assignments. Professional Service, Box 38, Northbridge, NSW, Australia.

INFORMATION, Any subject. Products, people, geography. \$1.00. Box 5996, Reno, Nevada 89503.

TOBACCO

YOUR Ad in this space will be read by more than 1,400 active mail order buyers. Join the march to greater profits, place your products and services in front of them today with a small low cost classified ad. For further details, write: C. A. Martin, Dept. 81N, Popular Mechanics, 575 Lexington Avenue, New York, New York 10022.

RAZORS

YOUR Ad in this space will be read by more than 1,400 active mail order buyers. Join the march to greater profits, place your products and services in front of them today with a small low cost classified ad. For further details, write: C. A. Martin, Dept. 82N, Popular Mechanics, 575 Lexington Avenue, New York, New York 10022.

WANTED—MISCELLANEOUS

GERMAN Military items. Douglas Kerley, 1102 Northwest 60th, Seattle, Wash.

MERCURY, Gold, Silver, Platinum; Ores assayed. Wholesale Terminal, Norwood, Mass.

PERSONAL

FREE. Booklet "Wills How To Make & Break Them," with 3 will forms \$1.00. Urban-Rural, Box 293, Fort Lee, N.J.

INVESTIGATORS, Free brochure. latest miniature electronic surveillance equipment. Ace Electronics, 11500-P NW 7th Ave., Miami, Florida 33168.

BLITZ Reducing! 5 pounds overnight! Guaranteed! Bijou, Box 1727-BM, Hollywood, California 90028.

BORROW \$1,233 Airmail! Repay \$54 for twenty-nine months. State licensed. Postal Finance, Dept. 17-P, Kansas City, Kansas 66117.

BIBLE Questions answered. Stamped envelope. Bylon, 17167 Bentler, Detroit, Michigan 48219.

SUBCONSCIOUS Conditioning remakes personality while you sleep. Free details. Sleep-Learning, Box 24N, Olympia, Washington.

SURVEILLANCE Equipment. New 1966 models. Free details. Write: Security Electronics-PM, 11 East 43 Street, N.Y.C. 10017.

LOW-Cost loans by mail. \$6.00 monthly repays \$104.50; \$56 monthly repays \$1,321.39. Borrow any amount. Guaranteed fast, confidential. Write today! Bankers Investment, 67-D, Box 1648, Hutchinson, Kansas 67501.

BORROW \$100 To \$1000 by Mail. Quick, easy, private. No co-signers. Repay in 36 small monthly payments. For the amount you want write today to: Dial Finance Co., 410 Kilpatrick Bldg., Dept. 8-214, Omaha, Nebraska 68102.

FREE Details solution to all financial problems. Amazing results. Loans available. Write Financial Consultants, 28 E. Jackson, Suite 1204-PM, Chicago 4.

BILL Problems? Poor credit no trouble. Not a loan company. Send for free application. Automatic Acceptance, 307PM Poccasset Ave., Providence, R. I. or 318PM Broadway Blvd., Reno, Nevada.

WIPE Out all debts—use secret law. Immediate relief. Free details. Counselor. Harlingen 7, Texas.

BORROW With confidence! Over 50 years of experience. Loans by mail, \$100 to \$1000. Budget Finance Co., Dept. MB-0100, 317 South 20th, Omaha, Nebraska 68102.

NEED MONEY? Borrow \$100-\$1000 by mail. Confidential. Repay in 36 months. Free loan application. American Loan Plan, Dept. MA-010A City National Bldg., Omaha, Nebraska 68102.

PAY Bills! Have cash left over. \$39.39 repays \$1000 in 36 months. World Finance Co., Dept. MW-010B, 620 Symes Bldg., Denver, Colorado 80202.

LOANS By mail, \$100-\$1000. Anywhere. Confidential. Write Union Finance, Dept. PM, 222 W. Osborne, P.O. Box 7457, Phoenix, Arizona.

MISCELLANEOUS

ORNAMENTAL Iron designs. Book of 1600 beautiful, practical designs for railings, columns, etc. Free literature. Cunningham, 3881 South 3200 West, Salt Lake City, Utah 84119.

LOG Cabins: Ship anywhere; 35 plans, specifications and prices. Send \$1.00. Write Bloch Brothers, Waterford 4, Michigan.

LOANS By mail, \$100-\$1000. Anywhere. Confidential. Write Union Finance, Dept. PM, 222 W. Osborne, P.O. Box 7457, Phoenix, Arizona.

BIRTH Certificates, Marriage Certificates, Diplomas! 2 blank forms \$1.00. Sample 10¢. Standard Forms, Box 482-M, Washington, D.C. 20044.

"CIGARETTES" — (Roll your own). Pipe, Chewing, Smoking tobaccos. Facts free. Write Fred Stoker, Dresden, Tennessee.

FREE Wholesale catalog! 100,000 products. Tremendous discounts! Taylor Distributors, Newton 2, New Jersey.

LISTEN-In device! Powerful! Monitor telephone conversations, etc. Unnoticed! \$3.98 (guaranteed). Research Enterprises, 29-SN4 Samoset, Woburn, Mass.

KILL Mosquitoes, crop destroyers. Electronically. Free information. Box P. 204, Metamora, Michigan 48455.

YOUR Name sent to 1000 importers, publishers, mailers, wholesalers, etc. on our mailing list. Year \$1.00. Dixie Mailers, King, N. Car. 27021.

WINEMAKERS, Free illustrated catalog of yeasts, equipment. Semplex, Box 7208, Minneapolis, Minn. 55412.

WHO Will inherit your property? Be sure! Make your will now! 3 blank forms. Instruction pamphlet, \$1.00. Satisfaction guaranteed. Dewey, 1035-E, Commerce City Colorado 80022.

HEARING Aid batteries wholesale. Free list. Habs, Box 51, York, Penna.

1000 BALL Pens \$35.95, twenty \$1.00. Unique Pen Co., Box 161, Forestville, Conn.

30 BALLPOINT Pens retractable. Fine quality, \$1.00 postpaid. Marsan Associates, Box 409, White Plains, N.Y.

OREGON Hops make the best homebrew—half gallon dried hops and authentic homebrewing recipes \$2. Nichols Gardens, Northpac, Albany, Oregon.

WINEMAKING . . . Grape, Elderberry, Dandelion, frozen juices, etc. Brewmasters' secrets revealed! Powerful methods! Complete instructions, recipes, \$1.00. Continental, Box 26034-PH, Indianapolis, Indiana 46226.

BABY Shoes—bronze plated. Free details. Hadley, 920 Harding, Janesville, Wisconsin 53545.

ZIP Code directory \$1.25. E. Lutchkus, P.O. Box 213, Carlisle, Pa. 17013.

HOME Winemaking . . . with fruit or frozen juices! Free illustrated catalog, recipes, supplies. Winemakers, Box 18216-PH, Indianapolis, Indiana 46218.

BOOKS On antiques and their prices. Free circular! P. Warman Publishers, Uniontown, Penna.

WINEMAKING From grapes, elderberries, frozen juices. Homebrewed beer like Grandma made. Instructions \$1.00. P.O. Box 996, Mobile, Ala.

HOW To make \$1,000,000. It is easy when you know how. Booklet describes almost practical fool-proof system. \$1.00. Radio Bookshop, Peterborough, New Hampshire.

SUPER Memory overnight! Success guaranteed! Bijou, Box 1727-M, Hollywood 28, California.

SLOPPY Messy wasteful toothpaste tubes? Not with re-usable squeeze keys. Save toothpaste, cements, oil colors, etc. Mail \$1.00 for dozen keys. Money back guarantee. Maudina Co., Box 218, East Northport, New York 11731.

MARRIAGE, Birth certificates, diplomas. Quality forms, \$1.20 each. Brungenheimer Publishers, Box 158-PM3, Lexington, Mass.

POPULAR MECHANICS



**This is a GM Original:
It leads a rough life.**



**This is a GM Replacement:
It leads the same life.**

GM Originals and GM Replacements do more than just look alike. They *perform* alike because they *are* alike.

That's your best reason for going where they use Genuine GM Parts. Especially if you have to replace anything like the hydraulic brake hose, a part that has to withstand tremendous pressures—plus the punishment of road salt, splash and gravel.

You'll find Genuine GM Parts, in GM and United Delco packages, just about everywhere. Note that for future reference. Like, say, when you go for your next regular brake check.

GENUINE GENERAL MOTORS PARTS



CHEVROLET • PONTIAC • OLDSMOBILE
BUICK • OPEL • CADILLAC • GMC TRUCKS

United
Delco



At the inventors exhibition

Personal car for roads and rail

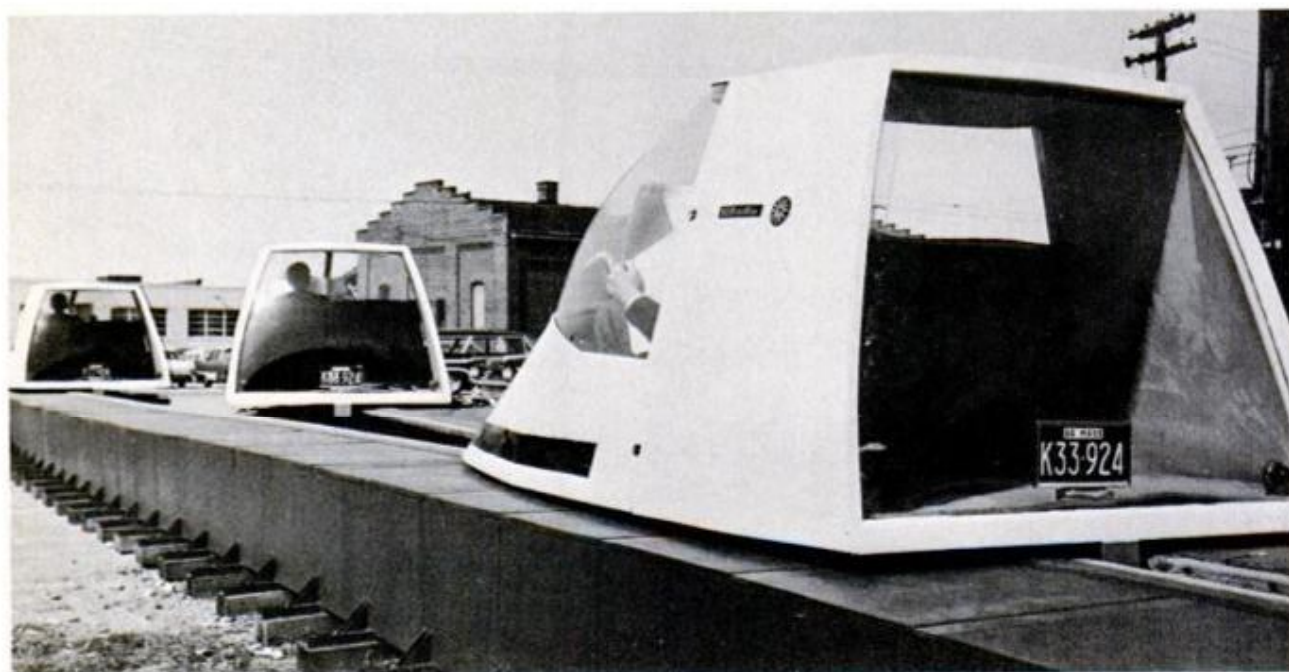

DRIVEN ON WHEELS to track, prototype StaRRcar shows how it could handle the entire door-to-door commute

A CROSSBREED that combines the mobility of automobiles and the efficiency of rapid-transit systems, StaRRcar may hold the answer to urban-suburban transportation of the future.

Here's how it works. A commuter takes from his garage a compact three-seat StaRRcar—rented from an operating company. By inserting a charge card into a slot on the dash, he activates the starter and signals a computer center that he is on his way.

StaRRcar is then driven conventionally until it reaches the nearest entrance ramp

to a guided track. Once on the track, the engine cuts out, and an electrical power pickup takes over. The commuter dials his destination exit, picks up the morning paper while traveling 60 mph and relies on automation for the rest. Upon reaching its destination, the car automatically whisks off on a spur track without decelerating—or holding up other cars.

The inventors, William L. Alden and Martin Gilvar, both of Boston, claim their system "can handle as many people per hour as public transit and 12 times as much as a lane of highway."—*M. J. Pedersen*

Meet PM editors and other staff members

Where: 2nd International Inventors and New Products Exhibition, New York Coliseum, N.Y.C.

When: September 9-18, 1966 (11 a.m. to 9:30 p.m.)

What: A forum for more than 1,200 exhibitors to display over 10,000 new products. Representatives from the U.S. Patent Office, the Small Business Administration and

many foreign inventors' associations will be available for advice on procedures for patenting and marketing inventions both in the U.S. and abroad.

Advance Tickets: May be obtained from the sponsor. Patent Exhibits, Inc., 554 Fifth Ave., N.Y.C. at \$2.50 (adults), \$1.00 (children 11 years and under), postpaid. A product directory is also available at \$2.50.



load instantly...

...shoot terrific super 8 movies with a new Kodak Instamatic camera!

What's so new and different about KODAK INSTAMATIC Movie Cameras that they make clearer, brighter movies a *sure thing*? Everything! They load instantly—no threading, no midpoint flip-over. And they take a new kind of movie film. The super 8 film cartridge is factory-loaded with improved KODACHROME II Film. You take pictures that are 50% larger

in area on the film than on regular 8mm. And you show them brilliantly on a super 8 projector (required for super 8 movies).

The KODAK INSTAMATIC M2 Movie Camera (above) has fast $f/1.8$ lens, battery drive and built-in filter. Takes movies that are spectacularly bright and colorful. Less than \$40.

Price subject to change without notice.



Kodak



Get twice the "grip" of ordinary pick-ups with a 'Jeep' Gladiator.

Just flip one simple lever into 'Jeep' 4-wheel drive.

On the way to the building site, a 'Jeep' Gladiator handles like a passenger car. But once you're there, a simple shift puts you from 2-wheel to 4-wheel drive to take you right to the door—even before the driveway is in. Mud, snow, sand, even slippery streets—duck soup for this extra traction. Just shift into 'Jeep' 4-wheel drive at any speed, and you'll make calls, handle jobs you couldn't touch with an ordinary pick-up. All the usual options you'd expect. And you've

TRADEMARK GENERAL MOTORS CORPORATION

made a real investment, because 'Jeep' vehicles are backed by years of 4-wheel drive experience and know-how.

Equip your Gladiator to fit your needs: 250 hp V-8 engine or Hi-Torque 6; choice of colors; standard or custom cab and trim; full width or bucket seats; 3 power-take-off points; 7 or 8-foot box; flat fender or stake with dual rear wheels; 3 or 4 speed transmission with standard shift, or Turbo Hydra-Matic.* (it's the only pick-up offering automatic transmission with 4-wheel drive); power steering and power brakes available; GVW's 5000 to 8600 lbs. **KAISER Jeep CORPORATION** TOLEDO 1, OHIO



You've got to drive it to believe it. See your 'Jeep' dealer. Check the Yellow Pages.

How to stay alive on the turnpikes

By E. D. FALES JR.

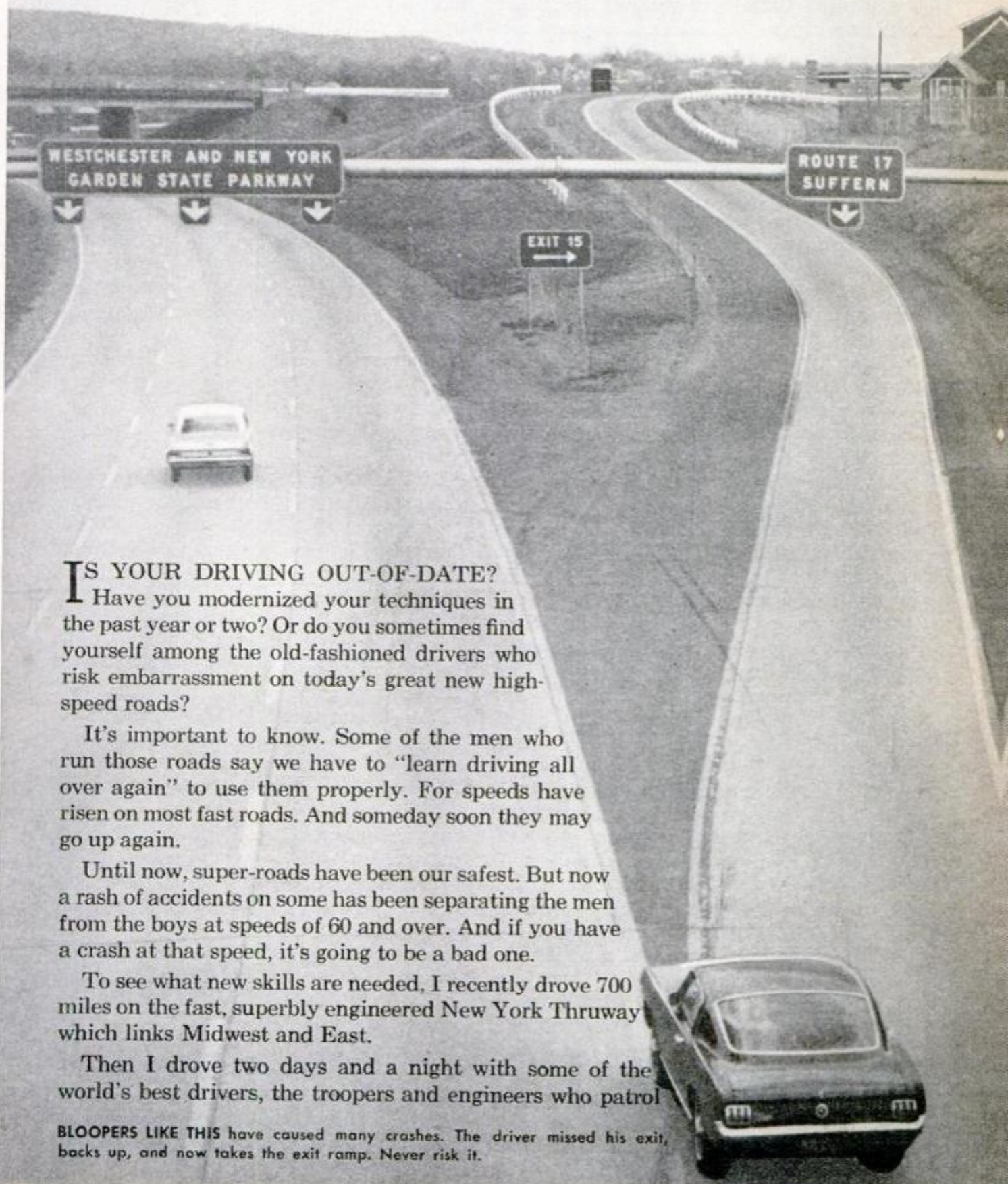

IS YOUR DRIVING OUT-OF-DATE?

Have you modernized your techniques in the past year or two? Or do you sometimes find yourself among the old-fashioned drivers who risk embarrassment on today's great new high-speed roads?

It's important to know. Some of the men who run those roads say we have to "learn driving all over again" to use them properly. For speeds have risen on most fast roads. And someday soon they may go up again.

Until now, super-roads have been our safest. But now a rash of accidents on some has been separating the men from the boys at speeds of 60 and over. And if you have a crash at that speed, it's going to be a bad one.

To see what new skills are needed, I recently drove 700 miles on the fast, superbly engineered New York Thruway which links Midwest and East.

Then I drove two days and a night with some of the world's best drivers, the troopers and engineers who patrol

BLOOPERS LIKE THIS have caused many crashes. The driver missed his exit, backs up, and now takes the exit ramp. Never risk it.

this very safe 65-mph cross-country track.

I wanted their suggestions to you for modern speed-driving. I didn't just want to hear the old familiar rules: "Be careful," "Keep your distance," "Stay awake."

Nor did I want the preaching we drivers so commonly hear: "Drivers are rude," "They're stupid," "They're inattentive, take chances."

I wanted some meaty new ideas that will save your life and make you look sharp. Here's what I learned:

- High-speed driving is getting to be more like piloting. You need an operational plan.

- An old-fashioned change of lanes, the quick "whip-out," can toss your car through five unsettling weight shifts.

- Normal tire pressure as recommended in some owners' manuals is simply not enough for long, fast trips.

- "Backing off" at the proper time becomes critically important, and you must know how to do it well.

- Some troublesome new impulses now ripple through traffic when it gets dense. These can hog-tie and throw you.

►My first discovery was that Phil Lee, director of traffic and services, and all troopers put extra air in their tires. And I found out why. In one test run in an official car (Mercury), with the recommended 24 pounds of air, we found five separate weight shifts in a single fast change of lanes.

There were three of us in the Merc. Ken Havill, former trooper and a traffic chief, was driving. At 60 he whipped into a quick left pullout. Suddenly the car sagged right. Then, as we angled diagonally left, it rebounded level—the second weight shift.

Shift No. 3 came as we straightened out in the passing lane: the car sagged left. To compensate, Ken gave slight left-rudder. The car now fishtailed the opposite way: shift No. 4. Then it swayed left for a fifth shift before settling down.

In amateur hands, a badly loaded vacation car could get in trouble in a pass like this, especially in rain.

But then we did what the troopers do. They usually add about six pounds of air. Since this was a heavy car, with three men, we boosted pressure to 32, up eight. Now we tried the fast pullout again. This time the Merc was stable as a rock. No squash, no unsettling weight shift. Thus

a few extra pounds of air (don't overdo it) adds stability at speed; it also adds coolness, keeps tires safer.

I also learned: Old, out-of-condition cars can't stand hour after hour speeds of 60 up. They break down. And a "must" is good, *fresh* tires. Old dry ones come apart.

►The "memory" danger. Director Lee told me that some strange new things happen in dense traffic at high speed. Quick communication of what's on your mind becomes a problem. So do G forces (as on lane changes and poorly executed exits). There's also something he calls marginal friction. This is the "rubbing" of small wayside hazards against fast traffic flow. Just the *nearness* of a hazard—such as a driver changing tires—creates eddies. And in these the unprepared amateur gets pushed around like a chip in a flood.

And then there is the new thing called "memory." On a super-road the other day, in very dense holiday traffic, a trooper saw a small accident. He stopped to guard the scene. Motorists saw his red flasher. They stopped, crept past and went on. It was over in five minutes.

But—

Half an hour later the trooper passed the spot again. To his astonishment, *cars were still doing a stop-and-go*. The "memory" of the mishap lingered in the traffic stream itself, making a second wreck possible.

This odd effect has been known to last for an hour and a half. The danger to you is that, in effect, a traffic jam is rushing toward you at 60 mph.

One of the aces I rode with was Safety Officer Gene Sherwood of Troop T ("T" stands for Thruway) of the New York State Police. Sherwood sits tall at the wheel, handles his car decisively, and is the most *alert* driver I have ever met. He drives the way a tomcat runs along a fence, calculating every inch. To give you a picture, when Sherwood begins a pull-out he does four things rapid-fire:

- Looks ahead. Asks himself: "Will that car slow down in the next five seconds while I'm switching to his lane?" He wants nothing to upset his timing.

- Checks his No. 1 mirror (inside). Sizes up entire road picture behind—and rate at which cars are coming up, shuffling, switching lanes. Reason: he wants a "clear" behind him *into which he can duck*

for safety if anything goes wrong ahead.

- Checks No. 2 mirror (outside left)—a quick, hard look. Who's back there in the blind spot?

- You'd think that was enough. But Sherwood has learned. Now he turns clear around and looks backward over his left shoulder—for one fleeting second. Why? In that quick look he sweeps not only

the blind spot but both lanes alongside to the left. He knows that cars now shuffle so fast at high speed that they can appear alongside even after your mirror-check.

► **A faster takeoff.** Sherwood also told me that driving a fast pike today is like flying. You don't just get in a plane and fly the thing. You have clearances, patterns and an operational plan. For example:

Spacing

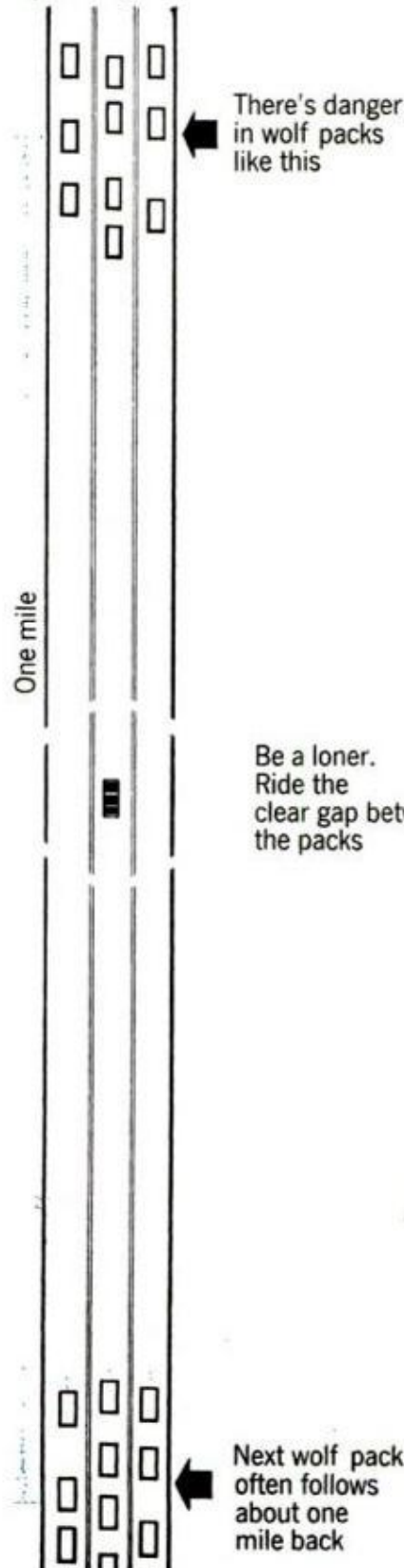

Old-fashioned: cars tailgating



Modern speed driving: more space

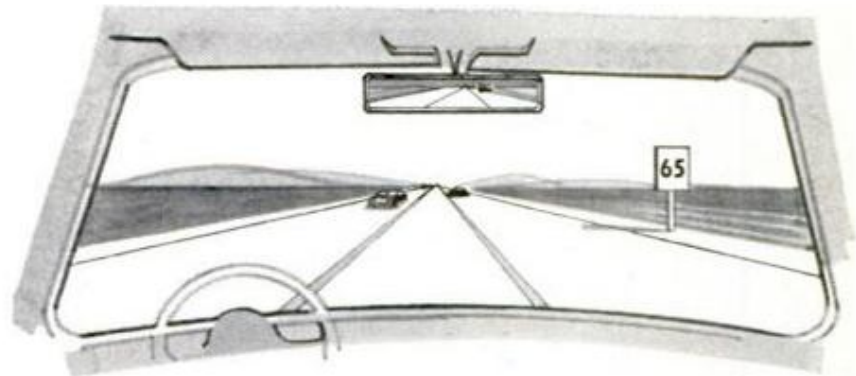
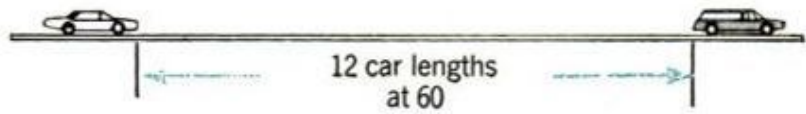

Be a loner.
Ride the
clear gap between
the packs

Know the speed groupings
When the road is empty ahead
and behind, the 65-mph speed limit may
be okay, but...

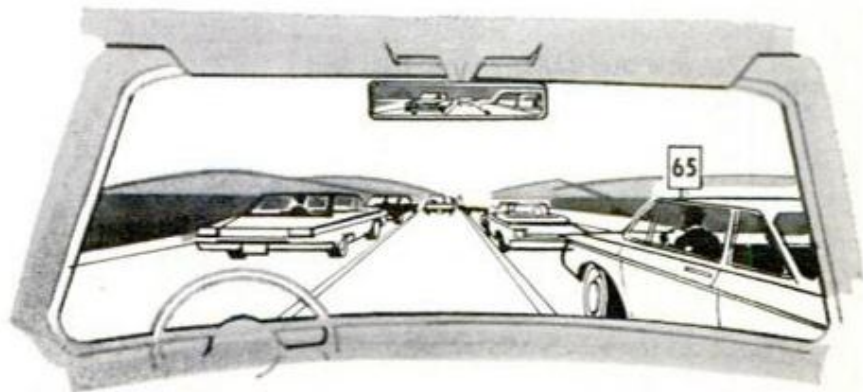

...when you see traffic like this ahead
(and in your mirror), back off to 58
and be ready for anything

Alertness and looking out



Troopers say many drivers glue eyes to road only 50 feet ahead. This is dangerous and very tiring.

High-speed piloting calls for eyes to constantly sweep the road. First the long look (A) up to a mile ahead; next the short look (B), about 1000 feet; then the close look (C), about 200 feet. Repeat

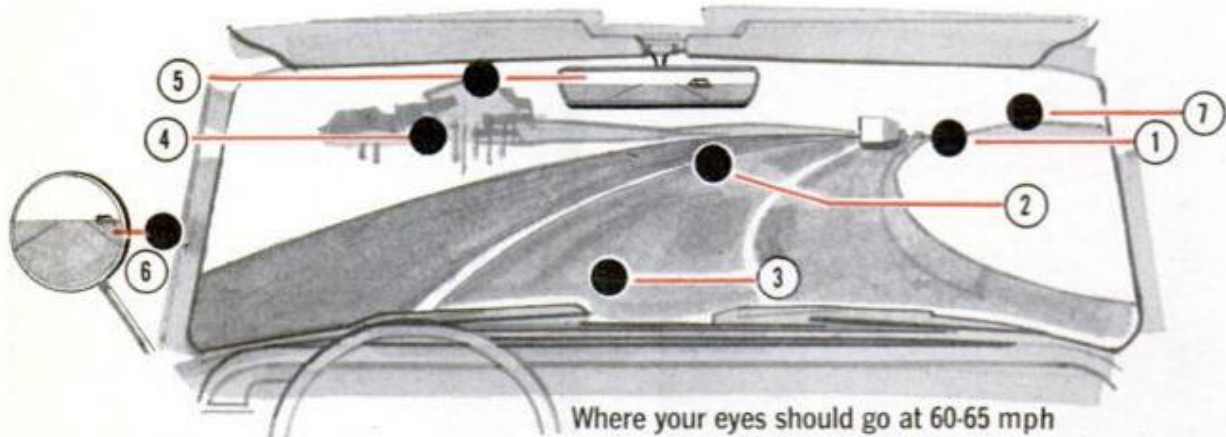

Where your eyes should go at 60-65 mph

1. Take a reading on events to come, 30-60 seconds ahead. 2. Check road for obstacles. 3. Check road close ahead. This gives you sense of speed, control, position.

4. Read the left side of the road. 5. Check rear mirror. 6. Check outside mirror at intervals for security. 7. Return eyes to the long look one-half mile to a mile ahead



At night, if you see an accident (lower left), do not stop if you see help has arrived. Keep bringing your eyes to the blind spot (circled) where drivers hit other cars they don't see, overturned



in road and hidden in darkness. Look for wandering, dazed people, and for injured or dead in road. Also look for wires down. At night (right) always study taillight groupings ahead; note any change in position

when you are getting aboard a fast pike you no longer wander in haphazardly from the entrance ramp like a Sunday driver. You treat the ramp as a runway. You've got to enter a fast pattern; you need timing and "tower clearance."

In this case you're both pilot and tower. So you give yourself your own clearance, after making sure there's room in the pattern to blend *without shoving somebody off his lane*.

This takes know-how. A lot of drivers don't work up enough speed, cut in too soon, cause accidents. It isn't always their fault; some ramps are long and some are absurdly short. (Some day, the engineers will post signs saying, "200-foot ramp" or

"100 feet" so you'll know the ramp length.)

So: Size up the ramp's length first. On a 65-mph pike like the Thruway you've got to pour on coal and get up to 55 or better for a safe blend. This is easy on the Thruway where ramps are often over 1000 feet.

► **Open up a "clear."** Once on the main line, surround yourself today with a vast amount of *space*. Trans-Atlantic pilots have been insisting on lanes 120 nautical miles wide (over 130 miles). They *know* the importance of space. Yet we drivers run in bunches so close we could hold hands. Some troopers call this "family" driving; others call it "wolf packs."

But by any name, wolf-pack driving is

for the amateurs. The packs usually come by about once every minute—or about a mile apart. Stay in the gap between. Open up a “clear” (1) ahead of you, (2) on either side and (3) behind. At 60 and up you want to be a loner.

► **Double the following distance.** Someone once thought up a pretty good rule: Stay one carlength back for each 10 miles

of speed. You know that old rule.

Today that’s still fine up to 45 mph. It may even be pretty good in very light traffic at 60.

But on a *busy* pike today, with two or three lanes running full, it’s suicide. Forget it. If anything goes wrong ahead, you’ve left yourself no out. You are only

(Please turn to page 185)

Entering and exiting

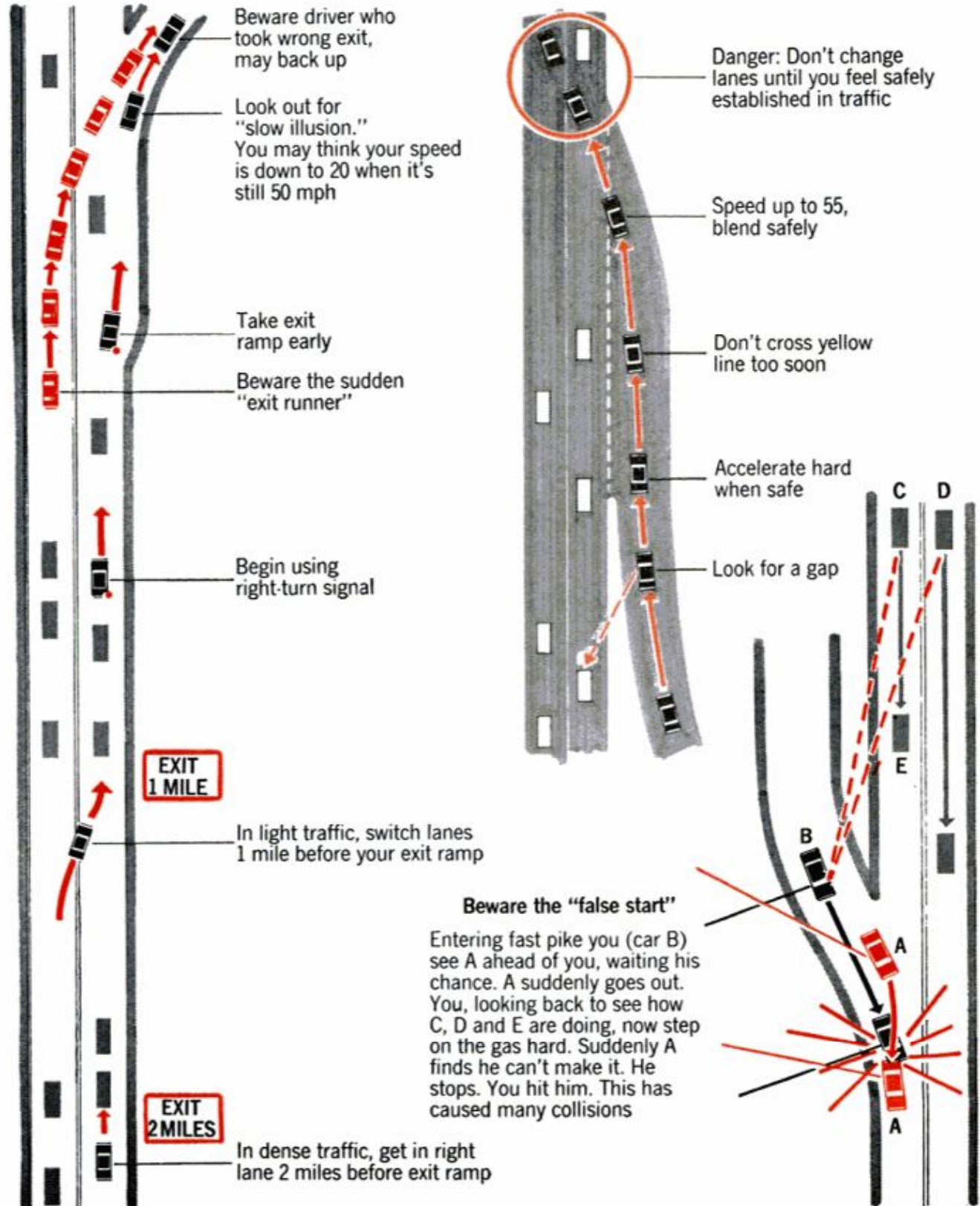



Riviera...New Yorker...

Three PM staffers on a grinding (literally!), all-roads trip through

NOT TOO OFTEN does the average guy get to drive Detroit's more exotic machinery. Most of us ogle the high-priced stuff and dream—and wonder what it would be like to drive it.

So, the thought was to have three PM editors alternate in driving three luxury cars roughly similar in price, power, weight and optional extras—Ford Thunderbird, Buick Riviera, Chrysler New Yorker—on a three-day, 1000-mile com-

parison trip and report test data and overall impressions.

The plan was to drive from New York City to Bangor, Me. and back on an all-road-conditions route plotted for us by the Mobil Travel Service people. Those people didn't plot, they schemed! The route was a beaut, complicated by rain and—in May, yet!—snow in New Hampshire's White Mountains. But the plan almost went awry right off the bat.



BLASE MANHATTANITES hurrying to work ignore caravan as it sets out on first leg of the 1000-mile test drive

PM STAFF MEMBERS Stuart James, Bill Kilpatrick and Kevin Brown alternated in driving each of the three cars under test. Opinions on the cars varied widely



Thunderbird...

New England report their impressions of three spectacular cars

In New York's notorious crosstown traffic, a ready-mix truck ran a red light and darn near flattened Aviation Editor Kevin Brown and the T-Bird. And then two buses and a cab scattered us, and we didn't get back in caravan until our first checkpoint on the Connecticut Thruway. Once underway, though, the trip settled into a comfortable routine.

We zipped along fabulous (but boring, in all) superhighways, stopping every 100

miles or so to stretch and change cars. The broad, open roads gave us a chance to do the acceleration tests. The results:

T-Bird—0-60 mph in 9.6 secs., 30-70 mph in 9.1 secs.

Riviera—0-60 mph in 8.8 secs., 30-70 mph in 7.9 secs.

New Yorker—0-60 mph in 8.3 secs., 30-70 mph in 7.7 secs.

Heavy rain hit us as we crossed over the Massachusetts border and continued

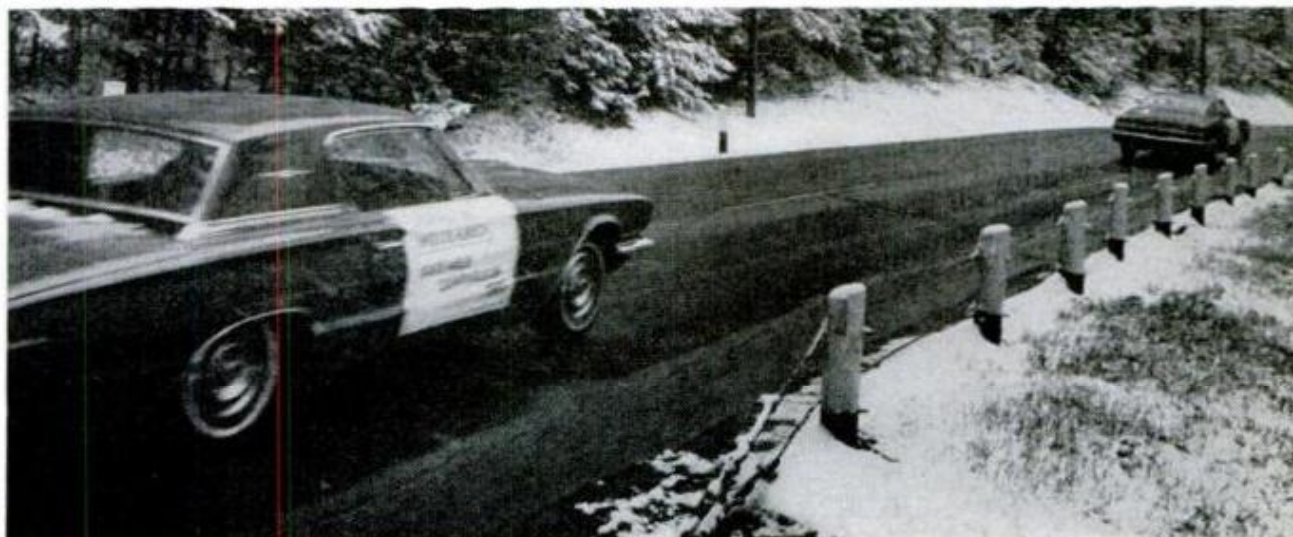

SNOW IN MAY met caravan in New Hampshire's White Mountains. Drivers also faced heavy rains, high winds
AUGUST 1966

on and off for the rest of the day. And then in a lovely little town called Thomaston, Me., a gremlin took over.

We had just passed through town and were in a line of slow traffic when up ahead someone slammed on the brakes and darted left. You can guess what happened. It was a chain reaction sort of thing, so typical it was embarrassing. When Outdoors Editor Stuart James tried to stop, the brakes on the Chrysler locked the wheels on the wet pavement, and he and car slid slowly and majestically into the rear of the car ahead. Scratch one New Yorker, victim of a severely pranged radiator. Red faces and all, we had to abandon the car at Miller's Garage in nearby Rockland.

Next day our now-two-car caravan drove up along the Maine coast to Bangor, where we hairpinned back toward New Hampshire. At this stage of the trip several narrow, twisting roads in the White Mountains—a few of 'em dirt—gave us a chance to wring out each car's handling and braking under far from ideal conditions.

The consensus had the T-Bird a bit more responsive to control, but the Riviera got the job done a lot more quietly and with less fuss. Cornering in each case was good, with body lean at a minimum. However, we all felt the Riviera would be the preferred car in a tight handling situation. The T-Bird, with discs up front,

(Please turn to page 180)

General Specifications of cars tested

	Riviera	T-Bird	New Yorker
Price (approx.)	\$4400	\$4400	\$4200
Engine	V-8	V-8	V-8
Transmission	Auto.	Auto.	Auto.
Horsepower	340	345	350
Displacement (cu. in.)	425	428	440
Compression ratio	10.25	10.50	10.00
Torque (lb.-ft./rpm)	465/2800	462/2800	480/2800
Weight (curb/lb.)	4316	4566	4415
Wheelbase (in.)	119	113	124
Length (in.)	211.2	205.0	219.0
Height (in.)	53.4	52.5	55.7
Width (in.)	78.8	77.3	79.5
Turning circle (ft.)	44.0	42.6	44.1
Tire size	8.45/15	8.15/15	8.55/14
Fuel capacity (gal.)	25	22	25

WHAT THE DRIVERS HAVE



STUART JAMES

Thunderbird: Despite its size, it has a sports-car feel; low bucket seats and the wraparound feeling of the body. The exterior styling has dash. But there the comparison ends. This is a long-distance turnpike car. It handles easily in city traffic, but out on the open road it really comes into its own. The acceleration from a standing stop is not remarkable, but once it gets underway that big engine pours on the power. Of all three cars, it seemed to me the most stable at speeds above 70 mph. Above the driver's head, centered over the windshield there is a panel of warning lights labeled: seat belts, flasher, door ajar, low fuel. This is a good idea, but I didn't notice the panel until near the end of the first day, and I never did get into the habit of looking up. An excellent feature is the rear-turn signal arrangement which flashes three lights in succession progressing toward the direction of the turn.

Riviera: The clean, sweeping lines of this car's exterior styling made the others look old-fashioned. It is big and sleek, a luxury car by any standard. And fast. The engine is about the same size as the T-Bird, but it is more responsive. The suspension seemed "mushy" at higher speeds and I felt uneasy above 70 mph, as though there was a noticeable lack of stability. On tight turns, however, it handled perfectly, leaning nicely on the drift and coming out with true stability at just a touch of the throttle. I particularly liked the speedometer on this car, a barrel-type with center line.

New Yorker: The conservative lines of this model give it an "old lady" look on the outside. But inside it is loaded with gadgetry and nice touches. Under the hood is a big powerplant that really moves this package along. I was impressed by the four-way power seat. It gives this car remarkable visibility and helps alleviate fatigue on a long haul. I also liked the adjustable steering wheel (which the Riviera also had), and changing its position during the trip eliminated considerable muscle strain. On performance and comfort I preferred this car over the others, but on exterior styling the Riviera comes out ahead. The toss-up? New Yorker.

TO SAY ABOUT THE CARS IN THE 1000 MILE TEST



BILL KILPATRICK

Thunderbird: As it has gone along, the T-Bird has become overburdened with styling "touches." The result is pleasing, but when broken down you find flaws. For example, the blanked-in rear-quarter

windows limit visibility. Driver access is only fair. Once in, though, the T-Bird is quite comfortable.

The dash is overdone. The bulbous four-in-a-row instrumentation is just funny. Pop's '32 Plymouth was class by comparison.

Acceleration is fair, although the car really marches once you get up steam. Disc brakes up front make possible rapid decommencing. But control in hard braking is a matter of driver skill and luck.

Car handles well, responds quickly, but gets hairy in tight bends. Wind and road noise is fairly high.

Riviera: Styling is severe and not my personal cup of tea. The impression I get is one of trying too hard to be all things to all people. Inside, it's nice and tasty. Dash is neat, functional, the instruments fairly easy to read. Visibility is better than in the T-Bird. Legroom is fine. The seats are too low.

This car can go, fella. Response is quick. Car handles well, is a tiger on long sweeps, "settles" nicely in tight turns. Of the three, it's the one in which I might be tempted (but would, I hope, know better) to do my Stirling Moss act. One reason I wouldn't is the braking; heavy-duty drums do the job, but are inclined to marshmallow after two or three severe stabs.

New Yorker: On styling, Chrysler has always seemed unable to resist reaching; if there's a chance to bypass a bauble, it's even money they'll nail it on anyway. Car looks nice but could have looked better. It's great inside. Visibility is better than in the others and I like the idea of sitting up there and paying attention. Dash is a dash, the instruments easy to read. Comfort is tops, legroom very good. Lots of hustle, in the 350-hp engine. Car goes like a bat. Disc brakes do a superb job of hauling it down. Braking control is excellent.

Didn't get much of a chance to handle this one. Liked what chance I got, however. Car seemed sensitive without making a fuss.

My pick? The New Yorker!



KEVIN V. BROWN

Thunderbird: It has the most distinctive styling of the three. Except for the banana-shaped body of a few years ago, I've always liked the T-Bird's looks. This model is no exception. Inside, I liked the compact luxury and, with its unique push-away steering post, the ease of getting in and out.

I didn't like the instrument panel with its four bug-eyed gauges staring at me, and I especially didn't like the location (on the floor console) of the radio dial. A small thing, but it became annoying after a while when, on a long trip like this, I was constantly twisting the dial to get new stations. A major thing—the T-Bird was not sensitive to steering control at high speeds. The car wandered slightly and I was constantly jockeying the steering wheel to keep it straight ahead.

Riviera: This was my overall favorite. The styling seemed a little more integrated and—this is a subjective thing—I felt I had more room inside. I loved the instrument panel, especially the speedometer. A small cylinder rolled the numbers past a slash mark and it was very readable. The steering wheel, which was very sensitive, could be adjusted up or down to suit any driving position, and I approve.

My only major complaint about the Riviera is that a housing just above the brake and gas pedals made me stub my toe several times when going from one to another. It could be dangerous.

New Yorker: It's a shame we couldn't have kept this car longer. It had a lot of plush extras on it and was certainly the most comfortable to sit in. I loved the power seat that moved up and down as well as forward and back, and I especially liked the resettable odometer, handy on trips like this. I got one 100-mile leg in the New Yorker. It was a pleasant one, but not long enough.

I didn't care for the styling. It just seemed bland compared to the other two sporty types. While all three cars rode well—and why shouldn't they, at those prices?—the Chrysler's rear end jumped out from under me on at least two 270° turns off expressways. And I wasn't going that almighty fast. All three cars gave me trouble with my left knee. None has a place to lean it on.

My pick? The Riviera.



By WILLIAM O. RAINNIE
Chief Pilot, The Alvin

Hour after grueling hour, day after frustrating day, my copilots and I probed the dark depths of a submerged mountain range, searching for a nuclear weapon while a nervous world waited and watched every move

IF YOU CLOSED YOUR EYES and threw a collar button out to the middle of a football field, and then looked for it at night with a flashlight, you'd have a good idea of what it was like trying to find that H-bomb.

I was on my job at the Woods Hole Oceanographic Institution in Woods Hole, Mass., when the B-52 bomber collided with the KC-135 jet-refueling tanker in the skies near Palomares, Spain on Jan. 17. We were in the process of giving *Alvin*, our deep-diving research submarine, a complete overhaul after successfully diving to 6000 feet off the Bahama Islands and Bermuda.

Like everyone else in the world, I was aware that three 20-megaton hydrogen bombs had fallen on Spanish soil, but when it was fairly well established that a fourth bomb was missing in the ocean, I had a feeling that this was a job for *Alvin*. Our crew chief, George "Brodie" Broderson, obviously had the same idea, and when we got the call from the Navy, he and his crew had *Alvin* ready to go. On Feb. 1 we loaded *Alvin* on a C-133 transport and took off for Spain.

The first test dive off Rota, Spain, near Gibraltar, was aborted. The batteries were leaking water. Repairs took three days, and this was a time of real excitement. We

AFTER THE BOMB WAS FOUND, *Alvin* wedged itself sideways in the trench and *Aluminaut* stood by below. The weapon was under scrutiny for 22 hours



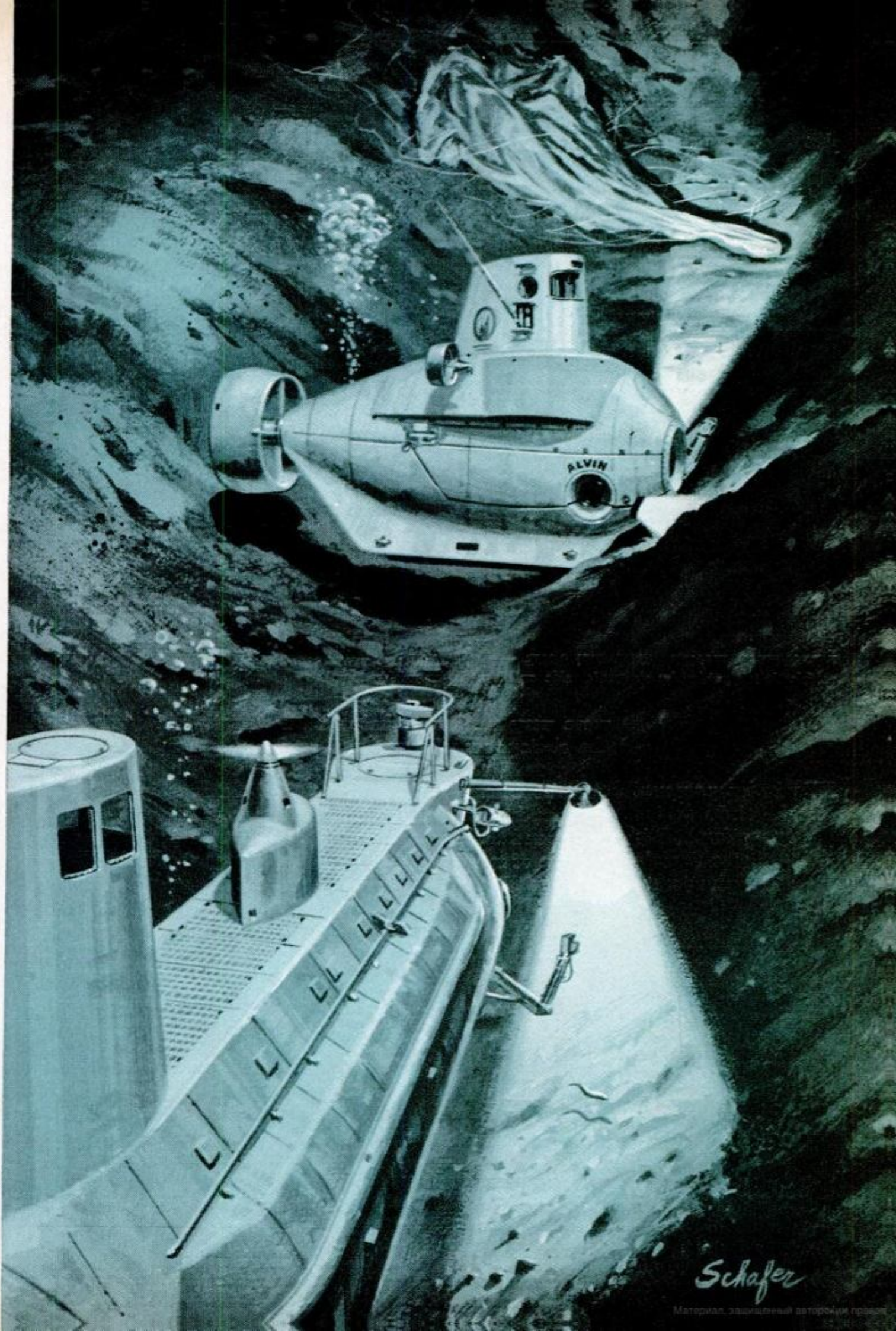

Schafer

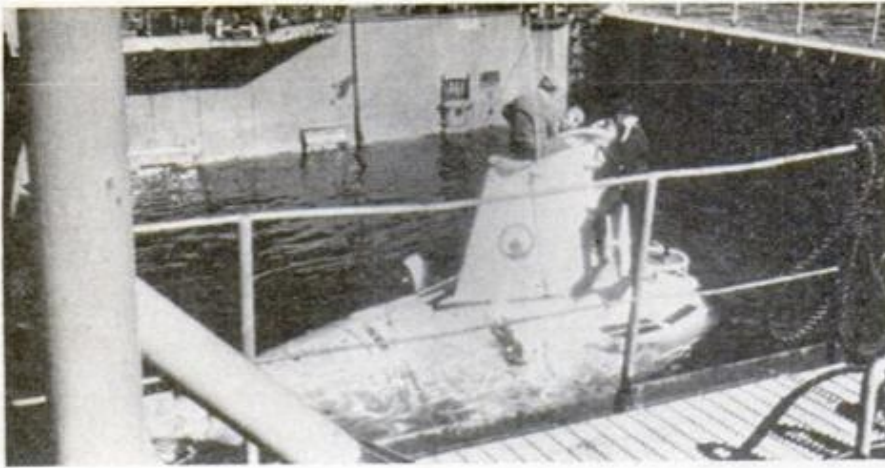

GETTING READY TO DIVE, *Alvin* floats in the flooded aft section of the LSD USS *Fort Snelling*. The submarine was attended by a nine-man crew

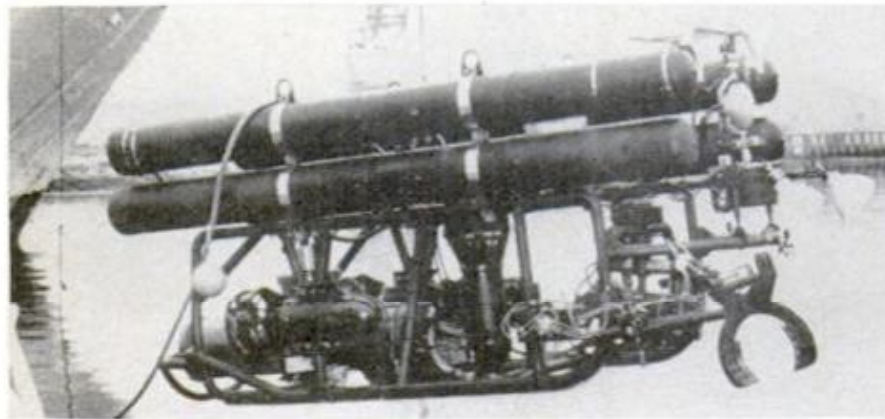

DEVICE THAT FINALLY RAISED THE BOMB was the CURV, an unmanned vehicle that is guided by electronic cable and is used for raising torpedoes



"We had a personal stake in the operation. This was Alvin's first job."

were very anxious to help find the missing H-bomb for the obvious reasons, but we also had a personal stake in the operation. This was *Alvin's* first job. We had proven that the little (22-foot) submarine could operate to 6000-foot depths, but there were still many critics who loudly contended that the entire deep submersible program was a waste of money. An additional prod was the knowledge that the Reynolds *Aluminaut*, a larger (51-foot) deep submersible, was also in on the search.

With the batteries repaired we made a second test dive on Feb. 9. That same day we went aboard the LSD (Landing Ship Dock) USS *Plymouth Rock*, and then we joined Task Force 65 off the coast of Garrucha, Spain. At the site of the search, *Alvin* was transferred to the LSD USS *Fort Snelling*, which remained our mother ship.

"Many critics loudly contended that the entire deep submersible program was a waste of money."

Surface control for *Alvin* was established aboard the Navy Research Laboratory's oceanographic research vessel *Mizar*, and on Feb. 14 I made the first dive. Marvin McCamis was my copilot and Valentine Wilson, a third pilot, was in charge of surface control. From this dive on, we rotated among the three of us.

From the beach off the mountainous coast line, the bottom of the Mediterranean is a long, gradual slope. About five miles from shore, where we were to begin our search,



PHOTOGRAPHED BY ALVIN at 2800 feet, the bomb was shrouded by a parachute billowing in the water, an element of danger to Alvin



PILOT MARVIN McCAMIS was operating Alvin when bomb was found



COPILLOT VALENTINE WILSON was first to see bomb lying in the trench

it suddenly dips into a 45° incline. At a depth of about 2400 feet there is a ridge, and the terrain is a steep 70° incline. It slopes off at about 3000 feet, then drops again on a steep incline, leveling off at 3600 feet.

The search was being concentrated in the area where a Spanish fisherman had reported seeing an object attached to a parachute go into the water. The Navy had the area mapped off in half-mile sections; our task was to move back and forth across an assigned section, trying to cover every inch of the bottom.

Alvin has a variable ballast system that utilizes interconnected pressureproof aluminum spheres and collapsible rubber bags which are partially filled with oil. Normally, when the submarine is descending, most of the oil is pumped to the spheres and water pressure compresses the rubber bags. To ease the rate of descent, oil is pumped from the spheres into the rubber bags. This increases the amount of seawater actually displaced by the submarine and results in greater buoyancy. Alvin then utilizes the main prop at the rear for thrust and two lift props on each side for moving up and down.

On that first dive we went to 1800 feet, and I had my first look at the bottom. It's dark at that depth, but with Alvin's powerful lights we had visibility of 20 to 30 feet.

"The search was being concentrated in the area where a Spanish fisherman had reported seeing an object attached to a parachute go into the water."

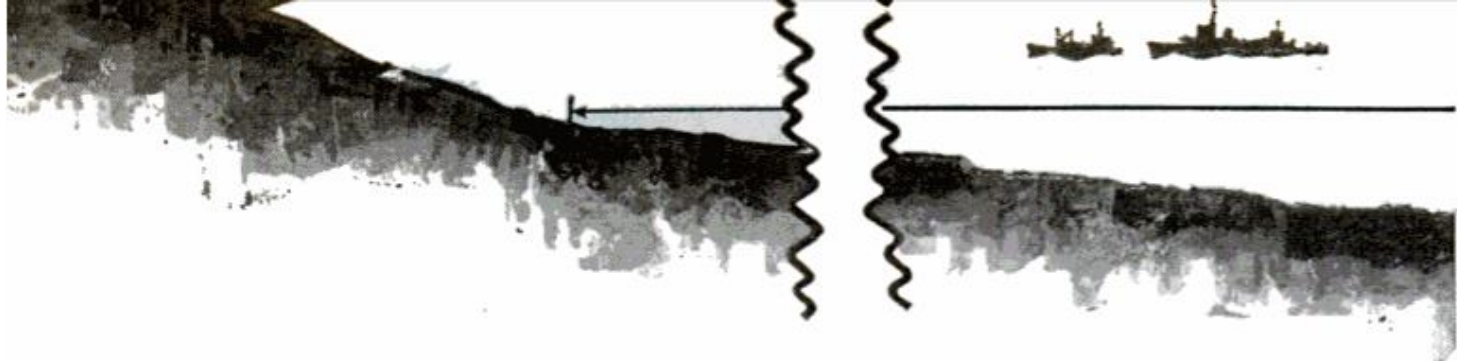

“On March 1, diving our tenth dive, we found the track of the bomb.”

The terrain on the slope was an undulating featureless mud flat. There was no vegetation, just a clay substructure topped by an inch or so of loose mud. If there was no current the mud stayed put, and it looked like a loose layer of pockmarked gray skin. When *Alvin* or marine life stirred the mud into clouds, visibility was nil.

Then followed the hours and days of interminable frustration. Tracking across the blank terrain was discouraging. When you listen to tapes of our conversation inside the steel sphere it's hard to believe that Val, Mac and I were actually working in complete harmony.

“Wait a minute. I see something.”

“What?”

“I'm not sure. A little to the left. That's it. No, dammit, you went over it. To the right.”

“What?”

“To the right, dammit! That's it. Right on target.”

“What is it?”

“Tin can.”

“You better get a closer look.”

“I know a damned can when I see it!”

“Well, let's get a picture of it.”

“Back off a little and bring the nose down. You hear me? Bring the nose down. How the hell can I get a picture with the damned camera up in the air.”

“How's that?”

“Okay. Good. I got it.”

We were diving four days, then taking off a day for rest and to recharge the submarine's batteries.

After two weeks of this I was for giving the Spanish fisherman an award for having the world's liveliest imagination. But on March 1, diving our tenth dive, we found the track of the bomb.

We were making a contour search of the relatively steep secondary slope. We had been over this area before, but now we were down close. Wilson was on the controls. And there it was dead ahead, unmistakable—a long deep gouge in the mud. All we had to do then was follow the track to the bomb. The terrain defeated us. We were nosed down the slope, trying to keep the track in sight. I relieved Wilson and had to maneuver to keep the rear prop from hitting bottom and stirring up the mud, and we lost it. It was maddening. We combed the area for five hours, but couldn't find the track.

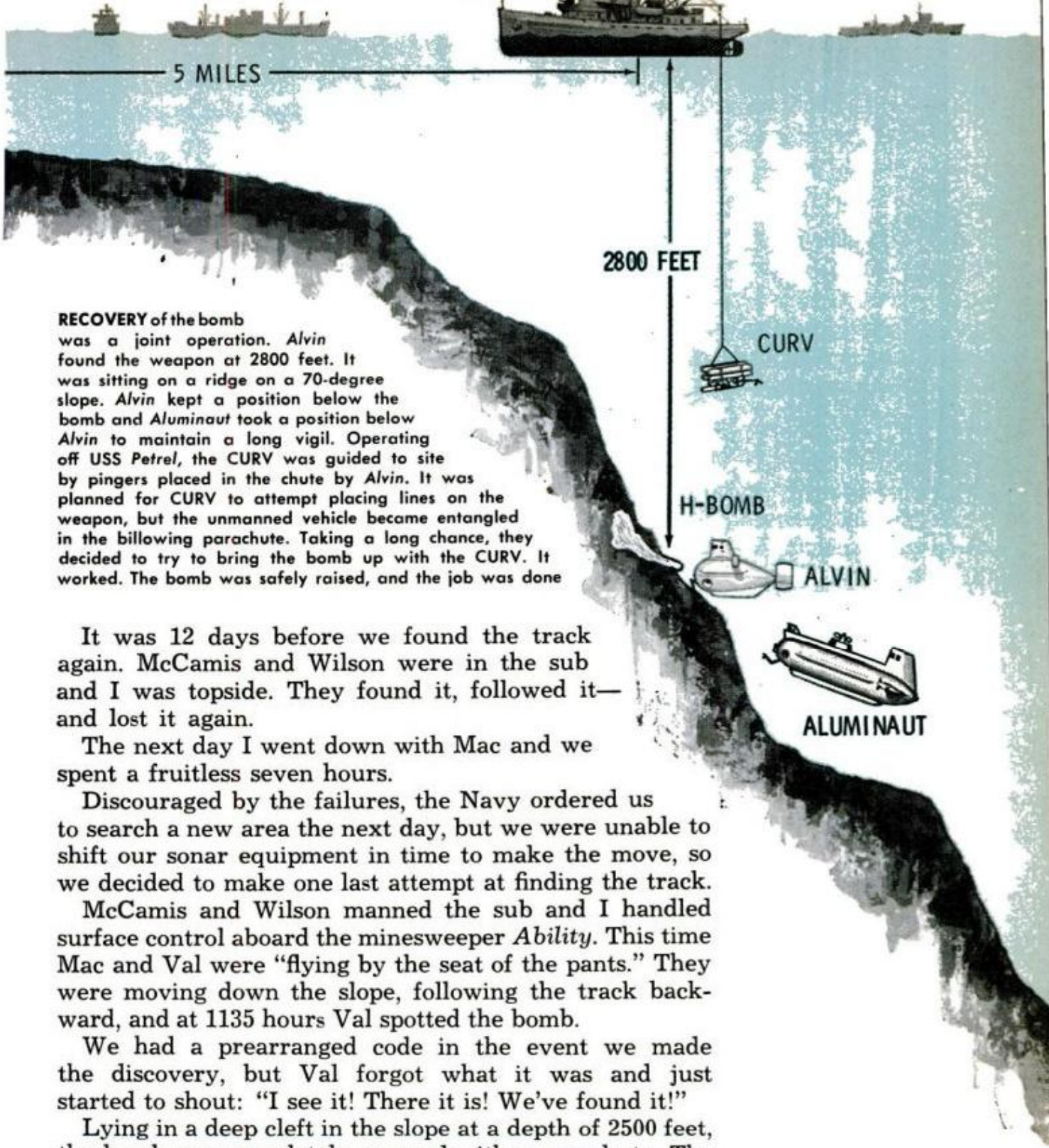

RECOVERY of the bomb was a joint operation. *Alvin* found the weapon at 2800 feet. It was sitting on a ridge on a 70-degree slope. *Alvin* kept a position below the bomb and *Aluminaut* took a position below *Alvin* to maintain a long vigil. Operating off USS *Petrel*, the CURV was guided to site by pingers placed in the chute by *Alvin*. It was planned for CURV to attempt placing lines on the weapon, but the unmanned vehicle became entangled in the billowing parachute. Taking a long chance, they decided to try to bring the bomb up with the CURV. It worked. The bomb was safely raised, and the job was done

It was 12 days before we found the track again. McCamis and Wilson were in the sub and I was topside. They found it, followed it—and lost it again.

The next day I went down with Mac and we spent a fruitless seven hours.

Discouraged by the failures, the Navy ordered us to search a new area the next day, but we were unable to shift our sonar equipment in time to make the move, so we decided to make one last attempt at finding the track.

McCamis and Wilson manned the sub and I handled surface control aboard the minesweeper *Ability*. This time Mac and Val were “flying by the seat of the pants.” They were moving down the slope, following the track backward, and at 1135 hours Val spotted the bomb.

We had a prearranged code in the event we made the discovery, but Val forgot what it was and just started to shout: “I see it! There it is! We’ve found it!”

Lying in a deep cleft in the slope at a depth of 2500 feet, the bomb was completely covered with a parachute. The chute was stretched tightly over one end, showing the cigar shape of the bomb, and then it was bloused out, the shrouds trailing up the slope.

Mac and Val maneuvered *Alvin* until they were wedged sideways in the crevice just below the chute. Then the *Aluminaut* was called in, and took a position just below *Alvin* with its nose into the slope in order to pinpoint the location with *Mizar*’s tracking system.

While preparations were being made to raise the object, the two submarines kept their positions. *Alvin* sat in the crevice for eight hours, then returned to the surface. The *Aluminaut* held its position for 22 more hours, while

Alvin charged batteries and mounted the mechanical arm.

Recovery operations began the next day, March 16. Using the mechanical arm, *Alvin* took down a 3/8-inch line and anchored it near the object. But the bottom was too soft, and when a heavier line was being sent down the anchor pulled loose.

Weather wiped us out the next day, and we resumed work on March 18. The *Mizar* tried to lower a camera sled on a cable, but the surface was too rough to maintain control and this was abandoned. *Alvin*, meanwhile, went down with a large clamp, like a lobster claw, attached to the mechanical arm. The object was to get a grip on the bomb to haul it up. But this, too, failed.

The weather worsened and the recovery operation was abandoned for four days. During this time a device called the "poodl" was built. It was a six-foot-by-six-foot steel frame designed to take down lines attached to grappling hooks and electronic pingers.

On March 23 we were back in operation. An anchor with a grappling hook attached was dropped within 70 feet of the bomb with the "poodl" by the *Mizar*; *Alvin*, with Wilson and McCamis at the controls, tried to pull the chute away from the weapon, but this failed. *Alvin* then tried to pick up the lines from the "poodl" and attach them to the chute. With one man handling the sub and the other operating the mechanical arm, and the lines wavering around in the water, it was impossible. They would zero in on a line and just as they moved ahead to grasp it, the line would move.

Giving up on "poodl," Mac maneuvered *Alvin* into position and Val picked up the grappling hook that was attached to the three-inch nylon anchor line. They finally managed to attach the hook to the parachute shroud lines.

The next day, *Alvin* secured the grapnel more firmly in the shrouds and risers and the *Mizar* attempted to lift the bomb, moving it up the slope into shallow water. We've never ascertained exactly what happened, but it's our belief that the line became entangled with the anchor on the "poodl" and broke. At any rate, the bomb dropped and was lost again.

The search resumed the next day, and we were following a track that went up the slope, which we thought had been made by the bomb. Now we believe that this track had been made by the anchor dragging on the bottom as it was pulled up the slope, and the bomb, when it fell, had actually dropped into its old track and skidded down the slope. But for nine days we searched up that slope. We then decided to take a look down the slope, and we came across the bomb just 300 feet below the previous location. It was resting in a crevasse at the foot of a

(Please turn to page 202)

"We've never ascertained exactly what happened, but it's our belief that the line became entangled with the anchor on the 'poodl' and broke. At any rate, the bomb dropped and was lost again."

"We came across the bomb just 300 feet below the previous location. It was resting in a crevasse at the foot of a 70-percent slope."

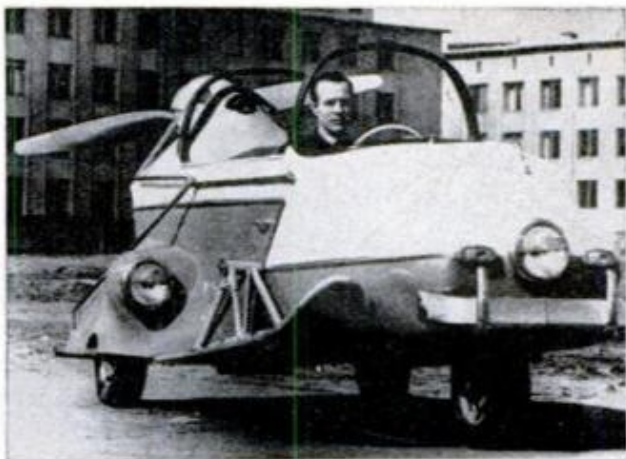

If it could fly, this Russian Rube Goldberg's car would have the transportation problem licked. Moscow designer/builder V. Kurunkov claims his "auto-aeromobile" will do 75 mph on land, 50 on snow and about 30 on water. Kurunkov hasn't been able to get his unique craft into the air, however. He is said to be working on a new air-cushion version.



Space-age playground ride, the "Sputnik" is a pendulumlike counterbalance that is sent into motion by a downward pumping action of the rider's feet. Used in Europe for five years, it is being imported by Miracle Equipment Co., Grinnell, Iowa.

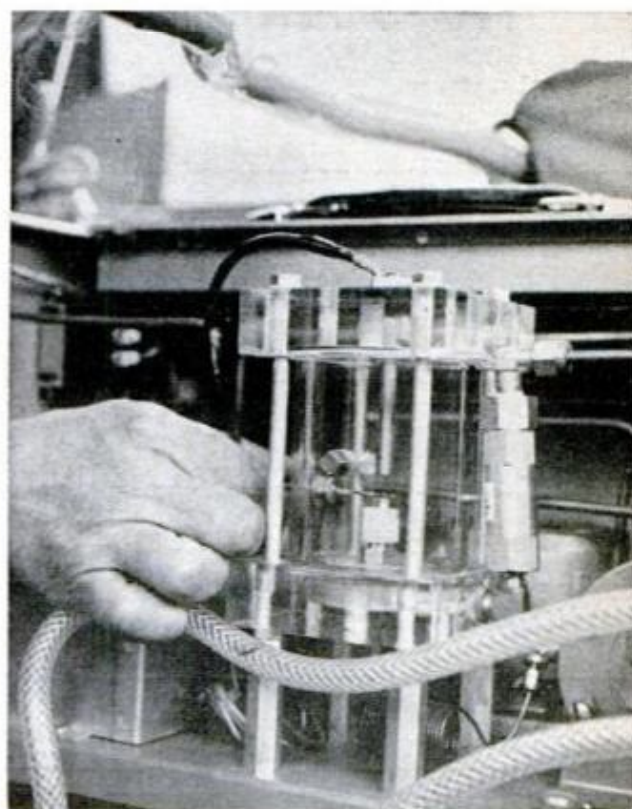

Land-Rover sniffs gas leaks. To find leaks in gas mains without digging holes in the road, England's Eastern Gas Board has equipped a Land-Rover with an electronic detection system. Technicians with probes (top) follow the routes of gas mains along roads and in yards. A very small amount of escaping gas picked up by a probe will act on a hydrogen flame (bottom photo) in such a way that the flame will conduct electricity. The leak then is noted on a recorder and measuring device in the vehicle.

ARCTIC OCEAN

Hudson Bay



PACIFIC OCEAN

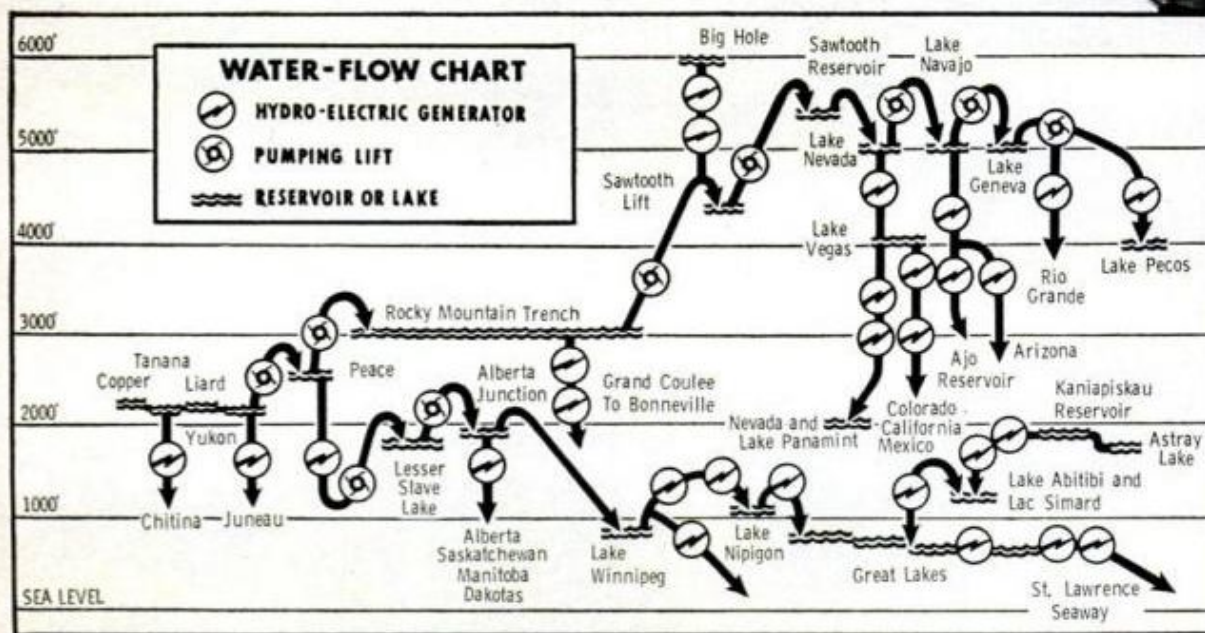

NORTH AMERICAN WATER COLOSSUS

USING THE ROCKY MOUNTAINS as a super-gigantic bed for a colossal network of flumes, engineers are planning to conduct surplus water "downhill" from the northwest corner of the continent to as far away as Mexico and the East Coast.

Some of the water would be used to restore the level of the Great Lakes, augmenting the generation of power at Niagara Falls and even contributing to the water supply of New York City.

Water would be delivered to 10 million thirsty acres in Canada's central



plains and to 40 million dry acres on both sides of the Rockies in the United States. Additional water would be available for municipal use in seven other states from Illinois to Pennsylvania.

Northern Mexico would receive 20 million acre feet of water from the Arctic every year, allowing for the irrigation of eight times as much land in Mexico as the new Aswan Dam will permit in Egypt.

The plan would make possible the movement of Great Lakes steamers to central Alberta, allowing development of northern Canada's resources.

The vast engineering scheme is named the North American Water and Power

Alliance (NAWAPA). It's based on 10 years of study by the international engineering firm of Ralph M. Parsons Co. of Los Angeles. Company engineers emphasize that it is not a "pie in the sky" dream, but is based on sound engineering and economics. The only thing unique about the concept is its unprecedented size, they say.

NAWAPA would cost about \$100 billion and yet could pay for itself within 50 years by the sale of water and surplus power.

What makes the idea practical is the very convenient Rocky Mountain Trench, an enormous gorge in the Canadian

(Please turn to page 190)

Owners report on Volkswagen's

By ALEX MARKOVICH

SOMEWHERE IN DETROIT there's a bookkeeper who dislikes her new Volkswagen 1600. She's the only one in the entire *PM* owners' survey who rated her car "poor"—and even she wasn't too outspoken in her criticism.

Most owners were lavish in their praise for the new, larger Volkswagen fastback

and squareback from Wolfsburg, Germany.

Praise went to the practical features. Typical remark by a Florida supervisor: "There's no gingerbread; everything is functional." Absence of annual styling changes also pleased people. "My car won't be obsolete when next year's models come out," a Minnesota attorney said. A nurse in Texas has grown so attached to her car that she nicknamed it



COMBINING QUICK STEERING (2.8 turns lock-to-lock) and small overall size gives nimble handling. But a few owners noticed a tendency of the rear end to slide out unexpectedly during very hard cornering



AWKWARD IGNITION SWITCH just missed list of top ten complaints. Other cockpit features that came in for criticism are shift lever, air vents, horn



DESIGNERS OF HEATING SYSTEM placed rear ducts at ankle level, where, some owners complain, they are apt to scald feet whether the heater is on or off

new fastback and squareback

Big Mama. And a Ford mechanic from California passed up a discount on a Ford to buy a Volkswagen because he preferred its "engineering perfection."

Even more important to VW owners is driving fun. Handling topped the list of best-liked features with an FMR (frequency-of-mention rating) of 57.5 percent. Economy of operation took second place with an FMR of 42.2 percent.

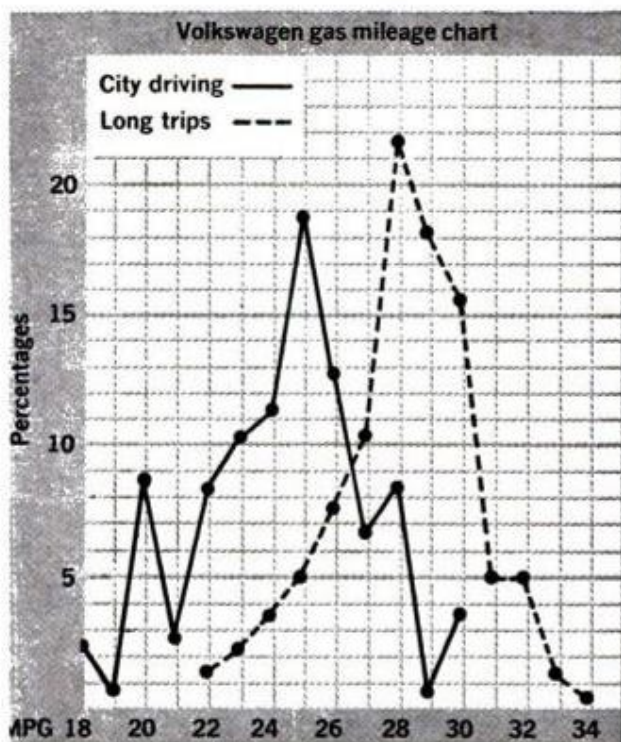

MILEAGE, averaging 24.3 mpg in city driving and 28.2 on trips, satisfied 79.2 percent of all owners



REAR SEAT FOLDS FLAT in squareback to form large luggage area. Though car is registered as a sedan, most owners think of it as a small station wagon

The biggest gripes among owners of the older, beetle-shaped VWs have been in power, room, comfort and styling. Since a whopping 63.7 percent of the new-model owners traded in an earlier Volkswagen, it's no wonder that these categories placed third, fourth and fifth among best-liked features in the more luxurious 1600 model.

Topping the brickbats was a persistent mechanical problem: Nearly one out of four owners (24.6 percent) reported oil leaks. And the heater and defroster, which have annoyed Volkswagen owners for years, still aren't improved in the 1600, according to 21.6 percent of the respondents. And, though handling was the best-liked feature, it also placed third among gripes with an FMR of 17.4 percent.

Overall, owners seem exceptionally happy with their cars; 97.5 percent stated that they would buy another VW. Loyalty to the make is often fierce. Typical is the Michigan truck driver, who says, "I've had three other VWs and I'd rather fight than switch."

Loyalty to dealers, however, isn't as warm. An unusually high percentage (10.1) complained of poor and expensive service.

Here is how the first five pluses stack up, in order of FMRs. Boldface comments are by the author.

"Handles easily on narrow, winding mountain roads and in city traffic."—North Carolina engineer.

► **Putting the engine in the rear gives lighter steering.**

"It has enough of a sporty feel to be fun on a twisting road."—Ohio personnel trainer.

"I feel I'm in control of the car at all times."—California engineer.

And VW owners are smiling all the way to the bank. They say this about economy:

Owners like:

Handling	57.5%
Economy	42.2
Room and comfort	32.7

But don't like:

Oil leaks	24.6%
Heater and defroster	21.6
Handling	17.4

"I don't have to buy antifreeze, heater hoses or thermostats, or have leaky radiators fixed. There's no radiator."—Ohio clerk.

"I get 26 mpg on trips. It's the most economical transportation I could hope for."—West Virginia attorney.

"I dismissed the thought of buying an American car. They depreciate too quickly."—Virginia Navy officer.

"Insurance is cheaper."—Mississippi dental assistant.

► It may not be for long. Insurance companies are finding that accident claims are no lower on small cars, and a few have already eliminated the 10-percent rate reduction.

Compared to the old Beetle, the VW 1600 is roomy and plush, as noted in the following quotes:

"It carries three people, skis, boots, suitcases, lunches and coats, all without crowding."—New Jersey engineer.

"With the rear seat folded flat in our squareback, my wife and I can sleep in the back with no trouble. And I'm six-foot-one."—California lifeguard.

"Lots of room for junk and kids."—Texas housewife.

"Seats are comfortable. Plenty of leg room."—California geologist.

The 1600 isn't exactly a hot rodder's delight, but those extra horses help (the 1600 has 65 hp versus the current Beetle's 50 and last year's 42).

"I have no trouble holding 80-85 mph."—Illinois engineer.

"Good pickup for passing."—Minnesota banker.

"The extra power allows me to blend into freeway traffic. With the 42-hp bug I had to wait for a sizable hole."—Colorado administrative assistant.

Most owners aren't ecstatic about the body styling: "Pleasant" is an adjective many use. On the other hand, few find it offensive. The lines are popular enough to rate fifth place in the praise department.

"Styling is clean and uncluttered. No gaudy chrome or useless overhang."—Maine optometrist.

"The car has better lines than the bug."—North Carolina postal clerk.

► Let's face it. Even a cockroach has better lines than the bug.

But into many VW owners' lives a little rain—or, in this case, oil—must fall.

"Oil leaks from engine studs."—Massachusetts butcher.

"Engine was pulled and the seal replaced, but there's still a small oil leak."—Georgia teacher.

"Oil leak in the transmission was corrected."—California computer operator.

Second place in the least-liked column went to the heater and defroster, which many feel are inadequate for town driving.

(Please turn to page 192)

Summary of Volkswagen Owners' Reports

Excellent . . . 74.5% Good . . . 23.8% Fair . . . 1.3% Poor . . . 0.3%

Best-liked features:

Handling	57.5%
Economy	42.2
Room and comfort	32.7
Performance	29.6
Styling	19.7
Luggage space	15.3
Size	13.6
Construction	9.5
Traction	7.8
Brakes	6.1

Least-liked features:

Oil leaks	24.6
Heater and defroster	21.6
Handling	17.4
Disc brakes	11.1
Carburetor	8.7
Poor economy	8.5
Engine noise	8.0
Transmission	7.1
Speedometer	6.3
Windshield wipers	6.1

Most like to see changed:

Heater and defroster	17.9
Handling	5.4
Horn	4.9
Seats	4.9
Air vents	4.9

Car traded in:

Volkswagen	63.7%
Pontiac	4.5
Corvair	3.9
Oldsmobile	3.4
Ford	2.8
Chevrolet	2.8
Buick	2.8
Porsche	1.7
Rambler	1.7

Dealer service:

Excellent	53.8
Average	36.1
Poor	10.1

Buy from dealer again?

Yes	87.1
No	12.9

Buy another Volkswagen?

Yes	97.5
No	2.5

Bought Volkswagen because:

Price or trade-in	28.5
Economy	26.8
Resale value	16.3
Workmanship	14.6
Styling	10.6
Service availability	8.1
Size	8.1

Considered other make?

Yes	44.8%
No	55.2

Make considered:

Mustang	16.1
Corvair	14.4
Chevrolet	13.6
Rambler	12.7
Volvo	12.7

Own another car?

Yes	61.6
No	38.4

Make of other car:

Volkswagen	35.3
Chevrolet	14.4
Ford	9.9
Buick	8.8
Oldsmobile	7.2
Pontiac	5.5
Rambler	5.0
Plymouth	4.4
Cadillac	4.4
Chrysler	2.8

Volkswagen body style:

Fastback	50.3
Squareback	49.7

Total miles driven: 1,181,113



Stretched out like an astronaut in his 17-foot **Starflite IV**, 26-year-old Gerry Walin recently streaked across Lake Havasu, Calif. at 130.9 mph to set a new world speed record for outboards. The Entrop hydroplane was powered by a modified Evinrude 100-S (fuel injection, special ignition, custom lower end) burning methanol and castor oil. The old record set six years ago was 122.9 mph.



Rotary tiller with 3-hp motor attaches to small tractor for garden preparation. The self-powered Lambert tiller is 20 inches wide but can be extended to 26 inches with extra tines. Chain-and-sprocket drive is completely enclosed.



Foldable containers, which can carry nearly 1500 gallons of liquids when full, take up only 5 percent of their maximum space when empty. The seamless "boxes" are replacing metal containers because of the ease of storing on overseas shipping routes. Twenty containers can be stored in the space formerly occupied by one empty metal container.

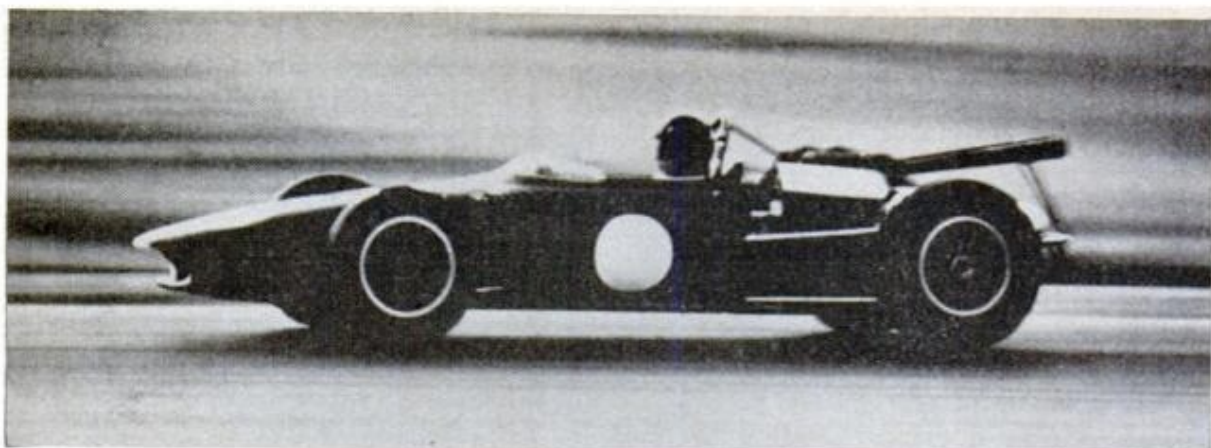

SCREAMING DOWN STRAIGHT at Riverside, Gurney's American Eagle speeds through its final test runs

The best driver in the whole world

Stocks, Formula One, Indy or sports cars—Dan Gurney has won races in all of them. His current ambition: To build the world's finest racing cars

By THOMAS E. STIMSON
PM's Western Editor

NO RACE DRIVER LACKS GUTS, but few can push a car to its absolute limits, lap after lap after lap. Such driving requires more than skill and courage. It demands a constant, instinctive awareness of that thin edge of top performance, beyond which the car becomes a projectile hurtling out of control. All great drivers possess this instinct to some degree. Dan Gurney has it in almost pure form.

Yet sprawled in his easy chair and pitching raisins into a big silver trophy cup across the room, Gurney hardly fitted my picture of America's top international race driver. I'd expected tight, clipped phrases and that stiff air of self-importance affected by some of his colleagues. Instead, he was completely relaxed, and his conversation had a pleasant easy flow about it.

Actually, Gurney isn't as easygoing as he appears. He couldn't be and still keep up with all his activities. I spent an hour with him in Los Angeles on a Friday. That weekend he was in Las Vegas, Nev., watching team driver Jerry Grant in the Gurney Lola, leading a road race until the gearbox failed. Monday, Dan was back in Santa Ana at All-American Racers, Inc., the California nest where he has been hatching his American Eagle racing machines, and where I caught up with him for a fast lunch. Tuesday he had a date at Riverside to test his personal American Eagle Indy car. Wednesday he took off for England where the 12-cylinder engines for his four three-liter Grand Prix cars were coming along. Five days later he was due at Indianapolis to start tuning the Indy cars. This schedule is par for the course.

Gurney is in a hurry because he has a job to do: to build and drive the best race cars the world has ever known. It's a personal thing with him. He has driven the world's best and found them wanting.

He has the background to do it, too. Big Dan (six feet three and now 35) is the world's only quadruple-threat driver. He has won Grand Prix events on both sides of the Atlantic and ranks fourth internationally in total points scored

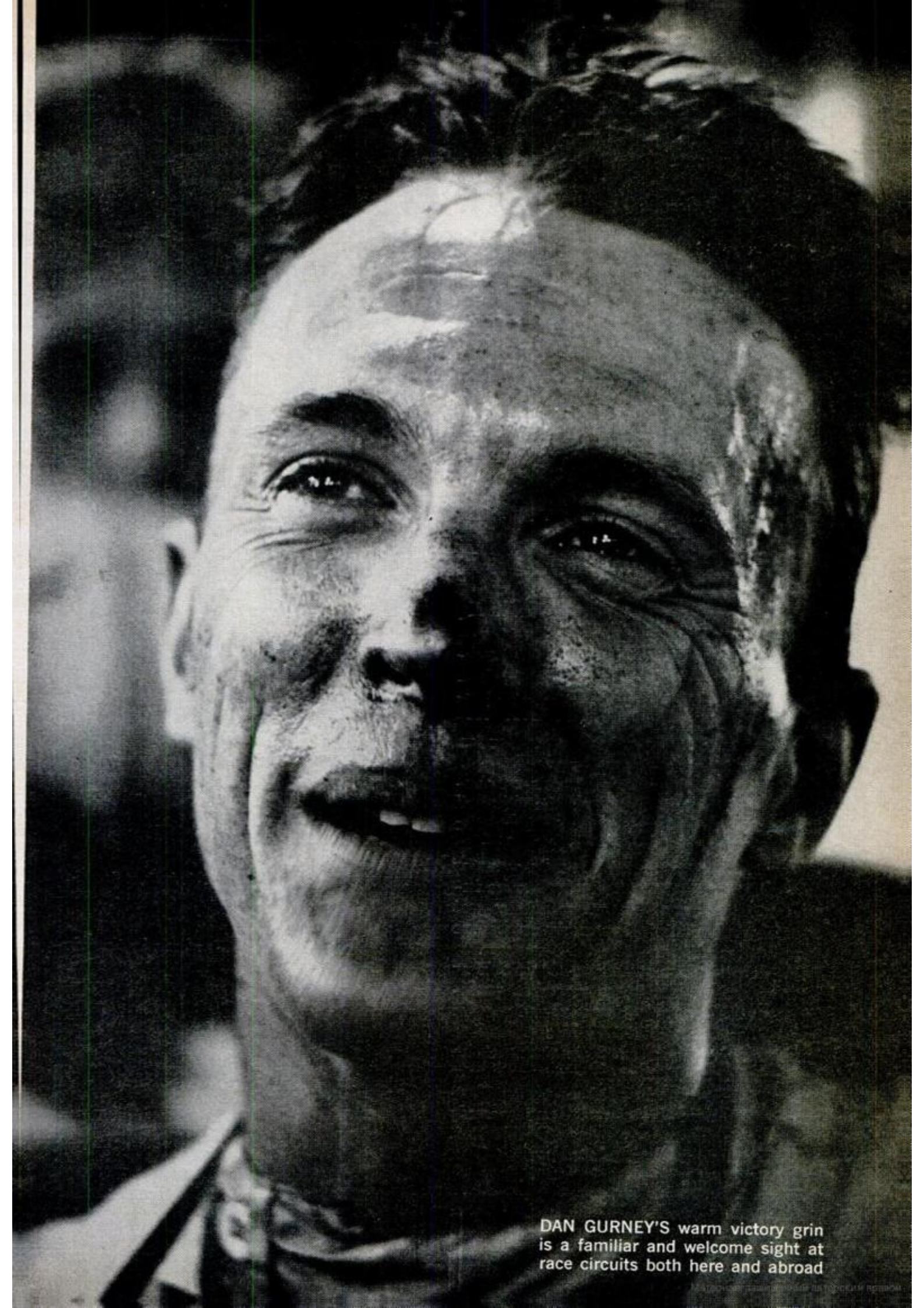

DAN GURNEY'S warm victory grin is a familiar and welcome sight at race circuits both here and abroad

At Sebring . . .

"He struggled for 90 seconds before he got his car started, and 62 other cars were out of sight when he took off. He passed 27 of them before the end of the first lap."

over the past five years in Formula One racing. He virtually "owns" the Riverside 500 stock-car race, which he has won in a Ford the last four years in a row.

He has started in the front at Indianapolis and finished second this year in both the Daytona Continental and Sebring 12-hour road races in the big Shelby-American Ford Mark II GT, which he shared with Jerry Grant.

There's another side to Gurney that isn't generally known, though it's a big factor in his driving competence. This is his engineering savvy. It's generally conceded that he's the one man responsible for the Indy rear-engine revolution.

Last spring while Jerry Grant was practicing in the Lola at Las Vegas and Dan was still at the factory, a desperate long distance call told him that the Lola's engine was blowing so much oil out of its breather tubes that the crankcase was running dry. There wasn't time for an engine rework. "What can we do?"

Overnight Dan fashioned an air-oil centrifugal separator to collect the oil, and added an electric fuel pump to force the oil back into the crankcase. He flew to Vegas with the device. With no generator in the car, an extra battery had to be installed to power the pump. They got everything working five minutes before race time, and it was the right answer.

At Sebring, Fla., this year a big, new Ferrari had set a new lap record in qualifying—a full six seconds quicker than the best of the Ford GT Mark II rear-engine jobs. Gurney took the Ford out on the track and decided that its spring rate was too soft. This was changed, and now Gurney could turn the circuit four seconds faster, but still not as fast as the Ferrari.

With only an hour left to qualify, Dan decided that the car might stick better to the track if a new design of anti-sway bar were installed. Brackets were hastily made for it, the bar installed and with



AMERICAN EAGLE, which ran at Indy, is a simplified Formula One car designed just for the old Brickyard

this improvement the Ford made the circuit one second faster than the Ferrari, winning the coveted fastest qualifying time.

Racing writer Max Muhleman, now associated with All-American Racers, tells what happened during the 12-hour contest. "Although Dan was first in line for the Le Mans-type start, he struggled for 90 seconds before he got his car started. Sixty-two other cars were out of sight when he took off. He passed 27 of them before the end of the first lap. An hour and a quarter later he was in the lead, and he and co-driver Jerry Grant were gunning through the pack time and again.



SPORTS CAR RACE at Riverside in 1965 saw Gurney burning up the track in a McLaren car. Dan started his racing career in such sports car events, campaigning an old Triumph roadster that he bought on time



STOCK CAR VICTORY at Riverside last year made it four in row for Gurney. While the American Eagle venture is taking up a great deal of his time, he still plans to drive in as many events as possible

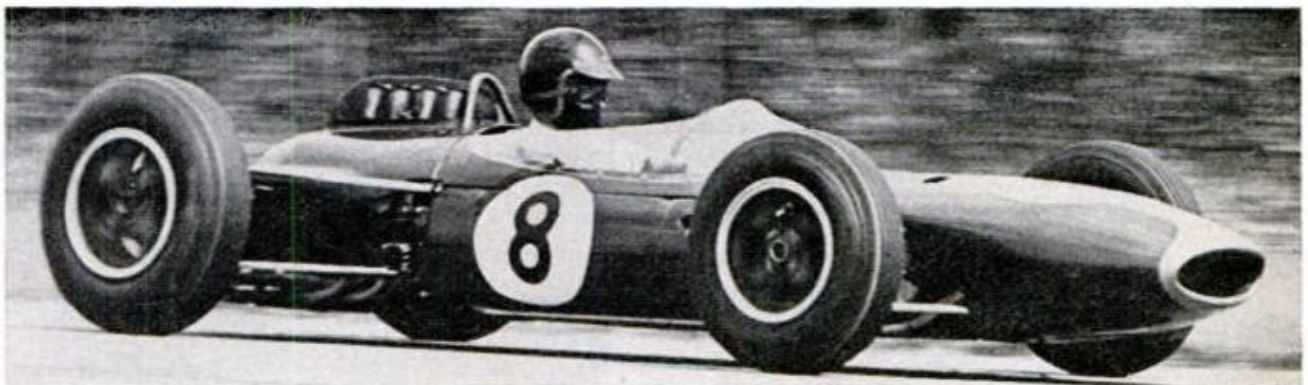

GRAND PRIX RACING has been almost a European monopoly up to now. Gurney, shown here in a Brabham at Rheims, plans to change all that with his American Eagles, powered by 12-cylinder engines

"With less than five minutes remaining, the Gurney Ford was more than five miles ahead of the fastest field in Sebring history. Then up bobbed the Gurney jinx. A sudden engine failure stopped the car 300 yards short of the finish. Dan got a course marshal's okay to push the car across, and meanwhile Ken Miles in another Ford went by twice and won. It was understood that Dan had won second place until officials decided there was a rule against pushing a car and disqualified him."

Dan didn't start his racing career until he was 24 years old, after he returned

from Korea. He bought a Triumph (on time) and placed close to the front in a couple of sports-car races. Then he traded the car as down payment on a faster Porsche. After a lot of practice on lonely roads back of his home town of Riverside he won first-in-class in several races. Meanwhile he was setting new lap records at a number of tracks.

When he began driving bigger, more powerful cars for other owners, he quickly became known as a driver who could take an also-ran and bring it in first. Some of his wins were in a Ferrari, and

(Please turn to page 182)



Fiberglass "survival capsule," a new concept in lifeboat design, is a flattened sphere large enough to hold 40 people. The 3000-pound craft is powered by a 40-hp diesel which enables it to cruise for approximately 30 hours at about four knots. Colored a bright orange, the capsule can be hoisted or lowered by means of a single steel loop atop the dome—which makes it possible for a helicopter to retrieve a whole boatload of survivors without transferring them.



Spiral pumps, the largest of their type in the world, lift sewage water from Germany's Rhine River to a purification plant. Driven by electricity, each unit is 10 feet in diameter and almost 40 feet long. Together, the pumps can lift approximately 90,000 cu. yds. of water per hour.



From farm to battleground: An ordinary crop sprayer has been turned into a tear-gas blower by the Army. A soldier, carrying the 32-pound device on his back, seals the mouth of a tunnel with his poncho and pushes a cloud of tear gas into a Vietcong hideout.

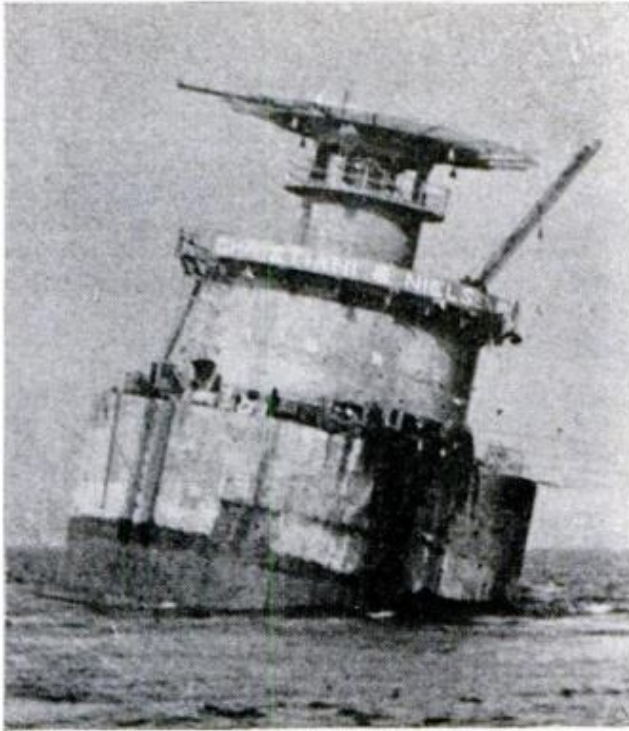

Transplanted lighthouse, built for the Irish by Danish engineers, rests in Dublin Bay. The unique lighthouse couldn't be built in the rough waters of the bay, so it was constructed in calm, shallow water, and floated out to the permanent site. There the foundation was sunk and secured, and the tower was raised and fixed in position.

AUGUST 1966



Corrugated-metal house, made of 114 steel plates formed into an oval shape, has been constructed in Tokyo. The unusual two-level dwelling has no foundation but rests on a bed of sand, because of the hazard of earthquakes.



Built from the top down, a London office building rises—or sets—in the heart of the business district. The elevator and stair shafts were built first, then an overhanging platform was erected and the framework and floors were constructed from the top floor down. When the building is completed the platform will be removed.

The ship you drive with one finger



SLIGHT TURN OF WHEEL on bridge console (at helmsman's right) instantly slows or speeds up the ship

She looks like any cargo ship — but what a difference! The *American Racer* has a built-in electronic brain that even keeps the log; one man can maneuver her, computers do the rest

By ROBERT P. CROSSLEY

I WASN'T ON HER THEN, thank God. She was new and untested and coming home from Rotterdam in the middle of January. The 60-foot waves she ran into off the Bay of Biscay were the highest her skipper, Capt. Richard O. Patterson, had seen in 43 years at sea.

The *American Racer*, pride of United States Lines' fast cargo fleet, was virtually hove to. Third Mate Richard Moody stood by the bridge console, one finger on a small wheel mounted on its top. The shaft rpms were down to 40—just enough to keep the ship's bow into the sea. The captain watched the angry waves. When he saw a really big one coming he'd call an order. Not "Slow ahead" or "Dead slow," but "Down five revolutions" or "Down 10 revolutions" or some other minutely calibrated decrease.

The mate would flick the wheel, and instantly the ship would respond. No lag while engineers reacted to a telegraph signal. No feverish opening and closing of the throttle down below. Just a smooth, quick response like that of a finely tuned automobile. As soon as the wave passed, the revolutions were re-

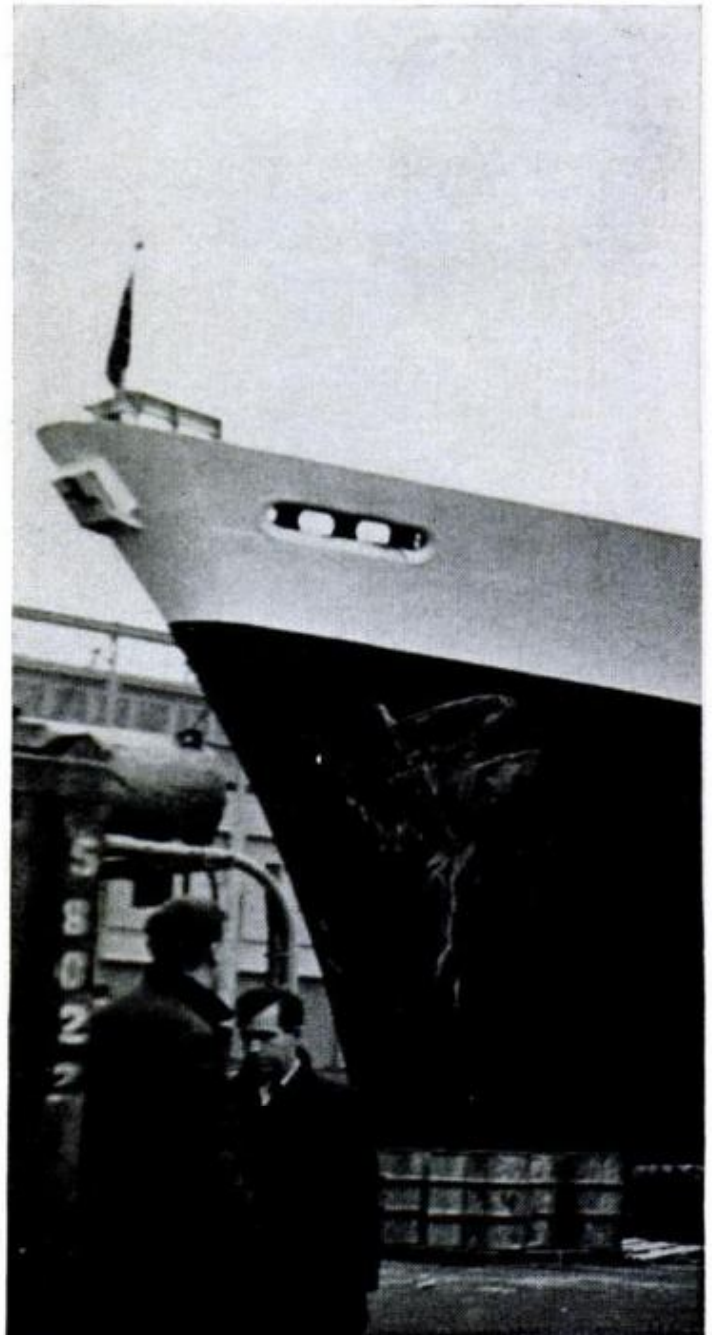

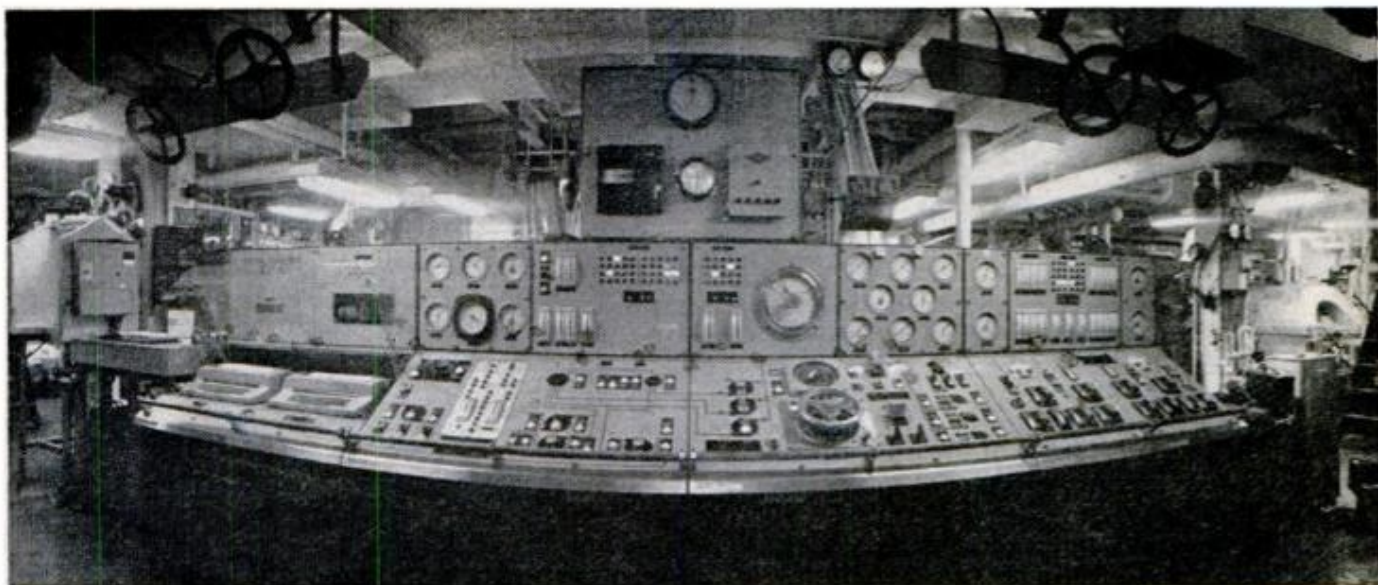

HEART—AND BRAIN—is 17-ft. engine room console, providing remote control for engines and boilers. Its front is straight, appearing to be curved because of distortion of special wide-angle camera used

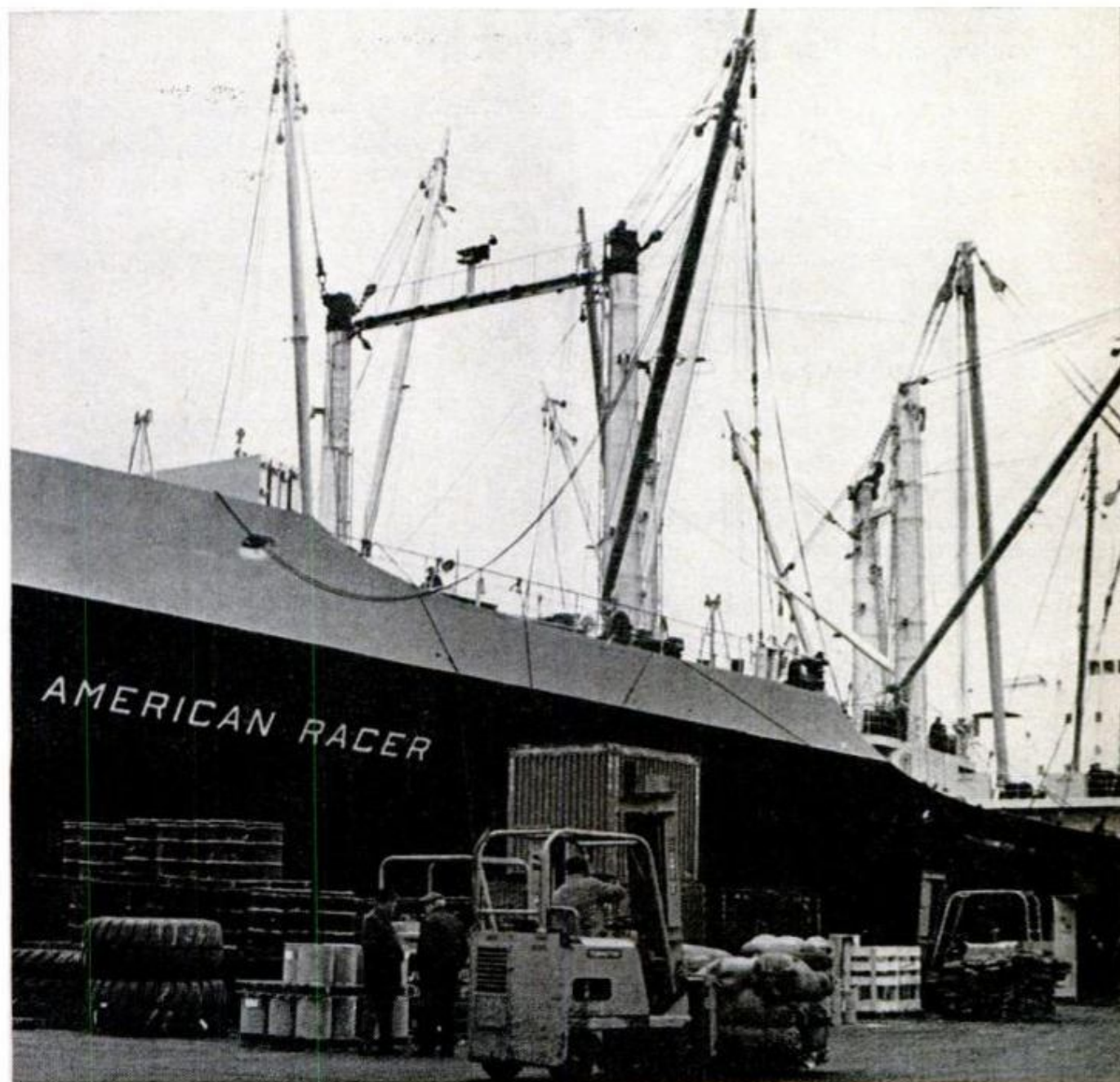

stored just as quickly, just as smoothly.

Such delicate control of speed made a world of difference. The *American Racer* escaped much of the beating other ships took in the same storm.

"On all previous ships," Capt. Patterson was telling me now, "by the time you notified the engine room and they could reduce speed for a big wave, it was too late. And when a thousand tons of water comes aboard, you know it."

Well, this wasn't the Bay of Biscay; it was Massachusetts Bay. The waves weren't 60 feet high. There had been only a little swell coming out of Boston. Soon we ducked inside the protective hook of Cape Cod. The lights of Plymouth sparkled off to starboard; to port we could see the brightly illuminated Pilgrim Tower at Provincetown, punctuated by sweeps of the Provincetown light.

The coastal pilot stood by the pilot-house window, giving only an occasional course change to the helmsman. It was his first ride on the 22-knot *Racer*, and he was feeling his oats about passing two freighters that had left Boston ahead of us.

I gazed out over the foredeck—305 feet—long as a football field, from the bridge to the bow. The massive king posts stood like ghostly goalposts in the light of the half-moon, their huge booms still erect, but swung in. The 70-ton, heavy-lift boom, one of the largest on any ship, lay in its cradle, a down-in-front gesture to give the pilot a better view.

I had been in the pilot house of big ships before, but this was the *American Racer*. She was different. Her bridge was different. Her engine room was different. So were her booms and hatch covers and a lot of other things. She was the first dry-cargo ship ever built fully-automated from the keel up in an American yard. I was aboard for *Popular Mechanics* to find out how she worked.

We sailed from Boston at 1900 (7:00 p.m.). Capt. Patterson suggested I watch the action in the engine room, usually the busiest place when a ship is getting under way. As I descended iron ladders, it looked no different at first from other engine rooms. White bulkheads, a maze of pipes and machinery. Then I saw it. The console. General Electric calls it the "Central Operating System," and that pretty well describes it unless you went to M.I.T.

Seventeen feet long, higher than a man's head, with one bank of indicators at desk height and more on a vertical panel behind them, it is the heart—and brain—of the whole ship. The *Racer* was designed so one man on the bridge could maneuver her with no outside help; this is where his commands are carried out. Not by engineers rushing around to open throttles by hand, put out boiler fires, and check a hundred gauges, but by the console. Two engineers, an officer and an unlicensed man, stand regular watches, but they don't have much to do.

First Engineer George Cain started to

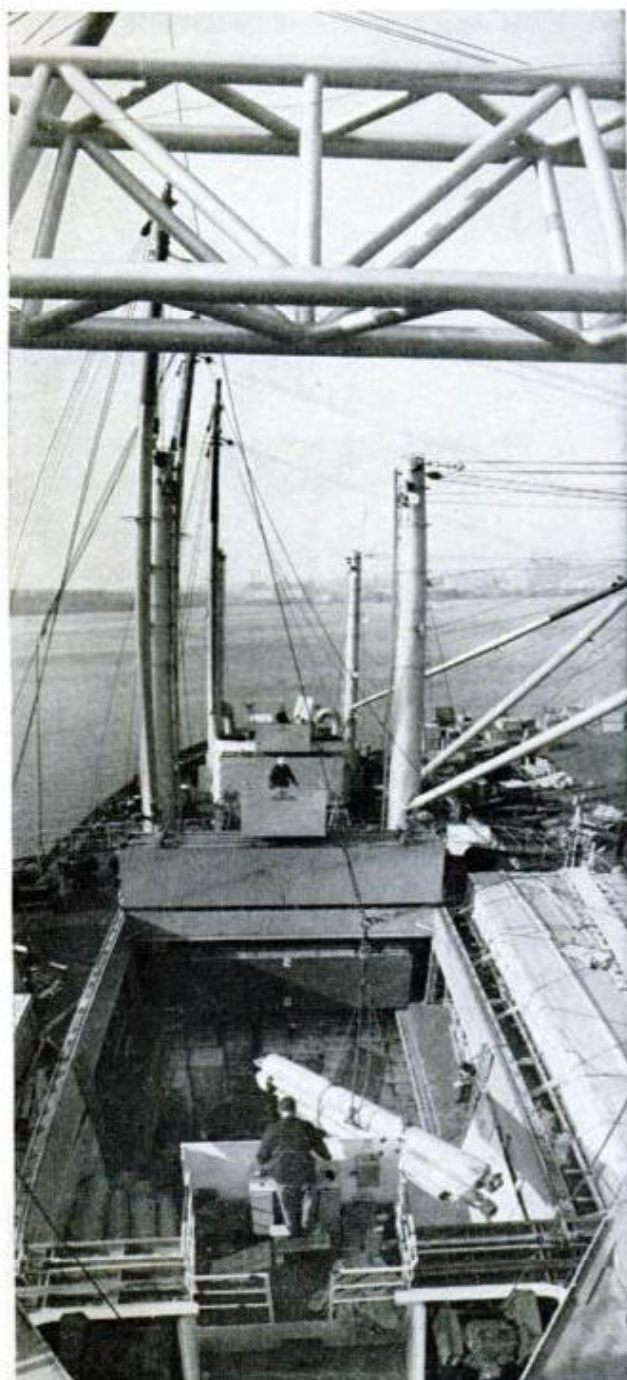

UNLIKE CONVENTIONAL RIGS, winch console gives the operator complete control of booms. With no hand power required on lines, cargo handling is speeded

explain the console. Suddenly a horn shattered the air like an angry bus in a tunnel. I jumped.

"Don't worry," he said. "The automatic flame scanner just put out a burner."

I tried to take a picture of the console, but I couldn't get it all in one shot. At the extreme port end, two IBM typewriters were clattering away under glass. I watched the one farthest outboard—the "bell-logger." Every time the mate up on the bridge turned his little wheel the keys clicked into action, recording every change in engine speed, ahead or astern. No one has to keep a written log of orders

from the bridge.

The inboard typewriter wasn't quite as busy. Once an hour it automatically types out a "data log" of temperatures and pressures at 20 key points. If the engineer wants to know how hot or how high any of them are right now, he can push a button and get an immediate reading.

The console provides remote control of the engines, the boilers and auxiliary equipment throughout the engine room. All major valves and pumps—all over the ship—are controlled by lighted push-buttons. Near the center of the lower pan-

(Please turn to page 188)

VESSEL		S/S AMERICAN RACER		VOYAGE		6 C/W		BOSTON MASS.												DATE				
TIME	STBD SUPER 31M PISC	PORT SUPER 31M PISC	MAX TEMP 31M STG HP PISC	MAX CONSUM AC KAC	AIR CONSUM IN KAC	SEA WATER °F	STBD B/L SUPER OUTLET °F	PORT B/L SUPER OUTLET °F	MAIN SW °F	STBD DESEUPER °F	PORT DESEUPER °F	STBD STM AIR IN °F	PORT STM AIR IN °F	STBD STACK GAS °F	PORT STACK GAS °F	F.O. PRESS STBD B/L PISC	F.O. PRESS PORT B/L PISC	F.O. TEMP TO BURNERS °F	PROPELLER RPM	FEI	DISTILLER WATER GAS SAKE	FUEL OIL B/LS CONSUMED	MAIN PROPELLER REVOLUTIONS	TOTAL KW HOURS
1300.0	001	046	002	00.5	29.5	056	230	721	205	271	542	249	278	244	283	005	086	194	002	487				
1400.0	004	044	003	00.5	29.5	056	223	711	201	272	541	249	278	236	282	005	086	197	002	487				
1500.0	003	044	003	00.5	29.5	056	215	712	197	272	541	249	278	229	282	005	085	198	002	487				
1600.0	003	043	003	00.5	29.4	057	210	718	194	272	542	249	278	224	283	005	089	196	002	487				
1700.0	003	043	003	00.5	29.5	056	205	714	191	272	542	250	279	220	282	006	084	196	002	487	2484320		0568	
1800.0	003	043	003	00.5	29.5	056	201	726	195	271	542	249	278	216	283	005	086	199	003	488				
1900.0	003	043	002	00.5	29.5	056	199	727	211	271	542	248	278	212	284	005	083	198	003	488				
2000.0	003	043	002	00.6	29.5	057	177	728	218	271	542	249	278	209	284	005	087	195	002	488				
2100.0	002	046	003	00.6	29.5	058	155	731	221	271	542	248	278	206	284	005	084	196	003	487	2484760		0569	
2200.0	003	043	002	00.5	29.5	057	137	729	224	271	542	248	278	204	284	005	089	199	002	487				
2300.0	003	042	003	00.5	29.5	057	126	724	220	271	542	249	278	202	284	005	083	197	003	488	2485110		0569	
0000.0	003	043	003	00.5	29.5	056	115	732	213	271	542	249	278	200	284	005	083	195	003	488				

AUTOMATICALLY TYPED LOG shows temperatures and pressures at 20 key points, which appear at top of strip

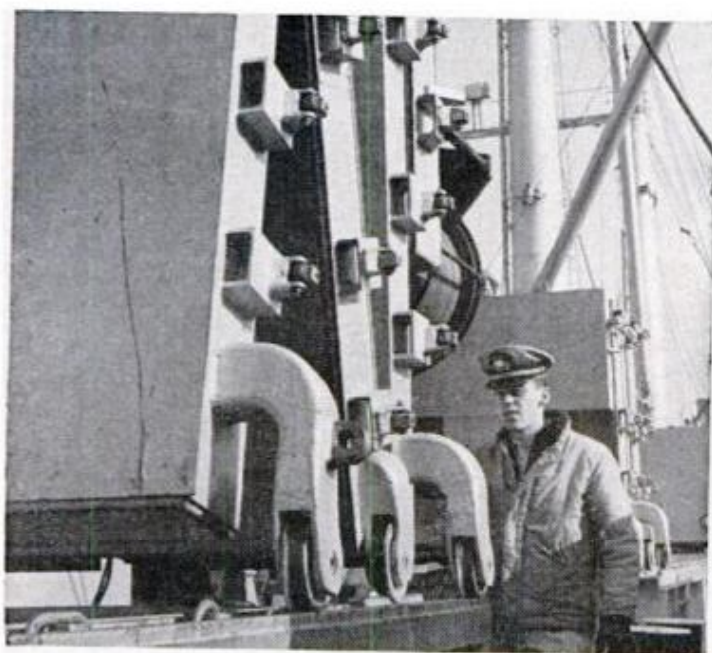

NO SWEAT NEEDED to open or close Racer's hatches. The covers ride on tracks and fold into sections as they're opened. Hydraulic rams do all the work

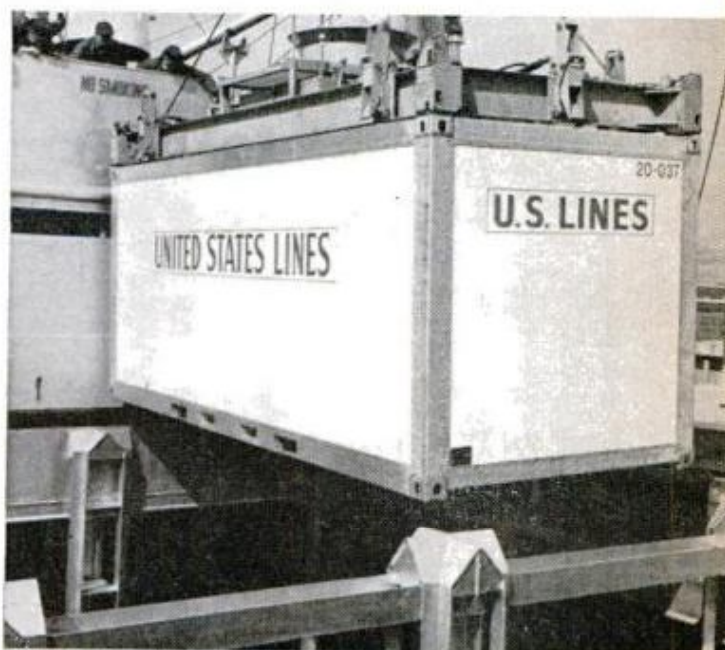

NEW METHOD OF CARGO HANDLING—containerization—was recently installed. Big container is packed by shipper, trucked to ship and taken aboard intact

More comfort for you

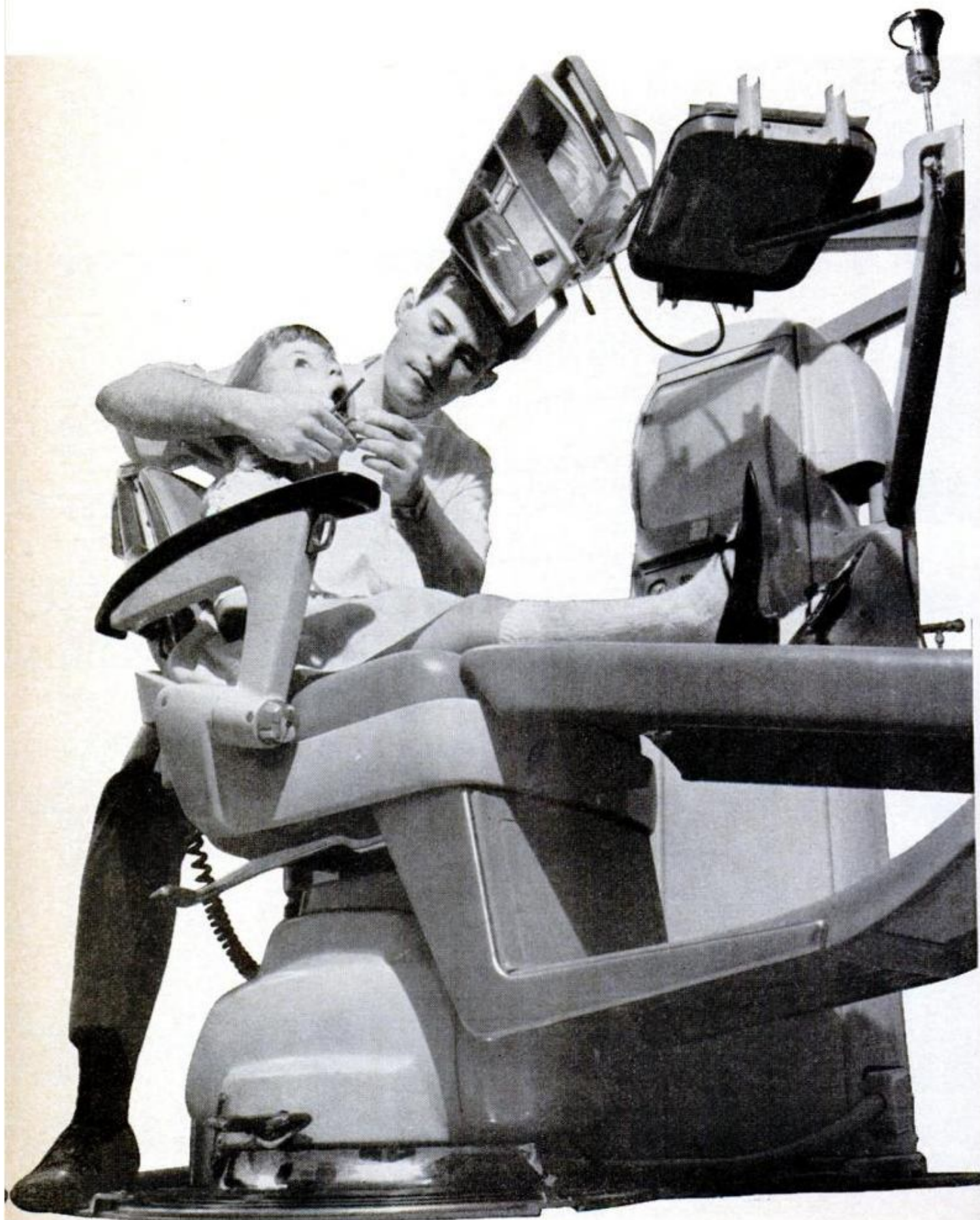

at the dentist's

Research is providing new, effective weapons against decay and gum disease. Scientists have even made startling progress in replacing lost teeth with transplants

By ROBERT GANNON



IF YOU HAVEN'T VISITED THE DENTIST for some time, you might be in for a surprise. The upright porcelain chair—with the steel-cabled praying mantis looming threateningly over it—is vanishing from the scene. Today's chair is a streamlined affair, and drills and other instruments are housed in a small compartment that is an extension of the dental tray. The treatment room itself, with equipment built in or concealed in cabinets, may look deceptively like a small kitchen—and cost as much as a small house.

What it all means for you is more comfort and more effective dentistry. The new look is a surface indication of vast changes going on behind the scenes. Equipment has just passed through a major revolution and, if research now under way pays off, cavities may be a thing of the past and gum disease may be as outdated as beriberi. If you accidentally lose a tooth, dental wizards may grow you a new one.

The cause of dental *caries*, technical name for tooth decay, used to be simple: Your teeth occasionally rotted. But now things have become more complicated. Microbiologists believe that certain colonizing streptococci change carbohydrates (mainly common sugar) to lactic and other acids, and these acids dissolve portions of the teeth if held tightly to the surfaces.

A substance called *plaque* does this holding nicely. Plaque is mainly a mass of bacteria, but it also contains components of saliva and food. It's the slimy stuff you can feel (if you haven't brushed since morning) along the front surfaces of your upper

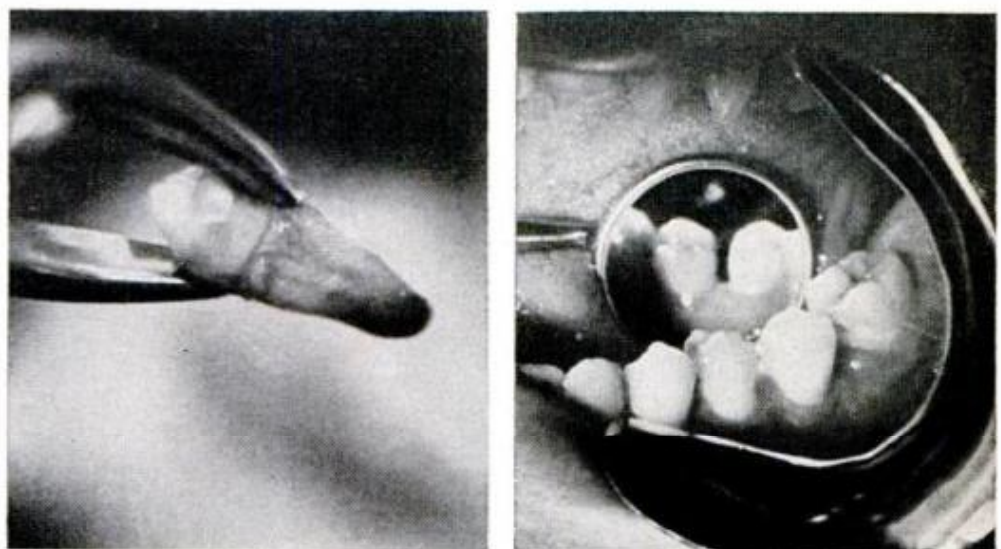

EXTRACTED FROM DONOR'S OVERCROWDED MOUTH, tooth is quickly transplanted in jaw of second patient. Four weeks after the operation, the tooth (second from right) is fairly firm in its new socket and functions effectively in chewing



NEW PANORAMIC MACHINE (left) takes picture of whole mouth in one exposure as X-ray tube swings around patient's face. Thick feature in center of film is spinal column. Camera angle is chosen to make patient's front teeth appear on either side of spine



PLASTIC MOUTHPIECE holds fluoride gel against teeth of children in cavity prevention experiments. Tiny mouthpiece shown next to it is used in animal tests

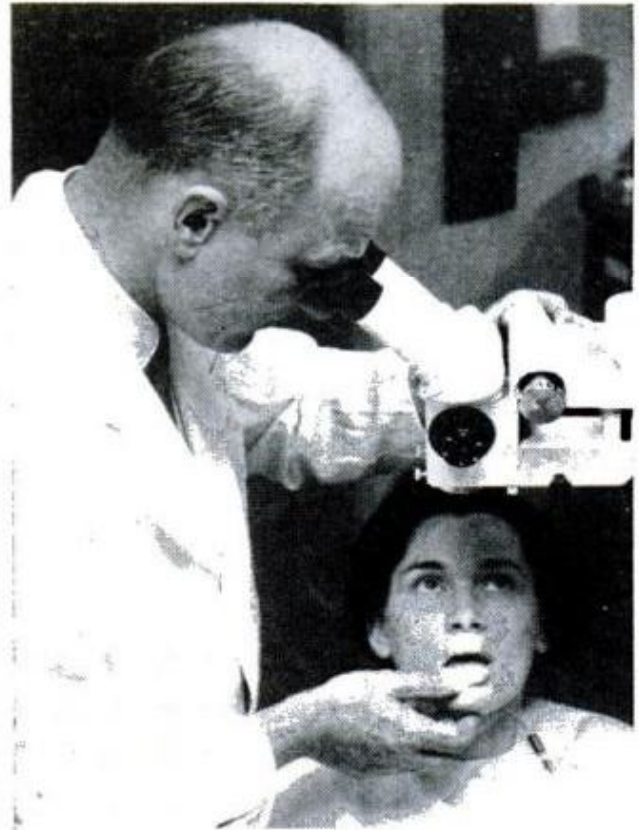

LESIONS TOO SMALL to see with naked eye are examined with microscope at the National Institute of Dental Research. Instrument magnifies 50 times

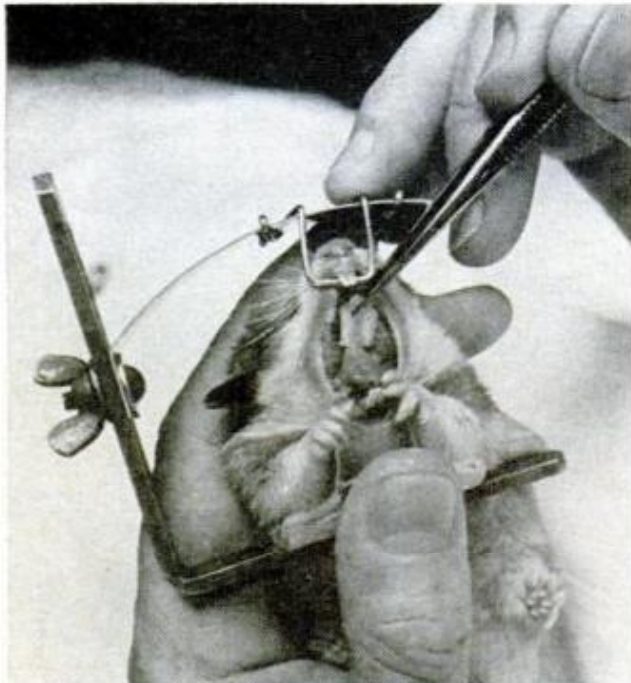

SWABBED WITH CHEMICAL, plastic is forced against hamster's upper teeth. Though in place for only a few minutes daily, mouthpiece retards tooth decay



PLASTIC-ENCAPSULATED RADIO TRANSMITTER is used to get information on nature of the chewing contacts between a patient's upper and lower teeth

teeth. Other factors involving decay are tooth shape and arrangement, inherited tendencies toward decay, how much "scrubbing food" (such as apples and carrots) is eaten. Such things as tooth "softness" and pregnancy used to be blamed for decay, but no longer.

Of the hundreds of different kinds of acid-producing bacteria found in the human mouth, few cause caries. Nobody has yet pinpointed the specific culprits for certain, but when the bugs are identified, scientists hope to develop a vaccine—a substance made up of dead or weakened decay-causing bacteria that tricks the body into manufacturing disease-fighting antibodies.

First, though, a major trouble must be overcome. Even if massive amounts of antibodies can be produced by the system, the only way to get them to the surface is through the saliva (ordinarily, antibodies are carried by the blood), and the saliva is a very poor transporter.

Penicillin provides clue

Quicker results may come to those dental researchers working with antibiotics. They've noticed that children treated daily with penicillin over a period of months (for, say, rheumatic fever) have a much lower rate of decay than average. So the tooth sleuths are trying to find selected antidecay antibiotics that are potent and have no side effects—such as buildup of immunity.

At the moment, however, a purely chemical approach seems best of all for fighting decay. Already the use of fluorides—in toothpaste, municipal water, through dental applications and home treatment—has suppressed decay in children to an impressive degree, probably by somehow making the enamel more resistant to acid.

In Buffalo, Boston and a few other cities, in a long-term experiment being conducted by the National Institute of Dental Research (NIDR), school children are globbing cherry-flavored fluoride gel onto molded plastic plates, then snapping the soft plastic into their mouths. The mouthguards hold the chemical tightly against their teeth.

It's too early to say for sure, but results so far look good, believes Dr. Paul H. Keyes, who is directing the research. Eventually, he says, a mixture applied to children's teeth with the applicator, worn

for 5 or 10 minutes every day, might contain: (1) fluoride, (2) antibacterial agents, (3) stains for disclosing plaque and (4) mild abrasive agents and detergents.

Encouraging work, too, is being done with vitamins. When Dr. Samuel Dreizen of Northwestern University Medical School gave lozenges of vitamin B-6 three times a day to children, they showed a 40 percent reduction in cavities. Now research is under way to find out why.

Even if a 100 percent effective anticavity chemical or vaccine is developed tomorrow, though, we'll still be faced with that other bugaboo, periodontal disease. For the most part, periodontitis (the collective name for various gum diseases) is painless—and so people don't know they have it until the dentist, while yanking, tells them. It causes more tooth loss in adults than all other causes combined and, depending on whom you talk to, anywhere between 70 and 94 percent of Americans past 35 have it to some extent.

Here's what happens:

1. Plaque forms along the gum line and becomes hard and crusty. (Then it's known as tartar by the public, *calculus* by the dentist.)

2. Calculus works down under the gum.

3. The gum becomes tender and pulls away from the tooth. Food particles wedge down and irritate.

4. A newly found bacterium—so new it's still unnamed—begins to multiply in the pocket. It produces toxins that eat away at the connections between tooth and gum and bone.

5. The calculus continues to build, the infection gets worse, the tooth support breaks down and the tooth comes out.

To treat gum disease in its initial stages, a dentist scrapes the accumulating calculus away; in advanced stages, part of the gum must be removed. "It's like a sliver under your fingernail," explains NIDR epidemiologist Dr. Loren Mills. "If you don't remove it, it festers. And if you can't get at it you must cut through the nail. That, essentially, is the treatment for periodontal disease."

Gum disease cure on the way

In the offing may be something better: a couple of wonder-type drugs that attack plaque bacteria. One of these, Vancomycin, is being tested on human beings by

(Please turn to page 198)



Shocking act produces "illuminated" music. Wearing a suit covered with electric light bulbs, an Englishman named Tom Platt allows 230 volts to travel through his body as part of a nightclub act in which he plays spoons electronically. The lamps light up as the spoons make and break the circuit. Platt attributes his remarkable resistance to electricity to a 5000-volt shock he received 24 years ago, while working as a shipyard electrician.

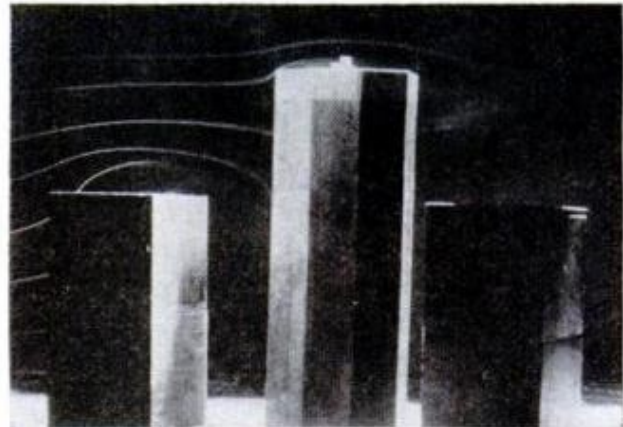

Helicopter landings on top of the PanAm building in New York City are made safer by a system of louvered aluminum vanes installed around the perimeter of the roof (photo, left). The vanes control air flow over the roof by catching turbulent currents and releasing them in a smooth flow. The system will allow safe operations in steady winds up to 60 mph and gusty winds up to 50 mph. Center building in the wind-tunnel study (above) has vanes that smooth out air currents.

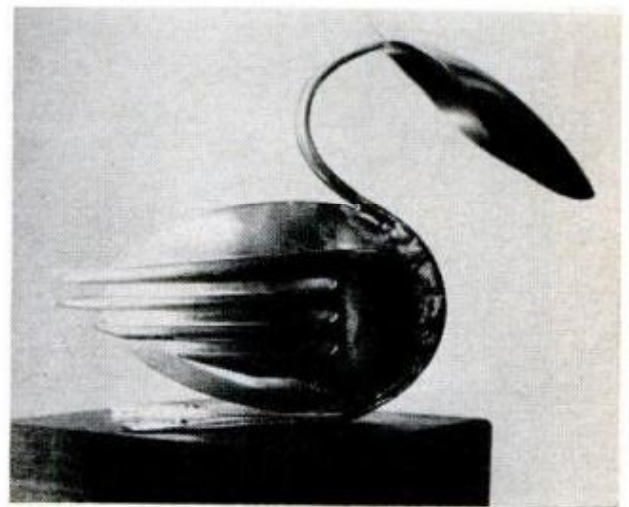

Spoon-fed artist. Making his living from spoons, which he welds together (left) into pieces of sculpture, Raul Zuniga of New York says he uses some 10,000 spoons a year—plus other tableware—in his work. At upper right, he holds the same type of pitcher that formed the bird's head. At lower right is another of his fork-and-spoon creations.



Floating tank, the LCM Monitor, carries more firepower than any other assault ship now used in Viet Nam. Its usual armament is a 40-mm cannon, two 20-mm cannons, a 50-cal. machine gun and an 81-mm mortar. It's capable of a speed of eight knots.



Giant claw can pick up a piggyback trailer and set it on or off a flat car within two minutes. The mobile crane, which rolls on its own wheels, can handle trailers up to 40 tons. The "Travelift" crane, which moves on rubber-tired wheels, is operating in the Chicago and Los Angeles terminals of the Santa Fe Railway.

SCUBA-DIVING FIRE-EATERS





TYPICAL DOCK FIRE was this one at Tacoma in 1963. Many believe scuba firemen could have controlled it. Swimming into the maze of a blazing wharf, these Los Angeles scuba firemen battle fires where they can best be fought—from below. Scuba men have proven themselves by stopping pier blazes in record time

BY BOB GRANT

A WHARF FIRE is a modern-day approximation of Dante's Inferno. A night-marish maze of heavy wooden timbers crisscrossed by thick stringers and decked with four-inch planking and a layer of asphalt, a typical big-city wharf is a breeding place for fire.

The Tacoma, Wash., dock fire in 1963 was typical. Started by a severed electrical connection, it grew unnoticed beneath the decking. When the first firemen arrived it was still a moderate blaze, but it couldn't be reached. It was impossible for fireboats to get water under the pier. Firemen had to use jackhammers, axes and crowbars to chop through the asphalt and decking, and by the time this was accomplished the fire was raging out of control. Before it was extinguished, Pier 7 had taken the life of Battalion Chief Arthur Strong, hospitalized 17 other firemen, destroyed one fire truck and damaged another, set a ship afire and inflicted one and a half million dollars in damage to the pier.

In 1960 the Matson Dock fire in Los Angeles took 24 hours to extinguish, but that fire was a turning point, a grim lesson that instigated the use of scuba divers to fight fires.

Started by Assistant Fire Chief W. W. Johnston, an experienced skin diver, the Los Angeles fire department began training a team of expert divers in new techniques of fighting a fire under a wharf.

They received their baptism in Sept., 1963 when they were called to battle a fire under the Catalina terminal pier. Three divers took hoses under the structure, and a half hour later the fire was out and they were on their way home.

In those days the scuba firemen, wearing "hard hats" in addition to regular wet suits, would simply take the hoses under the pier and lash them to a piling. But this method limited their mobility, so they invented a floating monitor to support the nozzle of the hose.

They started with an inner tube, then built a balsawood model. This gave way to a hollow metal tank which held the nozzle straight in the air. A standard 2½-inch line supplied water for the nozzle and for an underwater jet which was used for propulsion and steering. But this unit was heavy, and the underwater jet made it difficult to lift over obstacles in the water. Much lighter in



GASOLINE-LADEN MARKAY exploded at Los Angeles before the scuba unit was formed. The ship burned for three days, a dock for two



OVER THE SIDE go Los Angeles scuba firemen in a practice session. To fight a fire, they would proceed in the water, directing their monitors toward the blazing pier or ship

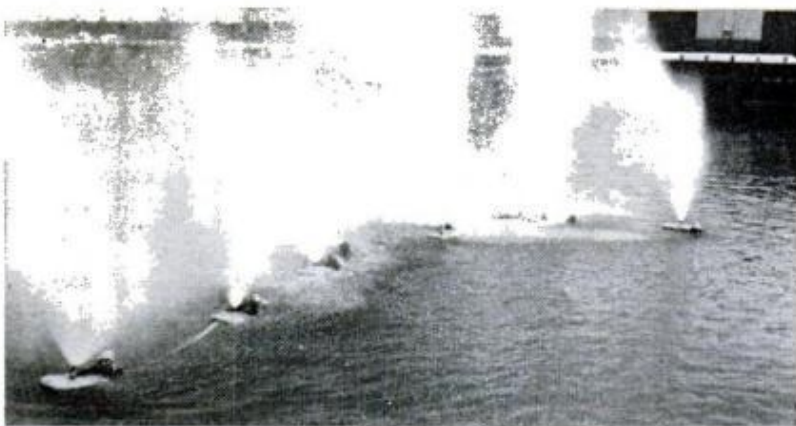

WATER CURTAIN results when monitors are strung together, forming an effective fire barrier when taken under a pier. Each monitor delivers 440 gallons of water a minute

weight, the newest model is constructed of very dense polyethylene foam covered with two layers of bright yellow fiberglass. It has no valves or moving parts, and the underside is perfectly smooth. Two handholds are recessed in the sides for easy lifting.

A straight copper pipe runs through the float, with a "T" connection in the center for the nozzle. A 2½-inch fitting on each end allows monitors to be used individually, in pairs, or linked together by a feed hose to form a chain, which can create a curtain of water beneath a burning pier. When dismantled the recessed nozzle connection permits easy stacking. The monitors weigh only 58 pounds, including the 11-pound adjustable spray nozzle, and are light enough for one man to get it in and out of the water with ease.

To move forward the diver simply weights the rear of the monitor with his body, thus squirting water from the nozzle back over his shoulder to drive the unit ahead. He goes into reverse by sim-

ply shifting his weight to the front of the unit.

The speed and efficiency of the scuba team was demonstrated in a recent test in which two divers placed a pair of monitors into action beneath a pier one minute and 15 seconds after entering the water.

Although they generally operate off a fireboat, the monitors can also be powered from land-based pumper trucks. Each monitor can deliver 440 gallons of water per minute at 100 pounds nozzle pressure.

There is still considerable debate over whether scuba firemen could have averted the Tacoma Pier 7 disaster, but it is a foregone conclusion that this method of attacking a wharf fire is effective. Since the introduction of this unit there has not been a major pier fire in Los Angeles, which has dock facilities stretching over 28 miles of waterfront.

Twelve major cities in the United States and British Columbia now have scuba fire-fighting units, and each year the list expands.

★★★

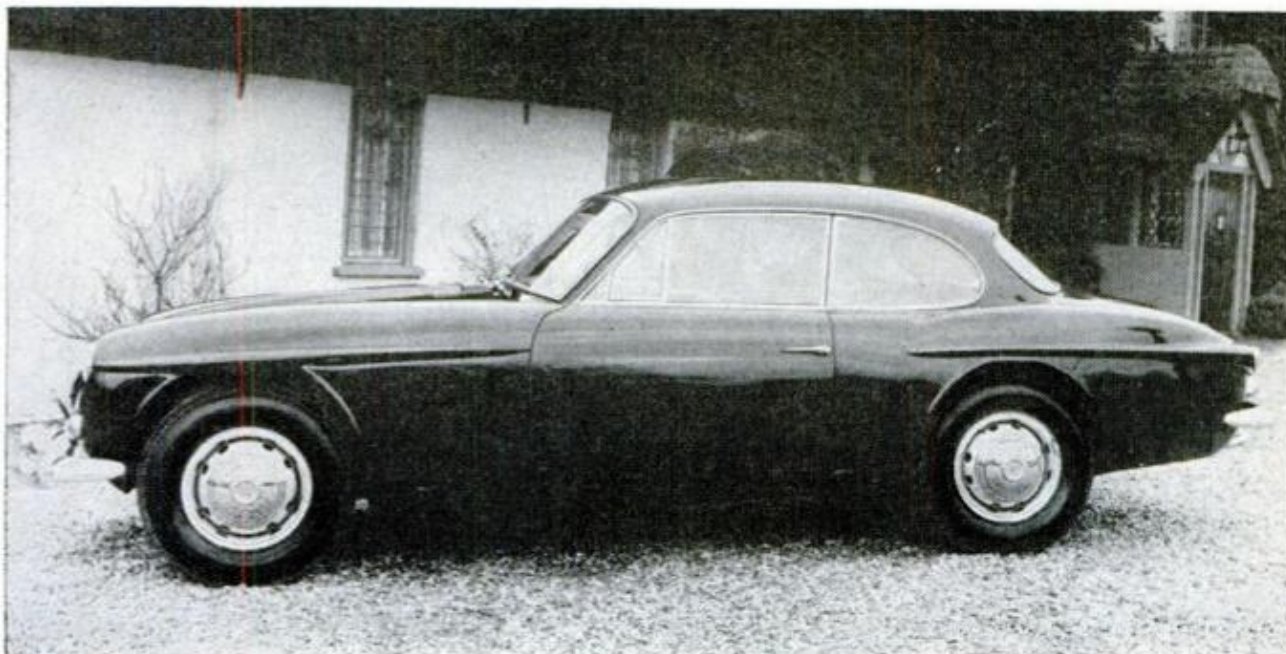

Four-wheel drive and aircraft-type antilock brakes mark the new Jensen F. F. (for Ferguson Formula), a Chrysler-powered 140-mph British luxury sedan based on the successful Jensen Mark III. Due in the U. S. later this year, the car is said to be virtually skidproof. Torque to all wheels allows variations in tire diameters, cornering rotational speeds.



Designed to frustrate car thieves is this dash-mounted dial from Belgium. To operate his car, a driver must dial his own three-digit combination, after which the key can be placed in regular ignition. If a thief dials the wrong number, the horn automatically blasts away — and can be stopped only by dialing correctly.



Sailor's tool kit in pocketknife form has a slotted "shackler blade," a 3-inch marline spike and a 3½-inch cutting blade. Called the Barlow Shackler Knife, the stainless steel tool is made by George Ibberson & Co., 108 Rockingham St., Sheffield 1, England.

NIGHT RAID on a poacher's camp, and two game wardens leap from their airboats to surprise culprits

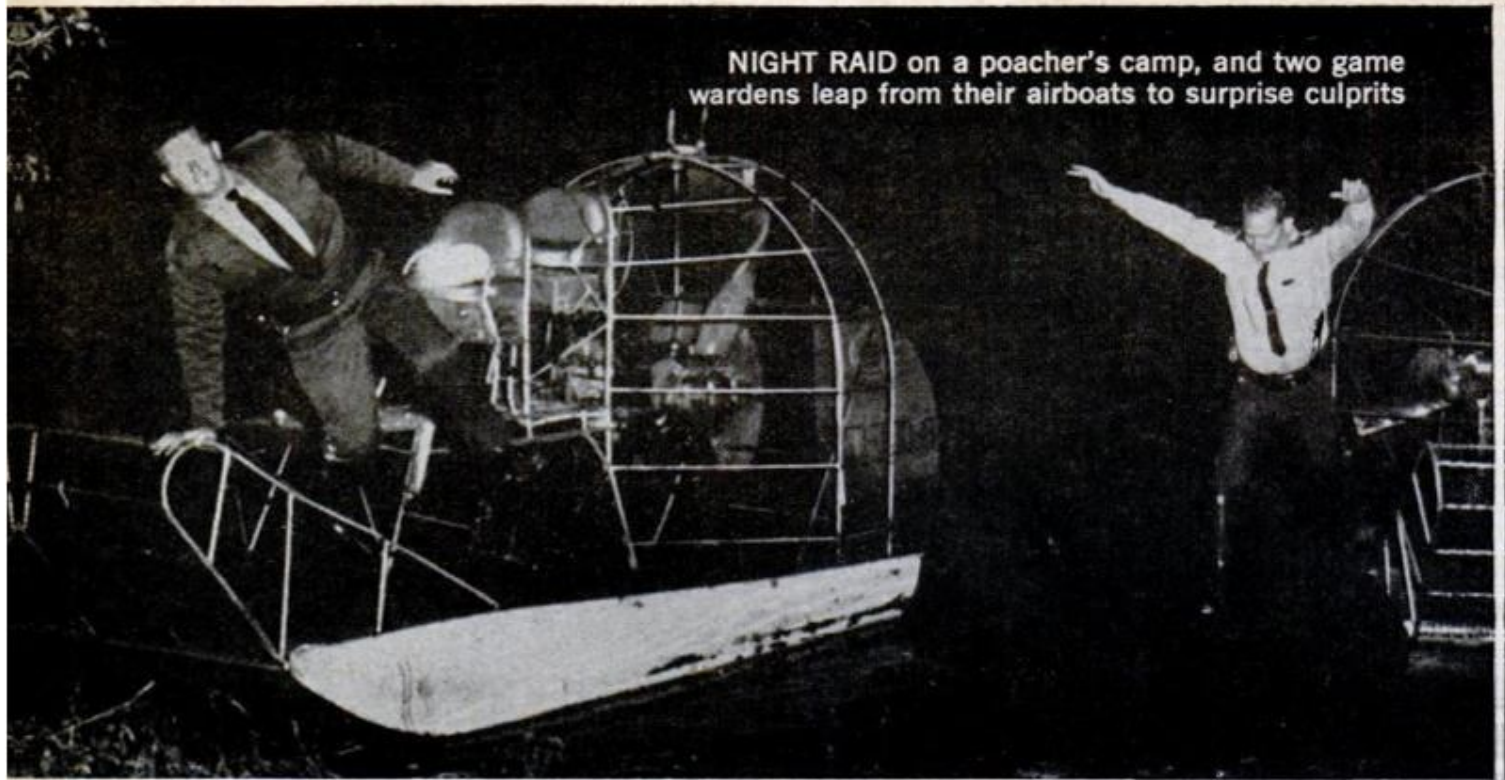

CAUGHT IN THE ACT, a Florida Everglades poacher turns over his kill to the two arresting officers



Crackdown on the Everglades 'gator poachers

Roaring across treacherous swamps in high-powered airboats, Florida's game wardens risk their lives in a relentless battle to end the illegal million-dollar traffic in alligator hides

By WILLIAM B. HARTLEY

FLORIDA'S EVERGLADES become mysterious, even ominous at night; lonely pools turn black and darkness engulfs the trees on scattered jungle islands. This is the killing time.

On such a night I was hurtling across the great, primitive marsh in an airboat. In the forward seat was Lt. Tom Shirley, law enforcement supervisor for the Florida Game and Fresh Water Fish Commission in the Everglades game management area. Tom's helmet-mounted spotlight picked up the red gleam of alligator eyes; but we were interested in a more dangerous quarry—poachers who kill alligators for their hides despite Florida's permanent closed season.

Tom and a force of some 12 officers match wits with these poachers in a gigantic tract occupying most of the Florida peninsula south of Lake Okeechobee.

As we slashed over water and wet grass, reaching speeds of 70 mph, I remembered a story I had heard at the commission's regional office in Fort Lauderdale. An officer up near Lake Okeechobee had pretended to be a poacher in order to gather evidence against a buyer of alligator skins. At their first meeting, the buyer warned, "I think maybe you're a warden. If I was sure, I'd kill you right now." It was no idle threat. Later, when the officer had his evidence and was making the arrest, the hide buyer ordered a companion to run for a shotgun. But the officer whipped out his revolver in time to discourage any gunfire.

"Of all law enforcement agencies," Tom had told me, "we have more reason to carry a gun than anyone else. We usually patrol alone and we're out where nobody can hear anything. These characters don't care much about a fine but they hate the idea of jail."

The war between alligator poachers and wardens is

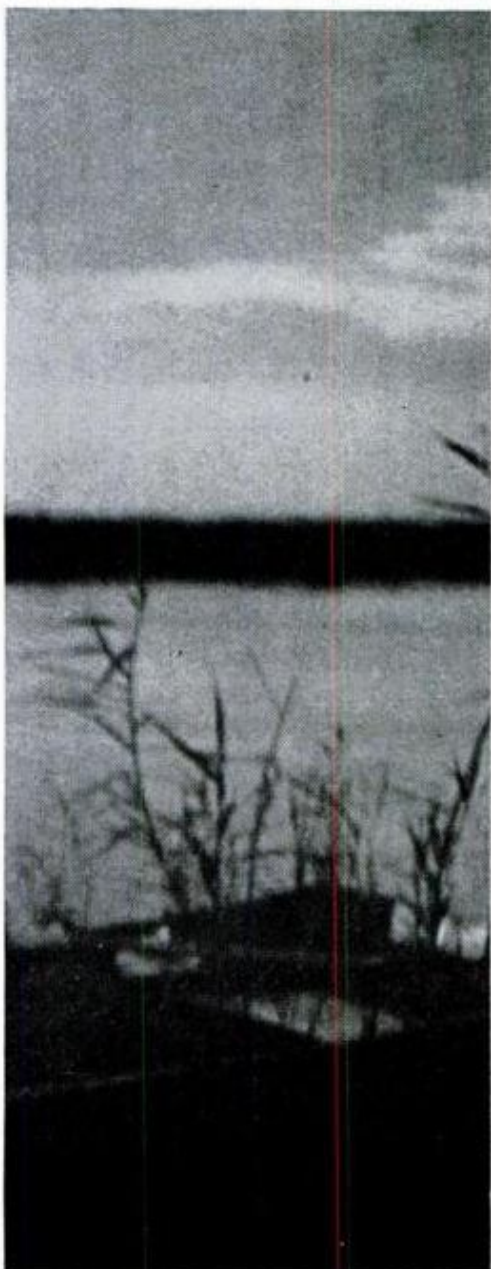
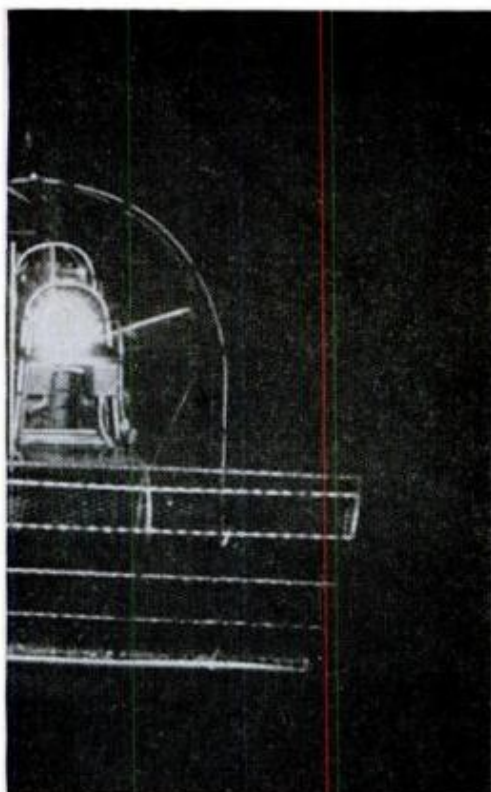



POACHERS WILL SHOOT to kill, and a pair of Florida's fish and game wardens make a cautious approach on a suspicious boat on a night run. The million-dollar traffic in hides makes it a dangerous game

POACHER'S PRIZE is a big alligator like this one caught in a beam of light. A hide sells for \$6 a foot, and this beast could bring as much as \$60. But the penalty is a stiff fine or a year in jail



SHACK IN THE EVERGLADES is a known poacher's camp. Staging a night raid, the wardens must take the occupants by surprise for their own safety and to get the evidence before it can be hidden

ONE NIGHT'S HAUL for a poacher fills the bottom of his boat. Caught in the act, he holds up a baby 'gator. The light on his hat spots the quarry, and his weapons include a shotgun and a .22-cal. rifle



bitter. Despite penalties ranging up to a \$500 fine or a year in prison, poachers slay thousands of 'gators every year. Since hides sell for as much as \$6 per foot, the traffic exceeds a million dollars a year.

Poachers, some of whom have permanent camps in the Everglades, operate from airboats, half-tracks, weasels and skiffs. Sometimes they use planes to spot concentrations of 'gators during daytime. They also have short-wave radios and walkie-talkies to warn of the approach of a warden.

Killing is done at night

Most of the killing is done at night. Poachers flash a light around quickly to spot a 'gator by the red reflection of its eyes. Then they slip up and shoot the reptile or kill it with a hatchet. As a result of the traffic in hides, only about 300,000 alligators remain in Florida.

Like the poachers, wildlife officers use planes, shortwave radios, airboats and other ground equipment. They are aided by a law that says: "It is illegal to have in your possession an alligator or parts thereof," but handicapped because they cannot get a warrant to search a man's house on a game violation.

The fight is a strange one. I have seen officers chatting pleasantly if warily with known poachers while the Everglades steamed beneath the afternoon sun. But when night fell, the atmosphere changed, faces hardened and any conversation at a landing ramp became cold as the wind.

Now I was out on the dark battleground, thoroughly chilled despite a heavy Army jacket. The wind clawed relentlessly, the roar of engine and airplane prop at my back was ear-splitting. Yet I knew that this noise was deceptive; anyone running another airboat could not hear it.

Tom's light picked out a faint trail through the deep grass that whipped past on either side. Sometimes he flicked the light into the black snarl of a jungle hummock or island, sideslipped near with the breathtaking maneuver peculiar to airboats, then swung back into open terrain.

Presently Tom turned off the spotlight and we roared along in almost total darkness. Light is the Achilles' heel of poachers and wardens alike; a pinpoint or glow of light can be seen for miles.

We were west of Andytown, a tiny settlement at the junction of U.S. 27 and Florida 84, and not far from a spot where Officer Jim Sistrunk had noticed a suspicious light last July.

Jimmy had seen the glow from a distance of about 18 miles. He found the boat occupied by a known 'gator hunter, Robert Craig Jr., and another man; but there was no sign of any hides and the boat was empty when the men finally brought it in. Jim correctly guessed that Craig and his companion would return later to pick up hidden plunder so he staked out near the boat and fought mosquitoes patiently until dawn.

Since he had to attend court in the morning, he then called Officers George Eddie and Gary Phelps to tell them what was going on. They hurried out and concealed themselves near the boat. At about 9:00 a.m., Craig and his companion appeared, launched the boat and were gone for several hours. When they finally returned, they simply slammed the boat up on a canal bank, hurled the sack into their car and started to race away.

Surrenders at gunpoint

As the officers blocked the road with their own car, Craig leaped into the canal and began to swim across. But he turned back when George Eddie drew his gun. With evidence of several dead alligators in the sack, Craig went to jail for five months.

On another occasion in the same area, fish and game airplane pilot Gerry Fiddler radioed George Eddie that he had spotted a light just west of the Andytown boat ramp. George arrived, saw no light but found a truck backed in behind a nearby building and a trailer partially concealed in the brush. He watched for a while, finally spotted the distant light and called Gary Phelps for assistance.

Shortly after Gary reached the landing, the light disappeared and was not seen again until about 3:00 a.m. Then it flashed on, the motor roared and the boat came straight in toward the landing.

There is a little clump of weeds just northwest of the Andytown boat ramp. Gary started to hide in them, changed his mind; and both officers raced to an embankment where they could crouch down and see over the top. The boat slowed while the occupants swept the

(Please turn to page 186)



The way-out world of **WACKY** INSURANCE CLAIMS

Indians bushwhacking a pickup truck; a Volkswagen swept up by a street sweeper—they're just routine for a claims adjuster

By CLIFFORD B. HICKS

USING HIS HEAD, a builder lifted bricks in a barrel, got hit with bricks then the barrel

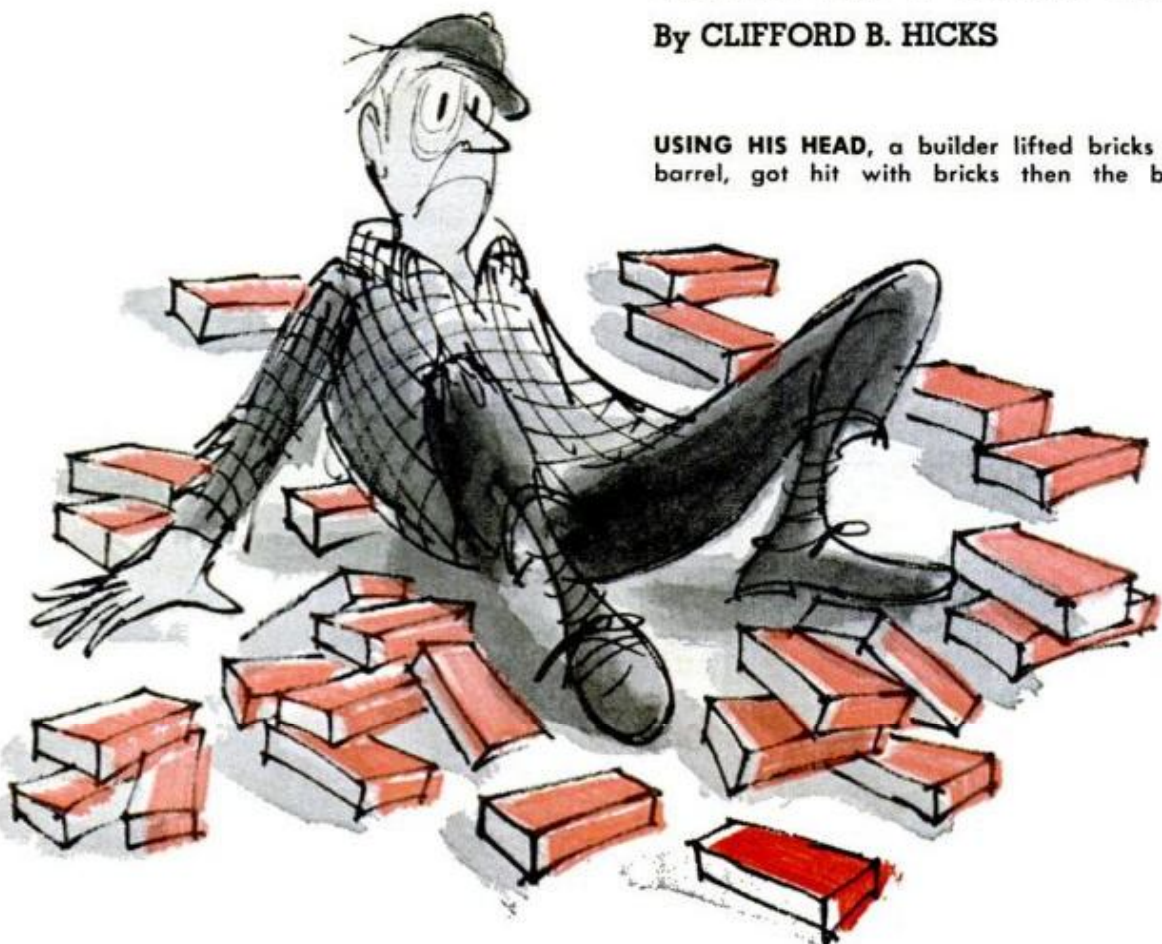

IF YOU'VE EVER had any dealings with an insurance adjuster (and who hasn't?), he probably was dressed in a sincere black suit. He listened to your story with a somber face and uttered pronouncements in a serious, unemotional voice.

And he may have laughed all the way back to his office.

No man's troubles are funny—to himself. But humor, by its very nature, is a glance at somebody *else's* problems; it is the function of the insurance adjuster to deal with such problems. As a result, he frequently finds himself sitting in somber judgment on situations far wackier than anything the Marx Brothers could conjure up.

Just as a sampler, take the case of the wide-awake policyholder who took a long drive through the sleeping city to cure his insomnia, and eventually found himself parked on the shores of Lake Michigan. It was a foggy night, and a mournful whistle sounded out on the lake. In playful response, the motorist tapped his own horn. Soon the two horns were carrying on a regular conversation. Honk; *toot!* . . . Honk; *toot!* Minutes later, the motorist was terrified to see a tugboat bearing straight down on him out of the fog. Instinctively he gave one final blast on his horn to ward off the monster; there was an answering

bleat just before the hull crunched up on the beach.

The owner of the tugboat sued the motorist for damages on the basis of "contributory negligence." The case illustrates a point in relation to your own insurance. No one has to prove that you *intended* to damage someone's property; only that you were instrumental in causing the damage. Such cases frequently become entangled in legal knots. In this one it cost the insomniac's insurance company a wad of money, but the adjuster and his colleagues are still chortling over the story.

Back in 1864 an American insurance pioneer developed the first accident policy to insure rail passengers against injury suffered in frequent train wrecks. He probably twitched in his grave recently when the owner of a Nationwide accident policy got himself embroiled in a typical cartoon sequence while building an addition onto his home. It certainly wasn't the type of protection the pioneer had in mind.

After closing in the second floor, the policyholder decided to move an oversupply of bricks back down to ground level. It should have been simple, for he had already rigged a homemade hoist—a barrel fastened to a rope, which ran up through a pulley in the roof peak and back down to the first floor, where



ANSWERING A FOG HORN, a motorist lured a tugboat onto the beach and was liable for damages



A COMPANY PAID for poodle x-rays and damages when "robbery" turned out to be inside job



ANNOYED by auto parked in a crosswalk, a pedestrian leaped on the roof and stomped it in

the rope was tied securely to the framing.

He loaded the barrel with bricks on the second floor, climbed down to ground level and untied the rope. Correction: He *overloaded* the barrel with bricks, for now it outweighed him. As the barrel dropped, he whistled upward, and the two hurtling objects collided. Although he lost some skin, our hero managed to hang on desperately, and quite literally sailed on up to roof height. At that point the barrel struck the ground, the bottom burst out, spilling its load of bricks and, thus lightened, promptly sailed upward again as the man plummeted down. More skin was lost, and when the man hit the ground, he lost his grip on the rope. You guessed it; the barrel fell two floors and landed on top of him.

As soon as the adjuster heard this tale of woe, he promptly paid the insurance claim against the man's accident policy. Nobody could make up a story like that.

Nor could even a Hollywood writer concoct the story of the Indian raid, with its ironic punch line. Seems that a couple of young braves from a Michigan tribe had been whooping it up over a bottle of firewater when one suggested they recreate Custer's last stand. What a magnificent idea! They staggered out into the night, and the first object they saw was a pickup truck rolling down the

road. They attacked with war whoops, beer bottles, rocks and anything else they could lay their hands on. In trying to escape with his scalp, the driver ran off the road and bashed into a telephone pole.

State Farm paid for repairs to the truck because the driver's collision clause covered *any* damage, even from an unforeseen Indian raid. In such cases, the company then tries to recover its money from the person or persons who caused the damage, and usually succeeds—so don't try heaving bricks at cars unless you have the law on your side. Oddly enough, in this case the Indians *did* have the law (or lack of it) on their side. Seems that this particular tribe had never signed a peace treaty with the United States, and the attorney for the braves successfully argued that, therefore, they were not liable under the law.

Not everyone can successfully sidestep the whooping redskins. A Volkswagen driver found himself in a fairly common predicament recently. In stopping for a signal, he inadvertently blocked the pedestrian lane. An irate pedestrian, already bugged by losing his job that day, climbed up on top of the "Beetle" and started jumping up and down on the roof. The Volkswagen Insurance Co. paid the damage claim, then recovered



SANTA CLAUS clobbered an automobile when he parachuted from the sky and landed on hood

its money from the thoroughly chastened pedestrian and even persuaded him to apologize to the driver.

VWs somehow lend themselves to ludicrous insurance situations. One woman had stopped her Beetle for a red light when suddenly what seemed to her like a gigantic hand began pushing her down the street, flinging her from side to side at the same time. She screamed, honked her horn, and finally managed to drive away from the monster. Her VW had been blithely swept down the road by a big street cleaner. "I didn't even see it," the driver of the sweeper told the adjuster later, while putting on his glasses.

The best thing about personal accident and collision insurance is that it doesn't matter *how* you or your property get bashed up. If you're covered, you are paid for the damage, no matter whether it's inflicted by man, inanimate object or vengeful beast. And believe it or not, animals find all kinds of ways to badger insurance companies.

One Nationwide policyholder, who had been fishing a pond in North Carolina, dumped his catch on the back seat of his car. While he was away picking up the rest of his gear, a horse rambled over and stuck his head through an open window.

(Please turn to page 179)

Tips that'll help you be savvy about insurance

- Know what your insurance covers by insisting that your agent explain every clause. Policies are written in legalese, not to confuse you, but so they can be interpreted in court.

- Keep the name, address and phone number of your auto insurance agent or broker in your car. A high percentage of drivers, surprisingly, are confused about the name of their insurance company.

- If you are involved in an accident, **shut up**. Give only facts: your name, address, license number and insurance company. Don't talk about the accident. Only lawyers or the courts can interpret **legally** what has happened.

- If you are involved in an accident, do everything you can to prevent a **second** one. Move off the highway. The other guy may have been totally responsible for the **first** accident, but if you stand there arguing, you may be held liable for a **second** one.

- Help the injured to save a life, but use common sense; if you make a serious mistake, **you** can possibly be held liable.

- Your auto insurance covers you on a drive through Canada, but **take along the policy** or other evidence of your coverage. Otherwise, in case of an accident, your car may be impounded while Canadian officials check your insurance.

- If you drive through Mexico, you must arrange separate coverage. Your existing policy is not in force once you leave the border area.

- If you rent a car, check the liability coverage. In no case are you permitted to haul a trailer. Rental-car insurance may cover you only in the rental state, or restrict the driving to the person who signs the rental agreement.

- If you drive a company car, investigate its insurance. The policy may not cover other drivers, non-business use, or may not be in effect on certain days of the week.

- If you have a "homeowner's policy," know **what** the personal liability clause covers. Such policies vary significantly in this respect.

- If an accident occurs on your property, you are **not necessarily** liable. The injured person may legally be at fault. Call your agent.

- If you are certain you have a legitimate claim against someone else and get no satisfaction from his company, write full details to your state insurance commission. Even the threat of such a letter may bring results.

NEW FOR
YOUR HOME
BY MARION MOREY



DUSTPAN for the workshop folds into a spout when you press the handle; nuts, bolts or nails then pour back into containers. Plastic units are 89 cents apiece; Foley Mfg. Co., 3300 Fifth St., Minneapolis, Minn.



POTTING TOOL aerates plant soil with two-pronged fork at one end and pots with pointed trowel at the other. Stainless 7-inch tool is 78 cents. Green Thumb Tool, Div. of Union Fork & Hoe, Columbus, Ohio

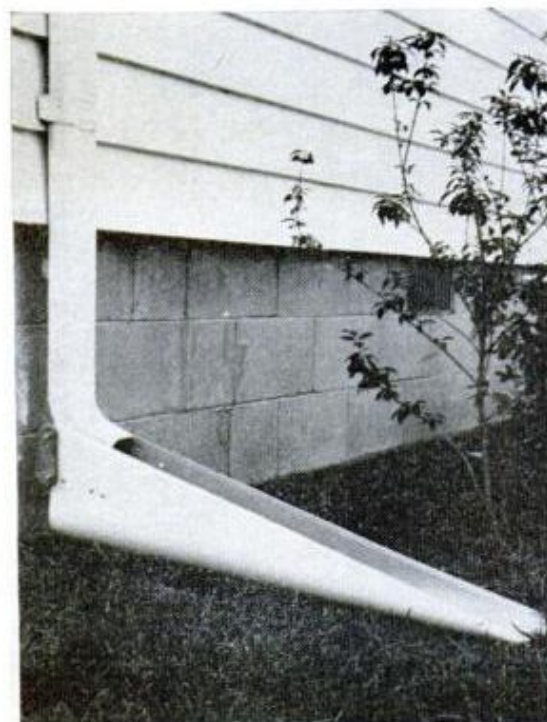
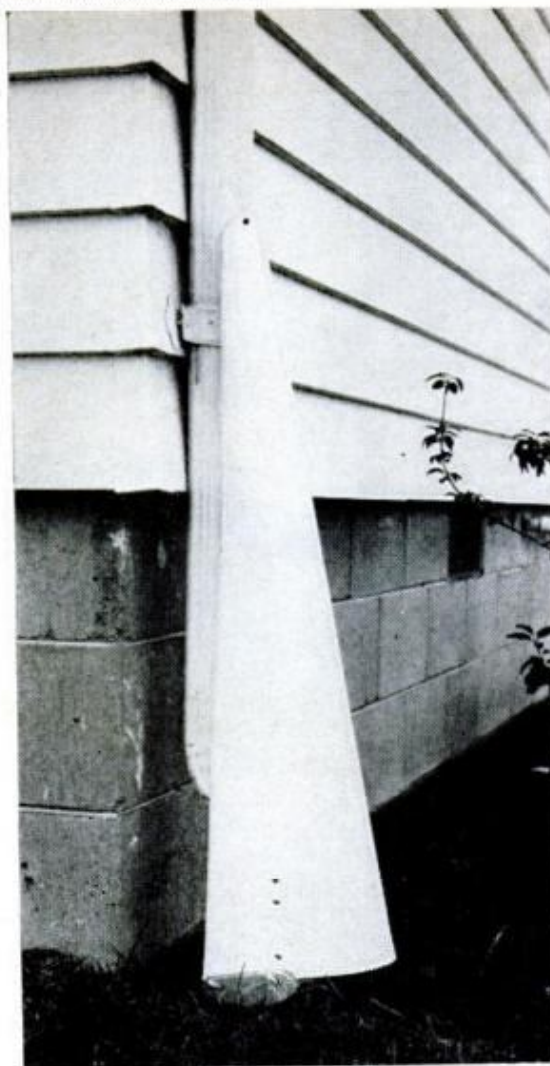

AUTOMATIC DRAINER for downspouts collects rain. Water weight lowers unit, unlocks latch and water drains out. When empty, drainer tips up, locks in place. \$8.98. Chapiewsky's, 116 Commercial St., Bangor, Wis.

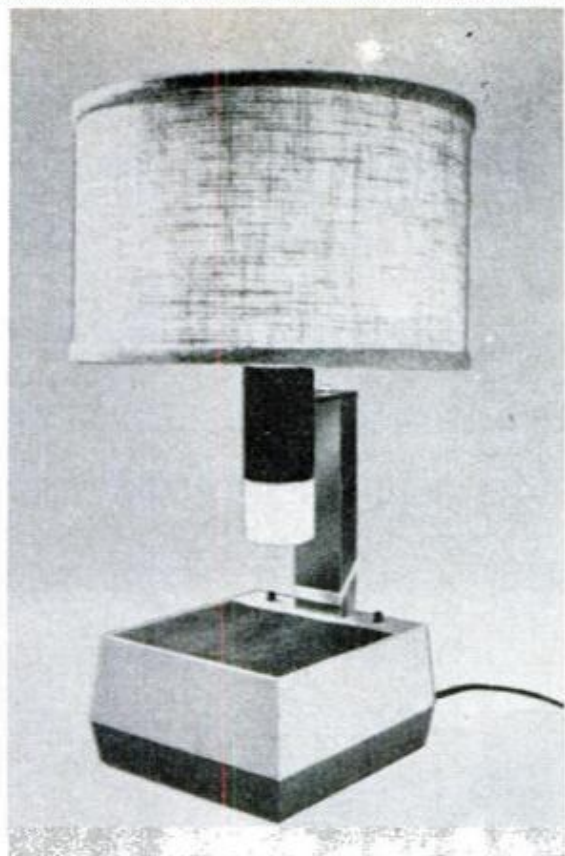

PORTABLE LAMP gives light when power fails, swivels for table or wall use. Plug it in or use a 6-volt battery. It's 15½ inches high and priced at \$18.50. Contact: Orville Kelsey, 53 Dadswoth, Hartford, Conn.

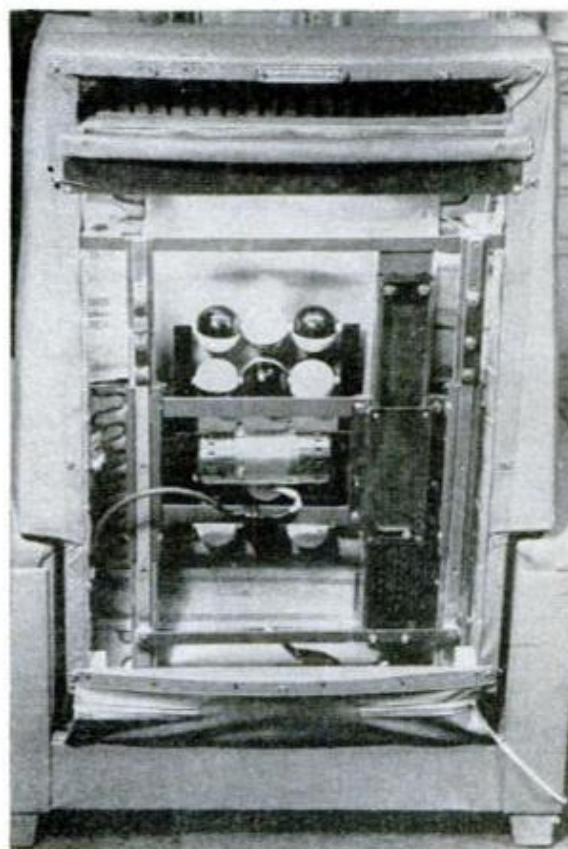

MASSAGE CHAIR gives you a complete back rub. You just sit back and press a button; 12 built-in sponge spheres on a roller move automatically over your back. \$450. By Niagara Therapy Mfg. Co., Adamsville, Pa.

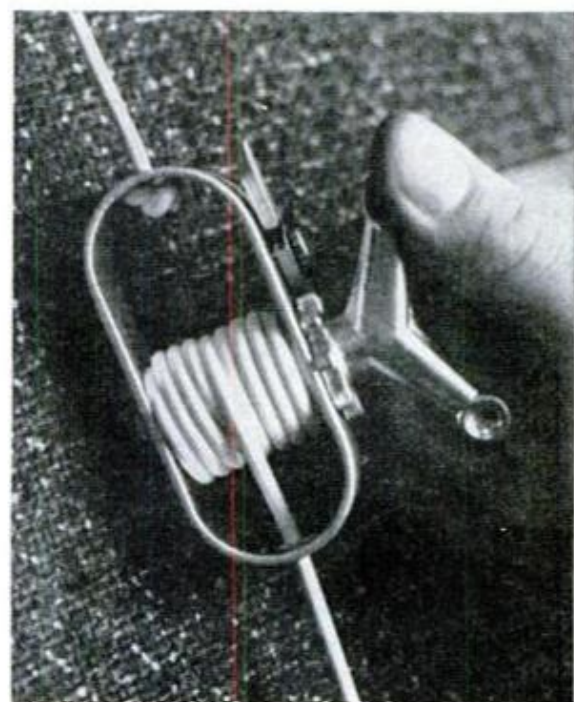

LINE STRETCHER keeps clothes lines, TV leads, fence wires taut. Thumb action works aluminum locking unit. Two stretchers plus 65 ft. of wire are \$3.98 pp. The Brown House, 3014 Boswell, Huntsville, Ala.

Birth control for bugs

We're sterilizing insects with atomic radiation, trapping roaches and moths with sex lures, infecting others with virus diseases. Our new battery of way-out weapons may soon eliminate the need for insecticides harmful to man

By HANS FANTEL

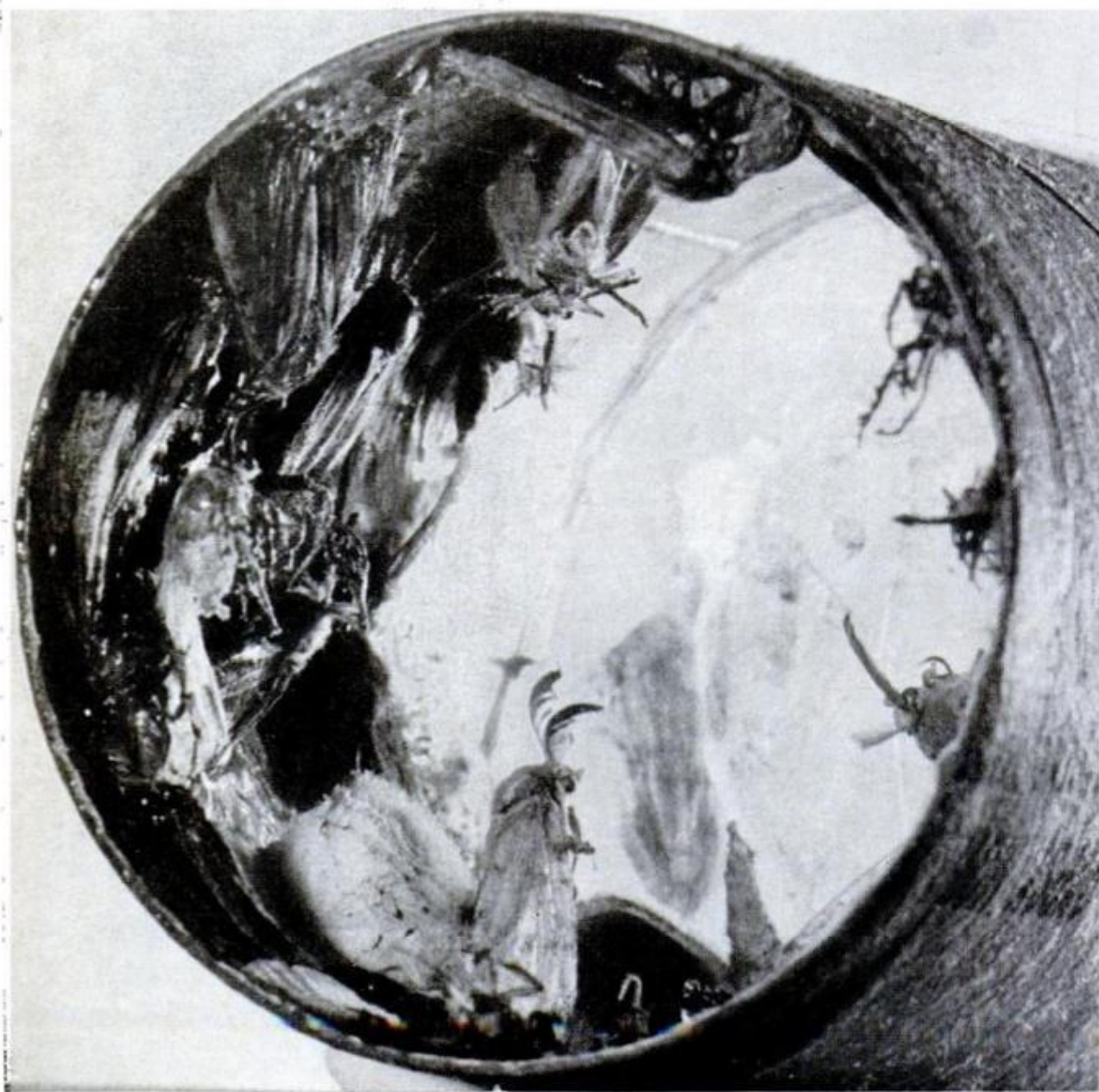

LURED BY FEMALE SCENT, these male gypsy moths entered trap. No ladies awaited them, only lethal goo

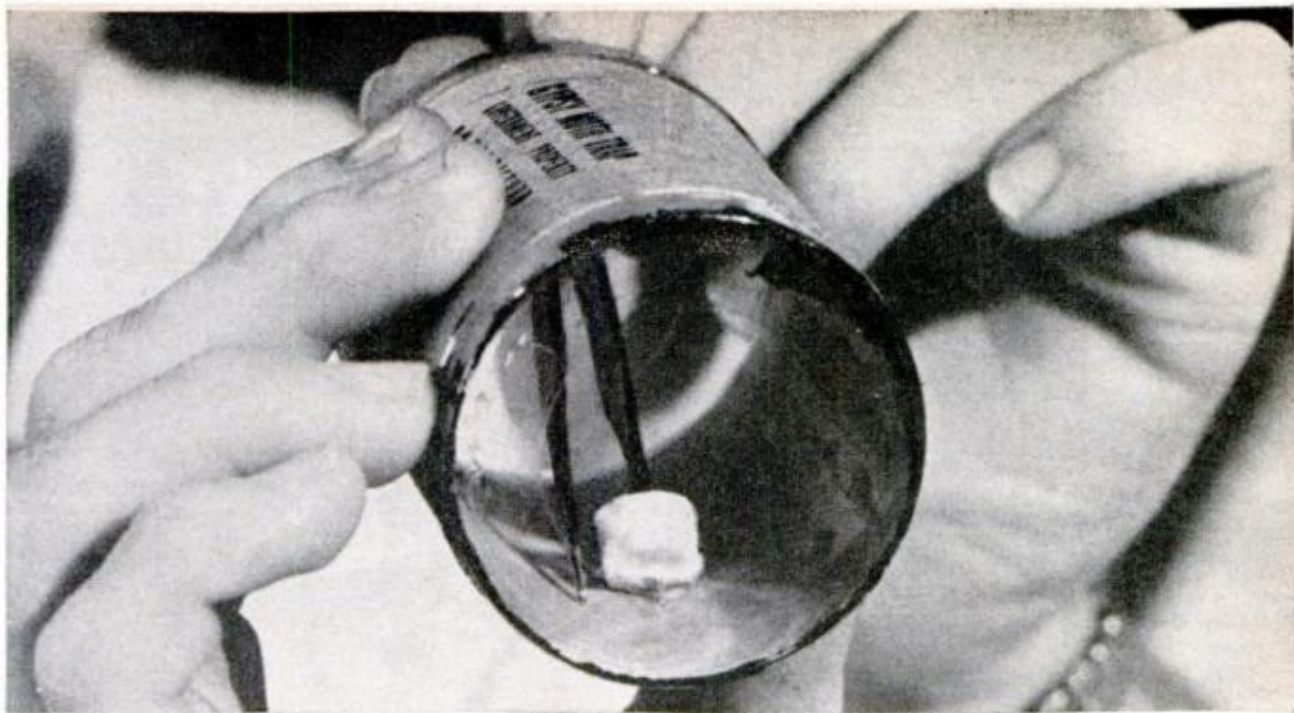

"GYPLURE," SYNTHETIC SEX ATTRACTANT, wafts from cotton in trap. It has stopped spread of destructive moth

WITH NEARLY 40 PERCENT of the world's planted food crops being nibbled away by insects, and a rising wave of protest raging against poisonous insecticides, entomologists (bug experts) are busily mapping a brand new, and weird, strategy against the buzzing freeloaders:

- In a Maryland lab, a scientist gulps down "soup" made by grinding up disease-ridden caterpillars. That "soup" consists of special virus strains capable of spreading deadly epidemics among crop-destroying insects. By drinking it, the scientist proves the virus harmless to humans.

- Near the palace of Versailles, where the kings of France once held sway, a technician digs dead grubs from microbe-infested cattle dung. His unappealing biological experiment may soon stamp out flies.

- In Texas, millions of maggots are carefully raised in a bug hatchery. Before they're turned loose, each gets a sterilizing blast of atomic radiation. Bug birth control of this kind helps eradicate fearsome cattle pests.

These new methods of insect control have one factor in common: they employ the principles of biological warfare, using germs, sterilization and other biological weapons. The idea is to sidestep the need for DDT and similar chemical bug killers. Though DDT still is the most powerful gun man has ever trained

on his insect enemies, it has a basic defect. It backfires.

DDT kills bugs, all right. But it also kills birds and fish, and is under suspicion in a few cases of death among people. To make matters worse, some crop-eating bugs have developed resistance to DDT. Bigger doses of the deadly stuff are therefore needed to make a dent in the bug population. Result: soil and groundwater are becoming polluted with dangerous chemical residues. Alarmed, the government shelled out \$25.5 million last year to launch a massive effort to find other methods of insect control.

Headquarters for the government's antibug campaign is the Agricultural Research Service of the U.S. Department of Agriculture, whose main laboratories spread over a huge tract of rolling farmland near Beltsville, Md. There I found Dr. Martin Jacobson bending over a bucket of cockroaches.

About 20 roaches, all male, were sitting around peacefully, seemingly asleep. Then Dr. Jacobson squeezed a medicine dropper to let a single drop of clear fluid fall into the bucket. Instantly the roaches were seized by a collective frenzy. They ran about wildly, wiggling ecstatically.

"It's their sex attractant," Dr. Jacobson calmly explained, pointing to the dropper.

To Dr. Jacobson, the roaches' uninhibited response meant a great deal. It had



EYE WOUND ON COW has become infested with screwworm maggots, typical of the way the insect attacks livestock. Yearly damage runs into millions



TOUGH STRAINS OF SCREWORM FLIES were selected for Agriculture Department's Texas "fly factory." The plant produces some 100 million bugs a week



START OF PRODUCTION LINE: Newly hatched larvae are beefed up with special food mixture and are kept a comfortable 99°F. in traylike heated vats



CANISTER FILLED WITH BUGS in pupa stage is pushed up into cobalt-60 chamber for sterilizing blast

taken him almost two years to isolate and synthesize the aphrodisiac perfume. Jacobson now plans to build cockroach traps baited with the sex lure. If enough male cockroaches are caught in an infested house, a sizable number of females may die childless spinsters. And if this keeps up over several cockroach generations, the total population would be sharply reduced.

"Males can smell the stuff a long way off, and they come running," Jacobson explains. Then he adds wistfully: "Of course, they may encounter a real-live female on the way to the trap." He hasn't yet figured out how to cope with that kind of competition.

Sexy perfumes are Dr. Jacobson's specialty. He banks on the fact that many male bugs are champion smellers who can sniff an attractive female as far as three miles away. More than 200 insect species respond to such smells. Following a notion picked up from German pioneer experiments, Dr. Jacobson decided to lead these bugs to perdition by the nose.

His first victim was the gypsy moth—a nasty species which every year lays waste huge forest areas throughout New England and now also threatens areas in the Midwest.

Male gypsy moths are interested only in virgins. So Dr. Jacobson and his team of researchers collected 500,000 young



FULLY DEVELOPED BUT STERILE MALE FLIES are dropped on infested areas. They mate with healthy females but produce eggs that do not hatch. Continued release of sterile flies eventually frees area of the pest.

females ripe with virginal attractant, and quite unromantically mashed them to goo.

Months of painstaking laboratory work were needed to isolate and identify the active compound. At every stage of the process, various chemical fractions had to be tried on male specimens. Humans, after all, have no way of judging what smells sexy to a bug. In fact, most insect aromas are undetectable to human noses.

After nearly two years the Beltsville scientists wound up with two drops of the ultimate extract—the total yield from half a million females.

Thanks to mass spectrometry and modern methods of analysis, even a single drop is enough to determine the chemical structure of a substance. Once Jacobson and his staff knew the molecular composition of the sex lure, they set out to synthesize it. The job turned out more difficult than expected. Minute traces of chemical impurity would cool the male bug's ardor. One atom out of place within the complex molecule, and no lusty moth would give the stuff another sniff.

Gradually Dr. Jacobson and his staff surmounted these technical difficulties. They came up with an inexpensive synthetic, called "gyplure," made from castor beans.

The Beltsville crew then designed a cheap trap with the new lure. Basically,

it is a small cardboard cup with a slanting lip at the opening. The moth lands on the lip and walks into the trap. Its walls are covered with a sticky substance that grips him by the feet.

Hundreds of thousands of such traps have been dropped by plane over the woodlands of New England, New Jersey and Pennsylvania during the last several years.

"So far," says Dr. Jacobson, "our effort has been merely a holding action—trying to prevent the moth from spreading into new areas. In that respect, we have been successful."

Present trapping methods are not efficient enough to eradicate the moth from areas where it is already entrenched. Trouble is that males are promiscuous and mate many times with different females. Females mate but once. So the surviving untrapped males are having a field day. But the Beltsville men are about to spoil their fun.

They're now working on a new idea: fill traps with a chemical that sterilizes the bug and then lets it escape. That way you don't just kill one bug with each capture; you kill (or prevent from being born) thousands of future offspring. For the sterilized male loses none of its sex drive. It goes after females with gusto. But all the eggs are duds. Besides, once mated, the females are out

(Please turn to page 194)



Veteran motorcycles race once a year in the Epsom to Brighton Rally in England. Two of this year's contestants were the 1904 Etna (left) and the 1913 Triumph (right). The Etna was disqualified for going too fast. Required by the rules to maintain an average speed of 12 mph, the powerful machine did over 60 mph in spots. The Triumph features an unusual wicker sidecar and front shoe brakes. The annual event was first organized in 1930.



Pocket TV almost: The tiny Minni-3 is the smallest set anyone has yet put together. It has a three-inch screen and measures a mere 6¾ by 6 by 3½ inches. Weight is 5½ pounds. It works on house current or nine self-contained C-cells. Made by Symphonic, the all-transistor set should show up at beaches, pools, picnics and the like.



Cable cars for the Swiss Alps were hoisted to the site by Russian MI-6 helicopters. The 1½-ton cars, flown from Stechelberg to Birg, are for the Schilthorn Railway in the Bernese Alps. The choppers were flown by Russian pilots.

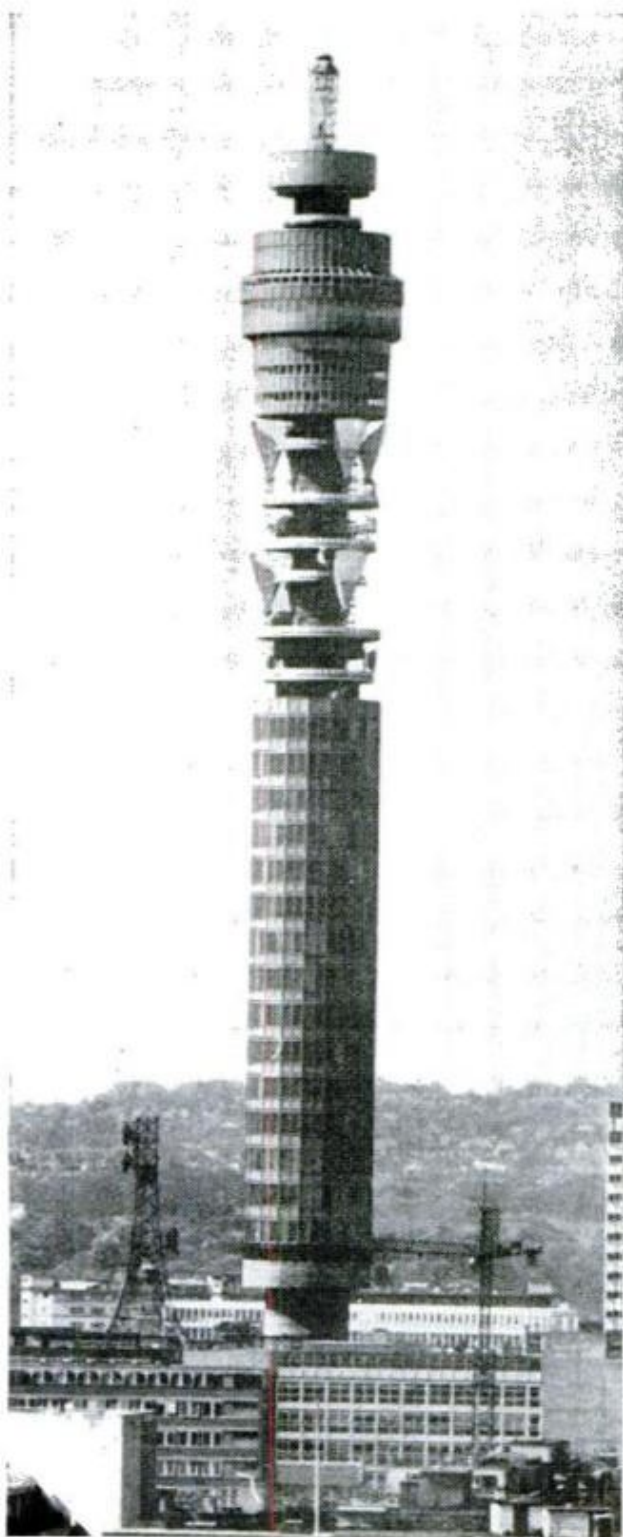

Way out and way up is London's new 620-foot General Post Office Tower, the old city's tallest building. When completed it will contain offices, a microwave relay station for telephone service and, near its top, a slowly revolving restaurant.



Wire jungle provides makings for cables that will link components in computer systems. This girl, working at the Honeywell plant in Lawrence, Mass., uses traditional textile industry weaving skills.



Hi-fi for the heart. Far more sensitive than conventional instruments is this new stethoscope that uses a microphone and six-transistor amplifier. The unit can easily pick up heart and chest sounds through several layers of clothing.

Triple-Deck Bunks

By Gene Rapp

BEDDING DOWN three youngsters in an average-size room with other furniture is usually impossible, but not when you stagger-tier three bunks.

The unit shown was built in an 11½-ft.-wide room. To accommodate it to a 12-ft. or larger wall, you have a choice of narrowing the ladder's width, doubling the 2x4 headboard members or building a deeper headboard with a cabinet on the side and a bookcase over it.

Both headboards consist of three verti-

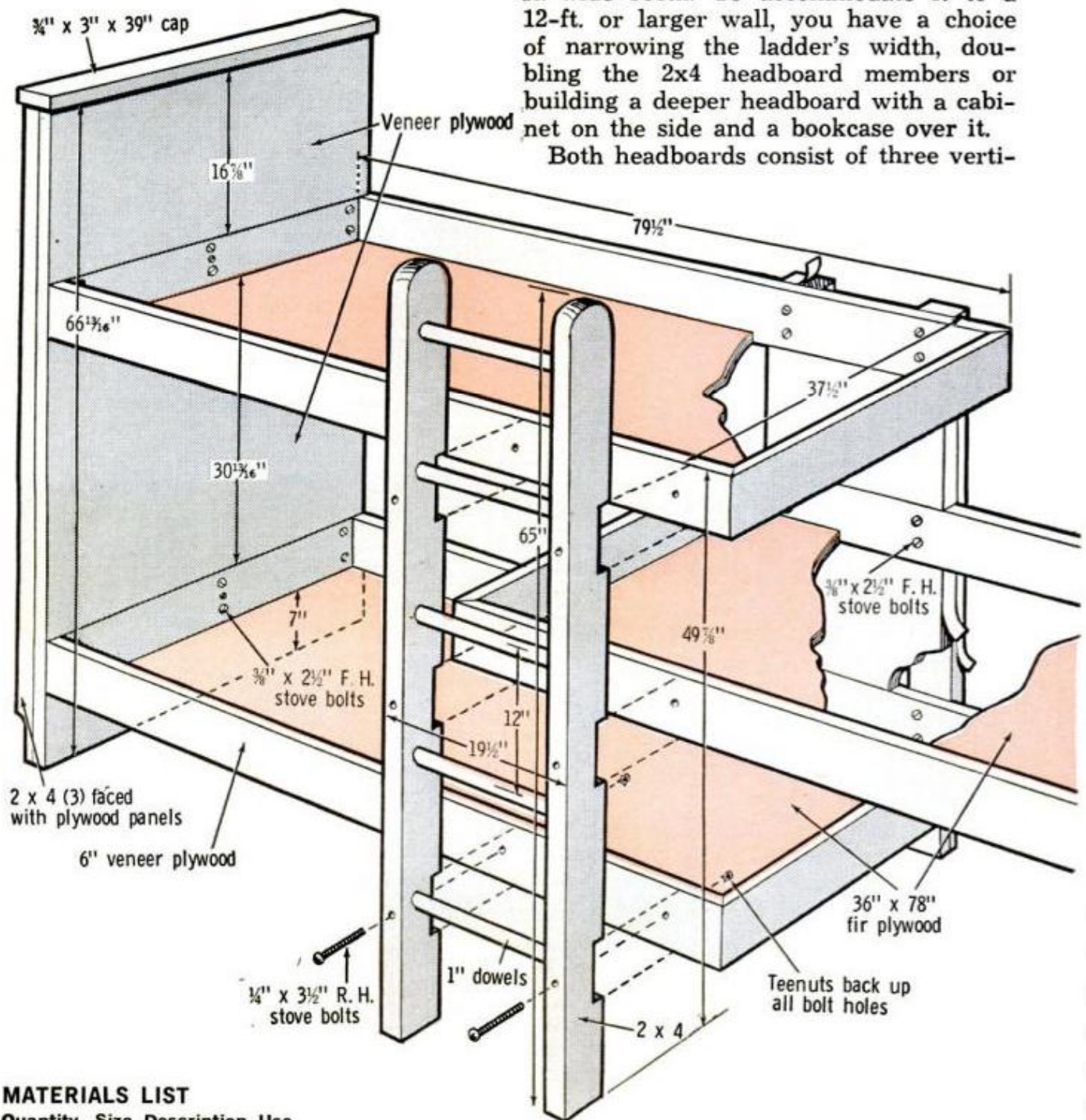

MATERIALS LIST

Quantity	Size, Description, Use
1 pc.	¾"x4'x8' fir plywood (bed platforms)
1 pc.	¾"x4'x8' veneer plywood (headboards, foot support)
1 pc.	¾"x4'x10' veneer plywood (rails, caps)
5 pcs.	2x4—10' pine (headboards, ladder, foot support)
9 rolls	1" veneer tape (plywood edges)
2 rolls	2" veneer tape (headboard edges)
26	¾"-16 Teenuts
6	¼"-20 Teenuts
26	¾"x2½" F.H. stovebolts
6	¼"x3½" R.H. stovebolts
3	4½" F.H. screws

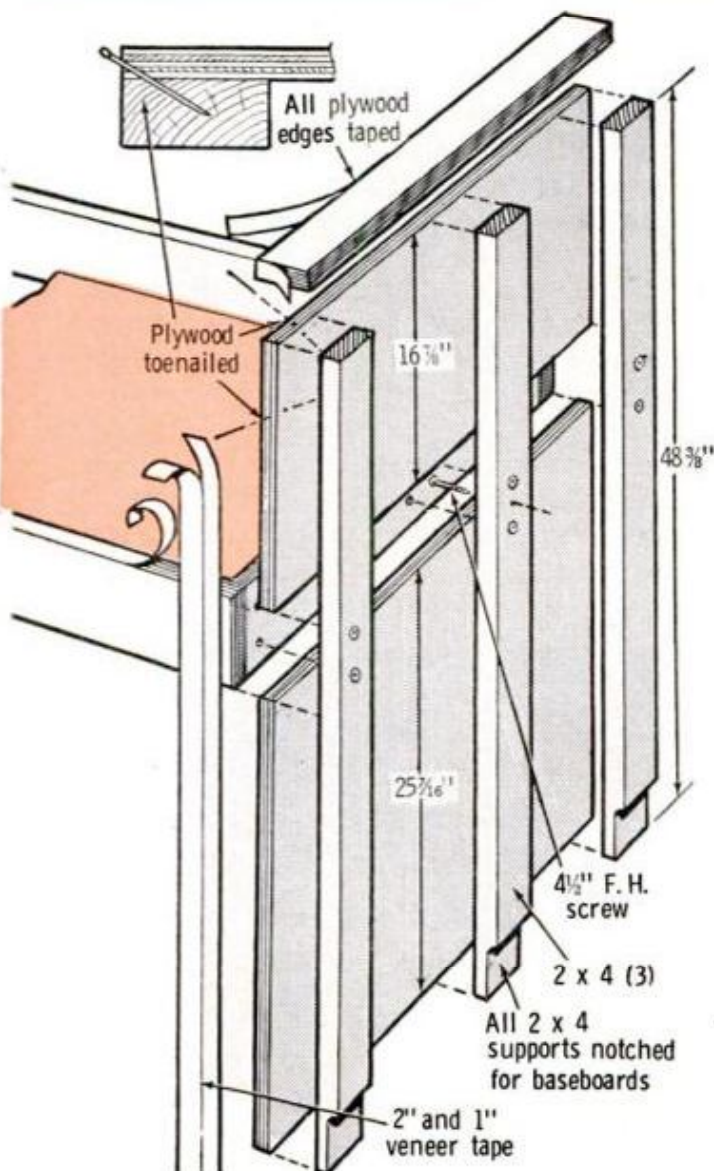
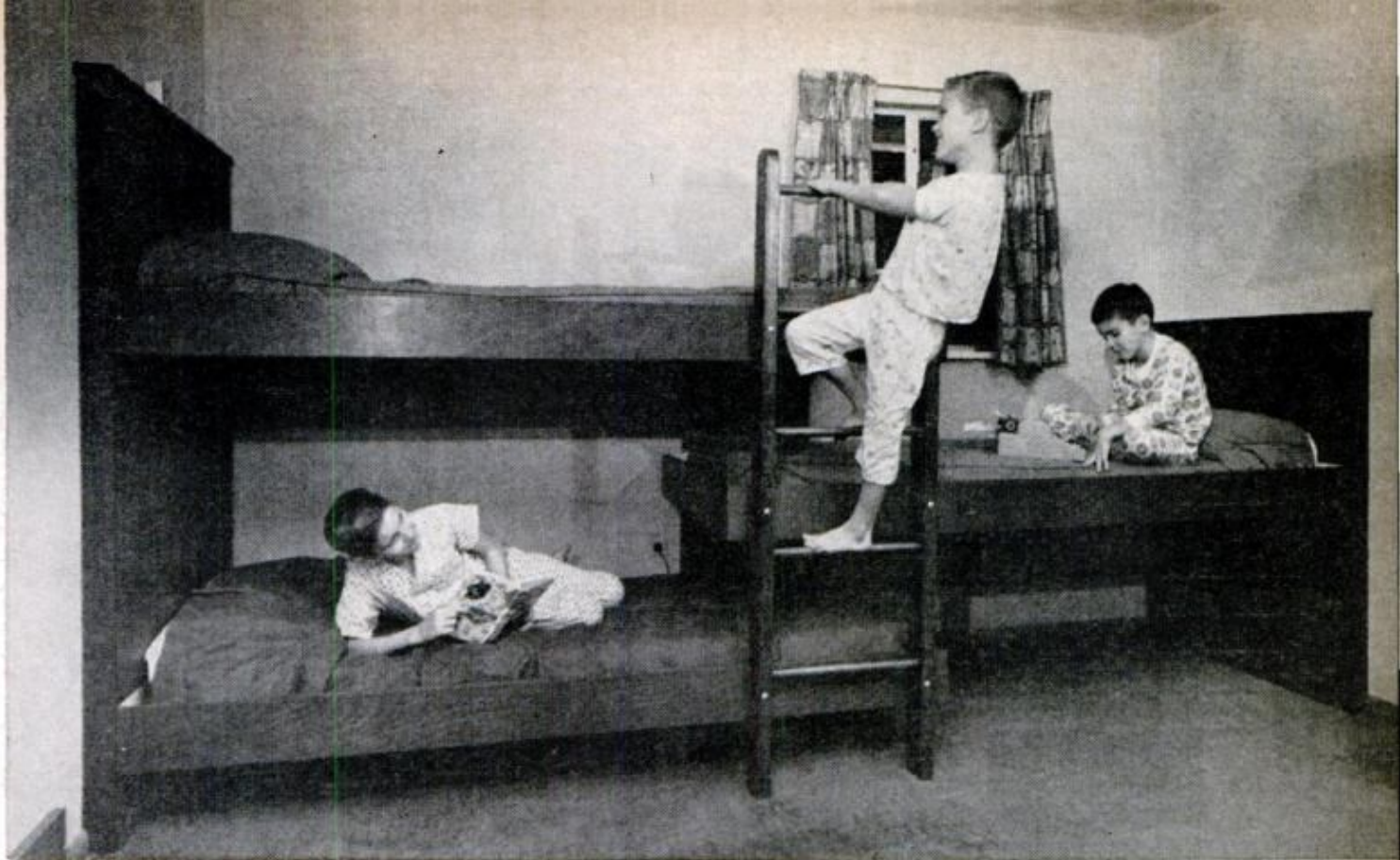

cal 2x4s with hardwood veneer plywood for facings, glued and nailed. In building the headboards, place the middle 2x4s off-center so as to fall over a wall stud for later screwing to the wall. Note that the headboards stand $1\frac{5}{8}$ in. from the back wall and that the plywood of both head and footboards is fastened to the 2x4s by edge toenailing.

Notch two 2x4 ladder rails on edges at the same height as the gaps in the headboards. Drill 1-in. holes halfway through the inner faces, 1 in. from the edge and 12 in. apart and then glue in 1x18-in. dowels.

The back support opposite the ladder is built with two 2x4s faced with three 18-in. plywood panels, measuring $12\frac{3}{8}$, $12\frac{3}{8}$ and 7 in. high.

Assemble the beds, headboards, ladder and foot support with clamps. Drill $\frac{3}{8}$ -in. holes through the bed rails and the 2x4s behind them and $\frac{1}{4}$ -in. holes through the ladder rails and bed rails. Counterbore $\frac{1}{2}$ and $\frac{3}{8}$ -in. holes, respectively in the rear for Teenuts.

Before bolting, glue veneer tape to all exposed plywood edges. Two-inch-wide veneer tape can be used to help cover the edges of the 2x4s. Sand and finish.

Assemble the bunk beds with $\frac{3}{8}$ -in. F.H. stove bolts everywhere except for the ladder. Here, use bright-plated $\frac{1}{4}$ x $3\frac{1}{2}$ -in. R.H. stovebolts. ★★★

Build Your slot-Car Track

New system brings the speed and versatility of commercial raceways right into your own basement. Assembly of flexible pre-painted sections requires no power tools, and 2, 3 or 4-slot tracks take $\frac{1}{32}$ or $\frac{1}{24}$ scale cars



NOW YOU CAN BUILD yourself a slot-car setup as fancy as any commercial layout, or as Spartan as the purest racing buff could want for test runs or perfecting his skills. You can customize a dream track or drag strip to your own design, or duplicate a famous track in miniature.

And you race—at home—the same cars you'd use on a commercial track. All slots are on 4-in. standard centers and are faced by solid aluminum rails cemented to the pre-routed edges of the roadbed. The 90° curved sections are available in five radii, as shown in the sample layout on the next page. A 2-slot track will be about 12 in. wide and a 4-slot track about 20 in. wide,

allowing ample "drift" for both size cars.

The new system is made by Sara, 2400 Greenleaf Ave., Elk Grove, Ill. It comes in five kits—including the 35-ft., 2-slot "Echo Valley" setup shown above. (Landscaping materials aren't included in the kits. The shale outcropping shown here was made with layers of randomly broken ceiling tile.) You can also buy individual components and slot boxes. Power is attached at any convenient point by the means of alligator clips or clamps.

The kits retail at \$35 to \$125. Straight track sections run around \$1.25 and curved sections from \$1.20 to \$2.40 each.

—Alfred W. Lees

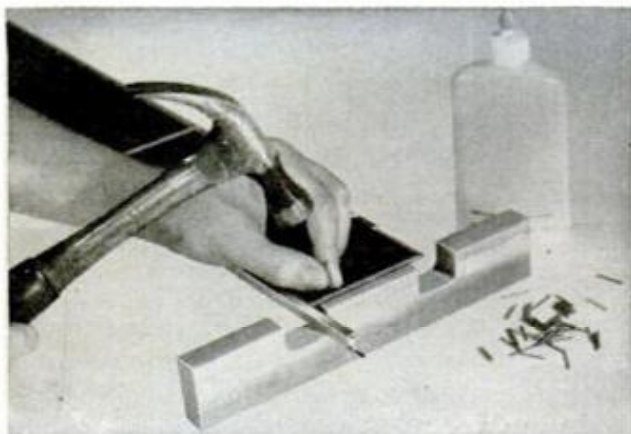

MODULAR SECTIONS are all designed for conventional 4-in. commercial standard slot widths. Pre-drilled holes simplify nailing or screwing track to under-construction as in cross-section on next page

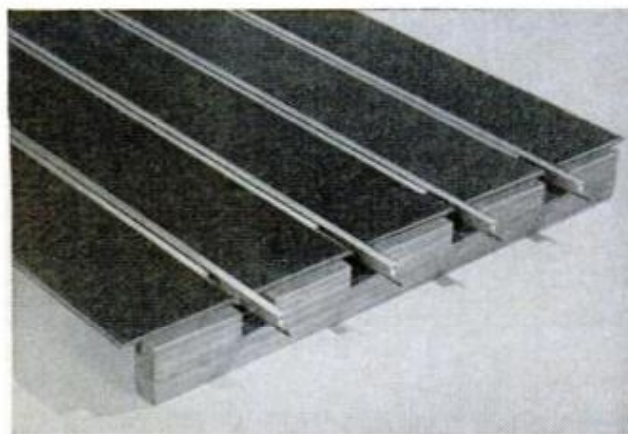

ONE TO FOUR LANES are possible with the sections, and only $\frac{3}{4}$ in. is needed under track. Positive locking connectors are needed only every 36 in.—the length of straight sections—eliminating power loss

PM

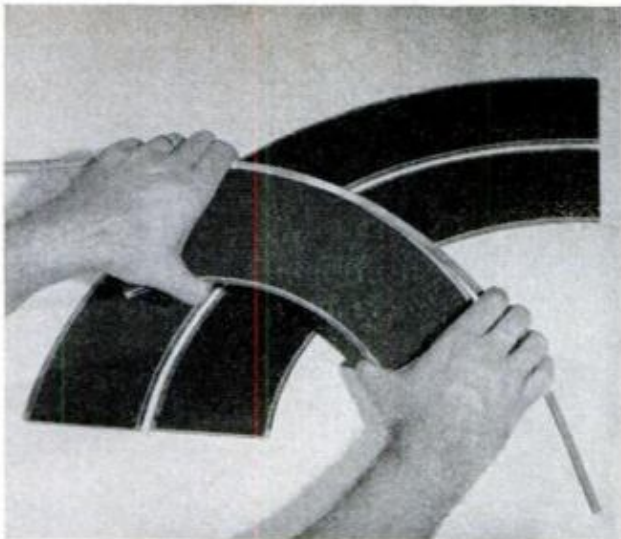

CURVES ARE MADE by bending slot-rail around edge of curved track section. No tools needed—it's just cemented in place. A projection is left beyond each end to create flexible suspension for next section

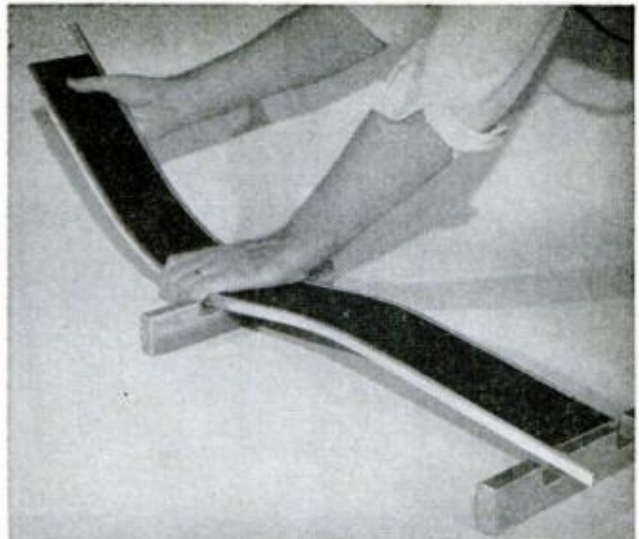

INCLINES ARE FORMED by simple hand bending after slot-rails are joined to section with dab of slow-setting cement every 3 in. Track sections are lightweight, yet support all pressures from normal racing

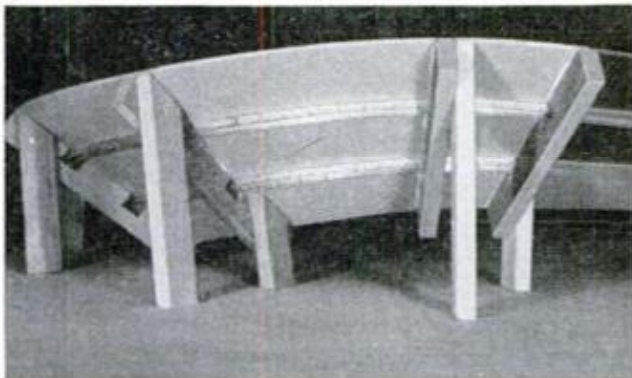

SUPPORTS ARE NEEDED only every 45° of a turn and each 18 in. of straightaways. Notching underside of rail permits sharp compound bends. Track can be sectioned (right photo) for storage, using jumper leads between rails and hinge leaves for alignment

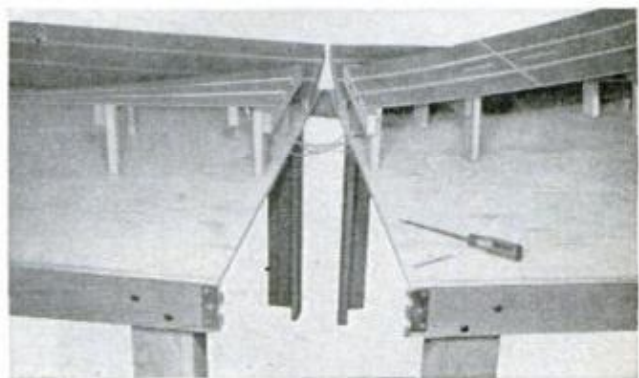

TYPICAL HOME TRACK (right) shows extreme curves possible with this system, minimizing space requirements. Total area is size of two 4x8 sheets of plywood. "Monza" turn is within 4 ft., banks to 40°

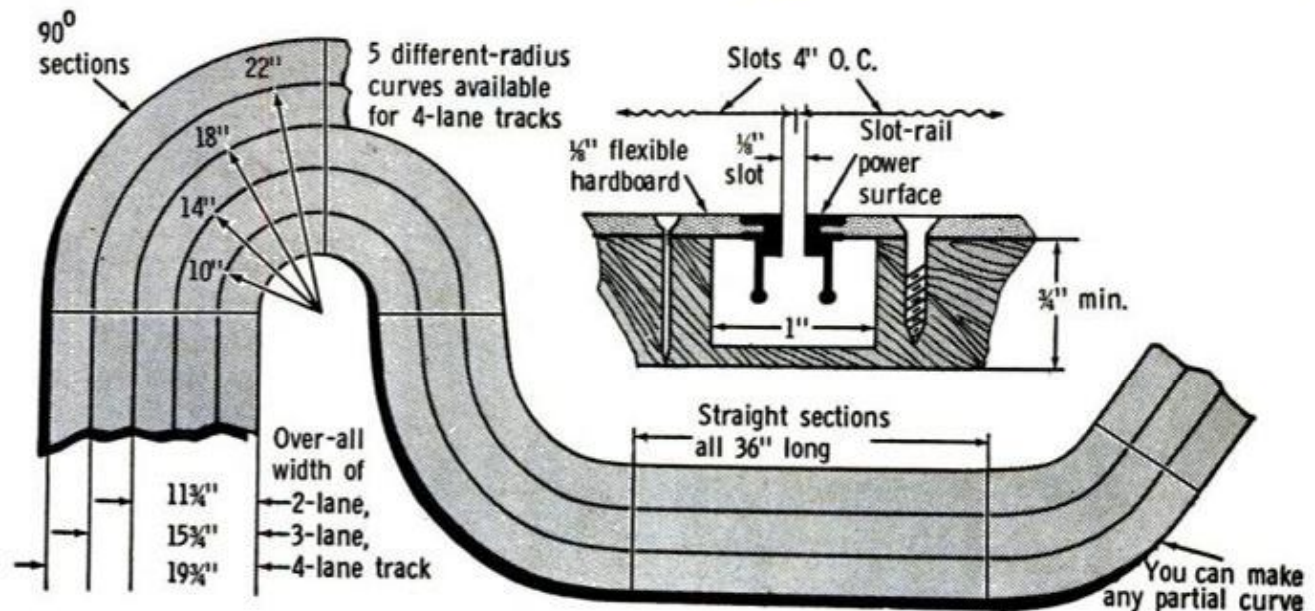
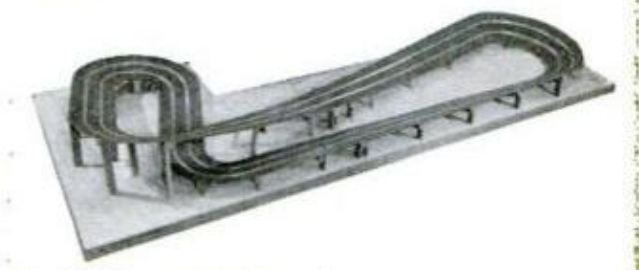



String along cold drinks

A new twist for the outdoorsman's trick for keeping drinks cold can be managed by any fisherman with a chain-type fish stringer. Clamp the necks of the bottles in the safety-pin hooks of the stringer and submerge them, attaching a length of line from the stringer. But if the fish start biting, you'd better throw the smaller ones back quickly and start drinking a little faster to make room for the catch—or carry an extra stringer.

—H. E. Guenther



Hiker's pocket lunch

If you want to travel extra light when hiking, an empty tobacco tin makes about as compact a lunch bucket as you could find. And you'll be surprised at what it will hold. Load it with crackers, cheese, lunch meat, sugar and tea bags. Simply as a survival kit, if you prefer, pack the tin with foods that won't spoil, such as dry soups, dried beef components from C-ration cans and tea bags, and seal the tin with waterproof tape.—John R. Clawson

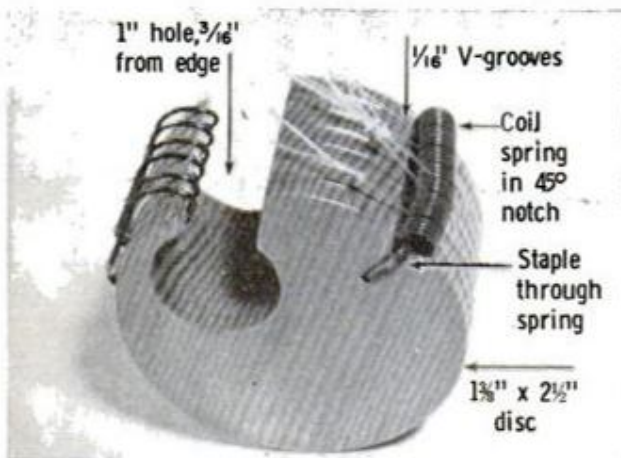

Hook-and-leader caddy

The tackle-box tangle that's the bane of every fisherman's existence can be a thing of the past with this fishhook spool. Cut a disc 2 1/2 in. in diameter; mount it on a lathe faceplate and turn several 1/16-in. grooves in the edge. Bore the hole; saw in from the edge, and cut the V-notch to seat a light coil spring 3/16 in. narrower than the spool. Drill 1/16-in. holes for one leg of each staple used to hold the spring loosely.

—William G. Waggoner

Color codes speed tent assembly



The manufacturer says you can set up an outside aluminum-frame tent in 20 minutes, but you know differently when it comes to matching up the frame joints. Solve it with paint across the assembled joints, a different color for each.

—John R. Walker

Jury-rigged candle lantern

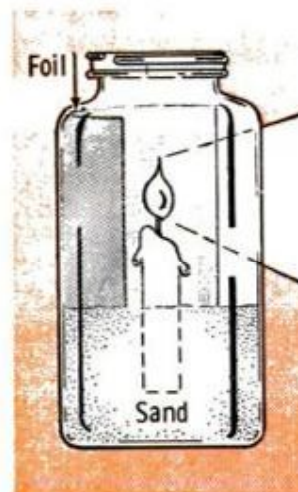

A good emergency light for blackouts or camping out can be had with a wide-mouth, half-gallon jar. Fill it one-third with sand or dirt and stand a candle in it, packing sand around it. Then line half the jar with aluminum foil to provide a reflector.

—Wm. B. Eagan

Easy but Elegant Patio Wall

BACK-YARD PRIVACY needn't be achieved at the expense of either beauty or breeziness. Instead of an unattractive, solid windscreen, build yourself a decorative block wall. You can add it to an existing patio, as pictured here, or build it on its own footing as a free-standing fence.

In the latter case, the first step is to dig a 10-in.-wide, 7-in.-deep excavation the length of the proposed wall. Then you dig

8-in.-dia. postholes 24 in. deep every 8 ft. for pilings.

If, as with the wall shown, you incorporate a raised flowerbed, it will be cheaper and easier to back up the bed with 8x8x16-in. concrete block for the first course than to pour a curbing of concrete. Packaged concrete and mortar, such as Sakrete, will also speed the job and save money over bulk-material purchases.



CARE IN LEVELING IS OF PRIME IMPORTANCE for appearance and strength. Any error would be magnified along the length of the wall and from course to course. Move your line level up 12 in. for every course to insure alignment. This will allow for mortar thickness. Here, the builder is laying narrow-gauge reinforcing wire to embed in the mortar



MORTAR IS TROWELED ON HEAVILY along horizontal joints and buttered on one vertical edge of each block. Check the positioning of the blocks to match up the directional pattern. It's a good idea to soak the blocks beforehand so they won't absorb moisture too quickly from the mortar, weakening the bond. The mortar mix itself helps to retard this



PRESS AND TAP BLOCK INTO PLACE, letting the mortar ooze out, until you have a joint thickness of $\frac{1}{2}$ in. and the block is checked for vertical and horizontal alignment. As a result, all mortar lines will be straight and each course will rest tightly against the posts, which are anchored to the wall with heavy nails embedded in the horizontal joints



DRESS-IT-UP TIME is after the mortar has set for about 15 minutes. Scrape away the excess mortar with the trowel and then strike the joints with a jointing tool for a neat, finished look. When the last course has been completed, trowel on mortar and cap the wall with uncolored 2 x 8 x 16-in. cement patio blocks laid lengthwise and butted

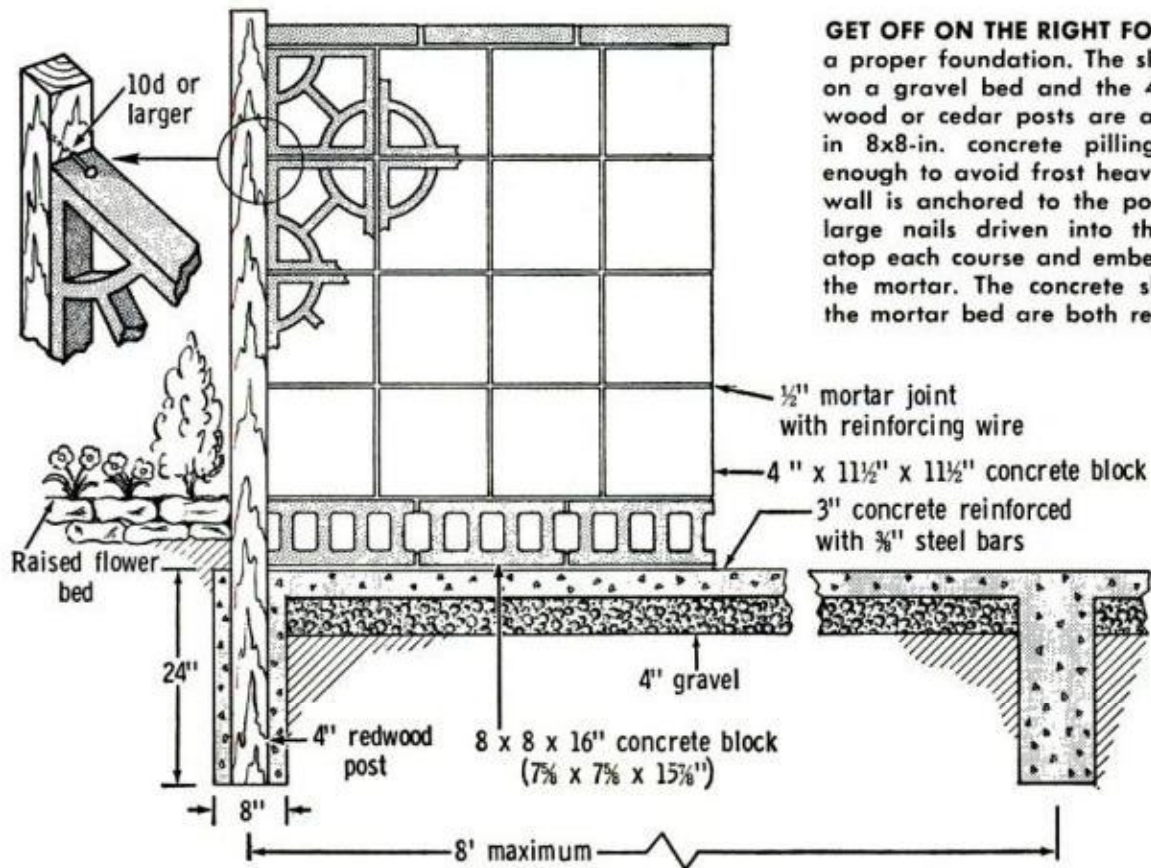
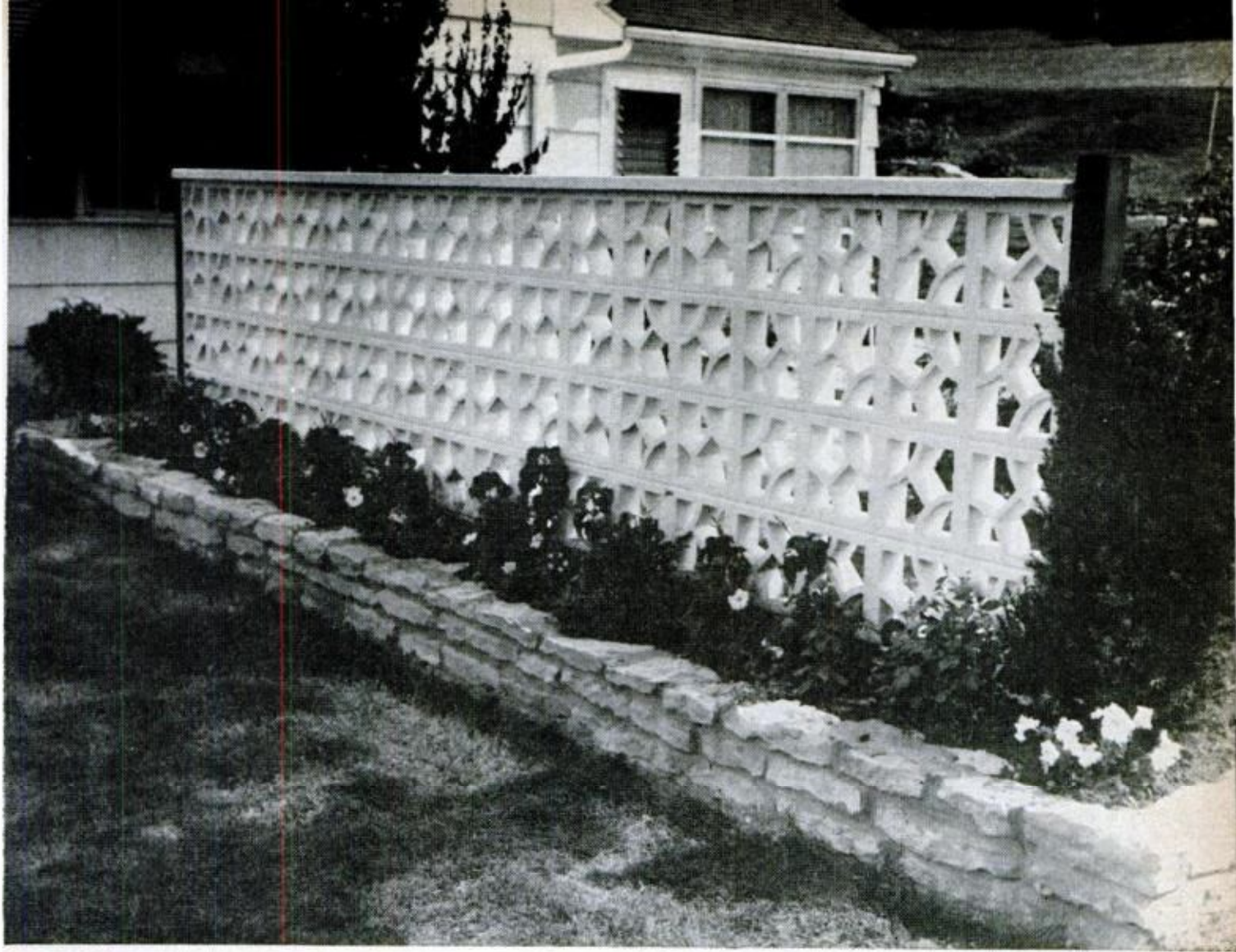

GET OFF ON THE RIGHT FOOT with a proper foundation. The slab rests on a gravel bed and the 4x4 redwood or cedar posts are anchored in 8x8-in. concrete pillings deep enough to avoid frost heaving. The wall is anchored to the posts with large nails driven into the posts atop each course and embedded in the mortar. The concrete slab and the mortar bed are both reinforced

Tuckaway Camper Cabana

BY JACK STOWELL

HAS YOUR SLEEPING CAMPER got you down, literally, when it comes to dressing? You can solve your cramped-space problem with this canvas-and-pipe cabana, which not only provides the convenience of a stand-up dressing room, but converts to a dining fly as well.

While designed for the teardrop camp-

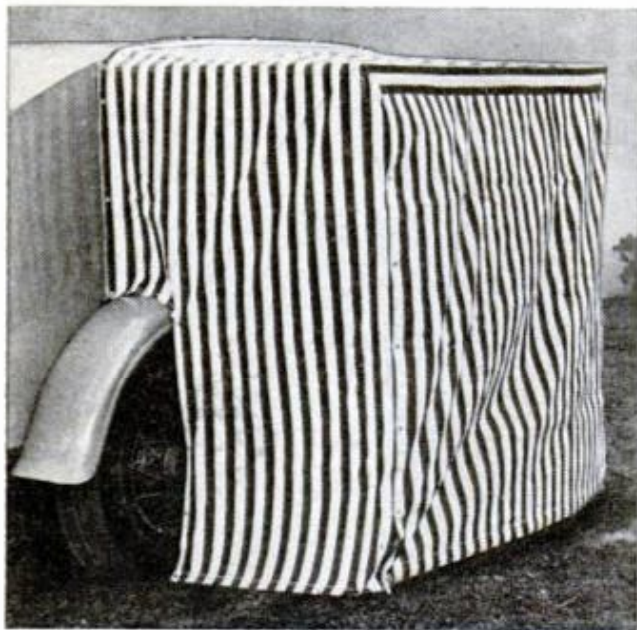

AS A DRESSING ROOM, the cabana provides an area 3 ft. deep and nearly 5 ft. high and wide. The camper's threshold makes a handy seat. The rear of the fabric is snapped to the camper body all around

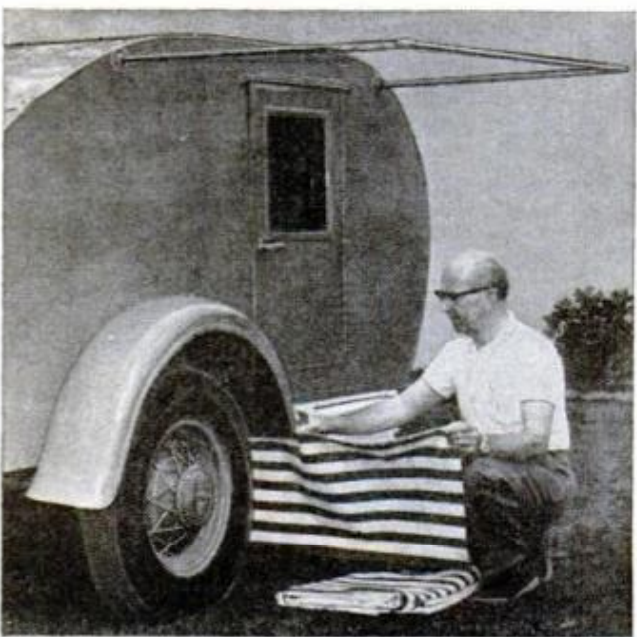

FOR COMPLETE PRIVACY and protection from drafts and rain, a skirt is snapped in place on the camper and at the lower ends of the cabana sides as well. The fabric is reinforced wherever snaps are mounted

er shown, the cabana can be adapted to any hard-top or bus-van camper.

The striped cover is awning material, hung over a pull-out supporting frame made from $\frac{3}{8}$ -in. i.d. galvanized pipe. The cover is stored inside the camper. The frame slides in two 1-ft. lengths of $\frac{3}{4}$ -in. plastic pipe attached to the underside of the camper's roof. These sleeves are clamped with pipe straps to full-width 1x4 braces which are fastened with caulked machine screws through the roof.

Outside the plastic pipes extend $\frac{1}{16}$ -in. through a pair of reamed-out $\frac{3}{4}$ -in. floor flanges bolted to the camper's side. When tucked away, the pipe framework itself makes an effective watertight seal. To keep it from being pulled out, run cotter pins through holes near the pipe ends.

Sew the canvas cover with heavy thread, lap-felling and double-stitching all seams. Add 2-in.-square reinforcing pieces where grommets are to be placed. Make a skirt to fit from the bottom of the camper to the ground.

Take the cover and skirt to an auto-top shop. Buy screw-in studs for the camper body from this source.

To support the flap, buy tent poles or make your own. For compactness, cut four 2½-ft. lengths of $\frac{3}{4}$ -in. dowel. Cut two 1-ft. lengths and four 3-in. lengths of $\frac{3}{4}$ -in. copper tubing. Drive a 3-in. piece onto an end of each dowel for reinforcement; crimp it into the wood in two places, using a wheel tubing cutter. On the other end of two dowels, push on the 1-ft. tubes 6 in. to create female sockets for joining the poles. Crimp.

Drill into the four ends with the 3-in. collars so as to force-fit $\frac{1}{4}$ x4-in. cold-rolled rods 2 in. deep. One pole tip goes into the ground; the other through the grommets.

To stiffen the front edge of the flap, use $\frac{5}{8}$ -in. dowels and copper tubing in the same way. On the outer ends, however, force on 1-in. collars and drill $\frac{5}{16}$ -in. holes through copper and wood to accept the pole tips. This stiffener is slipped into a stitched fold. A slit near each end short of the grommet lets the stiffener project. ★★★



AS A CAMPER PATIO, the cabana offers a shaded space for card table and chairs when flap is raised

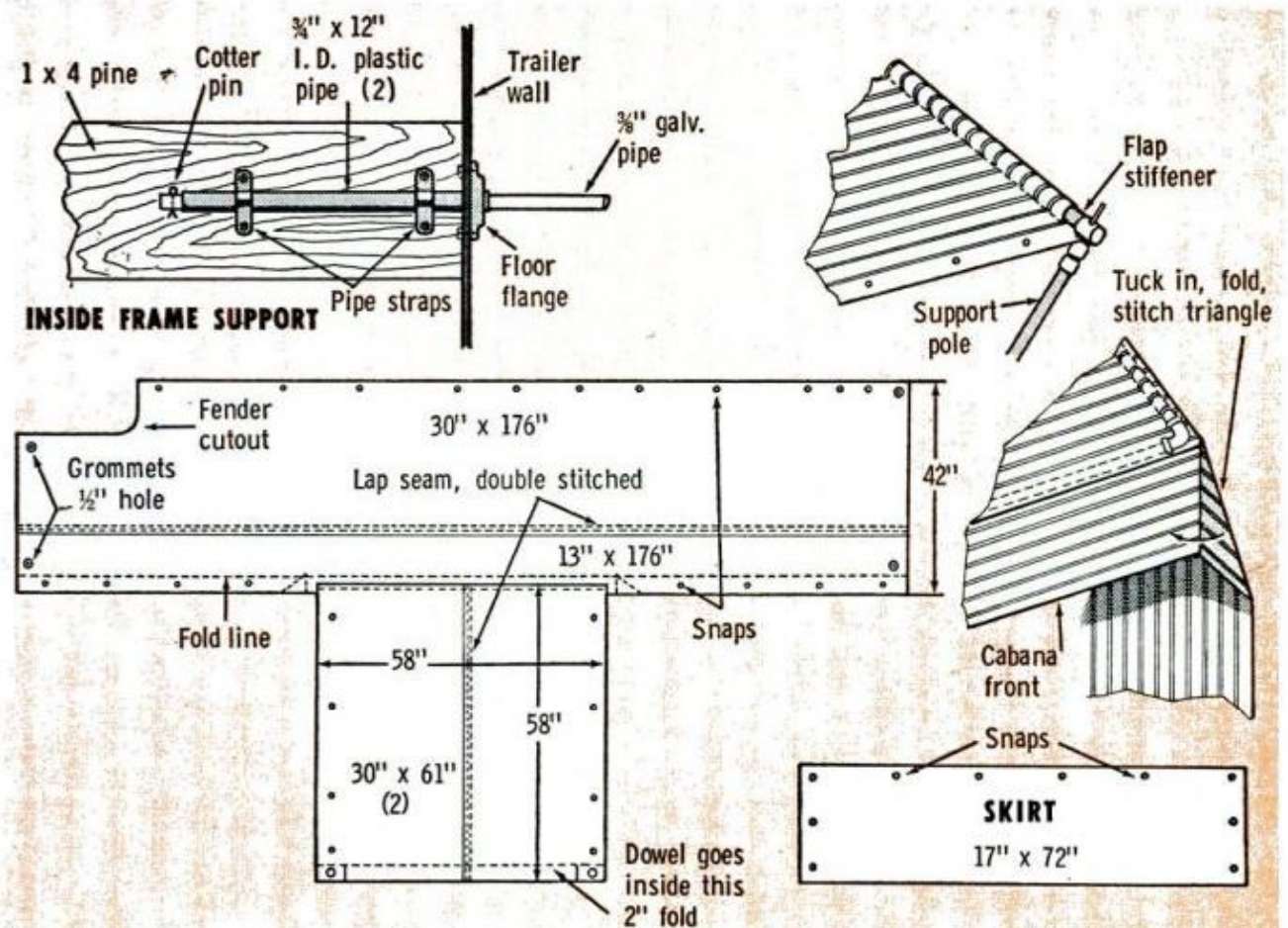

SOLVING HOME PROBLEMS



"SCOTCH STRINGS" on your shop apron? For convenience, why not sew extensions on them to make them longer so they can be tied in front?

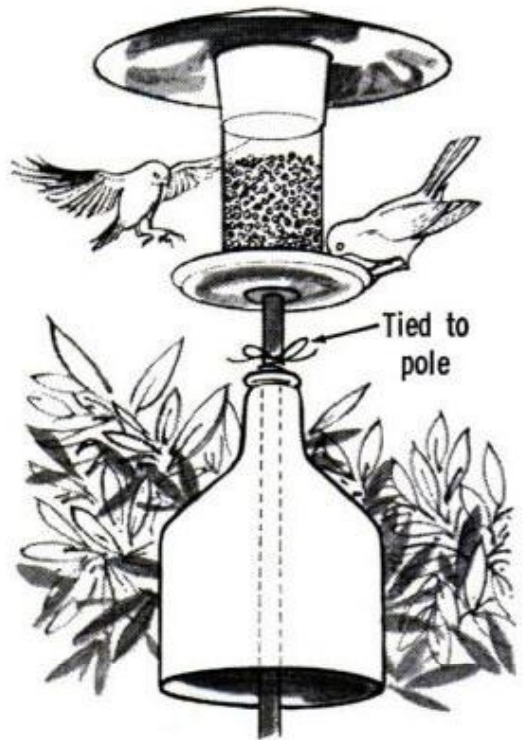

"CAT GUARD" ON YOUR BIRD-FEEDER will protect your feathered friends from Tabby, and their food from the squirrels. Cut the bottom out of a large plastic bottle, then tie the bottle to the feeder pole as shown

PULL-TOP CANS make plant-starters. Cut bottom so it falls in can to cover "drain" hole in top. Plant seed. To transplant, push out the seedling with a screwdriver

A STACK of heavy asphalt tile will be a lot easier to tote around when laying new floor when you make use of Junior's wagon to keep supply handy



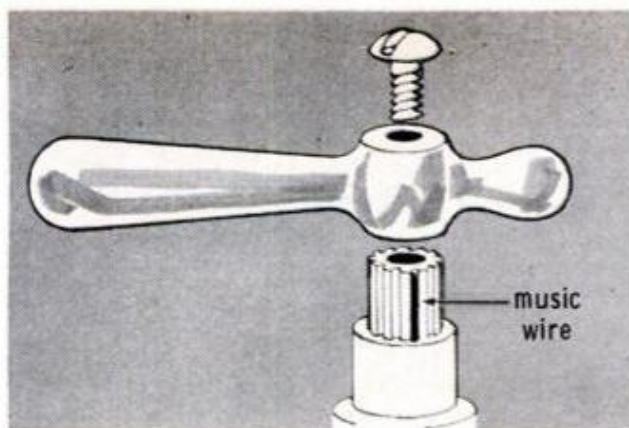

WORN TEETH on grooved end of a faucet shaft will cause faucet handle to slip so that valve can't be turned. A short length of No. 20 music wire placed in one of the grooves will give handle a new grip

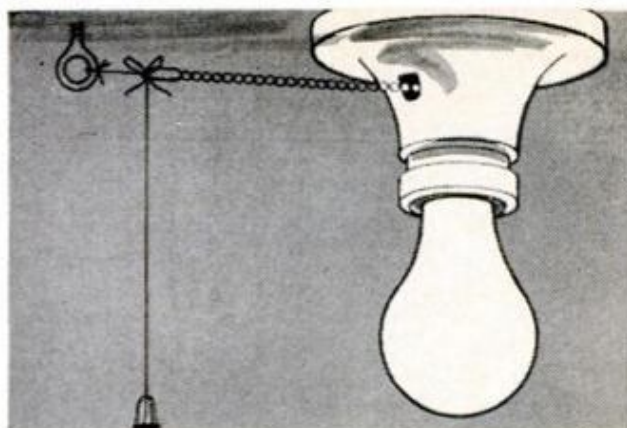

LENGTHEN THE LIFE of pull switches by the simple technique shown above. Give chain from switch a straight lead by tying it to line leading from screw eye. Pull-cord then provides straight in-out action

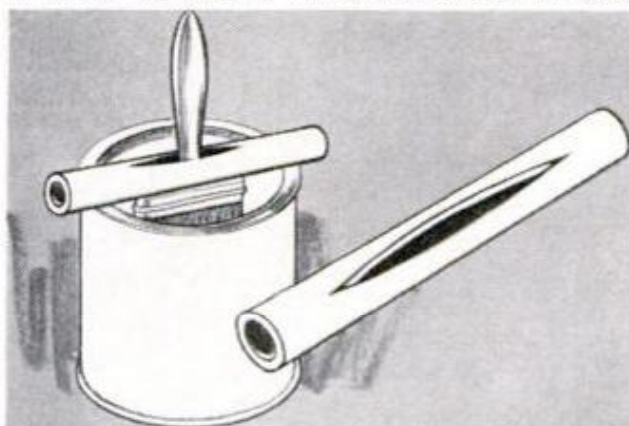

USE OLD GARDEN HOSE SECTIONS to suspend paint brushes in turp cans. Cut to required length, section is then slit through its center just enough so that brush handle is gripped when forced through it

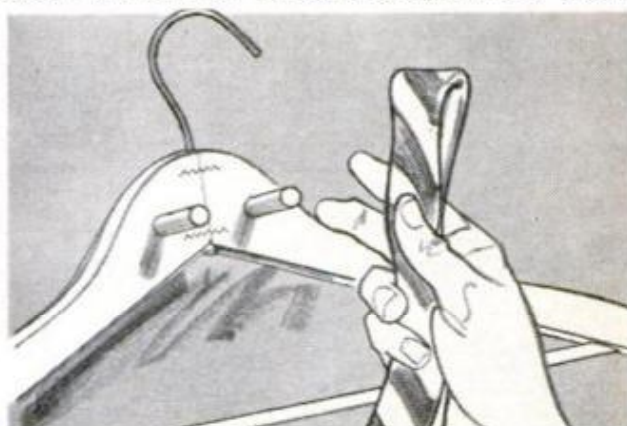

SOUP-UP A COAT HANGAR! Get maximum mileage from a wooden coat hanger by drilling two up-angled holes in one side, then insert two dowels as shown. From these pegs you can hang ties, belts and shirts

FOLD-UP KNIFE TRAY fastens to wall under kitchen cabinet. Plywood, scrap pine, aluminum fittings and two magnetic locks are all you need to make it (and wouldn't this make a nice gift for your wife?)

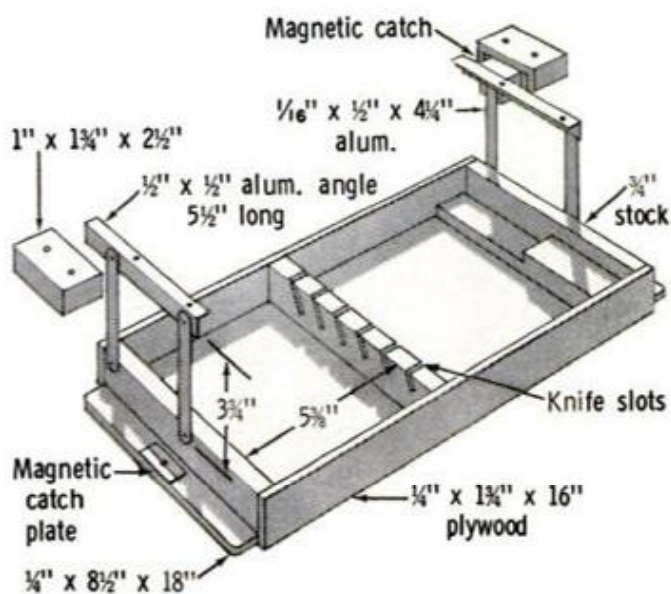
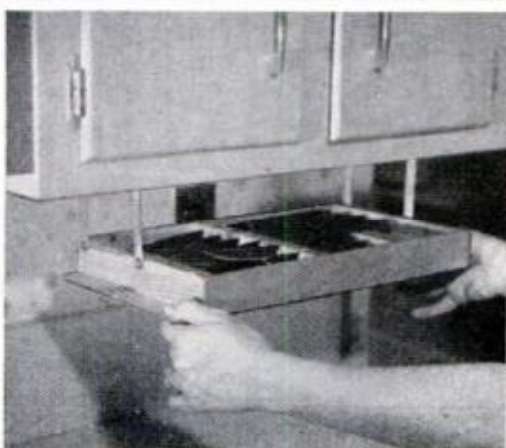

Pedal-Plane

You can add it to an existing

YOU DON'T NEED NASA to put your kids in orbit. They'll really get a blast out of this attachment that adds whiz-around variety to the back-and-forth motion of a set of swings. If your back yard is already graced with a sturdy swingset, you can add the whole pedal-plane unit at a cost of about \$14 for ma-

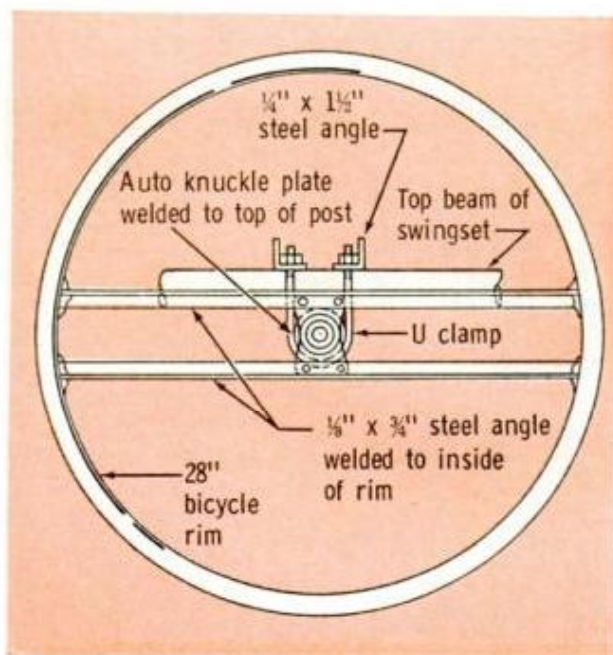

Whiz-Around

By David A. Gattis

back-yard swingset—or hang it from a freestanding pole

materials. The only power tools you'll need: an electric drill and an arc welder. Don't own the latter? Then you can prepare all pieces for assembly and take them to a welding shop. If you *don't* have a swingset now, you can erect the pedal-plane as a separate unit, taking a bit more care with the "planting" of the

pivot pole, and adding prop-type supports.

Roller and ball bearings eliminate virtually all drag, making the revolving mechanism surprisingly easy to operate. My three-year-old often "solos" at speeds up to 15 mph (circular miles) at an altitude of from one to four feet. My unit is designed for youngsters under 120



lbs., but additional supports could be added to adapt it for larger children. The truss and center post have been tested at over 200 lbs., but with this weight applied, only the most rugged swingset frames will provide necessary bracing.

In the sketch on the previous page, we show a two-seater unit, for small youngsters, balanced by a single-seater for older kids. In this arrangement, you've got a double pedal action, with both drive belts bearing on the same bicycle rim. But as the sketch below indicates, a single pedal-plane unit will spin the structure nicely, and you can provide balance

by hanging a baby swing, basket, hobby-horse or what have you from the other end of the beam. Surprisingly, the extra weight is hardly noticed by the pedaler.

The front of the seat unit actually hangs on the endless belt—its weight is what gives this drive loop enough tension against the pivoted bicycle rim to send the whole unit spinning. The belt (1/4-in. manila rope for economy) passes around the pedal pulley, up through guide pulleys behind the wind-spun prop, up past pulleys on the end of the support beam and across to the central rim. The front chain is merely a safety factor,

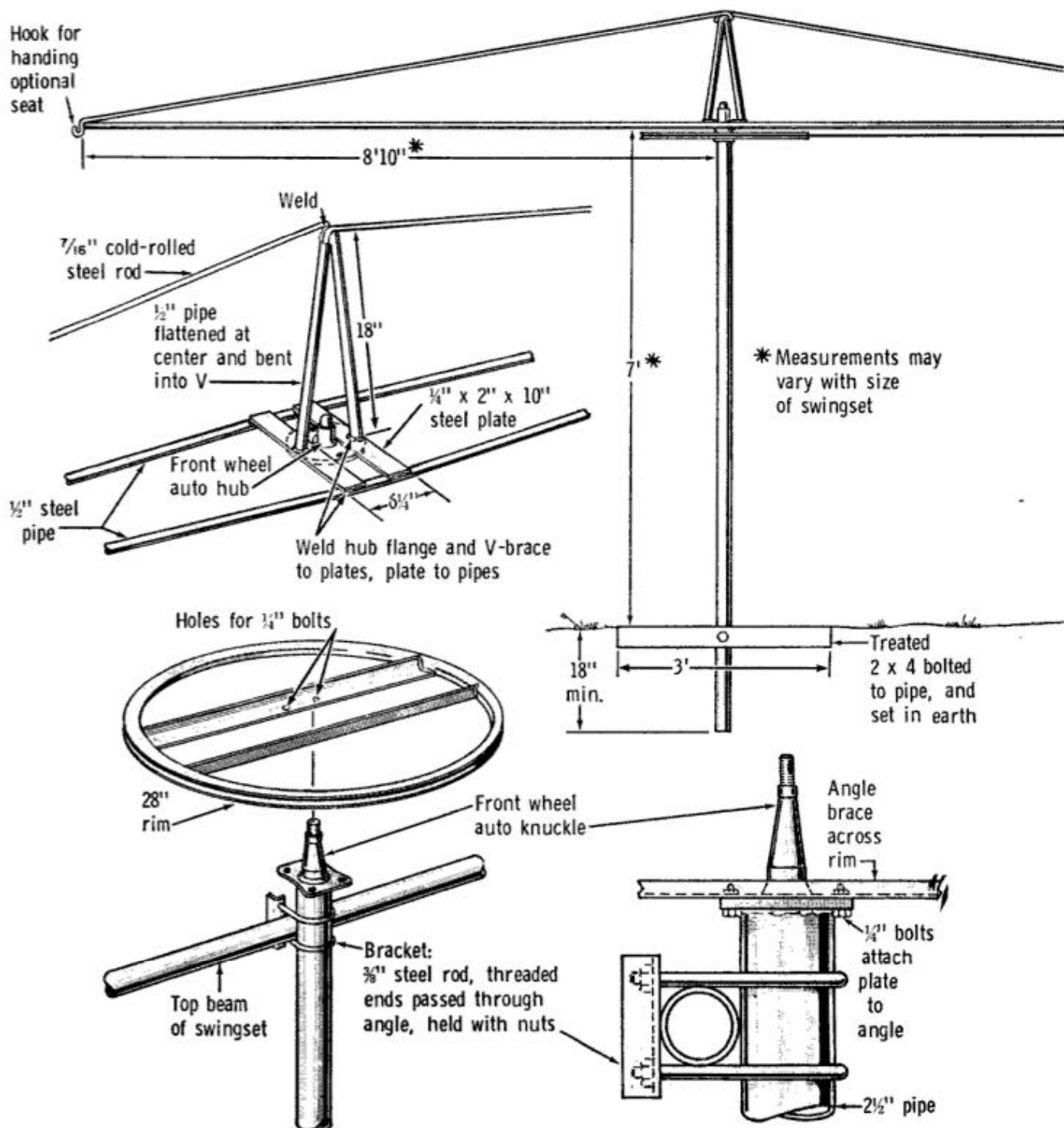

since the drive belt is subject to wear and could, in time, break; a small spring between a few top links keeps this chain taut in normal use. The rear chain is, of course, what holds the back of the plane up. It attaches about two feet above the center of gravity, for stabilization.

The belt is made by untwisting a foot of rope at one end and weaving the strands back through an untwisted portion of the other end. Trim off the loose ends and you've a splice that can't pull apart. To eliminate belt slippage, rubber electrical tape (or a strip of old inner-tube) is wrapped around the bicycle

rim and a vacuum cleaner belt is snapped over the drive pulley.

The plane unit itself is of the simplest possible construction. The seat frame is a double bend of 1/2-in. water pipe; the size indicated is adequate for two seats for children two to five years old, and the seat positions are adjustable.

The fork of an old tricycle provides the drive mechanism. Remove the wheel, but leave the 1/2-in. shaft at the center. With the crank I used, a 5/8-in. hole in the pulley just cleared the elbows. After positioning the pulley I shimmed the

(Please turn to page 184)

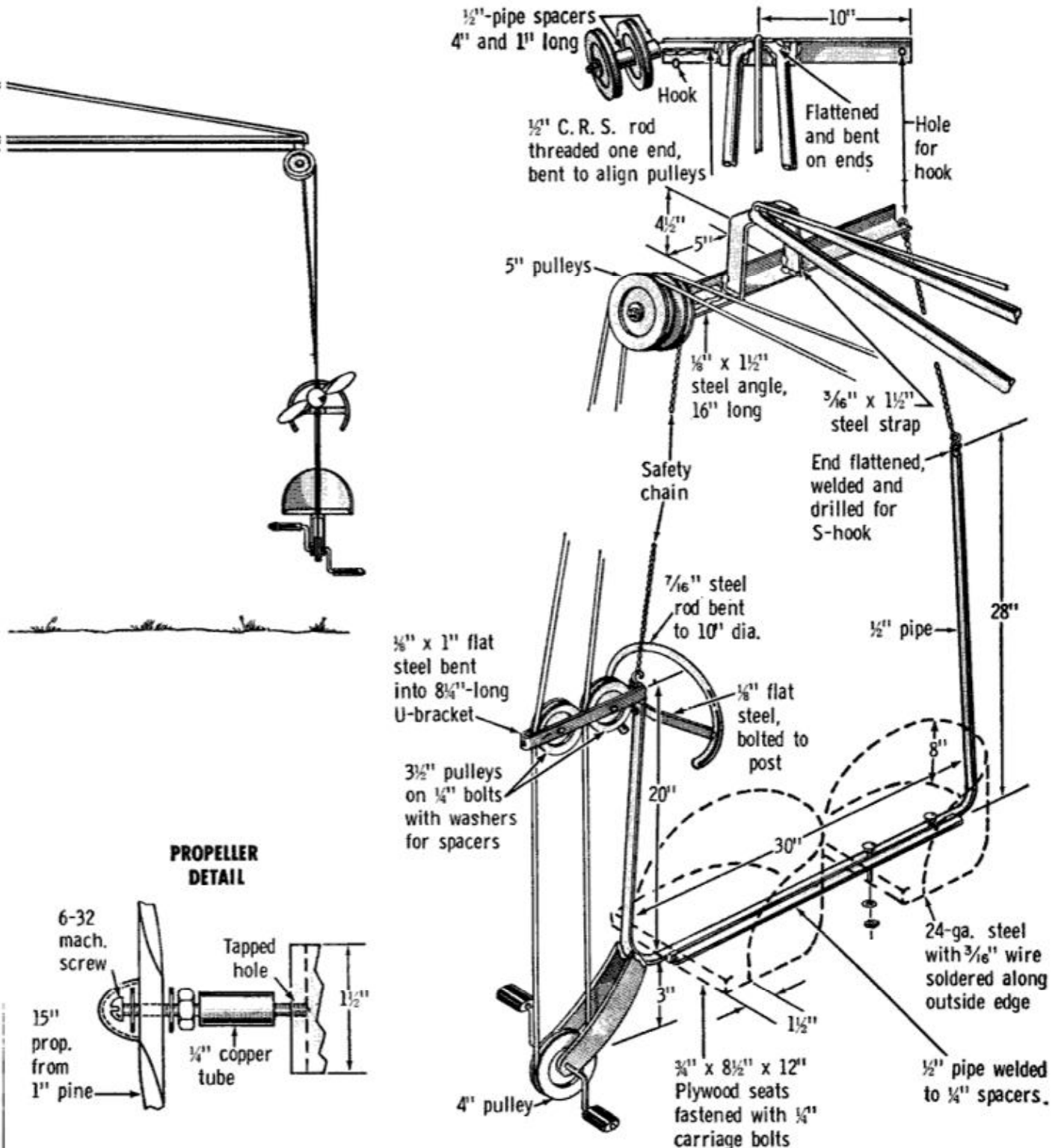

Which Glue Is Best for Wood

● POLYVINYL

● PLASTIC RESIN

● CASEIN

● EPOXY

● RESORCINOL

● CONTACT CEMENT

By James D. Thompson

THE "BEST" GLUE FOR WOOD is the one that will provide sufficient strength and durability at the lowest cost. Put it another way: The glue used for any job should be a little stronger than the wood that forms the joint being glued.

Let's delve a little deeper into the pros and cons of the more popular types of wood-joining glues on the market today. An elementary understanding of them will help you achieve cleaner, stronger, longer-lasting gluing jobs.

Polyvinyl, or white glue, is probably the most popular adhesive on the market today. It comes ready to use, applies easily and dries quickly.

How strong is it? Well, according to a leading maker of this glue, "polyvinyl is as strong as casein or plastic resin glue; however, its fatigue resistance under stress is not as great." This is a slightly roundabout way of saying that polyvinyl will make as strong a bond as other glues—so long as the bond is not subject to

undue amounts of stress and strain.

However, as the gluing chart on page 140 shows, there are only two instances in which polyvinyl glue is a *first* choice. For example, it is not recommended for furniture joints unless they are "self-supporting"—such as mortise-and-tenon and dovetail joints.

The shelf life of polyvinyl glue is almost unlimited, but it can still go bad. Watch for excessive thickening or separation. If the glue has started to separate, it is either bad or it has been extended.

This glue is said to be extended when it contains less than 55 percent *polyvinyl* solids. The "guts" of white glue are the polyvinyl resins it contains. Some manufacturers of cheap white glues use as little as 21 percent polyvinyl resins in their product. Instead, they *extend* their glue by using talc or clay as a filler to give the appearance of true polyvinyl glue to an essentially inferior product. Don't get stuck with this stuff; it won't stick. Be-

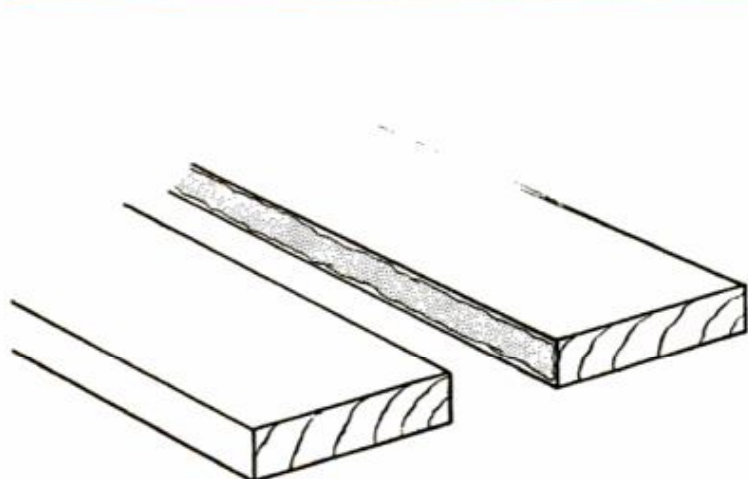

Butt joint relies on glue entirely

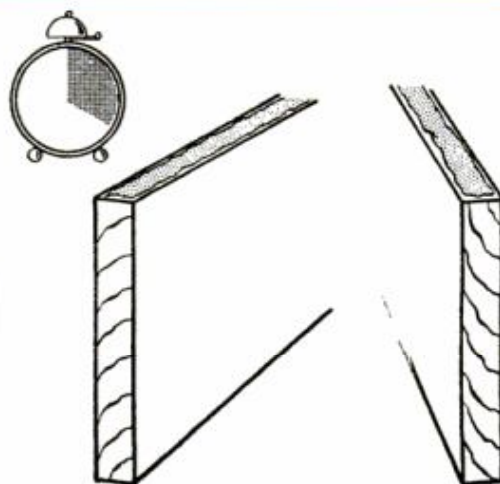

Let resorcinol glue stand 20 minutes

fore buying, check the label. It should stipulate "55 percent *polyvinyl solids*."

Polyvinyl does a beautiful job gluing end grain of lumber and edge grain of plywood. These surfaces soak up glue like a sponge, so the joining surfaces should first be sealed with glue, then a second coat applied when they are actually joined.

Bear in mind the following *don't's* when using polyvinyl glue:

- *Don't* apply it at temperatures lower than 60°F. If you do, it will not cure properly and the result will be a weak joint.

- *Don't* let excess glue dry on the surface of the work. Wipe it away with a damp cloth. This will permit the area to be stained later.

- *Don't* use excessive pressure when clamping work joined with white glue; high pressure will force out too much glue.

- *Don't* use a nail to seal the spout of your white-glue container; the glue vapors will corrode it and the corrosion will discolor the glue.

Plastic resin. This glue is a favorite among professional furniture makers and home craftsmen. It requires heavy clamping pressure which results in thin, almost invisible glue lines. High clamping pressure is essential because of the considerable shrinkage that takes place as this glue dries. However, shrinkage can be controlled and almost eliminated by adding furfural alcohol to the adhesive. Formerly available only in large quantities, smaller amounts of furfural alcohol can now be ordered from Wilhold Glues, Inc., 678 Clover, Los Angeles, Calif. The use of this additive introduces great flexibility to this type of glue.

Plastic resin glue consists of a powdered urea-formaldehyde resin and a powdered



RESORCINOL GLUE CURES FAST in hot weather. You'll prolong its pot life by packing ice around glue pot

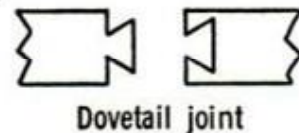
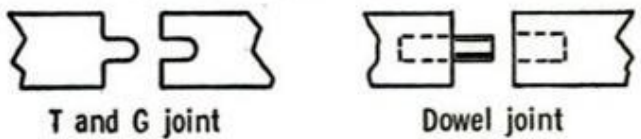

Self-supporting wood joints

catalyst. It is ready to use when mixed with water. When dry, it forms a rock-hard glue line that is a good deal stronger than the wood itself. It is stainproof and not susceptible to fungus, rot or bacteria. Because it is cold-waterproof, strong, workable and economical, many boat manufacturers use it. However, where absolute waterproofing is required, or for joints that are subject to physical or thermal shock, resorcinol glue should be used.

Because the plastic resin is chemically

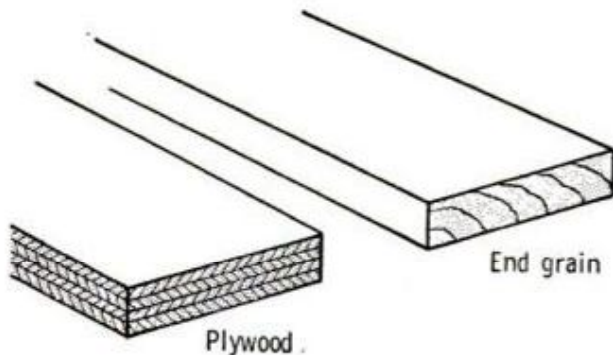

Edge grain requires initial coat

AUGUST 1966

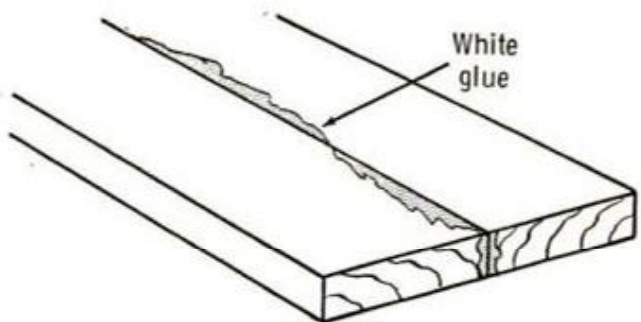

Wipe glue smears with damp cloth

139

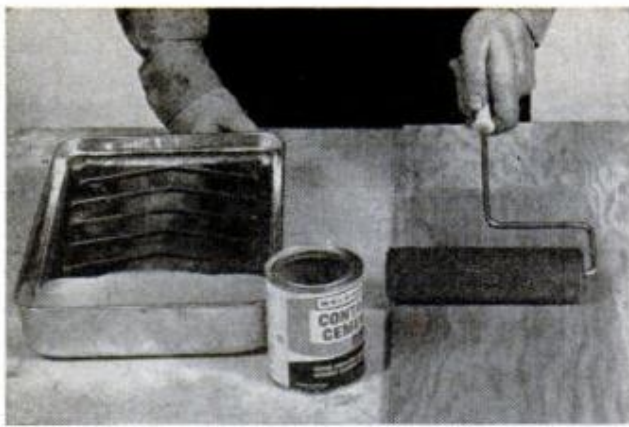

FOR SMOOTH, UNIFORM APPLICATION of contact cement to large areas, apply adhesive with a paint roller

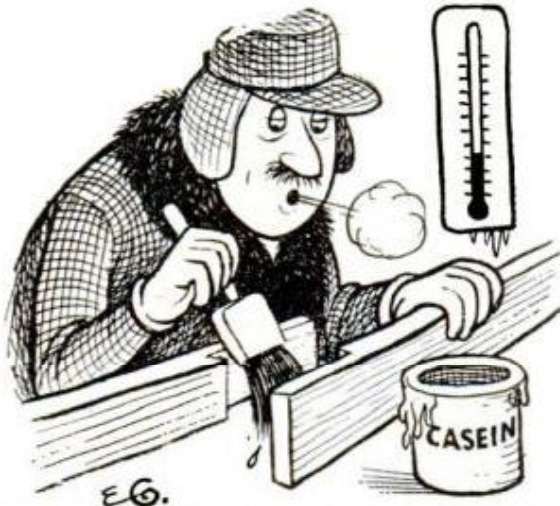

Only casein glue is safe below 60°F.

neutral, it will not stain acidic woods such as oak, mahogany and redwood as will casein glue, an alkaline substance.

Properly stored, plastic resin has a shelf life of about one year. If this glue does not dissolve thoroughly within 30 minutes, it is not usable and should be thrown away. But be sure you have mixed it according to the directions printed on the container; these vary from one manufacturer to the next.

Casein glue. The alkalinity of this glue is an advantage when oily woods such as teak, osage, pitch pine and yew are to be joined. Most of the oil can be removed from the surface of such woods by sponging the joint with acetone or a dilute caustic soda solution one hour before gluing. Any oil remaining will be saponified by casein's alkalinity, and the glue will then be able to get a good grip on the wood fibers.

Because its solid particles are coarser than those in plastic resin or polyvinyl, casein glue makes a slightly thicker glue line, so don't screw down too tightly on the clamps or too much will be squeezed out. Casein doesn't shrink much when drying, so it's great for filling gaps in poorly fitted joints. Highly water-resistant, but not waterproof, it is the only glue that

(Please turn to page 191)

WOODWORKERS' GLUING CHART

Data from The Borden Chemical Co.

TYPE OF WORK	GLUE FOR LOW-COST WATER-RESISTANT JOINT (In order of preference)	TYPE OF WORK	GLUE FOR LOW-COST WATER-RESISTANT JOINT (In order of preference)
All general gluing of hard and softwoods	Plastic resin glue Casein glue Polyvinyl glue	End-wood joints, mitered joints, scarf joints	Polyvinyl glue Casein glue (heavy mix)
Particle and chip boards to wood	Plastic resin glue Casein glue Contact cement Polyvinyl glue	Loose-fitting joints, relatively rough surfaces	Polyvinyl glue Casein glue (heavy mix)
Plywood to decorative plastic laminates	Casein glue Contact cement Plastic resin glue	Doweling	Plastic resin glue Polyvinyl glue
Laminating heavy framing members	Casein glue	Hardboard to plywood, wood or itself	Plastic resin glue Casein glue Polyvinyl glue Contact cement
Veneering, inlays, cabinet work	Plastic resin glue (extended) Polyvinyl glue	Porous materials, such as linoleum and canvas to wood	Plastic resin glue Casein glue Contact cement
Bonding oily woods (teak, pitch pine, osage, yew)	Casein glue (sponge surface with dilute caustic soda solution 1 hour before gluing)	Plastics, metal and foil to wood	Epoxy glue

Your Kids Will Get a

Out of This

IF YOU WANT to become a favorite uncle or make a hit with your own kids, make this Big Bertha cannon. It's perfectly safe indoors, since the "shells" are corks and the explosive is compressed air delivered by a hand pump.

The 13-in.-long barrel is 1 1/4-in. thinwall conduit. Solder a disc of sheet brass in one end so the barrel is airtight when corked. About 1/2 in. from this end, drill and tap a 1/4-in. hole to match the thread on a piece of 1/4-in. brass pipe cut 1 in. long. For strength, solder this piece, which is your air connection. File two or three crosswise grooves on the unthreaded end to grip rubber tubing. Smooth and round the inside lip of the muzzle and polish the last inch inside the tube with fine emery cloth.

Make the gun carriage according to the pattern below. Round out the V-groove in it with sandpaper wrapped around the bar-

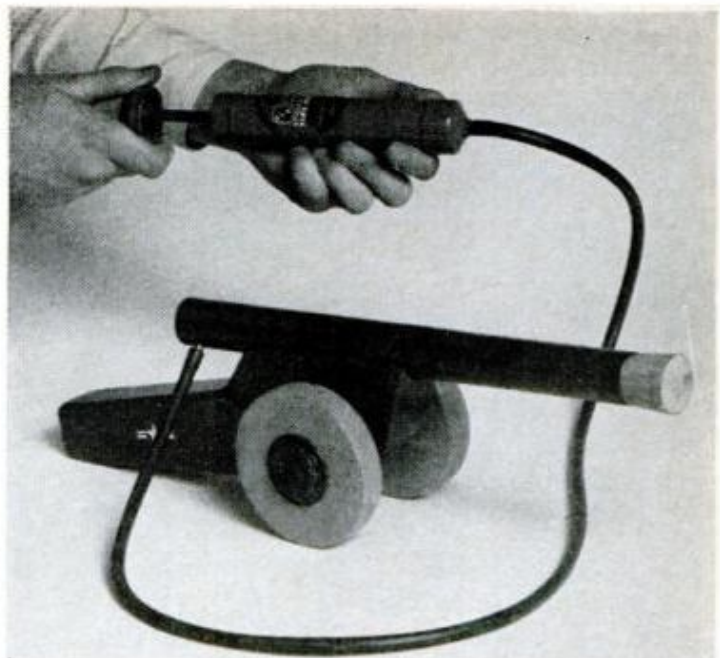

rel and bed the barrel with epoxy cement. Glue on the wheel spacer blocks.

The wheels are also made from 1-in. stock and have a 2-in. radius. Drill 1/4-in. holes through the spacer blocks, carriage and wheels for the axle. I made my axle from 1/4-in. brass tank float rod, cut to a 4 5/8-in. length and threaded 1/4-20. Use washers on both sides of the wheels; turn on nuts, and peen the ends of the axle. Tack on cocoa-tin lids for hub caps.

Hook up a length of windshield-wiper tubing to the air connection; attach a football or tire pump; press a cork in the muzzle, and go to war.—Howard W. Teter

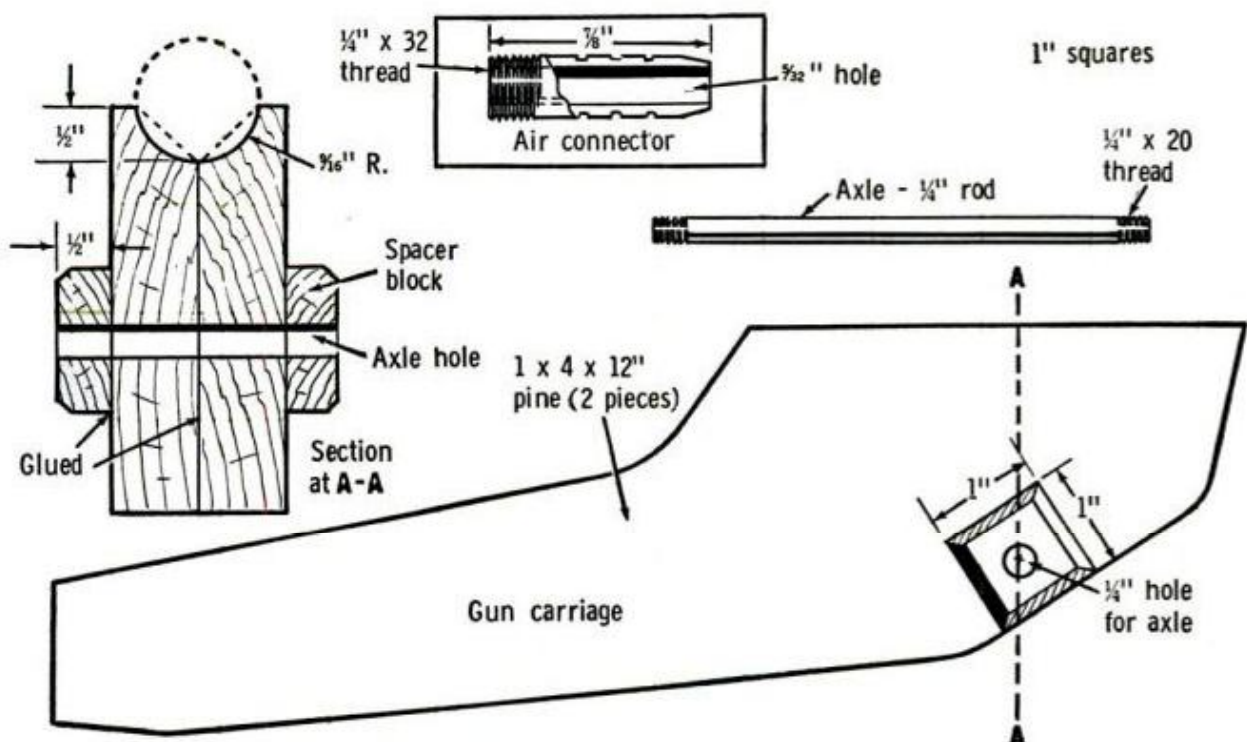

Helpful Photo Tips for Easier Picture Making

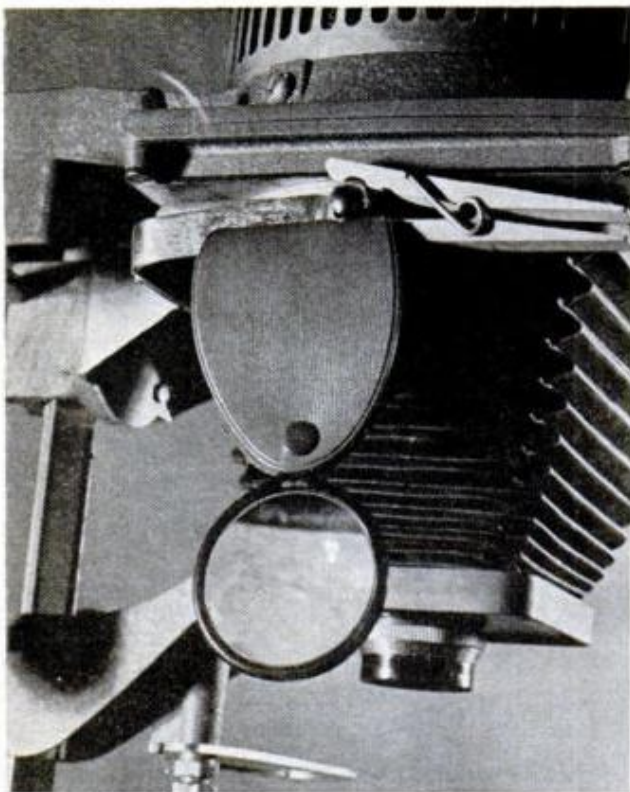

Darkroom eyestrain cure

The tiny engraved aperture markings on your enlarger lens can be made easier to read by clipping on a folding pocket magnifier with a clothespin. Attach it to the tilt arm if maximum-format enlarging is your custom or to the filter holder if you vary sizes by extending the bellows.

Fixing an air release flat

When your air-release bulb gets a hole in it, an emergency substitute—and one that is an improvement over the bulb—is a small plastic glue bottle. It will last indefinitely if not left lying in the sun and is perfect for a foot release since it will not roll on the floor.—*R.M. Eadie*

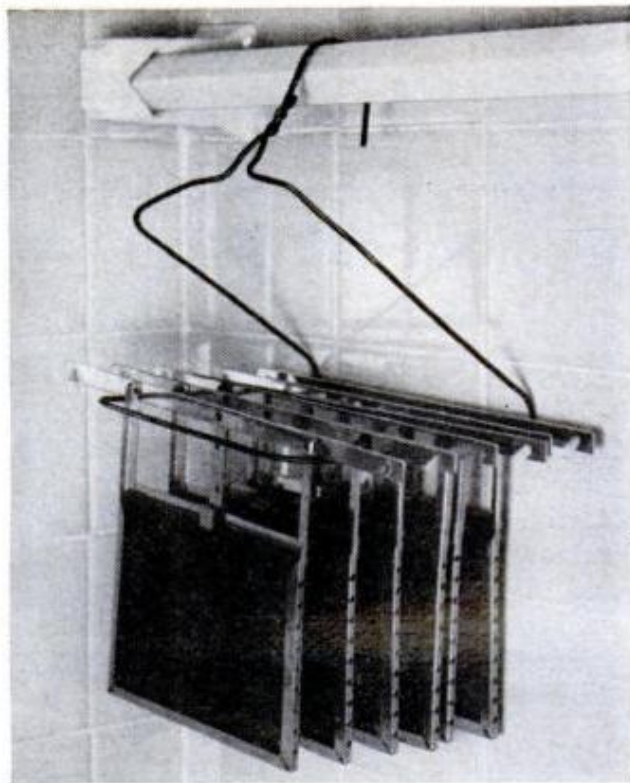
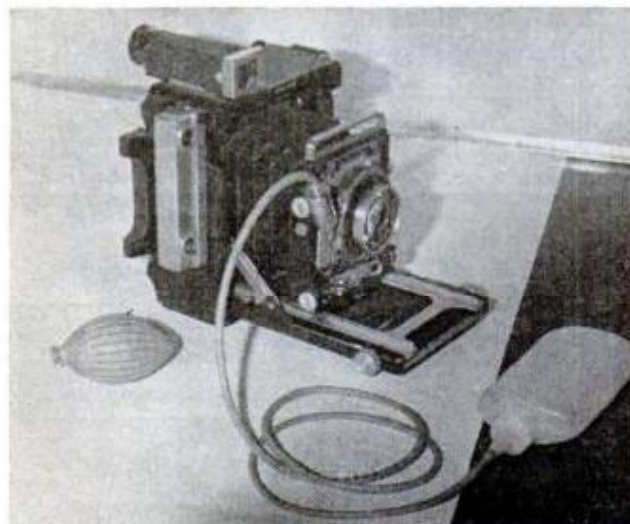

Handy holder for hangers

When you need extra rack space for drying sheet film in hangers, an easy out is this coat-hanger rack. Bend a heavy-gauge wire hanger to the shape shown, taking care that the center of the supporting arms is directly under the center of the hook to prevent tipping.—*Mike Brenish*

Folding flash extension

For off-camera and slave flash with your folding B-C flashgun, cut the existing flashcord and wire the stub to a multiple surface outlet. Attach the outlet to the case with epoxy cement and plug in a coiled strobe extension. The extra sockets provide for slaving.—*H.E. Guenther*



NEW FOR
CAMERA BUFFS
BY LEONARD SAMUELS



Goggle-eyed 18mm ultra-wide-angle f/9.5 Rokkor lens for Minolta SLRs sees through lens—no mirror lock-up needed. It covers 180° diagonally. Focus is fixed from 18 in. to infinity at f/22. Price not set but will include filters, cap, case. Minolta Corp., 200 Park Ave. S., New York, N.Y.

Photo images anywhere with Print-E-Mulsion at \$7.50 a pint. It's applied to any material under safelight, exposed under an enlarger and developed in standard manner. Rockland Associates, 333 E. 46th St., New York, N.Y.

Synchronize any tape recorder with automatic slide projector via Genie at \$5.95. It adheres to tape deck, is cued with pressure-sensitive foil tape on recording tape back. National Camera, 2000 W. Union, Englewood, Colo.

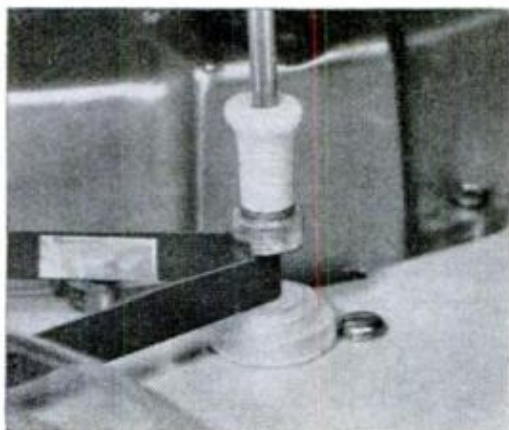

AUGUST 1966



Ready for action, cameras or binoculars held by the Universal Accessory Harness hug the chest. Scuba model at \$5.95 is rubber, stainless steel. Baseplate is extra. Elastic land model is \$3.95. W.J. Banks & Associates, Box 1048, Hanover, N.H.

Four-minute print dryer has nichrome heating elements. Thermagloss 12x17-in. unit for \$9.65 features a canvas duck platen that holds two 8x10s. Double-surface model at \$12.75 holds four. Sterling-Howard Corp., 236 South Sta., Yonkers, N.Y.

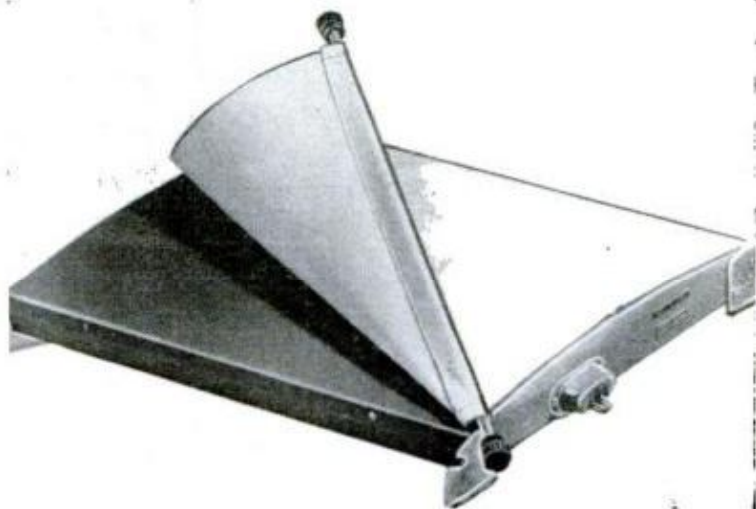

143

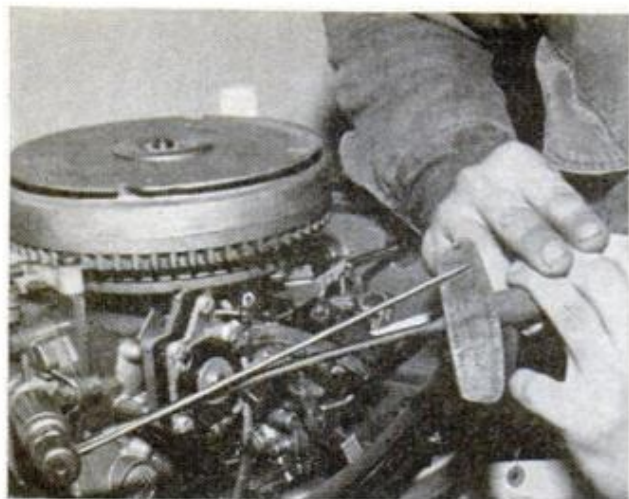

TORQUE WRENCH is an absolute necessity when installing sparkplugs. Tightening them too much or leaving them loose can both cause you plenty of trouble

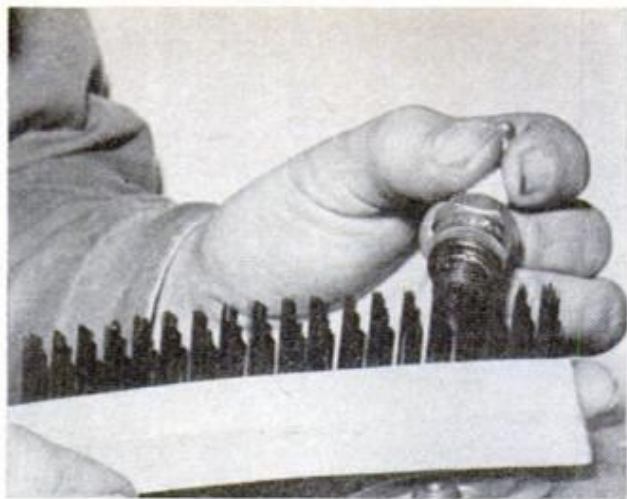

YOU DON'T NEED a sand blaster to clean plugs. A good scrubbing with a wire brush will remove all deposits and it saves you a trip to the gas station

YOUR OUTBOARD MOTOR

The Perfect Marine Plug

By Henry B. Notrom

WHY IS IT that any time an outboard so much as burps, the first thing most owners blame is the sparkplugs?

Sure, 60 percent of all problems reported to outboard shops center on plugs, but sparkplug failure is rarely caused by defective plugs. When a plug goes bad, it's usually traceable to one of three things: using the wrong plugs for your type of operation; improper installation of the plugs; or fouling the plugs with a fuel having a high tetraethyl lead content. Simply replacing the plugs, without correcting the condition which caused them to fail in the first place, doesn't make sense.

Recognizing that there is a problem certainly isn't difficult. Your engine will practically climb off the transom to tell you about it. Any of the three above conditions will cause it to miss or fail to develop full speed. A fouled or improperly installed plug can prevent it from starting, while your use of the wrong type of plug may cause rough idle or overheating.

Of course, any of these malfunctions can result from a multitude of other conditions inside the engine, so a careful examination is necessary. Servicing and analyzing plugs is a breeze. The only tools needed are a torque wrench, $\frac{13}{16}$ -in. deep socket, wire brush, point file, feeler gauge

and your eyes. Remember that sparkplugs have only one job—to transform the voltage provided by the ignition system into a spark of from 300° F. at idle to 1700° F. at full throttle. This spark ignites the fuel mixture, which makes your engine go putt-putt.

Remove the plug wire by grasping the boot and giving it a twist. Pulling on the wire itself may part strands.

Give the boot a careful examination inside and out. Look particularly at the inside where it was in contact with the plug porcelain. If you discover fine cracks along this surface, replace the boot. It's old and has lost its sealing ability. A long crack in the boot can indicate that the plug itself is cracked, allowing high voltage to leak through. That could well be the reason why your engine is misfiring. If you find such a crack, both plug and boot will have to be replaced.

To replace the boot, just pull it loose from the plug wire. On most engines, you'll notice a little coil spring set crosswise on the end of the wire that keeps the boot in place and making contact with the plug terminal. Incidentally, it will be a lot easier to put the boot back on the wire if you spray the inside with silicone lubricant.



TO GET AT ELECTRODES for filing, bend the ground electrode open slightly. The feeler gauge shown here has a special tang at one end just for this job

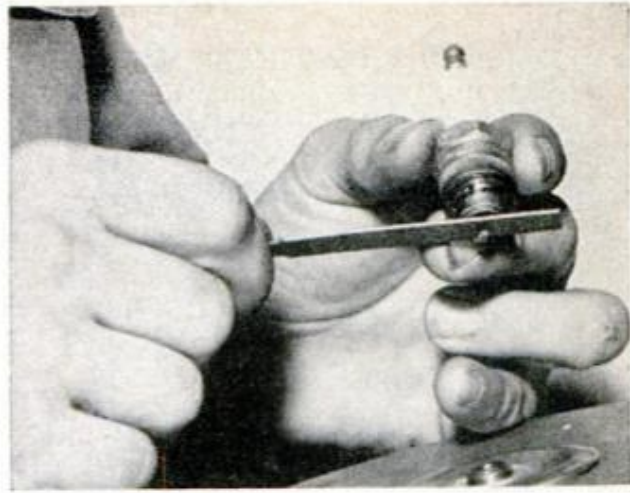

DON'T BE AFRAID to use that ignition file. Give both ground and center electrodes a good filing to clean and smooth the surfaces. You can reset the gap later

It's the sparkplug that matches your motor and your boating habits. Here's the way to find that ideal plug and how to get top performance from it

Up until three or four years ago, the plug gasket was separate from the body and would have normally been replaced, just to play safe. Today, the gasket is part of the plug body. You can't remove it, but give it a careful examination anyway. If it's in bad shape—really flattened or corroded—discard the plug for a new one.

Now that you have the plug out, how can you tell whether it's been the right

one for your type of operation? The best tip-off is the color of the porcelain. If a plug is right for operational conditions, the insulator body turns a dark brown or coffee color. An insulator that is pure white or has flaky white blisters on it indicates the plug is too hot for your type of engine operation. You've probably been doing high-speed running with a plug intended for lighter use. That plug wasn't able to

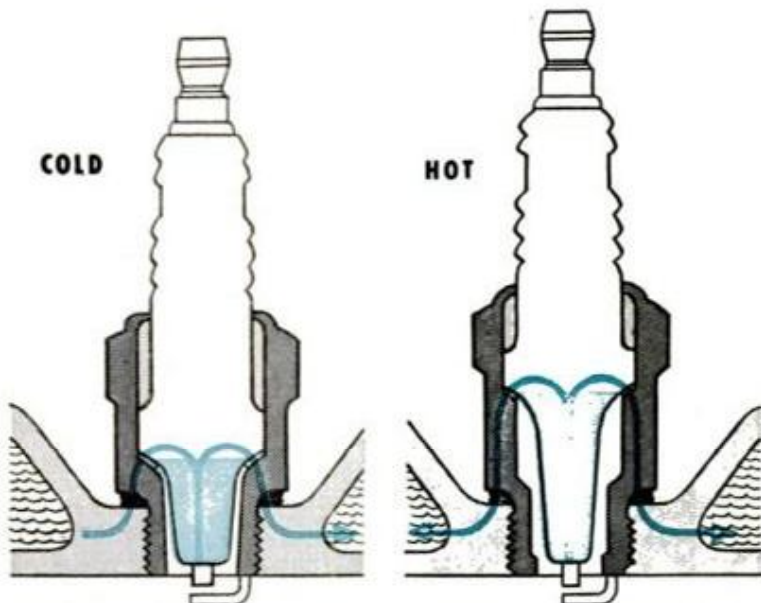
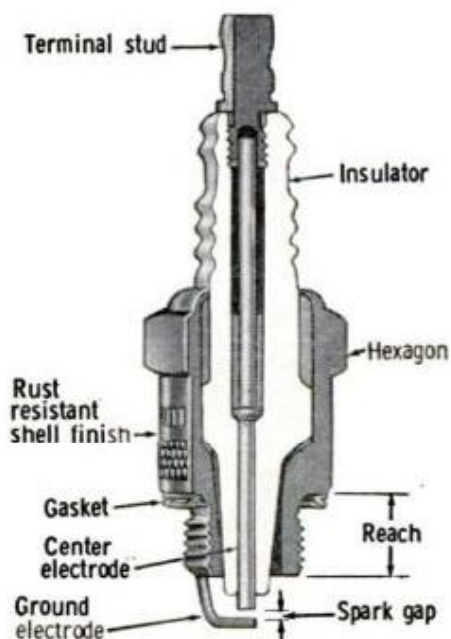

DIFFERENCE BETWEEN HOT AND COLD PLUGS is actually just the length of insulator nose. A cold plug cools quicker because heat has a shorter distance to travel to reach the water jacket

Merc's New Polar Gap



THUNDERBOLT is the name Kiekhaefer has given to the new electronic ignition system used on its 1965 950SS and 1100SS. According to the company, its voltage impact far surpasses that of conventional coil-and-battery systems. The super-cold Polar Gap plugs used with this system are said to operate at temperatures between 800° and 1000° cooler than standard plugs, virtually eliminating preignition, even with leaded fuels. Don't buy them for your motor, though. These plugs will only work with Thunderbolt ignition and, as of now, it's available only on the two engines mentioned

dissipate operational heat fast enough and became too hot, causing the insulator to sear or blister. Switch to a colder plug.

Conversely, if the plug you removed from the engine has an insulator that's black, it signifies the plug is too cold for engine operation. The plug has been transferring heat too quickly to burn off combustion deposits. You've probably done a lot of idling and low-speed running, while the plug is really meant to meet the needs of higher speeds.

Generally, then, a colder plug is needed

when most of your operation is going to be at high speed. A hotter plug is needed when most of your operation is at idle, low speed and light-load trolling.

Whether a plug is rated "hot" or "cold" has nothing to do with whether it provides a hotter or colder spark. A hot plug doesn't produce any hotter spark than a cold plug. The difference is in the length of the plug's insulator nose. Plugs with long noses transfer heat slowly and are considered "hot" plugs; those with short noses transfer heat rapidly and are known as "cold" plugs.

Where do you begin on the heat range chart? Each outboard manufacturer recommends a sparkplug type for "normal" operation—that is, a fairly equal amount of low-speed and high-speed operation. This is where to start. You'll find the recommended plug for your engine in the operating manual.

Now, if you have to switch to a colder or hotter plug, do it gradually. Don't jump all the way to one end of the heat range scale. Go only one step up or down.

For example, suppose you have a 1963 Mercury 500, which normally takes a Champion J6J plug (or an AC M44C, or an Autolite A3X). After several weeks' use, you find that the insulator remains white, pointing to the probability that the plug is too hot for your type of operation. You want a colder plug, so you say to the supply man:

"I've been using a J6J, but I need a plug that's one step colder."

He'll go to his conversion chart and give you that colder plug, which is a Champion J4J (or AC M42K or Autolite A21X).

It's as easy as that.

While a great many problems can plague

HOW TO "READ" A MARINE PLUG

PROBLEM	APPEARANCE	MALFUNCTION
Normal wear	Light tan or gray deposits. Little gap wear. Electrodes not burned.	None. Clean, file, re-gap and reinstall.
Wet (carbon) fouling	Wet or damp black oily deposits.	Gummy fuel residue; prolonged trolling (plug too cold for use); fuel not mixed well; improper fuel-oil mixture. Clean, file, regap and reinstall after correcting problem.
Overheating	Badly eroded electrodes. Blistered white or gray insulator.	Plug too hot for engine use; fuel mixture too lean; timing far advanced; piston rings sticking; bad water pump; engine lugging; clogged water jackets. Replace plug.
Gap bridging	Deposit lodged between ground and center electrode.	Accumulated deposits in combustion chamber probably resulting from too much trolling. Operate engine at high speed to clean out engine.
Worn out	Badly eroded electrodes. Light brown deposits on insulator.	Plugs kept in use too long. Should be changed every 100 hours of operation.

the electrode end of automobile spark-plugs, years of testing by outboard manufacturers show that one single factor affects plug life far more than any other—the gasoline used in the engine. Much of that trouble is simply lead fouling from too much tetraethyl lead.

It's a fact that marine white gasoline virtually eliminates lead fouling. It also does away with carbon fouling caused by the way in which some fuels burn to leave a gummy residue. (Carbon fouling can have other causes, however. Check the chart on the opposite page.)

Marine gasoline has an octane rating of 75 to 80 and contains no tetraethyl lead, but don't let the low octane rating throw you. A gasoline rated 75 to 80 may not do for today's high compression auto engines, but it is more than adequate for lower compression marine engines.

Even with leaded gasolines, the lead content can sometimes vary greatly from area to area. With one particular brand, for example, it was found that the lead content was 0.58 cc in Wichita, Kans., and 2.95 cc in Dallas, Tex.—that's an increase of over 400 percent in about 1000 miles.

If your plugs are lead-fouling, you'll find yellow or brownish deposits on the electrode end. No need to throw them away, though. They can be cleaned, filed,



REPLACING BOOT on the plug wire will be much easier if you take the time to spray the inside with a silicone lubricant first. Note the spring on wire

regapped and put back into service. However, the question remains as to what can be done to eliminate the fouling.

In the absence of marine white gas, the only thing you can do is to switch from gas brand to gas brand. You may be lucky enough to hit one that has a moderately low tetraethyl content.

To clean plugs, simply scrub the electrodes with a wire brush. It does a good job. When a plug is brushed clean, open the ground electrode slightly. Use a bending tool which is part of most feeler gauge

(Please turn to page 197)

OUTBOARD CLINIC

Q—My 1959 Johnson 35 is overheating. The cooling system, including the water pump, has been gone over with a fine-tooth comb. Are there any "strange" conditions I should look for?—T. K. L., Wisconsin

A—Three conditions which can cause overheating are often overlooked in this engine. For example, check the seal on the driveshaft to see if it has grooved the shaft. If it has, it isn't possible for the water pump to deliver adequate water for cooling.

Make sure that sealer has been used between the top face of the gear case and the impeller housing plate. If there's a leak here, exhaust gases may be getting into the recirculating system, resulting in too much air and too little water for cooling.

Finally, there's a plug in this engine that holds the water intake screen in place. If this plug is missing, exhaust gases can leak into the cooling system.

Q—I think I've been running my Mercury 650 on an over-rich fuel. (At least the plugs have fouled.) I've tried re-adjusting the carburetor, but no dice. What do you recommend?—T. L. S., South Carolina

A—Mercury suggests that you replace the high-speed carburetor jets with those now recommended for this engine and the Mercury 1000, too. The new jet, which Mercury dealers have, is .002 in. smaller than the ones now in your engine.

Q—PM's story on fishing motors (April, 1966) claims that McCulloch is the only outfit making small outboards equipped with electric starting. How about Chrysler?—B.E.M., Michigan

A—Information on Chrysler's new 9.2 and 20 Autoelectrics didn't reach us until after the story had gone to press.

Any Questions? For a personal reply to questions concerning repairing your outboard motor, write to Outboard Clinic, Popular Mechanics, 575 Lexington Ave., New York, N.Y. 10022. Enclose 25 cents in coin

SWING-UP STERN LADDER



1/2" No. 8 BRASS SCREWS AND GLUE SECURE 1x1 CLEATS TO LADDER

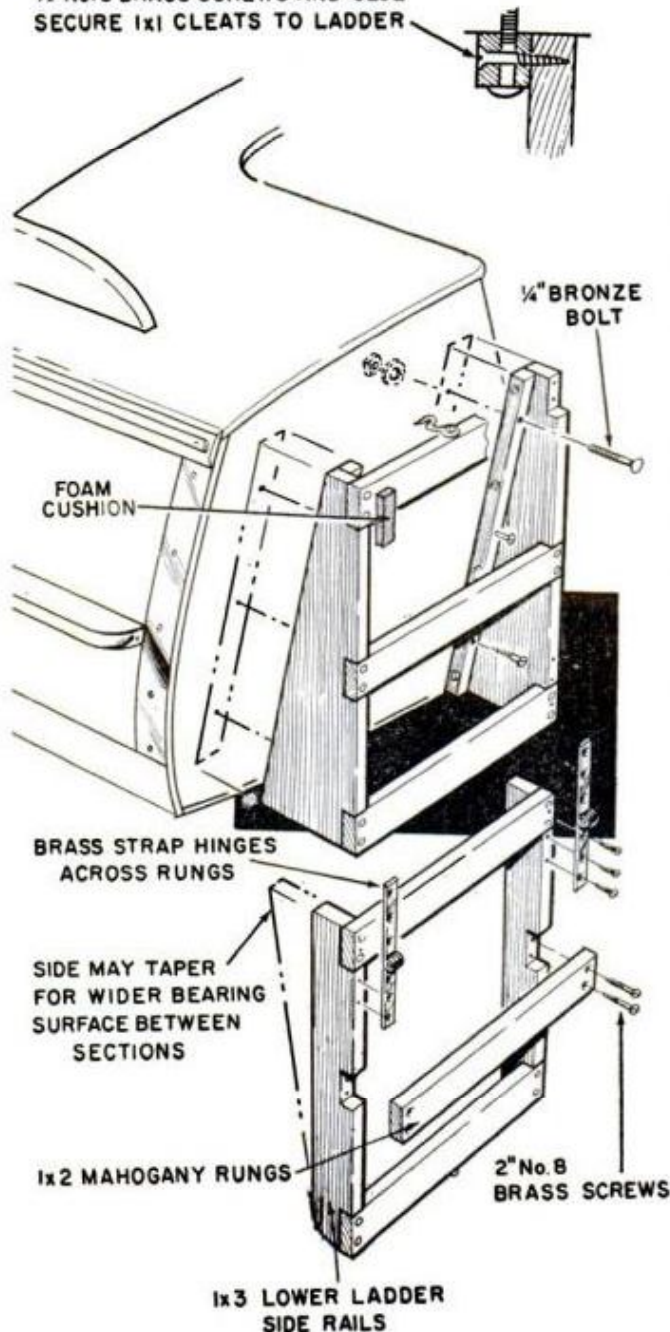

IF YOU'VE EVER TRIED to climb into a boat from the water without using a boarding ladder, you know just how necessary this accessory can be. It's almost a must for skiing or swimming. The swing-up model shown here has one big advantage over portable ladders—it's permanently mounted on the transom, thus self-storing.

The choice of materials is up to you. I used 3/4-in. mahogany, although white oak would make a somewhat stronger ladder. You can find out the proper angle for the two upper sides by dropping a plumb bob from the transom and measuring the triangle thus formed. The entire ladder must be tailored to match the transom height of your boat, so plan on running it from the deck down to a point slightly above the water line when the boat is on plane.

Cut the sides of the lower section the same length as those of the upper part to form an even joint when the ladder is folded. For appearance, the rungs should also be spaced to butt against each other when the ladder is swung up.

After determining the rung locations, cut notches in the sides and mount the rungs with glue and screws. If you use brass or bronze screws, the heads may be set flush with the surface and left exposed. For a deluxe job, however, countersink them and cover with wood plugs.

Finally, assemble the ladder according to the plan and paint or varnish it to match your boat.—*Hank Clark*

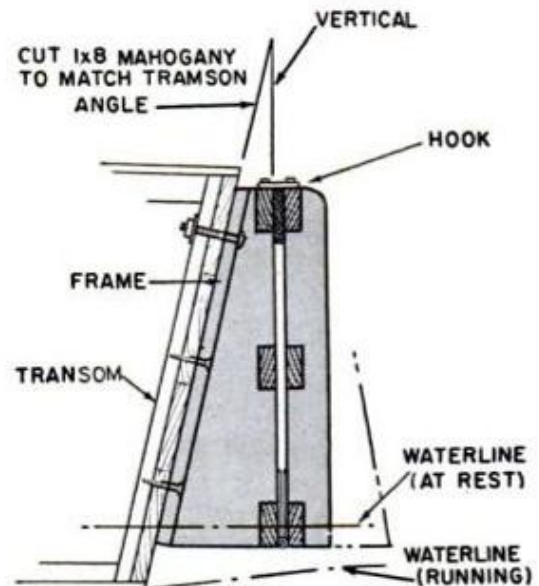

ROLLING SAW STAND FEATURES HANDY BINS

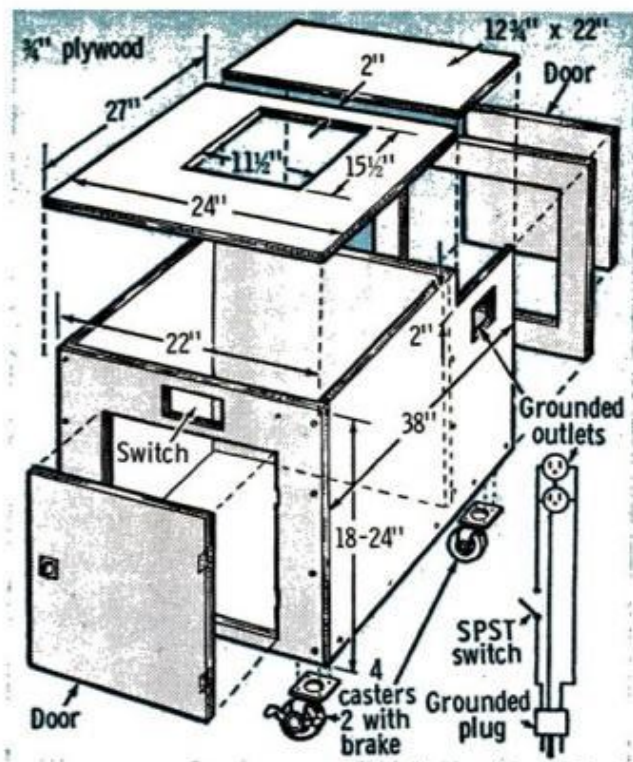

RIPPING AND CROSSCUTTING long lumber in a narrow basement shop becomes a lot simpler when you have your bench saw mounted on a caster-fitted stand which can be swung around easily to let you saw "with the room." Here's a dandy stand that fills the bill.

The overall height should be between 34 and 40 in., depending on your own height. Allow 3 in. for casters and 13 in. for 10-in. saw shown. The height of the base, then, is between 18 and 24 in. Use 2½-in. plate-type casters, the two for the front equipped with locking levers. The

step-down in the top permits the motor to rest securely in its belt. The entire base is made of ¾-in. fir plywood, cut from a 4x10-ft. sheet, joined with glue and screws.

The base is fitted with grounded ganged outlets near the rear that are controlled from a front switch. Use a dustproof switch box. Plugging in the motor, instead of wiring it permanently, permits it to be moved easily to another power tool. The other outlets can be used for a bench light and portable power tools. The power line from the base can be stored in the rear compartment when not in use.—*Ralph Treves*



SAWDUST BIN at front of the base keeps the shop clean. Weatherstrip the door all around to seal it

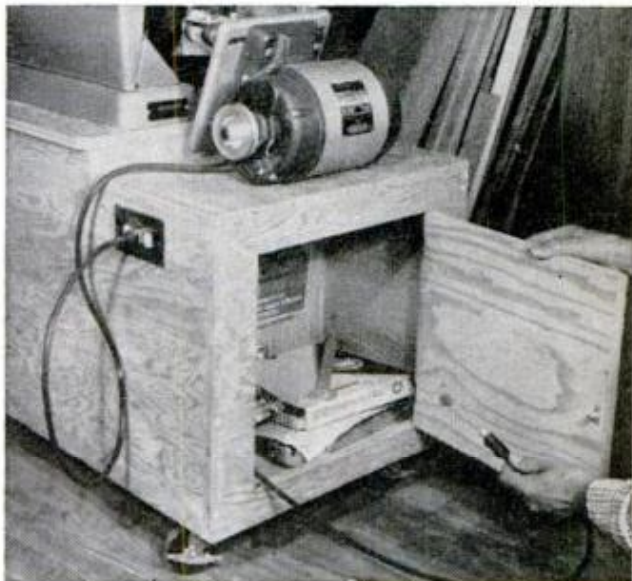

SAW ACCESSORIES and blades find a home in the rear compartment. Use cabinet catches to hold doors

Big-Load Carriers for Beetles

Many of you Volkswagen owners may boast of how efficiently you can pack your vehicles. Let's face it. You need these extra "pockets"

By Art Youngquist and Robert Hoppough

The Top Toter

The versatile Volkswagen sometimes needs help. The spare trunk and the conventional top rack will handle luggage and parcels, but have you ever tried hauling lumber or cartopping a boat?

Build this sturdy top toter and you can lash on anything your suspension can stand. It's designed for "Beetle" VWs only. With it, you're a cash-and-carry customer at the lumberyards, and lugging boats or toboggans and skis is a snap. All it costs you is \$5.

The fact that the rear supports attach to the rear bumper arms means that the car roof bears only half the load. The diagonal braces make an extremely rigid assembly and, because they are only bolted on, permit the carrier to be collapsed for compact storage. Mounting time is only five minutes.

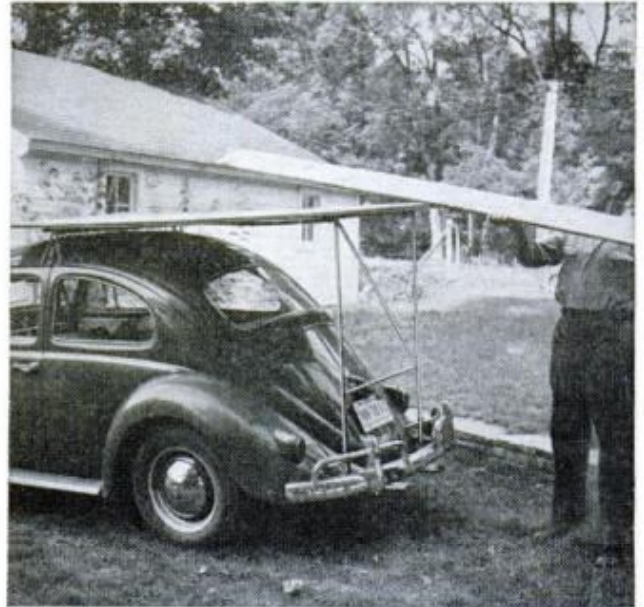

VWS CAN TOP MOST STATION WAGONS with this rack on which sheet building materials can lie flat. With the appropriate red flag at the rear end, you can even carry 14-ft. lumber with adequate support



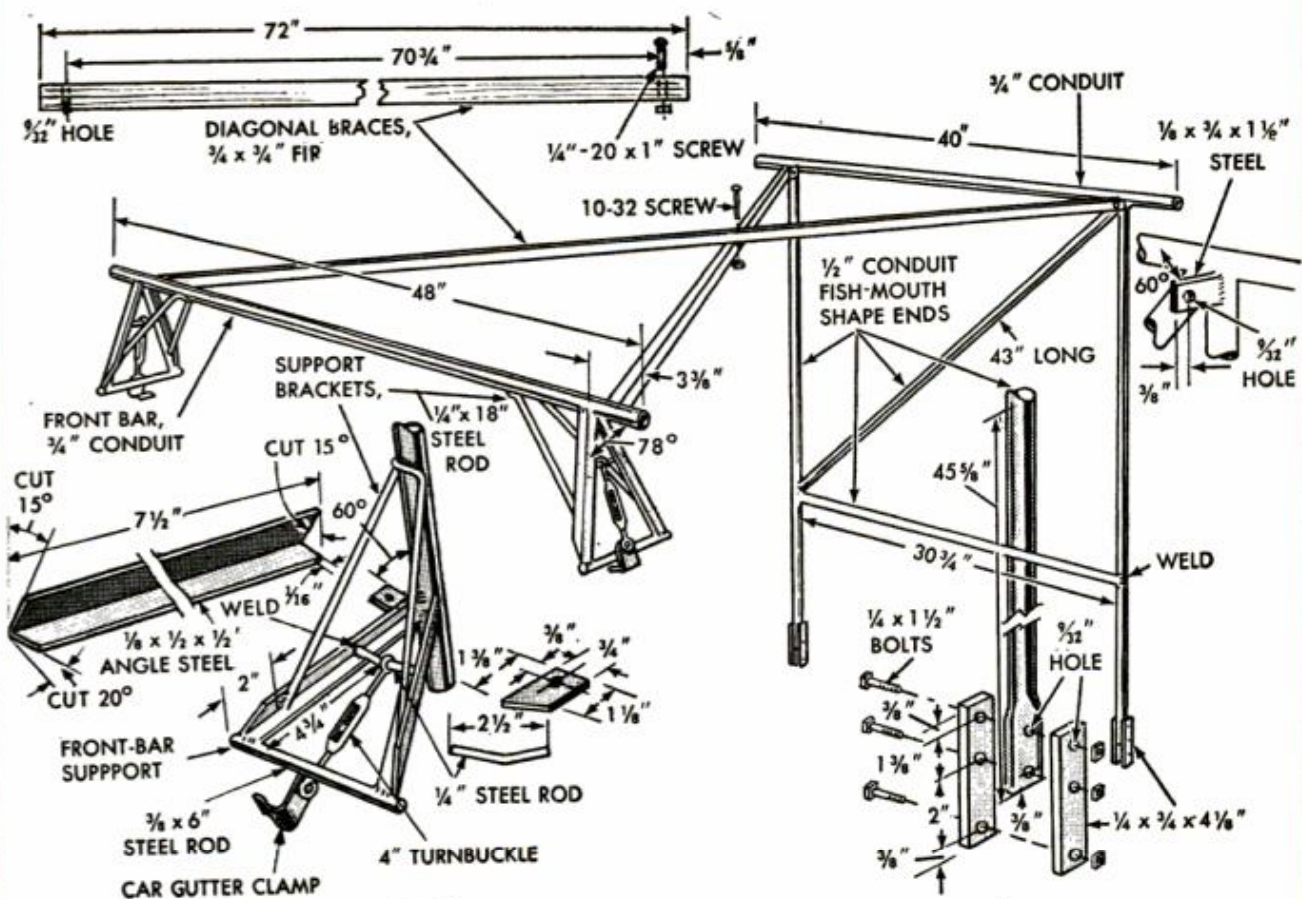

UNDERSIDE VIEW

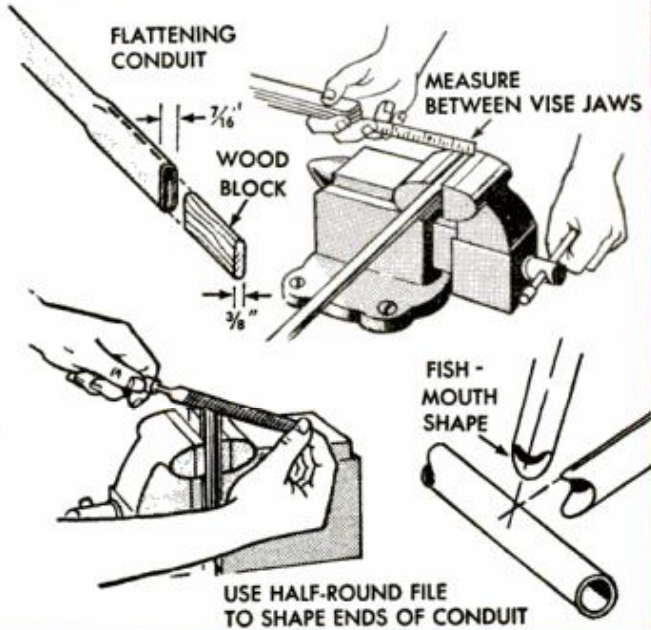
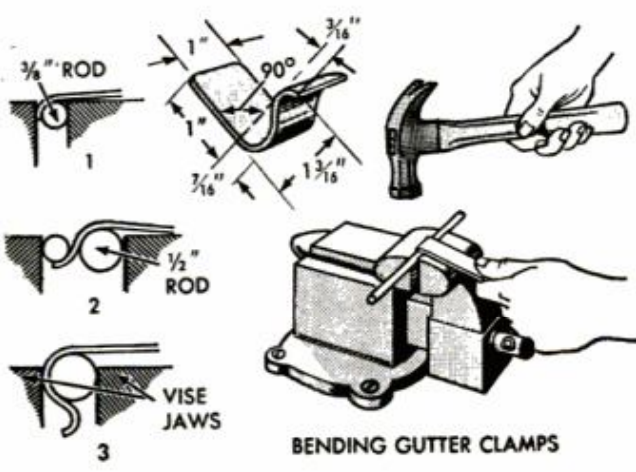
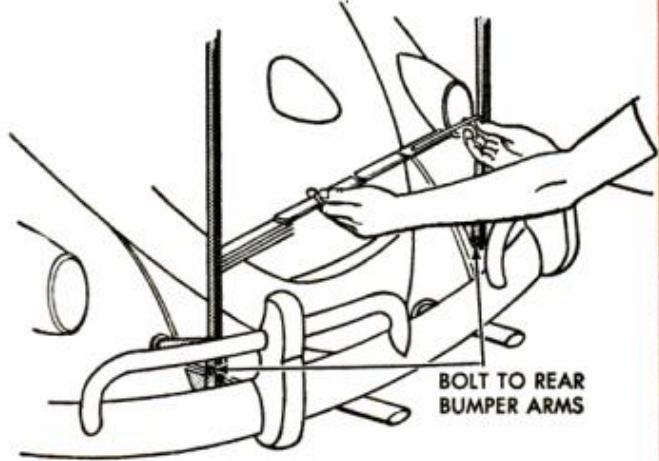
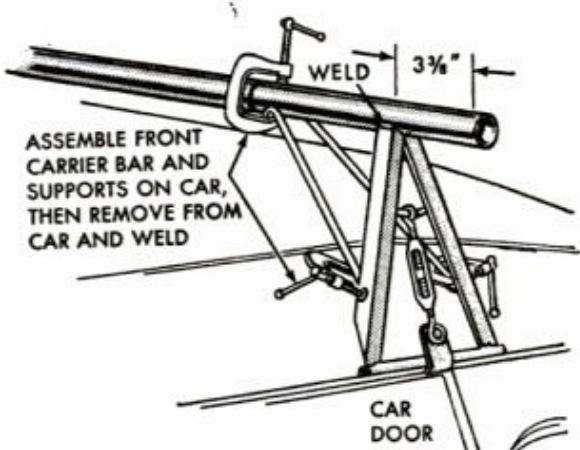

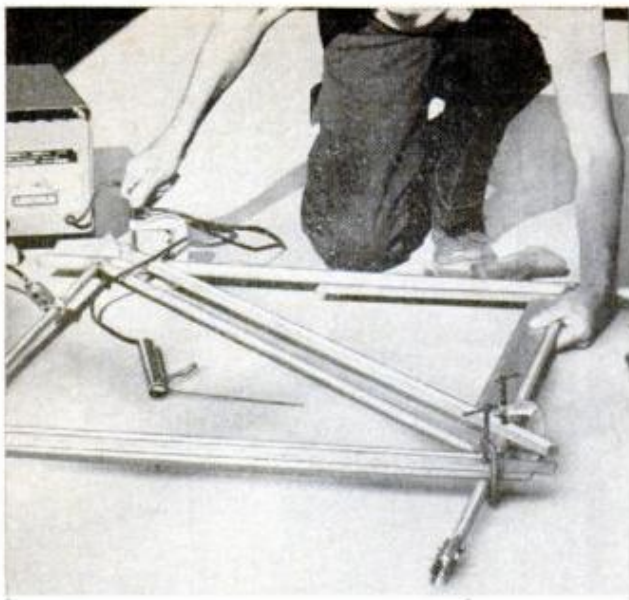

WELDING SETUP FOR REAR SUPPORT is assembled on the floor. After the conduit is cut and filed for maximum contact at joints, the assembly is squared up and clamped with boards before skip-welding

The front roof supports are tackled first. Before welding the $\frac{1}{4}$ x $2\frac{1}{2}$ -in. rods to the angle-iron supports, be sure to slide on the turnbuckles. The gutter clamps are bent as shown and tack-welded to the turnbuckles. You can save yourself this chore if you can obtain the clamps from a Volkswagen luggage rack. The setup is the same. These ready-mades are padded to protect the car's finish. If you make your own, pad the inside of the clamps and the $\frac{3}{8}$ x 6-in. rods on the bottom of the angle-iron supports with plastic rubber, or apply plastic tape.

Assemble the front supports on the car with a 48-in. length of $\frac{3}{4}$ -in. thin-wall conduit and the $\frac{1}{4}$ x 18-in. rod braces bent to shape against the conduit. Clean off the cadmium plating from the conduit where you will weld. Clamp them together in position and remove from the car for welding. To avoid distorting the conduit, run short skip welds on both sides alternately so one weld can cool before another is laid close to it.

To each rearward angle-iron support, weld at a 60° angle from the horizontal bar the steel tabs to which the top diagonal braces are bolted.

The toter's rear supports are $\frac{1}{2}$ x $45\frac{5}{8}$ -in. conduit. Partly flatten one end of each in a vise and insert blocks of wood to prevent further flattening. Drill through and bolt on the $\frac{1}{4}$ -in. clamp bars. Bolt the supports around the bumper arms. Then cut conduit to fit between them with fish-mouth-filed ends. Use a coarse half-round

file to shape them.

On the floor, assemble the uprights, the $\frac{3}{4}$ x 40-in. conduit for the top bar, the spreader conduit and a $\frac{1}{2}$ x 43-in. conduit for a diagonal brace. Square up the assembly and clamp with wood braces to hold this form. Tack-weld the setup, try it out on the car for fit and then run fast, small weld beads to avoid burning through the conduit. Again, skip-weld to prevent distortion. Weld on the diagonal-brace tabs at a 60° angle from the front of the rear horizontal bar.

The diagonal braces for the top, which bolt onto these tabs, can be made of $\frac{3}{4}$ -in.-square fir or oak or $\frac{1}{2}$ -in. conduit. Use shakeproof nuts or lock washers under all nuts. Paint the entire toter with rust-inhibiting primer and a metal enamel finish coat. Use an epoxy varnish if the diagonal braces are wood.

Materials List

Quantity	Size, Description	Use
2	$\frac{1}{2}$ " x 10' thinwall conduits	Rear support
1	$\frac{3}{4}$ " x 10' thinwall conduit	Bars
1	$\frac{1}{8}$ x $\frac{1}{2}$ x $\frac{1}{2}$ x 30" steel angle iron	Front support
1	$\frac{1}{4}$ x 41" steel rod	Front support brace
1	$\frac{3}{8}$ x 12" steel rod	Front support base
1	$\frac{1}{16}$ x 1 x 6" steel strip	Gutter clamps
1	$\frac{1}{4}$ x $\frac{3}{4}$ x $16\frac{1}{2}$ " steel bar	Bumper clamps
1	$\frac{1}{8}$ x $\frac{3}{4}$ x 6" steel bar	Brace tabs
1	$\frac{3}{4}$ x $\frac{3}{4}$ x 14' fir or oak	Diagonal braces
2	4" closed-length turnbuckles	Front support
4	$\frac{1}{4}$ -20 x 1" R.H. machine screws	Diagonal braces
1	10/32 x 2" R.H. machine screw	Diagonal braces
6	$\frac{1}{4}$ x $1\frac{1}{2}$ " machine bolts with lock washers, nuts	Bumper clamps

The Piggyback Bin

Another spacemaker for the popular VW, and one which other cars can't boast, is the easily built trash or luggage bin carried piggyback style as shown on the opposite page.

The bin folds for squeeze-in storage and can be put into service in a matter of seconds. Its legs slip into the rear bumper guards; its sides unfold, and you're ready to load up. Its forward center of gravity holds it in place on two suction cups. Only for high-speed driving would hold-down straps be desirable.

Then attach pipe clamps or nail large staples to the upper ends of the legs and run straps from them over the roof to the front bumper.

The frame is 1x2 pine or redwood. The rest of the bin can be cut from one 4x8-ft. sheet of $\frac{1}{4}$ -in. exterior-grade hardboard



PIGGYBACK BIN, a trash hauler, is the second versatile carrier for space-starved Volkswagens



FOLDED FOR COMPACT STORAGE, the bin can be set up in a jiffy after inserting legs in bumper guards

or plywood. Place the middle spreader so as to fall at the top of the VW's engine deck to provide a smooth surface for the suction cups.

The tailgate is hinged flush on the butts. The sides are hinged further in, so that their lower edges bear on the frames. As the tailgate folds first, provide clearance slots in the side for the hasps. ★★

Materials List

Quantity	Size, Description	Use
2	1x2 pine—8'	Frame
1	1x2 pine—10'	Frame
1 sheet	1/4" x 4 x 8' exterior-grade Hardboard or plywood	Sides, floor
3	Plated 2" butt hinges	Tailgate
2 pr.	2" strap hinges	Sides
1 pr.	Plated hasp hinges	Latch
5 doz.	1/2" F.H. machine screws	Hinges, latch
1/2 pt.	Plastic resin glue	
	Assorted nails	

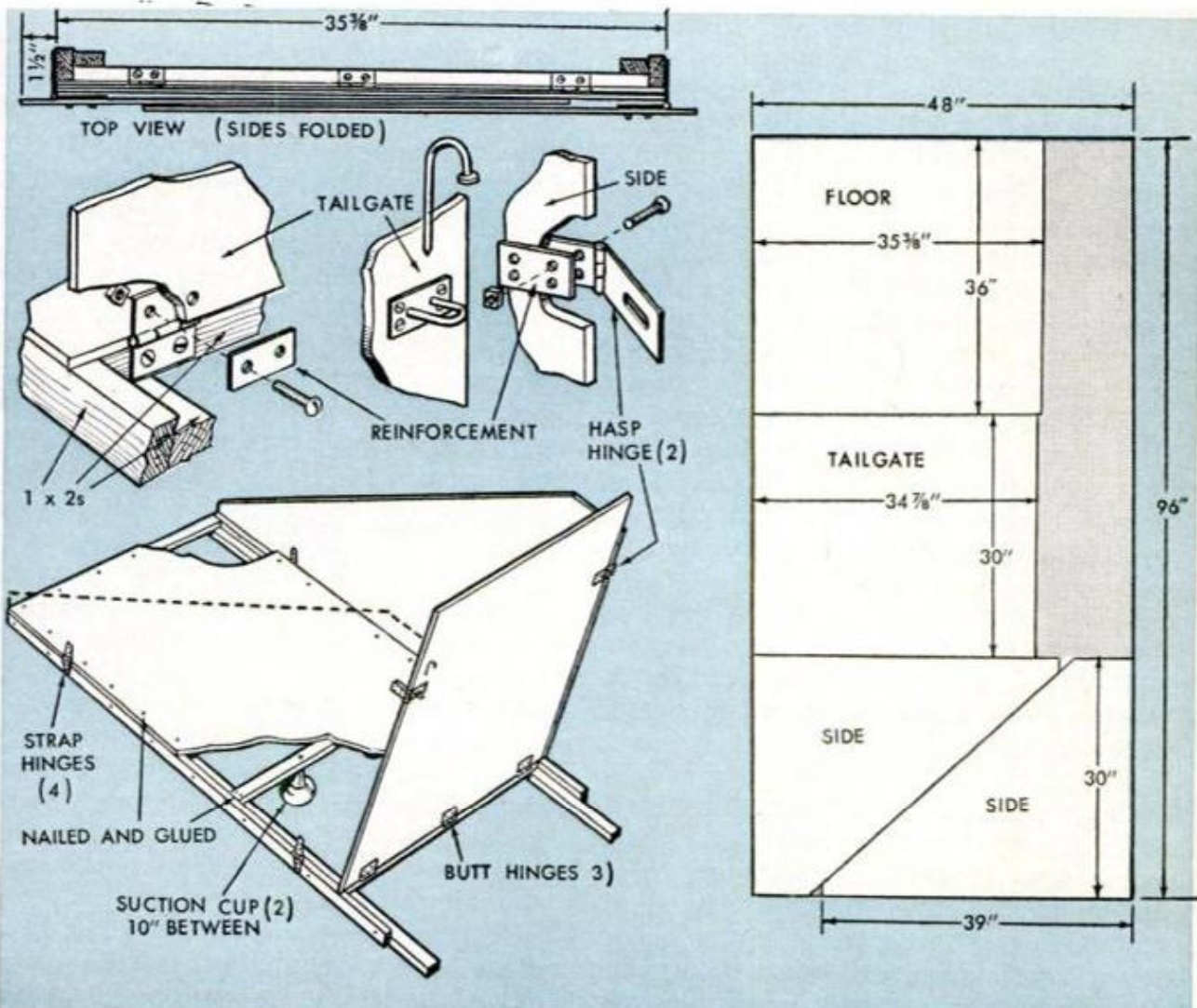

GET OUT FROM BEHIND THIS

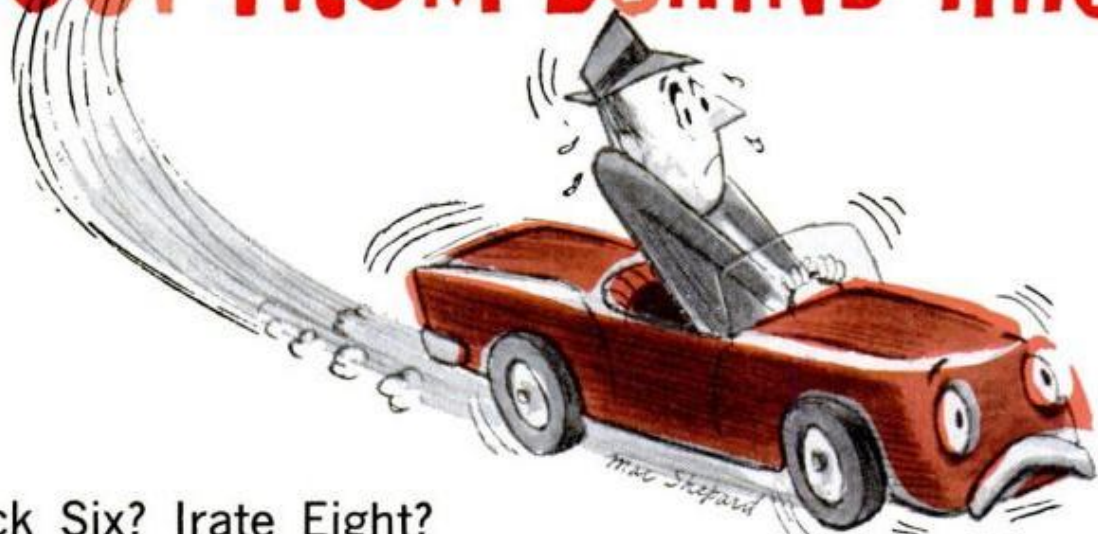

Gotta sick Six? Irate Eight?
Here are eight fast fixes
to snap it back into shape

By Morton J. Schultz

WHEN I GET 20 LETTERS describing the same car ailment, it's a sure sign that the trouble cited is more than a sometime thing with a mighty big group of car owners.

When the 30th letter arrives I figure it's epidemic.

But it's that 31st letter that I stand up and salute as a stern command to action.

Each of the eight automotive malfunctions etched on that 8-ball up there represent no fewer than 35 letters asking me how a guy should go about making that particular repair on his car.

But before I let my fix-'em cat out of the bag, friend, promise me one thing: That your car is tuned up "by the book." Why? Because these oft-posed ills are all of a type which pop up *after* a tune-up, or which a tune-up doesn't cure.

So here they are—eight hateful bugaboos that haunt the best of cars. Don't let 'em intimidate you. All these gremlins can be exorcised by any handy Saturday Mechanic.

⑧ Rough engine idle

Sometimes, no amount of adjusting of the carburetor mixture adjusting screws will smooth down rough engine idle. While this might mean the carburetor has an internal malfunction, don't rush to tear it down. You might spend hours doing what 20 seconds worth of work would have ac-

complished just as easily.

The whole trouble may be a simple little air leak into the carburetor that's upsetting the critical fuel/air balance. Tighten each of the carburetor hold-down bolts. When these bolts are loose, air can get past the carburetor gasket and into the engine's induction system. When this happens, the engine starts running with a leaner-than-normal fuel mixture, and it can't be corrected by attempts at engine-idle adjustment.

Also, air leaking into the carburetor through the base can speed up engine wear. This air isn't filtered and could be carrying abrasive contaminants directly to the engine.

⑧ Fouled sparkplugs

Examining all the sparkplugs in relation to each other and to their cylinder positions can tip you off to a number of internal engine malfunctions. This type of positive analysis is done by "racking" the plugs as you remove them.

Depending on whether yours is a six or eight-cylinder car, drill six or eight "plug-testing" holes in a scrapboard rack measuring about 10x18 in. These holes, large enough to take the threaded end of a sparkplug, represent the position of the plugs in the engine. As each plug is removed, insert it in its corresponding socket

EIGHT BALL!



in the rack. Now you're ready to check them out. Six types of sparkplug malfunctions are illustrated in the chart on page 156 and described in the next six paragraphs:

—If two adjacent plugs are fouled, look for a blown head gasket.

—Two fouled center plugs can cause raw fuel to “boil” out of the carburetor and into the intake manifold after the engine is shut off. This “boiling” can often be relieved by adjusting the float level, so long as the needle and seat seal are in good

condition. In some cases, installation of a fiber-gasket block spacer between carburetor flange and intake manifold will help. Fouled center plugs may also point to a blown head gasket.

—If four plugs are fouled with carbon, check for an unbalanced carburetor (in a multicarburetor setup). With the right-side barrel running rich, the four plugs noted would foul while the other four would operate normally.

—Four overheated plugs in the back four cylinder holes indicate a cooling-system problem; coolant is not circulating to the rear of the engine. A good flushing of the system should cure this problem.

—If just one plug has overheated, check the firing order of the engine. When the burned plug is the second of two adjacent, consecutive-firing plugs (in this case 5-7), the trouble is probably due to crossfire. Separating the lead going to these two plugs often corrects the trouble.

—If excessive sludge has plugged up the rear oil-drain holes in the cylinder head, oil can be pulled in around the intake-valve stems and foul the two rear plugs, especially in larger V8 engines. This condition usually leads to a smoky exhaust, and high oil consumption as well.

③ Incorrect rotor gap

Rotor gap is the distance between the tip of the rotor and the distributor, and it is critical to engine performance. If this gap is too wide, there will be a buildup of resistance in the secondary circuit of the

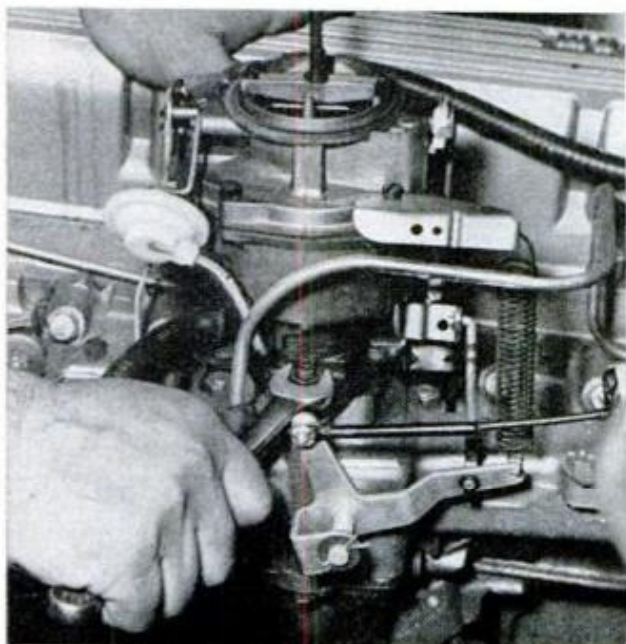

PERIODICALLY TIGHTEN carburetor mounting bolts to prevent air from leaking into induction system



POSITIVE SPARKPLUG ANALYSIS can be achieved with board drilled and numbered as shown (see text)

ignition system. When this happens, no amount of engine tuneup will eliminate short sparkplug life. Also, you won't get any clue to this problem by removing the distributor cap and rotor for a close inspection. Both will probably look okay. But think back—didn't you recently replace the rotor? You may have created the problem yourself by getting the wrong rotor for your particular car.

Keep in mind that all rotors are *not* the same, although several different ones might fit perfectly atop the distributor shaft. A mechanic friend of mine ran across this problem and, in checking, found that a mismatched rotor left a $\frac{3}{16}$ -in. gap between rotor tip and cap segments.

How can the wrong rotor affect plug life? Well, new plugs require a minimum of firing voltage, but as they wear their voltage requirements increase. If there is excessive rotor gap because of the wrong rotor, a point is quickly reached



where the ignition system can't supply enough voltage to overcome both the mismatched rotor gap and the wearing sparkplug electrode gap.

There's a moral to this tale: Whenever you replace a part—any part—with a new part, make sure it's the one specified for your car.

③ Poorly lubed cam

The distributor cam should be lubricated at each tuneup to prevent rapid wear of the cam follower. Most instructions tell you to apply a "light film" of lubricant. That's okay, because excessive lubricating

would lead to splattering of the lube around the inside of the distributor and contamination of the distributor breaker points. But just how much is a "light film"?

I put this question to the research boys at Champion Spark Plug Co. After a series of tests on different types of distributors, they determined that the correct amount of cam lube for all distributors is *that amount which would equal the size of a kitchen match head*. Remember this the next time you lubricate that cam.

③ Balky choke

What's the first part you blame when your car's hard to start? Probably the automatic choke. And in many cases you'd be right.

But a particular part of the choke that can contribute to hard starting is often overlooked. This is the choke unloader piston. If it sticks in its bore because of an accumulation of gum and dirt, the choke butterfly will stick in the wide-open position and the engine will be hard to start, especially in cold weather. (Not all cars have this type of choke setup.)

So here's another tip to stick in your

bonnet. Next time you tune up the car, squirt some carburetor cleaner into the opening in the carburetor air horn through which the piston link passes. The cleaner dissolves gum and frees the piston. Pull the choke valve open and closed a few times as you apply the cleaner.

③ Faulty multiple connectors

Today's cars are using an increasing number of quick-disconnect electrical connectors. These are multiple in nature and hook several individual wires or circuits together at a specific point. Watch 'em—they can be troublesome. A bent

Diagrams below illustrate various sparkplug ailments. Use a "racking board" (see text) to get positive analysis of each sparkplug, and of all plugs as they relate to each other in the engine. Malfunction is described at left of each diagram

Two fouled adjacent sparkplugs indicate a blown head gasket

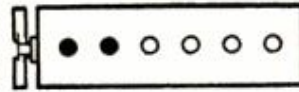

Fouled center plugs? Check gasket and the float-level adjustment

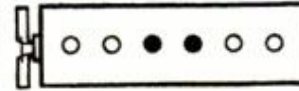

Unbalanced carbs (in a multicarburetor setup) can foul up four plugs

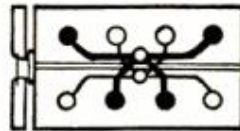

Cooling system may be to blame if back four plugs overheat. Flush system

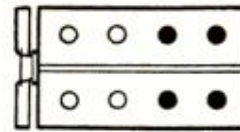

Just one plug overheats? Check the firing order. Crossfire may be faulty

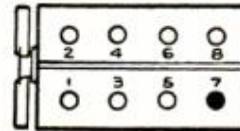

Two fouled rear plugs indicate sludge in cylinder head rear oil drain holes

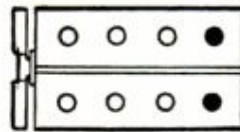

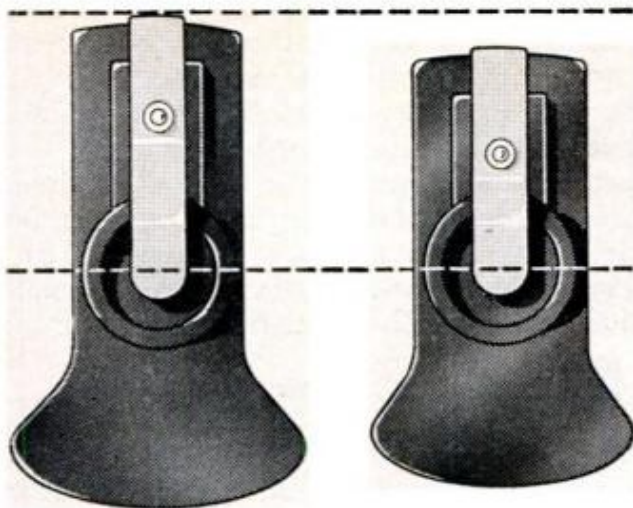

THOUGH DIFFERENT SIZES, these rotors will fit the same distributor. Be sure yours is of specified size

connector terminal in one of these units can stop your car dead in its tracks.

Most of these connectors are found on the engine side of the firewall bulkhead. When an odd electrical problem pops up—one that defies analysis—check multiple-connector alignment. Check this during tuneup too—to forestall trouble.

⑧ **Bad breaker-point adjustment**

We all know that the degree-for-degree relationship between distributor breaker-point dwell and ignition timing is critical. As little as a 1° variance of breaker-point adjustment changes initial timing by the same amount. If it's off by several degrees, engine performance will deteriorate noticeably.

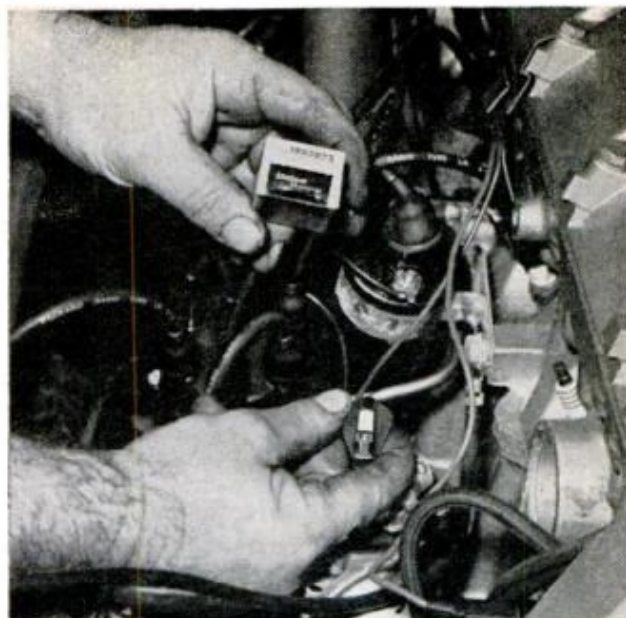

ALL REPLACEMENT PARTS must be of size specified. Match number of new part with that of original part

The best way to adjust point gap to manufacturer's specifications is with a dwell meter. However, if you have only a feeler gauge to work with, set the breaker point rubbing block on a high point of the distributor cam and adjust point gap until a *light* drag is felt on the feeler gauge. Lock the point assembly in this position.

If the point-gap specification for your car is given as a range setting—such as .014 in. to .019 in.—use the *higher* specification (.019 in.) for setting *new* breaker points. Research has shown that setting to the high side of the specification keeps point adjustment within the recommended range as the rubbing block wears.

If you set breaker-point spacing by means of a dwell meter, you'll find that

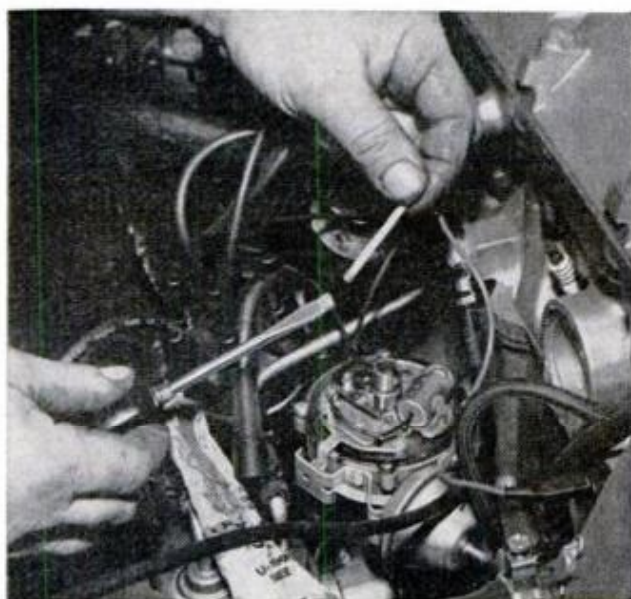

PROPER AMOUNT OF LUBE on the distributor cam is an amount equal to the size of a kitchen match head

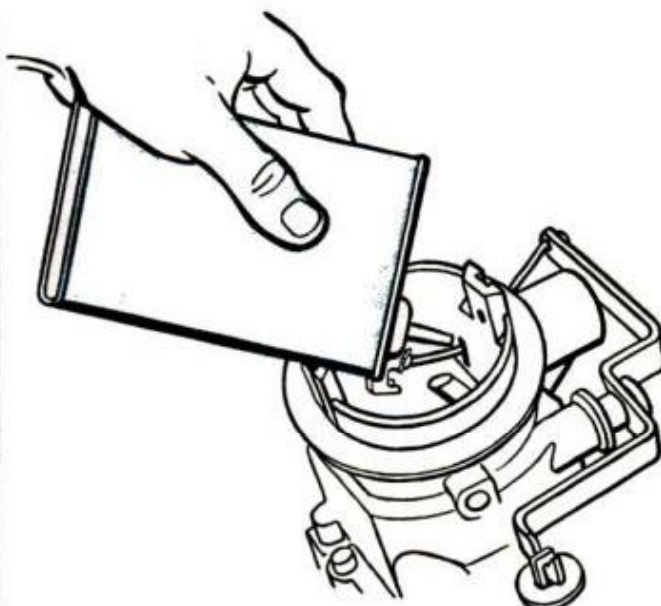

KEEP CHOKE PISTON OPERATING freely by occasionally squirting some carb cleaner in piston link hole

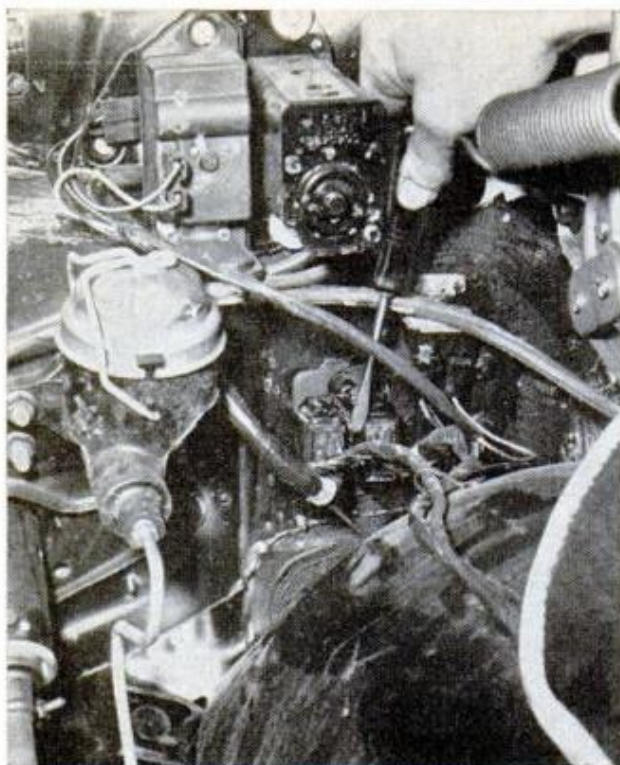

SOME HARD-TO-REACH MULTIPLE CONNECTORS are often found low down on the engine side of firewall

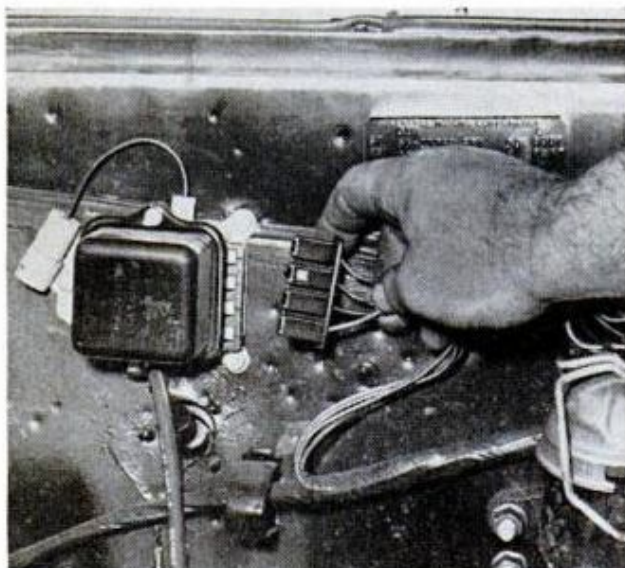

A BENT TERMINAL on a quick-disconnect multiple electrical connector can stop you dead. Check 'em

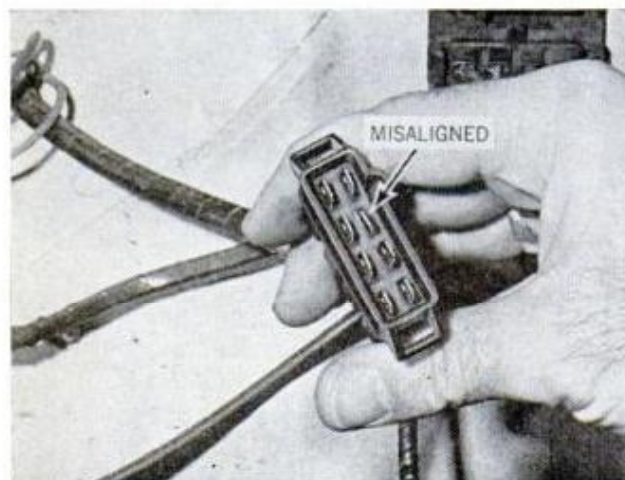

YOU CAN TELL if a terminal is bent by looking at the connector. Realign prong by bending it straight

specifications are usually given in degree ranges—for example, 28° to 32°. The recommendation here is that you split the difference and set points midway between the two, which, for the range cited, would be 30°. It's been found that this method keeps breaker-point spacing within the recommended range over the longest time.

In setting points, the right way is the only way. Points set too close will burn. Points set too wide apart will reduce coil output, especially at high speeds.

8 Frozen distributor

Saturday mechanics often find a distributor so firmly stuck in the block that they can't budge it to set timing. To loosen it, a hammer's *verboden*—but a CO₂ fire extinguisher isn't.

Aim the extinguisher's nozzle at the distributor beneath the bowl, then fire a few brief blasts at it. These frigid blasts of CO₂ should cause the distributor to contract so that it can be removed. If it still sticks, spray some heat-riser solvent right on top of the CO₂ adhering to the distributor. These solvents usually come in aerosol cans for easy application. Allow it to penetrate for a few minutes, then again try removing the distributor. If it still sticks, give it a couple of light taps with a mallet. That should allow the distributor to be removed with a twist of the wrist.

So there you have eight "popular" automotive ailments that can sink a financial 8-ball in any car-owner's side pocket. But you've also been given their symptoms and their cures—the "cues" that'll keep you ahead in this game, both financially and mechanically—and out from behind that 8-ball! ★★★

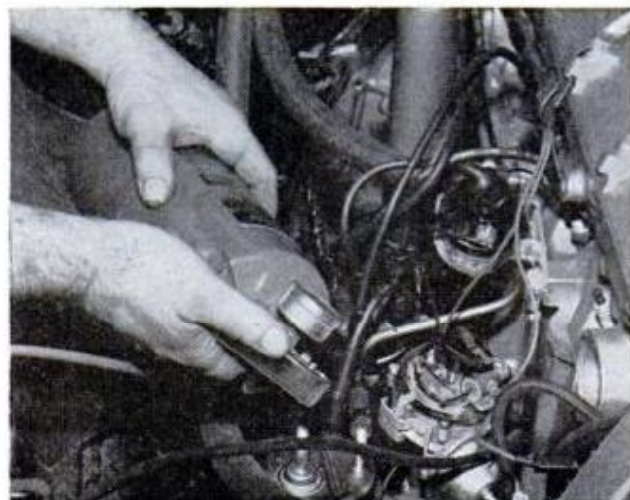

LOOSEN "FROZEN" DISTRIBUTOR with a blast from CO₂ extinguisher. CO₂ shrinks distributor for removal

Shortcuts for Saturday Mechanics

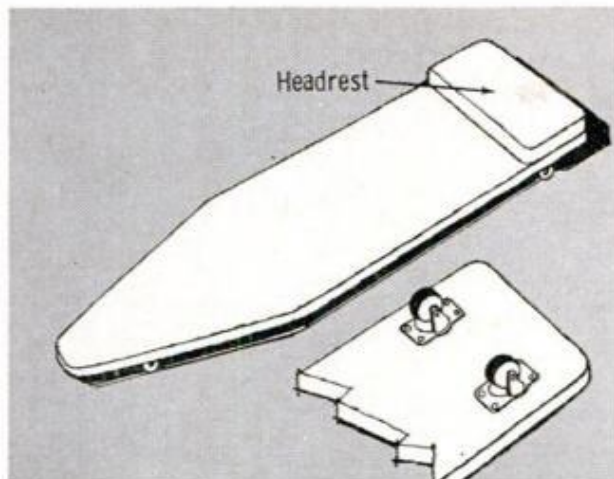

HERE'S HOW YOU CONVERT an old ironing board to a comfortable, wheeled garage creeper to lie on when making under-the-car repairs: Remove legs, then attach four swivel casters to the board in their place



A HANDY GREASE DISPENSER can be made from one of those chocolate-syrup jars which are fitted with a plastic pump. When the kids have used up the syrup, just wash the jar clean, then refill it with grease

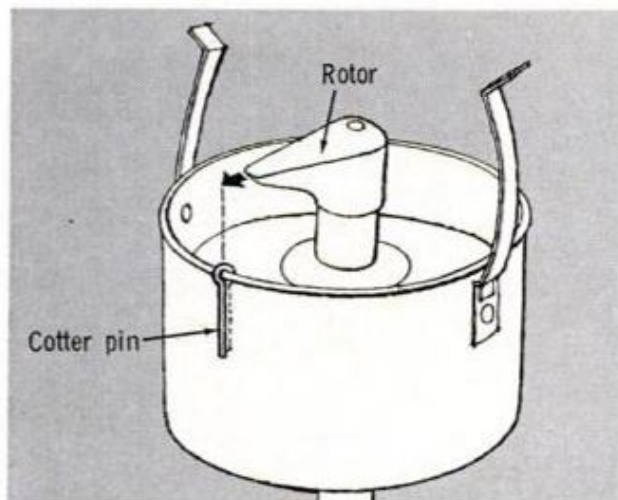

BEFORE REMOVING DISTRIBUTOR for repairs, mark rotor position with a cotter pin slipped over lip of distributor housing. This will eliminate chance of reassembling distributor in reverse firing order

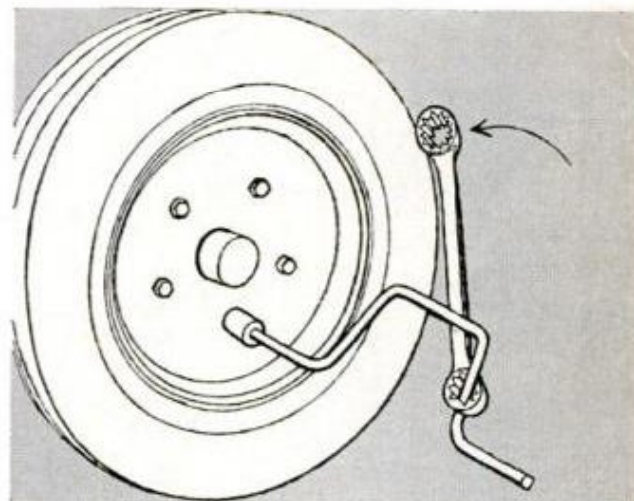

EVER YANK A WHEEL and almost strain your back trying to loosen those too-tight lug bolts? Next time try this: Slip an end of a box wrench over the lug wrench handle, as shown, to gain increased leverage

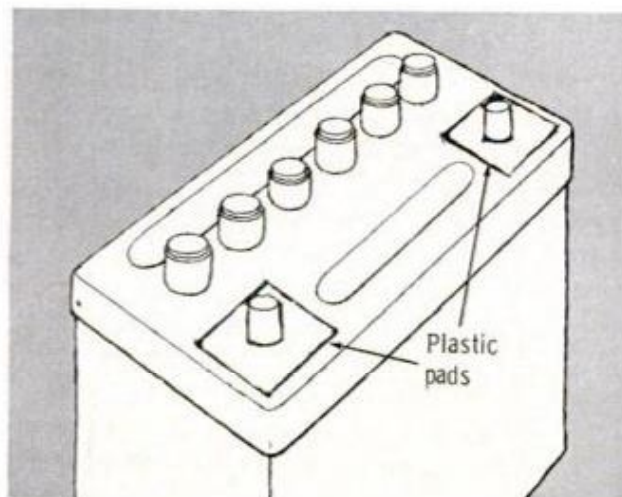

CUT DOWN ACID BUILDUP on battery connectors by means of two pads cut from a plastic container. Cut a hole in the pads, then force them down over the battery posts. They'll keep clamps acid-free longer

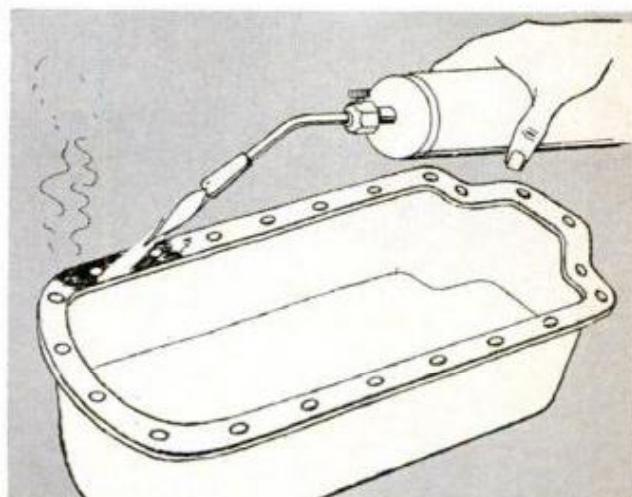

AN EASY WAY to remove a worn-out gasket from an oil pan is with the aid of a propane torch. Wash all excess oil from the pan, then use torch to heat gasket adhesive until gasket loosens and can be lifted off

Band Sander for Your

This inexpensive attachment is driven directly off the arbor —and you can even make the pulleys right on the saw itself



CLAMPED TO SAW, attachment makes use of tool's table as well as its motor. Note how doubled 2x4 base serves as backup plate for square sanding

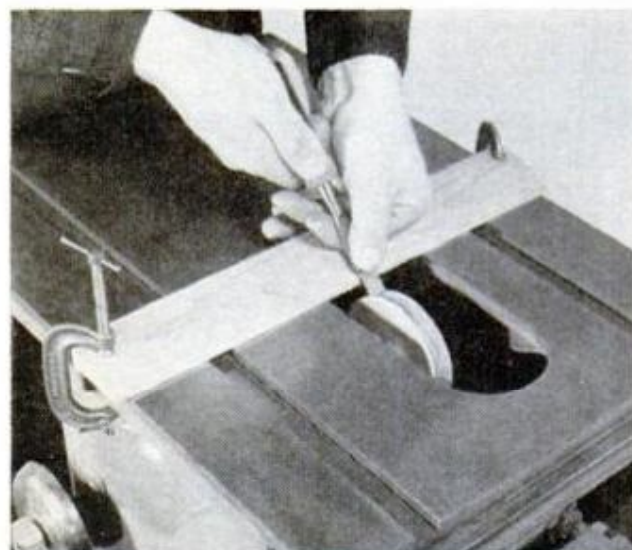

IMPROVISED LATHE results when you clamp rest for chisel—tapered molding, here—across table opening

WITHOUT THE COST or clutter of an extra stand and motor, you can add a flexible band sander to your shop simply by making this attachment for your bench saw. The handy little belt will whisk away burrs and smooth or polish wood, metal or plastic. The top pulley is spring-loaded to permit the belt to yield and conform to odd shapes, yet that part of the belt immediately above the table is backed up for square sanding, as shown at left.

Since the unit is so easy to attach (top right), it doesn't cut down on the convenience of your saw. You just replace the blade with the sander's drive pulley, then slip the belt over this as you lower the unit in place. A table insert positions the base, and two hook bolts anchor it firmly. To tension the belt, you merely turn the saw's blade-lowering crank.

I designed my unit for a 42x1-in. belt. It's an all-purpose emery cloth type, readily available since it's used on several commercial sanders; it comes in various grits for around 50 cents.

The novel aspect of this project is that you can create it on the very saw you'll use it on later. The pulleys are easier to make on a lathe, but you can turn them on the saw arbor by making them of two pieces of 1-in. stock. In the case of the idler pulley, you turn a half at a time, as shown at the left. Most arbors aren't long enough to take both halves at once, so to make the drive pulley (which must be mounted on the arbor later anyhow) you'll have to bore a large enough hole in one half of the blank to clear the arbor's flange washer. The three other pulley halves require a hole only the size of the mandrel. Glue and screw the two halves of the drive pulley together to form the turning blank.

Although the idler pulley halves are turned separately, it's a good idea to screw them together temporarily and spin them on the idler shaft to make certain the bearing holes are aligned. Then drill a couple of 1/4-in. holes through both halves to facilitate realigning with dowels, after turning. You may also prefer to cut the

Bench Saw

By Ray Shoberg

blanks to a rough round on a jig or band saw before separating them. When turning, remember that both pulleys should be slightly crowned to keep the belt centered.

The simplest idler bearing is none at all—you simply use a shaft that will fit the holes you've drilled for the saw arbor. If the pulley is hardwood and the shaft is polished and kept well oiled, the pulley will last a long time. But you may prefer to press a bronze bushing into the center hole or—best of all—go to sealed ball bearings. If you choose the latter, buy inch-size double-shielded bearings with a bore equal to your arbor diameter and press them into sockets in the outer face of each pulley half before turning. The socket size is critical, as too tight a fit on the outer race will cause it to collapse. If you're turning the pulley on a lathe, screw the blank to a faceplate so you can turn the bearing socket at the time you true the edge.

The base consists of two 3-in.-wide pieces ripped out of 2x4s, long enough to extend beyond the width of the saw table. Drill half-inch holes through the top board to pass two 10-in. bolts. Cut off the threaded portion of these bolts and round the cut ends so they'll slide freely in the idler yoke. The heads of these bolts set into recesses chiseled in the bottom board, which are left a little shallow so the heads will be clamped tightly between.

If you have the equipment for drilling straight deep holes, you can make the idler yoke of a solid 2x6; if not, make the yoke of two 1x6s and cut grooves on your bench saw in the mating faces, as shown on next page. If using a solid block, you'll have to kerf it down to the idler shaft hole so you can install bolts to pinch the shaft and hold it secure. With a two-piece yoke, just drill a slightly undersized shaft hole on the joint line and use bolts above and below.

Any good hardware store carries an assortment of springs that should yield a couple about 2½ in. long, of a diameter



ON AND OFF in minutes, attachment won't interfere with saw's usual function. Just put drive pulley on arbor and tighten two hook bolts to anchor base

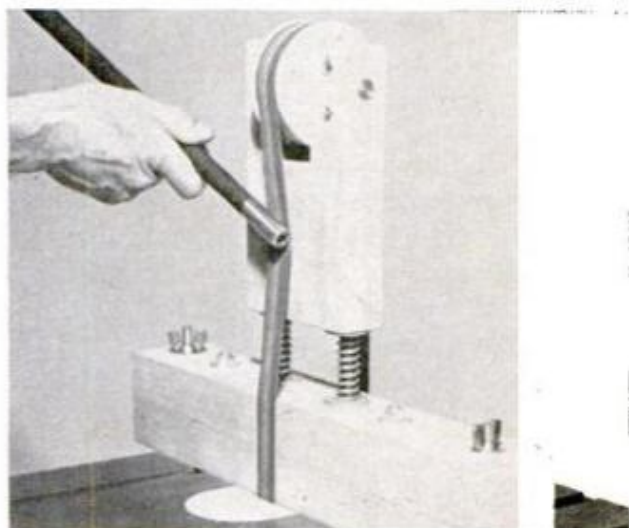

ROUND OR ODD-SHAPED items are polished or smoothed with flexible section of belt above base

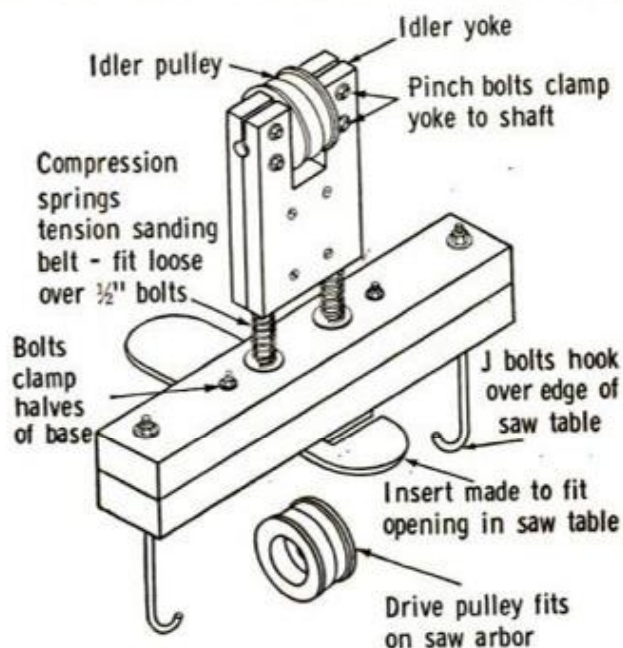



DRIVER PULLEY is at lower left. Three sample idler pulleys show choice of bearings, including (left to right) hardwood, ball bearing or bronze bushing. Turned halves are realigned by driving dowels flush

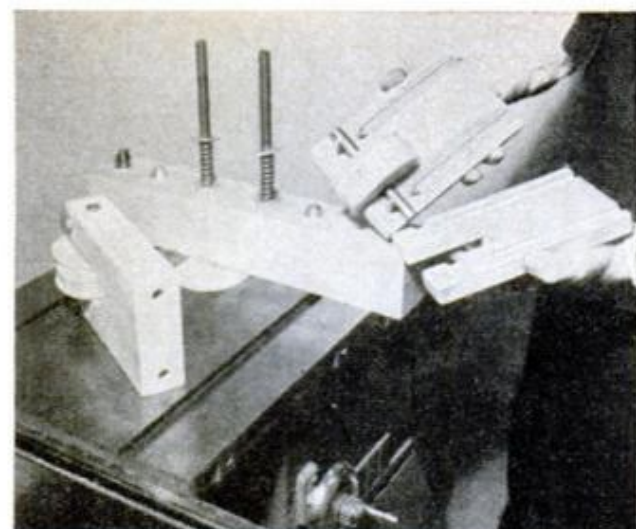

IDLER YOKE can be made solid as at left or in halves as at right. In split yoke, grooves replace deep drilled sockets for 1/2-in. upright bolts. Either way, sockets must be straight to let yoke slide freely on bolts

to slip over your upright bolts, and a length that will give the right tension against the idler yoke. Steel washers prevent the spring ends from digging into the wood.

With everything assembled, it's time for your shakedown cruise. Fasten the base to the saw table temporarily with a couple of C-clamps. When you put on the belt, note the directional arrow printed inside. Now, with the belt running at proper tension, loosen the clamps and shift the base, if necessary, till the belt runs in the center of the pulleys and just skims the base.

You can now properly position the hook bolts with respect to the edge of the saw table. If you can't buy such bolts, you can make them by reforming an eyebolt or bending threaded rod.

Lay out an insert to cover the saw table opening and cut it from thin plywood, hardboard or metal. Cut slots to pass the belt and mark the position of the sander base on the insert. Remove the unit and fasten the insert to the underside of the base with screws, to assure automatic realignment each time the unit is set in place on your saw table. ★★★

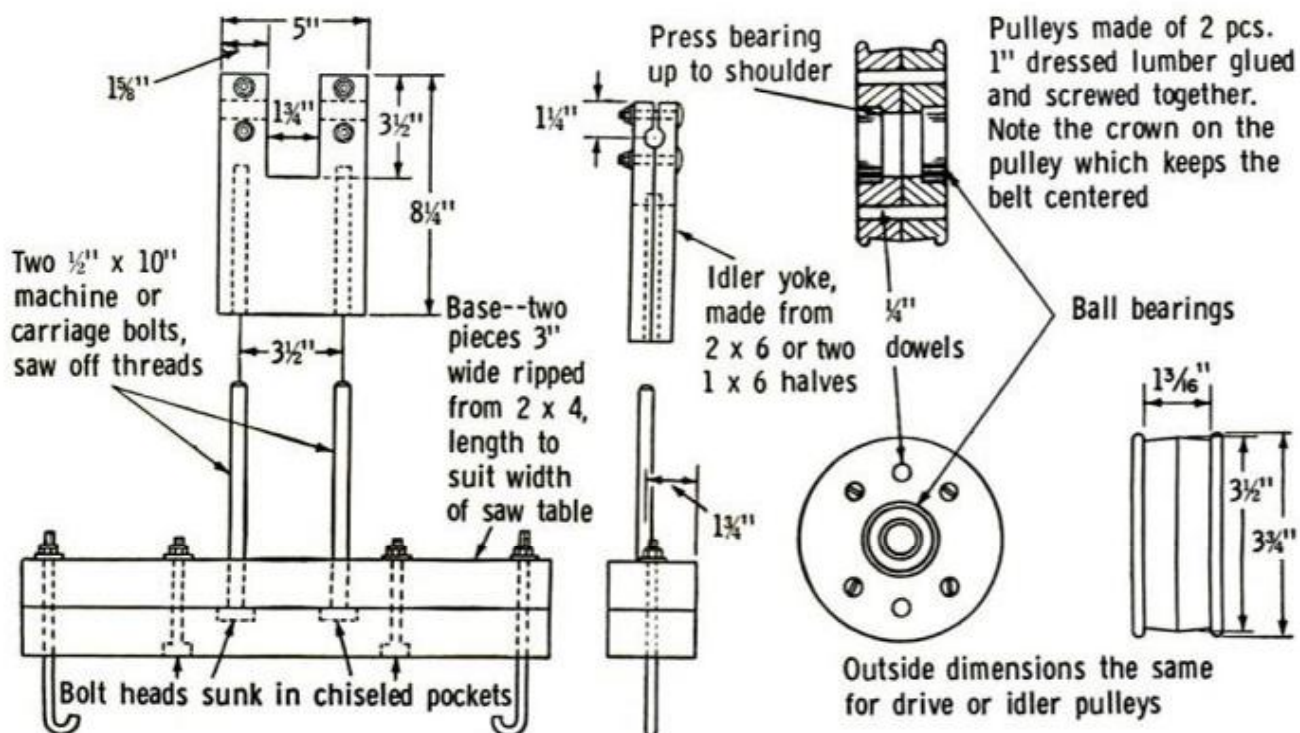

6 Good ideas from PM do-it-yourselfers

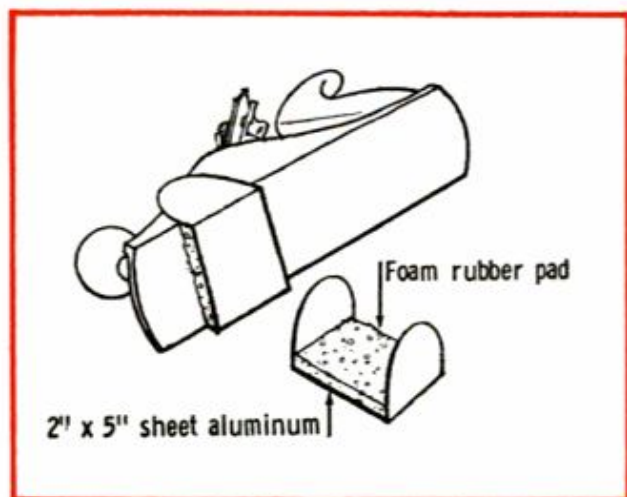

KEEP IT SET AND SAFE. Your block plane can be left set for an optimum shave if you protect the blade and your fingers. Fold a strip of sheet aluminum to fit snug and glue on a pad of foam rubber

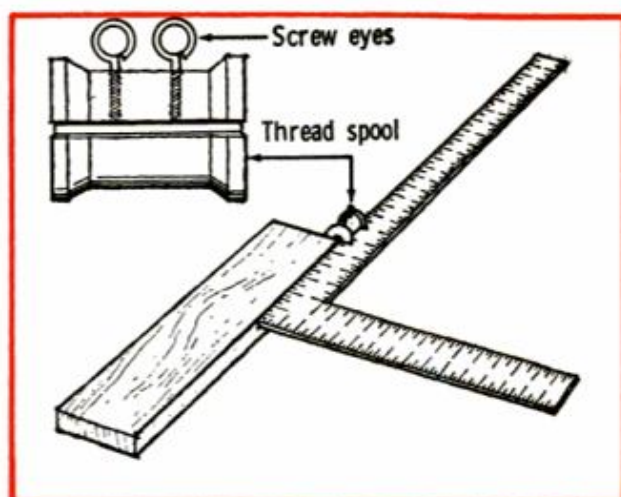

SPOOL GAUGE is a handy device for marking duplicate cuts. Slot a regular thread spool halfway to fit the edge of a framing square and drill through to the slot for two screw eyes to tighten the gauge

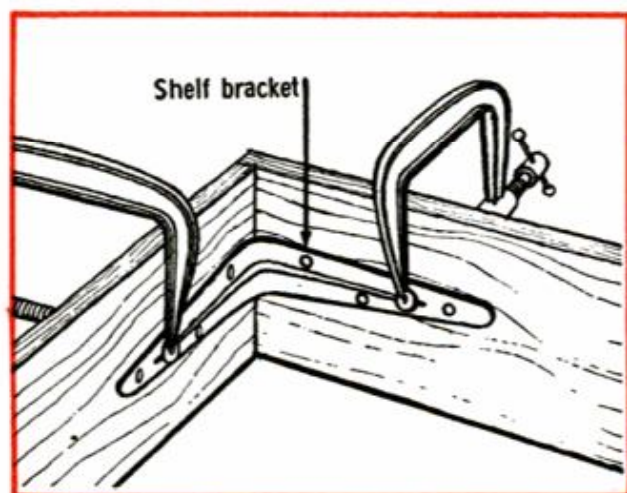

JOINT CLAMPING JIG is simplicity itself. Just clamp a heavy duty shelf bracket with two C-clamps to mitered or butted stock to hold it in place for nailing. It's ideal for frames, drawers, screens or molding

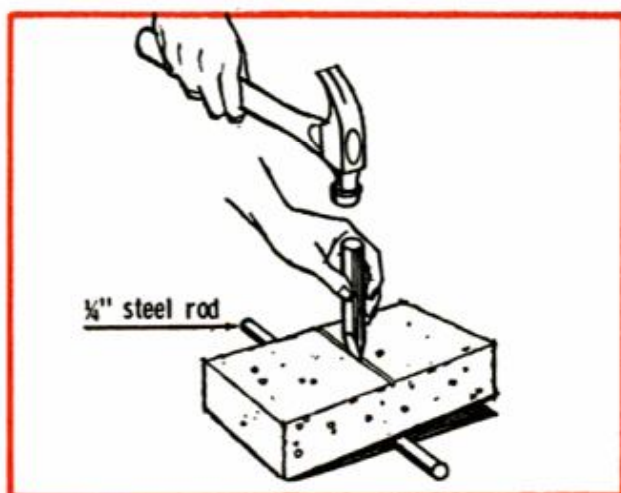

BRICK TRICK. To break a brick cleanly every time, score the brick at the cutting line, place a $\frac{1}{4}$ -in. steel rod directly under the score, place the chisel back in the score and give it a sharp tap, as shown

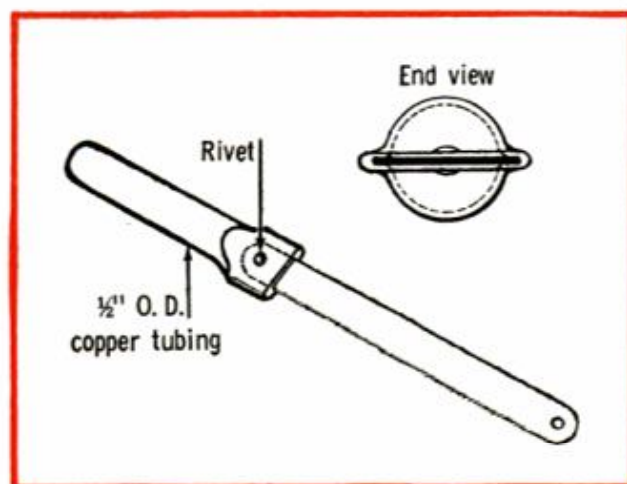

FRAMELESS HACKSAW is nifty for tight spots. Partly flatten $1\frac{1}{2}$ in. of a 6-in. piece of $\frac{1}{2}$ -in. O.D. copper tubing, insert the end of a hacksaw blade or stub, flatten the tubing further, drill through and rivet

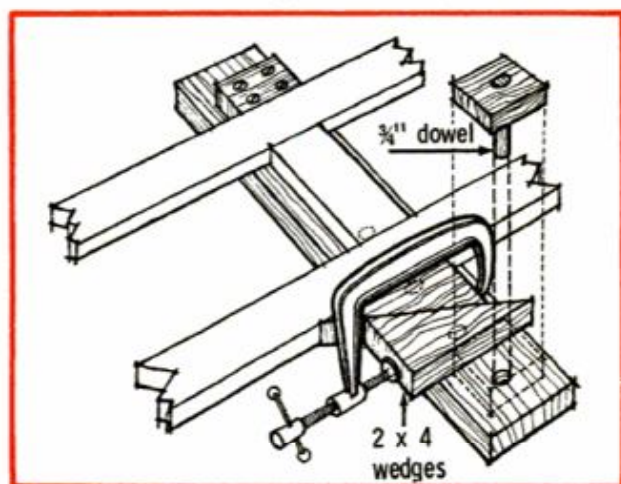

CLAMPS NOT LARGE ENOUGH? Screw a 2x4 block to a 2x4 base. From other end, drill $\frac{3}{4}$ -in. holes 2-in. apart. Drill and glue $\frac{3}{4}$ x3-in. dowel into another block. Wedges squeezed by C-clamp draw joints tight.

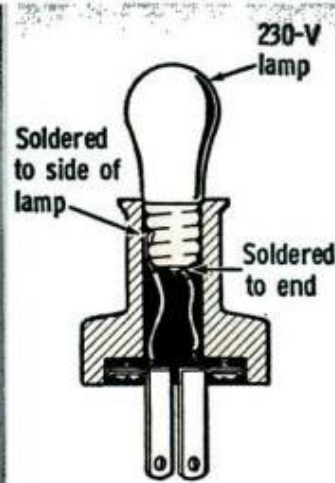
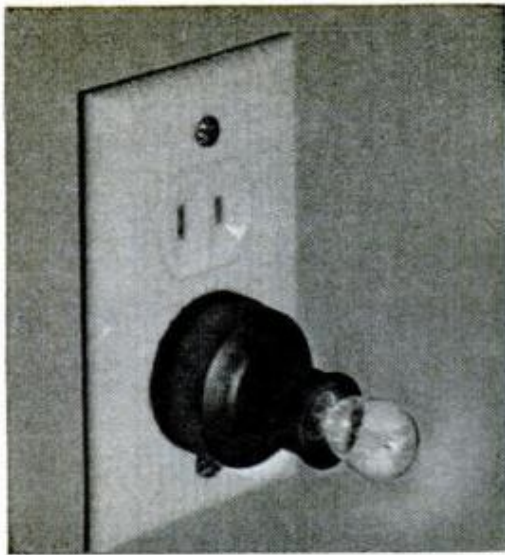

Quickie night light

By inserting a standard 230-v. candelabra lamp in a standard molded-rubber, handle cap having a $\frac{3}{8}$ -in. cord hole, you can improvise a night light which will burn indefinitely and be cool to the touch. The drawing shows how two wires connect the lamp to the blades of the cap. The lamp draws only half the wattage used by a regular 115-v. night light.—*Joseph Braunstein.*

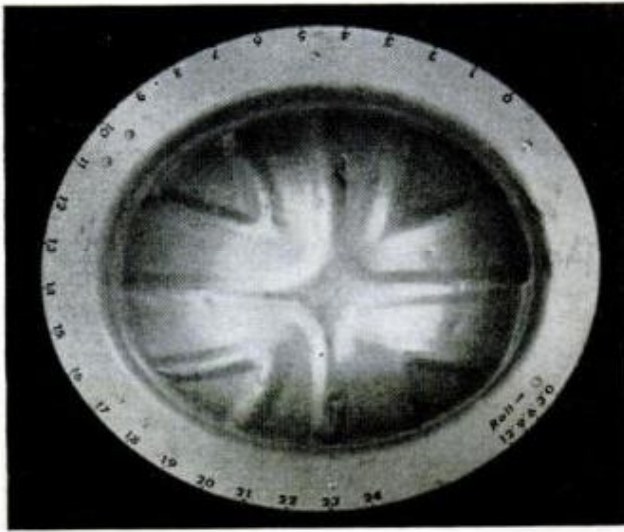

Golden rule for hard hats

You men with hard-hat jobs can always tote a ruler with you on your head and save many a long walk across a site to find a folding rule. In fact, this hat ruler will let you measure any continuous length. Just mark off the inches up to 2 ft. along the edge of the brim with a felt-tip marker or india ink. On the unmarked portion of the edge, mark a zero point and roll the hat until you come to a 3-ft. point, a 6, 9, 12 and any other useful length, and mark them. Use these multiples for proper spacing.—*Jim Reid*

Extension-cord reel has its own plug-in receptacle

Your extension cord becomes twice as handy when it's wired to a receptacle inserted in the hub of a 400-ft. movie-film reel. Not only is the reel always handy, but you can plug into the side of it without having to unwind the cord completely.

After cutting the holes in the side of the reel to accept an appliance receptacle, the latter is soldered in place and then the cord is brought through a hole in the hub. An underwriters' knot is tied in the cord before wiring it to the receptacle.

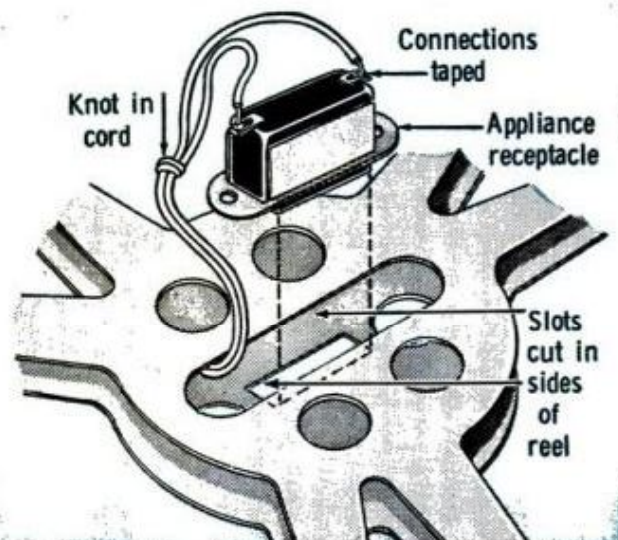
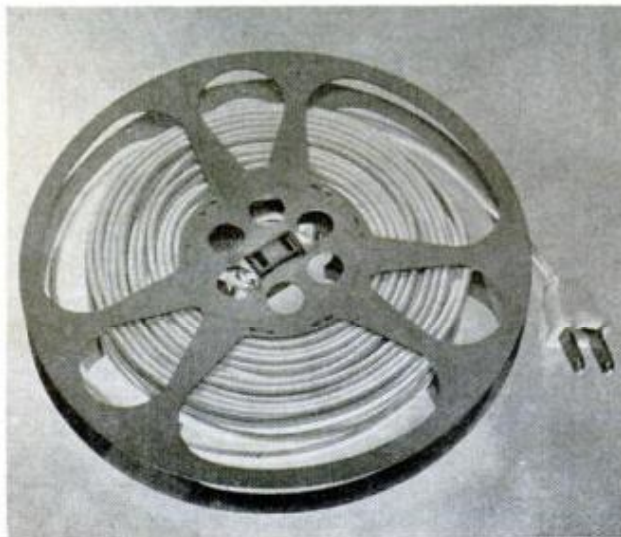



Up-and-Flying MODEL SAILBOAT

It's an 'aerohydrofoil'—a sailboat with a tall dorsal fin instead of a sail that skims over the surface on little foil legs

By Roy Clough, Jr.

STRIPPING A COUPLE OF YARDS of line from my spinning rod, I hooked the swivel to the stern of the weird little craft and set it gently in the water. Wind ruffled across the millpond and caught the stiff balsa sail. Immediately, ripples boiled away from the floats, then quickly narrowed to thin vee wakes as the hull lifted clear of the water. She was up and "flying"—one of the most exhilarating moments in my 20 years of model building.

The design was inspired by Bernard Smith's "Little Merrimac" described in his book, *The Forty-Knot Sailboat*. While it took a lot of experimenting to arrive at this configuration, construction offers

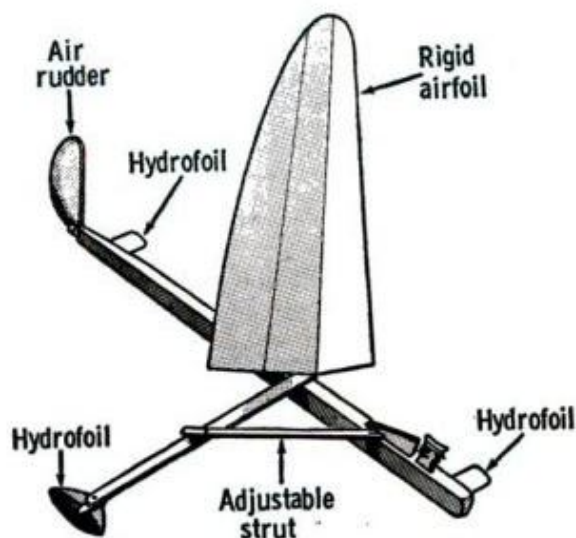

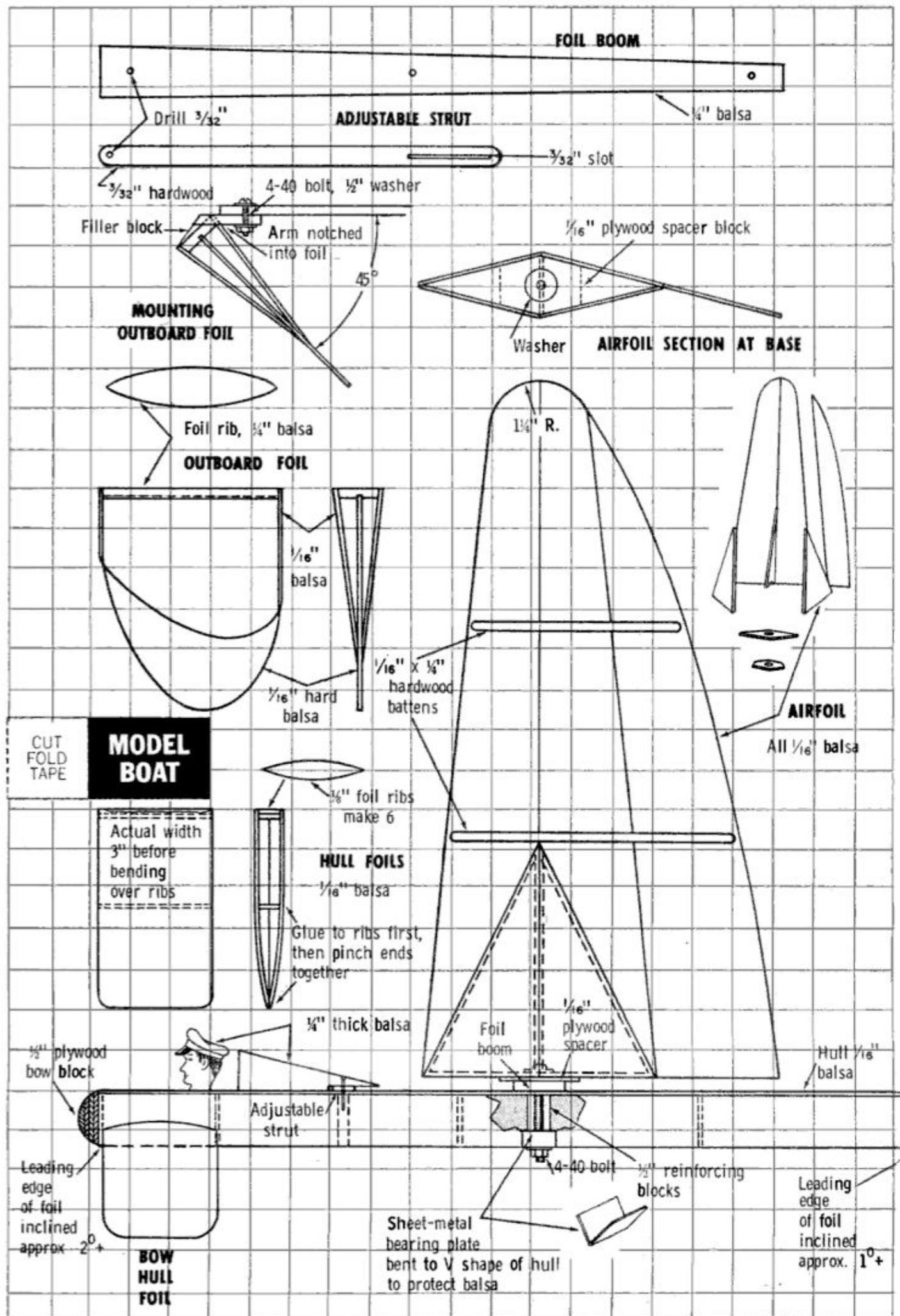

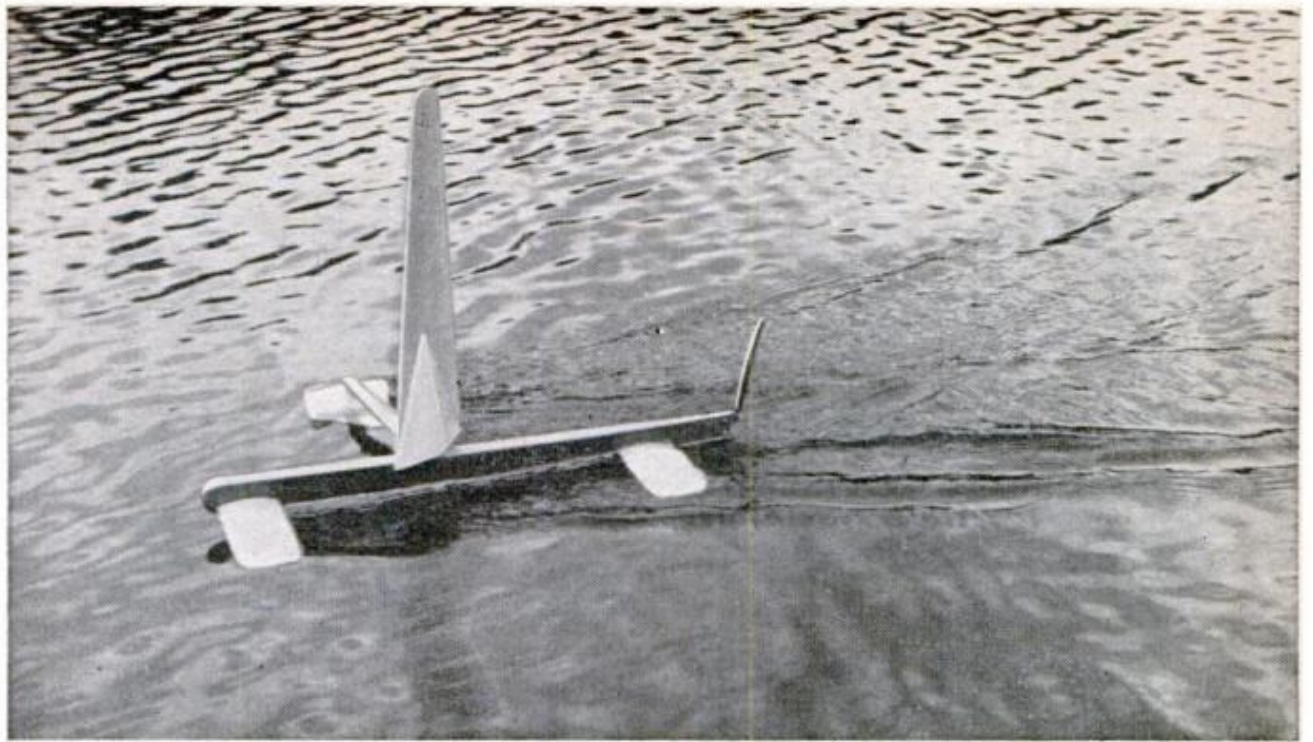

IT'S A REAL UFO (unconventional floating object), but you'll be amazed at the aerohydrofoil's performance

no difficulty to the average model builder. However, there are a few special wrinkles—the hull foils, for instance. Cement the sides to the ribs first. Then, after the cement dries, pinch the outboard ends together with a spring-type paper clip to generate the required form. The angles at which the foils are mounted are particularly important, so follow the plan carefully.

While the sail is shown with a leech, you might try it without this extra area if you have plenty of wind in your locality. The air rudder should also be trimmed to suit local conditions. Incidentally, don't

omit that pilot head and headrest. They act as tiny sails to prevent the boat from having too much weather helm.

The model can be sailed free, but I use a spinning rod and lightweight monofilament for easy retrieval. Ponds or pools small enough to prevent wave buildup are best for this boat, since it requires fairly smooth water to attain high speeds. The prototype proved to sail fastest when running about 30° off the wind.

Just follow the plans and finish as you would any boat model (three coats of clear dope on the foils before applying pigmented dope). Happy sailing! ★★★

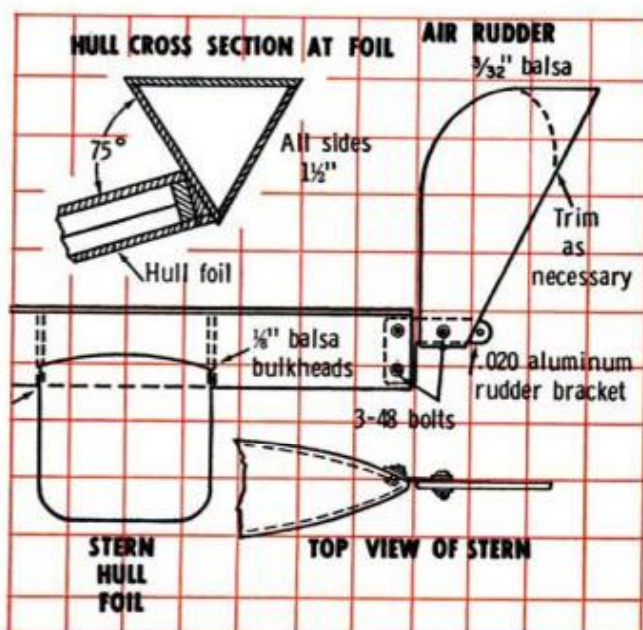

LINE ON STERN runs to a spinning rod, simplifying retrieval. Model can also run free, if you choose

Tips from readers



TWO-FOOT EXTENSION of grain tank of this corn picker-sheller increased capacity 25 bushels, letting driver finish a round instead of stopping in middle of field while truck is dispatched to unload. Plastic window tells driver when tank is full. Corner angles and wing bolts join the plywood panels

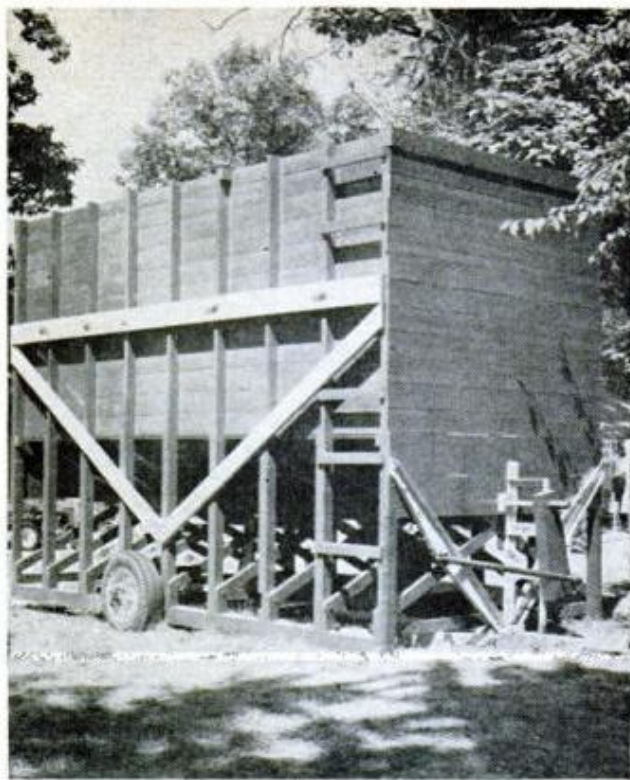

CORNCRIB ON WHEELS was built by Donald Rogers of Marshall County, Iowa, for wet storage of shelled corn after dryer was filled. It's a hopper 10 ft. high and 16 ft. long in a 2x4 frame. One man can auger 40 bushels per minute from it into the dryer hopper—even working at night or under muddy conditions

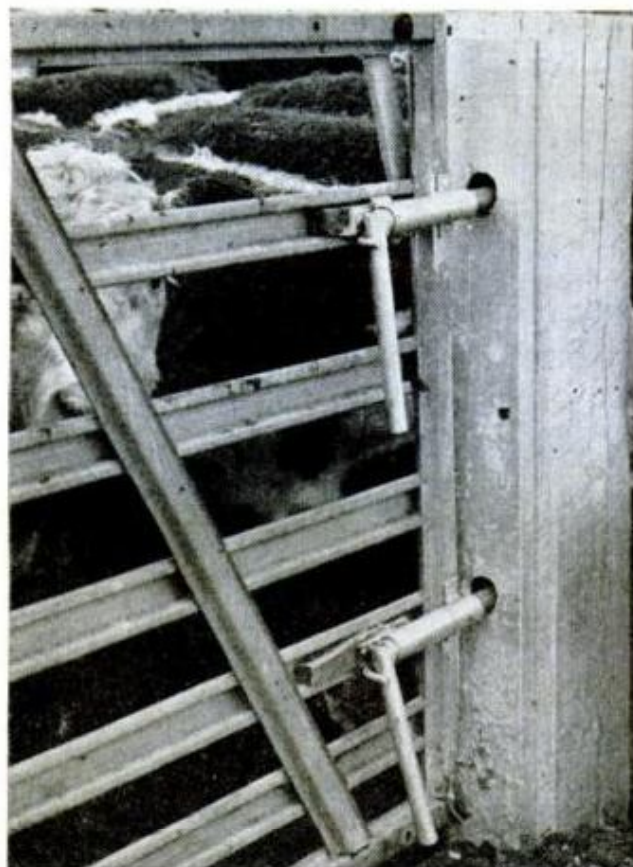

FEEDLOT GATE LATCHES stay closed of their own weight. Each consists of two lengths of iron pipe welded at right angles and slipped into a sleeve of larger pipe that's welded to the gate brackets. Welded-on hooks of iron rod lock the units in place once they're "shot" into sockets bored in the gatepost



LAZY SUSAN FEEDER distributes silage around circular trough, to accommodate 20 dairy cows at one time. The elevator, filled from a silo unloader, drops the silage on the peak of the cone, whose facets divide it equally as it tumbles downward—much easier than forking into straight troughs

How you can wire one bell to serve two doors

IF ONLY your front door is equipped with a doorbell, there's no need to install a second bell for the back door. The one bell can be wired to function as both a vibrating and a single-stroke type to serve callers at both doors. A single ring will tell you it's the back door.

The photo-diagram shows how the second button is tied into the existing bell, one lead (shown in color) being wired directly to the clapper contact ahead of the vibrator. Thus, when the back-door button is pressed, the bell's coil becomes a permanent magnet and the clapper strikes the bell just a single stroke. When there's a caller at the front door, the same bell rings normally.

—Joseph Braunstein

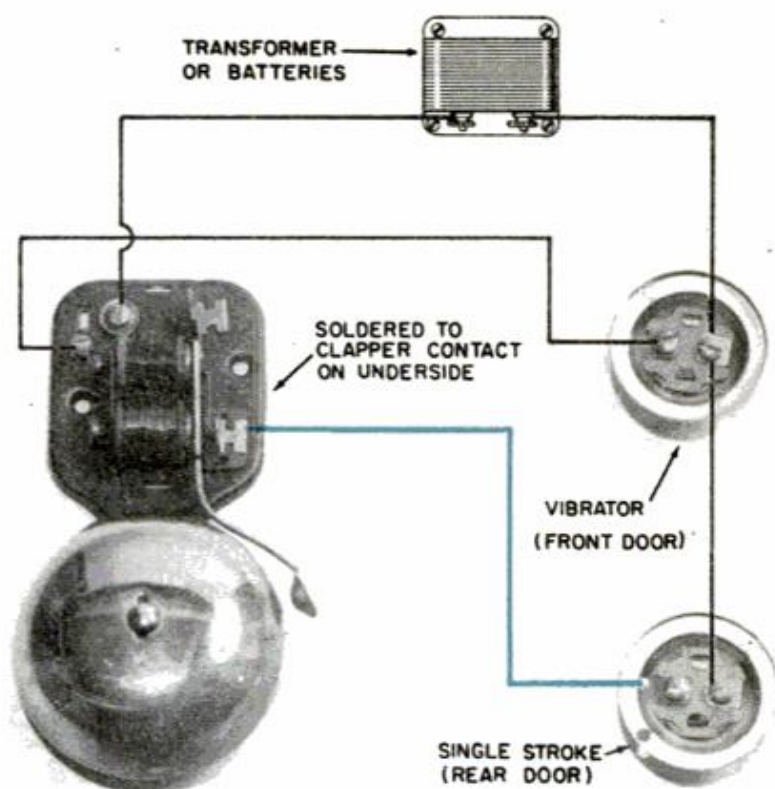

Don't overdo it. Oil-lubricated motors are too frequently overlubricated at sporadic intervals, which contributes materially to shortening their lives. According to Texaco Research Laboratories, two or three drops of oil per bearing every six months for motors in continuous service

and once per year for those in intermittent service, will be more than adequate for the larger motors. Of course, this oiling schedule does not apply to small motors with plain sleeve bearings which have no provision for retaining a reserve supply of oil; these do require frequent re-oiling.

NEXT MONTH IN SHOP AND CRAFTS

HOME IMPROVEMENT IDEAS GALORE. Whether you have been toying with such a major remodeling project as modernizing your dated bathroom or are merely on the lookout for quickie ideas for making your home more livable, you'll be eager to browse through some 40 pages of exciting home improvements in the September issue. You'll find complete plans for a glamorous bathroom budgeted to commercial accessories. There's also a built-in kitchen laundry wall for your washer and dryer, a deluxe home bar complete with brass rail and the last word in a sewing center—plus a bonanza of unique remodeling ideas of interest to homeowners anxious to improve the value and convenience of their homes.

SHOP VACUUM PLATE. A unique shop accessory that holds the workpiece by suction alone. It's extra useful where holddown clamps would interfere with surface grinding of the work. Can be easily made with metalworking tools from plans in a September craft feature.

LITTLE KNOWN HARDWARE. There are lots of special hinges you perhaps don't know about simply because they're so special the average hardware store doesn't stock them. But they are available and you're sure to spot several that you'll want to use on many of your shop projects. Be sure to read this informative story in September which not only pictures these unique hinges and tells you where to buy them, but also shows how to install them.

Twelve record-changer

Wow or rumble destroying the sound? Records not dropping? Changer not
By WALTER G. SALM

THEY'RE COMPLICATED BEASTS—those record changers that look as if they should never be touched. Actually there's nothing really mysterious about them. Every gear and cam has its own specific purpose and a little patient observation will reveal what that is. Once you know what each part does, repairs are relatively easy.

Turntable. If the turntable doesn't turn, is slow or slows or stops only during cycling, the trouble is in the drive train or the turntable is binding or scraping. Clean all friction drive surfaces with carbon tetrachloride and be sure that all

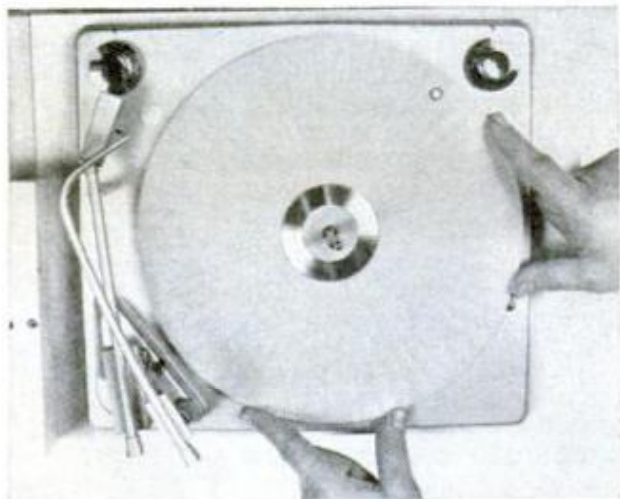

1. To remove turntable pry or push off U-clamp at base of spindle and lift turntable with rocking motion. Some changers use rubber retaining ring



2. Idler wheel is cause of many noise and cycling problems. It is also held in place by a U-clamp. Use small screwdriver to pry off and release the idler

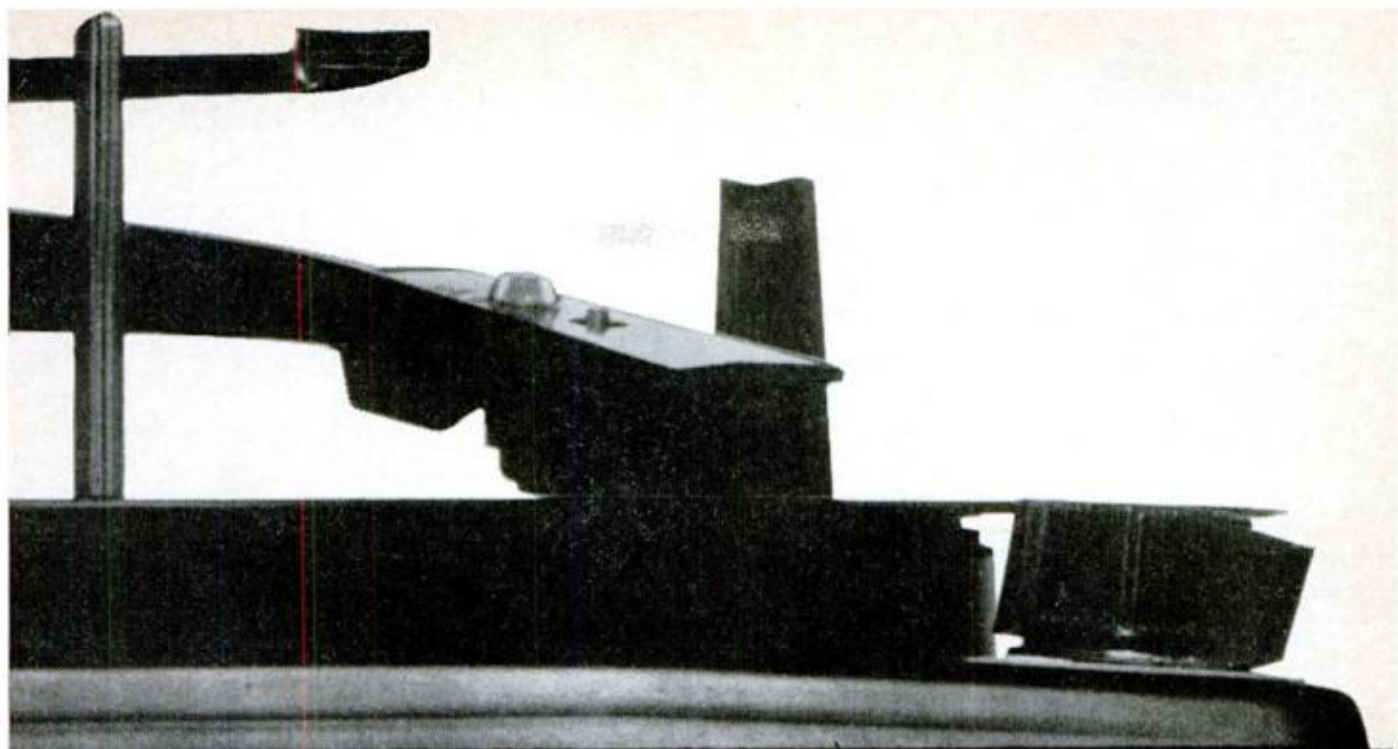

troubles you can cure

shutting off after the last record? These are easy to repair; here's how

rubber-metal contact points are free of grease. One missed spot can gum up the works. Give all metal-to-metal surfaces a dab of a fine grease, such as Lubriplate.

If the turntable seems to bind or scrape, check for missing washers above or below the ball-bearing ring in the spindle well.

Wow is another fault that appears with age. It is caused when the turntable does not run at a constant speed, but slips or slows down periodically. Check the rubber drive (idler) wheel that rotates the turntable. If the rubber is hard

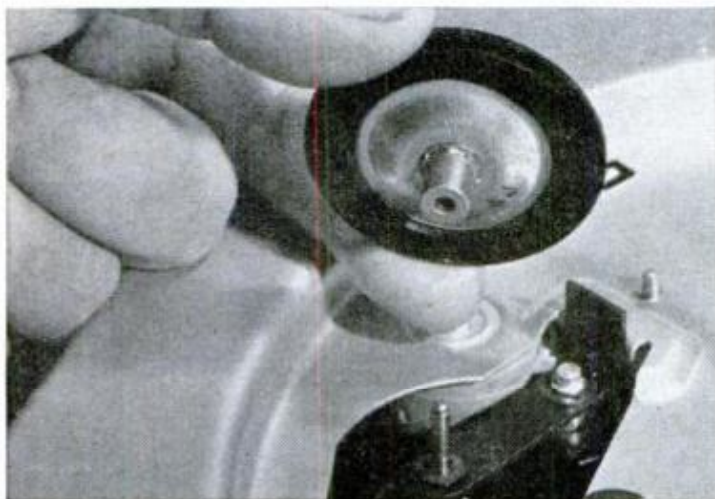

3. U-clamp removed, idler wheel comes right off. Inspect it for hard cracked rubber, flats which look like dents, slippery outer rim, or any other damage



4. Clean idler surface with carbon tetrachloride to remove traces of oil or grease. If necessary, liven up drive surface by rubbing with pencil eraser



5. Clean center axle hole and mounting shaft. Then place dab of grease on bottom of idler wheel hole. Do not get grease on rubber surfaces

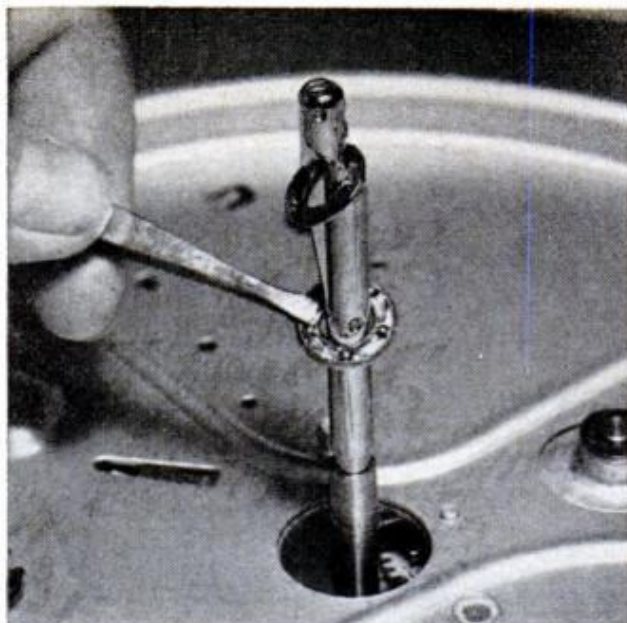

6. Thrust bearing slides off spindle, should have washer above and below. Clean and regrease. Check for smooth operation after re-installation

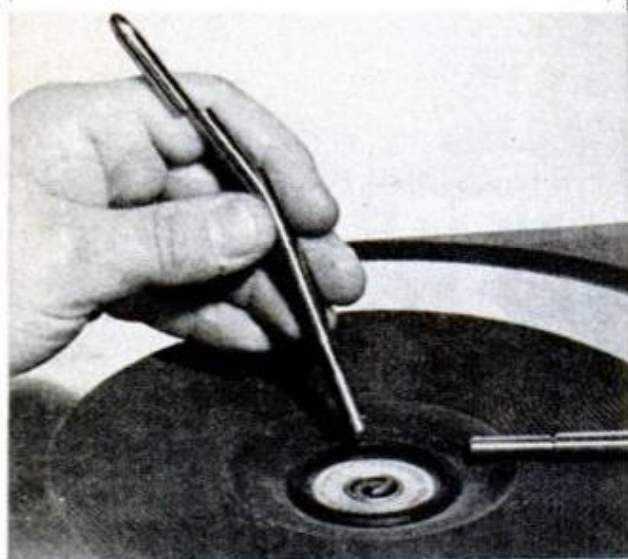

7. Changer with removable spindle requires that spindle be properly seated. Be sure it engages mechanism in well. Hand-rotate turntable to check

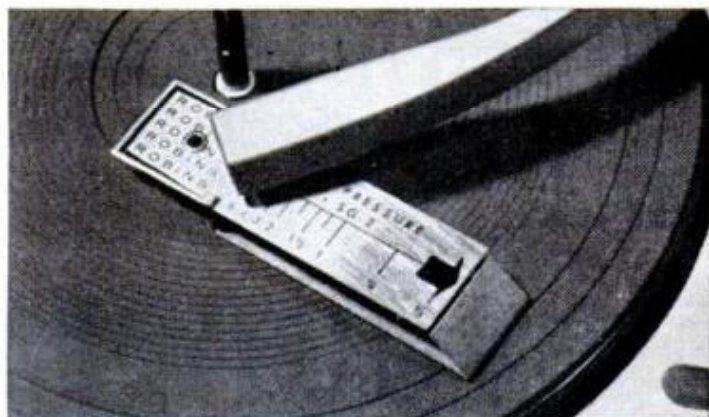

8. Stylus pressure is important. Too much can ruin records and needles. Too little can cause skipping, poor reproduction. Check with pressure gauge

and has a slippery surface, it must be cleaned or replaced. Use carbon tetrachloride to clean the rubber wheel and the inside of the turntable rim. If replacement is required, most electronic supply houses carry a line of parts. Idler wheels cost about \$1.50.

Sometimes excessive stylus pressure will cause wow, distorted sound and excessive record wear. Check this with a stylus pressure gauge. You might make certain the changer is level, too.

Rumble is common in low-cost changers and, to some extent, in more expensive units. Flats on the idler wheel are often at fault. These flattened portions of the drive surface are caused by prolonged contact with the turntable rim at the same point when the machine is turned off.

The only cure; replace the idler wheel.

Another cause of rumble is a thrust bearing that's not turning properly. It may need only cleaning and fresh lubrication.

Stylus. If the needle tends to jump or repeat grooves, look for a worn stylus. If it is worn and causing these difficulties, it has already done great damage to your records; and a new needle may also jump in grooves worn by the old stylus. Replacement is the only solution.

Pickup. One frequent problem is a pickup arm that doesn't land the needle in the lead-in groove. It may lead outside or inside of this groove, or completely off the record. Almost every changer has an adjustment, usually a screw at the rear of the pickup arm or on the arm's supporting pedestal. This one is strictly trial and

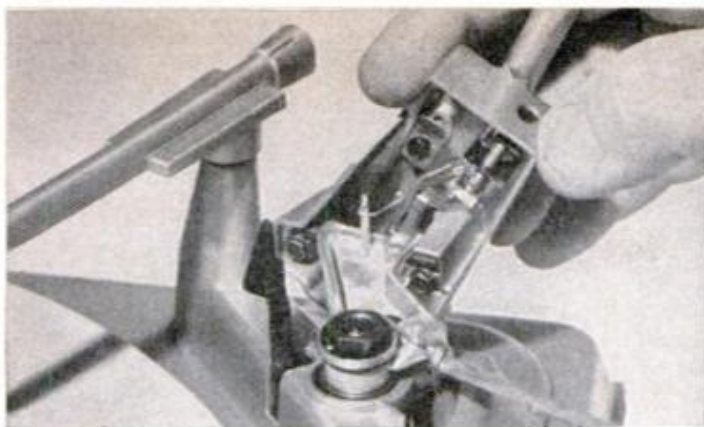

9. Needle setdown adjustment is usually found at pivot point of pickup arm. Final setting is a trial-and-error procedure until proper setting is found

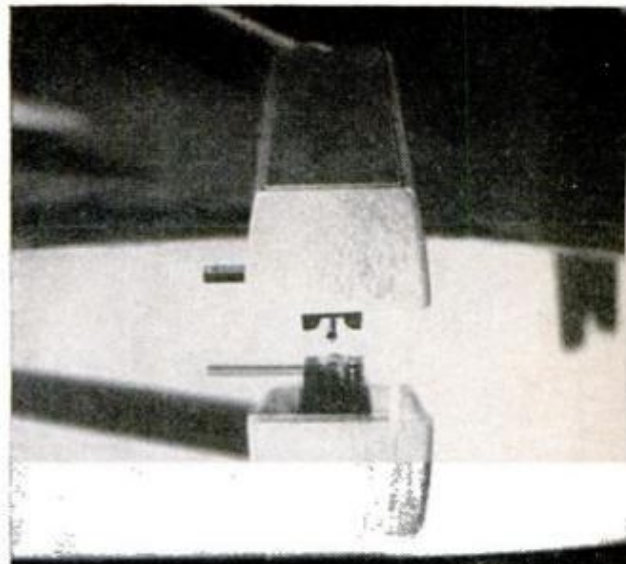

10. Perpendicular stylus alignment is checked with mirror in record-playing position. Double image must be straight perpendicular line

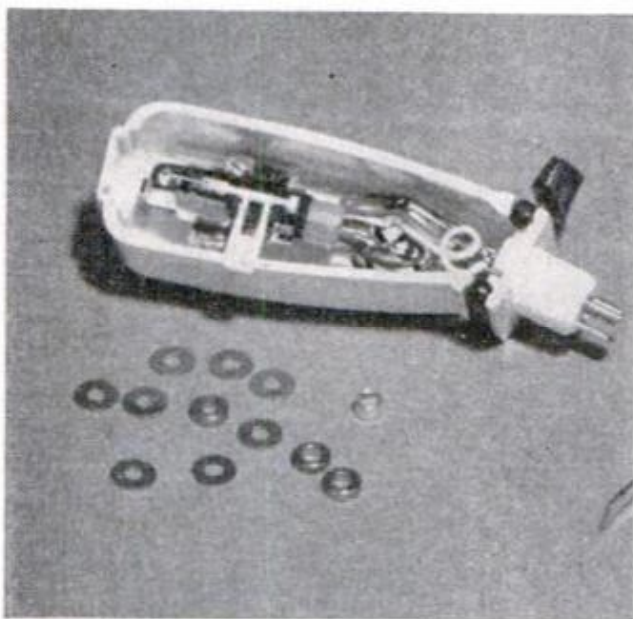

11. Plug-in heads make cartridge adjustments relatively easy. Remove head from pickup arm and loosen mounting screws that hold cartridge

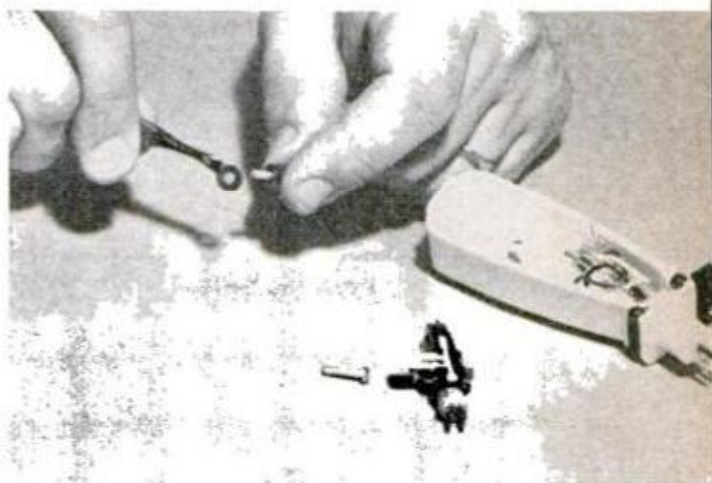

12. Brass shim washers slip under cartridge around mounting screw, compensate for tilt. Brass is a must. Iron can cause magnetic distortion

error, and you'll have to keep changing the adjustment until you get it right.

Shutoff. All record changers have an automatic shutoff. It is usually triggered by the record-leveling arm—the arm that swings over the top of the record stack and balances the discs. When the last record drops, this arm pushes a small lever underneath the turntable mechanism. When the changer starts to cycle after the last record has played, this shutoff lever is depressed, the pickup arm drops onto its rest, the idler wheel disengages from the turntable rim (in some models) and the control switch flips off.

The usual cause of shutoff failure is simply that the balancing arm doesn't drop far enough. Dirt in the shaft, lack of lubrication or improper operation of the shutoff

lever are the common reasons. Try moving the balancing arm up and down. If it moves freely and drops far enough, your trouble is in the linkage below; cleaning and lubrication are in order. If it tends to stick and doesn't always drop all the way down (past the spindle pusher mechanism), remove the shaft assembly, clean out the well with carbon tet (pipe cleaners to the rescue again) and clean the shaft itself. Use a very thin coat of grease on the shaft and work the shaft around as you re-insert it to spread the lubricant. If the shaft won't come out without major surgery, try a few drops of light machine or turntable oil alongside the shaft.

If a shaft gets bent from abuse, the only solution is replacement with new parts from the manufacturer. ★ ★ ★

NEW IN ELECTRONICS



World's first battery-powered TV tape camera has been shown by the Westel Co. The device will tape 30 minutes of broadcast-quality TV with on-location sound. Seven-pound camera permits operator to see and control TV picture as he shoots. Briefcase record unit on shoulder strap weighs 23 pounds with batteries and tape.



Add-on UHF TV antenna clips right onto the same pole now holding your VHF antenna. The new Snyder units are made in a variety of styles. Lead-in cable is attached to the antenna after it is installed and is connected to the UHF antenna terminals at the rear of the TV. The UHF-5 shown is \$2.95.



TV-radio-phonograph in suitcase includes a 9-inch battery-operated TV which can be removed from the case and used separately; all-transistor, 4-speed, hi-fi stereo record player; and AM-FM stereo radio. Electrohome makes this 40-pound, 30 x 16½ x 12-inch package.

Forget that nonsense about jumping over the net. Slump into a soft chair in the shade. Get someone to build you a tall, cold 7-Up Collins. Seven-Up smooths off the edges and fills out the flavor. It's the man's mixer.

Copyright 1966 by The Seven-Up Company



7-Up[®] the man's mixer

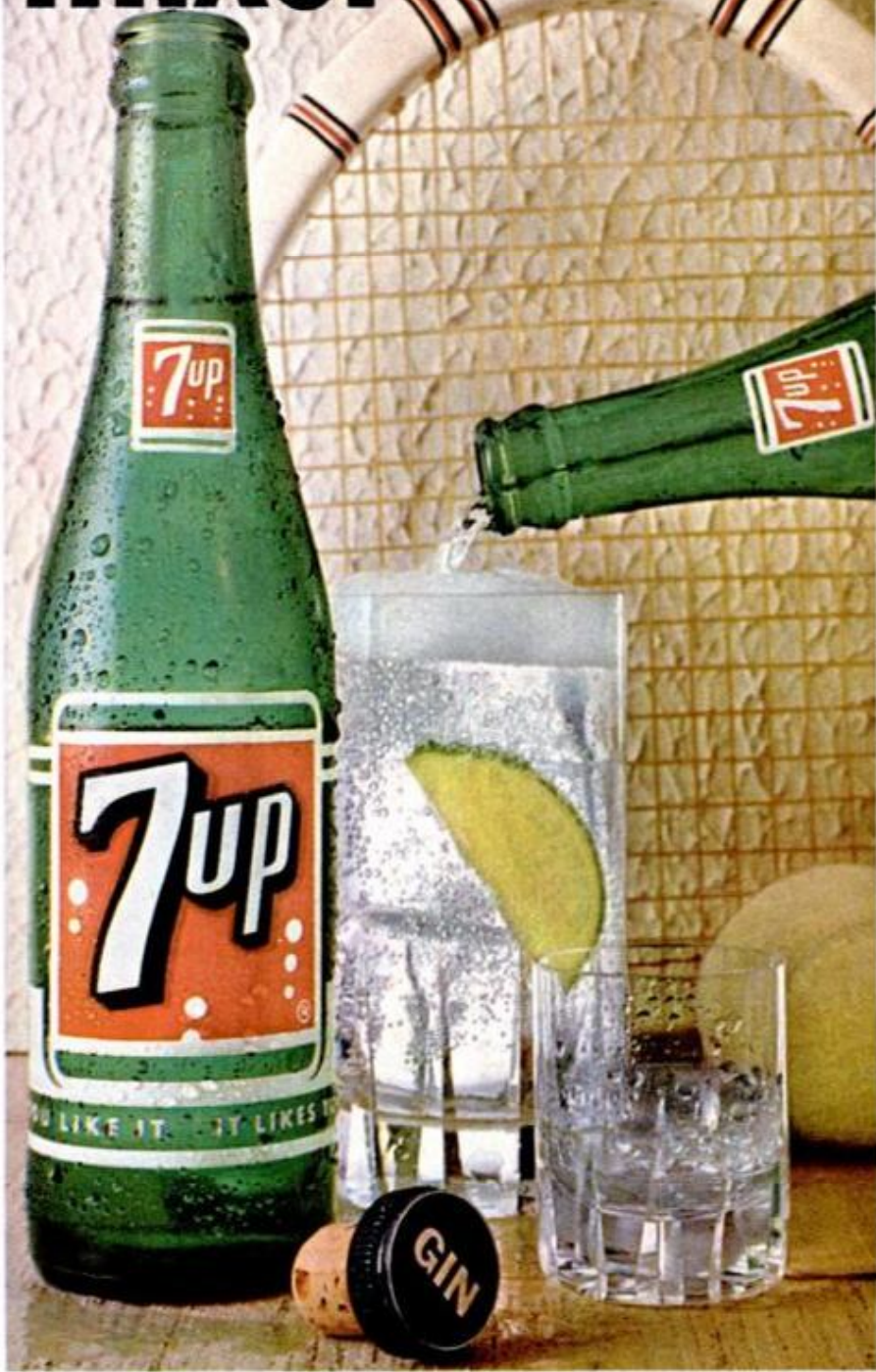

"SEVEN-UP" AND "7-UP" ARE REGISTERED TRADEMARKS IDENTIFYING THE PRODUCT OF THE SEVEN-UP COMPANY

Материал, защищенный авторским правом

However you measure pickups...

You're ahead in a Ford all the way!

What's important to you in a pickup? Riding comfort? Ruggedness? Performance? Check out a Ford and watch it deliver big—right across the board.

Check out Ford's Twin I-Beam suspension. See how two steel I-beam front axles work independently to absorb shocks before they reach the driver...smooth the ride on any road.

Notice, too, the husky forged radius rods



Ford uses to help hold wheel alignment and reduce tire wear.

Together, they make an independent suspension that no other pickup can match for smoothness ...toughness.

Next, look into Ford's new choice of high-performance engines: two big, seven-main-bearing Sixes, and a powerful 352-cubic-inch V-8.

And that's just the start. So work out your own pickup check-list. Then come in and let us prove... "You're ahead in a Ford all the way!"

FORD/66



Paint on a "new roof" in beautiful color

New aluminum roof coating • stops leaks

- restores old asphalt shingles
- adds harmonizing color



Before you spend money on a new roof, ask your paint dealer about a remarkable, brand-new aluminum roof coating being introduced this month. There's a choice of fade-proof colors. One coat weatherproofs and beautifies. And at a fraction of the cost of a new roof.

Users report they apply it for less than \$10 per 100 sq ft. It can add 5-10 years to the effective life of your present roofing.

Developed by Alcoa Research Laboratories, this new coating has been tested for more than five years under many weather conditions by Alcoa and several large paint companies.

They found it particularly effective on asphalt shingles, where it stops leaks by sealing small nail holes and cracks, bonds roofing granules, gives uniform appearance to old, patched surfaces.

New colored aluminum roof coatings, made with Alcoa® Pigments, will soon be marketed by many leading paint manufac-

turers. If your dealer doesn't stock these coatings, he can get them for you.

Aluminum Company of America
853-H Alcoa Building
Pittsburgh, Pa. 15219



Please send your folder on colored aluminum roof coating. My name and address is:

My dealer's name and address is:

Change for the better with Alcoa Pigments



Tows a load as big as a house carries everybody in the house



The Travelall[®] by International[®]

There's strength enough and power enough in the big family wagon to haul a travel trailer... or a boat trailer... or a camper trailer.

It can tow big loads at highway speeds without wagging its tail.

Because we gave the TRAVELALL a huskier frame and sturdier suspension than most wagons. And with a powerful INTERNATIONAL engine plus all-wheel drive, you can even go where roads don't go.

Inside, the TRAVELALL is also built for going places—with nine travelers plus their baggage, or six campers plus the camp, or three fishermen plus their boat. And it's

easy to get into.

You'll never know how good or different this big family wagon *really* is—until you try it. So try it. Any INTERNATIONAL Dealer is ready to show you what it can do.



**INTERNATIONAL HARVESTER
COMPANY**
CHICAGO, ILLINOIS

WACKY INSURANCE CLAIMS

(Continued from page 113)

One of the fish flopped, spooking the horse, which jerked its head back out and broke the window. The bump on the head so infuriated the stallion that he kicked in the whole rear end of the car. The insurance company paid.

In similar "accidents" a horse stuck his head in the front window of a car and ate up one of the seats, and a bull saw another bull in his pasture (actually his own reflection in a polished car door) and demolished the interloper—along with the entire side of the car. A motorist on Chicago's Eisenhower Expressway slammed on his brakes to avoid the charge of a brahma bull (which had escaped from a cattle truck), and was creamed from the rear by another motorist. Another driver was even more startled when an eagle swooped out of the western sky, snapped off his car antenna and carried it away as a souvenir. All of these claims were readily paid by the head-shaking adjusters.

Maternity benefits

But for a true animal story with an emotional tug, consider the doe that leaped out of the underbrush, crashed through the window of a passing car—and promptly gave birth to a fawn in the back seat. Sort of gets you right here, doesn't it? It got the State Farm adjuster, too, who not only paid the damage bill but also the bill for cleaning up the back seat.

One claim form submitted to Nationwide stated, incredibly, that the policyholder's dog had "attacked and chewed up the tires on a visitor's car." The adjuster promptly drove out to get the real story. Guess what happened. Yep, the dog ate the adjuster's tires, too.

Jewelry insurance meets special needs—and sometimes in special ways. A woman in Boston finally decided, after searching everywhere else, that her poodle *must* be responsible for the disappearance of her jewelry. She was right, too. The Traveler's adjuster paid her claim of \$11.50 for damage to the jewelry, and \$5 for "X-ray and enema to dog."

But the human animal can be even more imaginative than other animals in finding ways to damage property. As a prime example of *Homo sapiens'* yen for destruction, consider well the guy who parked parallel to a curb on a slight slope and went about his business. When he returned, his car was hemmed in by

a long line of cars behind, and a coal truck in front. Figuring that he could maneuver out if he could just move the truck a couple of feet, he climbed into the truck's cab and released the emergency brake. At least he *thought* it was the emergency brake; instead, he dumped five tons of coal on his car.

The case illustrates another point in regard to your own insurance: If you have the right kind of coverage, you can be as stupid as you like. The adjuster promptly paid the claim for damage to the coal-dumper's car. In any clear-cut case, a reputable company is determined to pay a claim pronto because it costs a surprising amount of money to keep an unsettled claim on the books.

Then there was the motorist who slammed into a light pole late at night. In good conscience he called the police who, upon arrival, suggested that he might have been drinking. In high dudgeon at this insult, the driver demanded—yes, *demanded*—a drunkometer test. At the station, the police discovered that their drunkometer was out of whack. The accused driver, an electronics engineer, offered to fix the machine on the spot. He quickly diagnosed what was wrong, repaired the gadget, was given the test—and promptly was charged with drunken driving.

Not quite so knowledgeable was a highway workman who didn't even know anything had happened to him until he woke up in the hospital. In fact, the State Farm adjuster had to piece together the story from available clues. The man was simply doing his job—making minor repairs along a curve of wooded highway—when lunchtime arrived. He unpacked his tunafish sandwich and sat down to dine in lonely grandeur on the top cable of the guard rail.

Human cannonball

Out of sight around the curve, a State Farm policyholder lost control of his car and struck the rail. *Whannnnng!* The cable snapped taut all the way around the curve. The workman shot an estimated 20 feet in the air, did a lazy loop in the sky and came down on the back of his neck, still clutching the tunafish. State Farm paid all medical expenses, although their errant policyholder was not even aware that he had triggered the human slingshot.

The first auto liability policy was written for a Buffalo, N. Y., dentist in 1898, and his annual premium was \$11.25. In those first years of auto in-

(Please turn to page 180)

WACKY INSURANCE CLAIMS

(continued from page 179)

insurance the companies only reimbursed clients for actual court judgments, and it was up to the insured to defend himself in court.

Today, the company takes on the burden of reaching a settlement, in or out of court. Sometimes an adjuster can be rather adroit in a controversial situation. A claimant in Virginia Beach, Va., had been stubbornly holding out for an outlandish settlement until the adjuster offered to toss in 50 Green Stamps which he just happened to have in his pocket. The claimant immediately signed.

The claims forms themselves, with their attention to what seems to be picaresque detail, lend themselves to sly humor in the hands of an aspiring comedian. One policyholder was driving down the road when a truck flipped a stone through his windshield. The Qs and As on his claim form read: Q. With what did you collide? A. *A pebble.* Q. Make? A. *Almighty God & Co.* Q. Model? A. *Sharp.* Q. Year built? A. *One.*

Not so funny on the claim form—at least to one State Farm policyholder—was his traumatic experience in a hospital. Rushed in by ambulance following an accident, he was bleeding about the head. As he was hauled on a stretcher into the emergency room, he protested faintly, "No! No!" The nurse on duty tried to calm him while she carefully snipped hair away from his wounds preparatory to shaving the scalp so the doctor could patch him up. As it turned out, the pride of the man's life was his toupee. State Farm not only paid the medical claims, but paid for a duplicate hairpiece, although the adjuster didn't know whether to list it in the company records as "medical payment" or "loss to wearing apparel."

Another hairpiece was involved in a claim when a cleaning lady arrived at a policyholder's home and carefully draped her wig over a pole lamp before going to work. Yep. The housewife walked in and switched on the light, the wig went up in smoke, and the adjuster paid another hair-raising claim.

Even Santa's a victim

You'd think that Santa Claus would be immune to damage claims, but even he has been a victim. To get the Yule season off to a spectacular start, a group of merchants hired a parachute jumper to come floating down in a Santa outfit. A gust of wind carried the bewhiskered gent off course and dumped him with a

whomp on a car, caving in the hood. The adjuster, who happened to be watching, agreed to pay the claim on the spot.

Adjusters report that two phrases pop up quite frequently in their work: 1. "You'll never believe this, but. . ." 2. "I was afraid you'd ask that. . ."

A good example of the use of the latter phrase is the fellow who submitted a medical claim for a broken toe. When the adjuster asked him how it happened, the man blushing stammered, "I was afraid you'd ask that. Well, my wife and I—we're still young enough to horse around a little. The other night she was getting ready to take a bath, and stooped over to pick up her clothes. I aimed my big toe at her, let fly with my foot, and our 2-year-old chose that moment to fling open the door. My toe hit the door. Now, are you going to pay the claim or not?"

You might try the other common phrase, "You'll never believe this, but . . ." the next time your wife gets a bee in her brassiere and loses control of the car (a fairly common claim), or is attacked by a jackrabbit while she's serenely watering the garden (which happened, and resulted in medical treatment). If the claim is covered by the contract, the company pays, no matter how wacky the situation.

Matter of fact, the adjuster probably will believe you. And will laugh all the way back to his office. ★★★

COMPARISON TEST

(Continued from page 70)

did a better job of braking than the Buick, which had a tendency to get mushy after a couple of haul-downs. But our main complaint at this point, believe it or not, was that the mountainous area prevented our getting a decent pickup of the Kentucky Derby broadcast.

Snow the next morning was a definite surprise. Not too welcome, either. We crossed over into Vermont and were well down near Massachusetts before we encountered completely clear roads. The countryside, however, was beautiful. From here on it was all downhill, the homebound leg being duck soup despite some moderate-to-heavy traffic apparently out for a Sunday afternoon's drive.

In all, we covered 1191.7 miles, just under half of it being strictly turnpike.

Mileage was about what you'd expect of cars "loaded" the way these were and driven mostly at highway speeds:

T-Bird—13.7 mpg overall.

Riviera—14.0 mpg overall.

New Yorker—13.3 mpg overall (while we had it, that is).

Here's the **EASY, Step-by-Step Way to**

FIX ANY PART OF ANY CAR

Engines, Brakes, Transmissions, Rear Ends, Generators—Yes, All These Parts

BRAND-NEW EDITION!



Now—Whether You're a Beginner or Expert Mechanic — You Can "Lick" Almost Any Repair Job on Any Car built from 1959 thru 1966

YES, now you can fix practically ANY part of ANY car—quickly, easily, and right! From carburetor adjustment to a complete overhaul, it's easy when you have MOTOR's famous Auto Repair Manual. It's like having a staff of factory experts and MOTOR's field-trained engineers beside you, guiding you every step of the way. No wonder so many thousands of beginners and experts alike use this step-by-step, illustrated manual.

MOTOR's Manual "starts from scratch"—leads you through entire job with easy step-by-step directions, clear "how-to" pictures. Tells you WHERE to start, what TOOLS to use. You just CAN'T go wrong!

3,800 Pictures! So Complete So Simple, You CAN'T Go Wrong!

NEW, REVISED edition covers all you need to know to repair almost any car, 1959-1966, including all the new models! 1,350 Giant pages. 3,800 "This-Is-How" pictures lead you every step of the way. 457 "Quick-Check" charts — 55,000 essential repair specifications. Over 225,000 service and repair facts. Instructions and pictures so clear you can't go wrong!

Experts and beginners alike are amazed by the time and labor-saving methods!

The "Meat" of 300 Official Shop Manuals

The editors have put together the "know-how" from 300 Official Shop Manuals and "boiled it down" into one fully-illustrated easy-to-understand guide.

Here's ILLUSTRATED step-by-step guidance on Automatic Transmissions, Generators, Ignition, Carburetors, Fuel Pumps, Steering Gears, Rear End, Brakes, PLUS MUCH MORE.

SEND NO MONEY

Try Book for 10 Days FREE

Just mail coupon. (Attach it to postcard if you wish.)

Test book in your garage or shop. **GUARANTEED** to pay for itself in 10 days or you owe nothing. **MOTOR Book Dept., 250 West 55th St., New York, New York**

OVER 5 MILLION COPIES SOLD!

Try Book for 10 Days **FREE**



Diagrams, tables and text take the "mystery" out of all ignition systems.

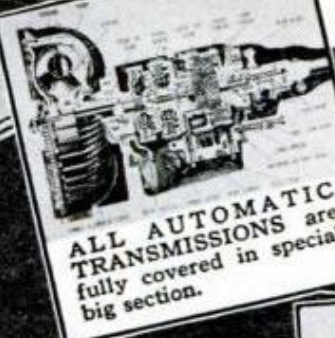

ALL AUTOMATIC TRANSMISSIONS are fully covered in special big section.

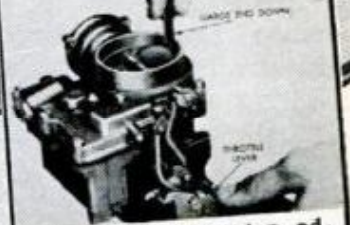

You get step-by-step adjustment procedures for all types of carburetors.



Expert Raves About Book... "Motor Manual is worth its weight in gold. I've done mechanic work for over 25 years. Motor has saved me many hours of brain-racking thinking."
—R. Carter, N. Carolina (Mechanic)



... So Does Beginner "In technical high school where I learned the auto mechanic's trade, Motor's Manual pulled me out of some rough spots. Now I'm in the Armed Forces," attached to motor pool."
—W. Bekemerer, Missouri (Apprentice)

MAIL COUPON NOW FOR 10-DAY FREE TRIAL

**MOTOR BOOK DEPT., Desk 618
250 W. 55th St., New York, N. Y. 10019**

Rush to me at once MOTOR'S New AUTO REPAIR MANUAL. If O.K., I will remit \$2 in 10 days, \$3 monthly for 2 months and a final payment of \$1.95 (plus delivery charges and sales tax, if any) one month after that. Otherwise I will return the book postpaid in 10 days.

Print Name..... Age.....
Address.....
City.....
State..... Zip Code.....

Also send me for 10 days' Free Trial MOTOR'S New TRUCK REPAIR MANUAL. If O.K., I will remit \$11, plus delivery charge and sales tax, if any, in 10 days. Otherwise I will return book postpaid in 10 days.

Check box and save shipping charge by enclosing WITH coupon in envelope entire payment of \$9.95 for Auto Repair Manual (or \$11 for Truck Repair Manual) plus sales tax, if any. Same 10-day return-for-refund privilege applies.

Same Offer on MOTOR'S New TRUCK REPAIR MANUAL

Covers all gasoline engines, plus Ford, GM, Cummins, Mack, Perkins, International diesels since 1955. Over 2,000 pictures! Check coupon for FREE TRIAL.

Brand-New—Covers All These Makes

- | | | |
|---------------|----------|-------------|
| American | Fury | Mercury |
| Barracuda | Corvette | Meteor |
| Bronco | Dart | Mustang |
| Buick | De Soto | Oldsmobile |
| Buick Special | Dodge | Olds F-85 |
| Cadillac | Edsel | Plymouth |
| Chevelle | Fairlane | Pontiac |
| Chevrolet | Falcon | Rambler |
| Chevy II | Ford | Studebaker |
| Chrysler | Imperial | Tempest |
| Comet | Jeep | Thunderbird |
| Continental | Lancer | Valiant |
| Corvair | Lincoln | Volkswagen |
| | Toronado | Marlin |

BEST DRIVER

(Continued from page 89)

it wasn't long before the Italian factory began hearing about the skinny Californian who had a magic touch with race machinery. Gurney was invited to Le Mans in 1958 as part of the Ferrari team, and he was on his way.

Gurney's instinctive ability to get the best possible performance from a car has led to some tense moments—so tense, in fact, that he has been known to frighten himself. At last year's Belgian Grand Prix, for instance: "My car developed a mysterious handling problem right after the start," Gurney recalls, "and then it began to rain, hard. This compounded my steering trouble, for every time I hit a puddle at upwards of 135 the car tried to get away. I finished the race safely, but I must have turned green six times."

In case you are curious about the part Gurney played in retiring the conventional roadsters that held sway at Indianapolis for so long, here's the inside story in Dan's own words:

Saw it coming in Europe

"After I saw the rear-engine cars take over in Grand Prix racing in Europe, it was clear that this would also happen at Indianapolis. It was just a matter of getting it started.

"I talked to Colin Chapman, the designer of the English Lotus, since to me he had the best grasp of what would be needed. And I talked to Ford about engines. I bought Chapman a round-trip ticket to Indianapolis and hoped he would be interested in what he saw. He was.

"So then we had a policy meeting with Ford. We agreed we'd need a car of not more than 1250 pounds and an engine weighing less than 350 pounds yet developing more than 350 hp. It should deliver six miles per gallon of gasoline.

"Chapman and Ford both got busy, and in 1963 Jimmie Clark finished second and I finished seventh in our brand new Lotus Fords. Next year, we both withdrew with tire trouble. Last year, of course, Clark won the race, and I failed to finish. This year there was only one front-engine roadster in the race."

Paradoxically, Gurney's fast, safe driving has caused him to set maybe a world's record for breakdowns. From 1959 to 1962, while driving on various European factory teams, Dan finished only three of the 21 European races that he entered. Every other time he was knocked out by mechanical trouble. Sometimes the trouble was accidental, as happened in his first Grand Prix race when a stone went

through the radiator of his Ferrari. Sometimes the failure was exasperating, as in 1959 when he had been leading the Le Mans 24-hour endurance race for hours, and then the headlight wiring went bad.

It was a mechanical fault that caused the only major accident in Gurney's career. That was in Holland, in 1960. Gurney was going 140 mph approaching a 180° hairpin corner that called for braking and down-shifting. "There was only one problem," Dan explains. "A brake line blew off when I hit the pedal. I kept going straight, hit a hill, flipped in the air and landed upside down 300 feet away."

Mechanical failures were Gurney's nemesis through much of last year. In part, the record reads like this: Led for eight hours in the Daytona Continental, then a wrist-pin lock in the modified Lotus Ford broke smashing the piston . . . leading at Sebring in the same car when the oil pump drive failed . . . among the leaders at Indianapolis when the cam drive gears went out . . . leading a Formula One race in England when the transistor ignition quit. And so on.

Gurney isn't the only top driver who has been plagued with breakdowns but he is one of the few who is doing something about it. "No fast driver will ever win a race if his equipment can't keep up with him," he reasoned, "so let's build better equipment."

He teamed up with Carroll Shelby, famed sports car driver and creator of the Cobra series, and opened All American Racers, Inc., in Santa Ana. There, this past spring, six Indianapolis cars and four Formula One Grand Prix cars were built.

Len Terry, who had been with Colin Chapman, was chief designer of these new American Eagle vehicles, with Gurney looking over his shoulder. "What we want to add is more reliability," Gurney instructed Terry. "We want most of these cars to finish the season without breaking down. And they must be easy to work on. Let's not waste time having to take a car apart just to make a simple adjustment."

Five of the Eagles qualified at Indianapolis and were the most talked-about cars there. In the wild, 16-car collision on the first lap, Dan's own car, No. 31, got smacked four times, and a year's work and hopes went down the drain in five seconds. After the restart, Bob Crossley, PM editor, was standing in Gurney's pit when Lloyd Ruby, who led for 68 laps in Eagle No. 14, went by, seemingly on his way to victory. Gurney looked up. "Ruby's all through," he said quietly. No one else had noticed anything, but Ruby was soon in the pits with oil sprayed all over his car. Gurney was right.

With today's trend toward erasing the differences between U.S. national championship and world championship cars, all of Gurney's Eagles are practically identical. All are of monocoque design, using steel, aluminum and fiberglass. Each has a 96½-inch wheelbase and a height of 36 inches at the top of the roll bar.

Each of the Grand Prix cars is equipped with a battery, starter and a five-speed-plus-reverse transmission, as called for by the rules. They will be powered by Gurney-Weslake 12-cylinder engines with a wedge-type combustion chamber to produce power comparable to the hemi design.

The Indianapolis cars have a two-speed shift, no starter or battery and are powered by 255-cu.-in. four-cam Ford engines. It's noteworthy that the Fords, with a list price of \$28,000 per copy, were reworked in Gurney's shop to the extent of another \$5000 each. Clearances and alignments were changed, different pistons, wrist pins, rings and rods were replaced.

Gurney's Eagles (and his Lola) were scheduled to compete in 35 races this season, here and abroad. Gurney hoped to squeeze his tall frame into the glovetight cockpits of his cars for 16 of those events.

Gurney's recipe for winning races is four-pronged: adequate financial backing,

a competent driver, a fast and reliable car ("keep it simple") and a top pit crew to prepare the car and service it during a race. Dan prefers the famed Wood brothers for his pit crew. He drives their beautifully set-up Ford at Riverside, and signed them up to handle his pit at Indy this year. (Ironically, the wreck left them with nothing to do.) In the 1964 Daytona 500 Gurney lost several laps in the pits when the Wood crew accidentally stripped the threads on a lug bolt while changing a tire. Gurney shrugged it off.

"They're still the best. The Daytona incident only proves that everyone is human. Sure, they could have waved me out on the track with the stripped bolts. But the safety of the driver and car comes first with this bunch, and they held me there while they replaced the bolts. That's the kind of decision I like."

This takes us back full circuit to the time when Daniel S. Gurney was seeking a name for his brood of racing machines.

"Dan, why did you select the 'American Eagle' name for your cars?"

"That's easy," Gurney smiled. "The eagle has been a symbol of battle all through history. And this is an American racing team that is in battle with the best of the rest of the world!" ★★★

New Portable LIGHT PLANTS

110-120 V. A. C. 1500 watts, 60 cycles. Weight 24 lbs. Size 10" x 5". Fanbelt driven from car, pickup or gas engine of 2½ or 3 h.p. Operates ½" Drills, Saws, T.V. Brand new. Money back guarantee. Regular \$89.50 now \$49.50. With switch, pully and voltmeter. Send check or money order.

VIRDEN PERMABILT CO.

Box 7066

Amarillo, Texas 79109

1966 MAIL ORDER BONANZA

BRAND NEW DIRECTORY tells where to obtain over 100,000 items from over 1000 sources. OVER 600 FIRMS WILL "DROP-SHIP" YOUR ORDERS! Complete facts and information. ORDER FROM THIS AD & RECEIVE SPECIAL SECTION ON "CO-PUBLISHING BUSINESS" EVERYTHING ONLY \$2 POSTPAID. SATISFACTION GUARANTEED.

T.E. McNAMARA
P.O. BOX 176, GUILDERLAND, N.Y.



AMAZING NEW "LISTEN-IN-COIL"

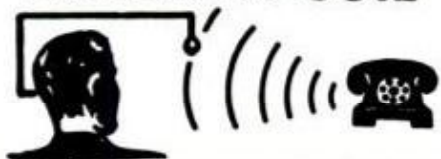

PICKS UP ANY TELEPHONE CONVERSATION!

NO CONNECTION TO TELEPHONE NECESSARY! You hear the entire two way conversation from a distance . . . undetected! Limited supply remaining at only \$1.98. SUPER-SENSITIVE model \$2.98. Satisfaction Guaranteed! Catalog of LISTENING DEVICES 35c. FREE with order! Save COD fee and send Check, Cash or M.O. to: Consolidated Acoustics, DEPT. 95, 1302 Washington, Hoboken, New Jersey.

ESTIMATOR SNAP-RULE

NEW to measure & estimate
boat & house paint,
wallpaper, concrete.



1.69

SAVE TIME
AND BE
ACCURATE TOO

No. C90

MEASURE-ZUM®
PATENTED

New dual purpose coiled steel rule snaps into rigid 6' length. One side, estimator charts, other side, regular 72" rule.

On sale at paint, hardware, building supply and lumberyard stores or send 1.69, check or money order. Rule sent postpaid.

HYDE TOOLS
SOUTHBRIDGE, MASS., U.S.A.
Write for Free Catalog





FOUR-WAY
BEST LOW COST
ARC WELDER
YOU CAN BUY
only \$14.95 Complete

WELD. BRAZE. SOLDER. CUT. Tops in performance and value. Ideal gift, educational, profitable, enjoyable. No experience needed. Use 1/8" welding rods and 1/4" carbons to make or repair auto bodies, fenders, trailers, boats, toys, furniture, farm equipment; garden tools, anything of metal. Operates on 110 V. line.
WORLD'S GREATEST WELDING VALUE. Over 500,000 in use by home owners, farmers, hobbyists, mechanics. **5-Year Unconditional Guarantee.** If inoperative will repair or replace without charge. **You Get: FULL FACE SHIELD,** heavy metal cabinet, ground clamp, 12 ft. heavy cables, special combination carbon arc torch & rod holder, carbons, welding and brazing rods, flux, solder, instructions.
ORDER on 10-DAY UNCONDITIONAL MONEY BACK TRIAL.
SEND ONLY \$2.00 and pay \$12.95 plus C.O.D. charges on delivery.
 or send only \$14.95 and we will ship prepaid. **Order today.**

FOUR-WAY WELDER CO.

DEPT. W2-H
 1810 S. FEDERAL ST.
 CHICAGO, ILL. 60616



Print Your Own

Cards, Stationery, Advertising, Circulars, labels, photo and movie titles, church work, tags, etc. Save money. Sold direct from factory only. Raised printing like engraving, too.

Own a Printing Business

Print for Others, Good Profit. Have home shop. Junior press \$15; Senior \$35 up. We supply everything. Easy rules. Pays for itself in short time. Write now for free details.
KELSEY PRESSES, Z-37 Meriden, Conn.



DRAINS cellars, cisterns, wash tubs; **\$8.95**
IRRIGATES - CIRCULATES - SPRAYS

1,001 u-es. Stainless shaft. Won't rust or clog! Use 1/6 HP motor or larger . . . 3/4 HP for up to 2,400 GPH; 450 GPH 80" high; or 1,800 GPH from 25' well. 1" inlet; 3/4" outlet. Coupling included free. **\$8.95.**
HEAVY DUTY BALL-BEARING PUMP. Up to 5,200 GPH; or 3,000 GPH from 25' well. 1 1/4" inlet; 1" outlet. **\$12.95**
 Postpaid if cash with order. **MONEY BACK GUARANTEE**

Centrifugal and Gear Pumps in All Sizes

LABAWCO PUMPS, Belle Mead 7, New Jersey



FACTORY DIRECT!

MINI-BIKE KIT! \$109.95

Build your own mini-bike in about 2 hours! No welding! Speeds to 30 mph.

You get:

- 2 1/2 hp 4 cycle engine
- Precision welded frame
- Complete instructions

\$10 Down
\$ 7 Month
 Assembled \$119.95

RUSH 25c for brochure to:

BIRD engineering, Box 427, Dept. PMO Omaha, Nebr. 68101

20 COURSE HOME STUDY PROGRAM

JUDO KARATE!
BOXING! MUSCLEBUILDING! YOGA!
STRONGMAN STUNTS! STRENGTH & ENDURANCE! HANDBALANCING! ETC.



YOU GET ALL THESE COURSES! *20 illustrated KARATE blows *SAVATE foot fighting *SECRET NERVE CENTER and ANATOMY charts *20 lethal JUDO throws *20 terrific STRONGMAN STUNTS *Complete MUSCLE-BUILDING course *Ancient YOGA secrets *HANDBALANCING stunts *Complete BOXING course. SECRETS OF ENDURANCE *WRESTLING holds *WEIGHTLIFTING *TENSION-FLEX COURSE *HEALTH & FITNESS EXERCISES *KEEP FIT PROGRAM *8-MAN Karate Dummy Chart. No C.O.D.'s. Canadian 75c. YOU GET THE LOT.

ONLY \$50c

COMPLETE HOME GYM PLANS—Build gym equipment: vault horse, rowing machine, etc. Convert basement, garage to gym. ONLY 50c with courses. Total \$1.00 compl.

OXFORD STUDIO, 146 Blake (PM-4), Mattapan, Mass.

NAME (print) **50c PROGRAM**
 Address
 City State

Free K-Man Practice Dummy showing attack points.

PEDAL PLANE WHIZ-AROUND

(Continued from page 137)

shaft with sheet-metal strips and, to eliminate slippage, I drilled the shaft to provide a seat for a setscrew. If no tricycle fork is available, suspend a bicycle crank between two hangers of steel plate, welded to the frame's front bend as shown in the sketch.

My guide pulleys were made from 3/4-in. waterproof plywood, with an old auto generator ball bearing epoxied in the center. Not owning a lathe, I turned my pulleys on my portable drill. I just inserted a bolt through the center of each rough disc and chucked it in the drill, which was secured in an upright bracket. Then, with a round file, I cut the edge groove about 3/8-in. wide and 1/2-in. deep. The bearing holes were cut with a circle cutter set for a diameter slightly less than that of the bearing. I degreased the outside of the bearing before I applied epoxy and drove it into the hole; before the cement set, I aligned the bearing so the pulley would spin without wobble.

My support post is 2 1/2-in. steel water pipe—the length determined by the height of your swingset's top beam. Two U-bolts clamp the pipes together, and a length of 2x4 is bolted across the post's lower end to keep the pipe from sinking. Or you could provide a concrete footing.

The hub and knuckle (spindle) were from an old Dodge front end; however, almost any type (except a ball joint) could be substituted. All parts attached to the hub and knuckle should be arc-welded to minimize heat distortion. You may have to modify the pipe to insert the knuckle shank. The knuckle-pipe weld should be as strong as possible.

The main beams are two lengths of 1/2-in. pipe flattened on each end. These ends are bent and welded together after you weld the beams to the hub plates.

If you want to add up-and-down motion, you could tilt the center pole or bolt the bicycle rim off center. And as long as there are no obstacles near the orbit path, you could provide the plane with a large rudder, controlled by the steering wheel, to add a little "swim" to the orbital ride. ★★★

Soft landing

Drop an egg from an 11-story building and it won't break if it lands on a new type of shock-absorbent padding. That's the claim of the maker, a big rubber company. The padding is used to cushion the fall of astronauts in training exercises.

TURNPIKE SAFETY DRIVING

(Continued from page 67)

one and one-half seconds behind the other car, with no room on either side to run.

What can go wrong? I live on fast roads, and let me tell you some of the things—just a few—I have seen . . . near Wilmington, N.C., logs bouncing toward oncoming

cars from a pulpwood truck . . . in Montreal, Canada, heavy oil drums rolling down a bridge ramp . . . in New England, 50-pound sacks of lime and cement fallen from flatbeds. And near Port Chester, N.Y., not long ago I got motion pictures of two huge granite boulders skidding down a 60-mph pike in traffic. They'd

(Please turn to page 193)

Passing

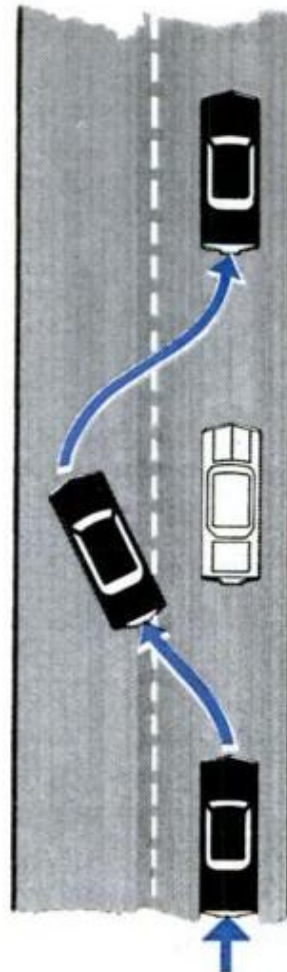
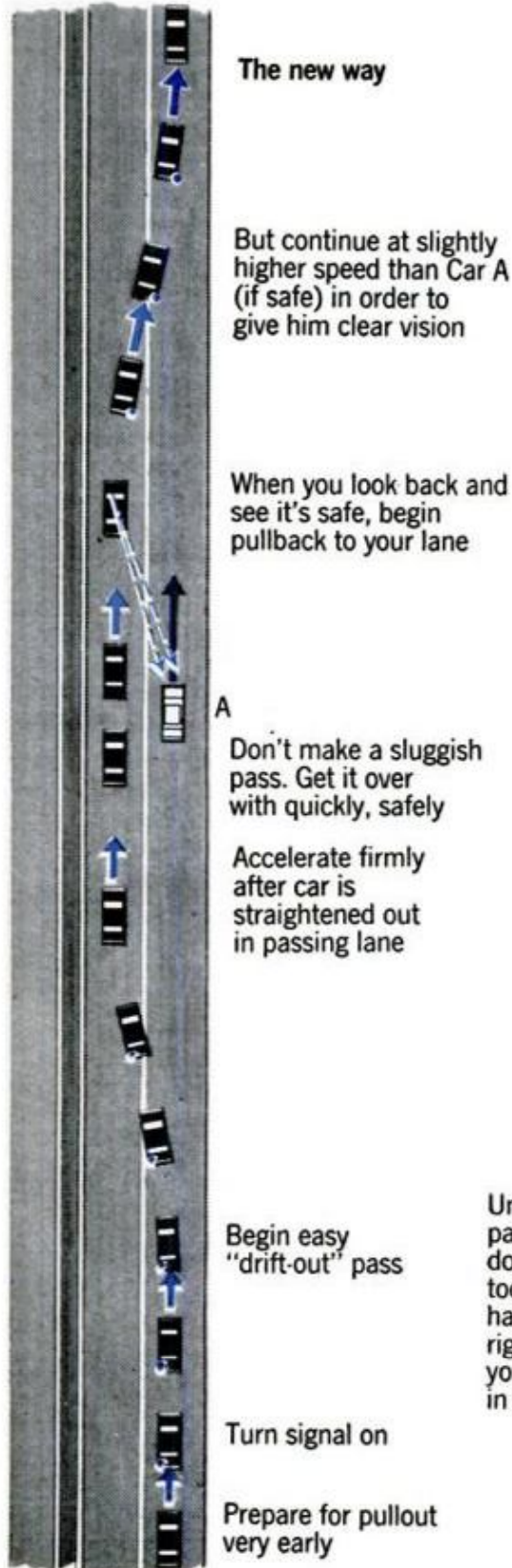

The old way

Remember how we used to sneak up behind A, roar out, gun it and wildly scramble to get ahead? Then we'd crowd back in front of him. We didn't have enough power for a really safe pass

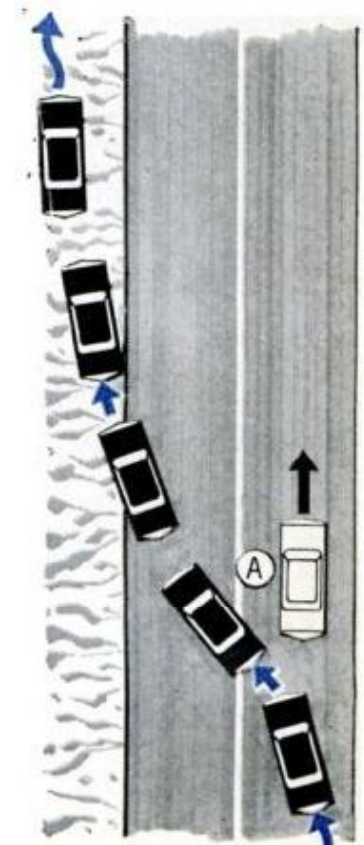

But don't do this

Unwise use of that fine passing power today can do this. You pull out too fast, kick the gas hard—and toss yourself right off the road before you can straighten out in the passing lane

REAL ESTATE

BE A BROKER

PAYS BIG! SEND FOR FREE, BIG, ILLUSTRATED CATALOG NOW! Graduates report making substantial incomes. Start and run your own business quickly. Men, Women, all ages, learn easily. Course covers Sales, Property Management, Appraising, Loans, Mortgages, & related subjects. **STUDY AT HOME** or in classrooms in leading cities. **DIPLOMA AWARDED. Write TODAY for FREE Booklet!** Accredited Member National Home Study Council. (Established 1936)
WEAVER SCHOOL OF REAL ESTATE
3521-P Broadway Kansas City, Mo. 64111

FREE
BOOK
TELLS
HOW

Shrinks Hemorrhoids New Way Without Surgery Stops Itch - Relieves Pain

For the first time science has found a new healing substance with the astonishing ability to shrink hemorrhoids and to relieve pain - without surgery.

In case after case, while gently relieving pain, actual reduction (shrinkage) took place.

Most amazing of all - results were so thorough that sufferers made astonishing statements like "Piles have ceased to be a problem!"

The secret is a new healing substance (Bio-Dyne®) - discovery of a world-famous research institute.

This substance is now available in suppository or ointment form under the name Preparation H®. Ask for it at all drug counters.

If You Can Draw A Straight Line (with a ruler) WE CAN TEACH YOU DRAFTING

Growing consumer and defense industries can't get enough trained draftsmen. Our new teaching methods let you learn in your spare time at home. You learn more, learn faster. Step up the wage ladder with a white collar skill that leads to the top. Send for sample lesson and course outline. Resident course also available on our Chicago Campus. Established in 1934 - 60,000 graduates.
AMERICAN INSTITUTE OF ENGINEERING & TECHNOLOGY
1125 Fullerton Pkwy - Chicago, Ill. 60614

Makes FALSE TEETH
up to 35% more
effective



Dental tests prove you can now chew better, eat faster with your false teeth - can make your dentures average up to 35% more effective - just by using FASTEETH Powder. Thousands of dentists recommend it. FASTEETH helps keep dentures from slipping. You feel more secure . . . speak without embarrassment. It cushions tender gums. Checks "denture breath." Dentures that fit are essential to health. See your dentist regularly. Get FASTEETH today at all drug counters.

'GATOR POACHERS

(Continued from page 109)

area with their light. Then they idled up to the exact clump of weeds where Gary had planned to hide and dumped out a sack.

While the suspects were loading the boat on their trailer, Gary retrieved the evidence and the arrest was made. Both men were fined \$250 and put on probation for 30 months.

Tom raced the airboat up to a pool, cut the engine and we rocked gently over the black water. I knew we were close to the middle of a roadless area 70 miles long and about 60 wide.

We sat quietly, watching for lights, and I recalled some of the other stories about poachers. There was the time Officer John Mapel eased a fugitive's car off a flood control levee in a chase.

Chase on the levee

John had spotted a light in the canal along the levee and had radioed Officer Tom Morris, 14 miles away, for assistance. While Morris was driving up without lights, the violators dragged their boat out of the canal, hitched up a trailer and took off in two cars. Then the chase began at 50 to 60 mph on the unsurfaced rim of the levee.

The order of this crazy procession was: 1. violator's brother-in-law in a Ford Falcon; 2. violator with trailer, alligator hides and a girl friend who had been serving as lookout; 3. John Mapel with his headlights on and siren screaming, and 4. Tom Morris on Mapel's tail without lights.

The violator with the trailer began beeping his horn to signal to the Ford the Falcon off the top of the levee and This was done but Mapel had no intention of being stopped. He simply nudged the Falcon off the top of the levee and kept going with Morris still behind.

Apparently the fugitive with the trailer was unaware that Morris was in back of Mapel. Anyway, he threw out a bundle of hides and Morris stopped to pick them up. Mapel, meanwhile, caught his quarry.

"You ain't got nothin' on me," he said. Then his mouth gaped as Morris drove up with the hides. "Where the hell you come from?" he screamed.

Later, he pleaded guilty and received three months in the county stockade. His brother-in-law was fined \$500 for his interference. The girl went free.

Not all cases involve dramatic chases. As we sat in the airboat, Tom Shirley told me about one that simply required the use of psychology and patience. Two

poachers had been trailed into his area by the supervisor of another game management area. Alerted by radio, Tom and his men found the violators at a lonely service station. A boat on their trailer showed signs of 'gator blood but no hides. Apparently the skins had been concealed in a canal along the road.

"Today we have serum to tell if it's 'gator blood but at that time we didn't," Tom told me. "However, I said we'd take a sample and have it checked in the morning by the sheriff's department. If it was 'gator blood, we'd come back.

"I wanted 'em to think we couldn't do anything until morning. That would give 'em a chance to think they were safe, sleep and pick up their skins."

After dressing like fishermen, Tom and his officers scattered to strategic points and waited through the night.

Tom and his men slapped mosquitoes until dawn. Then, just as expected, the violators appeared to collect their skins. They were promptly caught on the highway with evidence and later jailed.

There is little humor in the war between poachers and wardens. But Tom told me how he once used a beer can to lure a poacher into exposing himself. The idea was to keep the poacher occupied while Tom slipped up on him.

He bent the empty can in the middle and floated it off in the direction of the poacher. Caught in a flash of the poacher's light, the ends of the can looked exactly like a 'gator's eyes.

"Shot that beer can to death"

Tom said, "He sure shot that beer can to death while I was coming up to catch him with his skins."

It was growing late and the few lights we had seen were from known points—camps of honest hunters, a construction gang on the new road from Fort Lauderdale to Naples. Tom muttered something about the frustrations of night patrol and started up the engine. By the time we had bounced and slithered through the darkness to the Andytown ramp, we had covered a region about one-third the size of Rhode Island.

As we drove toward the glow of Miami, the car radio crackled and someone identified himself briefly. Tom responded with some mysterious instructions. The radio sputtered again and another officer spoke. As nearly as I could determine, these men were about 50 miles away and were interested in an unidentified airboat. It could be a frogger or fisherman, a moonshiner, a poacher or just someone coming in late from a camp. But the officers would check him out. ★ ★ ★

5 COLLECTOR COINS — only 10¢ each

Coins from Ethiopia, Somalia, Mexico, Cyprus, Guatemala: 10¢ each. Other 10¢ offers: Hong Kong Banknote, or 3 different pre-1925 Lincoln cents. Also selection of coins from approval service, returnable without obligation, and big catalog.

LITTLETON COIN CO., Dept. PM-8
Littleton, New Hamp. 03561



FIRST TIME EVER
AT THIS PRICE...
EXPENSIVE
LEAKPROOF CON-
STRUCTION ON...

HIGH PERFORMANCE PUMPS SAVE! BUY DIRECT FROM FACTORY!

Quickly Drain Pools and Cellars!
Fill Tanks! Irrigate! Spray!

Now... a pump for under \$50 with permanently leakproof ceramic-lapped precision mechanical seal construction... the same as in pumps for atomic submarines. Forget about the leaks and constant adjustments necessary with conventional gland seal pumps. Precision made to pump up to 5,000 GPH. Up to 60 ft. ht. Maintenance free, rust-proof aluminum castings. 1½" intake, 1" discharge. Fits any motor. Threaded suction discharge. Quality guaranteed by one of America's leading manufacturers of precision tools and pumps. Send check or M.O., or \$1 deposit on C.O.D.'s. Flexible drive coupling \$1 extra.

MONEY BACK GUARANTEE!

AMERICAN MACHINE & TOOL CO., Dept. PM-86, Royersford, Pa.



ALL FAMOUS BRANDS! **FARM TRUCK AUTO** AT LESS THAN WHOLESALE

TIRES! SAVINGS NEVER LESS THAN 50% up to 70% OFF REG. PRICE!

HEADQUARTERS for ALL SPORT CAR TIRE SIZES
FREE - SEND FOR YOUR FREE CATALOG - FREE!

RELIABLE TIRE DIST., 1111 Chestnut St., Camden, N. J.

ENROLL—EARN YOUR DEGREE

of Bachelor of Bible Philosophy (B.Ph.B.), Master of Bible Philosophy (M.Ph.B.), Graduate of Bible Philosophy (G.Ph.B.), Doctor of Metaphysics (Ms.D.), or Doctor of Divinity (D.D.). Chartered by State, Correspondence Courses only. Please write for FREE BOOKLET.

AMERICAN BIBLE INSTITUTE

Dept. PM, 408A W. 75th St., Kansas City, Mo. 64114

SHOOT A STAPLE
WHEREVER YOU'D DRIVE A NAIL!

ARROW®
T-50
HEAVY DUTY
STAPLE GUN

Uses 6
Staple sizes—
1/4" to 9/16"
and CEILTILE®

ARROW FASTENER CO., INC.
Saddle Brook, N. J. 07663

At Hardware, Building, Lumber, Stationery and Retail outlets everywhere.

SHIP YOU DRIVE WITH FINGER

(Continued from page 95)

el, 26 red buttons, arranged to mimic the actual installation, monitor bearing temperatures on the engines, reduction gears and propeller shaft. A button lights up if a bearing gets too hot, and the console takes steps to cool it off. On conventional ships an oiler has to walk around and climb ladders to inspect each bearing every hour. Then the watch engineer does the same thing on the half hour.

"Doesn't it make you a little nervous having someone run your engines from six decks above?" I asked Chief Engineer Richard O. Roberts. He pointed to a wheel on the console, an exact replica of the one in the pilot house. "We can take control immediately, if we need to," he said. "And should the console get fouled up, we've got three other ways to open or close the throttles."

The chief turned around to face the boilers. "Here's another first—automatic flame scanners. There's one on each of the four burners. They detect imperfect combustion from any cause and put out the flame.

"My last ship was a *Mariner*, the last word a few years ago. It had six fires in each boiler. During maneuvering it took five men in the engine room frantically building and putting out fires. On the *Racer* the fuel is atomized by steam pressure. It sure makes a difference. Instead of burners having to be turned off, steam atomization permits them to be turned down, automatically, as the bridge uses fewer revolutions. Two men can run this engine room during maneuvers."

We climbed down another ladder to see the *Racer's* "Single-Plane" propulsion system, a new design in which the turbines, condenser, reduction gears and propeller shaft are on one level. The *Racer* has only a single screw. But it is 22 feet in diameter and weighs 28 tons. Every time it revolves, the 13,000-ton ship moves nearly 24 feet.

She was moving, all right, by the time I came topside. We were rapidly clearing Boston harbor. The coastal pilot, already aboard, had taken over for the run down through the Cape Cod Canal. He called for 19 knots, about 80 rpm, and turned south.

Second Officer Robert D. Sparks had explained the bridge control console to me that afternoon. He was on watch now, and I had a chance to see him "drive." He stood to the right of the helmsman, behind a desklike cabinet that met his chest letter-high. On the console's top, at a lecturnish 45°, were three instruments:

an engine-room telegraph, used only when the engineers took control; a master clock that controled a slave in the engine room; and an iron wheel about a foot in diameter. The slightest twist of the mate's wrist, and it opened or closed the throttle as sensitively as the knob on your hi-fi adjusts the volume.

I stayed on the bridge to watch the tricky business of piloting a big ship through the canal at night, marveling at the pilot's skill as we passed other vessels in the 450-foot channel. I also marveled at the *Racer's* ability to respond. The next day, going up Delaware Bay, Capt. Patterson said the *Racer* could make it from Cape May to Philadelphia a half-hour faster than a nonautomated ship, even if the latter had more speed.

It was 1900 hours—just getting dark—when we steamed under the Walt Whitman Bridge between Camden and Philadelphia. Three other ships were tied up to U. S. Lines' big Pier 80 South, so we anchored in mid-river to await a berth. At 2100 the ship we were waiting for pulled out.

Capt. Patterson tapped me on the shoulder. "See that ship?" he said. "The *American Manufacturer*, a C-2. I commanded her for 14 years. It takes four hours to secure her for sea. We can do it in an hour."

"How big's her crew?" I asked.

"Fifty altogether."

"And the *Racer's*?"

"Thirty-nine."

Action on deck

Longshoremen were swarming over the ship like addled ants by the time I got on deck next morning. Winch operators, working from pulpitlike consoles, were already opening the main-deck hatches. On conventional ships longshoremen have to rig booms to open the covers, and the job takes at least half an hour per hatch.

On the *Racer* each hatch cover, not only the top ones, but those for lower decks, are opened and closed by hydraulic rams. The covers ride on wheels running along tracks on the rim of each hatch. Each cover is divided into sections to permit half-opening without disturbing or exposing cargo on or under the unopened part. Each section folds against itself like the lid over a piano's keys.

(Some months after my trip on the *Racer*, her two main holds were converted to containerized transport, a new and more efficient shipping method. Here's how it works: A container is furnished to a shipper for loading at his warehouse. He fills it with goods and then transports it by truck or rail to the port

city, where it's taken aboard. Upon arrival overseas, the container is unloaded and transported to its final destination. The system eliminates the handling of a lot of separate, small crates or boxes. Containers for the *Racer* measure 8 by 8 feet and are either 20 or 40 feet long. In loading, they're dropped into cellular structures resembling elevator shafts and are placed one atop the other. The *Racer* has room for 200 containers.)

On most ships there is only one winch for each boom. The vang guys, the lines that swing the booms in and out, often have to be hauled by hand, as does the schooner guy, which connects the booms at the top. The topping lift, which raises and lowers the boom, and the cargo hoist have to be connected to and disconnected from a single winch.

On the *American Racer* each wire has its own winch, controlled by a lever in the console. After lifting cargo from the hold, the operator swings it to the pier by "burtoning"—taking in on one hoist and paying out on the other.

Now a 15-minute job

The *Racer's* pride and joy, her 70-ton boom, is mounted amidships to serve No. 3 and No. 4 holds, the two biggest. It's a monster, with five sheaves on its main hoist and seven on its topping lift. It used to take four or five men two hours to get a boom this big ready for use. Boatswain Hugh Jones says he can get this one ready by himself in 15 minutes.

In the very bottom of Hold No. 5, two decks below one of the 11 reefer spaces whose total capacity is equal to 43 refrigerator cars, are tanks for high-quality cargo oil, such as lubricating oil or additives.

To get an idea of what hidden-away spaces like these looked like before they were covered over, Capt. Patterson spent more than two months at Sun Shipbuilding as the *Racer* neared completion.

"If we ever have trouble in some hard-to-get-at place," he explained, "at least I'll know what it looks like."

As we neared the Buzzards Bay end of the Cape Cod Canal, Capt. Patterson, who had been talking with me on the bridge, excused himself and stepped into the pilot house. Suddenly the whistle sounded a deafening blast, and lights flashed around the base of the dummy stack. I saw a shade go up in a window alongside the canal. A lamp flicked off and on, and an arm waved.

"Nice people," the captain said as he rejoined me. "We've been saluting each other for 12 years."

The *American Racer* might be automated. But she isn't run by robots. ★★

FREE MUSCLE COURSE!

Trade in that skinny scrawny, milk toast or overweight body of yours for a new Weider Jet-Charged body, rippling with mountains of muscles loaded with energy, drive and virility, the envy of every man and admiration of every woman, now! In 15 minutes I'll prove you can slap on 4 inches of muscles to your chest,—3 inches to each arm—give you life-guard shoulders, trim your waist to athletic size—give you speedy athletic legs. I don't care if you're short or tall, (skinny or fat) young or not so young, expect a muscle building miracle when you send for my FREE course. Send only 25 cents to cover postage and handling and write to the Trainer of "Mr. Universe", "Mr. America", "Mr. Europe".

JOE WEIDER, Dept. 38-86D
531 32nd St., Union City, N. J.



New! 2 LB. MAGNET lifts 125 LBS.

Revolutionary new non-electric magnet has double the power of Alnico 5. Full power lasts forever without a keeper. Won't demagnetize. Pulls 125 lbs. on steel block. Wt. 2 lbs. /4" x 2-1/2" x 1" No. X-125, \$8.95 postpaid.



ALNICO 5 SPECIALS/WE PAY POSTAGE/MONEY-BACK GUARANTEE

- No. MN25 Tiny retriever assembly pulls over 25 lbs. \$3.95
- No. GP3 Electric guitar pickup rod, 3 16" dia. x 1" 10 for \$1.95
- No. GP5 Electric guitar pickup rod, 5 16" dia. x 1-1/2" 12 for \$3.95
- No. CS Superpowered rod, rounded ends, 1 2" dia. x 3" \$1.25
- No. MM30 Small bar, polished, 1 8" x 3 16" x 1" 10 for \$1.00
- No. SC20 Science experiment & hobby kit, 10 assorted magnets \$2.00
- No. RM6 Flexible strip magnet, 3 16" thick x 5 16" wide 24" for \$1.00

No. X-125

SAMPLE PAIR SMALL BAR MAGNETS & BARGAIN CATALOG 25c

MAGNA MAGNETICS, 7777 SUNSET BLVD., LOS ANGELES, CALIF. 90046 Dept. M

A Money Making Opportunity For You Handymen

OWN PROFITABLE Saw Sharpening BUSINESS



If you're handy with tools, here's a practical way to increase your income and build security for your family. Earn extra money every week sharpening saws with a Foley Automatic Saw Filer. You can actually build your own business with it—without special training or previous experience.

FREE BOOK

"Money Making Facts" explains how you can get business from home owners, farmers, carpenters, schools, factories, etc., how to build your business and expand—every step of the easy way. Don't wait. Mail coupon now for this exciting book and easy pay plan. No salesman will call. Mail Coupon Today for Free Book.



Foley Manufacturing Co.
816-6 Foley Bldg., Minneapolis, Minn. 55418

Name _____

Address _____

City _____ State _____ Zip Code _____

Painful hemorrhoids?

All too often, humans who sit and stand pay the price of vertical posture. Sitting and standing combine with the force of gravity to produce extra pressure on veins and tissues in and around the rectal area. The result may be painful, itching or burning hemorrhoids.

The first thought of hemorrhoid sufferers is to relieve their pain and discomfort. However, of the products most often used for hemorrhoids, some contain no pain-killing agent at all...others have one too weak to provide necessary relief...and still others provide only lubrication.

Now at last there is a formulation which concentrates on pain. It actually has over 8 times more pain-killing power than the topical anesthetic most commonly used in hemorrhoid remedies. 8 times the power to ease the itching, pain, and burning of hemorrhoids.

The name of this product is Nupercainal. Nupercainal starts to work on contact. Provides prolonged relief from pain. Soothes and lubricates.

When you suspect you have hemorrhoids, check with your doctor. If hemorrhoids are the cause of your discomfort, chances are he'll recommend Nupercainal.

Nupercainal is available without prescription at professional pharmacies everywhere. Ask for ointment or new suppositories with free pocket-pack. (Say New-per-cane-all.)

Nupercainal®

over 8 times more pain-killing power

75 POWER TELESCOPE 25X-45X-75X \$4.98

NEW 3 in one telescopes. 3 variable 25X-45X-75X magnification. Brass bound. 25 power for ultra bright images. 45 & 75 power for long range. Guaranteed to bring distant stars, moons, objects, sports 75 times closer.

Most powerful scope anywhere at this amazing-low price. 5 sections. Opens 36" closes 1 ft.; Contains 4 ground & polished lenses. Can also be used as powerful microscope. American made. Mass production enables us to offer telescope complete including case \$4.98 post paid. Money back guarantee.

CRITERION CO., Dept. PMB 32, 331 Church St., Hartford, Conn.



FAMOUS DOT TEENUT® FASTENERS

Can't slip, flush-mounted, strong. ONLY nut that gives steel threads in wood!

- Now available in bright NEW finish!
- NEW red and yellow, skin-pack cards!
- Look for colorful NEW display carton, too!
- Handymen need TEENUTS!
- Sold at hardware stores.

COLUMBIA FASTENER

SUBSIDIARY OF UNITED-CARR
3229 South Ashland Avenue
Chicago, Illinois 60608

TEENUTS is a registered trademark of United-Carr

WATER COLOSSUS

(Continued from page 81)

Rockies at 3000 feet elevation that extends south into Montana. This would be used as a 500-mile-long storage reservoir.

The plan calls for building dams near the headwaters of the Yukon, Peace and other rivers in Alaska and northwest Canada, and installing hydroelectric generators. Some of the power thus produced would be used to pump part of the impounded waters high enough so that the water could flow via tunnels and existing water courses into the Trench.

From the southern end of the Trench the water would be pumped to an upper reservoir above the 5000-foot level. From this high point a main canal would follow mountain contours all the way to New Mexico, where it would bend east and then north, terminating in a pool serving Colorado, Kansas and Nebraska.

Branches from the main canal would carry water to arid areas of the far west, northern Mexico and into Texas and Oklahoma.

Numerous hydroelectric stations would manufacture electricity from the water as it flows downhill, providing surplus power even after pumping the water uphill at various points.

The Canadian-Great Lakes seaway and irrigation canal would be a separate waterway originating on the Peace River and flowing southeasterly to Lake Superior. En route it would control seasonal flooding in the Lake Winnipeg area, and allow development of a barge canal from that lake to Hudson Bay.

Never before in history has so huge an undertaking been contemplated. Naturally, some of the "details" seem fantastic. One of the dams would be more than 1700 feet tall. One tunnel in the Rockies would be 50 miles long and 80 feet in diameter. Twenty-five billion dollars would be spent on labor, a fifth of that on equipment. The plan calls for moving 45 billion cubic yards of earth and rock, for 5 billion sacks of cement, for 70 million tons of steel.

It would take about 10 years, it's estimated, to work out the international treaties and to prepare final drawings and arrange financing. Then would come 20 years of actual construction.

A special Senate subcommittee is so impressed with the plan that it has urged Washington to approach Canada to form a joint commission for further studies.

Its protagonists claim that NAWAPA would assure an adequate supply of water to the North American continent for 100 years.—Thomas E. Stimson

WHICH GLUE IS BEST?

(Continued from page 140)

can be used safely at low temperatures.

Resorcinol, or waterproof, glue comes as a two-part package—one part liquid, one part powder. The two parts interact as soon as they are mixed, and this mixture has a very short curing cycle at high temperatures. So do not use resorcinol at temperatures lower than 70° F., nor if the temperature is likely to fall below 70° before the glue has cured. If applied at lower temperatures, resorcinol will dry but will not cure. Result: a weak joint. Try to do your gluing in the morning with this glue so that it will cure before the temperature drops at night.

Resorcinol has a tendency suddenly to "dive" (soak) into the wood several minutes after application, so always leave the joint open for about 20 minutes after laying on this glue; then if it dives, you can always add more.

Contact cement is excellent for applying plastic laminates to wood and for other jobs where efficient clamping is impossible. The main disadvantage in working with this adhesive is the difficulty encountered in achieving a perfectly uniform bond, as the cement does not lend itself well to a smooth application. The best way to apply it is with a roller in the same manner as paint is rolled on a surface. This will give as smooth an application as possible without spraying it on. *But don't spray it on!* Most contact cements are highly flammable and spraying them could be very dangerous.

Epoxy resin has little use in woodworking. In fact, the poorest application for epoxy is wood-to-wood. This is not to say that epoxy won't hold wood; it will. But wood inhibits the curing of epoxy and draws certain of the chemicals out of the adhesive's resins. This weakens the epoxy and, hence, the joint it serves. Also, epoxy is far too expensive for general use on wood. Why pay \$5 to glue up a job when you can get results that are just as satisfactory with a \$1 glue?

Most of us have had gluing failures at one time or other. Avoid them in the future by keeping in mind that each glue has its own particular function and its own peculiarities. Using the glue that's made for the job at hand will keep failures at a minimum.

Cut out the gluing chart accompanying this article and tack it up on your workshop wall. Rely on it to tell you what kind of glue to use for a job. But remember: The correct use of any glue is just as important as the glue itself if you want a gluing job that will stay stuck. ★ ★ ★

GOVT. SURPLUS AND OTHER BARGAINS SAVE UP TO 90%



AC GEAR MOTOR Operates on 115 V. AC 60 cycle. Continuous duty. 1/15th HP 4 pole motor. 9 RPM @ output shaft. Contains extra heavy steel gears. Develops 750" lbs. torque. Face mounting. Great for conveyors, mixers, displays, etc. 9" L x 4 1/2" W x 8" H. Shpg. wt. 16 lbs. NEW. Special purchase. Specify model VW16-2. A \$38 value. NOW \$19.95

MOTOR SIMILAR TO ABOVE except 1/10th HP, 6 RPM, intermittent duty. Shaft faces towards motor. 9" L x 4 1/2" W x 7" H. Specify model VW16-1. \$17.95



HIGH VOLUME PUMP Pumps up to 11 GPM @ 35 psi @ 2000 RPM thru 1 1/2" pipe ports. For fuel, oil, hydraulic fluid. Water or water based insecticides. Pump has carbon veins, aluminum body. Complete with mounting base with 1/2" keyed drive shaft ready to couple to your 1/4 HP motor. NEW. 7" L x 4" W x 4" H. Wt. 5 lbs. Approx. GOV'T COST \$75. Now! \$17.50



GEAR HEAD MOTOR Heavy duty, all ball-bearing const. throughout. Excellent for conversion to winch drive unit for electrical car or golf cart motor. Reversible with 3/4" shaft. Turns approx. 400 RPM on 12 V.D.C. Can also run on 24 V. at increased speeds. Approx 3 HP Wt. 40 lbs. Like NEW. \$19.95

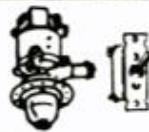

ELECTRIC PUMP WITH CONTROL SWITCH For boats, campers & trailers. Output 200 GPH. Can be used in fuel or water. 1/2" pipe bronze inlet. 12 or 24 V.D.C. Explosion proof motor. Shpg. wt. 9 lbs. Complete with wiring diagram. Approx. GOV'T COST \$200. NEW \$11.95



NEW! BIG! 1966 CATALOG

Send 25c for amazing catalog with 1000's of bargains in hydraulics; electrical, marine, automotive items, etc. Order from ad. Prices FOB. 50¢ deposit for COD. Pls. include your zip code number. Satisfying mail order customers thru-out the world since 1945.

AIRBORNE SALES CO. Dept. PM866

8501 Stellar Dr. • Box 2727 • Culver City, Calif. 90230

NOT TO BE CONFUSED WITH IMITATION
PLASTIC MODELS SELLING FOR LESS!!

\$5.95

Not Sold to Calif. or N.Y. res.

22 Cal. Blank Cart. 8 Shot Revolver
No Permit Required



Imported from ITALY
"BLACK VENDETTA"

Latest model, not a toy. Gun is of solid steel construction. Lightweight and perfectly balanced. Fires 8 rounds in 2 seconds! Double or single action. Precision crafted. 5 1/2 inches long. Ideal for stage, sporting events, boating, protection. Revolver \$5.95, deluxe leather holster \$2.25. Send cash, check or M.O. and save C.O.D. charges. \$1.00 deposit with C.O.D. orders.

BIG THREE ENT. INC. 1109 Sixth Ave., Dept. PM86, N.Y., N.Y. 10036



Solves Repair Problems

Durham's fills cracks and holes in plaster, wood and tile. Won't shrink or fall out. Economical, easy to use. Big 4-lb. can, only 1.60 at lumber, paint, and hardware dealers, or shipped direct postpaid in U. S. for \$2.00. Money-back guarantee. Order now. Donald Durham Co., Box 804-T, Des Moines, Iowa.

FREE!

Learn how you can buy used engines \$15 up, new engines \$30 with FREE confidential list and coupons when you order your plans

• BUILD THIS MINI-BIKE!
Plans reveal step by step details!

• BUILD A RACING KART!
Complete frame for less than \$10!



RUSH \$2 for plans (indicate type) or send 25¢ for brochure describing plans: PLANS, Box 517, Omaha, Nebr. 68101

VOLKSWAGEN OWNERS REPORT

(Continued from page 84)

"You have to get up over 50 mph to get heat."—Utah salesman.

"It blows in your face, but it won't defog the rear windows."—Illinois salesman.

"Back vents burn passengers' legs even when the heater is turned off."—Illinois factory worker.

Complaints about handling placed third.

"The wind jerks the front end, which makes one feel unsafe. I put 200 pounds of concrete under the front hood and it's a great improvement."—North Carolina artist.

► **That light front end is where the steering is. Such instability is common with rear-engined passenger cars.**

"Rear wheels tend to skid during a turn on wet pavement."—California salesman.

"I'd like a camber compensator for the rear swing axle."—Kentucky real estate broker.

► **They're available from accessory manufacturers and they improve cornering by giving the rear wheels a wider stance. But they also increase tire wear because the tires run on the shoulders instead of on the entire tread.**

Fourth brickbat concerned the front disc brakes, which performed bumps and grinds and exhibited other unseemly behavior.

"Stopping is uneven."—North Carolina housewife.

"Disc brakes squeal and grab."—Missouri printer.

► **Disc brakes are like babies. They all squeal.**

In fifth place was carburetor trouble.

"Starting is hard because of poor idle adjustment."—Army officer.

"Dual carbs are hard to keep synchronized."—California trailer park owner.

"Automatic choke doesn't work."—Washington attorney.

Back to the best-liked features, numbering six through ten. Luggage space got extra praise in the squareback model because of its station wagon-like rear loading area in addition to its front trunk.

"The back seat is easy to fold down."—Pennsylvania engineer.

"Side pockets are handy for storing papers."—Wisconsin public relations man.

Overall size and quality of construction rated seventh and eighth.

"Small enough to get into tight spaces."—Texas housewife.

"Body construction seems more solid than in new Detroit compacts."—Pennsylvania systems analyst.

"Workmanship is good both inside and out."—Colorado teacher.

"It's very tight. No rattles."—Maryland information specialist.

Evidently, owners took VW's superior traction on slippery surfaces for granted. This feature was buried way down in ninth place.

"Great in snow."—California lifeguard.

"I didn't have to buy snow tires."—Ohio Volkswagen parts manager.

► **And he even rated his car "excellent"?**

Enough owners liked the brakes to place them in tenth spot.

"Fade is practically eliminated, even during hard mountain driving."—Utah waiter.

"I can drive through deep puddles without losing my brakes."—Connecticut pharmacist.

Now for the last of the complaints, headed by poor economy in sixth place.

"I get 18-19 mpg in city traffic. That's not as good as I expected, but the dealer claims this will improve as the engine gets broken in."—Illinois professor.

"Not economical enough on short hops in city driving. I get only 22 mpg."—Pennsylvania professor.

Engine noise, in seventh place, drew some colorful remarks.

"Sounds like a garbage truck."—Arizona storekeeper.

"It's a buzzbox at high speed."—Utah retired.

"Needs more insulation around the engine."—Florida warehouse employee.

Next came a batch of assorted transmission woes.

"I had trouble with the second-gear synchronizer ring."—California insurance agent.

"My wife would like an automatic transmission."—New Jersey supervisor.

"Reverse gear is difficult to engage."—Pennsylvania meteorologist.

The next-to-last complaint concerns the speedometer.

"It doesn't register between 10 and 30 mph."—Indiana housewife.

"Speedometer reads low."—California missiles supervisor.

"There are birds in my speedometer."—Maryland information specialist.

Finally, trouble with the windshield wipers wraps up the gripes. A number of owners complained that wiper fuses blow with distressing regularity. There were other problems as well:

"Wipers don't start in cold weather."—Indiana merchandising manager.

"Wiper blades don't flex. There's too much tension, which causes smearing."—Washington attorney.

Then again, an unusually large number of owners had no complaints at all. There was the California housewife, for example, who said: "I can't think of a thing I'd want to change."

TURNPIKE SAFETY DRIVING

(Continued from page 185)

just fallen off the open tailgate of a contractor's truck.

Also causing trouble, troopers told me, are heavy retreads thrown from tires. Drivers in wolf packs see them, get scared and dodge, and sideswipe anybody running too close.

► **Have no one on either side.** If you find someone running parallel who won't pull ahead, back off a little and get rid of him.

► **Keep an escape route open behind you.** Try to have a 300-foot "clear" between you and the next car back whenever you can. And try also to keep an open gap in the adjoining lanes behind you, so you can switch lanes in emergency without creating a panic.

► **Know the alerts.** When a trooper sees a puff of dust ahead his ears go up. He knows someone has run off the road. He gets ready for a sudden stop.

Another alert troopers recognize is a sudden cluster of cars where there was a clear road far ahead. Another: small scraps of wood, metal or tire. Slow down. They often signal a pile of debris, or a whole retread a mile or so ahead.

► **Use an early-warning signal** if you do

sense possible trouble ahead. Tapping your brake a few times tells drivers behind you: "I'm not stopping yet, but I see something ahead. Stay alert."

► **Back off early** when you know there's trouble. Never risk getting involved in a fast stop with many cars at high speed. To avoid it, start flashing brake lights to get cars behind you *under control* before they plow into you. And add a big flag-down wave. Drivers pay more notice to waving arms than to lights.

And while backing off, keep a constant mirror-check and leave space for the other fellows trying to stop behind you.

► **Don't pass (or be passed) under bridges** if you can help it. On any pike where ice forms, troopers told me, try never to come abreast of another car as you go into an underpass. That's where ice patches send many cars spinning. Half a mile before an underpass, check mirror and if you see someone about to overtake you, speed up or slow down so you won't have him alongside in the slippery spots.

► **Never change lanes to pass on a high-speed curve**, especially a right curve. Reason: as you pull out, centrifugal force tries to toss you off the road.

► **Get passes over with—fast.** At 65, a sluggish pass can take a full mile. That

(Please turn to page 201)

WE'VE GOT the FORMULA For Solving Your Problems

Planning to build your own garage? Need instructions to make a burglar alarm or beds? Want help on household hints or workshop projects? Looking for plans for a model clipper ship or child's car?

SEND FOR YOUR FREE POPULAR MECHANICS SERVICE FILE

More than 300 subjects covered in Popular Mechanics library of books, booklets, blueprints, and patterns are listed in this tremendous reference file. Here's the handy guide which shows you where to find the answers to almost any do-it-yourself problem.

POPULAR MECHANICS, Service Bureau PM-8,
575 Lexington Ave., New York, N. Y. 10022

Please send your free SERVICE FILE to:

Name

Address

City Zone State



BIRTH CONTROL FOR BUGS

(Continued from page 119)

of circulation and lots of normal males remain bachelors.

Sterilizing traps have already proved successful in Southern California where they halted an invasion of the Mexican fruit fly. They are also being tested in Africa against the disease-carrying tsetse fly. But for the majority of harmful insects, no effective chemical sterilants have yet been found. Many promising substances proved disappointing, weakening with time and exposure. Further research in this area is a top priority project.

Lures, traps, and sterilants in combined use form a lethal trinity for bugs—the “triple whammy,” one of the researchers calls it. Yet because each type of insect has its own attractant, its own way of life, and often its special body chemistry, it is necessary to develop specific lures, specific traps, and sometimes specific sterilants for each species—an enormous task.

Slugging the screwworm fly

While chemical insect sterilants are only now being developed, other forms of sterilization are already well established. Sterilization by atomic radiation, for example, has nearly wiped out the screwworm fly.

This insect lays its eggs in small wounds—cuts, scratches, or even tick bites—of cattle, sheep and hogs. Often the raw navel of newborn animals serves as a target for the female fly. Once the maggots hatch, they burrow into the flesh, chew festering wounds deep into the helpless animal, which is literally eaten alive and dies within a few days. Cattlemen and ranchers were desperately looking for countermeasures against this gruesome bug.

Just before World War II, a young entomologist named Edward I. Knippling proposed an idea: sterilize the male flies and turn them loose. Then they'd breed themselves out of existence. This idea merely drew laughs. “We'd spend all our time gelding bugs,” his fellow scientists guffawed.

They had a point. At the time, there was no practical way to sterilize large numbers of flies. But by 1950 it had been discovered that bugs could be sterilized by sublethal doses of atomic radiation. Knippling, who by then had become chief of entomology research at Beltsville, finally was able to try out his idea. He built a fly factory in Texas where newly hatched flies were irradiated with a hunk

of cobalt-60, borrowed from the Atomic Energy Commission.

The chance for a big-scale test came in 1953, when the Dutch government sent out distress calls to the U.S. Department of Agriculture. Screwworm flies were eating up the goats of the island of Curaçao.

Knippling shipped big batches of sterilized male flies to the island and let them loose at the rate of 170,000 per week. Predictably, the treated males went buzzing off to mate with females. But the eggs didn't hatch—no maggots burrowed into the goats. The next generation just didn't get born. After just 14 weeks, amazed Dutch officials announced that the pest was extinct.

Riding high in the wake of this triumph, Knippling and his principal co-worker, Raymond Bushland, set up mass production of fixed flies. At Sebring, Fla., they were soon raising 50 million maggots per week in gory vats filled with beef blood and chopped kidney. After the crawling maggots changed into the capsule-like pupae from which the adult fly later emerges, they were packed into metal canisters and shoved into a radioactive chamber where the hot cobalt sterilized them with gamma rays.

A fleet of 20 planes then dropped the canisters, which open on impact, all over pasturelands and swamps. Soon after, sterile flies swarmed out over the landscape.

Within 18 months, the screwworm fly was extinct in the Southeast. Today, they're tackling the bug in Texas with an even bigger factory that turns out 100 million specimens a week, and the natural screwworm population is already down over 90 percent.

More than radiation needed

For a while it seemed that radiation was the universal answer to the bug problem. But Knippling realized that the process wouldn't work for crop and tree pests. “Before they kill off their own species, they'd eat up all the crops,” he explains. “We'd have to flood the area with millions of them. Sterilized males should outnumber normal ones by a large factor. Otherwise chances are that a normal male gets to the female first.”

The scientist believes that sterilizing traps now being developed may solve this problem. “By trapping, treating, and then releasing the insects, we use the natural bug population to breed itself to death,” he explains. “We don't have to swamp the area with factory-reared specimens.”

But birth control of a different sort is

(Please turn to page 196)

GIANT

\$1.00

Largest Distributors of new Gov't. Surplus Balloons in the USA. Inflate with air or gas. Fun at the Beach, Water Sports, etc., Flying Advt. visible for miles. Terrific for attracting crowds at Openings, Fairs, Roadside Stands, Gas Stations, Sports Events. Durable Neoprene Rubber. Guaranteed new. Plus 25c hdg. No C.O.D.



8 Ft.

2 ft. (Beach Ball) size	5 for \$1.00
4 ft. size	2 for \$1.00
8 ft. size	\$1.00 each plus 25c each hdg.
16 ft. size	\$3.00 each
24 ft. size	\$5.00 each

NOVEL PROD. CORP. 31SECONDAVE., Dept. 174
NEW YORK 3, NEW YORK

EVERLITE* World's THRIFTIEST Light Plants



THE CHAMPION \$144.50

The Champion - 1200 watts 115 volts AC for only \$144.50
Unbelievable but true—Brand new production methods now make possible world's finest design in a service free alternator light plant at this unprecedented price. Plant puts out a steady 1200 watts of 115 volt AC power to run power tools, oil burners, pumps, TV, or anything that requires up to 1200 watts. Powered by a rugged 3 HP. 4 cycle, easy start gas engine with 1 year factory warranty. Complete with carry handle and shock mounts. Why fool with short life 2 cycle plants when you can buy this rugged top quality machine at our factory price.
Item # 1265 wt. 65 lbs. \$144.50

MASTER MECHANIC MFG. CO., Dept. A-86 Burlington, Wis.
Southern Customers Write to Dept. A-86, Box 65, Sarasota, Florida

BASEMENT TOILET FLUSHES UP

TO OVERHEAD SEWER OR SEPTIC TANK. NO DIGGING UP FLOORS. INSTALLS EASY. Write
McPHERSON, INC. BOX 15133 TAMPA, FLA.

Train For
Your Own
PRESTIGE
TAX
BUSINESS



Men, women of all ages earn top fees. Part-full time home-office business. No investment! No bookkeeping or accounting needed. Earn \$10-\$15 hourly doing tax returns. Year 'round payroll tax service pays \$10-\$50 monthly per client. We train you, help you start quickly. FREE booklet. No salesman will call.
National Tax Training School,
Monsey, Q-20, N.Y. 10952

Lie'd NY
Ed Dent.

Why Can't You Control Your Memory?

A noted publisher in Chicago reports there is a simple technique for acquiring a powerful memory which can pay you real dividends in both business and social advancement and works like magic to give you added poise, necessary self-confidence and greater popularity.

According to this publisher, many people do not realize how much they could influence others simply by remembering accurately everything they see, hear, or read. Whether in business, at social functions or even in casual conversations with new acquaintances, there are ways in which you can dominate each situation by your ability to remember.

To acquaint the readers of this publication with the easy-to-follow rules for developing skill in remembering anything you choose to remember, the publishers have printed full details of their self-training method in a new book, "Adventures in Memory," which will be mailed free to anyone who requests it. No obligation. Send your name, address, and zip code to: Memory Studies, 835 Diversey Parkway, Dept. 135C, Chicago, Ill. 60614. A postcard will do.



AUTOMATIC HUBS for your 4-WHEEL DRIVE!

NOT EVEN A BUTTON TO PUSH on these amazing Lock-O-Matic selective drive hubs that automatically engage the front wheels in 4-w.d., automatically disengage them for 2-w.d. They stop front drive drag, save gas, gears, tires in 2-w.d.—automatically! For Lock-O-Matics—or popular Warn® Locking Hubs—see your dealer.

be happy—GO LOCK-O-MATIC!
WARN MANUFACTURING CO., INC.
9050-A Empire Way So. Seattle, Wash. 98118

*Not made for some 4-w.ds.

LEARN MEAT CUTTING AT NATIONAL Pay After Graduation

The steady dependable trade of Meat Cutting taught easily in 8 short weeks. YOU LEARN BY DOING under actual meat market conditions in big modern school at Toledo.

For beginners or men with experience. Get a profitable store of your own. Remember, PEOPLE MUST EAT! Big pay jobs. Free employment help. Thousands of successful graduates.

Buying, cutting, percentage, pricing, advertising, selling, etc. A complete retail meat education. National School established 43 years. Get National training now. Pay your tuition in easy monthly payments after you graduate. Send coupon for FREE 40 page school catalog—TODAY. G.I. approved.

AUGUST 1966

National School of Meat Cutting, Inc., Dept. 50-K, Toledo 4, Ohio

Send me your FREE school catalog on National Training at Toledo in Meat Cutting. Meat Merchandising and Self-Service Meats. No obligation. No salesman will call.

Name _____ Age _____

Address _____

City _____ State _____

Approved for Veterans

BIRTH CONTROL FOR BUGS

(Continued from page 194)

practiced by a French research team working at Versailles. They discovered that certain bacteria sweat out a substance poisonous to the larvae of the housefly, the deerfly, and certain types of mosquitoes. Since these flies like to lay their eggs in dung, the Frenchmen mixed this bacterial fluid into cattle feed. Fortunately, it didn't harm the cows. It passed unchanged through the cattle's gut and emerged at the other end with undiminished potency. When flies lay their eggs in the dung, it kills the grubs right after hatching. The same stuff has also proved successful when used with chickenfeed.

Germ warfare

Aside from sterilization, another basic tactic is used in biologic insect control—spreading fatal diseases among the bug population. Insects suffer from a variety of deadly ailments that man and other animals are immune to. Consequently, we can spread insect diseases without endangering ourselves.

Some bug-killing germ products have been available for some time—notably Japonex, which spreads milky-disease among Japanese beetles. But until quite recently, efforts to produce germ cultures large enough for extensive crop protection were snagged in difficulties. What looked promising in the lab often didn't work out in the factory. It was hard to keep the bacterial strains pure and potent in large-scale production. Much had to be learned about the living habits, rearing problems, and storage characteristics of the various microorganisms causing insect illness. But within the last two years, industrial bacteriologists made enough progress to surmount these hurdles.

New spray has more kick

One of the first commercially available germ-sprays is Thuricide, which is now widely used against such crop-destroying insects as the cabbage looper, the tobacco hornworm, the corn ear worm and the tomato fruit worm. The active ingredient is *bacillus thuringiensis*, which is deadly to some 120 species of moths and butterflies. It paralyzes the caterpillar's gut so that the bug starves with its belly full. After a few nibbles on a leaf sprayed with Thuricide, the bug simply has no room for any more, quits eating and dies.

Last year, a new, more potent formulation of this spray was used to repel

attacks of the gluttonous looper on the Arizona lettuce crop. This insect gets especially sassy in irrigated farming areas of the Southwest because the surrounding desert does not sustain any of the insect's natural enemies. Often the looper invades the fields just before harvest. No chemical insecticides can be used so late in the season because their residues would make the crop unfit to eat. Bacterial insecticides, by contrast, can be used anytime in the growing cycle. Last year's big-scale application proved so successful that many vegetable growers are now shifting from chemical pesticides to biological pest control, despite the somewhat higher cost.

The bacterial gut stopper, effective as it is, is only a crude beginning. Refinements are ready: virus epidemics tailor-made for just one specific insect type. "A virus and its host are chemically made for each other like lock and key," explains tall, scholarly Dr. A. M. Heimpel, insect pathologist at Beltsville. "The disease acts only on the target species. All others remain unaffected." Consequently, says Heimpel, viruses make it possible to confine the epidemic to just one specific kind of pest so as to cause a minimum disturbance of the overall balance of nature.

Down the hatch

To convince the Food and Drug Administration that his proposed bug epidemics will not harm humans, Dr. Heimpel and sixteen of his staff members staked their own health on their convictions. They swallowed generous helpings of virus soup—the slurry of viruses suspended in the liquefied bodies of the insect hosts. For good measure, Heimpel and his crew also injected the stuff into their veins, apparently being none the worse for it.

I remarked on his courage, but he declined the compliment. "There is no biochemical relation between insects and man," he insisted. "They have no common proteins between them. Consequently man and insects are immune to each other's virus infections."

Battle becoming decisive

The battle between man and bug now moves into a decisive phase. With two-thirds of the human population now going hungry, and worldwide famine forecast by international food authorities by 1980, it is evident that the human race can't afford coexistence with gluttonous insects. With the new methods of bug-slaughtering, man has at least a fighting chance. ★★★

PERFECT MARINE PLUG

(Continued from page 147)

sets. No screwdriver or pliers, please. You can crack the electrode off too easily. By the way, stay away from the center electrode with the bending tool. Once that electrode cracks, splits or chips, the plug is useless.

File both ground and center electrodes flat, square and bright with an ignition-point file. Now gap the plug to specification. Most plugs for outboards are gapped to either 0.025 in. or 0.030 in., although some go up to 0.035 in. Check the manual.

Remember to bend only the ground electrode when gapping. Don't touch that center electrode. Proper gapping is obtained when you feel a slight drag on the gapping tool as you slide it between the two electrodes.

It matters little whether you use a round-wire feeler gauge or a flat gauge. If filing was done properly, it will have eliminated any irregularities that would cause a flat gauge to bridge the electrode.

Also, always make sure that new sparkplugs are gapped to specification. Don't take it for granted that because they are new, they are properly gapped.

Put the plug back into the cylinder hole

and run it up until finger tight, then use a proper size deep socket in conjunction with a torque wrench to tighten the plug properly. Make sure you use a socket that fits correctly or you may crack the plug. Most outboard plugs should be tightened (and removed) with a 13/16-in. six-point deep socket. Torque to correct specification (check manual), normally 20 ft.-lb.

If you think this information on installation is academic, take a look at what can happen if plugs aren't properly installed:

Compression loss and early sparkplug failure—Insufficient torquing, preventing full seating.

Early destruction of plugs because of inability to dissipate heat—Excessive torquing.

Early plug failure due to overheating; high engine temperature; possible compression loss—Use of badly corroded or flattened gaskets.

High engine temperature and early plug failure because of overheating—Corroded threads in sparkplug hole (not too common, but if found, brush the threads clean before installing plugs).

When should you check plugs? If a problem suggests a plug breakdown, right away isn't too fast. Otherwise, every 50 hours of operation is sufficient. ★★★

My name is Charles Atlas. I can't promise you'll win the title of "World's Most Perfectly Developed Man" as I did. But I do believe I can make a powerful He-Man of you -- in a very short time. You can prove it to yourself -- at my risk. My big free book tells how to do it.



FREE BOOK Mail coupon now for free 32-page book. Tells how I can give you "Stand-Out" muscles -- how "Dynamic-Tension" can make you a new man -- confident, popular, successful. Rush coupon to me personally: **CHARLES ATLAS, Dept. 8H, 115 E. 23 St., N.Y. 10010**

CHARLES ATLAS, Dept. 8H, 115 East 23rd St., New York, N.Y. 10010

Dear Charles Atlas—Here's the Kind of Body I Want: (Check as many as you like)

- | | |
|---|---|
| <input type="checkbox"/> Broader Chest, Shoulders | <input type="checkbox"/> More Powerful Arms, Grip |
| <input type="checkbox"/> More Weight, Solid | <input type="checkbox"/> More Powerful Legs |
| <input type="checkbox"/> Slimmer Waist, Hips | <input type="checkbox"/> Better Energy, Sleep |

Send me, absolutely FREE, a copy of your famous book showing how "Dynamic-Tension" can make me a new man. 32 Pages, crammed with photographs, answers to vital questions, and valuable advice. No obligation.

Print Name.....Age.....

Address.....

City & State..... Zip Code.....

In England send to: Charles Atlas, Chitty St., London W. 1

NEW BOOK

ENGINE ABC's by DEAN BROWN

Written and illustrated to explain the operating principles of automotive engines plus basic carburetor and ignition systems.

NO MATH • EASY TO READ CUTS ALL THE TECHNICAL FOG

Fundamentals To Guide You In Troubleshooting, Tune-ups, Or To Better Judge Repair Advice
SPECIAL SECTIONS... Explain Valves, Valve Timing, and Valve Operating Mechanism

\$295 CHECK OR M'ORDER ENGINE ABC'S
In Calif. Add 12¢ Tax Box 653, Placentia, California 92670
Postpaid. Give your Zip Code

A PROFITABLE NEW PROVEN BUSINESS

Engrave plates such as door and desk plates, badges, identification plates, special signs, etc.—is simple, interesting and profitable. Businessmen, homes, office, factories, stores, boat owners, campers and many others require engraved plates and become a source of profit for you in your spare time. You can easily fill order after order for name plates with the SM-100-2 ENGRAVER (size 13" x 13") the machine that makes you a professional at this work. Puts extra dollars in your pocket the year around. Get details at once. Write today.

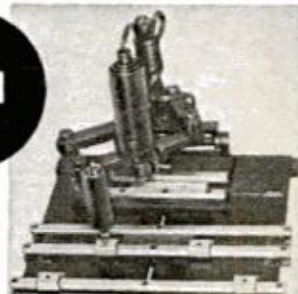

SM SCOTT MACHINE DEV. CORP.

215 Prospect Ave., Dept. PM-8
Walton, N.Y. 13856

COMFORT AT THE DENTIST'S

(Continued from page 99)

Dr. David F. Mitchell of Indiana University's School of Dentistry. Another study has convinced Dr. S. Wah Leung of the University of British Columbia that if certain enzymes were added to toothpaste, calculus formation would be reduced by about one-fourth in six months. He also suggests putting them in chewing gum.

Some cure for gum disease is coming; the big question is which one will be ready first.

If it's too late

In the meantime, if it's too late—if you're already toothless as a chicken—things are in the works to help you manage your store-bought choppers more easily. For example, New York City oral surgeon Stanley J. Behrman is implanting tiny magnets in patients' lower jawbones, while he molds other magnets in the indentures. This setup keeps false teeth in better and is less tiring for the patient, he says.

Other dentists are experimenting with denture snap-fasteners. The gum is opened, studs are planted and, when the gum heals, the teeth can be snapped into place.

"Autotransplanting" teeth—moving them around inside a person's mouth—is having surprising success. If a young adult loses one of his first molars, his dentist might pull out a "budding" wisdom tooth and stick it into the other socket. Dr. Harland Apfel of Los Angeles, who has autotransplanted some 350 teeth, claims 97 percent success.

At the University of Pennsylvania School of Dental Medicine, meanwhile, Dr. Louis I. Grossman is extracting hard-to-work-on-teeth, drilling and filling them, then replanting them. He's performed some 50 such operations so far.

From one person to another

Some dentists—Dr. Ralph Mezrow of Philadelphia's Albert Einstein Medical Center, and Dr. Miklos Cserepfalvi of Washington, D.C., for example—are transplanting living teeth from one person to another. Most teeth, removed to ease overcrowding, come from children and teenagers. Though Dr. Cserepfalvi reports that 9 out of 10 teeth mature, most dentists involved with transplants say that virtually all eventually fall out—rejected by the body in the same way as are transplanted organs.

But there are a few optimists. Dr. Richard J. Coburn, an oral pathologist with Tufts University School of Dental Medi-

cine, predicts that teeth stored in tooth banks will one day replace false teeth. "Maybe," says Dr. S. Sigmund Stahl of New York University, "but that's going to be one rough baby to crack. Sooner or later, though, somebody will come through with an answer to transplanting kidneys, and when he does, we'll know how to transplant teeth."

Others feel that a more likely prospect is plastic teeth implanted in the jaw. At Rhode Island's Brown University, in fact, Dr. Milton Hodosh is experimentally fitting baboons with artificial teeth. He pulls a tooth, fashions a new one of plastic, secures it in the gaping socket with a pin or bridge. Of the 125 implants tried so far, most are going strong—some for as long as three years. But some have failed. When he finds out why, he'll try the same thing on human beings.

Still other dentists think it might be possible to grow teeth outside the body. In a cluttered fourth-floor lab in New York University's Murry and Leonie Guggenheim Foundation Institute for Dental Research, anatomist Robert Gerstner gently removes 1/25-inch undeveloped teeth from the jawbones of unborn albino rats. Placed in nutrient, the teeth grow for about three weeks. Then they die.

"So far we don't know why," says Gerstner. "At the point where they are ready to form hard enamel from the soft matrix, they won't harden," he says. "A tooth bank must wait for the future."

The trouble with fillings

What else is for the future? A filling material that will do the job. Oddly, nothing now on the market will. The big problem is that nothing really bonds to teeth. That's why the dentist has to drill undercuts—to anchor the filling. And when you take a drink of cold water your filling may shrink more quickly than your tooth. A space forms where filling and tooth came together. Bacteria swarms in. This wouldn't happen if fillings were truly adhesive.

NIDR's Dr. Robert C. Likins estimates that about \$1 billion of America's yearly \$2.4 billion dental bill is spent on decay, with most of it going to repair old fillings.

New filling substances, however—one developed by EpoxyLite Corp., another by the 3M Co., a third by the American Dental Assn.—look good. If clinical tests now under way show they really are adhesive, they will, in the words of NIDR's Dr. Likins, "revolutionize the dental profession."

Another thing to look for: needleless anesthesia, Novocain *sprayed* into the skin by high compression. Some gadgets have

already been built, but they're still clumsy for in-the-mouth work. They'll get smaller, then find their way into local dental offices.

Lasers show promise

Further away is the use of lasers. Experimenters at Tufts University are now using the laser's intense heat to burn away tooth decay in hamsters. At the University of California at Los Angeles, researchers have found that laser "glazing" gives teeth more resistance to cavities. Eventually lasers might be used first to drill out decay, then to fuse filling material into place.

Meantime, equipment developed in the last few years is making things easier for everyone. The apparatus revolution began in the mid '40s when a few imaginative dentists, unhappy about the wear of their steel drills, tried two new materials: tungsten-carbide and steel coated with diamond dust. Then some dentists noticed that the faster the new burrs turned the more efficient they became. So they speeded them up from 4500 to 9000 rpm—and drilling time was instantly sliced by a quarter.

Further, they found that as soon as the speed topped 6000 or so, vibration-caused pain disappeared. The drillers were pleased; so were the drillees.

Just about then a Chappaqua, N.Y., dentist named Richard W. Page, a blue-eyed dynamo who sounds like W. C. Fields, decided that he'd try to boost speed even more. "It seemed to me that at those speeds it was like working with a buzz saw in the mouth," he recalls.

He redesigned a handpiece to eliminate most bearings, then fashioned a belt-driven model with large pulleys on the back and small ones in front. Result: an unheard of 150,000 rpm. "My ultrahigh-speed drill started the biggest revolution ever to come to dentistry," proclaims Dr. Page, beaming.

Other dentist-inventors made drills even more efficient—first using water-driven handpieces, then, after disappointing tries using sandblast and ultrasonic drills, with sophisticated air-driven models.

Drills that sculpture

Air-turbine drills today slice through teeth like sabre saws through soap, at speeds up to 500,000 rpm. Instead of drilling, a dentist now "sculpts" a tooth clean—only one ounce of pressure is needed, compared with two pounds for the drills of the '40s. Ten years ago patients were lucky if they could get a tooth cleaned and filled in one visit. Today a dentist may

clean and fill up to five cavities, or even more, in a single sitting. Four out of five American dentists now use ultra high-speed units, and the "dentists' callous," a horny spot on the second finger that marks the place where a handpiece leans, is seen no more.

With the advent of the high-speed drill, old-line dental equipment companies, after making the same tired equipment for decades, suddenly discovered research-and-development. Conventional dental equipment began to change. The revolution was on.

Dentist sits; you recline

Some results can be seen in the ultra-modern dentist office. (Your dentist may not have it yet, but in all likelihood will before too many years pass.) The room is dominated by a horizontal contour lounge you slide into like a sports car, then stretch out on. The dentist bends you at will by punching buttons on the chair back, and works on you while you lie flat as a flapjack. One such lounge even has a built-in vibrator to soothe you before the fun begins.

The modern dentist doesn't stand up anymore. He sits on a hydraulically raised, cushioned swivel stool. So does the hygienist who sits across from him. That's what they call dental "nurses" nowadays who assist the doctor in what the American Dental Assn. refers to as "four-handed dentistry."

Instead of a single spotlight overhead, two surgery lights peer down to cancel out shadows in your mouth. Trays glide out of the wall on beige or turquoise elbows. The swirling-water spittoon is gone, replaced by a high-suction mouth hose that sounds like a vacuum cleaner and makes you think that if you held your nose your head would promptly turn inside out.

X-ray also has been vastly improved. Now, using a panoramic machine, dentists can take a picture of your whole mouth in a single exposure. Not only is the procedure faster (2 minutes as compared with the 14 to 18 required by conventional tooth-by-tooth X-ray), but it tells the dentist more about the structure of the jaw and positions of teeth than does regular X-ray. However, "single frame" pictures still are best for the examination of individual teeth.

All in all, dentistry has made remarkable advances in recent years. But there's one critical area in which some practitioners have failed to keep up with the times. I refer to the collection of vintage magazines they feature in their waiting rooms. ★ ★ ★

THE EXPERTS' WAY TO GIVE A CRISP, NEW LOOK TO OLD FURNITURE



. . . With Hundreds of Illustrations . . . Complete Glossary of Terms . . . Precise, Easy-To-Follow Step-By-Step Instructions for Every Job.

Includes:

- Finishing Methods
- Sample Projects
- Sanding & Bleaching Techniques
- Major Repairs and Touch-Ups
- Tips on Unusual Finishes
- Tips On Buying and Care of Tools
- Refinishing of Metal Furniture
- Glazing & Highlighting
- Figures of Wood
- Varnishes, Veneers, Waxing
- Synthetic Finishes
- Types of Solutions
- Complete Glossary of Wood Terms
- Finishing Schedules
- Finer Points of Special Finishes
- Refinishing Antiques
- Reupholstering With Foam Rubber
- Lifting Dents & Bruises
- Weaving Rush Seats
- Oils & Oiling
- Wood Dyes
- Rottenstoning

. . . AND MUCH, MUCH MORE

Send \$4.95 Today to:

POPULAR MECHANICS BOOK DEPT.

575 LEXINGTON AVENUE

NEW YORK, N.Y. 10022

TURNPIKE SAFETY DRIVING

(Continued from page 193)

means you're exposed to collision for a mile. Once you start a pass, accelerate safely and legally, but get on with it. Cut the pass to a half mile or less if safe.

► **Watch for "marginal friction,"** especially in the right lane, when passing through towns. Cars entering from the right create eddies in traffic. Troopers have a rule: "Guard your right when passing entrance ramps." If you don't, someone with bad timing may shove you into the next lane. To keep things safe for all, help make room for any driver you see trying to enter from a ramp.

► **If you drive a station wagon,** close the tailgate tight in high-speed runs. Never leave small children in back with the window cracked open. They've been killed there by monoxide fumes sucked back in through the tailgate.

► **If a tire goes flat** on a bridge, or where there's no shoulder, keep right on going to a safe escape area. Troopers, who drive on special \$50 tires, have orders: Ruin the tire rather than risk collision by stopping in lane.

► **In a high-speed blowout** troopers have two tricks.

Trick No. 1 is this: they train themselves to expect the explosive "pow!" that comes with some blowouts and also the dull "bloop-a-boop" heard with others.

Unless you practice this mentally, you may be caught napping as many drivers are. *They don't know for several seconds that they've had a blowout—too late!*

Trick No. 2 is this: they never let the car veer even for a split second. Once the veer begins you're in trouble. They keep the wheel centered, lock elbows, and fight to keep arrow-straight control. They touch neither gas nor brake until speed drops to 40, or preferably 30. Then they try feathering the brake gently. Thus they have survived blowouts up to 90 mph.

► **Operational plan for an exit.** When you feel yourself getting hungry, troopers say, pick your exit at least five miles in advance. If traffic is light, look for the sign that says "Exit (or service area) 1 Mile." As you pass that sign swing into the right lane, then pick up your exit ramp.

But when traffic is heavy, watch for the earlier sign that, on many pikes, says: "Exit 2 Miles." To avoid a last-minute scramble, this is your signal to switch.

Above all, guard against the dangerous "exit runner," the fellow who stays in the fast lane until the last minute, then cuts across traffic in front of you and squeezes down the exit ramp. He's caused lots of accidents. ★ ★ ★

How can UNIMAT be exciting if it bores?

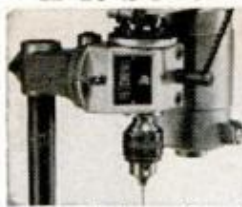

Simple. It also mills, drills, grinds, polishes and more. That's UNIMAT, a miniature machine shop that operates both as a precision lathe and multi-functional tool on metal, plastic and wood. Converts in just seconds. Only 17" long. UNIMAT has satisfied thousands of exacting hobbyists with its versatility and tool-room accuracy (up to .0005"). Performs like costly big equipment while taking up a minimum of space.

No prior experience is necessary to use this valuable tool. The basic unit plus lots of extras sells for \$139.50. Send for free literature, or \$1.00 and get the whole story in 'Miniature Machining Techniques'; a 40-page photo-packed manual. Write: American-Edelstaal, Inc., Dept. G-H6, 350 Broadway, New York, N.Y. 10013.



TO YOUR OWN DOCTOR'S PRESCRIPTION



EYEGASSES BY MAIL AT GREAT SAVINGS!

Mail orders filled by **\$9.95** licensed optician from

(Including single vision lenses, frame and case).

Doctor's prescription will be filled by a skilled, approved and licensed optician or your own prescription duplicated. Lenses are ground and manufactured to U.S. optical standards. Choose from complete catalog of men's, women's and children's glasses. Bifocals, trifocals, sunglasses or SAFETY HARDENED LENSES at low additional cost. We guarantee accuracy, perfect fit.

SEND FOR YOUR FREE CATALOG TODAY

PRISM OPTICAL INC.

Dept. PM-6 136 Liberty St., New York 6, N. Y.

The best wrench to have in a tight spot.

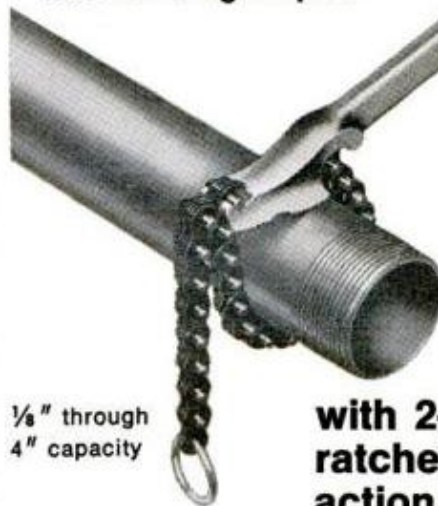

The **RIDGID** C-12 Utility Chain Wrench

1/8" through 4" capacity

with 2-way ratchet-like action.

Nothing equals this light and easy-to-use RIDGID Utility Chain Wrench for fast action in close quarters. Strong, flexible chain grips all shapes without crushing, is easy to lock and release. Double jaw turns pipe in either direction.

Buy a time-saving RIDGID Utility Wrench at your Dealer's. He has a complete stock of RIDGID Work Saver Tools from The Ridge Tool Company, Elyria, Ohio 44035.

RIDGID

the second set of tires is your first real choice!



Now it's just you and all the tires in the world. One of them is the only family-car tire certified safe at 100 mph. The four-ply Dunlop Gold Seal.

The same one has Dunlop patented* Safety-Shoulders. Lean into a corner, and the patent holds you on. Roll up and over a center line or shoulder, and the patent holds you without a lurch.

The same one has what tire men call a low profile. That means a 15% larger footprint area. More of the Gold Seal's wide tread is always on the road for better traction, greater safety, more miles of wear.

And this same one has the Dunlop water-ejecting tread pattern. That speaks for itself in the wet.

Yet the Gold Seal is popularly priced.

Doesn't that sound like a choice tire for a change? You can choose your Dunlop man out of the Yellow Pages.

Every new Dunlop tire meets or exceeds every official specification for safe performance.

* PAT. NO. 3,024,825



DUNLOP  . . . means quality in
BUFFALO, NEW YORK golf, tennis, and tires.

THE MISSING H-BOMB

(Continued from page 78)

70-percent slope.

We held our position until *Aluminaut* came down and took over.

The next day Wilson and McCamis went down and placed an electronic pinger on the parachute. This was to guide the CURV (Controlled Underwater Recovery Vehicle) to the spot.

Developed at the U.S. Naval Ordnance test station in Pasadena, Calif., for torpedo recovery, CURV is a steel frame 13 feet long, 6 feet wide and 5 feet high. Four ballast tanks are filled with water to lower it into the sea. Two small motors drive it forward and a third moves it up and down. It is equipped with sonar, two vapor-mercury lights, a TV camera and a large claw for grasping objects. It was controlled by a five-man crew aboard *US Petrel* by means of a long electronic cable. CURV was sent down to attach a line to the parachute, which was done.

Bad weather interrupted the operation for a day, and it was started again on April 5. It was decided to give a yank on the line to clear the parachute from the bomb. This was done by a surface ship, but it only succeeded in shifting the bomb and stirring up a cloud of silt.

Wilson and McCamis went down the slope after the bomb. They were moving cautiously through the silt when suddenly, billowing around them, was the chute. They described it as looking like a huge circus tent. This was a tense moment. It is possible to jettison the sphere from the main body of *Alvin*, but if they became entangled in the chute they'd be stuck down there. Wilson made a quick "back full," and *Alvin* responded like a frightened rabbit, coming around on the axis and moving away from the chute.

The next day, with *Alvin* standing by as observer, CURV was sent straight to the target. It managed to attach one line but the machine became hopelessly entangled in the billowing chute. It was decided to haul CURV to the surface and just hope that the bomb would come along. It worked. It was slow and nerve-racking, but the bomb rose along with CURV without mishap. At 200 feet Navy divers went down to attach additional lines, and then it was brought to the surface.

Alvin returned to the *USS Fort Snelling*. The job was done. It had taken us nearly two months. *Alvin* made 34 dives, operating at depths down to 3200 feet for 222½ hours. It was our hero. And most important, for us, *Alvin* had proved that a deep submersible can do a job. ★★ ★

All latex house paints are the same. Right?

Wrong.

Dutch Boy colors don't fade. It's the different latex house paint.

These houses were painted from two to six years before these photographs were taken, but they still look fresh and bright. That's because they were painted with Dutch Boy Latex House Paint. Dutch Boy's exclusive formulation gives unexcelled durability. Superior color retention. Resistance to chalking. Whites stay bright and fresh, clean colors don't fade. The

beauty lasts through years and years of weather.

And that's not all that's different. There's Dutch Boy PBL — Penetrating Bonding Liquid. Add it to Dutch Boy Latex House Paint and you won't have to prime or scrub off old chalk. With PBL, Dutch Boy Latex House Paint is guaranteed against peeling from a sound previously painted surface for

five years. Dutch Boy Latex House Paint is pure 100% acrylic latex to give you *all* the advantages of a latex paint.

Dutch Boy is a registered trademark of National Lead Company, which has a background of nearly 200 years of house paint experience.

See your nearby Dutch Boy dealer today. He's listed in the Yellow Pages.



West Coast



Middle Atlantic



Northwest



New England



Midwest



Dutch Boy Paints. More years to the gallon.

© 1964 American Tobacco Company

*Great new taste,
rich aroma...
pipe tobacco does it.*



Enjoy America's best-tasting pipe tobacco in a filter cigarette!

Product of The American Tobacco Company ©A.T.C.