

POPULAR MECHANICS

JUNE 1966
35 CENTS

EXCLUSIVE! The dirty, deadly tricks of the Viet Cong

**SECRET SNAPSHOTS
OF THE
'67 CARS**

THE SATURDAY MECHANIC:
How to get your
camper or trailer
ready for
summer trips

Circle-cutting
jigs for your
bench or
band saw!



**Build this handy garden
tractor from a kit!**

Chevy-Van's low price

buys a spacious 211-cu.-ft.  cargo area and
a tough body that's reinforced  all welded and
specially protected against rust  also
big wide doors  flat floor and
the dollar-saving power of a famous Chevy 6 



Curb-side doors available

What more could you ask for at any price?

*(See your Chevrolet dealer . . . Chevrolet Division
of General Motors, Detroit, Michigan.)*





Lucite® turns you loose



Paint your house less often. Live a little instead.

Du Pont LUCITE® House Paint will turn you loose from frequent repainting because it'll last and last. LUCITE doesn't give paint failure a chance to get started.

For instance: When temperature changes make house surfaces expand and contract, most paints stay rigid. So they crack and flake.

But Du Pont LUCITE flexes right along with your house.

LUCITE House Paint foils blistering, peeling, fading, chalking and mildewing just

as easily. It's been proven to resist them all far longer than leading oil-base paints.

LUCITE speeds you through painting. Starting and stopping points blend naturally. And you can paint over damp surfaces—even right after it rains.

It all adds up to extra free time for you to enjoy life.

Let LUCITE turn you loose.



Better Things for Better Living

...through Chemistry

Finest clear finishes for wood



Fabulon

Tough "bowling" finish for home floors; apply with brush or roller; dries fast; lasts for years.



Fabuloy

Mirror-gloss clear finish for all wood interiors; outstanding durability; excellent resistance to soap, stains, etc.



Wood Lore

Satin-lustre clear finish for panelling, etc.; unique formulation provides luxurious "hand-rubbed" effect without rubbing.



Pryme

First-coater and Wood Lightener; seals thirsty wood; helps control stain penetration; adds body and mileage to top coats.

At paint, hardware, lumber and building supply stores. Send 15c in coin for 24-page manual, "A SHORT COURSE IN NATURAL WOOD FINISHING".

PS PIERCE & STEVENS CHEMICAL CORP.
Dept. PM Box 1092, Buffalo, N. Y. 14240





NOW FIRESTONE OFFERS A NYLON TRUCK TIRE AT A PASSENGER CAR TIRE PRICE

Firestone's Transport Nylon truck tire gives you all the quality features you're looking for in a pickup or delivery truck tire—and at passenger car tire prices. You get our exclusive Sup-R-Tuf rubber compound for extra-long mileage, deep, gear-grip tread for positive stop-and-go traction, and a rugged Shock-Fortified nylon cord body. Get these rugged truck tires now—at passenger car tire prices—from the tire experts at your nearby Firestone Dealer or Store. Easy terms available.

Transport®. Sup-R-Tuf®



Firestone
TRANSPORT NYLON TRUCK TIRE

This One



4CQE-WL8-L9RS

POPULAR MECHANICS

INTERNATIONAL EDITIONS: AUSTRALIAN, SPANISH, CARIBBEAN, FRENCH, DUTCH, PORTUGUESE, DANISH, SWEDISH

AUTOMOBILES AND DRIVING

- [20 Detroit Listening Post](#)
- [36 Spotlight on the MGB-GT](#)
- [61 Secret Snapshots of the '67 Cars](#)
- [74 Owners Report on the Dodge Coronet](#)
- [78 Plastic Highways, by Caesar!](#)
- [116 Str-r-r-etch to a Luxury Limousine](#)
- [160 Auto Clinic](#)
- [162 Saturday Mechanic: Trailers and Campers Need Servicing Too](#)
- [167 Auto Tips from Readers](#)

SCIENCE AND INVENTIONS

- [10 New Inventions](#)
- [12 Science Worldwide](#)
- [80 Big Business Dives in the Ocean](#)
- [90 Bye-Bye, Bacteria](#)
- [95 Walls for Wandering Farms](#)

SHOP AND CRAFTS

- [145 How to Frame a Float](#)
- [148 3 Jigs for Cutting Wood Discs](#)
- [157 Pogo Shoes Give You a Lift](#)
- [158 Beauty Treatments for Rusty Tools](#)

HOME AND YARD

- [17 Homeowners' Clinic](#)
- [68 Cover Story: Lawn Mule](#)
- [88 New for Your Home](#)
- [100 Power Mower: Still a Tiger](#)
- [104 Gardens for Free](#)
- [107 Strange Berry Has Flavor Secret](#)
- [108 Be Lazy About Lawn Sprinkling](#)
- [120 Garden Mulch Making Machine](#)
- [126 Keep Garden Tools Cutting](#)
- [130 Assembling the Lawn Mule](#)
- [136 Sculptured Garden Ornament](#)
- [138 Solving Home Problems](#)
- [140 Patio Chaise: An Easy Project](#)
- [152 Build a Swimming Pool](#)

AEROSPACE, AVIATION AND MILITARY

- [14 News from the Military](#)
- [28 Aviation Jetstream](#)
- [70 Deadly Booby Traps in a Dirty War](#)

ELECTRONICS, RADIO AND TV

- [168 Build a Coneless Loudspeaker](#)
- [171 Electronic Kinks](#)
- [172 Sun-Powered Motor](#)

BOATING AND OUTDOOR RECREATION

- [30 What's New Outdoors](#)
- [141 Troubleshooting Remote Controls](#)
- [144 Outboard Clinic](#)

JOBS AND CAREERS

- [32 Career Barometer](#)
- [84 Here Comes Mr. Parade](#)
- [112 Moss Man from Missouri](#)

REGULAR FEATURES

- [6 Letters to the Editor](#)
- [35 Editor's Page](#)

Published By The Hearst Corporation
RICHARD E. BERLIN, PRESIDENT

President, Magazines Division:
RICHARD E. DEEMS

Publisher:
JOSEPH F. KERN

Editorial Director:
WALTER IAN FISCHMAN

Executive Editor:
RICHARD F. DEMPEWOLFF

Managing Editor:
JOHN A. LINKLETTER

Shop Crafts Managing Editor:
WAYNE C. LECKEY

CLIFFORD B. HICKS _____ Midwest Editor
THOMAS E. STIMSON _____ Western Editor
KEVIN V. BROWN _____ Aviation
ALFRED W. LEES _____ Home Workshop
RICHARD HOWE _____ Building and Landscape
ARTHUR MIKESSELL _____ Boating
JOHN F. PEARSON _____ Science
STUART JAMES _____ Outdoors
LARRY STECKLER _____ Electronics
JIM DUNNE _____ Detroit Automotive
WILLIAM KILPATRICK _____ New York Automotive
LEONARD SAMUELS _____ Photography, Shop Products
JOHN J. SHEAHAN _____ Production
TERRY HONIGFELD _____ Assistant Production
MURRAY COOPER _____ Assistant Art Director
LEO R. WEEKS _____ Assistant Art Director
GEORGE W. BLOW _____ Staff Artist
PHILIP F. HUY _____ Staff Artist
FRANK P. FRITZ _____ Chief Photographer
EUGENE A. COLANGELO _____ Staff Photographer
RALPH L. CLAR _____ Photographer
GARRY WINTER _____ PM Books
FRANKLYN JACOBY, ASID/IDI _____ Design Consultant
EVERETT JOHNSON _____ Cabinetmaker

ADDRESS COMMUNICATIONS TO: 575 Lexington Ave., New York, N.Y. 10022.
For additional sources of information on the articles and products in this issue, write to Bureau of Information, Popular Mechanics, for free "Where-to-Find-It" list.

L. PARK BENJAMIN, Advertising Director

ADVERTISING OFFICES: New York: 575 Lexington Ave., MUrray Hill 8-8500; Chicago: 520 N. Michigan Ave., 527-2400; Detroit: General Motors Bldg., TRinity 5-8711; Cleveland: Hanna Bldg., 1422 Euclid Ave., PRospect 1-0456; Los Angeles: 3460 Wilshire Blvd., DUmkirk 2-8458; San Francisco: 1101 Hearst Bldg., YUkon 2-0823.

SUBSCRIPTION SERVICE: Mail all subscription orders, changes of address, correspondence concerning subscriptions, and Postmaster notices of undeliverable copies to Popular Mechanics, Box 646, New York, N. Y. 10019.

Popular Mechanics is published monthly by The Hearst Corporation, 57th St. at 8th Ave., New York, N.Y. 10019, U.S.A. Richard E. Berlin, President; George Hearst, V-Pres.; Richard E. Deems, President of Magazines; John R. Miller, V-Pres. and Gen. Mgr. of Magazines; William S. Campbell, V-Pres. and Director of Circulation; Joseph F. Kern, V-Pres. for Popular Mechanics; Frank Massi, Treasurer; R. F. McCauley, Secy. Single copy in the United States and Canada, 35 cents. Subscription prices: United States and Possessions, \$4.00 for one year; \$7.00 for two years; \$10.00 for three years. Canada, add \$0.50 for each year. Pan American Postal Union countries, add \$1.00 for each year. All other countries, add \$2.00 for each year. When changing address, give old address as well as the new, with postal-zone number, if any, and allow six weeks for change to become effective. Second-class postage paid at New York, N.Y., and at additional mailing offices. Authorized as second class mail by the Post Office Department, Ottawa, and for payment of postage in cash. Registered as second-class matter at the Post Office at Mexico, D.F., Mexico, June 20, 1950. © 1966 by The Hearst Corporation. All rights reserved. Printed in U.S.A.



Guaranteed to shave as close as a blade or your money back!

Daring? You bet! But we can give this guarantee because of our new exclusive Micro-Thin shaving screen...the world's thinnest. Sets up whiskers and then cuts them down—gets to their base like a blade does. Cuts more beard per stroke than any other shaver. 36-blade stainless-steel cutters shear away behind the screen for the fastest action ever. Big "Super-Trim" clippers groom sideburns, collar zone, moustache. Power cleans itself, too. Try a Ronson "400". And remember, if it doesn't shave you as close as a blade, you get your money back.



RONSON
E automatically better ©

Ronson Corporation, Woodbridge, N.J.
Also available in Canada

Fix us with...



A moldable epoxy. For thousands of repairs around the home, farm, automobiles and marine equipment. The two sticks, when thoroughly mixed together, adhere to most surfaces. Hardens like steel in approximately two hours. Will not sag, run or drip. You can drill, saw, file, tap, sand, mold and paint it.



PLUMBING



FURNITURE



AUTOS



MARINE EQUIPMENT

AT YOUR DEALER

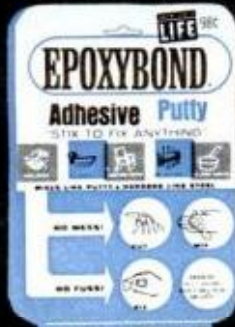

Atlas MINERALS AND CHEMICALS DIV.
THE ELECTRIC STORAGE BATTERY CO. 
MERTZTOWN, PA. • 19539

1 stick HARDENER
2 stick RESIN

LETTERS

TO THE EDITOR

For barefoot skiing

My *Hydro Dynamic* (page 144, March '63 *PM*) has touched 50 mph—and is probably near 45 in this photo.

With a 75-hp motor, this boat does a good job of pulling me barefoot—and that



is the primary reason it was built. We love it.

St. Paul, Minn.

DON MURRAY

Bigger little truck

My version of the mail truck (*Fun for Junior Mailmen*, page 174, Feb. *PM*) is considerably larger than the plans.

Automotive-type knuckle steering was used in place of that shown in the plan,



along with larger eight-inch diameter wheels. The headlights on the truck are

(Please turn to page 8)

This Free sample lesson can start you on a high-pay career as **ACCOUNTANT, AUDITOR or CPA**

You can learn in your spare time at home

THE demand for trained Accountants far exceeds the number available. Salaries keep going higher, promotions come faster. Why remain in a dull job with insufficient pay when you can qualify easily — *in your spare time* — for the big rewards which are being offered today by the Accounting profession?

To prove this to yourself, send for the interesting sample lesson which demonstrates the remarkable LaSalle method of home training. This lesson is yours free of cost or obligation. It will show you how you are guided step by step through actual Accounting work, how you learn by doing, how thoroughly you are prepared for every Accounting task you will be called upon to handle in the business world.

No previous experience required

LaSalle's distinguished faculty of expert Accountants and CPA instructors starts you right at the beginning, then supervises, corrects and grades your work all the way — right up to training you to take a Certified Public Accountant examination, if this is your eventual goal.

You train in your spare time — *at your own pace* — without losing a single day from your present job. The cost of instruction is remarkably low.

Which of today's many Accounting positions do you want?

Regardless of your present job — if you want to become a professional Accountant, Controller, Auditor, Income Tax Specialist, Government Accountant, or Public Accountant, LaSalle has the exact plan to prepare you rapidly and inexpensively.

For over half a century, LaSalle has been a world leader in business education. It has provided training at home to more than 1,000,000 ambitious men and women. That is why a LaSalle diploma in Accounting is a credential respected by employers. See for yourself. Mail the coupon now for your free sample lesson and a copy of the booklet "Opportunities in Accounting."

LA SALLE EXTENSION UNIVERSITY

A Correspondence Institution
417 South Dearborn, Chicago, Illinois 60605

This same lesson has helped thousands get started in one of the world's best-paid professions. Its simplicity will surprise you. Try it, enjoy it, without obligation.

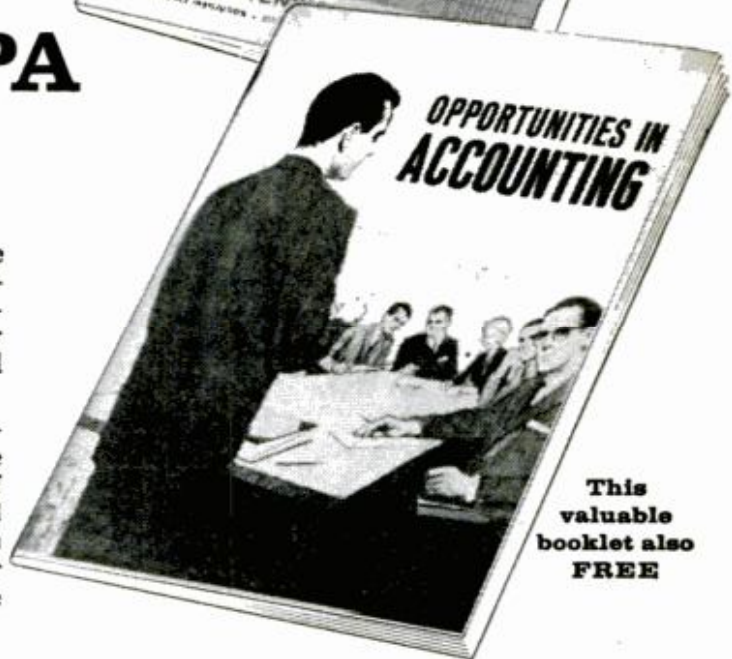
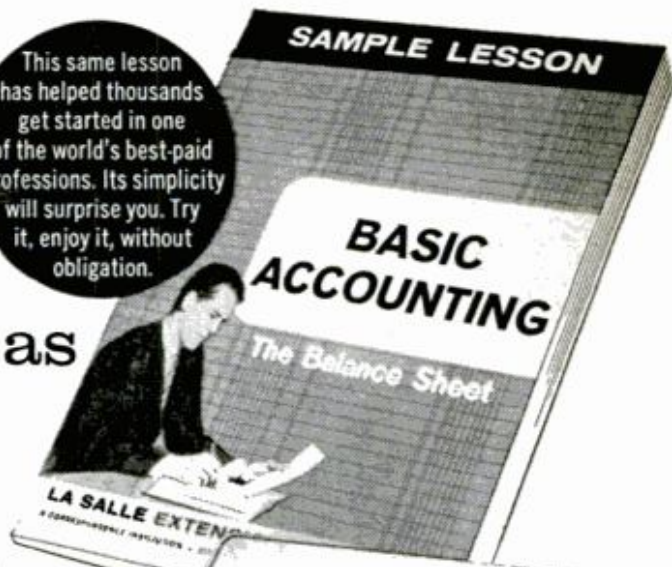

This valuable booklet also **FREE**

LaSalle graduates report up to 56% increase in pay within one year



"My income has increased over \$100 a month since I began taking your course. I recommend it highly to anyone."
—W. G. Hensley, Memphis, Tenn.

"My salary has more than doubled since enrolling with LaSalle and due to my fine training, my salary is still growing."
—William T. Black, Canoga Park, Calif.

"As a direct result of my LaSalle studies, my salary has increased 400%, since I first began my LaSalle success building program."
—Rudolf Urbatis, Port Chester, N. Y.

LA SALLE EXTENSION UNIVERSITY

A Correspondence Institution

417 South Dearborn, Dept. 54-084, Chicago, Illinois 60605

Please send me, free of cost or obligation, your sample lesson and illustrated booklet "Opportunities in Accounting."

Name..... Age.....

Address..... County.....

City..... State..... Zip No.....

Occupation..... Working Hours..... A.M..... P.M.

108



add a new dimension to your boating or camping fun... with

AQUANAUT

the floating air station that delivers \$2.50 worth of air for 15¢ worth of fuel

Now you can dive for pennies—literally—free of tanks and regulators and mouthpiece, and all the nuisance and recurring expense of refilling scuba tanks.

In its place you wear a comfortable face mask and shoulder straps, connected by 25 feet of light plastic hose to your floating air station. It skims along on the surface, guarding you with float and diving flag.

The Aquanaut is made to order for beginners. It lets you breathe easily and naturally—the way you do on the surface. And two can dive as cheaply as one.

Just 21 inches in diameter with float deflated (the Aquanaut inflates itself)—it tucks away in car trunk or boat—and runs for 45 minutes on 15¢ worth of outboard fuel.

See the Aquanaut at your Evinrude dealer (listed in the Yellow Pages). Catalog free. Write Evinrude Motors, 4409 N. 27th Street, Milwaukee, Wisconsin 53216.

EVINRUDE
first in  *outboards*
DIVISION OF OUTBOARD MARINE CORP.

LETTERS continued

Chevy backup lamps, battery powered. Assembly time was about three weeks of evenings and weekends. Total cost of materials was about \$55. Connersville, Ind. **DAVID L. HIDAY**

Blacksmith in Brooklyn

I was particularly stirred by the article *Whatever Became of the Village Blacksmith?* (page 106, Nov. '65 PM) as I dabble in this field in my spare time.

With a shop set up in my basement, I'm perhaps the only blacksmith in Midwood-Flatbush. I'm also a student at Brooklyn Technical High School.

I have been interested in blacksmithing almost from the time I could walk. My smith's anvil was sold to me by a blacksmith in Rockport, Mass. It's a 120-pound solid forged Sheffield steel anvil, built in the 19th century in England by Peter Wright. (Getting it home to Brooklyn was



really fun; it kept dragging our car nearly off the road.)

Last June, for \$14.50, I got a Buffalo forge, built in the late 1800s for the Navy. Never used, it had been lying in a warehouse for 40 years. I tied in a smoke line to our two-flue chimney, put in a good refractory lining and laid in 100 pounds of charcoal and 110 pounds of coke.

I've made horseshoes, but I never really have shod a horse; I'm afraid it might be traumatic for the horse. I stick to the other phases of smithing and make and repair things for my neighbors.

Again, many thanks for your fine article. Brooklyn, N.Y. **JOE MICHAELS**

Push-button ratchet wrench releases without a fight. New and only at **Sears**

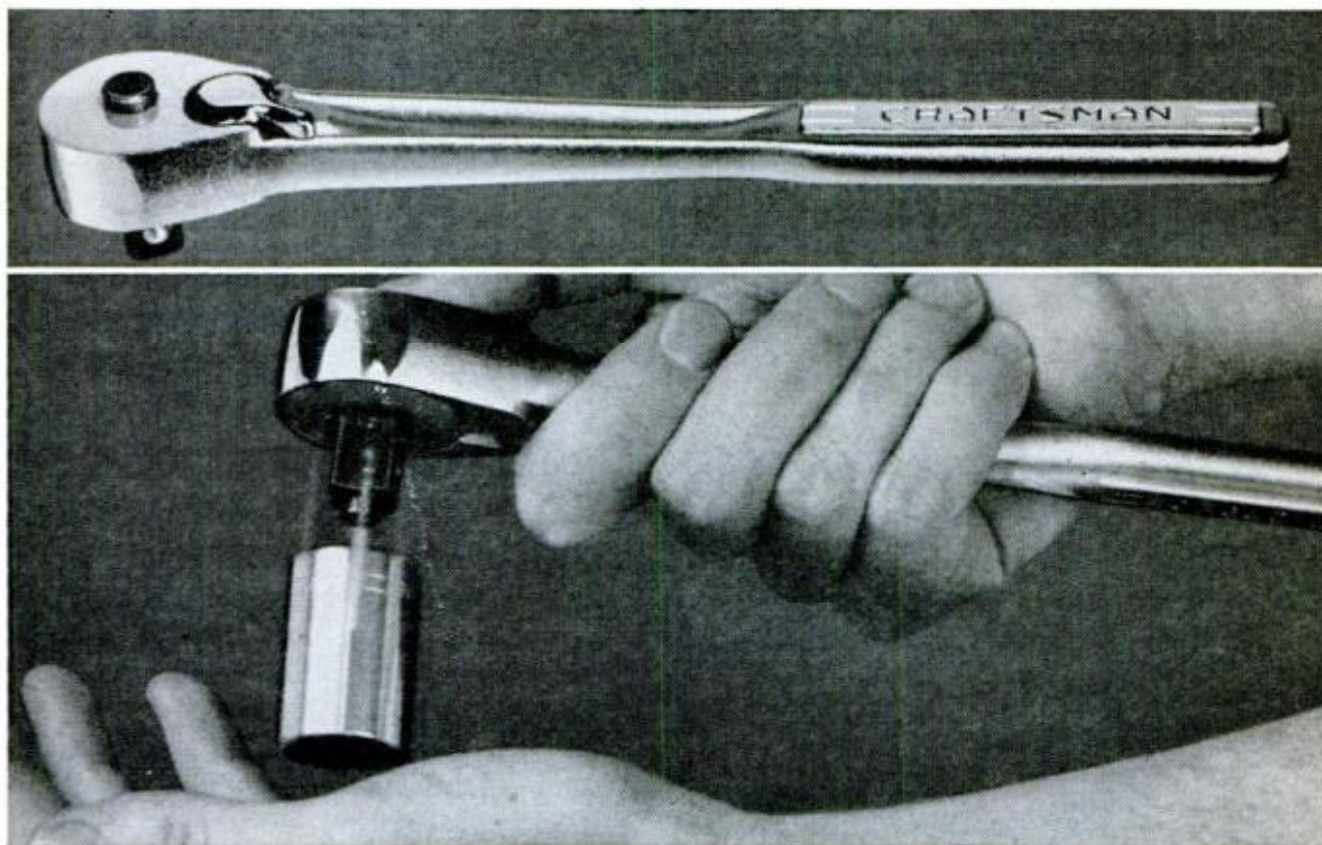

EVER tried to separate a socket from an ordinary ratchet wrench when your hands were greasy?

Forget it. You just press a button on Sears new Craftsman® wrench. They separate easily—no yanking.

The stroke is smooth and short, great for working in tight spots. Switch lever to reverse the action. The shaft and handle are drop-forged steel for strength without bulk.

In Sears factory tests, the ratchets

were operated over half a million times under full load with no serious wear.

See the newest invention in ratchet wrenches at Sears, Roebuck and Co. Available in $\frac{3}{8}$ " and $\frac{1}{2}$ " drive to fit all standard sockets. Prices: about \$5.50 to \$8.00 depending on length and drive.

You get an unconditional guarantee. If this Craftsman wrench fails to give complete satisfaction, return it—Sears will replace it free of charge.

See it now—at Sears.

**FREE
PLAN**

Be Your Own Boss New Business Opportunity **FILING SAWS**

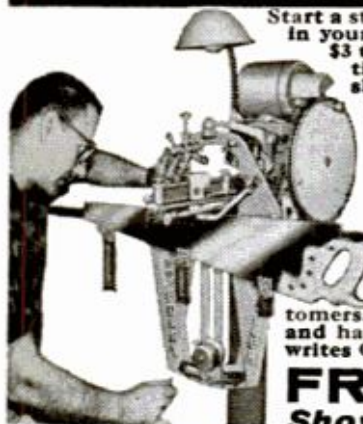

Start a steady repeat CASH business in your basement or garage. Earn \$3 to \$6 an hour in your sparetime! Excellent profits in saw sharpening business! Automatic Foley Saw Filer, easy to operate, files combination saws, hand, band, and circular saws. No experience needed. H. C. Delbert wrote us: "Since I got my Foley Filer 5 years ago, I have averaged 4½ saws each day since I started." Every saw you sharpen brings you more customers. "I rented a two-car garage and have all the work I can do," writes Charles H. Smith.

FREE BOOK Shows How to Start

Fact filled booklet tells you how to start a sparetime business immediately; how to get new business, how to advertise. Rush coupon now; get "Money Making Facts" and details on Easy Payment Plan. No Salesman will call.

Send Coupon for **FREE BOOK Money Making Facts**

FOLEY MANUFACTURING CO.
616-6 Foley Bldg., Minneapolis, Minn. 55418

Send **FREE BOOK**—"Money Making Facts",
and Time Payment Plan.

Name _____

Address _____



Earn **HIGH WAGES** as a **HEAVY EQUIPMENT OPERATOR**



Train your way to high pay in the booming construction industry! Learn the skills you need to qualify . . . NOT by correspondence, but by actual field training on machines like the ones used by the industry. Huge training grounds in North Carolina, a million dollars worth of school-owned diesel-engined machines, experienced instructors, full 220-hour and 440-hour courses. National, the original school of heavy equipment operation, is the recognized leader. Member American Road Builders Assn., Services and Supply Division, Associate Member A.G.C. Full-time Job Advisory and Counseling Director on staff. VA approved. For men ages 17 to 56. Train Now-Pay Later plan . . . other payment plans also available. Write **TODAY** for **FREE** catalog and **FREE** copy of school newspaper reporting news of National School graduates.

**NATIONAL SCHOOL
OF HEAVY EQUIPMENT OPERATION Dept. D-76**
P.O. Drawer 1686, Charlotte, N. C.

Please send me **FREE** illustrated school catalog and complete information. I understand there's no obligation.

Name _____ Age _____

Address _____

City _____ State _____ Zip Code _____

FROM THE PATENT OFFICE **NEW INVENTIONS**

BY M. J. PEDERSEN

Digital computer that teaches and programs itself can read any language, providing the language is identified and the frequency count of its letters is known. Receiving patent 3,237,161, Jacob Rabinow, Rockville, Md., explained the method as follows: The computer scans the first couple of paragraphs, noting in its memory the frequency of each letter. Such a count enables the computer to distinguish between, say, "e" and "s." From here it begins reading words. Wiring a "dictionary" to the computer would clear up any ambiguities occurring at this point, Rabinow noted. He likened this method to that used by cryptographers in breaking coded messages.

Plastic glue mends broken bones, sets in a few minutes and hardens in a day. Receiving patent 3,223,083 for this method of holding skin and other tissue together, Dr. Milton C. Cobey assigned patent rights to the directors of Georgetown University, Washington, D. C.

Decoder for pay TV system tested in Hartford, Conn., earned patent 3,238,297 for Myron G. Pawley, Riverside, Calif., and Jacob M. Sacks of Corona, Calif. Attached to home TV sets, the decoder is the key to the system inasmuch as it clarifies the video and audio signals, which are sent out "scrambled."

Weed killer chemicals for controlling undesirable vegetation, particularly along highways or railroad tracks, were awarded a total of seven patents—2,235,357 through 2,235,363. All rights were assigned to E. I. du Pont de Nemours and Co., Wilmington, Del., by the inventors, Dr. Harvey M. Loux, Edward J. Soboczenki, Donald S. Acker, Linus M. Ellis and Raymond W. Luckenbaugh.

The 1966 International Inventors and New Products Exhibition will be held at the Coliseum in New York City, September 9 through 18. Inventors interested in displaying new products may obtain a booth for \$180 by registering with the sponsors, Patent Exhibits, Inc., 554 Fifth Avenue, New York, N.Y. 10036. Entries needing financial backing are expected from all 50 states, plus several foreign countries.



**Ford Motor Company
adjusts distributor points for smooth
engine performance to an accuracy
of .002 inch—a hairsbreadth.**

**A car so precisely engineered
can be cared for best by the specialist—
your Ford or Lincoln-Mercury dealer.**

See him and be sure.



Special equipment, like this Rotunda wheel aligner, is a feature of your dealer's care. And he has factory-trained mechanics.



Only at Ford and Lincoln-Mercury dealers



UNUSUAL BARGAINS

... MANY U. S. GOV'T SURPLUS

See the Stars, Moon, Planets Close Up!

3" ASTRONOMICAL REFLECTING TELESCOPE

60 TO 180 POWER!
Famous Mt. Palomar Type!
An Unusual Buy!



See the Rings of Saturn, the fascinating planet Mars, huge craters on the Moon, phases of Venus. Equatorial Mount with lock on both axes. Aluminized and over-coated 3" diameter high-speed f/10 mirror. Telescope comes equipped with a 60X eyepiece and a mounted Barlow Lens. Optical Finder Telescope included. Hardwood, portable tripod. FREE with Scope: Valuable STAR (HART) plus 272-page

"HANDBOOK OF HEAVENS" plus "HOW TO USE YOUR TELESCOPE" BOOK.

Stock No. 85,050-H\$29.95 Postpaid

4 1/4" REFLECTING TELESCOPE—Up to 255 Power

Stock No. 85,105-H\$79.50 F.O.B., Barrington, N.J.

Superb 6" Reflector Telescope

Up to 576 Power Equatorial mount and Pedestal Base.

Stock No. 85,086-H\$199.50 F.O.B.

OPAQUE PROJECTOR

Projects illustrations up to 3" x 3 1/4" and enlarges them to 35" x 30" if screen is 6 1/2 ft. from projector; larger pictures if screen is further away. No film or negatives needed. Projects charts, diagrams, pictures, photos, lettering in full color or black-and-white. Operates on 115 volt, A.C. current, 6-ft. extension cord and plug included. Operates on 60 watt bulb, not included. Size 12" x 8" x 4 1/2" wide. W. 1 lb., 2 oz. Plastic case. Stock No. 70,199-H\$7.95 Postpaid



'FISH' WITH A WAR SURPLUS MAGNET

Go Treasure Hunting On The Bottom

Great idea! Fascinating fun and sometimes tremendously profitable! Tie a line to our 5-lb. Magnet—drop it overboard in bay, river, lake or ocean.

Troll it along the bottom—your "treasure" haul can be outboard motors, anchors, fishing tackle, all kinds of metal valuables. 5-lb. Magnet is war surplus—Alnico V Type—Gov't. Cost—\$50. Lifts over 125 lbs. on land—much greater weights under water. Order now and try this new sport. Stock No. 70,571-H. 5 lb. Magnet\$12.50 Postpaid
Stock No. 70,570-H. 3 1/2 lb. Lifts 40 lbs.\$8.75 Postpaid
Stock No. 85,152-H. . . . (lifts over 350 lbs.)\$33.60 F.O.B.

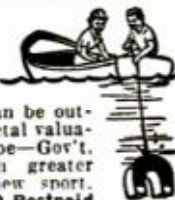

Precision Marine Time Piece Afloat or Ashore SHIP'S BELL CLOCK



Handsome metal case in either brass or chrome. Highly corrosion resistant for use on shipboard or home. Finely made, unusually high quality. 8-day clock has familiar 1 to 12 dial—also marked with 24-hour system of timekeeping and traditional watch periods from Evening (or First) Watch through Second Dog Watch. Chimes nautical half-hour intervals from 1 to 8 bells, (can be turned off). Thermometer at bottom of dial. Wt. 6 lbs.

Stock No. 70,781-H Brass\$60.00 Ppd.
Stock No. 70,782-H Chrome\$60.00 Ppd.

WAR SURPLUS AMERICAN-MADE 7x50 BINOCULARS

Big savings! Brand new! Crystal clear viewing—7 power. Every optical element is coated. An excellent night glass—the size recommended for satellite viewing. Individual eye focus. Exit pupil 7mm. Approx. field at 1,000 yds. is 376 ft. Carrying case included. American 7 x 50's normally cost \$274.50. Our war surplus price saves you real money.

Stock No. 1544-H Only \$78.40 Ppd.
8 x 30 Binoculars—similar to above.
Stock No. 963-H\$40.00 Postpaid
7 x 35 American Made Binoculars.
Stock No. 964-H\$55.00 Ppd.

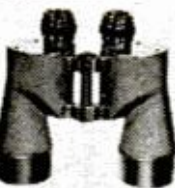

WAR SURPLUS ELECTRIC GENERATOR



Brand new Signal Corps Electric Generator for scientific experiments, electrical uses, demonstrations. Generates up to 90 volts by turning crank. Use in high impedance relays. Charge ground and bring up night crawlers for bait or study. 2 Alnico Magnets alone worth original price. Wt. 2 lbs. Cost to Govt. \$15.

Stock No. 50,225-H\$6.95 Pstpd.

Same type generator, mounted, with light, as electricity demonstrator.
Stock No. 50,365-H\$11.95 Postpaid

Order by Stock No.—Send Check or M.O.—Money-Back Guarantee
EDMUND SCIENTIFIC CO., Barrington, New Jersey

MAIL COUPON FOR FREE CATALOG "H"

Completely new 1966 Edition, 148 pages
Nearly 4500 Bargains.

EDMUND SCIENTIFIC CO., Barrington, N. J.
Please rush Free Giant Catalog "H".

Name.....

Address.....

City.....State.....Zip.....

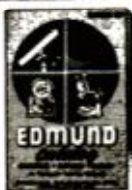

BY JOHN F. PEARSON SCIENCE WORLDWIDE

If you feel pooped a good deal of the time, you might be a victim of polluted air. So says Dr. John T. Middleton, director of California's Air Pollution Center, who identifies ozone as the chemical culprit. This highly reactive form of oxygen, which is formed in polluted air, slows down animals by closing down part of their lungs, forcing them to use more energy to get the oxygen they need.

There's value in space junk. British scientists report that there are some 200 objects now in orbit capable of serving as passive reflectors of radio messages. Some 10,000 are expected to be in orbit by 1975. The scientists say the orbiting junk could be used as a reliable standby system for communications in a military emergency.

Cereal in your morning paper? Government scientists are starting research on how starch, flour and other products made from corn, wheat and sorghum might be used in the manufacture of paper. Such products might be used with the conventional wood pulp to improve the strength of paper, to bond it and to serve as a coating.

A new way of branding livestock employs intense cold. It's better than hot branding, say Department of Agriculture researchers, because it's painless and causes less hide damage. All it takes is a 30-second application of a copper brand chilled in a dry ice-alcohol bath to minus 158° F.

Checkup needed for sick stethoscopes. Doctors at the University of Michigan Medical Center tested 17 different stethoscopes and found that no two of them performed alike. It's very possible, the researchers say, that physicians are overlooking important signs of illness because of built-in errors of their stethoscopes. They advise practitioners to shop for these instruments with all the care of the hi-fi enthusiast.

Penicillin mystery solved. For 37 years—ever since the discovery of penicillin—scientists have been puzzled by its ability to kill bacteria that invade the body without killing normal cells. Now scientists at the University of Wisconsin have come

up with the answer: The antibiotic stops invading bacteria from building their own cell walls, without which the bacterial cell can't maintain its stability. Human and other animal cells, on the other hand, do not need or have cell walls.

Tiny radio transceiver with a 10-mile range has been developed by a British firm. The 23-ounce FM "Courier" works on three channels, needs no aerial and can be worn beneath outer clothing. A miniature microphone and speaker clip behind the user's lapel.

Tattoos erased by laser—that's the most recent medical accomplishment with this remarkable scientific tool. Dr. Robert G. Wilson of the University of Cincinnati reports that the procedure is nearly painless and results in a minimum of scarring. Warts, horny growths and other non-inflammatory skin lesions can also be treated with good results.

Solar-electric propulsion of unmanned spacecraft to Mars appears to be entirely possible by the mid-1970s. That's the opinion of NASA scientists who describe a craft with four solar cell panels of 5000 square feet (a tremendous surface compared to the 70-square-foot panels used on Mariner IV in its 1965 Martian probe).

Power supplied by the big panels would be harnessed to a set of small ion-chamber engines. According to the NASA experts, solar-electric units appear to be the logical intermediate step between chemically powered and nuclear-electric powered spacecraft.

Man-made "northern lights." A high-speed proton gun is used by scientists at the University of Alaska to create auroral activity in the "test tube." Until now, the study of the mysterious auroral light in the atmosphere had to depend on the occurrence of the real thing, with scientists scrambling to make quick observations.

With the proton gun, researchers are able to create in the lab the same collision that occurs between particles in the regular aurora. The gun fires protons at very high speed into atmospheric gases (such as nitrogen) and the resulting collisions produce light, which can then be leisurely examined with a spectograph.

New for drive-ins is a system that broadcasts movie soundtracks through your car radio or transistor, eliminating the need for stanchion-connected speakers. The system uses a clear-channel AM frequency to prevent possible interference with other radio transmissions.

Win \$100, enter the Pliobond "Stickup"

Send us the most interesting, new use of the month for Pliobond®, and we'll send you back \$100.

PLIOBOND can seal and coat. Joins wood to metal to glass to cloth to rubber, etc. Resists impact, oxygen, water, chemicals. Actually grows stronger with age.

PLIOBOND glues, mends, insulates, waterproofs. Has a host of uses in your home, car, workshop. Best use we receive by last day of month of issue wins \$100.



PLIOBOND "STICKUP" CONTEST RULES

1. Describe in 50 words, or less, an interesting and unique use for Pliobond adhesives. Use an entry coupon from your local store, or plain paper no larger than 8 1/2 x 11 to enter.
2. Send as many entries as you like to Pliobond Stickup Contest, P. O. Box 9115, Akron, Ohio 44305. Send label or other evidence of purchase with each entry.
3. \$100 awards limited to one for each contest. Individual contests run in April, May, June, September, October, 1966. Entries must be postmarked by the last day of the contest in which you enter. All entries become property of The Goodyear Tire & Rubber Company and are not returnable.
4. Entries will be judged by Goodyear and the decisions of Goodyear will be final relating to questions about the contest and winners.
5. Contest open to everyone in the U. S. and possessions and Canada, except employees of Goodyear, the distributors of Pliobond adhesives and their immediate families. Contest subject to Federal and State Local Regulations.
6. All winners will be notified no later than November, 1966. List of winners will be sent on request enclosing self-addressed stamped envelope.

GOODYEAR

NEWS FROM THE
MILITARY
 BY WILLIAM R. KREH

Deflatable aircraft tires that will go flat on purpose are being designed by the Air Force. They are expandable sidewall folding tires which will deflate after take-off and inflate before the aircraft lands, requiring less storage space when retracted in flight. Air pressure from the aircraft's engine will be bled off to reinflate the tires before landing.



Blimp blankets. A year's supply of tarpaulins was made from a surplus Navy blimp envelope at the Long Beach (Calif.) Naval Supply Center, thus saving around \$6000. The covers, for outdoor-stored items, are waterproof, making them better than canvas which seeps some moisture.

Bandanas are back in style in the Army—at least in Vietnam. GIs there are being equipped with 36-inch-square "sweat cloths." They may be worn on the back of the head as a sun shield, tied around the neck, or used as large handkerchief.

A sea lion by the name of Peabody is working for Navy scientists at the San Francisco Naval Shipyard. The year-old mammal is being used by physiologists to study certain phenomena peculiar to his breed—the ability to make dives into the ocean's depths and automatically adjust to the changes in pressure by slowing down his body functions. Deep-sea dives are being simulated in a decompression chamber with Peabody as the diver. By observing and recording the reactions of the instrumented sea lion, scientists hope to learn what triggers his mechanism.

Watch those empties! A Vietcong officer was captured recently and among his equipment was a megaphone used to give orders to his troops. It was made entirely from empty beer cans that had been discarded by American GIs, with the name of an American brewer emblazoned on it.

A new device called "Readymads," an Army "computerized mechanic," can determine malfunctions of certain wheeled vehicles in less than five minutes. It detects faults, types out cause descriptions, and lists required parts by number and repair-manual reference. ★★★

<p>CHECK RUST & CORROSION <input checked="" type="checkbox"/></p> <p>around your house . . .</p>	 <p><input type="checkbox"/> CHECK YOUR GUTTERS AND DRAINPIPES</p>	 <p><input type="checkbox"/> CHECK YOUR GARAGE</p>
 <p><input type="checkbox"/> CHECK YOUR GARDEN TOOLS</p>	 <p><input type="checkbox"/> CHECK YOUR LAWN FURNITURE</p>	 <p><input type="checkbox"/> CHECK YOUR FENCES AND RAILINGS</p>

Derusto the Beautiful way to stop rust

DERUSTO PROTECTIVE COATING . . . a heavy duty—semi-gloss coating that actually penetrates and locks itself to metal surfaces. Primes, finishes, beautifies and protects. **DERUSTO** . . . the product with the built-in primer in an array of beautiful colors. **DERUSTO GALV-A-GRIP** . . . stops cracking, peeling and chipping on gutters and downspouts. Requires no etching or weathering. Primes, finishes, beautifies and protects. **DERUSTO GALV-A-GRIP** . . . the product with the built-in grip. Available in WHITE, Red, Gray and Green.



FREE!!!



POPULAR MECHANICS Editors REPORT ON RUST & CORROSION. Available FREE of charge at your local DERUSTO dealer, or send 35¢ for postage and handling to Master Bronze Powder Co., 415-435 E. 16th St., Chicago Heights, Ill.

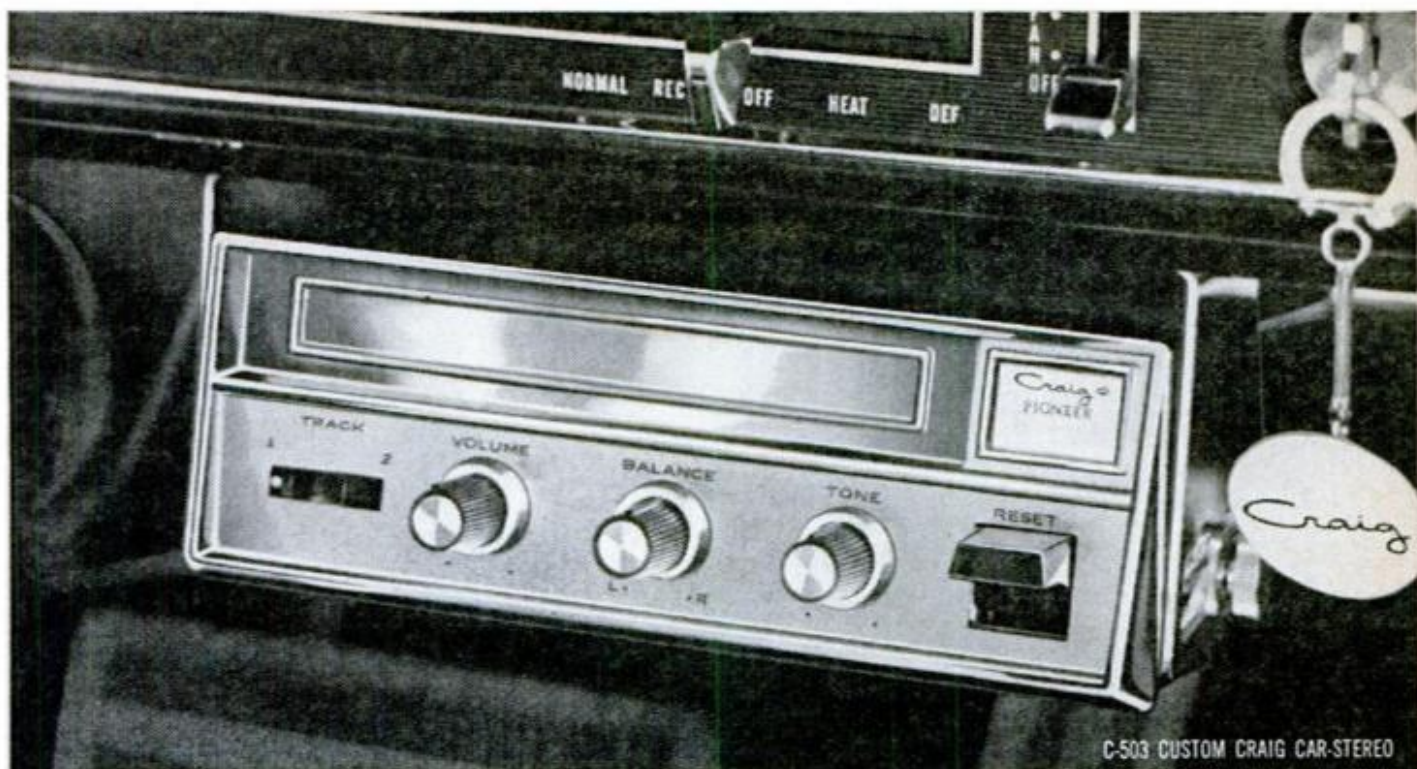

Tune up your car with Bach or Basie.

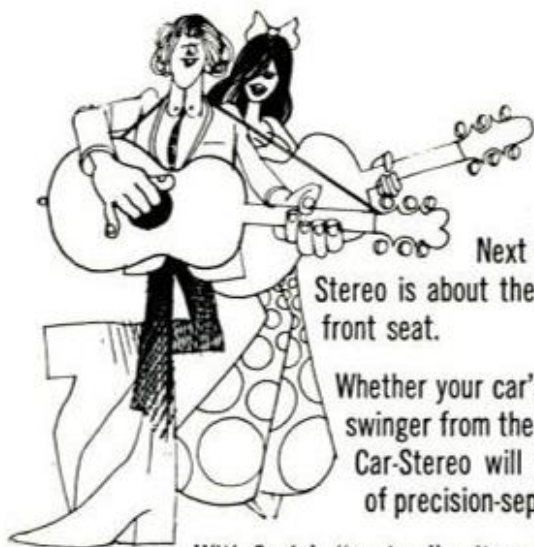

Or The Ventures.

Next to your favorite person, Craig Car-Stereo is about the neatest thing you can put in your front seat.

Whether your car's a sophisticated compact, a tiny swinger from the old country or a gun boat, Craig Car-Stereo will bring it alive with the sound of precision-separated, superb-fidelity stereo.

With Craig's "custom" unit you've got the best engineered Car-Stereo on the market. 4-tracks. Dual heads. Handsome, retracting dust cover to keep the heads dust-free. Capstan drive. 16 watts of power. Compact, all-chrome finish.

Your Craig Car-Stereo dealer's got a huge library of continuous-loop tape cartridges, too. If you don't dig the Count, Bach or The Ventures, how about putting your favorite show on the road?

See your Craig Car-Stereo dealer for a tune-up.

For the name of your nearest Craig Car-Stereo dealer, write:

Ⓞ CRAIG PANORAMA, INC.

2302 East 15th Street • Los Angeles, Calif. 90021 • (213) 623-2421 • TLX 674116



FREE!



Trial lesson in DRAFTING & DESIGN

LEARN AT HOME IN SPARE TIME

Check the want ads in any newspaper—SEE the big-pay opportunities open to you as a draftsman. What's more, you can learn this well-paid, prestige profession at home—quickly, easily! No special talent needed! Get complete, step-by-step Chicago Tech lessons in the mail, spend a few pleasant hours studying each week. In a short time you'll be a well-trained draftsman, ready to take your pick of many good jobs. Act now!

FREE INFORMATION—MAIL COUPON TODAY!

Get FREE TRIAL LESSON plus information about C.T.C. practical training. Learn what successful Chicago Tech graduates say about high pay and opportunities in drafting. No charge, or obligation.

Est. 1904 Accredited National Home Study Council

CHICAGO TECHNICAL COLLEGE

**G-204 Tech Bldg., 2000 So. Michigan Ave.
Chicago 16, Illinois**

Mail me FREE Lesson with information about big opportunities in DRAFTING.

Name..... Age.....
 Address.....
 City..... Zone..... State.....

EARN \$200 A WEEK

LEARN A TRADE YOU LIKE

After graduation you start as a mechanic in a good paying job; then advance to head mechanic or service manager. Many earn \$200 a week and up. You learn fast in our shops because you learn with tools on real equipment. Some students earn the greater part of their expenses while going to school.

- Check the course in which you are interested.
- | | |
|-------------------------------------------|---------------------------------------------|
| <input type="checkbox"/> DIESEL MECHANICS | <input type="checkbox"/> AUTO MECHANICS |
| <input type="checkbox"/> WELDING | <input type="checkbox"/> BODY FENDER REPAIR |

Mail to: AUTO-DIESEL COLLEGE

226 7th Avenue, North, Department 86, Nashville, Tennessee
 Send me FREE catalog about course I have checked, also information about your FREE Placement Service.

Name.....
 Address.....
 City..... State.....

EXCITING NEW PRODUCTS



The 7-in-1 Raemco stove is a portable unit that can charcoal-broil, smoke-cook, barbecue, fry, bake, roast and space-heat. It folds up for easy toting to any area. Cooking area is 10x15 in. Stove burns wood, charcoal or coal, burns 6 to 8 hours unattended. \$45.50 ppd. from Sam Richards, Traders, Dept. 644, Bantam, Conn.

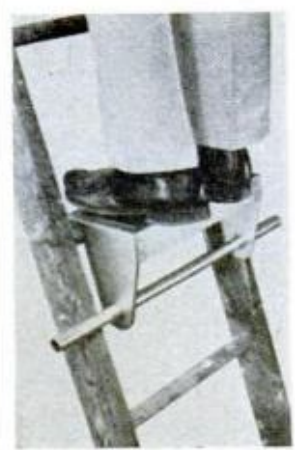

Tote-Step provides greater safety, eliminates leg and arch fatigue associated with ladder work. Removed from ladder, steel unit with rubber tread serves as a tool carrier. By Tote-Step Sales Corp., 606 W. Wisconsin Ave., Milwaukee, Wis. 53203. \$4.95.





load instantly...

...shoot terrific **Super 8** movies with
a new **Kodak Instamatic
Movie Camera!**



Just drop in the film and shoot movies that are *spectacularly* bright and sharp. The KODAK[®] Movie Cartridge is factory-loaded—no threading, no midpoint flip-over. Shoot 50 feet of continuous film and show it brilliantly on a super 8 projector (required for super 8 movies). The KODAK INSTAMATIC M2 Movie Camera has fast f1.8 lens; built-in filter that lets you use same film indoors and out. No winding—battery drive. Less than \$40.

Price subject to change without notice.

Kodak
TRADEMARK

Материал эскизів не є гарантією якості продукції

Now

the only four-wheel drive
in its class with

V-8 power... Bronco!



Want even greater action than Bronco's spunky Six? Give the new V-8 a go. 200 hp to drive all 4 wheels! That's power for the big jobs, and the big jaunts . . . to where the fun is and the roads aren't. A 34-ft. turning circle—smallest of any 4-wheeler—gives Bronco quicksilver handling. Bronco's tough, too—far tougher than its car-like ride lets on. A rugged frame is one reason. Heavy Mono-Beam suspension is another. It's a combination of features no competitor can match. Think it over. Chances are you and Bronco make a great combination, too.

**Bronco
wins at
Riverside!**

In the brutal Four Wheel Drive Grand Prix at Riverside, California, March 4-6, Bronco won top honors against all comers! Bronco 289-cu. in. stock V-8 won first in its class, while Bronco with a standard Six took Top Eliminator prize.

New
fun one
from **Ford**

HOMEOWNERS' CLINIC

BY W. CLYDE LAMMEY

Cesspool or Septic Tank?

I'm curious. Just what is the difference between a cesspool and a septic tank? I am currently building a house in a rural area that will require setting up my own sewage disposal system. I've been told a cesspool is a simpler, less expensive installation, but that it is less efficient than a septic tank.—G.T., Mont.

Put in a septic tank. It'll cost more, but it's worth it. Here's why:

A cesspool is nothing more than a stone-lined hole in the ground. Sewage enters it through a pipe from the house. Liquid sewage seeps away into the ground, while the solid matter accumulates and putrefies in the bottom of the cesspool. Unlike a septic tank—which digests and liquefies much of the solid sewage so that it can flow away into a drainage field—a cesspool merely collects it. As a result, cesspools are "dirtier" and have to be cleaned more frequently than septic tanks.

Repairing Rotten Columns

The bottom part of the 4x4-in. columns supporting our porch roof are pretty rotten. This rot extends almost to the top of the trim around their bases. Is it possible to repair them or will I have to put in all new columns?—N.K., Ala.

These columns can be repaired. Repair one column at a time so that the others will continue to support the roof.

Rip off the base trim, then force a length of 2x4 between the porch ceiling and the floor to serve as a temporary support. Saw the rotten portion of the column off square, then sand and paint the floor under the column. Replace the rotted section of column with a new piece of 4x4 set on four metal studs to permit air to circulate under it. Toenail the new piece to the main section of column, then paint it. Also, paint the backs of the new pieces of trim before nailing them around the base of the column, and cut shallow arches in the bottom of the trim to permit air circulation under the columns.

Holy Linoleum!

A number of small holes have been worn into the linoleum on our kitchen floor. Is there any technique for patching
(Please turn to page 18)

Test your automotive I.Q.



The tool in use here is _____ ?



What does this symbol stand for ?

A torque wrench, which helps a mechanic apply equal pressure to head bolts. The life preserver is the symbol of Quaker State Motor Oil. Quaker State is refined only from 100% Pure Pennsylvania Grade Crude Oil. It keeps your car on the road, out of the repair shop . . . saves you trouble and money. That's why it's the finest engine life preserver you can buy. Quaker State your car —to keep it running young!



Quaker State Oil Refining Corporation
Oil City, Pennsylvania

HOMEOWNERS' CLINIC

(Continued from page 17)

these holes that will not ruin the overall appearance of the linoleum?—T.S., Calif.

Try this. Use some fine steel wool to smooth the edges of the holes. Then crush a small piece of matching linoleum into a fine powder. Mix this with some spar varnish to make a paste. Force the paste into the hole and smooth it with a putty knife so it is flush with the surrounding linoleum. When the patch dries, sand it with very fine sandpaper. Then wax it.

Ogre in the Basement?

I'm getting an awful lot of rumbling noises from my hot-water tank these days. Sounds like an ogre's in the basement. The pipes between the heater and the hot-water tank are perfectly level, so I don't think they're at fault. Also, the tank is never heated over 130°, so I don't think the rumbling is due to excess steam in the tank. What the heck can it be?—T.C., Wis.

You've identified the problem without recognizing it. It's those "perfectly level" pipes between the heater and the hot-

water tank. These pipes should slope upward to permit the steam generated by the heating coil to move easily into the tank. Otherwise the water in the line will tend to block the steam, source of the rumbling noise. Reposition the pipes as described and that "ogre" will disappear.

How to Prime a Dragon

Last winter we moved into an old house that has a lovely fireplace in the dining room. We use the fireplace regularly, but have dubbed it "The Reluctant Dragon" because it always puffs smoke out into the room when we first light it. After a few minutes it begins to draw and doesn't give us any more trouble until the next time it's kindled. Do you know how to make our "dragon" behave?—Mrs. P.Y., N.Y.

All that dragon needs, Mrs. Y., is a little priming in the flame-throwing department. Before kindling it next time, throw a few sheets of crumpled newspaper onto the grate and light 'em. The fast, smokeless flame they give off will warm the flue—and a preheated flue creates a much better draft than a cold one. This is what that old dragon was trying to tell you all along.

Why does Mapleton use two aromatics when one would do?

For smoothness, man.
Smoothness.

Maple and rare rum—what a combination! Mapleton has just the right amount of each to smooth out the smoke as no single aromatic can. Some aromatic tobaccos taste too sweet... can't smoke smooth. But Mapleton Smoking Mixture mellows the rich full flavor of aged tobacco—for smoothness, man.



United States Tobacco Company

Get Set for Faster and Easier Movies



NOTHING COULD BE SIMPLER than using the new Fujichrome film cartridge, the unique hub of a home-movie system introduced to the United States this spring. Merely plop the extra-thin cartridge in the camera and you automatically set the film speed for shooting 50 continuous feet without stopping. You can even reverse the film for trick effects.

A product of Fuji Photo Film Co. and Ehrenreich Photo-Optical Industries, this Single 8 film (Fuji's name for the Super 8 format) has a strong, thin, stable polyester base and is mounted in a two-spools-in-line cartridge. Unlike other cartridges, this one has no gate; it uses a gate in the camera to insure that the film always lies in the proper optical plane. A rubber roller in the cartridge permits rewinding for lap dissolves and other professional tricks. Other makes of cartridges are not now reversible. Worldwide processing facilities have been established for the film.

This simplicity of design assures more jam-free operation and provides a cartridge that is only 1/2-in. thick, making possible the exceptionally thin Fujica P-1 camera, pictured at left above.

To make use of the concept, Fuji has launched the P-1, a lightweight, fixed-focus unit with automatic exposure control, and the zoom reflex model shown above. Rounding out the line are two projectors, one of them for sound.

Interest in the system has spread. Honeywell, Inc., already has a camera that can be adapted to Single 8. ★★★



GIANT KILLER



Enjoy the delicious flavor of Green Giant brand products, then save the cans for target shooting with America's newest, most exciting fun gun... Crosman's Powermaster 760 BB repeater rifle! A "giant killer" with power to spare! Unique, easy, short-stroke pump action! Two quick pumps for accurate indoor shooting; a few more easy pumps pack a sizzling muzzle velocity of over 500 ft. per second! Holds 180 Crosman Super BBs! Also shoots .177 cal. Super Pells,[®] single shot! Positive cross bolt safety! Visual loading magazine! Lifetime solid steel barrel, genuine hard wood stock, gold-tone trigger, adjustable sights! See this great new gun today at your Crosman dealer! About \$19.95.

Send for free book:
"More Shooting Fun"
describing all
Crosman guns.
Address Dept. PM066

Crosman/Going Great Guns
Crosman Arms Co., Inc., Fairport, N. Y.
Crosman Arms (Canada) Ltd.

DETROIT

LISTENING POST

BY JIM DUNNE

Create its own high-speed bank in a flat curve? Your car may one day be able to do just that. Dr. Yao T. Li, professor of aeronautics at Massachusetts Institute of Technology, has developed a suspension system that theoretically will produce the same effect on a car as a steeply banked track. Called "active roll mode suspension," Li's system leans a car's body *into* a curve rather than away from it. Key to operating the system is the force that puts a car in a skid. This "break-away" force is picked up by a "black box" and transmitted to a control device that mechanically leans the car in the opposite direction. The car automatically levels off as it comes out of a curve. Li says that because his system counteracts a car's tendency to roll over when cornering, softer suspensions for a more comfortable ride are possible. Also, he says greater vertical stability will make possible narrower body designs, thus reducing bulk and helping to solve certain aerodynamic problems (a wide, flat body at high speed tends to react like an airplane wing). Although Li's ideas have been proved on an experimental vehicle, they have yet to be tested on a racing car. If they work on a racetrack, there's the promise of higher speeds and obvious maneuvering advantages.

Spotlight on injuries, not accidents. In his sensational book, *Unsafe at Any Speed*, attorney Ralph Nader criticizes the U.S. auto industry for dragging its feet on safety advances. He says 75 percent of all auto injuries are caused by unsafe design. But what most people do not realize is that Nader is talking about causes of *injuries*, not causes of accidents. He concentrates on reducing the severity of so-called "second collisions"—what happens when passengers hit the interior of a car a split second after the initial impact. Safety experts agree permanent injury or death is too high a price to pay for a momentary unsafe driving lapse; they want cars built to protect passengers when an accident occurs, regardless of the reason for the accident. So, with its super-sensitive antenna extended and vibrating, look for Detroit to pay a lot more attention to making car interiors "survival capsules" as opposed to redesigning drastically such things as brakes, lights, tires, and so on.

Swept-back dash panels are also in the safety works. The idea is to get all protrusions out of the way of front-seat passengers and the driver. The best way to accomplish this, engineers believe, is to move the whole dash forward as was done in the Toronado and Riviera. Experts say this type of arrangement will sweep the industry in the next two years. But there are certain problems involved. Heater ducts, for example, as well as wipers, airconditioning devices, radios, stereo tape units and glove compartments, must be changed to fit the narrower space between the new dash and fire wall. Either that or they'll have to be relocated inside the engine compartment. This is one reason General Motors and Ford are working on a hinged instrument panel—just not enough room to install instruments and wiring. And, the work space is shrinking.

Collapsible chassis frames and front sheet metal designed to absorb head-on impacts are being developed by Ford as another safety contribution for its regular passenger cars. Ford's goal is to reduce the impact of a 30 mph head-on collision to, say, that of a 6 mph collision. Most of the work now being done is concentrated on the front of the chassis frame. Frame extensions forward of the engine mounts will be weakened by using smaller members and by extensive use of "lightening" holes, like Swiss cheese. More "box" sections are being built into the sheet metal skin of cars to improve the sudden deceleration "cushion." But don't look for these developments before the 1968 models; production changes such as these just can't be made any sooner.

(Please turn to page 22)

From an AC Engineer's notebook:

AC's filter material contains millions of "dirt traps"

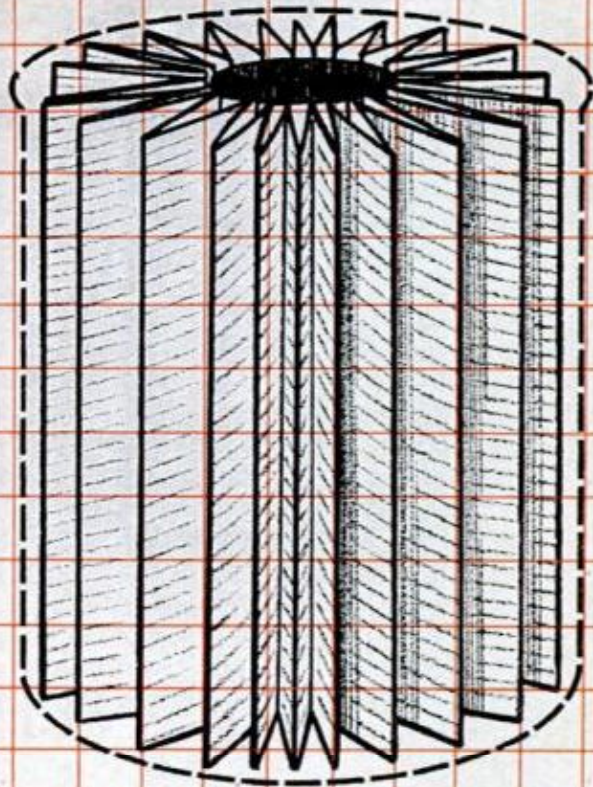

the AC Oil Filter removes dirt particles as small as 1/10th the diameter of a human hair and smaller



Every AC Oil Filter has millions of "dirt traps" to help protect the life of your engine

With its millions of "dirt traps," the AC Oil Filter catches and holds abrasive impurities that are as small as 1/10th the diameter of a human hair and smaller. This means it takes over 76,000 of these particles to cover the head of a pin. This unsurpassed filtering efficiency, together with AC's advanced full-flow design, assures you of a continuous flow of freshly-cleaned oil to vital engine parts. This reduces engine wear, increases engine protection. To help your engine run better, last longer, ask for an AC Oil Filter next time you change your oil.

AC SPARK PLUG DIVISION



DETROIT LISTENING POST

(Continued from page 20)

Your next new car may bear the imprint "Made in Canada." For almost a year the industry has been transferring production of certain models to Canadian assembly plants. The cars are then imported for sale to U.S. buyers. It's all part of a U.S.-Canadian trade agreement that calls for American car builders to bolster Canada's auto industry. As of now Chevrolet is planning to build 75,000 full-size models a year at a new assembly plant in Quebec, most of this production for sale in the New England area. Chrysler is already building Darts in Canada; Valiants, too. Ford is selling Canadian-built Galaxies in the Buffalo, N.Y., region. Many cars, however—Cadillac, Lincoln, Thunderbird, Imperial, Corvette and so on—apparently cannot be built economically in Canada. So automakers have upped Canadian production of the more common models to balance out the trade. The trend to "foreign" production will probably continue as long as the Canadian market keeps growing.

Chrysler will make a turbine car—if! The corporation says the two big roadblocks stopping production of a turbine

engine are acceleration lag and high fuel consumption. Beat these and the industry will be in the turbine business, period. Chrysler's next-generation turbine, already in the test stage, is expected to have these two problems under control. It will also have more horsepower than the 130 of present engines, about equal to the power of an existing 230 V8 piston engine. In a two-year test of turbine cars just completed, Chrysler said driver-testers liked best the cars' vibrationless ride at all operating speeds. Many mentioned a gliding sensation and said they felt fresh after long highway trips they thought would be wearisome in conventionally powered cars. Drivers also liked the lower maintenance requirements of the turbine, even though most did not drive it for long periods.

One-third of the drivers complained about acceleration lag, especially from a standing start. Chrysler says it has cut this lag to under two seconds in present engines. But it still has a long way to go before it can match the 0.4-second lag of most piston engines. Twenty-five percent of the testers were dissatisfied with mpg.

Chrysler did not release mileage figures, but it is known that proving-ground tests average 15 mpg under all operating conditions. ★★★

BE A WINNER!

...get with Italy's "hot one"!

Every body has more fun with a

Benelli

From skimming along the road to cross country hopping, from sporting fun to racing, you get more with Italy's fine "old world" crafted Benelli motorcycles! Prices start at *\$189.00 and the complete line of models and colors are sure to satisfy every rider's needs. Be a winner . . . see these snappy sports models today. For free color catalog and name of nearest dealer write today to:



COSMOPOLITAN MOTORS, INC., 5521 Wayne Avenue, Philadelphia, Pennsylvania 19144

*plus dealer's transportation and set-up charges

NEW

7½" Circular Saw—
shockproof*—
packed with the
power and speed
you need **\$3988**
for any job.



*Constructed of non-conductive miracle material, double insulated against electrical shock from product malfunction.

WORLD'S SAFEST SAW



NEW

¼" Variable Speed
Drill — Electronic
Trigger Speed Control
gives you fingertip
control for drilling wood,
metal, plastics, and glass.

Only **\$2488**

Also ⅜" Variable Speed Drill—\$2988



NEW

2-speed Jig Saw
— gives you high
and low cutting
speed for problem
materials. Base tilts
45° for added flexibility.

Only **\$2988**

Rockwell adds tools to Green Line

Here's a follow-up to the breakthrough introduction of Porter-Cable Green Line SHOCK-PROOF tools. Each new tool has 7 insulation barriers for maximum user protection. They are breakproof, too, with failure-proof motors. Saws, drills, sanders—your choice of 9 models. Mail coupon for full story.

Rockwell Manufacturing Company,
Power Tool Division
502F N. Lexington Ave., Pittsburgh, Pa. 15208



Rockwell
MANUFACTURING COMPANY

Please send me FREE brochure.

Name _____

Address _____

City _____ State _____ Zip _____



EARN UP TO \$50 A WEEK IN
YOUR SPARE TIME AS A
**TYPEWRITER
REPAIRMAN**

Great demand for trained men. Over 25 million typewriters need service and repairs! Cash in on this 300 million dollar market. Now you can get industry-approved training at home. Easy to learn. Low Cost. Qualify quickly in your spare time for a high paying job or a business of your own. Earn while you learn. Real typewriters, sub-assemblies, visual aids, and professional tools provided at no extra cost. Simple, clear illustrated lessons. Expert teachers personally guide you all the way. Fully licensed, accredited, and approved school. State authorized diploma. **Mail Coupon Today.** Typewriter Repair School, Little Falls, N.J. 07424

TYPEWRITER REPAIR SCHOOL **FREE**
DEPT. 310-066 **BOOK**
Little Falls, New Jersey 07424

Send **FREE BOOKLET** describing unlimited opportunities for Typewriter Repairmen. No obligation. No salesman will call.

Name.....
Address.....
City.....State.....Zip.....

ELECTRONICS

COYNE ELECTRONICS INSTITUTE

A quarter million dollars worth of equipment. Non-Profit Institute—Est. 1899. Courses: Electronics • Electricity • TV-Radio • F.C.C. • Electronics Engineering Technology. Mail coupon or write for **FREE BOOK** • No Salesman will call.

★ **NEW G. I. BILL STARTS JUNE 1** ★

COYNE ELECTRONICS INSTITUTE Educ. Serv. Dept. A6-S
1501 W. Congress Parkway, Chicago, Ill. 60607

NAME.....PHONE.....
ADDRESS.....AGE.....
CITY.....STATE.....



DRAINS collars, cisterns, wash tubs; **\$8.95**
IRRIGATES - CIRCULATES - SPRAYS

1,001 uses. Stainless shaft. Won't rust or clog! Use 1/2 HP motor or larger . . . 3/4 HP for up to 2,400 GPH; 450 GPH 80" high; or 1,800 GPH from 25" well. 1" inlet; 3/4" outlet. Coupling included free. **\$8.95.**
HEAVY DUTY BALL-BEARING PUMP. Up to 5,200 GPH; or 3,000 GPH from 25" well. 1 1/4" inlet; 1" outlet. **\$12.95**
Postpaid if cash with order. **MONEY BACK GUARANTEE**
Centrifugal and Gear Pumps in All Sizes
LABAWCO PUMPS, Belle Mead 7, New Jersey

WATCH REPAIRING

FREE BOOKLET • WRITE TODAY

Tells how you can learn to repair Swiss and American watches at home in spare time.
Free booklet and sample lesson. No obligation.
CHICAGO SCHOOL OF WATCHMAKING
DEPT. 166, FOX RIVER GROVE, ILLINOIS 60021

START YOUR OWN MONEY MAKING BUSINESS

Clean rugs on customers' floors — upholstery in their homes — even painted walls — with highly efficient electric machines which are making big money for others and giving them independence. Write today for complete information. It's **FREE!**
VON SCHRADER MFG. CO., Dept. 610 "R" Pl., Racine, Wis.

LIQUIDATION \$3,995 SALE... ONLY

ORIGINAL PRICE
\$12,500



**Food & Soft
Ice Cream
Mobile Unit**

Publicly owned corp. offers (while supply lasts) 1-ton Chev. food and soft ice cream mobile units, completely reconditioned **LIKE NEW. FULLY GUARANTEED.** Highest quality restaurant equipment serving hamburgers, hot dogs, and coffee, **PLUS** complete line of soft ice cream cones, sundaes, shakes, etc. No obsolete equipment. Replacement parts always available. This is a "Once-in-a-Lifetime" opportunity. Can finance if necessary. Act promptly for best selection. Give phone No.

TASTEE-FREEZ, 1200 N. Homan, Chicago, Ill. 60651, Dept. PM

PROFESSIONAL TAX CONSULTANTS

EARN BIG MONEY FASTER

Clean, dignified, high pay Tax Consultant Practice waiting for trained graduates. Busy Tax season pays \$1,000 to \$3,000 for spare-time work . . . leads to profitable year 'round Tax Service Business with monthly fees of up to \$50 per client. No previous experience. Low cost home training course, shows you the way. Licensed by N. Y. Education Dept. and Member Nat'l. Home Study Council. Write for **FREE LITERATURE.** No obligation. No salesmen.

NATIONAL TAX TRAINING SCHOOL, Monsey, 0-20, N.Y. 10952

WOOD VENEERS • TOOLS

Shop Equipment • Supplies
POWER TOOLS
at Lowest
Discount Prices!

SAVE MONEY on finest domestic and imported hardwoods . . . all dimensions. Over 1500 items for the home craftsman and woodworking hobbyist. Lamp parts, upholstery supplies, tile, power tools at discounts. **NEW CATALOG READY**
132 pages. Full Color. Send name, address and 35¢ to cover handling, and postage. Write . . .

CRAFTSMAN Wood Service Co. Dept. A-66
2729 S. Mary, Chicago, Ill. 60608



ALL FAMOUS BRANDS!
TIRES!
FARM TRUCK AUTO
AT LESS THAN WHOLESALE
SAVINGS NEVER LESS THAN 50% up to 70% OFF REG. PRICE!
HEADQUARTERS for ALL SPORT CAR TIRE SIZES
FREE - SEND FOR YOUR FREE CATALOG - FREE!
RELIABLE TIRE DIST., 1111 Chestnut St., Camden, N. J.



make your own Gems 36⁵⁰
The Gem Maker comes complete with all necessary equipment, including a super-charged diamond blade for sawing, and all the wheels for grinding, shaping and polishing; also complete instructions. The complete equipment as shown, less motor and belt for only \$36.50, f.o.b., Burlington, Wisconsin. Write today for information and literature.
B & I MANUFACTURING CO.
Dept. P, Burlington, Wis.

REAL ESTATE

BE A BROKER

PAYS BIG! SEND FOR FREE, BIG, ILLUSTRATED CATALOG NOW! Graduates report making substantial incomes. Start and run your own business quickly. Men, Women, all ages, learn easily. Course covers Sales, Property Management, Appraising, Loans, Mortgages, & related subjects. **STUDY AT HOME** or in classrooms in leading cities. **DIPLOMA AWARDED. Write TODAY for FREE Booklet!**
Accredited Member National Home Study Council. (Established 1936)
WEAVER SCHOOL OF REAL ESTATE
3521-P Broadway Kansas City, Mo. 64111

**FREE
BOOK
TELLS
HOW**

QUICK, PRACTICAL WAY TO HIGHER PAY WITH N. T. S. HOME TRAINING

Move up faster, make more money the "Project Method" way.



ELECTRONICS DIVISION

1. Electronics-TV-Radio Servicing and Communications
2. Master Course in Electronics-TV-Radio Advanced TV and Industrial Electronics
3. FCC License Course
4. Radio Servicing (AM-FM-Transistors)
5. Television Servicing (Including Color)
6. Stereo, Hi-Fi and Sound Systems
7. Basic Electronics
8. Electronics Math

NO KIT DEPOSITS

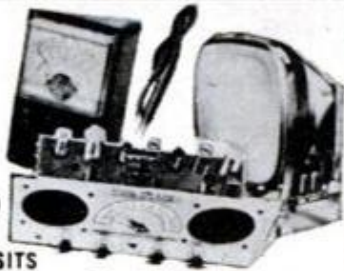

AUTO-MECHANICS DIVISION

1. Automotive-Diesel Master Course
 2. Automotive Mechanics
 3. Diesel Mechanics
 4. Engine Tune-Up and Electricity
- Eighty million cars and trucks need maintenance. Here's real opportunity! Get and keep valuable tools. No kit deposits, no extra cost.

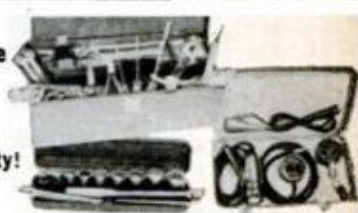

AIR CONDITIONING-REFRIGERATION DIVISION

1. Air Conditioning-Refrigeration Servicing Course
 2. Air Conditioning Refrigeration & Electrical Appliances Master Course
- Good income in servicing and installation. Big equipment kits with both courses at no extra cost. No kit deposits.



HOME APPLIANCES DIVISION

1. Home Appliances Master Technician's Course
 2. Home Appliances Servicing Course
- Prepare for full or part time career. Earn while you learn. No kit deposits. Tools included at no extra cost.



NATIONAL TECHNICAL SCHOOLS

4000 S. Figueroa St., Los Angeles, California 90037

HIGH SCHOOL AT HOME

National offers accredited high school programs. Take only subjects you need. Study at your own pace. Everything included at one low tuition. Check special High School box in coupon for complete FREE Diploma information.

CLASSROOM TRAINING AT LOS ANGELES

You can take classroom training in our famous Resident School in Los Angeles. Check Resident School box in coupon for full details.

SEND FOR FREE BOOK & SAMPLE LESSON



- NATIONAL TECHNICAL SCHOOLS, DEPT. 201-66
4000 S. Figueroa St., Los Angeles, Calif. 90037
Please rush FREE BOOK AND SAMPLE LESSON on Courses in the Division checked below. No obligation. No salesman will call. Please check one only.
- | | |
|--------------------------------------------------|------------------------------------------------------------------|
| <input type="checkbox"/> ELECTRONICS Division | <input type="checkbox"/> AIR CONDITIONING REFRIGERATION Division |
| <input type="checkbox"/> AUTO MECHANICS Division | <input type="checkbox"/> HOME APPLIANCES Division |
| <input type="checkbox"/> HIGH SCHOOL Department | |

Name _____ Age _____

Address _____

City _____ State _____ ZIP _____

Check here if interested only in classroom training at Los Angeles.

NATIONAL TECHNICAL SCHOOLS

WORLD-WIDE TRAINING SINCE 1905

4000 S. Figueroa St., Los Angeles, Calif. 90037

YOU ENROLL BY MAIL. NO SALESMAN WILL CALL.



LEARN TO EARN!

NO CORRESPONDENCE • NO HOME STUDY • CONTRACTOR OWNED • VA APPROVED



- Students train on the machines they will operate
- All training by fully qualified instructors
- Students live at the school
- Western's graduate students are readily accepted for employment
- Many courses of study are offered

WRITE TODAY FOR FREE SCHOOL CATALOG

WESTERN SCHOOL

OF HEAVY EQUIPMENT OPERATION

Associate member of Associated General Contractors and A.R.B.A.

BOX 510 • WEISER, IDAHO

Dept. M-21

NAME _____

ADDRESS _____

CITY _____ STATE _____

WORLD'S FINEST CORED SOLDER

ERSIN MULTICORE 5-CORE SOLDER

BUY IT AT RADIO-TV PARTS STORES

EASY DISPENSER ONLY 69¢

SAVE UP TO 85%

GOV'T SURPLUS and NEW EQUIP'T

Send 25¢ For 3 Big Catalogs

PUMPS	ELECTRONIC
WELDERS	BINOCULARS
WINCHES	GEAR MOTORS
SURVEYING	COMPRESSORS
TELEPHONES	SPEED REDUCERS
HYDRAULICS	WEED SPRAYING
GENERATORS	MANY OTHERS

SURPLUS CENTER Dept. PM-066 Lincoln, Nebraska

New Way to Big Pay!

LEARN AIR CONDITIONING, REFRIGERATION & HEATING

Want big money? A better job or a business of your own? Learn Air Conditioning, Refrigeration & Heating. Over 20,000 new mechanics needed yearly. CTI sends 25 kits. You build a refrigeration system (see picture at right). Many students earn as they learn. Mail coupon now for valuable FREE booklet.



COMMERCIAL TRADES INSTITUTE Dept. PM-666
1400 Greenleaf Avenue - Chicago, Illinois 60626

NAME _____ AGE _____
ADDRESS _____
CITY _____ STATE _____ ZIP _____

Accredited Member National Home Study Council

FREE!

Learn how you can buy used engines \$15 up, new engines \$30 with FREE confidential list and coupons when you order your plans

BUILD THIS MINI-BIKE!

Plans reveal step by step details!

BUILD A RACING KART!

Complete frame for less than \$10!



RUSH \$2 for plans (indicate type) or send 25¢ for brochure describing plans: PLANS, Box 478, Dept. PM8, Denver, Colo.



LEARN MEAT CUTTING

Train quickly in 8 short weeks at Toledo for a bright future with security in the vital meat business. Big pay, full-time jobs — HAVE A PROFITABLE MARKET OF YOUR OWN! Pay after graduation. Diploma given. Job help. Thousands of successful graduates. Our 43rd year! Send NOW for FREE catalog. No obligation. GI approved. NATIONAL SCHOOL OF MEAT CUTTING, INC., 50-H, Toledo, Ohio 43604

Build Your Own Business While Still Employed

Without quitting your job or losing one pay check, you can enjoy growing profits from your OWN nationally advertised business. Free 24 page book tells how men do it... how they grow to a full time, high profit business... how we guide men to success.

Hourly gross profit is \$9 plus \$6 on each serviceman.

Exclusive absorption process cleans and revives upholstery, rugs, carpets. Also 5 other on-location services. Your world-wide service is endorsed by McCall's, Parents' Magazine, carpet mills and furniture manufacturers.

You need no experience. We show you how. We finance you for all but a few hundred dollars. Easy to learn... easy to do... easy to build a steady income. We show you 15 tested ways to get customers.

L. Babbit writes, "I average \$2,600 monthly, part time." W. C. Smith earned \$650 in one week. Ed Kramsky said, "in two years I have two assistants, a home and security." G. F. Monroe, after 12 months, sold his business for 10 times his cost. Leo Lubel sold his for \$7,116 more than he paid.

This may be the opportunity of your life. Find out today before some one else gets your location. Mail coupon now for details and 24-page illustrated free book. No obligation. No salesman will call. Mail coupon now while territories are open.

DURACLEAN COMPANY

6-166 Duraclean Building, Deerfield, Illinois 60015

Send 24-page booklet telling how I can quickly enlarge my income in spare time while I build my own full time prosperous business. No obligation.

NAME _____
ADDRESS _____
CITY _____ STATE _____ ZIP CODE _____

A BUSINESS OF YOUR OWN

REPAIR HYDRAULIC JACKS



Earn while you learn at home. Trained and qualified mechanics needed NOW to service inoperative hydraulic jacks. BIG opportunity for ambitious men. We show you HOW — in your basement or garage, spare time cash income in an expanding industry. Don't wait, ACT NOW! Get the facts.

Write for folder PM6 and free bonus offer

HYDRAULIC JACK REPAIR MANUAL CO.
P. O. BOX 50 • BLOOMFIELD, N. J.

LAW FREE BOOK

THE LAW TRAINED MAN

Write today for a FREE copy of illustrated law book, "THE LAW TRAINED MAN," which shows how to earn the professional Bachelor of Laws (LL.B.) degree through home study of the famous Blackstone Law Course. All necessary books and lessons provided. Moderate cost; convenient monthly terms. Write for FREE law training book today.

Blackstone School of Law, 307 N. Michigan Ave.
Founded 1890 Dept. 50-A, Chicago 51, Illinois

GET INTO ELECTRONICS

V.T.I. training leads to success as technicians, field engineers, specialists in communications, guided missiles, computers, radar, automation. Basic & advanced courses. Electronic Engineering Technology and Electronic Technology curricula both available. Assoc. degree in 2 1/2 mos. B.S. obtainable. G.I. approved. Start Sept., Feb. Dorms. campus. High School Graduate or equivalent. Catalog.

VALPARAISO TECHNICAL INSTITUTE

DEPARTMENT D. VALPARAISO, INDIANA



PROFIT IN YOUR SPARE TIME



SMALL ENGINE REPAIR PAYS BIG!

Outboard • Powermower • Chain Saw • Tractor
MAKE EXTRA MONEY — or fix your own engines and SAVE! Illustrated, easy-to-learn Home Study Course qualifies you as expert. Free information. Write today!

LINCOLN TECHNICAL INSTITUTE
SUITE 6E, 427 MARKET STREET, NEWARK 5, N.J.

DRAFTING PAYS BIG MONEY



The need for skilled draftsmen is tremendous. Learn at home in your spare time. You can receive Christy's professional drafting training, portable drafting table, professional drafting instruments and equipment on PAY-LATER plan. FREE BOOK.

CHRISTY TRADES SCHOOL INC., Dept. D-8303
3214 West Lawrence, Chicago, Illinois 60625

ACCORDIONS • Big Discounts

Buy Direct

Importer-to-You

5-DAY HOME TRIAL

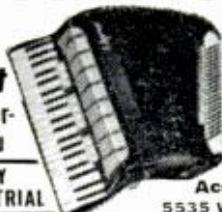

NEW ELECTRONIC MODELS

SAVE 1/2 42 "New Sound" Electronic and Standard models. Amplifiers too! All Famous Makes. Try before you buy—5-Day Trial. Easy Terms, Trade-Ins. Free Accessories. Money Back Guarantee. Free Color Catalogs, Handy Selection Guide, Discount Prices. Write

Accordion Corporation of America
5535 W. Belmont, Dept. R-66, Chicago 41, Ill.

New Portable LIGHT PLANTS

110-120 V. A. C. 1500 watts, 60 cycles. Weight 24 lbs. Size 10" x 5". Fanbelt driven from car, pickup or gas engine of 2 1/2 or 3 h.p. Operates 1/2" Drills, Saws, T.V. Brand new. Money back guarantee. Regular \$89.50 now \$49.50. With switch, pulley and voltmeter. Send check or money order.

VIRDEN PERMABILT CO.

Box 7066

Amarillo, Texas 79109

Tape this ad to the back of your TV or Radio Set

ALL TV-RADIO RECEIVING TUBES \$1 ea

● ALL BRAND-NEW, First Quality. All Types Available. ● Orders Shipped First Class Same Day Rec'd. ● Unconditionally Guaranteed. ● 24 Month Warranty.

Send \$1 for ea. tube + 50c. postage & handling of entire order. **FREE:** Write for TV Test Chart and Tube List to Dep't. PM-66

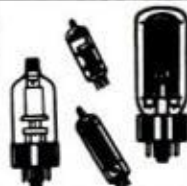

UNIVERSAL TUBE CO. Ozone Park, N. Y. 11417

130,000 CANDLE POWER FLAME THROWERS



WARREN AUTOMOTIVE

Fits all 4 light systems—bright sockets. American made for American cars. 65,000 candle power in each sealed beam unit. Over 2½ times as bright as the factory stock brights. Lets you really see where you are going.

\$995 pair

Prepaid U.S.A. No C.O.D. please
Box 563 Skokie, Illinois 60076

EARN \$600 PER MONTH HOTTEST FRANCHISE IN YEARS

Any Car WAXED & POLISHED with Famous

SIMONIZ PASTE WAX \$5.95

FASTEST CAR WAX WHILE YOU WAIT.

Complete job in less than 15 minutes for only \$5.95.

Revolutionary New Space-Age Miracle.



Exclusive new PATENTED "HAND MOTION POLISHING MACHINE" brings a completely new concept in car waxing! Unique machine enables anyone to deep-wax the entire surface of any car in 15 minutes—and turn out a perfect job every time! No streaks, swirls or burns as caused by buffing wheels. No training or experience necessary! Small investment. Terrific extra-income service and business builder for car washes, service stations, garages, parking lots, anybody already in the car service business. Tremendous business-of-your-own idea for independent concessionaires and route operators!

CYCLO-SHINE (201-763-3969)
BOX 273, MAPLEWOOD, N.J. 07040

Please rush details on dealership.

Name.....

Address.....

City..... State.....

My Phone No.....

EXCITING NEW WAY TO EARN UP TO \$15 AN HOUR INVESTIGATE ACCIDENTS



440,000 AUTO COLLISIONS, FIRES, STORMS EACH DAY CREATE A GREAT OPPORTUNITY FOR MEN 18 TO 60

CAR FURNISHED EXPENSES PAID

Needed Everywhere — City, Town and Farm

We CAN and WILL show you how to start your own profitable business. Begin part time — with your home as headquarters. Later expand to full time. Or if you prefer to be a Company Investigator — our Placement Bureau will give you REAL assistance. Over 500 leading firms — using tens of thousands of Accident Investigators and Claim Adjusters — have asked for Universal's monthly lists of recommended graduates. We train and place far more men in this booming Accident Investigation field than any other individual, company or school. Enjoy big pay, your own secretary, a car for personal use, and all business expenses paid.

— NOW! FREE BOOK GIVES YOU ALL THE FACTS —

UNIVERSAL SCHOOLS Dept. PM-6
6801 Hillcrest, Dallas 5, Texas
Rush me FREE Book on Amazing Opportunities In The Fast-Growing Accident Investigation Field. No obligation. No salesman will call.

Name.....

Address.....

City..... Zone..... State.....

Israel occupies an area smaller than Vermont, and is only 6½ miles wide at its narrowest point.

PLANER • MOLDER • SAW!



Now you can use this ONE power-feed shop to turn rough lumber into moldings, trim, flooring, furniture... ALL popular patterns. RIP... PLANE... MOLD... separately or all at once with a one HP motor. Use 3 to 5 HP for high speed output. Low Cost... You can own this power tool for only \$30.00 down payment.

Send postcard today for complete facts.

BELSAW POWER TOOLS, 906 Field Bldg., Kansas City 11, Missouri

DIESEL & AUTO MECHANICS NEEDED IN INDUSTRY & ARMED FORCES

96.4% of graduates placed!

Starting at approximately \$5,000 a year, you can rapidly advance to around \$10,000 a year.

Whether you plan to enter industry or the Armed Forces, it will pay you to investigate the tremendous opportunities in the Diesel Auto field!

Write for free catalog showing the best equipped, most beautiful school in the country. Veteran Approved.

HOUSING & PART TIME JOBS PROVIDED

FREE BOOKLET →

**BAILEY
TECHNICAL SCHOOLS**

1645 S. GRAND DEPT PM ST. LOUIS 4, MO.

Name _____ Age _____
Street _____
Town _____ Zone _____ State _____
Telephone _____



Big Profits in UPHOLSTERY Get Your Share... FAST!

EARN BIG MONEY 3 NEW EASY WAYS

1. Be your own boss, make up to 85% profit.
2. Start earning right away at home in spare-time—keep furniture you make, or sell for hundreds of dollars.
3. Today's home and office upholstery, re-upholstery, slipcover boom make it easy to take your pick of big-pay jobs.

LEARN FAST—EARN FAST

You get expert instructions, plus all tools, new wooden frames, materials, fabrics, business tips, wholesale privileges, decorating magic AT NO EXTRA CHARGE. FREE Book, sample lesson pages show you how—no obligation—no salesman. Write TODAY.

UPHOLSTERY TRADES SCHOOL
(Div. of Tech. Home Study Schools)

Dept. 510-066, Little Falls, New Jersey 07424
(N. J. State Approved. Accredited Member National Home Study Council. Vet Approved.)

MAIL COUPON TODAY

UPHOLSTERY TRADES SCHOOL, Dept. 510-066,
(Division of Technical Home Study Schools)
Little Falls, New Jersey 07424

Please send me FREE book, "Your New Way to a Successful Career," and FREE sample lesson pages. No obligation—no salesman will call.

Name.....

Address.....

City..... State..... Zip.....

FREE
Deluxe Illustrated
Book and Sample
Lesson Pages



Tools, Equip.,
Frames, Mate-
rials, Fabrics.
Supplies yours
with course.

Established
1939

BY KEVIN V. BROWN AVIATION JETSTREAM

Bombs up! The Air Force is testing a system of ejecting bombs upward instead of downward so its low-flying jets can destroy targets without destroying themselves. The jets fly low so they are exposed to enemy ground fire for shorter periods of time.

Preliminary studies show upward ejection increases bombing accuracy and provides more time for the jet to escape the bomb blast. Either conventional or nuclear weapons could be used.

The system is similar to the pilot's ejection seat. The bomb is on a platform connected to two vertical parallel cylinders. Gas generated by propellant cartridges is

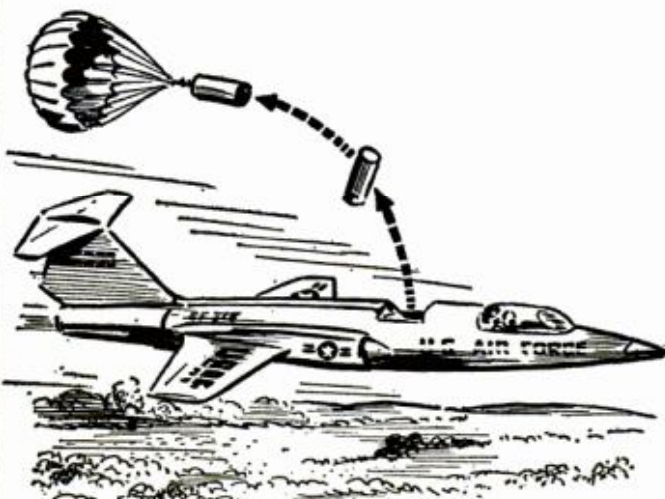

BOMBING UP allows pilot to escape before the blast

transmitted to pistons in the cylinders, accelerating the platform. It's designed to throw a 340-pound mass to a velocity of 100 f.p.s. with an 18-inch stroke.

An experimental model has already undergone static tests successfully, and a series of dynamic tests on a high-speed sled track at Holloman Air Force Base, N.M., this year. The runs will be made at various speeds up to twice the speed of sound. A dummy bomb will be ejected, simulating delivery by an aircraft. It will be set to rise about 150 feet above the sled track while cameras and scientific instruments record its behavior during flight. Flight tests may follow.

Low-level bombing is one of the most hazardous, but most efficient, of combat operations. Selected targets can be hit with pinpoint accuracy, but because of the proximity of enemy ground fire the pilots are placing themselves in the most vulnerable positions. ★ ★ ★

Would you believe there's a convertible rear window that won't discolor, resists scratching? Ford Motor Company has it!



A Ford first—convertible rear windows made of pliant, clear glass!

Take a seat in this '66 Ford-built convertible. Look behind you and you'll see one reason why people have come to expect the new ideas from Ford. The rear window in Fairlane, Comet, Ford, Mercury and Lincoln Continental convertibles is clear glass: a Ford *innovation*. Introduced in 1964, all-glass convertible rear windows won't yellow, wrinkle or rip and resist scratching. What's more, you don't have to unzip them to enjoy top-down travel. Made of special tempered glass, they *bend* as you lower the top. And because they're pliant (actually can take a 45° twist) these windows withstand shock and strain that would crack ordinary glass!

Other bright ideas you'll find in many Ford-built convertibles: top raising and lowering gear of exclusive low-friction design to produce long-lasting smooth operation, put less strain on batteries, save 40% of the effort. Special top-bow clips that prevent unsightly ballooning at turnpike speeds. Super-tough 5-ply top fabrics with heat-sealed seams and soil-resistant vinyl topcoating.

Take a look today at the latest fashions and features in convertibles! You'll find them at your Ford and Lincoln-Mercury dealers.



MUSTANG • BRONCO • FALCON • FAIRLANE • FORD • THUNDERBIRD • COMET • MERCURY • LINCOLN CONTINENTAL

ONLY HORSE WITH Wheel-a-Matic Drive

The all new work-proven Wheel Horse with no-shift automatic drive. Smooth and effortless as driving your car. An infinite selection of speeds! Instant response! Just touch the speed stick for Wheel Horse action. Move forward or back. Stop short or turn short. Wheel Horse handles any demand in stride. Thoroughbred thrift, too. Many great new features! Plus a wealth of bonus equipment for even greater value. Nine models from 6 to 12 hp. Up to 48-inch mowing capacity with rotary mower. Thirty-seven attaching tools make your Horse four-seasons useful. Plows, hauls, tills, removes snow! So easy to maneuver. So comfortable to ride and drive. Automotive-type steering. Wider, Turf-Saver tires. All this, plus the backing of the strong Wheel Horse guarantee.

Pick your favorite Horse from the Wheel Horse stable of Thoroughbreds. Discover how nice it is to have a Horse around the house. See your Wheel Horse dealer now for your exciting test ride. He's listed in the Yellow Pages. Wheel Horse, of course! Out of South Bend. Or write for free, full-color brochure, Wheel Horse Products, Inc., 555 W. Ireland Road, South Bend, Ind.

**Lawn and garden tractor, that is.*

THE MARK OF QUALITY IN LAWN AND GARDEN TRACTORS

Wheel Horse,
of course



WHAT'S NEW **OUTDOORS** BY STUART JAMES

Candle stubs, cardboard and a couple of cans make an efficient one-burner campstove, writes Roger Kimble of Princeton, W.Va. A strip of corrugated cardboard about two feet long and as wide as the depth of a coffee can is coated with the melted wax from the candles. The cardboard is then rolled into a tight coil and fitted into an empty coffee can. Next, you take a No. 10 can and cut out a two-inch square on the side at the open end and a one-inch square in the opposite side at the top. The waxed cardboard is lighted and the No. 10 can is placed over the coffee

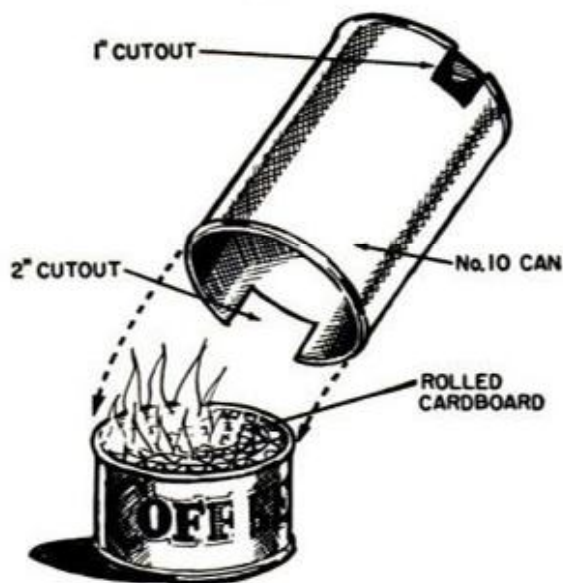

can, the two holes allowing a circulation of air. Cooking utensil is placed on top.

Sport parachuting accidents have been the subject of a lengthy study by the University of Wisconsin, and researchers have learned that one-third of the parachuting fatalities have been caused by drowning. Citing the major cause of death for skydivers, their report reads: "Unexplained are the parachutists who apparently make no effort to pull the ripcord." And you hardly ever get a second chance.

Annual bash for the Explorer's Club in New York featured the food delicacies of various cultures around the world, such mouth-watering delights as lambs' eyes, and unborn chicken removed from the egg five days before hatching, cooked and eaten—feathers and all. "I was stopped by an eskimo dish," one member explained. "It is best described as a sort of bacon rind that has been marinated in castor oil and seasoned with rancid seal blubber."

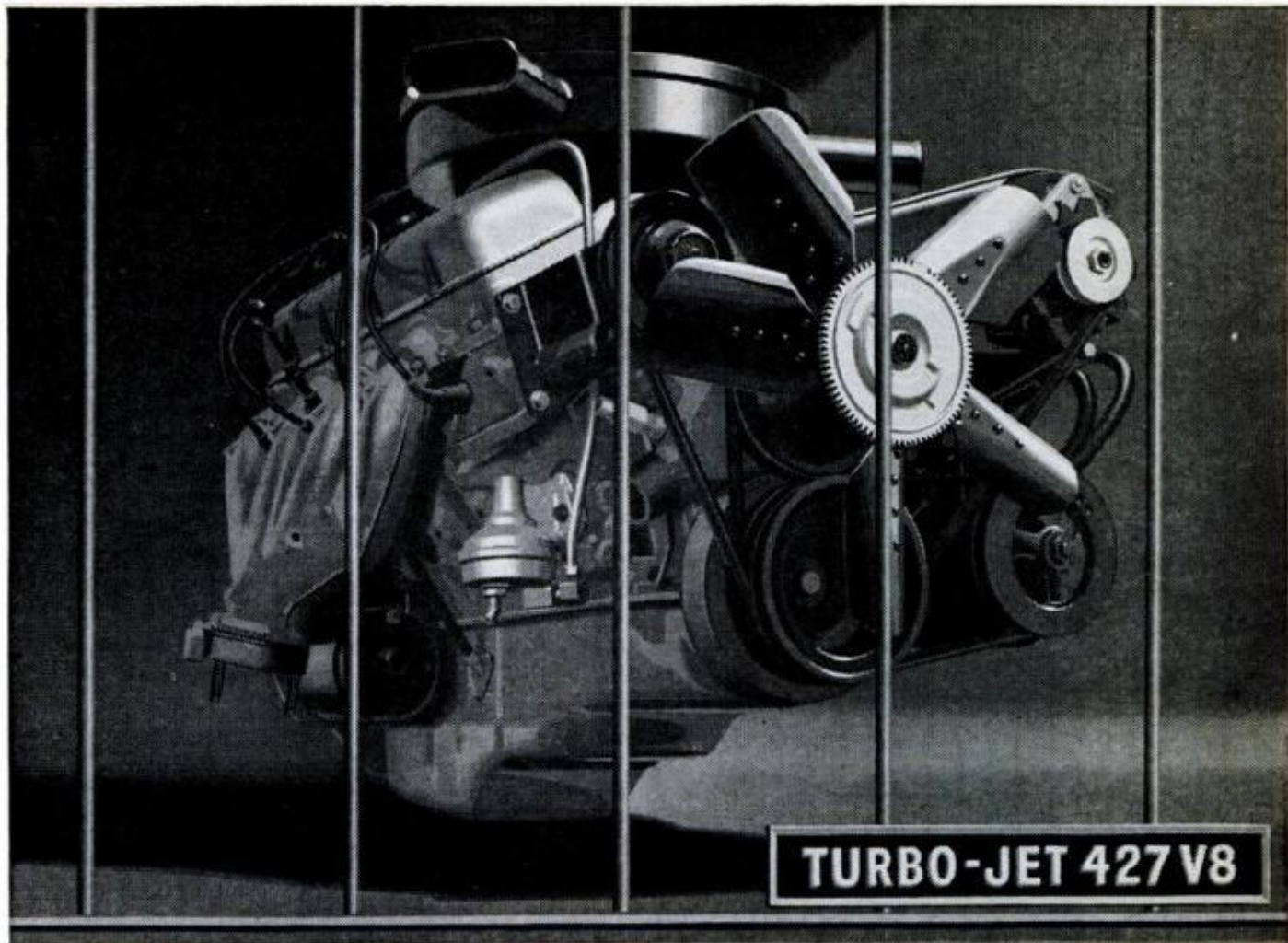

do not tease



'66 Chevrolet Impala SS Coupe—new standard safety package includes outside rearview mirror. Always check it before passing.

Poke the gas pedal of this new Chevrolet Turbo-Jet V8 and you get action. A full 427 cubic inches of it.

Its advanced design, with tilted valves and deep-breathing ports, sees to that.

Say you choose to cage it in that bucket-seated Impala SS above (it's available in 18 other Chevrolets, too). You can order it with hydraulic lifters and an output of 390 hp. Or you can order a version with

special-performance camshaft, solid lifters—and 425 hp. Either way, you get higher rate front and rear springs, heavy-duty shocks all around and 8.25 x 14 tires as part of the Turbo-Jet 427 package.

Sound like a lot of machine to you? As any road will show you, it's the most.



CAREER BAROMETER

BY CREIGHTON PEET

MAYBE THE THOUGHT of sitting at a desk and shuffling papers all day leaves you cold? Perhaps big-city smog and tensed-up decision-making are not for you? Well then, how about forestry—if you like fresh air and a rugged outdoor life and appreciate growing things? Forestry is a responsible job in which you are on your own much of the time and it has a special status. In your area you're an authority; people look up to you.

Forestry isn't a big-money career. You start around \$5,000 and can move up to \$13,000 or more. You need a college degree—an ordinary B.S. will do, but even though there are 25 accredited colleges of forestry in the United States graduating some 1500 men a year, there are still more jobs available than men to fill them. Of the nation's 17,000 professional foresters, 5000 are in the U.S. Forest Service, many are in other Federal jobs and the remainder work for state forestry departments or private forest industries.

Some best paying forestry jobs are with paper manufacturers, many of whom own immense tracts on which they harvest trees selectively, as a crop destined for their mills. They rely on foresters to keep their forests in shape, but most of their jobs require advanced technical degrees.

To start a forestry career, experts suggest you spend one or more summers with some forestry organization—Federal or industrial—during your college term. This will help you decide whether this is the life for you. Don't get the idea that a forester spends his time hunting, fishing and camping—for fun. He may spend days and weeks on the trail—on horseback, snowshoes or just walking—and some tours of duty are rugged, lonely and dangerous. An important duty is to watch for and supervise the fighting of forest fires—there's a story in the service of the forest ranger who, finding himself trapped by converging fires, quickly dug a hole and buried

(Please turn to page 34)

JOB TITLE	CURRENT NATIONAL		STATES WITH HIGHEST DEMAND				
	DEMAND	3-MONTH TREND					
Chemists, Biological	19	Demand steady	N.J. 3	Pa. 1	Ohio 3	Wis. 3	Calif. 2
Chemists, Organic	61	Very good increase	R.I. 4	N.J. 11	Pa. 7	Ala. 11	Ohio 7
Chemists, Inorganic	10	Some decline	Conn. 1	Md. 1	Pa. 3	Mo. 1	Tex. 1
Engineers, Metall.	72	Some increase	N.J. 16	D.C. 8	Pa. 7	Ga. 6	Wis. 5
Engineers, Civil	564	Very good increase	D.C. 67	N.C. 28	Fla. 27	Ohio 93	Calif. 80
Engrs. Elect. & Electron.	1037	Some increase	N.Y. 101	D.C. 52	Fla. 126	Ohio 38	Calif. 218
Engineers, Industrial	564	Very good increase	N.Y. 40	Pa. 42	Fla. 44	Ohio 66	Calif. 81
Engineers, Mechanical	1534	Tremendous increase	N.J. 83	Fla. 116	Ohio 153	Calif. 300	Wash. 86
Engineers, Aero.	572	Substantial increase	Pa. 71	Ohio 45	Mo. 60	Calif. 244	Wash. 120
Engineers, Mining	15	Some increase	D.C. 4	Kan. 1	N.M. 2	Ariz. 3	Calif. 2
Natural Scientists	162	Good increase	N.J. 20	D.C. 31	Pa. 11	Tex. 9	Wash. 53
Draftsmen, Architectural	90	Some decline	N.Y. 9	Fla. 8	Mich. 6	Calif. 16	Wash. 11
Draftsmen, Electrical	276	Demand doubled	N.J. 28	N.C. 20	Pa. 28	Mo. 20	Calif. 132
Draftsmen, Mechanical	475	Very good increase	Pa. 63	Ohio 49	Wis. 62	Calif. 44	Wash. 61
Draftsmen, all other	413	Very good increase	Conn. 26	Pa. 39	Mo. 53	Calif. 103	Wash. 38
Tool Designers	245	Very big increase	Ga. 50	Ill. 17	Kan. 50	Calif. 52	Wash. 30
Lab. Tech. & Assistants	122	Some increase	N.Y. 21	Ga. 11	Ind. 9	Tex. 9	Wash. 8
Sports Instr. & Officials	46	Big drop	Conn. 2	N.Y. 7	Md. 3	Iowa 2	Calif. 12
Surveyors	14	Some decline	N.C. 2	Ala. 1	Ill. 3	Ark. 1	Mont. 1
Techs. Eng'g & Phys. Sci.	726	Very good increase	Ala. 187	Fla. 52	Ohio 68	Calif. 105	Wash. 182
Tool Planners	99	Demand tripled	Ga. 50	Ohio 22	Ind. 7	Kan. 20	
Systems Engineers	41	Demand doubled	N.Y. 4	Pa. 2	Kan. 10	Mo. 21	Neb. 1
Programmers	303	Some decline	D.C. 17	Va. 12	Ohio 25	Calif. 88	Wash. 81
Systems Analysts	54	Some decline	N.Y. 5	D.C. 12	Ohio 4	Calif. 15	Wash. 8
Inspectors Pub. Service	13	Good increase	Wis. 3	Tex. 2	Calif. 1	Nev. 1	Wash. 6

PM's Career Barometer Chart, above, gives the actual number of men currently needed for specific jobs. "Current Demand" figures are true as of our closing date. Check this chart each month and it will tell you where your talents are needed, and how badly. For names of actual employers represented by these listings, contact the state employment agency in the capi-

tal city of the state indicated. Mention that you saw this in **POPULAR MECHANICS**.

Today, with proper schooling, you can qualify for many of the job categories shown. For a list of accredited correspondence and residence schools, write to **POPULAR MECHANICS' Information Bureau, 575 Lexington Ave., N.Y. 10022.**



WORKS WONDERS IN ONE COAT

MoorGard's "Magic Film" gives extra years of protection + Superb fade and chalk resistance + Speedy application with brush or roller; easy cleanup with soapy water + Colors that stay bright and crisp. It all adds up: MoorGard Latex House Paint means more for your money.

Benjamin
Moore 
paints

FREE BOOKLET TELLS HOW TO PROTECT WOOD.

"101 Tips For The Maintenance And Preservation Of Wood" tells how to prolong the life of wood with Woodlife®. Penetrating water-repellent preservative stops swelling, warping, paint peeling. Prevents rot, fungus; keeps out termites. Write Dept. PM 6-66.

U.S. Plywood Corporation
2305 Superior Avenue, Kalamazoo, Michigan.



FACTORY DIRECT!

MINI-BIKE KIT! \$109.95

Build your own mini-bike in about 2 hours! No welding! Speeds to 30 mph. You get:

- 2 1/2 hp 4 cycle engine
- Precision welded frame
- Complete instructions

\$10 Down \$7 Month

Assembled \$119.95

RUSH 25c for brochure to:

BIRD engineering, Box 427, Dept. PM6 Omaha, Nebr. 68101



GUNK GP

CLEANS

POWER MOWERS

GARAGE FLOORS

BRUSH IT ON
HOSE IT OFF

AT HARDWARE, FARM AND AUTO STORES

You'll Like Being a SKILLED LOCKSMITH

... and You'll EARN MORE, LIVE BETTER Than Ever Before in Your Life!



You'll enjoy your work as a Locksmith because it is more fascinating than a hobby—and highly paid besides! You'll go on enjoying the fascinating work, year after year, in good times or bad because you'll be the man in demand in an ever-growing field offering big pay jobs, big profits as your own boss. What more could you ask!

Train at Home—Earn Extra \$\$\$\$ Right Away! All this can be yours FAST regardless of age, education, minor physical handicaps. Job enjoyment and earnings begin AT ONCE as you quickly, easily learn to CASH IN on all kinds of locksmithing jobs. All keys, locks, parts, picks, special tools and equipment come with the course at no extra charge. Licensed experts guide you to success.

Illustrated Book, Sample Lesson Pages FREE Locksmithing Institute graduates now earning, enjoying life more everywhere. You can, too. Coupon brings exciting facts from only school of its kind Lic. by N.J. State Dept. of Education, Accredited Member National Home Study Council, VA Approved.

LOCKSMITHING INSTITUTE
Division of Technical Home Study Schools
Dept. 110-066, Little Falls, N.J. 07424

\$250 EARNED WHILE TRAINING



"While taking the course I was able to earn enough to pay for the course and extra tools, books and key blanks besides for the full time shop I intend to open soon."
Jacob A. King,
Hereford, Texas

306

Pieces of equipment
LOCKS, PICKS
and **TOOLS**
supplied
for use
with course



LOCKSMITHING INSTITUTE, Dept. 110-066 Est. 1948
Little Falls, New Jersey 07424

Please send FREE Illustrated Book—"Your Big Opportunities in Locksmithing," complete Equipment folder and sample lesson pages—FREE of all obligation —(no salesman will call).

Name
(Please Print)

Address

City State Zip

CAREER BAROMETER

(Continued from page 32)

himself until the fire had passed.

The young forester may find his headquarters shifted frequently at first but eventually he is assigned to a small, pleasant town. After earning advancement he will get a more permanent headquarters in a larger city. Permanent forest ranger jobs are under Civil Service.

Because of his specialized knowledge, a forester is often consulted by farmers, cattlemen, lumbermen, lumber mill owners, pulp mill operators and bankers, so that he sometimes acts as a teacher. It is thus essential that he have a good command of English. At times he may be asked to lecture at schools.

After a few years, a forester usually becomes an administrator who plans and supervises forest management, with perhaps a quarter-million acres under his care. His work is quite varied. At one time he may do a winter check of the elk living in a national forest—a job done on snowshoes. In a different season he may cover breeder pine cones with canvas bags to keep the squirrels away.

With a constantly growing population, more campsites are being built in national forests and in many private forests open to the public on a limited basis. The forester supervises the building of shelters, fireplaces, simple chairs and tables; also works with engineers on larger projects. His care of the timber and watershed is essential. Water flowing from his forests feeds streams which feed rivers which quench big city thirsts.

In remote areas the forester is an invaluable contact with the outside world. He brings in word of new methods and equipment, and offers suggestions on how a man can make his land more productive.

When a college graduate starts to work for the U.S. Forest Service, he is assigned to one of several ranger activities: range administration, wildlife management, recreation, timber stand management and watershed protection.

Unquestionably, many most profitable forestry jobs are with pulp and paper firms, and they provoke an argument as to just what forestry is. Some companies say a forester follows a log right through the plant until it's turned into a baseball bat or, maybe, the very page you're reading now. Not much outdoor life involved. But when you get that top job in a paper mill, it may be worth \$20,000.

For information on accredited schools and colleges of forestry, write to American Society of Foresters, 1010 16th St. N.W., Washington, D.C. 20036.

EDITOR'S PAGE

PM's mailbag adds up to about 100,000 letters a year. That's what Sophie Gronowicz (below) tells us, and Sophie should know. She runs our Information Bureau, which opens and responds to them all—with occasional help from an editor. The letters come from you readers, all over the world. What's in them? Recently a reader wanted to find a "new" kind of battery that appeared in our May, 1956 issue (he was steered to the source). King Michael of Roumania wrote in last summer asking for an "arogah horn" he'd seen in an old issue—the kind, he said, on his family's 1924-'28 Lincolns (We found one for him).



And last month, a reader filled in and returned a survey card bound into our May, 1930 issue (he's Henry Morehead of Los Angeles, an engineer, 50 years old, a *PM* reader since 1926, has a home workshop, likes to make replacement parts for old cars.) Obviously, he has a sense of humor. Mostly, this mail storm carries urgent requests for plans we've run; information on items we've carried; help on projects we've sponsored. More than a third of it gets a personal reply from Sophie or her three girls. If you've been among the recipients, thank Sophie. She found your answer.

Craig Breedlove, holder of the world land speed record (600.01 mph) with his famous "Spirit of America" jet car, was in New York for the auto show and some of us had dinner with him. He regaled us with tales of his early troubles—how, penniless, he moved his half-finished monster into his dad's garage, and finally the house (dad and mom moved out to escape the racket, and the machinery moved in); how he made his first bid for sponsorship by marching into the office of Shell's western

manager "in a clean pair of levis and a sport shirt," with the model car under his arm. The man knew another Breedlove, and thought it was *him*. But the five minutes Craig was allowed became an all-day session, and wound up with backing. This is a remarkable young man with a remarkable drive and determination to win. He hums with ideas about automobiles and what he hopes to do about them. You'll read about some of them in a future issue.

Unidentified flying objects have been sighted all over the place lately. Some reports came from Los Angeles in March, where witnesses saw glowing fireballs and objects with colored lights in the night sky. For once, witnesses were right. The "objects" had been launched by a pair of Caltech's practical jokers. They had rigged polyethylene balloons with flares in a hidden steam tunnel, and sent them soaring. Author Joe Bell warned you about those geniuses in our March issue. They're still at it. Incidentally, a reader of that article, Hjalmar Schuetze, called to tell us that in his copy, the last page of the story had been removed. He wanted to know if the missing page was a Caltech trick. Who knows?

Fred Duesenberg, whose dream car reincarnation of his father's famous automobile was featured on *PM's* cover in January, brought his dream to reality. His new Duesenberg now exists. The first produc-



tion prototype (above), was displayed at Indianapolis last March, where its predecessors won the "500" in '24, '25 and '27. Like it? \$19,500.

Spotlight on the

MGB—GT

Sporty 'two-seater' for the man with a small family

By ALEX MARKOVICH

DRIVING A SPORTS CAR used to be like flagpole sitting or marathon jitterbugging. You did it to see how much punishment you could take. Then those new civilized sports cars spoiled all the fun with their draft-free roll-up windows, good heaters and generous luggage space.

Yes, it was bound to happen. They've finally turned the MGB roadster into a family man's car (albeit, a *small* family).

The new MGB-GT is basically the two-seater with a fashionable fastback roof permanently tacked on. British Motor Corp. also added a rear luggage platform, a children's jump seat whose back folds flat and a rear door that hinges upward like a station wagon tailgate.

Climbing into the car is tricky because of the low roofline and narrow-opening doors. But once you get in, you find the accommodations comfortable (at least in the front seats). Headroom is adequate, legroom excellent. Seats offer a wide adjustment range, but the lever is a bit stiff. Rake of the seatbacks can be changed with a wrench.

Seating position is low enough to make a driver of average height feel uncomfortable at first. But visibility is good except for the rear-view mirror that gives a better view of the road surface than of the cars behind.

With headroom and legroom in back minimal, the jump seat accommodates only a couple of 5-year-olds or a single adult, preferably one you don't especially like.

The neat dash houses a prominent tachometer and speedometer as well as gauges for oil pressure, water temperature and fuel level. A warning light monitors amps. The dash has a glare-free black finish, but the chromed ashtray on the floor tunnel and the frame around the shift lever can be annoying.

The steering wheel is farther from the driver than in most British sports cars, but still too close for arms-out driving. Perhaps that's just as well, because the steering, though precise, is fairly heavy, even at speed.

The engine starts willingly, but requires full choke for a couple of miles, even in mild weather. The gearshift lever is well-placed and its travel is crisp. BMC still hasn't synchronized low gear, but the three higher gears are crunchproof



except during really brutal speed-shifting. At 2,030 pounds, the GT is slightly heavier than the roadster, but performance doesn't suffer—probably because of improved aerodynamics. The 110.5-cu.-in., 95-hp Four pushes the car from zero to 60 mph in 11.2 seconds. Passing speeds also are impressive—40-60 takes 5.1 seconds in second and third gears, and 50-70 takes 7.0 seconds in third gear only.

Under steady throttle over fairly level roads, our fuel-flow meter registered an awesome 32.26 mpg at 30 mph. Fuel consumption at 40 mph was 31.07; at 50 mph, 28.66; at 60 mph, 24.20; at 70 mph, 22.61. The speedometer was three mph fast at a true 30 and 40 and four mph fast at 50, 60 and 70.

The brakes (disc in front, drums in back) require more than average pedal pressure, but are fade-resistant.

Ride is firm and well-controlled, with a minimum of pitching. Handling is excellent, even better than in the MGB roadster. This is because an antisway bar, optional in the roadster, is standard in the GT. The only difficulty is rear-axle hop when cornering on a rough road, a characteristic of "live" rear axles.

The most welcome surprise was the quality of workmanship. Body panels fit perfectly, carpeting and upholstery have no rough edges or glue streaks, no rattles were apparent and in a heavy rainstorm not a drop found its way inside.

Interior luxury touches include a locking glovebox, a small storage box on the right kickpanel, and rear side windows that hinge out to extract air.

All in all, the MGB-GT is a bargain at \$3,095 (East Coast port of entry)—especially if you need that extra luggage and passenger space. ★★★

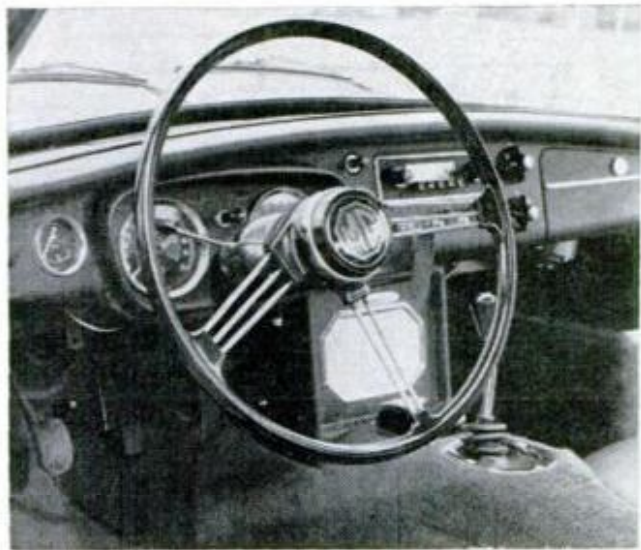

DASH PANEL is neat, functional. Speedometer and tach are situated directly in front of driver. All instruments and controls are easy to see and reach

MY SPARE TIME HOBBY MAKES ME \$5⁰⁰ an hour CASH PROFIT

—Grover Squires



START YOUR OWN SPARE TIME BUSINESS

You can turn your spare time into Big Cash Profits with your own **COMPLETE SHARPENING SHOP** . . . Grind saws, knives, scissors, skates, lawn mower blades . . . all cutting edges. Your Own Cash Business with no inventory . . . right at home . . . no experience needed.

FREE BOOK tells how you can start your own spare time business while you are still working at your regular job. Low Cost — time payments only \$15.00 a month. Send coupon today.



BELSAW SHARP-ALL CO. 716M Field Bldg., Kansas City 11, Mo.
Send Free Book "LIFETIME SECURITY". No obligation.

Name _____

Address _____

City _____ State _____

SPECIAL BARGAIN FOR PIPE SMOKERS!



While they last, a genuine imported briar plus full-size pouch of famous-name tobacco for only \$1⁰⁰

Hurry!

Order while they last.



HURRY—OFFER EXPIRES OCTOBER 30, 1966

GIFT OFFER, P.O. Box 581 New York, N.Y. 10046

Gentlemen: Please rush me a genuine imported briar pipe plus one pouch of (check one) _____ smooth Velvet or _____ slow-burning Granger. Here's my \$1.

Name _____

Address _____

City _____ State _____ Zip _____

Offer good only in U.S.A.—Void where taxed or otherwise restricted by law.

PUBLICATIONS **WORTH WRITING FOR**

BY MARION MOREY

"Europe '66" is a compact guide for travelers with small pockets who want facts instantly. A two-page spread of each country shows a map of major cities, lists a calendar of events for the year, offers tipping tips and a money converter. Copies cost one dollar from Europe '66, 155 E. 40th St., New York, N.Y.

"Cruising the U.S.A." is the title of a free 85-page book dedicated to the proposition that pleasure-boat cruising remains a delightful, private and economical way to travel. From Cape Cod to San Francisco Bay, the country's waterways are reviewed from both a local color and service standpoint. Such developments as new marinas, launching ramps and boat rental facilities are covered. References at the end of each section tell you where to get more info. Books are offered by The Kiekhaefer Corp., Fond du Lac, Wisconsin.

Every sailboat ought to sport a tag that shows this information: channel buoy markings, whistle signals, storm warnings and rules of passing. And the Outboard Boating Club of America has put out such a tag, called "Common Sense Afloat." Write them for a free one: 333 North Michigan Avenue, Chicago, Ill. 60601.

Having gardening problems? A handy garden dial offers 32 shortcuts to better lawn care and gardening. If you need to know—fast—how to keep evergreens green all summer, how to grow grass on steep slopes, how to control mildew or how to speed up the flowering of your plants, simply find your problem on the rim of the disc and dial your answer. Schneider & Sons, Landscape Research Service, 36 Wendover, Buffalo, New York, offers it for \$2.98.

NOW! WARN OVERDRIVE gives 'Jeeps' more Go!



New approved accessory cuts engine RPM 33% at any speed, reduces noise, vibration so you can drive your Jeep 4-w.d. comfortably at freeway speeds. Amazing synchromesh OD lets you shift up or down, on the go, anytime, in any gear, at any speed. Adds six forward speeds, two reverse. At Jeep dealers, or write us.



WARN SALES CO., Inc.
9050-A Empire Way South
Seattle, Washington 98118



REPOWER with a 6 or V-8. H.D. ADAPTORS for using Car, Compact and some Truck engines. Conversion Kits \$45.35 to \$56.90. Want fast action? Give us **FULL INFORMATION**. Send \$15.00 Dep. and we will ship correct kit, bal. COD. Send full amount for prepaid shipment. Wire, phone or write today. Details **FREE**

HOOSIER MACHINE PRODUCTS CO.
312 S. E. 6th St., Phone 276-3442, Pendleton, Oregon

Make Rubber Stamps for BIG PAY



Need more money? Earn \$60-\$75 a week, spare time, at home making rubber stamps for offices, factories, individuals. Hundreds of uses. Hundreds of prospects—everywhere. Right in your own community. Turn out special stamps for names, addresses, notices, prices, etc., in minutes with table-top machine. We furnish everything and help finance you, at less than bank rates. Write for free facts. No salesman will call.

Rubber Stamp Div., 1512 Jarvis, Dept. R-2-FX, Chicago 60626

DEEP FACE Hard Type RUBBER STAMPS

for better

.030
ORD.
TYPE

.050
DEEP
FACE

10 pt. and 12 pt. 20th CENTURY 605D

BUY DIRECT FROM MANUFACTURER **20% OFF** LIMITED TIME

COMPLETE SUPPLIES
STAMP MACHINES • RUBBER BOARD

BARCO TYPE Mfg. 237-A S. EVERGREEN
BENSENVILLE, ILLINOIS 60106

SEND FOR FREE BROCHURE



ONLY \$14.95

Money Back Guarantee **HEAVY DUTY-ARC WELDER** Five Year Guarantee

The New 1966 Model Heavy Duty 110 Volt Arc Welder works on any 110 volt house line. You can not buy a better welder anywhere at this low price. No experience necessary. Now anyone can braze, solder, cut and weld any metal up to 1/4" thick. Generates heat up to 10,000 degrees for cutting through steel plate, etc. **NOTHING ELSE TO BUY.** Comes complete with 12 ft. of heavy duty power cable, 1/16" and 1/8" welding and brazing rods, rod holder, twin carbon torch, helmet, instruction book, etc. **MONEY BACK GUARANTEE.** Try it for 10 days, if you are not completely satisfied we will immediately refund your money without question. —**FULLY GUARANTEED FOR FIVE YEARS.** If inoperative, we will repair or replace it free of charge. **SEND ONLY \$2.00,** and when delivered, pay postman \$12.95 plus COD postage, or send \$14.95 and we will ship postpaid. Over 10,000 National Electric Welders are in use throughout the world. (For an extra large supply of rods, carbons and flux, send an additional \$2.00.)

Order Direct from factory: **NATIONAL ELECTRIC, Dept. PM-6, DELRAY, FLORIDA**

Finest Basic Fishing Guide
Ever Published!

"THE ABC'S of CATCHING FISH"



Now YOURS
for only 25¢ from

SPORTS AFIELD

Wouldn't you like to catch your limit of fish almost every time you try? Then don't miss this chance to get all the know-how you need for success—all the "secrets & savvy" of the old pros—in a great new picture-guidebook from *Sports Afield: THE ABC'S OF CATCHING FISH*.

This is the finest basic fishing guide ever published. You'll see where & how fish live; how to approach without scaring them off; what kind of tackle to use; how to fish different kinds of water; how to select lures. You learn the best times to fish... how to find the fish... what you should do when you don't even get a nibble the first few minutes you're in a spot.

Everything you need to know is here—and when you put it to work, you'll amaze your friends with your new-found success. Get your copy today. Send coupon below with only 25¢.

WIN A VACATION IN CAPE CORAL, FLORIDA

Get some great gift ideas for Father's Day—and a chance to win a **FREE FAMILY VACATION** (up to four people) in **CAPE CORAL, Florida's Waterfront Wonderland!** Get a Free entry blank at any store that is an Official Sports Afield Father's Day Gift Headquarters. There's nothing to buy—and you have a chance to win! (All Official Headquarters are also listed in *THE A-B-C's of CATCHING FISH*.)

MAIL COUPON TODAY!

SPORTS AFIELD, Dept. PM-6
959 Eighth Ave., New York, N. Y. 10019

I want to catch lots of fish. Please rush me your new guide book: "THE A-B-C'S OF CATCHING FISH." I enclose 25¢ for each copy I want.

Print Name.....

Address.....

City.....

State..... Zip Code.....

SHOCK-PROOF MILLERS FALLS

Lifetime Guaranteed Tools
THOUSANDS OF EXCITING
TOOL VALUES



Send 25¢ today for our Big 148-Page Tool Catalog which features Millers Falls Hand and Electric Tools and Hundreds of other Nationally Advertised Brands of Tools too numerous to mention. We ship coast to coast at prices hard to beat
SILVO HARDWARE CO.
Dept. PM19, 107 Walnut St.
Phila., Pa. 19106

Add to your income Much as \$6 AN HOUR SHARPENING

Make money, spare or full time, whether employed or not. Own your own business sharpening knives, scissors, saws, tools.—FOR CASH! TREYCO Sharpeners making money for thousands.



Low factory-to-you prices, no salesman. Write...

FREE BOOK tells you how, Write...
FREE PLAN BOOK

TREYCO PRODUCTS
381 NIAGARA STREET
N. TONAWANDA, N.Y.



Secrets of Teaching Yourself MUSIC

Revealed in Your Home
This Money-Saving Way

YES! Now you can teach yourself to play Piano, Guitar, ANY instrument in your spare time—even if you've never played a note in your life! Famous proven Course makes it simple as A-B-C. Pictured lessons show you how. No teacher. No scales. No boring exercises. Amaze friends by playing favorite music. Write today for FREE 36-page illustrated book. **U.S. SCHOOL OF MUSIC, Studio 306, Port Washington, New York 11050.** (Est. 1898. Licensed N.Y. State Educa. Dept.) Tear out as a reminder.

FREE Electronics Bargain Catalogs for 1 Year!



Exclusive House Brands | Nationally Famous Makes | Closeout Special Buys

Stereo • CB • Parts • Kits.
Testers • Tubes • Tools • Tape.

Read the exciting catalogs of America's biggest nationwide electronics store chain. Get our latest issue today.

RADIO SHACK 2727 West 7th St.
Fort Worth, Texas 76107, Dept. PM

Name.....

Street.....

City.....

State..... Zip.....

Radio Shack Corp. — Division of Tandy Corp.

Fabspray

BY NU-COLOR CORP. OF AMERICA

RESTORES COLOR
TO
FADED FABRICS
AND VINYL



AT THE
TOUCH OF
A FINGER

18 DECORATOR COLORS

For Chairs, Sofas, Drapes,
Auto Interiors, Upholstery, Etc.

ECONOMY SIZE

24 oz. Giant Spray\$4.99

REGULAR SIZE

12 oz. Spray\$2.99

FOR ALL VINYL AND PLASTICS

16 oz. Color Spray\$2.99

SOLD AT LEADING

**MONTGOMERY
WARD**

PAINT DEPTS.

\$10.95 EPOXY COLOR DIAL TELEPHONES

Complete



Factory rebuilt Western Electric in white, beige, ivory, pink, green or blue. If 4 prong plug is required add \$2.00. Fully guaranteed.

Write for free list. All shipments F.O.B.

SURPLUS CENTER

DEPT. PM, WAYMART, PENNA. 18472



FREE GASKET MANUAL

Valuable Facts
for those who value
Top Performance:

- Rear End Gasket Installation Tips
- Correct Way to Install Pump Gaskets
- New Type Gaskets for Valve Covers
- Important Steps in Head Gasketing
- Metal Shim Gaskets
- How to Make Sure Gaskets Fit

32 pages of tips—hints—facts about gaskets and how to improve engine performance

Published as a service to the nation's mechanics, schools and car owners by Fel-Pro, Inc., one of the world's leading gasket manufacturers.

Write:
FEL-PRO, INC.
7452 N. McCormick
Blvd., Skokie, Illinois



Dept. PM-6
Division of Felt Products Mfg. Co.



"Silicone Seal saved me a \$25 repair job..."



"... Over six months ago, I used it to fix a ripped rubber seal in our washing machine. No leaks since. Saved \$25 replacement cost."

H. C. Bellman
San Fernando, Cal.

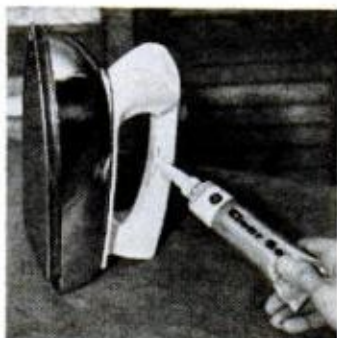

"Repaired a broken iron handle with Clear Silicone Seal. It wears and wears. Also repaired a broken lamp. I wouldn't be without it."

A. Zubuss
Philadelphia, Pa.



"I used Silicone Seal to cushion the noise of sliding closet doors. Placed dabs near top and bottom to stop bumping and rattling."

B. Crompton
North Kingstown, R. I.



"After trying every other caulk without success, and replacing tile over the tub four times, we finally solved our caulking problem with Silicone Bathtub Seal."

G. E. Dawes
Owatonna, Minn.

SUPER GLUE! Silicone Seal bonds to glass, ceramic, wood, metal, fabric, leather and other hard-to-glue materials. **PERMANENT CAULK!** Silicone Seal is permanently waterproof and flexible, won't crack or shrink. Use indoors or out.

"DO-IT-YOURSELF" RUBBER! Silicone Seal makes flexible door bumpers, protective strips, gaskets, noise and vibration dampeners.

FOUR COLORS. Transparent, white, aluminum, black.

Tell us about your unusual use for Silicone Seal. If we use it in ads, we'll pay you \$10. All ideas become our property. Write: Section.. BS-F, Silicone Products Department, General Electric Co., Waterford, N. Y.



3 oz. and 1 oz. tubes.

GENERAL ELECTRIC

SHOPPING FOR TOOLS

BY RICHARD HOWE

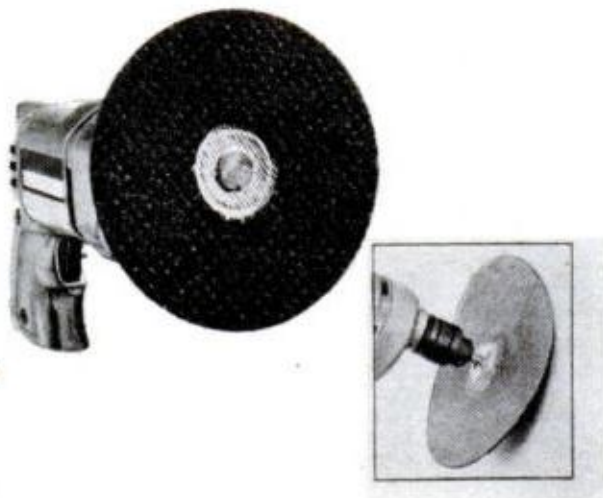

You get 20 times the useful life from the new No. 63A Rex-Cut Redressable Sanding Disc than from ordinary sanding discs. A product of U.C.P. Co., Fall River, Mass., the Rex-Cut is renewed by simply running a dressing stone across its rotating face. Disc removes paint, rust and scale from wood or metal, and sands plastic with minimum clogging. Comes with its own spindle to fit any electric drill. Lists for \$1.20.

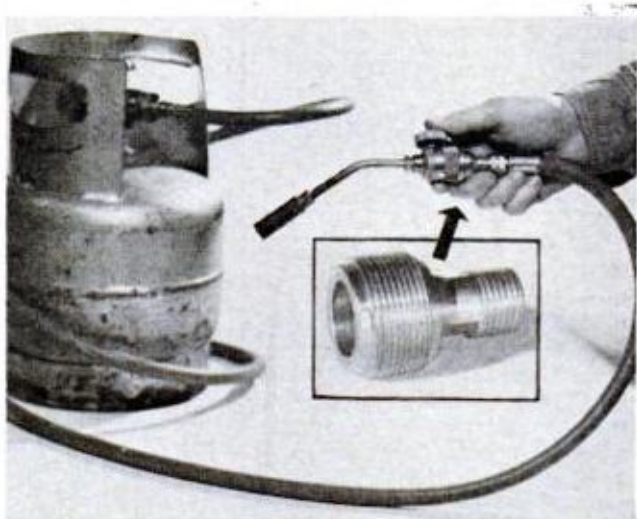

Heavy users of propane—for torches, campstoves or lanterns—will be interested in a special threaded-brass adapter that does away with the necessity of using those expensive, disposable cylinders. This money-saving fitting lets you make a hookup to a standard gas hose attached to a long-lasting, refillable-type tank. These fittings are available from Arnold N. Anderson, 6 Wyoming Dr., Hazlet, N.J., at \$3 each ppd.



Solid funpower! New V-6 in 4-wheel drive 'Jeep' Universal.

Nobody makes 'em like this one. It's solid all the way—solid build, solid looks, solid *fun!* Fly down the highway with the hot new 160 hp. V-6 engine—or choose the world-famous 4-cylinder 'Hurricane.' Head for the beach, the woods—go camping, fishing, skiing—there's hardly any place you can't go! And when the fun's



over, it works as hard as it plays. There's almost no end to its usefulness. Familiar "little guy" or jaunty 'Jeep' Tuxedo Park Mark IV. Options galore: 81" or 101" wheelbases; variety of tops, colors, trim; even bucket seats; plus equipment for pushing, pulling, towing, snow plowing, winching, etc. **KAISER Jeep CORPORATION**
TOLEDO 1, OHIO

You've got to drive it to believe it. See your 'Jeep' dealer. Check the Yellow Pages.

7-Up. the man's mixer



While you total your card, lace into a cool Mule—7-Up and Smirnoff.® A jigger of Smirnoff Vodka over the rocks, juice from $\frac{1}{4}$ lime and 7-Up to the brim. If you had a good round, you deserve it. If you had a bad round, you may need it.

Copyright 1966 by The Seven-Up Company



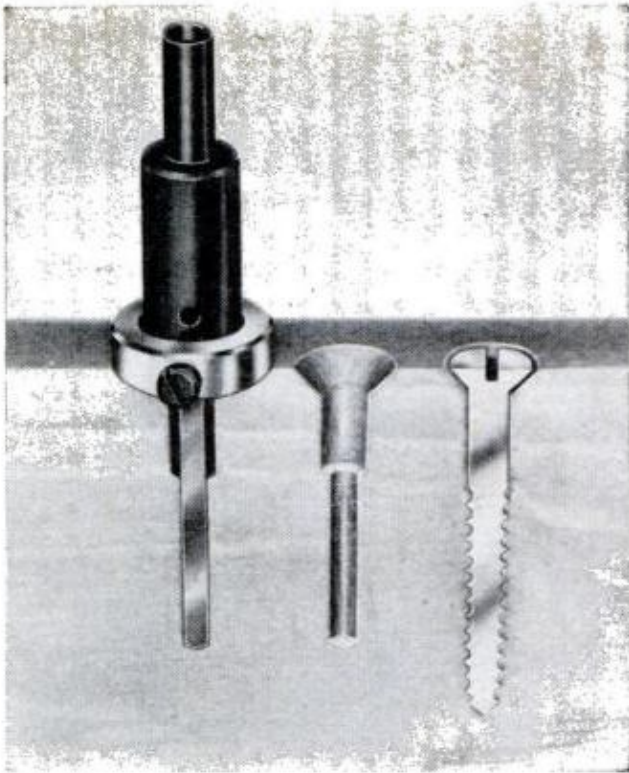

Four adjustable screw guides that pre-drill holes for all sizes and lengths of wood screws are being marketed by P&C Tool Co. of Portland, Ore. A simple adjustment readies these tools for correct hole sizes for screw thread and body, also for counter-sink and counterbore. Guides stay locked in position until setscrew is removed. All fit any 1/4-in. drill. Guides for Nos. 6, 8 and 10 screws: \$2.19 ea.; for No. 12s: \$2.35 ea.

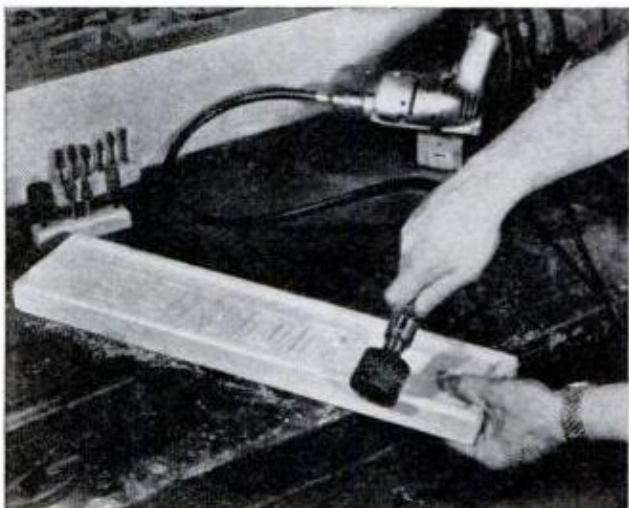

To "snake" a power head into an inaccessible area, you can't do better than use this 40-in. flexible shaft that fits any 1/4-in. drill. It comes with Jacobs chuck, chuck key, chuck-key holder and complete operating instructions. Excellent for driving 1/4-in. shank drills, grinding wheels, wire wheels and polishing heads. Made by Coastal Abrasive and Tool Co., Long Island City, N.Y., its retail price is \$12.

With these you can
do almost anything

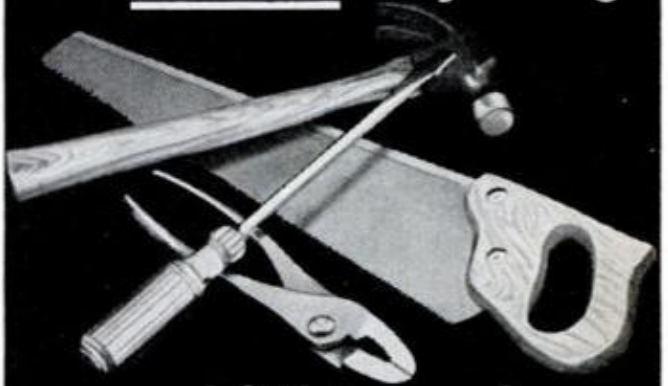

add this and
do everything



Remove paint . . . Lay floor tiles . . . Soften putty . . . Bend glass tubing . . . Hard or soft-solder metals . . . Sweat pipes . . . Start charcoal fires . . . Perform hundreds of household, hobby, and laboratory jobs.

The new Ronson Varafame Torch adjusts from pinpoint to blowtorch flame. Easy to handle. Comes with Multi-Fill® Butane Gas Injector (available everywhere), and big instruction/idea booklet.

\$4.95*
RONSON
Varafame
Torch Ronson Corp.
Woodbridge,
New Jersey

* Suggested Retail Price.
Available in Canada.

CLASSIFIED ADVERTISEMENTS

Rate: \$1.40 per word payable in advance each insertion. Minimum insertion ten words. To be inserted under the proper classification, copy must be in our office by the 15th of the second month preceding date of issue. The next available issue to place an advertisement in America's No. 1 Classified Section is August. The closing date is June 15. Send remittance and order to C. A. Martin, Popular Mechanics, 575 Lexington Avenue, New York, New York 10022.

POPULAR MECHANICS

AUTOMOBILES, MIDGET CARS

AUTOMOBILE Literature, antique, classic, rare reprints. Non-profit hobby club. Free information. Enthusiasts, Box 451B, Mt. Clemens, Mich. 48043.

YOUR Ad in this space will be read by more than 1,400,000 active mail order buyers. Join the march to greater profits, place your products and services in front of them today with a small low cost classified ad. For further details, write: C. A. Martin, Dept. 15N, Popular Mechanics, 575 Lexington Avenue, New York, New York 10022.

AUTO SUPPLIES AND EQUIPMENT

NEW And used parts savings. Complete guaranteed service all model cars and trucks. Largest in west. Jeep and Army parts specialists. Shifting hubs for all front-end drive vehicles. \$27.50 up. Foreign parts. Fast service. Pioneer, 734 W. 13th Avenue, Denver, Colorado 80217.

JEOP Owners—V8 conversions. Read Jeep Owners ad, page 38.

JEOP Parts catalog: Military and Civilian. For owners, dealers, garages, service stations. Save \$\$\$! Surplus and replacements. American Auto Parts Co., 1830 Locust, Kansas City, Missouri

FREE!! 1966 Automobile accessories catalog. Gray's, Box 875, Athens, Ala. 35611.

AUTO Welding repair training in world's largest non-profit welding school. Low tuition. Free booklet Hobart Welding School, Box M-66, Troy, Ohio.

SAVE \$150! Ring-Valve job while driving. \$6.00 postpaid. Safe! Guaranteed! 15th successful year! Motaloy, Grantham, Penna. 17027.

FOREIGN Car parts. Discounts. Catalog. Box 7, Elmont, N.Y.

HYDRAULIC Jack repair kits and supplies. Catalog 35¢ (in coin). Hydraulic Jack Packing & Tool Co., P.O. Box 50, Bloomfield, N.J.

BLINKING Light dashboard accessory is conversation piece and useful ignition spark analyzer. Simple installation. Chrome construction, \$2.98. Guaranteed. Lawson Electronics, Box 3132, San Antonio, Texas 78211.

AUTOMATIC Transmission band adjustment, loose leaf text, covers all popular models. (no special tools needed) \$1. Kruger & Swartz Company, Box 667, Long Beach, California 90801.

LIFETIME Accuracy tire gauge. Write: Larsons, 1717 Darlington, Tampa, Florida 33619.

WHITEWALL Tire cleaner—one quart super concentrate makes 10 pints \$2.95—free spray bottle. R&R Sales, 1811 Fairhaven, Indianapolis, Indiana.

STOP Thefts car etc. easily installed electronic system plans, \$1.00. Lusker, 1451 Nisson Rd., Tustin, Calif.

ANTIQUE Car pistons, gaskets, gears, valves, etc. Catalogue \$1.00. Antique Auto Parts, Milwaukee, Wisconsin 53204.

AUTOMATIC Transmission mechanics prepared this easy to understand literature, so you know how to prevent costly transmission repair bills. Send \$2 (check, money order, cash) J. D. W. Associates, Box 721, Ravenna, Ohio.

BUILD Or buy the complete famous, original Sydmar "CD" ignition system, subject of feature articles in Popular Mechanics, March '66, Popular Electronics June, October '65, August '65, Experimenters Handbook Spring '66. Write for Free literature & parts list. Sydmar Electronic Specialties, P.O. Box 25PM Midwood Station, Brooklyn, New York 11230.

CROSLLEY. New, used, parts. Discounts. Catalog. Box 7, Elmont, N.Y.

AUTO TRAILERS

PRE-Cut pickup camper kits. Ready to assemble. Literature, 15¢. Snowy Mountain Campers, Lewistown, Montana.

CAMPING Trailer kits. Sleep 6, basic kit, \$140.00 pickup camper kits. Circular, 10¢. Stratford Trailers, Seymour St., Stratford, Conn.

"CAMPER UNIT—Compact buses, vans—Build inexpensively—Plans, Photos, Instructions. Set PM2 for Volkswagens, PM-4 for Econoliner, Dodges. \$2.00 set. Dot Campers, Box 67, Saugus, California.

WILD Life decals, full color, large. Free folder. Washington Poster Co., 16824-PMC Pacific Highway So., Seattle, Wash. 98188.

PICKUP Camper, trailer or pickup-cover—build yourself, save! Complete plans \$3.95 each. Econoline Camper, foldout trailer, bus conversion drawings, \$2.95 each. Satisfaction guaranteed. Equipment Catalog \$1.00 (refundable on first order). Details 10¢ Viking Camper Supply, 94-F Glenwood, Minneapolis, Minn. 55403.

BUILD Your pickup camper. Precut kits. Blueprints. Supplies. Literature, 10¢. Comstock Trailers, Dept. 664, Parsons, Kansas 67357.

PICKUP Tent travel trailer. Blueprints. Illustrated circular, 25¢. Kamcraft, Box 1153, Milwaukee 1, Wis.

BUILD Aluminum pickup camper over-cab, hi-boy, lo-boy, blueprints, material, list, 3 models included, \$3.00. Bennett Custom Camper, 1500 S. Dallas, Auburn, Indiana 46706.

MOTORCYCLES, BICYCLES, MOTORSCOOTERS AND SUPPLIES

CUSHMAN Scooter \$15, Kart \$20, Mini-bike \$25, less engines. Engines \$4 up. Whizzer \$3. Moped \$25. (Mailorder Only). Send 25¢. (35¢ for first class mailing) for directory-catalogue number 128, listing the above and hundreds of similar bargains, parts, plans etc. Midget Motors Directory, Athens, Ohio.

BUILD Motorbike from Bicycle! Plans, \$1.00: Go-Byk Industries, Rothsay, Minnesota 56579.

HARLEY-Davidsons — Used bargains. New, used parts, accessories, all models. Bulletin 35¢. Knuth's (Factory Dealer), 1753 Muskego, Milwaukee, Wis.

YOUR Ad in this space will be read by more than 1,400,000 active mail order buyers. Join the march to greater profits, place your products and services in front of them today with a small low cost classified ad. For further details, write: C. A. Martin, Dept. 15N, Popular Mechanics, 575 Lexington Avenue, New York, New York 10022.



AVIATION

HOMEBUILT. Real enclosed helicopter, 24 pages ideas, information, \$2.00. Build "executive" helicopter, drawings, specifications, \$1.50. Helicopter Development, Box PM147, Washington, New Jersey.

HOT Air balloon kits, \$1.00 up, hang glider kits, plans, etc., send for free brochure. U.S. Sportcraft, Box 847, Woodland Hills, Calif.

PROPELLERS. Plans, kits, supplies for airboats, snowplanes. Gauges, spark plugs, gas-oil hose, oil coolers, primers, wrenches, switches, propeller hubs, engine mounts. Corvair-Volkswagon conversion parts. 125-150 Lycoming engines, manuals, gaskets, parts. Catalog, \$1.00. Banks-Maxwell, Box 3301E, Ft. Worth, Texas 76105.

BE A Government licensed aviation mechanic. Practical training. Free information. Aero Mechanics School, Municipal Airport, Kansas City 16, Missouri.



BOATS

FIBERGLASS Canoes. Three exciting models. Easily assembled kits. \$34.95 up (factory direct). Free literature. Riverside Canoes, P.O. Box 5595BB, Riverside, Calif.

BOAT Plans, frame kits, full size patterns all prepared specially for amateurs. Send 50¢ for new catalog illustrating 55 proven designs including sail, inboards and outboards from 7' to 28'. Glen Designs, 9152 Rosecrans, Bellflower, Calif.

FULL Size, cut-to-shape boat patterns, blueprints. Send 63¢ for big new illustrated "Build a Boat" catalog includes fishing boats, garvies, cruisers, catamarans, houseboats—outboards, inboards, sailboats—7½ to 38'. "How to Build a Boat," booklet, \$2.50. Cleveland Boat Blueprint Co., Box 18250, Cleveland, Ohio.

FREE Plans catalogue—kayaks, canoes, sailing rigs, accessories. Bruce Clark, PM: 115 McGavock Pike, Nashville, Tenn. 37214.

BUILD Your own boat from our large-scale blueprints. Books of plans give how-to-build help. Hundreds of professional designs—motor, sail or auxiliary—for amateur builders. Free catalog. MoToR Boat-ing, 959 Eighth Ave., Dept. RS, New York 19, N. Y.

VIKING Canoes, factory direct. Four canvas covered kit models, under \$25.00. Uncomplicated assembly. Free information. Sportsraft, Box 8393-P, Columbus, Ohio 43201.

HYDROPLANES, Runabouts, inboards, outboards, Ski and class. Plans, kits or complete. Big catalogue, 25¢. Champion Boats, Dept. 10F, Box 9215, Long Beach, California.

KAYAKS — One-man \$19.50; two-man \$24.50; Sailboat \$42.00. Exciting Sitka Kayak Kits known world wide for speed and safety. Assemble in one afternoon. Free pictorial literature. Box 78-P, Brecksville, Ohio 44141.

PRAM Kits eight foot, \$39.95 sailing rigs available. x 123, Marblehead, Mass. 01946.

BOAT Kits. Factory molded fiberglass or pre-assembled plywood, 50 models, 12' to 40'. Runabouts, Cruisers, Houseboats. Free catalog. Luger, Dept. BC-66, 9200 Bloomington Freeway, Minneapolis, Minnesota 55431.

MARINE EQUIPMENT AND SERVICES

NEW, Used, rebuilt marine motors. Marine conversions, fittings. Free catalog. Stokes Marine Supply, Dept. 24, Coldwater, Michigan.

FIBERGLASS Cloth, matt, polyester and epoxy resins. Lowest prices. Seifert's, Box 1206-M, Green Bay, Wisconsin.

CONVERT Auto engines to marine. Catalog, 50¢. Lehman Manufacturing Company, 800 Elizabeth Avenue, Linden 4, New Jersey.

ATHLETIC AND BODY BUILDING COURSES

"GIANT Arms." Dr. Young's, D.C. revolutionary discovery, \$2. Satisfaction or refund. Gaucho, Box 9309-S7, Chicago 90.

WEIGHT Exercising Equipment, free literature. Jubinville, Box 622, Holyoke, Mass.

LEARN How to defend yourself. New hand-to-hand combat, \$1.98. Satisfaction guaranteed. Lt./Colonel Van Fleet, 3104 Lomita, Springfield, Missouri 65804.

POWERFUL Muscles fast! Free brochure! Universal Bodybuilding, Box 4327-C, Northeastern, Dearborn, Michigan 48126.

BAR - BELL catalogue 10¢. Unusual strength feats 40¢. Good Barbell, B-1495, Hendersonville, N. Car.

SPORTING GOODS AND EQUIPMENT

BIG Money raising crickets and 12 inch African fishworms. Free literature. Carter Ranch, Plains, Georgia.

BASEBALL Batting ranges commercial or backyard. Allstar, 9025 Sepulveda, Sepulveda, Calif.

BOWIE Knife plans, build your own. complete instructions, Tempering, Shaping, etc.. \$1.00. Bowie Knife, Box 599, Levelland, Texas.

SILENCERS: Pistol, rifle details, simpler, cheaper! Plus new design for .22s \$1.00. Twin Enterprises, Box 192-A, Dunellen, New Jersey 08812.

SEND \$2.00 For 300-page shooting supplies catalogue. Quality gunsmithing—Lowest prices. Western Gun & Supply, 3730 N. 56th, Lincoln, Nebraska.

FREE Wingshooter's handbook. New helpful facts on shotgun shooting, shotgun chokes and how to save ammunition. Write to Poly-Choke Co., Dept. 645C, Hartford, Conn. 06101.

BEST Hydrofoils and rooster tail fins for water skis. Free literature. Dallas Research Enterprises, P.O. Box 2164, Dallas, Texas 75221.

JUDO, Karate supplies, accessories, 28 page catalog 25¢. Nozawa Trading, 232 East Second Street, Los Angeles, California 90012.

FISHING, TACKLE, LURES

FREE . . . Wholesale catalog. Beads, Spinners, Lure parts, Sinkers molds, Jigs, Reels, Flinnysports (ME), Toledo, Ohio 43614.

MOLDS For fisherman's sinkers, jigs, molds, casting and spinning lures. Free catalog. Sweet's Molds, Tonawanda 1, New York.

EARTHWORMS, LIVE BAIT

REDWORMS. Bait size, 1000—\$3.50, 5,000—\$15.00, Medium, 2500—\$5.00, 5000—\$8.50, 10,000—\$16.00. Postpaid. Hall's, Hilton, Georgia 31758.

AMAZING profits in worms. Free information. Hillaire Farms, Northville, Mich.

EARN Money raising fishworms for us! Exciting details free! Oakhaven—56, Cedar Hill, Texas.

SUCCESS For you! Raise Carter's Pure-bred hybrid red wiggler fishworms, crickets. "Known All Over the World." Write for free literature and our success story in Life Magazine. Pure-Bred Fishworms—3000—\$5.95, 5000—\$8.95, 10,000—\$16.95. Postpaid with Free Raising Instructions, Carter Redworms, Plains, Georgia.

MEN!—Women! Make money raising Bait for us at home. Wigglers, Warsaw 45, Indiana 46580.

HYBRID Redworms 1000—\$3.00, 3000—\$5.75, 5000—\$8.00, 10,000—\$14.00. Bedruns 20,000—\$19.00. Postpaid with raising instructions. Brazos Worm Farms, Route 9, Waco, Texas.

BIG Money growing fishworms. Free information. Fain's Hatchery-31, Edison, Georgia 31746.

FROGS, FISH, REPTILES

FROG Raising. Young frogs and giant breeders. Stock your lakes, pond. Nu-Tex Frog Farm, Box 4029, Corpus Christi, Texas.

HUNTING, GUNS, DECOYS

50,000,000 GUN Parts for modern, obsolete, foreign, domestic military and sporting arms. Write wants for quote—make, model # & specific part. Seedy reply—Include stamped self addressed envelope. Numrich Arms, 252 Broadway, West Hurley, New York.

SHOTGUN Owners improve your score, bag more game with amazing optical gun-sight. Free details. Nydar, Box 45-266, Glenview, Illinois 60025

YOUR Ad in this space will be read by more than 1,400,000 active mail order buyers. Join the march to greater profits, place your products and services in front of them today with a small low cost classified ad. For further details, write: C. A. Martin, Dept. 15N, Popular Mechanics, 575 Lexington Avenue, New York, New York 10022.



DOGS AND KENNELS

PEDIGREED White German Shepherds, no albinos. Ansonia Kennels, McHenry, N. Dak.

PICTURES, Pedigrees and Breeders Directory. For your copy send \$1.00 to Stud Dog Review, P.O. Box 197, North Hampton, New Hampshire 03862.

YOUR Ad in this space will be read by more than 1,400,000 active mail order buyers. Join the march to greater profits, place your products and services in front of them today with a small low cost classified ad. For further details, write: C. A. Martin, Dept. 15N, Popular Mechanics, 575 Lexington Avenue, New York, New York 10022.



GAME BIRDS

YOUR Ad in this space will be read by more than 1,400,000 active mail order buyers. Join the march to greater profits, place your products and services in front of them today with a small low cost classified ad. For further details, write: C. A. Martin, Dept. 15N, Popular Mechanics, 575 Lexington Avenue, New York, New York 10022.

HORSES & LIVESTOCK

APPALOOSA Horses: Time payments, working man's prices. Ruswin Ranch, Montello, Wisconsin.

RABBITS—FUR BEARING ANIMALS

RAISE Rabbits on \$500 month plan. Free details. White's Rabbitry, Mt. Vernon, Ohio.

MINK Raising information free. Lake Superior Mink Farm, Inc., Superior EE1, Wisconsin.

EARN \$10,000 Yearly raising Angora rabbit wool for us. Particulars 25¢ coin. Angora, Malta 12, Montana.

RAISE Rabbits successfully by knowing facts. 48 page illustrated book describing 25 breeds. Housing, breeding, feeding, markets, marketing etc. 25 cents. American Rabbit Association, 36 Arba Building, Pittsburgh, Penn.

PETS—BIRDS, CATS, HAMSTERS, ETC.

MAKE Money raising chinchillas, mink, rabbits, cavies for us. Free catalog. Keeney Brothers, New Freedom 2, Penna.

HAWKS, Reptiles, raccoons, skunks, squirrels. Catalogue 25¢. Trails End Zoo, St. Stephens, S.C.

FREE Coupons! Monkeys \$10.00! Cash discounts! Pets, gifts, curios! Exotic! Unusual! Save money! Buy direct! Confidential wholesale list, \$1.00. Dale Logston, Box 682 Saint Joseph, Missouri 64502.

SEAHORSES Guaranteed live. Easy to raise in jar or bowl. Mated pair \$1.95, two pairs \$2.95. Free feed & instructions. Seaquaria, Box 302, Shenandoah Sta., Miami, Florida 33145.

CAMPING EQUIPMENT AND TENTS

CAMPING Equipment, tents, sleeping bags, air mattresses, packs, trailer awnings, dining canopies, axes, knives, lanterns, stoves, refrigerators, compact camp furniture, dehydrated food, toilets, nested cook sets, poles, stakes. Every camping accessory imaginable. Free 100 page catalog. Morsan, 810R Route 17, Paramus, New Jersey.

FREE 1966 catalog. Request it from your camping center or trailer dealer, or write Golden Crown, 4515 Marquette St., Jacksonville, Fla. 32210.

JUMBO Catalog—tents, sleeping bags, camping supplies, GI Surplus, outdoor clothing. Free 132 page newest edition now ready. Write I. Goldberg, Dept. PM, 429 Market Street, Philadelphia, Pa. 19106.

BUILD Your own car top sleeper. Plans and photos, \$3.00. Dept. PM, 25 Millford Ave., Ottawa 12, Canada.

ENJOY Backpack Camping. Free booklet tells how. Gerry, Dept. 72, Boulder, Colorado 80302.

EMBLEMS, BRASSARDS, PATCHES

CLUB Emblems embroidered to your order. Ideal for club recognition. Low minimum. Send your design for free price quotation. Write for free catalog. Eastern Emblem Mfg. Corp., Dept. PM, P.O. Box 628, Union City, N.J. 07087.

TRAVEL AND RESORTS

EXCEPTIONAL Camping guide. 15,000 U.S.A. Campgrounds with facilities, \$3.95. Brooks P.O. Box 12382, Phoenix, Arizona 85034.

YOUR Ad in this space will be read by more than 1,400,000 active mail order buyers. Join the march to greater profits, place your products and services in front of them today with a small low cost classified ad. For further details, write: C. A. Martin, Dept. 15N, Popular Mechanics, 575 Lexington Avenue, New York, New York 10022.

ELECTRICAL SUPPLIES

METERS—Surplus, new, used, panel and portable. Send for list. Hanchett, Box 5577, Riverside, Calif.

LAMP Parts. Catalog, prices, wiring instructions. 50¢. Refunded first order. Gyro, 5208P N.W. 35 Ave., Miami 42, Fla.

BATTERIES, GENERATORS

BATTERY Reconditioning kit, includes molds, material, complete instructions. The Battery Shop, P.O. Box 416, Palm Desert, Calif.

AUXILIARY Battery wiring system for boats, auto campers. Details, \$1.00. Seaco, Box 356, Vermilion, Ohio 44089.

COMPLETE Rebuilding Manuals! Batteries \$3.00. Hydraulic jacks \$3.00. C.O.D. accepted. Bayer Publications, 938 Betty Avenue, Neenah, Wisconsin.

ENGINES, MOTORS, DYNAMOS

DIESEL Injector parts and fuel pumps wanted. GM51-53-71-110. Bares, 2093 East 19 Street, Cleveland 15, Ohio.

WINDING Data. 275 motors, single and three phase \$1.10. Data Company, 512 Kensington, Kansas City, Mo. 64124.

MOTOR Rewinding simplified. Details free. Modern, Box 10025, Kansas City, Mo. 64111.

MACHINERY, TOOLS AND SUPPLIES

STANLEY, Millers Falls, Skil, Diaston, Wiss, Plumb, Channellock, Bonney, Herbrand, Ridgid, and hundreds of other nationally advertised brands at prices hard to beat. Send 25¢ for our big tool catalog today! Silvo Hardware, 107PM Walnut, Phila. 6, Penna.

MACHINISTS. Toolmakers Chests. Circular free. Cepuder, 4715 Spencer, Lisle, Ill. 60532.

SPEED Up construction jobs with the new patented lineholder wound with 200' 103- test stretch length nylon twine \$1.50. 2 for \$2.75, blanks 75¢. 2 for \$1.25. Send checks or money orders to: Lineholder, P.O. Box 42086, Portland, Oregon. We ship post paid. No C.O.D.'s.

MAGNETIC Chuck V blocks & parallels, edge finders, center finders, thread measuring wires, sine bars. Hi-precision—first quality—low prices. Factory distributors wanted. Be the dealer in your locality. Buy for yourself and sell to others. Liberal discount, products guaranteed. Est. 1943. Write for brochures. Fisher Machine, 11704-M Inglewood, Hawthorne, Calif. 90250.

WELDING, SOLDERING, PLATING

FREE Catalog. Welders, kits. Build 350-ampere Welder. Plans, 25¢. Le Jay Manufacturing, Belle Plaine, Minnesota 56011.

WELDERS. 150 Amperes. \$49.50. Paul Morris, 1070 Inner, Schenectady, N.Y. 12303.

AIRCRAFT Generator welder instructions, plus surplus catalog with generators, rheostats, helmets, electrode holders. Both for 50¢. Trader, Box 8 PM, Thomasville, Penna.

WELD With car batteries. Plenty Amps. Instructions, \$1.00. Bob Hutson, 4707 Hillcrest Drive, Waco, Texas.

CHROME Plating equipment, supplies. All other finishes. Home workshop and production sizes. Send \$1.00 (refundable) for formulas, operating data, equipment guide and catalog. HBS Equipment Division L50, 3543 East 16th, Los Angeles, Calif. 90023.

YOUR Ad in this space will be read by more than 1,400,000 active mail order buyers. Join the march to greater profits, place your products and services in front of them today with a small low cost classified ad. For further details, write: C. A. Martin, Dept. 15N, Popular Mechanics, 575 Lexington Avenue, New York, New York 10022.

GOVERNMENT SURPLUS

REPAIRABLE Jeeps low as \$50.00. Buy in your area from Gov't. Information and our Giant (order by mail) Surplus Catalog \$1.00. Quality Surplus PM-6, 422 Washington Building, Washington, D.C.

JEEPS From—\$52.50. Typewriters from—\$4.15, cars from—\$31.50, Walkie-Talkies, Guns, Airplanes, Boats, Typical "As Is" Bid Bargains From Uncle Sam. Tremendous variety. Exciting free list. Write: Enterprises, Box 402X11, Jamaica, New York 11430.

GOV'T. Surplus. How and where to buy in your area. Send \$1.00. Surplus Information. Headquarters Building, P.M., Washington 6, D.C.

SURPLUS Directory closeout! Two \$2.00 Directories (\$4.00 Value). Special, Only \$1.00. Box 187M Abbottstown, Penna.

JEEPS Typically from \$53.90 . . . trucks from \$78.40 . . . boats, typewriters, airplanes, sporting equipment, used, 100,000 bargains direct from Government nationwide. Complete sales directory and surplus catalog, \$1.00. Deductible first \$10.00 order. Surplus Service, Box 820-A, Holland, Michigan 49424.

HOBBIES AND COLLECTIONS

50 JUNGLE butterflies \$2.00. Giant nature hobbies catalog 25¢. Collectors Wonderland, Box 1170, New York 8.

MIXED Seashells, \$1.50 per pt. for aquarium shellcraft jewelry. C. Davis, 3381 N.W. 8th Ct., Ft. Lauderdale, Fla. 33311.



STAMP COLLECTING

BREATH TAKING, 50 Mint Monaco pictorials, multicolors. \$1.00. Approvals, Stamp Exchange, Box 103, Fairfield, California.

50 YEARS Old, fifteen different United States, over fifty years old—10¢ with approvals. Jaxon, Box 145-P, Brooklyn, New York 11230.

"INVERTED Error," Dag Hammarskjold 5¢ with Approvals. Belmont Stamps, Washington, D. C. 20015.

RUSSIAN Space set 10¢. Russian approvals. Snedco, Box 68-P, Waldwick, N.J.

50 DIFFERENT Old U.S. Revenue stamps 50¢. Winchester stamps, Box 1592, Mansfield, Ohio 44907.

133 DIFFERENT Colorful stamps 10¢, approvals. Krehl, 1708 Nebraska, Orlando, Florida.

FREE! Congo triangle set! Boy Scout beauty! 25 others, different. Approvals, Cambridge, Box 411, Cambridge, Ohio.

100 OLD United States between 1861 and 1935, \$1.00. Roush Stamps, 51 Chestnut, Mansfield, Ohio.

225 STAMPS For only 10¢! This mammoth value includes airmails, pictorials; stamps from strange countries cataloging up to 25¢ each! Also approvals. Mystic Stamp Company, Camden 80, New York.

SELL Your surplus good grade stamps. Write, describing fully what you have. Vanroy Shirk, Lebanon, Pennsylvania.

500 DIFFERENT Stamps, \$1.00. Smith, 508-A Brooks, College Station, Texas.

PENNY Stamps! 1000 Mounted in book at 1¢ each. Trust Stamp Company, P.O.B. 132-P, Jamaica, N.Y. 11435.

ONE Pound value Geo. VI Bermuda, plus 100 worldwide 10¢, approvals. Stevens, Box 105A, Homecrest Sta., Brooklyn 29, N.Y.

60 DIFFERENT U.S. (30 commemoratives) 25¢. No approvals. Seidenberg, Salem 169, Oregon.

ABSOLUTELY Free 50 worldwide. Request inexpensive approvals. University Stamps, P.O. Box 326, Pompano Beach, Florida 33061.

AMAZING OFFER! 200 United States stamps—including commemoratives, airmails, high denominations to \$1.00. Only 10¢ to approval applicants! Illustrated bargain lists free. Mystic Stamp Co., Dept. 80, Camden, New York.

PENNY! Approvals! Regardless catalogue! Kloster, 4164 52nd St., San Diego 5, Calif.

64 PAGE U.S. and U.N. catalog free. Stone, 260 Washington, Boston 8, Mass.

FREE Sample. Interesting, illustrated, informative National Stamp News, Anderson, South Carolina 29621.

INTRODUCING Our better United States approvals we offer 15 United States stamps including Columbian, Bi-Centennials, famous American, airm, others: only 10¢. Ocean Stamps, Box 64-PM, Brooklyn 29, New York.

10 U.S. over sixty years old, 10¢. Robert Gallup, Albany, New York 12201.

UNITED States commemorative collection containing 33 different—10¢. Approvals, White, 516-A Avenue L, Brooklyn 30, New York

UNITED STATES price list, 132 pages, price 30¢. Mark Hanna, 335 Fifth Ave., Pittsburgh 22, Pa.

121 DIFFERENT Flag stamps free. Approvals, W-B Stamps, Wilkes-Barre, Pa.

U.S. Mint specials! Flag set, complete \$1.00. 1¢, 2¢, 3¢ famous Americans (21 different) \$1.00. Free list, Brooks, 2601 Avenue "U", Brooklyn 29, N.Y.

U.S. Approvals. Low prices. Eagle, 2221 Romine Ave., Pittsburgh 26, Pa.

GERMAN Commemoratives, 10¢ with approvals, Schaefer, Box 1704, Washington 13, D. C.

WOW! 110 All different Germany 10¢ Commemoratives, Airmails, high values, big catalog, bargain lists plus selections of fine stamps from our approval service, returnable without obligation. Jamestown Stamp, Dept. A66PM, Jamestown, N.Y. 14701.

FREE! Big bargain catalog—new edition listing thousands of bargains including U.S. & B.N.A. stamps, packets, albums, accessories and supplies. Plus selections of fine stamps from our approval service, returnable without obligation. Jamestown Stamp, Dept. E66PM, Jamestown, N.Y. 14701.

WOW! 1000 Different worldwide—valued over \$20.00 only \$1.00 with quality approvals. Universal, Box 6, Kenosha 5, Wisconsin 53141.

50 DIFFERENT U.S. Commemoratives 25¢. No approvals. Earl Mills, Box 272-K, Auburn, Mass. 01501.

FREE 1966 U. S. list, mint #704-15 \$4. #740-9 \$2.10. #859-99 \$6. #909-21 \$1. Simmy & Co., 40 Court St., Boston, Mass.

U.S. Bargain, 50 different 10¢. with beautiful worldwide approvals. Stamps, Kennebunk, Maine.

25 Different United States Commemoratives 1893 Up 10¢. Approvals, K. & B. Stamp Company, Box 70, Brooklyn 23, New York.

40,000 DIFFERENT. Amazing new plan builds your collection systematically, country by country. As low as 50¢ weekly. Ware, Monroe 75, Conn.

FIPEX—Tipex-Cipex-Ashville. Four miniature sheets used for \$1.00 if you ask for our bargain priced U.S. approvals. Triboro, 38 Park Row, New York, New York 10038.

FREE Stamp wallet with approvals. Wide selection collections by countries. Clark, Box 28-C, Wilmette, Illinois.

NEED Money fast? Loans made on stamp-coin collections. \$100, \$500, \$1,500 & up. Monthly repayments. Under State Supervision, L. T. Baker & Company, 30 West Washington Street, Dept. PM, Chicago 60602.

"COLORFUL" Set free! Worldwide approvals. Gorliz, Drawer 388PM, Park Ridge, Illinois.

MILLION Foreign stamps! 2¢ each! Send for thrilling, giant approvals! ABC Stamps, Box 6000-MB, San Francisco 1, Calif.

DEFECTIVE Old U.S. 1/5 Scott. Approvals, Swartz Stamps, Malden Bridge, New York.

200 DIFFERENT Worldwide 10¢ with approvals. Bydahl, Box 1293-MC1, Seattle, Washington 98111.

NEW Issues — Free weekly illustrated list. Brooks, 2601 Avenue "U", Brooklyn 29, N.Y.

FREE Surprise collection sent with approvals. Gould, 1784 Union, San Francisco 94123.

POLAND 25 Different large pictorials, 5¢, approvals, Hijop, Box 505, Norristown, Pa.

1500 FOREIGN \$1.00. 5000 \$3.00. 5000 USA-commemoratives, airm, revenues, 19th Century, high values, etc. \$3.00. 50 US Scott-listed revenues \$1.00. 1000 power foreign from 1860 to 1940 \$3.00. 5000 \$12.00. No approvals. Meyers, 5321 Fleming, Richmond, Calif.

SURPRISE Collection! Exotic mint British Colonials, absolutely free with approvals, Viking, Great Neck 8, N.Y.

DEALERS—Wholesale list. Postage, 5¢. Frank, 5031 Queensberry, Baltimore, Maryland, 21215.

FREE 50 World wide, plus Congo, Rwanda, Monaco, Niger. To approval applicants. Elkay Stamps, 210 Jewett Ave., Jersey City, N.J. 07304.

TRADE Your duplicates or purchase at one-quarter catalogue. Fischer 1530 Metropolitan, Bronx, N.Y. 10462.

FREE—World's greatest premium—5000 all different stamps, actual catalogue value over \$100.00 given approval buyers. Thrifty Stamps, Grossmont, California 92030.

"OLD GLORY" in flaming colors! U.S.A. flag giant beauty from Honduras. Enormous United Nations Mexican stamps. Plus strange gorilla issue. Duke of Windsor, Morocco lovely Macao flowers, wild buffalo stamps and others. 10¢ with approvals. Sunny stamp, Fruitport 2, Mich.

AMERICAN Historical collection!! Enormous airmail diamond! Pres. Kennedy & movie star Grace Kelly, 1st USA spaceman Shepard, plus midget soldier, Latin Orchid issue, old St. Pierre Fisherman, etc. 10¢ with approvals. Roseland Stamps, Spring Lake 2A, Mich.

STAMPS Free! New issues, new countries, triangles, rockets, Olympics, Scouts, birds, flowers, animals. Also old Canadian and U.S. stamps. Plus complete illustrated Canadian stamp catalog. Send 10¢ for mailing. Gray Stamp Co., Dept. PM, Toronto, Canada.

SPECIALS! 250 Different beautiful large pictorials, \$1.00; 500 different, \$3.00; 1000 different, \$6.00; Trial 100 different, 25¢. Free bargain list. Continental, 4 Grant, Dundas, Ontario, Canada.

25 DIFFERENT Space stamps, 10¢. Approvals, Erickson, 736 Cottage, St. Paul, Minnesota 55106.

5000 SPECIAL Grab bags, \$1.00 each! Satisfaction guaranteed. Free catalogue. Stamp Service, 14980PM7, Huntsville, Ontario, Canada.

200 MIXED U.S. various issues, including large commemoratives, 10¢ Mojar, 3004 Westknolls, Cincinnati, Ohio 45211.

PARAGUAY'S Latest Gemini Astronauts "Space Walk" commemoratives—Free! Plus 101 Bonus Sets. Approvals, William Deems, 226 Race, Ravenswood, West Virginia 26164.

FREE! 75 different U.S., plus Giant U.S. and Worldwide bargain pricelists, plus outstanding personally selected approvals. Hurry! Try us—We Satisfy! 5¢ postage please. Thanks. Yntema-Schneider, Box 1114L, Holland, Michigan 49423.

FROM War torn Vietnam 50 scarce pictorials \$1.00. Approvals accompany. Merryman Stamps, PO Box 50, Somerville, N.J.

FREE Monaco nudes. Approvals, Stamp Ranch, 902 Addison, Chicago 13, Ill.

ATTRACTIVE Triangle set free! Request approvals. Cutlass, Box 235P, Chicago 60645.

105 DIFFERENT U.S. Stamps, 25¢, approvals included. Shelron, Box 187, Hempstead, N.Y.

COINS, TOKENS, CURRENCY

LINCOLNS: 22 Different "S" including rare 1955S, \$1.60. 28 different before 1940, plus odd 1960D small date, \$1.60. 10 different "S" Jefferson nickels, \$1.60. All three \$4.50. Harris, Box 1147-P, Oceanside, California.

FREE Coin supplies! Giant coin list 10¢ (refundable). Economy Sales, Mansfield, Massachusetts.

HIGHEST Prices paid immediately for coins. Send 10¢ for 1966 buying prices. Wilmot's, 1067-F Bridge St., Grand Rapids, Mich., 49504.

CIVIL War specials: 1863 cent, \$1.75; 1863 civil war token, \$1.75; 1864 genuine confederate states of America \$10.00 bill, \$2.00. All three \$5.00. Rarcoa, 31 North Clark, Chicago 60602.

GIGANTIC Coin Clearance. Illustrated lists 10¢ (refundable). Hutchinson's, Box 6256, Philadelphia, Pa. 19136.

SPECIALS: Scarce date Lincoln cents. All good or better. Satisfaction guaranteed. 50¢ each 1916S, 1927S, 1939D, 1955S, 75¢ each 1915, 1915D, 1921S, 1924S, 1932, 1932D, 1933, \$1.00 each 1909VDB, 1913D, 1923S, \$1.50 each 1911D, 1912D, \$3.00 each 1913S, 1922D, 1931D, 1933D, \$4.50 each 1910S, 1915S, 1926S, \$5.00 each 1912S, 1914S, \$10.00 each 1911S, 1924D. Bryson Inc., 612A White, Toledo 5, Ohio.

SILVER Dollars uncirculated, 1878-79-80-81-82 S mint \$3.00 ea. Illustrated Catalogue 50¢. Shultz, Salt Lake City, Utah 84110.

OLD Time Lincoln cents, 15 different before 1931 only \$1.00. Gene Carlton, Chandler, Okla. 74834.

CLOSEOUT Bargains, free albums, scarce silver dollars, \$1.95, 5 different \$9.45. Latest 1966 illustrated selling, trading, accessories catalogue 25¢. Coin Center, 2614 Calhoun, Ft. Wayne, Indiana.

CONFEDERATE Money: Genuine CSA bills: 1864 \$5, \$10, \$20, \$1.00 each. Pete Williams, Box 494, Pendleton, S.C. 29670.

50¢ CALIFORNIA Gold pieces: (1849-1858), 75¢ each. Seven different, \$4.00. 25 assorted \$12.00: Plastic holders: Metropolitan Coin Ex. 1380-B, Penobscot Building, Detroit, Michigan 48226.

LARGEST Coin magazine, 288 pages, 50¢. Scrapbook, 7320-J Milwaukee, Chicago 31.

INVEST & Profit! 1909 VDB, the 1st Lincoln Cent—\$3. . . . U.S.'s only Steel Cents, uncirculated 1943 P-D-S in holder—\$4. . . . Treasure Chest of world coins & currency Lot of 10—\$1. . . . Coins from 50 different countries—\$5. . . . World's smallest silver coin! Dated 1865, Mexico's Emperor Maximilian—\$2. . . . \$2½ Genuine Gold Coin, Mexico's most beautiful—\$7 (with gold holder \$10). Centre Coin Co., 13831-B Ventura, Sherman Oaks, Calif. 91413.

FOUND In attic! Hoard of 19th Century U.S. Quarters. \$2 each; 10 for \$15; 100 for \$125. Hobbies Unlimited Box 5490-A, Sherman Oaks, Calif. 91413.

DISCOUNTS. Buy, sell, trade lists, 10¢. AWM Coins, Box 14377, Orlando, Fla.

BEAUTIFUL Uncirculated World coin sets: Algeria, Denmark, Madagascar, Pakistan, Panama, Uruguay, Yugoslavia, Zambia, each \$41.95. World's greatest bargain catalogue, \$1.00. World Coin Book, \$4.25. Redbook, \$1.85; Bluebook, \$1.00. Bebee's, Incorp., 4514 North 30th, Omaha, Nebr. 68111.

HONG Kong dollars—Guaranteed genuine! In clear, foam lined plastic cases, \$1.35 each—4/\$5.00 (checks O.K.) Johnson, Box 735-M, Arcadia, Calif.

UNCIRCULATED Silver dollars, \$2.00. 100 "S" Lincolns, \$3.25. Taylor, Box 1068, Whittier, Calif. 90603.

3 LINCOLN Cents, 1929D, 1919, 1923 plus catalog only 10¢. Approvals, Littleton Coin Co., Littleton W1, New Hampshire.

COIN Cleaning paste—all metals—safe—ounce tube, \$1.00. Postpaid, Ferry, 4432 Germantown Ave., Phila. Pa. 19144.

7 CURACAO Coins, complete set, send \$4.50. P.O. Box 2106, Curacao, Neth. Antilles.

15 DIFFERENT Brilliant uncirculated Lincoln cent errors, each one is labeled and identified. Only \$1.00 per set. International Investment Associates, Box 172, Hollywood, California 90028.

TEN Indianheads, \$2.90; Five V-nickels, \$1.35; silver dollar, \$1.75; terrific close-out list, 15¢. NELSON, 346-P, Rye, New York 10580.

2¢ COPPER \$1.60; 3¢ Nickel \$1.75; Morgan half \$1.15; VDB Lincoln \$.85; list. Fairway, 121-P Rye, New York 10580.

LINCOLN Cent sale! 1909-1940 PDS mints, 40 different, \$3.95. 60 different, \$8.95. Gemcoinco. Minneapolis, Minnesota 55426.

40 PAGE Illustrated United States and Canadian coin list 10¢. Stoney, 260 Washington, Boston 8, Mass.

ANTIQUES, RELICS, INDIAN GOODS AND CURIOS

TONS Of antique gun parts and supplies. All reproduction muzzle loading guns. Send \$1.00 for enlarged illustrated catalog No. 115. Dixie Gun Works, Union City 12, Tennessee.

SELLING 20,000 Ancient arrowheads, spearheads, etc. List free. Lear's, Glenwood, Arkansas.

ANTIQUES! Monthly magazine. Sample 25¢ or free circular. Antiques Journal, Uniontown, Penna. 15401.

ARROWHEADS, 10 for \$3.00. List free. Hyde's, Box 1788, Santa Fe, New Mexico.

"HOW To Find Indian Arrowheads." Exciting, beautifully illustrated, \$2.00. Canyon Publishing, Dexter, Oregon 97431.

10 ASSORTED Perfect arrowheads, \$3.00. George Smith, 9825 Conway Drive, Indianapolis, Indiana 46236.

YOUR Ad in this space will be read by more than 1,400,000 active mail order buyers. Join the march to greater profits, place your products and services in front of them today with a small low cost classified ad. For further details, write: C. A. Martin, Dept. 15N, Popular Mechanics, 575 Lexington Avenue, New York, New York 10022.

MODELS—SHIPS, TRAINS, PLANES, ETC.

SHIP Model kits and fittings: clippers, frigates, etc. Catalog paint-tool list, book list, 40¢. Model Shipways, Box 65, Bogota, N.J.

SLOT Racers! Trains! 25¢ brings 32 page bargain catalogue. Thousands of Lionel, Gilbert, Varney, Strombecker, Eldon, Aurora, Scalextric, Revell, etc. Trains, all gauges, racers all sizes. Hobby Surplus, P.O. Box 1106M, New Britain, Conn.

SHIP and yacht model fittings; Pine construction hull kits; blueprints. Send 50¢ for illustrated catalog. A. J. Fisher, Inc., 1002 Etowah Avenue, Royal Oak, Michigan 48067.

SHIP Models, Kits, fittings, plans, books, tools, engines, motors. Big illustrated catalog, 50¢. James Bliss & Co., Dept. SM, Route 128, Dedham, Mass. 02026.

ROCKETS: New illustrated catalog, 25¢. Single and multistage kits, cones, engines, launchers, trackers, rocket aerial cameras, technical information. Fast service. Estes Industries, Penrose 2, Colorado.

ROCKET Or fireworks fuse 3/32" diameter, water proof 60 feet with formulas, \$1.00 postpaid. Rigley, Box 138-B, Addison, Mich.

SLOT Racers—Free catalog of bargain equipment and exotic hard-to-get items. You name it, we have it. Fast service. Tom Thumb, 12640 N.E. 6th Ave., N. Miami, Fla. 33168.

BUILDING Materials, 1/4" & 1/8" scale, windows, doors, siding, roofing, lumber and structural shapes. Send 35¢ for catalog with samples. Small Sales Co., 6025 Martway, Mission, Kansas 66202.

GAMES, TOYS, NOVELTIES

YOUR Ad in this space will be read by more than 1,400,000 active mail order buyers. Join the march to greater profits, place your products and services in front of them today with a small low cost classified ad. For further details, write: C. A. Martin, Dept. 31N, Popular Mechanics, 575 Lexington Avenue, New York, New York 10022.

MAGIC TRICKS, PUZZLES, JOKER NOVELTIES

GIANT Magic Catalog and free trick only 10¢. Write today. Mailmart, M566, Box 616, White Plains, N.Y. 10602.

VENTRILOQUISM! Information free! Dummy catalog, 25¢. State age. Maher, Box 36-F, Kensington Station, Detroit 24, Michigan.

MAGIC Catalog. World's finest, 3000 tricks, (340) pages \$2.50. Beginners, amateurs, professionals. Kanter's, A-200 South 13th St., Philadelphia, Pa. 19107.

BE A Magician! Introductory catalog with free trick, only 35¢. Ireland Magic, 5082 Lincoln, Chicago, Illinois 60625.

500 TRICKS, Douglas famous catalog No. 36, only 10¢. Contains best in magic for pocket, parlor, club, stage. Fastest service to magicians for over 50 years. Douglas Magicland, Dept. 21, Dallas, Texas 75221.

COMPLETELY Illustrated catalog, 84 pages, 25¢. Manhattan Magic, Box 334-M, N.Y.C. 11.

WORLD'S Finest professional magic tricks. Joker's Novelties, Giant illustrated catalog 10¢. Top Hat, Evanston, Illinois.

FUN'n Magic catalog, 10¢. (1,500,399 tricks, jokes, novelties, puzzles, disguises). Elbee, 7408-P, San Antonio, Texas 78207.

"FATMAN" Decals, large, colorful, funny, 50¢ ea., 3/\$1.00 ppd. Fatman, 612 So. Long Beach Blvd., Compton, Calif.

COMIC Cards, Funnies ever printed, 60 assorted \$1.00. Babbit, Bethel, New York 12720.

164 PAGE Giant surprise catalog! Over 1000 tricks, professional magic, Jokers!! World's greatest! 800 pictures! Special only 10¢. Vick Lawston's Magic, Dept. PM6, Northeast Fifth Ave., Ft. Lauderdale, Florida 33308.

YOUR Ad in this space will be read by more than 1,400,000 active mail order buyers. Join the march to greater profits, place your products and services in front of them today with a small low cost classified ad. For further details, write: C. A. Martin, Dept. 41N, Popular Mechanics, 575 Lexington Avenue, New York, New York 10022.

BOOKS, PERIODICALS

PROPHET Elijah coming before Christ, Wonderful book free. E. Megiddo Mission, Rochester, New York 14619.

BOOKFINDERS! All subjects. Send wants! Sydney Jaher, 175-45 88 Ave., Jamaica, N.Y. 11432.

HOW To raise capital plus twenty nine self-improvement books. Free brochure. Box 725, Binghamton, N.Y. 13902.

CHALLENGING! Different! Unusual books! Free catalog. Ruby's, D-26, Paradise, Pennsylvania 17562.

INTERESTING Books, Free Catalog. Postal PM, 2217 Lackland, St. Louis, Missouri 63114.

BOOKS, Free general catalog, 60 pages. Text, vocational, educational, instructional subjects. Millions of volumes, new and used. Bargain prices. Books bought, Est. 1902. Long's College Book Co., Dept. PM, Columbus 1, Ohio.

PUBLISH Your book! Join our successful authors. All subjects invited. Send for free appraisal and detailed booklet. Carlton Press, Dept. PMD, 84 Fifth Avenue, New York 10011.

NEW 166 Page Technical book "Mechanical Components." Over 150 illustrations, 85 photos, 36 pages tech data and charts. \$1.95 postpaid (No C.O.D.) PIC Design Corp., East Rockaway, New York 11518.

OUT-Of-print books at lowest prices! You name it, we find it! Fast service. No obligation. International Bookfinders, Box 3003-PM, Beverly Hills, Calif. 90212.

BOATING Fans: "Encyclopedia of Outboard Motorboating." How to pick boat, motor, kits, etc. Only \$3.95 postpaid. Moneyback guarantee. Cruzan Co., E. 9605-PM Maxwell, Spokane, Wash. 99206.

FREE Catalog. Self-help books. Write Wilshire, 8721 Sunset, Los Angeles 69P.

PLAYS, STORIES, MANUSCRIPTS

WANT Your book published? Learn how we publish, advertise, promote, distribute. Many successes. Free booklet PM, Vantage, 120 West 31, New York City.

YOUR Ad in this space will be read by more than 1,400,000 active mail order buyers. Join the march to greater profits, place your products and services in front of them today with a small low cost classified ad. For further details, write: C. A. Martin, Dept. 15N, Popular Mechanics, 575 Lexington Avenue, New York, New York 10022.

BUSINESS OPPORTUNITIES

\$70.00 WEEKLY—home, spare time. Simplified mail bookkeeping. Immediate income, easy. Auditax, 34741a, Los Angeles 90034.

MAKE \$46 From square foot plywood; jigsaw necessary. Free details. Woodart, Bridgewater, Mass.

EARN Money raising fishworms for us! Write: Oakhaven-38, Cedar Hill, Texas.

IMPORT-Export opportunity, profitable world-wide, mailorder business from home, without capital; or travel abroad. We ship proven plan, for no risk examination. Experience unnecessary. Free details. Mellinger, Dept. X706, Los Angeles 90025.

MAKE Money from old tires. Operators clearing \$400 weekly. Equipment costs \$800. Get facts. S & S Patents, Inc., 3511 N. Lincoln, Chicago 13.

READ Progressive Mailtrade, the magazine that tells how to make money by mail. Quarter brings sample and special offer. Mailtrade, P.O. Box 357, Sheboygan, Wis. 53082.

COPUBLISH "Mail Sale Advertiser," leading mailorder paper. Copy and details 25¢. Vanroy Shirk, Lebanon, Pa. 17042.

MAILORDER Catalogs. No inventory required. Discounts 40% up, postpaid. Send 25¢ for 32 page sample catalog, featuring 150 unusual, fast-moving products and complete details. Satisfaction guaranteed. Gaylords, North Adams 7, Mass.

BIG Money raising fishworms and crickets. Free literature. Carter Farms, Plains, Georgia.

\$400.00 MONTHLY Raising giant fishworms. Soilless method. Charlie Morgan, Bushnell, Florida 33513.

COLORGLAZED Concrete pottery made without molds. Patented method. Cemetery products, novelties, tiles. Basement leak-sealing. Money-making projects. Booklet, details free. Men only. National Potteries Company, Grand Rapids, Minnesota.

PROFITABLE Catalog Mailorder Business! Vikari's, 835-PM, First Avenue, Salt Lake City, Utah 84103.

START Your own business on credit. Your own boss. Hundreds of dealers making \$100 to \$300 and more weekly. We supply stocks, equipment on credit. 300 home necessities. Sales experience unnecessary. Pleasant, profitable business backed by world-wide industry. Write Rawleigh, Dept. F-U-PPM, Freeport, Ill.

PLASTERCRAFT Molds, liquid rubber, plasters, flocks, candle supplies. Catalog and manual free. Blue Rapids Supply, Blue Rapids, Kansas.

FREE Book "990 Successful, Little-Known Businesses." Work home! Plymouth-972L, Brooklyn, New York 11217.

BUILD Custom cases at home for profit. Get orders by mail. We supply materials, instructions, everything. Free home business details. Customcase, CPL, Sunset, Los Angeles 12.

IMPORT-Export business made easy. Complete setup service. Not just instructions. Hermes, 152 West 42, New York City 10036.

ADDRESSERS And mailers needed. Send stamp for information. Lindbloom, 1508 West Erie, Chicago, 60622.

VENDING Machines. No selling. Operate a route of coin machines and earn amazing profits. 32-page catalogue free. Parkway Machine Corporation, 715 PMB Ensor Street, Baltimore 2, Maryland.

SELL Books by mail. 400% profit. Royal, Box 450-X, Cleveland, Ohio 44127.

DIFFERENT! Outstanding profits from high quality mailorder businesses. Complete setup services; not just instructions. Hermes Co., 152 West 42, New York City 10036.

CONCRETE Facts: Cement artists make big money at home. Simple equipment. Experience unnecessary. Copyrighted methods. Easy to make unlimited cement pottery designs, bird baths, wishing wells, rustic gardens, patio items, etc., without molds. Formulated, chemical coloring, marbled glazing. Free illustrated brochure. Hollywood Cementcraft, 602 Athens, Altadena, California 91001.

OPERATE Home mailorder business. Vosacek Printing, 4444AI Ute, San Diego, Calif. 92117.

WORLD'S Largest wholesale supply. Buy from 7853 American, European, Japanese wholesalers. Hong Kong tailored suits. 123 dropship catalogs. Rockbottom prices. Automobiles. Free details. International Buyers, 216-MM Jackson, Chicago 6, Illinois.

DOLLS! Dolls! Dolls! We teach you to repair, make, dress, also how to operate a Doll Hospital. Study at home. Earn while you learn. Or enjoy a fascinating hobby! Free informative booklet. Lifetime Career Schools, Studio MC-56, 11824 San Vicente Blvd., Los Angeles, Calif. 90049.

\$60.00 DAY, Manufacturing concrete posts. Carlyne, 1803 Fremont, Rapid City, South Dakota 57704.

EARN Extra money selling advertising book matches. Sample kit furnished. D-Lion Matchcorp, Dept. PM-66C, Chicago, Illinois 60632.

RAISE Rabbits on \$500 month plan. Free details. White's Rabbitry, Mt. Vernon, Ohio.

LEARN Landscaping and the growing of plants. Start a profitable business part or full time. Free information without obligation. Lifetime Career Schools, Dept. MC-56, 11824 San Vicente Blvd., Los Angeles, Calif. 90049.

HUGE Profits! Mail order importing. Free information. ITIS-PM-6, Box 454, Hollywood, Calif. 90028.

MAKE \$32 From 49¢ piece vinyl. PMA-1834 Edgeland, Louisville, Ky. 40204.

\$15.00 HOURLY Profit—Own Business with one serviceman. Quickly learned. Easy to do. Operate from home. Few hundred dollars builds your own nationally advertised business while continuing present job. Investigate immediately . . . before your territory is taken. Free booklet explains everything. Send today then decide. Duraclean, C6-165, Duraclean Building, Deerfield, Illinois.

SPARE Time earnings. With your table-saw, bandsaw or jigsaw. Write: Workshop, A3800 Harney, Vancouver, Washington 98660.

400,000 BARGAINS Below wholesale! Many free. Liquidations . . . closeouts . . . job lots . . . single samples. Free details. Bargainhunters Opportunities, Box 730A, Holland, Michigan 49424.

VENDING Machine big catalog. Rake, 1214A West Girard, Phila., Pa. 19123.

SELL Advertising book matches. Write us today; we put you in business by return mail, handling complete line ad book matches in demand by every business right in your town! No investment; everything furnished free! Top commissions daily! Superior Match, Dept. MX-666, 7530 S. Greenwood, Chicago 19, Ill.

EARN Money in your spare time repairing appliances, housewiring, motor rewinding, electrical maintenance. We show you how, send 8 trouble shooting instruments, business getting materials. Free book. Advance Trades School, Dept. E-1303 5944 Newark, Chicago 60631.

BECOME Tax consultant. Our students earn \$1,000-\$3,000 every tax season preparing returns evenings. Accredited State approved National Tax Training School, Monsey O-2, New York.

MOLDING Latex, flex-o-gel, casting supplies—materials! Complete information!! Exclusive Products, 624 High, Racine, Wisconsin.

BAKE New greaseless doughnuts in kitchen. Stores buy output. Start spare time. Profit 29¢ dozen. Small appliance. Free recipes. Montgomery, 3605 South 15th, Minneapolis 7, Minnesota.

TRAVELPAK Cartopper camper. Fits most cars. Distributorships available. Cartopper, 123 PM, Napoleon, Ohio.

RAISE Capital fast—easy proven sources. Free information. Advisor, Box 48337-PM2, Los Angeles 90048.

COMPLETE "Mailorder Course," twenty-four wonderful lessons, \$2.00. Dealers wanted. Neil H. Tasker, Shamokin, Pennsylvania.

BOOKKEEPING System. Substantial profit selling Start Service. Kern, Box 263, North Hollywood, California.

SECRETS! Secrets! Mail order success revealed by internationally famous expert who discovered how to make home business fortunes. Beginners: Get free copy "How to Make Money in Mail Order." Discloses free advertising, profitable products, everything! No obligation. Write Mallico, 1554 Sepulveda, Dept. X706, Los Angeles 90025.

"MAILORDER . . . Stop looking!" Get your own catalogue! Methods, 1815-FD, Lafayette Hill, Pennsylvania 19444.

FREE Report: "609 Unusual, Successful Businesses!" Box 51-PO, Des Plaines, Illinois 60017.

START Your own mail order business, sparetime. Whitlow, 735-PM Goldwood, Dallas, Texas 75232.

I MADE \$40,000.00 Year by Mailorder! Helped others make money! Start with \$10.00—Free proof. Torrey, Box 63566-Y Oklahoma City, Oklahoma 73106.

FREE Details—Start your own plastic laminating business. We supply everything. Jiffy, Box 23485P, Los Angeles, Calif. 90023

NEW! Six months on the job training. Import-Mailorder program for \$10. Free report! Donkar, 1914A LaCana, Hacienda Heights, Calif. 91745.

MAIL Order: cash in advance business. Operate at minimum cost, in spare time. Start receiving orders in just 30 days—If you act now! Promotion, 6344 Dubois, Department 101, Detroit 11, Michigan.

FREE "Franchise Profit Letter" tells how unique NFR service is helping thousands seeking profitable businesses. Write today. National Franchise Reports, W-528, 333 North Michigan, Chicago 60601.

NOTHING Succeeds like success! You can be your own boss. Investigate Western Auto's time-proven dealer plan. Now serving over 4000 dealers making it the largest of its kind. No retail experience necessary. Minimum investment \$15,000. No franchise fee. Get Free Booklet and complete details. Write Charles Wilson, Room 709, Western Auto, 2107 Grand, Kansas City, Mo. 64108. (Indicate geographical area preferred.)

VACUUM Form at home! Mold plastic products for big profit. Fabulous new machineryless method. Free facts. Nationwide Plastics, Box 23321-SD, Los Angeles, 90023.

BIG Money maker! Learn to upholster campers, trailers, boats, autos, plus all home furniture. Tremendous spare-full time earnings. No experience needed. We furnish everything. Easy home instruction, tools, supplies. Do some profitable jobs right away. Send for big free illustrated book. Modern Upholstery Institute, Box 899-AAM, Orange, Calif.

DEVELOP That hunch—convert that occasional intuitive impression into a real business opportunity. Your secret partner is your unused mental potential. Write today for a free copy of **The Mastery of Life**. It explains how thousands have learned to use this undeveloped power as you can! Address: Scribe K.W.K. The Rosercrucians, AMORC, San Jose, California 95114. Please include Zip Code if part of your address.

GENUINE Oil portrait—from photo! 100% profit. Treasures, Box 593, Jacksonville, Florida 32201.

MAKE Money clipping items from your local newspaper. Some worth \$10.00 each. Details free. Harvey, Box 692-N, Elkton, Maryland 21921.

WE Need Ginseng growers! \$3,000-\$20,000 annually. We buy your crop. \$1.00 brings seeds and information. Glass's Ginseng Exchange, P.O. Box 1969, Springfield, Mass. 01101.

FREE Report, "Home Business Opportunities." Immediate earnings! Wyman, E-75, Congers, N.Y. 10920.

\$1,100 LOST In mailorder! Avoid errors. Operate correctly. Free details. Garbo, 11756P Lanett, Phila. Penna. 19154.

NEW, Exclusive field. You must earn \$15,000 yearly or we return franchise fee. Records indicate \$30,000 per year possible. No inventory, no accounts receivable, no large capital needed. Over ten years of research and development were necessary to produce our patent pending and copy-righted proven system of operation. Send resume or \$1.00 for 26-page booklet (Returnable) describing this unique, exclusive, non-competitive opportunity. Your territory may still be open. We invite investigation by your banker. Executives, P.O. Box 4080, Dept. JPM, New Orleans, La.

PIANO Tuning learned quickly at home. Tremendous field! Musical knowledge unnecessary. Information free. Empire School of Piano Tuning, Box 327, Shenandoah Station, Miami, Florida 33145. (Founded 1935).

ALL Types of businesses coast to coast! Over 370 local offices to serve you. Call or write for free "Business and Income Property Bulletin." United Farm Agency, 612-PM West 47th St., Kansas City, Mo. 64112.

LEARN Bonsai! Make valuable oriental miniature Ming trees. Growing living Bonsai miniatures, and tiny forests. Free facts. Minitree, Box 23023-ZA, Los Angeles 90023.

EARN Big profits, mailing catalogs. Free instructions. Soren Lonnquist, Box 500, Bella Coola, B.C., Canada.

INCREASE Your income by breaking bad habits holding you back. Tested new studies. Details. Jerald, 5407 N. Christiana, Chicago 60625.

START At home your own successful business! Details free! Moore, 1832 North Fifth, North Las Vegas, Nevada 89030.

VENDING Machines: 1, 5, 10 and 25¢ bulk vendors, merchandise novelties, parts, supplies and service. Write for catalogue. Vendall Dist. Co., 1820 East 38th Street, Minneapolis 7, Minnesota.

NEW Streamlined home-study mail order course. Details free. Eljay Co., Box 356, Bartlett, Illinois 60103.

FREE—" \$10,000 home business secret." Just write: Ventures-331, Harlingen 1, Texas.

NOW! You can make money at home—40 Different ways! Traphagen's, 303 East 19th, Indianapolis, Indiana 46202.

LARGE Earnings easy with your own small business, full or spare time. FREE proof. Success Books, 205 Linda Court, Gretna, Louisiana.

EARTHWORM Growers needed! Good-paying home business! You raise, we buy! Free picture folder! Cal-Bait, 8616 Fair Oaks Boulevard, Carmichael, California 95608.

SIMPLE Method to get capital loans. Free letter. National Counselor, Harlingen 17, Texas.

FREE Catalog of forty money-making manuals. Dailey's, Box 4, East Montpelier, Vermont 05651.

BECOME A social security consultant—fast, easy, low cost home training. Growing field. Good money showing clients how to receive greatest Social Security benefits from Medicare, Retirement, Disability. Accredited Home Training School. Send for free information. No salesman. National Tax Training, Monsey O-302, New York 10952.

MAKE Extra money — show friends, neighbors—gifts, stationery, Christmas, all occasion cards. Experience unnecessary. Salable samples on approval, free catalog, free name imprinted Christmas card album. Hedenkamp, 361 Broadway, Dept. PM-90, New York.

NOW! Free circulars! 10 New, amazing mailorder ideas! Mendez, 426 Hill, Los Angeles, California 90013.

\$1000.00 MONTHLY Collecting delinquent accounts by mail. Continental Associates, 1004 Grand, Des Moines, Iowa 50309.

MAILORDER—Profitable items, drop-shipped. Everything supplied. National Mdrs., 3408 1/2 Motor, Los Angeles 90034.

PACKAGE At home for profit! We supply everything. No "selling." Free home business details. HPC-807HPL, Sunset, Los Angeles 12.

PROFIT With Popular Mechanics' subscription plan. No investment, no experience needed. Earnings begin immediately when you obtain subscription for Popular Mechanics, Good Housekeeping and others. High commissions, bonus. No experience needed. Deal directly with the publisher. Write Popular Mechanics, Room 6B, 250 West 55th St., New York 19, N.Y.

MONEYMAKING OPPORTUNITIES

LEARN The secrets of repairing junk batteries. "Fabulous Profits" at home. Details. The Batteryman, P.O. Box 416, Palm Desert, Calif.

VENDING Machines. No selling. Operate a route of coin machines and earn amazing profits. 32-page catalogue free. Parkway Machine Corporation, 715 PMM Ensor Street, Baltimore 2, Maryland.

EARN Money evenings, copying and duplicating comic cartoons for advertisers. Adservice, Argyle-1, Wisconsin.

\$200.00 FROM Sheet 1/4" plywood (scrap). 25¢ refundable. Novelties, 610 So. 24th, Elwood, Indiana.

MINK Raising information free. Lake Superior Mink Farm Inc., Superior, EE1, Wisconsin.

CIGARETTES—Make 20 plain or filter-tip for 10¢. Facts free. Moberly, Box 922, Owensboro, Kentucky.

EARN Big commissions full or part time. Show America's largest line low priced business printing and advertising specialties plus big catalog union label political advertising items. Calendars in season. Big free sales kit samples hundreds items used daily by businessmen and political candidates. Merchandise bonuses for you. Free gifts for customers. Build profitable repeat business. Start now. National Press, Dept. 147, North Chicago, Ill.

FREE. 206 Easy ways to make money taking orders for exciting new products—spare time. Send name, age for 5 months free subscription Opportunity Magazine, 850 N. Dearborn, Dept. 17-DM, Chicago.

BOOKKEEPERS Operate profitable book-keeping tax service. Universal, Box 664-M, Springfield, Missouri.

EARN \$240.00 a month at home, spare time, doing only two \$5.00 invisible mending jobs a day. Big money paid for service that makes cuts, tears disappear from fabrics. Steady demand. Details free. Fabricon, 1532 Howard, Chicago 26, Ill.

CLIP Newspaper items. \$1.00-\$5.00 each. Details free. Walter, Box 1023-P, Erie, Pa.

BIG Money raising fishworms and crickets. Free literature. Carter Hatchery, Plains, Georgia.

INSTANT Money! Plastics are the wave of the future. Big profits now! At home! Spare time! Materials costing 11¢ bring \$2.58 profits immediately. Free information! Rush name on postcard to: Warner, 1512 Jarvis, Dept. CL-2-DX, Chicago 60626.

MAKE Money writing short paragraphs! No tedious study! I tell you what to write, where and how to sell, and supply list of editors buying from beginners. Many small checks add up quickly. Write to sell, right away. Send for free facts. Benson Barrett, Dept. C-27-D1, 6216 No. Clark, Chicago 26.

GOLD! How and where to find it is explained in "Your Personal Gold Hunters Guide." Only \$2.00 Postpaid. Write GUIDE, P.O. Box 688, University, Alabama 35486.

AMAZING Ways to raise capital. Details free. Benton, 114-A Carrier, Liberty, New York 12754.

NEW Instant invisible mending. Learn in one hour, repair in five minutes. Make \$150.00 week. Literature free. Henson, P.O. Box 6136-6, Philadelphia, Pa. 19115.

MAKE \$50-\$100 Fast assembling Link Belts. Free details! Redikut's, Loganville, 40 Wisc.

FORTY Moneymaking—"Hobbylike"—Opportunities. Write: Homcraft, 40-21KG Bell, Bayside, New York 11361.

GET Out of debt—clear credit—immediate relief. Advisor, Box 48337-PM3, Los Angeles, 90048.

OVER \$16.50 An hour. Spare time at home! Rubber stamp industry needs small manufacturers. We furnish all equipment and know-how! Particulars free! Write: Roberts, 1512 Jarvis, Room CR-2-DX, Chicago 60626.

JEWELRY CRAFT for fun or profit! Catalog, 25¢. Modern Craft, Box 3614-RC, Cranston, R.I. 02910.

SHARP \$\$\$ Opportunity! One low-cost machine sharpens—serrated knives, scissors, pinking shears. Earn \$6-\$9 hourly in spare time. Professional results without experience. Free details. Beaver Machine, 636C Nielsen Bldg., Eugene, Oregon.

LOOK!!! Great new folio. Make money at home. Details only 25¢. R. C. Stephens, Bx. 131, Doran, Va. 24612.

\$400.00 MONTH Possible raising night-crawlers, redworms. Three Oaks Ranch, Dresden, Tenn.

MAIL Letters featuring real merchandise, get \$12.00 orders in every mail. \$8.00 profit. Everything furnished. Write: Dailey's, Box 4, East Montpelier, Vermont 05651.

MAIL Letters featuring real merchandise—Get \$10 orders in every mail—\$8 profit. Everything furnished. Universal, Dept. 15, 510 First National Bank Building, El Dorado, Arkansas 71730.

AMAZING Successes through franchises! Become exclusive franchise holder your territory. Information rushed. National Franchise Reports, WP-528, 333 North Michigan, Chicago 60601.

MAKE Money with low-priced imports. Write for valuable information on sources. Marilyn Associates, 400-PM Norton, New Haven, Conn. 06511.

MASTER Watchmaking at home. Free sample lesson. Chicago School, Dept. YFA, Fox River Grove, Illinois 60021.

MAKE Money clipping items from your local newspaper. Some worth \$10.00 each. Details free. Harvey, Box 692-N, Elkton, Maryland 21921.

SNOW Cone machines! Your own business. Adult or teenager can operate successfully. Spare time or full time. Small investment, big profits for your hobby or those extra things you want. Write for free catalog and name of nearest dealer. S. T. Echols, Inc., Box 808, Bismarck, Missouri.

Supercalifragilisticexpialidocious Money-maker, unique product. Details, 25¢. P.O. Box 96, Yonkers 1, N.Y.

\$25.00 — \$150.00 WEEKLY. Part, full time. Easy, sure, proven. No experience required. Few dollars start you. Wife can help, or do everything, working mostly at home. Success guaranteed or money refunded. Complete instructions, \$2.00. Robert Charles Associates, Box 1526, Montgomery, Alabama.

LEARN How to improve your auto trading skill. Free details. Guidelines, Box 6123, Nashville, Tenn.

MAKE Big extra money in spare time as accident investigator. College unnecessary. Keep present job. Work from home. Salary to \$8 an hour, plus expenses. State approved correspondence course trains you quickly. For free information write Liberty School, Dept. B56, 1130 W. Park, Libertyville, Illinois.

MAKE \$5,000 Yearly sparetime, raising milk, chinchilla, nutria, etc. Free booklet reveals proven plant. Write: Furs, Dept. E, Bewdley, Ontario, Canada.

GET Any Government job you want. Easy, streamlined, inexpensive! Thousands helped! Free details! Moore, 1832-A North Fifth, North Las Vegas, Nevada 89030.

OPERATE Your town's Ad Market. Do business home, mail, telephone. We establish you. Free details. Ad Market, Harlingen 4, Texas.

CUSTOMERS Call you! Learn Invitation Consulting. Copyrighted methods show how you earn \$10 hourly profit. No equipment. Proven system gets customers to call you. Star, 19 Grove, E6, Monsey, N.Y. 10952.

WANT To make money in mail order? Subscribe to Mail Sale Advertiser—Sample free. Howard's, 28 East Jackson, Suite 1204-PM, Chicago 60604.

FORTY Moneymaking plans. Free details. Continental Gift Shop, 314 County Street, New Bedford, Mass. PM-5.

BIG Profitable opportunity mail, 25¢. Doug, 1507 Murray, Worthington, Minn. 56187.

FREE Details on dozens home money-making opportunities. Midwest Mail Sales, 216-AL West Jackson Blvd., Chicago, Illinois 60606.

AMAZING Mailorder profits using proven methods. Particulars free. Unicis, Box 735-PH, Norwalk, Conn. 06852.

FREE Copy! "Quick profits collecting OLD, ODD, USELESS items." Send 25¢ handling. Skeeto, Fuquay-Varina, North Carolina.

HOTTEST Mail order plan ever. Start immediately. \$1.00 complete. Wofford's, Box 291-G, Center Point, Texas 78010.

MAKE Money Zip-coding mailing lists at home. Information free. Automated Mail, Dept. 126, Stamford, Connecticut 06904.

RAISE Rabbits and fishworms on \$500 month plan. Free details. White's Rabbitry, Mt. Vernon, Ohio.

PROFITABLE OCCUPATIONS

BAKE New greaseless doughnuts in kitchen Sell stores. Free recipes. Michael, 3605 South 15th, Minneapolis 7, Minn.

BIG Money raising fishworms and crickets. Free literature. Carter Wormery, Plains, Georgia.

RAISE Pheasants on \$100 week plan. Little capital and space can make you independent. Free details. Great Central System, Columbus 1, Kansas.

EARN \$240.00 A month at home, spare time, doing only two \$5.00 invisible mending jobs a day. Big money paid for service that makes cuts, tears disappear from fabrics. Steady demand. Details free Fabricon, 1586 Howard, Chicago 26, Ill.

INVESTIGATE Accidents. Earn \$750 to \$1,400 monthly. Car furnished. Expenses paid. No selling. No college education necessary. Pick own job location. Investigate full time. Or earn \$8.44 hour spare time. Men urgently needed now. Write for Free literature. No obligation. Universal, CPM-6, 6801 Hillcrest, Dallas, Texas 75205.

AUCTIONEERING—Resident and home study courses. Auction School, Ft. Smith, Ark.

MONEY: Become finance broker part or full time. Ra-Mar, P.O. Box 482, Desk 3, Oklahoma City, Oklahoma.

VENDING Machines. No selling. Operate a route of coin machines and earn amazing profits. 32-page catalogue free. Parkway Machine Corporation, 715 PMP Ensor Street, Baltimore 2, Maryland.

SHARPEN—Scissors, pinkers. Inexpensive equipment, tools, supplies. Blackhawk's, Sheldahl, Iowa.

FREE Facts and descriptive bulletin. Be an air conditioning, refrigeration, and heating serviceman. High pay, jobs open everywhere, operate your own service business, no school or correspondence necessary. Write Doolco, Trouble Shooter, 2016 Canton, Dallas, Texas.

BECOME Independent with your own franchise business. Thousands earning handsome incomes. Request interesting facts today. National Franchise Reports, PM-528, 333 North Michigan, Chicago 1.

MAKE Money writing short paragraphs. Information free. Barrett, Dept. C-27-D2, 6216 N. Clark, Chicago 26.

CHROME Plating. Instructions, equipment and supplies. Platers' Supply, P.O. Box 565, Lugo Station, Los Angeles, Calif.

FREE Book "990 Successful, Little-Known Businesses." Work home! Plymouth-97L, Brooklyn, New York 11218.

JANITORS, Custodians, cleaners make more money. Get a better job. Become a maintenance supervisor. Free homestudy information: Maintenance Training, 511-12th Niagara Falls, N.Y.

YOUR Own sign shop—Signs, 1017 W. Mulberry, Springfield, Ohio.

SALESMEN—DISTRIBUTORS

FREE. 206 Easy ways to make money taking orders for exciting new products—spare time. Send name, age for 5 months free subscription Opportunity Magazine, 850 N. Dearborn, Dept. 17-DS, Chicago.

SELL Advertising book matches. Write us today, we put you in business by return mail; handling complete line ad book matches in demand by every business right in your town! No investment; everything furnished free! Top commissions daily. Superior Match, Dept. M-666, 7530 S. Greenwood, Chicago 19, Illinois.

\$1,000.00 a month for making dramatic 3-second demonstration of amazing Lightweight Presto Fire Extinguisher. New chemical used by Airforce snuffs out fires instantly. Only \$4.95. Terrific commissions. Millions want it. Free Kit, Merlite, 114 E. 32nd, Dept. P-66Z, New York 16.

SENSATIONAL New longer-burning light bulb. Amazing free replacement guarantee—never again buy light bulbs. No competition. Multi-million dollar market yours alone. Make small fortune even spare time. Incredibly quick sales. Free sales kit. Merlite (Bulb Div.), 114 E. 32nd, Dept. C-73Z, New York 16.

DOWLRITE Adding machine. Carry in pocket or purse. Sample, \$1.00. Dowlrute, Box 754, Atlanta, Ga. 30301.

SELLS Itself!! Welcome to your town signs. 54% profits, write: Gilson's, Townville, Pa.

MEN Or women, sell hertel blue ribbon bibles. Full or part time. Finest reference bible available. Excellent commission. Demonstrator—supplies furnished. Write International Book, Box 118PM, Wichita, Kansas.

EARN Big commissions full or part time. Show America's largest line low priced business printing and advertising specialties plus big catalog union label political advertising items. Calendars in season. Big free sales kit samples hundreds items used daily by businessmen and political candidates. Merchandise bonuses for you. Free gifts for customers. Build profitable repeat business. Start now. National Press, Dept. 146, North Chicago, Ill.

AGENTS WANTED

MAKE \$50.00 Daily selling air operated vacuum cleaners to service stations. Free details. Inka Industries, 2401 Crocker, Houston, Texas 77006.

RAISE Rabbits for us on \$500 month plan. Free details. White's Rabbitry, Mt. Vernon, Ohio.

MAKE Up to \$50.00 daily soliciting delinquent accounts. Terrific commissions. General Finance Co., Dept. LG-80, Pickwick Bldg., Kansas City, Mo. 64106.

PRINTING. Advertising salesmen—Excellent moneymaking sideline selling decalcomania name plates, small quantities. Automobile initials, sign letters. Free samples. Raico, XL, Boston, Mass. 02119.

YOUR Own business—Used suits \$1.50; overcoats 65¢; mackinaws 35¢; shoes 12½¢; ladies coats 30¢; dresses 15¢. Enormous profits. Catalog free. Nathan Portnoy Associates, 2109-AA Roosevelt Road, Chicago 8, Ill.

CHRISTMAS Cards—business and personal. Customer's name imprinted. Earn unusually high commissions from this medium—and high-priced line. Free sample album. Process Corp. (our 45th year), S. 54th Ave., Chicago, Ill. 60650.

\$100.00 REWARD For information leading to the purchase of machine tools. Contact: Mandel-Camras Machinery Co., 1328 West Randolph Street, Chicago, Illinois 60607.

MAKE Extra money — show friends, neighbors—gifts, stationery, Christmas, all occasion cards. Experience unnecessary. Salable samples on approval, free catalog, free name imprinted Christmas card album. Hedenkamp, 361 Broadway, Dept. PM-90 New York.

JAPAN'S Fishing equipments. Sample, details, \$1.00. OHGA, PMP-2, Sigakenkusu, Japan.

ESTABLISH Your own business. Low prices on used clothing, shoes, household goods. Unlimited profits. Free catalog. Northwestern Distributors, 2129 No. Western Avenue, Chicago, Illinois 60647.

EMPLOYMENT INFORMATION

DIRECTORY Reports. Construction, aviation, shipping, oilfields, government, manufacturing, trucking, etc. foreign—stateside. Helpful information plus job-getting tips on preparing application letters. Unconditional money-back guarantee. Only \$3.00 (\$3.25 airmail) Research Services, Box 6768-PM, St. Louis, Missouri 63144.

TREMENDOUS Opportunities U.S.A.—Overseas. Choose jobs—locations—transportation. Free details. Occupations. International Airport, Box 100-C3, Jamaica 30, N.Y.

FOREIGN Employment: South America, Africa, Europe, Australia, USA. Earnings to \$2,000.00 monthly. Construction, all trades, professions, occupations. Many companies pay fare, housing, benefits, bonuses. Write: Universal, Dept. B-1, Woodbridge, Connecticut 06525.

JOB Resume guide, easy to follow. Plus sample resume and instructions, \$1.00—refundable. Bell Resume Service, 18 Tremont Street, Suite 924, Boston, Mass. 02108.

BOOMING Australia needs your skills! Government assisted passage. Details \$1.00. Irv Heyer, 321A S.W. Salmon, Portland, Oregon.

FEDERAL Jobs overseas! Details, \$1.00. Irv Heyer, 321-C S.W. Salmon, Portland, Oregon 97204.

BIG Demand for bricklayers. \$38.00 a day. Jobs waiting. Learn this trade now. Open to all. Train in your area. Information, \$1.00. TAG Corp., Brick Contractors, 406 S. 2nd St. M., Alhambra, California.

FOREIGN Employment. Construction, other work projects. Good paying overseas jobs with extras, travel expenses. Write only. Foreign Service Bureau, Dept. PM, Bradenton Beach, Florida.

FARMS—REAL ESTATE

ABANDONED Timber Leaselands! Choice 640 acre Sportsmen's paradises still available—\$20.00 plus \$6.50 Taxes yearly. Maps, pictures, \$1.00 (Refundable). Director, Erindale 4, Ontario, Canada.

CANADA'S Finest lands. \$4.00 an acre and up. Acquired through estate liquidations. Suitable for hunting, fishing, camps, cottages, farming, timber, minerals, investment. Small monthly payments. Free descriptive booklet. Canadian Estate Land, 2788-P Bathurst Street, Toronto, Canada.

"CAL-ORE Ranches" in Oregon's Rogue River Valley near Medford and Grants Pass. \$2995 to \$5995. Pay \$150 down, \$35 monthly. Free catalog. Cal-Ore Ranches, 1054PM South Riverside, Medford, Oregon.

CANADIAN Vacation lands: Full price \$385.00. 40 acres. \$10 month. Suitable cottage sites, hunting, fishing, investment. Free information. Land Corporation, 3768-C Bathurst, Downsview, Ontario, Canada.

CANADIAN Lands, seized and sold for taxes. Our 49th annual series of lists, describe many choice properties, situated from coast to coast, acquired by us through tax sale. Priced as low as five dollars per acre, guaranteed perfect title, small monthly payments, no mortgage. Beautifully situated hunting and fishing camps, where there is real sport: summer cottage sites, heavily wooded acreages. Now is the time to invest in Canada's minerals, forests and farms. Write today for free twenty page booklet with full explanation. Tax Sale Service, Room 301-D, 85 Bloor St., E., Toronto 5, Canada.

400,000,000 ACRES Government public land in 25 states. Some low at \$1.00 acre. 1966 report. Details \$1.00. Public Land, 422-PM-6 Washington Building, Washington, D.C.

FREE Summer catalog! Bargains galore! Coast-to-coast! Low prices, easy down payments! Safe-Buy Real Estate Agency, 712-PM, West Third, Little Rock, Ark. (Please include Zip Code.)

FREE! New 160-page Summer catalog! Over 1800 pictures! Farms, ranches, homes, businesses, vacation and retirement properties in 29 states coast to coast! United Farm Agency, 612-PM West 47th St., Kansas City, Mo. 64112.

FLORIDA Campsites—deep in the heart of the great Ocala National Forest. Good hunting and fishing. Free maps and photos. Howard Verner, DeLand, Florida. AD646369D

THE Only 'No-Risk Land Purchase Plan' in America—10 year money-back guarantee on any vacation, retirement or investment homesite in Boiling Spring Lakes—the multi-million, 14,000-acre development on the Carolina Coast. All facilities, electricity, roads, shopping center, motel, golf course, country club, already in. Private ocean beach. 1/4-acre homesites as low as \$435.00; \$5.00 down. Write for free literature, (not offered to residents of California, Florida, New York) Boiling Spring Lakes, Southport, I-U, North Carolina 28461.

15,000 CAMPGROUNDS, 250,000 campsites and latest information on camping (outdoor cooking, first aid, etc.) in the U.S.A. and Canada. Write: Pestekuoy, P.O. Box 70, North Aurora, Illinois.

FREE! Summer catalog! Big 180-pages! Selected Best throughout the U.S. Thousands of properties described, pictured—Land, Farms, Homes, Business—Waterfront, Recreation, Retirement. 66 Years' service, 490 Offices, 36 states coast to coast. Mail Free from the World's largest! Strout Realty, 7-CJ, So. Dearborn, Chicago, Illinois 60603.

\$1 ACRE—Canadian border—hundreds campsites, islands, farmlands, directly from tax authorities. (Non-profit). Lists, photographs mailed. Register, Room 203, 92 King St., E., Toronto 1, Canada.

FARM AND GARDEN EQUIPMENT

DRILL Your own water well for 2¢ per foot! New high-speed drilling rig only \$145 complete. Brochure and "How to Find Water on Your Property" 25¢. DeepRock Drilling Company, 605 Trafco, Opelika, Alabama 36801.

3hp HOEING Machine. Hoes between plants, rows. Depth adjustable. Self propelled. Month trial. Year warranty. Discount. Time payments. Send for literature. Autohoe, West De Pere 22, Wisconsin.

YOUR Ad in this space will be read by more than 1,400,000 active mail order buyers. Join the march to greater profits, place your products and services in front of them today with a small low cost classified ad. For further details, write: C. A. Martin, Dept. 15N, Popular Mechanics, 575 Lexington Avenue, New York, New York 10022.

FLOWERS, PLANTS and NURSERY SUPPLIES

WANT Greatest cash crop working for you? Write Ginseng, Asheville 53, N. C.

EXOTIC Plants: Firefern, Lipstick Plant, Swedish Ivy, Pink Brocade, Crown of Thorns, Burro Tail Cactus, Spider Plant, Firecracker Plant; \$1 each postpaid. All 7 \$5. Illustrated Catalogue 25¢. McComb Greenhouses, 900 N. Hague Ave., Columbus, Ohio 43204.

YOUR Ad in this space will be read by more than 1,400,000 active mail order buyers. Join the march to greater profits, place your products and services in front of them today with a small low cost classified ad. For further details, write: C. A. Martin, Dept. 15N, Popular Mechanics, 575 Lexington Avenue, New York, New York 10022.

HOME CRAFTSMEN

KNOCKDOWN Cedar chests, also over fifty kits. Catalog 25¢. Giles Kendall Co., Huntsville 2, Alabama.

2512 PLANS, Patterns, things to make, do. Fun. Profit. World's greatest selection. Catalog 10¢. Craftplans, 18250-A Harwood, Homewood, Ill.

101 PATTERNS Of smart gifts, novelties, shelves, action windmills plus "Make Money Jig Sawing." \$1.00. Mastercraft, 65M, 7041 Olcott, Chicago 60631.

PLANS, Bldr houses, feeders. Illustrated catalog, 25¢. Yeager, 1665 Linden, Homewood, Ill. 60430.

WOODWORKER—Home craftsman catalog containing clock kits, lamp parts, chair-cane, veneers, swiss musical movements, legs, furniture, hardware, mouldings, finishing materials, tools, etc., only 15¢. Barap Specialties, Box 2044-EA, Chicago 60609.

WALNUT And cherry tapered legs, lumber, gunstock, blanks, picture frame moulding. Midland Lumber Company, Box 262, Savannah, Missouri.

FREE! Big 80 page Leathercraft catalog. 100's of new items! MacPherson Bros., Dept. K, 730 Mission St., San Francisco, Calif. 94103.

PICTURE Frame moulding—Any size, style and wood. All original patterns! Details, 10¢. Japs, 126-P Seventh North, Hopkins, Minn. 55343.

COMPLETE Working plans, specifications, bill of materials for beautiful Picnic table. Send \$1.00 today. Ease-Crafts, 1819-9th Street, Rockford, Illinois, 61108.

PATTERNS Of exciting wooden souvenirs, 50¢. Fiesta, No. Conway, N.H. 03860.

DÉCOUPAGE Gold paper lace sampler \$1.00. Catalog, 25¢. Guaranteed! Mary Copeland, Box 174, Boston 12, Massachusetts.

PICTURE Frame moulding—Any size, style, wood. Original patterns. Write, Japs, 126-P Seventh North, Hopkins, Minn. 55343

NEW, \$1.00 tool eliminates all measuring for electrical outlet boxes when applying dry wall or paneling. R. M. Knott Co., P.O. Box 5082, Spokane, Wash.

SKIL-Crafts new '65-'66 Catalog. Largest and finest selections of leathercraft, artist, hobby-craft supplies in the world. Send 50¢ (refunded plus free gift with first \$5 minimum catalog order). Skil-Crafts, Box 105-P, Joplin, Missouri.

FREE "Do-it-yourself" Leathercraft catalog. Tandy Leather Company, 1001 Foch, N56, Fort Worth, Texas.

PLANS for pool table with extra two-face top for table tennis and model railroad. Blueprints B1209 and building instructions \$3.50. Popular Mechanics Service Bureau, 575-M Lexington Ave., New York, N.Y. 10022.

DO-IT-YOURSELF

MAKE Rotary mower into shredder and mulcher. Send \$1.50 for pattern. Minnie The Mulcher, 300 Fowler Street, Cortland, Ohio 44410.

FIREPLACES, Brick. Do it yourself. Save hundreds. For complete plans send \$3.50. Don Black, Taylor, Arizona.

FREE Information about Marshall's How-To-Do-It Book Directory. Marshall's, 1135A So. Birmingham, Tulsa, Oklahoma 74104.

CONVERT Mower engines into Air Compressors. Write—Showalter, Box 409P, Abilene, Kansas 67410.

FABULOUS Results. Grow your own fruits, vegetables, flowers without soil, indoors-outdoors. 40 lbs. tomatoes from single plant. Complete hydroponics kit, \$4.98 postpaid. Water Gardens, Inc., Box 5104, Tucson, Arizona.

SPORTSMAN'S Trophy clock kits. Details. 10¢. Leroy Buckley, Pell Lake, Wis. 53157.

WATER. Sink your own well. Easy illustrated instructions. \$1.00. Butler, Box 67, East Longmeadow, Mass.

CUT Your own hair, save \$40 yearly, no gadgets to sell, just instructions and diagrams. 50¢. Abbott Studios, P.O. Box 1895, Indianapolis, Indiana.

AUTOMATIC Washer repair manuals for: Frigidaire, General Electric, Hamilton, Hotpoint, Kelvinator, Kenmore, Norge, RCA Whirlpool, Speed Queen, Westinghouse, Maytag, Philco-Bendix. \$2.50 ea. PPD. Major Appliance, 13106 Caine Ave. (Dept. M), Cleveland 5, Ohio.

EXERCISE At home on build-it-yourself physical fitness equipment, including bicycle exerciser, rowing machine, belt massager, and abdominal board. Send \$2.50 for blueprints B1208 and instructions. Popular Mechanics Service Bureau, 575-K Lexington Ave., New York, N.Y. 10022.

FREE Check-list covering more than 300 classifications of projects, plans, instructions, service and repair information detailed in Popular Mechanics famous series of instructional booklets, books, patterns, and blueprints. List covers an extremely wide variety of do-it-yourself data on home remodeling, repair and improvement, hobbies, crafts, boating, games, lawn and garden, and hundreds of others. For your free copy of this helpful list, write: Service Bureau, Popular Mechanics, 575 Lexington Ave., New York 22, New York.

ARTS AND CRAFTS

PAINTING With seeds the newest hobby craze. Full-size patterns plus instructions, 55¢ each or five for \$2.00: Rooster, Hen, Peacock, Eagle, Fruit, Flowers, Swan, Matador, Oriental Scene, Stallion. Pat's Handicrafts, Box 1414, Bay City, Texas 77414.

2500 DIFFERENT plastic molds, figurines, crafts. Catalog, 25¢. Steece Bros., Box 177-PM, Sioux Falls, So. Dak. 57101.

MAKE Figurines, plaques, lawn ornaments. Molds, plastercraft kits, liquid rubber. Sample and catalogue 10¢. Wooley Company, Box 29-B, Peoria, Illinois.

YOUR Ad in this space will be read by more than 1,400,000 active mail order buyers. Join the march to greater profits, place your products and services in front of them today with a small low cost classified ad. For further details, write: C. A. Martin, Dept. 15N, Popular Mechanics, 575 Lexington Avenue, New York, New York 10022.

BINOCULARS, TELESCOPES, MICROSCOPES, MAGNIFIERS

SCIENCE Bargains! Lenses, telescopes, binoculars, microscopes, kits, parts, war surplus. Send \$1.00 for beginner's 10-lens kit with instruction booklet. Order Stock 2-CH. Request free 148 page Catalog CH. Edmund Scientific Co., Barrington, New Jersey.

BUILD Your own professional 8" reflector telescope (no lenses to grind!). Construction plans, parts list, send \$5.00. F. X. Tagan, 69 Mt. Cranmore Lane, Melrose 76, Mass.

BINOCULARS Direct from manufacturer. Finest quality, tremendous savings! Request catalog. Koyu, 3860 Crenshaw Blvd., Los Angeles, Calif.

BUILD Your own reflector telescopes. Complete kits; mirrors, eyepiece, tripods. Free catalog F describing other accessories sent on request. Also free brochure describing amazing line, world famous "Dynascope" reflector telescopes. Criterion Manufacturing, Dept. KPM 39, Hartford, Connecticut.



CAMERAS AND EQUIPMENT

TELL The more than 1,400,000 avid readers of Popular Mechanics about your products and services. It costs very little to place your classified message in front of these proven mail order buyers. For further details, write: C. A. Martin, Dept. 49N, Popular Mechanics, 575 Lexington Avenue, New York, New York 10022.

PHOTO SUPPLIES

TELL The more than 1,400,000 avid readers of Popular Mechanics about your products and services. It costs very little to place your classified message in front of these proven mail order buyers. For further details, write: C. A. Martin, Dept. 50N, Popular Mechanics, 575 Lexington Avenue, New York, New York 10022.

PHOTO FINISHING

A FREE Kodak roll returned with each black and white or Kodacolor developed and printed, fast service, lowest prices, guaranteed quality send for free mailers. Economy Photo Service, Dept. P. M., Box 1111, Albany 1, N.Y.

FAST. Hi-quality finishing. Kodacolor rolls: eight jumbo prints \$1.98. Twelve \$2.49. Twenty \$3.49. Reprints 15¢. Also low B&W prices. Custom Quality Studio, Box 4838-PM, Chicago 60680.

KODACOLOR: 8 Exposures, \$2.00. 12 Exposures, \$2.50. Black and White: 8 Exposures, .50¢. 12 Exposures, .70¢. Our 50th year. Free mailers. Savon Photo Service, Box 110M, Watertown, Wisconsin.

YOUR Photo on 25 photo Christmas cards (envelopes), \$2.50, 100 small or 50 large gummed photo stamps, \$2.00. Send photo. Krause, Box 197, Flatbush Station, Brooklyn, N.Y. 11226.

CAMERA Fans! Expert photofinishing and free film returned: 8MM Kodachrome \$3.10; 8 Exp Kodacolor \$3.10; 35MM Kodachrome, 20 slides, \$2.85; 8 exp black & white 90¢. We give you free photo stamps to redeem for gifts. Satisfaction guaranteed. Send exposed film or request mailers and complete price list. Direct Mail Photo, Box 8352-PM, Pittsburgh, Pa. 15218.

COLOR SLIDES

TRANSPARENCIES Wanted! Learn freelancing. American Color, Box 46372, Hollywood, California.

FLOWER, Trees, landscapes, by horticulturist photographer. Catalog 25¢. Colorpics, Bellport 25, N.Y. 11713.

8mm. MOVIES. 2"x2" Color slides—biggest selection anywhere! Hollywood classics, railroad, antique automobiles, circus, World War II, travel, wild life, many others. 16mm. films also. Big catalog free. Blackhawk Films, 24 Eastin-Phelan Bldg., Davenport, Iowa 52808.

MOTION PICTURES AND SOUND EQUIPMENT

16MM Sound films features and shorts. Bedner, 5300 So. Talman, Chicago.

8MM MOVIES. 2"x2" Color slides—biggest selection anywhere! Hollywood classics, railroad, antique automobiles, circus, World War II, travel, wildlife, many others. 16mm. films also. Big catalog free. Blackhawk Films, 24 Eastin-Phelan Bldg., Davenport, Iowa 52808.

FREE Catalog! Save on 8/mm.-16mm. film and supplies. Superior, 448 N. Wells, Chicago 10.

IMPERIAL'S 1966 8MM-16MM film catalog free. Features, shorts, projectors. Imperial's, 34 Park Row, New York 10038.

16MM sound-projectors, films, new, used for sale. Free catalog. National Cinema, 333 W. 57 Street, New York City, N.Y. 10019.

CASH Paid for 16MM sound features, shorts. Trades accepted Gaines-PM, 14544 Vanowen, Van-Nuys, Calif. 91405.

16MM SOUND Shorts, cartoons, features. Cinemax Films, 10134 Perry Ave., Chicago, Ill. 60628.

OUTLAW Motorcycle funeral! Only film coverage available. Other cameramen routed by rocks. (See Life Jan. 28, roaring tribute for 'Mother' Miles). 59 startling feet 8MM \$6.95, 16MM \$10.25. COLOR. Preview Club details free. Frenclal, Box 4127-B, Compton, Calif. 90224.

5,000 8-16 MM. Movie films. Free catalogues. International, Greenvale, N.Y.

RADIO, TELEVISION AND HAM EQUIPMENT

BRAND New tubes. World's lowest prices on radio, TV-industrial, special purpose tubes. Write for free parts catalog. United Radio, Newark, N.J.

33¢ RADIO & TV tubes. Free list. Cornell, 4213-17 University, San Diego 5, California.

SAVE Money on TV and radio repairs. Free catalog. Telefixit, Box 714, Manhasset 1, N.Y.

FREE Electronics catalog. Tremendous bargains. Send postcard. Electrolabs, Department C-645B, Hewlett, New York 11557.

CONVERTERS For automobile radios, receive Marine, Police, Fire. 2-3, 30-50, 100-200 megacycles. Any kit \$5.00. Meshna, Lynn, Mass. 09104.

HIFI, RECORDS AND ELECTRONICS

TAPE Recorders, hi-fi components. Sleep learning equipment, tapes. Unusual values. Free catalog. Dressner, 1523 Jericho Tpke., New Hyde Park 3, N.Y.

NEW B.S.R. record changers \$13. New Garard record changer \$27. AM-FM stereo tuner w/amplifier \$65. P.M. Changers, 2741 Sedgewick Ave., Bx., N.Y. 10468.

EXCLUSIVE Free catalogue; extraordinary hard to find hobby party records. Record Suppliers, 300 Chelsea, Louisville, Kentucky 40207.

GRAND Old Opry Gospel favorites. 48 recordings only \$2.98. Opry Records, Mount Healthy, Ohio.

RECORDS! Discounts on all LP's. Free details. Citadel Record Club, 545 Fifth Ave., Dept. 2, New York 17, N.Y.

MUSIC AND MUSICAL INSTRUMENTS

ACCORDIONS, Guitars, band instruments! Save to 50%. Famous makes. Easiest terms. Trades accepted. Free home trial. Free discount catalog. Mention instrument. International Music Mart, 5535-R Belmont, Chicago 60641.

VIOLIN And guitar makers, send for latest Free catalogue of woods & accessories. International Violin, PM-5, 414 East Baltimore St., Baltimore 2, Md.

ELECTRIC Guitars, amplifiers, wholesale. Free catalog. Carvin, PMM, Covina, Calif. 91722.

GUITAR. Banjo Making books. Plans, woods, necks, tools. List 20¢. Satinwood, 510 East 11th Street, New York 9, N.Y.

POEMS Wanted for new songs and records. Send poems. Five Star Music, 6M Beacon, Boston 8, Mass.

SONG Ideas wanted. Write with active professional songwriters with publisher contacts. Records made. Share royalties. Send ideas—free examination. Songwriters' Associates, 236 W. 55th, N.Y. 19-P.

PIANO Self-Teaching Book. Includes popular, classical, harmony, theory, chords, scales. Price \$5.00. LaPont Publishing Company, Box 606-P, Franklin, Michigan 48025.

SONG POEMS Wanted! Collaborate with professional songwriters equally. Share royalties. Songwriters Contact, 1619-D, Broadway, New York 19.

SONGPOEMS Wanted. Send poems for offer. Nashville Music Institute, Box 532-PM, Nashville, Tennessee.

BUILD An electric guitar. Complete easy instructions. \$1.00. Kits, blueprints, parts, bulletin, 25¢. Hills, 3526 California, Peoria, Illinois.

ACCORDION Manufacturing. 6343-P South Ashland, Chicago Illinois 60636. Piano Accordions, Chromatics, Hohners, Concertinas. Wholesale catalogs free.

SONGS Wanted by new commercial recording company. Royalty basis. Send material to Preview Records, 6311-B Yucca, Hollywood, California 90028.

INCOME Guaranteed two years for song-poems accepted! Free public releases! Castle's, 203PM West 46th Street, New York City 10036.

GUITARS, \$11.95. Electric double pick-ups with tremolo bar, \$49.95. Accordions, \$125.00. Concertinas, \$350.00. Drums pearl set, \$99.00. Wind instruments \$39.95. Free catalogs. E.Z. Terms. Melody Music, 4951 W. 95th St., Oaklawn, Ill.

SONGWRITERS Wanted! Send song material for recording consideration. Tin Pan Alley, 1650-P Broadway, New York 10019.

BANJOS — Guitars — amplifiers — strings — parts — equipment. Mail order catalog of name brands. Send 50¢ to: Artcom Corp., Box 315A, Park Ridge, Illinois 60068.

SWISS Musical movements. Mechanical-electrical. Spielman, 131 West 42nd, New York 10036.

SONGS, Poems wanted! Accepted songs published, recorded at our expense! Ted Rosen, 17-PM Longwood Road, Quincy, Mass.

PLAYER Piano books. Free catalog. Vestal Press, Vestal 11, N.Y. 13850.

EDUCATION AND INSTRUCTION

COMPLETE Your high school at home in spare time with 69-year-old school. Texts furnished. No classes. Diploma. Information booklet free. American School, Dept. KA45, Drexel at 58th, Chicago, Illinois 60637.

MEN Wanted. Earn \$125 a week and up. Master a trade with a future. Learn auto diesel mechanics in our shops. You learn with tools on real equipment. Earn while you learn. Many of our graduates earn \$125 a week and up. Write for free bulletin: Dept. 256, Auto Diesel College, Nashville 3, Tenn.

OWN Collection agency, "Little Gold Mine!" Franklin Credit, Roanoke, Virginia.

LEARN To drive tractor, trailer, trucks, buses. Short concentrated courses available. Write for free brochure. Driver Training Institute, 794 Bedford Ave., Brooklyn, N.Y. Ja 2-5080.

BOOKKEEPERS. Operate your own "Dollar-A-Week" system. Ellis, Box 200, Cedar Grove, North Carolina.

INVESTIGATOR'S Course. Credentials, diploma. Free information. Southwestern Institute Criminology, Box 201, Geronimo, Oklahoma.

PIANO Tuning pays. Big money in spare time. Learn at home. No musical knowledge necessary. Phonograph, records, tools and instructions furnished. Electronic tuning also taught. Free catalog. Capital Tuning School, 3160 S.W. 16th Court, Ft. Lauderdale, Fla.

MISSOURI Auction School. Free catalog! 1330-03 Linwood, Kansas City, Mo. 64109.

DETECTIVES—Secret investigations. Experience unnecessary. Detective particulars free. George Wagner, M125 West 86th, New York 10024.

FCC License in 6 weeks. First class radio telephone. Results guaranteed. Elkins Radio School, 2603D Inwood, Dallas, Tex.

DETECTIVE Course. Free information. Universal Detectives, Box 8180-F, Universal City, California, 91608.

SWEDISH Massage and Physical culture pays big profits. Learn at home. Diploma. Free catalog. National Institute, Dept. E66, 307 North Michigan, Chicago 1.

LEARN Auctioneering. Term soon. Free catalog. The Reisch American School of Auctioneering, Inc., Box 850, Mason City 1, Iowa.

LEARN Asleep or awake! Records, tapes, equipment! Free catalog! Drawer, PM-400, Ruidoso, New Mexico 88345.

AUTOSUGGESTION. Sleep-learning headquarters! Tapes, records, books. Gigantic catalog free. Research Association, Box 24-PM, Olympia, Washington.

FREE Sleep-learning catalog. Fletcher, 2407 Catherine, Dallas, Texas 75211-PM.

PIANO Tuning quickly learned with home study course. Diploma granted. American Tuning School, Gilroy, Calif.

USED Courses! Books! List 10¢. Smith's, 124 Marlborough, Salem, Mass.

SWEDISH Massage. Foot technique. Post graduate. Home study. Residential. Diploma. Dr. Swanson's Illinois Licensed School, 3809-PL Alta Vista, Chicago 13.

FREE Bible course. Degree. PM. 143 South Gregg, Charlotte, N.C. 28208.

BE A real estate broker. Big Earnings. Free catalog. Weaver School of Real Estate, 3519-P Broadway, Kansas City, Missouri 64111.

LEARN Civil and criminal investigation at home. Earn steady, good pay. State age. Institute Applied Science, 1920 Sunnyside, Department 166, Chicago, Illinois 60640.

PENMANSHIP Guide: Ornamental writing. Improve poor handwriting fast. Details free. M. Tevis, Chillicothe, Mo.

GET A British degree. Divinity, Philosophy, Radionics, 35 courses. Prospectus free. Brantridge Forest School, "Lodge" Brantridge Forest, Balcombe, Sussex, England.

USED Correspondence courses and books sold and rented. Money back guarantee. Catalog free. (Courses bought.) Lee Mountain, Pisgah, Alabama.

B.Sc. DEGREE (Engineering) by home study. Send \$1 for 1966 prospectus. CIST, Suite 804, 263 Adelaide Street, W., Toronto, Canada.

COLLEGE Courses at home on LP records by world famous professors (several Pulitzer Prize winners). Study English, Psychology, History, Anthropology. Credit towards degree at over 100 colleges. Free catalog. Institute For University Studies, Department 97, Bergenfield, New Jersey.

HIGH School diploma at home. Licensed teachers. Send age, highest grade completed for free detail. No salesman will call. Southern States Academy, Professional Bldg., Dept. 16, Decatur, Ga.

WATCH Repairing. Swiss and American watches. Develop skill step by step in spare time at home. Tuition only \$5 monthly. Diploma awarded. Free sample lesson. Chicago School, Dept. YF, Fox River Grove, Illinois 60021.

"INCREASE Your income" Full time, or part time employment. Apartment management offers new job opportunities everywhere. Send for free brochure. Ruth B. Krebs Associates Training School, 8155 Van Nuys Blvd., Suite 204 PM, Panorama City, California 91402.

MOVIE Camera and editing techniques for television and industry. Learn at home from a professional. Write Weston, Box 5216M, Madison, Wisconsin 53705.

USED Courses, books. Catalog. 10¢. Courses bought! Bayles 78B Courtright, Wilkes-Barre, Penna. 18702.

HOME Electronics course only \$26.95. Free literature. Send postcard. Edu-Kits, Department 644B, HEWLETT, New York 11557.

EARN College credits and degrees through correspondence, residence, and examinations. William Darren University, Fourteen North Central Avenue, Phoenix, Arizona 85002.

PENMANSHIP Corrector. Improve poor penmanship quickly. Details free. Ozment, Box 665-34, St. Louis 88, Mo.

FOR INVENTORS

INVENTORS: Your ideas and inventions (patented; unpatented) expertly searched and developed for commercial appeal and cash/royalty sales to manufacturers by professional Invention Developer with excellent record of experience. B.S., Industrial Engineering; U.S. Patent Office former Patent Examiner; U.S. Government former Patent Adviser. Second decade of reliable service! Free "Invention Record" and important information. Airmailed! Write Raymond Lee, Invention Developer 130-N West 42nd, New York City 10036.

PATENT And invention development, by licensed professional patent engineer and U. S. Patent Office former examiner, and engineering specialists. Your inventions and ideas engineered for patent protection and commercial value. Inventions developed by us negotiated for cash or royalties with our nationwide contacts. Send for free protection "Invention Certificates" and further interesting, valuable patent information. George Spector, Licensed Professional Patent Engineer, Woolworth Building, New York.

PROFESSIONAL Patent searches, \$6.00, including official U.S. Patent Office copies of related U.S. patents! Prompt, dependable service. Certified, airmailed! For free "Invention Record Folio" and important patent information every inventor should have, write: United States Inventors Service Company, 501-P Thirteenth Street NW, Washington, D.C. 20004.

\$50,000 FOR My best patent! Get your patent pending fast. Order my "Copy-Book-Materials" today! \$10 npd. Flipper, Inc. =P-6, Geneva, Ill.

IMMEDIATE Cash, for patent applications. Free patent searches. Write for details. Universal Patents, 184-D, Marion, Ohio.

PATENT Searches, including copies of related U.S. patents, \$6.00. Inventors, attorneys, manufacturers use my "world-wide" airmail service! "Invention Record" form and "Information Every Inventor Needs," sent free! Miss Hayward, 1029P Vermont, Washington 5, D.C.

INVENTORS Wanted immediately for promoting on cash or royalty. Patented, unpatented. Free booklet outlines royalty rates, requirements. Write Kessler Corporation, C-56-FI, Fremont, Ohio.

YOU Can invent and make money. Complete textbook, "Inventing To Sell," published at \$5.00. Order within 10 days, special \$2.98. Post-free. Ma'son Enterprises, Box 6654, Richmond, Virginia. (Department B)

Unlike Other publications that deal in useless generalities, "Opportunities For the Independent Inventor" is the first book (Not a pamphlet!) of detailed, complete, practical "how to" information and advice for independent inventors. Your inventing guide—"must" reading before investing in your ideas. \$2.75. Mardon Industries, P.O. Box 79, Annandale, Virginia 22003.

PATENT Office drawings skillfully executed; reasonable, free engineering and booklet "How to Invent." Pen-Ink, 50 East 42 Street, New York 17.

U.S. Patent Office Searches, 234 Broadway, Room 3615, New York. Free invention certificates.

INVENTIONS WANTED

INVENTORS: Protect your ideas! Free "Recommended Procedure." Washington Inventors Service, 422F, Washington Building, District of Columbia 5.

WE Either sell your invention or pay cash bonus. Write for details. Universal Inventions, 298-E, Marion, Ohio.

INVENTORS Wanted: Manufacturers need new items! Your inventions, ideas developed for cash/royalty sales. Free "Invention Record": Information. Raymond Lee, 130-P West 42nd, New York City 10036.

INVENTORS! Don't sell or license your invention for cash or royalties until you receive our offer. Financial assistance available. For free information, write Dept. 76, International Invention Institute, 17 Park Row, New York 38, N.Y.

INVENTORS Needing Help with any problem, financial, development, securing manufacturer, obtaining patent. Write the organization that delivers action and results—not promises. Pioneer Invention Service, Dept. 83, 150 Broadway, New York 38, N.Y.

ORIGINAL Worthwhile ideas, inventions, gadgets, patented, non-patented wanted. All fields, buy, sell, develop or market by experienced professional engineering corporation. Project Bold Venture, Inc., 126 Jackson, North Hopkins, Minnesota 55343.

INVENTIONS Wanted. Patented: unpatented. Tremendous manufacturers lists. Global Marketing Service, 2420G 77th, Oakland 5, California.

IF Your invention is adaptable to promoting we will contract for selling on cash or royalty. Free booklet outlines royalty rates, requirements. Kessler Corporation, C-55-IW, Fremont, Ohio.

INVENTIONS Wanted immediately for promoting on cash or royalty. Patented, unpatented. Free booklet outlines royalty rates, requirements. Write Kessler Corporation, C-58-IW, Fremont, Ohio.

MANUFACTURING

INVENTORS Services, Models, Manufacturing, Research, Consultants all fields available. William Parker, 32 Westminster, Worcester, Mass. 01605.

MODELS—Small lot manufacturing. Metals, plastics, etc. Milburn, Burlington, Kentucky.

BUY IT WHOLESALE

BARGAINS! Buy wholesale and below. Name brands. Appliances, furniture, sports equipment, televisions, cameras, watches, jewelry, thousands more. Huge discounts to \$1,000.00 on new automobiles. All makes. Free details. Write today: Worldwide Bargainhunters, Box 730-A, Holland, Michigan.

ELECTRIC Guitars, amplifiers, wholesale. Free catalog. Carvin PMW, Covina, Calif. 91722.

WHOLESALE RAMA, Bargain Catalog 20¢. Pair Sales, Box 5152-PM, Kingsport, Tennessee.

BARGAINS! Buy wholesale! Save money! Free catalog! Norris, 273 Merrick, Dept. 215, Lynbrook, N.Y.

HEARING Aid batteries wholesale. National Wholesale Battery Company, P.O. Box 825, Wichita, Kansas 67201.

NEW 6-Color Deluxe below wholesale catalog. Automobile catalog and others. Housewares, clothing furs, furniture, rugs, appliances, refrigerators, washers, dryers, vacuum cleaners, polishers, cookware, dinnerware, strollers, cribs, radios, stereos, phonographs, records, recorders, cameras, film, projectors, musical instruments, organs, typewriters, books, binoculars, luggage, sporting goods, bowling, golf, game tables, power/rider mowers, garden tractors, boats, motors, bicycles, clocks, watches, diamonds, jewelry. Huge discounts, hundreds name-brand products. For free list (factory prices) postcard: Selbyco-5, Decatur, Illinois 62522.

HUGE Savings on high ticket items. Write needs; We'll quote. No obligation. Box 287, Chicago 60645.

100,000 BARGAINS! Wholesale! Imports! Closeouts! Wholesalers, 1265-MP Broadway, New York 1, N.Y.

WORLD'S Largest wholesale supply. Buy from 7853 American, European, Japanese wholesalers. Hong Kong tailored suits. 123 dropship catalogs. Rockbottom prices. Automobiles. Free details. International Buyers, 216-M Jackson, Chicago 6, Illinois.

EXPORT-IMPORT

JAPAN: Mail-Order 26 page catalog, dolls, novelties, Manufacturers' names, addresses \$1.00; 1000 products illustrated trade directory \$3.00. Send cash. Yamagata Office, 814 Togin Bldg., Marunouchi, Tokyo.

YOUR Ad in this space will be read by more than 1,400,000 active mail order buyers. Join the march to greater profits, place your products and services in front of them today with a small low cost classified ad. For further details, write: C. A. Martin, Dept. 15N, Popular Mechanics, 575 Lexington Avenue, New York, New York 10022.

FOR THE HOME

"HOW To Choose Your House" new book, 104 photos saves \$\$\$ in buying, avoids boobytraps, shows how to improve, repair, \$3. Kent Publishers, Brookline, Mass.

STOP Leaky faucets instantly. Weavever seals, 5 \$1.00. Jordan, 743 Dorrance, Philadelphia, Pa. 19146.

RID Home of cockroaches permanently. Five cent stamp for details. Haun, 357, Catlin, Illinois.

OF INTEREST TO WOMEN

\$200.00 MONTHLY Possible, sewing babywear! Write: Cuties, Warsaw 9, Indiana 46580.

"MANUSCRIPT Typing Moneymaking"—Exciting! Dignified! Instructions, \$1.00. Magnetic, Box 3677-PMR, Washington 20007.

DRIVE New car, wear new clothes, buy color TV. Get daily cash income. Put spare hours to work. Write for 5 months free subscription Opportunity Magazine; see hundreds easy ways to make money. Opportunity, Dept. 17-DO, 850 N. Dearborn, Chicago.

\$45.00 THOUSAND My way, compiling lists, addressing from them; longhand, typewriter. Information, stamped, addressed envelope. Brewster, Box 397-J, Indian Rocks Beach, Florida 33535.

CANDLEMAKING & Decorating. Terrific hobby. Great business; Learn fascinating molding, dipping, creating & decorating candles for year-round demand—holidays, birthdays, weddings, anniversaries. All events. Spare time fun & extra income now; expand to colorful candle shop later. No age limit. Write for free facts on home instruction method. Candle Institute, Box 54-GE, Redondo Beach, Cal.

BUTTONS 800, \$1.00. Quiltpatches 300, \$1.00. Nylolaces 40 yards, \$1. Schaefer, Champlain, N.Y.

LEARN Expert cake decorating, candy making. Free details on home instruction method. Candy & Cake, Box 54 AKC, Redondo Beach, Calif.

MAKE Extra money—show friends, neighbors—gifts, stationery, Christmas, all occasion cards. Experience unnecessary. Salable samples on approval, free catalog, free name imprinted Christmas card album. Hedenkamp, 361 Broadway, Dept. PM-91, New York.

WOMEN! Make big money at home. \$10.00 profit in an hour possible with invisible mending. Make holes, tears disappear from clothing, fabrics. Steady year-round demand from cleaners, laundries, homes. Details free. Fabricon, 1533 Howard, Chicago 26, Illinois.

HOUSEWIVES. Teachers, students, office workers. If you need extra cash each week but household or other duties prevent you from taking a part-time job, learn how you can earn by accepting orders to Popular Mechanics, Good Housekeeping and all other magazines. No experience needed. Write Popular Mechanics, Room 6-W, 250 West 55th St., New York 19, New York.

WATCHES, OLD GOLD, JEWELRY

WATCH And clock repairing books. Free catalog. North American, Box 77-AT, Fox River Grove, Illinois 60021.

USED Pocket watches—as is—5 for \$25.00. Joseph Bros., 5 South Wabash, Chicago 60603.

WANTED, Gold, silver, platinum, scrap (any form), coins. Information free. Wilmot's, 1067-D Bridge St., Grand Rapids, Michigan 49504.

USED Brand name watches \$5 up. Free list. Southern Watches, 5-PM South Wabash, Chicago 60603.

CASH Immediately for old gold, jewelry, gold teeth, watches, diamonds, silverware, spectacles, platinum, mercury. Free information. Rose Industries, 29-A East Madison, Chicago 2.

HIGHEST Cash—Gold, Jewelry, Diamonds, Silver, Platinum. Mail articles. Free information. Chicago Gold & Precious Metals, 6 E. Monroe, Dept. 3258, Chicago 60603.

WEARING APPAREL

WORK Clothes used laundered short sleeve shirts and pants, \$2.00 per set, all sizes. M & S. Used work clothes 20457 Freeland Avenue, Detroit, Michigan 48235.

YOUR Ad in this space will be read by more than 1,400,000 active mail order buyers. Join the march to greater profits, place your products and services in front of them today with a small low cost classified ad. For further details, write: C. A. Martin, Dept. 15N, Popular Mechanics, 575 Lexington Avenue, New York, New York 10022.



SCIENCE AND CHEMISTRY

UNUSUAL Chemistry courses, kits! Information booklet, 25¢. National, Box 94, Redwood City, Calif. 94064.

SKYROCKETS, Firecrackers, fireworks—Make your own! 60 simple formulas \$1.00; 30 smoke formulas, 15 colors \$1.00; 10 fuse formulas 50¢. Paloma Pyrotechnics, Box 247, Auburn 5, California.

ROCKETS! Flight kits, testing equipment. Catalog 25¢. Rocket Development Corporation, Route 3, Seymour, Indiana 47274.

AMAZING New book of science experiments, formulas, and catalogue of laboratory supplies. Only 35¢. National Scientific Co., 13 S. Park Avenue, Dept. PM-5, Lombard, Illinois.

FIREWORKS Supplies, casings, end caps, plugs, chemicals, fuse, do-it-yourself kits, send 35¢ for samples and catalogue—Ecco, Box 189, Northvale, New Jersey 07647.

CHEMICALS And apparatus for industrial, analytical, and private laboratories. Catalog 35¢. Dept. M-50, Biological Supply Co., 1176 Mt. Hope Ave., Rochester 20, N.Y.

CHEMICALS, Apparatus, Biology, Catalog 25¢. Mid-States Scientific, 7053 N. Clark, Chicago, Ill.

SEARCHING For economically priced chemicals and apparatus? Gifts with catalog, 25¢. Starr Scientific, Manitowoc, Wisconsin 54220.

CONTACT Explosive. Explodes with touch of feather. Handled safely wet. Powerful. Ideal for jokes. Applies like paint. Made from household chemicals. Results guaranteed. Complete instruction for making both kinds only \$1.00. Franks Scientific Company, P.O. Box 156, Martelle, Iowa 52305.

ROCKETS, Single, multi-stage kits, parts amazing Accelerometer, Illustrated catalogue 25¢ Rocket Supply, Box 51B, Tappan, New York 10983.

ROCKETS: New illustrated catalog, 25¢. Single and multistage kits, cones, engines, launchers, trackers, rocket aerial cameras, technical information. Fast service. Estes Industries, Penrose 7, Colorado.

CHEMICALS, Laboratory apparatus, microscopes, mineralogy sets and telescopes. Catalog, 35¢. Sheard Science Supplies, Columbus, Wisconsin.

CHERRY Bomb fuse 60 feet with firework. Information, formulas, \$1.00 post-paid, 125 feet \$2.00. Wayno, Box 1184, Addison, Mich.

PROFESSIONAL Firecracker fuse, burns, underwater, 75 feet, \$1. Fireworks, explosives formulas, free information, Edcolabs, Box 99, Berlin, New Jersey 08009.

FIREWORKS—Explosives—detonators. New manual reveals formulas, preparations, only \$2. Free with order, \$2 certificate for fuse. Pyrochem, Box 169, Berlin, New Jersey 08009.

SCIENCE Fair booklet listing experiments, information, suggestions, \$1.00. Hagenow Laboratories, Manitowoc, Wisconsin 54220.

OVER 40 exciting formulas for making rockets, smoke trails, fulminates, etc. Comes in semi-hard cover, \$1.00 P.P. Iles Enterprises, Box 72, Dana Point, California.

PYROTECHNICAL Casings, 1" diameter 6" long heavy wall \$6.00 per hundred, aluminum powder, oxidizers unbeatable prices. K&E Components, Pompton Lakes, New Jersey.

GERMAN Rocket and fireworks formulas, \$1.00. Import, P.O. Box 71, Pottsville, Pa.

ROCKETS: New high altitude kits, engines, supplies. Illustrated catalog, 25¢. Central Rocket Company, Waupaca, Wisconsin 54981.

MAGIC Mixture makes clouds of red smoke, \$3.75 half-pound, \$6.50 pound post-paid. Zane Specialty Products, 541 N. Lincoln, Alliance, Ohio 44601.

64 PAGE Color catalog, Science, electronic, chemistry and hobby kits. Radio kit \$2.98. Solar Engine \$1.49. Send 25¢ Schoolmasters Science, 745 State Circle Ann Arbor, Michigan.

SKYROCKETS, Fireworks—easy instruction manual: 28 types—rockets (5000' high), aerial displays, fountains, whistles, firecrackers, balloons \$1.00; 63 formulas—contact explosives, most effective propellants, colored flares, smokes, fuses, sparklers \$1.00. Satisfaction guaranteed. Sentec, 433-X6 Ellis, San Francisco 2.

LIQUID Propellant rocket: 100 pounds thrust for seven seconds; 10 pounds payload to 6000'. 5' tall. Plans, \$2.98. Parts available. New: Amateur Rocketry Magazine, 50¢. Star Space Systems, Box 4353, Inglewood, California.

ILLUSTRATED Catalog: Chemistry, mineralogy, biology 25¢. Tracey Laboratories, Evanston, Illinois.

FORMULAS, PLANS, ETC.

LATE, Modern manufacturing formulas. List free. Moon Chemical, Martville, New York.

PROFITABLE Manufacturing formulas. Literature free. Pontesso, 2625 South Eighth, Terre Haute, Indiana.

FORMULAS—All kinds. Amazing big catalog, 10¢. Kemixal, Park Ridge, Ill.

FOR Proof of what you can do in specialty manufacturing get our literature. It's free! Miller, Chemist, 1517-P, Tampa, Florida.

SKYROCKETS, Fireworks, Manual, 125 Formulas, \$2.00. Skymail, Box 874-M, Sunnysvale 88, Calif.

10,000 FORMULAS. Free details. Reports, 2800a University, San Diego, California.

FREE Catalog of formulas, home business and money-making plans galore! No charge, no obligation. Western Chemicals, Box 19718-C, Los Angeles 90019.

PLASTICS

NEW Liquid casting plastic clear colors. Embed real flowers, butterflies, photos, coins. Send 25¢ for two handbooks "How to Cast Liquid Plastics" and "How to Make Extra Money at Home." Castolite, Dept. 66-101-G, Woodstock, Illinois.

BOXES, Plastic, 200 sizes. Free list. Author, 2260 Benson Ave., Brooklyn, N.Y.

PLASTIC Embedders, jewelry workers. We have everything. Findings, moulds. New catalog 25¢. David Co., 861 Broad St., Dept. M, Providence, R.I. 02907.

INSTANT Fossils! Projectable, kit \$4.00; sample-catalog 25¢. Fossilides, Snoqualmie, Washington.

FREE Samples plastic (polyethylene) bags for packaging. Tadco, Lafayette, New Jersey.

New, Highly profitable plastic laminating business. American presses 4 times faster . . . 4 times more profitable. American Machine, 1128-BA Dana, Hixson, Tennessee.

PLASTICS for arts & crafts, fun & profit. See how easy it is to work with liquid plastics. Turn your plastics hobby into \$ for you. Send 50¢ for catalog to PMI, 1644 20th, Santa Monica, California.

TREASURE FINDERS

POWERFUL Metrotech locators detect gold, silver, coins, relics. Moneyback guarantee, terms. Free information. Underground Explorations, Dept. A, Box 793, Menlo Park, California.

TREASURE, Gold, silver, relics. New 1966 detectors now available. Free information. Rayscope, Box 715, North Hollywood, California.

TREASURE, Find gold, silver, relics with super, powerful Detectron locators. Free information. Detectron, Dept. 6-PM, P.O. Box 243, San Gabriel, California.

BEFORE Buying a metal detector, find out about Sensitronix's new "Electronic Prospectors"—the latest development in treasure and coin detection equipment. Trade-ins accepted. Free information and treasure hunting guide. Sensitronix, 2225-C Lou Ellen, Houston, Texas 77018.

NEW Revolutionary selective transistor metal detector and six other models. Free catalog. Gardiner Electronics Co., Dept. 9, 4729 N. 7th Avenue, Phoenix, Arizona 85013.

COMPLETELY New prospecting technique developed by Relco. New transistor models detect buried gold, silver, coins, treasures. \$19.95 to \$129.50. Write for free catalog and "guide for beginners". Relco-A40, Box 10563, Houston 18, Texas.

TREASURE Metal detectors most complete line in U.S.A. Free catalog. Bill's Service Center, Box 1, Paramount, California.

FUN & Profit finding buried treasure, relics with Transistor M-Scope. Booklet, interesting customer comments FREE. Terms, Fisher Research, Dept. AAX, Palo Alto, California 94302.

NUCLEAR Locators! Coins, relics! write Howe, 811-C Kansas, Atchison, Kansas.

DETECT Buried Treasure! Wireless device detects buried gold, silver, coins, gems, etc., \$8.95 complete. Cash or C.O.D. The Idea Center, P.O. Box 3024, Alexandria, Virginia.

AUTHENTICATED Lost treasures. How and where to look, \$5.95. Brooks P.O. Box 12382, Phoenix, Arizona 85034.

PRECIOUS STONES AND MINERALS

EARTH Science, Educational magazine. Subscription, \$2.50. Sample, 35¢. Box 550-PM, Downers Grove, Ill. 60515.

DIAMOND, Guaranteed genuine, natural, \$2.00. Apprx. Weight 1/4 carat. Diamond pencil, \$2.95. C & J Diamond Company, Box 97-M, Plainview, L.I., N.Y. 11803.

GET Free catalog no serious rockhound, gem cutter, jewelry maker, hobbyist or craftsman can be without. Full of bargains, exclusive items, low prices from largest suppliers and authorities in the field. Free new catalog just off the press, yours for the asking. Write Grieger's, Dept. C-12, 1633 E. Walnut, Pasadena, California.

JADE Tie tack, rockhound catalogs, \$1.00. Daley, Box 405C, Driggs, Idaho.

SEMI-Precious uncut gems. Ten different for \$1.00. Request list 30. Prospectors Shop, 201 San Francisco, Santa Fe, New Mexico.

CARTOONING, COMMERCIAL ART, SHOWCARD & SIGN PAINTING, TATTOOING

SIGN Painting. Fascinating system. Straley, 410 South Western, Springfield, Ohio.

SIGN Painting and art. Instructions, brushes, equipment, everything. Free catalogue. Kaufmann Supply, Centertown, Missouri.

YOU Can entertain with chalk talks. Catalog 10¢. Balda the Cartoonist, Oshkosh, Wis.

ART Lessons \$6.00 a month. Includes drawing, painting, advertising art, cartooning. Art kits (worth \$25) and materials. Assignments corrected with overlays by mail and returned to you. Write for free book. No obligation. Washington School of Art, Studio 146, Port Washington, L.I. N.Y.

LEARN Sign painting at home. Free talent test. Ben Kerns, Box 812-PM, Greenville, S.C.

LEARN Profitable magazine cartooning. Free details. Hartman, Box 3097, Lincoln 10, Nebraska.

CARTOONING And commercial art. Easy home-study drawing course. Art background not necessary. Excellent creative money making opportunities part or full time. We show you how. Low monthly tuition. Free booklet. Continental Schools, Dept. 6A-2, 1330 W. Olympic Blvd., Los Angeles, Calif. 90015.

LIKE To draw? Splendid opportunities in professional cartooning. Write for free catalogue. No obligation. National School of Cartooning, Studio-H, Box 8958, Cleveland 36, Ohio.

ADVERTISING AGENCIES, ADV. SERVICE, MAILING LISTS

MAILING Lists most all kinds 1000 \$5.00. Free folder. Your circulars mailed \$4.00 1000. Dixie Mailers, King, N.C.

MAILING Lists, 1000 Names & Addresses on labels, \$3.99. Circle Publishing, Bartlett, Ill. 60103.

OUR Clients' mailorder advertisements in magazine and newspapers must pay. If yours don't, contact John O. Powers Advertising Agency, 116 John, New York 38.

10,000 NATIONWIDE Hobby outlets—\$10 thousand. Albano, 78-01 19th Avenue, Brooklyn 11214.

ADVERTISING Ratebook leading newspapers, magazines, free. Chicago Advertising Agency, 28-E Jackson, Chicago 4.

MAILORDER Record Book, 30 pages. Records inquiries, orders, advertising expense, etc. Most complete. Just send dime for postage and handling. C. A. Martin, Popular Mechanics, Dept. RB6, 575 Lexington Ave., New York, N.Y. 10022.

TYPEWRITERS, DUPLICATORS, OFFICE EQUIPMENT

OFFSET. Letterpresses, varitypers, typewriters, mimeograph, multigraph machines. Bargains. DixieGraph, King, North Carolina.

YOUR Ad in this space will be read by more than 1,400,000 active mail order buyers. Join the march to greater profits, place your products and services in front of them today with a small low cost classified ad. For further details, write: C. A. Martin, Dept. 15N, Popular Mechanics, 575 Lexington Avenue, New York, New York 10022.

RUBBER STAMPS AND OFFICE SUPPLIES

FREE 32 Page rubber stamp catalog. Signature stamps \$3.50. Youngers Stamp Shop, Princeton, Iowa.

CATALOG: Rubber stamps, daters, printing. Martin, 1425 Major, Jefferson City, Missouri 65101.

FREE Catalog: Rubber stamps, printing. Dowling Products, Dept. PM36, Pitts-town, N.J.

PRINTING, MULTIGRAPHING, MIMEOGRAPHING, GUMMED LABELS

1000 GUMMED Address labels, \$1.00. Walt's, Box 966-A, South Bend, Indiana 46624.

AMAZING Business printing values. Samples. Print Shop, Box 576, Greenville, R. I. 02828.

OFFSET Printing. Here's the one. 48Hr. Service—Lowest prices. Cisco's Duplicating, Atlanta, Illinois 61723.

GOLD Embossed business cards. Samples. MTL Printercraft, Box 947, Chicago 60690.

PRESTIGE Business printing values. Samples. Aircraft Press, Box 178, Brighton, Michigan 48116.

QUALITY Printing: Lowest prices. Samples. Dowling Press, Dept. PM-36, Pitts-town, N.J.

1000 EMBOSSED Business cards \$2.99. Agents wanted. Eldee, Allendale, N.J.

FREE Offset printing catalog: BLS, 6527 Telegraph, Oakland, Calif. 652-4787.

BUSINESS Cards embossed—1,000 \$4.10, postpaid. Goodall Printing, 68-N Joost, San Francisco 94131.

1,000 THERMOGRAPHED (Raised letter) business cards, \$4.95. Free samples! Griffin, 322 West State, Ithaca, New York 14850.

PRINTING & RUBBER STAMP OUTFITS—SUPPLIES

RUBBER Stamp manufacturers supplies. New products. Low prices. Catalog. Jackson Supply, 1433 Winnemac, Chicago, Illinois 60640.

MAKE Your own self-molding rubber stamps and printing cuts. Plexirubber, Argyle 1, Wisconsin.

RUBBER Stamp presses, hydraulic operated, electrically heated. Sizes 5" x 8", 8" x 12", 10" x 15". Starting outfits, supplies. Printing presses, Custom Manufacturing, 1464-P East Commercial, Springfield, Missouri.

PRINTING Presses, type, supplies. Lists. 5¢. Turnbaugh Service, Mechanicsburg, Pennsylvania.

DO Your own printing. Save money. Simple rules. We supply everything. Print for others: good profit. Raised printing like engraving too. Have home shop. Details free. Kelsey Presses, V-11, Meriden, Connecticut.

NEW Type Catalog No. 11, 96 Pages. Send One Dollar. Deductible First Order. Acme Type, 732 Federal, Chicago, Illinois.

TYPE And supplies for rubber stamp makers. New wholesale price list No. 3 free. Star Stamp Supply, 732 Federal, Chicago 5, Ill.

REMAILING SERVICE

SECRET Mail receiving system. Hedg-peth, 406-M South Second, Alhambra, California 91802.

HAWAII Secret Address. Remails 25¢. Receiving-forwarding \$3.00 monthly. Postcards, gifts, slides. Uppie, Box 984, Kailua, Hawaii 96734.

OLD Established \$3.00 unlimited monthly. DeGraff, Box 14156P, San Diego, California

MIAMI Remails 25¢. Monthly Rates. Marle, P.O.B. 1266, Coral Gables, Florida 33134.

PRIVATE Address, information 25¢, remails 25¢. Horton, 68 Kensington, Greenville, South Carolina 29609.

CONFIDENTIAL Remailing, 25¢ letter, free details. Krautz, Box 1328, Chico, California 95926.

CANADIAN Address. Details, 10¢. Moore's, Box 37, Wasaga, Beach, Ontario, Canada.

PHILADELPHIA Remails, 25¢. \$3.00 monthly. Lorenz, 240 Wanamaker, Essington, Penna.

CHICAGO Remails, 25¢. \$3.00 Monthly. Florentine, 714 No. Monticello, Chicago, Ill. 60624.

LOS Angeles, confidential remailing, 25¢. Marco, Box 65612, California 90665.

ALASKA Remail, 25¢ single, \$3.00 monthly, confidential. Malone, 274 So. Klevin, Anchorage, Alaska 99504.

REMAILING, 15¢ Per item. Cadillac, Box 101, Wildwood, New Jersey.

TIMELY Remailing 25¢. Confidential. Monthly \$3.00. Colorful Postcards. Schoen, Box 1963P Chicago, Illinois 60690.

SECRET Address, Central Ohio, 25¢, \$3.00 monthly. Information 25¢. Van's, Box 601, Shelby, Ohio 44875.

SO. AMERICA Registered re-airmails, \$1.00. Confidential, reliable. Genaro, Box 360, Guayaquil, Ecuador.

NATIONS Captial remails, 20¢. Six gorgeous postcards, \$1.00 remailed free. Box 28072, Washington, D.C. 20005.

BROOKLYN Remails secret, 25¢. Monthly rates, \$3.00. Krause, Box 197, Flatbush Station, Brooklyn, N.Y. 11226.

SAN Francisco remails. Letters 15¢, cards 10¢. 2165 51st Ave., Oakland, Calif. 94601.

OREGON Remail receiving, 25¢. University Town, Morris, 298 Hawthorn.

N.Y.C. Remails, 25¢, \$3.00 monthly. Dowling, P.O. Box 64, Staten Island, N.Y. 10307.

CONFIDENTIAL Remailing service. Details. Randolph, 3336-B Hillside, Cincinnati, Ohio 45204.

LOS Angeles address, remails. Confidential. Enarkay, 1805 Wilshire, Suite 206, California 90057.

FRANKFURT Germany on local remails. Confidential. O'Brien, P.O. Box 907, Beaverton, Oregon.

TRACTS Mailed anywhere. Christian Tract Center, 3905 Victoria, Hampton, Va.

SECRET Receiving and remailing. Discreet and confidential. Remail 25¢ single. 8050 S. Main, Houston, Texas.

REPAIRS AND SERVICING

HEARING Aids repaired, 6 month-guarantee, \$15.00. Florida Hearing Aid Repair, Box 11233, Ft. Lauderdale, Florida 33306.

PARTS Sheets, digrams, and instruction manuals for repairing air and electric power tools, hydraulic jacks, and chain hoists. Free catalog and samples. Tech-Aids, Box 381, Baton Rouge, La.

YOUR Ad in this space will be read by more than 1,400,000 active mail order buyers. Join the march to greater profits, place your products and services in front of them today with a small low cost classified ad. For further details, write: C. A. Martin, Dept. 15N, Popular Mechanics, 575 Lexington Avenue, New York, New York 10022.

SPECIAL SERVICES

FACTS. Any subject—product. Research, reports. Plan \$1.00. Box 1431, Greenville, South Carolina 29602.

LOCATING Service! Any items or product, Jake Barraco, 478 Gardner, South Beloit, Illinois.

EYEGASSES! Wholesale laboratory established 25 years. Mail eyeglasses or prescription for quote. Global Opticians, 16 East 23 St., New York, N.Y.

TOBACCO

BLACK Watch pipe tobacco, hand blended, mild & aromatic, \$1.00 cash-O.K. Vottis Pipe, 11-S, Pearl St., Albany, N.Y.

RAZORS

YOUR Ad in this space will be read by more than 1,400 active mail order buyers. Join the march to greater profits, place your products and services in front of them today with a small low cost classified ad. For further details, write: C. A. Martin, Dept. 82N, Popular Mechanics, 575 Lexington Avenue, New York, New York 10022.

WANTED—MISCELLANEOUS

STAMP Collections, accumulations. Eagle Stamp Co., 2221 Romine, Pittsburgh 26, Penna.

USED Double barrel shotguns L. C. Smith, Parker, Ithaca, Fox. Also 45 Automatics, Luger Pistols, others, Doug Powers, Perry, Florida.

MERCURY. Gold, Silver, Platinum; Ores assayed. Wholesale Terminal, Norwood, Mass.

PERSONAL

FREE Details solution to all financial problems. Amazing results. Loans available. Write Financial Consultants, 28 E. Jackson, Suite 1204-PM, Chicago 4.

LOANS By mail, \$100-\$1000. Anywhere. Confidential. Write Union Finance, Dept. PM, 222 W. Osborne, P.O. Box 7457, Phoenix, Arizona.

FREE. Booklet "Wills How To Make & Break Them," with 3 will forms \$1.00. Urban-Rural, Box 293, Fort Lee, N.J.

INVESTIGATORS. Free brochure, latest subminiature electronic surveillance equipment. Ace Electronics, 11500-P NW 7th Ave., Miami, Florida 33168.

BLITZ Reducing! 5 pounds overnight! Guaranteed! Bijou, Box 1727-BM, Hollywood, California 90028.

BORROW \$1,233 Airmail! Repay \$54 for twenty-nine months. State licensed. Postal Finance, Dept. 17-M, Kansas City, Kansas 66117.

GET Out of debt—clear credit, immediate relief. Advisor, Box 48337-PM1, Los Angeles 90048.

BILL Problems? Poor credit no trouble. Not a loan company. Send name for free application. Automatic Acceptance, 1326PM Plainfield St., Cranston, R.I. or 318PM Broadway Blvd., Reno, Nevada.

BIBLE Questions answered. Stamped envelope. Bylon, 17167 Bentler, Detroit, Michigan 48219.

CONSOLIDATE All your bills into one—small monthly payment! Borrow \$100 to \$1,000 by mail! Pay off all your debts—repay in convenient, monthly payments . . . take up to 36 months. \$5.00 repays \$104.65; \$14.00 repays \$293.03; \$25.00 repays \$532.26; \$33.00 repays \$819.57; \$40.00 repays \$1,009.36. Everything comes to you in plain envelope! "U.S. Mail" secrecy . . . no co-signers needed! Get the money you need fast . . . Write for information today! No obligation! Dial Finance Co., Dept. 6-214, 410 Kilpatrick Bldg., Omaha, Nebraska 68102.

FREE—"How to wipe out all debts." Just write: Counselor, Harlingen 7, Texas.

APTITUDE Test reveals your hidden interests. Specially prepared for you to take at home and score yourself. Helps you find happiness in your rewarding career. Complete kit, \$1: Donald Roberts Company, GPO Box 1667, New York, New York 10001.

"PAY Off your debt" No loans, no outside help. Information \$2.00. Sanom's Enterprises, Redford Heights, PO Box 6693, Detroit, Michigan 48240.

HOW To retire without money. Details free. Jackson, Box 7224-P, Jacksonville, Florida 32210.

SUBCONSCIOUS Conditioning remakes personality while you sleep. Free details. Sleep-Learning, Box 24N, Olympia, Washington.

MISCELLANEOUS

CIGARETTES—Make 20 plain or filter-tip for 9¢. Factory-fresh pipe tobaccos. Mild tropical flavored Philippine cigars. Facts free. Moberly, Box 905, Owensboro, Kentucky.

SAFEGUARD Privacy! New instrument detects electronic "bugs," wire-tapping and snooping devices. Free information. Dee Equipment, Box 7263-E4, Houston 8, Texas.

ORNAMENTAL Iron designs. Book of 1600 beautiful, practical designs for railings, columns, etc. Free literature. Cunningham, 3881 South 3200 West, Salt Lake City, Utah 84119.

LOG Cabins: Ship anywhere; 35 plans, specifications and prices. Send \$1.00. Write Bloch Brothers, Waterford 4, Michigan.

LOANS By mail, \$100-\$1000. Anywhere. Confidential. Write Union Finance, Dept. PM, 222 W. Osborne, P.O. Box 7457, Phoenix, Arizona.

SUPERSENSITIVE Listening-In-Device picks up any telephone conversation in vicinity. No connection to telephone necessary. \$2.98 complete. Consolidated Acoustics, 1302K Washington, Hoboken, N.J.

BIRTH Certificates, Marriage Certificates, Diplomas! 2 blank forms \$1.00. Sample 10¢. Standard Forms, Box 482-M, Washington, D.C. 20044.

"CIGARETTES" — (Roll your own). Pipe, Chewing, Smoking tobaccos. Facts free. Write Fred Stoker, Dresden, Tennessee.

FREE Wholesale catalog! 100,000 products. Tremendous discounts! Taylor Distributors, Newton 2, New Jersey.

LISTEN-In device! Powerful! Monitor telephone conversations, etc. Unnoticed! \$3.98 (guaranteed). Research Enterprises, 29-SN4 Samost, Woburn, Mass.

KILL Mosquitoes, crop destroyers. Electronically. Free information. Box P. 204, Metamora, Michigan 48455.

BOOKS On antiques and their prices. Free circular! P. Warman Publishers, Uniontown, Penna.

YOUR Name sent to 1000 importers, publishers, mailers, wholesalers, etc. on our mailing list. Year \$1.00. Dixie Mailers, King, N. Car.

BIG Mails 6 mo., \$1, 1 year, \$2. Domestic-International, Home Shopping Service, Lept. PM-20, Tomah, Wisconsin 54660.

EYE Glasses loose? Slipping down? Invisible Snug-Aids solve problem instantly. Send \$1.00, Snug-Aids, Box 3492, Granada Hills, California.

SILVER, Pure, 999 fine, three-ounces- ingot \$7; three \$20. Twelve-ounces-ingot \$27. Shonback, Box 22168, San Francisco, California 94122.

SCARCE Spare parts or other items. Satisfaction guaranteed. Box 287, Chicago 60645.

PUNCTURE PROOF—At last, bicycle tire sealant that does work. Not gummy, non hardening. Three years actual use research. Ask your bicycle dealer, or send \$1.98—for "Tiremate"—treats two tires. Tiremate Corp., 720 So Penn Ave., Alamogordo, New Mexico 88310.

LET A pharmacist tell you how to save money on your prescriptions and still get them from your neighborhood pharmacy. I have been a pharmacist for over thirty five years and the information I can give you will save you many dollars if acted upon. You do not have to be a large buyer however this is the same way hundreds of doctors, clinics, universities, corporations and governmental agencies, including U.S. Dept. of Agriculture, Dept. of Army and many more acquire the medicine and vitamins they need. This information applies to most modern medication and your money will be refunded if not as represented. Stop paying more than needed for your medicine. This applies to anyone whether you have reached the age for Medicare or not. Act now and save. Send one dollar to Pharmacist, P.O. Box 1813, Gary, Indiana.

CLEANING Towel, no soap or water. Removes stains, grease, etc. from hands, car, furniture, etc. Re-usable, durable. 79¢-3/\$2.00. Gemy 4175 Yale, La Mesa, 41 Calif.

LIKE Picnics then try newly developed tableclips to secure your tablecloth. Fits all tables. Six for \$1 postpaid. K & F Plastics 1987 Balfour, Windsor Ontario, Canada.

WINEMAKERS, Free illustrated catalog of yeasts, equipment, Semplex, Box 7208, Minneapolis, Minn. 55412.

CONVENIENT Business or personal checking accounts without service charges or minimum balance. List of banks \$1.00. Williamsburgh Company, Box 118-M, Brooklyn, N. Y. 11203.

WINEMAKER'S Supplies. Complete line. Send 25¢ for illustrated catalog. Presque Isle Wine Cellars, 5422-5 Glenwood Park Ave., Erie, Pa. 16509.

PROFESSIONAL Burglar alarm installation instructions, \$1.50. Eaco., Box 1001, El Dorado, Ark.

BURGLAR Alarm devices — Complete line, catalog, \$1.00. Also resident training course. Sootin's, 321 Northwest Third Ave., Miami, Florida.

MARRIAGE, Birth Certificates, Diplomas, Quality forms, \$1.20 each. Brugenheimer Publishers, Box 158-PM3, Lexington, Mass.

WHO Will inherit your property? Be sure!! Make your will now! 3 blank forms. Instruction pamphlet, \$1.00. Satisfaction guaranteed. Dewey, 1035-E, Commerce City Colorado 80022.

HEARING Aid batteries wholesale. Free list. Habs, Box 51, York, Penna.

MAILORDER Record Book, 30 pages. Records inquiries, orders, advertising expense, etc. Most complete. Just send dime for postage and handling. C. A. Martin, Popular Mechanics, Dept. RB6, 575 Lexington Ave., New York, N.Y. 10022.



Makes a fine second car. Or a wonderful first truck.

Does the car-like ride of Ford pickups mean we've gone soft? Quite the contrary. Instead of one, we now have two I-beam axles up front, one for each front wheel, working independently. Shocks at one wheel don't get passed over to the other. Or to the driver. Husky radius rods hold wheel alignment too. Even the engines have big muscle: two husky Sixes have such punch, we had to develop a big new V-8 to keep ahead of them. So relax. Enjoy Ford's smooth ride. Just remember that under that velvet is a solid truck, with toughness where it counts. Very comforting.



Two front axles of forged steel I-beam make Ford's Twin-I-Beam suspension the most durable independent suspension in any pickup.

YOU'RE AHEAD
IN A FORD
ALL THE WAY

FORD/66



Low-silhouette
9½ hp Evinrude
SPORTWIN

Compact
6 hp Evinrude
FISHERMAN

Budget-priced
5 hp Evinrude
ANGLER

Folding
3 hp Evinrude
LIGHTWIN

fishermen aren't all alike ...why should fishing motors be?

The only people who think all fishermen are alike are the women they're married to.

Here at Evinrude—where we've been building motors for fishermen ever since there were fishing motors — we know better.

We don't try to change the fisherman; we just design the motor to fit the kind of fishing he likes best.

We build all kinds of fishing motors. Compact motors, low-silhouette motors, deluxe motors, economy motors. Motors that fold into a carrying case and stow anywhere, and motors so weedless they'll go anywhere. Rugged,

quiet, twin cylinder motors that will start and run anytime, on any water in any weather, on any available outboard fuel.

We build more sizes and types of fishing motors than anyone else.

And we build each one as though our next fishing trip depended on it.

See your Evinrude dealer (listed in the Yellow Pages). Catalog free. Write Evinrude Motors, 4343 N. 27th St., Milwaukee, Wis. 53216.

EVINRUDE
first in  outboards
DIVISION OF OUTBOARD MARINE CORP. Патентный авторский правами



**This is a GM Original:
It's as tough as they come.**



**This is a GM Replacement:
It comes just as tough.**

These starter drives turn the flywheel that starts the engine of your GM car or truck. They're tough parts for a tough job.

With these and with all GM Originals and GM Replacements, the story is always the same. They look the same. They act the same. They *are* the same.

Another nice thing: GM Replacements, in GM and United Delco packages, are available just about everywhere. Go where they use them. Good service starts with good parts.

GENUINE GENERAL MOTORS PARTS



CHEVROLET • PONTIAC • OLDSMOBILE • BUICK • CADILLAC • GMC TRUCKS

United
Delco



More and more people are asking for

Miller High Life

in convenient no-deposit
no-return bottles

Sparkling
Flavorful
Distinctive!

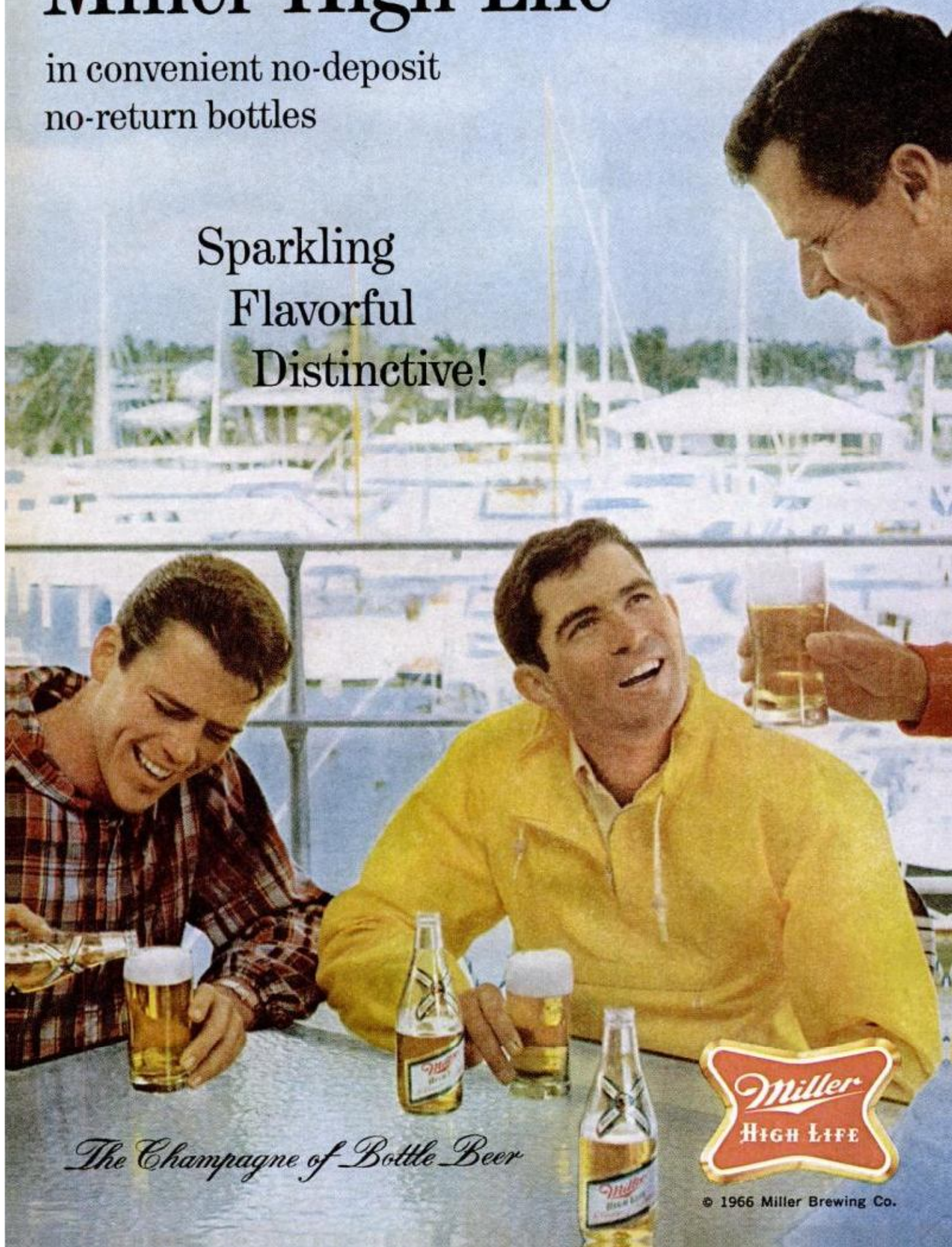

The Champagne of Bottle Beer



© 1966 Miller Brewing Co.

SECRET SNAPSHOTS OF THE '67 CARS

PM's Detroit auto 'spy' exercises cunning and daring (to say nothing of risking his neck) to bring you sneak photos and preview facts of the industry's plans for the coming model year

By Jim Dunne
PM's Detroit Automotive Editor

THREE COMPLETELY NEW CARS and a dramatic styling movement toward softer, more rounded lines: they're set for star billing this fall when Detroit trots out its 1967 models with fond hopes of making you—the average guy—bug-eyed.

Sporty new models will reach new heights in fastback styling, while the more balanced long trunk will remain a characteristic of the big four-door sedans. The crisp, highly defined appearance in vogue two years ago will take a back seat.

New and larger powerplants will fan the horsepower race. And, in frank recognition of a great ground swell of public opinion, you can count on the greatest influx ever of safety improvements.

Making their debut on the fall market are the greatly anticipated Panther from Chevrolet, Lincoln-Mercury's sporty little Cougar and the front-drive Cadillac, a luxurious hulk of comfort and precision. Late reports hint the two GM cars will have new names before fall introduction. But for now I'll call them Panther and Eldorado.

Panther will come in a two-door model and a convertible, a lot like the present Mustang. Wheelbase is set at 108 inches, the same as Mustang and Corvair. Seating will be the popular two-plus-two with center console and bucket seats, or a minimal three-plus-three with conventional bench seats front and rear. A special model with a sportier appearance and disappearing headlights is also set for fall unveiling.

With this car, Chevrolet will have three models—Chevy II, Corvair, Panther—of almost exactly the same size. Because of overlapping model offerings, especially in sportier versions, Chevy will drop some top-of-the-line Chevy IIs and Corvairs. Panthers will fill the gaps.

Panther obviously is aimed to compete directly with the sensationally successful Mustang. The one question auto buffs ask now is, "What took Chevy so long?" Ford has already sold well over one million Mustangs and will have a complete styling change for the '67s.

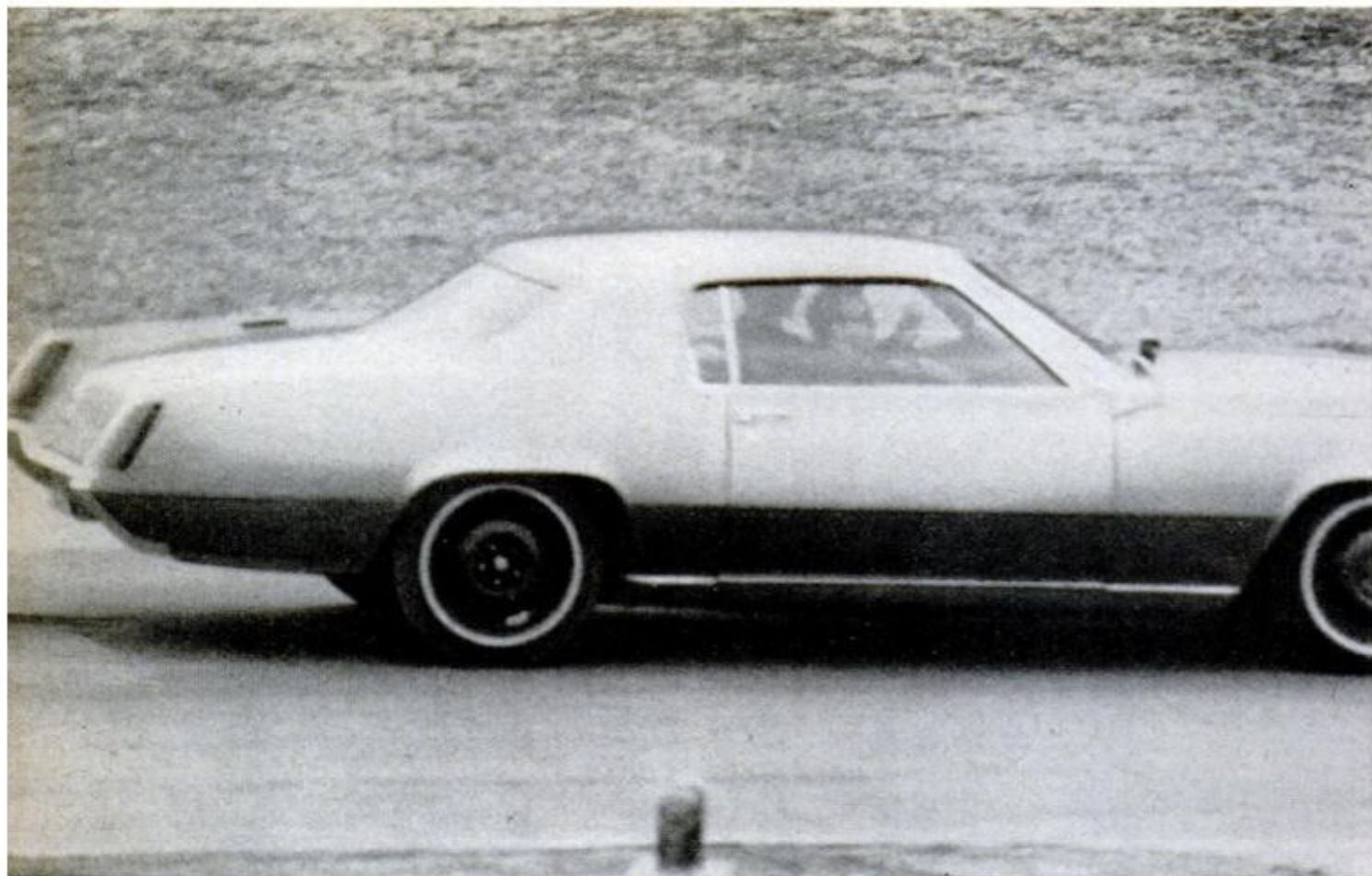

FRONT-DRIVE CADILLAC will debut this year. Dubbed "Eldorado," it reflects successful Toronado

The answer lies in the Corvair. Chevrolet saw the Mustang as a reaction to Corvair sales and thought the cars would be close competitors for years. But the little Ford skyrocketed past Corvair almost immediately. Now Chevrolet is hoping its Panther will stop the surge.

Panther will have all of Chevrolet's smaller power combinations to offer as options to the standard six-cylinder engine. Expect the V8 options to include the 327 cu.-in., 250-hp mill. The regular transmissions, three and four-speed manual and two-speed automatic, will be available. Look for the Panther price to be nearly identical with that of Mustang.

Cougar, another fall entry into the small, sporty car field, will be sold by Mercury dealers in one body style, a two-door hardtop. A sleek fastback will be added later in the model year. Cougar will have many of the Mustang components including engines, basic body, transmissions and options, but will be 3 inches longer in wheelbase for added rear-seat legroom.

Inside Cougar you'll find expensive trim touches making it even more attractive than the flashy Mustang interiors. The plan is to offer the car with V8 power only

for a basic price about \$150 above a stripped Mustang.

Eldorado, first front-drive car in the Cadillac Div., will be similar to the Olds Toronado in drive train design, passenger compartment dimensions and performance. There the likeness ends.

Cadillac is giving this car distinctively new styling even though the basic body is General Motors "E" type used by Toronado and Riviera. The front end will feature horizontally-placed, hidden headlights, and a waffle-textured grille framed by an overhanging hood and extended front fenders. Massive-looking, Eldorado will follow the current trend to semihermetically-sealed passenger compartments with flow-through ventilation systems and single-piece door windows. Bright trim will be tastefully limited on the outside. Rear-end styling will follow the conservative, long-deck design.

Like all other '67s, prices for the Eldorado will not be announced until next fall, but an educated guess places this Caddy in the \$7000 bracket with normal extra equipment. Look for it to be eminently successful right from the start, with a yearly sales goal of 20,000 to 30,000 units.



DESIGN OF 1967 FORDS will feature sheet-metal changes for cleaner lines

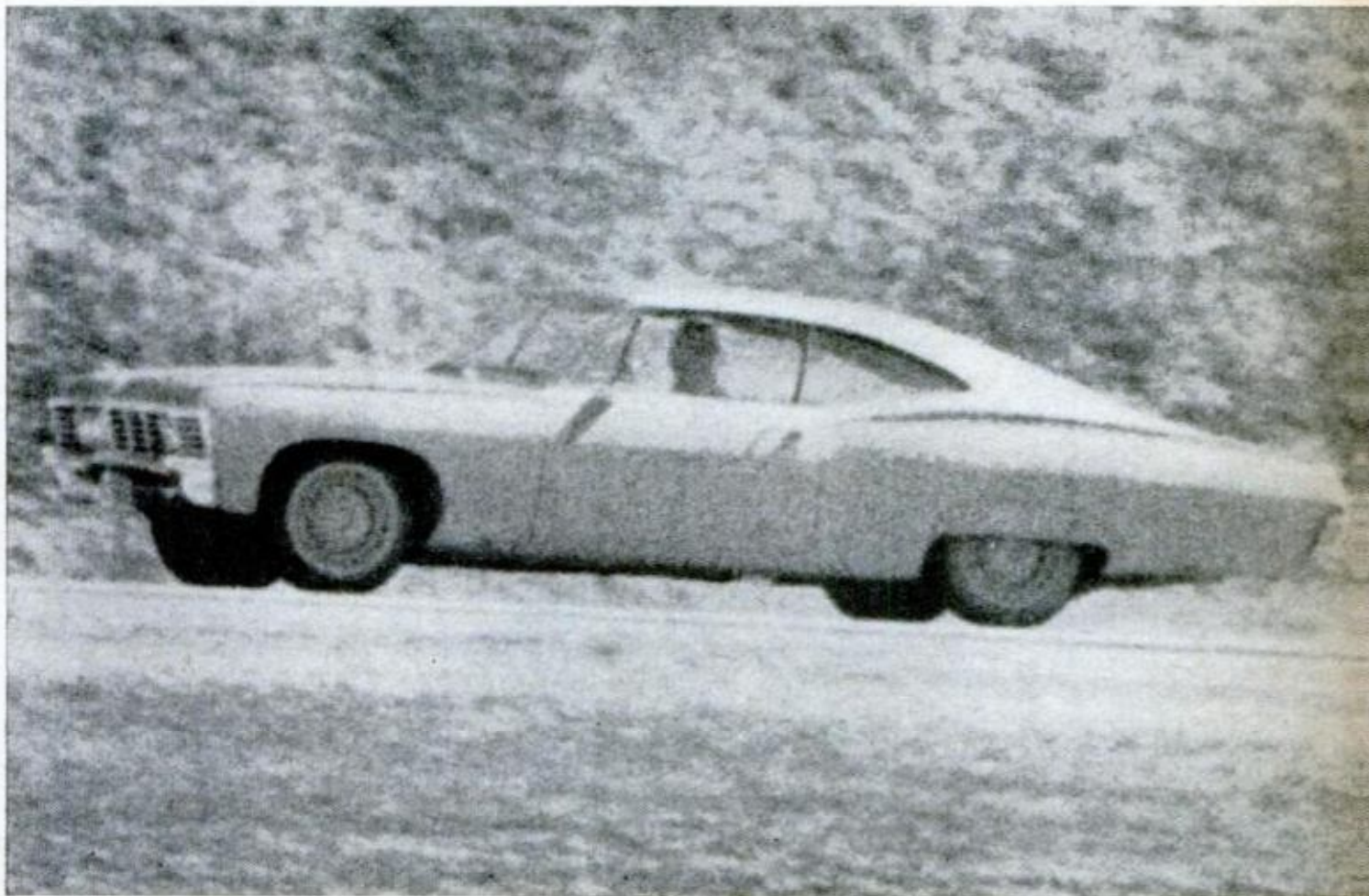

CHEVROLET FOR 1967 will continue graceful, semi-fastback line of present models, lengthen bodies

What the snapshots don't show . . .



MERCURY grille will feature severe overhang

OLDS re-creates former Cadillac hood bulge

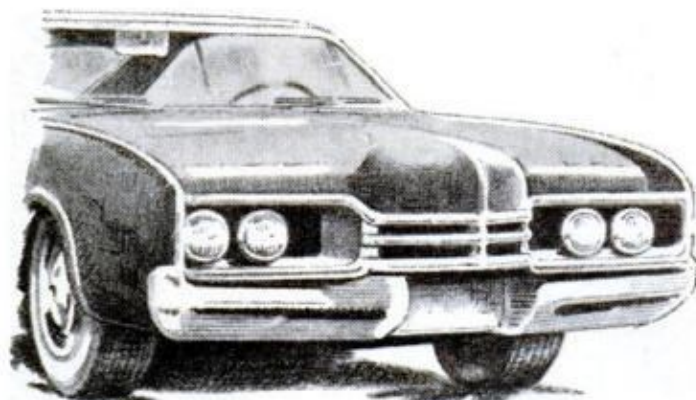

CHEVROLET displays clean, functional look aft

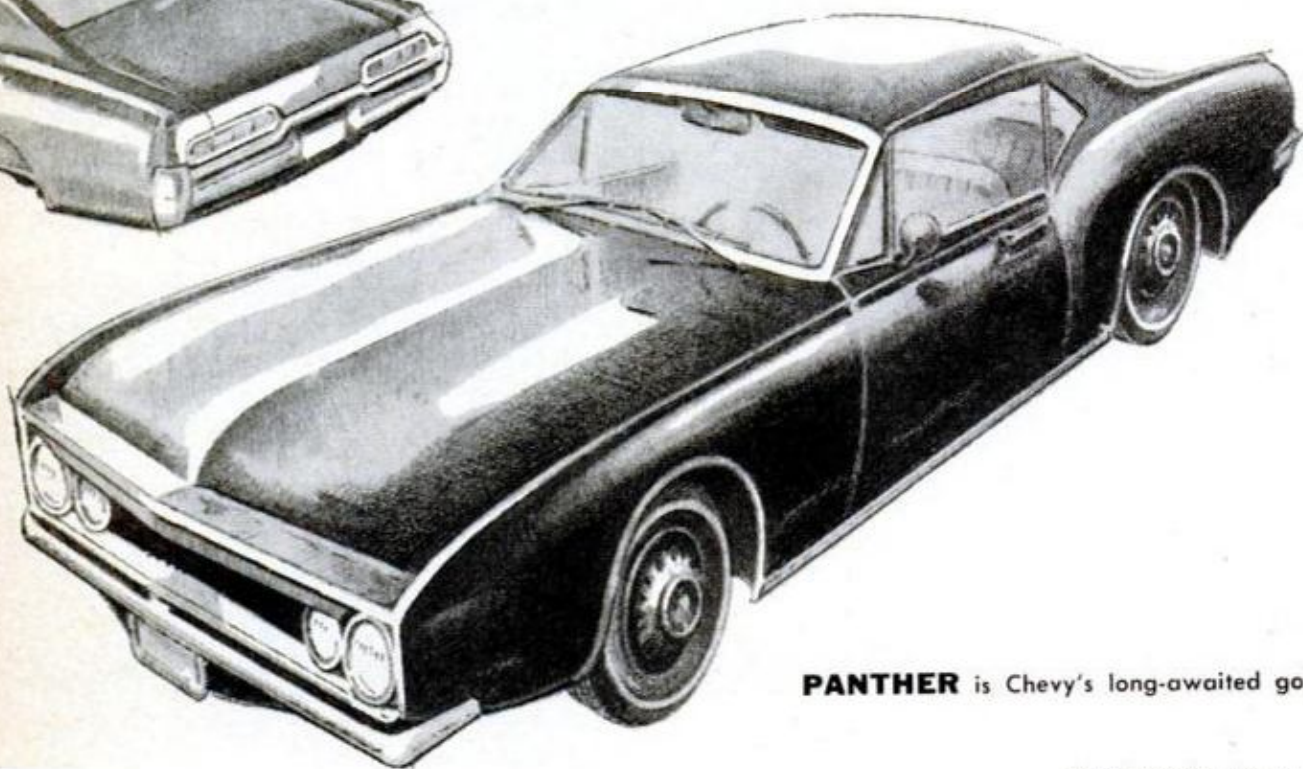

PANTHER is Chevy's long-awaited go-go entry

Drawings by Henry Comstock

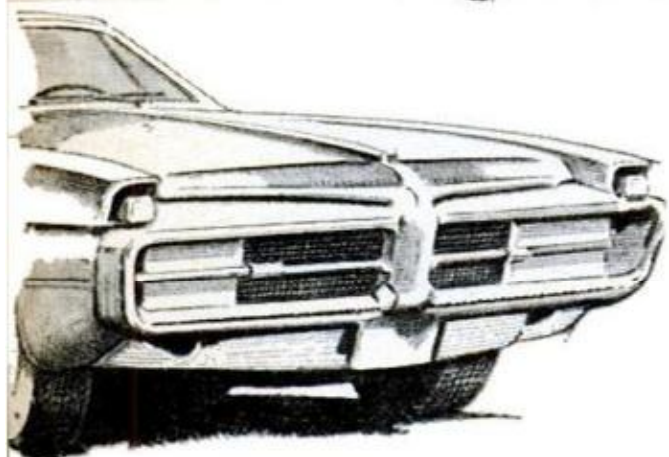

PONTIAC may be overdoing it a bit up front . . .

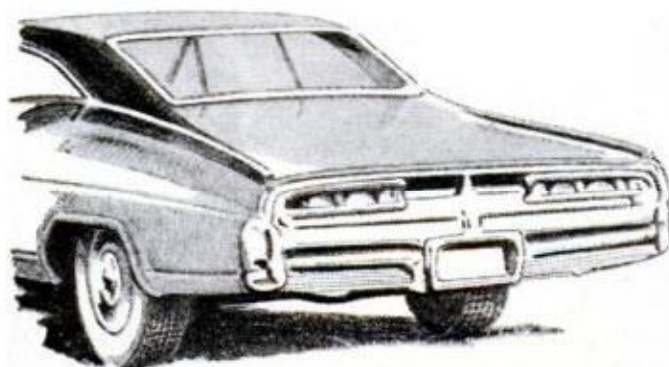

. . . **BUT AFT** the lines are crisp, purposeful

Differences between Toronado and Eldorado drive trains will be restricted mostly to universal joint design, differential ratios and valving in the transmission shift points—all made to accommodate the heavier weight of the new Cadillac and its 429-cu.-in. engine.

Thunderbird, Imperial and Barracuda will also undergo significant changes in 1967 versions.

Thunderbird will have two body styles for '67: a two-door hardtop and, for the first time, a four-door sedan. T-bird's convertible will be dropped for the time being, to be introduced later in the model year. Wheelbase will stretch at least four inches from the present 113 with the extra length going for back seat legroom. Unit body design will give way to a separate frame and body using a torque box perimeter frame design similar to the present Galaxies.

The big "sail" at the "C" pillar that has become a T-bird trademark will be retained; this makes the car easily recognizable in spite of extensive changes. On the two-door model, the small rear side window cranks back into the wide "C" pillar instead of straight down toward the wheel well when opened. Caddy's new Eldorado has the same type action. On the four-door model, both doors lock on the center "B" post a la Lincoln. Vent windows in the front doors have been dropped, adding to the sleekness of exterior styling. For rear styling, there's a severely chopped deck and a grille-like design on the back of the trunk lip which echoes the front-end look. Full-width taillights are retained.

Ford engineers have gone to extreme lengths to reduce the transmission hump

in the front floor by tipping up the front of the engine at a sharp angle. In one T-bird I saw, the engine appeared to be installed at about a 20° angle from the horizontal.

Barracuda will get extra attention from Plymouth this fall to make it more competitive with the "Mustang" group of vehicles. Fastback styling will continue on a single model bearing little resemblance to the regular Valiant line. Plymouth wants to separate Valiant and Barracuda as much as possible next year. Later in the model run, probably about January, Plymouth is expected to bring out a convertible in the Barracuda line.

Imperial will get the biggest change of all Chrysler Corp. cars for '67. And no matter how they explain it, the Imperial is being downgraded. The difference is in a smaller body shell. Imperial will discontinue its exclusive Chrysler Corp. use of separate body and frame construction and take on a modified version of the big Chrysler basic body using unit construction. Wheelbase, 129 inches now, will shrink somewhat but will not go all the way down to the 124 of the Chryslers. Modifications in the stub frame ahead of the main Chrysler body will enable Imperial to stretch wheelbase, get a longer automobile and come up with different styling proportions than the regular Chrysler line.

The new Imperial will benefit in several ways from the changes. It will take on a sound body design that has been improved over the years Chrysler has used it. It will cost less, too; the same tooling used for Chryslers is now shared with Imperial. And it will look more modern

(Please turn to page 200)

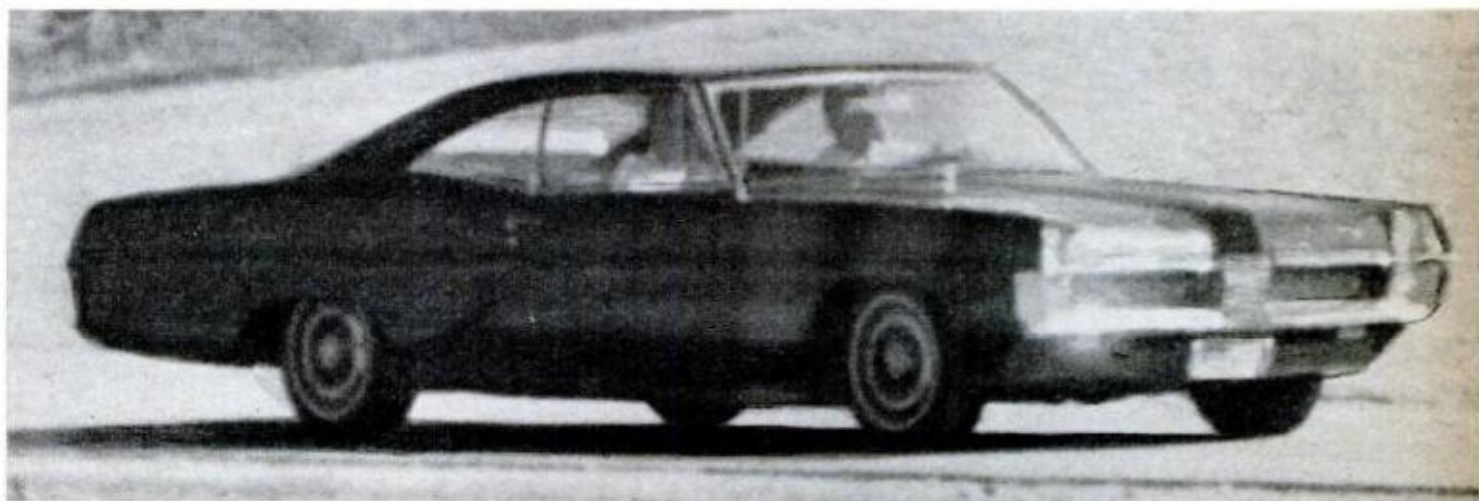

PONTIAC FOR 1967 retains basic '66 lines, but will introduce new grilles for Catalina, Grand Prix

PM's JUNE NEWS BRIEFS



Cool island in the sun is provided by this reinforced paperboard lounge which protects surf sirens and other sun worshippers from scorching sand. It can be elevated for tanning, laid out flat for picnics and games, and then folded up for easy toting and storage. The colorfully decorated lounges are marketed by Stickel Enterprises, Inc.



"Dirty Cars Wanted" is what the sign says. And with the help of an old milk truck, a used water tank, a small gasoline-driven a.c. generator—plus such things as cloths, soap and wax—Frank Milstin of Hollywood, Fla., conducts what is perhaps the only mobile auto bathing business in the world. His profit-making setup even includes a portable canopy to provide shade for waxing jobs.

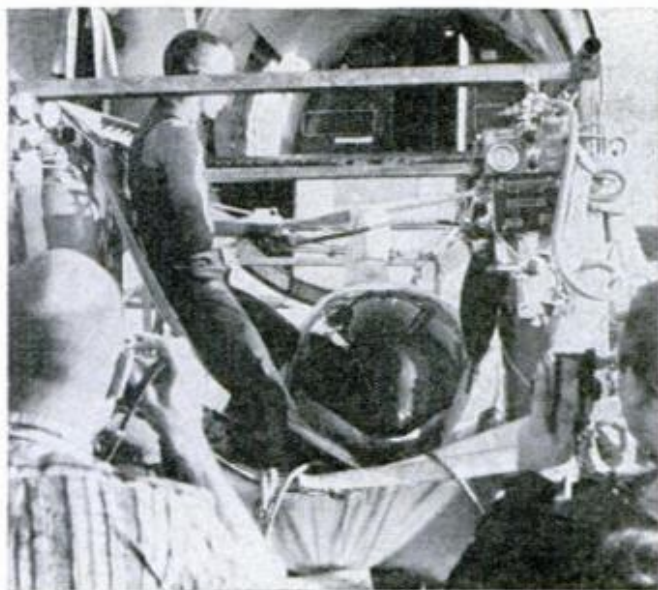

First killer whale to fly, Shamu was transported from Puget Sound, Wash., to an aquarium in San Diego, Calif., by truck and plane, riding in a sheepskin-lined cradle. She let out a squeal of joy when lowered into the salt-water pool. Only one of two killer whales in captivity, the young female—she's thought to be 2 years old—is 14 feet long, weighs 2300 pounds and eats several hundred pounds of fish each day.

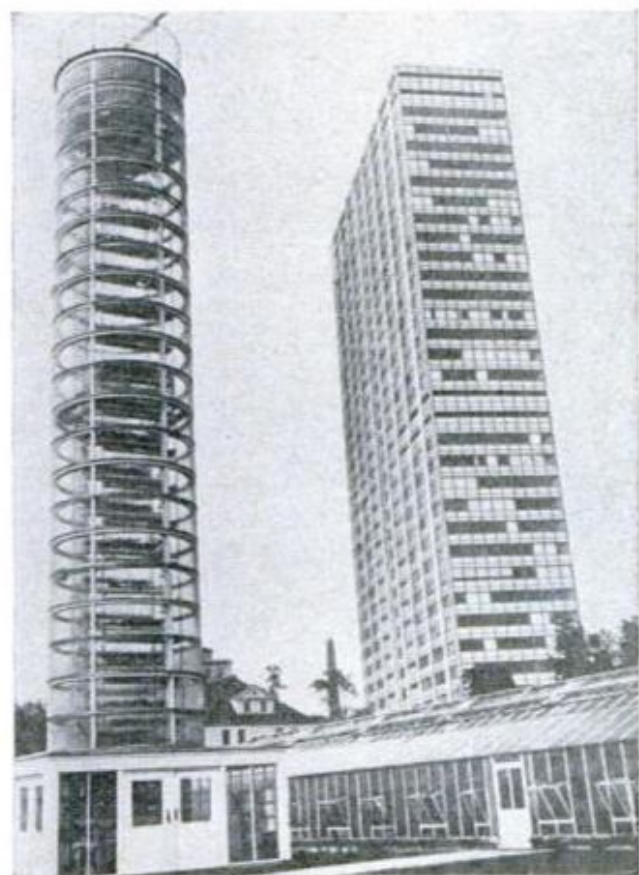

Strange structure is not a big bird cage but a 24-story plastic greenhouse for botanical research. It was erected in Leverkusen, Germany, near another imposing building of conventional design. The second structure isn't in danger of falling—it suffers only from camera-angle tilt.



Nylon shutters that eliminate painting and reduce maintenance are being offered with snap-on fasteners. Prefinished, the Du Pont shutters are said to be rotproof and impervious to weather exposure. The fasteners consist of aluminum straps and spring clips that remain hidden when the shutters are snapped into place. They are said to hold securely in high winds.

COVER STORY

Lawn Mule



It's a new concept in garden tractors—tricycle design with front-wheel drive for turn-on-a-dime maneuverability and a single control for throttle, brakes and steering.

By ART MIKESELL

SOMETHING REALLY NEW in lawn equipment doesn't come up every day, but a squat, little yard-long garden tractor called the "Lawn Mule" qualifies as big news on at least three counts.

- Just introduced by Technoid Corp., it's the first garden tractor ever offered in kit form. If you can handle a screwdriver and wrench, you can save \$125 of the \$450 suggested retail price by putting it together yourself. (For a detailed story on assembling the \$325 kit, see page 130).

- It has a novel configuration, but not just for the sake of novelty. It has but three wheels. Now, any tricycle-type vehicle normally has a much tighter turning radius than a four-wheeler, and with front-wheel drive that radius is even smaller.

The Mule, driven through its front wheel, is amazingly maneuverable—most welcome if your lawn is small or broken up with numerous beds. You can nose it right up to a wall, swing the front wheel around parallel with the wall and make a right-angle turn without backing up.

- The control system is another design departure. You direct all operations through a single “control bar”—actually a streamlined handlebar. Depress it and the Mule accelerates; release it and the Mule brakes automatically; swing it to one side and the Mule turns.

As garden tractors go, the Lawn Mule is something of a midget—about a yard long, 41½ inches wide (to fit a 42-inch door opening) and 34 inches high at the control bar. It weighs approximately 300 pounds; almost half being dead weight cast into the body to provide extra traction and stability.

Depending on the driver's weight, this puts the center of gravity at a low 16-to-20 inches above the ground near the center of the supporting triangle.

The heart of the Lawn Mule is that driven front wheel with engine above. Under the name, “Power Wheel,” this unit has survived eight years of rugged industrial use as a drop-in power component for any materials-handling vehicle.

The engine, a 3½-hp, four-cycle Lawson with aluminum block and recoil starting, provides enough power for the Mule to tow up to 3500 pounds on level ground.

All tires are pneumatic—tubeless with automotive-type treads in the rear and a tube-type “knobby” mounted on the front,

IT'S A FOUR-HOUR KIT!

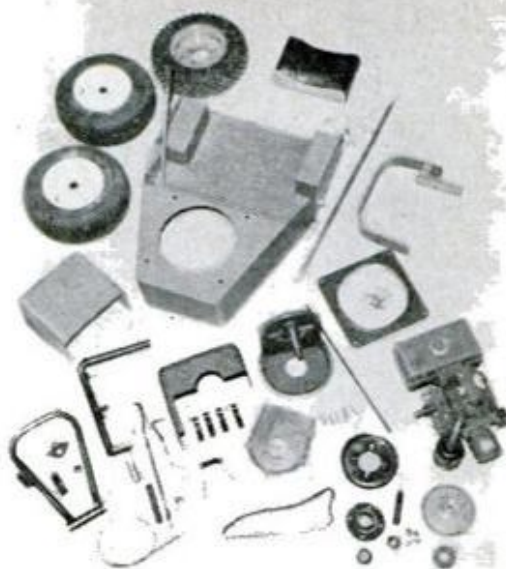

TURN TO PAGE 130 for a step-by-step story on assembling the Lawn Mule from a kit.

split wheel. If your lawn is extra soft, the manufacturer recommends the automotive tread for all wheels. One for the front is available at extra cost.

You may use the Mule with most standard towable lawn implements—spreaders, ganged reel mowers, rollers—but it's scheduled to have its own family of custom-matched accessories by the time you read this. A dumping trailer is now in production.

Present plans also include a 42-inch three-blade rotary mower (\$179) and a 42-inch snow blower (\$195)—push-type units powered by 3½-hp engines. ★★ ★

Why you can spin the mule completely around in only twice its own length

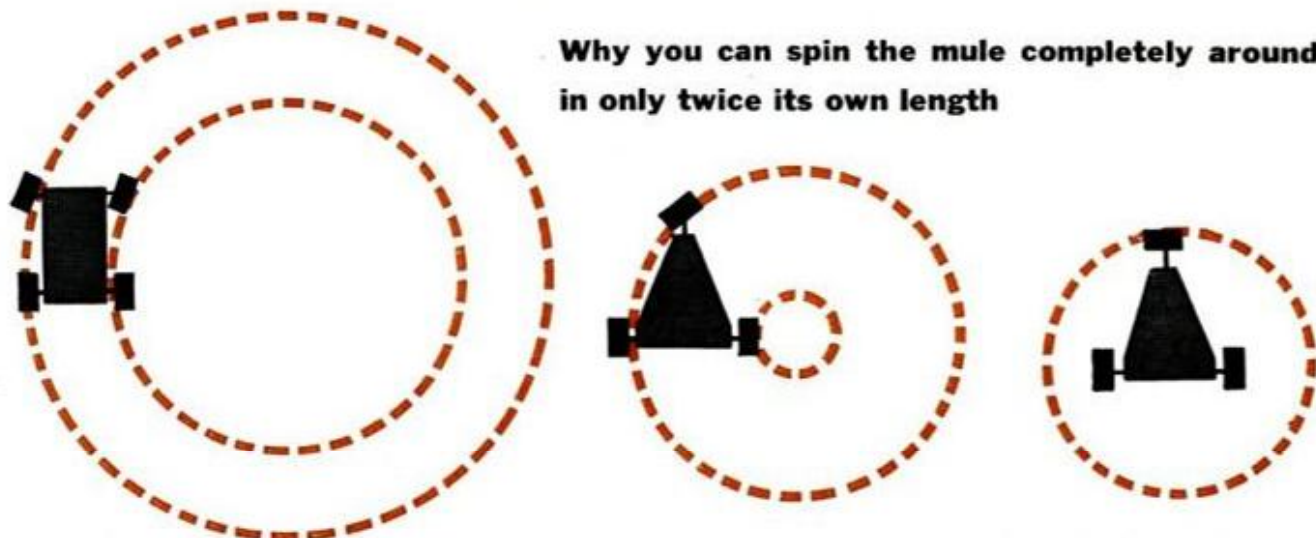

TURNING RADIUS of a four-wheeled vehicle (left) is determined by how sharply you can cramp the front wheels. A three-wheeled rear-drive vehicle (center) will normally make a tighter turn because you can cramp that single front wheel more sharply. However, the rear wheels have to travel in order to propel it through the turn. With power delivered to the front wheel, the Lawn Mule (right) will turn without any forward motion



1.

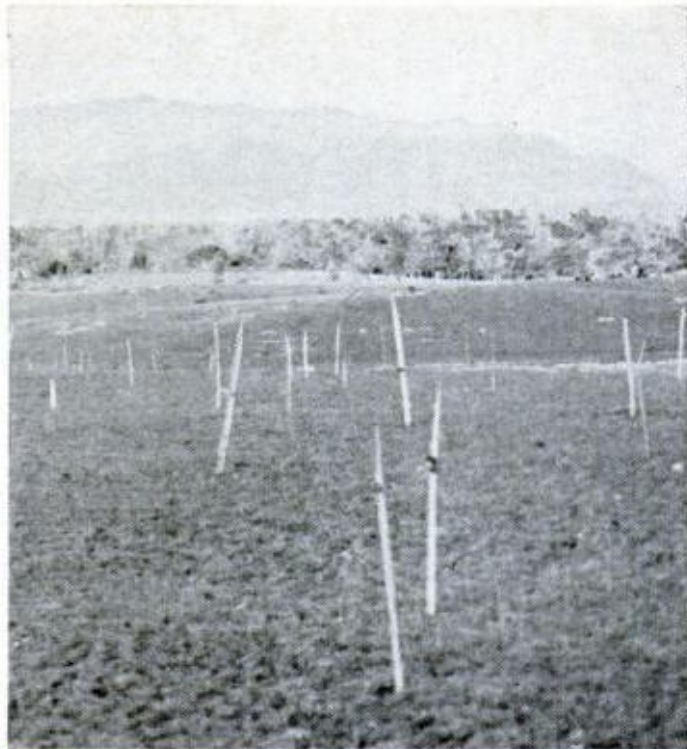

Deadly booby traps in a dirty war

Many GIs are victims of an enemy they never see. They are impaled on razor-sharp 'punji' stakes, caught in leg-crushing 'tiger traps,' bitten by venomous snakes tethered in trees — even blown up by children with hidden bombs laced to their bodies

By EDWARD HYMOFF

VIETNAM IS A DIRTY WAR in more ways than one. You don't have to tell it to the Marines. They know.

The officer commanding the Third Battalion, Ninth Marine Regiment, had moved up with his outfit to what was left of a tiny village. A map clutched in one hand, Lt. Col. Robert Tunnell of Fallbrook, Calif., snapped orders to his staff. The wiry officer, a camouflaged helmet sitting atop his close-cropped head, was a savvy combat commander, with two wars behind him. He wasn't about to get caught by the Vietcong as he kept tabs on the

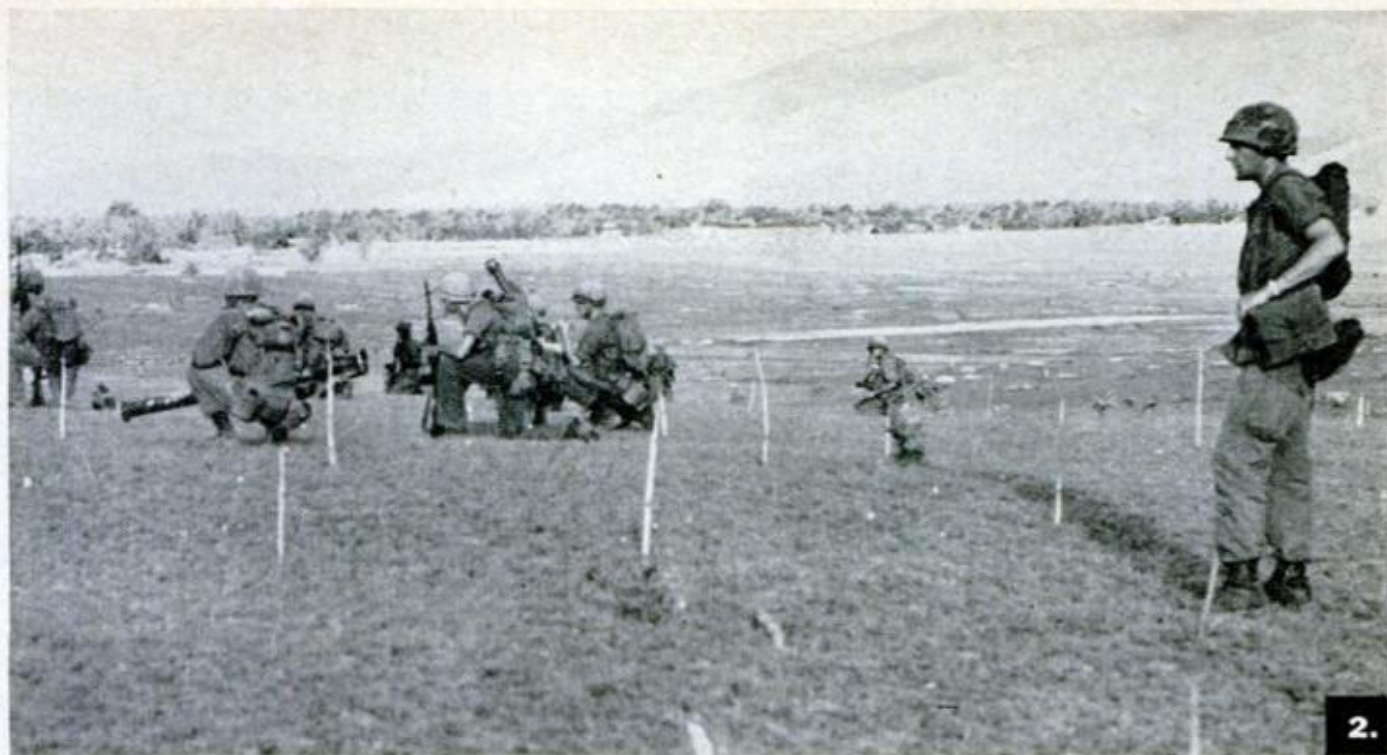

2.



3.

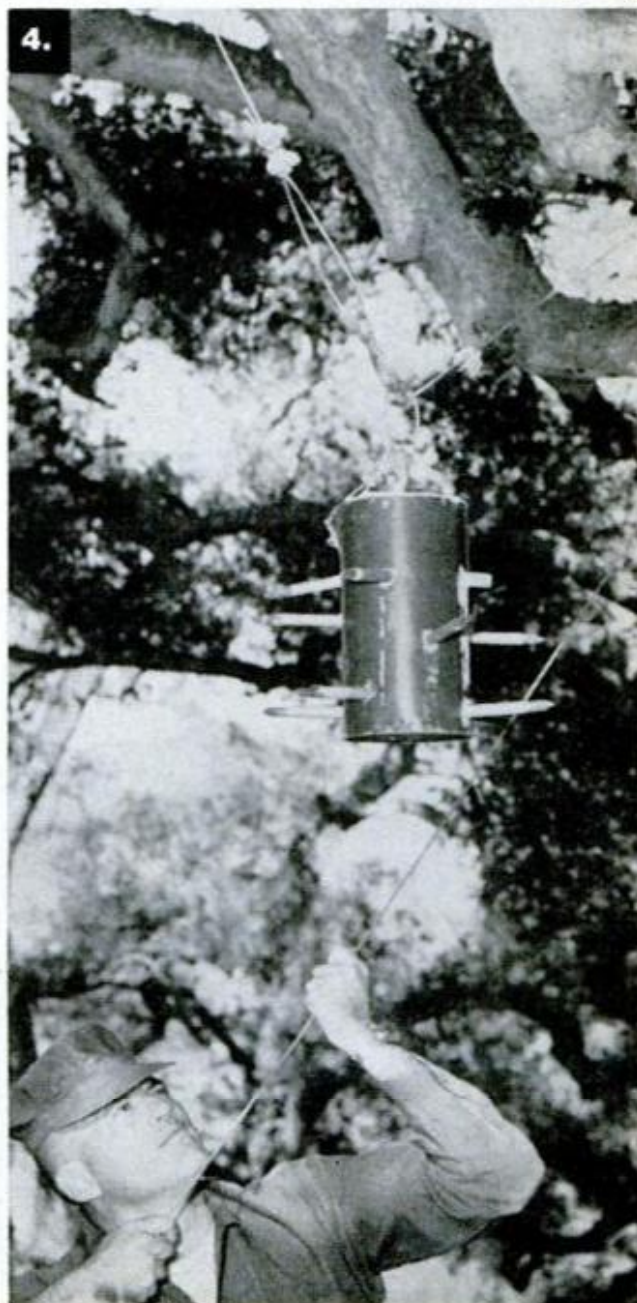

4.

battalion's patrols that were seeking out the elusive enemy guerrillas.

He glanced at his terrain map and then looked up, automatically taking a few steps forward to confer with one of his officers. The soft ground beneath the leatherneck commander suddenly erupted in a geyser of black earth,

1. Spearlike punji stake being examined by crewmen ripped through helicopter on making landing

2. Night setdown on this "spiked" field near Da-nang could have been nightmare for U.S. choppers

3. Spike trap, normally hidden by grass cover, snaps together on leg above protective GI boots

4. Instructor rigs tree with mace. Weighted, it's designed to slam into chest of oncoming soldier



VIETCONG CROSSBOWS are aimed along jungle paths. They're triggered by cleverly concealed trip lines



PRIMITIVE SPRING WHIP, with spikes at its business end, is used in stateside demonstration course



TRIPPED BY WIRE, rakelike "Malaysian gate" slams forward, plunging wicked bamboo stakes into victim



DEADLY BAMBOO VIPERS such as this specimen are used by Vietcong to booby-trap caves and tunnels

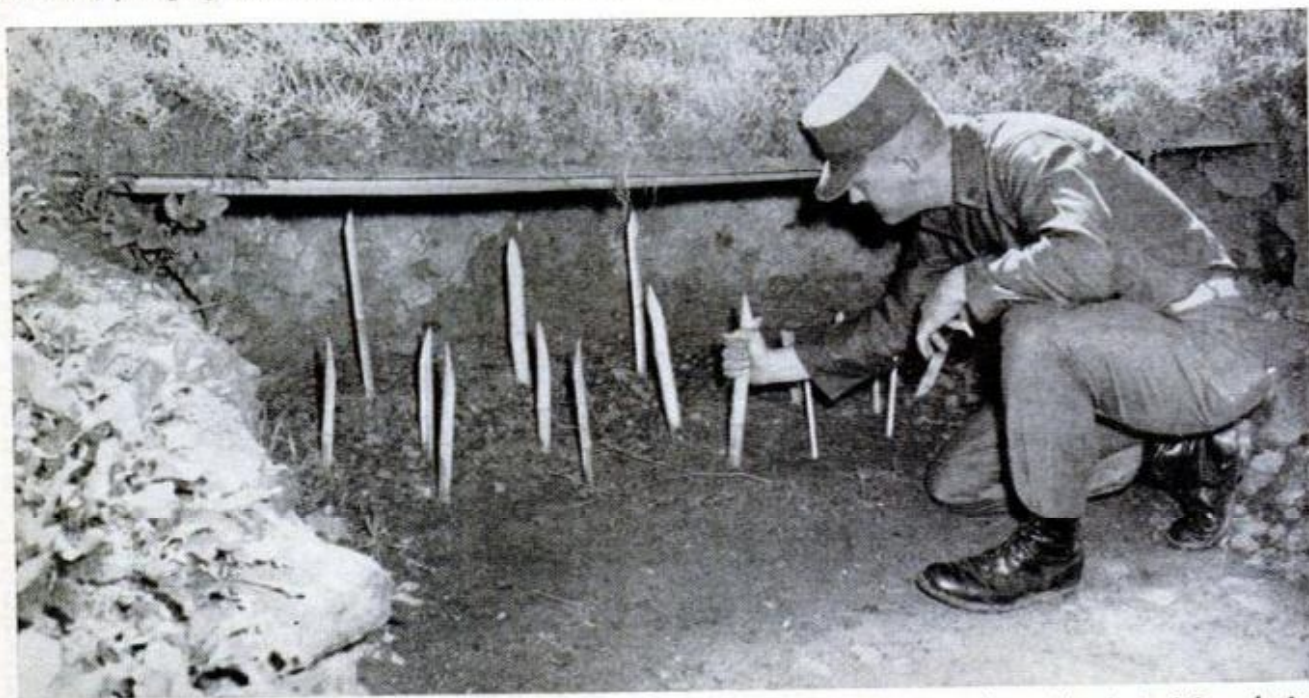

LATTICEWORK AND DIRT hide lethal "punji pits" along trails. This "cutaway" version is training device

grass and smoke. Col. Tunnell was lifted up by the blast. His body slammed to the ground a few yards away.

"Corpsman!" cried Sgt. Adolf Hartschlag, the closest man to the CO, as he ran toward the crumpled body. Another explosion erupted, this time beneath the sergeant.

Marines suddenly froze where they stood. One shouted: "Booby trap!" Those who began moving about the area gingerly lifted one foot and then set it down lightly before thrusting the other foot forward. The area was mined. One-pound blocks of TNT armed with homemade pressure fuses were dug up as men probed the soft ground with wood or metal rods. It took time for the medical corpsmen to reach the badly mutilated victims. Col. Tunnell had lost his right leg. Sgt. Hartschlag, his left.

The elusive communist guerrillas hadn't fired a shot. In fact, until United States military forces in Vietnam went into action on a large scale, at least 60 percent of all casualties were caused by ingenious homemade weapons in what one ordnance officer has called "this booby-trap war."

In Vietnam today the art of booby-trapping has reached a diversity that is frightening. Some of the sudden-death weapons are startling in their simplicity; others are surprisingly complex. Simple or complex, however, they are effective.

Many of the simpler traps are based on the *punji* stake, which is no more than a length of bamboo with a sharpened end that sometimes is fire-hardened. But for all its primitiveness, it's capable of doing tremendous damage, as our soldiers first found out back in the days when they served merely as military advisers.

Major has close call

Maj. Patrick Delevan, an Army helicopter pilot who was awarded the Distinguished Service Cross for a series of adventures in Vietnam in which he was shot down nine times and wounded five times, received one of the clusters to his Purple Heart when he fell into a trap.

In an effort to evade Vietcong snipers who were firing at his downed helicopter, he crawled through the grass lugging his trusty shotgun and tumbled into a camouflaged ditch that was studded with bamboo stakes sharpened to a deadly point. Fortunately, he fell between the stakes, though one pierced his arm. He was res-

cued a short time later and rushed to medical treatment because of the danger of infection. The Vietcong smear their punji stakes with human excrement which, after a few days, turns into a fast-acting poison. Luckily for the balding aviator, the trap was an old one and the poison that was smeared on the points of the stakes had long since dried up and lost effectiveness.

All-purpose weapon

As more helicopters began to come into use, the guerrillas used punji stakes for other purposes. Large ones were hidden in the tall elephant grass of possible landing zones and time and again helicopters were disabled when stakes pierced vital fuel tanks or fuel lines. Of course, the classic use of the stakes by the Vietcong was to line the sides of trails with them and then spring an ambush. Soldiers would dive into the underbrush to escape the enemy's fire and impale themselves.

It's a Vietcong axiom that if you can knock out one American soldier at least four others will have to go to his aid. That means that anywhere from two to five men are taken out of action just to care for one casualty. What better way to rack up casualties and tie down fighting men than with simple weapons like pieces of board with nails hammered through them? The boards are buried in the ground with the points of the nails probing up through the grass. Many Americans were knocked out of action by this trap as they stepped on nails that pierced the relatively soft leather soles of their boots and caused painful injuries. The U.S. Army countered by ordering a new type of combat boot with a steel plate for an inner sole. At least this was one antidote to this type of booby trap.

It didn't take long for the Vietcong to come up with an effective counterweapon, an antipersonnel bullet mine. A 30-cal. bullet is held upright by four nails hammered into a flat piece of wood. A fifth nail, hammered in from the other side of the board with its point resting beneath the base of the cartridge, serves as a striker. The pressure of a foot on the bullet shoves it against the striker which, in turn, fires the cartridge. No steel plate in a boot can stop this simple weapon.

Ingenuity is an integral part of guerrilla warfare and the Vietcong have come

(Please turn to page 210)

1966 Coronet owners report: Great handling, indifferent workmanship



By BILL KILPATRICK, PM's New York Automotive Editor

SOMEWHERE IN MASSACHUSETTS there's a cool, calm iceman who claims his 1966 Dodge Coronet is the best handling car he has ever owned. And out in Southern California there's a hot-under-the-collar engineer fomenting his own style of Dodge rebellion by reporting his Coronet "had 30 major defects when I let it go back to the bank."

At opposite ends of the poll (sic) though they may be, the comments pretty much summarize *PM's* survey of 1966 Coronet owners.

The loud praise is for handling, styling and ride, which received FMRs (frequency-of-mention ratings) of 44.5, 26.5 and 25.2 percent respectively.

Heavy-pedal squawks were raised against wind noise (14.8 percent), what the owners feel is shoddy workmanship (14.2 percent) and assorted rattles and squeaks (12.6 percent).

Other Coronet strong points, the owners report, are performance (15.7 percent) and overall economy (11.3 percent). Yet overall economy (rather, lack thereof) is also right up there on the gripe list (11.5 percent), followed at 8.7 percent by complaints about lack of headroom.

So it seems you pay your money and take not only your choice, but also your chances.

Coronet owners responding to *PM's* survey rolled up a total of 1,189,754 miles during which they averaged 16.2 mpg for both around-town and long-trip

driving. Specifically, here's what they had to say for and against (all owner comments are listed in order of frequency mentioned; those in boldface type are the author's):

"I have to admit I'm pleasantly surprised by the overall handling of my Dodge."—Ohio crane operator.

"Steers and drives better than any; handles very well in traffic."—Missouri shoemaker.

"Torsion bar handling is what I like most about this car."—Washington salesman.

"Corners like a tiger."—California mechanic.

"Rally suspension makes it a solid car and it handles very well at highway speeds."—West Virginia teacher.

After its handling characteristics, Coronet owners just plain like the way the car looks. For example, a Michigan repairman says:

"It is one of the best looking cars on the road today, bar none."

"The car has a clean appearance."—California artist.

"The front end has a look all its own."—Iowa plant expediter.

► **The Dodge Boys fervently hope so, anyway.**

Some of the strongest praise for the Coronet boiled down to the car's riding characteristics. In *PM's* test car, an "as is" Dodge sales demonstrator from Scarsdale, N.Y., I found the ride to be typical of the Chrysler Corp. breed: that is, a palatable blend of rump-soothing mushiness and Spartan control:

"Rides like a heavier car with very good roadability. No side sway on curves at high speed."—Indiana businessman.

"It's comfortable to ride in, with smooth starting and stopping."—Minnesota farmer.

"Eats up the rough roads."—Nevada retired.

► **And spits nails, too.**

". . . the feel of the car is solid."—New Jersey businessman.

Owners like:

Handling	44.5%
Styling	26.5
Ride	25.2

But don't like:

Wind noise	14.8
Workmanship	14.2
Rattles, squeaks	12.6

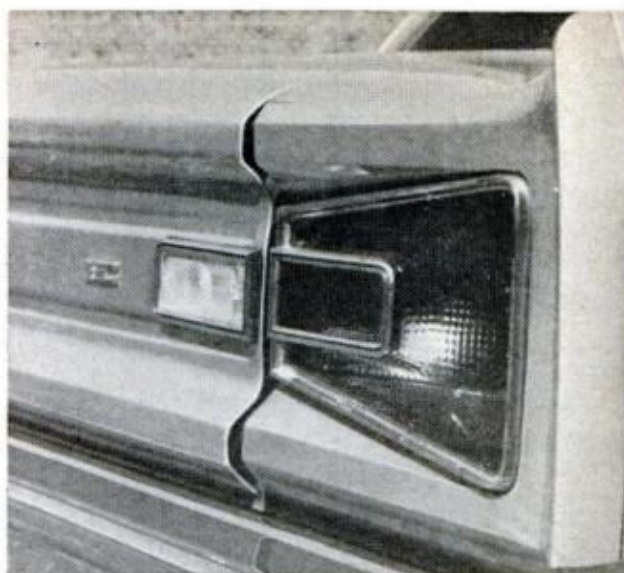

POOR FIT of body components, careless assembly and overall indifferent quality control brought forth the most vociferous complaints from Coronet owners

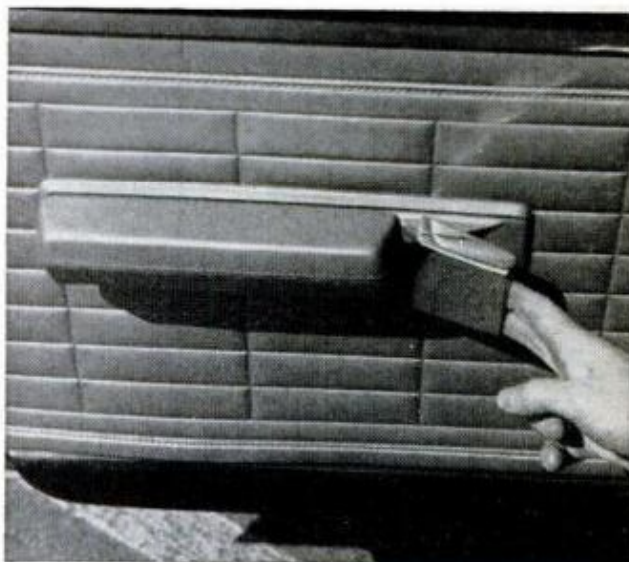

SAFETY DOOR HANDLES, say New York cab drivers, are often mistaken for ashtrays, at times resulting in a few surprises all around. Handles operate easily

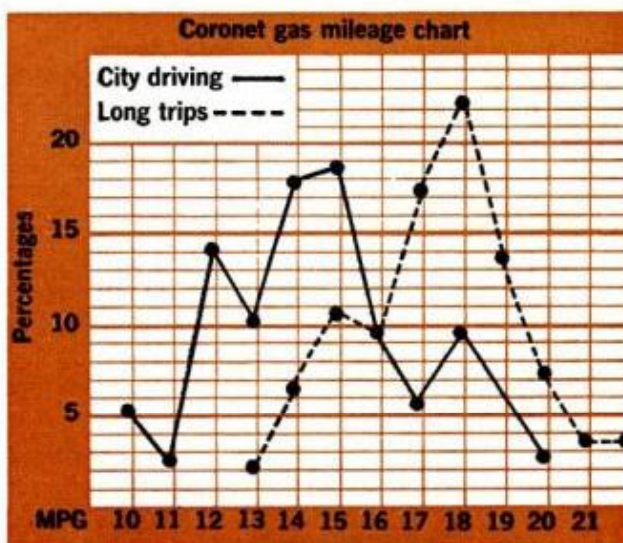

CORONET GAS MILEAGE is about average for car of its power and weight. Engine options include a single 145-hp Six, four V8s ranging from 180 to 325 hp

Coronet owners who like the car's performance aren't the least bit stingy in their praise. It may be the current Batman nonsense, but several replies referred to the car's get-up-and-go in terms such as "zap," "whoosh" and "zowie":

"My car will outrun, outpull or outperform any competitive brand of car with equal horsepower."—Mississippi market manager.

"Plenty of zip. No trouble to pass at any time."—North Dakota farmer.

"It's faster than any car I've ever driven."—Texas mechanic.

► **The fact that Tex has the 325-hp V8 helps.**

"I like its lively zing."—Ohio programmer.

► **He obviously responds to beer commercials.**

Okay. For now enough huzzahs. Let's hear a few owner slings, arrows and brickbats. The big complaint about the Coronet is one that seems to be plaguing the entire industry—wind noise. Car buyers appear to like the idea of a quick box on wheels, but they wish it would zoom through its trajectory noiselessly:

"At 60 to 65 mph the wind noise is so loud a person has to holler to be heard. Dealer claims it's the body design and he can't fix it."—California clerk.

► **This dealer is telling the truth.**

"The wind noise around the doors is much too great."—Nebraska accountant.

"The whistling drives me nuts."—New York police officer.

Drawing almost as many complaints as

wind noise was what the owners deemed poor or, at least, indifferent workmanship. It's another industry-wide bugaboo. These people have a valid beef; with a high-ticket item like an automobile there's no excuse for what at best are sins of omission; at worst, acts of downright incompetence and indifference:

"Glove compartment was sprung, console panel damaged, dimmer switch did not work, selector panel light was not connected, 'Park' gear would not hold, backup light was not connected."—Ohio superintendent.

"When I got the car it would only go in 'R' and 'D' and the backup lights didn't work, the right-hand windshield wiper flew off, a long strip of chrome came off the left side, when it rained water poured in around the windshield, the transmission and differential leaked."—Texas repairman.

"Several chips in the paint job. A dent in the body had been painted over."—Missouri factory worker.

"The hood doesn't close properly, there are a lot of squeaks in the dash, the back-seat side panels don't fit anywhere near where they should."—Washington mailman.

"Trunk leaks dust to such an extent it and the back seat are unusable."—Iowa newspaperman.

► **These people are mad. One of these days there may be a march on Detroit to protest industry quality control. But customers are**

(Please turn to page 196)

Summary of Coronet Owners' Reports

Excellent 54.2% Good 36.1% Fair 7.2% Poor 2.5%

Best-liked features:		
Handling	44.5%	
Styling	26.5	
Ride	25.2	
Performance	15.5	
Economy	11.3	
Comfort	9.2	
Interior styling	6.7	
Visibility	6.3	
Least-liked features:		
Wind noise	14.8	
Workmanship	14.2	
Rattles	12.6	
Poor economy	11.5	
Headroom	8.7	
Ashtray (dash)	5.5	
Brakes	4.9	
Handling	4.4	
Road noise	4.4	
Most like to see changed:		
Headroom	10.4	
Better workmanship	9.8	
Ashtray (dash)	6.4	
Wind leaks	5.2	
Taillights	4.0	
More engine options	3.5	
Better performance	2.9	
Spare tire location	2.9	
Car traded in:		
Dodge	32.4	
Chevrolet	13.8	
Plymouth	11.0	
Ford	9.0	
Rambler	6.2	
Comet	3.3	
Buick	2.9	
Falcon	2.4	
Others	16.6	
Dealer service:		
Excellent	50.2	
Average	35.4	
Poor	14.4	
Buy from dealer again?		
Yes	79.1	
No	20.9	
Buy another Coronet?		
Yes	89.8	
No	10.2	
Bought Coronet because:		
Price or trade-in	49.1	
Style	14.9	
Dealer	8.4	
Past experience	5.2	
Warranty/guarantee	6.2	
Size	5.0	
Considered other makes?		
Yes	68.6	
No	31.4	
Own another car?		
No	60.7	
Yes	39.3	
Make of other car:		
Dodge	23.2	
Plymouth	19.0	
Chevrolet	13.7	
Rambler	7.4	
Ford	7.4	
Others	52.8	
Coronet transmission:		
Automatic	83.2	
Three-speed manual	6.8	
Four-speed manual	5.6	
Not given	4.4	
Coronet engine:		
V8	80.4	
Six	11.2	
Not given	8.4	
Total miles driven:		1,189,754

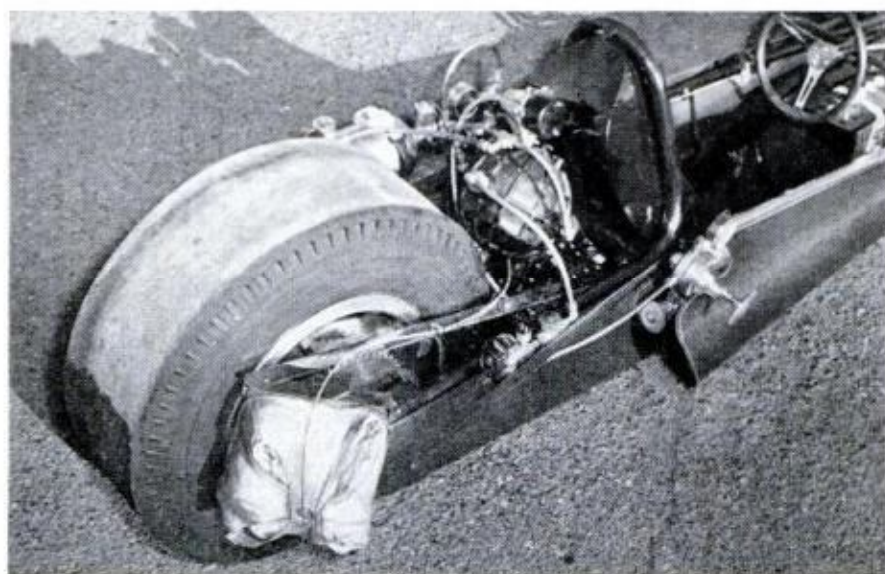
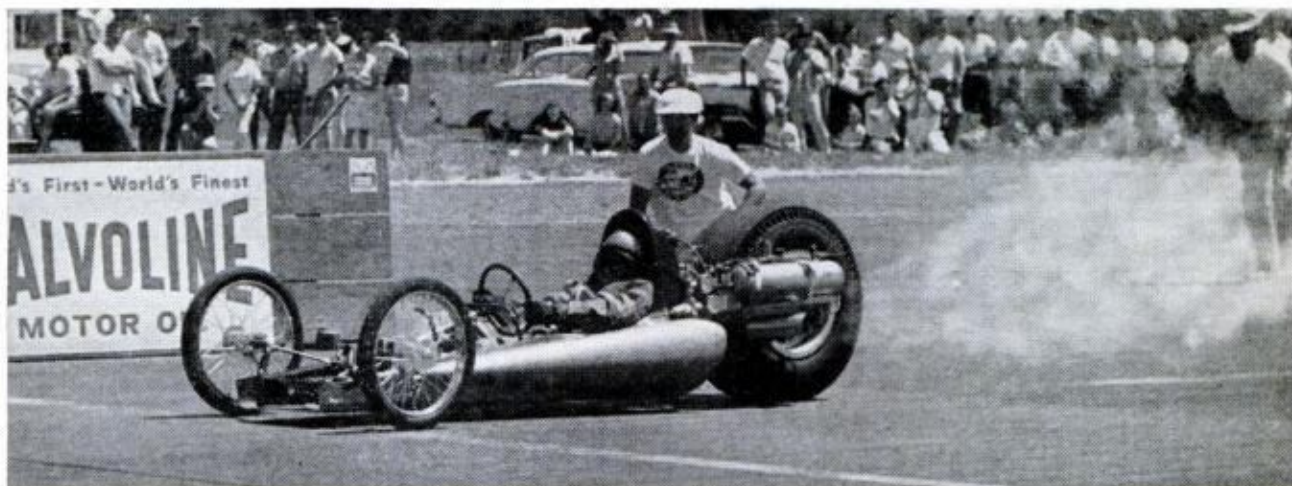

A zooming 200 mph is the aim of dragster builder/driver Marlowe Treit of Portland, Ore., in a tiny three-wheeler called "Miss Demeanor II."

The package totals only 300 pounds, is powered by a Turbonique single-stage free-turbine weighing 58 pounds. Needing no gearbox or clutch assembly, power is delivered directly to the massive single rear wheel via a chain-and-sprocket arrangement.

Using only a fraction of the power available, Treit has topped 150 mph in standing quarter-mile practice runs.



Make-believe fireplace operates on electricity. Just plug it in and logs light up and glow (without heat), hi-fi set plays and hot plate warms coffee. Storage areas hold bar accessories and records. Made in Germany, it is sold complete or plans can be purchased for home project.



Rechargeable runabout. Speeds of 20 to 25 mph over distances of up to 25 miles on a single charge are routine for this electric runabout designed and built by George B. Vasen, Quincy, Ill. Using running gear from a '49 Crosley, Vasen added motor power via a Delco-Remy 12-volt bus generator. Juice comes from five 6-volt batteries. Car has four forward speeds, reverse. Body is of plywood and aluminum, all joints glued and screw-fastened.

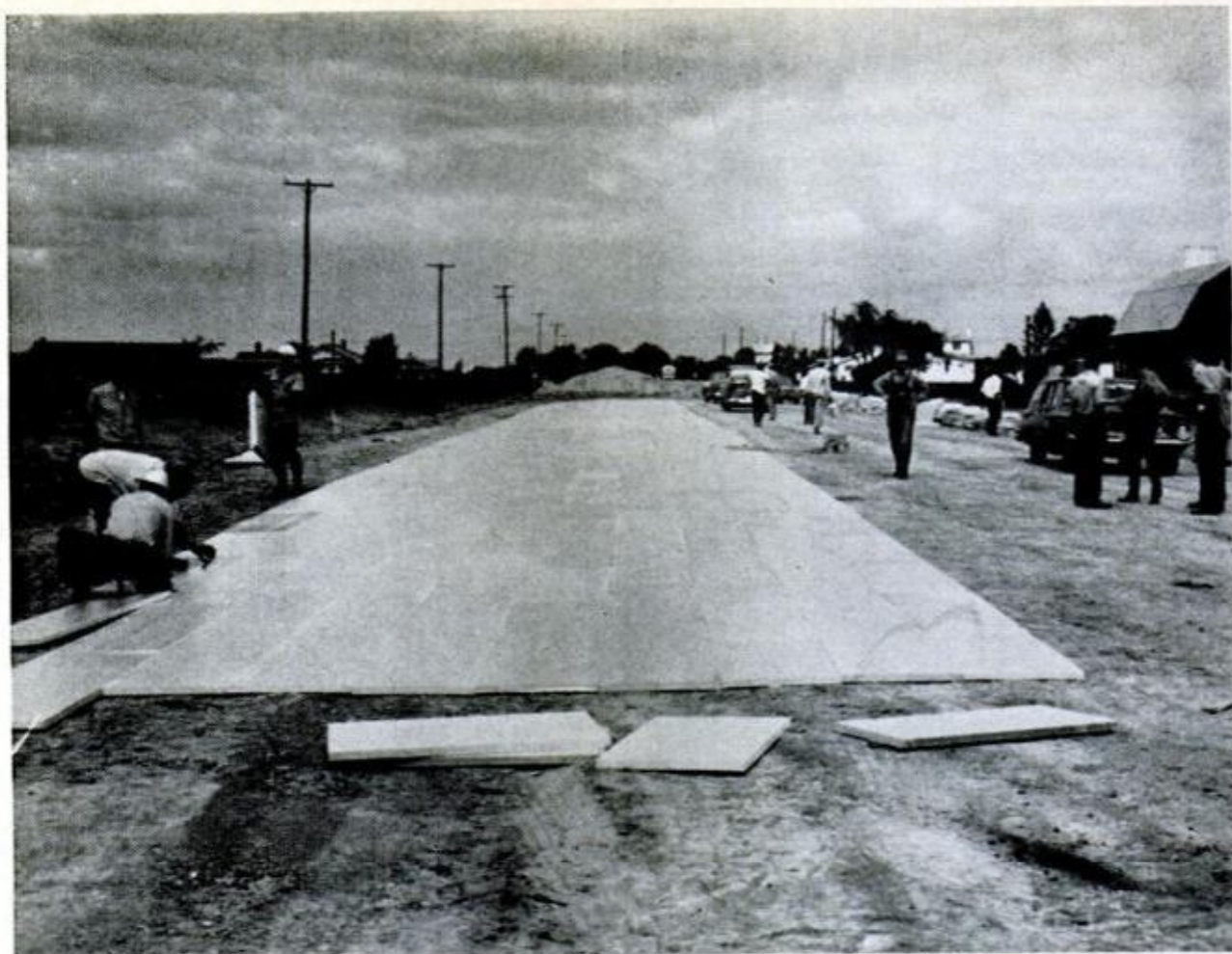

STYROFOAM BOARDS are pegged into ground with wooden skewers to insulate roadbed from frost destruction

Plastic Highways,

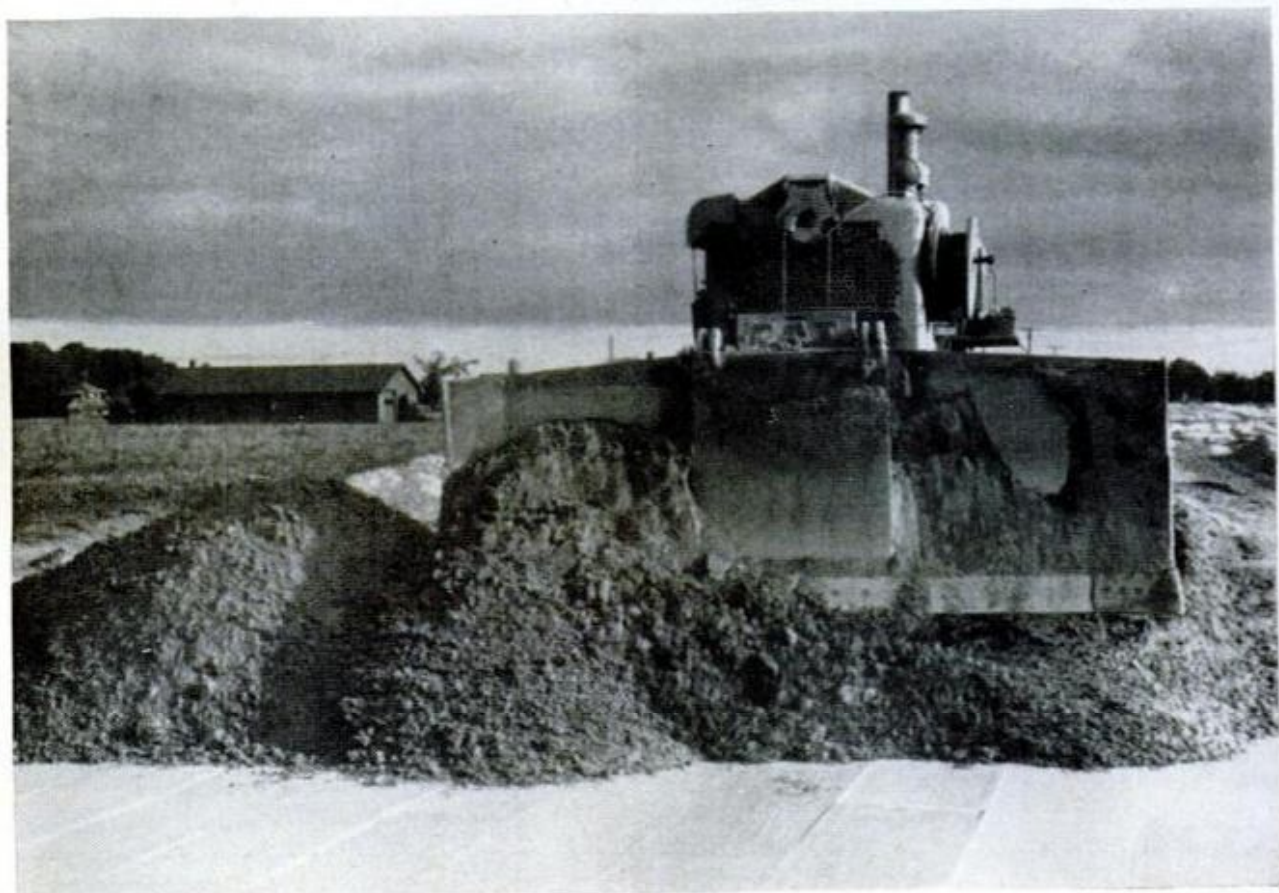

SUBBASE MATERIAL is rolled over foam plastic. This will be topped with asphalt. Concrete uses no subbase

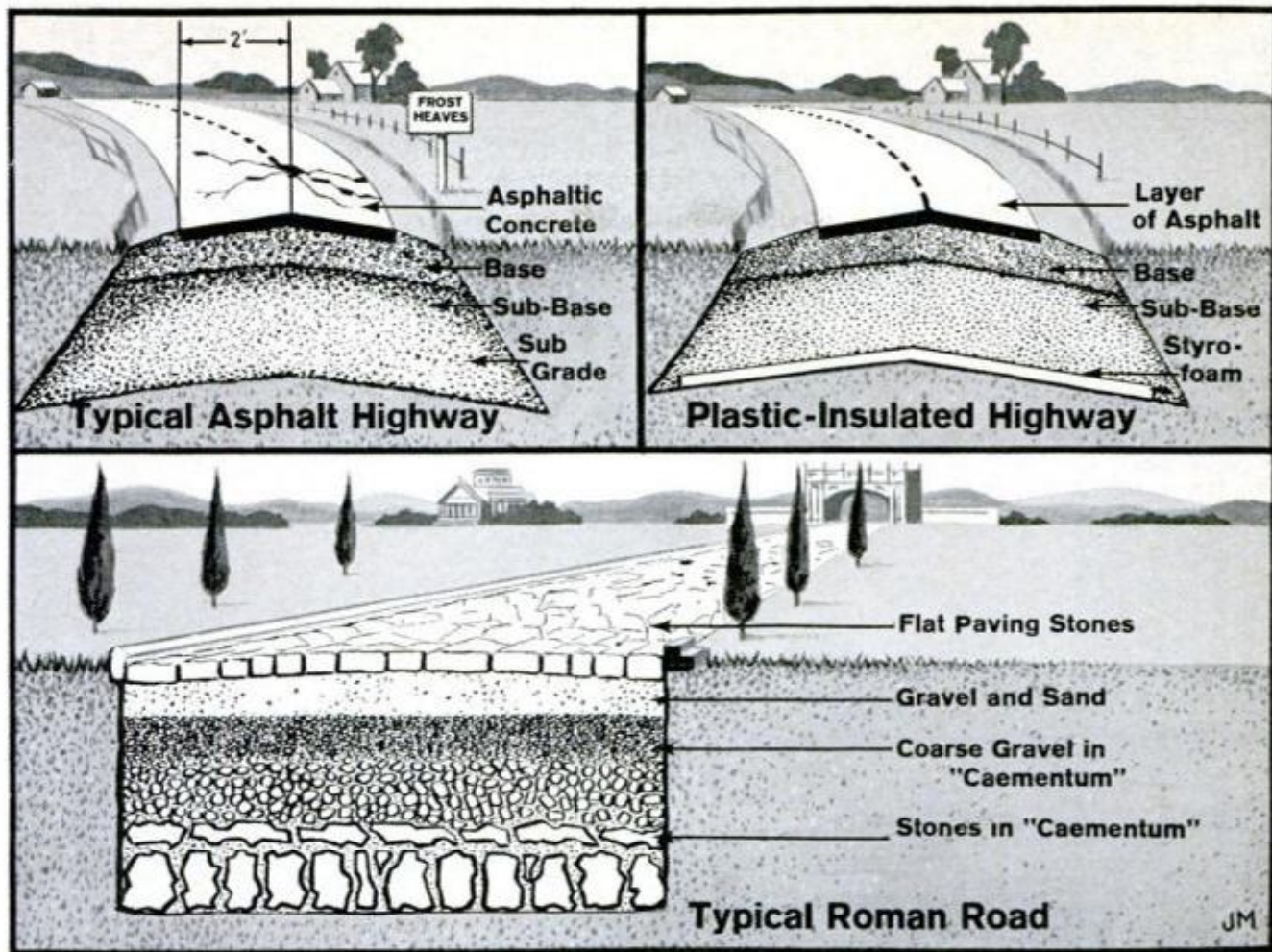

TWO TYPES of modern highways compared with old Roman roads. Typical Roman road was dug much deeper

By Caesar! By Clifford B. Hicks

HOW DID THE ROMANS build highways?

This innocent question has turned up a "new" construction technique that promises to save millions of dollars annually.

Because the Romans intended their empire to last forever, they built their highways to last accordingly. The empire passed, but the highways endured. Roman engineers built nearly 250,000 miles of highways; you can still ride them in comfort from northern Europe to Ethiopia.

The secret was the way the Roman engineers prevented frost damage. They solved this problem by removing existing soil to depths of more than eight feet—and replacing that soil with materials which would not freeze. In most cases these materials consisted of stones (of decreasing size from bottom to top) laid in "caementum," a material almost as good as modern cement. Frost could not penetrate and heave such a roadbed; ergo, the roads lasted 20 centuries.

Experts at Purdue University's School of Civil Engineering tackled the same

problem of frost damage with the help of Dow Chemical Co. research. Their solution to the age-old problem may not go as deep as that of the Roman engineers, but tests indicate it is even more effective, and much less work.

Sections of highway in Manitoba, Michigan, Minnesota and Iowa have been underlaid with Styrofoam boards, to insulate the pavement from frost. The blocks are pegged into place with wooden spikes, then overlaid directly with concrete, or with a sand and gravel subbase and then covered with asphalt.

The results have been spectacular. In the Iowa installation, for example, a 1½-inch layer of foam plastic has replaced more than three feet of conventional granular material, and provided superior protection from frost damage.

As a result of the research, you may soon be riding on "foam-plastic highways." You may also pay relatively low taxes for highway upkeep—as did your Roman counterpart.

Big business takes

Part 2 of our underwater frontier exploration: American industry joins



a dive in the ocean

the ocean-bottom search for new sources of food and raw materials.

By HANS FANTEL

NINE FEET HIGH and wide enough to hold two men, the round steel chamber looks like an outsize howitzer shell with warts and windows. Pipes and high-pressure hoses crawl over its bright yellow surface like an exuberant vine. Hissing and snorting, compressed gas spurts from relief valves.

The whole contraption dangles out over the water, hanging from a crane. Then as the crane plays out its line, it plops into the waves, gurgles and sinks.

The odd item just submerged is the newest of a new breed of diving gear that is now spear-heading the human invasion of the ocean floor. Unlike diving craft designed merely to explore the ocean, the *Cachelot* means to put men and machines to work in the sea.

The *Cachelot* is a typical example of the new machinery that is now sparking a business boom on the ocean floor. A growing number of the country's biggest companies have taken the plunge. Some have already set up shop on the sea bottom:

- Off the African coast, they're blasting the sea floor with powerful jets and sucking up high-grade diamonds.
- In the Pacific, a 14-foot robot stalks the offshore oilfields near Oregon, maintaining undersea wells and pipelines with wrench-like "hands."
- In the Bahamas, ocean-mining machines dig for oolitic aragonite, a vital source of chemicals

UNDERWATER SEARCH for profits was accelerated by breakthrough in diving techniques. Pressurized housings, like *Cachelot* (right), take divers down to desired depths, allow them to work outside and return without former time-consuming slow ascent

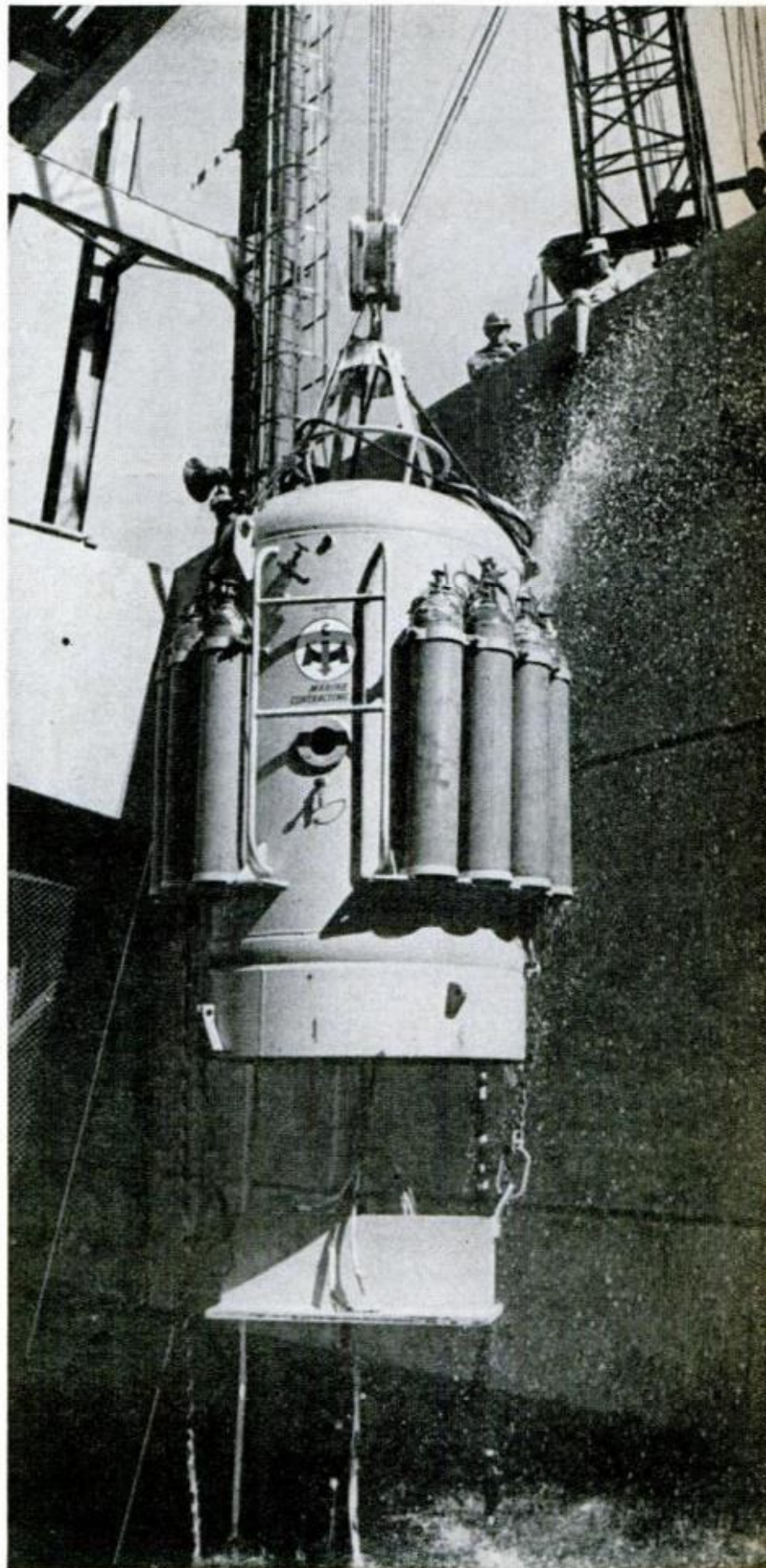



REMOTE-CONTROL MOBOT is sent to bottom by itself and operated from control panel aboard mother ship

used in making steel, fertilizer and feed.
 • In Alaska, the gold rush is on again—this time underwater. Deep dredges are hauling up nuggets near Nome.

• Strange underwater craft are under test by the Navy—surface-controlled diving robots equipped with grasping claws and huge snares to recover missiles from the ocean and for salvage of sunken ships.

Even stranger machines are already taking shape:

• Remote-controlled bottom crawlers to pick up the lumps of magnesium and iron that cobble the Pacific floor.

• “Rock-Eaters” to bite into the ocean bottom like termites into wood, chewing their way along veins of valuable ore.

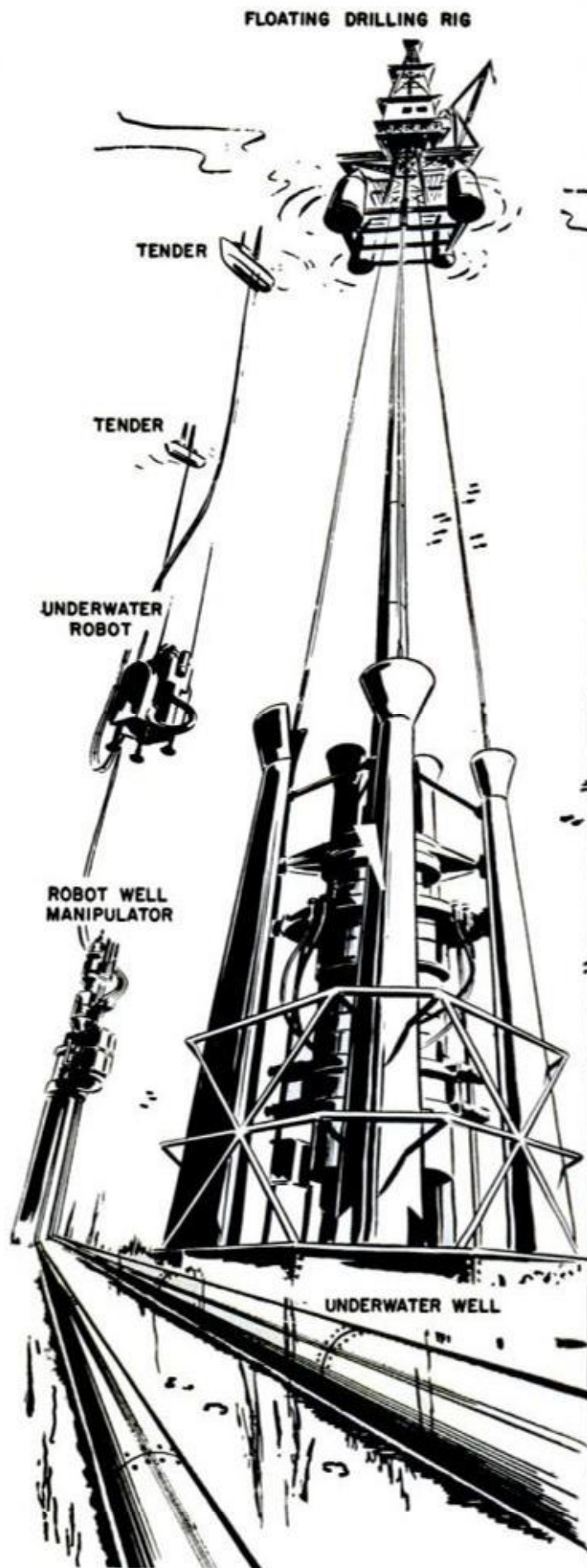

DEEP-SEA DRILLING RIG, shown here in Smithsonian Institution model, will work oil fields on ocean floors up to 2000 feet below surface within 20 years

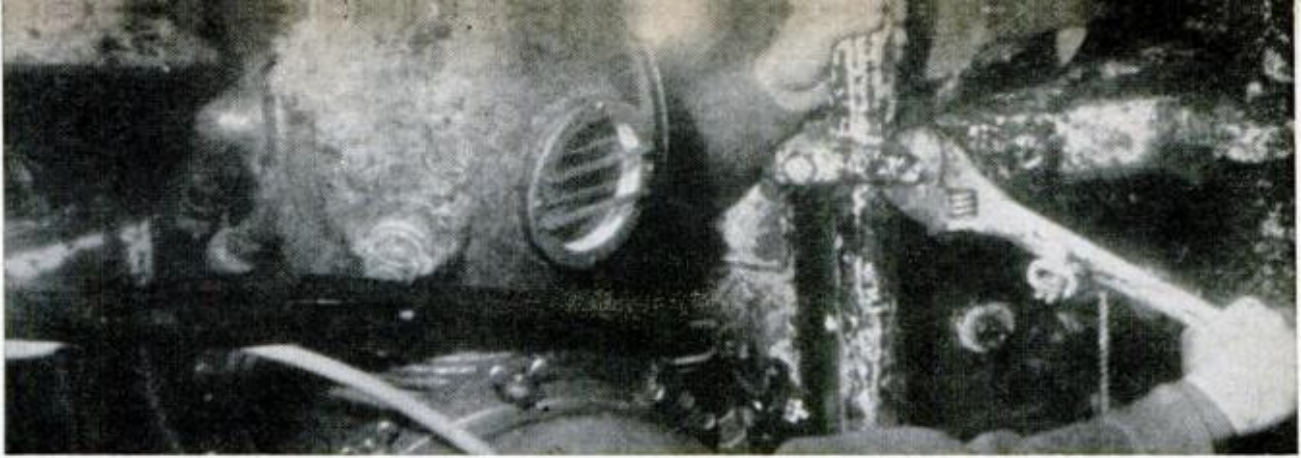

UNDERWATER WORK, except for water, is as routine as any on surface. And with new diving equipment men can stay down much longer than in old days when an hour's work meant tedious five-hour ascent to surface

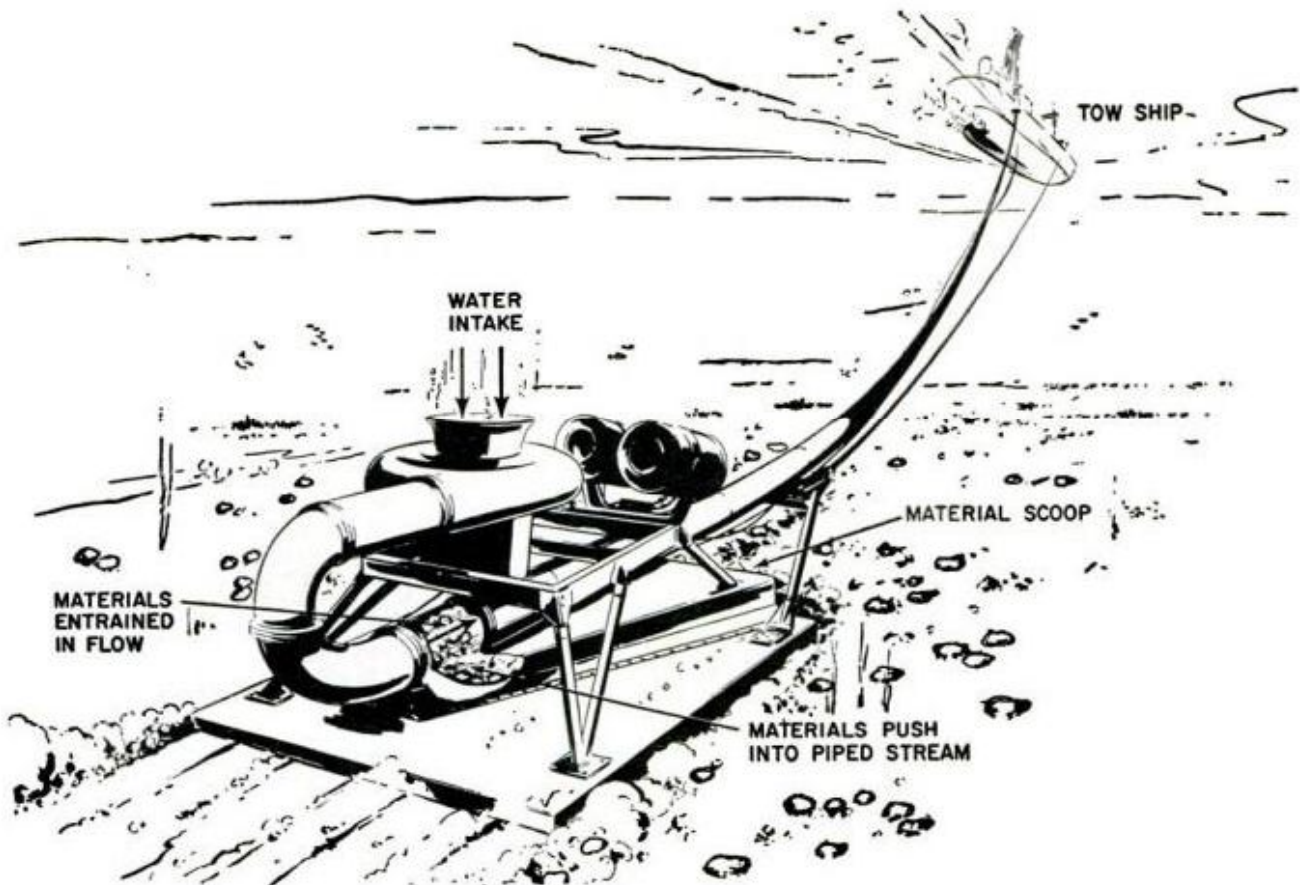

DREDGING RIG, a form of strip mining, will scrape off top of ocean floor for valuable minerals. One enterprising company has already sucked diamonds off bottom mud along African coast near Cape of Good Hope

The mounting pace of undersea activity evidences a new trend in American industry: Big business takes a dive.

Even though the vast territory beneath the sea is still mostly unknown, we've already had a few glimpses of what's waiting there. Rich lodes of iron and titanium run through the continental shelves—the shallow depths that surround the continents. Phosphors are plentiful, promising to relieve a worldwide shortage of fertilizer. Deeper down, vast deposits of copper, cobalt, manganese and platinum await the undersea prospector. Sunken beaches and submerged rivers off the coasts of Thailand and Indonesia hold tin ores. And submarine oil reserves

are estimated to exceed the total land-based supply.

But the most vital product to be gained from the sea is neither oil nor minerals—it's food. With half the world hungry and the food crisis growing worse rapidly, ocean scientists point out that the continental shelves alone provide an estimated 85 percent of the edible protein needed to feed the global population.

Up till now, these riches have been unreachable. The best that men could do was to explore small patches of ocean floor—sometimes with submersible craft but more often just by dangling instruments from surface ships. Lately, empha-

(Please turn to page 204)

HERE COMES

MR. PARADE

From Atlantic City to Liberia, LeRoy Vaughn is the man they see when it comes to staging a first-class parade

By A. R. ROALMAN

HE'S A QUIET MAN who doesn't smile often, but he has helped produce more noisy, fun-filled parades than any other man in history.

On a given day, LeRoy Franklin Vaughn may be working with a junior chamber of commerce group that wants to organize a parade for a California city, the commercial trade director of a new African nation, a representative from a Pennsylvania Lions Club, promotion men from Australia, Florida's Orange Bowl committee, and officials of a northeastern city getting ready to celebrate an anniversary.

Or an enthusiastic Texan may be talking to Vaughn by phone: "We're going to celebrate our 100th birthday next year and we want the biggest parade anybody ever put together. We understand you know how to do these things."

The big Texan understands right. Vaughn has built floats for thousands of parades. His huge works of art have appeared in everything from the Miss America Pageant to Miami's Orange Bowl and the Minneapolis Aquatennial bash.

Rare indeed is the parade, no matter how small or large—from an amateur Fourth of July march in Glen Ellyn, Ill., to the St. Patrick's Day marathon in New York—that doesn't have Vaughn materials or advice in it. Each parade demands a high order of



PARADE FLOATS start with a sketch, and art director James Baran (left) confers on an original design with LeRoy Vaughn before construction begins



MILES OF COLORFUL PAPER are used to cover the floats; Vaughn's factory has ovens where the tissue is dried to backing before being pinned into place

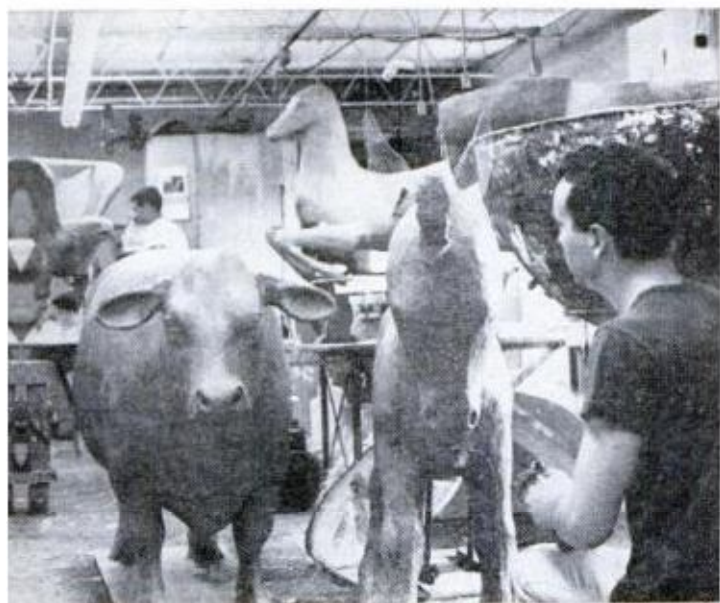
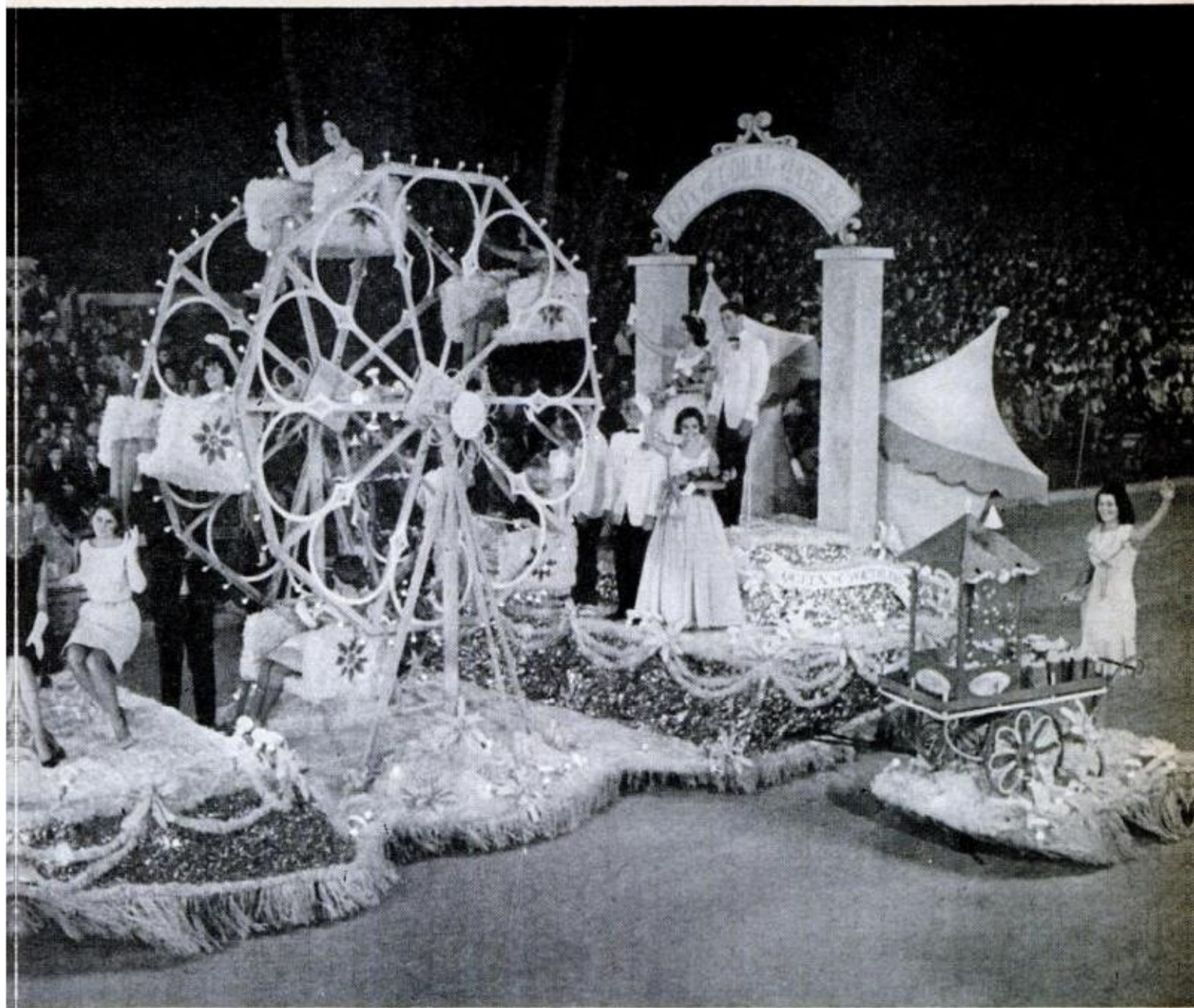

THE ANIMAL FARM is the section where papier-mâché animals are built. A workman, finished with a cow, staples the final touches to a donkey's head

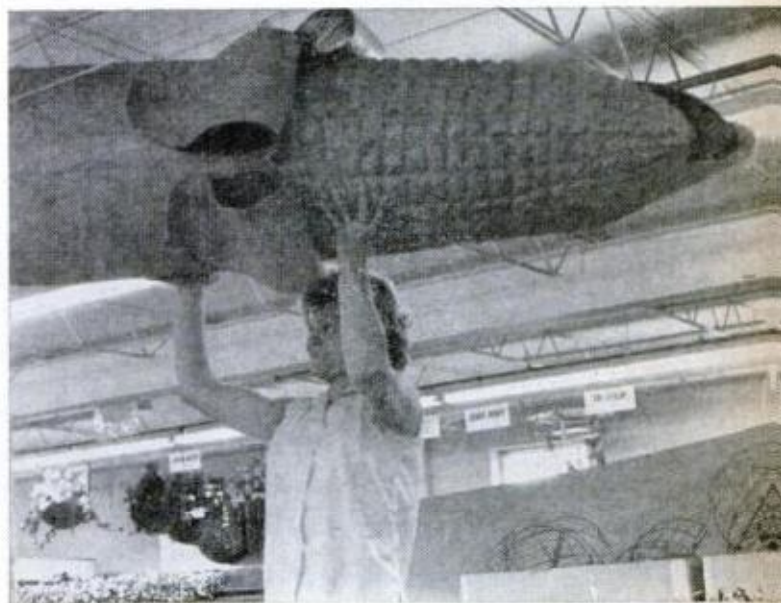

BIGGER THAN LIFE, the products of the parade factory are mostly make believe. This huge ear of corn is made of a papier-mâché and it weighs 20 pounds

mechanical skills and entertainment know-how.

"Putting on a parade is like putting on a Broadway production," muses Vaughn. "You've got to entertain. Really entertain. Millions of people go to parades in the United States. Baseball and football get very few spectators compared with parades. But parade watchers want entertainment."

Vaughn and his experts are paid handsome fees to fly all over the world from their Minneapolis base to consult with parade organizers and provide that entertainment.

"The toughest people to work with are the townsfolk who are having an anniversary celebration," says Vaughn. "An anniversary parade is a one-time thing and they've never produced one before. Most of them think a parade is fairly simple—you just get some floats, some pretty girls, some bands and away you go."

In fact, he points out, you must be worried about such seemingly mundane things as:

- *Which float goes first in the parade?* "Everybody wants to be first, and the amateur chairman thinks the best float should be first. It shouldn't. It should be last."

- *How high are the telephone wires on the parade route?* "There's nothing sadder than a long line of pretty floats stopped dead by a power line."

- *How close together should band units be spotted if the buildings along the parade route are high?* "Band music echoes off high walls and gets all mixed up if the units are too close together."

- *What if some units are late in arriving for the start?* "You start on time, no matter what. Go."

- *What to do with the parade after it ends?* "Few people think of this. I've seen an inexperienced parade organizer plan everything well, except that he had no place for the parade units to disband. When the first unit reached the end of the parade route, it just stopped. So did the second, and pretty soon that parade was backed up for blocks. Those poor bands blew up a storm waiting for somebody up ahead to start moving."

Problems come in all sizes and shapes. Consider the sad plight of a medium-sized northern city. In the parade was a



CHRISTMAS AND THE SPACE AGE are intermingled as a workman applies a coat of paint to a simulated rocket and large holiday ornaments hang in rear



AMERICAN EAGLE is a popular item for Fourth of July parades. The papier-mâché department always has a supply on hand, like this one being painted



LIFE CAN BE ROUGH on parade float animals, and the repair department at Vaughn's factory is always busy with jobs like repairing this deer's leg

troupe of marchers dressed like early American trappers. Several carried muzzle-loading rifles, loaded to the muzzles with blanks.

It was a great day for a parade and the trappers were in a fine mood. When the parade got under way, some of the more exuberant pointed their guns to the sky and blazed away. Blam! Several horses in the following contingent bolted and suddenly everyone was scrambling for safety, including spectators, horses, riders and the intrepid trappers in the coonskin caps. It made an exciting—but terrifying—climax to a poorly planned parade.

Souvenirs can be dangerous

In another town, one of the floats had a pretty girl who was throwing small souvenirs to the crowd. As often happens in such situations, children scrambled into the street and grabbed for the trinkets. Two were seriously injured when a horse bolted into the crowd of youngsters swarming around. ("Parades shouldn't have anyone throwing souvenirs," warns Vaughn. "It creates an invitation for children to leave the curb and dart toward the parade floats.")

Parades in the United States aren't the same as those in Europe, Asia or South America. Ours are made to *look at*; parades in many other countries are designed for complete participation—everybody parades and there are no spectators.

Vaughn describes the horror of one parade-float builder who was not familiar with this difference. He built a beautiful float for a Caribbean island parade. In the United States, the float would have drawn gasps of appreciation. In a land where residents joined in the fun, the float crumpled with the first onslaught and, two blocks later, looked like a crawling stack of wastepaper. Delicate outriggers were snapped off, flimsy decorations smashed and torn, and the "queens" riding on the carefully balanced float felt like they were on a roller coaster that had flown off the tracks. Fortunately, the local citizens were having such a good time they hardly noticed.

Vaughn's experience with parades goes back to Iowa, where he was born 59 years ago. In those days the Midwest was parade-happy. In addition to its own parades, every town experienced a bang-

up circus parade once a year. Vaughn fell in love with the blaring bands and wildly decorated animal wagons.

By 1929 Vaughn was in Tucson, Ariz., working in a dime store; he suddenly became the window trimmer when the regular man became ill. He carried the experience with him during the next few years of the Depression as he drifted around seeking work. Finally he settled in Florida, where he opened a window-trimming business. In 1936, he designed and built seven floats for Fort Lauderdale's Labor Day parade.

Six days before the Fourth of July, 1938, Vaughn and his wife rolled into Bemidji, Minn., a resort town, on a vacation.

"The town was all set for a parade, but nobody knew how to make a float," recalls Vaughn. "When we said we had

Tip to do-it-yourselfers:

Read "How to Frame a Float"
on pages 145-147

such experience, we were hired on the spot to decorate nine of them for \$50 each. That's when I got the idea that maybe I could make a career out of parades.

"That also was the year the Orange Bowl became a national event, and I got the contract for several floats in that parade."

The next year he got contracts for a dozen or so floats that were to participate in the Blue and Gray parade in Montgomery, Ala., and the year after that came contracts to build floats for the Aquatennial parade in Minneapolis.

During World War II, Vaughn's factory turned out materials for patriotic parades. One of his productions, a 40-foot replica of the USS *Minneapolis*, was perhaps the "most viewed" cruiser of the war. Hundreds of thousands of people saw it during those years.

By the end of the war he was operating from a converted ice-skating rink, had about 15 employees, and was producing all the floats and many of the stage props for the Miss America Pageant in Atlantic City.

"We used to make floats in Minneapolis for Atlantic City and ship them from here on special freight cars. Once in a while somebody would come up during

(Please turn to page 189)

NEW FOR
YOUR HOME
BY MARION MOREY



CLOTHES DRYER, mirror, light, radio, barometer and clock are one combination in a new "Inner-Wall" cabinet series. Just 5½ inches deep, unit can be built in or hung on wall. Howard Miller Clock Co., Zeeland, Mich.



OPEN-HEARTH GRILL holds charcoal vertically so both sides cook meat and grease doesn't drip on coals. You can perk coffee or fry potatoes on top grill. Cast-iron movable unit costs \$48. Ratcliffe & Sons, Marengo, Ill.



ANTIQUING PROCESS for furniture and woodwork takes just two steps; base coat goes right over old finish. Kits, complete to paint stirrers, are \$4.95, will do two chairs, Acme Quality Paints, 8250 St. Aubin, Detroit, Mich.

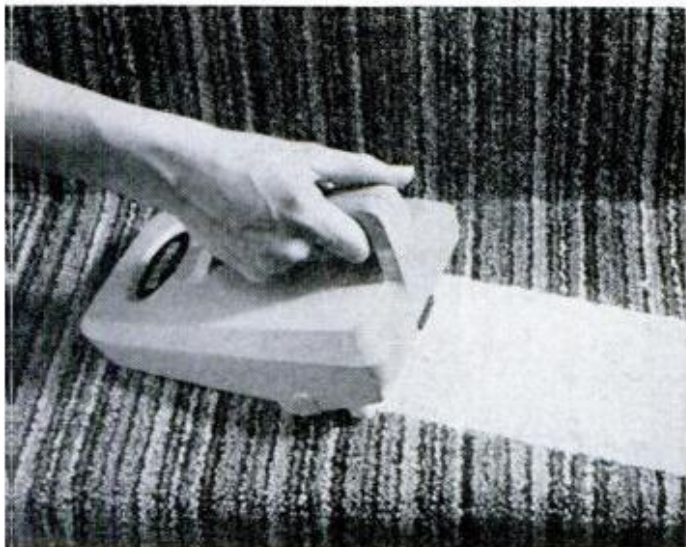

CARPET CLEANUP hand applicator works well on high-traffic areas such as stairs and car rugs. Sponge roller with snap-out brush head spreads powder and brushes it in. Vacuum picks up dirt later. \$4.95. By Bissell.



FAT SEPARATOR removes all liquid fat from soups to gravy stock while it's hot. Fat rises to top of heat-resistant container in seconds and clear broth pours out spout. \$4 from Fat-A-Way, Dept. TH-35, Albany, Ore.

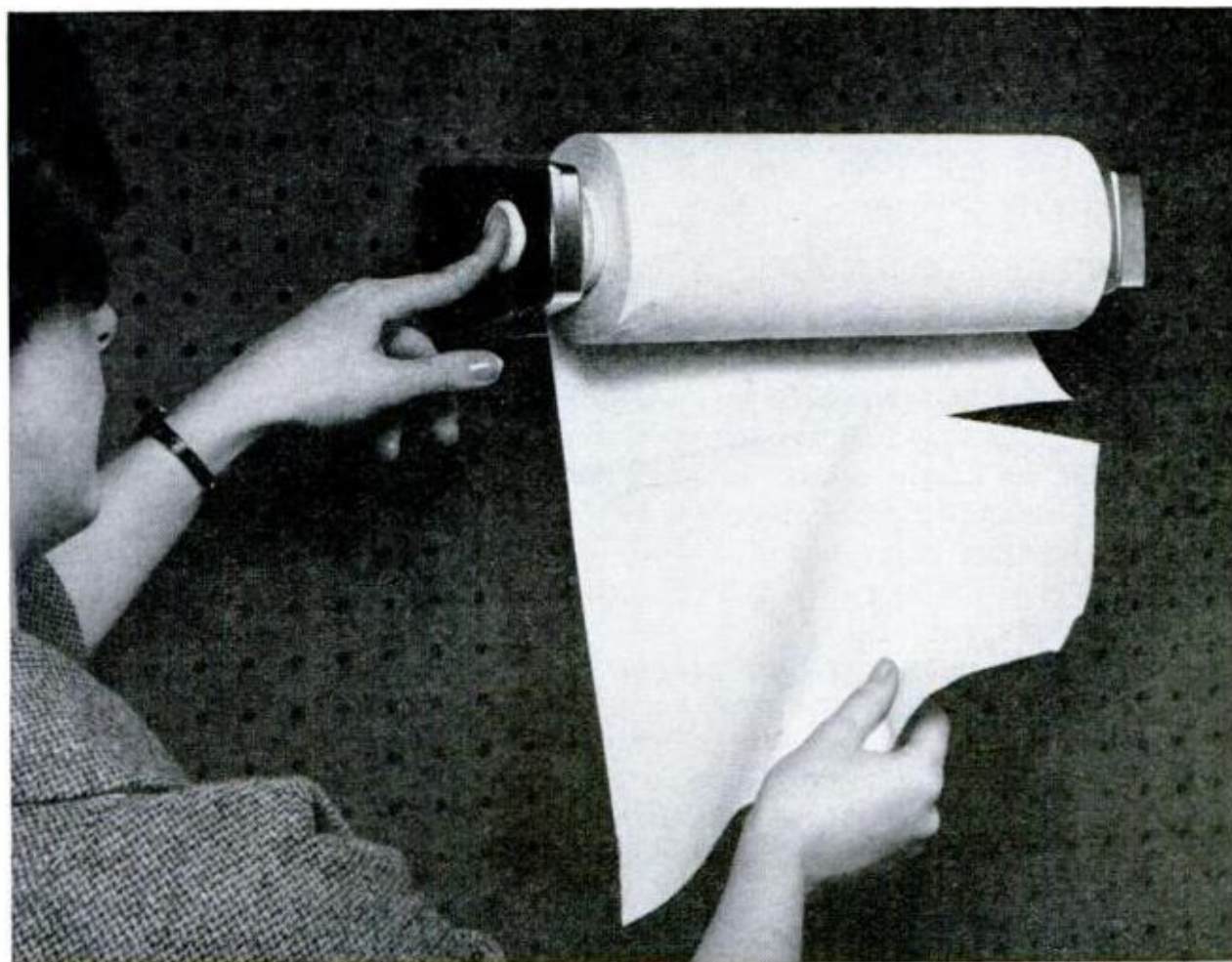

AUTOMATIC PAPER TOWEL DISPENSER unrolls one towel at a time at the push of a button—then locks into place as you tear off towel. Both right and lefthanders can avoid the usual "wet-grab" for towels. Flashlight batteries operate the dispenser. It mounts under cupboards, to the side of a sink, virtually anywhere. The light, rustproof units of enameled aluminum are available for \$7.95 from Nassau Shores H & G, 5500 Merrick Rd., Massapequa, N.Y.

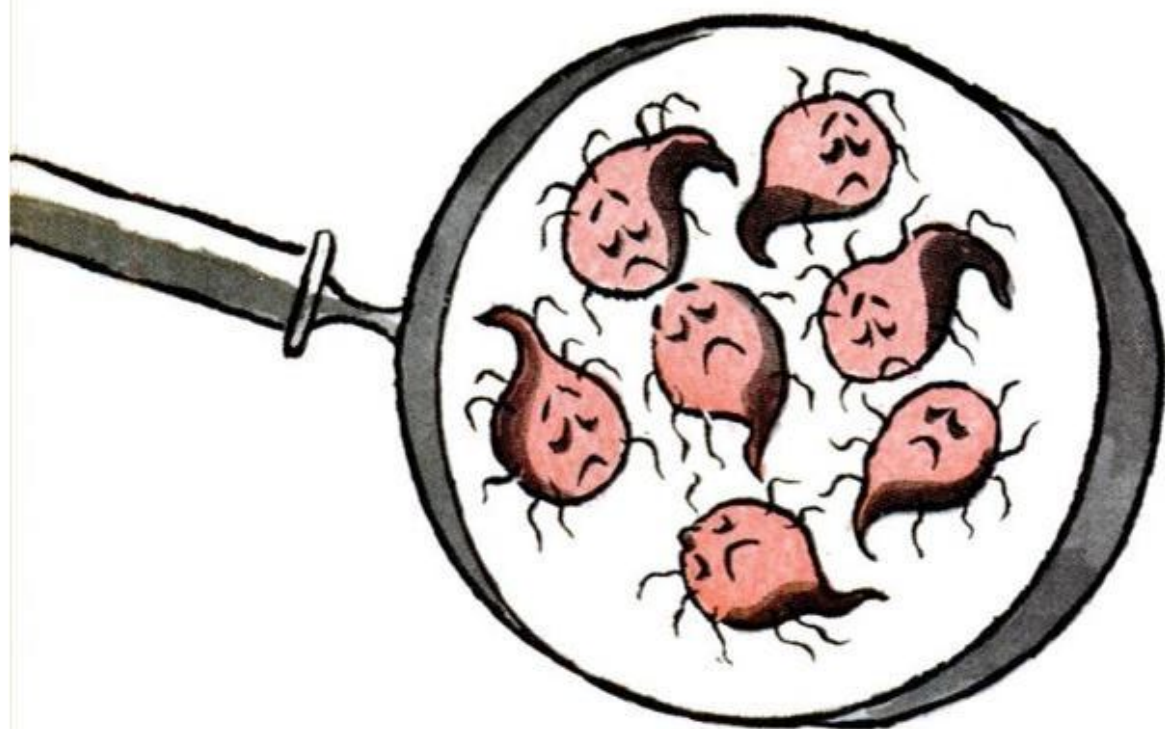

Bye-bye, bacteria!

The clothes we wear, the rooms we live in, the beds we sleep in are now being made with built-in germ resistance—but don't count on its effectiveness in every case. / By Theodore Irwin

AFTER A ROUND OF GOLF, you walk barefoot in the clubhouse locker room, unaware that the concrete floor has been impregnated with a special chemical to ward off the fungus causing athlete's foot. Buying a new hat in a store, the leather bands and lining of those you try on may be wholly free of any nasty germs from some other customer's hair. If you're planning to wood-panel a room at home, you can even get plywood with "sealed-in" protection against sundry bacteria and fungus.

Almost everywhere you turn nowadays, a silent built-in war is going on against unfriendly bacteria. It's not enough that Americans, fanatics on cleanliness, take 500 million baths a week. Avidly we go for whatever is marked "germ-proof," "sanitized," "antiseptic" or "bacteriostatic." The trend has so accelerated that today at least 7000 different consumer items are infused with germ-discouraging chemicals, helping to sell a whopping billion dollars in products each year. More and more, smart businessmen are trading on our fear and horror of germs.

Reputable companies, however, have learned to be cautious in their claims, using words like "retards," "inhibits," "repels" or "resists" germ growth, "bacteria fighters" and "bacterial barriers." But fly-by-nights, attracted to the gold in them that pills, use such phrases as *permanent miracle germicide* or *kills all bacteria*. The federal government, through the biological unit of the Department of Agriculture, cracks down on wild claims.

The trend, nevertheless, has been catching on like wildfire. Consider our clothes,

for instance. Microbe-resistant chemicals have been added in the manufacture of everything from socks and shirts to girdles and bras, infants' training pants and men's suits. J.C. Penney has treated more than 100 million pairs of shoes. In knit fabrics and garments, at least 14 different chemical formulas are involved. During the last Olympics in Tokyo, every warm-up suit worn by the U.S. team was made from a germ-repelling material.

Chemically-treated underwear, however, can have a drawback. Three years ago, a manufacturer overtreated a brand of men's shorts. Result: Many men suffered intolerable skin irritations. Legal suits had to be settled, merchandise pulled off shelves and burned—for a loss of some \$100,000. So today you'd have a hard time finding any "germ-free" men's underwear.

Much antigerm activity lately has been seen with paper products—napkins, tissues, disposable diapers and garbage bags with locked-in defenses against a host of organisms. Our government watchdogs are keeping an eye on some, particularly kitchen-shelf paper fortified with a "poison" for roaches. What happens if raw food is put on the shelf paper or a child chews on the paper? Investigation is under way.

Some self-sterilizing paints, said to be bacteria-hostile and mildewproof, have been introduced. One, which boasted that it "kills TB germs," vanished from the market after the government stepped in. But a number of floor paints are available to kill the spores of athlete's-foot fungus.

Germ-rebuffing floor waxes have been tried but use of too much chemical might be dangerous to toddlers. Tile manufacturers have been attracted to the gimmick for shower-room floors and approaches to swimming pools; and chemicals may go into the cracks between tiles. At least one big company has developed a special floor cement.

For ceilings, acoustical tile producers have come up with a new surface that doesn't trap dust and bacteria. You'll find it in hospitals, where epidemics of staph infections have long been a problem. Dread of the insidious staphylococcus has even led to germ-repelling casters on hospital beds that may be rolled from one room to another. The company's slogan: "Don't give staph a free ride!"

For plastic, rubber and cloth toys, the chemicals tend to be tied up so thoroughly that they're not dangerous to children. But how germ-free are they? After examining them, Dr. Leander S. Stuart, the veteran USDA microbiologist, told

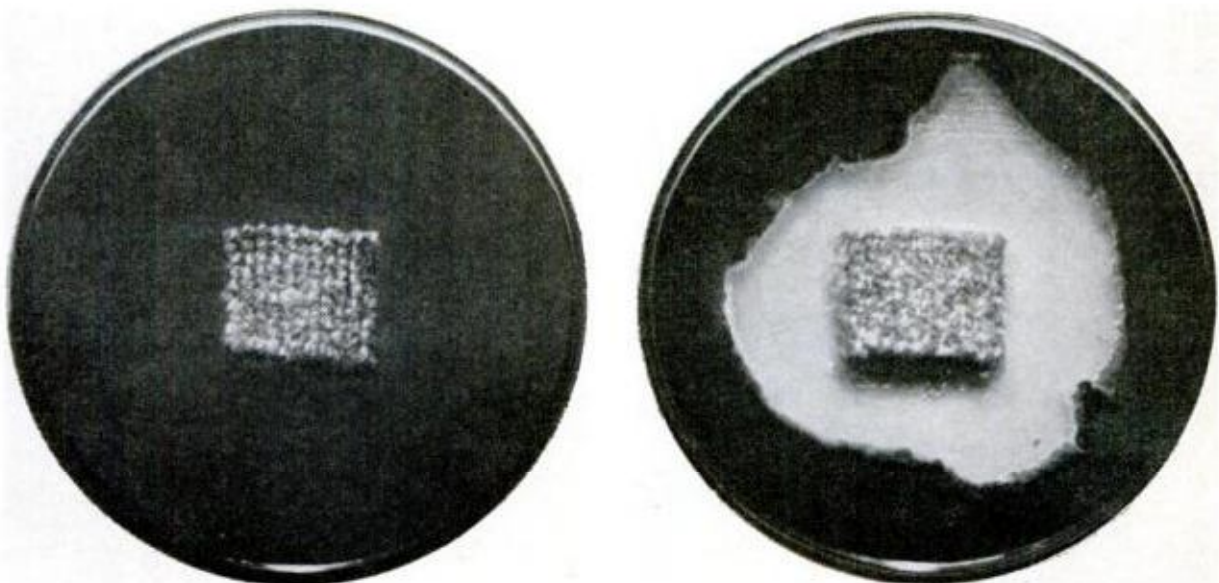

UNTREATED AND TREATED carpet samples illustrate effectiveness of bacteriostat chemical. Treated sample (right) builds up "zone of inhibition," although no treatment can claim complete inhibition



RESEARCH LABORATORIES, independently operated, test claims of "germ-resistant" products. Best consumer can hope for is partial germ protection

PM: "No, they're not aseptic. There's no guaranteed protection."

Similarly, when the maker of a plastic nursing bottle said it was "self-sanitizing in use," tests showed that not enough of the germ-fighting chemical leached out of the plastic to do any good. If the chemical—phenylmercuric borate—did percolate out, it could cause infant diarrhea. The claim had to be dropped.

Still the bacteriological warfare continues hot with blankets, towels, draperies, curtains, bathmats and tablecloths—all locked into the fabrics. Treated pillows proved a great success. One store chain, in an experiment, displayed "germproof" pillows at a higher price than the same quality pillows without the added attraction. The higher priced, germproof pillows

sold out before the other pile was touched.

One of the largest-selling toothbrushes has "germ-barrier" chemicals in the bristles, backing and handle. Brush your teeth, hang up the toothbrush and before it's dry the bacterial count is down to a low level, contends the manufacturer. Chemicals, leaching out in tiny amounts, are said to last for months.

Among the latest to be treated with built-in bacteriostats are women's wigs and hair curlers. And you can buy germ-resistant shades, luggage, carpeting, shower curtains, serving trays and plastic dish-washing racks.

Notice that we keep saying "germ-resistant" rather than "germ killers." The Department of Agriculture draws a sharp distinction. *Bacteriostats* must prevent growth of bacteria. *Sanitizers* must reduce bacterial counts to safe levels, as judged by public health requirements. *Fungistats* must stop development of fungi. In contrast, a *germicide* must not only prevent growth but kill all bacteria except those forming spores.

Microbes against which we are—hopefully—safeguarded range from *salmonella* (food poisoning, gastroenteritis, typhoid) to *streptococcus pyogenes* (throat infections). If everything you wore and used did a complete germ-battling job, you'd also have "protection" against dysentery, TB, infants' diarrhea, whooping cough, diphtheria, glandular fever, carbuncles and boils.

Germ-inhibiting chemicals generally used today are organic tins—Bis (tri-n-butyltin) oxide—and nonmetallic organic compounds such as salicylic acid, quaternary ammonium salts, the "mir-

DARTMOUTH FOOTBALL TEAM won the Ivy League Championship in 1965 after eliminating a plague of infections



acle" hexachlorophene and some antibiotics like neomycin. All are well-known enemies of microbes. Chemicals are sold directly to manufacturers or specific formulas are tailor-made for certain products by companies specializing in the field.

With 125 different formulations, the front-running specialist is Sanitized, Inc. of New York, which markets its chemicals under the trademark "Sanitized." The business of making bacteria uncomfortable was first sparked back in World War I when chemist L.D. Clement developed "Sanitized" while working with the U.S. Army. Experimenting with chemical warfare gases, Clement noticed one gas sterilized the soil for a long period.

But not until 1933 was Sanitized, Inc. set up to make the formula—then, primarily zinc and magnesium chloride. Slowly it started to take hold in the manufacture of shoe and suit linings. The big boom in bacteriostats finally broke out a few years ago when American businessmen woke up to the great selling power of "treated" products. Today, Sanitized, Inc. licenses over 900 manufacturers and its trademark is registered worldwide.

Another leader in the industry is the giant M&T Chemicals, Inc. of Rahway, N.J., which promotes bio-Met (trademarked) for "hygienic protection" in over 50 types of products. In all, at least 25 companies sell components for bacteriostats in consumer goods.

You and I are paying for such protection. Just how effective is all this built-in anti-germ warfare? Mrs. Bettyjane Hilton, president of Sanitized, Inc., points out that 30,000 quality control tests of Sanitized-treated products were made last

year by independent research labs. Each licensee must submit a product sample each month for various checks, depending on claims made. If, for example, a Sanitized-treated shirt is said to be "durable" in its protection, it goes through 15 washings and is then tested to see if the chemical is still there.

For an objective appraisal, we turn to Dr. Stuart, for 20 years the man to convince at the Department of Agriculture's bacteriological unit. All germicidal chemicals used in inanimate surfaces are under federal jurisdiction and must be registered as "economic poisons." For enforcement, the department has three microbiologists in Washington, four at the Agricultural Research Center in Beltsville, Md. and 16 field investigators.

With sophisticated lab techniques, including infrared and ultraviolet spectrophotometric methods and gas chromatography, Dr. Stuart and his staff can detect quantities of chemicals in parts per billion in samples submitted to them.

Evaluating the crop of germ-resistant products, Dr. Stuart is inclined to be wryly skeptical. "You have to be from Missouri," he says.

Interviewed a few weeks ago for *PM*, Dr. Stuart stressed these points:

"Many bacteria die themselves at a terrific rate, under ordinary conditions. But it's hard to kill the very resistant staph and TB germs. The most you can expect is a mitigating effect that reduces the chances of infection by some degree. However, if a bacteriostat prevents one person out of a hundred from getting an infection, then I believe it's worthwhile. But people

(Please turn to page 203)





Scooped-out cruiser design of the Viking 24 combines high freeboard with plenty of fish-fighting room. You have a choice of control stations—the one shown here or a much more compact model. Able to shave 34 mph with a single 110-hp outdrive, it should be great for anything from family camping afloat to off-shore fishing.

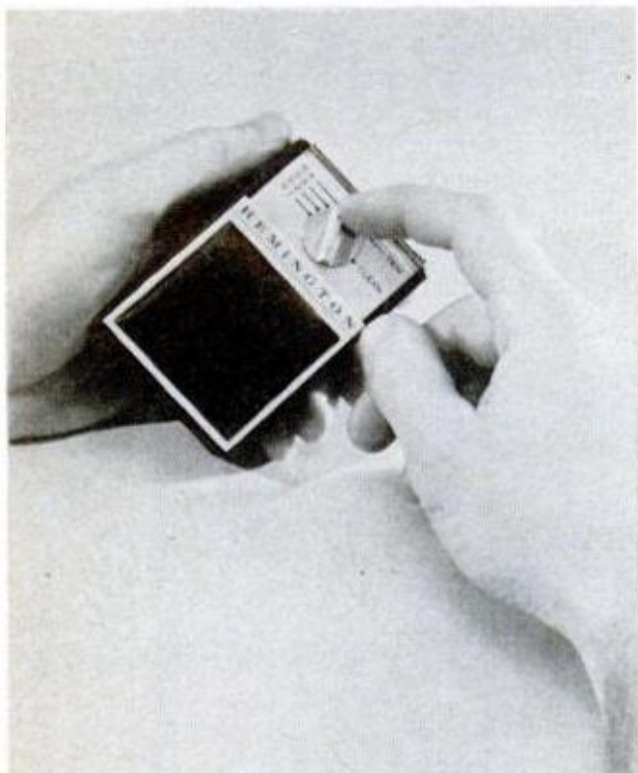

Dial-a-shave design of the new Remington 300 Selectro Shaver features dial-controlled shaving heads which raise through four different shaving positions, a pop-up position for trimming sideburns and a flip-open position for cleaning. The suggested retail price is \$32.95.



The ear-pounding crash of the pile driver isn't heard with the Bodine Resonant Driver atop pile in photo. Two gasoline engines energize a mechanical oscillator that makes pile vibrate so strongly that the soil breaks apart, letting pile slip in. The Bodine rig also is said to be much faster than conventional pile drivers.



Everything but a varsity letter is included in a new kit which converts any canoe into a racing scull. Designed by a college crew coach, the "Canoe-Swift" is made by Tool Tech Corp., Windsor Locks, Conn., and is priced at \$175.00.



Walls for wandering farms

Annual rains remove tons of topsoil. The solution, says a self-taught engineer, is a unique system of dikes. Some experts snort, but satisfied farmers say it works

By ARTHUR WHITMAN, Photos—CURT GUNTHER

PRESENT LAND AND WATER CONSERVATION practices are worse than nothing—they're harmful and wasteful," says Krekel Karch of Harristown, Ill. "I'm not the only man in the country who knows the extent of the waste, but I probably am the only man who can end it."

Karch, a big cavalry charge of a man, means what he says; he's not given to idle boasting. And many people are beginning to agree with him—both that present practice is bad and that he's the man who can do something about it.

The heart of the water-control problem, from which stem such other problems as soil erosion, floods and lowered underground water tables, is to keep rain (and melting snow) from running off the farms and woodlands that make up the upland watersheds of rivers, lakes and reservoirs. Conservation measures are essentially the same for farm and forest. Land is terraced along its higher elevations, with fields broken into small sections separated by ditches or "waterways." During a rain that lasts any time at all, a percentage of the water that falls soaks into the soil. The rest puddles over the surface and runs down the terrace slopes to the waterways. These carry it to

larger roadside ditches and, eventually, to streams, lakes, rivers and the sea.

"The net effect of the practice is to squander the farmer's two most precious resources—land and water," says Karch. "The water loss is obvious. It just runs away. The land is lost in two ways. One is that area devoted to ditches is nonproductive, the other is that the water washes tons of topsoil off the land every year."

The extent of this topsoil loss is staggering. Engineers, who gauge losses with complex formulas based on amounts of rain falling yearly on different types of soil, estimate that 4 billion cubic yards of topsoil wash off American farms every year. This lost soil adds to the water problem, in turn, by silting up lakes and rivers, often polluting them with chemical fertilizers. In Karch's own central Illinois, conservation authorities think in terms of a "perfection level" attainable with standard practices that assumes a loss of five tons of topsoil per acre per year. Less perfect control results in per-acre losses of hundreds of tons a year, literally shrinking farms as useful land turns into eroded gulleys.

Karch's approach is almost the direct



BEFORE: Water runoff cut a channel through this field in Illinois. The badly eroded tract couldn't sustain crops and remained unplanted for 50 years



ALUMINUM PIPES that Krekel Karch straddles are installed in base of dike to provide drain for water that might otherwise remain on land too long

opposite of standard practice—he holds the rain on the land. He became convinced during his boyhood on an Illinois farm that standard practices were all wrong. "My old man went by the conservation book," he says, "but it didn't make a damn bit of difference to anything. Come a dry year, you'd pray for rain. Finally you'd see some, and all it would do was wash away half the topsoil, carrying it off to silt up the cattle pond."

Completely self-taught as an engineer, the six-foot-three, 230-pound Karch experimented with his own ideas as a sideline to a small, prosperous earthmoving and roadbuilding firm that has supported him for years. He finally came up with an ingeniously simple technique he calls by the jawbreaking name, Hydrosol Intransitive Land Engineering (HILE) on which he has obtained patents in the United States and 12 other countries.



AFTER: In 1945 Karch installed water-retaining dikes on the field. That same fall, the farmer harvested crops that more than paid for Karch's work

HILE starts with the grade-school science principle that the ability of water to carry suspended matter depends on the speed at which the water flows. Fast-running water can carry a heavy soil burden. Slow water carries less; still water, none. "The principle is as old as the Egyptians," says Karch. "They figured it out from watching the Nile flood every year, drop topsoil it had picked up a thousand miles away and recede, leaving them with fertile fields. Somehow, though, the principle got lost in the conservation shuffle."

To put the misplaced principle to work again, Karch starts out by leveling fields with the earth. That is, he follows natural benches and elevations in the land, as determined by surveying, so that when he is through, the surface of the field is smooth, although the field is not flat. Next, he builds one or more HILE structures, as

may be required. These are earthen dikes set across the paths where water would tend to flow off the land. The structures slope gently and are farmed along with the rest of the field.

When it rains, water backs up behind a HILE structure to form a broad, shallow pool. Fast-moving water, coming off higher elevations, strikes the pool, drops its soil and becomes still itself, extending the existing pool to stop ever more water and soil in a continuing cycle. Multi-structure installations are designed so that when the pool behind one grows too large and water begins to run off, it can flow only into another pool, behind another dike. Thus an interrelated series of pools may cover an entire field after only relatively small amounts of rain.

To keep pools from standing too long, souring the soil and damaging crops, Karch installs a straight pipe through the base of each structure. By varying the size of the openings, he discharges water slowly past the dike in calculated periods of time—usually 18 to 60 hours. Since few rains last this long, most of the overflow occurs after the rain has stopped and all but the deepest pools are

(Please turn to page 178)



FLOW OF WATER through drains is controlled by plate at end of pipe. By varying size of opening in plate, water is run off at a predetermined rate



Steps to better hunting are crank-shaped rods with a wood-screw end that are easily turned into the trunk of a tree—without injury to the tree—making it simple for a hunter to climb above the ground for better visibility and safety. A set of four steps cost \$8.95 from Deer Me, Box 345, Anoka, Minn.



New life preserver, worn like a parachute harness, includes usual water wings, blinker light and whistle, plus hoist ring for easy rescue at sea. Wings, when deflated, fit snugly under the arms, and whole rig can be worn during daily chores without discomfort. Wings inflate automatically.



New robot bank teller does everything but smile. It "reads" the denominations of coins and bills, totals them, and stamps the receipt. All the customer has to do is put money in proper slots and make out a deposit slip. The device is being tested in several banks in Florida.



Water runner is a 13-foot contraption that's made for walking on water. To make it go, you simply slip your feet into shoe stirrups and start running. It was developed by Loyd J. Livaudais, Memphis, Tenn., who hopes to manufacture it commercially. His pilot model weighs 150 pounds and folds to fit in a station wagon.



Oysters by the string—that's the way they're grown at a Bureau of Fisheries lab on the Maryland shore. They're suspended in batches of 30 from plastic cords that hang from the bottom of a raft (shown). The suspended oysters grow faster than their bottom-dwelling cousins, say researchers, and their quality is better.



This seat warms you—from your own body heat. The heat is absorbed by the cellular-foam structure of the Kozy Cushion and is immediately reflected back to the user's body. The seat weighs just one pound and folds for carrying or storage. Made by Borg-Warner, it is sold by automotive and department stores.

STILL A

TIGER

IN YOUR TOOLSHED

They're loading mowers with safety features, but the spinning blade of a rotary unit is still lethal if you don't respect it.

By **ROBERT P. CROSSLEY**

NEVER PULL A MOWER UPHILL as this homeowner is doing, because one slip and your foot could be under the housing and in contact with the rotary blade.



YOU'VE PLAYED THOSE PINBALL machines where a steel ball comes up out of a hole and gets flicked around by swinging paddles. Or those amusement-park games that toss baseballs at you to bat back.

Well, this was the busiest, bounciest pinball machine of all time—and the most deadly. Instead of smooth steel balls, it batted nice, friendly objects like nails, rusty screws and pieces of bent wire—the kind of junk that lurks in deep grass and even in the best-kept lawns.

The "bat" was the whirling blade of a 20-inch rotary mower, mounted over a base of hard plywood in the center of a "bulletproof," transparent box of ¼-inch Lexan plastic. The nails and screws and pieces of wire were "fired" upward through a steel pipe, to be sent hurtling against a backstop 40 inches behind the rear edge of the mower housing, which could be raised and lowered. There were foul balls, bouncers and home runs, depending on how solidly the spinning blade "connected" with each shrapnel-like projectile. A high-speed camera, mounted in the mower, recorded the trajectory of each.

This was not some fiendish toy, but a controlled experiment. It was set up by the University of Iowa's Institute of Agricultural Medicine, which has been studying rotary mower accidents for three years and trying to figure out how to prevent them. Its work has been supported by the U. S. Public Health Service and by the Outdoor Power Equipment Institute, whose "Safety Seal" program, announced earlier this year, included some of the University's recommendations, but, in the opinion of Prof. L. W. Knapp Jr., chief of the Institute of Agricultural Medicine's Accident Prevention Section, doesn't go far enough.

Prof. Knapp and W. H. McConnell Jr., an agricultural safety engineer, made an intensive study of 77 mower accidents in 1964. They talked to victims in six Iowa counties, interviewed their doctors, examined the mowers and the scene of the accident, took pictures of severed boots and toeless feet. It was a grisly business.

The doctors, accustomed to amputating arms caught in corn pickers, often rated the rotary mower the most dangerous machine that their patients—even farmers—had occasion to use. Some even say that

all rotary mowers should be outlawed.

Prof. Knapp doesn't go *that* far. "Rotaries are an efficient way to cut your lawn and they *are* getting safer," he points out. "Safe, but not safe enough."

As the researchers studied mower accidents, some patterns began to emerge. Two out of three accidents involved the legs or feet. Four out of five happened with hand-propelled mowers, and seven out of ten of the mowers were less than three years old.

Of course, not all of the accidents could be blamed on the mowers. Some were due to plain carelessness like pulling the mower backwards over your toes. Prof. Knapp described these as "Man-Faults." Others were due to "Machine-Faults" like clumsy steering on a riding mower or

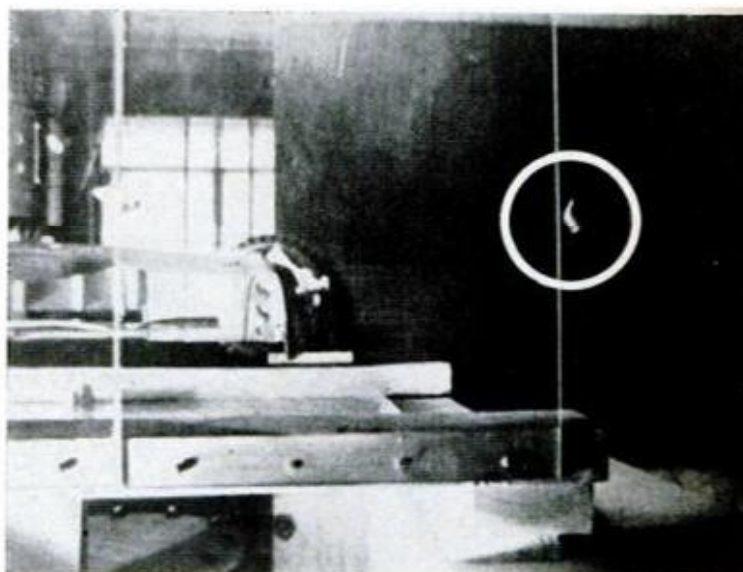

HIGH-SPEED PHOTOGRAPHY in laboratory test of rotary mower's lethal power shows a nail (circle) being thrown by the blade with the force of buckshot

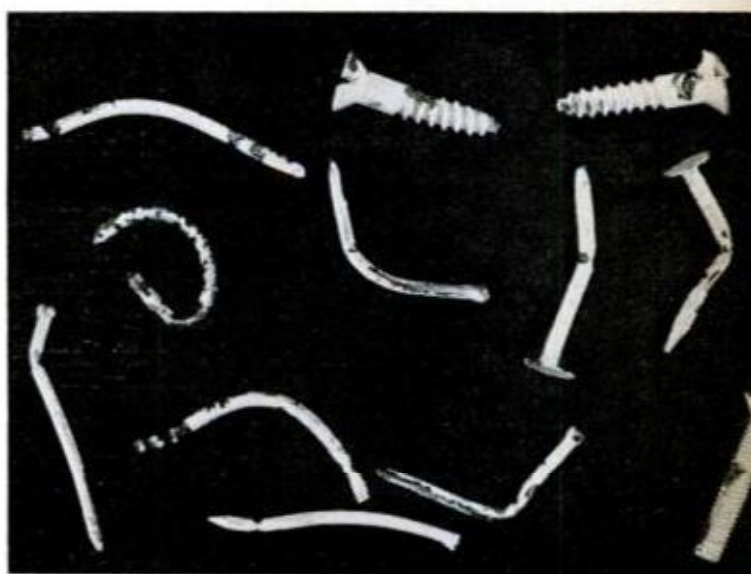

INNOCENT-LOOKING screws, nails and pieces of wire were deadly projectiles that inflicted injury when they were picked up on lawn and thrown by mower

Things to look for . . .



SAFETY HANDLE cannot be pushed beyond stop without side pressure to release it, making it difficult for an operator accidentally to walk into mower



LOOK, MA, NO HANDS are used to clean this mower. Hole in this deck takes water from garden hose and flushes clippings out through vent in the side

wheels that kept coming out of adjustment. Still a third group were blamed on "Environment-Faults" like rough ground or lethal objects in the grass. Prof. Knapp feels that a really safe mower should tend to prevent or overcome all three.

The accidents also seemed to sort themselves into five categories, regardless of who or what was to blame. The University labeled them "Thrown Objects," "Bystander," "Malfunction," "Unsafe Act" and "Non-Operational."

More victims were hit by thrown objects than were injured in all of the other ways put together. Most were hit below the knee while mowing straight ahead by objects



DANGER OF STANDING one foot on mower to pull the starter cord is eliminated by this crank handle that folds out of the way when it is not in use

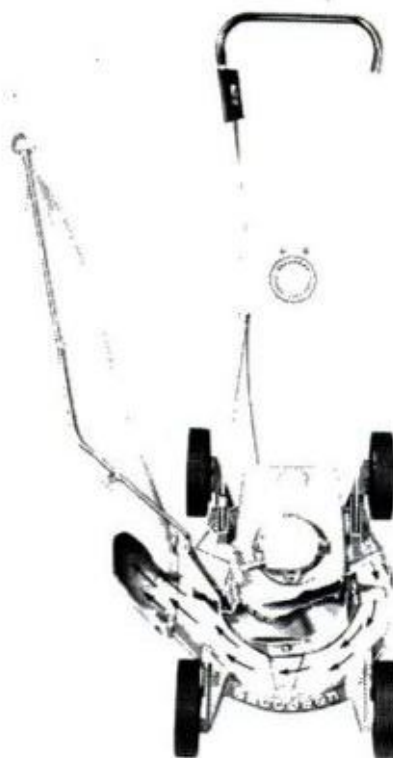

HEAVY-DUTY GRASS CATCHER BAG with four-blade cutter helps to contain most foreign objects and is most effective when partially filled with clippings

shooting or ricocheting out from under the rear of the mower.

One victim was struck 9 inches up the side of his leg even though his mower had a side discharge. Whatever it was hit him so hard he fell to one knee.

"It felt like I had been hit by a hammer," he said. No one else was home, and he had trouble stopping the blood. He finally got to a doctor. The doctor probed the wound and, finding no object, dressed it and sewed it up.

Instead of healing, the leg swelled, and the pain got worse. He went to another doctor who put him in a hospital and took X-rays. They showed an inch-and-one-

half piece of wire imbedded three-fourths of an inch into the bone.

Wire is just about the most dangerous projectile. Rocks and similar objects usually bounce off, but wire will puncture the flesh and lodge there or in the bone. For that reason X-rays should always be taken when the skin has been broken by a thrown object.

You can get hit even on a riding mower. One operator was struck by an object that

was thrown out from under the mower and ricocheted off the steering mechanism.

You *hear* a lot about "Bystander Accidents." Though much rarer than injuries to the operator, they are the ones that get in the papers. A variation of the "Thrown Object," they can, of course, be quite serious. An Iowa boy was hit on the head by a rock. The mower that threw it was 55 feet away. He was standing on a bench,

(Please turn to page 188)

Things to avoid . . .



CARELESSNESS is a major accident cause, and a rotary mower that is left unattended for conversation is an irresistible attraction for small children



KEEP YOUR FEET OFF the housing when starting the mower and when it is running, and hands should never come in contact with engine in operation



DON'T PUSH THE MOWER UPHILL. Always mow slopes sideways and you eliminate danger of mower rolling back on your toes—and it's also less strenuous



NEVER REFUEL A HOT ENGINE, or the result may be a flash fire that could inflict serious burns or a sudden explosion that could easily maim or kill



A CLOSE MANICURE is often the result of trying to unclog a running machine. This foolishness is the cause of two-thirds of the rotary mower accidents

Gardens for free

Bathe simple cuttings in electrically controlled mist, and presto—you have well-rooted plants and hedges

By KEN WARNER

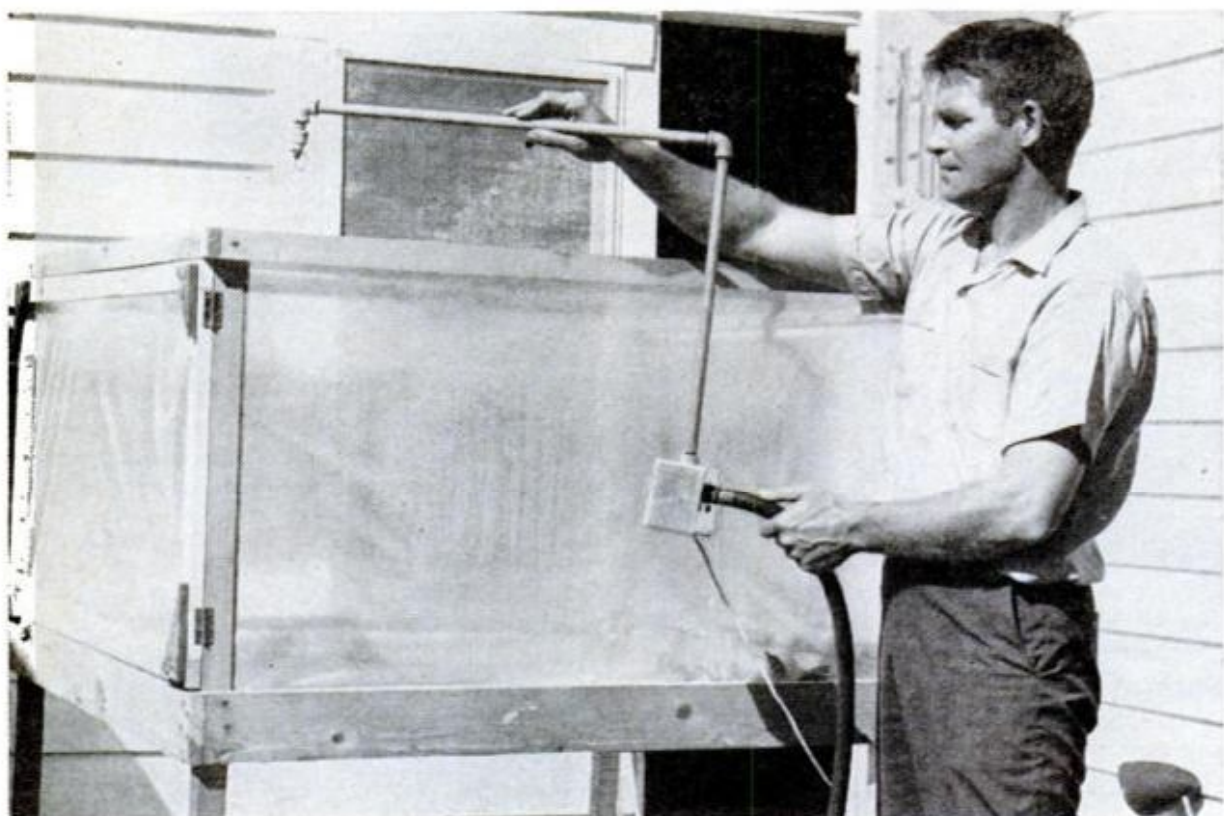

GARDEN HOSE supplies the water for simple mist propagator. The water jet gives a fine spray like an atomizer for four seconds every minute, keeping the cuttings sufficiently wet throughout the day

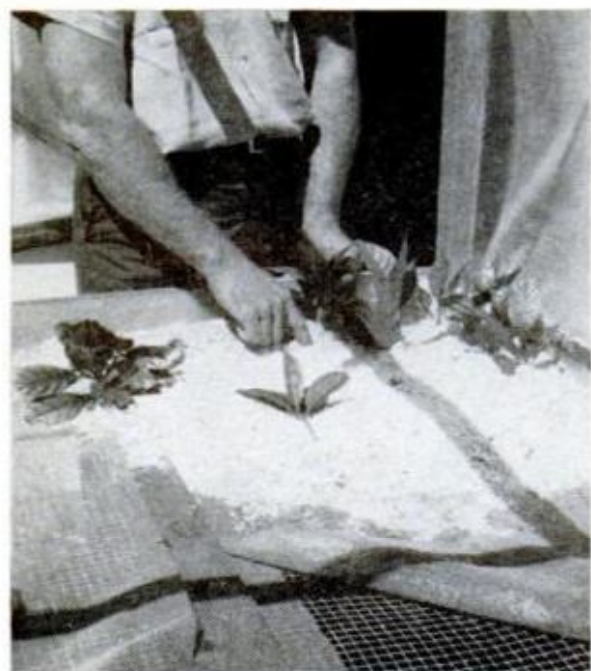

HARDWARE CLOTH BASE insures drainage. Medium used here to make cuttings take root is perlite

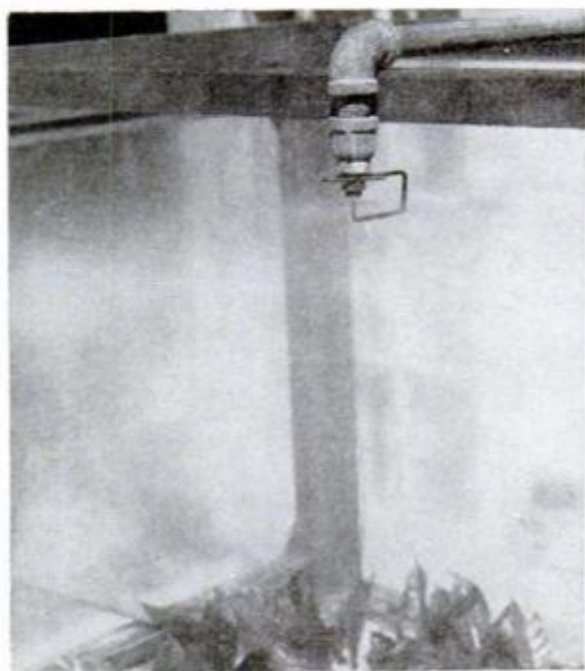

ATOMIZING SPRAY HEAD delivers fine, even spray that keeps plants wet without soaking them

JET AGE GARDENING has arrived. With simple cuttings from a friend's garden and a system called mist propagation it is possible to have "instant" gardens at no cost.

Used by professional nurserymen for a long time, mist propagation has been limited by the cost of equipment. But now there are low-cost units available to the home gardener that will make a Luther Burbank out of any average "green thumb."

Originally called *constant mist*, mist propagation is the technique of bringing roots out of stem and leaf cuttings by keeping them moist, never letting them dry. The mist system works because it prevents the excessive loss of water by transpiration after a cutting is severed from the parent plant, thus making it possible for the cutting to grow new roots. The mist system is accomplished in nonsoil media, eliminating many insect and disease problems found in ordinary cutting beds.

Mist propagation is not a cure-all. Some plants, both herbaceous and woody, do not root well by this method. On the other hand, many hard-to-root cuttings root easily under mist. Rose and chrysanthemum cuttings 14 inches long are examples of plants that root easily. Cuttings too large for ordinary systems work fine under mist, thus providing a head start toward a larger plant.

Misting at intervals is important for reasons of economy in water use. The technique requires only that the leaf surfaces remain damp to wet, as in early morning dew. Under most circumstances misting at night is not required, but in areas where the humidity is extremely low or where drying winds occur regularly, a night mist will be essential.

With one exception, the mist-propagating bed should be placed in direct sunlight. The exception is for cuttings from plants that require shade or that actually grew in shade. These should be misted in partial shade. But for all other plants the sunlight decreases the chance of plant disease and increases the rate of life processes.

The length or width of the propagation bed is dependent upon the individual operation, but it should be at least three-quarters of an inch deep and well-drained. The medium—the material used in place of soil—can be of several types, with fine gravel, perlite or wood shavings recommended for best results.

The actual process of making a setting is simple. An herbaceous cutting, such as chrysanthemum, is generally four inches or longer, with three or four sets of leaves. The lower leaf (or leaves) is removed and the cutting is set into the medium just deep enough to hold it upright. Deeper settings take longer to root. The mist is now applied to the setting until it takes root and is ready for trans-

You can use these three types of cuttings



SIMPLE LEAF CUTTING (left), leaf bud (center) and herbaceous cutting will all take root



HEALTHY ROOT SYSTEM ready for transplant was grown on a hibiscus cutting in 60 days under the mist



POTTED FOR JUST THREE WEEKS after developing root system in propagation, plant is extremely strong

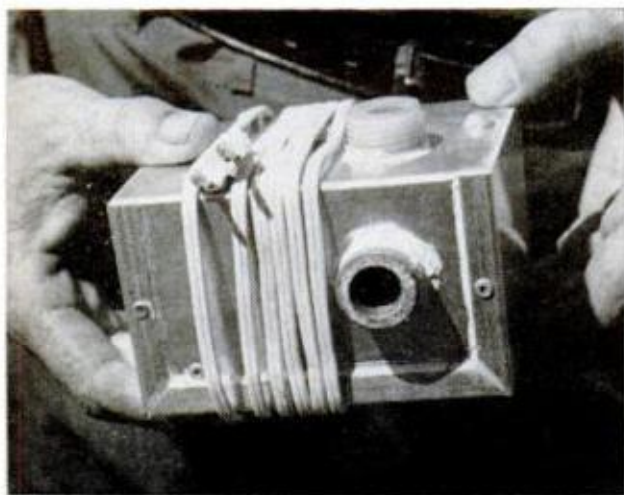

CONTROL UNIT for Mist Master shows the electrical connection, the inlets for hose and atomizer head

planting in the soil. The time necessary for growing roots varies with the species of plant. An hibiscus, for example, will take about 60 days to develop a strong growth of roots, but a box hedge would take considerably longer.

Leaf bud cuttings work with some plants. A leaf and its auxiliary bud (the bud that grows at the juncture of the leaf stem and the twig), plus a section of twig above and below the bud, are removed from the plant. These are placed in the propagation bed with the bud completely covered by the medium.

Leaf cuttings will also take root under a mist propagation system. Cuttings are made by taking the leaf blade and petiole (the slender stem that supports the blade of foliage leaf) only. The petiole is set three-quarters of an inch beneath the surface of the medium.

The big expense in a mist propagator has always been the regulatory device, the timer that keeps plants wet but does not allow them to become soaked and rot.

Automatic mist control

When this problem was attacked by John Strong of Sarasota, Fla., he came up with a control unit which he calls "Mist Master." Strong incorporated a timer, solenoid, filter and valve in one small sealed box, ran it 24 hours a day for six months, then applied for patent. His device sprays water for four seconds every minute. He also has a photoelectric control which automatically turns the unit on at sunrise and off at sunset.

"I can adjust this thing here at the bench to deliver a mist at any interval from one to 59 seconds in a minute," Strong explained. "I sell it as a sealed unit because that way I know it's my fault if anything goes wrong." Seeking a mist interval that would meet most climate situations, Strong settled for the four-second mist bursts for his "Mist Master" on the advice of university horticulture experts. For extremely dry climates he increases the length of the spray prior to sealing the control unit.

The basic "Mist Master" unit is priced at \$35 and is guaranteed for a year. The photocell control is an additional \$10. Strong also puts out a kit which includes all the necessary equipment for a propagator unit with the exception of wood frame, fasteners and hinges, and he has this priced at \$41. ★★★

Strange Berry Has a Flavor Secret



EAT ONE OF THESE olive-sized berries and it will make sour food taste sweet. "Magic" ingredient is found in the pulp, not in skin or dark, shiny pit



SINCE HE FOUND the first shrub four years ago, Bob Snow has collected a yard full of the plants. They're slow growers but reach height of 10 feet

EAT A LEMON and it tastes far sweeter than the ripest orange; bite into a sour pickle and you find your mouth filled with a taste of pleasant sweetness. These are tricks you can play on your palate if you first munch the pulp of a red berry from Africa called "miracle fruit."

For centuries, West Africans have used the berry, which grows on the shrub *Synsepalum dulcificum*, to make their sour palm wine potable. About 100 years ago an English botanist recorded the unusual properties of the fruit. New interest in the plant was created four years ago when Bob Snow of Lakeland, Fla., came across a specimen in a Florida nursery. He soon sold his employer—International Minerals & Chemicals Corp.—on the idea of a research project.

IMC scientists learned a number of interesting things:

- Miracle fruit contains a substance that affects the taste-sensing organs, changing their response but not the flavor of the food.

- The effect lasts for about an hour. You have to chew the berry first; there is no taste-masking if pulp from the berry is merely mixed with other foods.

- Miracle fruit doesn't work on salty or bitter-tasting foods.

- It adds no calories to the food.

The one thing the researchers couldn't determine was how the strange berry works. They were unable to isolate the ingredient that so effectively confounds the taste buds.

But this failure in no way dampened their enthusiasm for the fruit itself. One of the chief investigators declared that the berry creates "a more desirable sweetness than any other." Its effect on strawberries, he said, was "out of this world," and it causes citrus fruits to become marvels of delicate flavor.

At present there seem to be no commercial applications for the berry. But if it ever gives up its secret to probing scientists, it could be a boon to diabetics and to weight-watchers who can't leave sweets alone.

★★★

BE LAZY ABOUT LAWN SPRINKLING

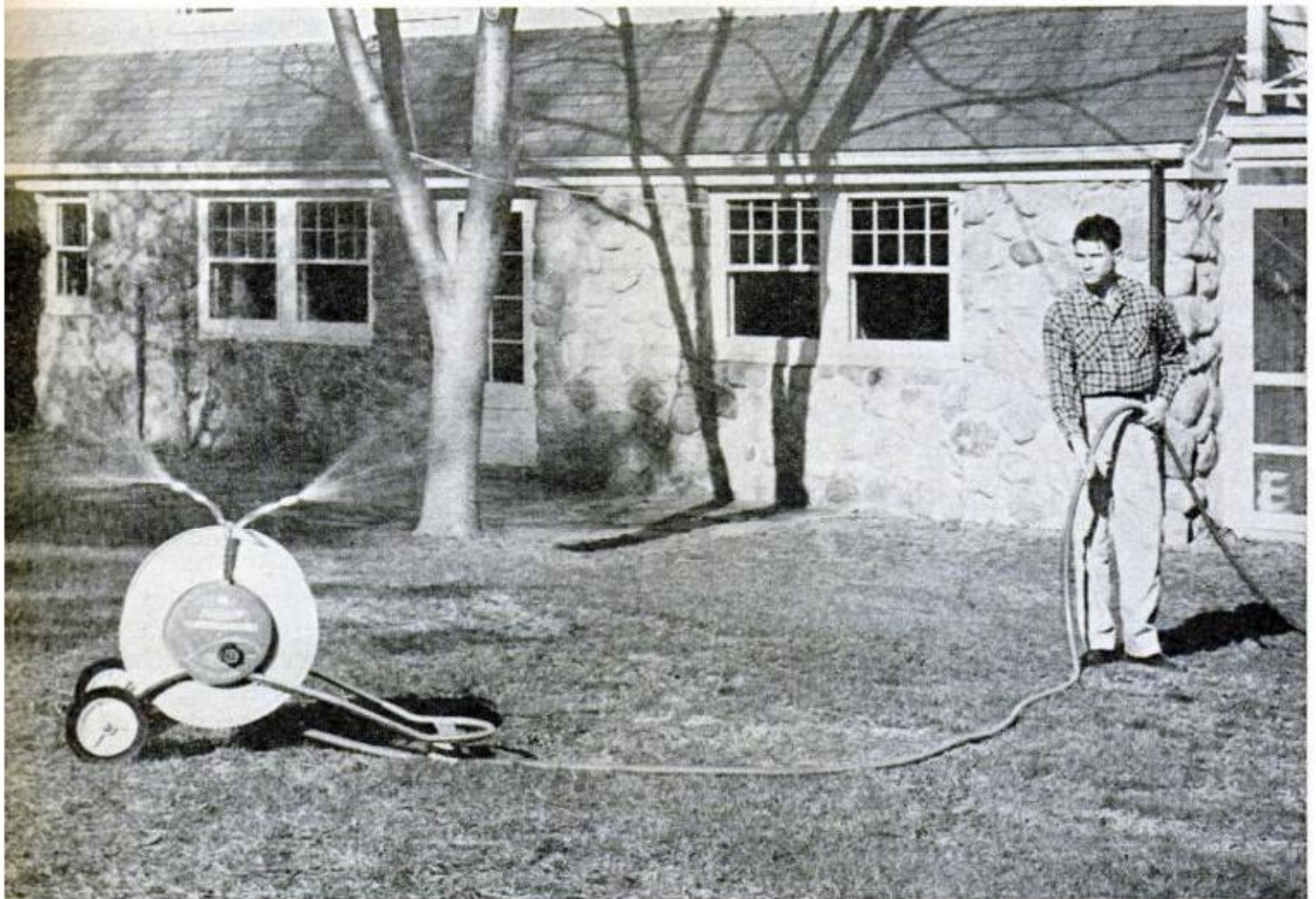

ROBOT REEL NOT ONLY SPRINKLES LAWN, but rolls up hose. You lay out hose in sprinkling pattern, then turn on water. The robot faithfully plods over lawn, slowly reeling in the hose. Finally, an automatic shutoff valve turns robot off. Sprinkler is made by Melnor Industries, Moonachie, N. J.

MOST GRASSES show remarkable tolerance to drought. Grasses may become brown and dormant if not watered, but generally they recover when the fall rains come."

You'll find this observation in an authoritative volume, the *Yearbook of Agriculture*. The message is clear: If you have the necessary psychic stamina to look at a brown lawn all summer, you don't have to get into a sweat about watering.

But if you're like most of us, your conscience won't permit you to turn your back on that expanse out front that should be lush and green. The only way out for the average lazy gardener is to make the watering as automatic and self-

propelled as possible. That's what the equipment shown on these pages is all about. You'll find all kinds of labor-saving devices, including sprinklers with "brains," robot reels and automated systems. Let them do the work while you, your conscience clear as that of a baby, loll in the hammock.

All that's required is a modicum of planning and know-how. If you'd like a quick refresher course, here's some advice from Robert M. Hanna, a soil specialist at New Jersey's Rutgers University.

Some plants are more efficient users of soil water than others, explains Hanna. The greater the depth and density of roots, the greater the plant's ability to take up enough water to withstand the

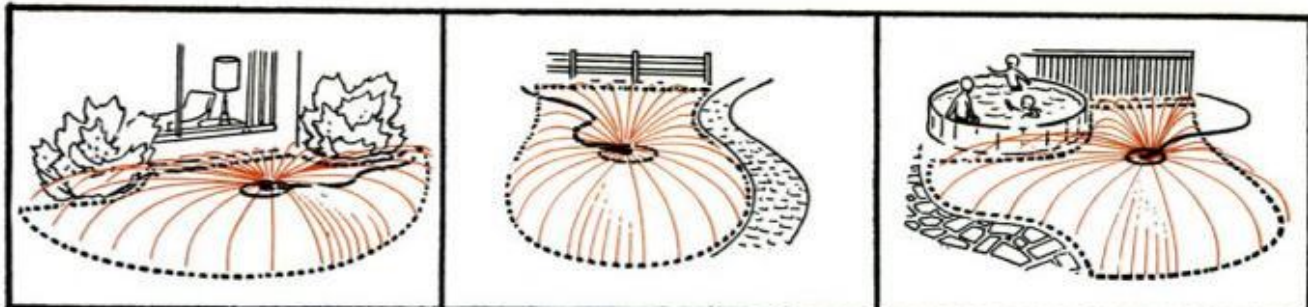

SPRINKLER WITH A BRAIN SPRAYS THE EXACT PATTERN of your lawn, no matter how irregularly shaped. You "program" 16 different adjustment knobs to the contour of your lawn. This permits you to avoid areas that you want to keep dry. Made by the Gates Rubber Co., Denver, Colo., gadget costs under \$20



HANDY WATER TIMER measures quantity of water flow and has automatic shut-off feature. It's made for Melnor sprinkler but will also work with other makes

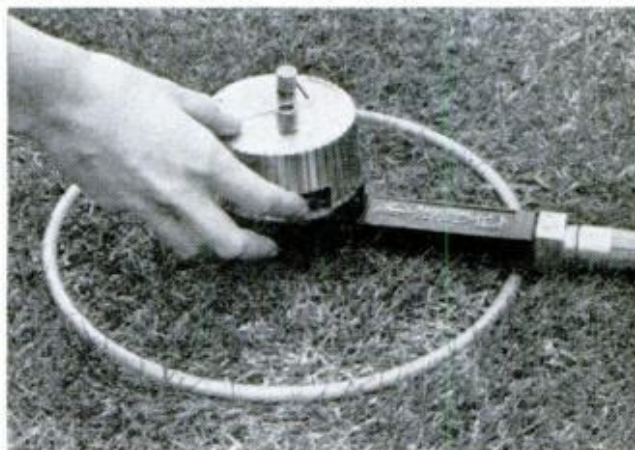

SPRINKLER "REMEMBERS" PATTERN, once it's set. Substitute discs, quickly slipped into the Gates watering device, enable you to program several areas

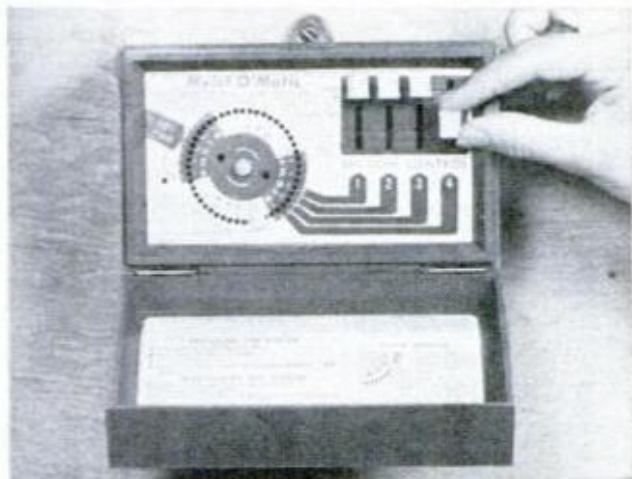

TIMER YOU CAN PROGRAM to sprinkle any section of your lawn, day or night, is heart of the Toro system, which is sold in kit form at price of \$189.95



COVERAGE UP TO 8500 SQUARE FEET is provided by timer, sprinklers and flexible pipe in the basic Toro kit. Pipe is buried at a minimum depth of 4 inches



WAVE SPRINKLER in Toro underground layout throws water fan covering rectangular area of 2500 square feet. Sprinkler is installed flush with the ground



SLEEK CRAWLER moves across lawn by reeling up a metal tape. Dial permits adjustment of sprinkling path from 5 to 50 feet wide. Maker is Sunbeam Corp.



BLAST OF PLANT-TREATING CHEMICALS is applied with Aquablast. It has 30-gallon tank and a 1-hp electric motor to provide the power. Cost is \$595

effects of rapid water loss during very hot, dry weather. You encourage deep root growth by proper watering.

Frequency of watering is determined by the type of grass, the soil in which it grows, weather conditions and the availability of water. The type of soil may be the most important factor. Hanna recommends that you water a sandy soil every 5 to 8 days and a loamy soil every 7 to 10.

Normally, the root system goes down to about 12 inches. That means that watering should penetrate to a depth of at least 6 to 8 inches. If a lawn has regularly been given light waterings, the root system probably is shallow. That's a condition to be avoided. During a dry, hot spell the top inches of soil lose moisture

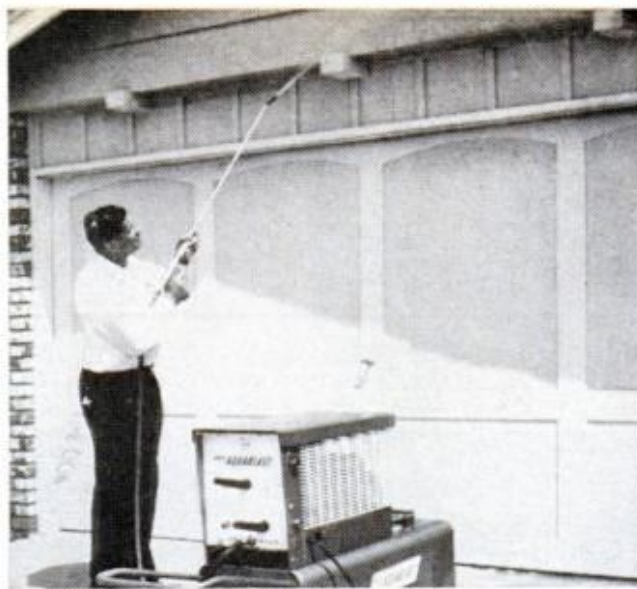

PRODUCING VARIETY OF SPRAYS are discs that slip into wand of the Aquablast, also used to wash cars, fences, buildings. Made by FMC Corp., San Diego, Cal.

first, leaving the root system high and dry.

"There are times when a light application is called for," the soil expert points out. "For instance, you don't want to put too much on when you have a new lawn. Then the root system is near the surface and only making use of an inch or two of soil." And when fertilizer is applied, it may be advisable to water lightly to get the fertilizer in solution and into the ground.

How do you determine how much water you've put on? Hanna advises adding a water timer to your garden equipment. Actually, a timer is a metering device that measures quantity of flow and is much more reliable than the practice of putting several empty coffee cans on



DIAL AMOUNT OF WATERING you want and timer does the rest, even compensating for changes in water pressure. It's easily installed on any sillcock



SQUARE-SHAPED HOSE is secret of new sprinkler system designed for foundation and border areas. Anchor spikes hold hose. It's sold by Sears, Roebuck



EASY AS PIE to hop over this exceptionally flat spray. Low angle of the Gates sprinkler eliminates windblown spray, permits watering under windows

the lawn in order to measure the fall.

Hanna would like to dispel some of the incorrect notions people have about watering. Many gardeners think the evening is the best time to water. Wrong, says Hanna. Watering at that time of day increases chances of mold or a fungus to get started. The morning hours are, by far, the best. Early in the morning the temperature of the water and ground are very close. If you choose the hottest part of the day, on the other hand, there's danger of steaming or "cooking" the grass. It's also a good way to waste precious water.

Here are some other tips offered by the soil expert:

- Water your lawn at least once in mid-spring.



ELECTRICALLY OPERATED CONTROL automatically opens and closes low-voltage valve assemblies at preset intervals. The control works on 110-120 volts



TRENCH CUT FOR HOSE leads to stake, where sprinkler in Sears Sprinkler-Matic system will be installed. Single head can water area 80 feet in diameter

- For sandy soil, begin your regular watering schedule in early June; for loamy soil in mid-June. An exceptionally dry May calls for an earlier starting date in either case.

- Water lightly only after planting new seeds or when the weatherman predicts rain in a couple of days.

- Water "deep" most of the time, especially before going away for any extended period.

- The use of a hose instead of a sprinkler is the chief reason for underwatering, which is more harmful than overwatering. Use a sprinkler—it's much more efficient and helps eliminate wasted "runoff."

- Moisture in the soil makes fertilizers available to the plants. ★★★



POP-UP HEADS are planted in holes 16 inches deep and held in place with coarse stone fill. When not in use, sprinkler head cover lies flush with ground



BUFORD MORGAN, who began his underwater farm about 15 years ago, is now No. 1 moss man in country, harvesting from 60,000 to 100,000 plants daily. And he sells all of them

Moss man from Missouri

His farm is under water and he never plants a crop, but the harvest rolls in every day of the year

By SHIRLEY ALTHOFF and DICK WEDDLE

AS A FARMER, Buford Morgan has it made. He specializes in a crop that requires little planting or cultivation and produces a harvest every day of the year. Neither drought nor flood nor heat nor cold affect its growth, and government subsidies or soil bank problems don't worry him one bit.

In case you think Morgan must live in an agricultural never-never land, he doesn't. His farm is quite real—but it's under water.

The crop he grows is moss—the feathery, fragile-looking plants that make aquariums seem more like home-sweet-home to millions of fish throughout the United States.

Buford Morgan is probably the largest underwater farmer in the country. Each year, some 35 to 40-million moss plants are shipped to wholesalers from "The Narrows," his aquatic farm in Oregon County, just seven miles from the Arkansas border in southern Missouri.

More than 10 varieties of moss grow in the four big springs that gush from the limestone cliffs on his 208 acres. They include the popular fern-like myriophyllum, which outsells all other kinds two to one; giant and dwarf anacharis, with their shiny, almost transparent leaves; ceratophyllum, which looks like a small spruce tree; and vallesneria, which

MOSS FARMER (right) wades through crop to harvest myriophyllum, shaking water from plants before loading in his boat. Cut year round, moss replenishes itself every three months



SPECIAL TOOL, butcher knife attached to long wooden handle, gathers moss between blades, then flips the plants over and cuts



AFTER CUTTING, moss is carried to "moss house" where it is sorted and packed. *Myriophyllum*, shown here, is the best seller





CUSTOMER ORDERS are prepared in moss house. Most customers have large standing orders with Morgan. One wholesaler buys 8000 dozen plants every week



MOSS ENDS UP in aquariums throughout nation, decorating both aquariums and homes. About 40 million of these fragile-looking plants are shipped yearly

resembles a small-scale iris or jonquil.

It was the lovely springs that attracted Morgan to the property in the first place. They pour 150 million gallons of water a day (enough for the daily needs of a city with approximately a half-million population) into the Eleven Point River.

Fifteen years ago, he came across the farm while on a hunting and fishing trip from his home in Chaffee, Mo., where he worked as a railroad brakeman. The wooded land slopes up sharply from the highway to a precipitous "hog-back" ridge, which gives the farm its name—"The Narrows." On top of the ridge, you can see the Eleven Point flowing south from one side and, only a short distance away on the other, you look down on the north-flowing Frederick Creek. The farm has a mile of frontage on both streams.

After close examination of the triangular acreage, Morgan decided he wanted to buy it. His late wife, Dorothea, agreed with him. (She died last year.)

"Then all we had to do," he recalls wryly, "is figure out how we could make a living here."

Learning that the former owners sold a little of the moss that abounded in the springs to a few local dealers, he explored the possibilities of expanding this business. Using his railroad pass, he traveled to various parts of the United States, talking to wholesalers of aquarium supplies. He found quite a demand for fresh, healthy water plants.

A compactly built, soft-spoken man with

bushy eyebrows and neatly clipped moustache, Buford Morgan began to educate himself on mosses. He read every book and pamphlet on plants he could get his hands on, and began to experiment with different cutting and packing techniques.

"Mostly, it was a case of just learning by doing," he admits with a grin.

For the first few years, he and his wife donned waders and worked right along with their crews. Moss farming was, and still is, a week-long, year-round operation.

"The spring water stays at 58° F. winter and summer," Morgan explains. "Actually, this has a temporizing effect on the air. In cold weather, you just add a few more warm clothes when you're wading."

In a few years, moss sales caught on.

"When we started out, we often worked as many as 10 people because our methods and system of operation were much cruder," Morgan points out. "But now things are pretty well organized and four full-time employees usually can handle things. As for me, I hardly do any more gathering. I just concentrate on business."

Each day, the men cut enough moss to fill standing orders and others that come in, averaging 60,000 to 100,000 plants daily. Wading in the springs, they use a Rube Goldberg-like tool—a sharp butcher knife attached to a long wooden handle. They gather a bunch of moss between the two handles and then deftly flip the blade over, cut the plants and pile them in a boat.

Mature moss lies on top of the water and the men harvest it in strips, generally

working from the mouth of a spring to its entrance into the river. Within three months after being cut, the moss replenishes itself and is ready for the harvesters again.

After it is cut, the moss is sorted and packed in the "moss house," a concrete block building. There, the workers check the plants, discarding those with buds (which means that growth has stopped) and clipping about eight inches from the tips of the others. These are bundled in groups of 13 and placed in wire-bound wood crates lined with damp newspapers.

"We always use a 'baker's dozen' count," says Morgan, "to give our customers a break, just in case a few of the plants don't make it through shipment."

The speedy quartet of employees can cut, sort and bundle 2000 dozen plants apiece during their usual working hours of 7:00 a.m. to 2:30 p.m.

When a crate is filled with 350 dozen plants, it is taken to a nearby walk-in cooler to await shipment. At the end of a day, Morgan or one of the men drives 20 miles to Thayer, Mo., to ship the crates.

To make sure the aquarium plants stay fresh in warm weather, an eight-pound block of ice is added to each crate. The moss farmer freezes his own ice in half-gallon milk cartons which he buys from youngsters in the area for 50 cents a dozen. He leaves the ice in the wax-coated carton and wraps it in an insulating layer of newspaper so it will last on long trips.

About 10 years ago, Morgan began experimenting with some of the more expensive species of moss—such as the attractive red ludwegia and snowflake-like fontanalis—planted in concrete tanks he built around the edge of the old mill pond at Morgan Spring. All of the species flourished but, even now, this more or less cultivated crop represents only about 10 percent of his business.

Morgan has no desire to expand. "I deal with about 30 wholesalers now," he says, "and I've got just about as much business as I can personally handle. Most of them have good-size standing orders. For instance, we send one fellow in Michigan 96,000 plants every week."

"No, I don't have an aquarium," Buford Morgan confesses somewhat shamefacedly. "I keep thinking about it but I've just never got around to doing anything about it. I guess you might say that I'm like the barber who always needs a haircut." ★ ★ ★



CERATOPHYLLUM, which looks like small spruce tree, is third-largest seller at Morgan farms, and is one of 10 varieties of moss to grow on his 208 acres



MYRIOPHYLLUM is best-selling and most abundant of Morgan's mosses. Popular fern-like plant outsells all other types by huge ratio of two to one



GIANT ANACHARIS, featuring shiny, transparent-appearing leaves, looks almost artificial. But it is second largest seller next to favorite myriophyllum

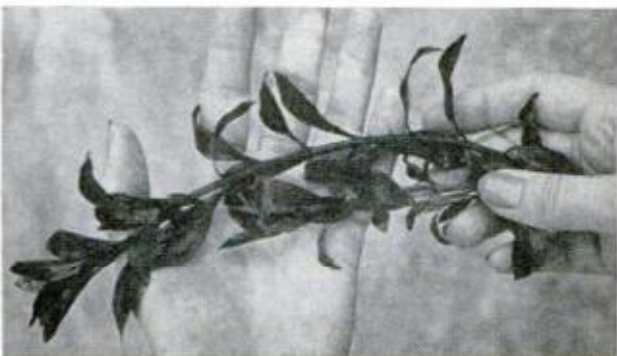

RED LUDWEGIA, deep maroon in color, is one of rare plants grown by Morgan. More expensive, it is grown in special tanks, sold to special customers

STR-R-R-ETCH TO A

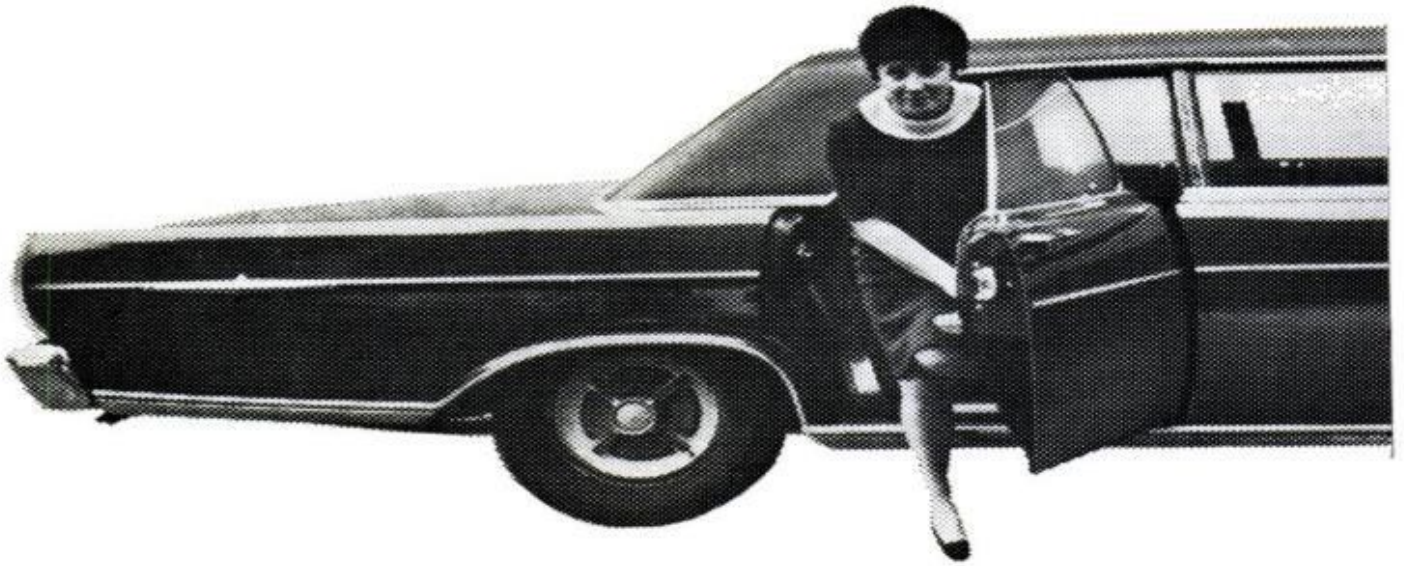

Tycoons, oil sheiks and maharajas are sending their stock cars to a Chicago taffy-pull that tugs them to extravagant lengths. You, too, can have a baubled, bulletproof behemoth for \$15,000 plus.

By ARTHUR WHITMAN, photos—CURT GUNTHER

THE CAR IS A SHADE over 22 feet long, weighs just under three tons, and has a 462-cu.-in. V8 engine that develops 340 hp. Some versions are bulletproofed.

A tank? Not at all—just America's newest prestige car, the Lincoln Continental Executive Limousine, made in Chicago by the Lehmann-Peterson Coach Co., Inc., the only independent shop in the country that makes limousines on a production basis.

Cadillac makes limos on its own production lines, as do Germany's Mercedes and England's Rolls-Royce. Others are built on a one-shot basis, usually by ambulance makers and custom shops. Only Lehmann-Peterson is in the business of converting standard cars to limousines and selling them through dealers.

Among the firm's customers are Lyndon B. Johnson, the Queen of the Netherlands, Spain's Franco, UN Ambassador Arthur Goldberg, various oil shieks and the U.S. Joint Chiefs-of-Staff. For every car made for a dignitary, five or so go to corporations who like their executives to travel in regal style. Some, like Ford, keep only a dignified one or two and use them mainly for important visitors. Others, like North American Aviation, keep a fleet of five.

Lehmann-Peterson also supplied the special car used by the Pope during his visit to this country in Nov. 1965. The car was made for testing by Lincoln in 1962, when the coachmakers first went into business. At the time of the Pope's visit it had been driven 170,000 miles. It was converted into a miniature throne room—complete with special screens, lights and a public address system—on eight days' notice and at a cost rumored to be in the neighborhood of \$25,000, paid by Catholic laymen's groups.

Curiously, few celebrities—as opposed to dignitaries—own the car.

"Jerry Lewis bought one of the first ones we made," says George Lehmann. "He seemed to love it for a few months, then got tired of it. We were delighted to buy it back from him. The car itself is our best ad, and with so few of them around at the time, we didn't want any of them trapped in garages. Since then we've learned that

LUXURY LIMOUSINE

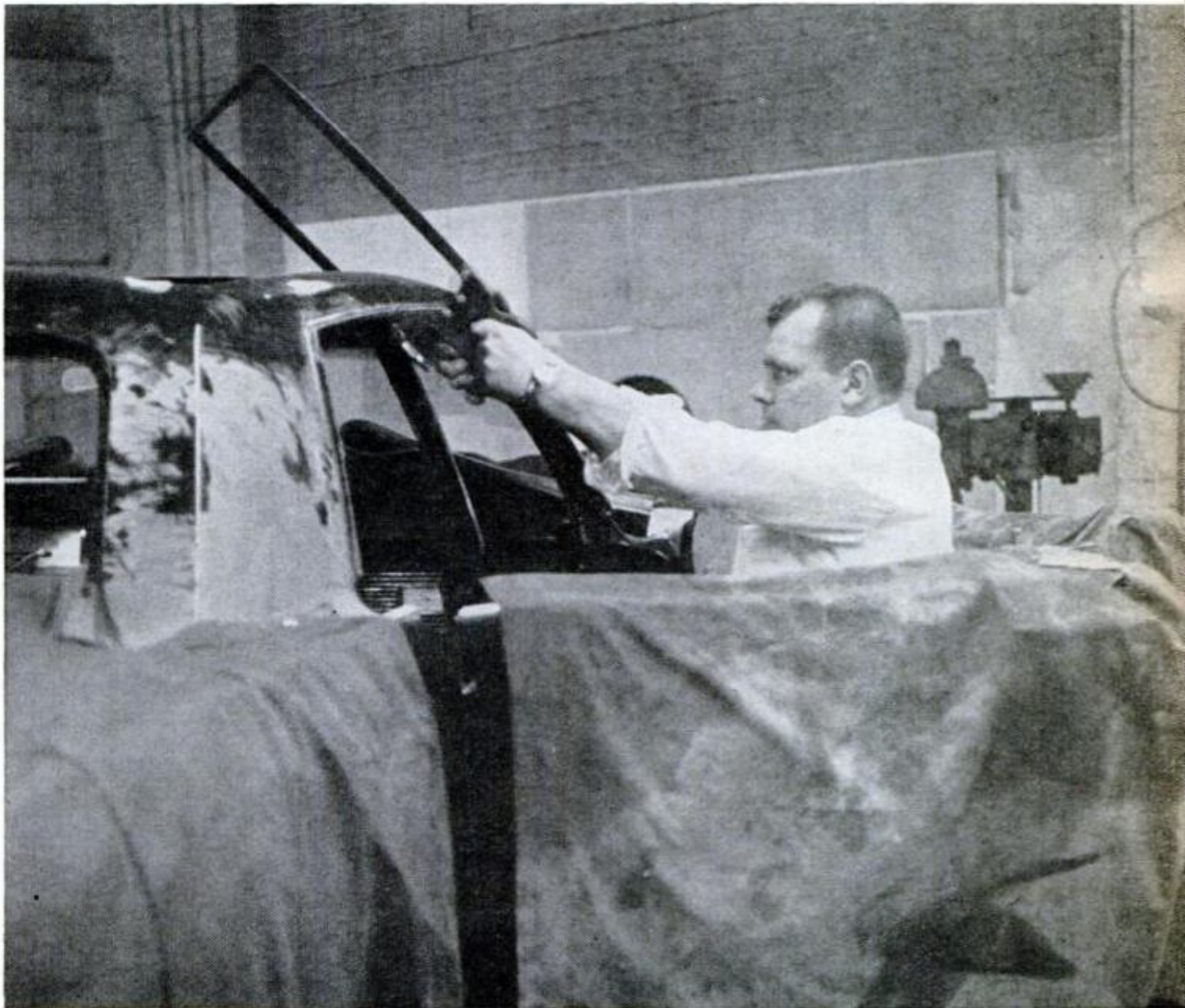
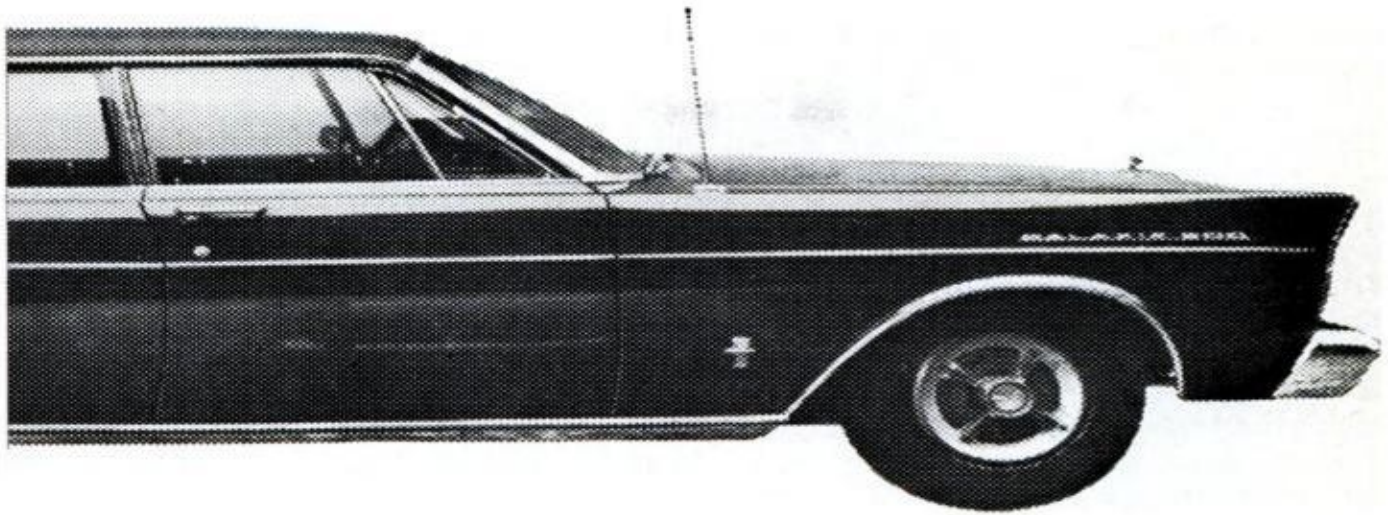

CAR IS SAWED IN HALF just behind door posts, following stripping of interior and cutting away of rooftop
JUNE 1966

most show-biz and sports types are more interested in 'pizzaz' than dignity. We have quite a few cars in Hollywood now, but they're all owned by studios—Warner Brothers, Revue—who use them for VIP visitors. The stars seem to go in for hopped-up foreign jobs and sportsters."

The unique coach business started in 1962 when Lehmann, then 24, found himself fresh out of the Army and fresh into a substantial inheritance. "He had enough money so he could spend his life sitting on his duff," says an associate. But duff-sitting is clearly an unthinkable occupation for the peppery Lehmann. He has too much energy to sit still in his office for more than five minutes, even with the distractions of visitors, three telephones that never stop, a public address system for communicating instantly anywhere in the shop, and a six-inch stack of daily paperwork. This is on a slow day. Busy, it's exhausting just to think about him.

"I didn't know what I wanted to do," he says. "I love cars and wanted to get into the auto business. But how? What?"

In time, he met Robert Peterson. "Pete" was half-again his age and everything he is not—slow-moving, shirt-sleeved, relaxed, exuding equal parts of charm and torpor. The torpor is deceptive, though. An auto designer and industrial dabbler, he has spent most of his life building up businesses and then selling them out.

New market

When he met Lehmann, Peterson had just sold a successful propane gas supply business that had begun to bore him. He had long been thinking there was room in the auto business for newcomers, and he thought he knew just where it was—making limousines for the affluent and burgeoning executive market.

After preliminary talk and planning, the two decided they could hardly manufacture and distribute a car from scratch, but that they certainly could convert existing cars—stretching them to limousine size. They approached Ford, whose Lincoln-Mercury Div. produces some 14,000 Lincoln Continentals a year, but stopped making limousines in the 1920s. They offered to convert the conventionally luxurious Lincoln into an even more opulent car, providing Lincoln would sell them through its dealers.

The Lincoln people thought this might make some sense, but only if George and

Pete could meet and maintain engineering standards. They ordered two cars made and test drove them for 100,000 miles each. The cars held up beautifully—one of them, as we've pointed out, still in good enough shape to have been converted for use by the Pope—and tiny, newborn Lehmann-Peterson Coach Co. found itself closely affiliated with one of the world's largest corporations.

To fill dealer orders, Lincoln sends L-P standard "unibody" production cars, equipped with a limousine conversion kit. The kit consists of heavy-duty springs, shock absorbers and tires, an extra air-conditioning system and an outsized cooling system. The extra cooling power keeps the cars from overheating when they spend long hours idling while waiting for passengers, as many limousines do.

Sliced in two

L-P strips the Continental's interior, removes the rooftop and cuts the car in half at the doorposts. Thirty-four-inch steel panels are inserted to "stretch" the rear compartment, and new floor pans are welded in to compensate for the added length. The roof is replaced and covered with padded vinyl. The only important mechanical change is the installation of a new, elongated driveshaft.

Standard trim and fittings include a chauffeur's compartment, a rear compartment containing five seats, the biggest armrest in creation and an AM-FM hi-fi rig supported on a walnut liquor cabinet. Also standard is an umbrella, thoughtfully tucked under the front seat so that passengers are never inconvenienced by the weather. Even better, it's the chauffeur, of course, who has to remember not to leave it behind someplace.

Extras include a remote-control system to signal the chauffeur that His Nibs is ready for a spin, intercoms, full-scale public address systems, and just about any gingerbread the customer wants.

"We can do anything to either the interior or the exterior," explains Peterson, who does all the designing on the cars. "The only qualifications are that the customer wants it, can pay for it and that Ford doesn't find it offensive."

Pretty Jazzy

So far, inoffensive, paid-for modifications have included oversized trunks with
(Please turn to page 185)



ROUGH EDGES are carefully removed, all gaps filled to assure flawless fit of finished limo's vinyl top



PADDED ROOFTOP is elegant feature of all Lehmann-Peterson conversions and typical of coachmaker's art

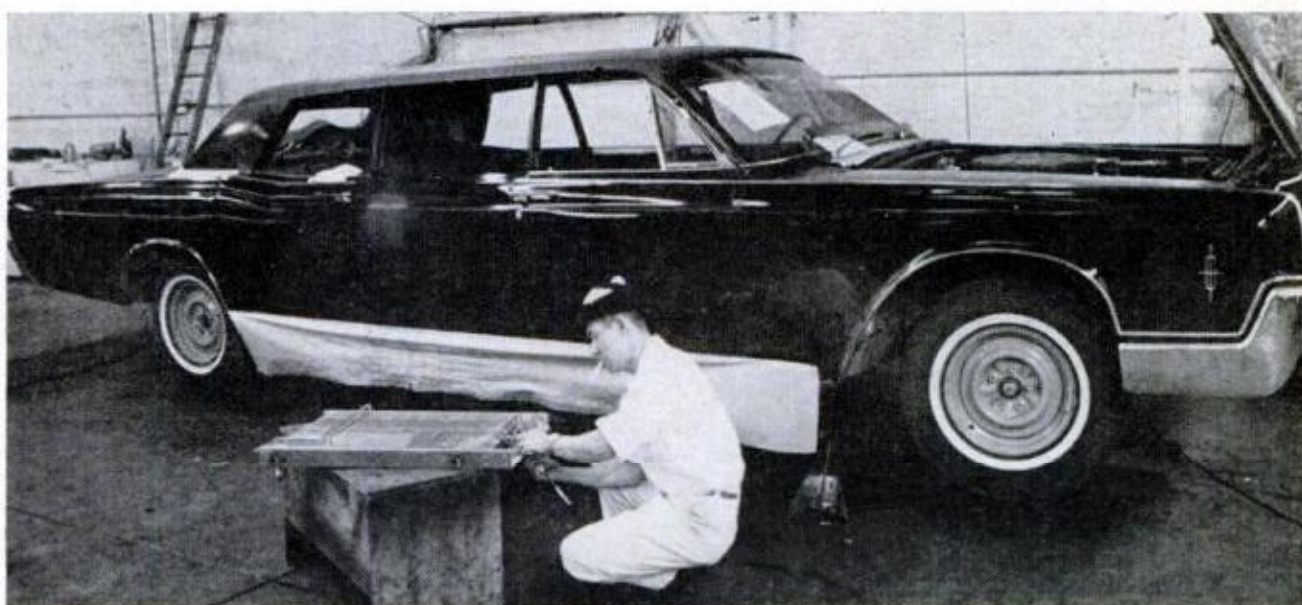

OUTSIZE RADIATOR core is part of heavy-duty cooling system, needed because limos often "stand and wait"

Old lawnmower provides GARDEN MULCH

By Manly Banister

ANY GARDENING BUFF knows the best way to fertilize the garden is with organic material and that the cheapest organic material is home-grown compost. Mulches for the garden also come dearly and you're tossing out valuable humus by setting out your clippings at the curb.

Now you can build this mulchmaker to help turn grass clippings, leaves and non-seed-bearing weeds into valuable compost or mulch. What the machine will do for you is shred the material, permitting a more thorough mixing of compost activators with the refuse, speeding its decay into compost, and making compost or mulch easier to shovel and spread.

You can make this mulchmaker from a 16-in. hand lawnmower and a 3-hp gasoline engine or a 1 to 1½-hp electric motor. The first job is to strip the lawn-

mower of its handle, wheels and roller. Remove and discard the gears on the reel shaft. Follow the dimensions shown in the illustrations below if a 16-in. mower is used. The width would have to be varied for any other size mower.

Cut mitered notches at the corners of the angle irons to be used for the carriage frame and cut the other pieces to length. Bend the mitered areas into sharp corners and clamp to a welding table or to scrap plywood insulated from the table you're working on. This will prevent warping of the frame from the welding heat. Clamp the other pieces of the leg assemblies, corner braces, motor mount, mower supports and hood lugs and the pipe handles and weld them. All welds are made on the underside of the frame wherever possible.

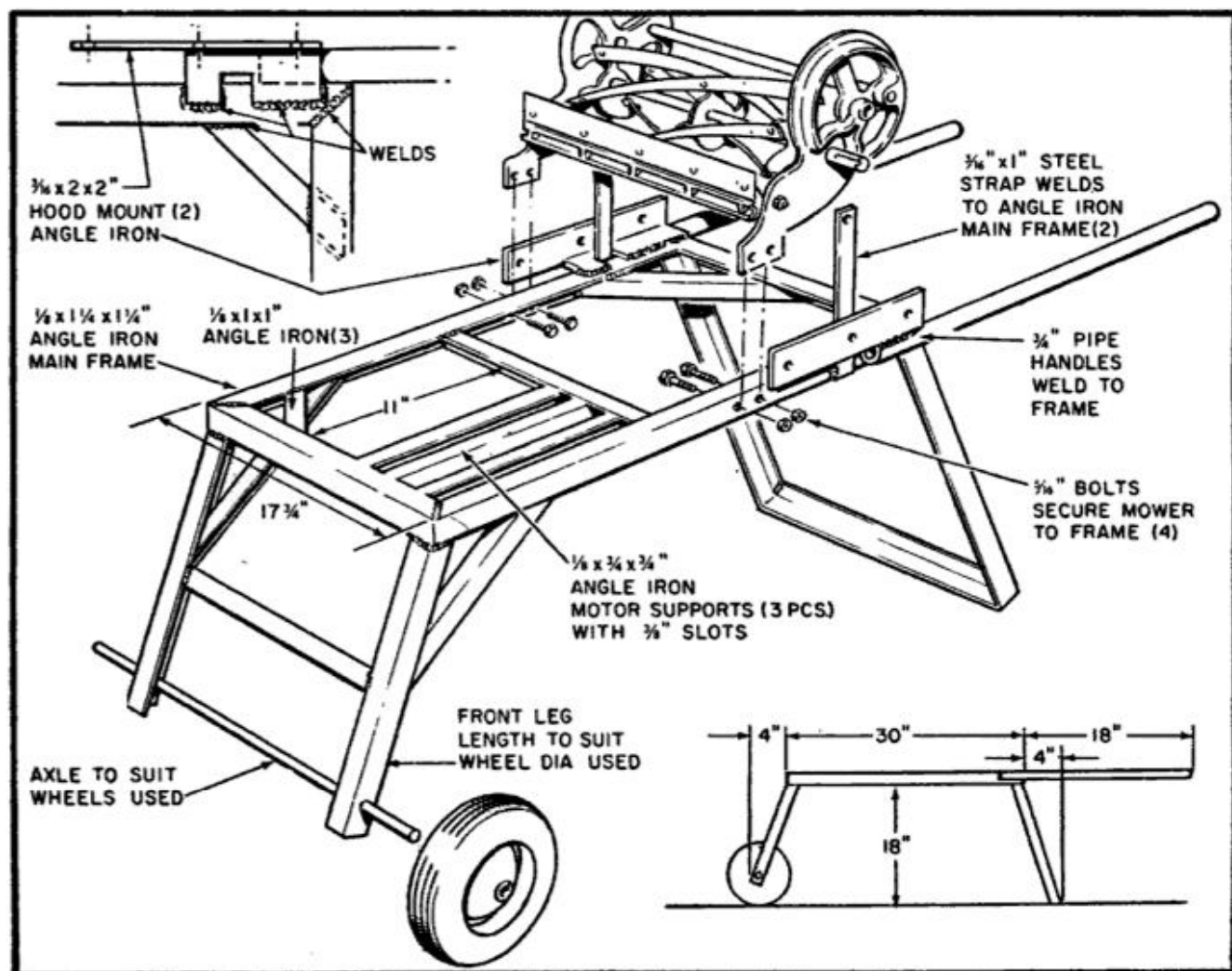

cutter for this

MAKING MACHINE

The lengths of the legs and the height of the carriage depends on the diameter of the wheels used. You can use the wheels from the mower, but they'll require a large axle. I bought 10-in. rubber-tired wheels, cut the legs to suit and mounted them on a 1/2-in. axle.

Drill and bolt the mower to the frame through the back roller mounts with 3/16-in. bolts. Then bolt the mower-frame support bars to the mower's wheel hubs. The position of the mower places the bed knife pointing up.

The reel shaft requires an extension for a pulley. Drill a 3/8-in.-deep hole in 3/4-in. steel rod with a diameter to match that of the reel shaft. In our case, the diameter was 1/16 in. (see drawing on page 123). Before welding this extension in place, mill a keyway to accept a 3/16-in. key in the

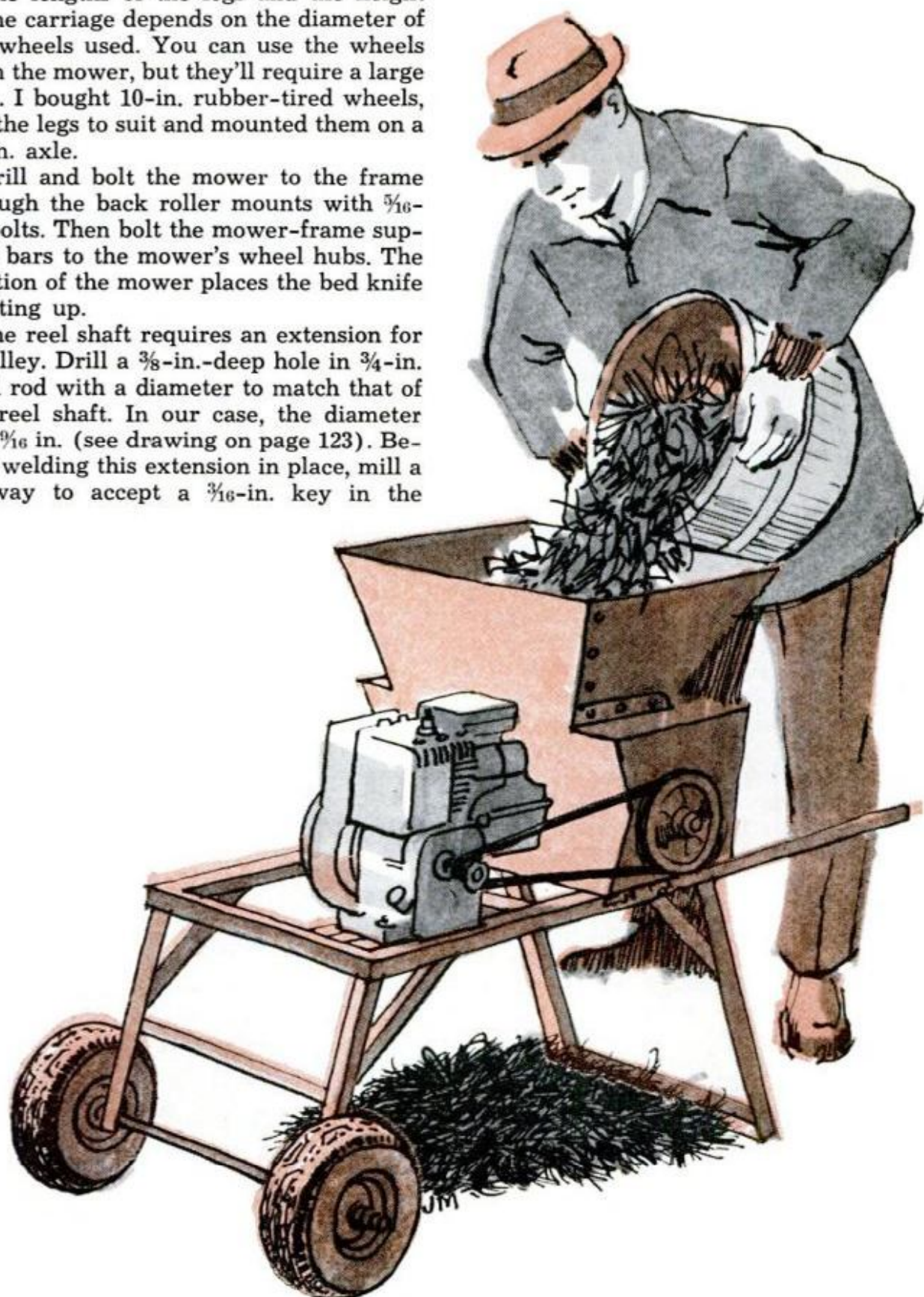



STURDY CARRIAGE for the mulchmaker is completely welded. The board to which the frame is clamped to prevent warping is insulated from the table for safety. In this position, most welds are concealed

pulley, or file a $\frac{3}{32}$ -in. flat to take a set-screw.

The sheet-metal work comes next. About as thick a sheet metal as could be readily worked and bent by hand was selected—24-ga. galvanized. All the bends can be made easily by clamping the work between two boards or between a board and a table edge. A 2 x 4 with a beveled edge of the required angle will handle other than right-angle bends.

Lay out the patterns on the sheet, as shown on the facing page, indicating the junction of lines with a punch mark. Then you can lay a straightedge across the marks and scribe the bending or cutting lines.

Note that some of the tabs are for riveting and some are hems to be folded flat to avoid sharp exposed edges. The sides of the hopper are canted 17° and its backplate is inclined 45° . This assures an even feed and a wide enough opening.

Clamp the hood to the hood lugs with C-clamps, then punch and drill for the retaining bolts. Three $\frac{1}{4}$ -in. stove bolts on each side and, later, two through the backplate and the angle iron welded to the rear of the carriage, will be enough. When you have the hood bolted in place, cut the backplate to size and clamp it on. Drill No. 30 or $\frac{1}{8}$ -in. holes and secure it to

the hood with short Pop rivets spaced 2 to 3 in. apart.

Transfer the pattern for the hopper to a sheet measuring $18\frac{1}{2} \times 41$ in., as shown on page 124. You can work from the linear measurements without having to measure any angles. Install the three-sided part of the hopper carefully, making sure that it goes into place square and will clear the reel blades by about $\frac{1}{4}$ in. Clamp it to the hood tabs; punch, drill and secure it with Pop rivets. Cut the hopper backplate, bend

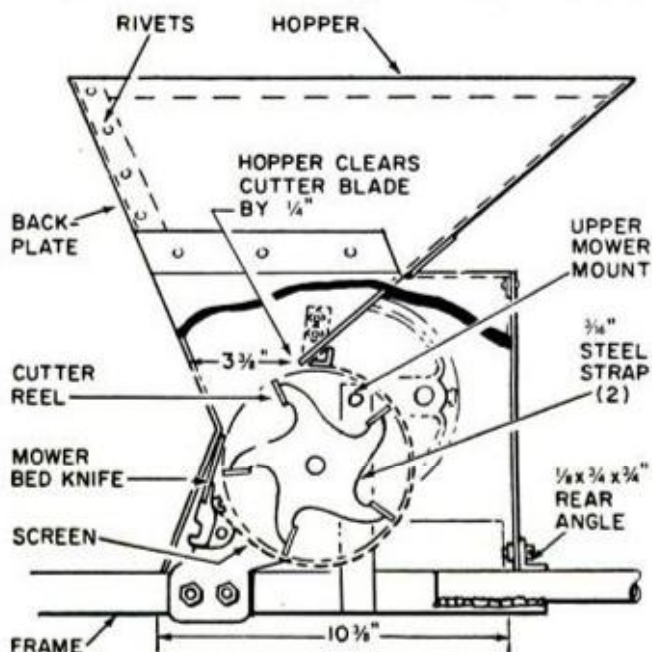

the tabs, clamp it and rivet it into place.

The screen you install next holds back the material fed into the machine so it can be ground finer and provides a guard under the cutter blades. With a crayon, mark the uppermost reel blade in such a position as to indicate just where the rear edge of the hopper opening is. A properly adjusted bedknife will help insure this. Then remove the hood-and-hopper assembly.

Obtain a piece of 1/2-in. 18-ga. rolled expanded-metal screen (preferably heavier) 16 in. long and as wide as the mower bed—16 1/4 in. in this case. Pass it over the reel, under the mower bar and keep it close around and under the reel. Then bring it up inside and snug against the bed. Drill for 1/4 x 3/4-in. stove bolts at the ends of the bed where they will not interfere with the reel, and attach the screening.

If you have difficulty in finding expanded metal screen, make your own by drilling 1/4-in. to 3/8-in. holes in a screen pattern in 16-ga. or heavier sheet metal.

Now, cut away one side of the angle of 1/8 x 3/4 x 3/4-in. angle iron to fit between the wheel frames so that there is a tab 1 1/2 in. wider at each end. Bend these up at right angles and then place the angle iron on top of the screen, positioning its front edge just behind the crayon mark so the screen will not be in the way of the hopper opening. Finally, clamp it to the wheel-frame spokes.

Pull the screen up tight and bend it back over the angle iron. Reinstall the hopper to check for fit, then remove it

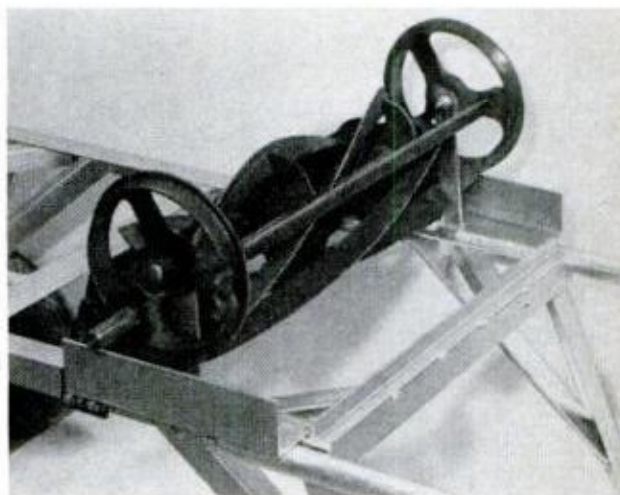
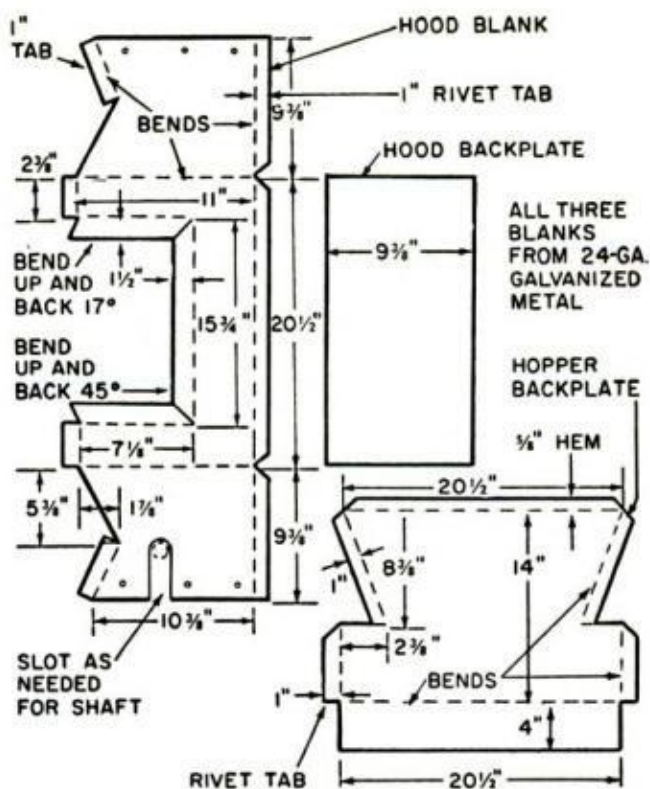

MOUNTED MOWER is attached on both sides through rear roller brackets to the carriage forward of the hood-support lugs, and to welded-on bars that are bolted through the hubs of the mower's wheel frames

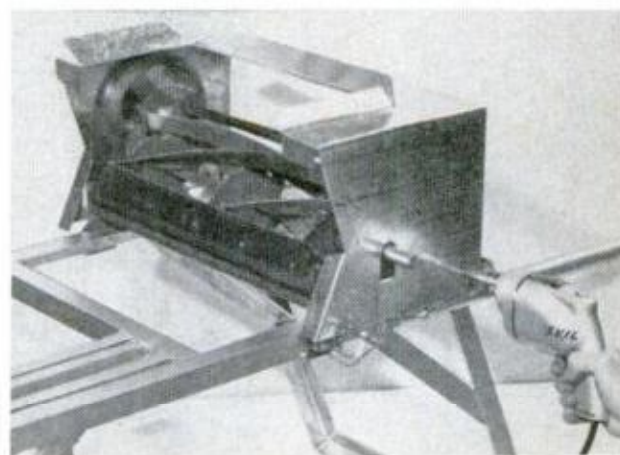
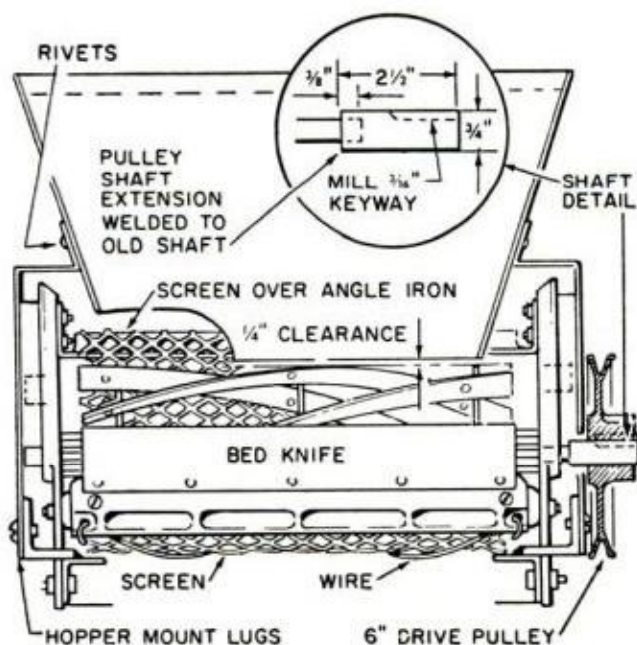

MULCHER HOOD is clamped in position and holes drilled through it and the welded hood lugs. Protruding from the side is not the reel shaft, but the extension to hold the pulley outside the hood

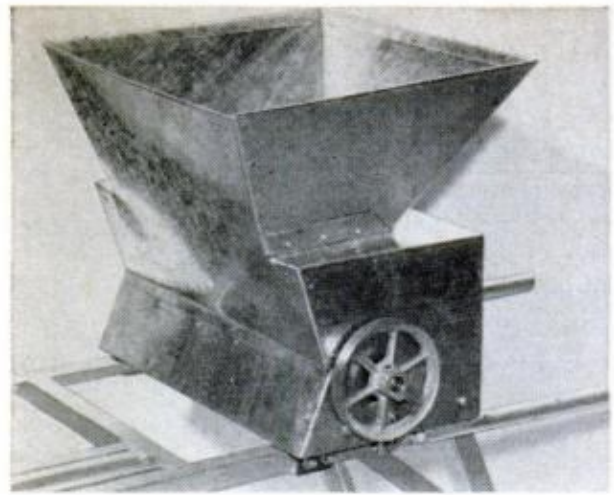
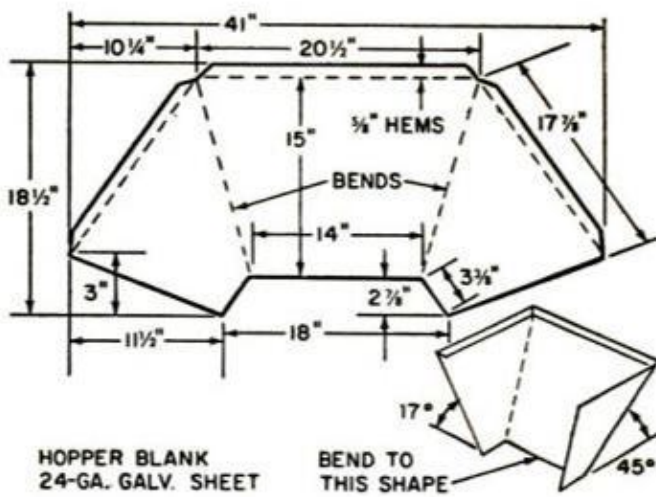

COMPLETED HOOD-AND-HOPPER ASSEMBLY is riveted throughout. Note that the tabs of the hopper's upper edge are folded flat to eliminate sharp edges. Three sides of the hopper blank are cut from one sheet

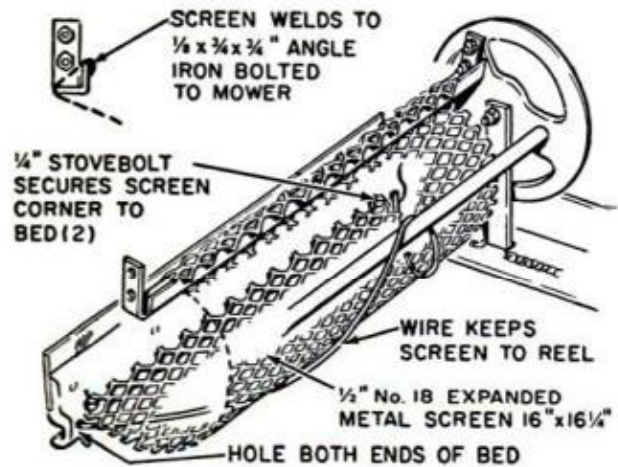
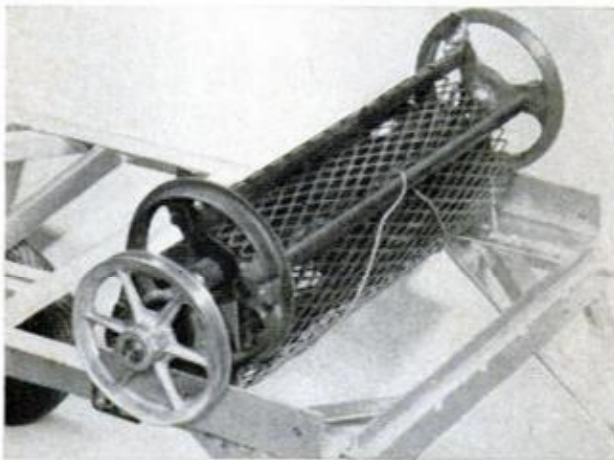

SCREENED REEL produces finer mulch and covers the whirling blades underneath. With the help of the retaining wire, the screen is a close fit upon the reel and functions as myriad additional bed knives

again. Spot-weld the screen to the leading edge of the angle iron, using a 1/16-in. or 3/32-in. welding rod and the lowest possible amperage.

Finally, pass the screen-retaining wire around the mower bar, as indicated in

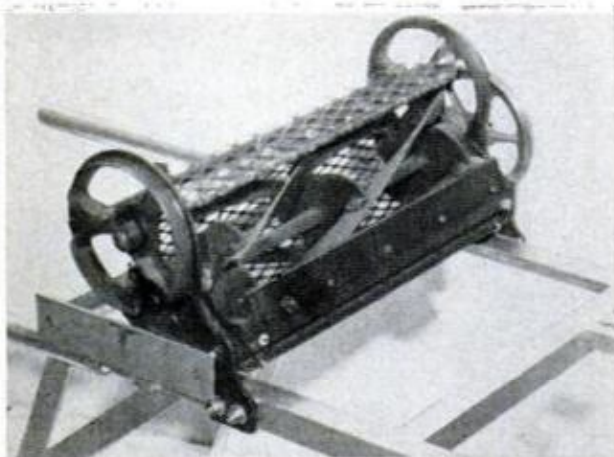

FRONT VIEW OF SCREENED REEL shows screen mounting bolts, looped ends of the retaining wire and the mounting of the angle-iron bar at the screen's top

the illustrations above. The ends of this wire, which should be stiff and heavy, are hooked through 1/4-in. holes drilled in the lower ends of the mower bed. Draw the wire tight to take up slack and sag in the screen, but make sure the reel can just rotate. After adjusting the screen for proper fit, reclamp the angle iron to the spokes of the wheel frames. Drill through for two 1/4-in. bolts on each end.

Replace and bolt on the hood-hopper assembly; install the engine or motor, proper size pulleys for 1200 rpm and the belt. The job is done.

There's a right way and a wrong way to handle the mulchmaker. Feed material slowly. If the reel jams, the belt will slip, but shut off the engine before freeing it by pulling the reel pulley backwards. Don't decrease the reel pulley's size to increase the speed or you'll burn out your bearings. And if children are around, it would be wise to make a belt and pulley guard out of sheet metal. ★ ★ ★

Drum up this lazy-susan brazier for backyard cookouts

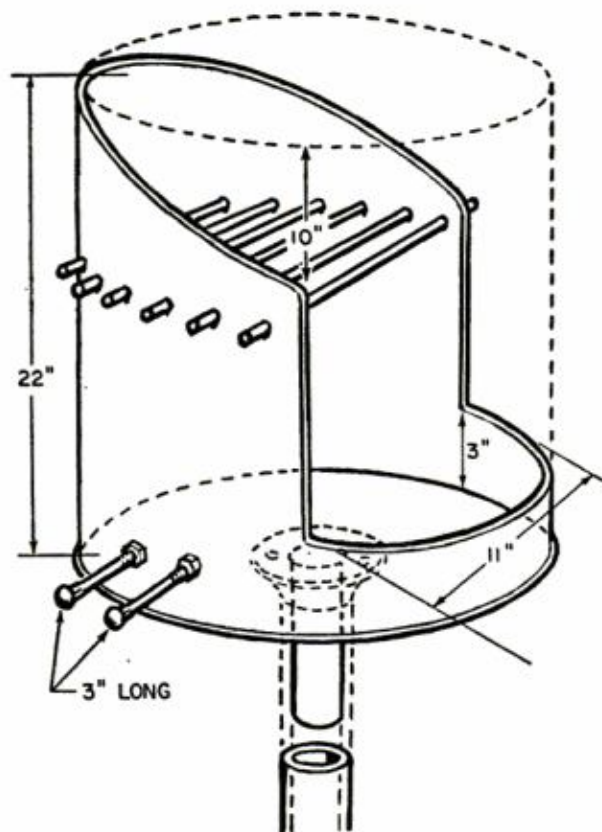

When barbecuing, you want the scent of steak to waft past your nose—not smoke. This convenient and easy-to-build Texas-style brazier can be turned to block the wind, and emptied easily by lifting off.

First, thoroughly clean out the interior of a 32-gallon steel drum. Then, using chalk, mark the drum for cutting with a hacksaw. Bolt a pipe flange to its bottom to take

a 1½-in. x 1-ft. pipe which will fit inside a 2-in. x 4½-ft. pipe anchored in concrete poured in a 6-in. x 1½-ft.-deep hole.

Drill six opposing ½-in. holes on each side of the drum and 10 in. above the bottom for ½-in. steel rods to form a grill. Cut the rods 2-in. wider than the drum. Near the bottom, drill for 3-in. bolts to hold your utensils.—*John Blaine*

Decoy stows its anchor

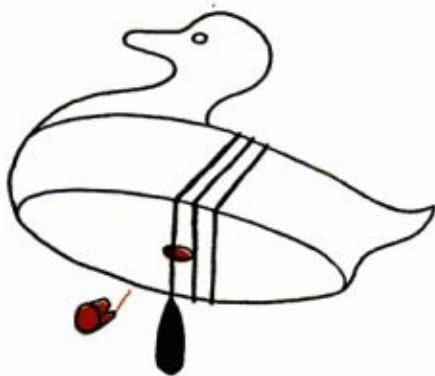

Why spend half your hunting day un-snarling duck-decoy anchor lines. You can carry them neatly by drilling the bottoms to fit a cork. Wrap the line around a decoy and pinch it in the hole with a cork notched near the small end.

Slatted seat stays dry

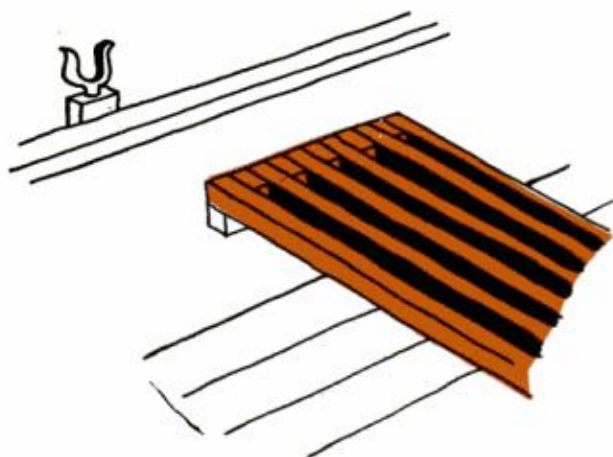

Your rowboat seats will dry faster after a shower and you won't slide when rowing if you make them slatted from ¾ x 1-in. lumber. Use ¼-in. spacer blocks at each end and nail each slat to each spacer as you go.—*G. E. Hendrickson*



Keeping electric garden tools cutting

Now's the time to get these power garden tools in shape; cleaning, lubricating and perhaps a couple of new brushes are usually all it takes.

By Steven J. Howard

BRUSHES ARE REACHED for inspection or renewal by removing access screws in motor housing of the tool

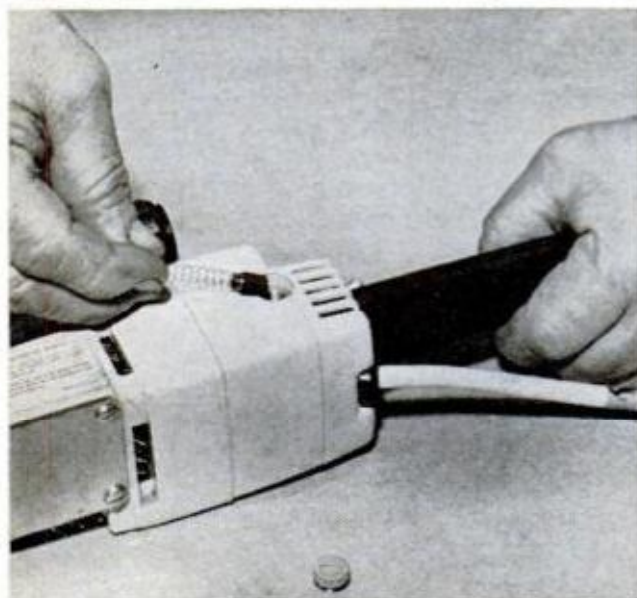

FRICTION CLUTCH—it's a coil spring around a split gear—helps prevent motor burnout and blade damage

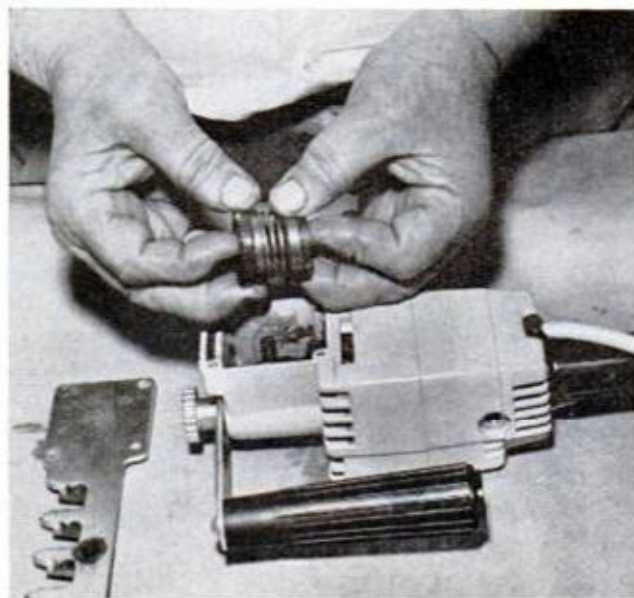

POWERWISE, all electrical power garden tools are pretty much the same. Hedge trimmers, grass shears, edgers and cultivators all get their get-up-and-go from the same type of booster—invariably a small, compact universal motor rated at 115 v., 60 cycles and around 2.5 amps. It is usually only the gear arrangements of these tools which may differ slightly from brand to brand.

Some garden tools are direct-drive units in which the spinning armature drives the gears which activate the cutting blades. Other units incorporate a friction-type clutch—essentially a heavy coil spring positioned between a split gear. A clutch saves wear and tear on a tool by reducing the possibility of blade damage in permitting the blade to slip when it hits an obstruction.

Maintenance procedures for both types are essentially the same, except the coil spring of the clutch type must be checked for tension.

In tackling this seasonal maintenance and repair chore, stick to the procedure outlined below. During disassembly, lay out the parts neatly and in sequence to facilitate reassembly after servicing.

It has been found that over 90 percent of all troubles that develop in these tools

originate either with the commutator part of the armature or with the brushes. These components should be checked first.

Plug in the tool and run it for a few minutes. Does it operate normally? Fine! In that case all you'll have to do is check the brushes to make sure they're in good enough shape to make it through the summer. You should also lubricate the gears, and perhaps sharpen the cutting blade.

Most of these tools have two access screws which enable you to take out the brushes without dismantling the unit. To check the commutator and brushes of units not having access screws, you'll have to remove the tool's rear cover. Also, though only one brush may be badly worn, *both* brushes should be replaced with new ones. Any brush less than $\frac{3}{16}$ in. long should be replaced. New brushes run about 35 cents each.

Run the tool with the cover off to make sure the brushes are making full contact with the commutator. If they are, you'll probably be able to see a fine line of arcing between commutator and brushes. Poor contact will show up as bright sparks or blue streaks jumping from brushes to commutator.

If arcing occurs even though the brushes

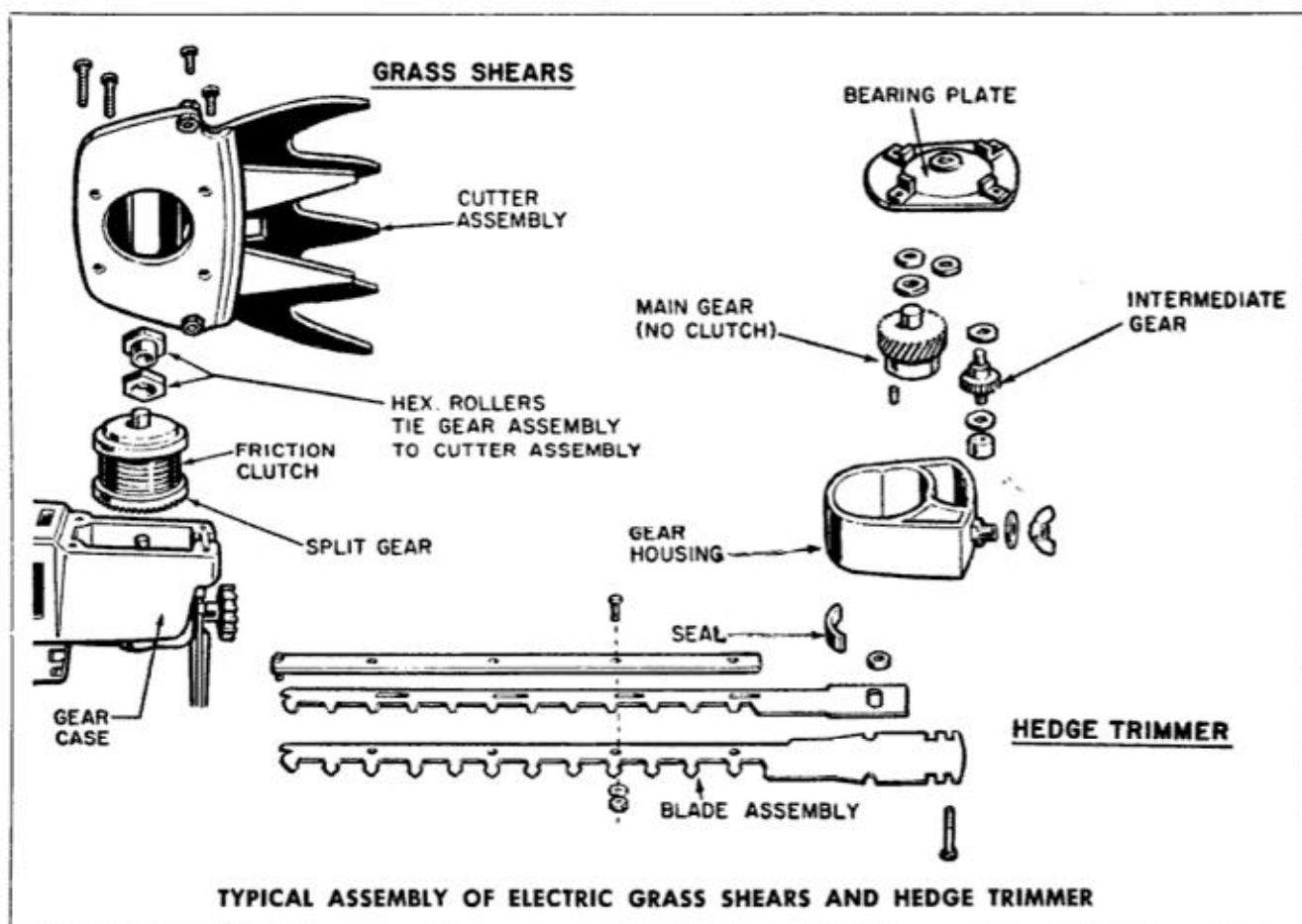

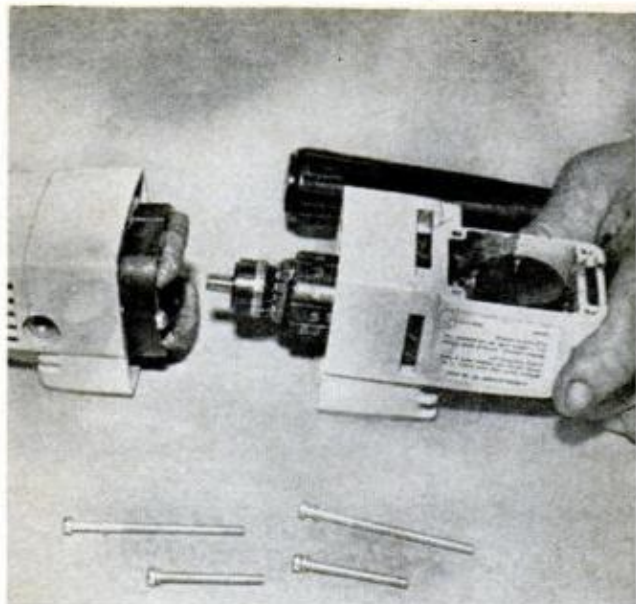

TO SERVICE THE ARMATURE, separate the motor housing by removing the screws which join its two parts

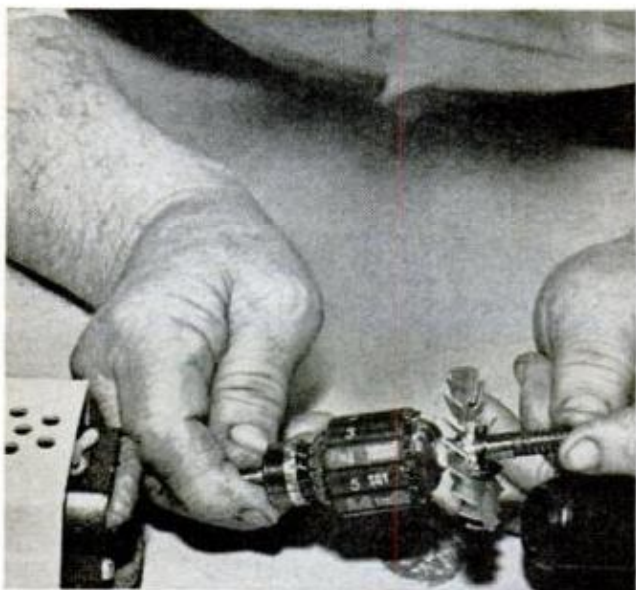

EXAMINE ARMATURE and commutator for dirt and melted solder. Note small fan which cools motor

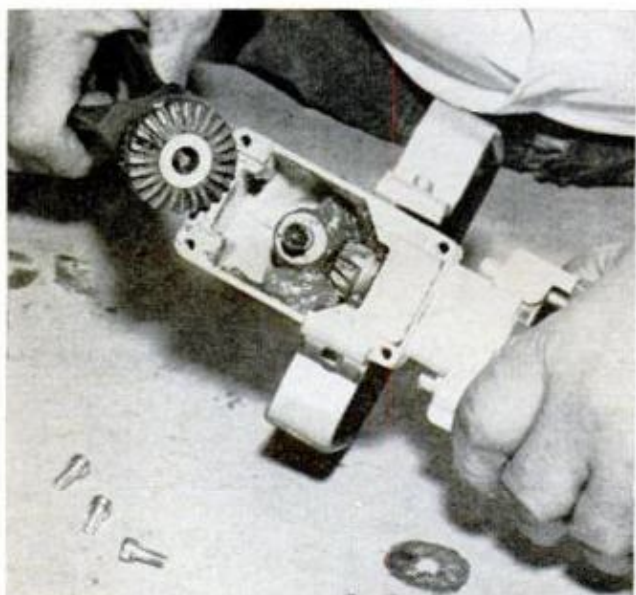

DIRECT-DRIVE TOOL uses no friction clutch; a main gear meshes with drive gear to operate cutting blade

are okay, you've probably got a damaged commutator. Check it carefully. Revolve it by hand and inspect it for rough spots and dirt. If you find any, smooth the commutator with a few *light* strokes of No. 3/0 (or finer) sandpaper. Then try wiggling the commutator segments with your finger. All should be tight. If any are loose, replace the armature.

Check it too for burned spots, and be sure the spacing between segments is uniform. If some spaces are irregularly wide, the armature should be replaced. New armatures sell for about \$6 or \$7.

To replace an armature, first remove the tool's blade. Then pull the gear case away from the main case. The armature is attached to the gear case cover with the geared end of the armature shaft protruding into the case and meshing with the drive gears there.

You will note that the armature is held to the gear case cover by a small grease seal which fits around the geared end of the armature shaft. This seal prevents the lubricant in the gear case from entering the armature case. Remove the seal. If it is damaged—cut or flattened, for example—replace it (you can order a new one from the dealer in your area who sells your make of tool). With the seal removed, the armature can then be replaced.

When positioning the old brushes against a new armature, be sure the curvature at their ends matches the curvature of the commutator. In other words, reinstall each brush in the same position it had formerly.

The use of new brushes will sometimes prevent good electrical contact and less-than-perfect tool performance until they wear into place around the commutator. This wearing-in process can be hastened by applying an abrasive called brush-seating stick compound to the commutator while it is spinning. The stuff can be purchased at any auto supply store.

Maintenance of the gear case involves cleaning out old lubricant and replacing it with new. If you replaced the armature, the gear case is already open. If you didn't replace the armature, you still needn't rip the tool apart to get to the gears. Usually, removing the blade opens up the gear-case housing. In some tools the gears are reached by removing an access plate.

Clean out old lubricant with kerosene. Inspect all gears for broken or chipped

teeth and replace any that look bad. Gears can be purchased from the manufacturer or dealer.

Repack the case with fresh grease made specifically for power tools. Make sure gears are in place when you lubricate to prevent overfilling the case. If too much grease is applied it can seep into the armature compartment, so fill the gear case only half to three-quarters full.

You'll have discovered by now whether yours is a direct-drive tool or one equipped with a friction clutch (coil spring). This spring fits around a split gear from which it should now be removed, one coil at a time. Replace it if any obvious distortion is apparent or if resiliency and tension are noticeably lacking.

What if nothing happens?

Now let's suppose you plug in that hedge trimmer, turn on the switch—and nothing happens. You can be sure that one of the following ills is afflicting the motor:

- A bad armature, or brushes so badly worn that they're failing to make contact with the commutator. Well, you've already checked on this, so maybe it's—
- A defective line cord or a bad switch. Finally, check for—
- A break in the field circuit.

A break in the field circuit means that the motor is probably *kaput*. In this case, the game (of having the motor rewound) isn't worth the candle (what the job will cost you). Recommended solution: buy a new trimmer.

A continuity tester with needle probes can be used to check the line cord and switch—and they're the more likely trouble spots anyway.

First, detach any extension cord you may have hooked the tool into—it could be the culprit. Plug the tool cord directly into the wall outlet. If it still doesn't run, wiggle the cord at the point it enters the handle (a break, when it occurs, usually happens here). If the tool starts as you're wiggling the cord, you've found the trouble.

If it still fails to respond, check out the switch. The best clue to a bad switch is its failure to give off a sharp *click* when it is turned on or off.

To replace the cord or switch, use a pair of pliers to pull down the Bakelite or

(Please turn to page 182)

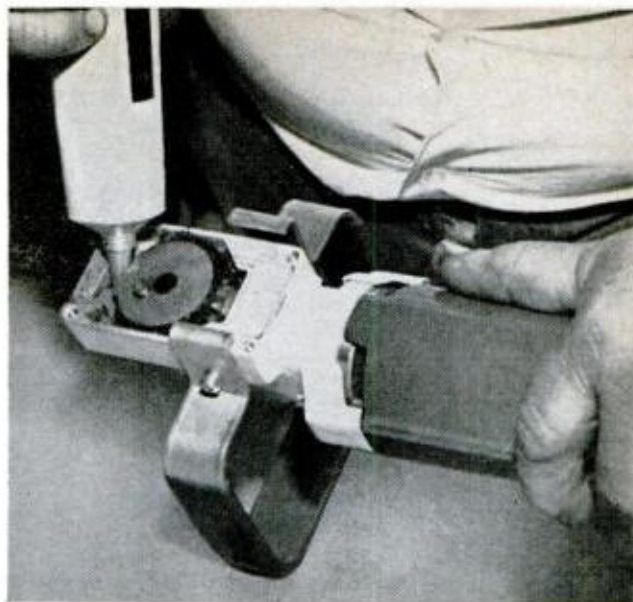

USE KEROSENE to remove old grease from gear case. Repack case only two-thirds full with fresh grease

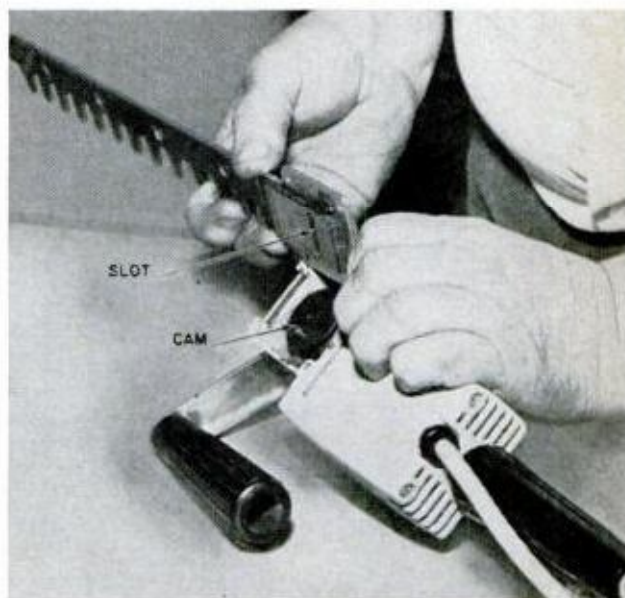

WHEN REATTACHING BLADE, be sure slot on underside of the blade is fitted securely over the gear cam

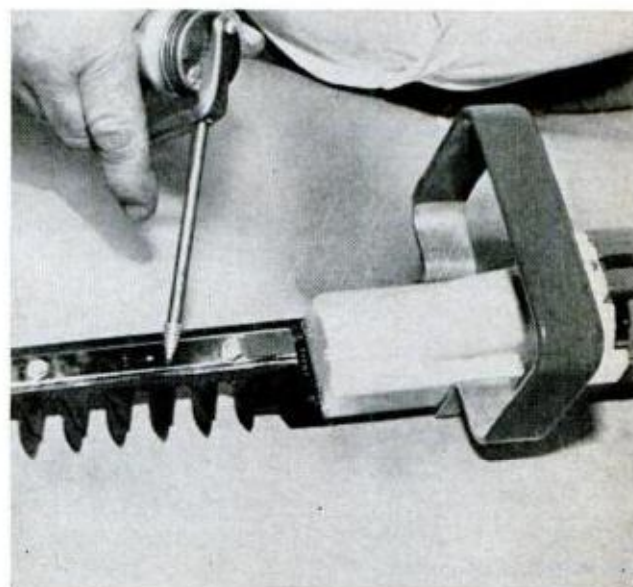

FINISH UP BY OILING the cutting blade; continue periodic oiling of the blade throughout the season

IT'S A FOUR-HOUR KIT

Assembling

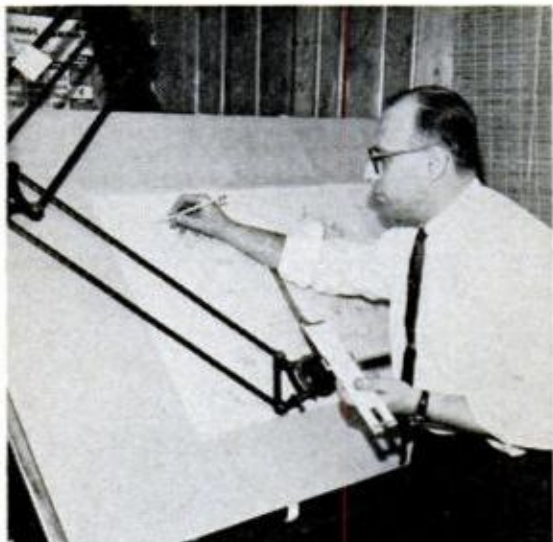

Power-Wheel Truck

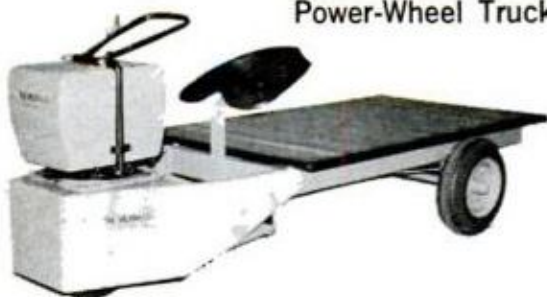

How the mule was born. PM's editorial director, Walter Ian Fischman, deserves the title of "Father of the Lawn Mule."

It all started when he spotted an item in an industrial paper about a materials handling device called the "Power Wheel"—a wheel with an engine on top which could be mounted in any chassis to turn it into a powered vehicle. Thinking that this might be a good item for use in a do-it-yourself project, he called the manufacturer, Technoid Corp., and set up an appointment with the president, Peter Prohaska (above), to see the unit in action.

While watching a Power-Wheel-powered cart carry a mountain of machinery through a tight zigzag course, he remarked, "You know, that could be turned into a fine little garden tractor." Prohaska started preliminary design work that very night.

Naturally, the story is a **PM** exclusive.

IF YOU CAN HANDLE a screwdriver and a wrench, you'll have no trouble putting the Lawn Mule together. It's about as foolproof as any kit could be.

You don't have to do any welding, shaping or fitting, since all the parts are completely finished and ready to bolt together. Just to be on the safe side, any subassembly which *might* present a problem, is put together at the factory. All you have to do is install it. Even the painting is taken care of—everything that should be painted is shipped painted.

The job is so simple you can start on a Saturday morning and be running the Mule around the lawn that same afternoon.

Before tackling any big lawn jobs, however, try a short practice run to familiarize yourself with the Mule's unusual steering-control system. Once you get the feel of it, hitch up the mower or trailer and go to work.

The special trailer for the Mule is shipped knocked down. The body measures 18 x 36 x 42 in., and it's a sturdy welded construction. Load capacity is 1200 lbs.

Two catches on each side make possible



TRAILER TAILGATE swings down level with bed to accommodate long loads and increase carrying space

the Lawn Mule

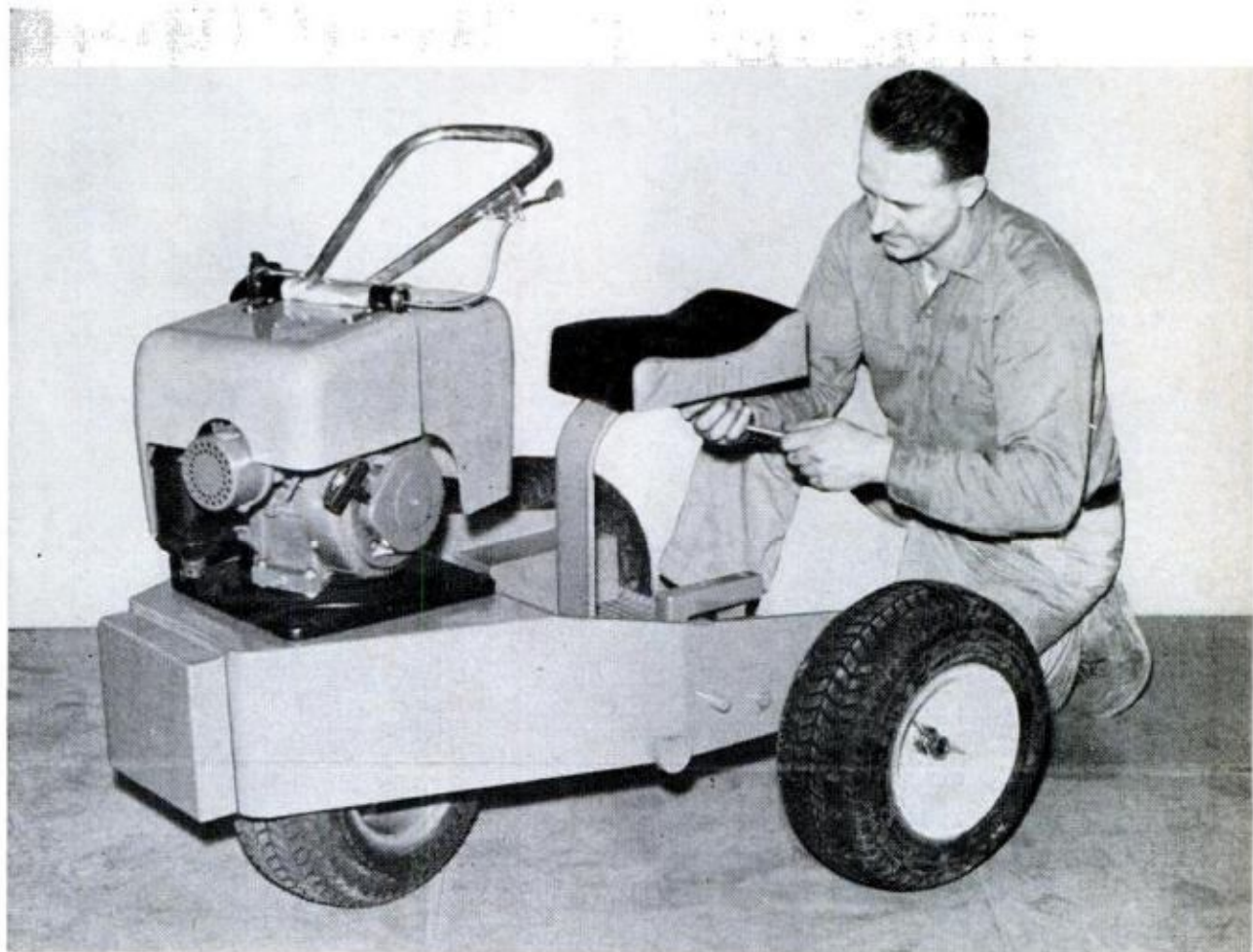

DUMPING LEVER is located on the trailer tongue, can be operated from driver's seat. Tailgate swings out

JUNE 1966



TO TAKE OFF the tailgate entirely, just release two catches on each side. This often simplifies loading

ASSEMBLE THE POWER WHEEL . . .

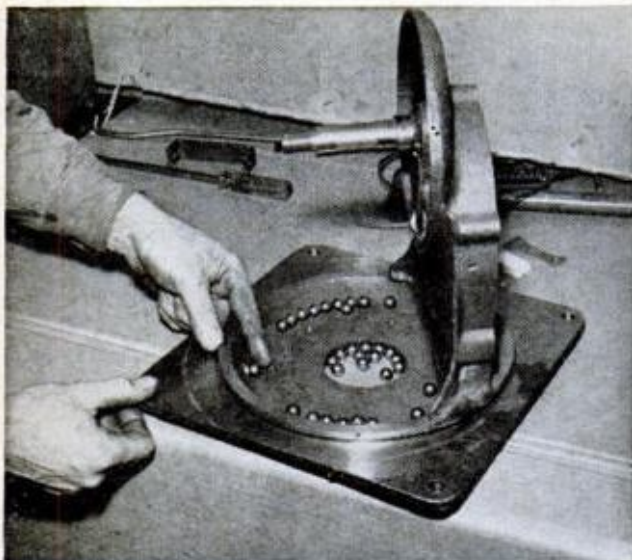

1. **TURNTABLE** subassembly is the first step. Once ball race is filled, hole is plugged with a screw

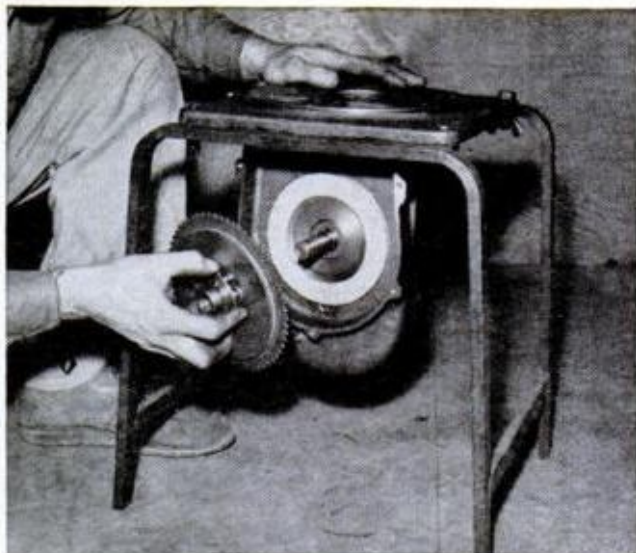

2. **CLUTCH ASSEMBLY** slides onto the countershaft after turntable has been placed on assembly stand



CUT,
FOLD,
TAPE

LAWN
MULE

3. **CLUTCH-BRAKE CAM** and its control rod are installed next, followed by assembled control handle

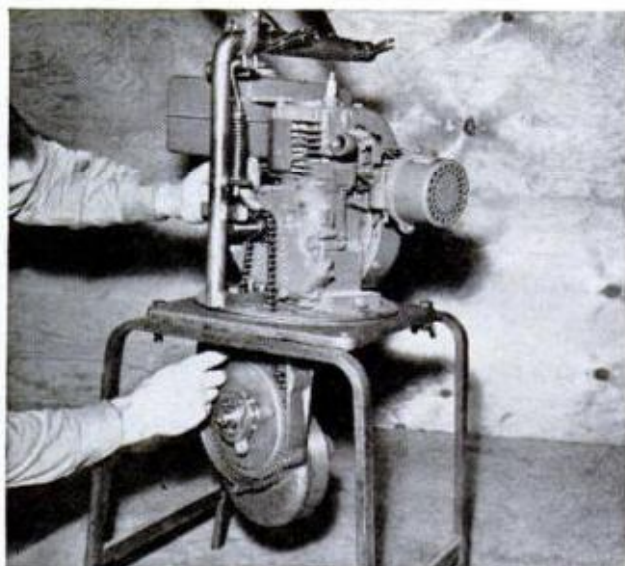

4. **ENGINE** is bolted to turntable, then the drive sprocket is secured to shaft and chain connected

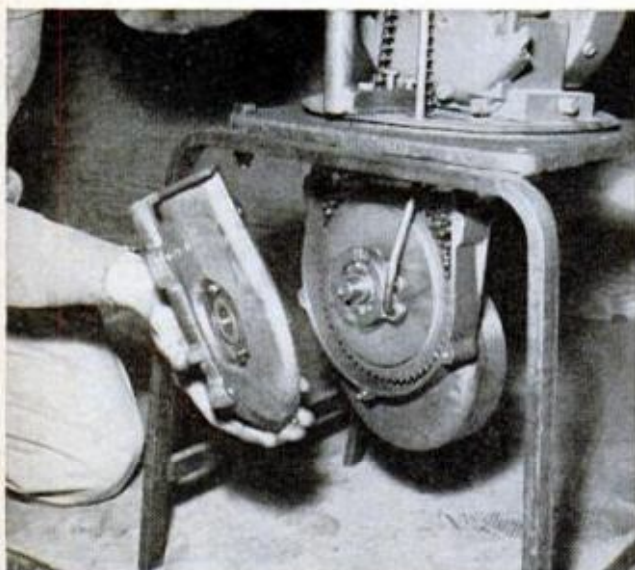

5. **HOUSING COVER**, with sealed ball-bearing assembly in place, goes on last. It's held by five bolts

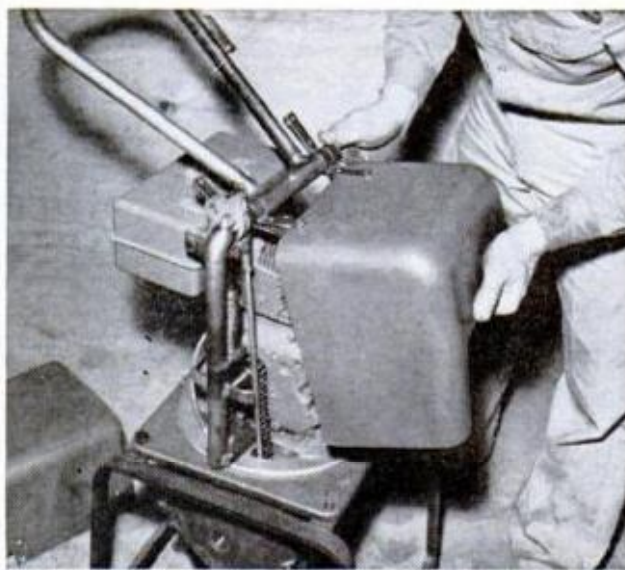

6. **ADD THE HOOD** and the Power Wheel is complete (except for the wheel), ready to go into the Mule

. . . THEN BUILD THE MULE!



7. REAR AXLE fits into holes in body, is held by bolt through hole in body into tapped hole in axle



8. REAR WHEELS are secured with castellated nuts and cotter pins, taking care that they turn freely



9. POWER WHEEL can be slipped into the body once the front has been propped slightly above level



10. FOUR BOLTS hold the Power Wheel in the body. Be sure these are tight before you continue assembly

pivoting of the tailgate from either top or bottom, so you can use it to extend the trailer bed for long loads or for dumping bulk loads. Dumping is controlled from the driver's seat through a lever located on the trailer tongue. Once you've emptied the trailer, just pull the body back down until it latches to the tongue again (there's a grab handle for this on the front panel of the body).

Bolting the axle, catches and other fittings to the body shouldn't take you more than an hour.

Through a special arrangement with PM, the manufacturer is offering the Yard Mule kit for \$325 until July 31, 1966. After that date, only the completely assembled Mule (\$450) will be available. The trailer

sells for \$99.95.

As of this writing, two additional accessories for the Lawn Mule are now in the final stages of testing—a 42-in. 3½-hp rotary lawnmower and a 42-in. snowblower with a 3½-hp winterized engine. The mower will sell for \$179, the snowblower for \$195. According to the manufacturer, these will be available in time to ship with the Lawn Mule kit.

Incidentally, all prices mentioned here are f.o.b. the manufacturer: Technoid Corp., Box 276, Portland, Pa. Shipping charges will be billed c.o.d.

To show you just how simple it is to assemble this kit, we've covered the whole job in step-by-step photos. Basically, it's two separate operations: assembling the



11. **FRONT WHEEL** slips over studs in the hub of the Power Wheel. Tighten nuts so there's no play left

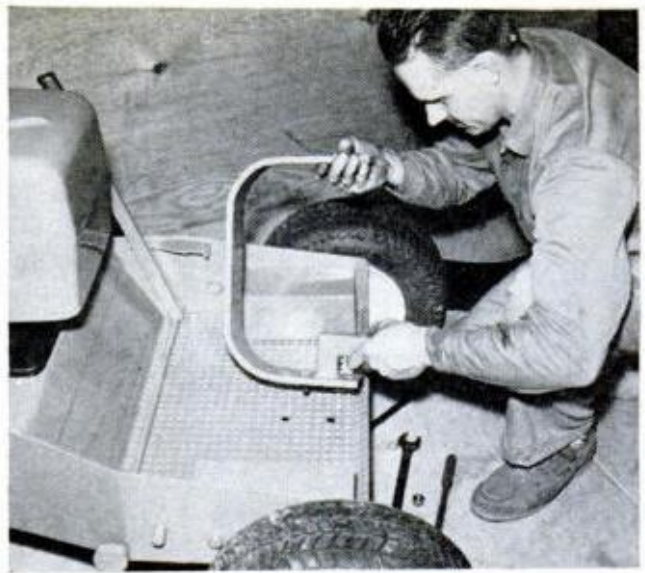

12. **SEAT SUPPORT**/trailer hitch is mounted with two bolts which fit into tapped holes in the body



13. **PADDED SEAT** bolts to the seat support arm and completes the assembly. Total time? About 4 hours

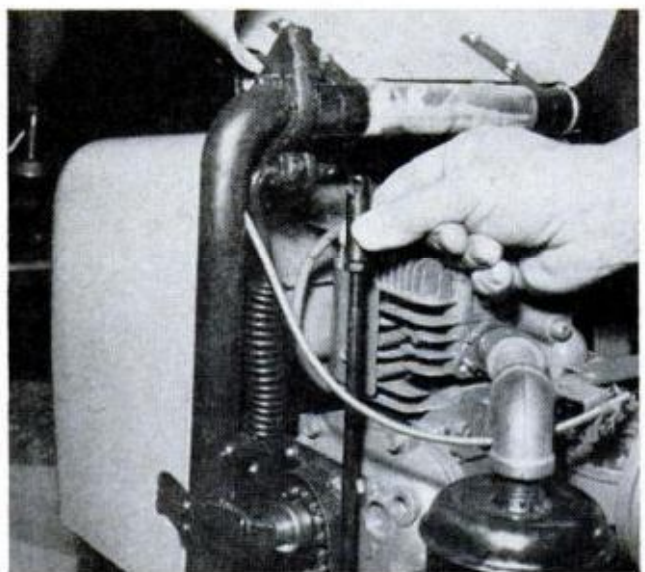

14. **ADJUSTING** combination clutch-brake control is a simple job which takes only a minute or so

Power Wheel and putting the rest of the vehicle together. Installing the Power Wheel in the body is a matter of tightening only four bolts.

The Power Wheel must be put together on some sort of simple assembly stand which will support it in a vertical position. Plans for such a stand are included with the kit, but you could just as well knock together a rough stand from a couple of sawhorses and scrap lumber. Anything will do so long as it's strong enough to hold the unit in an upright position with the drive mechanism off the floor.

Only one step is omitted from the step-by-step photos on assembling the Power Wheel. Before you attack that turntable subassembly, the control handle should be mounted on the handle support. Clamp the support in a vise, slide the handle onto the support and secure it with a cotter

pin. It's now ready to bolt in place.

There are few possibilities for error when assembling the Mule. Be sure that you tighten all bolts and nuts securely, with the exception of those holding the rear wheels on the axle. Here you should allow only enough play for the wheels to turn freely.

Adjusting the clutch-brake control is the final step. Roll the Mule outside, put gasoline in the tank, open the fuel shut-off valve and start the engine. Then, by trial and error (it shouldn't take more than two of each) find the proper height for the control rod so that the brake doesn't drag when the handle is in neutral position and the clutch doesn't slip when the handle is pushed all the way down.

That's all there is to it—from first assembly step to final adjustment in only four hours. ★★★

Fun With a Unicycle

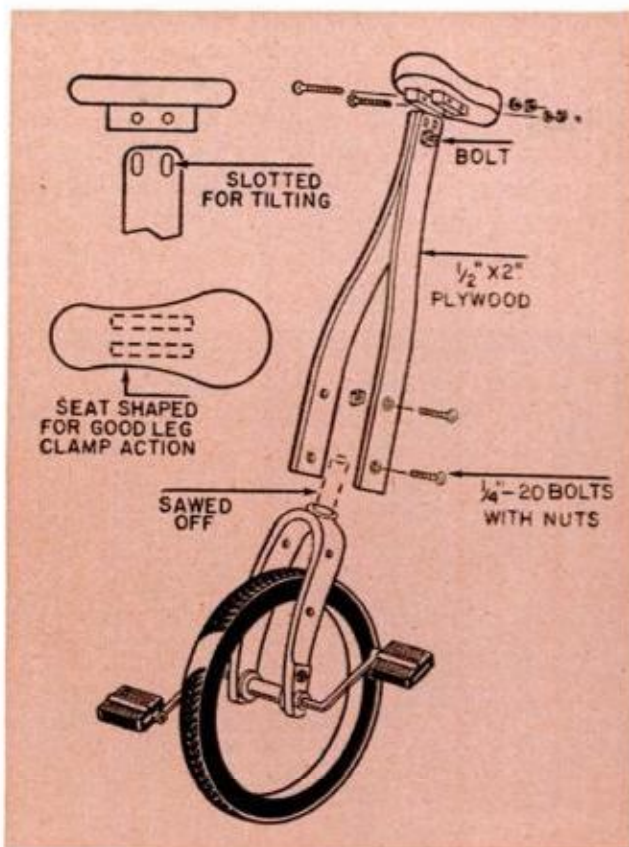

ONE LITTLE WHEEL—a unicycle—can make any “well-balanced” boy a Big Wheel in his neighborhood.

As can be seen from the above drawing, a unicycle is a fairly simple assembly requiring few parts. The wheel, fork and pedals are taken from the front-wheel assembly of an old tricycle. The tricycle fork is then bolted between a larger fork made of two lengths of $\frac{1}{2} \times 2$ -in. plywood which

supports the seat. Buy or make a comparatively narrow seat or saddle of the type shown to better enable you to clamp the seat between your legs while learning to ride the unicycle. And make no mistake: learning to ride one of these solo wheels takes *practice, practice and more practice*. Don't give up after the first 50 attempts. On that 51st try you'll probably start to get the hang of it.—Hank Clark

Add Shock Absorbers to Your Bike

AN IMAGINATIVE young reader from north of the border, Karl Friesen, 14, of Grande Prairie, Alberta, sent in this original idea for installing coil springs on the front wheel of a bicycle. Cost: \$1.50.

Two 50-lb. expansion springs are snapped in place between clamps attached to each side of the fork, then to two identical steel plates that bolt to the bottom of the fork and which advance the axle slot about 2 in. The axle of the wheel is then bolted in the axle slots of these two “rocker” plates. The result is a real “knee-action” ride that absorbs bumps and introduces new comfort to bike riding.

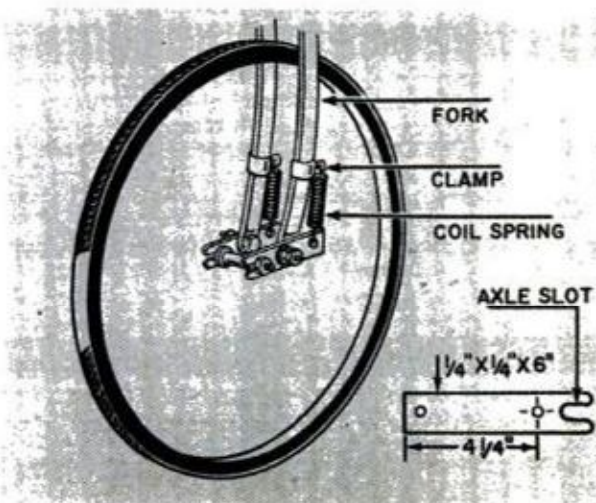

Sculptured Garden Ornament

BY ROBERT HOPPOUGH

EVERY GARDEN needs a focal point. For top dramatic effect, you can use your own sculpture, instead of a tree or shrub.

Forget about mallets and chisels for this job. Just odds and ends and your fingers will do for tools. Wood scraps, sand, ce-

ment and iron rod are the basic materials.

This Polynesian tiki, or anything your imagination can conjure, is an apt subject, but choose a shape that will be stable when set upon its base.

First, construct a frame for a mold—in



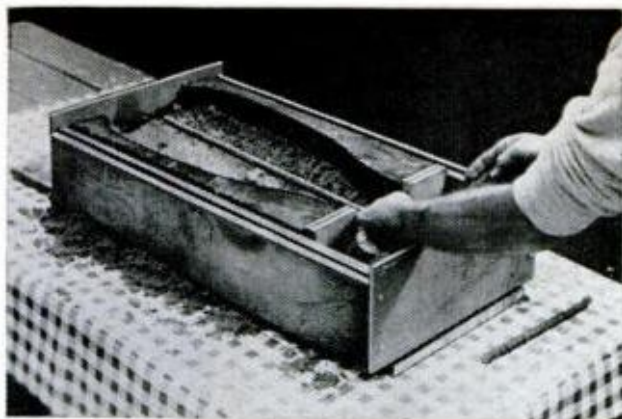

BEFORE CASTING, measure a reinforcing rod against mold. A bend will carry the rod across the base

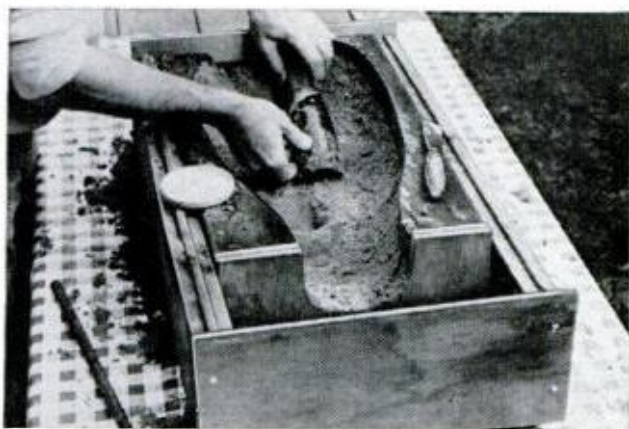

ANY APPROPRIATELY SHAPED TOOL can be used to impress facial features into sand, which must be moist



AFTER THE MOLD IS FILLED, press in the reinforcement at least 1 in. below the surface. Smooth over

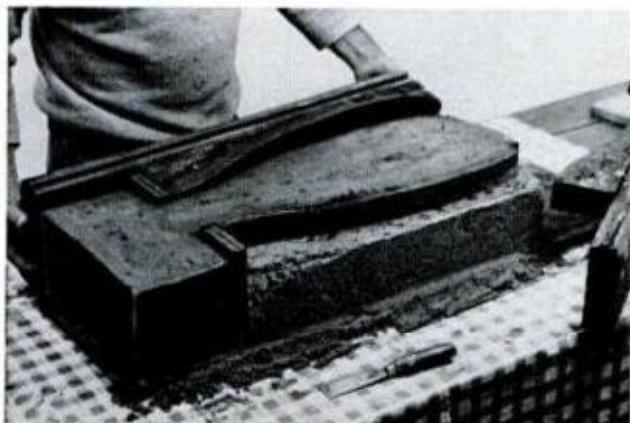

WHEN SCULPTURE HAS SET, but not fully hardened, remove mold and brush away sand except under face

JUNE 1966

this case, merely a rectangle with a separator to form a flat-topped base. Jigsaw additional wood pieces to form the tiki's outline and support its edges. Then place the frame on a board the size of the frame.

Bend and cut a length of iron rod, tubing or other metal that can be used for reinforcement. It should clear the mold by at least an inch at all points.

Now lay in some moist sand and round it out for the shape of face desired. Work quickly to prevent the sand from drying out and crumbling. Contour the facial details, using any appropriately shaped objects, such as bottles, spoons or fingers.

Mix the concrete and add dry coloring, if you wish. Make enough at one time so you won't have to try to match the color in a later batch. Remove some of the concrete to a coffee can and thin with water to a consistency that will not damage the facial details when poured in and that will fill in the features completely. For extra protection, pour this mix through your fingers to break its force. Finally, fill in the rest of the mold with the regular mix. Press in the reinforcing rod and smooth over.

When the concrete has set enough to lose its plastic quality, but before it has fully hardened, remove the mold and raise the casting to an upright position, using the loose bottom board for support. Smooth the casting with burlap and work in finer details. Finally, cure the concrete by wrapping it with burlap and sprinkling with water for three days.

Select the site for your tiki near a garden wall based on whether the sculpture is to be viewed from within the garden, from a window or from a patio or terrace. For nighttime viewing, run wiring to a spot or floodlight and orient the light for the most dramatic effect. ★★★



STAND UP SCULPTURE by means of bottom board, smooth off the surfaces and put in finishing detail

SOLVING HOME PROBLEMS

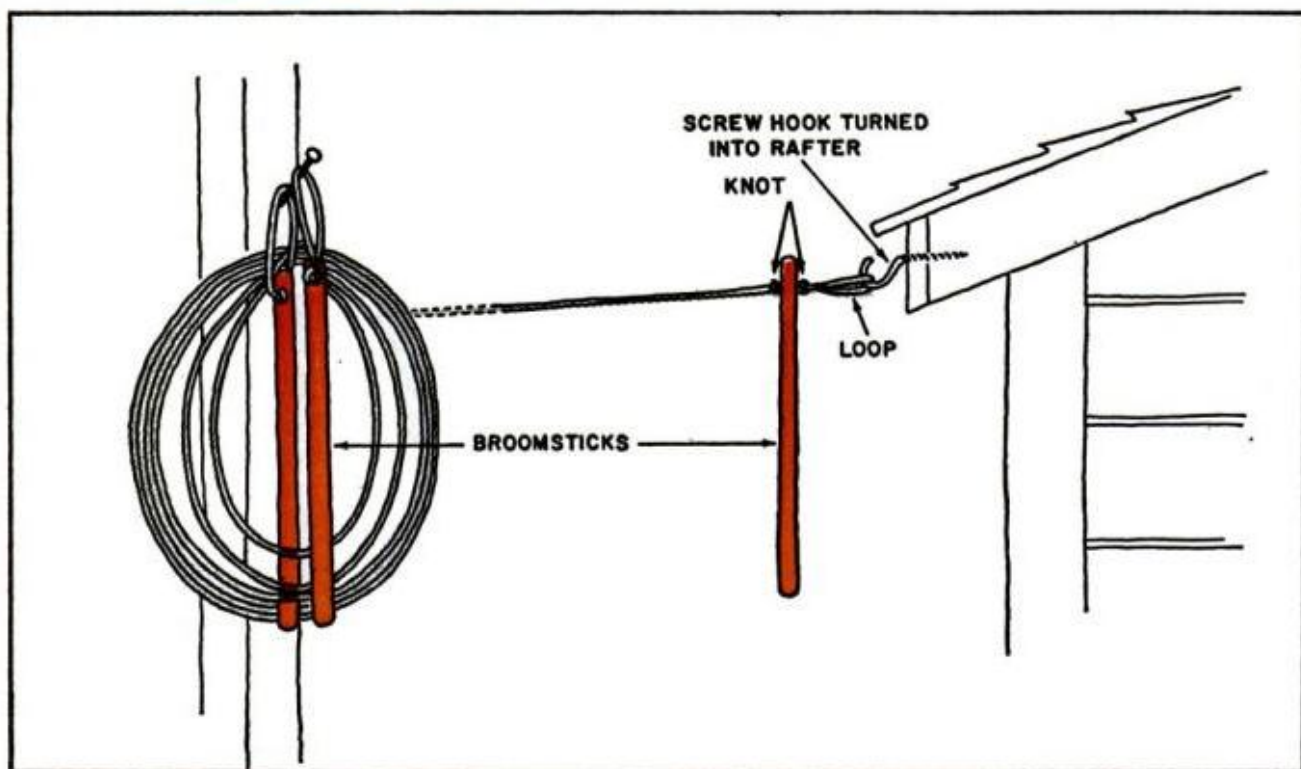

JUMP-ROPE CLOTHESLINE running between house and garage slips over screw hooks installed at the eaves, can be taken down when not needed. Long dowel handles on either end make it easy to slip loops over hooks



SHORTCUT TO TRIMMING a child's bangs in a clean, straight line involves taping bangs to forehead and using the upper edge of tape as a cutting guide

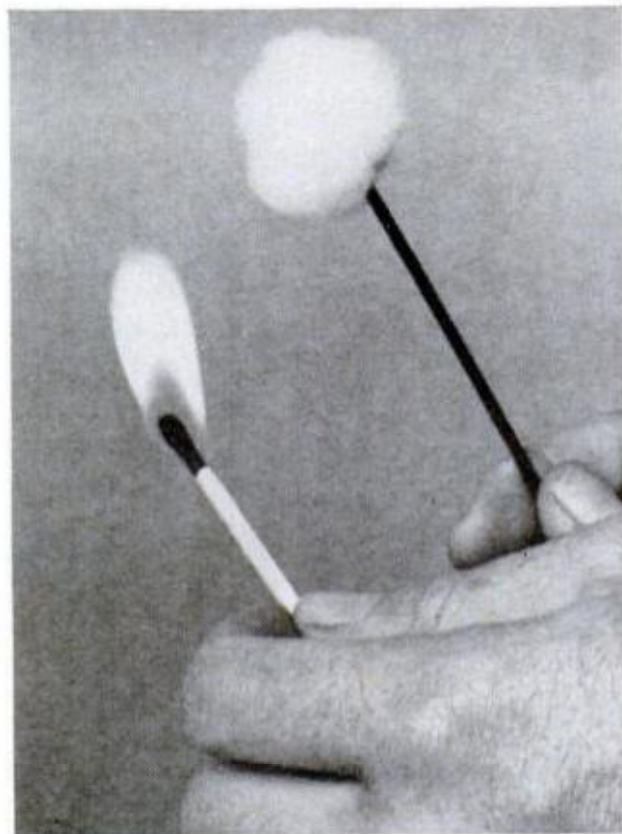

SUPER MATCH for lighting pilots is made by slipping a ball of absorbent cotton over the end of a hooked stiff wire. It won't blow out or leave any ash

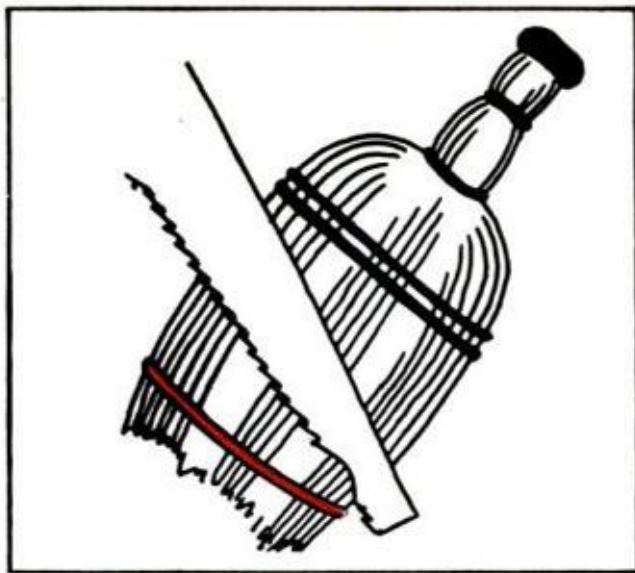

DEWHISKERING a worn whiskbroom is easy if you snap a rubber band around the end, dip it in water and freeze it, then use a saw to cut straws even

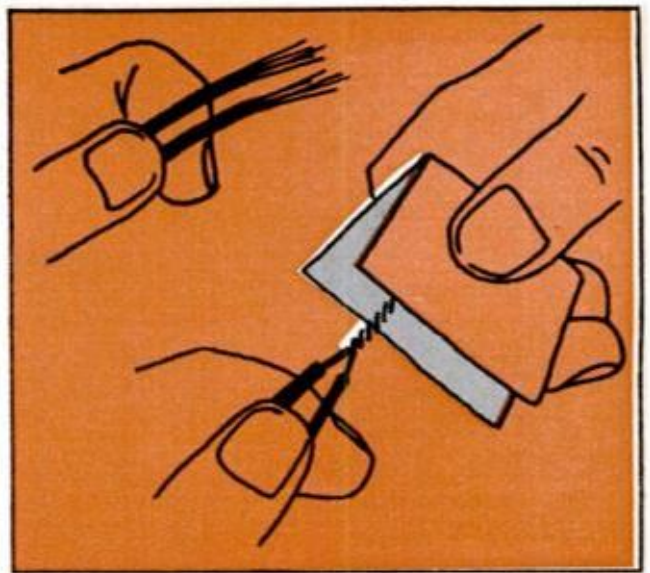

SURE METHOD of cleaning copper wires prior to soldering is to twist them together in a fold of garnet paper, not with bare fingers or pliers

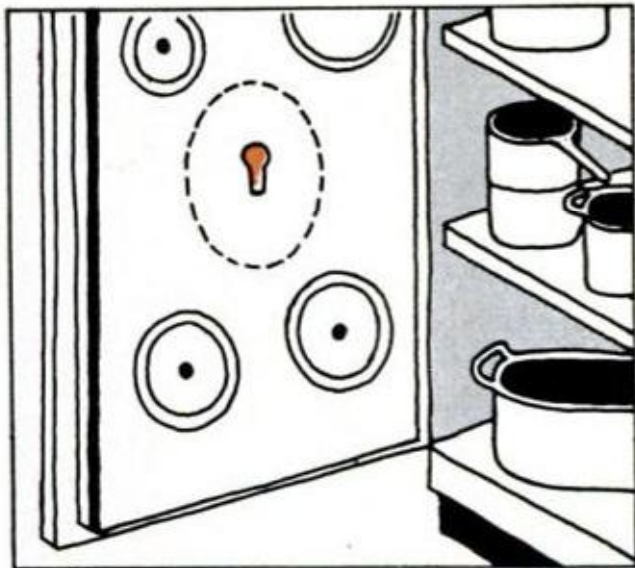

HIDDEN RACK for holding pot lids can be added to inside of cupboard door. Cut keyhole slots for lid knobs in hardboard panel and mount on 1 x 1 frame

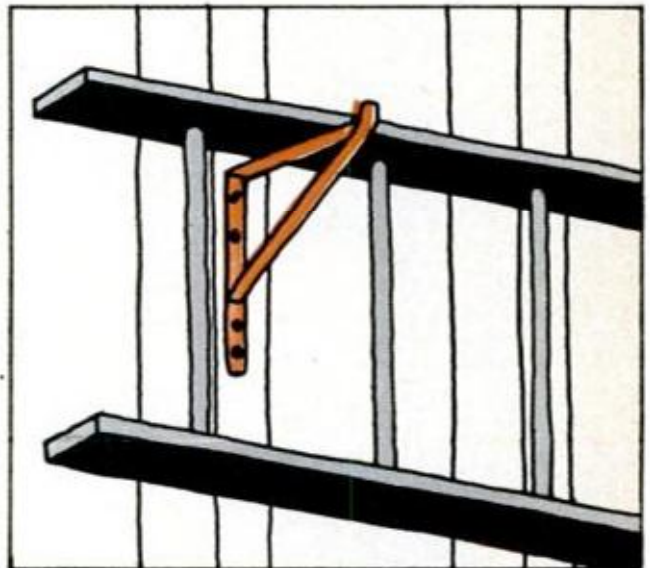

EASIEST WAY to store a ladder is on two or three shelf brackets fastened to garage studding. Bend up the tip of each arm to hold ladder on the rack

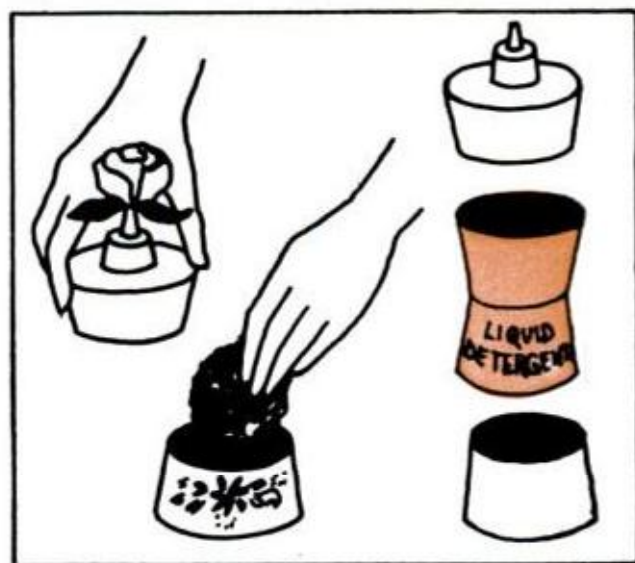

YET ANOTHER TIP involving plastic bottles: You can make a container for scouring pads from the top and bottom portions of a liquid detergent bottle

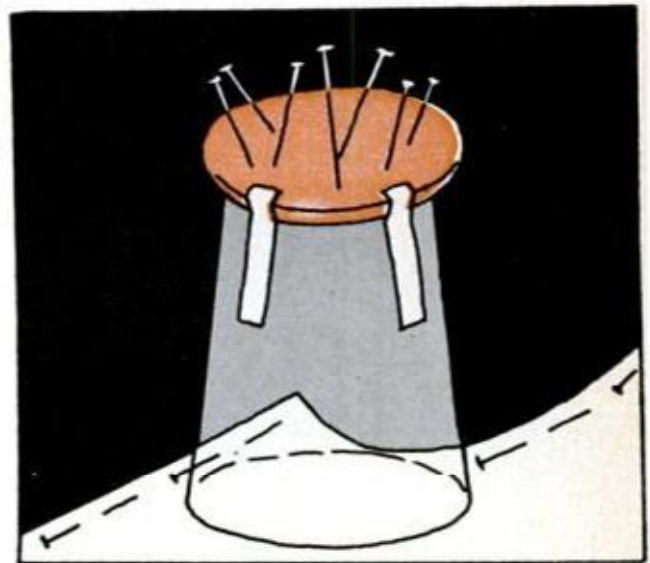

INVERTED TUMBLERS are fine for holding dress patterns in place when pinning them to the material. Tape a pincushion to each for extra convenience

An Easy Project for Easy Living

TAKE IT EASY! Build this simple patio chaise on Saturday and snooze in it on Sunday.

Your main materials are $\frac{3}{4}$ x 36 x 72-in. plywood good on two faces, a 4-ft. x 1½-in. closet-pole dowel and 45 yds. of 2-in. plastic webbing.

Enlarge the side patterns and paste the halves together, overlapping as shown. When transferring the pattern

to the wood, punch through to mark the countersunk $\frac{3}{16}$ -in. screw holes.

Attach the legs first, using waterproof glue and 1¼-in. No. 10 F.H. screws. Then attach the dowels and braces with glue and 1½ in. F.H. screws. Paint.

With tacks or a staple gun, attach the crosswise webbing around and inside the sides. Interweave the lengthwise strips and tack to the dowels.

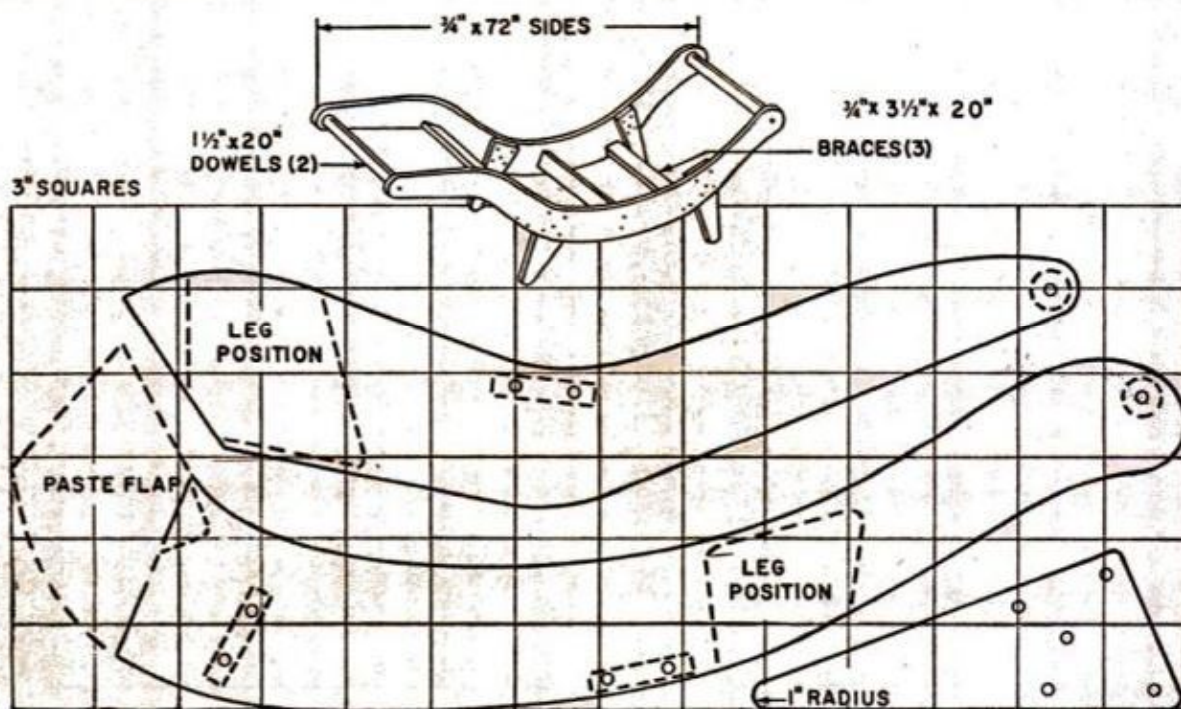

IF YOU PREFER TO WORK from full-size patterns, send 75¢ to Steve Ellingson, Popular Mechanics Pattern Dept., P.O. Box 2383, Van Nuys, Calif., and ask for pattern No. 93.

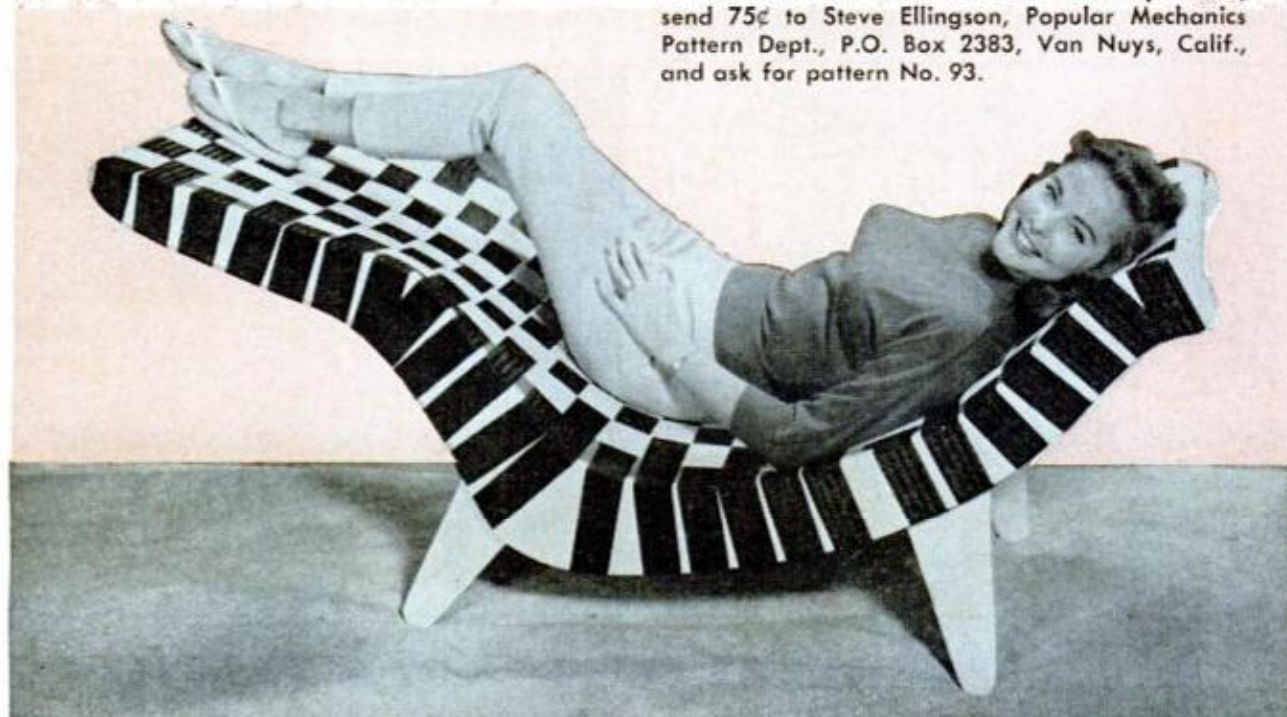

YOUR OUTBOARD MOTOR

Troubleshooting Remote Controls

You're more likely to have trouble with the cable than the box, but here's the A-B-C procedure for finding out what's wrong and how to put it right

By Henry B. Notrom

THE GREAT THING about troubleshooting remote controls is that they're relatively simple gadgets. Nine times out of ten, you can locate the cause of a malfunction by checking a couple of critical areas.

The key to finding out what's wrong lies

in following a set and orderly procedure. With so many different remote-control units on today's market, however, it's impossible to give specific troubleshooting information on every single one. Thus, we'll cover the possible areas of failure in any control and let you apply this to your

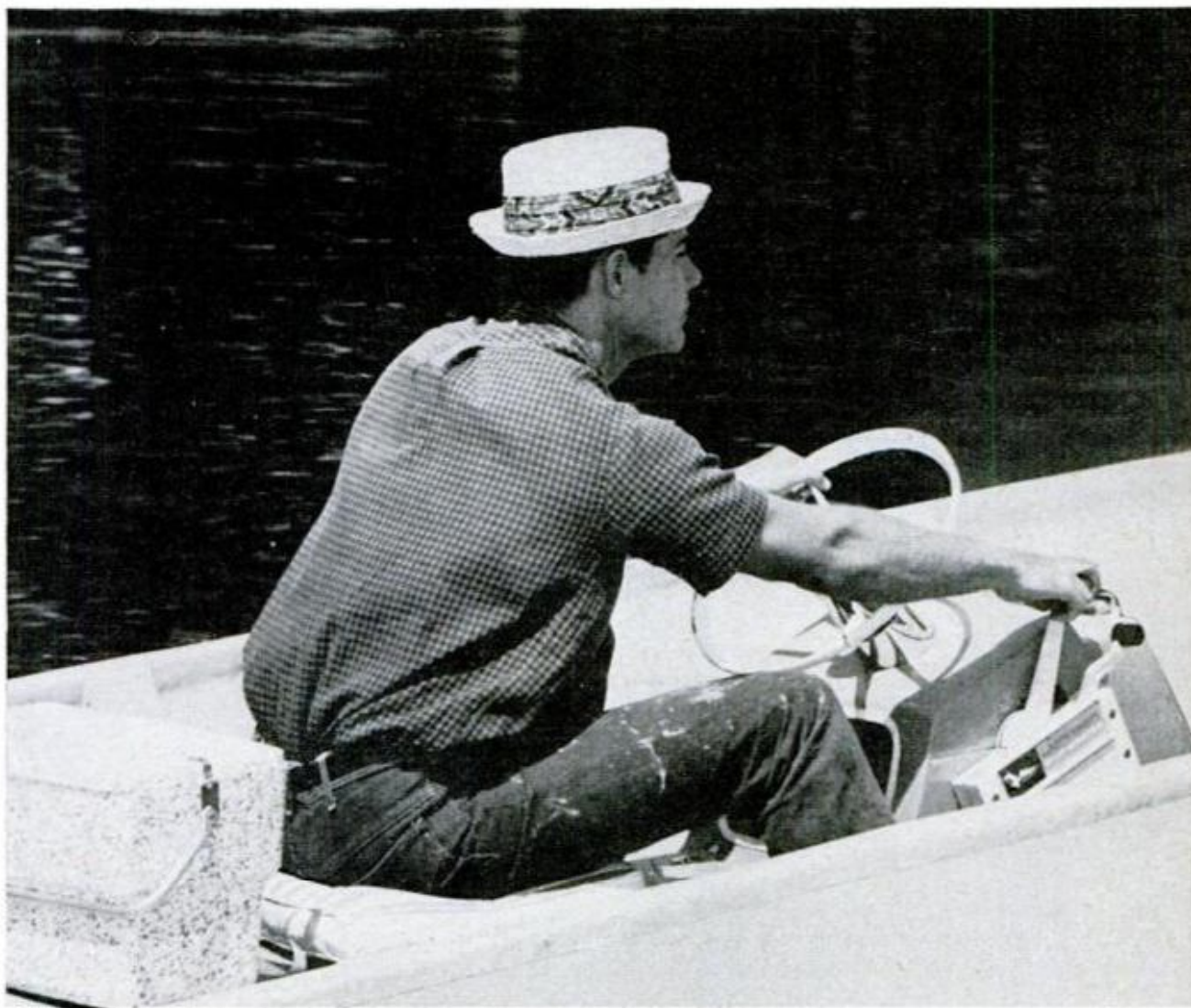



TO CHECK CABLE functioning, disconnect the cables from the engine. This involves only two connections



MOVE THE LEVER (or levers, with dual controls) while keeping your eye on cable ends. They should move

particular unit, whether it's single or dual-lever, mechanical or electrical.

Okay, let's suppose you start the engine, shove the remote control lever into gear and nothing happens. Or possibly you start to move but when you shove the lever forward to give it the gun, you continue to move at a crawl.

Back up to the dock, Jock, and let's begin checking it out. As explained last month, shift failure can signify a problem with either the remote control or the lower unit. So the first test is to disconnect the control cable at the motor and try shifting the engine manually.

If the engine doesn't shift into gear by

hand, the problem's in the lower unit, so go back to last month's article. If it does shift, then the trouble is with the remote control setup.

Now, if the shift works fine, but the engine fails to speed up when you shove the lever forward, the problem is most likely with a faulty remote throttle control. But it could also be with the throttle control on the engine or with the linkage. To find out which, disconnect the throttle control cable at the engine and goose the throttle by hand. If the engine does speed up, the problem is a remote control one.

More often than not, a remote control problem is centered in the cables. Each

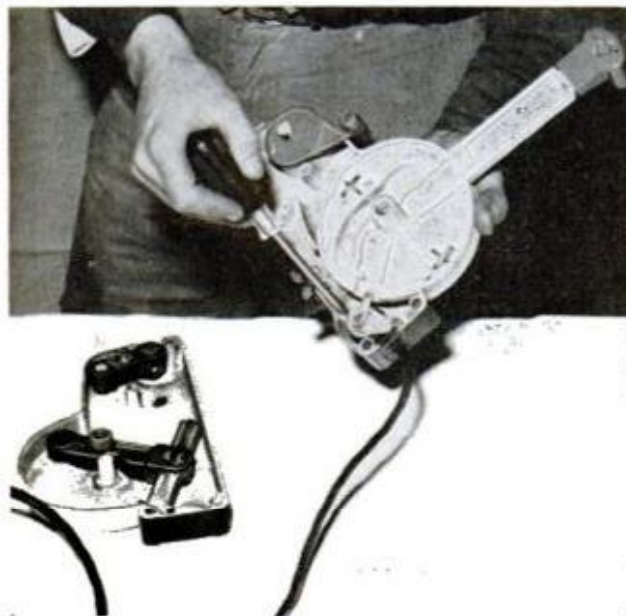

ELECTRICALLY OPERATED remote unit is shown here with shift switch in neutral. Note position of cam

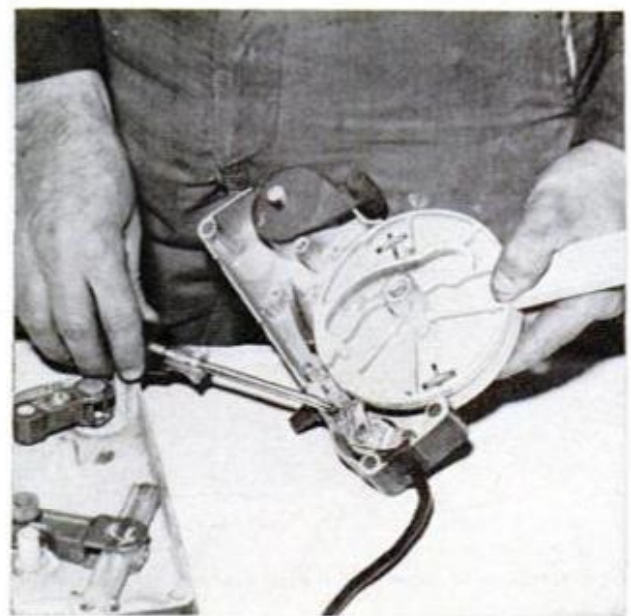

PUSHING LEVER into gear trips the switch cam, sending current to engine which shifts gears electrically

cable is actually two cables in one, an inner cable inside an outer cable. One controls shifting, the other throttle.

Cables can freeze up, or the inner cable can bend or kink. There is only one solution to a bad cable—replace it.

The first thing you have to find out, though, is whether the problem is actually with the cable or in the control box. So, activate the lever or levers (if you have a dual-lever box) and watch the cables, which have been disconnected from the engine. If the cables are working properly, you'll see them move throughout the entire range of lever operation.

If a cable is fouled, it has to be disconnected from the control box as well as from the engine before you can replace it. The control box must be unbolted from the side of the boat and the cover taken off. The cable end is then disconnected from its position in the box.

Before removing the cable, however, make sure it hasn't come loose from the lock setscrew that attaches it to the rack gear or cam. If it has, your problem is here, so just hook the cable back up and make sure the setscrew is tightened.

In determining how much new cable you'll need, measure the boat from the center of the control box back to the transom and then over to the center line of the transom. To this measurement, add:

— $\frac{1}{2}$ foot of additional cable for 6-cylinder, direct-reversing engines with left-side mounting.

— $\frac{1}{2}$ foot for 2-cylinder engines with left-side mounting.

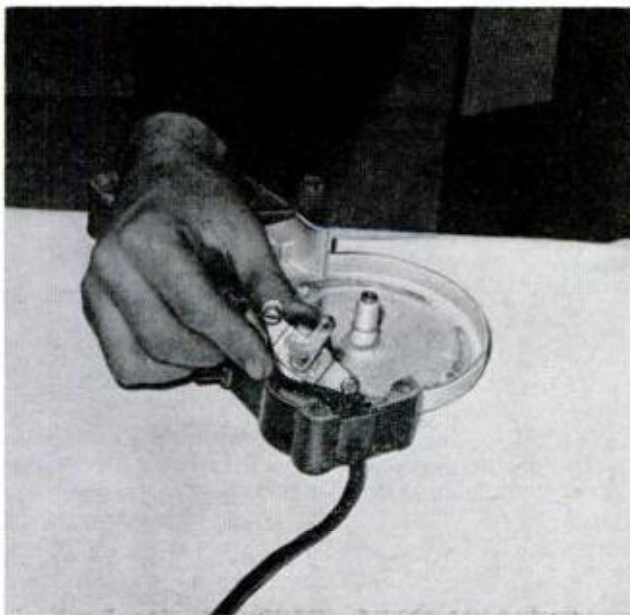

TO REPLACE SWITCH, simply unscrew it and remove it from the box. You'll have to replace the wires, too

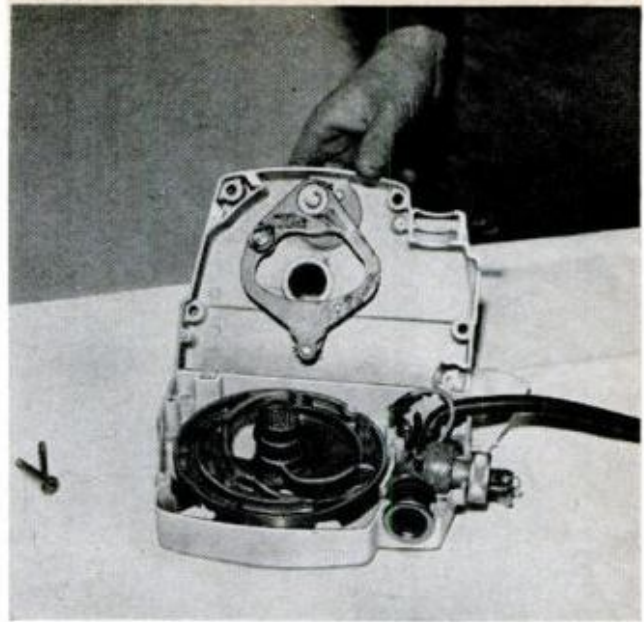

SINGLE-LEVER CONTROL without rack gear is difficult to work on, better left to a pro mechanic

— $1\frac{1}{2}$ feet for 6-cylinder, full-gear-shift models with right-side mounting.

— $1\frac{1}{2}$ feet for all 2- and 4-cylinder models with right-side mounting.

There are only a few things which can go wrong inside the remote box itself.

The single-lever control which doesn't have a rack gear works by means of cam action. As you move the control lever, a timing series in the cam allows one cam to shift the engine into gear before the throttle takes over. The shift cam is then overridden by the throttle cam.

This is a tricky box to work on but, luckily, the tricky part almost never goes wrong. For anything more complicated than a cable problem or lever replacement, however, take it to a mechanic.

Evinrude's pushbutton-shift control is electric all the way down. Two coils in the lower unit are controlled by the forward and reverse buttons on the remote box. Energize the forward coil and it engages the engine in forward gear; reverse operates the same way. When the neutral button is pushed, neither coil is energized.

While it's possible for one of the coils to short out, the only problems you might run into are a loose wire in the control box or a mechanical failure of the button switches. Even these are uncommon. It's a relatively trouble-free setup.

Despite the outer appearance, two-lever control boxes represent design simplicity. The unit itself is actually two single controls in one box separated by a plate. One lever operates the gear shift, the other operates the throttle. Both sides of the box

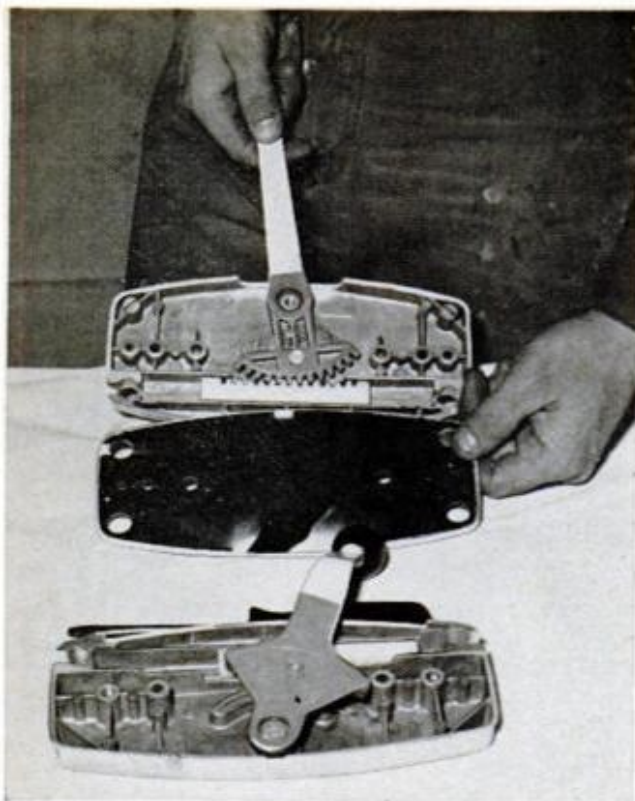

DUAL-LEVER CONTROL box (this one is an OMC unit) has shift control on one side and throttle control on the other, but both operate basically the same

are the same in makeup, and both sides make use of a rack gear.

Prevalent problems with this type of box include cable fouling, handle breakage and wires disconnecting from the lock set-screw in the rack gear.

Electrically operated control boxes aren't too tough to work on. (Electrical, incidentally, applies only to gear shifting.) As you move the handle into forward or reverse gear, the cam to which the handle is attached trips an electric switch. The switch sends current to the shifting to provide electric shifting.

Troubles which arise in this box are cable fouling, handle breakage, and also that electric switch. If the engine fails to shift, and the lower case and cable check out okay, the switch should be removed and replaced. Electric wires to the switch have to be replaced with the switch.

Generally, remote-control units function perfectly, but when they do go wrong, remember that the trouble is most likely in the cable. Treat that box as innocent until it's proven guilty. ★★★

OUTBOARD CLINIC

Q—The lower cylinder sparkplug of my 5-hp Sea King outboard is always black and wet with oil. The plug in the upper cylinder is always clean. I've checked, and both cylinders are getting a hot spark. I've also tried a hotter plug, carburetor adjustment and changing plug gap. What do you think?—J. G. B., Illinois

A—Despite your check of ignition, I'm still of the opinion that your trouble is probably in the magneto. If you checked the spark by holding the plug wire a little away from the powerhead and cranking the engine, you've checked only the secondary. The trouble could be in the ignition primary, and I think you should have the magneto tested with a regular magneto tester. Other things which could cause the trouble are a scored bottom piston and a bottom crankshaft seal that's not properly seated.

Q—I have a 1961 75-hp Evinrude that overheats but runs fine when I remove the inner parts from the thermostat housing. The impeller and thermostat are new, so what's wrong?—B. F., New Jersey

A—What about the water pump cover being new? It's always recommended that whenever the im-

peller is replaced, the cover be replaced, too (it could be eaten away). You could, of course, have an internal engine problem, such as a scored piston. But I'd try a new cover first.

Q—My 1958 35-hp Johnson has a complete new powerhead, carburetor and reed valve plate. Starting, though, is a problem. When the engine has been shut off for two hours or longer, it requires 10 good pulls on the starter pulley to get it going. After it does start, no more trouble.

The bulb is firm on the feed line, the gas tank is new, there's no water in the gas, the fuel filter bowl is full, and I have tried no choking, moderate choking and heavy choking. Plugs are also new. Can you suggest a possible solution?—R. D. S., Minnesota

A—I've got a hunch that your problem may be caused by one of two things.

There's a small ceramic-type filter where the line enters the carburetor bowl. If this is plugged up, it could be impeding the flow of gas to the carburetor, so get it cleaned and keep it clean.

There may be a pinhole in the fuel pump diaphragm which is causing gas to hold back on the initial start. If so, the diaphragm should be replaced.

Any Questions? For a personal reply to questions concerning repairing your outboard motor, write to Outboard Clinic, Popular Mechanics, 575 Lexington Ave., New York, N.Y. 10022. Enclose 25 cents in coin



How to Frame a Float

Whether it's simply a festooned convertible (for the Parade Queen to wave from) or a platform on a trailer or truck bed (for an elaborate tableau), here's how to turn a plain vehicle into a handsome float

THE DRUMS ROLL, the trumpets blast a fanfare, the brightly uniformed band steps off—and the parade (trailed out behind, frozen but alert) leaps suddenly to life.

If you're at curbside along the route, or in the viewing stand at the fairgrounds, you needn't dread the approach of the float *you* worked on for your club (or your child's school class) while you wince at the quality of the competition. Float-making can be an art, as you've seen on pages 84 to 87, but the actual construction involved can be quite simple. You can do a respectable job with ordinary lumber and a handsaw. It's merely a question of creating a shell to hang over a car, or a

skirt for a truck or trailer. And since you probably have a reputation around town as a craftsman, sooner or later you'll be asked to create this underpinning. On the next two pages, we give several examples of framing that should take care of any hometown parade requirements.

In the case of the Queen's car, the main problem is hanging the frame from that shiny convertible without leaving permanent scars. You take your measurements from the car itself and cut the 1x4 skirt-frame to suit. The only thing to watch is that you allow sufficient width for the front wheels to turn without binding.

The frame is hung from cloth strips passed over the hood and trunk deck. The

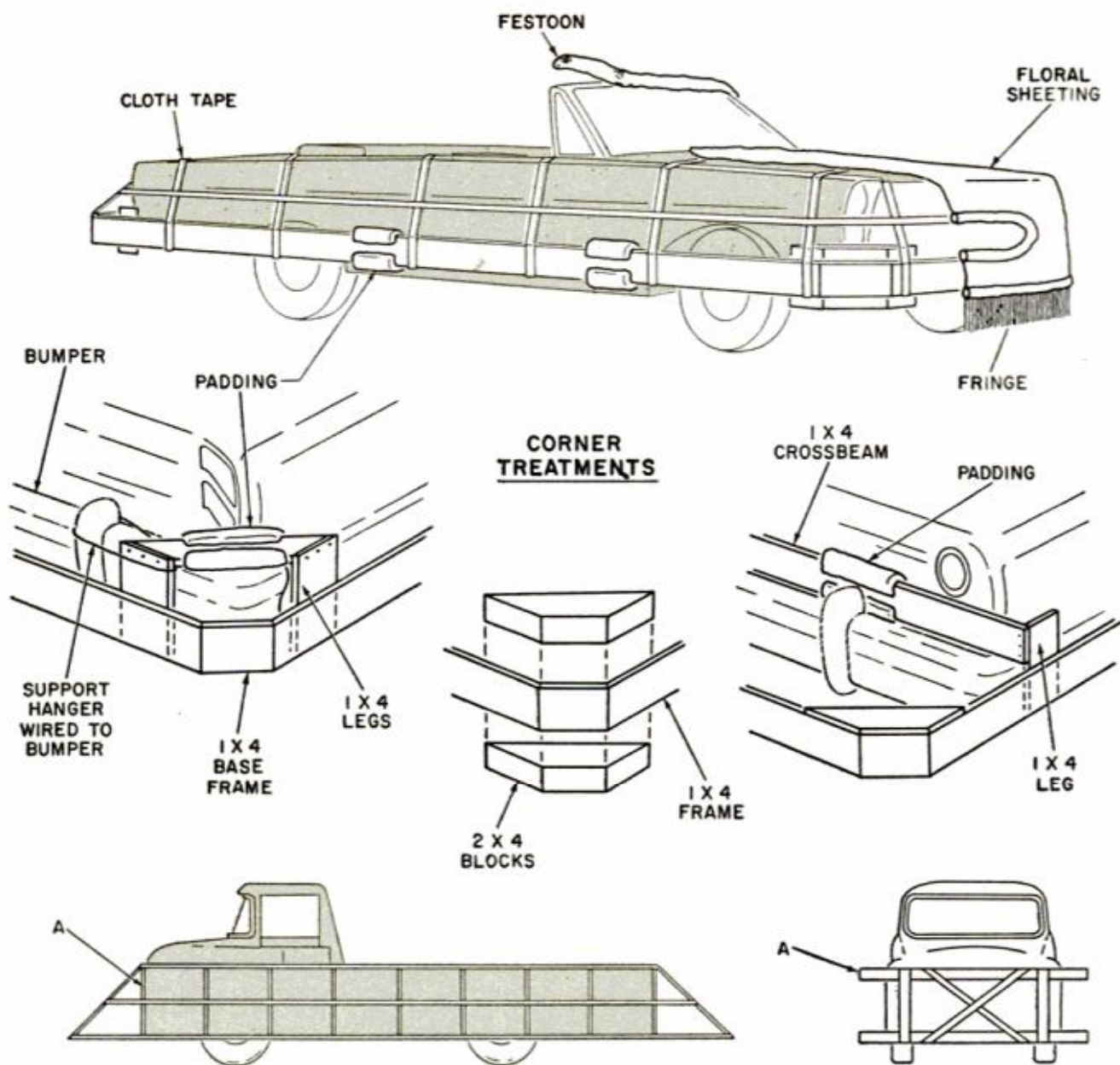

square design of today's cars makes this fairly simple. But the "beveled" corners of the frame must be tied on the bumpers to avoid "hoop-skirt sway" when the float's in motion. Where a bumper protrudes enough at each side to permit it, you can just sandwich it between two 1x4 blocks nailed across the corner to form a pocket. Rear bumpers often require a different treatment. When they're molded close to the body, you may be able to hang the frame from each end by means of a U-bracket, as shown in the left detail, above. (Remember that the side rails can be snugged to the rear fender since these wheels don't pivot.) Place cloth or foam-rubber padding under the bracket to avoid scratching the chrome, and use wire with heavy insulation to secure the bracket to any handy part of the bumper.

Where the bumper extends back from the body, there's often space to wedge a 1x4 crosspiece in front of the bumper. If

so, merely nail short legs at each end from which the side rails can be hung.

The bottom edge of the frame should ride about 15 in. from the ground, and should be generously padded at all points where it might rub the body. Scraps of foam rubber, attached to the inside face of the rails with rubber cement, are ideal for this purpose.

The cloth strips can be cut from canvas or other durable material, or you could use upholsterer's webbing or cotton venetian blind tapes. These strips pass all the way across the hood and rear deck, and are stapled to the rails at each end. At the center of the body, they can be tied to window handles or around armrests.

Cover the entire frame with floral sheeting, obtainable from a florist's supplier. To prevent wind from lifting the seams while the car's moving, start at the top-rear of the body and pin the sheeting to the cloth strips, lapping toward the back

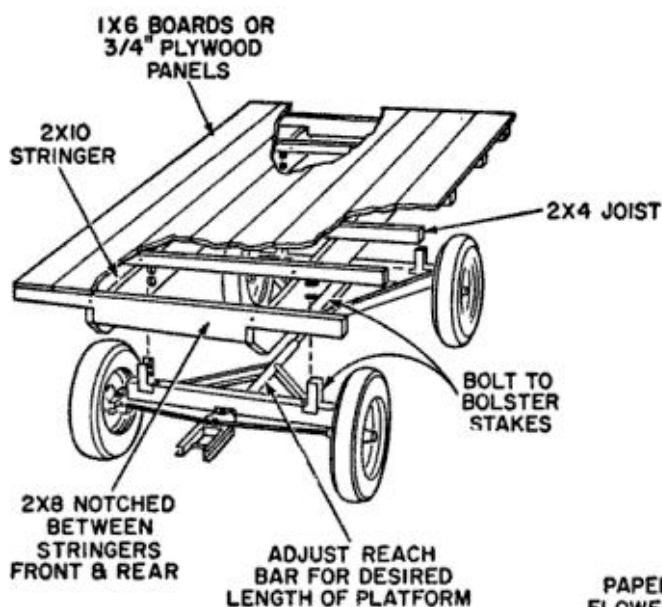

SUPERSTRUCTURE design depends on number of riders to be posed there. It's often just the sturdy two-step platform shown below. Background can be any shape cut from wallboard or plywood, firmly braced

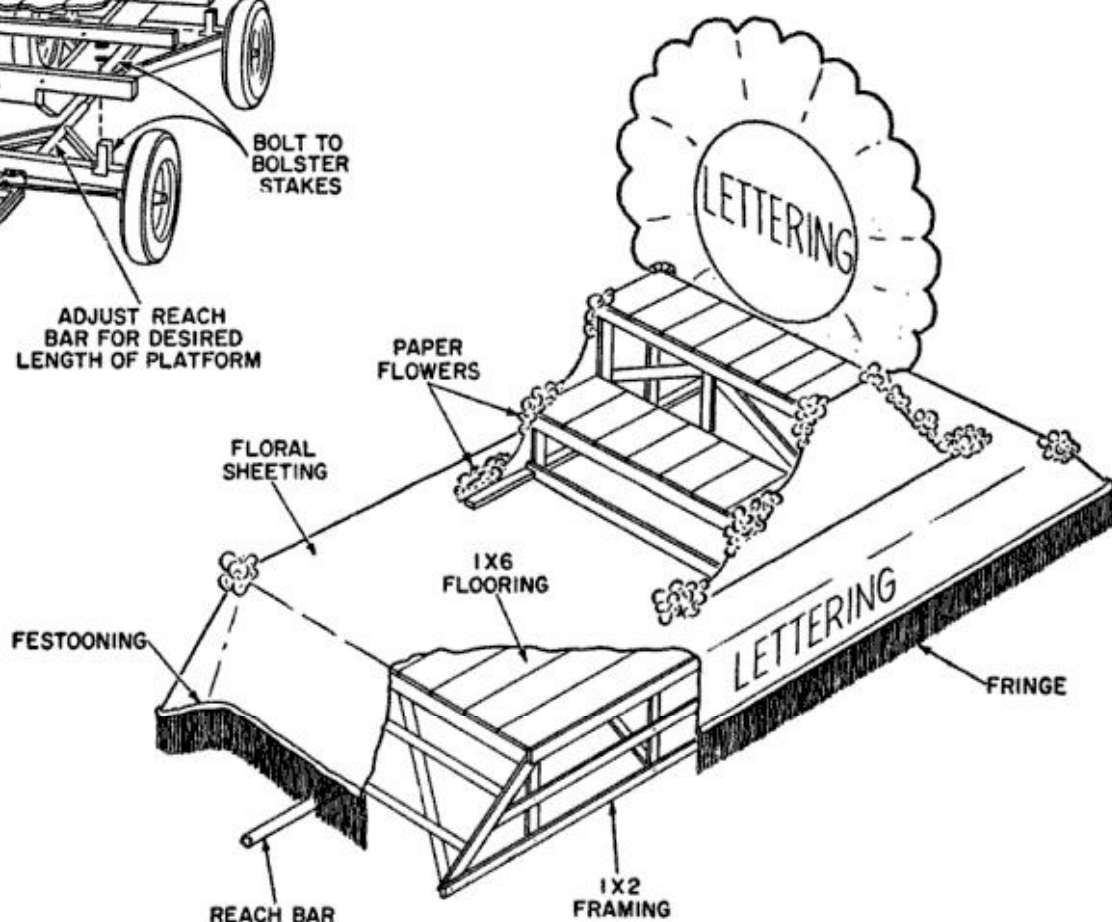

as new sheets are applied. Lap about an inch, and be sure to bring the pin points outside so they won't scratch the car.

Staple the sheeting along the rails, then staple the fringe on top the sheeting's bottom edge, and cover this joint with a strip of festoon. Don't block the air-intake grille. Leave an opening here—you can trim the edge with festoon and apply a number of vertical strips to mask the gap.

Framing a skirt for a flatbed truck is even simpler, since here you needn't worry so much about the vehicle. The frame marked "A" in the sketch on the previous page is nailed up of 2x4s (with 1x4 cross-bracing) and wired to the front bumper. This frame should be as wide as the truck bed, assuming this allows proper clearance for the front-wheel pivot. The height should bring the top rail a few inches above the hood. The side aprons are 1x2s, framed to any desired shape.

Using a technique similar to that for the convertible, apply floral sheeting,

fringe and festoon. The appearance will improve if you carry the sheeting across the hood—but leave a few inches of air space between hood and sheeting to prevent fire hazard.

The most effective common vehicle for a float is a "wagon gear" of the type used for farm trailers. These rigs have an adjustable column (reach bar) between the axle assemblies, so you can adjust for any length float you wish. If the float is to be over 25 ft. long, bolt 2x12 stringers to the bolster stakes, instead of the 2x10s indicated above. The 2x4 cross members are set on edge, just like floor joists in house construction, and are toenailed to the stringers. The platform surface is either 1x6 flooring and 3/4 plywood.

Determine apron dimensions by measuring the distance between the top of the platform and the ground, then deduct 15 in. for the fringe drop. When stapling the fringe in place, leave about a 2-in. ground clearance to keep the fringe clean. ★★

3 jigs for cutting wood discs

There's a point to cutting true discs with these simple jigs—a pivot point. Pick the jig that's right for your saw and you can cut any size disc quickly and accurately.

By Dr. C. E. Banister

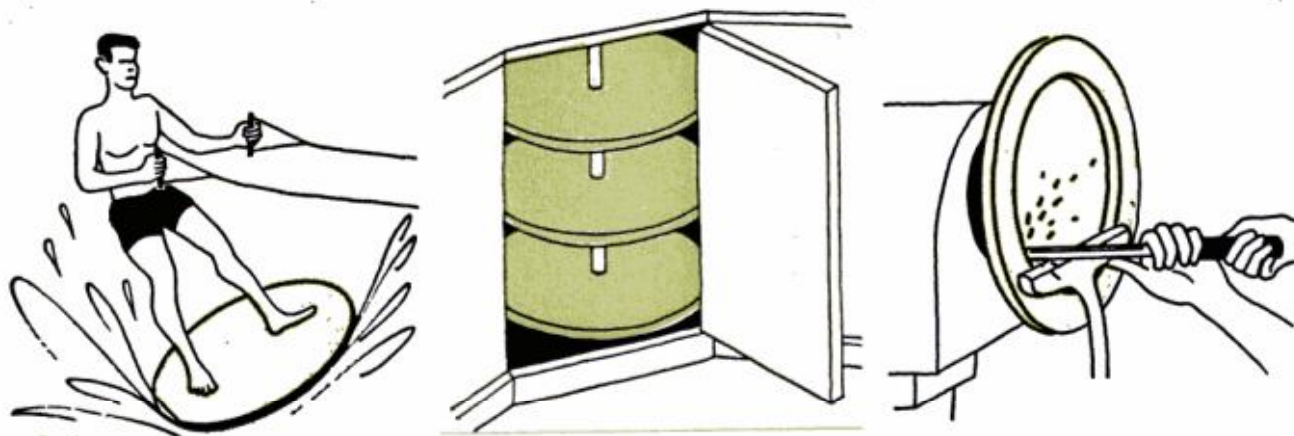

SAUCER SKIING, lazy-Susan corner cabinets, blanks for turning wooden trays—these are only samples of projects that require accurately-cut discs. Round tabletops are also much in vogue, for everything from simple nested serving sets to elaborate tier tables.

Cutting discs for such projects is a tedious (and usually inaccurate) chore on a bandsaw or jigsaw if you attempt to feed the stock to the blade by hand. On a bench saw, it's virtually impossible. But an adjustable jig makes fast work of circle cutting on whatever type of stationary power saw you own. And one of the three designs shown here should be just about right for your needs. In the interest of safety, accuracy and durability, all three are designed to be as sturdy as commercial workshop equipment.

The adjustable jig lets you cut discs of from 2½ to 24 in. dia. on an average bench saw. To make it, square up a rectangle of ¾-in. plywood and dado a ¼-in.-deep groove across the center, as shown. Widen this groove on each side to a depth of ⅛ in. for the hardboard strips that lock

the slide in place and prevent its being bent when work is removed from the pivot point. The groove dimensions shown were to fit a 7-in. sliding chest-lid support I used to carry the pivot point. I removed the mounting bracket and drilled a hole in the opposite end to take a 6d common nail, cut to a ⅝-in. length and ground to a point. I soldered the nail to the slide and ground the head thin enough to permit easy movement in the track.

Now, drill a hole at the exact center of the groove and counterbore the opposite face to take a Teenut. Dado this bottom face at right angles to the top groove and set in a hardwood bar that will provide a sliding fit in the miter-guide grooves of your bench saw. My saw's grooves call for a bar ⅞ in. thick by ¾ in. wide.

Attach the hardboard strips with glue and screws and finish the wood parts with a coat of sealer and a coat of varnish. Tap the Teenut into place, slip the slide into the track and secure it with a bolt through its center slot. Wax both faces for easier sliding and pivoting.

To use the jig, cut a square plank

1 Adjustable jig for small discs on bench saw

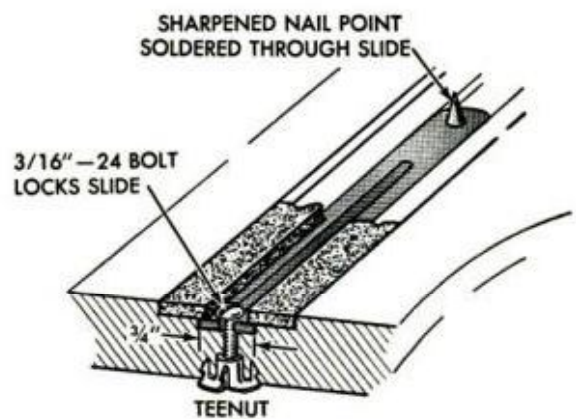
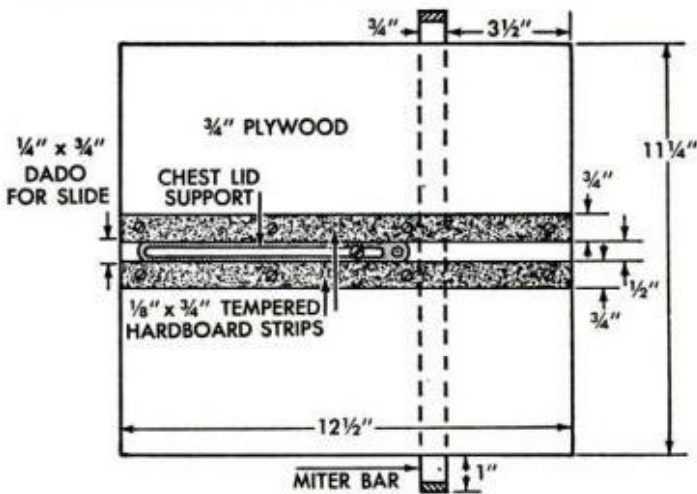
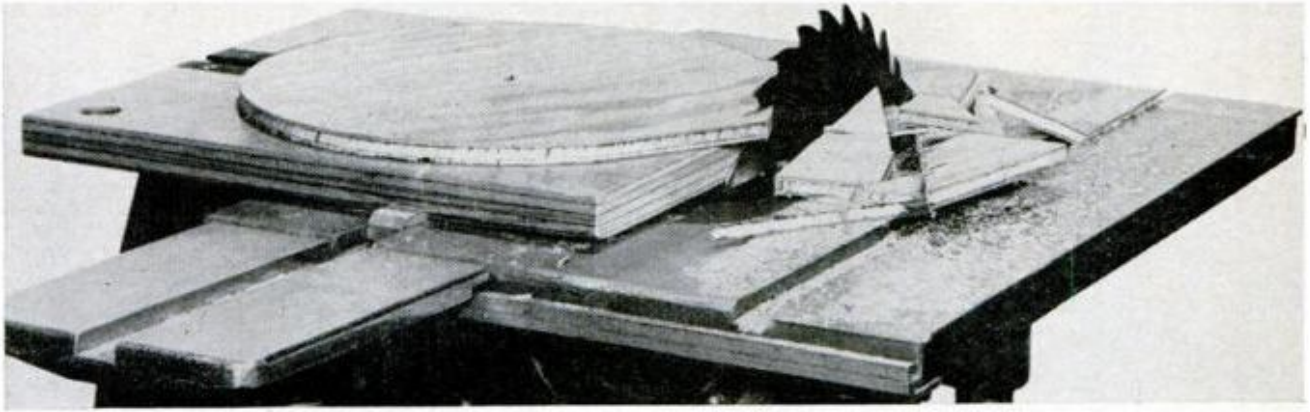

2 Extension-table jig for big discs on Shopsmith

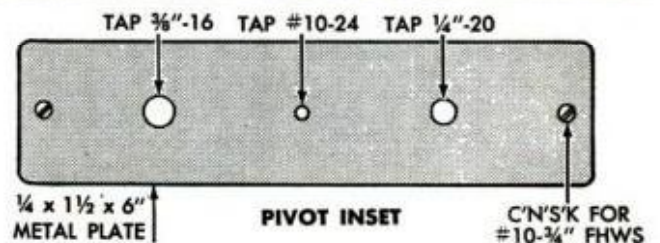
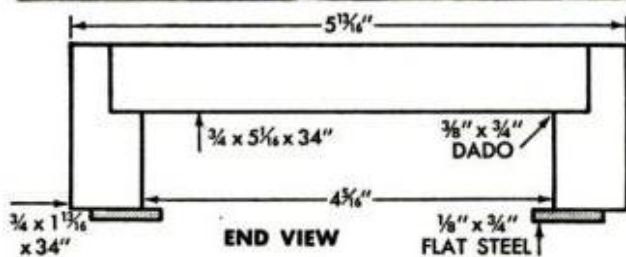
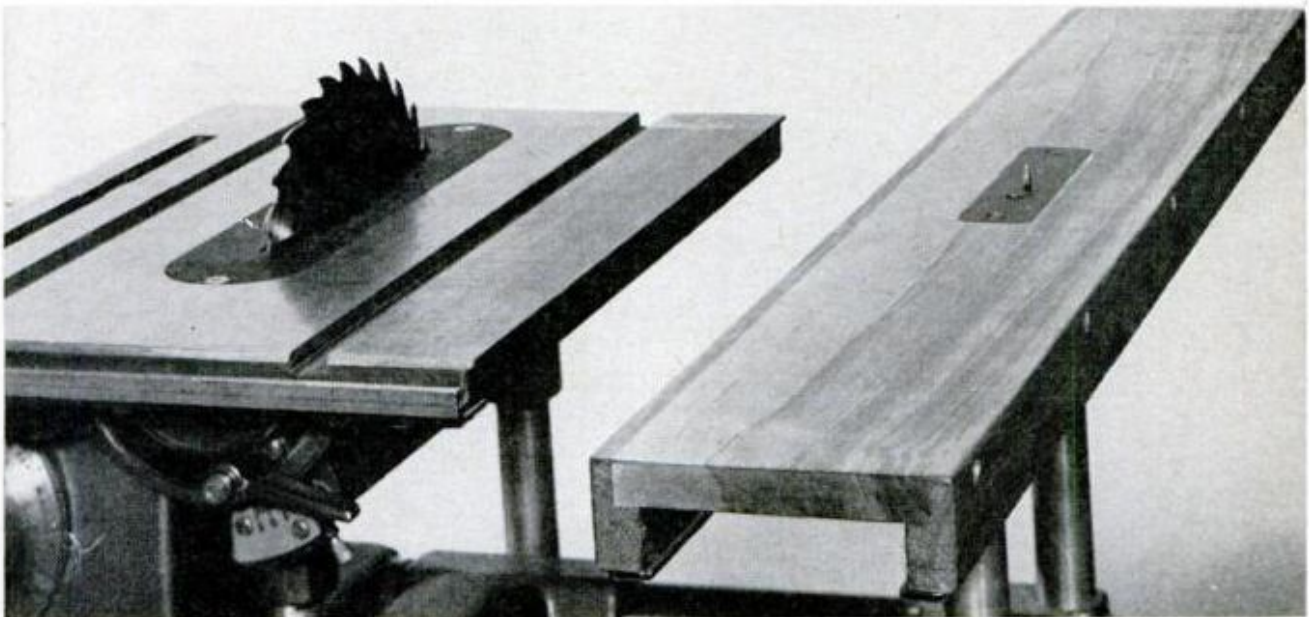

3 Dual-purpose jig for large discs on bandsaw

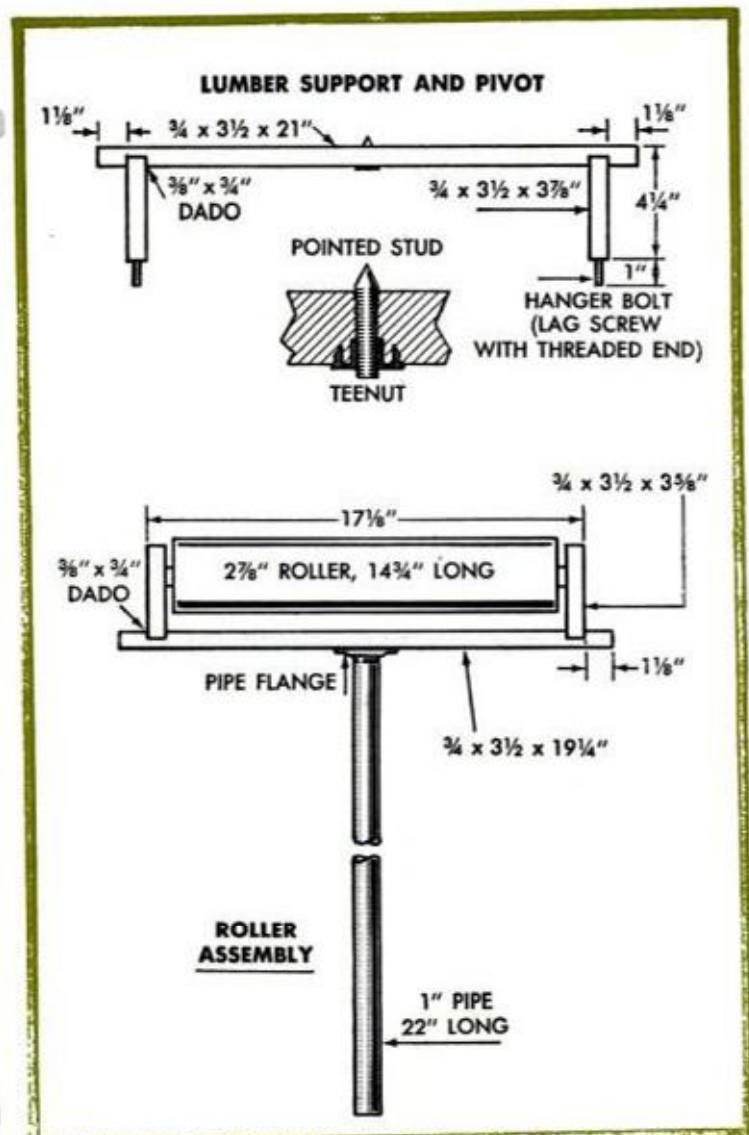
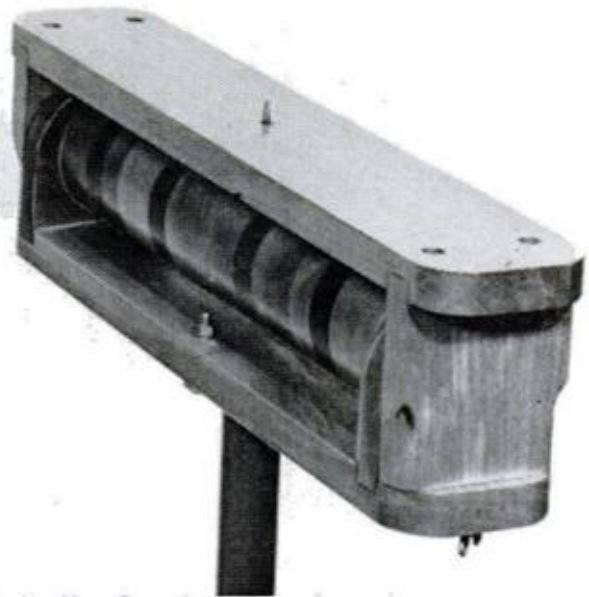
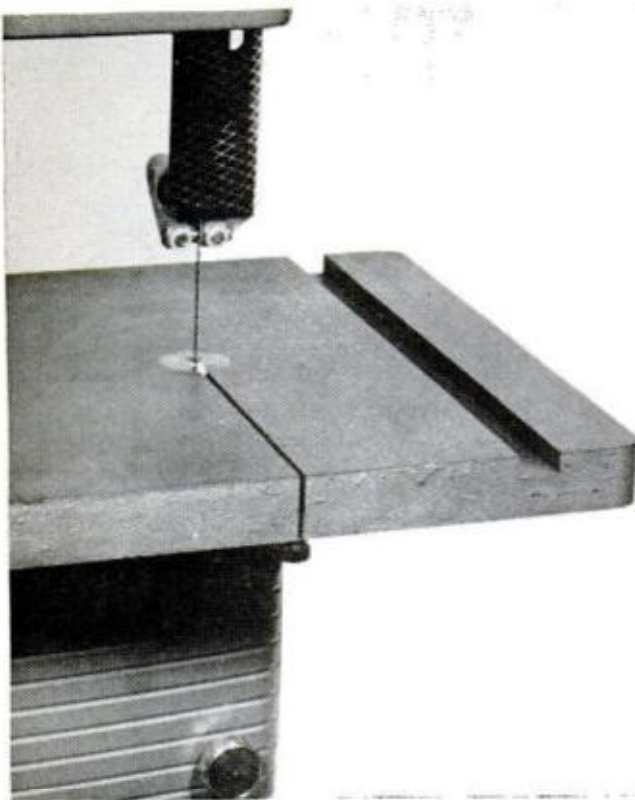

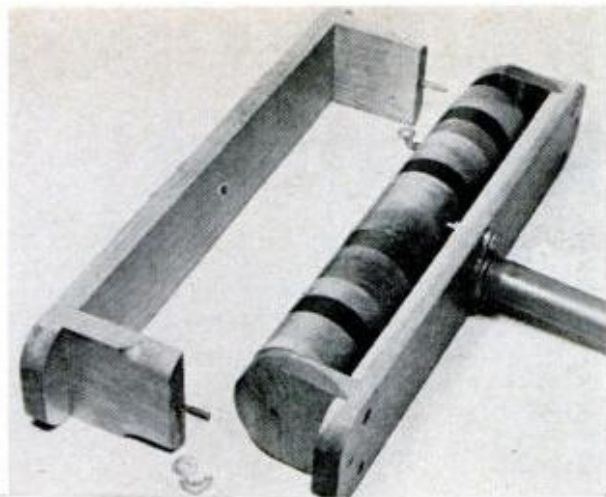

WHEN PIVOT ISN'T NEEDED, yoke detaches, exposing roller to support lumber projecting beyond saw table

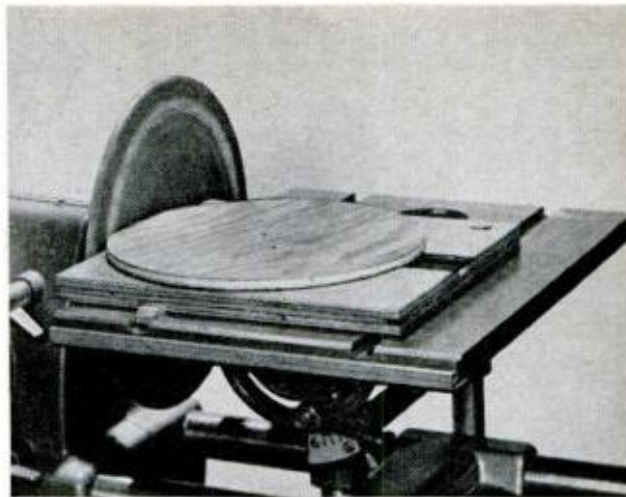

USE OF ADJUSTABLE JIG doesn't end with cutting. Edges can be smoothed by using jig with disc sander

slightly larger than the diameter of the disc you need, scribe lines from corner to corner and punch with an awl where they cross. Flip the panel over and place this mark on the pivot of the jig, then tap the upper face with a mallet to drive the point in. To figure the jig adjustment, space the pivot point the desired radius from the saw tooth nearest you as you stand at the saw, then tighten the lock bolt to hold this position while you work.

Next, pivot the work to present a corner to the blade and make a straight pass, as if cutting a miter. Trim off the other corners until the work is a rough octagonal shape. Now crank the blade to its highest point and reposition the pivot the desired distance from the new first tooth. Turn the disc slowly into the blade. The cut will be slightly tapered, but it's easy to true up the edge later by pivoting it against a sanding disc mounted on the saw's arbor.

For cutting, always use a combination blade with medium set—and be sure it's sharp. To prevent splintering, replace the metal inset on your saw with one made of 1/4-in. tempered hardboard or plywood, slotted with the same blade you'll later use, in order to obtain fuller support for the underside of the work.

The second jig is designed specifically for the popular multi-purpose Shopsmith. It's simply a saddle that slips over the tool's extension table. Since you can move the table itself back and forth to adjust for the desired radius, only a stationary point is required here. This jig lets you cut circles from 20 to 72 in. in diameter, and then edge-sand them on the outboard disc sander.

The jig is easily made from three scraps

of hardwood, assembled with glue and No. 10 F.H. screws. Rout a recess in the top face to sink the metal inset flush, and attach this inset with two screws. The center hole is tapped to receive the pivot point, made by grinding a 10-24 bolt to a long point and then cutting it off to leave just enough threads to pass through the plate. The other two holes are optional; they allow for predrilling the center hole of the disc when absolute accuracy is desired. Shoulder studs or bushings can be used to fit various sized center holes.

Attach the flat steel strips along the bottom edge of the sides to prevent the jig from tipping. Polish the sides of the extension table with emery paper for smooth sliding action. The castings that attach to the table may have to be filed slightly to allow for free sliding of the jig.

The dual-purpose jig is a versatile unit that you can use with both a band [\(Please turn to page 175\)](#)

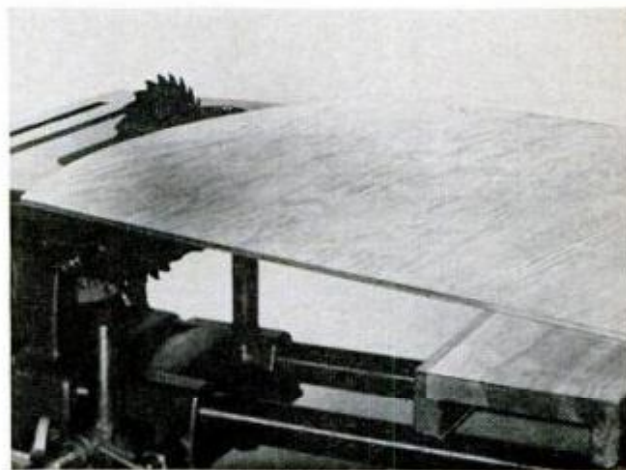

LARGE RADIUS CUTS on plywood panels are possible with extension-table jig on Shopsmith. It's faster and more accurate than hand-guiding a sabre saw

Build a swimming pool just for the fun of it

By digging a hole and lining it with a fiberglass shell, you can have the pool you've always wanted for as little as \$850, complete with pump and filter.

By Denton Wirkus

IF THE THOUGHT of building your own pool makes your head swim, you're in for a surprise. With a lightweight fiberglass shell that sets in the ground, you can build this fun-packed 12 x 27-ft. pool in less than 75 hours—it's that simple.

In starting out, we wanted to build the lowest cost pool possible, yet one that would give years of service. Second, we

wanted one that would be the easiest of all to build. Lugging heavy concrete blocks wasn't for me and besides, they're not cheap. By the time you'd pour footings and a bottom, a block pool of this size (lined with vinyl) would run close to \$2000; a pool of vinyl alone is less expensive, but it's subject to puncturing. So we decided on fiberglass as the cheapest, the

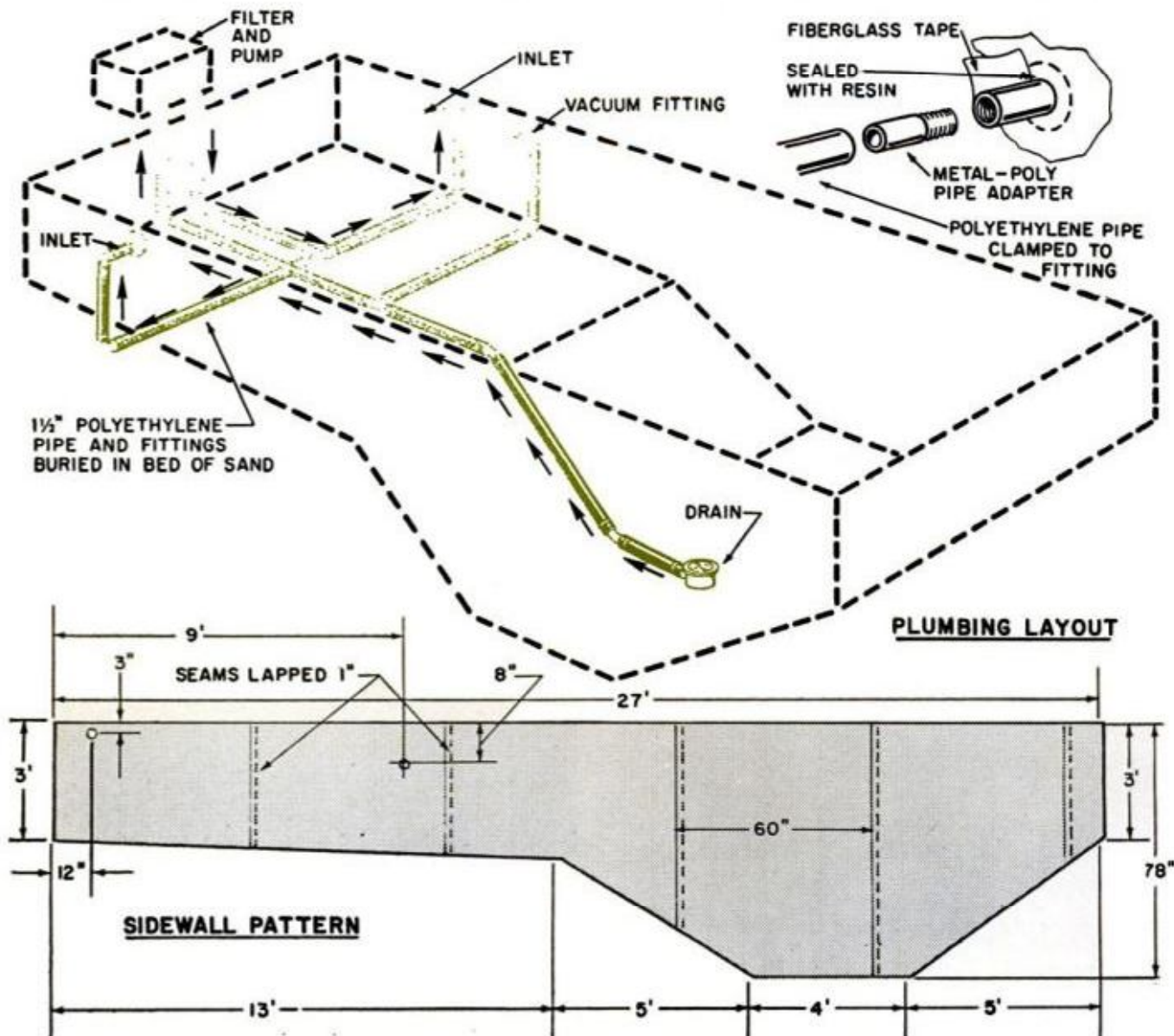

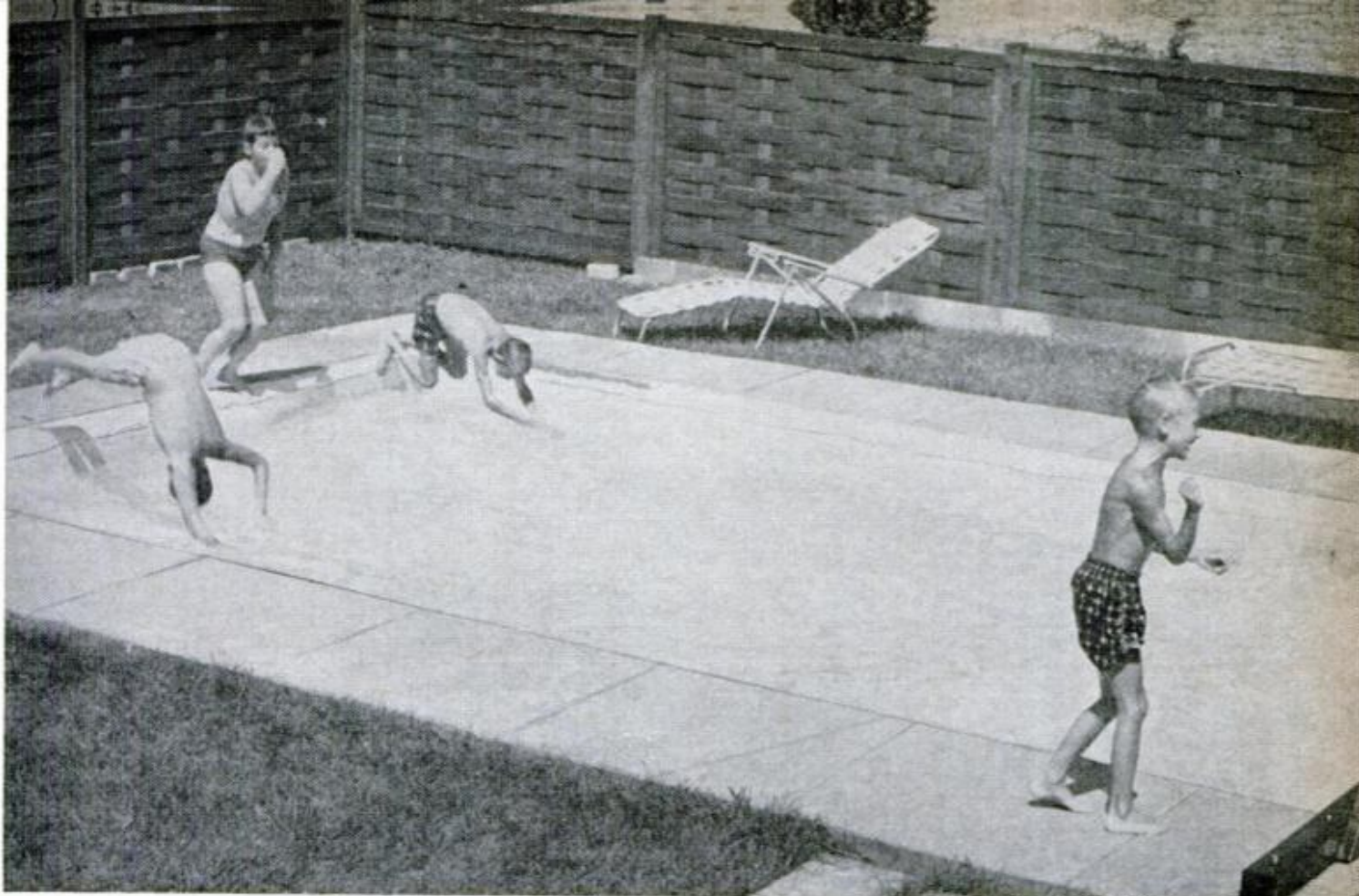

Ames Daily Tribune photo

strongest and certainly the easiest material for anyone to handle.

No one in his right mind is about to dig the hole himself, so we hired out this job at a cost of \$110. The hole was dug just slightly oversize to keep backfilling to a minimum. The bottom was dug out as near to the pool's profile as possible with the power shovel and then we took over and carved out the deep end to the exact contour shown. You don't want to disturb any more of the firm soil than is necessary and, of course, you are way ahead where

the soil is compact enough to let you carve a hole that won't cave in.

When the excavation is completed, you are ready to install the plumbing lines. I used 1½-in. plastic pipe and regular chrome fittings (designed for concrete pools) for the drain, inlets and vacuum-cleaner outlet. These fittings are available from both Sears and Wards, as well as pool supply firms, and are joined to the plastic pipe with special metal adapters and stainless-steel clamps. After passing through the filter and pump, pool water is

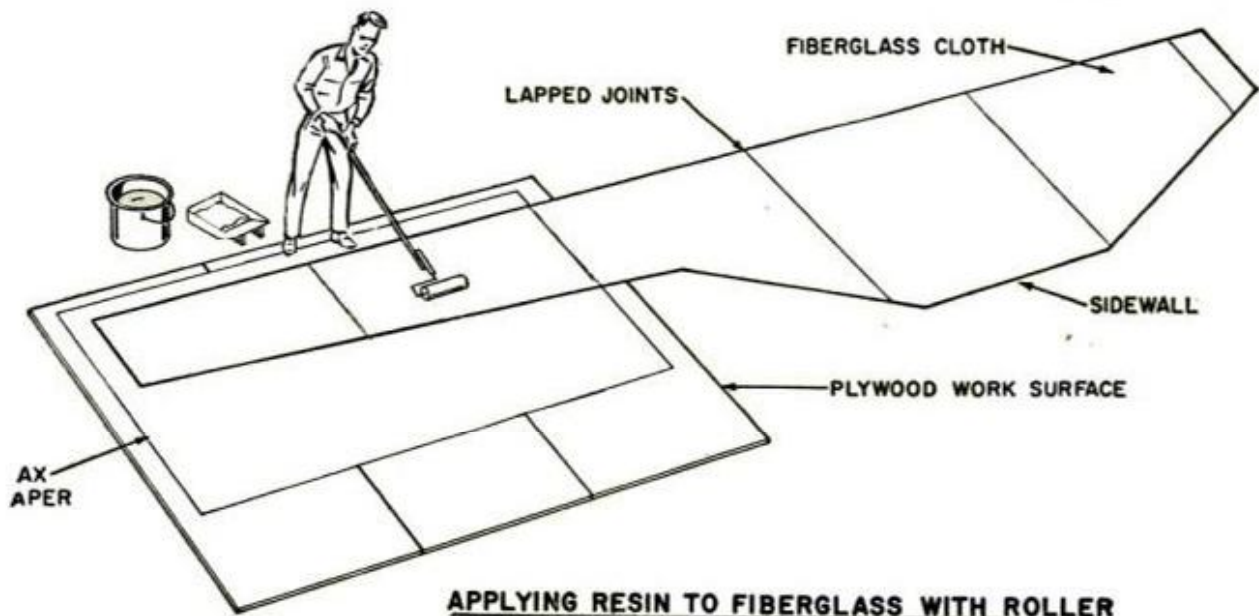

APPLYING RESIN TO FIBERGLASS WITH ROLLER



EXCAVATED FOR INLET PIPE

PLUMBING BURIED IN LAYER OF SAND

CUT,
FOLD,
TAPE

FIBER-GLASS POOL

LOWERING FIBERGLASS SIDEWALLS IN PLACE

returned to the pool through the inlets. The drain fitting draws dirty water from the bottom of the pool.

The exact way the pipe lines are run is not important, outside of placing the drain at the deepest point and locating the vacuum-cleaner outlet far enough below the water level to insure that no air enters the line during the filtering operation. The sidewall pattern shows the hole for this fitting—9 ft. from the end of the pool and 10 in. down from the top. The two inlet fittings are mounted about 3 in. down from the top, one on each side and near the end of the pool to save on pipe. Both inlets lead directly to the filtering unit.

Since the drain, vacuum and inlet fittings are inserted in holes cut in the fiberglass liner before they can be connected to their pipes, the fittings must be left off until the shell is in place in the excavation. Where there isn't sufficient room on the outside of the shell to bring the pipes up the side, notches can be cut for them in the dirt bank. All pipe lines are buried in a 6-in. layer of sand which is spread

evenly over the bottom of the whole pool.

The $\frac{1}{16}$ -in.-thick fiberglass panels are all prepared outside of the excavation, flat on the ground. Sidewalls and endwalls are made in pairs, whereas the pool bottom is made up of four separate panels. The lining consists of fiberglass cloth which comes in rolls 60 in. wide. This is cut into pieces and then lapped an inch or so to make a panel 27 ft. long.

The cloth is made semirigid by saturating it with polyester resin containing a blue pigment and a hardening agent. Three 4 x 8-ft. panels of $\frac{1}{8}$ -in. hardboard, covered with wax paper to prevent sticking, make a good work surface for applying the resin to the cloth. I used a long-handle paint roller with a mohair cover to apply the resin, saturating the first section thoroughly and letting it harden an hour.

As each section hardens, the work is pulled part way off the work surface and another section is lapped along the edge, coated and left to harden. This is repeated to produce an unbroken sheet of reinforced plastic. A gallon of resin will saturate 18 to 22 sq. ft. of cloth, and since the pot life is short, you have to watch to see that you do not mix more than you can use in an hour's time. Instructions for mixing come with the resin. A second coat is applied after the first has hardened, to make the panel completely waterproof.

All panels are coated this same way and, while they're drying and curing, you can start making the curved fillet strips which are used to join the panels after they are lifted into the excavation. A curved form

Cost Breakdown

Filter, including pump and motor . . .	\$225
53 yds. 60-in. fiberglass cloth, 42 gal. resin, 22 units pigment, solvent, rollers, sleeves	345
Fine sand for pool bottom	10
Polyethylene pipe, pool fittings, miscellaneous plumbing costs	100
Excavation and dirt removal	110
Building and plumbing permits	10
Ready-mix concrete for pool apron . . .	50
	<hr/>
	\$850

is needed for this which is easily made by bending sheet metal to a 13-in. radius and nailing this to three plywood brackets. The form is covered with wax paper and then a piece of cloth 24 in. wide is placed on top of it, for coating. I made each fillet 5 ft. long, but you can make them longer if you wish. Each 5-ft. section is left on the form to harden and then given a second coat. You'll need approximately 100 lineal feet of these fillet strips.

Short sheet-metal (aluminum) screws are used to attach the fillet strips to the panels, running pieces up the corners in joining the ends of the sidewalls, and along the bottom in joining the sides to the bottom panels. After this, all joints and screw-heads are covered with additional strips of cloth and saturated in place with a generous application of resin. Any roughness along the seams is sanded smooth after the resin has hardened. Thin as they are, the

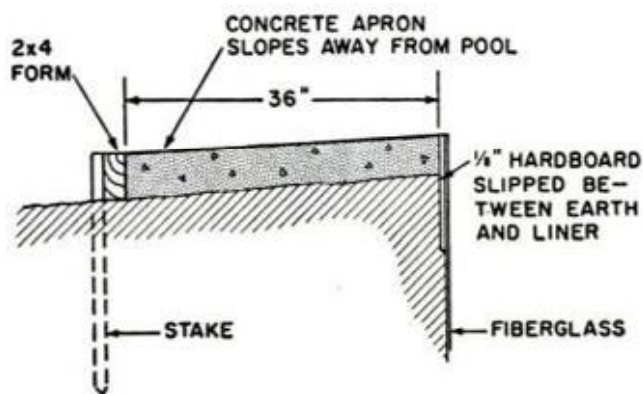

HOW APRON IS FORMED ALL AROUND POOL

fiberglassed panels are plenty strong to walk on and will flex a bit without fear of tearing or cracking.

Seams in the bottom panels are sealed in a similar manner with strips of cloth embedded in resin to insure no leaks. Inlet, drain and vacuum fittings are sealed in their holes with fiberglass tape wrapped around the back side and then generously coated with resin.

Backfilling the shell should be done gradually at the time the pool is being filled with water, so that water pressure against the walls can be equalized by the tamped fill. Unless absolutely necessary, the pool should not be drained over winter. The water level can be lowered some, but there is danger of the shell caving in without the constant pressure of the water.

To help keep the pool clean it's desirable to have a 3-ft.-wide concrete apron completely around it and sloped away a

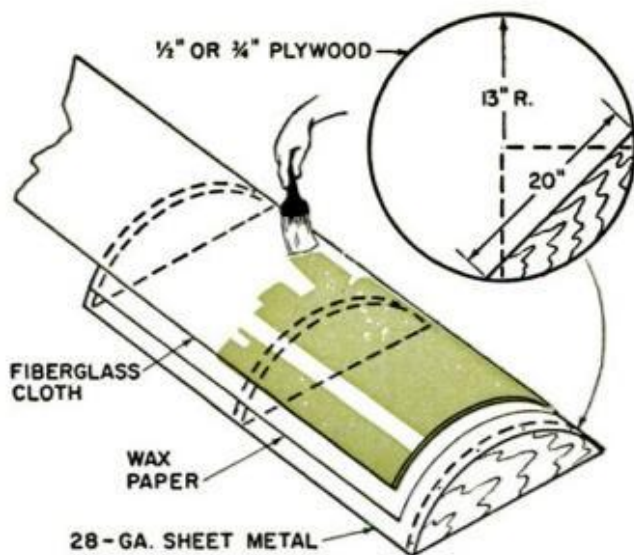

APPLYING RESIN TO COVE STRIPS

bit. This can be poured right up to the shell by inserting 12-in.-wide strips of hardboard between the shell and the dirt walls to serve as an inner form. Staked 2 x 4s will do for an outside form. Scrap lumber placed crosswise of the pool will brace the hardboard against the pressure of the concrete. Here again, the pouring should be done after the pool has been filled. Finally, 12-in. strips of resin-saturated fiberglass are folded over the top edges of the shell and along the apron.

Filtering instructions come with the filter. Time to filter the water will run anywhere from 1 to 8 hours, depending on the swimming load, dust in the air and dirt in the filter. A screw-in plug in the vacuum fitting permits attaching the 30-ft. cleaning hose. Cleaning requires only 15 to 20 minutes once a week. ★★ ★

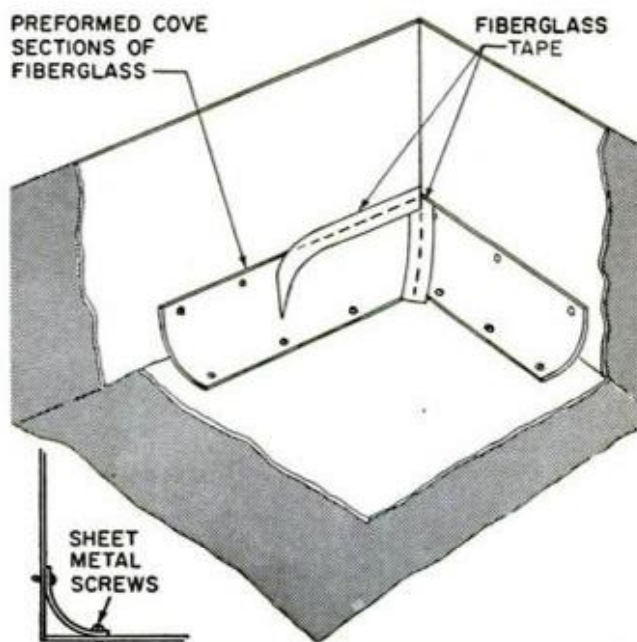

HOW BOTTOM AND SIDE WALLS ARE SEALED

TIPS

FROM READERS

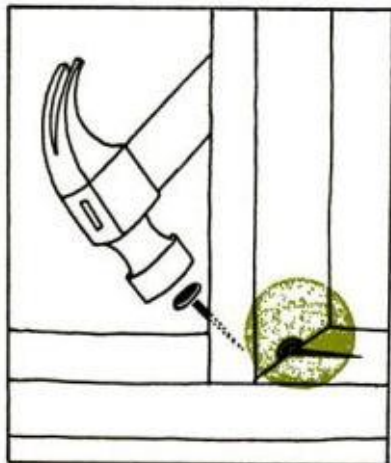

TO HOLD A STUD for toenailing, drive the head of a horizontal spike halfway into the sill on opposite side of stud as shown

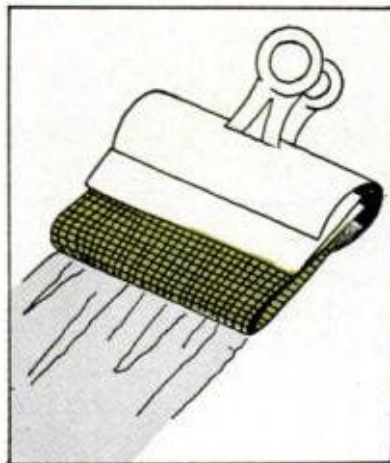

LOST YOUR GLUE BRUSH? A scrap of window screen, folded over, then gripped by a paper clamp, makes big-job applicator



STRENGTHEN AN AX HANDLE at the "breaking point" by wrapping it tightly near the head with three or four layers of plastic tape

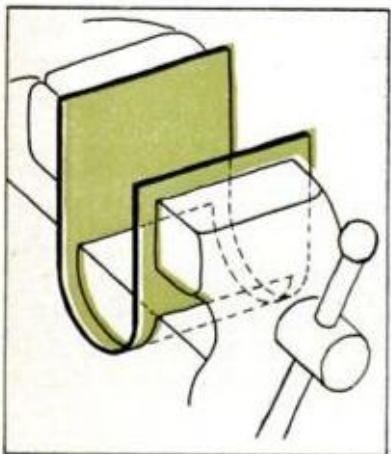

PADDED VISE JAWS won't damage gripped work. Thick leather pad with center cut out is U-bent to fit over vise beam, as shown



SUPPORT LONG BOARDS being cut on a bench saw with a jig of 2x2s and 3/4-in. dowels which fit in holes drilled in sawhorse

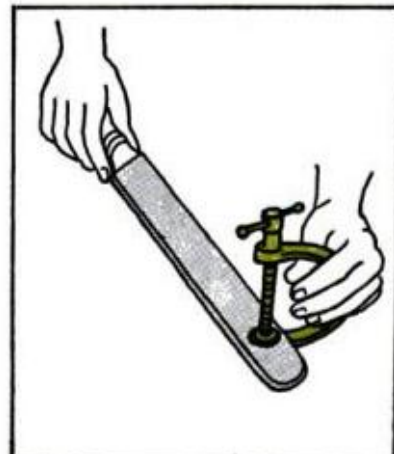

A C-CLAMP "handle" on the end of a file provides a better grip, better control, and keeps your hand off the file's sharp ridges



TO PAINT (both sides), and stack shelves for drying, nail scrap wood pieces to ends. Drive nails halfway for easy removal later

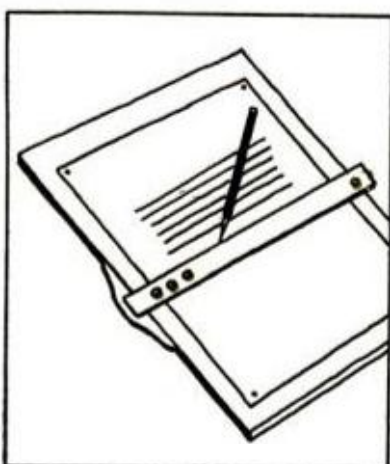

BETTER CONTROL of a T-square is achieved by drilling three finger holes through the T-square at positions indicated in sketch



STRAIGHTEN bent wire by snaking it between spaced nails held in a vise. Cardboard holds nails till vise grips them all at once



Pogo Shoes Give You a Lift

BY JACK WILEY

WITH BUNYANESQUE SHOES, it's now possible to literally bounce on air. They're so simple, it's a wonder no one came up with them before. They're safer, too, than conventional coil-spring jumping shoes. They consist of merely a pair of sneakers, canvas bags and small boat-trailer inner tubes.

Haul out that old pair of tennis sneakers and cut out the soles with a razor blade. From heavy canvas, cut the pieces shown at the right. Make the tops and bottoms about 7 or 8 in. wider and longer than your soles, which will serve as patterns on the tops.

Make the patterns for the rear and sides a little shallower than the thickness of the inner tube, about $3\frac{3}{4}$ in.

Cut a 3-in. lengthwise slit in the middle of the bottoms and stitch around it, as with a buttonhole, to reinforce the openings. This will provide access to the tubes' valves.

Place the tops and bottoms, with the gussets between, in inside-out positions and

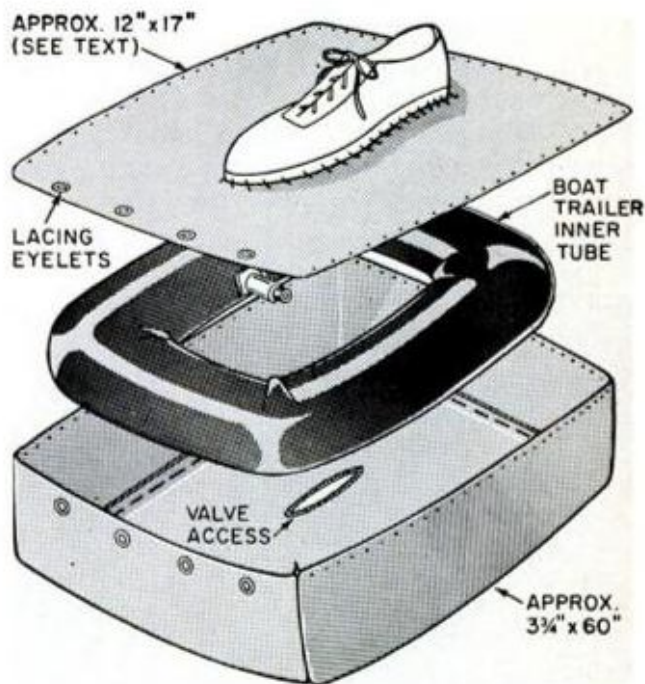

stitch on three sides. When you turn them right side out, the seams will be concealed. Provide eyelets or small grommets in the front edges for lacing closed after the inner tubes are inserted. You're finished! ★★★

Beauty Treatments For Rusty Tools

By Walter E. Burton

WHETHER YOU HAVE a hobby of collecting and restoring old hand tools or just keeping your own shop tools bright and shiny, there are numerous beauty tricks you can perform in removing the "wrinkles" from corroded and rusted metal. These before-and-after examples show how such neglected tools respond to certain face-lifting treatments.

Rust-removing techniques range from cleaning with rust solvents to grinding down to clean metal with abrasive wheels or belts. Now and then, along comes a new method to make rust-busting easier.

One such for the initial steps in the job of face-lifting is a nonwoven nylon pad that is impregnated with an abrasive. First, you soak the rusty metal in a commercial rust remover for the specified time. Then, while the tool is still wet, you scrub off the loosened corrosion. Repeat to eliminate any stubborn spots.

For smoothing the steel, you can take to a steel-wire hand-brush or a wheel that mounts on an arbor of your grinder, drill press or electric drill. Or, you can use a brass-bristled brush, which does the job and imparts a faint brass plating to the tool. Still another method for smoothing is to use a buffing wheel charged with a

medium to fine-grit abrasive, such as tripoli or aluminum oxide. A final smoothing can be given with jeweler's rouge.

Generally, deep corrosion on steel leaves dark-colored pits and dull areas that are not easily polished out. They may not interfere with tool performance or comfortable use, but since we are launched on a beauty treatment, why stop here?

One easily applied cosmetic is a metallic-powder paint, such as aluminum or chromium paint. Dredge some pigment-rich paint from the bottom of the can and apply with a cloth. This fills the pits and leaves a thin metallic film on the surface. After it's thoroughly dry, apply a clear finish, but test it first to be certain that its solvent doesn't disturb the paint.

For filling large flaws, try tinning the tool with liquid solder. If you have the inclination and want to work with the acids and toxic chemicals involved, you might try electroplating (page 197, June '56, and page 191, July '56, *PM*).

When restoring an antique, like the old corkscrew shown, it's not necessary, or even desirable, to bring the metal to its original luster. Get rid of all loose rust and dirt, but don't file or grind away any of the remaining metal. Buff vigorously



1 RUST IS RUBBED OFF with a nonwoven nylon pad impregnated with an abrasive after being loosened in a commercial rust-solvent bath

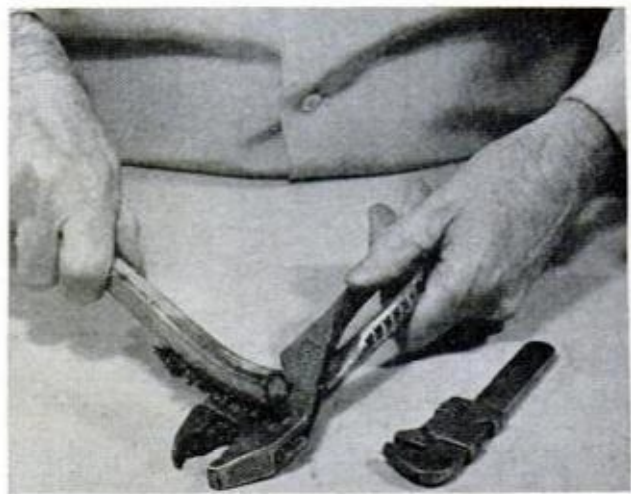

2 SMOOTHING AND POLISHING is the next step. Here, a brass-bristled brush is used to even out the finish and slightly plate a plier-wrench

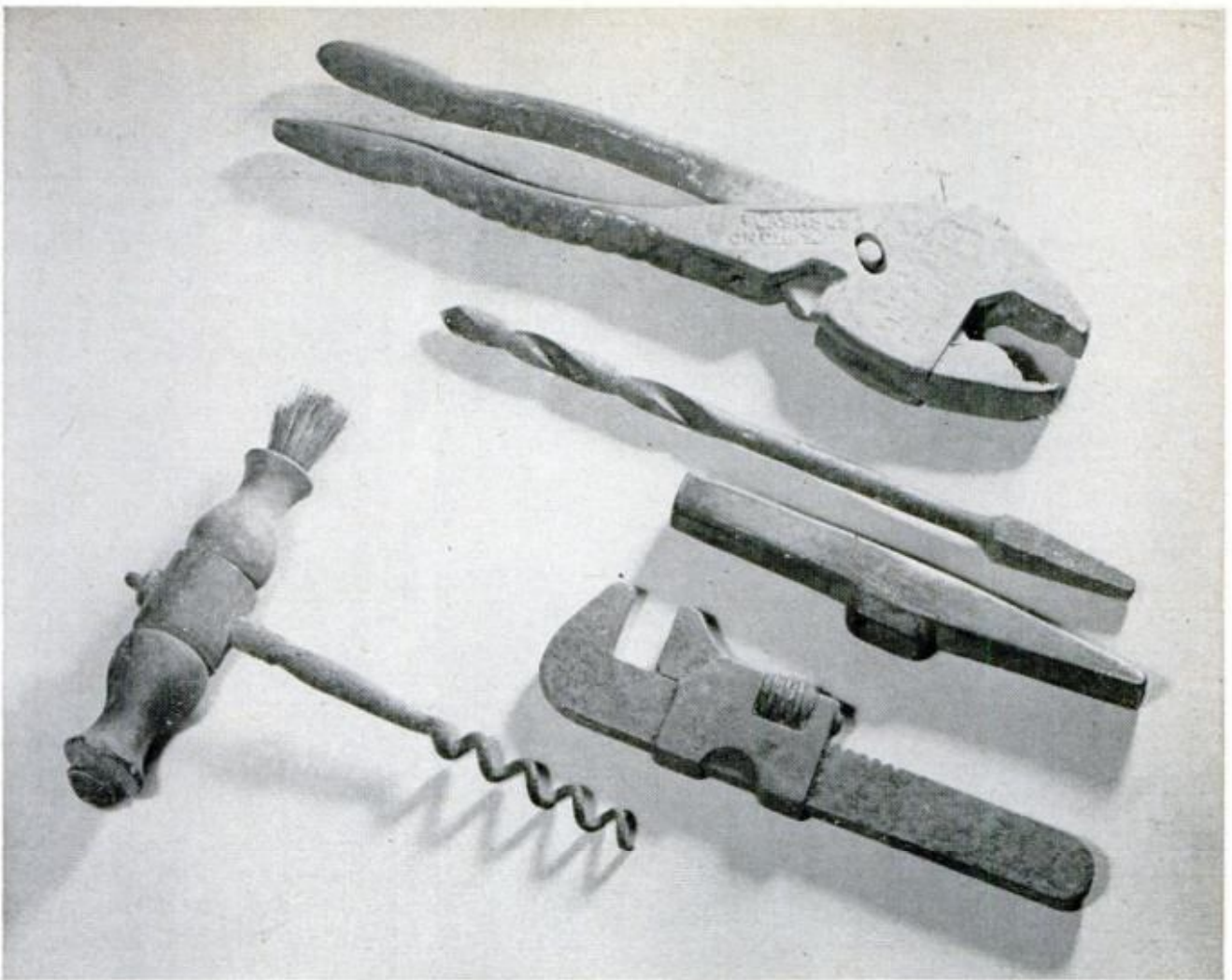

ARE THESE YOUR TOOLS? They may work in this condition, but the cutting edges are dulled and moving parts stick. This sorry lot cost 50 cents at an auction sale. The tack-hammer head has been partly cleaned

with a steel-bristled, suede-shoe brush and apply a protective coating of clear lacquer, shellac, boiled linseed oil or wax. Some of these may darken the metal.

Before tackling the metal, though, clean any wood parts, preferably with a solvent that doesn't raise the grain or destroy a patina of age. Paint remover is one, but

you may have to try several, depending on the existing finish and dirt. Lacquer thinner and alcohol also often work well. When clean, the tool can be rubbed with boiled linseed oil and polished. After it's dry, apply thinned shellac and buff it down with a cloth. For final protection apply two coats of furniture wax. ★★★

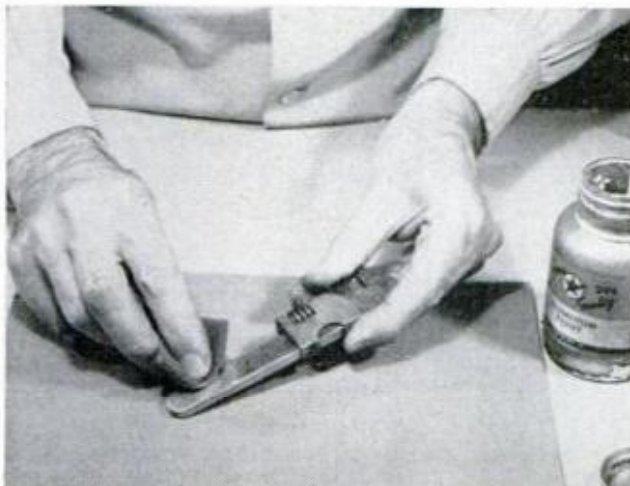

3 FINISHING STEP involves applying a metallic paint or solder to conceal blemishes and give the impression that the item has been replated

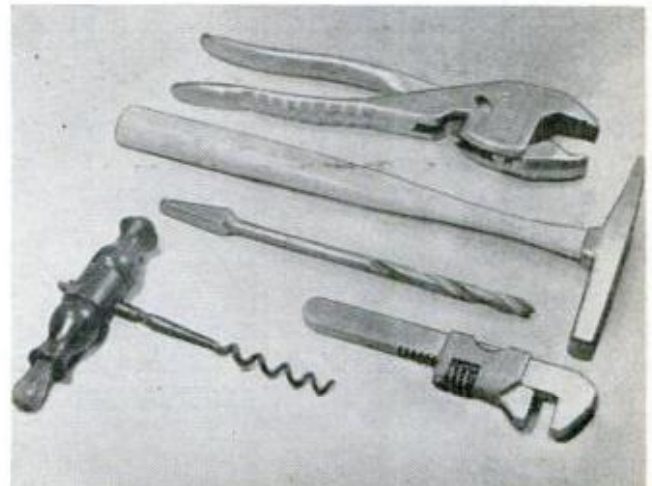

4 BEAUTIFIED, the tools are respectable and serviceable. Antique corkscrew was cleaned and lacquered, the others polished and painted

SOLUTIONS FOR MECHANICAL HEADACHES

AUTOMOBILE CLINIC

BY MORT SCHULTZ

Aided Reader Writes

You may recall that some time ago I wrote you of the troubles I was having with my 1962 Pontiac Tempest timing chain. You advised me to replace it with the company modification, Part No. 9772801. I did, and have now had this chain in since Feb. 1965. I have now put 21,000 miles on it without having it give me any trouble at all. I also put in slightly heavier spacers which permit a better arrangement on the chain side. Many thanks for the good advice.—Jim Reidy, Ventura, Calif.

My pleasure, Jim.

VW Valves Von't Vork

Our '63 Volkswagen won't retain a proper valve adjustment. It's been driven 37,000 miles with dealer maintenance every 3000 miles. The dealer sets intakes to .008 in. and exhausts to .012 in. Why won't the car maintain a valve adjustment?—B.A. Moss, Bluff City, Tenn.

First, your dealer better recheck the specs for this car. My little book says that all those valves should be set to .008 in.

If your beetle is not maintaining valve clearance, check out the rocker arm studs to make sure they're tight; if they're not, there's your trouble. By the way, there's a kit on the market that can be used to take up the play in the studs, thus eliminating the need for replacement. Ask your dealer or local auto parts outlet about it.

If the studs look okay, check the cam lobes. Loose lobes can also cause the valve setting to deviate. In this case, the only solution I know of is to replace the camshaft.

Normal It Ain't!

Our '64 Ford Fairlane sports coupe has a standard three-speed gearbox and a 289 V8 engine. Shortly after it clocked 13,000 miles, the car began slipping out of second gear when cruising down a grade under 40 mph and against compression. Our Ford dealer went through a lot of trouble trying to correct the problem. He tore down the transmission and replaced the input, output and needle bearings. Linkage checked out okay. However, the problem persists.

I've been told this problem was "normal" for this car, but I doubt it because I don't think my dealer would have gone to all

that trouble if it was. What do you think?—Graham Wilcox, Boise, Ida.

I think like you: It is not normal. You might softly suggest these two other possibilities to that gem of a dealer you describe: (1) you may have a bad synchromesh unit in the transmission; or (2) the transmission may be out of line with the bell housing.

Tire Wear on a Corvair

My car is a 1962 Corvair 700. Six months ago I put new rubber on the rear. Today the inside edges of both tires have worn badly. Viewing the car from the rear, I can see that the rear wheels slant in at the top. Any ideas?—Carl Rathje, Wyomissing, Pa.

Yes, and it seems this is a problem peculiar to Corvairs. I know of only one solution to it: replace the rear springs with heavy-duty springs which are carried by your Chevy dealer. The design of the '65 and '66 Corvairs makes this a fairly simple operation.

(P.S. If any of you guys have another cure for this malady, we'd like to hear about it.)

A Band Is a Band Is a Band

It says in the owner's manual for my '65 Olds Vista Cruiser with Jetaway transmission that I should have the transmission band adjusted at 24,000 miles, but the mechanics at the Olds dealer's where I bought the car say there's no adjustment to be made. What's up?—H.B. Smith, Winters, Texas.

I suggest you find yourself another shop. Like the manual says, that transmission band should be adjusted every 24,000 miles—period.

Falcon's Reluctant Shifting

My '62 Falcon with 170 engine and automatic transmission doesn't shift from low to high until I've driven it about 1½ miles after starting it cold. Once it heats up, it works fine. The trouble developed recently. I've changed the transmission fluid and diaphragm, even poured in an additive. Nothing helped. I'd appreciate a possible solution.—Mel Roth, New York City.

This is a pretty "popular" complaint, and the probable solution is one that all readers can paste in their hats and remember. Chances are the trouble is due to a sticky valve in the transmission valve body. When these get plugged up they must be removed and cleaned.

Un-Valiant Shifting Linkage

I'm having trouble with my '64 Valiant V-200 with standard shift. The shifting linkage rattles and is very loose. The dealer claims that it's a defect that can't be fixed. Is he right?—J.E. Thomas, Mondeville, La.

Nuts! While certain "bugs" can develop in any part of a new vehicle, the manufacturer is soon made aware of them and quickly issues service bulletins to the dealers which describe how to correct a particular problem. Here's the correction for *your* problem:

At the base of the steering column jacket (inside) are nylon bushings. You'll

find two capscrews there. Loosen them (don't remove them), then tap down on them. This action causes the shifting lever to tighten up on the bushings that are causing the trouble.

Rotating Tires

What is the accepted procedure for rotating the tires on a car?—Billie Jay, Carson City, Nev.

As follows, Billie: Right front to right rear; right rear to left front; left front to left rear; left rear to spare, and spare to right front (see sketch below).

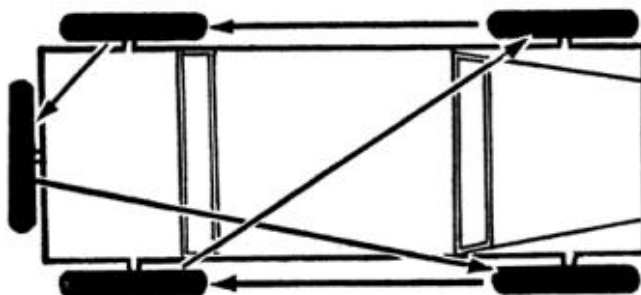

Service Tips

- **DODGE THOUGHT IT IMPORTANT** enough to issue a TSB about it (D66-35), so we'll emphasize it too. All brake hoses on 1964, '65 and '66 Darts should be inspected for routing and amount of bend. There must not be more than a 15° bend in any of the front-wheel brake hoses. A greater degree of bend can cause interference on turns and lead to premature failure. Check these hoses the next time you take your Dart in for servicing.

- **OLDSMOBILE HAS SWITCHED** a fuse in its '65 models. It's the one for the dome lamp, courtesy lamps, clock and cigar lighter located at the lower left corner of the fuse panel. An SAE 20-amp. fuse was used in all models except those with rear-seat lighters. Fine. **But** an AGC 25-amp. fuse was used in those cars with the rear-seat lighters. **Not** so fine. The latter should be replaced with an AGC 30-amp. fuse.

- **THERE'VE BEEN A FEW BEEFS** about oil leaks at the parking shaft bore of '65 Pontiacs with Turbo Hydra-Matic. While this repair should be made by a professional, there's no reason why you shouldn't know the procedure so you can be sure it's done right. This is it:

1. The car is put on a hoist and the area around the parking shaft bore is brushed clean with a solvent.
2. A small amount of sealer (Part No. 1050026) is applied to a 3/8-in.-dia. cup plug (Part No. 8620318).
3. The cup plug is then placed in position with the open end facing the front of the transmission.
4. A 3/8-in.-dia. rod is then used to drive the plug into the parking shaft bore until it's flush with the case.

By the way, the nice thing about this particular repair is that it can be done without removing the transmission.

Each month Auto Clinic answers your questions on car repair. For a personal reply to a particular question, enclose 25 cents in coin to cover mailing and handling. Write to Auto Clinic, Popular Mechanics, 575 Lexington Ave., New York, N.Y. 10022.

Trailers and Campers Need Servicing Too!

By Morton J. Schultz

Now folks are buying the workhorse of the breed—the utility trailer. These are great for moving and hauling. Got one? Fine!

Here's how to keep it fine.

SAY "TRAILER" TO SOMEBODY and what image does the word usually evoke? Either a travel trailer or a mobile home . . . right? Yet many Americans own smaller trailers. Millions own boat trailers, for instance. And campers. And utility trailers—those all-purpose tow-behinds so handy for moving furniture, equipment and materials.

These small trailers deserve the same kind of care and coddling as their larger, more luxurious cousins, particularly as regards maintenance of tires, wheels, wheel bearings, lights and braking system (if there is one).

Needless to say, a trailer poses a lot fewer maintenance problems than the car that pulls it. Still, like a car, a trailer must be regularly serviced if optimum performance and safety standards are to be main-

tained. Best of all, servicing a trailer—unlike tackling many automotive repairs—is something anybody with a rudimentary knowledge of mechanics can do.

Start with the tires

Tire care. It doesn't require extrasensory perception to know when a tire—any tire—needs replacing. If either (or any) of your trailer tires are badly worn or cut, replace 'em with new ones.

Bear this in mind too: trailer tires rot faster than they wear out, because a trailer is often left "lying fallow" for long periods of time. If it's left on the greasy floor of a garage, tire deterioration will be accelerated. Gradual tire deflation will speed the process.

When a trailer is to be parked for a long time, park it on an oil-free surface, then



TO SERVICE BEARINGS: remove dust cap, cotter pin, adjusting nut, then wheel; pull bearing from spindle



USE A DRIFT to knock out inner bearing. Races of bad bearings should be knocked out and replaced too



U-Haul Rental System, Inc. photo

READY TO GO. Typical utility trailer is shown correctly loaded, with the weight concentrated at the front

jack it up (or put it on blocks) so that the tires *just touch* the ground or floor. Somehow, this slight contact with the parking surface seems to retard deterioration of the tire rubber.

Trailer tires must be inflated properly to insure safe trailering. So note this: the pressures in trailer tires must be *much higher* than the pressures you'd use in an

automobile tire of comparable size.

For example, what's the normal inflation for a 6.70-15, 2-ply car tire—26 lbs.? Maybe you go as high as 30 lbs., but no more. If you have 6.70-15 tires on your trailer, you should inflate them to 55 lbs. to insure safe towing.

The need for higher air pressure in trailer tires is fairly obvious. There is

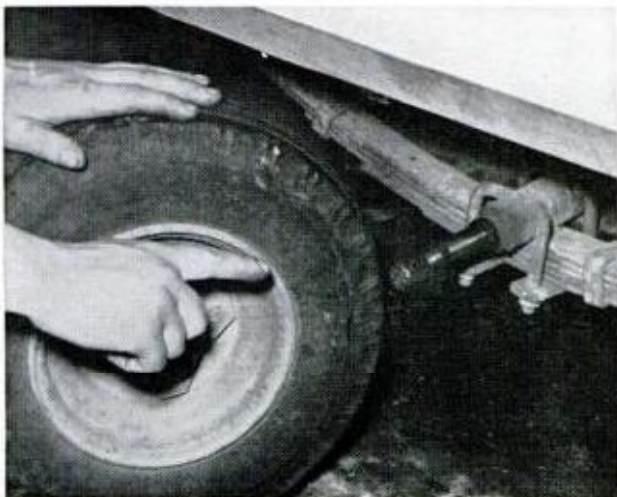

"LOOK, MA, NO BRAKES"—on the utility trailer at the left. The one at the right, however, is equipped with an inertia-type braking system; to check out its wheel cylinders for leaking fluids, pull away the rubber as shown



FRONT END of inertia brake system on trailer tongue consists of master cylinder, shock absorber, springs

generally more weight concentrated on trailer tires than there is, proportionately, on a car's tires. Higher pressures help support that weight and keep the trailer on an even keel. Too-low tire pressure can result in side-to-side trailer sway that could become violent—and dangerous—at high speeds.

TABLE II (page 166) gives the recommended pressures for various sizes of trailer tires. Check it against the tire pressure you are currently using. The inflations suggested in TABLE II should be maintained whether the trailer is loaded or empty.

Check inflation when tires are cold, and deflate overinflated tires *only* when they are cold—never when they're hot. A tire increases its pressure as it runs and in that way protects itself against heat. So don't destroy that protection.

Those all-important wheels

Wheel balance. As you read in "What



TAKE A PEEK into the master cylinder to check the fluid level. Keep an eye peeled for leaks here too

You Should Know About Wheel Alignment" (page 180, Apr. '66 PM) an out-of-balance wheel on a car affects vehicle stability and riding comfort; but if a trailer wheel goes out of balance, the rig will actually hop, especially if it's light-loaded or empty.

Trailer wheels go out of balance statically, causing the trailer to vibrate vertically. Static rebalancing of trailer wheels is done in exactly the same manner as it is for automobile wheels. A trailer wheel should be rebalanced whenever you replace one tire with another.

Wheel bearings. Under ordinary circumstances, wheel bearings should be serviced once a year. However, if you have a boat trailer which is often rolled into the water—especially salt water—these bearings should be serviced every few weeks during the boating season.

A technique for lubricating trailer wheel bearings without having to pull the wheels is to have a grease fitting tapped into each

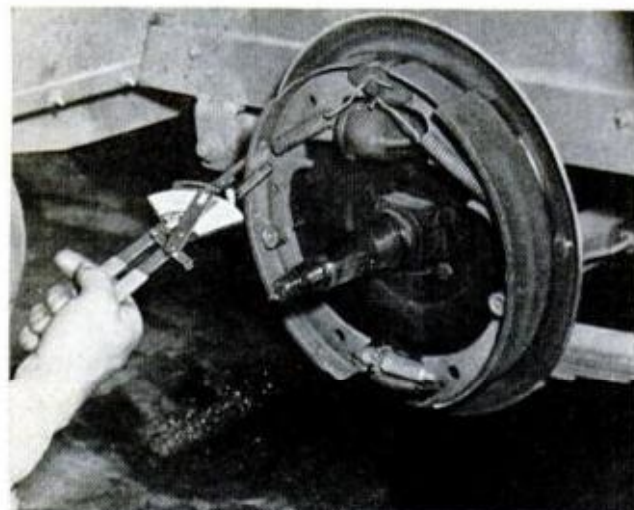

CHECK TRAILER BRAKE LININGS with a lining gauge. Replace the linings if they are less than $\frac{1}{16}$ in. thick



HOW ARE BRAKE DRUMS? If only slightly damaged they can be turned, but replace badly scored drums

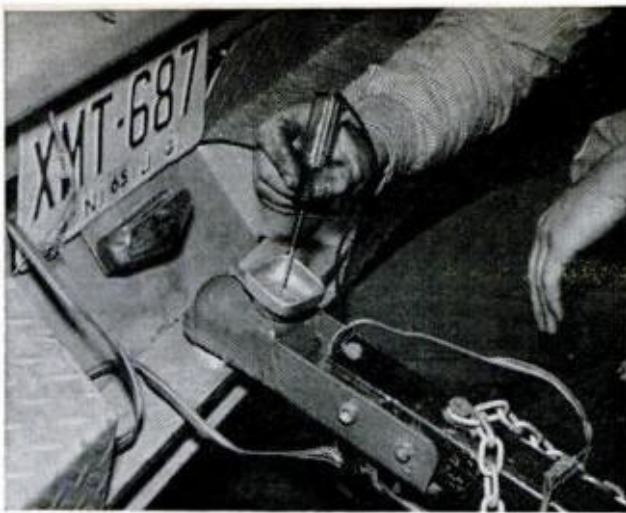

CHECK LIGHTS with trouble light. Hook to car, touch prod to trailer; if tester lights—bad ground

hub. Then you can grease the bearings with a hand gun whenever they need it.

Worn or damaged wheel bearings in your trailer will cause it to track poorly and sway from side to side like a drunken camel. When they get *really* bad they can even shear off a wheel.

To get at wheel bearings for inspection or servicing is a fairly simple job, as can be seen in the photographs at bottom of page 162. In adjusting the bearings after they've been serviced, run up the adjusting nut until the wheel's tight, then check for end play. If there is play, turn the nut tighter. When end play is eliminated, back off the nut to the next notch, then insert the cotter pin.

How's the suspension?

Springs. Make sure the springs are tight and have no broken leaves. Push the trailer from side to side. If a spring is bad and needs to be replaced, you'll notice an unusual amount of "play" as the trailer is

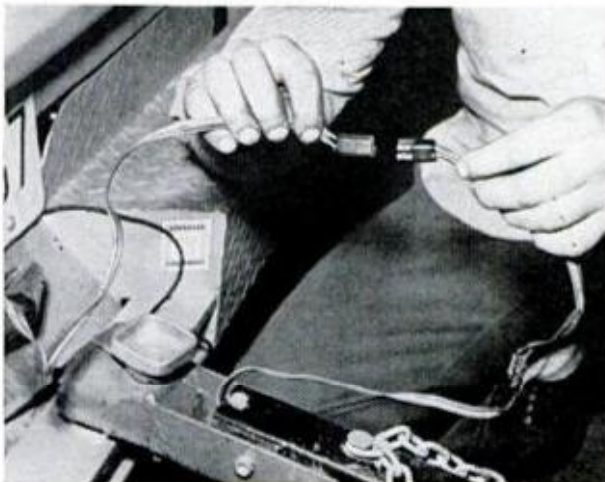

WIRING HARNESS carries current from car to trailer lights by means of simple male and female connectors

JUNE 1966

swayed. By the way, this is one trailer repair job that can be a knuckle-buster, especially if the bad spring has become "frozen" at its connections. You might be smart letting a pro tackle the replacement.

Be sure you can stop it

Brake system. Most boat and utility trailers, being relatively small, do not have those self-contained braking systems called *inertia brakes*. These small rigs rely on the braking power of the towing vehicle to stop them. However, some trailers do have these systems which tie into the towing vehicle through the ball hitch. It works like this:

As the towing vehicle slows, the inertial force of the trailer exerts pressure against the ball. This in turn forces the fluid in a master cylinder through the brake lines and thence to the wheels where conventional hydraulic principles serve to brake the trailer by activating brake shoes on the wheels.

A trailer's braking system presents a fair number of parts to check on. These include:

- The master cylinder (for fluid level and leaks).
- Shock absorbers and coil springs (for adequacy of tension).
- Wheel cylinders (for leaks).
- Brake linings (for wear).
- Brake drums (for damage, such as scoring).

Inspection and maintenance of the brake system should be done once a year. Do it at the same time you pull the wheels to check the bearings.

Don't forget the lights

Lighting system. A trailer will have three or four wires leading to it from the car. One wire will go to the trailer's tail-lights, and two to the (turning) signal lights. There may be a fourth wire for the ground, though in some trailers the ground is established by metal-to-metal contact of ball to hitch.

Trailer lights fail for any of three reasons: a bad ground, burned-out bulbs or worn wiring.

You can check the condition of the ground with a test lamp. Hook one wire of the lamp to the tow vehicle's bumper, then touch the prod to trailer metal. If the test lamp lights, you have a bad ground.

In the case of a trailer grounded through

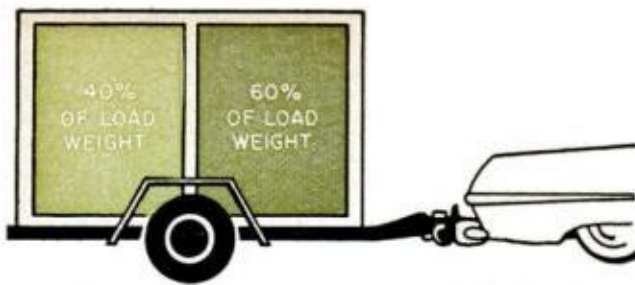

PROPER LOAD DISTRIBUTION FOR A UTILITY TRAILER

the ball, the poor ground is probably due to corrosion or dirt around the trailer's ball-and-socket hitch. Clean these connectors, using an abrasive if necessary.

If there's a ground wire, remove it at the ground connection and make sure the connector and ground-wire terminal are free of corrosion and dirt. Then reconnect it and try again. If the ground still proves faulty, replace the wire.

Trailer wires are generally supplied in harness form; thus, to replace one you must replace all. One end of the harness

TABLE I. Maximum Controllable Speeds

Trailer Size	Open Rig	Closed Rig
4' x 6' single axle	65 mph	65 mph
4' x 7' single axle	60 mph	60 mph
5' x 8' single axle	60 mph	55 mph
6' x 8' single axle	55 mph	50 mph
5' x 10' single axle	50 mph	45 mph
5' x 12' tandem axle	45 mph	45 mph
6' x 14' tandem axle	45 mph	45 mph

TABLE II. Tire Information for Utility Trailers

Tire Size	Ply Rating	Maximum Trailer* Load	Inflation
4.80/4.00-8	2	380 lbs.	30 lbs.
	4	600 lbs.	65 lbs.
4.80/4.00-12	4	790 lbs.	65 lbs.
5.70/5.00-8	4	710 lbs.	50 lbs.
	6	900 lbs.	75 lbs.
	8	1030 lbs.	95 lbs.
5.30/4.50-12	4	915 lbs.	55 lbs.
6.90/6.00-9	4	850 lbs.	40 lbs.
	6	1080 lbs.	60 lbs.
	8	1275 lbs.	80 lbs.
	10	1450 lbs.	100 lbs.
6.00-12	4	1010 lbs.	40 lbs.
	6	1290 lbs.	60 lbs.

*This figure is the maximum load that can safely be placed on each tire. Double maximum trailer load for a 2-wheeled trailer; quadruple it for a 4-wheeled trailer.

hooks into the car's lighting system; the other is connected to the trailer by means of a connector plug.

When towing a trailer at night, the importance of reliable, working taillights cannot be overemphasized. Always check them before you pull out onto the road. Also, carry a spare bulb or two and a couple of spare fuses—just in case.

... and tow with confidence

Loading and towing. A trailer must be loaded so there's a 60- to 40-weight ratio between front and back. In other words, 60 percent of the load must be concentrated at the front of the trailer so it bears on the rear of the tow car. If the load is centered over the trailer wheels or is concentrated in the rear, the trailer will tend to whip from side to side, especially when towed at high speeds.

For any trailer-towing car there is a speed beyond which the driver will be unable to control the vehicles. This limit is known as the maximum controllable speed (see TABLE I at left). For everybody's sake—your own included—*don't exceed this speed.*

Remember, too, that no matter what the maximum controllable speed happens to be for your rig, the *legal speed* for a car with trailer is *the same as the posted speed limit for trucks.*

Finally, be sure your own car is in top condition before you put it to work hauling a trailer. It just wouldn't make much sense to tow a tip-top trailer behind a ruffraff car. ★★★

AUTO TIPS

FROM PM READERS

Sandbagging a patch

- When using patching fabric, with adhesive, to repair small holes and rips in a convertible top, cover the patch with an emptied sugar or salt bag partially filled with sand. The bag will conform to the shape of the top and hold the patch in place until the adhesive dries.

Masking wire spokes

- Tired of tape-masking those wire spokes every time you want to paint the wheels? Try this: split one side of the required number of soda straws right down the middle with a razor blade, then snap a straw around each spoke (a bit of tape may be needed at the ends). When you're finished spray-painting, pull the straws off.

"X" marks the light

- Carry a roll of reflective tape in the car in case a headlight dies on you some night. Make an "X" of the tape over the darkened lens to help oncoming drivers discern which side of your car has the light, thus enabling them to pass you safely.

For easier timing

- When timing marks on an engine are difficult to read, thoroughly clean them, then apply thin stripes of luminous paint

to 'em with an artist's brush. The marks will stand out under the timing light.

Target—tar

- If wet tar from a newly covered roadway is flung against your car's finish, remove it safely by daubing the tar spots with lard. When the lard soaks in, the tar can then be wiped away.

Funneling with a tube

- A funnel is handy when you want to pour liquid additives such as valve-freeing and moisture-removing stuff into the gas tank. Otherwise, cardboard from a roll of waxed paper or aluminum foil will serve as a substitute.

To remove a stud . . .

- Here's how to remove a stud without damage to the threads: run two nuts down on the stud until the top nut is flush with the top of the stud. Lock the two nuts together firmly. With a wrench on the lower nut, turn out the stud. The two nuts are then easily removed with wrenches.

Removing dents from doors

- To remove dents from the lower half of car doors, insert a long punch or pry bar up through a water hole. Then use the bar to pry out the dents.

NEXT MONTH IN SHOP AND CRAFTS

KEEP SHARP. For efficient cutting edges, it's important to know which honing stone to use on what tool. Next month we show you how to choose and use the proper shape and grit of stone for chisels, plane blades, carving knives, sickles, shears and bits. There'll never be a dull moment around your house once you master these tips

DOCTORING A DUNKED OUTBOARD. It's bound to be a big headache, but knowing what to do from the first moment that soggy motor emerges from the water can mean the difference between minor overhaul and major disaster. It's all in next month's **PM**—from "what to do until the mechanic comes" to stripping down a wet engine

SULKY FOR YOUR ROTARY MOWER. While a self-propelled mower beats one that you have to push, it still doesn't take the walking out of mowing. This power sulky hitches on behind to help push as it lets you ride in lazy-man style. You'll find complete plans in the June **PM**

TRICKS OF AGING FURNITURE. Making furniture look old before its time is an art that can fool the most savvy collector. Beating the surface with a bunch of keys, rolling it with a broken grinding wheel and wiping it with tobacco juice are a few tricks of the trade used by the pros to "age" Colonial reproductions

Build a FANTASTIC CONELESS LOUDSPEAKER! Here are the complete plans that you asked for after reading about this amazing speaker in our December issue

HERE THEY ARE—complete instructions by William Ashworth for building one of his coneless loudspeakers (page 36, Dec. '65 *PM*), as requested by many readers. Once you have the know-how, this speaker is surprisingly easy to put together.

Some of the parts needed to build a coneless speaker may be difficult to obtain, and, for this reason, Ashworth will supply kits of parts for these speakers for \$3.95 each (see parts list on page 170 for address).

The kit will contain a C-frame (the mounting bracket) complete with the 2-inch disc spot-welded to it. It also includes the coil, which consists of 4000 turns of No. 37 enameled wire, such as Formvar. Then there are the 37 half-inch silicone steel E-laminations, the brass, gap-spacing spring and the adjusting screw with two locking nuts.

Epoxy cement and solder are also needed to assemble a speaker, but these are not provided with the kit.

Important note: In the original story we stated that this speaker would cost only 38 cents to make. This price was a manufacturer's cost when turning out several thousand units using automated ma-

chinery. Obviously, in smaller quantities the materials cost more.

Once you have the parts you need, assembly begins. Start by bending the C-frame into its final shape but do not bend the side of the frame with the disc until later. Then with epoxy cement, fasten the laminations into place. You can insert a small screw through the holes in the frame and laminations to hold them firmly in place while the cement sets. When the epoxy is dry, slide the coil onto the center shaft of the laminations. Make sure the coil leads come up from the top.

Now you can make the final bend on the frame. Then solder or epoxy-cement the head of the adjusting screw to the brass spring. Solder or epoxy the free end of the spring to the end of the C-frame fastened to the 2-in. disc. Again you'll have to wait for the cement to harden.

The next step is to put the locknuts into place but do not tighten them at this time. The speaker is now assembled. Connect it to an amplifier circuit as shown on page 170. With amplifier on, adjust the gap spacing for maximum volume with no metal-to-metal contact between the flat C-frame arm and the bottom of laminations.

This unit is designed for vacuum-tube

SILICONE STEEL TRANSFORMER LAMINATIONS (37) EPOXY CEMENT INTO C FRAME

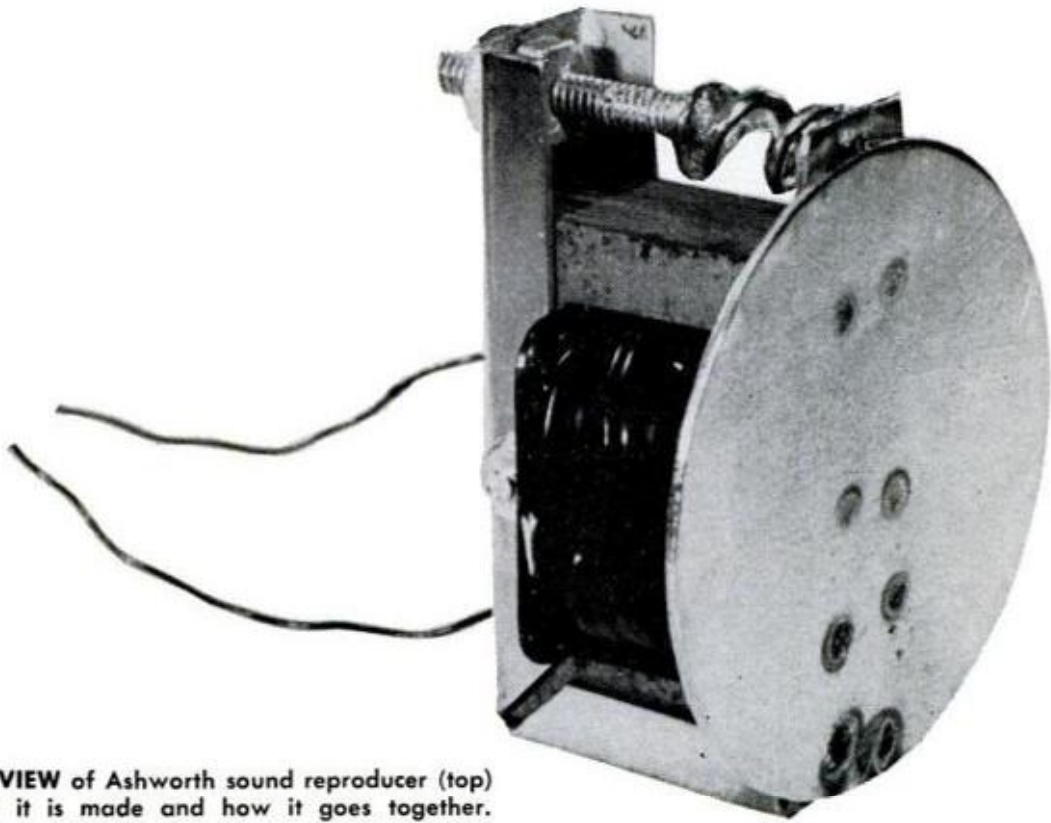
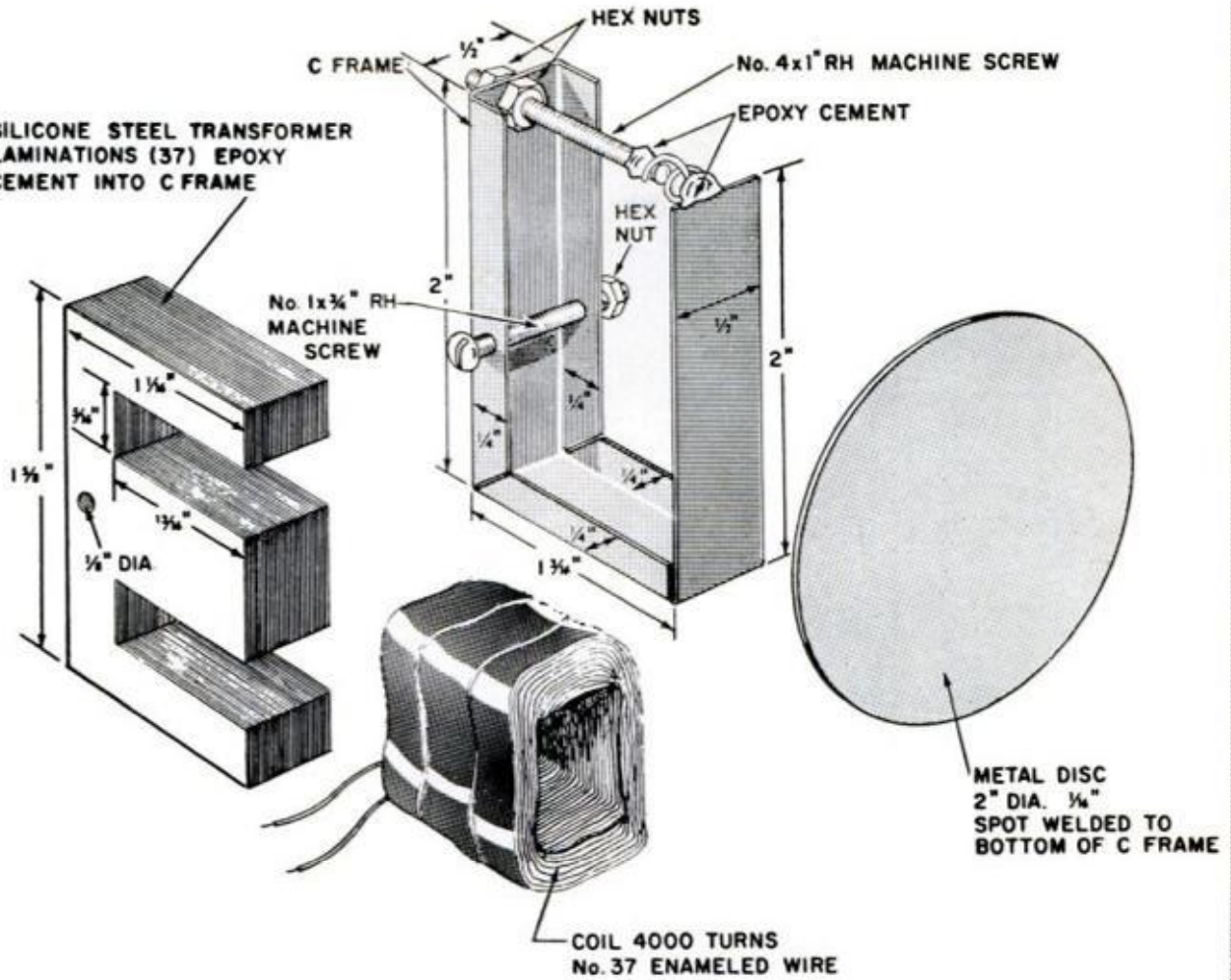

EXPLODED VIEW of Ashworth sound reproducer (top) shows how it is made and how it goes together. Laminations are glued in place with epoxy before the coil is slipped on. The sound reproducer disc is welded to the bottom leg of the "C" frame. The completely assembled speaker unit is shown at bottom right

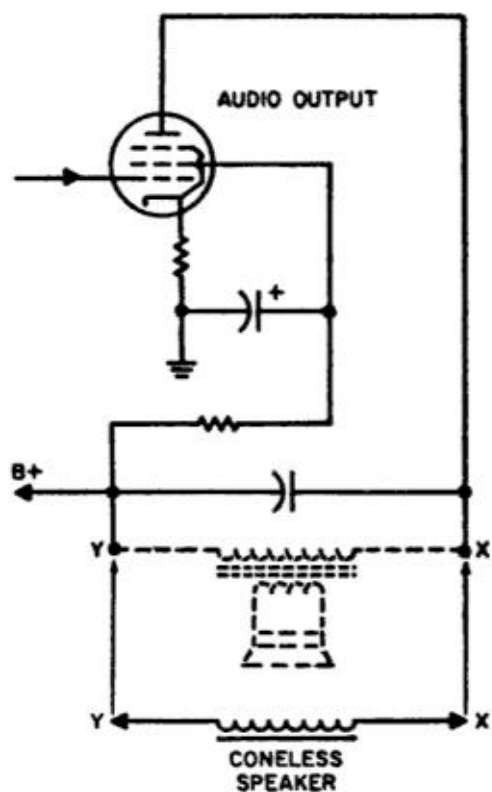

CONNECT THE CONELESS SPEAKER into an amplifier circuit following this diagram. You'll note that it replaces the primary of an audio output transformer

amplifiers and, as the schematic (above) shows, it is connected in exactly the same way you would hook up the primary of a standard audio output transformer. In other words, the Ashworth unit is connected directly between the B-plus supply line and the plate of the output tube.

How can you best use a coneless speaker? The possibilities are almost endless. Here are a few of them. Please note that in all applications the 2-in. disc is cemented to the surface you wish to use as the sounding board.

In a child's record player, cement the disc to one side of the case. This makes the entire case a sound-producing element. You'll be surprised at the improvement in the sound.

If you cement one of these units to a wood door or the rear of a large plywood panel, the entire door or panel becomes a sound-producing source. You can do the same thing with most hard materials—such as doors, mirrors, windows.

If you connect the speaker to the bottom of a coffee table, the tabletop will become a speaker.

Among early proposals for potential coneless loudspeaker applications was one

from a discotheque operator who said he could use it to turn his dance floor into one giant speaker so that dancers would then feel, as well as hear, the music. Obviously, this will take a much larger unit, but he might just be able to do it.

If a deaf person holds one of these tiny speakers in the palm of his hand, he will feel the vibrations of music and speech. (*Caution note:* Beware the high voltage. Make certain a unit so used is well insulated by wrapping electrical tape around coil, laminations and top of C-frame.) This could become a very helpful aid in teaching such people to dance and talk.

We are sure that many more possible uses for this amazingly adaptable device will come from our readers. If you discover an unusual application, drop a line to our electronics editor and tell him what you've accomplished with the Ashworth sound reproducer.

The unit that has been described here is designed to handle up to five watts of audio signal. For greater power output the entire unit must be scaled up. We have no plans or instructions for this, but here is another area open for some interesting experimentation.

Only limitation is frequency response. The top, about 6000 cycles, isn't hi-fi but it's more than ample for speech, AM radio, intercoms or a child's phonograph.

For a final word of caution: Always be certain that the leads going to the coneless speaker, as well as the speaker itself, are carefully insulated. Remember, the coneless speaker is connected in the B-plus circuit, which can carry up to 200 v. d.c.—a dangerous level of electricity.

PARTS LIST

C-frame—made from piece of 1/16-in. steel as shown in exploded view, page 169

Sound-reproducer disc—2-in. dia. x 1/16-in. sheet steel

Transformer E-laminations—37 pieces silicone steel shaped as shown in exploded view

Coil—4000 turns No. 37 enameled wire

Adjusting screw—No. 4 x 1-in. RH machine screw with 2 hex nuts

Lock nuts—No. 4 (2)

Lamination holding screw—No. 1 x 3/4-in. RH machine screw with hex nut

Compression spring—1/2-in. spiral brass

Epoxy cement

Solder

A complete kit of parts, less epoxy cement and solder is available from William J. Ashworth, Ashworth Research & Development Laboratory, Highway 78 East, New Albany, Miss. The cost is \$3.95.

ELECTRONIC KINKS



Increase tape recorder battery life. Get 8 to 10 times the recording time before a battery change is required by using a heavy-duty battery to replace the tiny 9-volt unit normally used. Or, you can make a battery from six pen-light cells connected in series. Add connectors to couple the pack to recorder and you're done.—*John W. Connors*

JUNE 1966

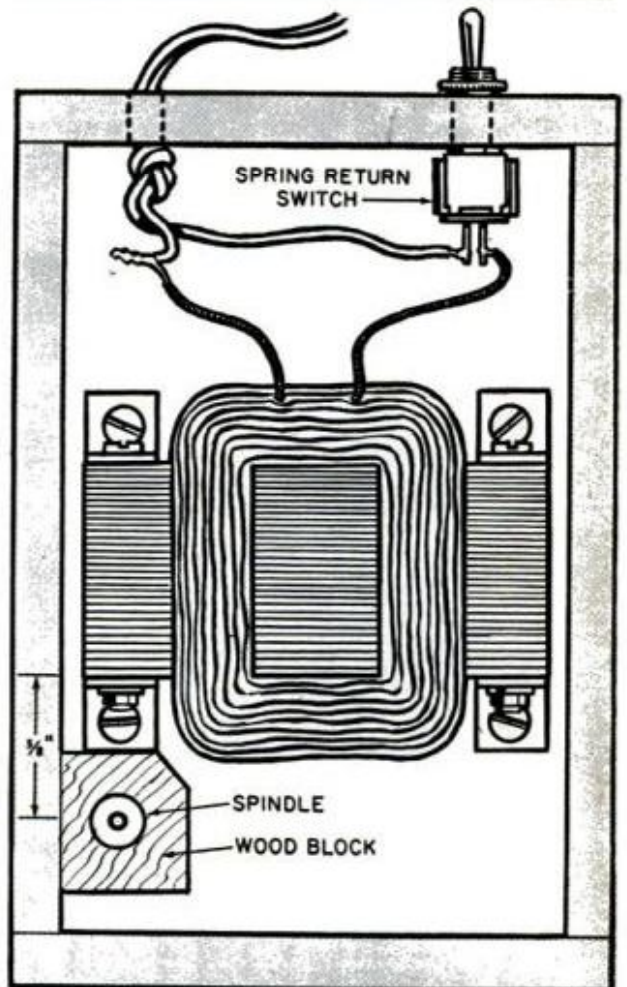
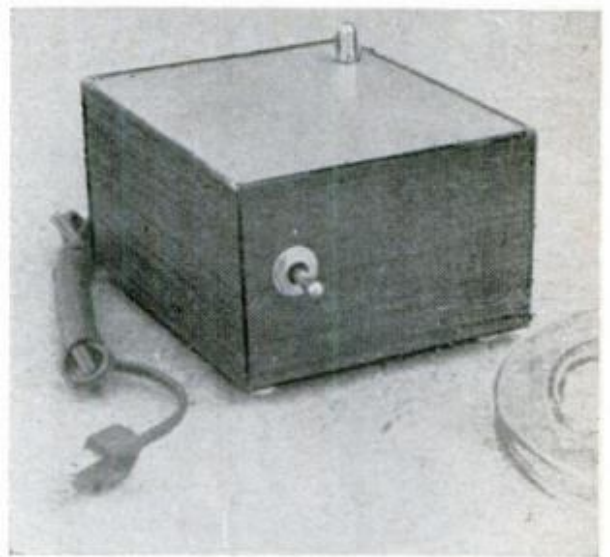

Build a bulk tape eraser. Start with an old power transformer from a TV set. Take it apart, being careful not to damage the coil. Separate the laminations; then reinsert them in the coil, making sure all are turned the same way. Fit in as many as possible. Mount in a wood box and hook up switch and a.c. cord as shown.—*Cecil H. Avery*

171

Put it in the sun and watch it spin

By Robert Bramms and Max Parnes

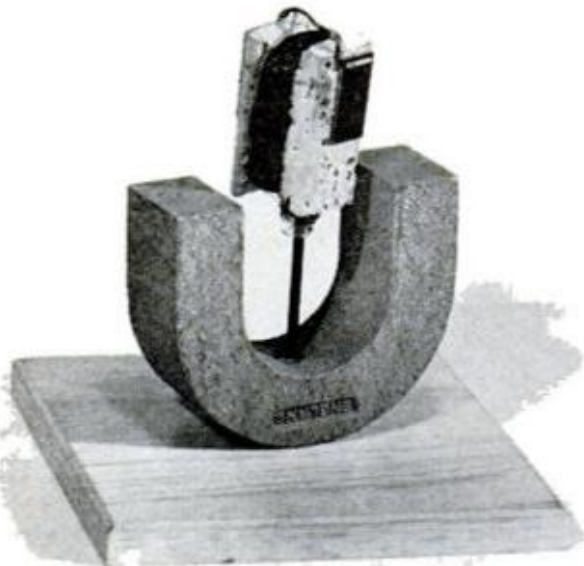

FINISHED MOTOR ready to run is shown above. Put it in direct sunlight and give it a starting spin and it goes like mad (below). Exploded view (below right) shows how it is assembled. Photocells are cemented to sides of cork. Any large heavy-duty magnet will work

POWERED BY THE SUN, this ultrasimple electric motor is easy to build and fascinating to watch in operation. Cut base about 4½ in. square from ¾-in. stock. Grind one end of a 3½-in. length of coat-hanger wire to a tapered point and drive it through the base. Drill a hole to fit the wire through head of a heavy-duty, horseshoe-type alnico magnet; place it on spike.

Now, drill a ⅜-in. hole through a large bottle cork to fit an eyedropper tube, then cut a ⅜ x ⅛-in. groove endwise around the cork and insert tube, pointed end up. Wind 350 turns of 32-gauge enameled wire in the groove and take a few turns around the dropper to hold it in place. Connect coil ends to the leads from two B2M photocells, as shown. Cement cells to opposite sides of cork, then place armature assembly over the spike.

Set the motor in direct sunlight, start it spinning and watch it whirl. ★★★

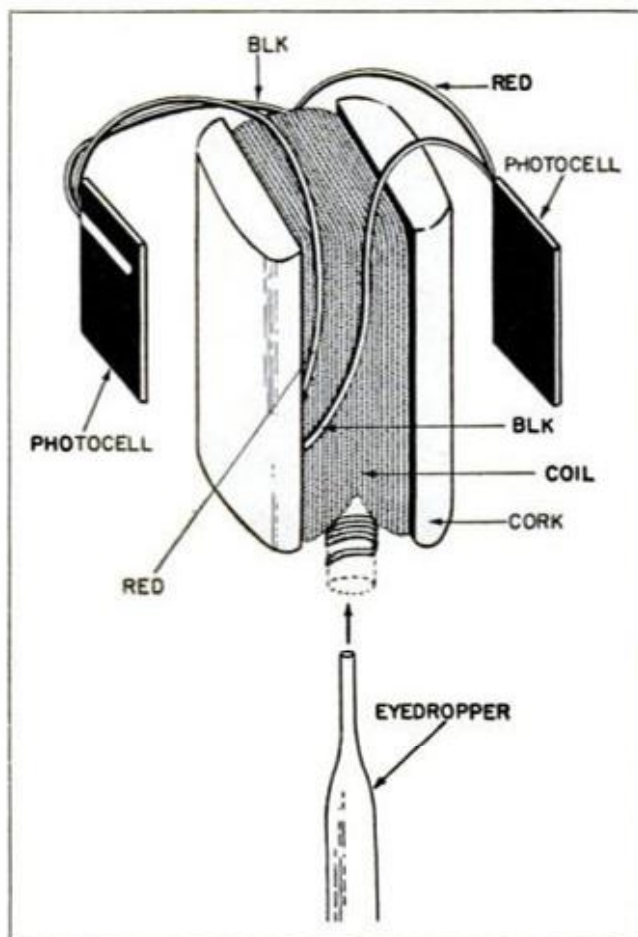
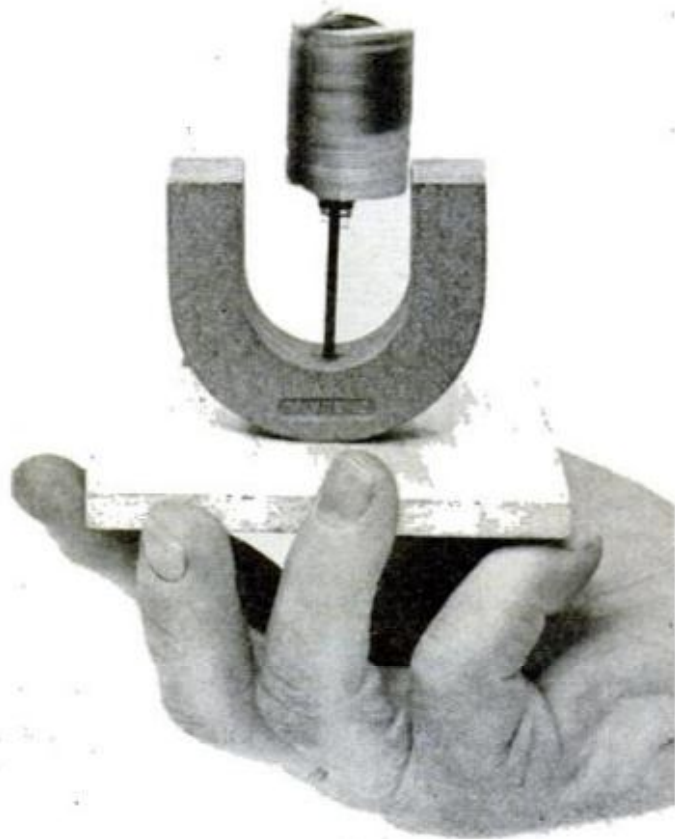



America's
#1
pipe tobacco
cigarette

**Get a pocketful of great taste
and rich aroma. Pipe tobacco
in a filter cigarette.**

(You'll like 'em fine...and that's putting it mildly!)

**Since all vans these days
are pretty much the same price,
how do you pick out the best?**

Check the name.



The most important name to you is **GMC**. These three letters stand for three things. Built, sold and serviced by truck people. That's the difference between Handi-Van and the others. A mighty important difference, you'll agree.

Giant rear doors make for easy loading and unloading. Virtually the whole rear end of Handi-Van opens up, to simplify your job.

Handi-Van's underbody has been specially treated to resist rust and corrosion. All critical joints are sealed. Rugged construction like this saves money. Also, low initial price and economical operation give you a van that'll help you make money every year you own it.

Load space galore. Handi-Van measures 211 cu. ft. inside. That'll hold over a one ton payload. 2,200 lbs. to be exact.

The engine is a 6-cylinder, 120-h.p. engineering gem. If you want more muscle you can specify a 140-h.p. work horse.

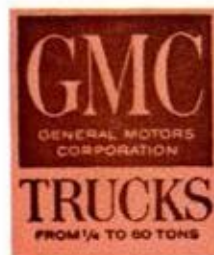

Vehicles may be shown with other than standard equipment.



3 JIGS FOR CUTTING DISCS

(Continued from page 151)

and a bench saw—or with a disc sander. The pivot-point yoke lifts off to expose a lumber roller that'll offer you a "third hand" when you're ripping long stock.

This free-standing unit must be rigidly anchored to be of service, so a heavy base is essential. I obtained the base shown on page 150 from a medical supply store; they were happy to sell it for next to nothing because it's outmoded. If you're less lucky, you can make a heavy base from scrap metal—such as a discarded brake drum—or from plumbing materials—iron pipe and fittings—increasing the weight by pouring in melted lead.

The locking screw for my telescoping stand is a short piece of threaded rod screwed into an old TV knob and turned into a tapped hole through the 1¼-in. pipe. The 1-in. pipe is attached to the base of the assembly with a floor flange.

Making your roller

If you have a readymade roller, buy whatever bearings you need to mount it. If you make a roller, as I did, you'll need bearings that will take a 1-in. dowel and that can be recessed flush with the inner face of the bracket ends. (When assembling, leave at least one of these ends unglued, in case you must disassemble at a later date.) I cut my recesses on the lathe, relieving the center so the inner race would turn freely. The roller itself was glued up of scrap hardwood discs cut on the adjustable jig and centerbored for the 1-in. dowel. I applied glue to all joint surfaces and slipped the discs on the dowel, alternating the grain direction, and allowing a 1½-in. projection at each end. I clamped this assembly until set, then centered it carefully in the lathe and turned and sanded it to a smooth finish. I turned the dowel projections to fit the bearings snugly, trimmed them to the right length and made two cuts at right angles in each end, to the depth of the bearing. After assembly, I drove a No. 6 R.H. screw through a ¼-in. hole in each end support and into the intersection of the cuts, to insure a tight fit in the bearing race.

The circle-cutting yoke consists of three pieces of hardwood. The top piece is drilled for a Teenut and dadoed for the legs. The pivot is a piece of bolt ground to a point that extends ⅜ in. above the surface. Drill a ⅜-in. hole 1½ in. deep in the bottom of each leg to receive a ¼-in. hanger bolt. For ease of assembly, drill the matching holes in the roller support ⅜ in. oversize and turn a couple of wingnuts on the bolts after you pass them through. ★★ ★

"Undercover protection for your car!"



DURO

5 New Special Agents

Just Spray On — Save Time and Trouble



At better auto accessory departments.

"No. 1" Belt Grip & Dressing.....	89¢
"No. 2" Penetrating Lubricant.....	89¢
"No. 3" Automatic Choke Cleaner.....	1.39
"No. 4" Engine D-Greaser.....	1.89
"No. 5" Auto Body Under Coating.....	1.89

The WOODHILL Chemical Corp., Cleveland, Ohio 44128

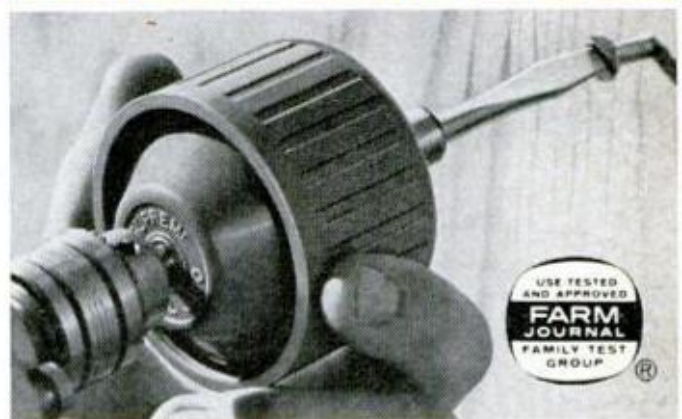

To drive screws . . . use your power drill and job-tested **VERSAMATE**

Versamate is a speed reducer made exclusively for the blister-building business of screw driving. The secret is 7-to-1 speed reduction that boosts power seven-fold and slows down the drill speed until it's perfect for sinking any screw—large or small. See your tool dealer for this \$5.95 beauty.

RIDGID
Supreme

POWER TOOL EQUIPMENT

THE RIDGE TOOL COMPANY, ELYRIA, OHIO, U.S.A.

Mr. Clifford Turkel has a prize-winning idea



Using the curved rim of the can to remove excess paint will quickly ruin your brush. The simple, prize-winning solution to longer-lasting brushes: stretch a heavy rubber band over the can!

Anyone can win in the Schenley Household Hints Contest.

Mr. Clifford Turkel of Newburgh, N.Y. won the first prize of a De Walt Radial Arm Saw in the Schenley Household Hints Contest. Every month Schenley will award five prizes for the best money-saving, time-saving, do-it-yourself ideas. Here are the other prizes and winners in this month's contest:

2nd prize: Ansco Camera Kit—Mr. R. J. Deah, Streator, Illinois.

3rd prize: Melnor Lawn Sprinkler and Reel—Mr. R. A. Kelso, Paulion, New York.

4th and 5th prizes: Power Hand Saws—Mr. H. D. Whittle, Greenwich, Connecticut and Mrs. Beatrice E. Wheeler, Chicago, Illinois.

Send your ideas today to the Schenley "House-Hold-Hints" Contest, Contest Manager, Room 1303A, 10 E. 40th Street, N.Y.C. Entries must be postmarked no later than midnight, June 30, 1966 to be judged in this month's contest. All ideas submitted become the property of Schenley Distillers Co., and all decisions of judges are final. Offer not made to minors or residents of states where illegal.

Schenley tip for home bartenders:
Don't run out of ice at your parties. A good gauge is to have 1 pound of ice cubes on hand per guest.



BLENDED WHISKEY, 86 PROOF. 65% GRAIN NEUTRAL SPIRITS. ©SCHENLEY DIST. CO., N.Y.C.

OVER
300
DIFFERENT
MOLDS

you can use to
make and sell
YOUR OWN
ORNAMENTAL
CONCRETE ITEMS



Get
The Full Story



SEND \$2.00

CONCRETE MACHINERY COMPANY, INC.
839 Lenoir Rd. - P. O. Box 99 - Hickory 2, N. C.

BASEMENT TOILET FLUSHES UP



TO OVERHEAD SEWER OR SEPTIC TANK.
NO DIGGING UP FLOORS. Write
McPHERSON, INC. BOX 15133 TAMPA, FLA.

PLAY GUITAR IN 7 DAYS OR MONEY BACK



TOP GUITARIST ED SALE'S famous 66 page secret system worth \$3.00 teaches you to play a beautiful song the first day and any song by ear or note in seven days! Contains 52 photos, 87 finger placing charts, etc. plus 110 popular and western songs, (words and music): a \$1.00 Chord Finder of all the chords used in popular music; and a \$3.00 Guitarist Book of Knowledge.

TOTAL VALUE \$7.00 \$2.98
—ALL FOR ONLY

SEND NO MONEY! Just your name and address, pay postman: \$2.98 plus C.O.D. postage. Or send \$3.00 with order and I pay postage. (Sorry, no C.O.D. outside Continental U.S.A.—please remit with order).

Unconditional Money-Back Guarantee
ED SALE Studio 153-G AVON BY THE SEA, N. J.

Liquid WRENCH

LOOSENS RUSTED NUTS, BOLTS, PARTS IN SECONDS
at Service Stations, Auto and Hardware Stores
RADIATOR SPECIALTY COMPANY, CHARLOTTE, N. C.



A PROFITABLE NEW PROVEN BUSINESS

Engrave plates such as door and desk plates, badges, identification plates, special signs, etc.—is simple, interesting and profitable. Businessmen, homes, office, factories, stores, boat owners, campers and many others require engraved plates and become a source of profit for you in your spare time. You can easily fill order after order for name plates with the SM-100-2 ENGRAVER (size 13" x 13") the machine that makes you a professional at this work. Puts extra dollars in your pocket the year around. Get details at once. Write today.

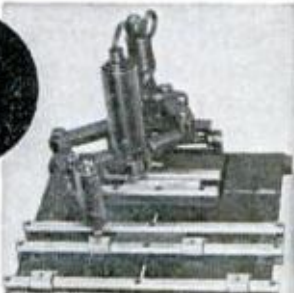

SCOTT MACHINE DEV. CORP.

215 Prospect Ave., Dept. PM-6
Walton, N.Y. 13856

FREE

WINDOW PLANNING IDEAS

to help you make your home more beautiful, more valuable. Send today for new, full-color folder packed with illustrated ideas and a complete description of the Andersen Window line.

(Clip and mail today!)



I plan to build. PM-66
 I plan to remodel a _____

Mr.
Mrs. _____

Address _____

City _____ State _____

Andersen Windowalls TRADEMARK OF ANDERSEN CORPORATION
Andersen Corporation • Bayport, Minnesota

Get more
POWER with
a big (MAN'S)
motorcycle!



BSA LIGHTNING

Excitingly fast BSA 40 cubic inch twin! Rocket-like acceleration without constant gear shifting. Big, muscular power and confident handling. See the LIGHTNING at your BSA dealer!

BSA MOTORCYCLES

Write to the nearest factory branch for free catalog of all the new 1966 BSA models. (Catalog offer limited to U.S. residents.)

WEST: **BSA MOTORCYCLES-WESTERN**
Dept. N, 3074 Broadway, Oakland, California 94611

EAST: **BSA MOTORCYCLES Incorporated**
Dept. N, 639 Passaic Avenue, Nutley, New Jersey 07110

WANDERING FARMS

(Continued from page 97)

dry, which allows even the small amounts of discharged water to soak usefully into the land instead of running off.

In addition to conserving virtually all the water that falls on the land, HILE obviously prevents soil loss. Soil may shift over the surface, but it never leaves the field. In fact, HILE almost always adds soil to fields as rain washing off uncontrolled lands deposits soil behind the dikes.

Shook up by lake

Simple and effective as the system is, seeing it work for the first time can be unnerving. One farmer, who had hired Karch after inspecting installations on other farms, watched with satisfaction as the big yellow earthmovers completed work on his land just hours before the onset of a rain that was to last a full day. When the weather cleared, he went out for a look. "My first thought was that Karch was a dangerous nut who had to be done away with," he recalls. "I had 80 acres under water—as high as four feet near the dikes. I rushed to the phone and told him to get his tail out here and look at the mess he'd made. He said he'd be out first thing in the morning.

"By the time he arrived, I'd cooled down some. I wasn't going to shotgun him on sight anymore, but I was thinking of drowning him in the swamp he'd made of my field. But when we got there, the water was gone, and there were a whole series of ridges where my neighbor's topsoil had dumped on my land."

Karch installed his first structure in 1945, and has since made more than 200 other installations, all in central Illinois. All are still in use, and all have substantially improved the value of the farms on which they were installed.

Despite the success and growing acceptance of his work, Karch still faces what appears to be implacable opposition by the Soil Conservation Service. Karch's patents allow him to license his work to be done by other engineers for a royalty—though no licensed work has been done to date—and the SCS maintained for years that it could not properly comment on the value of a privately held patent.

After a decade of pressure from interested farmers, however, the SCS did send teams around to inspect HILE work in 1964, and report on their findings. The report, which was never made public, is said to draw some scary conclusions about the cost and value of HILE installations, and to make assertions about

maintenance on HILE structures, claiming in substance, that they erode in the rain and are in constant need of repairs. The only maintenance that the structures have ever required, according to Karch, is an occasional clearing of the discharge pipes with a long stick when small animals nest in them.

Opposition from the SCS is as serious as it is inexplicable, since this agency virtually controls farm conservation through subsidies it pays farmers for following approved practices. No subsidy money has ever been paid for Karch work. However, there is such a growing and outspoken group of satisfied Karch customers that the interest of several Midwestern water engineers has been attracted. All have agreed substantially with the opinion of Tom Blair, former chief engineer of the Santa Fe Railway, who studied Karch's work a decade ago as a possible means of reducing the railroad's extensive bridgebuilding needs.

"There is absolutely no doubt that Karch is doing everything he claims," says Blair. "Anybody who says HILE doesn't work doesn't know engineering."

Dry but happy town

A significant HILE side effect shows what it might accomplish in still another area. A paved farm-to-market road near Harristown, Ill., used to wash out after every rain along a low point that drains 500 acres of watershed—less than two square miles. In the late 1940s, the state took matters in hand and put in a small highway bridge—actually a 9½ by 5-foot concrete box culvert with related structures. That helped. The road now washed out only after heavy rains. Then, in 1952, the farmer who owned the land bordering the road engaged Karch to give his field the HILE treatment. The huge, \$10,000 culvert has been dry and overgrown ever since. The Karch pipe that has drained all the water running off the land for 13 years has an 8-inch diameter. No one remembers the last time it discharged a noticeable amount of water.

Speaking from dozens of similar experiences, Karch claims: "If HILE were installed wherever it could and should be—which is wherever land slopes, the entire uplands—it would reduce the flow of water under inland bridges by as much as 90 percent. The savings on bridge costs alone would more than pay for the work. The increase in productivity and value of the land treated would be astronomical."

Broad as the statement is, it is difficult to argue with it on a rainy day, standing in a dry culvert that used to funnel torrents of muddy water to the sea. ★★★



RALLY 'ROUND THE FUN WITH **YOUNG AMERICA**

Get on a Harley-Davidson Sportcycle and get with the In Crowd! Rally 300 swingin' miles between gas pumps. You're free as a breeze for pennies a week. Quality? We wrote the book! Dellorto carb, Pirelli tires, full lighting and brakes, easy handling. You get more for your money now, more for your bike later with Harley-Davidson's better trade-in value. Five models from 50 cc. to 250 cc. starting around \$225. Low-cost financing and insurance from your dealer. See him for the action time of your life. Now!

HARLEY-DAVIDSON



50 cc. models start around **\$225**

HERE COMES MR. PARADE

(Continued from page 87)

a parade and buy a float right on the spot for one of the big carnival parades in Cuba or some other country."

By then Vaughn also was supplying materials to the Kentucky Derby and Indianapolis 500 parades. Foreign countries were seeking his floats, his advice or his materials.

"Guam became a steady customer. We still aren't too sure what they do there, but they apparently love parades. We also sell to New Zealand, Liberia and about a dozen other countries. Venezuela is a good customer.

"Once a four-engined bomber from a Caribbean country landed at the Minneapolis airport and a lot of men came over waving cash. They bought a whole planeload of parade materials. We still don't know what they did with them.

"Another time, before Castro—and even before Batista—we sold \$25,000 worth of materials to people in power in Cuba. Later I saw a notice in the Havana paper that the materials had cost \$200,000. Somebody was making a lot more money from my parade material than I was."

It was during those days that Vaughn became one of the biggest automobile owners in the country.

Large old cars best floats

"I bought Packards, Pierce Arrows and Cadillacs by the dozens. They were old ones, usually 1928 to 1932 models. They had especially big frames and big running boards. We cut the bodies off and built mammoth floats around them, using the running boards for supports. I owned perhaps 100 cars. If I only had them now. Today, people pay a couple of thousand dollars each for such cars. I paid \$35 to \$50.

"Now there are special tractors for parade floats, and some people build special frames around modern cars. But modern cars tend to heat up at slow parade speeds, especially if the radiators are covered over with decorations."

Eventually Vaughn began drifting into the production of materials for parades. Such materials—plus consultation with city officials who need advice on how to put on a parade—are his mainstay today, although he also produces Christmas decorations.

About three quarters of the second floor of his factory could be called the "animal farm," although its official title is the papier-maché department. There, craftsman and laborers produce gargan-

tuan roosters, bulls, heifers, pigs, buffalo, horses, camels and eagles. You can also spot globes, ears of corn, maps, huge hats, snowmen and airplanes, all designed for floats.

The main floor of the factory is a tinkerer's paradise. One machine slices through a huge stack of tissue sheets so thin each is almost transparent—the cut must be so clean that it doesn't crinkle the delicate paper. Each tissue cutout then is glued to a cloth backing and moves through a drying oven. The end result is the backbone of the parade-float business—floral sheeting. Vaughn ships big rolls of it all over the world.

Another Vaughn machine is fed long rolls of colored cellophane. Dies come down under pressure and produce dozens of cuts. The result is a spine of cellophane that has tiny, flexible strips that come alive in the breeze when they are stapled to a float.

From crowns to camels

Hanging from the ceiling of the factory are an Alaskan dog sled and six huskies—papier-maché, of course. Thousands of flags are stored in racks. Workers paint simulated rockets, daub colorful spots of blue on an Uncle Sam, and package the end results for towns in the farthest reaches of the world.

The Vaughn parade productions are shipped to about 500 professional builders of parade floats and thousands of amateurs. In the company's catalog are listed such diverse items as "jeweled" crowns for queens, polyethylene daffodils, flameproofing compounds, five-foot-high ice cream cones, six-foot-high cacti and seven-foot-high camels.

"Mr. Parade" has traveled about a million business miles—the equivalent of 400 times around the world—much of it by truck and trailer. Now he is beginning to change his way of living. "I read philosophy and history a lot today," he says.

But even in his glimpses back through history he can't get away from his first love. "They had the equivalent of an Orange Bowl parade back in Babylon," he points out. "It must have been a challenge to decorate a float those days!" ★★

Deep-diving buoy

A new Navy buoy dives to pre-programmed depths as low as 20,000 feet, takes readings on undersea noise, temperature and other conditions, records them and then rises and radios its location so it can be recovered. Only moving parts are a tape recorder and fluid valves. The Navy will use it in underwater research.

Want a light ski engine for the kids plus a tough fishing motor with a 2-year warranty for yourself? Solution: the new Sea-Horse 20

Pizazz it has! This biggest of the Sea-Horse Compacts now packs 10% more horsepower. Hold your hat when you hit it because acceleration is up.

This has to be one of the best buys in the line. Combines real power with real portability. Weighs just 17 lbs. more than the Sea-Horse 9½! For the kids' ski needs, with a proper boat and a special accessory prop, it's plenty big without being too big. And for

fishing, it's fast enough to open new, farther off grounds. If you've been eyeing a pontoon boat, here again it's ideal.

Like all '66 Sea-Horse engines, the new 20 thrives on a 50 to 1 regular grade gas-oil mix. This not only lengthens plug life 50%, it saves you enough on oil in one year to pay for your oil the next. Among the 20's other virtues

are hospital quiet, thermostatic cooling, full gear shift and a fuel pump so efficient it eliminates vapor lock. There are 16 new Johnson engines this year in 10 power classes. The man to see is your Johnson dealer. He's in the Yellow Pages. P.S.

Johnson also makes a full line of Johnson Boats and Johnson Skee-Horse snowmobiles.

From 3 to 100hp, every '66 Johnson features:

- Famous 2-year warranty*
- Full corrosion protection
- 50 to 1 gas-oil mix

*For 24 months after purchase, Johnson Motors will replace, without cost to the original purchaser, any part of its manufacture which upon inspection proves to have failed in normal use due to faulty material or workmanship.

first in dependability

Johnson

Johnson Motors, 2173 Pershing Road, Waukegan, Ill. Division Outboard Marine Corporation



ELECTRIC GARDEN TOOLS

(Continued from page 129)

metal retainer found on the bottom of the handle. Then remove the handle from the tool so that the wires are exposed. You'll see four wires—two from power line to switch, and two from switch to motor.

In older model tools, the wires are removed by loosening or removing the screws that hold them. The more modern units use spring-type retainers as wire connectors. These will release the wires when a nail or awl is used to probe the vacant slot adjacent to each wire where it leads into the switch.

When installing a new wire—these wires are color-coded—connect the new leads to the same terminals to which were attached the color-coded counterparts they replace. To secure each lead, simply push it into its retainer clip with a nail.

Bearings wear out too

Occasionally you'll rev up one of these garden tools and it'll sound like a shook-up cocktail shaker—amplified. This is its subtle way of announcing a bum bearing. You can verify this trouble by jiggling the armature in the bearing. If "jiggle-able"—that's it. Most of these tools have

press-fitted bearings, so to replace a bearing the entire cover must be replaced.

The cutting blades of many types of power garden tools are self-sharpening and self-cleaning, thus eliminating this particular servicing chore. Double-edged hedge-trimmer blades are an example of the self-sharpening type. When these blades seem to lose their cutting efficiency, you simply tighten down on their tension screws to get them shearing again. The natural rubbing action of the blades keeps them sharp.

However, some types of blades do require sharpening—the *movable* blade of a single-edged hedge trimmer, for instance.

Remove this blade and brush it clean. To sharpen it, clamp the blade horizontally in a vise, teeth up. Using a file held flush against the beveled cutting edge of the teeth, give each tooth one long, steady stroke while moving the file toward the pointed end of the tooth. One pass with the file is usually sufficient, though two passes may be required for badly dulled blades.

Rotary blades are usually found on edgers. If these are gouged or heavily nicked they should be replaced. Otherwise, they can be sharpened on a grinding wheel. ★★★

How to pick the right glue to do the job right!

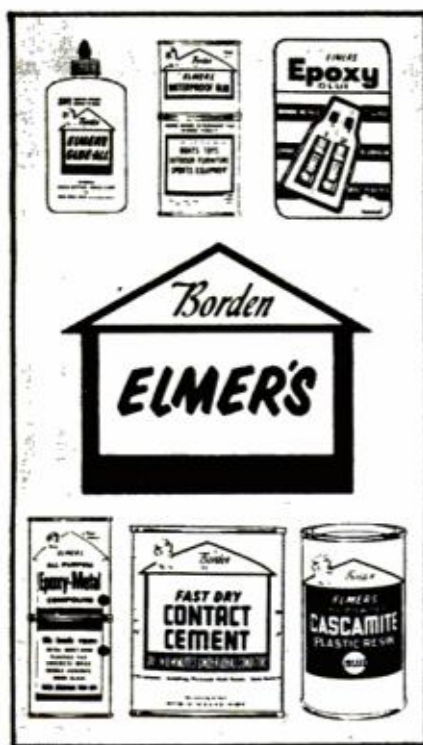

1. Look for the name—ELMER'S

2. Send for this FREE BOOKLET

It tells you how to match the right glue to the type of job and the kind of material...so that you get a perfect bond every time. It gives you scores of tips to make gluing faster and easier. It's yours if you'll just send a stamped, self-addressed envelope to: The Borden Chemical Company, Dept. M-2, 350 Madison Avenue, New York, N.Y. 10017.

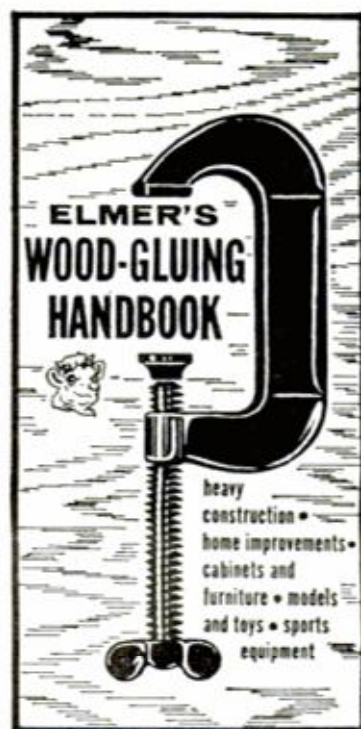

 BORDEN
CHEMICAL



Old Volkswagen Station Wagons never die.

The things some people can do with an old box.

But then, he didn't start with any old box.

He started with a Volkswagen Station Wagon.

Which has about twice the amount of space as an ordinary station wagon.

There was room for everything.

A refrigerator, a stove, a table, an instant chili dispenser, and of course, the proverbial kitchen sink.

And a way for it all to get in. The two side

doors open into a huge 4' by 4' hole.

Also, its roof may be high compared to other wagons, but its overhead is low. Our Standard VW wagon costs only \$2,337.*

However, if you're planning to go into the restaurant business, better not buy one new. (The body's been welded into one solid piece of steel, the tires alone will last for 35,000 miles, and on top of everything else, there are four coats of protective paint.)

It'll take too long to get a new one into bad enough shape.



If you've never driven this pickup...

You'll quickly notice that the engine works smoothly, powerfully—whether it's our famous 6, V-8 or 4. And you can believe what our man says about economy.

It's quieter than ever because there's a new acoustical headliner in the cab. A balanced drive line reduces vibration. Improved clutch linkage lessens pedal effort.

The ride on the highway is so gentle you may wonder how it behaves when the going gets rough. No worry. INTERNATIONAL® knows how to build the frame,

springs and shocks to take almost anything.

For the ultimate in pickup luxury, ask about the plush cab interiors we offer. Extras like padded dash and door panels, nylon carpet on the floor, colorful seat upholstery—a lot of things that'll make you want our pickup for a second car.

See your INTERNATIONAL Dealer soon. He can add much more to this story. And it'll have a surprise ending—prices are less than you'd think.

INTERNATIONAL HARVESTER CO.
CHICAGO, ILLINOIS



...your International dealer can show you what you're missing

LUXURY LIMOUSINE

(Continued from page 118)

jazzed-up lids; running boards; bullet-proof bodies (about which no one likes to talk except to say they exist); installation of photochrome glass that looks clear but grows darker as the sun grows brighter, and removable tops for cars to be used in parades and the like. Interiors have ranged from the Papal car with its hydraulic throne to a number known around the shop as "The Funeral Special." Sold to an undertaker, it is painted a dignified black but upholstered in ear-shattering scarlet.

With standard equipment, the limo sells for a neat \$14,666.66. With modifications, there is no price limit.

Biggest surprise is growth

The biggest surprise the young company has had to date is the rate at which it has grown. Having converted just two 1963 models—both for testing—they produced 15 1964s and 85 1965s. They expect to convert about 200 of the 1966 model. Their plant has grown from a two-car garage on Chicago's West Side to three substantial buildings. Staff has increased from four to 45. Panels, floor pans and other parts for the stretched car, once handmade, are now ordered from suppliers and inventoried.

From every indication, the growth will continue, too.

"You could reasonably say that people are standing in line for the car," says Lehmann. "Our backlog of orders varies at different seasons, but the trend is unmistakable. We're just not stretching cars fast enough." ★★★

This unsteady earth

Slight wobbles in the earth's motion as it revolves around the sun caused the climate changes, known as Ice Ages, which now have been quite accurately charted for the last 200,000 years. Reporting on his new theory, Dr. Wallace S. Broecker of Columbia University's Lamont Geological Observatory, asserts that it also explains the high level of glaciation that occurred some 19,000 years ago.

Dr. Broecker's theory assumes that the interaction of temperature levels between the atmosphere and the ocean has only two stable states—glacial or interglacial. Rapid transitions between these states are triggered when solar radiation levels are at their highest. However, fluctuations about either of these two stable states occur in response to smaller changes in radiation not large enough to cause the rapid transitions.



would
your tires
be
safe at
100 mph

The Dunlop Gold Seal is certified safe at 100 mph. So you're safe at 60, 70, or 80. And yet the Gold Seal is popularly priced.

And there's more safety to the Gold Seal.

? It has treads on the sides. Safety-Shoulders. They take the fight out of a tight turn, carry you smoothly up and over center lines or road shoulders without a lurch. They're patented*.

Then the Gold Seal has what tire men call a low profile. That means a 15% larger footprint area. More of the Gold Seal's wide tread is always on the road for better traction, greater safety, more miles of wear.

Doesn't the Gold Seal sound like a choice tire for a change? Drive carefully to your nearest Dunlop man. He's listed in the Yellow Pages.

Every Dunlop tire meets or exceeds every official specification for safe performance.

*PAT. NO. 3,024,825



DUNLOP  . . . means quality in golf, tennis, and tires.
BUFFALO, NEW YORK

NEW DREMEL ELECTRIC ENGRAVER

with
solid carbide
engraving point



Permanently marks any material

This new compact Dremel permanently engraves names or identification numbers on steel, copper, brass, silver, aluminum, glass, wood, plastic. Handy for marking tools, personal and business valuables, jewelry, industrial tools and dies — anything requiring permanent identification. Weighs only 7 ozs. Exclusive calibrated stroke adjustment regulates depth of engraving. Solid carbide engraving point. Diamond points also available.

See your dealer or write for literature.

Model 290 with molded storage case . . . **\$14.95**

DREMEL MFG. CO.

Dept. 86-F

Racine, Wisconsin

FIX ANY CAR FAST!

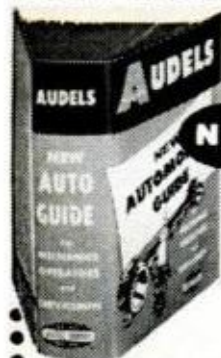

with the
1966 AUDEL

NEW AUTO GUIDE

**STEP-BY-STEP REPAIR GUIDE
COVERS EVERYTHING:** Trouble-shooting—unique symptoms-and-causes charts • Tune-up • Spark Plugs • Batteries • Distributors • Ignition • Starters and Generators • Lighting • Brakes • Front Suspension • Steering • Wheel Alignment • Chassis, Springs and Shocks • Fuel Pumps • Carburetors • Cooling Systems • Lubricating Systems • Pistons and Rings • Crankshafts and Connecting Rods • Camshafts • Valves • Transmissions, etc. — **ABSOLUTELY EVERYTHING YOU SHOULD KNOW TO FIX ANY CAR!** Illus. 736 pages, only **\$6.95**

ONLY \$6.95

FREE 10-DAY TRIAL • SEND NO MONEY

THEODORE AUDEL & CO. Since 1879 P-66
4300 W. 62nd St., Indianapolis, Indiana 46206

Please mail me the 1966 Audel Auto Guide for 10 day **FREE EXAMINATION**. I agree to mail \$3 in 10 days and the remainder of the purchase price, plus shipping costs, the following month. If I'm not completely satisfied I may return the book.

**MAIL
COUPON
TODAY!**

Name _____

Address _____

Employed by _____ I have bought Audel books before

SAVE SHIPPING COSTS. Check here if you enclose complete payment (plus sales tax, if any) with order. We pay postage. Same return privilege.

Painful hemorrhoids?

All too often, humans who sit and stand pay the price of vertical posture. Sitting and standing combine with the force of gravity to produce extra pressure on veins and tissues in and around the rectal area. The result may be painful, itching or burning hemorrhoids.

The first thought of hemorrhoid sufferers is to relieve their pain and discomfort. However, of the products most often used for hemorrhoids, some contain no pain-killing agent at all... others have one too weak to provide necessary relief... and still others provide only lubrication.

Now at last there is a formulation which *concentrates on pain*. It actually has over 8 times more pain-killing power than the topical anesthetic most commonly used in hemorrhoid remedies. 8 times the power to ease the itching, pain, and burning of hemorrhoids.

The name of this product is Nupercainal. Nupercainal starts to work *on contact*. Provides *prolonged* relief from pain. Soothes and lubricates.

When you suspect you have hemorrhoids, check with your doctor. If hemorrhoids are the cause of your discomfort, chances are he'll recommend Nupercainal.

Nupercainal is available without prescription at professional pharmacies everywhere. Ask for ointment or new suppositories with free pocket-pack. (Say New-per-cane-all.)

Nupercainal®

over 8 times more pain-killing power



**If FALSE TEETH
get on nerves**
use special powder

When false teeth get on your nerves, many dentists give special **FASTEETH Powder**. It helps hold teeth in place—helps keep them from slipping or dropping so you feel more secure. **FASTEETH** cushions tender gums so you can bite harder, eat faster with greater comfort. **FASTEETH** helps you speak more clearly without embarrassment. It checks "plate odor." Dentures that fit are essential to health. So see your dentist regularly. Get **FASTEETH** today at all drug counters.

ARROW T-50
ALL PURPOSE
STAPLE GUN

HEAVY DUTY



Model T-50
\$12.50

Uses 6 Staple Sizes — 1/4" to 9/16" and Ceilite™

OTHER MODELS FROM \$4.95

SHOOTS A STAPLE WHEREVER YOU'D DRIVE A NAIL!

FASTER! CHEAPER! BETTER!

for 1001 Home Improvement Fastening Jobs: Ceiling Tile, Insulating, Upholstering, Screening, etc.

Available at hardware, lumber, building supply, stationery and other retail outlets.

ARROW FASTENER CO., INC.
One Junius Street • Brooklyn 12, N. Y.

hallicrafters new CB-12 citizens band transceiver gives you

maximum effective range



greater talk power... far less noise... 12 channels... only \$179.95!

Dual conversion receiver • Sensitivity less than 1 μ v. for 10 db/SN • Jack for external speaker or "loud hailer" • Full-time noise limiter • 3.5 watts audio output • Insignificant battery drain • Illuminated channel selector • All-solid state



Write today for full specifications.

hallicrafters
Dept. 7, 5th & Kostner Aves., Chicago, Ill. 60624

"Quality through Craftsmanship"

TABLE-TOP CAR RACING



FIRST AUTHENTIC GUIDE to the exciting new indoor sport that is sweeping America!
GRAND PRIX RACING IN MINIATURE

TABLE-TOP CAR RACING

A POPULAR MECHANICS BOOK
by Richard F. Dempewill

A Popular Mechanics book tells how the fun started . . . how you can build the scale model cars, realistic track and scenery . . . and how to race these free wheeling little cars in a wide variety of scale sizes.

It is all here including a list of manufacturers of parts and components. \$4.95 plus postage. Popular Mechanics Books, 575 Lexington Ave., New York, N.Y. 10022

Check the Kind of Body You Want

Charles Atlas . . . and I'll Show You How **EASILY** You Can Have It!

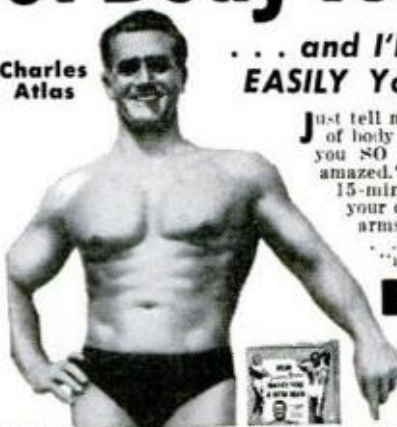

Just tell me, in coupon below, the kind of body you want—and I'll give it to you **SO FAST** your friends will be amazed. "Dynamic-Tension," my easy, 15-minute-a-day method, will make your chest and shoulders bulge . . . arms and legs surge with power . . . your whole body feel "alive!"

FREE BOOK Learn how I became "World's Most Perfectly Developed Man"—Mail coupon! **CHARLES ATLAS**, Dept. 8F, 115 East 23rd Street, New York City, N. Y. 10010

CHARLES ATLAS, Dept. 8F, 115 East 23rd St., New York, N. Y. 10010

Dear Charles Atlas: Here's the Kind of Body I want:

(Check as many as you like)

<input type="checkbox"/> Broader Chest, Shoulders	<input type="checkbox"/> Powerful Arms, Legs, Grip
<input type="checkbox"/> More weight—Solid—	<input type="checkbox"/> Slimmer Waist, Hips
<input type="checkbox"/> in the Right Places	<input type="checkbox"/> Better Sleep, More Energy

Send me absolutely FREE a copy of your famous book showing how "Dynamic-Tension" can make me a new man—32 pages, crammed with photographs, answers to vital questions, and valuable advice. No obligation.

PRINT NAME..... AGE.....

ADDRESS.....

CITY..... STATE..... ZIP CODE.....

In England send to: Charles Atlas, Chitty St., London, W. 1

TIGER IN YOUR TOOLSHED

(Continued from page 103)

and his head was 7 feet above the ground! A 5-year-old girl was hit on the back of her heel by an 8-inch piece of heavy wire while standing 3½ feet to the right and 5 feet behind a mower. The mower had a plastic guard on the discharge chute, but it was too light to stop a heavy object.

"Malfunctions" were those injuries where failure of the machine to operate properly caused the operator to take an unsafe action to correct the trouble. A badly designed mower often invites carelessness by an exasperated operator. If it keeps getting clogged up or if the wheels keep coming out of adjustment, the operator is tempted to do risky things. Of 10 victims of this type of accident, five suffered injuries to their hands and five to their feet. Two underwent amputations. Riding mowers accounted for half of the accidents in this category.

"This indicates the need for safer design in riding mowers, especially," says Prof. Knapp. "On a riding mower you have the problem of steering—like you have with a car. If you mow on a hillside you have the stability problem. You can back it up like a car, so you have to remember to look behind you. We know of accidents where people have backed over kids."

Carelessness big factor

Most of those who lost a finger or a piece of foot were careless, or absent-minded. They brought on their injuries—the most severe, but not the most numerous in any of the groups—by their own "Unsafe Acts."

One of these hapless victims even had a little help from his wife. She moved an empty bottle-gas cylinder while he was mowing and he backed into it—pulling the mower backwards was *his* contribution. He went head over heels, with his right foot under the mower. The blade cut clear through an engineers' boot plus five of the man's toes.

In the last group, "Non-Operational Injuries," five out of seven victims were injured while tightening or loosening the blade, an indication, says the university, that a safer method of attachment or removal is needed.

Because more than half of the injuries

were caused by flying objects, Prof. Knapp and his associates believe the industry's first responsibility is to design a mower that won't throw things. That's why they dreamed up the "pinball machine." They wanted to find out what really happens when a strip of hard steel spinning at 2500 rpm connects with a rock or piece of metal. What happens inside the metal housing before the rock or piece of metal comes hurtling out as a deadly missile? . . . when you raise or lower the housing? . . . speed up or slow down the blade?

To show that it took the problem seriously, too, the Outdoor Power Equipment Institute gave them a research grant.

No one knows for sure how many persons are injured by power mowers; 80,000 per year is a good guess. That's a lot of toes and fingers. The hazard isn't going to disappear by itself.

25 million mowers

The industry expects to sell 4½ million new mowers this year—1 million of them to first-time owners. By the end of the year, there'll be 25 million, a million more than in 1965. The prospect sobered even the men who make them.

They were also sobered fast when Sen. Warren G. Magnuson, of Washington, jumped on them in a Senate speech a year ago. They remembered the hell that broke loose on automobile safety after a couple of Senators blasted Detroit.

OPEI's members didn't wait for other critics to jump on their backs. They called a government-industry seminar on power mower safety in Washington last winter and invited safety experts to participate.

One of those who did was Dr. Aaron W. Christensen, deputy surgeon-general of the U. S. He laid it on the line: "Entirely too many people are getting hurt by rotary mowers. This is a problem of sufficient magnitude to be of concern to the Public Health Service."

Mando S. Ariens, president of OPEI, speaking for the mower makers agreed: "We admit we have an inherently dangerous product."

But, he added, the manufacturers are doing something about it. He then announced OPEI's "Safety Seal" to be displayed on mowers meeting specifications set up by the American Standards Assn. About 90 percent of the mowers sold in

(Please turn to page 190)

THINKING ABOUT BUYING A NEW RUNABOUT?

BETTER THINK
ABOUT ME
BEFORE YOU DO!

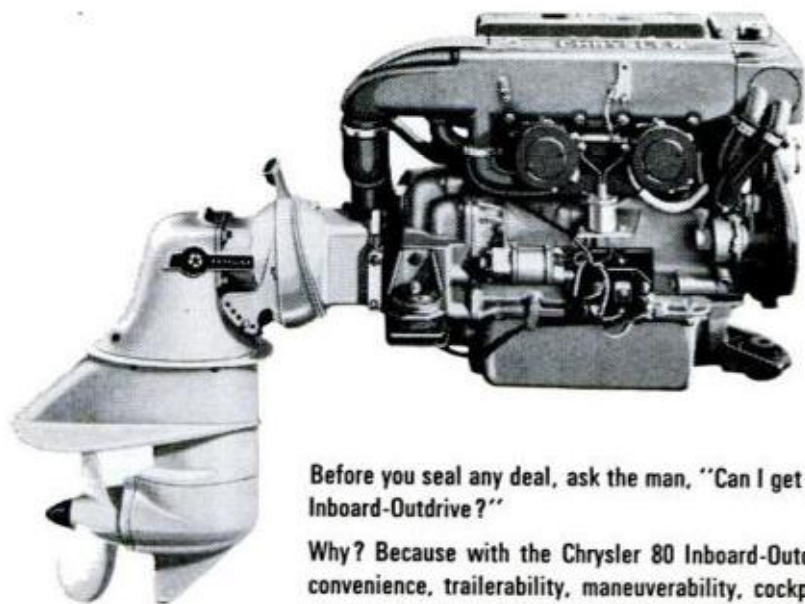

**CHRYSLER 80
INBOARD-OUTDRIVE**
80-hp., 4-cylinder, 4-cycle,
fresh-water-cooled engine; 91-
cu.-in. displ.; 2-1 bbl. carburetors;
compr. ratio 8.6:1. Single
transom-hole mounting. Weight
complete: 350 lbs.

Before you seal any deal, ask the man, "Can I get my boat with a Chrysler 80 Inboard-Outdrive?"

Why? Because with the Chrysler 80 Inboard-Outdrive, you'll get all of the convenience, trailerability, maneuverability, cockpit room and storage ease of an outboard—but none of the disadvantages!

You'll get a no-nonsense, 4-cycle, fresh-water-cooled Chrysler 80-hp. engine that runs on regular gas, starts in a hurry and extends your cruising range by miles. You'll be able to put people where you now put gas cans, and be able to forget all about gas-oil mixes, won't-starts, konk-outs and paddles. As a matter of fact, you'll be getting the best of two worlds—inboard *and* outboard!

Thinking about a big boat? Chrysler has *eleven* I/O's—one to meet your exact needs (see below). Ask about them at your boat dealer. Put one in your new boat!

Marine Division, Chrysler Corporation, Marysville, Michigan.

MARINE DIVISION



CHRYSLER
CORPORATION

Chrysler I/O's come in 11 models, 8 horsepower ratings:

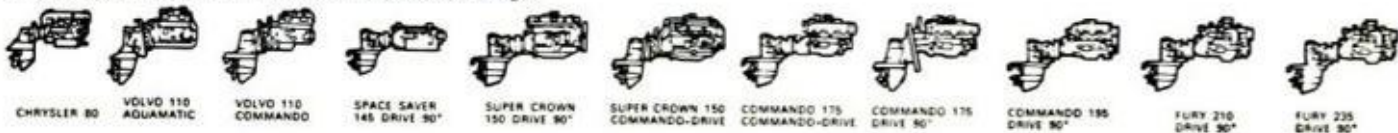

CHRYSLER 80

VOLVO 110
AQUAMATIC

VOLVO 110
COMMANDO

SPACE SAVER
145 DRIVE 90°

SUPER CROWN
150 DRIVE 90°

SUPER CROWN 150
COMMANDO-DRIVE

COMMANDO 175
COMMANDO-DRIVE

COMMANDO 175
DRIVE 90°

COMMANDO 195
DRIVE 90°

FURY 210
DRIVE 90°

FURY 235
DRIVE 90°

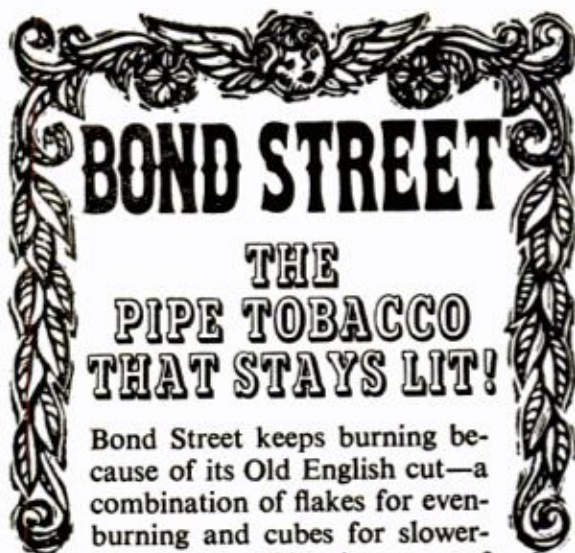

Bond Street keeps burning because of its Old English cut—a combination of flakes for even-burning and cubes for slower-burning. You'll like its aroma of fine domestic and imported tobaccos, too.

How to clear a clogged pipe



When you can't get a cleaner through your pipe, don't throw it away. Try holding the bowl over the spout of a boiling kettle, and let the steam pass through. Then, insert a dry cleaner and leave it in overnight.

Little pipe of mighty power, charmer of an idle hour . . . PHILIPS

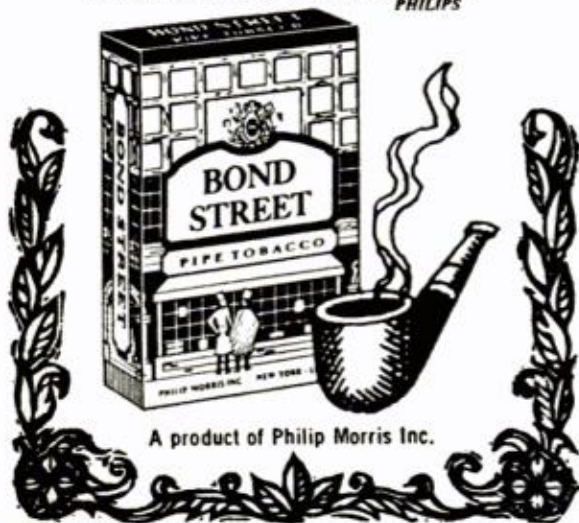

A product of Philip Morris Inc.

TIGER IN YOUR TOOLSHED

(Continued from page 188)

1966 are expected to carry the seal.

To earn the seal a mower must be made of sturdy materials and have a smaller discharge opening with a lower angle of discharge, a guard to keep feet away from the blade, a positive stop on the handle to prevent "swing-over," all moving parts enclosed, a blade-tip speed not over 21,000 feet per minute and a housing that extends at least 1/8 inch below the blade.

In addition, riding mowers must have enough stability not to upset when tilted 20° forward, 30° to the rear or 40° to the front, and must have wheel brakes or enough motor drag to stop the machine.

A blade-tip speed of 21,000 f.p.m. is still pretty fast. The trouble is, no one



SAFETY SEAL for mowers that meet ASA standards

really knows how slow you can run a blade and still cut grass. One thing the Iowa tests did show was that the faster you run the blade, the farther things will fly. When the blade on the pinball machine ran at only 1500 rpm, objects were thrown to a mean height of 8.5 inches. But when Prof. Knapp speeded it up to 2500 rpm, they soared to 13.2 inches! The obvious lesson: Run your blade as slowly as you can and still cut grass.

One thing the Iowa researchers won't buy is the old alibi that "all accidents are due to the carelessness of the operator." And even when you do get forgetful, it shouldn't cost you a toe. Nor do they think it's enough to tell a buyer to check and be sure the wheels are big enough and the wheel adjustments reliable. The OPEI seal will eliminate some of the guesswork.

But Prof. Knapp thinks the industry must come up with still safer machines.

He wants to see a mower that won't throw objects, either from the discharge chute or out the rear.

He wants to see cutting heights adjusted by a single lever that raises or lowers all four wheels. "Then we'll eliminate the

(Please turn to page 192)

HEAVY DUTY BALL-BEARING PUMP

IRRIGATE
DRAIN SPRAY
CIRCULATE

Famous, all-metal, rust-proof XB pump with stainless shaft. Use 1/4 HP or larger. 1 HP for up to 5,200 GPH 60' high or 3,000 GPH from 25' well. 1 1/4" inlet. 1" outlet. For belt or direct drives. Only \$12.95

Famous Type P won't rust or clog. Bronze bearing. Hundreds of thousands in use. Up to 2,400 GPH. 1" inlet. 3/4" outlet. Only \$8.95

Postpaid cash with order.
Money Back Guarantee. **LABAWCO PUMPS** Belle Mead 104, N. J.



PLUMB Ball Peen Hammer

with **NON-BREAKABLE FIBER-GLASS HANDLE**

Guaranteed Not to Break, Bend or Collapse in Normal Use.

MOLDED DURA-CUSHION GRIP

Non-Slip • Absorbs Shock • Reduces Fatigue

Patented **PERMABOND®**

Keeps Handle Tight

BUY THE BEST

BUY . . .

PLUMB®

Available in 7
head weights
8 oz. to 40 oz.

Flexural Strength Tests Prove
Plumb Fiber-Glass Handles are
34% STRONGER than Solid Steel Handles
74% STRONGER than Tubular Steel Handles

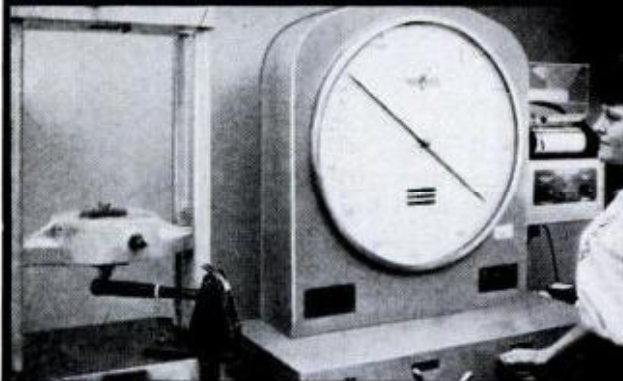

Photograph taken in Plumb Laboratory of
Flexural Strength Test being performed on
Tinius-Olsen Universal Testing Machine

Diagram of test shows how
load is applied same as
in withdrawing nail.

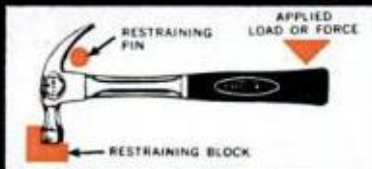

Fayette R. Plumb, Incorporated • Philadelphia, Pennsylvania 19137

Ocean floor may have sunk

Parts of the Eastern Indian Ocean floor may have sunk as much as a mile since the bottom rocks were formed some 30 million years ago. By dredging the flank of a large submerged volcano southwest of Sumatra up 12,000 feet, scientists recovered basalt with tiny, almost spherical cavities. Usually, basalt extracted from this depth does not have cavities.

Although some changes in depth would be due to the addition of ocean water, scientists believe that geological processes forming the undersea Indonesian Trench have caused the entire bordering sea floor to be depressed.

Milkshake in lieu of T-bone

Incaparina tastes good like a milkshake should. No ordinary milkshake, though,

this specially developed drink contains as much protein as a good-sized chunk of meat.

Developed at the Institute of Nutrition of Central America and Panama, Incaparina is a vegetable concentrate derived from a variety of grains and seeds, which is added to soups, puddings and cookies as well as the popular milkshake.

Known as avena, atole or colada (depending on the country), the drink is a favorite at soda fountains in Central America and Panama.

Since its introduction six years ago, this nutritional milkshake has also attained enormous popularity among school children, to whom it is given every morning in a government-sponsored program to make up for the meat they lack. The drink is described as the flavor and thickness of a thin vanilla milkshake.

**Bore 35 standard holes
with just one tool**

New IRWIN Expansive Bit

lets you dial your size

Just turn the dial and you're set to go with this new Irwin Expansive bit. No hunting for the size you need. Fits all hand bit braces. Clean, fast, accurate boring action from $\frac{3}{8}$ " to 3"—35 standard hole sizes in all!

And what a really fine precision tool to own. It's drop-forged from special bit steel, heat treated full length, machined for accuracy and sharpness, highly polished, too. Two cutters supplied with each bit. Model No. 21 with $\frac{5}{8}$ " to 1 $\frac{3}{4}$ " boring range also available. Ideal for home handyman, professional woodworker, or farm. See your independent hardware dealer soon.



IRWIN

Wilmington, Ohio

the original solid
center auger bit

screw drivers
screw driver bits

THE SPRAY WITH THE PAY-OFF

IN BETTER,
FASTER,
EASIER WORK

Goes on in seconds—
dries in minutes!
No brush marks,
no muss, no fuss!

NEW!

For auto touch-up,
use KRYLON
exact-matching
car colors.

**KRYLON...
AMERICA'S NO. 1
SPRAY PAINT**

A Product of Borden Chemical



TIGER IN YOUR TOOLSHED

(Continued from page 190)

accidents where guys get disgusted and kick at the individual wheel levers and stick their foot under the mower."

He wants to see a standardization of controls, with all of them on the handle. Riding mowers should be made harder to start. Self-propelled mowers should be made easier to stop. Electric mowers, which tend to "windmill," should have some device to stop the blade right now. All mowers should have some sort of "deadman control."

"Some of these features are available now on a few mowers," he says. "Others await further research and development. No one really knows, for example:

"The amount of horsepower needed to cut grass. The industry is trying to come up with an engine which will run slower, but this isn't easy. We can talk about 1800 rpm, which might be enough to cut grass, but getting an engine to run that slow and still have power is something else. Right now the manufacturers have two choices: Put in a big engine and run it slow, or put in a little engine and run it fast.

"No one knows the minimum tip speed which will cut grass cleanly. No one knows the maximum diameter of a blade to minimize the throwing of objects. No one knows the effect the amount of suction designed into rotary mower blades has upon the tendency to throw objects. No one knows the least hazardous location for the discharge chute. No one knows the housing design that would keep objects from flying out the rear. No one knows the minimum safe height for mowing grass."

Safety sparks competition

As fast as these things are learned, manufacturers can be expected to apply the answers to their mowers—at least to top-of-the-line models. Already some makers offer lighter-weight housings of cast aluminum and magnesium. Some do have single-lever wheel-adjusting and bigger, easier-to-push wheels that roll more easily over bumps and depressions, and spark arresters on mufflers to prevent accidental ignition of gasoline.

In what President Ariens describes as "a competition to put the safest mower on the market," at least two makers have a washout port" in the deck, through which

(Please turn to page 194)

VACATION ALL YEAR

with a vacation house of
all-weather **homasote**

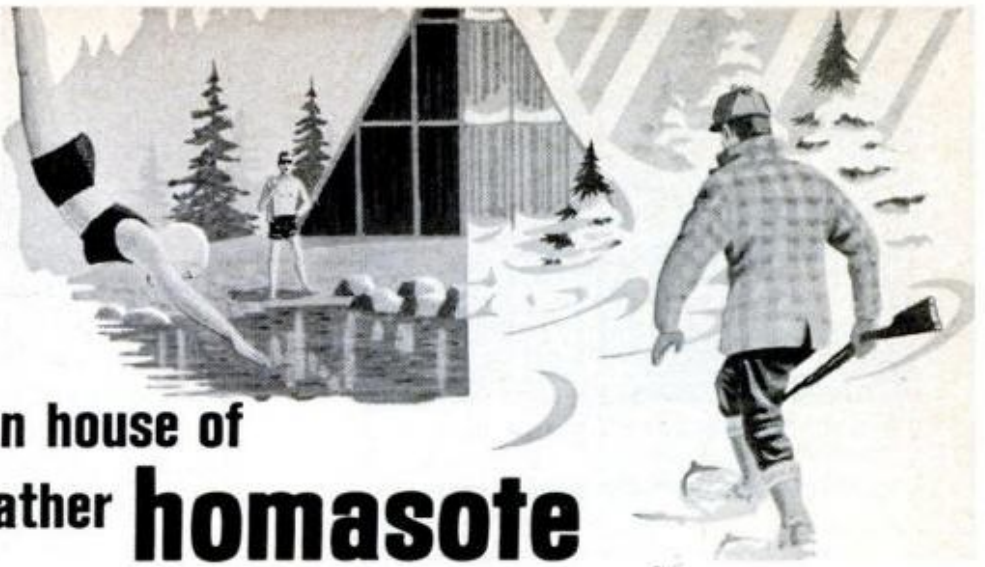

Building your vacation home is easy with Homasote products. "Easy-ply" Roof Decking provides the ceiling and roof sheathing ready to receive composition or other roof covering. 4-Way Floor Decking forms the structural floor sheathing combining moisture protection, termite resistance and insulation.

Color-coated Homasote offers structural sheathing and finish for interior walls, partitions and ceilings. New U/L approved panels are now available for added fire protection. Literature and building ideas available from your local lumber dealer or write direct to Dept. F-1



Write today for your copy of "Vacation House Plans Book," no charge, from Homasote Company, Trenton, N.J.

6-081-1

homasote Company

Trenton, N. J. 08603



GENUINE ALNICO MAGNETS

AMAZING. PERMANENT. NON-ELECTRIC. HIGHLY PRACTICAL. Conduct interesting experiments. Hundreds of uses. Retrieve valuable steel items such as guns, tackle from fresh or salt water, tools from tanks and drains. **GUARANTEED.** Try any magnet one week. Money back if you are not well pleased.

- M-710 (Wt. 53 oz.) Has pull of 225 lbs. on steel block.....\$18.50
- M-625 (Wt. 49 oz.) Has pull of 125 lbs. on steel block.....\$12.50
- M-575 (Wt. 18 oz.) Has pull of 75 lbs. on steel block.....\$ 7.50
- M-500 (Wt. 13 oz.) Has pull of 50 lbs. on steel block.....\$ 5.50
- M-90 (Wt. 5 oz.) Has pull of 15 lbs. on steel block.....\$ 3.50
- M-44 Rod Magnets for Electric Guitars 1 1/2" DIA. x 11 1/4" 12 for \$ 4.00
- M-47 Hot pad Magnets.....10 for \$1.00.....50 for \$ 4.87

SPECIAL INTRODUCTORY PRICE ON RUBBER MAGNETS
 M-R-110 Rubber Magnet Kit.....10 Assorted pairs \$ 2.25
 M-R-24 Flexible Strip Magnet (easy to cut)
 1 3/2" x 3" x 2 1/2".....\$2.00 each.....2 for \$ 3.50

SEND M.O. OR CHECK—WE PAY POSTAGE—SORRY NO C.O.D.'s
 MIAMI MAGNET COMPANY, 3240 N.W. 27th Ave., Miami, Fla. 33142

Swiss saw blades and frames



for intricate, precise and very close detail Operation on metal, wood, plastic, etc.

Saw Frame—5.00—saws—60 doz., 4.00 gr.

THE RADE CO. IMPORTERS

4574 N. Mobile Ave., Chicago, Ill. 60630.

World's Only PRE-SMOKED PIPES!

Dr. Grabow

WORLD'S FINEST IMPORTED BRIAR

- Starfire\$4.95
- Commodore \$7.95
- Viscount ...\$5.95
- Eldorado ..\$10.00

NEED NO BREAKING-IN

Your favorite blend never had it so smooth, right from the very first puff because: the world's only pre-smoked pipe needs no breaking-in! What curing does for tobacco, pre-smoking does for your Dr. Grabow.



For FREE Information Booklet, Write Dept. PM, DR. GRABOW Pre-Smoked Pipes, Greensboro, N.C.

Sure beats smoking!



Enjoy Copenhagen: Place a small pinch between cheek and gum. No chewing.

United States Tobacco Company



Transistor Radio with Battery \$1.96

17-Jewel Watch \$2.87



Derringer Pistol \$5.74

HOME-IMPORT BUSINESS—Make Big Profits

New Drop Ship Plan offers you first day profits! Deal direct with overseas sources at prices shown. Dazzling bargains with no investment. Full or spare time. Write for FREE BOOK today to...

MELLINGER, 1554 S. Sepulveda, Dept. X256, Los Angeles 25



The Ideal Cookout Companion

sterno®
CANNED HEAT®
COOKING FUEL

Famous STERNO, the solid fuel, makes your cookout fire any time, anywhere. Just set up the STERNO stove, drop in a match and you're cooking with STERNO. It's the safe cooking fuel that won't spark or spill. When finished, just flip the lid...the fire's out!



A Subsidiary of Colgate-Palmolive Co.
300 Park Avenue, New York, N.Y. 10022

TIGER IN YOUR TOOLSHED

(Continued from page 192)

you can squirt a hose while the blade is running. Some have put the discharge chute in front. Others have deflecting rods in the chute and several do have deadman switches, requiring pressure or a slight twist on the handle. One rider cuts off power to blades and wheels whenever you leave the seat. Several have new blade designs. One is S-shaped and is supposed to hit objects with only a glancing blow. Another has four small blades on a disc; all retract when you hit a hard object. One mower has two blades: one for cutting, one for cleaning. Several heavy-duty riding mowers have hydraulic lifts to raise or lower the rotor.

Prof. Knapp thinks this is to the good.

Smaller blades are generally less hazardous than big ones. Still, with more than one blade, he thinks you have a greater chance of something coming loose.

Grass-catcher problem

Another gadget that's getting a big play this year is the good, old grass-catcher, without which no hand-powered reel mower was complete. They're showing up on rotaries, touted as safety devices.

Prof. Knapp has mixed emotions.

"A big grass-catcher attached to the chute can impair the stability of the mower. When the bag's full of grass, the grass may stop a thrown object like they say. But we bought a grass-catcher for my boy, who does custom mowing. The first day he got three big slits where things went right through the bag."

Safety costs money, on mowers as well as on automobiles.

"A lot of people," notes Prof. Knapp, "will pay \$49.50 for a mower, but not many are willing to pay \$100 to get extra shielding, all the controls on the handle, and an engine big enough to provide maneuverability. On a cheap mower the maker has to leave off the 'frills' which give you real control over the machine. But if it meets the ASA standards as to housing and chute design, blade recessing, tip speed and handle stops, it can get the Safety Seal, and that's progress.

"The one thing to remember is that whether a mower has 2 hp or 10, costs \$40 or \$400, it still has one potentially dangerous element—a rotary blade." ★★★

FIX CARS FASTER!

with **MOTOR'S** great

2-IN-1 AUTO REPAIR MANUAL

① Famous **MANUAL** pages show how you can

FIX ANY PART OF ANY CAR

Quick, Easy, Right the first time — just about ANY Car, 1959-1966, including all Compacts

② **TROUBLE-SHOOTER**

section spots 2300 car troubles for you immediately ... leads you to exact repair needed



TRY BOOK **FREE** FOR 10 DAYS

WANT TO FIX ALMOST ANY PART OF 2,300 CAR MODELS from 1959 through 1966 — fast, easy, right—the first time you try? MOTOR's new 2-in-1 Auto Repair Manual practically does it for you. Makes every job easy as A-B-C. Turns beginner mechanics into experts, gives experts real time- and money-saving tips.

"Meat" of 300 Official Shop Manuals

MOTOR's Manual gives you a wealth of "know-how" from 300 Official Shop Manuals and hundreds of factory bulletins. No guesswork! Crystal-clear directions and big pictures guide your hands thru every repair job. "Trouble-Shooter" section spots any of 2,300 car troubles fast — leads you to exact repair needed. Then famous Manual pages show you where to start, what tools to use, how to use them. Every job is made so easy you CAN'T go wrong!

No wonder over 5 MILLION copies of MOTOR's Manual have already been sold! No wonder it is used by U.S. Army and Navy, thousands of garages and schools!

Here's What You Get

NEW, REVISED, ENLARGED 1966 edition covers more than 2,300 popular-make models since 1959, including all the new cars! 1,300 Big pages, 3,800 Pictures, 457 Easy-to-read charts, 55,000 Repair specs, 225,000 Service and repair facts. PLUS adjustment tables of measurements and clearances, overhaul and replacement facts, tune-up data. Everything you need to fix cars fast, easy, right — the first time you try!

USE **MOTOR'S** AUTO REPAIR MANUAL **FREE** FOR 10 DAYS

MAIL COUPON BELOW NOW — WITHOUT MONEY!

Try Book FREE 10 Days

Just mail coupon. We'll rush Manual to your home or shop. USE it for 10 days. If it doesn't pay for itself in this time, return it and pay nothing. Mail coupon TODAY to: MOTOR Book Dept., 250 West 55th St., New York, N. Y. 10019 (SCHOOLS, BOOKSTORES: write for discounts.)

FIX THESE PARTS

Ignition	Automatic Transmissions
Alternator	Overdrive
Generator	Suspensions
Generator Regulators	Differentials
Starting Motors	Brakes
Carburetors	Steering
Fuel Pumps	Dash Gauges
Engines	Starter Switches

FIX THESE CARS

Volkswagen	Mercury	Comet
Mustang	Ford	Cervair
Barracuda	Fury	Buick
Jeep	Chevelle	Special American
Chevy II	De Soto	Olds F85
Pontiac	Chevrolet	Falcon
Thunderbird	Edsel	Lancer
Buick	Chrysler	Fairlane
Imperial	Plymouth	Tempest
Cadillac	Studebaker	Corvette
Lincoln	Rambler	Valiant
Dart	Dodge	Meteor
Continental	Oldsmobile	Marlin
Toronado	Branco	



COMPLETE AND SIMPLE. "I always rely on my MOTOR Books. They're well illustrated—complete and simple."

—Mr. Erve Jones, Mankato, Minn. (Garage Owner)



GETS HIM OUT OF TIGHT SPOTS. "Last summer, I made over \$4,500.00 on repair work alone. Motor helped me out of tight spots."

—Dick Hollingshead, Ogden, Iowa (Owner)

Same 10-Day FREE OFFER on New TRUCK REPAIR MANUAL

Covers 98% of all trucks, 1955 thru 1966, including new economy models. Over 2,000 illus.; 300,000 facts. Covers all gasoline engines, plus GM, Cummins, Mack, Perkins, Ford, Int'l, Caterpillar diesels. For FREE Trial, check coupon.



MAIL COUPON NOW FOR 10-DAY FREE TRIAL (Attach to Postcard for Fast Action)

MOTOR BOOK DEPT., Desk 616
250 W. 55th St., New York, N. Y. 10019

Rush to me at once the book(s) I have checked below:

MOTOR'S New AUTO REPAIR MANUAL. If O.K., I will remit \$2 in 10 days, \$3 monthly for 2 months and a final payment of \$1.95 (plus delivery charge and sales tax, if any) one month after that. Otherwise I will return the book postpaid in 10 days.

Print Name.....Age.....

Address.....

City & State.....

ZIP CODE (9500-90)

Also send me for 10 days' Free Trial MOTOR'S New TRUCK REPAIR MANUAL. If O.K., I will remit \$11. plus delivery charge and sales tax, if any, in 10 days. Otherwise I will return the book postpaid in 10 days.

Check box and save shipping charge by enclosing WITH coupon entire payment of \$9.95 for Auto Manual for \$11 for Truck Manual) plus sales tax, if any. Same 10-day return-for-refund privilege applies.

CORONET OWNERS' REPORT

(Continued from page 76)

entitled to road-test the car they buy before taking it home.

Part and parcel of the same overall complaint are rattles:

"There's an annoying rattle in the horn ring and from the spare tire cover."—Washington engineer.

"Rattles have been present since the first day I got the car."—New York salesman.

"The rattle in the horn ring gets on my nerves. No one can seem to fix it."—California technician.

Lack of economy ranked fourth on the complaint list. One man said he got only 8 mpg around town, 11 mpg on the open road. He's the extreme, granted, but a lot of people expressed something other than fascination with the mileage they are getting. Their comments are as subtle as baseball bats:

"Don't get enough mileage."—Texas cattleman.

"I'm disappointed by the mileage I get on this car. I realize I didn't buy an economy car, but still it ought to do better than 10 miles to a gallon."—Colorado miner.

► Yep. It should.

Apparently a few Coronets are oil burners—either that or there's a leak somewhere. Some sample comments:

"Car uses a quart of oil every 100 miles."—Oregon engineer.

"In the first 3500 miles, I added seven quarts of oil."—Ohio technician.

These complaints about Coronet oil and gas economy were, however, outvoted by owners who felt their cars were money-saving little jewels. For example, an Ohio farmer—obviously a frustrated ad man—wrote:

"It's a thrifty beauty at a low-low price."

"I get fine mileage. Car runs like a top."—Oklahoma salesman.

"Sure is easy on gas and oil."—Michigan factory worker.

"I get good economy and still get all the power I need."—Alabama truck driver.

The Coronet also drew owner applause for comfort. Replies to PM's survey cited such items as seat construction and position, general interior roominess and overall design:

"The best seat support I've ever seen or felt."—Iowa manager.

"The seats are very comfortable all 'round."—New York secretary.

"It's more restful than other cars I've driven."—New York retired.

"Although not a big car, it's roomier

than others in the same class."—New York biochemist.

► Not necessarily. However, he's happy.

"The interior of my Coronet is very well finished."—Kentucky purchasing agent.

"The interior is beautiful."—Wisconsin foreman.

Rounding-out Coronet owners kudos were many mentions of good visibility:

"Car offers excellent driver vision."—California policeman.

"You can see where you're going."—Texas manager.

"Dashboard above steering wheel is made low and does not block view."—North Carolina laborer.

While the view may be nifty, quite a few owners felt that cramped headroom reduced the joys of rubbernecking.

"The front roof slant cramps headroom."—Florida postman.

"I keep bumping my head on the roof."—Texas dentist.

► It feels so good when you stop—right?

"I hit my hat every time I enter or get out of the car."—Minnesota superintendent.

Another owner complaint was the dash ashtray.

"The ashtray is right below the ignition. They should have put one either on the right side below the glove box or in the middle."—California salesman.

"It needs another ashtray on the passenger side and also an ashtray light."—USAF, Delaware.

"You can't find the ashtray in the dark."—Michigan barber.

Ranked seventh on the gripe list were brakes, most complaints being that they were noisy. A Nebraska engineer said simply:

"They squeal."

"I get vibration and noise when applying brakes at high speed."—Florida factory supervisor.

"My brakes grab and squeal when wet."—Iowa farmer.

A few Coronet owners said they thought handling could be improved.

"Roadability isn't what it should be. Car seems a little light at 60 mph or better."—Montana salesman.

"I'd like it to take curves and corners a little better."—Georgia merchant.

"It's hard to control on snow or ice and doesn't get much traction."—Colorado technician.

Winding up Coronet complaints, several owners turned thumbs down on what they felt was inadequate insulation against road noise. Their comments along this line were summed up bluntly by a Texas plant supervisor: "Road noise is terrible, just terrible." ★★★

GIANT 8 Ft.

\$1.00

Largest Distributors of new Gov't. Surplus Balloons in the USA. Inflate with air or gas. Fun at the Beach, Water Sports, etc., Flying Advt. visible for miles. Terrific for attracting crowds at Open-



ings, Fairs, Roadside Stands, Gas Stations, Sports Events. Durable Neoprene Rubber. Guaranteed new. Plus 25c hdg. No C.O.D.

2 ft. (Beach Ball) size	5 for \$1.00
4 ft. size	2 for \$1.00
8 ft. size	\$1.00 each plus 25¢ each hdg.
16 ft. size	\$3.00 each
24 ft. size	\$5.00 each

NOVEL PROD. CORP. 31 SECOND AVE., Dept. 173
NEW YORK 3, NEW YORK

I-N-V-E-N-T-O-R-S WE NEED INVENTIONS

Sell your invention for cash—need money for Patent?—Are technical problems holding you back? Universal Inventions has helped inventors all over the world—just like yourself—why not you? Inventions provide the magic spring-board to sudden riches. REMEMBER, we either sell your invention or pay you a cash bonus. Write for details.

UNIVERSAL INVENTIONS, Dept. 13, Marion, Ohio

BILL TROUBLES?

NOBODY REFUSED UP TO \$15,000.00

Bad Credit ■ No Problem ■ Not a Loan Co.

Send your name and address for **FREE** application to nearest office for faster service

● **ATLANTIC ASSOCIATES, Dept. 15** ●
● 146 Westminster St., Providence, R. I. ●
● 3312 N. Central Ave., Phoenix, Arizona ●



**FOUR-WAY
BEST LOW COST
ARC WELDER
YOU CAN BUY
only \$14.95 Complete**

WELD, BRAZE, SOLDER, CUT. Tops in performance and value. Ideal gift, educational, profitable, enjoyable. No experience needed. Use $\frac{3}{16}$ " welding rods and $\frac{1}{4}$ " carbons to make or repair auto bodies, fenders, trailers, boats, toys, furniture, farm equipment; garden tools, anything of metal. Operates on 110 V. line.
WORLD'S GREATEST WELDING VALUE. Over 500,000 in use by home owners, farmers, hobbyists, mechanics. **5-Year Unconditional Guarantee.** If inoperative will repair or replace without charge. **You Get: FULL FACE SHIELD,** heavy metal cabinet, ground clamp, 12 ft. heavy cables, special combination carbon arc torch & rod holder, carbons, welding and brazing rods, flux, solder, instructions.
ORDER ON 10-DAY UNCONDITIONAL MONEY BACK TRIAL.
FREE: Order from this ad and receive extra \$2.00 gift of rods, flux & solder.

SEND ONLY \$2.00 and pay \$12.95 plus C.O.D. charges on delivery, or send only \$14.95 and we will ship prepaid. **Order today.**

FOUR-WAY WELDER CO. DEPT. W2-F
1810 S. FEDERAL ST.
CHICAGO, ILL. 60616

BIG BOOM CARBIDE CANNON

4.95



Sounds like dynamite blast! **BRILLIANT FLASH!** Mighty roar echoes for blocks. Fine July 4th noisemaker, starting gun, celebrations, etc. Safe. No recoil. Hundreds of shots for few cents. Uses carbide. Fast firing. Attractively made of heavy cast iron. Money back guarantee. **9" Cannon (Illustrated) \$4.95 Post. paid. Big 17" Cannon \$9.95. Mammoth 25" Cannon \$13.95. Ammunition 39c tube (500 shots), 3 tubes \$1.25. Add 50c postage on all orders. 75¢ west of Miss. Standard American Cannon Co., Dept. 6PMC, 1 Park Ave., N.Y. 16, N.Y.**

Standard American Cannon Co., Dept. 6PMC, 1 Park Ave., N.Y. 16, N.Y.



Look what we've gotten ourselves into!

The Ford GTs that finished 1-2-3 at the 1966 Daytona Continental.

And the Ferrari that won the 1965 Le Mans.

The same 240-A electric fuel pump is available at your local garage, speed shop, or automotive parts store.

Need we say more?



240-A electric fuel pump

S-W
STEWART-WARNER 
INSTRUMENT DIVISION
1840 Diversy Parkway, Chicago, Illinois 60614

Meet the SKIL

**Operates at any speed
It's a power wrench!**

The Drive-R-Drill is much more than a drill. It drives and removes screws, nuts and bolts. You can actually drill a hole in metal, thread the hole, drive a bolt in, and finally tighten a nut on the bolt all with the same tool! You can even drill holes in glass!

Trigger Speed Control lets you select the exact speed for drilling or driving any material simply by squeezing the trigger. The harder you squeeze, the faster the speed. Brings a whole new dimension of flexibility to conventional drill accessories such as sanding discs, grinding wheels, wire wheel brushes, polishing bonnets.

Drive-R-Drills available in $\frac{1}{4}$ ", $\frac{3}{8}$ " and $\frac{1}{2}$ " sizes. Prices start under \$30. See them at your Skil dealer today. Skil Corporation, 5033 Elston Avenue, Chicago, Illinois 60630.

Go with the pick of the pros...

SKIL®
POWER TOOLS

PATENTED SKIL TRIGGER SPEED CONTROL

most useful tool invented!

DRIVE-R-DRILL!

... forward or reverse! It's a power screwdriver!
It's an all-purpose drill! It threads holes in metal!



Drive and remove screws
in any material

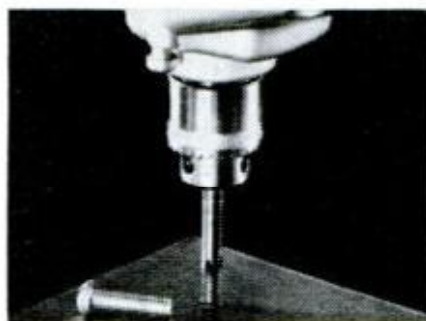

Thread and re-thread screw
holes in metal



Tighten and remove most
nuts and bolts

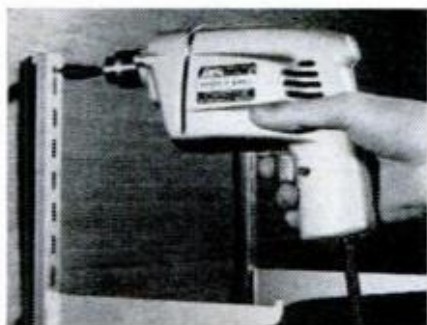

Install bookcases, shelves,
drapery hardware



Drill holes in masonry
faster and easier



Assemble and take apart
knock-down items



Drive self-tapping screws
without center-punching



Drill cleanly into glass or
ceramic surfaces



Sharpen mower blades, tools,
knives, clippers

SNAPSHOTS OF THE '67 CARS

(Continued from page 65)

than the present stodgy, boxy-lined Imperial.

Safer cars. You can't talk cars nowadays without mentioning safety. State and federal laws, government vehicle specifications, insurance rates, lawsuits, charges of neglect—these and more have made Detroit supersensitive to the safety problem. Though the industry has brought out new safety developments annually, the next two years will see more progress in making cars safer than the preceding 20.

Dual-cylinder brake systems will be standard on 1967s. Available on Cadillacs and American Motors cars for some time, they are designed to prevent full loss of braking power if a hydraulic brake line is ruptured. Brakes will improve too. For the first time, more than half of the new cars will offer discs. Mostly, they'll be optional for installation on front wheels only.

Collapsible steering columns for the '67s have been announced by GM and American Motors and Chrysler is expected to follow. Ford is sticking with a modified version of the deep-dish steering wheel it introduced back in 1956. Both column and wheel are designed to prevent chest injuries in sudden stops or head-on collisions, and both meet government specifications for doing the job. Also, to reduce "second collision" injuries inside the car, dashboards will get thicker padding and the shelf they form in the front of the car



THUNDERBIRD for '67 will introduce a 4-door sedan, but hold off on convertible till later in year



MERCURY'S COUGAR will debut as 2-door hardtop with fastback added as '67 "half-year" model

will shrink in size as the safer, swept-back dashboards are brought into production.

Most significant safety changes this coming year result from Congressional pressure. The best example is the list of 17 safety items required by the General Services Administration on all cars purchased by the federal government after next Sept. 30. We'll have to wait until the 1968 model year before some really basic safety changes are made available in quantity, such as wraparound seats, collapsible frame, heavily padded interiors and safety instrument panels.

Substitute materials like aluminum in radiators (Lincoln) and plastic in outside trim (Pontiac) will become more common on '67s. Also, look for more use of airconditioning, stereo tape systems, automatic door locks and, perhaps later in the year, wrist-twist-type steering controls.

Spare tires—there's a real possibility of their elimination. One auto supplier has developed a second wheel to fit around the wheel inside a standard tire. In case of a flat, the second wheel will protect the rubber of the regular tire and permit you to drive miles to a service station for repairs. It's also a safety item since it eliminates the sudden lurch that accompanies a blowout at high speeds.

Here is a summary of what to look for in the rest of the '67s:

American Motors. Ambassador and Classic will get completely new sheet metal and two-inch-longer wheelbases. Overall length will stretch four inches. Styling will depart from the present hard, angular lines to follow the rounded, sloping look of the big Chevrolets.

The company is going all-out to challenge the big Fords, Chevys and Plymouths with big cars that offer luxury, not economy. To most observers this is like the Vietcong building tanks to challenge the 1st Marine Division—sheer folly leading to disaster. However, AM's new 290-cu-in. V8 may replace the current 287-cu-in. V8 on Classics and Ambassadors.

Wraparound taillights will be easy to see from the side on AM's '67s, a feature the company will "sell" as a safety extra.

Don't look for a small car like the AMX this year or even next spring. It's hardly possible to bring one out before 1968 model time.

Ford: Mustang, the car that spawned a whole new class of American motoring, is newly styled for 1967. But the changes are subtle. It will lose its crisp look, switching to a squat, burly appearance, but there will be no mistaking it's a Mustang. In pictures, the car appears nearly identical

to present models. A startling two-door fastback with aerodynamic lip on the rear end will star in Mustang's 1967 lineup.

The big Fords and Mercurys will have all-new sheet metal to make the cars appear rounder, but the general look will be virtually unchanged. One exception: a new two-door hardtop that comes close to being a full fastback. Ford and Mercury will have a similar roofline except that from the top of the back window to the end of the roof the roof outline will be slightly concave—a stretched-out version of present two-door hardtop roofs. Mercury will call this model the Marquis, and also offer a top-of-the-line four-door to be called Brougham. Mercury taillights will be banana-shaped and upright, following the outline of the rear fenders. Up front, '67 Mercs look a lot like Lincolns with a severely overhanging hood taking up almost half of the grille area.

Lincoln will have minor styling refinements, but won't change to separate frame and body construction until 1968.

Comet, Fairlane and Falcon are in line for minor appearance and mechanical refinements. As an example, Falcon will have this year's grille split by two aluminum bars—one vertical, one horizontal—which cross in the middle of the grille opening. The front fender will get stamped-in wind tears placed just behind the front wheel opening.

Chrysler: By the time this is printed, some announcement will have been made on the turbine program. Speculation now looks for announcement of a new turbine "under development," with further study to be made before a turbine car can be produced. Chrysler will continue to milk publicity out of the Ghia-built turbine test cars by taking them on a cross-country tour of such places as college campuses to "test the reaction of young people."

Valiant and Dart will get the most attention of the company's production cars. Both will have completely new bodies, but don't expect anything spectacular. Chrysler has swung from one styling extreme to another. Now their cars are conservatively styled. Once a leader, the company now seems content to follow style trends set by others.

Sheet-metal changes will be extensive on Furys and the big Dodges with a lot of metal sculpturing on the sides and a brand new roofline for the two-door hardtops—to match the Chevys and Fords. Front and rear fenders on Fury are pointed, making the car look longer, bigger. Coronet and Belvedere facelifts will be minor since they were all new this year. Big Chryslers will sport new sheet-metal changes

(Please turn to page 202)

BIG JOB SCRAPER



5" DOUBLE EDGE BLADE
14" LONG HANDLE
RED KNOB GRIP
CHROME HAMMER HEAD

Sold in paint, hardware and building supply stores

\$3.00

EXTRA BLADES
65 EACH

If not available
send check or
money order

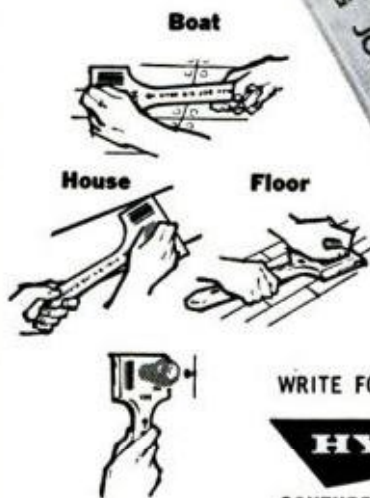

WRITE FOR FREE CATALOG

HYDE TOOLS
SOUTHBRIDGE, MASS., U.S.A.

THE ORIGINAL PRE-ASSEMBLED BOAT KITS

40 NEW CUSTOM-CRAFTED MODELS

Years ahead in Design - Styling - Performance. Cruisers - Runabouts - Prams - Skiffs - Sailboats - Racers. NEW CATALOG 50¢. Send \$1.00 for new Catalog PLUS Boat Building Handbook.



BOAT PLANS - PATTERNS - FRAME PACS

Over 200 proven, modern designs by famous Naval architects. Prams - Cruisers - Runabouts (Inboard-Outboard) - Hydroplanes - Houseboats plus all Kit Boats. NEW DESIGN CATALOG \$1.50 (Refundable). Send \$2.00 for Catalog plus Boat Building Handbook.

CUSTOM BOAT DESIGNS — DEPT. A — BUFFALO, N. Y. 14207

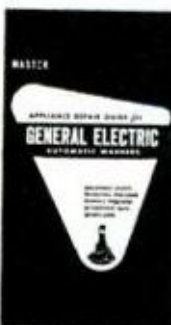

BENRODD'S MASTER APPLIANCE REPAIR GUIDES WILL SHOW YOU HOW TO FIX ANY WASHING MACHINE

... Quickly, easily, and above all the correct way. No guesswork... clear concise wording and illustrations. You will be shown step by step how to troubleshoot and repair. Can be used handily by beginners or pro's over any trouble spots.

Each Guide Contains Trouble Diagnosis and Checking Procedures. Illustrated Service Techniques and Parts Descriptions.

You Save Valuable Time and Money... By doing the Job the Right Way.

MAIL THIS COUPON

NAME _____	Benrodd Repair Guides 1736 55 Street Brooklyn, New York 11204
ADDRESS _____	
CITY _____	Please send me Repair Guide (s) indicated below. I enclose \$2.98 for each Guide. (Check or MO only)
STATE _____	
PLEASE USE ZIP CODE NUMBER _____	
<input type="checkbox"/> WASHER <input type="checkbox"/> DRYER <input type="checkbox"/> GAS <input type="checkbox"/> ELECTRIC	
PLEASE STATE MAKE _____	

Sharpest deal in electrical tape



new dispenser with super-sharp blade

When the job calls for a tough, durable tape, get the brand that's easy to work with: "Scotch" Brand #33 Plastic Electrical Tape. This sturdy, stretchy, black vinyl tape makes fast work of insulating and protecting jobs because it conforms to any shape; it's waterproof, resists oils, acids, alcohol and weathering. And it now comes in a new dispenser with a sharp blade that cuts the tape quick, clean. Look for it at your favorite retail store. See offer on opposite page.



3M
COMPANY

SNAPSHOTS OF THE '67 CARS

(Continued from page 201)

and share the unique two-door hardtop roof with the big Dodges and Plymouths. This roof, shaped like the top of a "Z", has the rear window glass flowing gradually into the deck. Look for a more generous use of clear plastic shields ahead of the headlights on Imperials and Chryslers.

General Motors: Cadillac will have flow-through ventilation on standard models next year, as will all the big Oldsmobiles and Buicks. Also new on Caddy will be the sheet metal below the beltline, grille and rear-end styling, but it will still appear like the '66s.

Pontiac, Olds, Buick and the big Chevrolets are to share the same basic body shells for the most part, and will have the graceful two-door fastback shown in the Chevrolet and Pontiac pictures on these pages. Front fenders on the four-door sedans will be stretched and given a rounder appearance. Buick's grille, most conventional of the four, will offer little change.

Pontiac is introducing two different grilles for Catalina and Grand Prix. A novel arrangement for the Grand Prix has hideaway headlights mounted horizontally and turn signals tucked up under the peak of the front fenders. Olds' new grille is nearly split in two by a hood section which oozes over the top center, something like Barracuda's. Toronado and Riviera plan slight changes in grille and rear-deck appearance. Toronado will eliminate the "eyebrows" over the front lights.

Chevelle will pull back on its extreme styling of two-door fastbacks. That back window will be aligned with the curve of the rear roof and facelifts are set for the grille and rear end. Corvair and Corvette plan minor changes, but watch Corvette for something special later in 1967. ★★

Heat curbs cancer growth

Raising body heat briefly to a high level may effectively control the growth of cancer cells, according to an East German physicist. Dr. Manfred von Ardenne reports that tests raising the body temperature of 20 young-adult cancer patients to 110° F. for 30 to 45 minutes killed 95 percent of the malignant cells. The treatment is best used, he says, following surgery to remove the primary tumor.

While critics argue that heat can kill normal cells and that cancer cells may become resistant to periodic heat therapy, Dr. von Ardenne declares in *Medical World News* that anticancer drugs will be more effective after the heat treatment.

BYE-BYE, BACTERIA

(Continued from page 93)

should not believe that by buying those germ-resistant products they need not follow normal personal sanitary practices in protecting the health of their families."

While some critics contend the germ-fighting chemicals can be dangerous, Dr. Stuart denies there are hazards in those approved for general sanitizing. What about people subject to allergies? Today, before a germ-resistant product can be cleared by the Department of Agriculture, the manufacturer must hire a research lab to do skin-sensitizing patch tests against the chemicals.

Meanwhile, more and more anti-germ consumer products are coming out, giving cleanliness-obsessed citizens—especially the American housewife—a "whiter-than-white" sense of security. We still don't have germproofed dollar bills, telephones or playing cards which one doctor called "germ sponges." Nor has it been possible yet to sanitize acrylic materials, which don't absorb anything. On the bandwagon, General Motors is said to be studying ways to sanitize new cars.

The way we live, the perfect germless home doesn't seem possible even in the world of tomorrow. Actually, Dr. Stuart reminds us, many bacteria are beneficial, "even essential to the well-being of man."

Despite Dr. Stuart's skepticism, there must be something to the antiseptic gimmick. Look at what happened to Dartmouth. In 1964, after it had a so-so football season, the coach wrote plaintively in the alumni magazine that about one-third of his 80-man squad had been out of action at one time or another because of staph and other infections. One loyal alumnus, a vice-president at M&T Chemicals, offered to help with something called "Project Touchdown."

Last August, he brought his bio-Met bacteriostat to Dartmouth, had the laundry and mop water-treated, the lockers scrubbed with the chemical. During the '65 football season, a fogging machine sprayed the varsity locker rooms. A control test was conducted with the freshman team, which went without benefit of bio-Met—and got "a disturbing number of infections" as in the past.

How did the varsity team make out? No infections last fall. Incredibly, Dartmouth went on to an undefeated football season, won the Ivy League championship and the Lambert Trophy, recognition as the strongest team in the East!

If you've got to be germ-free to win, maybe we all ought to be sanitized, after all.

★ ★ ★

Brightest deal in electrical tape



Dark Chaser lantern only \$2⁹⁵ (less batteries)

Molded of unbreakable polypropylene plastic. Resists rust, fungus, battery acid. Flashes red, glows, or throws white beam up to ¼ mile. \$2.95 with plaid tab from roll of "Scotch" #33 Plastic Electrical Tape. Use coupon below or see specially marked packages.

Mail to: DARK CHASER
P.O. Box 9043, St. Paul, Minnesota 55177
Send me () Dark Chaser Lantern(s). I enclose \$2.95 and the plaid tab from a roll of "Scotch" #33 Electrical Tape for each.

Name _____

Address _____

City _____ State _____ Zip _____

Make checks payable to DARK CHASER. Offer good in U.S.A. and Puerto Rico, except where prohibited or otherwise restricted. Not good in Canada. Allow 4 weeks for delivery. Offer expires December 31, 1966.

3M
COMPANY

"SCOTCH" AND THE PLAID DESIGN ARE REGISTERED TRADEMARKS OF 3M COMPANY, ST. PAUL, MINNESOTA 55119 ©1966 3M CO.

BIG BUSINESS UNDERSEAS

(Continued from page 83)

sis has shifted to a new idea: ocean engineering. The object is big-scale exploitation of ocean resources.

The key to this new branch of engineering is equipment designed to let men work safely and efficiently underwater. The *Cachelot*, made by Westinghouse, is the latest and possibly the most important entry in this field.

The first time I saw the *Cachelot* in action, oddly enough, was a long way from the sea: high up in the Virginia mountains at Smith Power Dam near Roanoke. A huge steel grate had come apart at the bottom of the dam.

From a small wooden shack atop the dam, I watched the operation via closed-circuit television. Except for those special tools and the sleek rubber suits worn by the divers, the action on the TV screen—lit by sealed headlights installed on the scene—looked like ordinary construction work.

"That's just the point," explains George R. Wiswell, the lanky president of Marine Contracting, who supervised the project. "We can now do underwater almost any building job normally done on land. The main thing is—we can stay down long enough to get the job done."

This was not always so. In the past, a diver could not put in much working time at the bottom. "Most of his day he spent just hanging in the water," recalls Wiswell, himself a veteran diver. "He had to be pulled up very slowly. After an hour's work at 250 feet, it took five hours to get back to the surface."

No 'bends' to worry about

Reason for the slow ascent is that the body can't tolerate a rapid pressure drop. If the diver rises too fast, he gets the "bends"—a horribly painful and sometimes fatal condition caused by air bubbles boiling out of the blood as the outside pressure decreases. The deeper you go, the longer it takes for the body to readjust to normal surface conditions. "On a deep dive," says Wiswell, "we were lucky if a guy did 20 minutes' work per day—at the rate of \$2000 per dive."

The *Cachelot*, by contrast, permits instant ascent. No time is wasted in decompression after each trip to the bottom. Instead, divers stay at bottom pressure all the time—even after they get back on deck.

Cachelot divers travel to the bottom in the round steel cabin described earlier. Basically it is a diving bell with a big bottom hatch. Air pressure inside the

chamber is adjusted to match water pressure outside. As a result, no water bursts in. Even when the hatch in the floor is opened, the chamber stays dry and lets the divers breathe without diving suits and masks. Only when they reach bottom do the divers slip on their face masks, latch lines for breathing, communications and telemetering to the belts of their heated diving suits and swim out.

While the men work, the submerged chamber hovers nearby to serve as home base, safety retreat, workshop and toolshed. The divers swim in and out—from dry to wet surroundings—as easily as walking through a door.

"We're never more than a moment from shelter," says Jim Burgess, a husky, curly-haired diver for Marine Contracting; "That's good for morale."

Pressurized home on deck

But the *Cachelot's* real payoff comes at quitting time. No longer does the diver have to be inched up for hours. He just climbs into the submerged chamber, shuts the hatch to seal in the pressure, and it is whisked back on board like an express elevator. Since the pressure inside the chamber stays put, his physical reactions are unaffected by the fast rise.

Back on deck, the submersible chamber is "married"—joined with an airtight connecting passage—to the second part of the *Cachelot*, the deck chamber.

Sleeping bunks, writing tables, bookshelves, a record player and a toilet provide all the comforts of home—except a kitchen. Cooking odors would contaminate the high-pressure atmosphere. So food is passed in from the ship's galley through a pressure lock.

Here the divers—four of them in the current model—sleep and spend their free hours. Thanks to this pressurized deck chamber, divers remain at bottom pressure even in off-duty periods. They "commute" to and from the underwater work site without delay.

Except for weekend "climb-outs" they stay pressurized the entire workweek. And even when they do decompress for time off or when the job is finished, the lengthy process takes place while they relax in the safety and comfort of the deck chamber.

The *Cachelot* and similar devices now under construction are opening up new areas of the ocean floor to commercial ventures. Present equipment is designed to a maximum operating depth of 600 feet, but before long divers expect to go twice as deep. With a diving limit of 1200 feet, man will have direct access to

(Please turn to page 206)

The Fish-Snitcher

The Fish-Snitcher is G.E.'s answer to the WW II walkie-talkie, only 25 years better.

It's lighter, tougher and you can work it easily with one hand.

Instead of wasting a day looking for the big ones hit-and-miss style, you and your buddy take along a

pair of Fish-Snitchers and separate.

When one of you finds where they're biting, the other one gets the good news via Fish-Snitcher.

G.E. makes two kinds of Fish-Snitchers. The Y-7000 with a 56-inch whip antenna and an effective range of 2 miles for \$59.95* a pair.

And the Y-7010 (shown at right) with a 59-inch whip antenna and a range of 3 miles for \$75* a pair.

Bonus: To convert your G.E. Fish-Snitcher into a G.E. Kid-Snitcher, Wife-Snitcher, Husband-Snitcher or Friend-Snitcher, do the following: Take it home.



GENERAL ELECTRIC

Radio Receiver Department, Utica, N. Y.

"So far
I drowned
12 worms.
How are they
biting down
by you?"

"Like it was
going out of style.
Come on over.
Just try not
to sound like
a parade."

*Manufacturer's suggested retail price. Actual price varies with dealer. Slightly higher South and West.

Материал, защищенный авторским правом

BIG BUSINESS UNDERSEAS

(Continued from page 204)

an ocean floor area equal to all of Africa.

Despite these advances in diving equipment, the oceanologists hope that man will be able to exploit the ocean without having to spend too much time in the water. Once sea-bottom facilities are set up, they are expected to run with little or no human help. "Our problem," quips Ron Dozier, "is how to succeed in this business without getting wet."

Dozier, an engineer for the Shell Oil Co., managed to stay dry by helping design equipment that drills and maintains undersea wells and pipelines by remote control from surface ships. With TV cameras for eyes, sonar for ears, and a variety of wrenches, screwdrivers and pliers as "hands" on its long flexible arms, the Shell *Mobot* responds "almost like a man" to electronic commands.

Oilfields 2000 feet down

Up to now, offshore drilling has been confined to shallow coastal areas. But with new diving techniques and undersea automation, oil companies are heading for the open sea. John Loudon, chairman of Royal Dutch Petroleum—the parent

company of Shell Oil—declares boldly that within two decades underwater oilfields will be operating at depths to 2000 feet and that crude oil will be stored in gigantic undersea containers.

Robotlike undersea devices with electronic sensors and tool-tipped arms are an outgrowth of the remote-controlled manipulators used to handle radioactive materials in the nuclear industry.

The evolution of these heavyweight sea monsters often goes on in secret. Rumor has it that America's biggest shipyard, Newport News Shipbuilding and Dry Dock Co., is hatching a herd of the big submersible robots, and the company won't deny it. But when I asked one of their executives about details, he just gulped. To keep competitors from sneaking a look at their mechanical scavengers, some companies keep their gadgets dismantled until they're out at sea.

An industry insider reports privately that a Pittsburgh manufacturer of automatic mining equipment is converting his trackless cutters, loaders and haulers for use in the sea floor.

Toughest part of the job? "It's like bottling whiskey. Gotta cork it tight. Except with whiskey you try to keep the liquid

(Please turn to page 208)

Sears

LOOKING FOR EXTRA COMFORT AND LONGER WEAR?

GET SEARS **Gold Bond**® CUSHIONED OXFORDS WITH **NEOPRENE SOLES!**



Order
No. 82260-Black
No. 82261-Brown
Wide range of sizes and widths

Treat your feet to a walking-on-air feeling. Put on Sears Gold Bond Service Oxfords. These handsome huskies have air cushion insoles all the way from the heel to the toe—fight off foot fatigue all day long.

What's more, Gold Bonds are made especially tough to take the roughest wear for a long, long time. Their Neoprene soles and heels outlast ordinary soles and heels by many steps. Resist oil, grease, gasoline, and most chemicals.

See Gold Bonds now at your Sears, Roebuck and Co. retail store, or shop at home through the big Sears catalog.



Better Things for Better Living . . . through Chemistry

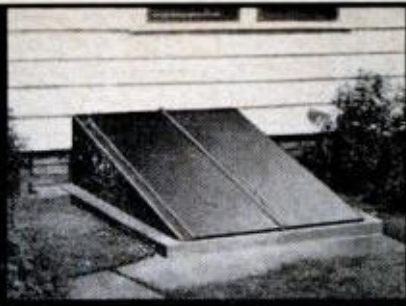

EASY TO REPLACE

THIS MODERN WAY

Bilco

**AMERICAS FINEST
BASEMENT DOOR**

Here's the way to add amazing new beauty and convenience to your home. Replace that troublesome wood door with a modern Bilco. All steel, permanent, watertight, opens and closes at a touch. A new Bilco Door will do wonders for your home . . . and for you!

The Bilco Co., Dept. R-66 New Haven 5, Conn.
Please send me your free illustrated folder and name of local dealer.

Name _____
Address _____
City _____ Zone _____ State _____

HOME WORKSHOP ARC WELDER!



**ELECTRIC
WELD BRAZE,
SOLDER, CUT
ALL METALS**



**New 1966 Model
LIFETIME BURNOUT GUARANTEE—10 day money back**

trial. Works on any 110 volt "Plug in". Welds up to 1/4" steel with 1/16" to 1/4" rods. **EXTRA** Special twin pressure type arc torch (shown) develops up to 10,000 deg. heat—**HAS A MILLION USES—** for **CARS—HOME—FARM—FACTORY**. No experience needed—**FREE** Welding book teaches **YOU**. Thousands of users. **SEND ONLY \$2.00** (cash, Ck, MO) and pay postman \$12.95 COD Postg. or send \$14.95 for postpaid delivery in USA. **COMPLETE** ready to use with 12 ft. H.D. Cables, Arc torch rod holder, carbons, welding and brazing rods, flux solder, work clamp and full face mask. **FREE EXTRA** "Bark" eye goggles—if you order at once. **THIS BEST FOR THE MONEY** welder sold **ONLY** by **MIDWAY WELDER**, Dept. DPM-6, Kearney, Nebr.



**NOW WE MAKE
THE WORLD'S
FINEST WOOD
STAIN, TOO!!**



'Round The World Cruise

**Only
\$159⁹⁵**



**NEW!
HEATHKIT® 10-Band Portable!**

Travel 1st Class Anywhere In The World on Long-wave, standard AM, FM and 7 Shortwave bands with this "go-anywhere" 16-transistor portable. "Visit" hundreds of foreign, amateur radio, aircraft, marine, AM & FM stations. Features powerful 4" x 6" speaker plus separate AM & FM tuners and IF strips for the finest portable listening; easy 10-hour assembly; rugged metal cabinet; and much more . . . see Free Catalog!

Kit GR-43, 17 lbs. \$159.95

Send For FREE 108-Page Catalog!

**HEATH COMPANY, Dept. 17-6
Benton Harbor, Michigan 49022**

Please send **FREE** Heathkit Catalog
 Enclosed is \$159.95, plus shipping. Please send Kit GR-43.

Name _____
Address _____
City _____ State _____ Zip _____
Prices & specifications subject to change without notice. GX-149

STOP THAT OIL DRIP



BEFORE Engineal AFTER Engineal



End unsightly oil stains on floor and driveway

\$3.95 at your service station or ppd SILOO INC.
395 Seventh Ave., N.Y., N.Y. 10001

North America's smallest and rarest bear is the Blue or Glacier Bear, which stands only two feet high at the shoulder. Its habitat is the Mount St. Elias region of southern Alaska.

EVERLITE* World's THRIFTIEST Light Plants



THE CHAMPION \$144.50

**The Champion—1200 watts
115 volts AC for only \$144.50**
Unbelievable but true—Brand new production methods now make possible world's finest design in a service free alternator light plant at this unprecedented price. Plant puts out a steady 1200 watts of 115 volt AC power to run power tools, oil burners, pumps, TV, or anything that requires up to 1200 watts. Powered by a rugged 3 HP, 4 cycle, easy start gas engine with 1 year factory warranty. Complete with carry handle and shock mounts. Why fool with short life 2 cycle plants when you can buy this rugged top quality machine at our factory price.
Item # 1265 wt. 65 lbs. \$144.50

MASTER MECHANIC MFG. CO., Dept. A-66, Burlington, Wis.
Southern Customers Write to Dept. A-66, Box 65, Sarasota, Florida

PROTECTS FLOORS



INDOTHANE Polyurethane Clear Wood Finish

Outlasts conventional varnishes 2 to 1. Gloss or Satin finish. Never needs waxing. So tough it resists scuffs. Best indoors for floors, doors, stairs.

Best outdoors for natural wood siding, picnic tables, wooden lawn furniture. Sold at leading hardware, building supply, paint and specialty stores.

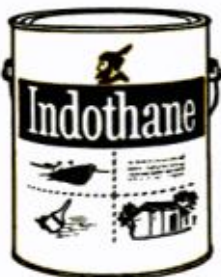

DAP

DAP INC., Dayton 31, Ohio
SUBSIDIARY OF *Plough, Inc.*

BIG BUSINESS UNDERSEAS

(Continued from page 206)

in. Here the trick is to keep the seawater out so it won't corrode the working parts."

It is anticipated that some of these undersea machines will carry out complex routines entirely without human supervision—not even shipboard monitors—as commanded by tape or punched cards.

Surprisingly, the most successful sea mining operation so far was carried out with fairly simple equipment. An enterprising Texan named Sam Collins bet on a hunch that South Africa's famed diamond fields also extend offshore. So he bought an old 800-ton tug and installed powerful pumps to suck up bottom mud near the Cape of Good Hope. Within a month he had enough gem-grade diamonds in his sifting screens to pay back the cost of his boat.

Texan after bigger diamonds

But mud-borne diamonds weren't big enough for the ambitious Texan. To pry loose bigger rocks from the ocean bottom, he built a 3800-ton floating device called *Diamantkus* from which massive 16-inch pipes reach down as far as 400 feet. Powerful air jets ring these bottom feelers, blasting encrusted gravel. A suction line pulls loosened rocks aboard.

Experts believe that ocean farming, too, will be fully mechanized. "You can harvest material from the sea floor just like you harvest corn on the surface," says the head of one underseas division.

The toughest problem has already been worked out. It was not technical but legal. To whom did the sea belong? According to international law (page 94, May '66 PM), the continental shelf along the coasts and to "wherever superadjacent waters admits to exploitation" belongs to whatever nation they adjoin. Competition for the ocean floor has already begun on the international level, with France, Britain, Japan, The Netherlands, and the Soviet Union among the main contenders. U.S. scientists are prodding Congress for still more money to stay in the race. Today, these scientists argue, the sea is the last remaining frontier on earth. It holds greater promise than all the frontiers of the past. For beneath the water lies 71 percent of our planet's total area. The rewards of ocean pioneering, some scientists believe, are more immediate than the rewards of space exploration. One eminent member of a Congressional advisory committee—apparently a salty type himself—sums up this viewpoint: "The ocean's bottom is more important than the moon's behind." ★★



AUTOMATIC HUBS for your 4-WHEEL DRIVE!

NOT EVEN A BUTTON TO PUSH on these amazing Lock-O-Matic selective drive hubs that automatically engage the front wheels in 4-w.d., automatically disengage them for 2-w.d. They stop front drive drag, save gas, gears, tires in 2-w.d.—automatically! For "Lock-O-Matics" or popular Warn® Locking Hubs—see your dealer.

be happy—GO LOCK-O-MATIC!
WARN MANUFACTURING CO., INC.
9050-A Empire Way So. Seattle, Wash. 98118

*Not made for some 4-w.ds.

HOT SHOT HOT SHOT

Amazing New BENJAMIN 30 30 CO₂ GAS BB CARBINE REPEATER

—Packs a PUNCH that's so POWERFUL it will Drive STEEL BBs thru Both Sides of a 5 Gal. Steel Pail at close range! (26 ga. .018")

You're in for a thrill you'll never forget the first time you shoot HOT SHOT! The Hardest Shooting CO₂ Gun on the market—New Model 30 30 embodies features that also assure Flawless Performance: Permanent Alnico V Cast Magnet Shot Holder . . . a Positive, Jam-proof method of loading Ammo in firing position; Convenient, Positive Hammer Safety; 30-BB Mag.; 30 Shots per cartridge; Quality Built. Lightweight—Accurate—Field Tested—Lowest Shooting Costs—use Indoors/Outdoors.

\$21.00 Ask Dealer for Demonstration.
BENJAMIN AIR RIFLE COMPANY
896 Marion St., St. Louis, Mo. 63104

FREE Catalog Benjamin Single Shot and Repeaters—Cal. .22 or .177 or .22. Also Special Hunting Knife Offer. Write today!

You Can DEPEND on BENJAMIN

**LEARN WELDING AT HOME
WE SEND YOU A WELDER**

A trade with a future—In demand everywhere
We have trained thousands—Men who earn up to \$4.50 an hour. Learn Arc, Heli-Arc and Gas Welding. We supply equipment that lets you earn while you learn. Practical lessons on brand new, industrial rated machines. Both arc and flame welding. On completion the equipment is yours. Set up your own shop or work in any shop on any job. Send today for full information.
AMERICAN INSTITUTE OF ENGINEERING & TECHNOLOGY
1131 W. Fullerton Parkway, Chicago, Illinois

**Shrinks Hemorrhoids
New Way Without Surgery
Stops Itch — Relieves Pain**

For the first time science has found a new healing substance with the astonishing ability to shrink hemorrhoids and to relieve pain — without surgery.

In case after case, while gently relieving pain, actual reduction (shrinkage) took place. Most amazing of all—results were so thorough that sufferers made astonishing statements like "Piles have ceased to be a problem!"

The secret is a new healing substance (Bio-Dyne®)—discovery of a world-famous research institute.

This substance is now available in *suppository* or *ointment form* under the name *Preparation H®*. Ask for it at all drug counters.

The Original "Wedge-type" Screwdriver

QUICK-WEDGE®
SCREW-HOLDING SCREWDRIVER



Easier to use:
NEW BEVELLED TUBE* slides easier to grip and to release the screw.

Firmer grip: new tube, combined with **NEW STRONGER BLADES** provide a more positive wedge-action to grip the screw.

More rugged construction:
NEW EXTRA-STRONG TIPS won't bend or distort in normal use.

14 sizes Unconditionally Guaranteed!
© 1966 by Kedman Company * patented
KEDMAN COMPANY
233 South 5th West, P.O. Box 267
Salt Lake City, Utah 84110

How to choose a MOTORCYCLE!

Before you buy—check these facts:

Among brands of motorcycles the most important differences are built in from the start. Triumph's 60-year leadership in engineering and design guarantee total riding pleasure, full performance. A nationwide network of Triumph dealers assure you of on-the-spot service and the ready availability of parts.

To get the most out of the two-wheeled sport, buy a man-size motorcycle... the kind experienced riders choose. All Triumphs are built for men who want the solid power of the real thing in motorcycling thrills.

Rely on a dealer's advice. Your Triumph dealer has the know-how to help you choose the motorcycle that fits your needs to a "T." Talk to him. And while you're at it, why not ask him to arrange for a test ride?



Triumph holds the A.M.A. approved **WORLD'S ABSOLUTE SPEED RECORD**, Bonneville, Utah, 230.269 m.p.h. (with streamlined shell).



This model is Triumph's T100/R—a middle weight road model, ideal for day-to-day fun and transportation.

**NOW! Mail this coupon today for
FREE CATALOG in color**

West
JOHNSON MOTORS, INC.
P. O. BOX 457
Pasadena, Calif. 91102

East
THE TRIUMPH CORPORATION
Baltimore, Md. 21204

Name _____ Age _____

PLEASE PRINT

Street _____

City _____ State _____ Zip _____

Telephone Number _____ Dept. P

Cut or Tear

DEADLY BOOBY TRAPS

(Continued from page 13)

up with a variation of the antipersonnel bullet mine. Two .45-cal. cartridges are imbedded in a small board which rides on wood dowels connected to a baseboard. Again, nailheads are used as strikers. Once this booby trap is stepped on, its victim is wounded by a bullet in his groin and a second one in the vicinity of his armpit.

Another way the Vietcong have circumvented metal-plated GI boots is through the use of a carefully camouflaged pit in which four needle-sharp punji stakes are set in a square and connected by interlacing wires. The pressure of a boot on the wires forces the stakes to close on the ankle of the victim. The same principle works in another series of foot traps, called "tiger traps," "spike traps" or the "crow's foot." One spike trap consists of a buried box in which flap-type doors bristling with metal spikes close tightly on the vulnerable upper portion of a soldier's boot.

Acting instinctively, the victim pulls back in an effort to extract his pinned foot. Thus the spikes are driven deeper into the wound. Some of these traps occasionally are rooted in concrete, forcing a victim's comrades to dig out the whole works and carry it along with the casualty to the nearest aid station, often under fire.

Every combat unit in Vietnam has collected many types of booby traps that American fighting men have been fortunate enough to discover before it was too late. One Marine outfit near Danang uncovered 43 roughly hewn, metal spring traps, some of them four feet in diameter. When one leatherneck was snared in such a "tiger trap," six of his buddies were unable to release his crushed leg. The booby-trap casualty writhed in agony for two hours before several heavy crowbars could be flown in by helicopter to a nearby landing zone that was under intense enemy fire. It took three men with these bars to loosen the jaws of this trap.

"There's no limit to the Vietcong's imagination," explains Sgt. John L. Saulnier, chief instructor at the Marine Corps booby-trap school that was set up at Danang and is now referred to as the "Punji Palace." Actually, it's a simulated native village that is a display course for the leathernecks who spend a day learning how to avert instant death.

An innocent-looking village gate is checked for a booby trap before it's opened. A grenade (actually a dummy) rigged to explode when the gate opens is not too hard to find. In fact, it's meant to be found. There's generally a second gre-

nade, better concealed. The Palace also places emphasis on other diabolical devices like a 200-pound chunk of bamboo tree trunk that is hung over a doorway. A heavy foot on the hut's threshold unleashes a punji stick-studded deadfall that comes swinging down chest high into the doorway like a fullback plunging through the line. No man can withstand the force of this trap and its deadly spikes.

There are, of course, more prosaic types of booby traps like bottles of native beer. At the Palace two full bottles of beer are sitting on a shelf in one hut, apparently forgotten by hastily departing guerrillas. More than likely, Sgt. Saulnier points out, they contain beer mixed generously with battery acid, formaldehyde and slivers of glass.

Fresh fruits may be injected with snake venom, and ice used for cooling drinks can contain slivers of glass.

The Marines call it a "sick war." Sadistic and sneaky—but effective. "These booby traps are all so simple," Sgt. Saulnier emphasizes. "They work well. From the looks of most of the stuff we've captured, the Vietcong must send their people to Booby Trap U where they learn to use nature itself in designing these things. They also make do with what is available and they can work wonders with bamboo."

Saved by a hair

Unfortunately, there has been a tendency on behalf of many Americans to look down their noses at guerrilla soldiers whom, they claim, "are no match for our boys." However, that's not the way that Pfc. Albert LaVallee of Tupper Lake, N.Y., looks at it. He's a Marine and this is his second war. He fought in the trenches and bunkers of Korea, and when Marines were sent to Vietnam, he decided to reenlist. Actually, LaVallee was lucky in Korea and returned home without having been wounded. His luck held out last year after he stepped into a foot-deep hole rigged with a booby trap. He missed the trip wire by a fraction of an inch and thanks his lucky stars that he wears a size 8 boot instead of an 8½.

"I pulled my foot out quick," he recalls. "I still didn't realize the hole was a booby trap." Again, he barely missed tripping a grenade, "Then I saw it, a piece of fishing line running out the hole and tied to a tree a few feet away. That's when I looked in the hole and spotted the grenade. If I had kicked the trip I'd hate to think of the shape I'd be in now."

With pliable bamboo a part of South Vietnam's natural flora, the Vietcong have

(Please turn to page 212)

This new tool bonds almost anything in 60 seconds

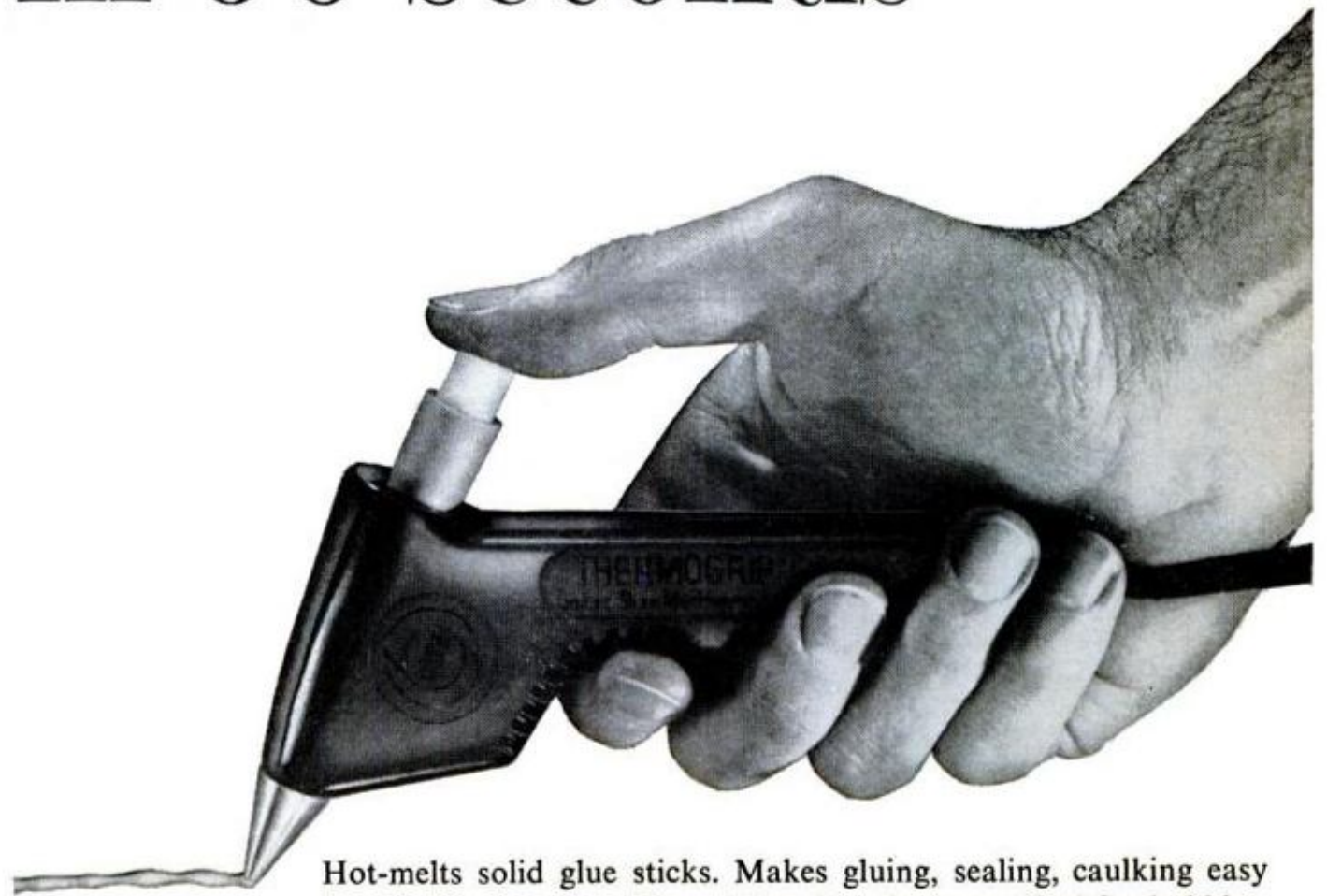

Hot-melts solid glue sticks. Makes gluing, sealing, caulking easy for all. No clamping. No waiting. No clean up. Ideal for hobbies, repairs, crafts. Try the Thermogrip Electric Glue Gun at \$7.95^{list} your hardware dealer. Or write us for complete information.

THERMOGRIP[®]
electric glue gun



Consumer Products Center, United Shoe Machinery Corporation, 221 Oley St., Reading, Pa.

Get a Tight Grip on Your Pipe Work



WITH A
RIDGID
BENCH
YOKE VISE

8 Sizes,
1/8" through 6" Capacities

Every home and farm workbench needs a **RIDGID** Pipe Vise. It makes threading and cutting for pipe, conduit or rod repairs a pleasure—not a chore. Yoke and base are extra rugged. Yoke can latch on right or left, opens instantly for easy removal of long lengths. Base includes handy bender. Sharp, full-width jaws, made of hardened tool steel, assure tight, slip-proof grip.

See the Complete Line of **RIDGID**
Work-Saver Tools at your Dealers!

RIDGID

THE RIDGE TOOL COMPANY, ELYRIA, OHIO, U.S.A.

Renew it with COLORCRETE



YOU CAN MAKE GOOD MONEY re-surfacing stucco, concrete, other masonry with Colorcrete. Easy to apply with spray-gun, becomes a permanent part of the masonry. Wide choice of colors. Write for free Colorcrete Opportunity Book.

W. E. DUNN MFG., CO., 570 Ottawa Ave., Holland, Mich.

How can UNIMAT be exciting if it bores?



Simple. It also mills, drills, grinds, polishes and more. That's UNIMAT, a miniature machine shop that operates both as a precision lathe and multi-functional tool on metal, plastic and wood. Converts in just seconds. Only 17" long, UNIMAT has satisfied thousands of exacting hobbyists with its versatility and tool-room accuracy (up to .0005"). Performs like costly big equipment while taking up a minimum of space.

No prior experience is necessary to use this valuable tool. The basic unit plus lots of extras sells for \$139.50. Send for free literature, or \$1.00 and get the whole story in "Miniature Machining Techniques"; a 40-page photo-packed manual. Write: American-Edelstaal, Inc., Dept. G-P6, 350 Broadway, New York, N.Y. 10013.



DEADLY BOOBY TRAPS

(Continued from page 210)

devised any number of effective booby-trap weapons that, even if they don't kill, can seriously wound and possibly demoralize fighting men who are eager to come to grips with an elusive foe. One of the most fearsome devices in the Vietcong's arsenal of bamboo weapons is the punji whip or "Malaysian gate," a rakelike affair that is strained back and tied along a jungle trail. Released by a tripwire, it slams forward, burying an array of knife-sharp stakes in the victim's chest or back.

The Marines have had their share of danger from booby traps as have other fighting men from U.S. Army infantry units. During "Operation Crimp," carried out in January, 1966, the hard-fighting paratroopers of the 173rd Airborne Brigade had to contend with rusty cans hanging chest high from the branches of trees. Hidden by dense foliage, the cans are hard to see. But just brush against one and you set off a devastating blast that rips through flesh and bone like grapeshot. This booby trap, tied motionless with catgut or communications wire, is fitted with a pressure detonator that is sprung once the can is moved from its inert position.

Green and deadly

Still another deadly booby trap, as old as war itself, has caught many an unwary GI and Marine. Bamboo vipers, dark green, three-foot-long snakes peculiar to the jungles of southeast Asia, have been hung from branches over trails used by American troops. Their heads hanging shoulder high, these venomous snakes strike with a hiss. One GI paratrooper walking into a cave in the central highlands was warily feeling his way in an effort to avoid the more conventional booby traps. Suddenly, something from above lashed at his cheek. Something else nipped at his shoulder and a cold, slimy something slid along his neck. He had walked into a curtain of snakes hanging from the cave's ceiling. Hungry, angry, frustrated, they bit the soldier furiously. He died in minutes.

For the Vietcong, there's even the ultimate in this sneaky, effective, sadistic and "sick war." It's the human booby trap. At the Punji Palace leatherneck units that are given this course in guerrilla warfare survival shudder when they hear about the "soda water girl." Each afternoon she peddled cold drinks to Marines stationed in outposts and bunkers outside her village near Danang.

"You buy? You buy?" she'd entreat the

(Continued on page 214)

For Only Fine Lawns . . . **Locke Reel**
is Ideal . . . It trims as it mows

In your heart you know a Locke Reel is best! Precision blade is first thing to touch grass. Travels on rubber rolls. Our dealers Demonstrate and Service!

- from 25" to 75" • 3 to 9 hp
- reverse transmission
- riding sulky



1075-L Connecticut Avenue
Bridgeport, Connecticut



Locke Manufacturing Companies, Inc.

If You Can Draw A Straight Line (with a ruler)
WE CAN TEACH YOU DRAFTING

Growing consumer and defense industries can't get enough trained draftsmen. Our new teaching methods let you learn in your spare time at home. You learn more, learn faster. Step up the wage ladder with a white collar skill that leads to the top. Send for sample lesson and course outline. Resident course also available on our Chicago Campus. Established in 1934—60,000 graduates.

AMERICAN INSTITUTE OF ENGINEERING & TECHNOLOGY
1125 Fullerton Pkwy—Chicago, Ill. 60614



**BIG BLAST
CARBIDE CANNONS**

Loud! Sounds like dynamite blasts! Brilliant flash! Mighty roar echoes for blocks.

- 9" Field Cannon \$4.95 (Illustrated)
- Extra Loud 17" Modern Field Cannon \$9.95
- Mammoth 25" Field Cannon \$13.95

All Prices Postpaid
UNITED SAFETY SUPPLY
349 Manufacturers Exchange
Kansas City 5PM, Mo.

"\$8,500 PROFIT MY
FIRST YEAR"

WITH INLAND 3-IN-1 RADIATOR SHOP"
—John Burrus, Sr., Fredericksburg, Va.

Inland shop owners make good money testing, cleaning, repairing auto-truck-tractor radiators. You can too! Compact shop only 11'7" x 3'6". Inland, world's largest radiator equip. mfr., trains you free in 2 weeks or less. Pay-As-You-Profit purchase plan. Proved merchandising assures volume. Write for FREE BOOK, owner letters, details on program. Profitable dept. for garage or gas station.

INLAND MFG. CO., Dept. PM-6, 1108 Jackson, Omaha, Neb., 68102



**AMAZING SPEED REDUCER
for Portable Electric Tools**



Cuts Speed in Half of any AC-DC MOTOR up to 6 1/2 amps or 750 watts without loss of Torque!

**DOUBLES LIFE
OF MOTORS**

Increases the life of incandescent bulbs 4 times or more. Just plug into this electronic speed reducer. No moving parts. Nothing to wear out . . .

WORKS on portable Electric Drills, Saber Saws, Buffers, Sanders, Grinders, Polishers, Routers, Saws, Impact Tools, etc. Cuts electric consumption and heat output in half.

Send check or money order. Satisfaction guaranteed.

EFENBEE CO. Dept. P-6,

3019 S. Komensky, Chicago, Ill. 60623

\$2.45
Post Paid
3 for \$6.95

GOVT. SURPLUS AND OTHER BARGAINS SAVE UP TO 90%



AC GEAR MOTOR Operates on 115 V. AC 60 cycle. Continuous duty. 1/15th HP 4 pole motor, 6 RPM @ output shaft. Contains extra heavy steel gears. Develops 750 lbs. torque. Face mounting. Great for conveyors, mixers, displays, etc. 9" L x 4 1/2" W x 7" H. Shpg. wt. 16 lbs. NEW. Special purchase. Specify model VW16-1. A \$38 value. NOW, \$19.95.

MOTOR SIMILAR TO ABOVE except 1/10th HP, 9 RPM, intermittent duty. Shaft faces away from motor. 9" L x 4 1/2" W x 8" H. Specify model VW16-2. \$17.95.



HIGH VOLUME PUMP Pumps up to 11 GPM @ 35 psi @ 2000 RPM thru 1 1/2" pipe ports. For fuel, oil, hydraulic fluid. Water or water based insecticides. Pump has carbon veins, aluminum body. Complete with mounting base with 1/2" keyed drive shaft ready to couple to your 1/4 HP motor. NEW. 7" L x 4" W x 4" H. Wt. 5 lbs. Approx. GOV'T COST \$75. Now! \$17.50



GEAR HEAD MOTOR Heavy duty, all ball-bearing const. throughout. Excellent for conversion to winch drive unit for electrical car or golf cart motor. Reversible with 5/8" shaft. Turns approx. 400 RPM on 12 V.D.C. Can also run on 24 V. at increased speeds. Approx 3 HP motor. 14" L. x 5 1/2" W. approx GOV'T. COST \$250. Shpg. Wt. 40 lbs. Like NEW. \$19.95



ELECTRIC PUMP WITH CONTROL SWITCH For boats, campers & trailers. Output 200 GPH. Can be used in fuel or water. 1/2" pipe bronze inlet. 12 or 24 V.D.C. Explosion proof motor. Shpg. wt. 9 lbs. Complete with wiring diagram. Approx. GOV'T COST \$200. NEW \$11.95



NEW! BIG! 1966 CATALOG

Send 25c for amazing catalog with 1000's of bargains in hydraulics; electrical; marine, automotive items, etc. Order from ad. Prices FOB. 50% deposit for COD. Pls. include your zip code number. Satisfying mail order customers thru-out the world since 1945.

AIRBORNE SALES CO. Dept. PM666
8501 Stellar Dr. • Box 2727 • Culver City, Calif. 90230

ENROLL—EARN YOUR DEGREE

of Bachelor of Bible Philosophy (B.Ph.B.), Master of Bible Philosophy (M.Ph.B.), Graduate of Bible Philosophy (G.Ph.B.), Doctor of Metaphysics (Ms.D.), or Doctor of Divinity (D.D.). Chartered by State, Correspondence Courses only. Please write for FREE BOOKLET.

AMERICAN BIBLE INSTITUTE

Dept. PM, 408A W. 75th St., Kansas City, Mo. 64114

Fill Flaws

In Plywood

Fill them *quick* with Plastic Wood. Handles like putty—hardens into wood. Easy to sand, paint or varnish.

For surest results always use GENUINE



PLASTIC WOOD
Handles like putty—hardens into wood!



PREVENTS DROP OUTS

MAC'S Sealer and Stop Leak holds the diploma for turning leaky radiators into straight-A performers.

In fact, MAC'S is the **only** sealer and stop leak that's guaranteed to stop a 20-pound high pressure leak — and hold it indefinitely.

So why not play it smart? Make sure that problem radiator doesn't flunk out.

Add a can of MAC'S Sealer and Stop Leak today.

**MAC'S
SUPER GLOSS CO., INC.**
Los Angeles 90042
Cincinnati 45226

DEADLY BOOBY TRAPS

(Continued from page 212)

young American fighting men as she passed among them with a beguiling smile. She was about 12 years old and cute as a button. It was a hot day and eight thirsty Marines who had been digging fortifications clustered about the youngster. They didn't notice her fingering something under her loose cotton blouse.

A homemade bomb was strapped to her body.

She triggered the bomb and blew herself to eternity. Six Americans joined her in death. They had no chance to defend themselves; they didn't even die with dignity, facing the enemy. But that's the way it is in Vietnam's booby-trap war.

Two can play at this game

The Vietcong rely heavily on captured weapons. In what might appear to be an act of generosity bordering on treason, U.S. Special Forces combat patrols are "giving" weapons to the enemy. What they do is leave behind cartridges that blow up in Vietcong guns when they are fired, mortar shells that backfire and kill gun crews, and grenades with fuses so short they go off before they leave the hand of a guerrilla trying to throw one.

One particularly devious device is a fake 105-mm shell which "fails" to explode when it strikes the target area. Invariably, the thrifty Vietcong think it's a dud and send a team to recover it so as to use its fuse later in a land mine. But inside is a time bomb that goes off after the enemy has cached the shell.

A high—or low—point in Vietcong trickery was reached last October when reports were broadcast that some of the souvenir dolls that Americans had sent home to their families were booby-trapped. Police departments throughout the United States were called by alarmed recipients of the death dolls to take them away. U.S. Army, Marine and Navy demolition experts were called in to investigate. Finally, the "all clear" was given. None of the dolls was booby-trapped. That's the official explanation.

But a Navy chaplain believes otherwise. Lt. Evan Greco, "the flying father" who served aboard the aircraft carrier *Coral Sea*, recalls a close call he had with the souvenir dolls. "A lot of guys on the ship had bought the dolls for their families and friends back home," he explained. "I had one of them myself." Then several blew up aboard the ship and the ammo handlers with demolition training collected them for disarming. Like the "soda girl," the dolls were cute—but deadly. ★★★

BUILD YOUR OWN CAMPER AND SAVE!

Complete, easy to follow plans, instructions and materials list. Satisfaction Guaranteed . . . \$3.95

ALSO
FACTORY
BUILT UNITS

Travel Trailer Plans \$3.95

Econoline Camper

Pickup Cover Plans, in-

or Bus Conversion Plans \$2.95

structions, material list \$2.00

Equipment Catalog \$1.00

Returnable on first order.

WE HAVE PARTS, SUPPLIES, EQUIPMENT, ALUMINUM SKIN

Ask about our low cost
PICKUP COVER PACKAGE

MAIL COUPON TODAY!

VIKING CAMPER SUPPLY
94-88 Glenwood Ave., Minneapolis,
Minn. 55403

NAME
ADDRESS CITY STATE



SEND
DIME
FOR DETAILS

SEND CHECK OR MONEY ORDER
VIKING CAMPER SUPPLY 94-88 Glenwood Ave.
Minneapolis, Minn. 55403

If you want to STOP SMOKING here's how!



by Whitey Ford

The famous Major League pitcher who holds the most World Series records tells what happened when he decided smoking was not good for his physical fitness.

I talked to my doctor about smoking and he advised me to quit. I did. But it was hard. Then I heard about a little pill called Bantron. I was surprised to find that it helped a lot to keep me from smoking. Now, when I feel like relapsing, I just take Bantron instead.

Bantron was discovered by doctors in the research department of a great American University. Tests on hundreds of people showed that it helped more than 4 out of 5 of all people who wanted to stop smoking to do so in five to seven days. Even those who didn't stop completely had drastically cut down.

And the Bantron way is so easy and pleasant! Bantron does not affect your taste, is not habit forming. It acts as a substitute for the nicotine in your system, and curbs your desire for tobacco.

Try Bantron. You will be amazed at the results you get. It's so safe when taken as directed, that you can get it at all drug stores without a prescription.

Bantron
BRAND
Smoking Deterrent Tablets

1,400,000 AMERICANS ARE CURED OF CANCER



Print Your Own

Cards, Stationery, Advertising, Circulars, labels, photo and movie titles, church work, tags, etc. Save money. Sold direct from factory only. Raised printing like engraving, too.

Own a Printing Business

Print for Others, Good Profit. Have home shop. Junior press \$15; Senior \$35 up. We supply everything. Easy rules. Pays for itself in short time. Write now for free details. **KELSEY PRESSES, Z-37 Meriden, Conn.**

FIRST TIME EVER
AT THIS PRICE...
EXPENSIVE
LEAKPROOF CON-
STRUCTION ON...

HIGH PERFORMANCE PUMPS SAVE! BUY DIRECT FROM FACTORY!

Quickly Drain Pools and Cellars!
Fill Tanks! Irrigate! Spray!

Now . . . a pump for under \$50 with permanently leakproof ceramic-lapped precision mechanical seal construction . . . the same as in pumps for atomic submarines. Forget about the leaks and constant adjustments necessary with conventional gland seal pumps. Precision made to pump up to 5,000 GPH. Up to 60 ft. ht. Maintenance free, rust-proof aluminum castings. 1 1/2" intake, 1" discharge. Fits any motor. Threaded suction discharge. Quality guaranteed by one of America's leading manufacturers of precision tools and pumps. Send check or M.O. or \$1 deposit on C.O.D.'s. Flexible drive coupling \$1 extra.

MONEY BACK GUARANTEE!

AMERICAN MACHINE & TOOL CO., Dept. PM-66, Royersford, Pa.



\$9.95
ppd.

Heavy Duty
Ball Bearing
Model . . . \$13.95
ppd.

7,000,000 STUDENTS

SAY "YES"!

More than 7,000,000 men and women have studied I.C.S. home-study courses since 1890, and there's one good reason why: because I.C.S. courses PREPARE YOU TO GET AHEAD FASTER AND MAKE MORE MONEY.

I.C.S. courses are job-related, with facts you can put to work right away. Texts, written by authorities, are easy to understand and profusely illustrated. Your I.C.S. instructor answers any questions you have. Studying at home, you have enough time to REALLY UNDERSTAND YOUR SUBJECT! And the I.C.S. diploma you earn will prove you're a man trained—and determined—to move forward!

How can you get ahead faster? By ACTION—RIGHT NOW! Choose the field you are interested in from the list at right—and this is only a PARTIAL listing of the more than 200 I.C.S. courses. Then fill out one of these postpaid cards and mail it. You'll receive, absolutely FREE, three valuable booklets available only from I.C.S.: (1) "How to Succeed," an analysis of the reasons for success and failure; (2) a booklet outlining opportunities in your field of interest; and (3) a sample I.C.S. lesson ("Selling Your Ideas").

There's no obligation when you mail the card. And it could be the most important step of your life.

DO IT RIGHT NOW!

75th YEAR

I C S

Scranton, Penna. 18515

Accredited Member, National Home Study Council

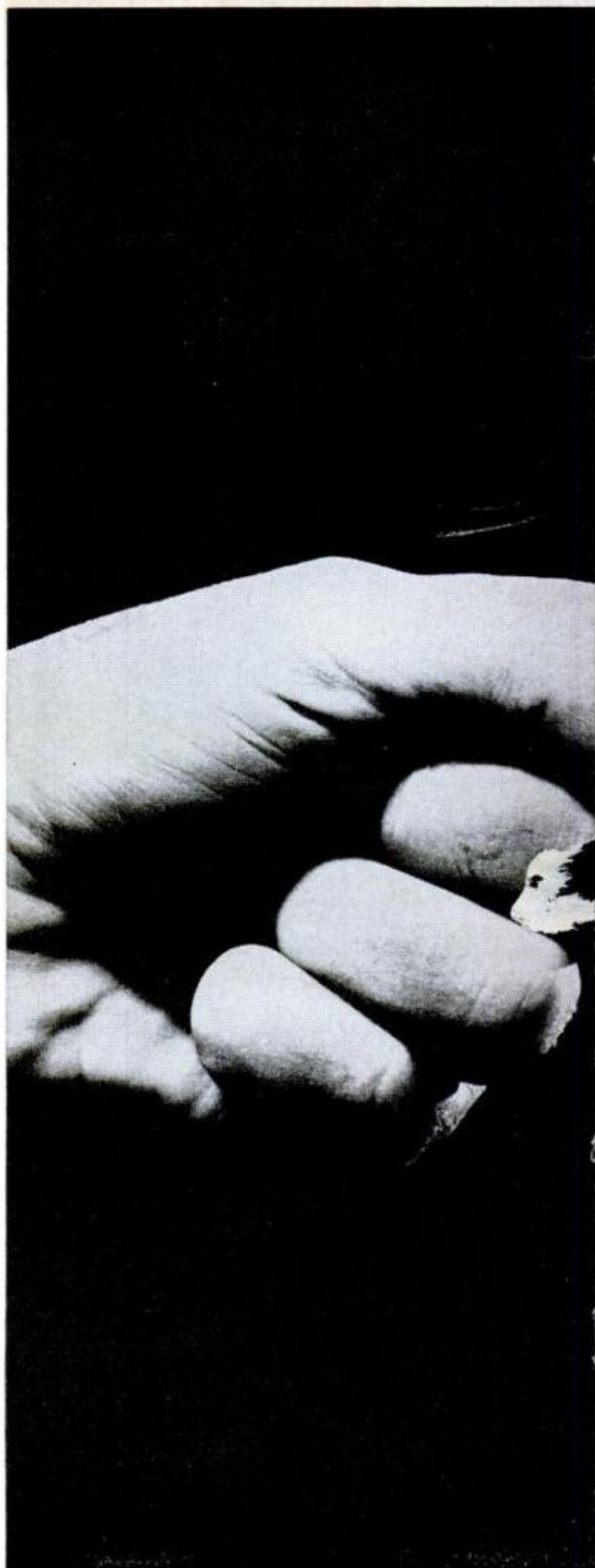

**"CAN I
GET
AHEAD
FASTER?"**

**MAIL
ONE
OF
THESE
CARDS**

CHOOSE FROM THIS PARTIAL COURSE LISTING

ARCHITECTURE and BUILDING TRADES

Air Conditioning
Architecture
Arch. Drawing
Building Contractor
Carpentry & Millwork
House Planning
Painting
Plumbing & Heating

ART and DESIGN

Commercial Art
Interior Decorating
Illustrating
Show Card & Sign
Painting
Sketching & Painting

AUTOMOTIVE

Auto Electrical
Technician
Automotive Mechanic
Engine (Gas & Diesel)
Engine Tune-Up
Transmission
Specialist

BUSINESS

Accounting
Cost Accounting
Public Accounting
Bus. Administration
Executive Training
Marketing
Personnel-Labor
Relations
Practical Accounting
Programming for
Digital Computers
Purchasing Agent
Real Estate
Salesmanship
Sales Mgmt.
Small Business Mgmt.
Traffic Mgmt.

CHEMICAL

Analytical Chemistry
Chem. Engineering
General Chemistry
Chemical Laboratory
Technician
Nuclear Energy
Plastics
Pulp, Paper

CIVIL ENGINEERING

Civil Engineering

Highway Blueprints
Highway Engineering
Structural Blueprints
Sanitary Engineering
Structural Engineering
Surveying & Mapping

DRAFTING

Architectural
Drafting Technology
Electrical and
Electronic
Mechanical

ELECTRICAL

Electrical Appliance
Servicing
Electrical Engineering
Electric Motor
Repairman
Industrial
Telemetering
Instrument Technician
Practical Electrician
Practical Lineman

ELECTRONICS

Automation
Electronic Computers
Electronics Technician
General Electronics
Hi-Fi Stereo and
Sound Systems
Industrial Electronics

ENGINEERING (Professional)

Chemical Civil
Electrical
Mechanical

ENGLISH and WRITING

Better Business
Writing
Introductory
Technical Writing
Short Story Writing
Practical English

HIGH SCHOOL (Diploma)

High School Business
High School General
High School Math
High School
Secretarial
High School
Vocational
College Preparatory

LANGUAGES

(Edited by Berlitz)
French German
Italian Spanish

MECHANICAL and SHOP

Gas and Electric
Welding
Industrial Engineering
Industrial
Instrumentation
Machine Design
Machine Shop
Practice
Mechanical
Engineering
Reading Shop
Blueprints
Tool Design
Toolmaking
Safety Engineering

SECRETARIAL

Clerk-Typist
Legal Secretary
Medical Secretary
Professional
Secretary
Shorthand
Stenographic
Typist

STEAM and DIESEL POWER

Boiler Inspector
Power Plant
Engineering
Stationary Diesel
Engineering
Steam Engineering

SUPERVISION

Foremanship—
Supervision
Personnel—
Labor Relations

TV-RADIO

Radio and
TV Servicing
Radio-Telephone
License
TV Technician
Practical Radio-TV
Engineering

MISCELLANEOUS

Textile
Other
(please specify)

Who's got everything for your Ford



from Compasses... An accurate, dependable device for getting bearings in unfamiliar territory. Attaches to windshield, instrument panel or garnish molding. Illuminated for nighttime driving. **\$7.95***



to tachs...

Ideal for all 6- and 8-cylinder engines, 6- or 12-volt systems. Tach head mounts in instrument panel, contains complete unit. Hooks up to ignition inside passenger compartment. Cobra 6000 or 9000 RPM—4-inch face, from **\$43.10***



to baby seats...

A miniature bucket seat with tie-in harness. Held firmly in place with standard equipment seat belt and other straps... cushion back. **\$29.20***



to wire wheel covers...

In gleaming stainless steel with solid wire spokes. These beauties will put you one up on the opposition. Fit 14" and 15" wheels. Set of four. **\$95.65***

*Manufacturer's suggested retail price. Installation charges, state or local taxes are extra.

Your Ford Dealer of course!

You'll get the most for your driving pleasure from your Ford Dealer!

