

# POPULAR MECHANICS

MAY 1966  
35 CENTS

SPECIAL! THE GOOD LIFE OUTDOORS

Wrap-up: great gear for campers, fishermen

COMPLETE PLANS: □ \$50 family-size canoe,  
□ 'No-squat' pickup camper fits garage

Assemble

PM's fabulous

Aqua-car!



'66 TEMPEST & RAMBLER: CHEERS & BOOS!

BUY '66 — WILDEST POWER GRAB EVER!



# WHEN THE OUTDOORS CALLS,

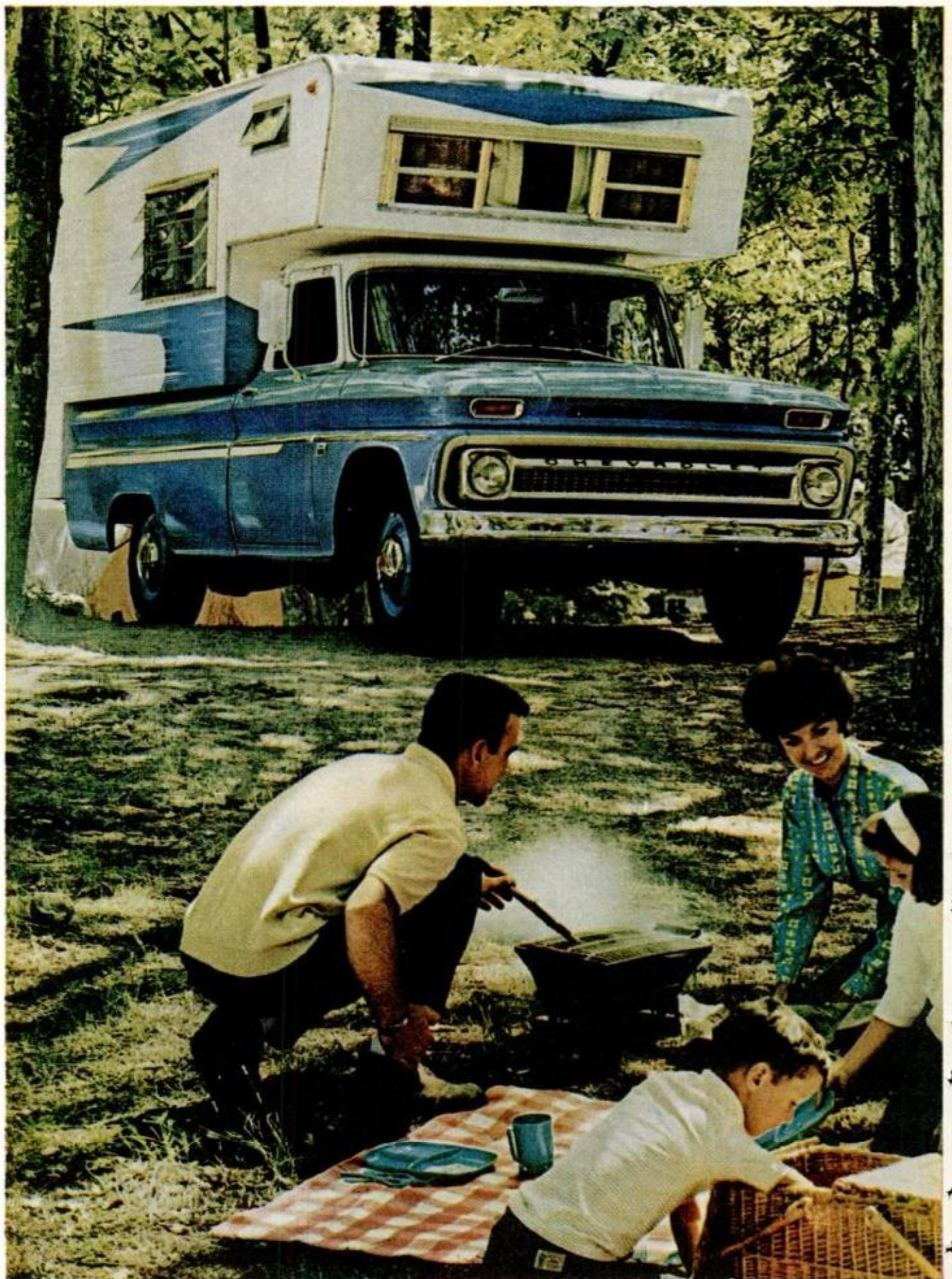



# CHEVROLET HAS ALL THE ANSWERS

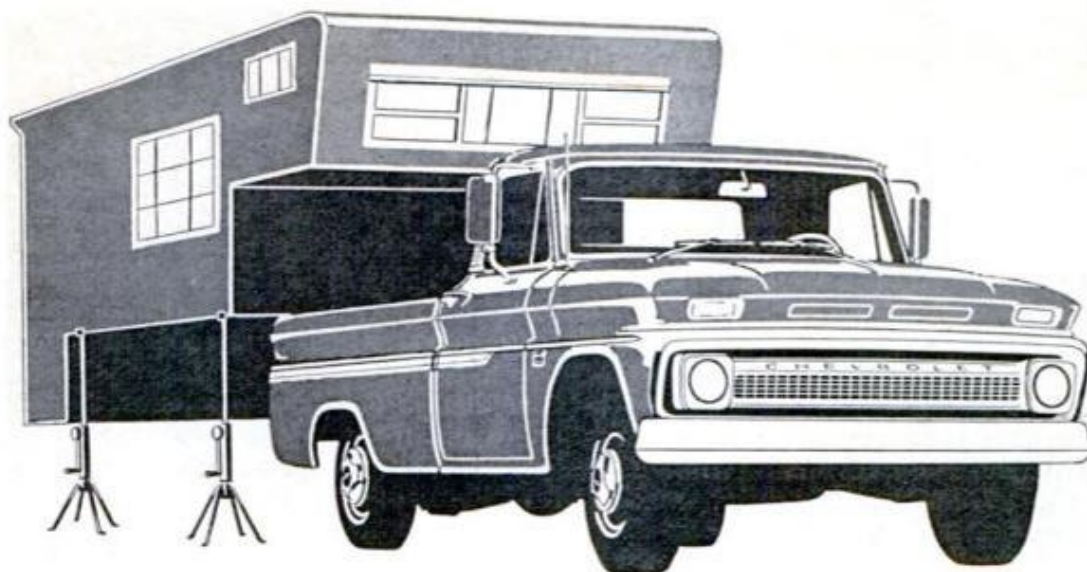

## NEW CUSTOM CAMPER PLUS A FULL LINE OF PLEASURE TRUCKS

Getting away from it all is becoming America's most popular pastime. That's why Chevrolet has come up with so many ways to go. Take the Custom Camper, a rugged  $\frac{3}{4}$ -ton Chevy pickup especially fitted out for extra comfort, eye-appeal and strength. It will carry the camper body of your choice beautifully. And serve you as a deluxe pickup when you remove the camper body between trips.

Need more room? A chassis-cab model can tote

a larger unit. Even the sporty El Camino can be equipped with a roomy camper body. If you prefer a self-contained vehicle, there are Chevy-Van and Step-Van conversions. And the Chevrolet Carryall is a natural for camping duty. Get the full story of Chevrolet pleasure trucks by mailing in the coupon below. Better yet, stop in and see your Chevrolet dealer. . . . Chevrolet Division of General Motors, Detroit, Michigan.

**TRAVEL THE CHEVROLET WAY**



CHASSIS-CAB



CHEVY-VAN CONVERSION



STEP-VAN TRAVEL COACH

"Pleasure Trucks" Dept. PM  
Chevrolet Motor Division  
P.O. Box 7271  
Detroit, Michigan 48202

Please  
Truc **This One**

NAM

ADD: **J4FR-JCE-2Q87**

CITY \_\_\_\_\_ STATE \_\_\_\_\_ ZIP \_\_\_\_\_



# Want a fishing engine that's little, light, lively and loaded with big motor features? Answer: the new Sea-Horse 6

The new Sea-Horse 6 demonstrates beautifully just how much you can put into a 51-pound powerpack. Literally, every big-motor feature that makes sense is standard equipment on this super deluxe, super light, new 6. Full gear shift and twist-grip throttle. Fixed high-speed carburetor jets factory-set for peak efficiency. A high-capacity fuel pump. Full range silencing. Thermostatic cooling to lengthen engine life. You

name it, the Sea-Horse 6 has it. *3 still more compact Compacts.* There are three Sea-Horse engines smaller than the new 6. The strong, new 5. Two new 3's (one High-thrust model, one that's a tiger in heavy weeds). All are economy motors—as simple and light and low-priced as an engine can be and still be all Sea-Horse. Like all 16 new

Johnson motors, these sip sparingly of regular grade fuels. Each thrives on a 50 to 1 gas-oil diet to halve oil costs. For the right engine to fit your needs, see your Johnson dealer. Check your Yellow Pages. Check your will power at the door. P.S. Johnson also makes a full line of Johnson Boats and the Johnson Skee-Horse snowmobiles.

From 3 to 100hp, every '66 Johnson features:

- Famous 2-year warranty\*
- Full corrosion protection
- 50 to 1 gas-oil mix

\*For 24 months after purchase, Johnson Motors will replace, without cost to the original purchaser, any part of its manufacture which upon inspection proves to have failed in normal use due to faulty material or workmanship.

*first in dependability*

Johnson Motors, 2177 Pershing Road, Waukegan Ill. Division Outboard Marine Corporation

# Johnson





# Build a workshop phone shelf

You supply the skill.

We'll supply the extension phone—and its installation.

Then, you can make calls right from your shop. And put the job aside, instead of putting it away.

An extension phone doubles your telephone convenience—the convenience of

the whole family if you put your extension near your bench and near the laundry or game room.

But it adds only a fraction to your telephone bill.

For the handy extension phone, just call your Bell Telephone Business Office or ask your telephone man.



Phone shelf has a wide drawer, recess for phone directory, and pull-out panel for listing often-called numbers. Major pieces can be cut from one 4' x 8' sheet of  $\frac{3}{4}$ " fir plywood. For drawer sides and back, use  $\frac{1}{2}$ " plywood and for drawer bottom use  $\frac{1}{4}$ " plywood. Ends of plywood finished with  $\frac{3}{4}$ " x  $\frac{1}{4}$ " white pine. Assemble with sixpenny nails and glue.

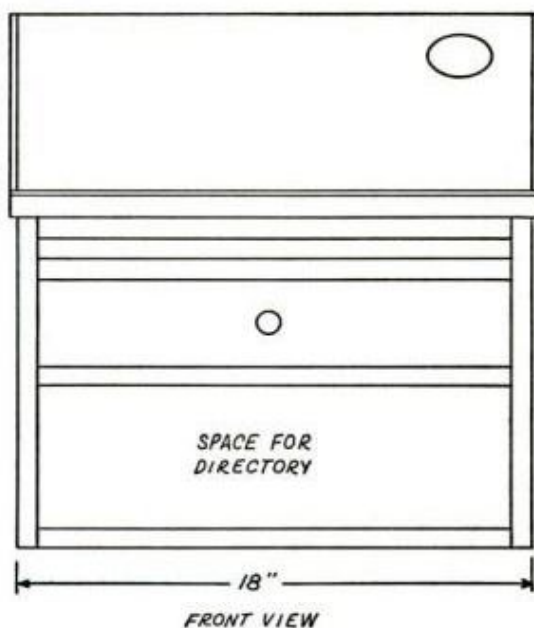
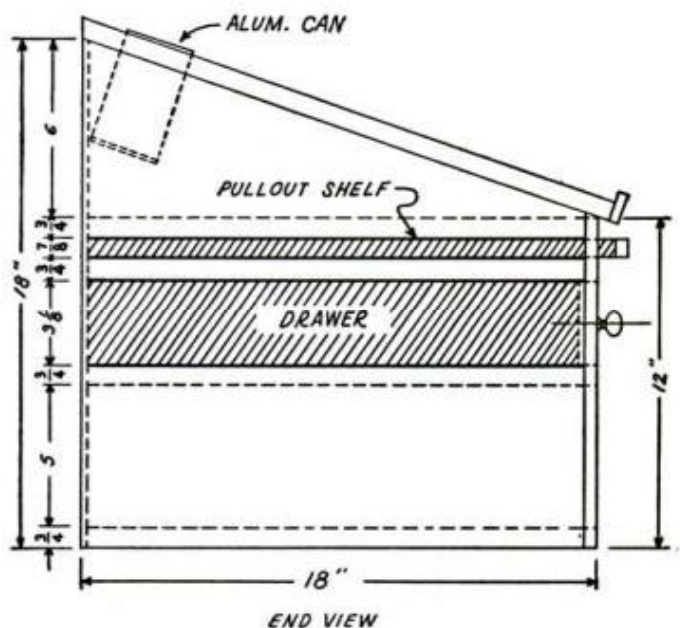

**Bell System**

American Telephone & Telegraph  
and Associated Companies



# POPULAR MECHANICS

INTERNATIONAL EDITIONS: AUSTRALIAN, SPANISH, CARIBBEAN, FRENCH, DUTCH, PORTUGUESE, DANISH, SWEDISH

## PM CAMPING SPECIALS THIS MONTH!

- 106 WHAT'S NEW FOR CAMPERS**  
A gaggle of gear to keep campers comfortable
- 112 ROUGHING IT IN HIGH STYLE**  
Luxury trailer brings home to the outdoors
- 116 RUGGED CAMPS TURN BOYS INTO IRON MEN**  
Outward Bound camps are the world's toughest
- 124 TRY CAMPING AFLOAT**  
For a fresh get-away-from-it-all feeling
- 128 NEW TACKLE TO HOOK FISHERMAN**  
Design innovations and new equipment add to the comfort of the angler
- 132 BUILD A HIGH-LOW PICKUP CAMPER**  
You can stand tall in the galley, yet park it in your garage
- 134 BUSH BUGGY**  
Anyone can assemble PM's fabulous Aqua-Car Kit
- 145 BUILD THIS 14-FOOT CANOE FOR \$50**  
A fast, stable, lightweight canoe—perfect for two

## FEATURES OF SPECIAL INTEREST

- 74 1966 at Indy: Big Power Shoot-Out**
- 78 Whoosh! There it Goes: The Flying Stovepipe**
- 82 Tempest Owners Report: A Tiger in Performance, a Dog on Gas**
- 86 Rambler American Owners Report: Handling Tops Economy**
- 90 Planning a War? See Sam**
- 94 Our Newest Frontier Is Underwater**
- 112 Roughing It in High Style**
- 120 He Stalks Sharks by Kayak**

## FOR THE SHOPCRAFTSMAN

- 132 Build a High-Low Pickup Camper (File Flag)**
- 138 Bush Buggy (File Flag)**
- 145 Build This 14-Foot Canoe for \$50**
- 148 Galley Adds Spice to Patio Fun**
- 158 The Lowdown on Lower Units**
- 163 Realistic Spring Maintenance Program (File Flag)**
- 170 Chip Shields for Milling Machine**
- 174 Multi-Action Paint Shaker**
- 180 Electronics' New Gee-Whiz Kits**

## REGULAR DEPARTMENTS

- |                               |                            |                                   |
|-------------------------------|----------------------------|-----------------------------------|
| <b>6 <u>Letters</u></b>       | <b>26 <u>Military</u></b>  | <b>60 <u>New for Home</u></b>     |
| <b>12 <u>Science</u></b>      | <b>28 <u>Aviation</u></b>  | <b>73 <u>Editor's Page</u></b>    |
| <b>16 <u>New Outdoors</u></b> | <b>30 <u>Detroit</u></b>   | <b>156 <u>Home Problems</u></b>   |
| <b>22 <u>Inventions</u></b>   | <b>34 <u>Careers</u></b>   | <b>161 <u>Outboard Clinic</u></b> |
| <b>24 <u>Home Clinic</u></b>  | <b>48 <u>Spotlight</u></b> | <b>168 <u>Auto Clinic</u></b>     |



Published By The Hearst Corporation  
**RICHARD E. BERLIN, PRESIDENT**

President, Magazines Division:  
**RICHARD E. DEEMS**

Publisher:  
**JOSEPH F. KERN**

Editorial Director:  
**WALTER IAN FISCHMAN**

Executive Editor:  
**RICHARD F. DEMPEWOLFF**

Managing Editor:  
**JOHN A. LINKLETTER**

Shop Crafts Managing Editor:  
**WAYNE C. LECKEY**

Art Director:  
**RAYMOND A. SCHULZE**

CLIFFORD B. HICKS \_\_\_\_\_ Midwest Editor  
THOMAS E. STIMSON \_\_\_\_\_ Western Editor  
KEVIN V. BROWN \_\_\_\_\_ Aviation  
ALFRED W. LEES \_\_\_\_\_ Home Workshop  
RICHARD HOWE \_\_\_\_\_ Building and Landscape  
ARTHUR MIKESSELL \_\_\_\_\_ Boating  
JOHN F. PEARSON \_\_\_\_\_ Science  
STUART JAMES \_\_\_\_\_ Outdoors  
LARRY STECKLER \_\_\_\_\_ Electronics  
JIM DUNNE \_\_\_\_\_ Detroit Automotive  
WILLIAM KILPATRICK \_\_\_\_\_ New York Automotive  
LEONARD SAMUELS \_\_\_\_\_ Photography, Shop Products  
JOHN J. SHEAHAN \_\_\_\_\_ Production  
TERRY HONIGFELD \_\_\_\_\_ Assistant Production  
MURRAY COOPER \_\_\_\_\_ Assistant Art Director  
LEO R. WEEKS \_\_\_\_\_ Assistant Art Director  
GEORGE W. BLOW \_\_\_\_\_ Staff Artist  
PHILIP F. HUY \_\_\_\_\_ Staff Artist  
BONNIE J. ANDERSON \_\_\_\_\_ Staff Artist  
FRANK P. FRITZ \_\_\_\_\_ Chief Photographer  
EUGENE A. COLANGELO \_\_\_\_\_ Staff Photographer  
RALPH L. CLAAR \_\_\_\_\_ Photographer  
GARRY WINTER \_\_\_\_\_ PM Books  
FRANKLYN JACOBY, ASID/IDI \_\_\_\_\_ Design Consultant  
EVERETT JOHNSON \_\_\_\_\_ Cabinetmaker

ADDRESS COMMUNICATIONS TO: 575 Lexington Ave., New York, N.Y. 10022.  
For additional sources of information on the articles and products in  
this issue, write to Bureau of Information, Popular Mechanics, for free  
"Where-to-Find-it" list.

**L. PARK BENJAMIN, Advertising Director**

ADVERTISING OFFICES: New York: 575 Lexington Ave., Murray Hill 8-8500;  
Chicago: 520 N. Michigan Ave., 527-2400; Detroit: General Motors Bldg.,  
TRinity 5-8711; Cleveland: Hanna Bldg., 1422 Euclid Ave., PRospect  
1-0456; Los Angeles: 3460 Wilshire Blvd., DUnkirk 2-8458; San Fran-  
cisco: 1101 Hearst Bldg., YUkon 2-0823.

SUBSCRIPTION SERVICE: Mail all subscription orders, changes of address,  
correspondence concerning subscriptions, and Postmaster notices of  
undeliverable copies to Popular Mechanics, Box 646, New York, N. Y.  
10019.

Popular Mechanics is published monthly by The Hearst Corporation,  
57th St. at 8th Ave., New York, N.Y. 10019, U.S.A. Richard E. Berlin,  
President; George Hearst, V-Pres.; Richard E. Deems, President of Maga-  
zines; John R. Miller, V-Pres. and Gen. Mgr. of Magazines; William S.  
Campbell, V-Pres. and Director of Circulation; Joseph F. Kern, V-Pres. for  
Popular Mechanics; Frank Massi, Treasurer; R. F. McCauley, Secy.  
Single copy in the United States and Canada, 35 cents. Subscription  
prices: United States and Possessions, \$4.00 for one year; \$7.00 for two  
years; \$10.00 for three years. Canada, add \$0.50 for each year. Pan  
American Postal Union countries, add \$1.00 for each year. All other  
countries, add \$2.00 for each year. When changing address, give old  
address as well as the new, with postal-zone number, if any, and allow  
six weeks for change to become effective. Second-class postage paid at  
New York, N.Y., and at additional mailing offices. Authorized as second  
class mail by the Post Office Department, Ottawa, and for payment of  
postage in cash. Registered as second-class matter at the Post Office at  
Mexico, D.F., Mexico, June 20, 1950. © 1966 by The Hearst Corporation.  
All rights reserved. Printed in U.S.A.

Only riding mower  
with exciting

# Reo-matic Drive

A great experience in *automatic* lawn care. Reo Lawn Skiff with exclusive, no-shift Reo-Matic Drive. Instant response forward or reverse at the touch of a foot pedal. A choice of two speed ranges to fit mowing conditions. Unmatched smoothness and safety from a wide track tilt-proof chassis. Big 32-inch cutting capacity in a "Float-a-Mow" rotary with rear discharge that follows lawn contour and prevents scalping. Short-turning maneuverability lets you trim close around trees and shrub lines. And still more touches of greatness in the Reo Lawn Skiff . . . the positive-locking parking brake, the "easy-chair" bucket seat with backrest, and big power from a heavy-duty, 4-cycle, 6 hp engine that starts electrically or with recoil starter.

See the Reo Lawn Skiffs. See the complete selection of self-propelled and push-type rotaries, too. Reo Insta-Matic Mowers—21-inch rotaries, with the handy convenience feature that lets you set mowing height instantly with one lever. Reo big capacity rotaries with quality value in every model. They're all on display at your Reo dealer. See the Yellow Pages or write direct to Wheel Horse Products, Inc., 425 West Ireland Road, South Bend, Indiana.



**Reo lawn skiff**

*instant response—no shift*

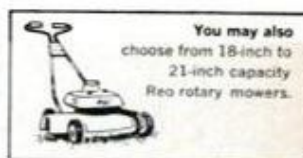

You may also  
choose from 18-inch to  
21-inch capacity  
Reo rotary mowers.







**T**oughness is engineered into every MASTER Padlock—from the laminated steel case to the hardened steel shackle. This is no ordinary padlock . . . it's the strongest in the world! So get a MASTER and get the best. \$1.75 to \$4.00 in a variety of styles and sizes, at your hardware store or locksmith. Also available in sets keyed-alike (with interchangeable keys) or master-keyed. If it's worth locking up, it's worth a MASTER Padlock!

**Master**  
WORLD'S STRONGEST PADLOCKS

## LETTERS TO THE EDITOR

### Praise for praise

This letter is from a woman who enjoys *PM* and from the magazine has culled many helps in keeping machinery operating on a small ranch.

The article *Praise the Lord and Pass the Lug Wrench* (page 82, Dec. *PM*) should be brought to the attention of all Christians. The article very vividly describes the abilities that all workers in backward countries must possess. If only more magazines would publish this kind of article! Bremerton, Wash. MRS. CLARENCE THORNE

### Sorry . . . didn't know it was loaded

The caption for the Firefish target boat (page 141, March *PM*) notes that ships practice on them with "radar guns."

The fact is that 11 Firefish boats have been sunk to date, two by aircraft and the balance by surface guns aboard ships. In short, the Firefish is a very live target at which live ammunition is fired.

Ryan Aeronautical Co. JACK G. BROWARD,  
San Diego, Calif. Chief, News Bureau

### Top for Mini-Moke

In *Spotlight on That Preposterous Mini-Moke* (page 30, Oct. *PM*) you mentioned that this vehicle has no weather protection. We felt, therefore, that your readers would be interested to know that we pro-



duce a fiberglass hardtop (shown in the photo), sidescreens and other accessories. Barton Motor Co. D. J. PHILLIPS  
Plymouth, England

### Needs a label

I read *Lost Radium . . . Killer at Large* (page 100, Feb. *PM*) with great interest. I can't see why such a dangerous product  
(Please turn to page 10)



# "Look who's smiling now!"

"The department head's job had just been left vacant. When the boys in the office learned I was gunning for it, they gave me their widest grins. One thing they didn't know: I had made up my mind sometime back to take LaSalle training that would prepare me for a better job. My study paid off so fast it surprised even me—I was picked for that shiny promotion over everyone's head. Who wouldn't be smiling with a neat new \$1,500 increase!"

LA SALLE'S files are filled with letters from graduates who have rapidly climbed the ladder of success. You, too, can qualify for the job opportunity of your choice through LaSalle home study—without interfering with your present work—and by devoting only a little of your spare time.

LaSalle has been leader in home education for more than half a century and has enrolled more than 1,000,000 ambitious men and women. Its faculty includes some of the country's foremost practicing specialists and instructors. Your training is in good, experienced hands.

Mailing the LaSalle coupon below may be the first step in getting a better job, higher pay, and all of the good things that go with success. Simply check the program in which you are most interested, and we will send you a valuable free booklet describing the opportunities in that field. Mail to LaSalle, 417 Dearborn, Chicago, Illinois 60605.



## LA SALLE EXTENSION UNIVERSITY

A Correspondence Institution • 417 South Dearborn, Dept. 53-112, Chicago, Illinois 60605

Please send me, without cost or obligation, FREE booklet and full information on the field I have checked below:

### ACCOUNTING

- Complete Accounting with CPA Training
- General Accounting
- Income Tax
- Accounting Fundamentals
- Auditing
- Controllorship
- CPA Training
- Modern Bookkeeping

### BUSINESS MANAGEMENT

- Complete Business Management
- Credit and Collections
- Office Management
- Personnel Management
- Business Correspondence

### LAW COURSES

- Bachelor of Laws Degree
- Business Law
- Insurance Law
- Claim Adjusting Law
- Law for Police Officers
- Law for Trust Officers

### SALESMANSHIP

- Sales Management
- Complete Sales Training

### DRAFTING

- Basic Drafting
- Aeronautical Drafting
- Architectural Drafting
- Electrical Drafting
- Mechanical Drafting
- Structural Drafting

### REAL ESTATE

- Complete Real Estate
- Real Estate Brokerage
- Real Estate Management
- Real Estate Sales

### TRAFFIC AND TRANSPORTATION

- Complete Traffic Mgt.
- Transportation Law
- Rates and Tariffs

- Agency and Services
- Motor Truck Traffic

### STENOTYPE

- Machine Shorthand

### TECHNICAL COURSES

- Mechanical Refrigeration
- Air Conditioning, Refrigeration and Heating
- Diesel

### HIGH SCHOOL

- High School Diploma

### CAREERS FOR WOMEN

- Interior Decorator
- Dental Assistant
- Secretarial
- Accounting
- Bookkeeping
- Real Estate

Name..... Age.....

Address..... County.....

City & State..... Zip No.....

Occupation..... Working Hours..... A.M..... P.M.



## 1. Training Means Money These Days

In today's job market, men with specialized training get the good jobs—and good pay. Trained men get the promotions and pay raises that count. In virtually every field, TRAINING spells the difference between staying where you are—and moving ahead.

Look over the list of fields below. In each, I. C. S. has been training men and women for years. Giving them up-to-date knowledge that will let them advance in their present job... or break into an entirely new field. I. C. S. can do the same for you—starting RIGHT NOW.

## 2. Jobs in Architecture, Building

**ARCHITECTS**—Qualify for advanced positions in architectural, engineering offices. I. C. S. courses begin with basics. Knowledge to help prepare for A.I.A. exams. Math. Drawing. Design. B'ld'ng, M'ch'n'c'l trades. Write "Architecture" on coupon for FREE booklets.

**ARCH. DRAWING**—One-course stepping-stone to architecture. Emphasis on drawing practice. No previous experience necessary. Apply now.

**CARPENTRY**—Largest demand area in building trades. \$4.07 average hourly wage. Over 20,000 openings yearly. Training needed. Send coupon NOW.

**PLUMBING-HEATING**—Earn \$4.30 hourly—average for plumbing-heating specialists. I. C. S. course has proven track record. Starts with basics. Mail coupon for FREE Success Kit.

## 3. Art Talent Sought

**COMMERCIAL ARTISTS**—Experienced artists earn \$150 and more weekly. But training is essential. Course starts with fundamentals. Job-related. Personalized instruction. Break into field full- or part-time. Write "Commercial Art" on coupon.

**INTERIOR DECORATING**—Non-technical course for homemaker, home furnishings salesperson. Study carpets, furniture, walls, windows, decor, color, taste. Mail coupon now.

**SIGN PAINTING**—Course prepares you to break into field. Covers all aspects: layout, design, painting, gilding, screen process. Send coupon for 3 FREE booklets.

**SKETCHING & PAINTING**—Like to draw? Feel you have talent? Get training. For spare-time enjoyment, or use in present line of work. Course starts with basics, covers popular art mediums.

## 4. Automotive Specialists

**AUTO ELECT. TECHNICIAN**—More electrical equip. on cars—more need for elect. specialists. I. C. S. course covers the circuits, headlamp to taillights. Simply written, illustrated texts. Send coupon for 3 FREE booklets.

**MECHANIC (GEN'L)**—700,000 employed. 20,000 openings yearly, and employment on the upswing. Famous I. C. S. course taken by thousands in field. Coupon brings Success Kit.

**TRANSMISSION SPEC'L'ST**—If you now know cars, why not become a specialist? Course covers transmission troubles, testing, repairing, overhauling. Auto., standard.

## 5. Businessmen Make \$\$\$\$

**ACCOUNTANTS**—20,000 openings a year in this high-pay field. I. C. S. courses cover the basics plus 10 vital accounting specialties. Get information. Send coupon right NOW.

**ADMINISTRATION**—The key to business success. Famous I. C. S. course covers 3 vital areas: management, production, marketing. Write "Business Administration" on coupon.

**EXEC. TRAINING**—A company's as good as its top people. Learn to train men, to spot "comers." Mail the coupon.

**MARKETING MEN**—Advance to management? You'll need marketing knowledge. Course covers management practices, principles, with emphasis on marketing. Get started now.

**PROGRAMMERS** for digital computers. Space-age specialty. Earn up to \$15,000 yearly. Specialized—training vital. This course gives it.

**PURCHASING**—Advance to purchasing agent? Break into field? Take this course. Demand for PA's rising. Experienced men earn average salaries of \$8-\$15,000. Send for Success Kit.

**SALESMANSHIP**—I. C. S. is famous for this course. Covers basics of selling that stay same, no matter the field. 1,000,000 new salesmen needed 1965-75. Get started NOW. Write "Salesmanship" on coupon.

**YOU  
CAN  
GET  
A  
BETTER  
JOB**  
by spare-time study  
with I. C. S.

**SMALL BUSINESS MGT.**—Run your own business. Course tells how. Covers purchasing, merchandising, sales, taxes, accounting, etc.—all you need to know.

**TRAFFIC MGT.**—Employment forecasts show upward trend for trained traffic people. Course covers entire traffic picture. Prepares you to enter or advance in field. Send coupon today.

## 6. Chemistry

**CHEM. ENGINEERS**—Youngest engineering field, expanding with industrial development. Course prepares you for registration exams. Also for breaking into chemical design, development or production departments. Send coupon for Success Kit. It tells whole story.

**GEN'L CHEM.**—A good course in gen'l chemistry? What easier way than at home, in spare time. Also covers basic math, physics.

**NUCLEAR ENERGY**—Course for engineers, technicians, maintenance men who want to enter nuclear field. Covers basic math, physics & chemistry leading to study of radioactivity and nuclear energy.

**PLASTICS**—Qualify as plastics technician. Take this course. Texts easy to read, written by experts. Mail the coupon for 3 FREE booklets.

**PULP, PAPER SPECIALISTS**—Courses cover engineering to paper machine operator. Demand field, exp'ct'd to increase 75% in next 25 years. Write for information.

## 7. How to Become a Civil Engineer

**CIVIL ENGINEER**—Famous course recognized by many states, prepares you to take exams. All aspects of civil engineering. Thousands of graduates. Write now for 3 FREE booklets.

**HIGHWAY ENGINEER**—Advance in field. Course complete, covers theory, practice. Recognized by many states. Send coupon now.

**STRUCTURAL BLUEPRINTS**—How to read them. A key to advancement for ironworkers, patternmakers, builders of concrete structures. Mail coupon now.

**SANITARY ENG'N'R'NG**—Men trained in this field in constant demand. Course covers water treatment-supply, sewerage, eradicating menaces to health. Apply now.

**SURVEYING, MAPPING**—Course for man who wants to enter civil engineering field, but undecided about branch. Texts illustrated, simply written. Personalized instruction. Mail coupon.

## 8. Draftsmen in Demand

**DRAFTSMEN**—Over 4000 openings yearly. Senior draftsmen earn average \$550/month. Break into field? I. C. S. training in specialized area can help you. Don't delay. Choose field, then clip coupon.

**ARCHITECTURAL** drafting course covers arch. drawing, house planning, freehand & ornamental drawing, shades & shadows.

**ELECTRICAL**—Arithmetic, electricity basics, projection drawing, machine sketching, electrical drafting, other subjects.

**ELECTRONIC**—Math, mechanical drawing, formulas, electricity, electronic & printed circuit drafting, others.

**MECHANICAL DRAFTING**—Arithmetic, algebra, geometry & trig, projection drawing, mechanical drawing, machine sketching, others.

## 9. Electronics, Electricity

**APPLIANCE SERVICING**—More appliances mean more demand for servicemen. I. C. S. gives you know-how worth money from start. Clip coupon for Success Kit.

**ELECTRICAL ENGINEERS**—Demand field. Jobs in gov't, industry. I. C. S. training helps worker in field advance to junior, sr. eng'n'r'ng positions. Also helpful in preparing for registration exam. Starts with basics, if you have limited knowledge. Send coupon for 3 FREE booklets.

**ELECTRIC MOTOR REPAIRMAN**—Course starts with basics, covers AC, DC motors—perfect for would-be maintenance men, or those who seek advancement to supervisor.

**INSTRUMENT TECHNICIAN**—Specialists in electrical measuring & control equip. will be scarce in late '60's. Take advantage! Course gives training, starting with gen'l principles. Send for Success Kit right away.

**PRACTICAL ELECTRICIANS** earn an average of \$4.37 per hour. Get the know-how! Course covers building wiring, elect. equipm't. Helps prepare for licensing, journeyman exams.

**INDUSTRIAL ELECTRONICS**—Technical-level course—through grounding in electronics. Take first step to cracking this rapidly expanding field. Mail the coupon.

**ELECTRONICS TECHNICIANS**—With 5 yrs. exp., they average \$6500—many earn more!



Be a specialist in this booming field! Course prepares you. Theory—you learn it. Plus practical application. Mail coupon now.

### 10. Engineering—a Profession

Take your first step to becoming a registered, professional engineer, with the help of famous I. C. S. courses. There are two routes to eng'n'ng: college and 4 yrs' exp. in field; or high school and 8 yrs' exp. Then, state registration exam. I. C. S. courses help you obtain work where you can gain necessary field experience; give you knowledge you need to pass exams. Instruction available in Civil, Chemical, Electrical, Mechanical Engineering. Texts authored by authorities, are illustrated and simply written for quick comprehension. Study now, in spare time, for future success or retirement career in engineering. Write "Professional Engineer" on coupon. Do it now.

### 11. Success, Pleasure Through Better English Writing

**BUSINESS WRITING**—Command the written word—a key to business success! Course covers composition, copywriting, editing, typography, report writing. Send coupon for FREE Success Kit.

**FREE-LANCE WRITING**—A career for anyone with talent for writing. Course treats techniques, forms and—how to sell articles. Step-by-step instruction. Send coupon.

**SHORT STORY WRITING**—An avocation that can lead to spare-time profit. Course covers English grammar, elements of a good story. Emphasis on actual writing. Get started now.

**PRACTICAL ENGLISH**—A bedrock study of basic English. To improve your speech, writing. As refresher in the basics. People judge you by your language. Send coupon today.

### 12. More Formal Education

**FINISH HIGH SCHOOL**—It's never too late. And H.S. completion means much greater earning power and job security. I. C. S. High School programs let you complete your schooling at home, in spare time, at your own pace. Variety of courses offered: Business, Secretarial, Vocational, General. Complete only work you need for I. C. S. High School diploma. Start doing it now—by filling out coupon and mailing it!

**COLLEGE PREPARATORY** high school course also available. Take credits you need for I. C. S. H. S. diploma that prepares you for college entrance exams. It's never too late to start—if you have the desire. How about now?

**LEARN LANGUAGES**—Special, low-cost courses. Instruction by records, text, the world-famous Berlitz way. Specify language you're interested in: French, Italian, German or Spanish.

### 13. \$\$\$\$ in Mechanics, Shopwork

**AIR CONDITIONING EXPERT**—Experienced men make \$125 a week, average, and demand is rising. If you have basic mechanical knowledge, take this course. Instruction in maintenance, too. Write "Air Conditioning" on coupon.

**INDUSTRIAL ENGINEERING**—Advance to higher position in operation/management of industrial plant: this course gives the knowledge you'll need. Also first step to becoming registered eng'n'r. Send coupon.

**INSTRUMENTATION**—Several thousand new jobs a year in this demand field. A basic course. Write for Success Kit.

**MACHINE DESIGN**—A technical field itself, this knowledge is vital to draftsmen, and a big plus for production men, shop workers.

**MACHINE SHOP PRACTICE**—A basic course, giving overall knowledge of shop oper'tns. Emphasis on practical facts. Personalized instruction. A must for the man who wants to advance. First step? Mail coupon.

**MECHANICAL ENGINEERING**—Within your grasp a high-pay field where at least 2600 new jobs open yearly. Write for Success Kit.

**SHOP PRINTS**—And how to read them. An authoritative, factual study. Vital to men who want to advance in shop work. Mail coupon now.

**REFRIGERATION SPECIALISTS**—Enter this booming field and learn the hard way? There's no need. Training spurs advancement—it's never been truer! Fill out coupon for complete information.

**TEXTILE TECHNICIAN**—The job outlook is good—for trained men. Course designed to help you break into field—or advance to management. Write "Textile" on coupon.

**TOOLMAKING**—The average toolmaker earns \$26 daily. For good reason: he knows a specialized skill. I. C. S. course equips machinists to crack this specialty, where over 4000 jobs open up annually.

**SAFETY ENGINEERING**—A comparatively new field, and men with formal training are scarce. Be one. Take I. C. S. course. Covers math, plant design, equipment placement, psychology, safety principles, practices. Apply now. Clip coupon.

**WELDING**—6000 openings yearly for welders, and pay in line with demand. I. C. S. offers several courses, from the basics to specialized areas. Write "Welding" on coupon for 3 FREE books.

### 14. Secretarial Help Wanted

**WHERE THE MONEY IS**—It's in specialized secretarial work. Few secretaries know specialized terminology, procedures. Those who do are in demand, command good pay.

**LEGAL SECRETARY**—Course covers instruction in typing, English, Gregg method sh'rt'h'nd, business law, insurance, office practice, public relations, legal shorthand. Equips you to work in law office. Apply immediately—the coupon's how.

**MEDICAL SECRETARY**—Basic secretarial skills covered in detail. Plus: instruction units on duties of a medical secretary, medical terminology, related subjects. Send coupon NOW for information.

**STENO-TYPIST**—Want to be a secretary? Break into steno-typist work first. Send coupon for facts on I. C. S. training in typing, stenography, business practice—all you'll need to know.

**CLIP COUPON HERE—TAKE YOUR FIRST BIG STEP TO REAL SUCCESS!**

I. C. S., Scranton, Penna. 18515

Accredited Member, National Home Study Council

## INTERNATIONAL CORRESPONDENCE SCHOOLS I C S

Dept. 1477, Scranton, Penna. 18515

Without cost or obligation, rush me "HOW TO SUCCEED," the opportunity booklet about the field I have indicated below, and a sample I.C.S. lesson.

Field of interest \_\_\_\_\_

Name \_\_\_\_\_

(Indicate Mr., Miss, Mrs.)

Address \_\_\_\_\_

City \_\_\_\_\_

State \_\_\_\_\_

Zip Code \_\_\_\_\_

Occupation \_\_\_\_\_

Employed by \_\_\_\_\_

Working Hours \_\_\_\_\_

A.M. to \_\_\_\_\_ P.M.

Low rates to members of U.S. Armed Forces.

Special training programs for industry. New! Special WICS package for women!



# Patches Walls

DAP VINYL-  
PASTE  
SPACKLING

No mixing—ready to use. Patches cracks, holes, joints in plaster and wall-board. Fills even deep holes quickly, easily. Creamy smooth, fast drying, easy sanding. Takes paint. Sold at leading hardware, building supply, paint and specialty stores.



**DAP** DAP INC., Dayton 31, Ohio  
SUBSIDIARY OF *Plough, Inc.*

## LETTERS continued

is kept in a container that's not too outstanding; it should carry an eye-catching color or some other mark.  
Eel River Crossing, N.B. AMEDEE LANDRY

## Back-yard skyscraper

My husband built this tree house according to the plans in *Build a Modern*



*Tree House* (page 126, June PM). Our four children and their friends have found many hours of enjoyment playing in it, thanks to your magazine.  
Sidney, Ohio MRS. DONALD E. HALL

## Addition to ignition

Your readers' response to my story, *Electronic Ignition Takes to the Water* (page 200, March PM), indicates need for additional information. Resistor R8, which does not appear in the schematic, connects from COIL to TAC terminals on the barrier strip. Capacitor C7 is not always needed; if the system works without it, leave it.

And on page 203—where instructions are given for system failure—after the wires are connected to the TAC terminal, you must also connect A+ to COIL+.  
Brooklyn, N.Y. MURRAY GELLMAN

## Wrong island

The photograph you show in the short article *New Outpost Down Under* (page 96, Dec. PM) is a familiar one, but it does not show Anvers Island. It is a helicopter photo of the British Antarctic Survey Station south of Anvers.

Woodbridge, Va. RAYMOND A. BUTLER

*The Navy had identified the picture as Anvers Island—and the Navy now acknowledges its error. (No matter which island you're looking at, it seems there's enough snow and ice for everybody.)*

THE EDITORS

# The Devil has quite a temper!



We're proud of the temper in Red Devil's high carbon steel blades . . . just one of the quality features in our full line of putty knives, wall scrapers, wood scrapers and other home patch-up tools. Buy the best! Buy Red Devil!

**Red Devil inc**

UNION, N. J., U.S.A.



15737-B



**NEW! A complete closed-circuit TV camera including vidicon tube, 25mm. f 1.9 lens, cable, cabinet and complete instructions for only \$209.50!**



**Hundreds of uses in homes, schools, offices, plants, stores**

**Available as kit or fully assembled**

**One year guarantee on all parts (90-day guarantee on vidicon tube)**

**NOTHING ELSE TO BUY!**

- Connects instantly to any TV set
- Operates up to 6 sets without amplifiers

This versatile, high-quality, Conar Model 800 adds a new dimension to the electronic hobbyist's activities; provides the affordable answer for anyone needing an easy-to-use, reliable surveillance camera. At the low kit price of \$209.50 (\$259.50 assembled) you get everything you need to be operational. All you do is hook camera leads to antenna terminals on any standard TV set, turn to an unused channel (2 to 6) and switch it on! Use indoors or out at any distance up to 1,000 ft. A 150-watt bulb provides all the light you need indoors. Optional wide-angle and telephoto lenses and tripod available. Rush coupon for complete information. Easy monthly payment plan.

**MAIL TODAY**

**CONAR** is a division of the National Radio Institute



**IDEAL FOR HOME AND HOBBYIST**



**EXCELLENT FOR SURVEILLANCE USE**



**PERFECT FOR EDUCATION, TRAINING**

**CONAR** 3939 Wisconsin Avenue  
Washington, D. C. 20016  
EH6C

Please rush data on Model 800 TV Camera

Name \_\_\_\_\_

Address \_\_\_\_\_

City \_\_\_\_\_

State \_\_\_\_\_ Zip \_\_\_\_\_



BY JOHN F. PEARSON  
**SCIENCE**  
WORLDWIDE

**Breaking brain codes** is tedious, but research on it is coming along. Brains, as scientists have known for nearly 40 years, give out electrical waves that can be picked up by electrodes placed against the scalp. Epileptic attacks kick up a regular brainstorm of waves, and brain tumors cause recognizable changes in wave pattern.

Scientists reasoned that other mental conditions could be read from the recorded waves. But for a long time nobody could decode them, partly because of the vast mass of data collected by the electrodes. Now computers are used to scan, classify and catalogue this data, and it's beginning to make sense.

A British experimenter says he can tell by wave patterns whether the subject is an adult or child, or a mild psychopath or just plain normal. An American scientist says it's possible to determine what color the person is looking at while the brain-wave pattern is being recorded.

**Tunnels are rough.** A series of tests by Department of Commerce researchers showed that passengers on a railroad train speeding through a tunnel at speeds of 55 to 70 mph experience the same air pressure build-up that they would diving 6000 to 7000 feet a minute in a nonpressurized plane. (The Civil Aeronautics Board says 2000 feet per minute is limit for comfort.) The tests were part of a long-range investigation of the possibilities of improving high-speed ground transportation.

**Cosmic billiards.** Space navigators of the future may route their trips through the gravitational fields of other planets in order to gain the equivalent of a "tail wind." So says John C. Niehoff of the IIT Research Institute in Chicago who's studying gravity-assist techniques for NASA.

It's estimated, for example, that a trip to Mars would be greatly speeded up by allowing the ship to be attracted by Venus. That planet's gravitational field—as long as the ship didn't get too close—would provide a tremendous boost.

**Potent pastry.** New Zealand plans to feed 50,000 Asian children a year with a new type of high-protein biscuit. An ounce of the biscuit, developed by the New Zea-

land Dairy Research Institute, has as much food value as half a pint of milk. The biscuit is made from processed cheese and is freeze-dried for easy storage. To please Eastern palates, it comes in curry and smoked-fish flavors.

**More bounce to the ounce** is claimed for a new French tennis racket that's made of chrome-plated tubing and stainless-steel wire. Tests show it to be more resilient and durable than the traditional wooden racket.

**Oysters, like people,** don't perform well when sick. Infections suffered by the mollusks, Japanese scientists have found, result in a low output of quality cultured pearls. A quick dip in an antibiotic solution has proved the best medicine, resulting in a 30 percent increase in the production of top-quality pearls.

**Sensitive paint** that changes color when it gets hot is helping Lockheed company engineers to develop space vehicles. Models of the vehicles are coated with the paint before being put in high-speed wind tunnels. As the temperature rises at certain points on the model, the paint changes color to match temperature—from pink to blue to yellow to brown to black.

**Despite slurs** against it as an effective snakebite remedy, some forms of alcohol really do some good. Experimenting with rats, an Arizona scientist recently found that Scotch and vodka helped combat venom. Grain alcohol did not, and tequila and brandy actually increased mortality.

**You sleep to dream,** not to rest. That, in substance, is the theory of two British researchers who say that the human brain, like a computer, needs to scan and reorganize its programs periodically in order to maintain efficiency. Thus, a dream serves primarily as a "memory filter" for examining the mass of material collected during the day with a subsequent rejection of unnecessary trivia at night.

**"Washboard" runways** for airports are being investigated by British and U. S. engineers. It's thought that the grooves, by breaking up large sheets of water, will reduce chances of a plane's wheels hydroplaning on wet runways.



KEEP PACE WITH SPACE AGE! SEE MANNED MOON SHOTS, SPACE FLIGHTS, CLOSE-UP!



# AMAZING SCIENCE BUYS

for FUN, STUDY or PROFIT

SCIENCE FAIR HEADQUARTERS!  
FREE! CATALOG

## 'FISH' WITH A WAR SURPLUS MAGNET

### Go Treasure Hunting On The Bottom

Great idea! Fascinating fun and sometimes tremendously profitable! Tie a line to our 5-lb. Magnet—drop it overboard in bay, river, lake or ocean. Troll it along the bottom—your "treasure" haul can be outboard motors, anchors, fishing tackle, all kinds of metal valuables. 5-lb. Magnet is war surplus—Alnico V Type—Gov't. Cost—\$50. Lifts over 125 lbs. on land—much greater weights under water. Order now and try this new sport. Stock No. 70,571-HA. 5 lb. Magnet .....\$12.50 Postpaid  
Stock No. 70,570-HA. 3½ lb. Lifts 40 lbs. ....\$8.75 Postpaid  
STOCK NO. 85,152-HA... (lifts over 350 lbs.) .....\$33.60 F.O.B.

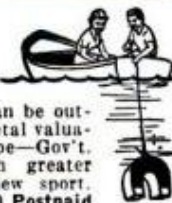

## See the Stars, Moon, Planets, Close Up! 3" ASTRONOMICAL REFLECTING TELESCOPE



60 to 180 POWER! Famous Mt. Palomar Type! An Unusual Buy! See the Rings of Saturn, the fascinating planet Mars, huge craters on the Moon, phases of Venus. Equatorial Mount with lock on both axes. Aluminized and overcoated 3" diameter high-speed f/10 mirror. Telescope equipped with a 60X eyepiece and a mounted Barlow lens. Optical Finder Telescope included. Hardwood, portable tripod. FREE with Scope: Valuable STAR CHART plus 272-page "HANDBOOK OF HEAVENS" plus "HOW TO USE YOUR TELESCOPE" BOOK.  
Stock No. 85,050-HA .....\$29.95 Postpaid

4¼" Reflecting Telescope—up to 225 Power  
Stock No. 85,105-HA .....\$79.50 F.O.B.

## OPAQUE PROJECTOR

Projects illustrations up to 3" x 3¼" and enlarges them to 35" x 30" if screen is 6½ ft. from projector; larger pictures if screen is further away. No film or negatives needed. Projects charts, diagrams, pictures, photos, lettering in full color or black-and-white. Operates on 115 volt. A.C. current. 6-ft. extension cord and plug included. Operates on 60 watt bulb, not included. Size 12" x 8" x 4½" wide. W. 1 lb., 2 oz. Plastic case. Stock No. 70,199-HA .....\$7.95 Postpaid



SOLVE PROBLEMS! TELL FORTUNES! PLAY GAMES!  
NEW WORKING MODEL DIGITAL COMPUTER  
ACTUAL MINIATURE VERSION OF GIANT ELECTRONIC BRAINS  
Fascinating new see-through model computer actually solves problems, teaches computer fundamentals. Adds, subtracts, multiplies, shifts, complements, carries, memorizes, counts, compares, sequences. Attractively colored, rigid plastic parts easily assembled. 12" x 3½" x 4¾". Incl. step-by-step assembly diagrams, 32-page instruction book covering operation, computer language (binary system), programming, problems and 15 experiments.  
Stock No. 70,683-HA .....\$5.98 Ppd.

## WAR SURPLUS AMERICAN-MADE 7x50 BINOCULARS

Big savings! Brand new! Crystal clear viewing—7 power. Every optical element is coated. An excellent night glass—the size recommended for satellite viewing. Individual eye focus. Exit pupil 7mm. Approx. field at 1,000 yds. is 376 ft. Carrying case included. American 7 x 50's normally cost \$274.50. Our war surplus price saves you real money. Only \$78.40 Ppd. 8 x 30 Binoculars—similar to above. Stock No. 963-HA .....\$40.00 Postpaid  
7 x 35 American Made Binoculars. Stock No. 964-HA .....\$55.00 Ppd.



"Balls of Fun" for Kids . . . Traffic Stoppers for Stores . . . Terrific for Amateur Meteorologists . . .

## SURPLUS GIANT WEATHER BALLOONS

At last . . . available again in big 8-ft. diameter. Create a neighborhood sensation. Great backyard fun. Exciting beach attraction. Blow up with vacuum cleaners or auto air hose. Sturdy enough for hard play; all other uses. Filled with helium (available locally) use balloons high in the sky to attract crowds, advertise store sales, announce fair openings, etc. Amateur meteorologists use balloons to measure cloud heights, wind speed, temperature, pressure, humidity at various heights. Photographers can utilize for low-cost aerial photos. Recent Gov't. surplus of heavy, black, neoprene rubber.  
Stock No. 60,568-HA .....\$2.00 Ppd.

SLIGHTLY HEAVIER RUBBER—LATER MANUFACTURE!  
Stock No. 60,562-HA . . . 4 ft. diam. size .....\$2.00 Ppd.  
Stock No. 60,564-HA . . . 8 ft. diam. size .....\$4.00 Ppd.

## MAKE YOUR OWN POWERFUL ASTRONOMICAL TELESCOPE

Grind Your Own Astronomical Mirror. Kits contain mirror blank, tool, abrasives, diagonal mirror and eyepiece lenses. You build instruments ranging in value from \$75.00 to hundreds of dollars.

Stock No.	Diam.	Mirror Thickness	Price
70,003-HA	4¼"	¾"	\$ 7.50 ppd.
70,004-HA	6"	1"	11.95 ppd.
70,005-HA	8"	1¾"	19.50 ppd.
70,006-HA	10"	1¾"	30.75 }
70,007-HA	12½"	2½"	59.95 } f.o.b.

ORDER BY STOCK NUMBER. SEND CHECK OR MONEY ORDER. SATISFACTION GUARANTEED.  
EDMUND SCIENTIFIC CO., BARRINGTON, N. J.

## NEW! SCIENCE FAIR PROJECT KITS

Edmund Kits are carefully planned to give any boy or girl the fun and excitement of discovering science facts. Such carefully planned projects can lead the student to awards or scholarships. Adults too will find them an excellent introduction to the various fields of science.  
Write for Free Bulletin 47-HA "Your Science Project" covering all phases of Science Fair projects.



## MINIATURE WATER PUMP



Wonderful for experiments, miniature waterfalls, fountains, Christmas gardens, 110 gage railroad backdrops, hobbyists, labs, schools. Pumps continuous flow of water etc. Tiny (2½" x 1¾") electric motor and pump ideal for hobbyists, labs, schools. Pumps continuous flow of water at rate of one pint per minute at a 12" head. With 2 D Batteries in series will pump to 24" high. Works in either direction. Stock No. 50,345-HA .....\$2.25 Postpaid

## WOODEN SOLID PUZZLES

12 Different puzzles that will stimulate your ability to think and reason. Here is a fascinating assortment of wood puzzles that will provide hours of pleasure. Twelve different puzzles, animals and geometric forms to take apart and reassemble, give a chance for all the family, to test skill, patience, and best of all to stimulate ability to think and reason while having lots of fun.  
Stock No. 70,205-HA .....\$3.00 Postpaid



## SCIENCE TREASURE CHESTS

For Boys—Girls—Adults!



Science Treasure Chest—Extra-powerful magnets, polarizing filters, compass, one-way-mirror film, prism, diffraction grating, and lots of other items for hundreds of thrilling experiments, plus a Ten-Lens Kit for making telescopes, microscopes, etc. Full instructions included.  
Stock No. 70,342-HA .....\$5.50 Postpaid  
Science Treasure Chest DeLuxe—Everything in Chest above plus exciting additional items for more advanced experiments.  
Stock No. 70,343-HA .....\$10.50 Postpaid

## BUILD A SOLAR ENERGY FURNACE

A fascinating new field. Build your own Solar Furnace for experimentation—many practical uses. Easy! Inexpensive! Use scrapwood! We furnish instructions. This sun powered furnace will generate terrific heat—2000° to 3000°. Fuses enamel to metal. Sets paper aflame in seconds. Use our Fresnel Lens 11" sq. F.L. 19".  
Stock No. 70,533-HA .....\$6.00 Postpaid



## WAR SURPLUS ELECTRIC GENERATOR

Brand new Signal Corps Electric Generator for scientific experiments, electrical uses, demonstrations. Generates up to 90 volts by turning crank. Use in high impedance relays. Charge ground and bring up night crawlers for bait or study. 2 Alnico Magnets alone worth original price. Wt. 2 lbs. Cost to Gov't. \$15.  
Stock No. 50,225-HA .....\$6.95 Ppd.  
Same type generator, mounted, with light, as electricity demonstrator.  
Stock No. 50,365-HA .....\$11.95 Postpaid



## Diagnose Hidden Trouble with PROFESSIONAL STETHOSCOPE

Designed for use by physicians, this super-sensitive stethoscope is ideally suited for detecting faults in machines and engines, and in fluid, air and gas leakage. Dozens of uses in auto repair shops, labs, hobby, educational applications.  
Stock No. 50,270-HA  
BARGAIN PRICE STETHOSCOPE—excellent value.  
No. 50,223-HA .....\$2.95 Postpaid



## Power Experiments, Models, Displays with NEW SOLAR DRIVE MOTOR

Sunlight can now be used as power source for precision miniature motor by International Rectifier. Attach to our Silicon Solar Cell or use 2 standard "D" flashlight batteries, or our Nickel Cadmium Cell No. 40,798 (Catalog page 147). Motor operates on 0.35 V to 1.5 V. Anti-friction sleeve bearings. .078 diam. shaft extends 7/16" from housing, has V-groove pulley, Copper brushes, metal and plastic housing 1½" diam., 15/16" high, wt. 2 oz.  
Stock No. 40,872-HA (Motor) .....\$3.95 Ppd.  
Stock No. 60,392-HA (Solar Cell) .....\$3.95 Ppd.



Order by Stock No.—Send Check or M.O.—Money-Back Guarantee  
EDMUND SCIENTIFIC CO., Barrington, New Jersey

## MAIL COUPON FOR FREE CATALOG "HA"

Completely new 1966 Edition, 148 pages  
Nearly 4000 Bargains.  
EDMUND SCIENTIFIC CO., Barrington, N. J.  
Please rush Free Giant Catalog "HA".

Name.....  
Address.....  
City..... State..... Zip.....





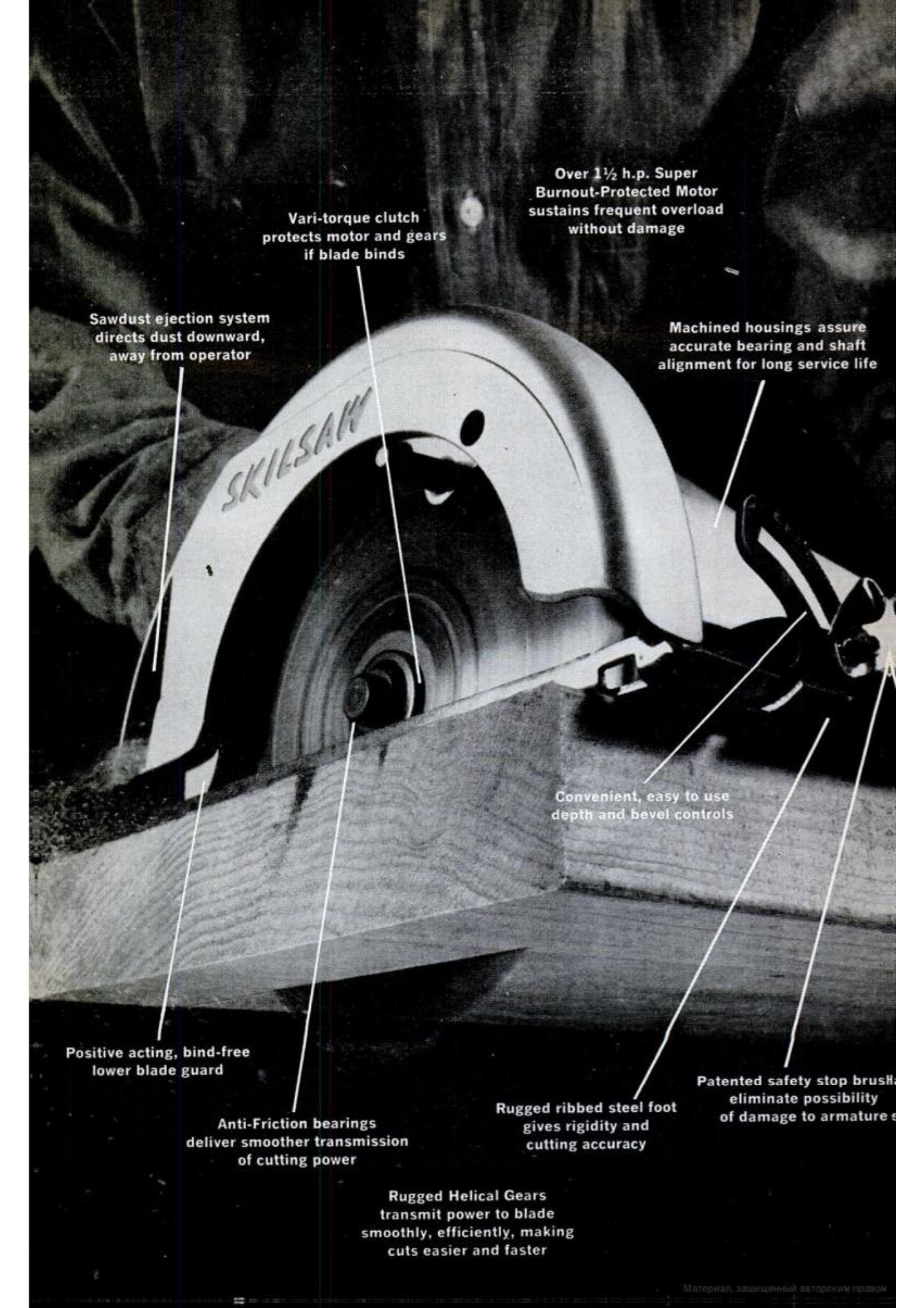

Over 1½ h.p. Super  
Burnout-Protected Motor  
sustains frequent overload  
without damage

Vari-torque clutch  
protects motor and gears  
if blade binds

Sawdust ejection system  
directs dust downward,  
away from operator

Machined housings assure  
accurate bearing and shaft  
alignment for long service life

Convenient, easy to use  
depth and bevel controls

Positive acting, bind-free  
lower blade guard

Anti-Friction bearings  
deliver smoother transmission  
of cutting power

Rugged ribbed steel foot  
gives rigidity and  
cutting accuracy

Patented safety stop brush  
eliminate possibility  
of damage to armature

Rugged Helical Gears  
transmit power to blade  
smoothly, efficiently, making  
cuts easier and faster



# New! Skilsaw® 7¼" power saw! Skilsaw quality! Skilsaw exclusives! Famous Skil Guarantee! Priced under \$40

Any genuine Skilsaw power saw in the under forty-dollar department is news! But when it's a super capacity saw like the new Model 574 7¼-incher, that's something else!

This one's got the extra blade capacity for cutting to a depth of 2⅜" at 90°, or for cutting 2-inch lumber at 45°. It's got the extra power to finish any cut you start without having to back off for a second try. And it's got the heft to handle everything from wood to metal, asbestos, cement materials, plastics, concrete, stone, ceramic tile and laminates.

Nobody offers as many features or as much saw for the money! Best way

to find out is to ask any 574 owner, or your hardware, department store or lumber dealer. They'll all tell you the same thing.

The Skilsaw 7¼" Model 574 power saw is another Skil "Lifetime" power tool. Which means it is guaranteed forever against defective materials or workmanship.

Skil Corporation, 5033 Elston Avenue, Chicago, Illinois 60630.

*Go with the pick of the pros...*

**SKIL®**  
POWER TOOLS



# FREE!

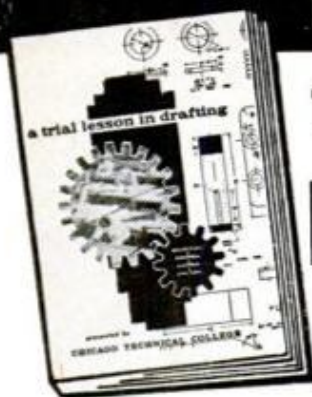

## Trial lesson in **DRAFTING & DESIGN**

### LEARN AT HOME IN SPARE TIME

Check the want ads in any newspaper—SEE the big-pay opportunities open to you as a draftsman. What's more, you can learn this well-paid, prestige profession at home—quickly, easily! No special talent needed! Get complete, step-by-step Chicago Tech lessons in the mail, spend a few pleasant hours studying each week. In a short time you'll be a well-trained draftsman, ready to take your pick of many good jobs. Act now!

### FREE INFORMATION—MAIL COUPON TODAY!

Get FREE TRIAL LESSON plus information about C.T.C. practical training. Learn what successful Chicago Tech graduates say about high pay and opportunities in drafting. No charge, or obligation.

Est. 1904 Accredited National Home Study Council

### CHICAGO TECHNICAL COLLEGE

E-204 Tech Bldg., 2000 So. Michigan Ave.  
Chicago 16, Illinois

Mail me FREE Lesson with information about big opportunities in DRAFTING.

Name..... Age.....  
Address.....  
City..... Zone..... State.....

### LAFAYETTE RADIO ELECTRONICS

# FREE!

## 512 Pages 1966 Catalog 660

Featuring Everything in  
Electronics for  
• HOME • INDUSTRY  
• LABORATORY

Mail the Coupon Today for Your  
FREE 1966 Lafayette Catalog 660

LAFAYETTE Radio ELECTRONICS  
Dept. LE-6, P.O. Box 10  
Syosset, L.I., N.Y. 11791

Send me the Free 1966 Lafayette Catalog 660

LE-6

Name.....  
Address.....  
City.....  
State..... Zip.....

# WHAT'S NEW OUTDOORS

BY STUART JAMES

**Canned worms** are now available for fishermen, and they are dispensed from a vending machine. If you've ever run out of bait late at night and then thumped around in the woods with a shovel and flashlight looking for worms, the idea of a 24-hour supply at the end of a dock is a welcome innovation. The vending operation is called the Cap'n Jones Night'n Day Bait Shop and also offers canned grubs, mullet bait and shrimp bait. All we need now is a second machine that sells fish.

**The bucket that breathes**, is the way they describe a new bait bucket made by Arndt & Son, Inc., Hamilton, Ohio. Made of insular Styrofoam, the "Aer-a-bucket" is equipped with a squeeze bulb that pumps air down through a narrow chamber and up through tiny holes in the bottom. This aerates the water and keeps live minnows frisky in much the same way that an air pump keeps tropical fish alive.

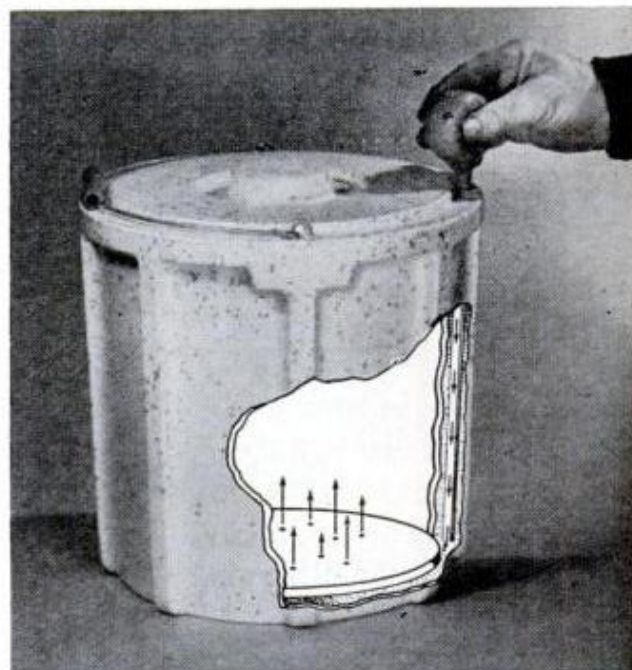

SQUEEZE BULB aerates the water in new bait bucket

A few squeezes on the bulb every half hour give the fish plenty of oxygen. The bucket weighs 11 ounces empty and holds 11 quarts. It is priced at \$4.95.

**Newest danger** to scuba divers is monofilament fishing line. Fishermen lose it when they get hung up on submerged wrecks, and it doesn't rot. Last year two divers were entangled and drowned off Long Island, N.Y. ★★★



# 7 FISHING LURES WORTH \$5.55 FOR \$1.00



Just send the top flap from a 5-pack of **Wm. Penn** Cigars with this coupon and your dollar.

Men are really "hooking on" to this great offer from Wm. Penn Cigars! Just like they've taken to Wm. Penn mildness — because Wm. Penn is the mildest full-size cigar you can buy. Pick up a Wm. Penn 5-pack containing the Fishing Lure Coupon or use the coupon in this ad. This is one catch you can't afford to miss.

Mail this coupon along with \$1 and the top flap of a 5-pack of Wm. Penn Cigars. Send to Lures, Box 860, Pilgrim Park Station, Warwick, Rhode Island. Offer expires December 31, 1966. Please send the 7 Fishing Lures to

PRINT NAME \_\_\_\_\_

ADDRESS \_\_\_\_\_

CITY \_\_\_\_\_ STATE \_\_\_\_\_ ZIP CODE \_\_\_\_\_



Lures by Atlantic Lures, Inc., Providence, R.I.





**This is a GM Original:  
It comes in GM carburetors.**



**This is a GM Replacement:  
It goes in GM carburetors.**

Once you've seen one, you've seen them both. GM Replacements look, act, and are just like GM Originals.

When one comes out, make sure the other goes in. Whether it's this carburetor power valve (sometimes called an "economizer" valve) that does so much for engine performance and efficiency—or any other important part.

So go where you know they use GM Parts. Look for the distinctive GM and United Delco packages. Good parts are a sign of good service.

## **GENUINE GENERAL MOTORS PARTS**



CHEVROLET • PONTIAC • OLDSMOBILE • BUICK • CADILLAC • GMC TRUCKS

**United  
Delco**







# SPORT

## *'66 MerCruiser...most carefree stern drive ever built*

MerCruiser's dependability is part of the fun. It takes you way out fast to where the line yankers are, helps you chase 'em down and bring 'em in, then brings you back. And it will do this day after day, year after year. That's the kind of dependable performance you'd expect from the world's most popular stern drive. Only MerCruiser has sure-going features like sturdy, one-piece lower unit; special impact protection; Super Flow cooling system and efficient Jet-Prop exhaust. Ruggedness is continually tested and proven at our Lake X, Florida, where MerCruisers ram through hyacinths and silt and over logs and sandbars to assure the strength of the stern drive unit. Then we

take the MerCruisers to Florida's west coast for testing under all salt water conditions. Each MerCruiser prototype churns through thousands of torture hours so we'll catch any problem before you do. No wonder MerCruiser is the most dependable stern drive you can buy—and far and away the world's best seller. See your MerCruiser dealer!

60, 110, 120, 150, 170, 225, 310-hp gasoline; 60-hp diesel



Worldwide Sales and Service

**MERCUISER**   
STERN DRIVE POWER PACKAGES FIRST IN MARINE PROPULSION





Camper Special Pickup by Ford—Camper body, clothing and equipment by Sears, Roebuck and Co.

# Ford's smooth-riding pickup makes a great traveling companion. Very accommodating.

Make Ford the one you camp on, and the easy life starts the moment you leave home. Twin-I-Beam suspension sees to that. Each front wheel has its own axle—a steel I-beam. Each axle works independently to dampen road shocks before they reach the driver... smooth the ride on any road. You find smoothness also in the clean response of Ford's big new 300-cu. in. Six and 352-cu. in. V-8 engines. Ford makes a special long-wheelbase pickup for campers. All the heavy-duty features to carry a big camper body are built right in. Makes travel wonderfully carefree. And when you think of it, that's the whole vacation idea.



## FORD/66



# Push-button ratchet wrench releases without a fight. New and only at **Sears**

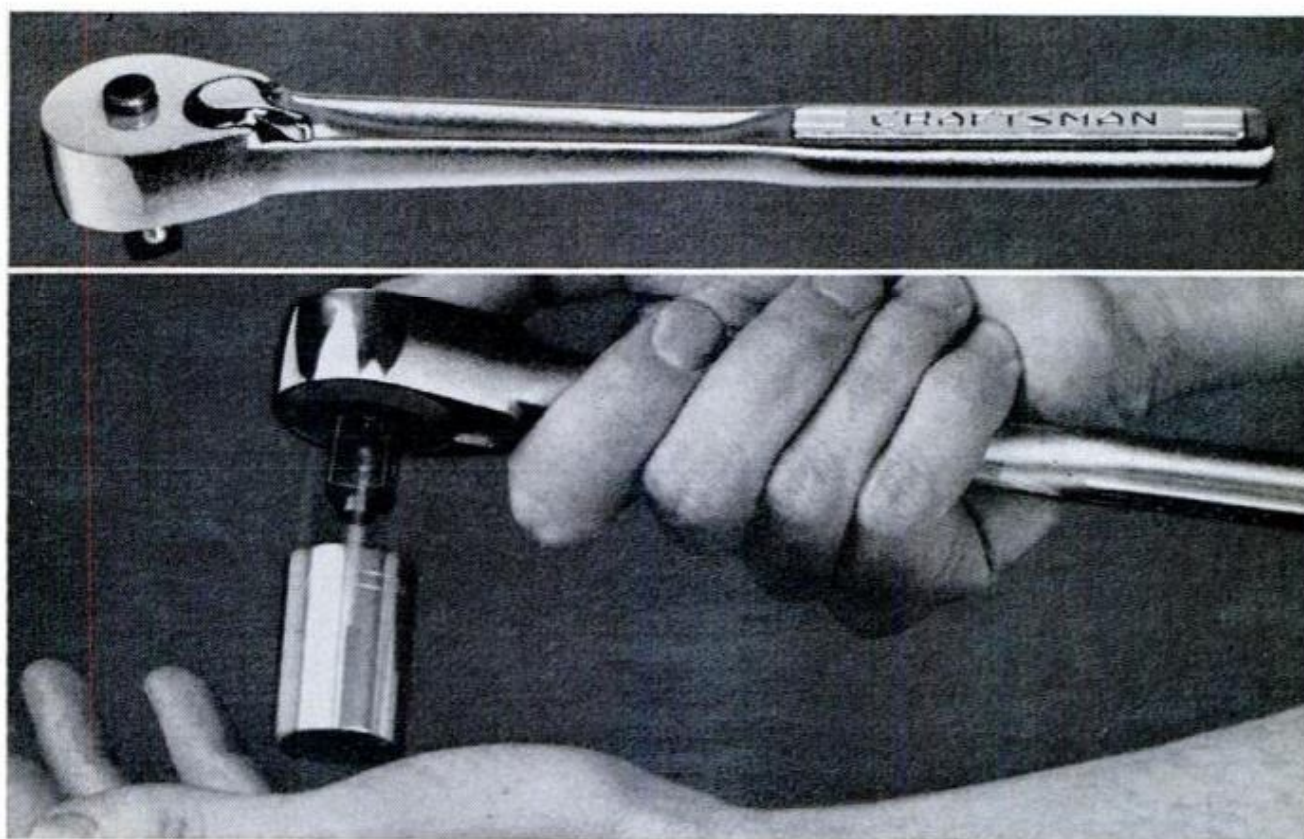

**E**VER tried to separate a socket from an ordinary ratchet wrench when your hands were greasy?

Forget it. You just press a button on Sears new Craftsman® wrench. They separate easily—no yanking.

The stroke is smooth and short, great for working in tight spots. Switch lever to reverse the action. The shaft and handle are drop-forged steel for strength without bulk.

In Sears factory tests, the ratchets

were operated over half a million times under full load with no serious wear.

See the newest invention in ratchet wrenches at Sears, Roebuck and Co. Available in  $\frac{3}{8}$ " and  $\frac{1}{2}$ " drive to fit all standard sockets. Prices: about \$5.50 to \$8.00 depending on length and drive.

You get an unconditional guarantee. If this Craftsman wrench fails to give complete satisfaction, return it—Sears will replace it free of charge.

See it now—at Sears.



FROM THE PATENT OFFICE **NEW INVENTIONS**  
BY M. J. PEDERSEN

**Colored pictures** from black and white film. Using various filters or light sources, Dr. Edwin H. Land, Polaroid Corp., Cambridge Mass., is able to project colored images stereoscopically from black and white photographs. However, only one or two colors, as they are normally described, are actually present. Patent 3,221,599 and 3,221,600 were awarded Dr. Land, whose colleague, Nigel W. Daw (a British mathematician) shared patent 3,221,600. Dr. Land also received patents 3,222,168 and 3,222,171 for his methods of making positive prints and enlargements—by projecting the image on a compressed material, such as rubber, then stretching the material after the image has been fixed.

**Pouched necktie**, designed to foil pick-pockets, hides on the reverse side a zippered pocket in which money or other valuables may be kept. Sol Sherman, New York, earned patent 3,206,765.

**Fold-up scaffold** for use by the homeowner or apartment dweller in window washing, painting and other chores, may be stored in the closet. Robert N. Brown, New York, received patent 3,231,043 for the device, which has been tested for 800 pounds.



**Electron-sensitive film** with ultrathin layers of silver halide produces unusually sharp images. Devoid of the customary gelatin to hold grains, the film can be developed, fixed and washed in about three seconds. Its most promising use lies in photographically tagging tiny electronic components, now too small for imprinting identification. A series of seven patents covers—in addition to the film—techniques for mechanically transferring the images without the use of chemicals. Patents 3,219,444, 3,219,445 and 3,219,448 through 3,219,452 were awarded Dr. Gershon M. Goldberg, James E. LaValle, Ignatius E. Theodorou, John G. Pack, Melvin H. Saxe and Edward Hartouni.



**This year why not invest in a vacation (instead of spending one)**

When we talk about "spending" a vacation, too often we mean just that—SPEND. Two weeks at a resort or hopping from hotel to motel, and nothing to show for it in the end except photos and fatigue.

Why not change all that this year. Introduce your family to Nimrodding. You'll be investing in vacation pleasure for years to come. And, you'll have a camping headquarters you can take with you anytime of the year, not just two weeks in July. Take a look at the new Nimrod Riviera . . . an ideal combination of style, mobility and comfort. The steel body with baked-on enamel finish resists road wear. Two slideout double beds with polyfoam mattresses provide real sleeping comfort. And the huge triangular picture windows drink in breezes or zip up snug in bad weather. And, there's a hardtop Riviera, too.

There are six Nimrod camping trailers from which to select. One is certain to find a place in your budget without making a big dent. Then you're set for travel fun.

Explore the exciting world of Nimrodding. See your local dealer. To find his name and location, call Western Union by number and ask for Operator 25. Or, write us and we'll send along our full-color brochure.

**GET DOWN TO EARTH BUT UP OFF THE GROUND...WITH NIMROD**  
Ward Manufacturing, Inc. • 516 Ford Boulevard • Hamilton, Ohio  
World's largest manufacturer of camping trailers and pickup coaches  
(Dealer franchises available in some areas)



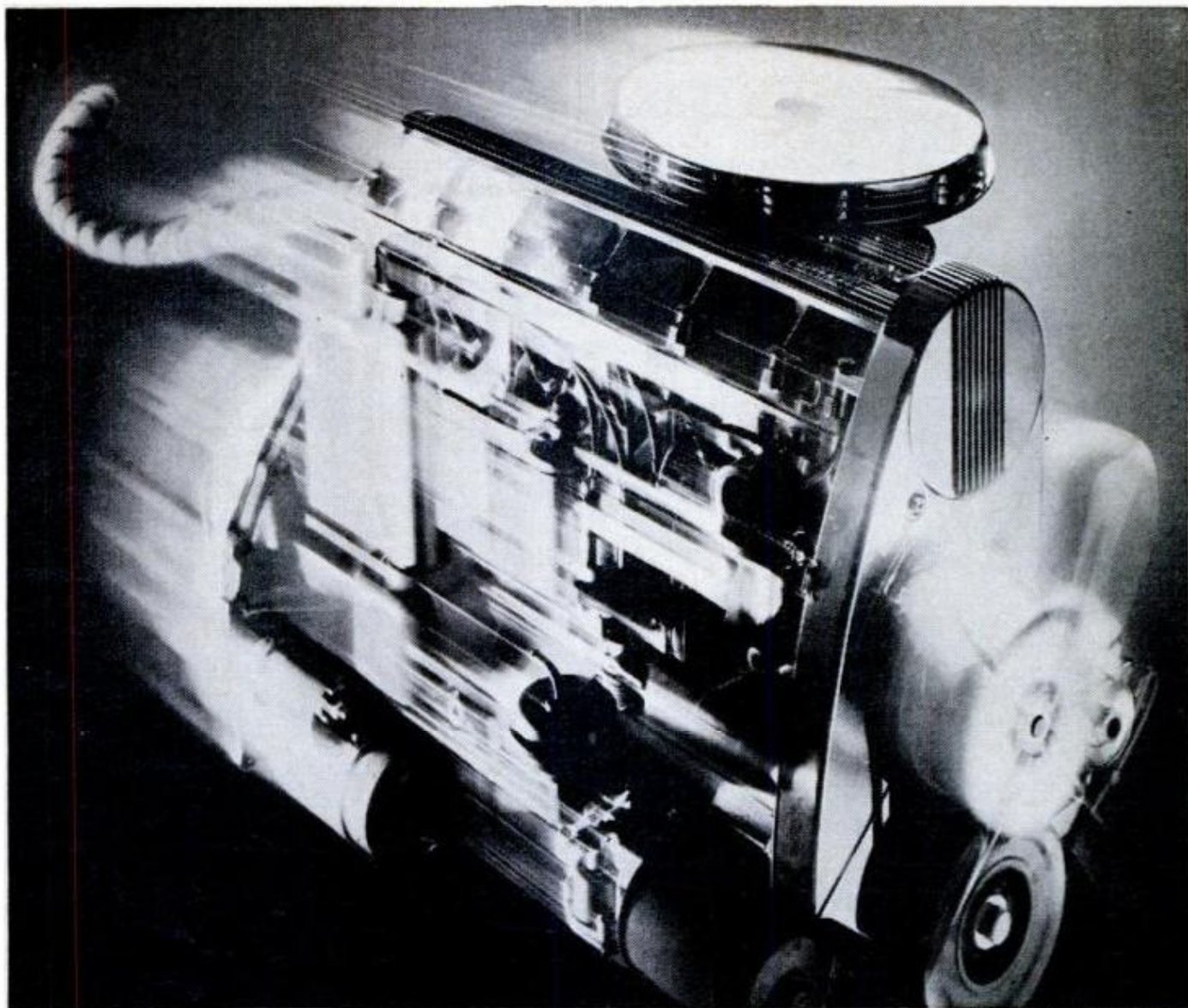

Pontiac Motor Division

## Our OHC 6 is no ordinary six. Obviously.

And the special Sprint version of it is no ordinary OHC 6 either.

You know that the minute its chromed low-restriction air cleaner, 4-BBL pot and split exhaust manifold blink back at you from underhood.

But our OHC Sprint didn't come by its performance just by tacking on options. To begin with, it has its camshaft up over the valves, like the great European road machines have them. And drives the shaft with a revolutionary, glass fiber, reinforced, neoprene belt, instead of with the heavy noisy chain that every other OHC engine has.

All that not only shaves the pounds off, it does away with enough moving parts to develop its rated 207 horsepower at 5,200 rpm's.

Besides which, the OHC 6 is just an all-around

tougher engine. With heavy-duty valve springs. High performance bearings. Block-stiffening skirts around the crank, and a camshaft drive-belt which will outlast practically anything in the car but the driver.

We splashed a little glory elsewhere in the Sprint, too: a tighter, tougher suspension underneath. A three-speed, all-synchro floorshifter within. And, on the sides of 2-door models, a set of swaggering sports stripes. (The standard Pontiac safety items, like front and rear belts and such, go without saying.)

If you think all this sounds like an unusual animal, you ought to drive one. You can find the OHC Sprint option on Pontiac Tempests and Pontiac LeMans. And those you can find at your Pontiac dealers.

**OHC Sprint by Pontiac** 



# HOMEOWNERS' CLINIC

BY W. CLYDE LAMMEY

## How to tap a duct

*In my home the warm-air wall risers are tapped into one long aluminum duct. A small basement room is uncomfortably cold during winter and I'm wondering if there isn't some simple way of diverting heat to this room. Can you suggest a procedure I can carry out myself, inexpensively?—R.N., Ind.*

Sure—assuming you can tap into the main duct and run straight into the room without any turns. As fittings, you'll need a 3½ x 12-in. side takeoff; one or more lengths of branch rectangular pipe, same size; a straight head for the through-the-wall opening; and a flush-type wall diffuser with adjustable vanes. Lay out the opening for the side takeoff on the main duct and cut along the lines with a sharp chisel, inclining it to make a shearing cut. Cut only the two sides and across the end of the opening nearest the furnace. Then pull the waste piece out and snip it off, leaving a 3-in. projection. Bend this back inside the opening and locate it at an angle of about 45° to serve as a diverter. Then attach the takeoff with sheet-metal screws, cut an opening in the room wall to take the head, and fit and attach the piping and diffuser.

Strap the joints of the piping with strips of sheet metal fastened with short sheet-metal screws. Support the run of piping (if there's more than one length) with sheet-metal brackets attached to the joists. With the diffuser set at open, this installation should scoop off sufficient heat to keep that small basement room at a comfortable temperature.

## Jiggle-joggle room

*When I walk across the living-room floor of my new home it feels as if I was walking on thin ice—furniture jiggles and lamps joggle. The basement is under this room. Any relationship? Anyway, what's wrong and what can I do about it?—I.W., Tenn.*

Judging from your graphic description I'd guess the joists are inadequate in sectional size and the span too long.

Firming up the center beam on a row of posts might do the trick, but this would be at the expense of basement floor space. Or you can run in extra lines of bridging or double the joists. The latter choice would probably be the best. If the doublers can't run the full span with a bearing at each end on existing sills, shorter doublers may be used as follows:

Cut the doublers as long as possible. Now mark the joists at 24-in. intervals. Place a liberal smear of waterproof glue at these points on both the existing joist and the doubler. Then raise the doubler into place and clamp it securely to the joist. Drill a ⅜-in. hole through both boards at each mark, then pass through ⅜-in. carriage bolts, tightening them with washers under the nuts. Remove the bridging for each doubler as you go along. The wood will probably shrink after a time and you will have to re-tighten the nuts. Replace the bridging, cutting each member to fit.

Unless the existing joists are badly sagged, you won't need to raise them with jacks for this job.

## When picture windows crack

*A few years ago I installed a plate-glass picture window in the front wall of our house. Due to warpage of the frame, vibration or other cause, a crack about 8 in. long has appeared that runs up from the bottom of the window. Is there any way to hide or disguise this crack, or at least keep it from spreading?—T.G., Fla.*

There is no way to hide the crack, but there is a way to prevent it from spreading until you get around to the job of replacing the window. A bit of cautious drilling is required.

First, stick some short lengths of masking tape across the crack at about 4-in. intervals; these will serve to help hold the bit "on target" when drilling through the glass. Then, using a variable-speed drill, *very carefully and slowly* drill four small, equally spaced holes through the crack where the tapes cross it. While drilling, lubricate the bit with turpentine. Insert four small bolts—each with two felt-covered washers—through the holes and gently snug up the nuts.



## A PROFITABLE NEW PROVEN BUSINESS

Engrave plates such as door and desk plates, badges, identification plates, special signs, etc.—is simple, interesting and profitable. Businessmen, homes, office, factories, stores, boat owners, campers and many others require engraved plates and become a source of profit for you in your spare time. You can easily fill order after order for name plates with the SM-100-2 ENGRAVER (size 13" x 13") the machine that makes you a professional at this work. Puts extra dollars in your pocket the year around. Get details at once. Write today.

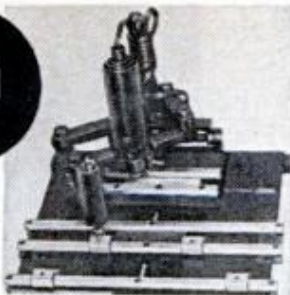

**SCOTT MACHINE DEV. CORP.**  
215 Prospect Ave., Dept. PM-5,  
Walton, N.Y. 13856

## LICKITY WACO LOG SPLITTER

Splits Big Profits from  
toughest woods—Ends  
Splitting Drudgery  
with 18 ton  
hydraulic power!

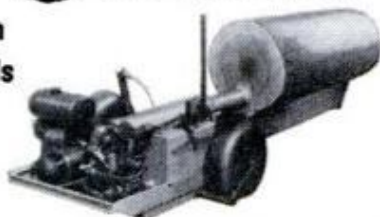

7 H.P. trailer unit squats under power to load logs without dead lift. Has 2 speeds, auto-shift, auto-stroke. 26" ram travel splits logs up to 34", any diameter — with extended frame and adjustable wedge splits up to 60". **NEW LOW COST** Economy model for farmers and small wood lots. Also ask about the 60L Series for logs up to 8½ ft. long—Details free.

Piqua Engineering Inc., Dept. P, Box 605, Piqua, Ohio

## You get 2 tools in 1 in the New RIGID RAPRENCH DUAL PURPOSE

(Pipe Wrench and Hammer)



Available in  
10" size only!

EXTRA HANDY  
IN EVERY TOOL BOX  
AS A WRENCH  
AND A HAMMER!

A special housing design makes this new 10" RIGID Raprench an extra-handy, "two-use" tool. As a wrench, it offers all the same outstanding qualities found in our regular RIGID Heavy-Duty wrenches. The housing, however, is deeper and broader to create a strong, smooth, striking surface. It's this broad, flat surface, plus added head weight, that make this new RIGID Raprench ideal for occasional hammering use.

See and buy this new  
RIGID RAPRENCH  
at your Dealers.

**RIGID**

THE RIDGE TOOL COMPANY, ELYRIA, OHIO, U.S.A.

MAY 1966

Not everyone does as well, but T. N. CODY,  
who started a business of his own, reports...

For 12 months I've averaged

# \$800

per month income

— most of it clear profit for me!



• Many men have discovered how to be independent, to be free of layoffs and bosses. C. G. Naples grossed more than \$200 his first week. A father-son combination grossed \$44,000 their second year. H. Lemon says, "I netted \$133 in one 8-hour day."

How much you earn depends largely on you, but we help you to start and work with you for your success. You need no special skill, no large investment. Start part time if you wish. Hire helpers as needed.

**NO SHOP NECESSARY** • Our PORTABLE ELECTRIC DETERGER shampoos rugs, carpets right on customer's floor. Wonderful results bring you repeat business, large fees. So efficient and safe, it is used by largest hotels and railroads.

**OURS IS NOT A LEASE ARRANGEMENT** • You are free to operate in an independent manner. You sign no contract. You own the detergent outright and are always your own boss... and every dollar you take in is yours to keep. You pay no fees, or dues, or royalties to anyone, and enough supplies come with it to return far more than your investment. Many earn the cost of the detergent in a week or two. It costs nothing to get the details... write TODAY.

Mail Coupon Today for FREE Book

VON SCHRADER MFG. CO.  
510 "R" Pl., Racine, Wisconsin

Without obligation send me FREE booklet about your RUG DETERGER and tell me how I can start my own permanent, profitable business.

Name \_\_\_\_\_

Address \_\_\_\_\_

City \_\_\_\_\_ Zone \_\_\_\_\_ State \_\_\_\_\_

20 COURSE  
HOME STUDY  
PROGRAM



# KARATE!

JUDO BOXING! MUSCLEBUILDING! YOGA!  
STRONGMAN STUNTS! STRENGTH &  
ENDURANCE! HANDBALANCING! etc.

YOU GET ALL THESE COURSES! \*20 illustrated KARATE blows \*SAVATE foot fighting \*Secret NERVE CENTER and ANATOMY charts \*20 lethal JUDO throws \*20 terrific STRONGMAN STUNTS \*Complete MUSCLE-BUILDING course \*Ancient YOGA secrets \*HANDBALANCING stunts \*Complete BOXING course. Secrets of ENDURANCE \*WRESTLING holds \*WEIGHTLIFTING \*TENSION-FLEX COURSE \*HEALTH & FITNESS EXERCISES \*KEEP FIT PROGRAM \*K-MAN Karate Dummy Chart. No C.O.D.'s, Canadian 75c. YOU GET THE LOT.

ONLY  
50c

COMPLETE HOME GYM PLANS—Build gym equipment; vault horse, rowing machine, etc. Convert basement, garage to gym. ONLY 50c with courses. Total \$1.00 compl.

OXFORD STUDIO, 146 Blake (PM-3), Mattapan, Mass.

NAME (print) \_\_\_\_\_ \$50c PROGRAM

Address \_\_\_\_\_ \$1.00 with GYM

City \_\_\_\_\_ State \_\_\_\_\_

Free K-Man Practice Dummy showing attack points.



## Four for fun!



# Ariens Fairway-4<sup>®</sup>

## RIDING MOWER

Four h.p. engine gives you the power for any mowing job . . . four speeds forward (plus reverse) means there's a speed to meet the cutting need. Add up all the features of the Fairway-4 — 26" rotary mower; rear-mounted engine; easy height adjustment; meets American Standards Assn. safety standards, and you have plenty of reason for its choice. See your Ariens dealer or write for free details.



**Ariens COMPANY**

161 Calumet St., Brillion, Wis.

## NEWS FROM THE **MILITARY** BY WILLIAM R. KREH

**Sears catalogs** have a new and unusual use—helping win the war in Vietnam. An Air Force logistics specialist found that purchasing agents were having communications problems with the local merchants. The agents, who have to buy many small hardware items such as light fixtures, pipe elbows and flashlights, needed pictures of these things so they could make the merchants understand clearly what they wanted. The supply people went to work, and soon Sears sent a batch of used catalogs for use in Vietnam.

**Like Whitey Ford**, helicopter gunners will be able to throw curve balls if a new missile system called *Teton* proves out. It uses an infrared beam of light which locks on the target and stabilizes the sight even though both aircraft and target take evasive action. The missile will chase the target like an enormous curve ball.

**The Navy sank a sub** off San Diego recently. The submarine *Squaw*, a 134-foot training model, wasn't lost, though—it was moored at a depth of 200 feet about 20 miles off the coast where it will serve as a sonar training target for the next 10 years or so. Precise navigation was needed for each mooring peg, and an exact amount of tension was necessary to insure that the target submarine would maintain its proper depth and position.

**In living color.** Army engineers have obtained the first successful night-time aerial color photographs made with the aid of electronic flash. The pictures were shot at slightly under 1000 feet in the intensely bright light projected by a souped-up flash system. They show such color differences as slight gradations among parked cars, the bold orange and white of a water tank, the wide range of hues among a cluster of small boats and the detail of an oceanside boardwalk.

The experiments are aimed at improving photo-surveillance during darkness, when reconnaissance flights are usually less hazardous, and more visual intelligence can be obtained from color photos than from black and white. For example, experts say that even slight differences in the hues of distant objects such as vehicles and artillery may be a telling feature in distinguishing signs of enemy activity. ★ ★ ★



# Junior Finds Her Sealegs

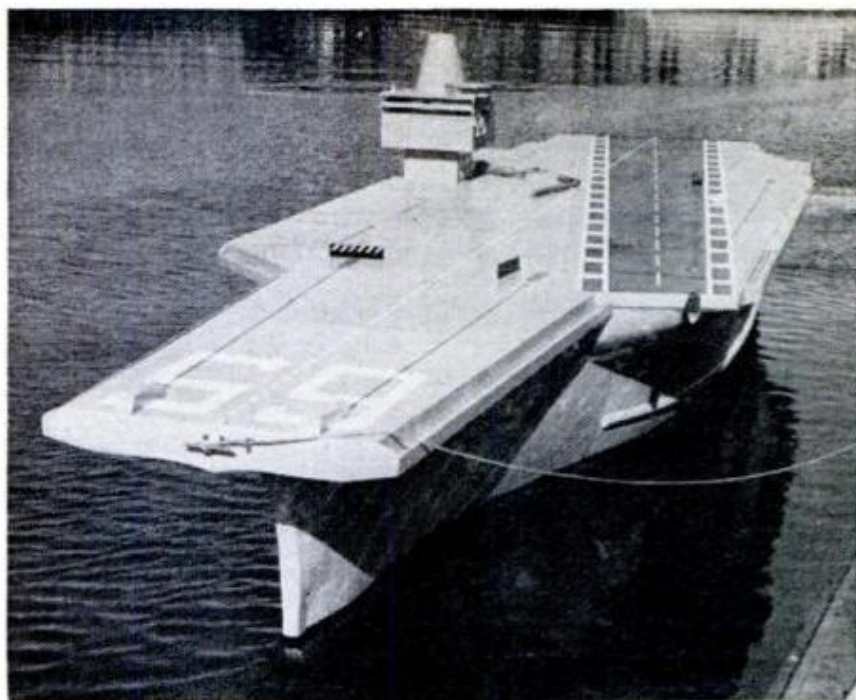

**ENTERPRISE JR.**, afloat, now measures 53 feet long. A new bow section, joined to the original hull (below), extended the scale model's length six feet at water line without disturbing structure's watertight integrity



**GRIT NO-SLIP PAINT**, applied as a final treatment to the flight deck, helps insure numerous successful takeoffs for this radio-controlled model F4U Corsair

“BABY” FLATTOPS of World War II are giants compared to the Navy's newest aircraft carrier. She's the USS *Enterprise Jr.*, launched at the 1965 Seattle Boat Show.

*Junior*, a replica of her famous namesake, was converted from a Coast Guard buoy boat in 3300 man-hours. She is operated from a position within the superstructure, and steered by an electric/hydraulic system. The model can be operated by one person except for docking.

The model—intended to promote general interest in the Navy and stimulate recruiting—has already been used for display and model meet participation. During her first flight operations at NAS Seattle, three successful launches, one air recovery and two arrested landings were made from the carrier's deck with a radio-controlled model F4U.—V. E. Benner



**SURPLUS COAST GUARD BUOY BOAT**, on delivery to the U. S. Naval Supply Depot, Seattle, was stripped, recaulked and then rehabilitated as a carrier and fitted with a new diesel engine



BY KEVIN V. BROWN  
**AVIATION**  
 JETSTREAM

**Shotgun marriages** between metals may be necessary for the 8000-mph Scramjet reported in the story, "There Goes the Flying Stovepipe," beginning on page 78. Aircraft that fly that fast through the atmosphere encounter such high heat from friction that ordinary metals, including some of those planned for the supersonic transport, may be too soft.

Research scientists at General Dynamics are experimenting with firing shotgun shells into trapped metal powders in attempts to crush them into new alloys.

Remote triggering sends a small steel projectile crashing into the powder metal, which has been poured into a die, at speeds up to 2000 f.p.s. This force immediately compresses the powder into a solid.

One of the benefits of such a system is that it combines metals that are ordinarily difficult to mix, such as soft metals with low boiling points and hard metals with high boiling points to get a composite light enough and tough enough to withstand high-speed flight.

**High-speed psychosis** may afflict both passengers and crew on such hypersonic flights. Because locations around the world will be brought so close together, people will have considerable difficulty adjusting to the rapid time changes.

The Federal Aviation Agency has been conducting tests to find out how traveling through seven to ten time zones, east to west and west to east, affects the body—and the effects are considerable.

Besides fatigue, confusion and abnormal body functions result, and the effects linger up to five days afterward. The test passengers had trouble doing simple arithmetic after such flights, and all showed tension and increased perspiration rates.

Traveling north to south through the same time zone, apparently, had no effect other than simple fatigue.

The tests led one examiner to ask whether getting someplace twice as fast might mean resting twice as long later.

"Is it worth it?" he asked.

The tests will continue with the cooperation of pilots flying Trans World Airlines routes. If the passengers are so affected, how do the men who are flying them fare?

The results of the two series of tests may have a bearing on flight rules during the next decade when supersonic and hypersonic transports take to the skies.

## CHECK RUST & CORROSION

around your house . . .



CHECK YOUR GUTTERS AND DRAINPIPES



CHECK YOUR GARAGE



CHECK YOUR GARDEN TOOLS



CHECK YOUR LAWN FURNITURE



CHECK YOUR FENCES AND RAILINGS

## Derusto the Beautiful way to stop rust

**DERUSTO PROTECTIVE COATING** . . . a heavy duty—semi-gloss coating that actually penetrates and locks itself to metal surfaces. Primes, finishes, beautifies and protects. **DERUSTO** . . . the product with the built-in primer in an array of beautiful colors. **DERUSTO GALV-A-GRIP** . . . stops cracking, peeling and chipping on gutters and downspouts. Requires no etching or weathering. Primes, finishes, beautifies and protects. **DERUSTO GALV-A-GRIP** . . . the product with the built-in grip. Available in WHITE, Red, Gray and Green.



**FREE!!!**



**POPULAR MECHANICS Editors REPORT ON RUST & CORROSION.** Available FREE of charge at your local DERUSTO dealer, or send 35¢ for postage and handling to Master Bronze Powder Co., 415-435 E. 16th St., Chicago Heights, Ill.



**WHAT FITS IN 14, 15, 16-FOOT  
RUNABOUTS, STARTS LIKE "GO",  
RUNS ON REGULAR GAS, HYPOS  
YOUR CRUISING RANGE AND  
GIVES YOU THE FEELING YOU'RE  
CAPTAINING A PT BOAT?**

**ME.**

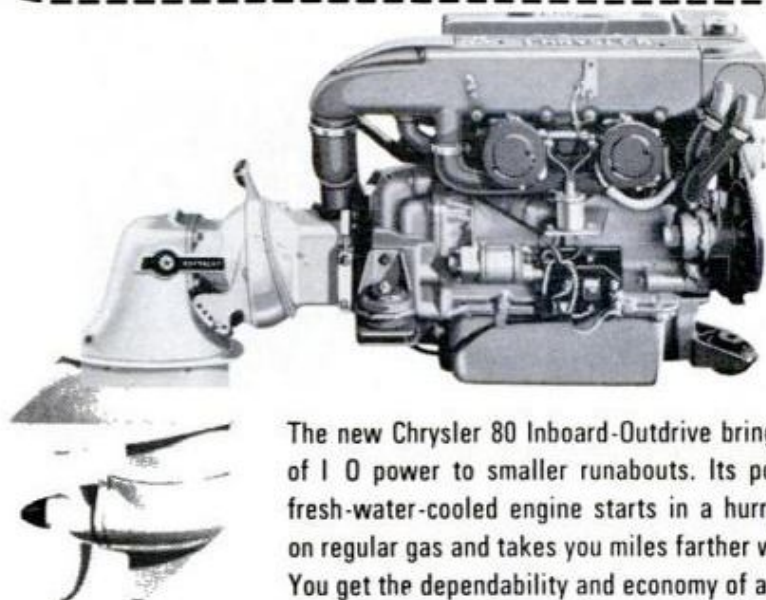

**CHRYSLER 80 INBOARD-OUT-DRIVE.** 80 hp., 4-cylinder, 4-cycle, fresh-water-cooled engine; 91 cu. in. displ.; 2-1 bbl. carburetors; compr. ratio 8.6:1. Single transom hole mounting. Weight complete: 350 lbs.

The new Chrysler 80 Inboard-Outdrive brings all of the advantages of I/O power to smaller runabouts. Its powerful 80 hp., 4-cycle, fresh-water-cooled engine starts in a hurry, purrs like a pussycat on regular gas and takes you miles farther without stopping for fuel. You get the dependability and economy of an inboard combined with the maneuverability, roominess and trailerability of an outboard.

Say good-bye to gas-oil mixes, konk-outs and paddles. When you put a Chrysler 80 in a 14, 15 or 16-foot runabout, you're going first class!

And that's not all! The new Chrysler 80 is just *one* of a great line of Chrysler Inboard-Outdrives (see below). Ask about them at your boat dealer. Order one in your next boat!

MARINE DIVISION



**CHRYSLER  
CORPORATION**

Chrysler I/O's come in 11 models. 8 horsepower ratings:

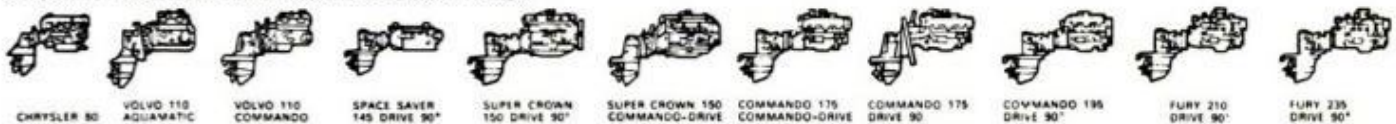

CHRYSLER 80

VOLVO 110  
AQUAMATIC

VOLVO 110  
COMMANDO

SPACE SAVER  
145 DRIVE 90\*

SUPER CROWN  
150 DRIVE 90\*

SUPER CROWN 150  
COMMANDO-DRIVE

COMMANDO 175  
COMMANDO-DRIVE

COMMANDO 175  
DRIVE 90\*

COMMANDO 195  
DRIVE 90\*

FURY 210  
DRIVE 90\*

FURY 235  
DRIVE 90\*



DETROIT

# LISTENING POST

BY JIM DUNNE

**Chevrolet's sporty new Panther** will be introduced next fall, along with the rest of Chevy's 1967 model lineup. So that the public will be primed to buy when it hits dealer showrooms, the car will get a big advertising buildup. Chevy officials expect Panther to take sales away from top-of-the-line Chevy II and Corvair models. Panther will debut in a single body style—a two-door fastback. An earlier Panther prototype that looked much like a Mustang hardtop has been scrapped, insofar as production goes. However, the model is still to be tested to prove out suspension, drive train and body construction. By introduction time even the Panther name may be changed; Chevy says it's looking for something different—a new name that begins with the letter "C."

**Debut of Mercury's new Cougar** will precede the Panther (or whatever) by one month. At first it will be built in a two-door hardtop. Mercury plans to introduce the Cougar in late August to get a jump on the rest of the industry. Later, a two-door fastback will be brought out. Look for this second version just after the first of the year. Cougar will have a wheelbase of 111 inches—three more than Mustang. All the extra length will be back-seat legroom. But even with Panther and Cougar, 1967 will not be entirely the "year of the cat";—Cadillac's front-drive may bear the "El Dorado" name.

**Thiefproof cars** are the aim of General Motors for 1967. On all models GM will have special new locks and an entirely new locking system. The keys will look the same as present ones, but will have 2000 possible combinations rather than the present 1500. So-called master keys, now available from mail-order houses, will not open as many locks as in the past. Master keys are designed for all locking systems, but the masters you can buy by mail are actually manipulation, or tryout, keys that require some skill to open a lock. They are the kind your locksmith uses to open your car when you've lost the keys.

**Are dual brake systems really necessary?** As predicted here (Feb. '66 PM), dual brake systems will be standard equipment on the '67 cars. But how much better are they than the present single-cylinder type? Not very, say auto bigwigs. Chevrolet Div. alone delivers more than three million vehicles each year and it presently has no claims against it for failure of its braking system. Ford tells approximately the same story.

**Ford will not use a collapsible steering column** on its 1967 models even though GM and American Motors have announced they would. Ford will continue with the deep-dish wheel design it originated in the '50s. Ford executives say the dished steering wheel meets the same government requirements as does the collapsible steering column.

**Pros and cons of the front-wheel-drive design continue.** A top-level Ford executive says the setup is too expensive, costing \$200 to \$300 more than standard front engine-rear drive. Cost is great even on smaller cars like Ford's German-built Taunus. Our informant says even Taunus may drop its front-drive configuration.

**Plastic cars in your future?** Since World War II, experts have been predicting cars will eventually be made out of some synthetic material. Yet steel seems to remain the only economical body for high production cars. But this may change soon. New body plastics that can be turned out on high production presses are being developed, their output already beginning to encroach on steel. Favorable plastic features include lighter weight, more flexibility of styling, cheaper styling changes and rust-resistance, among others. Right now, in addition to Corvette bodies, plastics are used as fender extensions, grilles, bright trim on car exteriors, special hoods. Soon major annual facelifts will become possible at a lower price by using plastic body parts. Today's cars use about 35 pounds

*(Please turn to page 32)*



## Tune-up notes from AC:

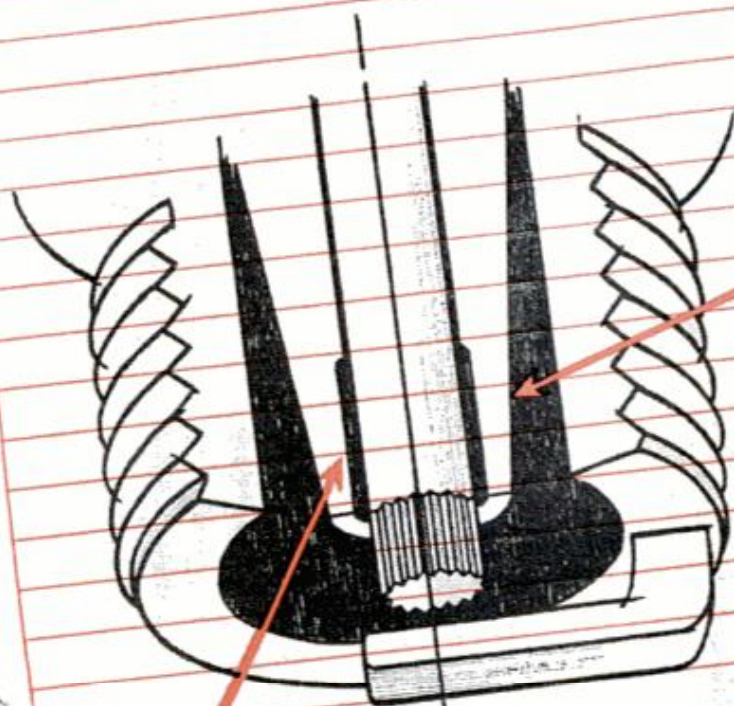

*tapered-tip  
design opens up  
more  
scavenging area.*

*thin recessed tip  
heats faster to burn  
away fouling deposits.*



## How AC's Self-Cleaning Hot Tip Insulator promotes peak power longer.

Because of its ultra-thin, recessed design, AC Spark Plug's Self-Cleaning Hot Tip Insulator gets hotter, faster—to stay cleaner, longer. The hot tip burns away fouling deposits and promotes more powerful, more responsive engine performance. AC's exclusive recessed tip also cools faster to minimize pre-ignition. With their faster heating and cooling properties, AC Fire-Ring Spark Plugs can be driven harder with less danger of overheating—can be used for slower speeds with less danger of fouling. Make your own tune-up note now. Promote maximum power and performance in your car's engine. Insist on AC Fire-Ring Spark Plugs next time you change.

AC SPARK PLUG DIVISION



**FIRE-RING  
SPARK PLUGS**



Be An Engine Repair Expert

# INCREASE YOUR PAY

## Learn at Home

Skyrocketing sales of power equipment (lawn-mowers, outboard motors, power saws, etc.) have placed skilled servicemen in great demand. Result: Many job opportunities for men who are experts on engines.



## Learn While on Present Job

No need to quit present job. You learn fast the Gale Institute way, a leader in the field of technical instruction for nearly a quarter of a century. Write today—no obligation—Find out how you can learn at home the easy way—and about our easy payment plan. No salesman will call!



**GALE INSTITUTE**  
Mpls., Minn. 55408

Gale Institute Room 511-6  
3006 Hennepin Ave., Mpls., Minn. 55408  
Please send complete information on Small Engine Course.

Name \_\_\_\_\_  
Address \_\_\_\_\_  
City \_\_\_\_\_  
State, Zip Code \_\_\_\_\_

# Own a Business

You now have an opportunity to double your income in your own business. A big 24-page book tells how others start in spare time—then expand to a full time operation. Gross hourly profit \$9.00—PLUS \$6.00 additional on each service man. Income unlimited.

In this business your service is Nationally Advertised. It's a business that's world-wide and endorsed by McCall's and Parents' Magazine. Exclusive *absorption* process cleans and *revives* upholstery and carpets, also 5 other on location services.

You need no experience—no shop. We show you how and finance you for all but a few hundred dollars. Easy to learn—easy to do—easy to build up to a good, steady volume on our 15 tested ways to get customers.

G. F. Monroe, after 12 months, sold his business for 10 times his cost. Leo Lubel sold his for \$7,116 more than he paid. L. Babbit writes, "I average \$2,600 monthly, part time." W. C. Smith earned \$650 in one week. Ed Kramsky said, "In two years I have two assistants, a nice home and real security."

This may be the opportunity of your life. Find out today before someone else gets your location. Mail the coupon now for full details and 24-page illustrated free book. No obligation. No salesman will call. Mail coupon now before it's too late to get territory.

### DURACLEAN COMPANY

6-165 Duraclean Building, Deerfield, Illinois 60015

Please send me your 24-page illustrated book that tells how I can double my income in a business of my own. Everything you send me now is free and I am under no obligation. No salesman will call.

NAME \_\_\_\_\_

ADDRESS \_\_\_\_\_

CITY \_\_\_\_\_

STATE \_\_\_\_\_ ZIP CODE \_\_\_\_\_

## DETROIT LISTENING POST

(Continued from page 30)

of plastic. In five years this may jump to more than 70 pounds.

### One way to halt traffic glut in cities?

It has been suggested in London that new cars be sold only on condition the buyer can prove in advance he has parking space available. If not, he gets no car. The idea came from Japan, where such a law has actually been in effect for some time. A man in Tokyo who wants a car must go to the police station, show on a map the precise location of his parking spot. Only on verification of his claim is he allowed to buy the car. Coming soon to big U.S. cities? Hmmmmmm.

### Double your power, double your fun.

Japan's Toyo Kogyo car company has just produced a slick, sporty two-door, 2-plus-2 that has a twin-unit Wankel engine. This is like the student stealing a march on the master. NSU, of Neckarsulm, Germany, the parent firm, had a double-rotor engine in last year's Frankfurt Salon. But it was for display purposes only. Toyo Kogyo calls its new car the Mazda. Though only a prototype, this uniquely-powered edition has rolled over 65,000 miles and is said to be doing well. Horsepower is 110 SAE and top speed is 103 mph. Meanwhile, NSU is expected to make '67 headlines with a twin-rotor, Wankel-powered four-door sedan.

**Tire studs** are running into unexpected opposition from state legislatures. A number of northern states have outlawed studs. Industry efforts to repeal such laws are running aground. Designed to stop a car *right now* on icy roads, studs are not harmful to all roads. But tests have shown that asphalt roads can be scarred by studs in sudden stops. Also, it is claimed that hard braking on dry pavement with studs causes excessive skidding. A third objection is that studs are sometimes thrown from tires at high speeds.

### Military vehicle demand in Vietnam

has doubled the Army order for Ford's M-151 quarter-ton truck. Orders for this successor to WWII's Jeep jumped from 69 to 125 daily in March. Home of the M-151 is Ford's Highland Park, Mich. assembly plant, the original home of Ford's famous Model T. The sophisticated mechanism of this modern Jeep bears about as much resemblance to the original WWII models as the Model T does to a 1966 Ford. Will Vietnam requirements cut into civilian production? Maybe, but not in the foreseeable future.



# Who's got everything for your Ford

## from Air Conditioners...

For driving comfort in the warm months ahead, have a Ford Air Conditioner installed in your car now. This attractive, easy-to-operate unit offers exceptionally high performance — cools, cleans and dehumidifies the air. **\$230.35\***



## to Polishes...

See your Ford Dealer for a complete line of car-care products ranging from polishes, to cleaners, to lock lubricant. He's got everything for your car from top to bottom, inside and out.

## to Spotlights

This stylish addition features a long-distance sealed-beam lamp to help you pick out addresses and read signs on the darkest night. Can be adjusted to any position from within car. **\$29.95\***

\*Manufacturer's suggested retail price. Installation charges, state and local taxes, are extra.



# Your Ford Dealer of course!

You get the most for your driving pleasure from your Ford Dealer.





# CAREER BAROMETER

BY CREIGHTON PEET

**F**ROM NOW ON, no matter what line of work you end up in, it will be to your great advantage to have a working knowledge of "programming" for data-processing machines—computers. It is a basic skill that is becoming as essential as a knowledge of typing. And, of course, there is an increasing number of jobs, in the computer field itself.

A few years ago anything to do with computers meant an advanced college degree and years of specialization. But already some phases of this business have been simplified. If you have a real aptitude for math and a logical mind, a high school diploma will get you in.

Computers generate two general types of jobs: field service engineers (maintenance men) and programmers. The service man needs a high school diploma and from two months to two years in a good technical school specializing in electronics. After this, he'll spend six months training with the company (for which he is paid \$100 a

week). Field service engineers start off at \$5500 and work up to \$10,000.

Picking your firm is a factor because all systems are slightly different. If you start with International Business Machines, Burroughs, General Electric or National Cash Register, you can't transfer to other machines without further study.

Programmers write the directions for a computer. Until recently, they had to understand and work through the binary arithmetic system in which computers operate. Now, however, it is possible to program a problem for a computer with COBOL (Common Business Oriented Language). This is quite easy to understand. While the computer still uses the binary system, it does an instantaneous, back-and-forth translation job.

As a result, an increasing number of not-too-complex programming jobs now require about 6 months of special training for what some call "application program-

*(Please turn to page 36)*

JOB TITLE	CURRENT NATIONAL DEMAND		3-MONTH TREND	STATES WITH HIGHEST DEMAND				
Chemists, Biological	18		Slight decline	N.J. 5	Ohio 3	Wis. 3	Calif. 2	Alaska 1
Chemists, Organic	61		Slight increase	N.J. 11	Pa. 7	Ala. 11	Ohio 6	Calif. 4
Chemists, Inorganic	8		Slight decline	Conn. 1	Md. 1	Pa. 2	Ohio 1	Mo. 1
Engineers, Metall.	53		Slight decline	N.J. 14	D.C. 5	Pa. 7	Wis. 5	Calif. 5
Engineers, Civil	530		Very good increase	D.C. 66	N.C. 25	Fla. 26	Ohio 96	Calif. 62
Engrs. Elect. & Electron.	1031		Very good increase	N.Y. 101	D.C. 48	Fla. 127	Ariz. 40	Calif. 244
Engineers, Industrial	550		Good increase	N.Y. 40	Pa. 42	Fla. 44	Ohio 60	Calif. 81
Engineers, Mechanical	1524		Very good increase	N.J. 87	Fla. 116	Ohio 152	Calif. 308	Wash. 96
Engineers, Aero.	556		Very good increase	Pa. 71	Ohio 45	Mo. 60	Calif. 242	Wash. 120
Engineers, Mining	15		Slight increase	D.C. 4	Fla. 1	N.M. 2	Ariz. 3	Calif. 2
Natural Scientists	155		Good increase	N.J. 20	N.Y. 8	D.C. 26	Pa. 11	Wash. 53
Draftsmen, Architectural	111		Slight decrease	N.Y. 9	Mich. 10	Ill. 15	Calif. 16	Wash. 9
Draftsmen, Electrical	269		Very large increase	Mass. 24	N.C. 20	Pa. 26	Mo. 20	Calif. 133
Draftsmen, Mechanical	453		Almost doubled	Pa. 61	Ohio 54	Wis. 46	Calif. 41	Wash. 63
Draftsmen, all other	405		Very good increase	Mass. 39	Pa. 38	Mo. 42	Calif. 84	Wash. 37
Tool Designers	213		More than doubled	Ga. 50	Ill. 14	Kans. 50	Calif. 25	Wash. 30
Lab. Tech. & Assistants	123		Good increase	N.Y. 21	Pa. 9	Va. 15	Ill. 7	Iowa 7
Sports Instr. & Officials	52		Considerable drop	Conn. 2	Vt. 15	N.Y. 7	Ind. 2	Calif. 12
Surveyors	18		Some drop	Mass. 6	N.C. 2	Ill. 3	Iowa 1	Colo. 1
Techs. Eng'g & Phys. Sci.	685		Very good increase	Ala. 187	Fla. 42	Ohio 67	Calif. 102	Wash. 182
Tool Planners	99		Demand tripled	Ga. 50	Ohio 22	Ind. 7	Kans. 20	—
Systems Engineers	39		Very good increase	N.Y. 4	Pa. 1	Ohio 2	Kans. 10	Mo. 20
Programmers	323		Slight decline	N.J. 17	D.C. 17	Ohio 23	Calif. 88	Wash. 77
Systems Analysts	55		Considerable drop	N.Y. 5	D.C. 12	Ohio 5	Calif. 15	Wash. 8
Inspectors Pub. Service	14		Good increase	Wis. 3	Tex. 2	Calif. 1	Nev. 1	Wash. 7

PM's Career Barometer Chart, above, gives the actual number of men currently needed for specific jobs. "Current Demand" figures are true as of our closing date. Check this chart each month and it will tell you where your talents are needed, and how badly. For names of actual employers represented by these listings, contact the state employment agency in the capi-

tal city of the state indicated. Mention that you saw this in **POPULAR MECHANICS**.

Today, with proper schooling, you can qualify for many of the job categories shown. For a list of accredited correspondence and residence schools, write to **POPULAR MECHANICS' Information Bureau, 575 Lexington Ave., N.Y. 10022**.





Transistor Radio with Battery \$1.96

17-Jewel Watch \$2.87

Derringer Pistol \$5.74

## HOME-IMPORT BUSINESS—Make Big Profits

New Drop Ship Plan offers you first day profits! Deal direct with overseas sources at prices shown. Dazzling bargains with no investment. Full or sparetime. Write for FREE BOOK today to . . .

MELLINGER, 1554 S. Sepulveda, Dept. X255, Los Angeles 25

## LAW FREE BOOK THE LAW TRAINED MAN

Write today for a FREE copy of illustrated law book, "THE LAW TRAINED MAN," which shows how to earn the professional Bachelor of Laws (LL.B.) degree through home study of the famous Blackstone Law Course. All necessary books and lessons provided. Moderate cost; convenient monthly terms. Write for FREE law training book today.

Blackstone School of Law, 307 N. Michigan Ave. Dept. 55, Chicago 51, Illinois  
Founded 1890



## WANT MORE MONEY? GET INTO PHOTOGRAPHY

Coast-to-coast, high-paying jobs in photography are waiting for people with the "know-how" to fill them. You can quickly, easily qualify at home with the world-famous NYI Learn-by-Doing Method. Write today for free catalog. Also resident training in New York. Our 56th Year.

NEW YORK INSTITUTE OF PHOTOGRAPHY  
Dept. 49-5 10 West 33 St. New York 1, N.Y.

## 10 FT. HOT AIR BALLOON TEN FEET TALL

Rises to amazing heights on just hot air. Safe as no flames are carried aloft. Use it over & over. Ideal for celebrations, science clubs, advertising. Will carry parachutes, instruments and small animals for space tests aloft. Multi-colored, pre-cut gores. Complete kit & instructions for inflating, launching. Only \$2.98 postpaid or 2 for \$5.50. Send cash, check or money order to—

STANDARD AMERICAN SUPPLIERS  
Dept. 5-PMAB, 1 Park Ave., N.Y., N.Y. 10016



AMERICA'S NO. 1 CLASSIFIED SECTION CAN BE FOUND ON PAGE 63 IN THIS ISSUE

## BUILD YOUR OWN CAMPER AND SAVE!

Complete, easy to follow Camper Plans, instructions, materials list. \$3.95

PICKUP COVER PLANS \$2.00

Equoline Camper or Bus Conversion Plans. . . ea. \$2.95

Satisfaction Guaranteed!

EQUIPMENT CATALOG \$1.00 Also Factory Built Units Refundable on first order. SEND CHECK OR M.O.—FOR DETAILS SEND DIME



MAIL  CAMPER  COVER  CATALOG

TODAY NAME.....

ADDRESS.....

CITY..... STATE.....

VIKING CAMPER SUPPLY 94-B Glenwood Ave. Minneapolis, Minn. 55403



## Sugar is for candy (and tenderfoot pipesmen)

Revelation is for pipe smokers who're tired of sweet, syrupy blends. You get the rich naturally mellow flavor of five great tobaccos. It's a taste you can stick with all day long.

## Revelation is for the experienced pipe smoker.



A product of Philip Morris Inc.

## REAL ESTATE BE A BROKER

PAYS BIG! SEND FOR FREE, BIG, ILLUSTRATED CATALOG NOW! Graduates report making substantial incomes. Start and run your own business quickly. Men, Women, all ages, learn easily. Course covers Sales, Property Management, Appraising, Loans, Mortgages, & related subjects. STUDY AT HOME or in classrooms in leading cities. DIPLOMA AWARDED. Write TODAY for FREE Booklet! Accredited Member National Home Study Council. (Established 1936)

FREE BOOK TELLS HOW

WEAVER SCHOOL OF REAL ESTATE 3521-P Broadway Kansas City, Mo. 64111





## Of Course... Red Top Air Filters Are Better!

WIX didn't put the "Red Top" on Polymite Air Filters for "kicks." That distinguishing feature identifies a technically improved product... one which is nearly impossible to install in the car upside down. The part number is imbedded in the "Red Top"—not stamped on. That's mighty useful when it's time to change the Filter.

The technical improvements that save you money are: positive seals to prevent leaking dirty air and "Arch Pleats" for greater efficiency, more mileage and greater savings on gasoline. "Arch Pleats" are important where the pleats of ordinary filters pinch together and impede the flow of air half-way down the fold, the "Arch Pleat" does not collapse. Thus, you get a bonus in extra value and substantially greater mileage.

Ask your service man for WIX Polymite Air Filters. Don't let him kid you about all Air Filters being the same. If he doesn't have WIX, call up a local WIX jobber... he'll tell you where you can get them.

**WIX**  
FILTERS  
WIX CORPORATION • GASTONIA, N. C.  
THE GOLD STANDARD IN FILTRATION

## CAREER BAROMETER

(Continued from page 34)

ming." They will produce a basic program for a customer, such as a banker, shoe manufacturer, or operator of a supermarket chain. However, it's only fair to point out that the number of such jobs will shrink in coming years as more "canned" programs are put to use. People in the same business tend to have the same problems; a program designed for one bank can almost certainly be adapted to others.

There are also "middle ground" careers in programming which require some college. In these you work permanently for a company which owns its own data-processing equipment. In some cases, companies prefer to have confidential information processed in the plant by their own people. As a business must be flexible, this means revising the company's basic program periodically. Thus, a lifetime career may be found.

More sophisticated programming usually requires a college degree (sometimes two). People producing these more complex programs are known as systems analysts or "programmers' programmers." They work out basic elements in the canned programs and do original scientific research, such as the kind required for the space program. All computer manufacturers have staffs of experts working to produce more versatile machines. Here, salaries may reach \$15,000-\$20,000.

While the makers say they expect programmers to have a solid college education, they admit that persons who have never been to college periodically turn up with unusual mathematical ability and take to computers with amazing alacrity.

The war in Vietnam, which is taking some 300,000 of the 350,000 men over 20 who would normally be joining the labor force this year, is creating an acute manpower shortage in many plants all over the country. In GE's jet propulsion engine plant at Cincinnati, employees who persuade qualified workers to join the company, are given cash bonuses of \$200 for an engineer and \$100 for a machinist. In Des Moines, a homebuilder who was planning 100 single-family houses this year has cut back to 35 because of what he calls "a critical shortage of carpenters."

General Telephone and Electronics is increasing its recruiting budget by 40 percent in hope of attracting skilled and semi-skilled men. Some have compared the feverish talent hunt to football recruiters. To develop home-grown skills, GE is giving workers aptitude tests and tuition for two-year night courses. ★★★



# Become a "NON-DEGREE ENGINEER"



## in the Booming World of ELECTRONICS

Electronics is booming! Trained men needed in broadcasting, 2-way radio, computers, electronic automation, aerospace, etc. Thousands of real engineering jobs open to men without college degrees who know electronics fundamentals. Our home study courses make it easy to learn. Graduates must pass Gov't FCC License exam or get money back.

**WRITE FOR FREE BOOK.** Send your name & address to: Cleveland Institute of Electronics, Dept. PM-7, 1776 E. 17th St., Cleveland, Ohio 44114.



## YOUR OWN BIKE \$119.50 to 179.50

Even Mom'll go for this one—costs less, runs for just pennies (nearly 100 miles on a gallon of gas). And it's American made! It's the popular **CAMPUS BIKE!**

Literature FREE • Parts Catalog \$1.00  
Box 797PM • Janesville, Wis. 53546

**FOX**



SYDMUR "MARANER", the ULTIMATE TRANSISTORIZED "CD" IGNITION SYSTEM. As described in March 1966 **POPULAR MECHANICS**. Kit—6, 12 or 24 volts, Neg. Grd. \$54.50, 1 yr. guar. Assembled—\$79.95, 2 yr. guar. Send Check or M.O. Write for **FREE** literature and parts list.

SYDMUR, Box 25P, Midwood Station, Bklyn., N.Y. 11230

## ELECTRIFY PLAYER PIANOS PUMP ORGANS

**YOU CAN QUICKLY END TIRESOME FOOT-PUMPING**  
With a Compact Low-Cost Lee Silent Suction Unit



EASY TO INSTALL  
FULLY GUARANTEED  
1000'S IN USE

write to  
**LEE MUSIC MFG. CO.**  
Box 595, Tujunga, Calif.



## ENROLL—EARN YOUR DEGREE

of Bachelor of Bible Philosophy (B.Ph.B.), Master of Bible Philosophy (M.Ph.B.), Graduate of Bible Philosophy (G.Ph.B.), Doctor of Metaphysics (Ms.D.), or Doctor of Divinity (D.D.). Chartered by State, Correspondence Courses only. Please write for **FREE BOOKLET**.

### AMERICAN BIBLE INSTITUTE

Dept. PM, 408A W. 75th St., Kansas City, Mo. 64114

## BASEMENT TOILET FLUSHES UP



TO OVERHEAD SEWER OR SEPTIC TANK.  
NO DIGGING UP FLOORS. Write

McPHERSON, INC. BOX 15133 TAMPA, FLA.

# Be a LOCKSMITH



**JOEL DAIGLE says,**  
"Earned \$1138.75 while training. Now have excellent locksmith job—and enjoy every minute of the work."  
**Fort Kent, Me.**



**JOHN SCHMITZ says,**  
"What a happy way of life. My own successful shop—a completely outfitted mobile unit and a substantial income."  
**Butler, N. J.**



**JOE E. WARREN says,**  
"Paid entire tuition and made \$800 besides in spare-time, even before completing training."  
**Overland Park, Kan.**

# 306

Pieces of Professional Equipment.  
**LOCKS, PICKS & TOOLS** supplied for use with course.



## TRAIN AT HOME—EARN WHILE YOU LEARN

Add to **YOUR INCOME FAST**—even double it with easy sparetime earnings. Cash in on the nation-wide shortage of trained locksmiths. Quickly step into a big pay job, or start a high-profit shop of your own!

## EARN EXTRA MONEY RIGHT AWAY!

You can quickly qualify as a skilled locksmith. Age, education, minor physical handicaps don't matter in this ever-growing trade. So easy to learn it's like a fascinating new hobby!

Study at home as little as one hour a week. All special professional tools, supplies, including files, calipers, tweezers, cylinders, door handles, assemblies, gages, pins, springs, extractors, picks, locks and keys—supplied **FREE**. Gain practical experience by doing real jobs on car locks, house locks, padlocks, safe locks, etc.

Send for **FREE BOOK**, "Your Opportunities in Locksmithing." No cost, no obligation, no salesman will call.

Only school of its kind: Licensed by State of New Jersey, Accredited Member National Home Study Council.

### APPROVED FOR VETERANS

## LOCKSMITHING INSTITUTE, Dept. 110-056,

(A Division of Technical Home Study Schools)—Little Falls, New Jersey 07424

Copyright 1966,

Locksmithing Institute

### MAIL THE COUPON AT ONCE

LOCKSMITHING INSTITUTE,  
(A Division of Technical Home Study Schools), Dept. 110-056, Little Falls, New Jersey, 07424

Please send without obligation the **FREE** illustrated book, "Your Opportunities in Locksmithing." I understand no salesman will call.

Check here if eligible for veteran benefits.

Name \_\_\_\_\_

Address \_\_\_\_\_

City \_\_\_\_\_ State \_\_\_\_\_ Zip \_\_\_\_\_





## NO JOB WORRIES

PLASTEX INDUSTRY needs manufacturers on small scale for big production of Lamps, Clock Stands, Art Goods, Novelties in Plastic Marble imitation. No experience necessary. 1/2¢ material makes regular 10¢ store sellers. Moulds furnished for fast production. Small investment brings good profit. Big wholesale orders now being placed. Ambitious men have chance for real prosperity and job security. Our NEW FREE booklet will interest and benefit you.

**PLASTEX INDUSTRIES, Dept. A**  
3400 Third Ave. New York 56, N. Y.



### Compact Tach/Dwell Tester

No Batteries—Transistor Type Circuit—Tune Any Car—4-6-8 Cylinder—6-12-24 Volt Regular or Transistorized Ignition Systems—R.P.M. Scales—0-3000, 0-4000, 0-6000—Cam Angle Degrees—0-45°, 0-60°, 0-90°. 2 Year Unconditional Guarantee Save Money—Order Direct \$19.95

#### LANDMESSER TOOLS

980 S. Cass Lake Rd., Pontiac, Mich. 48054

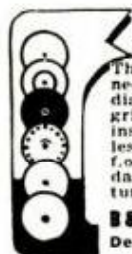

### make your own *Gems* 36<sup>50</sup>

The Gem Maker comes complete with all necessary equipment, including a super-charged diamond blade for sawing, and all the wheels for grinding, shaping and polishing; also complete instructions. The complete equipment as shown, less motor and belt for only \$36.50, f.o.b., Burlington, Wisconsin. Write today for information and literature.

**B & I MANUFACTURING CO.**  
Dept. P, Burlington, Wis.



## A "NEVER-BEFORE" OPPORTUNITY to Learn Quick—Earn Quick at Home

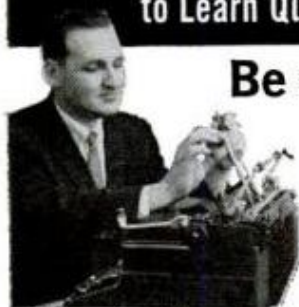

### Be a TYPEWRITER REPAIRMAN

NOW, for the FIRST TIME, you can get into this booming, uncrowded, high-income field! You can easily, quickly cash in on the one skilled trade with proved industry training, never before available by home study!

- Earn up to \$50 per week in Spare Time
- Step into well-paid jobs
- Be the Boss of a big-profit business of your own

Great DEMAND for trained men. Over 25 million typewriters need service and repairs. Find out how YOU can cash in FAST on this 300 million dollar market. WRITE TODAY: Typewriter Repair School, Dept. 310-056, Little Falls, New Jersey 07424. N. J. Lic'd. Acct'd. Member Nat'l. Home Study Council

Earn while you learn to fix, rebuild, resell ALL MAKES AND MODELS, you get real typewriter, sub-assemblies, professional tools all at NO EXTRA COST with course. Illustrated step-by-step instruction under guidance of industry experts. Get full facts in FREE BOOKLET from only school authorized to give you industry-approved training and State Approved Diploma.

MAIL COUPON NOW!

TYPEWRITER REPAIR SCHOOL, Dept. 310-056, Little Falls, New Jersey 07424

Send FREE BOOKLET about opportunities for Typewriter Repairmen. No obligation. No salesman will call.

Name \_\_\_\_\_

Address \_\_\_\_\_

City \_\_\_\_\_ State \_\_\_\_\_ Zip \_\_\_\_\_

Check here for Veteran Information

## SHOPPING FOR TOOLS

BY RICHARD HOWE

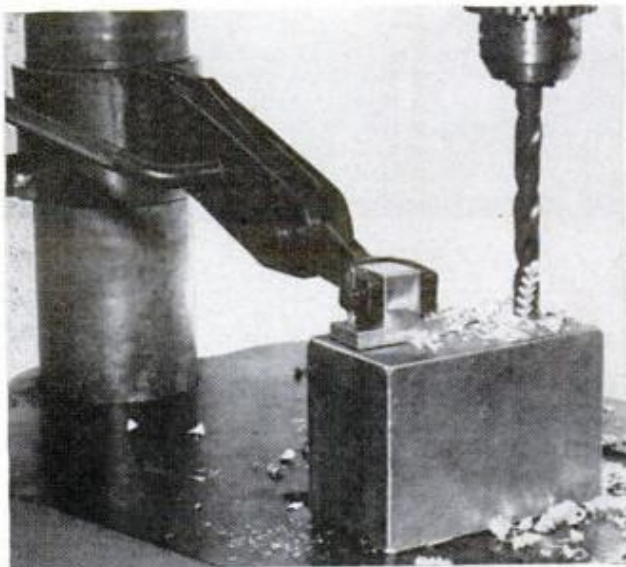

Added safety for drill-press operators is offered by this Cam-Lock Clamp with a single lever which locks part and clamp in position in one motion. Adjustable, it fits a 2 3/4-in.-dia. column, has 400 lbs. holding pressure. Made by Welch Drill Bushing Co., 1630 Flower St., Glendale, Calif.

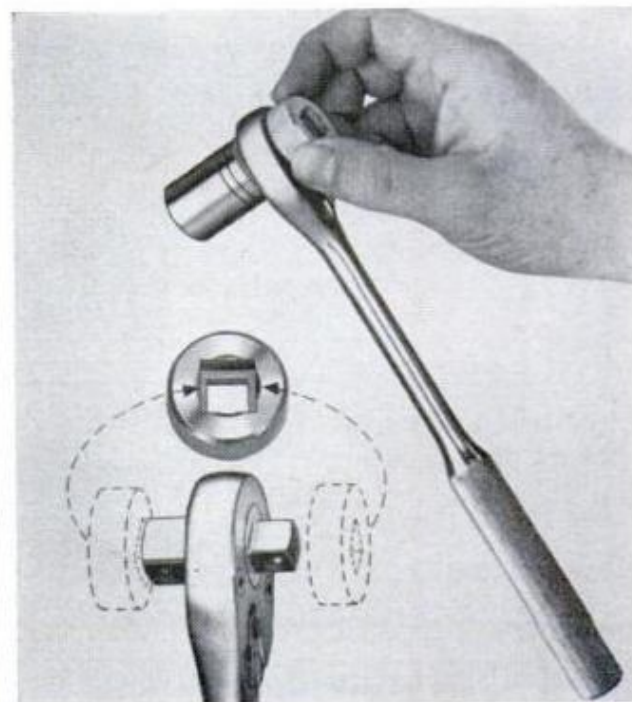

**Two tools in one!** It's the Vogel Double-Drive Ratchet, with spinner. Spinner fits 3/8-in. and 1/2-in. drive plugs for fast spinning of loose nuts, bolts and sparkplugs. Available through better hardware stores for \$8.95, it's made by Neff Enterprises, Inc., 1575 W. Rialto Ave., San Bernardino, Calif.





**New 12-in., gap-bed wood lathe** has improved variable-speed control. An industrial tool, it offers an infinite variety of speeds from 230 to 3200 rpm, depending on type of 3/4-hp motor used. It will do metal spinning; turn wood, nonferrous metals, plastics. Rockwell Mfg. Co., Pittsburgh.

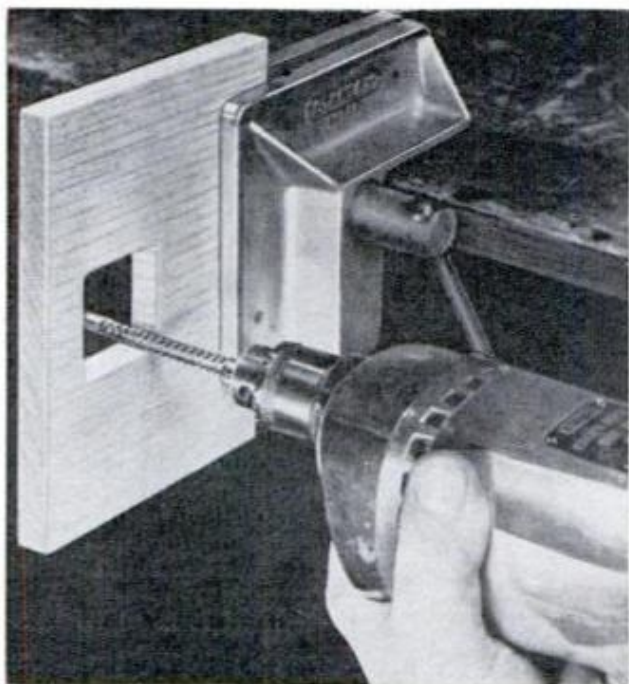

**Startling versatility** is the hallmark of the drill saw, a drill-shaped tool used with a portable electric drill or drill press to cut, drill or shape wood, plywood, plastics and nonferrous metals. Made by The Stanley Works of New Britain, Conn., it will cut square or round holes and shape designs.

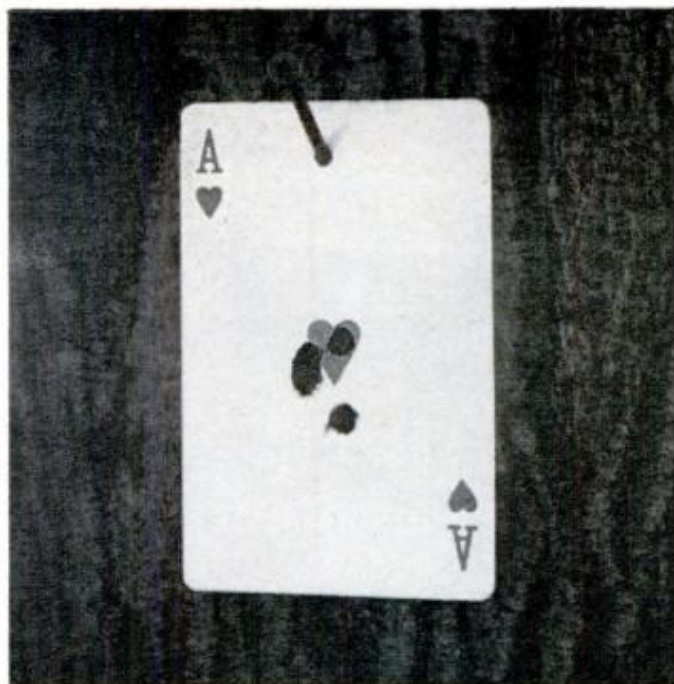

# HEART-BREAKERS

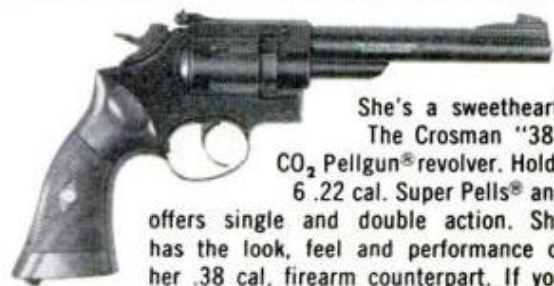

\$27.50

She's a sweetheart. The Crosman "38" CO<sub>2</sub> Pellgun® revolver. Holds 6 .22 cal. Super Pells® and offers single and double action. She has the look, feel and performance of her .38 cal. firearm counterpart. If you want accuracy, you want this heart-breaker with six-inch rifled steel barrel.



\$27.50

Perhaps, the Crosman "600" semi-automatic CO<sub>2</sub> Pellgun Pistol is more to your liking. Shoots 10 .22 cal. Super Pells® in 3 seconds. Micro-click rear sight. Thumb rest target grip. Swing feed boltless loading. Positive safety.

She's a honey, too. See both at your Crosman dealer.

Free Book: "More Shooting Fun" describes all Crosman guns. Address Dept. PM056.

**Crosman/Going Great Guns**

Crosman Arms Co., Inc., Fairport, N. Y.  
Crosman Arms (Canada) Ltd., Dunnville, Ont.



*"Undercover protection  
for your car!"*



**DURU**  
PLASTIC

**5 New Special Agents**



Just Spray  
On —  
Save Time  
and Trouble

At better auto  
accessory departments.

- "No. 1" Belt Grip & Dressing ..... 89¢
- "No. 2" Penetrating Lubricant ..... 89¢
- "No. 3" Automatic Choke Cleaner ..... 1.39
- "No. 4" Engine D-Greaser ..... 1.89
- "No. 5" Auto Body Under Coating ..... 1.89

The WOODHILL Chemical Corp., Cleveland, Ohio 44128



## Print Your Own

Cards, Stationery, Advertising, Circulars, labels, photo and movie titles, church work, tags, etc. Save money. Sold direct from factory only. Raised printing like engraving, too.

### Own a Printing Business

Print for Others, Good Profit. Have home shop. Junior press \$15; Senior \$35 up. We supply everything. Easy rules. Pays for itself in short time. Write now for free details. **KELSEY PRESSES, Z-37 Meriden, Conn.**

KELSEY PRESSES

when it's time to think of college  
you should read this  
**FREE CAREER BOOKLET**  
about engineering at

# MSOE



**MILWAUKEE MS-236**  
**SCHOOL OF ENGINEERING**  
Dept. PM-566 1025 N. Milwaukee Street  
Milwaukee, Wisconsin 53201

Tell me about an engineering career through residence study in:

- Mechanical fields                       Electrical fields

Name.....Age.....

Address.....

City, State.....

New Table Top Invention Puts You In...

## PROFITABLE RUBBER STAMP BUSINESS

Home Operators now make  
**\$16.50 AN HOUR** in Business  
once monopolized by  
a few big companies

Special rubber stamps bring high prices—cost only pennies to make on new, low-cost table top machine. Take 27 cents worth of material, make perfect stamps, the kind businesses and offices now buy by the dozen at \$2.75 each. Make up to \$16.50 an hour. Start in spare time in your own home. Run machine on kitchen table using ordinary electrical outlet. Make any kind of stamp. We'll send you free information without obligation about this established, highly profitable business. **We'll even help finance your start.** For free information send name and address today on a postcard to: Rubber Stamp Div., 1512 Jarvis, Dept. R2EX, Chicago, Ill. 60626



## GET INTO ELECTRONICS

V.T.I. training leads to success as technicians, field engineers, specialists in communications, guided missiles, computers, radar, automation. Basic & advanced courses. Electronic Engineering Technology and Electronic Technology curricula both available. Assoc. degree in 29 mos. U.S. obtainable. G.I. approved. Start Feb., Sept. Dorms. campus. High School Graduate or equivalent. Catalog.

**VALPARAISO TECHNICAL INSTITUTE**  
DEPARTMENT D. VALPARAISO, INDIANA



## BUILD FINE GRANDFATHER CLOCK NOW

Simple, sensible. Red-i-Kut shop tested plans. Build for yourself or sell at a good profit. SAVE 100's \$\$\$! Narrow waist 83" tall models "Spirit of the Century" and new "Spirit of Peace" with amazing 221/2° front corners or stately straight side "Spirit of America". "HOW-TO" Photopack Plans with LIFE SIZE PATTERNS tell all—plus CLOCK BUYER'S GUIDE. Jet Age heavy brass weight. (Kuemple Original) Westminster, tube-bell chime movements, gorgeous bronze-silver MOVING MOON dials, LYRE pendulums, 3/4" solid mahogany Jiffy-Joint Kwik-Bilt case kits, \$1.00 each plan. Rush \$2.50 all three plus Free Bonus "Petite Grandmother" plan, as folks have for over 50 years. Kuemple Chime Works, 27 Kuemple Bldg., Minneapolis, Minn. 55416

Kuemple Chime Works, 27 Kuemple Bldg., Minneapolis, Minn. 55416

## PROFIT IN YOUR SPARE TIME

**SMALL ENGINE REPAIR PAYS BIG!**  
Outboard • Powermower • Chain Saw • Tractor  
**MAKE EXTRA MONEY** — or fix your own engines and SAVE! Illustrated, easy-to-learn Home Study Course qualifies you as expert. Free information. Write today!

**LINCOLN TECHNICAL INSTITUTE**  
SUITE 5E, 427 MARKET STREET, NEWARK 5, N.J.

# Plas-Slick

Pressure-sensitive vinyl plastic letters, and numbers are easy to apply, adhere to any surface. They're weatherproof, washable, permanent . . . indoors and outdoors. Thousands of uses in the home and office. In five colors (red, white, blue, gold, black) and four sizes (5/16", 1/2", 1", 2", high). Money-back guarantee.

Over **1,000** for **\$1.00**

Please specify size and color.  
Over 1,000 characters for \$1 in 5/16" size;  
Over 500 for \$1 in 1/2" size; Over 200 for \$1 in 1" size; Over 100 for \$1 in 2" size.

**WESTWOOD SALES CO.**  
Dept. PM56, P.O. Box 661, Westwood, N. J.



# It's Like Having Auto Factory Experts Right Beside You...

SHOWING YOU

## HOW TO FIX ANY PART OF ANY CAR!



Now—Whether You're a Beginner or an Expert Mechanic—You Can "Breeze Through" Just About ANY Auto Repair Job—**QUICKLY—EASILY—RIGHT!**

SUPPOSE you had an automobile factory engineer standing right beside you . . . guiding your hands through every step of even the toughest car repair jobs! Think how you'd "whiz through" every job! No wonder, then, that 5 million MOTOR'S Auto Manuals have been sold. No wonder so many thousands of beginner and expert mechanics alike are already using MOTOR'S brand-new AUTO REPAIR MANUAL. It shows you, in step-by-step words and pictures, factory-approved repair procedures for fixing practically ANY part of ANY car listed here — 1959 through 1966!

No guesswork! MOTOR'S Manual "starts from scratch" — leads you through entire job with easy directions. You CAN'T go wrong!

OVER 1,300 BIG PAGES —  
3,800 BIG PICTURES

NEW, REVISED, ENLARGED Edition covers everything you need to know to fix practically any car model from 1959 thru 1966, including all the "in-between" models. 1,325 Giant pages. 3,800 "This-is-How" pictures. 457 "Quick-Check" charts. More than 55,000 essential repair specifications. Over 225,000 service and repair facts. Plus a big handy Trouble-Shooting section!

Even a green beginner mechanic can do a good job with this giant manual before him. And if you're a top-notch mechanic, you'll find short cuts that will amaze you. No wonder this guide is used by the U.S. Army and Navy! No wonder hundreds of thousands of men call it the "Auto Repair Man's Bible"!

Engineers from every automobile plant in America worked out these time-saving procedures for their own motor car line. Now the editors of MOTOR'S have gathered together this wealth of "know-how" from 300 Official Shop Manuals and "boiled it down" into crystal-clear terms in one handy indexed book!

### EXACTLY WHAT YOU NEED TO KNOW

Includes Transmissions, Overdrives, Power Steering, Power Brakes, Carburetors, Fuel Pumps, Starting Motors, 12-Volt Systems, Generators, Alternators, Voltage Regulators, Distributors, Axles, etc. Factory Specifications and Adjustment Tables. Tune-up Charts. Overhauling, Replacement Facts. New section on general engine service. Much, much more!

### Covers These Makes

Barracuda	Fury
Bronco	Imperial
Buick	Jeep
Cadillac	Lancer
Chevrolet	Lincoln
Chevrolet	Marlin
Chevy II	Mercury
Chrysler	Mustang
Comet	Oldsmobile
Continental	Olds F-85
Corvair	Plymouth
Corvette	Pontiac
Dart	Rambler
De Soto	Studebaker
Dodge	Tempest
Edsel	Toronado
Fairlane	Thunderbird
Falcon	Valiant
Ford	Volkswagen

MOTOR'S  
AUTO  
REPAIR  
MANUAL

- CARBURETOR
- GENERATOR
- FUEL PUMP
- ENGINES
- BRAKES
- DISTRIBUTOR
- AUTOMATIC TRANSMISSIONS
- STARTING MOTORS
- OVERDRIVES
- STEERING GEAR
- IGNITION
- MUCH MUCH MORE!

TRY BOOK **FREE**  
FOR 10 WHOLE DAYS

### SEND NO MONEY NOW

Just mail coupon. (Attach it to postcard, for faster action.) Unless you agree this book is the greatest time- and work-saver you've ever seen — return it in 10 days, pay nothing. Mail coupon to MOTOR Book Dept., 250 West 55th St., New York, N. Y. 10019. (Schools, Bookstores: Write for Discounts.)



### Same FREE Offer On MOTOR'S Brand-New Truck Repair Manual

Covers practically every job on gasoline and diesel trucks made since 1955! Over 2,000 pictures. Over 1,000 big pages. FREE 10-Day trial. Check proper box in coupon.

### MAIL COUPON NOW FOR 10-DAY FREE TRIAL

(Attach to Postcard if More Convenient)

MOTOR BOOK DEPT., Desk 615  
250 W. 55th St., New York, N. Y. 10019

Rush to me at once MOTOR'S New AUTO REPAIR MANUAL. If O.K., I will remit \$2 in 10 days, \$3 monthly for 2 months and a final payment of \$1.95 (plus delivery charges and sales tax, if any) one month after that. Otherwise I will return the book postpaid in 10 days.

Print Name..... Age.....

Address.....

City & State..... Zip Code.....

Also send me for 10 days' Free Trial MOTOR'S New TRUCK REPAIR MANUAL. If O.K., I will remit \$11.00 plus delivery charges and sales tax, if any, in 10 days. Otherwise I will return book postpaid in 10 days.

Check box and SAVE delivery charges by enclosing WITH coupon in envelope entire payment of \$9.95 for Auto Repair Manual (or \$11 for Truck Repair Manual) plus sales tax, if any. Same return-for-refund privilege applies.



# Spotlight on the Alfa Romeo Giulia TI

This under-\$3000 sedan combines sports-car responsiveness, five-passenger convenience and a truly Latin personality

By ALEX MARKOVICH

**I**TALIAN CARS are like Italian women: they're temperamental but—oh so interesting.

Take the Alfa Romeo TI sedan, for example. Throughout my driving test it behaved like a perfect lady until one icy, winter morning, when it refused to start. I cranked the starter, hooked up jumper cables, tried a rolling start down a steep hill, all to no avail. The TI just coasted to a stop at the bottom of the hill and sat there smugly. I wished I knew some Italian curse words as I was kicking the tires.

"Okay," I grumbled, walking away. "Just sit there." (I often talk to cars.) When I returned 10 minutes later—tow truck and all—I tried cranking the starter just once more. The car started right up, much to my embarrassment.

Poor starting had been a common complaint among Alfa owners until the recent switch to Bosch ignition parts. Now, the problem is "generally cured" (except in our test car, of course).

Otherwise, the TI is one of the most delightful cars I've ever driven. Its big

claim to fame is that it combines the impeccable road-holding of a fine sports car with comfortable accommodations for four or even five "adult-sized" adults—all for \$2927. It's a familiar sight in Italy, but it has only recently become available in this country.

The styling? It can best be described as "early shoebox." But once you're under way, this doesn't matter. The little double-overhead-cam Four is a masterpiece of engineering. Though it wrings 104 hp out of a mere 95.8 cu. in. (at 6000 rpm), it can pull away smoothly from 25 mph in fifth gear (if you're heartless enough to try it).

Yes, fifth. Five crisp, fast, beautifully synchronized gears. Actually, fifth is an overdrive gear with a ratio of 0.79 to 1.

Visibility is the best of any sedan I've driven. Seats are unusually high—unfortunately with some sacrifice in headroom—and a sloping hood and plenty of glass area assure a fine view in all directions.

Seats have adequate fore-and-aft





*Wash away* oil and grease spots on concrete!



New de-greaser quickly removes ugly surface grease from concrete driveways, carports, garage floors • Just apply, brush in with broom, flush clean with water • Also removes cooking oil stains from patios and hardened grease and oil from car engines, other mechanical equipment

**Klean-Strip's**

**DRIVEWAY CLEANER**

The Klean-Strip Co., Inc. — Memphis, Tennessee

LEARN TO BE A

**DENTAL MECHANIC**



**SECURITY • PRESTIGE • GOOD PAY**

Learn at home, in your spare time, to make Crowns, Plates, Bridgework, etc. Dental Mechanics are employed by Dentists, Dental Laboratories or open your own shop, full or spare time. **FULL EQUIPMENT OF TOOLS AND MATERIALS INCLUDED WITH COURSE.** Low tuition. Easy Terms. Write for **FREE BOOK** about this money-making profession that's not affected by automation.

**McCARRIE SCHOOL OF MECHANICAL DENTISTRY**  
127 So. 13th Street, Dept. 93, Philadelphia 7, Pa.

**WATCH REPAIRING**

FREE BOOKLET • WRITE TODAY

Tells how you can learn to repair Swiss and American watches at home in spare time.

Free booklet and sample lesson. No obligation.

**CHICAGO SCHOOL OF WATCHMAKING**  
DEPT. 156, FOX RIVER GROVE, ILLINOIS 60021



**Solves Repair Problems**

Durham's fills cracks and holes in plaster, wood and tile. Won't shrink or fall out. Economical, easy to use. Big 4-lb. can, only 1.60 at lumber, paint, and hardware dealers, or shipped direct postpaid in U. S. for \$2.00. Money-back guarantee. Order now. Donald Durham Co., Box 804-T, Des Moines, Iowa.

**BORROW BY AIRMAIL**

\$37<sup>00</sup> Monthly Repays \$827<sup>40</sup>



**IF YOU'RE BETWEEN 25 AND 65, YOU NEED ONLY HAVE A STEADY INCOME TO QUALIFY.** Simplified transaction is handled entirely by airmail, you receive your money in a few days. Your friends, employer will not know of the loan. Take advantage of this fast, dignified loan service today!

**BANKERS INVESTMENT CO. 67D-S**  
Bankers Inv. Bldg., Hutchinson, Kans. 67501

NO embarrassing investigations; NO representative will call on you. Collateral and co-signers are not required; all loans are granted on your personal signature!

EXAMPLES	
Cash You Get	Repay Monthly
\$357 <sup>18</sup>	\$18 <sup>00</sup>
\$637 <sup>00</sup>	\$31 <sup>00</sup>
\$724 <sup>00</sup>	\$33 <sup>00</sup>

Mr. Geo. Gustafson, Asst. V.P.  
**BANKERS INVESTMENT CO. 67D-S**  
Bankers Inv. Bldg., Hutchinson, Kans. 67501  
Please rush "Loan Agreement" in plain envelope.

AMOUNT I NEED \$ \_\_\_\_\_

Name \_\_\_\_\_ Age \_\_\_\_\_  
Address \_\_\_\_\_ Occupation \_\_\_\_\_  
City \_\_\_\_\_ State \_\_\_\_\_ ZIP# \_\_\_\_\_

**"INVESTIGATING ACCIDENTS**

Brings Me Up To

**\$10000 A DAY CASH"**

— L. L. Baird  
Universal graduate



**Step Into This Booming \$19 Billion A Year Industry**

You can earn up to \$15 an hour...repeat, year-round income...in the exciting, fast-growing Accident Investigation field. Car furnished. Business expenses paid. NO selling. NO higher education necessary. NO equipment needed. And age is NO barrier. You can earn while you learn. Keep present job until ready to switch. Rush coupon for all facts and material.



**UNIVERSAL SCHOOLS**

Dept. PM-5

6801 Hillcrest, Dallas, Texas 75205

Send **FREE** Book on Big Money In The Amazing Accident Investigation Field. No obligation.

Name \_\_\_\_\_

Address \_\_\_\_\_

City \_\_\_\_\_ State \_\_\_\_\_ Zip Code \_\_\_\_\_

**FREE Key Machine**

Kind master locksmiths use. Sells for \$125, but yours **FREE** with Belsaw Locksmithing Course.



**You Can Learn To Be A LOCKSMITH**  
in your spare time

There's a big demand for skilled locksmiths. You can earn big money either full or part-time in your own home. BELSAW INSTITUTE training, recommended by professional locksmiths, teaches you to make keys, open and repair locks on homes, cars and buildings. Easy, illustrated lessons complete with tools and supplies. Tells you how to build a secure cash profit business. Send for **Free Book**—no agent will call. BELSAW INSTITUTE, 106L Field Bldg., Kansas City 11, Mo.





## Earn **HIGH WAGES** as a **HEAVY EQUIPMENT OPERATOR**



... and years of future security in the multi-billion dollar construction industry, in this country and *overseas!* Learn how at National, the original school of heavy equipment operation. For men ages 17 to 56. National is NOT a correspondence school. You train on school-owned diesel-engined machines at National's huge proving ground in North Carolina. Full 220 and 440 hour courses. Full-time Job Advisory and Counseling Director for the exclusive benefit of graduates. VA approved. Payment plans available. Write TODAY for FREE catalog. National School is a Member of American Road Builders Association Service and Supply Division.

Since National School was founded 11 years ago, students from all 50 states and 28 foreign countries have been enrolled. Hundreds of graduates are now working in construction for higher wages than they ever made before.

Ask about our Train Now—Pay Later Plan!

**NATIONAL SCHOOL  
OF HEAVY EQUIPMENT OPERATION Dept. D-75**  
P. O. Drawer 1686, Charlotte, N. C.

Please send me FREE illustrated school catalog and complete information. I understand there's no obligation.

Name..... Age.....

Address..... Phone No.....

City..... Zone..... State.....



## **AUDEL** SKILL-BUILDING **GUIDES**

### **NEW AUTO GUIDE!**

**FIX ANY CAR FAST!** Step-by-step 1966 Repair Guide shows you how to troubleshoot and repair every part and system in any make or model car. Features

unique symptoms-and-causes charts. Covers absolutely everything from axles to valves, including engine tune-up. Hundreds of illustrations. 736 pages. To order, check No. 1 below. Only.....\$6.95

#### USE THIS HANDY ORDER FORM

- No. 1 **AUTO GUIDE**, 736 pages..... \$ 6.95
- No. 8 **Carpenters & Builders Guide**, 4 Vols. 1616 pgs. 16.95
- No. 15A **New Electric Library**, 10 Vols. 6016 pages..... 25.00
- No. 2 **Home Appliance Service Guide**, 608 pages..... 6.95
- No. 14A **Home Refrigeration & Air Conditioning**, 576 pgs. 6.95
- No. 26 **Masons & Builders Guide**, 4 Vols. 1476 pages... 10.50
- No. 6 **Plumbers & Steamfitters Guide**, 4 Vols. 2272 pgs. 10.50
- No. 12N **Machinists & Toolmakers Guide**, 3 Vols. 1312 p. 13.50
- No. 10 **Welders Guide**, 624 pages..... 4.95
- No. 4 **Handy Book of Practical Electricity**, 1088 pgs. 5.95

#### FREE 10-DAY TRIAL • SEND NO MONEY

**THEODORE AUDEL & CO.** Since 1879  
4300 W. 62nd St., Indianapolis, Ind. 46206

P-56

Please mail me for 10 days FREE EXAMINATION the books checked above. I agree to mail \$3 in 10 days for each book or set ordered, and to mail \$3 a month for each book or set until I've paid the purchase price, plus shipping costs. If I'm not completely satisfied with my Audel Guides I may return them.

**ORDER  
TODAY!**

Name.....

Address.....

Employed by.....  I have bought Audel books before

**SAVE SHIPPING COSTS.** Check here if you enclose complete payment (plus sales tax, if any) with order. We pay postage. Same return privilege.

## SPOTLIGHT ON ALFA ROMEO

(Continued from page 48)

travel, adjust for rake. Location of steering wheel, floor shift, handbrake and other controls is convenient. But the speedometer is of the hard-to-read ribbon type and the tachometer is small. Other gauges show oil pressure, water temperature and fuel level. Dash lights warn of low amps, or low fuel level and tell when lights, heater or high beams are on.

There's an insidious floor button to the left of the pedals, disguised as a dimmer switch. If you innocently press it, the results can be disconcerting: the windshield squirter goes into action.

There's quality workmanship throughout. All panels match perfectly. Doors close easily and solidly. The pleated leather upholstery is flawlessly stitched. Full carpeting covers the floor, and the dash and visors are padded.

Fire her up and the fun starts. Barreling down a bumpy back road, you find the ride comfortable and well-controlled. There's no wind noise, no matter whether windows are up or down. Steering is light at cruising speeds, fast and precise; brakes (power-assisted discs all around) are progressive and virtually fade-free.

And performance is more than adequate. Going through the first three gears, I reached 60 mph in 12.8 seconds. Top speed is over 100. Yet gas mileage for combined city and highway driving averaged about 22 mpg—which, with a fuel-tank capacity of 12.1 gallons, promises a cruising range of well over 250 miles.

In short, the TI is nothing less than a roomy, camouflaged Alfa Giulia sports car. Truly a wolf in sheep's clothing, it's an ideal choice for the family man who appreciates fine machinery, is tolerant of its inherent whimsies and needs room for a handful of urchins. ★★★

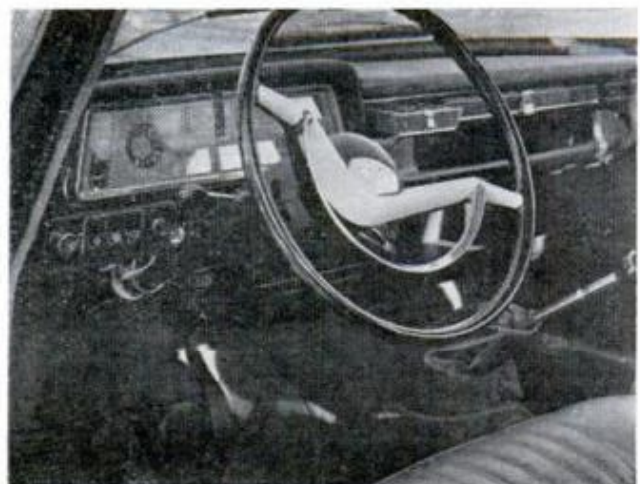

**DASH IS FUNCTIONAL**, if not sumptuous. Placement of floor pedals makes possible easy heel-and-toe work. Interior complements overall "classy" feeling



SCOUT is the registered trademark for a vehicle manufactured exclusively by the International Harvester Co.



## Newest ways to answer the call of the wild

The very newest ways to hit the trail are with the great INTERNATIONAL® campermobiles.

Rough, tough, powerful INTERNATIONAL pickups—with two or four-door styling and fancy interiors—will carry your camper just about anywhere you want to go.

You can get a husky chassis with 131-in. wheelbase—and slide a fully-equipped camper into a new 8-ft. Bonus-Load body. Or you can get an extra-strong chassis with a long 140-in. wheelbase—and fit a roomier full-mount camper on it.

If you don't need all that room or power, try our SCOUT® camper. With

all-wheel drive, it'll go way back in where the fishing is really good. And you can get it with custom interior and comfortable bucket seats.

Then there's our TRAVELALL®

International Harvester Company  
Dept. PM-4, P. O. Box 7333  
Chicago, Illinois 60601

Please send me your Camper Catalog.

Name \_\_\_\_\_

Address \_\_\_\_\_

City \_\_\_\_\_

State \_\_\_\_\_

wagon, which you can see at any INTERNATIONAL Dealer. A big, family wagon—available in two or four-wheel drive—it carries nine people plus their gear. And it hauls a house trailer without wagging its tail.

For anything else you want to know about our great line of recreational vehicles, see an INTERNATIONAL Dealer. Or fill in the coupon and mail it to us. We'll send you free a big, handsome catalog on our pickups, SCOUT and TRAVELALL.



**INTERNATIONAL HARVESTER  
COMPANY**  
CHICAGO, ILLINOIS



# Since when do bankers, lawyers, doctors and executives dress like this?



## Since new Lee Union-Alls.

Here's a whole new breed of garment. New Lee Union-Alls... the coveralls with a sense of fashion. We've added a smart convertible collar... half raglan sleeves... even a shape holding waistband. And now in proportioned sizes for even greater comfort. Sanforized, too. New Lee Union-Alls. Rugged enough for the man on the job. Handsome enough for the man around the house. You'll be seeing them in all the best backyards.

## LEE UNION-ALLS

designed for the do-it-yourselfer

H. D. Lee Company, Inc., Kansas City, Mo. 64141. World's Largest Manufacturer of Union-Made Workwear. ALSO AVAILABLE IN CANADA.





# Lucite® turns you loose



Less frequent house painting means more time to do the things you really want to do.

Du Pont LUCITE® House Paint will turn you loose to enjoy life by keeping its fresh, clean look.

You'll paint less often because LUCITE does something about the very things that make other paints fail.

Such as the invisible moisture vapor that's always trying to escape through the outside walls.

Du Pont LUCITE House Paint lets it out. (Lots of paints form a clogging seal that makes the paint blister. And peel.)

LUCITE House Paint has also been proven to resist cracking, flaking, chalking and mildewing far longer than leading oil-base paints.

LUCITE goes on easily—there's no tiresome "brush drag." And it'll dry in 30 minutes.

Protect your house and your leisure time for the long haul.

Let LUCITE turn you loose.



Better Things for Better Living

... through Chemistry



# YOUR DODGE DEALER HAS MORE KINDS OF HOMES THAN THE AVERAGE SUBDIVISION

(And changing neighborhoods is as easy as turning a key)



D200 CREW CAB



A100 SPORTSMAN WAGON



W200 4-WHEEL-DRIVE



DODGE MOTOR HOME



A100 PICKUP



CHASSIS-CAB



D200 CAMPER SPECIAL

*Enjoy the great outdoors with Dodge*

DODGE DIVISION



**CHRYSLER**  
MOTORS CORPORATION



**LEARN MEAT CUTTING**



Train quickly in 8 short weeks at Toledo for a bright future with security in the vital meat business. Big pay, full-time jobs—**HAVE A PROFITABLE MARKET OF YOUR OWN!** Pay after graduation. Diploma given. Job help. Thousands of successful graduates. Our 43rd year! Send NOW for FREE catalog. No obligation. GI approved. NATIONAL SCHOOL OF MEAT CUTTING, INC., 50-G, Toledo, Ohio 43604

**WOOD VENEERS • TOOLS**  
Shop Equipment • Supplies  
**POWER TOOLS**  
at Lowest Discount Prices!

**SAVE MONEY** on finest domestic and imported hardwoods . . . all dimensions. Over 1500 items for the home craftsman and woodworking hobbyist. Lamp parts, upholstery supplies, tile, power tools at discounts. **NEW CATALOG READY** 132 pages. Full Color. Send name, address and 35¢ to cover handling, and postage. Write . . .

**CRAFTSMAN** Wood Service Co. Dept. A-56  
2729 S. Mary, Chicago, Ill. 60608

**DRAFTING PAYS BIG MONEY**



The need for skilled draftsmen is tremendous. Learn at home in your spare time. You can receive Christy's professional drafting training, portable drafting table, professional drafting instruments and equipment on PAY-LATER plan. FREE BOOK.

**CHRISTY TRADES SCHOOL INC., Dept. D-8203**  
3214 West Lawrence, Chicago, Illinois 60625

**TABLE-TOP CAR RACING**



**TABLE-TOP CAR RACING**  
A POPULAR MECHANICS BOOK  
by Richard F. Dampowski

A Popular Mechanics book tells how the fun started . . . how you can build the scale model cars, realistic track and scenery . . . and how to race these free wheeling little cars in a wide variety of scale sizes. It is all here including a list of manufacturers of parts and components. \$4.95 plus postage. Popular Mechanics Books, 575 Lexington Ave., New York, N.Y. 10022

**"TOOK IN \$217 FIRST 10 DAYS"**

Some make more, some less . . .

**We help you to start Your Own All-Year Business**

**Make Big Money!** With our easily operated, highly efficient Wall Washer, Charles Stelle took in \$217 in first ten days. E. L. Goss took in more than \$10,000 in one year. G. H. Jones wrote, "I made a net profit of \$1200 on one job." And no wonder—this machine washes walls 6 times faster and better than by hand and with no mess—no drop cloths needed.



**Your Money-Making Opportunity •** We want more men to go into this profitable business for themselves and enjoy independence—freedom from layoffs and bosses. Customers everywhere—homes, offices, schools, churches, hotels, etc. How much you earn depends largely on you, but we help you to start and work with you for your success. Training and consulting with experts is available at no additional cost. What you take in is mostly profit. No need to rent shop or office; operate from home. Can start spare-time until your full time is justified.

**OURS IS NOT A LEASE ARRANGEMENT •** You are free to operate in an independent manner. You sign no contract. You own the detergent outright and are always *your own boss* . . . and every dollar you take in is *yours* to keep. You pay no fees, or dues, or royalties to anyone and enough supplies come with it to return far more than your investment. Many earn the cost of the detergent in a week or two. It costs nothing to get the details . . . write **TODAY**.

**Lose No Time—Send Coupon Today for All the Facts**

**FREE BOOK! MAIL COUPON TODAY!**

• **VON SCHRADER MFG. CO.**  
• 510 "W" Pl., Racine, Wisconsin

• Send at once (no obligation) your **FREE** booklet containing information about your **WALL WASHING MACHINE** and how I can start my own permanent, profitable business.

• Name \_\_\_\_\_

• Address \_\_\_\_\_

• City \_\_\_\_\_ State \_\_\_\_\_ Zip \_\_\_\_\_

**DRAINS** cellars, cisterns, wash tubs; **\$8.95**  
**IRRIGATES - CIRCULATES - SPRAYS**



1,001 uses. Stainless shaft. Won't rust or clog! Use 1/6 HP motor or larger . . . 3/4 HP for up to 2,400 GPH; 450 GPH 80' high; or 1,800 GPH from 25' well. 1" inlet; 3/4" outlet. Coupling included free. **\$8.95.**

**HEAVY DUTY BALL-BEARING PUMP.** Up to 5,200 GPH; or 3,000 GPH from 25' well. 1 1/4" Inlet; 1" outlet, **\$12.95**

Postpaid if cash with order. **MONEY BACK GUARANTEE**

**Centrifugal and Gear Pumps in All Sizes**  
**LABAWCO PUMPS, Belle Mead 7, New Jersey**



# PUBLICATIONS **WORTH WRITING FOR**

BY MARION MOREY

**Tall men** who ask, "What type of shoe will make my foot look smaller? or "Should a 6'6" man wear a narrow tie or a plaid shirt?" will find answers to these and dozens of questions in the booklet, "Good Grooming for King-Size Men." It's invaluable in helping you get the most for your clothing dollar. Send 25 cents to King-Size, Inc., Dept. PM 2, 746 Forest St., Brockton, Mass.

**Calculate mileage** by pointing an arrow, say at Chicago, and a glance will let you know that Madison, Wisconsin is 142 miles away, New York City is 840 and Cincinnati, 291. It's possible with sectional maps on 7½-inch dials. They eliminate the fuss of cumbersome road maps, giving not only total mileage from starting point to destination, but also intermediate mileages for overnight stops, refueling, etc. Each of six sectional maps (60 cents apiece) has 46 major cities and 1,620 planned routings. The entire U.S. set costs \$3.50. Write

Plumly Manufacturing Corp., Dept. PM 8, 5532 Calmont, Ft. Worth, Texas.

**Pocket billiard king**, Willie Mosconi, has authored a recent book, *Winning Pocket Billiards*. For both beginners and advanced players, with a special section on trick shots, the 140-page book discusses the fascinating geometry of the game. Diagrams and photos show you how it's played. Published by Crown, Dept. PM 5, 419 Park Avenue South, N.Y., N.Y., the book costs \$1.95.

**Where can you find** that article you read some months back on repairing asphalt driveways or building a ruby laser? Right in "Index to How to Do It Information," a handy 134-page book which indexes leading how-to magazines. The most recent issue, 1964 (soon to be followed by 1965), is divided into eleven major interest areas such as workshop, electronics, model making. In

## POPULAR MECHANICS SHOPPING GUIDE

### Secrets of Teaching Yourself MUSIC

Revealed in Your Home This Money-Saving Way

**YES!** Now you can teach yourself to play Piano, Guitar, ANY instrument in your spare time—even if you've never played a note in your life! Famous proven Course makes it simple as A-B-C. Pictured lessons show you how. No teacher. No scales. No boring exercises. Amaze friends by playing favorite music. Write today for FREE 36-page illustrated book. U.S. SCHOOL OF MUSIC, Studio 305, Port Washington, New York 11050. (Est. 1898. Licensed N.Y. State Educa. Dept.) Tear out as a reminder.

### Beautiful, Authentic, Full Color WILD LIFE DECALS



pairs only

11" to 17"

BASS, N. PIKE  
STEELHEAD  
SALMON, TROUT  
C. GOOSE, BOB  
WHITE, MALLARD  
PHEASANT—DEER  
ELK, MOOSE, BEAR

Ideal for:  
Campers, Trailers,  
Boats, Pick-ups,  
Cabins etc.

\$3.50 PAIR  
Postpaid

Satisfaction  
Guaranteed

Send For Free Folder

WASHINGTON POSTER CO. Dept. PM  
16824 Pac. Hy. So., SEATTLE, WASH. 98188

### Diving Watch

17-JEWEL CALENDAR  
AIRMAILED FROM  
SWITZERLAND  
AT A FRACTION  
OF U.S. PRICE!



CHROME STEEL case with CALENDAR, ROTATING BEZEL, LUMINOUS figures, SHOCK-PROTECTED. Pressure tested at 500 ft. (with case, crown, crystal intact). Luxurious matching Stainless Steel Watch Band included. IMMEDIATE shipment via REGISTERED AIRMAIL. Send \$13 in dollar bills, money order or bank check. (No personal checks.) Deluxe AUTOMATIC SELF-WINDING Model \$33. (To attract your order place 15¢ postage on envelope.) FREE Catalog on request via ordinary mail. For airmail enclose 50¢ stamps.

OLLECH & WAJS, Dept. L-12  
8039 ZURICH, SWITZERLAND



ONLY \$14.95

Money Back  
Guarantee

### HEAVY DUTY-ARC WELDER

Five Year  
Guarantee

The New 1966 Model Heavy Duty 110 Volt Arc Welder works on any 110 volt house line. You can not buy a better welder anywhere at this low price. No experience necessary. Now anyone can braze, solder, cut and weld any metal up to ¼" thick. Generates heat up to 10,000 degrees for cutting through steel plate, etc. **NOTHING ELSE TO BUY.** Comes complete with 12 ft. of heavy duty power cable, 1/16" and 1/8" welding and brazing rods, rod holder, twin carbon torch, helmet, instruction book, etc. **MONEY BACK GUARANTEE.** Try it for 10 days. If you are not completely satisfied we will immediately refund your money without question.—**FULLY GUARANTEED FOR FIVE YEARS.** If inoperative, we will repair or replace it free of charge. **SEND ONLY \$2.00,** and when delivered, pay postman \$12.95 plus COD postage, or send \$14.95 and we will ship postpaid. Over 10,000 National Electric Welders are in use throughout the world. (For an extra large supply of rods, carbons and flux, send an additional \$2.00.)

Order Direct from factory: NATIONAL ELECTRIC, Dept. PM-5, DELRAY, FLORIDA



those sections, over 230 subjects are covered which refer to 1300 articles. A cross reference is included. The index is offered for three dollars by Norman Lathrop Enterprises. Dept. PM 6, P.O. Box 83, Flint, Michigan.

**Backpackers:** Hit the trail without staggering under too large and poorly packed a load. "The Art and Science of Backpacking," a 16-page pamphlet, tells hikers, hunters and campers how to arrange the light, efficient pack to allow for complete mobility. For example, it details a 3-day hike pack weighing under 20 pounds. Tips on sleep equipment, clothing, kitchen gear and food are also offered. Free copies of the pamphlet are available from Himalayan Industries, Dept. PM 8, 807 Cannery Row, Monterey, Calif.

**New touring atlas** provides complete information for year-round driving and vacationing throughout the U.S., Canada and Mexico. Prepared by Rand-McNally, the 11 by 14-inch, 220-page atlas is illustrated by 219 photos of tourist attractions and contains nearly 300 detailed, easy-to read maps including national parks and special areas.



**Scientific method builds  
Powerful Muscles  
in 3 minutes a day**

An entirely new, tested method of muscle-building that combines isotonic and isometric contraction has been developed by physiologists at the famed Max Planck Institute in West Germany. The unique Tensolator® method was successfully used to train the German Olympic team and other champion athletes all over the world. A quick series of 7-second exercises positively strengthens each set of muscles without tedious, strenuous workouts. 3 to 5 minutes a day is all it takes for maximum results (guaranteed or money back). The Tensolator method builds powerful muscles, broadens shoulders, trims waist, increases lung capacity. FREE lavishly illustrated, step-by-step brochure shows you how Tensolator works for men 20, 40, 50 years old or more. Send 25¢ for postage and handling to Dept. PM-1, Thoylo Corp., 509 Fifth Ave., New York, N.Y. 10017.



**THOUSANDS OF  
EXCITING TOOL  
VALUES!**

Stanley, Millers Falls, Skil, Disston, Wiss, Dremel, Speedy Sprayers, Plumb, Porter, Channellock, Bonney, Herbrand, Helios, Kennedy Boxes, Huot, Vise Grip, Ridgid and many other Nationally Advertised brands of Tools & Supplies too numerous to mention. We Ship Coast To Coast At Prices Hard To Beat Send 25¢ today for our Big 148-page Tool Catalog.

**SILVO HARDWARE CO.**  
Dept. PM5, 107 Walnut St.  
Phila., Pa. 19106

**GIANT 12 FT.  
METEOROLOGICAL BALLOON**



Playing with one of these is great fun! Brand new government surplus, it's made from durable neoprene rubber, easily inflates with gas or air to 12 to 18 ft. Fine as advertisement at openings, sports events, etc. \$2.95 ppd. Day Co., Dept. PM5, Box 311, Gracie Sta., N. Y. 28.

**FREE Electronics Bargain  
Catalogs for 1 Year!**



Exclusive House Brands | Nationally Famous Makes | Closeout Special Buys  
**Stereo • CB • Parts • Kits.  
Testers • Tubes • Tools • Tape.**  
Read the exciting catalogs of America's biggest nationwide electronics store chain. Get our latest issue today.

**RADIO SHACK** 2727 West 7th St.  
Fort Worth, Texas 76107, Dept. PM

Name \_\_\_\_\_  
Street \_\_\_\_\_  
City \_\_\_\_\_  
State \_\_\_\_\_ Zip \_\_\_\_\_  
••• Radio Shack Corp. — Division of Tandy Corp. •••

**\$10.95 EPOXY COLOR DIAL TELEPHONES**



Complete Factory rebuilt Western Electric in white, beige, ivory, pink, green or blue. If 4 prong plug is required add \$2.00. Fully guaranteed.

Write for free list. All shipments F.O.B.  
**SURPLUS CENTER**  
DEPT. PM, WAYMART, PENNA. 18472

**A FORTUNE IN YOUR POCKET?**



**COIN VIEWER**

Terrific Father's Day gift for the coin collector! Feed a stack of random coins into the "Scan-O-Matic". Its powerful, lighted magnifier discloses every mark! Automatically flips coin over or ejects it, then feeds another into place for study. U. L. approved. Guaranteed to please! **POSTPAID \$9.95**

• FREE catalog of coin values with order!  
**COLLECTORS UNLIMITED**  
BOX 208-P, NEWTOWN SQUARE, PA.

**STOP RUST**

*under cars, trucks, trailers with  
Rustopp®*

All you need is a paint brush or low-pressure spray gun (vacuum cleaner attachment type). And one-half gallon of Rustopp! Thirty minutes later your car is fully undercoated with a resilient new coating that will not -cannot- flake, peel or collect moisture. Rustopp inhibits existing rust from spreading and provides complete protection for other exposed areas. One coat—properly applied is unconditionally guaranteed to last the life of your car, truck or trailer! Just \$7.95 plus postage for 12-gallon.

Send Check or Money Order to:  
**ROYALE RESEARCH COMPANY**  
(Division of M.S.C.) Dept. P.M.  
1244 Mason Ave. N.E., Grand Rapids,  
Michigan 49503

**PAINT WITH PROFESSIONAL RESULTS**

Paint autos, planes, boats, windows, doors, walls, etc.—anything that requires Masking for precise separation of color, or protection of areas from paint during application. TAPE-TULE® is a simple, sturdy tool for dispensing and precision application of masking tape. Blades are blue steel, with sharp, heat treated, serrated edges. It makes easy, fast and inexpensive what normally is the toughest, slowest and costliest part of painting. *It's acclaimed by body and paint shops!*

**TAPE-TULE-Marketing Div. 51-400 Arant St.-North Charleston, S.C. 29406**

**TAPE-TULE®**

Only \$15.95 Postpaid  
With Clear Instructions

Check or M.O.—No COD's







## Excitement! Security! Good Pay! CRIME DETECTION

**LEARN AT HOME IN SPARE TIME—START NOW!**  
Crime everywhere is on the rise! Learn now, in your own home, the profitable profession that enables you to track down criminals and bring them to justice! Hundreds of Identification Bureaus employ I. A. S. graduates . . . trained in fingerprinting, police photography, handwriting identification, firearms and investigation. Our 44th year! FREE "Blue Book of Crime" . . . packed with crime facts and the full story of famous I. A. S. training. State exact age. No salesman will call. Rush Coupon!  
*A Correspondence School Founded in 1916.*

**FREE**  
Blue Book  
of Crime  
**MAIL**  
COUPON

INSTITUTE OF APPLIED SCIENCE, Dept. 1355  
1920 Sunnyside Avenue, Chicago 40, Ill.  
Rush Blue Book of Crime . . . FREE!

NAME . . . . . Age . . . . .  
ADDRESS . . . . .  
TOWN . . . . . STATE . . . . .



## AUTOMATIC HUBS for your 4-WHEEL DRIVE!

NOT EVEN A BUTTON TO PUSH on these amazing Lock-O-Matic selective drive hubs that automatically engage the front wheels in 4-w.d., automatically disengage them for 2-w.d. They stop front drive drag, save gas, gears, tires in 2-w.d.—automatically! For Lock-O-Matics—or popular Warn Locking Hubs—see your dealer.

**be happy—GO LOCK-O-MATIC!**  
WARN MANUFACTURING CO., INC.  
9050-A Empire Way So. Seattle, Wash. 98118

\*Not made for some 4-w.ds.

In addition, a 16-page section covers the history, terrain and climate of the U.S. The atlas costs two dollars from Texaco dealers.

**Aircraft owners**, student mechanics and pilots who want to know more about planes and how to inspect them: "Personal Aircraft Inspection Hand-Book" explains the basics in Part I and covers a typical inspection in detail in Part II. Arrows on illustrations pinpoint text references. The 71-page guide costs 50 cents from the Superintendent of Documents, U.S. Government Printing Office, Washington, D.C. 20402.

**Photo flash:** If you need more light on the subject, General Electric's "Photolamp & Lighting Data" booklet may prove helpful. Of special value is a center chart which gives the correct light source and filter for various types of color film. Booklet is free from Photolamp Dept., GE, Nela Park, Cleveland, Ohio.

Two or four-wheel drive  
**JEEP OR SCOUT**  
OWNERS

**REPOWER** with a 6 or V-8 H.D. ADAPTORS for using Car, Compact and some Truck engines. Conversion Kits \$45.35 to \$56.90. Want fast action? Give us FULL INFORMATION. Send \$15.00 Dep. and we will ship correct kit, bal. COD. Send full amount for prepaid shipment. Wire, phone or write today. Details FREE

HOOSIER MACHINE PRODUCTS CO.  
312 S. E. 6th St., Phone 276-3442, Pendleton, Oregon

## DIESEL & AUTO MECHANICS NEEDED IN INDUSTRY & ARMED FORCES

96.4% of graduates placed!

Starting at approximately \$5,000 a year, you can rapidly advance to around \$10,000 a year.

Whether you plan to enter industry or the Armed Forces, it will pay you to investigate the tremendous opportunities in the Diesel Auto field!

Write for free catalog showing the best equipped, most beautiful school in the country. Veteran Approved.

HOUSING & PART TIME JOBS PROVIDED

**FREE BOOKLET** →

**BAILEY  
TECHNICAL SCHOOLS**

1645 S. GRAND DEPT PM ST. LOUIS 4, MO.

Name . . . . . Age . . . . .  
Street . . . . .  
Town . . . . . Zone . . . . . State . . . . .  
Telephone . . . . .

Your  
Future  
in  
DIESEL and  
AUTO  
MECHANICS

## ACCORDIONS • Big Discounts

Buy  
Direct  
Importer-  
to-You

5-DAY  
HOME TRIAL

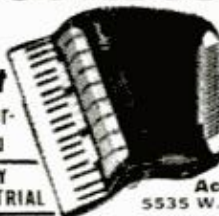

**NEW ELECTRONIC MODELS**

SAVE 1/2 42 "New Sound" Electronic and Standard models, Amplifiers too! All Famous Makes. Try before you buy—5-Day Trial. Easy Terms, Trade-ins. Free Accessories. Money Back Guarantee. Free Color Catalogs, Handy Selection Guide, Discount Prices. Write

Accordian Corporation of America  
5535 W. Belmont, Dept. R-56, Chicago 41, Ill.

## FREE! How to Improve Your Fishing Skill

Complimentary full color BROWNING catalog not only illustrates and details fishing rods—but ALSO contains helpful information on fishing equipment and techniques. Hints on spinning, bait casting, fly casting and two handed casting. Shows preferred line, lure, reel sizes.

**FOR FREE COPY WRITE:**

Browning Arms Co., Dept. B80,  
P.O. Box 450, St. Louis, Mo. 63166

Name . . . . .  
Address . . . . .  
City . . . . . State . . . . .



# QUICK, PRACTICAL WAY TO HIGHER PAY WITH N.T.S. HOME TRAINING

Move up faster, make more money the "Project Method" way.



## ELECTRONICS DIVISION

1. Electronics-TV-Radio Servicing and Communications
2. Master Course in Electronics-TV-Radio Advanced TV and Industrial Electronics
3. FCC License Course
4. Radio Servicing (AM-FM-Transistors)
5. Television Servicing (Including Color)
6. Stereo, Hi-Fi and Sound Systems
7. Basic Electronics
8. Electronics Math

NO KIT DEPOSITS

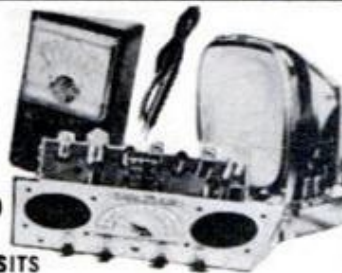

## AUTO-MECHANICS DIVISION

1. Automotive-Diesel Master Course
  2. Automotive Mechanics
  3. Diesel Mechanics
  4. Engine Tune-Up and Electricity
- Eighty million cars and trucks need maintenance. Here's real opportunity! Get and keep valuable tools. No kit deposits, no extra cost.

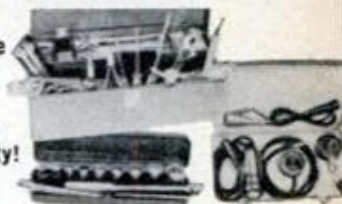

## AIR CONDITIONING-REFRIGERATION DIVISION

1. Air Conditioning-Refrigeration Servicing Course
  2. Air Conditioning Refrigeration & Electrical Appliances Master Course
- Good income in servicing and installation. Big equipment kits with both courses at no extra cost. No kit deposits.



## HOME APPLIANCES DIVISION

1. Home Appliances Master Technician's Course
  2. Home Appliances Servicing Course
- Prepare for full or part time career. Earn while you learn. No kit deposits. Tools included at no extra cost.



## NATIONAL TECHNICAL SCHOOLS

4000 S. Figueroa St., Los Angeles, California 90037

## HIGH SCHOOL AT HOME

National offers accredited high school programs. Take only subjects you need. Study at your own pace. Everything included at one low tuition. Check special High School box in coupon for complete FREE Diploma information.



## CLASSROOM TRAINING AT LOS ANGELES

You can take classroom training in our famous Resident School in Los Angeles. Check Resident School box in coupon for full details.

SEND FOR FREE BOOK & SAMPLE LESSON



## NATIONAL TECHNICAL SCHOOLS, DEPT. 201-56

4000 S. Figueroa St., Los Angeles, Calif. 90037  
Please rush FREE BOOK AND SAMPLE LESSON on Courses in the Division checked below. No obligation. No salesman will call. Please check one only.

- |  |  |
|--|--|
| <input type="checkbox"/> ELECTRONICS Division    | <input type="checkbox"/> AIR CONDITIONING REFRIGERATION Division |
| <input type="checkbox"/> AUTO MECHANICS Division | <input type="checkbox"/> HOME APPLIANCES Division                |
| <input type="checkbox"/> HIGH SCHOOL Department  |  |

Name \_\_\_\_\_ Age \_\_\_\_\_

Address \_\_\_\_\_

City \_\_\_\_\_ State \_\_\_\_\_ ZIP \_\_\_\_\_

Check here if interested only in classroom training at Los Angeles.

## NATIONAL TECHNICAL SCHOOLS

WORLD-WIDE TRAINING SINCE 1905

4000 S. Figueroa St., Los Angeles, Calif. 90037

YOU ENROLL BY MAIL. NO SALESMAN WILL CALL.



## PROFESSIONAL TAX CONSULTANTS

EARN BIG MONEY FASTER

Clean, dignified, high pay Tax Consultant Practice waiting for trained graduates. Busy Tax season pays \$1,000 to \$3,000 for spare-time work . . . leads to profitable year 'round Tax Service Business with monthly fees of up to \$50 per client. No previous experience. Low cost home training course, shows you the way. Licensed by N. Y. Education Dept. and Member Nat'l. Home Study Council. Write for FREE LITERATURE. No obligation. No salesmen.

NATIONAL TAX TRAINING SCHOOL, Monsey, N-20, N.Y. 10952

# MAGIC MAIL PLAN

that comes with this Little Machine CAN MAKE YOU \$1200 AN HOUR

The machine is turning out a job that will bring operator \$2.58, by mail. Material cost, only 11c



Write today for free facts about the newest and most fascinating of all new home operated businesses. For the first time, a simplified machine brings the fabulous profits of Plastic Sealing and Plastic Laminating within reach of the small operator. Anyone can learn to operate it with a few minutes practice. Then—with our MAGIC MAIL PLAN—can get mail orders pouring in daily with cash in every envelope.

### No Canvassing or Selling

Fill orders at home in spare time to start. Then expand to full time business. We even supply circulars to bring back cash and orders. Rush name for all the facts you need to start. A postcard will do. No charge.

WARNER ELECTRIC CO., Dept. L2-EX  
1512 Jarvis, Chicago, Ill. 60626

## You Can Develop A Profitable Business on A Shoestring

Make \$5.00 an Hour in Your Own Home

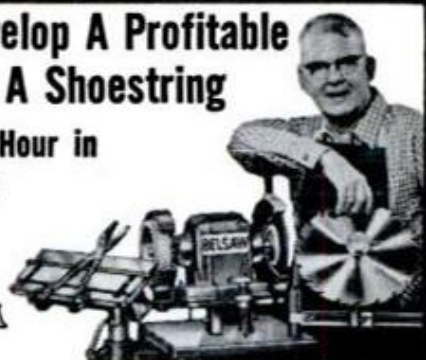

I wish there was space here to print the hundreds of letters received from men I've put in business with the Belsaw Sharp-All. With this precision machine you can sharpen all popular household, garden and shop tools easily and quickly. You need no previous experience . . . no inventory, no selling, no space to rent.

### I've Done It for 40,000 Men

I have been helping men get into this profitable business for over 30 years. I'll finance you to get started . . . give you all the instructions and help you'll need to really succeed. I'll keep you informed HOW others are making big cash profits every day. No obligation.

So don't delay. Send coupon for FREE book today.

STAN FIELD, President  
Belsaw Sharp-All Company  
716L Field Bldg., Kansas City, Mo. 64111

Name \_\_\_\_\_

Address \_\_\_\_\_

City \_\_\_\_\_ St. \_\_\_\_\_ Zip \_\_\_\_\_







## EARN \$1,000 A MONTH

### LEARN A TRADE YOU LIKE

Start as a mechanic in a good paying job; then advance to shop service manager. Many make \$1,000 a month and up. You learn fast in our shop because you learn with tools on real equipment. Some students earn part of their expenses while going to school.

### CHECK AND MAIL COUPON

- |   |  |
|---|--|
| <input type="checkbox"/> AUTO MECHANICS   | <input type="checkbox"/> AUTO BODY REPAIR        |
| <input type="checkbox"/> DIESEL MECHANICS | <input type="checkbox"/> AUTOMATIC TRANSMISSIONS |
| <input type="checkbox"/> GAS, ARC WELDING | <input type="checkbox"/> MOTOR TUNE-UP           |
| <input type="checkbox"/> HELIARC WELDING  |  |

Mail to: **AUTO-DIESEL COLLEGE**  
226 7th Ave., No., Dept. 86, Nashville, Tenn.

Please send without obligation free catalog

NAME \_\_\_\_\_  
(please print or write plainly)

ADDRESS \_\_\_\_\_

CITY \_\_\_\_\_ STATE \_\_\_\_\_

# ELECTRONICS

## COYNE ELECTRONICS INSTITUTE

A quarter million dollars worth of equipment. Non-Profit Institute—Est. 1899. Courses: Electronics • Electricity • TV-Radio • F.C.C. • Electronics Engineering Technology. Mail coupon or write for FREE BOOK, "Your Opportunities in Electronics." No Salesman will call.

COYNE ELECTRONICS INSTITUTE Educ. Serv. Dept. 56-S  
1501 W. Congress Parkway, Chicago, Ill. 60607

NAME \_\_\_\_\_ PHONE \_\_\_\_\_

ADDRESS \_\_\_\_\_ AGE \_\_\_\_\_

CITY \_\_\_\_\_ STATE \_\_\_\_\_

**300 POWER** . . . . .



**Complete Telescope Lens Kit** only **\$3.98** postpaid

Conquer Space, Explore the Universe, Planets, Moon craters, New Stars etc. Complete Lens Kit consists of 80 inch focal length ground and polished objective lens, eyepiece lenses for 50 POWER, 100 POWER, 150 POWER, 200 POWER, 250 POWER, 300 POWER, and all necessary lens fittings. Easy to make from simple step by step instructions. (Tripod and mount not included.) Money back guarantee.

**BUSSE SALES CO., Hartford, Conn., Dept. PM-90**

# EXCITING NEW PRODUCTS

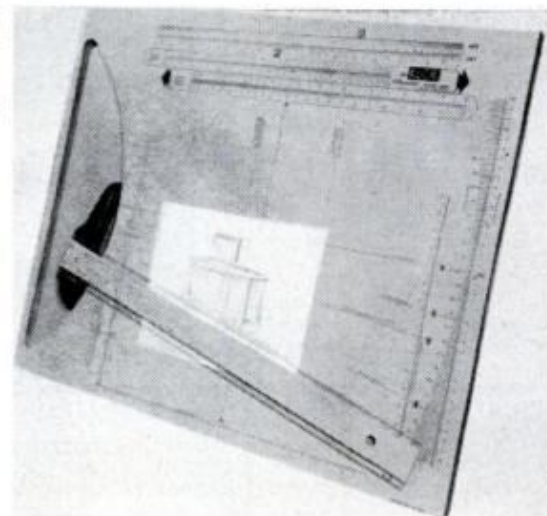

**Perspective sketching is a cinch**, once you learn to use the special board and T-square of the Klok System. Vanishing points are established by edge scales as the T-square swings within a curved recess. The set—with complete instructions that start you out on simple cubes and soon have you drawing furniture or house exteriors—is \$35 ppd. from Wilson Studios, P.O. Box 1605, Grand Rapids, Mich. 49501.

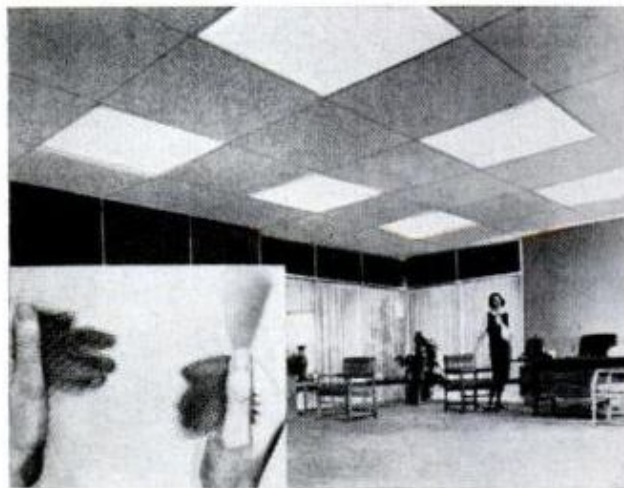

**Prismatic glass lighting panels** in sizes up to 4x4 ft. are being marketed by Corning Glass Works, Corning, N.Y. Called *Corning Crystal 79*, they're available in standard glass and chemically strengthened glass. Panels combine light control efficiency with a soft, rich appearance similar to that of opal diffusers. About 1/8 in. thick, the panels have even greater impact strength than 1/4-in. tempered glass.



# "\$7,108.50 First Year SERVICING RADIATORS!"

— Hank Konter, Newcastle, Wyo.

Make good money servicing auto-truck-tractor radiators with new Inland 1-Piece Radiator Shop. Easy to test-clean-repair radiators. Inland, world's largest radiator equip. mfr., trains you free. Small down payment starts you. Easy-pay plan lets you pay from profits. Proved merchandising assures volume. Profitable dept. for garage or service station. WRITE for Free Book. INLAND MFG. CO., Dept. PM-5, 1108 Jackson, Omaha 2, Neb.



NEW!

## PLAY GUITAR IN 7 DAYS OR MONEY BACK



TOP GUITARIST ED SALE'S famous 66 page secret system worth \$3.00 teaches you to play a beautiful song the first day and any song by ear or note in seven days! Contains 52 photos, 87 finger placing charts, etc. plus 110 popular and western songs, (words and music); a \$1.00 Chord Finder of all the chords used in popular music; and a \$3.00 Guitarist Book of Knowledge.

TOTAL VALUE \$7.00 **\$2.98**  
—ALL FOR ONLY

SEND NO MONEY! Just your name and address, pay postman: \$2.98 plus C.O.D. postage. Or send \$1.00 with order and I pay postage. (Sorry, no C.O.D. outside Continental U.S.A.—please remit with order.)

**Unconditional Money-Back Guarantee**

ED SALE Studio 153-F AVON BY THE SEA, N. J.

## NEW 1966 MODEL BB AIR RIFLE and SHOT GUN

Lloads 60 BB's At One Time

Two guns in one!  
Use as air rifle re-  
peater or shot gun  
blaster. New in-  
stant choke  
loader  
holds 60  
BB's.



**STANDARD AMERICAN—Dept. 5-PMBB**  
1 Park Avenue, New York, N. Y. 10016

Packs a knockout punch. So powerful it will drive steel BB's through both sides of a 3 gal. pail. Rugged steel construction. Deluxe walnut wood stock, lifetime finish. Dye cast loading mechanism. Double safety. Easy lever action. Precision accuracy for target practice, hunting small game. Order now! We include target, interesting book on guns. (Parent's signature if under 16). Send only \$8.95 check or money order plus \$1.00 PP & Hldg. Mail coupon.

## You Can Start A PROFITABLE BUSINESS In Rug Cleaning

Earn \$10 An Hour  
In Your  
Sparetime

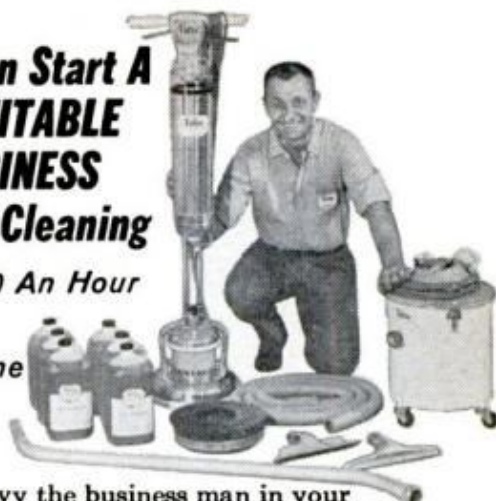

Don't envy the business man in your town who has a business of his own! You, too, can be that man. New lucrative Foley-Care rug and floor cleaning service available to aggressive men who lack capital. Minimum investment! You can start in sparetime while still on your present job.

### FREE Booklet Tells You How...

The complete story is told in this interesting booklet, "A Business of Your Own". It reveals why a Rug Cleaning Service is so profitable, why it's in a growing demand, how you can get started at once and produce income in just a few days. Write today! No salesman will call!

**FOLEY CARE, Dept. 502-6**  
3333 Fifth St. N. E., Minneapolis, Minn. 55418

Please send Free "Business of Your Own" Booklet on Rug Cleaning

Name \_\_\_\_\_  
Address \_\_\_\_\_  
City, State, Zip code \_\_\_\_\_



# FOLBOT

fits in every  
home or car

CHOICE of CHAMPIONS

belongs  
to You

Most inexpensive too

GENUINE Folbot RECREATION for just ONE small investment, WITHOUT the continuous burdens of complicated "big rig" operation. You GO CAREFREE anytime with COMPACT Folbot . . . rocky streams, lakes, marsh, surf & open sea. Superior non-sinkable designs provide SAFEST low gravity center, balanced low & high seating, substantial construction, protective decks & EXCLUSIVE swivel-back COMFORT. ALL within your reach. In handy Folbot YOU GLIDE smoother, faster & NOISELESS with paddles, oars, or sails and ride softly w. 1 to 10 HP. motors. Many styles & sizes from 1 to 4 seaters, FOLDING or rigid PORTABLE come in PREFAB KIT, or expertly FACTORY BUILT

**NATIONAL SAFETY RECORDS**

**WORLD RECORD  
FISHING**

NOW  
at SPECIAL  
SAVINGS  
YACHT-SMART  
large DACRON  
Sail Rig  
\$99

PREFAB  
from \$55

FACTORY BUILT

\$146

NEW  
Fabulous  
16 foot  
\$119

Factory BUILT

Folding from  
\$179 Factory finished

**FREE**  
ACTION CATALOG

Mail coupon or address

to: FOLBOT CORP., Dept. PM-566  
Charleston, S. C. -29405

Name \_\_\_\_\_

Address \_\_\_\_\_

City \_\_\_\_\_ State \_\_\_\_\_

for  
**YOUR SPORT & FAMILY FUN**

MAY 1966

61



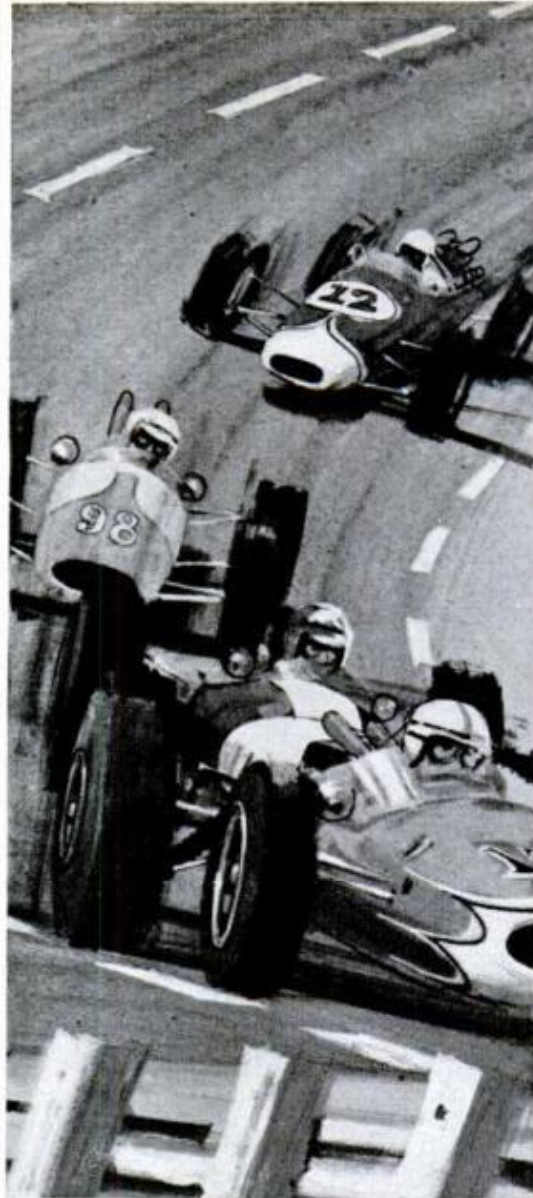

## Georgia... sports capital of the South!

Georgia's spectator sports are strictly big league! Examples? Atlanta's new \$18 million stadium becomes the official "home of the Braves" this spring . . . and in the fall, will be the scene of pro football battles with the new NFL Atlanta Falcons. Golf? There's the world-famous Masters at Augusta each April. Racing? NASCAR classics at the Augusta and Atlanta International Raceways. Water Sports? The World Water Ski Tournament at Callaway Gardens each summer. Championship Skydiving? Sure, see the meets at Stone Mountain. It's a fact: no other southern state offers so much big-time sports activity. Idea: take a vacation visit to your favorite event in Georgia soon!

**VACATION GEORGIA '88**



Visit the Georgia Welcome Centers for travel information when you enter Georgia.

For information on Georgia Sports Events, write:  
Georgia Dept. of Industry & Trade,  
Tourist Division  
100 State Capitol, Atlanta, Georgia 30334

NAME \_\_\_\_\_

ADDRESS \_\_\_\_\_

CITY & STATE \_\_\_\_\_ ZONE \_\_\_\_\_



# CLASSIFIED ADVERTISEMENTS

Rate: \$1.40 per word payable in advance each insertion. Minimum insertion ten words. To be inserted under the proper classification, copy must be in our office by the 15th of the second month preceding date of issue. The next available issue to place an advertisement in America's No. 1 Classified Section is July. The closing date is May 15. Send remittance to order to C. A. Martin, Popular Mechanics, 575 Lexington Avenue, New York, New York 10022.

## AUTOMOBILES, MIDGET CARS

NEW Car every year at little cost through local dealers. Explosive guide of startling facts shows how. Free literature. CarResearch, P.O. Box 2332D, St. Louis, Missouri 63114.

AUTOMOBILE Literature, antique, classic, rare reprints. Non-profit hobby club. Free information. Enthusiasts, Box 451B, Mt. Clemens, Mich. 48043.

## AUTO SUPPLIES AND EQUIPMENT

CROSLY. New, used, parts. Discounts. Catalog. Box 7, Elmont, N.Y.

NEW And used parts savings. Complete guaranteed service all model cars and trucks. Largest in west. Jeep and Army parts specialists. Shifting hubs for all front-end drive vehicles. \$27.50 up. Foreign parts. Fast service. Pioneer, 734 W. 13th Avenue, Denver, Colorado 80217.

NEW Warning, safety and electronic devices for car, home, boat. Free catalog. Earn money selling these items. Details free. Electronic Products Co., Dept. D, Box 8485, St. Louis, Missouri 63132.

JEOP Owners—V8 conversions. Read Jeep Owners ad, page 58.

JEOP Parts catalog: Military and Civilian. For owners, dealers, garages, service stations. Save \$\$\$ Surplus and replacements. American Auto Parts Co., 1830 Locust, Kansas City, Missouri

FREE!! 1966 Automobile accessories catalog. Gray's, Box 875, Athens, Ala. 35611.

AUTO Welding repair training in world's largest non-profit welding school. Low tuition. Free booklet. Hobart Welding School, Box M-56, Troy, Ohio.

SELF Stick visor or vanity mirrors or car, boat, locker, home. Send \$1.00 to: Kwik Stik Mirror, 13440 Cedar Road, Cleveland, Ohio 44118

HOW To get the most from your new car warranty. Send \$1.00 for this valuable money saving booklet. Wynnewood House Creations, P-56, 115 Calvarese Lane, Wayne, Penna. 19087.

SAVE \$150! Ring-Valve job while driving. \$6.00 postpaid. Safe! Guaranteed! 15th successful year! Motaloy, Grantham, Penna. 17027.

BATTERY Tester, new compact, floating colored balls indicate 4 Battery conditions. Leak proof, unbreakable case. \$1.98 ppd. The Thrift Mart, P.O. Box 65, Dept. 4, Bronx, New York 10467.

CAR Parking guide aids driver in positioning car in home garage. Easily installed. Postpaid. B.S.W. Co., Chag'in Falls, Ohio.

FOG-BUSTERS. Amazing safety aid for fog driving at night. Snaps on low-beam. \$1.00 pair. Will-Win, 7124 W. Center, Dept. P, Milwaukee, Wisconsin 53210.

FOREIGN Car parts. Discounts. Catalog. Box 7, Elmont, N.Y.

## AUTO TRAILERS

BUILD Aluminum pickup camper over-cab, hi-boy, lo-boy, blueprints, material, list, 3 models included. \$3.00. Bennett Custom Camper, 1500 S. Dallas, Auburn, Indiana 46706.

PRE-Cut pickup camper kits. Ready to assemble. Literature, 15¢. Snowy Mountain Campers, Lewistown, Montana.

CAMPING Trailer kits. Sleep 6, basic kit, \$140.00 pickup camper kits Circular, 10¢. Stratford Trailers, Seymour St., Stratford, Conn.

"CAMPER UNIT—Compact buses, vans—Build inexpensively—Plans, Photos, Instructions. Set PM2 for Volkswagens, PM-4 for Econolines, Dodges. \$2.00 set. Dot Campers, Box 67, Saugus, California.

WILD Life decals, full color, large. Free folder. Washington Poster Co., 16824-PMC Pacific Highway So., Seattle, Wash. 98188.

PICKUP Camper, trailer or pickup-cover—build yourself, save! Complete plans \$3.95 each. Econoline Camper, foldout trailer, bus conversion drawings, \$2.95 each. Satisfaction guaranteed. Equipment Catalog \$1.00 (refundable on first order). Details 10¢ Viking Camper Supply, 94-F Glenwood, Minneapolis, Minn. 55403.

PICKUP Camper kits, covers to 14 foot Cabovers. Complete plans, \$3.95 each. Catalog \$1.00 (refundable) Details 10¢. Guaranteed. Financing available. King Camper and Supply, 1405PM Mitchell Boulevard, Fort Worth, Texas.

VOLKSWAGEN Bus camper (two double beds); Tent Trailers; Plans—each \$3.00; Details free; Compact Manufacturing Company, Box 10843, Pittsburgh, Pennsylvania 15236.

PICKUP - Tent - travel - trailers. Blueprints. Brochure 25¢. Kamcraft, Box 1153, Milwaukee 1, Wis.

BUILD Your pickup camper. Precut kits. Blueprints. Supplies. Literature, 10¢. Comstock Trailers, Dept. 664, Parsons, Kansas 67357.

## MOTORCYCLES, BICYCLES, MOTORSCOOTERS AND SUPPLIES

HARLEY-Davidsons — Used bargains. New, used parts, accessories, all models. Bulletin 35¢. Knuth's (Factory Dealer), 1753 Muskego, Milwaukee, Wis.

CUSHMAN Scooter \$15. Kart \$20. Mini-bike \$25, less engines. Engines \$4 up. Whizzer \$5. Moped \$25. (Mailorder Only). Send 25¢. (35¢ for first class mailing) for directory-catalogue number 128, listing the above and hundreds of similar bargains, parts, plans etc. Midget Motors Directory, Athens, Ohio.

BUILD Motorbike from Bicycle! Plans, \$1.00; Go-Byk Industries, Rothsay, Minnesota 56579.



## AVIATION

BE A Government licensed aviation mechanic. Practical training. Free information. Aero Mechanics School, Municipal Airport, Kansas City 16, Missouri.

HOMEBUILT. Real enclosed helicopter, 24 pages ideas, information, \$2.00. Build "executive" helicopter. drawings, specifications, \$1.50. Helicopter Development, Box PM147, Washington, New Jersey.

HOT Air balloon kits, \$1.00 up, hang glider kits, plans, etc., send for free brochure. U.S. Sportcraft, Box 847, Woodland Hills, Calif.

PROPELLERS. Plans, kits, supplies for airboats, snowplanes. Gauges, spark plugs, gas-oil hose, oil coolers, primers, wrenches, switches, propeller hubs, engine mounts. Corvair-Volkswagon conversion parts, 125-190 Lycoming engines, manuals, gaskets, parts. Catalog, \$1.00. Banks-Maxwell, Box 3301E, Ft. Worth, Texas 76105.



## BOATS

BOAT Kits. Factory molded fiberglass or pre-assembled plywood. 30 models, 12' to 40', Runabouts, Cruisers, Houseboats. Free catalog. Luger, Dept. BC-66, 9200 Bloomington Freeway, Minneapolis, Minnesota 55431.

FIBERGLASS Canoes. Three exciting models. Easily assembled kits. \$34.95 up (factory direct). Free literature. Riverside Canoes, P.O. Box 5595BB, Riverside, Calif.

BOAT Plans, frame kits, full size patterns all prepared specially for amateurs. Send 50¢ for new catalog illustrating 55 proven designs including sail, inboards and outboards from 7' to 28'. Glen Designs, 9152 Rosecrans, Bellflower, Calif.

FULL Size, cut-to-shape boat patterns, blueprints. Send 60¢ for big new illustrated "Build a Boat" catalog includes fishing boats, garies, cruisers, catamarans, houseboats — outboards, inboards, sailboats—7½ to 38". "How to Build a Boat." booklet, \$2.50. Cleveland Boat Blueprint Co., Box 18250, Cleveland, Ohio.

FREE Plans catalogue—kayaks, canoes, sailing rigs, accessories. Bruce Clark, PM; 115 McGavock Pike, Nashville, Tenn. 37214.



**FIBERGLASS** Cloth and resin. World's finest cloth and non-run resin, at direct mill prices. Flotation foam. Complete line of plastics, silicon bronze and brass screws, save 60%. No sales tax. Boat Plans. Free catalogue. Freight prepaid. Stiles Boat Supply, Box 11P, Linden Ave., Mantua Hts., N.J.

**BUILD** Your own boat from our large-scale blueprints. Books of plans give how-to-build help. Hundreds of professional designs—motor, sail or auxiliary—for amateur builders. Free catalog. MoToR Boating, 959 Eighth Ave., Dept. RS, New York 19, N. Y.

**NYLON** Or multifilament rope 1/4 inch size, 100 feet for \$2.00 postpaid anywhere in United States. Other sizes proportionately low in nylon polyethylene polypropylene or cotton solid braid or hollow braid. Write for list & prices. Dealers Wanted. Dixie Rope Co., Box 142, Shelby, N.C.

**WORLD'S** Finest boat kits! Frame kits! Models from 8' to 24'. Prams—skiffs—runabouts—cruisers. All leaders in styling and performance. Send 50¢ for catalog. \$1.00 for catalog plus boat building handbook. Custom Boat Designs, 1709-P Niagara Street, Buffalo, New York 14207.

**VIKING** Canoes, factory direct. Four canvas covered kit models, under \$25.00. Uncomplicated assembly. Free information. Sportsraft, Box 8393-P, Columbus, Ohio 43201.

**BOAT** Trailers. Bueprints, \$1.00. Illustrated parts list, 30¢. Kamcraft, Box 1153, Milwaukee 1, Wis.

**HYDROPLANES.** Runabouts, inboards, outboards. Ski and class. Plans, kits or complete. Big catalogue, 25¢. Champion Boats, Dept. 10E, Box 9215, Long Beach, California.

**FIBERGLASS** Resin, \$5.15 gallon, hardener included. 44" cloth, \$1.50 yard. Vicon, Inc., 533 Randolph St., Meadville, Pa. 16335.

**205** BOAT Plans, patterns, kits. Catalogs: Powerboat, large \$1.00, condensed 50¢. Sailboat 40¢. Marinecraft, Box 161-M, Brighton, Mass. 02135.

**KAYAKS** — One-man \$19.50; two-man \$24.50; Sailboat \$42.00. Exciting Sitka Kayak Kits known world wide for speed and safety. Assemble in one afternoon. Free pictorial literature. Box 78-P, Brecksville, Ohio 44141.

**SWIMMERS.** Boaters and Water-sports fans—Something new for you—Magic Belt. Write for free brochure: Floatmaster Ltd., Box 205, Station E., Toronto, Canada.

**DC-14 CATAMARANS.** We have an attractive money-saving and money-making proposition for sailors who would like to own and show off our fabulous DC-14 Phantom racing sloop in exclusive territories. Write Duncan Sutphen, Inc., 342 Madison Avenue, New York, N.Y. 10017.

**BOAT** Plans, world's largest selection. Frame kits and full size paper patterns. Designed for the amateur. Over 200 proven designs from all over the world. Fishing boats—cruisers—sailing—inboard and outboard hydroplanes. Send \$1.50 for catalog. \$2.00 for catalog plus boat building handbook. Custom Boat Designs, 1709-P Niagara Street, Buffalo, New York 14207.

### MARINE EQUIPMENT AND SERVICES

**FIBERGLASS** Boat covering. Wholesale prices. Free literature and sample. Seifert's, Box 1206-M, Green Bay, Wisconsin.

**MARINE** Conversions. Ford, Chevrolet, Jeep engines. Catalog 25¢. Lehman Manufacturing Company, 800 Elizabeth Avenue, Linden 4, N.J.

**KITS**—Build your own inboard engine from Chevrolet, Ford, etc. Big catalog shows how, 50¢. Star Marine, Berkeley 10, California.

**MOTORS.** Build your own electric outboard motor. Operates on six or twelve volt car battery. Various speeds. Can be built complete for less than \$10.00. Plans \$1.00. Phillips Iron Works, Smithfield, North Carolina 27577.

**CELESTIAL** Time computer: New dial type. Gives Greenwich Mean Time, Meridian passage, Greenwich Hour Angle, from any Longitude. \$3.00. Par-D Navigation Co., P.O. Box 2012, Knoxville, Tennessee 37901.

**NEW.** Used, rebuilt marine motors. Marine conversions, fittings. Free catalog. Stokes Marine Supply, Dept. 24, Coldwater, Michigan.

### ATHLETIC AND BODY BUILDING COURSES

**APPEAR** Taller! Free growth facts! Stature PM5, Box 10, Brooklyn 7, N.Y.

**"GIANT** Arms." Dr. Young's, D.C. revolutionary discovery, \$2. Satisfaction or refund. Gaucho, Box 9309-S7, Chicago 90.

**LEARN** How to defend yourself. Now! First time outside armed forces learn real hand-to-hand combat. Not Karate! Not Judo! The real thing! Send only \$1.98 today for your postpaid copy to Van Fleet Enterprises, 3104 Lomita, Springfield, Missouri 65804.

**BAR BELLS.** Exercise equipment, key to health, strength, physique, 25¢. Reading Barbell Co., West Reading, Pa.

**WEIGHT** Exercising Equipment, free literature. Jubinville, Box 622, Holyoke, Mass.

**HUGE** Arms. Miracle method. Never fails, or money back. Only \$5 postpaid. LBA, Box 432, Teaneck, N.J. 07666.

**FEAR** No bully! Master authentic Chinese kungfu unbeatable techniques! Defeat within seconds any attacker including giant judo-karate experts. Free details by air. Write Asia's Greatest Master, Leong-fu, MI/14, 119 Anderson Road, Ipoh, Malaysia.

**POWERFUL** Muscles fast! Free brochure! Universal Bodybuilding, Box 4327-C, Northeastern, Dearborn, Michigan 48126.

### SPORTING GOODS AND EQUIPMENT

**SURFBOARDS** Illustrated manuals. Build your own \$3.00. Repair your own \$2.00. Or send \$4.00 for both. Surf, Box 173, Manahawkin, N.J. 08050.

**GOLF** Shoe conversion kit. New easy method. Money-back guarantee. Send \$2. Den-Bar Products, 1020 Washington, Genoa, Ohio.

**BIG** Money raising crickets and 12 inch African fishworms. Free literature. Carter Ranch, Plains, Georgia.

**FREE** L.L. Bean catalog—100 illustrated pages of practical fishing, camping and hunting specialties, clothing and footwear for men and ladies. Write L. L. Bean, Inc., Dept. #4, Freeport, Maine 04032.

**BASEBALL** Batting ranges commercial or backyard, Allstar, 9025 Sepulveda, Sepulveda, Calif.

**BOWIE** Knife plans, build your own, complete instructions, Tempering, Shaping, etc., \$1.00. Bowie Knife, Box 599, Levelland, Texas.

**BASEBALL** Indoor target and backstop for exercise, training and fun. Free details or send \$8.85 to Indoor Backstop, Box 435, Cove Station, Weirton, W. Va.

**SILENCERS:** Pistol, rifle details, simpler, cheaper! Plus new design for .22s \$1.00. Twin Enterprises, Box 192-A, Dunellen, New Jersey 08812.

**MAGIC** Belt for swimmers. See Floatmaster ad under Boats.

**SEND \$2.00** For 300-page shooting supplies catalogue. Quality gunsmithing—Lowest prices. Western Gun & Supply, 3730 N. 56th, Lincoln, Nebraska.

**FREE** Wingshooter's handbook. New helpful facts on shotgun shooting, shotgun chokes and how to save ammunition. Write to Poly-Choke Co., Dept. 545C, Hartford, Conn. 06101.



### FISHING, TACKLE, LURES

**MOLDS** For fisherman's sinkers, jigs, squids, casting and spinning lures. Free catalog. Sweet's Molds, Tonawanda 1, New York.

**MOLDS** For casting your own fishing sinkers. Free illustrated booklet. Reading Instrument Co., Box PM78, Reading, Penna.

**DOUGH** Bait—Retired commercial fisherman's recipes, 10 Catfish, 50¢. 8 Carp, 50¢. Baits, Corydon, Iowa 50060.

**AUTOMATIC** Fish scaler. Boat activated. Literature free. Penland's, Monroe, Georgia.

**FREE** Details! Electronic fish call. Perkins, PM566, 6322 Sloan, Houston, Texas 77017.

**OVER** 5,000 Hard-to-Find fishing specialties and kits galore. Send for free 170 page catalog. Netcraft Co., Dept. PM, Toledo, Ohio 43613.

**FREE** Wholesale catalog. Beads, Spinners, Lure parts, Sinkers, Jigs, Reels, Finnsports (ME), Toledo, Ohio 43614.

### EARTHWORMS, LIVE BAIT

**RED** Wigglers: Select breeders or fishing size \$3.50—1,000; \$14.25—5,000; bed-run \$9.95—10,000. Postpaid. Free folder "Growing Fishbait." Fain's Bait Farm, Box 56C, Edison, Georgia 31746.

**REDWORMS.** Bait size, 1000—\$3.50, 5,000—\$15.00. Medium, 2500—\$5.00, 5000—\$8.50, 10,000—\$16.00. Postpaid. Hall's, Hilton, Georgia 31758.

**AMAZING** profits in worms. Free information. Hillaire Farms, Northville, Mich.

**EARN** Money raising fishworms for us! Exciting details free! Oakhaven—56, Cedar Hill, Texas.

**SUCCESS** For you! Raise Carter's Pure-bred hybrid red wiggler fishworms, crickets. "Known All Over the World." Write for free literature and our success story in Life Magazine. Pure-Bred Fishworms—3000—\$5.95, 5000—\$8.95, 10,000—\$16.95. Postpaid with Free Raising Instructions. Carter Redworms, Plains, Georgia.

**MEN!**—Women! Make money raising Bait for us at home. Wigglers, Warsaw 45, Indiana 46580.

**HYBRID** Redworms 1000—\$3.00, 3000—\$5.75, 5000—\$8.00, 10,000—\$14.00. Bedruns 20,000—\$19.00. Postpaid with raising instructions. Brazos Worm Farms, Route 9, Waco, Texas.

### FROGS, FISH, REPTILES

**"FROG** Raising!" Nu-Fond giant breeders ready now. Season just starting. Broel-A, Box 50506, New Orleans, Louisiana 70150.

**FROG** Raising. Young frogs and giant breeders. Stock your lakes, pond, Nu-Tex Frog Farm, Box 4029, Corpus Christi, Texas.



### HUNTING, GUNS, DECOYS

**SHOTGUN** Owners improve your score, bag more game with amazing optical gun-sight. Free details. Nydar, Box 45-256, Glenview, Illinois 60025.



**CARTRIDGE** Case trimmers. National Rifle Ass'n. Approved. Complete Preset. Specify Cartridge, \$4.35. A. Zimmerman, 127-P Highland Trail, Denville, N.J. 07834.

**TERRIFIC:** New sport, rubber gun sling, ammo-rack, wider, no hardware, guaranteed. \$2.95 postage. 45¢ Alaska 78¢, Michigan tax 4%. Flexomatic Company, Bruce Crossing, Michigan 49912.

50,000,000 **GUN** Parts for modern, obsolete, foreign, domestic military and sporting arms. Write wants for quote—make, model = & specific part. Seedy reply—Include stamped self addressed envelope. Numrich Arms, 252 Broadway, West Hurley, New York.



### DOGS AND KENNELS

**PEDIGREED** White German Shepherds, no albinos. Ansonia Kennels, McHenry, N. Dak.



### GAME BIRDS

**YOUR Ad** in this space will be read by more than 1,400,000 active mail order buyers. Join the march to greater profits, place your products and services in front of them today with a small low cost classified ad. For further details, write: C. A. Martin, Dept. 15N, Popular Mechanics, 575 Lexington Avenue, New York, New York 10022.

### RABBITS—FUR BEARING ANIMALS

**RAISE** Rabbits successfully by knowing facts. 48 page illustrated book describing 25 breeds, housing, breeding, feeding, markets, marketing etc. 25 cents. American Rabbit Association, 36 Arba Building, Pittsburgh, Penn.

**RAISE** Rabbits on \$500 month plan. Free details. White's Rabbitry, Mt. Vernon, Ohio.

**MINK** Raising information free. Lake Superior Mink Farm, Inc., Superior EE1, Wisconsin.

**EARN \$10,000** Yearly raising Angora rabbit wool for us. Particulars 25¢ coin. Angora, Malta 12, Montana.

### PETS—BIRDS, CATS, HAMSTERS, ETC.

**LIVE** Seahorses, marine specimens, aquarium supplies. Illustrated catalog 15¢. Marine, Box 248-110, Dania, Florida.

**MAKE** Money raising chinchillas, mink, rabbits, cavies for us. Free catalog. Keeney Brothers, New Freedom 2, Penna.

**HAWKS,** Reptiles, raccoons, skunks, squirrels. Catalogue 25¢. Trails End Zoo, St. Stephens, S.C.

### CAMPING EQUIPMENT AND TENTS

**ENJOY** Backpack Camping. Free booklet tells how. Gerry, Dept. 72, Boulder, Colorado 80302.

**CAMPING** Equipment, tents, sleeping bags, air mattresses, packs, trailer awnings, dining canopies, axes, knives, lanterns, stoves, refrigerators, compact camp furniture, dehydrated food, toilets, nested cook sets, poles, stakes. Every camping accessory imaginable. Free 100 page catalog. Morsan, 810R Route 17, Paramus, New Jersey.

**FREE** 1966 catalog. Request it from your camping center or trailer dealer, or write Golden Crown, 4515 Marquette St., Jacksonville, Fla. 32210.

**JUMBO** Catalog—tents, sleeping bags, camping supplies. GI Surplus, outdoor clothing. Free 132 page newest edition now ready. Write I. Goldberg, Dept. PM, 429 Market Street, Philadelphia, Pa. 19106.

### EMBLEMS, BRASSARDS, PATCHES

**CLUB** Emblems embroidered to your order. Ideal for club recognition. Low minimum. Send your design for free price quotation. Write for free catalog. Eastern Emblem Mfg. Corp., Dept. PM, P.O. Box 628, Union City, N.J. 07087.

### TRAVEL AND RESORTS

**UNSPOILED** Vermont uncrowded private area. Trailers, tents, cabins. Tall Timber, Box 461, Rutland, Vermont.

### ELECTRICAL SUPPLIES

**LAMP** Parts. Catalog, prices, wiring instructions. 50¢. Refunded first order. Gyro, 5208P N.W. 35 Ave., Miami 42, Fla.

**MAGNETS.** Alnico-ceramic-flexible-assemblies. What you need, we have. Special—two 7" "pick-up magnets. \$1.00. Maryland Magnet, 5412-A Gist, Baltimore, Maryland 21215.

**ELECTROPLATE** In Gold, silver, rhodium, chrome, nickel at home for profit. Electroplater sensationally priced at \$35.95. Details free. "How To Plate" booklet, 50¢. George Kent Labs, 61 East 11 Street, New York, New York 10003.

**METERS**—Surplus, new, used, panel and portable. Send for list. Hanchett, Box 5577, Riverside, Calif.

### BATTERIES, GENERATORS

**COMPLETE** Rebuilding Manuals! Batteries \$3.00. Hydraulic jacks \$3.00. C.O.D. accepted. Bayer Publications, 938 Betty Avenue, Neenah, Wisconsin.

**BATTERY** Reconditioning kit, includes molds, material, complete instructions. The Battery Shop, P.O. Box 416, Palm Desert, Calif.

### ENGINES, MOTORS, DYNAMOS

**MOTOR** Rewinding simplified. Details free. Modern, Box 10025, Kansas City, Mo. 64111.

**DIESEL** Injector parts and fuel pumps wanted. GM51-53-71-110. Bares, 2093 East 19 Street, Cleveland 15, Ohio.

**REWIND** Motors yourself. Complete instructions. \$1.00. Lewis Manufacturing, Howell, Michigan.

**WINDING** Data. 275 motors, single and three phase \$1.10. Data Company, 512 Kensington, Kansas City, Mo. 64124.

### MACHINERY, TOOLS AND SUPPLIES

**MAGNETIC** Chuck V blocks & parallels, edge finders, center finders, thread measuring wires, sine bars. Hi-precision—first quality—low prices. Factory distributors wanted. Be the dealer in your locality. Buy for yourself and sell to others. Liberal discount, products guaranteed. Est. 1943. Write for brochures. Fisher Machine, 11704-M Inglewood, Hawthorne Calif.

"**SMALL** Shop Supplies." Production—hobby. Machinist Tools, 1424 Barclay, Springfield, Ohio 45505.

**STANLEY,** Millers Falls, Skil, Disston, Wiss, Plumb, Channellock, Bonney, Herbrand, Ridgid, and hundreds of other nationally advertised brands at prices hard to beat. Send 25¢ for our big tool catalog today! Silvo Hardware, 107PM Walnut, Phila. 6, Penna.

**ALUMINUM** Solder, 10-9"—Rods, P.P. \$1.00. 20-9"—Rods, P.P. \$1.75. Catalogue. Wholesale Tools, 691 Boxford Road, Haverhill, Mass. 01830.

"**RAFTERULE**" Solves any rafter cutting problem. Free literature. Emmert, Sycamore, Illinois 60178.

### WELDING, SOLDERING, PLATING

**CHROME** Plating equipment, supplies. All other finishes. Home workshop and production sizes. Send \$1.00 (refundable) for formulas, operating data, equipment guide and catalog. HBS Equipment Division L50, 3543 East 16th, Los Angeles, Calif. 90023.

**FREE** Catalog. Welders, kits. Build 350-ampere Welder. Plans, 25¢. Le Jay Manufacturing, Belle Plaine, Minnesota 56011.

**WELDERS,** 150 Amperes. \$49.50. Paul Morris, 1070 Inner, Schenectady, N.Y. 12303.

### GOVERNMENT SURPLUS

**JEEPS** Typically from \$53.90 . . . trucks from \$78.40 . . . boats, typewriters, airplanes, sporting equipment, used, 100,000 bargains direct from Government nationwide. Complete sales directory and surplus catalog. \$1.00. Deductible first \$10.00 order. Surplus Service, Box 820-A, Holland, Michigan 49424.

**REPAIRABLE** Jeeps low as \$50.00. Buy in your area from Gov't. Information and our Giant (order by mail) Surplus Catalog \$1.00. Quality Surplus PM-5, 2546 W. Michigan, Indianapolis, Indiana.

**REPAIRABLE** Jeeps low as \$50.00. Buy in your area from Gov't. Information and our Giant (order by mail) Surplus Catalog \$1.00. Quality Surplus PM-4, 422 Washington Building, Washington, D.C.

**GOVERNMENT** Surplus. Complete sales directory \$1.00. Surplus Publications, Box 45781, Los Angeles 45, California.

**HOW** And where to buy Government surplus in your area. Complete! Send \$1. Surplus, Box 64A, Staten Island, N.Y. 10307.

**JEEPS** From—\$52.50. Typewriters from—\$4.15. cars from—\$31.50. Walkie-Talkies, Guns, Airplanes, Boats, Typical "As Is" Bid Bargains From Uncle Sam. Tremendous variety. Exciting free list. Write: Enterprises, Box 402X10, Jamaica, New York 11430.

**GOV'T.** Surplus. How and where to buy in your area. Send \$1.00. Surplus Information. Headquarters Building, P.M., Washington 6, D.C.

### HOBBIES AND COLLECTIONS

**WANTED.** Cigarette, tobacco cards. Write: Charles Bray, East Bangor, Penna.

**COLLECTORS** Matchbook covers, 100 different unused, \$1.00. Album, \$3.25. Catalog, 25¢. Helene Edelman, 1311-C East 84, Cleveland, Ohio 44103.

**NEW** And unusual millionaire magazine, 1 yr. \$7.50. Domestic-International Magazine-Periodical Subscription Service, Dept. PM-2020MM, Tomah, Wisconsin 54660.

**THOUSANDS** Of amazing items! Mummified animals—bull horns—western pictures—relics—weapons—terrifically different hobby kits, 35¢ for Fantastic list! Rareties, Box 413-P, Torrance, California.

**TEN** Different colorful airlines embroidered emblems, \$1.00. Nord, Tuxedo Park, N.Y. 10987.

**50** JUNGLE butterflies \$2.00. Giant nature hobbies catalog 25¢. Collectors Wonderland, Box 1170, New York 8.



### STAMP COLLECTING

**105** DIFFERENT U.S. Stamps, 25¢, approvals included. Shelron, Box 187, Hempstead, N.Y.

**BREATH**TAKING, 50 Mint Monaco pictorials, multicolors. \$1.00. Approvals, Stamp Exchange, Box 103, Fairfield, California.



50 YEARS Old, fifteen different United States, over fifty years old—10¢ with approvals. Jaxon, Box 145-P, Brooklyn, New York 11230.

PENNY Foreign stamps neatly mounted in jumbo books in Scott order, Bullot Approval, 1454 Coney Is. Ave., Brooklyn 30, New York.

"INVERTED Error." Dag Hammarskjold 5¢ with Approvals. Belmont Stamps, Washington, D. C. 20015.

RUSSIAN Space set 10¢. Russian approvals. Snedco, Box 68-P, Waldwick, N.J.

50 DIFFERENT Old U.S. Revenue stamps 50¢. Winchester stamps, Box 1592, Mansfield, Ohio 44907.

133 DIFFERENT Colorful stamps 10¢. approvals. Krehl, 1708 Nebraska, Orlando, Florida.

FREE! Congo triangle set! Boy Scout beauty! 25 others, different. Approvals. Cambridge, Box 411, Cambridge, Ohio.

100 OLD United States between 1861 and 1935. \$1.00. Roush Stamps, 51 Chestnut, Mansfield, Ohio.

225 STAMPS For only 10¢! This mammoth value includes airmails, pictorials; stamps from strange countries cataloging up to 25¢ each! Also approvals. Mystic Stamp Company, Camden 80, New York.

SELL Your surplus good grade stamps. Write, describing fully what you have. Vanroy Shirk, Lebanon, Pennsylvania.

500 DIFFERENT Stamps, \$1.00. Smith, 508-A Brooks, College Station, Texas.

PENNY Stamps! 1000 Mounted in book at 1¢ each. Trust Stamp Company, P.O. B. 132-P, Jamaica, N.Y. 11435.

ONE Pound value Geo. VI Bermuda, plus 100 worldwide 10¢. approvals. Stevens, Box 105A, Homecrest Sta., Brooklyn 29, N.Y.

60 DIFFERENT U.S. (30 commemoratives) 25¢. No approvals. Seidenberg, Salem 169, Oregon.

ABSOLUTELY Free 50 worldwide. Request inexpensive approvals. University Stamps, P.O. Box 326, Pompano Beach, Florida 33061.

AMAZING OFFER! 200 United States stamps—including commemoratives, airmails, high denominations to \$1.00. Only 10¢ to approval applicants! Illustrated bargain lists free. Mystic Stamp Co., Dept. 80, Camden, New York.

PENNY! Approvals! Regardless catalogue! Kloster, 4164 52nd St., San Diego 5, Calif.

64 PAGE U.S. and U.N. catalog free. Stone, 260 Washington, Boston 8, Mass.

FREE Sample. Interesting, illustrated, informative National Stamp News. Anderson, South Carolina 29621.

INTRODUCING Our better United States approvals we offer 15 United States stamps including Columbian, Bi-Centennials, famous American, airs, others; only 10¢. Ocean Stamps, Box 64-PM, Brooklyn 29, New York.

FREE Monaco nudes. Approvals. Stamp Ranch, 902 Addison, Chicago 13, Ill.

10 U.S. over sixty years old, 10¢. Robert Gallup, Albany, New York 12201.

UNITED States commemorative collection containing 33 different—10¢. Approvals. White, 516-A Avenue L, Brooklyn 30, New York.

UNITED STATES price list, 132 pages, price 30¢. Mark Hanna, 335 Fifth Ave., Pittsburgh 22, Pa.

121 DIFFERENT Flag stamps free. Approvals. W-B Stamps, Wilkes-Barre, Pa.

TEN Different nudes, 20¢. Approvals. Stamp Farm, 2M10, Oxford, Wisconsin 53952.

U.S. Mint specials! Flag set, complete \$1.00. 1¢, 2¢, 3¢ famous Americans (21 different) \$1.00. Free list. Brooks, 2601 Avenue "U", Brooklyn 29, N.Y.

230 DIFFERENT U.S. commemoratives, \$1.00 approvals. H. Holub, 18 East 198th Street, Bronx, N.Y. 10468.

U.S. Approvals. Low prices. Eagle, 2221 Romine Ave., Pittsburgh 26, Pa.

GERMAN Commemoratives, 10¢ with approvals. Schaefer, Box 1704, Washington 13, D. C.

THOUSANDS Of worldwide sets and singles on approval. Highest quality! Cole, Box 223A, Buffalo, N.Y. 14221.

FREE—Mammoth collection, \$10,000 airmail, world's smallest stamp. Scott's International, master global albums given approval buyers. Bargain stamps, Tustin, California.

WOW! 110 All different Germany 10¢ Commemoratives, Airmails, high values, big catalog, bargain lists plus selections of fine stamps from our approval service, returnable without obligation. Jamestown Stamp, Dept. A56PM, Jamestown, N.Y. 14701.

FREE! Big bargain catalog—new edition listing thousands of bargains including U.S. & B.N.A. stamps, packets, albums, accessories and supplies. Plus selections of fine stamps from our approval service, returnable without obligation. Jamestown Stamp, Dept. E56PM, Jamestown, N.Y. 14701.

WOW! 1000 Different worldwide—valued over \$20.00 only \$1.00 with quality approvals. Universal, Box 6, Kenosha 5, Wisconsin 53141.

50 DIFFERENT U.S. Commemoratives 25¢. No approvals. Earl Mills, Box 272-K, Auburn, Mass. 01501.

FREE Mint set. Approvals accompany. Stamps, Box 22092, Memphis, Tennessee 38122.

ATTRACTIVE Triangle set free! Request approvals. Cutlass, Box 235P, Chicago 60645.

FREE 1966 U. S. list, mint =704-15 \$4. =740-9 \$2.10, =859-99 \$6, =909-21 \$1. Simmy & Co., 40 Court St., Boston, Mass.

U.S. Bargain, 50 different 10¢, with beautiful worldwide approvals. Stamps, Kennebunk, Maine.

25 Different United States Commemoratives 1893 Up 10¢. Approvals. K. & B. Stamp Company, Box 70, Brooklyn 23, New York.

40,000 DIFFERENT. Amazing new plan builds your collection systematically, country by country. As low as 50¢ weekly. Ware, Monroe 75, Conn.

GIANT Stamp collection including Astronauts, Satellites, Moonrocks, Boy Scout issue, complete UN set, recent Olympic & sport issues from many countries, etc.; plus big stamp dictionary and Approvals. Everything 10¢! Stampex, Box 47-RM, White Plains, N.Y.

1500 FOREIGN \$1.00. 5000 \$3.00. 5000 USA—commemoratives, airs, high values, revenues, 19th Century, etc. \$3.00. No approvals. Meyers, 5321 Fleming, Richmond, California.

WORLDWIDE Approvals, discount price. Wendell Heywood, Star Route, St. Johnsbury, Vermont 05819.

PIPEX—Tipex-Cipex-Ashville. Four miniature sheets used for \$1.00 if you ask for our bargain priced U.S. approvals. Triboro, 38 Park Row, New York, New York 10038.

SENSATIONAL Clearance. Forty different packets only, \$1.00. Norge, Ho-Ho-Kus, N.J.

FREE Stamp wallet with approvals. Wide selection collections by countries. Clark, Box 28-C, Wilmette, Illinois.

TERRIFIC Collection seven complete sets, 10¢ with approvals. Beattles, Box 16052, Tampa, Fla.

NEED Money fast? Loans made on stamp-coin collections, \$100, \$500, \$1,500 & up. Monthly repayments. Under State Supervision. L. T. Baker & Company, 30 West Washington Street, Dept. PM, Chicago 60602.

"COLORFUL" Set free! Worldwide approvals. Gorliz, Drawer 388PM, Park Ridge, Illinois.

MILLION Foreign stamps! 2¢ each! Send for thrilling, giant approvals! ABC Stamps, Box 6000-MB, San Francisco 1, Calif.

FREE—Mint British Colonials from Antarctic Territory, Borneo, Brunel, St. Christopher, Nevis, Caymans, Trengganu, Pitcairns. Free with approvals. Viking, Great Neck 8, N.Y.

450 FINE Mixed U.S. 15¢. Wright, Box 753-M, Hagerstown, Maryland.

DEFECTIVE Old U.S. 1/5 Scott, Approvals. Swartz Stamps, Malden Bridge, New York.

100 WORLDWIDE, 10¢—Approvals. Jayne, 510 N. 30th Ave., St. Petersburg 4, Fla.

FREE! 55 triangles, rockets, others. Colorful, low-priced approvals. L. Baird, PM-15, Box 8128, Portland, Oregon 97207.

OLD Scarce U.S. seconds on approvals. Slight imperfections, lowest prices. Hernefield, Box 318, Irvington, N.J. 07111.

FIRST Day cover approvals! Included free, valuable airmail cover. Myers, Coopersburg, Penna.

PAKISTAN 25 Different, 5¢ approvals. Hijop, Box 505, Norristown, Pa. 19404.

FREE—World's greatest premium, 5000 all different stamps, actual catalogue value over \$100.00 given approval buyers. Thrifty Stamps, Grossmont, California 92030.

OVER 1000 mixed worldwide, \$1.00. Stamps, Box 92-PM, Brooklyn 18, N.Y.

Free 50 Different Canada plus bargain stamp catalog. Terry, Box 765, Pacifica, California 94044.

WORLDWIDE Stamps 500 different \$1. Meier, Box 3875, St. Louis, Missouri 63122.

100 DIFFERENT Free! 1/4¢ Upward British Commonwealth or word approvals. Bush, Newlyn Way, Poole, England.

105 SURPRISE Stamps, gift coupons, 10¢. Terrific approvals. Trio, Box 1806-YM, New York, N.Y. 10017.

SEND 100 different and 25¢. Receive 100. Boulanger, 3116 Hochelega, Quebec 10, Canada.

FINE Stamps sale! Mona Lisa packet 31¢. Generous bargain lot \$1. Giant assortment, all fine stamps \$5. High value packet extra special \$3. Gift with any order. Persile, 436 N.Y. Ave., Brooklyn 25, N.Y.

FREE! 222 Worldwide, 25¢ handling. Penny approvals. Jung, 1601 North Stanley, Los Angeles 90046.

200 DIFFERENT Worldwide 10¢ with approvals. Bydahl, Box 1293-MC1, Seattle, Washington 98111.

75 DIFFERENT U.S.—5¢! Giant U.S.—Worldwide bargain pricelists, approvals. Yntema-Schneider, Box 728F, Holland, Michigan 49424.

CANADIAN Approvals. Your want lists filled. Valley Stamps, Little Valley, New York 14755.

U.N., Mint, souvenir sheet special! 1965 I.C.Y. emblem—Cat. 145, price, 70¢. Warren Burness, 177 Park Pl., Irvington, N.J.



NEW Issues — Free weekly illustrated list. Brooks, 2601 Avenue "U," Brooklyn 29, N.Y.

**MONGOLIA** Pioneers, large diamond shaped, three varieties Free with request for attractive low priced World approvals. Free new United States Price List. 92 pages with over 400 illustrations sent on request. George Gregory, Box 156-M, Petoskey, Michigan 49770.

**THOUSANDS** Of stamps, 2¢ each. Skerritt, 30 Grandy, Albany, N.Y. 12205.

**SEVEN** 3¢ Plate blocks, \$1.00! Approvals. Gordon Davison, Henniker, New Hamp. 03242.

**BEAUTIFUL** Topical collection includes olympic sports stamps, wild animals, bi-color triangles, colorful birds, outer space stamps, Poland kitten stamps and others. 10¢ with approvals. Sunny Stamps, Fruitport 2B, Michigan.

**QUEEN** Elizabeth on stamps—A beautiful collection of 50 different stamps from 22 countries—all bearing the portrait of the Queen of England. 10¢ with approvals. Roseland Stamps, Spring Lake, 2C, Michigan.

**FOUR** Different African stamps. Guaranteed. Fantastic buy. Send 25¢ and stamped envelope. Mala Company, Box 218, Kingsbridge Station, New York 10463.

**RARE** Stamp free. Also new packet Aden to Urundi, with Kennedy, Triangles, space, sports ships, dogs, cats, Reptiles, plus others. All free. Send 10¢ for mailing. Empire Stamp Co., Dept. PM, Toronto, Canada.

**FREE** Surprise collection sent with approvals. Gould, 1784 Union, San Francisco 94123.

## COINS, TOKENS, CURRENCY

**40 PAGE** Illustrated United States and Canadian coin list 10¢. Stoner, 260 Washington, Boston 8, Mass.

**LINCOLNS:** 22 Different "S" including rare 1955S, \$1.60. 28 different before 1940, plus odd 1960D small date, \$1.60. 10 different "S" Jefferson nickels, \$1.60. All three \$4.50. Harris, Box 1147-P, Oceanside, California.

**COIN** Date guaranteed. Restores dates on worn nickels. \$1.00 bottle. Box 276F, Mooreville, N.C.

**1966 CATALOG** Now ready. 50¢ with refunding certificate. Hobby Sales, St. Paul, Minnesota 55116.

**FREE** Coin supplies! Giant coin list 10¢ (refundable). Economy Sales, Mansfield, Massachusetts.

**HIGHEST** Prices paid immediately for coins. Send 10¢ for 1966 buying prices. Wilmot's, 1067-F Bridge St., Grand Rapids, Mich., 49504.

**CIVIL** War specials: 1863 cent, \$1.75; 1863 civil war token, \$1.75; 1864 genuine confederate states of America \$10.00 bill, \$2.00. All three \$5.00. Rarcoa, 31 North Clark, Chicago 60602.

**GIGANTIC** Coin Clearance. Illustrated lists 10¢ (refundable). Hutchinson's, Box 6256, Philadelphia, Pa. 19136.

**SPECIALS:** Scarce date Lincoln cents. All good or better. Satisfaction guaranteed. 50¢ each 1916S, 1927S, 1939D, 1955S. 75¢ each 1915, 1915D, 1921S, 1924S, 1932, 1932D, 1933, \$1.00 each 1909VDB, 1913D, 1923S, \$1.50 each 1911D, 1912D, \$3.00 each 1913S, 1922D, 1931D, 1933D, \$4.50 each 1910S, 1915S, 1926S, \$5.00 each 1912S, 1914S, \$10.00 each 1911S, 1924D. Bryson Inc., 612A White, Toledo 5, Ohio.

**SILVER** Dollars uncirculated, 1878-79-80-81-82 S mint \$3.00 ea. Illustrated Catalogue 50¢. Shultz, Salt Lake City, Utah 84110.

**100 LINCOLNS** 1909 up, \$4.95. No two alike. Earl Sprague, Kingston Drive, Muskego, Wis. 53150.

**OLD Time Lincoln** cents. 15 different before 1931 only \$1.00. Gene Carlton, Chandler, Okla. 74834.

**25 BEAUTIFUL** Coins from 25 countries. Mostly uncirculated. Terrific assortment. \$1.00 Hindley, Box 708, Aurora, Illinois. 60507

**SCARCE** Lincoln S. mint cent, V.G., 6 to 10 dates. \$1.65 roll ppd. Southern Cross coins, Box 11584-A, Fort Worth, Texas 76110.

**DISCOUNTS.** Buy, sell, trade lists, 10¢. AWM Coins, Box 14377, Orlando, Fla.

**LAS Vegas** gaming tokens, casino replacements of silver dollars, 2 Different, \$3.00—list free. Dimaria, 2401 Burbank, Burbank, Calif. 91506.

**UNCIRCULATED.** Brilliant, scarce United States silver dollars over 70 years old, for only \$3.00 each while supply lasts. Indianhead pennies, which are becoming scarcer every day, 10 different dates \$3.00; 30 different dates for only \$8.00. George Gregory, Box 156-M, Petoskey, Michigan 49770.

**SPECIALS!** Silver dollar \$1.75; Eagle cent \$2.90; 2¢ Copper \$1.85; Large cent \$1.80; 1909vdb Cent 70¢; All five \$8.75. Nelson, 346-P Rye, New York 10580.

**CLOSEOUT** Bargains, free albums, scarce silver dollars, \$1.95. 5 different \$9.45. Latest 1966 illustrated selling, trading, accessories catalogue 25¢. Coin Center, 2614 Calhoun, Ft. Wayne, Indiana.

**CONFEDERATE** Money: Genuine CSA bills: 1864 \$5, \$10, \$20, \$1.00 each. Pete Williams, Box 494, Pendleton, S.C. 29670.

**LIBERTY** Nickel with terrific price list, 30¢. Fairway, 121-P, Rye, New York 10580.

**4 INDIAN** Cents \$1.00. 4 Liberty nickels \$1.00. Doktor, 5028 W. Pico, Los Angeles, Calif. 90019.

**WORLD** Dollars uncirculated—Austria, Bermuda, Canada, Greece (Royal wedding), Norway, Panama, Zambi, each \$2.75. World's greatest bargain catalogue, \$1.00. Bebee's, Inc., 4514 North 30th, Omaha, Nebraska 68111.

**50¢ CALIFORNIA** Gold pieces: (1849-1858). 75¢ each. Seven different, \$4.00. 25 assorted \$12.00: Plastic holders: Metropolitan Coin Ex. 1380-B, Penobscot Building, Detroit, Michigan 48226.

**TRUNKFUL** 25,000 Indian-Lincoln cents mixed (from the 1920's & older). Grab-bag style. 400 mixed, \$25.00. Sample bag of 20, \$2.00. Mrs. Fischer, Box 5490, Sherman Oaks 4, California.

**LARGEST** Coin magazine, 288 pages, 50¢. Scrapbook, 7320-J Milwaukee, Chicago 31.

## ANTIQUES, RELICS, INDIAN GOODS AND CURIOS

**10 ASSORTED** Perfect arrowheads, \$3.00. George Smith, 9825 Conway Drive, Indianapolis, Indiana 46236.

**TONS** Of antique gun parts and supplies. All reproduction muzzle loading guns. Send \$1.00 for enlarged illustrated catalog No. 115. Dixie Gun Works, Union City 12, Tennessee.

**SELLING** 20,000 Ancient arrowheads, spearheads, etc. List free. Lear's, Glenwood, Arkansas.

**ANTIQUES!** Monthly magazine. Sample 25¢ or free circular. Antiques Journal, Uniontown, Penna. 15401.

**MINIATURE** Indian baskets. \$3.00 brings sample. Coleman's, Box 101a, Kearny, Arizona.

**ARROWHEADS,** 10 for \$3.00. List free. Hyde's, Box 1788, Santa Fe, New Mexico.

## MODELS—SHIPS, TRAINS, PLANES, ETC.

**BUILDING** Materials, 1/4" & 1/8" scale, windows, doors, siding, roofing, lumber and structural shapes. Send 35¢ for catalog with samples. Small Sales Co., 6025 Martway, Mission, Kansas 66202.

**SHIP** Model kits and fittings: clippers, frigates, etc. Catalog paint-tool list, book list, 35¢. Model Shipways, Box 85, Bogota, N.J.

**SLOT Racers!** Trains! 25¢ brings 32 page bargain catalogue. Thousands of Lionel, Gilbert, Varney, Strombecker, Eldon, Aurora, Scalextrix, Revell, etc. Trains, all gauges, racers all sizes. Hobby Surplus, P.O. Box 1106M, New Britain, Conn.

**SHIP** and yacht model fittings: Pine construction hull kits; blueprints. Send 50¢ for illustrated catalog. A. J. Fisher, Inc., 1002 Etowah Avenue, Royal Oak, Michigan 48067.

**SHIP** Models. Kits, fittings, plans, books, tools, engines, motors. Big illustrated catalog, 50¢. James Bliss & Co., Dept. SM, Route 128, Dedham, Mass. 02026.

**ROCKETS:** New illustrated catalog, 25¢. Single and multistage kits, cones, engines, launchers, trackers, rocket aerial cameras, technical information. Fast service. Estes Industries, Penrose 2, Colorado.

**ROCKET** Or fireworks fuse 3/32" diameter, water proof 60 feet with formulas, \$1.00 postpaid. Rigley, Box 138-B, Addison, Mich.

## GAMES, TOYS, NOVELTIES

**YOUR** Ad in this space will be read by more than 1,400,000 active mail order buyers. Join the march to greater profits, place your products and services in front of them today with a small low cost classified ad. For further details, write: C. A. Martin, Dept. 31N, Popular Mechanics, 575 Lexington Avenue, New York, New York 10022.

## MAGIC TRICKS, PUZZLES, JOKER NOVELTIES

**164 PAGE** Giant surprise catalog! Over 1000 tricks, professional magic, jokers!! World's greatest! 800 pictures! Special only 10¢. Vick Lawston's Magic, Dept. PM6, Northeast Fifth Ave., Ft. Lauderdale, Florida 33308.

**GIANT** Magic Catalog and free trick only 10¢. Write today. Mailmart, M566, Box 616, White Plains, N.Y. 10602.

**VENTRILOQUISM!** Information free! Dummy catalog, 25¢. State age. Maher, Box 36-E, Kensington Station, Detroit 24, Michigan.

**MAGIC** Catalog. World's finest. 3000 tricks. (340) pages \$2.50 Beginners, amateurs, professionals. Kanter's, A-200 South 13th St., Philadelphia, Pa. 19107.

**BE A Magician!** Introductory catalog with free trick, only 35¢. Ireland Magic, 5082 Lincoln, Chicago, Illinois 60625.

**500 TRICKS,** Douglas famous catalog No. 36, only 10¢. Contains best in magic for pocket, parlor, club, stage. Fastest service to magicians for over 50 years. Douglas Magicland, Dept. 21, Dallas, Texas 75221.

**COMPLETELY** Illustrated catalog, 84 pages. 25¢. Manhattan Magic, Box 334-M, N.Y.C. 11.

**142 AMAZING—Easily** learned tricks, \$1.00. Crest, Box 994, Mount Royal, New Jersey 08061.

**WORLD'S** Finest professional magic tricks. Joker's Novelties, Giant illustrated catalog 10¢. Top Hat, Evanston, Illinois.

**VENTRILOQUISM** For fun or money, new method, easy. R. Marlette, 554 Lynn Ct. Apt. A, Glendale Hgts., Ill.

**EXCLUSIVE** Magic, novelties. Catalog, 10¢. Web, 4735 Fulton, Chicago, Illinois 60644.

**FUN'n** Magic catalog, 10¢. (1,500,399 tricks, jokes, novelties, puzzles, disguises). Elbee, 7408-P, San Antonio, Texas 78207.



## BOOKS, PERIODICALS

FREE Catalog. Self-help books. Write Wilshire, 8721 Sunset, Los Angeles 69P.

PROPHET Elijah coming before Christ. Wonderful book free. E. Megiddo Mission, Rochester, New York 14619.

BOOKFINDERS! All subjects. Send wants! Sydney Jaher, 175-45 88 Ave., Jamaica, N.Y. 11432.

HOW To raise capital plus twenty nine self-improvement books. Free brochure. Box 725, Binghamton, N.Y. 13902.

FREE—Seven original editions. Details. Poets Corner, 444-M, Fort Lee, N.J. 07024.

RARE Special magazines information, 10¢. Patrick Casey, 1665-11th St., Santa Monica, Calif.

CHALLENGING! Different! Unusual books! Free catalog. Ruby's, D-26, Paradise, Pennsylvania 17562.

INTERESTING Books. Free Catalog. Postal PM, 2217 Lackland, St. Louis, Missouri 63114.

OUT Of print bookshop. PM, Montford, Asheville, N.C. Send Wants.

UNUSUAL Book bargains! Fascinating and stimulating books for all. Four (4) sample books plus complete listing only \$1.00. Satisfaction guaranteed or money refunded. Mail today! Books, Box 296, Snowdon, Montreal, Canada.

BOOKS, Free general catalog, 60 pages. Text, vocational, educational, instructional subjects. Millions of volumes, new and used. Bargain prices. Books bought, Est. 1902. Long's College Book Co., Dept. PM, Columbus 1, Ohio.

## PLAYS, STORIES, MANUSCRIPTS

WANT Your book published? Learn how we publish, advertise, promote, distribute. Many successes. Free booklet PM, Vantage, 120 West 31, New York City.

## BUSINESS OPPORTUNITIES

PACKAGE At home for profit! We supply everything. No "selling." Free home business details. HPC-807HPK, Sunset, Los Angeles 12

\$70.00 WEEKLY—home, spare time. Simplified mail bookkeeping. Immediate income, easy. Auditax, 34741a, Los Angeles 90034.

MAKE \$46 From square foot plywood: jig saw necessary. Free details. Woodart, Bridgewater, Mass.

EARN Money raising fishworms for us! Write: Oakhaven-38, Cedar Hill, Texas.

IMPORT-Export opportunity, profitable world-wide, mailorder business from home, without capital; or travel abroad. We ship proven plan, for no risk examination. Experience unnecessary. Free details. Melinger, Dept. X705, Los Angeles 90025.

MAKE Money from old tires. Operators clearing \$400 weekly. Equipment costs \$800. Get facts. S & S Patents, Inc., 3511 N. Lincoln, Chicago 13.

READ Progressive Mailtrade, the magazine that tells how to make money by mail. Quarter brings sample and special offer. Mailtrade, P.O. Box 357, Sheboygan, Wis. 53082.

COPUBLISH "Mail Sale Advertiser," leading mailorder paper. Copy and details 25¢. Vanroy Shirk, Lebanon, Pa. 17042.

MAILORDER Catalogs. No inventory required. Discounts 40% up, postpaid. Send 25¢ for 32 page sample catalog, featuring 150 unusual, fast-moving products and complete details. Satisfaction guaranteed. Gaylords, North Adams 7, Mass.

BIG Money raising fishworms and crickets. Free literature. Carter Farms, Plains, Georgia.

\$400.00 MONTHLY Raising giant fishworms. Soilless method. Charlie Morgan, Bushnell, Florida 33513.

COLORGLAZED Concrete pottery made without molds. Patented method. Cemetery products, novelties, tiles. Basement leak-sealing. Money-making projects. Booklet, details free. Men only. National Potteries Company, Grand Rapids, Minnesota.

PROFITABLE Catalog Mailorder Business! Vikari's, 835-PM, First Avenue, Salt Lake City, Utah 84103.

START Your own business on credit. Your own boss. Hundreds of dealers making \$100 to \$300 and more weekly. We supply stocks, equipment on credit. 300 home necessities. Sales experience unnecessary. Pleasant, profitable business backed by world-wide industry. Write Rawleigh, Dept. E-U-PPM, Freeport, Ill.

PLASTERCRAFT Molds. Liquid rubber, plasters, floccs, candle supplies. Catalog and manual free. Blue Rapids Supply, Blue Rapids, Kansas.

FREE Book "990 Successful, Little-Known Businesses." Work home! Plymouth-972Y, Brooklyn, New York 11217.

WANT To make big money at home? \$10.00 profit in an hour possible with invisible mending. Make tears, holes disappear from clothing, fabrics. Steady year-round demand from cleaners, laundries, homes. Details free. Fabricon, 1585 Howard, Chicago 26, Ill.

BUILD Custom cases at home for profit. Get orders by mail. We supply materials, instructions, everything. Free home business details. Customcase, 805CPK, Sunset, Los Angeles 12.

FREE Booklet! Profitable, spare-time business bronzing. PearlKoting baby shoes! Complete set-up on credit. Kiktavi, Box 34861-B, Los Angeles, California 90034.

IMPORT-Export business made easy. Complete setup service. Not just instructions. Hermes, 152 West 42, New York City 10036.

ADDRESSERS And mailers needed. Send stamp for information. Lindbloom, 1508 West Erie, Chicago, 60622.

VENDING Machines. No selling. Operate a route of coin machines and earn amazing profits. 32-page catalogue free. Parkway Machine Corporation, 715 PMB Ensor Street, Baltimore 2, Maryland.

SELL Books by mail. 400% profit. Royal, Box 450-X, Cleveland, Ohio 44127.

DIFFERENT! Outstanding profits from high quality mailorder businesses. Complete setup services; not just instructions. Hermes Co., 152 West 42, New York City 10036.

CONCRETE Facts: Cement artists make big money at home. Simple equipment. Experience unnecessary. Copyrighted methods. Easy to make unlimited cement pottery designs, bird baths, wishing wells, rustic gardens, patio items, etc., without molds. Formulated, chemical coloring, marbleglazing. Free illustrated brochure. Hollywood Cementcraft, 602 Athens, Altadena, California 91001.

OPERATE Home mailorder business. Vosacek Printing, 4444AI Ute, San Diego, Calif. 92117.

PROFITABLE Home mail order business spare time. Write Gericke, Box 791, Milwaukee 1, Wisconsin.

WORLD'S Largest wholesale supply. Buy from 7853 American, European, Japanese wholesalers. Hong Kong tailored suits, 123 dropship catalogs. Rockbottom prices. Automobiles. Free details. International Buyers, 216-MM Jackson, Chicago 6, Illinois.

DOLLS! Dolls! Dolls! We teach you to repair, make, dress, also how to operate a Doll Hospital. Study at home. Earn while you learn. Or enjoy a fascinating hobby! Free informative booklet. Lifetime Career Schools, Studio MC-56, 11824 San Vicente Blvd., Los Angeles, Calif. 90049.

\$60.00 DAY. Manufacturing concrete posts. Carlayne, 1803 Fremont, Rapid City, South Dakota 57704.

EARN Extra money selling advertising book matches. Sample kit furnished. D-Lion Matchcorp, Dept. PM-56C, Chicago, Illinois 60632.

INSTALL Burglar alarms without previous experience or costly equipment. Big profit. Free details. Nasco, 11071 Massachusetts, Dept. X705, Los Angeles 90025.

"START-Operate Successful Small Business" reveals big, profitable ideas, plans, methods. Free eye-opening facts: Aladdin, Box 5183-E, Oakland, California 94605.

INVESTIGATE Accidents. Earn to \$1,400 monthly, part or full time. Pick own location. Car furnished. Expenses paid. No selling. No college education necessary. We train you at home spare time. Keep present job until ready to switch. Men urgently needed now. We place far more men in this booming field than any other individual, company, or school. All facts free. Write: Universal, CPM-105, 6801 Hillcrest, Dallas, Texas 75205.

RAISE Rabbits on \$500 month plan. Free details. White's Rabbitry, Mt. Vernon, Ohio.

LEARN Landscaping and the growing of plants. Start a profitable business part or full time. Free information without obligation. Lifetime Career Schools, Dept. MC-56, 11826 San Vicente Blvd., Los Angeles, Calif. 90049.

HUGE Profits! Mail order importing. Free information. ITIS-PM-5, Box 454, Hollywood, Calif. 90028.

MAKE \$32 From 49¢ piece vinyl. PMA-1934 Edgeland, Louisville, Ky. 40204.

OPERATE Debt Re-finance Service. A.D.C.S., 1222 Pioneer Bldg., St. Paul, Minn. 55101.

\$15.00 HOURLY Profit—Own Business with one serviceman. Quickly learned. Easy to do. Operate from home. Few hundred dollars builds your own nationally advertised business while continuing present job. Investigate immediately . . . before your territory is taken. Free booklet explains everything. Send today then decide. Duraclean, C6-165, Duraclean Building, Deerfield, Illinois.

SPARE Time earnings. With your table-saw, bandsaw or jigsaw. Write: Workshop, A3800 Harney, Vancouver, Washington 98660.

SELL Books by mail. 400% profit. Shalimar Enterprises, Box 772, Shalimar, Florida 32579.

MAKE 50% Profit selling toupees. Alamon Importing Company, Route #5, Box 340, Greenville, South Carolina.

MAKE Gorgeous original candles for all holidays and special occasions. Learn expert Candle decorating, candlemaking, use of professional molds. Free details on home instruction method. Candle Institute, Box 54-FX, Redono Beach, California.

400,000 BARGAINS Below wholesale! Many free. Liquidations . . . closeouts . . . job lots . . . single samples. Free details. Bargainhunters Opportunities, Box 730A, Holland, Michigan 49424.

VENDING Machine big catalog. Rake, 1214A West Girard, Phila., Pa. 19123.

MAKE Big money. Own and operate your own fix-it shop. Service household appliances, motors, mowers, etc. Every neighbor, every stranger your prospect. Millions of appliances everywhere need fixing. \$6-7 per hour often charged by appliance service technicians. Christy's shop method home training program, illustrated lesson manuals, Professional testing equipment sent on special pay later plan. Write for free book. No obligation. Christy Trades School, Dept. A-8103, 3214 W. Lawrence, Chicago 60625.



**SELL** Advertising book matches. Write us today: we put you in business by return mail, handling complete line ad book matches in demand by every business right in your town! No investment; everything furnished free! Top commissions daily! Superior Match, Dept. MX-566, 7530 S. Greenwood, Chicago 19, Ill.

"Mail-Order plan of the month". New Service for those wanting their own Mail-Order Business. Free details. Volz-UN, Ypsilanti, Michigan.

**EARN** Money in your spare time repairing appliances, housewiring, motor rewinding, electrical maintenance. We show you how, send 8 trouble shooting instruments, business getting materials. Free book, Advance Trades School, Dept. E-1203 5944 Newark, Chicago 60631.

**BECOME** Tax consultant. Our students earn \$1,000-\$3,000 every tax season preparing returns evenings. Accredited State approved National Tax Training School. Monsey N-2, New York.

**EARN** Extra money! Amazing profits! Try home mailorder. Easy, inexpensive, fun! Details free. Rogers, 13205 Ridge Drive, Rockville, Md.

**HOW** And where to get capital, loans, cash to launch a business. Free details. National Counselor, Harlingen 17, Texas.

**EARN** Big profits, mailing catalogs. Free instructions. Soren Lonquist, Box 31, Bella Coola, B.C. Canada.

**\$1000.00 MONTHLY** Possible in Collection Agency. Continental Credit, 1004 Grand, Des Moines, Iowa.

**MOLDING** Latex, flex-o-gel, casting supplies—materials! Complete information! Exclusive Products, 624 High, Racine, Wisconsin.

**MAKE** Money mailing our postcards! Work home, full, sparetime. Particulars, 10¢. Westlee, Western Springs 1, Illinois.

**LIQUID** Molding rubber also liquid plastic free information. Chaney's, 5415-A San Jose Blvd., Jacksonville, Fla. 32207.

**BIG** Profits mailing catalogs, postcards. Matteson, 1341 Stonelane No. Kingstown, Rhode Island 02852.

**BAKE** New greaseless doughnuts in kitchen. Stores buy output. Start spare time. Profit 29¢ dozen. Small appliance. Free recipes. Mongomery, 3605 South 15th, Minneapolis 7, Minnesota.

**MAIL** Order bonus, your products added free, attractive dropship catalog. Mail order plans. Details 25¢ (refundable). Sterling, Box 248-3, Dania, Florida 33004.

**COPUBLISH** "Merchandise on Parade." Mail-order magazine, 25¢. Brings copy information. Link, 1711 Debeney, Houston, Texas 77039.

**TRAVELPAK** Cartopper camper. Fits most cars. Distributorships available. Cartopper, 123 PM, Napoleon, Ohio.

**RAISE** Capital fast—easy proven sources. Free information. Advisor, Box 48337-PM2, Los Angeles 90048.

**100% PROFIT** Making costume jewelry. Details and sample jewelry, \$1.00. Universal, Box 817, Shalimar, Florida.

**COMPLETE** "Mailorder Course," twenty-four wonderful lessons, \$2.00. Dealers wanted. Neil H. Tasker, Shamokin, Pennsylvania.

**FREE** Report, "Profitable Home Businesses." Proven! Wyman, D-87, Congers, N.Y. 10920.

**BOOKKEEPING** System. Substantial profit selling Start Service. Kern, Box 263, North Hollywood, California.

**SELL** Books by mail, 500% profit. Greene, 1927 Columbia Drive, Decatur, Ga. 30032.

**BANKER** tells, "How To Have More Money To Spend." W. B. Kidd, Box 982, Monahans, Texas 79756.

**NET \$250.00** week. Pleasant mailorder. Send \$1.00 today. Crestmore, 409 W. Liberty, Rome, N.Y. 13440.

**BIG** Money maker! Custom furniture upholstery, plus auto trim, slip covers, drapes. Tremendous spare-full time earnings. Men, women, all ages. No experience required. We furnish everything: Easy home instruction, tools, supplies to build roomful of beautiful furniture . . . yours to keep-sell! Send for Big Free Illustrated book, Modern Upholstery Institute, Box 899-YX, Fallbrook, California.

**\$\$\$ IN Pocket** same day! 100 most needed restaurant, bar supplies in palm of your hand. No inventory. National leader, 20th year! Free details. Write Standard, Dept. AI, P. O. Box 148, Santa Ana, Calif.

**SECRETS!** Secrets! Mail order success revealed by internationally famous expert who discovered how to make home business fortunes. Beginners: Get free copy "How to Make Money in Mail Order." Discloses free advertising, profitable products, everything! No obligation. Write Mailco, 1554 Sepulveda, Dept. X705, Los Angeles 90025.

"MAILORDER . . . Stop looking!" Get your own catalogue! Methods, 1815-FD, Lafayette Hill, Pennsylvania 19444.

**OPERATE** Restaurant or diner. Free booklet reveals profitable plan. Write Restaurant Business School, Dept. EC-56, 1920 Sunnyside, Chicago, Illinois 60640.

**FREE** Report: "609 Unusual, Successful Businesses!" Box 51-PO, Des Plaines, Illinois 60017.

**FREE** Booklet, "Guide To Mail Order." Bradley Company, 502 N.E. Brazee, Portland, Oregon 97212.

**START** Your own mail order business, sparetime. Whitlow, 735-PM Goldwood, Dallas, Texas 75232.

**INCREASE** Income! Repair small appliances with new Tester. Details free. Craft, Box 606L, Westfield, N.J.

**FREE** Booklet! Make money raising large fishworms. Blevins Farms, Stevenson, Alabama 35772.

**I MADE \$40,000.00** Year by Mailorder! Helped others make money! Start with \$10.00—Free proof. Torrey, Box 63556-Y Oklahoma City, Oklahoma 73106.

**FREE** Details—Start your own plastic laminating business. We supply everything. Jiffy, Box 23485P, Los Angeles, Calif. 90023

**BUY** At 5¢ above factory price. Thousands of name brands. Household items, watches, rings, jewelry. Buy one item or more. Details, one dollar. James Carlson, New Idria, Calif. 95027.

**INVESTIGATE** Western auto's time proven dealer success plan. Own your own Western Auto store like over 4,000 others now operating. Free training. No retail experience necessary. Minimum investment \$14,000. No franchise fee. For free booklet with complete details, write Charles Wilson, Room 708, Western Auto, 2107 Grand, Kansas City, Missouri 64108. (Indicate geographical area preferred.)

**START** Your own janitorial business. Free details. Janitorial Center, 511-12th, Niagara Falls, N.Y.

**ROPE** Loose in boxes you can put in hanks or rolls and you are in the rope business. 50 lbs. nylon, assorted sizes, \$26.00. 50 pounds cotton, assorted sizes, \$13.00. 50 lbs. polyethylene, assorted sizes, \$24.00. You pay the freight. Dixie Rope Co., Box 142, Shelby, N.C.

**INTERESTED** In mail order? Get mail dealers handbook, \$3.00. Postpaid. Details, 10¢. Daufeldt PM, Atalissa, Iowa 52720.

**EARTHORM** Growers needed! Good-paying home business! You raise, we buy! Free picture folder! Cal-Bait, 8616 Fair Oaks Boulevard, Carmichael, California 95608.

**NEW!** Six months on the job training. Import-Mailorder program for \$10. Free report! Donkar, 1914A LaCana, Hacienda Heights, Calif. 91745.

**IMPORT-Export**, represent manufacturers. Course 14 books free. Details, 10¢. Benko, Box 188-A, New York 21, N.Y.

**TRAIN** For solid, high-paying electronics career. 14 Big kits included. Free fact pack. RTS, Dept. 60042, E. Rosecrans, Los Angeles 90059.

**MAIL** Order: cash in advance business. Operate at minimum cost, in spare time. Start receiving orders in just 30 days—If you act now! Promotion, 6344 Dubois, Department 101, Detroit 11, Michigan.

**RADIO** Mail order, \$50,000 in one month possible. No cost percentage plan. Walthay Box 53-M-5, Los Angeles 90032.

**HAWAII**, 27 Ways to make money. Unusual. Free gift included, \$1.00. Happy Hawaiian, 3758 Likini, Honolulu, Hawaii.

**FREE** "Franchise Profit Letter" tells how unique NFR service is helping thousands seeking profitable businesses. Write today. National Franchise Reports, W-528, 333 North Michigan, Chicago 60601.

## MONEYMAKING OPPORTUNITIES

**RAISE** Rabbits and fishworms on \$500 month plan. Free details. White's Rabbitry, Mt. Vernon, Ohio.

**LEARN** The secrets of repairing junk batteries. "Fabulous Profits" at home. Details. The Batteryman, P.O. Box 416, Palm Desert, Calif.

**VENDING** Machines. No selling. Operate a route of coin machines and earn amazing profits. 32-page catalogue free. Parkway Machine Corporation, 715 PMM Ensor Street, Baltimore 2, Maryland.

**EARN** Money evenings, copying and duplicating comic cartoons for advertisers. Adservice, Argyle-1, Wisconsin.

**\$200.00 FROM** Sheet 1/4" plywood (scrap). 25¢ refundable. Novelties, 610 So. 24th, Elwood, Indiana.

**MINK** Raising information free. Lake Superior Mink Farm Inc., Superior, EE1, Wisconsin.

**HAVE** Successful, home mailorder business! Celebrated professional tells "How!". Gain independence, security. Live better! Exciting details Free! Unicis, Box 735-PG, Norwalk, Conn. 06852.

**CIGARETTES**—Make 20 plain or filter-tip for 10¢. Facts free. Moberly, Box 922, Owensboro, Kentucky.

**EARN** Big commissions full or part time. Show America's largest line low priced business printing and advertising specialties plus big catalog union label political advertising items. Calendars in season. Big free sales kit samples hundreds items used daily by businessmen and political candidates. Merchandise bonuses for you. Free gifts for customers. Build profitable repeat business. Start now. National Press, Dept. 147, North Chicago, Ill.

**FREE**, 206 Easy ways to make money taking orders for exciting new products—spare time. Send name, age for 5 months free subscription Opportunity Magazine, 850 N. Dearborn, Dept. 17-DM, Chicago.

**QUICK** Money by mail working with us. Details free. Worldwide, 694 Kerr St., Columbus, Ohio.

**BOOKKEEPERS** Operate profitable book-keeping tax service. Universal, Box 664-M, Springfield, Missouri.

**EARN** \$240.00 a month at home, spare time, doing only two \$5.00 invisible mending jobs a day. Big money paid for service that makes cuts, tears disappear from fabrics. Steady demand. Details free. Fabricon, 1532 Howard, Chicago 26, Ill.



CLIP Newspaper items. \$1.00-\$5.00 each. Details free. Walter, Box 1023-P, Erie, Pa.

BIG Profits in coins and stamps at home. Free details. Haun, 425 Sandusky, Catlin, Illinois.

BIG Money raising fishworms and crickets. Free literature. Carter Hatchery, Plains, Georgia.

INSTANT Money! Plastics are the wave of the future. Big profits now! At home! Spare time! Materials costing 11¢ bring \$2.58 profits immediately. Free information! Rush name on postcard to: Warner, 1512 Jarvis, Dept. CL-2-DX, Chicago 63625.

MAKE Money writing short paragraphs! No tedious study! I tell you what to write, where and how to sell, and supply list of editors buying from beginners. Many small checks add up quickly. Write to sell, right away. Send for free facts, Benson Barrett, Dept. C-27-D1, 6216 No. Clark, Chicago 26.

INVESTIGATE Fires, storm damage, accidents for insurance, transportation companies; full or part time. Pays up to \$8 an hour, plus car, business expenses. Have second income on side. No college necessary. Home training approved by State Board. Many men earn while they learn. Good jobs open everywhere. For free information write Liberty School, Dept. A 54, 1139 W. Park, Libertyville, Illinois.

GOLD! How and where to find it is explained in "Your Personal Gold Hunters Guide." Only \$2.00 Postpaid. Write GUIDE, P.O. Box 688, University, Alabama 35486.

AMAZING Ways to raise capital. Details free. Benton, 114-A Carrier, Liberty, New York 12754.

NEW Instant invisible mending. Learn in one hour, repair in five minutes. Make \$150.00 week. Literature free. Henson, P.O. Box 6136-6, Philadelphia, Pa. 19115.

MAKE \$50-\$100 Fast assembling Link Belts. Free details! Redikut's, Loganville, 40 Wisc.

FORTY Moneymaking-"Hobbylike"-Opportunities. Write: Homecraft's, 40-21KF Bell, Bayside, New York 11361.

GET Out of debt—clear credit—immediate relief. Advisor, Box 48337-PM3, Los Angeles, 90048.

MAKE Money with a ready made mail-order setup. Complete plan, \$2.00. Dime brings details. B. L. Dickinson & Co., 4413 Duke St., Alexandria 4, Virginia.

WATCH Repairing. Swiss and American watches. Develop skill step by step in spare time at home. Tuition only \$5 monthly. Diploma awarded. Free sample lesson. Chicago School, Dept. YEA, Fox River Grove, Illinois 60021.

SWEEPSTAKES Contests. How to win. Write for free particulars. General Contests, 1609-18 East Fifth, Duluth, Minn. 55812.

"MAIL Order World Of Opportunities." Latest issue; prints all kinds of bargains and new product sources. Rush only \$1.00 for your copy today. George J. Singh & Sons, De Gannes Village, Siparia, Trinidad, W.I.

IRRESISTIBLE. Inexpensive Swiss electric shaver sells on sight! \$5.95 brings demonstrator, big-profit quantity price list. White-Graff, Box 5091, Long Beach, Calif.

OVER \$16.50 An hour. Spare time at home! Rubber stamp industry needs small manufacturers. We furnish all equipment and know-how! Particulars free! Write: Roberts, 1512 Jarvis, Room CR-2-DX, Chicago 60626.

BUY Original oil paintings from importer. McDaniel, 3632 Topaz, Claymont, Delaware 19703.

\$150 WEEKLY. Typing. 10 plans \$1.00. Guaranteed. Camill, 202 Brownell Street, New Bedford, Massachusetts 02740.

RETIRED Machinists—supplement Social Security with year-round part time work in low-cost vacationland. Barnhart Machine, Waupaca, Wis.

JEWELRY CRAFT for fun or profit! Catalog, 25¢. Modern Craft, Box 3614-RC, Cranston, R.I. 02910.

10,000 FORMULAS. 800 page encyclopedia tells how to make practically anything. Free information. Reports, 2800c University, San Diego, California.

103 UNIQUE Home work opportunities. \$1. James Carlson, New Idria, Calif. 95027.

NOW! Free details! 10 new mailorder ideas! Mendez, 426 Hill, Los Angeles, California 90013.

PROFITABLE Business building information. Modern Exclusive. Write Buchwalter Sales, 834-175th St., Dept. 65, Hammond, Indiana 46324.

MAIL Order plan, dropshippers guide, homework. All \$1.00. Wofford's, Center Point, Texas 78010.

OPERATE Your town's Ad Market. Easy \$5. hour. Free proof. Ad Market, Harlingen, Texas.

SHARP \$\$\$\$ Opportunity! One low-cost machine sharpens—serrates knives, scissors, pinking shears. Earn \$6-\$9 hourly in spare time. Professional results without experience. Free details. Beaver Machine, 563 Nielsen Bldg., Eugene, Oregon.

SELL Quality G-pens, 3.9¢ by volume, free literature. Sample pen, 6¢. G-Sales, Box 417, Russellville, Arkansas.

LOOK!!! Great new folio. Make money at home. Details only 25¢. R. C. Stephens, Bx. 131, Doran, Va. 24612.

TYPISTS! Homeworkers! Make money at home! Mailers, 2 Madison, Greencastle, Indiana.

"SPARETIME Money Plan." Be your own boss all the way. Don't split profits. Keep it all. Fill your own \$2.00 orders for 15¢ each. Complete ready to go plan, \$2.00 or send for more details free. Harry Solow, Box 1146 G.O.P., New York, Dept. P 10001.

MAKE Money selling manuals, free details. Mertmann, 209 Herkimer, N. Bellmore, N.Y.

MAKE \$7 on \$10 perfume sale. Details. Nichols, 296 PM, Port Richey, Florida.

\$400.00 MONTH Possible raising night-crawlers, redworms. Three Oaks Ranch, Dresden, Tenn.

MAIL Letters featuring real merchandise, get \$12.00 orders in every mail. \$8.00 profit. Everything furnished. Write: Daley's, Box 4, East Montpelier, Vermont 05651.

START A profitable subscription business in spare time! We need men and women (young and old) as representatives for all leading national magazines. Liberal commissions on all subscriptions. Supplies free. No experience needed. Send this ad with your name and address to: Popular Mechanics, Room 5-O, 250 W. 55th St., New York 10, N.Y.

MAIL Letters featuring real merchandise—Get \$10 orders in every mail—\$8 profit. Everything furnished. Universal, Dept. 15, 510 First National Bank Building, El Dorado, Arkansas 71730.

AMAZING Successes through franchises! Become exclusive franchise holder your territory. Information rushed. National Franchise Reports, WP-528, 333 North Michigan, Chicago 60601.

## PROFITABLE OCCUPATIONS

YOUR Own sign shop—Signs, 1017 W Mulberry, Springfield, Ohio.

BAKE New greaseless doughnuts in kitchen. Sell stores. Free recipes. Michael, 3605 South 15th, Minneapolis 7, Minn.

BIG Money raising fishworms and crickets. Free literature. Carter Wormery, Plains, Georgia.

RAISE Pheasants on \$100 week plan. Little capital and space can make you independent. Free details. Great Central System, Columbus 1, Kansas.

EARN \$240.00 A month at home, spare time, doing only two \$5.00 invisible mending jobs a day. Big money paid for service that makes cuts, tears disappear from fabrics. Steady demand. Details free Fabricon, 1586 Howard, Chicago 26, Ill.

INVESTIGATE Accidents. Earn \$750 to \$1,400 monthly. Car furnished. Expenses paid. No selling. No college education necessary. Pick own job location. Investigate full time. Or earn \$8.44 hour spare time. Men urgently needed now. Write for Free literature. No obligation. Universal, CPM-5, 6801 Hillcrest, Dallas, Texas 75205.

AUCTIONEERING—Resident and home study courses. Auction School, Ft. Smith, Ark.

MONEY: Become finance broker part or full time. Ra-Mar, P.O. Box 482, Desk 3, Oklahoma City, Oklahoma.

VENDING Machines. No selling. Operate a route of coin machines and earn amazing profits. 32-page catalogue free. Parkway Machine Corporation, 715 PMP Ensor Street, Baltimore 2, Maryland.

SHARPEN-Scissors, pinkers. Inexpensive equipment, tools, supplies. Blackhawk's, Sheldahl, Iowa.

FREE Facts and descriptive bulletin. Be an air conditioning, refrigeration, and heating serviceman. High pay, jobs open everywhere, operate your own service business, no school or correspondence necessary. Write Doolco, Trouble Shooter, 2016 Canton, Dallas, Texas.

BECOME Independent with your own franchise business. Thousands earning handsome incomes. Request interesting facts today. National Franchise Reports, PM-528, 333 North Michigan, Chicago 1.

MAKE Money writing short paragraphs. Information free. Barrett, Dept. C-27-D2, 6216 N. Clark, Chicago 26.

CHROME Plating. Instructions, equipment and supplies. Platers' Supply, P.O. Box 565, Lugo Station, Los Angeles, Calif.

BIG Profits, manufacturing bookends, plaques statuary. Easy home business. Plastex, Box 3051, Denver 18, Colorado.

FREE Book: "609 Unusual, Successful Businesses." Box 51-PQ, Des Plaines, Illinois 60017.

PROFESSIONAL Investigators needed everywhere! Many attain these prestige positions earning to \$1,000 monthly. Spare time training through fully approved home study course. College unnecessary. Operate own business, or become Insurance Company Investigator with car furnished, expenses paid. Employment help. Free booklet. No obligation. United Schools, 5628, 416 Louisville, Monroe, Louisiana.

I Work home—Made \$20,000 last year. Help launch others. Free details. Ventures-331, Harlingen 4, Texas.

CUSTODIANS, Janitors, cleaners. Get a better job. Make more money. Become a maintenance supervisor. Free home study information. Maintenance Training, 511-12th St., Niagara Falls, N.Y.

GET That higher-pay position you want now. Unique guide shows how. Free literature. Research, Box 943, Asbury Park, New Jersey 07713.

HOW To be a radio dispatcher. Send \$1. for manual to Jason Boyer, 1601 Coral Gate Dr., Miami, Florida 33145.



**FREE Book "990 Successful, Little-Known Businesses."** Work home! Plymouth-97Y, Brooklyn, New York 11218.

**START A magazine subscription business.** Earn generous commissions on Popular Mechanics. Good Housekeeping and all others. Best commissions, bonus, all material sent free. No experience needed. Write Popular Mechanics, Room 5-P, 250 West 55th St., New York 19, N.Y.

### SALESMEN—DISTRIBUTORS

**EARN Big commissions full or part time.** Show America's largest line low priced business printing and advertising specialties plus big catalog union label political advertising items. Calendars in season. Big free sales kit samples hundreds items used daily by businessmen and political candidates. Merchandise bonuses for you. Free gifts for customers. Build profitable repeat business. Start now. National Press, Dept. 146, North Chicago, Ill.

**FREE. 206 Easy ways to make money** taking orders for exciting new products—spare time. Send name, age for 5 months free subscription Opportunity Magazine, 850 N. Dearborn, Dept. 17-DS, Chicago.

**SELL Advertising book matches.** Write us today, we put you in business by return mail; handling complete line ad book matches in demand by every business right in your town! No investment; everything furnished free! Top commissions daily. Superior Match, Dept. M-566, 7530 S. Greenwood, Chicago 19, Illinois.

**NEW Plan! Pays up to \$25.00 an hour!** Little as 4 hours weekly. Place Thriftie self-service displays in stores. No cost to merchant. No experience needed. Free details. Indiana Laboratories, Dept. 502, Elkhart, Indiana 46515.

**SALESMEN: Big demand items.** Every home prospect. Good profit. Free details. Midwest, 13 Shireford, Ferguson, Mo.

**\$1,000.00 a month for making dramatic 3-second demonstration of amazing Light-weight Presto Fire Extinguisher.** New chemical used by Airforce snuffs out fires instantly. Only \$4.95. Terrific commissions. Millions want it. Free Kit. Merlite, 114 E. 32nd, Dept. P-66Y, New York 16.

**NEW Concept in soap can make you rich.** Lato, 508 Peosta, Helena, Mont.

**SILVERLINE Imprinted pens, sample, details 50¢; Manning, Box 8636, Honolulu, Hawaii.**

**KNIFE—Fantastic! 100% profit! 1000's sold! Fabulous English steel 12" knife.** Slices meat, frozen foods. Luxuriously boxed! Free details. Sample, \$1.00. R-Van, Inc., 129-C South 9th, Philadelphia, Pennsylvania 19007.

**NEW! Latch keeps small-children out of cupboards.** Free details. Sample pkg. of 4, \$1.00. Tot Products, 1506 Gainey, Flint, Mich. 48503.

**CALENDARS, Novelties, Full or part time.** Liberal commissions. Fleming, 6535-A Cottage Grove, Chicago 37.

**SENSATIONAL New longer-burning light bulb.** Amazing free replacement guarantee—never again buy light bulbs. No competition. Multi-million dollar market yours alone. Make small fortune even spare time. Incredibly quick sales. Free sales kit. Merlite (Bulb Div.), 114 E. 32nd, Dept. C-73Y, New York 16.

### AGENTS WANTED

**ESTABLISH Your own business.** Low prices on used clothing, shoes, household goods. Unlimited profits. Free catalog. Northwestern Distributors, 2129 No. Western Avenue, Chicago, Illinois 60647.

**MAKE \$50.00 Daily selling air operated vacuum cleaners to service stations.** Free details. Inka Industries, 2401 Crocker, Houston, Texas 77006.

**RAISE Rabbits for us on \$500 month plan.** Free details. White's Rabbitry, Mt. Vernon, Ohio.

**SAVE 90%, make your own professional looking advertising signs.** It's easy, no skill required. Free literature. Aero-Signs, Box 1035, Commerce City, Colorado 80022.

**NAME Pins. Beautiful sample, 25¢.** Kass, Box 2734, Philadelphia 19120.

**MAKE Up to \$50.00 daily soliciting delinquent accounts.** Terrific commissions. General Finance Co., Dept. LG-80, Pickwick Bldg., Kansas City, Mo. 64106.

**MEN! Show wife this idle hour money making offer!** Friends, neighbors, give lots of orders for famous Hollywood cosmetics. For free samples and easy plan to make up to \$5.00 for one hour, write. Studio Girl Dept. OP363, 1510 N. Kostner, Chicago, Illinois 60651.

**PRINTING. Advertising salesmen—Excellent moneymaking sideline selling decalcomania name plates, small quantities.** Automobile initials, sign letters. Free samples. Ralco, XL, Boston, Mass. 02119.

**\$300.00 WEEKLY Possible finding serviceable vacuum cleaners.** For information send \$1.00 to Vaisey, Box 206, Parishville, N.Y.

**AGENTS Wanted, \$1. To Henthorn, 12 Adlington Street, Oldham, England.**

**YOUR Own business—Used suits \$1.50; overcoats 65¢; mackinaws 35¢; shoes 12½¢; ladies coats 30¢; dresses 15¢.** Enormous profits. Catalog free. Nathan Portnoy Associates, 2109-AA Roosevelt Road, Chicago 8, Ill.

### EMPLOYMENT INFORMATION

**FOREIGN Employment. Construction, other work projects.** Good paying overseas jobs with extras, travel expenses. Write only. Foreign Service Bureau, Dept. PM, Bradenton Beach, Florida.

**DIRECTORY Reports. Construction, aviation, shipping, oilfields, government, manufacturing, trucking, etc. foreign—stateside.** Helpful information plus job-getting tips on preparing application letters. Unconditional money-back guarantee. Only \$3.00 (\$3.25 airmail) Research Services, Box 6768-PM, St. Louis, Missouri 63144.

**TREMENDOUS Opportunities U.S.A.—Overseas. Choose jobs—locations—transportation.** Free details. Occupations, International Airport, Box 100-C2, Jamaica 30, N.Y.

**FOREIGN Employment: South America, Africa, Europe, Australia, USA.** Earnings to \$2,000.00 monthly. Construction, all trades, professions, occupations. Many companies pay fare, housing, benefits, bonuses. Write: Universal, Dept. B-1, Woodbridge, Connecticut 06525.

**ARIZONA Job opportunities, Trends, occupational demands, Helpful-information, \$1.00.** Arizona Employment Information Service, Box 2223, Dept. A, Phoenix, Arizona 85002.

**JOB Resume guide, easy to follow.** Plus sample resume and instructions, \$1.00—refundable. Bell Resume Service, 18 Tremont Street, Boston, Mass. 02108.

**BOOMING Australia needs your skills!** Government assisted passage. Details \$1.00. Irv Heyer, 321A S.W. Salmon, Portland, Oregon.

### HELP WANTED

**MAKE \$280.00 getting just 10 growers to try Campbell's Plant Food.** Sample free. Campbell, Rochelle 24, Illinois.

### FARMS—REAL ESTATE

**\$1 ACRE—Canadian border—hundreds campsites, islands, farmlands, directly from tax authorities.** (Non-profit). Lists, photographs mailed. Register, Room 203, 92 King St., E., Toronto 1, Canada.

**ABANDONED Timber Leaslands! Choice 640 acre Sportsmen's paradises still available—\$20.00 plus \$6.50 Taxes yearly.** Maps, pictures, \$1.00 (Refundable). Director, Erindale 4, Ontario, Canada.

**CANADA'S Finest lands, \$4.00 an acre and up.** Acquired through estate liquidations. Suitable for hunting, fishing, camps, cottages, farming, timber, minerals, investment. Small monthly payments. Free descriptive booklet. Canadian Estate Land, 2788-P Bathurst Street, Toronto, Canada.

**"CAL-ORE Ranches" in Oregon's Rogue River Valley near Medford and Grants Pass.** \$2995 to \$5995. Pay \$150 down, \$35 monthly. Free catalog. Cal-Ore Ranches, 1054PM South Riverside, Medford, Oregon.

**CANADIAN Vacation lands: Full price \$385.00, 40 acres, \$10 month.** Suitable cottage sites, hunting, fishing, investment. Free information. Land Corporation, 3768-C Bathurst, Downsview, Ontario, Canada.

**CANADIAN Lands, seized and sold for taxes.** Our 49th annual series of lists, describe many choice properties, situated from coast to coast, acquired by us through tax sale. Priced as low as five dollars per acre, guaranteed perfect title, small monthly payments, no mortgage. Beautifully situated hunting and fishing camps, where there is real sport: summer cottage sites, heavily wooded acreages. Now is the time to invest in Canada's minerals, forests and farms. Write today for free twenty page booklet with full explanation. Tax Sale Service, Room 301-D, 85 Bloor St., E., Toronto 5, Canada.

**GOVERNMENT Lands . . . Low as \$1.00 acre!** Millions acres throughout U.S. Free details! Land Digest, Box 26034-PE, Indianapolis, Ind. 46226.

**400,000,000 ACRES Government public land in 25 states.** Some low as \$1.00 acre. 1966 report. Details \$1.00. Public Land, 422-PM-5 Washington Building, Washington, D.C.

**400,000,000 ACRES Government public land in 25 states.** Some low as \$1.00 acre. 1966 report. Send \$1.00 National Land, 422-PM-5, Washington Building, Washington, D.C.

**BUY Without risk for Retirement, Vacation, or Investment—under America's only "No-Risk Purchase Plan"—in Carolina Coast multi-million dollar, 14,000 acre development.** 10 year money-back guarantee. Payments less than \$5.00 monthly. Shopping Center, motel, hunting, fishing, golf, country club, right on property. Private ocean beach. Write for free literature. (Not offered to residents of California, Florida, New York.) Bolling Spring Lakes, Southport 1-T, North Carolina 28461.

**FREE Summer catalog! Bargains galore!** Coast-to-coast! Low prices, easy down payments! Safe-Buy Real Estate Agency, 712-PM, West Third, Little Rock, Ark. (Please include Zip Code.)

**PEACEFUL Southern Utah land, 2½ acres, \$125 cash or terms.** Dept. PM, Box 17401, Salt Lake City, Utah 84117.

**FREE! New 160-page Summer catalog!** Over 1800 pictures! Farms, ranches, homes, businesses, vacation and retirement properties in 29 states coast to coast! United Farm Agency, 612-PM West 47th St., Kansas City, Mo. 64112.

**ONE Of Florida's greatest homesite values.** High, dry ¼ acre site, \$495. Price increase to \$545, act now! No money down, \$10 monthly. Free Photos. Write Dept. AI-5, Rainbow Park, Box 521, Ocala, Florida (AD5-6067).

**FLORIDA Campsites—deep in the heart of the great Ocala National Forest.** Good hunting and fishing. Free maps and photos. Howard Vernor, DeLand, Florida, AD646369D

### FARM AND GARDEN EQUIPMENT

**3hp HOEING Machine.** Hoes between plants, rows, depth adjustable. Self propelled. Month trial, Year warranty. Discount. Time payments. Send for literature. Autohoe, West De Pere 22, Wisconsin.





## PLANTS AND NURSERY SUPPLIES

**GINSENG** bringing \$14 pound. Have seeds, plants. Full information. K. Collins, Viola, Iowa 52350.

**600 ASSORTED** Sweet onion plants with free planting guide, \$3.00 postpaid. Topco, "home of the sweet onion," Farmersville, Texas 75031.

**WORLD'S Largest** canna flower farm—red, yellow, pink, orange; four bulbs, list, \$1.00 stamps-postpaid promptly. Guaranteed. Neil Horn, Carnegie, Okla. 73015.

**WANT** Greatest cash crop working for you? Write Ginseng, Asheville 53, N. C.

## HOME CRAFTSMEN

**FREE "Do-it-yourself"** Leathercraft catalog. Tandy Leather Company, 1001 Foch, N56, Fort Worth, Texas.

**KNOCKDOWN** Cedar chests, also over fifty kits. Catalog 25¢. Giles Kendall Co., Huntsville 2, Alabama.

**2512 PLANS.** Patterns, things to make, do. Fun. Profit. World's greatest selection. Catalog 10¢. Craftplans, 18250-A Harwood, Homewood, Ill.

**101 PATTERNS** Of smart gifts, novelties, shelves, action windmills plus "Make Money Jig Sawing," \$1.00. Mastercraft, 55M, 7041 Olcott, Chicago 60631.

**PLANS.** Bird houses, feeders. Illustrated catalog, 25¢. Yeager, 1665 Linden, Homewood, Ill. 60430.

**WOODWORKER**—Home craftsman catalog containing clock kits, lamp parts, chair-cane, veneers, swiss musical movements, legs, furniture, hardware, mouldings, finishing materials, tools, etc., only 15¢. Barap Specialties, Box 2044-DW, Chicago 60609.

**WALNUT** And cherry tapered legs, lumber, gunstock, blanks, picture frame moulding. Midland Lumber Company, Box 262, Savannah, Missouri.

**FREE!** Big 80 page Leathercraft catalog, 100's of new items! MacPherson Bros., Dept. K, 730 Mission St., San Francisco, Calif. 94103.

**THREE Weeks** spare time build 19'x34' x8" reinforced concrete swimming pool, \$1350. I did. Name brand filter, pump, motor, lint-catcher, skimmer, vacuum equipment; plumbing, coping included. Any shape easily built. Smaller size—smaller cost. Complete construction details, designs, drawings, actual construction photographs. \$10.00. Brainerd, Rt. 4, Broken Arrow, Okla.

**SKIL-CRAFTS** New '65-66 catalog. Largest and finest selection of leathercraft, artist, hobby-craft supplies in the world. Free gift with first order. Send 50¢. Refundable with first order. Skil-Crafts, Box 105-F, Joplin, Missouri.

**SPORTSMAN'S** trophy clock kits. Details, 10¢. Leroy Buckley, Pell Lake, Wis. 53157.

**CONSTRUCT** Inexpensive storage unit for nails, bolts, etc. For blueprints mail 50¢. Blueprint, Box 515, Stuarts Draft, Virginia 24477.

**COMPLETE** Working plans, specifications, bill of materials for attractive swinging or stationary Wren House. Send \$1.00 today. Ease-Crafts, 1819-9th Street, Rockford, Illinois 61108.

**PICTURE** Frame moulding—Any size, style and wood. All original patterns! Details, 10¢. Japs, 126-P Seventh North, Hopkins, Minn. 55343.

**PLANS** for pool table with extra two-face top for table tennis and model railroad. Blueprints B1209 and building instructions \$3.50. Popular Mechanics Service Bureau, 575-M Lexington Ave., New York, N.Y. 10022.

## DO-IT-YOURSELF

**AUTOMATIC** Washer repair manuals for: Frigidaire, General Electric, Hamilton, Hotpoint, Kelvinator, Kenmore, Norge, RCA Whirlpool, Speed Queen, Westinghouse, Maytag, Philco-Bendix. \$2.50 ea. FPD, Major Appliance, 13106 Caine Ave. (Dept. M), Cleveland 5, Ohio.

**FLUORESCENT** Tubes rejuvenated at no cost. Instructions \$1.00. Rejuvenators, 172 Bolton St., Portland, Me.

**BUILD** Your own fall out shelter. Blueprints. Material list. Send \$3.95—Don't delay. Developers, 516 Hoke Dr., Petersburg, Virginia 23803.

**EXERCISE** At home on build-it-yourself physical fitness equipment, including bicycle exerciser, rowing machine, belt massager, and abdominal board. Send \$2.50 for blueprints B1208 and instructions. Popular Mechanics Service Bureau, 575-K Lexington Ave., New York, N.Y. 10022.

**FREE** Check-list covering more than 300 classifications of projects, plans, instructions, service and repair information detailed in Popular Mechanics famous series of instructional booklets, books, patterns, and blueprints. List covers an extremely wide variety of do-it-yourself data on home remodeling, repair and improvement, hobbies, crafts, boating, games, lawn and garden, and hundreds of others. For your free copy of this helpful list, write: Service Bureau, Popular Mechanics, 575 Lexington Ave., New York 22, New York.

## ARTS AND CRAFTS

**MAKE** Figurines, plaques, lawn ornaments. Molds, plastercraft kits, liquid rubber. Sample and catalogue 10¢. Wooley Company, Box 29-B, Peoria, Illinois.

## BINOCULARS, TELESCOPES, MICROSCOPES, MAGNIFIERS

**AMAZING** Offer, microscopes, telescopes, binoculars. Lowest prices. Free brochure. University Optics, Box 1205-M, Ann Arbor, Michigan.

**SCIENCE** Bargains! Lenses, telescopes, binoculars, microscopes, kits, parts, war surplus. Send \$1.00 for beginner's 10-lens kit with instruction booklet. Order Stock 2-CH. Request free 148 page Catalog CH. Edmund Scientific Co., Barrington, New Jersey.

**BUILD** Your own professional 8" reflector telescope (no lenses to grind!). Construction plans, parts list, send \$5.00. F. X. Tagan, 69 Mt. Cranmore Lane, Melrose 76, Mass.

**BINOCULAR** Sale! Free color catalog 100 models \$9.95-\$250.00. Write, United, 9043 So. Western BCAT-6408, Chicago 60620.

**BUILD** Your own reflector telescopes. Complete kits; mirrors, eyepieces, tripods. All other accessories. Request free illustrated literature. Criterion Manufacturing, Dept. KPM38, Hartford, Connecticut.

**DYNASCOPE** — Amazing world-famous reflector telescope. Request free brochure. Criterion, Dept. DP 26, Hartford, Connecticut.

**BINOCULARS** Direct from manufacturer. Finest quality, tremendous savings! Request catalog, Koyu, 3860 Crenshaw Blvd., Los Angeles, Calif.



## CAMERAS AND EQUIPMENT

**TELL** The more than 1,400,000 avid readers of Popular Mechanics about your products and services. It costs very little to place your classified message in front of these proven mail order buyers. For further details, write: C. A. Martin, Dept. 49N, Popular Mechanics, 575 Lexington Avenue, New York, New York 10022.

## PHOTO SUPPLIES

**TELL** The more than 1,400,000 avid readers of Popular Mechanics about your products and services. It costs very little to place your classified message in front of these proven mail order buyers. For further details, write: C. A. Martin, Dept. 50N, Popular Mechanics, 575 Lexington Avenue, New York, New York 10022.

## PHOTO FINISHING

**CAMERA** Fans! Expert photofinishing and free film returned: 8MM Kodachrome \$3.10; 8 Exp Kodacolor \$3.10; 35MM Kodachrome, 20 slides, \$2.85; 8 exp black & white 90¢. We give you free photo stamps to redeem for gifts. Satisfaction guaranteed. Send exposed film or request mailers and complete price list. Direct Mail Photo, Box 8352-PM, Pittsburgh, Pa. 15218.

**A FREE** Kodak roll returned with each black and white or Kodacolor developed and printed, fast service, lowest prices, guaranteed quality send for free mailers. Economy Photo Service, Dept. P. M., Box 1111, Albany 1, N.Y.

**TRIAL** Offer, 8 enlarged prints from roll 40¢; 12-50¢, 8 Kodacolor prints from roll \$1.50; 12-\$2.00; 20-\$3.00. Guaranteed highest quality. Young Photo Service, 45M, Schenectady 1, N.Y.

**FAST,** Hi-quality finishing. Kodacolor rolls: eight jumbo prints \$1.98. Twelve \$2.49. Twenty \$3.49. Reprints 15¢. Also low B&W prices. Custom Quality Studio, Box 4838-PM, Chicago 60680.

## COLOR SLIDES

**8mm, MOVIES,** 2"x2" Color slides—biggest selection anywhere! Hollywood classics, railroad, antique automobiles, circus, World War II, travel, wild life, many others. 16mm. films also. Big catalog free. Blackhawk Films, 24 Eastin-Phelan Bldg., Davenport, Iowa 52808.

**FREE!** Illustrated lists comic title slides. Colonial, 247-A, Swarthmore, Pa.

**TRANSPARENCIES** Wanted! Learn free-lancing. American Color, Box 46372, Hollywood, California.

## MOTION PICTURES AND SOUND EQUIPMENT

**5,000** 8-16 MM. Movie films. Free catalogues. International, Greenvale, N.Y.

**16MM** Sound films features and shorts. Bedner, 5300 So. Talman, Chicago.

**8MM MOVIES,** 2"x2" Color slides—biggest selection anywhere! Hollywood classics, railroad, antique automobiles, circus, World War II, travel, wildlife, many others. 16mm films also. Big catalog free. Blackhawk Films, 24 Eastin-Phelan Bldg., Davenport, Iowa 52808.

**FREE** Catalog! Save on 8/mm.-16mm. film and supplies. Superior, 448 N. Wells, Chicago 10.

**CAPTURED** Nazi film. Guaranteed authentic. Samples \$1.00. Sanford, Fairview, Pennsylvania.

**IMPERIAL'S** 1966 8MM-16MM film catalog free. Features, shorts, projectors. Imperial's, 34 Park Row, New York 10038.

**16MM** sound-projectors, films, new, used for sale. Free catalog. National Cinema, 333 W. 57 Street, New York City, N.Y. 10019.

## RADIO, TELEVISION AND HAM EQUIPMENT

**CONVERTERS** For automobile radios, receive Marine, Police, Fire, 2-3, 30-50, 100-200 megacycles. Any kit \$5.00. Meshna, Lynn, Mass. 09104.

**BRAND** New tubes, World's lowest prices on radio, TV-industrial, special purpose tubes. Write for free parts catalog. United Radio, Newark, N.J.



**REMARKABLE** Television Magnifiers, sizes, fit 4" to 24" sets. Free brochure. "Magna-Lens" 2367 David Court, San Mateo, California.

**RADIO** Station callbooks, log sheets, reporting forms, SWL supplies. Catalog free. Gilfer, Box 229, Park Ridge, New Jersey 07656.

**FREE** Electronics catalog. Tremendous bargains. Electrolabs, Department C-643B, Hewlett, New York 11557.

33¢ **RADIO & TV** tubes. Free list. Cornell, 4213-17 University, San Diego 5, California.

**DYNAPLATE** Radiotelephone grounding unit saves you money . . . compact, install in minutes. Standard (equivalent 12 sq. feet) \$14.75. Giant \$49.50. Aquadynamics, 6940 Farndale, North Hollywood, California.

## HIFI, RECORDS AND ELECTRONICS

**RECORDS!** Discounts on all LP's. Free details. Citadel Record Club, 545 Fifth Ave., Dept. 2, New York 17, N.Y.

**TAPE** Recorders, hi-fi components. Sleep learning equipment, tapes. Unusual values. Free catalog. Dressner, 1523 Jericho Tpke., New Hyde Park 3, N.Y.

**NEW B.S.R.** record changers \$13. New Garard record changer \$27. AM-FM stereo tuner w/amplifier \$65. P.M. Changers, 2741 Sedgewick Ave., Bx., N.Y. 10468.

**LP RECORDS.** 35-55% discount. Disclub. One Fisher, Mount Vernon, New York 10552.

**TELEPHONES.** Automatic answering units. Complete catalogue. Metropolitan Teletronic Corp., 35 West 35 Street, New York, New York. Inclose 25¢ for handling and postage.

**EXCLUSIVE** Free catalogue; extraordinary hard to find hobby party records. Record Suppliers, 300 Chelsea, Louisville, Kentucky 40207.

**ELECTRONICS** Handbook. Packed with information. Definitions, charts, tables, etc., \$1.50. General Research, P.O. Box 545, Warrenton, Virginia.



## MUSIC AND MUSICAL INSTRUMENTS

**PLAYER** Piano books. Free catalog. Vestal Press, Vestal 11, N.Y. 13850.

**ACCORDIONS,** Guitars, band instruments! Save to 50%. Famous makes. Easiest terms. Trades accepted. Free home trial. Free discount catalog. Mention instrument. International Music Mart, 5535-R Belmont, Chicago 60641.

**SONGS** And song poems wanted. Royalties. Tin Pan Alley, Inc., 1650 Broadway, New York, N.Y. 10019.

**VIOLIN** And guitar makers, send for latest Free catalogue of woods & accessories. International Violin, PM-5, 414 East Baltimore St., Baltimore 2, Md.

**ELECTRIC** Guitars, amplifiers, wholesale. Free catalog. Carvin, PMM, Covina, Calif.

**GUITAR.** Banjo Making books. Plans, woods, necks, tools. List 20¢. Satinwood, 510 East 11th Street, New York 9, N.Y.

**POEMS** Wanted for new songs and records. Send poems. Five Star Music, 6M Beacon, Boston 8, Mass.

**SONG** Ideas wanted. Write with active professional songwriters with publisher contacts. Records made. Share royalties. Send ideas—free examination. Songwriters' Associates, 236 W. 55th, N.Y. 19-P.

**PIANO** Self-Teaching Book. Includes popular, classical, harmony, theory, chords, scales. Price \$5.00. LaPont Publishing Company, Box 606-P, Franklin, Michigan 48025.

**SONG POEMS** Wanted! Collaborate with professional songwriters equally. Share royalties. Songwriters Contact, 1619-D, Broadway, New York 19.

**SONGPOEMS** Wanted. Send poems for offer. Nashville Music Institute, Box 532-PM, Nashville, Tennessee.

**SONGWRITING** Services. Collaboration. Free details. Modern Music, Box 193-A, Bloomfield, Conn.

**BUILD** An electric guitar. Complete easy instructions, \$1.00. Kits, blueprints, parts, bulletin, 25¢. Hills, 3526 California, Peoria, Illinois.

**ACCORDION** Manufacturing, 6343-P South Ashland, Chicago Illinois 60636. Piano Accordions, Chromatics, Hohners, Concertinas. Wholesale catalogs free.

**EASY** Instruments for No-Talent musicians. Free catalog. Wayne Anderson Co., Dept. PM, 545 W. 111th St., New York, N. Y. 10025.

**SONGS** Wanted by new commercial recording company. Royalty basis. Send material to Preview Records, 6311-B Yucca, Hollywood, California 90028.

**INCOME** Guaranteed two years for song-poems accepted! Free public releases! Castle's, 203PM West 46th Street, New York City 10036.

**GUITARS.** \$11.95. Electric double pickups with tremolo bar, \$49.95. Accordions, \$125.00. Concertinas, \$350.00. Drums pearl set, \$99.00. Wind instruments \$39.95. Free catalogs. EZ. Terms, Melody Music, 4951 W. 95th St., Oaklawn, Ill.

**PLAYER** Piano rolls, send for free catalog. Melodee, Wexford, Pennsylvania.

**LEARN** Harmony, arranging, 10 lessons complete course. Box 504, Miami Beach, Fla. 33139.

**GUITARS!** Famous brands. Big discounts. Free catalogs. Write: National Guitar Sales, Dept. PM-5, Box 417, Parkersburg, West Virginia 26101.

**PEDAL** Instrument, plucks strings for amplified bass fiddle sound with piano, guitar. Write for details, Taylor-Creager Music, Box 1803, Atlanta, Georgia 30301.

## EDUCATION AND INSTRUCTION

**PENMANSHIP** Corrector. Improve poor penmanship quickly. Details free. Ozment, Box 665-34, St. Louis 88, Mo.

**COMPLETE** Your high school at home in spare time with 69-year-old school. Texts furnished. No classes. Diploma. Information booklet free. American School, Dept. X-545, Drexel at 58th, Chicago, Illinois 60637.

**MEN** Wanted. Earn \$125 a week and up. Master a trade with a future. Learn auto diesel mechanics in our shops. You learn with tools on real equipment. Earn while you learn. Many of our graduates earn \$125 a week and up. Write for free bulletin: Dept. 256, Auto Diesel College, Nashville 3, Tenn.

**OWN** Collection agency. "Little Gold Mine!" Franklin Credit, Roanoke, Virginia.

**LEARN** To drive tractor, trailer, trucks, buses. Short concentrated courses available. Write for free brochure. Driver Training Institute, 794 Bedford Ave., Brooklyn, N.Y. Ja 2-5080.

**BOOKKEEPERS.** Operate your own "Dollar-A-Week" system. Ellis, Box 200, Cedar Grove, North Carolina.

**INVESTIGATOR'S** Course. Credentials, diploma. Free information. Southwestern Institute Criminology, Box 201, Geronimo, Oklahoma.

**PIANO** Tuning pays. Big money in spare time. Learn at home. No musical knowledge necessary. Phonograph, records, tools and instructions furnished. Electronic tuning also taught. Free catalog. Capital Tuning School, 3160 S.W. 16th Court, Ft. Lauderdale, Fla.

**MISSOURI** Auction School. Free catalog! 1330-03 Linwood, Kansas City, Mo. 64109.

**LEARN** Special investigation. 20 Lessons, credentials, diploma, future. International Academy of Police Science, Oklahoma, City, Oklahoma.

**DETECTIVES**—Secret investigations. Experience unnecessary. Detective particulars free. George Waggner, M125 West 86th, New York 10024.

**FCC** License in 6 weeks. First class radio telephone. Results guaranteed. Elkins Radio School, 2603D Inwood, Dallas, Tex.

**DETECTIVE** Course. Free information. Universal Detectives, Box 8180-F, Universal City, California, 91608.

**SWEDISH** Massage and Physical culture pays big profits. Learn at home. Diploma. Free catalog. National Institute, Dept. E56, 307 North Michigan, Chicago 1.

**LEARN** Auctioneering. Term soon. Free catalog. The Reich American School of Auctioneering, Inc., Box 850, Mason City 1, Iowa.

**LEARN** Asleep or awake! Records, tapes, equipment! Free catalog! Drawer, PM-400, Ruidoso, New Mexico 88345.

**AUTOSUGGESTION.** Sleep-learning headquarters! Tapes, records, books. Gigantic catalog free. Research Association, Box 24-PM, Olympia, Washington.

**FREE** Sleep-learning catalog. Fletcher, 2407 Catherine, Dallas, Texas 75211-PM.

**PIANO** Tuning quickly learned with home study course. Diploma granted. American Tuning School, Gilroy, Calif.

**USED** Courses! Books! List 10¢. Smith's, 124 Marlborough, Salem, Mass.

**SWEDISH** Massage. Foot technique. Post graduate. Home study. Residential, Diploma. Dr. Swanson's Illinois Licensed School, 3809-PL Alta Vista, Chicago 13.

**APARTMENT** Management. Prepare for the fast growing apartment industry. Learn professional apartment management at home. Fine job opportunities everywhere. Send for free brochure. Ruth B. Krebs Associates Training School, 8155 Van Nuys Blvd., Suite 204 PM, Panorama City, California 91402.

**FREE** Bible course. Degree, PM, 143 South Gregg, Charlotte, N.C. 28208.

**BE** A real estate broker. Big Earnings. Free catalog. Weaver School of Real Estate, 3519-P Broadway, Kansas City, Missouri 64111.

**MINISTERIAL** Home study course. Free qualifying examination. Soms, 5955 Powdermill Road, Kent, Ohio.

**LEARN** Civil and criminal investigation at home. Earn steady, good pay. State age. Institute Applied Science, 1920 Sunnyside, Department 165, Chicago, Illinois 60640.

**PENMANSHIP** Guide: Ornamental writing. Improve poor handwriting fast. Details free. M. Tevis, Chillicothe, Mo.

**GET** A British degree. Divinity, Philosophy, Radionics, 35 courses. Prospectus free. Brantridge Forest School, "Lodge" Brantridge Forest, Balcombe, Sussex, England.

**USED** Correspondence courses and books sold and rented. Money back guarantee. Catalog free. (Courses bought.) Lee Mountain, Pisgah, Alabama.

**FAME,** Fortune through dynamic manly voice. Free literature. Voicecraft, 1709-PM Fremont, Madison, Wisconsin 53704.

**MASTER** Watchmaking at home. Free sample lesson. Chicago School, Dept. YE, Fox River Grove, Illinois 60021.

**B.Sc. DEGREE** (Engineering) by home study. Send \$1 for 1966 prospectus. CIST, Suite 804, 263 Adelaide Street, W., Toronto, Canada.



**SLEEP Learning!** Sensational record makes over your life! Instant self-power . . . control others. Free trial offer!! Forum, 333-JX5, Michigan, Chicago 60601.

**LEARN** Gunsmithing, America's oldest complete course. VA Approval. 2-year curriculum. Degree of Associate in Science. Large shops. Modern equipment. Competent staff. Recommended by leading arms companies. Write: Dean of Students, Trinidad State Junior College, Trinidad, Colorado.

**PASS** Civil service examinations. Aena, 1513 64th Street, Brooklyn, New York 11219.

**DRAW** Perfect pictures. Newest methods. Results guaranteed. Mail \$1.00 for drawing kit, simple instructions, free criticisms. Fraser, 2610 Glenwood, Brooklyn, New York 11210.

**PROFITABLE** National Camera Repair School training at home! PM5, Englewood, Colorado.

**HOME** Study courses—drafting, design. Zero Engineering, 2437 West 69, Chicago 60629.

**BECOME** An ordained minister! Get D.D. degree and your chartered branch church. Send 25¢ today for complete information. Seminary, Box 1029-A, Glendale, Calif. 91209.

**COLLEGE** Courses at home on LP records by world famous professors (several Pulitzer Prize winners). Study English, Psychology, History, Anthropology. Credit towards degree at over 100 colleges. Free catalog. Institute For University Studies, Department 90, Bergenfield, New Jersey.

**HIGH** School diploma at home. Licensed teachers. Send age, highest grade completed for free detail. No salesman will call. Southern States Academy, Professional Bldg., Dept. 16, Decatur, Ga.

## FOR INVENTORS

**U.S. Patent Office** Searches, 234 Broadway, Room 3615, New York. Free invention certificates.

**INVENTORS:** Your ideas and inventions (patented; unpatented) expertly searched and developed for commercial appeal and cash/royalty sales to manufacturers by professional Invention Developer with excellent record of experience. B.S., Industrial Engineering; U.S. Patent Office former Patent Examiner; U.S. Government former Patent Adviser. Second decade of reliable service! Free "Invention Record" and Important Information. Airmailed! Write: Raymond Lee, Invention Developer, 130-N West 42nd, New York City 10036.

**PATENT** And invention development, by licensed professional patent engineer and U.S. Patent Office former examiner, and engineering specialists. Your inventions and ideas engineered for patent protection and commercial value. Inventions developed by us negotiated for cash or royalties with our nationwide contacts. Send for free protection "Invention Certificates" and further interesting, valuable patent information. George Spector, Licensed Professional Patent Engineer, Woolworth Building, New York

**PROFESSIONAL** Patent searches, \$6.00, including official U.S. Patent Office copies of related U.S. patents! Prompt, dependable service. Certified, airmailed! For free "Invention Record Folio" and important patent information every inventor should have, write: United States Inventors Service Company, 501 Thirteenth Street NW, Washington, D.C. 20004.

**INVENTORS** Complete guide book lists needed inventions; tells how to develop and patent your idea; how to market your invention, and hundreds of other facts for inventors, \$4.95 Postpaid. Literature free. Castellazzo, 3257-1E Kansas, Oakland, Calif. 94602.

**\$50,000 FOR My best patent!** Get your patent pending fast. Order my "Copy-Book-Materials" today! \$10 pnd. Flipper, Inc. #P-5, Geneva Ill.

**IMMEDIATE** Cash, for patent applications. Free patent searches. Write for details. Universal Patents, 184-D, Marion, Ohio.

**EVERY** Inventor, scientist, engineer must have this booklet, "Sources of Financing." Listing 200 venture, business, property, risk capital sources. Send \$1.25. Crump, 601 South Vermont, Los Angeles, California, 90005.

**SELL** Unpatented inventions, unique protection plan, \$1.00. Sponsalco, Box 8181, Tulsa, Okla.

**INVENTORS**—Do you want to sell or license your invention on cash or royalty basis? Write: Kessler Corporation, C-55-FI, Fremont, Ohio.

**PATENT** Searches, including copies of related U.S. patents, \$6.00. Inventors, attorneys, manufacturers use my "worldwide" airmail service! "Invention Record" form and "Information Every Inventor Needs," sent free! Miss Hayward, 1029P Vermont, Washington 5, D.C.

## INVENTIONS WANTED

**WE** Have markets for worthwhile inventions. Harvey Engineers, Cambridge, Maryland 21613.

**INVENTORS:** Protect your ideas! Free "Recommended Procedure." Washington Inventors Service, 422F, Washington Building, District of Columbia 5.

**WE** Either sell your invention or pay cash bonus. Write for details. Universal Inventions, 298-E, Marion, Ohio.

**INVENTORS** Wanted: Manufacturers need new items! Your inventions, ideas developed for cash/royalty sales. Free "Invention Record"; Information. Raymond Lee, 130-P West 42nd, New York City 10036.

**INVENTORS!** Don't sell or license your invention for cash or royalties until you receive our offer. Financial assistance available. For free information, write Dept. 76, International Invention Institute, 17 Park Row, New York 38, N.Y.

**INVENTORS** Needing Help with any problem, financial, development, securing manufacturer, obtaining patent. Write the organization that delivers action and results—not promises. Pioneer Invention Service, Dept. 83, 150 Broadway, New York 38, N.Y.

**ORIGINAL** Worthwhile ideas, inventions, gadgets, patented, non-patented wanted. All fields, buy, sell, develop or market by experienced professional engineering corporation. Project Bo'd Venture, Inc., 126 Jackson, North Hopkins, Minnesota 55343.

**INVENTIONS** Wanted. Patented; unpatented. Tremendous manufacturers lists. Global Marketing Service, 2420G 77th, Oakland 5, California.

## MANUFACTURING

**MODELS**—Small lot manufacturing. Metals, plastics, etc. Milburn, Burlington, Kentucky.

**IF** One man in each state is interested in an exclusive manufacturing franchise, write Shafer's, Box 112, Idaho Springs, Colorado.

**INVENTORS** Services, Models, Manufacturing, Research, Consultants all fields available. William Parker, 32 Westminster, Worcester, Mass. 01605.

## BUY IT WHOLESALE

**WORLD'S** Largest wholesale supply. Buy from 7653 American, European Japanese wholesalers, Hong Kong tailor-made suits, 123 dropship catalogs. Rockbottom prices. Automobiles. Free details. International Buyers, 216-M Jackson, Chicago 6, Illinois.

**BARGAINS!** Buy wholesale and below. Name brands. Appliances, furniture, sports equipment, televisions, cameras, watches, jewelry, thousands more. Huge discounts to \$1,000.00 on new automobiles. All makes. Free details. Write today: Worldwide Bargainhunters, Box 730-A, Holland, Michigan.

**NEW** 6-Color below wholesale catalog. Automobile catalog and others. Housewares, clothing, furniture, appliances, stereos, guitars, typewriters, luggage, golf, bowling, pool, bicycles, watches, jewelry. Huge discounts. Thousands name-brand items. For free list (factory prices) postcard: Selbyco-15, Decatur, Illinois.

**ELECTRIC** Guitars, amplifiers, wholesale. Free catalog. Carvin PMW, Covina, Calif.

**WHOLESALE** RAMA, Bargain Catalog 20¢. Fair Sales, Box 5152-PM, Kingsport, Tennessee.

**BARGAINS!** Buy wholesale! Save money! Free catalog! Norris, 273 Merrick, Dept. 215, Lynbrook, N.Y.

**BUY** Direct from Hong-Kong, information and color catalog, \$2.00. Dons, P. O. Box 157, Arkadelphia, Arkansas 71923.

**100,000 BARGAINS!** Tremendous discounts available! Wholesalers, 1265-MP Broadway, New York 1, N.Y.

**HEARING** Aid batteries wholesale. National Wholesale Battery Company, P.O. Box 825, Wichita, Kansas 67201.

## EXPORT-IMPORT

**IF** You need exporters, importers, agents. Worldwide, write Thomas International, 152 West 42nd St., Suite 536, New York.

**PEARL** Earrings only \$3.00 (bills). Japan Jewel Center, C. P. O. 187, Tokyo.

**JAPAN:** Mail-Order 26 page catalog, dolls, novelties, Manufacturers' names, addresses \$1.00; 1000 products illustrated trade directory \$3.00. Send cash. Yamaguchi Office, 814 Togin Bldg., Marunouchi, Tokyo.

## FOR THE HOME

**RID** Home of cockroaches permanently. Five cent stamp for details. Haun, 357, Catlin, Illinois.

**"HOW** To Choose Your House" new book, 104 photos saves \$\$\$ in buying, avoids boobytraps, shows how to improve, repair, \$3. Kent Publishers, Brookline, Mass.

**ADHESIVE**—Stronger than glue! For concrete, wood, metal etc. Four ounces in handy squeeze bottles. Send \$1.98. Epoxy Adhesive, PM, Box Q, Brigham City, Utah 84302.

**GOLD** In your future! Exquisite 24K gold—chrome-plated. "Dial Your Shower Head." No clogging. Spray fine to coarse. Unscrew the old, screw on the new! Postpaid, \$19.95. Evenel Originals, 170 Broadway, New York, N.Y. 10007.

**SENSATIONAL** New economic fireplace originally designed for British Government. Send 50¢ for booklet with history and plans. Unitherm, Mays Landing 08330.

**STOP** Leaky faucets instantly. Weavever seals, 5 \$1.00. Jordan, 743 Dorrance, Philadelphia, Pa. 19146.

## OF INTEREST TO WOMEN

**WOMEN!** Make big money at home. \$10.00 profit in an hour possible with invisible mending. Make holes, tears disappear from clothing, fabrics. Steady year-round demand from cleaners, laundries, homes. Details free. Fabricon, 1533 Howard, Chicago 26, Illinois.

**\$200.00** MONTHLY Possible, sewing babywear! Write: Cuties, Warsaw 9, Indiana 46580.



**MAKE** Money zip-coding mailing lists at home. Information free. Automated Mail. Dept. 125, Stamford, Connecticut 06904.

**MAKE** Extra money—25 detailed plans, proven successful. Big profits using your spare time. \$1.00 Guaranteed. Brookes House, Sudbury, Mass.

**COMPLETE** Denison party guide book, \$1.00. Crest, Box 13PM, Merrick, N.Y. 11566.

\$100 **WEEKLY** Sewing, 8 plans, \$1.00 guaranteed. Camille, 202 Brownell Street, New Bedford, Massachusetts 02740.

**"MANUSCRIPT** Typing Money-making"—Exciting! Dignified! Instructions, \$1.00. Magnetic, Box 3677-PMR, Washington 20007.

**BOOK** Reveals secret of sticking to your diet, \$2.00. Guaranteed. Lyn's, Box 5074, Spartanburg, S.C.

**DRIVE** New car, wear new clothes, buy color TV. Get daily cash income. Put spare hours to work. Write for 5 months free subscription Opportunity Magazine; see hundreds easy ways to make money. Opportunity, Dept. 17-DO, 850 N. Dearborn, Chicago.

### WATCHES, OLD GOLD, JEWELRY

**HIGHEST** Cash for gold, jewelry, gold teeth, rings, diamonds, watches, silver, platinum. Mail articles today. Free gift with information. Chicago Gold & Precious Metals, 6 E. Monroe, Dept. 3158, Chicago 60603.

**WATCH** And clock repairing books. Free catalog. North American, Box 77-AS, Fox River Grove, Illinois 60021.

**USED** Pocket watches—as is—5 for \$25.00. Joseph Bros., 5 South Wabash, Chicago 60603.

**CASH** Immediately for old gold, watches, diamonds and jewelry. Write Bill, Joseph Bros., 5 South Wabash, Chicago 60603.

**WANTED**, Gold, silver, platinum, scrap (any form), coins. Information free. Wilmet's, 1067-D Bridge St., Grand Rapids, Michigan 49504.

**WATCHMAKERS** Tools, materials, supplies, watches. Catalog. Gales, Box 1000, Chicago 90, Ill.

**USED** Brand name watches \$5 up. Free list. Southern Watches, 5-PM South Wabash, Chicago 60603.

**AMAZING** Offer, diamond-like rings. Free brochure. Ellis, Box 224, Prospect Heights, Illinois 60070.

**BATTERY** Clock movement, plans, 7.25 Armor, Dept. PM, Box 103, Station A, Flushing, New York 11358.

**STURDY** Swiss watches, wholesale. Easy selling Men's, chrome or yellow with stretch bands. Ten, only \$49.90. Samples \$5.85. Guaranteed two years. Keyes National, Croydon 85, Pennsylvania.

**WATCHMAKER'S**—Jewelers supplies, instructions. Catalog 50¢. Bengal's, 10717 Venice, Los Angeles 34, California.

**CASH** Immediately for old gold, jewelry, gold teeth, watches, diamonds, silverware, spectacles, platinum, mercury. Free information. Rose Industries, 29-A East Madison, Chicago 2.

### WEARING APPAREL

**AMAZING** Clothing bargains—Surplus merchandise. Free catalogue. Ace, 515-PM5 Court, Brooklyn 31, New York.

**SIAM**—Mail order—Siam hand-woven Thai silk dress made to order. One-piece dress U.S. \$25.—Two-piece dress U.S. \$26.—All lined, European supervision. Free measurement-form & Silk sample-book available. Thai silk neck-ties, four for U.S. \$6.—airmailed. Unique Temple Rubbings Wall-pictures (21"x23") Four for U.S. \$5.—airmailed. Information: Spectrum Ltd., GPO Box 2133, Bangkok, Thailand.



### SCIENCE AND CHEMISTRY

**ILLUSTRATED** Catalog: Chemistry, mineralogy, biology 25¢. Tracey Laboratories, Evanston, Illinois.

**UNUSUAL** Chemistry courses, kits! Information booklet, 25¢. National, Box 94, Redwood City, Calif. 94064.

**SKYROCKETS**, Firecrackers, fireworks—Make your own! 60 simple formulas \$1.00; 30 smoke formulas, 15 colors \$1.00; 10 fuse formulas 50¢. Paloma Pyrotechnics, Box 247, Auburn 5, California.

**ROCKETS!** Flight kits, testing equipment. Catalog 25¢. Rocket Development Corporation, Route 3, Seymour, Indiana 47274.

**AMAZING** New book of science experiments, formulas, and catalogue of laboratory supplies. Only 35¢. National Scientific Co., 13 S. Park Avenue, Dept. PM-5, Lombard, Illinois.

**UNDERWATER** Fuse—90 feet \$1.00 post-paid—plus fireworks catalogue. Christy, Box 85, Bergenfield, New Jersey 07621.

**FIREWORKS** Supplies, casings, end caps, plugs, chemicals, fuse, do-it-yourself kits, send 35¢ for samples and catalogue—Ecco, Box 189, Northvale, New Jersey 07647.

**CHEMICALS** And apparatus for industrial, analytical, and private laboratories. Catalog 35¢. Dept. M-50, Biological Supply Co., 1176 Mt. Hope Ave., Rochester 20, N.Y.

**CHEMICALS**, Apparatus, Biology, Catalog 25¢. Mid-States Scientific, 7053 N. Clark, Chicago, Ill.

**SEARCHING** For economically priced chemicals and apparatus? Gifts with catalog, 25¢. Starr Scientific, Manitowoc, Wisconsin 54220.

**CONTACT** Explosive. Explodes with touch of feather. Handled safely wet. Powerful. Ideal for jokes. Applies like paint. Made from household chemicals. Results guaranteed. Complete instruction for making both kinds only \$1.00. Franks Scientific Company, P.O. Box 156, Martelle, Iowa 52305.

**FIREWORKS**—Bombshells, firecrackers, fountains, displays and commercial catalog, 50¢. American Fireworks, Hickory Lane, Fairfield, Connecticut.

**ROCKETS**, Single, multi-stage kits, parts amazing Accelerometer, illustrated catalogue 25¢ Rocket Supply, Box 51B, Tappan, New York 10983.

**ROCKETS:** New illustrated catalog, 25¢. Single and multistage kits, cones, engines, launchers, trackers, rocket aerial cameras, technical information. Fast service. Estes Industries, Penrose 7, Colorado.

**CHEMICALS**, Laboratory apparatus, microscopes, mineralogy sets and telescopes. Catalog, 35¢. Sheard Science Supplies, Columbus, Wisconsin.

**FREE** Science catalog, Chemicals, glassware, physics, biology. Frey Scientific, 465 S. Diamond, Mansfield 3, Ohio.

**CHERRY** Bomb fuse 60 feet with firework. Information, formulas, \$1.00 post-paid. 125 feet \$2.00. Wayno, Box 1184, Addison, Mich.

**PROFESSIONAL** Firecracker fuse, burns, underwater, 75 feet, \$1. Fireworks, explosives formulas, free information, Edcolabs, Box 99, Berlin, New Jersey 08009.

**FIREWORKS**—Explosives—detonators. New manual reveals formulas, preparations, only \$2. Free with order, \$2 certificate for fuse. Pyrochem, Box 169, Berlin, New Jersey 08009.

**SCIENCE** Fair booklet listing experiments, information, suggestions, \$1.00. Hagenow Laboratories, Manitowoc, Wisconsin 54220.

### FORMULAS, PLANS, ETC.

**FREE** Catalog of formulas, home business and money-making plans galore! No charge, no obligation. Western Chemicals, Box 19718-C, Los Angeles 90019.

**LATE**, Modern manufacturing formulas. List free. Moon Chemical, Martville, New York.

**PROFITABLE** Manufacturing formulas. Literature free. Pontesso, 2625 South Eighth, Terre Haute, Indiana.

**FORMULAS**—All kinds. Amazing big catalog, 10¢. Kemixal, Park Ridge, Ill.

**FOR** Proof of what you can do in specialty manufacturing get our literature. It's free! Miller, Chemist, 1517-P, Tampa, Florida.

### PLASTICS

**PLASTICS** for arts & crafts, fun & profit. See how easy it is to work with liquid plastics. Turn your plastics hobby into \$ for you. Send 50¢ for catalog to PMI, 1644 20th, Santa Monica, California.

**NEW** Liquid casting plastic clear colors. Embed real flowers, butterflies, photos, coins. Send 25¢ for two handbooks "How to Cast Liquid Plastics" and "How to Make Extra Money at Home." Castolite, Dept. 66-101-E, Woodstock, Illinois.

**BOXES**, Plastic, 200 sizes. Free list. Althor, 2260 Benson Ave., Brooklyn, N.Y.

**FREE** Samples plastic (polyethylene) bags for packaging. Tadco, Lafayette, New Jersey.

**NEW**, Highly profitable plastic laminating business. American presses 4 times faster . . . 4 times more profitable. American Machine, 1128 Dana, Hixson, Tennessee.

**PLASTIC** Embedders, jewelry workers. We have everything. Findings, moulds. New catalog 25¢. David Co., 861 Broad St., Dept. M, Providence, R.I. 02907.

### TREASURE FINDERS

**NEW**, Coin locator! Free literature! Howe, 811-C Kansas, Atchison, Kansas.

**POWERFUL** Metrotech locators detect gold, silver, coins, relics. Moneyback guarantee, terms. Free information. Underground Explorations, Dept. A, Box 793, Menlo Park, California.

**TREASURE**, Gold, silver, relics. New 1966 detectors now available. Free information. Rayscope, Box 715, North Hollywood, California.

**TREASURE**, Find gold, silver, relics with super, powerful Detectron locators. Free information. Detectron, Dept. 5-PM, P.O. Box 243, San Gabriel, California.

**DIMONS** Gold indicators, Pamphlet free. Simpson, 18788 Cajon Blvd., San Bernardino, California.

**BEFORE** Buying a metal detector, find out about Sensitronix's new "Electronic Prospectors"—the latest development in treasure and coin detection equipment. Trade-ins accepted. Free information and treasure hunting guide. Sensitronix, 2225-C Lou Ellen, Houston, Texas 77018.

**NEW** Revolutionary selective transistor metal detector and six other models. Free catalog. Gardiner Electronics Co., Dept. 9, 4729 N. 7th Avenue, Phoenix, Arizona 85013.

**COMPLETELY** New prospecting technique developed by Relco. New transistor models detect buried gold, silver, coins, treasures. \$19.95 to \$129.50. Write for free catalog and "guide for beginners". Relco-A40, Box 10563, Houston 18, Texas



**EXCITING** Adventure locating hidden loot, treasure, relics, etc., with power-ful, electronic M-Scope locator. Lightweight. Guaranteed. Very easy terms. Send for free booklet, interesting customer reports. Fisher Research, Dept. AAY, Palo Alto, Calif. 94302.

**METAL** Locator, \$2.98. Free details. Christmas Valley Enterprises, Box 265, Sisters, Oregon 97759.

**TREASURE** Metal detectors most complete line in U.S.A. Free catalog. Bill's Service Center, Box 1, Paramount, California.

**SAVE!** Build transistorized treasure finder. Details free. Del Research, Box 347-B, Alden Manor, Elmont, N.Y.

### PRECIOUS STONES AND MINERALS

**SEMI-Precious** uncut gems. Ten different for \$1.00. Request list 30. Prospectors Shop, 201 San Francisco, Santa Fe, New Mexico

**EARTH** Science. Educational magazine. Subscription, \$2.50. Sample, 35c. Box 550-PM, Downers Grove, Ill. 60515.

**DIAMOND**. Guaranteed genuine, natural, \$2.00. Apprx. Weight 1/4 carat. Diamond pencil, \$2.95. C & J Diamond Company, Box 97-M, Plainview, L.I., N.Y. 11803.

**DIAMOND** Tie-tack! Guaranteed genuine! \$2.00 postpaid. . . . Jaklagem-PM, Saint Charles, Illinois 60174.

**GET** Free catalog no serious rockhound, gem cutter, jewelry maker, hobbyist or craftsman can be without. Full of bargains, exclusive items, low prices from largest suppliers and authorities in the field. Free new catalog just off the press, yours for the asking. Write Grieger's, Dept. C-12, 1633 E. Walnut, Pasadena, California.

### CARTOONING, COMMERCIAL ART, SHOWCARD & SIGN PAINTING, TATTOOING

**LIKE** To draw? Splendid opportunities in professional cartooning. Write for free catalogue. No obligation. National School of Cartooning, Studio-H, Box 8958, Cleveland 36, Ohio.

**How** To make money with simple cartoons. Everyone who likes to draw should have this book: Free. Send name, zip code. Cartoonists' Exchange, 95 Pleasant Hill, Ohio 45359.

**SIGN** Painting. Fascinating system. Straley, 410 South Western, Springfield, Ohio.

**SIGN** Painting and art. Instructions, brushes, equipment, everything. Free catalogue. Kaufmann Supply, Centertown, Missouri.

**CARTOONERAMA** Teaches you cartooning in a new low priced 24 lesson course. Free brochure. CFA, Box 263-9Y, Branford, Conn.

**YOU** Can entertain with chalk talks. Catalog 10c. Balda the Cartoonist, Oshkosh, Wis.

**ART** Lessons \$6.00 a month. Includes drawing, painting, advertising art, cartooning. Art kits (worth \$25) and materials. Assignments corrected with overlays by mail and returned to you. Write for free book. No obligation. Washington School of Art, Studio 145, Port Washington, L.I. N.Y.

**LEARN** Sign painting at home. Free talent test. Ben Kerns, Box 812-PM, Greenville, S.C.

**CARTOONING** And commercial art. Easy home-study drawing course. Art background not necessary. Excellent creative money making opportunities part or full time. We show you how. Low monthly tuition. Free booklet. Continental Schools, Dept. 6A-2, 1330 W. Olympic Blvd., Los Angeles, Calif. 90015.

**LEARN** Profitable magazine cartooning. Free details. Hartman, Box 3097, Lincoln 10, Nebraska.

### ADVERTISING AGENCIES, ADV. SERVICE, MAILING LISTS

**ADVERTISING** Ratebook leading newspapers, magazines, free. Chicago Advertising Agency, 28-E Jackson, Chicago 4.

**MAILING** Lists most all kinds 1000 \$5.00. Free folder. Your circulars mailed \$4.00 1000. Dixie Mailers, King, N.C.

**MAILORDER** Record Book, 30 pages. Records inquiries, orders, advertising expense, etc. Most complete. Just send dime for postage and handling. C. A. Martin, Popular Mechanics, Dept. RB9, 575 Lexington Ave., New York, N.Y. 10022.

### TYPEWRITERS, DUPLICATORS, OFFICE EQUIPMENT

**OFFSET**. Letterpresses, varitypers, typewriters, mimeograph, multigraph machines. Bargains. DixieGraph, King, North Carolina.

### RUBBER STAMPS AND OFFICE SUPPLIES

**FREE** Catalog: Rubber stamps, printing. Dowling Products, Dept. PM36, Pitts-town, N.J.

**BEAUTIFUL** Embossed business cards, 40% discount on rubber stamps. Evero Co., Box 9233, Phoenix, Arizona.

**TWO** Pocket stamps, \$1.50! (3-Lines ea.) Gusman, Box 643-M, New York, 10459.

**FINEST** Quality stamps, three lines, \$1.00. Lornel Industries, Tolleson, Arizona.

**FREE** 32 Page rubber stamp catalog. Signature stamps \$3.50. Youngers Stamp Shop, Princeton, Iowa.

### PRINTING, MULTIGRAPHING, MIMEOGRAPHING, GUMMED LABELS

1,000 **THERMOGRAPHED** (Raised letter) business cards, \$4.95. Free samples! Griffin, 322 West State, Ithaca, New York 14850.

1000 **GUMMED** Address labels, \$1.00. Wait's, Box 966-A, South Bend, Indiana 46624.

100 **TWO** Color porcelain finish business cards, \$1.00. Eslick's Craft Studio, Delavan, Wisconsin.

**EXCELLENT** Business printing, moderate prices. Lombard, 212 West 7th, Boston, Mass. 02127.

**AMAZING** Business printing values. Samples Print Shop, Box 576, Greenville, R. I. 02828.

1000 **EMBOSSSED** Business cards \$2.99. Agents wanted. Eldee, Allendale, N.J.

**OFFSET** Printing. Here's the one. 48Hr. Service—Lowest prices. Cisco's Duplicating, Atlanta, Illinois 61723.

**GOLD** Embossed business cards. Samples. MTL Printercraft, Box 947, Chicago 60690.

**GOOD** Business cards. Moderate prices. Goodall Printing, 68-N Joost, San Francisco 94131.

**PRINTING**—8 Page catalog—11c; 5M 8 1/2 x 11. =1/S, \$15.00. Free price list. Copen, 337 Butler Street, Brooklyn 1, N.Y.

**PRESTIGE** Business printing values. Samples. Artcraft Press, Box 178, Brighton, Michigan 48116.

**PRINTING?** Speed, quality, economy. Samples. JLP, Box 817, Ft. Lauderdale, Florida.

**QUALITY** Printing: Lowest prices. Samples. Dowling Press, Dept. PM-36, Pitts-town, N.J.

### PRINTING & RUBBER STAMP OUTFITS—SUPPLIES

**TYPE** And supplies for rubber stamp makers. New wholesale price list No. 3 free. Star Stamp Supply, 732 Federal, Chicago 5, Ill.

**RUBBER** Stamp manufacturers supplies. New products. Low prices. Catalog. Jackson Supply, 1433 Winnemac, Chicago, Illinois 60640.

**MAKE** Your own self-molding rubber stamps and printing cuts. Plexirubber, Argyle 1, Wisconsin.

**RUBBER** Stamp presses, hydraulic operated, electrically heated. Sizes 5" x 8", 3" x 12", 10" x 15". Starting outfits, supplies. Printing presses, Custom Manufacturing, 1464-P East Commercial, Springfield, Missouri.

**PRINTING** Presses, type, supplies. Lists, 5c. Turnbaugh Service, Mechanicsburg, Pennsylvania.

**DO** Your own printing. Save money. Simple rules. We supply everything. Print for others: good profit. Raised printing like engraving too. Have home shop. Details free. Kelsey Presses, V-11, Meriden, Connecticut.

**NEW** Type Catalog No. 11, 96 Pages. Send One Dollar. Deductible First Order. Acme Type, 732 Federal, Chicago, Illinois.

**RUBBER** Stamp presses, mounts, supplies. Martin, 1425S Major, Jefferson City, Missouri 65101.

**RUBBER** Stamp outfits, supplies. Kiewiet, 2025 Barney Road, Kalamazoo, Mich. 49007.

### REMAILING SERVICE

**SECRET** Receiving and remailing. Discreet and confidential. Remail 25c single. 8050 S. Main, Houston, Texas.

**SECRET** Mail receiving system. Hedg-peth, 406-M South Second, Alhambra, California 91802.

**ARABIAN** Re-airmails. Receiving and forwarding. Postage, \$1.00. Sadiegle, Box 469, Al Khobar, Saudi Arabia.

**HAWAII** Secret Address. Remails 25c. Receiving-forwarding \$3.00 monthly. Postcards, gifts, slides. Uppie, Box 984, Kailua, Hawaii 96734.

**OLD** Established \$3.00 unlimited monthly. DeGraff, Box 14156P, San Diego, California.

**REMAIL:** Secretly successfully. Details free. 2165 51st Ave., Oakland, California 94601.

**MIAMI** Remails 25c. Monthly Rates. Marle, P.O.B. 1266, Coral Gables, Florida 33134.

**TIMELY** Remailing 25c. Confidential. Monthly \$3.00. Postcards. Schoen, Post Office Box 1963, Chicago, Illinois 60690.

**LOS ANGELES**, Hollywood, San Fernando Valley—25c single; \$3.00 monthly. Confidential, 10437 Lanark Street F, Sun Valley, California 91352.

**NATION'S** Capital remails, 20c. Gorgeous postcards, 6 \$1.00 remailed free. Box 28072, Washington, D.C. 20005.

**PRIVATE** Address, information 25c, remails 25c. Horton, 68 Kensington, Greenville, South Carolina 29609.

**CONFIDENTIAL** New York City mail address \$3.00 month. Remails 25c. Details free. Birnhan, 152 W. 42, New York City 36.

**HOUSTON** (Space city) remails, 20c. Davila, Box 8931, Houston, Texas 77009.



**PITTSBURGH** Remails, 20¢. \$2.50 monthly. Details free. Karim, 2853 Louisiana, Pittsburgh, Pennsylvania 15216.

**SECRET** Remails from famous, exciting Miami Beach, 25¢ each, \$2.50 monthly. Private mailing address also available. Write Confidential Services Division, The Foreman Company, Department B-100, Box 4437, Normandy Branch, Miami Beach, Florida.

**ATLANTA, Georgia.** Dependable remails, 25¢. Monthly \$3.00. King, Box 1803, Atlanta, Georgia.

**ITALY** Re-airmails, \$1.00. Sample postcard, information, 35¢. Capodilupo, Box 7096, Nomentano, Rome, Italy.

**ENGLAND:** Re-airmails \$1.00 London; Stratford; Coventry. Postcards \$3.00 dozen. Desborough, 17, Charlewood, Coventry, England.

**LOS Angeles** address, remails. Confidential. Enarkay, 1805 Wilshire, Suite 206, California 90057.

## REPAIRS AND SERVICING

**PARTS** Sheets, diagrams, and instruction manuals for repairing air and electric power tools, hydraulic jacks, and chain hoists. Free catalog and samples. Tech-Aids, Box 381, Baton Rouge, La.

## SPECIAL SERVICES

**EYEGLASSES!** Wholesale laboratory established 25 years. Mail eyeglasses or prescription for quote. Global Opticians, 16 East 23 St., New York, N.Y.

**FACTS.** Any subject—product. Research, reports. Plan \$1.00. Box 1431, Greenville, South Carolina 29602.

**INFORMATION** Any subject. Products, climate, geography. \$1.00. 1220 Hardesty Drive, Reno, Nevada 89502.

## TOBACCO

**FREE** Catalog. Big Savings on Meerschaum and Briar pipes, tobacco. Smoker's accessories. Pipes, Box 125F, St. Ann, Mo. 63074.

**BLACK** Watch—hand blended premium tobacco. \$1, cash ok. Vottis Tobacco, 11 S. Pearl, Albany, N.Y.

**FREE!** How To Work With Tools and Wood. Cigar Smokers! Get this 488 pg. paperback book free! Clip this ad, send with 25 cigar bands from one shape of any one brand to P. O. Box 16421, Phila., Pa. 19122. Include name, address, zip code. Expires July 15, 1966.

**PIPES.** Finest Japanese cherrywood, specify straight, bent. Each \$2.00. Postpaid. Benwolf, Box 45, Teaneck, N.J.

## RAZORS

**YOUR** Ad in this space will be read by more than 1,400 active mail order buyers. Join the march to greater profits, place your products and services in front of them today with a small low cost classified ad. For further details, write: C. A. Martin, Dept. 82N, Popular Mechanics, 575 Lexington Avenue, New York, New York 10022.

## WANTED—MISCELLANEOUS

**MERCURY.** Gold, Silver, Platinum; Ores assayed. Wholesale Terminal, Norwood, Mass.

**STAMP** Collections, accumulations. Eagle Stamp Co., 2221 Romine, Pittsburgh 26, Penna.

## PERSONAL

**SUBCONSCIOUS** Conditioning remakes personality while you sleep. Free details. Sleep-Learning, Box 24N, Olympia, Washington.

**FREE** Details solution to all financial problems. Amazing results. Loans available. Write Financial Consultants, 28 E. Jackson, Suite 1204-PM, Chicago 4.

**LOANS** By mail, \$100-\$1000. Anywhere. Confidential. Write Union Finance, Dept. PM, 222 W. Osborne, P.O. Box 7457, Phoenix, Arizona.

**RUPTURED.** Relief and comfort. No understraps, elastic or steel. Write Hand-Lock Products, Preston 4, Ont., Canada.

**FREE.** Booklet "Wills How To Make & Break Them," with 3 will forms \$1.00. Urban-Rural, Box 293, Fort Lee, N.J.

**INVESTIGATORS.** Free brochure, latest subminiature electronic surveillance equipment. Ace Electronics, 11500-P NW 7th Ave., Miami, Florida 33168.

**SURVEILLANCE** Equipment. New 1966 models. Free details. Write: Security Electronics-PM, 11 East 43 Street, N.Y.C. 10017.

**BLITZ** Reducing! 5 pounds overnight! Guaranteed! Bijou, Box 1727-BM, Hollywood, California 90028.

**BORROW** \$100 To \$1000 by mail. Quick, easy, private. No co-signers. Repay in 36 small monthly payments. For the amount you want write today to Dial Finance Co., 410 Kilpatrick Bldg., Dept. 5-214, Omaha, Nebraska 68102.

**BORROW** \$1,233 Airmail! Repay \$54 for twenty-nine months. State licensed. Postal Finance, Dept. 17-M, Kansas City, Kansas 66117.

**I.Q. TEST.** Know your I.Q. free sample. Test Center, Box 139X, Fresh Meadows, New York 11365.

**GET** Out of debt—clear credit, immediate relief. Advisor, Box 48337-PM1, Los Angeles 90048.

**BILL** Problems? Poor credit no trouble. Not a loan company. Send name for free application. Automatic Acceptance, 1326PM Plainfield St., Cranston, R.I. or 318PM Broadway Blvd., Reno, Nevada.

**FREE** Proof—Debt escape plan works. Just write: Counselor, Harlingen 7, Texas.

**TEN** Effective verses from the Bible, free. New Purpose Publications, 11224 Big Bend, Kirkwood, Missouri 63122.

**NEED** Money? Borrow \$100-\$1000 by mail. Confidential. Repay in 36 months. Free Loan application. World Finance Co., Dept. HW-0125, 620 Symes Bldg., Denver, Colorado 80202.

**PAY** Bills! Have cash left over. \$39.65 repays \$1000 in 36 months. Write for details. Budget Finance Co., Dept. HB-0125, 317 South 20th, Omaha, Nebraska 68102.

**BORROW** With confidence! Over 50 years experience. Loans by mail, \$100 to \$1000. Write today. American Loan Plan, Dept. HA-0125, City National Bldg., Omaha, Nebraska 68102.

**BIBLE** Questions answered. Stamped envelope. Bylon, 17167 Bentler, Detroit, Michigan 48219.

## MISCELLANEOUS

**HEARING** Aid batteries wholesale. Free list. Habs, Box 51, York, Penna.

**CIGARETTES**—Make 20 plain or filter tip for 9¢. Factory-fresh pipe tobaccos. Mild tropical flavored Philippine cigars. Facts free. Moberly, Box 905, Owensboro, Kentucky.

**SAFEGUARD** Privacy! New instrument detects electronic "bugs," wire-tapping and snooping devices. Free information. Dee Equipment, Box 7263-E4, Houston 8, Texas.

**ORNAMENTAL** Iron designs. Book of 1600 beautiful, practical designs for railings, columns, etc. Free literature. Cunningham, 3881 South 3200 West, Salt Lake City, Utah 84119.

**LOG** Cabins: Ship anywhere; 35 plans, specifications and prices. Send \$1.00. Write Bloch Brothers, Waterford 4, Michigan.

**LOANS** By mail, \$100-\$1000. Anywhere. Confidential. Write Union Finance, Dept. PM, 222 W. Osborne, P.O. Box 7457, Phoenix, Arizona.

**SUPERSENSITIVE** Listening-In-Device picks up any telephone conversation in vicinity. No connection to telephone necessary. \$2.98 complete. Consolidated Acoustics, 1302K Washington, Hoboken, N.J.

**BIRTH** Certificates, Marriage Certificates, Diplomas! 2 blank forms \$1.00. Sample 10¢. Standard Forms, Box 482-M, Washington, D.C. 20044.

**WIGS**—Eye lashes—wig boxes. The wig business is booming. Get your share of this market. Write for all information to: Box 74, Dept. P., Canarsie Station, Brooklyn, N.Y.

**WINEMAKERS** Equipment, supplies, books: Write Kraus, Box 451, Nevada, Missouri.

**"CIGARETTES"** — (Roll your own). Pipe, Chewing, Smoking tobaccos. Facts free. Write Fred Stoker, Dresden, Tennessee.

**FREE** Wholesale catalog! 100,000 products. Tremendous discounts! Taylor Distributors, Newton 2, New Jersey.

**HOME** Winemaking simplified. No kits or expensive equipment necessary. Dandelion, chokecherry, beet wine and others. Instructions and recipes. \$2. Richard Berg, Willow River, Minn.

**EXCELLENT** Gift for any occasion! Address books. Write Robert Silver, 155 E. 52nd Street, New York, N.Y. 10022.

**I** Buy worthless stock certificates. Winn, Box 265, Alamo, Calif.

**BURGLAR** Alarm devices, Complete line. Catalog \$1.00. Also resident training course. Sootin's, 321 Northwest Third Avenue, Miami, Florida.

**LISTEN**—In device! Powerful! Monitor telephone conversations, etc. Unnoticed! \$3.98 (guaranteed). Research Enterprises, 29-SN4 Samoset, Woburn, Mass.

**DIVORCE,** Marriage, death, birth, official records. How to obtain copies, every state. \$1. Dana, Box 291, Livingston, N.J.

**VARIETY** Bargains, postpaid, guaranteed; bonus premiums; free catalog. D-S-M., Gulliver, Michigan 49840.

**KILL** Mosquitoes, crop destroyers. Electronically. Free information. Box P. 204, Metamora, Michigan 48455.

**MAIL** Order at low prices. Send \$1.00 to World Products, 514 Ames Court, Hampton, Virginia. Receive \$2.00 Certificate and catalogs containing items produced worldwide. Shipments from overseas to you. Cameras, projectors, tape recorders, jewelry, clothing, wigs, gifts, many others.

**MAGNETS:** 1200 1/4x1/2x1 alnico cost 27¢, sell 17¢ each. Edward Schultz, 113 S. 7th St., Buffalo, Minn. 55313.

**BOOKS** On antiques and their prices. Free circular! P. Warman Publishers. Uniontown, Penna.

**HEARING** Aid batteries wholesale. National Wholesale Battery Company, P.O. Box 825, Wichita, Kansas 67201.

**YOUR** Name sent to 1000 importers, publishers, mailers, wholesalers, etc. on our mailing list. Year \$1.00. Dixie Mailers, King, N. Car.



# V8 for Rambler American



BIGGER TIRES, WHEELS, BRAKES and rear axle mark American Rogue models powered by AMC's new V8 engine

**Y**OUR IMPRESSION of the Rambler American as being strictly a docile economy car is in for a bit of alteration; if you want one, American Motors Corp. has a spanking new V8 engine capable of turning this heretofore prosaic package into at least a semblance of a real hustler. Not that AMC's competitors need lose any sleep, but there very definitely is a new contender in the field of small, relatively high-performance cars.

Thanks to modern thin-wall casting techniques, the new engine weighs only 540 pounds. In a two-barrel carburetor version, rated at 200 hp at 4600 rpm, compression ratio is 9 to 1. Another version—this one requiring premium fuel—cranks out 225 hp at 4700 rpm and has a compression ratio of 10 to 1.

Features of the new engine include a special lubricating system designed to speed up oil flow during cold-weather starting, a lube system relief valve that heads off oil-flow stoppage due to a clogged filter (i.e., the oil simply bypasses a clogged filter), and water jackets surrounding all cylinders over the full operating length of the walls, an attempt to maintain equal and constant temperatures for all cylinders. Combustion chambers are the wedge-type.

In a car powered by the new engine, *PM's* test showed performance to be fairly lively. The car—with driver, passenger and test equipment—weighed 3270 pounds, quite a load for performance runs with the smaller, 200-hp engine. Still, I did 0 to 60 in 11.65 seconds. Zero to 30 was 4.5 sec-

onds, and the highway passing range from 40 to 60 mph was timed at 5.14 seconds. Reduce the load, however, and I'm sure times would have been a bit more brisk. Also a factor in the test car's modest performance figures was a 3.14 rear end ratio.

How about mileage, always a Rambler American strongpoint? Not bad—at a steady 40 mph coming and going the test car delivered an average of 20.2 mpg.

The new engine will do all the routine jobs—back and forth, about-town driving and respectable freeway-type marching. All in all, I'd rate it as a slick compromise between dash and thrift and, for AMC's sake, let's hope that's enough.

—Jim Dunne

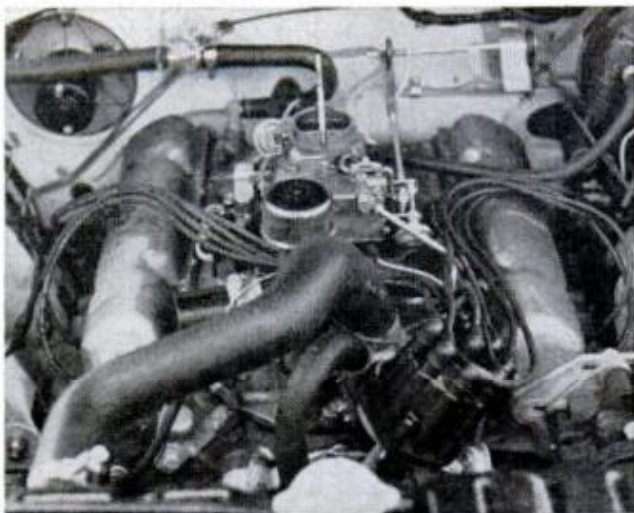

**TYPHOON V8** (that's what AMC calls it, not us) fits neatly in Rogue, allowing space for power options



# 7-Up. the man's mixer

Plunk down and shoot the breeze with a couple of good friends—7-Up and Seagram's 7 Crown. Build yourself a long, tall one. Seven-Up never gets pushy. Never crowds good drinking whiskey. It's the man's mixer.

Copyright 1966 by The Seven-Up Company







You get  
twice the traction  
of ordinary pick-ups  
with a 4-wheel drive  
**'Jeep' Gladiator.**

TRADEMARK GENERAL MOTORS CORPORATION

Send for free, illustrated 'Jeep' Camper-Trailer "how to" booklet. Write Dept. PM Box 903, Toledo, Ohio 43601.

Cross a stream. Climb a mountain. Hit the trail where it's rough and tough. That's the fun of camping. And that's why you need a 4-wheel drive 'Jeep' Gladiator for your camper unit. It goes places no ordinary camper truck can! Through deep off-road mud, sand, or snow. On the road, 'Jeep' Gladiator handles like a passenger car! Wide choice of options: hot new engines—250 hp



V-8 or Hi-Torque 6; power steering, power brakes; bucket seats; 3- or 4-speed transmission with standard shift; or Turbo Hydra-Matic\* (the only pick-up offering automatic transmission with 4-wheel drive); standard or custom cap and trim; variety of colors; camper modifications available, 7- or 8-foot box, GVW's 5000 to 7000 lbs. Test drive it today! **KAISER Jeep CORPORATION**  
TOLEDO 1, OHIO

You've got to drive it to believe it. See your 'Jeep' dealer. Check the Yellow Pages.



# EDITOR'S PAGE

Turning January into June is common practice in monthly magazine circles. About the time we're supposed to create leafy, limpid summertime cover photos, the blizzard of the year is sweeping the nation—which was precisely the case with this month's cover.

It had to be ready for the engraver last February. So we loaded our Bush Buggy on a van bound for Naples, Fla.—a place that guarantees summertime all the time. Ask Dave Pfaff of the Chamber of Commerce



there. "No matter what the weather is elsewhere, it's better in Naples," he says, with a tone of authority.

Art Mikesell and Gene Colangelo—our writer-photographer team—flew down next day and walked out into one of sunny Naples' "dewy" mornings. The particles of dew were about the size of grapes. "For two solid days," Mike reports, "it was too dewy to take pictures—blinding sheets of dew." So they splashed through the sparkle picking out sites, rounding up props and hiring models.

But when the day for picture-taking arrived, Pfaff, good as his word, produced sunny summertime (local U.S. Weather Bureau, via C. of C., reported Naples as the "warmest spot in the nation"). An old friend, Don Schlerf—the local Johnson dealer—put a fast boat at the disposal of our crew for offshore shots. By day's end, the cover was on film.

Being faithless and cynical, home-team editors put expert model-builder, George Blow (above) to work building a model of the Bush Buggy—just in case. It wasn't needed, of course. Motto: have faith.

**Computers influence people** in more ways than just stealing their jobs, according to Creighton Peet, who keeps our Career Barometer (page 34) in working order. "Recently," he tells us, "after tremendous effort, my wife and I found a nice, intelligent cleaning lady who does a marvelous job for a reasonable price. Last week she said she had to hurry along to her 'class.' Turned out to be a computer-programming course at IBM's school.

That's when I began to notice that all the decorative objects and knick-knacks in our apartment were now being arranged in orderly lines and patterns—even in the bathroom—like this:"

0 0 0 0 0	0 0 0 0 0
0 0 0 0	0 0 0 0 0
0 0 0	0 0 0 0 0
0 0	0 0 0 0 0
0	0 0 0 0 0

**New frontiers** are waiting to be explored right here on Earth. Robert Crossley's article on page 94 tells about it in vivid detail. While Crossley was bearding U.S. "sea" lions in their oceanographic dens, regarding their plans for submarine explorations in an array of fantastic vehicles, our roving Paris staffer Richard Thomas interviewed Capt. Jacques-Yves Cousteau (below, left). Cousteau told PM that he is concentrating on the continental shelf lying 300 to 425 feet beneath the surface. Such shelf areas extend for miles seaward from nearly every continental coastline in the world. Soon, all such submarine regions will be accessible to a strange-looking breed of new vehicles and tanks in which men will live and explore.

All of this jibes with the exciting news



Crossley unearthed. The shelf, Cousteau reveals, comprises an area as large as all Asia. It contains a trillion tons of manganese, ten trillion tons of phosphorus and unknown treasures in petroleum and other minerals. Cousteau believes that vast stocks of "aquaculture" will one day be made edible and will feed the world.

R. F. D. [Signature]



# 1966 at Indy: Big

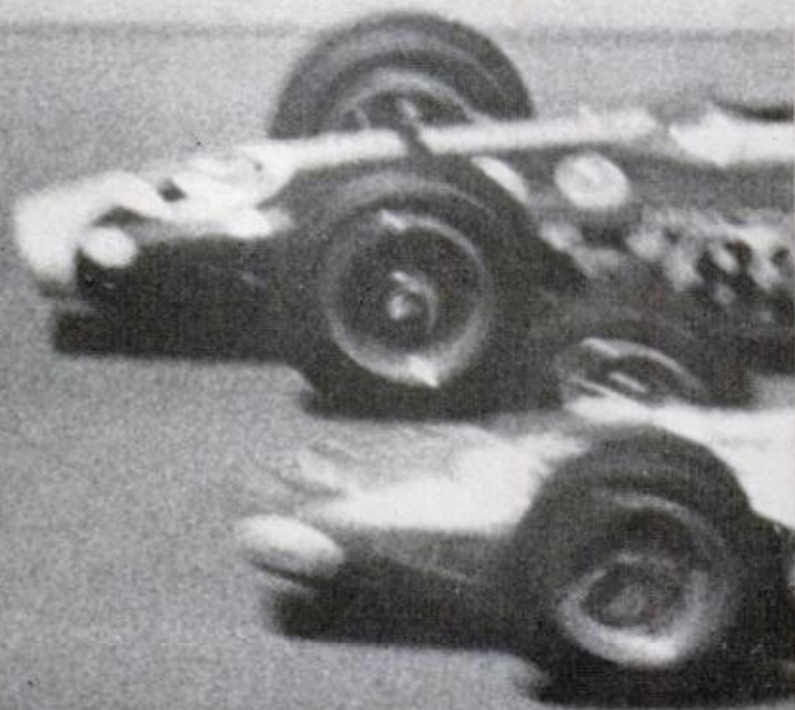

*Entrenched Offys and Fords may have real competition as revitalized Novis*

By **PACK BRYAN**

**L**IKE A BLINDING WHITE LIGHT in a darkened room, the sound that slams against your ears at the start of the annual Indianapolis "500" is almost painful in its intensity. If you could put an audio spectrometer to the sound, you'd find that—like the blinding white light—it was made up of many different parts; more than 30 wildly revving engines.

This year, instead of a fairly even match between four-cylinder Offenhauser and V8 Ford engines, there'll be a broad variety of powerplants.

There'll be several of the old Offys, of course, plus a preponderant number of Fords. But mixed into the din of their exhaust notes will be the raucous rattle of some interlopers, the likes of which

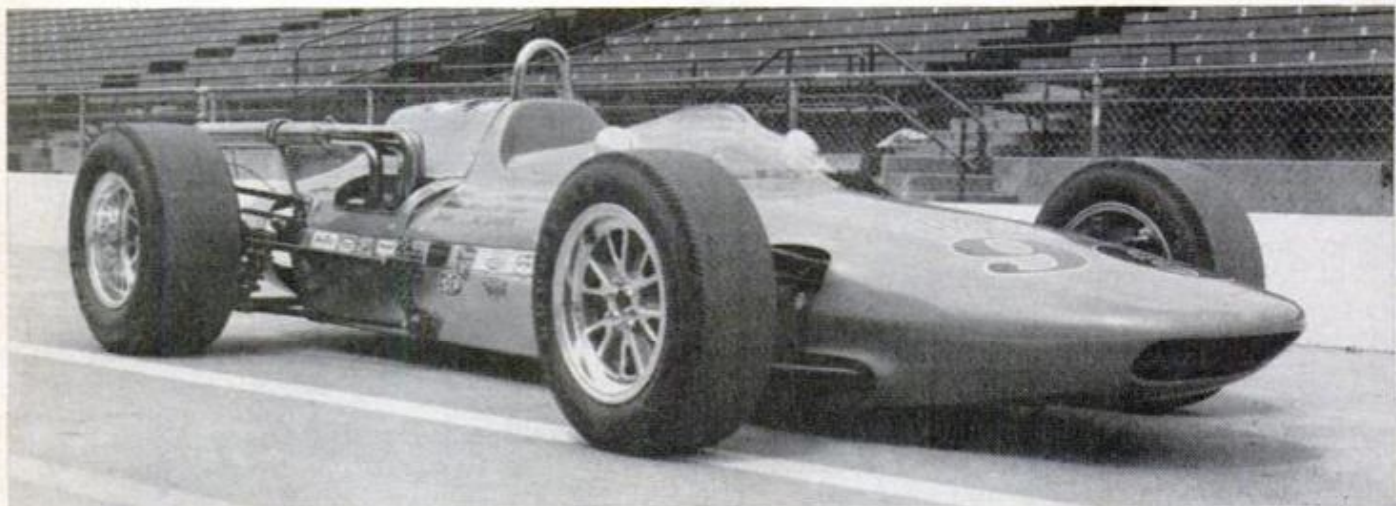

**POWERED BY CHEVY 254-INCH ENGINE**, this '65 car by Jerry Eisert typifies new Indy trend to "stockers"



# power shoot-out

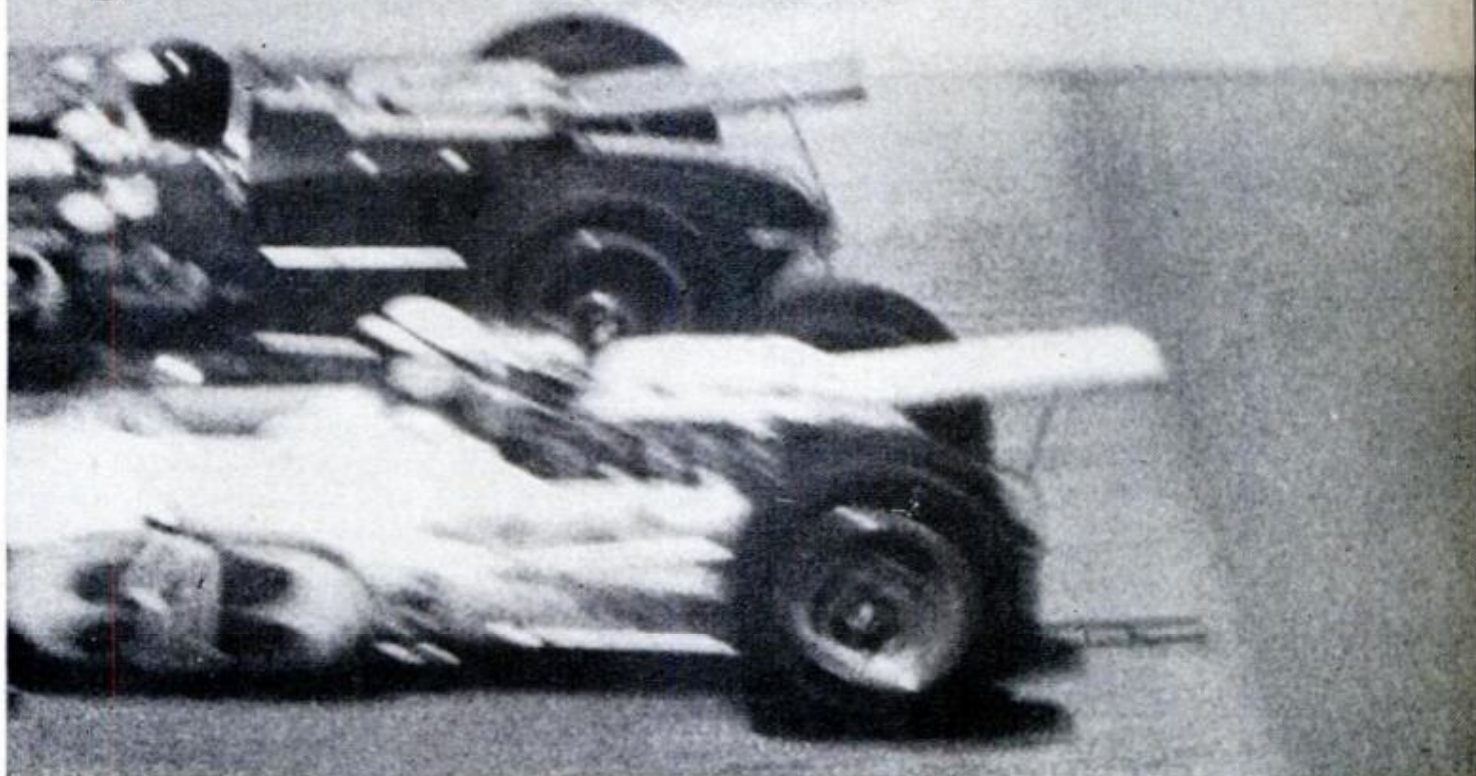

*and a sprinkling of stock Chevys come roaring onto the old brickyard*

haven't been heard at the famed old brickyard in many years. The deep roar of Chevys modified for racing will be heard, along with the throaty, biting blast of a few supercharged Offys. And above all, like an off-key soprano grating over the mixed voices of a male chorus, will be the bellow of the fabled Novi, a fan favorite that for 20 years has displayed much potential and little success.

Why the new sounds? Wasn't the racing fraternity happy with the admittedly narrow choice between the time-proved Offy and the Johnny-come-lately Fords? It was, but Indy management wasn't. Costs have been climbing too high, so the rule-makers moved to again open up racing for the little guy. They did it by giving a 20 percent displacement advantage to obviously cheaper stock block, non-overhead-

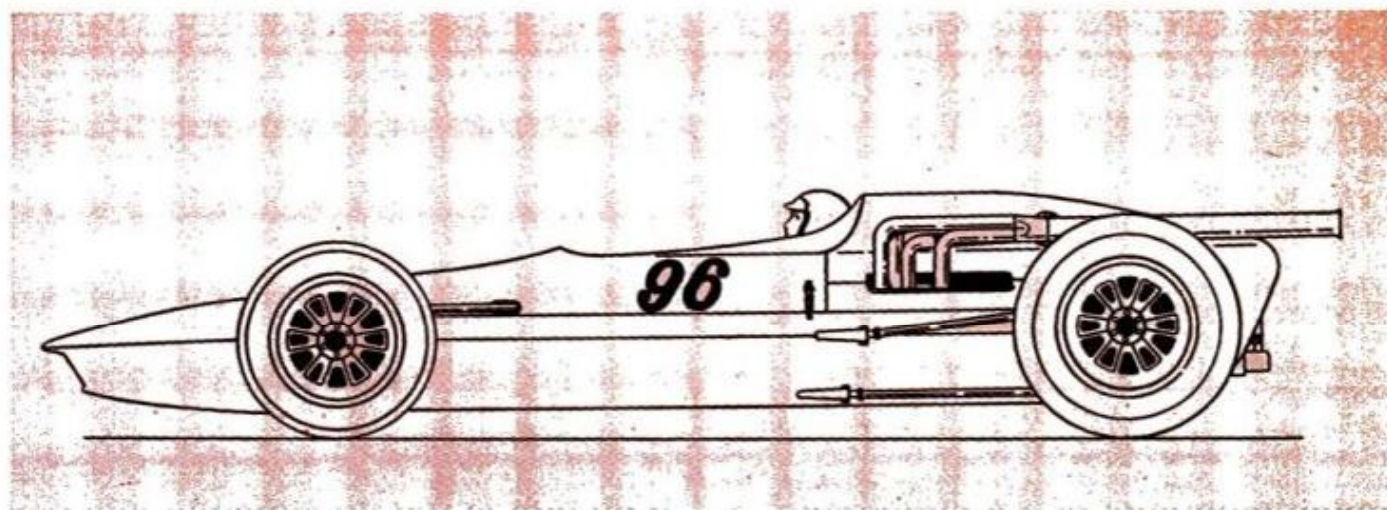

**EISERT CAR FOR '66** features 305-inch Chevy power, is narrower, lower, can hit 200 mph on straights  
MAY 1966



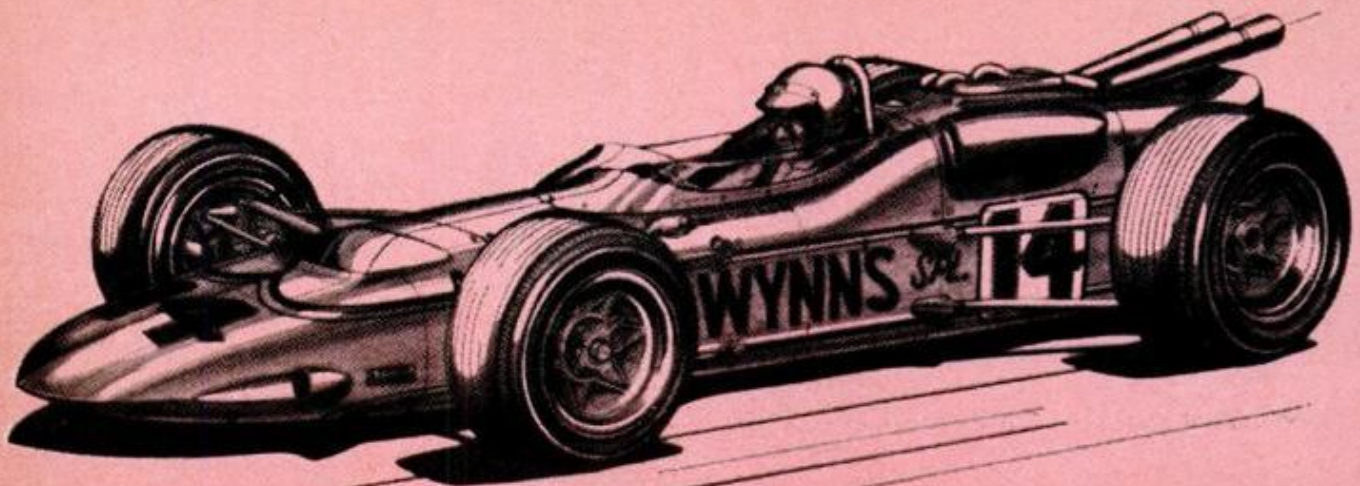

**AT INDY THIS YEAR** will be A. J. Watson's rear-engined design, featuring new suspension, narrower body

cam engines. Will it work? Odds and history say "No," but it should be fun.

Back in 1930 you weren't in racing if you didn't have a Miller, a car that cost about \$15,000. So, to encourage use of relatively inexpensive stock engines, the Speedway raised engine displacement limits from just over 91 to 366 cubic inches. Every garage mechanic with a taste for speed and a thirst for fame began dreaming of his own hopped-up, cut-down Backyard Auto Parts Special.

One young driver, for example, plunked down \$9 for an old DeSoto engine, rebuilt it and almost made the "500" that year. The engine ran well, but a kingpin gave away during qualifying and Mauri Rose had to wait several years before making it to the winner's circle.

Also in 1930, L.L. Corum, co-winner of the 1924 race, qualified an absolutely stock Stutz and finished tenth. And we mean stock! In racing "trim," the car weighed over 4000 pounds with fenders, windshield, spare tires and running boards removed. Stiffer springs and a few extra shock absorbers had been added, but everything else remained.

Russell Snowberger, driving a Studebaker that had cost him about \$2000 in out-of-pocket expenses, finished eighth in that same race and fifth the following year, giving Studebaker officials a bad case of racing fever. In 1932 Studebaker brought eight cars to Indy, qualified five, and watched all five finish in the first 15.

Stutz, DeSoto and Studebaker weren't the only stock cars or engines around in those days. There were many Duesenbergs, of course. Not only had Duesenberg built

and sponsored many out-and-out race cars, but their fabulous "A"—a single-overhead-cam straight-eight—was yanked out of several big sedans and dropped into racing chassis, a number of which also used such stock items as brakes, axles, transmissions and shocks. Ford engines—both the "T" and the "A"—were plentiful, as was the V8 soon after its introduction.

This sort of ad lib racing activity continued until the late '30s. By then the Depression had wiped out Stutz and the all-powerful Duesenberg and most of the remaining manufacturers were having a tough time just staying in business. Harry Miller died and Meyer and Drake's Offenhauser became *the* powerplant to use, maintaining its leadership until Ford entered the picture in 1963.

The Ford-Lotus invasion unintentionally brought with it a tremendous boost in the cost of racing. It's safe to say this year's winning car will have cost its owner roughly twice what A.J. Foyt's 1964 winner cost (see chart at end of story).

In addition to the costs listed in the chart, other fringe expenses have made running in the "500" a fantastically expensive proposition, particularly if there's a run of bad luck. With the old tubular frame roadsters, for example, the results of a mild bash against a wall could be corrected by torching and bending the frame back into shape and pounding out the body dents. But today, with the monocoque rear-engined cars, there is no frame; if you bend one of these, you've just got to start all over again because while you can straighten out a twisted pipe cleaner, you play hell trying to re-



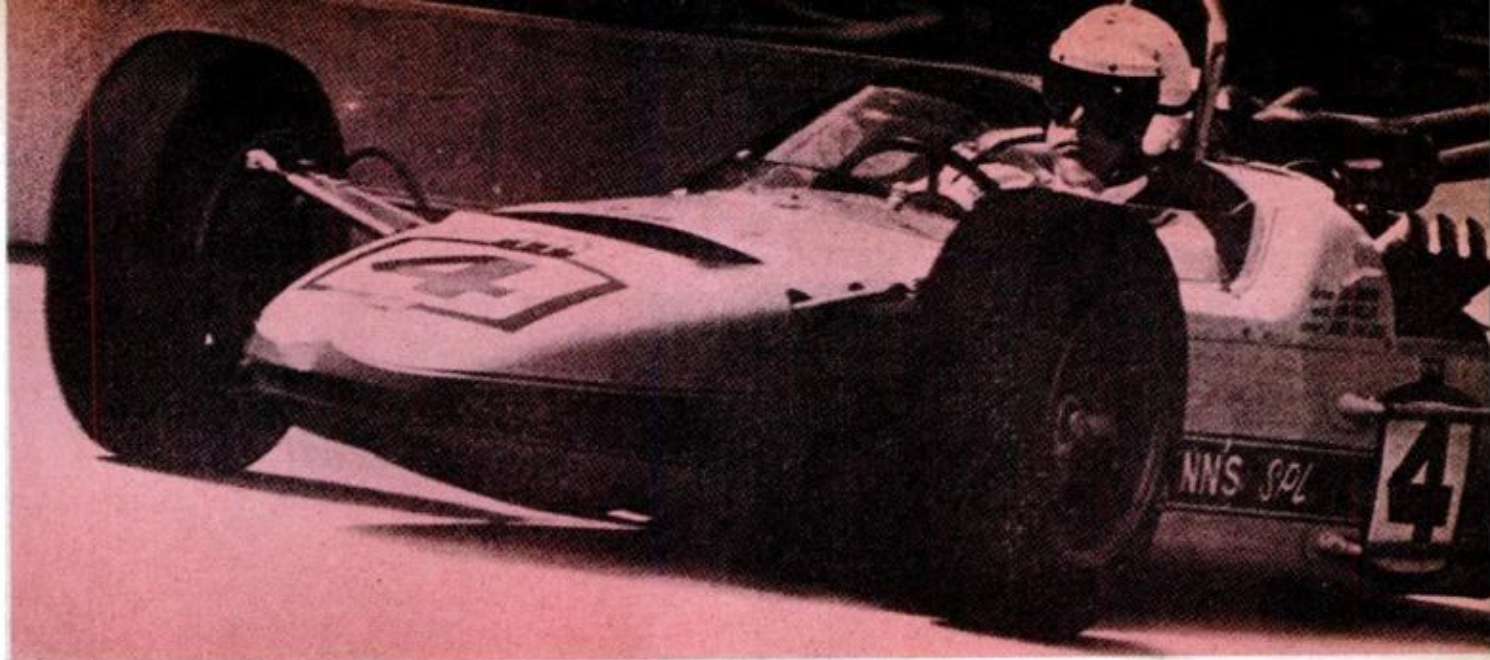

**DON BRANSON** powers into a turn during '65 Indy in A. J. Watson's special. Car had handling troubles

shape and make round a flattened straw.

Ford's racing engine has about twice as many pieces as the Offy, thus has twice as many things that can go wrong with it and takes twice as long to rebuild. Surprisingly reliable when it's running right, the quadruple-overhead-cam design is a tough one to master when it isn't. Unlike the Offy, the Ford hasn't been around long enough for almost everyone to have one stored in the back of his garage. So you start at fresh prices. "List" for one from Lou Meyer, who's now building them for Ford, runs about \$28,000. An Offy costs about \$15,000, ready to go.

An exotically-modified stock engine could be built for less than \$10,000, and you might even put a right combination together for about \$4000.

The rules change specifies that the engine be a single, non-overhead camshaft, removable head-type with a maximum of

305.1 cu. in. (5000 cubic centimeters), as compared with 256.284 cu. in. (4200 cc) for the most common racing engines (Offys and Ford's Indy engine). Thus the "rocker boxes" are only being given a 20 percent displacement advantage.

The Chevrolet 327 block has a bore of four inches and a stroke of three and one quarter inches. If you install the three-inch stroke crankshaft from the Chevy 283 block, and bore the cylinders 20-thousandths over, you come up with 305 cu. in. . . . just within Indy limits for stock engines. Naturally, special heads, cam, ignition and all the rest are going to cost plenty if you want to be competitive but, with blocks and cranks easy to come by, the cost of putting together an engine gets down to where you needn't be a millionaire to get the job done.

Jerry Eisert, builder and chief mechan-

*(Please turn to page 239)*

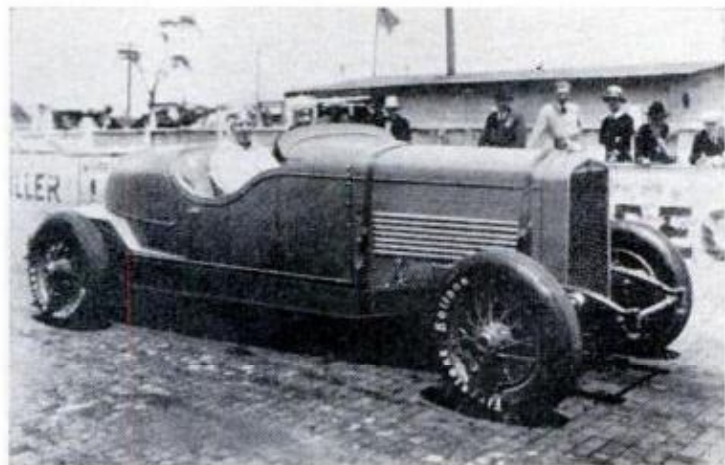

**STOCK STUTZ** (and we mean stock) was driven to 10th place in 1930 Indy by L. L. Corum. In racing "trim," car weighed more than two tons. Note door handles



**RUSSELL SNOWBERGER** spent \$2000 building Studebaker for 1931 Indy. He finished 5th, gave factory a bad case of racing fever; it entered eight cars in '32



**WHOOSH!**

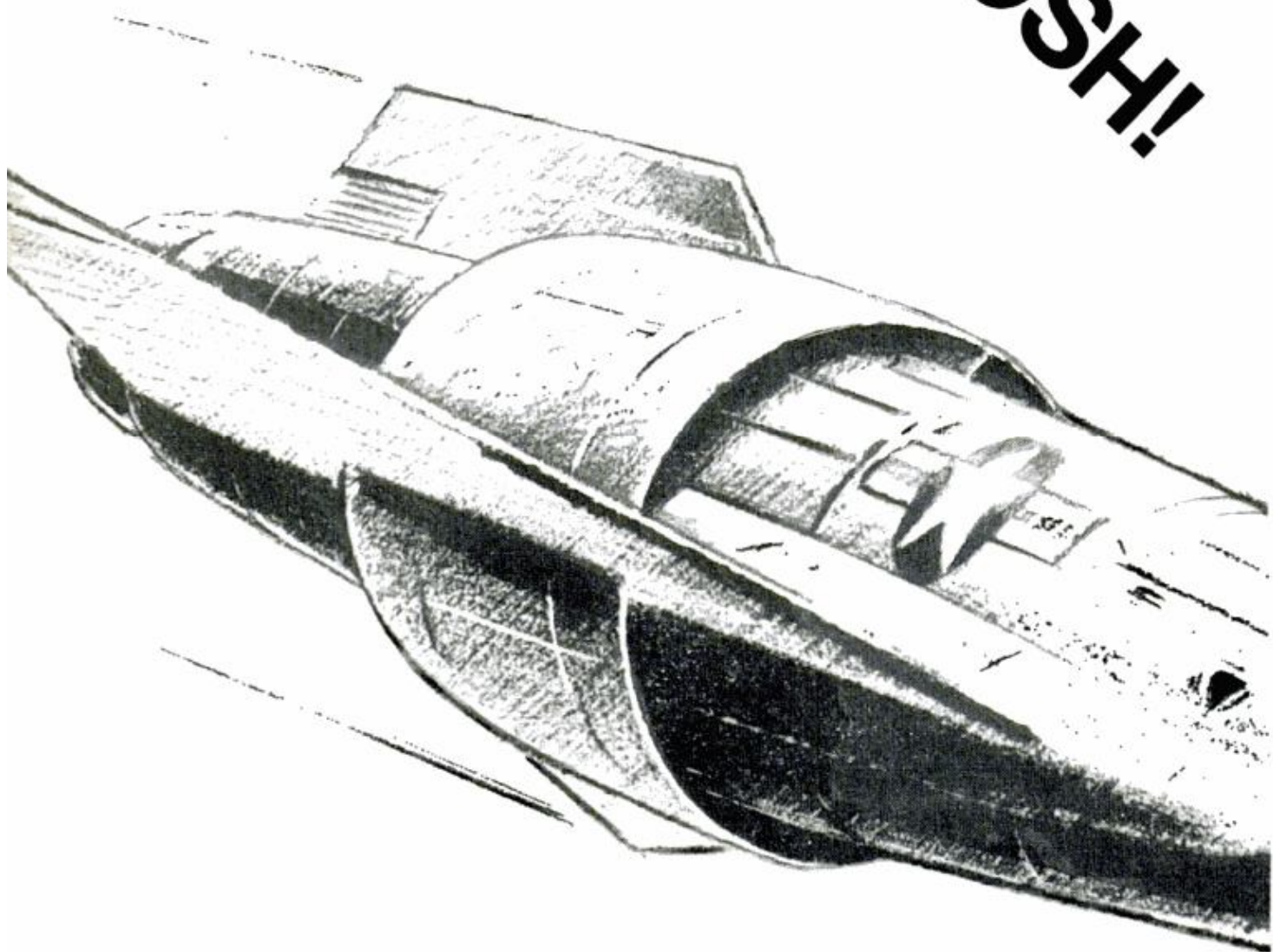

**The flying**



Supersonic transport? Forget it! They're working on a Scramjet that will fly you 8000 mph

By KEVIN V. BROWN

**WANT TO GO FOR A RIDE?** I mean a *real* ride! You've been in a big jet? That's like 600 mph tops. Nothing. You hope to ride in a supersonic transport? They'll do well to make 2000 mph. Still nothing.

Like the man said, you ain't seen nothing yet. Climb aboard the Scramjet. We're going for a *real* ride!

The cockpit looks as if it's all throttles. I count nine of them. The pilot uses just one for takeoff. Halfway down the runway, accelerating rapidly, he rolls the nose back and we start climbing at an angle of nearly 45°. Still climbing, still accelerating, we watch the mach gauge jump from .95 to 1.1. We're supersonic at 30,000 feet and still going up.

At 70,000 feet, doing about Mach 2.5, the pilot kicks in the other eight engines. Now we really take off! Whoosh! The pilot levels off at 100,000 feet and the mach gauge becomes a blur as it rushes past Mach 3, 4, 5 and on up until it slows down, hesitatingly, around Mach 10.

We're cruising along, straight and level, at 8000 mph.

How is it possible? The X-15, on rocket power, does only a little better than 4000 mph—and for very brief periods. Yet the Scramjet will cruise from New York to India in 60 minutes, carrying passengers, or non-stop around the world in less than three hours.

How? Well, it's a combination of old and new technology, and the heart of the whole system is the old ramjet engine.

The World War II German V-1 buzz bomb was a ramjet of sorts, and our Bomarc anti-aircraft missile uses a ramjet.

The concept of a ramjet engine is an engineers' dream — it has no moving parts—and they've longed to see it put to more widespread use. As its name implies, it is a jet engine that is rammed through the air. The ramming compresses the air for burning, eliminating the compressor of an ordinary turbojet or the pistons of a piston engine. The ramjet has been

There it goes...  
stovepipe





## HOW SCRAMJET WORKS

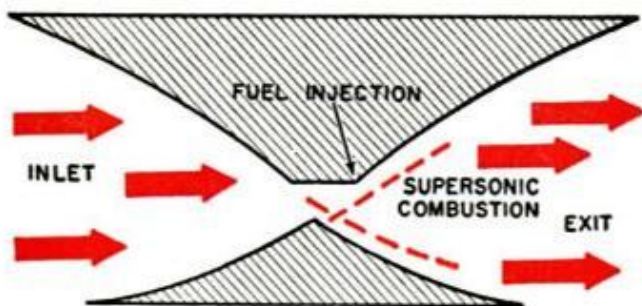

**SCRAMJET ENGINE**, simplicity itself, has no moving parts, just inlet, combustion area and exit nozzle

called a "flying stovepipe," because it is almost a hollow tube. Air is rammed into the front end, fuel is injected and burned, and the exhaust goes out the rear end. Just that simple.

However, such simplicity has obvious drawbacks. The ramjet has to be moved through the air before it can begin functioning, so it needs auxiliary power to get off the ground, probably a turbojet engine. And, until recently, it could not maintain combustion supersonically. The air was rammed in the front end at supersonic speeds, slowed down inside to subsonic speeds for burning, then exhausted. This system, while it produced supersonic thrust up to about Mach 6, created high temperatures (which necessitated bulky construction) and inefficient fuel consumption. So, with isolated exceptions like the Bomarc, ramjets were ignored.

Now comes the Scramjet (for supersonic-combustion ramjet). It isn't built yet, but the Air Force is spending money on it and experts see commercial uses.

The breakthrough that made it all possible occurred less than two years ago when an experimental Scramjet engine was kept burning with air moving through it at more than 7000 mph.

One spokesman told me, "That's like keeping a match lit in an open-top convertible while speeding along the Los Angeles Freeway."

What kept the engine lit was the fuel—liquid hydrogen—and a highly sophisticated fuel-control system. Hydrogen has a low ignition temperature and burns rapidly, so the Scramjet can go back to the simple "stovepipe" type of construction and move through the air supersoni-

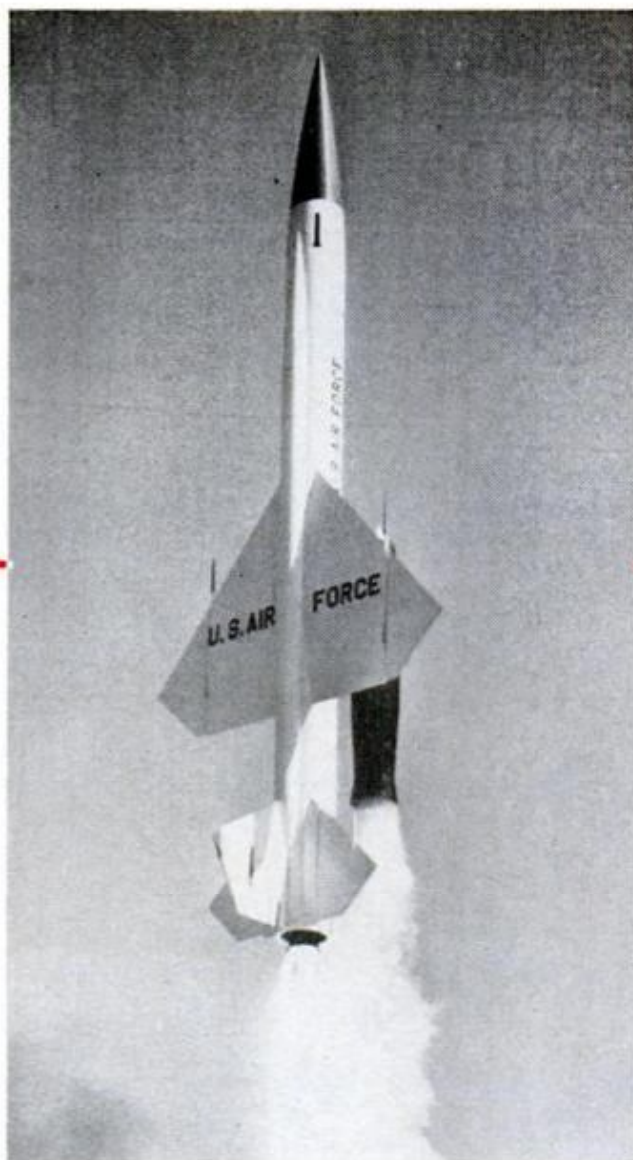

**BOMARC MISSILE**, used as anti-aircraft weapon, is sole current operational use of ramjet engine. It uses auxiliary takeoff power before kicking in ramjet

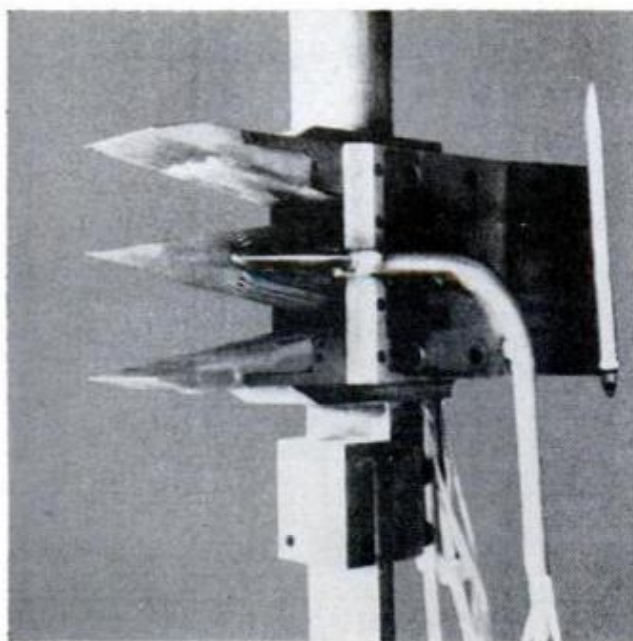

**FIRST SCRAMJET** breakthrough was this engine which was kept burning continuously while air was forced through it at speeds clocked in excess of 7000 mph



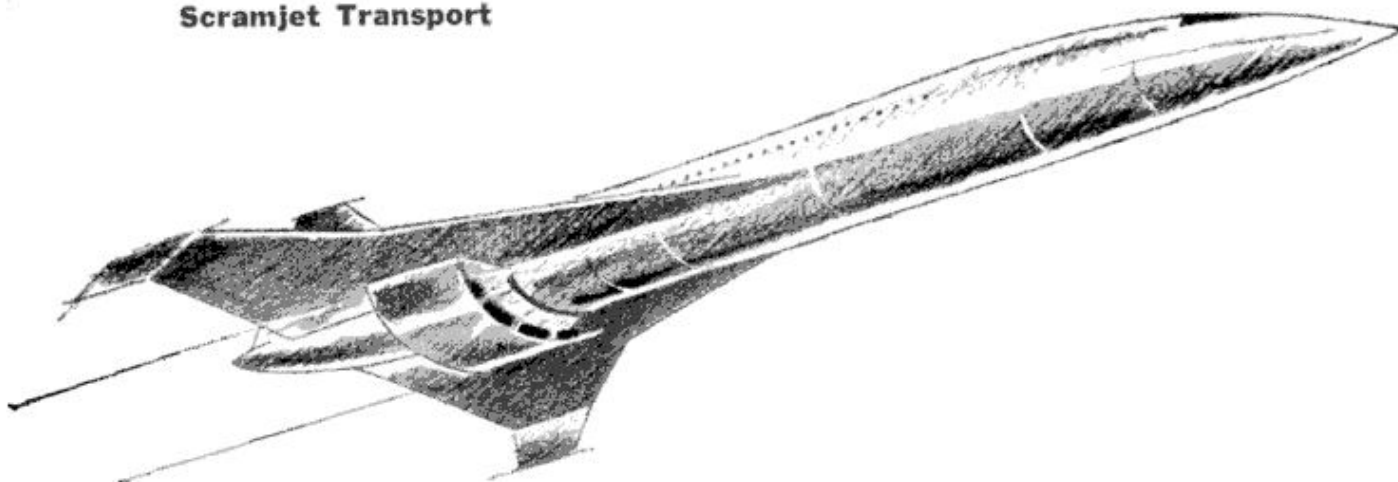

**HYPERSONIC AIRLINER** that will carry you at cruising speeds of 8000 mph might look like this. Scramjet engines may be wrapped all the way around the fuselage or just strapped to the underside alone as in SST

cally without slowing the air to burn it.

The Air Force awarded a study contract to the Marquardt Corp., which has made ramjet engines for the Bomarc missile and others, and the first unmanned Scramjet flights should result.

It all begins with the engine. I sat in the Marquardt offices in Van Nuys, Calif., and was briefed on what's planned.

Marquardt's engines will be based on what it calls the modular concept. The engines will be strapped to the fuselage in such a way that the fuselage itself becomes part of the engine, the nose of the vehicle serving as part of the inlet and the tail as part of the exhaust nozzle. The first Scramjets, in fact, will very likely have four or eight of them strapped all around the fuselage. Later, larger versions may have them placed under the fuselage.

They'll work just the way a ramjet works now, with the basic exception that the airstream remains supersonic.

As we said, it's an engineer's dream—a simple, solid piece of machinery with no moving parts. The only problem is to keep that "match lit on the freeway." Marquardt believes it has that problem licked with hydrogen fuel. The fuel, in fact, came with a bonus. Since it must be kept in a supercooled state—minus 425° F.—for maximum efficiency, it can be circulated behind the nose and leading edges of the aircraft to reduce the intense heat of friction.

The dream becomes even more inviting because, apparently, the Scramjet engine becomes more efficient the faster it goes. They showed me the ever-present graphs, comparing efficiencies of turbojets, ramjets and Scramjets at various speeds. The

first two had short and erratic lines, but the Scramjet was a long smooth line all the way out to Mach 20.

The faster it goes, of course, the higher it can go because it will be gulping more air. Scientists believe that the thin air of high altitudes will still be thick enough to support a cruising Scramjet comfortably up to about 160,000 feet.

Meanwhile, back in the metal shops, the boys are coming up with other breakthroughs in other fields. Titanium and columbium are relatively new metals combining relatively light weight with high melting points, and future hypersonic vehicles might be constructed primarily of these and similar alloys.

This parallel development in new metals was a large factor in renewed interest in ramjet engines and their applications in very high speeds of hypersonic flights.

What are some of these applications? Why bother with such extreme speeds? Well, they've been asking much the same questions since before Columbus, before Lindbergh, before the subsonic jets and even now about the supersonic jets.

The military, of course, is always interested in going farther faster. If it doesn't, some aggressor nation might. One Civil War general said it best: You win by getting there "fustest with the mostest."

The Air Force could use Scramjets as reconnaissance or strike aircraft, getting in and out before any enemy even knew they had taken off. A secondary, but no less important, role would be as specialized cargo carriers, transporting small loads of vital parts to strategic areas—parts, like electronic equipment, that, if

*(Please turn to page 236)*



# '66 Tempest: A tiger in performance, a dog on gas



By JIM DUNNE, PM's Detroit Auto Editor

**A**MERICA's NEWEST ENGINE—Pontiac's overhead cam Six—wins praise from its owners for snappy performance, but draws strong complaints for poor gas mileage.

*Popular Mechanics* questioned Tempest owners from all over the United States about their new car and its revolutionary engine. Their three best-liked features are handling, styling, performance. The three least-liked characteristics are poor fuel economy, lack of headroom, poor rear vision. A significant number (24.4 percent) find no outstanding faults at all.

After 823,700-plus miles with the new engine, Tempest Six drivers averaged 17.4 mpg, a fair record in gas economy for most cars but not good enough to satisfy over a third of those paying Tempest fuel bills. (Mileage figures are based almost entirely on results with the 165-hp engine. The 207-hp Sprint option was not in high production at the time of our sampling and results of that powerplant make up less than 2 percent of the survey.)

Economy was the primary reason for ordering the OHC Six, the owners report. That could be why poor mileage is so high among gripes.

Enough power in the engine? 94.2 percent of the owners say yes.

Owners related top-ranked handling of the car to quick power steering, intermediate outside dimensions and low center of gravity. Special praise for styling went to the two-door hardtop model with its sloping roofline. Many called Tempest the best styled car on the road, regardless of price.



## Tempest Pros

Surprisingly, the new OHC engine is not the best-liked feature of Tempest; 40.5 percent of owners put handling first by a big margin. Some comments:

"I drive many rental cars all over the United States and this is the best-handling car I have ever driven. On snow, ice or curves, it almost drives itself."—Illinois executive.

► On icy curves most cars do drive themselves; that's where you get in trouble.

"I'm impressed by the short turning radius and easy handling in and out of traffic."—Washington insurer.

"With heavy-duty coils and shocks, my car handles extremely well over winding roads."—Pennsylvania salesman.

Smart styling gleaned 36.6 percent of owner raves and OHC Six performance drew 28.3 percent, making these features No. 2 and 3 on our list.

"It has exceptional good looks as compared with other '66 models in the same price range. In fact, it has the class of a high-price car."—Missouri housewife.

## Tempest Gripes

Owners were vehement in blasting Tempest on fuel economy; 16.4 percent rated this the worst feature of the car. Here's how they explain it:

"I would prefer a V8 had I known I was to get such poor gas mileage with the Six."—New York steel worker.

"I'm very displeased with gas mileage. I hope it will improve. Getting 11 mpg average with standard 165-hp engine."—New York draftsman.

► Check our mileage chart; you are way out of the norm. I suspect something besides engine design is affecting your mileage.

Numbers two and three on the gripe list could be anticipated by most people who have driven the Tempest. Poor headroom was noted by 11.6 percent of the owners while 10.1 percent said rear vision was not up to their standards.

"It is uncomfortable getting in and out of the car. There is no head room. I can't wear a hat because there is no roof space."—Michigan toolmaker.

► Pontiac says most people who buy this car  
(Please turn to page 84)

### Top three owners' likes

Handling	40.5%
Styling	36.6
Performance	28.3

### Top three owners' complaints

Poor gas mileage	16.4%
Poor headroom	11.6
Poor rear vision	10.1

### Why I bought Tempest

Styling	39.1%
Value, cost	37.9
Past Pontiac experience	23.7

### What I would like changed

Rear vision	14.4%
Headroom	12.8
Gas mileage	5.3



REAR VISION is limited by low roofline, wide, sloping "C" pillars. But styling ranked high on like list

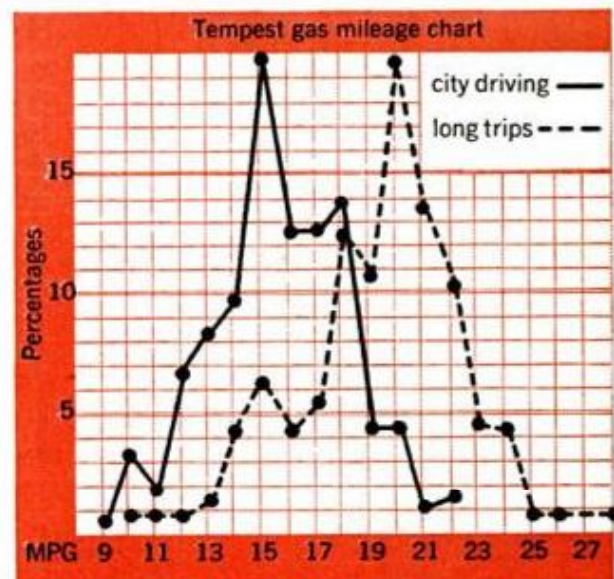

GAS ECONOMY was below par, say owners. Even on long trips, the average did not top 20 mpg



## Tempest Pros

(Continued from page 83)

"I like smooth lines of the sportive, but unexaggerated body design. Looks more expensive than it actually cost!"—North Carolina teacher.

► **Don't bang that fender or the cost may be more expensive than it actually looks.**

"Performance of OHC Six is excellent; 165-hp engine moves out as well as the bigger V8s."—New Jersey manager.

► **Owners mostly concurred, but said car had little performance under 25 mph.**

*Smoothness of ride (18 percent), economy of operation (15.7 percent), comfort (10.2 percent) placed fourth, fifth and sixth among owners' brags.*

"It has a smooth and comfortable ride."—Delaware manager.

"I need a car that delivers good gas mileage and doesn't cost a fortune to repair. So far, this Tempest fills the bill."—Connecticut accountant.

► **This thinking led to the fast growth of the Tempest-type intermediate car market.**

"It is large enough to be a comfortable—  
(Please turn to page 230)

## Tempest Gripes

(Continued from page 83)

**don't wear hats anyway. (I knew they must have some rationale behind this obvious design limitation.)**

"Lower yourself in the rear seat gently or top of the rear window will smack your head."—New Jersey mailman.

"The inside mirror isn't worth a damn. You can only see about one block behind you."—Ohio optometrist.

► **I suggest you see an eye doctor. You may need glasses.**

*Despite the auto industry's drive for quality, poor paint jobs (9 percent) and oil leaks (8.4 percent) placed fourth and fifth among owner dislikes. In sixth place (7.4 percent) was lack of power from the new engine.*

"Interior paint was too thin and uneven on panel between the front and rear doors."—Illinois supervisor.

"The car still leaks oil despite the main seal being replaced three times."—Illinois professor.

► **A number of owners singled out leaks from  
(Please turn to page 230)**

## Summary of Tempest Owners' Reports

**Excellent .56.7% Good . . . .37.9% Fair . . . . .4.6% Poor . . . . .0.8%**

Total Miles Driven:	823,711
Average miles per gallon:	
City driving	15.6
Long trips	19.3
Overall	17.4
Mileage opinion:	
Better than expected	17.7%
As expected	47.3
Not as good	35.0
Best-liked features of the car:	
Handling	40.5
Styling	36.6
Performance	28.3
Ride	18.0
Economy	15.7
Comfort	10.2
Engine	9.1
Quietness	7.9
Size	7.9
Interior styling	7.5
Least-liked features:	
Gas mileage	16.4
Headroom	11.6
Rear vision	10.1
Color, paint job	9.0
Oil leaks	8.4
Lack of power	7.4
Rattles and noise	6.9
Transmission linkage	5.6
Carburetor trouble	4.7
Engine noise	4.2
Exterior features liked most:	
Style	38.0
Simplicity of design	22.3
Rear window	11.8
Grille	9.6
Paint finish	7.9

Exterior feature liked least:	
Rear visibility	31.0%
Taillights too small	18.6
Plastic grille	7.6
Rear-end styling	6.2
Lack of chrome	4.8
Interior feature most liked:	
Instrument panel	39.9
Seats	26.4
Upholstery	14.4
Styling	6.3
Roominess	4.8
Interior feature liked least:	
Lack of headroom	16.9
Ashtray location	13.1
Instrument panel	10.0
Idiot lights	5.6
Small glove compartment	5.0
Poor legroom	5.0
What influenced purchase?	
Styling	39.1
Cost, value	37.9
Past experience	23.7
New engine	22.1
Pontiac name	17.8
Did you consider another car?	
Yes	62.9
Make of the other car:	
Chevrolet	42.0
Ford	14.6
Dodge	10.8
Buick	10.2
Reason for buying Tempest Six:	
Cost, trade-in, deal	50.0
Styling	14.7
New engine	10.3
Dealer	10.3

Is Tempest only family car?	
Yes	54.0%
Other cars owned:	
Pontiac	41.9
Chevrolet	25.6
Ford	6.8
Buick	6.8
What would you like changed?	
Rear vision	14.4
Headroom	12.8
Gas mileage	5.3
Ashtray location	4.3
Idiot lights	4.8
Dealer service:	
Excellent	57.8
Average	32.3
Poor	9.9
Buy from dealer again?	
Yes	92.2
Car traded in:	
Pontiac	38.5
Chevrolet	15.4
Ford	7.1
Rambler	7.1
Corvair	5.5
Would you buy another Tempest?	
Yes	95.0
OHC engine perform differently?	
The same	21.6
Different	78.4
Why did you buy OHC engine?	
Economy	33.8
Performance	23.4
Came with car	22.9
Reputation, magazine write-ups	19.0
Does it give satisfactory power?	
Yes	94.2





**Air stair.** Special inflatable ladders coated with white urethane rubber are used to inspect the insides of the Saturn missiles' rocket-fuel tanks, because ordinary ladders are too large to fit inside the 18-inch access ports. They can support two men.



**Hot-dog scull** introduced by a German firm at the Hamburg Boat Show is basically just an inflated plastic tube which folds into a compact package for carrying. The six-meter boat is said to cost only a third as much as traditional wood models.



**Migrating birds** can travel in style and ease without a flap of their wings. Built by Ernie Day of Toddington, England, the "Bird-Mobile" is designed for bird lovers who want to take their feathered pets along on vacation trips. The unit is built on a boat trailer frame.



**Scooter skimmer** from England gives 100-hp excitement with a 10-hp outboard. Less than seven feet long, the fiberglass "Aqua-scooter" sells for under \$300 (motor not included) f.o.b. Union Dynamics Ltd., Wessex Shipyard, Satchell Lane, Hamble, Hampshire, England.



# Rambler American owners:

By BILL KILPATRICK, PM's New York Auto Editor

**H**ERE'S A SURPRISING SWITCH: The long-standing image of the Rambler American as the foremost U.S. economy compact is—for 1966, anyway—taking a back seat to handling and overall “feel,” according to owners surveyed by *PM*.

In expressing what they liked about the car, owners placed handling at the top of the list with a frequency-of-mention rating of 49.3 percent. Economy of operation was second with 32.8 percent and performance third with 29.3 percent.

Mentioned most frequently on the minus side were wind noise and water leaks (11.6 percent), squeaks and rattles (8.8 percent) and—hold onto your hat—poor fuel economy (7.5 percent). Almost one third of the owners, however, had no specific complaints.

Rambler American owners responding to *PM*'s survey reported a total of 858,916 miles driven under all types of road and weather conditions and during which they averaged overall 20.5 mpg. Figures for Rambler's new V8 are not included in this survey.



## American Pros

“I like the fact it's easy to handle in traffic.”—Illinois engineer.

“The car feels heavier than it actually is.”—Connecticut factory worker.

“For a small car, it handles very well on open highway.”—Iowa salesman.

“Gets around good in ice and snow.”—Ohio mechanic.

“This car rides the bumps well.”—Rhode Island technician.

“I like it because I don't get the feeling I'm steering a boat, or some such.”—Texas postal clerk.

### ► Neither snow, nor rain . . .

Despite the preponderance of owner accolades for handling, Rambler American's traditional economy is still a big plus, rating second as most popular feature. Typical comments:

“In start-and-stop city driving, it

*(Please turn to page 88)*

### Owners like:

Handling	49.3%
Gas mileage, economy	32.8%
Power, performance	29.3%

### Owners dislike:

Wind noise and water leaks	11.6%
Rattles and squeaks	8.8%
Gas and oil economy	7.5%

### Why they picked Rambler

Economy of operation	38.6%
Cost	31.6%
Past experience with Rambler	27.6%

### What should be changed:

Larger tires, wheels	7.9%
Better gas consumption	5.3%
Interior room	5.3%

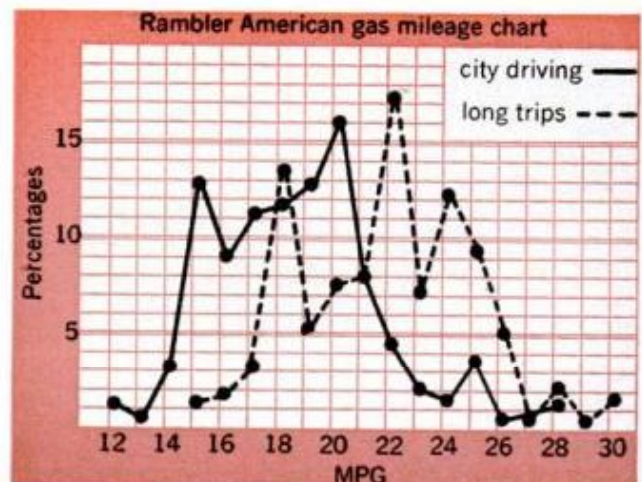

**HIGHER HORSEPOWER** ratings of '66 Rambler engines cut mileage. Still, overall mpg was 20-plus



# Handling tops economy



## American Gripes

*American Motors advertising claims "quality is built-in, not added on." A number of Rambler owners think otherwise. Wind noise and water leaks led complaints, with rattles and squeaks second.*

*"Weatherstripping around doors leaks."*  
—New Mexico illustrator.

*"This car has noises—a whistling from the front, a draft from right front fire-*

*wall, a leak in rear window and trunk."*  
—California mailman.

*"There's a leak around the gas tank. Water runs under floor mat. Dealer so far unable to fix leak."*—Alabama accountant.

*"I've got a couple of undetected rattles and get a resonant wind whistle at 30-40 mph. Heater blower is pretty loud."*  
New Jersey engineer.

*(Please turn to page 88)*



**FUEL STOPS** are occasional things for owners of Ramblers. However, some reported poor economy



**KIDS DEFINITELY FIT** back seat. Majority of owners say car offers enough room for most family needs



## American Pros

(Continued from page 86)

traveled 200 miles for \$4."—Ohio insurance underwriter.

"It costs me very little to operate my car."—California office manager.

"I drive 84 miles a day to work and I'm sold on Rambler economy. This is my third one."—New York factory worker.

"It saves more gas than my Corvair."—Pennsylvania decorator.

*Not normally deemed a marcher, the Rambler American nevertheless gets owner points for performance, in third place.*

"I was very surprised at the amount of power."—Georgia forestry scientist.

"I took a trip to New York. The car acted like a tiger."—Missouri manager.

### ► Another entry in the automotive jungle.

"My Rambler has more passing pickup than Falcon or Valiant."—Ohio chemist.

"Car has plenty of zip without excessive horsepower."—Georgia mechanic.

*Fourth on the huzzah list for the Rambler American is styling (18.8 percent).*

"I like the overall appearance of the body and interior better than other cars

(Please turn to page 232)

## American Gripes

(Continued from page 87)

"Car needs to be tightened to eliminate rattles."—West Virginia office manager.

### ► Don't we all?

"Road noise is high."—New Jersey bookkeeper.

"Kick pad on right front door rattles."—North Carolina textile worker.

"Tailgate doesn't fit worth a damn."—Connecticut engineer.

"Brakes are noisy."—New York realtor.

### ► A number of owners agreed.

"When we got the car the interior wasn't finished."—Ohio meat cutter.

"Door on driver's side does not shut every time and sometimes it locks itself."—New Hampshire nurse.

"Not enough attention to final details. Anti-freeze leaked through loose hose connection. Heater was not connected."—New Jersey insurance agent.

*Engines covered in this survey include the 128 hp, which overall averaged 21.6 mpg, the 145 hp, averaging 19.8 mpg, and the 155 hp, 18.9. Impressive figures when*

(Please turn to page 234)

## Summary of Rambler American Owners' Reports

**Excellent .61.6%    Good . . . . .33.6%    Fair . . . . .3.4%    Poor . . . . .1.4%**

Total miles driven . . . 858,916

Average miles per gallon:

City driving . . . . .18.6  
Long trips . . . . .22.0  
Overall average . . . . .20.5

Average mpg by horsepower:

128 hp engine . . . . .21.6  
145 hp engine . . . . .19.8  
155 hp engine . . . . .18.9

Transmissions:

Automatic . . . . .58.4%  
3-speed manual . . . . .39.8  
4-speed, overdrive . . . . .1.7

Horsepower of owners' cars:

128 hp . . . . .61.7  
145 hp . . . . .6.5  
155 hp . . . . .31.8

Mileage opinion:

Better than expected . . . . .16.4  
As expected . . . . .35.5  
Not as good . . . . .48.1

Best-liked features:

Handling . . . . .49.3  
Gas mileage, economy . . . . .32.8  
Power, performance . . . . .29.3  
Styling . . . . .18.8  
Ease of parking . . . . .17.5  
Compact size . . . . .17.0  
Ride . . . . .14.4  
Quality construction . . . . .10.5  
Brakes . . . . .8.7  
Room-interior . . . . .7.9

Least-liked features:

Wind noise, water leaks . . . . .11.6  
Rattles and squeaks . . . . .8.8  
Gas and oil economy . . . . .7.5  
Too-light weight . . . . .6.8  
Workmanship . . . . .6.8  
Brakes . . . . .5.4  
Engine . . . . .5.4  
Roadability, ride . . . . .5.4

Hard shifting . . . . .5.4%  
Room inside . . . . .4.8  
Dealer service . . . . .4.8

Best-liked exterior features:

Style, looks . . . . .35.6  
Simplicity of lines . . . . .24.9  
Finish, color . . . . .9.6  
Compactness, size . . . . .9.0  
Trim or lack of it . . . . .8.5

Least-liked exterior features:

Single headlights, location . . . . .11.1  
Rear end styling . . . . .10.0  
Gas intake position . . . . .7.8  
Bumpers . . . . .6.7  
Overall styling . . . . .6.7

Best-liked interior features:

Seats and seat height . . . . .25.3  
Dashboard, padded panel . . . . .21.1  
Reclining seats . . . . .15.6  
Head and leg room . . . . .11.1  
Trim, interior styling . . . . .10.0

Least-liked interior features:

Glove compartment size, lock . . . . .10.7  
Seats . . . . .5.8  
Dome light not door-operated . . . . .5.8  
Rear view mirror position . . . . .5.8  
Courtesy lights not standard . . . . .5.8

Interior room:

Big enough for my needs . . . . .94.1  
Not big enough . . . . .5.9

Do you like short length?

Yes . . . . .95.7  
No . . . . .4.3

What influenced purchase most:

Economy of operation . . . . .38.6  
Cost . . . . .31.6  
Past experience . . . . .27.6  
Looks, styling . . . . .17.1

Quality construction . . . . .14.5%  
Size . . . . .11.4  
Reputation . . . . .10.1

Did you consider another car?

Yes . . . . .64.5

Other make considered:

Chevrolet . . . . .33.8  
Falcon . . . . .17.3  
Ford . . . . .15.1  
Volkswagen . . . . .12.2  
Valiant . . . . .11.5  
Dodge . . . . .10.8  
Mustang . . . . .10.1  
Plymouth . . . . .9.4  
Corvair . . . . .7.9  
Pontiac . . . . .6.5  
Comet . . . . .5.0

Is Rambler family's only car?

Yes . . . . .59.1

Make of other car:

Rambler . . . . .20.2  
Chevrolet . . . . .18.1  
Ford . . . . .9.6  
Buick . . . . .8.5  
Dodge . . . . .7.4  
Pontiac . . . . .6.4  
Volkswagen . . . . .6.4  
Chrysler . . . . .5.3

How is dealer's service?

Excellent . . . . .57.5  
Average . . . . .32.1  
Poor . . . . .10.4

Would you buy another Rambler?

Yes . . . . .95.6

What changes would you like?

Larger tires, wheels . . . . .7.9  
Better gas economy . . . . .5.3  
More room . . . . .5.3  
Better styling . . . . .4.6  
Better roadability, ride . . . . .3.9  
Better heater . . . . .3.9



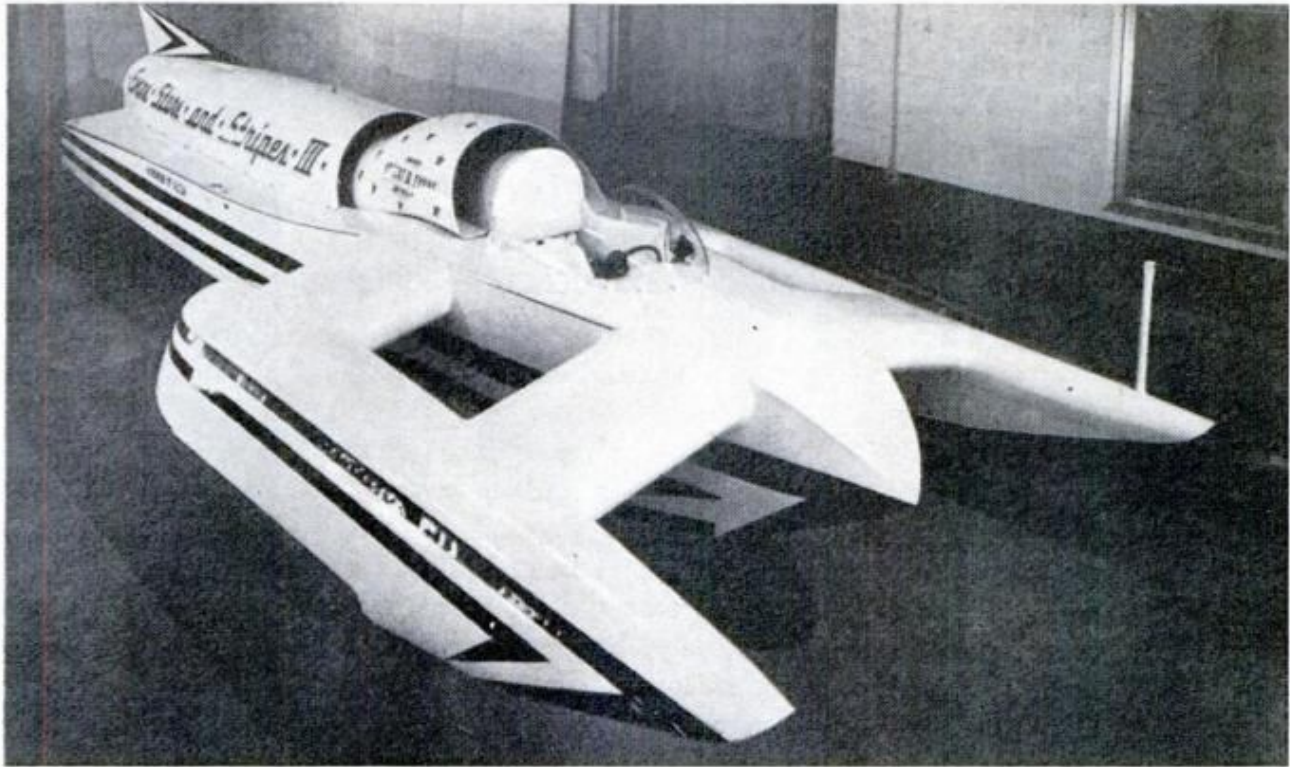

**Record breaker?** Robert Evans, who designs and owns high-speed boats, and Les Staudacher, who builds and drives them, will have at it again with this jet-powered beauty. "It" is the attempt to better the world waterspeed mark of 276 mph. The "Stars and Stripes III," made of aluminum, is 31½ feet long and weighs 5800 pounds. The sponsons are 16 feet long.



**Tropics in a bottle.** Even in a cold country, tropical plants can be grown inside special glass enclosures made by a London firm. The soil and the plant leaves give off moisture which condenses and runs down to the roots in a continuous cycle.

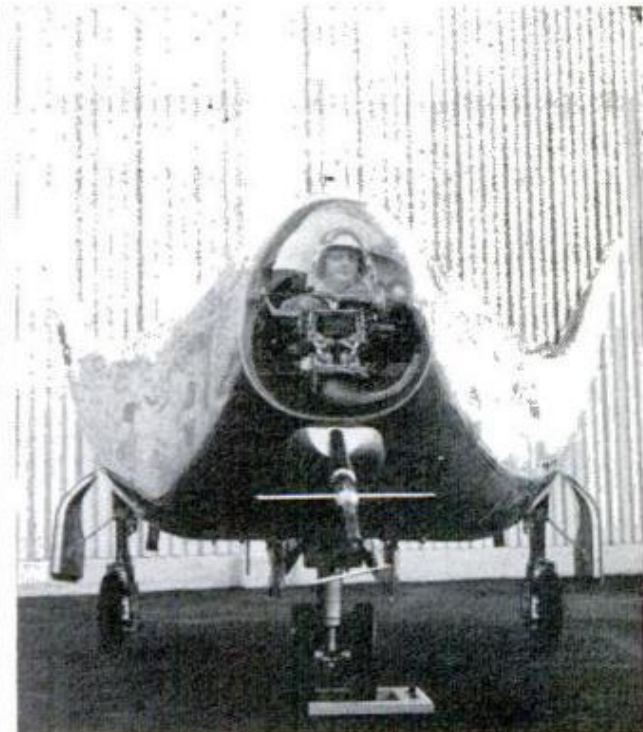

**It's not a Batmobile,** but a lifting body to be used as an experimental vehicle for high-speed glides back to earth from orbit. Lifted aloft under the wing of a B-52, the craft will glide dead stick or get a 12-second boost from small landing rockets. The experiments are to find a vehicle that astronauts can fly back like an airplane.



# Planning a war?

## SEE SAM!

He owns more small arms than the U.S. has in active service, and could equip 75 divisions tomorrow—with everything from bayonet pistols to cannons and rocket launchers

By ARTHUR WHITMAN

**T**HE FIRST THING YOU NOTICE when you meet Sam Cummings is that he's not wearing shorts and knee socks. Tall and portly, with dark hair and a gravely handsome face, he looks like a Boy Scout leader who hasn't been hiking for a while. The rest fits, too. Thirty-six years old, married, two nice kids. Philadelphia Main Line family. Prep school, all of that. He doesn't smoke; his drink is lemonade, easy on the sugar. This is a good man—proper, modest, four-square. The only thing wrong with the picture is what you knew before you met him, about how he makes his living. Sam Cummings is the world's biggest arms dealer.

Founder and head of the International Armaments Corp., a worldwide network that embraces eight other corporations in as many countries and spins webs of steel and currency on a global basis, he owns more small arms than the United States has in active service and he could equip 75 divisions with light infantry weapons tomorrow. "But I'd hate to handle the logistics for that army," he says with a diffident laugh. "You'd have one division with Japanese rifles and Russian ammo. Another would have half Mausers, half Mannlichers, and so on. A confused mess!"

There are some other confusions about his business that Sam hates and likes to clear up at once. The first is the idea that he's a clandestine operator. "Illicit traffic in arms doesn't amount to a wart on an elephant," he says. "The old romantic notions about gun-running just don't hold true today—if they ever did. Whenever you hear of 'clandestine traffic,' you can be sure politics is being played by some government. During

the Congo troubles, for example, arms were going to the rebels from Zanzibar and Dar es Salaam steadily.

The shipments to and from these countries were disguised, but nobody was in the dark about what the crates contained. Rifles aren't diamonds, after all. You can't put a million

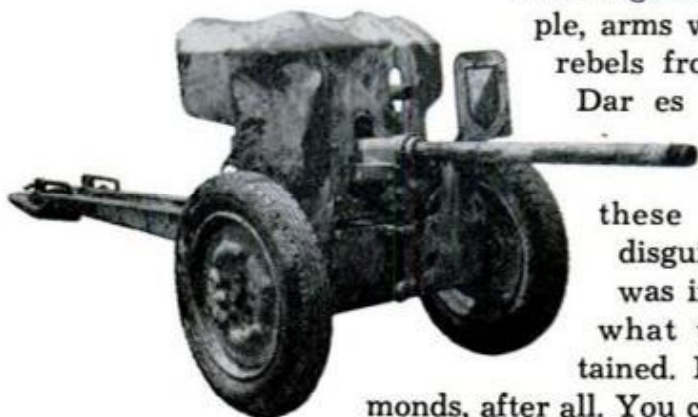

Photo above by Arnold Newman; all others by Curt Gunther





**SAM CUMMINGS** and a few of his \$10-million worth of guns. His aggressive ways have captured nearly 85 percent of nongovernment arms market outside Communist-bloc nations



**RARE GUNS** are a specialty. This is drum-fed Farquar-Hill .303-cal. semi-automatic developed in England after World War I. Only 20 were made and are prized by gun buffs

MAY 1966



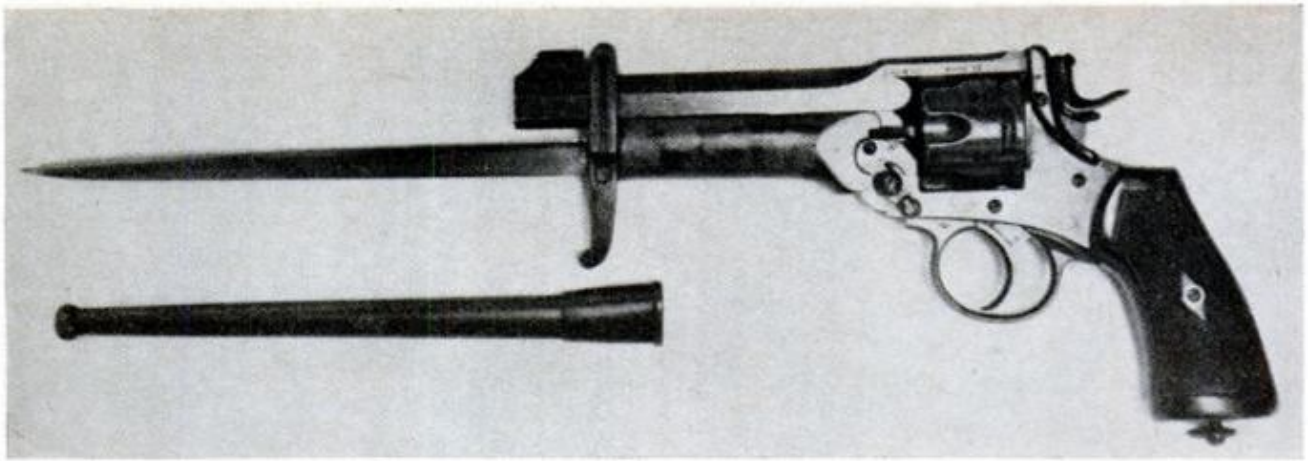

**BAYONET PISTOL** designed for English officers proved ridiculous weapon. No more than 40 were ever made

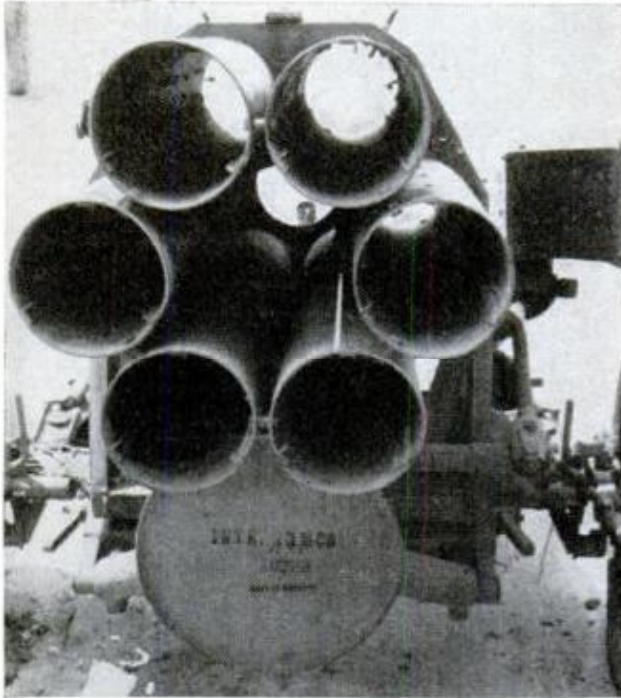

**ROCKET LAUNCHER** is World War II German Nebelwanfer. Anti-infantry weapon was very effective



**20-SHOT REVOLVER**, only design of its kind, was made in Belgium in early 1900s. Most disappeared

dollars' worth of them in your pocket and sneak across a border.

"Every transaction I make is licensed by either the U.S. or British governments and the recipient is known. I suppose that we've sometimes been involved in arming rebels, but only indirectly. A government buys from us to replace the arms it has in service, say, then passes the obsolete equipment on to some undercover crowd it likes. Interarmco has nothing to do with the second half of the deal."

Another confusion Sam hates is the notion that he's a "Merchant of Death"—a tag European magazines love particularly to hang on him. It's far from the whole truth, which harks back to politics in one form or another. You can see how things really work from Sam's first big

deal, the one that made Interarmco.

Back in the mid 50s, Rafael Trujillo's Dominican Republic had hardly a friend in the world. No significant government would be counted a supporter of the former Caribbean dictator, and some, like nearby Costa Rica and Nicaragua, were for practical purposes at war with him. They encouraged anti-Trujillo dissidents of every stripe, supplied them, allowed them operating bases for invasions.

Whatever else he was, Trujillo was not stupid, and it was clear to him that even a pipsqueak invasion could topple his precarious government like a wrecker's ball striking a summer shack. How do you prevent invasions? By owning enough arms to make a frightening show of [\(Please turn to page 198\)](#)



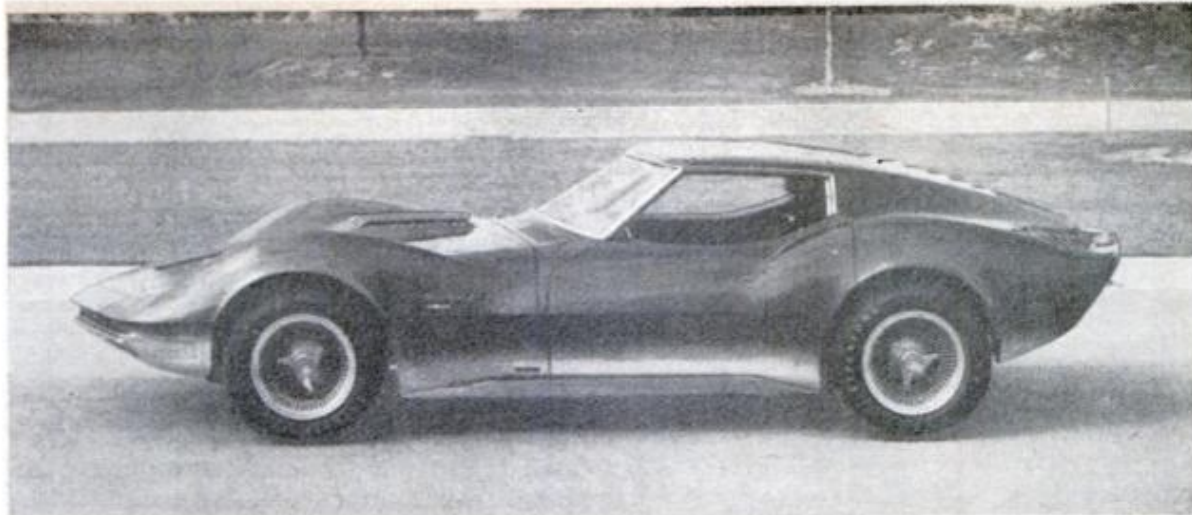

SHARK II

## SHARK AND COBRA

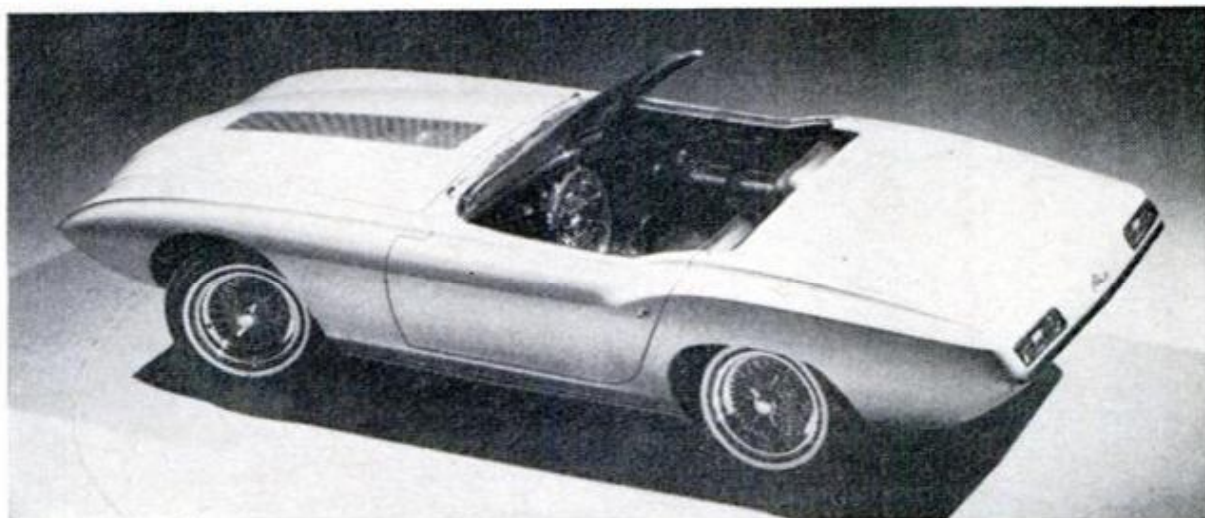

NEW COBRA

## SLEEK NEW BREED

By Batman (who else?) out of Chevrolet and Ford are these loaded-with-goodies prototypes, both of which point unerringly in the direction Detroit is taking—a deep bow in the direction of the go-go set and an old college try to make bombing or cruising as rapid and effortless as possible.

Chevrolet's *Mako Shark II* houses no less than 17 servo motors to drive a host of nifties including a slideaway roof section, cornering light louvers, hideaway headlights and windshield wipers, self-positioning headrests and—are you ready?—"stabilizing" flaps that can be extended from the trailing edge of the tapered and upswept tail section. Horses total 425, pounds 3875. Roof is powered, can be removed. Hood tilts forward for engine access. Chevy brass won't say so (it would spoil the game), but scuttlebutt has it certain Shark II features will be available on '67 production "hot ones."

Ford's experimental/show *Bordinat Cobra*, honoring styling V.P. Gene Bordinat, features among other things bucket seats bolted directly to the frame (the four-inch tubular steel siderails of which also house two mufflers); a button adjusts brake and accelerator pedals fore and aft for leg room. Power is Ford's 427-cubic-incher, total package weight is 2450 pounds. Body is plastic and the three-piece, zippered convertible top can be removed and stowed in the luggage boot.—Bill Kilpatrick



# Our newest frontier

A fleet of bug-eyed monsters is preparing to explore the greatest unknown 'land' on earth, the Continental Shelf, where 500 million acres of oil, gold and minerals are there for the taking

By Robert F. Crossley





# is underwater!

WITH SO LITTLE FANFARE that you probably haven't heard about it, the United States has just acquired the biggest single piece of undeveloped territory in our history. It's nearly twice the size of Alaska, bigger even than the Louisiana Purchase. Some have compared it with the opening of the West a century or more ago.

There's only one catch. It's flooded.

The territory is the Continental Shelf, the shallow sea bottom extending from our coasts for as much as 400 miles in some places. Beyond the "three-mile limit" it used to belong to nobody. Now, by a United Nations agreement, it's ours. Other nations have similar title to the shelves along their coasts.

Not only did we gain sovereignty over what geologists consider the true Continental Shelf, the bottom down to 200 meters, but—and here's the real bonanza—to "wherever the depth of superadjacent waters admits to the exploitation of the natural resources." That's another way of saying: "Come and get it!"

Already a growing fleet of bug-eyed little submarines are nosing around at 300 to 1000 feet. One has twice prowled the bottom at 6000. Another went to 6250 feet while this article was being written.

Last summer astro-aquanaut Scott Carpenter camped for 30 days in the Navy's Sealab II 205 feet below the surface of the Pacific. That, by coincidence, is approximately the average depth of the Continental Shelf. He was joined by relays of roommates who stayed for 15 days and "worked" with him outside the 57-foot steel cylinder.

About the same time, six of Jacques-Yves Cousteau's French oceanauts were spending three weeks in a spherical house 325 feet beneath the Mediterranean. Part of the time they worked on a dummy oil-well casing at 370 feet.

Not to be outdone by the French and Americans, eight British divers from the Royal Navy last fall took movies, sawed metal and performed other tasks at 600 feet in the Mediterranean.

"There is more unexplored land on this

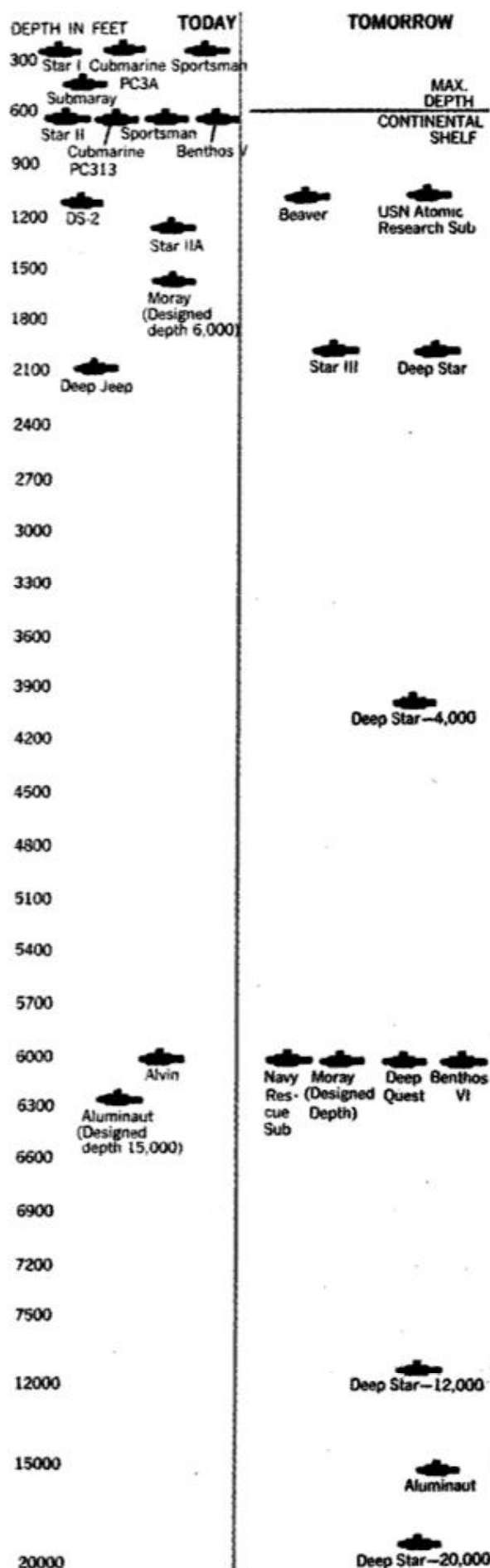



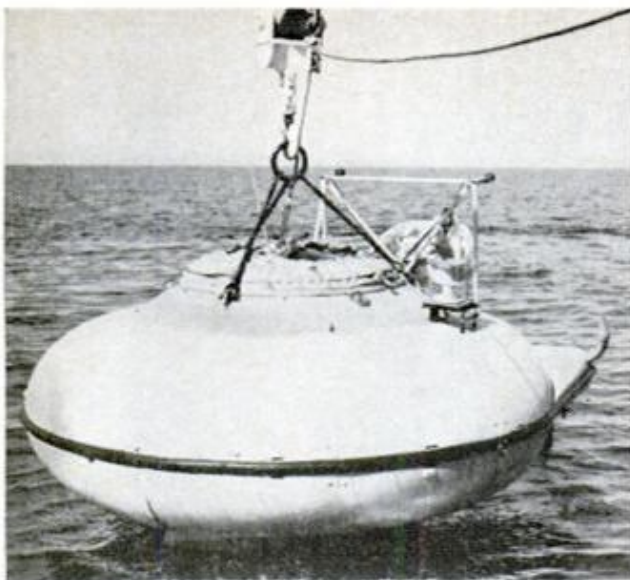

**UNDERWATER EXODUS**, begun before U.N. decision, is now underway in earnest. This is "Diving Saucer," built by Capt. Jacques-Yves Cousteau for 1000 feet



**NAVY'S MORAY**, another underseas vehicle, has dived to 2000 feet, may eventually go to 6000. Military and scientific groups are both interested in shelf

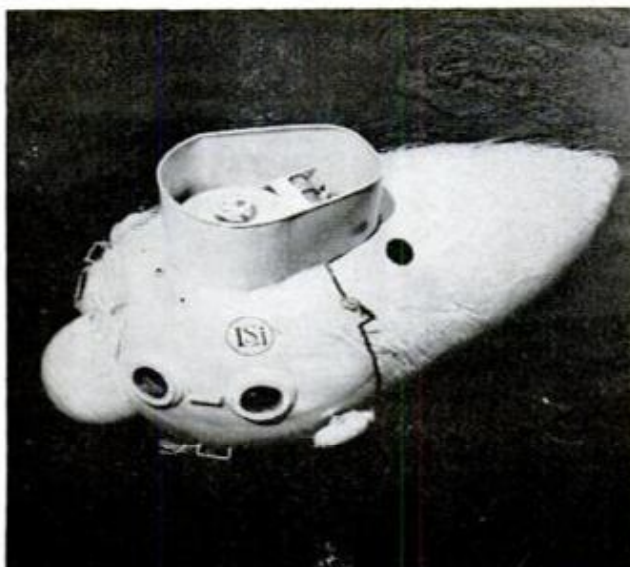

**TWO-MAN CRAFT**, Benthos V ("bottom dweller"), has been tested at 600 feet. All these craft are exploratory vehicles. The exploiters are yet to come

Earth," declared one senator, painting a glowing picture for his colleagues, "than on the moon. Beneath the surface of the sea lie the busiest, most fertile, most mysterious regions of the Earth. Their resources stagger the imagination."

The shelf and as much of the deeper ocean floor contiguous to our own coasts as we can explore and exploit is ours—along with their minerals, oil and other resources. The pattern will doubtless be as it always has been: First the explorers—the Lewis and Clarks and the Fremonts; then the exploiters—the trappers, the miners and the farmers.

I went up to Woods Hole, Mass., and talked with one of the explorers, the first man to captain a really maneuverable submarine a mile beneath the surface. He was William O. Rainnie, Jr., senior pilot of the *Alvin*. Last summer he and copilot Marvin J. McCamis tested the stubby, 22-foot research craft successfully at 6000 feet in the Bahamas and again off Bermuda. He put it this way:

"Just because we can go to a given depth doesn't mean we can exploit it. Exploiting means extracting something we can use. Look at the history on land. The people who gained riches out of a territory were not the ones who went there first, explored it and brought back some idea of what was there. The commercial people moved in behind them. Will it be any different in the ocean? I don't think so."

The riches are there all right. You name it. The ocean has it.

No one knows how much oil there is under the sea. It's so abundant that in several places off California it "leaks" up to the surface. The familiar Texas Tower brought in wells in water up to 60 feet deep. Now oil companies are drilling from ships and barges in 250 feet of water. Last November a British crew struck a 64-foot-thick pocket of natural gas beneath the North Sea. It is yielding 3,600,000 cubic feet per day. Five other companies are drilling nearby with rigs costing up to \$10 million apiece.

Last April a thousand-foot hole was bored in the Blake Plateau, more than 3000 feet beneath the surface of the Atlantic off Jacksonville. The project, called JOIDES (Joint Oceanographic Institutions Deep Earth Sampling), was



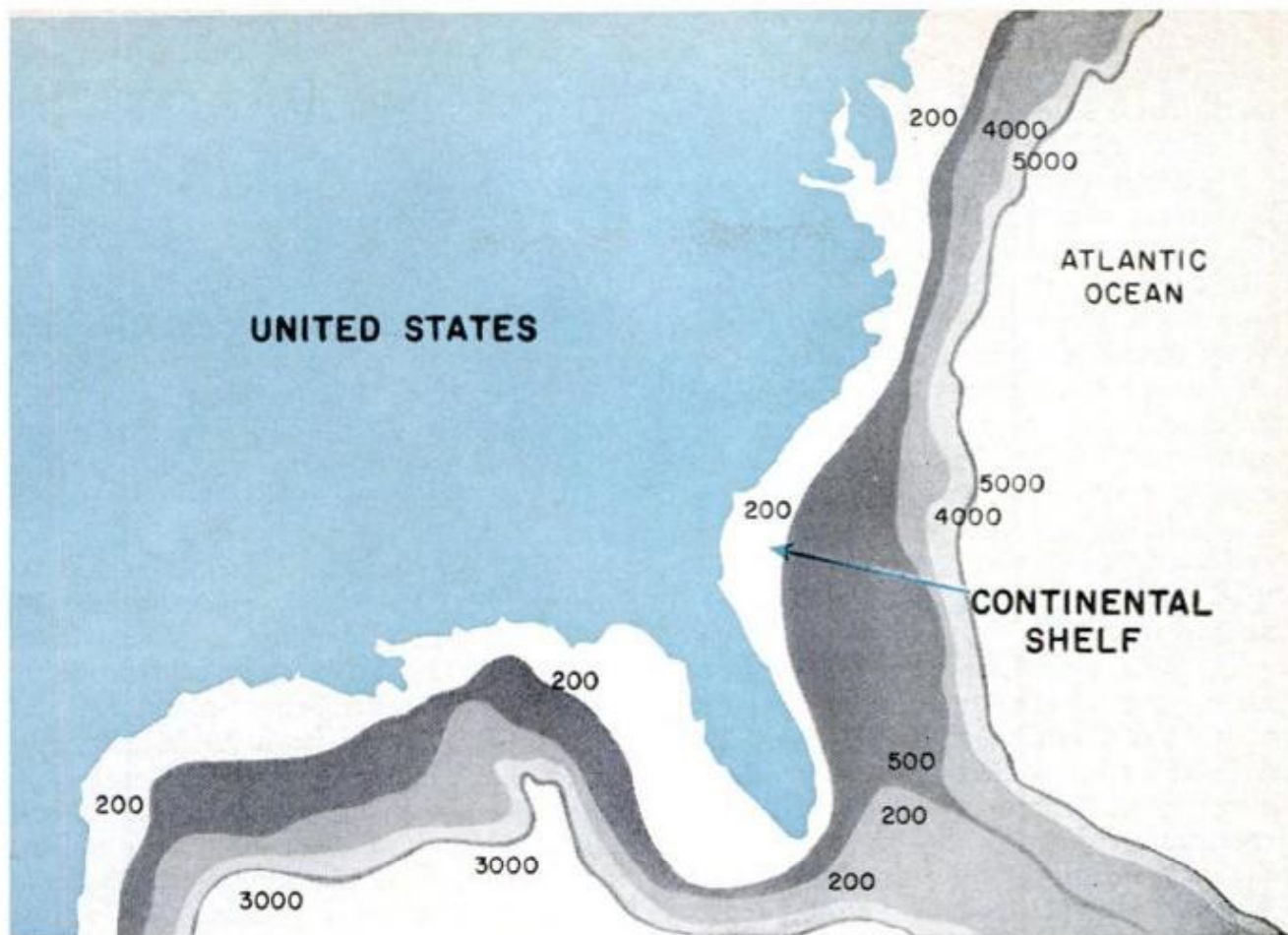

**CONTINENTAL SHELF** extends off U.S. coast at depth of about 200 meters (656 feet). Atlantic, Gulf coasts have relatively large shelves, Pacific coast almost none. Huge shelf, bigger than Alaska, extends about 400 miles into Bering Sea. All of this the U.N. gave to the United States to explore, plus anything beyond it

a venture of Woods Hole, Scripps, Lamont and the University of Miami. No attempt was made to find oil, but geologists connected with JOIDES say the ship they used could have drilled in 6000 feet of water.

John Loudon, chairman of Royal Dutch Petroleum, believes that by 1990 manned submarines will be tending undersea oil fields 2,000 feet down and that crude oil will be stored in sea-floor containers.

Coal has long been mined in Britain and Canada from shafts extending under the ocean. The Japanese actually build islands from which they can sink shafts into their Shelf.

Tin is dredged in shallow water off Indonesia. Iron is mined from beneath the Shelf off Newfoundland and from sandy bottoms off Japan. Oil companies are prospecting for gold in the Nome Sands off Norton Sound in Alaska, on the theory that if there was gold along the streams ashore, some of it must have washed into the sea. Even diamonds are being mined from the ocean off South Africa.

There are an estimated 10 trillion tons

of manganese in the Pacific alone, most of it precipitated in rock-like nodules lying loose on the ocean floor. Deep-sea cameras have revealed areas off the west coast of Central America 80 to 90 percent covered with nodules. Nodules often contains cobalt, nickel, zirconium and copper—all more valuable than manganese. It had been thought they occurred mainly in deep water, but Dr. Frank Manheim, of the U.S. Geological Survey, made a world study and discovered that manganese nodules develop as readily in shallow water as in deep, although those with the most cobalt, nickel and copper are found at greater depths.

"Want to see one?" he asked as we talked in his office at Woods Hole. I had read about nodules "as big as grapefruit." The one he lugged in was the size of my typewriter—a little flatter perhaps—and smooth as a bowling ball. It was streaked like a slab of bacon.

"See those black layers?" he said. "They're manganese. This nodule came from 2500 feet down."

"Would it pay to go after them?"

"I don't know," he replied. "In Ghana



you can dig high-grade manganese by strip-mining. It's hard to compete with that. But we have little manganese of our own. In an emergency we might have to go after nodules."

Fertilizer companies have been eyeing phosphate deposits off California and on the Blake Plateau. One company rented 30,000 acres of California sea bottom from the Department of the Interior. They found the phosphates all right, but also a no-man's land of unexplored ammunition. The area had been used for ordnance testing. Although not many spots would be so heavily booby-trapped, unexploded mines, torpedoes, and naval shells are a form of "pollution" underwater engineers will have to reckon with.

To comprehend the potential of the sea floor, you have to know something about the Continental Shelf. It has been defined as extending to various depths, down to 200 meters—656 feet. A more realistic yardstick sets the edge of the shelf at the first real jumping-off place. Worldwide, this occurs at an average depth of 432 feet and about 40 miles offshore. These are averages: Some shelves extend for hundreds of miles. Off other coasts, there's no shelf at all. A few slope gradually without a sharp break to depths as great as 1800 feet.

"Of all parts of the sea," wrote the late Rachael Carson, "continental shelves are most important to man as a source of material things." Only on the shelves does seaweed grow, and all of the world's great fisheries are over shelves. Beyond the drop-off there are no plants. The animals eat each other.

Our own shelf, to which we gained title by the U.N. convention ratified in 1964, adds more than 850,000 square miles to our "territory." (The Louisiana Purchase added 827,987.) This counts only the shelf proper—down to 200 meters (656 feet)—not the deeper bottom we can claim if we go after it.

Our 200-meter shelf stretches for 200 miles off Cape Cod, narrows to 100 miles off the Mid-Atlantic states, drops to 19 off Cape Hatteras, widens to 60 off Georgia, disappears altogether off Miami. It extends from 50 to 200 miles into the Gulf of Mexico, but barely 1 to 20 miles along our whole Pacific Coast. Off Alaska, it runs for 400 miles beneath the Bering Sea. Geologists say this vast underwater plain is among the flattest areas its size on Earth.

The drop-off or Continental Slope, averages about 80 miles in width in the Atlantic. It falls to from 2700 feet in some places to 9000 feet in others,

*(Please turn to page 210)*

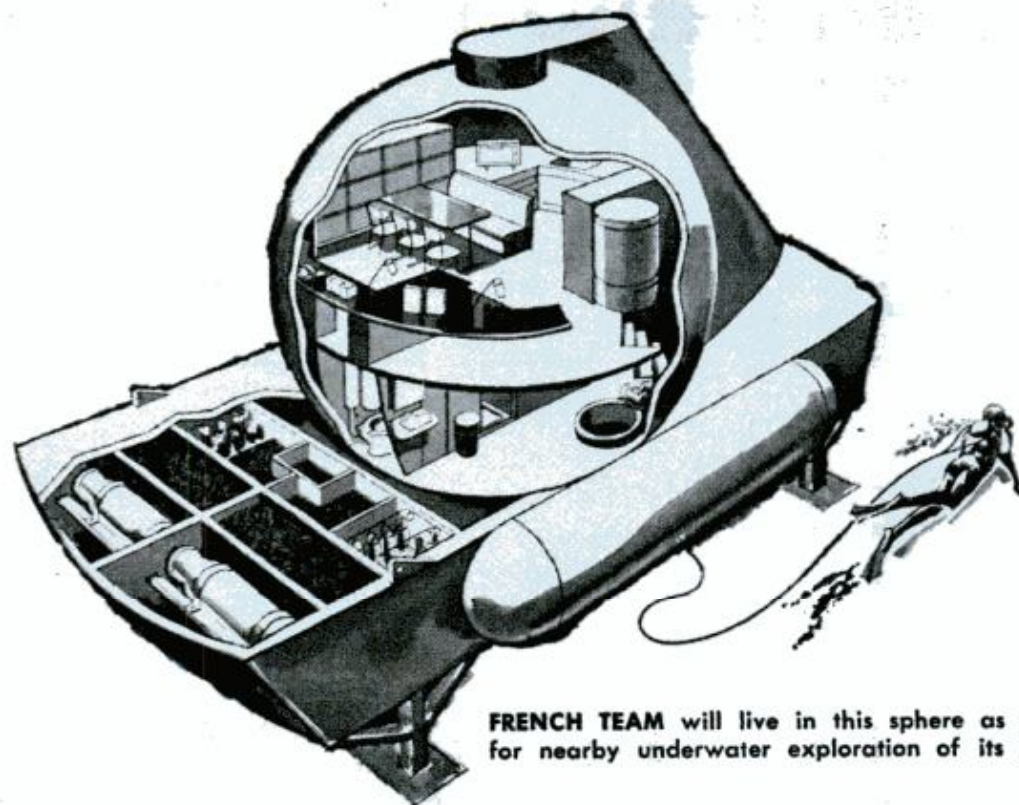

**FRENCH TEAM** will live in this sphere as base for nearby underwater exploration of its shelf





**Aggressive cowards** can now practice wrestling holds on an adversary that will not fight back. Designed by Jean Földeak, a trainer with the German Athletes Assn., a dummy made of plastic and stuffed with flexible foam withstands extreme punishment, and is equipped with arms and legs to simulate a live combatant.



**New at Le Mans** this year will be Ford's GT-P, presumably the car destined to spearhead the company's all-out racing effort once the GT Mark II is phased out. Only 38 inches off the ground, the rear-engined car features what designers hope are improved aerodynamics, automatic transmission and a 427 cubic-inch, 475-hp powerplant.



**Flip-top bow** on the new Welldeck runabout is full of surprises. The foredeck is actually a hinged lid concealing a large bow compartment ahead of the cockpit. The cover can be removed entirely if you want to run with the bow open. You'll find another lid in the floor of the bow compartment and under this is a small self-bailing compartment which makes a fine ice chest to keep drinks cold. If you're fishing, it becomes a fish box. If you're neither fishing nor drinking, it's a good place to stow odds and ends. Available in 15 and 17-foot models, the runabout is made by Wellcraft Mfg., Inc., Sarasota, Fla.



NEW FOR  
**YOUR HOME**  
BY MARION MOREY



**WINDOW GREENHOUSE** installs outside window casing. Ventilator and water reservoir allow environment control. Window and shelves hold four pots. \$89. American Cyanamid, Box 350, Wakefield, Mass.



**LIGHTED DOOR CHIMES** powered by low-voltage wiring give off a soft glow through amber-colored translucent bottle glass. Price: \$14.95. By Nutone, Madison and Red Bank Rds., Cincinnati 27, Ohio



**GAS GRILL** cooks like indoor oven, gives outdoor flavor. Twin burners heat from 350° to 1000° F. for roasting and grilling simultaneously. With 340-square-inch area and 8-inch depth, grill holds 22-pound turkey with lid down. Features: 360° swivel action for facing unit from wind and a flip-over cooking grid for searing. Unit costs \$65 uninstalled; trays and rotisserie are optional. Arkla Industries, 810 E. Franklin, Evansville, Ind.

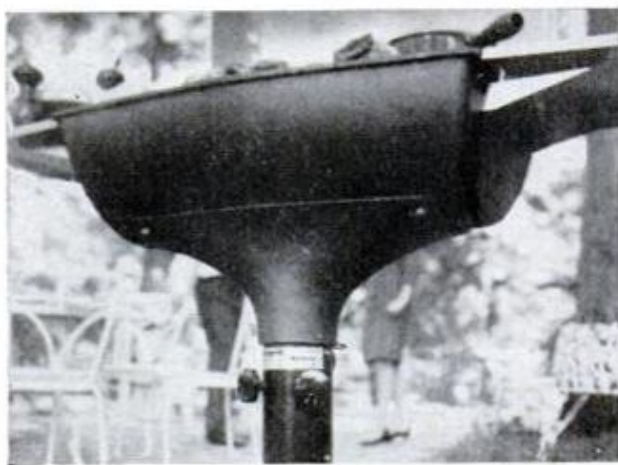





**AUTOMATIC CLOTHESBRUSH** vacuums hidden dirt and sweeps lint from clothes. Twelve-ounce unit operates 12 days with overnight recharge. Nylon brush comes out for washing. \$14.95. General Electric



**BRIEFCASE VACUUM CLEANER** just 8 inches wide features disposal bags with handles. Simply lift bag away; no dirt spills. All-steel enameled custom model on wheels costs \$80. Made by Sunbeam



**VAPORIZER FOR CHILDREN** looks like a toy and cheers those with colds or croup. Of unbreakable plastic, it holds a night's supply of water, shuts off automatically. \$12.95 from Purepac Corp., Elizabeth, N.J.



# OCTOPUS RASSLIN' IS HAND-TO-HAND-TO-HAND-TO-HAND

By William L. High

Octopus wrestling originated with Puget Sound skin divers in an area where octopuses—weighing up to 100 pounds and stretching 20 feet or more—abound. In contests, divers wear snorkels during 2½ hours of hunting, and scuba gear for one hour. World championships, sanctioned by the Underwater Society of America, are usually held in spring when octopuses are abundant in the Puget Sound area. Divers use no weapons.







**MOST DANGEROUS TIME** is when diver tries to pry octopus loose (left). The creature could wrap several arms around diver while clinging to rocks with other arms. Usually, however, if diver lets go, so will octopus. Full-length diving suits protect body from welts of suction cups (above), although many divers have lost swim fins and breathing gear. After weighing and tagging (for research purposes), octopuses are returned unharmed to sea.

Two things work for the hunters. The octopus is basically timid, and divers work in teams. One man goes down (about 50 feet) and tries to force an octopus from his cave. When he comes up for air, the second man goes down and tries to pry the octopus loose from the rocks. If he's not up in 30 seconds, the third man goes down. They don't harm the animals. They just weigh them and throw them back in.

Why do they do it? Well, why not?





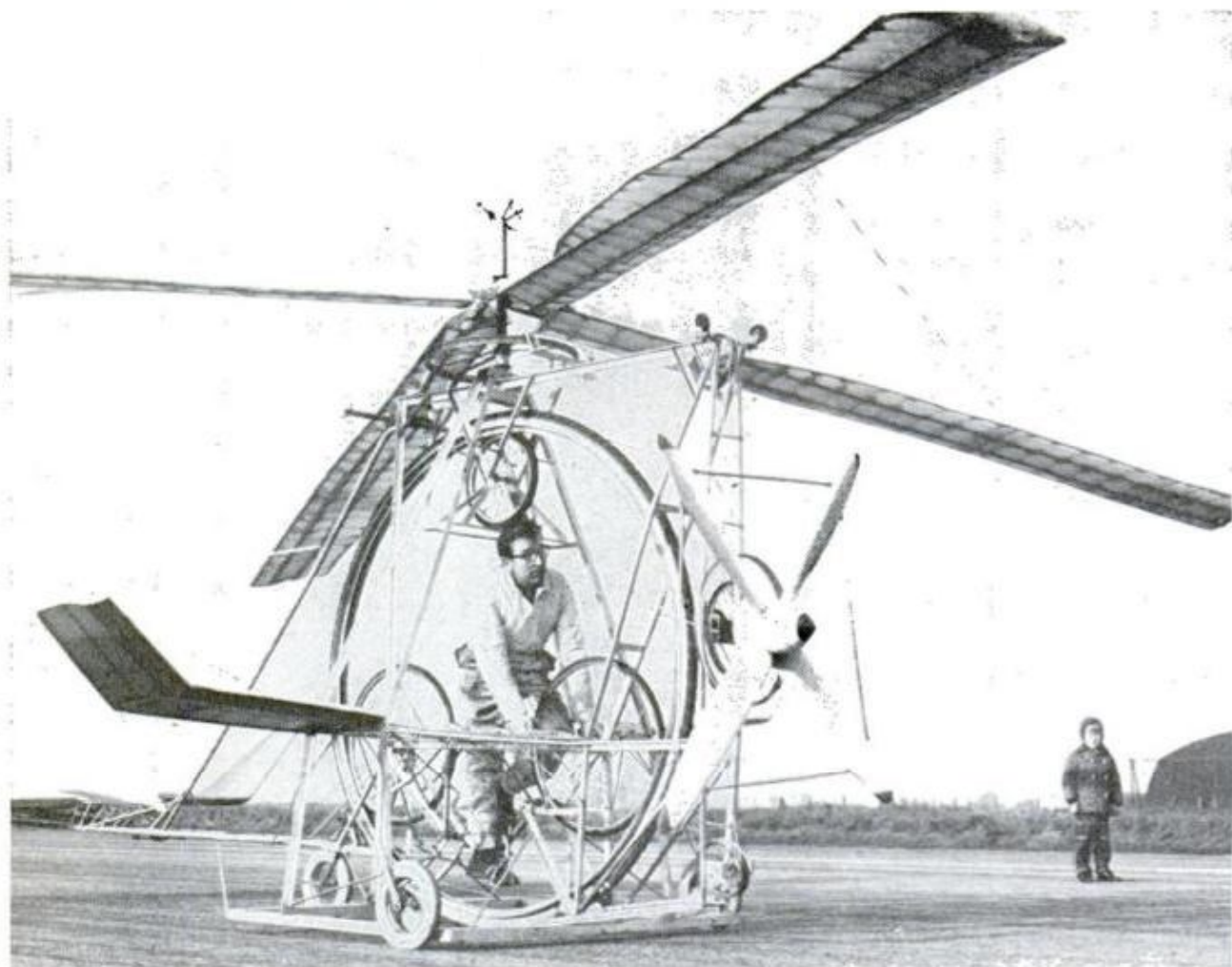

**Earthbound** is the fate of this lofty-minded Briton and his flying machine. Competing for a £5,000 prize, Bob Wilson didn't quite make it off the ground in his autogyro bike, despite its abundance of mechanical paraphernalia—13 wheels, 40-odd gears, 4 rotor blades, a tailplane and rudder, and port and starboard wings.



**Plastic skating.** To extend the old-time winter favorite to a year-round sport, an enterprising Dutchman, Kryn Noels, designed a new type of skate. Its tiny, sharp-edged wheels cut into the plastic just like regular blades into ice. Plastic plates of approximately 2 by 27 yards form the rink surface.





**Verdant slopes** of Swiss countryside stretch out beneath skiers hurtling through the air on a hot day in July. Undeterred by lack of snow, jumpers may now train all summer on jump runs covered with a special, heavy-duty, plastic mat—reportedly almost as slippery as snow. At Ruschegg these determined young athletes carry on summer practice.



**Strictly for the birds.** To afford birds the fresh-air pleasures enjoyed by other household pets, Phil Benjamin built this "bird-pram." Its fully-equipped cage is detachable and may be hung indoors.



**Clean livin'.** Marine Corps Staff Sgt. Walter Mothershed beat the shortage of laundries in Vietnam. Taking a steel box (which once contained twelve time fuses), ammunition rods (to serve as legs) and ammunition boxes (to provide the base), he built his "Mothershed Machine." Steel handles turn the box and agitate the clothes inside.



## WHAT'S NEW FOR CAMPERS

Portable showers and electric toilets, fluorescent lights and infrared cookers, piggy-back car campers and folding motels—a gaggle of gear just to keep campers comfortable.



**FOR CAMP CHILLS**, Snuggle Rug is a pile-lined zippered bag of Naugahyde that comes up to the waist



**TOTEMOTEL** is a fibreglass camper that weighs only 375 pounds and mounts on any station wagon or sedan. It will sleep 11 persons, and is equipped with a butane stove, a sink, an ice chest and a chemical toilet





**PATIO** with slide-out canopy is a feature of the "dream camper" designed for Chevrolet truck chassis

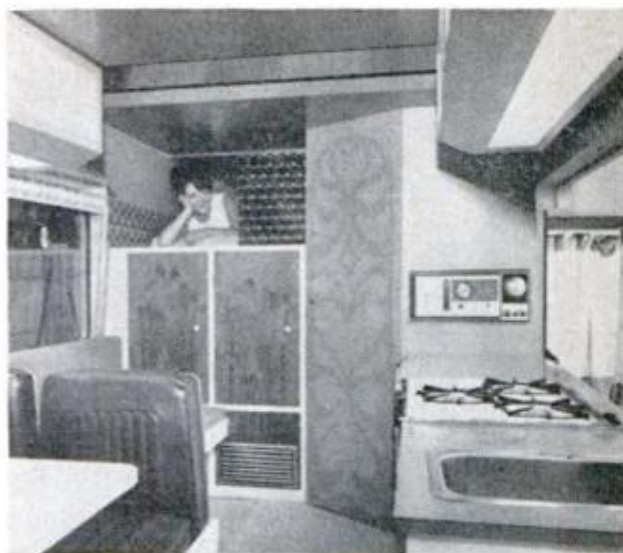

**LUXURY INTERIOR** sleeps four, has full kitchen, toilet, shower, airconditioning and AM-FM radio



**PORTABLE SHOWER** has a five-gallon water tank on a swivel that operates by gravity for 12 minutes

MAY 1966

**THE ROBIN** has been displaced as the harbinger of spring.

In his place is the sight of hundreds of thousands of sleeping bags being aired on the clotheslines of suburbia and tents popping up in back yards to have their seams tested.

This is a result of the camping boom; one of the great phenomena of our time. It has been estimated that in 1965 approximately one-fifth of the total population went camping. This year 5 million new campers will take to the outdoors.

To accommodate this deluge, the National Park Service has built 2108 new campsites, bringing their total to 29,890 in 77 areas. All of the state parks are expanding their facilities and private campgrounds are mushrooming all over the country.

One of the major causes of this boom is modern equipment. As the makers of camp gear have learned, behind every successful camper there's a woman. To lure a lady into the forest has never been a simple task, but equipment manufacturers have solved the problem by making camping as comfortable as her home.

A survey of new camping equipment proves this point.

The folding tent trailers are a good example. Just two years ago they were the epitome of comfort under canvas with two large foam-rubber beds, and last year you could get optional equipment for them like a stove, sink and ice box. But this year, they're complete motels on wheels. I looked through the Apache, Nimrod and Starcraft—the three most luxurious models — and they're



equipped with full kitchens, folding dinettes and chemical toilets. They're bigger than ever and, with double bunks in place, they'll sleep eight people comfortably. And they're even equipped with fluorescent lights.

A sure sign that the camping boom is here to stay is the Coleman Company's introduction of a new line of sleeping bags and tents. And here, too, the emphasis is on comfort and convenience for the family camper. Ignoring weight factors that are crucial to the backpacker, their bags are large and thickly packed, weighing as much as 17 pounds. They've eliminated the overhead flap on the contention that most campers will not be sleeping out under the stars. The bags come with a zippered duffle bag for carrying. In their tents they've come up with a new springbar device that makes them amazingly simple to erect and eliminates any center poles.

Sears, Roebuck and Co., another old-timer in camping gear, is following the trend with a pickup camper coach that sells for \$1895.

A low-priced tent camper of unusual design is the "Flipper." It sleeps only two, but it folds up into a metal box that weighs 145 pounds. With another man I was easily able to hold it up over my head. It is hauled on the top of the car and set up on the ground at the campsite on adjustable legs. The price is appealing, \$349, and it's made by Met-L-Fab, Inc., 7235 Shawnee Run Rd., Cincinnati, Ohio.

The Thermos jug has been going camping for so long that one has a tendency to forget that the original was made by the Thermos Co. This year they've added a stainless steel model that is a beauty. They also have a lantern with the light on the bottom side to give a direct beam of light and it burns any type of gasoline.

I also tried erecting one of their new pop-up tents, and nothing could be faster or easier. This is a big thing when you come wheeling into a campsite about dusk after a long drive, and the kids are hungry, and the last thing you feel like doing is wrestling with canvas and tent poles. And to break camp, you just push down on the peak of the tent, lift it up like a folded umbrella and toss it into the station wagon.

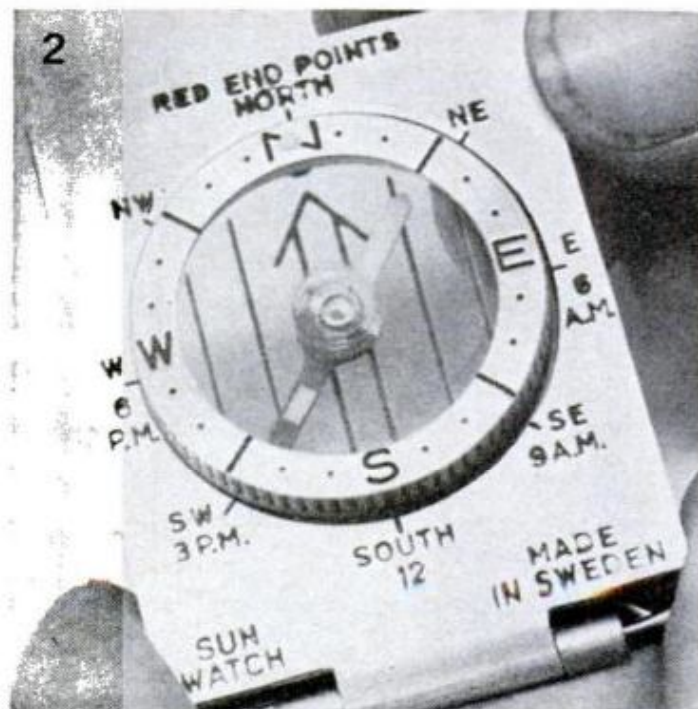
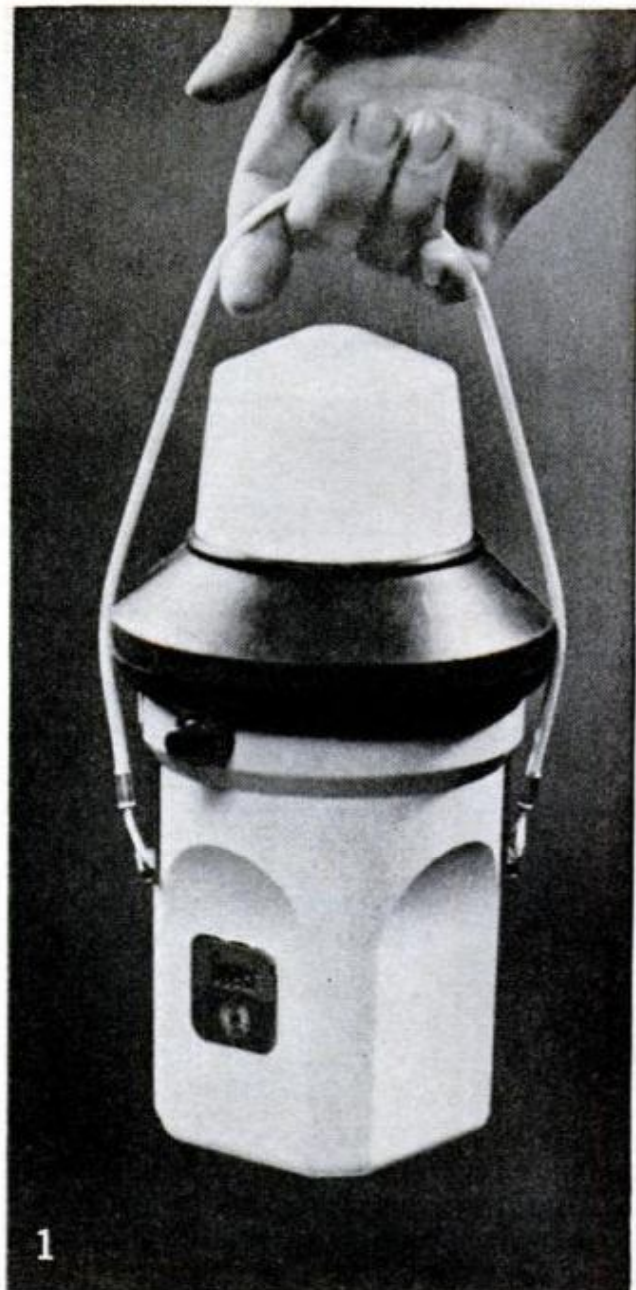



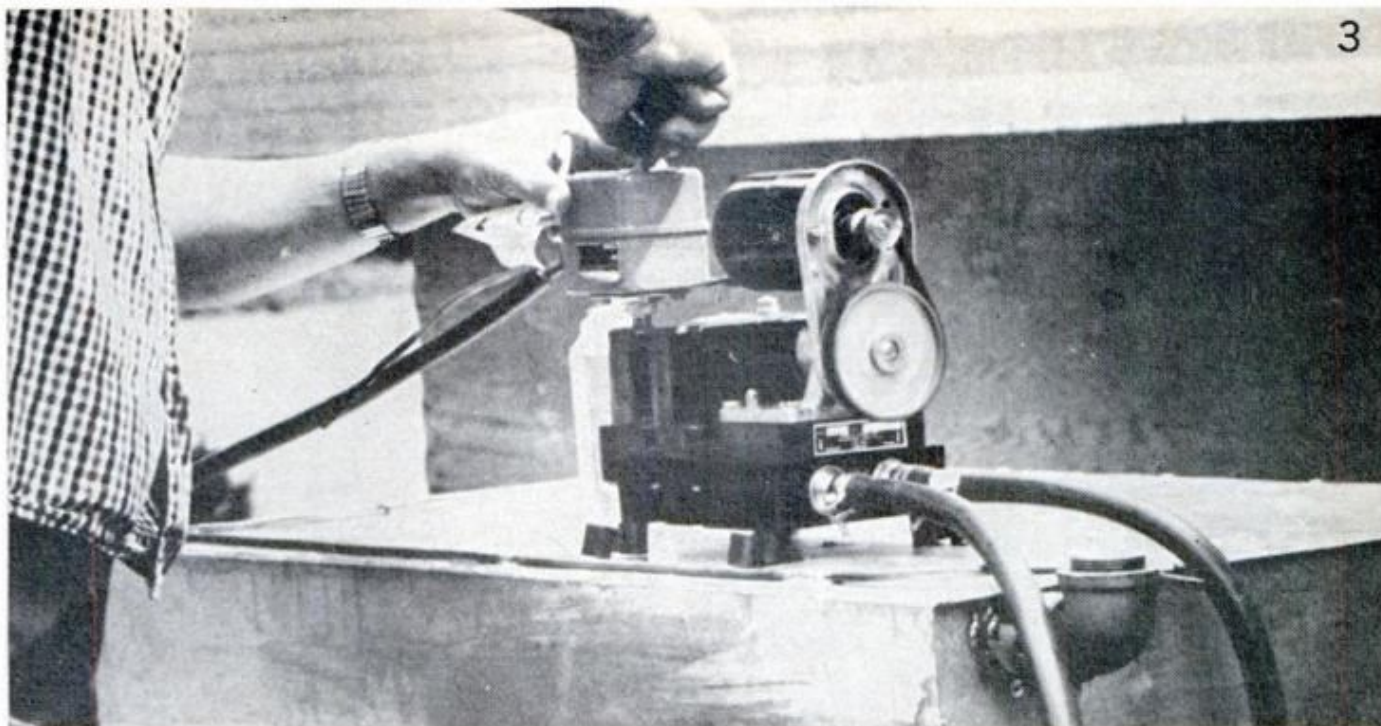

3

**1. BATTERY-OPERATED Camp Lamp** gives off a diffused light on high or low beam. It has an unbreakable plastic case and can be hung in any direction

**2. TWO-INCH POCKET COMPASS** combines a protractor and a sundial to give approximate time of day. It's made by Silva, LaPorte, Ind., sells for \$5.95

**3. TINY WATER PUMP** is the size of a loaf of bread. Operating off 12-volt car battery, it pumps three gallons a minute, turns off and on automatically

**4. FLUORESCENT LIGHT** with a 12-inch tube operates off dry cell batteries and can be used in a tent or carried in the woods. It also runs off a.c. current

**5. POCKET-SIZE MONOCULAR** is 10x20-power precision instrument, weighs four ounces. Available from Camp & Trail, 112 Chambers St. New York, for \$11.75

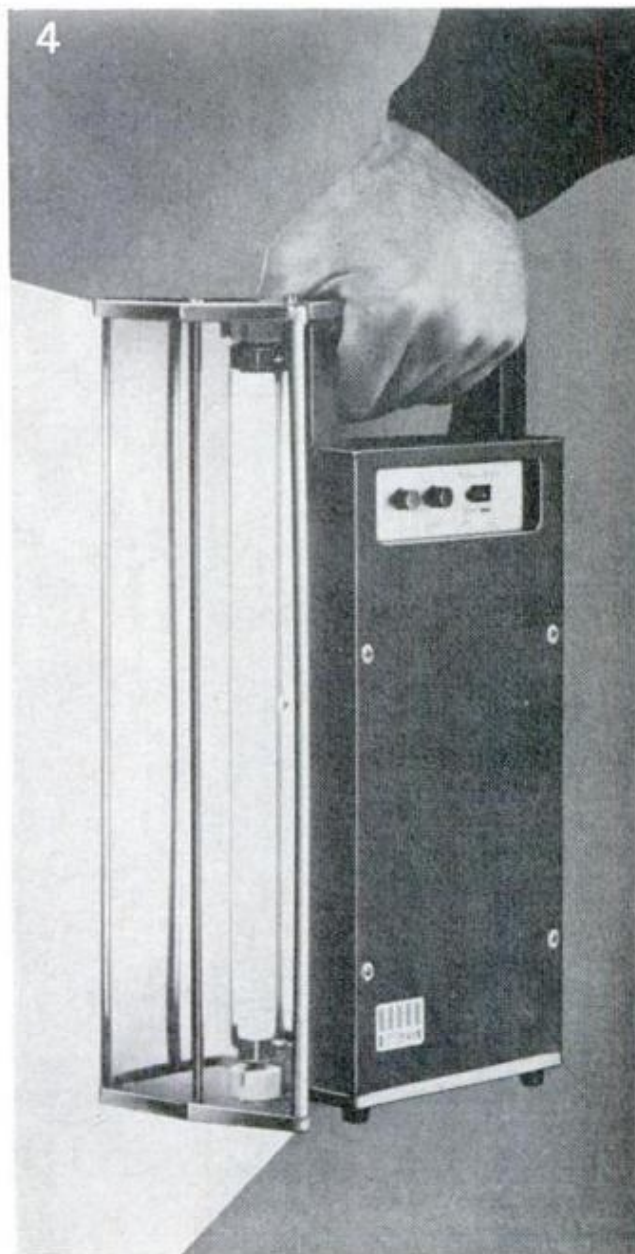

4

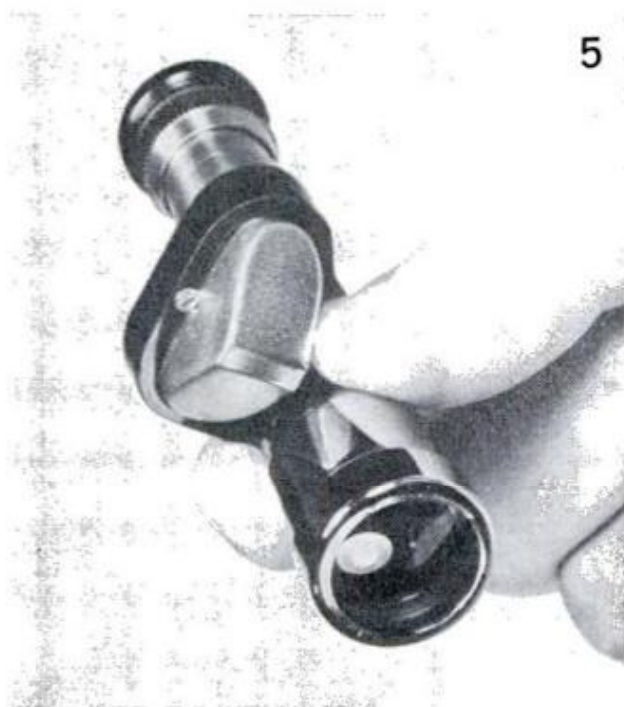

5



## Multi-purpose Cutting Tool

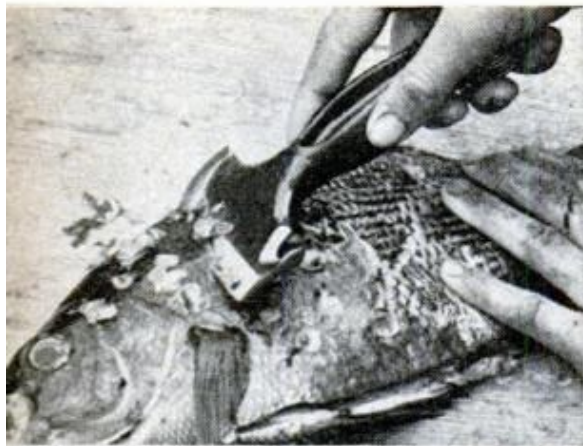

**THE SKACHET** is a cross between a bowie knife and a tomahawk. Ideal for skinning game, it also scales and guts fish. It cuts its own handle for use as a hatchet, cuts rawhide laces, and can be used as a hammer. Sold for \$7.50, it is available from Skachet, Inc., Box 302, Springfield, Va.

Like last year and the year before, there are new accessories to turn the campsite into an indoors at the outdoors.

There is a portable infrared heater and cooker that can be connected to any large propane gas cylinder. The heater puts out 6500 B.T.U.s an hour; when the head is turned, it becomes a grill to accommodate a 10-inch pan. It's priced at \$22.95 from Paulin Products Co., 2536 St. Clair Ave., Cleveland, Ohio.

Kampers Kupboard table is a metal food storage cupboard with three shelves and a two-by-five-foot table that folds into a 10-inch package for traveling. It's made by Geo-Drill Co., 4509 W. 113th St., Minneapolis, Minn., and sells for \$34.95.

A water pump about the size of a loaf of bread is available for truck campers. It operates off a 12-volt battery and pumps three gallons a minute. It's made by Peters and Russell, Inc., 550 Liberty St., Springfield, Ohio, and costs \$105.50.

Specifically for the woman in the woods, Camp'otel Corp., 3452 W. Vickery, Fort Worth, Tex., has a portable shower with a colorful canvas shelter and a five-gallon water tank that runs by gravity for 12 minutes. It is priced at \$39.95.

A pair of battery-powered camp lights are new this year. The Camp Lamp, made by the Guest Corp., Bloomfield, Conn., gives off two levels of diffused light. It can be carried or hung by its lanyard or it can be mounted on a tree or tent pole by a special bracket. It sells for \$14.95. The Safari Lite is a fluorescent light with a 12-inch tube. It is completely portable, but will also operate off a.c. current. It's made by Burgess Battery Co., Freeport, Ill., and sells for \$29.50.

A change in camping equipment this year is that there is a noticeable lack of the gimmickry that is usually on the market as a lure to the new and inexperienced campers.

"The camper of today isn't easily taken in," explained a major equipment manufacturer. "If he's been camping for a few seasons he knows what he wants. And if he's just starting out he'll have neighbors or friends who will give him tips."

Another factor is the growing trend for the first-time camper to rent his equipment to find out if his family is going to enjoy camping.

"I'm for anything that makes camping more pleasurable," a veteran camper told me. "We're not out for a survival test; we're here to relax and enjoy the outdoors. I'm just waiting for somebody to come up with a portable dishwasher."—*Stuart James*



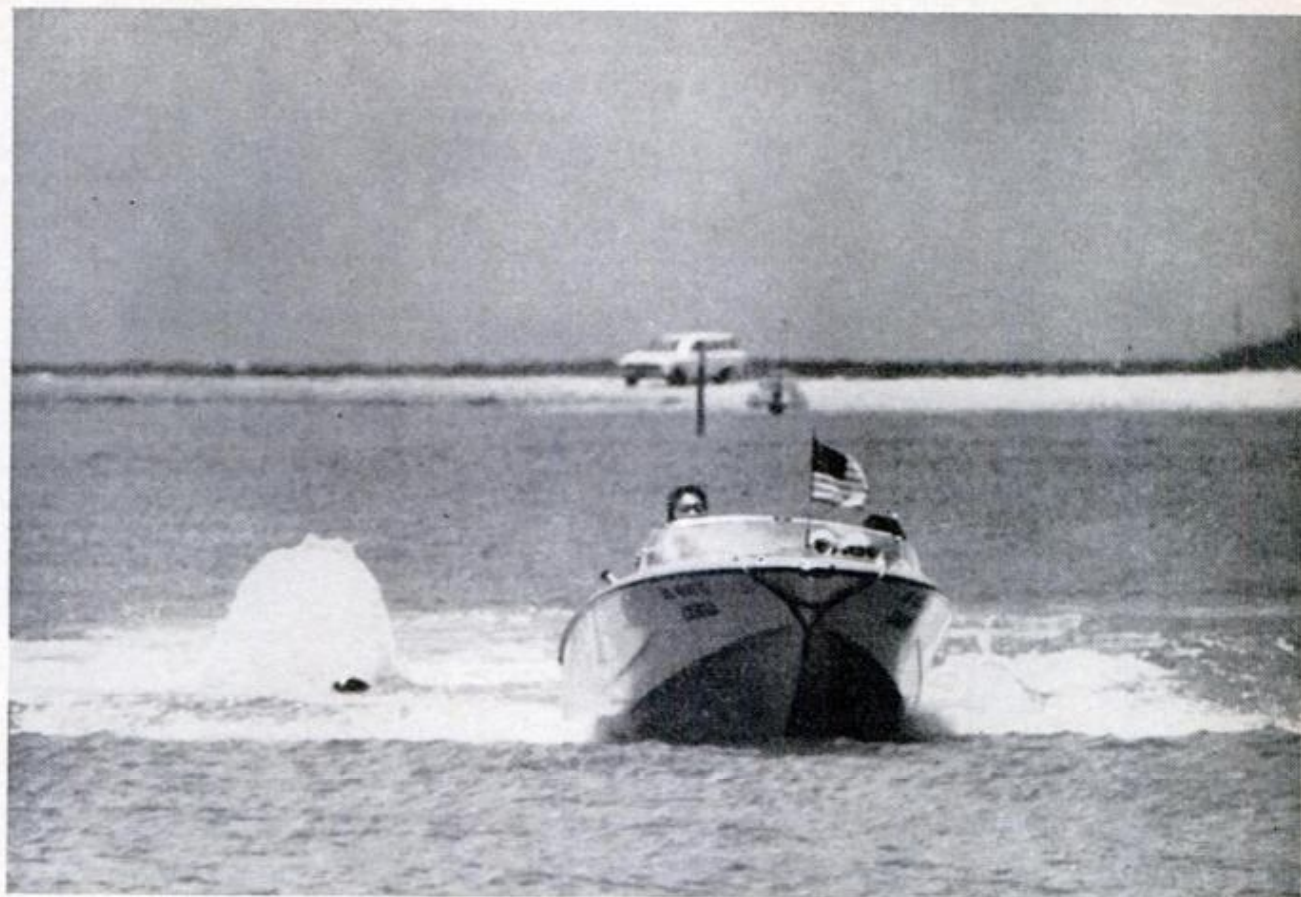

**One size fits everyone.** The Sea Sarong, a wet-suit jacket without seams, fasteners or closures, is made of a single strip of synthetic foam rubber. Wind it tightly around the trunk, placing a leg through a single hole at one end and the arms through two holes at the other. Innerspace Corp., 19017 E. Leadora Ave., Glendora, Calif. 91740.



**Seagoing backslider.** Pulled along by a boat at speeds close to 30 mph, Archie McPherson goes water skiing on his back. The skier can lie flat or sit upright. In the former position, a cone of water splashes over him (top photo), created by the turbulence of his head being propelled through the water. When he breaks through the surface, the cone becomes a geyser.



# Roughing it in high style

*Hot popovers for breakfast, iced wine with dinner; airconditioning, electric lights, running water and foam rubber beds!*

*This is par for camping indoors at the outdoors*

*By STUART JAMES, PM Outdoors Editor*

HIGHLY MANEUVERABLE, the 14-foot "Scotty" bounced over a rutted dirt road with ease, and we camped right next to a boiling trout stream for a day of fishing away from the crowds

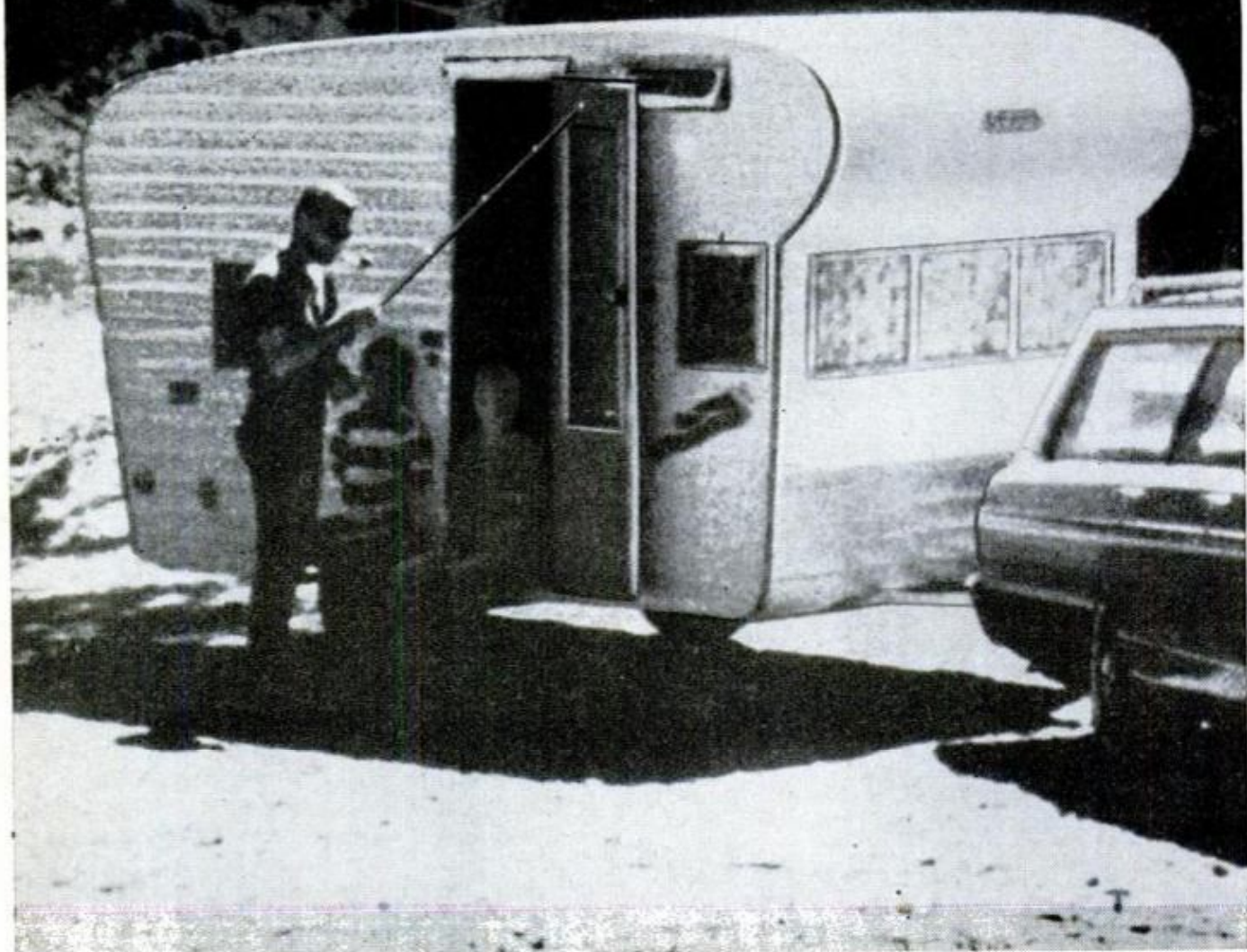



**H**EADING SOUTH FROM MONTEREY we followed the scenic coast highway at a leisurely pace, the 14-foot travel trailer tracking the Plymouth station wagon like a docile and obedient lamb.

Where were the driving difficulties I had been led to expect from the trailer: the swaying, balancing and jolting? They never occurred. I had to adjust to viewing the rear through the large side mirror, but other than that the rig handled with complete ease.

When we reached Big Sur we pulled into the entrance to a private campgrounds, wound down through a stand of towering redwoods, clattered across a wooden bridge and stopped at the gatekeeper's office.

The manager, Burley Farber, came to the window to ask how long we'd be staying, quoted his fee of \$2 a night or \$10 for the week, then asked, "Sun or shade?"

"Sun," I said.

"Better take shade," he said. "You'll cook in that thing during the day."

I was later to prove him wrong by parking all day under a hot sun (the little trailer stayed as cool as morning mist), but I could see that he wasn't used to being argued with. I was out of the car to fill out a registration card, which Burley read and filed. Then he came out of his office, slid behind the wheel of the wagon, and proceeded to park the trailer in its appointed campsite.

"Do you do this for everybody?" I asked.

"If they're inexperienced," he said. "There's nothing to backing them around





## Roughing It . . . High Style

once you get the hang of it, but it's a little tricky at first."

"How do you—am I wearing a sign or something?"

"Brand new trailer," he said, grinning. "First time out, right?"

"Right."

"Just want you to start off easy. We like a happy camp. You can hook into the water right there." He pointed to a pipe and faucet growing out of the hard-packed earth at the side of the trailer. "The electric is on that tree. Need any help with anything just holler." He left.

When he was out of sight I threw a few handfuls of dust at the trailer to dirty it up a little. Holler for help, he said. And my two kids right there to hear the whole thing. Not on your life, fella!

The water hookup was easy. (A book of directions came with the trailer.) A length of rubber hose attaches to the faucet and a connection in the side of the trailer. Turn on the faucet. Running water. I plugged the heavy-duty electric cord into the outlet in the side of the trailer and carried the other end to the outlet box mounted on the tree. It wouldn't fit. The plug on the trailer cord was a large, three-pronged affair. The out-



**MAKESHIFT ADAPTER**, two-prong plug on stiff wire, helped make industrial plug fit campground outlet

let took a normal-sized plug. My son, a 12-year-old, shook his head. My daughter, a 7-year-old, said, "I'll get the man."

"Never mind! I'll go!"

I found Burley in his gatehouse office. "There's something wrong with your outlet," I said.

"Oh, you've got one of those industrial plugs," he said cheerfully. "Damned if I know why they put them on all the trailers. There isn't a campground in the country uses that type outlet. Have you fixed up in a few minutes."



**ROUNDED BODY** of this 24-foot Airstream is designed to cut down wind resistance. The aluminum reflects the sun, keeping the interior relatively cool even in an open area such as this one at Cape Hatteras, N.C.





**REAR END** of this 14-foot "Scotty" trailer is a spacious divan. The top bunk is folded away overhead



**MAKING BEDS** is a simple matter of pulling out the divan and letting hinged top bunk drop into place

We hiked back to the campsite. With an electric drill he put holes in two of the large prongs. Then he took a normal-size male plug on two short lengths of stiff wire, attached it to the industrial plug and carefully taped it. "That'll do the trick," he said, gathering up his tools. "I'll put the 50-cent rental for the plug on your bill." He left again.

The kids ran around the trailer and clambered inside. I plugged into the outlet and shouted, "Let there be light!" And there was light.

For the next five minutes we were like a tribe of aborigines suddenly catapulted into a modern house. We turned the faucets on and off, rushed outside to see the water drain onto the ground. We flicked the lights on and off, sat at the dinette with an opened book, marveling that we could read the words—ignoring the fact of sunlight streaming through the window.

When the four-burner gas stove did not work it was Burley who discovered that [\(Please turn to page 222\)](#)



**FOUR-BURNER** gas stove and oven is a feature that appeals to women who abhor campfire inconvenience



**TOP BUNK** in this 24-foot model folds down from the wall. Divan, below, pulls out to make double bed



# Rugged camps turn

Outward Bound camps are the world's toughest. Every kid must swim with arms





# boys into IRON MEN

tied, run cross-country, climb mountains and hunt alone for food for 72 hours

By JAMES R. BERRY



"WE'RE NOT IN THE RECREATION BUSINESS," they told me . . . and they're not. I saw boys bob and gasp for air while trying to stay afloat with arms bound behind them. I saw boys crawl over a rope bridge that swayed and writhed some 40 feet above solid ground. I saw boys, still sweaty from a two-mile run, leap from a 25-foot-high pier into seawater cold enough to kill a man in 45 minutes.

Nobody would call *that* recreation, least of all the men who run the Hurricane Island Outward Bound School, one of four such schools in this country where boys 16 to 23 years old discover they're capable of physical exploits that would have staggered a grizzled pioneer. "Here, guys develop a different attitude toward overcoming obstacles, one that carries over to everyday life," says George Thomas, staff member on Hurricane Island. "That's the real point of Outward Bound."

The Hurricane Island and other Outward Bound schools make no secret of their tough programs. Still, to kids accustomed to all the comforts of home, the rugged routine often produces a daily barrage of physical and emotional jolts. "I expected something like this, but nothing as rough as I've gone through," Jose Morales told





**1.** Perhaps toughest on the boys' nerves is the rappel descent, learned only days before, down the face of 110-foot cliff

**2.** It takes teamwork and agility to scale the 13-foot wall on the Hurricane Island obstacle course. Here is how it's done

**3.** "Float-breathe" technique enables kids to stay afloat for hours. Arms are tied behind the back to simulate muscle cramp

**4.** No instructor accompanies boys at Colorado school on four-day hike. It's a demanding test of their survival know-how

**5.** The end of a rugged race on Hurricane Island. Seconds after this photo was made, the runner collapsed from exhaustion

**6.** Water survival is stressed at Maine school. Kids even learn to like seafood that they're taught to hunt and prepare

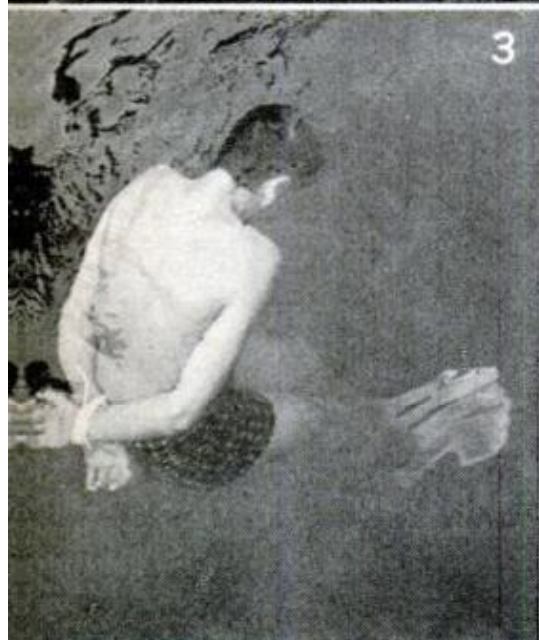



me. Jose is a slim lad of 16 whose olive skin and accented speech are instant reminders of his birthplace, Puerto Rico. Now a New York City "slicker," he told me with a mixture of astonishment and pride: "I just finished three days on an empty island. Alone. Me, alone for three days! It was nutty, but I made it."

He referred to the "solo," an event every Outward Bound student must cope with. Early one morning toward the close of his stay on Hurricane Island, Jose had snatched a quick breakfast and boarded a small motorboat with half a dozen tight-lipped comrades. With a roar echoing through the predawn stillness, the craft started up and ploughed through the choppy Maine waters, dropping off each boy on one of the dozens of small, deserted islands in the vicinity. Finally, Jose's turn came.

Two weeks before, he might have panicked as the fog folded around the disappearing boat. Instead, Jose swallowed hard and checked his gear: a sharp knife, poncho, several feet of string, a packet of salt and 12 matches. These things and the clothes on his back were all he had to keep warm, fed and dry until he was picked up 72 hours later. Plus his training, of course.

By nightfall, Jose had explored the island, built a pine bough lean-to, eaten a meal of stewed mussels and wild berries, and was comfortably installed on an insulating bed of pine needles. The next day's activity: some casual fishing with a thorn hook and rest. "Man, once I found I could make it on that

island, I just rested as much as I could," he later explained. "That's why they have solo. Otherwise they'd be sending home skeletons."

### Lost track of time

The solo is often the first time a boy is really on his own. Most, like Jose, make out amazingly well. In one instance, a boy from Hurricane Island lost track of time and thought he had another day coming. For that evening's meal he had prepared a banquet of wild greens and five kinds of seafood. "We let him cook the meal in back of the mess hall" says George Thomas. "That night he ate better than we did."

Days at an Outward Bound school start at 6:00 o'clock with a two-to-five-mile run, followed by a dip in an icy stream or the sea. For 15 hours afterwards, students are peppered with instruction in such things as wilderness survival, mountaineering, meteorology, first aid, map reading, navigation and water-rescue techniques.

Each of a school's three summer sessions lasts just 26 days, barely time enough to cram in all the instruction and put it to practice. Consequently, initiation into Outward Bound's routine is swift.

At the school in Minnesota, for example, new arrivals are met by Director Bob Pieh, a muscular man with graying, crew-cut hair and a warm manner. One new group's experience is typical. "I realize you're all tired from traveling,"

*(Please turn to page 206)*





# He stalks sharks by kayak

By GEORGE X. SAND

*Open seas hold no terror for adventurous Ben Logan, Florida fisherman, who goes after the big ones in a fabric-covered boat.*

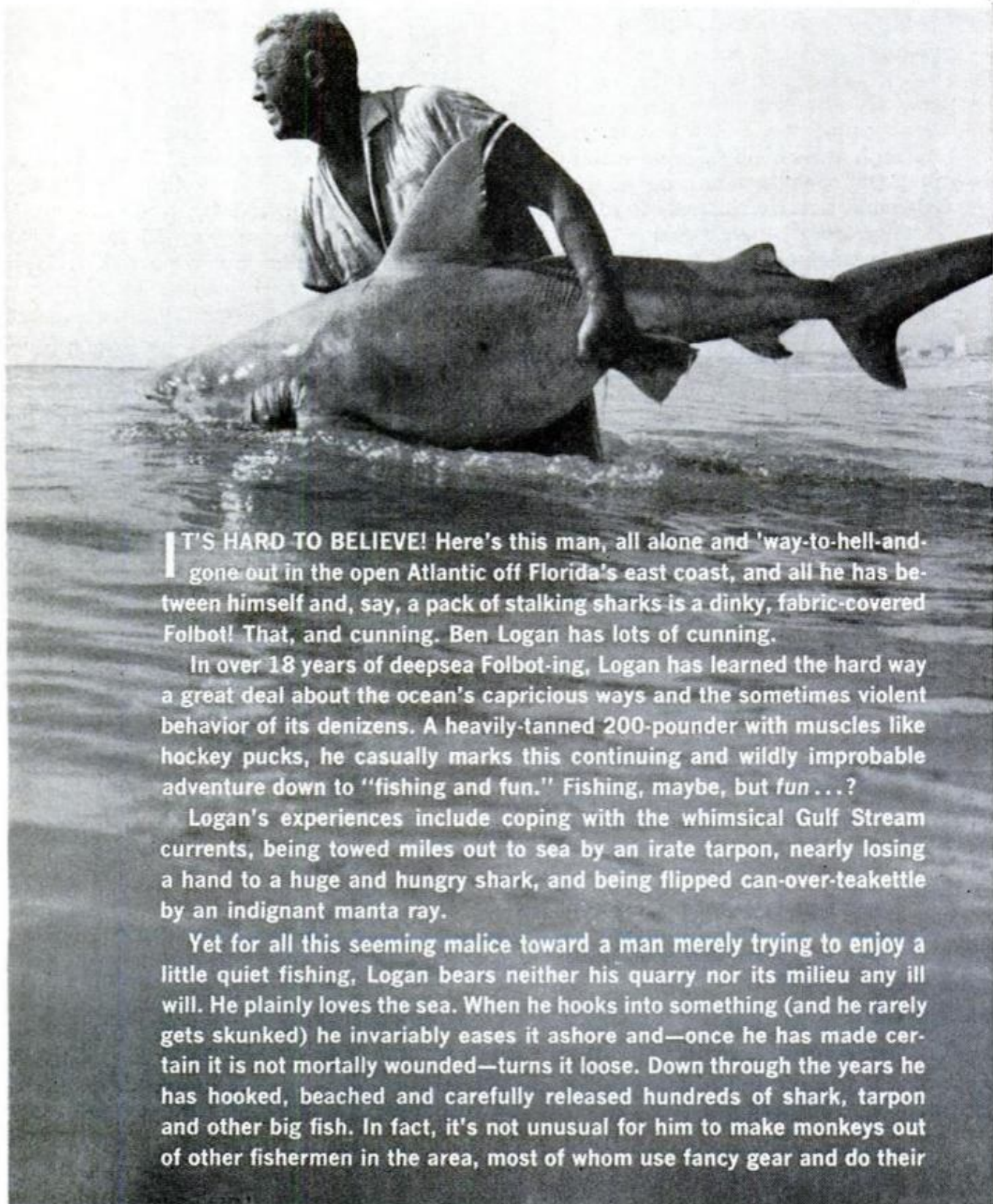

**I**T'S HARD TO BELIEVE! Here's this man, all alone and 'way-to-hell-and-gone out in the open Atlantic off Florida's east coast, and all he has between himself and, say, a pack of stalking sharks is a dinky, fabric-covered Folbot! That, and cunning. Ben Logan has lots of cunning.

In over 18 years of deepsea Folbot-ing, Logan has learned the hard way a great deal about the ocean's capricious ways and the sometimes violent behavior of its denizens. A heavily-tanned 200-pounder with muscles like hockey pucks, he casually marks this continuing and wildly improbable adventure down to "fishing and fun." Fishing, maybe, but *fun*...?

Logan's experiences include coping with the whimsical Gulf Stream currents, being towed miles out to sea by an irate tarpon, nearly losing a hand to a huge and hungry shark, and being flipped can-over-teakettle by an indignant manta ray.

Yet for all this seeming malice toward a man merely trying to enjoy a little quiet fishing, Logan bears neither his quarry nor its milieu any ill will. He plainly loves the sea. When he hooks into something (and he rarely gets skunked) he invariably eases it ashore and—once he has made certain it is not mortally wounded—turns it loose. Down through the years he has hooked, beached and carefully released hundreds of shark, tarpon and other big fish. In fact, it's not unusual for him to make monkeys out of other fishermen in the area, most of whom use fancy gear and do their





**LOGAN CRASHES THROUGH SURF** en route to open water and a go at the big 'uns. Fabric-covered boat ships surprisingly little water, is unsinkable thanks to inflated air bags



**GAFFING A BIG SHARK** requires caution and dexterity. Logan finds Folbot both seaworthy and maneuverable. Paddle is nine feet long and spoon-shaped, jointed for easy stowage

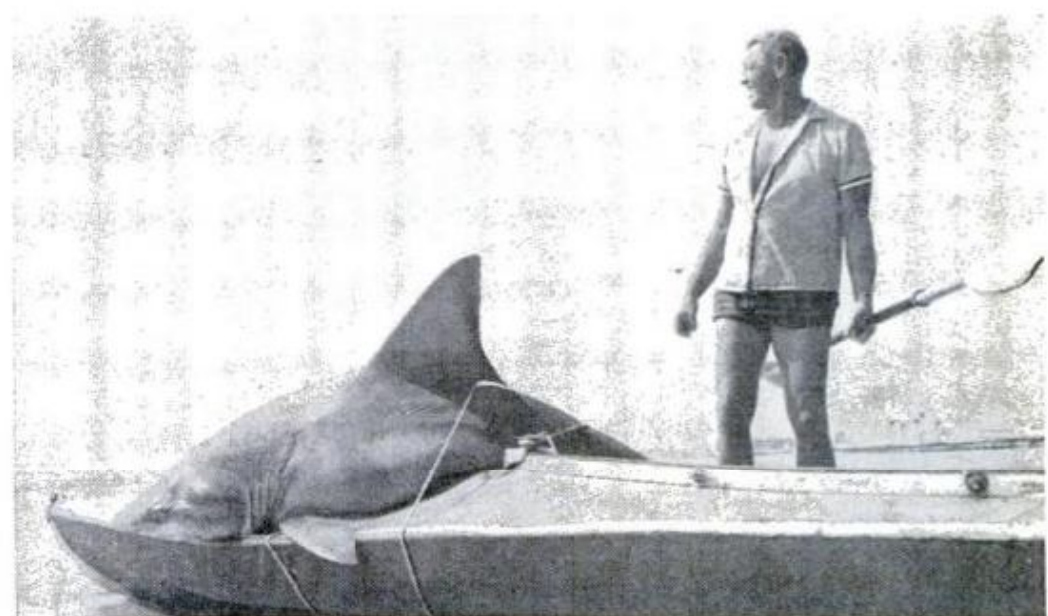

**LOGAN LUGS HIS CATCH ASHORE** where it will be released once he's made sure it will survive. Big fish can be dangerous during release; Logan's hands bear many hook scars







**A KEEN STUDENT** of lures, Logan says Pikie minnow is best for his comparatively slow trolling speeds. He uses several feet of steel leader and a big swivel

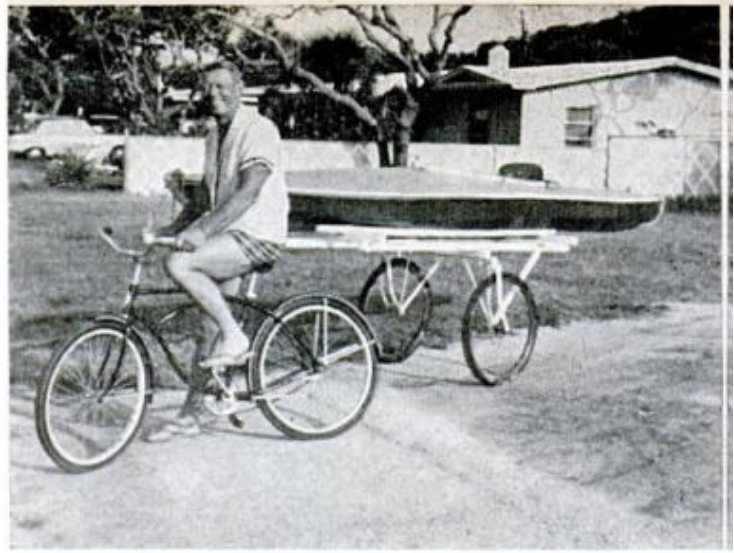

**LOGAN DESIGNED** and built this special trailer, uses it to haul his Folbot on short trips near his home. On longer trips, he packs boat on rack atop his car

angling from large, comfortable boats.

"If the weather's good I can go anywhere they can," Logan says matter-of-factly. "Because I'm truly portable I can get to a lot of places those other fellows can't. If I'm driving along and spot some feeding fish, why I can launch and paddle out without losing too much time."

During a typical fishing trip, Logan, a civilian technician at Cape Kennedy, may roam great distances, at times 30 or more miles offshore. He may stay out an hour or so, 24 hours or even several days. His fishing "uniform" is a pair of swim-trunks, period. No hat, no sunglasses. Once during a trip to Bimini in the Bahamas (Yes, Bimini!) Logan battled rough water for 36 hours only to realize the Gulf Stream current had carried him hopelessly off course. When a Coast Guard cutter stumbled across him he was salt-seared and painfully sunburned, his eyes blackened and swollen nearly shut. Offered a line and a lift ashore, Logan assured his would-be benefactors he didn't need any help and reluctantly put about and headed back home.

One night during a 50-mile paddle along the coast to New Smyrna, Logan got hungry and opened a can of tuna. As he held it over the side to drain off the oil he spotted in the moonlight an enormous convoying shark, its jaws about six inches from his hand.

"I didn't argue," Logan says wryly. "I just dropped the can."

Logan once hooked a big tarpon that took off like a shot and towed him sev-

eral miles. The joyride came to an abrupt halt when the fish dragged Logan and his 58-pound boat across a patch of water that suddenly changed color. Too late, Logan recognized a giant manta ray.

"Next thing I knew I was launched straight up, boat and all," Logan recalls. "I felt the tarpon jerk the rod out of my hands and then I came down—hard. All I could think of was sharks and that I had tied the paddle to the boat. Otherwise I'd have been up the creek."

Logan credits most of his fishing success to the fact he can quietly approach schools of fish. He has followed schools and caught fish for hours without alarming them. His favorite lure is a 6-inch Pikie minnow that he rigs with a strong wire leader and swivel and alters by replacing the gang hooks with two single 9/0 barbs. He does so because ganged hooks are not accepted in world fishing competition, and Logan figures one of these days he'll grab off a record tarpon.

"Shrimp boats around here regularly net 300-pound tarpon," Logan says, "and the world rod-and-reel record is only 283 pounds. I figure I've got a chance."

He trolls his converted Pikie about 100 feet astern, using a heavy rod and about 500 yards of 60-pound Dacron line on a 6/0 reel. He keeps the drag set at light and when the reel suddenly bursts into song he comes about, puts the paddle down and joins the battle.

And as an oceangoing Folbot fisherman, he knows the battles can be knockdown, drag-out thrillers. ★★★





**A flying chair that whizzes** up to 100 mph was built from a kit by Capt. Trevor Hampton of Dartmouth, England, who is shown (above) flying it. According to the kit manufacturers, the vehicle has a cruising speed of 60 to 80 miles an hour. Capt. Hampton substituted floats for the kit's wheels.

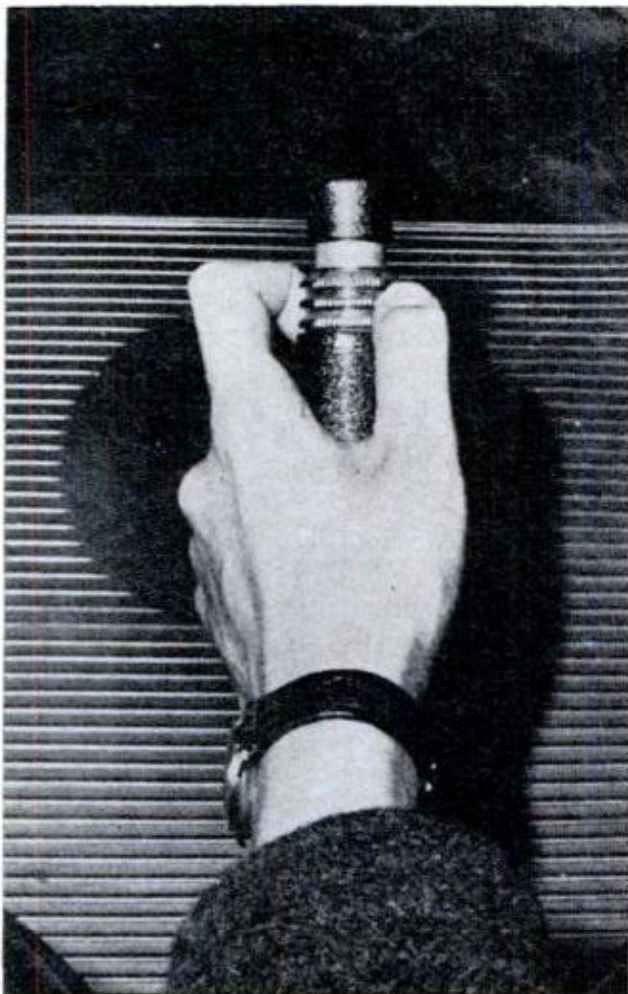

**Lock your car like a safe,** using a combination or cipher lock to secure the car's hand-brake in the "on" position. Made by WASO Ltd., 1 Tribune Dr., Sittingbourne, Kent, England.



**Pleasure boats go to war.** The Navy is receiving a fleet of 120 fiberglass boats—originally designed as cabin cruisers—to be used in Viet Nam for patrol duty in and around the Mekong Delta. Built by United Boatbuilders, Bellingham, Wash., the boats are 31 feet long and utilize a water-jet propulsion system powered by twin 220-hp diesel engines. The boats have been armed (machine guns fore and aft) and beefed up with some armor plate for protection of machinery and a crew of four.



FOR A FRESH GET-AWAY-FROM-IT-ALL FEELING

## TRY CAMPING AFLOAT

With waves slapping softly against the hull and the boat rocking gently at anchor, you'll wonder why anyone would ever pitch a tent on the beach

By PATRICK PERRETT

**F**RANKLY, OUR FIRST CAMP-OUT aboard a 17-foot runabout turned out to be less than a rousing success.

Once we pulled away from the launching ramp, it didn't take long to realize that we had twice as much gear as we needed. There was barely room to sit, much less stretch our legs—and cooking dinner in such cramped quarters was a nightmare.

We made out that night, but in the morning we headed right back to the launching area and transferred all the useless extras to the trunk of the car.

So that's how we learned the first two rules of small-boat camping—*keep equipment to an absolute minimum and have a detailed plan for stowing everything you take along.*

In spite of the crowding, however, our first night afloat was a pleasant experience. Before the sun went down, we dropped anchor about 50 feet off a sandy beach and cooked dinner—sizzling steaks from a charcoal hibachi.

We turned in early that evening, unrolling our sleeping bags on air mattresses placed over the fold-down lounge seats. Stretched out comfortably in the cockpit, with the boat rocking gently at anchor, we had a feeling of being far from civilization, free of all problems. The 50 feet separating us from the beach could have been miles. In short, we were hooked on camping afloat.

Camping aboard a small open boat requires a lot of ingenuity and planning, but once you get used to it, this becomes a real part of the enjoyment of the outing. There are three main considerations: sleeping, cooking and recreational activities (including fishing, skiing, swimming and cruising).

Sleeping accommodations don't usually present a problem. Those back-to-back seats that convert to sun lounges make excellent bunks for a couple of adults, and in most boats there is room for a youngster or two to bed down on the cockpit floor. Some boat campers rig a tot's bed under the foredeck.

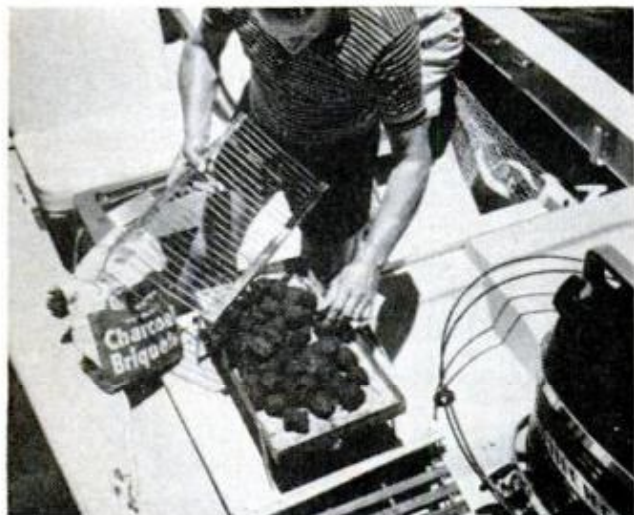

**JUST LIKE HOME.** There's nothing like a charcoal-broiled steak whether you're home or on a boat. Just take along your brazier, charcoal and lighter fluid

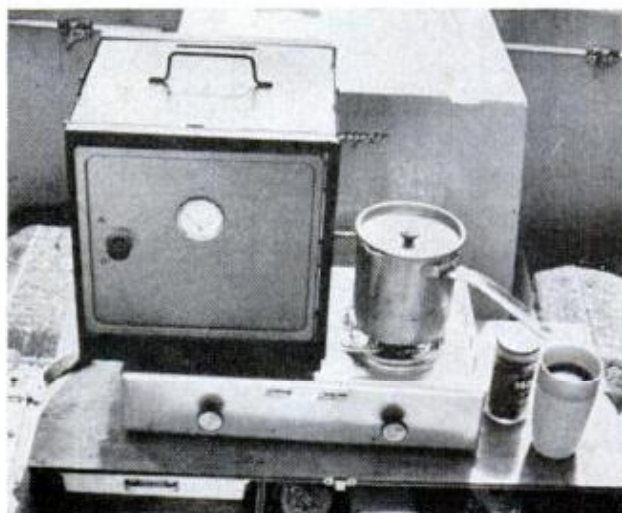

**CAMP OVEN** on board your boat will enable you to prepare such treats as roast turkey or roast beef, topped off with rolls and a frozen, prepared pie





**READY FOR BED** when sun goes down, they wisely took care of all chores while there was still daylight



**ODDS AND ENDS** that every camper needs—such as staples and paper plates—are best stored in a wood box with a hinged lid. Box doubles as bench or table

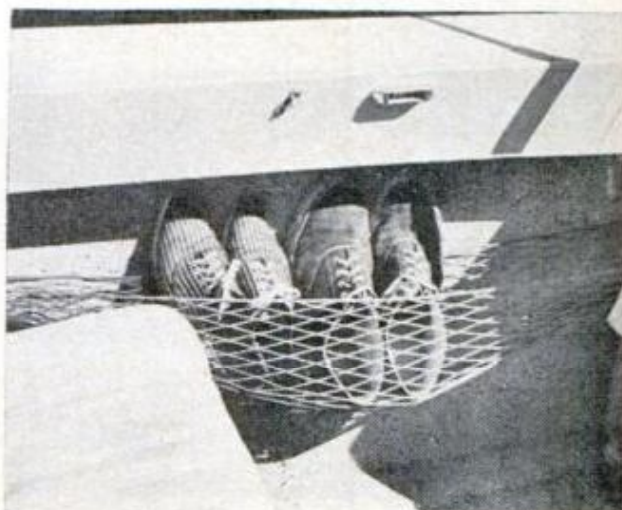

**NOBODY STUMBLES** over shoes and other articles stored out of the way in a hammock net. The nets will stretch to hold all kinds of odd-shaped objects





**HOMEMADE SUPPORT** for a Dacron covering that fits over the rear of the boat's cockpit is made of aluminum tubing and held in place with shock cord

Pipe bunks, popular in travel-camping vehicles, can be fitted into many boats. Four U-shaped brackets support the bunk ends. The bunk itself, which rolls up for daytime storage, is simply canvas supported by two side pipes.

An air mattress or a soft pad is a necessity, not a luxury. Its easy-to-stow size makes it ideal. Foam rubber mattresses designed especially for camping are comfortable but require more storage room.

Even in summer months, occasional rain can be expected in most areas so it's well to provide some sort of shelter. Boat-tents can range from a simple fly rigged with a couple of poles, some line and your boat cover to an elaborate canvas camper top. If your boat has a folding canvas top there are many designs and methods for joining another canvas piece to the rear



**LET IT RAIN.** With the homemade Dacron covering over the rear of the cockpit, the boat's occupants are well protected from rain or nighttime dew

of the top and spreading it over the boat tent-fashion. You can even design your own boat-tent. Once you've snuggled down in your sleeping bag it's a good feeling to know a sudden shower won't disturb your slumber.

Cooking probably is the greatest challenge to the boat camper. Meals can range from elaborate menus to simple snacks. We usually stick to a simple meal with only one special dish.

Our favorite breakfast fare is eggs and sausage (much easier to handle than bacon) served with hot rolls or freshly baked biscuits prepared in the folding camp oven. The biscuits are refrigerated and come in a cardboard tube ready for the oven. Six-ounce cans of juice provide easy-to-store individual servings. Instant coffee or tea suits us although many of our camping friends enjoy freshly brewed coffee.

The above is a much bigger breakfast than our family usually consumes at home but, with the swimming and skiing, it barely tides us over until lunch time. The midday meal is quickly assembled, using standard sandwich makings, fresh fruit, cookies and drinks from the ice chest.

If the fish haven't been biting, broil hamburger or steak for dinner. Green salads, premixed at home, will stay cold and crisp in a plastic bag in the ice chest. When the steaks are done, you can use the grill to toast French bread. In the cool of the evening with the grill still giving off warmth and a light breeze stealing across the water . . . that's living!

There are many suitable stoves available. An alcohol stove, such as Flame Boy, is universally accepted for marine use. Alcohol fumes, being lighter than air, quickly dissipate themselves. Also, alcohol flames can be extinguished with water.

Still, many boat campers prefer a gasoline stove because of the hotter flame or because they already have one on hand for conventional camping use. Even though small boaters live constantly with gasoline fuel tanks, extra care must be exercised when cooking with such a stove aboard a small boat.

#### **Cook away from fuel tanks**

Stoves should be kept in excellent working order and operated as high in the boat and as far from fuel tanks as practicable. The high placement gives better ventila-

*(Please turn to page 196)*





## Covered cot for campers

During the day, Slumberella can be a hooded chaise longue for comfortable sunning; at night, add a zippered cover of water-repellent duck and it becomes a one-man (or girl) tent for off-ground camping. Zippered side panels come with mosquito netting. The cot is 78 inches long; total unit weighs 22 pounds. It's available from Guardian Aluminum Co., South El Monte, Calif., at \$79.95.



**IT FOLDS** for easy carrying (left) and, with tent removed (right), Slumberella makes an ideal canopied lounge for relaxation on the beach. Tri-section metal frame has a locking device to keep canvas taut



# NEW TACKLE TO

Bonnets for hooks, instant pop-up sinkers, rods for traveling salesmen



CASUAL APPROACH to fishing is helped by adjustable plastic rod holders that attach to sides of the boat



FOUR-SECTION FIBERGLASS spinning rod made by Old Pal, Inc., Lititz, Pa., weighs only four and a half ounces, can be easily packed in a tackle box



PISTOL GRIP and curved handle add balance to the ThumCaster rod. The line travels up through the handle and can be controlled by the thumb



# HOOK FISHERMEN

and automatic scalers—it all adds to the comfort of complete anglers



**STILL FISHERMEN** don't have to move at all with a fishing chair that incorporates a tackle box under the seat and has two wire holders for the rods



**TIPPING THE SCALES** in favor of easy fish cleaning, the Bear Paw automatic fish scaler scrapes off fish scales with an effortless brushing motion

By Stuart James

PM Outdoors Editor

**M**ORE THAN 30 MILLION Americans will go fishing this year. They'll wade streams, row boats and troll with motors. They'll lug around tackle boxes that collectively would weigh hundreds of tons. And if the equipment inside those boxes does what it's supposed to do, there won't be a fish left in the United States.

Thrashing the waters of a thousand lakes, the anglers will try their luck and patience with the usual glut of "guaranteed" new lures. Like last year and the year before, they wiggle, waggle, hop and pop, gurgle, glisten and glow. And if they do nothing else, they'll break the monotony for the fish.

"Frankly," said a fishing guide in northern Wisconsin, "most of the stuff that clutters up a tackle box has nothing to do with catching a fish. It just gives the fisherman something to fool around with when the fish aren't biting."

In the past year I traveled from coast to coast and fished in 11 states. I talked with a lot of fishermen and tested a lot of new equipment. I came to one conclusion. Don't worry about the fish population.

Skill, fish-savvy and downright determination will continue to be the ingredients that will take the most fish.

Where new equipment and design innovations make a difference is for the convenience and comfort of a fisherman.

There's a little item I picked up, for instance, called a hook bonnet. It's a little plastic cover that slips over a treble hook, protecting hands and eliminating the nuisance of lures getting tangled in a tackle box. They're made by U.S. Line Co., Westfield, Mass., and you can buy seven for 25 cents.

And then there's Rudy's Snell Tyer. Now I'm one of the people with ten thumbs when it comes to tying a clinch knot in monofilament, so this little



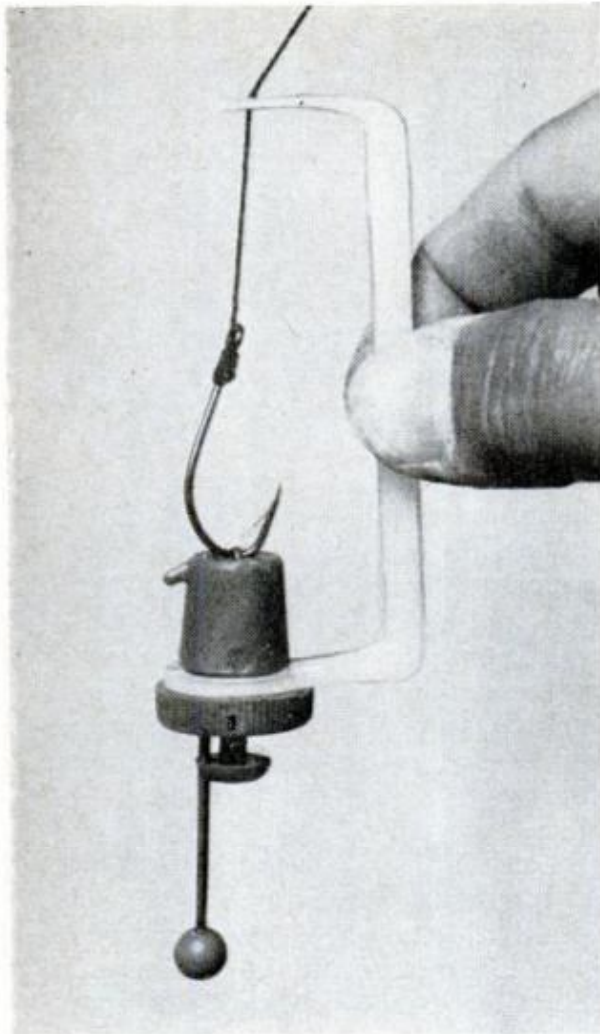

**MONOFILAMENT** knots are easily handled with the Snell-Tyer, which holds the hook and line in place

**INSTANT POP-UP SINKERS** in seven sizes are cast with ease in the hand-held Silverbell Vari-Mold

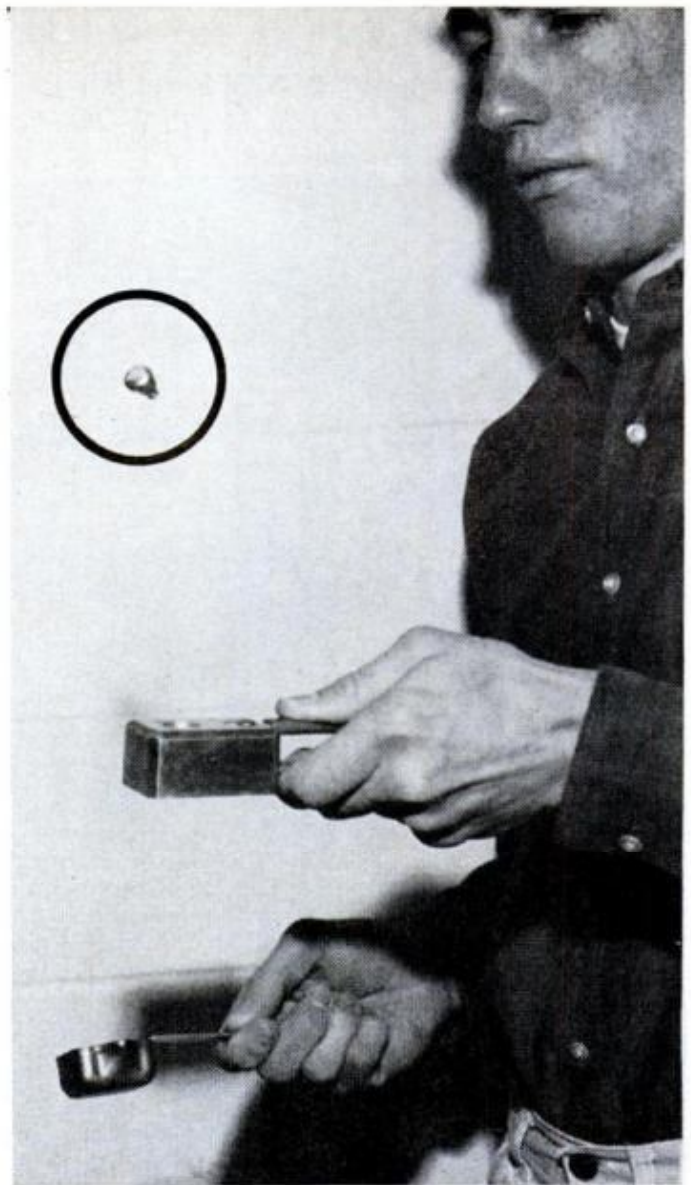

pocket-size rig was right down my alley. It's a "U"-shaped jig with a device on one side to hold the hook and a slot in the other side to hold the line. When the line is threaded through the eye of the hook and inserted in the slot, the hook holder turns to make the required number of loops in the line. It makes the whole job simple and gives you a neat, strong knot. It sells for \$1 from Rudy Masson Products, 4015 W. Verdugo Ave., Burbank, Calif.

Another small item that is large in convenience is a synthetic salmon egg called Salmon-ettes. I had given up on salmon eggs as bait because I had found them virtually impossible to keep on the hook or cast without having them break. Salmon-ettes are like a rubberized plastic; they go on the hook easily, but you have to pull hard to tear them. A two-

ounce jar is 45 cents; they're made by Salmon-ettes Co., Inc., 744 Oliver Building, Pittsburgh, Pa.

The Fred Arbogast Co., Akron, Ohio, has a new weedless protector for a treble hook that I could have used last summer. I was fishing a small lake near Hayward, Wis., that was a maze of submerged trees and logs, and in a dozen casts I lost five lures. The northerns wouldn't touch a surface lure; you had to go down into the trees for them, and as soon as you did you were hung up. It was months later that I saw the new Arbogast weedless treble, and it brought that day's frustration back like a flood. It would have been ideal for that water.

For the casual fisherman there's a folding chair that comes with a built-in tackle box and two rod holders. It is made by Emco Specialties, Inc., Box 864,



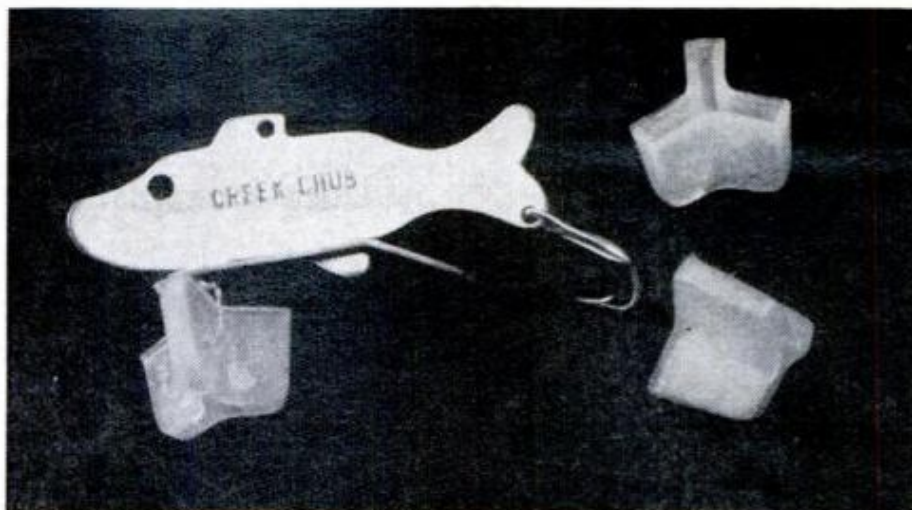

**HOOK BONNETS** are small plastic caps that fit over the treble hooks on a lure, making them easy to handle safely and eliminating tackle box-snags

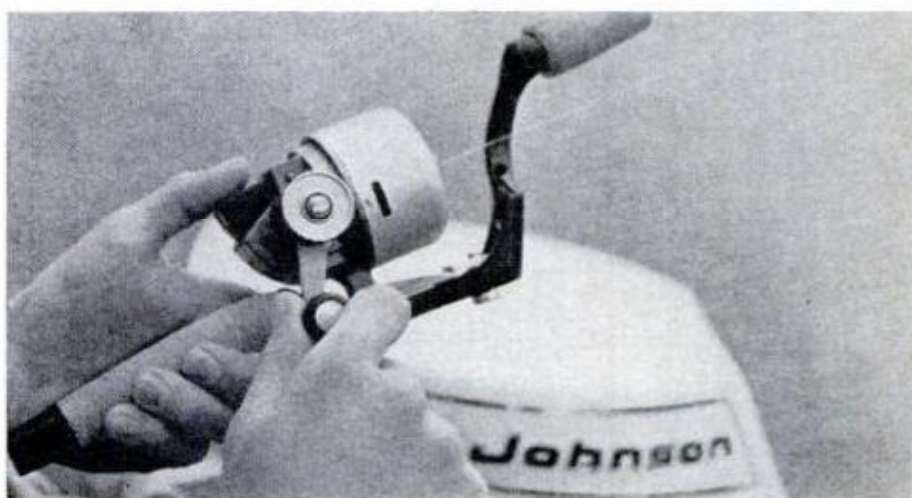

**UNDER-CAST** is a unique design in a rod handle that allows the line to pay off below the rod for underhand casting, resulting in greater accuracy

Des Moines, Iowa, and it sells for \$14.95. And if you like to snooze in your boat, Tempo Products Co., 6200 Cochran Rd., Cleveland, Ohio, has a plastic rod holder that attaches to the boat side and adjusts to three positions. It sells for \$5.95.

The fly fisherman's hat is traditionally the repository for his flies, despite the fact that nothing could be more inconvenient. A major problem with flies is to have them where you can get at them easily and not have them crushed. I've come across an item that solves both problems. It's called the "Fly-Flask." This is a clear, plastic tube six inches long with a Styrofoam core that slides in and out on an elastic spring. One end attaches to the belt by a cord, so you just lift it and pull out the core with one hand and remove the desired fly from the Styrofoam with the other. This

is a handy item, well made, and it sells for \$2.95 from Pioneer Sales, Inc., 41 E. Main St., Mesa, Ariz.

A constant gripe I hear from anglers is that when they take fish home their wives refuse to scale and clean them. I usually recommend a sound beating as the next best thing to a divorce, but now I can suggest an electric fish scaler that takes the work out of scaling and does a beautiful job. It is sold by Meininger & Rade Co., 19000 Doris St., Livonia, Mich., and it comes in two models. For \$7.95 they have the scaler that runs off an electric drill, and the deluxe model complete with motor sells for \$19.95. It is simply a device with a handle and a multi-toothed tool that spins and peels the scales off.

I'm now making my own sinkers. I

*(Please turn to page 189)*



# Build a High-Low

You can stand tall in its work area and yet park it in your garage. Every feature is designed for maximum comfort



**THIS COMPACT CAMPER** can go nearly anywhere the open half-ton pickup can and is rugged enough (and it's insulated) for the high country. It provides all the facilities, except a head, that two wanderers need

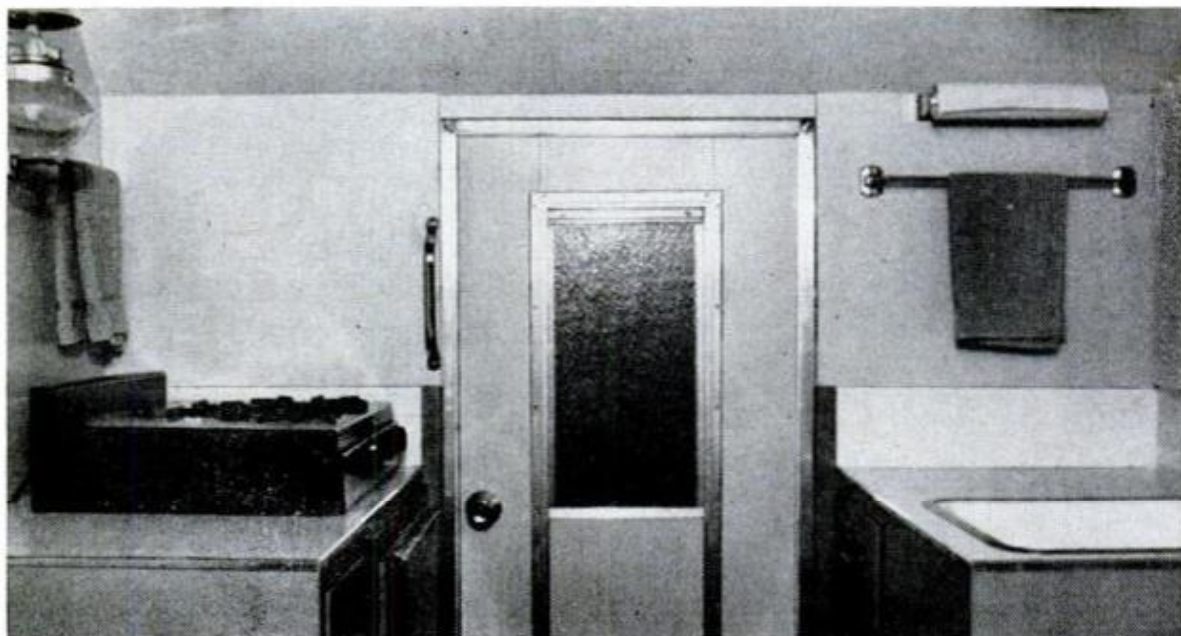

**INTERIOR VIEW** of completed camper looking aft shows the comfortable galley area. Between sink and stove is a sump offering 5 feet 11 inches headroom. Stove and lamp are gas-operated



# Pickup Camper

**I**F TRAILER CAMPING suggests roughing it because of equipment apparently designed for midgets, take heart: This life-size pickup camper sports custom conveniences and structural features not otherwise available. It will make you glad to hit the road instead of just glad to get back.

This camper tops the ready-mades because:

- It offers headroom of 5 ft. 11 in. in the work area, and yet . . .
- You can drive it through an 8-ft.-high garage doorway.
- It's light enough to be carried on a half-ton pickup truck, and yet . . .
- It's rigid enough to avoid racking.
- It has a full-size double bed.
- It has generous closet space for two adults.
- It's adequately insulated.

• It provides most of the conveniences found in the better campers, such as propane gas tank, stove, lamp, water storage tank and pump, cabinet sink, refrigerator, 12-volt exhaust fan over the stove and screened windows and door.

The camper costs about \$650 to build, as against \$850 for a comparable commercial vehicle. What makes it worthwhile to build—the headroom and garageability—is a combination totally lacking in commercial versions.

The feat of combining these features was achieved by placing a pit, or sump, in the floor of the truck, a half-ton Chevrolet pickup with an 8-ft.-wideside body. This truck was selected because it has a wood floor that makes modification easier.

When it's off-season for the camper, you can hoist it with a winch in the loft of your garage and still be able to park the truck under it.

The camper weighs 670 pounds—light enough to ride easily on the half-ton vehicle, which is more economical and easier to drive than a ¾-ton unit. Significant fringe benefits from the camper's low height are its clearance height and stability, reducing wind resistance and side sway. Rigidity is provided by oak

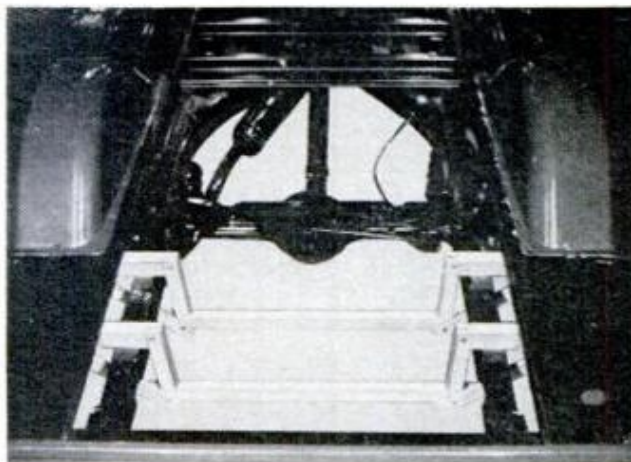

**SUMP FRAMEWORK** in Chevy pickup must replace channel irons and spare-tire brackets. Oak frame with half-lapped joints is held together with carriage bolts and waterproof glue. Treat with pentachlorophenol



**COMPLETE SUMP ASSEMBLY** will take exposure to the elements. It is joined with waterproof glue and countersunk screws, waterproofed and painted with gloss enamel before being mounted on the chassis

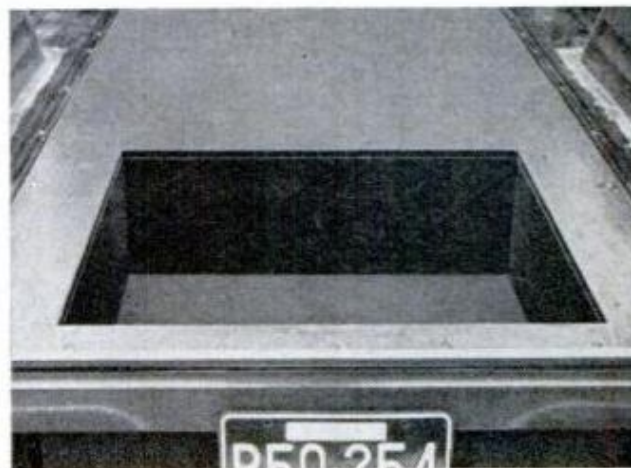

**PICKUP'S FLOORING** between the wheel wells is replaced with exterior-grade plywood, which is screwed (not glued) to the sump box's framework. This strengthens the box, keeps the interior dust-free



## MATERIALS LIST

Quantity	Size, Description, Use
270 ft.	1 x 1½ oak (camper and sump framing)
2 pcs.	¾ x 1—8' oak (reinforcement)
1 pc.	¾ x 1—6' oak (reinforcement)
6 pcs.	2 x 2—6' fir or pine (reinforcement)
1 pc.	2 x 4—6' fir or pine (hoisting support)
1 pc.	1 x 2—10' fir or pine (cabinet frames)
2 pcs.	1 x 2—8' fir or pine (cabinet frames)
2 pcs.	1 x 2—6' fir or pine (cabinet frames)
1 pc.	1" dia. x 2' dowel (closet pole)
1 pc.	5⁄8" x 4' x 10' ext. grade fir plywood (truck floor)
1 pc.	5⁄8" x 4' x 8' ext. grade fir plywood (sump)
1 pc.	¾" x 4' x 8' ext. grade fir plywood (alt. sump)
3 pcs.	¾" x 4' x 8' plywood (bed, hampers, counters)
11 pcs.	¼" x 4' x 8' plywood (interior walls)
11 sq. ft.	.020" aluminum siding
62 ft.	aluminum drip rail (rain gutter, corner molding)
2 pcs.	.040" x 4' x 8' aluminum (roofing)
1 pc.	.030" x 2' x 8' aluminum (flashing)
1 pc.	3' x 4' plastic laminate (countertops)
125 sq. ft.	1" polystyrene foam (insulation)
2 pcs.	5 x 30 x 75" polyurethane foam (mattresses)
20 ft.	¾" copper tubing, connections (water, gas syst.)
1	1¼ x 15" filler pipe, 2 elbows (water tank filler)
12 ft.	10-ga. stranded auto wire (main from fuse panel)
15 ft.	12-ga. stranded auto wire (fan, shaver socket)
50 ft.	16-ga. stranded auto wire (lights)

Quantity	Size, Description, Use
25 doz.	¾" No. 6 FH screws (interior assemblies, walls)
6 doz.	3" No. 10 FH screws (framing)
½ lb.	¾" 18-ga. aluminum nails (siding)
1 gross	¾" No. 8 panhead aluminum sheet-metal screws (roofing, molding)
3 doz.	¼ x 3" carriage bolts (wall assembly, sump)
14	¼ x 4" carriage bolts (sump)
6	5/16 x 2½" machine bolts (camper-pickup fasteners)
8	¼ x ½" machine screws (pickup reinforcement)
1	¾ x 6" eyebolt (hoist)
10 ft.	5/16 x 1" self-adhesive rubber gasket (tailgate)
Misc.	1 pt. white glue (framing, walls, cabinets); ½ pt. contact cement (laminates); 1 qt. polystyrene cement (insulation); 1 pt. sealing compound (siding, roofing); 1 pt. plastic resin or resorcinol glue (sump); 2 qts. latex paint (interior)
Misc. fittings, equipment	Aluminum trailer door and windows, grab handle, propane gas stove, propane gas lamp, 5½-gal. propane tank, 12-gal. plastic water tank, trailer sink and pump, refrigerator, roof ventilator, low-voltage exhaust fan, low-voltage dome lights, ICC clearance lights (2 orange, 2 red), towel racks, and hardware for drawer, door and curtains.

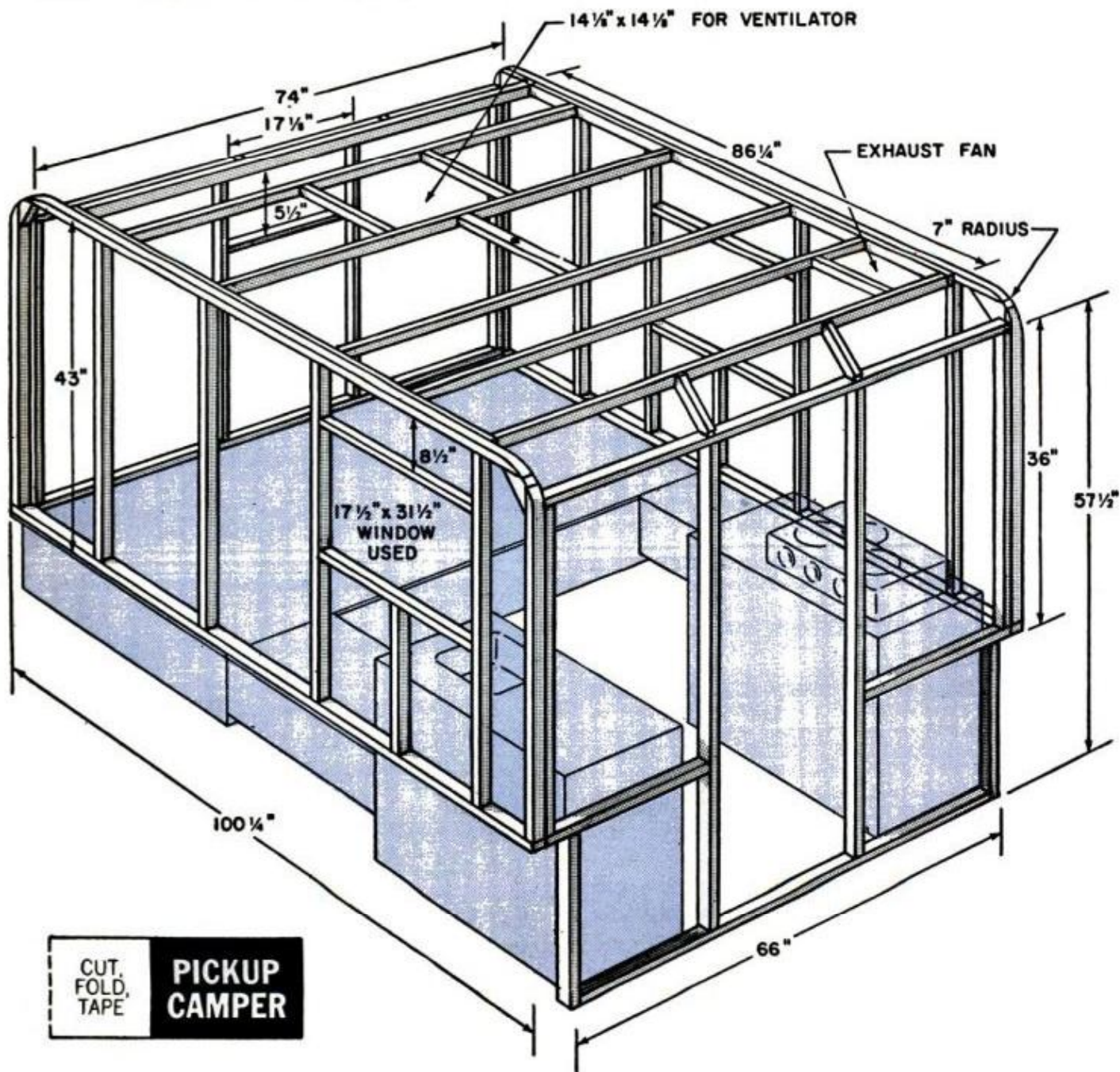

CUT,  
FOLD,  
TAPE  
**PICKUP  
CAMPER**



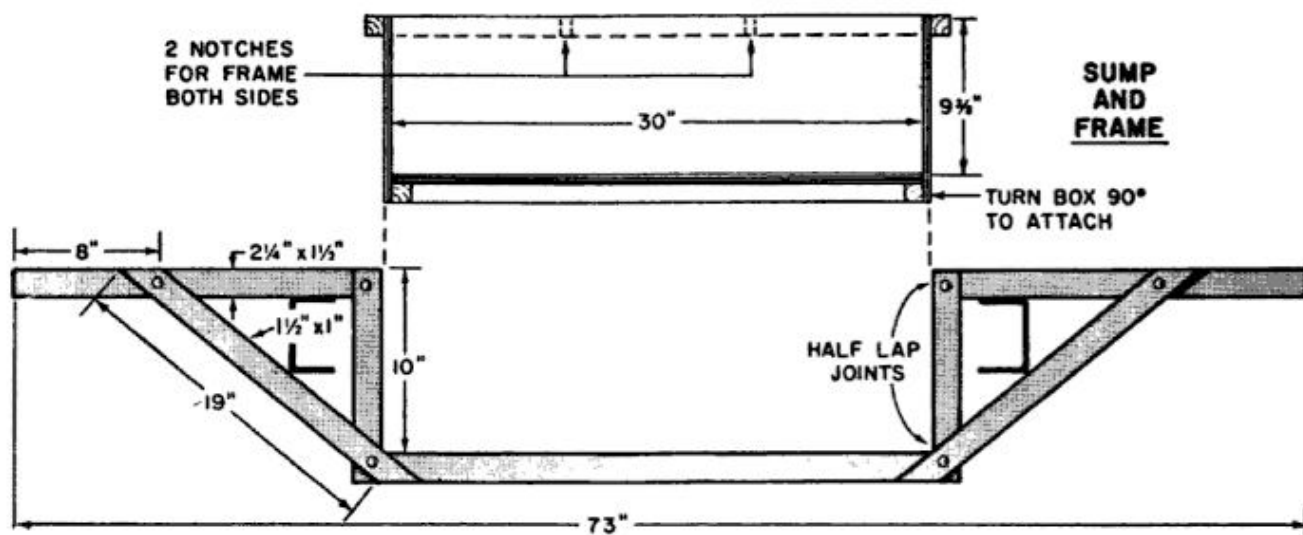

framing, glued and screwed throughout to 1/4-in. plywood.

You'll go a far piece before you find a camper with a mattress wider than 48 in. The full-size double bed (54x74 in.), in this unit triples in brass as a table or ironing board with the loose section inverted and as a sofa with that section tipped up against the closet.

Defer building the camper until the door and windows are on hand or until you are reasonably sure of their dimensions. The door, windows, stove, sink, refrigerator, propane lamp, roof ventilator and other trailer supplies can be purchased through a trailer supply catalog, such as that of All-Trailer Parts and Accessories, Elkhart, Ind., but some items may be obtained locally through camping equipment dealers.

Standard aluminum camper siding comes in 8-ft. lengths, but it would be worth a search to turn up 10-ft. siding to avoid seams. Otherwise, you can buy truck siding or have a tinsmith cut .020-in. aluminum to length and pleat it on his brake for appearance.

### Get to work on the pickup

The 10x30x30-in. sump sits between the chassis frames behind the rear axle, normally a storage area for the spare tire. In the 1962 pickup used here, construction is as detailed below and in the drawings.

First, remove the tailgate, rear bumper (temporarily) and spare-tire mounting brackets. Remove the bolts holding the pickup body to the chassis. Then take out the floorboards between the wheel

wells and remove the two channel irons behind the rear axle.

Fabricate two oak frames with waterproof glue and bolts, as shown in the drawing above and the photos on page 133. Clamp the channel irons to the oak frames to transfer the bolt holes. Make the sump box of 3/8-in. exterior grade plywood with a 5/8-in. bottom. The box with its own frame is screwed and glued to the transverse frames. Coat both box and frame inside and out with a wood preservative and paint. Slide the assembly in place and bolt. You will need longer bolts than were removed.

Next, cut a sheet of 5/8-in. exterior-grade plywood 43x97 1/8 in. to replace the floorboards. Coat it with the preservative. The plywood floor is screwed to the box, which serves to reinforce it and its frame.

More recent models of the truck are built similarly, except that chassis frames

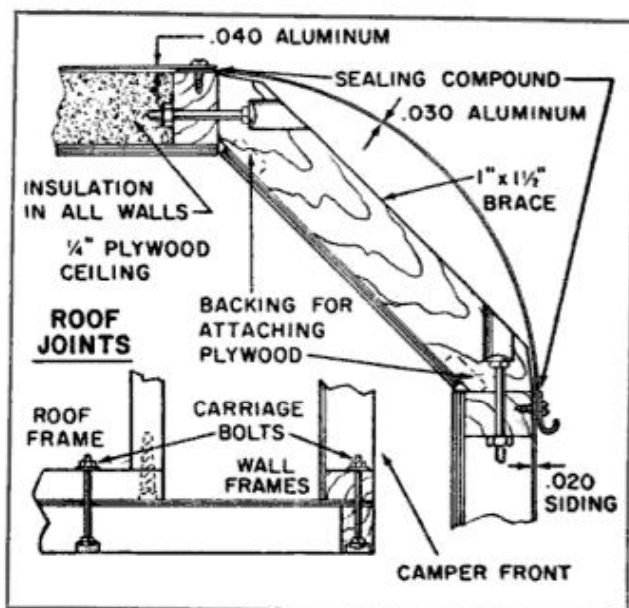



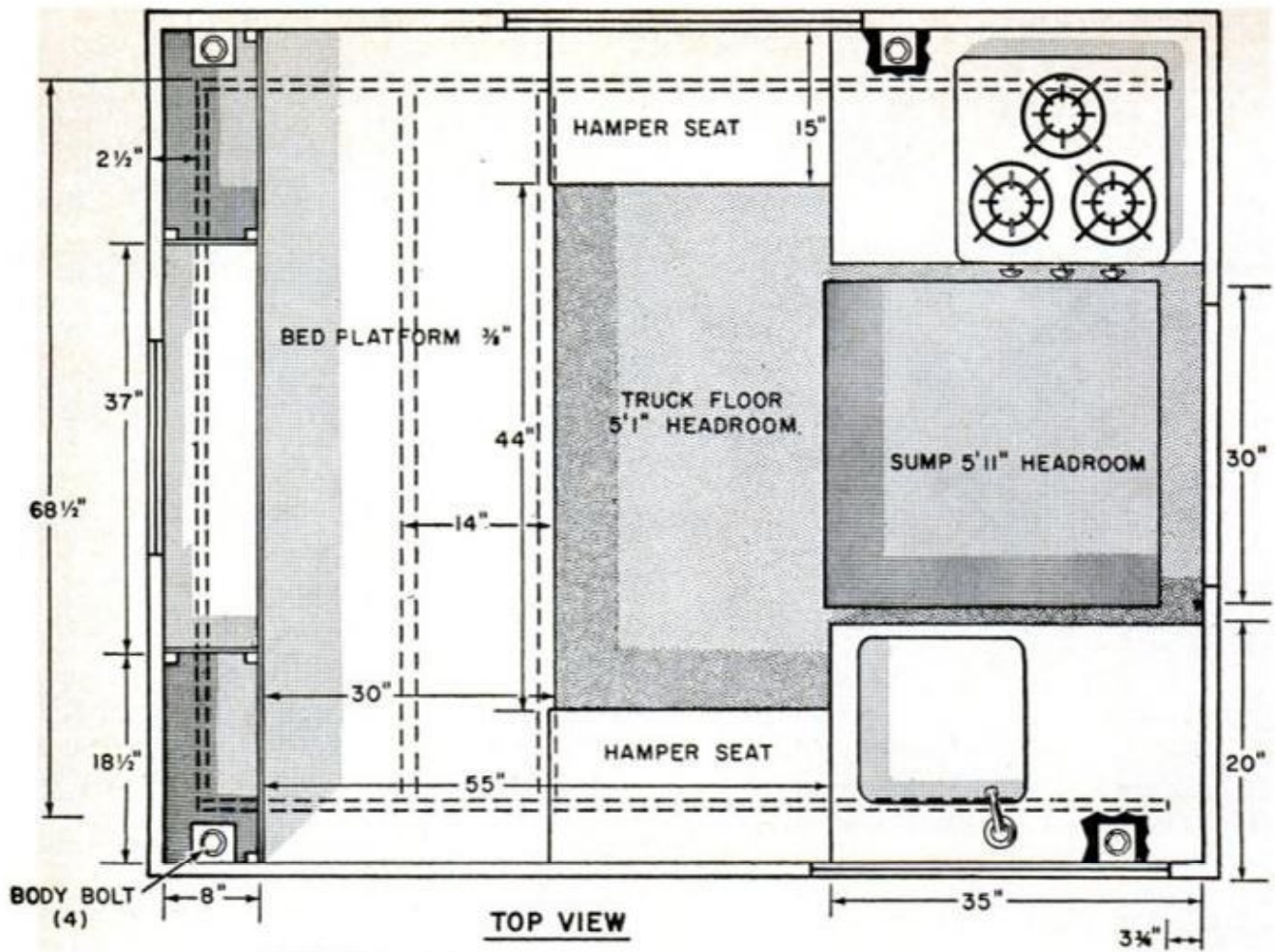

**BOTTOM VIEW**

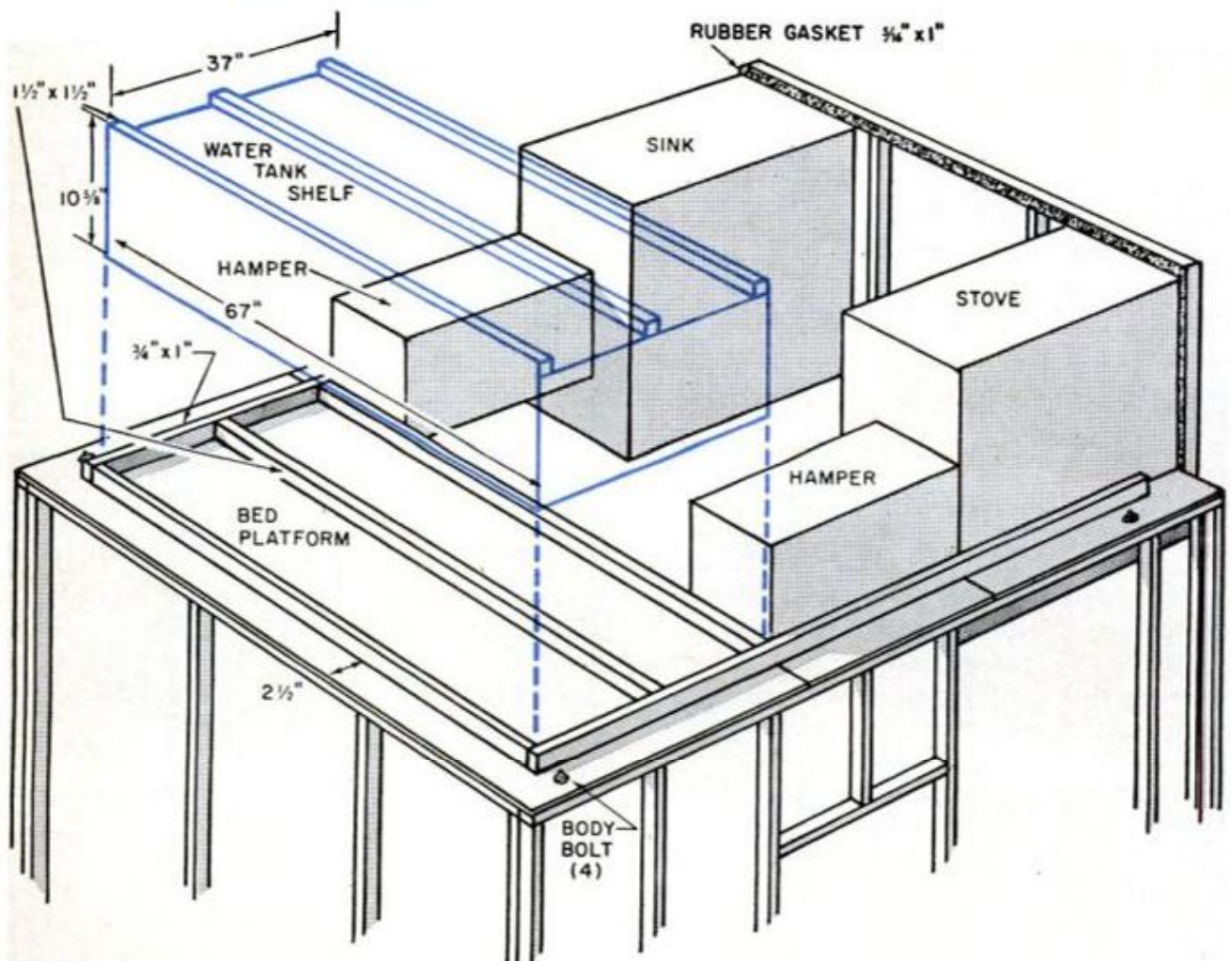



are closer together—27½ in. apart instead of 36 in. To optimize the floor space, build the sump as follows:

Make the horizontal pieces of 2¼-in. oak as before for floor supports, 21 in. long. These will be bolted to the chassis frame and the pickup floor.

Because no sump floor supports are provided, the floor should be built of ¾-in. plywood, and because of its narrowness, extra toeroom should be provided by extending the floor out under the chassis on both sides.

### Wall panels are prefabricated

Cut all framing with half-lap or butt joints to result in the dimensions given in the perspective drawing on page 134. Assemble each wall of the camper separately. Framing studs should be placed to create a wall thickness of 1½ in.; similarly, each plate should be placed flat. Note that the upper corners of the side frames are rounded on a 7-in. radius. Glue up oak scrap to make these corner inserts.

Fasten ¼-in. plywood to the "interior" surface of each frame with flathead screws, countersunk. Let the seams on the side walls fall in the closet area. Apply glue to all joints and to contact areas of the plywood.

Clamp the walls together and drill them for ¼-in. carriage bolts. Glue and bolt together, with the end frames be-



**CLOSET FOR TWO** covers front wall of camper. From rods behind top panels, there are 32 inches of hanging space. The shorter center space has rods. Drawers below bed hold bedding and other clothing

tween the side frames. Fabricate the braces between the end frames and the roof. (See detail drawings on page 135, bottom.) The braces are of regular oak framing stock. Run strips of wood between the ends of the braces to provide a surface for the edges of the interior plywood to bear on.

Turn the camper upside down. Glue and screw ⅜-in. plywood, 39½x77 in., for the fixed portion of the bed platform to the bottom edges of the front and side walls. Cut and reinforce a 24x74-in. piece of ¼-in. plywood for the other half. Attach a ¾x1-in. frame with two lengthwise members inside it to the center 43½ in.

*(Please turn to page 190)*

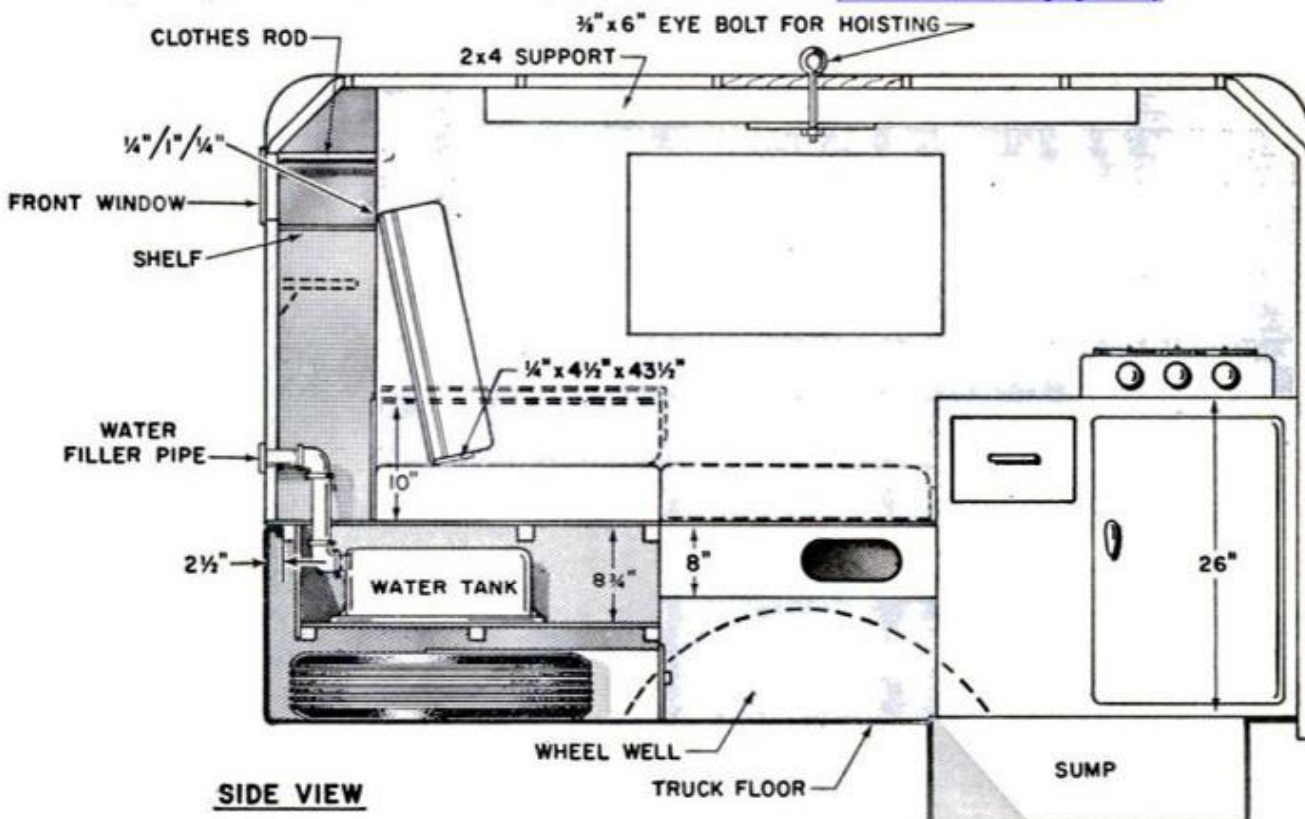

**SIDE VIEW**



Land or water, it makes no difference with PM's amphibious

# Bush Buggy

You can use it for darned near anything—a fishing boat, a duck blind, a wilderness carryall. Or, if you like, for just putt-putting around the campsite

By Art Mikesell

**W**HAT'S SO GREAT about this vehicle? Instead of piling up superlatives, let's take a look at designer Peter Prohaska's no-nonsense description of his Bush Buggy and let the project speak for itself:

"Basically, this is a relatively inexpensive, off-highway vehicle which has the advantage of being amphibious. It's extremely stable, both on land and in the water. The position of the load has very little effect on this stability, so in addition to providing land transportation over reasonably rough terrain, it may also be used safely as a fishing or swimming platform."

No wild claims there. Quite frankly, the Bush Buggy *isn't* the world's greatest off-trail powerwagon (with 4 hp? who would we be kidding!). And as a boat, it's more of a low-power raft. But what a fun combination to be crammed into a build-it-yourself package.

Building any powered vehicle normally requires a high degree of technical skill

in a number of areas, but the Bush Buggy is one of those welcome exceptions. Anyone familiar with basic home-workshop techniques can tackle the job, because it's an easy combination of original construction and simple kit assembly.

To cut costs, all the operations which can be handled by the average craftsman in his home workshop are left to you. Thus, you construct the plywood body; you shape the Styrofoam pontoons, fiberglass them and mount them on the body.

The kit consists of all those mechanical components which would be impossible to fabricate in the average shop—the engine, transmission, steering mechanism, controls and other miscellaneous parts. All the necessary instructions for installing these in the body you've built are included.

As for specs, the Bush Buggy is 9 ft. long and approximately 6 ft. wide at the front wheels, the widest point. It weighs a shade under 450 lbs. and has a pay-



**SPECIAL TOWBAR**, a \$25 extra-cost option with the kit, lets you hitch the Bush Buggy behind your car



**IT HANDLES** rough terrain, even though the vehicle isn't specifically designed for normal off-trail travel





load capacity of almost 500 lbs. And, as you might expect in a vehicle designed for both land and water use, it has two power systems and two steering systems.

The basic power train consists of a 4-hp electric-start engine equipped with a starting generator. This is connected to a combination clutch-brake mechanism by means of a chain drive. From there it's a direct drive to the four-speed transmission (high-low, both forward and reverse) which drives the rear wheels through a secondary chain drive. The rear wheels are mounted on roller bearings and sealed against leakage.

That clutch-brake mechanism is a disc-type arrangement which is power-

controlled. When you first step on the pedal it disengages the clutch; further pedal pressure engages the brake. Shifting is controlled by a pair of gearshift levers mounted in the cockpit and linked to the transmission by push-pull cables.

The Bush Buggy has rack-and-pinion steering with push-rod linkage. The outer extremities of the rod are connected to sliding pins which move in slots in the wheel levers. The ratio is approximately  $3\frac{1}{2}$  turns, lock to lock.

On the water, the Bush Buggy's power delivery and steering system is exactly like that of a boat. Power is supplied by an electric trolling motor running off the battery used with the gasoline engine;



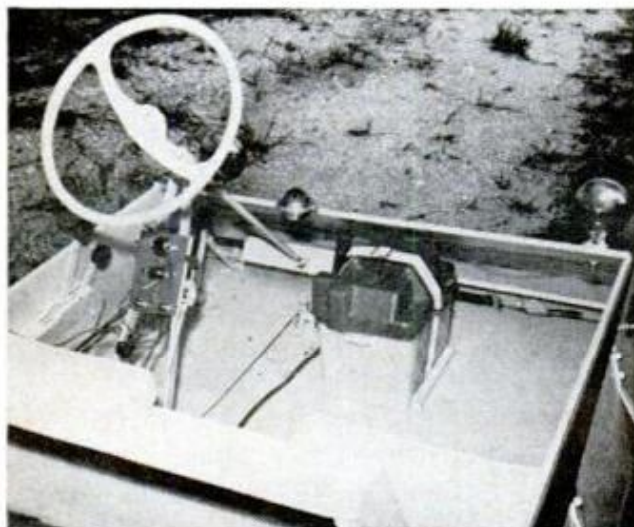
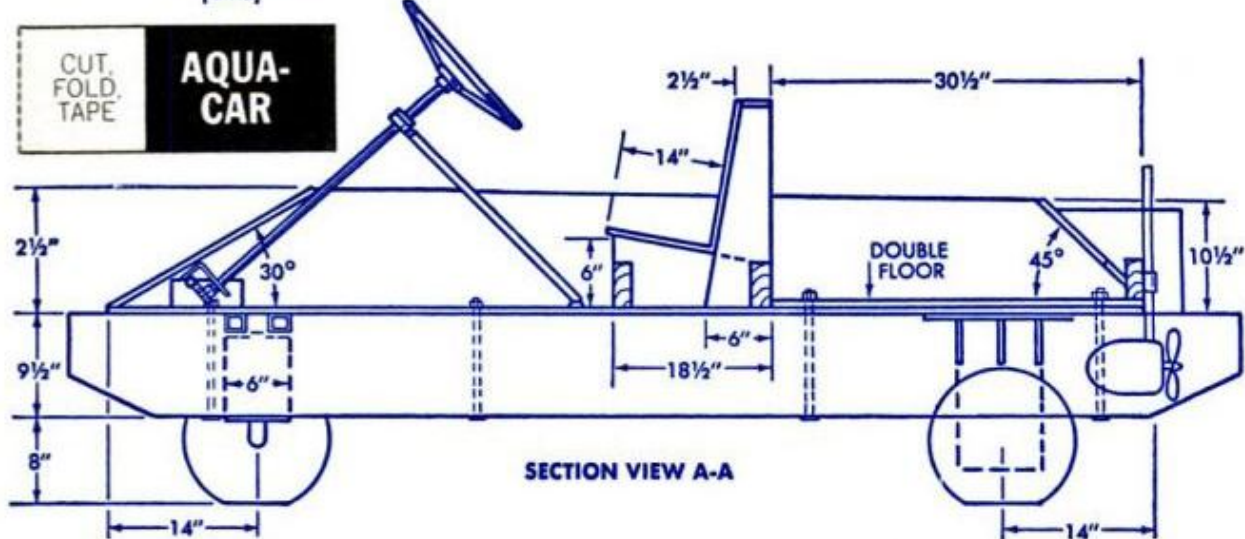
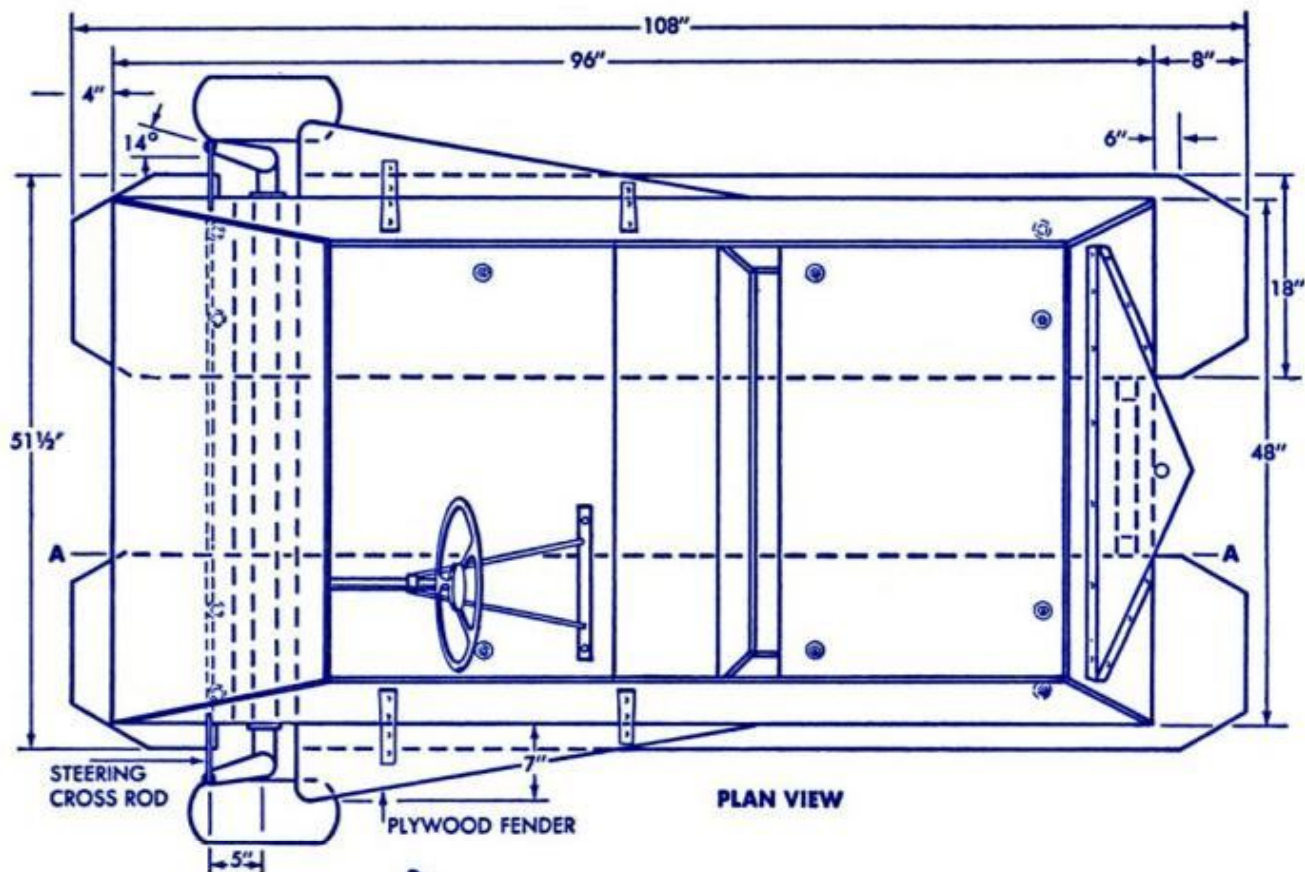

**COCKPIT VIEW** of the Bush Buggy shows steering linkage. Battery is carried here to improve trim afloat

this gives you extra-long running times, since you can recharge the battery by running the inboard.

On the prototype shown in the photos, a small underwater troller was used, the idea being that you could retract it easily by loosening a thumbscrew and drawing up the shaft. Unfortunately, this type of motor proved to be too weak, so a larger troller with standard swing-up retraction was substituted.

The trolling motor isn't included in the kit, partly because designer Prohaska isn't sure that such an arrangement will provide enough power to suit every builder of the Bush Buggy. A large troller is sufficient to move the vehicle



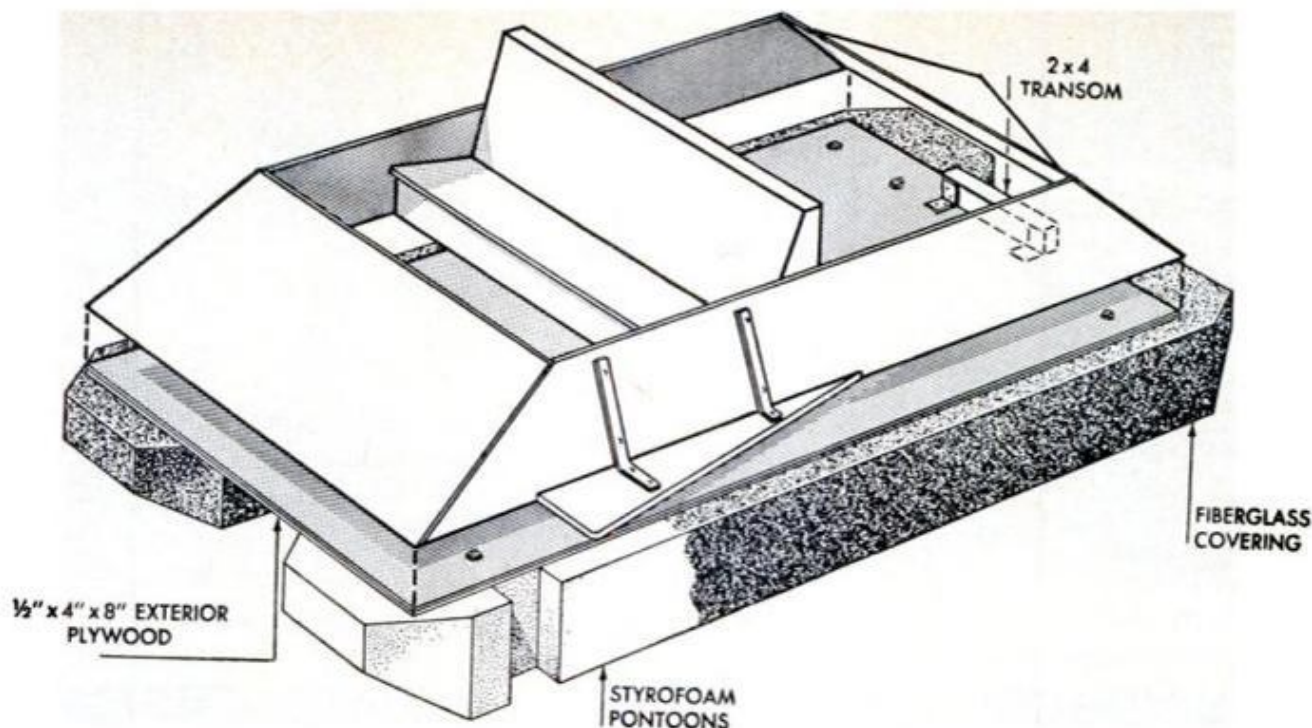

**PLYWOOD BODY** is basically just a box with slanting sides. Both nails and glue are used at all joints. Two Styrofoam Pontoons bolted to this box body provide plenty of flotation for a 500-lb. payload

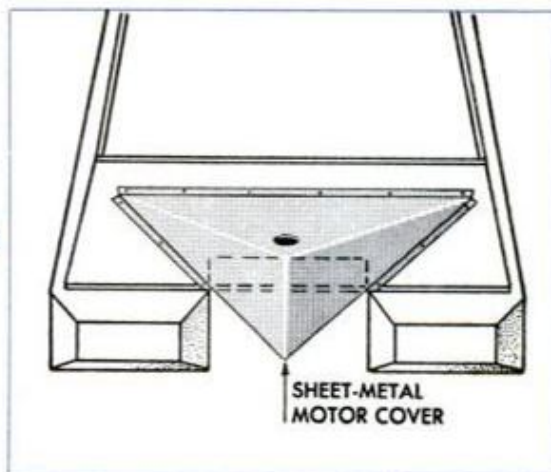
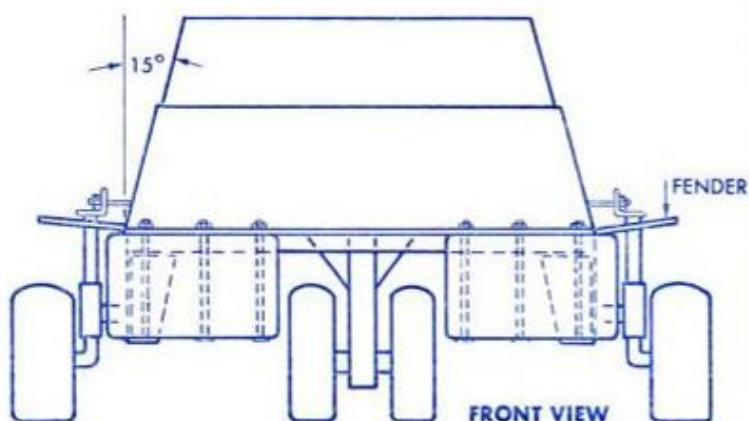

through the water but at no great speed.

For those who plan to use the Buggy primarily around water, he suggests that a small gasoline-powered fishing motor be substituted for the electric.

Incidentally, the only way to leave the water once you've had your cruise is to back up the beach. No outboard motor used on a craft (?) of this size would have the power to push it high enough on the beach for the rear drive wheels to get a grip.

The body is assembled on the floor plate, a 4 x 8-ft. panel of 1/2-in. exterior-grade plywood, good on both sides. The 1/2-in. plywood sides are installed temporarily with braces to hold them at the

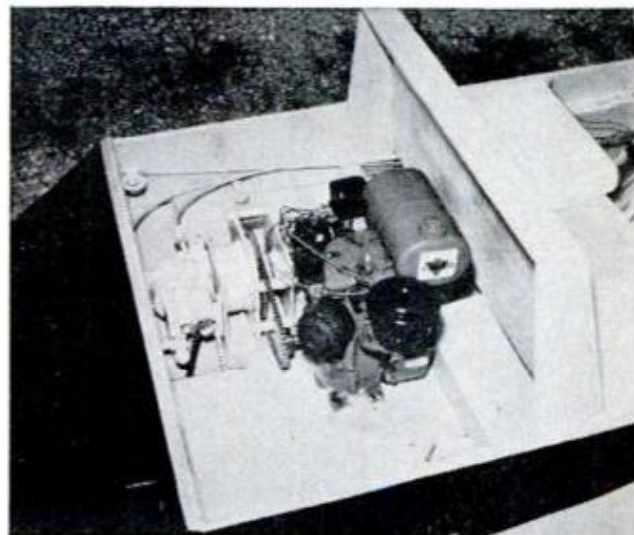

**ENGINE COMPARTMENT** located behind seat is left open for better engine cooling and extra load space





**TEMPORARY BRACING** is provided by angle brackets. Tacking end panels in place serves the same purpose

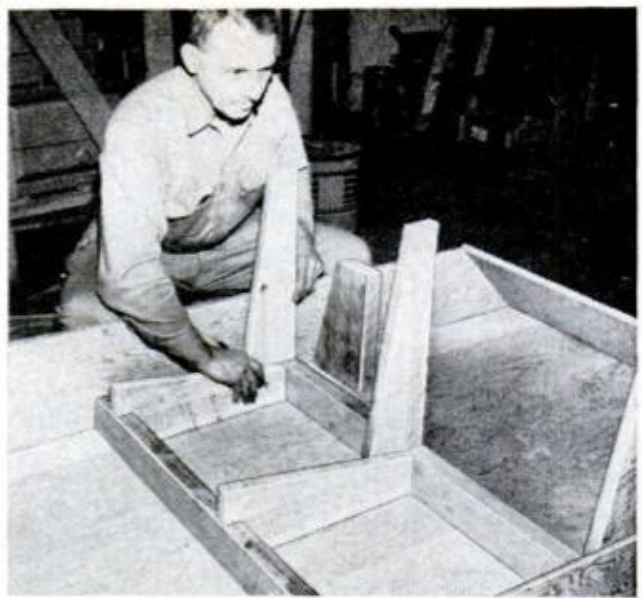

**SEAT FRAME** forms the central supporting structure of the vehicle. For strength, 2 x 4 rails are used

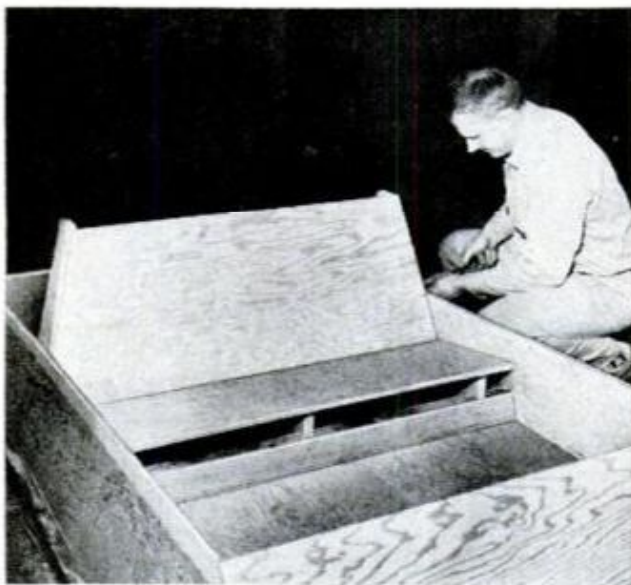

**WHEN YOU'VE ASSEMBLED** the seat, attach the side panels to it and remove all the temporary bracing

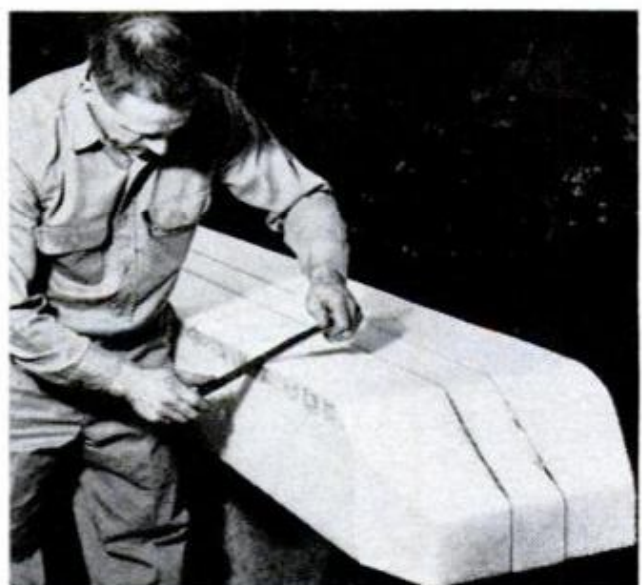

**AFTER LAMINATING** Styrofoam planks to form pontoons, cut to shape with a handsaw and round edges



**WHEEL BRACKET**, a part of the kit, is mounted on the plywood platform and notched into the pontoon

proper angle until you've completed the seat. Once the seat is complete, the sides are attached to that and the temporary blocking may be removed.

The pontoons are cut from foam blocks made by laminating Styrofoam planks with dry-wall adhesive (DAP or similar) or epoxy glue. (*Don't use contact cement. It reacts with the Styrofoam.*)

Once you've achieved the proper shape and cut notches in front for the axle brackets, round all edges slightly—a ¼-in. radius will do—before you begin fiberglassing. If not, the glass cloth will bulge—it's too stiff to bend around a sharp angle. Cover whole pontoon with a single fiberglass layer, then go back and reinforce all edges with fiberglass tape.

Next, lay the two completed pontoons

*(Please turn to page 224)*



# CAMPING

## TIPS FROM READERS



**NIGHT FISHERMEN** will have less trouble spotting their gear if they identify it with strips of luminous tape that glow in dark

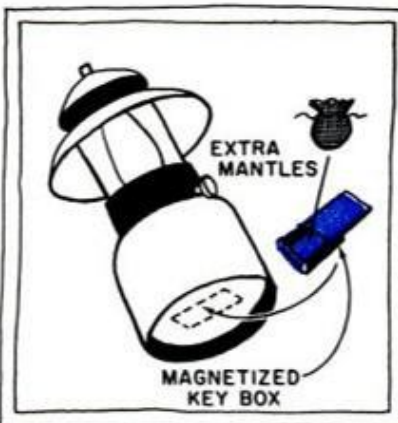

**MAGNETIZED HIDE-A-KEY BOX** is handy for storing extra mantles for your camp lantern, and sticks snugly to bottom of lantern

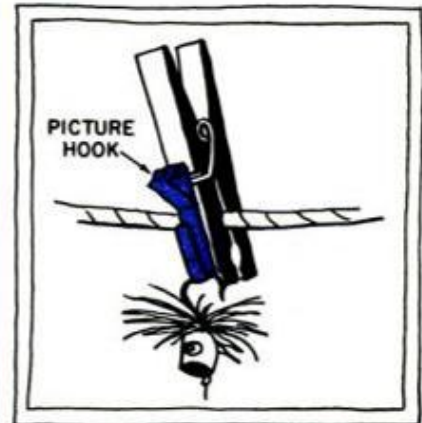

**A HANDY PLACE** for a fella to hang a fly while he dresses his line is on small hook tacked to spring-type clothespin as shown

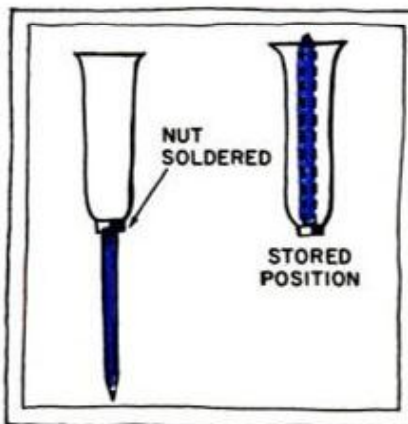

**A SAND SPIKE** for surf fishing: weld nut to hole drilled in bottom of old front shock absorber; grind point on shaft; then paint

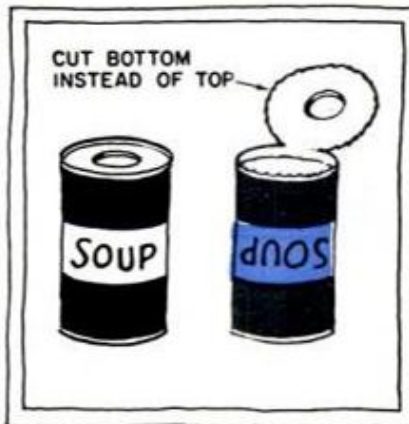

**OPEN SOUP CANS** at the bottom to get the most from them with least amount of scraping; thick settlings will pour easily



**CAN A ROTARY CAN OPENER** open cans in camp? Sure! Mount it on a board, lash board to tree as shown and you're in business



**PAPER TOWELS** aid camp clean-up jobs. Just tie 'em to a tree as shown; weight of roll prevents towels blowing away in the wind



**A "THIRD HAND"** for the night fisherman is a flashlight taped to the handle of his landing net to "spotlight" fish for landing



**SCRAP OF FORMICA** makes a great outdoor cutting board. It's lighter and easier to clean than wood, takes little space to tote



## "Self-raising" jack hikes wheel when trailer is backed

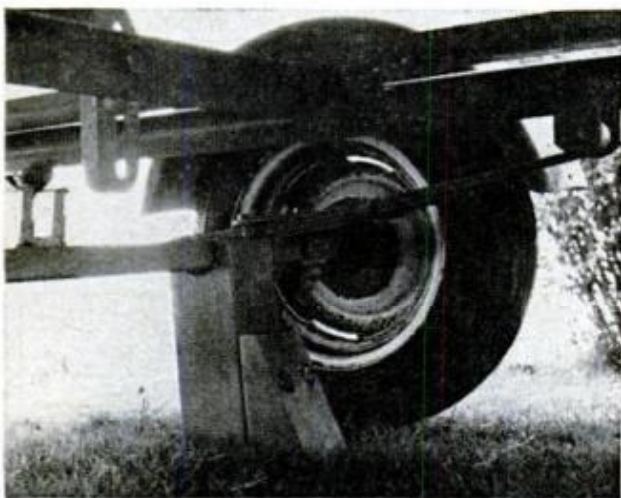
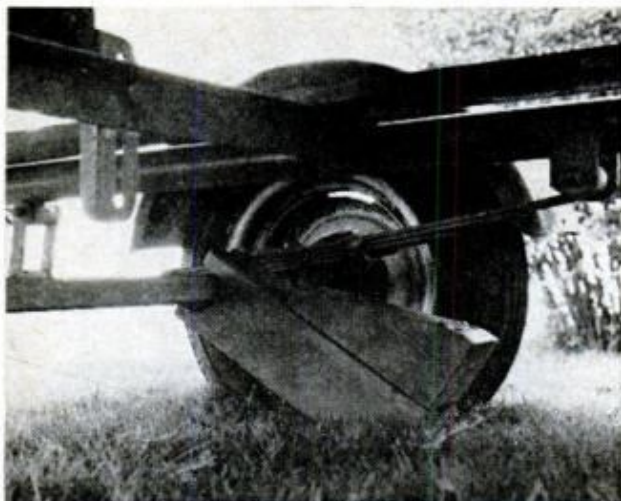

A flat on a boat-trailer tire can be a problem because most bumper jacks just don't work on these trailers. So make yourself this "self-raising" jack, altering the plans to accommodate your own trailer.

The photos at left show how the jack is used. The crotch of the jack is nudged under the trailer axle. The car is then backed until the jack is forced upright, supporting the trailer. To "lower" the jack, drive the car forward.—*Floyd Close*

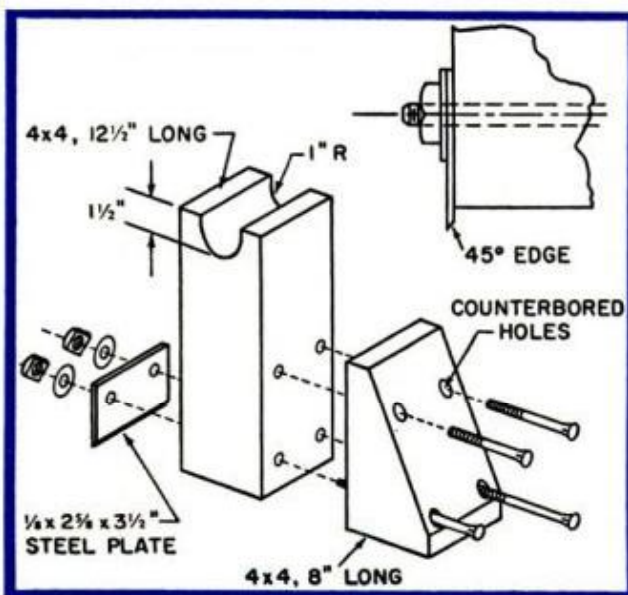

## Bike lock for outboard

A bicycle lock can serve to discourage outboard-motor thieves. To attach the lock, tighten the stern-bracket clamp-screw handles until they point downward. Then pass the lock through the holes provided in both handles. Now the motor cannot be removed from the boat until the lock is removed.

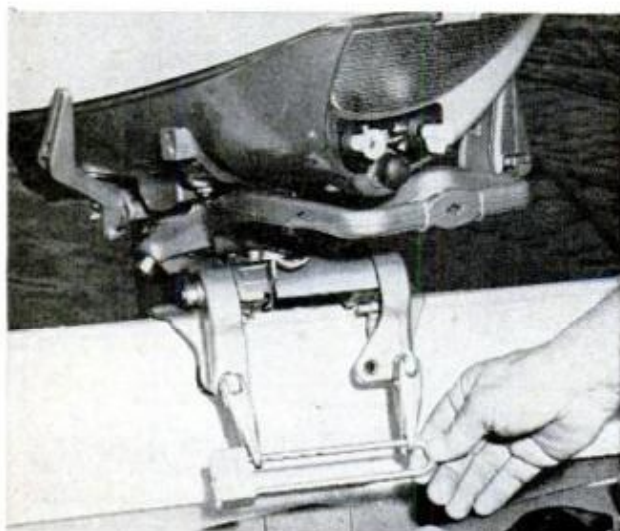

## "Wadeless" launching trick

Strips of high-friction nonskid tape laid along the rear bumper of your car provide a good step-ledge where you can stand while maneuvering your trailered boat in and out of the water. This self-adhesive tape will give you the traction needed to stay high and dry at launchings.—*Victor W. Kindra*







## Build this 14-foot canoe for \$50

By Roy W. Beeching Jr.

**O**F THE NUMEROUS TECHNIQUES I know for building a canoe, the one described here is by far the easiest. Two instances: the canoe has no ribs, and no steam-bending is required. Its principal ingredient is  $\frac{1}{8}$ -in. marine plywood—two 4x8-ft. panels sawed in half lengthwise. Gunwales, keelson, thwarts and breasthooks are stock lumber (fir or pine). On completing it you will have a fast, stable, lightweight canoe—perfect for two, perfect for lake or river, and perfect for camping trips. You can build it for under \$50.

Start by making the two breasthooks and by cutting the two  $\frac{3}{4}$  x  $\frac{3}{4}$ -in. inner gunwales to a length of 12 ft., 3 $\frac{1}{2}$  in. All four gunwale strips (the outer ones go on later) are cut from the same  $\frac{3}{4}$ -in. stock so that they will bend uniformly. The inner strips are now fitted and attached to the notches of the breasthooks with waterproof glue and three 1 $\frac{1}{2}$ -in., brass flathead wood screws, all countersunk.

The center frame is made next. It is double thickness with the joints staggered. Be sure the grain of the wood runs with the *length* of each piece. This section is now glued and screwed together as shown in the drawing, using the same size brass screws as were used in assembling the gunwales and breasthooks.

The keelson, midship thwart and two stems are next cut to shape and assembled with glue, screws and dowels. Attach the stems to the breasthooks first; then, with the keelson centered in the bottom notch of the center frame, move the stem pieces outward until the notch of each stem fits snugly over the keelson.

At this point, cut the 1x2 $\frac{3}{4}$ -in. keelson *long*. Taper it from its 2 $\frac{3}{4}$ -in. center to  $\frac{3}{4}$  in. at the ends, then fit it in place. The keelson should be cut long initially because different woods bend differently. Once you determine exactly how it will fit, then it can be cut to length (the one shown measures 11 ft., 8 in.).

Be sure the thwart is in place on the center frame before attaching it to the gunwales. It cannot be installed later, as its forked ends fit under the gunwales.

At this stage of construction, the frame will be unstable and must be handled with care. It will stiffen up later when the plywood hull is put on. In the meantime, to prevent the frame from twisting out of shape, a strongback made of 1x4s (shown in color in the drawings) must be set in place inside the frame where it is then temporarily screwed to the stems.

Attach the two crosspieces of the strongback to the inner gunwales by drilling a small hole for a finishing nail,



then driving the nail only part way in to facilitate its removal later. The cross pieces are not supposed to fit tightly, but are intended to hold the canoe in shape while construction is completed. While their exact position is not important, they should be clear of the seat positions.

### Attaching the hull

Now place the frame of the canoe upside down on two sawhorses and attach the first section of  $\frac{1}{8}$ -in. plywood. Four sheets of  $\frac{1}{8}$  x 24-in. marine plywood, 8 ft. long, are required.

Strike a center line down the keelson and position the plywood along it so that one end is on the curving center line formed by the laminated center frame. Using glue and  $\frac{1}{2}$ -in.-long fh brass wood screws spaced about 2 in. apart, attach the panel to its half of the keelson and as far out along the cen-

ter frame as flatness permits (in this case the distance will be about 9 in.).

Apply a generous coating of glue along the section of gunwale to which the panel will be fitted. Now toss a length of rope around the panel about halfway between the center frame and the stem and use it to draw the panel snug against the gunwale to which it is then screwed in place.

Here you will note that a triangular piece must be cut from the end of the panel at the center frame; this permits the panel end to lie flush against the center line of the center frame so it will not lap the panel that will butt it from the other end. Attach the three remaining panels in the same way.

Where the keelson ends, drive several long screws through the panels and into the stem piece to secure them against the outward pressure of the bent plywood. Trim off the panels flush with the gunwales and around the curves of the ends.

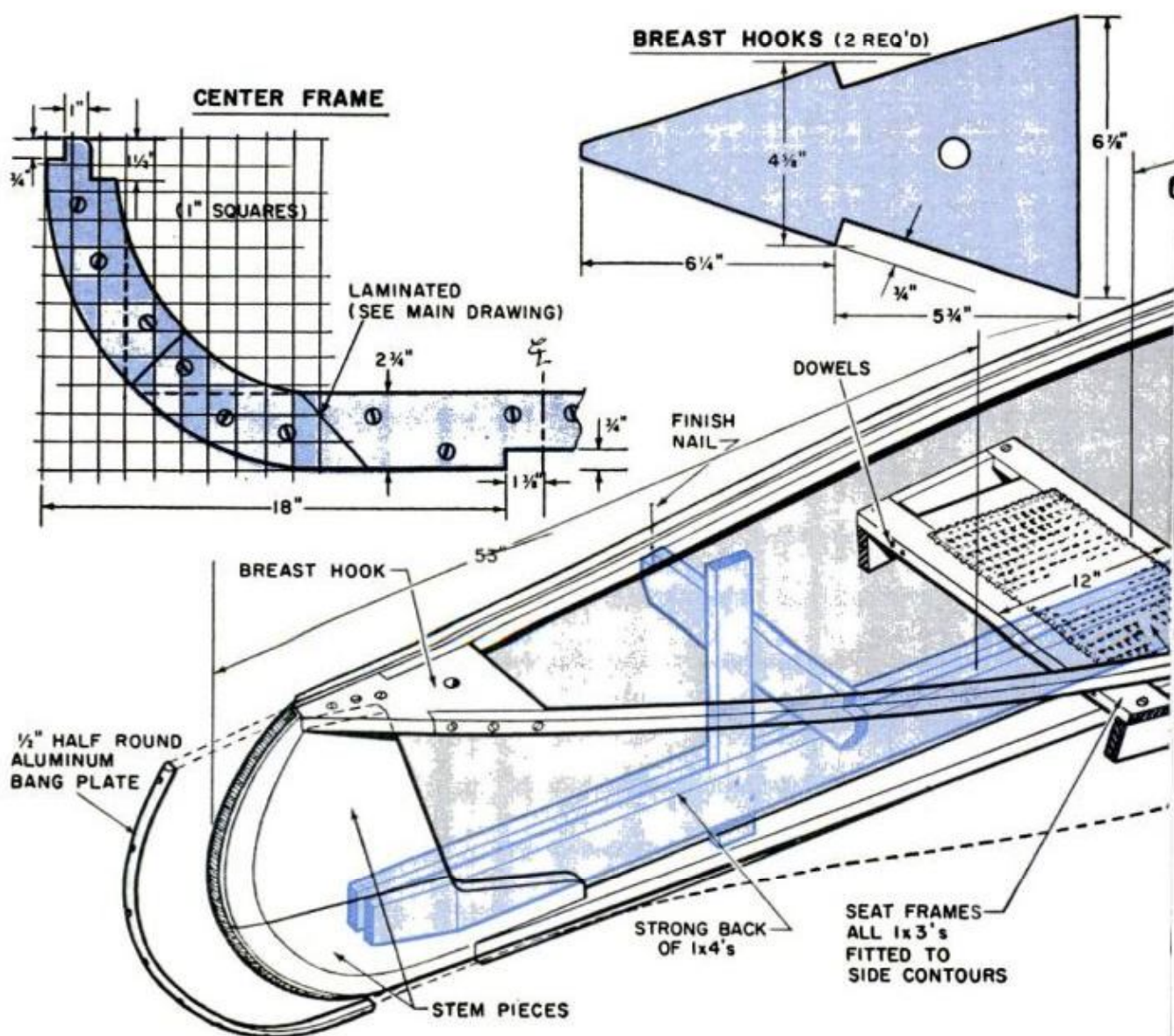



Sand all edges smooth. Cut and insert a small filler piece at the gunwale where the two panels butt at the center frame. With the plywood hull in place you may notice a slight "lump" at the center about 6 in. below the gunwale. This little bulge, common to this type of marine construction, is completely harmless and not worth the bother of removing it.

### Installing the seats

Next, cut, fit and install the seat blocks as shown. Be sure these blocks are level. Use plenty of glue and at least five  $\frac{5}{8}$ -in.-long screws driven from the outside into each block. The height of the seats above the keelson will determine that stability of your canoe. You can make them lower than shown, but not higher. Remember, however, when you're paddling in a kneeling position, your feet will be under the

*(Please turn to page 226)*

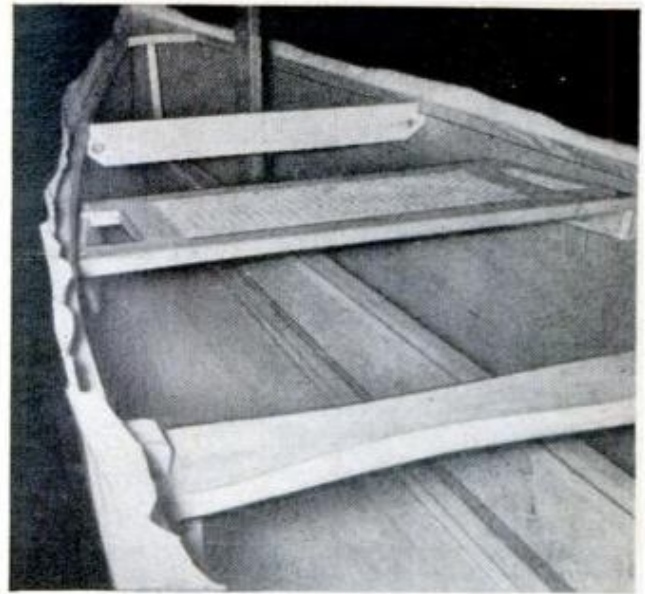

**CANOE NEARS COMPLETION** with its canvas skin glued and tackled to the hull. Outside gunwales are tacked on next, and the canvas edges trimmed. Note strongback that supports boat's shape during construction

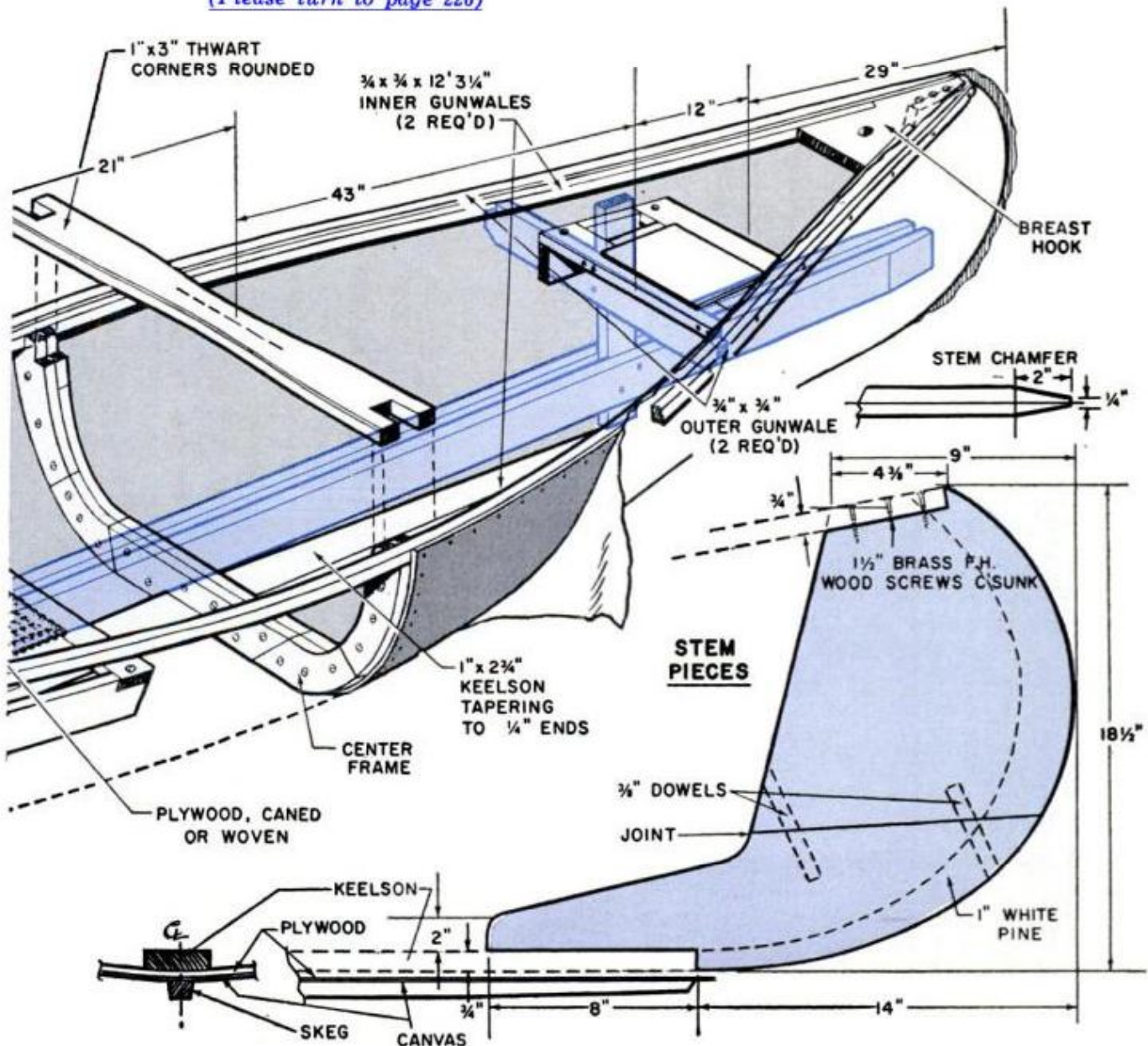



# Galley spices up patio fun

What's this cart lacking?  
Only you. It stores every-  
thing, including charcoal,  
and is easy to build.

By Steve Ellingson



**W**HETHER YOU FANCY YOUR-  
SELF a barbecue jockey or are a  
reluctant weekend galley slave, this patio  
cart will make duck soup out of your cook-  
ery chores.

Convenience is the word for this easy-  
to-build portable kitchen. It stores silver  
and dishes, or perhaps your bar neces-  
saries, and sports a rear-loaded charcoal  
bin. Above its nearly 5-ft. folding work  
surface are shelves for seasonings and a  
compartment for your barbecue uten-  
sils. Doubling as a cover for the com-  
partment is a serving tray.

The first step is to build the front  
frame from 1 x 2s. Attach a 1-in.-thick  
wheel spacer block to the projecting  
end of the longer vertical member. Drill a  
 $\frac{1}{2}$ -in. hole through the middle of  
this 2-in. stub. Repeat for the back of  
the cart later. All vertical members are  
attached to the rear of the horizontal  
ones, flush at the bottom, but  $\frac{3}{4}$  in.  
down from the top edge to clear the slid-  
ing top.

The front leg is a separate piece  
screwed to the rear of the lower rail.  
For style, splay the leg slightly. Use it  
for a pattern to duplicate the leg shape  
in the rear.

All side-panel and center-panel boards  
are the same width, but the center ones  
are only  $26\frac{3}{4}$  in. long. Use 1 x 2s to  
join the boards at top and bottom on  
the inside, and at the bottom on the out-  
side, lining them up with the front rails.  
At top left, however, the 1 x 2 is only  
10 in. long to provide clearance for the  
charcoal chute. The inside bottom cleats  
also serve as floor supports.

Join the backboards with an inside  
cleat at the bottom and add the caps  
across the top edges. The rear handle is  
secured with glue and corrugated fast-  
eners. The hole for the charcoal chute  
is 6 x 9 in.

The  $16\frac{1}{2}$  x  $28\frac{1}{4}$ -in. floor is made from

## MATERIALS LIST

Quantity	Size, Description, Use
1 pc.	1 x 2—12 ft. (framing)
1 pc.	1 x 12—12 ft. (framing, all panels)
4 pcs.	1 x 12—10 ft. (drawers)
1 pc.	$\frac{1}{4}$ " x 18" x 24" plywood (drawer bottom, chute sides)
1 pc.	$\frac{1}{2}$ " x 20" x 24" plywood (shelf, charcoal deflector)
1 pc.	$\frac{1}{4}$ " x 6" dowel (door hangers, locking pin)
1 gross	$1\frac{1}{2}$ " No. 8 flathead screws
Misc.	assortment of 6d, 5d, 3d, 2d finishing nails, 15" piano hinge with $\frac{1}{2}$ " screws, 1" butt hinge with $\frac{1}{2}$ " screws, a pair of 6" rubber-tire wheels, $\frac{1}{2}$ " x 2' steel rod for axle, $\frac{1}{2}$ " steel washers, cotter pins, corrugated fasteners, turnbuttons, plastic resin glue, plastic wood



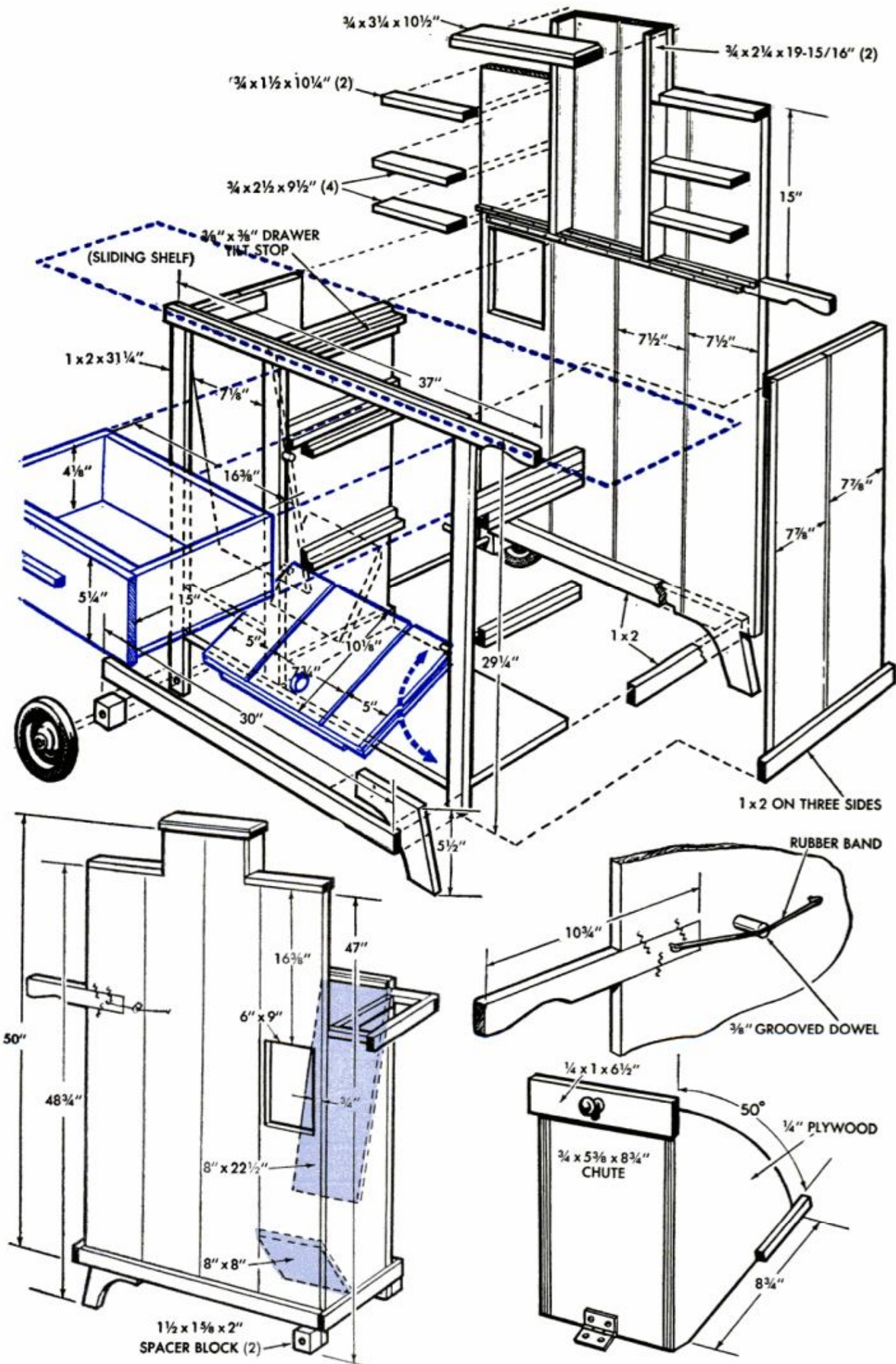



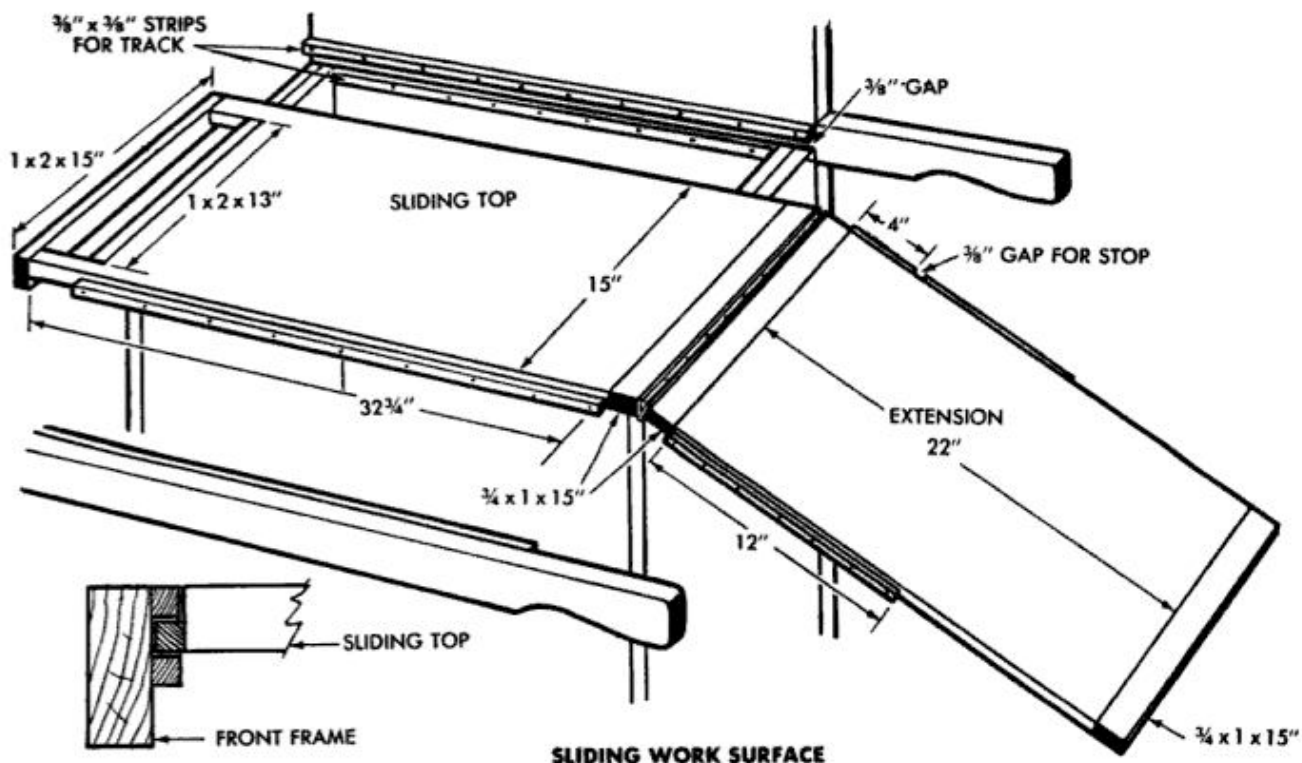

SLIDING WORK SURFACE

glued-up widths of scrap, notched to fit flush with the center upright of the front frame. Attach 1 x 2 cleats inside the front frame for the floor to bear on.

To keep the charcoal fed forward, insert an 8 x 8-in. piece of 1/2-in. plywood at a 45° angle in the left rear corner. The front panel of the bin slopes away from the front, leaving a 4 1/2-in. gap behind the filler panel at the bottom.

Mount the door and drawer slides as shown, with the dowels positioned directly ahead of the open areas of the door slides. The doors then pivot up and are pushed back on the slides. Adjust the door widths according to whether the edges are dadoed or 1 1/2 x 1/2-in. strips are nailed on. A shelf of 1/2-in. ply-

wood rests across the top of the lower door slides.

Attach a 3/8 x 3/8-in. strip to the top cleat on the center panel to prevent the drawer from tipping when it is pulled out.

The track for the sliding top is formed with 3/8 x 3/8-in. strips with a 3/8-in. gap between. The top has full-length 3/8-in. strips, but the extension has only 12-in. strips, with a break in the rear one to admit a locking pin. Both top and extension are made of glued-up boards. The end of the locking pin in the rear is grooved for a rubber band for automatic operation.

The serving tray (detailed below) is held in place with a pair of turnbuttons.

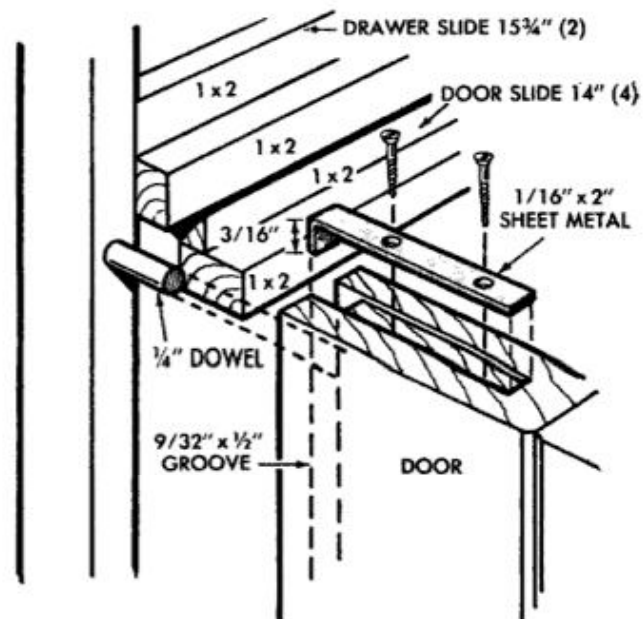

DOOR HANGER AND TRACKING

If you prefer to work from full-size patterns, send \$1 to Steve Ellingson, Popular Mechanics Pattern Dept., P.O. Box 2383, Van Nuys, Calif., and ask for pattern No. 342.

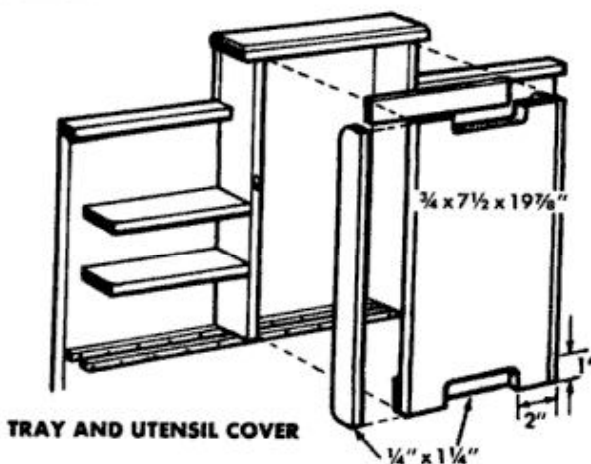

TRAY AND UTENSIL COVER



## Lifeline for back-yard pool

A prime nominee for the title of the world's best seagoing material should be rigid polyurethane foam. It floats better than cork, weighing only 2 lbs. per cu. ft., and cuts easier than balsa. It can be sanded, filed, glued and even painted.

It can be used for marker buoys and boat bumpers, but one easy project for most of you is a lifeline float for the back-yard pool. All it takes is the foam, a few plastic discs and a length of polyethylene rope. Polyethylene is preferred because it, too, will float. Cut the foam into the blocks needed, sanding the corners round, if you choose. Drill through the ends and through the reinforcing discs for the rope. Ideal for these discs are plastic poker chips. Finally, string them and the blocks, knotting the rope on the outside of each disc.—*V. Lee Oertle*

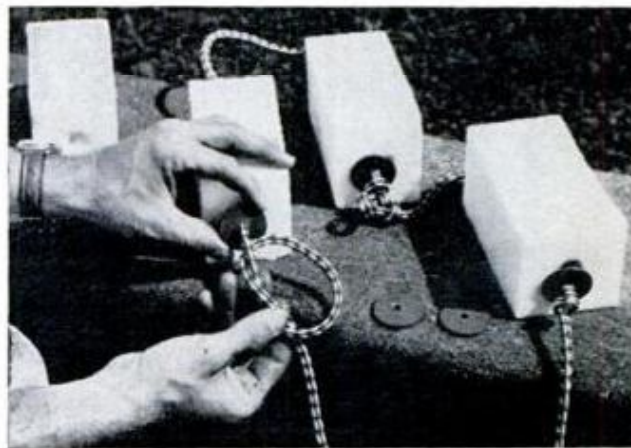
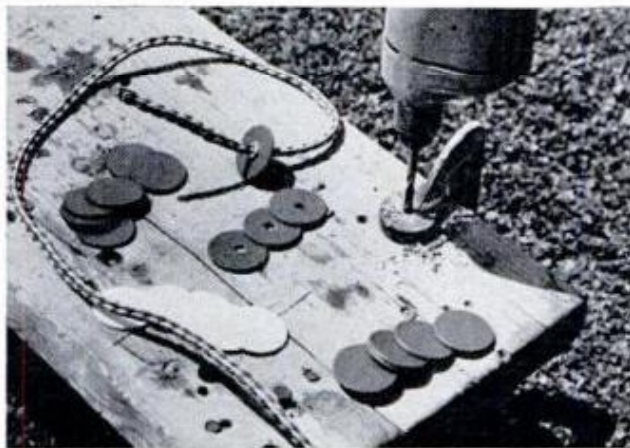

## Chummer's chum for fresh-water fishing

Is a fuller creel your goal? Bottom chumming for fresh-water panfish and cisco (a whitefish) in lakes is an effective way to increase your catch. What you need is this jig.

Start with an empty No. 2 can. Invert it and run an eyebolt through it and the lid from a No. 3 can which has the edges turned up.

To use it, half fill the can with small shore minnows, pull up the loose lid and shake the can vigorously to stun the minnows. Then lower it to the lake bottom alongside your regular tackle. Jerk the can's line to free a few minnows. Their presence around your tackle will then lure the game fish. It's perfectly legal in most states, but check first anyway just to be sure.—*Norbert Engels*

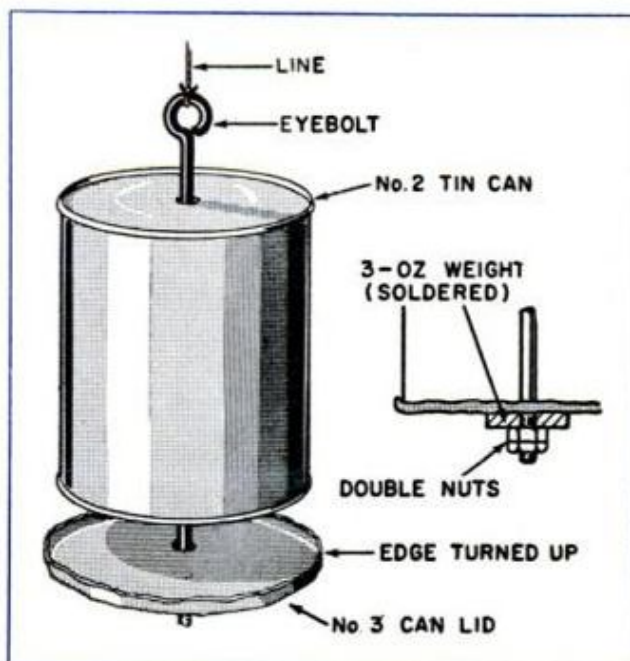



## Silicon rectifier reduces light intensity of enlarger

Good quality enlargements are hard to obtain from "thin" negatives. You can get them by cutting the intensity of the enlarger lamp from 150 to 60 watts. Installing a silicon rectifier and switch in the enlarger cord will reduce light output about 50 percent (and that's the secret).



Either a s.p.d.t. or s.p.s.t. toggle switch can be used.

Drill holes through facing sides and lid of a plastic parts box. Remove the enlarger-cord plug and pass the cord through the holes. Cut one of the wires of the cord inside the box and strip both ends. Mount the switch to the box lid then solder the wires of the cord and rectifier to the switch terminals. Put the plug back on the cord and cement box to the enlarger base.—*Frank P. Fritz*

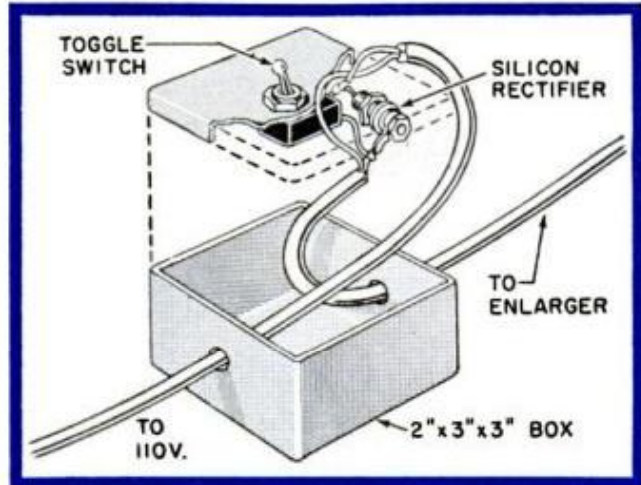

## Developing aid takes three reels of film at once

Developing as many as six reels of 35-mm film simultaneously in a 1-gal. tank is a cinch with a pair of the simple developing aids shown here. In use, one to three reels of film are dropped over the rod and the top plate is threaded onto the end. The unit is then immersed in the developing solution. The film is agitated by slowly withdrawing the unit, turning it upside down, then returning it to the developer every 30 seconds until processing time has elapsed.

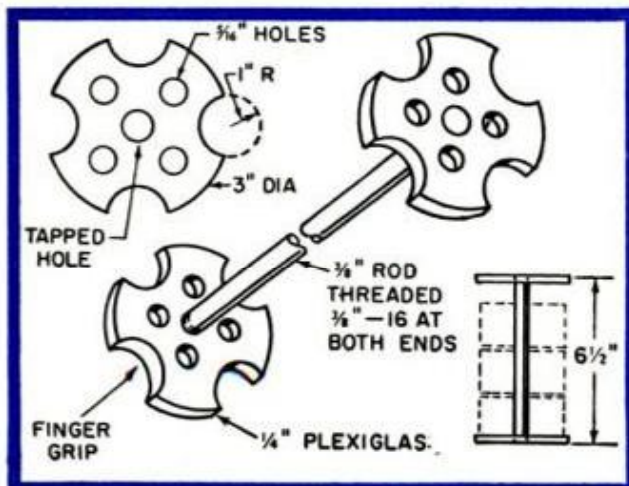

The rod is  $\frac{3}{8}$ -in. Plexiglas  $6\frac{1}{2}$  in. long. Lay out and drill all holes then cut the outside edge of the plates. All holes are  $\frac{3}{16}$  in. with center holes tapped to fit the  $\frac{3}{8}$ -in. No. 16 threaded ends of the plastic-center rod.





# NEW FOR CAMERA BUFFS

BY LEONARD SAMUELS



**Electronic simplification** is the hallmark of the Olympus 35-LE. Both shutter and diaphragm are combined in a single set of blades, which is programmed by a CdS cell and a six-transistor amplifier for optimum speed and aperture. Cross-coupled flash sets the aperture as camera is focused. Price is \$100. Scopus, Inc., 257 Park Ave. S., New York, N. Y.



**Solid-state bandwagon** has on it the full-frame Yashica Electro 35. Its shutter is transistor-diode controlled, with a speed range between 1/500 and 30 seconds. This CdS/transistor-comparator system will also make changes in speed during exposure. Lights indicate improper exposure. Price is under \$100. Yashica, 50-17 Queens Blvd., Woodside, N. Y.

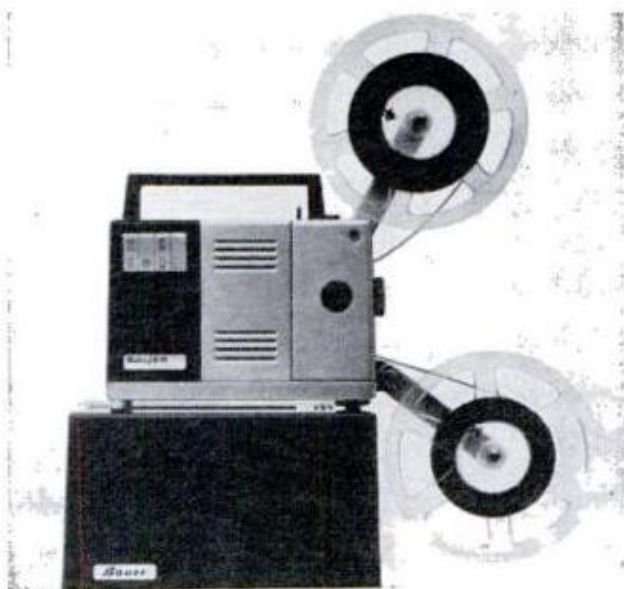

**Affordable talkies** are now yours with the Bauer T1-S Super 8 projector. The 5 x 6¼ x 10-in. unit offers built-in sound synch with a tape recorder at 3¾ i.p.s. Other features include automatic film threading, 12-volt quartz-iodine lamp, f/1.3 zoom lens, pushbutton controls, still projection. Price is \$179.95. Allied Impex Corp., 300 Park Ave. S., New York, N. Y.



**Electronic automation** can be found in the Minolta Electro Shot. It features a six-transistor, three-diode electronically programmed shutter with a CdS cell. The shutter is also a single set of blades. Flash exposure is set automatically. Through-the-lens meter compensates for filters. Price is \$114.95. Minolta Corp., 200 Park Ave. S., New York, N. Y.



## Bird's-eye-view camera tripod fits ladder in a jiffy



Can't get high enough with your camera? This 4-ft. ladder and camera support will let you look down on things at twice the height of a regular tripod.

The support is fitted with a pan head mounted on an angle bracket and held by a  $\frac{1}{4}$ -20 machine screw. A metal disc is soldered into the screw slot to make it a thumbscrew. Just under the top platform is a hinged  $\frac{5}{8}$ -in.-plywood brace to which the support is attached with a carriage bolt via another angle bracket. The foot of the support fits into a slot in plywood that covers the ladder's workshelf.

—O. A. Nelson

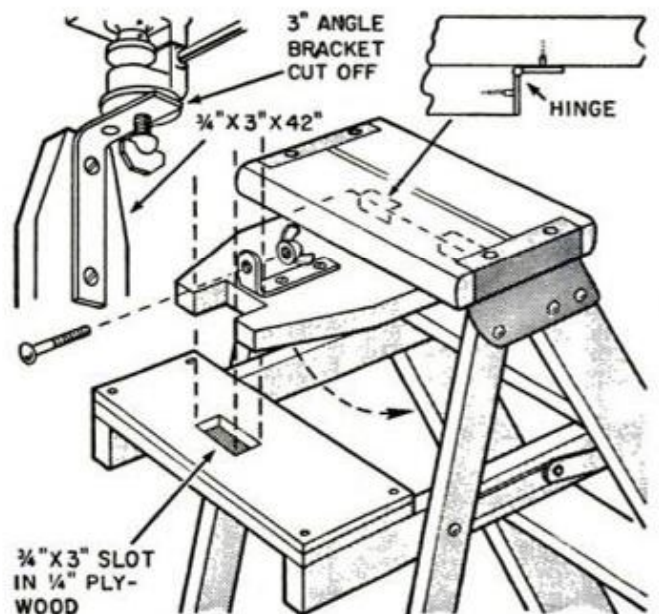

## Screen press speeds drying of matte finish prints

Air is the key to fast drying of photographic prints. Two-faced press for matte prints allows free circulation of air around them by means of fiberglass screening stretched across the frame's inner faces.

The double-hinged frame will take two 16 x 20-in. prints back to back with a blotter between. A screen-door hook holds the frame closed. For faster drying, warm air and use a fan.—Manly Banister

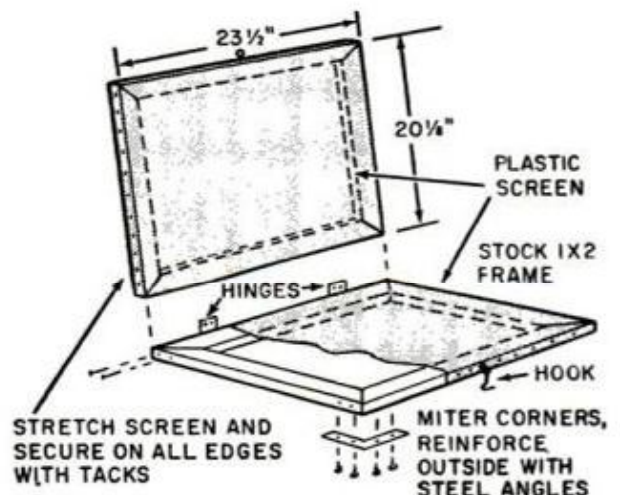
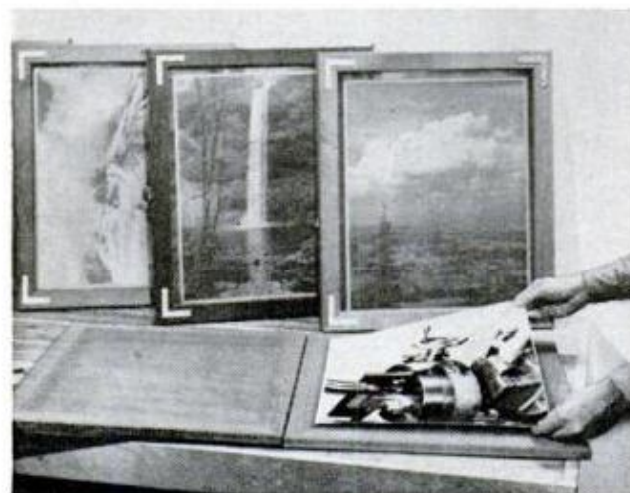



# Molding Character Into Flush Doors

**N**OTHING BEATS A FLUSH DOOR— unless it's a Spanish door, a traditional door or a contemporary door. In other words, the decorative door is back in style.

The *bas-relief* patterns applicable to flush doors are gaining a new acceptance among homeowners. And the great thing about this new decor in doors is that any handyman homeowner can do it himself— can invest the unrelieved flatness of any flush door in his home with dramatic three-dimensional beauty. All it takes is a handful of white pine molding which is available at most any lumberyard.

That's why the new popularity of the sculptured look in doors is not hard to understand . . . it's easy to achieve, the

cost of treatment is negligible and the result is the addition of character to a previously characterless flat surface.

The tools and materials you'll need for the job include a miter box and saw, a coping saw, carpenter's rule, some white glue, finishing nails and fine sandpaper.

Set the miter box at 45° and cut the molding so that tight, right-angle joints can be formed. Lay out the desired pattern on the door, then glue and nail the molding in place, countersinking all nails. You may need the coping saw to cope the butting ends of molding used as cross-pieces against the concave face of adjoining molding. When the job is done, sand the molding smooth, then finish to suit.

Patterns courtesy Western Wood Products Assn.

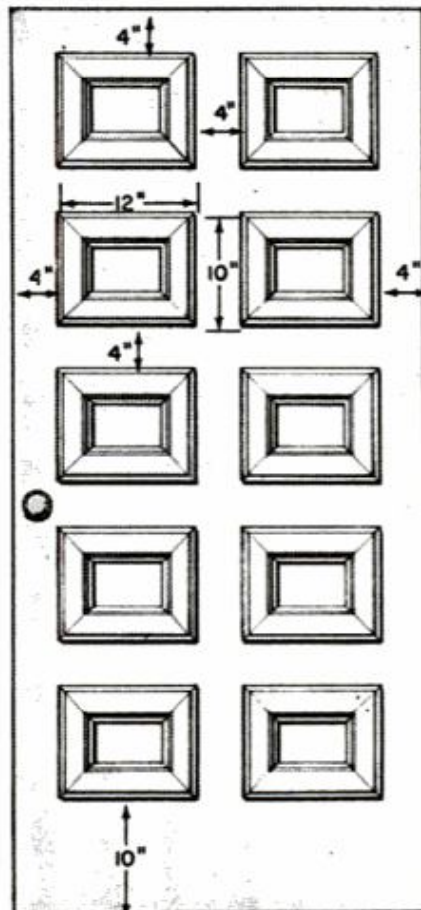

SPANISH STYLE

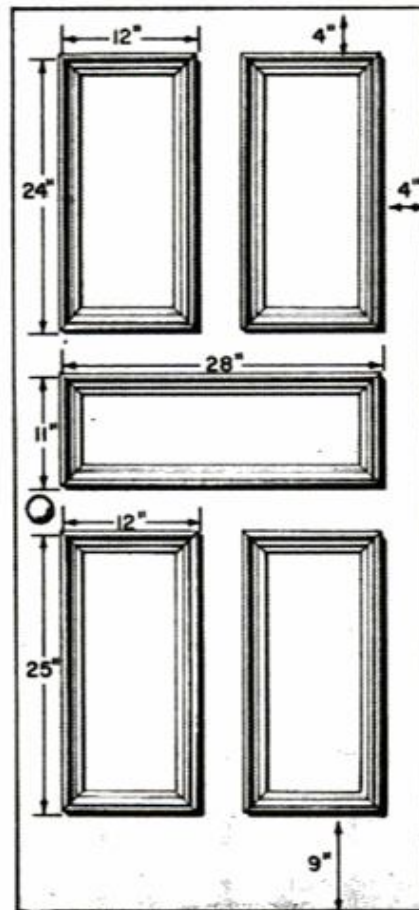

TRADITIONAL STYLE

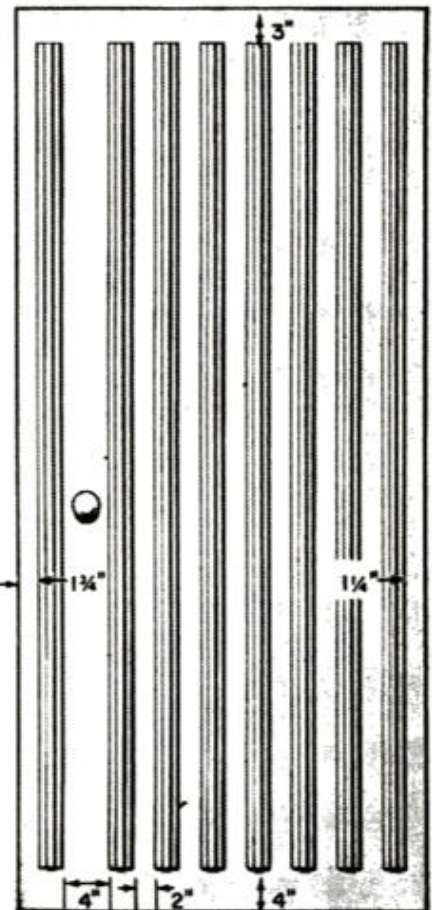

CONTEMPORARY STYLE

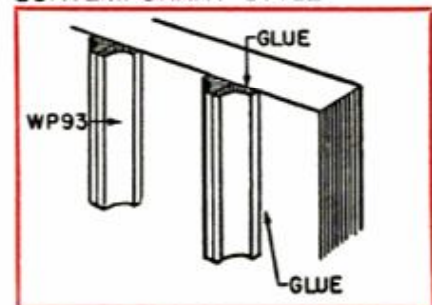
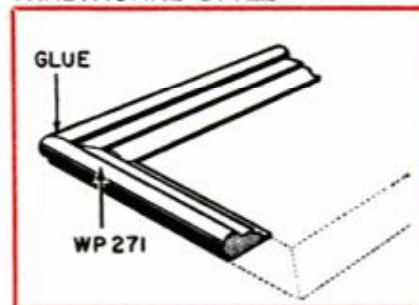
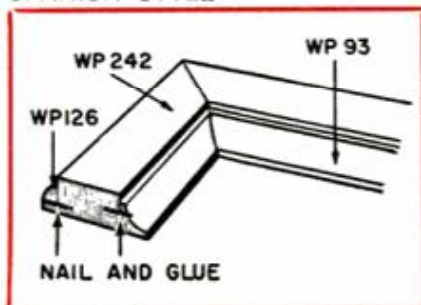



# SOLVING HOME PROBLEMS

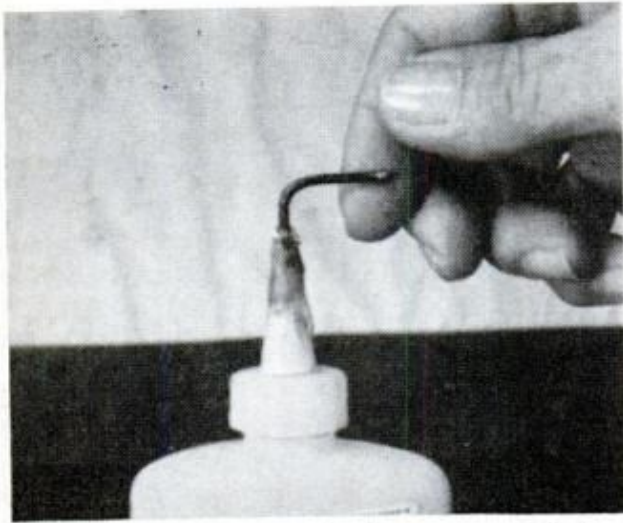

**NEW TWIST** for sealing glue dispensers which don't have push-pull tops is to bend an aluminum nail at right angles and push this into the hole. To remove, just give it a quick turn to break the seal and pull

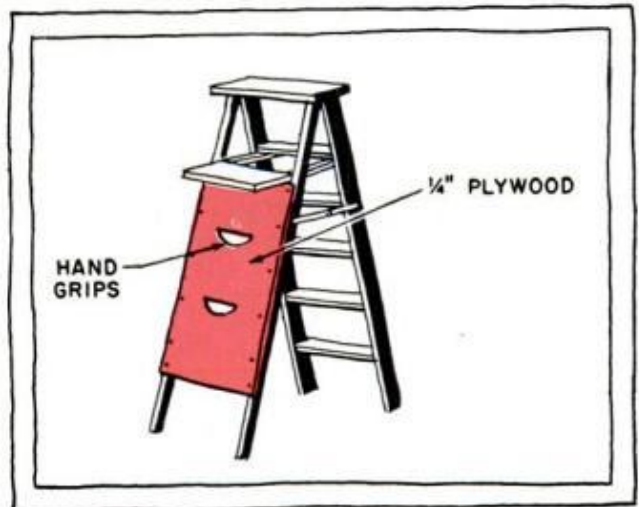

**PANEL REPLACEMENT** for regular cross braces on stepladder offers greater rigidity. Cut a sheet of 1/4-in. plywood to fit over the legs, add carrying holes and attach it with nails or screws and glue

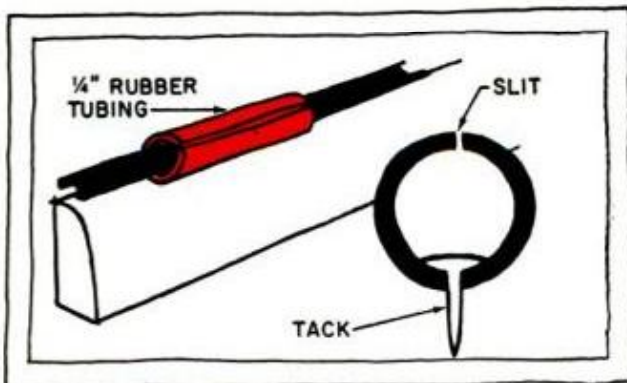

**LAMP AND APPLIANCE CORDS** can be kept tangle-free and off floor with baseboard holders made of short lengths of rubber tubing. A slit along one side permits tacking in place and easy removal of cord

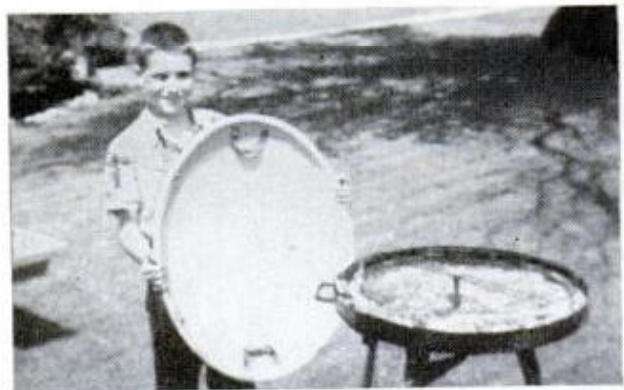

**OFF-SEASON USE** for a child's flying saucer sled is protecting a portable barbecue grille when kept on the patio. It makes a perfect rain cover and is heavy enough to stay in place even in a strong wind

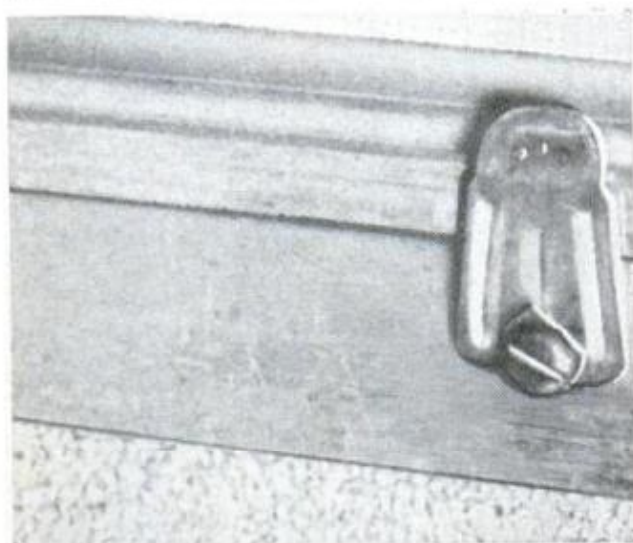

**SAVE THOSE** lift tabs from easy-open beer cans. They make fine turnbuttons for holding storm windows and screens in place. Simply remove the surplus strip, drill a hole for the screw and you're all set

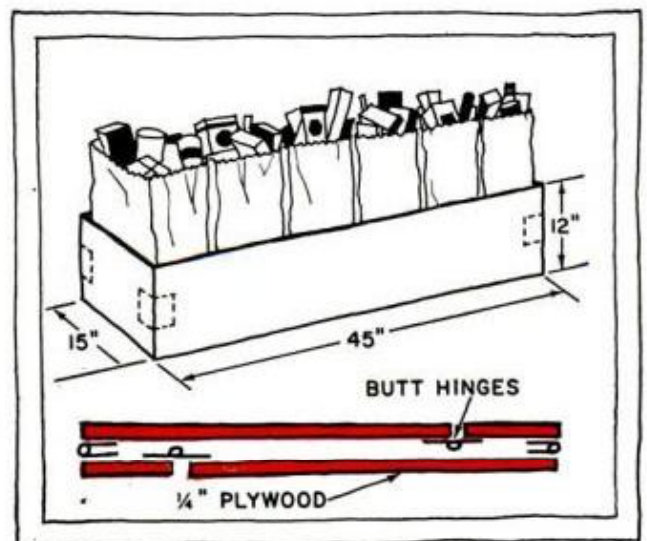

**FOLDING FENCE** for the back of your station wagon corrals grocery bags, prevents them from toppling. Made from 1/4-in. plywood and butt hinges, the one shown takes six bags. Size it to suit your load



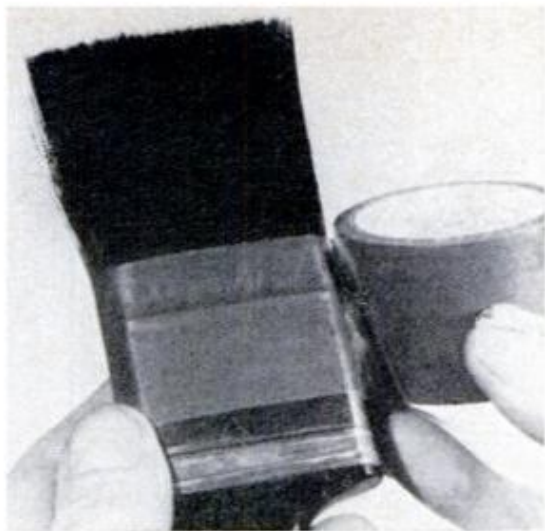

**PRECLEANING PAINTBRUSHES** involves wrapping the top of the bristles and ferrule with masking tape before you start the job. When you're done painting, strip off the tape. You'll find it saves a lot of work

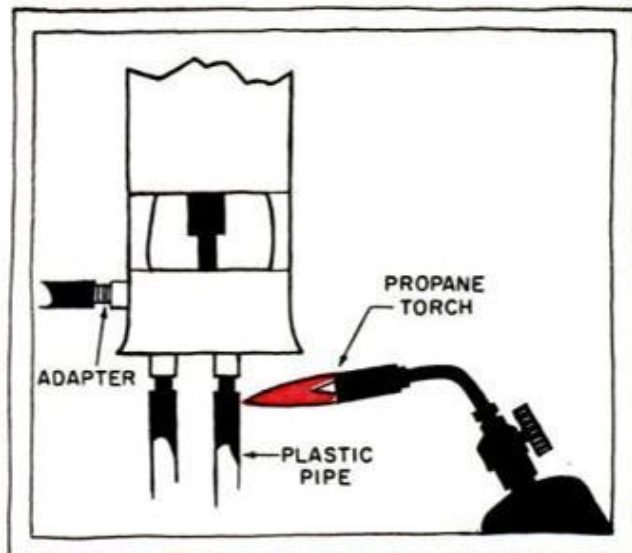

**HERE'S A HOT TIP** on removing plastic pipe from adapters when repairing a water system. A little heat from a propane torch at the joints expands pipe so it slips off easily. But keep that flame moving

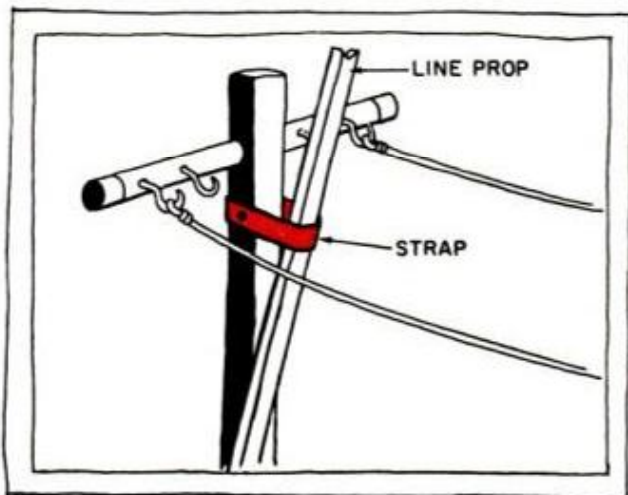

**POLE HOLDER** on a clothesline post provides a place to store the clothesline pole where it won't fall down into the snow or mud. Nail or staple a loose loop of wire or strap metal near the top of the post



**IF YOU ARE AFRAID** of a ring being left when using gasoline (outdoors) to remove a spot from clothing, try this tip: Rub the spot first with a strong salt solution, then apply the gas. There'll be no ring



**INSTANT CANDLE** for use in an emergency can be made by sticking a Q-Tip into a jar of petroleum jelly until the top touches the jelly. Dip the exposed end of the Q-Tip in the jelly before lighting it

MAY 1966

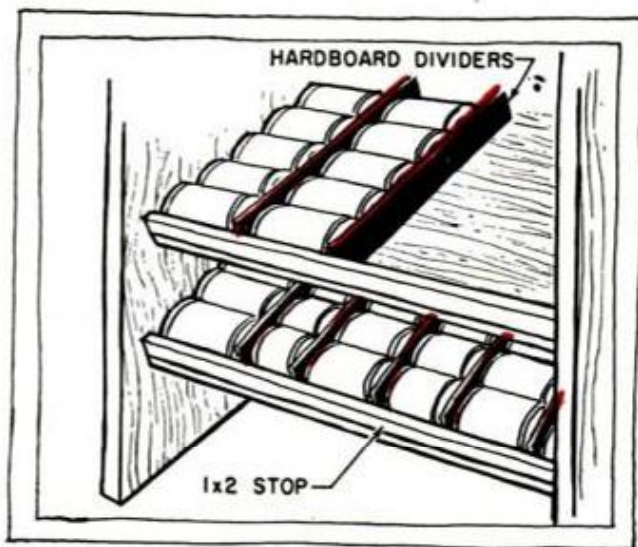

**WHY NOT COPY** the convenience of supermarkets when building can-goods storage in your kitchen? By installing the shelves at an angle, the rows of cans will automatically roll to the front to end searching

157



## YOUR OUTBOARD MOTOR

# The Lowdown on Lower Units

As a rule, major troubleshooting is a job for a pro. However, here are some inside tips on what you CAN do to keep that bottom end in top shape.

BY HENRY B. NOTROM

**L**ET'S FACE ONE THING right off the bat: Mechanically, your outboard's lower unit is a bag of snakes, several of 'em mean and nasty. From the point of view of home repair, it's the most complex part of the motor and one into which only experts and fools generally dare to delve. Angels know better.

However, there *are* certain basic repair and maintenance steps you can take not only to save a dollar or two here and there, but also to assure longer lower-unit life and smoother overall operation.

Whether or not you want to go whole hog regarding lower unit repair depends upon your available time (you'll need plenty), ability to muddle through and willingness to spring for a service man-

ual. You can get a necessary schematic breakdown of your motor's lower unit for \$4.95 from an all-types lower unit service manual from Abos Marine Division, Technical Publications, Inc., 1014 Wyandotte St., Kansas City, Mo.

So assuming you're brave, have some tools, time and a service manual, where do you start? Well, the first thing you have to determine is the way in which your particular motor shifts gears.

If you have a small motor of the fishing type, gear shifting is usually done by means of a handle control located on the motor itself.

The second most prevalent type of arrangement is shifting by means of a remote-control unit located up by the steering gear. This type of remote-control shifting could either have come with

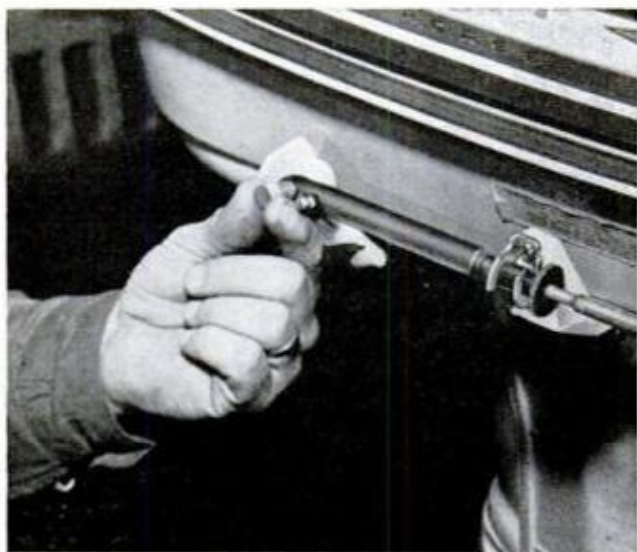

**TO TEST** lower-unit operation on engines shifted by remote control, disconnect cable held to shifter by thumb screw. Be careful, and don't lose the spring!

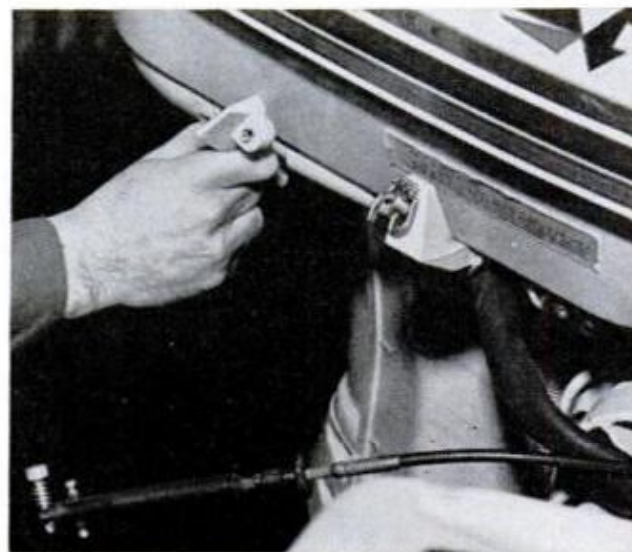

**YOU CAN SHIFT** the motor through its gear range by hand once the cable is disconnected. If you can't, chances are you've got trouble in the shift setup



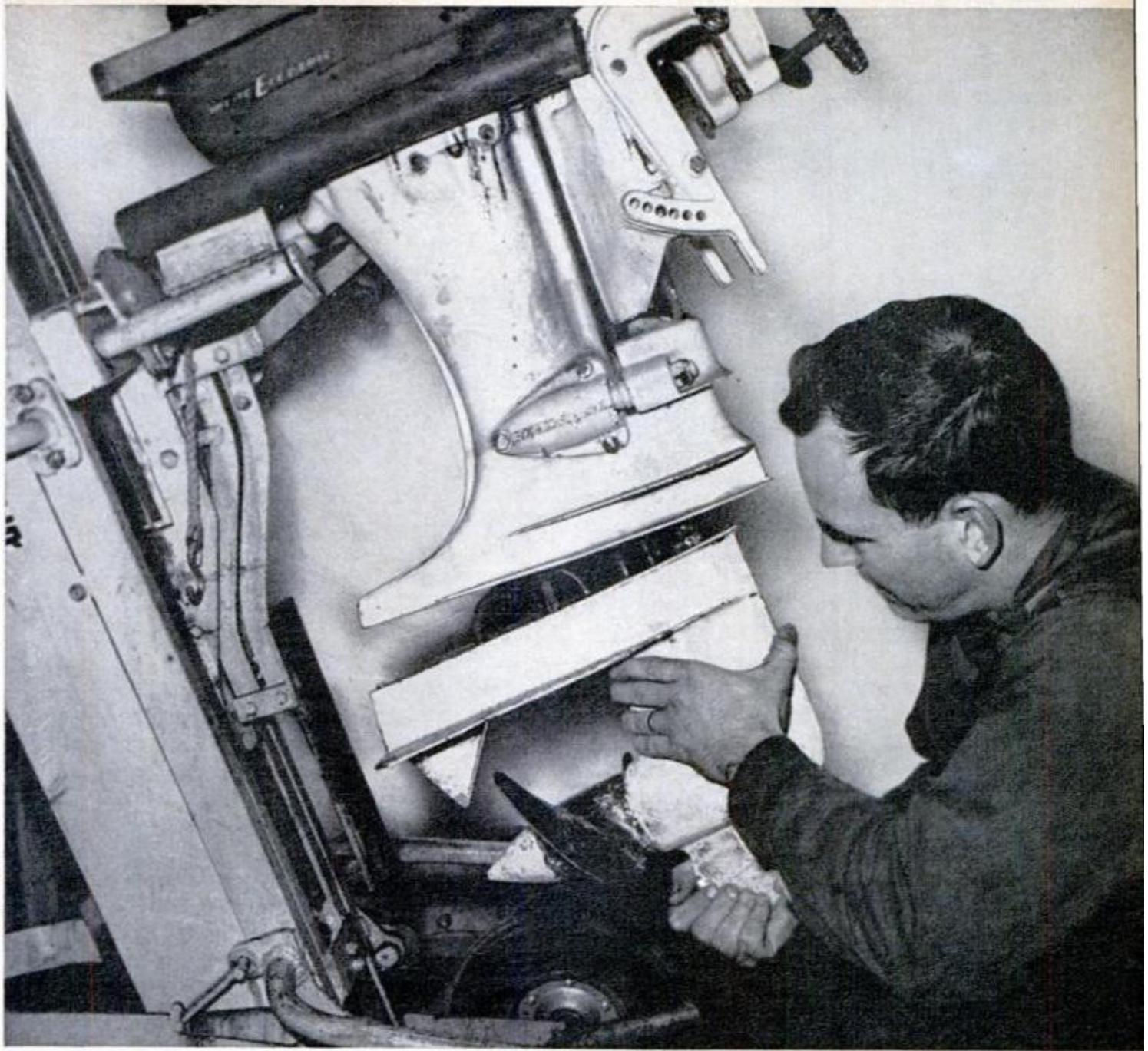

the motor when you bought it or you could have had it put on. Remote-control shifting, for example, can be adapted to small motors which ordinarily would be shifted by handle.

Finally, there's electrical shifting, found primarily on OMC engines of the 40-and-more horsepower class.

No matter what type of shifting arrangement you have, a lower-unit breakdown makes itself known in three ways.

- There's just no shift. The engine won't go into forward and/or reverse gear.
- You can go forward, but you can't get it to shift back into neutral.
- You can shift, but the engine keeps jumping in and out of gear.

When any of these occurs on an engine with a handle control, there's no

doubt you have a problem in the shifting setup. However, a shifting problem in motors with remote control can be caused by trouble in the remote setup or in the lower unit. How do you tell?

You disconnect the remote-control unit cable at the motor. Although operated by remote control most models have a means of shifting the motor by hand at the point where the cable is disconnected. If the engine does not shift into gear by hand, the trouble's in the shifting setup. If it does shift, the problem is with the remote-control box—could be a broken cable, a worn gear, a chipped gear, a busted gear or what have you. To find out, control unit cables have to be checked from fore to aft. If cables are okay, then the remote control





**MERCURY-TYPE MOTORS** have this spring-loaded ratchet shift dog arrangement. Gears are designed for quick meshing, wear better is snap-shifted to full limit

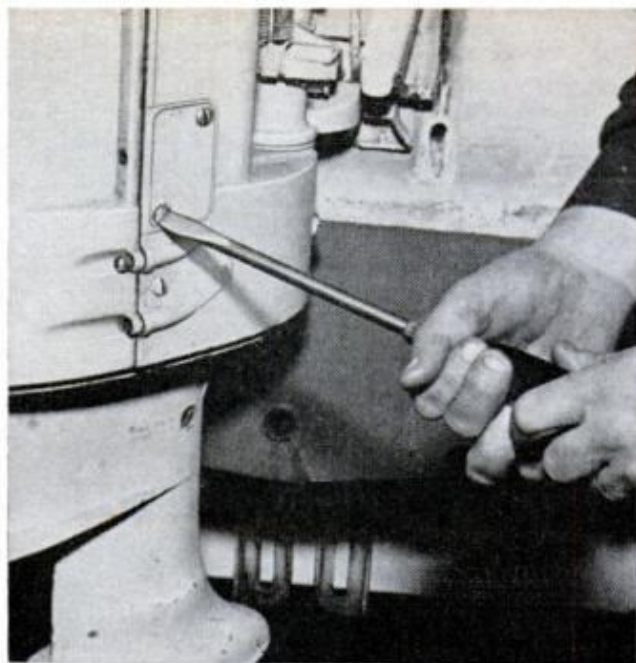

**TO GET AT BOTH** upper and lower shift rods in OMC-type motors, look for and take off outer plate. The inner plate must be unbolted for access to the case

box has to be taken apart and repaired.

As far as electric shifting is concerned, the problem could be in the electrical wiring or in the lower unit. All you can do yourself is look for a break in the exposed wires on the powerhead side. If none shows, then the remainder of the electrical harness has to be checked by disconnecting it and hooking in a shop test harness. If with the test equipment the motor shifts, your harness is at fault. If it doesn't, there's trouble somewhere in the shifting mechanism.

Mechanically, there are two types of basic shifting arrangements in use today. One—let's call it the Mercury-type unit—is a spring-loaded, ratchet-type shift

dog in forward gear. The other kind—call it the OMC-type—is a non-spring-loaded, ratchet-type shift dog.

You can tell which one you have if you have other than an OMC or Mercury engine by scanning the lower-unit case. The OMC-type has an inspection plate somewhere on the case which, when removed, provides access to the shift rods. There is no such inspection plate on Merc-type units.

Those of you who have OMC shifting arrangements will find that you're able to go farther in repairing the most common problems yourself than those who have Merc-type units. As soon as a shifting problem becomes apparent with

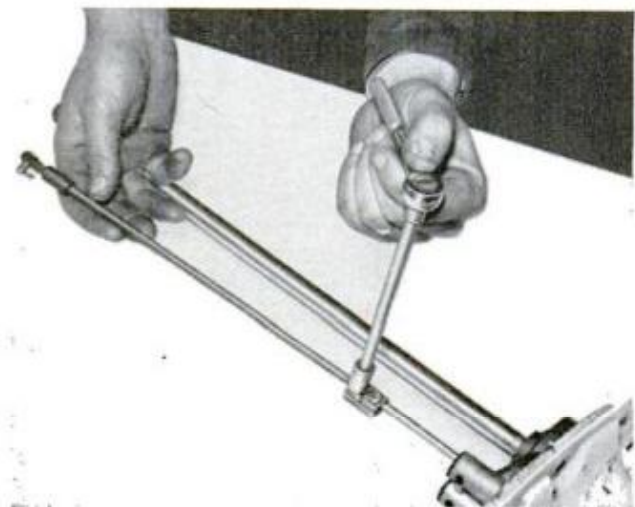

**WE DROPPED** the lower unit to show upper and lower shift rod setup. You needn't do this: rod bolts can be checked, tightened or replaced with unit intact

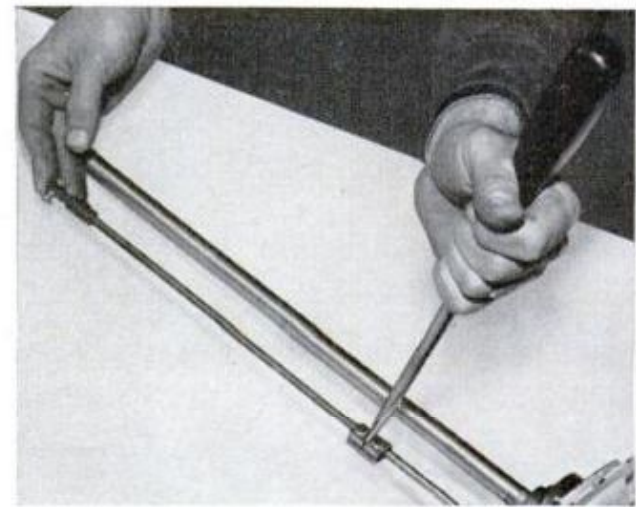

**TO CHECK THE CLEVIS PIN** for tightness and/or wear, pick up on the upper shift rod. To get at the pin, powerhead must be removed, at times a rugged job



OMC types, the first thing to do is remove the inspection plate and look inside. After removing both the external and internal plates you'll see the upper and lower shift rods, connected to each other by bolts. If a bolt is missing or loose, you've solved the trouble right away. Replace or tighten.

If things are okay between upper and lower shifting rods, insert a screwdriver between the rods and pick up on it. If there's upward play as you move the screwdriver, the gearshift clevis pin is worn or loose and has to be replaced or tightened. Again, this job may or may not be something you want to tackle yourself. To get at the clevis pin, the powerhead has to come off. In some engines, this isn't too much of a problem—in others, it's real rough.

Other than these two problems, the most common trouble cropping up in OMC-type shifting setups is a bad shifter clutch dog. Getting at this part, of course, necessitates disassembly of the lower unit.

According to OMC, "wear of gear and clutch dogs can be very much accelerated by operators who possess the mistaken belief that gentle shifting (easing into gear) is the proper practice to safeguard the shifting mechanism. . . . Actually, the thought is *totally erroneous*, because easing into gear causes the ears of gears and clutch dogs to rap and slide off their edges many times during one shift maneuver before gear engagement is finally accomplished. This repeated rapping-and-sliding-off process is the direct and principal cause of accelerated ear wear as well as a cause of their slipping."

OMC lays down five shifting rules that you'd be well off following to keep lower unit problems away from your engine. These are:

1. Do shift only at recommended idle speeds (600 rpm  $\pm$  100).
2. Do smartly snap-shift (a quick, snappy movement of the gearshift lever).
3. Don't shift above recommended idle speeds.
4. Don't ease into gear.
5. Don't slam into gear.

Owner and service reports indicate the major problem experienced with Mercury-type shifting mechanisms is breakage of the shift rod. You'll know  
*(Please turn to page 202)*

# OUTBOARD CLINIC

**Q** *I have a good deal of trouble starting my '61 Scott. The engine's tuned to perfection, yet it seems that the compression is just too much for the starter and battery to handle. What gives?*  
—R. C., Fla.

**A** The two most common causes of this complaint are (1) the battery is too low in amperage output for the engine, and (2) there's a burnt armature in the starter. Incidentally, it's generally conceded that an outboard battery should be rated at 65 to 70 amps.

**Q** *I recently bought a used '55 5-hp job that's in good shape despite its age—except for one thing. It floods out on me after a run of 20 or 30 minutes at maximum speed. The local shop tells me there's nothing wrong, so why the flooding?*—F. L. E., Me.

**A** It sounds to me like a sticky reed valve.

**Q** *My 5-hp Johnson runs like a top when set for fast speed, but dies out when I troll. The engine's reconditioned, so I can't figure it. Can you?*—J. H. G., Okla.

**A** You don't say what year your engine is. In some models, there was a bit of a problem with carburetor gaskets going bad. I'd replace 'em just to be on the safe side, and make sure the engine's tuned to perfection.

**Q** *Whenever I start my 12-hp Sea King, I get a thump like I've hit an underwater obstacle. It only happens once a start. After that, it's okay. Why?*—M. T., Ill.

**A** It's rough to figure out a noise problem without hearing it. Likely causes are too much prop shaft play or the way in which the engine drops down on its tilt pins. It could also be a normal thing. Depends on the ferocity. I'd let a good mechanic check it.

**Q** *I've got a '55 Evinrude which runs okay at high speed, but hits on only one cylinder at idle. Had points, condensers and coils checked, installed new plugs and wires. Can you figure out what the problem is?*—D. K., N.J.

**A** If a good tune-up failed to correct the condition, I'd be suspicious of a scored piston or cylinder. Pull the inspection plate and check pistons, rings and walls.

*For a personal reply to questions concerning repairing your outboard motor, write to Outboard Clinic, Popular Mechanics, 575 Lexington Ave., New York, N.Y. 10022. Please enclose 25 cents in coin to cover postage and handling.*



## Foam spacer block holds golf tubes securely in bag



If you head for that first tee with a minimum number of clubs and a small bag, here's an idea that will let you protect the shafts and grips with golf tubes without the usual problems. Normally, when there aren't enough tubes to fill the bag, everything rattles around loosely and even the simple act of replacing a club in its tube requires a certain amount of fumbling.

This spacer block is designed to solve such problems. It's cut from foam plastic (Styrofoam, urethane, Ethafoam or similar) to fit the opening of your bag. Use coarse sandpaper to achieve the final fit and taper required. Lay out the pattern of 1 1/4-in. holes to take the number of clubs you carry. Cut them with a hole saw, cut notches for braces and the spacer is ready to use.—Gene Florida

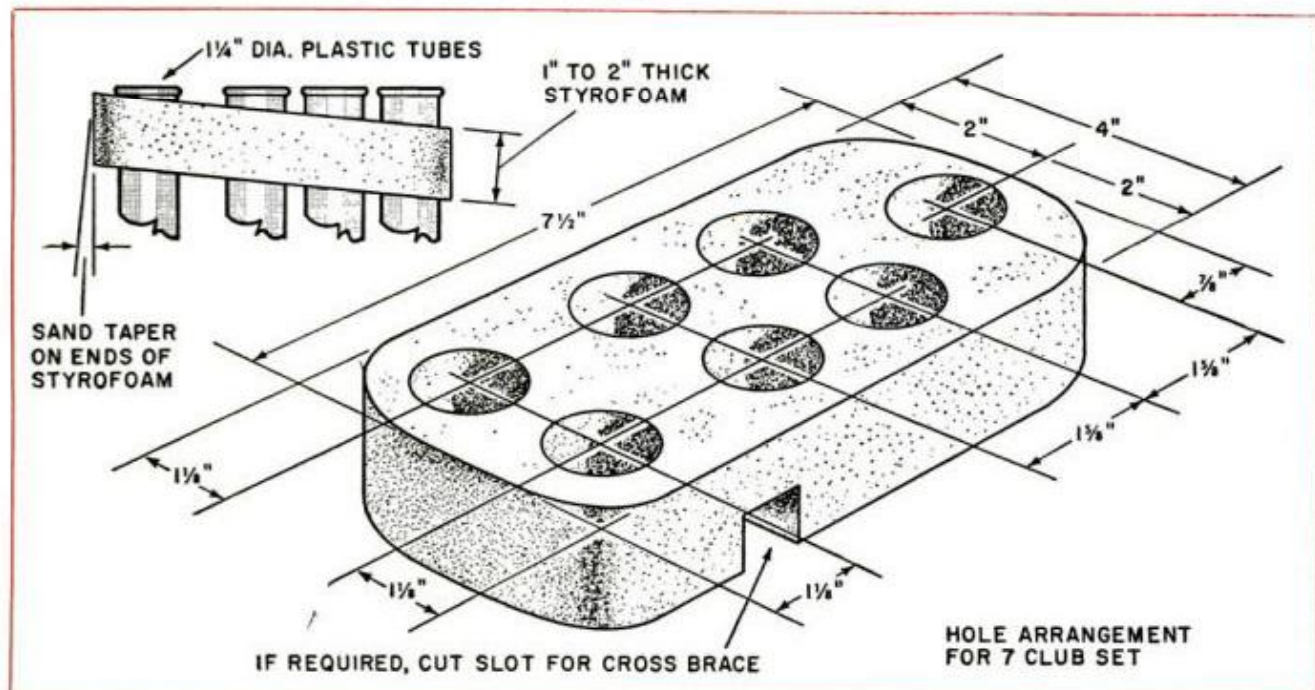

## Coffee-can tom-tom

A great rainy-day project for one little Indian or a whole tribe, this tom-tom is just a bottomless two-pound coffee can covered with wood-grained adhesive vinyl. Punch two holes for the carrying strap (a leather bootlace) and tie knots inside the can to hold it. You'll need about 10 more yards of the bootlace to weave between the two plastic snap-on lids. Make the beater from a length of 1/4-in. dowel and a cork fishing float covered with a scrap of Leatherette. Decorate with paint and feathers.—Gene Florida



# Realistic Spring Maintenance Program

Your chrome chariot's carried you through another winter, so favor it now with a checkup/changeover for the warm-weather days ahead. This article tells what you must do, what you can do and what you can skip

By Morton J. Schultz

**M**EMORIZE THESE TWO FACTS before servicing your car this spring for carefree summer driving:

- You can save a bundle of cash by doing most of the work yourself.
- If you have a mechanic do the work, you'll still save money by spelling out to him exactly what you want done.

Most mechanics have their own pet spring maintenance procedures. Too often they include services that are simply not needed as part of a spring maintenance program. In short, there seems to be a good deal of confusion as to what constitutes proper spring maintenance.

For example, every spring maintenance

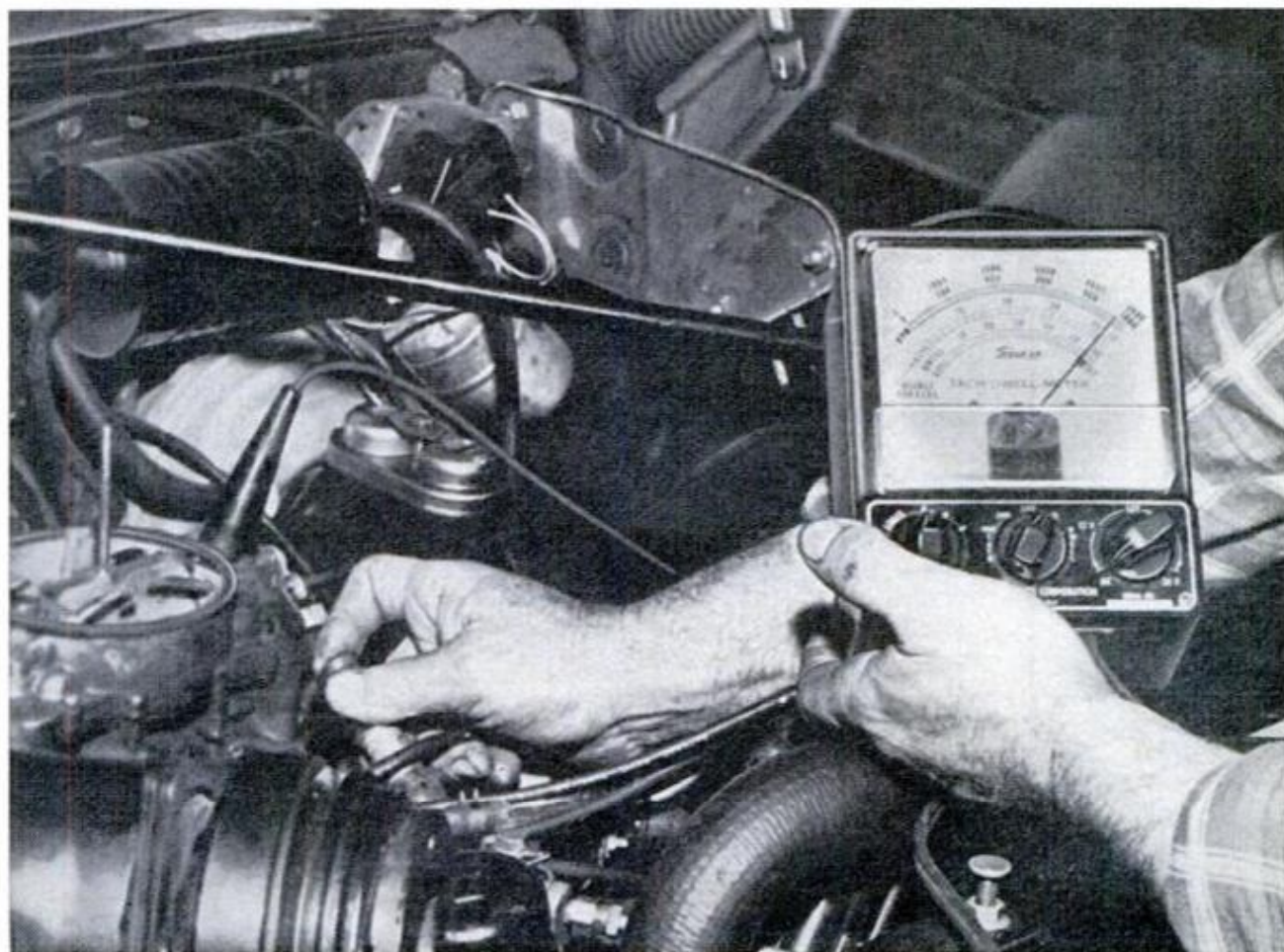

**USE TACHOMETER** to check positive crankcase ventilation system (PCV). Disconnect ventilation hose at PCV valve and cover end with your finger. Idle speed will show a drop if the system is not clogged





CUT,  
FOLD,  
TAPE

**SPRING  
TUNEUP**

**CHECK COOLING SYSTEM** with pressure tester connected to radiator fill cap. As tester is pumped, leaks will be revealed where coolant is forced out

list I looked at called for **CHASSIS LUBRICATION** in big, bold letters. Well, you and I know that for some years now manufacturers have recommended a chassis lubrication interval of anywhere from 6000 to 32,000 miles or longer, depending on the car. If the recommendation for your car is every 12,000 miles, and the odometer shows that fewer than 12,000 miles have passed since the last lubing, do you grease the chassis simply because it's spring? Why *sure*—if you want to shell out a couple of extra bucks for no good reason.

Most lists I looked at also stipulated repacking of the front wheel bearings. I'd be the first to admit this is important. However, you don't have to do it just because you sighted your first robin. You do it when the car's odometer says it needs doing.

The key to spring maintenance, then, is realism. Some services are done because of the season while others are determined strictly by mileage checks.

Table I on page 165 shows a maintenance "package" advertised by a popular garage in my area as a *Spring Service Special* (the parenthetical asides are mine). Labor costs for this "package" total \$18. Of course, this doesn't include probable additional costs for parts and materials. The average bill for this "Special"—assuming the customer gave the shop *carte blanche*—could very likely run to \$35 or more.



**TRY PLUGGING SMALL LEAKS** by pouring in a quality cooling-system sealer. If the stuff doesn't "take," better let a professional make the required repairs

Now compare this with Table II (same page) which is what I consider a sensible approach to spring maintenance. Here the parts of a car that are listed as requiring spring servicing are those which can be assumed to have had a particular strain put on them during the winter, or those which require adjustment to prepare the car for the hot-weather operation it will be subject to during the summer months ahead.

**Cooling system.** Because cold-weather driving usually means short-range driving, the cooling system may seldom have heated up last winter to temperatures at which it could operate efficiently. The effect could be that the system is now knocked for a loop.

The first thing to do is check for leaks. With the radiator cap removed, connect a pressure tester to the radiator fill hole. As you pump up pressure, coolant will be forced out at any point a leak exists. Small leaks can be plugged by pouring in some cooling-system sealant. Larger leaks should be mended by a professional.

Whether you drain the antifreeze now will depend on the type used, or on how long it's been in the system. If you installed one-year coolant last fall, leave it in until this coming fall. However, if you installed one-year antifreeze last spring, you should drain it now and refill with fresh coolant.

If you're using two-year antifreeze,





**IS COOLANT OKAY?** Check with a hydrometer. Two-year coolant that has changed color should be replaced; so should any coolant where rust is present

give the liquid a careful inspection. All extended-period coolants incorporate a color-changing chemical which indicates when they should be replaced. Any coolant that's rusty should be drained out. By the way, if the system is drained and/or if there are deposits of rust or scum on the inside of the filler neck, take time to reverse-flush or chemically clean it.

When adding new coolant, remember that cars with aluminum engines and those with airconditioning require the use of permanent-type antifreeze all year round. In other cars plain water can be used during warm weather.

Check the radiator pressure cap. Screw it onto the end of the pressure tester, then pump the tester until the meter shows the same pounds pressure as is imprinted on the cap. If it does not hold steady at this reading for at least a few seconds, the cap is bad and should be replaced.

Hoses are checked out in one of two ways. If you don't drain the system, at least *feel* the hoses. Any that feel spongy should be replaced. A more positive check can be made with the system drained. Disconnect each hose and run your finger (or a screwdriver) around the inside. If rubber flakes come off, replace the hose—its rotting.

**Exhaust system.** The exhaust system suffers from the ravages of rust more than any other section of the car. This is because it must endure extremes of heat

**TABLE I**  
**COMMERCIAL 'SPRING SERVICE SPECIAL'**

Servicing Item	(Author's Comments)
Drain antifreeze	(might be necessary)
Flush radiator	(ditto)
Install rust inhibitor	(if antifreeze is drained)
Tighten and check all hoses	(okay)
Inspect fan belts	(sure)
Lubricate chassis	(not necessary)
Change engine oil	(okay)
Change differential oil	(nuts)
Change transmission fluid, adjust bands	(forget it)
Inspect battery, clean terminals	(I'll buy that)
Tune motor	(only if it's off-key)
Clean and space sparkplugs	(phooey)
Adjust ignition timing	(not just because it's spring)
Clean carburetor air filter	(not necessary)
Set carburetor for summer	(absolutely)
Repack front wheel bearings	(not necessary)
Inspect brake linings	(brakes, yes; linings, no)
Check all lights and focus	(If they were okay in winter, they'll be okay in summer)
Adjust generator charging rate	(skip it)
Inspect steering mechanism	(not seasonal)

**TABLE II**  
**REALISTIC SPRING MAINTENANCE PROGRAM**

System	Service
<input type="checkbox"/> Cooling	<ol style="list-style-type: none"> <li>1. Check system for leaks.</li> <li>2. Drain radiator if filled with one-year antifreeze; examine two-season coolant for contamination.</li> <li>3. Test radiator pressure cap.</li> <li>4. Check fan belts for wear and proper tension.</li> <li>5. Check thermostat operation.</li> <li>6. Check all hoses, tighten clamps.</li> <li>7. Refill system if drained; add rust inhibitor, water-pump lubricant.</li> </ol>
<input type="checkbox"/> Exhaust	<ol style="list-style-type: none"> <li>1. Check muffler and tailpipe for rusted-through spots.</li> <li>2. Check clamps for tightness.</li> <li>3. Check exhaust pipe-manifold connection for leaks.</li> </ol>
<input type="checkbox"/> Brakes	<ol style="list-style-type: none"> <li>1. Check brake-pedal "feel" and travel; if spongy or low, bleed and adjust.</li> <li>2. Check fluid level in master cylinder.</li> <li>3. Check for presence of brake fluid on inner walls of tires, indicating a wheel-cylinder leak.</li> </ol>
<input type="checkbox"/> Lubrication	<ol style="list-style-type: none"> <li>1. Change oil and replace filter.</li> <li>2. Clean PCV valve.</li> </ol>
<input type="checkbox"/> Carburetor	<ol style="list-style-type: none"> <li>1. Adjust accelerator pump stroke.</li> <li>2. Adjust automatic choke.</li> </ol>
<input type="checkbox"/> Electrical	<ol style="list-style-type: none"> <li>1. Check battery, clean terminals.</li> </ol>
<input type="checkbox"/> Windshield wipers	<ol style="list-style-type: none"> <li>1. Test wiper-arm tension.</li> <li>2. Check condition of wiper rubber.</li> <li>3. Test windshield washer spray outlets to be sure they're clear.</li> </ol>
<input type="checkbox"/> Body	<ol style="list-style-type: none"> <li>1. Clean out drain holes.</li> </ol>



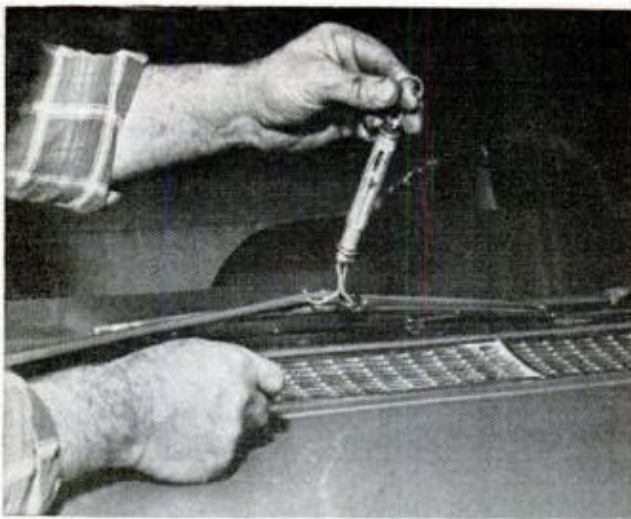

**PROPER WINDSHIELD-WIPER TENSION** is 1 oz. for each inch of assembly. A spring gauge of the type shown above is used in checking tension adjustment

(when the car is operating) and cold (when icy slush is thrown against it).

Run your hand over the exhaust pipe, muffler and tailpipe. Any rust that flakes off is a sign of deterioration and fair warning that that part isn't long for this world. Moral: replace the part.

Watch this too: exhaust parts will often corrode from the inside out, so don't be deceived by a part that *looks* good on the outside. Feel it. If it feels weak or gives way under pressure, replace it.

Now check for leaks between the exhaust-pipe flange and exhaust manifold. Start the engine and put your ear to the joint. A leaky joint will make a popping



**USE A SCREWDRIVER** or other reaming tool to clean drain holes in bottoms of doors. If these remain clogged, rust will soon start to work on the body

noise. Another sure sign of a leak here is a whitish, powdery deposit around the joint. Try tightening the flange nut. If popping persists, replace the gasket.

All other exhaust-system parts should be wrenched-up too. Rust isn't the only thing that can ruin a part. A loose tailpipe, for example, can bang itself to death against another part of the car.

**Brake system.** Here's another area which is exposed to the ruining effects of snow-piled roads and those high ridges of icy slush. Fluid lines and fittings, for example, could have been damaged, resulting in a slow brake-fluid leak.

A quick test of the brakes can be made by simply stepping on the brake pedal. If it feels soft (cushy), there's probably air in the system and the brakes will have to be bled. Of course, if the pedal can be depressed close to the floor before the brakes "catch," a brake-adjustment job is called for.

Continue this check with a look into the master cylinder reservoir. Fluid level should be not lower than  $\frac{1}{4}$  in. below the top of the cup. The possibility of a leak is indicated if it is. With the car on a lift, examine the inside walls of the tires to determine if a wheel cylinder is leaking. Fluid on a tire means that that wheel should be pulled and brake parts checked.

**Lubrication.** "Suppose I changed the oil in February," you may ask, "and my service guide tells me I'm good for 4000 miles between oil changes. Why do you say change it again, and the filter too, although I haven't hit the 4000-mile mark?"

In a nutshell . . . because of all that stop-and-go driving you did during the winter. During cold weather, unburned fuel, condensation, carbon and other foreign matter accumulate rapidly inside the engine and mix with the oil. The cumulative effect is dilution and adulteration of the oil. Since the oil filter is also affected by this contamination, replace it as well.

The positive crankcase ventilation (PCV) system is also subjected to a higher incidence of carbon, moisture, sludge and gum during the winter than in other seasons. A quick and positive check of the system's efficiency can be made with a tachometer. Warm up the engine, connect the tach and note the idle speed. Now disconnect the ventilation hose at the PCV valve and cover the open end of the hose with your finger. The idle speed



should drop 20 to 60 rpm or more. If it doesn't, then the valve, hose or carburetor passage is clogged. To find out which, remove your finger from the hose end. A noticeable change in idle speed, along with a smoothing-out of the engine, indicates a clogged valve which should be cleaned or replaced. If idle is not affected, look for a clogged hose or carburetor passage. Rinse the hose in kerosene and blow it out with compressed air. The carburetor passage can be reamed with wire.

**Carburetor.** The accelerator pump stroke of many carburetors is adjustable. Check your service manual for the height at which to adjust the stroke for summer and winter driving. As a general rule, the length of the stroke is reduced for warm-weather driving by moving the link inward to the next hole in the operating lever.

Likewise, automatic chokes can be re-adjusted to use a leaner fuel mixture during warmer weather. (See page 180, Oct. '64 *PM* for a complete discussion of chokes and how to adjust them.)

**Electrical.** Check the battery with a hydrometer to make sure it's up to snuff.

It's been working on a reduced output for several months now and it might be ready for a good charging; or you may discover you need a new battery.

**Windshield wipers.** Often overlooked in a spring tuneup are the windshield wipers and blades. They receive rough treatment in winter and should be checked out. Since brackets and arms may have become bent moving heavy snow loads, check the wiper arms, then wet the windshield and run the wipers to see if the blades are cleaning properly. If they streak the windshield, replace 'em. While you're at it, clear out the spray outlets with a fine wire.

**Body.** Finally, take a screwdriver and open any clogged drain holes beneath the body and doors. When these become plugged, water running down the inside of the doors will collect in the lower panels, creating a paradise for rust.

And there you have the essence of a basic, yet essentially comprehensive spring maintenance program for your car. Doing most of this work yourself will be like putting \$20 to \$40 in your pocket. The money you save may represent a full, free month of driving this summer. ★★

## Time-Saver Tips from Saturday Mechanics

**AN EASY WAY** to guide a new V-belt into the groove of the pulley to which it leads is shown above. Keeping tension on a length of cord turned around the belt as shown, lead the belt to the pulley, then have someone crank the engine—with the ignition off! After a few short spurts, the belt will snap into its groove

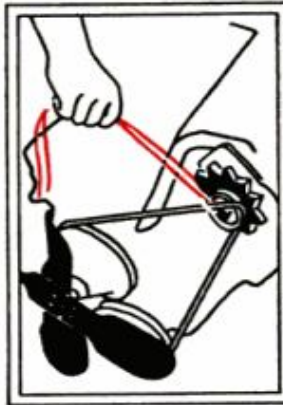

**FLIMSY BUMPERS**—the curse of small cars—are often bent inward when bumped fairly gently. To pull a bumped-in bumper back into shape, insert a crowbar between bumper and car so it bears against a couple of husky wood blocks bearing against tires. Then pull on the bar until the bumper is bent to normal position

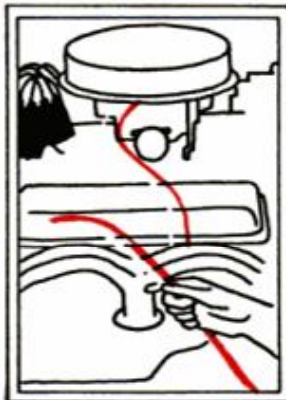
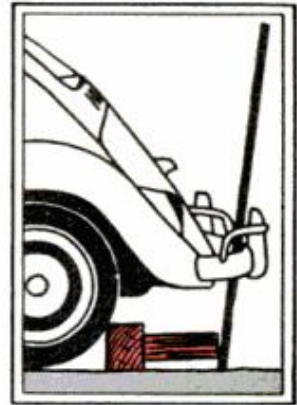

**FAKE IGNITION** lead will effectively "lock" a car that must be left unattended for a long period of time. Simply yank out the single high-tension lead between distributor and ignition coil and replace it with a piece of black rubber tubing. This is faster and less trouble than the bother of removing the distributor cap

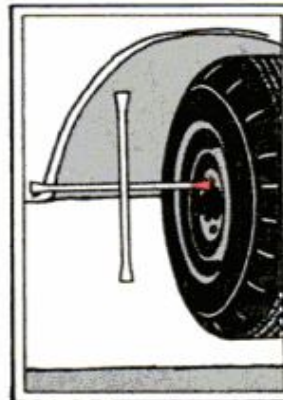

**STOP GUESSIN'** and messin' every time you have to yank a wheel with that four-way lug wrench. You'll save time and your temper by painting—with a contrasting paint—the particular socket that fits the wheel nuts on your car. This is a tip you'll appreciate whenever you're out changing a flat in the rain



# SOLUTIONS FOR MECHANICAL HEADACHES

# AUTOMOBILE CLINIC

BY MORT SCHULTZ

## Springs, Be Seated

*My '65 Corvair Monza produces a bad metallic chatter-rattle in the front suspension spring when I drive it over washboard roads. Shocks have been tightened as much as possible. Any suggestions?—Jack Crumbaker, Billings, Mont.*

I've seen more than one Corvair whose front coil springs weren't seated properly. This may be your problem. To check out the trouble, loosen the springs and rotate them. Don't turn them end to end, just turn them in their seats until they are positioned correctly and properly seated.

## Tailpipe Tales

*Upon starting my car in the morning, a cloud of white smoke billows from my tailpipe. I'm not burning oil, but my mechanic says internal engine work is indicated. Should I have him go ahead with it?—Leon D. Munger, Westerly, R.I.*

*What's that watery-looking discharge I occasionally get from my car's tailpipe in the morning? Unburned fuel?—Ronald L. Monte, Lafayette, La.*

The answer to both your questions, gentlemen, is No. Water or condensation is the cause of the smoky white exhaust and the watery discharge. During the night, air hitting the engine surface—which is warm at first, and then cools down—causes condensation to form on the inside of the block. The white smoke and watery discharge are the engine's way of getting rid of this condensation.

## Hozapoppin'!

*My '65 Delta Olds popped its lower water hose the other day, and I lost all the coolant. I had the hose put back on, all the clamps tightened real well and more coolant added. Next day—pop!—off it came again. Back to the dealer, and he replaced the hose, put on new clamps and again replaced the coolant. Two days later—you guessed it—off it*

*popped again! Maybe you can shed some light on what I can do to keep my hose (and my mind) in place.—Miles Magoc, Chicago.*

First you determine which of two causes is behind the problem: a build-up of internal pressure or a mechanical condition. Check out each possibility as follows:

1. Pressure. Make sure the valve in the radiator pressure cap is opening properly so that internal pressure is allowed to vent off. The cap in your car is rated at 17 lbs., which means the valve should open when pressure builds up to 17 lbs.

2. Mechanical. Check your front motor mounts. It's possible that one may be loose. The resulting vibration causes the engine to "hop" and could cause the hose to work itself off.

## "... It's the Humidity"

*I'b dot a code (and it's a beaut), and all credit goes to the factory-installed airconditioner in my '65 Ford Custom. Every time I turn a corner, water spills out on the floor of the car from the heater outlets, although both drain tubes are open. I'll cure my cold. Can you cure my runny-nosed airconditioner?—Larry Martindale, Warco, Calif.*

Okay, Larry. Put on your galoshes and wheel down to your jovial Ford dealer. He's got a technical service bulletin put out by the company to stop this nonsense. Here's what's happening: There's a pan into which the hoses connect that's supposed to catch condensation from the airconditioner and toss it away beneath the car. Either the hoses have come loose or the pan has to be resealed.

## It Is Written in the Cars

*Oh mighty solver of mysterious car ills, kindly crystal-ball this one: a '61 Chevy that leaks fuel from the transmission into the engine. I discovered it when I checked the engine oil. Nobody can tell me*



*how fluid flows "upstream" from transmission to engine. Can you, oh honored seer?*  
—Martin Sjostrom, Hayward, Wis.

This humble and unworthy personage will attempt an answer. Although you don't say so, I'll bet you have a Powerglide transmission in the car. Such transmissions have been known to suck fluid by vacuum through a bad modulator and into the engine. Suggested cure: replace dishonored modulator.

### **VW Voodoo**

*Here's a kind of spooky malfunction: How come my '64 VW won't start when*

*the clutch is depressed, but only when the gear shift is in neutral?*—R. Caffin, Goose Bay, Labrador, Canada.

You've got a bad carbon release bearing. This means that the pilot shaft of the transmission is unable to overcome the drag exerted on the clutch pressure plate by the release bearing. You can do one of three things: live with it the way it is; install a new carbon release bearing (about \$2); or replace the bad carbon bearing with a transporter release bearing (around \$6 or \$7). A transporter bearing will probably last the life of the car.

---

## **Service Tips**

● **HEY! DODGE IS FLASHING** all you guys who took possession of '66 8-cylinder cars equipped with high-capacity radiators (this means all except Darts, and some Monacos and Polaras with airconditioning). Anyway, the affected vehicles are equipped with a plastic fan shroud with a metal plate attached to the lower left corner just above the radiator hose, and which may be interfering with the hose. Result could be a busted hose and loss of all coolant. Simplest cure for this problem is to remove the plate and lose it.

● **TRANSMISSION OIL LEAK** has troubled more than one owner of a '65 Pontiac with Turbo Hydra-Matic. Here's why. In some cases these leaks are apparent only when the engine is shut off. So if transmission oil keeps going down, down, down—check for leaks with the engine stopped as well as with it running. One likely point for such a leak is a hairline split in the oil-filler pipe seam near the case or the O-ring seal groove. Spot it? Good. Replace the pipe.

● **PAY ATTENTION** when you replace the ignition coil of your '64 or '65 Olds F-85 V-6. They're different. The one for the '64 is brown and comes with a wiring harness which does **not** have a built-in resistance. Coils for the '65 V-6s are black and have a built-in 1.8-ohm resistance.

● **GAS-GAUGE STICKING** has been reported in some '65 Pontiac station wagons. The trouble's often been traced to the tank unit float contacting the side of the tank. It can be fixed as follows: Remove tank unit gauge from the tank. With the wire to the dash unit connected, and the tank unit grounded to the frame, raise and lower the float arm while eyeing the dash unit. If the gauge is still erratic, replace the tank unit. But if the dash unit follows the movement of the float arm—indicating normal operation—the trouble is due to improper position of the float in the tank.

This latter malfunction is corrected by bending the float arm down 1 in. from the float stop. Bend the float arm sideways so the end of the float is centered with the strainer. While bending it, be sure the float arm is supported to avoid damaging the rheostat.

---

Each month Auto Clinic answers your questions on car repair. For a personal reply, please enclose 25 cents in coin to cover mailing and handling. Address questions to Auto Clinic, Popular Mechanics, 575 Lexington Ave., New York, N.Y. 10022.



# Chip Shields for Milling Machine

By Walter E. Burton

**CROSS-FEED SCREWS** on many milling machines are exposed, subjecting the threads to clogging and rapid wear from flying chips. The photos and sketches on these two pages show how one such mill was equipped with shields of polyethylene sheet—a system easily adapted to other machines with exposed screws.

The front shield feeds off a spring-loaded roller that's bracketed to the front of the mill's knee, near the hand-wheel. The other end is anchored to the dovetail block that links the knee and work table, as seen in the bottom photo.

The shields can be any flexible material not affected by oil. Polyethylene is the easiest to brush clean. You can buy it—either transparent or black—from any large mail-order house. Use at least the 4-mil thickness for durability, and cut it long enough to span the maximum length of exposed screw. Leave extra for turning a ½-in. hem at one end. Stitch the other end to a 1¼-in. strip of thin muslin for cementing to the roller.

The roller is a section of brass fixture pipe, ¾-in. longer than the shield is wide, turning around a brass or steel

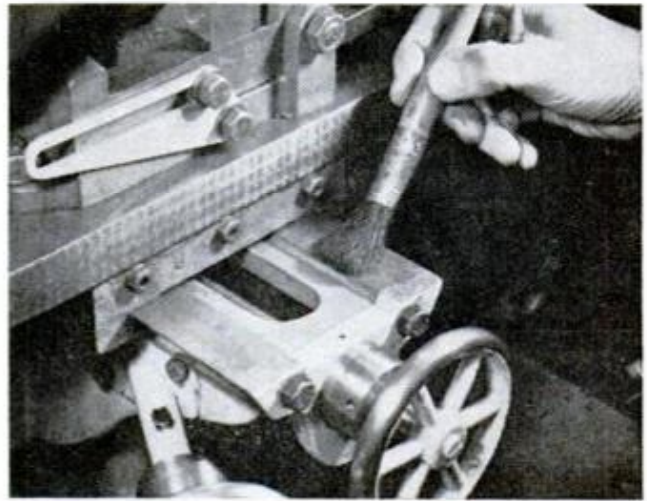
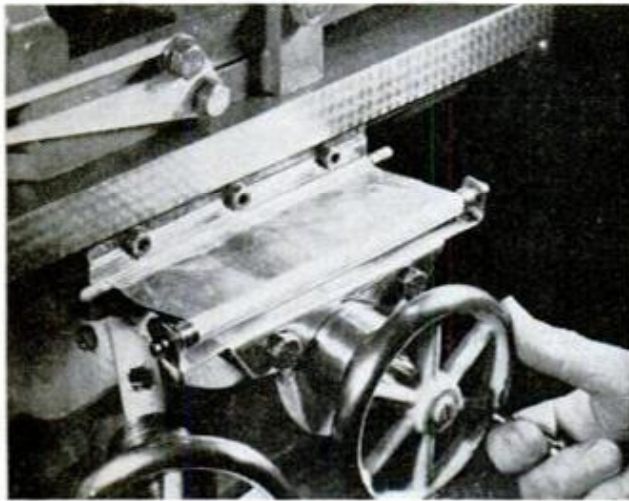

**LIKE A MINIATURE WINDOW SHADE**, horizontal sheet unreels from springloaded roller as cross-feed screw backs off (left photo). Without shield (right) screw and ways are exposed to chips, so need constant brushing

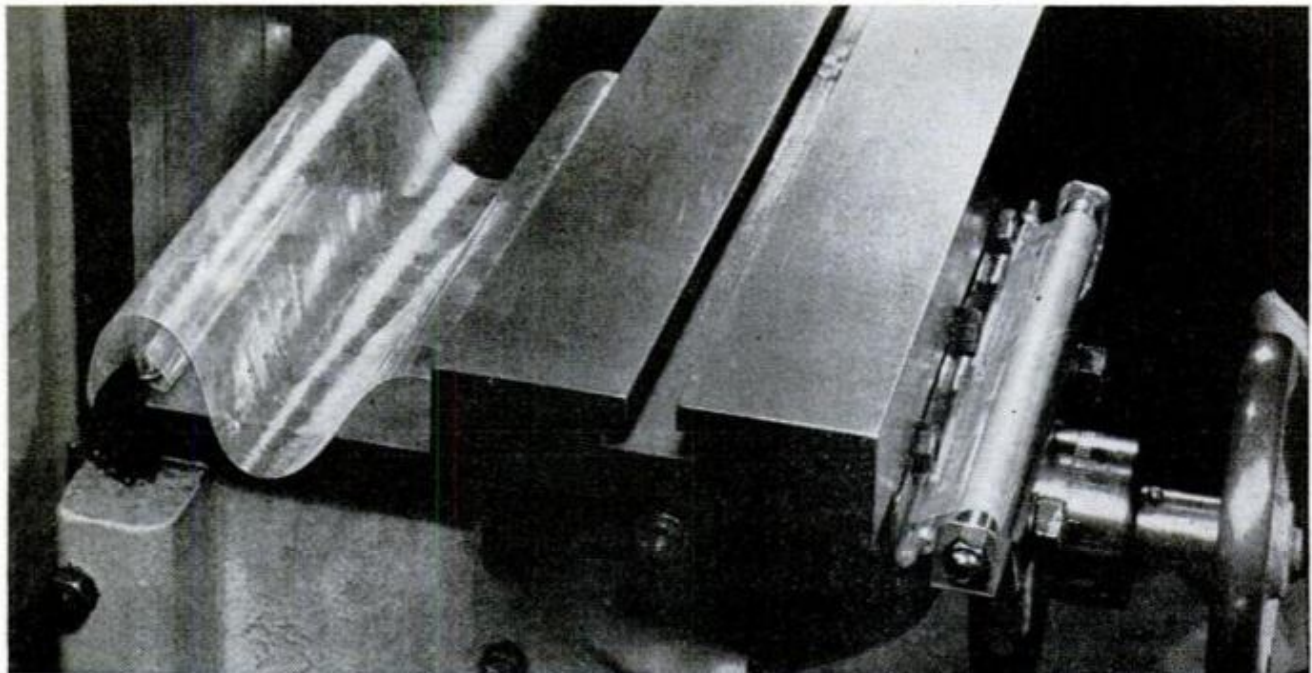

**LIKE A CAMERA BELLOWS**, shield for rear portion of screw simply unfolds as dovetail block is moved out. Note front shield in rolled-up position at right side of table. Rear shield could be on roller, too, if preferred



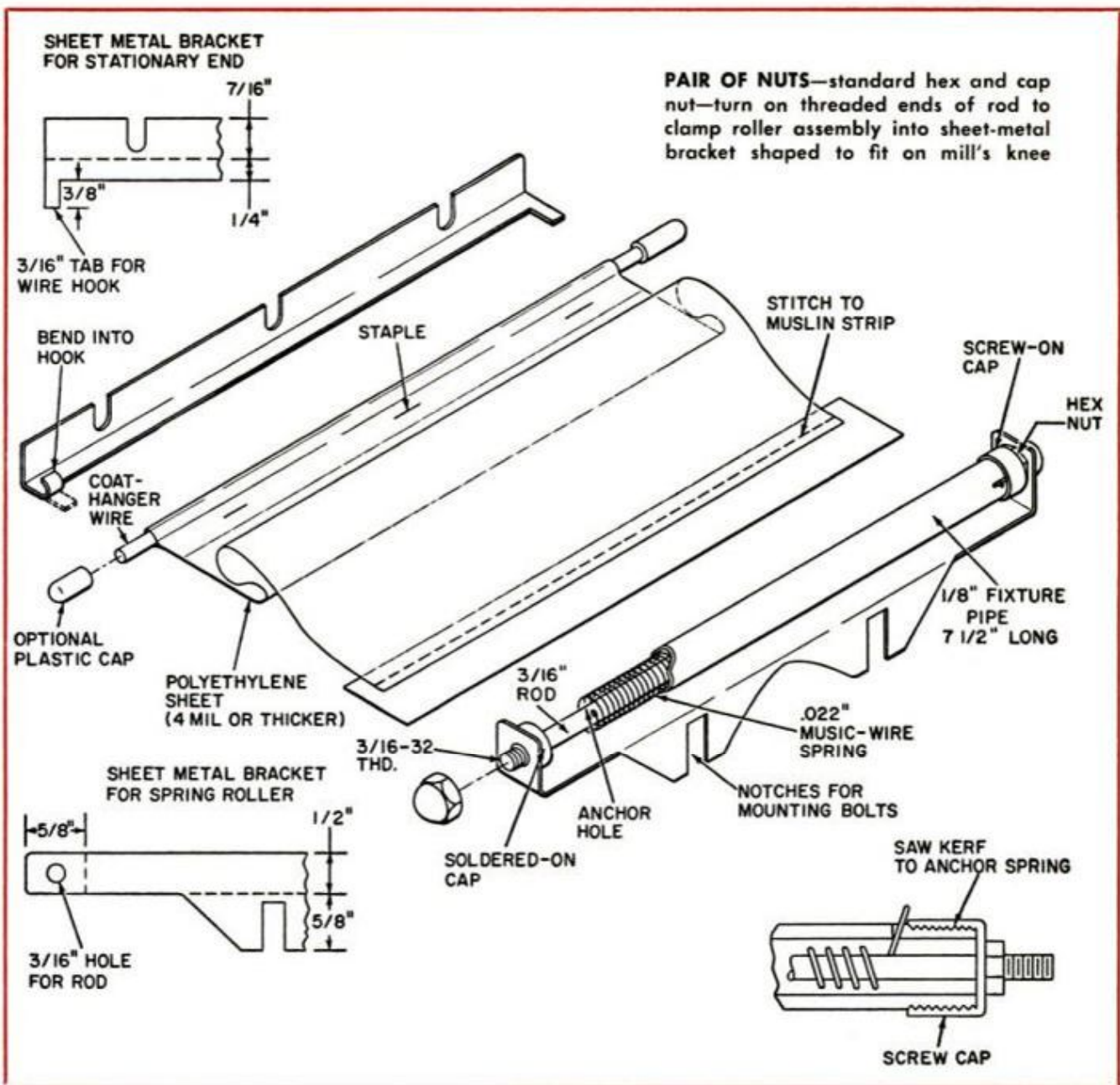

**PAIR OF NUTS**—standard hex and cap nut—turn on threaded ends of rod to clamp roller assembly into sheet-metal bracket shaped to fit on mill's knee

rod that's 1 in. longer than the roller. The pipe ends are capped, and the holes center-drilled to let the rod pass through. At least one of these caps should be the screw-on type, to permit access to the spring. You can make the spring by winding piano wire (No. 9 gauge) tightly around the 3/16-in. rod for a distance of about 5 in. One end of this spring hooks into a small hole drilled about 1 1/2-in. from one end of the rod; the other end hooks into a kerf cut just far enough into the threaded end of the pipe to clear the cap. Install the roller so the plastic sheet unwinds from the top as the spring winds tighter to keep the sheet taut.

No roller is needed for the rear shield as it will lie in loose accordion folds when its full length isn't required. The loose-fitting wire bracket rides up and down the dovetail so as not to interfere when the work table is raised and lowered. ★ ★ ★

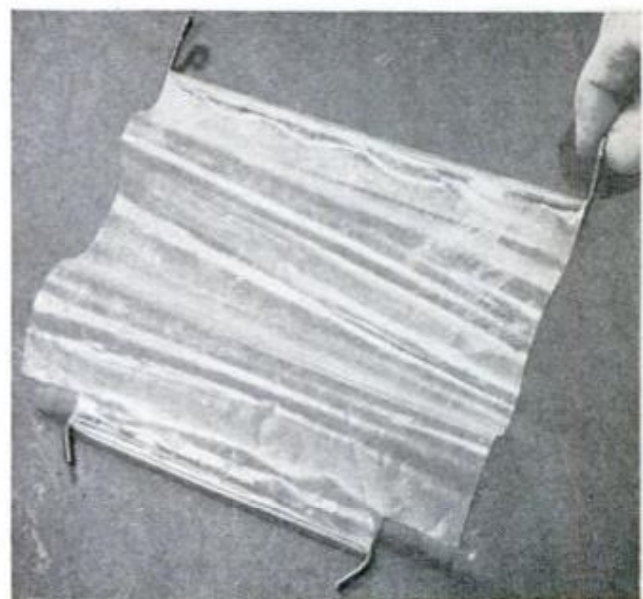

**REAR SHIELD BRACKETS** are coat-hanger wire through stapled hems. Foreground wire slips loosely over column dovetail. Other wire, 2 1/2 in. longer than hem, has ends bent for tight grip on dovetail block



## Quick-set power hacksaw vise figures all the angles

Why bother measuring every cutting angle for your power hacksaw? Use your machinist's square once and put it away.

Fabricate the shelf, angle bracket and two locking handles as shown, adjusting critical measurements to your own saw. Then swing the vise out using the machinist's square to form a 45° angle between the vise base and the saw blade. Clamp and drill through the shelf via the guide hole in the vise. Repeat for other settings, using a protractor.

Then, insert a sharp-pointed 3/8-in. rod through the angle bracket hole and scribe an arc across the shelf to within 1/2 in. of the edge. Drill a 5/8-in. hole at both ends. From the width of these holes mark off dotted lines on both sides of the scribed line and parallel to it with a center punch. Use a torch to cut the slot and round the edge of the shelf. The nut just fits the slot and its welded-on washer bears against the underside.—Mike Brenish

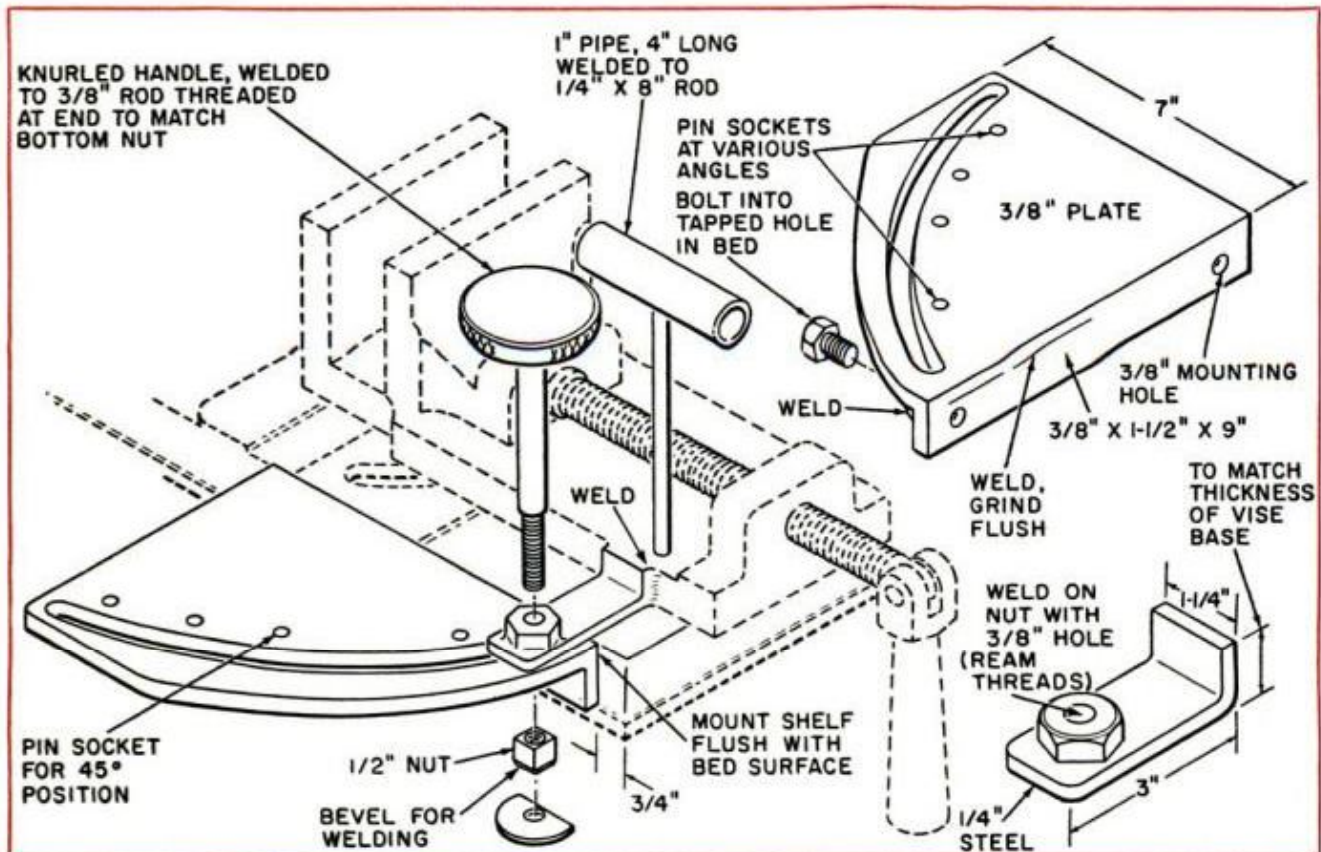
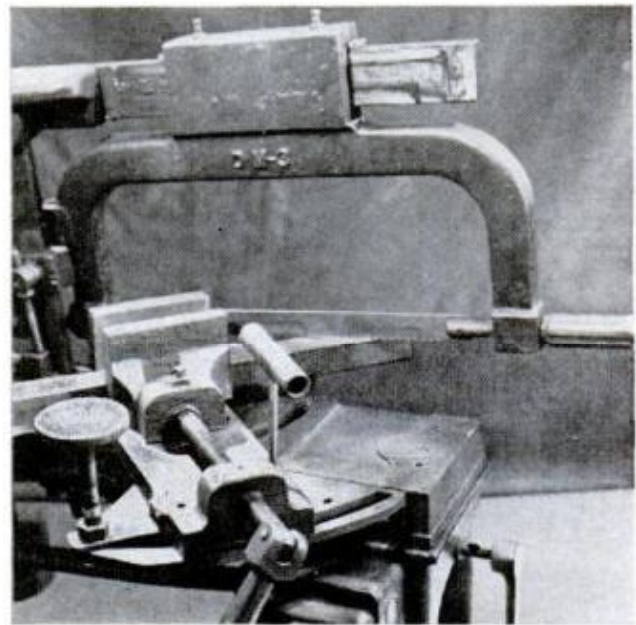
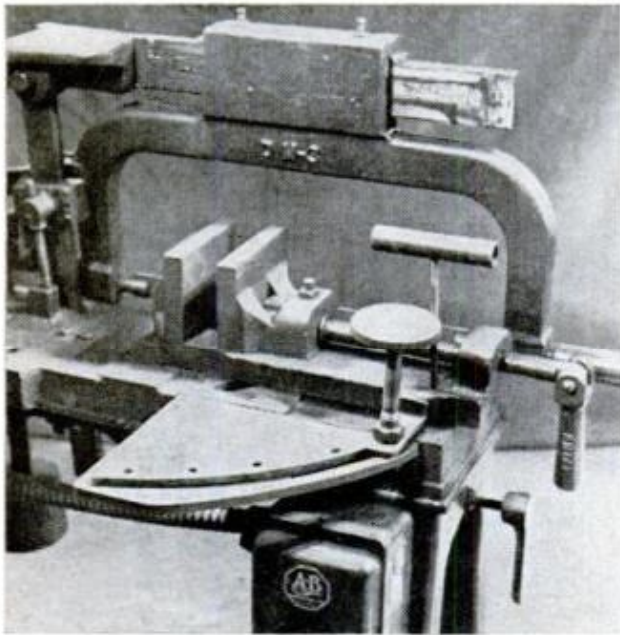



## Quickie follow-rest travels with your lathe compound

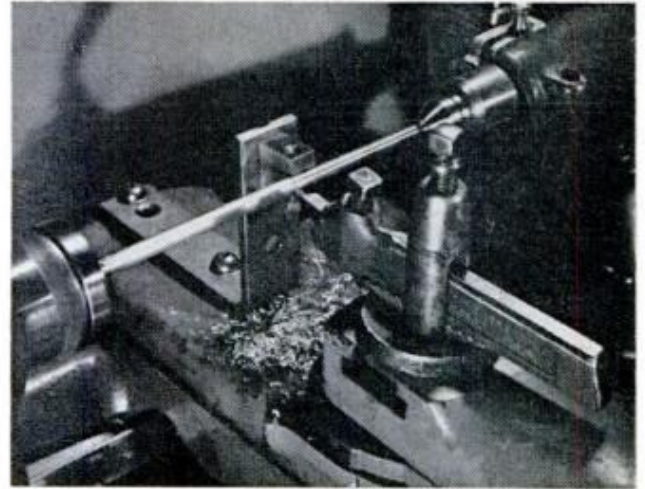
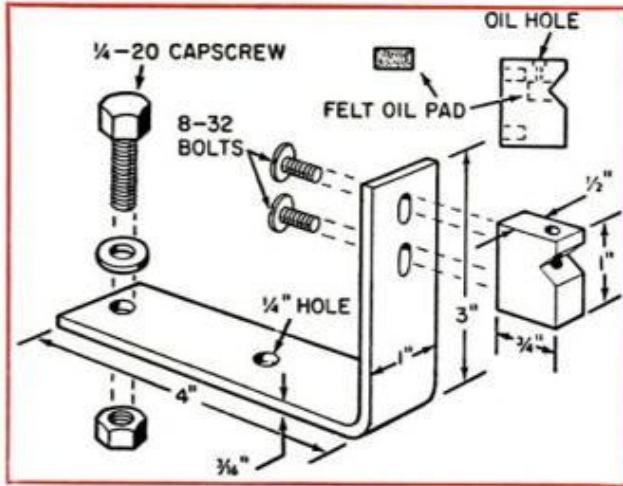

Don't fret if your lathe lacks a follow-rest. You can whip this one up in almost no time at all from a large steel angle bracket, a small block of steel and a few bolts. Since the attachment is bolted to the lathe's cross-slide, its position is adjusted with the compound slide, and it travels right along with it when the carriage lead screw is engaged. The toolpost is placed so the bit will lead the V-block

by about  $\frac{1}{4}$  in. Dimensions of the block are not critical; those given are for a 9-in. lathe. A variety of blocks can be made with different V-notches. The holes in the bracket by which the block is attached should be elongated to permit vertical adjustment. The hole in the vee takes a felt oiling pad. Hardened tool steel used for the V-block will lengthen its life.  
—David W. May

## Shop Notes Under Your Nose

At your fingertips is the idea for things that are handy in your shopwork. Even better than that is this idea for keeping dimensions and cutting data right in view atop a radial-arm saw. A notepaper-roll holder can be made from sheet metal and strap steel and fastened with screws in tapped holes. Then again, you can buy one ready-made and attach it.

—Bob Gilmore

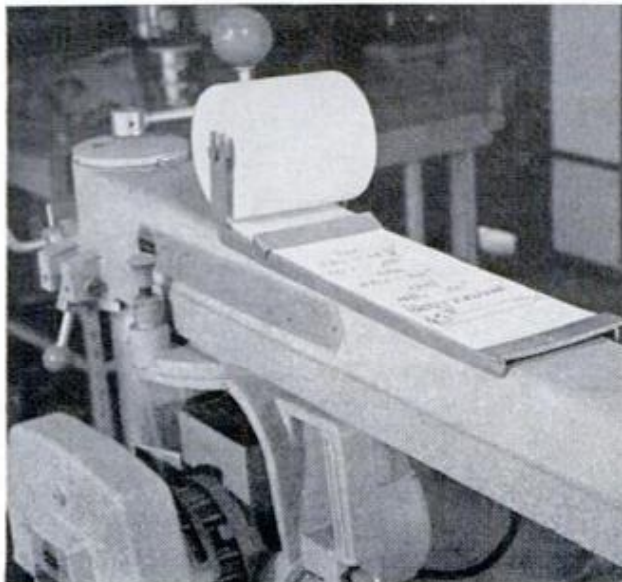

## Portable to Bench Sander

A portable belt sander can be converted quickly to a table model for sanding tiny parts with this vise-clamped jig. Cut padded motor-supporting blocks and handle rest to fit. A spring grips the handle, while the sander's screw-in knob passes through a hole in an angle bracket to anchor the sander securely. A vertical wood member braces the jig against the vise guide.

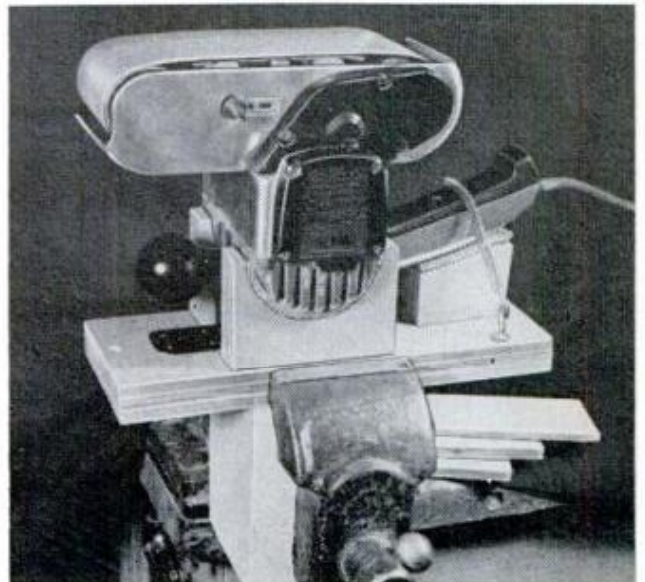



# Multi-Action Paint Shaker

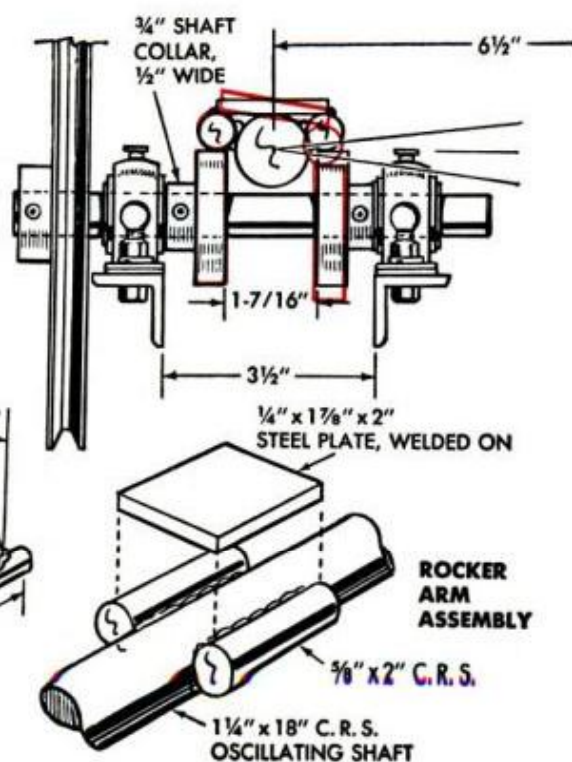
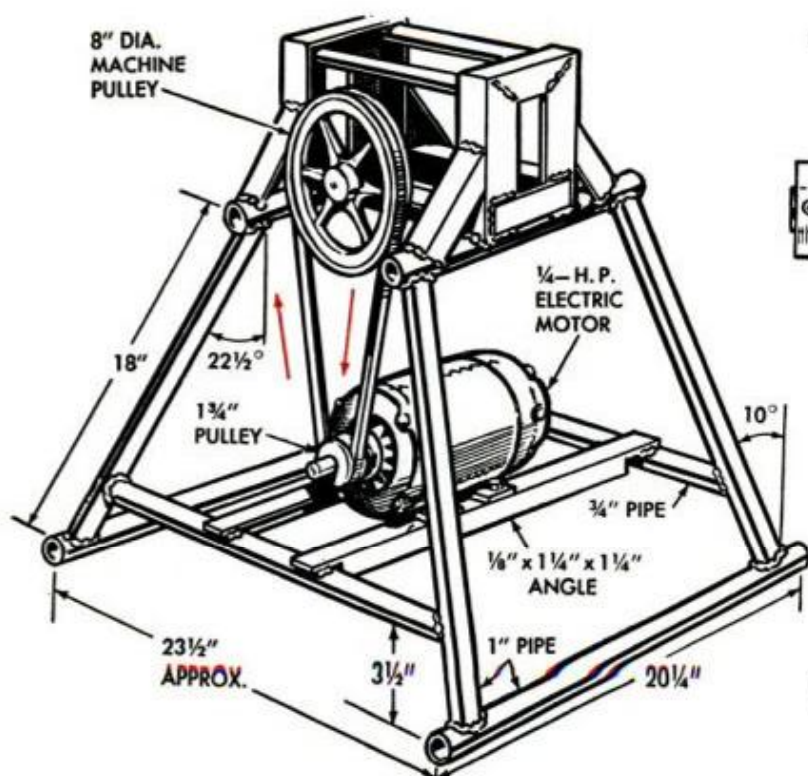
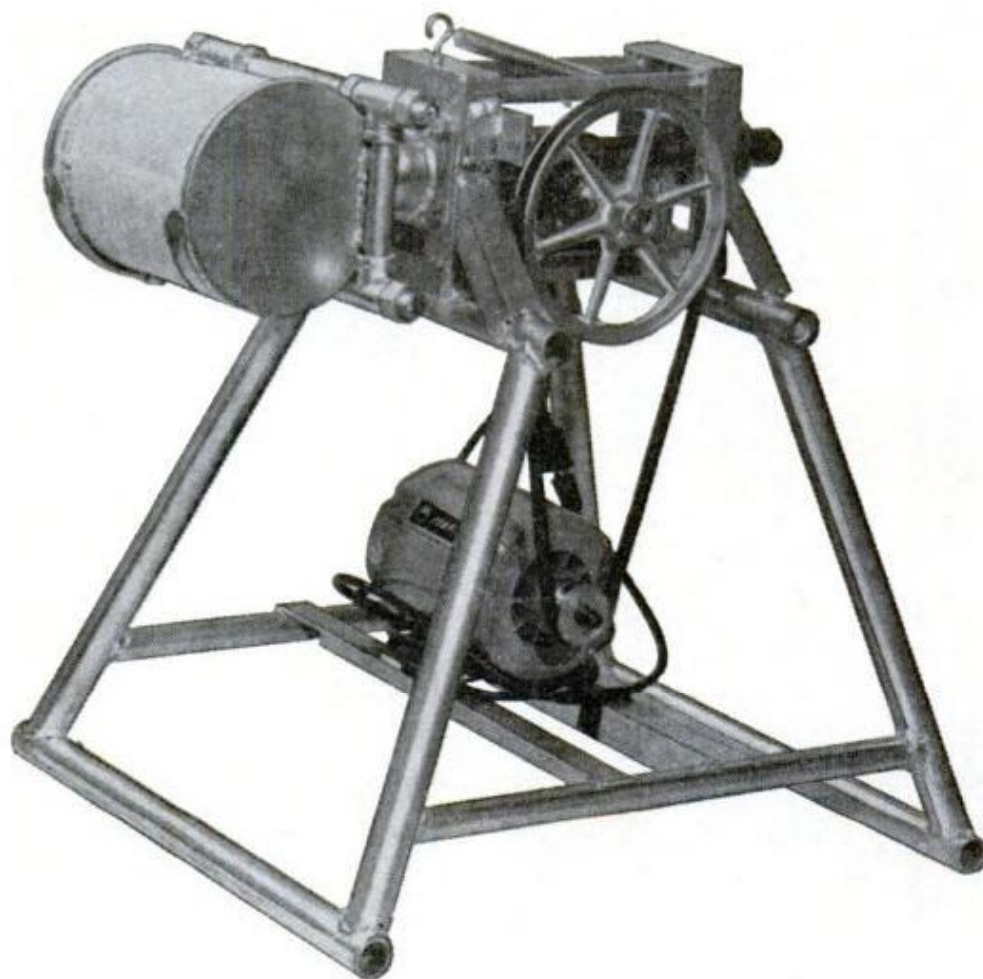







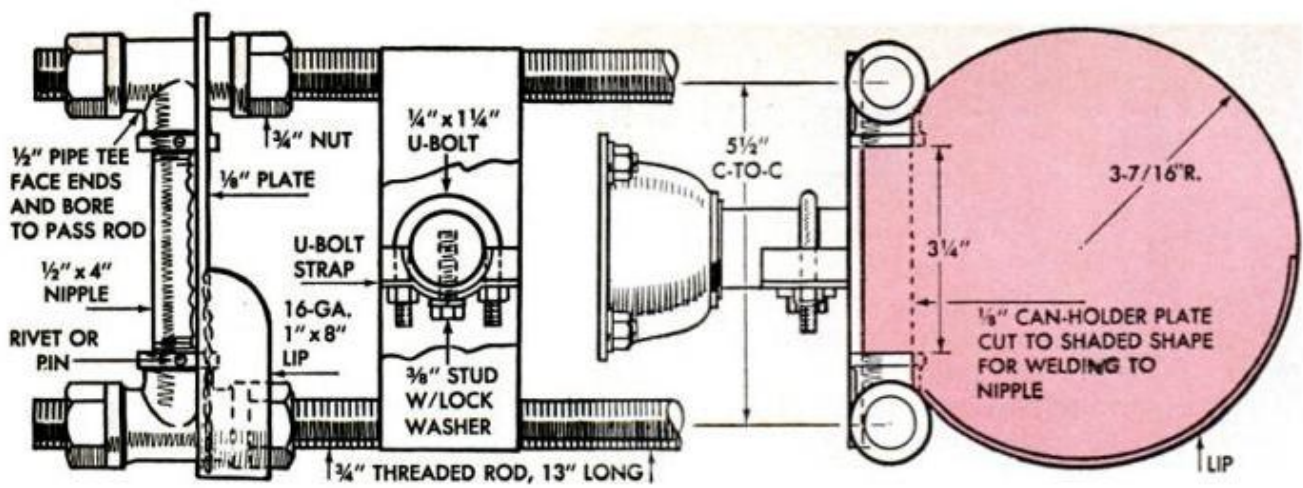

slot forces it to travel back and forth as well. A spring opposes this reciprocation of the shaft and keeps the action constant. This spring is a stock hardware store item— $\frac{3}{4}$  in. in dia., with a compressed length of 4 in., not counting the end loops.

Start construction with the machinery cage, welding up the angle-iron end frames first of all. (Note that the bottom ends are shaped to “saddle” over the pipe base.) Now, clamp the horizontal rails—angle iron at the bottom and steel rod at the top—between the end frames, check for squareness and weld. Join this assembly to the pipe base, adding diagonal braces to support the cage against side thrust.

In locating holes for the bearing retaining bolts in the end frames, bear in mind that the dimension shown as “A” on the previous page should be calculated loosely to avoid too tight a fit between cams and rocker arms. Allow at

least a  $\frac{1}{16}$ -in. excess for shimming up the camshaft bearings.

A study of the camshaft assembly will indicate that the cams are shafted  $\frac{7}{32}$  in. offcenter in opposite directions, which results in a total lift of  $\frac{7}{16}$  in. You can avoid machining by selecting  $2\frac{1}{4}$ -in. cold-rolled steel rod for the cam stock. Cut off a  $1\frac{1}{4}$ -in. slice and face both ends in the lathe. Locate the shaft center  $\frac{7}{32}$  in. from the work center and punch it. How you proceed from there is demonstrated in sketches and photos in the box at far right.

After the stock has been sliced in two, face each piece in the lathe, reducing the cams to a  $\frac{1}{2}$ -in. thickness. Cut the camshaft to length and either mill a keyway or grind a flat at one end for the drive-pulley setscrew. Position the first cam on the shaft by thrusting it against a shaft collar; weld the cam to the shaft with the work held vertically in a vise. To avoid overheating, use as

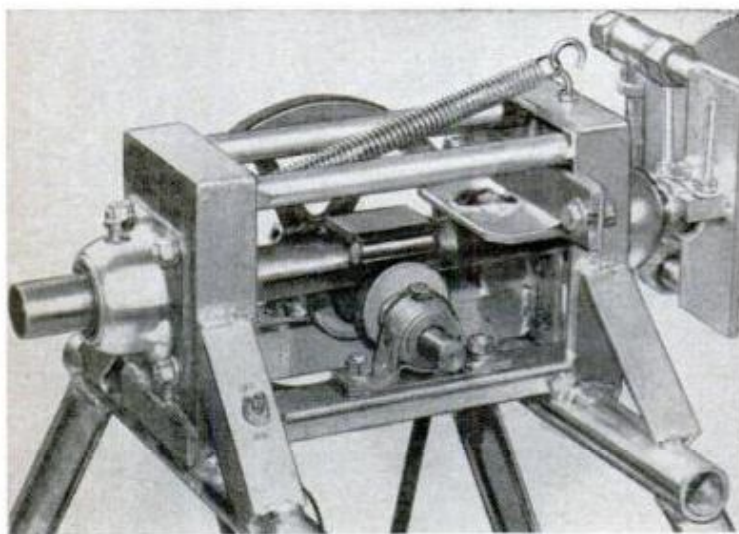

**ASSEMBLED SHAKER**, ready to switch on, has been adjusted to center of oscillation (note sheet-metal shim under camshaft bearing). Reciprocation slot, in angle bracket to right of rocker-arm assembly, is grease-packed to minimize wear

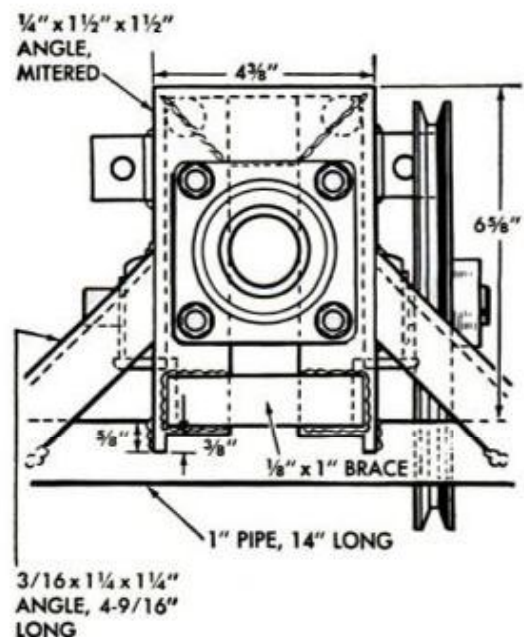



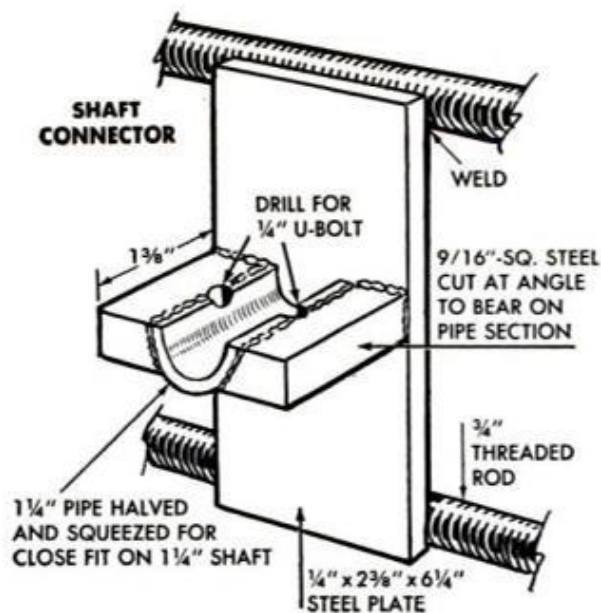

low an amperage as will strike an arc. Immediately after welding, bury the work in dry sand or ashes so it will cool slowly enough to avoid warp.

The lower sketch shows the lathe set-up for accurate positioning of the second cam in relation to the first. After locating the high point (Pos. 1) of the welded cam, move the dial indicator to Pos. 2 and locate the low point of the loose cam. (The dial indicator must be precisely over the shaft's centerline.) Secure this position with a clamp, then weld as before.

The rocker-arm assembly consists of two short 5/8-in. rods tack-welded to the shaft and capped with a welded-on piece of sheet steel for backing strength. No matter how you clamp the work down, the shaft is likely to warp from the welding heat. If so, weld a bead along its axis (on the underside) for the length of the rocker-arm assembly. Grind this off and check again with the straightedge. If there's still a bow, run another bead over the first and grind.

Install the camshaft in its bearings, but don't tighten the bolts. Slip the oscillating shaft in through the top of the cage; adjust and secure its bearings, then check the cams against the rocker arms with both the off-center axes and the rocker arms horizontal. Now, shim the camshaft bearings until both cams just touch the rocker arms.

Make the reciprocation unit and position it roughly with its attaching lugs bolted on. Clamp the lugs to the sides of the frame and—with rocker arms horizontal—punch the oscillating shaft at

*(Please turn to page 204)*

## MOUNTING THE CAMS

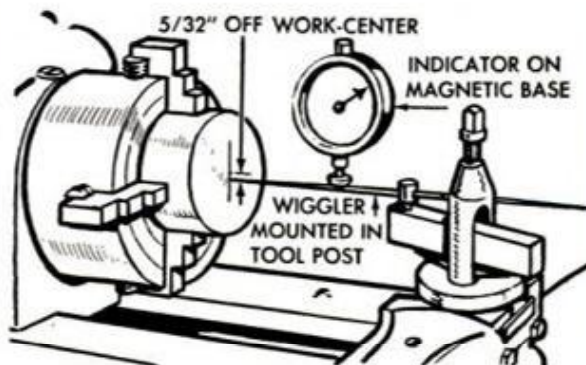
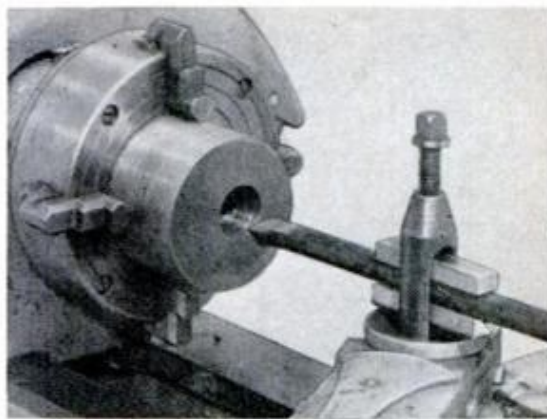

**POSITION CAM STOCK** with wiggler in off-center punch mark. When dial indicator reads  $7/32$  in., replace wiggler with  $1/2$ -in. drill, finish with boring tool as shown in top photo.

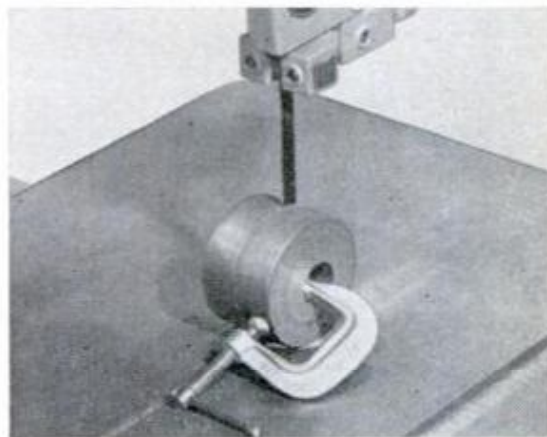
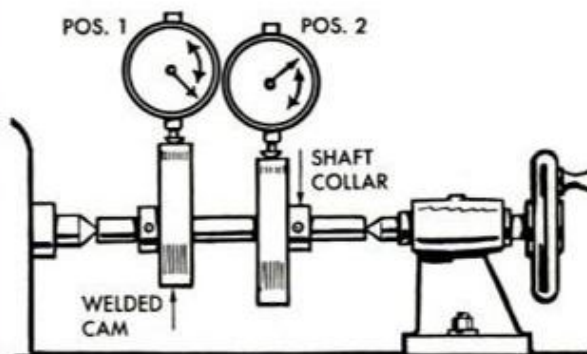

**SLICE STOCK IN TWO** on metal-cutting band-saw, using clamp to prevent turning. Weld one cam to shaft, mount in lathe and position second with comparative readings (sketch above)



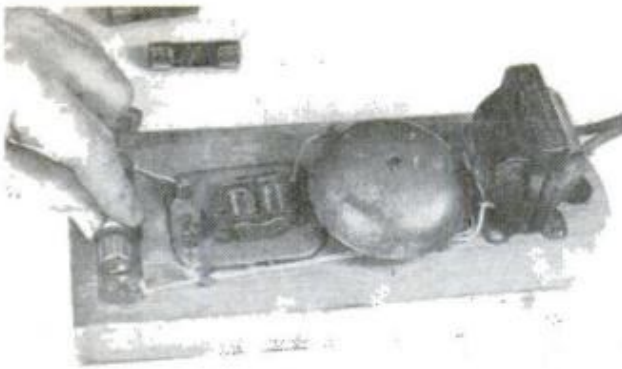

### Cartridge fuse tester

Good fuses ring the bell on this simple tester made by mounting an old doorbell on a block of wood. Two copper strips tacked to the block a short distance apart and connected to the bell terminals act as contacts for the end caps of the fuses. It takes only a minute to test a whole series of fuses by laying them across the contacts, one at a time, and listening for the bell.—*H. J. Gerber*



### Stay-put shop casters

Discarded casters from office chairs are ideal for putting your shop machines on wheels. Simply thread the stem for a nut and use  $\frac{1}{8}$ -in. pipe as a spacer. Use large washers to prevent rolling when in use, placing one under each caster. Feather the outer circumference of the washer on your grinder to make it easier to roll the machine into place.—*W. G. Waggoner*

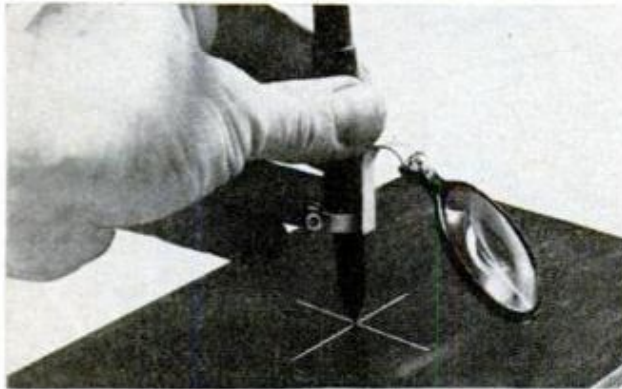

### Accurate prick punching

To assure "on the button" centering when using a prick punch, add a simple accessory which lets you see the exact location of the point before tapping it. It's only a dime-store magnifying glass mounted on the end of a bent sheet-metal strip which in turn is attached to the punch with a sheet-metal sleeve. The cost is low, yet it's good insurance against expensive mistakes.

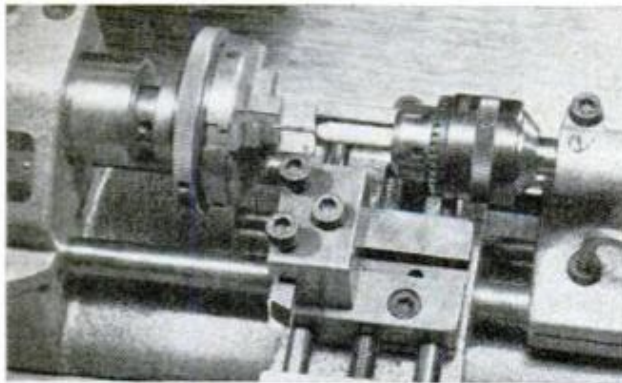

### Support for slender pins

When turning slender pins, you can prevent them from bending under tool pressure by improvising a tailstock-mounted support. Just taper a hardwood dowel at one end and cut a conical cup in the tip with a drill point. Clamp this in the tailstock chuck, oil the tip and run it up against the end of the pin. It's a sure cure for an old problem.

—*Walter E. Burton*



### Easy oil filming

You can apply a thin film of oil to any gun or piece of machinery without getting a drop on your hands if you make up a special applicator from a plastic shoe-polish bottle equipped with a sponge. After disassembling the polish applicator and giving it a thorough cleaning, simply fill the bottle with oil. It's always covered and protected from dust.

—*Charles Westbrook*



## Transformers let you mount wall clock anywhere

Since it is not advisable to run more than six feet of lampcord as a permanent thing from an outlet carrying 110-volt current, I was stumped on how to connect an electric wall clock located some 25 feet from a receptacle. I did not want to go to all the trouble of installing a new outlet.

How did I finally solve the problem? I hit upon the idea of changing the 110-volt current to low-voltage current between the wall outlet and the clock. This required two small transformers, one of which I

mounted near the wall outlet and the other inside the clock. I then connected the two with common bell wire, running it along the baseboard. The clock was connected to the transformer inside the case and the other transformer was plugged into the 110-volt outlet. There is no limit to the amount of low-voltage wiring one can run, and if you wish, you can connect a second clock into the line anywhere between the two transformers.

—Joseph Braunstein

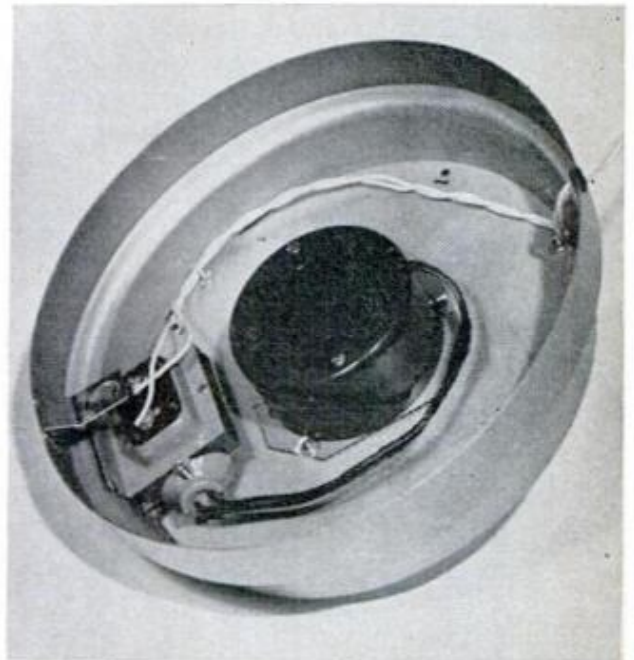
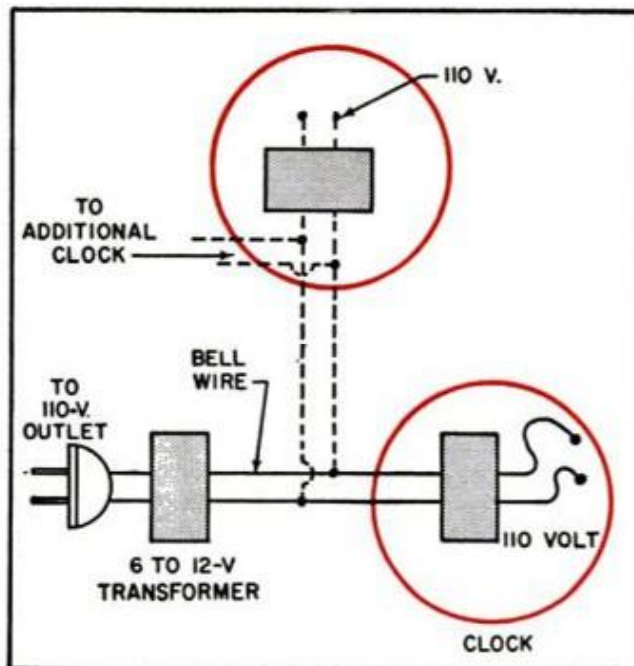

## NEXT MONTH IN SHOP AND CRAFTS

**MULCH-MAKING MACHINE.** Dump your weeds, grass clippings and leaves in the hopper of this power-driven chopper and out comes valuable, finely-cut mulch for your flower beds and vegetable garden. It's built around an old hand-pusher lawnmower and driven by a gas engine.

**FIBERGLASS SWIMMING POOL.** You're only \$850 away from your first dip in this 12 x 27-ft. pool which is made by lining a hole in the ground with sheets of fiberglass and running plumbing lines of polyethylene pipe to a commercial pump and filter. Price includes the hard part—having the hole dug.

**KEEP 'EM ROLLING.** Like your car, camping and utility trailers need to be in top shape for those long vacation hauls. Checking up beforehand on the condition of the tires, wheels and wheel bearings, lights and braking system can prevent a costly breakdown along the way.

**LAWN MULE THAT'S A WORKHORSE.** Harness this little three-wheel riding tractor to your yard chores and all the back-breaking work is taken out of mowing the grass, carting heavy loads and moving mountains of snow. Features unique front-wheel drive, turns on a dime and comes in a kit.



# Electronics' new gee-whiz kits

TV camera, amateur radio transceiver, hi-fi receiver, color TV, miniature tube tester and CB radio all come in kit form. Here's a preview of what they're like — to build and use.

By Larry Steckler

**K**IT BUILDERS' PARADISE" would have made quite an apt sign for my office door of late. For a while, it seemed as if I was wiring kits in my dreams. But now that they've been built and tested, I can tell you about them.

First, and what I consider the most interesting, is a television camera. This kit, made by Conar, is something that just hasn't been done before — a complete package including vidicon camera tube and lens. When assembled, it's ready to be connected to the antenna terminals of any convenient TV.

Almost all parts are blister-packaged, which makes it easy to find the part you need. After a slice or two with a razor blade or sharp knife you've got it your hand. There are no loose parts floating around looking for a place to get lost.

The instruction book is neat and clear, but must be read carefully if you want to avoid wiring errors. I found that I slipped over a point or two and had to go back and redo a couple of steps. I found my errors when rechecking the manual, which, by the way, is about the only one that includes an extra row of boxes to be checked as you go over your wiring after completing each section of the assembly.

Assembly, like that in most modern kits, is straightforward and reasonably uncomplicated. A printed circuit board saves time and reduces the possibility of wiring errors.

Ten working hours after unpacking the kit I had a completed TV camera ready for testing. I hooked it up to a nearby TV set and got a few surprises, but after this initial setup the camera worked better than expected. With normal room lighting (instructions recom-

mend at least a 150-watt lamp) clear and viewable pictures appeared on the screen. With more light (such as a single type A photoflood) bright, sharp and clear pictures were easy to get.

What do you do with a TV camera? I'm going to set mine up as an electronic baby-sitter. Tucked away in a corner of the kids' playroom (up on the wall out of reach), it will keep a wary eye on their shenanigans. Cathy, my wife, will need only to glance at a portable TV in the kitchen, upstairs bedroom or back yard while hanging up the wash to see how they're behaving. And if I add an audio link, she'll be able to hear them too.

Have a big house? Use it to see who's at the front door without going to open it. And, of course, the camera becomes a good hedge on TV tape recorders. When they really do become practical pricewise, you'll already have a camera to feed yours. You can also have a bit of fun showing friends and relatives what they look like on TV. All in all, this is a very satisfying project to build and use.

After putting the camera aside, I moved on to an Eico ham radio. It's their Model 753 Tri-Band SSB/AM/-CW transceiver. This is a set that requires some experience to put it together. Don't buy this kit as a gift for your son who hopes to become an amateur radio operator. But if he has a ham ticket now, he won't have any trouble getting this unit on the air.

Critical sections of the set are pre-wired, which eases setup adjustments and alignment after the transceiver is completed. Not having an amateur license, I could not test the unit firsthand, so I turned it over to a licensed



## TV Camera

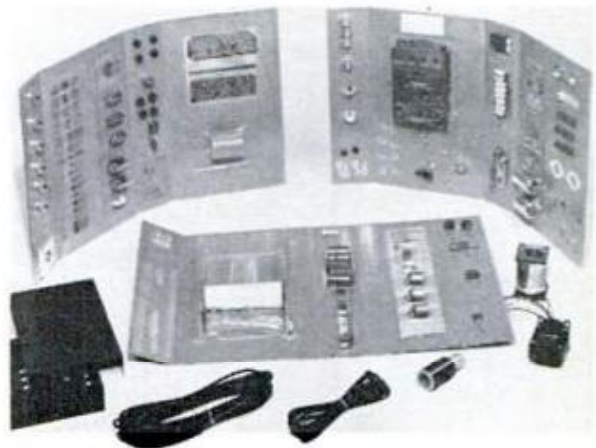

**FINAL CHECK OF TV CAMERA** (top) comes when you hook it to a TV set and see the results. Wired sub-assemblies are shown (left) at halfway point in construction. Parts are conveniently blister-packed (right)



### Amateur Transceiver

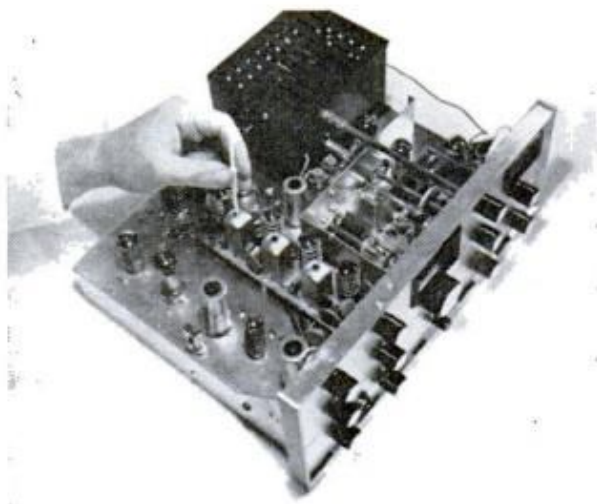

**HIGH-QUALITY HAM TRANSCEIVER** takes extra care in assembly. Finished set can be used in the shack or as mobile unit. Offers SSB (single-sideband) transmission, code or voice on 20, 40 and 80 meters

### Hi-Fi Receiver

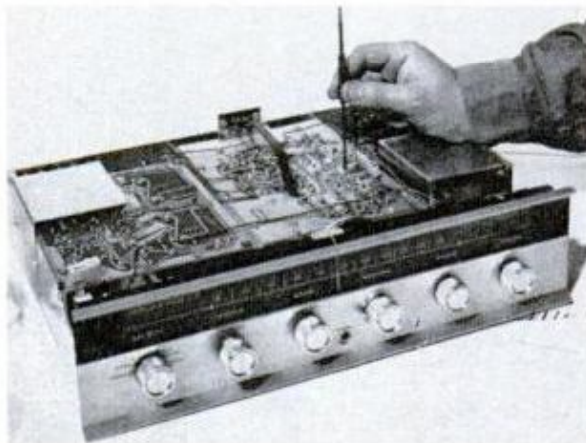

**FOR LOW-COST STEREO**, combine this receiver with basic record changer. You'll have FM stereo, stereo records and an excellent all-transistor amplifier. Power output is limited to 10 watts per channel

friend of mine. He reports it works well and seems easy to operate, but he hasn't used it enough for a more detailed report.

This two-way amateur radio can be used both in the home and a car or boat. It's merely a matter of selecting the appropriate power supply. You might even use the same set in both places. It is easily moved and if you leave the d.c. power supply and mounting brackets in your car it only takes a few minutes to install the set and put it into operation. It takes even less time to yank it out and set it up in the ham shack when you return.

Next on the list was a low-cost stereo hi-fi set. Made by Heathkit, the AR-14 costs only \$99.95. But despite the mod-

est outlay, it is a complete stereo amplifier and FM stereo tuner in a single package. There are 31 transistors in this all-semiconductor set. It delivers 10 watts of audio per channel; has inputs for stereo phono and tape recorder and a pair of stereo auxiliary inputs.

The FM tuner has an IHF (Institute of High Fidelity) sensitivity rating of 5 millivolts—a bit on the high side, but quite adequate for normal reception. There's even a front-panel headphone jack. A complete complex of controls makes the unit as versatile as it can get.

Assembly is smooth and easy. Two big circuit boards take most of the parts and there is a minimum of place-to-place wir-



## Color TV

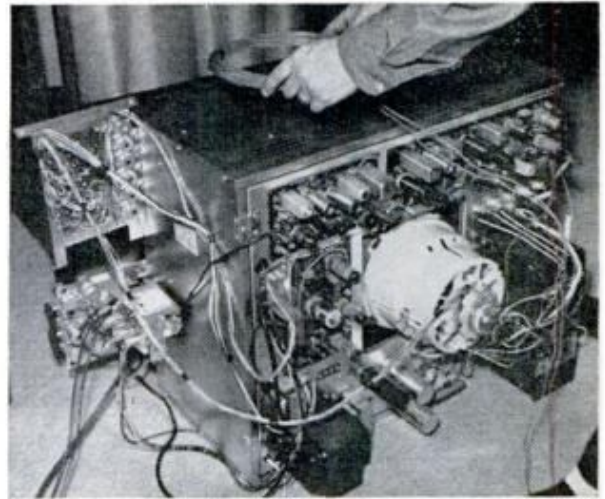
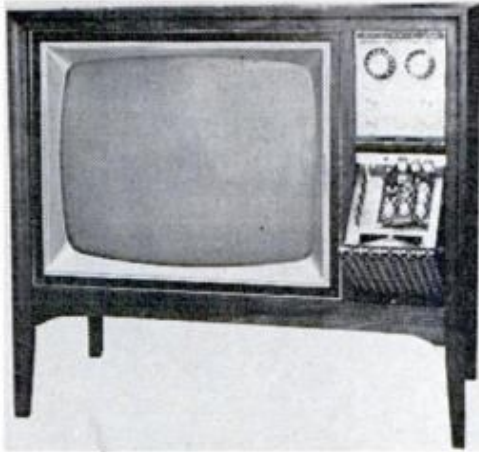

**COLOR TV WITH 25-INCH SCREEN** is easier to assemble than many other kits. Complexities of the set are reduced to a minimum through careful use of printed circuits and excellent instructions

## Portable Tube Tester

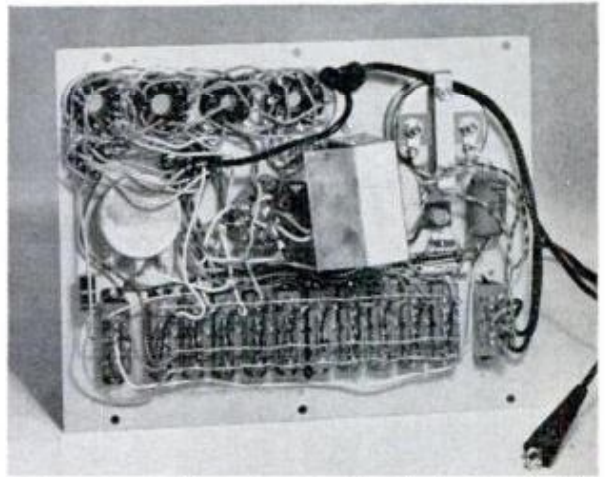

**BASIC TUBE TESTER** is handy to have around the house. Use it to run quick checks for bad tubes before calling in the service technician. You'll be surprised how many service calls you avoid in this manner

ing, though you still have to take some care with the selector switch.

In operation the sound is great. You can't drive large, low-efficiency speakers very well, but outside of this there is no problem. Whether you listen to the low end of the theater organ or the high-frequency chimes of the triangle, every bit of sound comes through. For the price, here's a really good buy.

One of the most elaborate projects that comes in a kit is a color TV set, and yet the Heathkit GR-25 goes together rather easily. I was able to assemble this 25-inch monster in about 21 hours. In the process I made two wiring errors. They were easy to find and did no harm.

Instructions are so clear and exact and so tied in with five printed circuit boards that this kit is actually easier to assemble than many less elaborate devices.

It is truly satisfying, after completing a kit like this one, to sit back and watch a color broadcast.

Perhaps the most valuable part of this kit is its instruction manual. This book is practically a complete course on how to service color TV. With it you can locate and repair most troubles yourself; it should save you many a repair bill. The kit also saves you the cost of test equipment as it includes a degaussing coil (a must for demagnetizing a color set) and a built-in dot generator (necessary



## CB Radio

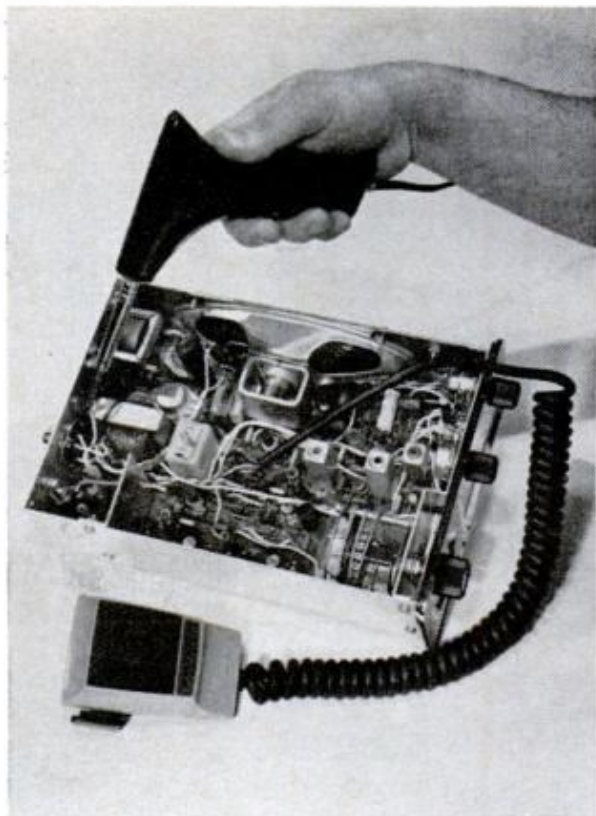

**HIGH-POWERED CITIZENS BAND RADIO** fits into a neat little package, delivers the maximum legal signal. All 23 channels are switch-selected for easy tuning. Squelch circuit keeps background noise down

if you are to set up the color convergence). If you build one of these sets you can be sure you'll take great pleasure in informing visitors at your home that "I built it myself."

There are still plenty of vacuum tubes around the house; transistors haven't eliminated them yet. For this reason, it might be handy to keep a tube tester around. The Knight-Kit 400A is a good example. It costs \$23.95 and will check just about any tube you have in your house. As the circuit is simple, even a beginner should have little difficulty in putting the tester together. This doesn't take very long either—four to five hours.

The completed instrument will detect shorted and gassy tubes on an element-by-element basis. Then it will run a cathode emission test to determine a good or bad rating. The tester is housed in a convenient, wood carrying case. You'll probably find yourself using it more than you expect.

The last kit in the group is an all-transistor, 5-watt CB (Citizens Band) transceiver. This Heathkit can be used in your car as a mobile unit or, with the

addition of an a.c. power supply, at home as a base station. Up to 23 channels can be switched in or out as desired, but the unit does not come with any crystals and you will have to buy a pair for each channel you wish to use. A squelch circuit eliminates unnecessary noise.

Construction can be tricky, so follow the instructions carefully, especially when it comes to lead placement in r.f. signal circuits.

When connected to an appropriate antenna, results are excellent. I have crystals only for channel 18 and determined that in my area (suburban residential) a range of 12 miles could be expected very reliably. As a mobile unit with a whip antenna, transmitting range was reduced, but reception was satisfactory even beyond that point. A greater range is certainly possible, but I did not have the occasion to test this set to its maximum capacity.

These are the new kits, spreading over a wide range of types and uses. There's **bound to be at least one** that you'll find interesting. I hope you enjoy building your choice as much as I did. ★ ★ ★



If you like to shoot, you owe a lot to a genius named Henry.

B. Tyler Henry worked for us at Winchester over 100 years ago. And patented the repeating rifle which made Winchester famous. And the rimfire cartridge you use in your 22.

But Mr. Henry should see how we've improved 22 ammo since then. He'd hardly recognize his brainchild today.

The smokeless powder we use, for example, packs a lot more punch and burns cleaner. Our primers are now non-corrosive and non-fouling. And

our bullets are actually lubricated so they handle cleanly, won't lead the barrel and shoot straighter.

And we've got bullet design down to a science. We now know exactly what shape and weight bullet to use to get the flattest, straightest trajectory.

Which brings up an important point.

When it comes to making 22 ammo who knows better than Winchester-Western? After all, we had a head start.

Just so you don't forget it, we stamp an "H" on all Winchester 22 shells.

(In honor of our Mr. Henry.)

# Henry was here.



**WINCHESTER®**  
*Western®*



# BRAND-NEW

## NOW—A BIG, BEAUTIFUL LINE OF OUTBOARDS

### CHRYSLER 105

Want *top power*? Try Chrysler's spectacular 105 (*most powerful outboard ever certified by O. B. C.\**). It puts out more than 25 hp. in each of its four mighty cylinders. Packed with premium-quality features: V-reed intake valves, hydraulic shock absorbers, full-length silencing, optional remote controls and power-tilt. Try it! You'll never be happy with less!

\*Outboard Boating Club of America—official reporting agency for Boating Industry Association.



### CHRYSLER 75

Seventy-five horses of dependable power for action-packed boating fun. New in engineering design, beautifully new in styling. Long-life, "million dollar" baked-enamel finish in snow-white and royal gold. Develops a full 25 horsepower per cylinder, for more power, less weight. Same quality features of Chrysler 105. Hydraulic shock absorbers optional.

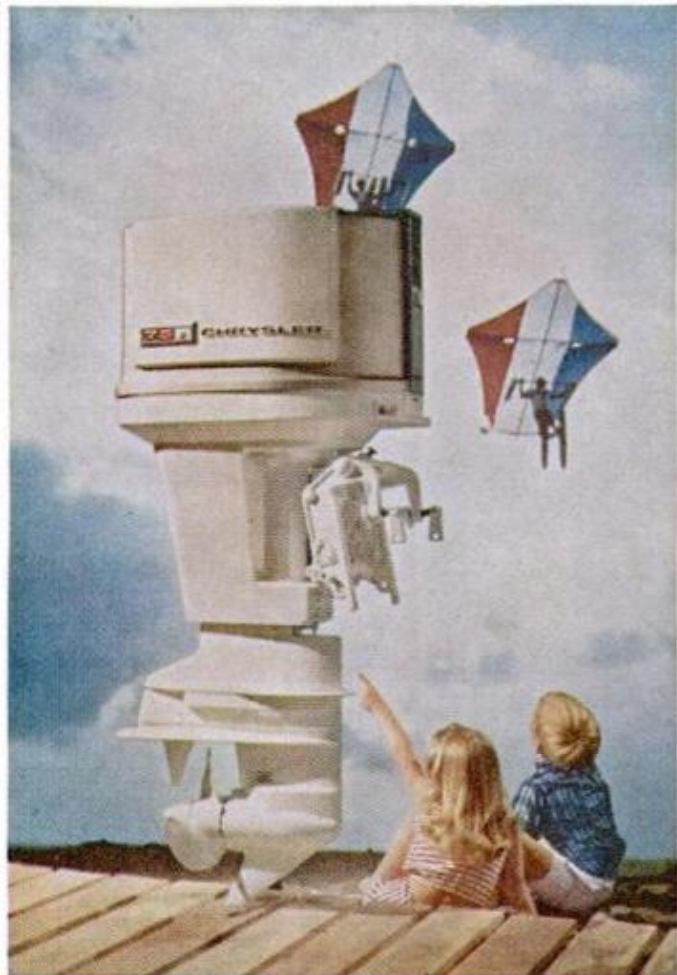



# BRAND: CHRYSLER

## FROM THE POWER PEOPLE...THE CHRYSLER CREW

### CHRYSLER 50

Here's the two-cylinder outboard that delivers a full fifty horsepower. Light weight, of course, for unusually economical operation. Yet it has the rugged dependability you're looking for. Perfect ski-power for light cruisers and runabouts—you name it. This superb Chrysler outboard is known for its endurance and record-breaking performance the world over.

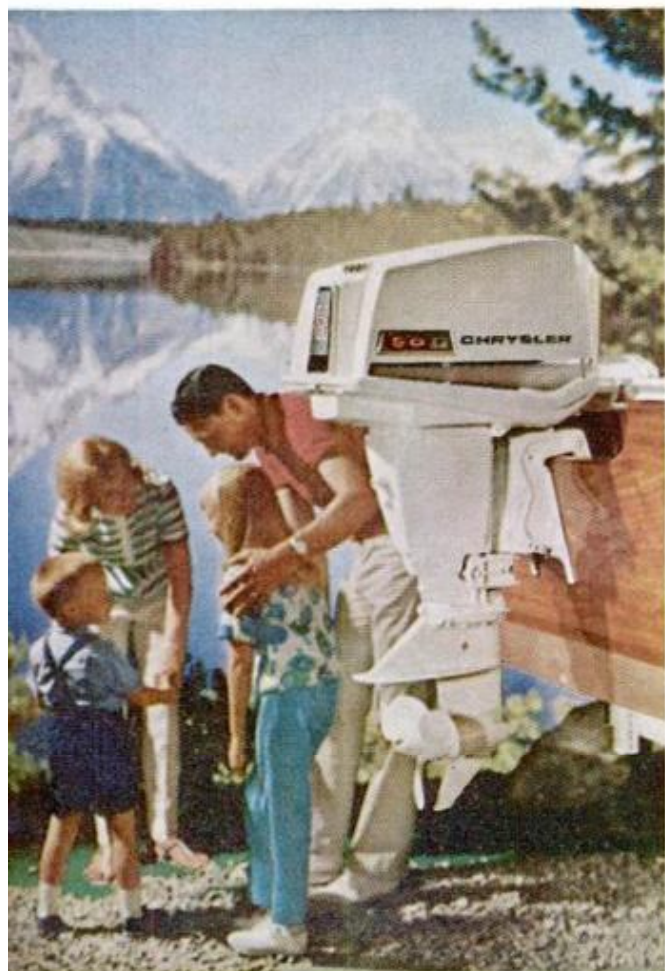

Here's big news in boating . . . a complete power line of slick, quick outboards, styled and engineered in the Chrysler tradition of leadership. Brand? Chrysler! Reputation? Quality!

Superbly styled in gleaming white and gold, to enhance the good looks of any boat, the new Chrysler line features a broad range of horsepower selections: 3.5, 6, 9.2, 20, 35, 45, 50, 75 and a spectacular 105 (see left). Choose from 21 different models, including two new Chrysler "AUTOELECTRICS"—electric starting 9.2- and 20-horsepower fish 'n fun engines with unique 360° utility light, electric starter-generator and optional remote control.

Before you buy *any* outboard, get the story on America's brand-new brand in outboarding: *Chrysler*, built by the power people. See your nearby Chrysler Outboard dealer today (his name is in your Yellow Pages, under "Outboard Motors"). Chrysler Outboard Corporation, Hartford, Wisconsin.



CHRYSLER MARINE PRODUCTS—BOATS, TRAILERS,  
OUTBOARDS, INBOARDS AND INBOARD-OUTDRIVES





**Beer? Busch!**

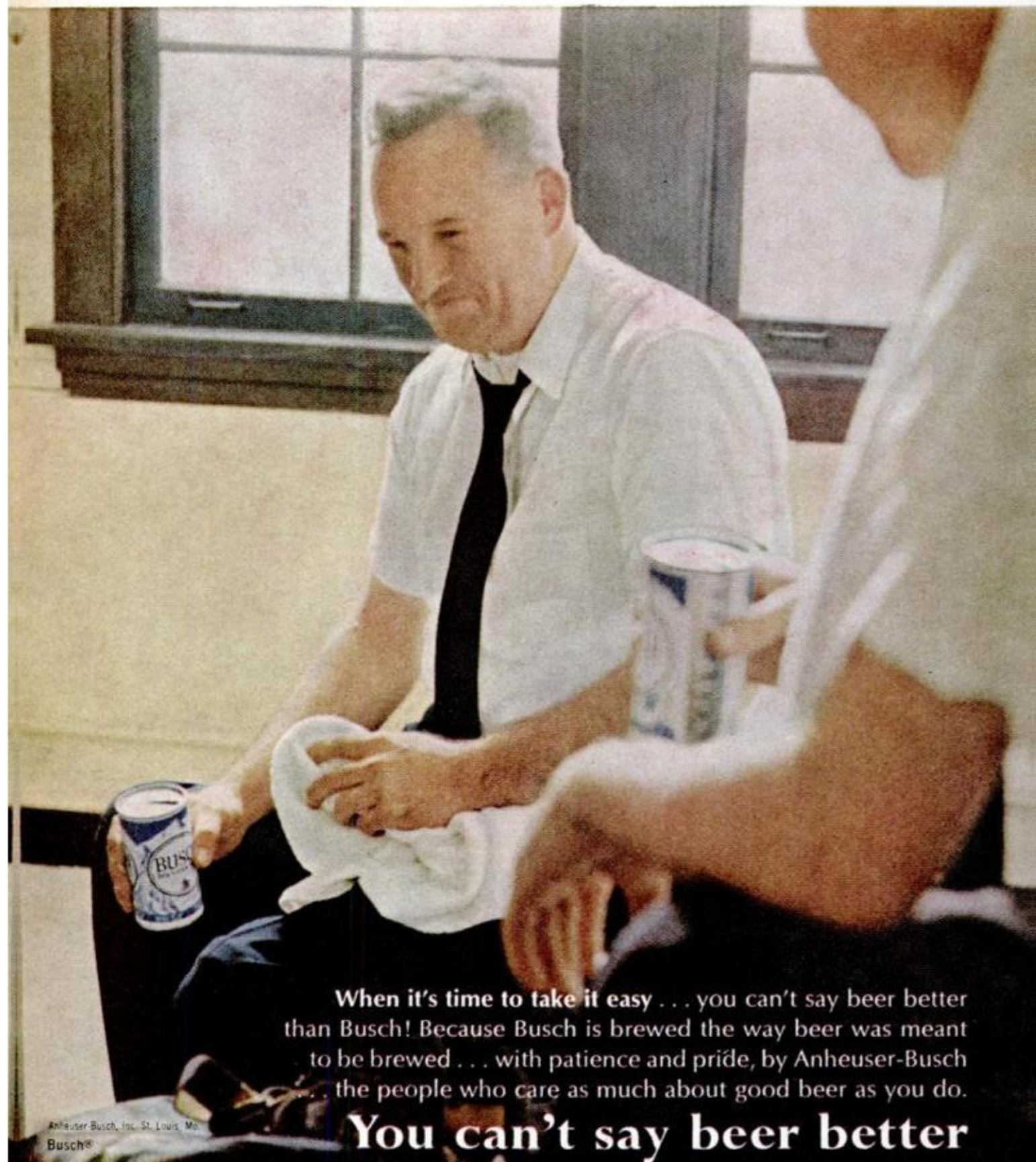

When it's time to take it easy . . . you can't say beer better than Busch! Because Busch is brewed the way beer was meant to be brewed . . . with patience and pride, by Anheuser-Busch . . . the people who care as much about good beer as you do.

**You can't say beer better**

Anheuser-Busch, Inc. St. Louis, Mo.  
Busch®

Материал, защищенный авторскими правами



## NEW TACKLE

(Continued from page 131)

have a new rig, the Silverbell Vari-Mold, a little hand-held lead mold that makes seven sizes of sinkers. What makes it unique is that it also molds the eye onto the sinker, and when the lead has hardened it has a spring device that you trigger with your hand and the sinker pops right out. I can make eight sinkers in one minute. It's made by La Point Enterprises, Inc., Box 8217, Albuquerque, N.M., and it sells for \$5.95.

Like most fishermen, I suppose, I'm reluctant to accept radical new designs in fishing rods. For the most part, this attitude has merit, because most of the odd-ball designs are little improvement over existing equipment. This year, however, I tried two design innovations that I feel have genuine merit.

### Spincasting made easier

The ThumCaster is the invention of George Henson of Colorado Springs, Colo. He has taken the conventional spinning rod, given an arc to the handle, added a pistol grip and designed it so the line runs from the reel through a hole in the grip and along the top of the pole. The result is that you can combine the ease of spincasting with the accuracy of bait casting. The curved handle and grip gives the rod an uncanny balance, and you have your thumb riding over the line to brake it when you're ready to have the lure drop. One thing I particularly liked about the ThumCaster was the ease with which children can be taught to use it. I had a seven-year-old making excellent casts with it after just a few demonstrations. It's priced at \$18.95 from The Henson Corp., 3339 E. Highway 24, Colorado Springs, Colo.

If you like casting underhand, the Angler Rod Co., 1426 Oakland Ave., St. Clair, Mich., has a rod called the Under-Cast with a handle designed to pay the line off the reel below the plane of the rod. It sells for \$12.95.

My latest acquisition is a spinning rod that breaks down in four sections and is easily packed in a suitcase to haul along on business trips. This is a real beauty. It's the Eagle Claw "Trailmaster." It comes in a zippered carrying case and is priced at \$21.95. And along with this I have the newest Eagle Claw spinning reel, their model ECL. It weighs only eight ounces, but it is a rugged, precision machine. It sells for \$31.95. This is my idea of convenience. I'm now ready for fishing wherever I go. ★ ★ ★

# 3 STEPS TO SELLING A TOY INVENTION

## STEP 1 — Design and Development

The basic toy idea is engineered to meet highest standards of good product design.

## STEP 2 — Presentation and Sale

Selected manufacturers view completed product designs. Sale is made and royalty contract is executed.

## STEP 3 — Patents and Royalties

Patent application is made for the product in U.S. Patent Office. Royalties on sale of toy are forwarded to inventor.

JAMES BOND

007 

ATTACHE CASE



created by

**PLAYTHINGS RESEARCH, INC.**

... A CREATIVE GROUP ORIENTED TO THE TOY,  
GAME & HOBBY INDUSTRY

TO: PLAYTHINGS RESEARCH INC.  
132 LAFAYETTE ST.  
NEW YORK, N.Y. 10013

Send complete brochure, no obligation.

NAME \_\_\_\_\_

ADDRESS \_\_\_\_\_

CITY \_\_\_\_\_ STATE \_\_\_\_\_



## HIGH-LOW PICKUP CAMPER

(Continued from page 137)

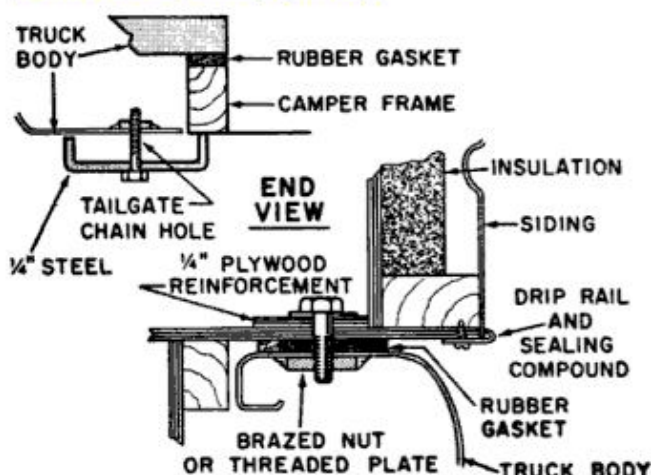

**CAMPER MOUNTING** gets an assist from the snug-up brackets (above left). After tightening them, insert the bolts tying the camper to the truck. The hole in the truck body is backed up by a threaded steel plate

of this loose platform. Cover the bottom of the frame with  $\frac{1}{4} \times 24 \times 43\frac{1}{2}$  in. plywood and face the sandwich with  $\frac{1}{4}$ -in. plywood  $4\frac{1}{2}$  in. high. The upper portion of this will hold the mattress edge.

From  $\frac{3}{8}$ - and  $\frac{1}{4}$ -in. plywood, build the laundry hampers to fit over the wheel wells, reinforcing them inside with full-length glue blocks (see drawings on pages 136 and 137). The hampers sit inside the truck body, but their tops are attached to the undersides of the camper frame, butting the bed platform. Cover the overhangs in the galley area with  $\frac{3}{8} \times 5\frac{1}{4}$  in. plywood strips. Later, you can attach the hampers' free ends to the galley units.

Construction of the hampers requires that the loose bed platform, which rests across the hampers, sit  $\frac{1}{4}$  in. higher than the fixed one. However, with 5-in. foam mattresses, this difference doesn't matter.

Glue and screw  $1\frac{1}{2} \times 1\frac{1}{2}$ -in. reinforcing ribs to the bed platform, as shown in the floor plan to page 136. Reinforcements, measuring  $\frac{3}{4} \times 1$  in., are run outside (and attached to) the hampers from a point  $3\frac{3}{4}$  in. from the rear frame to one  $2\frac{1}{2}$  in. from the front of the camper. Another piece runs between the forward ends. These reinforcements stop short of the rear because of the narrowing tailgate area.

To finish up the forward section, build a box without a top or front to house the water tank, as shown on pages 136-137. Made of  $\frac{3}{8}$ -in. plywood, the box reaches from the free edge of the platform to the  $\frac{3}{4}$ -in. reinforcement on the other three sides. Add reinforcing strips to its bottom.

Drill for the fill pipe at the left side of the bed platform and front wall so

that the spout will clear the truck cab.

Attach the box to the underside of the bed platform; install the water tank. Later, after the siding is on and the fill line installed, couple the tank to the fill line and pump and then screw on the removable front panel.

Space underneath the tank shelf will store the spare tire displaced by the sump. Runnerless drawers can be placed alongside for additional storage.

Paint the underside of the camper. When it's dry, attach strip-rubber gasketing to the inside of the lower section of the rear frame where it contacts the truck's tailgate area.

To load the camper on the truck, run a  $\frac{3}{8}$ -in. eyebolt through the roof strut provided for it and through a 2x4 temporarily placed inside for support. Then hoist it with a winch (see side view, page 137). Fabricate the U-shape straps as shown in drawing above, drilling them to fit bolts that thread into the vacant tailgate chain holes. Tightening the bolts will snug up the camper to the truck, making a seal at the gasket just installed.

Glue  $\frac{1}{4}$ -in. pieces of plywood to the spots where you will drill  $\frac{7}{16}$ -in. body bolt holes through the camper and into the top of the pickup's body panels, as shown above and on page 136. The forward holes should fall inside the closet, not in the sleeping area. Remove the camper and apply sponge rubber gasketing to it under the holes.

Attach with machine screws or braze on  $\frac{3}{16}$ -in. strips of steel to the underside of the holes in the truck. The steel strips must be drilled and tapped for  $\frac{3}{16}$ -in. bolts. Each time the camper is bolted down, the U-straps may be removed.

Frame the sink and stove cabinets to accommodate their fixtures: the sink, shelf and drawer on the one hand and refrigerator on the other. Only  $\frac{3}{8}$ -in. plywood need be used for countertops if the area around the sink is reinforced to a thickness of  $\frac{3}{4}$  in.; only  $\frac{1}{4}$ -in. plywood is needed for the rest of the cabinets. You will have to make cutouts where the cabinets cross the wheel wells. Also, keep the wells in mind when placing the refrigerator.

The clothes closet is built out from the wall and then faced with  $\frac{1}{4}$ -in. plywood. Each side section is  $18\frac{1}{2}$  in. wide and the center, 37 in. Closet pole should be attached between upper front panels and the front wall, just below the slope in the wall. This will provide 32 in. of hanging space. Use two hanger rods in the center section.

Cement 1-in. polystyrene insulation to  
(Please turn to page 192)



# 3 great Specials from **DISSTON** to help you fix up your nest this Spring

These Spring Specials now available for a limited time at your local Hardware, Department Store or Lawn and Garden Outlets. **ASK FOR THEM—AND SAVE!**



## A FREE LAWN RAKE COMES WITH THIS DISSTON SPRINKLER SAVE \$3.45

The perfect pair for cleaning up and greening up your nest. Disston's best "grass grower" sprinkler adjusts to 4 patterns (10' x 90', 20' x 80', 40' x 70', 40' x 64'). Made from rustproof materials for long life. The free rake has 18 spring-action, steel tines for easier, cleaner raking. Won't damage turf.

A \$16.95 Value  
Now Spring priced at just \$13.50



## OLD RULE TRADE-IN SAVE \$1.00

Tired of measuring with a rule that's always too short? Trade it in on this Disston I-o-n-g 50-foot tape. It's long enough for any measurement around the house—inside or out. Rugged metal case.

A \$5.00 Value Now Spring priced at just \$4.00  
(with trade-in)



## 1¢ DISSTON SAW SALE SAVE \$6.24

Just in time for spring projects. Buy the Disston D-23 and for only 1¢ more, get the R-1 companion. Both belong in every home workshop. Full-length, tempered steel blades. Great for starting teenagers with a set of professional quality handsaws.

A \$16.20 Value  
Now Spring priced at just \$9.96

**PORTER**

**HARDWARE AND INDUSTRIAL  
PRODUCTS DIVISION  
H. K. PORTER COMPANY, INC.**



## To Make and Sell Ornamental Concrete Items

You Need **MOLDS**

For Thorough Info  
On Over 300  
Different Molds  
You Can Buy And  
Use Plus Complete  
Start To Finish  
Professional Instructions  
RUSH \$2.00 for book



**TURN CONCRETE INTO GOLD**

CONCRETE MACHINERY COMPANY, INC.  
839 Lenoir Rd. - P. O. Box 99 - Hickory 2, N. C.

# Liquid

## WRENCH

LOOSENS RUSTED NUTS, BOLTS, PARTS IN SECONDS  
at Service Stations, Auto and Hardware Stores  
RADIATOR SPECIALTY COMPANY, CHARLOTTE, N. C.



## 100% FUN CAMPER



NEW

# WAYFARER



**Mark 7**

Go back to Nature in comfort, in a Wayfarer Mark 7. Sleeps 10; 2-divan lounging area; large dining table; stove; sink; refrigerator. Aluminum body. Fast set up.

Dealer Franchises Available

**FREE WAYFARER BOOKLET**

on complete trailer line

WAYFARER CAMPERS  
582 Ford Blvd., Hamilton, Ohio  
Send me the all-color booklet on the  
Wayfarer Mark 4, 6, and 7 Campers

Name \_\_\_\_\_

Address \_\_\_\_\_

City, State, Zip \_\_\_\_\_

## HIGH-LOW PICKUP CAMPER

(Continued from page 190)

the plywood between the studs, but the roof should be fully packed with it to permit the use of light-gauge roofing.

Drill holes through the ceiling and insulation for wiring to dome lights. Install a cigaret lighter socket in the side of the sink cabinet for an electric shaver (with adapter and converter).

Run a No. 10 wire from the fuse panel, fused at 15 amps, to the left rear corner of the truck. Hook it with a ground wire and a line from the taillight into a connector into which the camper's wiring can be plugged. This will be under the sink.

Run No. 12 wires from the No. 10 line and ground to the fan switch and cigaret lighter. Run No. 16 wire to the dome light locations from the hot side of the fan switch. From the taillight lead, run No. 16 wire to the ICC clearance-light locations.

Attach the base of the propane lamp to the wall over the stove counter.

### Next comes the skin

If aluminum truck siding is used because of its readier availability, install it wrong-side-out to simplify finishing the corners. Determine the location of the ribs for appearance and economy of material and mark where they fall on the framing. Notch the framing to accommodate them.

Drill holes for the clearance-light wires and attach siding with  $\frac{3}{4}$ -in., 18-gauge aluminum nails, spaced 3 in. apart and close enough to the edges to be hidden by corner molding. Use inverted drip rail and sealing compound to attach the lower edge of the siding to the frame.

Attach the roofing at front and rear (overlapping at the middle and on the sheets that curve down to meet the siding) with sealing compound and  $\frac{3}{4}$  in., No. 8 aluminum sheet-metal screws. Use the sealing compound wherever metal butts metal or overlaps. Apply drip rail, inverted, as corner molding at the top of the sides and down the corners, fastening it with the sheet-metal screws.

Install the door, windows, roof ventilator, exhaust fan and water tank filler tube using sealing compound in each case. Connect and attach the clearance lights, orange in front and red in rear.

Apply countertop laminate and edge with metal trim or self-edge. Cut in and install the sink and water pump, hooking up the pump to the water tank with

(Please turn to page 194)





To assure smooth, precise power steering, Ford Motor Company engineers design important parts to tolerances 100 times thinner than a human hair.

A car so precisely engineered can be cared for best by the specialist—your Ford or Lincoln-Mercury dealer.

See him and be sure.



Expert factory training is provided for dealers' mechanics. Your dealer also has genuine parts, special equipment.



Only at Ford and Lincoln-Mercury dealers





# CLEAN YOUR POWER MOWER

and  
GARAGE FLOOR

with

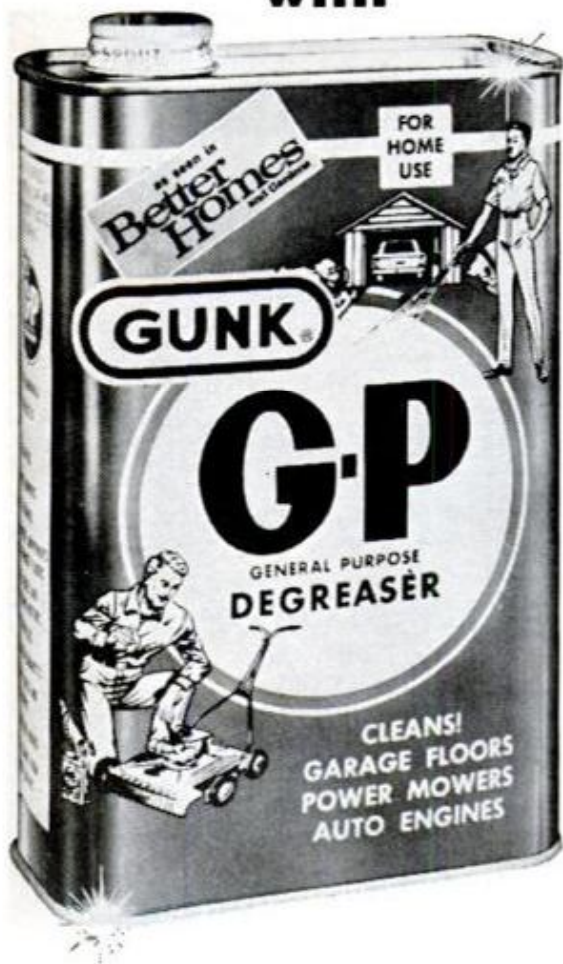

Gunk G-P is the safe way to get your mower really clean without using volatile flammable solvents! Save your gas for cutting grass! . . . Just brush or wipe G-P onto your mower. Grease, grime, and grass rinse away easily in a safe, soapy emulsion by hosing or sponging with water. Your mower shines like a new penny! No dangerous fumes—no oily rags!

G-P works the same miracle with oily spots on concrete driveways and garage floors. In fact, G-P tackles most any job too tough for household cleansers! . . . Gunk G-P is at your hardware or auto accessory store. Get it!

**GUNK** Laboratories, 5829 W. 66th St., Chicago Illinois 60638

**GUNK CHICAGO CO.**  
River Forest, Ill.  
serving the Midwest and Southwest

**RADIATOR SPECIALTY CO.**  
Charlotte, N. C.  
serving the East, Southeast  
and far West

In Canada: RADIATOR SPECIALTY CO. OF CANADA LTD., TORONTO

## HIGH-LOW PICKUP CAMPER

(Continued from page 192)

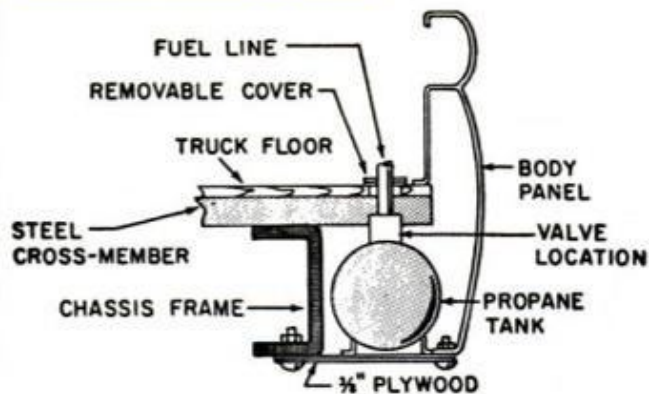

CRADLED UNDER THE BODY PANELS is the propane tank that feeds the stove and lamp. A removable panel in the truck's floor, through which the fittings protrude, provides an access to the tank's valve

$\frac{3}{8}$ -in. copper tubing run through the hamper.

Just forward of the right rear wheel, a 5½-gallon horizontal propane tank is installed, as shown in the drawing above. A smaller size tank could be mounted behind the wheel under the stove, but the 5½-gallon size will last for five weeks of camping, using the lamp and cooking all meals on the stove. A slot should be cut in the pickup floor under the water tank shelf to accommodate the pipe rising from the valve on the tank and to provide a hand hole for operating the valve from inside the camper. Provide a cover with a hole in it for this slot, which can be slid up the pipe for access.

Bolt the stove to the countertop. Run gas lines from the stove and the propane lamp under the counter, through the hamper and down to the tank valve.

Drill holes through the truck floor for drains from the sink and refrigerator, and drill one in the corner of the sump to drain spills. Fit this one with an adjustable vacuum-bottle stopper. Get a small rubber cork or plug to seal the eyebolt hole in the roof. Finally, provide for grounding the siding to the truck.

Sandpaper the interior, fill all screw holes and paint. Install the dome lights and other interior hardware. Cut the foam mattresses to fit. Then let the lady of the house take over for such jobs as making curtains and zippered mattress covers, placing towel racks and other accessories. A screen-door catch will do nicely in holding a wastebasket in place against the side of the sink. Carpeting for the truck floor between the wheel wells and vinyl tiles for the kitchen sump floor are finishing touches. ★ ★ ★



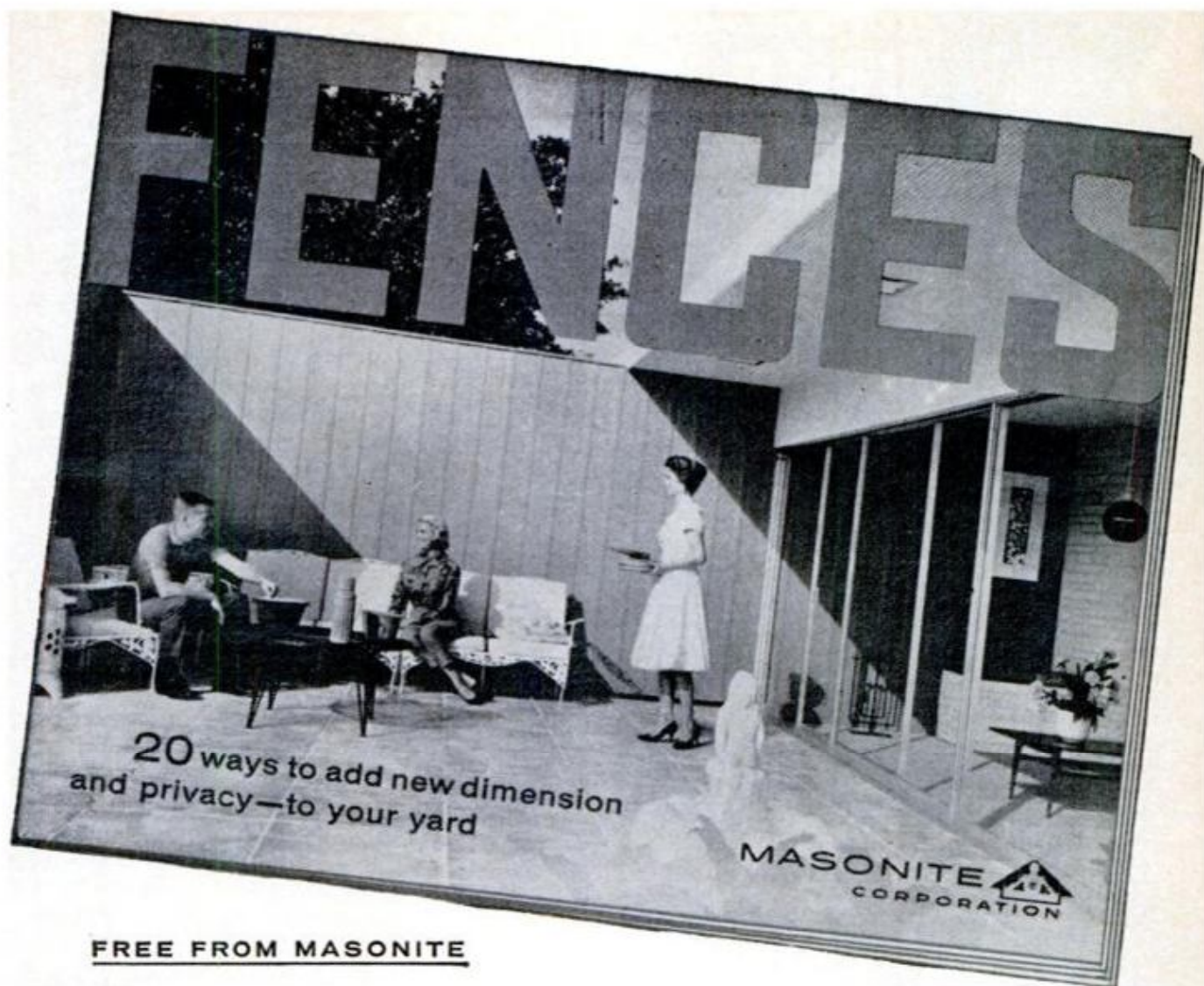

FREE FROM MASONITE

## How to surround yourself with beauty and comfort

Want more privacy?...a convenient windbreak...more attractive landscape? Your copy of "Fences" shows how these benefits can be yours. Twenty pictures and sketches offer a style show of fences, patio walls and screens. You also get important construction hints, learn how easily fences and partitions can be built. The secret is Masonite hardboard panels. Example: Masonite X-ninety panels—grain free for maximum workability, surface primed to take and hold paint beautifully, dent resistant for years of good looks. Or try new Weatherall, the general purpose, utility panel for almost any outdoor job. Weatherall features a baked-in primer, can actually go unpainted as long as a year. More information? Send for "Fences" today.



# MASONITE

*...does it better*

Masonite, X-ninety and Weatherall are registered trademarks of Masonite Corporation.

Masonite Corporation, Dept. PM-5  
Box 777, Chicago, Illinois 60690

I'd like to know more about fence design and  
Masonite panels for easy construction.  
Send my copy of "Fences."

Name \_\_\_\_\_

Address \_\_\_\_\_

City \_\_\_\_\_ County \_\_\_\_\_

State \_\_\_\_\_ Zip Code \_\_\_\_\_



# MAGNETIC BRAD DRIVER

The handy tool for home owners, wood workers, cabinet workers, hobbyists, model makers, etc.

Quality tool with hardwood handle and steel barrel with magnet insert will pick up, drive and countersink brads 12 to 19 gage, 1" long and smaller.

No. C22

**2.90**



On sale in paint and hardware stores or send \$2.90 tool sent postpaid.

**HYDE TOOLS**

Write for Free Catalog SOUTHBRIDGE, MASS., U.S.A.

## TRY CAMPING AFLOAT

(Continued from page 126)

tion and produces increased heat during operation. (It also makes it easy to toss the stove overboard should it flame up.)

Although on the heavy side, a favorite charcoal brazier for boat use is the Japanese hibachi, which is inexpensive and comes in many sizes and shapes. It is designed to use a small amount of fuel for the maximum amount of heat produced. Carefully timed, an entire meal can be cooked with a single load of briquets. An even better system for charcoal broiling is to use a brazier which hangs overboard. Marine stores offer several styles or you can fashion your own from a heavy-gauge, industrial-type bucket.

A compact and easy-to-use stove for boat camping is one using LP gas. The fuel comes in disposable cans which are inserted into place. The stove is lighted by turning a handle and using a match. There's no pumping or priming or lighter fuel to fiddle with.

Paper plates and cups are a must (buy plastic-coated plates and hot cups).

An aluminum nesting cook kit is ideal for providing a variety of pans, but you'll probably be happiest if you include a cast-iron or heavy-duty aluminum frying pan along with your cook kit. Square frying pans pack easier, and if you get one that is divided in the middle you can prepare eggs and sausage at the same time.

When boat camping it's much more convenient to store your fresh water in several small containers instead of one that is too cumbersome to handle easily. An ideal container is a gallon plastic bottle originally used for distilled water.

How about food? Few small boats are outfitted with lockers, so to store food, utensils and stove you will need something more durable than cardboard boxes which inevitably get wet and begin to come apart. A couple of medium-sized wooden boxes, rather than one large container, are best for ease in handling and stowing. Wooden boxes will stand abuse and can be stacked one on another; they can also serve as tables or benches. Suitable used wooden boxes are difficult to find, so your best bet is to construct them from lightly framed 1/4-inch plywood.

When you camp aboard, you never run out of campsites. There's lots of room—thousands of square miles of navigable North American waters. You leave behind elbow-to-elbow shore camping, the dialogue of the neighbors in the adjoining tent and the blare of their radio. Each night you drop anchor in your own private world. ★ ★ ★

## THE BEST KNOWN IS KNOWN BEST



**FOR  
REMOVING  
FINISHES**



**KUTZIT . . .** Savogran's fast acting liquid-benzol paint remover is recommended for removing old finishes from horizontal or flat surfaces. Its low wax content permits maximum penetration of paint, varnish, shellac and stains in less time. Available in pints, quarts and gallons.

"WHERE PAINT IS SOLD"

**SAVOGRAN**

Addison, Ill. NORWOOD, MASSACHUSETTS Los Angeles, Cal.





RALLY 'ROUND THE FUN WITH **YOUNG AMERICA**

Get on a Harley-Davidson Sportcycle and get with the In Crowd! Rally 300 swingin' miles between gas pumps. You're free as a breeze for pennies a week. Quality? We wrote the book! Dellorto carb, Pirelli tires, full lighting and brakes, easy handling. You get more for your money now, more for your bike later with Harley-Davidson's better trade-in value. Five models from 50 cc. to 250 cc. starting around \$225. Low-cost financing and insurance from your dealer. See him for the action time of your life. Now!

**HARLEY-DAVIDSON**

MAY 1966

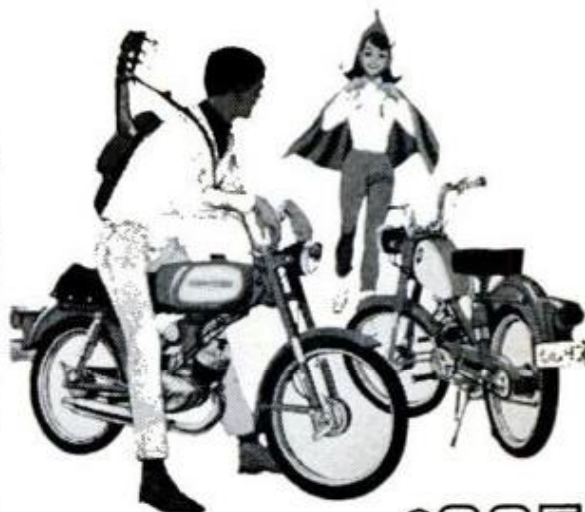

50 cc. models start around **\$225**

197



## PLANNING A WAR? SEE SAM!

*(Continued from page 92)*

strength. Where do you get arms when no government will sell them to you? Ah!

Sam did all right on the deal—about \$4,000,000 worth of all right. For whatever reasons, the United States made no move to stop the deal, possibly because it didn't like the politics of the rebel groups then hoping to overthrow the government at the time. A bloody invasion was prevented, and, inevitably, Trujillo was finally cut down by homegrown dissidents. Meanwhile, the United States had "done nothing," and Cummings made a bundle.

Cummings spends the equivalent of eight months a year traveling from his Monte Carlo home, setting up deals for his company to handle. In addition to office and administrative setups in Monte Carlo, the United States and England, Interarmco has two main bases.

Cummings estimates the value of arms on hand at the two depots at any given time at about \$10,000,000 in cost to Interarmco. For some idea of the profits of pawnery, their resale value to Interarmco is about \$30,000,000.

In a very real sense, Cummings has been involved in his strange trade since earliest childhood. When he was five years old, an American Legionnaire friend of his family gave the Cummings's an old Maxim '08 machine gun that his Legion post had been displaying on the lawn.

### **Hobby made him an expert**

After World War II, he went to Oxford briefly, batted around Europe and returned to the United States to finish college at George Washington University. On graduation, in 1952, the job that had been invented for Sam Cummings found him. Western Arms, at the time a West Coast buyer of military surplus, sent him abroad with one of their salesmen-buyers as an arms expert. He stayed with them two years, learning the trade and piling up a salary and small commission while living on an expense account. When he quit, late in 1953, he had \$25,000.

With a little money in his kick he was ready to step out and start building his empire, with the aggressive imagination of a Caesar. One of his secrets is a sure knowledge of guns and markets. Sam's knowledge has enabled him to pull off some breathtaking coups.

Browsing through some Netherlands warehouses while looking for ammo a few years after he started his business, Sam noticed some unusual rifles racked in shelves by the hundreds. They were U.S. Johnson semiautomatics, built for

the Netherlands Indies forces before World War II. These were superb rifles, admired by gun lovers throughout the world, but only a few thousand had ever been made because they were not well adapted to use in jungle terrain and were expensive to boot. Collectors knew of them, of course, and were panting to buy them. But the Dutch government didn't know it had them.

Sam bought them on the spot with money he had to borrow later. The rifles had cost the Dutch government \$200 apiece. Sam bought 6000 of them—virtually the entire stock in the world—for \$15 each. He sold them easily for \$200 each.

Another of Sam's secrets is that, unlike most arms dealers, he'll make any kind of deal that involves arms. Most dealers will buy X number of rifles and sell them. Sam will buy and sell anything that relates to his business.

One NATO nation (A) wants to buy modern light machine guns produced in another NATO nation (B). Nation A can't pay for the guns it wants in cash, so it makes an agreement to sell Interarmco obsolete rifles and ammo to the value of the machine-gun purchase. Interarmco doesn't pay nation A for the goods it receives, but deposits the money in the bank of the gun manufacturer in nation B, which then authorizes the shipment of guns to A. Simple. A gets the guns it needs, B makes a sale it needs and Sam gets a few million dollars' worth of merchandise at bargain prices.

Some deals have involved three and four-nation swaps of trucks, new arms, old arms, ammo, blankets, tenting, anything. Banking arrangements for some of the deals are so complex that everyone knowledgeable in the field assumes that Interarmco now owns a Swiss bank through some fronts. It figures. Sam is married to a wealthy Swiss girl. He spends months in Switzerland every year. And nothing else would explain some of the deals that have been made, part jawbone and part in staggering sums of cash.

Not all of these deals with the millions they represent are Cummings's alone. In countries where Interarmco is incorporated, he owns only 10 percent of the stock, usually because of local regulations forbidding arms dealing with foreigners or foreign-owned corporations.

What Sam doesn't add is that he's so big now—he controls 85 percent of non-governmental arms sales made outside Communist-bloc nations—that any agent in his right mind would take a deal to him first. Thus he skims the top green off the arms trade, leaving the smaller operators



to scuffle for the harder dollars. If there is another operator ready to bid for 500,000 Enfield rifles from the British government, offer Spain \$1 million for Russian infantry weapons captured and stored since the Civil War in 1937, or buy one billion rounds of Mauser ammo from Argentina (all of which Interarmco has done recently), he hasn't come forward yet.

Nor are all of Sam's deals profitable. In 1959, the company was stuck for \$250,000 worth of rifle ammunition it bought from Finland and Argentina. "Most of it was so old it was worthless," says Sam, "and I blame myself. The governments sold in good faith; they just didn't know the stuff was bad. I did the inspection myself, but it turned out wrong."

### TNT deal backfired

Another disaster resulted from a brainstorm that struck Sam in 1960. "I had the idea of going into the commercial explosives business in competition with DuPont, by buying military TNT and repackaging it into blasting-block form. I bought 150 tons of old but usable German explosives from Denmark and had it shipped to the States. On arrival, I learned there were dozens of ICC and Coast Guard regulations that we hadn't complied with.

"We finally had to put the whole lot into railroad cars because the railroads are the only carriers authorized to handle the stuff, and keep it moving constantly up and down the East Coast while we figured out what to do with it. In the end, we sent it down to the Army Engineers in Atlanta. They loaded it back on a ship, took it out on the Atlantic and dumped it.

But Interarmco wasn't built on booboos. For every bad deal Cummings has made, there have been a hundred others profitable enough to support a little youthful ebullience or impatience. However, there are problems on the horizon. "With the change in production from bolt-action to semiautomatic and automatic weapons that's been happening since World War II, the sports end of the business has to start disappearing before too long—say 10 years or so. In addition, the one thing I can't compete with is giveaway programs. You have no idea of the number of weapons the Czechs, Bulgars and Chinese are happy to give to people every year, to say nothing of Uncle Sam.

"But I do think it will be two generations or so before everyone has the automatic weapons they want and the picture really changes for us."

And meanwhile? "Meanwhile, things just continue. After all, it's a living." ★★★

# Blue-print for action

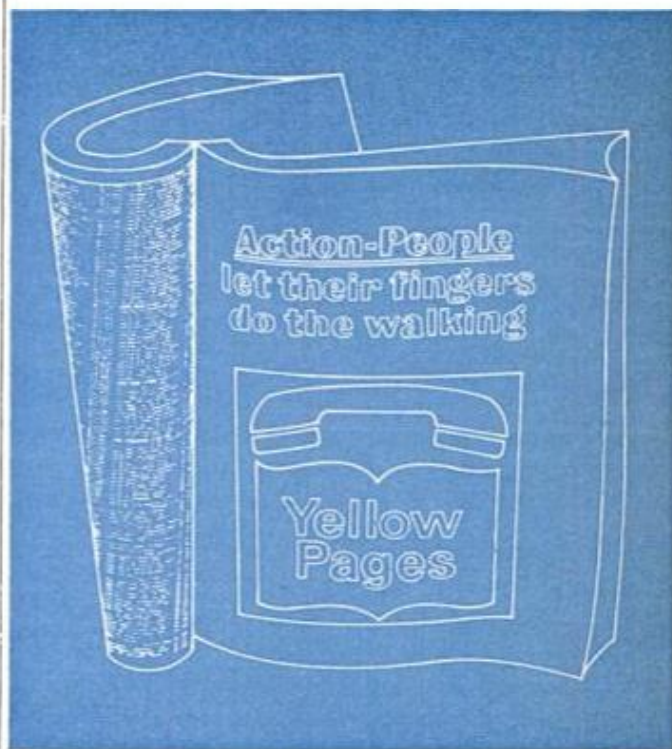

**Yellow Pages will show you where to get architects, contractors, masons, plumbers, carpenters... anyone. Just let your fingers do the walking. Action-People do.**



# Sears has the right glue for the job.

15 Craftsman® glues and cements—sold only at Sears, Roebuck and Co.—let you bond, join, laminate, caulk, fair, waterproof, repair, patch or fill practically any materials you can name.



**Craftsman White Glue**—a quick-setting glue for most household purposes. Joins wood, paper, cloth and other porous materials. Dries clear. 4 oz.—\$.39



**Craftsman Casein Glue**—an easy-to-mix dry powder glue. Makes a strong water-resistant bond. Use with wood, fiberboard, Formica. \$.79



**Craftsman Contact Cement**—for bonding plastic laminates. Also bonds wood, metal, glass, concrete to each other. Bonds instantly on contact. 4 oz.—\$.49



**Craftsman Pliobond Liquid Adhesive**—adheres almost any surface to any other. Sets dry and clear in 30 minutes. An excellent primer, sealer. \$.59



**Craftsman Waterproof Resorcinol Glue**—perfect for assembly woodworking, like boat construction. Withstands boiling water, extreme climates. ¼ pt.—\$1.09



**Craftsman Stitchless Mender**—joins fabrics. Flexible, washable, won't stain. Stops runs in nylons. Puts patches or zippers on tents, awnings, overalls. \$.59

Craftsman adhesives, like famous Craftsman tools, are made to high professional standards.

That's why Sears stocks so many glue and cement formulations. You'll find Sears

has exactly the one you need for every job around your home or workshop.

Pick up a free glue chart in the hardware department of your nearest Sears store.





**Craftsman Epoxy Cement**  
— all-purpose waterproof cement. Unaffected by water or gasoline. Bonds metals, wood, masonry, glass, ceramics. \$.59

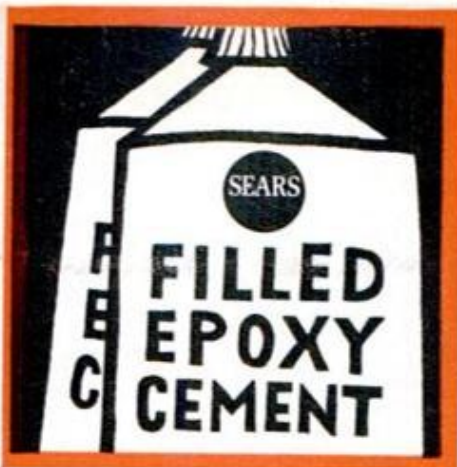

**Craftsman Filled Epoxy Cement**  
— waterproof, shrinkproof, unaffected by gasoline. Needs little or no clamping. Excellent for patching and crack filling. \$1.89



**Craftsman Hide Glue**— the cabinet-maker's choice. Makes a joint stronger than the wood itself. Excellent for veneering. Needs no heating. 4 oz.—\$.49



**Craftsman Plastic Resin Glue**  
— excellent for veneering, edge-gluing, laminating any porous materials. Non-staining and highly water-resistant. 2½ oz.—\$.39



**Craftsman Plastic Rubber Cement**  
— tough elastic rubber putty. Use to waterproof, insulate, caulk and repair rubber or fabric. Mend holes in hoses, boots. \$.69



**Craftsman Weatherstrip Adhesive Paste**— adheres to glass, rubber, metal, wood or cloth. Adds new life to old adhesive that's dry and hardened. \$.59

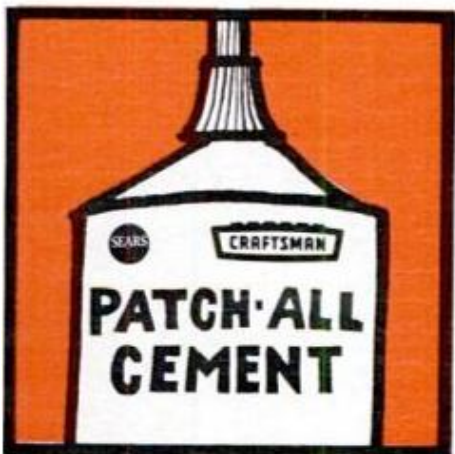

**Craftsman Patch-All Cement**— ideal for most metals. Use for patching, caulking and fairing. Secure loose wooden handles on kitchen utensils. \$.69



**Craftsman Cement for Polystyrene Plastic**— clear, waterproof, quick setting. Perfect for constructing and repairing model cars, planes, ships. \$.19



**Craftsman New Vinyl Household Cement**— dries clear and flexible. Withstands oil, gas, boiling water. Repairs vinyl plastics, china, wood, leather, paper, cloth. \$.49.

**Sears** has everything in glues



# the second set of tires is your first real choice!



Now it's just you and all the tires in the world. One of them is the only family-car tire certified safe at 100 mph. The Dunlop Gold Seal.

The same one has Dunlop patented\* Safety-Shoulders. Lean into a corner, and the patent holds you on. Roll up and over a center line or shoulder, and the patent holds you without a lurch.

The same one has what tire men call a low profile. That means a 15% larger footprint area. More of the Gold Seal's wide tread is always on the road for better traction, greater safety, more miles of wear.

And this same one has the Dunlop water-ejecting tread pattern. That speaks for itself in the wet.

Yet the Gold Seal is popularly priced.



Doesn't that sound like a choice tire for a change? You can choose your Dunlop man out of the Yellow Pages.

Every Dunlop tire meets or exceeds every official specification for safe performance.

\* PAT. NO. 3,024,825

**DUNLOP**  . . . means quality in  
BUFFALO, NEW YORK *golf, tennis, and tires.*

## LOWDOWN ON LOWER UNITS

(Continued from page 161)

when it happens by the way in which the engine shifts or—better—doesn't.

You'll be able to shift into forward gear, but you won't be able to get back into neutral. This is an advantage, of course, if shift rod breakage occurs on the water. You'll at least be able to get back to shore. In addition, a problem is apparent when the shift lever moves without any effort at all. It'll feel plain sloppy. This requires replacement of the shift rod.

As important as this may be to you, there's another more vital tip. Replacing the shift rod and not correcting the reason for its breaking in the first place is as ridiculous as painting the hull without scraping off the barnacles.

When you experience shift rod breakage in Mercury-type setups, check the motor mounts. Chances are that one or all of the mounts are bad, causing the rod to break.

Whether you tackle lower unit work yourself or leave it to a pro, there's no sense doing half-a-job. By half-a-job I mean taking the lower unit apart, replacing a bad part and putting everything back together without giving mind to anything else. A total job requires a careful inspection of *all* parts to find and replace other components that might be in process of going bad.

So, before reassembling the unit, you or the man doing the job should do the following:

**1. Bearings.** Check or replace them. Cartridge needle bearings, for example, should always be replaced when the lower unit is ripped down, and especially if traces of rust are present. These bearings are not expensive.

Inspect roller bearings to make sure they're not worn. As a matter of fact, it's recommended that they too be replaced when lower units are torn down.

**2. Seals.** Always replace oil seals when unit teardown is done. They're cheap and new ones can save a lot of trouble later on.

**3. Shafts.** Check drive and prop shafts for worn spots, twists and bends. If damage shows, replace the shaft.

**4. Gears.** Check all gears for worn, pitted, chipped or broken teeth. Make sure there are no rounded, chipped or otherwise damaged corners.

**5. Clean up everything.** Finally, before reassembly, make sure the lower unit housing and all parts are perfectly clean. And don't forget to add lubricant when everything's back together again.



## REDWOOD FINISH FOR ALL WOODS!

Seals and colors  
in one coat

Allows natural  
grain to show

Beautifies interiors  
and exteriors

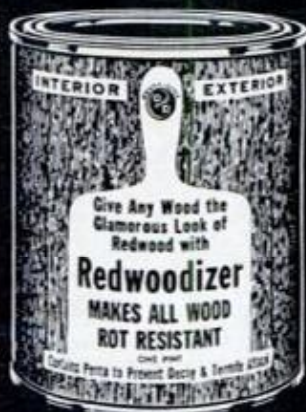

## REDWOODIZER

in pints,  
quarts and gallons

Now—rich redwood glamour on Philippine mahogany, cypress, cedar and other woods! REDWOODIZER even makes redwood handsomer! With Penta protection from rot and insects. Seals out moisture; kills termites and fungus. For new wood or over old finishes.

## PERFECT SEALER FOR PLYWOOD!

Controls "wild grain"

Provides hard coating  
as base for finish

Prevents rot and  
insect damage

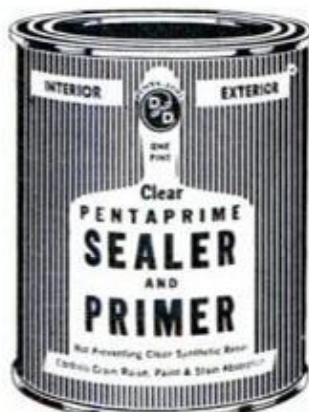

## PENTAPRIME

in pints,  
quarts and gallons

Seal, prime, protect—in one easy step! PENTAPRIME seals moisture out, primes and equalizes surface porosity for even painting or staining over hard or soft grain areas; controls grain raise. Prevents fungus growth, rot, attack by termites and other wood borers.

## SCUFF-TOUGH FLOOR FINISH!

Gyms, hallways,  
heavy-traffic areas

Flows easily,  
dries fast and hard

Glass-smooth,  
high gloss for all wood



## TRAFICON

in pints,  
quarts and gallons

Rugged! Beautiful! Carefree! TRAFICON is a clear, polyurethane finish "too tough to scuff." Dries fast—walk on it in an hour! Never needs waxing! Ready to use—no mixing. No strong, lacquer-like fumes; no highly flammable solvent. For furniture, cabinets, bar-tops, too.

*ask for these quality products wherever paints are sold*

**DeMERT & DOUGHERTY, INC.**

General Offices: Chicago, Illinois  
Plants Coast-to-Coast

*master chemists to the building trades*



MAKERS OF: SUPER-SAFE, STRIPRITE, NU'AGIN, COVERZIT, VINYLZY, DRY MURIC, SILICOAT, CEDARIZER, BRUSH-FLUSH AND OTHER HOME PRODUCTS.



# Test your automotive I.Q.



*What do piston rings do in your car?*



*What does this symbol stand for?*

Piston rings provide a compression seal, and control oil flow. The life preserver stands for Quaker State Motor Oil, the best engine life preserver for your car. Quaker State is refined from 100% Pure Pennsylvania Grade Crude Oil. It helps keep your car on the road, out of the repair shop. Saves you money. Ask for your engine life preserver by name. Quaker State your car—to keep it running young!



**Quaker State Oil Refining Corporation  
Oil City, Pennsylvania**

## MULTI-ACTION PAINT SHAKER

*(Continued from page 177)*

the middle of the angled slot. This is where you drill the socket for the reciprocation pin, which is a  $\frac{3}{8} \times 1\frac{1}{4}$ -in. Allen-head setscrew with a  $\frac{1}{16}$ -in.-dia. head. Now, unbolt the unit without disturbing the clamped positions of the lugs. Remove the oscillating shaft, weld the lugs to the frame, then drill and tap the shaft for the reciprocation pin.

After reassembly, file and try the pin movement in the slot until the pin moves easily with each full revolution of the drive pulley. The approximate configuration you'll need on the edges of the slot is indicated in the three cross-sections shown with the detail.

The drag of the cams will pull the oscillating shaft toward the rear of the machine, so the spring must be installed to pull it forward. The setup shown is correct if the drive motor rotates clockwise when viewed from the pulley end. If not, the spring must be attached in the opposite direction.

To avoid warp when welding the center plate of the can holder to the threaded rods, face the ends of the tees, bore them as indicated, screw up the pipe-fitting crossarms and install them, with nuts, on the rods. Leave this assembly on the welding table till cool.

Weld the shaft connector to the rear of the center plate and clamp it on the end of the oscillating shaft by drawing the U-bolt tight. Now drill a  $\frac{3}{16}$ -in. hole up between the arms of the U-bolt and completely through the shaft. Switch to a  $\frac{25}{64}$ -in. drill to bore a clearance hole through the connector fitting and the bolt strap, then remove the can holder and tap the shaft hole  $\frac{3}{8}$ -in. x 16 for the stud shown in the top sketch on page 176.

The can-holder plates are, of course, adjustable and should be positioned to center the can on the shaft. Once this adjustment is made, the right-hand plate can be left in place, since you need only loosen and pull back one to insert or remove a gallon can. When a new can is cradled in place, press the removable plate tightly against the lid, run the nuts down and tighten with a wrench.

Apply cam grease liberally to both cams and the reciprocation slot and pin—and always turn the machine by hand to check for smooth action before flicking the motor on. In this simplified form of construction, the shaker is intended for intermittent operation and shouldn't be run continuously. This won't be any handicap—unless you're planning to paint the whole town red. ★★★



CHOOSE YOUR  
**Simplicity**<sup>®</sup>  
 WAY OF LIFE



Good Deals shown make Simplicity America's No. 1 line of lawn and garden power equipment. Simplicity Good Dealers add to value with integrity and service you'll appreciate. There's a dealer near . . . ready to help you choose your Simplicity way of life. Look him up.

New Simplicity Landlord<sup>®</sup> 101 tractor (lower right). Big power for big jobs. New Simplicity Wonder-Boy<sup>®</sup> 401 (lower left). 4-hp mower pre-shrinks lawn-care hours. Simplicity Broadmoor<sup>®</sup> (top left). 6-hp tractor offers workability you'd expect only in larger machines. Simplicity Super Wonder-Boy<sup>®</sup> (top right). More than a mower, this 6-hp package works year 'round.

Simplicity Manufacturing Co., Inc.  
 6635 Spring St., Port Washington, Wis.

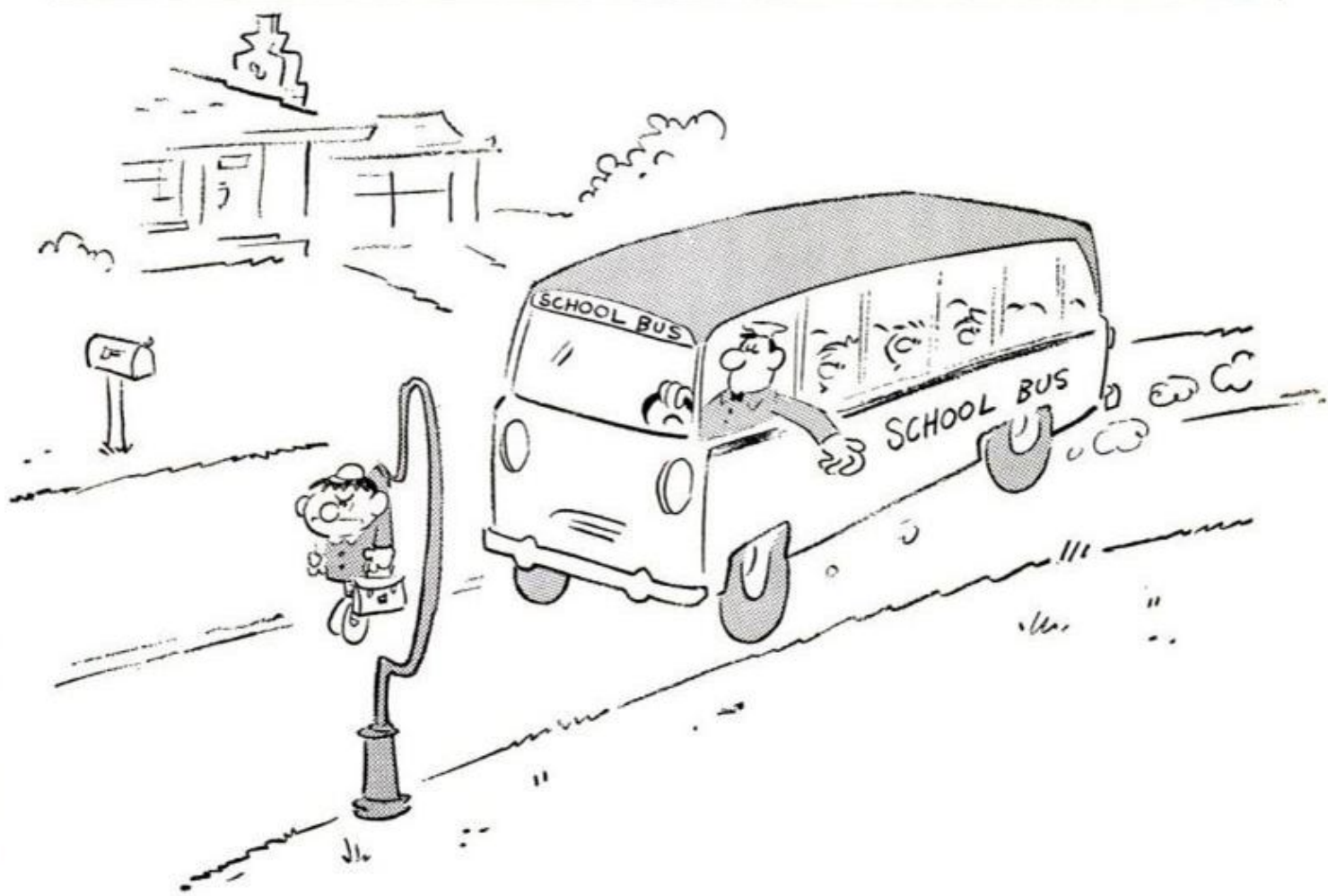





Unretouched photo of Stren® and competitive premium monofilament being fished under similar conditions. "Stren" is on left, and its superior visibility is apparent. Which line could you fish best?

## See why Du Pont "Stren" fluorescent line can make you a better fisherman!

"Stren" fluorescent monofilament fishing line is the one that's easiest for you to see. And that makes "Stren" the line easiest for you to fish.

The reason is the amazing fluorescence of "Stren". Instead of fading out against the background, "Stren" glows a brilliant blue. So you can track your line with greater accuracy as you work your lure or bait.

You see it... but fish miss it (opp. page)—no wonder "Stren" fluorescent can make you a better fisherman!



BETTER THINGS FOR BETTER LIVING  
... THROUGH CHEMISTRY



U.S. PATENT NOS. 3057040 AND 3061189

## RUGGED CAMPS

(Continued from page 119)

Pieh told the fresh arrivals after they had changed into sneakers, "so we've only scheduled a trip through the woods for this afternoon. I hope you enjoy it." With that he marched into the forest, the youngsters following in tight bunches. Then, Pieh broke into a trot.

Two and a half hours later—flushed faces raining sweat, breath coming in great heaves, bodies plastered with the muck of a swamp—the boys emerged from the forest. Through glazed eyes, they saw the tents of base camp. "Almost home," Pieh called out cheerily as he broke into a sprint. It was an hour before the last stragglers, accompanied by instructors stationed along the route, staggered into camp.

### How it all began

The roots of Outward Bound schools go back to World War II when packs of Nazi U-boats torpedoed British shipping almost at will. As casualties mounted, merchant marine magnate Lawrence Holt noticed that older sailors made up the greatest proportion of survivors. Younger seamen, though usually physically stronger, seemed to give up in desperate situations. In a few cases, young sailors who had reached a lifeboat committed suicide rather than endure the elements and the uncertainty of rescue.

To give young seamen some mental steel, Holt, along with Kurt Hahn, a former headmaster, established the first Outward Bound school on the bleak Welsh coast. The experiment was a success and deaths among torpedoed graduates dropped markedly. After the war, the school stayed open, first as a training ground for RAF pilots, then for civilian youths. The idea, which gained the backing of a group of educators and industrialists, eventually spread. Today 20 Outward Bound schools exist in a dozen countries, including one in Puerto Rico run by the Peace Corps. The first American school, chartered by Outward Bound Inc., the founding U.S. committee, opened in 1962.

While chartered by the same committee, minor differences do exist among the four U.S. schools. The one in Colorado, located amid the Rockies, stresses mountaineering; the Minnesota school emphasizes woodsmanship, and on Hurricane Island students get a large dose of seamanship. The fourth, organized in Oregon only last January, will undoubtedly have a slightly different program.



But the purpose of the school is identical. "We're not training young men for the mountains, woods or sea," says Joshua Minor, president and founder of Outward Bound Inc. "We're training them *through* the elements so they can discover a resourcefulness in themselves."

### Island of fog and stone

To see how such resourcefulness is acquired, I recently visited Hurricane Island, an hour's ferry ride off the coast of Rockland, Me. The island, roughly a mile in diameter, once served as a quarry and giant blocks of gray granite are scattered over it. Stunted pines shove their way through the thin soil and out of cracks in the stone bluffs. A thin haze constantly hangs over the island. It's a perfect place to learn fortitude.

Now it is also a cultural melting pot. Kids used to private schools and genteel table manners mix easily with dropouts from urban slums. About half the students pay the stiff \$350 tuition. The remainder are sponsored by industries, settlement houses or government-sponsored youth projects like Boston's A Better Chance or New York's Mobilization for Youth. Despite the rugged program, very few boys quit. "I'm glad it's rough, one boy told me. "I'd stick it out even if it was tougher. But I don't enjoy it. You don't enjoy something like drown-proofing."

I found out what he meant the next day. "Drownproofing is a float-breathe, water-survival technique," explained Reagh Wetmore, the country's leading expert on the method. We were at an abandoned, water-filled quarry and a class was underway. Groups of boys stood listening to instructors and some were already in the water. Two boys were tying the arms of a third behind him.

"Before we're through, each boy knows how to survive 24 hours in a choppy sea fully clothed and with multiple cramps," Wetmore said. "Most of all he knows how to control panic. And it's panic that's responsible for 95 percent of all drownings." The boy with the bound arms had been eased into the water and, head submerged, was floating. Only a patch of back showed above surface. Quickly, he exhaled, pulled up his head for a quick gulp of air and resumed floating.

"Tying up legs or arms simulates cramps," Wetmore said, nodding toward the floating student. "He's ready for other exercises now. Diving 10 feet and picking up a rubber band in his teeth with a pair of limbs tied, for instance.

*(Please turn to page 208)*

Photographed at Cypress Gardens by Buddy Gaines



Unretouched underwater photo of Stren® and competitive premium monofilament being fished under similar conditions. "Stren" is on left, and its low visibility is apparent. Which line do you think is most apt to hook your fish?

## See why Du Pont "Stren" fluorescent line can make you a better fisherman!

"Stren" "blindfolds" the fish to everything but your lure or bait.

Where ordinary monofilaments "silhouette" against the light-blue water-sky background seen by the fish, "Stren" is a fluorescent blue itself, and thus blends into the background. Only "Stren" is both easy for you to see and hard for fish to see.

Should you pay more for "Stren" fluorescent? Obviously. You expect it to make you a better fisherman! E. I. du Pont de Nemours & Co. (Inc.), Rm. 2889 Wilmington, Del. 19898.



BETTER THINGS FOR BETTER LIVING  
... THROUGH CHEMISTRY



U.S. PATENT NOS. 3057040 AND 3063189



With these you can  
do almost anything

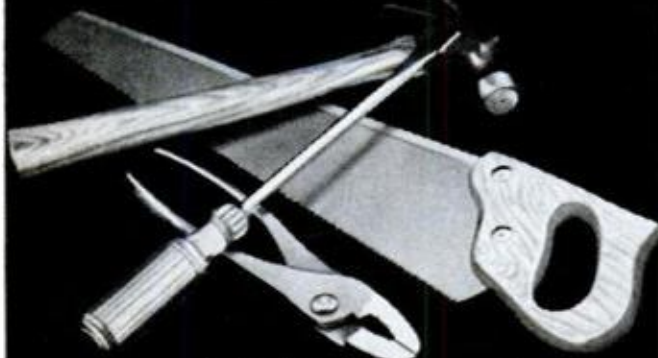

add this and  
do everything



Remove paint . . . Lay  
floor tiles . . . Soften  
putty . . . Bend glass tub-  
ing . . . Hard or soft-solder  
metals . . . Sweat pipes . . .  
Start charcoal fires . . .  
Perform hundreds of  
household, hobby, and lab-  
oratory jobs.

The new Ronson Varafume  
Torch adjusts from pin-  
point to blowtorch flame.  
Easy to handle. Comes  
with Multi-Fill® Butane  
Gas Injector (available  
everywhere), and big in-  
struction/idea booklet.

**\$4.95\***  
**RONSON**  
**Varafume**  
**Torch**

Ronson Corp.  
Woodbridge,  
New Jersey

\* Suggested Retail Price.  
Available in Canada.

## RUGGED CAMPS

(Continued from page 207)

That's to show just how much a person is capable of doing."

### Jump from cliff

One side of the quarry ended in a smooth, 85-foot-high cliff, the site of Hurricane Island's mountaineering instruction. At the cliff's base, chunks of jagged granite pointed upwards like sharp spears. I heard the faint commands of an instructor and, still at the dock, looked up. A student, his body silhouetted against the sky, was standing at the cliff's edge. Suddenly he leaped off backwards. Suspended by a rope, he dropped four feet below the top breaking his fall against the cliff's face with his feet.

Using a classic mountaineering descent technique called the rappel, one that all Outward Bound students learn, the youngster lowered himself by pushing into mid-air with his legs while letting out a few feet of line at a time. "Some guys think drownproofing is the worst, but jumping backwards off that cliff is the scariest thing I've ever done," a lanky teen-ager from California told me.

Naturally, students build up to rappelling and drownproofing in carefully coached steps. Introduction to other skills and knowledge, however, can be abrupt. It was for a group of students being exposed to ecology, a course in wild foods. The instructor picked up a sea urchin along the shore. Opening up the animal he scraped out its eggs and plopped the gooey mass into his mouth. "Delicious," he exclaimed, smacking his lips as the new students gaped. "Now you all try it." They did.

Other Outward Bound programs develop teamwork. In a glade half the size of a football field, a network of ropes, catwalks and rope ladders—some 40 feet high—crisscross the sky like a web of jungle vines. Logs suspended from wire cables hang between trees and a tall wooden wall blocks a narrow entrance path. Getting through this obstacle course quickly demands close coordination among "watches" (the 96 students are split into 8 groups called watches). To encourage teamwork, the school periodically springs a surprise marathon ending at the rope course.

Such competition among watches often brings out leadership qualities that have long remained dormant. In one instance a Negro youth who had been indifferent to most of the school's programs found during a practice session he had a knack for climbing through the rope



roadblocks. During the confusion of the first marathon, he spontaneously assumed command shouting out crisp orders to the rest of his team. His watch won. "It's times like this that the boys see each other for what they really are," says George Thomas of Hurricane Island. "Suddenly, they're submerged in problems greater than their differences."

#### Measures for safety

Training at an Outward Bound school may be rugged, but it's definitely not foolhardy. Mountaineering students always sport a safety rope when climbing, poor swimmers wear lifejackets around water, and boys on solo are briefed on an emergency signal in case of trouble. These precautions taken, students are expected to muster enough determination to tackle all activities, whatever their fears.

At a drownproofing class, for example, a boy unexpectedly panicked 10 feet from the dock. Forgetting all instruction, he thrashed wildly, somehow rising a few inches in the 12-foot-deep water. Then, his eyes wild with fright, he sank.

When his head rose moments later he managed to flail to the dock where an instructor was watching. Swiftly, the instructor explained what went wrong, then ordered him out again. Dumbfounded the student glared back.

"I almost drowned!" he bellowed. The instructor still looking down, pointed out to the water. "Damn," the boy said. "You're not human." Half in fury, half in determination, he paddled out again. There was good reason why this student was having trouble. Three days before he couldn't even swim.

Building a will to meet tough-looking situations like rappelling, solo and drownproofing doesn't mean fear has been eliminated. A boy's ingrained terror of water or heights may always remain. But his ability to conquer panic often makes a permanent change in attitude. Statistics compiled by Outward Bound indicate that school grades often improve after the training, and instructors agree that most boys leave with a heightened self-confidence and determination. Said one youngster after finishing the Colorado school: "Rappelling down that 110-foot cliff was the most terrifying experience of my life. Nothing could ever be worse. But it is the last time I'll tell myself 'I can't do it.'"

"Young people want adventure, challenge and excitement," says Joshua Minor, founder of Outward Bound in the United States. "Yet they live in a cult of comfort and safety that discourages such things. We hope Outward Bound fills this gap." ★★★

# Carburetor gum can choke the life out of your engine

Remove it easily with **GUMOUT**

**T**HE gasoline constantly being evaporated in your carburetor leaves a residue of varnish and gum. As this builds up, your carburetor has trouble "breathing." The symptoms are hard starting, stalling, rough idling, power loss, poor gas mileage.

Some premium grade gasolines now have an additive which, with continuous use, cleans the carburetor throttle plate area after about 5,000 miles. This is the roundabout, costly, time-consuming way to do the job. And the results are never complete.

**GUMOUT** is the right way to clean a carburetor. **GUMOUT** is a hard-working solvent you simply add to the gas tank. It goes to work instantly, removing harmful gum, varnish and moisture from your entire fuel system. Your carburetor *cleans itself* as you drive. **GUMOUT** does a fast, thorough cleaning job because it has a greater concentration of cleaning power than additives in premium gas.

By adding **GUMOUT** to your gas tank only three or four times a year, you'll get the performance your engine is designed to deliver, cut gasoline waste, and prevent a major cause of engine trouble. Get **GUMOUT** at your service station or auto supply store and let your carburetor clean itself!



## GUMOUT

Cleveland, Ohio 44104



## OUR NEWEST FRONTIER

(Continued from page 98)

before leveling off into a broad apron, the Continental Rise, which, in turn, leads to the Abyssal Plain, some 15,000 feet down. Only 40 percent of the bottom lies below this depth.

Since the U.N. convention, the shelf has, in effect, had two definitions—a legal one and a geological one. The convention defines the shelf as the bottom to 200 meters and to whatever depth beyond can be exploited. This is a little like announcing that the Rocky Mountains extend to the Kansas line, and geologists don't really accept it. They say you can't change geology by law.

There has been loose talk about the importance of "getting there first." Actually, under the convention no nation can exploit the ocean floor off another country. If you have the capability of mining nodules at 3000 feet, you can't cruise across deeper water and work the 3000-foot bottom on the other side. That belongs to the nation whose shelf and shore it adjoins.

"It's true," explains Fred Mangelsdorf, administrative aide to the director of Woods Hole, "that as soon as a nation has the ability to exploit beyond the 200-meter depth, its rights over the sea bed extend out to that depth of exploitation. But the rights of every other country then extend to the same depth. They don't have to be capable of exploiting it themselves."

This means, most likely, that underdeveloped countries will lease their sea bottoms the way Mid-East sheiks grant oil rights in the Arabian desert.

The convention was designed to head off a "race to the bottom of the sea" and the sort of dogfights that followed the discovery of America. But it may create as many problems as it solves. The whole North Sea is a Continental Shelf. Who owns it—the British or the Dutch? By the new definition a large part of the North Atlantic bottom from Europe to Greenland will be "shelf" as soon as someone mines the ocean somewhere at 6000 feet. Who will own that?

For 150 years oceanographers studied the bottom from "small, pitching platforms." Jacques Piccard, who took the *Trieste* down nearly seven miles, has compared netting samples from the surface to "a blind man making a butterfly collection."

When Rachael Carson wrote her famous book, *The Sea Around Us*, in 1951, the deepest penetration of the ocean was by Otis Barton. He had gone down 4,500

feet in his benthoscope. Eleven years later, Piccard and the *Trieste* went to 35,800.

Meanwhile Jacques-Yves Cousteau, inventor of the aqualung, had built a highly maneuverable, small submarine. Dubbed the "Diving Saucer" because of its appearance, the first model was lost in 1957 when a cable snapped as it was being lowered, unmanned, from a ship. A second saucer, *DS-2*, has since made hundreds of dives, many to 1000 feet, and has done more than any other vehicle to bring the Continental Shelf of the whole world—an area equal to Asia—within reach of man.

Dr. Francis Shepard, dean of marine geologists, used it to explore an undersea canyon off La Jolla, Calif. He was amazed at the resemblance to Grand Canyon.

As he climbed out, he declared, "I've been studying Scripps Canyon for more than 30 years, but I have learned more in my three dives in the saucer than in all my years of study from the top."

---

**Alvin**, one of three submersibles called in by the Navy to search for an H-bomb lost off the coast of Spain, located and photographed the 20-megaton weapon in 2500 feet of water in mid-March. The bomb fell from a B-52 after a collision with a jet tanker.

---

Piccard is a Swiss; Cousteau, a Frenchman. Although their pioneering craft are now in this country, the United States has waded gingerly into deep water. When Columbia University's Lamont Geological Observatory wanted to study the 27,500-foot Puerto Rico Trench it had to borrow another French vehicle, the bathyscaphe *Archimede*. Construction of both *Alvin* and Reynolds Metals' *Aluminaut*, designed for 15,000 feet, was under way by 1963, but neither was finished when the nuclear submarine *Thresher* sank in 8400 feet of water on April 10 of that year. The *Trieste* was brought from California and finally located the wreckage, but it maneuvered ponderously and could not have rescued anyone if the *Thresher* had been intact. This focused attention on our need for deep-diving, highly maneuverable submersibles. The Navy finally got started last year on a project to build deep-submergence rescue vessels, capable of "mating" to a sunken submarine and taking off survivors. But the first one won't be built until 1967.

"Like the conquest of space, the conquest of the marine environs requires the development of complicated equip-

(Please turn to page 221)



# Changing Your Address?

If you're planning to move, please let us know six weeks before changing your address. Attach address label and fill in your name and *new* address. This will insure prompt service on your subscription.

ATTACH LABEL HERE  
(address label found on cover of Popular Mechanics)  
Send label with your name and new address to:  
Popular Mechanics, Subscription  
Dept. 250 W. 55th St., N.Y. 10019

My name is \_\_\_\_\_ (please print)

My new address will be \_\_\_\_\_

City \_\_\_\_\_ State \_\_\_\_\_ Zip Code \_\_\_\_\_



## Makes Rust A Go Go

MAC'S No. 13 is *in* — more radiators than any other rust inhibitor.

Reason: rust can't roost where No. 13 is boss. Furthermore — MAC'S No. 13 is *guaranteed* to keep rust away for an entire year.

So why be bugged by radiator rust?

Tell it to get lost — the only way it understands. With a can of MAC'S No. 13.

**MAC'S**  
**SUPER GLOSS CO., INC.**  
Los Angeles 90042  
Cincinnati 45226



# FREE 1966 NEW YORK TRAVEL GUIDE



## **BIG! NEW!** 88-page, full-color guide to New York State!

Where to go. ■ How to get there. ■ Facts about over 500 resorts and resort areas. ■ Information about historic landmarks, scenic wonders, children's attractions, museums, too. ■ Hours of opening and admission prices (if any) are included.

## **FREE. MAIL COUPON TODAY.**

### **FREE VACATIONLANDS GUIDE**

Mail this coupon today to:

New York State Dept. of Commerce  
Room 218, Box 1350, Albany, N.Y. 12201

NAME \_\_\_\_\_

ADDRESS \_\_\_\_\_

CITY \_\_\_\_\_

STATE \_\_\_\_\_ ZIP \_\_\_\_\_

don't  
forget to  
come back



*You will want to stay forever if you travel in a new 1966 Del Rey Travel Coach. Del Rey gives you light-hearted luxury and enduring comfort that you will enjoy year after year.*

*Write for free colorful brochure describing Del Rey's 1966 Royal Line of superb travel coaches.*

**Del Rey**  
INDUSTRIES, INC.



3961 Cassopolis St., Elkhart, Indiana



## OUR NEWEST FRONTIER

(Continued from page 210)

ment and specialized systems," Maine's Sen. Edmund S. Muskie told the Senate.

One reason we haven't got more of these is that we haven't spent much money.

"We run *Alvin* all year on a small fraction of the cost of one space shot," observes Bill Rainnie.

In the first 11 years after World War II, government expenditures on oceanography totalled \$13 million. This year Federal appropriations will amount to \$141.6 million—still a drop in the bucket compared to the space program.

But there are signs that Uncle Sam may no longer be asleep in the deep. The "opening up" of the Continental Shelf produced no fewer than 17 oceanography bills in this session of Congress. They range from a modest proposal to set up a National Council on Marine Resources and Engineering Development, with an annual budget of only \$1 million, to a sweeping plan to create a cabinet-level Department of Marine and Atmospheric Affairs.

Do we need a central agency to coordinate undersea exploration—a "wet NASA"? We already have 22 Federal agencies dabbling in oceanography, but relatively little attention has been paid to ocean engineering.

Fred Mangelsdorf expressed it this way: "We don't need one for basic science. But if we're talking about how to conquer the oceans for the best uses of man, then a central agency which could say, 'By 1970 we want to be able to inhabit the sea floor at 600 feet for long periods of time; by 1975 we want to live at 20,000 feet'—and had the money to back up such goals—would cause a whale of a lot of work to be done."

### Webster goofed

They laughed when Tom Jefferson sent Lewis and Clark out to explore the plains and desert we had just bought from Napoleon. A quarter of a century later Daniel Webster was still unconvinced.

"What do we want," he demanded, "with this vast, worthless area? This region of savages and wild beasts, of deserts, of shifting sands and whirlwinds, of dust, of cactus and prairie dogs?"

It's been almost a hundred years since the Russians unloaded that barren wasteland, Alaska, on us. "Seward's Iceberg," we called it for 30 years.

Thirteen states were eventually carved from Louisiana, and no one wants to give Alaska back to the Soviets except a few disgruntled Texans. ★★ ★

# Enjoy Independence



With A Sparetime  
**BUSINESS**  
OF YOUR OWN

Here's a proven, practical way to earn sparetime cash while you develop a money-making business of your own. Investment is small. There's no overhead, no stock to carry, no selling involved. Automatic Foley Saw Filer, easy to operate, files combination saws, hand, band and circular saws. No experience needed.

## Earn \$3 to \$6 An Hour In Sparetime

Get started now and watch your business grow! Thousands are earning cash this easy way—many build a complete sharpening service with year around profits. You can, too, with the easy-to-follow Foley Plan—write us today!



## FREE BOOKLET SHOWS HOW

Fact filled booklet tells you how to start a sparetime business; how to get new business. Rush coupon, get "Money Making Facts" and details on Easy Payment Plan. No salesman will call.

Foley Manufacturing Co.  
516-6 Foley Bldg., Minneapolis, Minn. 55418

Send FREE BOOK—"Money Making Facts", and Time Payment Plan.

Name \_\_\_\_\_

Address \_\_\_\_\_

City \_\_\_\_\_ State \_\_\_\_\_ Zip Code \_\_\_\_\_

## BILL TROUBLES ?

**NOBODY REFUSED UP TO \$15,000.00**

**Bad Credit ■ No Problem ■ Not a Loan Co.**

● Send your name and address for FREE application to nearest office for faster service ●

● **ATLANTIC ASSOCIATES, Dept. 15** ●

146 Westminster St., Providence, R. I.

● 3312 N. Central Ave., Phoenix, Arizona ●

At Last a New Amazingly Simple

## GAS TURBINE JET ENGINE

Build from easy to follow plans. Length 15", Dia. 8½", Wt. 15 lbs. Fuel: Gasoline or Kero.



"Screamin Demon" develops 20 H.P. Ideal project for serious-minded hobbyists, students; scientific and industrial arts classes. Make on 9" metal cutting lathe with milling attachment. For use on small racing boats, midget cars, etc. Full size assembly drawings with critical dimensions, bill of materials and photos. Price \$5.00. No C.O.D.

**SAVOY SCIENTIFIC, BOX 1398, SANTA MONICA, CALIFORNIA**

## HOW TO FINISH WOOD



Get this 32-page full color book written by experts. Tells how to obtain professional finish on interior and exterior natural wood. Floors, wall paneling, antiques, boats, many more. Only 25 cents p.p. Send coin today.

**McCLOSKEY VARNISH COMPANY**  
DEPT. PM56, 7600 STATE RD., PHILADELPHIA 36, PA.



## ROUGHING IT . . . HIGH STYLE

*(Continued from page 115)*

the butane tank had not been filled, a problem he remedied with dispatch. It was also Burley who showed me how to jack up the tongue to get the trailer off the hitch, and get it level so that the gas would operate properly.

As a matter of fact, one thing I learned quickly about trailering is that you don't have to know anything. If the operator of the campgrounds doesn't provide all the help you need, veteran trailer owners seem to pop up like magic whenever you're in difficulty, and they're all eager to take a novice by the hand and help him over those rough first days.

When John Linkletter, *PM* Managing Editor, pulled into a private park near Virginia Beach, Va., in a 24-foot Airstream, he was besieged with help. Besides having a number of campers guide him into his site, a nearby camper helped him level the trailer, set up the electrical system, and even loaned pieces of equipment.

### **Happy home on the road**

If you're not sociable, forget about trailer camping, because the moment you pull into a campground you're going to be swamped with friendly, talkative people. You're going to be up to your axles in dogs and there seems to be a kid hanging from the limb of every tree.

Frankly, trailering is not camping. It is a way to travel in comfort, hauling a cabin with you to areas where you can enjoy the outdoors. A campground for trailers is an itinerant community, and these vie with one another in the extent of comforts they can provide. The Big Sur Campground, for instance, is rustic by comparison to others we visited, but even here there was a children's playground, modern bathroom facilities with showers, and a self-service market. And every night there was a community social on the large concrete dance floor.

Most campgrounds have paved roads, and the better ones have a concrete slab in each site for level parking. They will also have a coin-operated automatic laundry. Some have a central recreation hall for dancing, with rooms for television and cards and table tennis. They are also equipped with swimming pools staffed with lifeguards. I encountered one "campground" in California that also had a beauty salon, a nursery for small children, offered guided tours of local historic sites, and rented portable television sets.

In Michigan, near Grand Traverse Bay on Lake Michigan, a new 325-acre trailer park named "Timber Shores," will offer

tennis and shuffleboard courts, a golf course, a heated swimming pool, a stocked trout stream, a licensed nursery, a restaurant, a library, game rooms and evening movies. The fee for a week of "camping" for the entire family is \$24.

This combination of luxury and economy is the major appeal of the travel trailer. A family of five stopping in motels and eating in restaurants would spend about \$16 a day for lodgings and about \$30 a day for food. In one week that amounts to \$322. In a trailer, the same family would spend a maximum of \$20 for campground fees for the week, and food would be just slightly higher than what they would spend for a week at home. Bridge and highway tolls are higher with a trailer. Linkletter's Airstream had two axles, and the tolls ranged from five cents more to about three times the cost of the car toll. It also takes more gas to haul a trailer, particularly the larger models. Driving a Pontiac Bonneville, John averages 11.8 mpg without the trailer and 9.8 mpg with it. Hauling the 14-foot Scotsman, I didn't notice any difference in the mileage.

But even with these additional costs a trailer vacation is inexpensive.

A travel trailer ranges in length from 13 to 35 feet. After that it is classified a mobile home. The most popular length for a family is from 18 to 24 feet. They range in price from about \$700 to \$7000, depending on size and equipment. The 14-foot "Scotty" is priced at less than \$1000 and it has foam cushion beds for four, a sink, four-burner gas stove, icebox, a four-place dinette, closet with full-length mirror and ample storage. When you get into wall-to-wall carpeting, gas-operated refrigerator and oven, shower, chemical toilet and extra lounges that convert to beds, the price goes up with the added conveniences.

### **Beef up your car for hauling**

Except for the smallest trailers, the car for hauling should have eight cylinders. For the heavier trailers the car should be equipped with heavy-duty front and rear springs and shock absorbers, heavy-duty brake linings, heavy-duty wheels and 8-ply tires. Most auto manufacturers are now offering a special towing package that incorporates these features as well as an extra-cooling radiator and fan.

The hitch I used was simply bolted to the frame of the car, and it performed beautifully, but for the larger trailers all of the manufacturers recommend a welded frame hitch with an equalizing device to shift part of the weight to the front wheels. Most states require brakes on a trailer whose weight exceeds 1500 pounds



loaded. I didn't have brakes on the small trailer and I noticed that it does take more braking time to stop.

It's difficult to find anything wrong with a travel trailer. Once I had learned how everything worked, and my son stopped muttering, "Boy, some outdoors editor," it was the epitome of convenience. Driving along a highway, for instance, we encountered a stream that looked like good trout water. We found a rutted road that took us right to the bank of the stream and that's where we parked. The gear was in the closet and in ten minutes we were fishing. Cold drinks were near at hand. We had dinner in the trailer, fished until dark and camped right there, fished again in the morning and then drove off. No packing or anything. Just locked the trailer door and away.

### Speed cut—not adventure

The speed limit on trailers in most states is from 50 to 55 mph. Some people find this an objectionable limitation, but it is a logical safety measure for the larger trailers. I found it relaxing to travel at this speed.

"It's sort of wild if you get off the beaten path," Linkletter reported. "We did on a few occasions and I found myself doing a turnaround in someone's front yard at the end of a dirt road."

A vehicle with LP gas bottles is generally not permitted in tunnels and Linkletter found himself making circuitous routes to avoid tunnels. His worst experience was on the approach to the George Washington Bridge in New York City, an expressway that runs under several apartment buildings.

"We were directed off the expressway because of the gas bottles," he reported, "and wound up wandering around in heavy traffic on side streets and finally in a complete traffic jam. I never felt so vulnerable on the road as I did then."

But he ended his report with: "A trailer is a marvelous bit of equipment. This was the most relaxing camping I've ever done." ★★★

### Microscopic Warfare

Germ warfare is being waged against citrus red mites in order to save the lives of countless lemon, orange and other citrus fruit trees. To check the destructive activity of these pests, agricultural scientists are infiltrating the bodies of citrus red mites with a virus disease. The disease is spread by spraying natural field populations of mites with water suspensions containing ground-up infected mites. Live infected mites are also released into the field.

## Here's how to refurbish your boat in 8 hours with

**NAUTOLEX**<sup>®</sup>  
SUPPORTO VINYL MARINE FABRICS



1. Eleven year old hull still sound, but deck needs refinishing. Nautolex eliminates days of hard work, restores beauty at low cost.



2. Wood deck has been faired, sanded. Nautolex vinyl decking cut to fit. Mastic bonds Nautolex to wood.



3. Ready! Looks like fine wood, yet Nautolex is scuff-proof, resists oils, gas, alcohol, weather. Wipes clean with soap and water. Available in 17 patterns and colors. At marine stores.

To: THE GENERAL TIRE & RUBBER COMPANY,  
TOLEDO, OHIO  
DEPT. PM-5

Send FREE SAMPLE OF  
NAUTOLEX and literature  
without obligation.



NAME \_\_\_\_\_  
ADDRESS \_\_\_\_\_  
CITY \_\_\_\_\_ STATE \_\_\_\_\_



# Win \$100, enter the Pliobond "Stickup"

Send us the most interesting, new use of the month for PLIOBOND®, and we'll send you back \$100.

PLIOBOND can seal and coat. Joins wood to metal to glass to cloth to rubber, etc. Resists impact, oxygen, water, chemicals. Actually grows stronger with age.

PLIOBOND glues, mends, insulates, waterproofs. Has a host of uses in your home, car, workshop. Best use we receive by last day of month of issue wins \$100.



## PLIOBOND "STICKUP" CONTEST RULES

1. Describe in 50 words, or less, an interesting and unique use for Pliobond adhesives. Use an entry coupon from your local store, or plain paper no larger than 8½ x 11 to enter.
2. Send as many entries as you like to Pliobond Stickup Contest, P. O. Box 9115, Akron, Ohio 44305. Send label or other evidence of purchase with each entry.
3. \$100 awards limited to one for each contest. Individual contests run in April, May, June, September, October, 1966. Entries must be postmarked by the last day of the contest in which you enter. All entries become property of The Goodyear Tire & Rubber Company and are not returnable.
4. Entries will be judged by Goodyear and the decisions of Goodyear will be final relating to questions about the contest and winners.
5. Contest open to everyone in the U.S. and possessions and Canada, except employees of Goodyear, the distributors of Pliobond adhesives and their immediate families. Contest subject to Federal and State Local Regulations.
6. All winners will be notified no later than November, 1966. List of winners will be sent on request enclosing self-addressed stamped envelope.

# GOODYEAR

## BUSH BUGGY

(Continued from page 142)

Next, lay the two completed pontoons on the floor in the proper relationship to each other and place the body (minus the front and rear panels) in the correct position on the pontoons. Pile weights on the bottom plate to hold it in this position while you drill six holes through the plywood and into each pontoon for the threaded assembly rods included in the kit.

Complete these holes with a long masonry drill, bolt the pontoons to the body, and you're ready to put in the engine, steering and other kit components. From here on, follow the installation instructions included in the kit.

For a limited time only, the materials necessary to build the pontoons may be purchased as a kit from Defender Industries, 384 Broadway, N.Y., N.Y. 10013. The kit consists of 10 yds. of 10-oz. 44-inch. width fiberglass fabric, 2 gals of epoxy resin, 2 rolls of 2-in. fiberglass tape and 3 9-ft. Styrofoam planks. Until June 15, 1966, this kit will be priced at \$69.50, a saving of at least 20 percent over prevailing prices. After that date, the materials may be purchased at normal catalog prices.

Please enclose your name, address and a check or money order. Shipping and handling costs will be billed C.O.D.

As a service to *Popular Mechanics* readers, a special production run of all the mechanical components required to build the Bush Buggy has been scheduled to begin June 15, 1966. (Lights and trim are not included.) Readers ordering the kit before this date may obtain all these components for \$490, a price made possible by volume production. A discount coupon good for 25 percent off on a My-te electric outboard is also included.

After June 15, the kit will be sold at a much higher custom-machining price, the specific figure depending on the cost of labor and materials at the time the order is received.

Address all orders to the manufacturer, Technoid Corp., Box 276, Portland, Pa. 18351. Enclose your name, address and a check or money order (add \$25 if an automobile tow bar is desired). Allow 30-60 days after June 15 for delivery. Shipping costs will be billed C.O.D. ★★★

While *Popular Mechanics* is pleased to call the reader's attention to the source of supply of parts for the construction of this project, it does so only as a reader's service, and the building and use by the reader of this project can only be at the reader's own risk. *Popular Mechanics* makes no representations or warranties—express or implied—concerning the project or parts.



# ***Fairlane has a smart answer to the great manual-vs.-automatic question:***



## ***Fairlane GT/A***

Used to be if you wanted a manual shift (because you really enjoy bossing a car) and your wife wanted an automatic transmission, one of you had to lose. That was before Fairlane's hot new GT came up with its amazing automatic option, GT/A.

Fairlane GT/A solves the problem once and for all with a new kind of Sport Shift Cruise-O-Matic drive. The quadrant now reads "P-R-N-D-2-1" and the little woman can ignore everything below "D." Sport Shift will think for her . . . smoothly, efficiently, effortlessly . . . as Cruise-O-Matic always has (and for you too when you're lazy). But if you want to do what no conventional automatic can — think *ahead* — all it takes is one quick flick of the lever.

Pick "1" and you get First, nothing else. For inching along in the city, or crawling up the side of a mountain it's First all the way no matter how you accelerate.

Pick "2" and you get Second, nothing else. Great for downshifting before a hairpin corner, for saving your brakes on a mountain grade, for the crawl, sprint, crawl, sprint of heavy freeway traffic. And like First, Second hangs in there until you decide it's time for a change. In short, Sport Shift gives you the fun of manual shifting. The only thing that's missing is having to pump a clutch . . . and who needs that?

The only way to get the true meaning of Sport Shift is to slip behind the wheel of a Fairlane GT/A. That way you discover one of those rare situations in which you *can* have your cake and eat it too!



AMERICA'S  
TOTAL PERFORMANCE CARS  
**FORD**  
MUSTANG • FALCON • FAIRLANE  
FORD • THUNDERBIRD



**ARROW**  
ALL PURPOSE  
**STAPLE GUN** T-50

**HEAVY DUTY**



Model T-50  
**\$12.50**

Uses 6 Staple Sizes — 1/4" to 9/16" and Ceiltile<sup>®</sup>

OTHER MODELS FROM \$4.95

**SHOOTS A STAPLE WHEREVER YOU'D DRIVE A NAIL!**

**FASTER! CHEAPER! BETTER!**

for 1001 Home Improvement Fastening Jobs: Ceiling Tile, Insulating, Upholstering, Screening, etc.

Available at hardware, lumber, building supply, stationery and other retail outlets.

**ARROW FASTENER CO., INC.**

One Junius Street • Brooklyn 12, N. Y.

# FREE

## WINDOW PLANNING IDEAS

to help you make your home more beautiful, more valuable. Send today for new, full-color folder packed with illustrated ideas and a complete description of the Andersen Window line.

*(Clip and mail today!)*



- I plan to build. PM-56  
 I plan to remodel a \_\_\_\_\_

Mr. \_\_\_\_\_  
Mrs. \_\_\_\_\_

Address \_\_\_\_\_

City \_\_\_\_\_ State \_\_\_\_\_

**Andersen Windowalls** AW<sup>®</sup>  
Andersen Corporation • Bayport, Minnesota

## 14-FOOT CANOE FOR \$50

*(Continued from page 147)*

seat. Now make the seat frames and fit them to the seat blocks. The seats can be simple plywood panels, caned seats, or they can be made by lacing cord diagonally.

### The canvas skin

The canoe is now ready for its canvas skin. The canvas—8 or 10-oz. duck—is put on in two halves. Each piece measures about 28 in. by 15 ft. Fold one of the pieces crosswise so it measures 28 in. by 7½ ft. Coat one panel of the canoe with canvas cement. Place the folded edge of the canvas at the center frame and one long edge overlapping the keelson center line by about ½ in. Press the canvas onto the cemented area, smoothing it out by working from the center toward the edges; then fasten with brass tacks to the keel line and gunwale.

Pull the canvas around the stem and tack closely with plenty of cement. Now coat the remaining half of the same side, unfold the canvas, press and smooth it in place and tack as before. A triangular piece will lap the keel line at the ends; trim this so it laps the center line by only ½ in. Repeat the above procedure for the other side of the canoe, making sure all tacks will be covered by the skeg, bang plates and outer gunwales.

The skeg and keel (here, the same piece) is now shaped and placed in position. Extend it far enough toward the ends that the bang plates cover the ends. Apply canvas cement to the seam under the skeg and drive screws at about 12-in. intervals to hold the skeg to the keelson.

One-half-inch, half-round aluminum strips are used to make the bang plates. You will have to drill additional holes in these to permit screwing them at 3-in. intervals to the ends of the boat.

Final assembly is completed when the outer gunwales are secured to the inner gunwales with brass fh wood screws, countersunk and spaced about a foot apart. Taper the last foot of each end to ¼ in.

Now remove the strongback by very carefully sawing it in half and twisting out the endpieces.

Stain and varnish the gunwales and inside of the boat. Give the canvas skin a coat of canvas cement. When dry, follow with two coats of marine paint.

And that's it.

You now have a canoe that, with reasonable care, will last you many years. Very likely it will prove the center of fun on your next vacation. Maybe the kids will even let you use it once in a while. ★ ★ ★



# Elmer's Epoxy—the "can do" twins

For bonding steel, iron, aluminum, bronze, brass, concrete, brick, tile, glass, porcelain, china, crockery, leather, and most plastics...

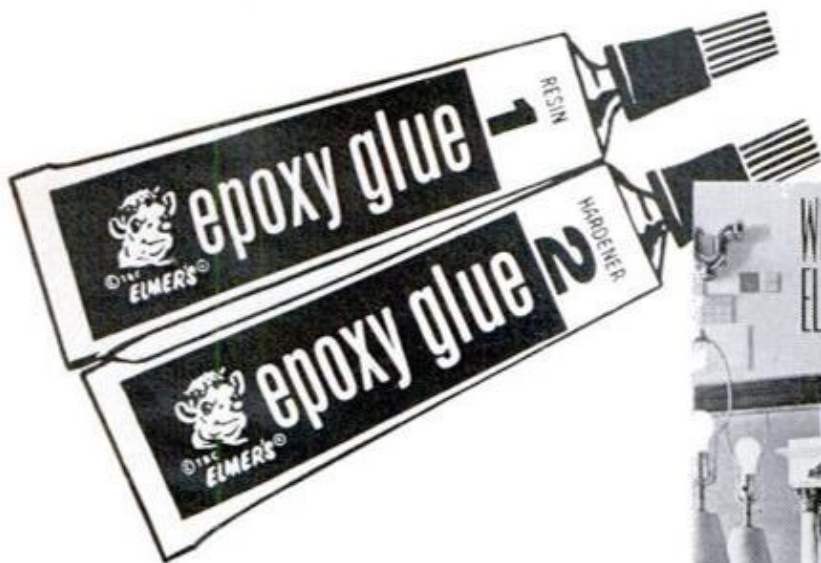

## Other Famous Members of Elmer's Family

- Glue-All
- Contact Cement
- Waterproof Glue
- Cascamite Plastic
- Resin

Products of Borden Chemical



## SEND FOR THIS FREE BOOKLET

Send a stamped, self-addressed envelope to: The Borden Chemical Company, Dept. P-1, 350 Madison Avenue, New York, N.Y. 10017



Get more **POWER** with a big (MAN'S) motorcycle!

## BSA LIGHTNING

Excitingly fast BSA 40 cubic inch twin! Rocket-like acceleration without constant gear shifting. Big, muscular power and confident handling. See the LIGHTNING at your BSA dealer!

## BSA MOTORCYCLES

Write to the nearest factory branch for free catalog of all the new 1966 BSA models. (Catalog offer limited to U.S. residents.)

WEST: **BSA MOTORCYCLES-WESTERN**  
Dept. N, 3074 Broadway, Oakland, California 94611

EAST: **BSA MOTORCYCLES Incorporated**  
Dept. N, 639 Passaic Avenue, Nutley, New Jersey 07110

MAY 1966



## 2 ways I catch big bass with the Jointed Jitterbug®

by **DICK KOTIS**, President  
Fred Arbogast Company, Inc.

I usually start by letting the Jitterbug lie in the water until all the ripples disappear. I start the retrieve with a short, quick jerk to make the Jitterbug climb up slightly in the water, rest, then retrieve it about 5 feet, stop, and repeat the sequence. Another way is to cast to a good spot, let the Jitterbug sit motionless for 2 full minutes, then twitch it ever so slightly. Takes patience, but lands the lunkers.



now available with weedless treble hooks

NEW "HOW TO CATCH FISH" RECORD (33 1/3 rpm) by Dick Kotis. 2 sides. Personal instruction by Dick Kotis on his fish-catching secrets. New 4-color Arbogast Catalog included. Send 25¢ for record and catalog.

Fred Arbogast Company, Inc.  
2200 W. North St., Akron, Ohio 44303





# Do you have any idea how to win this prize?

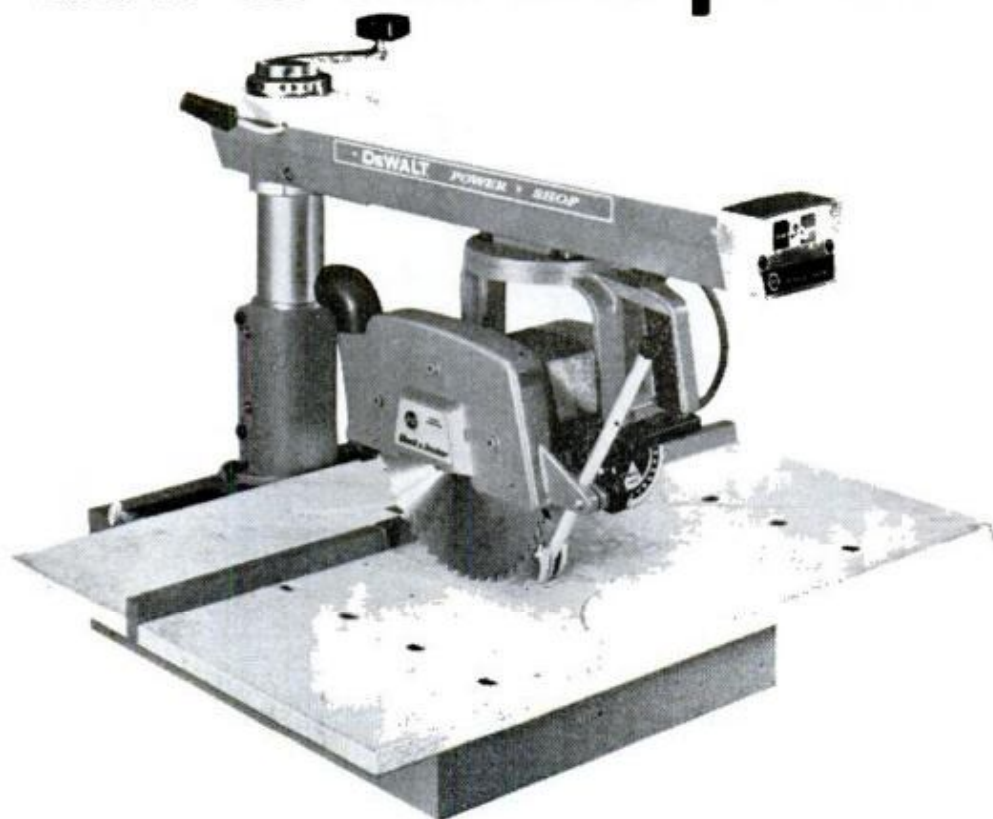

## Send it in!

### Enter the Schenley "Household-Hints" Contest

Got an idea? Any do-it-yourself trick, time-saver or money-saving idea can be a winner. Any idea you may have to make household and workshop jobs a little easier. Every month Schenley Distillers will offer five prizes like these:

**1st PRIZE: DE WALT RADIAL ARM SAW**

**2nd Prize: Ansco 35mm Camera Outfit**

**3rd Prize: Melnor Lawn Sprinkler and Reel**

**4th Prize: Wen Power Hand Saw**

**5th Prize: Wen Power Hand Saw**

Send in your ideas today to the Schenley "Household-Hints" Contest, Contest Manager, Room 400, 575 Lexington Ave., N.Y. N.Y. 10022. Entries must be postmarked no later than midnight, May 31, 1966 to be judged in this month's contest. All ideas submitted become the property of Schenley Distillers Co., and all decisions of judges are final. Offer not made to minors or residents of states where illegal.

**Here's a helpful Schenley tip for home bartenders:**

When serving drinks that call for fruit or fruit juice—be sure to slice or squeeze just before using. Fruit and juices go stale, even under refrigeration.



BLENDING WHISKEY, 86 PROOF, 65% GRAIN NEUTRAL SPIRITS. © SCHENLEY DIST. CO., N.Y.C



***“When we give you a 25-month warranty you can be sure that your OK used car has been inspected and road-tested.*”**



***“We’re Chevy dealers.”***

Talk to any Chevy dealer. A used car doesn't get his OK until it really is.

Why is he so careful? Because he backs his OK with a 25-month warranty. It helps keep customers satisfied. And satisfied customers make Chevrolet dealers No. 1.

You see, he hopes to sell you your next car, too. Perhaps a new Chevy. So look at all his used cars. Especially those with his OK. You can be sure they really are.

Chevrolet Division of General Motors, Detroit, Michigan.

Every Chevy dealer authorized to use the OK warranty backs up every OK used car like this:

1. Every OK-tagged car has been inspected, road-tested and reconditioned as necessary to be in serviceable condition when you buy it.

2. For thirty days after purchase: he will pay 50% of parts and labor repairs (excluding tires, tubes, glass, radio or air conditioning), required to return the car to serviceable condition should it fail mechanically under normal use conditions (not collision) provided the repairs are made in his shop . . . and the balance is paid in cash . . . and that those repairs do not qualify for adjustment under any new vehicle warranty; and he will furnish replacement tires, tubes and/or labor at a 25% discount from his normal retail prices if you pay

the rest in cash.

3. For the next two years on work done in his shop, the dealer will pay 15% of all parts and labor repairs.

4. This dealer warranty is, of course, void if the car is used "for hire"; it's not transferable; and it's not valid unless signed by both a dealer's authorized department head and purchaser, and presented when a claim is made.

5. *This Warranty is expressly in lieu of any other warranties, expressed or implied, including any implied warranty of merchantability or fitness for a particular purpose, and any other obligations or liabilities on the Dealer's part, and Dealer neither assumes nor authorizes any other person to assume for it any other liability in connection with the sale of the vehicle.*

**GET A NO. 1 BUY FROM A NO. 1 GUY—YOUR CHEVY DEALER**

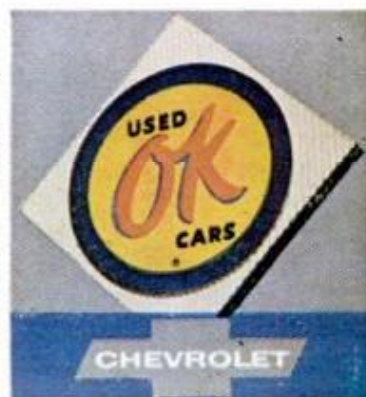





**Continuous testing makes the  
56 Mercurys the most dependable  
outboards ever built**

Lake X. 11,000 acres in central Florida. Stumps, logs, sandbars, water hyacinths and wire grass. Average July high, 91°. Humidity, 89%. Water can be glassy-smooth — or 7-foot waves. Lake X is the world's toughest marine proving ground. Tough—and honest. Run by Mercury people who believe only in facts. There's no compromise, no quarter. We'll run outboards day and night for weeks at full throttle ... over timed, measured distances ... hit sandbars ... 40 mph to test the shocks ... plow through saw grass trying to clog the cooling system ... run into logs, run in the rain, run wide open and at trolling speed, beat motors, take them apart, tabulate, compare. When we're through, there's little we don't know about an engine. Same thing

happens at Mercury's Siesta Key, Florida, proving grounds. Tests are just as rough. Only this time the enemy is salt water, sandbars, oyster beds, rocks. This is how we test marine propulsion at Mercury, testing not only Mercurys, but other brands. This is how we know the score. It's one example of the plus you get with Mercury ... dependability plus performance. See what we mean at your Mercury dealer. 3.9, 6, 9.8, 20, 35, 50, 65, 95 and 110 hp.



**MERCURY**



Kiekhaefer Corporation, Fond du Lac, Wisconsin and Kiekhaefer Mercury of Canada, Ltd., Subsidiary of Brunswick Corporation

Материал, защищенный авторским правом



THE ORIGINAL PRE-ASSEMBLED  
**BOAT KITS**

40 NEW CUSTOM-CRAFTED MODELS

Years ahead in Design - Styling - Performance. Cruisers - Runabouts - Prams - Skiffs - Sailboats - Racers. NEW CATALOG 50¢. Send \$1.00 for new Catalog PLUS Boat Building Handbook.



**BOAT PLANS** - PATTERNS - FRAME PACS

Over 200 proven, modern designs by famous Naval architects. Prams - Cruisers - Runabouts (Inboard-Outboard) - Hydroplanes - Houseboats plus all Kit Boats. NEW DESIGN CATALOG \$1.50 (Refundable). Send \$2.00 for Catalog plus Boat Building Handbook.

CUSTOM BOAT DESIGNS — DEPT. A — BUFFALO, N. Y. 14207



**FREE**  
72 ROUNDS  
OF BLANK  
CARTRIDGES

**ITALIAN  
SNUB NOSE  
AUTOMATIC** \$4<sup>98</sup>

Identical duplicate in styling of automatic detective revolver. Fires 12-4.5 cal. blank cartridges in 10 seconds. Not a CO<sub>2</sub> or Pellet gun.  
FREE—72 rounds of blank cartridges included. Perfect for sports, stage, etc. Illustrated gift carton.

Postpaid  
Send cash,  
check or M.O.  
No COD's please.

Request  
**FREE**  
Catalog

FEDERAL 6652 N. Western/Chicago, Ill. 60645  
Dept. GPM 5



**E-Z SHARP Drill Grinding Guide**

No turning. No twisting. No guessing. 1 Simple grinding motion. Sharpen twist drills 1/16" to 1" dia. any length. Fits standard grinders. Money back guarantee.

Only \$4.95 Postpaid  
Linlee Products, Dept. P5, Rochelle, Ill. 61068

**WHY BE BALD?**



When you can wear a Taylor Topper. Patented, clean, cool vinyl base, contoured to each individual bald area. NO NET, NO GLUE, NO FUSS, NO MUSS. The only answer — TAYLOR TOPPER.

MAIL COUPON NOW, COMPLETE DETAILS FREE  
TAYLOR TOPPER INC., 123 West 28 St., New York,  
N. Y. 10001, Dept. 5 Please mail FREE literature on TAYLOR TOPPER in plain white envelope.

Name .....

Street .....

City ..... State .....

Phone .....

**Hard-to-clean soil disappears like Magic**

AEROSOL CAN



HANDY cleans paint, grease, ink, stains, grime from hands—even tiny crevices and wrinkles in the skin. No water needed. An on-the-job hand cleaner. Leaves skin soft and smooth. Get Handy at your paint or hardware store, or send \$1. Satisfaction guaranteed.

Wilson-Imperial Co., 123 Chestnut St., Newark 5, N. J.



**UNIMAT**

the precision lathe and professional multi-purpose tool that lets hobbyists grind, polish, bore, mill and drill with no prior skill. For free literature, write American-Edelstaal, Inc., Dept. GE-6, 350 Broadway, New York, N.Y. 10013.

**LIVE PET SEAHORSES \$1**



Fascinating hobby for children and adults; keep Seahorses in ordinary bowl or jar. Amusing, adorable pets - in this species FATHER Seahorse gives birth to cute babies! Free food and instructions included. One Seahorse is \$1; Mated Pair for \$2; two Mated Pairs only \$2.98. Live delivery guaranteed. Florida Seahorse Co., Dept. PMZ, Box 300, Miami Beach 39, Fla.

**SAILBOAT KITS**

Send for free complete color catalog of popular Snipe, Windmill, and Blue Jay sailboats and accessories. Also cruisers, runabouts, catamarans, hydrofoils, etc.

Taft Marine Woodcraft  
Dept. PM56, 636 39th Avenue N. E.,  
Minneapolis, Minnesota 55421

**Shrinks Hemorrhoids  
New Way Without Surgery  
Stops Itch — Relieves Pain**

For the first time science has found a new healing substance with the astonishing ability to shrink hemorrhoids and to relieve pain — without surgery.

In case after case, while gently relieving pain, actual reduction (shrinkage) took place.

Most amazing of all—results were so thorough that sufferers made astonishing statements like "Piles have ceased to be a problem!"

The secret is a new healing substance (Bio-Dyne®)—discovery of a world-famous research institute.

This substance is now available in suppository or ointment form under the name Preparation H®. Ask for it at all drug counters.





**FOUR-WAY  
BEST LOW COST  
ARC WELDER  
YOU CAN BUY**  
**\$14.95** Complete

WELD, BRAZE, SOLDER, CUT. Tops in performance and value. Ideal gift, educational, profitable, enjoyable. No experience needed. Use 3/16" welding rods and 3/32" carbons to make or repair auto bodies, fenders, trailers, boats, toys, furniture, farm equipment; garden tools, anything of metal. Operates on 110 V. line.  
**WORLD'S GREATEST WELDING VALUE.** Over 500,000 in use by home owners, farmers, hobbyists, mechanics. 5-Year Unconditional Guarantee. If imperative will repair or replace without charge. You Get: **FULL FACE SHIELD**, heavy metal cabinet, ground clamp, 12 ft. of heavy duty welding cables, twin carbon arc torch, rod holder, carbons, welding and brazing rods, flux, solder, instructions. Order on 10-DAY UNCONDITIONAL MONEY BACK TRIAL.  
**SEND ONLY \$2.00** and pay \$12.95 plus C.O.D. charges on delivery, or send only \$14.95 and we will ship prepaid. Order today.

**FOUR-WAY WELDER CO.** DEPT. W2-E  
1810S. FEDERAL ST.  
CHICAGO, ILL. 60616

## Tempest Pros

(Continued from page 84)

riding car as opposed to a small compact. Yet it is not quite as large as a Chevrolet."—Maryland salesman.

"Feels like a well-made car and changes gears so easily that it is almost imperceptible."—Minnesota supervisor.

Owners like Tempest for a wide variety of reasons, clearly shown in the last four of the top ten features. Note the range of difference between engine (liked by 9.1 percent), quietness (7.9 percent), size (7.9 percent) and interior styling (7.5 percent).

"The OHC Six is an excellent compromise between the power of a big V8 and the economy of a regular Six."—Illinois die maker.

► True, but sometimes when you compromise between extremes nobody is satisfied with the results.

"I'm impressed by the quietness of the interior and the quietness of the motor"—New Jersey glazier.

"Much roomier inside; more trunk area than earlier years."—Ohio underwriter.

"Factory blending of exterior and interior blues (color) is one of the most attractive features of Tempest."—North Carolina teacher.

## ENJOY FLYING YOUR OWN BENSEN



THE GYROCOPTER—EASY TO BUILD—SIMPLE. SAFE TO FLY

Acclaimed by novices and pros around the world. Lowest cost flying. Kits available, also building plans and flying instructions. Get 3-View Drawings, specs, photo for \$3, or of Gyroglider \$2.

BENSEN AIRCRAFT CORP., Dept. PM-56  
Raleigh-Durham Airport, Raleigh, N. C. 27602

NAME \_\_\_\_\_

ADDRESS \_\_\_\_\_

## EVERLITE\*

World's **THRIFTIEST** Light Plants



THE CHAMPION \$144.50

The Champion — 1200 watts 115 volts AC for only \$144.50 Unbelievable but true—Brand new production methods now make possible world's finest design in a service free alternator light plant at this unprecedented price. Plant puts out a steady 1200 watts of 115 volt AC power to run power tools, oil burners, pumps, TV, or anything that requires up to 1200 watts. Powered by a rugged 3 HP, 4 cycle, easy start gas engine with 1 year factory warranty. Complete with carry handle and shock mounts. Why when you can buy this rugged top quality machine at our factory price.  
Item # 1265 wt. 65 lbs. \$144.50

## RECHARGE ALL BATTERIES

Only Everlite

- Charges 6 batteries
- Charges 3 times faster
- Charges all batteries

Including hearing aid, flashlight, lantern, radio, in fact any battery up to 12V. Save Money and have the convenience of fresh batteries always. Simple and 100% Safe. Plugs into any 115V. outlet. Guar. for one year. Send \$6.95 plus \$.65 for shipping

695



Model 75

**MASTER MECHANIC MFG. CO., Dept. A-566 Burlington, Wis.**

Southern Customers Write to Dept. A-566, Box 65, Sarasota Florida

## Tempest Gripes

(Continued from page 84)

the engine's rear main seal. New engines do have defects that the maker discovers only after extensive customer driving.

"OHC Six engine performance has been overplayed. Performance is fine at high speeds, but pickup with its 165 hp is very poor."—Hawaii insurer.

Rattles and noises (6.9 percent), loose transmission linkage (5.6 percent), carburetor trouble (4.7 percent) and engine noise (4.2 percent) filled the last four places among the top ten gripes.

"In cold weather I have bearing noise in the drive chain(?). It can't be detected in warmer weather."—Wisconsin mechanic.

► Chain drive is the new rubber-like belt that turns overhead camshaft on the engine. Few owners detected any noise from it.

"Transmission linkage causes vibrations and tunings up the steering column with my stick shift."—Illinois manager.

"Carburetor has always been bad. It sticks and floods."—Okla. programmer.

"I get noise from my cams when starting in cold weather."—Illinois manager.



## BUY THE BEST AT BARGAIN PRICES

### FA57 HAMMER

- Non-Breakable Fiber-Glass Handle
- Molded Dura-Cushion Grip
- Permabond®—Keeps Handle Tight

REGULAR \$5.95  
HARDWARE WEEK  
SPECIAL \$4.99

Also  
Available  
in Ripping  
Patterns



### AUTOGRAF HAMMER

- Tested Second Growth Hickory Handle
- Permabond®—Keeps Handle Tight
- Balanced for free and easy swing

REGULAR \$4.75  
HARDWARE WEEK  
SPECIAL \$3.99

BUY NOW AND SAVE **PLUMB®**

FAYETTE R. PLUMB, INCORPORATED • PHILADELPHIA, PA. 19137

### Sharp-Toothed Crawler

A fossilized toothed and tail-wagging little worm with a peculiar bar protruding from the back of its head is one of the most recent and unusual relics of prehistoric animal life to turn up.

According to its discoverer, Francis J. Tully of Lockport, Ill., the Tully monster, as it's been nicknamed, roamed the offshore waters of northern Illinois about 280 million years ago. Estimated to have grown to between 2 and 10 inches long, this creature had several small, triangular teeth in its snout and thin, mobile fins in its tail. It's been formally dubbed a new genus by Eugene S. Richardson of the Chicago Natural History Museum.

### Drugged Fish Forget

Goldfish are helping explain human differences between long-term and short-

term memory. According to Dr. Bernard Argranoff, professor of biochemistry at the University of Michigan's Health Research Institute, goldfish injected with the antibiotic puromycin indicate that memory is not "fixed" immediately, but after a specific interval following training.

In experiments, trained goldfish swam over a hurdle upon a light signal to avoid an electric shock. They remembered the trick for several months. However, fish drugged before training forgot the trick in three days; drugged up to 30 minutes after training, they showed the same memory loss; drugging one hour after training did not affect their memory whatsoever.

Dr. Argranoff suggests that short-term memory might be bio-electric and long-term memory chemical, since it is known that puromycin (which disrupts permanent learning) blocks protein synthesis necessary for the formation of new cells.



**Sure beats smoking!**



Enjoy Copenhagen: Place a small pinch between cheek and gum. No chewing.

United States Tobacco Company

**SAVE \$80 DOLLARS**  
**AIR CONDITION YOUR OWN CAR**

Easy. We supply everything you need: Kit, tools, illustrated step-by-step instructions. Just 5 hours to install. Made by leading auto air conditioning manufacturer. 12 month, 12,000 mile warranty. Our price to you just \$149 (you save at least \$80). Fits all U. S. cars. Send \$1 for complete instructions, applicable against purchase price. Please state size of engine, make and year of car.



FREE LITERATURE  
**COMFY-KIT**®  
1707 E. Ohio Street  
Dallas, Texas

Dept. PM

FIRST TIME EVER  
AT THIS PRICE...  
EXPENSIVE  
LEAKPROOF CON-  
STRUCTION ON...

**HIGH PERFORMANCE PUMPS** SAVE! BUY DIRECT FROM FACTORY!

Quickly Drain Pools and Cellars!  
Fill Tanks! Irrigate! Spray!

Now... a pump for under \$50 with permanently leakproof ceramic-lapped precision mechanical seal construction... the same as in pumps for atomic submarines. Forget about the leaks and constant adjustments necessary with conventional gland seal pumps. Precision made to pump up to 5,000 GPH. Up to 60 ft. ht. Maintenance free, rust-proof aluminum castings. 1 1/4" intake, 1" discharge. Fits any motor. Threaded suction discharge. Quality guaranteed by one of America's leading manufacturers of precision tools and pumps. Send check or M.O., or \$1 deposit on C.O.D.'s. Flexible drive coupling \$1 extra.

MONEY BACK GUARANTEE!

AMERICAN MACHINE & TOOL CO., Dept. PM-56, Royersford, Pa.



**Americas Lowest Priced Jet Engine**

Hell cat takes off all by itself or powers model autos, plane, boat, train, etc. Strong constant thrust for exciting experiments. Operates on ram jet principle. Fast starting. No Moving Parts. Operates on Solid Fuel. Only \$1.50. + 50¢ for Fuel.

STANDARD AMERICAN, Dept. 5-PMJE  
1 Park Ave., New York, N.Y. 10016

**American Pros**

(Continued from page 88)

of a similar size and price range."—Oklahoma secretary.

"It's an inexpensive car, but it doesn't look cheap."—Georgia warehouseman.

"The straight, simple lines of its styling do not distinguish it as a particular year's model."—Florida secretary.

"So nice looking, people don't even know it's a Rambler."—Indiana supervisor.

► **What do they think it is?**

Apparent big plusses with many owners are comparative ease of parking and the compact size, rated fifth and sixth, respectively, at 17.5 and 17 percent.

"Because of its size, it's easy to park."—Massachusetts housewife.

"Small enough to maneuver easily and park, yet big enough to compare with other compact cars."—California technician.

"I seem to be able to park about anywhere."—Michigan store manager.

"Not too little and not too big."—Pennsylvania house painter.

Many owners said they liked the way the car rode, with 14.4 percent placing it in the seventh slot for overall comfort.

"It rides like a big car and you can set the seat in four different positions."—Indiana bartender.

"It's like sleeping on a good mattress."—Louisiana saw filer.

► **No comment.**

"The long parallel springs at the rear axle give a smoother ride than coil springs."—Montana clerk.

Although a few precincts reported otherwise (see Gripes), owners considered the car pretty well glued together. Construction was cited in 10.5 percent of reports.

"Very solid and rattle-free."—North Dakota mailman.

"A deluxe piece of merchandise and equipment; the excellent way in which the car is made, inside and out, influenced my decision to buy."—New Jersey laboratory technician.

Owner reaction to Rambler's dual brake system, ranked ninth with 8.7 percent, is typified by this comment from a retired gentleman living in Wisconsin:

"I'm happy to know I have the dual brake system."

Compact, schmcompact! Many owners said the car was plenty big enough. Interior room (7.9 percent) wraps up the best-liked list.

"I have found it especially good for tall drivers."—Virginia nurse.

"It has plenty of room, both in front and in the trunk."—Maryland carpenter.



# MODERN HOMEOWNERS RENT...

There's Nothing Like  
the Right Equipment...  
and Knowing  
Where to Rent It!

Your nearby American Rental Association store has the right kind of equipment ready for you to use. Renting is convenient, economical, efficient. Your local A.R.A. man is an independent businessman with many services to offer you. Look for him in the yellow pages under "Rental Service — Stores & Yards."

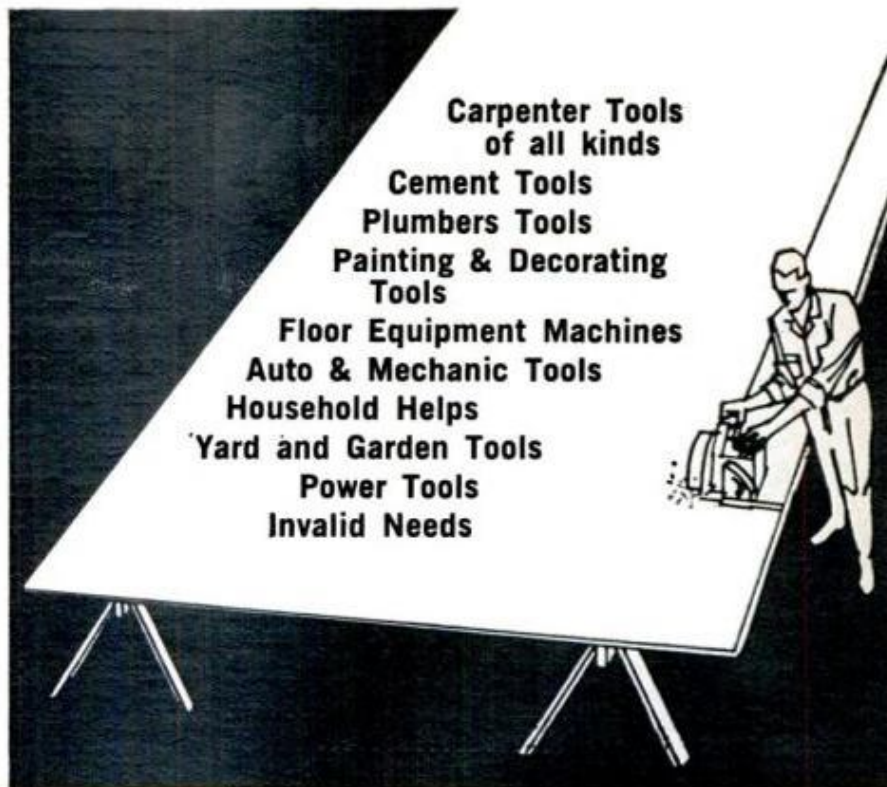

Carpenter Tools  
of all kinds  
Cement Tools  
Plumbers Tools  
Painting & Decorating  
Tools  
Floor Equipment Machines  
Auto & Mechanic Tools  
Household Helps  
Yard and Garden Tools  
Power Tools  
Invalid Needs



For further information write:  
**AMERICAN RENTAL ASSOCIATION**  
1919-5th Ave., Moline, Illinois  
Att: C. A. Siegfried, Jr., Executive Secretary

## NOW! WARN OVERDRIVE gives 'Jeeps' more Go!



New approved accessory cuts engine RPM 33% at any speed, reduces noise, vibration so you can drive your Jeep 4-w.d. comfortably at freeway speeds. Amazing synchromesh OD lets you shift up or down, on the go, anytime, in any gear, at any speed. Adds six forward speeds, two reverse. At Jeep dealers, or write us.



**WARN SALES CO., Inc.**  
9050-A Empire Way South  
Seattle, Washington 98118

## 130,000 CANDLE POWER FLAME THROWERS



**WARREN AUTOMOTIVE**

Fits all 4 light systems—bright sockets. American made for American cars. 65,000 candle power in each sealed beam unit. Over 2½ times as bright as the factory stock brights. Lets you really see where you are going.

**\$995 pair**

Prepaid U.S.A. No C.O.D. please  
Box 563 Skokie, Illinois 60076

## If You Can Draw A Straight Line (with a ruler) WE CAN TEACH YOU DRAFTING

Growing consumer and defense industries can't get enough trained draftsmen. Our new teaching methods let you learn in your spare time at home. You learn more, learn faster. Step up the wage ladder with a white collar skill that leads to the top. Send for sample lesson and course outline. Resident course also available on our Chicago Campus. Established in 1934—60,000 graduates.  
**AMERICAN INSTITUTE OF ENGINEERING & TECHNOLOGY**  
1125 Fullerton Pkwy—Chicago, Ill. 60614



# Keep cool on porch or patio

**AS LOW AS \$79.50**

Nothing beats a large-bladed Hunter Ceiling Fan for moving lots of air quietly. It keeps you cool and also blows away insects. Choose 2-speed 36" or 3-speed 52" blades. Maintenance-free motor. Patented Adaptair on Model FR52A gives direct or indirect air flow.

*Write for literature:*

# Hunter Ceiling Fans

**HUNTER DIVISION, ROBBINS & MYERS, INC.**

2693 Frisco Ave., Memphis, Tenn.—38114





**GRINDS**      **POLISHES**  
**DRILLS**      **SHARPENS**  
**CARVES**      **DEBURRS**

No. 2  
Moto-Tool Kit  
Illustrated

## MOTO-TOOL THE POCKET SIZE MACHINE SHOP

Handiest tool you'll ever own. Does fine detail work with pin point accuracy. Eliminates time consuming hand work. Gets into places difficult to reach with larger tools. 27,000 RPM. Collet sizes 1/8", 3/32" and 1/16". An industrial favorite since 1936. Wt. 13 oz.

**NO. 2 MOTO-TOOL only** ..... \$19.95  
**NO. 2 MOTO-TOOL KIT with 23 accessories in steel case** ..... \$29.95

### NEW HEAVY DUTY NO. 3 MOTO-TOOL

New high torque motor designed for hard industrial use. Same features as No. 2 plus 50% increase in power.  
**NO. 3 MOTO-TOOL only in steel case** ..... \$29.95  
**NO. 3 MOTO-TOOL, 23 accessories, steel case** .. \$37.95

SEE YOUR DEALER OR WRITE FOR CATALOG  
 Dremel Mfg. Co. • Dept. 116-E • Racine, Wis.

## American Gripes

(Continued from page 88)

stacked against the known gas-gulpers, but many owners weren't satisfied, ranking fuel economy third among gripes.

"Mileage isn't as good as the ads claim it is."—Pennsylvania, retired.

"I expected at least 27 mpg. All I get is 19."—Massachusetts pharmacist.

"I was told to expect 20-21 mpg. I don't get it. I bought the car for economy, but I'm disappointed in the mileage."—Mississippi tax collector.

"Had to add ten quarts of oil before 4000 miles. Dealer says chrome rings are not yet seated."—Georgia experimental mechanic.

### ► Uh-huh. What else did he say?

A number of beefs "enjoyed" equal (or almost so) frequency-of-mention ratings. Tied in fourth place (6.8 percent) were lack of weight and workmanship. Four categories came out even (5.4 percent) for the sixth to ninth spots: brakes, engines, roadability and ride, and hard shifting.

"This car is wind sensitive at high speeds."—New Jersey executive.

"The car is light for high speed driving. It has a tendency to float at speeds over 70 mph."—Florida shop owner.

"Brakes seem to pull in one direction one time and in a different direction the next."—New York service manager.

"Brakes good except in deep water."—Minnesota security guard.

### ► Plays hell with the ventilation, too.

"I should have gotten a larger engine."—Virginia mechanic.

"The ride's not as smooth as I'd hoped it would be."—Connecticut sales clerk.

"My father, at 77, complains it drives like a truck."—New York manager.

### ► Get him to tell you about the Pope-Hartford.

"Shift very sticky. Back to dealer for adjustment. Still sticky."—Connecticut housewife.

### ► Dealer very shifty?

Rounding out complaints were interior room and dealer service (4.8 percent each).

Sometimes one wonders what people have on their minds. Having purchased the car, now seems an odd time to make such comments as:

"There's not enough legroom for either the driver or the rear seat passengers."—Wisconsin engineer.

"The distance between the back seat and back of the front seat is too short."—U.S.A.F. airman.

Summarizing a number of owner complaints is the following from an Indiana factory worker: "My dealer is just plain rotten about service."

## SAW SHARPENING IS EASY

Super Filer No. 11 joints and sharpens circular saws 6" to 10" with all teeth correct in height, depth, pitch, bevel. When file hits steel roller, teeth are finished. \$9.95  
 Saw runs true with no side pull. Includes 8" file. PPD.

FREE LITERATURE



"TRU-CIRCLE" saw set automatically sets teeth at 10° \$2.95 or more. PPD.

MONEY BACK GUARANTEE

A. D. McBURNEY, 1600 Victory Blvd., Glendale, Calif. 91201, Dept. A-56

TAPE THIS AD TO THE BACK OF YOUR TV SET

## ALL TV-RADIO RECEIVING TUBES

\$1  
ea.

ALL BRAND NEW, all at a flat discount price of only..

No exceptions . . . all tubes \$1, regardless of list price. Virtually all types available, including the new color tubes.

- All Tubes 1st QUALITY MADE IN U.S.A.
- All Sold on Written 24-MONTH WARRANTY
- All Orders SHIPPED 1st CLASS SAME DAY REC'D.!



Order replacements for your defective tube @ a flat \$1 each, plus 50¢ postage and handling for your entire order. Address Dept. PM-46, Write today to Dept. PM-56

**UNIVERSAL TUBE CO.**  
Ozone Park, N. Y. 11417





Gravely Super Tractor with Rider and 40" Rotary Mower

## For the MAN-SIZED JOBS...GRAVELY

*Gravely doesn't give up when the going gets rough. Its high-torque engine, all-gear drive powers through the toughest jobs.*

*Your choice from 39 year-round lawn, garden, and grounds-care tools. Designed for long life and rugged work. Fast change—power attachments use four bolts, others a single pin.*

*Ride—or walk, depending on the job. Instant control—no clutching, just a flip of a lever. Four all-gear speeds forward, four reverse. Power attachments are out-front for safety, and you keep an eye on the job comfortably!*

*See the one that does the job—every time, all the time. At your local Gravely Dealer. Or, get more facts from our free catalog. Write Now! Gravely, 5705 Gravely Lane, Dunbar, West Virginia 25064.*

**Look under the hood . . .  
and you'll get a Gravely.**

**GRAVELY**  
TRACTOR DIVISION  
**Studebaker**  
CORPORATION





## THE FLYING STOVEPIPE

(Continued from page 81)

missing, could cripple an entire complex.

As for civilian applications, who wants to go from New York to India or from Los Angeles to Paris in one hour? Well, lots of people. They said much the same thing about our current jets, the 707s and the DC-8s, but once they went into service, they all but obsoleted the piston-engine planes. Who wants to ride a 300-mph plane when there's a 600-mph plane around? The same thing will happen with the supersonic transport. Who'll ride the 600-mph jet when there's a 2000-mph bird available? And beyond that, the Scramjet.

The early Scramjet transports may be small, 25-passenger jobbies, but they may ultimately go to 200-passenger vehicles with cruising ranges above 5000 miles. As for sonic booms, they'll produce them, but mostly over water. The great bulk of these hypersonic flights will be transoceanic. There isn't much point flying so fast over shorter distances. You'd have to start slowing down as soon as you took off.

But beyond all this is something both the Air Force and the National Aeronautics and Space Administration are looking at seriously. They know that 8000 mph is not the limit of the Scramjet's capability. It could be boosted to speeds above 17,000, or close enough to orbital speeds that another small auxiliary rocket engine could send it the final distance into space.

### More payload; less booster

Why bother? For two good reasons. Because the Scramjet is an air-breather, it doesn't carry any oxidizer with it as current rocket boosters do. This savings in weight can be translated into payload. It is estimated that, where an ordinary rocket booster is 90 percent booster and 10 percent payload, a Scramjet could be 85 percent payload and 15 percent booster. Moreover, since it is configured as an aircraft, it could be flown back to earth and landed as an ordinary aircraft—the first recoverable booster. Consequently, it could fly personnel or supplies to space stations in earth orbits and fly back to its original base, a self-contained two-way spacecraft. The boys in the budget department are rubbing their hands in glee over this.

There's still a long way to go, however, before this prospect becomes reality. But hope abounds. I sat at a seminar and heard

Gen. Bernard Schriever comment, "Scramjet is the most promising approach we have today for sustained hypersonic flight. It has flexibility which would permit economical and efficient ranges in speed from 2500 to 17,000 mph." General Schriever commands the Air Force Systems Command, which is developing the Scramjet.

To get some further insight on what the AFSC hopes to accomplish, I visited Washington and talked with Dr. Bernhard Goertert, the AFSC chief scientist and Schriever's right-hand man.

"The turbine engine," he told me in his handsomely furnished office near the Capitol, "has just about reached a saturation point. And the rocket engine, because it has such tremendous fuel consumption, has limitations. The Scramjet will carry only one-fifth to one-eighth of its total weight in fuel."

He thumbed three copies of *Popular Mechanics* which he had hurriedly purchased when he heard I was coming to interview him, admitting he had bought them to study, not to show off.

"So the Scramjet is both possible and practical." He folded his hands just above his belt, and looked at the far wall. "It would be most effective as a quick-response vehicle, especially for our ever-expanding cargo needs. Just think, an aircraft that could carry a piece of vital electronic equipment half-way around the world in an hour's time!"

He looked at the ceiling. "The major requirements, I think, are that the engines be intimately integrated with the aircraft and that they have as few configuration changes as possible."

He was referring here to the suggestion by some that the Scramjet engines should have variable inlet and exit configurations for various speeds, upsetting the basically simple design of the "flying stovepipe."

As for size, he was still conservative. "Perhaps 25 passengers to start, 100 tops." But he shrugged. "Later on, perhaps bigger. The stubby wings of such a fast aircraft are much more susceptible to building bigger aircraft than those with large wings. In fact, the Scramjet as it grows bigger becomes better and better."

How soon then?

He hedged, "With unlimited funds, perhaps by 1972, but I would rather bet on 1975."

So within 10 years we might be traveling at 8000 mph. Are you ready?



# NEW Clamping Tool You Can Operate with ONE HAND

## CHANNEL LOCK®

### No. 910 GripLock

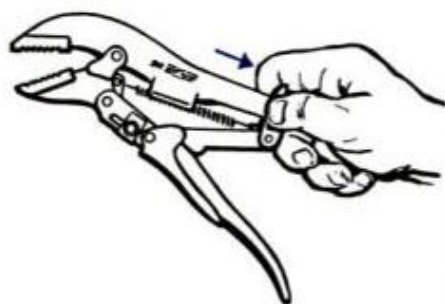

#### 1. OPEN IT!

With one hand, easily to a full 1 3/4". Just pull back on the patented jaw operator. (Pat. No. 2997903)

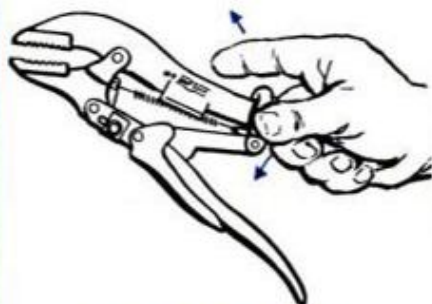

#### 2. LET GO!

The spring closes the jaws. No screw to adjust. Another patented feature. (Pat. No. 2531285)

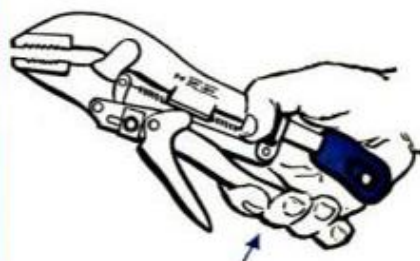

#### 3. LOCK IT!

Still with one hand. Simply close the handle to lock the jaws on the work.



#### 4. E-Z RELEASE!

With one finger-tip operation, trip the patented release lever. (Pat. No. 2576286)

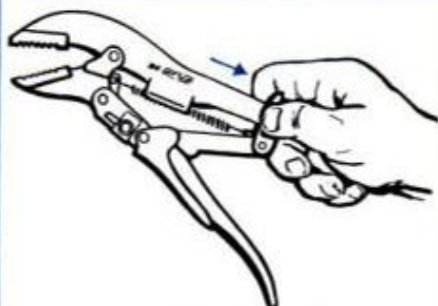

#### 5. OPEN IT!

Two-finger pull on the jaw operator releases jaws from the work.

Simple... Easy...  
Fast... Efficient

ALL WITH  
ONE HAND

Made Only By CHANNEL LOCK, INC., MEADVILLE, PENNSYLVANIA



# ASSEMBLE YOUR OWN ALL-TRANSISTOR Schober ELECTRONIC ORGAN



3 NEW MODELS	
Recital	\$1500
Console II	\$850
Spinet	\$550

This is the new, all-transistor Schober Console II...the most luxurious "home-size" organ available today. Full 61-note manuals, 17 pedals, 22 stops and coupler, 3 pitch registers, and authentic theatre voicing leave little to be desired. Comparable to ready-built organs selling from \$1800 to \$2500.

The pride and satisfaction of building one of these most pipe-like of electronic organs can now be yours... starting for as low as \$550. The Schober Spinet, only 38 inches wide, fits into the smallest living room. The all-new, all-transistor Schober Recital Model actually sounds like a fine pipe organ; its 32 voices, 6 couplers, 5 pitch registers delight professional musicians... making learning easy for beginners.

**AND YOU SAVE 50% OR MORE BECAUSE YOU'RE BUYING DIRECTLY FROM THE MANUFACTURER AND PAYING ONLY FOR THE PARTS, NOT COSTLY LABOR.**

It's easy to assemble a Schober Organ. No special skills or experience needed. No technical or musical knowledge either. Everything you need is furnished, including the know-how. You supply only simple hand tools and the time.

You can buy the organ section by section...so you needn't spend the whole amount at once. You can begin playing in an hour, even if you've never played before—with the ingenious Pointer System, available from Schober.

Thousands of men and women—teen-agers, too—have already assembled Schober Organs. We're proud to say that many who could afford to buy any organ have chosen Schober because they preferred it musically.

Send for our free 1966 Schober Catalog, describing in detail the exciting Schober Organs and optional accessories; it includes a free 7-inch "sampler" record so you can hear before you buy.

**THE Schober Organ CORPORATION**

43 West 61st Street, New York, N. Y. 10023

Also available in Canada, Australia, Hong Kong, Mexico, Puerto Rico, and the United Kingdom

THE SCHOBER ORGAN CORP., DEPT. PM-18

43 West 61st Street, New York, N. Y. 10023

Please send me FREE 1966 Schober Catalog and FREE 7-inch "sampler" record.

Enclosed find \$2.00 for 10-inch quality LP record of Schober Organ music. (\$2.00 refunded with purchase of first kit.)

Name \_\_\_\_\_

Address \_\_\_\_\_

City \_\_\_\_\_ State \_\_\_\_\_ Zip No. \_\_\_\_\_

## REAL FLYING MODELS ROCKETS!

Flights up to 2500 ft.

BLAST OFF!... with a flying scale model

### IDEAL STARTER KIT

- WAC Corporal (shown) with 2 powerful rocket engines, all parts, instructions, design booklet and FREE illustrated catalog, ORDER NO SK-2 \$2.00
- Or SK-6, same as above, plus igniter-launcher \$6.00

PLEASE USE ZIP CODE WHEN ORDERING

**ESTES INDUSTRIES**  
PENROSE 15, COLORADO



25 exciting new rockets for you to build and fly

Giant illustrated catalog... 25¢

Dealer inquiries invited

Many flights - Parachute recovery

# EARN MONEY FAST!

### REPAIR HYDRAULIC JACKS

Earn while you learn at home. Trained and qualified mechanics needed NOW to service inoperative hydraulic jacks. BIG opportunity for ambitious men. We show you HOW - in your basement or garage, spare time cash income in an expanding industry. Don't wait, ACT NOW! Get the facts.



Write for folder No. PM5 and free bonus offer  
**HYDRAULIC JACK REPAIR MANUAL CO.**  
P. O. BOX 50 • BLOOMFIELD, N. J.

## I-N-V-E-N-T-O-R-S WE NEED INVENTIONS

Sell your invention for cash—need money for Patent?—Are technical problems holding you back? Universal Inventions has helped inventors all over the world—just like yourself—why not you? Inventions provide the magic spring-board to sudden riches. REMEMBER, we either sell your invention or pay you a cash bonus. Write for details.

**UNIVERSAL INVENTIONS, Dept. 13, Marion, Ohio**

**FREE!**

Learn how you can buy used engines \$15 up, new engines \$30 with FREE confidential list and coupons when you order your plans

### BUILD THIS MINI-BIKE!

Plans reveal step by step details!

### BUILD A RACING KART!

Complete frame for less than \$10!



RUSH \$2 for plans (indicate type) or send 25¢ for brochure describing plans: PLANS, Box 478, Dept. PMS, Denver, Colo.

**LIQUIDATION SALE... ONLY \$3,995**

ORIGINAL PRICE \$12,500



**Food & Soft Ice Cream Mobile Unit**

Publicly owned corp. offers (while supply lasts) 1-ton Chev. food and soft ice cream mobile units, completely reconditioned LIKE NEW. FULLY GUARANTEED. Highest quality restaurant equipment serving hamburgers, hot dogs, and coffee, PLUS complete line of soft ice cream cones, sundaes, shakes, etc. No obsolete equipment. Replacement parts always available. This is a "Once-in-a-Lifetime" opportunity. Can finance if necessary. Act promptly for best selection. Give phone No.

TASTEE-FREEZ, 1200 N. Homan, Chicago, Ill. 60651, Dept. PM



## 1966 AT INDY

(Continued from page 77)

ic of the Harrison Special, is taking this approach. Using a modified stock ignition, his Chevy conversion has pulled about 480 hp on the dynamometer.

Few others are expected to take advantage of the Chevy combination. *PM* checked several builders of racing Chevys, among them Jim Travers and Frank Coon. Both old hands at Indy, they were co-mechanics for two-time winner Bill Vukovich. Their Traco brand speed equipment is well known to performance fans and it seemed logical they'd be in the vanguard of the Chevy march. Surprisingly, Coon told us they thought it would cost too much to prepare one of their engines for a successful attempt.

### Supercharged Offy

The other engine you'll be hearing a lot about at race time is the new supercharged Offenhauser. Displacement has been reduced from 255 inches to 168 and they've hooked on a positive displacement blower, gear-driven at  $\frac{5}{8}$  crankshaft speed. Early dynamometer tests rate the engine at 530 hp at 8500 rpm, putting it up past Ford's 490-to-510 hp at 9000 rpm and giving it a better torque curve.

Two drivers have already tested the engine and plan to use it. Rodger Ward hit close to 160 at Indy during fall tire tests, using it in an old car. Parnelli Jones set an unofficial mile track record at Phoenix in a '66 Indy car built by Fred Gerhart.

An improved Novi will again pull the crowd to its feet this year. Greg Weld is scheduled to drive. The supercharged V8 of 157 cubic inches, claimed to be putting out 768 hp during dyno tests in January, will be mounted in the redesigned and rebuilt four-wheel-drive car that clocked 161 mph in practice last year before driver Bobby Unser deliberately wrecked it to avoid hitting another car.

But, these new engines aside, it's always easier in any organized competition to go with a known combination. We're not saying that every rear-engined car is a copy of the Lotus, but let's see what equipment is being planned this year:

Colin Chapman, the man who started it all when he brought the first two "Loti" to Indianapolis in 1963 for Jimmy Clark and Dan Gurney, will be back again with

(Please turn to page 240)

## GOVT. SURPLUS AND OTHER BARGAINS SAVE UP TO 90%



**1500-1' GEAR HEAD MOTOR** Speed 6 RPM @ 24 V.D.C. Reversible. 5 AMPS. Also runs well on 12 V.D.C. on reduced power. Excellent for small drive unit for winches, kids cars, powered displays, capstan, etc. Has  $\frac{5}{8}$ " drive shaft. Shpg. Wt. 7 lbs. Like new. Tested prior to shipment. 9" L x 5" H x 3 $\frac{1}{2}$ " W. Approx. GOV'T COST \$97.50. Just \$12.95

**200 AMP ARC WELDING KIT** Build your own arc welder-battery charger. You get all this—200 Amp. Gen., Voltage Reg., Ammeter, Shunt, Welder's Helmet, Electrode Holder, Welder's Gloves, Reactor Coil, Toggle Switch, Rheostat, Voltmeter. All 11 items guaranteed pre-tested. Wt. 72 lbs. Approx. GOV'T COST \$600. Complete with welding & battery charging diagram \$39.95

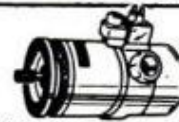

**AC-DC GENERATOR** rated 200 AMP DC @ 24 to 30V. Also produces 1200 watts of AC current. Excellent for making your own arc welder. Also for lights and many cooking accessories. Size 14" L. x 6" dia. Tested prior to shipment. Shpg. wt. 55 lbs. Approx. GOV'T COST \$350. Special \$14.95

**DC JET GENERATOR ARC WELDING KIT** complete with GE Type CM Gen (30 V. D.C., 400 AMP, 3000 RPM: ampere rating is for continuous duty, intermittent amperage is 500 to 600 amps). Also 2 rheostats, 1 voltage reg., 1 voltmeter, 1 electrode holder, 1 welder's mask, 1 toggle switch, 10 lb. vacuum packed  $\frac{1}{8}$  in. welding rods, pair welder's gloves & spline coupling. All units guaranteed pre-tested. Wt. 110 lbs. Approx. GOV'T COST \$700. All items \$64.50



**HEAVY DUTY MAGNET** Fantastic power, will pull 125 lbs. on steel block. Excellent as underwater retriever. Picks up all ferrous metals. 4 $\frac{1}{8}$ " L x 1 $\frac{5}{8}$ " W x 4" H. Shpg. Wt. 3 lbs. \$7.95



### NEW! BIG 1966 CATALOG

Send 25c for amazing catalog with 1000's of bargains in hydraulics; electrical, marine, automotive items, etc. Order from ad. Prices FOB. 50% deposit for COD. Pls. include your zip code number. Satisfying mail order customers thru-out the world since 1945.

## AIRBORNE SALES CO. Dept. PM566

8501 Stellar Dr. • Box 2727 • Culver City, Calif. 90231

## 1001 USES! WELDWOOD® FLEXIBLE WOOD-TRIM®



### PROFESSIONAL LOOK TO PLYWOOD PRODUCTS

Beautiful wood veneer, paper-backed, in handy 1" & 2" rolls 8' long, for edging plywood. Also, decorate lamp shades, book ends, do inlay work, etc. Apply with Contact Cement or Presto-Set® White Glue. Oak, birch, African mahogany, walnut, fir, Korina®. At lumber, paint, and hardware dealer's. United States Plywood, Dept. PM5-66, 2305 Superior Ave., Kalamazoo, Michigan.

## New Portable LIGHT PLANTS

110-120 V. A. C. 1500 watts, 60 cycles. Weight 24 lbs. Size 10" x 5". Fanbelt driven from car, pickup or gas engine of 2 $\frac{1}{2}$  or 3 h.p. Operates  $\frac{1}{2}$ " Drills, Saws, T.V. Brand new. Money back guarantee. Regular \$89.50 now \$49.50. With switch, pulley and voltmeter. Send check or money order.

### VIRDEN PERMABILT CO.

Box 7066

Amarillo, Texas 79109

SQUEAKY DRAWERS LOVE  
**DIXON**  
**slip-stik**  
Another Golden Oval Lubricant



## end messy hose-handling!

### AMES HANDI-TRUK FLOW-THROUGH HOSE REEL

no kinking . . . no knotting  
. . . no tripping!

Ames makes a job a joy! Since water flows right through this hose reel, all you do is unwind the length needed, then start sprinkling. Hose rewinds easily . . . stays clean, dry and safely out of the way when not in use. Reel rolls from faucet to faucet . . . holds up to 150 feet of hose. Remove reel and you have a hand truck for moving fertilizer. About \$17.00. At your department, garden supply or hardware store.



Win a Millionaire's Backyard! Enter Ames 3rd Annual Giant Giveaway! Get entry blank from your dealer or write O. Ames Co., Parkersburg, W. Va.

**AMES**  
SINCE 1774

IN PAINTING ...

**IF YOU PRIZE IT...  
KRYLON-IZE IT!**

Goes on in seconds—  
dries in minutes!

Primer  
Flat  
Enamel  
Acrylic Lacquer

**KRYLON...  
AMERICA'S NO. 1 SPRAY PAINT**



## 1966 AT INDY

(Continued from page 239)

a trio of cars: one for Clark, last year's winner and world champion. Basically similar to the Model 38 which won the marbles last year, the new car is not expected to be very different, boasting only a few minor changes to take advantage of the new tires and expected higher speeds. USAC National Champion Mario Andretti and two-time winner A.J. Foyt are also having Chapman build cars for them and all "Loti" will be powered by Ford.

### More British designs

Lotus chief designer, Len Terry, left England to move to California last year and now works for Dan Gurney's All-American Racers, Inc., an organization heavily sponsored (it is reported, anyway) by such as Goodyear and Autolite. He has designed six new cars patterned after the basic design he developed with Chapman. Lloyd Ruby, recent winning co-driver of the Daytona 24-hour race, Joe Leonard and Gurney himself will drive three of the cars under All-American's colors. The other three will be driven and sponsored as follows: Roger McCluskey driving for Lindsey Hopkins, Jerry Grant for Bardahl, Gordon Johncock for Weinberger Homes. They'll use Ford power.

Eric Broadley, another Englishman, built a reputation for his own version of the Lotus—called a Lola—that was usually somewhat sturdier. The two he built last year were driven by Al Unser and Bud Tinglestad to ninth and sixteenth places. For his second try at the big payoff, Broadley is building three Lolas. They will be driven by two-time-winner Roger Ward, Walt Hansgen and European star Jackie Stewart. Hansgen and Stewart will use Fords; Ward, the new Offy.

Two other British-built cars—the BRP driven in '65 by Masten Gregory and Johnny Boyd—will be handled this year by Boyd and Jimmy Clark's '65 teammate, Bobby Johns. Extensively reworked during the winter by mechanics George Salih and Howard Gilbert, they're much like the now ubiquitous Lotus.

Ted Halibrand, who built several rear-engined cars in '64 and '65 using cast magnesium bulkheads supporting an aluminum shell, told PM's reporter he'd cancelled all orders for '66 cars in order to

(Please turn to page 242)



**SAVE UP TO 85%**

**GOV'T SURPLUS and NEW EQUIP'T**

Send 25c For 3 Big Catalogs

PUMPS	ELECTRONIC
WELDERS	BINOCULARS
WINCHES	GEAR MOTORS
SURVEYING	COMPRESSORS
TELEPHONES	SPEED REDUCERS
HYDRAULICS	WEED SPRAYING
GENERATORS	MANY OTHERS

**SURPLUS CENTER** Dept. PM-056 Lincoln, Nebraska

**LEARN WELDING AT HOME  
WE SEND YOU A WELDER**

A trade with a future—in demand everywhere. We have trained thousands—Men who earn up to \$4.50 an hour. Learn Arc, Heli-Arc and Gas Welding. We supply equipment that lets you earn while you learn. Practical lessons on brand new, industrial rated machines. Both arc and flame welding. On completion the equipment is yours. Set up your own shop or work in any shop on any job. Send today for full information.

**AMERICAN INSTITUTE OF ENGINEERING & TECHNOLOGY**  
1131 W. Fullerton Parkway, Chicago, Illinois

**HEAVY DUTY BALL-BEARING PUMP**

**IRRIGATE DRAIN SPRAY CIRCULATE**

Famous, all-metal, rust-proof XB pump with stainless shaft. Use 1/4 HP or larger. 1 HP for up to 5,200 GPH 60' high or 3,000 GPH from 25' well. 1 1/4" inlet. 1" outlet. For belt or direct drives. Only \$12.95

Famous Type P won't rust or clog. Bronze bearing. Hundreds of thousands in use. Up to 2,400 GPH. 1" inlet. 3/4" outlet. Only \$8.95

Postpaid cash with order.  
Money Back Guarantee. **LABAWCO PUMPS** Belle Mead 104, N. J.

**NEW! AMAZING FIBERGLASS REPAIR KIT FOR HOME REPAIR**

- CAR • BOAT! PATCH WOOD
- METAL • FIBERGLASS IN JUST 15 MINUTES! NO MEASURING!

**NO MIXING!  
EASY TO APPLY!**

**POLYPATCH™**

**Fiberglass Repair Kit**

**\$7.00**  
plus 25¢ handling charge

2-4" x 5" IMPREGNATED PATCHES  
1-ATOMIZER

Every homeowner, handyman and mechanic needs Polypatch. Use this newest discovery of modern science in hundreds of ways and for practically unlimited repairing and patching. Your car—fix mufflers, floor boards, rocker panels, fenders, rust damage; your boat—hull damage, deck repair, canoes, storage containers. Also repair aircraft, farm equipment, and hundreds of around-the-home repairs. Simple to use (everything is mixed and ready). Polypatch is not affected by weather, water, acids and gasoline. Available in primer white, grey, black.

Send check or money order for your Polypatch kit, today.

**POLYPATCH**

Dept. PM, 904 Ridge Pike, Conshohocken, Pa. 19428

**NEW DYNAMIC MARK 88 INDUSTRIAL TRANSFORMER ARC WELDER**

**YOU CAN WELD, BRAZE, CUT, SOLDER, HEAT, ETC. STEEL, BRASS ALUMINUM**

Build and repair anything of metal. Save time and money with this **BRAND NEW, PROFESSIONAL ARC WELDER!** Rugged metal cabinet, baked Hammerloid finish. Ideal for home, shop, farm and industrial use. Expert work on your **FIRST JOB. POWERFUL** glass insulated transformer welds 1/2" metals with 3/8" rods. 4 heat settings, 20 to 80 amps. Operates on 110 Volt AC line fused for 30 amps. Complete with fibre glass helmet, electrode holder, ground clamp and cables, solder, assorted rods and simplified welding manual. **DOUBLE PROTECTION GUARANTEE.** 10 day money back trial plus full 5-yr. warranty. If inoperative return prepaid, we will repair or replace without charge. **ORDER TODAY. ONLY \$47.50 COMPLETE (220 V. at \$49.50) SEND ONLY \$6.00.** Pay balance plus C.O.D. charges on delivery or write for easy "PAY AS YOU WELD" plan. Low Down Payment. Welder details FREE.



**DYNAMIC WELDER CO.**

Dept. D2-E  
1808 S. Federal St.,  
CHICAGO, ILL. 60616

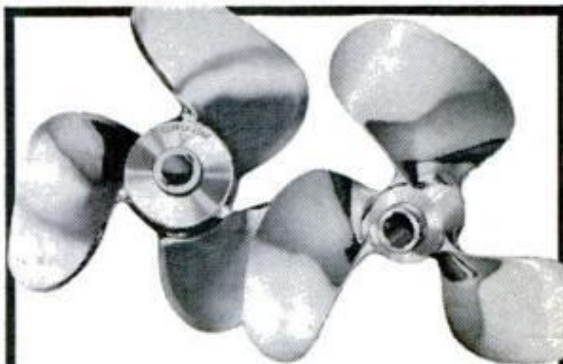

*You should know about these*  
**PROPELLERS!**

Very fast cupped-edge outboard props . . . trophy winners that will increase the speed of your outboard. "Featherweight" props cast of Michalloy-K bronze . . . so strong that you get a lifetime guarantee against blade breakage at the hub. Standard bronze and aluminum props featuring new pitch generation principle . . . dynamically balanced. Hundreds of propeller styles and sizes; one to exactly suit your motor, boat and use combination. See your Michigan dealer now; ask to see the all new Michigan catalog with factory engineered recommendations that make you a propeller expert. You'll be delighted at performance improvements when you use the right prop. Michigan Wheel Co., Grand Rapids, Michigan 49502.

**MICHIGAN**



**NOW WE MAKE THE WORLD'S FINEST WOOD STAIN, TOO!!**





## HOME WORKSHOP ARC WELDER!



**ELECTRIC WELD BRAZE, SOLDER, CUT ALL METALS**  
**New 1966 Model**  
**LIFETIME BURNOUT GUARANTEE—10 day money back**  
 trial. Works on any 110 volt "Plug in". Welds up to 1/4" steel with 1/16" to 1/8" rods. **EXTRA** Special twin pressure type arc torch (shown) develops up to 10,000 deg. heat—**HAS A MILLION USES—** for **CARS—HOME—FARM—FACTORY**. No experience needed—**FREE** Welding book teaches **YOU**. Thousands of users. **SEND ONLY \$2.00** (cash, Ck, MO) and pay postman \$12.95 COD Pstg. or send \$14.95 for postpaid delivery in USA. **COMPLETE** ready to use with 12 ft. H.D. Cables, Arc torch rod holder, carbons, welding and brazing rods, flux solder, work clamp and full face mask. **FREE EXTRA "Dark" eye goggles—if you order at once.** This **BEST FOR THE MONEY** welder sold **ONLY** by **MIDWAY WELDER**, Dept. DPM-5, Kearney, Nebr.

THIS SPACE CONTRIBUTED BY THE PUBLISHER



### We could save one out of two. We don't.

Cancer is not necessarily a killer. Many cancers are curable today. Doctors have the knowledge... the skills... the equipment to save 1 out of 2 cancer patients!

Yet each year, more than 90,000 people die needlessly. Because they do not go to their doctors in time. Early diagnosis and proper treatment could have saved them.

Be a life-saver. Yours. See your doctor regularly!

**American Cancer Society**

### Alaska is the hub

Alaska is the "global center" of the United States. Kodiak Island, southwest of the Alaska mainland, is the center of the smallest circle that can be drawn to include all the States and the various territories and possessions such as Guam, American Samoa, and the Pacific Trust Territories.

## 1966 AT INDY

(Continued from page 240)

devote full time to designing and building a pair of cars for and with Parnelli Jones. Neither would reveal details, but it is likely—based on his earlier experience with the Gerhart car—Jones will use the supercharged Offenhauser for power.

Young "old master" A.J. Watson couldn't seem to find the right combination with his first two tries at designing and building a rear-engined car and has gone back to the drawing board once again.

His '66 cars will resemble last year's, with a shark-like nose featuring angled intake and outlets for an inclined radiator. They'll feature stiffer, redesigned suspension mountings to correct handling difficulties. Both cars are Ford-powered and will be assigned to Johnny Rutherford, one as a spare.

Jack Zink, an early devotee of the rear-engined cars, is sponsoring a new Brabham-type built for driver Jim McElreath by crew chief Danny Moore and powered with a Ford engine. Zink was pleased with the ruling opening the race to stock engines, feeling it will help to reduce costs and attract more interest.

Joe Huffaker, whose MG Liquid Suspension Specials have had bad luck with engines and drive lines in the last two years, is building four new cars for Indy. They'll use full monocoque construction and a different set-up for suspension arms, but will retain the same spring-shock apparatus from the MG Sport Sedan. Two will definitely use the blown Offy, one a Ford and the fourth either a 305 Chevy or another blown Offy.

Finally, Huffaker is building a car to be powered by two Porsche engines, one up front and one in back. Paul Russo put a similar design on the pole in 1946, powered by a pair of small Offenhausers. He lasted only 16 laps, but maybe this time the concept will fare better. ★★★

### RELATIVE COSTS OF RACING

Item	1964	1966
Chassis	\$12,000	\$20,000
Engine	10,000	28,000
Extra parts, tires	12,500	17,200
Driver, crew	28,000	34,000
Entry fee	750	1,000
	<u>\$63,250</u>	<u>\$100,200</u>

These are average costs. Some crews will naturally have bigger budgets, while others must "make do" with less. Fuel, sparkplugs and batteries are usually free, supplied by manufacturers.



1965  
FORD or  
DODGE

\$899

'64 Cars  
\$599

LATE MODEL   
CARS AT HALF PRICE!

4-dr, 6 cyl, autom. trans.; good tires; spare, heater. Ex-taxis. No signs or markings. Present appearance no different than reg. pass. cars.

FREE CATALOG Write, wire, call, visit.  
UNIVERSAL AUTO WHOLESALERS, INC.  
Est. 1959 • Larry Shandel, Pres.  
235-51 Penhorn Ave., Secaucus, N.J. 07094  
(10 minutes from NYC off U.S. 1 & 9)  
Phone: (201) 866-7500 • NYC: (212) 244-1580



PELLET FIRING  
"45" AUTOMATIC

ONLY  
**\$1.98**

- Fires 8 Rounds
- Magazine Clip
- 8 Moving Parts

Most authentic full-size model of a "45" we have ever seen. A pull on the trigger fires it and automatically works the slide to reload just like a real automatic. Comes with full instructions for easy assembly, a generous supply of pellets and scoring target. Full money back guarantee. Send \$1.98 plus 27c shipping charges or order C.O.D.  
Honor House Products Corp. Dept. 96AU17 Lynbrook, N.Y.

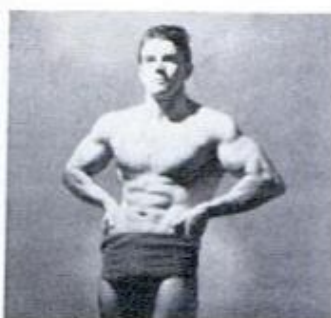

TRIM THAT WAISTLINE—NEW! NEW! Great new heat belt! Fits snugly around waist to create heat with the slightest exertion. Ruggedly built to give with any type of movement without slipping down or up. Wear it to work or a workout! Send waist size. \$2.95 POSTPAID. House of Health, Dept. PM-5, 310 East 1st St., Dayton, Ohio 45402

BIGGER BETTER **8th EDITION SMALL ENGINES SERVICE MANUAL** 

It's ready... 8th edition Small Engines Service Manual. More than 300 pages of authentic easy-to-follow information on repair and upkeep of small engines. 1302 models of popular domestic and foreign makes. Many new models. Practical information. Written by expert mechanics in down-to-earth language and with lots of helpful illustrations. **EVERYTHING MECHANICS NEED!**

MAKE \$\$\$  
in Your  
Spare Time

for minor tune-up to major overhaul... Read how, see how from 780 photos and drawings. Big field and big part-time and full-time profits repairing Mowers, Garden Tillers, Cycles, Scooters, etc... Order yours NOW and start a busy business... only \$4.95 postpaid.

**4.95**  
post paid

SMALL ENGINES SERVICE MANUAL, Dept. 166  
1014 Wyandotte Kansas City, Mo. 64105

MAY 1966

The Original "Wedge-type" Screwdriver

**QUICK-WEDGE**  
SCREW-HOLDING SCREWDRIVER



Easier to use:  
**NEW BEVELLED TUBE\*** slides easier to grip and to release the screw.

Firmer grip: new tube, combined with **NEW STRONGER BLADES** provide a more positive wedge-action to grip the screw.

More rugged construction:  
**NEW EXTRA-STRONG TIPS** won't bend or distort in normal use.

14 sizes Unconditionally Guaranteed!  
© 1966 by Kedman Company \* patented

**KEDMAN COMPANY**  
233 South 5th West, P.O. Box 267  
Salt Lake City, Utah 84110

hallicrafters new CB-12 citizens  
band transceiver gives you

**maximum  
effective  
range**



greater talk power... far less  
noise... 12 channels... only \$179.95!

Dual conversion receiver • Sensitivity less than 1  $\mu$ v. for 10 db/SN • Jack for external speaker or "loud hailer" • Full-time noise limiter • 3.5 watts audio output • Insignificant battery drain • Illuminated channel selector • All-solid state



Write today for full specifications.

**hallicrafters**

Dept. 7, 5th & Kostner Aves., Chicago, Ill. 60624

*"Quality through Craftsmanship"*



# This new tool bonds almost anything in 60 seconds



Hot-melts solid glue sticks. Makes gluing, sealing, caulking easy for all. No clamping. No waiting. No clean up. Ideal for hobbies, repairs, crafts. Try the Thermogrip Electric Glue Gun at \$7.95<sup>list</sup> your hardware dealer. Or write us for complete information.

**THERMOGRIP<sup>®</sup>**  
*electric glue gun*



B.B. Chemical Division, United Shoe Machinery Corporation (Dept. M), Cambridge, Mass. 02139





## WORKS WONDERS IN ONE COAT

MoorGard's "Magic Film" gives extra years of protection + Superb fade and chalk resistance + Speedy application with brush or roller; easy cleanup with soapy water + Colors that stay bright and crisp. It all adds up: MoorGard Latex House Paint means more for your money.

Benjamin  
**Moore**   
paints



# the case for the folding motor



2-year warranty: For 24 months after purchase, Evinrude will replace without cost to the original purchaser any part of its manufacture which upon inspection proves to have failed in normal use due to faulty material or workmanship.



*Stows like a traveling case.*

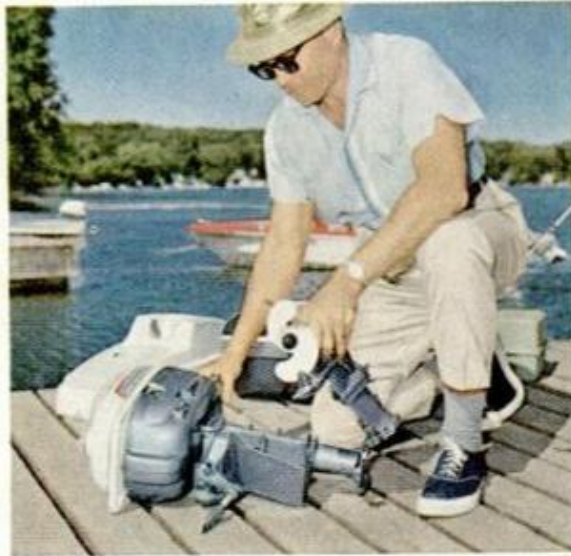

*Folds like a jack knife.*



*Ready for action in seconds.*

If the only place you can find to park an outboard motor is the front hall closet, you've got a problem.

But we've solved it.

If you've tried to squeeze a long-handled motor into a compact car trunk after your wife's bags are in—forget it.

Only a folding motor will do it.

If you're a camper and don't have an outboard, you're missing half the fun. But you can make a choice.

Leave one of the kids at home.

Or get an Evinrude folding motor.

The 3 hp Lightwin is a problem solver. It fits into a clean, compact traveling case.

It's easy to carry and handy to stow in car trunk, closet, or camp trailer.

The way people stop on the dock to stare when you unfold it, you'd think it was the biggest thing that ever happened to fishing.

Maybe it is.

See the new folding motors at your Evinrude dealer (listed in the Yellow Pages). Catalog free. Write Evinrude Motors, 4265 N. 27th Street, Milwaukee, Wisconsin 53216.

**EVINRUDE**  
first in  outboards  
DIVISION OF OUTBOARD MARINE CORP.

Материал защищен авторским правом