

POPULAR MECHANICS

JAN. 1966
35 CENTS

'66 DUESENBERG

7 big cars
rich people drive!

3 racing engines
for your car!

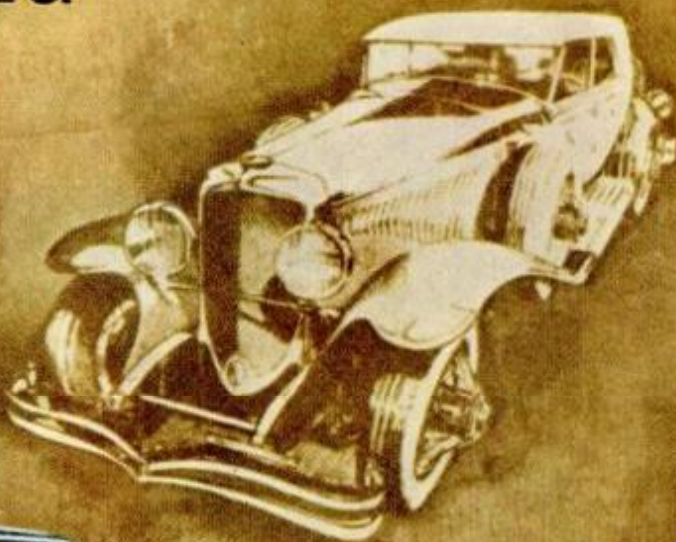

SNOWMOBILES

Duesenberg

Hottest cold-weather sport!

BUILD 'TEACUP'

The boat that teaches you to sail!

Your wife will be twice as safe this winter with 'Jeep' 4-wheel drive.



In a 'Jeep' Wagoneer with 4-wheel drive, she's got twice the traction of ordinary station wagons...twice the "bite" in deep snow. And she's twice as safe on slippery streets. That same extra grip will take you off the road...up onto the ski slopes, hunting, or just plain exploring. Choice of engines: 'Vigilante' V-8, or new Hi-Torque 6. Turbo Hydra-Matic* automatic transmission, other power options. Your family will be safer on the highway...on city streets...or off the road...have more fun this winter, in a 'Jeep' Wagoneer with 4-wheel drive.

* TRADEMARK GENERAL MOTORS CORPORATION

**NOW! THESE 10
SAFETY FEATURES
ARE STANDARD:**

- Seat belts front and rear
- Padded sun visors
- Padded dashboard
- High-impact windshield
- Outside rear-view mirror
- Dual brake system
- Self adjusting brakes
- 4-way warning flashers
- Back-up lights
- Windshield washer and dual-speed wipers

KAISER Jeep CORPORATION
TOLEDO 1, OHIO

'Jeep' Wagoneer

You've got to drive it to believe it. See your 'Jeep' dealer.

100 HP

Most powerful Sea-Horse ever built!

The word is out on the new 100hp Sea-Horse Golden Meteor and the word is performance. Never has an outboard engine provided such blazing response or so much usable power.

What's more, fuel economy is beautiful. This new V-100 uses no more fuel than 2-cycle engines of substantially less horsepower. In fact, we'd like you to compare it with any 4-cycle outboard, inboard or stern drive.

What's behind the performance breakthrough? A new, high-thrust, low-drag lower unit. The

extra dig this adds at early rpm is dramatic. The new tuned exhaust contributes, too. This, coupled with improved carburetion and the V-100's straight-through fuel induction system, gives you a power bonus with no increase in fuel.

There's more. New die-cast, tin-plated pistons made with special Johnson know-how resist sticking, scuffing and burning. And new molybdenum-filled piston rings make break-in easy and add to engine life.

There are 16 new Johnson

engines this year—from 3 to 100hp. All are quiet as 4 A.M. All are at home in salt water. All use regular grade fuel. And all are backed by our famous 2-year warranty* good on parts and labor.

For the right engine to fit your boating needs, visit your Johnson dealer. He's listed in the Yellow Pages. For facts, not sea stories, he's your man.

P.S. Johnson also makes a full line of Johnson Boats and the new Johnson Skee-Horse snowmobiles.

*For 24 months after purchase, Johnson Motors will replace without cost to the original purchaser, any part of its manufacture which upon inspection proves to have failed in normal use due to faulty material or workmanship.

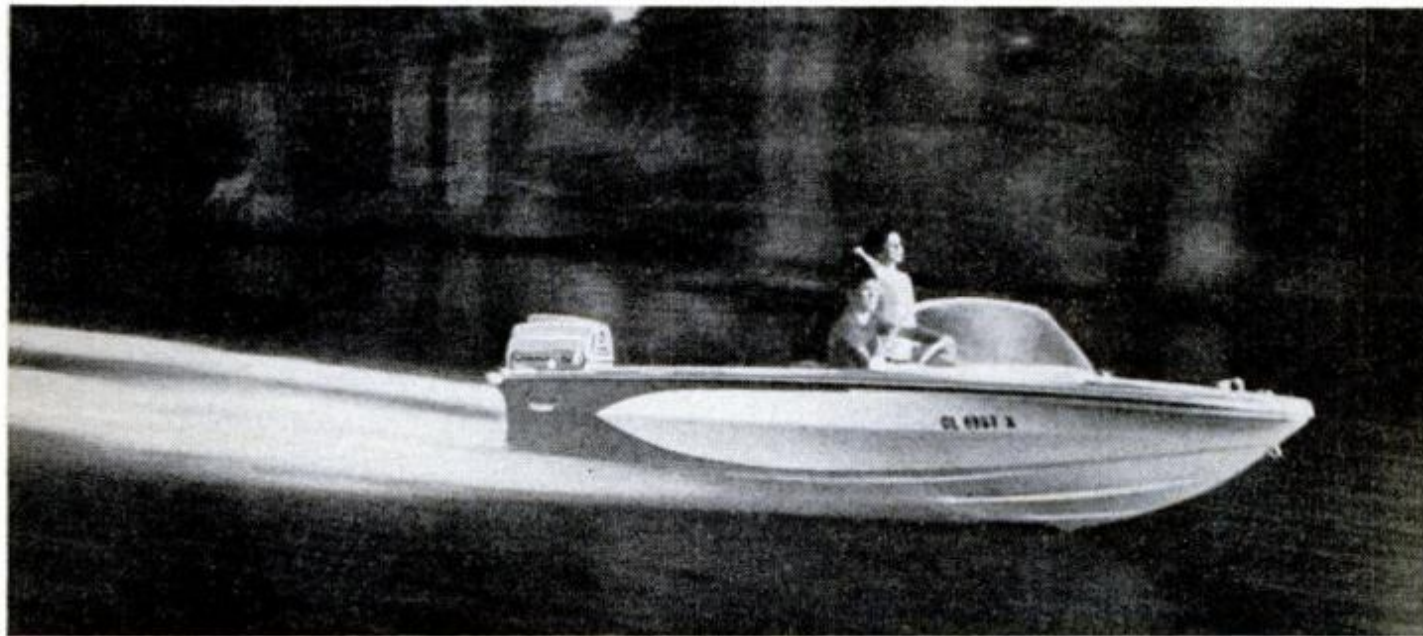



first in
dependability

Johnson

Johnson Motors, 2112 Pershing Rd., Waukegan, Ill. Div. Outboard Marine Corp.

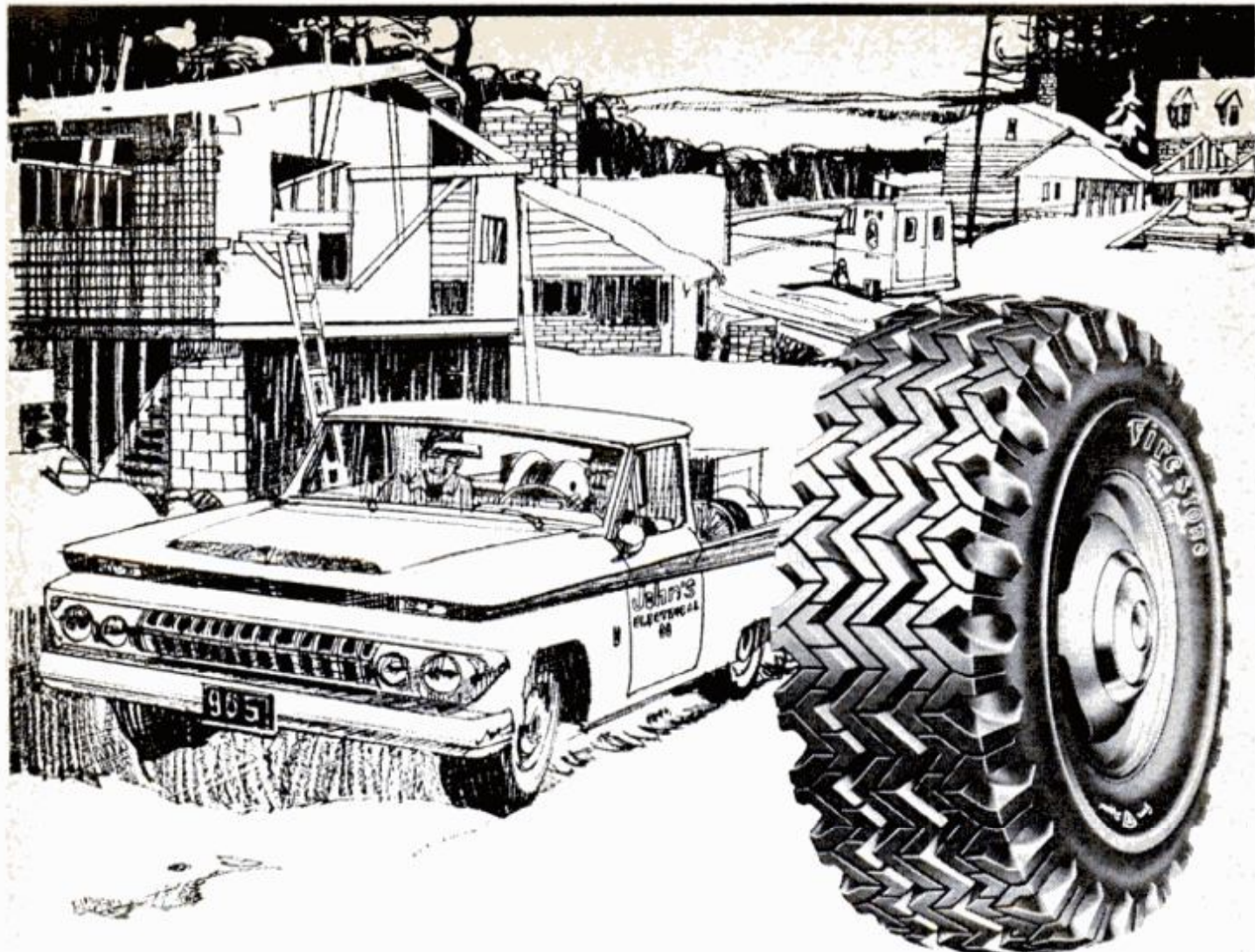

KG7D-ZWH-9G0E



NOW... FIRESTONE TOWN & COUNTRY TRUCK TIRES ARE GUARANTEED TO GO THRU ICE, MUD AND SNOW OR WE PAY THE TOW!*

Firestone Town & Country truck tires keep you going when others are stuck. That's our guarantee. And it's backed up in writing. What's more, we've built in a couple of new features that make these tires as smooth riding on paved streets as they are sure-footed on back roads. No pavement whine. And no snow-tire thump because Sup-R-Lon, a totally new tire cord, resists roughness

and distortion. Our long-wearing Sup-R-Tuf rubber gives you the extra mileage you expect from Firestone. For worry-free winter driving put on a pair of Firestone Town & Country truck tires at your nearby Firestone Dealer or Store.

*Guarantee applies for the life of original tread design on new Town & Country truck tires when used on drive wheels. Claims paid where guarantee was issued.

Town & Country® Sup-R-Tuf® Sup-R-Lon® Transport®

GET NYLON TRUCK TIRE PERFORMANCE AT PASSENGER TIRE PRICES WITH THE FIRESTONE TRANSPORT TIRE.



Firestone

YOUR SYMBOL OF QUALITY AND SERVICE

STP ... who uses it?



2 out of 3
at Indianapolis

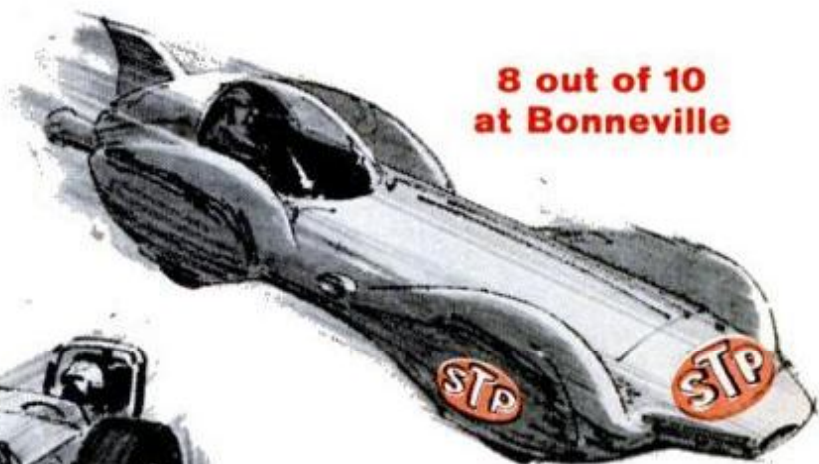

8 out of 10
at Bonneville

9 out of 10
at Drag Races

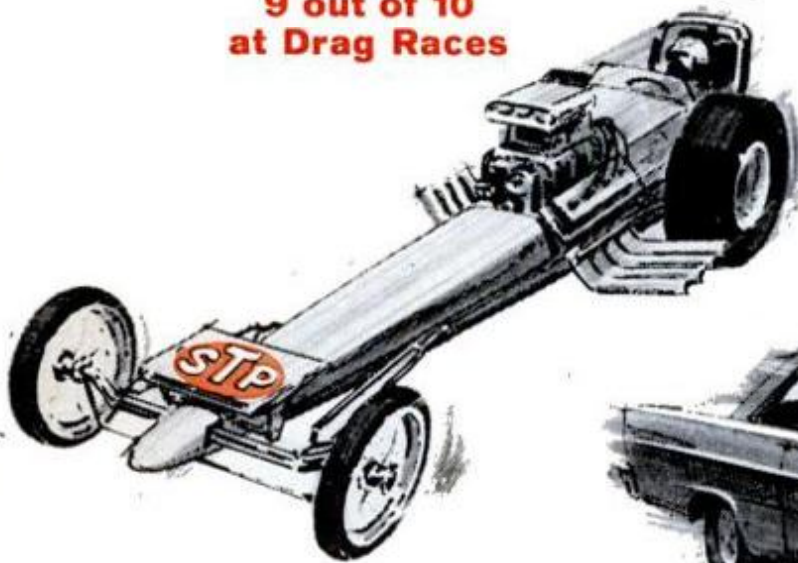

4 out of 5
USAC Stocks



AND MILLIONS AND MILLIONS OF MOTORISTS IN CARS LIKE YOURS—NEW AND OLD

Racing drivers use **STP** because it's the world's most effective protection against engine wear.

They know that **STP** is a 100% pure petroleum product. That it coats engine parts and surfaces with a tough, clinging protective film that refuses to break down. Cushions and lubricates every piston

stroke. Boosts ring seal and compression. Prolongs engine life.

STP is also used by millions of motorists like you, in new cars and old cars, for the same reasons.

So, next time you need oil... every time you change oil... add a pint of **STP**. The world's largest selling oil treatment.



POPULAR MECHANICS

INTERNATIONAL EDITIONS: AUSTRALIAN, SPANISH, CARIBBEAN, FRENCH, DUTCH, PORTUGUESE, DANISH, SWEDISH

PM AUTOMOTIVE SPECIALS THIS MONTH!

- 94** THE LUXURY CARS RICH PEOPLE DRIVE
What you get for the treasure they cost
- 100** THREE HOT RACING ENGINES HIT THE ROAD
Extra power spree adds fun and caution to driving
- 104** COMFORT-LIVABILITY INDEX FOR THE NEW MODELS
The 29 vital measurements of 35 current cars
- 106** YOUR SERVICEMAN LOOKS AT THE '66 CARS
The anatomy of more sophisticated innards
- 112** DUESENBERG—BACK FROM THE ROMANTIC PAST
Details on a luxury classic for anyone with \$19,500
- 116** ELECTRONIC CLINICS FOR SICK CARS
Dials diagnose it; a white-coated man cures it

FEATURES OF SPECIAL INTEREST

- 88** Supersonic Transports—Too Fast for Comfort?
- 122** The Great Relaxing Bonanza
- 127** Snowmobile Shakedown
- 130** Sledding at a Mile a Minute
- 134** No Land? Then Build it on Air
- 142** Cameras to Trap Crooks
- 194** Wireless Mike in Your Shirt Pocket
- 196** Private Ear for Silent TV Viewing

FOR THE SHOP CRAFTSMAN

- 146** Teacup—Build a Boat that Teaches Sailing
- 152** Winter Tuneup for Your Cycle, Part I
- 158** Build Anything with Slotted Angles
- 164** Lathe Fun from Alpine Novelties
- 168** Specifics of Specific Gravity
- 170** Pan Gold with a Gas-Driven Drywasher
- 176** Carving Signs with Router Templates
- 184** You CAN Get More Miles per Gallon
- 190** Nibbler Attachment for Your Sabre Saw

REGULAR DEPARTMENTS

10	<u>Letters to the Editor</u>	50	New Inventions
14	<u>Science Worldwide</u>	52	New Products
20	<u>Aviation Jetstream</u>	56	Worth Writing For
22	<u>Career Barometer</u>	87	Editor's Page
28	<u>News from the Military</u>	140	New for Your Home
30	<u>What's New Outdoors</u>	160	Photo Hints
32	<u>Detroit Listening Post</u>	162	Solving Home Problems
38	<u>Homeowners' Clinic</u>	174	Tips from Readers
42	<u>Spotlight: Dodge's Fastback</u>	182	Automobile Clinic

Published By The Hearst Corporation
RICHARD E. BERLIN, PRESIDENT

President, Mag. Division:

RICHARD E. DEEMS

Publisher:

JOSEPH F. KERN

Editorial Director:

WALTER IAN FISCHMAN

Executive Editor:

RICHARD F. DEMPEWOLFF

Managing Editor:

JOHN A. LINKLETTER

Shop Crafts Managing Editor:

WAYNE C. LECKEY

Art Director:

RAYMOND A. SCHULZE

CLIFFORD B. HICKS _____ Midwest Editor

THOMAS E. STIMSON _____ Western Editor

KEVIN V. BROWN _____ Aviation

ALFRED W. LEES _____ Home Workshop

RICHARD HOWE _____ Building and Landscape

ARTHUR MIKESSELL _____ Boating

JOHN F. PEARSON _____ Science

STUART JAMES _____ Outdoors

LARRY STECKLER _____ Electronics

ALEX MARKOVICH _____ New York Automotive

JIM DUNNE _____ Detroit Automotive

ROBERT B. BERGER _____ Photography

FRANK X. SMITH _____ Production

MURRAY COOPER _____ Assistant Art Director

LEO R. WEEKS _____ Assistant Art Director

GEORGE W. BLOW _____ Staff Artist

PHILIP F. HUY _____ Staff Artist

JAMES V. MEDLER _____ Staff Artist

ROBERT A. AUSTIN _____ Staff Artist

DANIEL J. COOK _____ Art Assistant

FRANK P. FRITZ _____ Chief Photographer

EUGENE A. COLANGELO _____ Staff Photographer

RALPH L. CLAAR _____ Photographer

GARRY WINTER _____ PM Books

FRANKLYN JACOBY, ASID/IDI _____ Design Consultant

EVERETT JOHNSON _____ Cabinetmaker

ADDRESS COMMUNICATIONS TO: 575 Lexington Ave., New York, N.Y. 10022. For additional sources of information on the articles and products in this issue, write to Bureau of Information, Popular Mechanics, for free "Where-to-Find-It" list.

L. PARK BENJAMIN, Advertising Director

ADVERTISING OFFICES: New York: 575 Lexington Ave., Murray Hill 8-8500; Chicago: 520 N. Michigan Ave., 527-2400; Detroit: General Motors Bldg., TRinity 5-8711; Cleveland: Hanna Bldg., 1422 Euclid Ave., PRespect 1-0456; Los Angeles: 3460 Wilshire Blvd., DUmkirk 2-8458; San Francisco: 1101 Hearst Bldg., YUkon 2-0823.

SUBSCRIPTION SERVICE: Mail all subscription orders, changes of address, correspondence concerning subscriptions, and Postmaster notices of undeliverable copies to Popular Mechanics, 250 West 55th St., New York, N.Y. 10019.

Popular Mechanics is published monthly by The Hearst Corporation, 57th St. at 8th Ave., New York, N.Y. 10019. U.S.A. Richard E. Berlin, President; George Hearst, V.Pres.; Richard E. Deems, President of Magazines; John R. Miller, V.Pres. and Gen. Mgr. of Magazines; G. Harry Chamberlaine, V.Pres. for Research and Marketing; William S. Campbell, V.Pres. and Director of Circulation; Joseph F. Kern, V.Pres. for Popular Mechanics; Frank Massi, Treasurer; R. F. McCauley, Secy. Single copy in the United States and Canada, 35 cents. Subscription prices: United States and Possessions, \$4.00 for one year; \$7.00 for two years; \$10.00 for three years. Canada, add \$0.50 for each year. Pan American Postal Union countries, add \$1.00 for each year. All other countries, add \$2.00 for each year. When changing address, give old address as well as the new, with postal-zone number, if any, and allow six weeks for change to become effective. Second-class postage paid at New York, N.Y., and at additional mailing offices. Authorized as second class mail by the Post Office Department, Ottawa, and for payment of postage in cash. Registered as second-class matter at the Post Office at Mexico, D.F., Mexico, June 20, 1950. © 1965 by The Hearst Corporation. All rights reserved. Printed in U.S.A.



HOMELITE XL CHAIN SAWS

World's greatest

LIGHTWEIGHT • OUTDOOR

work-savers

Cut a 12" log in 10 seconds! Do all kinds of woodcutting jobs faster, have more time for fun . . . your Homelite XL Chain Saw will cut firewood, clear land for cottage or campsite, trim and prune fruit and shade trees, and many others.

Homelite XL engine starts easily in any weather . . . weighs as little as 12 lbs. 12 oz., less bar and chain; you get correct balance and easy handling. You get straight bars from 12" to 36" that cut trees up to 4 feet in diameter — automatic or manual chain oiling.

See your HOMELITE dealer today. He's in the Yellow Pages. Try a HOMELITE XL — then take it home.

FREE! Write for colorful, 8-page booklet, "Man's Guide to Woodcutting".



HOMELITE

10201 RIVERDALE AVENUE
PORT CHESTER, NEW YORK

Atextron
DIVISION



Famous HOMELITE
XLs — world's fastest
selling chain saws.

DANA ANDREWS, Star of Stage, Screen and TV. . . Reports on AMERICA'S MOST REMARKABLE BUY IN PROFESSIONAL QUALITY POWER TOOLS. . .

DANA ANDREWS . . . Star of "CRACK IN THE WORLD" in Technicolor—a Paramount Release—writes . . . "Like most people, I guess, I sure had my doubts about how anyone could sell machines that are supposed to do so much . . . for so very little. I was never more pleasantly surprised! Every claim for them—and more—is true. Putting them through the most rugged workouts, has convinced me that the AMCO people know something no other manufacturer in America has been able to find out. These machines are, without question, a most remarkable buy in professional quality power tools."



BUY DIRECT FROM OUR FACTORY



POWER TOOLS

SAVE AS MUCH AS

80%

**8" TILT ARBOR
POWER
SAW**

\$14.95
f.o.b. factory. Wt. 25 lbs.
Includes completely assembled cast iron and steel 8" tilt arbor power saw with ground cast iron table . . . less blade. If desired, RIP FENCE for easier work alignment, \$3.50 additional



REVOLUTIONARY PATENTS DECREASE COSTS, INCREASE EFFICIENCY
Full scale power tools of heavy duty 100% cast iron and steel. Streamlined design reduces weight, cuts material and production costs. Special patents provide added efficiency, accuracy, savings. Parts made, assembled, tested and packed right in our own factories, shipped direct . . . save store profits.

DOES WORK OF \$75 BENCH SAW as is. Converts easily to equal any \$300 floor model cabinet units! Crosscuts, rips, mitres, cuts compound angles, dadoes, makes coves and mouldings. **FREE CABINET BASE PLANS** Use as portable bench saw as received (inset photo) . . . or transform easily and inexpensively into floor model (as shown) guar. to do work of floor models costing \$300. **FREE plans** . . . sheet of 3/4" plywood and 3-4 hours are all you'll need. Use your AMCO saw for cutting. Plans provide 27" x 24" work surface, 33" height, pullout sawdust bin, tool storage compartment. **10-YEAR FULL SERVICE GUARANTEE ***

BLADE TILTS . . . TABLE STAYS LEVEL
• Locks securely at any angle to 50°
• raises, lowers 0"-2 1/4"
• Patented tilt mechanism, accurate etched scale
• Patented motor mount takes std. 1/4 h.p. or larger motor, keeps belt tight, assures perfect alignment at any angle, transmits full power
• Takes std. blade, saw insert removes to take dadoe heads, cutters, etc. (not incl.)
• Accurate mitre gauge assembly
• Ground spindle
• Enclosed steel base
• "Compo" bearings
• Accessories available at factory prices
• RIP FENCE, if desired for easier work alignment: Std. size (for bench saw) \$3.50; larger fence (for cabinet base, as ill'd.) \$4.50.

**6" SWING
3-FT. LATHE**

\$9.85
f.o.b. factory
Optional Faceplate for turning bows, trays, lamp bases, rosettes, etc. \$2.50



Complete as shown
DOES THE WORK OF \$40 UNITS—Sturdy all cast iron power tool turns wood or plastics with the precision and speed of machines selling for 4 times as much: Tubular steel bed, ball thrust cup center, spur center. T-Rest assembly, lever action tail stock. 2 speed pulley. Fits any motor. **10-YEAR FULL SERVICE GUARANTEE ***

FULL 22" LONG, 4 1/8" JOINTER-PLANER

\$19.95
F.O.B. Factory Complete as shown
100% precision ground cast iron and steel.



UNCONDITIONAL 10-DAY MONEY BACK GUARANTEE
You must be fully satisfied. If not, return in 10 days, freight collect. Money refunded in full, no questions asked.

DOES WORK OF \$60 UNITS
Now, at little more than a hand tool price, a guaranteed professional quality precision machine which does same work as skilled hand planing . . . much faster, more accurately. Make accurate glue joints; rabbeting cuts for doors, window frames, table drawers; square taper cuts for chair legs; accurate beveling.
• Precision ground cast iron tables, adjustable for depth of cut
• Rigid cast iron base
• New patent-pending design holds clearance between knives and tables at any depth
• Rabbet depth 3/8"
• Hardened, ground high speed steel knives
• Patent-pending fence adjustable to any position, any angle 0°-50°
• Patent pending lift-off guard (nothing to loosen!)
• Balanced steel cutter head. **10-YEAR FULL SERVICE GUARANTEE ***

OR
1/2 HP ELECTRIC MOTOR
SPECIAL AMCO PRICE (when purchased with any unit in this ad)
\$12.95
f.o.b. factory
If purchased separately, \$18.95



SPECIAL LIMITED TIME ONLY
Brand new factory-fresh motors for use with any of the units on this page. Limited quantity purchase . . . first come, first served. Wt.: 17 lbs. **FULL SERVICE 1-YEAR WARRANTY *** Otherwise, as described below

PRECISION 4"x36" BELT SANDER

\$14.95
f.o.b. factory Wt. 15 lbs.
Optional Disc Sander incl. disc, bracket, ground cast table (tilts 0-45°): \$7.95 add'l. Mitre gauge: \$1.95 add'l.



DOES WORK OF \$50 SANDERS
After 23 mos. of design and testing, AMCO offers the world's most talented belt sander at a fraction of the usual cost. Heavy cast sander incl. 4" x 36" sanding belt, V-pulley drive, multi-purpose drive spindle for 1/4" shank acc'ssy tools. Changes from horizontal to vertical sanding in secs. Uses 1/3 hp or larger motor. **10-YEAR FULL SERVICE GUARANTEE ***

MAIL COUPON TODAY!

AMERICAN MACHINE & TOOL CO., Dept. PM-16A, Royersford, Pa.
Please send me the units checked. Payment in full enclosed \$. . . or \$3 deposit each item enclosed, balance C.O.D.
 I MUST BE FULLY SATISFIED OR WILL RETURN UNIT WITHIN 10 DAYS FOR FULL REFUND. No questions asked.
 8" Power Saw at \$14.95 Jointer-Planer at \$19.95
 Long Rip Fence #354C at \$4.50 Lathe at \$9.85 with
 Standard Rip Fence #354 at \$3.50 faceplate \$12.35
1/2 hp Motor: \$18.95 \$12.95 (purchased with other item)
 Belt Sander at \$14.95 Disc Sander at \$7.95
 Mitre gage at \$1.95

NAME
ADDRESS
CITY ZONE/ZIP STATE

***10-YEAR FULL SERVICE GUARANTEE** Any part or parts of any AMCO power tool which may become inoperative for any reason within ten years after the purchase date will be repaired or replaced by the factory without cost to the purchaser. Your only cost: for postage.

KEEP PACE WITH SPACE AGE! SEE MANNED MOON SHOTS, SPACE FLIGHTS, CLOSE-UP!



AMAZING SCIENCE BUYS

for FUN, STUDY or PROFIT

SCIENCE FAIR HEADQUARTERS!
FREE! CATALOG

'FISH' WITH A WAR SURPLUS MAGNET

Go Treasure Hunting On The Bottom

Great idea! Fascinating fun and sometimes tremendously profitable! Tie a line to our 5-lb. Magnet—drop it overboard in bay, river, lake or ocean. Troll it along the bottom—your "treasure" haul can be outboard motors, anchors, fishing tackle, all kinds of metal valuables. 5-lb. Magnet is war surplus—Alnico V Type—Gov't. Cost—\$50. Lifts over 125 lbs. on land—much greater weights under water. Order now and try this new sport. Stock No. 70,571-H. 5 lb. Magnet\$12.50 Postpaid
Stock No. 70,570-H. 3 1/2 lb. Lifts 40 lbs.\$ 8.75 Postpaid
Stock No. 85,152-H . . . (lifts over 350 lbs).....\$33.60 F.O.B.



See the Stars, Moon, Planets, Close Up! 3" ASTRONOMICAL REFLECTING TELESCOPE

60 to 180 POWER! FAMOUS

Mt. Palomar Type! An Unusual Buy!

See the Rings of Saturn, the fascinating planet Mars, huge craters on the Moon, phases of Venus, Equatorial Mount with lock on both axes. Aluminized and overcoated 3" diameter high-speed f 10 mirror. Telescope equipped with a 60X eyepiece and a mounted Barlow Lens. Optical Finder Telescope included. Hardwood, portable tripod. FREE with scope: Valuable STAR CHART plus 272-page "HANDBOOK OF HEAVENS" plus "HOW TO USE YOUR TELESCOPE" BOOK.

Stock No. 85,050-H\$29.95 Postpaid

4 1/4" Reflecting Telescope—up to 225 Power
Stock No. 85,105-H\$79.50 F.O.B.

Superb 6" Reflector Telescope
Up to 576 Power. Equatorial mount and Pedestal Base.
Stock No. 85,086-H\$199.50 F.O.B.

OPAQUE PROJECTOR

Projects illustrations up to 3" x 3 1/2" and enlarges them to 35" x 50". If screen is 6 1/2 ft. from projector, larger pictures if screen is further away. No film or negatives needed. Projects charts, diagrams, pictures, photos, lettering in full color or black-and-white. Operates on 115 volt, A.C. current. 6-ft. extension cord and plug included. Operates on 60 watt bulb, not included. Size 12" x 8" x 4 1/2" wide. W. 1 lb., 2 oz. Plastic case. Stock No. 70,199-H\$7.95 Postpaid



Fascinating New Kaleidoscope Insert. Same unit as above, but provides endless additional projects with everchanging kaleidoscope patterns.
Stock No. 60,714-H\$10.00 Ppd.

SOLVE PROBLEMS! TELL FORTUNES! PLAY GAMES! NEW WORKING MODEL DIGITAL COMPUTER

ACTUAL MINIATURE VERSION OF
GIANT ELECTRONIC BRAINS

Fascinating new see-through model computer actually solves problems, teaches computer fundamentals. Adds, subtracts, multiplies, shifts, complements, carries, memorizes, counts, compares, sequences. Attractively colored, rigid plastic parts easily assembled. 12" x 3 1/2" x 4 3/4". Incl. step-by-step assembly diagrams, 32-page instruction book covering operation, computer language (binary system), programming, problems and 15 experiments.
Stock No. 70,683-H\$5.98 Ppd.



WAR SURPLUS AMERICAN-MADE 7x50 BINOCULARS

Big savings! Brand new! Crystal clear viewing—7 power. Every optical element is coated. An excellent night glass—the size recommended for satellite viewing. Individual eye focus. Exit pupil 7mm. Approx. field at 1,000 yds. is 378 ft. Carrying case included. American 7 x 50's normally cost \$274.50. Our war surplus price saves you real money.
Stock No. 1544-HOnly \$78.40 Ppd.
8 x 30 Binoculars—similar to above.
Stock No. 963-H\$40.00 Postpaid
7 x 35 American Made Binoculars.
Stock No. 964-H\$55.00 Ppd.



Diagnose Hidden Trouble with Professional Stethoscope

Designed for use by phys., ans, this super-sensitive stethoscope is ideally suited for detecting faults in machines and engines, and in fluid, air and gas leakage. Dozens of uses in auto repair shops, labs, hobby, educational institutions.



Stock No. 50,270-H\$6.95 Postpaid
BARGAIN PRICE STETHOSCOPE—excellent value.
No. 50,223-H\$2.95 Postpaid

Bargains Galore! Hours of Fun! Only \$5

NEW POPULAR SCIENCE FUN CHEST

Here are Edmund's 9 top selling science toys and curiosities in one fascinating, low-cost package. Perfect gift item. Amuse and delight young and old for hours on end. Educational, too! Teach basic science principles in a wonderful new fun way. Incl.: Solar Radiometer—spins at 3,000 rpm; Albert the Bobbing Bird—runs continuously on thermal energy; Amazing Sealed Mercury Puzzle; Five 2-sided Ceramic Magnets; Big 3 1/2" Burning Glass in Zip-Lip Poly Bag; Magnetic Doggie and Spinning Ball—ball spins as dog approaches; Diffraction Grating—Rainbow Viewer; PIK-UP Ring (with Edmund TAK); Popular booklet, "Astronomy and You". All in die-cut storage box with complete instructions.



Stock No. 70,787-H\$5.00 Ppd.

ORDER BY STOCK NUMBER. SEND CHECK OR MONEY ORDER. SATISFACTION GUARANTEED.

EDMUND SCIENTIFIC CO., BARRINGTON, N. J.

NEW! SCIENCE FAIR PROJECT KITS

Edmund Kits are carefully planned to give any boy or girl the fun and excitement of discovering science facts. Such carefully planned projects can lead the student to awards or scholarships. Adults too will find them an excellent introduction to the various fields of science.
Write for Free Bulletin 47-H "Your Science Project" covering all phases of Science Fair projects.



MINIATURE WATER PUMP



Wonderful for experiments, miniature waterfalls, fountains, Christmas gardens, 110 gage railroad backdrops, hobbyists, labs, schools. Pumps continuous flow of water etc. Tiny (2 1/4" x 1 3/4") electric motor and pump ideal for hobbyists, labs, schools. Pumps continuous flow of water at rate of one pint per minute at a 12" head. With 2 D Batteries in series will pump to 24" high. Works in either direction. Stock No. 50,345-H\$2.25 Postpaid

WOODEN SOLID PUZZLES

12 Different puzzles that will stimulate your ability to think and reason. Here is a fascinating assortment of wood puzzles that will provide hours of pleasure. Twelve different puzzles, animals and geometric forms to take apart and reassemble, give a chance for all the family, to test skill, patience, and best of all to stimulate ability to think and reason while having lots of fun.
Stock No. 70,205-H\$3.00 Postpaid



SCIENCE TREASURE CHESTS

For Boys—Girls—Adults!



Science Treasure Chest—Extra-powerful magnets, polarizing filters, compass, one-way-mirror film, prism, diffraction grating, and lots of other items for hundreds of thrilling experiments, plus a Ten-Lens Kit for making telescopes, microscopes, etc. Full instructions included.
Stock No. 70,342-H\$5.50 Postpaid

Science Treasure Chest DeLuxe—Everything in Chest above plus exciting additional items for more advanced experiments.
Stock No. 70,343-H\$10.50 Postpaid

BUILD A SOLAR ENERGY FURNACE

A fascinating new field. Build your own Solar Furnace for experimentation—many practical uses. Easy! Inexpensive! Use scrapwood! We furnish instructions. This sun powered furnace will generate terrific heat—2000° to 3000°. Fuses enamel to metal. Sets paper aflame in seconds. Use our Fresnel Lens 11" sq. F.L. 19".
Stock No. 70,533-H\$6.00 Postpaid



WAR SURPLUS ELECTRIC GENERATOR

Brand new Signal Corps Electric Generator for scientific experiments, electrical uses, demonstrations. Generates up to 90 volts by turning crank. Use in high impedance relays. Charge ground and bring up night crawlers for bait or study. 2 Alnico Magnets alone worth original price. Wt. 2 lbs. Cost to Gov't. \$15.
Stock No. 50,225-H\$6.95 Pstd.
Same type generator, mounted, with light, as electricity demonstrator.
Stock No. 50,365-H\$11.95 Postpaid



Brand New, Quick-Charge, Industrial Surplus NICKEL-CADMIUM BATTERY

Unparalleled Value

For the first time a 6-volt, light-weight nickel-cadmium battery in stainless-steel, strap type casing, 4-amp hour capacity. Almost unlimited life—thousands of discharge-charge cycles with minute deterioration—charges fully in approx. 1 hr. with Edmund charger kit. Just a few drops of water per year provide full maintenance. Hundreds of uses for hobbyists, amateur photographers, campers, model builders, etc. Unequaled for rechargeable lanterns, cycle scooters, and boat lights; portable fluorescent and ultra-violet lights; electronic flash units. Battery requires minimum of electrolyte; is sealed to prevent loss; delivers nearly 100% of output below freezing temperatures compared to 50% by lead-acid batteries. No corrosive fumes under any stage of recharge. Can't be damaged by accidental charge in reverse (but not recommended). Stud type terminals on top 1 1/4" apart marked for polarity. 6/32 thread, nuts and lock-washers, 6"x2"x4". Wt. approx. 2 lbs.
Stock No. 70,776-H\$15.00 Ppd.

CHARGER KIT FOR 6-VOLT BATTERY. Charges in approx. 1 hr. Shuts off automatically, attaches to Stock No. 70,766 battery case. Includes transformer, ballast resistors, charger circuit board, mounting hardware, 8-ft. cord, plug switch, assembly instructions.
Stock No. 79,807-H\$8.00 Ppd.

ONE 1.2 VOLT NICKEL-CADMIUM CELL
Stock No. 40,798-H\$3.95 Ppd.

Order by Stock No.—Send Check or M.O.—Money-Back Guarantee
EDMUND SCIENTIFIC CO., Barrington, New Jersey

MAIL COUPON FOR FREE CATALOG "H"

Completely new 1966 Edition, 148 pages
Nearly 4000 Bargains.

EDMUND SCIENTIFIC CO., Barrington, N. J.
Please rush Free Giant Catalog "H".

Name.....
Address.....
City.....Zone.....State.....



ACCOUNTING

Accounting for Business
 Programmers
 Accounting (Canadian)
 Auditing
 Business Law
 Cost Accounting
 C.P.A. Review
 Estate & Trust
 Accounting
 Executive Accounting
 Federal Tax
 General Accounting
 Industrial Accounting
 Junior Accounting
 Legal Accounting
 Office Accounting
 Personal Income Tax &
 Social Security
 Practical Accounting
 Public Accounting
 Small Business
 Accounting
 Starting & Managing a
 Small Bookkeeping
 Service

**ARCHITECTURE
AND BUILDING**

Architectural Drawing &
 Designing
 Architecture
 Building Contractor
 Building Estimator
 Building Inspector
 Building Maintenance
 Carpenter-Builder
 Carpentry & Millwork
 House Planning & Interior
 Design
 Mason
 Painting Contractor
 Reading Arch. Blueprints
 Review in Arch. Design &
 Practice
 Review of Mech. Systems
 in Buildings

ART

Amateur Artist
 Commercial Art
 Commercial Cartooning
 Interior Decorating
 Oil Painting for Pleasure
 Show Card & Sign
 Production
 Show Card Writing
 Sign Painting & Designing
 Sketching & Painting

AUTOMOTIVE

Automatic Transmission
 Specialist
 Automobile Body
 Rebuilding & Refinishing
 Automobile Electrical
 Technician
 Automobile Engine Tune-Up
 Automobile Technician
 Automotive Mechanic
 Diesel-Gas Motor Vehicle
 Engines

BUSINESS

Advertising
 Basic Inventory Control
 Business Administration
 Business Management &
 Marketing
 Business Management &
 Production
 Canadian Business Courses
 COBOL Programming
 Condensed Business
 Practice
 Direct Mail & Mail
 Order Advertising
 Industrial Psychology
 Magazine & Newspaper
 Advertising
 Managing a Small Store
 Marketing
 Marketing Research
 Modern Executive
 Management
 Office Automation
 Office Management
 Programming for Digital
 Computers
 Programming the IBM 1401
 Computer
 Purchasing Agent
 Retail & Local Advertising
 Retail Business
 Management
 Retail Merchandising
 Retail Selling
 Systems and Procedures
 Analysis

CHEMICAL

Analytical Chemistry
 Chemical Engineering
 Chemical Engineering Unit
 Operations
 Chemical Laboratory Tech.
 Chemical Process Operator
 Elements of Nuclear Energy
 General Chemistry
 Instrumental Laboratory
 Analysis

CIVIL ENGINEERING

Civil Engineering
 Construction Engineering
 Highway Engineering
 Principles of Surveying
 Reading Highway
 Blueprints
 Sanitary Engineering
 Sewage Plant Operator
 Structural Engineering
 Surveying and Mapping
 Water Works Operator

DRAFTING

Architectural Drafting
 Design Drafting
 Drafting Technology
 Electrical Drafting
 Electrical Engineering
 Drafting
 Electronic Drafting
 Introductory Mechanical
 Drafting
 Mechanical Drafting
 Pressure-Vessel and Tank
 Print Reading
 Sheet Metal Layout for
 Air Conditioning
 Structural Drafting

ELECTRICAL

Electric Motor Repairman
 Electrical Appliance
 Servicing
 Electrical Contractor
 Electrical Engineering
 (Power option or
 Electronic option)
 Electrical Engineering Tech.
 Electrical Instrument Tech.
 Industrial Electrical Tech.
 Power Line Design and
 Construction
 Power Plant Operator
 (Hydro or Steam Option)
 Practical Electrician
 Practical Lineman
 Reading Electrical
 Blueprints

**CAST
 YOUR
 BALLOT
 FOR
 A
 SUCCESSFUL
 FUTURE!**

253

I.C.S.

Convenient Payment Plan

Special in-plant training programs for industry

New! Special Package for Women



I.C.S. is the oldest, largest school of its kind. Over 200 courses for men and women. High school, business, secretarial, interior decorating, engineering. One for **you**. Direct, job-related. Bedrock facts and theory plus practical

application. You learn from experts. Diploma to graduates.

Clip and mail the coupon **now**. You'll receive, absolutely FREE, 3 valuable booklets that have helped thousands. But don't delay. Cast **your** "ballot" today!



**ENGINEERING
(Professional)**

Chemical
Civil
Electrical
Industrial Management for Engineers
Mechanical

ENGLISH AND WRITING

Better Business Writing
Free Lance Writing for Fun & Profit
Introductory Technical Writing
Modern Letter Writing
Practical English
Short Story Writing

HIGH SCHOOL

High School Business
High School (Canadian)
High School College Prep. (Arts)
High School College Prep. (Engineering & Science)
High School General
High School Mathematics
High School Secretarial
High School Vocational

LANGUAGES

(Edited by Berlitz)
French
German
Italian
Spanish

LEADERSHIP

Basic Supervision
Industrial Foremanship
Industrial Supervision
Personality Development
Personnel-Labor Relations

MATHEMATICS

Advanced Mathematics
Mathematics and Mechanics for Engineering
Mathematics & Physics for Technicians
Mathematics and Physics for Engineering
Modern Elementary Statistics

MECHANICAL

Aircraft & Power Plant Mechanic
Industrial Engineering
Industrial Instrumentation
Machine Design
Mechanical Engineering
Quality Control
Safety Engineering Tech'g'y
Tool Design
Value Analysis

PETROLEUM

Natural Gas Production & Transmission
Oil Field Technology
Petroleum Production
Petroleum Production Engineering
Petroleum Refinery Operator
Pipeline Engineering

PLASTICS

Plastics Technician

**PLUMBING, HEATING,
AIR CONDITIONING**

Air Conditioning
Air Conditioning Maintenance
Domestic Heating with Oil & Gas
Domestic Refrigeration Heating
Heating & Air Conditioning with Drawing
Industrial Air Conditioning
Industrial Heating
Plumbing
Plumbing & Heating
Practical Plumbing
Refrigeration
Refrigeration & Air Conditioning
Steam Fitting

PULP AND PAPER

Paper Machine Operator
Paper Making
Pulp Making
Pulp & Paper Engineering
Pulp & Paper Making

SALESMANSHIP

Creative Salesmanship
Real Estate Salesmanship
Sales Management
Salesmanship

SECRETARIAL

Clerk-Typist
Commercial
Legal Secretary
Medical Secretary
Professional Secretary
Shorthand
Stenographic
Typewriting

SHOP PRACTICE

Drill Operator
Foundry Practice
Industrial Metallurgy
Lathe Operator
Machine Shop Inspection
Machine Shop Practice
Machine Shop Practice & Toolmaking
Metallurgical Engineering Technology
Milling Machine Operator
Multicraft Maintenance Mechanic
Practical Millwrighting
Reading Shop Prints
Rigging
Tool Engineering Tech'g'y
Tool Grinder
Toolmaking
Turret Lathe Operator
Welding Engineering Technology

**STEAM AND DIESEL
POWER**

Boiler Inspector
Industrial Building Engineer
Power Plant Engineering
Stationary Diesel Engines
Stationary Fireman
Stationary Steam Engineering

TEXTILES

Carding
Carding and Spinning
Dyeing & Finishing
Loom Fixing
Spinning
Textile Designing
Textile Mill Supervisor
Textile Technology
Warping and Weaving

TRAFFIC

Motor Traffic Management
Railway Rate Clerk
Traffic Management

TV-RADIO-ELECTRONICS

Communications Techn'gy
Electronic Fundamentals
Electronic Fundamentals (Programmed)
Electronic Fundamentals with Electronic Equipment Training
Electronic Instrumentation & Servo Fundamentals
Electronic Principles for Automation
Electronics and Applied Calculus
Electronics Technician
First Class Radiotelephone License
Fundamentals of Electronic Computers
General Electronics
General Electronics with Electronic Equip. Trng.
Hi-Fi Stereo and Sound Systems Servicing
Industrial Electronics
Industrial Electronics Engineering
Industrial Electronics Engineering Technician
Practical Radio-TV Eng'g
Practical Telephony
Principles of Radio-Electronic Telemetry
Principles of Semiconductor-Transistor Circuits
Radio Servicing with Equipment Training
Radio & TV Servicing
Radio & TV Servicing with Equipment Training
Second Class Radiotelephone License
Sound Systems Specialist
Telephony, Electronics and Radio Communications
TV Receiver Servicing
TV Technician

COURSES

In Hawaii: P. O. Box 418, Honolulu

In Canada: I. C. S. Canadian, Ltd.

Clip coupon—and take your first big step to real success! I. C. S., Scranton, Penna. 18515

In other countries: I. C. S. World, Ltd.

**FREE! THE I.C.S. SUCCESS KIT!**

Three valuable booklets sent to you free when you mark and mail the I.C.S. coupon. No obligation.

1. "How to Succeed"—A new, exciting booklet that lets you evaluate yourself and your future in an entirely different way!
2. Complete catalog outlining job opportunities and outlook in your field of interest.
3. Sample lesson to demonstrate the success-proved I.C.S. method of spare-time study.

Accredited Member, National Home Study Council

INTERNATIONAL CORRESPONDENCE SCHOOLS ICS

Dept. 1447, Scranton, Penna. 18515

Without cost or obligation, send me "HOW TO SUCCEED," the opportunity booklet about the field I have indicated below, and a sample lesson.

Course in which I'm interested: _____
(Select from listing above)

Name _____ Age _____

Address _____
(Indicate Mr., Mrs., or Miss)

City _____ State _____ Zip code _____

Occupation _____ Working hours _____ A.M. to _____ P.M.

Employed by _____ I am in the U.S. Armed Forces.
Tell me about special low rates.



Our 20th Anniversary Model* 3/8" drill looks like this. It costs \$250! About 10 times as much as our ...



standard \$25 model that looks like this... Same great performance built into both, but for status...*

The Standard Shopmate model #1838 (above) also comes in three useful variations. #1836 is a trigger-touch variable speed drill, 0 to 1000 RPM. #1837 offers two speeds—1000 to 800 RPM. #1839 is reversible. All powered by Life-Weld 1/4 HP, 3.4 amp. motor. Industrial listed. Double reduction gears, multi-ball thrust and self lube bronze bearings, geared chuck and key. Handsomely housed in bright mirror finish die-cast aluminum. Average \$25.00 retail. (Gunsmith Hand Engraved #1838, top illustration, \$250. Limited to 20 hand-crafted originals (Serially numbered 1 to 20). Includes lined walnut case, engraved placque. 1 month delivery.)

***Hurry, we're only making 20!**

WE ALSO MAKE EXCELLENT...



Electric Screw Drivers • Circular Saws • Sabre Saws

"20 Years of Power Tool Progress"

SHOPMATE

Portable Electric Tools, Inc., 1200 E. State St., Geneva, Ill.

LETTERS

TO THE EDITOR

Blunder at Stone Mountain

I enjoyed reading *They're Burning a Memorial into a Mountain* (page 134, Nov. PM). It might be of interest to you to know that Gutzon Borglum had agreed to return to Stone Mountain and revise the work several years prior to his death, but funds were not available at that time.

I should like to comment on the statement that Borglum committed a blunder in transferring his designs to the side of the mountain and they had to be removed.

I have some knowledge of these matters, am very familiar with the whole Stone Mountain story, and for several years did the engineering on The Rushmore Memorial—and completed the project after the death of Gutzon Borglum. It is the only successful mountain carving in the country today.

The methods used to enlarge the models on Rushmore were basically the same as those pioneered at Stone Mountain by Borglum. Since they were completely successful at Rushmore and on a much larger scale (over five times the size of Stone Mountain), any distortion would be greatly increased.

There are two factors in mountain carving that must be considered. One is sunlight and the other is scale. To be effective, the sun must light the carving as much as possible, to make it beautiful. The scale must be in keeping with the size of the stone, or you get the effect of a postage stamp on a barn door.

Stone Mountain faces to the north, and about halfway down this side of the rock, it drops from about a 45-degree angle to a vertical. Anything below this point is almost always in shadow. Borglum's heads were larger than the present carving and placed above this shadow line. The basic blunder at Stone Mountain was their destruction.

Hermosa, S.D.

LINCOLN BORGLUM

Marines Are OK . . . but

It is not a fact that the *Jungle Boots* (page 139, Oct. 1965 PM) were made for the Marines in Vietnam. The boots have been adopted by the Marines. They were originally designed and made exclusively for the Special Forces of the Army—the Green Berets!

I think the Marines are great, but let's

(Please turn to page 12)

LEARNING RADIO-TELEVISION, ELECTRONICS IS FAST, EASY, INTERESTING WITH NRI

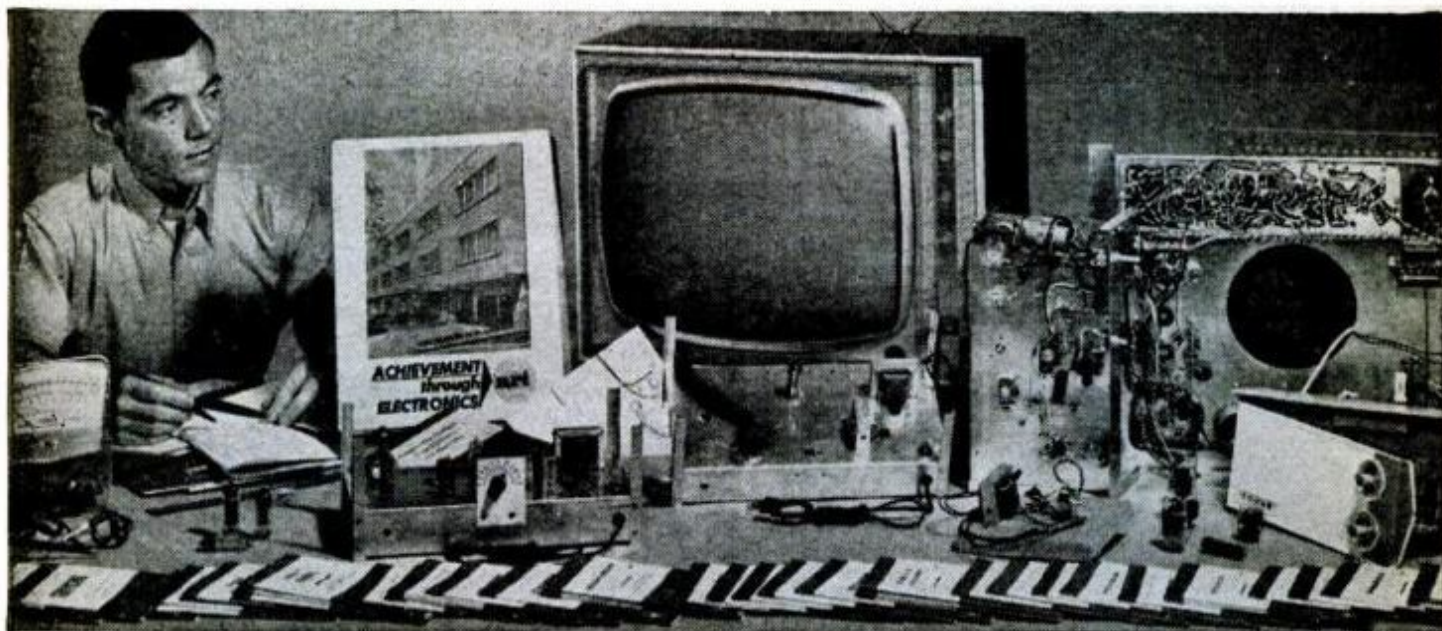

NEW ACHIEVEMENT KIT—CUSTOM TRAINING KITS—"BITE-SIZE" TEXTS YOU GET MORE FOR YOUR MONEY FROM NRI

All the material you see above is included in just one NRI home training course. Other courses are equally complete. But NRI training is more than kits and texts. It's also personal services which have made NRI the 50-year leader in training at home for fast growing Radio-TV, Electronics.

Choose From 10 NRI Training Plans

NRI has a training plan to fit every interest, every need in Radio-TV, Color TV and Electronics. You can be your own boss in a Radio-TV Servicing business of your own or you can make \$3 to \$5 an hour fixing sets in your spare time. Or you can be a part of the Electronics "revolution" in business and industry. You may want to get into the fascinating fields of broadcasting-communications. You may want to take part in missile, rocket, satellite or other government programs. An understanding of computers may be necessary in your work. Perhaps you want to "brush up" on math, electronic terms or basic principles. Whatever your interest, you'll find an NRI course tailored to your needs.

Revolutionary "3-Dimensional" Method

Regardless of your educational background, you can effectively learn the Electronics field of your choice the NRI "3-Dimensional" way. NRI has simplified, organized and dramatized subject matter to make your training at home entertaining, easy. Catalog gives you complete information. Read about the exclusive Achievement Kit NRI sends you the day you enroll. Read about custom designed training equipment NRI gives you at no extra cost, to give you essential, practical experience. Equip-

ment you build, tests you make bring to life what you read in NRI's unique "bite-size" lesson texts.

Move Ahead In Fast Growing Industry

TV-Radio, Electronics is moving ahead fast. The demand for skilled technicians is great and growing. Discover how you can be a part of the Electronics Age — starting soon. Mail coupon now for free NRI Catalog. NATIONAL RADIO INSTITUTE, Electronics Division, Washington, D. C. 20016. No salesman will call. No obligation.

Thousands Owe Success to NRI



F. W. COX, Hollywood, Calif., averaged \$150 a month spare time while training, now has his own full time TV-Radio service business. ALLAN R. TOWNSEND, Topeka, Kan., is a missile officer at Atlas ICBM site, fixes radios and TV sets spare time. R. L. WOOD, Fargo, N. D., got his FCC license and is Master Control Engineer with KXIB-TV. J. J. JENKINS, San Diego, Calif., says his NRI training is priceless. He is Frequency Coordinator for the 11th Naval District.



Mail Now for FREE Catalog

NATIONAL RADIO INSTITUTE 100-016
Electronics Division, Washington, D.C. 20016

Send me your FREE Catalog. (No salesman will call.)

Name _____ Age _____
(Please print)

Address _____

City _____ State _____ Zip Code _____

ACCREDITED MEMBER NATIONAL HOME STUDY COUNCIL



Over 50 Years of Leadership
in Electronics Training

**FREE
PLAN**

Be Your Own Boss

New Business Opportunity

FILING SAWS

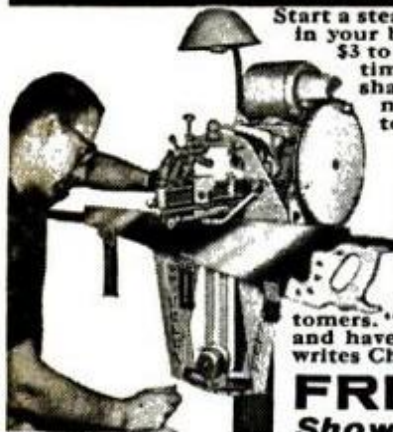

Start a steady repeat CASH business in your basement or garage. Earn \$3 to \$6 an hour in your spare-time! Excellent profits in saw sharpening business! Automatic Foley Saw Filer, easy to operate, files combination saws, hand, band, and circular saws. No experience needed. H. C. Deibert wrote us: "Since I got my Foley Filer 5 years ago, I have averaged 4½ saws each day since I started." Every saw you sharpen brings you more customers. "I rented a two-car garage and have all the work I can do," writes Charles H. Smith.

FREE BOOK Shows How to Start

Fact filled booklet tells you how to start a sparetime business immediately; how to get new business, how to advertise. Rush coupon now; get "Money Making Facts" and details on Easy Payment Plan. No Salesman will call.

Send Coupon for FREE BOOK Money Making Facts

FOLEY MANUFACTURING CO.
116-6 Foley Bldg., Minneapolis, Minn. 55418

Send FREE BOOK—"Money Making Facts",
and Time Payment Plan.



Name _____

Address _____

Even without this famous guarantee a **RIGID** would still be your best pipe wrench buy.



Choice of
10 Sizes
6" through 60"

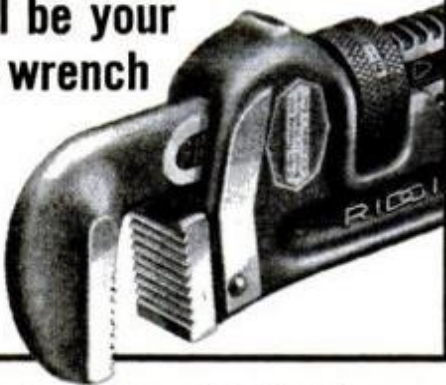

RIGID Heavy-Duty pipe wrenches are tough. That's the way we build them. And that's why they'll outperform and outlast all others. Jaws are made of tough, alloy tool-steel. Patented spring jaw suspension gives instant, slip-proof grip. Jaws can't lock... always release fast. Every **RIGID** Wrench is completely work-tested before shipment. Try one and you'll be sold on a **RIGID**.

See the complete line of **RIGID** Work-Saver Tools at your dealers



RIGID THE RIDGE TOOL COMPANY, ELYRIA, OHIO, U. S. A.

LETTERS continued

not give them the credit for my boots.
6th Special Forces PFC. HARVE SAAL
Fort Bragg, N.C.

Likes the Big Steps

Congratulations on a very fine article in your November issue—*Three Giant Steps to the Moon*, Part 2 (page 116). As manufacturers of the giant crawler-transporter mentioned in your article, we have approved and released many articles and ads on the machine. I think we can say without qualification that yours is one of the best articles we've seen on the subject. Marion Power Shovel Co. ROBT. F. LOWRY
Marion, Ohio

Still His Favorite

I built the *Sidewalk Classic* (page 146, November 1963 PM) for my son's fourth birthday. After driving the car for almost a year, he still regards it as his favorite toy.

I made one change in the plans. In place of the pushbutton foot switch, I made a

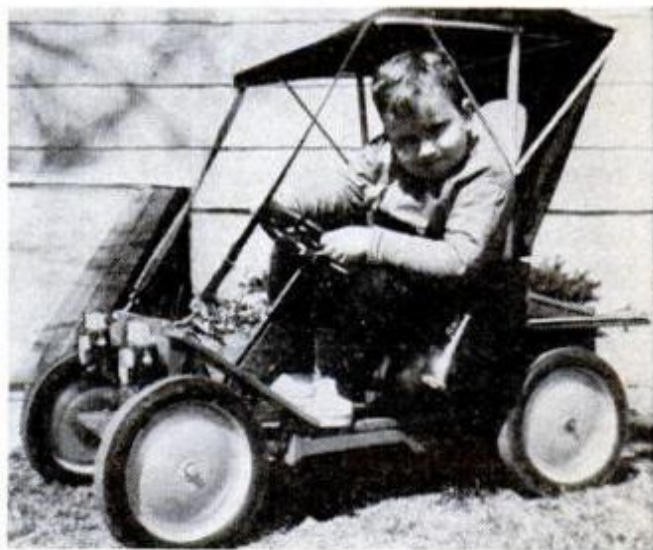

switch of two pieces of laminated plastic and two strips of copper. It works by scissors action and is connected by linkage to the accelerator pedal.

Smithtown, N.Y. ROBERT PATTERSON

Rage in the Bay

I'm enraged. On page 102 of the November PM you describe as a "San Francisco Train" one of the new BART (Bay Area Rapid Transit) cars. I'm tired of having new or good things in the Bay Area accredited to San Francisco. I'm from Oakland.

Oakland, Calif.

STEVE BAILEY

There! You've got your train back.

THE EDITORS

- For Action, Security, Big Pay -

WE CHALLENGE YOU TO TOP THIS JOB!



Earn To \$15 An Hour ★ Work Part-Time Or Full-Time ★ Car Furnished — Expenses Paid ★ No Selling — No Previous Experience Needed ★ Only Average Education Required

**NO OTHER CAREER OFFERS YOU
A BRIGHTER FUTURE**

Consider this fact. In the short time it takes you to read this page 1,100 accidents will take place. Over 440,000 will occur before this day ends. *These accidents must be investigated.* The law demands it. Yet in 4 out of 5 cities, towns and rural communities, no one has been trained for this vital work.

**KEEP PRESENT JOB
UNTIL READY TO SWITCH**

Step into this fast-moving Accident Investigation field. *Already* hundreds of men we have trained are making big money. Joe Miller earned \$14,768 his first year. A. J. Allen earned over \$2,000 in ten weeks. Robert Meier says "I'm now earning \$7.50 to \$15.00 an hour in my own business... Universal's course is wonderful."

FREE EMPLOYMENT HELP GIVEN

We CAN and WILL show you how to rapidly build your own full-time or part-time business. Or if you wish a big-pay job as Company Claims Investigator, our Placement Service will give you *real* assistance. Hundreds of firms needing men call upon Universal. *We place far more men in this booming field than any other individual, company or school.*

WE FINANCE YOU

Write today for complete information. Costs are less than you'd imagine. And even on these low costs you need pay only a portion—less than half—in order to complete your training. We finance the rest for you. You may pay out of actual earnings. And you can keep present job while learning. Send now for free book. No salesman will call. You are not committed in any way.

EARN WHILE YOU LEARN

Let us show you how easy it is to get into this exciting new career in just a matter of weeks. You need NO prior experience or higher education. There's NO investment in expensive equipment. You do NO selling. Furthermore, this fast-growing Accident Investigation field has no seasonal layoffs...no time out for strikes...no oversupply of men...no worry about automation. We ask you to compare these terrific advantages with the job you now have! Cash in on this big demand for trained men NOW. *Write today!*

Mail Now for FREE BOOK

M. O. Wilson, Dept. PM-1
Universal Schools,
6801 Hillcrest, Dallas, Texas 75205

Please rush me your FREE BOOK on Big Money in The Booming Accident Investigation Field. I will be under no obligation — and no salesman will call upon me.

Name.....
Address.....
City..... State..... Zip Code.....



BY JOHN F. PEARSON
SCIENCE
WORLDWIDE

Can a computer play Ping-Pong? Scientists at MIT will try to find out in an experiment that's part of a program to develop robots that can do work in environments hostile to man. Matched with a human opponent, the computer will follow the ball with a TV camera eye and try to return it with a paddle held by a metal arm. But don't rush to buy a ticket for the contest. It won't take place for at least a year.

Cosmic rays will be used to search for hidden passages in the ancient pyramids of Egypt. American and Egyptian scientists will try the method on a pyramid called Cephron, the shell of which still has not been fully explored.

A tunnel beneath Cephron is available in which gamma-ray detecting equipment can be placed. This would record rays from space that penetrate the sandstone structure. Data processing by computers in the U.S. would determine whether irregularities, indicating secret passages and rooms, showed up on the detectors.

A high-intensity flash from an ordinary flashgun has been used by a Canadian researcher to sterilize male flies and mosquitoes. A single flash sterilized more than 80 percent of a group of small chalcid male flies while two flashes either killed the flies or sterilized them. A single flash killed 26 percent of the male mosquitoes and all the survivors were found to be sterile.

Hypnosis works best on children, especially those in the 8-to-12 bracket. That's one of the findings in an eight-year study of hypnotism by Ernest R. Hilgard, professor of psychology at Stanford University. As you grow older, your response seems to decrease.

The study also shows that men and women are about equally susceptible and that normal subjects are more hypnotizable than neurotic or mentally disturbed persons.

Stereo by satellite is a possibility for the future. In recent tests, according to NASA, a stereo signal was transmitted from earth, received by an orbiting satellite and re-transmitted back to earth with no deterioration of sound quality. Could

be that when the London Philharmonic booms into its opening concert a few years hence, U.S. listeners will be able to hear the live performance.

Sexual behavior of cabbage is being studied by a Cornell University researcher who hopes to find ways to improve hybridization techniques.

It seems that flowers from certain vegetables such as broccoli, turnip and cabbage sometimes reject their own pollen but readily accept pollen from other plants. The effective use of this characteristic, says the Cornell scientist, will result in the production of improved hybrid varieties.

Study of ostriches may eventually help out cattle in South Africa. At least that's what some scientists there are hoping. Researchers are investigating the bird to try to discover the secret of its resistance to drought conditions; it needs only a diet of green plants to satisfy all its water needs. Cattle, on the other hand, die of thirst by the thousands each year in South Africa.

First French Aero-Train is slated to start operating early this year. Supported by an eight-inch air cushion, it will glide over a platform fitted with a central guiding rail at speeds up to 125 mph. The train will connect points in the Paris suburbs.

Satellite moves a mountain. Study of some 300 photos taken over Antarctica by Nimbus I, the weather satellite, shows that present relief maps are in error. As a result, according to the U.S. Geological Survey, 10,000-foot Mt. Siple will be repositioned 45 miles further west.

A portable solar still that can collect enough water for survival in the desert has been devised by two government physicists. It consists largely of a sheet of clear plastic that is used to cover a hole about 40 inches in diameter and 20 inches deep. The sun draws up ground moisture, which condenses on the underside of the plastic and drops into a small container placed underneath. The scientists say that the yield may be increased by placing cut pieces of cactus or even polluted water in the pit.

[\(Please turn to page 16\)](#)



When you draw lots, hope you get ours.

A few colored lights can brighten up any used car lot.
But they still don't tell you much about the cars.
Here's a better indicator: The Top Quality Used Car sign,
at your nearby Chrysler and Plymouth Dealer's.
It's a sure sign of a responsible dealer.
And the first sign of a good used car.

CHRYSLER - PLYMOUTH DIVISION  **CHRYSLER**
MOTORS CORPORATION



You, too, can be an Accident Investigator

Thrilling New Way To Earn Up To \$8 An Hour!

Even while you read this, more than 2,000 accidents, fires, and windstorms are occurring across the U.S.A. Insurance and transportation companies are in dire need of men trained to investigate and adjust the thousands of claims that result from these incidents. Such claims are required by law to be settled *quickly*, yet there are hundreds of cities and rural areas where there are not enough men to handle this vital work. This creates a golden opportunity for men up to 65.

We are training scores of accident investigators by mail and helping to place them in the fast-growing, highly profitable Accident Investigating Field. No previous experience is required. A car is usually furnished; expenses are paid. Many men earn while they learn. Only average education is required.

Here are just a few reports of recent earnings: Bob Durant jumped his salary to \$7500 as soon as he started. Bill Peck made \$943.00 in just 5 days, checking hurricane damage! Bob Pritchard reports companies in his area offering men \$8,000 a year to start, plus car and expenses! (Many men are earning \$8 an hour on the side in their spare time.) No wonder Art Victoria writes, "I recommend Liberty School's Home Study Course for those seeking a better life."

Keep Old Job Until Ready to Switch

Only 15 minutes reading a day puts you on the high road to success as an accident investigator. Progress as fast or as slow as you like. Many men get their diplomas in a matter of weeks! (We give you FREE Employment Help through our nation-wide **PLACE-MENT SERVICE**—or show you how to start an investigating business of your own at home.) Dozens of big companies with job openings are making good use of our monthly graduate list.

Let us prove how easily you can quickly switch into this exciting new career that provides prestige, security, a bright future! Sending for FREE Brochure does not obligate you in any way. No salesmen will call. Mail postcard or coupon to Dept. 51, Liberty School, 1139 W. Park, Libertyville, Ill. (Liberty School is fully licensed as a Business School by the State of Illinois.)

Your Steps
to Success as an
ACCIDENT
INVESTIGATOR

Eric P. McNair, President, Dept. 51
Liberty School of Claim Investigating
1139 W. Park, Libertyville, Illinois

**FREE
BROCHURE**

Rush me your FREE BROCHURE showing how I can gain job security and prestige and make as much as \$1,000 a month by getting into the Booming Accident Investigating Field. Also include the actual names and locations of successful graduates all over the country. This does not obligate me in any way, and no salesman will call.

Name _____ Age _____

Address _____

City _____ State _____ Zip Code _____

(Continued from page 14)

Cushion of air may aid the recovery of patients with severe burns. Researchers in England have devised a "bed" that consists of warm air moving upward at 5000 cu. ft. per minute. Though tests have been made mostly with animals, the bed has supported a 250-pound man.

The technique aids and speeds burn recovery by eliminating high-pressure areas on the burned skin surface and by drying the wounds and speeding scab formation. The rapid drying, say the researchers, also helps to reduce the risk of infection.

A Geiger counter no bigger than a paper clip has been developed to aid in the treatment of cancer. The device, according to scientists at Columbia University, is implanted in cancerous tissue, where it measures the action of radioactive chemicals being used against the cancer. This provides a means of ascertaining whether a given chemical treatment will prove helpful.

A toothpick is helping the San Antonio symphony find out which of its selections are the most popular. One is given, with an IBM card, to each member of the audience. The card lists the selections to be played followed by spaces that can be punched out with the toothpick. The listener is asked to punch out one of five holes, each keyed to a different evaluation of a piece of music.

A giant hovercraft is being built by an English technical college. British scientists plan to use it in Antarctica. They want to find out if the snow, icing and low temperatures in that area will have any marked effect on the powerful air flow that keeps the hovercraft aloft and propels it forward.

Antimatter matters. If your theory of the universe makes no provision for antimatter, you may be ignoring half of the objects in the sky. That's the view of Swedish scientist Hannes Alfvén, who emphasizes that elementary-particle physics has demonstrated the complete symmetry between the two basic types of matter.

Therefore, he says, "it seems logically unsatisfactory that cosmological theories should be based on the assumption that the universe contains only matter and no antimatter." For an interesting wrap-up of current thinking on antimatter, read "The Way-Out World of Antimatter" in *PM* (December 1965).

"Young man, be an accountant!"

from an article in Esquire Magazine

OF ALL the professions, few now offer higher incomes than the profession of accounting. And the doors to newcomers are wide open. Actually there are more fine positions available in accounting today than there are trained people to fill them.

"The whole profession makes good money," says an article in *Esquire Magazine*. "According to a recent survey of 1700 chief executives of listed companies, more of them started in finance and accounting than in any other department."

Do you know that, regardless of your present position or previous experience, you can become an accountant through spare-time home study?

With the modern training plan offered by LaSalle Extension University, a correspondence institution, you study in privacy, during hours of your own choosing—without

the loss of a single day's pay in your present job.

Your lessons are mailed to you. LaSalle's distinguished faculty starts you right at the beginning, explains basic accounting principles and methods, gives you actual accounting problems with your lessons, then corrects and grades your work. You are thoroughly prepared for the accounting tasks you will be expected to handle in the business world.

LaSalle has more than half a century's experience in home education. It has enrolled more than 1,000,000 students in that time. A LaSalle diploma is a credential respected by employers.

If you would like a copy of an interesting illustrated booklet, "Opportunities in Accounting," as well as a free sample lesson, send the attached card or write to LaSalle, Dept. 49-036, 417 S. Dearborn, Chicago, Illinois 60605.

This accountant is the control center of his company's business. The financial performance of every department depends on his information and skills. No wonder he is valued so highly.



EARN WHILE YOU LEARN DIESEL AUTO MECHANICS and AUTO BODY

LATEST DIESEL FUEL PUMP
CALIBRATING MACHINE

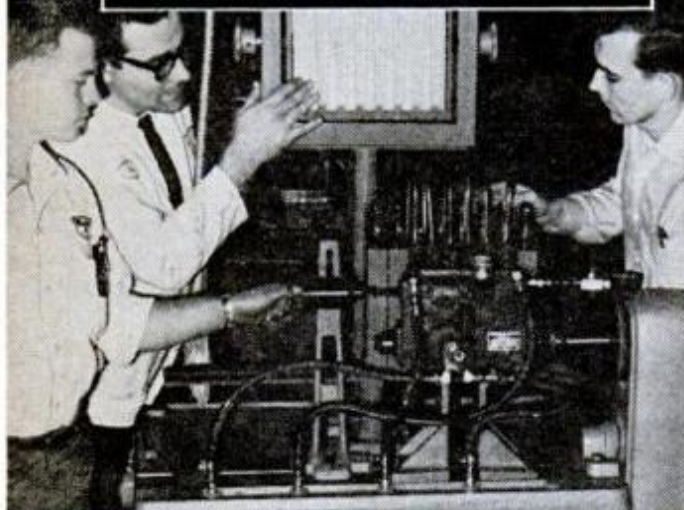

Prepare NOW for BIG PAY JOBS in industry or ratings, with MORE PAY, in the service.

96.4% graduates placed in big paying jobs! Start about \$5,000 a year . . . rapidly advance to \$10,000 a year. Earn to \$2,200 a month if you start your own business with 75% financing!

More BIG PAY JOBS than we can fill. Let us show you actual waiting list of Diesel dealers who have tried Bailey graduates, found them outstanding & keep coming back for more.

Both DIESEL & AUTO training
for PRICE OF ONE!

See the most beautiful school in the country with best equipped modern shop.

Get free booklet showing step-by-step tour thru our big shops. See students as they Learn-By-Doing with Famous Bailey Method of training. Housing & part time jobs provided—national placement for graduates.

BAILEY Technical SCHOOLS

1645 S. GRAND Dept. PM ST. LOUIS 4, MO.

MAIL TODAY FOR FREE BOOKLET

- DIESEL MECHANIC
- AUTO MECHANIC
- MASTER MECHANIC
- AUTO BODY



Name _____

Address _____

City _____ State _____

Telephone _____ Age _____

BY KEVIN V. BROWN

AVIATION

JETSTREAM

Yellow airplanes? Yes, and orange, turquoise, blue, ochre and beige ones, too.

Braniff International, which flies commercial routes over North and South America, has embarked on a campaign to attract passengers by attracting attention with a heavy paintbrush.

The fuselages of airliners have traditionally been white or the natural color of the metal, with a few distinctive markings of the individual airlines. Now, Braniff's entire fleet will have solid-color fuselages with pure white wings, engines and control surfaces. The planes will look like flying cigars in technicolor. Braniff calls it "the end of the plain plane."

The redecorating extends to the planes' interiors and down the ramp to the service area and ticket counter. Even the hostesses, which is Braniff's new name for its stewardesses, have pretty new uniforms in "raspberry," "apricot-melon," "fuchsia" and "flame," topped by bellboy-type hats that tie under the chin, and bottomed out by pink boots. On rainy days the girls can cover their bonnets and heads with a transparent dome that resembles an astronaut's helmet.

Well, only time will tell whether this splash of color will entice more passengers, but one thing's certain now. If you see a bunch of airliners on the ramp, you won't have any trouble spotting which one is Braniff's.



HOSTESS HELMET keeps rain off Braniff's bonnets

Your ticket to a high-pay job in electronics

**AN FCC LICENSE
issued by the
UNITED STATES
GOVERNMENT**



These men will tell you how to get it!



Matt Stuczynski, Senior Transmitter Operator, Radio Station WBOE.

"The Commercial FCC License is a 'must' for a career in broadcasting. I took CIE's Home Study Electronics Course and, thanks to their 'Auto-Programmed' teaching method, passed the 1st Class FCC License Exam on my first try! I now have a good job in studio operation, transmitting, proof of performance, equipment servicing."



Chuck Hawkins, Chief Radio Technician, Division 12, Ohio Dept. of Highways.

"My Cleveland Institute Course enabled me to pass both the 2nd and 1st Class License Exams on my first attempt . . . even though I'd had no other electronics training. I'm now in charge of Division Communications and we service 119 mobile units and six base stations. It's an interesting, challenging and extremely rewarding job."



Glenn Horning, Local Equipment Supervisor, Western Reserve Telephone Company.

"I owe my 2nd Class FCC License to Cleveland Institute. Their FCC License Program really teaches you theory and fundamentals . . . is particularly strong on transistors, mobile radio, troubleshooting and math. Our Company has 10 other men enrolled with CIE and it's going to help every one of them just like it helped me."

How about you? If lack of an FCC License is holding you back, it's time you looked into Cleveland Institute of Electronics Home Study. All you have to do is send us the coupon . . . and in a few days, you'll have the complete story. And remember . . . Cleveland Institute backs their programs with this exclusive, money-back warranty: "A CIE License Course will quickly prepare you for a Commercial FCC License exam. If you complete the course but fail to pass the exam on your first attempt, CIE will refund all tuition."

Get started now. Send coupon for free booklet "How To Get an FCC License." There's no obligation.

**Cleveland Institute
of Electronics**

1776 E. 17th St., Dept. PM5 • Cleveland, Ohio 44114



CIE

**Cleveland Institute
of Electronics**
1776 E. 17th St., Dept. PM5
Cleveland, Ohio 44114

**HOW TO GET A
COMMERCIAL
FCC LICENSE**



Yes! I want to know how to get a Commercial FCC License. Please send me your FREE booklet . . . without obligation.

My Occupation is _____

Name _____ Age _____

Address _____ County _____

City _____ State _____ Zip _____

A leader in Electronics Training . . . since 1934

CAREER BAROMETER

BY CREIGHTON PEET

EVEN IF THE BOSS is delighted with your work, you should look at your job critically—and selfishly, especially if you are only a few years out of school. Are you making the most of your native talents? Should you be moving up to better money in your company, and/or switching to a different job? Do you feel you'd do better in a different spot?

At least one authority on fitting the right people into the right jobs, Johnson O'Connor, who has spent a lifetime devising and giving aptitude tests, believes that everyone should think along these lines. If you don't, you may wake up to find you are 40, dissatisfied with your work and unable to do much about it. O'Connor tells of a young man who became a lawyer. At 35 he decided he was bored with it. So he became manager of a con-

struction firm. Not having sufficient background, he failed at this, and drifted from job to job. Now at 52 he's out of work. An aptitude test, taken when he was young, might have saved him a latter life of fear and uncertainty.

If you are jogging along in a routine job, it may be to the interest of some employers to keep you there. Finding a replacement upsets things, and it might be weeks before they can turn up a man who will do as well as you. But don't let this go to your head. What's good for the company isn't necessarily good for you.

The important thing to possess is good, solid, impersonal information about your own native abilities. This is where aptitude testing comes in. And don't confuse

(Please turn to page 24)

JOB TITLE	CURRENT DEMAND	3-MONTH TREND	STATES WITH HIGHEST DEMAND				
Chemists, Biological	21	Substantial decrease	N.J. 5	N.Y. 3	Penn. 2	Ohio 2	Wisc. 2
Chemists, Organic	51	Slight decrease	Conn. 4	N.J. 10	Ala. 11	Ind. 4	Calif. 4
Chemists, Inorganic	9	Good increase	Conn. 3	Penn. 1	Ala. 1	Fla. 1	Ky. 2
Engineers, Metall.	53	Good increase	Conn. 2	D.C. 6	S.C. 10	Ind. 6	Calif. 10
Engineers, Civil	507	Heavy increase	Conn. 31	D.C. 64	N.C. 21	Calif. 159	Wash. 31
Engrs. Elect. & Electron	1077	Good increase	Conn. 41	D.C. 42	Md. 58	Fla. 138	Calif. 389
Engineers, Industrial	388	30% increase	Conn. 24	N.J. 31	Ill. 28	Penn. 24	Calif. 106
Engineers, Mechanical	1186	Heavy increase	Conn. 63	N.J. 56	Penn. 72	Ohio 61	Calif. 300
Engineers, Aero.	397	Substantial decline	Penn. 11	Fla. 25	Mo. 60	La. 17	Calif. 263
Engineers, Mining	10	Unchanged	D.C. 3	Penn. 1	Fla. 2	Kan. 1	Mont. 1
Natural Scientists	74	Substantial decline	D.C. 25	Penn. 5	Mo. 5	Calif. 11	Wash. 10
Draftsmen, Arch.	164	Very heavy increase	Mass. 6	Mich. 7	Ohio 5	Wisc. 5	Calif. 108
Draftsmen, Electrical	184	Demand tripled	Fla. 7	Ohio 4	Ill. 5	Mo. 20	Calif. 136
Draftsmen, Mechanical	325	Heavy increase	Penn. 39	Ohio 63	Ill. 12	Wisc. 36	Calif. 108
Draftsmen, all other	383	Heavy increase	Conn. 16	Miss. 18	S.C. 13	Mo. 20	Calif. 227
Tool Designers	54	Considerable drop	Conn. 7	Penn. 4	Ill. 10	Wisc. 4	Calif. 15
Lab. Tech. & Assistants	95	Demand steady	Mass. 6	N.Y. 13	Ky. 9	Ind. 13	Calif. 8
Sports Instr. & Officials	188	Very heavy increase	Mass. 7	Vt. 104	Va. 5	Colo. 48	Calif. 13
Surveyors	34	Slight increase	Conn. 3	Mass. 5	N.C. 9	Ohio 3	Iowa 3
Techs. Eng'g & Phys. Sci.	267	Slight decline	Maine 12	Va. 20	Ala. 77	Fla. 57	Calif. 55
Tool Planners	10	Slight decline	Ohio 2	Ind. 7	Cal. 1		
System Engineers	19	Slight decline	N.Y. 4	Penn. 1	Ill. 1	Mo. 10	Neb. 2
Programmers	206	Some decline	N.J. 18	D.C. 19	Wisc. 7	Mo. 12	Calif. 92
Systems Analysts	48	Some decline	Conn. 3	D.C. 12	Ohio 3	Ind. 3	Calif. 15
Inspectors, Pub. Service	23	Good increase	Md. 1	Ohio 1	Neb. 10	Calif. 2	Wash. 7

PM's Career Barometer Chart, above, gives the actual number of men currently needed for specific jobs. "Current Demand" figures are true as of our closing date. Check this chart each month and it will tell you where your talents are needed, and how badly. For names of actual employers represented by these listings, contact the state employment agency in the cap-

ital city of the state indicated. Mention that you saw this in **POPULAR MECHANICS**.

Today, with proper schooling, you can qualify for many of the job categories shown. For a list of accredited correspondence and residence schools, write to **POPULAR MECHANICS' Information Bureau, 575 Lexington Ave., N.Y. 10022**.

ELECTRICITY

**EARN as you LEARN—
In Your Spare Time at Home**



S. T. Christensen
President

This is a "Push Button Age" — everything is becoming automatic — men with Electrical "Know How To" are needed everywhere — and will always be needed.

HERE IS MY OFFER

If you want to increase your income — by having a part or full time business of your own — or a big paying career job in Electricity — I will send you everything you need to get started NOW.

17 BIG TRAINING KITS

Professional trouble shooting electronic equipment — quickly locate electrical problems (shorts, open, power failures, etc.); professional electric repair tools; audio recordings that bring the instructors' voices into your home, making things easy to understand; thousands of exploded views, photographs and drawings showing how parts fit together, how buildings and electrical equipment are wired — charts telling you how to fix things quickly, correctly — ALL ARE SENT TO YOU.

REPAIR ALL APPLIANCES

ATS (Advance Trades School) training is complete training, is easy training, is approved training. You learn how to fix irons, toasters, coffee makers, washing machines, refrigerators, air conditioners, etc. There are over 400 million appliances in use. Over 160 different appliances! ALL eventually need servicing and repair. ATS shows you how to fix all of them! !! Hundreds of my students, the country over, in cities and small towns alike, have reported earnings of \$15, \$25, \$50 and even more per week while training. Would you like to do the same?

INDUSTRY NEEDS MEN who can service electric equipment. Top wages are paid to Electrical Maintenance Men, Electric Technicians, Plant Engineers, Electric Construction Men, etc. ATS trains you quickly, trains you well. ATS has no fancy frills, no wasted time. You get practical training, actually do 17 shop projects in your own home. Many ATS graduates hold "key" positions in Industry. Start your training NOW.

MOTOR REWINDING homes today have ten, fifteen or more motors. Electric shavers, washing machines, food mixers, vacuum cleaners, refrigerators, power tools, to name but a few. Without motors factories could not operate. ATS teaches you to put motors in good repair — you even build your own rewinding and testing equipment as part of your training program. You learn with ATS by working with your hands. You make and keep valuable testing equipment.

LEARN WIRING You learn how to completely wire or rewire homes, garages, barns and factories — their lighting and power equipment. There are no half ways with ATS training.

NO EXPERIENCE NEEDED

ATS shows you how, gives you the equipment to do it. Your own kitchen table can be where you first "set up shop." ATS men are nationally recognized by wholesale suppliers of parts and materials. We show you how to get repair business, how to charge fair and profitable prices for your work. ATS keeps graduates informed as new appliances, improved electrical techniques develop. It is a regular part of the continuing ATS training program and why ATS training is preferred by so many. You owe it to yourself to investigate the complete ATS Electrical Training Program.

FREE 36 page—4 color book
"EARNINGS BY ELECTRICITY"

This seal certifies full accreditation by the National Home Study Council the official accrediting agency of the U. S. Office of Education.

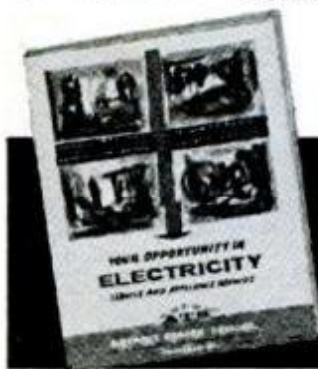

**MAIL COUPON
FREE BOOK**
No Cost or Obligation

ELECTRIC APPLIANCE REPAIR

**Industry Pays
Trained Electricians
Top Wages**

Some of the
Equipment I send
YOU



LET ATS MEN TELL YOU IN THEIR OWN WORDS

- "Earning \$50.00 more weekly. Made over \$1,000 while training." O. Harness, St. Charles, Ill.
- "Received two promotions — worker to foreman to assistant manager." J. Swanton, Oaklawn, Ill.
- "My work piles up and I get behind with my studies." M. Bobo, Sr., Tacoma, Wash.
- "I am now maintenance man at a large motel at a much higher salary." J. Martin, Kansas City, Mo.
- "2 raises in pay since I started with the State Highway Dept. in electrical maintenance." C. DeHut, Phoenix, Ariz.
- "Should have taken your course 20 years ago." A. Knoll, Michigan City, Ind.
- "Chief maintenance man now at double my former income besides having a profitable sideline business." R. DeWitt, McHenry, Ill.
- "One job more than paid for the training." E. Hutson, Chicago
- Former \$2.30 hour mechanics — "Now Head Maintenance man at Heinenman's Bakeries — wages are nearly \$200.00 a week." C. Fontenot, Hales Corner, Wis.
- "Not a high school graduate but I find the lessons easy to understand." W. Wolf, Grand Rapids, Mich.
- "Until my disability I was a tool maker. Your course is a new life to me." W. Haebig, Kenosha, Wis.
- "\$1,000 Christmas for my family. Got everything we wanted. Will now return to my studies." D. Behrmann, Two Rivers, Mich.

ADD TO YOUR INCOME—MAIL TODAY

S. T. Christensen, President Dept. E-303
Advance Trades School
5944 N. Newark Ave., Chicago, Ill. 60631

Send me your FREE BOOK "Earnings by Electricity." I want to add to my income.

Name Age

Address

City Zone State

START A MONEY-MAKING BUSINESS FOR LESS THAN \$50!

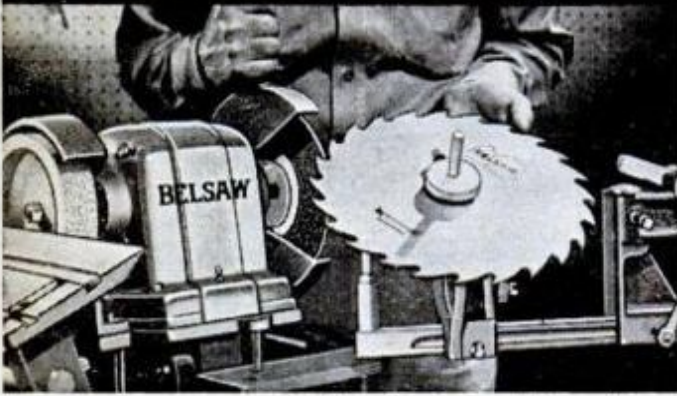

You can have your own lifetime business right at home . . . work in spare time . . . and make up to \$200 a month CASH! My FREE PLAN gives you all the facts: How to start, how to grow. You don't need previous experience. You don't have to sell. I'll even finance you. People bring you the work and pay cash. Over 90c of every dollar you collect is clear cash profit. And you work when you want to. Let me prove you can't find a more certain, lower cost, higher paying business of your own.

Just Mail Coupon—No Salesman Will Call

BELSAW SHARP-ALL CO., Stan Field, President
716G Field Bldg., Kansas City, Mo., 64111

Name _____
Address _____
City _____ State _____



MAGNETIC BRAD DRIVER

The handy tool for home owners, wood workers, cabinet workers, hobbyists, model makers, etc.

No. C22

2.90

Quality tool with hardwood handle and steel barrel with magnet insert will pick up, drive and countersink brads 12 to 19 gage, 1" long and smaller.



Brad or finishing nails

On sale in paint and hardware stores or send \$2.90 tool sent postpaid.

HYDE TOOLS

Write for Free Catalog SOUTHBRIDGE, MASS., U.S.A.

CAREER BAROMETER

(Continued from page 22)

your aptitudes with your I.Q., or the results of a College Entrance Board Exam. The first is a kind of average of all your abilities; the second a measure of your scholastic attainments. A high rating in either of these is a useful indicator of your ability to learn. But for a particular job you need particular abilities.

Aptitude tests rate you separately on 15-20 particular abilities, such as: accounting aptitude; structural visualization; finger dexterity; creative imagination; inductive reasoning; deductive reasoning; mechanical reasoning; three dimensional thinking; memory for design; proportional appraisal; tonal memory, etc.

Such tests are usually of several kinds; written, oral, physical (blocks that must be arranged or fitted together, for instance). Testers are concerned about "interest patterns." They know, for example, that a person with a good aptitude in mathematics may well show an interest in classical music. On the other hand a man scoring high in scientific interests and computational problems often will have a low score in literature.

If you make a good showing in three or four aptitudes, the testers know that you might do well in certain particular lines of work. But here Alexander Clark, Director of Placement and Career Planning at Columbia University, throws in a caution. One essential to real success in any kind of work, he says, is that you like it. You can put up a big fight and *make* yourself do a job for awhile, he points out, but sooner or later you'll be in trouble. Clark believes that enthusiasm is quite as important as having the right aptitudes. Some men, he says, will work like fury to become engineers, salesmen, or technicians, and achieve some degree of success, even though tests show them not particularly fitted for their work.

There's one aptitude which tops all others, O'Connor (and all other experts) agree. This is vocabulary—an understanding of a large number of words. Amazingly, every top executive O'Connor has tested, has had a superior vocabulary. Recently he had an interesting proof of this. A minor executive appeared for a test. Something was wrong, he said. He seemed to be performing his job satisfactorily but he wasn't getting anywhere.

His aptitude test showed that he had good aptitudes in the abilities needed for his job. But his vocabulary was limited—in fact it was terrible. He refused to believe the results of his test, and it was

(Please turn to page 26)

Here's what
VON SCHRADER
 has to offer YOU...

if you would like to go into
 a profitable business
 of your own (full or part-time)

1 • **VON SCHRADER** offers you these 3 money-making businesses: **RUG CLEANING, UPHOLSTERY CLEANING, WALL WASHING.**

2 • **ALL DETERGERS** are reasonably priced. Many **VON SCHRADER** Associates make more than the price they paid in the first month and from the original supplies that come with the Deterger.

3 • **SOME VON SCHRADER** Associates start spare-time . . . and later on change to full time.

4 • **NO SHOP** is needed . . . all work is done in customers' homes or on their premises.

5 • **NO COSTLY OVERHEAD** . . . you work from your own home and hire helpers only when your business justifies.

6 • **YOU ALWAYS OWN** your Detergers . . . no one can ever take them from you.

7 • **ALL THE MONEY** you take in is yours alone . . . you never pay any fees, or dues, or royalties to anyone; you are truly **YOUR OWN** boss in **YOUR OWN** business.

8 • **YOU WORK WHEN** and where you care to . . . you have no quotas to meet, no extensive forms to keep, no reports to make.

9 • **FULL OPERATING INSTRUCTIONS** come with the detergers. They are easy to read and to follow; anyone can operate; you need no special skill or training.

10 • **VON SCHRADER BUSINESS MANUAL** is complete; it tells everything you need know to make a success out of your venture, including how to go about getting business, suggested sales letters, who to call on, tips on keeping your books and tax records, suggested telephone book and newspaper advertisements, radio announcements, etc. Handout literature is also included.

11 • **VON SCHRADER** cooperation and assistance is always at your service. We continue to help you solve unusual problems regardless of nature. Training and consulting with experts is also available at no extra cost.

12 • **VON SCHRADER** perfected the first **RUG DETERGER** and we are by far the oldest and largest company manufacturing machines of this type.



• Read below what a few of our many Associates have to say about the success of **VON SCHRADER'S FREE ENTERPRISE PLAN.** Then return the coupon or write **TODAY.** It costs nothing to get the details.

HOMER KENDALL, Indiana • "Your business helps and training are really wonderful. How could anyone fail?"

LESTER VERNON, Wisconsin • "Have had my Rug Deterger almost two weeks, have earned 2/3 its cost already."

J. M. ROGERS, Pennsylvania • "Worked 7 hours yesterday, earned \$85.56. Part-time last week netted \$103.70."

ROY NELSON, No. Carolina • "I am doing real well with the Upholstery Deterger. I grossed \$204 in four days last week and have plenty more work. Everyone is very well satisfied."

BOB GREENBERG, California • "First month I made over \$800; now 80% to 90% are old customers."

EMMET FREMONT, Colorado • "It's amazing what the Wall Deterger will do. I'm more than satisfied."

SEND FOR THE FACTS TODAY

VON SCHRADER MFG. CO.

110 "A" Place, Racine, Wisconsin

Please rush information about your

RUG, **UPHOLSTERY,** **WALL DETERGER** and how I can start my own profitable business.

Name _____

Address _____

City _____ State _____ Zip _____

VON SCHRADER MFG. CO.

CAREER BAROMETER

(Continued from page 24)

only after he had completed three tests that he would face the fact he really did have a poor vocabulary.

It's dangerous to change your line of work after you reach middle age. Employers are prejudiced. O'Connor recalls a man who found himself out of work when he was over 40. With heavy family responsibilities, he decided to become a high-powered salesman and make a pile. The first year he did, too. He led all the salesmen in his new company. But each year thereafter his sales dropped drastically. He became a recluse, and hardly left the house. In a panic, he consulted O'Connor. Tests showed that selling was the last thing he should be doing. All his aptitudes lay in other fields. Pursuing leads in fields indicated by the tests led him back to a comfortable living.

How and where do you get aptitude tests? Every year several hundred thousand high school seniors get free counseling, and sometimes aptitude tests, from the U.S. Employment Service operating through the local offices of the state employment agencies. However, such counseling is almost exclusively for boys going directly to a job from high school.

There are said to be around 20,000 people who are giving complete aptitude tests in the U.S. today. While universities do not test incoming students, many have testing laboratories, usually connected with their psychology departments. For a fee, anyone can be tested.

The "Directory of Approved Counseling Agencies," which costs \$2, can be ordered from the Am. Board on Counseling Services, 1605 New Hampshire Ave., NW., Washington DC. It lists hundreds of testing labs, by states. A complete aptitude test may cost from \$75 to \$100, and involve several sessions of a number of hours each. But it may spell the difference between your future success or failure.

Many industrial plants give what they call aptitude tests for new employees, but usually these are concerned only with the job for which you are applying. They're not much good to you personally, although they show the company whether you can do the job in hand. Other tests come later. A beginner on an assembly line looking to a better job, is often given an aptitude test, but again the company is only interested in the particular job for which he's being hired, not the man himself. Only an outside testing outfit will investigate all your potential abilities.

LOOKING FOR EXTRA COMFORT AND LONGER WEAR?

KINNEY *S* **TALWARTS**

with **NEOPRENE SOLES!**



Kinney "STALWARTS" combine dress oxford styling with ruggedness for long wear and on-the-job comfort.

Toe-to-heel cushioned insoles, cushion side-arch supports are features of Kinney "STALWARTS" that make a big hit with men whose work is tough on shoes.

Soles and heels of long-wearing Du Pont Neoprene provide another "plus" . . . long service life that means more wear for the money. Neoprene resists oil, grease, chemicals and cold-weather cracking . . . helps ease you through your working day because of its lasting resilience. Du Pont Company, Elastomer Chemicals Dept., Wilmington, Delaware 19898.

STALWARTS are available at 600 Kinney shoe stores coast to coast. \$7.99 a pair



Better Things for Better Living . . . through Chemistry

Who's got everything for your Ford



from Road Lamps...

Give your car a GT flair with these sporty looking yet highly practical road lamps. The lamps come with clear lenses or amber ones for maximum fog-piercing effect. Universal mount with adjustable bracket for all bumpers. \$25.00*



to Wheel Covers

Choose from gleaming stainless steel wheel covers such as this racy "Mag" type to distinctly customize your car. We've got wheel covers to blend perfectly with any car's design. In sets of four from \$20.82*

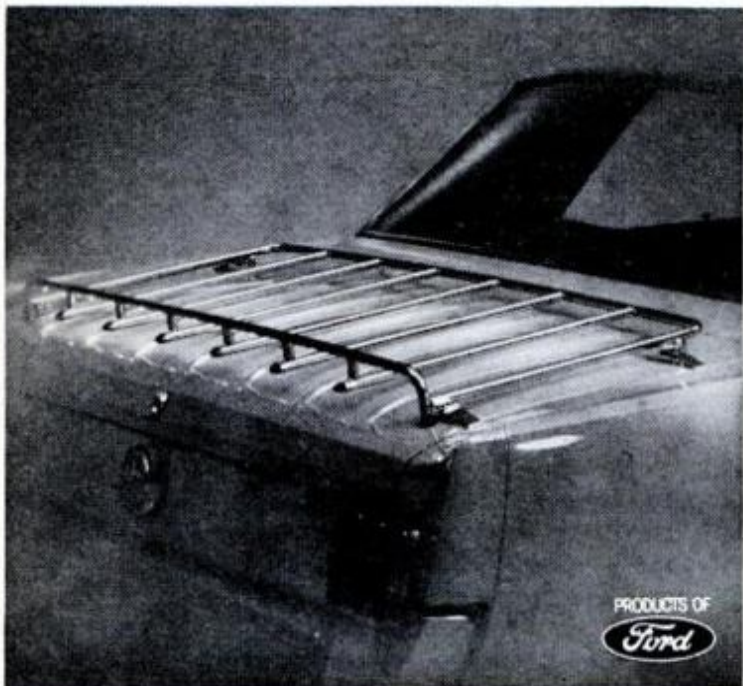

to Luggage Racks

Here's a special for Mustang rear deck lids . . . a handy dual-use, chromed-steel luggage rack. Carries vacation-sized load . . . or converts for water or snow skis by means of special adapter. \$39.95*

*Manufacturer's suggested retail price. Installation charges, state or local taxes extra.

Your local Ford Dealer of course!

You'll get the most for your driving pleasure from your Ford Dealer.

Thinking of college and
a space age career?

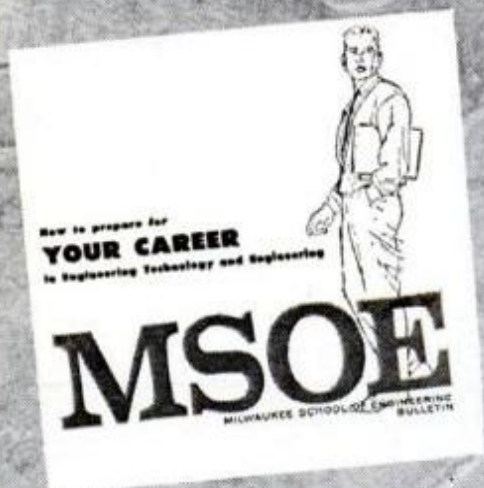

Send for this booklet on
**ENGINEERING TECHNOLOGY
AND ENGINEERING**

Learn how you can prepare for a dynamic career as an electrical or mechanical engineering technician or engineer in such exciting, growing fields as avionics, missiles, reliability control, fluid mechanics, data processing, metallurgy, microelectronics, and advanced aerospace research.

MSOE offers residence study programs leading to these degrees in engineering technology and engineering:

- 2 years — Associate in Applied Science
- 4 years — Bachelor of Science

Also get facts about scholarships and financial aids, job placement and other student services, plus photographs of MSOE technical laboratories and student activities. For your copy, just mail the coupon — no obligation.

MSOE

Milwaukee School of Engineering

Milwaukee School of Engineering
Dept. PM-166, 1025 N. Milwaukee Street
Milwaukee, Wisconsin 53201

Please send the "Your Career" booklet.
I'm interested in

- Electrical fields Mechanical fields

Name..... Age.....

Address.....

City..... State..... ZIP.....

MS-227

NEWS FROM THE **MILITARY** BY WILLIAM R. KREH

Lazy Dog is the least glamorous and simplest weapon being used by Navy carrier planes in Vietnam. Essentially, it's nothing more than a .45-cal. slug with fins. It's dropped in quantities from planes against enemy troops or small vehicles. As it falls, the fins keep it stabilized so that it acts much like a projectile from a gun when it strikes its target. For practical purposes, dropping clusters of Lazy Dogs has about the same effect you'd expect from using a huge shotgun loaded with .45-cal. slugs.

Research balloons, formerly lost after a single launching, can now be recovered and used again under a system developed by the Air Force. The system uses two parachutes—one to return the scientific instruments, another to bring down the balloon. As the balloon is deflated, its parachute creeps over it and "wraps" it in a nylon package for protection on the way down. This is done with an opening in the center of the chute, through which the balloon is pulled as it deflates. Through the hole, it passes into the protective nylon sleeve. The balloons cost from \$2000 to \$30,000 each.

Pure and portable. A small, portable water-purifying unit is now being furnished Navy photo intelligence teams operating in remote areas or aboard ship where pure water is often scarce. The photo men use about four gallons of water a minute to wash prints and the newly-developed purifying unit enables them to use the same water over and over.

Super dog, an attempt to breed a special canine that would be ideal for detecting guerrilla ambushes, may become a priority Army research project. Researchers are reviewing the characteristics needed for such a dog and biologists and animal-behavior scientists are studying the feasibility of starting such a breeding program, which Army officials think is needed because 95 to 98 percent of the dogs now offered the military are rejected.

The ambush problem in Vietnam has led U.S. authorities to seek many ways—most of them unorthodox—to help troops avoid or spot ambushes in advance. At least one such project reviewed last year called for specially-trained birds as ambush spotters.



I'll guide you step by step into your own thriving business

● While keeping your present job, would you like to gross \$12 or \$18 profit per hour?

a true story by Bob Ferrel

SOME YEARS AGO I was a printer in a small Michigan town. I drew a pretty fair pay check but it wouldn't stretch far enough to provide the kind of living I wanted for my wife and five children.

Then one day I was reading a magazine just as you now are and I saw an ad. It intrigued me. It offered me the steadily growing income I had always hoped for. It said I would have greater security and personal independence... and that's what I had been wanting.

I was a little skeptical, but I said to myself, "for a postage stamp I can find out." So I mailed the coupon. In a few days, I got a letter with a booklet that gave the whole story. It opened my eyes. I could see why owning my own business was so much easier than I had always thought... why the day to day guidance of a successful worldwide organization could assure my own success.

I read the booklet several times. It just seemed too good to be true. I talked it over with my wife. We decided that now was the time to make the forward step... there was no reason to keep postponing an income increase.

So, I applied for a Duraclean dealership and I was accepted. I stayed with my job... ran a few ads... sent some mailings... contacted a few stores and told my friends about the superior services I was now equipped to give them. Evenings and Saturdays, I rendered the service. As the business grew, I added servicemen.

I found that I didn't have to develop a single idea myself. Every step had been prepared for me and pre-tested. Hundreds of other men had already proven my methods successful.

It didn't take long to see that I was making three to four times (yes, 3 to 4 times) as much per hour in my own business as in my printing job. So, after only seven months with a good following of customers, I quit my job to go full time on my own. In the meantime, I had enjoyed all this extra income on top of my salary.

Each day, we realized what a serious mistake not mailing that coupon would have been... and how that little act that seemed so trivial at the time actually changed our lives.

The steadily growing income brought us

many things we could not afford before. My efforts were so much more productive. I scheduled my time to my own liking. When we wanted a day or two off, we took it. I worked hard but, if I wanted to be home early or quit at noon, I did.

This is not a business for a lazy man. But if a man is ambitious and will work to deserve those nice things in life we all want, this business is made to order for such a man.

I became so enthusiastic about this business and so appreciative of what it had brought my family that, whenever a man opened a dealership near me, I helped him get a quick start.

The company learned about this and had each new dealer in my section of Michigan spend a day with me. One day the president of Duraclean Company asked me how I would like to move to Headquarters and spend my entire time helping dealers to increase their sales and profits.

That was good news to my ears. Since then I have worked with hundreds of our dealers in their own towns and at regional meetings, conventions and dealer group meetings. But much of the time I am right here at my desk in touch with our dealers by letter and telephone.

Incidentally I sold my dealership at a good profit. Dealers sell their Duraclean businesses for up to ten times their cost. After 30 months, Leo Lubel sold for \$7,116 above his cost. If for any reason a dealer wants to sell, we maintain a service to locate buyers and help him sell.

Our job here at headquarters is to show each individual Duraclean dealer how to use his own abilities to bring him greatest success. I know hundreds of our dealers on a first name basis. We work together as one happy family. If you become a Duraclean dealer, I'll be as close to you as your telephone or mail box.

It's Easier than You Think To Build Your Own Business

If you've wanted to BE YOUR OWN BOSS... to become financially independent and have a fast growing income, now YOU CAN. And you own a Nationally Advertised business.

You can stay at your present job while your customer list grows... then switch to full time, lining up jobs for your servicemen to do. One job a day brings a good starting income.

If you hire two servicemen (full or part time) while you keep your job, the national price guide provides you a gross profit of \$12 an hour on their work and this is much easier to do than you think. We show you how... step by step. That's \$420 for a 35 hour week.

Your gross profit on three servicemen is \$18 per hour. Duraclean dealers find it easy to gross \$6 per hour on EACH serviceman plus \$9 an hour on any service they themselves render. The 24 page illustrated booklet we'll mail you (with no obligation) explains how most of your gross profit becomes clear net profit. Your income is limited only by the number of servicemen you employ.

You can operate from a shop, office, or your home. Equipment is light and portable.

At the start, you may want to render service yourself... or you can start with full or part time servicemen. This business is easy to learn... easy to start... so easy to service that women dealers do it. We prefer you have no experience... not have to "unlearn" old ways.

We are NOW enlarging this worldwide system of individually-owned service businesses. If you are reliable, honest and willing to work to become financially independent, we invite you to mail the coupon.

When you receive our illustrated booklet, you will see the way we show you step by step how to quickly get customers... and still more customers from their recommendations.

You have 6 superior services that are rendered "on location" in homes, offices, hotels, theaters, clubs, motels and institutions.

These are not ordinary services. You have

the prestige and endorsement of leading furniture makers and carpet mills, of Parents' Magazine and McCall's, of Research and Testing Laboratories.

National magazine advertising explains superior merits of your services, builds your customer confidence and brings job leads to you.

We and a Duraclean dealer will train you and assist you. He'll reveal his successful, proven methods. You have pre-tested newspaper and yellow-page ads, commercials, and a full mailing program.

Stores, upholsterers, insurance adjustors, and decorators refer jobs to our dealers. These year 'round services are in constant demand.

Start Small, Grow Big in this Booming Business

Many men have said to us, "I can't afford to give up my job till I know I have a sure thing... a sound business that will provide both security and a better living for my family."

That made sense to us so we worked out such a plan... and those same men are now enjoying a Duraclean dealership in many communities. You don't experiment. You use tested, proven methods. You have our backing and "know how."

Does this appeal to you? Don't decide now. Mail the coupon so you'll have the facts to decide wisely. There is no obligation. You'll then know whether this is what you want.

You can start small and grow big. A third century ago Duraclean was an idea... but it caught fire and spread to a world wide service. Why did it spread? (1) superior processes. (2) proven customer-getting methods (3) Day to day guidance from Headquarters.

Our first service, the care of upholstery and carpets not only cleans, it enlivens the fibers... revives dull colors. Pile rises with new life. There's no harsh machine scrubbing. No soaking. Mild aerated foam lightly applied lifts out dirt, grease, many unsightly spots like magic. Furnishings are used again in a few hours.

Government figures show service businesses are growing faster than industries and stores... \$750 million yearly potential just in rug and furniture cleaning. Your 5 other services are explained in the free booklet we'll mail you.

A few hundred dollars establishes YOUR OWN business. A day's profit more than pays the monthly payments we finance for you.

Men frequently take in partners.

We furnish electric equipment and, with first shipment, enough materials to return your TOTAL investment. If you have good habits and know the importance of customer satisfaction, you can likely qualify for a Duraclean dealership.

TODAY is the time to reserve a Duraclean dealership, before someone takes your location.

It's been said, "Opportunity knocks but once at every man's door." This could be that one rare opportunity in your life.

It is surprisingly easy to learn this business. You can decide from the information we will send you whether to apply for a dealership. So, with no obligation whatever, mail the coupon TODAY. Cut it out NOW so you won't forget to mail it.

Mail this coupon TODAY It may put you in business

Duraclean Co., 6-161 Duraclean Bldg. Deerfield, Ill. 60015

With no obligation, mail 24 page illustrated booklet telling how and why I can quickly increase my income and family security while still employed, how you'll help finance me. No salesman will call.

Name _____

Address _____

City _____ Zone _____ State _____

Save 1/2 on New ACCORDIONS

Save up to 1/2 Off Prices of Comparable Accordions

5 DAY FREE TRIAL
IMPORTER-TO-YOU PRICES!



ALL FAMOUS MAKES!
40 NEW MODELS—
Electronic Accordions—Amplifiers!

Buy on EASY TERMS

Get in on these sensational values in world's finest Italian-made accordions! Play most popular instrument of all—for fun, leadership and profit! 40 newest models of glorious tone and breath-taking beauty offered at the amazing low prices. Buy direct from world's largest accordion dealer. Small down payment; easiest terms on balance. Extra bonus gifts FREE if you buy during sale. Trade-ins accepted. Try before you buy on FREE 5-day No-Risk Plan. Satisfaction Guaranteed or Money Back.

RUSH COUPON TODAY!

See how easily you can now own and play a fine accordion. Rush coupon now for big new COLOR Catalogs and Low Importer to You Prices... ALL FREE! No obligation. Write to:
ACCORDION CORPORATION OF AMERICA, Dept. R-16
5535 W. Belmont, Chicago, Ill. 60641

FREE BONUS GIFTS

for promptness
• E-Z Lessons
• Music Stand
• DeLuxe Case
other gifts, too!

MONEY BACK GUARANTEE

FREE
COLOR CATALOGS
and lowest prices

Send FREE Color Catalogs and low importer to you prices.

NAME _____

ADDRESS _____

CITY _____

STATE _____

ZIP CODE _____

Check here if you have accordion.

ACCORDION CORPORATION OF AMERICA, Dept. R-16
5535 W. Belmont, Chicago, Ill. 60641

HOW MANY HANDY DANDYS DO YOU NEED?

Handy Dandys are sturdy, plastic caps that snap into 1/8" pegboard and securely hold quarter-twist glass jars such as those used for baby food. If you are up to your neck in saved baby food jars (or you know someone who is), put those jars to work. With Handy Dandys you can make your workshop neat and clean. Perfect for storing nuts, bolts, cotter pins, washers, screws, fuses, small tools and other important items needed around the house and shop. Handy Dandys positively keeps contents dustproof. Just what you've been looking for. Put a pegboard on the back of a door for mama with Handy Dandys for buttons, pins, rubber bands, clips, stamps, etc. Have the things you need at your fingertips—inexpensively—with Handy Dandys. Sample order 12 for \$1.00; 3 dozen for \$2.50; 6 dozen for \$4.00; 500 for \$25.00. Shipped USA postage prepaid. Include payment with order—no C.O.D.'s. Order enough, you'll want more when you start using Handy Dandys. Available from manufacturer only.



WICKLIFFE INDUSTRIES, INC. Dept. AA
Wickliffe, Ohio 44092

WHAT'S NEW OUTDOORS

BY STUART JAMES

Lewis and Clark took three years to explore their famous route from St. Louis to the Pacific Ocean, and according to their journals, they faced innumerable hardships on the 3700-mile trip.

But their trials and tribulations were minor compared to the problems now involved in creating a recreation area that will follow their historic trail.

This had long been a dream of the late J.N. "Ding" Darling, famed editorial cartoonist for the Des Moines Register, and when he died a group of conservation-minded Des Moines businessmen started out to make it a reality. Last year Congress voted to create a commission to mark and commemorate the Lewis and Clark Expedition route, and Sherry R. Fisher, vice president of the Central National Bank and Trust Co. of Des Moines was named chairman.

I talked recently with Mr. Fisher, and asked how things were coming along.

"Wonderful," he said. "The Bureau of Outdoor Recreation has outlined a detailed plan for the acquisition and development of the historic, wildlife and other recreational resources along the trail, and this was accepted by the commission at a meeting we had in St. Louis in September.

"There are going to be problems, of course, but if the public response is anything like what we found in St. Louis, this trail is going to be a reality."

Here's part of the problem. The trail goes through 11 states, and it will require the cooperation of a lot of people and agencies. On the federal level alone, it involves the Department of the Interior, Corps of Engineers, Bureau of Land Management, Bureau of Indian Affairs, National Park Service, Department of Agriculture and Department of Defense. Double this on the state level, then the local level, and then add the private ownership of lands. Now, to make this trail a reality, all these agencies must work together toward the achievement of a common goal.

Will it work? "Absolutely," says Sherry Fisher. "This is the most exciting idea since the development of Yellowstone Park. It stirs the imagination."

I agree. And most important, if all these people can work together, it is going to be a giant step for the advancement of conservation and outdoor recreation in the United States.

If you're always short of cash . . .

WATCH REPAIRING

Offers a sure way to add to your income



Excellent opportunities now for full or part time earnings



Trained, part time repairmen report earnings of \$5-\$6 an hour. This is a second income trade that's made to order. You can be your own boss . . . work where you please, full or part time. And earning opportunities now are the best in years.

You can assure yourself of lifetime income. Forget fears of strikes, automation, layoffs, or retirement. Watch repairing is light, clean, fascinating. It's work you'll enjoy. There's nothing boring about watch repairing. Every repair job is a new challenge to your skill.

DEVELOP YOUR SKILL STEP BY STEP IN YOUR SPARE TIME AT HOME

No need to leave home or job. Professional watch repairmen will teach you this trade in the privacy of your home at a fraction of what you'd pay to attend school in person. It's practical, shop method training that shows you how to repair all types of Swiss and American watches. You need no previous experience. Age is no barrier. Diploma awarded. Send today for free sample lesson and complete information. No obligation, of course. No salesman will call.

SPECIAL TOOLS PROVIDED



This set of tools is offered in your course at no extra tuition cost. They enable you to start repairing right away.

CSW has been training men and women for this trade since 1908

Why not be one of our successful graduates? Learn how Chicago School's streamlined home training can speed *your* success.

CHICAGO SCHOOL OF WATCHMAKING
Founded 1908

310 Lincoln Ave., Fox River Grove, Illinois 60021

MAIL COUPON TODAY!

FREE SAMPLE LESSON

CHICAGO SCHOOL OF WATCHMAKING

310 Lincoln Ave., Dept. 116 Fox River Grove, Ill. 60021

Please rush **FREE SAMPLE LESSON** and full information to tell me how I can learn watch repairing at home.

NAME _____ AGE _____

Address _____

City _____ Zone _____ State _____

DETROIT

LISTENING POST

BY JIM DUNNE

'Bird gets glandular trouble

Next year's all-new Thunderbird will look like a slightly inflated and stretched-out version of this year's model, but it will still be recognizable as a T-bird. The sharply slanting hood will definitely be longer, giving a look of thrusting power. The C (side) pillar will be wider for more rear-seat privacy. And the trunk will look like this year's—that's how small it appears.

The heavy chromed look of past T-Bird front ends is gone. Headlights will be hidden behind the full-width grille, which will have vertical bars about six inches high. Ford is taking its time developing a four-door version, but that model is said to be even bigger looking.

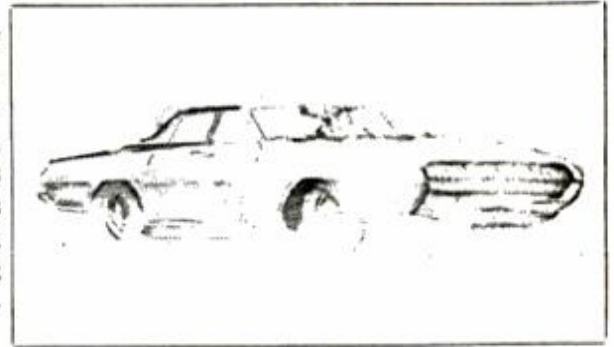

Wheel-less steering for Chrysler

Wrist-twist steering, pioneered by Mercury, is also getting attention from Chrysler. It's being tested on a number of cars at Chrysler's Chelsea Proving Grounds, and should show up on production models within two years, or soon after Mercury gets into production with its version. Look for wheel-less steering on high-priced cars at first.

Chev puts horse before cart

Front-wheel drive for Chevy's new Mustang-type car, the Panther: That's what the latest reports predict. Stories that this car would be out this spring have been explained away by Detroit insiders this way: The first designs made the car look almost exactly like the Mustang, and Chevy officials had second thoughts. So a completely new styling job was done, which set the introduction back to this fall. You'll be kept up-to-date in the *Listening Post* in coming months.

Car makers hold hands under table

Did you know the auto companies give their competitors samples of their new cars even *before* they are available to the public? General Motors, for instance, had 1966 Ford cars on test at their Milford Proving Grounds long before Ford dealers got them. The same thing happened at Chrysler, too. This year, Ford's Dearborn Test Track had no less than five new Toronados under evaluation the week before Oldsmobile's official introduction date. The trade usually is a straight swap—one model for one model. The advantages are obvious: Companies learn what they are up against early enough to get advertising campaigns going while the new models are still fresh, and engineers get a good look at new mechanical innovations. The auto makers also have another way of learning about competitors' products, a cut-rate one that is used frequently. Car divisions rent new cars from dealers of competing makes. Let's say American Motors wants to study the top-raising mechanism of a Thunderbird. Instead of buying a new car, they rent a 'Bird from a Ford dealer for two weeks. These cars are usually in better than stock shape when returned to the dealer, because the parts that were studied are completely hand rebuilt by skilled engineers.

Clean air costs money

You'll pay \$18-\$45 more for your 1968 car because of exhaust-control devices. California's pioneering anti-smog program, which has forced all of the auto companies to clean up engine emissions, is establish-

(Please turn to page 34)

From an AC Engineer's notebook:

Heat-shrink bonding process assures firm seating of sealing gaskets to prevent leakage between insulator and shell.

Shell is assembled to insulator under terrific heat and pressure. As the shell cools, the metal contracts, shell tightens around insulator to form a one-piece, gas-tight assembly.

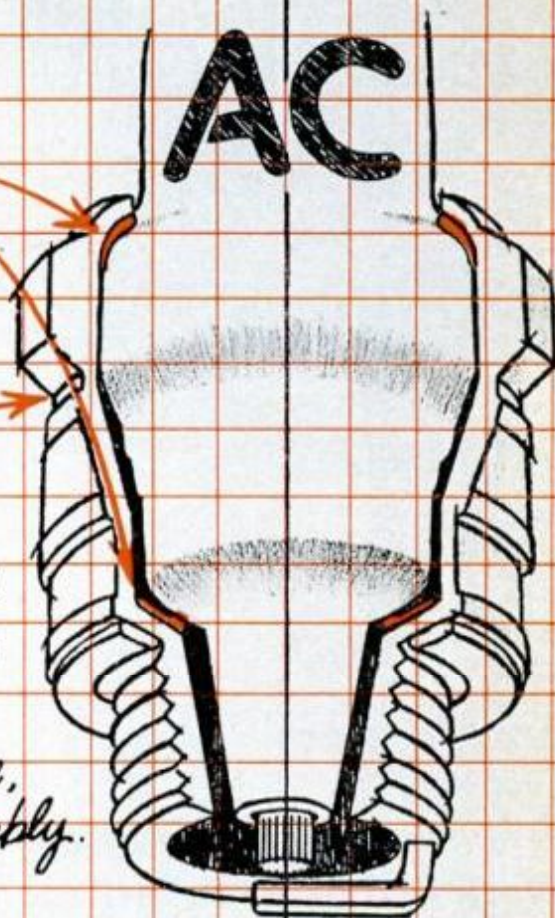

How AC's Heat-Shrink Bonding gives extra protection against leakage, helps preserve peak engine power

AC Spark Plugs are not only positively sealed against combustion gas leakage around the center electrode, but they also have gas-tight sealing between insulator and shell. Thus ACs provide you with additional protection against the power-robbing compression loss that escaping combustion gases can cause. AC's positive sealing also provides better heat conduction to help assure longer, sure-firing action. Gain the benefits of AC's heat-shrink bonding process that adds to positive sealing protection. Promote maximum power and performance in your car. Insist upon AC Fire-Ring Spark Plugs at your next engine tune up.

AC SPARK PLUG DIVISION OF GENERAL MOTORS



**FIRE-RING
SPARK PLUGS**



Be Your Own Boss
with profitable
**Rug and Floor
Cleaning
Business**

*Earn \$10
An Hour
At Once,
In Sparetime*

"Took in \$9000
Last Year in
Sparetime"... A.I.

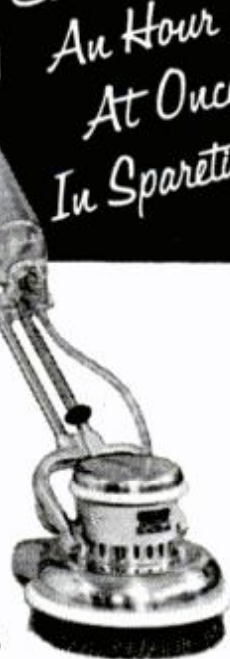

Work Out of Your Own Home!

Here's ideal way to start in business for yourself without a big investment. You don't even need a shop or office. Work out of your own home, use your present car. You do business in other people's homes. And you can start in sparetime—and graduate to full time.

No Experience Needed! We Start You!

Foley-Care equipment is fool-proof. It works for you. No need to have weeks of training. We don't charge you a dime for helping you get started.



Free Booklet Tells You How

Send for this free "Business of Your Own" booklet! See for yourself why this might be the chance you've always wanted to be in business for yourself. It tells the complete story about this profitable service business—lets you decide for yourself. Write today! No salesman will call.



**FOLEY CARE, Dept. 102-6
3333 Fifth St. N. E., Minneapolis, Minn. 55418**

Please send booklet on how to start a rug cleaning service.

Name _____

Address _____

City, State, Zip code _____

DETROIT LISTENING POST

(Continued from page 32)

ing new standards that every other state will have to follow in the near future. The federal government now has legislation on the books that sets national criteria for auto-engine emissions, standards that almost duplicate California requirements. If Washington's timetable is carried out, all cars sold in this country by 1968 will have to be equipped with both "blow-by" devices and exhaust-emission controls of the kind required in California right now. The auto industry has already said that it can have these devices ready by that time.

Dash hinges open for easy repair

A hinged instrument panel that swings out for easy access to gauges and dashboard accessories is being developed by General Motors and Ford. The biggest benefit is at the factory. As the car goes down the assembly line, the instrument panel is pivoted open. After all connections are made, the panel is swung up into position with the same motion you use when closing a glove-box door, and is secured with two bolts. Another benefit: The dashboard-windshield juncture also looks smoother.

Troubleshooting the Fords

How good are the '66 Fords? That's what Ford would like to know. For the first time it is dispatching engineers from the home office out to Ford dealerships across the country to check on the quality of new models and to get the word back to the factory quickly if anything's wrong. If this works as planned, Ford will make this a yearly practice. Then look for other manufacturers to follow suit.

Studded tires beat icy roads

Ice studs are now used on 95 percent of winter tires in some European countries, and manufacturers predict that they will eventually capture a major share of the U. S. market in winter tires. Embedded in snow tires, these small, tack-like metal inserts give exceptional bite when driving over icy roads. This winter, some two million studded tires are expected to be sold in the United States. They last about 20,000 miles, or about the life of the tire; they are recommended for both front and rear tires, since 60 percent of the braking force is on the front wheels; they damage roads only superficially, and then only during panic stops; and they are safe at up to 90 mph for long periods of time. Only 27 of the states now approve use of these tires, but more of them are expected to give their okay soon.

TEST YOUR TALENT

**AWARDED MONTHLY:
\$595.00 Scholarship in
Commercial Art**

Draw the Viking in pencil—and make your drawing a different size from the picture to the right.

If you win the art scholarship prize, you get the complete course in commercial art taught by America's largest home study art school, Art Instruction Schools. You will receive personal attention from professional commercial artists in the fields of advertising art, illustrating, cartooning and painting.

Even if you do not win, you will get a professional estimate of your talent without cost.

Entries for February contest must be in before February 28, 1966. None can be returned. Our students and professional artists are not eligible. Mail your entry in right away!



ART INSTRUCTION SCHOOLS

Studio 4136 • 500 South 4th St., Minneapolis, Minn. 55415

Please enter my drawing in your draw-a-head contest. Also send information about your Art Course at no cost or obligation.



Accredited by the Accrediting Commission of the National Home Study Council.

(PLEASE PRINT)

Name _____
Occupation _____ Age _____
Address _____ Apt. _____
City _____ State _____
County _____ Zip Code _____

Just Pick the Kind of Body YOU Want

CHECK THE COUPON BELOW

...Prove to Yourself How **EASILY** You Can Have It... Almost Overnight!

JUST tell me, in coupon below, the kind of body you want—and I'll give it to you **SO FAST** your friends will be amazed! "Dynamic Tension," my easy, 15-minutes-a-day method, can make your chest and shoulders bulge . . . your arms and legs surge with power . . . your whole body feel "alive!"



FREE 32-page Illustrated Book

32 Pages on how "Dynamic Tension" changed me from a 97-lb. weakling into "World's Most Perfectly Developed Man"—and what it has done for others. Mail coupon NOW! CHARLES ATLAS, Dept. 8A, 115 E. 23rd St., New York City, N. Y. 10010.

**CHARLES ATLAS, Dept. 8A,
115 East 23rd St., New York, N.Y. 10010**

Dear Charles Atlas—Here's the Kind of Body I want:
(Check as many as you like)
 Broader Chest, Shoulders Slimmer Waist, Hips
 More Powerful Arms, Grip More Weight, Solid
 Better Energy, Sleep More Powerful Legs
Send me, absolutely FREE, a copy of your famous book showing how "Dynamic Tension" can make me a new man. 32 Pages, crammed with photographs, answers to vital questions, and valuable advice. No obligation.

Name _____ Age _____
(Please print or write plainly)

Address _____
City & State _____ Zip Code _____

In England mail: Charles Atlas, Chitty St., London, W. 1.

JAN. 1966

ARROW T-50
ALL PURPOSE
STAPLE GUN

HEAVY DUTY

Model T-50
\$12.50

Uses 6
Staple Sizes —
1/4" to 9/16"
and CeatiteK

OTHER MODELS FROM \$4.95

**SHOOTS A STAPLE
WHEREVER YOU'D DRIVE A NAIL!**

FASTER! CHEAPER! BETTER!

for 1001 Home Improvement Fastening Jobs:
Ceiling Tile, Insulating, Upholstering, Screening, etc.

Available at hardware, lumber, building supply,
stationery and other retail outlets.

ARROW FASTENER CO., INC.

One Junius Street • Brooklyn 12, N. Y.

HOMEOWNERS' CLINIC

BY W. CLYDE LAMMEY

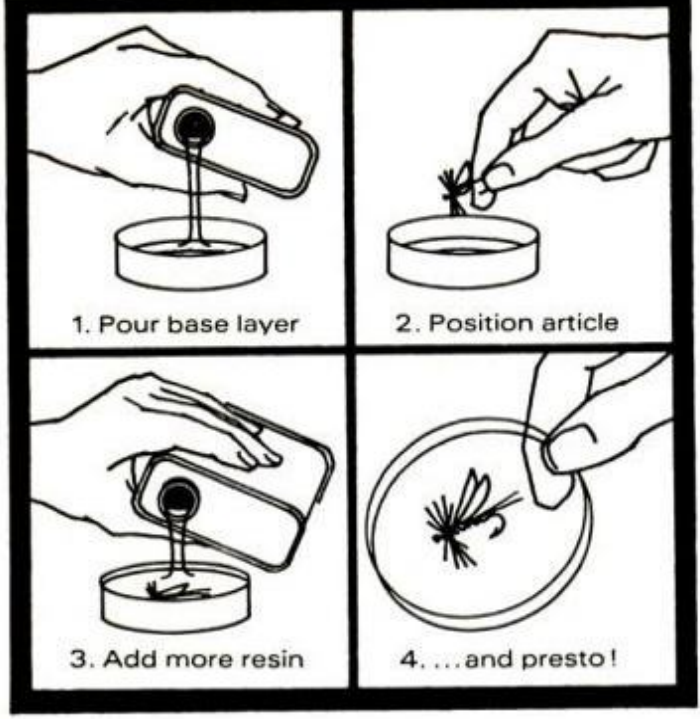

1. Pour base layer

2. Position article

3. Add more resin

4. ...and presto!

NOW!

... Cast imaginative plastic forms, embed decorative materials, preserve precious objects!



Cast your ideas into glass-clear plastic panels and blocks on your first try. Embed leaves, photos, coins, jewelry to create beautiful plaques, table-tops, trays, dividers, desk sets, etc. Preserve objects permanently. It's easy and it's fun. Ask for Glass Plastics Clear Casting Resin at your hardware store or hobby shop. If they don't have it, write GLASS PLASTICS direct.

FREE

GLASS PLASTICS CORPORATION
1261 West Elizabeth Avenue
Linden, New Jersey 07036

Please rush me a free copy of
Creating with Clear Casting Resin.

NAME _____
ADDRESS _____
CITY _____ STATE _____



Out, Out, Darn Spot!

Drippings from a colored wax candle have stained my linen tablecloth. When I tried pouring boiling water on the two stain spots, the wax disappeared but not the stains. I do hope you have some magic formula for removing these stains.—N.H., Texas.

Sad to report, my magic wand is in for repairs just now. But I doubt if waving it over your problem would do much good anyway. I have a sinking feeling about that boiling water you poured on the stains; I'm afraid that may have "set" the stains for good. You can give it the old college try, however, with that old standby, lighter fluid.

Spread the stained area of the tablecloth over several thicknesses of clean paper towels on your (clean) kitchen table. Apply the solvent to the stains a little at a time, then immediately rub lightly with a clean, folded paper towel, working from the edge of the stain toward the center.

Another type of solvent which often removes stains from white fabrics is a jelly-like compound called "Quickie" which painters use to remove paint from their hands. Apply this stuff to the stains with your fingertips, allow it to "work" for a minute or two, then wash it away with a soapy solution followed by a thorough rinsing with clear water. Note: don't use this stuff on dyed fabrics.

Some "Drips" Are Creaks

Whenever I draw hot water from either the kitchen or bathroom faucet I hear a noise that sounds just like dripping water. I've searched everywhere but can't find any sign of a leak. Since our home is a new one, I'm very puzzled by this dripping sound. Can you suggest the cause?—D.L., Tenn.

This is a toughie, but I'll hazard a guess. First, I'll assume you're right about that invisible "leak": there isn't any. Hence, whence the "dripping" sound?

Look for a long run of hot-water line and find where it passes through any openings in the walls. Set up a listening post at these points, then have someone turn on the hot water. It may be that a

(Please turn to page 40)

New Nailless Royalcote Panel Application System

takes the hard work out of paneling a room

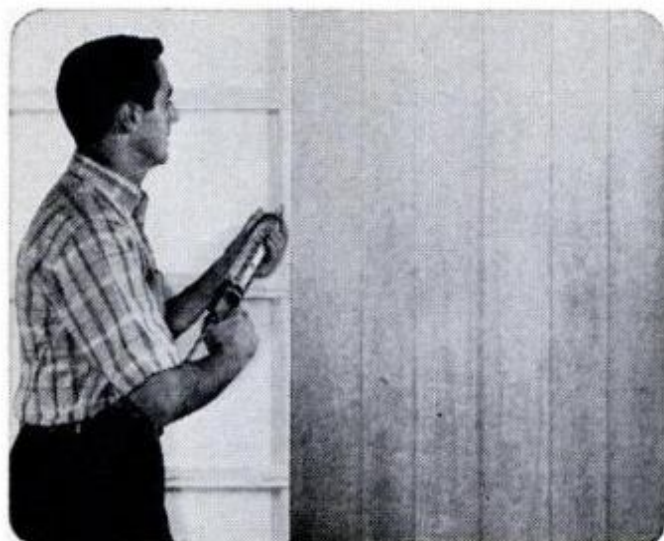

New Royalcote general-purpose adhesive quickly and permanently affixes Royalcote Panels in place. No unsightly nail holes. Apply with caulking gun over solid backing, furring strips, or studs.



Large, precision-cut Royalcote Panels are made to order for do-it-yourselfers. Easy to handle, easy to line up. They cover a wall in no time flat. Adhesive forms a permanent bond, dries quickly, yet allows adjustment.



Finish the job with Royalcote color-matched moldings. Your choice of metal, or vinyl-covered wood, including base, cove, casing inside and outside corners. Moldings also can be applied with Royalcote Adhesive.



For a beautiful, professional-looking finished job that's as easy as one, two, three—see your lumber dealer and choose from 13 Royalcote woodgrains, plus Marbletone. Send coupon for full-color booklet.

 **MASONITE**
...does it better

Royalcote and Marbletone are registered trademarks of Masonite Corporation

MASONITE CORPORATION Dept. PM-1
Box 777 • Chicago, Ill. 60690

Please send me the full-color, eight-page booklet,
"How To Be Your Own Decorator Using Royalcote
Woodgrain Paneling."

Name _____

Address _____

City _____ State _____ Zip Code _____

THE BEST KNOWN IS KNOWN BEST



**FOR
REMOVING
PAINT**



STRYPEEZE Semi-Paste is a non-benzol, general purpose paint remover, that clings to rounded or vertical surfaces.

STRYPEEZE Semi-Paste will not raise wood grains . . . is not harmful to natural fibers. Available where paint is sold.

QUALITY PRODUCTS SINCE 1875

SAVOGRAN

Addison, Ill. NORWOOD, MASSACHUSETTS Los Angeles, Cal.



GRINDS **POLISHES**
DRILLS **SHARPENS**
CARVES **DEBURRS**

No. 2
Moto-Tool Kit
Illustrated

MOTO-TOOL THE POCKET SIZE MACHINE SHOP

Handiest tool you'll ever own. Does fine detail work with pin point accuracy. Eliminates time consuming hand work. Gets into places difficult to reach with larger tools. 27,000 RPM. Collet sizes 1/8", 3/32" and 1/16". An industrial favorite since 1936. Wt. 13 oz.

NO. 2 MOTO-TOOL only \$19.95
NO. 2 MOTO-TOOL KIT with 23 accessories in steel case \$29.95

NEW HEAVY DUTY NO. 3 MOTO-TOOL

New high torque motor designed for hard industrial use. Same features as No. 2 plus 50% increase in power.
NO. 3 MOTO-TOOL only in steel case \$29.95
NO. 3 MOTO-TOOL, 23 accessories, steel case .. \$37.95

SEE YOUR DEALER OR WRITE FOR CATALOG
Dremel Mfg. Co. • Dept. 116-A • Racine, Wis.

HOMEOWNERS CLINIC

(Continued from page 38)

slight expansion of the pipe occurs when the hot water flows through it, and that this is enough to cause the pipe to creak against the sides of the opening in the wall. The cure? Enlarge the opening slightly using a sheet of sandpaper wrapped around the pipe grit-side-out, then work it back and forth against the sides of the hole.

To Fur or Not to Fur

I want to panel one wall of our kitchen-dining area with 4x8-ft. grooved panels. It's a house-side plaster wall in good condition, covered with wallpaper. Can I apply the paneling directly over the papered surface without furring, or must furring strips be installed?—B.Y., Mass.

Horizontal furring strips are recommended if the panels are the type that are nailed only at the seams where one panel joins another (otherwise you might have trouble getting the panels to "break" right for nailing to the studs). When nailing the furring into the studs, install one strip at the ceiling, one at floor level and at least two at equal distances between.

If the panels are a type that can be nailed at any point, then forget about the furring and set 'em up against the wall and nail 'em directly to the studs.

Don't bother removing the wallpaper.

Her Plants Quit in Winter

This is the second winter I've tried to keep plants indoors—without success. After a month or so the leaves lose their luster and drop off, and I can't seem to bring the plants back to bloom. I must be doing something wrong.—U.L., Nebr.

The symptoms you describe are usually due to insufficient humidity. The best way to overcome this problem—especially if you keep all your plants in one room—is to install a small humidifier and keep the door to the room closed.

Or place the pots in large shallow pans half filled with small pebbles to help maintain about a 1/8-in. water level.

Most plants require plenty of sunshine, so be sure they're near a window where they can get it, and turn them frequently.

Periodically spraying water on the foliage will help prevent leaf drop. Stir the soil in the pots occasionally, too.

Finally, consult a local nurseryman for advice on what nutrients your plants might require to enable them to flourish.

★★★

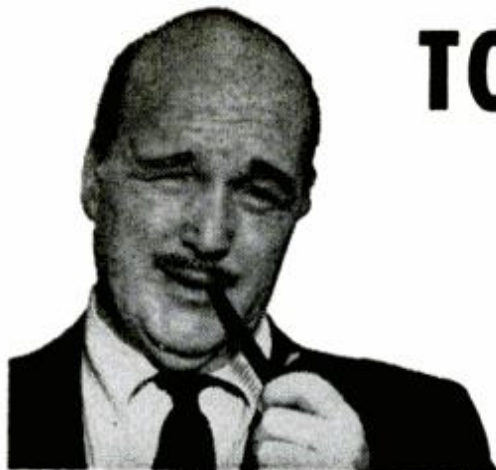

TOM McCAHILL SAYS:

"A lot of people could make themselves valuable FAST"

Everyone talks about high school dropouts and automation changing jobs and what to do after retirement. I know some full grown high school students who can't find summer jobs. I have known family men who thought the end of the world had come when the plant moved out of town.

I hope this doesn't sound like a two-bit sermon, but there are solutions to remedy almost any situation. A lot of people could make themselves valuable fast in a job field that nobody seems to know much about—yet, and that's fixing electrical appliances.

As you know, the day is long past when the average home had only one or two electrical appliances. Most homes today are loaded with electrical gadgets that are used for everything from drying milady's hair to cooking dinner and cooling or heating the house.

These appliances break down and that's where you come in.

Appliances have become a major part in our living habits, and in most areas, good appliance repairmen are as scarce as old maids in Corvettes.

What makes sense about this field is that it offers opportunities to men of any age. You'd be surprised at the extra income you can pick up doing good appliance servicing for your neighbors—or the possibilities of starting your own business with little or no investment. There are also good jobs to be had working for some one else who's already in the business.

How easy is it to break into this field?

A lot easier than you think, if you take a look at

the home-study course offered by the Appliance Division of the National Radio Institute. You've probably seen the NRI ads. They've been one of the biggest and best schools around since 1914.

The course is good. It's easy. It costs less than many people shell out for one month's payment on that Detroit monster parked in the driveway. They train you fast, in an interesting way, to do some real *professional* appliance servicing on just about every type of appliance from small to large, including most farm and commercial appliances. It even covers small gasoline engines. And they have a separate arrangement to teach you air conditioning and refrigeration.

The point I want to make is this: About the worst thing anyone can do is to sit down and worry about where the extra bucks are coming from. It's not good for your digestive system. It isn't good for those who have to live with you. About the best thing any man can do is help himself.

Do a favor for the guy you see in the mirror every day. Get the details about this course. They send you some books that are worth reading—FREE. Send the coupon below or drop them a note.

No need to tell them I recommended the course. Get the details and see for yourself. Might be a whale of a smart move to do this today.

TOM McCAHILL

APPLIANCE DIV., NATIONAL RADIO INSTITUTE
WASHINGTON, D. C. 20016

600-016

OK—prove to me this training is as good as McCahill says. Send me the Free Book on Professional Appliance Servicing and Sample Text. No Salesman.

NAME.....

ADDRESS.....

CITY..... STATE..... ZIPCODE.....

Accredited Member National Home Study Council

Spotlight On Dodge's New Fastback

By Jim Dunne



This Coronet in wolf's clothing will be out stalking Mustangs.

IT HAS A FASTBACK ROOF, retracting headlights, rear seats that fold flat to form a deck like a station wagon's, and it boasts Chrysler Corp.'s first flow-through ventilation. "It" is the new four-seater Dodge Charger, which goes on sale this January.

The car may share its 117-inch-wheel-base chassis with the Dodge Coronet, but its interior is strikingly different. The instrument panel is new, and the headliner is made of one-piece fiberglass.

Station wagon in disguise

With the rear bucket seats pushed forward and a security panel folded back into the trunk, there's a flat luggage space—like the one in the Plymouth Barracuda—roomy enough for you to position two air mattresses side by side, 76 inches long in all.

With security panel up, length is cut to a bassinet-size 36 inches. Either of the rear seats can be folded forward individually, leaving room for three passengers, while still providing extra utility space.

But Dodge could have made better use of all that room. For one thing, the floor of the storage compartment begins about

12 inches behind the back of the front seat, leaving an inconvenient gap. Small articles tend to fall in. And there is a difference of about six inches between the levels of the trunk floor and storage area inside the cabin, which would make overnight sleeping a backbreaker.

People-room is adequate

The car is roomy enough to carry its designed load of four passengers in complete comfort. Back-seat headroom is adequate even with that sloping roof, but leave your hat home whether you sit in front or in back. All these new cars are hatmakers' enemies.

The back-seat arrangement is especially comfortable. An arm rest for both passengers is formed by the padded control console that runs the full length of the passenger compartment. Of course, you pay a penalty for this comfort: You can't seat a fifth passenger.

Charger road handling is similar to that of the Coronet two-door, even though the fastback has a higher center of gravity (the culprits are the big rear window and long roof). Lean isn't too acute in sharp turns. The combination of a 383-cu.-in. engine and automatic transmission makes for alert and responsive performance. Most of the Coronet options are being made available on the Charger as well,

[\(Please turn to page 44\)](#)



I'd like to give this to my fellow men... while I am still able to help!

I was young once, as you may be—today I am older. Not too old to enjoy the fruits of my work, but older in the sense of being wiser. And once I was poor, desperately poor. Today almost any man can stretch his income to make ends meet. Today, there are few who hunger for bread and shelter. But in my youth I knew the pinch of poverty; the emptiness of hunger; the cold stare of the creditor who would not take excuses for money. Today, all that is past. And behind my city house, my

summer home, my Cadillacs, my winter-long vacations and my sense of independence—behind all the wealth of cash and deep inner satisfaction that I enjoy—there is one simple secret. It is this secret that I would like to impart to you. If you are satisfied with a humdrum life of service to another master, turn this page now—read no more. If you are interested in a fuller life, free from bosses, free from worries, free from fears, read further. This message may be meant for you.

By Victor B. Mason

I am printing my message in a magazine. It may come to the attention of thousands of eyes. But of all those thousands, only a few will have the vision to understand. Many may read; but of a thousand only you may have the intuition, the sensitivity, to understand that what I am writing may be intended for you—may be the tide that shapes your destiny, which, taken at the crest, carries you to levels of independence beyond the dreams of avarice.

Don't misunderstand me. There is no mysticism in this. I am not speaking of occult things, of innumerable laws of nature that will sweep you to success without effort on your part. That sort of talk is *rubbish!* And anyone who tries to tell you that you can *think* your way to riches without effort is a false friend. I am too much of a realist for that. And I hope you are.

I hope you are the kind of man—if you have read this far—who knows that anything worthwhile has to be *earned!* I hope you have learned that there is no reward without effort. If you have learned this, then you may be ready to take the next step in the development of your karma—you may be ready to learn and use the secret I have to impart.

I Have All The Money I Need

In my own life I have gone beyond the need of money. I have it. I have gone beyond the need of gain. I have two businesses that pay me an income well above any amount I have need for. And, in addition, I have the satisfaction—the deep satisfaction—of knowing that I have put more than three hundred other men in businesses of their own. Since I have no need for money, the greatest satisfaction I get from life is sharing my secret of personal independence with others—seeing them achieve the same heights of happiness that have come into my own life.

Please don't misunderstand this statement. I am not a philanthropist. I believe that charity is something that no proud man will accept. I have never seen a man who was worth his salt who would accept something for nothing. I have never met a highly successful man whom the world respected who did not sacrifice something to

gain his position. And, unless you are willing to make at least half the effort, I'm not interested in giving you a "leg up" to the achievement of your goal. Frankly, I'm going to charge you something for the secret I give you. Not a lot—but enough to make me believe that you are a little above the fellows who merely "wish" for success and are not willing to sacrifice something to get it.

A Fascinating and Peculiar Business

I have a business that is peculiar—one of my businesses. The unusual thing about it is that it is needed in every little community throughout this country. But it is a business that will never be invaded by the "big fellows." It has to be handled on a local basis. No giant octopus can ever gobble up the whole thing. No big combine is ever going to destroy it. It is essentially a "one man" business that can be operated without outside help. It is a business that is good summer and winter. It is a business that is growing each year. And, it is a business that can be started on an investment so small that it is within the reach of anyone who has a television set. But it has nothing to do with television.

This business has another peculiarity. It can be started at home in spare time. No risk to present job. No risk to present income. And no need to let anyone else know you are "on your own." It can be run as a spare time business for extra money. Or, as it grows to the point where it is paying more than your present salary, it can be expanded into a full time business—overnight. It can give you a sense of personal independence that will free you forever from the fear of lay-off, loss of job, depressions, or economic reverses.

Are You Mechanically Inclined?

While the operation of this business is partly automatic, it won't run itself. If you are to use it as a stepping stone to independence, you must be able to work with your hands, use such tools as hammer and screw driver, and enjoy getting into a pair of blue jeans and rolling up your sleeves. But two hours a day of manual work will keep your "factory" running 24 hours turning out a product that has a steady and

ready sale in every community. A half dollar spent for raw materials can bring you six dollars in cash—six times a day.

In this message I'm not going to try to tell you the entire story. There is not enough space on this page. And, I am not going to ask you to spend a penny now to learn the secret. I'll send you all the information, free. If you are interested in becoming independent, in becoming your own boss, in knowing the sweet fruits of success as I know them, send me your name. That's all. Just your name. I won't ask you for a penny. I'll send you all the information about one of the most fascinating businesses you can imagine. With these facts, you will make your own investigation. You will check up on conditions in your neighborhood. You will weigh and analyze the whole proposition. Then, and then only, if you decide to take the next step, I'll allow you to invest \$15.00. And even then, if you decide that your fifteen dollars has been badly invested I'll return it to you. Don't hesitate to send your name. I have no salesmen. I will merely write you a long letter and send you complete facts about the business I have found to be so successful. After that, you make the decisions.

Does Happiness Hang on Your Decision?

Don't put this off. It may be a coincidence that you are reading these words right now. Or, it may be a matter that is more deeply connected with your destiny than either of us can say. There is only one thing certain: If you have read this far you are interested in the kind of independence I enjoy. And if that is true, then you must take the next step. No coupon on this advertisement. If you don't think enough of your future happiness and prosperity to write your name on a postcard and mail it to me, forget the whole thing. But if you think there is a destiny that shapes men's lives, send your name now. What I send you may convince you of the truth of this proverb. And what I send you will not cost a penny, now or at any other time.

VICTOR B. MASON
1512 Jarvis Ave., Suite M-2-AX
CHICAGO, ILLINOIS 60626

Prepare Now For **\$7,500**
BIG MONEY!



THE TRAINED AUTO MECHANIC IS TOMORROW'S "BIG WHEEL"

You can aim as high as you want when you are an expert Auto Mechanic. Foreman, Fleet Superintendent, Engine Rebuilder, Automotive Distributor, Technical Expert in Detroit...name it...your basic qualification in Auto Mechanics opens the door!

Lincoln Tech graduates have advanced to all of these jobs. They learned by *DOING...not home study*. There are 80,000 big pay jobs open right now for graduate Auto Mechanics, Ignition Tune-Up and Transmission Specialists. Lincoln Tech training will qualify YOU! You learn by actually working with live engines, automatic transmissions, power steering, brake systems, etc.

FREE PLACEMENT SERVICE

There are LINCOLN TECHNICAL INSTITUTE schools in principal cities. You can train in the one nearest you, knowing your Lincoln Tech diploma is nationally recognized for excellence in training and individual student instruction. There are no fees for placement of graduates.



Act *NOW!* Get your start in America's industry of unlimited opportunity. New classes start every four weeks. Write for FREE catalog.

LINCOLN TECHNICAL INSTITUTE

472 Market St., Newark, N.J. 07105

Lincoln Technical Institute, Suite I-E
 472 Market St., Newark, N.J. 07105
 Please send me full information on the Lincoln Tech Automotive School nearest my home. I am interested in the courses checked below.

- Automotive Mechanics
- Automatic Transmission
- Ignition and Tune-Up

Name _____

Address _____

City _____ State _____

(Continued from page 42)

including the 426-cu.-in. hemi engine. The rotating headlights mentioned earlier are housed in a diecast chrome piece that also serves as part of the grille when the lights are hidden. The small electric motors that turn the lights are geared down 450:1 to ensure reliable operation even in icy conditions. A push-pull light switch turns on the lights and rotates them as well. If the headlights are not in proper position, a red dash light warns the driver. A separate switch allows the driver to keep the headlights in aimed position even when they are turned off. Also, they can be manually rotated in case of power failure.

Let there be light

The full-width taillight has six bulbs, all of which light up when the headlights are turned on and brakes applied. Turn signals flash a bank of three lights on one side of the lens.

A large box section built in just behind the rear window contains a plenum chamber for exhausting air from the passenger compartment through two large vents covered over by rubber flaps. These flaps act as one-way valves to keep dust from entering.

The futuristic rear window is a tipoff on things to come; the glass is curved up at the outer edges in gullwing fashion. Look for other cars to pick this up soon. ★★★

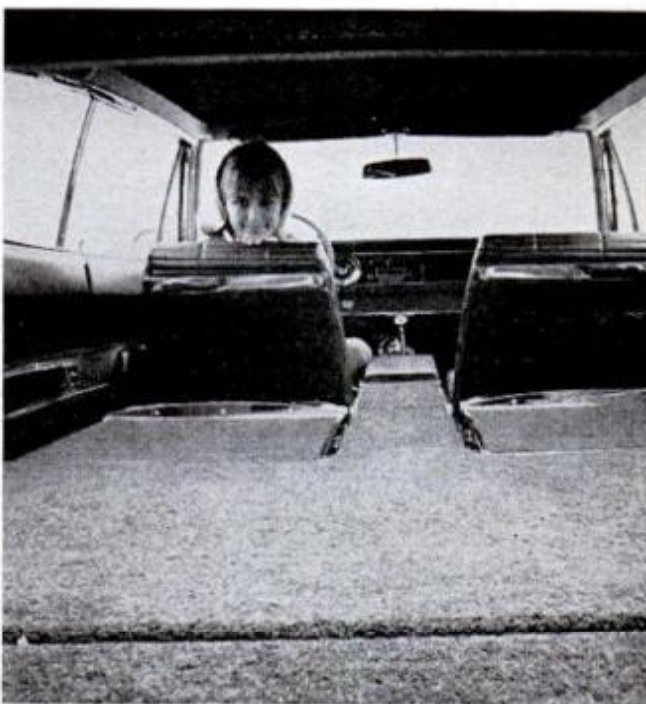

FOLD-DOWN rear seat and trunk partition provide wide-open spaces for luggage—even skis. But a six-inch step makes sleeping there uncomfortable

MAKE MORE MONEY AT HOME IN YOUR OWN BUSINESS

in spare time

LEARN UPHOLSTERY



**MEN ...
WOMEN ...
ALL AGES**

PROFITABLE BUSINESS

BIG PAY JOB

SECOND INCOME

**NO EXPERIENCE OR
BIG CAPITAL REQUIRED!**

EARN AS YOU LEARN RIGHT FROM THE START—Make beautiful Custom Furniture. Turn old furniture into new for **BIG PROFITS**. Reupholster chairs, divans, footstools. Repair furniture of all types. Make Slip Covers, Drapes, Cushions. Your home is your workshop. No overhead and no expensive equipment.

SKILLED UPHOLSTERS URGENTLY NEEDED NOW! Shops desperate for help! Can't satisfy Upholstery demand created by population explosion, gigantic new home, apartment, hotel, motel, office, restaurant construction. Upholsters earn **TOP MONEY**, are needed *Everywhere!*

WE WILL GIVE YOU EVERYTHING: 1) Most Modern, Complete Course ever offered. 2) Complete Set of Tools 3) Practical "Learn-by-Doing" Projects. 4) Professional guidance every step of the way.

FREE TOOLS



GET THIS **FREE BOOK** YOURS FOR THE ASKING!



Air Mail Coupon for **FREE** Illustrated Book, Useful Sample Lesson and Plan for Operating a Profitable Business at Home ...

All 3 are Yours FREE!

We are proud to be Member of the Association of Home-Study Schools. We subscribe to "Home-Study" in order to follow international for the purpose of attaining the highest possible standards of education through Home Study.



FREE materials, fabrics, tools, supplies to make a **ROOM-FULL** of beautiful furniture like this... **YOURS** to **KEEP** or **SELL!**



BE YOUR OWN BOSS—Start small, at home... Enjoy a good income for life! • Send for your **FREE ILLUSTRATED BOOK** and **SAMPLE LESSON**... **TODAY!**

MODERN UPHOLSTERY INSTITUTE
Box 899-TH, Orange, California
Please send **FREE** Illustrated Book and **SAMPLE LESSON**. No obligation — No salesman will call.

Name _____ Age _____
Address _____
City _____ Zone _____ State _____

MODERN UPHOLSTERY INSTITUTE, Box 899-TH, Orange, California

Learn **DRAFTING** at home



SAY GOODBYE TO THANKLESS, LOW-PAY JOBS!

GOOD NEWS for men working in low-paying, no-future jobs. We offer you the opportunity, without a penny of cost, to find out what it takes to become a draftsman.

The Draftsman is the key man in industry

Practically everything that is built or manufactured is constructed from drawings prepared by the draftsman. Machines can never replace his skilled work. Today there is a shortage of men trained in drafting and the nation's fast technical growth will require many more. This adds up to good salaries and job security for the trained draftsman.

Work is clean, pleasant Drafting is interesting, professional work—the kind you'll like. As a draftsman, you will command respect in business and community activities, enjoy more of the good things of life through additional earnings, and be able to look forward to promotion and a secure future.



Drafting does not require unusual talents or artistic ability. So if you're discontented in any way—or concerned about your future—consider the advantages of this high-pay field. Chicago Tech's practical method of teaching makes it easy for you to learn drafting at home in your spare time.

YOURS FOR THE ASKING

So get the facts right away about Chicago Tech's college-level training at home—plus a free trial lesson. See for yourself how your own natural abilities measure up to the needs of this high-paying profession. Learn how you can become a draftsman the Chicago Tech way. Act now! **MAIL THIS COUPON TODAY.**

SEND FOR FREE TRIAL LESSON AND ILLUSTRATED BOOK

CHICAGO TECHNICAL COLLEGE

ESTABLISHED 1904
Accredited Member Nat'l Home Study Council

A-204 Tech Bldg., 2000 So. Michigan Ave. Chicago, Ill. 60616
Yes, please send Free Trial Lesson and illustrated book on drafting and its opportunities. No obligation.

Name _____ Age _____
Address _____
City _____ State _____ Zip _____

New From Wen

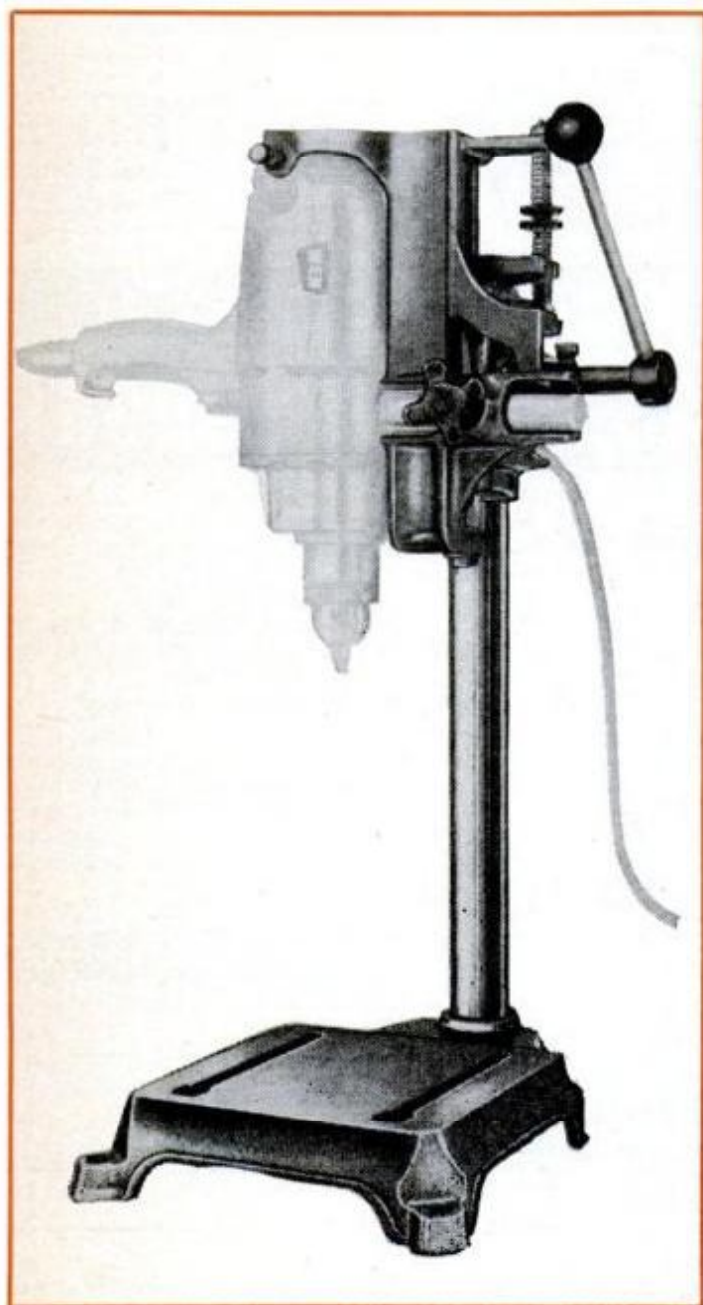
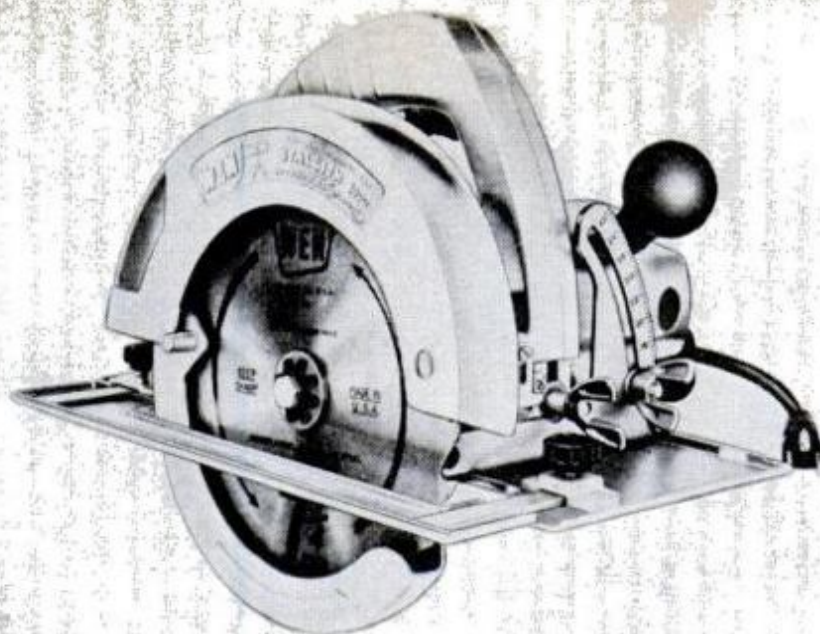

WITH THE INTRODUCTION recently of two new industrially rated 7¼-in. circular saws—the heavy-duty Stallion 1000 and the Stallion 960—Wen Products, Inc. rounds out its line of economically priced portable power tools. Both are rugged items that appear to incorporate safety with stability, and to provide a nice balance that insures proper ratio of down/forward cutting force at all cutting depths and angles.

Designed primarily for commercial work, the 12-lb. Stallion 1000 (shown above) features a 2½-hp, 12-amp air-cooled motor with a no-load running speed of 5300 rpm. Frictionless ball and needle bearings are used throughout. It sells for \$54.95.

The Stallion 960 is a made-to-order tool for the homeowner-handyman-craftsman. Its 1¾-hp, 10-amp. burnout-proof air-cooled motor turns at 5200 no-load rpm on perpetually lubricated needle bearings. This one weighs about 11⅔ lbs., sells for \$44.95.

Both saws feature low profiles and low centers of gravity and come with a 7¼-in. alloy steel, chrome-plated blade and a ⅝-in. round arbor. A safety clutch on each prevents kickback. A zero depth adjustment permits setting the blades from zero to a 2½-in. cut at 90° and 1⅞-in. at 45°. Of course, both will plow, groove or dado.

Wen's new drill-press stand (right) is the companion tool to its four-speed reversible ½-in. All-Drill, introduced last year. Made of heavy aluminum and steel, the stand permits the drill to be clamped snugly and securely to it in seconds. This goodie lists for \$35.95. ★★★

**LEARN MORE
EARN MORE!**

NEW

**AUDEL HELPS PUT
MORE SKILL IN YOUR
HANDS—MORE MONEY
IN YOUR POCKET!**

AUDEL SKILL-BUILDING PRACTICAL GUIDES

HOME APPLIANCE SERVICE GUIDE

How to fix all large and small appliances, both gas and electric. Covers basic principles, operation & servicing. Tells how to locate troubles, take appliances apart & reassemble. Covers new models. Illus. 608 pages. \$6.95

Circle No. 2 in Coupon

AUTO RADIO REPAIR GUIDE

Complete servicing guide for all types of auto radios, including all-transistor & FM. Fully illustrated with many typical schematic diagrams. Step-by-step removal instructions for all late-model radios. 224 pages. \$4.50

Circle No. 94 in Coupon

REFRIGERATION & AIR CONDITIONING

Full information on servicing, operation & repair of all systems and machines, freezers, lockers, water coolers, etc. Describes basic principles of all units. Includes dozens of tables of vital data. Indexed. Illus. 1090 pages. \$6.00

Circle No. 14 in Coupon

COMMERCIAL SOUND INSTALLATIONS

How to install, operate, service & maintain all types of sound & intercom equipment used in factories, schools, stadiums, vehicles, and other commercial fields. Covers selection of equipment and systems. 384 pages. \$5.95

Circle No. 92 in Coupon

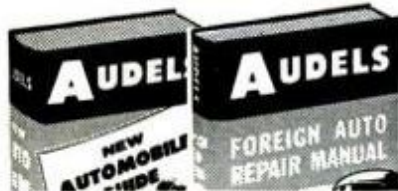

AUTO MECHANICS GUIDE

Ready guide for mechanics, students, car owners. Theory, construction and servicing of modern cars. 1000 Illus. 1132 pages. \$6.00

Circle No. 1 in Coupon

FOREIGN AUTO REPAIR MANUAL

Complete, up-to-date service data for all the popular imports: English, French, German, Italian, Swedish. Illus. 592 pages. \$5.00

Circle No. 53 in Coupon

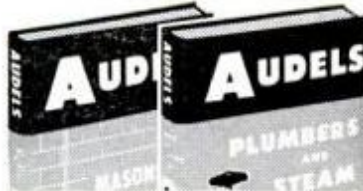

MASONS AND BUILDERS GUIDES

Four practical vols. for bricklayers, stone masons, cement workers, plasterers, tile setters. 2000 Illus. 1440 pages. Set \$10.50

Circle No. 26 in Coupon

PLUMBERS & STEAMFITTERS GUIDES

Four vols. of ready reference for plumbers, steamfitters, gas fitters, sheet metal workers. 3600 Illus. 1833 pages. Set \$10.50

Circle No. 6 in Coupon

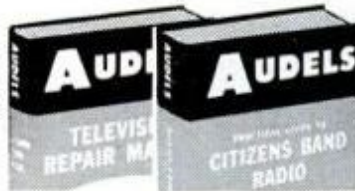

TELEVISION REPAIR MANUAL

Latest information on TV circuits & how to install, troubleshoot and repair all TV sets, including color. Illus. 512 pages. \$5.00

Circle No. 3B in Coupon

2-WAY CB RADIO GUIDE

Explains how to select, install, operate, maintain all types of CB radios. Latest equipment; FCC regulations. 288 pgs. \$4.95

Circle No. 95 in Coupon

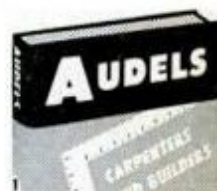

CARPENTERS and BUILDERS GUIDES

Four all-inclusive vols. Modern construction and inside trade information for carpenters, builders and all woodworkers. 3700 Illus. 1900 pages. 4-Volume Set. \$10.50

Circle No. 8 in Coupon



OUTBOARD MOTOR & BOATING GUIDE

Practical details on all phases of outboard motor repairs and maintenance. An essential boating tool! Illus. 414 pages. \$4.00

Circle No. 49 in Coupon

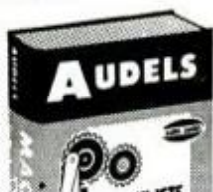

MACHINISTS and TOOLMAKERS GUIDE

Modern shop practice for machinists, toolmakers, draftsmen. How to set up & run all machine tools. 1256 pages. \$6.95

Circle No. 12 in Coupon

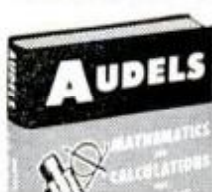

MATHEMATICS FOR MECHANICS

A complete guide to the mastery of practical math. Simplified method makes learning fast and easy. Ill. 672 pgs. \$4.95

Circle No. 11 in Coupon

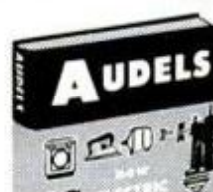

new ELECTRIC LIBRARY

10 volume electrical encyc. Answers questions on thousands of electrical problems. 9000 Ill. 5558 pgs. Set \$25.00

Circle No. 15A in Coupon

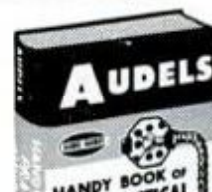

PRACTICAL ELECTRICITY

Complete handbook; practical, simplified, ready reference on all electrical subjects. 2600 Illus. 1052 pages. \$5.95

Circle No. 4 in Coupon



BLUEPRINT READING

For mechanics and construction men. Step-by-step explanation of how to read all types of blueprints; easy to understand. Ill. 430 pgs. \$3.95

Circle No. 25 in Coupon

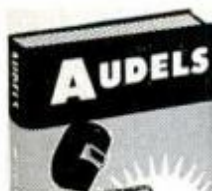

WELDERS GUIDE

Concise, practical guide to theory, operation and maintenance of all types of electric & oxy-acetylene welding. Illus. 588 pages. \$4.95

Circle No. 10 in Coupon

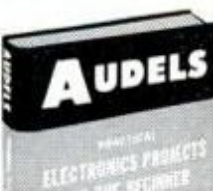

PRACTICAL ELECTRONICS PROJECTS

Learn basic electronics through building useful, working transistorized devices. Hundreds of illus. 256 pages. \$4.95

Circle No. 96 in Coupon

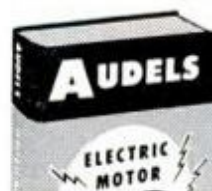

ELECTRIC MOTOR GUIDE

Covers hookups, control, maintenance and troubleshooting of all types of motors. Fully indexed. 600 Ill. 1036 pgs. \$5.95

Circle No. 27 in Coupon

ADDITIONAL IMPORTANT TITLES

Circle the numbers wanted in the MAIL ORDER coupon below.

All books are sent for FREE EXAMINATION.

No. 5	TRUCK & TRACTOR GUIDE, 908 pages.	\$5.95
No. 59	HOME GAS HEATING & APPLIANCE MANUAL, 320 pages.	3.50
No. 93	PRACTICAL GUIDE TO TAPE RECORDERS, 288 pages.	4.95
No. 97	SERVICING ELECTRONIC ORGANS, 256 pages.	4.95
No. 54	PROGRAMMED BASIC ELECTRICITY, 272 pages.	4.00
No. 7	PAINTING & DECORATING MANUAL, 592 pages.	4.95
No. 48	GAS ENGINE MANUAL, 468 pages.	4.00
No. 28	OIL BURNER GUIDE, 420 pages.	3.95
No. 9	DIESEL ENGINE MANUAL, 544 pages.	6.00
No. 29	SHEET METAL PATTERN LAYOUTS, 1152 pages.	7.50
No. 40	PUMPS, HYDRAULICS, AIR COMPRESSORS, 1219 pages.	6.95
No. 42	MILLWRIGHTS & MECHANICS GUIDE, 1166 pages.	6.95
No. 34	Q & A FOR ELECTRICIANS EXAMINATIONS, 288 pages.	3.50
No. 37	POWER PLANT ENGINEERS GUIDE, 966 pages.	6.95
No. 41	HOUSE HEATING GUIDE, 1074 pages.	3.95
No. 13	WIRING DIAGRAMS FOR LIGHT & POWER, 320 pages.	4.00
No. 38	Q & A FOR ENGINEERS & FIREMANS EXAMS, 536 pages.	4.00
No. 30	SHEET METAL WORKERS HANDY BOOK, 398 pages.	3.95
No. 52	DOMESTIC COMPACT AUTO REPAIR, 816 pages.	5.95
No. 36	ELECTRIC DICTIONARY, 550 pages.	3.50
No. 34	RADIOMANS GUIDE, 448 pages.	5.00
No. 56	HOME MODERNIZING & REPAIR GUIDE, 288 pages.	2.95
No. 55	HOME WORKSHOP & TOOL HANDY BOOK, 448 pages.	5.00



10-DAY FREE EXAMINATION

SEND NO MONEY—Pay the postman nothing! We are glad to send you any of the Audel Guides for absolutely FREE examination in your own home. We take all the risks and leave all the decisions up to YOU. There is no obligation! If you decide to keep the books of your choice you may pay for them under our astounding easy-pay plan of only \$3 a month.

HERE IS ALL YOU DO—IT'S EASY TO ORDER: In the No-Risk Mail Order Coupon at the right just draw a circle around the number of Audel Guides you want us to send you for FREE EXAMINATION. We will send them to you at once to help you build a brighter future by increasing your SKILL. If you are not COMPLETELY satisfied, return the books, and that will end the matter! NO STRINGS OR CATCHES TO THIS OFFER.

MAIL THIS NO-RISK COUPON TODAY!

THEODORE AUDEL & CO.—Self Improvement Publishers Since 1879—
4300 W. 62nd Street, Indianapolis, Indiana 46206

P-16

Please mail me for 10 days' FREE EXAMINATION the books I have circled at right. I agree to mail \$3 in 10 days on each book or set ordered, and to further mail \$3 a month on each book or set ordered until I have paid the purchase price, plus shipping costs. If I am not completely satisfied with my Audel Guides I may return them.

Name _____

Address _____

Occupation _____

Employed By _____

SAVE SHIPPING COSTS! Check here if you enclose complete payment with order (plus sales tax, if any). We pay postage charges. You have same return privilege.

1	2	3A	3B	4
5	6	7	8	9
10	11	12	13	14
15A	25	26	27	28
29	30	34	36	37
38	40	41	42	48
49	52	53	54	55
56	59	92	93	94
		95	96	97

I have bought Audel books before

THEODORE AUDEL & CO.
division of HOWARD W. SAMS & CO., INC.
Indianapolis • New York

New flying pod for

TALK ABOUT a fun boat! Here's a little water bug that stands right up on its three legs and scoots across the surface.

It's one of the first production hydrofoils using outboard power. Like a Volkswagen, it's so ugly it has "character." And like the famous beetle, it uses a minimum of power, a minimum of fuel, and is surprisingly maneuverable.

The "Water Spyder" lifts two adults in a fast cruise some 14 to 18 inches above the surface. Its stilts are two hydrofoils fastened to the hull and a rear stabilizer that projects behind the craft. From the pod-type cockpit you operate a control handle that alters the angle of the stabilizer only 5°, but this is enough to bring the craft up on its foils.

The Spyder will take any long-shaft motor from 20 to 35 hp. Actually, the horsepower within that range makes little difference. Once it's up on its aluminum

foils, the craft will scoot along at 40 mph with a 20-hp engine as easily as with a 35; at full speed the total surface touching the water is only 15 square inches (less surface than the palm of one hand), and it doesn't take much power to keep it moving at top speed with such little drag.

The water bug is 12 feet long and 7 feet 4 inches wide, including foils. For docking or trailering, the foils are pivoted up and locked against the fiberglass hull. Exclusive of motor, the craft weighs only 180 pounds.

Its performance is surprising. Not only will it stand up on its stilts in a hurry (four seconds with 35 horses), but it can be whipped around in a 35-foot turning radius without dropping back into the water.

The Spyder retails for \$970, complete with upholstered seats, lights, speedometer, windshield and steering hardware.



GETTING UNDER WAY, designer Lstiburek's sleek little craft looks like a conventional runabout, except for that extra plumbing hanging from the sides



CLIMBING to a planing attitude as power is applied, the foil struts kick up a fine spray. This disappears once the hull breaks free of the water



high-speed boating

A larger model, available by the time you read this, will be 19 feet long and will lift six adults. Designed for any motor in the 60 to 100-hp class, it also will have a maximum speed of 40 mph. It will retail for \$1800, or the equivalent of \$300 per seat for the ride of your life and the privilege of being the focal point of every boater's eyes this side of the horizon.

Designer of the two Spyders is Joseph Lstiburek, who has had years of experience in designing aircraft components, experience that obviously shows in his first two hydrofoil boats.

The firm (Water Spyder Marine, Ltd., 157 Richard Clark Drive, Downsview, Ont.) soon will offer a kit of hydrofoils—not the first on the market, by the way—with complete instructions for installing them on any planing-type hull. If these catch on, watch a good many boaters become airborne.—*Clifford B. Hicks*



EVERYTHING FOLDS up snug to the hull so that the tiny flyer can be transported on a normal boat trailer. The stabilizer swings over into the cockpit



FLYING above the surface on its foils, the pod picks up speed rapidly. Running flat out, the boat rides on only 15 square inches of the foil surface

FROM THE PATENT OFFICE

NEW INVENTIONS

BY M. J. PEDERSEN

A floating runway of around 200 by 40 feet may one day zip in and out of busy harbors, carrying ready-to-fly airplanes as passengers. Equipped with jet engines, the hydrofoil runway would skip along the surface, reaching speeds of 100 mph or more. It would whisk from port only one loaded airplane at a time and, while speed-along, allow the plane to take off from its deck. Receiving patent 3,191,566, Fred H. Wilken and Herman Roberts, Demarest, N.J., noted that aircraft cannot overshoot or undershoot the runway because the hull forming the runway travels along with and under the aircraft as long as needed for

Floating fuel station, connected to a shoreline supply tank, may enable boaters to "fill 'er up" without chugging all the way back to shore and the crowded boat docks. Jerome H. Mandel, Forest Hills, N.Y., received patent 3,190,495.

Supermarket aisle traffic regulations: Speed limits, stop signs and perhaps even a traffic light at the intersection of the meat counter and the frozen foods bin? It's not as far-out as it may sound, what with a new motorized grocery cart that incorporates a throttle and a steering mechanism in its handle. To allay male fears concerning reckless women drivers, it should be added that the cart does not exceed normal walking speed. Moreover, the motor stops as soon as the throttle is released so there's no danger of a run-away cart. James H. Swinny of Natchez, Miss., received patent 3,190,386.

Surgeons' dirty hands can be cleaned in 30 seconds by an alcohol and abrasive cleaning machine that earned patent 3,205,620 for Harmon H. Woodworth, Los Altos, Calif., and Peter M. Newgard, Redwood City, Calif. A motor in tank of alcohol drives abrasive particles such as sand through jets at high velocity while the doctor holds his hands under the stream.

Preventing cannibalism by means of separating little fish from the big ones is one advantage of an apparatus for grading young live fish that earned patent 3,204,605 for Paul E. Vroman of Philomath, Ore.

THE BACKBONE OF THE TOOL BOX... SUPERBAR

You've got a hammer! You've got a pair of pliers! You've got a screwdriver! You've still got an incomplete tool box. Make it complete with the fourth basic tool—Superbar.

Superbar is the backbone of any tool box because it has versatility. Pries, lifts, scrapes, pulls and cuts nails. Only \$2.59. If you really care for the best, you'll

find it at your hardware outlet. Or he'll find it for you. If all else fails, you can always write to us. Vaughan & Bushnell Manufacturing Co., 135 S. LaSalle Street, Chicago, Illinois 60603.

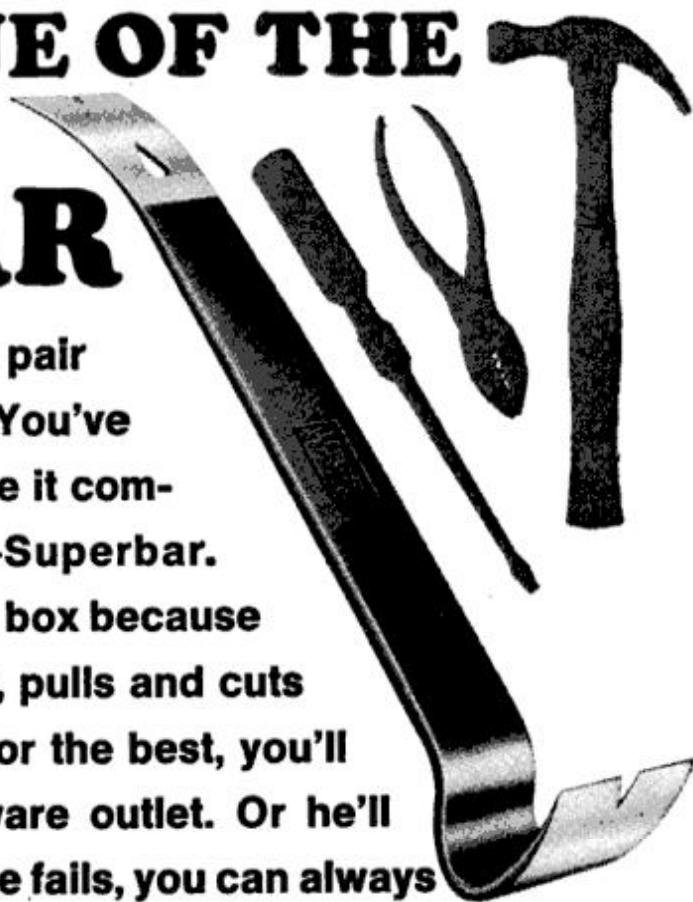

McCulloch electrifies the fishing world!

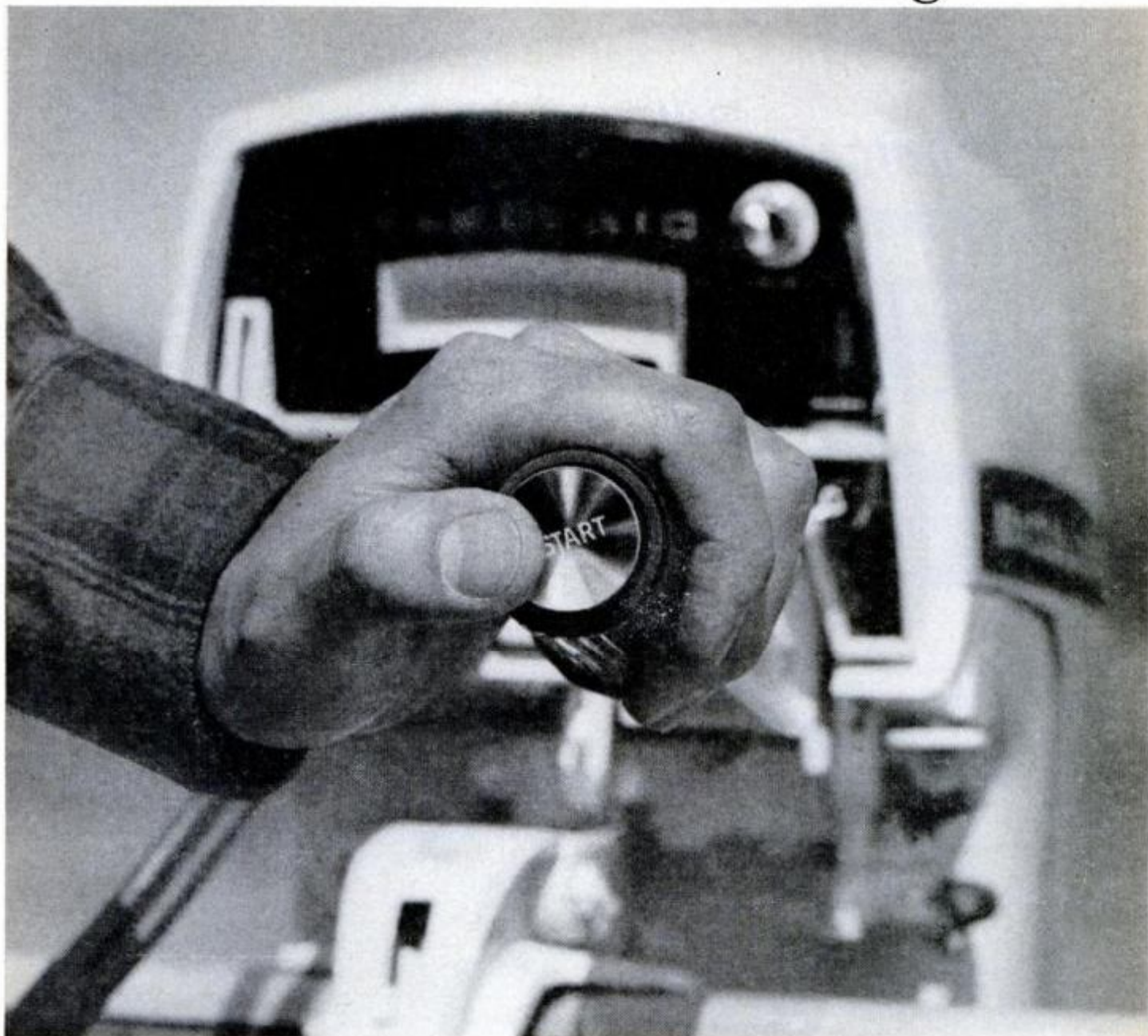

World's first lightweight 7½ with Golden-Touch™ electric starting.

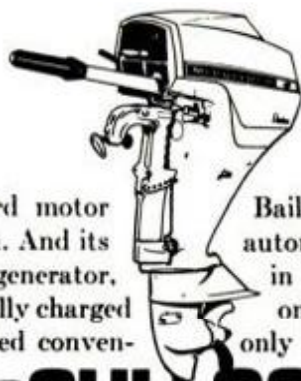

At last—a lightweight, compact outboard motor that's ready to go at the touch of a button. And its revolutionary direct-coupled starter is a generator, too. No gears to jam. Keeps your battery fully charged for running lights or other electric powered conveniences. This great new McCulloch outboard also features: A weedless propeller. Twist-grip throttle. Full forward-neutral-reverse gearshift.

Bail-a-Matic® that bails up to 120 gallons per hour automatically. ShallowWater Drive® that lets you run in as little as 6" of water. □ The 7½ electric runs on economical 40/50:1 or 100:1 fuel mix. Weighs only 53 lbs. Stands just 35" high—only 11" over the transom. See the 7½ at your McCulloch dealer. And check the entire McCulloch line, from the 75 to the new air-cooled 4 h.p.

MCCULLOCH
OUTBOARDS • CHAIN SAWS
LEADERSHIP THROUGH CREATIVE ENGINEERING
LOS ANGELES, CALIFORNIA 90045

Features & Specifications subject to change without notice or obligation.

free

send today for your

ALLIED

**money-saving 1966
ELECTRONICS CATALOG**

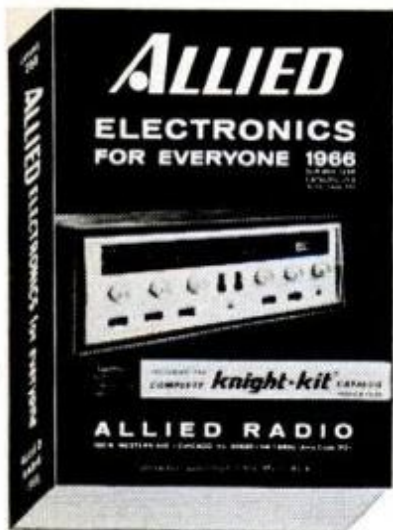

**508 PAGES
value-packed**

**MORE OF THE
BEST & NEWEST
IN ELECTRONICS
FOR EVERYONE**

**SAVE
MOST**

**NEW build-your-own
knight-kits®**



Safari-I
23-Channel CB
Transceiver Kit



KG-375 Auto
Analyzer Kit



KG-221 FM Monitor
Receiver Kit



KG-371
Auto DC
Power
Timing
Light Kit

WIDE SELECTION

see dozens of Knight-Kits
for every need—wonder-
fully easy to build!

GET THIS FAMOUS CATALOG
for Experimenters, Kit Builders,
Hi-Fi Fans, CB'ers, Amateurs,
Servicemen. Save on:

- Stereo High Fidelity*
- Tape Recording*
- CB 2-Way Radios*
- FM-AM & AM Radios*
- Portable TV • Phonographs*
- Short-Wave & Ham Gear*
- Automotive Electronics*
- Test Instruments*
- Intercoms & P. A.*
- Power Tools, Hardware*
- TV Tubes & Antennas*
- Parts, Tubes, Transistors*

EASY TERMS: Use the conven-
ient Allied Credit Fund Plan.
satisfaction guaranteed
or your money back

EXCITING
**NEW
PRODUCTS**



It had to happen! Crofton Plastics of
Byron Center, Mich., are marketing their
Koto-Matic Pressure-Fed Paint Roller
(\$49.95). Unit has paint tank, pressure
pump, vinyl tubing and a 9-in. paint-feed-
ing roller with a control valve on the
handle.

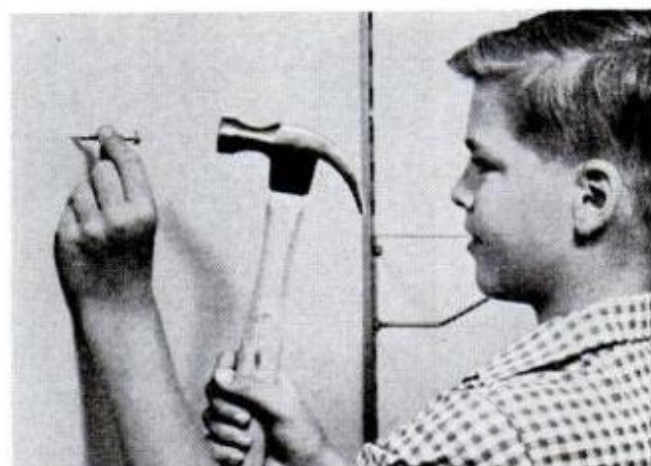

The world's first hammer-in wall anchor
eliminates need to pre-drill holes. In three
sizes, these Shure-Set anchors set securely
into dry wall up to 3/4 in. thick, into ply-
wood up to 3/8 in. thick. Three for 39 cents.
By Ramset of Olin Mathieson Co.

ALLIED RADIO

**FREE
catalog**

ALLIED RADIO, Dept. 6-A
100 N. Western Ave., Chicago, Illinois 60680
 Send FREE 1966 Allied Catalog.

Name _____
PLEASE PRINT

Address _____

City _____ State _____ Zip _____

New Free Book Discusses How to Go About Selling Your Invention

If you have an invention or an idea for an invention, whether patented or unpatented, that you wish to sell outright or on a royalty basis, the booklet we offer free in the coupon below may be very valuable in saving you both time and money.

We are specialists in representing inventors and submitting their inventions and ideas to manufacturers. We work continuously with scores of manufacturers seeking new products, and we have connections from coast to coast and in foreign countries. We are well informed which manufacturers may be especially interested in your particular kind of invention. Hundreds of these manufacturers have written us descriptions of the types of inventions they want.

Our service is designed to do all the many things the average inventor does not have the time or facilities for doing, or who lacks knowledge of the proper markets. When you appoint us to represent you, we prepare sales material that points up your invention, its advantages, its construction, its market potential and profit possibilities.

For presenting your invention to selected manufacturers we charge a modest fee (which is refunded if we handle the sale of the invention for you) and the customary commission. We are a Nationally known concern, with an impeccable reputation for ethics and integrity. We believe ours is the finest service offered inventors.

We are not patent attorneys. However, if you have need for a patent attorney and do not know one, write us and we will tell you how to obtain the names of all U. S. Patent Attorneys in your area, and you can make your own choice.

To encourage inventors, whether their inventions are patented or unpatented we have prepared a booklet entitled "How to Go About Selling Your Invention." This booklet contains such information as current royalty rates being paid by manufacturers, discusses various types of inventions and the markets for them, and tells the most effective methods you can use in presenting your invention for sale, whether you employ us or do it yourself.

You can obtain a copy of this booklet merely by mailing the coupon below. It will be sent to you with our compliments, free, without any obligation whatever. If you wish to write us for comments about your invention, please do so. We make no charge for consultation. But please do NOT send blueprints or models. Just describe your invention briefly, its nature and purpose.

REFERENCES: Your own bank, attorney, or Chamber of Commerce.

K. O. Kessler, President
KESSLER SALES CORPORATION
Accredited as a Corporation
Under the Laws of Ohio
FREMONT, OHIO

MAIL THIS COUPON FOR FREE BOOKLET

Mr. K. O. Kessler, President
Kessler Sales Corporation, Dept. D-51, Fremont, Ohio

Please mail me a copy of your FREE Booklet, "How to Go About Selling Your Invention," which reveals many points about selling inventions and explains your service. It is understood that there is no charge for this booklet now or at any other time and I am not obligated in any way.

MY NAME.....

STREET ADDRESS.....

CITY..... STATE..... ZIP CODE.....

LEARN

ELECTRONICS

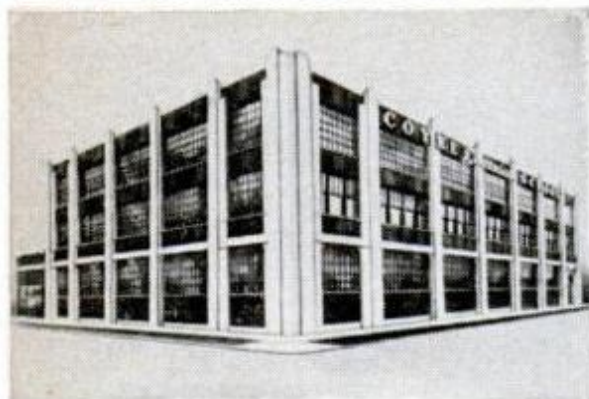

FOUNDED 1899

NOT-FOR-PROFIT

COYNE ELECTRONICS INSTITUTE

Electronics Engineering Technology	—	Degree (2 Yrs.)
Electrical-Electronics Technician	—	Diploma (40 Wks.)
TV-Radio-Electronics Technician	—	Diploma (40 Wks.)
Combined Electronics Technician	—	Diploma (80 Wks.)
Practical Electrical Maintenance	—	Diploma (32 Wks.)
Practical Refrigeration Air Conditioning and Appliance Repair	—	Diploma (24 Wks.)
Specialized Industrial Electronics	—	Diploma (16 Wks.)
Introduction to Electricity-Electronics	—	Certificate (8 Wks.)
FCC First Class Radiotelephone	—	Certificate (100 Hrs.)

Special finance plans. Part time employment service while in school. Also Free graduate employment service.



Use this coupon to get our FREE BOOK "YOUR OPPORTUNITIES IN ELECTRONICS" COYNE ELECTRONICS INSTITUTE, Dept. of Electronics 16-S 1501 W. Congress Parkway, Chicago, Illinois 60607

Name _____ Age _____
 Address _____ Phone _____
 City _____ Zone _____ State _____

Unlike most other schools, we do not employ salesmen
 I only want information on Home Study Courses

Men! Women!
ADVERTISING PAYS BIG
 No previous experience, writing or art ability necessary

Hundreds big pay opportunities coast-to-coast for qualified men, women in advertising. Help fill huge need with agencies, stores, manufacturers, newspapers, etc., or open profitable full or spare time advertising agency in your own town. No investment, no costly overhead. Your home is your office. Learn at home, spare time. Famous advertising experts guide you step-by-step... tell you what to do, how to do it. Send for FREE ADVERTISING CAREER KIT including illustrated Book, "Opportunities in Advertising," Job Opportunities Chart and full Home-Business Details—ALL FREE! Write: NORTH AMERICAN SCHOOL OF ADVERTISING, University Plaza, Campus Drive, Dept. 171, Newport, Calif. 92660.



AUTOMATIC HUBS for your 4-WHEEL DRIVE!

NOT EVEN A BUTTON TO PUSH on these amazing Lock-O-Matic selective drive hubs that automatically engage the front wheels in 4-w.d., automatically disengage them for 2-w.d. They stop front drive drag, save gas, gears, tires in 2-w.d.—automatically! For Lock-O-Matics—or popular Warn® Locking Hubs—see your dealer.

be happy—GO LOCK-O-MATIC!

*Not made for some 4-w.ds.



WARN MANUFACTURING CO., INC.
 9050-A Empire Way So. Seattle, Wash. 98118

Swiss saw blades and frames



for intricate, precise and very close detail operation on metal, wood, plastic, etc.

Saw Frame—5.00—saws—.60 doz., 4.00 gr.

THE RADE CO. IMPORTERS
 4574 N. Mobile Ave., Chicago, Ill. 60630.

NEW CATALOG Hard-to-find tools

Exciting new tools rarely found in stores or other catalogs. For model makers, craftsmen, hobbyists, light industry. Superb quality tools that solve problems, make projects easier, more fun. Send 10¢ today (stamps or coin).

BROOKSTONE COMPANY

92 River Road Worthington, Massachusetts 01098



If you can sing, whistle or hum a tune, you can play the Musical Saw. No notes to read, no musical knowledge required. Since 1921 we have furnished the entire world this unusual, sweet-toned instrument. If you are 10 or 70, you play or no pay. Musical Saw, soft hammer, bow, resin and lessons mailed on 5 days' trial. Write for details. MUSSEHL & WESTPHAL, 101 Fort St., Fort Atkinson, Wis.

FREE CATALOG
 MAKE YOUR OWN RODS AND LURES

Send for FREE Wholesale Catalog. The most complete and fully illustrated catalog of reels, rods, beads, spinners, jigs, lure bodies and parts, sinker molds, feathers, tools, hooks rod blanks, rod parts, swivels, wire, etc.

FINNYS SPORTS
 2066X SPORTS BUILDING TOLEDO, OHIO 43614

MAKE BIG MONEY—ALL PROFIT—AT HOME

INVISIBLE MENDING

Pays up to \$10 in an Hour!

Make moth holes, cigarette burns, tears, rips, disappear from all fabrics. Little-known craft pays extra spare-time profits at home. Write today for exciting details FREE!

FABRICON, 1555 Howard St.
 DEPT. 321, CHICAGO 26, ILLINOIS



NEW RUBBER STAMP BUSINESS PAYS BEGINNERS UP TO \$16.50 AN HR.

**START AT HOME
IN SPARE TIME**
with Table Top Machine!

We Help Finance You
... at less than bank rates!

The multi-million dollar Rubber Stamp business—once controlled by a few big companies—is now being taken over by small operators—one in each community throughout the United States. Men and Women who have this inexpensive machine can turn out huge quantities of Rubber Stamps with special wording that buyers once were forced to buy from big cities. Material costing only 27c makes a stamp that sells for \$2.75. The machine that does the work is simple and easy to operate and it turns out as many as six Rubber Stamps at a time, each with different wording such as names, addresses, notices, stock numbers, prices and other "copy" needed by offices, factories and individuals. Working full capacity, it can earn as much as \$33.00 an hour for the operator! Now you can get into the big-pay business yourself, with your own home as headquarters. You don't need experience. We supply everything, including complete instructions and eight ways to get business coming in fast. We even help finance your start. Start making up to \$16.50 an hour from the very beginning. Cash in on the profitable Rubber Stamp business in your community, right away. We'll mail full particulars FREE and no salesman will call. Be first in your locality. Rush coupon today or send your name on postcard to:

RUBBER STAMP DIV., Dept. R-2-AX
1512 JARVIS AVENUE • CHICAGO, ILL. 60626



RUBBER STAMP DIV.
1512 Jarvis Ave., Dept. R-2-AX
Chicago, Illinois 60626

FREE!

Please rush full particulars about your financing plan and the little machine that can get me started in the profitable Rubber Stamp business at home in spare time. Everything you send me is FREE and no salesman will call.

NAME _____
ADDRESS _____
CITY _____ STATE _____ Zip Code _____

FOLBOT

fits in every home or car

CHOICE of CHAMPIONS

belongs to You

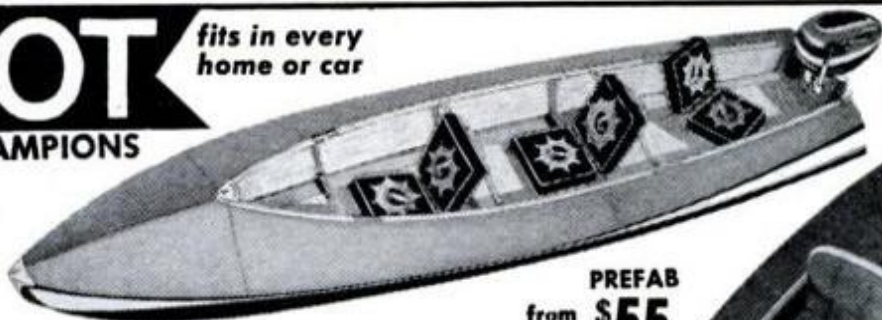

FACTORY BUILT
\$146

Most inexpensive too

PREFAB
from \$55

GENUINE Folbot RECREATION for just ONE small investment, WITHOUT the continuous burdens of complicated "big rig" operation. You GO CAREFREE anytime with COMPACT Folbot . . . rocky streams, lakes, marsh, surf & open sea. Superior non-sinkable designs provide SAFEST low gravity center, balanced low & high seating, substantial construction, protective decks & EXCLUSIVE swivel-back COMFORT. ALL within your reach. In handy Folbot YOU GLIDE smoother, faster & NOISELESS with paddles, oars, or sails and ride softly w. 1 to 10 HP. motors. Many styles & sizes from 1 to 4 seaters, FOLDING or rigid PORTABLE come in PREFAB KIT, or expertly FACTORY BUILT

NOW at SPECIAL SAVINGS

YACHT-SMART large DACRON

Sail Rig \$99

NEW Fabulous 16 foot \$119

Factory BUILT

Folding from \$179 Factory finished

FREE ACTION CATALOG

Mail coupon or address

to: FOLBOT CORP. Dept. PM-166
Charleston, S. C. -29405

**NATIONAL SAFETY RECORDS
WORLD RECORD FISHING**



for **YOUR SPORT & FAMILY FUN**

Name _____

Address _____

City _____ State _____

Don't shoot until you know what's moving! That's pretty basic, and Winchester goes on from there in "The Fundamentals of Clay-bird Shooting," aimed at the novice trap and skeet shooter. In nontechnical terms it explains proper stance, correct mounting, sight alignment and follow-through. Illustrations are good. Twenty-five cents will secure your 40-page copy from Winchester, 460 Park Ave., New York, N.Y.

Keeping kids happy when they're sick in bed is difficult. The right choice of toys and play materials, however, may speed recovery and keep morale up. A leaflet, "Toys and Ideas for Children When Ill," gives common-sense ideas and lists suitable toys by age groups. Also one section discusses toys for children in hospitals. Write B. Shackman & Co., Dept. PM 7, 2 W. 35th St., New York, N.Y. for your free copy.

A binocular brochure, "Binoculars from Japan," provides practical and reliable information on how to judge and select your glasses. Whether you intend to follow the plays in a basketball game or zero in on your favorite opera star, the brochure lets you know what to expect from the binoculars you buy. The 18-page publication is free from Japan Light Machinery Information Center, Dept. PM 5, 437 Fifth Ave., New York, N.Y.

"Simplified Electric Wiring Handbook," a 56-page indexed manual, is useful for both city and farm homeowners who want to do their own wiring. Such topics as overhead and underground wiring, outdoor lighting, dimmer switches and circuit breakers are covered, step-by-step. Projects include running cables inside walls in older homes. The handbook is available for 50 cents at Sears, Roebuck and Co. retail stores.

Washday blues at home? Change your wife's tune with "A Primer of Home Laundry Planning," geared to help set up laundry locations, select equipment, allow for storage and counter space and combine sewing and ironing facilities, depending on your needs. The advice, packed into 16 illustrated pages, is offered at no cost from the Home Laundry Center. Dept. PM 4, Maytag Co., Newton, Iowa.

Photographer's computer is designed to simplify centering and mounting prints. Without tedious measuring and adjustments, the print centering device will align and center any sized print in less than 30 seconds. Three margin ratio scales are provided: 30/70, 40/60 and 50/50. The unit, complete with instructions cost \$2.95 postpaid from Kipco., Dept. PM 3, P.O. Box 309, San Francisco, Calif. 94101.

Burpee SEED CATALOG



Have the added pleasure Burpee Hybrid Flowers and Vegetables bring to gardening! Old favorites improved, amazing new kinds created. Many are available only in this popular catalog.

128 pages, many in color, FREE to you. Write today!

Burpee Seeds Grow

W. ATLEE BURPEE CO.
579 Burpee Bldg., Philadelphia, Pa. 19132
Send new Burpee Seed Catalog FREE.

Name..... Box No.....
St..... R. D.....
P.O. & ZIP
State..... Code.....



THOUSANDS OF EXCITING TOOL VALUES!

Stanley, Millers Falls, Skil, Disston, Wiss, Dremel, Speedy

Sprayers, Plumb, Porter, Channellock, Bonney, Herbrand, Helios, Kennedy Boxes, Huot, Vise Grip, Ridgid and many other Nationally Advertised brands of Tools & Supplies too numerous to mention.

We Ship Coast To Coast At Prices Hard To Beat
Send 25¢ today for our Big 148-page Tool Catalog.

SILVO HARDWARE CO.
Dept. PMD1, 107 Walnut St.
Phila., Pa. 19106

DOLLS!

A THRILLING CAREER AWAITS YOU

We teach you how to operate a Doll Hospital, repair, dress and make dolls of all kinds.

Start your own profitable part or full time business—we show you how. Or, enjoy an enchanting hobby. May we send free and without obligation the information on our fascinating home study course?

Norm & Sue Morris
LIFETIME CAREER SCHOOLS • Studio M-16
11824 San Vicente Blvd., Los Angeles, Calif. 90049



Money Back Guarantee

HEAVY DUTY-ARC WELDER

Five Year Guarantee

The New 1966 Model Heavy Duty 110 Volt Arc Welder works on any 110 volt house line. You can not buy a better welder anywhere at this low price. No experience necessary. Now anyone can braze, solder, cut and weld any metal up to 1/4" thick. Generates heat up to 10,000 degrees for cutting through steel plate, etc. **NOTHING ELSE TO BUY.** Comes complete with 12 ft. of heavy duty power cable, 1/16" and 1/4" welding and brazing rods, rod holder, twin carbon torch, helmet, instruction book, etc. **MONEY BACK GUARANTEE.** Try it for 10 days, if you are not completely satisfied we will immediately refund your money without question. **FULLY GUARANTEED FOR FIVE YEARS.** If inoperative, we will repair or replace it free of charge. **SEND ONLY \$2.00,** and when delivered, pay postman \$12.95 plus COD postage, or send \$14.95 and we will ship postpaid. Over 10,000 National Electric Welders are in use throughout the world. (For an extra large supply of rods, carbons and flux, send an additional \$2.00.)

Order Direct from factory: NATIONAL ELECTRIC, Dept. PM-1, DELRAY, FLORIDA

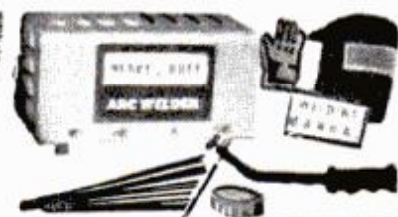

ONLY \$14.95

AIR LIFT AIR SPRINGS



HANDLE ANY OVERLOAD

✓ The only air-adjustable overload spring — fits any car or light truck.

✓ A safe, level ride for vacationers, sportsmen, businessmen, trailerites.

✓ Quickly installed — no parts removed from car.



FREE literature: Dept. PM
OVER 1,000,000 SETS IN USE

AIR LIFT AIR LIFT COMPANY
Lansing, Michigan

Stamp Your Name PERMANENTLY

reg. size Identify articles
you own
\$3.95 ppd. **EVERSTAMP**



Hardened
tool steel. Reg.
Size 1 1/2"
15 letters max.
last name only.

Names shown actual size

SMITH

Large size 3/4" \$5.25
10 letters max.

Stamp just about anything you own with one blow of a hammer. Made by the Henry A. Evers Co., Inc., makers of quality marking devices since 1898. Makes thousands of impressions. Send check or money order.

HENRY A. EVERS CO., INC.
Dept. P 72 Oxford St., Prov., R. I. 02905

- DIE TOOL**
Comparable to a \$9.00 die tool, now available at this special price.
- TOOLS
 - LUGGAGE
 - BOOKS
 - SPORTS EQT.
 - PAINT BRUSHES
 - PIPES
 - GUNS
 - FLASH-LIGHTS
 - DRAFTING TOOLS
 - PLUS HUNDREDS OF OTHER ITEMS



Today let these
**AMAZING
SHOES**
ADD INCHES TO
YOUR HEIGHT!

Nothing like a pair of "ELEVATORS" to help you get up in the world! In seconds, these miraculous height-increasing shoes make you almost 2 inches taller! And no one will suspect that you're wearing them because "ELEVATORS" look just as smart and feel just as comfortable as any other fine shoes.

Write for FREE CATALOG today.

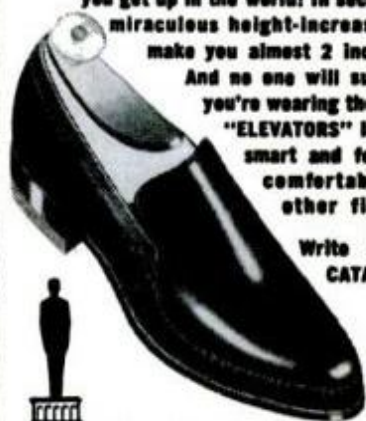

ELEVATORS® HEIGHT-INCREASING SHOES

Breckton Footwear, Inc.
Dept. 1101G Brockton 68, Mass.
Please send free catalog

Name _____
Street _____
City _____ State _____

CLIP AND MAIL COUPON NOW

A beginning boatbuilder can build it. A beginning sailor can sail it. It's "Teacup," a 9 1/2-foot sailboat that can be made from plans starting on page 146.



Art LESSONS \$6 a month

Study Art for pleasure and profit. Learn Drawing, Painting, Advertising Art at home in spare time for only \$6 a month. Assignments corrected with overlays and returned to you by mail. Write for FREE BOOK. No obligation.

WASHINGTON SCHOOL OF ART, Studio 141, Port Washington, New York 11050. Established 1914. Accredited, National Home Study Council. Tear out ad.



FREE "NOTE-FINDER"

Guides Your Fingers to Right Key For Every Note — Play Real Tunes Your Very First Day

LEARN PIANO! (Or Guitar, Accordion, Sax—Choice of 14 Instruments.) Mail ad today! We'll send you famous U.S. School of Music PIANO "Note-Finder" absolutely FREE. Then you can prove to yourself how you can play real music—properly, by note—even if you don't know a single note now.

Stop Denying Yourself These Joys!

Music can bring you new friends. Gay parties. Good times. A career. Extra Money. Help you relax, banish worries and frustrations. Satisfy your desire for self-expression, creative urge. Gain self-confidence!



SEND FOR FREE "NOTE-FINDER" AND BOOK. Illustrated book describes fascinating story of wonderful proven Course that has you playing delightful pieces right away—from your very first lesson.

Simple as A-B-C. Learn at home, only few cents a lesson. For FREE "Note-Finder" and Book, mail ad today to U.S. School of Music, Studio A301, Port Washington, N.Y. 11050. Est. 1898—Lic. by N.Y. State Education Dept.



FREE BOOK

Print Name _____
Address _____
City & State _____ Zip _____

FREE!
97 money saving ideas using linseed oil



... tips for refinishing antiques, preserving paint brushes, glazing windows, refinishing gun stocks, protecting golf clubs, treating fence posts, preventing rust... many others. A "MUST" on every work bench. Free! Use coupon.



Send me free Money Saving Ideas handbook.

Name _____
Address _____
City _____ State _____ Zip _____
Mail to: ADM, 733 Marquette Avenue
Dept. 95, Minneapolis, Minn. 55440 L-9

Assemble the finest instrument your money can buy
NEW ALL-TRANSISTOR Schober®

ELECTRONIC ORGAN



meets AGO specifications

New Recital Model
 compares musically
 to instruments
 costing 4 times
 the price!



PIPE ORGAN VOICING—separate, distinct—32 in Recital Model. LIBRARY OF STOPS™ Kit feature adds extra plug-in voices



ALL TRANSISTOR Models give instant response, easier assembly, full 5 year guarantee



PIPE ORGAN TONE—all four families of pipe tone in all models



REVERBATAPE® Unit — adds "auditorium" depth and power

plus **FULL THEATRE AND CHURCH VOICING, PERCUSSION,** many other quality features!

How is it possible to acquire the skill needed to build a splendid organ—without any previous knowledge of electronics or music?

While the complete organ is a complex instrument, Schober Organ kits are specially designed for do-it-yourselfers. Printed circuitry eliminates a lot of the work and makes errors almost impossible. Many parts come preassembled. You simply follow detailed illustrated instructions for easy assembly, then place in assembled and pre-finished cabinet.

You save costly factory assembly, retail store mark-up—put every penny into fine musical parts. You enjoy the finest instrument your money can buy.

Schober Organ kits cost as little as \$550 in kit form, and you may spread this cost by ordering in sections.

THE *Schober Organ* CORPORATION
 NEW YORK, N. Y. 10023

SEND FOR FREE CATALOG WITH FREE "SAMPLER" RECORD

The Schober Organ Corp., Dept. PM-17
 43 West 61st Street, New York, N. Y. 10023

- Please send me without cost or obligation FREE SCHOBER ORGAN Booklet describing models. FREE 7-inch "sampler" record included.
- Enclosed find \$2 for high-quality LP 10" SCHOBER RECORD DEMONSTRATING all three models with different music (\$2 refunded with purchase of first kit).

NAME _____
 ADDRESS _____
 CITY _____ STATE _____ ZIP NO. _____

PLANER • MOLDER • SAW!

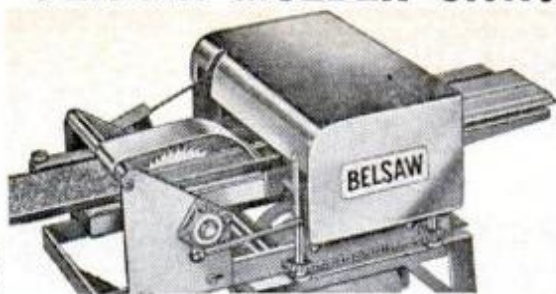

Now you can use this ONE power-feed shop to turn rough lumber into moldings, trim, flooring, furniture... ALL popular patterns. RIP... PLANE... MOLD... separately or all at once with a one HP motor. Use 3 to 5 HP for high speed output. Low Cost... You can own this power tool for only \$30.00 down payment.

Send postcard today for complete facts.
 BELSAW POWER TOOLS, 906 Field Bldg., Kansas City 11, Missouri

SMALL SIZE.. BIG PERFORMANCE

SM-100
 TAG ENGRAVER

EARN ENGRAVING
 BY DOOR PLATES
 DESK PLATES
 BADGES, ETC.



SCOTT MACHINE DEV. CORP.

215 PROSPECT AVENUE, PM-8
 WALTON, NEW YORK 13856

DON'T QUIT SMOKING before giving my pipe a 30 Day Trial

New principle that contradicts every idea you've ever had about pipe smoking. I guarantee it to smoke cool and mild hour after hour, day after day, without rest, without bite, bitterness or sludge. To prove it, I'll let you try a new Carey Pipe. Send your name and address today for my free complete trial offer. Write:

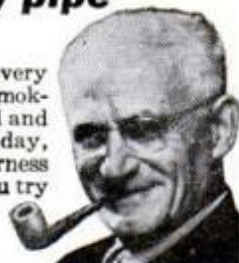

E. A. CAREY, 1920 Sunnyside Ave., Dept. 252-A, Chicago 40

BUILD YOUR OWN POWER TOOLS



METAL PARTS KITS AT LOW FACTORY DISCOUNT PRICES FOR: **SAVE \$50 OR MORE**

- 10-IN. TILT ARBOR SAW
- COMB. DRILL PRESS-LATHE
- 12-IN. BAND SAW
- 18-IN. BAND SAW
- 6-IN. BELT SANDER
- SPINDLE SHAPER

PLANS \$1.00 EACH Full Size Patterns DEDUCTIBLE

Kits from \$15.50 to \$39.95. Satisfaction guaranteed. Built and sold for 18 years. 45,000 units in use. Send for Plans today!

FREE CATALOG

GILLIOM MFG. CO.

Dept. PM-1

St. Charles, Mo.



Only 50¢ VANISHING KEY!

Now you see it—now you don't! Hold it up and P-O-O-F — it's gone! Vanishes faster than a woman can change her mind. Clever and astonishing. Comes complete with easy directions for 4 amazing tricks! You can do it! Lots of fun! Mystify others! Be the Life of the Party! Send check, cash, money order.

FREE WITH EACH ORDER YOU GET OUR WORLD-FAMOUS CATALOG — 160 Pages of 1000 Exciting Tricks.

House of 1000 Mysteries • Dept. PM16-4018 N. E. Fifth Ave. Ft. Lauderdale, Florida

It's Like Having Auto Factory Experts Right Beside You...

SHOWING YOU

HOW YOU CAN FIX 2,341 CAR MODELS!

Now—Whether You're a Beginner or an Expert Mechanic—You Can "Breeze Through" Just About ANY Auto Repair Job—QUICKLY—EASILY—RIGHT!

SUPPOSE you had an automobile factory engineer standing right beside you . . . guiding your hands through every step of even the toughest car repair jobs! Think how you'd "whiz through" every job! No wonder, then, that 5 million MOTOR'S Auto Manuals have been sold. No wonder so many thousands of beginner and expert mechanics alike are already using MOTOR'S brand-new AUTO REPAIR MANUAL. It shows you, in step-by-step words and pictures, factory-approved repair procedures for fixing practically ANY part of ANY car listed here — 1958 through 1965!

No guesswork! MOTOR'S Manual "starts from scratch" — leads you through entire job with easy directions. You CAN'T go wrong!

OVER 1,300 BIG PAGES —
OVER 3,800 PICTURES

NEW, REVISED, ENLARGED Edition covers everything you need to know to fix practically any car model from 1958 thru 1965, including all the "in-between" models. 1,325 Giant pages. 3,800 "This-is-How" pictures. 457 "Quick-Check" charts. More than 55,000 essential repair specifications. Over 225,000 service and repair facts. Plus a big handy Trouble-Shooting section!

Even a green beginner mechanic can do a good job with this giant manual before him. And if you're a top-notch mechanic, you'll find short cuts that will amaze you. No wonder this guide is used by the U.S. Army and Navy! No wonder hundreds of thousands of men call it the "Auto Repair Man's Bible"!

Engineers from every automobile plant in America worked out these time-saving procedures for their own motor car line. Now the editors of MOTOR'S have gathered together this wealth of "know-how" from 300 Official Shop Manuals and "boiled it down" into crystal-clear terms in one handy indexed book!

EXACTLY WHAT YOU NEED TO KNOW

Includes Transmissions, Overdrives, Power Steering, Power Brakes, Carburetors, Fuel Pumps, Starting Motors, 12-Volt Systems, Generators, Alternators, Voltage Regulators, Distributors, Axles, etc. Factory Specifications and Adjustment Tables. Tune-up Charts. Overhauling, Replacement Facts. New section on Volkswagens! Much, much more!

Covers These Makes

American	Falcon
Barracuda	Ford
Buick	Imperial
B. Special	Jeep
Cadillac	Lancer
Chevlele	Lincoln
Chevrolet	Mercury
Chevy II	Wetear
Chrysler	Mustang
Comet	Oldsmobile
Continental	Olds F-85
Corvair	Plymouth
Corvette	Pontiac
Dart	Rambler
De Soto	Studebaker
Dodge	Tempest
Edsel	Thund'bird
Fairlane	Valiant
	Volkswagen



MOTOR'S AUTO REPAIR MANUAL

CARBURETOR

GENERATOR

FUEL PUMP

ENGINES

BRAKES

DISTRIBUTOR

AUTOMATIC TRANSMISSIONS

STARTING MOTORS

OVERDRIVES

STEERING GEAR

IGNITION

MUCH MUCH MORE!

TRY BOOK

FREE

FOR 10 WHOLE DAYS

SEND NO MONEY NOW

Just mail coupon. (Attach it to postcard, for faster action.) Unless you agree this book is the greatest time- and work-saver you've ever seen — return it in 10 days, pay nothing. Mail coupon to MOTOR Book Dept., 250 West 55th St., New York, N. Y. 10019. (Schools, Bookstores: Write for Discounts.)

Same FREE Offer On MOTOR'S Brand-New Truck Repair Manual

Covers practically every job on gasoline and diesel trucks made since 1955! Over 2,000 pictures. Over 1,000 big pages. FREE 10-Day trial. Check proper box in coupon.

MAIL COUPON NOW FOR 10-DAY FREE TRIAL (Attach to Postcard if More Convenient)

MOTOR BOOK DEPT., Desk 611
250 W. 55th St., New York, N. Y. 10019

Rush to me at once MOTOR'S New AUTO REPAIR MANUAL. If O.K., I will remit \$2 in 10 days, \$3 monthly for 2 months and a final payment of \$1.95 (plus delivery charges and sales tax, if any) one month after that. Otherwise I will return the book postpaid in 10 days.

Print Name.....Age.....

Address.....
City & State.....Zip Code.....

Also send me for 10 days' Free Trial MOTOR'S New TRUCK REPAIR MANUAL. If O.K., I will remit \$11.00 plus delivery charges and sales tax, if any, in 10 days. Otherwise I will return book postpaid in 10 days.

Check box and SAVE delivery charges by enclosing WITH coupon in envelope entire payment of \$9.95 for Auto Repair Manual (or \$11 for Truck Repair Manual) plus sales tax, if any. Same return-for-refund privilege applies.



Here's How You Can Have a
**Profitable Lawn Mower
Sharpening Business**



EARN \$5 AN HOUR!

Earn extra cash right from the start—average \$5 an hour. The Foley Lawn Mower Sharpener is a complete shop in one machine. No experience is needed to start—anyone can operate it, and turn out professional-like jobs. All operations are done quickly, easily and accurately.



Operate in Sparetime, in Your Own Home

An ideal sparetime business—although many find it so profitable, they devote full time to it. For complete fact-filled booklet, send coupon. No salesman will call:

Foley Mfg. Co. 107-6 Foley Bldg., Mpls., Minn. 55418
Send booklet on Lawn Mower Sharpening business.

Name _____

Address _____

City _____ State _____ Zip Code _____

"\$33,000 LAST YEAR"
**OPERATING AUTO
RADIATOR SHOP**

— Mercier Bros., Lowell, Mass. Make big money repairing radiators — servicing cooling systems. Inland's Proven Program includes: training, equipment, "How-to-Operate" Manual, advertising aids and "Pay-As-You-Profit" purchase plan. **START YOUR OWN SHOP OR ADD TO PRESENT BUSINESS.** Market Growing — More vehicles on road each year. Small modern cooling systems and air conditioning are adding extra stress on radiators—demanding frequent service. Cash in now!



FREE! **INLAND MFG. CO., Dept. PM-1**
1108 Jackson Street, Omaha, Nebr. 68102
Send free 42-page booklet and money-making plan.
Print Name _____
Address _____
City _____ State _____



**Professional quality
WOOD CARVING
TOOLS**

New 1966 catalog contains complete collection of professional quality wood carving and pattern making tools—chisels, gougers, knives, rifflers, etc. . . . in all sizes and shapes. Made of finest tempered W. German surgical steel for precision sharpness. Seasoned hardwood handles are lacquer soaked and fused to tool by unique inside ferrule for greater strength and long life. Tools from \$1.30. Write for **FREE** catalog. Dealers inquire.

BEE VEL PRODUCTS, Dept. PM-1,
451 Moss St., Burbank, Calif. 91502.

GET INTO ELECTRONICS

V.T.I. training leads to success as technicians, field engineers, specialists in communications, guided missiles, computer, radar, automation. Basic & advanced courses. Electronic Engineering Technology and Electronic Technology curricula both available. Assoc. degree in 29 mos. B.S. obtainable. G.I. approved. Start Feb., Sept. Dorms, campus. H.S. Graduate or equivalent. Catalog.

VALPARAISO TECHNICAL INSTITUTE
DEPARTMENT D, VALPARAISO, INDIANA



HOTTEST \$1.00

Seller on the Market

Ideal for Fund Raising

Join the many people making \$50, \$100, \$150 or more with our famous "Hexe" **AUTOMATIC NEEDLE THREADER**—the amazing invention that threads all size needles with the simple press of a button. Show to friends, neighbors, fellow-workers, in stores, offices, factories. Everyone buys. Order from this ad at **LOW WHOLESALE PRICES**—only \$3.00 per doz.; \$5.80 for 3 doz.; \$30.00 for 12 doz.; \$144.00 for 60 doz. (Or, send \$1.00 for 3 samples.) Our **PROVEN SALES PLAN** shows you how to make big spare time profits. Order today! Full 30-day money back guarantee.
DISPLAY SALES, Dept. PM-16
2349 Devon Ave., Chicago, Ill. 60645

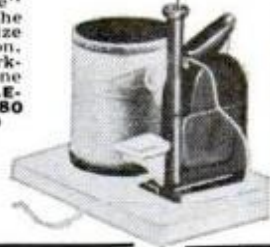

LEARN TO BE A DENTAL MECHANIC



SECURITY • PRESTIGE • GOOD PAY

Learn at home, in your spare time, to make Crowns, Plates, Bridgework, etc. Dental Mechanics are employed by Dentists, Dental Laboratories or open your own shop, full or spare time. **FULL EQUIPMENT OF TOOLS AND MATERIALS INCLUDED WITH COURSE.** Low tuition. Easy Terms. Write for **FREE BOOK** about this money-making profession that's not affected by automation.
McCARRIE SCHOOL OF MECHANICAL DENTISTRY
127 So. 13th Street, Dept. 90, Philadelphia 7, Pa.

ENROLL—EARN YOUR DEGREE

of Bachelor of Bible Philosophy (B.Ph.B.), Master of Bible Philosophy (M.Ph.B.), Graduate of Bible Philosophy (G.Ph.B.), Doctor of Metaphysics (Ms.D.), or Doctor of Divinity (D.D.). Chartered by State, Correspondence Courses only. Please write for **FREE BOOKLET.**

AMERICAN BIBLE INSTITUTE

Dept. PM, 408A W. 75th St., Kansas City, Mo. 64114

**FIRES
70 ROUNDS
ZIP GUN AUTOMATIC
RAPID FIRE REPEATER**



Amazing new 1966 model WALTHER automatic . . . Holds and fires 70 rounds automatically from oversize chamber at incredible firing speed. Peak accuracy firing power to distances of 40 feet and more. Smooth jam-proof action guaranteed. No recoil. Non-lethal. Safe. No permit needed but not sold to minors under 16 years of age.
Use for target practice indoors and outdoors. Stops Animal pests fast. Walnut-Color stock is contoured to fit the hand. **Send \$2.98** cash, check or money order plus 27¢ shipping charge. We include free ammo. Satisfaction guaranteed or money back.
STANDARD AMERICAN—Dept. I-PMZ, 1 Park Ave., N.Y. 10016
(200 rounds \$1.) (400 rounds \$2.) (1000 rounds \$5.)

**PLAY GUITAR IN 7 DAYS
OR MONEY BACK**

TOP GUITARIST ED SALE'S famous 66 page secret system worth \$3.00 teaches you to play a beautiful song the first day and any song by ear or note in seven days! Contains 52 photos, 87 finger placing charts, etc. plus 110 popular and western songs, (words and music); a \$1.00 Chord Finder of all the chords used in popular music; and a \$3.00 Guitarist Book of Knowledge.

TOTAL VALUE \$7.00 \$2.98
—ALL FOR ONLY
SEND NO MONEY! Just your name and address, pay postman: \$2.98 plus C.O.D. postage. Or send \$3.00 with order and I pay postage. (Sorry, no C.O.D. outside Continental U.S.A.—please remit with order.)
Unconditional Money-Back Guarantee
ED SALE, Studio 153-A AVON BY THE SEA, N. J.



DRAINS cellars, cisterns, wash tubs; **\$8.95**
IRRIGATES - CIRCULATES - SPRAYS



1,001 uses. Stainless shaft. Won't rust or clog! Use 1/6 HP motor or larger . . . 3/4 HP for up to 2,400 GPH: 450 GPH 80' high; or 1,800 GPH from 25' well. 1" inlet; 3/4" outlet. Coupling included free. **\$8.95.** **HEAVY DUTY BALL-BEARING PUMP.** Up to 5,200 GPH: or 3,000 GPH from 25' well. 1 1/4" inlet; 1" outlet. **\$12.95** Postpaid if cash with order. **MONEY BACK GUARANTEE**

Centrifugal and Gear Pumps in All Sizes

LABAWCO PUMPS, Belle Mead 7, New Jersey

Two or four-wheel drive
JEEP or SCOUT
owners

REPOWER

with V-8 or 6 Cyl. engines. **H.D. ADAPTORS** for TRUCK, CAR or COMPACT engines. Immediate del. Write, wire or phone **TODAY.** Free details.

HOOSIER MACH. Prods. Co.
312 SE 6th Pendleton,
Ph. 276-3442 Oregon



Build This Beautiful Grandfather Clock

We show you how at price you can afford. Send only \$1.00 for complete plans and instructions plus information-packed catalog of clock movements, dials, blueprints and kits for constructing Grandfather, Grandmother, Terry and other fine clocks.

MASON & SULLIVAN CO.
DEPT. PM OSTERVILLE, MASS.

NOW! WARN OVERDRIVE
gives 'Jeeps' more Go!



New approved accessory cuts engine RPM 33% at any speed, reduces noise, vibration so you can drive your Jeep 4-w.d. comfortably at freeway speeds. Amazing synchromesh OD lets you shift up or down, on the go, anytime, in any gear, at any speed. Adds six forward speeds, two reverse. At Jeep dealers, or write us.

WARN SALES CO., Inc.
9050-A Empire Way South
Seattle, Washington 98118



TRIM THAT WAISTLINE

—NEW! NEW! Great new heat belt! Fits snugly around waist to create heat with the slightest exertion. Ruggedly built to give with any type of movement without slipping down or up. Wear it to work or a workout! Send waist size. \$2.75. **House of Health, 310 East 1st St., Dayton, Ohio 45402.**

AUTOMATIC RETOOTHER
MAKES NEW PROFITS for HAND SAWS

Cuts new teeth in 50 seconds—any size 4 to 16 points. Old teeth fall off as chips. Easy to operate. A perfect job.

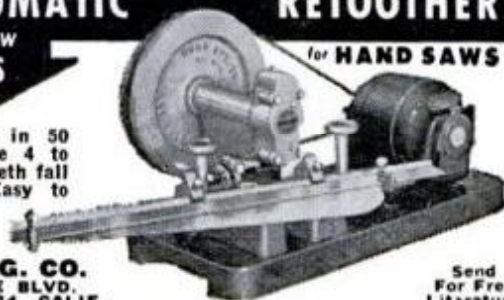

BURR MFG. CO.
8933 VENICE BLVD.
LOS ANGELES 34, CALIF.

Send For Free Literature

EARN BIG MONEY!
Learn Electric APPLIANCE REPAIRING
At Home In Your Spare Time



START YOUR OWN BUSINESS!
EARN WHILE YOU LEARN!

You can now be trained to fix refrigerators, irons, washing machines, motors, and all kinds of electrical equipment in homes, stores and factories. Using our Electronic Trouble Tracer Kit and easy-to-understand, illustrated instructions you quickly learn to make professional repairs. Set up your own profitable fix-it shop in your kitchen, basement, or garage. Earn \$5 to \$6 per hour, even while you learn. Age is no barrier—nor are minor physical handicaps. Start now . . . **PAY LATER** from your earnings.

Rush name, address, for FREE BOOK

CHRISTY TRADES SCHOOL
Dept. A7703 • 3214 W. Lawrence Ave., Chicago 60625

NAME _____
ADDRESS _____
CITY _____ ZONE _____ STATE _____

Send FOR FREE BOOK!

Big Profits in UPHOLSTERY
Get Your Share . . . FAST!

EARN BIG MONEY 3 NEW EASY WAYS

FREE
Deluxe Illustrated Book and Sample Lesson Pages

1. Be your own boss, make up to 85% profit.
2. Start earning right away at home in spare-time—keep furniture you make, or sell for hundreds of dollars.
3. Today's home and office upholstery, re-upholstery, slipcover boom make it easy to take your pick of big-pay jobs.

LEARN FAST—EARN FAST
You get expert instructions, plus all tools, new wooden frames, materials, fabrics, business tips, wholesale privileges, decorating magic **AT NO EXTRA CHARGE.** FREE Book, sample lesson pages show you how—no obligation—no salesman. Write TODAY.

UPHOLSTERY TRADES SCHOOL
(Div. of Tech. Home Study Schools)

Dept. 510-016, Little Falls, New Jersey 07424
(N. J. State Approved. Accredited Member National Home Study Council. Vet Approved.)

Tools, Equip., Frames, Materials, Fabrics. Supplies yours with course.

MAIL COUPON TODAY

UPHOLSTERY TRADES SCHOOL, Dept. 510-016,
(Division of Technical Home Study Schools)
Little Falls, New Jersey 07424

Established 1939

Please send me FREE book, "Your New Way to a Successful Career," and FREE sample lesson pages. No obligation—no salesman will call.

Name _____
Address _____
City _____ State _____ Zip _____

FREE

GIANT NEW CATALOG

1966 ANNUAL CATALOG
RADIO-TV-ELECTRONICS

BA
SINCE 1927

100'S OF BARAINS NOT IN ANY OTHER CATALOGS

TOP VALUES IN POWER & HAND TOOLS

SAVE ON CAMERAS, FILM & PHOTO EQUIPMENT

TUBES, PARTS ETC. AT LOWEST PRICES

EVERYTHING IN HI-FI AND STEREO

SAVE UP TO 50% ON CHOICE KITS

100'S OF BIG PAGES CRAMMED WITH SAVINGS

BURSTEIN-APPLEBEE CO.

Dept. PM, 1012 McGee, Kansas City, Mo. 64106

Rush me FREE 1966 B-A Catalog.

Name

Address

City State

Please be sure to show your Zip No.

SEND FOR IT TODAY

FREE

POWERFUL NEW INVENTION, ONLY 2" LONG SHOTS THRU 100 PAGES-THIS BOOK! 'B-B SHOT'



MAKE THIS TEST... Load your 'BB Shot' and fire against this magazine. Notice that it drives BB's through more than 100 pages. Though only 2" long x 1" in diameter, this pocket-size device has amazing power and accuracy. Use it for targets, pests and hunting. Scientifically designed for high power, operating ease and safety.

FREE! Get the 'BB Shot' now—we'll include an extra Velocity Cone and FREE Target, BB's and Automatic BB Dispenser... all for only \$1.98 ppd. 3 for \$5.00 ppd. Money Back Guarantee. Not sold to N. Y. C. residents or minors

GRAYSON CO. • Dept. C-16, 210 Fifth Ave., N. Y. 10

MONEY-BACK GUARANTEE

Name

Address

City State

\$1.98
ppd.

YOU CAN MAKE MONEY IN LANDSCAPING



We prepare you to cash in on countless money-making opportunities in modern landscaping and show you how, by easy steps, to start your own business part or full time. You will learn latest developments in Modern Landscaping, including creative design—plant propagation—revolutionary new methods of growing in manufactured soils—practical soil testing—growth regulators—the low down on fertilizers—easy ways of plant identification—estimating and contracting. My unique home study course features easy to understand assignments with careful detailed illustrations. Certificate Awarded. May I send FREE, and without obligation, my informative **BOOKLET? TRAINING ACCREDITED BY NATIONAL HOME STUDY COUNCIL.**

NORM MORRIS LIFETIME CAREER SCHOOLS • Dept. M-16
11826 SAN VICENTE BOULEVARD • LOS ANGELES, CALIFORNIA 90049

ONE-MAN SAWMILL AS LOW AS \$50.00 DOWN



Take BELSAW Portable Sawmill right to the trees—turn out valuable lumber for home and farm—sell to local yards—make up to \$50 a day custom sawing for neighbors. BELSAW lasts a lifetime. No crew needed. Power with tractor or auto engine. Beginners get excellent results. Send today for **FREE BOOK.**

BELSAW MACHINERY CO.
3456 Field Bldg. Kansas City 11, Missouri

FREE BOOK



WANT MORE MONEY? GET INTO PHOTOGRAPHY

Coast-to-coast, high-paying jobs in photography are waiting for people with the "know-how" to fill them. You can quickly, easily qualify at home with the world-famous NYI Learn-by-Doing Method. Write today for free catalog. Also resident training in New York. Our 56th Year.

NEW YORK INSTITUTE OF PHOTOGRAPHY
Dept. 49-1 10 West 33 St. New York 1, N.Y.



Build BEAUTIFUL CLOCKS

Send just 25¢ for 1966 illustrated clock book—the most complete available, describing plans for grandmother, grandfather, wall and shelf clocks easily and inexpensively made with simple tools. Also pictured are a wide selection of finest dials, quality movements, and kits in high-grade cherry, mahogany and walnut.

CRAFT PRODUCTS, Elmhurst, (1) Illinois

At Last a New Amazingly Simple

GAS TURBINE JET ENGINE



Build from easy to follow plans. Length 15", Dia. 8 1/2", Wt. 15 lbs. Fuel: Gasoline or Kero.

"Screamin Demon" develops 20 H.P. Ideal project for serious-minded hobbyists, students; scientific and industrial arts classes. Make on 9" metal cutting lathe with milling attachment. For use on small racing boats, midget cars, etc. Full size assembly drawings with critical dimensions, bill of materials and photos. Price \$5.00. No C.O.D.

SAVOY SCIENTIFIC, BOX 1398, SANTA MONICA, CALIFORNIA

Have Business of Your Own

Big Money

REPAIRING SMALL ENGINES



Every community needs more repairmen! Record sales of outboard motors, power mowers and tools, other equipment with motors, increase need for skilled repairmen. Excellent opportunity for full time or sparetime business of your own!

Learn at Home—Easy Course!

No need to quit present job. You learn fast the Gale Institute way, a leader in the field of technical instruction for nearly a quarter of a century. Write today—no obligation—find out how you can learn at home—the easy way—and about our easy payment plan. No salesman will call!



GALE INSTITUTE
Mpls., Minn. 55408

Gale Institute Room 111-6
3006 Hennepin Ave., Mpls., Minn. 55408

Please send complete information on Small Engine Course.

Name

Address

City

State, Zip Code

JOHN F. KENNEDY 1964 COIN SETS

**MINTAGE
ENDED**

WITH THESE, THE LAST OF THE
TRUE SILVER COINS, AN HIS-
TORICAL ERA COMES TO AN END



These are the last of the beautiful U.S. .900 fine silver coins . . . so brilliant, uncirculated . . . superior in every way. For instance, all the quarters listed here contain 23½¢ worth of silver, while the new '65 quarter costs less than 3¢ to mint. Heirlooms of the future . . . no longer minted, rapidly disappearing, an investment in dollars and history.

GUARANTEED • POSTPAID

BIG STATE COIN CO. (Dept. B8A), 1416 Commerce St., Dallas 1, Texas

— 1964-P \$2.95	— 10 Sets \$27.50
— 1964-D \$2.65	— 10 Sets \$24.50
ALSO FRANKLIN UNCIRCULATED	
SILVER COIN SETS 1960 THRU 1963	
— 1963-P \$3.95	— 5 Sets \$17.50
— 1962-P \$4.95	— 5 Sets \$22.50
— 1961-P \$5.45	— 5 Sets \$24.50
— 1960-P \$5.95	— 5 Sets \$27.50
— 1963-D \$3.45	— 5 Sets \$14.50
— 1962-D \$3.95	— 5 Sets \$17.50
— 1961-D \$4.45	— 5 Sets \$19.50
— 1960-D \$4.95	— 5 Sets \$22.50

- 1 Set of All P-Coin Sets (5 Sets) \$21.50
- 1 Set of All D-Coin Sets (5 Sets) 18.50
- 1 SET OF EVERY DATE, BOTH
P AND D (10 SETS IN ALL) \$39.50

Total Amount Of Order \$ _____

NAME _____
STREET _____
CITY _____
STATE _____ ZIP _____



FOX

YOUR OWN BIKE \$119.50 to 179.50

Even Mom'll go for this one—
costs less, runs for just pennies
(nearly 100 miles on a gallon of
gas). And it's American made!
It's the popular CAMPUS BIKE!

Literature FREE • Parts Catalog \$1.00
Box 797PM • Janesville, Wis. 53546



Earn HIGH WAGES as a HEAVY EQUIPMENT OPERATOR

. . . and years of future security in the multi-billion dollar construction industry, in this country and *overseas*! Learn how at National, the original school of heavy equipment operation. For men ages 17 to 56. National is NOT a correspondence school. You train on school-owned diesel-engined machines at National's huge proving ground in North Carolina. Full 220 and 440 hour courses. Full-time Job Advisory and Counselling Director for the exclusive benefit of graduates. VA approved. Payment plans available. Write TODAY for FREE catalog. National School is a Member of American Road Builders Association Service and Supply Division.

Since National School was founded ten years ago, students from all 50 states and 28 foreign countries have been enrolled. Hundreds of graduates are now working in construction for higher wages than they ever made before.

**NATIONAL SCHOOL
OF HEAVY EQUIPMENT OPERATION Dept. D-71
P. O. Drawer 1686, Charlotte, N. C.**

Please send me FREE illustrated school catalog and complete information. I understand there's no obligation.

Name..... Age.....
Address..... Phone.....
City..... Zone..... State.....

MAKE UP TO \$100 A WEEK IN YOUR SPARE TIME WEARING SHOES WE GIVE YOU!

Imagine getting high fashion shoes without cost—and making yourself an easy \$5 to \$10 in an hour in your spare time! You can do it just by showing comfortable, latest style Mason Shoes to friends, relatives, neighbors. No experience needed. You start to take orders, make money, right away. You'll offer 275 different styles for men and women for dress, work and sports. You draw on our stock of 300,000 pairs. Nationally advertised Mason shoes are NOT sold in stores. Folks must buy from YOU! That means automatic repeat and referral business. Mail coupon today!



FREE! EVERYTHING YOU NEED! We send you everything you need to start a successful spare time business. No investment, no inventory, no overhead. You keep 100% of your profits. Mail coupon today and we'll rush you a FREE Starting Outfit with everything you need to start making big money right away. No obligation. Mail coupon now.

— Rush Coupon for Your FREE OUTFIT —

The Mason Shoe Mfg. Co. Dept. G-202
Chippewa Falls, Wisconsin

Please rush FREE and postpaid everything I need to start making money the very first spare hour in my own "Shoe Store Business" I can run from my home.

print
Name _____
Address _____
Town _____ State _____ Zip _____
(If Known)

Earn more with safety . . . PLUS FREE GIFTS FOR NEW OR

ADDED SAVINGS
DURING
JANUARY, 1966

UTAH SAVINGS *and Loan Association*
65 NORTH UNIVERSITY AVENUE — PROVO, UTAH

5%
PER YEAR
Compounded
Semi-Annually

5 REASONS WHY

- Assets Exceed \$26 Million
- Higher Savings Return
You actually earn \$5.06 yearly per \$100 in savings.
- Located in the Center of Growing Western America.
- 45 Years Continuous Service.
- Savers-By-Mail in 50 States and 45 Foreign Countries.

Gentlemen:

.... Enclosed is \$..... to open my account.
.... Please send further details.

NAME(S) ON PASSBOOK

ADDRESS

CITY

STATE

GIFT CHOICE

SAVE BY JAN. 31ST - EARN FROM THE 1ST

COMPLETE AND
MAIL TODAY!

UTAH SAVINGS
& Loan Association
65 N. University
Provo, Utah

- \$100 OR MORE
Nine Piece Manicure Set OR
Magnetic Flash Light
 - \$250 OR MORE
Set of Six Insulated Mugs OR
Outdoor Thermometer
 - \$300 OR MORE
Men's or Ladies' Timex Wrist Watch OR
Johnson & Johnson First Aid Kit
 - \$750 OR MORE
Plastic Suit or Dress Travel Bag
(specify which) OR
Presto Electric Manicure Set.
 - \$1,000 OR MORE
Casco Heating Pad OR
Dymo Personal Embosser
 - \$1,500 OR MORE
10 Transistor Portable Radio OR
Dymo Label Maker
 - \$2,500 OR MORE
Cordless Electric Alarm Clock OR
Knapp-Monarch Pop Corn Popper
 - \$3,500 OR MORE
Polaroid Camera "The Swinger" OR
50-Piece Wm. Rogers Stainless Steel Flat-ware.
 - \$5,000 OR MORE
Benrus or Gruen Wrist Watch (Mens or Ladies) OR
Electric Carving Knife
 - \$10,000 OR MORE
Westinghouse Portable Tape Recorder OR
Kodak 8mm Movie Camera or Projector
 - \$15,000 OR MORE
Polaroid Camera - Model 104 Color-Pack
- GIFTS SUBJECT TO STATE AND ASSOCIATION REGULATIONS . .

CATCH THEM ALIVE AND UNHURT!

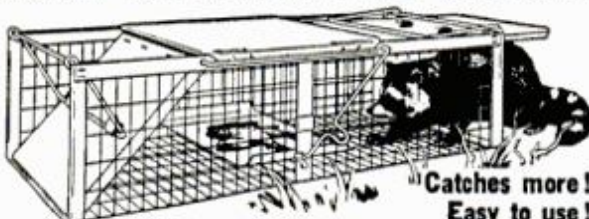

Catches more!
Easy to use!

Amazing HAVAHART trap captures raiding rats, rabbits, squirrels, skunks, pigeons, sparrows, etc. Takes mink, coons without injury. Straying pets, poultry released unhurt. Easy to use—open ends give animal confidence. No jaws or springs to break. Galvanized. Sizes for all needs. FREE illustrated practical guide with trapping secrets.

HAVAHART, 136-J Water Street, Ossining, N. Y.

Please send me FREE new 48-page guide and price list.
Name
Address

NEW WESTERN HAIG

.12 CALIBER
SPECIAL FACTORY
OFFER!



\$300
post-paid

USES POWDER CHARGE

This small bore gun shoots .12 cal lead bullets fired by small 4.4 mg. powder charge. Not a CO₂ gun! You'll like the handsome lines, grip, and balance. Western in style, but patented ball and cap action allows this low price. 9 3/4" steel barrel cased in knurled styrene stock, overall 13 1/2". Develop pistol form, accuracy at a fraction of cost of large caliber pistols. Comes with 50 lead bullets. Satisfaction guaranteed. Send \$3 to: Haig Mfg. Co., P. O. Box K-4, Alhambra, Calif. 91802

MACHINE TOOL RECONDITIONING & THE ART OF HAND SCRAPING
REWINDING SMALL MOTORS, OPTICAL TOOLING, INDUSTRIAL HYDRAULICS, MACHINE SHOP ESTIMATING.

Book catalog free to machinists, toolmakers, engineers.

MACHINE TOOL PUBLICATIONS
215-P Commerce Bldg., St. Paul, Minn. 55101



MASONS!

Send today for free catalog of Masonic & Eastern Star books and rituals

EZRA A. COOK PUBLICATIONS, INC.

P. O. Box 796 Dept. A-49 Chicago 90, Ill.

Secrets of VENTRILOQUISM
Now Revealed!



Easy to learn in 60 to 90 days with our Home Study Course. **RESULTS GUARANTEED** Make Money! Be Popular! Have Fun! Big Opportunity! Radio, Television, Stage Appearances! For FREE information regarding price and terms WRITE. You must state your age. Dummy Catalog 25c.
MAHER HOME COURSE OF VENTRILOQUISM
Box 36, Studio PM-1, Kensington Station
Detroit 24, Michigan

NEW Improved Accurate Scope-Shot

SCOPE-SHOT COMPLETE WITH 50 DISINTEGRATING PELLETS They crack like a rifle when they hit—leave mark—puff of smoke! **\$195 P.P.**

World's Finest Precision **SLINGSHOT** Scope-type sight!

Millions Sold! Patent No. D-178,837

Pure gum rubber slings. Beautifully polished cast aluminum stock. Pistol grip. So powerful it kills small game. Fits pocket perfectly! Guaranteed. **FREE** shooting manual.

EXTRA RUBBER SLINGS, 4 pairs \$1.00 p.p. Leather Pouch & Sling assembly only 40c p.p. Order NOW from:

GENERAL SPORTS
4184-MA Apple Street, Cincinnati, Ohio 45223

ROUTES PESTS! Price without pellets **\$150 P.P.** Order Now!

AUTOMATIC 60-SHOT PELLET STINGER

Dogs, Other Animals, Assaultants Instantly Repulsed. The pellet is harmless but STINGS. Holds and fires 60 pellets automatically as fast as you can pull the trigger to knock most stubborn assaultants off guard. Portable. Fits easily in pocket or purse. Made of high impact styrene for long life, trouble-free use. Fully guaranteed. More humane to animals than kicking or hitting. Send **\$1.98** cash, check or money order plus 27c to cover handling and we include 50 stinging pellets. Not sold in N.Y.C. (100 pellets \$1) (250 pellets \$2) (1000 pellets \$5) **BARGAIN CO., Self-Defense Dept. 1-PMS, 1 Park Ave., New York, N.Y. 10016.**



BILLIARD SUPPLIES

Build your own TABLES for Rec. Room or Profit

ALL PRICE RANGES
Plans 6 to 9 ft. sizes
Duraflake or Slate

Send .35 for catalog and cloth samples

CAMPBELL BILLIARDS
BOX 260A, HARTLAND, WISCONSIN



Enjoy Independence



With A Sparetime BUSINESS OF YOUR OWN

Here's a proven, practical way to earn sparetime cash while you develop a money-making business of your own. Investment is small. There's no overhead, no stock to carry, no selling involved. Automatic Foley Saw Filer, easy to operate, files combination saws, hand, band and circular saws. No experience needed.

Earn \$3 to \$6 An Hour In Sparetime

Get started now and watch your business grow! Thousands are earning cash this easy way—many build a complete sharpening service with year around profits. You can, too, with the easy-to-follow Foley Plan—write us today!

FREE BOOKLET SHOWS HOW

Fact filled booklet tells you how to start a sparetime business; how to get new business. Rush coupon, get "Money Making Facts" and details on Easy Payment Plan. No salesman will call.



Foley Manufacturing Co.
143-6 Foley Bldg., Minneapolis, Minn. 55418

Send FREE BOOK—"Money Making Facts", and Time Payment Plan.

Name _____

Address _____

City _____ State _____ Zip Code _____



"I Have My Own Shop Now!"

Says **FREEMAN J. JEFFRESS, Oklahoma City, Okla.**
"Your locksmithing course is so good, I wouldn't take back the money I paid for it. I have a nice little shop set up in my home and it has already paid for itself!"

306 pieces of professional equipment

Supplied for use with course.

Professional Equipment includes **LOCKS—PICKS—PARTS—KEYS SPECIAL TOOLS & SUPPLIES**

Est. 1948

Be a LOCKSMITH

Train at HOME—Earn While You Learn. Add 50%-100% to YOUR INCOME with easy spare time earnings. Cash in on the nation-wide shortage—trained locksmiths in great demand! Quickly step into a big pay opportunity job or start a high-profit shop of your own.

Earn Extra Money RIGHT AWAY! All Master Locksmiths Special Tools, Equipment and Supplies furnished for use with course.

Age, education, minor physical handicaps don't matter in this growing trade. You can quickly qualify as a skilled locksmith. It's like a fascinating hobby. Study at home as little as one hour a week. Gain practical experience through complete well-illustrated lessons. Do real jobs on car locks, house locks, padlocks and safe locks, under the guidance of experts. **FREE** Illustrated Book, write now.

LOCKSMITHING INSTITUTE.
(Div. Technical Home Study Schools)

Dept. 110-016, Little Falls, New Jersey 07424

MAIL COUPON for FREE ILLUSTRATED BOOK

For a future as your own boss or in a high-pay job, write now for **FREE** Illustrated Book.

Only school of its kind: Licensed by State of New Jersey; Approved for Veterans.

Acc'd Member Nat'l Home Study Council.

MAIL COUPON NOW

LOCKSMITHING INSTITUTE, Dept. 110-016 Little Falls, New Jersey 07424

Please send **FREE** Illustrated Book—"Your Big Opportunities in Locksmithing," complete Equipment folder and sample lesson pages—**FREE** of all obligation—(no salesman will call).

Name..... (Please Print)

Address.....

City..... State..... Zip.....





EARN UP TO \$50 A WEEK IN
YOUR SPARE TIME AS A

TYPEWRITER REPAIRMAN

Great demand for trained men. Over 25 million typewriters need service and repairs! Cash in on this 300 million dollar market. Now you can get industry-approved training at home. Easy to learn. Low Cost. Qualify quickly in your spare time for a high paying job or a business of your own. Earn while you learn. Real typewriters, sub-assemblies, visual aids, and professional tools provided at no extra cost. Simple, clear illustrated lessons. Expert teachers personally guide you all the way. Fully licensed, accredited, and approved school. State authorized diploma. Mail Coupon Today. Typewriter Repair School, Little Falls, N.J. 07424

TYPEWRITER REPAIR SCHOOL
DEPT. 310-016
Little Falls, New Jersey 07424

FREE
BOOK

Send FREE BOOKLET describing unlimited opportunities for Typewriter Repairmen. No obligation. No salesman will call.

Name.....
Address.....
City..... State..... Zip.....

ARE YOU MAKING ALL THE MONEY YOU CAN?

U.S. DEPT OF
LABOR CITES
IMMEDIATE NEED FOR
SKILLED TECHNICIANS

Prepare for the better paying jobs at the World's largest, most modern and best equipped Trade School. Greer's expert instruction and actual shop training teaches you how. Job placement aid and help in obtaining convenient living accommodations nearby. Resident training and Home Study courses. Over 100,000 successful graduates.



- | | |
|---|---|
| <input type="checkbox"/> AUTOMOTIVE MECHANICS | <input type="checkbox"/> ENGINEERING DRAWING* |
| <input type="checkbox"/> AUTOMATIC TRANSMISSIONS* | <input type="checkbox"/> BLUEPRINT READING* |
| <input type="checkbox"/> MOTOR TUNE UP* | <input type="checkbox"/> TWO YEAR AUTOMOTIVE AND DIESEL TECHNOLOGY* |
| <input type="checkbox"/> BODY & FENDER REPAIR* | <input type="checkbox"/> TRUCK DRIVER TRAINING |
| <input type="checkbox"/> DIESEL MECHANICS | <input type="checkbox"/> HEAVY EQUIPMENT OPERATORS |
| <input type="checkbox"/> MACHINIST, TOOL & DIE* | <input type="checkbox"/> CONSTRUCTION EQUIPMENT MECHANICS* |
| <input type="checkbox"/> REFRIGERATION & AIR CONDITIONING | |
| <input type="checkbox"/> GAS & ARC WELDING | |
| <input type="checkbox"/> HELIARC WELDING | |

NAME..... Age.....

ADDRESS.....

TOWN..... STATE.....

*Resident Courses Only. Resident Home Study

GREER TECH INSTITUTE

Box A 2236 S. Michigan Ave., Chicago, Ill. 60616

ELECTRIFY PLAYER PIANOS PUMP ORGANS

YOU CAN QUICKLY END TIRESOME FOOT-PUMPING
With a Compact Low-Cost Lee Silent Suction Unit



EASY TO INSTALL
FULLY GUARANTEED
1000'S IN USE

write to
LEE MUSIC MFG. CO.
Box 595, Tujunga, Calif.



Learn Profitable Profession in few months at Home



MEN AND WOMEN, 18 TO 60

\$4.00 to \$5.00 for 1-hour treatment is the established charge for a skilled operator. Easy to learn and do. Diploma awarded. Open your own office or earn good income from Doctors, Hospitals, Clubs and other health or recreational centers. Wonderful part-time profession. Low monthly payments. Write today for free Anatomy Charts and catalog. No obligation.

ANDERSON SCHOOL OF SCIENTIFIC MASSAGE
Dept. A-1, Princeton, Illinois

BOAT KIT Catalog FREE

FIBERGLASS OR PLYWOOD

Save \$1000 to \$2500 on 18', 20', 22' Luger Luxury Cruisers... save to \$4000 on 22' Houseboat and 26' and 30' Cruisers... to \$500 on speedy 14' or 16' Molded Fiberglass Runabouts! Over 50 Models! Easily assembled. Every part and every section pre-cut, pre-assembled or precision molded. Just put together! 3 Years to Pay! MONEY BACK GUARANTEE! Rush name, address for full color catalog—56 pages—FREE!

Low Down Payment
EASY TERMS

LUGER BOAT KITS, Dept. B-16
9200 Access, Minneapolis, Minn. 55431

Don't put up with bad-tasting water!

SEND FOR FREE 16 PAGE BOOKLET

You can eliminate excess chlorine, sulphur, other bad tastes or odors from home drinking water. Simple. Inexpensive. Write: Cuno Engineering Corporation, Meriden, Conn.

CUNO® AQUA-PURE® filters



MAKE BIG MONEY

MAKING COSTUME JEWELRY AT HOME!

Thrilling spare-time. MONEY-MAKING hobby! Make newest, beautiful jeweled earrings, necklaces, bracelets, pins, pendants, cuff links, tie clips! Quick, easy to make—easier to sell to friends, neighbors, stores, at big profit! Details FREE!

DON-BAR CO., Dept. A-196
2934 W. Fullerton Ave., Chicago, Ill. 60647



I-N-V-E-N-T-O-R-S WE NEED INVENTIONS

Sell your invention for cash—need money for Patent?—Are technical problems holding you back? Universal Inventions has helped inventors all over the world—just like yourself—why not you? Inventions provide the magic spring-board to sudden riches. REMEMBER, we either sell your invention or pay you a cash bonus. Write for details.

UNIVERSAL INVENTIONS, Dept. 13, Marion, Ohio

EARN BIG MONEY



Learn in your spare time at home for a BIG PAY job in electronics. Christy training is fun, easy because you work with actual equipment. EARN while you LEARN. Send for FREE books, lessons and pay-later plan.

Christy Trades School Inc., Dept. T-403
3214 W. Lawrence Ave., Chicago 60625

BILL TROUBLES?

NOBODY REFUSED UP TO \$9,000.00

BAD CREDIT - NO PROBLEM - NOT A LOAN CO.
SEND YOUR NAME FOR FREE APPLICATION
ATLANTIC ASSOCIATES - DEPT. 43
144 WESTMINSTER ST., PROVIDENCE 3, R. I.

BRONZE FOUNDRY

Since 1935

Schools • Home Workshops • Inventors
Make your own castings of aluminum, copper, bronze, silver. Foundry sets are available in six sizes, capacity 1½ lb. to 48 lb. of red brass. 2400 Deg. F. blast furnace included with each. Write for Free Circular.

KANSAS CITY SPECIALTIES CO. Dept. P-1, P.O. Box 193, Middleton, Wis.

REAL ESTATE

BE A BROKER

PAYS BIG! SEND FOR FREE, BIG, ILLUSTRATED CATALOG NOW! Graduates report making substantial incomes. Start and run your own business quickly. Men, Women, all ages, learn easily. Course covers Sales, Property Management, Appraising, Loans, Mortgages, & related subjects. STUDY AT HOME or in classrooms in leading cities. DIPLOMA AWARDED. Write TODAY for FREE Booklet!

Accredited Member National Home Study Council. (Established 1936)
WEAVER SCHOOL OF REAL ESTATE
3521-P Broadway Kansas City, Mo. 64111

FREE BOOK TELLS HOW

LAW FREE BOOK

THE LAW TRAINED MAN

Write today for a FREE copy of illustrated law book, "THE LAW TRAINED MAN," which shows how to earn the professional Bachelor of Laws (LL.B.) degree through home study of the famous Blackstone Law Course. All necessary books and lessons provided. Moderate cost; convenient monthly terms. Write for FREE law training book today.

Blackstone School of Law, 307 N. Michigan Ave. Dept. 51, Chicago 51, Illinois
Founded 1890

130,000 CANDLE POWER FLAME THROWERS



Fits all 4 light systems—bright sockets. American made for American cars. 65,000 candle power in each sealed beam unit. Over 2½ times as bright as the factory stock brights. Lets you really see where you are going.

\$995 pair

Prepaid U.S.A. No C.O.D. please
Box 401 Skokie, Illinois 60076

WARREN AUTOMOTIVE

Live Better Electronically With

LAFAYETTE RADIO ELECTRONICS

512 Pages

FREE!

Now BETTER THAN EVER
1966 Catalog 660



Stereo Hi-Fi • Citizens Band • Ham Gear • Tape Recorders • Test Equipment • TV and Radio Tubes and Parts • Cameras • Auto Accessories • Musical Instruments • Tools • Books

Featuring Everything in Electronics for HOME • INDUSTRY • LABORATORY from the "World's Hi-Fi & Electronics Center"

LAFAYETTE Radio ELECTRONICS
Dept. LA-6 P.O. Box 10
Syosset, L.I., N.Y. 11791

Send me the Free 1966 Lafayette Catalog 660

Name

Address

City State

Zip

(Please Give Your Zip Code No.)

NEW! 100

WORLDWIDE STAMP COLLECTION

just released



plus WINSTON CHURCHILL MEMORIAL ISSUE

GET THIS giant new collection of 101 different stamps — from the world's far corners. NEW ISSUES — commemoratives, pictorials, multi-colors. Lincoln, JFK, Churchill — Tristan da Cunha, Afghanistan, Rwanda, many more. PLUS exciting older issues showing beasts of prey, ancient life, jungle scenes. Supply limited. All only 10c. EXTRA! Other exciting stamps to examine; returnable, no obligation.

GARCELON STAMP CO., Dept. 1PM7, Calais, Maine

GARCELON STAMP CO., Dept. 1PM7, Calais, Maine
Enclosed is 10c. Rush 101 Worldwide Stamp Collection. EXTRA! Other exciting stamps to examine; returnable, no obligation.

FREE Key Machine

Kind master locksmiths use. Sells for \$125, but yours FREE with Locksmithing Course



You Can Learn To Be A LOCKSMITH in your spare time

There's a big demand for skilled locksmiths. You can earn big money either full or part-time in your own home. Be your own boss; earn steady, year 'round income with no layoffs. The BELSAW INSTITUTE training, recommended by professional locksmiths, teaches you to make keys, open and repair locks on homes, cars and buildings. Easy, step-by-step illustrated lessons complete with all tools and supplies. We tell you how to get servicing jobs, how much to charge, how to earn while you learn and how to build a secure cash profit business.

Mail Coupon for FREE Book Today!

BELSAW INSTITUTE, 106G Field Bldg., Kansas City 11, Mo.
Send FREE book, "Keys To Your Future!"
No obligation. No salesman.

Name

Address

City State



Excitement! Security! Good Pay! CRIME DETECTION

LEARN AT HOME IN SPARE TIME—START NOW!
Crime everywhere is on the rise! Learn now, in your own home, the profitable profession that enables you to track down criminals and bring them to justice! Hundreds of Identification Bureaus employ I. A. S. graduates... trained in finger printing, police photography, handwriting identification, firearms and investigation. Our 44th year! FREE "Blue Book of Crime"... packed with crime facts and the full story of famous I. A. S. training. State exact age. No salesman will call. Rush Coupon!
A Correspondence School Founded in 1916.

FREE
Blue Book
of Crime
MAIL
COUPON

INSTITUTE OF APPLIED SCIENCE, Dept. 1351
1920 Sunnyside Avenue, Chicago 40, Ill.
Rush Blue Book of Crime... FREE!

NAME.....Age.....
ADDRESS.....
TOWN.....STATE.....

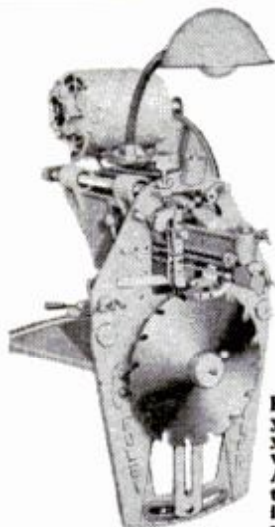

MAKE
\$20 to \$30
A WEEK
EXTRA
MONEY

Here's a practical way to increase your income and build security for your family. Earn extra money every week sharpening saws with a Foley Automatic Saw Filer. You can actually build your own business with it—without special training or previous experience.

TURN YOUR SPARE TIME INTO CASH. Make from \$3 to \$6 an hour evenings, week-ends. Start in your basement or garage. No canvassing. "I advertised in our local paper and got in 83 saws"—says M. L. Thompson. Every saw you sharpen with the Foley Filer brings you more customers. Hundreds are making extra money this sure, fast, easy way. You can too.

FREE
BOOK
SHOWS
YOU HOW
TO START

"Money Making Facts" explains how you can get business from home owners, farmers, carpenters, schools, factories, etc., how to build your business and expand—every step of the easy way. Don't wait. Mail coupon now for this exciting book and easy pay plan. No salesman will call.

MAIL COUPON FOR FREE BOOK

FOLEY MANUFACTURING CO.
129-6 . Foley Bldg., Minneapolis 18, Minn.
Rush free book, "MONEY MAKING FACTS", and details on easy pay plan.

Name.....
Address.....
City.....State.....



109 Stamps for only **10¢**
featuring **MAN IN OUTER SPACE**

Yes, only 10¢ brings you this fascinating collection of 109 different stamps from all over the world. Includes unique issues showing U.S. space heroes, Russian "twins," "walk-in-space," Congo "rockets," many more. You also get Midget Encyclopedia of Stamp Collecting, plus a selection of other fine stamps on approval for free examination. Buy only those you want—or none at all—return balance within 10 days. Satisfaction guaranteed.

Rush 10¢ today. Ask for Lot FO-59
ZENITH, 81 Willoughby St., Brooklyn, N.Y. 11201



PROFIT IN YOUR SPARE TIME

SMALL ENGINE REPAIR PAYS BIG!



Outboard • Powermower • Chain Saw • Tractor
MAKE EXTRA MONEY — or fix your own engines and SAVE! Illustrated, easy-to-learn Home Study Course qualifies you as expert. Free information. Write today!

LINCOLN TECHNICAL INSTITUTE
SUITE 1E, 472 MARKET STREET, NEWARK 5, N.J.

BUILD FINE GRANDFATHER CLOCK NOW



Simple, sensible, Red-I-Kut shop tested plans. Build for yourself or sell at a good profit. SAVE 100's \$\$\$.
Narrow waist 83" tall models "Spirit of the Century" and new "Spirit of Peace" with amazing 22 1/2" front corners or stately straight side "Spirit of America".
"HOW-TO" Photopack Plans with LIFE SIZE PATTERNS tell all—plus CLOCK BUYER'S GUIDE. Jet Age heavy brass weight, Kueple Original Westminster, MOVING MOON dials, LYRE pendulums, 3/4" solid mahogany Jiffy-Joint Kwik-Bilt case kits. \$1.00 each plan. Rush \$2.50 all three plus Free Bonus "Petite Grandmother" plan, as folks have for over 50 years.

Kueple Chime Works, 25 Kueple Bldg., Minneapolis, Minn. 55416

PAGE FOR TILLING PLOWING MOWING

A FULL LINE — 10 AND 12 HP
with complete gear drive and reverse
FREE CATALOG • LOW PRICES • EASY TERMS
Over 40 years experience
OVER 60 ATTACHMENTS AVAILABLE!

PAGE Richfield 4
Wisconsin



DEALERS WANTED

EARN
MONEY
FAST!

REPAIR HYDRAULIC JACKS

Earn while you learn at home. Trained and qualified mechanics needed. NOW to service inoperative hydraulic jacks. BIG opportunity for ambitious men. We show you HOW — in your basement or garage, spare time cash income in an expanding industry. Don't wait, ACT NOW! Get the facts.



Write for folder No. PM1 and free bonus offer
HYDRAULIC JACK REPAIR MANUAL CO.
P. O. BOX 50 • BLOOMFIELD, N. J.

PROFESSIONAL TAX CONSULTANTS

EARN BIG MONEY FASTER

Clean, dignified, high pay Tax Consultant Practice waiting for trained graduates. Busy tax season pays \$1,000 to \$3,000 for spare time work... leads to profitable year 'round Tax Service Business with monthly fees of up to \$50 per client. No previous experience. Low cost home training course, shows you the way. Licensed by N. Y. Education Dept. and Acctd. by Nat'l. Home Study Council. Write for FREE LITERATURE. No obligation. No salesmen.

NATIONAL TAX TRAINING SCHOOL, Monsey, J-20 N. Y.



PELLET FIRING
LUGER AUTOMATIC

- MAGAZINE LOADING CLIP
- OVER 15 MOVING PARTS
- FULLY AUTOMATIC

ONLY
\$198

Automatic full size model of a Luger Automatic pistol — contains over 15 moving parts. Loads 8 complete rounds which snap into the hard butt simulating a Luger. Fires 8 bullet shaped pellets. Has automatic slide action.

MOST AUTHENTIC MODEL GUN WE'VE EVER SEEN
Comes to you with working parts disassembled with cleverly engineered springs, full instructions, supply of pellets and targets. **Full Money Back Guarantee.** Simply send \$1.98 plus 27¢ shipping charge. N.Y. State residents add 4¢ sales tax.

HONOR HOUSE PROD. CORP., Dept. 96LG13, Lynbrook, N. Y.

Magic Mail Plan-Make up to \$12 an Hour!



Get **ORDERS** and **CASH** from your mailman—do work in **SPARE TIME** at home—or expand into **FULL TIME** business. Send coupon for Free facts about the newest and most fascinating of all home operated businesses. For the first time a simplified machine brings the fabulous profits of **Plastic Sealing** and **Plastic Laminating** within the reach of the small operator. Anyone can learn to operate the machine with a few minutes practice—then with our **Magic Mail Plan** can get mail orders pouring in daily with cash in every envelope. **No canvassing—no selling.** We even

Get into **PLASTIC LAMINATING** at home

WE'LL EVEN HELP FINANCE YOU

supply the circulars you mail to bring back cash and orders, financing help, too. Rush name. We'll send you **FREE** and postpaid, pictures, prices, details, finance plan, all the facts you need. Mail coupon or send name on postcard. No charge. **Vanner Electric Co., 1512 Jarvis Av., Dept. L-2-AX, Chicago, Ill. 60627**

THIS MAN . . . is taking out of the machine a Plastic Sealing Job—ordered by mail—only 11c in material cost brings back \$2.58 in cash by mail. Capacity of machine: **\$25.00 profit per hour of operation.**

Make Thousands of Beautiful Art Creations

COSTUME JEWELRY • CIGARETTE BOXES TRAYS • CANDLESTICKS • COASTERS LAMP BASES • BOOK ENDS...ALL IN SPARKLING COLORED PLASTIC



WARNER ELECTRIC CO., 1512 Jarvis Av. Dept. L-2-AX, Chicago, Ill. 60626

At no cost to me, please rush full details and financing plan, postage prepaid. No obligation.

Name.....
Address.....
City.....Zone.....State.....

FREE 20-PG BOOK REVEALS HOW...

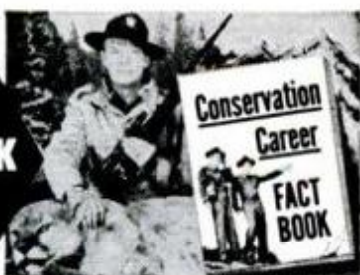

You can prepare in spare time for Wildlife-Forestry Dream Career. Positions as bounty hunter, game warden, forester, aids, etc., open ages 17-40. Adventure, thrills, public service, plus good pay, low living cost, security. Plan to live the life you love.

Accredited member National Home Study Council. Write for **FREE BOOK** today: State your age. **NORTH AMERICAN SCHOOL OF CONSERVATION** Campus Drive, Dept. 171, Newport, Calif. 92660

FREE MUSCLE COURSE!

Trade in that skinny scrawny, milk toast or overweight body of yours for a new **Weider Jet-Charged** body, rippling with mountains of muscles loaded with energy, drive and virility, the envy of every man and admiration of every woman, now! In 15 minutes I'll prove you can slap on 4 inches of muscles to your chest,—3 inches to each arm—give you life-guard shoulders, trim your waist to athletic size—give you speedy athletic legs. I don't care if you're short or tall, (skinny or fat) young or not so young, expect a muscle building miracle when you send for my **FREE** course. Send only 25 cents to cover postage and handling and write to the Trainer of "Mr. Universe", "Mr. America", "Mr. Europe".

JOE WEIDER, Dept. 38-16D 531 32nd St., Union City, N. J.



LEARN MEAT CUTTING AT NATIONAL

Pay After Graduation



The steady dependable trade of Meat Cutting taught easily in 8 short weeks. **YOU LEARN BY DOING** under actual meat market conditions in big modern school at Toledo.

For beginners or men with experience. Get a profitable store of your own. Remember, **PEOPLE MUST EAT!** Big pay jobs. Free employment help. Thousands of successful graduates.

Buying, cutting, percentage, pricing, advertising, selling, etc. A complete retail meat education. National School established 43 years. Get National training **NOW**. Pay your tuition in easy weekly

payments after you graduate. Send coupon for **FREE** school catalog—**TODAY**. G.I. approved.

National School of Meat Cutting, Inc., Dept. 50-C Toledo 4, Ohio
Send me your **FREE** school catalog on National Training at Toledo in Meat Cutting, Meat Merchandising and Self Service Meats. No obligation. No salesman will call.

Name..... Age.....
Address.....
City..... State.....
Approved for Veterans

**MY SPARE TIME HOBBY
MAKES ME
\$5⁰⁰ an hour
CASH PROFIT**

—Grover Squires

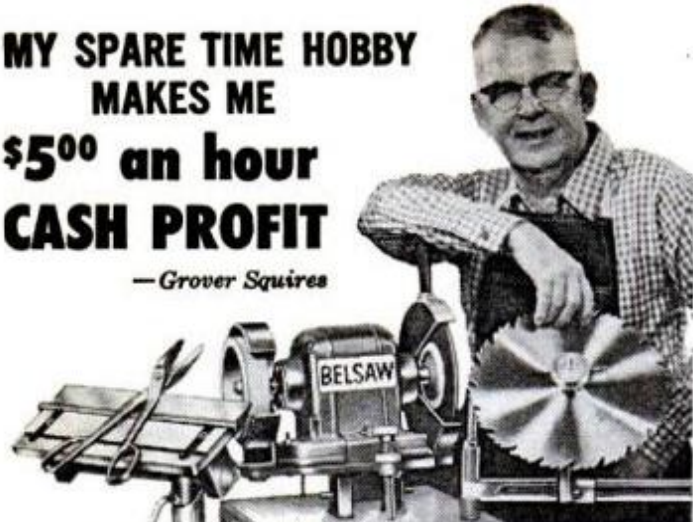

START YOUR OWN SPARE TIME BUSINESS

You can turn your spare time into Big Cash Profits with your own **COMPLETE SHARPENING SHOP** . . . Grind saws, knives, scissors, skates, lawn mower blades . . . all cutting edges. Your Own Cash Business with no inventory . . . right at home . . . no experience needed.

FREE BOOK tells how you can start your own spare time business while you are still working at your regular job. Low Cost — time payments only \$15.00 a month. Send coupon today.



BELSAW SHARP-ALL CO. 716W Field Bldg., Kansas City 11, Mo.
Send Free Book "LIFETIME SECURITY". No obligation.

Name _____

Address _____

City _____ State _____

FUN TO BUILD—EASY TO FLY!



Bensen Copter—build with ordinary hobbyshop tools. Safest, easiest to fly. Plans, factory kits available. Get 3-View Drawings, specs, photo for \$3, or simpler Gyroglider \$2.

BENSEN AIRCRAFT CORP., Dept. PM-16
Raleigh-Durham Airport, Raleigh, N. C. 27602

NAME _____

ADDRESS _____

**Start Your Own
BIG PROFIT
HOME
IMPORT
BUSINESS**
With Dazzling
Bargains Like These



**4 TRANSISTORS
TAPE RECORDER**

Records, play back, erases, rewinds. Dynamic speaker. Includes microphone, tape, reels. **\$6¹⁰**

Buy Below Wholesale

Amazing plan starts you **FAST** . . . to opportunities far beyond your wildest dreams. Start now at home, full time or part time. Cash in big without previous experience or capital investment. Pocket cash even before ordering imports. We show you how . . . help you every step. Beginners—make first import transaction 10 minutes after you get plan. Send for free book, "How to Import and Export" tells all . . . rush name, address. Airmail reaches **MELLINGER CO.** us overnight.

1554 S. Sepulveda, Dept. X251, Los Angeles, Calif. 90025

Here are examples of thousands of import bargains that can pay you up to 200% profit.

- Transistor Radio . . \$1.96
- Human Hair Wig . . \$2.00
- Electric Train 1.50
- Cigarette Lighter . . .21
- Beer Stein13
- Wrist Radio 2.90

SEND NO MONEY
Do not order products from us. Plan shows you where to buy bargains like these for big profits. Prices shown are direct from overseas suppliers. Rush name today.



FREE

**MUSCLE BUILDING
INFORMATION**

Sensational New Isometrics
Less Time—Less Effort—Better results
BODY-TONE, Box 638, North Miami 61, Fla.

**LEARN WELDING AT HOME
WE SEND YOU A WELDER**

A trade with a future—In demand everywhere We have trained thousands—Men who earn up to \$4.50 an hour. Learn Arc, Heli-Arc and Gas Welding. We supply equipment that lets you earn while you learn. Practical lessons on brand new, industrial rated machines. Both arc and flame welding. On completion the equipment is yours. Set up your own shop or work in any shop on any job. Send today for full information.

AMERICAN INSTITUTE OF ENGINEERING & TECHNOLOGY
1131 W. Fullerton Parkway, Chicago, Illinois

**BASEMENT
TOILET FLUSHES
UP**



TO OVERHEAD SEWER OR SEPTIC TANK.
NO DIGGING UP FLOORS. Write
McPHERSON, INC. BOX 15133 TAMPA, FLA.



EARN \$1,000 A MONTH

LEARN A TRADE YOU LIKE

Start as a mechanic in a good paying job; then advance to shop service manager. Many make \$1,000 a month and up. You learn fast in our shop because you learn with tools on real equipment. Some students earn part of their expenses while going to school.

CHECK AND MAIL COUPON

- | | |
|---|--|
| <input type="checkbox"/> AUTO MECHANICS | <input type="checkbox"/> AUTO BODY REPAIR |
| <input type="checkbox"/> DIESEL MECHANICS | <input type="checkbox"/> AUTOMATIC TRANSMISSIONS |
| <input type="checkbox"/> GAS, ARC WELDING | <input type="checkbox"/> MOTOR TUNE-UP |
| <input type="checkbox"/> HELIARC WELDING | |

Mail to: **AUTO-DIESEL COLLEGE**
226 7th Ave., No., Dept. 86, Nashville, Tenn.

Please send without obligation free catalog

NAME _____
(please print or write plainly)

ADDRESS _____

CITY _____ STATE _____

CLASSIFIED ADVERTISEMENTS

Rate: \$1.40 per word payable in advance each insertion. Minimum insertion ten words. To be inserted under the proper classification, copy must be in our office by the 15th of the second month preceding date of issue. The next available issue to place an advertisement in America's No. 1 Classified Section is March. The closing date is January 15. Send remittance and order to C. A. Martin, Popular Mechanics, 575 Lexington Avenue, New York, New York 10022.

POPULAR MECHANICS

AUTOMOBILES, MIDGET CARS

AUTOMOBILE Literature, antique, classic, rare reprints. Non-profit hobby club. Free information. Enthusiasts, Box 451B, Mt. Clemens, Mich. 48044.

AUTO SUPPLIES AND EQUIPMENT

JEEP Parts! For military and civilian. At great savings. Largest inventory. Catalog for owners and dealers. Inquiries invited. American Auto Parts Co., 1830-PM Locust, Kansas City, Mo.

JEEP Owners—V8 conversions. Read Jeep Owners ad, page 61.

AUTO Welding repair training in world's largest non-profit welding school. Low tuition. Free booklet. Hobart Welding School, Box M-16, Troy, Ohio.

ANTIQUE Car pistons, gaskets, gears, valves, etc. Catalogue \$1.00. Antique Auto Parts, Milwaukee, Wisconsin 53204.

FOREIGN Car parts. Discounts. Catalog. Box 7, Elmont, N.Y.

NEW And used parts savings. Complete guaranteed service all model cars and trucks. Largest in west. Jeep and Army parts specialists. Shifting hubs for all front-end drive vehicles. \$27.50 up. Foreign parts. Fast service. Pioneer, 734 W. 13th Avenue, Denver, Colorado 80217.

CROSLLEY. New, used, parts. Discounts. Catalog. Box 7, Elmont, N.Y.

CAR Trouble shooters pinpoint in a flash over 2,300 causes of car trouble! Transmissions, brakes, engine, elec. system, etc. Tells how to do simple repairs. Saves time, work, money. A must for all who work with cars. Send only \$2 (money-back guarantee) to Motor-Book Dept., Desk A-11, 250 W. 55th St., New York 10019.

JUST Out! New 244-page auto parts, accessories catalog. Save up to 50% on over 100,000 items for all makes models of cars, trucks, foreign and sports cars, Model "A", "T" from 1909 thru 1966. Latest Hollywood accessories, custom and hi-speed equipment. Rush 25¢ for postage, handling—refundable on first order. Whitney, 1919-PM1, Archer, Chicago, Ill. 60616.

NOW Available direct! Only super all-12 gasoline additive guaranteed to have 12 powerful ingredients! Get up to 2-3 more MPG, 8% more HP, 99.9% combustion! No deposits! Reduces exhaust fumes 53%. Use regular, get premium performance! 10 Billion proved miles. \$3.00 can of concentrate treats 200 gallons or approximately 15 tankfuls. (12 Cans, Discount 20%) Postpaid. Send your order direct to: Fuels Research Corporation, 2114P Curtis, Denver, Colorado 80205.

NEWLY Invented Snowmat gets your stuck car out of snow—no rolling—no throwing. Moneyback guarantee. \$1.50 postpaid. Box 617A, Franklin, Michigan.

SAVE \$150! Ring-valve job while driving. \$6.00 postpaid. Safe! Guaranteed! Many mechanics recommend. Motaloy, Grantham, Penna. 17027.

AUTO TRAILERS

PRE-Cut pickup camper kits. Ready to assemble. Literature, 15¢. Snowy Mountain Campers, Lewistown, Montana.

BUILD Inexpensive compact bus camper unit; Volkswagens, Econoliners, Dodge, ChevyVan, Literature. Dot Campers, Box 67M, Saugus, California.

PICKUP Camper, trailer or pickup-cover. Build yourself, save! Complete plans \$3.95 each. Bus conversion (and houseboat interiors) Drawings \$2.95. Equipment catalog, \$1.00 (refundable). Satisfaction Guaranteed. Details 10¢. Viking Camper Supply, 94-F Glenwood, Minneapolis, Minn. 55403.

BUILD Your own—Save! Econoline camper plans, foldout trailer, or bus conversion drawings, including materials catalog \$2.95 each. Guaranteed satisfaction. Catalog, \$1.00 (refundable). Details, dime. Campers, Box 263-F, Hopkins, Minn.

BUILD Your pickup camper. Precut kits. Blueprints. Supplies. Literature, 10¢. Comstock Trailers, Dept. 664, Parsons, Kansas 67357.

BUILD Aluminum pickup camper over-cab, hi-boy, lo-boy, blueprints, material, list, 3 models included, \$3.00. Bennett Custom Camper, 1500 S. Dallas, Auburn, Indiana 46706.

MOTORCYCLES, BICYCLES, MOTORSCOOTERS AND SUPPLIES

HARLEY-Davidsons — Used bargains. New, used parts, accessories, all models. Bulletin 25¢. Knuth's (Factory Dealer), 1753 Muskego, Milwaukee, Wis.

RECONDITIONED Motorcycle motors. Large stock Indian Cushman Vespa Mustang NSU parts. Indian Motorcycle Sales, Kansas City, Missouri. 64127.

Kart Frame \$12. Three wheeled motor-scooter \$29, Vespa \$30, Sears Kart \$40, Hydroplane \$20, Snowmobile. Engines \$5 up. (Mailorder only.) Send 25¢ (35¢ for first class mailing) for directory-catalogue number 127 listing these and hundreds of other bargains, homebuilders parts, plans, etc. Midget Motors Directory, Athens, Ohio.

ELECTRIC Drive bicycle conversion do it yourself. Cheap to build and operate. Practical, smooth, silent, clean. Photos, plans and instructions, \$2.00. Electrobike, 115 W. 37 St., Long Beach, Calif.

BUILD Motorbike from Bicycle! Plans, \$1.00. Go-Byk Industries, Rothsay, Minnesota 56579.



AVIATION

FREE Catalog aviation/space books Aero Publishers, Inc., 329 PM Aviation Road, Fallbrook, California 92028.

HOT Air balloon kit 10'. \$4.00 pp. complete. U.S. Sportcraft, Box 847, Woodland Hills, California.

HOMEBUILT. Real enclosed helicopter, 24 pages ideas, information, \$2.00. Build "executive" helicopter, drawings, specifications, \$1.50. Helicopter Development, Box PM147, Washington, New Jersey.

PROPELLERS, Plans, kits, supplies for airboats, snowplanes. Gauges, spark plugs, gas-oil hose, oil coolers, primers, wrenches, switches, propeller hubs, engine mounts. Corvair-Volkswagon conversion parts, 125-190 Lycoming engines, manuals, gaskets, parts. Catalog, 50¢. Banks-Maxwell, Box 3301E, Ft. Worth, Texas 76105.

BE A Government licensed aviation mechanic. Practical training. Free information. Aero Mechanics School, Municipal Airport, Kansas City 16, Missouri.



BOATS

KAYAKS—One man \$16.50; two-man \$22.50; sailboat \$39.00. Exciting Sitka Kayak kits known world wide for speed and safety. Assembled in one afternoon. Free pictorial literature. Box 78-P, Brecksville, Ohio 44141.

FULL Size, cut-to-shape boat patterns, blueprints, 7½-38 feet. Big new illustrated "Build a Boat" catalog of 64 designs, including catamarans, cruisers, runabouts, skiffs, outboard boats, sailing, racing, houseboats, 50¢. "How to Build a Boat" booklet, \$2.50. Cleveland Boat Blueprint Co., Box 18250, Cleveland, Ohio.

BUILD Your own boat from our large-scale blueprints. Books of plans give how-to-build help. Hundreds of professional designs—motor, sail or auxiliary—for amateur builders. Free catalog. MoToR Boating, 959 Eighth Ave., Dept. RS, New York 19, N. Y.

WORLD'S Finest boat kits! Frame kits! Models from 8' to 24'. Frames—skiffs—runabouts—cruisers. All leaders in styling and performance. Send 50¢ for catalog. \$1.00 for catalog plus boat building handbook. Custom Boat Designs, 1709-P Niagara Street, Buffalo, New York 14207.

BOAT Plans, world's largest selection. Frame kits and full size paper patterns. Designed for the amateur. Over 200 proven designs from all over the world. Fishing boats—cruisers—sailing—inboard and outboard hydroplanes. Send \$1.50 for catalog. \$2.00 for catalog plus boat building handbook. Custom Boat Designs, 1709-P Niagara Street, Buffalo, New York 14207.

BOAT Kits. Factory molded fiberglass or pre-assembled plywood. 50 models, 12' to 40'. Runabouts, Cruisers, Houseboats. Free catalog. Luger, Dept. BC-66, 9200 Access Road, Minneapolis, Minnesota 55431.

HOUSEBOAT Hull 29'x9'6". Build for \$600.00. Trailerable. Plans include ideas for Dayboat, Half Cabin, Floating Cottage—sleeps six. \$2.50. 'King,' Box 5652, Sarasota, Florida.

PATIO Boat 8'x24'. Build your own and save. Has diving board, awning and accommodates 20 people. Instructions, \$2.00. 3813 Donna Circle, N. Highlands, California.

FIBERGLASS Canoes. Three exciting models. Easily assembled kits. \$34.95 up (factory direct). Free literature. Riverside Canoes, 5806 Victoria Ave., Riverside, Calif.

SAILS—U.S. dacrons, quality, economy, satisfaction. Bowen, 12 Jackmuir, Scarborough, Ontario, Canada.

FREE Plans catalogue—kayaks, canoes, sailing rigs, accessories. Bruce Clark, PM: 115 McGavock Pike, Nashville, Tenn. 37214.

BOAT Plans, frame kits, full size patterns all prepared specially for amateurs. Send 50¢ for new catalog illustrating 55 proven designs including sail, inboards and outboards from 7' to 28'. Glen Designs, 9152 Rosecrans, Bellflower, Calif.

MARINE EQUIPMENT AND SERVICES

NEW. Used, rebuilt marine motors. Marine conversions, fittings. Free catalog. Stokes Marine Supply, Dept. 24, Coldwater, Michigan.

KITS—Build your own inboard engine from Chevrolet, Ford, etc. Big catalog shows how, 50¢. Star Marine, Berkeley 10, California.

FIBERGLASS Boat covering. Wholesale prices. Free literature and sample. Seifert's, Box 1206-M, Green Bay, Wis.

FIBERGLASS Cloth, matt, polyester and epoxy resins. Lowest prices. Seifert's, Box 1206-M, Green Bay, Wis.

MARINE Conversions. Ford, Chevrolet. Jeep engines. Catalog 25¢. Lehman Manufacturing Company, 800 Elizabeth Avenue, Linden 4, N.J.

ATHLETIC AND BODY BUILDING COURSES

POWERFUL Muscles fast! Free brochure! Universal, Box 4327-C, Northeastern, Dearborn, Michigan 48126.

"GIANT Arms." Dr. Young's, D.C. revolutionary discovery, \$2. Satisfaction or refund. Gaucho, Box 9309-S7, Chicago 90.

APPEAR Taller! Free details! Stature, PM-2, Box 10, Brooklyn 7, N.Y.

SPORTING GOODS AND EQUIPMENT

GOVERNMENT Surplus Bargains. In guns, ammunition, edged weapons, hunting, camping, fishing items. Write for giant free catalog. P & S Sales, Box 155, Tulsa, Oklahoma.

SILENCERS: Pistol, rifle details. Simpler, cheaper! New design for .22s, \$1.00. Twin Enterprises, Box 192, Dunellen, New Jersey 08812.

SWIMMERS. Boaters and Water-sports fans—Something new for you—Magic Belt. Write for free brochure: Floatmaster Ltd., Box 205, Station E., Toronto, Canada.

CROSSBOWS—Silent, powerful, accurate, economical. Free details. Gunsco, Soquel, Calif.

SILENCERS, Pistols, rifles—details, construction, operation, \$1.00. Gunsco, Soquel, California.

BIG Money raising crickets and 12 inch African fishworms. Free literature. Carter Ranch, Plains, Georgia.



FISHING, TACKLE, LURES

FREE . . . Wholesale catalog. Beads, Spinners, Lure parts, Sinkers molds, Jigs, Reels, Finny sports (ME), Toledo, Ohio 43614.

MOLDS For fisherman's sinkers, jigs, squids, casting and spinning lures. Free catalog. Sweet's Molds, Tonawanda 1, New York.

FISHERMAN'S Dream book free! 170 pages. Sweetest pocket size catalog ever! Do-it-yourself stuff galore: for making nets, turtle traps, landing nets, rods, lures, sinkers, plastic worms, flies, fish smoking rig. Here's everything including latest rods, reel 'n' gadgets. Send card: Netcraft Co., Dept. PMM, Box 5510, Toledo, Ohio 43613.

MOLDS For casting your own fishing sinkers. Free illustrated booklet. Reading Instrument Co., Box PM78, Reading, Penna.

EARTHWORMS, LIVE BAIT

RED Wigglers: Select breeders or fishing size \$3.50—1,000; \$14.25—5,000; bed-run \$9.95—10,000. Postpaid. Free folder "Growing Fishbait." Fain's Bait Farm, Box 56C, Edison, Georgia.

EARN Money raising fishworms for us! Exciting details free! Oakhaven—56, Cedar Hill, Texas.

HYBRID Redworms 1,000—\$3.00, 2,000—\$5.00, 5,000—\$8.00, 10,000—\$14.00. Bedruns 20,000—\$20.00. Postpaid with raising instructions. Brazos Bait Farms, Route 9, Waco, Tex.

MEN!—Women! Make money raising Bait for us at home. Wigglers, Warsaw 45, Indiana 46580.

REDWORMS. Tough, lively, handpicked. 2500—\$5.00, 5000—\$8.50, 10,000—\$15.00. Postpaid. Live count guaranteed. Hall Farm, Hilton, Georgia 31758.

BIG Profits Raising Redworms, Crawlers—Soilless method. Three Oaks Ranch, Dresden, Tenn.

AMAZING Profits in worms. Free information. Hillaire Worm Farms, Northville, Mich.

SUCCESS For you! Raise fishworms and crickets. Write for free literature and our success story in Life Magazine. Let us teach you our secrets of success. Hybrid redworms 3000, \$5.95. Carter Redworms, Plains, Georgia.

FROGS, FISH, REPTILES

FROG Raising. Young frogs and giant breeders. Stock your lakes, pond. Nu-Tex Frog Farm, Box 4029, Corpus Christi, Texas.



HUNTING, GUNS, DECOYS

ANTIQUE & modern military arms and equipment, largest selection of military goods in the East . . . guns, swords, edged weapons, hats, helmets, insignia, uniforms, books, medals and accoutrements. Large, fully illustrated Catalog—\$1.00. ZM Military Research Co., Inc., Dept. PM, 80 Nassau St., New York, N.Y. 10038.

SHOTGUN Owners improve your score, bag more game with amazing optical gun-sight. Free details. Nydar, Box 45-216, Glenview, Illinois 60025.



DOGS AND KENNELS

TELL The more than 1,400,000 avid readers of Popular Mechanics about your products and services. It costs very little to place your classified message in front of these proven mail order buyers. For further details, write: C. A. Martin, Dept. 14N, Popular Mechanics, 575 Lexington Avenue, New York, New York 10022.



GAME BIRDS

BOBWHITE Quail eggs. Breeders. State inspected. Hickman, Box 4711, Memphis, Tennessee 38104.

RABBITS—FUR BEARING ANIMALS

RAISE Rabbits successfully by knowing facts. 48 page illustrated book describing 25 breeds. Housing, breeding, feeding, markets, marketing etc. 25 cents. American Rabbit Association, 36 Arba Building, Pittsburgh, Penn.

RAISE Rabbits on \$500 month plan. Free details. White's Rabbitry, Mt. Vernon, Ohio.

MINK Raising information free. Lake Superior Mink Farm, Inc., Superior EE1, Wisconsin.

EARN \$10,000 Yearly raising Angora rabbit wool for us. Information 25¢ coin. American Angora Company, Malta 12, Montana.

PETS—BIRDS, CATS, HAMSTERS, ETC.

LIVE Seahorses, marine specimens, aquarium supplies. Illustrated catalog 15¢. Marine, Box 248-110, Dania, Florida.

MAKE Money raising chinchillas, mink, rabbits, cavies for us. Free catalog. Keeney Brothers, New Freedom 2, Penna.

PETS. Hamsters, mice, monkeys, squirrels, chipmunks, guinea pigs, skunks, raccoons. Picture catalog twenty-five cents. Moore's Hamster Ranch, Shepherdstown 25, West Virginia.

HAWKS, Reptiles, raccoons, skunks, squirrels. Catalogue 25¢. Trails End Zoo, St. Stephens, S.C.

CAMPING EQUIPMENT AND TENTS

CAMPING Equipment, tents, sleeping bags, air mattresses, packs, trailer awnings, dining canopies, axes, knives, lanterns, stoves, refrigerators, compact camp furniture, dehydrated food, toilets, nested cook sets, poles, stakes. Every camping accessory imaginable. Free 100 page catalog. Morsan, 810R Route 17, Paramus, New Jersey.

TRAVEL AND RESORTS

TELL The more than 1,400,000 avid readers of Popular Mechanics about your hotels, lodges and travel services. It costs very little to place your classified message in front of these hunters, fishermen, vacationers. For further details, write: C. A. Martin, Dept. 19N, Popular Mechanics, 575 Lexington Avenue, New York, New York 10022.

ELECTRICAL SUPPLIES

METERS—Surplus, new, used, panel and portable. Send for list. Hanchett, Box 5577, Riverside, Calif.

LAMP. Electrical parts, wholesale. Thousands of items for repairing, converting. Catalog 35¢. Brown Lamp, Box 305, Clayton 5, Missouri.

LAMP—Appliance parts. Wholesale catalogue, 25¢. SECO, 112 South 20th Street, Birmingham, Alabama 35233.

NEW Variable speed control unit for A.C.-D.C. motors up to 7½ amphs. \$12.95. No C.O.D. Brochure, 10¢. Bagomatic, 5518 West Pico Blvd., Los Angeles, California 90019.

LAMP Parts. Catalog, prices, wiring instructions, 50¢. Refunded first order. Gyro, 5208P N.W. 35 Ave., Miami 42, Fla.

BATTERIES, GENERATORS

BATTERY Reconditioning kit, includes molds, material, complete instructions. The Battery Shop, P.O. Box 416, Palm Desert, Calif.

DOUBLE And strengthen life auto, truck, golf car batteries guaranteed. A. & G. Equipment Co., Mayville, Wis.

NICKEL Cadmium storage battery cells, many sizes—low prices. Rockey, Box 25017, Los Angeles 90025.

ILLUSTRATED! Battery rebuilding manual (a real one, not just a few sheets) \$3.00. Supply catalog 25¢. Battery charger repair manual \$2.00. All \$5.00 postpaid. Complete line battery rebuilding and manufacturing equipment including plates. Capital Battery Equipment, Box 7154, Montgomery, Alabama.

COMPLETE Rebuilding Manuals! Batteries \$3.00. Hydraulic jacks \$3.00. C.O.D. accepted. Bayer Publications, 938 Betty Avenue, Neenah, Wisconsin.

ENGINES, MOTORS, DYNAMOS

WINDING Data. 275 motors, single and three phase \$1.10. Data Company, 512 Kensington, Kansas City 24, Mo.

REWIND Motors yourself. Complete instructions. \$1.00. Lewis Manufacturing, Howell, Michigan.

DIESEL Injector parts and fuel pumps wanted. GM51-53-71-110. Bares, 2093 East 19 Street, Cleveland 15, Ohio.

REWIND Electric motors! Details free! Modern, Box 10025, Kansas City, Mo. 64111.

MACHINERY, TOOLS AND SUPPLIES

"SMALL Shop Supplies." Production—hobby. Machinist Tools, 1424 Barclay, Springfield, Ohio 45505.

STANLEY, Millers Falls, Skil, Distant, Wiss, Plumb, Channellock, Bonney, Herbrand, Ridgid, and hundreds of other nationally advertised brands at prices hard to beat. Send 25¢ for our big tool catalog today! Silvo Hardware, 107PM Walnut, Phila. 6, Penna.

BUILDERS! Make rafter cutting easy! Free information. Emmert Products, Sycamore, Illinois 60178.

BRONZE, Aluminum foundries, 5 sizes. Free information. Pyramid Products, Box 65, Fayetteville, Arkansas.

PAT. 3191.471 Lathe toolholder. Does everything. Box 387, Benicia, Calif.

FACTORY Prices! Brand new, first quality, fully guaranteed saw chain low as \$10.00; hardnose bars from, \$14.00. Big savings on parts, accessories for all makes of chain saws. Free catalog. Zip-Penn, Box 179NB, Erie, Pennsylvania 16512.

WELDING, SOLDERING, PLATING

WELDERS, 150 Amperes. \$49.50. Paul Morris, 1070 Inner, Schenectady, N.Y. 12303.

ACETYLENE Welding outfits new \$69.50; used \$50.00; Arcwelders \$69.50. Eagle Welding, Dept. P.M. 5085 Broadway, Chicago, Illinois 60640.

CHROME Plating equipment, supplies. All other finishes. Home workshop and production sizes. Send \$1.00 (refundable) for formulas, operating data, equipment guide and catalog. HBS Equipment Division L50, 3543 East 16th, Los Angeles, Calif. 90023.

GOVERNMENT SURPLUS

JEEPS \$53.90—Trucks, airplanes, thousands of other bargains selling at a fraction of their original costs to the taxpayer. For complete information on how to buy, and new 1966 sales directory, send only \$1.00 to U.S. Surplus, Box PM 92, Keego Harbor, Michigan.

JEEPS Have sold low as \$53.90 from U.S. Surplus. Bidders information and our over 400 item (order by mail) Surplus catalog, \$1.00. Quality Surplus, 422 (PM-1) Washington Building, Washington, D.C.

JEEPS \$62.50, autos, boats, thousands others available used direct from Government! Free exciting details! Global, Box 18216-PL, Indianapolis, Indiana 46218.

CHEEP Jeeps. Buy from Gov't. Full information, 25¢. Box 789PMTF, York, Penna.

WAR Surplus catalogue, generators, pumps, gearboxes, hydraulics, winches, motors, 25¢ stamps or coin. Trader, Box 8PMTF, Thomasville, Penna.

JEEPS—Jeeps—Jeeps. Direct from Government. Directory and our over 400 item (order by mail) surplus catalog, \$1.00. Quality Surplus, Dept. PM-1, 2546 W. Michigan, Indianapolis, Indiana.

JEEPS From \$53.90, trucks from \$78.40, boats, typewriters, airplanes, sporting equipment, 100,000 Bargains, as is, direct from Government in your area. Complete sales directory and surplus catalog, \$1.00. Deductible first \$10.00 order. Surplus Service, Box 820-A, Holland, Michigan.

GOVERNMENT Lands . . . low as \$1.00 acre. Millions acres! For exclusive copyrighted report . . . plus "Land Opportunity Digest" listing lands available throughout U.S., send \$1.00. Satisfaction guaranteed! Land Disposal, 2230-RM Wisconsin Avenue, Washington, D.C. 20007.

GOVERNMENT Surplus. Complete sales directory \$1.00. Surplus Publications, Box 45781, Los Angeles 45, California.

GOV'T. Surplus. How and where to buy in your area. Send \$1.00. Surplus Information, Headquarters Building, P.M., Washington 6, D.C.

HOBBIES AND COLLECTIONS

AMERICAN Newspaper, complete, original, dated before 1880, \$1.50, 25¢ stamps brings catalogue, D. R. Spaight, Bookseller Tall Timbers 1, Maryland 20690.

50 JUNGLE butterflies \$2.00. Giant nature hobbies catalog 25¢. Collectors Wonderland, Box 1170, New York 8.

HOBBYIST—Get the new precision lathe converter. To mill, shape, plane, drill, etc. Send for free literature. 50 North Erie, Hamilton, Ohio.

EUROPEAN Railway and streetcar photographs, slides. Send stamp for listing. Antar, 270 Fenway Drive, Syracuse, New York 13224.

MATCHBOOK Covers—110 unused, all different, \$1.00. List 10¢. Harold Hamilton, 7150 South Cyril, Chicago, Illinois 60649.

INTRODUCTORY Five military emblems and illustrated catalog, 25¢; Foreign Medal, 50¢; 10 Military decals 25¢. Hobbies, Box 71-S, Rockaway 94, New York.

STAMP COLLECTING

U.S. Bargain, 50 different 10¢, with beautiful worldwide approvals. Stamps, Kennebunk, Maine.

40,000 DIFFERENT. Amazing new plan builds your collection systematically, country by country. As low as 50¢ weekly. Ware, Monroe 75, Conn.

MILLION Foreign stamps! 2¢ each! Send for thrilling, giant approvals! ABC Stamps, Box 6000-MB, San Francisco 1, Calif.

FREE Surprise collection sent with approvals. Gould, 1784 Union, San Francisco 94123.

25 DIFFERENT United States Commemoratives 1893 up 10¢. Approvals, K&B Stamp Company, Box 70, Brooklyn 23, New York.

105 DIFFERENT U.S. Stamps, 25¢, approvals included. Shelton, Box 187, Hempstead, N.Y.

BREATHTAKING, 50 Mint Monaco pictorials, multicolors. \$1.00. Approvals. Stamp Exchange, Box 103, Fairfield, California.

50 YEARS Old, fifteen different United States, over fifty years old—10¢ with approvals. Jaxon, Box 145-P, Brooklyn, New York 11230.

PENNY Foreign stamps neatly mounted in jumbo books in Scott order. Bullot Approval, 1454 Coney Is. Ave., Brooklyn 30, New York.

"INVERTED Error." Dag Hammarskjöld 5¢ with Approvals. Belmont Stamps, Washington, D. C. 20015.

RUSSIAN Space set 10¢. Russian approvals. Snedco, Box 68-P, Waldwick, N.J.

50 DIFFERENT Old U.S. Revenue stamps 50¢. Winchester stamps, Box 1592, Mansfield, Ohio 44907.

PIPEX, Tipex, Cipex, Ashville. Four miniature sheets used for \$1.00 if you ask for our bargain priced U.S. approvals. Triboro, 38 Park Row, New York, New York 10038.

133 DIFFERENT Colorful stamps 10¢, approvals. Krehl, 1708 Nebraska, Orlando, Florida.

FREE! Congo triangle set! Boy Scout beauty! 25 others, different. Approvals. Cambridge, Box 411, Cambridge, Ohio.

100 OLD United States between 1861 and 1935, \$1.00. Roush Stamps, 51 Chestnut, Mansfield, Ohio.

225 STAMPS For only 10¢! This mammoth value includes airmails, pictorials; stamps from strange countries cataloging up to 25¢ each! Also approvals. Mystic Stamp Company, Camden 80, New York.

SELL Your surplus good grade stamps. Write, describing fully what you have. Vanroy Shirk, Lebanon, Pennsylvania.

500 DIFFERENT Stamps, \$1.00. Smith, 508-A Brooks, College Station, Texas.

PENNY Stamps! 1000 Mounted in book at 1¢ each. Trust Stamp Company, P.O.B. 132-P, Jamaica, N.Y. 11435.

ONE Pound value Geo. VI Bermuda, plus 100 worldwide 10¢, approvals. Stevens, Box 105A, Homecrest Sta., Brooklyn 29, N.Y.

60 DIFFERENT U.S. (30 commemoratives) 25¢. No approvals. Seidenberg, Salem 169, Oregon.

ABSOLUTELY Free 50 worldwide. Request inexpensive approvals. University Stamps, P.O. Box 326, Pompano Beach, Florida 33061.

AMAZING OFFER! 200 United States stamps—including commemoratives, airmails, high denominations to \$1.00. Only 10¢ to approval applicants! Illustrated bargain lists free. Mystic Stamp Co., Dept. 80, Camden, New York.

PENNY! Approvals! Regardless catalogue! Kloster, 4164 52nd St., San Diego 5, Calif.

163 WORLDWIDE, 10¢. Also approvals. Siegel, Box 92-PM, Brooklyn 18, N.Y.

64 PAGE U.S. and U.N. catalog free. Stone, 260 Washington, Boston 8, Mass.

FREE Stamp wallet with approvals. Wide selection collections by countries. Clark, Box 28-C, Wilmette, Illinois.

FREE Sample. Interesting, illustrated, informative National Stamp News, Anderson, South Carolina 29622.

INTRODUCING Our better United States approvals we offer 15 United States stamps including Columbian, Bi-Centennials, famous American, airs, others; only 10¢. Ocean Stamps, Box 64-PM, Brooklyn 29, New York.

1025 DIFFERENT, \$1.30 with approvals. Klondike, 682 Jefferson, Elgin, Illinois.

FREE Monaco nudes. Approvals. Stamp Ranch, 902 Addison, Chicago 13, Ill.

10 U.S. over sixty years old, 10¢. Robert Gallup, Albany, New York 12201.

UNITED States commemorative collection containing 33 different—10¢. Approvals. White, 516-A Avenue L, Brooklyn 30, New York.

FINE Stamps! Large bargain lot, \$1. Giant Assortment, \$5. High Value Packet, \$3. Literature, coupons, free. Persile, 436 N.Y. Ave., Brooklyn 25, N.Y.

COLORFUL Set free Worldwide approvals. Gorliz, Drawer 388PM, Park Ridge, Illinois.

220 DIFFERENT U.S. commemoratives, \$1.00. Rockefeller, 40 West Market, Red Hook, N.Y. 12571.

UNITED STATES price list, 132 pages, price 30¢. Mark Hanna, 335 Fifth Ave., Pittsburgh 22, Pa.

DEFECTIVE, Old U.S., 1/3 Scott. Swarz, Box 373, Venice, Fla.

ATTRACTIVE—Mint Indonesian pictorials, plus bargain catalogue featuring U.S. stamps, packets, accessories, 10¢ with approvals. Bydahl, Box 1293-MA, Seattle, Washington 98111.

121 DIFFERENT Flag stamps free. Approvals. W-B Stamps, Wilkes-Barre, Pa.

217 DIFFERENT U.S. commemoratives \$1.00. (Limit one) Carstamps, 739 Ordway, Freeport, Illinois.

1500 FOREIGN \$1.00. 5000 \$3.00. 5000 USA—commemoratives, airmails, high values, revenues, 19th Century, etc. \$3.00. No approvals. Meyers, 5321 Fleming, Richmond, California.

U.S. MINT C7-9, C34-36 \$2.00. Cooper, Box 3751M, Oak Park, Mich. 48237.

GIANT Stamp collection including: Astronauts, Satellites, Moonrockets, Boy Scout issue, complete U.N. Set, recent Olympic and sports issues from many countries, etc. Plus big stamp dictionary and approvals. Everything, 10¢. Stampex, Box 47-RM, White Plains, N.Y.

TEN Different nudes, 20¢. Approvals. Stamp Farm, 2M6, Oxford, Wisconsin.

CANADA Sports complete, 10¢. Canada approvals. Valley Stamps, Little Valley, New York 14755.

5000 GRAB Bags! Dollar each. Satisfaction guaranteed. Catalogue. Stamps, 14980 Huntsville, Ontario, Canada.

U.S. Mint specials! Flag set, complete \$1.00. 1¢, 2¢, 3¢ famous Americans (21 different) \$1.00. Free list. Brooks, 2601 Avenue "U", Brooklyn 29, N.Y.

FREE—World's greatest premium—5000 all different stamps, actual catalogue value over \$100.00 given approval buyers. Thrifty Stamps, Grossmont, Calif. 92030.

SELECTED U.S. approvals. Brunner's, 121 Glen Moore Circle, Lancaster, Penna. 17600.

FREE Mint set. Approvals accompany. Stamps, Box 22092, Memphis, Tennessee.

10 CANADIAN Commemoratives including Seaway issue, 10¢. Approvals. Lewis Stamp Co., 360 Fundy Drive, Lancaster, New Brunswick, Canada.

CLEARANCE. Twenty different packets, 50¢. No approvals. Norge, Ho-Ho-Kus, N.J.

DEALERS—Wholesale list. Postage 5¢. Frank, 5031 Queensberry, Baltimore, Maryland 21215.

FREE 50 World wide plus Congo, Niger, Somalia, Mauritania. To approval applicants. Elkay Stamps, 210M Jewett Ave., Jersey City, N.J. 07304.

50 DIFF. U.S.A. Commemoratives, 25¢ approvals. Peter's Stamps, P.O. Box 4073, Baltimore, Md. 21222.

STAMPS Free! Ask for coupons. Large bargain lot, \$1. Persile, 436 N. Y. Ave., Brooklyn 25, N.Y.

FREE U.S. catalog. Mint #704-15, \$4.00; #740-9, \$2.00; 859-93, \$6.00; 909-21, 90¢. Simmy Co., 40 Court, Boston, Mass.

OLD Scarce U.S. seconds on approvals. Slight imperfections, lowest prices. Hernefield, Box 318, Irvington, N.J. 07111.

WILL Rogers air! Helicopter triangle! Plus Monte Carlo dove triangle! Stamp printed in solid gold! New York Empire State Bldg., airmail, lovely Congo orchids in full color, etc. 10¢ with approvals. Sunny Stamps, Fruitport 2A, Michigan.

U.S. \$\$ Stamps free! Columbus issue. Pony Express, Antarctic Territory, Beatles, Togo Kennedy, etc. Send 10¢ for mailing. Empire Stamp Corp., Dept. PM, Toronto, Canada.

FANTASTIC Hippo, deer triangles. Valuable "Ben Franklin" on Canal Zone! Flaming bi-colored volcano triangle! Lovely Olympics triangle! Plus icy Greenland, weird wild beast issue and others. 10¢ with approvals. Roseland Stamps, Spring Lake 2, Michigan.

STAMP Collecting outfit, includes worldwide stamps, nine triangles, two diamonds, New African Nations, Topicals, package hinges, millimeter-perforation gauge. Everything, 25¢ with approvals. Lorraine Brown, Marion, Michigan 49665.

U.S. STAMPS. Giant bargain catalog, 25¢. Raymax, 35-VZ Maiden Lane, NYC 38.

FREE—Mint British Colonials from Antarctic Territory, Borneo, Brunel, St. Christopher, Nevis, Caymans, Trengganu, Pitcairns. Free with approvals. Viking, Great Neck 8, N.Y.

WOW! 110 All different Germany 10¢ Commemoratives, Airmails, high values. Big catalog, bargain lists plus selections of fine stamps from our approval service, returnable without obligation. Jamestown Stamp, Dept. A16PM, Jamestown, N.Y. 14701.

FREE! Big bargain catalog—new edition listing thousands of bargains including U.S. & B.N.A. stamps, packets, albums, accessories and supplies. Plus selections of fine stamps from our approval service, returnable without obligation. Jamestown Stamp, Dept. E16PM, Jamestown, N.Y. 14701.

FREE—Mammoth collection, \$10,000 Airmail, world's smallest stamp, Scott's International Master Global Albums given approval buyers. Bargain Stamps, Tustin, California.

FREE! Surprise "Mystery" packet. Approvals. Premiums. Dancer, 75-P61, Mansfield, Ohio.

230 DIFFERENT U.S. commemoratives, \$1.00 approvals. H. Holub, 18 East 198th Street, Bronx, N.Y. 10468.

BARGAIN Approvals, highest quality. J. R. Baker, Stamp Approvals, Box 748, Santa Barbara, California.

"ERROR"—1935 United States Farley, 10¢ with approvals. Potomac Stamps, Washington, D.C. 20015.

315 DIFFERENT Worldwide stamps, including multi-color John F. Kennedy Memorial issue of Columbia, Russian space set, Communist propaganda, rockets, colorful big pictorials, high values, air mails, etc. Only 25¢. Other attractive stamps for sale on approval included. Capital Enterprises, P.O. Box 1914-PMA, Washington, D.C. 20013.

50 DIFFERENT U.S. commemoratives 10¢. Approvals. Gordon Davison, Henniker, New Hamp.

STAMP Finder and dictionary (32 pages), 10¢ to approval applicants. Capital Stamps, 2F, Ferrysburg, Mich. 49409.

SENSATIONAL Offer! Forty different packets only \$1.00. Norge, Ho-Ho-Kus, N.J.

KENNEDY Memorial 1st day cover. Valuable collector's item: Official first day issue of the John Fitzgerald Kennedy Memorial postage stamp mounted on commemorative envelope bearing portrait of famous President. Postmarked with highly-prized first day cancellation! Also, to introduce you to World's most rewarding hobby: Complete set of 36 U.S. Presidents. "How To Collect" booklet, and new JFK stamp offers just released. Send only 25¢. We'll include selections of fine stamps from our approval service returnable without obligation—plus free collector's catalog! Kenmore, Milford KP, New Hamp.

FREE. Commemoratives, pictorials with approvals. Wisehart, Dept. 10, 3105 West Broad, Columbus, Ohio 43204.

SPECIAL—1500 Worldwide \$1.00. (Mixture list 25¢.) Steele, Box 242-PL, Colorado Springs, Colorado 80901.

225 WORLDWIDE Including triangles, commemoratives, pictorials, 10¢. Approvals. Kata, 130-12 232nd Street, Laurelton, New York 11413.

JFK, Churchill, Pope, Lincoln, Roosevelt sets, 10¢. Approvals. Postmark, Great Neck 15, N.Y.

100 DIFFERENT Free! 1/4¢ Upwards British Commonwealth or world approvals. Bush, Newlyn Way, Poole, England.

TRADE Your duplicates! (Toward foreign approvals.) Complete information 10¢. VSS, Box 98-P, Newton Highlands, Mass. 02161.

500 FINE Mixed U.S. 15¢. Wright, Box 753-M, Hagerstown, Maryland.

TERRIFIC Collection seven complete sets, 10¢ with approvals. Beatties, Box 16052, Tampa, Fla.

FREE! 25 Egypt, 10¢ handling. Approvals. Bellet, Mapledale, Hazel Park, Michigan 48030.

U.S. Approvals. Low prices. Eagle, 2221 Romine Ave., Pittsburgh 26, Pa.

100 DIFFERENT Canada, 25¢ with approvals. Riverside Stamps, Box 1044, Riverside, California.

WORLDWIDE Pictorial's approvals with 5 sets mint stamps, only 20¢. Wald Stamps, 3747 West Belmont Avenue, Phoenix, Arizona 85021.

PRESIDENT Kennedy, Winston Churchill, Eleanor Roosevelt, Pope Paul stamps, 10¢. Approvals. Miller, Box 600F, Palo Alto, California.

FRENCH Colonies—20 different colorful stamps—includes animals, sports, 4 triangles, diamonds. Only 5¢ with approvals. Moulblow, 19F Cedarhill, East Northport, New York 11731.

SUPERB Approvals plus gift set, Broad Stamps, P.O. Box 866, Lexington, Kentucky 40501.

20 DIFFERENT Triangles 25¢; without approvals. Picture Stamps, Box 46193, Hollywood, California 90046.

PENNY Approvals, large selection, Premiums with purchases. Penny Stamps, Orange, California 92669.

FREE! 222 Worldwide, 25¢ handling. Penny approvals. Jung, 1601 North Stanley, Los Angeles 90046.

ISRAEL—Special value collection, 100 different Israel stamps, regular price \$3.00, yours for only \$1.00 while they last with approvals. Cornetta, P.O. Box 367, Olympia, Miami, Florida 33165.

COLLECTION Gigantic commemoratives, 10¢ approvals. Robbins, 486 Shiloh, Dayton, Ohio 45415.

12,000 PENNY Approvals waiting for you. Many from exotic countries, pictorials, airmails, new issues. Tilbury, Box 862, Newark 1, N.J.

FREE 20 different U.S. with approvals. Collier, Box 265, Chamblee, Ga. 30005.

PARAGUAY'S "John Fitzgerald Kennedy Memorials" with PT109, Jacqueline, Caroline, John-John—free! Approvals. William Deems, 226a Race, Ravenswood, West Virginia 26164.

SENSATIONAL Offer. Sixty different packets only \$2.00. Norge, Ho-Ho-Kus, N.J.

CHINA, 25 Different 10¢, to buyers our foreign approvals. West Coast, Dept. "C", 1609 South Park, Santa Ana, California.

GERMAN Commemoratives, 10¢ with approvals. Schaefer, Box 1704, Washington 13, D. C.

FREE 50 Turkey, 25 Persia plus Kennedy Memorial, 10¢ handling. Approvals. Berchtold Stamps, Troy, Ohio.

GERMANY 100 Different, 5¢ Approvals. Hijop, Box 505, Norristown, Pa. 19404.

THOUSANDS Of worldwide sets and singles on approval. Highest quality! Cole, Box 223A, Buffalo, N.Y. 14221.

COINS, TOKENS, CURRENCY

10 DIFFERENT Indian cents \$2.25. Hutchinson's, Box T-6256, Philadelphia, Penna. 19136.

RARE Silver Dollars, 1879, 80, 81 S mint \$3.00 ea. Uncirculated. New Catalogue, 50¢; Shultz, Salt Lake, Utah 84110.

25 BEAUTIFUL Coins from 25 countries. Mostly uncirculated. Terrific assortment. \$1.00 Hindley, Box 708, Aurora, Illinois. 60507

TWENTY Page 1965 retail price list of USA and Canadian coins 10¢. Our retail selling prices on thousands of coins and coin collectors supplies. Bryson Incorporated, 612A White, Toledo 5, Ohio.

LARGEST Coin magazine, 288 pages, 50¢. Scrapbook, 7320-J Milwaukee, Chicago 31.

40 PAGE Illustrated United States and Canadian coin list 10¢. Stoney, 260 Washington, Boston 8, Mass.

FREE Price list, or add 15¢ postage for free coin album. Suburban Coin, 607-G Mesquite, Corpus Christi, Texas.

LINCOLNS: 22 Different "S" including rare 1955S, \$1.60. 28 different before 1940, plus odd 1960D small date, \$1.60. 10 different "S" Jefferson nickels, \$1.60. All three \$4.50. Harris, Box 1147-P, Oceanside, California.

COIN Date guaranteed. Restores dates on worn nickels, \$1.00 bottle. Box 276F, Mooreville, N.C.

1966 CATALOG Now ready. 50¢ with refunding certificate. Hobby Sales, St. Paul, Minnesota 55116.

FREE Coin supplies! Giant coin list 10¢ (refundable). Economy Sales, Mansfield, Massachusetts.

GENERAL MacArthur Philippine set \$6.65, large dollar bill, \$6.95; new, \$14.75. World's greatest bargain catalogue, \$1.00. Beebe's, Inc., 4514 North 30th, Omaha, Nebr. 68111.

TRUNKFUL 25,000 Indian-Lincoln cents mixed (from the 1920's & older). Grab-bag style. 400 mixed, \$25.00. Sample bag of 20, \$2.00. Mrs. Fischer, Box 5490, Sherman Oaks 1, California.

TOPS! Free illustrated booklet, "How to collect coins." Plus large illustrated catalog. Approvals, Littleton Coin Co., Littleton El, N.H.

SILVER Dollar \$1.85; 2¢ copper \$2.00; 3¢ nickel \$2.25; large cent \$2.00; 1/2-dime \$2.25; All five \$9.95. Fairway 121-P Rye, New York.

COIN Collectors! New scientific instrument detects buried coins, gold, silver, treasures, \$19.95 up. Free catalog. Reico-F40, Box 10563, Houston 18, Texas.

HIGHEST Prices paid immediately for coins. Send 10¢ for 1966 buying prices. Wilmot's, 1067-F Bridge St., Grand Rapids, Mich., 49504.

FREE Coins for collectors! Long list and information only 25¢. Gene Carlton, Chandler, Okla. 74834.

BUYING Old coins, tokens, etc., send insured. Lowar Company, Box 134, Marinette, Wis. 54143.

10 DIFFERENT Indian cents better grade, \$3.00; 20 different Indians special, \$10.00. Gregory, P.O. Box 156, Petoskey, Mich.

50¢ CALIFORNIA Gold pieces 1849-1858; 75¢ each, seven different \$4.00. 1878-1904 silver dollars \$1.75; uncirculated \$2.50, ten assorted \$23.00. Metropolitan Coins, 497 W. Lantz, Detroit, Michigan 48203.

NEW Zealand coins. Florin, shilling, and sixpence. Three coins uncirculated \$1.50. Post free. Martain, Box 5804, Auckland CI, New Zealand.

CIVIL War specials: 1863 cent, \$1.75; 1863 civil war token, \$1.75; 1864 genuine confederate states of America \$10.00 bill, \$2.00. All three \$5.00. Rarcoa, 31 North Clark, Chicago 60602.

ANTIQUES, RELICS, INDIAN GOODS AND CURIOS

TONS Of antique gun parts and supplies. All reproduction muzzle loading guns. Send \$1.00 for enlarged illustrated catalog No. 115. Dixie Gun Works, Union City 12, Tennessee.

ANTIQUES! Monthly magazine. Sample 25¢ or free circular. Antiques Journal, Uniontown, Penna. 15401.

SELLING 20,000 Ancient arrowheads, spearheads, etc. List free. Lear's, Greenwood, Arkansas.

ALLIGATOR—Gar arrowheads, Florida. Rare in collections. Ten, \$1.00. Flint arrowhead-making secret, ancient illustrated methods. Guaranteed. \$1.00. Circulars, 25¢. Blackhawk, Umatilla 16, Oregon.

ARROWHEADS, 10 for \$3.00. List free. Hyde's, Box 1788, Santa Fe, New Mexico.

MODELS—SHIPS, TRAINS, PLANES, ETC.

SHIP Model kits and fittings: clippers, frigates, etc. Catalog paint-tool list, book list, 35¢. Model Shipways, Box 85, Bogota, N.J.

SHIP and yacht model fittings; Pine construction hull kits; blueprints. Send 50¢ for illustrated catalog. A. J. Fisher, Inc., 1002 Etowah Avenue, Royal Oak, Michigan 48067.

SHIP Models, Kits, fittings, plans, books, tools, engines, motors. Big illustrated catalog, 50¢. James Bliss & Co., Dept. SM, Route 128, Dedham, Mass. 02026.

STEAM Engines for operating toys and models. Free catalogue. O'Connor, Box 775, Baker, Oregon.

SLOT Racers! Trains! 25¢ brings 32 page bargain catalogue. Thousands of Lionel, Gilbert, Varney, Strombecker, Eldon, Aurora, Scalextrix, Revell, etc. Trains, all gauges, racers all sizes. Hobby Surplus, P.O. Box 1106M, New Britain, Conn.

BUILDING Materials, 1/4" & 1/8" scale, windows, doors, siding, roofing, lumber and structural shapes. Send 35¢ for catalog with samples. Small Sales Co., 6035 Martway, Mission, Kansas 66202.

AUTHENTIC Civil War cannon plans. Complete with two barrels, caisson & limber. Eleven pages card stock. Instructions, \$6.00. Satisfaction guaranteed. Valor Plans, 4032 N. Kostner, Chicago, Ill. 60641.

CUT-Away-village—complete village, 26 buildings to cut out and put together. Colorful, entertaining, educational. Approx. H.O. gauge, \$1.00. Write: Robert Kunkel, 13855 Northline, Southgate, Mich.

LIVE Steam and gasoline model engine kits, fascinating hobby for model mechanics. Boilers, fittings, accessories. Pictured catalog, 50¢. H.P.K. Models, Box 34, Centuck Station T, Yonkers, New York.

ROCKETS: New illustrated catalog 25¢. Single and multistage kits, cones, engines, launchers, trackers, technical information, etc. Fast service. Estes Industries, Penrose 2, Colorado.

GAMES, TOYS, NOVELTIES

GAMES Inventors! We are interested in new and novel child and adult game ideas. Nationally-known game manufacturing and marketing firm. Send for details. Hagglund and Associates Research, Dept. A, 650 Ottawa Ave. N., Minneapolis 22, Minnesota.

MAGIC TRICKS, PUZZLES, JOKER NOVELTIES

NEW Edition, 1965 catalog, 500 tricks, only 10¢. Fastest same-day service to magicians for 40 years. Send 10¢ today. Douglas Magicland, Dept. 21, Dallas, Tex.

COMPLETELY Illustrated catalog, 84 pages, 25¢. Manhattan Magic, Box 334-M, N.Y.C. 11.

MAGIC Catalog! World's finest, 3000 tricks (408 pages) \$2.50. Beginners amateurs, professionals. Kanter's, A-200 South 13th St., Philadelphia, Pa. 19107.

WORLD'S Finest professional magic tricks, Joker's Novelties, Giant illustrated catalog 10¢. Top Hat, Evanston, Illinois.

FREE Bargain magic lists, Wisheart's, 3105 West Broad Street, Columbus, Ohio 43204.

OPPORTUNITY—Novelty bargain mail, 25¢. Mitchell, Box 1686, San Angelo, Texas 76902.

FUN'n Magic catalog, 10¢. (1,500,399 tricks, jokes, novelties, puzzles, disguises). Elbee, 7408-P, San Antonio, Texas 78207.

BE A magician! Two booklets explaining sixty-eight tricks plus large professional catalog \$1.00. Magic, Inc., 5082 Lincoln, Chicago, Illinois 60625.

164 PAGE Giant surprise catalog! Over 1000 tricks, professional magic, jokers!! World's greatest! 800 pictures! Special only 10¢. Vick Lawton's Magic, Dept. PM6, Northeast Fifth Ave., Ft. Lauderdale, Florida 33308.

PROFESSIONAL Catalog, 175 pages, 25¢. Williams, 900 Plymouth, Ellwood City, Penna.

GIANT Magic Catalog and free trick only 10¢. Write today. Mailmart, M1265, Box 616, White Plains, N.Y. 10602.

BOOKS, PERIODICALS

PROPHET Elijah coming before Christ. Wonderful book free. E. Megiddo Mission, Rochester, New York 14619.

BOOKFINDERS! All subjects. Send wants! Sydney Jaher, 175-45 88 Ave., Jamaica, N.Y. 11432.

FREE Catalog unusual books. Murry Company, Dept. 365, 3000 Truman, Kansas City, Mo. 64127.

BOOKS, Free general catalog, 60 pages. Text, vocational, educational, instructional subjects. Millions of volumes, new and used. Bargain prices. Books bought. Est. 1902. Long's College Book Co., Dept. PM, Columbus 1, Ohio.

OUT-Of-print books at lowest prices! You name it, we find it! Fast service. No obligation. International Bookfinders, Box 3003-PM, Beverly Hills, Calif.

BOOKLOVERS, Seekers—subscription, \$1.00. Ivory Tower Journal, 444-M, Fort Lee, N.J. 07024.

CHALLENGING! Different! Unusual books! Free catalog, Ruby's, D-26, Paradise, Pennsylvania 17562.

PAPERBACKS, Lafayette Hill, Pa. 19444. Catalog 5¢. Paperback books, records, tapes, stationery.

NOW Available, booklet, "God's Holy Word," \$1.00. Bremen Church, Chester, Illinois.

NEW Books, 35¢ up. Free catalogue. Postal Books, 2217 Lackland, St. Louis, Missouri 63114.

FREE Catalog. Self-help books, O'Keefe, Box 207, Hauppauge, New York 11788.

BOOKS. All subjects. Free catalogs. F & E Specialties, Fenton, Michigan 48430.

FREE Catalog. Self-help books. Write Wilshire, 8721 Sunset, Los Angeles 69P.

PLAYS, STORIES, MANUSCRIPTS

WANTED Writers! Short stories, articles, books, plays, poetry. Will help place, sell your work. Write today, free particulars! Literary Agent Mead, Dept. 20A, 915 Broadway, New York 10, N.Y.

WANT Your book published? Learn how we publish, advertise, promote, distribute. Many successes. Free booklet PM, Vantage, 120 West 31, New York City.

BUSINESS OPPORTUNITIES

SPARE Time earnings. With your table-saw, bandsaw or jigsaw. Write: Workshop, A3800 Harney, Vancouver, Washington 98660.

SELL Advertising book matches. Write us today; we put you in business by return mail, handling complete line ad book matches in demand by every business right in your town! No investment; everything furnished free! Top commissions daily! Superior Match, Dept. MX-166, 7530 S. Greenwood, Chicago 19, Ill.

SIMPLE, Pleasant, mailorder can net \$12,000 year. Write Rutward, 2610 Bryant, Columbia Station, Ohio.

BAKE New greaseless doughnuts in kitchen. Stores buy output. Start spare time. Profit 29¢ dozen. Small appliance. Free recipes. Montgomery, 3605 South 15th, Minneapolis 7, Minnesota.

FREE "Franchise Profit Letter" tells how unique NFR service is helping thousands seeking profitable businesses. Write today. National Franchise Reports, W-528, 333 North Michigan, Chicago 1.

PACKAGE At home for profit! We supply everything. No "selling." Free home business details. HPC 807HPG, Sunset, Los Angeles 12.

FREE Facts and descriptive bulletin. Be an air conditioning, refrigeration, and heating serviceman. High pay, jobs open everywhere, operate your own service business, no school or correspondence necessary. Write Doolco, Trouble Shooter, 2016 Canton, Dallas, Texas.

\$70.00 WEEKLY—home, spare time. Simplified mail bookkeeping. Immediate income, easy. Auditax, 34741a, Los Angeles 90034.

MAKE \$46 From square foot plywood; jigsaw necessary. Free details. Woodart, Bridgewater, Mass.

Write: Oakhaven-38, Cedar Hill, Texas.

IMPORT-Export opportunity, profitable world-wide, mailorder business from home, without capital; or travel abroad. We ship proven plan, for no risk examination. Experience unnecessary. Free details. Mellinger, X701, Los Angeles 90025.

PIANO Tuning learned quickly at home. Tremendous field! Musical knowledge unnecessary. Information free. Empire School of Piano Tuning, Box 327, Shenandoah Station, Miami, Florida 33145. (Founded 1935).

400,000 BARGAINS below wholesale! Many free. Liquidations, job lots, single samples. Free details. Bargainhunters Opportunities, Box 730-A, Holland, Michigan.

MAKE Money from old tires. Operators clearing \$400 weekly. Equipment costs \$800. Get facts. S & S Patents, Inc., 3511 N. Lincoln, Chicago 13.

READ Progressive Mailtrade, the magazine that tells how to make money by mail. Quarter brings sample and special offer. Mailtrade, P.O. Box 357, Sheboygan, Wis. 53082.

COPUBLISH "Mail Sale Advertiser," leading mailorder paper. Copy and details 25¢. Vanroy Shirk, Lebanon, Pa. 17042.

MAILORDER Catalogs. No inventory required. Discounts 40% up, postpaid. Send 25¢ for 32 page sample catalog, featuring 150 unusual, fast-moving products and complete details. Satisfaction guaranteed. Gaylords, North Adams 7, Mass.

BIG Money raising fishworms and crickets. Free literature. Carter Farms, Plains, Georgia.

\$400.00 MONTHLY Raising giant fishworms. Soilless method. Charlie Morgan, Bushnell, Florida.

COLORGLAZED Concrete pottery made without molds. Patented method. Cemetery products, novelties, tiles. Basement leak-sealing. Money-making projects. Booklet, details free. Men only. National Potteries Company, Grand Rapids, Minnesota.

PROFITABLE Catalog Mailorder Business! Vikari's, 835-PM, First Avenue, Salt Lake City, Utah 84103.

START Your own business on credit. Your own boss. Hundreds of dealers making \$100 to \$300 and more weekly. We supply stocks, equipment on credit. 300 home necessities. Sales experience unnecessary. Pleasant, profitable business backed by world-wide industry. Write Rawleigh, Dept. A-U-PPM, Freeport, Ill.

PLASTERCRAFT Molds, liquid rubber, plasters, flocks, candle supplies. Catalog and manual free. Blue Rapids Supply, Blue Rapids, Kansas.

I MADE \$40,000.00 year by mailorder! Helped others make money! Start with \$10.00—Free proof. Torrey, Box 3566-Y, Oklahoma City, Oklahoma 73106.

FREE Book "990 Successful, Little-Known Businesses." Work home! Plymouth-972R, Brooklyn, New York 11217.

WANT To make big money at home? \$10.00 profit in an hour possible with invisible mending. Make tears, holes disappear from clothing, fabrics. Steady year-round demand from cleaners, laundries, homes. Details free. Fabricon, 1585 Howard, Chicago 26, Ill.

BUILD Custom cases at home for profit. Get orders by mail. We supply materials, instructions, everything. Free home business details. Customcase, 805CPG, Sunset, Los Angeles 12.

FREE Booklet! Profitable, spare-time business bronzing. PearlKoting baby shoes! Complete set-up on credit. Kiktavi, Box 34861-B, Los Angeles, California 90034.

YOUR Own home business, interesting, profitable, different. Details free. Richey, 441 East Main, Greenville, Ohio 45331.

IMPORT-Export business made easy. Complete setup service. Not just instructions. Hermes, 152 West 42, New York City 10036.

EXTRA Money making plastic signs at home, free details. Napco, Box 23485-P, Los Angeles, Calif. 90023.

stamp information. Lindbloom, 1508 West Erie, Chicago, 60622.

VENDING Machines. No selling. Operate a route of coin machines and earn amazing profits. 32-page catalogue free. Parkway Machine Corporation, 715 PMB Ensor Street, Baltimore 2, Maryland.

SELL Books by mail. 400% profit. Royal, Box 450-X, Cleveland, Ohio 44127.

FREE! 128 Page illustrated catalog. More than 2000 name Brand items; below wholesale prices. Sell full or part time. Save hundreds of dollars on purchases for yourself! Watches, jewelry, cameras, radios, phonographs, tape recorders, appliances, housewares, cookware, hardware, power tools, luggage, musical instruments, sporting goods, toys, many others. 8 floors of Name Brands. Orders shipped within 24 hours. Continuous supply. Send for free catalog now! H. B. Davis Corp., Dept. PM, 145 West 15th Street, New York, N.Y. 10011.

MAIL Multi-colored catalogs printed with your address for big profits! Details. Sample 25¢ (refundable). Specialties, Box 148, Ypsilanti, Michigan 48197.

NEWSPAPERS. Sawdust. Tin-Cans. 200 uses. Instructions. \$1.00. Charles Company, 42-GPS, Norwood, Ohio.

EARN Money at home in spare time repairing all appliances, do housewiring, motor rewinding, electrical maintenance. We show you how, send 8 trouble shooting instruments, business getting materials, etc. Write for free book. Pay later plan. Advance Trades School, Dept. E-203, 5944 Newark, Chicago 60631.

ARNOLD Palmer offers you unequalled opportunity to profit from tremendous popularity of golf and power of Palmer. Highly profitable exclusive Palmer Golf Franchises available. Complete national program. Hefty profits—minimum investment. Write for details. Arnold Palmer Enterprises, Dept. CR, Pleasantville, New Jersey. Tel. 609-646-3500.

SELL Uncle Sam! Depression proof home business buying Old Gold. Successful plan shows how. Details free. Patton, Dept. PM-16, Box 283, Arlington Heights, Illinois.

LIQUID Molding rubber, free information. Chaney's, 5415-A San Jose Blvd., Jacksonville 7, Fla.

DIFFERENT! Outstanding profits from high quality mailorder businesses. Complete setup services; not just instructions. Hermes Co., 152 West 42, New York City 10036.

CONCRETE Facts: Cement artists make big money at home. Simple equipment. Experience unnecessary. Copyrighted methods. Easy to make unlimited cement pottery designs, bird baths, wishing wells, rustic gardens, patio items, etc., without molds. Formulated, chemical coloring, marbleglazing. Free illustrated brochure. Hollywood Cementcraft, 602 Athens, Altadena, California 91001.

WE Search the World over for the unusual, so that you may have something different to sell. Details free. Chandler's, Dept. 3125, Wailuku, Hawaii 96793.

EUREKA! Mail baby catalogs to new mothers. Fabulous profits. Details, catalog, 25¢. Mail-O-Vend, 4158 Greeby St., Phila., Pa. 19135.

VACUUM Form at home! Mold plastic products for big profit. Fabulous new machineryless method. Free facts. Nationwide Plastics, Box 23321-MX, Los Angeles 90023.

WORLDWIDE Merchandise free brochure. Pat. 270 East 60th Street, Hialeah, Florida 33012.

SELL By mail. Interesting, profitable. Start small, grow big. Spare time, at home, free literature. Froner, P.O. Box 1624, Eugene, Oregon.

OPERATE Home mailorder business. Vosacek Printing, 4444AI Ute, San Diego, Calif. 92117.

VENDING Machines: 1, 5, 10 and 25¢ bulk vendors, merchandise novelties, parts, supplies and service. Write for catalogue. Vendill Dist. Co., 1820 East 38th Street, Minneapolis 7, Minnesota.

PROFITABLE Home mail order business spare time. Write Gericke, Box 791, Milwaukee 1, Wisconsin.

anteed proof. Amazing information. 15¢. Lenore Feigen, 30 Washington, Oak Park, Ill. Dept. PPM.

LIQUID Rubber. Plastercraft supplies. Plouffe's, 82A Pleasant Street, Worcester, Massachusetts.

SELL Champion, AC, Autolite spark plugs. Reconditioned, electroplated, guaranteed 10,000 miles. 100% profit. Free sample. Lee Plugs, 1608-A Roberts, Houston 3, Texas.

MEN—Women. Everybody likes fine candy. Make professionally home. (Our 51st year). Ragsdale Candies, B107, East Orange, New Jersey.

"HOW To operate home importing business." Free details. Livingston's, Box 5332, North Charleston, South Carolina 29406.

FREE Report. "Businesses You Can Launch At Home." Immediate earnings! Wyman Enterprises, B-44, Congers, N.Y. 10920.

WORLD'S Largest wholesale supply. Buy from 7853 American, European, Japanese wholesalers. Hong Kong tailored suits. 123 dropship catalogs. Rockbottom prices. Automobiles. Free details. International Buyers, 216-MM Jackson, Chicago 6, Illinois.

BIG Money. Operate bookkeeping tax service. Unversal, Box 664-M, Springfield, Mo.

TEAR Out this ad and mail with name, address for big box of home needs and cosmetics for Free Trial, to test in your home. Tell your friends, make money. Rush name. Blair, Dept. 31CA, Lynchburg, Va. 24505.

ALL Types of businesses coast to coast. Over 350 local offices to serve you. Write for free "Business and Income Property Bulletin." United Farm Agency, 612-PM West 47th St., Kansas City, Mo. 64112. Plaza 3-4212.

DOLLS! Dolls! Dolls! We teach you to repair, make, dress, also how to operate a Doll Hospital. Study at home. Earn while you learn. Or enjoy a fascinating hobby! Free informative booklet. Lifetime Career Schools, Studio MC-16, 11824 San Vicente Blvd., Los Angeles, Calif. 90049.

EARN Money at home, mailing postcards to new mothers. Particulars, 10¢. Westley, Western Springs 1, Illinois.

MAKE Fast selling childrens item from scrap plywood. Details free. Clifford Richards, Rt. 1, Huron, Ohio.

LEARN Speedometer repair. Earn top wages or own your own shop. Share secrets only few know. Always be in demand. Train in spare time. Complete home study course covers both speedometers and tachometers. Instrument Training School, Speedometer Division, Box 5319, Tulsa 4, Oklahoma.

"MAILORDER Laws and Regulations" Latest revised issue only \$2.00. Free "Big-Mall" with each folio. George Shorey, 6215 Chef Menteur, Hwy., New Orleans, La. 70126.

RADIO Mail order, \$50,000 in one month possible. No cost percentage plan. Walthay, Box 53-M-4, Los Angeles 90032.

"PROMOTER'S Manual." Complete guide for selection and successful operation of your own business. Unusual. \$1.00. Continental Publishing Company, 1529 Indiana, Houston, Texas 77006.

\$60.00 DAY. Manufacturing concrete posts. Carlayne, 1803 Fremont, Rapid City, South Dakota 57704.

LEARN Easy candlemaking. Professional techniques. Harvey, 3500 W. University, Gainesville, Florida.

NEW. Highly profitable plastic laminating business. American presses 4 times faster . . . 4 times more profitable. Free literature. American Machine, 1128 Dana, Hixson, Tennessee.

STREAMLINED Home-study mailorder course, \$2.00. Twenty-four complete lessons. Dealers wanted. Sample imprint circular free. Neil H. Tasker, Shamokin, Pennsylvania.

EARN Extra money selling advertising book matches. Sample kit furnished. Matchcorp, Dept. PM-16, Chicago, Illinois 60632.

All occasion assortments. Easter, Valentines, Stationery, Gifts, Toys, Jewelry. Experience unnecessary. Sample samples on approval. Free catalog, bonus plan. Write Hedenkamp, 361 Broadway, Dept. CD-2, New York.

EARN \$12.00 an hour as Tax Advisor. Profitkeeping, 2909-A Sheridan, Chicago 60657.

HOW To get finance capital, loans, grants, cash to start a business. Free details. National Counselor, Harlingen 17, Texas.

INSTALL Burglar alarms without previous experience or costly equipment. Big profit. Free details. Nasco, 11071 Massachusetts, Dept. X701, Los Angeles 90025.

WANTED: Mailorder dealers, Salesman! American Business Card, Box 166F, NYC 10459.

BE A landscape contractor. Learn modern landscaping for exciting hobby or profit. Thousands of spare or full time money making opportunities. Start a profitable business—we show you how. Study and earn your certificate at home. Write today for Free Book. Lifetime Career Schools, Dept. MC-16 11826 San Vicente Blvd., Los Angeles, Calif. 90049.

GOLD Plated and silver hand-made German filigree jewelry. Details free. Hyder Imports, 64-A Chatham City Apts., Savannah, Ga. 31408.

BIG Profits mailing catalogs, postcards. Matteson, 1341 Stonylane, No. Kingston, Rhode Island 02852.

MAIL Baby catalogs to new mothers! Profitable! Northland Enterprises, Rhine-lander, Wisconsin.

"START-Operate Successful Small Business" reveals big, profitable ideas, plans, methods. Free eye-opening facts: Aladdin, Box 5183-A, Oakland, California 94605.

EARN Big money invisibly reweaving damaged garments at home. Free information, Eastern Reweaving School, PM-16 Main, Hempstead, New York 11551.

DISTRIBUTOR Wanted. New service station item. Marvin Fonville, 2401 Crocker, Houston, Texas 77006.

RED Carpet exclusive, copyrighted franchises available. Proven profitable—net over \$20,000 annually. Rapidly expanding market. Complete package: truck, equipment and training. Less than \$1000 cash required with approved credit. Write: Red Carpet Franchises, 2387 Peachtree Rd. Atlanta, Ga. 30305.

\$60.00 DAY, Manufacturing concrete posts. Carlayne, 1803 Fremont, Rapid City, South Dakota 57704.

MAILORDER—New sales program. Details. Value House, 550-M Fifth Avenue, N.Y.C. 10036.

MAKE Money, spare-time sewing. Fashions, home items. Write: Berkman Co., 676 Irving Park Rd., Chicago.

WORK Home, mailing our catalogs! Free details! Cam Company, Dept. 215, Verona, N.J.

INVESTIGATE Accidents. Earn to \$1,400 monthly, part or full time. Pick own location. Car furnished. Expenses paid. No selling. No college education necessary. We train you at home spare time. Keep present job until ready to switch. Men urgently needed now. We place far more men in this booming field than any other individual, company, or school. All facts free. Write: Universal, CPM-101, 6801 Hillcrest, Dallas, Texas 75205.

CANDLEMAKING & Decorating. Terrific hobby. Great business: Learn fascinating molding, dipping, creating & decorating candles for year-round demand—holidays, birthdays, weddings, anniversaries. All Events. Spare time fun & extra income now; expand to colorful candle shop later. No age limit. Write for free facts on home instruction method. Candle Institute, Box 54-DA, Redondo Beach, Calif.

LEARN Bonsai! Duplicate exactly \$500 imported Oriental Tiny Trees in few hours! Grow living miniatures too; and tiny forests in bowls. Profitable home business! Request free fact pack, free sample seeds! Minitree, Box 23023-XT, Los Angeles 90023.

revealed by international famous expert who discovered how to make home business fortunes. Beginners: Get free copy "How to Make Money in Mail Order." Discloses free advertising, profitable products, everything! No obligation. Write Mallico, 1554 Sepulveda, Dept. X701, Los Angeles 90025.

RAISE Rabbits on \$500 month plan. Free details. White's Rabbitry, Mt. Vernon, Ohio.

MONEYMAKING OPPORTUNITIES

EARN \$240.00 a month at home, spare time, doing only two \$5.00 invisible mending jobs a day. Big money paid for service that makes cuts, tears disappear from fabrics. Steady demand. Details free. Fabricon, 1532 Howard, Chicago 26, Ill.

BIG Money raising fishworms and crickets. Free literature. Carter Hatchery, Plains, Georgia.

NEW Instant invisible mending. Learn in one hour, repair in five minutes. Make \$150.00 week. Literature free. Henson, P.O. Box 6136-6, Philadelphia, Pa. 19115.

AMAZING Successes through franchises! Become exclusive franchise holder your territory. Information rushed. National Franchise Reports, WP-528, 333 North Michigan, Chicago 1.

MAKE Plastic novelties for extra income. Low cost home training now available. Write for free booklet. Interstate Training Service, Dept. D-3, Portland 12, Oregon.

WORK Home, part-time, mailing our catalogs! Free details! Cam Company, Dept. 53, Verona, N.J. 07044.

MAKE Money writing short paragraphs! No tedious study! I tell you what to write, where and how to sell, and supply list of editors buying from beginners. Many small checks add up quickly. Write to sell, right away. Send for free facts. Benson Barrett, Dept. C-27-A1, 6216 No. Clark, Chicago 26.

RAISE Rabbits and fishworms on \$500 month plan. Free details. White's Rabbitry, Mt. Vernon, Ohio.

CLIP Items from daily newspapers. Get \$1.00 to \$5.00 each. Details free. Walter, Box 1023-P, Erie, Penna.

WIN Cold cash! Prizewinner sizzles with terrific contests, torrid tips, impertinence! Free sample! Box 11569, St. Petersburg, Fla.

LEARN The secrets of repairing junk batteries. "Fabulous Profits" at home. Details. The Batterymen, P.O. Box 416, Palm Desert, Calif.

START Your own home mailorder business, sparettime! Easy; fascinating; profitable! Alfano, 19-PM, Pine, Closter, New Jersey 07624.

MEN—Women! Sparettime opportunity. Secretarial homework. Refundable instructions, \$1.00. Interstate, 37 Besch, Albany, New York 12209.

HAVE Your own good paying, money-making business! Full, sparettime. Particulars free! Ashe's, Box 62-PM, Elmhurst, New York 11373.

MOBILE Home roof coatings. Guaranteed not to leak. Dealers needed. Aluminum Industries, Dept. PC-115, Kansas City 11, Missouri.

VENDING Machines. No selling. Operate a route of coin machines and earn amazing profits. 32-page catalogue free. Parkway Machine Corporation, 715 P.M.M. Ensor Street, Baltimore 2, Maryland.

INVEST In coins. Fantastic Profits. Free details. Suburban Coin, 607-H Mesquite, Corpus Christi, Texas.

JEWELRYCRAFT For fun or profit! Details free! Write: Modern Craft, Box 3614-R, Cranston, R.I. 02910.

EARN Money evenings, copying and duplicating comic cartoons for advertisers. Adservice, Argyle-1, Wisconsin.

\$200.00 FROM Sheet 1/4" plywood (scrap). 25¢ refundable. Novelties, 610 So. 24th, Elwood, Indiana.

Superior Mink Farm Inc., Superior, EE1, Wisconsin.

WATCH Repairing. Swiss and American watches. Develop skill step by step in spare time at home. Tuition only \$5 monthly. Diploma awarded. Free sample lesson. Chicago Schools, Dept. YAA, Fox River Grove, Illinois 60021.

MAKE Big easy profits making costume jewelry at home, spare time! Quick, easy to make; easier to sell! Details Free! Don-Bar, 2934 Fullerton, Dept. 206, Chicago, Ill. 60647.

DISC Jockey—\$10,000/year. Free details. Box 3364, Anaheim, California.

\$200.00 WEEK Selling Exclusive Swiss Imports, Vicor's, Grafton, Nebraska 68365.

MAKE Big money taking orders for Stark Dwarf fruit trees. Everybody can now grow giant size Apples, Peaches, Pears in their yards. Also Shade Trees, Shrubs, Vines, Roses, etc. Outfit free. Stark Bro's, Desk 30116, Louisiana, Missouri 63353.

PAINT Portraits for PROFIT! Everything you need to learn, includes Flesh-tone oil paints, in one easy course. Anyone can do it—even in spare time. Details free. Merlin Enabnit, Dept. 1D4, 141 W. Jackson, Chicago 60604.

HAVE Successful, home mailorder business! Celebrated professional tells "How!" Gain independence, security. Live better! Exciting details Free! Unicis, Box 735-PC, Norwalk, Conn. 06852.

UNLIMITED Earning possibilities selling books by mail. Complete instructions only \$3.00. Ppd. Further details, 25¢ (refundable). Free "Big-Mail" with each folio. George Shorey, 6215 Chef Menteur Hwy., New Orleans, La. 70126.

BECOME Foreman, superintendent, manager; make more money where you work. How to instruction booklet \$1.00. Ern-Mar, Clermont, Florida 32711.

SEASHELLS. Shellcraft and jewelry supplies. Wholesale catalog 25¢, refunded first order. Our 32nd year. Florida Supply House, Box 847M, Bradenton, Fla.

CIGARETTES—Make 20 plain or filter-tips for 10¢. Facts free. Moberly, Box 922, Owensboro, Kentucky.

EXCLUSIVE 77 Page mailorder guide on sale. Profitable business building information. Buchwalter Sales, 834—175th St., Dept. 21, Hammond, Indiana 46324.

FABULOUS Opportunity for women, any age. Earn \$25 day or more as beauty advisor. No experience. Get details, sample Hollywood cosmetics: Studio Girl, Dept. OP356, 1510 N. Kostner, Chicago.

EARN Big commissions full or part time. Show America's largest line low priced business printing and advertising specialties plus big catalog union label political advertising items. Calendars in season. Big free sales kit samples hundreds items used daily by businessmen and political candidates. Merchandise bonuses for you. Free gifts for customers. Build profitable repeat business. Start now. National Press, Dept. 147, North Chicago, Ill.

BIG Money as management advisor. Profitkeeping, 2909-B Sheridan, Chicago 60657.

FREE. 206 Easy ways to make money taking orders for exciting new products—spare time. Send name, age for 5 months free subscription Opportunity Magazine, 850 N. Dearborn, Dept. 17-AM, Chicago.

BECOME Notary public! Dignified sideline. Prestige, profitable contacts. Details free. Stationers Exchange, Box 617, Kilgore, Texas 75662.

HOW I make \$50 day operate Ad Market. Work home. Free details. Ad Market, Harlingen 4, Texas.

ONE Hundred dollars for one! Certain paper dollars wanted. Free list for stamped, self addressed envelope. Box 241, Rockaway, N.J.

MEN—Women—Make big money—"Enjoyably"—spare time. Bestseller, 40-21 KB Bell, Bayside, New York 11361.

OPPORTUNITY Seekers, homeworkers. Over 80 unique opportunities, \$1.00. Lee, Box 252P, Goleta, Calif.

AMAZING Income. Learn oil burner servicing. Free information. Mar-Lin Institute, Box 66095, Portland, Oregon 97266.

MAILORDERS Top trade magazine, 25c. Mailway, Box 171-K, Capitola, Calif.

WHY Worry about work! Read How to Acquire an Adequate Income for Life. Details free. Dexter's, Box 101-PM, Cranbury, N. J.

PROFITABLE OCCUPATIONS

VENDING Machines. No selling. Operate a route of coin machines and earn amazing profits. 32-page catalogue free. Parkway Machine Corporation, 715 PMP Ensor Street, Baltimore 2, Maryland.

BECOME Independent with your own franchise business. Thousands earning handsome incomes. Request interesting facts today. National Franchise Reports, PM-528, 333 North Michigan, Chicago 1.

MAKE Money writing short paragraphs. Information free. Barrett, Dept. C-27-A2, 6216 N. Clark, Chicago 26.

CHROME Plating. Instructions, equipment and supplies. Platers' Supply, P.O. Box 565, Lugo Station, Los Angeles, Calif.

SHARPEN-Scissors, pinkers. Inexpensive equipment, tools, supplies. Blackhawk's, Sheldahl, Iowa.

FREE Book "990 Successful, Little-Known Businesses." Work home! Plymouth-97R, Brooklyn, New York 11218.

YOUR Own sign shop—Signs, 1017 W. Mulberry, Springfield, Ohio.

BAKE New greaseless doughnuts in kitchen. Sell stores. Free recipes. Michael, 3605 South 15th, Minneapolis 7, Minn.

BIG Money raising fishworms and crickets. Free literature. Carter Wormery, Plains, Georgia.

RAISE Pheasants on \$100 week plan. Little capital and space can make you independent. Free details. Great Central System, Columbus 1, Kansas.

EARN \$240.00 A month at home, spare time, doing only two \$5.00 invisible mending jobs a day. Big money paid for service that makes cuts, tears disappear from fabrics. Steady demand. Details free Fabricon, 1586 Howard, Chicago 26, Ill.

DISC Jockey—\$10,000/year. \$1.00. Rac, Box 3364, Anaheim, California.

INVESTIGATE Accidents. Earn \$750 to \$1,400 monthly. Car furnished. Expenses paid. No selling. No college education necessary. Pick own job location. Investigate full time. Or earn \$8.44 hour spare time. Men urgently needed now. Write for Free literature. No obligation. Universal, CPM-1, 6801 Hillcrest, Dallas, Texas 75205.

SCIENTIFIC Massage: Big earnings, uncrowded profession. Learn spare time at home. Diploma awarded. Free catalog. Write: Anderson School, Dept. A-1C, Princeton, Illinois.

LEARN Professional exterminating. Profitable new methods. Camco, Box 11355-A, St. Louis 5, Missouri.

LEARN Silk screen printing at home. Fun profitable instructions, \$1.00. Herman Co., 562 Sumner, Akron, Ohio.

YOUR Own bookkeeping service pays big. Profitkeeping, 2909-C Sheridan, Chicago 60657.

POLAROID Camera owners, others, money making opportunities, write: Polaroid Prints, 1300 Dover, San Pablo, California 94806.

MONEY: Become finance broker part or full time. Ra-Mar, P.O. Box 482, Desk 4, Oklahoma City, Oklahoma.

AUCTIONEERING—Resident and home study courses. Auction School, Ft. Smith, Ark.

SALESMEN—DISTRIBUTORS

SELL Advertising book matches. Write us today, we put you in business by return mail; handling complete line ad book matches in demand by every business right in your town! No investment; everything furnished free! Top commissions daily. Superior Match, Dept. M-166, 7530 S. Greenwood, Chicago 19, Illinois.

ASTONISHING Automatic toilet bowl cleaner, deodorizer. Works when toilet is flushed. Housewives buy on sight for every bathroom, at only \$1.98 each. Make up to \$10.00 in hour, spare time. Free sales kit. Merlite, 114 East 32nd, Dept. G71T, New York 16.

LEARN To sell the Holy Bible. We teach you how. For attractive profits, deal direct with publisher of 22 editions. Write Department PM, Bible Publishers, Box 5065, San Antonio, Texas 78201.

\$1,000.00 a month for making dramatic 3-second demonstration of amazing Light-weight Presto Fire Extinguisher. New chemical used by Airforce snuffs out fires instantly. Only \$4.95. Terrific commissions. Millions want it. Free Kit. Merlite, 114 E. 32nd, Dept. P-66T, New York 16.

SENSATIONAL New longer-burning light bulb. Amazing free replacement guarantee—never again buy light bulbs. No competition. Multi-million dollar market yours alone. Make small fortune even spare time. Incredibly quick sales. Free sales kit. Merlite (Bulb Div.), 114 E. 32nd, Dept. C-73T, New York 16.

NEGRO People buy on sight. 100% profit. Nationally advertised cosmetics. Free sample offer. Valmor, Dept. KD, 2411 Prairie, Chicago 16.

LONG Needed invention. Man to contact service stations. Huge profits. Cyclo Mfg., 3816 Dahlia, Dept. 100, Denver, Colo.

CALENDARS. Novelties. Full or part time. Liberal commissions. Fleming, 6535-A Cottage Grove, Chicago 37.

EXCITING New product. Big profits! Exclusive! Test it yourself. Sample Offer. Send no money. Just your name. Kristee 164, Akron, Ohio.

EARN Big commissions full or part time. Show America's largest line low priced business printing and advertising specialties plus big catalog union label political advertising items. Calendars in season. Big free sales kit samples hundreds items used daily by businessmen and political candidates. Merchandise bonuses for you. Free gifts for customers. Build profitable repeat business. Start now. National Press, Dept. 146, North Chicago, Ill.

FREE. 206 Easy ways to make money taking orders for exciting new products—spare time. Send name, age for 5 months free subscription Opportunity Magazine, 850 N. Dearborn, Dept. 17-AS, Chicago.

EARN Big commissions full or part time—New fishing rod rack, holds 4 rods & reels, clamps on gunwale of fishing boats, removable in seconds for storing rods at home. Sell to fishermen & Resort owners. List \$5.95. Send \$3.75 for sample and free information. L. A. Schumaker Manufacturing Co., Inc., Box 101, Boonville, Mo.

AGENTS WANTED

RAISE Rabbits for us on \$500 month plan. Free details. White's Rabbitry, Mt. Vernon, Ohio.

MAKE Up to \$50.00 daily soliciting delinquent accounts. Terrific commissions. General Finance Co., Dept. LG-78, Pickwick Bldg., Kansas City, Mo. 64106.

PRINTING. Advertising salesmen—Excellent moneymaking sideline selling decalcomania name plates, small quantities. Automobile initials, sign letters. Free samples. Ralco, XL, Boston 19, Mass.

YOUR Own business—Used suits \$1.50; overcoats 65¢; mackinaws 35¢; shoes 12½¢; ladies coats 30¢; dresses 15¢. Enormous profits. Catalog free. Nathan Portnoy Associates, 2109-AA Roosevelt Road, Chicago 8, Ill.

ESTABLISH Your own business. Low prices on used clothing, shoes, household goods. Unlimited profits. Free catalog. Northwestern Distributors, 2129 No. Western Avenue, Chicago, Illinois 60647.

SALESMEN Make big profits selling "do-it-yourself" sign kits to merchants. Information free. Signmakers, Inc., Dept. PM4, Box 6626, Denver 16, Colorado.

MAKE \$50.00 Daily selling air operated vacuum cleaners to service stations. Free details. Inka Industries, 2401 Crocker, Houston, Texas 77006.

JAPAN'S Earrings! \$1.00 refundable. Free details. OHGA, PM-597, Sigakenkutsu, Japan.

BUSINESS Kit free! Postcard puts you in business! Complete line 275 shoe styles, jackets! New Discoveries pay Big Commissions. No investment. Send for free kit. Mason, Chippewa Falls K-544, Wisconsin 54729.

WILL You test new items in your home? Surprisingly big pay. Latest conveniences for home, car. Send no money. Just your name. Kristee, 145, Akron, Ohio.

SELL Greeting cards, make extra money. All Occasion assortments, Easter, Valentines, stationery, gifts, toys, jewelry. Experience unnecessary. Salable samples on approval. Free catalog, bonus plan. Write Heidenkamp, 361 Broadway, Dept. CD-2, New York.

MEN! Show wife this amazing offer! Famous nationally, advertised Hollywood cosmetics pay big. Make \$25 day up. For free samples, details, write Studio Girl, Dept. OP354, 1510 N. Kostner, Chicago.

FREE. 206 Easy ways to make money taking orders for exciting new products—spare time. Send name, age for 5 months free subscription Opportunity Magazine, 850 N. Dearborn, Dept. 17-AA, Chicago.

JOHN F. Kennedy's wall plaque in metal—bronze. Tremendous profits. Part-full time. Free brochure. Write: Gallo, 339 Fifth Avenue, New York 10016.

LADIES Slips, gowns, petticoats, baby dolls. Free catalog. Victor's, Box 3818, Cleveland, Ohio 44110.

BE The Popular Mechanics representative in your neighborhood and earn big profits in your spare time. Write Popular Mechanics, Room 1-A, 250 West 55th St., New York 19, N.Y.

EMPLOYMENT INFORMATION

FOREIGN Employment: South America, Africa, Europe, Australia, USA. Earnings to \$2,000.00 monthly. Construction, all trades, professions, occupations. Many companies pay fare, housing, benefits, bonuses. Write: Universal, Dept. A-2, Woodbridge, Connecticut 06525.

DIRECTORY Reports. Construction, aviation, shipping, oilfields, government, manufacturing, trucking, etc. foreign—stateside. Helpful information plus job-getting tips on preparing application letters. Unconditional money-back guarantee. Only \$3.00 (\$3.25 airmail) Research Services, Box 6768-PM, St. Louis, Missouri 63144.

TREMENDOUS Opportunities U.S.A.—Overseas. Choose jobs—locations—transportation. Free details. Occupations, International Airport, Box 100-C21, Jamaica 30, N.Y.

BOOMING Australia needs your skills! Government assisted passage. Details \$2.00. Irv Heyer, 2913 Chestnut, Costa Mesa, Calif.

TREMENDOUS Job opportunities. Foreign-U.S.A., construction, trucking, manufacturing. Government, shipping, thousands more. Up to \$2,000.00 monthly! Money-back guarantee. Directory plus sample application form. Send only \$1.00 (\$1.25 Air Mail). Worldwide Opportunities, Box 730-A, Holland, Michigan.

FOREIGN Employment. Construction, other work projects. Good paying overseas jobs with extras, travel expenses. Write only. Foreign Service Bureau, Dept. PM, Bradenton Beach, Florida.

HELP WANTED

MAKE \$280.00 getting just 10 growers to try Campbell's Plant Food. Sample free. Campbell, Rochelle 24, Illinois.

FARMS—REAL ESTATE

CANADIAN Vacation lands: Full price \$385.00. 40 acres. \$10 month. Suitable cottage sites, hunting, fishing, investment. Free information. Land Corporation, 3768-C Bathurst, Downsview, Ontario, Canada.

CANADIAN Lands, seized and sold for taxes. Our 49th annual series of lists, describe many choice properties, situated from coast to coast, acquired by us through tax sale. Priced as low as five dollars per acre, guaranteed perfect title, small monthly payments, no mortgage. Beautifully situated hunting and fishing camps, where there is real sport; summer cottage sites, heavily wooded acreages. Now is the time to invest in Canada's minerals, forests and farms. Write today for free twenty page booklet with full explanation. Tax Sale Service, Room 301-D, 85 Bloor St., E., Toronto 5, Canada.

400,000.000 ACRES Government public land in 25 states. Some low as \$1.00 acre. 1966 report. Send \$1.00 National Land, 422PM, Washington Building, Washington, D. C.

FLORIDA Campsites—deep in the heart of the great Ocala National Forest. Good hunting and fishing. Free maps and photos. Howard Vernor, DeLand, Florida. AD646369D

FREE Fall-winter catalog! Bargains galore! Coast-to-Coast! Low prices, easy down payments! Safe-Buy Real Estate Agency, 712-PM West Third, Little Rock, Ark. (Please include Zip Code)

"CAL-ORE Ranches" in Oregon's Rogue River Valley near Medford and Grants Pass. \$2995 to \$5995. Pay \$150 down, \$35 monthly. Free catalog. Cal-Ore Ranches, 1054PM South Riverside, Medford, Oregon.

\$1 ACRE—Canadian border—hundreds campsites, islands, farmlands, directly from tax authorities. (Non-profit). Lists, photographs mailed. Register, Room 203, 92 King St., E., Toronto 1, Canada.

ABANDONED Timber Leaselands! Choice 640 acre Sportsmen's paradises still available—\$20.00 plus \$6.50 Taxes yearly. Maps, pictures, \$1.00 (Refundable). Director, Erindale 4, Ontario, Canada.

CANADA'S Finest lands. \$4.00 an acre and up. Acquired through estate liquidations. Suitable for hunting, fishing, camps, cottages, farming, timber, minerals, investment. Small monthly payments. Free descriptive booklet. Canadian Estate Land, 2788-P Bathurst Street, Toronto, Canada.

BUY Without risk for retirement, vacation, or investment—under America's only "No-Risk Purchase Plan"—in Carolina coast multimillion dollar, 14,000 acre development, 10 year money-back guarantee. Payments less than \$5.00 monthly. Shopping center, motel, hunting, fishing, golf, country club, right on property. Private ocean beach. Write for free literature. Boiling Spring Lakes, Southport 1-N, North Carolina 28461.

FLORIDA Land and Odd Lots, starting at \$49.00 each. Free List. Casper Investment, 3970 N.W. 177th Street, Miami, Florida.

FREE! New 152-page illustrated Spring 1966 catalog! Over 1700 pictures! Farms, ranches, homes, businesses, vacation and retirement properties. In 28 states coast to coast! United Farm Agency, 612-PM West 47th St., Kansas City, Mo. 64112. Plaza 3-4212.

FREE Strout catalog. Big 180 exciting pages of top value offerings. 490 offices in 35 States. Coast-to-Coast. Our 65th Year. Get your free catalog today. Strout Realty, 7-CJ S. Dearborn, Chicago, Ill. 60603.

GOVERNMENT Lands . . . low as \$1.00 acre. Millions acres! For exclusive copyrighted report . . . plus "Land Opportunity Digest" listing lands available throughout U.S., send \$1.00. Satisfaction guaranteed! Land Disposal, 2230-PA Wisconsin Avenue, Washington, D.C. 20007.

FLORIDA Water wonderland — home, cottage, mobilsites. Established area, \$590 full price, \$9.00 a month. Swimming, fishing, boating. Write: Lake Weir, Box KK 38, Silver Springs, Florida. AD 6-1070 (F-1)

FARM AND GARDEN EQUIPMENT

YOUR Ad in this space will be read by more than 1,400,000 active mail order buyers. Join the march to greater profits, place your products and services in front of them today with a small low cost classified ad. For further details, write: C. A. Martin, Dept. 43N, Popular Mechanics, 575 Lexington Avenue, New York, New York 10022.



PLANTS AND NURSERY SUPPLIES

WANT Greatest cash crop working for you? Write Ginseng, Asheville 53, N. C.

HOME CRAFTSMEN

101 PATTERNS Of smart gifts, novelties, shelves, action windmills plus "Make Money Jig Sawing." \$1.00. Mastercraft, J5M, 7041 Olcott, Chicago 60631.

FREE! Big 80 page Leathercraft catalog. 100's of new items! MacPherson Bros., Dept. K, 730 Mission St., San Francisco, Calif. 94103.

SKIL-CRAFTS New '65-66 catalog. Largest and finest selection of leathercraft, artist, hobby-craft supplies in the world. Free gift with first order. Send 50¢. Refundable with first order. Skil-Crafts, Box 105-P, Joplin, Missouri.

PLANS, Bird houses, feeders. Ready built houses and feeder. Illustrated catalog, 25¢ coin. Yeager, 1665 Linden, Homewood, Ill. 60430.

WOODWORKING Catalog and manual, 25¢. Plus free "101 Project Ideas." World's most beautiful veneers, lumber, plywood! Wood finishing, upholstery supplies. Furniture hardware, 2,000 needed workshop products. Constantine, 2051-A Eastchester Road, Bronx 10461.

WALNUT, Cherry, silver maple, gun stocks, squares lumber, picture frame moulding. Midland Lumber Company, Box 262, Savannah, Missouri.

WOODWORKERS — Home craftsmen! Catalog containing lamp parts, veneers, lazy susan bearings, Swiss movements, chair cane, folding metal legs, wooden legs, mouldings, furniture hardware, finishing materials, etc., only 15¢. Barap Specialties, Box 2044-DH, Chicago 60609.

MAKE \$100.00 Formica counter tops with few dollars' material. Complete instructions \$1.00. Build cabinets like professionals, with new manual. "Cabinet-making Made Easy." \$2.00. Japs, 126-P Seventh North, Hopkins, Minn. 55343.

FREE "Do-it-yourself" Leathercraft catalog. Tandy Leather Company, 1001 Foch, N56, Fort Worth, Texas.

KNOCKDOWN Cedar chests, also over fifty kits. Catalog 25¢. Giles Kendall Co., Huntsville 2, Alabama.

BAND Saw 12"—18"—24" sizes. Request bulletin. Paul Kornau, 6503 Hamilton Ave., Cincinnati, Ohio 45224.

2512 PLANS, Patterns, things to make, do. Fun. Profit. World's greatest selection. Catalog 10¢. Craftplans, 18250-A Harwood, Homewood, Ill.

PLANS for pool table with extra two-face top for table tennis and model railroad. Blueprints B1209 and building instructions \$3.50. Popular Mechanics Service Bureau, 575-M Lexington Ave., New York, N.Y. 10022.

DO-IT-YOURSELF

BUILD A dependable pressure washer for cars & trucks. Send \$2.00 for details. Deco Mfg., Iowa Falls, Ia. 50126.

AUTOMATIC Washer repair manuals for: Frigidaire, General Electric, Hamilton, Hotpoint, Kelvinator, Kenmore, Norge, RCA Whirlpool, Speed Queen, Westinghouse, Maytag. \$2.50 ea. PPD. 50¢. Major Appliance, 13106 Caine Ave. (Dept. M), Cleveland 5, Ohio.

NOW—Marshall's directory of How-To-Do-It books, \$1.00. Marshall's, 1135A So. Birmingham, Tulsa, Oklahoma 74104.

CHAIN Link fence. Posts, fittings, gates, kennels. Discount prices. Install—earn to \$5.00 hour. Detailed instructions, catalog 50¢. Cordry Manufacturing, Dept. PM, 2400-06 Truman Rd., Kansas City 6, Missouri.

FERRIS Wheel—for two children 6 to 60. Instructions, \$1.00. 3813 Donna Circle, N. Highlands, California.

PARTS For washing machines, dryers, refrigerators, freezers, ranges, etc. Illustrated instruction book for washers, \$4.25. Mailorder Parts, 117 Broadway, Hicksville, N.Y.

BUILD Concrete block machine. Easy, inexpensive. Motor or hand operated. Make block per minute. Write—Clyde Lee, Mountain View, —PM, Oklahoma.

ORNAMENTAL Iron: Direct from factory to you at wholesale prices, install yourself and save. Duley Steel Products, P.O. Box 351, Dexter, Mo. 63841.

EXERCISE At home on build-it-yourself physical fitness equipment, including bicycle exerciser, rowing machine, belt massager, and abdominal board. Send \$2.50 for blueprints B1208 and instructions. Popular Mechanics Service Bureau, 575-K Lexington Ave., New York, N.Y. 10022.

FREE Check-list covering more than 300 classifications of projects, plans, instructions, service and repair information detailed in Popular Mechanics famous series of instructional booklets, books, patterns, and blueprints. List covers an extremely wide variety of do-it-yourself data on home remodeling, repair and improvement, hobbies, crafts, boating, games, lawn and garden, and hundreds of others. For your free copy of this helpful list, write: Service Bureau, Popular Mechanics, 575 Lexington Ave., New York 22, New York.

ARTS AND CRAFTS

MAKE Figurines, plaques, lawn ornaments. Molds, plastercraft kits, liquid rubber. Sample and catalogue 10¢. Wooley Company, Box 29-B, Peoria, Illinois.

BINOCULARS, TELESCOPES, MICROSCOPES, MAGNIFIERS

BUILD Your own reflector telescopes; complete kits; Mirrors, eyepieces, tripods. All other accessories, request free illustrated literature. Criterion Manufacturing, Dept. KPM-32, Hartford, Connecticut.

BINOCULAR Sale! Free color catalog 100 models \$9.95-\$250.00. Write, United, 9043 So. Western BCAT-6008, Chicago 60620.

BUILD Your own reflector telescopes; Complete kits; mirrors, eyepiece, tripods. Free catalog F describing other accessories sent on request. Also free brochure describing amazing line, world famous "Dynoscope" reflector telescopes. Criterion Manufacturing, Dept. KPM 34, Hartford, Connecticut.

SCIENCE Bargains! Lenses, telescopes, binoculars, microscopes, kits, parts, war surplus. Send \$1.00 for beginner's 10-lens kit with instruction booklet. Order Stock 2-CH. Request free 148 page Catalog CH. Edmund Scientific Co., Barrington, New Jersey.

STAR Finder. 30 illuminated star charts projected on the night sky. Stars located, named. Ideal for teachers, counselors, schools, churches, fraternal organizations, camps. Scout merit badge qualification. \$1.00 Kit, \$2.00 Assembled. TRI-G, 1731W Washington, Venice, California.

DYNASCOPE — Amazing World-famous reflector telescope. Request free brochure. Criterion, Dept. DP-24, Hartford, Connecticut.

BINOCULARS Direct from manufacturer. Finest quality, tremendous savings! Request catalog, Koyu, 3860 Crenshaw Blvd., Los Angeles, Calif.



CAMERAS AND EQUIPMENT

YOUR Ad in this space will be read by more than 1,400,000 active mail order buyers. Join the march to greater profits, place your products and services in front of them today with a small low cost classified ad. For further details, write: C. A. Martin, Dept. 49N, Popular Mechanics, 575 Lexington Avenue, New York, New York 10022.

PHOTO SUPPLIES

PHOTOGRAPHY For pleasure or profit. Learn at home. Practical basic training. Long established school. Free book. American School of Photography, 835 Diversey Parkway, Dept. 3451, Chicago, Illinois 60614.

SAVE Up to 45% over free film prices! Yes, you can definitely save enough to buy a fresh roll of Kodak film and still have money left over. Compare our prices for processing: 12 Ex. Kodachrome \$2.25. Black and white 49¢. All jumbo size. \$1.10 for 8MM. \$1.15 for Kodachrome 20 Ex. Over 28 years of service with ultra modern processing facilities enables us to give you highest quality, lowest prices and same day service. Send now for free mailer and processing price list. Best Photo Service, Inc., PM1 PO Box 497, Syracuse, New York.

TELL The more than 1,400,000 avid readers of Popular Mechanics about your products and services. It costs very little to place your classified message in front of these proven mail order buyers. For further details, write: C. A. Martin, Dept. 50N, Popular Mechanics, 575 Lexington Avenue, New York, New York 10022.

PHOTO FINISHING

FAST. Hi-quality finishing. Kodachrome rolls: eight jumbo prints \$1.98. Twelve \$2.49. Twenty \$3.49. Reprints 15¢. Also low B&W prices. Custom Quality Studio, Box 4838-PM, Chicago 60680.

COLOR Movie Fans! 8 MM expertly processed for just \$3.10 including fresh Kodachrome Film. All mailed back next day First Class. Craftsmanship guaranteed. Send exposed reel or request Free Mailers and Price List of complete services. Direct Mail Photo, Box 8352-PM, Pittsburgh, Pa. 15218.

A FREE Kodak roll returned with each black and white or Kodachrome developed and printed, fast service, lowest prices, guaranteed quality send for free mailers. Economy Photo Service, Dept. P. M., Box 1111, Albany 1, N.Y.

COLOR SLIDES

NEW YORK World's Fair, 1964 exclusive set 100 35mm. 2"x2" color slides, \$14.99 plus 28¢ postage. Biggest selection high quality slides available anywhere. Catalog free. Blackhawk Films, 423 Eastin-Phelan Bldg., Davenport, Iowa 52805.

MOTION PICTURES AND SOUND EQUIPMENT

8MM MOVIES, 2"x2" Color Slides—biggest selection anywhere! World's Fair, railroad, antique automobiles, circus, World War II, Hollywood classics, travel, wild life and many others. 16mm. new, used films also. Big Blackhawk catalog free. Blackhawk Films, 424 Eastin-Phelan Bldg., Davenport, Iowa 52805.

FREE Catalog! Save on 8/mm.-16mm. film and supplies. Superior, 448 N. Wells, Chicago 10.

CAPTURED Nazi film. Guaranteed authentic. Sample 50¢. Sanford, Fairview, Pennsylvania.

16MM sound-projectors, films, new, used for sale. Free catalog. National Cinema, 71 Dey Street, New York City, N.Y.

16MM SOUND Shorts, cartoons, features. Cinemas Films, 10134 Perry Ave., Chicago, Ill. 60628.

MOVIE Film! Free catalog! ESO-R, 47th Holly, Kansas City 12, Missouri.

5,000 8-16 MM. Movie films. Free catalogues. International, Greenvale, N.Y.

HART Industries buys used 8mm movies! Box 452, Birmingham, Michigan 48012.

16MM Sound films features and shorts. Bedner, 5300 So. Talman, Chicago.

RADIO, TELEVISION AND HAM EQUIPMENT

GOVERNMENT Surplus electronics, infra-red equipment. Catalog 20¢. Meshna, Nahant, Mass.

BRAND New tubes. World's lowest prices on radio, TV-industrial, special purpose tubes. Write for free parts catalog. United Radio, Newark, N.J.

WORLD'S Finest radios. Free catalog. Mini-tronics, 1613, 1983 Via Del Rio, Corona, California 91720.

KITS, Diode radio, \$1.25; audio amplifier, \$1.50; Solar radio, \$3.95; wireless transmitter, \$3.95. Lectronix, Box 1067, Southgate, Mich. 48195.

SAVE Money on TV and radio repairs. Free catalog. Telefixit, Box 714, Manhasset 1, N.Y.

FREE Electronics catalog. Tremendous bargains. Electrolabs, Department C-637B, Hewlett, New York 11557.

BEGINNERS Kits. Diode radio, \$1.50. Solar powered radio, \$3.95, no soldering. Lectronix, Box 1067, Southgate, Michigan 48195.

33¢ RADIO & TV tubes. Free list. Cornell, 4213-17 University, San Diego 5, California.

HIFI, RECORDS AND ELECTRONICS

TAPE Recorders, hi-fi components. Sleep learning equipment, tapes. Unusual values. Free catalog. Dressner, 1523 Jericho Tpke., New Hyde Park 3, N.Y.

EXCLUSIVE Free catalogue; extraordinary hard to find hobby party records. Record Suppliers, 300 Chelsea, Louisville, Kentucky 40207.

FREE — Free — Free — Free — Free — Free. Send in for your Free one year subscription to Olson Electronics' fantastic value packed catalog, unheard of low, low prices on brand name speakers, changers, tubes, tools, Stereo, amplifiers, tuners, CB and other values. Credit plan available. If you have a friend interested in electronics send his name and address for a Free subscription also. Olson Electronics, Inc., 450 S. Forge St., Akron, Ohio 44308.

NEW Mfrs B.S.R. record changers, UA15 model with stereo cartridge \$13 each. Parts guaranteed or units exchanged. Quantity discount. Changers, Box 144 Jerome Ave. Sta., Bronx N.Y. 10468.

STEREO Tapes. Save up to 60% (no membership fees, postpaid anywhere USA). Free 60-page catalog. We discount batteries, recorders, tape accessories. Beware of slogans "not undersold," as the discount information you supply our competitor is usually reported to the factory. Saxitone, 1776 Columbia Road, Washington, D.C. 20009.

McGee Radio Company. Big 1966 catalog sent free. America's best values, hi-fi—amplifiers, speakers, electronic parts. Send name, address and zip code number to McGee Radio Company, 1901 McGee St., Dept. PM, Kansas City, Missouri 64108.

RECORDS! Discounts on all LP's. Free details. Citadel Record Club, 545 Fifth Ave., Dept. 2, New York 17, N.Y.



MUSIC AND MUSICAL INSTRUMENTS

SONG Ideas wanted. Write with active professional songwriters with publisher contacts. Records made. Share royalties. Send ideas—free examination. Songwriters' Associates, 236 W. 55th, N.Y. 19-P.

ELECTRIC Guitar kits, patterns, parts. Send 25¢. Kits, 3526 California, Peoria, Illinois.

USED Professional guitar, amplifiers, drums. Send 25¢. Hills, 3526 California, Peoria, Illinois.

INCOME Guaranteed two years for song-poems accepted! Free public releases! Castle's, 203PM West 46th Street, New York City 10036.

PIANO Self-Teaching Book. Includes popular, classical, harmony, theory, chords, scales. Price \$5.00. LaPont Publishing Company, Box 606-P, Franklin, Michigan 48025.

SONGS, Songpoems: Wanted for radio show. Hollywood Music Productions, 6425-B15, Hollywood Boulevard, Hollywood, California 90028.

ACCORDION-O-RAMA. Top brand accordions. Tremendous discounts. 120 bass, 5 switches from \$119.00. Trades accepted. Free brochure. Accordion-O-Rama, 874 Broadway, New York, N.Y. 10003.

PLAYER Piano books. Free catalog. Vestal Press, Vestal 11, N.Y. 13850.

GUITARS! Lowest prices, best deal in country. Famous brand catalogs free. Universal Guitars, 20 Cent, Great Neck, N.Y.

SONGPOEMS Wanted. Send poems for offer. Nashville Music Institute, Box 532-PM, Nashville, Tennessee.

ACCORDIONS, Guitars, band instruments! Save to 50%. Famous makes. Easiest terms. Trades accepted. Free home trial. Free discount catalog. Mention instrument. International Music Mart, 5535-R Belmont, Chicago 60641.

SONGS And song poems wanted. Royalties. Tin Pan Alley, Inc., 1650 Broadway, New York, N.Y. 10019.

SONGS Or song ideas wanted by new commercial recording company for release to disc jockeys and public. Preview Records, 6311-B Yucca, Hollywood, California 90028.

VIOLIN And guitar makers, send for latest Free catalogue of woods & accessories. International Violin, PM-13, 414 East Baltimore St., Baltimore 2, Md.

WHO Else wants songwriting success? Details free. Melody Writers, 2 Emma Street, Greenville, S.C.

ACCORDION Manufacturing, 6343-P South Ashland, Chicago, Illinois 60636. Piano Accordions, Chromatics, Hohners, Concertinas, Guitars. Wholesale catalogs free.

POEMS Wanted for musical setting and recording. Send poems. Free examination. Crown Music, 49-C West 32, New York 1.

ELECTRIC Guitars, amplifiers, wholesale. Free catalog. Carvin, PMM, Covina, Calif.

FREE Recording, your songpoem. For information send poems: Musicrest, 12044 Chandler Blvd., So. Hollywood, Calif.

SWISS Musical movements. Mechanical—electrical. Spielman, 131 West 42nd, New York 10036.

GUITAR, Banjo Making books, Plans, woods, necks, tools. List 15¢. Satinwood, 510 East 11th Street, New York 9, N.Y.

SPINET Piano (new) \$399.00. 15 year Warranty. No money down. Send for our free brochure. Wonderland Musical Instrument Company, Box 621PM, Detroit, Michigan.

CLARINETS, Trumpets, guitars, violins. All band and orchestra instruments. At lowest prices, 10 day free trial. No money down. Send for our free brochure (specify instrument). Wonderland Musical Instrument Company, Box 621PM, Detroit, Michigan.

DRUM Sets, lowest prices, no money down, 10 day free trial. Send for our free catalog. Wonderland Drum Company, Box 621PM, Detroit, Michigan.

POEMS Wanted for new songs and records. Send poems. Five Star Music, 6M Beacon, Boston 8, Mass.

EDUCATION AND INSTRUCTION

PIANO Tuning quickly learned with home study course. Diploma granted. American Tuning School, Gilroy, Calif.

LEARN Civil and criminal investigation at home. Earn steady, good pay. State age. Institute Applied Science, 1920 Sunnyside, Department 161, Chicago, Illinois 60640.

MASTER Watchmaking at home. Free sample lesson. Chicago School, Dept. YA, Fox River Grove, Illinois 60021.

USED Correspondence courses and books sold and rented. Money back guarantee. Catalog free. (Courses bought.) Lee Mountain, Pisgah, Alabama.

HIGH School diploma at home. Licensed teachers. Send age, highest grade completed for free detail. No salesman will call. Southern States Academy, Professional Bldg., Dept. 16, Decatur, Ga.

PENMANSHIP Corrector. Improve poor penmanship quickly. Details free. Ozment, Box 665-34, St. Louis 88, Mo.

COMPLETE Your high school at home in spare time with 69-year-old school. Texts furnished. No classes. Diploma. Information booklet free. American School, Dept. X145, Drexel at 58th, Chicago, Illinois 60637.

MEN Wanted. Earn \$125 a week and up. Master a trade with a future. Learn auto diesel mechanics in our shops. You learn with tools on real equipment. Earn while you learn. Many of our graduates earn \$125 a week and up. Write for free bulletin: Dept. 256, Auto Diesel College, Nashville 3, Tenn.

OWN Collection agency. "Little Gold Mine!" Franklin Credit, Roanoke, Virginia.

LEARN To drive tractor, trailer, trucks, buses. Short concentrated courses available. Write for free brochure. Driver Training Institute, 794 Bedford Ave., Brooklyn, N.Y. Ja 2-5080.

BOOKKEEPERS. Operate your own "Dollar-A-Week" system. Ellis, Box 200, Cedar Grove, North Carolina.

INVESTIGATOR'S Course. Credentials, diploma. Free information. Southwestern Institute Criminology, Box 201, Geronimo, Oklahoma.

BE A real estate broker. Insure security for yourself and your family. Study at home. Prepare for state examination. Write for free book today. Weaver School of Real Estate, 3519-P Broadway, Kansas City, Mo. 64111.

PIANO Tuning pays. Big money in spare time. Learn at home. No musical knowledge necessary. Phonograph, records, tools and instructions furnished. Electronic tuning also taught. Free catalog. Capital Tuning School, 3160 S.W. 16th Court, Ft. Lauderdale, Fla.

SWEDISH Massage. Foot technique. Post graduate. Home study. Residential. Diploma. Dr. Swanson's Illinois Licensed School, 3809-PL Alta Vista, Chicago 13.

MISSOURI Auction School. Free catalog! 1330-03 Linwood, Kansas City, Mo. 64109.

FINGERPRINTING Easily learned at home. Many job opportunities. Diploma awarded. Alabama School of Fingerprinting, Fairfield, Alabama.

USED Courses! Books! List 10¢. Smith's, 124 Marlborough, Salem, Mass.

B.Sc. DEGREE (Engineering) or College Entrance by home study. Send \$1 for 1966 prospectus. CIST, Suite 804, 263 Adelaide St., W., Toronto, Canada.

LEARN Special investigation. 20 Lessons. Credentials, diploma, future. International Academy of Police Science, Oklahoma City, Oklahoma.

GET A British degree. Divinity, Philosophy, Radionics. 35 courses. Prospectus free. Brantridge Forest School, USA Representative, Box 357, Lincoln, Montana.

DETECTIVES—Secret investigations. Experience unnecessary. Detective particulars free. George Wagner, M125 West 86th, New York 10024.

FCC License in 6 weeks. First class radio telephone. Results guaranteed. Elkins Radio School, 2603D Inwood, Dallas, Tex.

TELEVISION: Appliances: Appliance Repairing; Mailorder: (Low cost courses) Guaranteed. Brochure free. Mike Blizzard Company, Dept. PM-2, Linwood, N.J.

DETECTIVE Course. Free information. Universal Detectives, Box 8180-F, Universal City, California, 91608.

WOODWORKING And cabinetmaking course for beginning and advanced home craftsmen. Only complete low-cost home training program available. Write for free booklet. Interstate Training Service, Dept. G-3, Portland 12, Ore.

PROFITABLE National Camera Repair School training at home! PM1, Englewood, Colorado.

MEN, Women—Want Higher Pay? Take advantage of hundreds of well paying jobs in business and industry. Unusual training. Study courses at home while you work. Get literature. Aladdin Home Study Courses, Dept. B, 409 St. Louis, Springfield, Mo. 65806.

SWEDISH Massage and Physical culture pays big profits. Learn at home. Diploma. Free catalog. National Institute, Dept. E16, 307 North Michigan, Chicago 1.

PICTORIAL Study in amateur radio. Free details. Dwite Cross, 1212 Lynch, St. Louis, Mo. 63118.

"STAMMER—Stutter—no more." (Dr. Young.) Write: Gaucho, Box 9309-S7, Chicago 90.

GAME Warden, Government hunter, forestry, park and wildlife services announce job openings regularly. Prepare at home for outdoor work, good pay, security. Complete information free! Write North American Schools of Conservation, 941-AZ North Highland, Los Angeles, Calif. 90038.

IDEAS—Think them up yourself! 30-step course with slide chart, \$5.00. Ritterby, 660 Pinecrest, Holland, Michigan.

LEARN Spanish rapidly (plain talk—no grammar). Free lesson. "Instant Spanish." Dept. A-1, 68 River Route, Kingman, Arizona.

"HOW To Train Horses"—Everyone who likes horses or ponies should have this book: free. Send name, zip code. Beery School, 1101, Pleasant Hill, Ohio 45359.

RADIO Course only \$26.95. Guaranteed. Free catalog. Progressive, Department 636B, Hewlett, New York 11557.

ENGINEERING And Art Degrees earned through home study. Electronics, Mechanical, Liberal Arts. When writing specify course desired. Pacific International College of Arts & Sciences, primarily a correspondence school. Resident classes also available. 5507-B Santa Monica Blvd., Hollywood, California 90038.

LEARN Electronics, Radio, Television, by practicing at home. Train with accredited school for important jobs in fast growing field. Use special equipment furnished at no extra cost to acquire new skills. Make extra money fixing sets in spare time. Write for Free catalog. National Radio Institute, Dept. 119-016, Washington, D.C. 20016.

BECOME Licensed real estate broker or salesman quickly. Highly profitable. Thorough, practical training including real estate salesmanship. Home study. Free information. Wall Realty Institute, 477-M Jackson, Pasadena, California 91104.

USED Courses! Books! Catalog, 10¢. Courses bought! Bayles, 78B Courtright, Wilkes-Barre, Penna. 18702.

PENMANSHIP Book: Improve poor writing quickly, plus ornamental. T. Tevis, Chillicothe, Mo.

LEARN Auctioneering. Term soon. Free catalog. The Reich American School of Auctioneering, Inc., Box 12, Mason City 1, Iowa.

MENTAL Breakthrough! Sensational record introduces "autosuggestion" discovery! Instant self-power . . . control others. Free trial offer!! Forum, 333-JX1 Michigan, Chicago 1.

ELECTRONIC Training. Fundamental and advanced correspondence courses. Free sample lesson. Huntington Institute, Division of Lantec, Box 2244-D, Huntington Park, California.

LEARN Asleep or awake! Records, tapes, equipment! Free catalog! Drawer, PM-400, Ruidoso, New Mexico.

LEARN Introductory accounting, \$25.00. Terms. Box 1225; United Accounting Extension; Akron, Ohio.

DRAFTING Pays big money! Learn at home with professional equipment, pay later. Free book. Christy Trades School, Dept. D-7903, 3214 W. Lawrence Ave., Chicago 60625.

AUTOSUGGESTION. Sleep-learning headquarters! Tapes, records, books. Gigantic catalog free. Research Association, Box 24-PM, Olympia, Washington.

FOR INVENTORS

PROFESSIONAL Patent searches, \$6.00, including official U.S. Patent Office copies of related U.S. patents! Prompt, dependable service. Certified, airmailed! For free "Invention Record Folio" and important patent information every inventor should have, write: United States Inventors Service Company, 1311 "G" Street NW, Washington 5, D.C.

SAVE High fees! Prepare your patent application yourself! New "Do-It-Yourself" patent kit now makes it easy! Free "Registration Form." Miss Blaine, 306A Carry Building, Washington 5, D.C.

IMMEDIATE Cash, for patent applications. Free patent searches. Write for details. Universal Patents, 184-D, Marion, Ohio.

PATENT Searches, including copies of related U.S. patents, \$6.00. Inventors, attorneys, manufacturers use my "worldwide" airmail service! "Invention Record" form and "Information Every Inventor Needs," sent free! Miss Hayward, 1029P Vermont, Washington 5, D.C.

INVENTORS: Save time and money. Prepare and file your own patent application. Our complete "Patent Kit" makes it easy. Includes detailed instructions and all necessary material. Only \$14.75. Money back guarantee. Don't delay. Send check or money-order today to National Inventors Service, 1244-19th Street, N.W., Washington, D.C.

U.S. Patent Office Searches. 234 Broadway, Room 3615, New York. Free invention certificates.

TREMENDOUS—Savings! Prepare your patent application yourself—easily, with our New "Patent Kit." Complete instructions, materials, sample application—send \$8.95 for immediate delivery. Money-back guarantee! Congress Invention Company, 210 McKim Building, Washington 5, D.C.

INVENTORS: Your ideas and inventions (patented; unpatented) expertly searched and developed for commercial appeal and cash/royalty sales to manufacturers by professional Invention Developer with excellent record of experience. B.S., Industrial Engineering; U.S. Patent Office former Patent Examiner; U.S. Government former Patent Adviser. Second decade of reliable service! Free "Invention Record" and Important Information. Airmailed! Write Raymond Lee, Invention Developer 130-N W. 42nd, New York City 10036.

INVENTORS—Send for revealing, money making information. Lock 3913 Castro Valley Blvd., Castro Valley, Calif. 94546.

INVENTORS Wanted immediately for promoting on cash or royalty. Patented, unpatented. Free booklet outlines royalty rates, requirements. Write Kessler Corporation, C-58-FI, Fremont, Ohio.

PATENT Pitfalls! New law hurts! Free help! Send self-addressed, stamped envelope. Flipper, Geneva, Illinois.

"INVENT & Get Rich." A new book for inventors. \$2. per copy. Check or M.O. Wilbro Publications, P.O. Box 507, Muncie, Indiana.

PATENT And invention development, by licensed professional patent engineer and U. S. Patent Office former examiner, and engineering specialists. Your inventions and ideas engineered for patent protection and commercial value. Inventions developed by us negotiated for cash or royalties with our nationwide contacts. Send for free protection "Invention Certificates" and further interesting, valuable patent information. George Spector, Licensed Professional Patent Engineer, Woolworth Building, New York.

INVENTIONS WANTED

WE Either sell your invention or pay cash bonus. Write for details. Universal Inventions, 298-E, Marion, Ohio.

INVENTORS Wanted: Manufacturers need new items! Your inventions, ideas developed for cash/royalty sales. Free "Invention Record": Information. Raymond Lee, 130-P W. 42nd, New York City 10036.

INVENTORS Needing Help with any problem, financial, development, securing manufacturer, obtaining patent. Write the organization that delivers action and results—not promises. Pioneer Invention Service, Dept. 83, 150 Broadway, New York 38, N.Y.

INVENTIONS Wanted. Patented: unpatented. Tremendous manufacturers lists. Global Marketing Service, 2420G 77th, Oakland 5, California.

WE Have markets for worthwhile inventions. Harvey Engineers, Cambridge, Maryland 21613.

ATTENTION Inventors. Mid-Western manufacturer receptive to protected new product ideas. Will help finance and research ideas. Presently manufacturing in industrial field. Structural steel shop, machine shop, and electronic shop facilitate product development. Will produce and sell product after financial arrangements with inventor. Direct confidential inquiries to P. O. Box 2179, Columbus, Ohio.

CHEMICAL Products inventions: Household, automotive, or other desired. Send your idea for free confidential evaluation; if marketable we will make offer. No brokerage fee, we are nationally known manufacturers. Write P.O. Box 18802-B, Indianapolis, Indiana.

INVENTORS: Protect your ideas! Free "Recommended Procedure." Washington Inventors Service, 422F, Washington Building, District of Columbia 5.

MANUFACTURING

MODELS—Small lot manufacturing. Metals, plastics, etc. Milburn, Burlington, Kentucky.

INVENTORS Services, Models, manufacturing, research. Consultants all fields available. William Parker, 32 Westminster, Worcester, Mass. 01605.

BUY IT WHOLESALE

BARGAINS! Buy wholesale and below. Name brands. Appliances, furniture, sports equipment, televisions, cameras, watches, jewelry, thousands more. Huge discounts to \$1,000.00 on new automobiles. All makes. Free details. Write today: Worldwide Bargainhunters, Box 730-A, Holland, Michigan.

ELECTRIC Guitars, amplifiers, wholesale. Free catalog. Carvin PMW, Covina, Calif.

BARGAINS! Buy wholesale! Save money! Free catalog! Norris, 273 Merrick, Dept. 115 Lynbrook, N.Y.

SAVE \$\$\$\$\$\$ Buy wholesale or below, thousands of items direct from U.S. and Foreign Manufacturers. Many items free! Write: Global, Box 18216 PA, Indianapolis, Indiana 46218.

TRAIN Sets \$1.36, Recorders \$6.70, Pistols \$5.74, Walkie-Talkies, Binoculars, Cameras. Buy from American, European, Japanese wholesalers. Exciting details free. Enterprises, Box 160-X9, Jamaica, New York 11430.

NEW 6-Color deluxe below wholesale catalog. Automobile catalog and others. Housewares, clothing, furs, furniture, appliances, refrigerators, washers, dryers, vacuum cleaners, polishers, cookware, dinnerware, strollers, cribs, radios, stereos, phonographs, recorders musical instruments, organs, typewriters, books, binoculars, luggage, sporting goods, bowling, golf, game tables, motor scooters, motor golf carts, power mowers, chain saws, boats, motors, bicycles, clocks, watches, diamonds, jewelry. Huge discounts, hundreds name-brand items. For free list (factory prices) postcard: Selbyco-5, Decatur, Illinois.

USED And new watches \$2 up. Free list Southern Watches, 5-PM So. Wabash, Chicago 3

PAINT Your own wall mural! Inexpensive, easy paint-by-numbers pattern kit includes oils, brushes—everything! 35 decorator designs. Color catalog, 10¢. Mural-art, 4401-AZ Birch, Newport, California 92660.

WORLD'S Largest wholesale supply. Buy from 7853 American, European, Japanese wholesalers. Hong Kong tailored suits. 123 dropship catalogs. Rockbottom prices. Automobiles. Free details. International Buyers, 216-M Jackson, Chicago 6, Illinois.

100 FINEST Razor blades only \$1.00 Postpaid. Buhl, Princeton, Florida.

MEN'S Dress shirts. Any size white, color. Samples. Dozen, \$6.88. Postpaid. Frank Cirella, Waldoboro, Maine 04572.

FREE! Illustrated catalogue of 1965 and 1964 cars at prices from \$599 complete. Fantastic Values! Write Today! Universal Auto Wholesalers, Inc., 235-A Penhorn Avenue, Secaucus, N. J. 07094

100,000 PRODUCTS Wholesale! Terrific bargains! Wholesalers, 1265-MR Broadway, New York, N.Y.

EXPORT-IMPORT

THREE Bit screwdriver-flashlight combination, \$2.50. Luis Martinez, Box 13143, Columbus, Ohio 43213.

JAPAN: Mail-Order 26 page catalog, dolls, novelties. Manufacturers' names, addresses \$1.00; 1000 products illustrated trade directory \$3.00. Send cash. Yamagata Office, 814 Togin Bldg., Marunouchi, Tokyo.

FOR THE HOME

TELL The more than 1,400,000 avid readers of Popular Mechanics about your products and services. It costs very little to place your classified message in front of these proven mail order buyers. For further details, write: C. A. Martin, Dept. 63N, Popular Mechanics, 575 Lexington Avenue, New York, New York 10022.

OF INTEREST TO WOMEN

MAKE Money writing short paragraphs. Information free. Barrett, Dept. C-27-A3, 6216 North Clark, Chicago, Illinois.

WOMEN! Make big money at home. \$10.00 profit in an hour possible with invisible mending. Make holes, tears disappear from clothing, fabrics. Steady year-round demand from cleaners, laundries, homes. Details free. Fabricon, 1533 Howard, Chicago 26, Illinois.

\$200.00 MONTHLY Possible, sewing babywear! Write: Cuties, Warsaw 9, Indiana 46580.

HAVE Your own home moneymaking business! Addressing, sewing, other easy ways! Exciting "Opportunities Packet," 25¢. Jones Opportunity Mart, 40-PM, Ministerial Branch, Bedford, New Hampshire 03102.

MAKE Extra money introducing new runless seamless nylons at amazing low direct-from-mill price, 59¢ a pair! Friends snap them up by the dozen. Write for free sample stocking and kit. American Hosiery Mills, Dept. 119, Indianapolis, Ind.

DOLLS! Ideal husband and wife business—never tied down. Money-making opportunities everywhere! Start in home—open shop later. We teach you at home to make repair and sell all kinds of dolls and accessories. Free information. Lifetime Career Schools, Studio MC-16A, 11824 San Vicente Blvd., Los Angeles, Calif. 90049.

DRIVE New car, wear new clothes, buy color TV. Get daily cash income. Put spare hours to work. Write for 5 months free subscription Opportunity Magazine; see hundreds easy ways to make money. Opportunity, Dept. 17-AO, 850 N. Dearborn, Chicago.

BEAUTY Demonstrators—To \$5.00 hour demonstrating Famous Hollywood Cosmetics, your neighborhood. For free samples, details, write Studio Girl, Dept. OP355, 1510 N. Kostner, Chicago.

SHOP Your Thai handicrafts at home. Free samples airmailed postage \$1. Suetrum Ltd., G.P.O. Box 2133, Bangkok, Thailand.

WATCHES, OLD GOLD, JEWELRY

WATCH And clock repairing books. Free catalog. North American, Box 77-AO, Fox River Grove, Illinois 60021.

CASH Immediately for old gold, watches, diamonds and jewelry. Write Bill, Joseph Bros., 5 South Wabash, Chicago 60603.

USED Pocket and wrist watches, needing repairs, 5 for \$10.00; in running condition, 5 for \$25.00. Joseph Bros., 5 South Wabash, Chicago 3.

WATCHMAKERS Tools, materials, supplies, watches. Catalog. Gales, Box 1000, Chicago 90, Ill.

WATCHMAKER'S—Jewelers supplies, instructions. Catalog 50¢. Bengal's, 10717 Venice, Los Angeles 34, California.

WANTED, Gold, silver, platinum, scrap (any form), coins. Information free. Wilmot's, 1067-D Bridge St., Grand Rapids, Michigan 49504.

CASH Immediately for old gold, jewelry, gold teeth, watches, diamonds, silverware, spectacles, platinum, mercury. Free information. Rose Industries, 29-A East Madison, Chicago 2.

HIGHEST Cash for gold, jewelry, gold teeth, rings, diamonds, watches, silver, platinum. Mail articles today. Free gift with information. Chicago Gold & Precious Metals, 6 E. Monroe, Dept. 2758, Chicago 3.

WEARING APPAREL

TELL The more than 1,400,000 avid readers of Popular Mechanics about your products and services. It costs very little to place your classified message in front of these proven mail order buyers. For further details, write: C. A. Martin, Dept. 66N, Popular Mechanics, 575 Lexington Avenue, New York, New York 10022.



SCIENCE AND CHEMISTRY

AMAZING New book of science experiments, formulas, and catalogue of laboratory supplies. Only 35¢. National Scientific Co., 13 S. Park Avenue, Dept. PM-1, Lombard, Illinois.

SKYROCKETS, Firecrackers, fireworks—Make your own! 60 simple formulas \$1.00; 30 smoke formulas, 15 colors \$1.00; 10 fuse formulas 50¢. Paloma Pyrotechnics, Box 247, Auburn 3, California.

CHEMICALS And apparatus for industrial, analytical, and private laboratories. Catalog 35¢. Dept. M-50, Biological Supply Co., 1176 Mt. Hope Ave., Rochester 20, N.Y.

300 PAGE Chemical, apparatus catalog, \$2.00. Laboratory Materials, 1330 Hyde-Park, Chicago 60615.

ROCKETS: New illustrated catalog 25¢. Single and multistage kits, cones, engines, launchers, trackers, technical information, etc. Fast service. Estes Industries, Penrose 7, Colorado.

SEARCHING For economically priced chemicals and apparatus? Gift with catalog. 25¢. Starr Scientific, Manitowoc, Wisconsin 54220.

SCIENCE Fair booklet listing experiments, information, suggestions, \$1.00. Hagenow Laboratories, Manitowoc, Wisconsin 54220.

ILLUSTRATED Catalog: Chemistry, mineralogy, biology 25¢. Tracey Laboratories, Evanston, Illinois.

UNDERWATER Fuse 3/32" diameter 50 feet with fireworks information, \$1.00 postpaid, 110 feet \$2.00. Wayno, Box 182, Addison, Mich.

64 PAGE Color catalog. Science, electronic, chemistry and hobby kits. Radio kit \$2.98. Solar Engine \$1.49. Send 25¢. Schoolmasters Science, 745 State Circle, Ann Arbor, Michigan.

ROCKET-Liquid Propellants. 10-lb. Payload. Plans, \$2.98. Kits, \$34.95. Star Space Systems, 605 West Hyde Park Blvd., Inglewood, California. (Formerly Missile Research of Anaheim.)

UNUSUAL Chemistry courses, kits! Information booklet, 25¢. National, Box 94, Redwood City, Calif. 94064.

UNDERWATER Fuse—36 feet \$1.00 postpaid—plus fireworks catalogue. Christy, Box 85, Bergenfield, New Jersey 07621.

NEW 50 H.P. gas turbine jet engine dia. 7½", length 31". Complete drawings hand book, \$5.00. No C.O.D. Trojan Scientific, 1451 Ridgeley Dr., Los Angeles 19, Calif.

FREE Science catalog. Chemicals, glassware, physics, biology. Frey Scientific, 465 S. Diamond, Mansfield 9, Ohio.

FIRECRACKERS Exploding fireworks, complete instructions. Easy home construction, \$1.00. Mailmart, Soquel, Calif.

CHEMICALS, Apparatus, Biology. Catalog 25¢. Mid-States Scientific, 7053 N. Clark, Chicago, Ill.

FORMULAS, PLANS, ETC.

LATE. Modern manufacturing formulas. List free. Moon Chemical, Martville, New York.

PROFITABLE Manufacturing formulas. Literature free. Pontesso, 2625 South Eighth, Terre Haute, Indiana.

FORMULAS—All kinds. Amazing big catalog, 10¢. Kemixal, Park Ridge, Ill.

FOR Proof of what you can do in specialty manufacturing get our literature. It's free! Miller, Chemist, 1517-P, Tampa, Florida.

MAKE Your own rust remover for .10c a gallon. Formula and Instructions \$1.00. Tradewind, Box 57-A Tekonsha, Mich. 49092.

OUTSTANDING Encyclopedia of formulas, processes, trade secrets. Free information, Cassill, Box 1535, Eugene, Oregon 97401.

PLASTICS

PLASTIC Embedders, jewelry workers. We have everything. Findings, moulds. New catalog 25¢. David Co., 861 Broad St., Dept. M, Providence 3, R.I.

NEW Liquid casting plastic clear colors. Embed real flowers, butterflies, photos, coins. Send 25¢ for two handbooks "How to Cast Liquid Plastics" and "How to Make Extra Money at Home." Castolite, Dept. 66-101-A, Woodstock, Illinois.

NEW! Pressure sensitive plastic laminating machine. Supplies. Details. Burr, 7645 Oakland, Kalamazoo, Mich. 49002.

HOBBY. Laminated engravers, rubber stamp makers supplies. Prices. Bedford, Box 366, Stanton, California 90680.

BOXES. Plastic. 200 sizes. Free list. Author, 2260 Benson Ave., Brooklyn, N.Y.

TREASURE FINDERS

TRANSISTOR Treasure detectors. Underwater detectors. Many models. Free catalog. Gardiner Electronics Co., Dept. 9, 4729 N. 7th Avenue, Phoenix, Ariz.

TREASURE. Find gold, silver, relics with super, powerful Detectron locators. Free information. Detectron, Dept. 1-PM, P.O. Box 243, San Gabriel, California.

COMPLETELY New prospecting technique developed by Relco. New transistor models detect buried gold, silver, coins, treasures, \$19.95 to \$129.50. Write for free catalog and "guide for beginners". Relco-A40, Box 10563, Houston 18, Texas

SAVE! Build transistorized treasure finder. Details free. Del Research, Box 347-B, Alden Manor, Elmont, N.Y.

NEW. Coin locator! Free literature! Howe, 811-C Kansas, Atchison, Kansas.

METAL Locator kits and assembled models from \$39.90. Terms. Transistorized models available. Free catalog. Electronic Applications, Dept. M, Box 6095, Alexandria, Virginia.

POWERFUL Metrotech locators detect gold, silver, coins, relics. Moneyback guarantee, terms. Free information. Underground Explorations, Dept. A, Box 793, Menlo Park, California.

TREASURE Metal detectors most complete line in U.S.A. Free catalog. Bill's Service Center, Box 1, Paramount, California.

TREASURE. Gold, silver, relics. New 1966 detectors now available. Free information. Rayscope, Box 715, North Hollywood, California.

FUN & Profit finding buried treasure, relics with transistor M-Scope. Known worldwide for super-sensitivity, dependability. Guaranteed. Very easy terms. Send for Free literature, fascinating user experiences. Fisher Research, Dept. AAZ, Palo Alto, Calif.

TREASURE-Fone automatic. A new principle in electronic metal detection. Patent Pending. Write: Highlander Co., Dept. 23, 10308 Brenda Way, Rancho Cordova, Calif.

PRECIOUS STONES AND MINERALS

SEMI-Precious uncut gems. Ten different for \$1.00. Request list 30, Prospectors Shop, 201 San Francisco, Santa Fe, New Mexico.

DIAMOND. Guaranteed genuine, natural, \$2.00. Apprx. Weight ¼ carat. C & J Diamond Company, Box 97-M, Plainview, L.I., N.Y. 11803.

U.S. AND foreign mineral specimens, lists 10¢. Minerals, Winston, New Mexico 87943.

EARTH Science. Educational magazine. Subscription, \$2.50. Sample, 35¢. Box 550-PM, Downers Grove, Ill. 60515.

GET Free catalog no serious rockhound, gem cutter, jewelry maker, hobbyist or craftsman can be without. Full of bargains, exclusive items, low prices from largest suppliers and authorities in the field. Free new catalog just off the press, yours for the asking. Write Grieger's, Dept. C-12, 1633 E. Walnut, Pasadena, California.

CARTOONING, COMMERCIAL ART, SHOWCARD & SIGN PAINTING, TATTOOING

SIGN Painting and art. Instructions, brushes, equipment, everything. Free catalogue. Kaufmann Supply, Centertown, Missouri.

YOU Can entertain with chalk talks. Catalog 10¢. Balda the Cartoonist, Oshkosh, Wis.

LEARN Sign painting at home. Free talent test. Ben Kerns, Box 812-PM, Greenville, S.C.

LEARN Profitable magazine cartooning. Free details. Hartman, Box 3097, Lincoln 10, Nebraska.

LIKE To draw? Splendid opportunities in professional cartooning. Write for free catalogue. No obligation. National School of Cartooning, Studio-H, Box 8958, Cleveland 36, Ohio.

DRAFTING: Mechanical, architectural, electronic. Box 641, Los Alamos, New Mexico.

How To make money with simple cartoons. Everyone who likes to draw should have this book! Free. Send name, zip code. Cartoonists' Exchange, 91 Pleasant Hill, Ohio 45359.

"KEY to a Cartoon Career." Send for booklet, 50¢ handling. Cartooning, Box 3176, Colorado Springs, Colorado 80907.

SIGN Painting. Fascinating system. Straley, 410 South Western, Springfield, Ohio.

ADVERTISING AGENCIES, ADV. SERVICE, MAILING LISTS

MAILING Lists most all kinds 1000 \$5.00. Free folder. Your circulars mailed \$4.00 1000. Dixie Mailers, King, N.C.

OUR Clients' mailorder advertisements in magazines and newspapers must pay. If yours don't, contact John O. Powers Advertising Agency, 116 John, New York 38.

ADVERTISING Ratebook leading newspapers, magazines, free. Chicago Advertising Agency, 28-E Jackson, Chicago 4.

MAILORDER Record Book. 30 pages. Records inquiries, orders, advertising expense, etc. Most complete. Just send dime for postage and handling. C. A. Martin, Popular Mechanics, Dept. RB1, 575 Lexington Ave., New York, N.Y. 10022.

TYPEWRITERS, DUPLICATORS, OFFICE EQUIPMENT

OFFSET. Letterpresses, varitypers, typewriters, mimeograph, multigraph machines. Bargains. DixieGraph, King, North Carolina.

RUBBER STAMPS AND OFFICE SUPPLIES

HARD Type for rubber stamp making and printing, free catalog. Barco Type, 237 S. Evergreen, Bensenville, Ill.

FINEST Quality stamps, three lines, \$1.00. Lornel Industries, Tolleson, Arizona.

FREE Catalog: Rubber stamps, printing, Dowling Products, Dept. PMC5, Pitts-town, N.J.

CATALOG: Rubber stamps, business cards. Martin, 1425 Major, Jefferson City, Missouri 65101.

LOGOTYPES For making stock rubber stamps. Deep faced, many designs, free sample. Custom-made. Logotypes, 237 S. Evergreen, Bensenville, Ill.

PRINTING, MULTIGRAPHING, MIMEOGRAPHING, GUMMED LABELS

BUSINESS Printing. Catalog Free. Bill's Press, 538-P Leffingwell, Kirkwood, Missouri 63122.

OFFSET Printing—500—8½x11's \$3.90. Postpaid to 7th Zone. Cisco's Duplicating, Atlanta, Illinois.

AMAZING Business printing values. Samples. Print Shop, Box 576, Greenville, R. I.

1000 NAME, Address labels, \$1.00. Buyers, P.O. Box 565, South Laguna, California 92677.

PRINTING—8 Page catalog—1½¢; 5M 8½ x 11. = 1/S, \$15.00. Free price list. Copen, 337 Butler Street, Brooklyn 1, N.Y.

MIMEOGRAPHING—8½x11's 200, \$1.70; 500, \$3.25. Superior Stamps, Litchfield, O.

PRINTING—Quality business cards, rubber stamps, envelopes. P-B Sales Company, Box 185, Yorktown, Indiana.

QUALITY Printing: Lowest prices. Samples. Dowling Press, Dept. PMC5, Pitts-town, N.J.

LETTERHEADS. Envelopes. Samples. Clyde Williams, 6767 Plank Road, Charlotte, North Carolina.

BUSINESS Cards—Catalog 10¢. Pace Card Company, Box 7, Flushing, New York 11352.

LABELS, Self-sticking. Advise needs. Literature. Eddy, 7 Greenacres, West Hartford, Conn. 06107.

1,000 THERMOGRAPHED (Raised letter) business cards, \$3.75. Free samples! Griffin, 322 West State, Ithaca, New York 14850.

1000 GUMMED Address labels, \$1.00. Walt's, Box 966-A, South Bend, Indiana 46624.

1000 EMBOSSED Business cards \$2.99. Agents wanted, Eldee, Allendale, N.J.

100 PRINTED 5½x8½ letterheads and 100 = 6¾ envelopes \$2.75. Price list free. Purple Enterprises, Box 16291-AN, Jacksonville, Florida 32216.

PRINTING & RUBBER STAMP OUTFITS—SUPPLIES

RUBBER Stamp presses, hydraulic operated, electrically heated. Sizes 5" x 8", 8" x 12", 10" x 15". Starting outfits, supplies. Printing presses. Type cases and cabinets. Custom Manufacturing, 1464-P East Commercial, Springfield, Missouri.

DO Your own printing. Save money. Simple rules. We supply everything. Print for others; good profit. Raised printing like engraving too. Have home shop. Details free. Kelsey Presses, V-11, Meriden, Connecticut.

NEW Type Catalog No. 11, 96 Pages. Send One Dollar. Deductible First Order. Acme Type, 732 Federal, Chicago, Illinois.

RUBBER Stamp outfits, supplies. Kiewit, 2025 Barney Road, Kalamazoo, Mich. 49007.

TYPE And supplies for rubber stamp makers. New wholesale price list No. 3 free. Star Stamp Supply, 732 Federal, Chicago 5, Ill.

RUBBER Stamp manufacturers supplies. New products. Low prices. Catalog. Jackson Supply, 1433 Winnemac, Chicago, Illinois 60640.

DEEP Faced, hard type for better rubber stamps—buy direct from manufacturer. 20% discount for limited time only. Send for brochure. Barco Type Manufacturing, 237 S. Evergreen, Bensenville, Ill.

MAKE Your own self-molding rubber stamps and printing cuts. Plexirubber, Argyle 1, Wisconsin.

REMAILING SERVICE

SECRET Mail receiving system. Hedgpath, 406-M South Second, Alhambra, California 91802.

MIAMI Remails 25¢. Monthly Rates. Marie, P.O.B. 1266, Coral Gables, Florida 33134.

HAWAII Secret address. Remails 25¢. Receiving—forwarding \$3.00 monthly. Postcards, gifts, slides. Coe, Box 984, Kailua, Hawaii 96734.

ATLANTIC City, N.J., International, P.O. Box 1394. Secret. Letters. 20¢; monthly, \$2.50. Also business details.

PRIVATE Address, information 25¢, remails 25¢. Horton, 68 Kensington, Greenville, South Carolina 29609.

OLD Established, 25¢, \$3.00, monthly. DeGraff, Box 14156-P, San Diego, California.

ST. Petersburg, Florida remails, 25¢. Monthly rates. Confidential. 4505-80th Avenue, Pinellas Park, Florida 33565.

ITALY Re-airmails \$1.00. Sample postcard, information 35¢. Capodilupo, Box 7096 Nomentano, Rome, Italy.

REMAILS 25¢. Richards, 222 17th Avenue South East, Calgary, Canada.

CONFIDENTIAL New York City mail address \$3.00 month. Remails 25¢. Details free. Birnhan, 152 W. 42, New York City 36.

LOS Angeles address, remails. Confidential. Enarkay, 1805 Wilshire, Suite 206, California 90057.

SECRET Receiving and remailing. Discreet and confidential. Remail 25¢ single. 8050 S. Main, Houston, Texas.

REPAIRS AND SERVICING

TELL The more than 1,400,000 avid readers of Popular Mechanics about your products and services. It costs very little to place your classified message in front of these proven mail order buyers. For further details, write: C. A. Martin, Dept. 79N, Popular Mechanics, 575 Lexington Avenue, New York, New York 10022.

SPECIAL SERVICES

EYEGLASSES! Wholesale laboratory established 25 years. Mail eyeglasses or prescription for quote. Global Opticians, 16 East 23 St., New York, N.Y.

FACTS. Any subject—product, Research, reports. Plan, \$1.00. Box 1431, Greenville, South Carolina 29602.

TOBACCO

YOUR Ad in this space will be read by more than 1,400,000 active mail order buyers. Join the march to greater profits, place your products and services in front of them today with a small low cost classified ad. For further details, write: C. A. Martin, Dept. 81N, Popular Mechanics, 575 Lexington Avenue, New York, New York 10022.

RAZORS

TELL The more than 1,400,000 avid readers of Popular Mechanics about your products and services. It costs very little to place your classified message in front of these proven mail order buyers. For further details, write: C. A. Martin, Dept. 82N, Popular Mechanics, 575 Lexington Avenue, New York, New York 10022.

WANTED—MISCELLANEOUS

MERCURY, Gold, Silver, Platinum; Ores assayed. Wholesale Terminal, Norwood, Mass.

USED Tennis-golf balls, paper backed books. American Company, Merrick 7, N.Y.

STAMP Collections, accumulations. Eagle Stamp Co., 2221 Romine, Pittsburgh 26, Penna.

PERSONAL

INVESTIGATORS. Free brochure, latest subminiature electronic surveillance equipment. Ace Electronics, 11500-P NW 7th Ave., Miami, Florida 33168.

BLITZ Reducing! 5 pounds overnight! Guaranteed! Bijou, Box 1727-BM, Hollywood, California 90028.

BORROW \$1,233 Airmail! Repay \$54 for twenty-nine months. State licensed. Postal Finance, Dept. 17-M, Kansas City, Kansas 66117.

BIBLE Questions answered. Stamped envelope. Bylon, 17167 Bentler, Detroit, Michigan 48219.

HOME I.Q. test. Free sample. Test Center, Box 139, Fresh Meadows, N.Y.

SUBCONSCIOUS Conditioning remakes personality while you sleep. Free details. Sleep-Learning, Box 24N, Olympia, Washington.

FREE Details solution to all financial problems. Amazing results. Loans available. Write Financial Consultants, 28 E. Jackson, Suite 1204-PM, Chicago 4.

SURVEILLANCE Equipment. New 1966 models. Free details. Write: Security Electronics-PM, 11 East 43 Street, N.Y.C. 10017.

LOANS By mail, \$100-\$1000. Anywhere. Confidential. Write Union Finance, Dept. PM, 222 W. Osborne, P.O. Box 7457, Phoenix, Arizona.

WILL Write short paragraphs, up to 80 words, any subject, \$3.00. Professional Writers, Box 1325, Mission, Kansas.

RUPTURED. Relief and comfort. No understraps, elastic or steel. Write Hand-Lock Products, Preston 4, Ont., Canada.

INTELLIGENCE, Aptitude, personality tests. Complete self-test set \$3.95. Free sample. Spencer Co., 5307 West 8th St., Los Angeles, Calif. 90036.

BORROW \$100 to \$1000 by mail. Quick, easy, private. No co-signers. Repay in 36 small monthly payments. For the amount you want write today to Dial Finance Co., 410 Kilpatrick Bldg., Dept. 1-214, Omaha, Nebraska, 68102.

HOW To wipe out all debts. Clear credit. Free details. Counselor Reports, Harlingen 7, Texas.

NEED Money? Borrow \$100-\$1000 by mail. Confidential, repay in 36 months. Free loan application. Budget Finance Co., Dept. AB-256, 317 So. 20th, Omaha 2, Nebraska.

LOW-Cost loans by mail. \$6.00 monthly repays \$104.50; \$56 monthly repays \$1,321.39. Borrow any amount. Guaranteed fast, confidential. Write today! Bankers Investment 67-C, Box 1648, Hutchinson, Kansas 67501.

MISCELLANEOUS

BIRTH Certificates, Marriage Certificates, Diplomas! 2 blank forms \$1.00. Sample 10¢. Standard Forms, Box 482-M, Washington, D.C. 20044.

SUPER Memory overnight! Success guaranteed! Bijou, Box 1727-M, Hollywood 28, California.

FREE Wholesale catalog! 100,000 products. Tremendous discounts! Taylor Distributors, Newton 2, New Jersey.

YOUR Name sent to 1000 importers, publishers, mailers, wholesalers, etc. on our mailing list. Year \$1.00. Dixie Mailers, King, N. Car.

CESSPOOLS, Septic tanks, dry wells, clogged drains cleaned by Sursolvent. Saves pumping, digging, etc. Electric Sewer Cleaning Co., Boston, Mass. 02134.

HEARING Aid batteries wholesale. Free list. Habs, Box 51, York, Penna.

CIGARETTES—Make 20 plain or filter-tip for 9¢. Factory-fresh pipe tobaccos. Mild tropical flavored Philippine cigars. Facts free. Moberly, Box 905, Owensboro, Kentucky.

ANEMOMETER (Electric wind speed indicating system) complete with meter, cable, transmitter and walnut desk stand, plus free rain gauge, \$19.95. Send money order and save shipping charges. Pioneer Sales Co., Box 7151, Dallas, Texas.

HEARING Aid batteries wholesale. National Wholesale Battery Company, P.O. Box 825, Wichita, Kansas 67201.

MARRIAGE, Birth certificates, diplomas. Quality forms, \$1.00 each. Brugenheimer Publishers, Box 158-PM3, Lexington, Mass.

SAFEGUARD Privacy! New instrument detects electronic "bugs," wire-tapping and snooping devices. Free information. Dee Equipment, Box 7263-E4, Houston 8, Texas.

ORNAMENTAL Iron designs. Book of 1600 beautiful, practical designs for railings, columns, etc. Free literature. Cunningham, 3881 South 3200 West, Salt Lake City, Utah 84119.

HUNDREDS Novelties, jokes, tricks, hobbies, books, gadgets, giftwares, clothing. Empire, 1916 Fifth, Sacramento, Calif. 95814.

LOG Cabins: Ship anywhere; 35 plans, specifications and prices. Send \$1.00. Write Bloch Brothers, Waterford 4, Michigan.

WANT Greatest cash crop working for you? Write Ginseng, Asheville 53, N. C.

CORNELIUS. 3-Stage air compressors 1500 P.S.I. and 3000 P.S.I. \$12.50 up. Rocky, Box 25017, Los Angeles 90025.

HOME Planning kit. Walls, doors, windows, partitions, cabinets, estimate book included. \$4.45 postpaid. Satisfaction guaranteed. Bonnie-Lee Gifts, Box 17383, Dallas, Texas 75217.

Patents Pending: Disposable unfiltered mouthpiece instantly change any flat end cigarette to recessed tip. Also cigarette holder with novel filter type disposable head. Joseph Banoczi, Post Office Box 22, Noroton Heights, Connecticut 06823.

INDESTRUCTIBLE — Visual — thinnest — New — guaranteed Injector razor-blade knife — 1000 uses. Clear sheet nylon Wallet of key case, \$1.00 each. P.O. Box 98, Walnut Creek, California.

LOANS By mail, \$100-\$1000. Anywhere. Confidential. Write Union Finance, Dept. PM, 222 W. Osborne, P.O. Box 7457, Phoenix, Arizona.

LET Us tell you how to turn the reading habits of your friends into profit for you. \$10.00, \$25.00 or \$50.00 can easily and quickly be made under our Popular Mechanics subscription plan. No experience needed. Write Popular Mechanics, Room 1-M, 250 West 55th St., New York 19, N.Y.

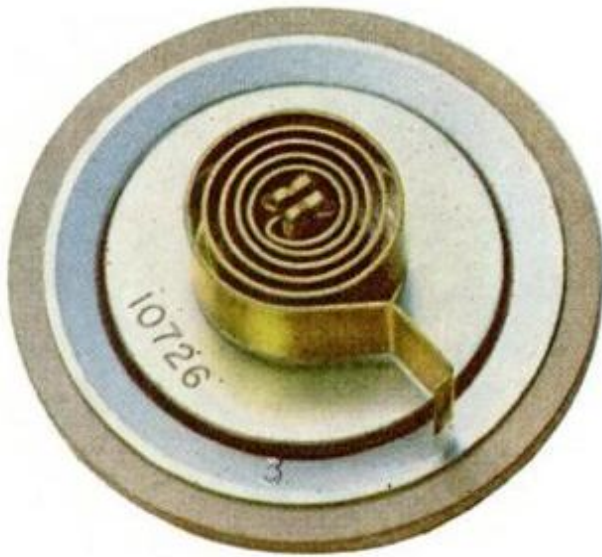

**This is a GM Original:
It responds to temperatures.**

A General Motors replacement automatic choke coil looks, acts, and is like a General Motors Original.

Its spring coil winds and unwinds as the temperature changes, regulating the fuel and air mixture needed for prompt, sure starts.

It's always a good idea to replace any GM

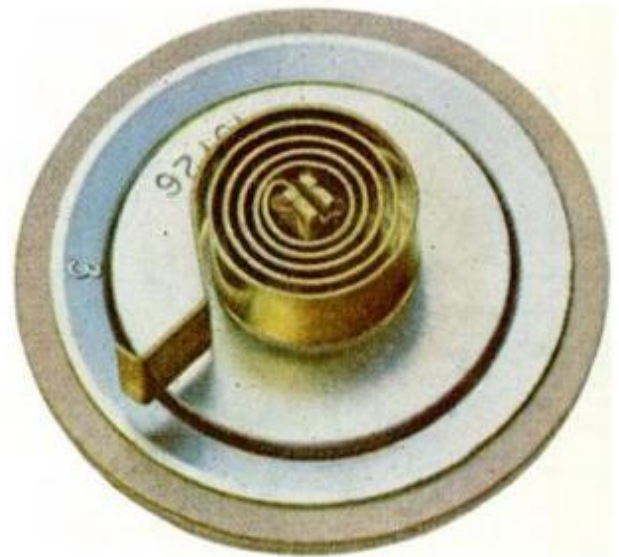

**This is a GM Replacement:
It's every bit as sensitive.**

Original with a genuine GM Replacement. Good parts go with good service.

So be sure to take your car or truck where they use Genuine General Motors Parts. You'll find them all over the country in distinctive GM and United Delco packages. Just like the ones shown here.

GENUINE GENERAL MOTORS PARTS



CHEVROLET • PONTIAC • OLDSMOBILE • BUICK • CADILLAC • GMC TRUCKS

United
Delco





Our new Sixes are messing up the Ford V-8 image!

Great!

For years "Ford V-8" has meant powerful performance. Smooth. Responsive.

It still does.

But today Ford pickups offer another way to get great performance. You get it in our new Sixes. Seven main bearings give them a smoothness you expect only in V-8's. They retain the economy you look for in a Six, yet their size and power (up to 300-cu. in. and 170-hp) put them squarely in the V-8 capability class.

If our new Sixes challenge the Ford V-8 image, that's all right with us.

Who cares about cylinder count? The important thing is the pep and response and smoothness

you get in an engine. And you get it with either a Ford Six or Ford V-8.

Our smoothness in engines is matched by smoothness in ride. Ford's Twin-I-Beam suspension sees to that. Two front axles work independently to absorb road shocks. At the same time, they hold wheel alignment and reduce tire wear.



Big . . . powerful . . . economical . . . smooth? Somehow we kind of like this image.

FORD/66

EDITOR'S PAGE

Suburba-Car contest entrants sent our Shop and Crafts secretary, Carol Schultz, to the Virgin Islands for New Year's. She said she needed a rest after handling the deluge of mail that left her awash in car body designs. They ran the gamut from crayon drawings to precise engineering elevations. The contest, announced in November *PM*, closed at midnight on December 20, and it looks like a tough decision for our panel of judges who must reach a verdict in time for our March issue. Meanwhile, the chassis (with wheels below), has been put in top running order for the winner. The people shown in the Suburba-Car are Alan Flowers and a friend. He's one of the inventors, and is now designing cars for Ford Motor Co. Co-inventor Bryan Skogler is designing cars for General Motors.

It's a frosty dawn for taxidermy nowadays, we hear. The news is that, instead of skinning things like snakes, rabbits and birds, then stuffing them, for those exhibits in the natural history museums, they are freeze-drying them in the exact position needed for the dioramas. The specimen is shaped by hand; the taxidermist uses liquid nitrogen to freeze local parts in place, then puts the pre-set specimen in the deepfreeze to harden. Finally he puts it in a freeze-dry chamber where it becomes a permanent natural statue. You can read the details in next month's *P.M.*

"It's great to be rich," according to Alex Markovich, our New York auto editor, who test-drove some of the world's most expensive cars for the luxury car story on page 94. "There's this Cadillac driver down the street," he told us, "who wheels past my house every morning about the time I'm leaving for the office. Well, he'd always gone right by without glancing in my direction—until the morning I had that Rolls Royce in my driveway. He came past on schedule, but off script—



obviously hit right smack in his status. He nearly left the road while swivel-necking; his eyes looked like a pair of alarm clocks, and his lower jaw was on the floorboards." Alex's third-grade son, however, wasn't nearly as impressed when he found the Rolls waiting to pick him up at school. His classmates stared and scratched their pates, but all young Markovich wanted to know was: "Can it burn rubber?"

The picture at the bottom of this column was captioned "What do I do now?" when it hit this desk. That's what our astute outdoors editor, Stu James, asked the photographer who was taking pictures of him "at work in the field" for a series of *PM* ads. Here's how it happened, according to Stu: The photographer was in position and our editor began his bird stalk. He moved with careful, deliberate steps, shotgun poised—the classic picture of a hunter stalking a ringneck pheasant. Spotting a bird in the brush, our man tensed, ready for the split second of exploding flight. But the silly bird hadn't read the script. He walked up to our "hunter" like a curious penguin, pecked at his boots, circled him once and then flapped up like a chicken homing in on a roost to perch on Stu's shoulder. "And that," our expert explains somewhat lamely, "is a very difficult shot, believe me." We have to believe him. You don't.



Supersonic Transports— Too Fast for Comfort?

By Thomas E. Stimson

The pilots fly blind, the passengers eat cold meals and on some flights they'll land before they take off.

THE AIRLINE'S CHIEF PILOT was sitting in the mock-up of a supersonic transport, peering through the windshield at the craft's long needle nose that drooped down in front.

"Now," said the factory technician, "we'll raise the nose to cruise position." He pressed a button and the nose crept up over the windshield. It was almost like raising a blackout curtain in front of the

cockpit, partially obscuring his vision.

"You mean," the chief pilot demanded, "that my pilots will be flying blind at 1800 miles per hour with 250 passengers if we buy this thing?"

"Not entirely," was the answer. "The pilot has quite a bit of vision overhead and through the side windows in the nose. He can see the weather; he can always see the horizon.

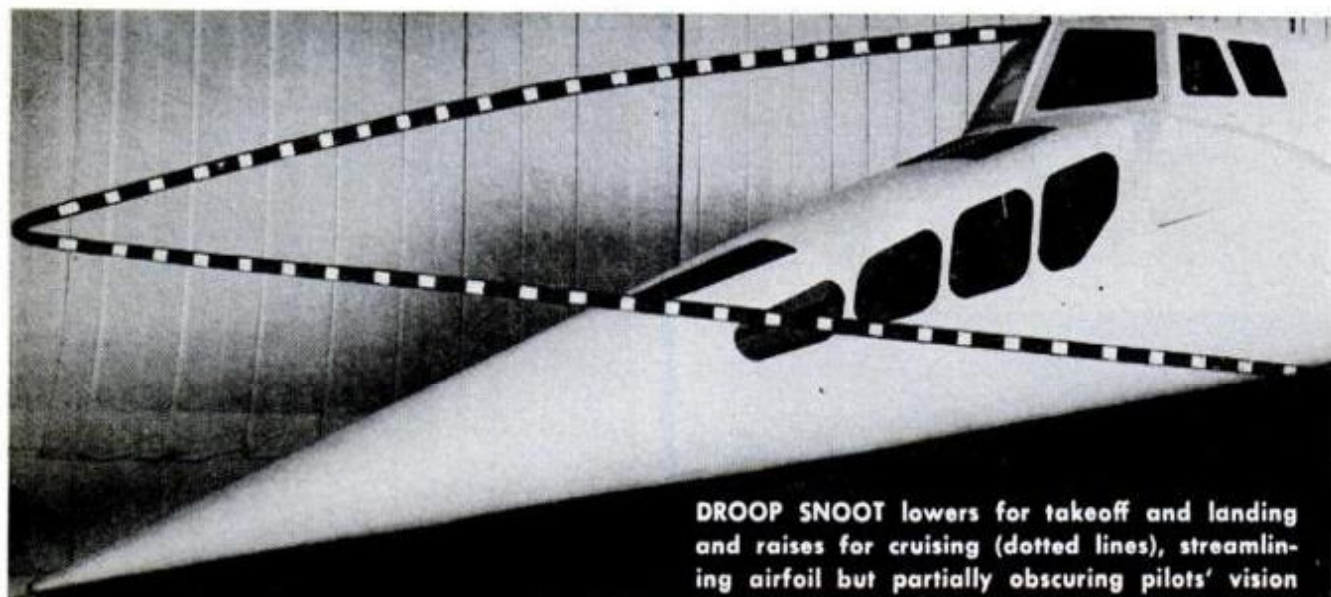

DROOP SNOOT lowers for takeoff and landing and raises for cruising (dotted lines), streamlining airfoil but partially obscuring pilots' vision



PILOT'S EYE VIEW from cockpit of supersonic transport. When nose is up during cruising, his vision is partially obscured (left). When nose is down for takeoffs and landings (above), he has normal vision. Instrument panel will also dispense with round dials, displaying information on moving tapes

"Even with complete forward vision he'd never see another aircraft in time to avoid it. So the SSTs will have their own flight corridors, with no other traffic. There will be no need to maintain a sky watch. When the pilot is descending for a landing he'll simply rotate the nose down again, exposing the windshield. This gives him all the vision he needs."

All the European and American SST

designs are using the "droop snoot" or some variation of it. No better way has been found to protect the windshield at high speed. The friction of the cold air blasting against the windshield would raise the temperature of the glass above 500°, creating a number of problems. Besides, the mere drag of the unstreamlined windshield would "cost" 12 passengers on every trans-Atlantic crossing if it were



DOUBLE-DELTA WING version of supersonic transport offers fixed wing without usual horizontal tail. All controls, except rudder, are in wing

to be left exposed at supersonic speeds. The windshield is only a sample of the problems being encountered—and solved—by the engineers who are designing aircraft that will hurl passengers from New York to Paris in three hours, or New York to Los Angeles in less than two. To begin to get an idea of the forces involved, consider this: The four engines of a 250-ton SST will produce more than half the thrust an Atlas intercontinental rocket!

Now that the United States is well along in designing supersonic transports, an international race is developing over which country will get its plane into service first. It's a race in which the United States is likely to come in last and still win first prize.

The Concorde (French-British) may begin carrying passengers in 1972. The Russians are shooting for the same year. Not for an additional 24 months or so, probably, could the U.S. entry be in airline service.

So how could the United States win first prize?

The answer is that the American entry (or entries) will be faster and larger, and the airlines have learned that passengers won't take a slow plane if seats on a faster one are available. Too, the larger aircraft are more comfortable and cost less to operate per seat-mile. Those are reasons why the U.S. entry is expected to outsell its competition and win first prize.

The Concorde will be red-lined at Mach

2.2. (1450 mph at 60,000 feet) because its aluminum structure would literally wilt from aerodynamic heat if it flew faster. The Russian SST is judged to be of aluminum too; hence it will have the same speed limit.

But Boeing and Lockheed, the two companies competing for the task of building America's entry, have gone a step farther. Each has developed new techniques for fabricating titanium, a stubborn metal that is far more resistant to heat than is aluminum.

Result: Each company plans a titanium aircraft that will cruise at Mach 2.7 at the start (1800 mph at 60,000 feet) and that can "grow" to 2000 mph with larger engines.

All this has brought on a bit of "gentlemanly" trans-Atlantic bickering. The Concorde people, for instance, suggest that neither U.S. design is good enough to have won government support. Fact: Each design looks so good that it's hard to decide which is best, and so more research money has just been granted both companies.

Too, the Europeans say that the United States started to design a 2000-mph aircraft, then had to compromise on a slower one "because of the unknowns in little-known metals that have been tested only modestly." Fact: We settled for 1800 mph at the start because the engine builders need more research time for designing even faster engines.

In turn, more than one U.S. engineer

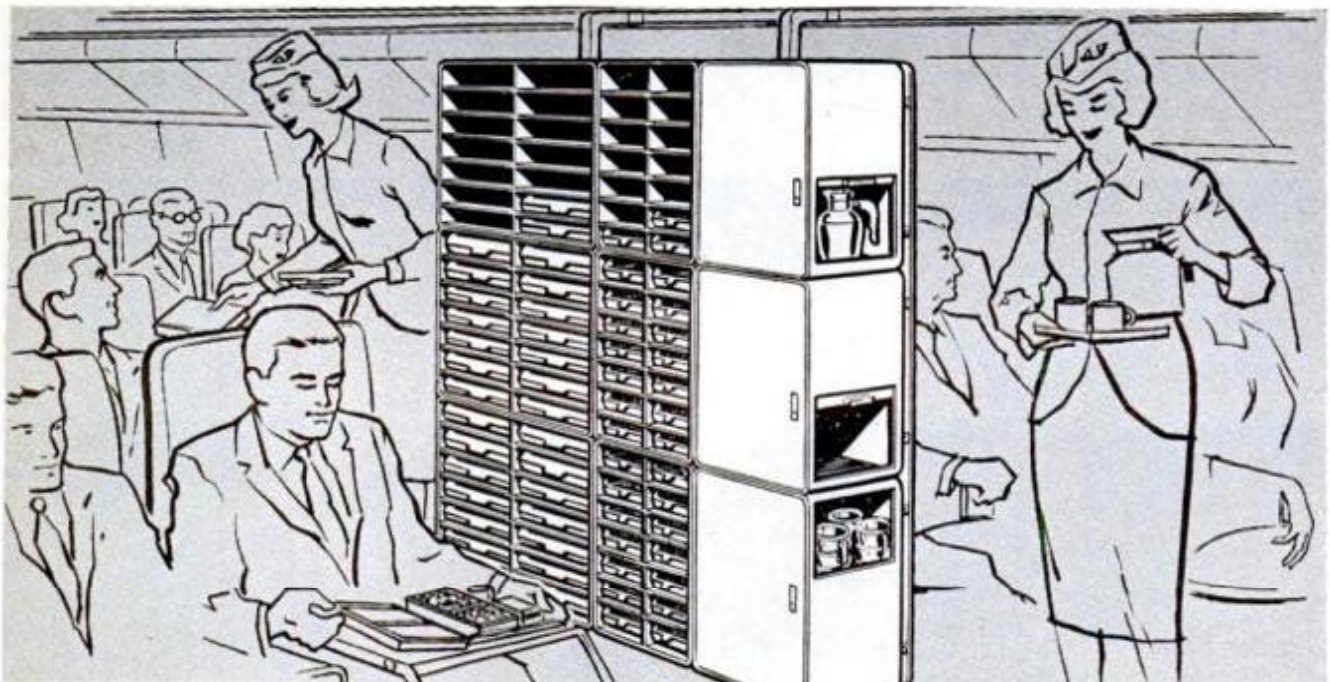

FOOD SERVICE in 250-passenger plane traveling at 2000 mph is another problem. Food cart on overhead trolley is one solution. Each packaged unit can be supplemented with hot item by stewardess on spot



CABIN INTERIOR emphasizes tunnel-like construction. SSTs will be longer but narrower than current subsonic jets. Seats, five across, will be smaller and lighter but provide more space for each individual passenger

feels that the Concorde may encounter problems that could seriously delay its optimistic schedule. For one thing, they don't like the way that the Concorde maintains stability when going supersonic. It's done by pumping a great deal of fuel from its forward tanks to tanks in the rear. American engineers don't think this is the best solution to its trim problem.

They are disturbed, too, by the way its designers grouped the Concorde's engines. There's a single nacelle under each wing, with two engines side by side in each

nacelle. Some weight is saved, yet there are serious objections:

- It is hard to start the second engine in a nacelle because the one already started is grabbing most of the available air. There are ways to solve this, however.

- If one engine in a pair goes out during supersonic flight, a shock wave builds up in front of it (because the air is blocked) and the shock wave drastically cuts the power of its companion engine. Drag goes away up, thrust goes away down, all on one side. The result could be a violent yaw and this might be disastrous.

- The shock wave may beat the nacelle to pieces, producing a complete loss of power on one side. The name for this condition is "inlet buzz."

- A fire in one engine could spread to its companion.

Those are reasons why both American companies have isolated each engine in a separate nacelle. They feel this is by far the safest arrangement.

However, there is some controversy—call it difference of opinion—between the U.S. competitors themselves. Boeing favors a variable-sweep wing for the SST, while Lockheed is betting on its double-delta wing. Each company has spent millions in company funds (in addition to federal millions) on basic research, wind tunnel models and mock-ups. Each has appointed an engineer as "sales manager"

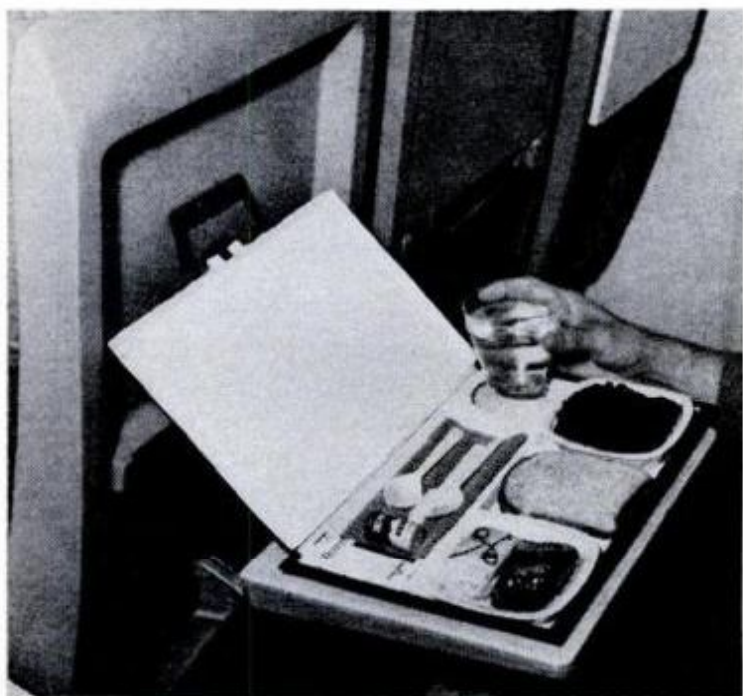

COLD FOOD, literally a box lunch stored in each seat back, is another solution to food problem

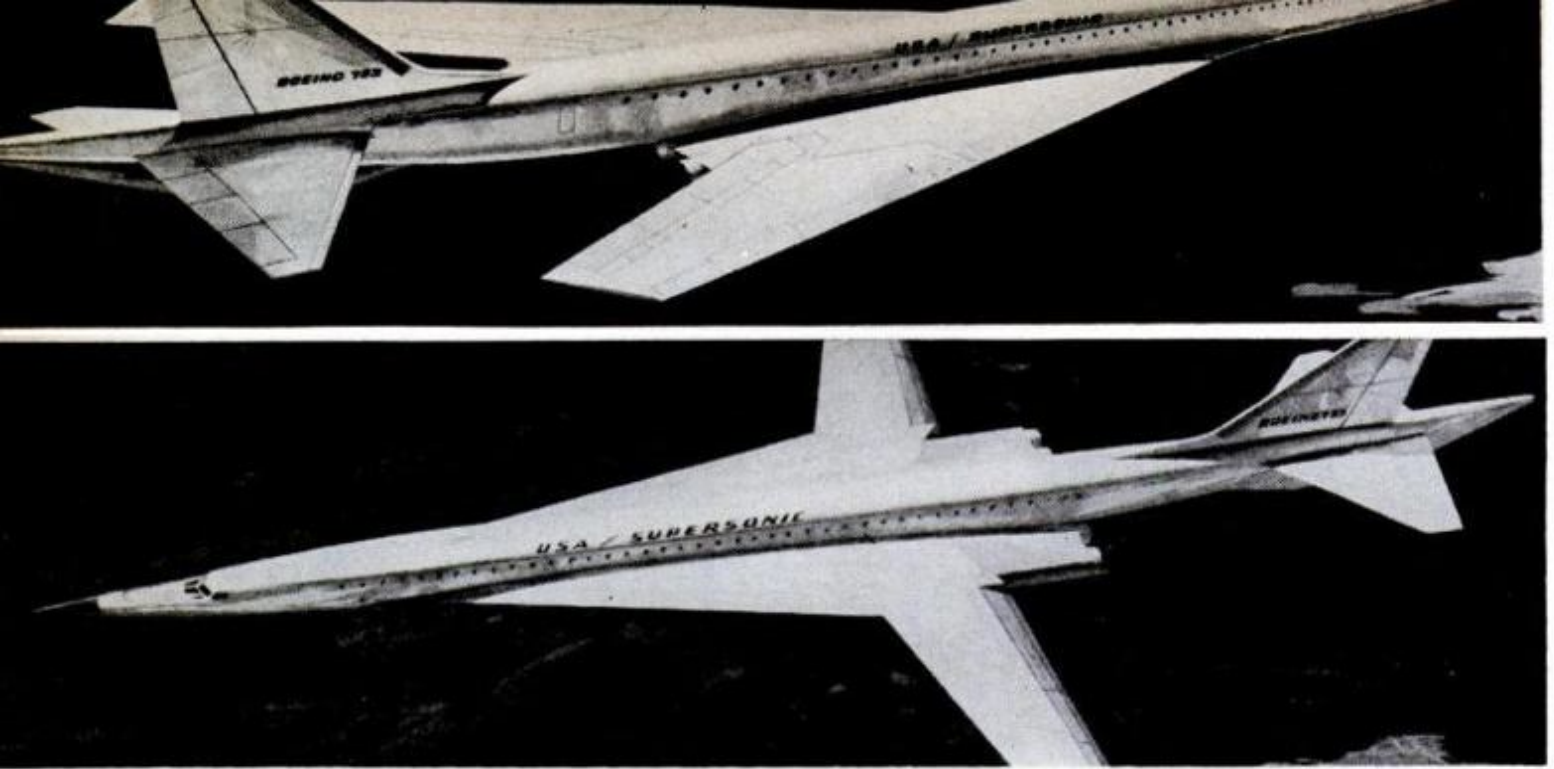

VARIABLE-SWEEP WING version of supersonic transport will extend wing for better control during takeoffs and landings and sweep wing back for transonic and supersonic flight. Both this and delta-wing version have backers in runoff competition and some say there is room for both versions in supersonic age

to help convince the airlines and the FAA that his company's design is best.

To learn why the different philosophies exist, *PM* went direct to the companies. We interviewed William C. Becker, supersonic transport sales manager of the Boeing Co., and P. A. Colman, director of sales, supersonic transport, Lockheed-California Co.

Here's what Bill Becker says: "The Boeing SST is an efficient subsonic aircraft with its wings extended, and becomes an efficient supersonic aircraft with its wings folded back. It can take off and land in appreciably shorter distances than a 707 or a DC-8 and is no more complicated to fly than the present jets.

"The wing joints just happen to be movable joints instead of fixed joints. They are rotated through 52° by means of screwjacks. We've operated a test joint, under load and in hot and cold environments, through 18,000 cycles with no signs of fatigue. Even if the wings could not be swept forward to land, the aircraft could be flown subsonically with its wings folded back and landed in distances not exceeding field lengths available world wide."

In turn, Phil Colman summarizes his company's approach: "The Lockheed L-2000 configuration is the simplest approach to SST requirements, which means greater safety and lower maintenance.

The double-delta is efficient and aerodynamically stable in both the subsonic and supersonic speed ranges without the use of a horizontal tail or the transfer of fuel.

"The wing is called a double-delta because it starts as a narrow delta or chine just aft of the cockpit and then, part way along the fuselage, broadens to the full delta shape. It's a big wing. Its maximum angle of attack is less than halfway to the stall angle. Takeoff and landing speeds are comparable to the present jets."

Expensive as it would be, the industry would prefer to have both designs built and flown. That would be the best way to determine which is superior. The fact is that the SST market is beginning to look so large that there may be room for building both in quantity if some airlines like one design and other airlines prefer the other.

Little details that seem silly today will suddenly become important in the SST age unless they are solved ahead of time. For instance, what's the best way to clean the ashtrays in the cabin? This has been the subject of serious research. It's important because the cleaning of ashtrays (including chewing gum and paper stuffed into them) is the most time-consuming part of cabin housekeeping; seconds count when turn-around time on the ground may be no more than half an hour.

[\(Please turn to page 206\)](#)

Vacation house that can travel

COMPLETELY SELF-CONTAINED and maintenance-free, a new type of vacation house introduced by Outboard Marine Corp., is designed to mount on screw jacks with minimum site preparation.

Produced in cooperation with Alcoa, the walls are laminated sandwich panels of aluminum and foam plastic locked together with Alcoa's Snug-Seam joining system. The inner surface is covered with vinyl, while the outer surface has a baked-on enamel finish. The one-piece roof is a molded fiberglass sandwich panel.

The 10 by 14-foot Deluxe Hideout features built-in facilities to meet all water, fuel and waste-handling requirements, and sells for \$3685. A Spartan camper version lists at \$2985.—*Art Mikesell*

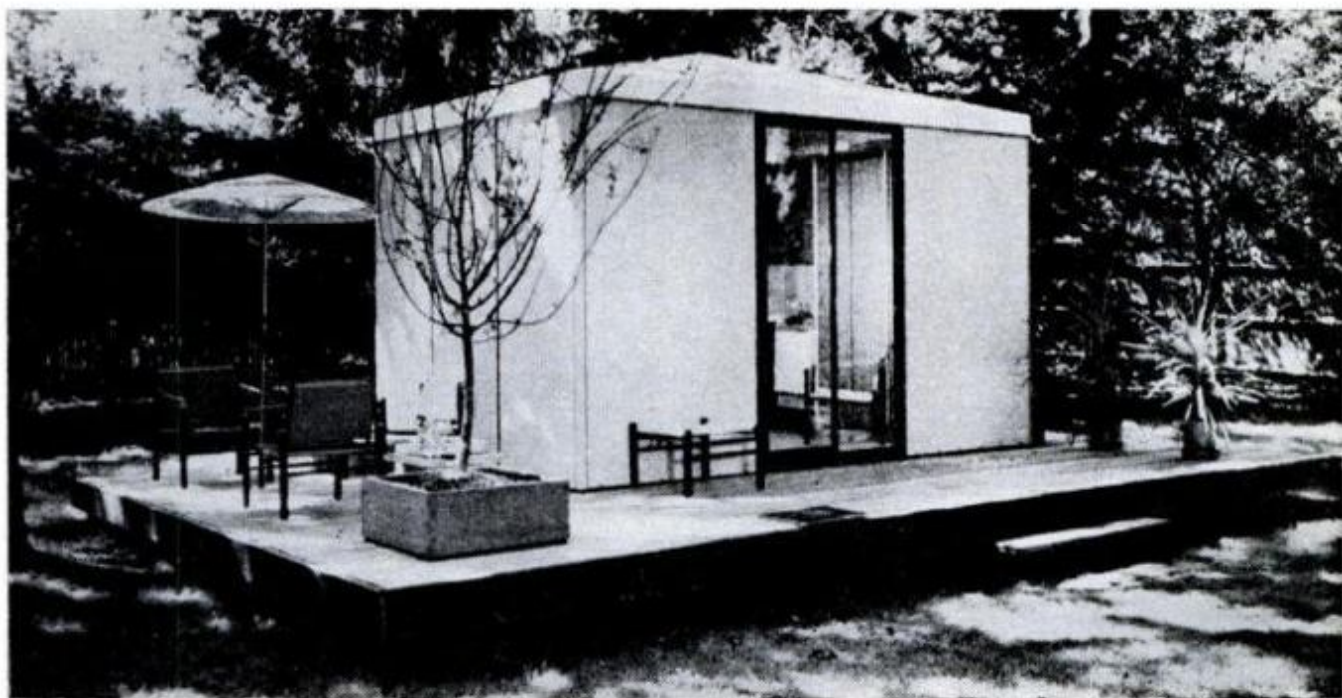

PORTABLE HIDEOUT weighs between 2500 and 3000 pounds, moves on flatbed trailer



CAMPER MODEL has 5 by 10-foot bunk above convertible sofa. Telescoping table shown in "up" position is extra-cost option

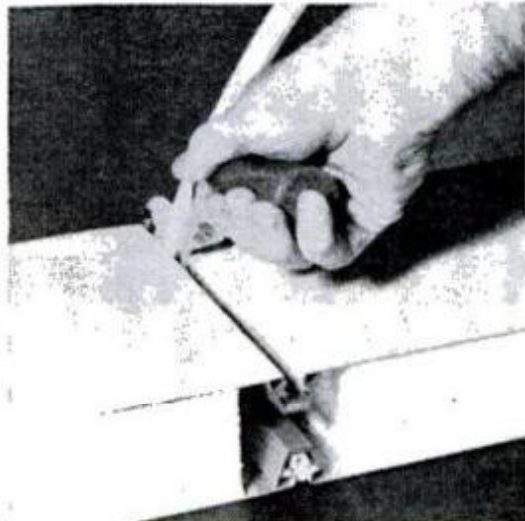

HOOKED EDGES of panels first slide into extrusions, then are locked in place and sealed tightly with neoprene strip gaskets

HOW PLUSH IS A *Luxury car?*

These are six of the cars the rich people drive — and here's why they cost from \$5000 to \$20,000 more

By Jim Dunne and Alex Markovich

Rich smell of wood and leather . . .

is an important part of the Rolls-Royce's appeal. New Silver Shadow, at right, was not available for testing, but should be sold here soon. Styling and engineering are modernized. Most prominent feature of Silver Cloud (farther right) is massive radiator with finely sculptured and detailed ornament. Many purists groaned when Rolls switched to quad headlights recently; we were undecided about the aesthetics, but had to admit that lighting is improved. Front armrests (far right) can be adjusted up and down



Cushiest seats on wheels . . .

are in the Mercedes 600. Double exposure shows how the driver's seat is adjustable six ways to fit anyone from two to twelve feet tall. Reclining rear seat has adjustable headrests. Headroom and legroom are fine except for prominent floor tunnel. Draw drapes on rear and small side windows give privacy, if desired. On a winding country road, set the shocks on "firm" and corner with wild abandon. Lean is negligible, and wheels stick to pavement like glue, thanks to the air suspension



“WHY, YOU CAN practically buy a house for that kind of money,” a neighbor observed as he looked over the \$20,500 Mercedes-Benz 600 in the driveway.

Why would anyone spend this kind of money and even more on a car? Especially when the ads tell you, in effect: Put air-conditioning, stereo music, power seats, power windows and tilt steering on a Galaxie and you have all the luxury you could want. To find out, we drove six of the world's most luxurious cars—Cadillac, Imperial, Lincoln Continental, Jaguar 4.2 Mk X, Mercedes-Benz 600 and Rolls-Royce Silver Cloud III.

For one thing, plenty of extra items on the big cars still make them more comfortable than anything else on the road. Things like Cadillac's “hot seat,” which warms your posterior; Lincoln's automatic tem-

perature control; Imperial's bench-type split front seat with individual six-way power positioning. Then there are television sets, automatic headlight dimmers, variable-ratio steering, automatic leveling devices, adjustable reading lights, more passenger room. True, some of these features are already available on lower-priced cars, but by '67 luxury cars will offer still more exclusive goodies.

The foreign luxury cars offer much the same features as do the U.S. ones, but in even more polished form. The power windows in the Mercedes rise so fast they practically snap to attention. Mercedes and Rolls allow you to vary shock-absorber settings—and hence ride stiffness—with the flick of a dashboard switch. In addition, the Mercedes air suspension allows the car to be raised via a dash switch for



World's biggest sedan . . .

is still Imperial, which tops the field in length, and ties with Cadillac in width. Its interior is plushiest of the U.S. cars, featuring individually adjustable seats with ornate embossing and optional headrests. Fine wood and carpeting add to luxury flavor. Trunk is huge, well laid out. Even spare is carpeted. The 18.5 cu. ft. of usable luggage space is 1.4 more than the Cadillac's; 0.5 more than Lincoln's. The torsion-bar suspension gave Imperial the edge in handling among U.S. cars, but the three foreign luxury cars we test-drove cornered better



Fully automatic everything . . .

If it's not standard on the Cadillac, chances are you can get it as an option—no matter what it is. Door panels are carefully inlaid with thick walnut, and picnic tables fold out in Brougham model. Traditional rear fins reached high point seven years ago, gradually were cut down in recent years. Styling changes from last year are subtle, but overall effect is noticeable. Front end especially looks more tasteful and rich, less chrome-y

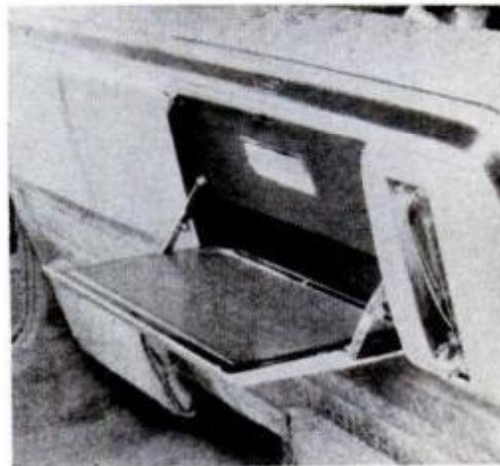

greater ground clearance on bad roads.

The Jaguar Mk X boasts two 12-gallon fuel tanks, each with its own electric fuel pump. This setup came in handy in our test car. It had been in an accident before we got it, and we soon discovered a leak in the fuel pump. No problem. We simply switched to the other tank.

An exclusive feature is the triple-safe brakes in the Rolls—two independent hydraulic systems plus mechanical linkage to the rear wheels. Normally, all work together, but they can work independently in the event of a failure.

We started our tests with an Imperial equipped with airconditioning, automatic speed control, six-way power seats, power windows and vents, and central door-lock control.

On the freeway, we set the speed control and sat back. First thing we noticed was

that conversation was as easy as talking to your favorite bartender. Wind noise is barely noticed.

The big V8 held 75 with no strain, up hill and down, with no noticeable power surges. The airconditioning, adjusted for the just-right temperature, kept us comfortably cool that hot afternoon, without the sound of rushing air.

Cadillac lent us a meticulously prepared Series 60 Special Brougham with Automatic Climate Control, power windows and vents, six-way power seat, front-seat armrest, tinted glass, padded roof, automatic headlight control, high-low-beam control, AM/FM radio, automatic speed control plus all the regular goodies.

When we started the engine in the dark garage, headlights and airconditioning automatically went on. With the shift into Drive, the parking brake automatically



released. The variable-ratio steering was noticeable as soon as we pulled out, but the difference was subtle. The car seemed to glide. Even the brakes seemed smoother.

Outside the garage, the headlights shut themselves off. The cabin stayed at the preset 70° F.

Corners could be negotiated with just half a turn of the steering wheel. And that big 429-cu.-in. V8 moved the Sixty Special's 4700-plus pounds easily and quietly. Actually, you don't notice the quietness until you roll down a window and street noises come in.

Parking this 21-footer is easy—if you can find the room. Variable-ratio steering eliminates frantic cranking.

Our Lincoln test car had a long list of servomechanisms, including automatic temperature control, speed control and electric locks. Its 462-inch V8 is the big-

gest in the industry, and its 340 hp moves its 5285-pound load easily.

The new transmission is one of the smoothest. And the front disc brakes give a clear edge in stopping power.

Big cars tend to ride better than do small cars, and at speed Lincoln's ride is hard to match. But at low speed, both Lincoln and Imperial felt harsh. Other gripes in the Lincoln: windshield wiper chatter, high engine and exhaust noise, and wind leakage around the vent window, all especially irritating in a car of this price.

The Imperial's interior was the cheeriest of the three. Its color schemes were bright. The Crown Imperial steering wheel, dash and door trim are inlaid with claro walnut, a wood so expensive it isn't even used in fine furniture.

Lincoln uses synthetic wood grain, while

Cadillac has rich $\frac{3}{8}$ -inch-thick walnut paneling on Fleetwood doors.

All the cars carry a wider range of upholstery fabrics and colors, and choice of exterior paints is about 40 percent greater than on regular cars. Cadillac sometimes uses more material in testing a fabric than goes into cars during a year's production.

Imperial carpeting is a deep-pile, cut carpeting. It looks and wears better. Another example of costly design is the Imperial front arm rests. They contain power-window switches, the door handle, central lock switch for all doors, an overriding switch that cuts out individual window controls on the other three doors, and a

compartment roomy enough for a purse.

The most exotic technique for testing upholstery is Cadillac's "mink test," which ensures that clothes won't be damaged by too abrasive a fabric. Three mink coats are worn by female employees during 50-mile trips. Any hairs that rub off on the seat are picked up on a small tape-covered card. The new material passes or fails depending on how many hairs are picked up.

Of the three American cars, Lincoln has the most stringent testing procedure. Every car is road-tested 12 miles. Before a car is sold, it has had an oil change, a new oil filter and a new oil pan.

Heavyweight champs. Luxury cars have always been big and heavy, and this

Over 2½ easy-riding tons . . .

need a big engine to push them along. Lincoln's 462-incher is the biggest. The dash is modern, not as sumptuous as those of the other cars. High-speed ride was excellent. Lincoln makes the only four-door convertible available today; rear doors hinge in back for maximum ease of exit and entry. One drawback in convertible, however, is that with top lowered, trunk space is practically nonexistent. Vented disc brakes in front stopped quickly and with little fade, but foreign cars' brakes still felt more sensitive and progressive. Steering was slow



Posh racing tradition . . .

reflects in Jaguar Mark 10 engine, whose one hp per cubic inch gives sporty performance. The "Jag" is really in a category apart from the other cars, since its primary purpose is performance. It's a driver's car more than the others are, and its handling is the best of the lot, though Mercedes and Rolls are a close second and third. The Jaguar tends to be the most temperamental probably because its engine is so highly tuned. High oil consumption is a long-time Jaguar characteristic, and the Mark 10 is no exception. But for the money, it's a bargain for the driver who wants to go fast luxuriously



isn't accidental. An extra measure of strength is built in for trouble-free service. Each car has more wiring than does a five-room house. A Lincoln front door weighs 129 pounds. An Imperial convertible has 17 motors in addition to the engine. Bigger engines allow reduced-ratio rear differentials, which in turn give lower engine speeds, quietness, economy and less wear.

But all isn't perfection. Cadillac, for example, is having trouble with window seals and weatherstripping. The culprits are a new sealing technique and pillar design.

Lincoln's four-door convertible, the only one made today, has one incredible flaw. With top down, even a two-suitcase

won't fit in the trunk. Trunk space in the sedan, on the other hand, is cavernous.

Imperial's big drawback is its stodgy, old-fashioned styling. But for sheer size, you can't beat the car.

A \$300 grille. Our foreign-car tests started with a Rolls-Royce Silver Cloud III. The Silver Phantom runs \$32,000, or even more with custom coachwork, but our test car was the poor man's model. Only \$17,675 including airconditioning. It's identical to the short-wheelbase Bentley, except for the handmade, hand-soldered, stainless-steel grille (an extra \$300).

Rolls factory testing is the most thorough of all. Every car is run at least 130

[\(Please turn to page 230\)](#)



THREE HOT ENGINES HIT THE STREET

They're not for maiden aunts or people with bad nerves, and they require skillful driving; but if you love performance, check out the Ford, Chrysler and Chev 425-hp tamed-down racing V8s.

By Jim Dunne

DETROIT'S THREE MIGHTIEST ENGINES, the 425-horsepower monsters from Ford, Chrysler and Chevrolet may create a whole new breed of careful drivers. They'd better! Otherwise you may see people come out of their driveways doing rear wheel stands.

All that power demands a degree of alertness and caution that has never before

Chevrolet

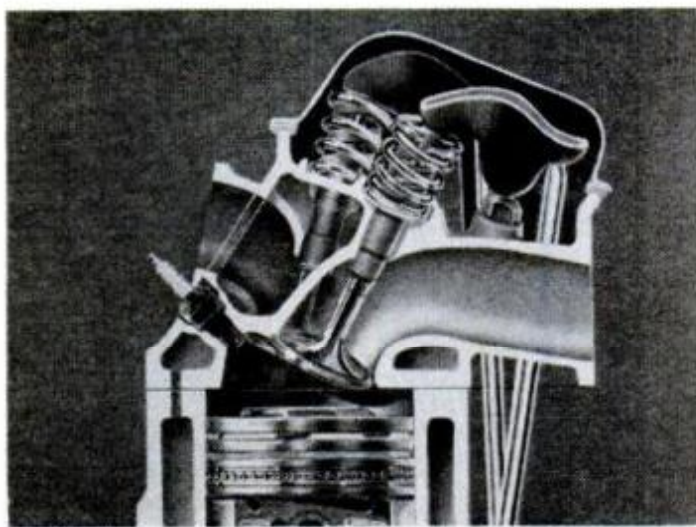

WITH ALL THAT POWER, Chevrolet proved to be a handful on gravel roads. It was the only test car with conventional soft suspension. New 427 engine, only one of the three with a single four-barrel carburetor, felt more docile than the others, though its performance was competitive. Mild carburetion, combined with ultra-efficient porcupine-valve head design, gave by far the best fuel economy. Valves jut out in all directions like a porcupine's quills; their main advantage is to provide a smooth, unrestricted flow of fuel through the ports, without the usual sharp bends

been required of the driver of an average automobile. There is too much Go in these engines for anyone to be careless behind the wheel.

But the big powerplants add fun to your driving too. Besides providing power to get out of dangerous traffic quickly, the engines furnish more control over the action of the car; something seldom experienced nowadays in Detroit's automated sedans.

Now, for the first time, domesticated versions of all the companies' seven litre race engines are available for drivers who need everyday transportation, but still want to use the dragstrip for amateur competition. All have identical 425 h.p. ratings. Ford offers the 427 cubic inch V8 in Galaxie models; Chevrolet's "porcupine" 427 comes in Impalas and Corvettes; Chrysler's hemi 426 is available in Coronets, Belvederes and Chargers.

We took three cars equipped with these engines and put them through controlled tests to see just what such power feels like on the road. Ford supplied a 7 Litre 2-door hardtop, Chevrolet an Impala SS convertible and Dodge a Coronet 2-door hardtop for sampling. They were run through acceleration, handling and gas economy tests. All three cars were built with standard factory parts and tires. The engines were the same ones you can get from your dealer. There was nothing special done to the cars that was not spelled out in the specs. They were strictly stock, beefed up with the safety and handling equipment that is normally recommended by the factory for street driving.

Our test showed the cars to be pretty evenly matched in performance. Because

Ford

HYDRAULIC VALVE lifters limit the revs on Ford 7 Litre engine, but they're quieter than mechanical lifters. Street options such as automatic transmission, power steering, power brakes and airconditioning, not available with racing 427 engine, can be had with 7 Litre. However, heavy-duty suspension, standard with racing engine, is optional in this car. Front power disc brakes are standard on 7 Litre, optional in other Galaxies. Exterior identification is provided by striping, special wheel covers, 7 Litre emblem

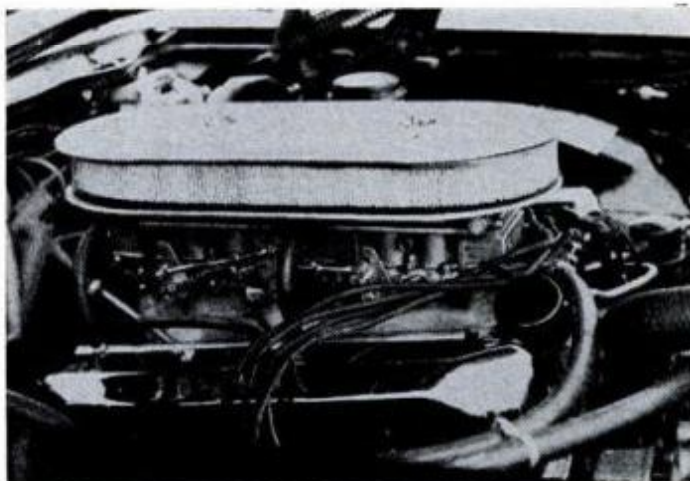

of the different equipment, each did best in different phases of the performance testing. With the same tires and rear-end ratios, it took the skill of the driver to tip the scales in favor of one car or the other.

Acceleration runs showed Chevrolet to be fastest in the sprints: zero to 30, 0-60 and 0-90 miles per hour. The Coronet hemi was fastest in speeds in the passing ranges from 40-60 and 60-80 miles per hour. And somehow Ford managed to win the quarter mile run with an elapsed time of 14.5 seconds, even though it was second or third in every other acceleration run.

Fuel consumption is a different story. Here, Chevrolet came out the undisputed champ with 17.65 mpg. The Dodge went 13.8; Ford lagged far behind at 11.4.

I ran the Ford test first, in a 7 Litre 2-door hardtop. The car was loaded with options: transistorized ignition, disc brakes in front, AM/FM radio, power bucket seat, center console, power door locks and a new safety convenience panel that lights up like a Chicago jukebox.

Ford Division had the car outfitted with heavy-duty suspension, oversize wheels and 8.15 x 15 Firestone 500 tires. There also was a heavy-duty clutch and a 4.11 rear axle for maximum torque off the line. All told, the Ford weighed 4506 pounds during acceleration runs. As mentioned, this car had the best quarter-mile time. It was a tenth of a second behind Chevy on the 0-30 run, but

[\(Please turn to page 226\)](#)

Chrysler



STREET HEMI 426, available only in Dodge Coronet and Charger and Plymouth Belvedere, is basically the racing hemi but with milder cam, lower compression. Test Coronet was at slight disadvantage because it was only car with automatic instead of four-speed manual transmission. But TorqueFlite proved efficient and positive. Optional heavy-duty suspension gave almost harsh ride, but handling was fine. Traction off line was no problem, thanks to good gearing, limited-slip differential. No axle hop, either.



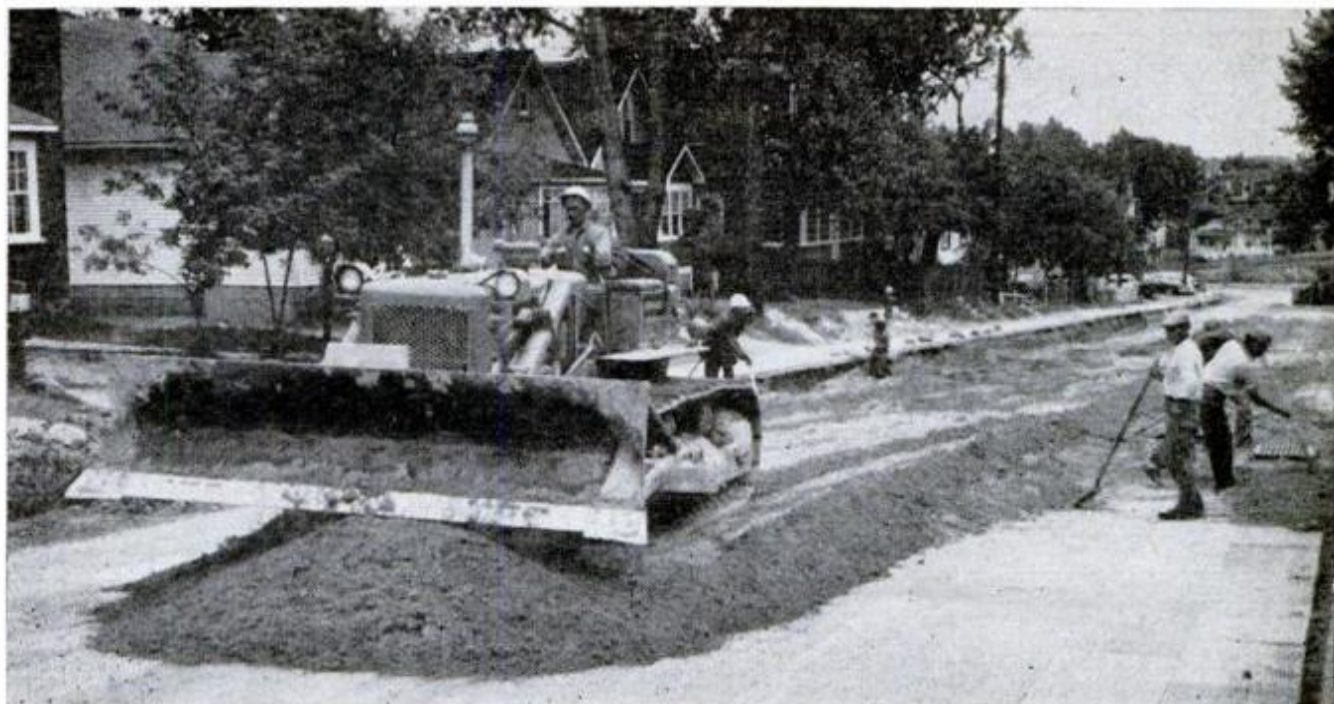

To beat Jack Frost. Canadian engineers are experimenting to determine if a layer of two-inch-thick polystyrene boards between the asphalt surface and the base course of a road will prevent heaving in extremely cold weather. Test site is a 100-foot section of road in Ontario. Thermocouples were buried in the roadbed to provide constant temperature readings.

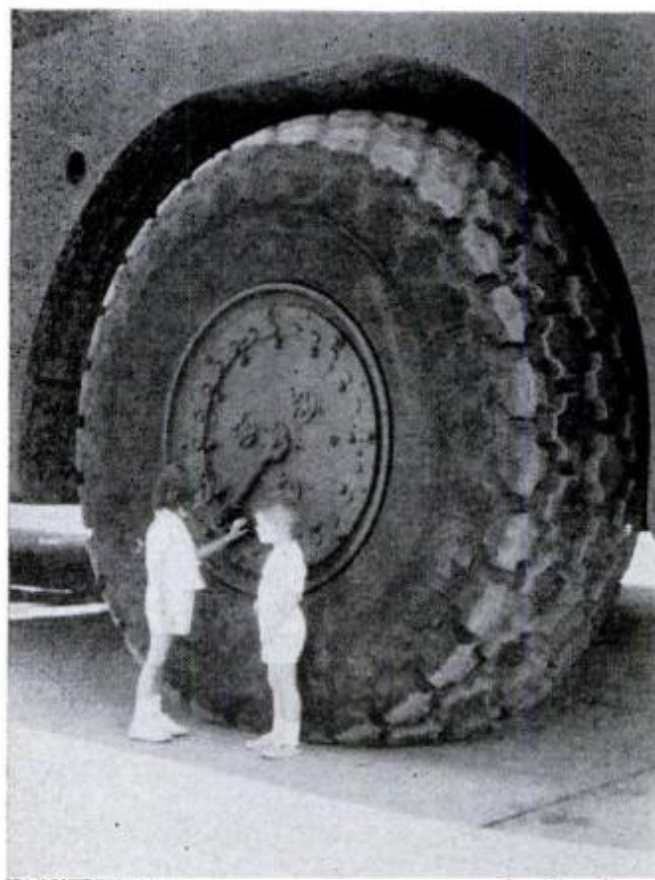

Nine-and-a-half-foot tire towers over small fry. It's one of four used on Army's new amphibious "Bard," a 100-ton vehicle that will haul 120,000 pounds of cargo or 100 soldiers over land or water. Each tire weighs nearly 1½ tons and includes enough rubber for 600 passenger car tires.

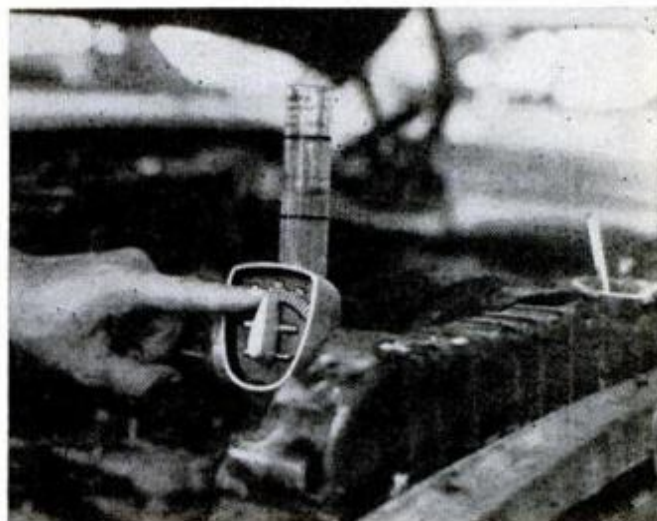

Cooling-system tester. When your engine is overheating you can quickly trace the trouble to a sticking thermostat, balky water pump or clogged water passage by connecting the flow pipe of the new Morgan Tester between the radiator and its inlet hose. Action and level of the water after it passes through a butterfly valve and tiny hole into a clear plastic standpipe tell the story with readings on a simple flow meter. The tester also reveals if the system needs flushing or has a combustion leak into the water jacket. It is sold, complete with adapters for 1¼ to 2-inch hoses, for \$24.95 by the Morgan Manufacturing Co., 29 S. Brown Ave., Scottsdale, Ariz.

Comfort-Livability

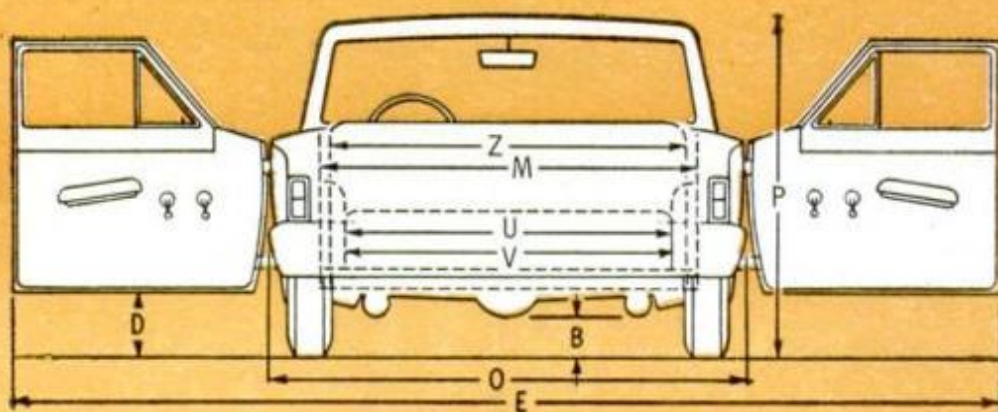

	A	B	C	D	E	F-G	H-I	J	K	L	M			
	Max. driveway departure angle ^a	Max. depth doorsill to floor	Min. road clearance	Min. front-end curb clearance	Open-door curb clearance	Open-door wingspread	Front-door opening horizontal x vertical	Rear-door opening horizontal x vertical	Head clearance under hood	Head clearance under trunk lid	Luggage lifting height	Trunk-opening width	Usable luggage capacity, cu. ft.	Standard Steering ratio (: 1)
Ambassador	13.7	4.3	5.6	8.0	15.0	142.4	35.0x36.5	33.0x36.0	71.5	63.3	21.1	49.8	15.2	28.4
American	16.7	3.5	6.0	8.0	14.3	137.1	34.8x37.0	33.0x36.0	66.0	63.8	26.8	45.5	12.0	29.0
Belvedere	9.9	4.0	4.4	8.0	14.5	145.6	30.5x36.5	30.0x36.0	67.5	61.0	22.4	48.3	16.8	29.0
Barracuda (2-Dr.)	11.8	2.5	5.0	7.5	14.3	150.5	41.0x36.5	—	6.75	56.0	23.4	48.8	5.7	28.9
Buick	15.5	0.3	5.5	7.1	12.3	148.5	37.0x38.5	33.0x38.5	73.8	71.3	27.9	57.5	17.0	33.2
Cadillac	13.7	1.3	7.2	9.0	13.3	148.9	34.0x36.5	31.0x36.5	76.0	71.0	27.2	57.5	17.1	NA
Chevelle	13.0	2.0	4.8	9.0	12.8	134.7	43.0x36.5	29.3x36.5	71.0	71.0	28.9	52.3	17.1	28.0
Chevrolet	12.0	2.5	5.7	7.5	12.5	163.8	33.5x37.0	30.0x37.5	71.5	71.0	24.8	54.0	18.3	28.2
Chevy II	17.0	2.0	6.1	8.5	13.5	134.0	32.0x37.5	31.0x37.5	67.0	69.3	23.2	53.5	13.0	25.4
Chrysler	10.1	2.5	5.4	8.0	15.0	152.6	35.0x36.5	32.0x36.5	72.5	72.5	25.8	54.5	17.4	32.1
Classic	13.7	4.0	5.9	7.5	14.0	142.4	34.8x36.5	33.0x35.8	67.0	63.3	21.1	49.8	15.2	28.4
Comet	14.1	2.5	5.5	10.0	14.0	138.9	31.8x36.8	30.0x35.5	73.0	67.3	29.1	51.8	15.0	29.4
Coronet	11.6	3.5	4.5	7.5	14.0	145.6	33.0x36.5	29.5x36.0	70.0	66.5	NA	46.0	22.5	29.0
Corvair	20.0	4.0	5.4	10.5	12.0	131.3	30.8x35.0	28.0x34.5	65.0	72.0	27.6	48.0	7.0	23.3
Corvette (2-Dr.)	17.0	6.5	5.0	8.0	14.0	139.3	33.5x32.5	—	68.0	—	—	—	10.6	20.2 ¹
Dart	12.5	2.8	4.9	8.0	14.5	139.2	33.0x36.0	28.3x35.5	72.5	64.5	20.4	46.0	17.3	28.9
Dodge	10.8	2.5	5.4	7.0	13.0	152.6	37.0x38.0	33.4x37.0	72.3	64.0	22.7	48.5	NA	32.0
F-85	16.0	1.0	5.5	7.0	13.0	135.0	31.0x37.5	28.3x37.0	73.0	68.0	30.1	53.3	20.1	28.3
Fairlane	13.1	3.0	5.4	9.5	14.3	158.2	31.5x36.3	29.0x35.5	73.0	65.5	22.4	51.8	15.2	29.4
Falcon	15.9	4.0	5.6	7.5	13.8	158.2	31.5x36.8	29.0x35.8	71.0	58.3	23.1	49.5	12.3	29.4
Ford	11.9	2.0	5.5	9.0	14.0	164.1	31.8x37.0	29.0x36.0	72.0	63.3	23.4	49.5	19.1	30.9
Imperial	9.2	1.5	4.3	8.0	15.0	154.0	35.0x38.5	26.0x37.5	73.0	68.0	27.8	60.0	18.5	19.4 ²
Lincoln	12.2	3.3	5.5	9.8	13.3	148.9	33.5x37.5	30.0x36.0	81.0	68.8	26.2	68.0	18.0	20.5 ³
Martin	14.0	3.0	6.2	9.0	13.5	155.5	44.3x35.3	—	67.0	55.5	24.7	25.8	11.7	28.4
Mercury	13.3	1.5	5.9	9.8	13.0	145.6	32.0x37.0	30.0x37.0	74.0	68.0	24.4	56.5	18.6	31.1
Mustang (2-Dr.)	17.1	4.0	5.2	8.0	14.5	150.2	42.0x33.0	—	75.0	57.0	27.5	50.3	9.0	27.0
Oldsmobile	13.1	0	5.6	8.8	13.8	143.8	33.0x39.0	33.0x38.5	74.0	74.0	27.9	57.3	19.4	33.4
Plymouth	10.4	3.5	5.2	7.5	14.25	152.6	35.0x37.5	30.0x37.0	74.0	62.5	18.1	54.3	17.0	32.0
Pontiac	13.2	1.3	6.0	8.2	12.8	143.6	33.3x37.8	30.0x38.3	74.3	66.3	29.0	53.5	19.2	29.8
Riviera (2-Dr.)	16.8	0	4.8	7.8	13.0	163.2	43.0x38.0	—	76.0	69.0	26.9	45.8	10.3	16.4 ²
Special	17.5	1.5	6.0	8.0	12.5	134.1	31.0x37.0	29.5x36.5	71.0	67.0	28.4	56.0	18.9	28.6
Tempest	14.8	2.0	5.7	6.5	12.5	134.5	32.0x36.0	29.5x36.0	73.0	66.5	29.1	51.5	21.6	28.3
Toronado (2-Dr.)	13.0	0	5.0	8.5	12.0	170.2	31.0x38.8	—	74.0	64.0	31.6	50.5	14.5	17.8 ³
Thunderbird (2-Dr.)	12.9	4.0	5.5	8.0	12.8	NA	45.0x37.0	—	69.0	57.0	27.1	65.5	11.5	20.4 ²
Valiant	11.6	2.5	5.0	7.5	12.5	139.2	34.0x36.5	28.5x36.0	71.0	60.0	23.2	50.0	14.1	28.9

¹17.6 optional ²2.9 optional ³power steering standard

Index to the 1966 Cars

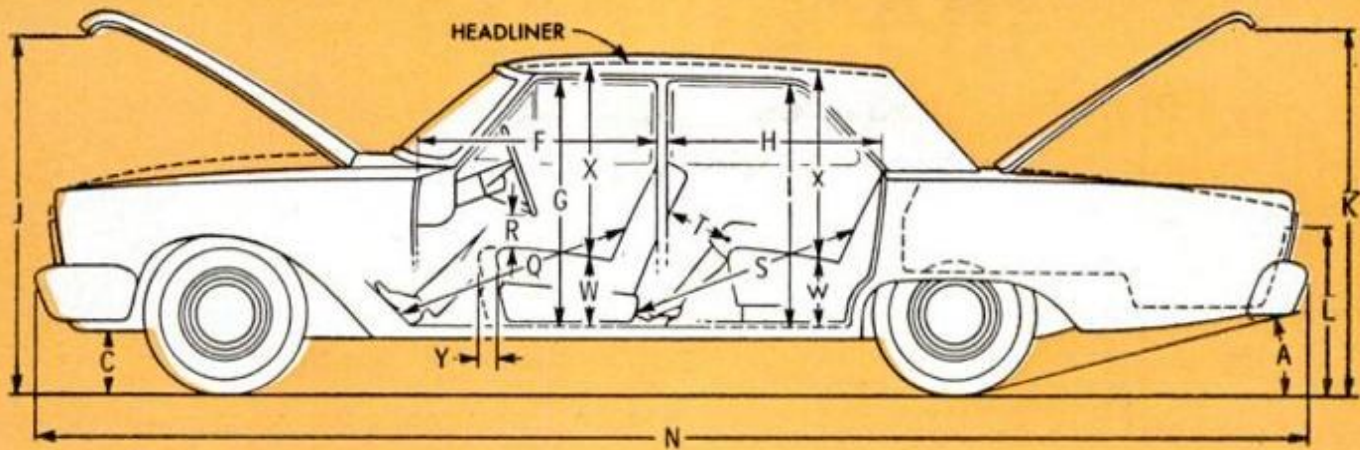

N-O-P

Q

R

S

T

U

V

W

X

Y

Z

Overall length x width x height	Turning circle curb-to-curb, ft.	Wheel turns lock-to-lock	Wheelbase	Max. front legroom	Min. steering wheel thigh clearance	Min. rear legroom	Min. rear kneeroom	Front-seat hiproom	Rear-seat hiproom	Seat height front/rear	Headroom front/rear	Front-seat travel	Min. shoulder room	Glove box depth x opening width x opening height
200.0x74.5x55.0	39.0	6.0	116.0	41.0	4.3	41.0	5.0	60.2	60.1	11.8/13.1	39.2/37.0	6.0	57.8	5.8x15.0x5.5
181.0x69.5x54.5	38.0	6.0	106.0	41.0	4.1	36.5	3.8	57.2	57.1	11.8/12.6	39.2/37.0	6.0	54.8	5.0x17.3x6.0
200.5x75.5x54.9	40.6	5.4	116.0	42.0	4.3	34.2	4.4	60.4	60.6	8.6/11.0	38.7/37.2	4.5	58.0	5.5x19.0x6.0
188.3x70.2x53.0	37.1	5.3	106.0	40.7	2.9	30.6	1.1	56.9	57.0	8.0/10.3	38.2/36.8	4.5	52.6	6.0x10.3x4.5
217.0x80.0x55.2	43.2	5.8	123.0	42.2	4.2	39.0	5.6	63.7	62.9	10.7/14.2	38.9/37.7	4.8	61.4	7.0x14.5x5.5
224.0x80.0x55.6	44.7	NA	129.5	41.0	3.5	41.6	8.1	61.9	62.5	12.5/14.7	39.5/38.4	4.8	60.8	10.0x11.3x5.5
197.0x75.0x53.0	40.3	5.5	115.0	41.9	3.9	36.0	3.5	59.9	59.9	10.9/13.2	38.5/37.3	4.0	58.7	6.0x12.5x4.0
213.2x79.6x55.4	40.8	5.4	119.0	42.2	4.0	39.5	5.7	63.7	62.9	11.4/14.2	38.1/37.3	4.8	61.3	8.0x15.5x5.3
183.0x71.3x55.1	38.4	4.5	110.0	40.7	3.5	36.2	3.3	59.2	58.6	12.0/12.5	38.8/37.3	4.0	55.2	5.0x17.5x5.0
219.0x79.5x55.5	44.0	5.8	124.0	42.0	4.4	40.8	7.4	63.3	63.4	8.9/11.8	39.3/38.5	4.5	60.0	8.0x13.0x6.0
195.0x74.5x54.3	39.0	6.0	112.0	41.0	4.3	41.0	5.0	60.2	60.1	11.8/13.1	39.3/37.0	6.0	57.8	6.0x15.0x5.3
195.9x73.8x55.0	41.5	5.0	116.0	42.1	4.3	33.9	4.2	59.5	58.3	10.7/13.7	38.8/37.3	5.0	56.7	8.0x12.5x4.8
203.0x75.3x53.7	40.9	5.4	117.0	42.0	4.3	36.5	4.4	60.4	60.4	8.6/11.0	38.8/37.8	4.5	58.0	6.0x19.3x6.0
183.3x69.7x51.2	35.2	4.7	108.0	41.1	3.1	35.4	3.0	5.61	56.1	10.0/11.6	37.6/36.4	4.0	54.3	6.5x11.0x6.0
175.1x69.2x49.6	39.9	3.4 ²	98.0	42.7	4.5	—	—	50.9	—	9.0/—	37.0/—	4.0	48.4	6.5x16x17.5
196.3x70.8x52.7	38.6	5.3	111.0	40.7	3.0	35.6	4.5	56.9	57.0	8.0/11.6	38.2/37.3	4.5	54.2	6.0x8.5x4.5
213.3x80.0x55.4	43.4	5.8	121.0	42.0	4.4	40.8	7.4	63.3	63.4	8.9/12.0	39.3/38.5	4.5	60.0	6.0x11.2x5.5
204.2x75.4x54.5	41.0	5.6	115.0	41.3	3.4	36.0	3.6	59.9	59.9	11.1/13.3	38.1/37.2	4.0	58.8	9.0x9.3x5.5
197.0x74.7x55.0	41.5	5.0	116.0	42.1	4.3	36.1	4.2	59.5	59.5	10.7/NA	38.5/37.5	5.0	58.0	6.5x14.0x5.0
184.3x73.5x54.6	39.8	5.0	111.0	42.1	4.3	36.0	2.2	59.5	59.5	10.7/NA	38.4/37.7	5.0	58.0	6.4x14.0x5.3
210.0x79.0x55.6	41.0	5.8	119.0	41.8	4.2	37.7	4.7	62.6	62.7	10.3/NA	38.9/37.7	5.5	59.9	5.5x13.0x4.0
227.8x80.0x56.6	47.7	3.2 ²	129.0	41.5	3.8	40.4	8.8	61.0	60.2	8.4/11.3	38.4/38.7	5.0	62.0	7.0x15.0x4.8
220.9x79.7x54.5	47.4	3.8 ²	126.0	41.0	4.0	40.5	7.8	62.0	62.0	12.4/13.3	39.4/38.6	5.5	59.8	5.3x15.8x3.1
195.0x74.5x54.2	39.0	6.0	112.0	41.0	4.3	36.0	3.9	60.2	59.4	11.8/11.0	38.8/36.5	6.0	54.6	6.0x15.5x5.8
220.4x79.6x56.0	43.6	5.3	123.0	41.9	4.2	37.6	4.4	62.6	62.7	10.6/13.2	38.8/37.7	5.5	58.7	7.0x13.0x6.5
181.6x68.2x51.5	38.9	4.6	108.0	41.8	3.2	28.8	0.6	54.7	50.9	9.2/NA	37.4/35.6	5.0	53.9	7.8x13.3x3.0
217.0x80.0x55.5	43.6	5.5	123.0	41.1	3.8	39.0	5.3	63.7	62.8	10.8/14.4	38.8/37.8	4.8	61.4	6.3x15.5x4.3
209.8x78.7x54.9	42.7	5.8	119.0	42.0	4.4	38.7	5.6	63.3	63.5	8.9/11.9	39.0/37.7	4.5	60.0	7.0x17.0x5.0
214.8x79.7x55.3	42.8	5.0	121.0	42.6	4.5	38.3	4.5	63.7	56.4	11.0/14.3	38.4/37.2	4.8	61.3	8.0x15.0x3.8
211.2x78.8x53.4	44.0	4.0 ²	119.0	41.3	4.0	35.2	3.9	62.2	54.4	10.8/12.2	38.0/37.5	4.8	57.4	9.0x11.3x5.0
204.0x75.0x55.3	40.6	5.6	115.0	41.1	3.4	36.0	3.5	59.9	60.0	10.6/13.3	37.8/38.3	4.0	58.8	5.8x14.3x3.8
206.4x74.4x54.0	40.9	5.0	115.0	41.2	3.6	35.7	3.6	59.9	59.9	11.0/13.0	38.1/37.3	4.0	58.6	6.5x11.8x4.0
211.0x78.5x52.8	43.0	3.4 ²	119.0	41.5	4.1	35.5	4.1	62.2	55.6	10.9/12.3	37.9/37.5	4.8	57.8	6.8x12.3x4.0
205.4x77.3x52.5	42.6	3.6 ²	113.0	39.7	3.2	33.2	2.7	59.7	49.9	10.7/NA	37.4/37.6	4.0	54.0	5.0x9.3x6.0
188.3x70.2x53.0	37.1	5.3	106.0	40.7	3.0	34.2	3.1	56.9	56.4	8.0/11.6	38.6/37.3	4.5	54.2	6.3x8.5x4.5

NA not available.

Your serviceman looks at the '66 cars

Dual points on that Chrysler hemi need adjusting?
Toronado shocks need desqueaking? Here's how

By Todd Douglas

IT'S THE YEAR of the big engines. Detroit is adding cubes and making the innards more sophisticated—which means extra horses and, in some cases, new servicing techniques.

Other than that, 1966 is a quiet year, but for a few notable exceptions. There's the Oldsmobile Toronado with front-wheel drive and a brand-new, unusual chassis; a new four-barrel carburetor for several GM cars; a couple more cars with optional disc brakes, and lots of minor refinements.

Why polish and improve these seemingly unimportant hidden components when last year's models had no major ailments? Engineers don't make deliberate changes just for the sake of change. Between model years, researchers run fatigue tests on various parts to deliberately wreck them and to find any hidden weakness that could eventually lead to failure or even just customer irritation. The result of their work is improved quality.

The engine population is growing. This year more than 85 engines are offered with carburetion ranging from single venturis (Vs) to two 4Vs and even three 2Vs. Some car divisions have 9 engines with different horsepower ratings, others have 11, and Chrysler has 13. Chevrolet alone

has almost 60 carburetors with different part numbers for their nine engines.

Stars of the engine world should include the Chrysler Corp. hemi-head 426-inch V8 for Belvedere and Coronet, the 230-inch overhead-cam Six by Pontiac, the 250-inch overhead-valve, in-line six from Chevrolet (also available in short-wheelbase Olds models) and the "big daddy" of them all, the whopping 462-inch job from Lincoln-Mercury.

Other engines, almost without exception, have increased power and performance stemming from improved distributor advance curves, better intake manifolding, better control of fuel-air mixtures and improved cams.

The exciting performance entry this year is the street version of Chrysler's famous hemi-head. Designated the HP², it has a compression ratio that is reduced from the competition 12.5:1 down to a more modest 10.25:1 and a gentle cam with less valve overlap for improved low-speed running. Add two four-barrel carbs and you wind up with 425 horses at 5000 rpm.

Dual distributor points make dwell setting somewhat different. First adjust one set and then the other, each time with the opposite set insulated by a small piece of



TORONADO . . . rides on all-new suspension with brand new drive posing all new problems



DODGE CORONET . . . with street hemi engine has unusual problems in setting dual points

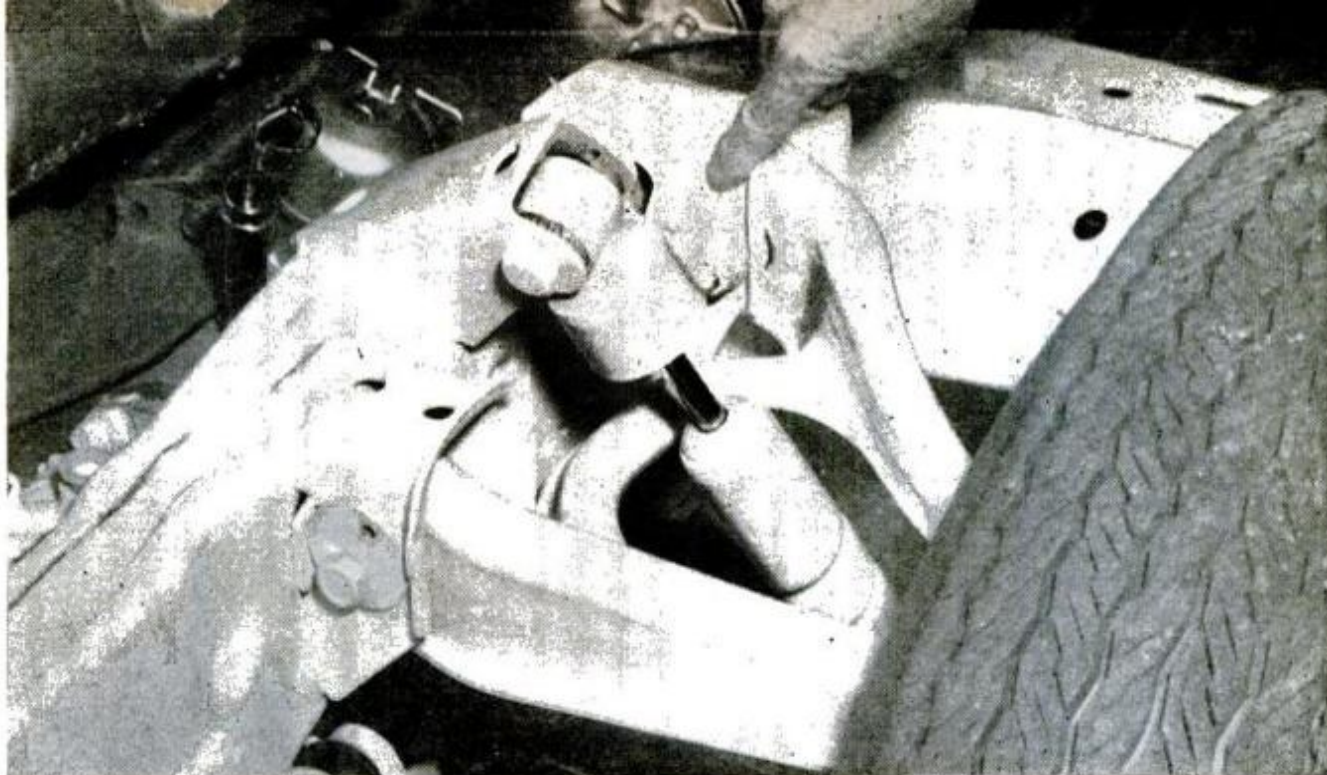

CAM-TYPE CASTER and camber adjustment points are indicated here. Steering gear is horizontally located

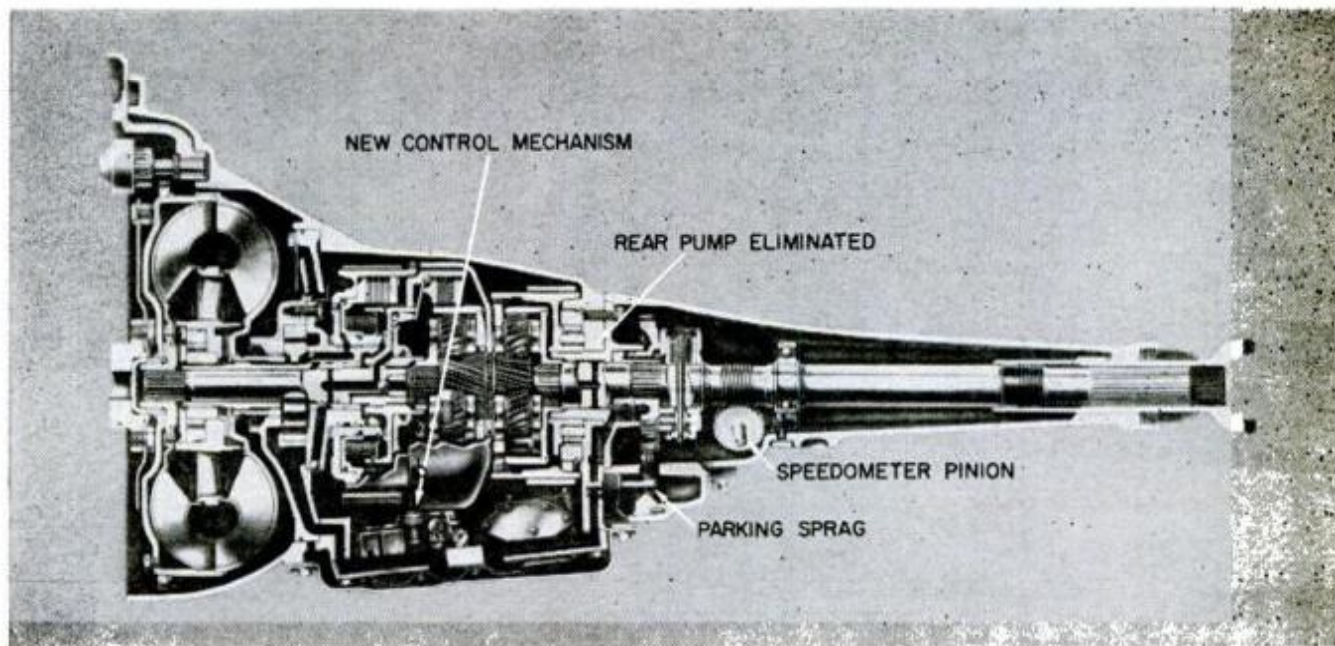

SIMPLICITY is the trend in automatics. Improvements in Chrysler TorqueFlite allow elimination of rear pump



TEMPEST GTO . . . with overhead-cam Six has neoprene timing belt that can be adjusted easily
 JAN. 1966



LINCOLN . . . boasts industry's biggest engine, a 462-incher. Few '65 engine parts fit it

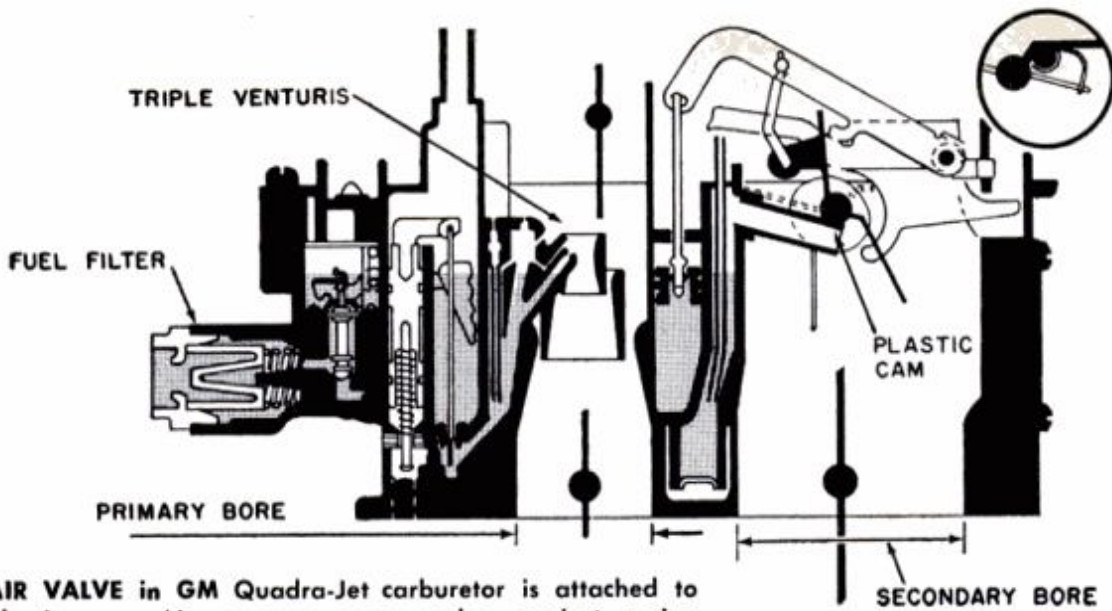

AIR VALVE in GM Quadra-Jet carburetor is attached to plastic cam. Air pressure opens valve against spring pressure (circled inset), which in turn rotates cam

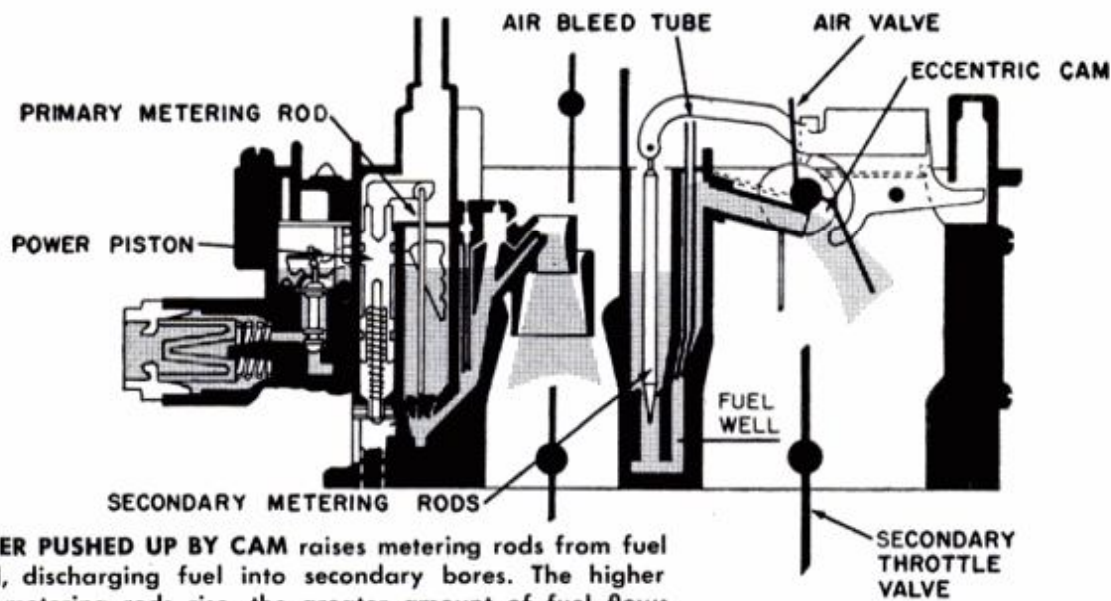

LEVER PUSHED UP BY CAM raises metering rods from fuel well, discharging fuel into secondary bores. The higher the metering rods rise, the greater amount of fuel flows

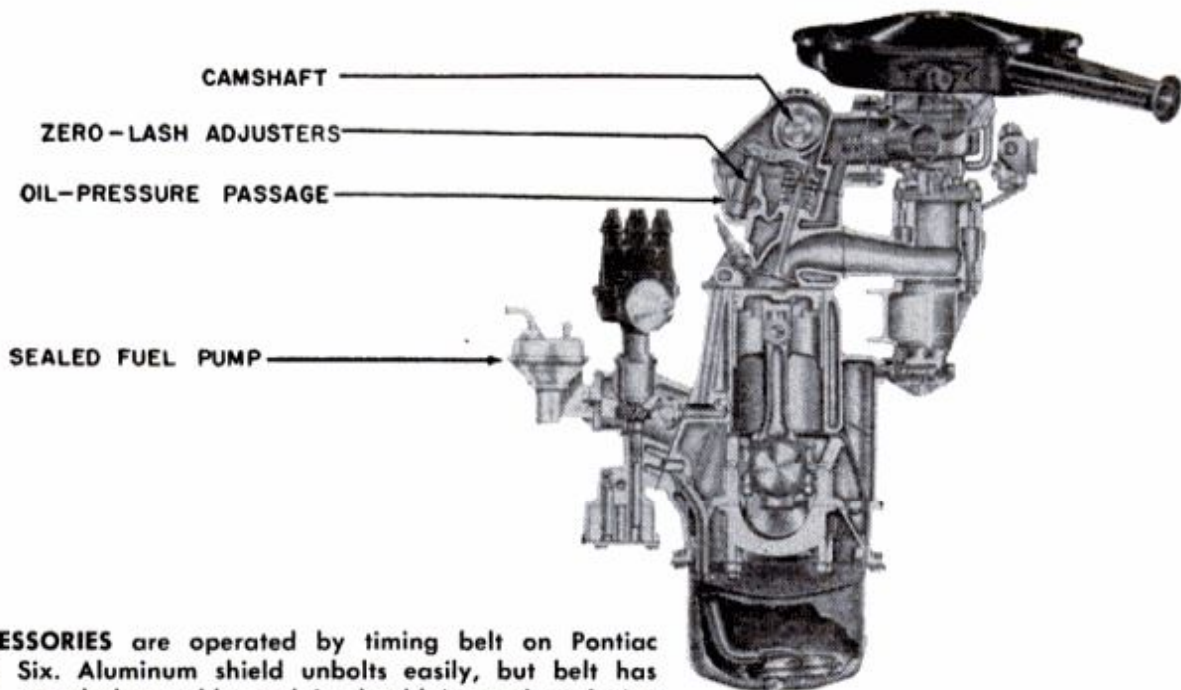

ACCESSORIES are operated by timing belt on Pontiac OHC Six. Aluminum shield unbolts easily, but belt has been tested thoroughly and it shouldn't need replacing

cardboard, for dwell readings of 27 to 32°. Then, with both sets working together in the circuit, dwell should be 37 to 42°.

Besides its new cam arrangement, the Pontiac OHC has many other unusual engineering features. For example, the neoprene timing belt, beefed up with fiberglass cords woven into the material to resist stretch and wear, performs more than one function. Deep teeth on its inner surface permit it to drive the distributor, fuel pump and oil pump through a single sprocket with a common shaft. These units are contained in a removable aluminum casting that is also the mounting for the engine oil filter. Belt adjustment is simple: Loosen the mounting bolts of the die-cast housing and shift the entire assembly within the slotted holes.

Mechanics will appreciate the simplicity of design and the accessibility of parts for service. And there are no valve lifters or push rods to cause heavy power-gobbling inertia forces.

Correct valve lash, or clearance, is maintained by zero-lash hydraulic adjusting mechanisms that are fed oil under pressure through passages in the engine head. These adjusters are unique in that they work directly against individual rocker arms while the cam lobes function on the top side of these cam rockers. As a result, cam lobes have only one job: to force the valve open. With all adjustable screws, lock devices and valve-train push rods eliminated, maintenance is not needed.

The largest-displacement engine is the 462-cu.-in. Lincoln Continental V8, which puts out a modest 340 hp at 4600 rpm with 4V carburetor. Basically, it is a refinement of last year's proven 430-incher. But parts interchangeability between the two engines is limited, since bore and stroke have gone from 4.30 x 3.70 to 4.38 x 3.83 inches. New, lighter pistons, new cylinder heads with larger porting, new intake valves with increased head diameter (now 2.03 inches) and a new camshaft with higher lift lobes are used. Add to this a new crankshaft with longer stroke plus an intake manifold with smaller diameter passages (also called runners) that, amazingly, provide better breathing and you have 10 percent more performance without loss of gas mileage.

Top Chevrolet engineering planners told their staffs to take the old 144-hp in-line Six and boost it at least 10 more horses—

but drop the rpm. And they did it. Their new 155-hp version gets this rating at a low 4200 rpm out of 250 cubic inches. Both the 144 and 155 have the same bore (3 $\frac{7}{8}$ inches), but the larger engine has an almost $\frac{9}{32}$ -inch-longer stroke. Compression height (measured from the centerline of the piston pin to the top of the piston head) is now different than in the 144 power plant, so pistons cannot be interchanged. Oil pans may look alike on the outside, but different baffling prevents switching.

This new Six is as easy to maintain and service as any other Chevrolet Six, since all external operating units, such as the distributor and fuel pump, are about in the same location. Tune-up specs are identical to those of the 144 except for initial timing, which is 6° BTDC.

Some other new engines for 1966 include the 440-cu.-in. power plant for some Dodges, Plymouths and Chryslers, and for all Imperials. There is also the new increased-horsepower 390-incher for Mercury and some Ford models and the 425-incher optional on full-size Oldsmobiles and standard on the Toronado.

Lubing the Toronado. This classy 4500-pound front-drive fastback needs little or no lubrication. Engineers have discarded frequent front- and rear-wheel bearing repacks. They are recommended only at the time of major brake overhaul, and only on the rear wheels, which rotate on dead rear-axle spindles.

Also, no lubrication is necessary for the Rzeppa-type, constant-velocity U joints (two are used at each drive axle), alternating-current generator, starter motor, upper and lower control-arm pivot points (they're rubber bushed), and front and rear attachments for the hardened-steel torsion bars, which take the place of coil springs. Nor should rubber-mounted units such as shock absorbers (four at the rear, two up front) and the rubber bushings in the front suspension pivot points be greased or oiled. They can be "desqueaked" with a soapy-water solution.

Break-in oil, tune-up juice or other friction-reducing compounds are not recommended in the Olds 425 engine. Just keep a good MS engine oil in the crankcase and change the oil and filter every six months or 6000 miles, whichever comes first. That MS label means the oil has passed the carmakers' tests for low-tem-

[\(Please turn to page 224\)](#)

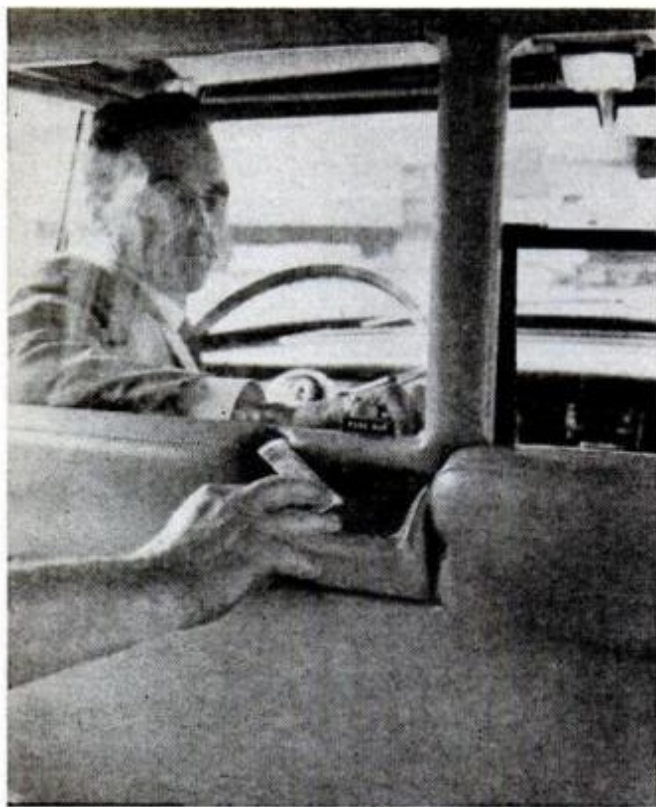

Cab drivers can be safe from robbery and other attacks by back-seat passengers in taxis fitted with a new bulletproof glass partition. A pass-through hatch enables fares to be paid and change given without lowering the window. In case of emergency, a switch panel beside the steering wheel allows the driver of the "Safeguard" cab to automatically lock the rear doors, raise the bulletproof partition, and set off a flashing warning light.

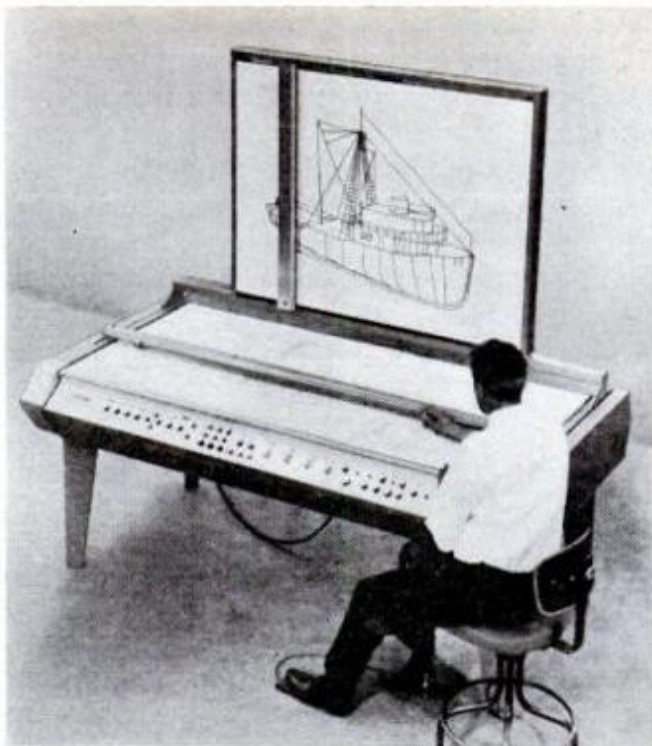

Drawings by computer. A new computer-directed machine enables a draftsman to quickly convert two-dimensional drawings into accurate perspective illustrations. The draftsman uses two styluses on the horizontal table to trace front and side blueprint views of an object. Information flows from the styluses into a computer, which guides the plotter pen that produces the three-dimensional view on a vertical easel. Maker is Perspective, Inc., of Seattle.

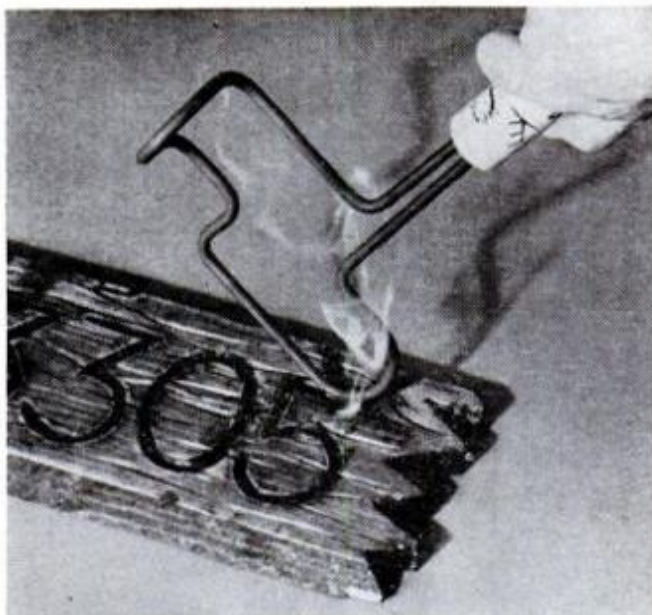

Electricity on the range. The West just ain't what it used to be! Cowhands can now do their branding electrically with the Thermark electric branding iron which plugs into any 110-volt outlet and takes only two minutes to heat, and will mark anything that will burn. It has a two-inch half circle and four-inch running bar, and sells for \$7.95 from Everhot, 57 S. 19th Ave., Maywood, Ill.

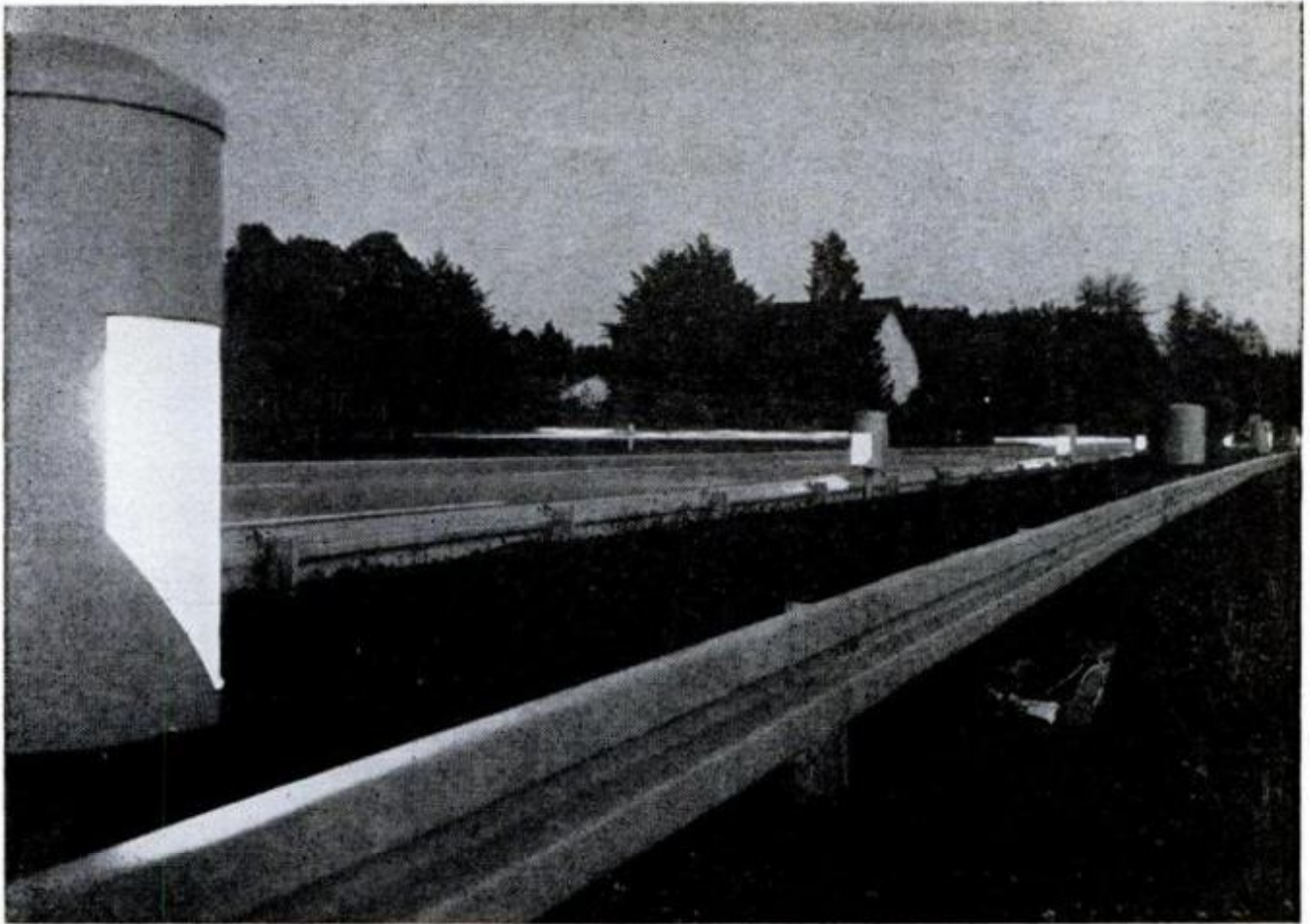

Low lights cut the overhead on maintenance of the 45,000 lamps illuminating the 930 miles of the Olympia Strasse in Munich, Germany. Resembling giant soup cans, the 125-watt mercury vapor lights utilize mirrors to reflect the light at a low angle across the roadway. They have proved highly effective in fog and in lighting objects on the road.



Shirt-pocket TV. A mere 3½ inches high, 4½ inches long and less than 2 inches wide with a 1-inch diameter picture tube, this Westinghouse TV is a true pocket portable. It works off batteries or can be plugged into a wall outlet. Built with microcircuits, the set dramatically shows how small, small can be. This TV is the only one of its kind and will not be sold commercially.



Pneumatic-tired track supports and propels a new Army amphibious cargo carrier over all terrains, normal hard surfaces, swamps and marshland, tundras and open water. Each inflated cell has cleats for better traction over soft surfaces.

DUESSE

BACK FROM THE

It's a brand-new \$19,500 beauty, equipped with every imaginable

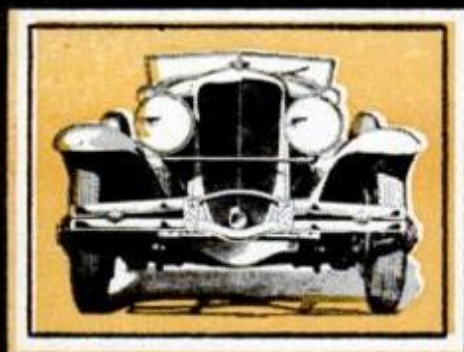

A MONSTER BODY, a powerful engine, rich leather, rare wood and sky-high price — all the tradition of the old Duesenberg will soon be reborn in a new version, designated the Model D.

This new Duesenberg, which will debut in March, is a genuine descendant of the original Model As and Js of 1921-37. The builder is Fred Duesenberg, son of one of the two brothers who started the Duesenberg legend. The car will incorporate the styling of Virgil Exner and coachwork by Ghia Body Works of Italy.

A number of innovations will make it as modern as any car on the road — at a price. It will cost \$19,500, with features such as airconditioning and automatic speed control standard. It will dwarf any existing six-passenger sedan. At nearly 6000 pounds, it will be half a ton heavier than the Lincoln sedan, the present world's heavyweight champ. It also will be almost a foot and a half longer than the Imperial. The hood alone will stretch 82 inches, a full 20 inches longer than any of the standard production Cadillacs.

By Jim Dunne

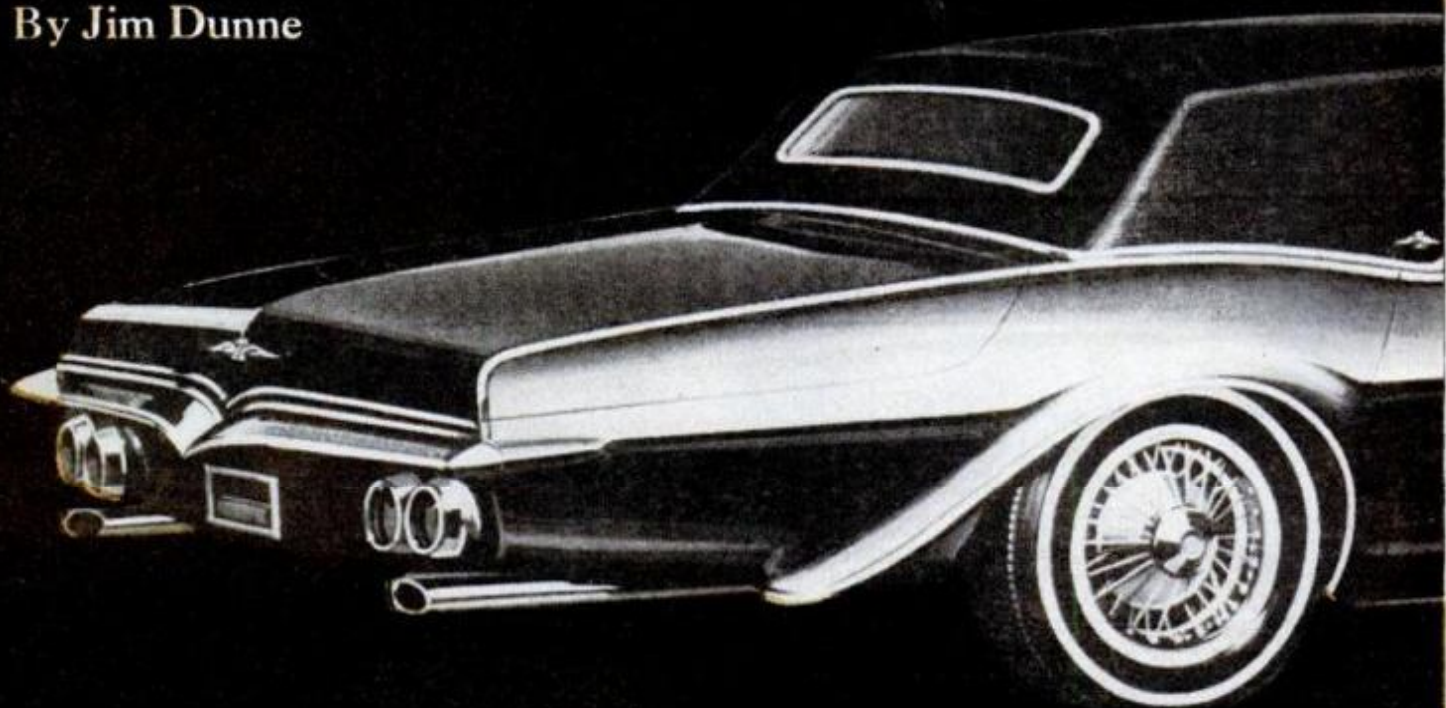

NBERG

ROMANTIC PAST

luxury feature and destined to be a classic as soon as it is born

Each car will have a practically hand-made steel body from Italy. But all mechanical components, including electric window cranks, airconditioning, windshield-wiper motors, lights, gauges and electric door locks, will be American-made to insure parts availability.

Steel was chosen for the body in spite of the claimed advantages of plastic for low-volume cars. Fred Duesenberg believes plastic, though economical, is not what the owners of this class of car would want. Right now, stamping dies for body panels are being made up in Italy to turn out production parts and build up a supply to be warehoused in the U.S. The dies will be used for five years at least, with a minimum of yearly styling changes.

The body follows modern practices, but retains the glamor of the old models. The classic clamshell fenders are still there, and the massive grille has much of the old look so quickly copied by early Duesenberg competitors. A late change in styling to double-bar bumpers is not shown in the pictures.

Any color available in acrylic lacquer may be ordered, though the company anticipates most buyers will prefer dark, conservative blues, grays and blacks.

In the heavily soundproofed passenger compartment, luxurious leather from

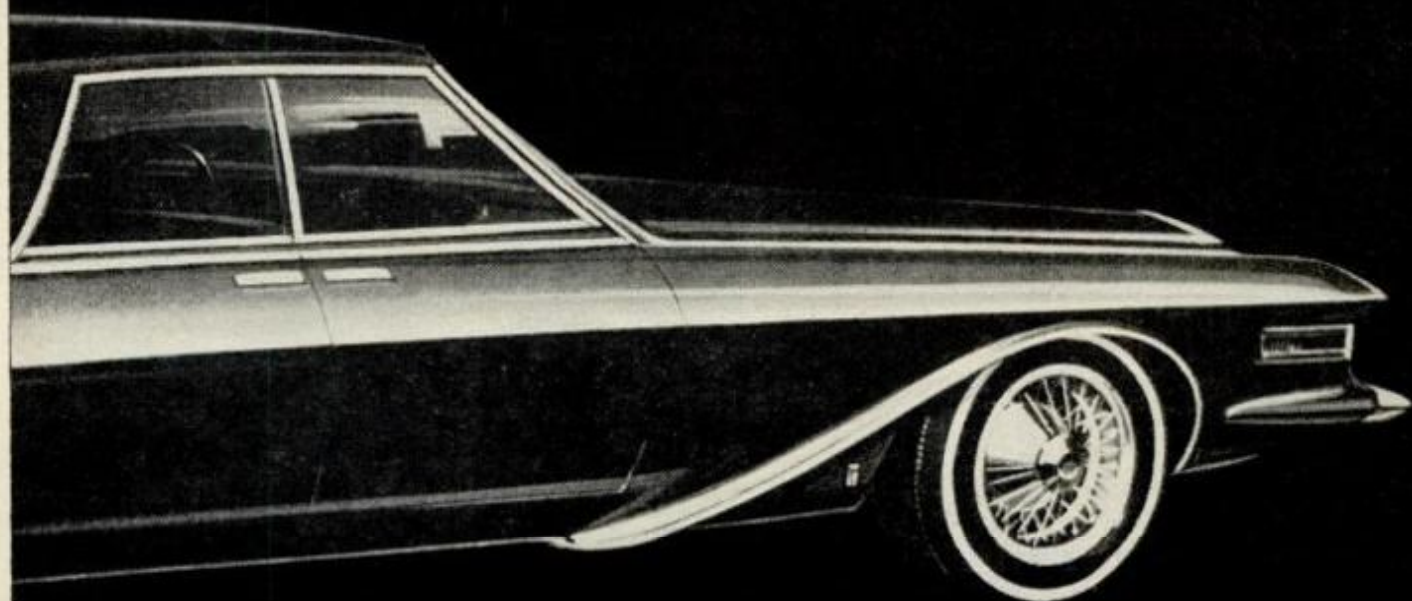

a 200-year-old German tannery is used. The dashboard looks like something out of Project Gemini, with controls for an altimeter, tachometer and two fuel tanks in addition to the regular instruments. Natural mahogany wood paneling—not a veneer or plastic substitute, but honest-to-goodness stuff you can knock on—is used liberally.

Passenger accommodations are spacious, with a conventional bench seat in the rear and modern, individually adjustable split-front seats providing room for six. Head and legroom promises to be inches longer than in any sedan now on the road.

There is one obvious drawback to having body styling that is as balanced as that of the new Duesenberg. Big as the car is, its massiveness does not show up readily—especially in pictures—because the lines are so well proportioned. Oversize tires add to the illusion. Viewed alone, the car could be either large or small, its styling is that well done.

But it's not just the measurement of a fender or the length of the hood. Everything is big on this car. As a comparison, the Cadillac 75 limousine is as long as the Duese, but its styling balance is upset by the stretched-out passenger compartment. The same fenders that look so massive on the Cadillac coupes look a bit dinky on the 75. Not so on the Duese. Its lines are proportioned exclusively for this car.

Chassis design is the tried-and-true separate-frame construction. The frame will be built in Italy and hand-matched to the body there. The whole package then will be flown to Indianapolis for mating with the running gear. Torsion bars are the only springs that Duesenberg engineers figure can carry the extreme weight of the front end and still retain enough life to deliver a soft ride. Conventional multileaf springs will be used in the rear.

Chrysler Corporation's 440-cu.-in. engine and TorqueFlite transmission will provide power. The stock engine is rated at 350 hp, but Duesenberg will add 25 hp with carburetor and ignition adjustments. Contactless electronic ignition will be standard.

Disc brakes on all four wheels are a near necessity for stopping all that weight. The company wanted to use 16-inch wheels right from the start, but found that modern car design had obsoleted these. Fifteen-inch wheels will be on the car when it is

first introduced, but 16-inchers with 8.90 tires will be used later, when they become available.

An unusual feature is two 16-gallon fuel tanks, one in each rear fender. They're made of the same porous rubber material now required in race cars in the Indianapolis 500. Advantages include more trunk room and extra safety; in a collision, the rubber cells are rupture-resistant, thus lessening the danger of fire.

The warranty is unique: three years without regard to mileage, and it covers all parts and labor.

As far back as last summer, the company had 25 firm orders, accompanied by deposits of up to \$5000—a strong ante in any game, and a good indication of the kind of money needed to own a car of this type. Phil Wrigley, the Chicago baseball and chewing-gum magnate, placed the first order, and will get car number one. Wrig-

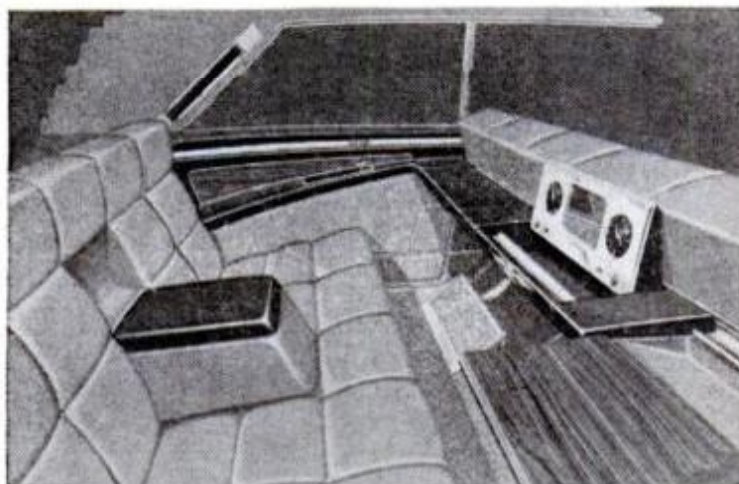

LUXURY OF BISCUITED LEATHER, mahogany paneling, personal vanity with clock and radio make this rear compartment like no other one on the road

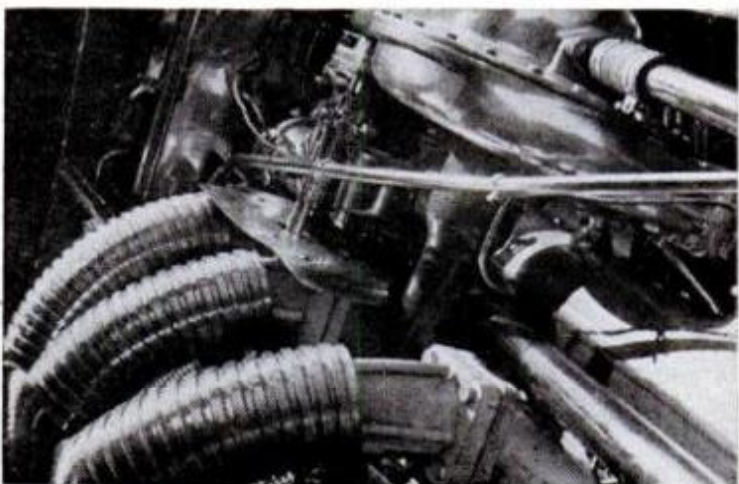

GLEAMING CHROME, liberally applied, and externally flexible exhaust pipes were a hallmark of early Duesenberg engines. Supercharger was optional item

ley's interest in Duesenberg goes way back. At one time his family owned five of them.

The company will build only one model at first, a six-passenger sedan. Later a convertible and limousine will be added. Limousine production was planned from the beginning, but the decision to build a convertible was forced on the company by the strong demand from West Coast buyers.

Duesenberg plans to build 50 cars the first year, 200 the next and 500 a year soon after. He also hopes eventually to have 50 dealers across the country, mostly "duals" who are engaged in selling other makes as well.

The last of the Duesenbergs, built in 1937, was the Model J, remembered as *the Duesenberg* among classic-car buffs. Ahead of its time in design and engineering, the Model J had a double-overhead-

cam straight-eight engine. Horsepower was 265, or 320 supercharged, and displacement was a modern 420. The sedan had a wheelbase of 142.5 inches—stretched to a bridge-length 153.5 inches in the limousine.

From 1921 to 1928 Duesenberg built a Model A, a fairly big car that sold for \$7200. It was the first car with hydraulic brakes on all four wheels. Although 900 Model A's were built compared with 480 Model J's, the first car never did have as strong an effect on its owners as the J. There are still 300 Model J's in existence today, according to an estimate of the Duesenberg Club, and they bring high prices in the restorers' market. A collector recently paid \$15,000 for the first Model J to come off the line in 1928. And that's remarkably little depreciation when you consider the original price was approximately the same. ★★★

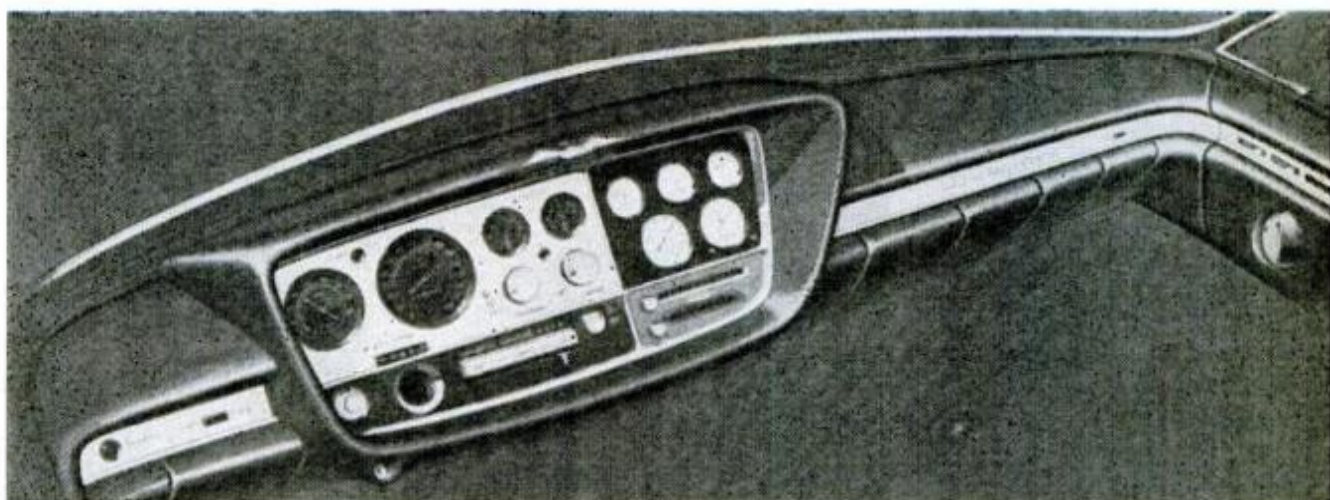

DASHBOARD LOOKS LIKE A CHRISTMAS TREE, bristling with blinking lights, toggles and gauges. Besides normal instrumentation, there's an altimeter, two fuel gauges, ashtray and brake lights, speed control and stop watch

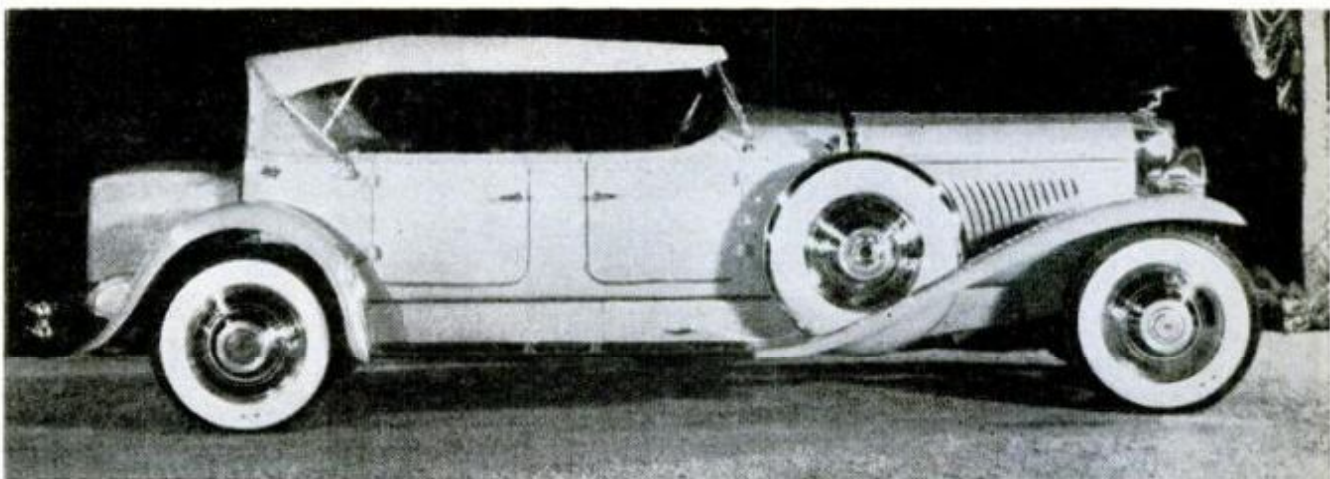

Photo courtesy of Detroit Public Library

TRADITIONAL CLAMSHELL FENDERS and double-bar bumpers show up on this 1931 model. Top is easily lowered for open-air driving. Special tires had white sidewalls on both sides. Grille was widely copied by competitors

Electronic Clinics for Sick Cars

Amid spinning dials and clacking electronic switches, auto diagnosticians will pinpoint your car's ailments; but where you have them cured is entirely up to you.

By Pack Bryan

A SINGLE TECHNICIAN drives car down the line in Mobil Repair Center while assistant adjusts console and checks instrument readings.



THE MAN IN THE WHITE COAT turned off the machine and removed a maze of wires. Then he motioned me into a small consultation room and we sat down, facing each other across a desk.

"Basically, you're in good shape," he began, "but I do have a few suggestions."

I wasn't a patient in a modern medical clinic, about to learn that I'd been smoking too much. Just a crestfallen Saturday Mechanic, learning that all the equipment in one of the new electronic diagnostic clinics had caught me goofing up a plug and point change on the family bus. I really goofed. After the mechanics at the center corrected my mistakes, I found that they had added almost 10 percent to the horsepower available at the wheels, and had tacked on a bonus of an extra mile per gallon. And I thought the car had been running well.

My job was checking out those new "auto clinics" for *Popular Mechanics*. They've been springing up all across the country. By the end of 1965, about three dozen were operating, so it was easy to pick several between Chicago and Milwaukee.

Like many auto buffs, I had often wished that I could run my car onto a dynamometer—one of those large treadmills with instrumented rollers that work against the rear wheels to measure a car's exact horsepower. But dynos are expensive. To find one, you either had to know

someone in Detroit's top engineering circles, or be prepared to fork over next month's car payment to have the car tested on one of the few that existed in the back garages of the racing-circuit boys.

Using every electronic aid you can get—from sophisticated electronic strobe timing lights to accurate dwell meters and specially modified oscilloscopes—you can tune a car up to running condition as it's never been tuned before. But all the electronic tuning gadgetry is calibrated by dynamometer tests. Until you run a car under load on a dyno, you will never be sure what it's putting out. The dyno lets you "blast down the highway at top speed," while the car is sitting still. Instruments measure and record everything.

If these dynamometers are so great, how come they haven't been on the scene long before? Up to now no one was willing to gamble that a fully equipped analysis setup could be sold to the public. Most major oil companies, and many successful dealers and service organizations, are now betting that the time has come. The 36 centers that now exist probably are the forerunners of hundreds that will soon open in metropolitan centers.

The word "metropolitan" is a key to the success of the idea. You can't drop \$100,000 on an installation for once-in-a-while use. Many centers run a 16-hour day.

Folks pay with a smile. A trip through

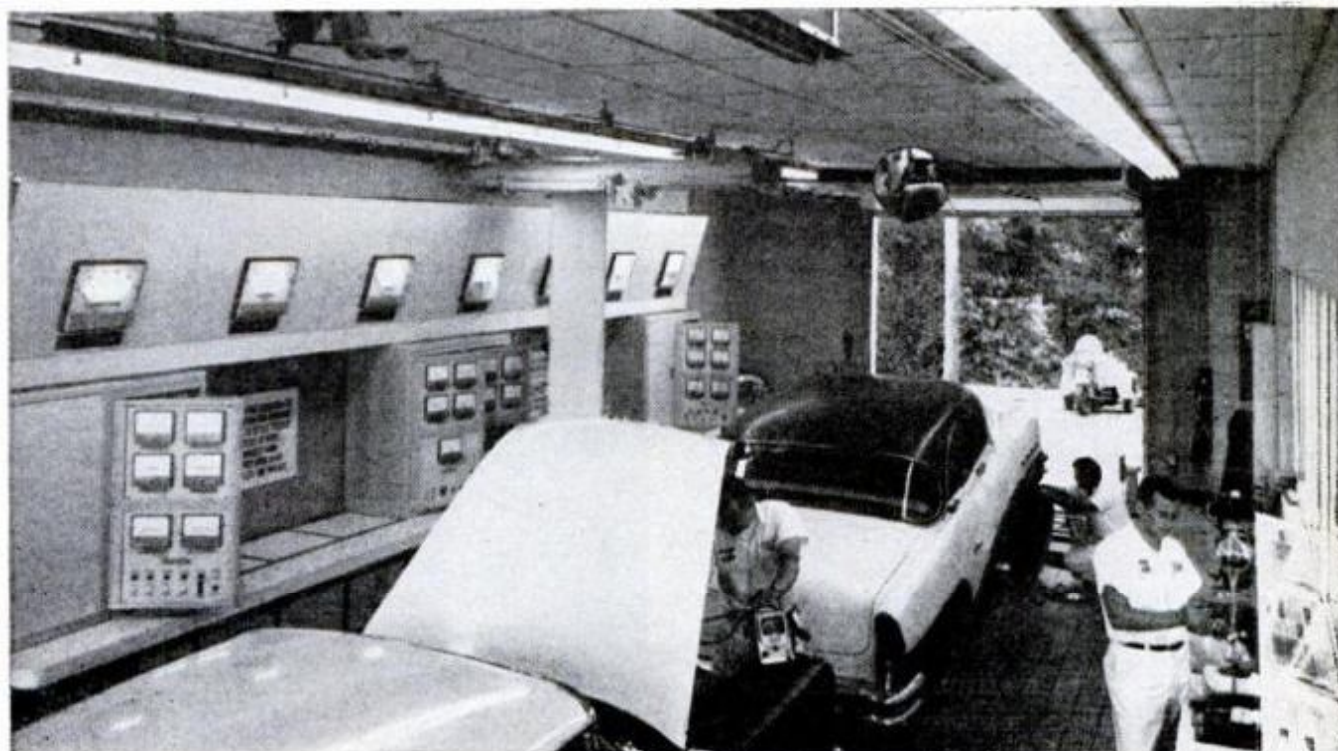

ASSEMBLY-LINE OPERATION is key to service centers' success. Tests are similar from one center to another

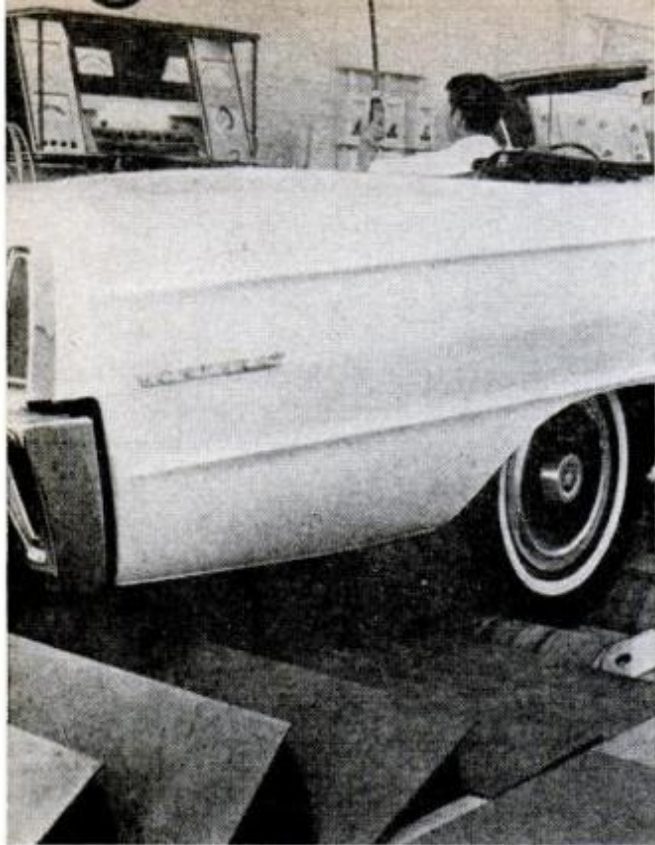

TUNEUP IS double-checked on a dynamometer. Rear wheels of the car transmit power to rollers, which feed the road-horsepower data to the test gauges

one of these centers costs between \$5.95 and \$9.95. Operators count on their diagnostic lanes to refer plenty of business to their adjacent repair and service operations. And so far, they've been right. Most centers report average service tickets of around \$70—almost double the usual amount. And the customers are happy. They get a written guarantee on the work.

To get an idea of how the various lanes work, I ran a '64 Chevelle through four of the clinics. The car is equipped with the small 195-hp, 283-cu.-in. V8, automatic transmission and power steering.

You start with a phone call for an appointment. Don't be late. They work on a tight schedule. When you arrive, a receptionist in a pleasant waiting room takes your name and the basic information about your car, including any unusual problems. If the car has been pulling to the left on braking, for example, they'll pull the left front wheel instead of the usual right, and will utilize whatever special extra equipment is necessary to trace down the fault.

A single diagnostician stays with your car on its trip through the lane. The sequence of steps varies among centers, headlight focus and brightness checks being first on the list at some places and last on others. In between, anywhere from

75 to more than 100 different tests are made. Some are obvious, like checking windshield squirters, wiper speeds, turn signals, horns, parking brakes, shocks, engine-oil level, air filter condition and temperature protection of your antifreeze. Fan belts, battery cables, mufflers, tail pipes, springs, heater hoses and thermostats, power steering, fuel tank and lines, tire tread depth and condition, brake system backing plates and the running gear get thorough visual tests.

Some tests are exotic. Checking the condition of your automatic transmission fluid is important. The diagnosticians let three drops fall off the dipstick into a vial of special fluid that measures acidity. If transmission oil needs changing, the fluid turns color. Later, as the car moves onto the dyno, they check the shift points under various loads at road speeds and compare them with factory specs. As each car goes through the lane, it is accompanied by a clip board containing the "clinical report" plus a master chart listing all factory specs.

Another fluid check, used by a Chicago dealer, uses a special valved bottle attached in place of the radiator cap. The bottle contains a liquid that indicates by a color change any head-gasket leaks into the cooling system.

In the dynamometer section, the car's front wheels are placed on the rollers, which are belt-driven by electric power.



RETAINER keeps wheels from hopping on dynamometer rollers, which would give an inaccurate reading, and prevents the car from running off the machine

These rollers measure braking efficiency and determine whether both front wheels are providing the same stopping power. Generally, a gradual stop is made, and then two crash stops to burn off glaze and detect line restrictions. The tests are repeated with the rear wheels.

Then a wire harness is connected between the ignition system and the dyno's analysis equipment. With the engine running and the dynamometer receiving power from the wheels, the gauges quickly show up bad plugs, point bounce and errors in distributor advance and dwell settings. An oscilloscope gives visual comparison among the sparkplugs to check the condition of each and of the wire that feeds it. The output of the generator and voltage regulator are checked here, as is the cranking voltage. An exhaust analyzer determines combustion efficiency. The actual road horsepower (the part that gets to the wheels after accessories and drivetrain friction take their toll) is then measured at a specific rpm.

I was still disappointed to learn that my almost-200-hp engine delivers less than half that power to the rear wheels. However, the analysis people admit they take readings at a low rpm and that many big engines with wild cams will barely budge the needle until rpm climbs past 4000.

Last on most of the lanes I visited is a front-end dynamic alignment tester, de-

veloped by the Merrill Engineering Labs. Using powered rollers again, this machine checks camber, caster and toe-in with the wheels spinning at 40 mph. I had been told that shop techniques and equipment hadn't yet caught up with the accuracy of the machine. This was proved after one of the best shops in the area did an expensive alignment job on my car before I visited the clinics. The first machine I went through showed up a bad caster setting, and every subsequent machine duplicated the findings.

After the tests, the diagnostician meets you at the door, introduces himself and leads you into a small office. There he goes over the diagnostic report with you step by step. Most centers allow plenty of time for your questions. I was unable to stump them.

The low-pressure sell. If your car needs work, the diagnostician makes out an estimate form covering parts and labor. Surprisingly, he'll then tell you that the work needn't be done at his center. You're free to take your diagnostic report to your own mechanic for his estimate or actual work. If you get the work done at the center, they'll stick within the limits of the estimate to the penny and will also give you a guarantee on the job. But don't ask to take the cost estimate with you. Nor can they be sure the estimate will be valid

[\(Please turn to page 220\)](#)

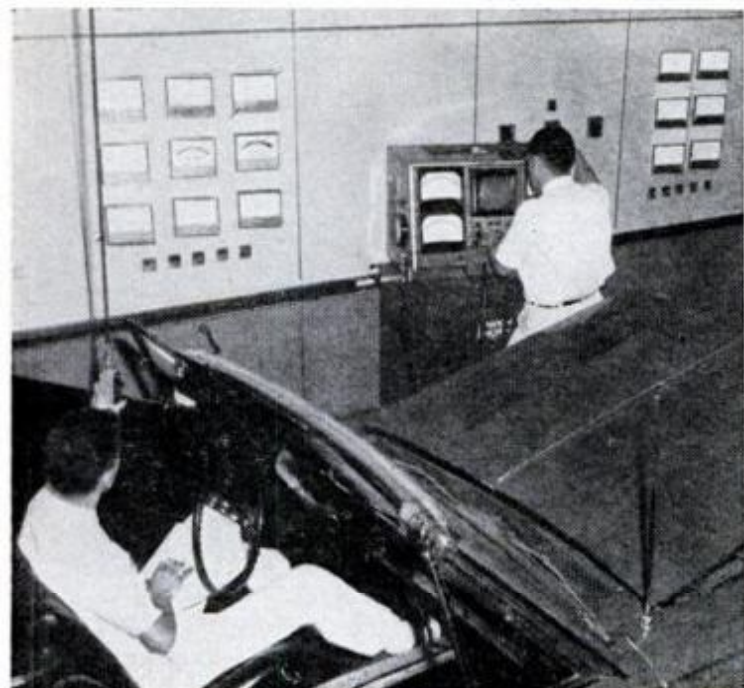

FULL-POWER TESTS enable technicians to check for ignition weaknesses such as plug shorts under load by means of input adjustments to the oscilloscope

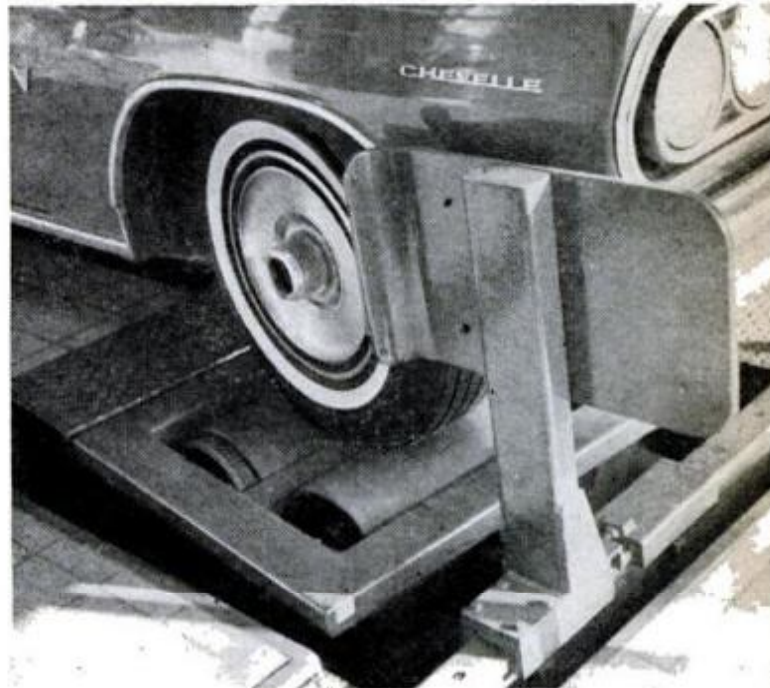

ULTRA-ACCURATE Merrill tester, standard at most new centers, spins the front wheels at the equivalent of 40 mph, and measures caster, camber, toe-in

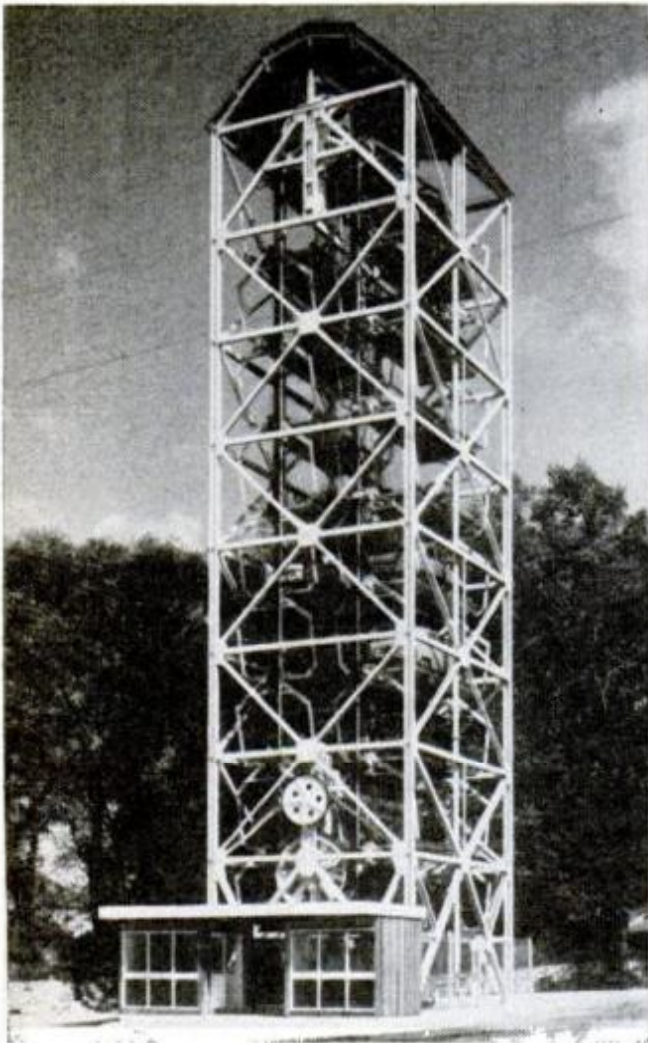

Like a ferris wheel. In the space it usually takes to park two cars, the Wulpa Parking Tower can accommodate 20 vehicles in its 79-foot steel structure. Hitched to a chain, compartments can be rotated at the push of a button to permit parking and retrieving of cars by their owners.



It's a mad rush. Because of the distance from the ready room to the flight line, Marine pilots of Marine Aircraft Group II at Da Nang, Vietnam, now scoot for a scramble. They bought the motorbikes to cut down the time needed to answer alerts.

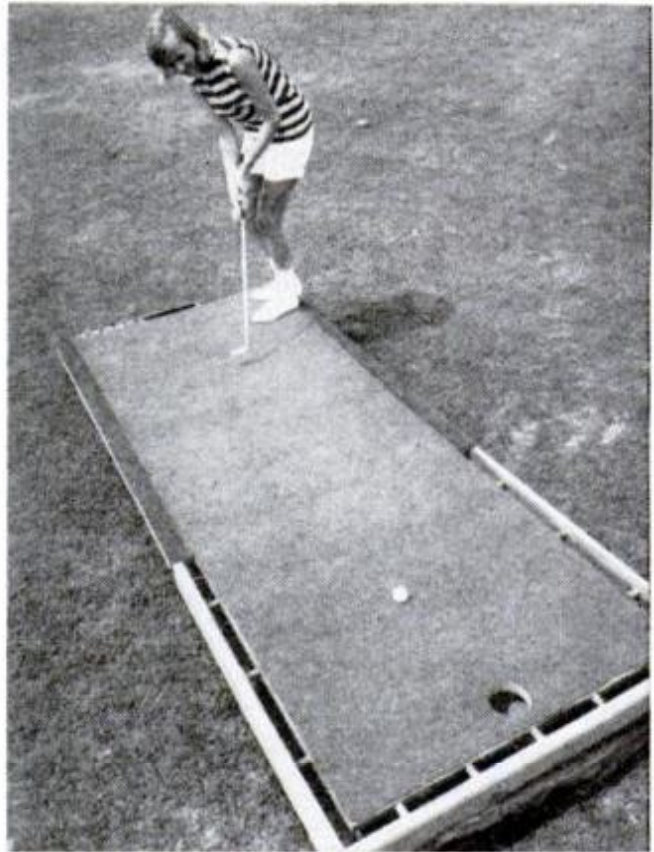

Robot practice green for indoor-outdoor use tilts up, down, left, right or any combination of these at touch of a pushbutton. Measuring 9 by 4 feet, Roputt has a simulated bentgrass top to approach actual conditions for various putting situations. Four Micro Switch pushbuttons (bottom photo) control motor-driven jacks, operating from 110-volt outlet. Unit weighs 175 pounds and is priced around \$350 by Wichman Industries Inc., 7110 S. France Ave., Minneapolis, Minn. 55410.



Supersonic missile TOW (tube-launched, optically tracked, wire-guided) automatically scores bull's-eye on moving or stationary tank-sized target more than mile away. Army gunner simply aims through telescopic sight and launches the missile, which flies to the target as he keeps crosshairs aligned on it. Hughes Aircraft Co. is developing the new antitank device, which fires from a variety of military vehicles or a ground tripod.

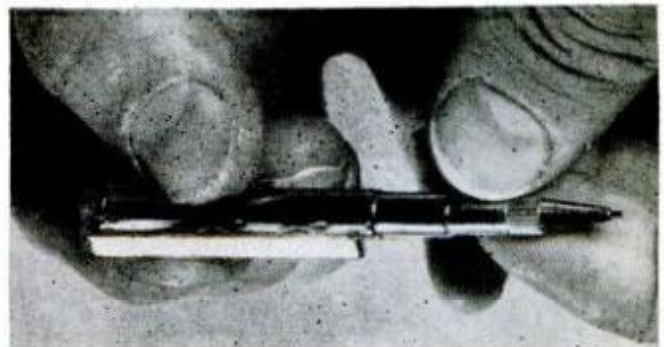
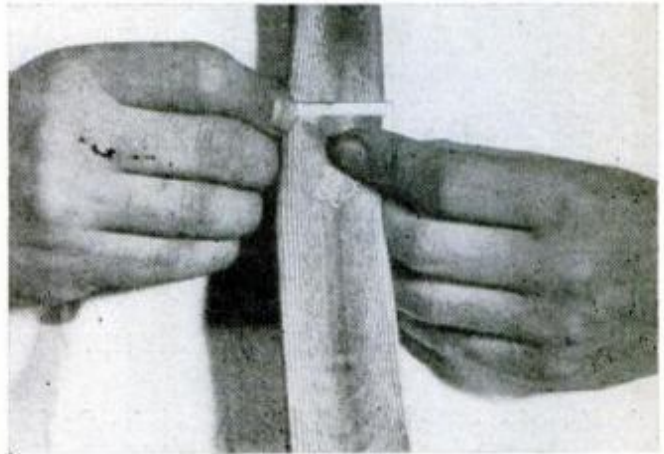

Take note of this tie clip. Only $2\frac{3}{8}$ inches long, a gold-plated tie clip is attached to a telescopic chrome mechanical pencil that expands in three sections for writing. It is priced at \$2.95 from Gene Mueller Co., 1100 N. La-Salle St., Chicago, Ill.



Auto thieves get the surprise of their lives when the stolen car runs out of gas a half mile from where it was taken, thanks to Gaslok, a small supplemental gas container installed between the main tank and the fuel pump. When Gaslok is turned on and locked, the main fuel supply is cut off, leaving enough fuel to move the car in a parking lot. It is priced at \$15 from Fisher Machine Shop, Inc., 11704 Inglewood Avenue, Hawthorne, Calif.



New Coast Guard image—well, everybody else is doing it!—will include a bold slash of color on all ships and aircraft. The Coast Guard shield of blue and white will be imprinted over the huge slash of international orange. A smaller slash of white separates the orange from a trailing slash of blue.

THE GREAT RELAXING BONANZA

By Walter Ian Fischman

Feeling tense? Can't sleep? Let the sleep merchants pamper your nerves with musical beds, silent alarms and piped pine scent; or cry yourself to sleep on a waterproof pillow with a decision-making case



FROM THE PLUSH but nervous-making bastions of New York's Madison Avenue to the so-called restful valleys of California, there's a disturbing trend in progress. Tension is on the rise. All across the land, day-by-day pressures and irritations have zoomed out of control. Even the mere routine of living can rub raw the nerve endings of emotion until some chance circumstance triggers a wild case of screaming hysteria.

A bathroom faucet drip at 3 a.m. can multiply to sledgehammer intensity. Ditto for the coffeepot that boils over or the cacophony of car brakes just outside the window. Without logic or sense the pace-that-kills has mounted in intensity and there's no letup in sight.

The only happy note in this sad picture is the skyrocketing popularity of the tension easers. The frantic search for relief has given rise to a booming new mass market: the relaxing bonanza. Clamoring for attention are a fantastic assortment of pills and potions, gimmicks and gadgets, all designed to unwind spring-taut nerves, relax muscle spasms or bring euphoria to a migraine-muddled mind.

Spearheading the parade of unwinding aids are the tranquilizers. Sales of these "happy pills" totaled a half billion dollars last year and are still climbing.

The barbiturates—the sleep-producing drugs—are an entirely different story. Medicines such as Nembutal and Seconal (affectionately tagged "yellow bombers" and "red sluggers") do not ease the fears, anxieties and tensions of modern living. Instead, come nighttime, they clobber the conscious mind into accepting sleep. And red-eyed insomniacs watching the sky lighten outside the window gulp them in ever increasing quantities. Doctors, alarmed at the senseless, careless drugging, have tried to stem the tide, but Americans, frantically reaching out for "just one night's good sleep," continue to stagger to the medicine cabinet.

All this despite the fact that there is no real Rx to happiness. "Man can-



not solve his problems of daily living with a pill," says Dr. David P. Allman, president of the American Medical Assn. The Mental Health Assn. also decries all the running away from fear and worry. According to that group, anyone who doesn't worry is truly a candidate for the laughing farm. We live in a tempestuous era and only a vegetable or a mind so warped that it makes no contact with reality can be utterly free of worry. A little anxiety is normal. It's the balance that's so hard to come by.

For most people, the dark hours after sundown are the roughest. With wry humor, confirmed insomniacs tag these open-eyed periods, "cultural hours." But apparently, sleep has always been a problem.

King Louis XI, who looked after France in the 15th century, had his own approach to sleep. He never got up. The royal throne was a great, billowy, ornately carved bed. The official name for this rig was "Lit de Justice" (bed of justice) and his majesty conducted the business of France while flat on his back with

the comforters tucked neatly under his chin. There were members of the royal court who served Louis for years without ever seeing his imperial highness assume anything like a vertical position.

The top authority on the sleep habits of Americans is neither a doctor, psychologist or researcher. He is Norman Dine, the proprietor of New York's gadget-stuffed "Sleep Shop." During the past 25 years he has helped thousands of restless human beings drift gently off to sleep. According to Dine, physical tension and emotional tension are firmly linked together. If you can unwind one—either one—the other also goes limp. While psychiatrists concentrate on relaxing emotional tension, Dine tackles the other side of the

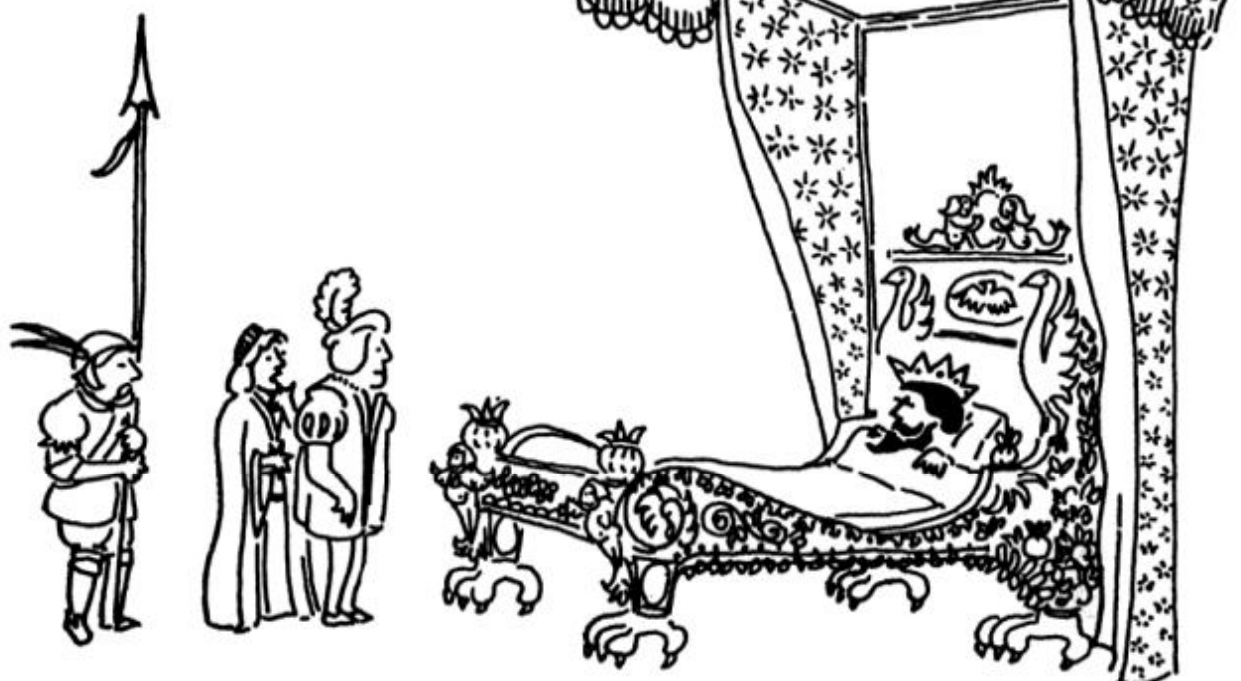

problem. With over 3200 gadgets on his many shelves, he sells physical ease. These unrest cures range from a five-foot bookshelf of do-it-yourself relaxing texts to an incredible array of gadgets. Most expensive item in the emporium is a \$1500 bed with a push-button-controlled mattress that flexes fore and aft like an awakening cobra. The contortions can be manipulated for reading or just easing leg muscles. A vibrator hums restfully while it massages. Soft music on a hi-fi tape recorder combines with a time sunlamp to ease the tensions of the



day. If this doesn't do the trick, a flick of the finger will send out the tranquil aroma of a pine forest while a motor-driven control slowly dims the bedlamp.



Deluxe bedlamps equipped with an intricate assortment of lenses funnel the light down to a narrow, page-size beam that leaves the rest of the room in darkness. To hush the faint on-off click, the lamp uses a silent mercury switch. A noiseless alarm clock awakens with a beam of light. The effect can be restricted to one side of a double bed, thereby sparing a late-rising bedmate. A strange set of right-angled "Bedspecs" will permit you to read in bed stretched out flat and relaxed. Remote controls attach to fan, radio or lamp so you can click them off from bed with a lazy jab of a fingertip.

Silent radios have a palm-sized speaker that murmurs softly under your pillow. There's a little switch that fits under one leg of your bed and automatically turns on a small night light to illuminate the floor should you arise at night. Bright red nightcaps complete with tassel are back to deflect drafts from a sleeper's thinning thatch. And if cold feet are really a problem, a set of electrically warmed anklets will bring them up to temperature. To spare you that morning shock, there's a French alarm clock that gently coaxes you awake with the tinkling music-box strains of a waltz.

Pillows come in infinite variety from small to jumbo in size and from limp to plump in filling. A special contour pillow will cradle your head without bunching up at the shoulders. An even more intricately shaped headrest has cutout edges like a jigsaw puzzle. If you can't find a comfortable head surface with this assortment, you're too tense for science.

If things are really tough, cry yourself to sleep on a Heart-ache pillow. The waterproof surface will emerge unharmed by your hot little tears, thus saving you the tension-producing worry about soaking the bed. If, like the guy who sorts eggs, it's the decisions that are tying

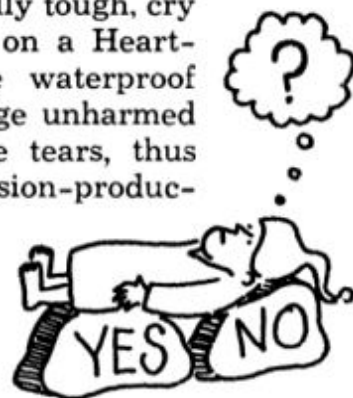

you up in a knot, try a decision pillow-case. One side says "yes"; the other, "no."

Even basic slumbertime accessories are getting more complex. Time was when a man stifled a yawn and announced that he was going to hit the hay, he did just that. He unlaced his boots and stretched out on a huge sack filled with hay, straw or maybe corn shucks. Nowadays, just the simple process of picking out a sleeping surface can create a nervous wreck.

First of all, there's the firmness factor, carefully worked out on a scientific basis. The degree of "give" starts at 20 percent, which offers the approximate resilience of a subway platform. From here you can go all the way up to a fleecy softness of 90 percent. It's a matter of personal taste.

Travelers who have wandered off the turnpikes into the rockbound recesses of Maine or Vermont claim that feather beds are still in use. Slipping into one of these is not a casual affair. The accepted technique is to dive in over the footboard. The huge billowy mass of mattress sinks down in the center while the sides fold over you like a cobra digesting an egg. It is, according to all reports, an unnerving experience.

Currently underway is a huge research program backed to the tune of several million dollars by the Simmons Mattress Co. Trained scientists are taking a close look at the sleeping pattern of the average American. Volunteer sleepers are paid a fee for snoozing nightly in a laboratory bedroom. Before turning in, each

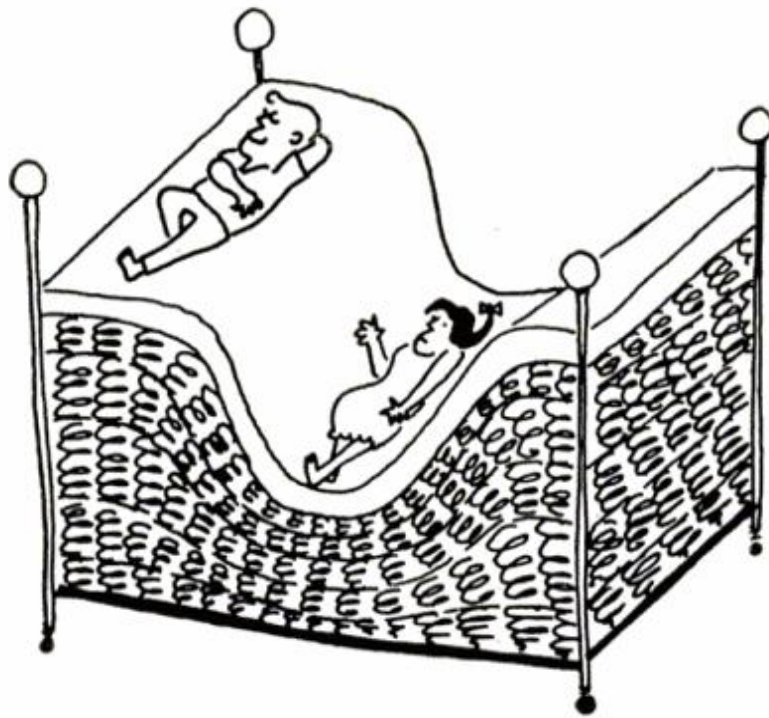

volunteer is connected up to a mass of wires that record each twist, turn and sleep-muffled contortion. As the data is cataloged (the belly sleepers sorted out from the side curlers and the snorers separated from the groaners), researchers have come up with recommendations for a host of changes.

Mattresses six inches longer are now being manufactured to accommodate our skyscraping younger generation. The standard 54-inch-wide double bed is gradually giving way to the 72 or even 78-inch-wide king-sized number. You can buy a sort of "his-and-her" mattress, one side firm and the other soft. Available on custom order is a mattress with a built-in bundling board; keeps husband and wife from "clonging" together in the center of the bed like a couple of Coke bottles in a hammock. Hair stuffing, once the aristocrat of mattress fillings, has long since relinquished the title to foam rubber, and even this bouncy bedding is giving way to a new type of plastic foam.

Color consultants have elbowed into the relaxing act. According to Hal Antin, tint and hue adviser to the Sapolin Paint Co., you can't always blame your 3:00 a.m. pillow-thumping on the salami sandwich you ate just before bedtime. The color of your bedroom walls may be the cause of your insomnia. If so, switch to beige, advises Antin. Pale yellow, soft gray or light

green will also ease your path to slumber, but avoid red at all costs. With this hot, aggressive color encasing your boudoir, sleep will come slowly and you'll awaken with the temperament of a hungover bear.

Alan Murray, the world's most expensive shoemaker, tackles the anxiety problem from another direction. "When your feet are happy . . . your body is happy," says Murray. The custom footwear he turns out are molded from a plaster cast of the customer's foot, fit like a glove and, according to thousands of customers, afford incredible comfort. Totally different from any other footgear on the market, these ground grippers are short, wide and contoured inside to cradle each toe and callus. Price: \$75 and up per pair.

Addicted to these "space shoes" have been a host of pavement pounders ranging from mailmen and traffic cops to Danny Kaye and Mrs. Litvinov, widow of the former Russian ambassador, which would seem to indicate there is tension behind the Iron Curtain.

For easing his own tension, Murray follows an offbeat system. He has the only private ice-skating rink in midtown Manhattan. It's in the rear of his shop where customers, their feet encased in slowly hardening plaster, can watch him gracefully twirling in figure eights, arabesques and other maneuvers befitting an expert.

(Please turn to page 210)



Riot protector. A bottle smashes harmlessly against a clear polycarbonate plastic shield designed to help riot police ward off flying bricks, rocks and other objects. The Polyguard shield has a built-in arm shock absorber of foam. It's made by Rowland Products Inc., Box DA2, Kensington, Conn., and is priced at \$29.95.



Don't move the patient, is a time-honored warning when there may be neck or spine injuries, and Dr. William Terry of San Diego State College has devised a rescue board for diving and swimming accidents that serves as a body splint. Made of $\frac{3}{4}$ -inch plywood, the board is six feet long and two feet wide; there are handles 18 inches from the end on both sides, and auto safety straps at top and bottom secure the victim at the shoulders and knees, keeping the body rigid while being moved.

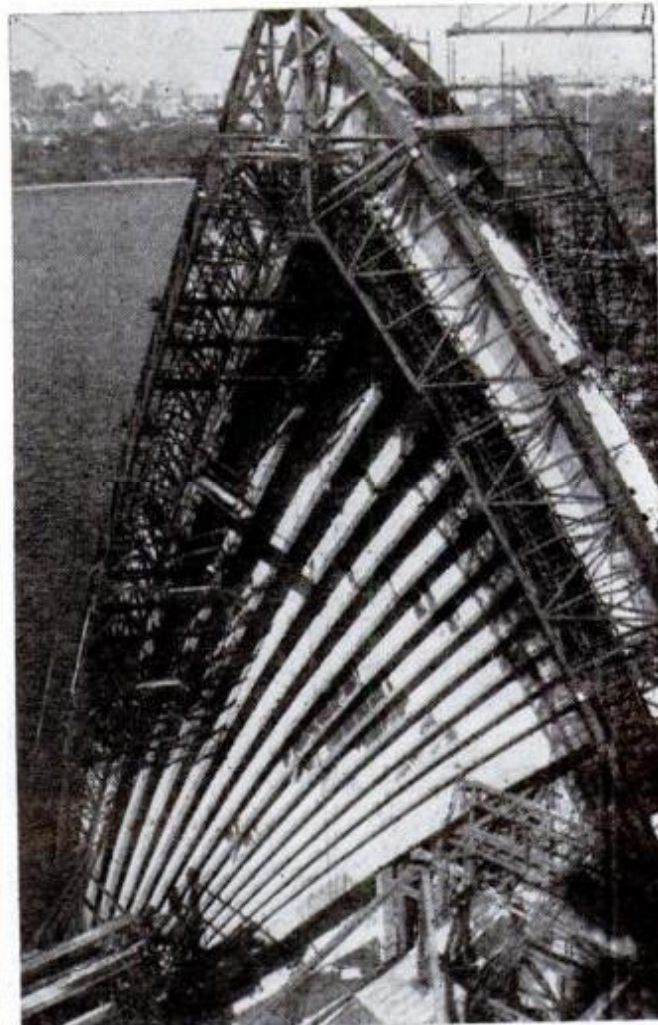

Sail-like "shells" of pre-cast concrete form the controversial roof of the Opera House in Sydney, Australia. Special scaffolding and tower cranes were required to support and raise these huge "shells," which will be clad with Swedish ceramic tile resembling old Ming china. Because of its location on a peninsula which juts out into the harbor, the 100,000-ton structure also demanded extensive piling and foundation work.



The Hodag Endurance Run: Snowmobile Shakedown

Frozen washboard lakes, swamps, tangled woods, bone-shuddering corduroy roads scramble brains and jar innards — but even the novices try to win

By Stuart James, PM Outdoors Editor

SPECTATORS LINED the snow-packed, downtown street in Rhinelander, Wis., their bodies canted out and heads turned toward the starting gate where 107 snowmobiles snarled and popped, double-filing toward the start of the Hodag 35-Mile Cross-Country Marathon.

They were starting two machines at a time at ten-second intervals. My turn was coming up. I remember looking down that channel of people, my hand nervously revving the throttle of the snowmobile, and thinking, "I hope I don't run over somebody before I even get out of town."

Then I was in the starting gate, and I was recalling my five minutes of instruction in snowmobile driving. "You just press your thumb on the throttle and away she goes. Nothing to it.

You can sit down to drive it, but most fellows kneel on the seat to get better control." I was kneeling. Until the day before I had never seen a snowmobile, but I wanted to at least *look* like I knew what I was doing.

We were off. The machine next to me roared out ahead. I was mostly concerned with not maiming anyone. We went a block on the hard-packed snow, made a right turn and roared across a vacant lot. I was getting the feel of the machine and it seemed as though the race was going to be a snap. At the end of the lot there was a small hill, a sharp turn and the course dropped down to a lake. There was a crowd of people at that spot.

Now, on a snowmobile, when you make a sharp turn at full speed, you're supposed to lean off to the side in the direction

you're turning. If you don't, particularly if you're kneeling on the seat like a real pro, you'll get thrown off on your head.

As usual, I learned it the hard way. I should have known that crowd was waiting down there to be entertained. I gave them the best laugh of the day.

But I picked myself up, staggered around until I found the machine, and then got it out on the lake. There was about three miles of open track, and I thought that it was going to be fun.

Let me tell you about snowmobiles. I was driving a Johnson Skee-Horse, which is essentially a tractor tread with a seat on it, a pair of skis out front that are steered by handlebars, and a 14-hp engine that turns the tread off a chain drive. Now this machine weighs 369 pounds and there are no springs, and the closest thing to



WARMING UP, a squadron of snowmobiles churns up clouds of snow as the vehicles growl across a snowfield prior to the start of the race. Out of a total of 107 starters, accidents and engine trouble took their toll of 19 machines



FIGHTING FOR POSITION on a narrow trail is tough enough, but trees and underbrush make it even more difficult



OPEN TRAIL is unusual in a cross-country endurance run, but even this is a jarring experience taken at top speed

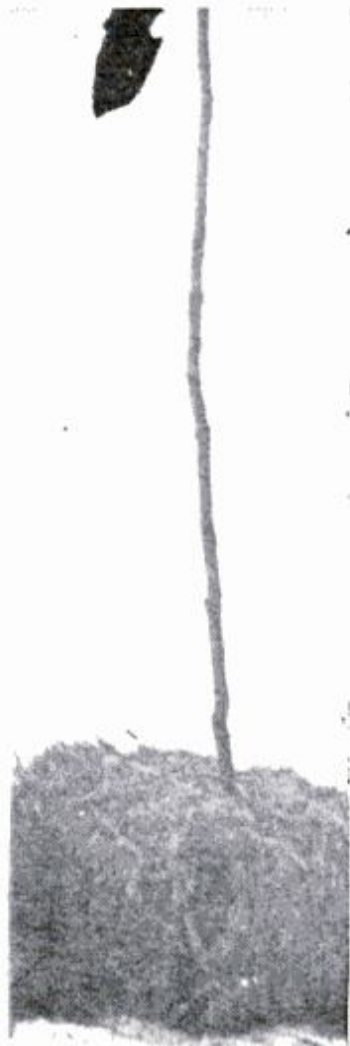

driving it across a snow-covered lake at 40 mph is being strapped to a jackhammer that is running amok in a granite quarry.

But, wait; there's still 32 miles of this winterized lunacy to go.

The course was marked with flags, but as I neared the end of the lake I thought there was a mistake. The flags seemed to indicate that I was to plunge straight into dense woods. It was no mistake.

I followed the narrow, twisting trail, and ducked down behind the plastic windshield to avoid being slapped off by low-hanging branches. I came down a sharp drop, skidded around a turn, didn't make it and slammed into a tree. I sailed over the windshield, glanced off the tree and landed in the deep snow. I wasn't hurt, but the snowmobile was smacked up close to

[\(Please turn to page 218\)](#)



KNEELING ON THE SEAT enables the driver to shift his weight quickly from side to side for turns and also stand up to absorb the shocks with his legs



LAYING INTO A TIGHT TURN, the drivers lean far out to counterbalance the weight of the machines and slide them around. Polite tactics give way to every-man-for-himself when they're battling for position like this

Sledding at a mile a

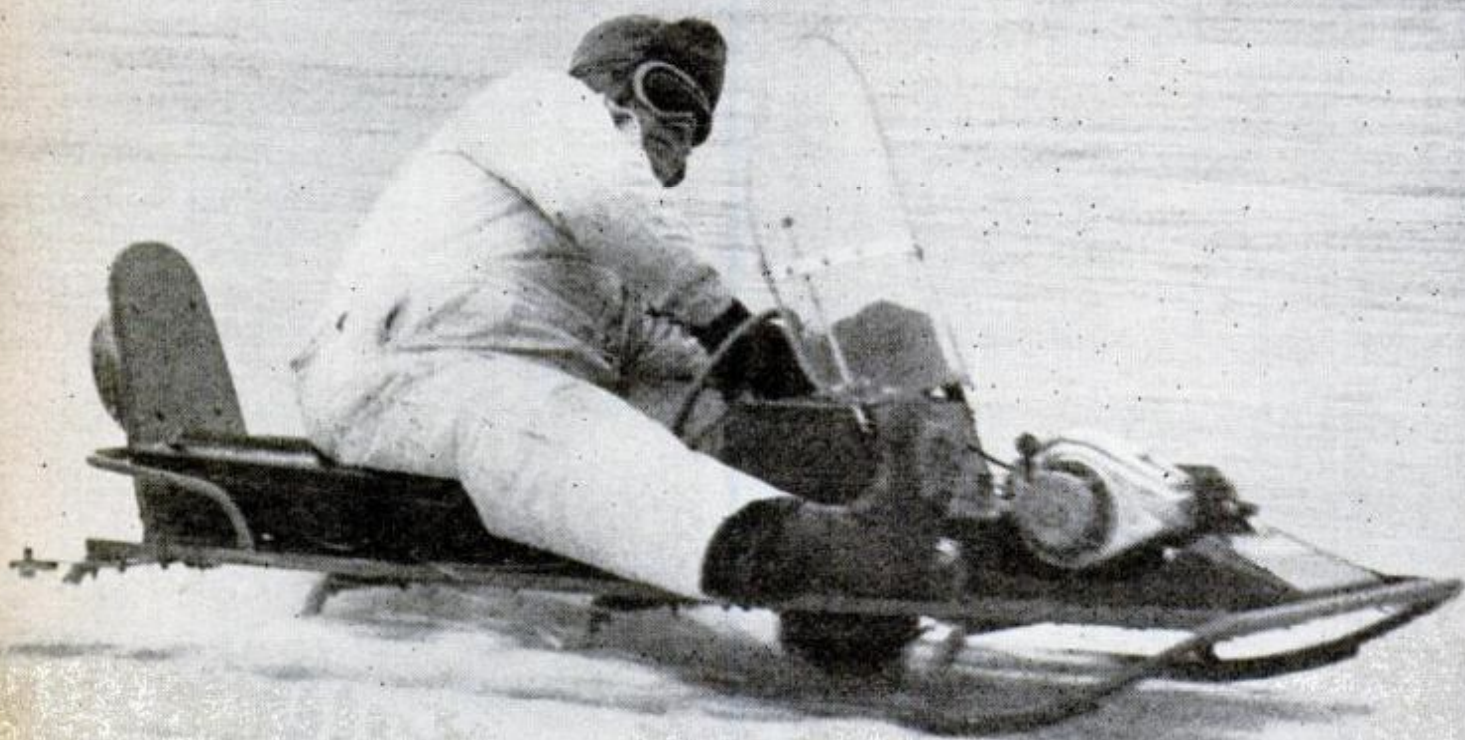

BLURRING THE LANDSCAPE, a Simko Power Sled flashes across the ice at top speed. The driver is leaning to put his weight into a turn to attempt a slide, but even with this maneuver the sled has been designed with such stability that the turn was still wide

minute

"ICE BOATING is a great sport," I said Jim Simko, "but I wanted something that would give the same thrills and wouldn't be such a prima donna about weather and ice conditions."

The result was the Simko Power Sled, a go-kart on runners that rockets over the ice at 60 mph, and is so safe and easy to run that a 10-year-old can handle it with ease.

Muffled against the biting wind of a Michigan cold spell, I accompanied Jim Simko to a small lake on the outskirts of Detroit where two dozen ice-sled enthusiasts were racing pell-mell from one end to the other.

The sled is a tubular steel frame with angle iron runners. A Briggs & Stratton 10-hp engine turns a toothed wheel under the sled that just barely bites into the ice. It has a centrifugal clutch and a hand-operated dead man's throttle. A steering wheel turns a pair of rudders at the rear, and it is equipped with a comfortable bucket seat.

I took this rig out and did everything to try to spin it out or turn it over. Impossible. At top speed I jerked the wheel left and right. I only fishtailed. And yet you can race it in formations and it handles beautifully. I took it over a submerged log at top speed and it just sailed through the air, landed and went into a long, graceful slide. In that one afternoon I became a complete fan of power sledding.

A single-passenger sled sells for \$199 complete, but you can also buy it in a kit and a set of plans costs only \$3 from Simko Power Sleds, 4420 West Jefferson, Ecorse, Mich.—*Stuart James*

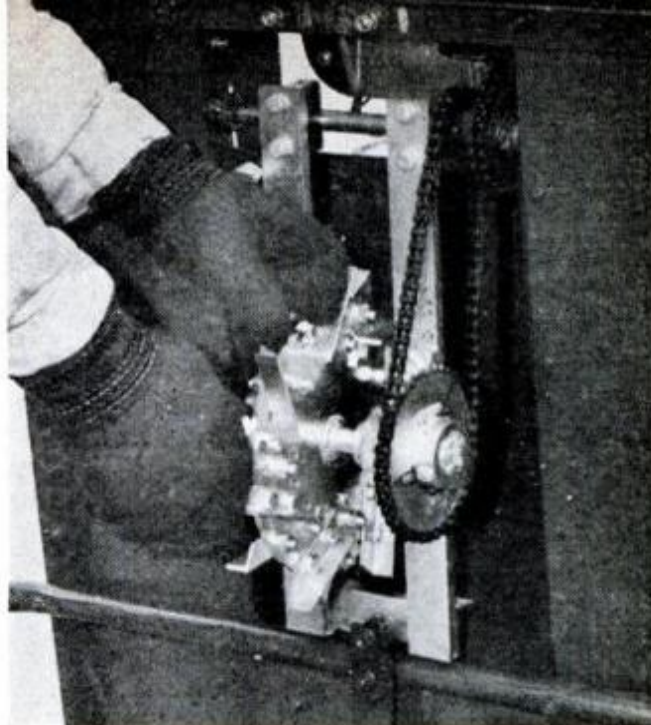

TURNED BY CHAIN DRIVE off a kart engine, the source of locomotion is this wheel with adjustable teeth that just barely bite into the ice surface

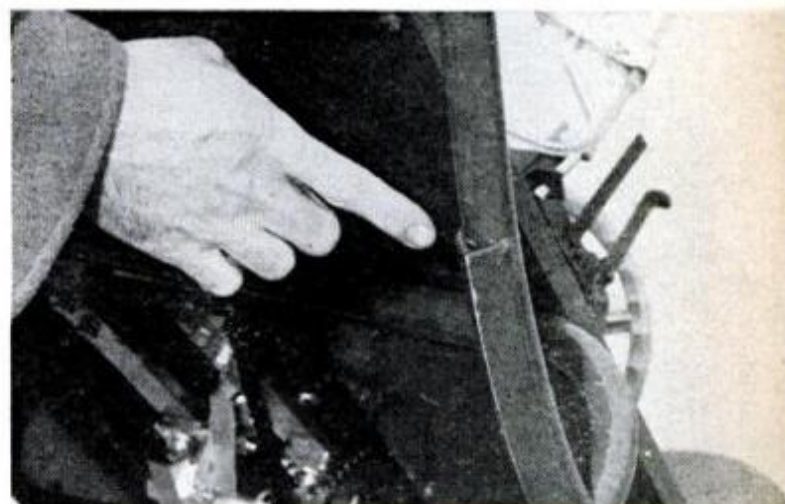

SLED RUNNERS are angle iron welded to the tubular steel frame. The sharp edge, acting like the edge of an ice skate, adds to the sled's stability



DEAD MAN THROTTLE is a safety device. It must be held forward to activate the engine; when it is released it automatically cuts off the power

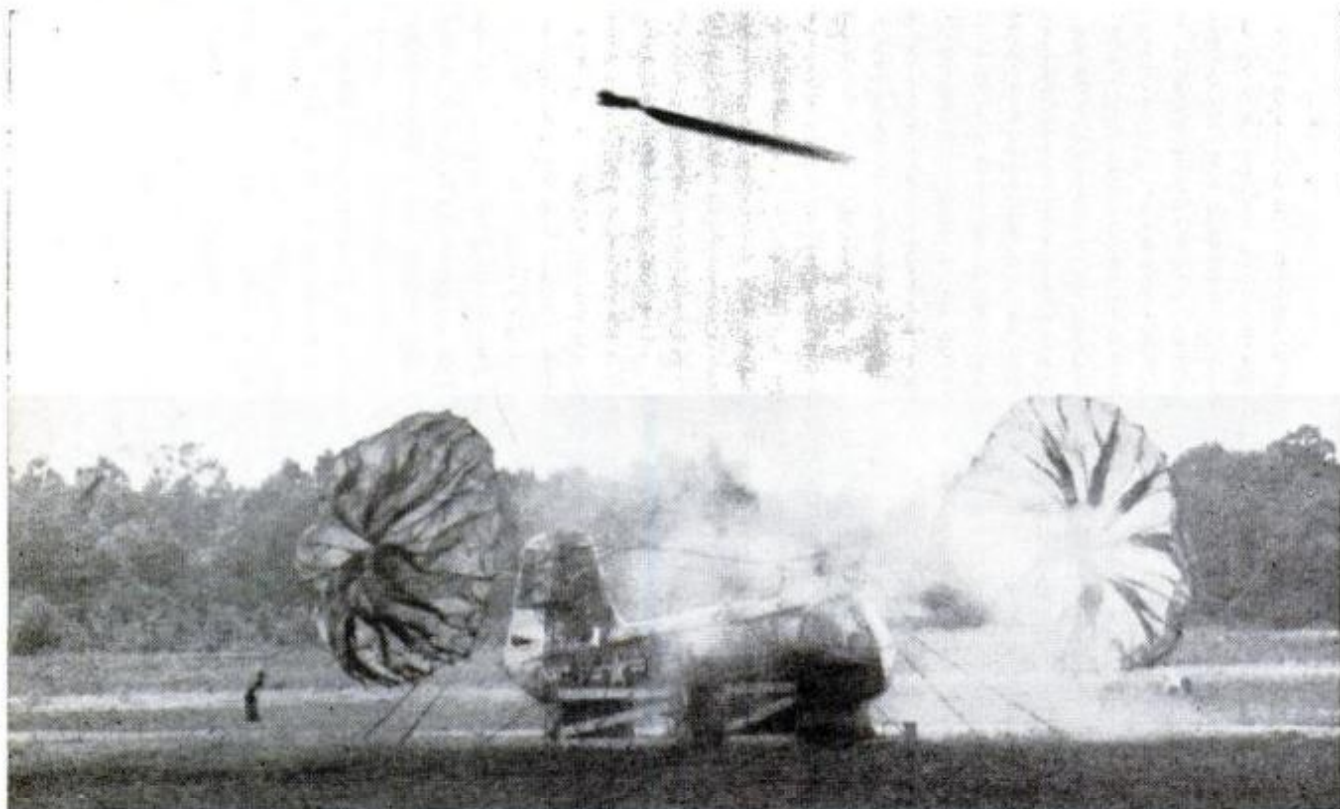

Chopper dropper. Lives of passengers and crew in about 80 percent of helicopter crashes could be saved by destroying the rotor blades and parachuting the copter to earth. In Navy tests the pilot pulls a handle which fires a cartridge that cuts the rotor shaft and separates the rotor blades (top photo). Simultaneously, rockets propel the severed parts free and parachutes shoot out of containers (lower photo). Tests have been done from as low as 200 feet.



Reactionary spectacles. Eyeglasses that darken on exposure to sunlight and then become clear again indoors or after sundown are the end product of a new ophthalmic glass developed by Corning Glass Works. After a one-hour exposure to direct sunlight at 85° F., light transmittance of the new glass drops to 66 percent, similar to lightly shaded green sunglasses.

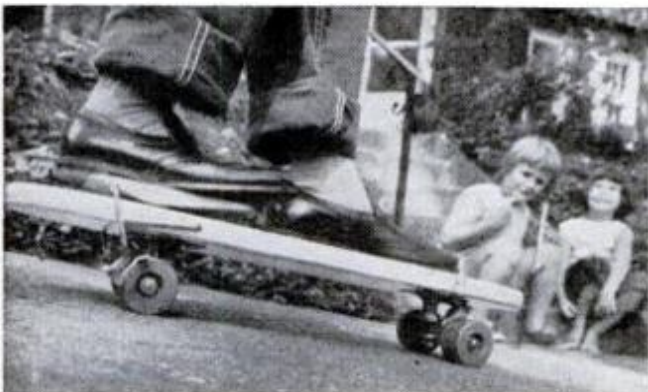

Skateboard brake. Attach the Surfbrake to your skateboard for a braking action that won't interfere with steering or balancing. The self-compensating pedal is designed to avoid abrupt stops and is easily detached or made inoperative at will. It's supplied in kit form by Electro-Mech Industries Inc., 825 New Hampshire Ave. N.W., Washington, D.C. 20037.



Battlefield fuel supply is neatly delivered in a rubber self-sealing drum by a Wessex refueling helicopter, newly developed for Great Britain's Unison 65, formerly called the commonwealth interservice study.



Great Lakes super ship, SS Tarantau is 730 feet long and has a depth of 40.5 feet and breadth of 75 feet, allowing her to carry 30,000 tons of coal or rock. Three conveyor belts running through the bottom of the hull can unload 4200 tons of coal an hour. A 9000-hp steam turbine powers the ship, which is owned by Canada Steamship Lines.

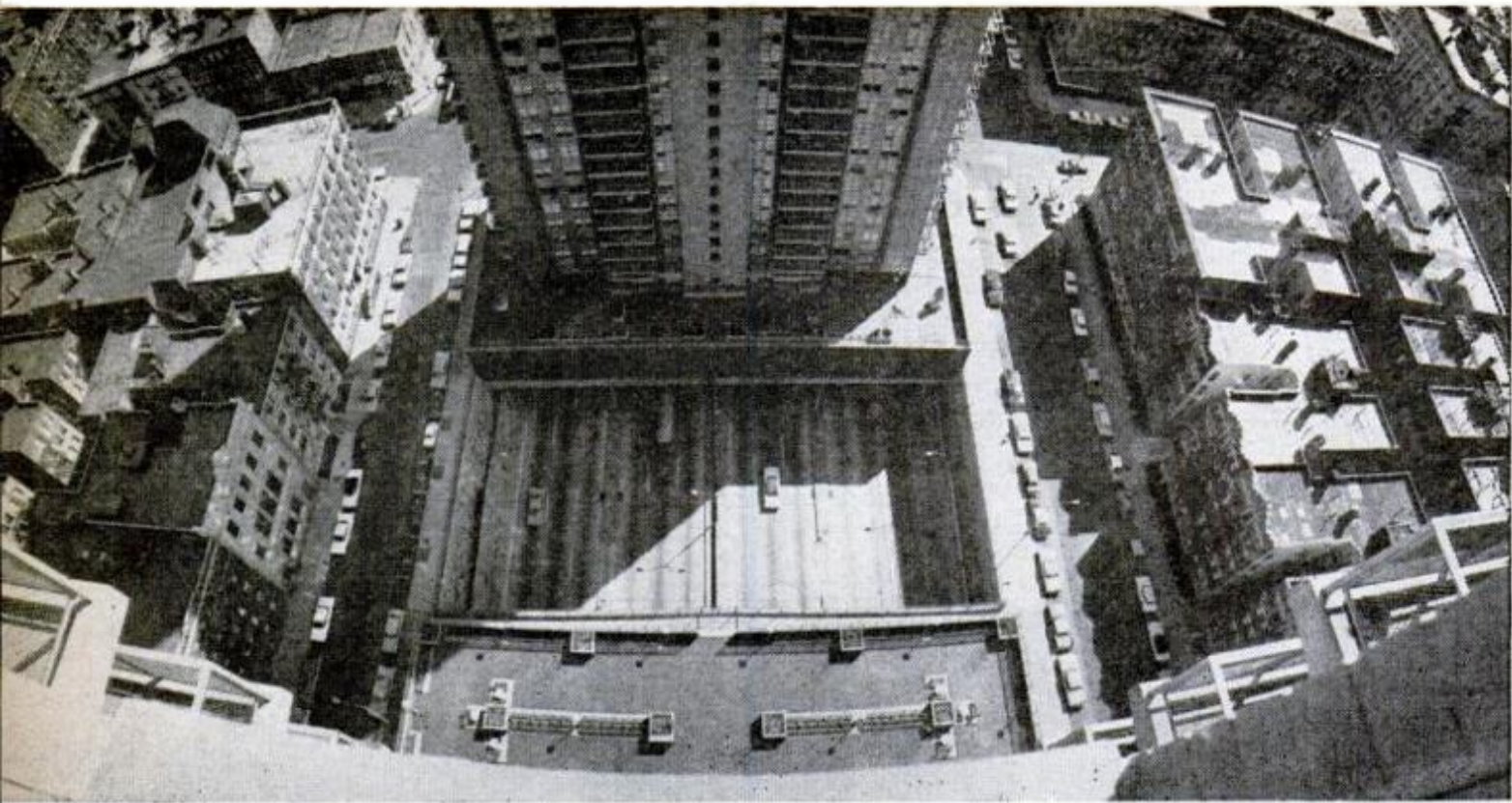

NO BASEMENT RUNS UNDER THIS APARTMENT building. Instead, there's a highway leading to the George Washington Bridge. Steel trusses span the roadway and support the massive structure

No land? Then build it on air!

The hardest thing to find in a modern city is vacant land. So real estate men erect giant structures over railroads, highways and even other buildings

BY CREIGHTON PEET

IN CHICAGO, BOSTON, NEW YORK and other big cities, real estate men more and more frequently are closing multimillion-dollar deals that involve parcels of empty air. That's right—air. It's perfectly legal, too. Builders use these "boxes" of air space to put up skyscrapers over railroad tracks, subways, highways and even other buildings.

One of the hardest things to find downtown in our cities is a vacant lot. So builders have to knock down existing buildings or acquire air rights.

Air rights are more substantial than they sound. You control air rights to a piece of property if you own your own home. Walk outdoors and look straight up. According to our man-made laws, you (and perhaps your mortgage company) own a slice of the heavens for as far as you can see. It's all yours, an infinite number of heavenly cubic feet.

That's the kind of "property" that some real estate agents are now selling. But buildings constructed on air rights have unique problems. For instance, they usually have small basements, often none at all. Their only contact with solid ground is through long steel legs reaching down into another owner's land.

New York City's Waldorf-Astoria Hotel, which fills a solid city block, is built on 216 steel piles. It sits over two levels of main line railroad tracks



IN ALL, FOUR 32-STORY APARTMENT HOUSES and a bus terminal (behind them) straddle the 12-lane highway on the west side of New York City. Beyond the bridge is the New Jersey shore



LOOMING LIKE A GLEAMING MOUNTAIN above the Illinois Central tracks in Chicago is the Prudential Building. It stands 41 stories high and is reported to have cost \$42 million



A SIMILAR CONSTRUCTION PROBLEM was involved in putting up a big office building on New York's Park Ave. Trains continued to roll while the steel foundation was put in place

and a railroad yard and, as a consequence, has a very small basement area. Its wine "cellar" is on the fifth floor, steam for heating its 47 floors is supplied by a utility plant some 15 blocks away, and all its laundry is washed in a remote part of town.

Having no basement gives rise to other problems. Two recently completed Park Ave. skyscrapers, the Pan Am and the Union Carbide Buildings, start their elevators on the second floor because there is no room for essential elevator pits below the street level. That space is used by the New York Central R.R. Thus, the pits are on the first floor in each case, and escalators take tenants to elevators on the second.

Sometimes these valuable parcels of aerial real estate cover 50 acres or more. And sometimes deals involve structures using hundreds of thousands of cubic feet of air space entirely inside another owner's building, but not touching it at any point. Perhaps the smallest air-rights agreement in existence involves the \$25 a year that the city of New York collects because an aluminum lady's bosom projects more than 18 inches beyond a front building line. The city claims that the lady—a statue on the facade of an art gallery—constitutes an infringement of the air rights over a city street.

Bridges between buildings over city streets are commonplace, and the same type of air-rights arrangement is even used for big projects. One of the most monumental to date consists of four 32-story apartment houses that straddle the 12-lane approach to the George Washington Bridge on the New York City side. Each of the steel bridges supporting these buildings consists of four trusses 10 feet tall and 45 feet long. Air rights were sold

by the city to the developers for \$1,100,000. Air rights are usually leased for those big electric signs you see on buildings. Similarly, eight of the best paying tenants of the Empire State Building use space above the roof. They're the eight television antennas fastened to the 222-foot steel mast anchored to the roof above the 103rd floor.

The towerlike top of the building is very strong. Built in 1932, when the dirigible was still giving the airplane competition, the tower was designed to be a mooring for the big lighter-than-air ships. Special steel bracing was installed in the tower to enable it to resist tugs from wind-buffed dirigibles.

Though never used as a mooring, the strong tower made it safe to add the TV mast in later years. Today, rent from the eight antennas has made the slender column of air space above the 103rd floor worth around \$700,000 a year.

The narrow width of New York's Manhattan Island encouraged the building of skyscrapers, and later the development of air rights. The first of the big air-rights projects was started in 1913 when Grand Central Terminal was built on top of a steel and concrete roof stretching over 29 acres of railroad tracks. By covering the tracks, builders transformed a dirty, shabby "railroad avenue" into the Park Ave. we know today, one of the plushiest and most valuable pieces of real estate in the country.

Between 42nd and 52nd Sts., in addition to Grand Central Terminal, some 23 luxury apartments and hotels were built. In recent years, many of those buildings have been replaced with tall office buildings, making the air-rights revenue to the railroad greater than ever.

And now Pennsylvania Station, the sec-

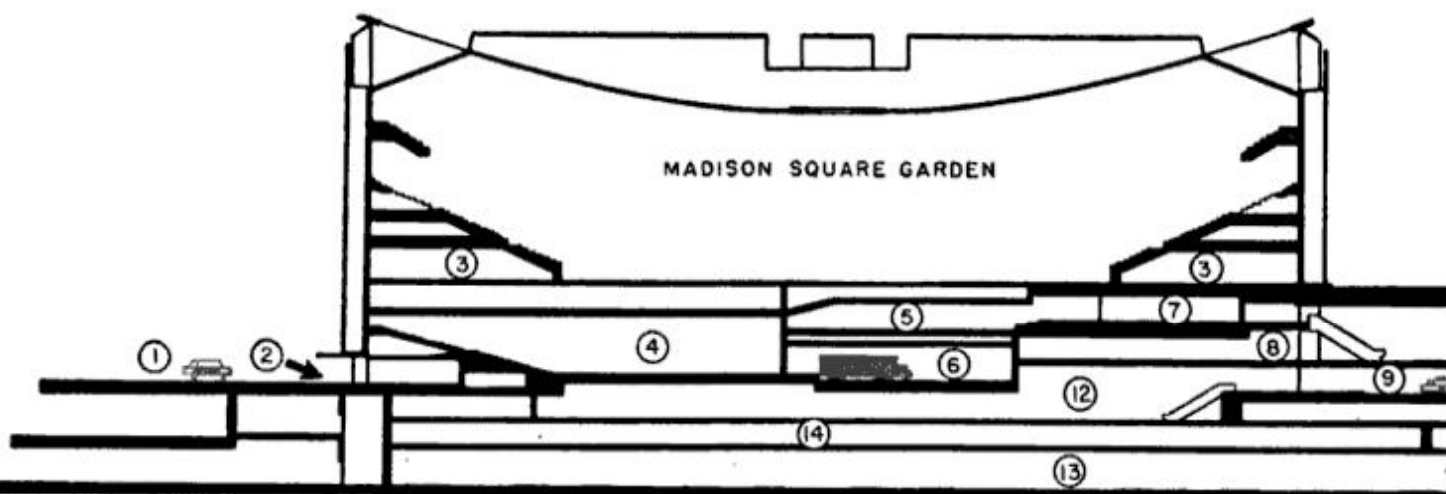

CUTTING TORCHES, sledge hammers and giant cranes are transforming New York's Pennsylvania Station into the new Madison Square Garden Center. Situated above the railroad facilities will be an office building, various entertainment areas and a sports arena with a top capacity of 22,000. A diagram (below) of the project shows: 1. Eighth Ave. location; 2. amphitheatre; 3. exhibition hall; 4. the 4000-seat amphitheatre; 5. bowling center; 6. truck unloading area; 7. museums; 8. sports center; 9. taxi drive; 10. enclosed mall; 11. entrance to office building; 12. railroad concourse; 13. track level; 14. railroad concourse, and 15. Seventh Avenue location



GIANT TRUSS THAT WILL SUPPORT section of new center runs right through Penn Station's big concourse. It's anchored on steel "legs"

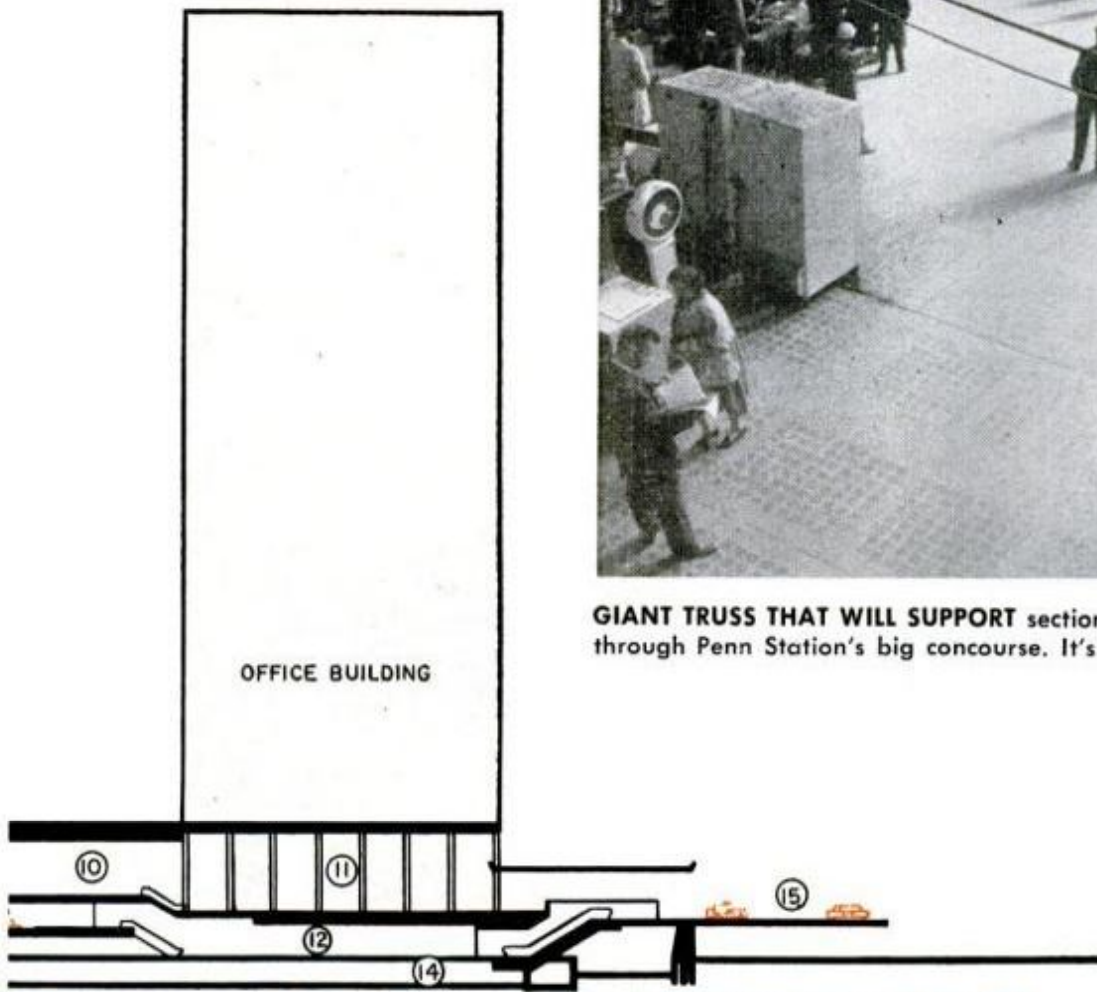

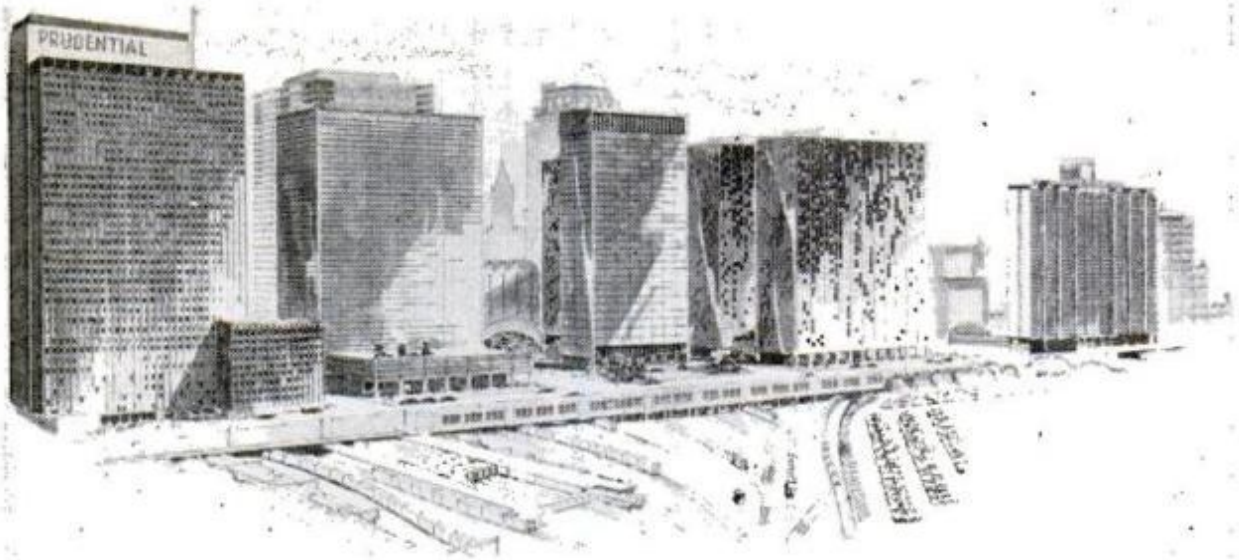

BIG TARGET for developers is the expanse (left) above the Illinois Central tracks in Chicago. Area between Prudential Building (left) and new apartment house is tied up in litigation. The drawing shows how the area may look after construction in future

ond big railroad terminal in New York, is being demolished. It will soon be replaced by a vast new Madison Square Garden, a 29-story office building, a movie theater, bowling alleys and other facilities, all occupying air space above a shrunken, below-ground railroad station.

Intricate structural problems often complicate air-rights construction. When the new 38-story CBS Building was put up recently in New York, air rights over a two-track subway line, which runs diagonally under its basement, were involved. To support the skyscraper, some of the most massive short pieces of steel fabricated in recent years were placed to form a bridge over the subway.

The subway line had been built some 30 years before when the land was occupied by small brick buildings, many only four to five stories high. They were adequately supported by the subway's concrete slab roof. But a lot more support was needed for a 38-story building.

Another type of air-rights arrangement involves using space within an existing structure. Some years ago, Bell

Laboratories gave the New York Central System permission to construct a tunnel carrying a two-track freight line through their building in lower Manhattan. Since it was feared that the movement of cars would cause vibrations that might interfere with delicate electronics experiments, a steel framework to support the two tracks was built inside the third and fourth floors of the Bell Labs Building.

The framework doesn't touch the Bell Building at any point; it rests entirely on its own steel supports sunk 86 feet below the street. The tunnel involves 250,000 cubic feet of air space. Use of this line was discontinued some time ago, but the railroad still has its tracks and its air rights.

There have been cases where air-rights tenants have been troubled by vibrations from traffic underneath. Some years ago a sensitive guest on one of the upper floors of a Park Ave. hotel complained that she was being kept awake by the rumble of trains. Though no one else could hear anything, the woman was so insistent that engineers investigated.

[\(Please turn to page 222\)](#)

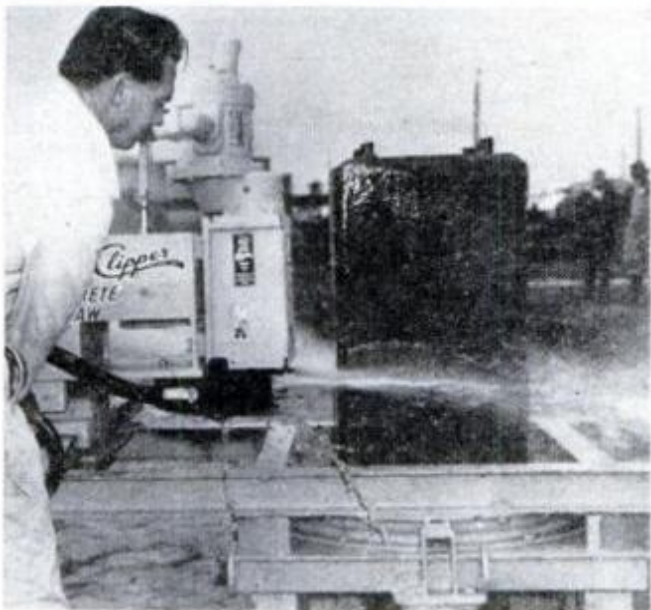
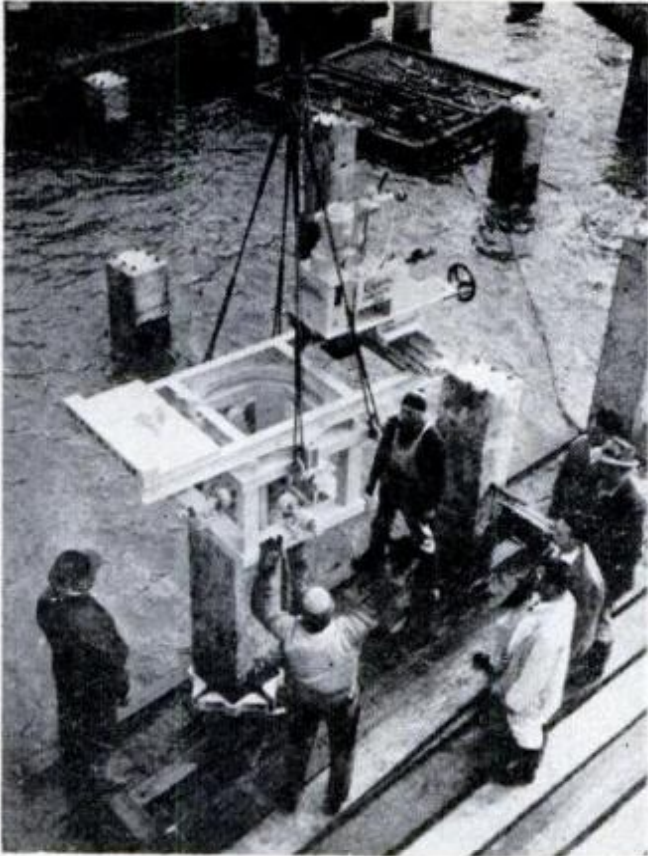

Concrete-cutting saw. Capable of slicing through reinforced concrete, the saw is used in Australia, where it was developed, to lop the tops from harbor piles. It has a diamond-edged blade that's horizontally mounted, driven by compressed air and water-cooled. The saw's frame, which is adjustable, is dropped over the top of the pile. The tool can cut piles up to 18 inches square.



Jumping alligators at Homosassa Springs, Fla., have learned that a clanging dinner bell means a free meal—a fishy morsel, usually mullet, dangling on a string. Never rated among the smartest of wildlife, the 'gators became adept at jumping as much as two-thirds of their length.

After determining that they would jump for mullet, the feeder experimented with marshmallows. At the sound of a crushed plastic container, the alligators would jump. However, white sponge or white sack substitutes were rejected by the creatures.



Collapsible five-gallon jug folds into a two-inch-thick package weighing only one-half pound. Ideal for camping or boating, the polyethylene Lug-A-Jug is priced at \$2.19. It's made by Dewitt Plastics, Auburn, N.Y.

NEW FOR
YOUR HOME
 BY MARION MOREY



PEWTER WAX gilds or restores almost any surface. Apply with finger or soft cloth, let it dry one minute and buff to luster. Price: \$2 per one-ounce jar. Offered by Connoisseur Studio, P.O. Box 7187, Louisville 7, Ky.

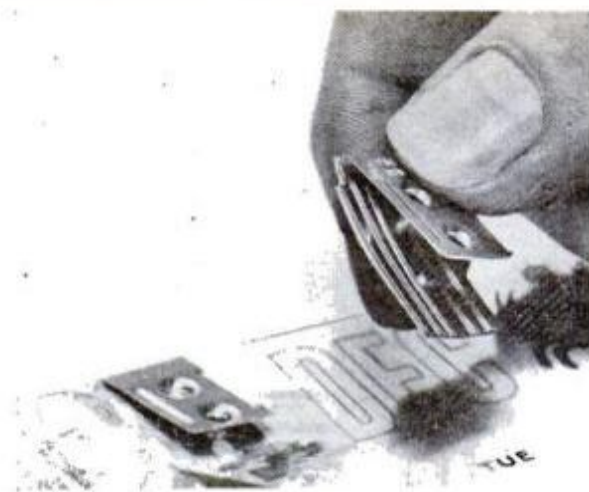

STICK CLIPS of metal adhere to any clean, dry surface and hang whatever you need hung. Open clips, slide them onto material, press to wall or window. 6 for 39 cents; Klip-Stix, 58 Seabring St., Brooklyn, N.Y. 11231



DOOR SIGNS stop annoying doorbells. Plastic messages hang on doorknob, cover most occasions. Even preschoolers can understand them. \$1.50 per set of 12. World Wide Products, Box 2857, San Francisco, Calif.

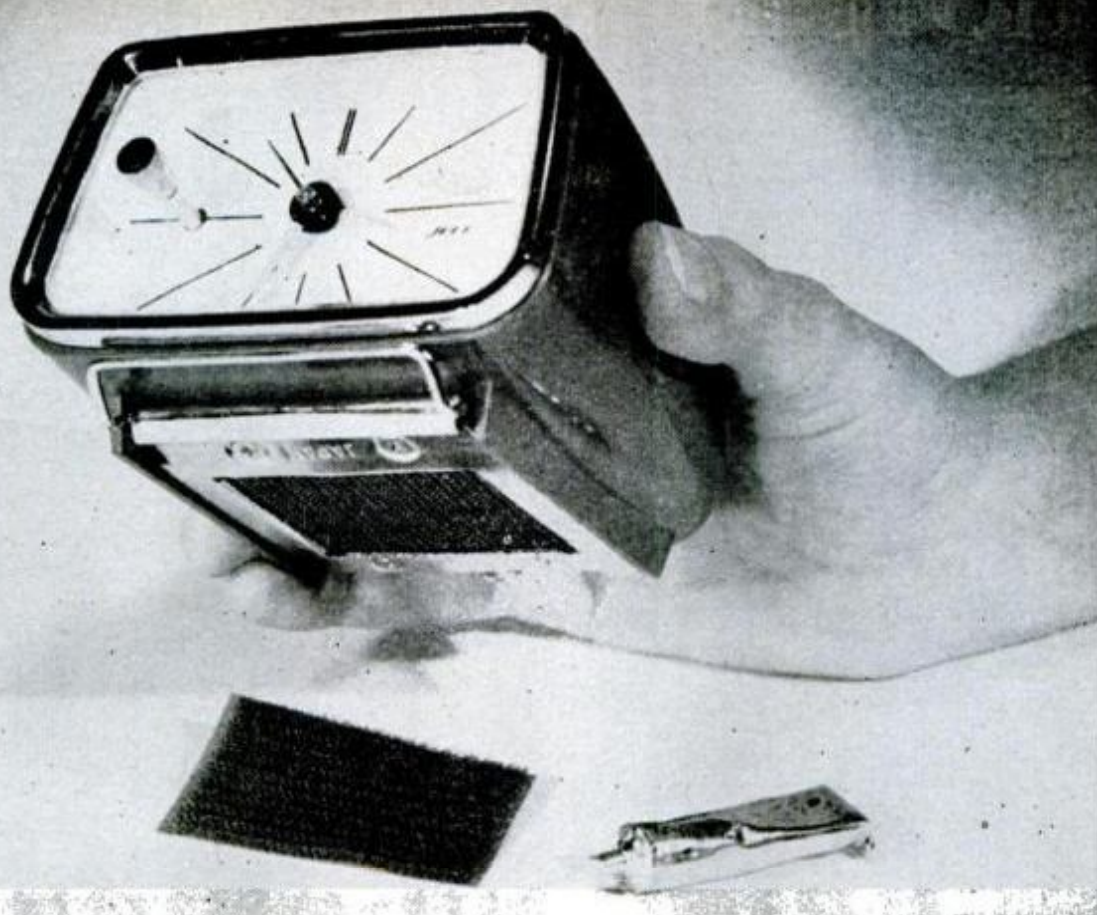

BATTERY-OPERATED PORTABLE CLOCK runs for a year with good accuracy on a single "C" battery. Mounted in a $3\frac{1}{4}$ by $3\frac{1}{2}$ by $2\frac{1}{2}$ -in. gray plastic case, the clock suits car, boat, camping, travel and home use. A fiber-mesh base lets you position clock on metal, wood or plastic; it adheres firmly, resists jolting. Simply glue bottom mesh piece where you want it and set clock on it. Unit costs \$19.75 from Gilwin Corp., 250 Culver Ave., Jersey City, N.J.

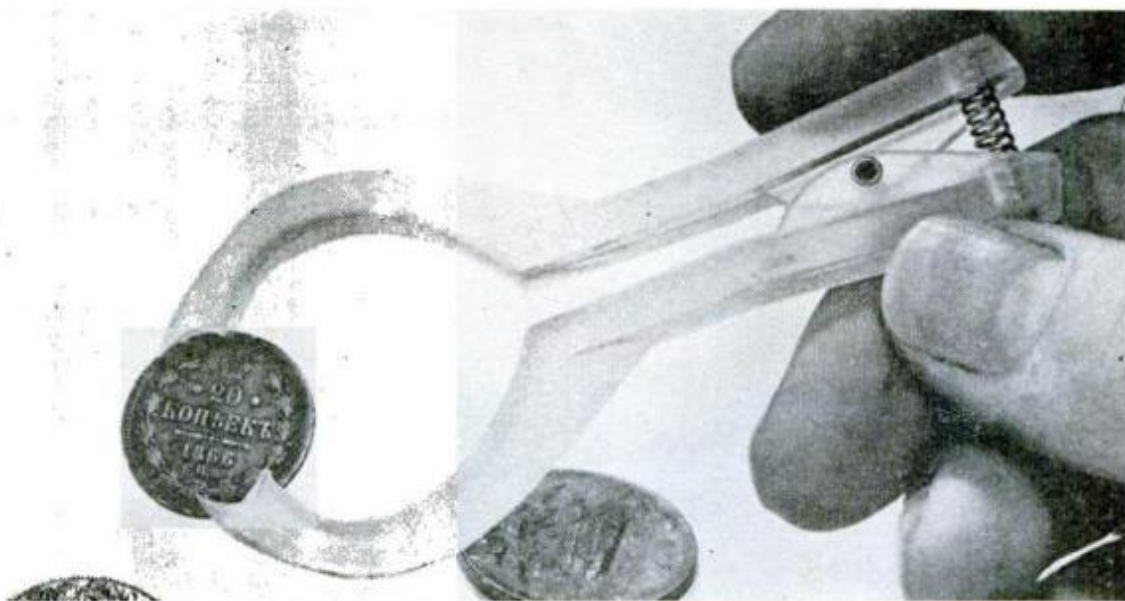

COIN COLLECTOR'S CLAMP takes the smudge out of numismatics; the plastic tool picks up and holds securely any size coin from any surface, including glass. You don't have to touch a coin with your fingers. The grip-tight jaw of the clamp permits safe transfer of coins in either a vertical or horizontal position and allows you to use a magnifier while holding a coin in one hand. For beginner or advanced collector, the clamp is 69 cents. Bemco, Inc., Kasson, Minn.

atic



MURDER WEAPON is photographed on light box in elaborately equipped police laboratory

CAMERAS TO TRAP CROOKS

The face on the car door, imprint on fabric, the mark of a paint rub—cameras found these telltale clues and sent the killers to jail

By Arthur J. Maher

ONE DAY IN 1957, a masked man strode into the office of a Cleveland savings-and-loan. While the man brandished a gun, a woman accomplice emptied almost \$2400 from a teller's cage into a paper bag. Then the two hurried out to a waiting car—driven by a second woman—and sped away. A fast robbery, well planned and neatly carried out—except for one minor detail. The whole thing had been recorded on film.

The savings-and-loan, which had been robbed so often that some called it the shooting gallery, had installed a secret movie camera only the day before. Within hours, television stations in Cleveland and other cities were showing the world's first televised bank holdup. Next day, the masked man surrendered. He'd fled to Indiana, but upon learning of his "fame," realized the proverbial jig was up.

Meanwhile, still photographs taken from the film had led detectives to the driver of the getaway car and a boy friend who'd provided the car in return for \$1000 of the loot. Finally, an anonymous phone call helped to locate the woman

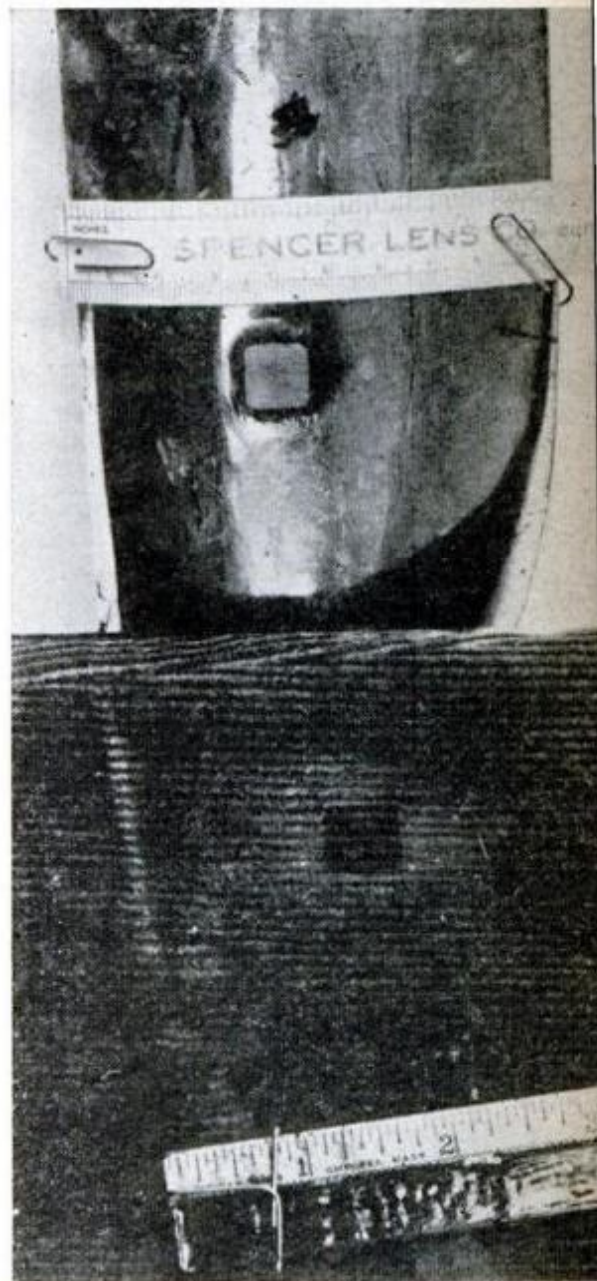

PHOTOGRAPHING CLOTH from the trousers of hit-and-run victim proved suspect's truck bumper flattened corduroy nap. Imprint convinced jury



SNOWPRINT TRAPS BANDIT. In their haste to get away, two men who had just held up a Canadian loan company backed their car into a snow drift. Police photographed imprint of license for evidence. Men were caught in hours

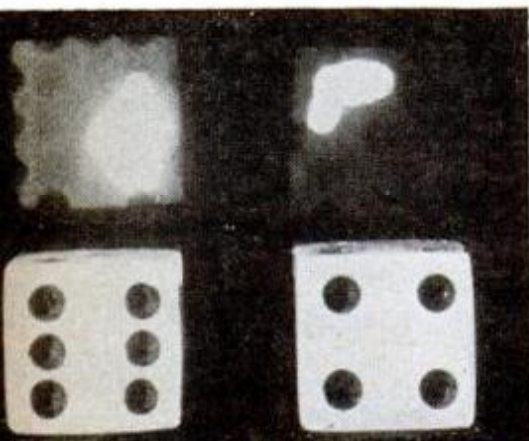

X-RAY PHOTOS PROVED DICE (above, left) were loaded. Cutting dice open would have made it impossible to show how loads insured seven at every roll. Photo at right shows how X-rays detect contraband hidden in heel of shoe

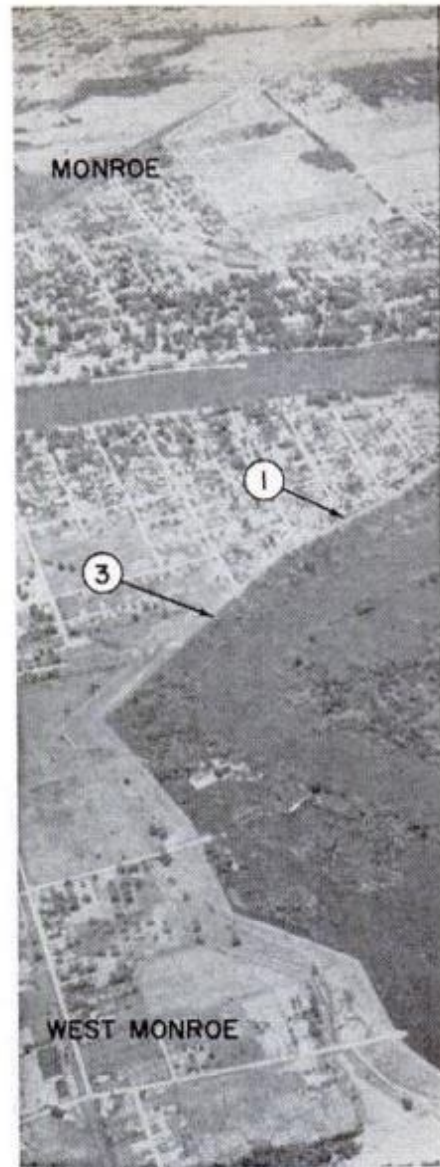

WEST MONROE

with the paper bag. Another woman, viewing the holdup on TV, noticed something distinctive about the way the girl bandit popped open the bag. Later, watching a rerun of the film, she remembered that she'd once noticed a certain supermarket cashier had a characteristic way of opening paper bags. Her phone call led to the guilty party. All four suspects were convicted.

In another case, a Manhattan Beach, Calif., nursery was burglarized five times during 1956. Each time, the culprits had broken a window pane in an adjoining hothouse, then the door between that hothouse and the nursery. In January, 1957, the owners wired a hidden camera and infrared flash to snap when the door was opened. Every night upon closing, they religiously set the camera mechanism for action.

One morning, they found that the shutter had been snapped. Local police rushed the infrared film to the FBI, which developed a clearly identifiable shot of two men entering the nursery. Circulation of this picture, which showed a tattoo on one man's right arm, led to arrest of the suspects.

The above two cases are far from unique. They are presented here as typical of the thousands of cases each year in which photographs help bring criminals to justice.

The use of photographs in crime detection is almost as old as photography itself. In 1841, for example, two years after Louis J.M. Daguerre invented the daguerreotype process, the Philadelphia Public Ledger reported, "Whenever any suspicious person or criminal is arrested in France, the officers have him immediately daguerreotyped and he is likewise placed



FLOODED RIVER carried murder victim's body from point 3 to 2. To prove this at trial, a sheriff photographed river before water receded to normal banks

in the criminal cabinet for future reference. . . ." And one historian reports that in 1839 an irate husband spiced a divorce trial with a daguerreotype taken of his wife during a tryst.

In this country, the San Francisco police department used mug shots to speed identification of criminals as early as the mid-1850s, and in New York City, a rogues' gallery of 450 ambrotypes (an early, short-lived photo process) was established in 1858. Other cities were quick to follow suit, with the result that an estimated 5000 to 6000 men are now active in police photography, spending \$8 to \$10 million a year on photo supplies.

The variety of crimes now solved through, or with the aid of, photos ranges from the use of loaded dice to homicide. In connection with the latter, Sheriff Bailey Grant, Ouachita Parish, La., used



GATHERING TRIAL EVIDENCE, European police often take stereo shots of accident scenes with photogrammetric instruments. Photos aid figuring of distances

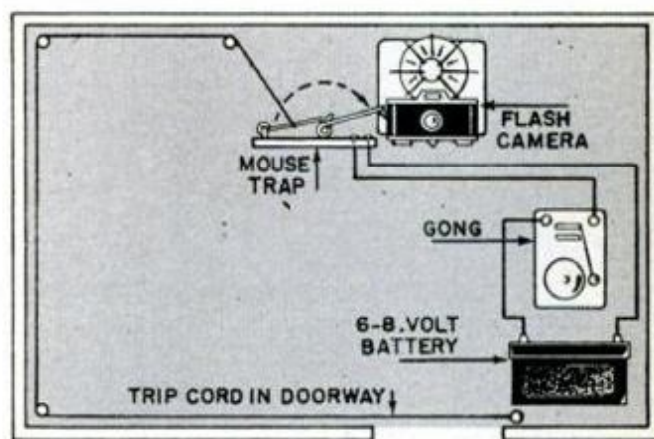

CROOK TAKES HIS OWN PICTURE and sets off gong when he breaks trip cord. This springs mousetrap which triggers infrared camera and rings the gong

photos to show a jury how the body of a murder victim could be washed from the scene of the crime to a point 1½ miles away. At the time of the murder, the Ouachita River in northern Louisiana was flooded. By the time of the trial, however, it had receded to its normal banks.

Grant and a deputy, anticipating this problem, had photographed the area from a light plane to show clearly the river's channels and flow at flood stage. Without such photos it would have been impossible to show how the body reached the point where it was discovered. The suspect in this case was convicted and sentenced to death.

Photographs also proved decisive in a Massachusetts hit-and-run case. Shortly after alighting from a school bus, a 10-year-old boy was struck from behind and

[\(Please turn to page 208\)](#)

TEACUP

A Basic-Basic Sailboat

Only 9½ feet long, this salty little pram is small enough for a 10-year-old to handle easily, large enough for dad to enjoy. And it's an easy project, even for the first-time boat builder

By M. M. Matthews



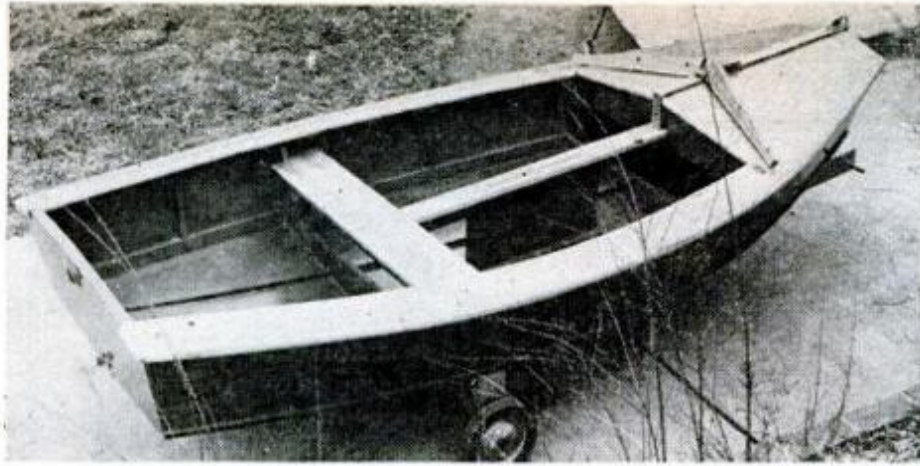

TEACUP'S SAUCER is a simple 2 x 4 cradle mounted on wagon wheels. Build it to provide support for the hull at frame 3 and at the bow, padding where necessary with strips of carpeting to avoid marring the finish. Using this simple storage dolly, even the young sailor at right has no trouble when launching and hauling out

TEACUP IS A DESIGN that gets right down to the basics.

With almost 5 feet of beam, it's a stable sturdy craft that handles nicely, an ideal learner's boat. While not a hot boat, by any means, *Teacup's* performance has enough sparkle to make this a fun little day sailer for anyone.

Construction is a blend of economy and simplicity. To simplify the two most difficult parts of hull building, *Teacup* has a pram nose instead of a curved bow and a dagger centerboard rather than the more complicated swing-up board. Even the sail plan is simple.

If you've never tried your hand at boat building, *Teacup* is a perfect choice as a first project. Dimensions were planned to utilize 10-ft. sheets of plywood, available on special order from your lumber dealer.

Naturally, 8-ft. sheets might also be used, but this will require butt joints in the planking.

Frames and form. Begin frame construction by laying out full-size patterns of the stem, frames, and transom on large sheets of heavy wrapping paper. The stem and transom frames are backed with $\frac{3}{8}$ -in. exterior plywood. Gussets for the No. 2 and No. 3 frames are $\frac{1}{4}$ -in. plywood. Use waterproof glue and flathead No. 7 x 1-in. screws to assemble the frame members. Temporary crosspieces should be clamped in place until the frames have been checked on the building form.

For the building form, you'll need two straight 2 x 4s. The ends are cut to length and angled as shown on page 149. Make angled cuts accurately, because the stem and transom will be positioned directly on



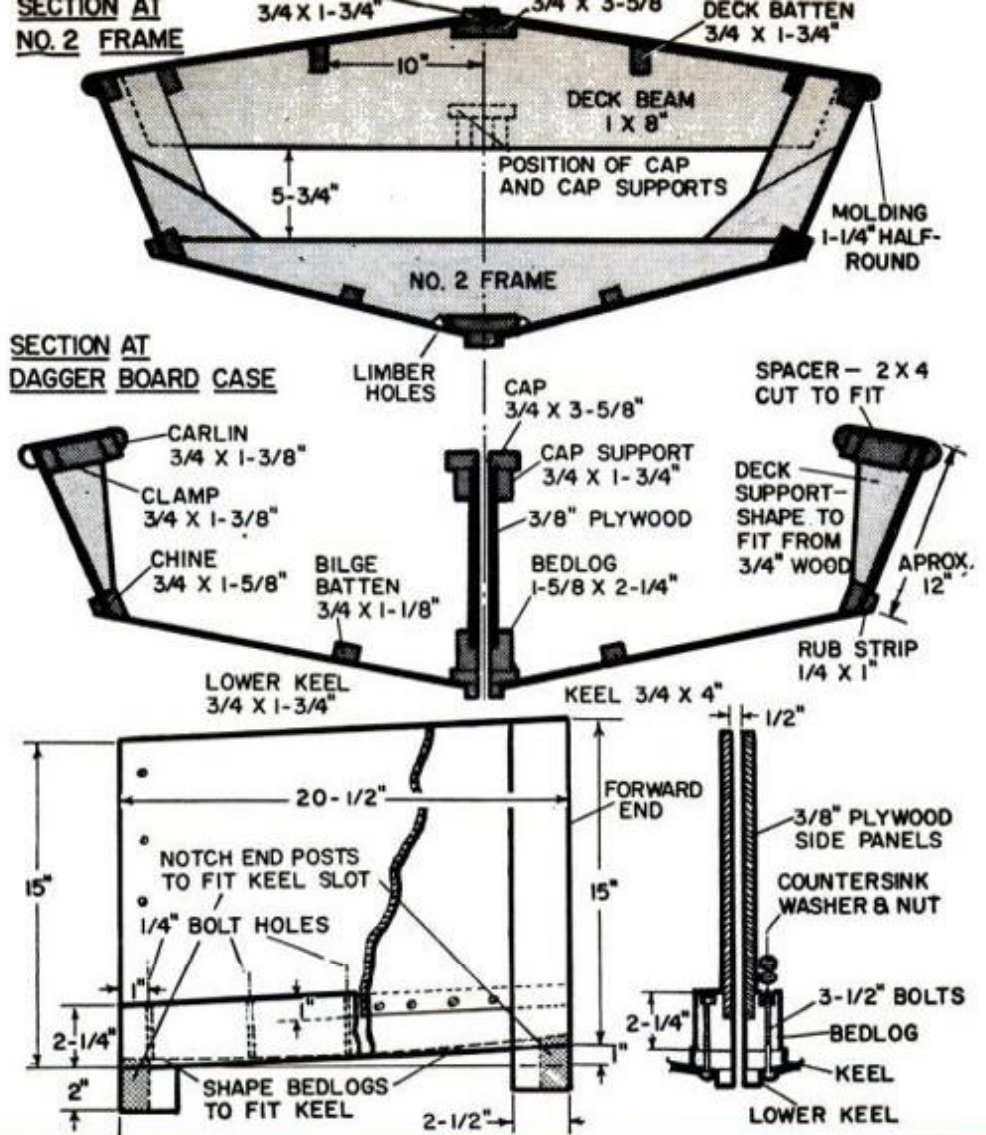
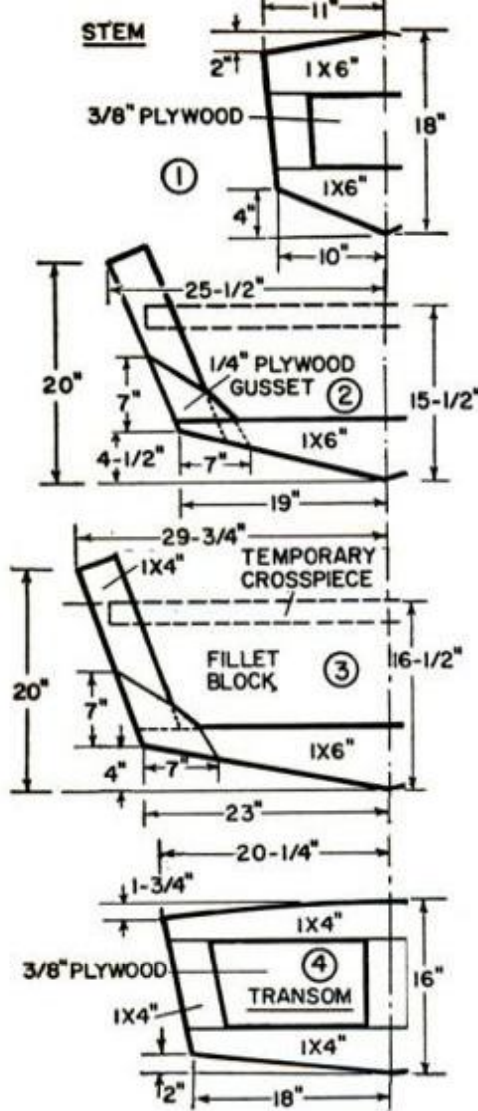

FRAMES

PLAN AND PROFILE

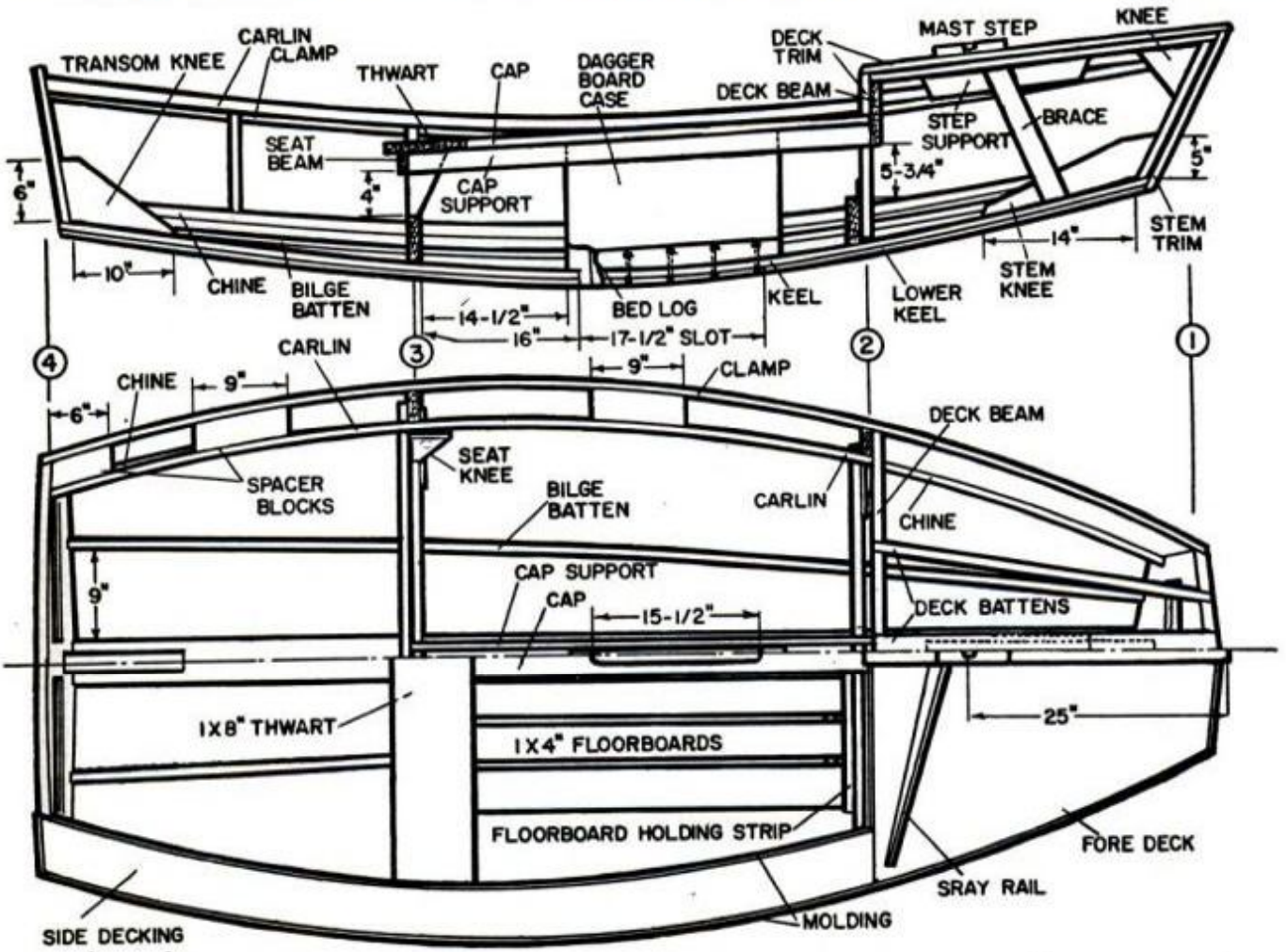

the cut surfaces. Assemble the form with the 2 x 4 crosspieces cut perfectly square. This will help to hold the building form square. If necessary, add diagonal braces to square up the form.

Place the building form on a pair of leveled sawhorses. Center, level and fasten the transom frame to the transom end of the form with two No. 10 x 2½-in. wood-screws. Clamp the No. 2 and No. 3 frames in position but do not fasten yet. Use flexible 1-in. battens to help locate stem frame on the building form. Once the stem is correctly positioned, screwfasten it to the building form with two No. 10 x 2½-in. screws.

Now go back and align frames 2 and 3. The chine line is most critical, and once it conforms to the bend of the batten, the keel line will follow naturally. Screwfasten the temporary crosspieces on the frames, then screwfasten the crosspieces to the building form. Use diagonal braces fastened to No. 2 and No. 3 frames and the building form, as shown below. Clamp the 10-ft. battens to the stem, frames and transom, and the frames are ready for notching.

Keel, chines and clamps. It won't hurt to leave a few inches of extra material on each end of the keel. These ends can be removed and the keel sanded flush with transom and stem when the frame is faired.

Clamp the ¾ x 4-in. keel in place and mark the frames for notching. If the wood doesn't bend easily, wrap it in rags and soak with boiling water, then leave clamped in position while the wood dries.

Cut notches and screwfasten the keel in place with No. 10 x 2-in. screws and glue. To avoid splitting wood, always predrill holes before driving screws. Dip the thread of the screw in glue and it will drive easier.

Notch the transom, frames and stem for the chines. You can save yourself some fairing time later on if you prebevel chines with a bench saw. To avoid twisting the frame, start at the transom and work one frame at a time, fastening both chines. As you are fastening the chine to each frame, keep the complete chine bent to its final shape.

Again, the chines can be longer than necessary and trimmed off later.

Clamps should be put in position and allowed to assume a natural bend. In this position, they should be approximately 11 to 12 in. from the chines. Adjust the clamps so that both sides of the boat will be equal, then mark and notch the frames. The clamps are assembled to each frame like the chines, working forward from the transom.

The hull frame is now ready to be trimmed and faired. The keel, chines and

BUILDING FORM

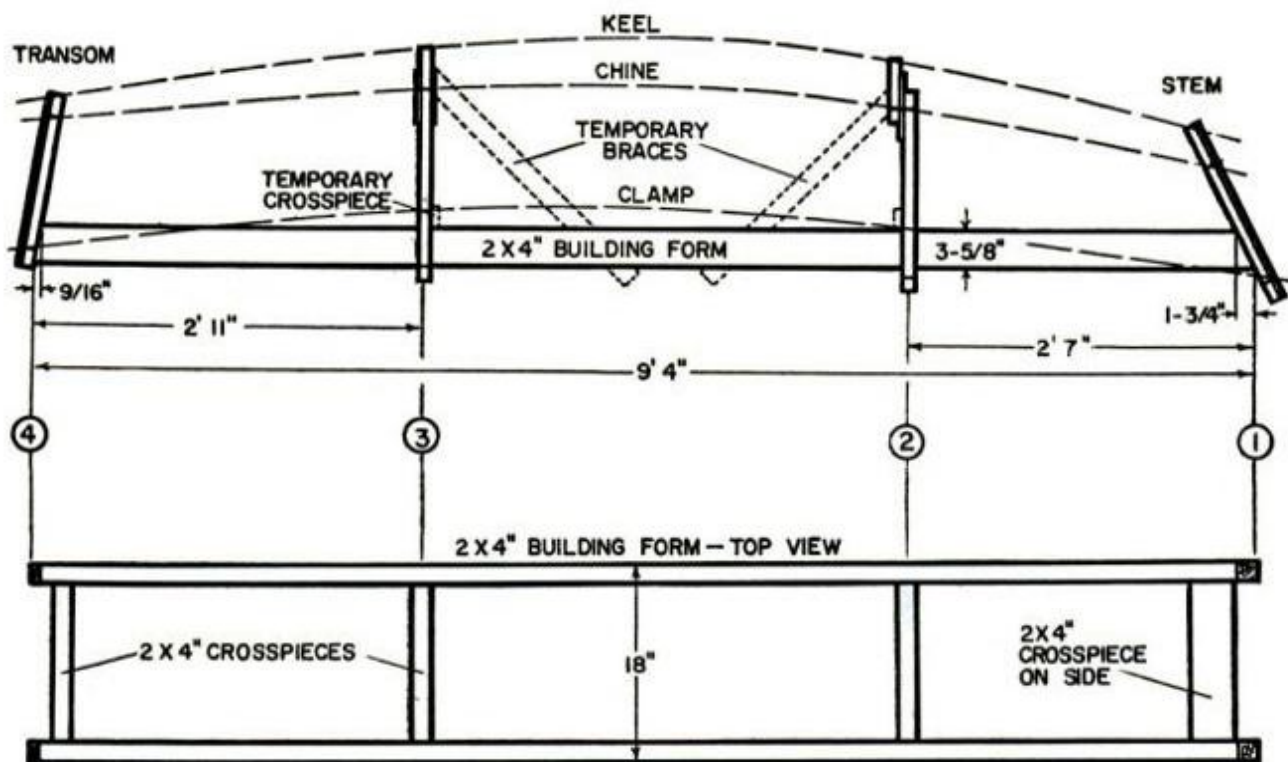



CUT, FOLD, TAPE
TEACUP SAILBOAT

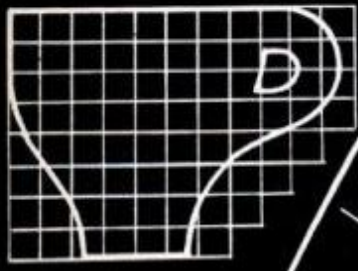

SAIL EMBLEM

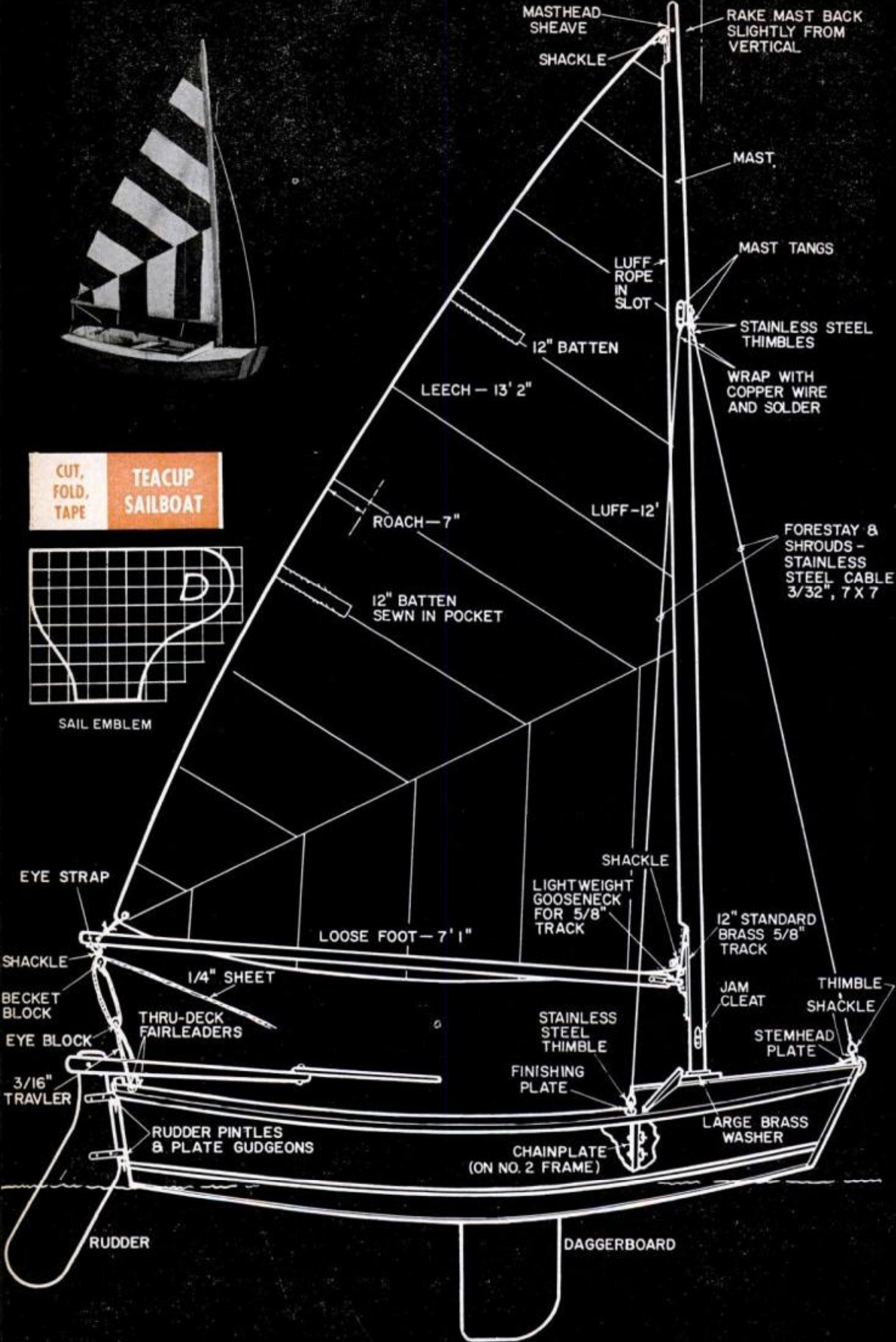

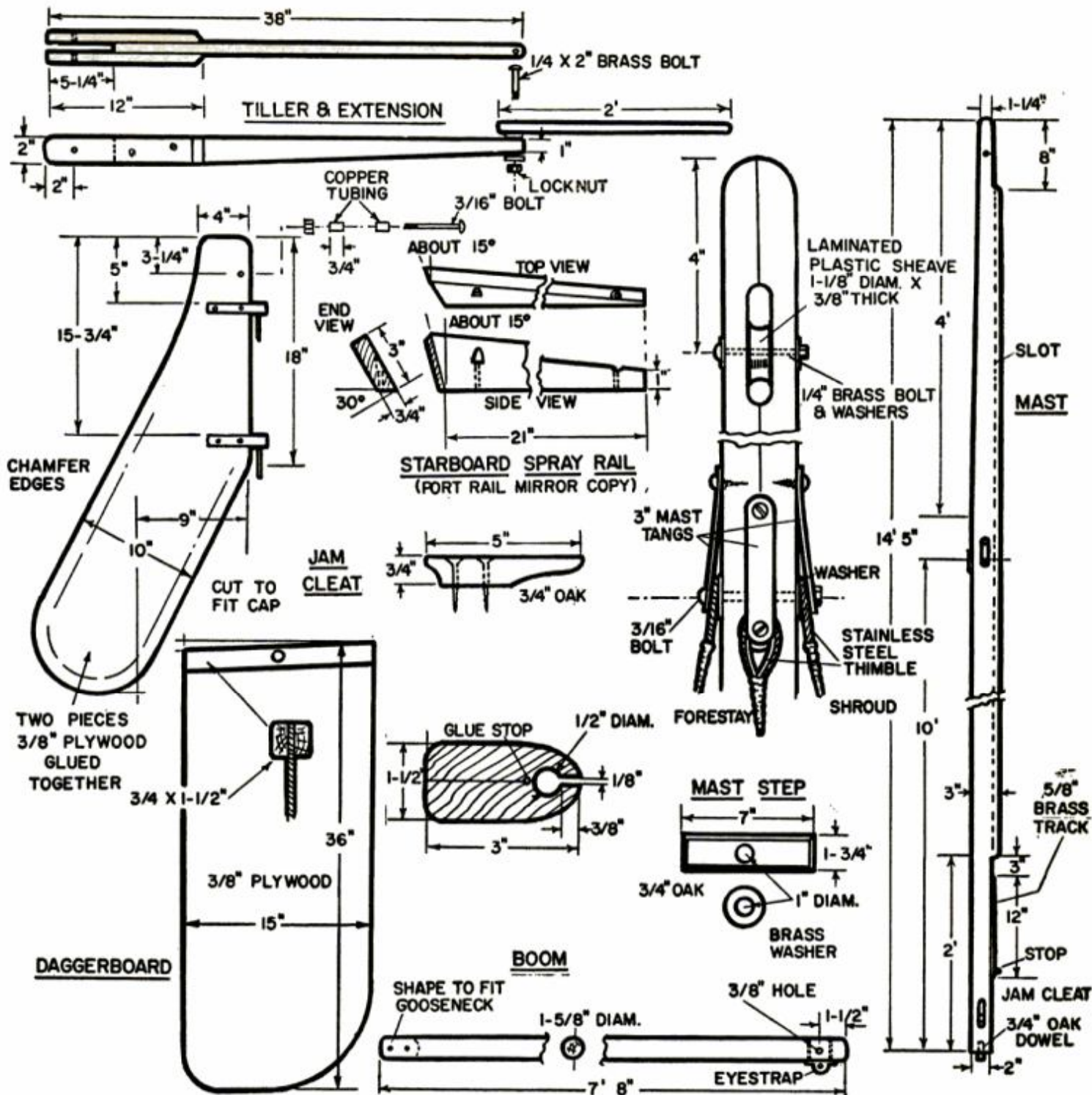

SPARS, DAGGERBOARD AND RUDDER

frames are beveled so that they will make flat contact with plywood planking. Since there are no compound curves, fairing can be easily checked by running a straight piece of wood along the chine and the keel, as well as along the chine and clamp.

If you're good at handling a belt sander, it will do a fast job of fairing for you. A slip can be disastrous, however, so don't choose this job to learn how to use the tool. A sharp jack plane and a wood rasp are slower, but much safer.

Bilge battens should now be set in place. Battens are placed approximately 9 in. from the keel at the transom and led forward so that they will end midway be-

tween the keel and chines at the stem.

Cut limber holes (small triangular notches) in No. 2 and No. 3 frames, so that water can run to the low part of the bilge, where it can be more easily bailed or pumped.

Now is a good time to set the transom and stem knees, while the frame is open and easily accessible. Cut a cardboard pattern and use this to cut knees from 2-in. fir lumber. Use a plane or belt sander to get an exact fit, and fasten knees in place with glue and screws.

Center the 1 3/4-in. lower keel on the main keel, and glue and screwfasten in place, being careful not to locate screws

(Please turn to page 202)

Winter Tune-up for Your Cycle

How to Keep Your Lightweight Leaping

Part I

If you're like most motorcyclists—"cooling it" during these frosty days—now's your chance to turn the weather to good advantage by giving your bike a complete tuneup so you'll have a machine that's rarin' to go when the warm weather rolls around again

BY MORTON J. SCHULTZ

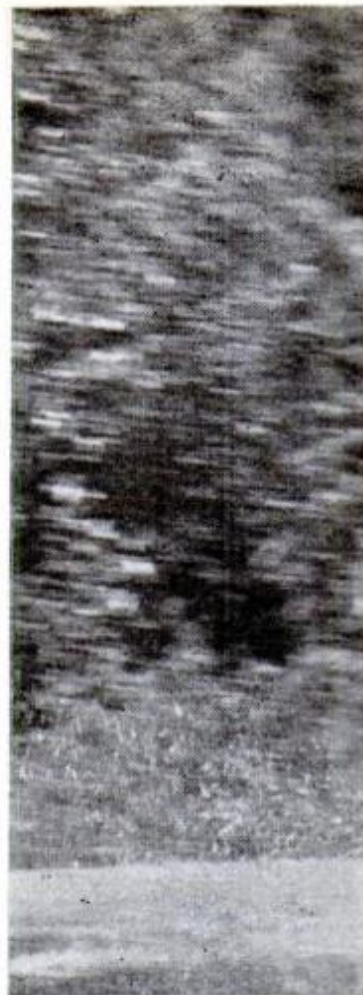

This is the first of a two-part series on motorcycle maintenance. Watch for next month's article which will describe tuneup and maintenance on servicing the heavier, standard motorcycles.

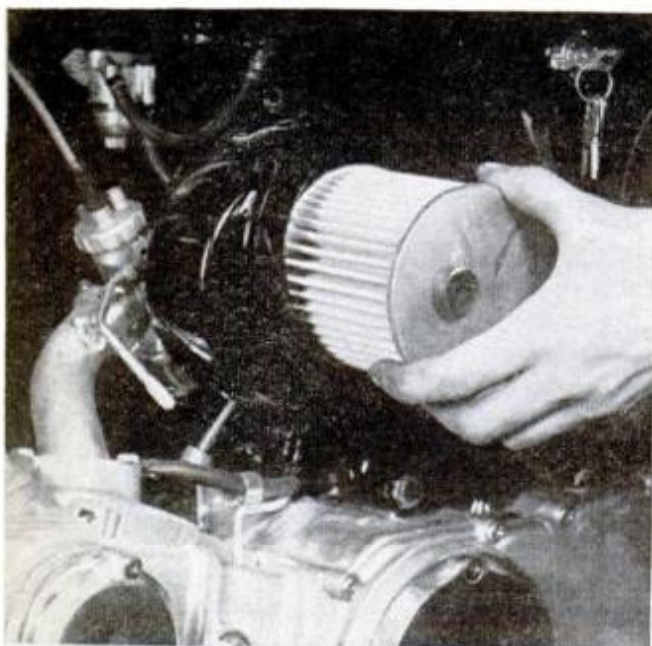

MOST AIR-CLEANER UNITS on motorcycles use a paper element, as the one above. Remove unit, tap it to shake off loose dirt, then blow clean with air hose

NOW IS THE TIME, during the current wintry weekends, to give your motorcycle a leisurely, careful and thorough tuneup. And careful it must be, since cycle work, though less complicated, is more critical than car servicing.

Before starting to work, break out your owner's manual. It describes procedures and contains specifications. We're not going to parrot this book. Instead, this article will stress those services which are the most important, and some which aren't in the manual.

Wheels and tires. Riding a motorcycle with unsafe rubber can be suicide. Give both tires a close inspection. If they are worn or show any breaks, replace 'em.

Consider switching the tires—putting the back one on the front wheel and vice versa. A tire kept in continuous service—on the front wheel especially—will begin to wear irregularly and start to peak. This will affect your ability to handle the bike.

Test for loose spokes by striking each spoke individually with a wrench. If they're tight, they'll "ping." A dull response means the spoke is loose. Tighten loose spokes with a spoke nipple torque wrench.

Replace any broken spokes. To do this you must deflate the tire and pull it off the rim in the area of the bad spoke.

Finally, always make sure both tires are



inflated to the recommended air pressure.

Carburetor. The fuel setup of light-weight motorcycles is quite simple. They have no mass of fuel lines—just a length of hose leading from the gas tank to an uncomplicated carburetor. There's no fuel pump either; gas flows to the carburetor by gravity.

However, a cycle carburetor is sensitive and should be checked, cleaned and adjusted at least as often as an auto carb. If one little passage gets plugged, gas stops feeding to the engine cylinder.

Whether you have a four-stroke engine which feeds on raw gas, or a two-stroker which runs on a mixture of gas and oil, servicing is as follows:

- Clean the air cleaner as outlined in the manual. Many mechanical problems can be traced to a plugged-up cleaner which has thrown the meticulously balanced fuel/air ratio out of whack. The rich fuel mixture that results can lead to loss of power, overheating and high fuel consumption.

- Check the fuel strainer. The strainer cleans dirt from the fuel before it enters the carburetor. It's usually located where the fuel line connects into the carburetor bowl. If it gets blocked, fuel is blocked.

To remove the strainer, shut off the fuel supply and unhook the fuel line. Then clean the strainer in gasoline.

- Test the functioning of the carburetor idle by letting the engine warm to operating temperature. If the engine races or rough-idles, turn the idle-speed stop screw in or out. If the carburetor isn't dirt-clogged, the idle will smooth out. If the carb is blocked, disassemble and clean it.

This is easily done. In the case of a common four-stroke engine of the type shown in the accompanying photographs, drop the bowl and remove the two jets with a screwdriver. Wash the parts in carburetor cleaner and blow them clean with air pressure. While you're at it, remove the fuel line and clean that too. It might be clogged with residue (varnish).

Ignition. Your motorcycle's ignition system has the one job of generating a spark powerful enough to jump the sparkplug electrode gap.

To check if it's doing its job, remove the sparkplug, reattach the plug wire, ground the plug by holding it across the head, then crank the engine. If you see a spark jump the gap, all's well. If no spark, check out the ignition system until you find the trouble.

Even if you get a nice spark, you should time the ignition to the specs given in the manual. You'll need a timing light for this job. If you don't have one, let your cycle shop time the ignition. Remember that

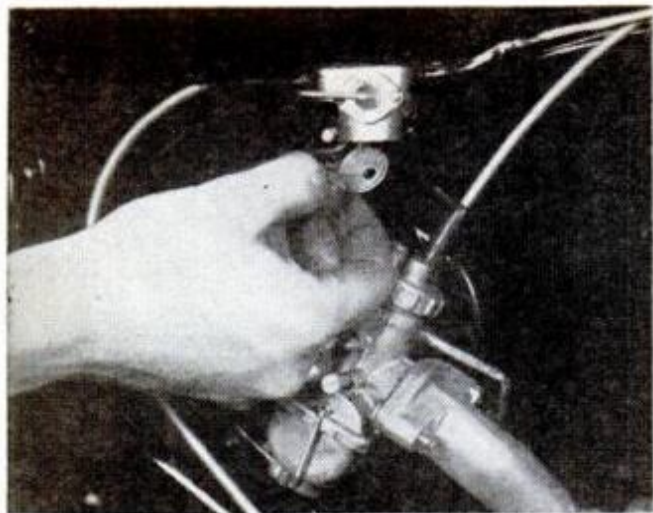

CLEAN THE METAL FUEL STRAINER in gasoline. This one is located in gas shutoff on fuel-tank side of fuel line. Other types are located at carburetor inlet

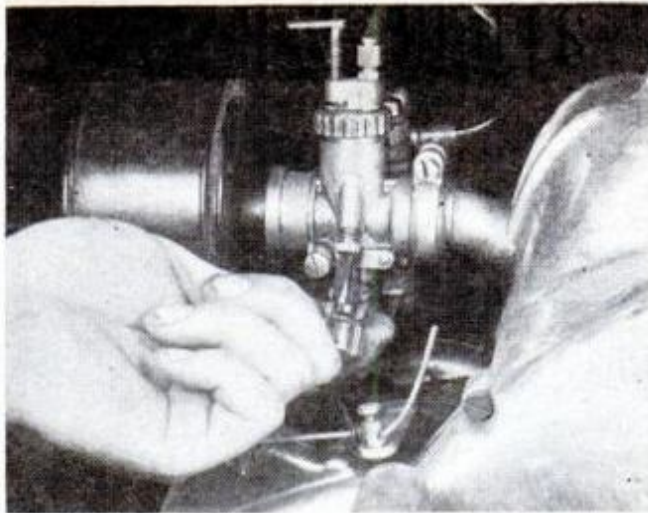

SMOOTH OUT ROUGH-IDLE or racing of the engine by turning idle-speed stop screw. Turn screw to right for a richer mixture; to left for a leaner mixture

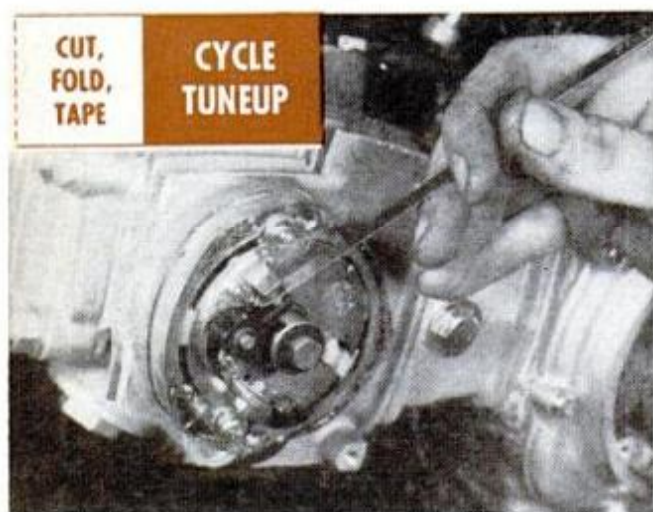

ADJUSTING BREAKER POINTS (static timing) is done with feeler gauge to specs in your owner's manual. Final adjustment is then made with a timing light

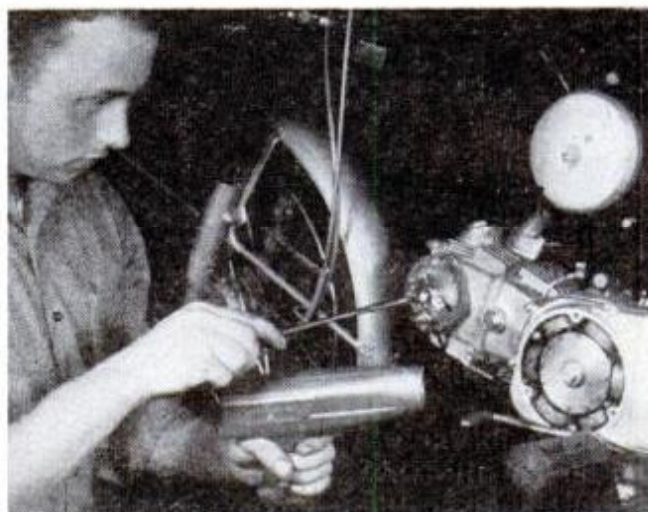

USE A TIMING LIGHT when making fine adjustment of the ignition timing. A timing light measures ignition timing and timing at the end of spark advance

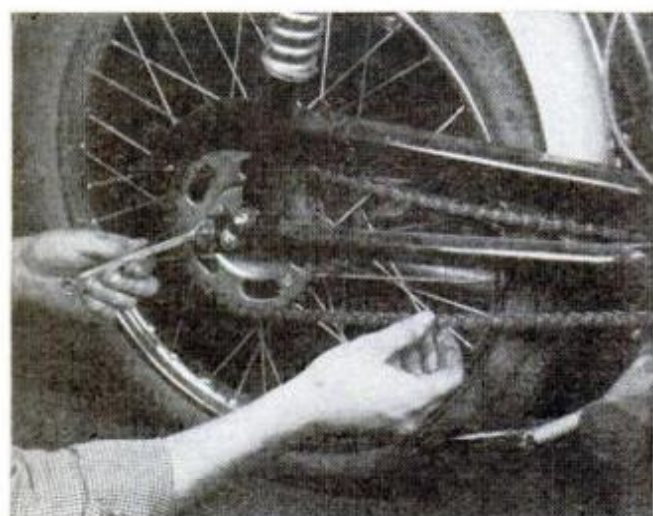

TIGHTEN OR LOOSEN DRIVE CHAIN by turning adjusting nut on rear fork. A slack chain will slap; if too taut, power transmission to rear wheel is hindered

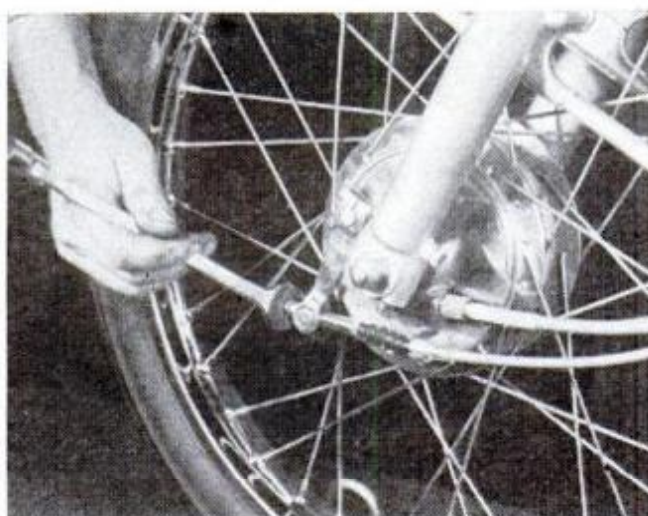

BRAKE ADJUSTMENTS are made by activating brake lever on handlebar and brake pedal while turning brake adjusting nuts on the front and rear wheels

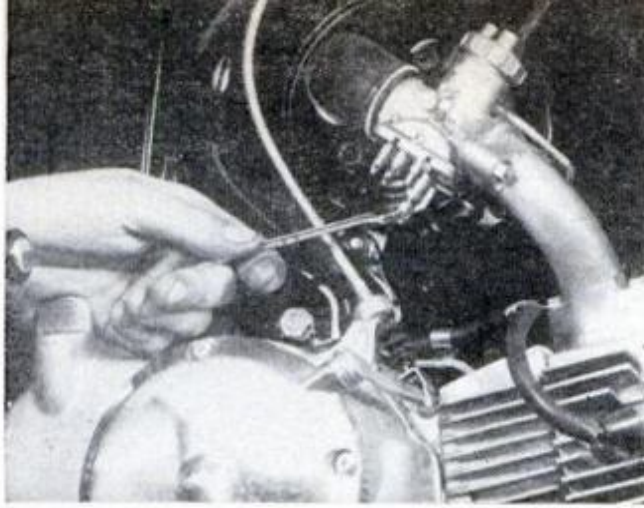

DIRT IN THE CARBURETOR can shut off fuel to the engine. Clean the carb in gasoline after disassembling it by unscrewing the carburetor jets as shown

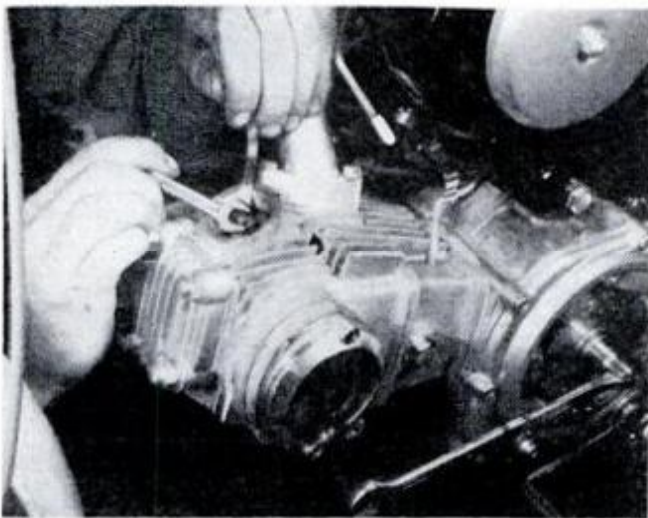

FEELER GAUGE IS USED to adjust fuel intake valve as shown, while piston (lower right) is held at top dead center. Exhaust (below head) is adjusted too

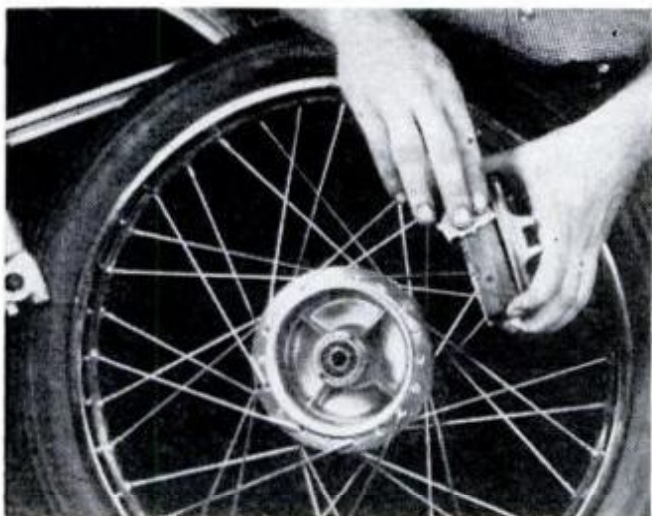

WHEELS SHOULD BE PULLED every 5,000 to 10,000 miles and the brake linings inspected. If they are glazed, clean 'em with emery cloth or armature paper

a retarded spark will reduce power output of your engine, and an advanced spark can severely damage the engine.

Check the condition of the breaker points. If they're badly burned or pitted, replace them—and the condenser. Also, adjust the points to specifications.

Check all wiring for breaks and fraying and replace any bad wires.

Now turn your attention back to the sparkplug. If the electrode end is worn or damaged, or the porcelain cracked or broken, or if the gap is too wide, replace the plug.

Keep in mind that sparkplugs of motorcycles wear faster than those in a car, and that those of two-stroke engines wear faster than the plugs of four-strokers.

The sparkplug in a two-stroke engine can tip you off to one of the most critical of all conditions for these engines: the gas/oil mixture ratio. If the plug end has a layer of carbon over it, check the manufacturer's recommendations concerning this mixture. A two-stroke engine that is constantly run with an improper mixture will burn up sooner or later.

Battery. If your bike uses a battery—and all four-stroke engines do—check it out as follows:

The winter lay-up may have caused the battery to run down. If so, recharge it with a trickle charger. Note: Never use a charger having an ampere-hour rating greater than that of the battery; it *could* cause the battery to explode! Match the ampere-hour rating of the battery (it appears on the case) to the ampere-hour rating of the charger. Cycle batteries are rated from 2 to 15 ampere hours.

All cycle batteries are equipped with a vent tube which permits battery gases to escape. This tube must be kept clear. To be sure it is, remove it and blow it out with compressed air.

If the battery is equipped with screw-on connectors, remove the terminals from the posts and clean corrosion off both elements. Apply a thin coating of Vaseline to posts and terminals, then reconnect.

Check the battery electrolyte level. If the battery needs water, use only distilled water.

Valves. Adjust the valves at least once every 1,500 miles. The manual will tell you how to do it for your particular bike. In general, the piston is brought to top dead center, then valve adjustments are made with a feeler gauge to the required specs. This should be done while the engine is cold.

Two-stroke cycle engines have exhaust ports instead of an exhaust valve. Examine these ports to make sure they are

[\(Please turn to page 221\)](#)

Spoon Rack and Planter

SETTING OFF the soft glow of antique silver against a mellow fruitwood finish, this tasteful display rack was designed specifically for exhibiting a collection of antique and commemorative spoons. Slots are provided for eight spoons. The bottom shelf is deep enough to hold a shallow planter tray, but might also be used to show off two or three fine china cups.

With butt joints used throughout, cutting and assembling the rack is a simple operation. Be sure to counterbore all screw holes and conceal the screws with wood plugs. After staining, give the rack a couple of coats of low-gloss varnish to resemble a hand-rubbed finish.

If you would prefer to work from a full-size pattern rather than enlarging the cutting drawings on the grid below, send 50 cents to Steve Ellingson, Popular Mechanics Pattern Dept., Box 2383, Van Nuys, Calif. 91409, and request pattern No. 112.

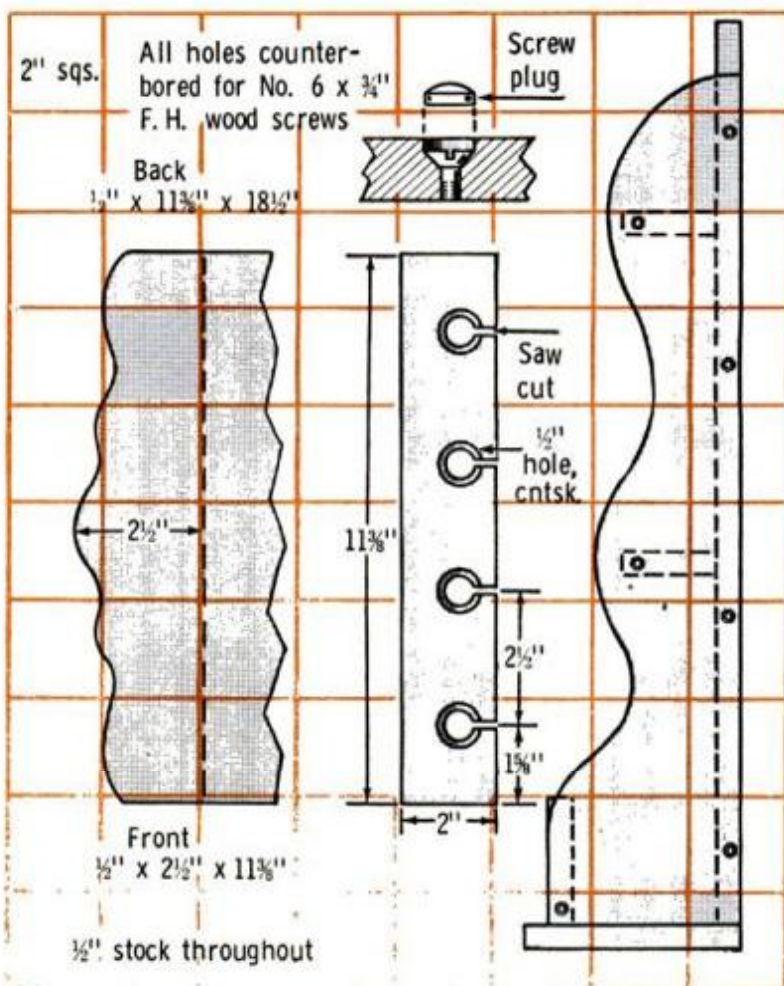
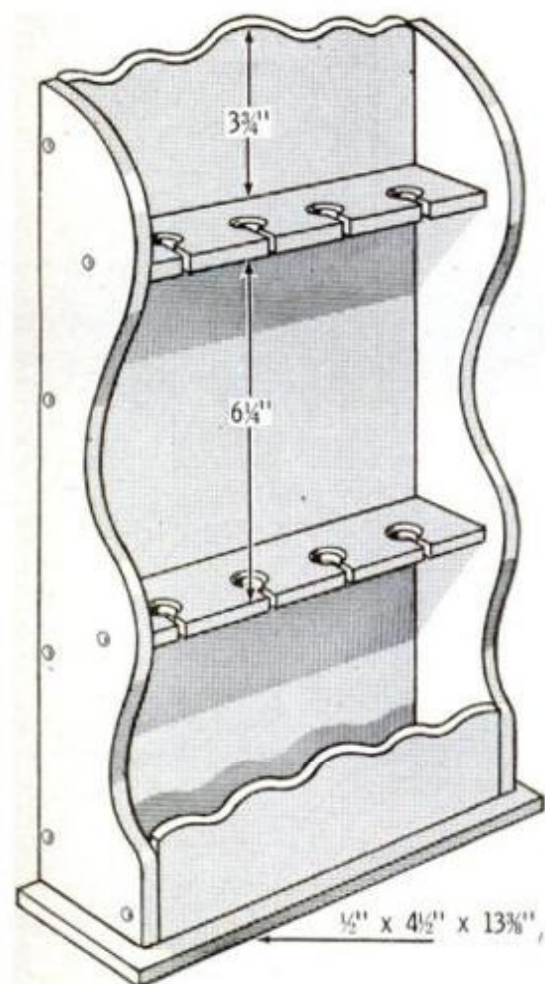

TIPS FROM READERS

$\frac{1}{8}$ " to $\frac{3}{16}$ " ground off flush



SMALL SOCKETS used on thin nuts and thin-head bolts have a tendency to wear out at the lip. To renew such a worn socket, grind $\frac{1}{8}$ in. to $\frac{3}{16}$ in. off end of socket



CHOOSING the right bit to drill a hole for the right top is no problem if you use the nut of the bolt that's to fit hole. Simply pick a bit that just passes through nut

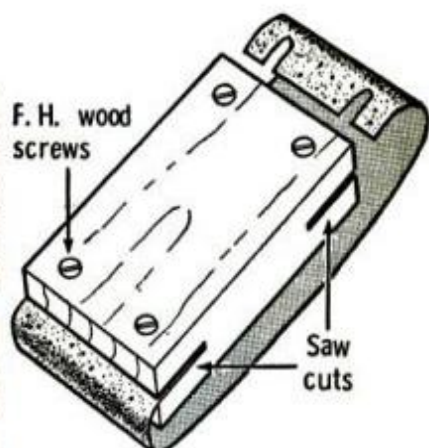

PALM-SIZE sanding block for small jobs can be made by cutting a $3\frac{1}{2}$ -in. piece of 1x2 stock, sawing slits in the ends and using No. 6 screws to clamp the sandpaper

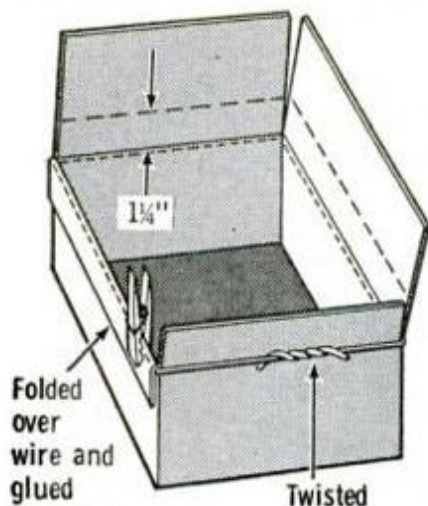

TO MAKE a tough scrap box from a cardboard carton, trim the flaps to a width of $1\frac{1}{4}$ in. and fit a length of heavy wire around top, then glue flaps down over wire

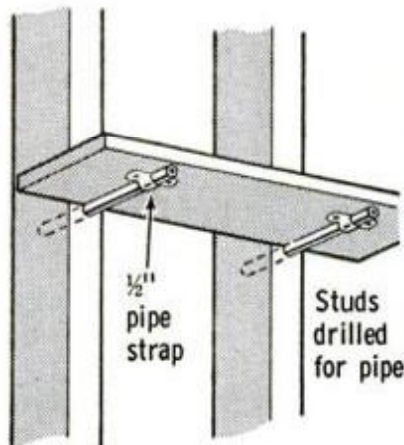

HEAVY-DUTY shelves for your garage needn't be difficult. Bore holes in the studs for pieces of $\frac{1}{2}$ -in. pipe and fasten shelves to them with regular pipe straps

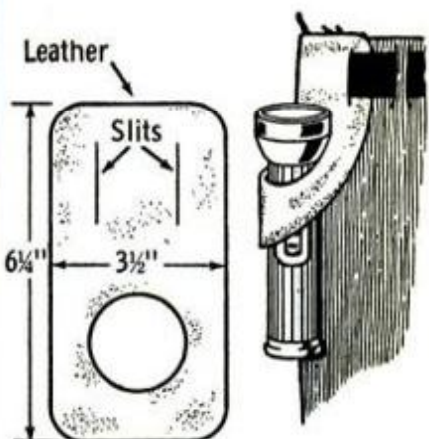

HOLSTER for carrying a flashlight hangs from your belt, saves wear and tear on your pockets. To make it, cut a piece of leather or flexible belting to dimensions

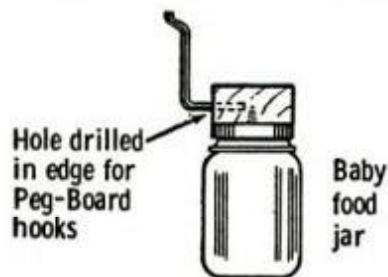
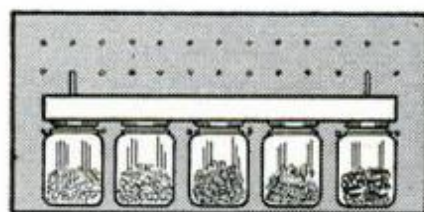

TO HANG a rack of baby-food jars on a perforated hardboard panel, drill holes in a length of 1 x 2 slightly undersize for the angled fixture hooks and mount as shown

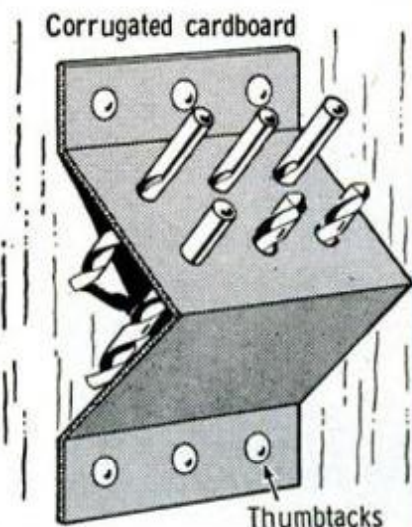

IMPROVED drill rack can be made from a piece of cardboard by folding down the middle, bending short flanges, punching holes above fold and tacking it to wall

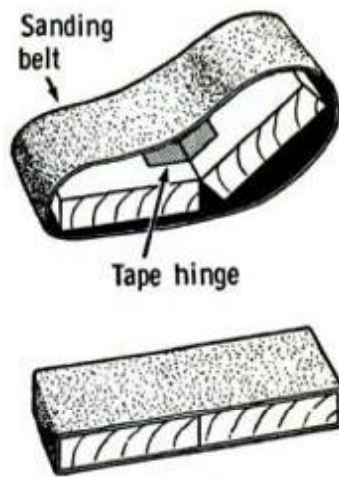

IF YOU run out of sheet sandpaper of desired grit, you can finish job with a spare sanding belt. Just slip it over pair of blocks hinged with tape to fit inside belt

Build Anything with



HERE'S A FUN MATERIAL which will remind you of a construction toy you may have played with as a boy. Called Dexion, it's slotted steel angle which goes together with nuts and bolts like its toy counterpart and lets you build practically anything with the greatest of ease—and in short order. You simply cut the material to the lengths you want and then bolt them together with the special corner plates that come in the same package. No drilling is necessary, a hacksaw and wrench are the only tools you need—the pieces are even painted with a baked enamel finish.

What can you make with it?—you name it. It's great for the framework of light-weight game and hobby tables, tool stands and workbenches. Mere working with it will suggest many other applications.

Where can you buy it?—at your local hardware store and lumberyard. It's packaged in two sizes, light duty which measures 1 x 1 in., and standard duty which measures 1 1/4 x 1 1/4 in. You get ten 5-ft. lengths of light duty angle for \$10.50, and eight 6 ft.-6 in. lengths of standard duty for \$12.75. Both bundles come complete with 75 nuts and bolts and 20 corner plates.

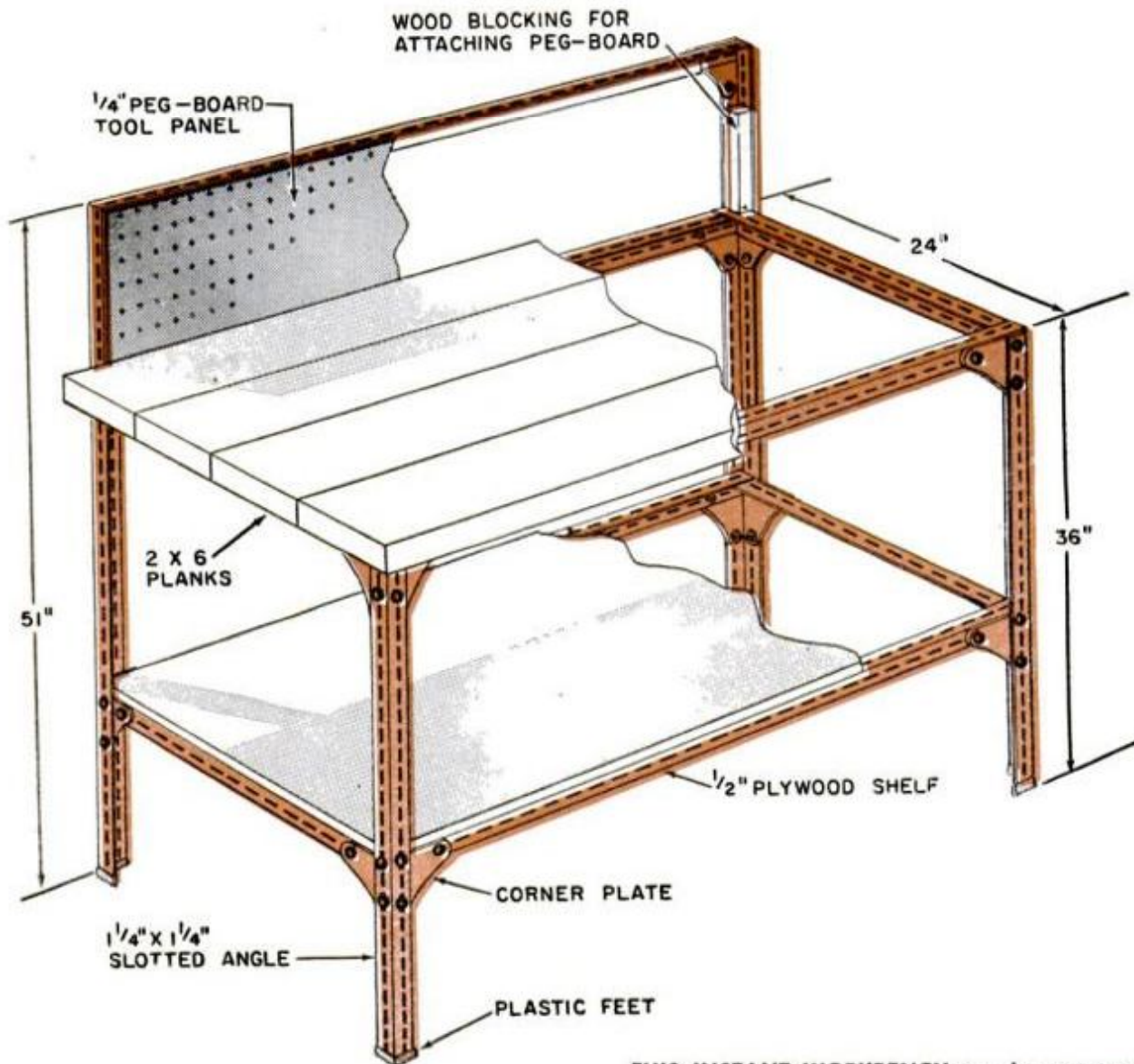

THIS INSTANT WORKBENCH can be put together in one evening from one package of material. Add a plank top, a plywood shelf and a Peg-Board tool panel to the slotted angle framework and you're in business. Length can vary; this one measures 48 in.

Slotted Angle

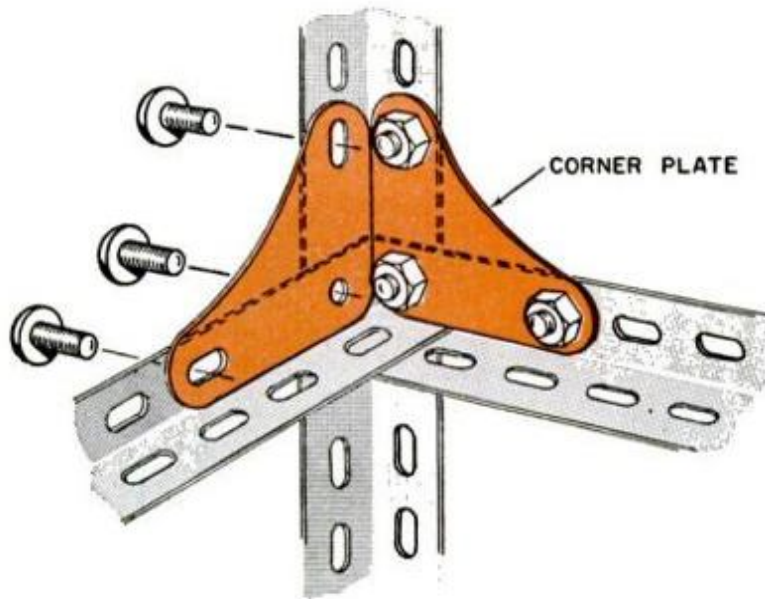

SLOTS IN METAL ANGLE make alignment of bolt holes in corner plates quick and easy when joining

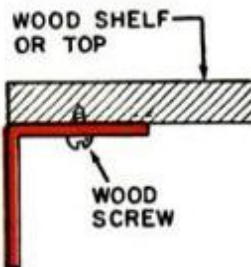
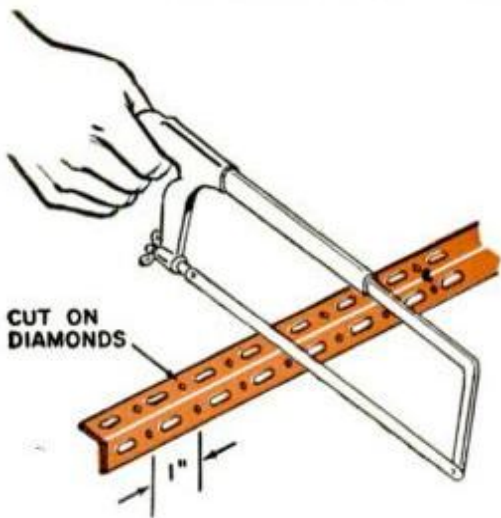

NO RULER IS NEEDED to measure the slotted angle—
"inch marks" are built-in to show you where to saw

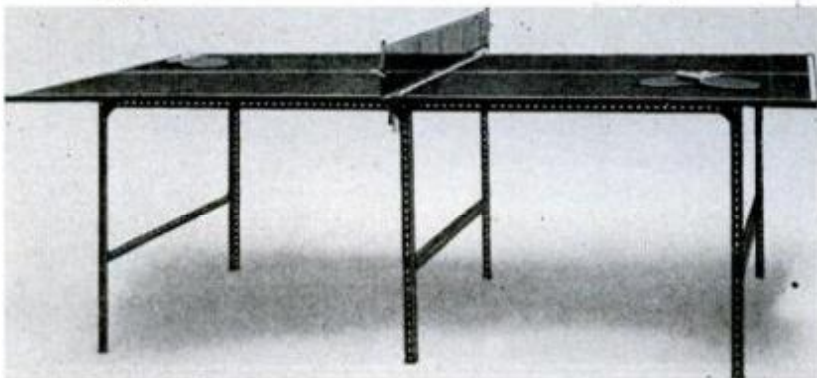
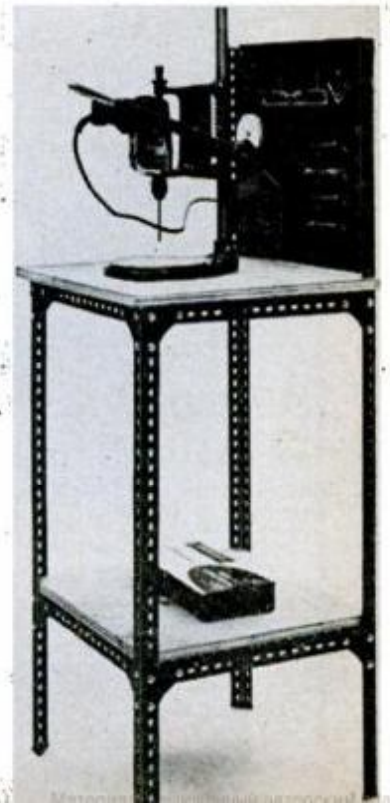
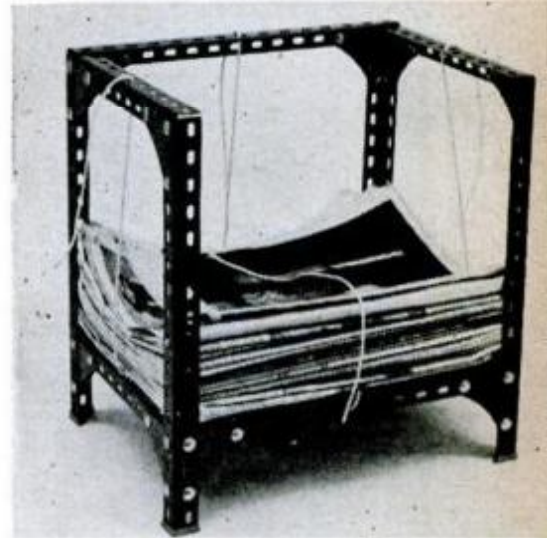
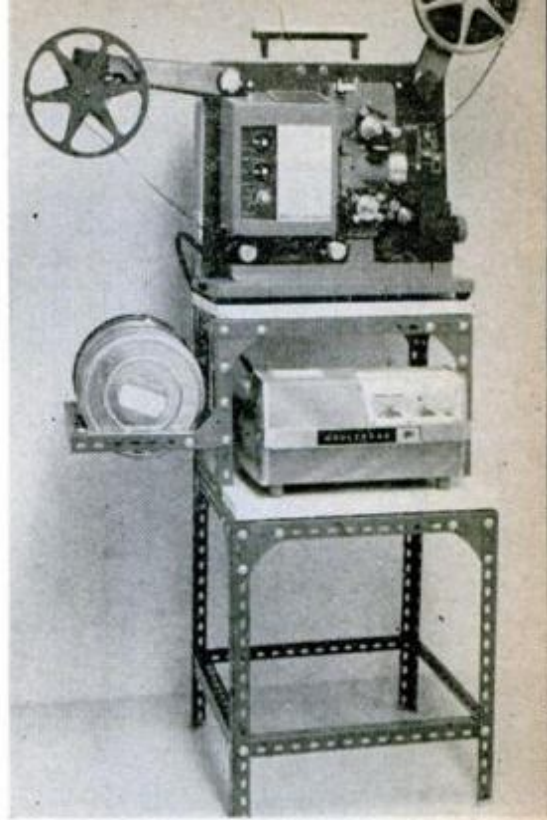

Fun with a Nearsighted

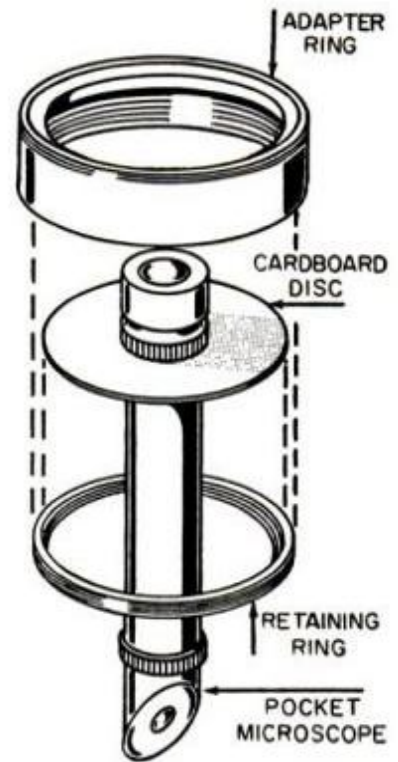

HERE IS HOW cardboard disc, sandwiched between adapter and retaining rings, is used to attach microscope to camera

PHOTO HINTS



THERE'S NO NEED to paw through a tangle of flash cords in your gadget bag to find the one you want. Just cut a piece of cardboard to fit in the bag on top of the other equipment, then staple 1/2-in. elastic to the cardboard to form a series of loops

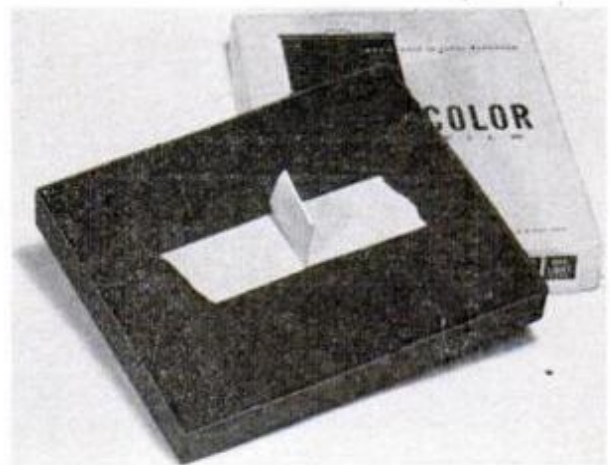

THE THREE-PART BOXES used by most manufacturers of sheet film tend to be difficult to open when working in darkness. An easy solution is to stick a tab of tape to the bottom of the box. This will act as a handle and will fold flat when the box is covered

Camera

THERE COMES A FRUSTRATING TIME in the life of nearly every photographer when he feels that there just aren't any new subjects for his camera. I know—it happened to me not long ago. But then I decided to try my hand at microphotography, and now I'm convinced that I'll never run out of things to photograph. Even such humdrum items as salt and laundry detergent become exciting subjects when you move in for a close-up with camera and microscope.

A laboratory setup for taking microphotographs can run into thousands of dollars. But that's for the pro. My entire cash outlay came to only \$2.70, for a 50x microscope called the Micro-Pen. I ordered mine from the Edmund Scientific Co., Barrington, N.J. There was no need to buy a special camera—my 35mm single lens reflex filled the bill perfectly.

The drawing shows how I connected the 'scope to the camera. A hole cut in a cardboard disc provided a snug fit for the barrel of the microscope. An adapter ring and retaining ring are used to hold the disc in front of the camera lens. The rings are standard items in any photo shop.

Through trial and error I've found that a 7-watt frosted night-light bulb positioned an inch or so below the microscope objective supplies sufficient illumination for

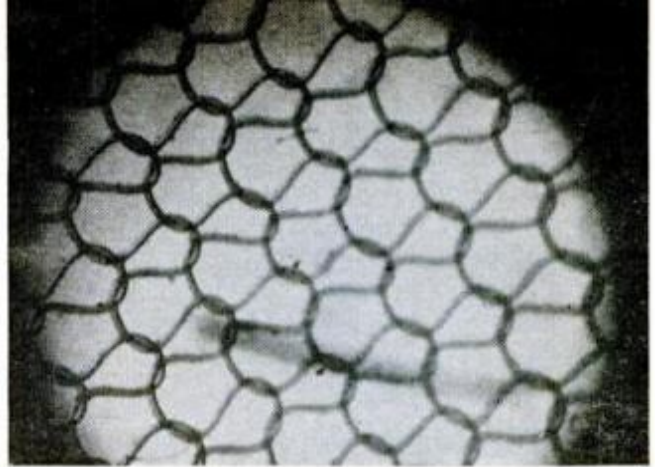

WIFE'S NYLON STOCKING was subject of this shot

focusing and photographing at reasonable speeds. It's not possible to give any definite recommendations about exposure time; that is something you'll have to determine by experimentation. But as a starting point you may want to consider shooting between 1/25 and 1/100 sec. at f/3.5 on 400 ASA film.

If no microscope slides are available, slide cover glasses of the type used for mounting color transparencies may be used. Your kitchen cabinets and medicine chest should yield an abundant supply of interesting photographic subjects.

Before making the photograph, be sure to place the camera on a sturdy tripod. If you don't, magnification of camera movement may ruin the picture. If your camera has a built-in self timer, use it to trip the shutter. Otherwise, a cable release will do the job.—*Rene Zentner*

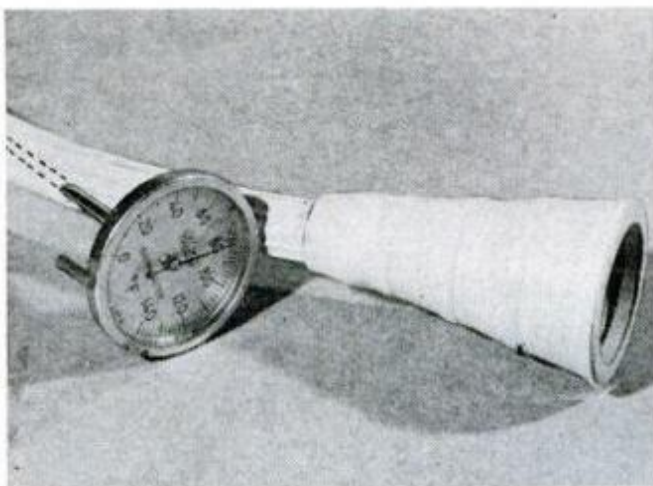

KEEPING A CONTINUOUS CHECK on the temperature of the circulating water bath around your film tank and chemical bottles is no problem. Punch a hole in a faucet hose attachment and insert the sensing stem of your darkroom thermometer as shown

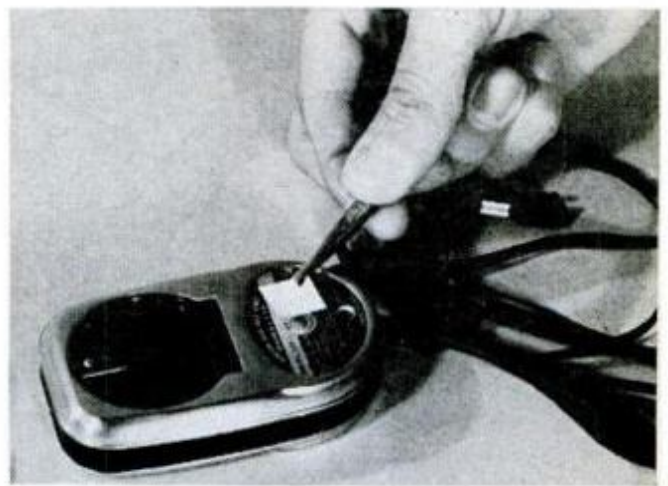

ON MANY EXPOSURE METERS an external zero adjustment screw is provided. The screw is usually very easy to turn and may accidentally be moved when carrying, causing an incorrect reading. To prevent this, secure screw with small piece of adhesive tape

SOLVING HOME PROBLEMS



ICE-CREAM STICK dipped in a can of paint and fastened to it with a heavy rubber band will show you the exact color of the paint when dry. Locate the rubber band to indicate the level of paint inside can



FACIAL TISSUE BOX placed near the phone makes an ideal no-knock cradle for the receiver, sparing the party on the other end of the line from that loud noise when the receiver is placed on a hard surface

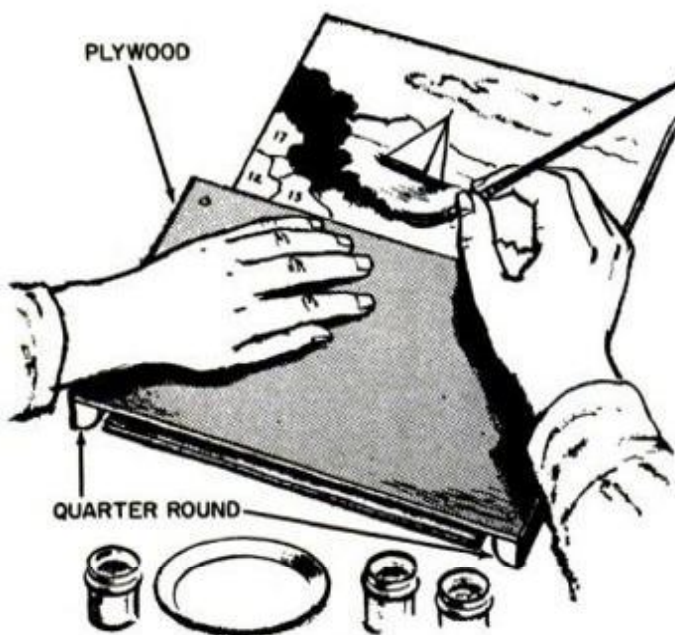

HANDY ACCESSORY for paint-by-numbers hobbyists is a hand "bridge" of plywood about 3 in. wider than the picture. It lets you work comfortably on any part of the picture without smearing other areas



BOILING CLOTHESPINS in a strong salt solution will make them less apt to split and prevent them from freezing to clothes. A bit of salt dissolves on the wet clothes and lowers the freezing point of the water



FIRST RULE OF SOLDERING is to brighten the surface of the metal. For those rare home soldering jobs, the fine wire bristles of a suede shoe brush do good job where you lack a regular scratch brush

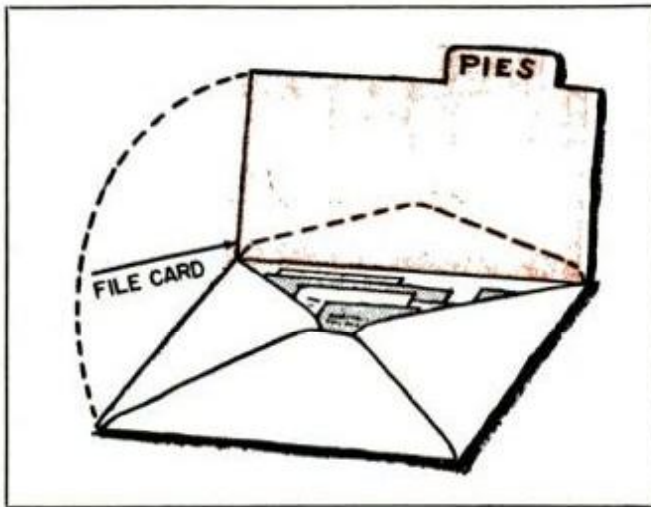

FILE POCKET for holding recipes clipped from magazines and newspapers can be made by sticking the gummed flap of an envelope to a card file. Folding the envelope over for filing automatically seals it

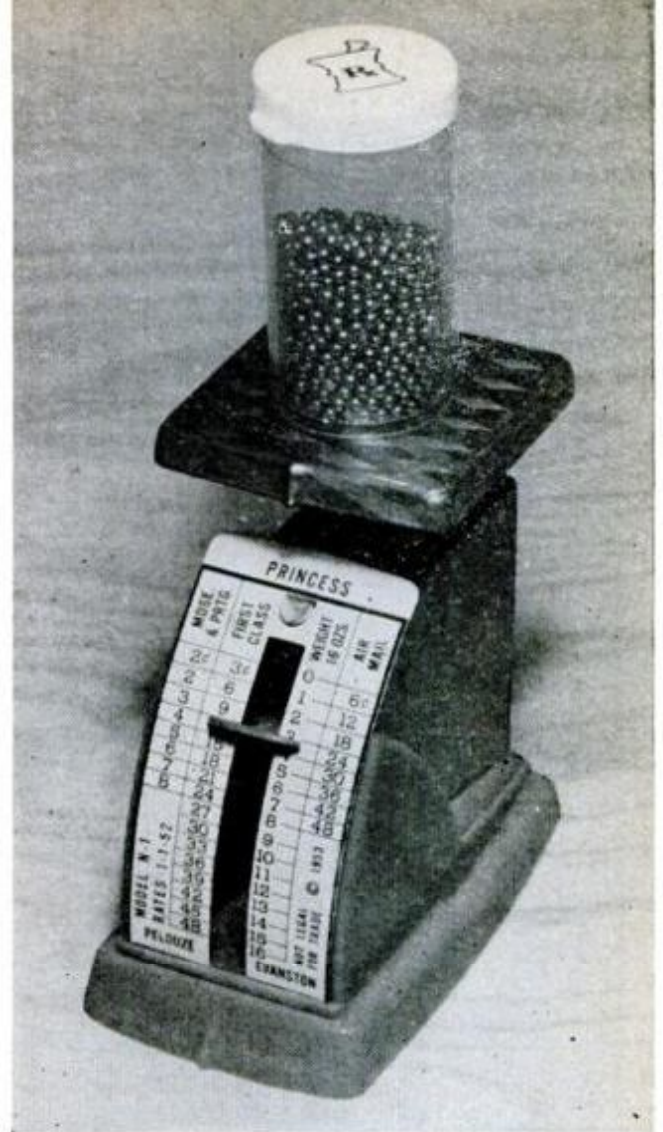

CALIBRATING a spring-type postal scale is easy if you have a standard weight. To make one, take a plastic pill bottle and some lead shot to the post office and have the clerk make up a 3-oz. weight



YOU CAN MAKE a replacement for the wooden handle of a frying pan if it's the type held by a threaded rod. Just bore a hole lengthwise through a wooden chisel handle and shape small end to fit socket on pan

Lathe Fun from

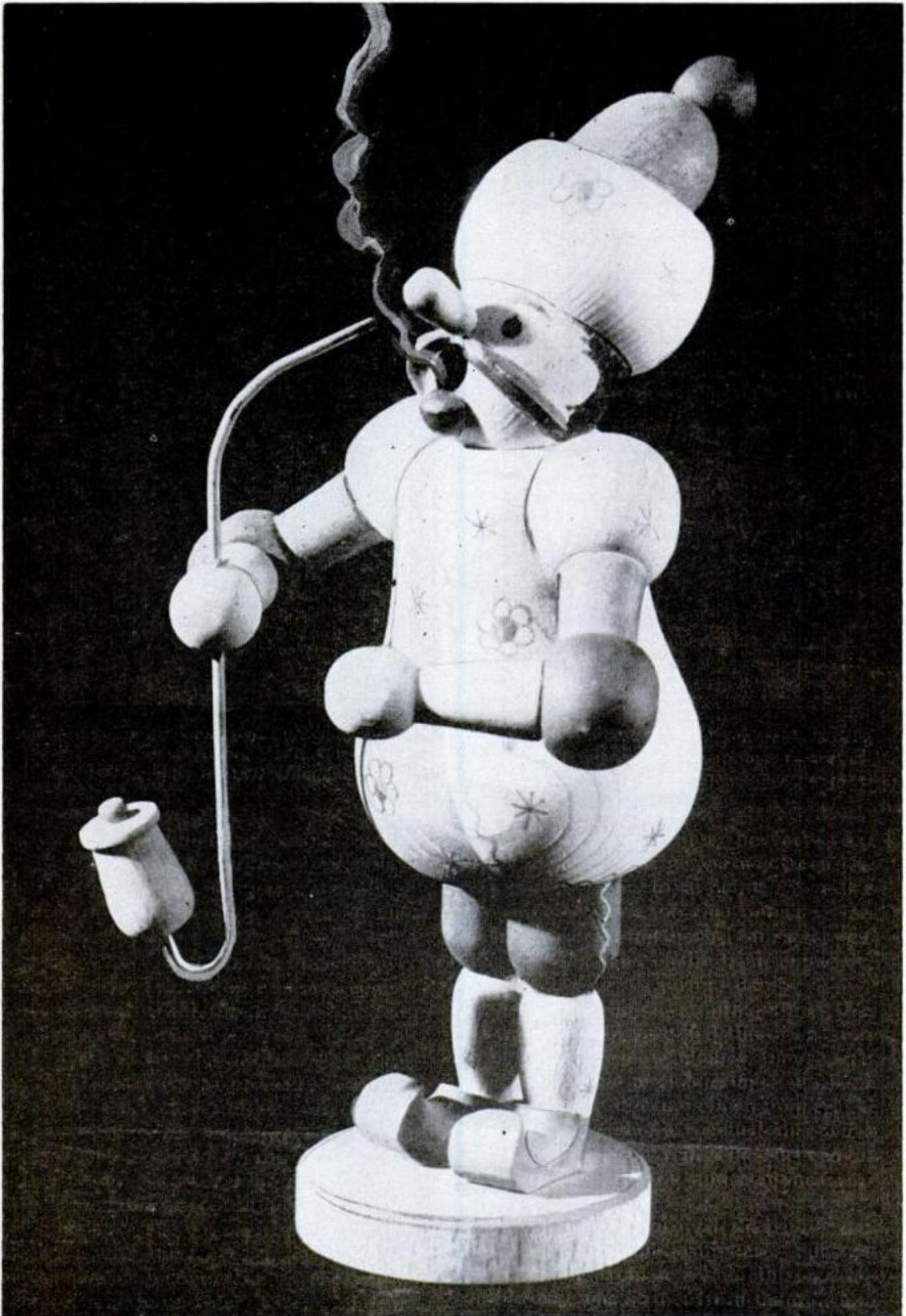

Alpine Novelties

BY HI SIBLEY

Smoking Caliph

NO NEED TO HOP a jet to the Alps if you hanker for some of those colorful "cartoons in wood" that German carvers are famous for. And no need, either, to gag at the fancy price-tags Ye Olde Gift Shoppe hangs on such pieces. You can make 'em yourself! Never tried wood-carving? Doesn't matter—the hand knifework on the three "animated" novelties detailed on these four pages is kept to a minimum. Most of the shaping can be done in no time on your lathe. The incense-puffing Caliph at left is a good starting project. Only the turned-up-toes sandals are hand-carved.

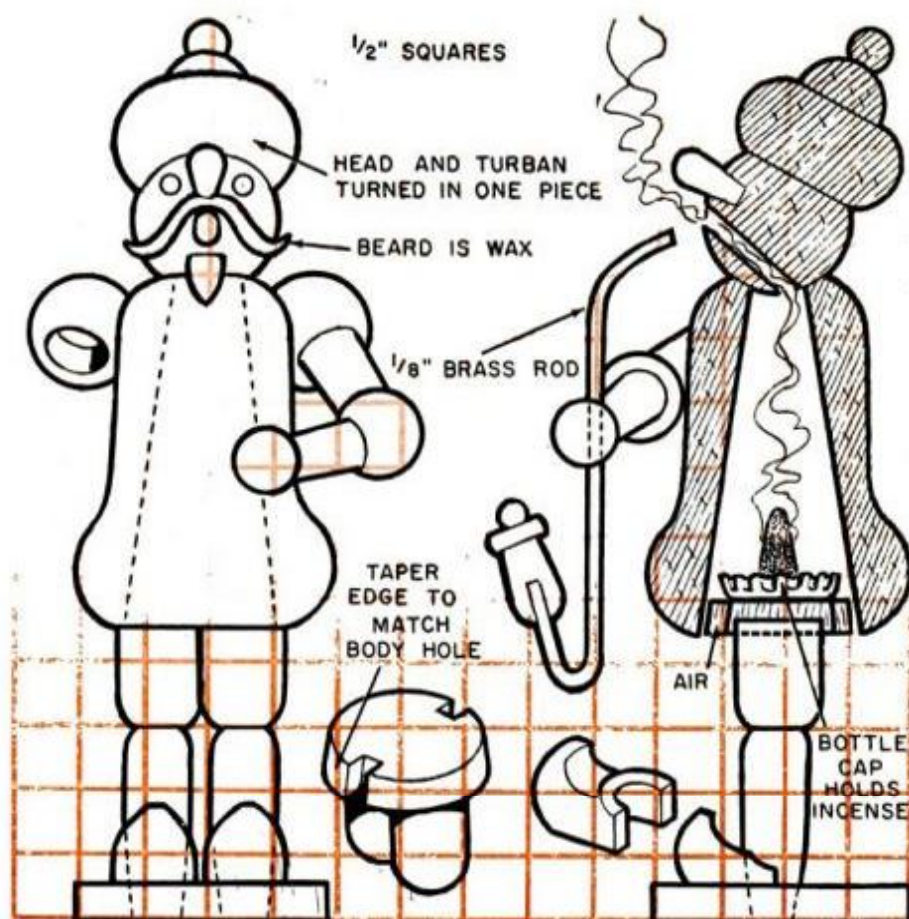

Otto the Drunk

MAKE IT FUNCTIONAL and you've added a lot to the appeal of a carved cartoon. The Caliph is an incense-holder; the other novelties (detailed on the next two pages) are bottle-stoppers. That's an ironical job for Uncle Otto, here—his own bottle is *never* corked. Press on the back lever and Otto's drinkin' arm swings up as his mouth opens wide in thirsty anticipation. After a swig, the arm drops and the mouth snaps shut. The torso and hat are lathe-turned. To avoid carving the face, you can turn the head, too, and *paint* the features on. The jaw is controlled by cords—an elastic one through the head shuts it.

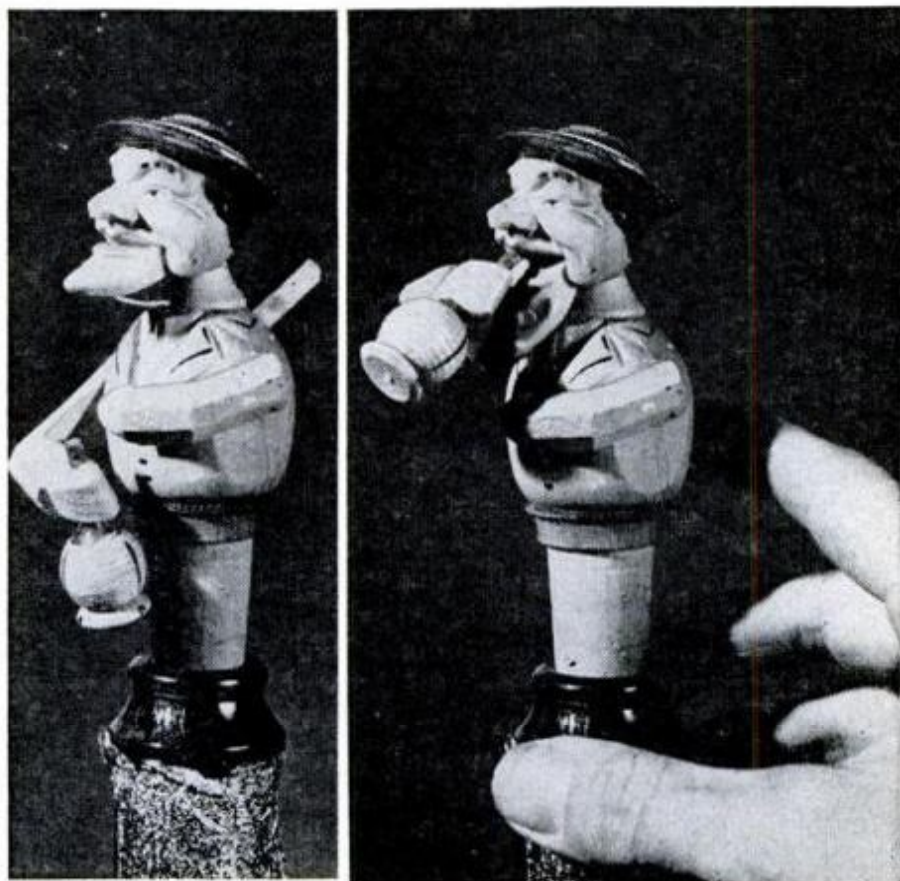

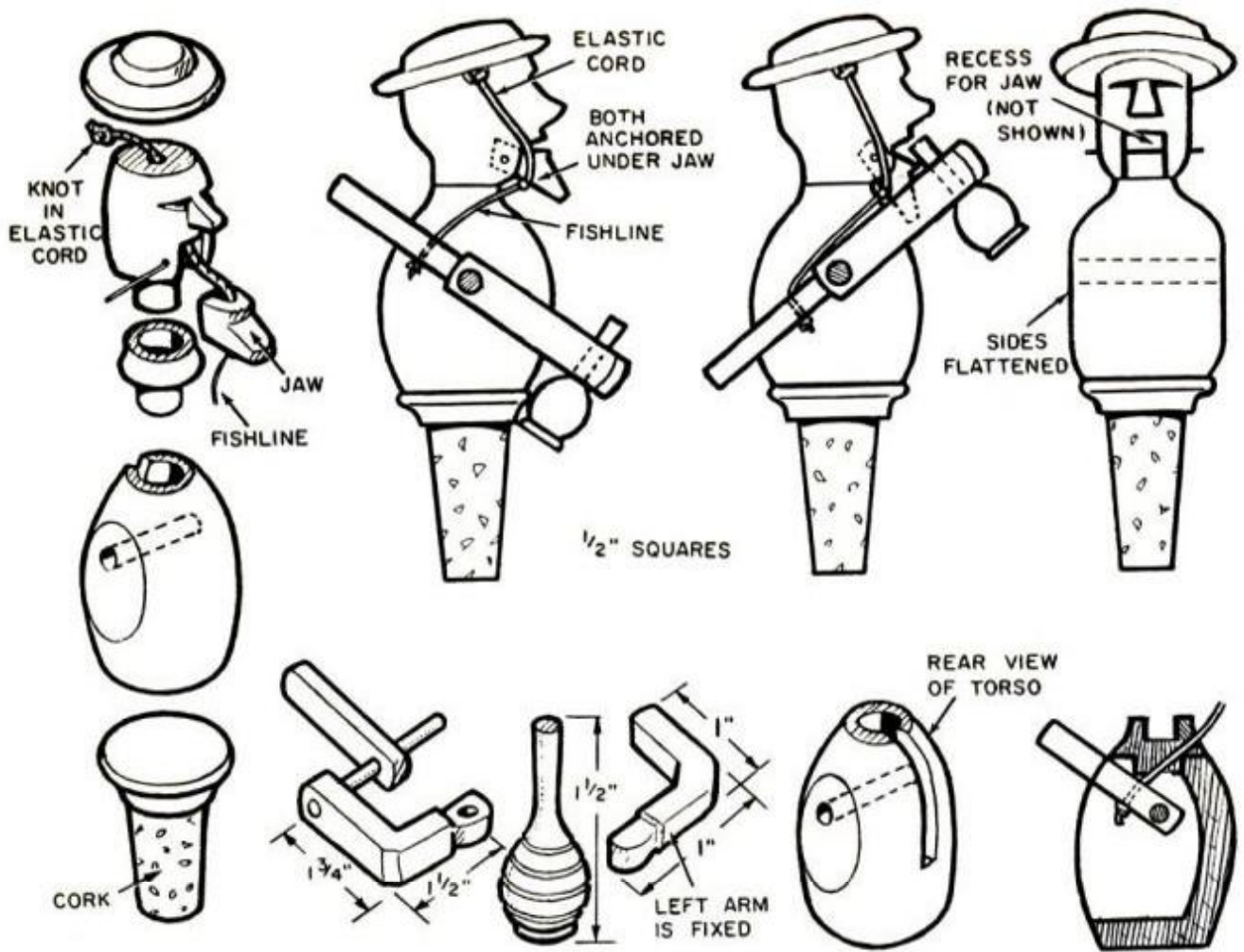

Fritz und Frieda Bottle Stopper

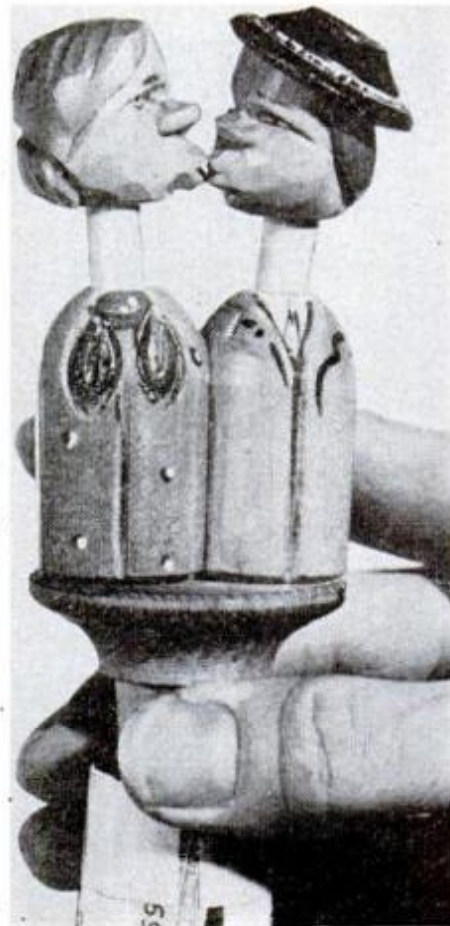

ANY MISTLETOE left over from Christmas? It sharpens the gag if you hold a sprig over this perpetually-puckered pair before you press their back lever. They seem to be whistling a duet up till then, but—zow!—as they turn toward one another their dowel necks stretch and they exchange a good Chermom smack you can almost hear! Light-compression coil springs in each hollow body break up the clinch when you release the lever. Turn both bodies (the decorations are carved in later), then cut away a section of each so they can be joined with a common hollow and lever slot, as seen in the section views, next page. ★★★

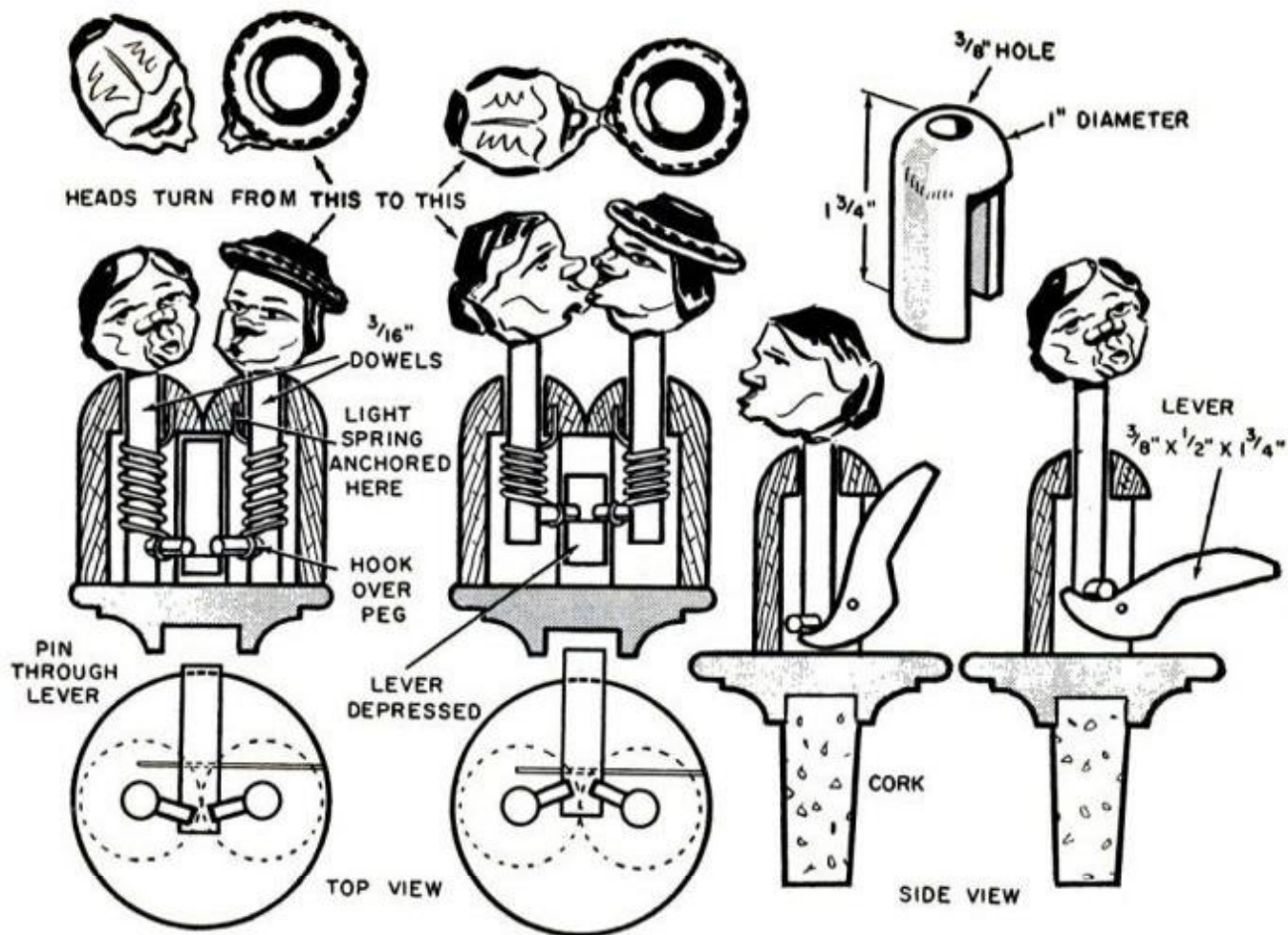

PARTY TABLE MASCOTS

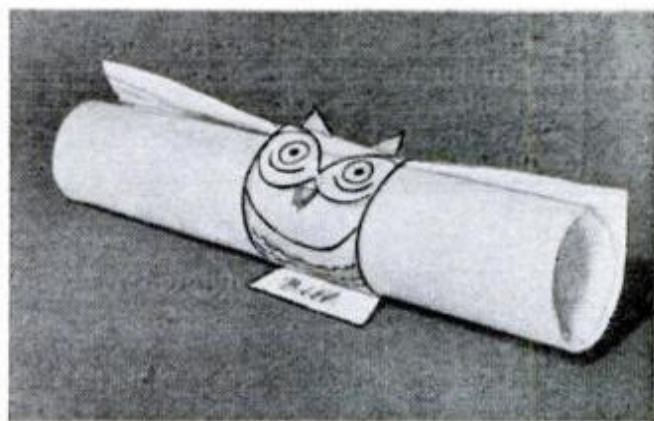
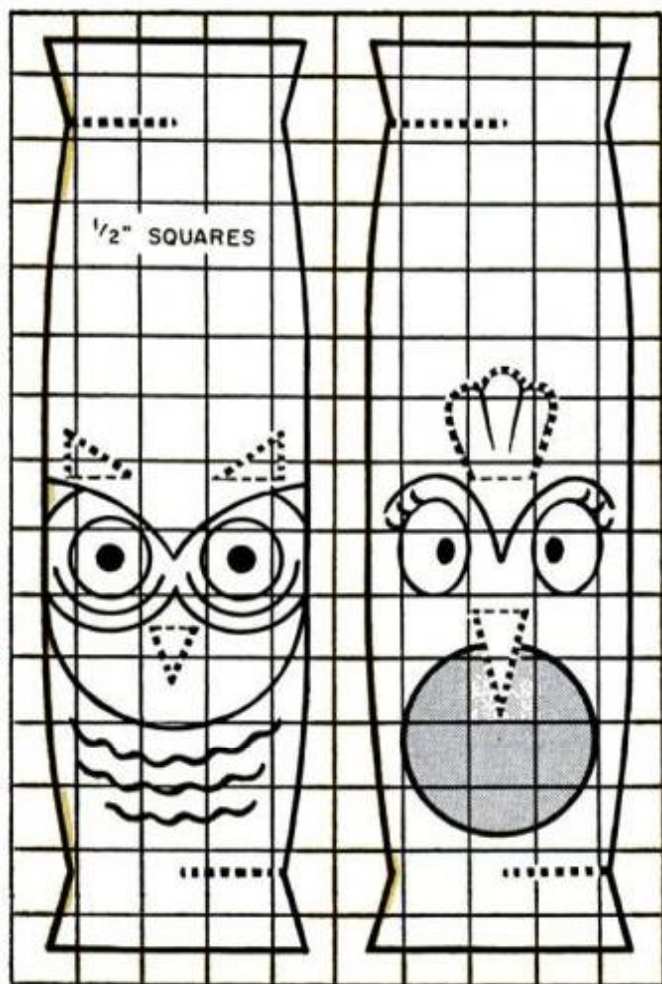

LADY GUESTS will be all a-twitter, and the men will get quite a hoot out of these whimsical party favors, which double as place-cards and napkin rings. Enlarge the patterns shown, tape the enlargement to a light-box (or a sunlit window) and place sketching paper over it so you can trace through. Using soft color pencils, outline the owl in brown, the ladybird in blue, and color both bills orange. Cut out, loop each strip around to notch into itself, slip a paper napkin in and watch your dinner party take wing.—*Roberta Fairall*

Specifics of Specific Gravity

This simple yet accurate experiment proves Archimedes' principle of specific gravity

By Harold P. Strand

Specific Gravity: the ratio of the mass (density) of a body to the mass of an equal volume of water.

HERE'S A CLASSIC EXPERIMENT your youngster can first conduct at home, then perform for his science class at school. Properly conducted, it verifies the theory of specific gravity as first set forth by Archimedes some 2,000 years ago.

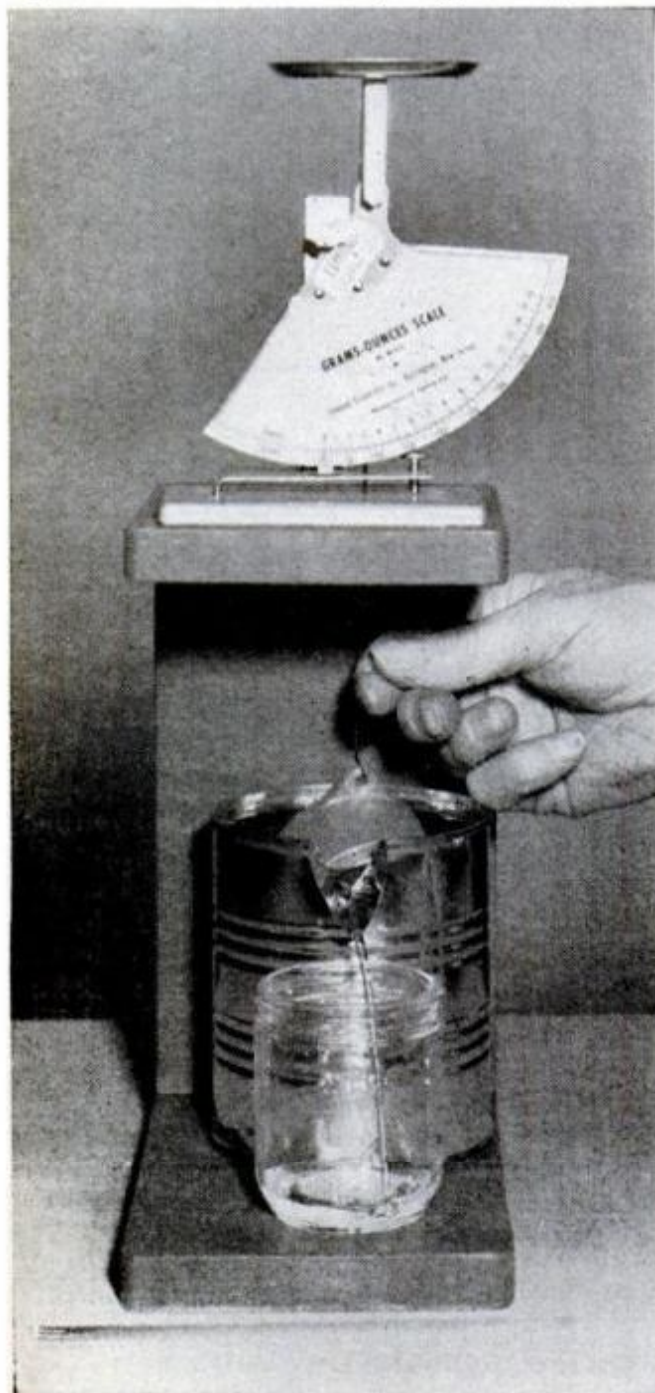

The only scientific equipment required is an inexpensive gram-ounce balance.* A simple wooden stand (see drawing) is then constructed to support the balance, water container and catch jar. The water container can be made from a tin can with a soldered-on pouring spout, as shown. Any test object can be used, so long as it can be immersed in the water container. A small aluminum casting was used here.

Place the balance on the top platform of the support, then tape a short length of small-diameter steel rod to one of its pan supports so the rod extends down through a hole drilled in the platform. The test object will be suspended in the water from a hook bent on the end of this rod. Adjust the balance so the indicator points to 0 lbs.

Now weigh the test object, then the catch jar, on the balance. Place the jar under the spout of the tin can which is filled to the brim with water. Tie a piece of fine thread to the object with a loop 'round the other end, then hang it from the rod's hook with the object suspended—immersed—in the water container. Next weigh the catch jar *with* the water that overflowed into it.

The specific gravity of the object is found by subtracting the original weight of the empty jar from the weight it now has *with* the displaced water. The *difference* between these two weights is the specific gravity of the object. Or:

$$\text{specific gravity} = \frac{\text{loss of weight in water}}{\text{weight of object in air}}$$

Our aluminum casting showed a weight loss in water of 51 grams. Using the above formula, 135 grams (its weight in air) divided by 51 grams (its loss of weight in water) gives it a specific gravity of 2.65 grams—pretty close to the true specific gravity of 2.7 grams for aluminum.

The volume of an object is the same as the water it displaces. Thus we apply the relation of 1 gram (weight of 1 cc of water) to the loss of weight of the object; or, 51 grams \times 1 = 51 cc—its volume.

These general principles apply also to buoyant objects. However, the addition of a lead sinker to pull the object under water is required. ★★★

*This balance may be ordered from Edmund Scientific Co., Barrington, New Jersey, for \$6.65 ppd.



BEFORE CONDUCTING experiment, adjust balance to read zero lbs.

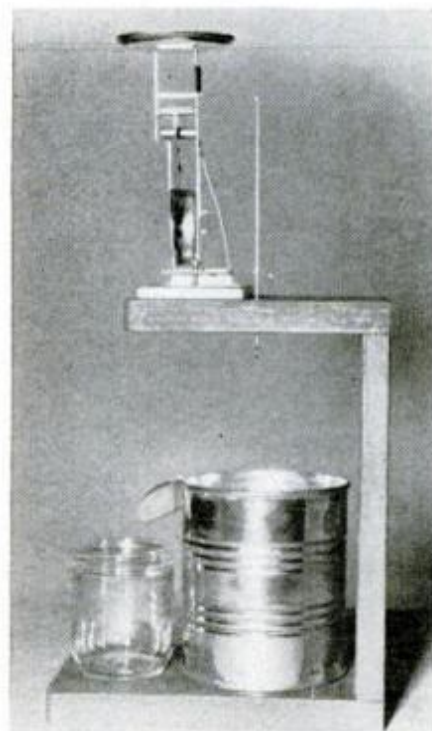

TEST OBJECT is suspended from wire taped to pan of the balance

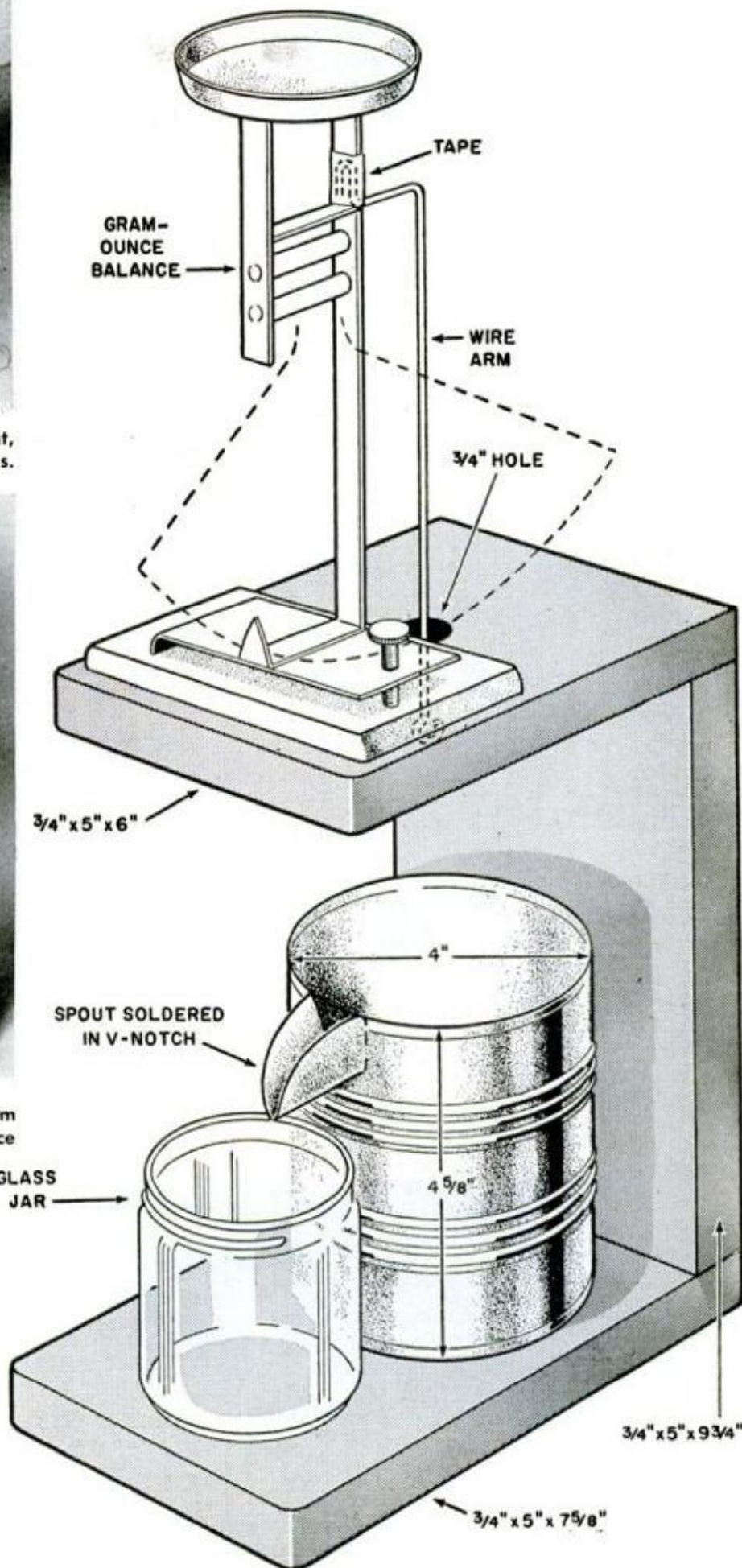

You Can Find **GOLD** in Them Thar Hills with This Gas-Driven Drywasher

You'll "strike it rich" in half the time with this vibrating rig which lets you sift for gold without water

By John E. LaVallee

ATENTION, YOU GOLD DIGGERS! If you were one of the thousands who sent 5 cents for a list of 220 U.S. counties where placer gold can be found (*Glittering Gold Rush Vacation*, page 102, June '65 PM), chances are you're more than mildly interested in the new family sport of finding the glittering crumbs the '49ers overlooked.

The fun of panning for gold becomes twice as exciting (and profitable) when you can work regions which are not swarming with other "claim jumpers." In his search for gold, the old-timer prospector stuck pretty much to streams and riverbeds and passed up desert placers because of a lack of water. The same holds true in the current gold rush of '66. But



IN ARID AREAS the sifting operation can kick up a cloud of dust, so to protect the engine, I added a heavy-duty air cleaner high above trommel. It's optional, as is the engine, since drywasher can be hand-cranked

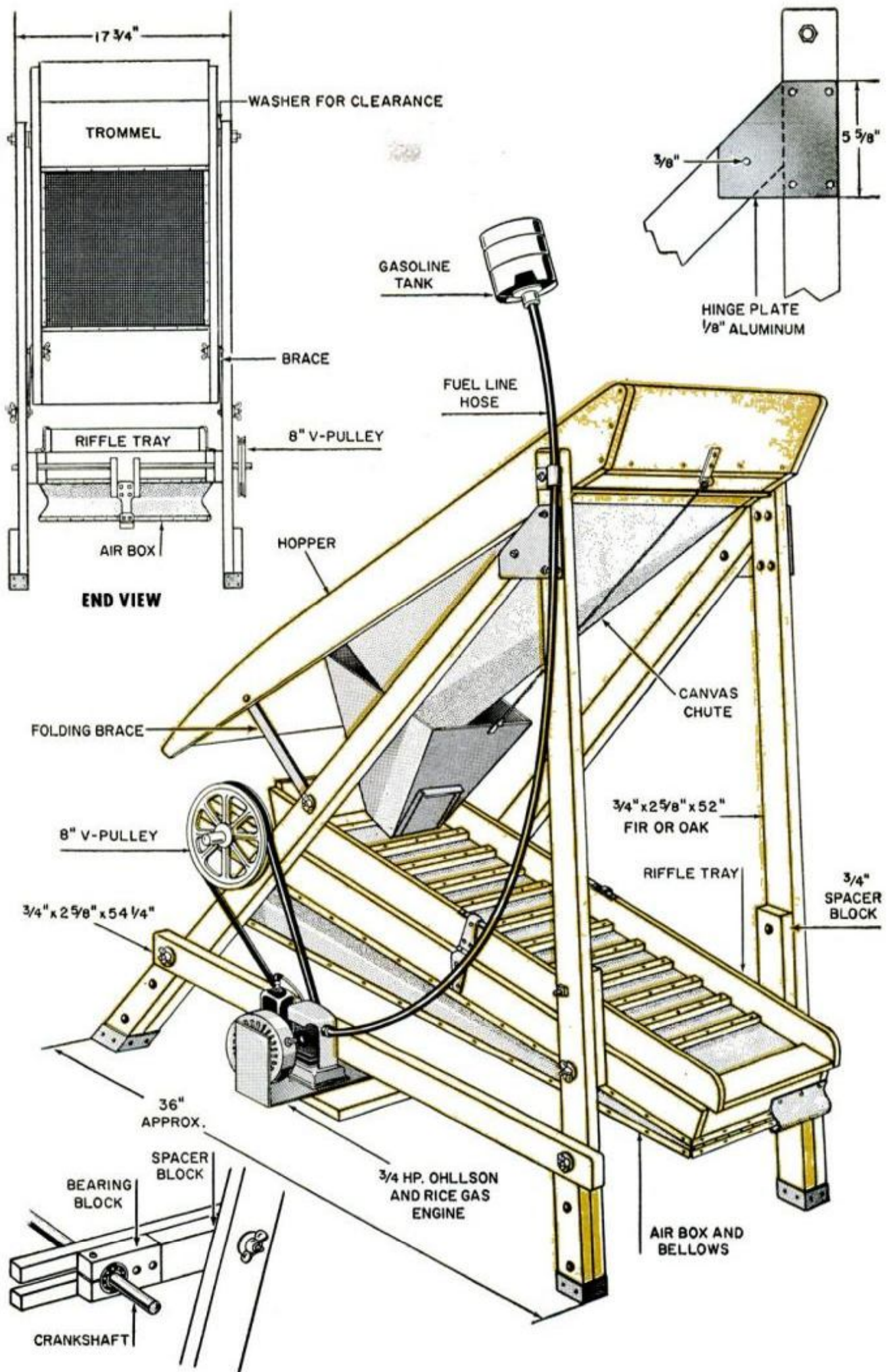

with this build-it-yourself drywasher, the modern-day sourdough and his vacationing family are able to work off-stream diggin's and old mine dumps with as little as a tub of water, since only the screened concentrate needs to be washed.

The drywasher is nothing more than a motorized sifter which jiggles vigorously to separate the gold from the sand and gravel you shovel into it. In actual operation, the earth being tested is shoveled onto a slanting screen-covered tray called a trommel, where it sifts through onto a canvas chute and flows into a hopper.

When the hopper and chute are full right up to the trommel, the engine is started and the gate in the hopper is opened about $\frac{3}{4}$ in. The material in the hopper flows onto an inclined tray which is fitted with cross cleats called riffles. Rapid air pulsations, produced by a bellows mounted below the tray and operated by a crankshaft, bounce the screenings 2 to 3 in. above the cloth bottom of the tray. This jiggling action causes the heavier part of the material (the gold) to settle to the bottom of the tray and collect behind the beveled riffles, while the lighter portion flows over the cleats and off onto the ground as waste.

When the hopper is empty, the engine is shut off the riffle tray is lifted from the air box on which it sits. The concentrate held by the riffles is carefully poured into a pan of water and washed in the usual way to check the presence of gold in the concentrate. The process is repeated over and over—until you have all the gold you can carry.

Basically, the drywasher consists of four main parts: the trommel, riffle tray, air

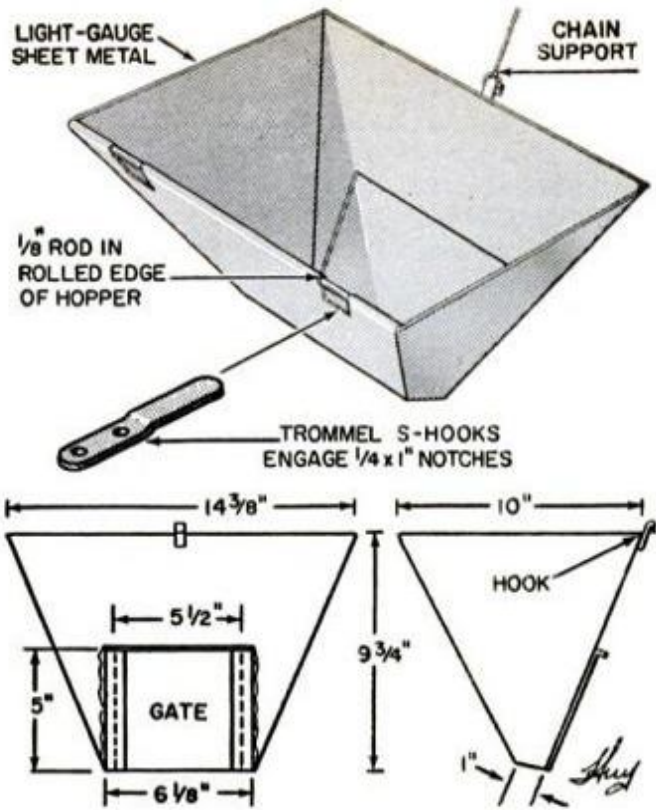

box and hopper—each being detailed individually in the drawings. Standing on A-frame legs fitted with wingnuts, the rig can be quickly dismantled for carting to and from the site. The cloth used in the bottom of the riffle tray must be sufficiently porous to allow air from the bellows to pass through freely.

Chances are you won't get rich from this fascinating hobby, but you might be interested to know that my "pardner," Clayton Mendham, recovered \$1700 worth of gold last summer with a drywasher similar to mine—and that's not hay. Good luck and good diggin'! ★★★

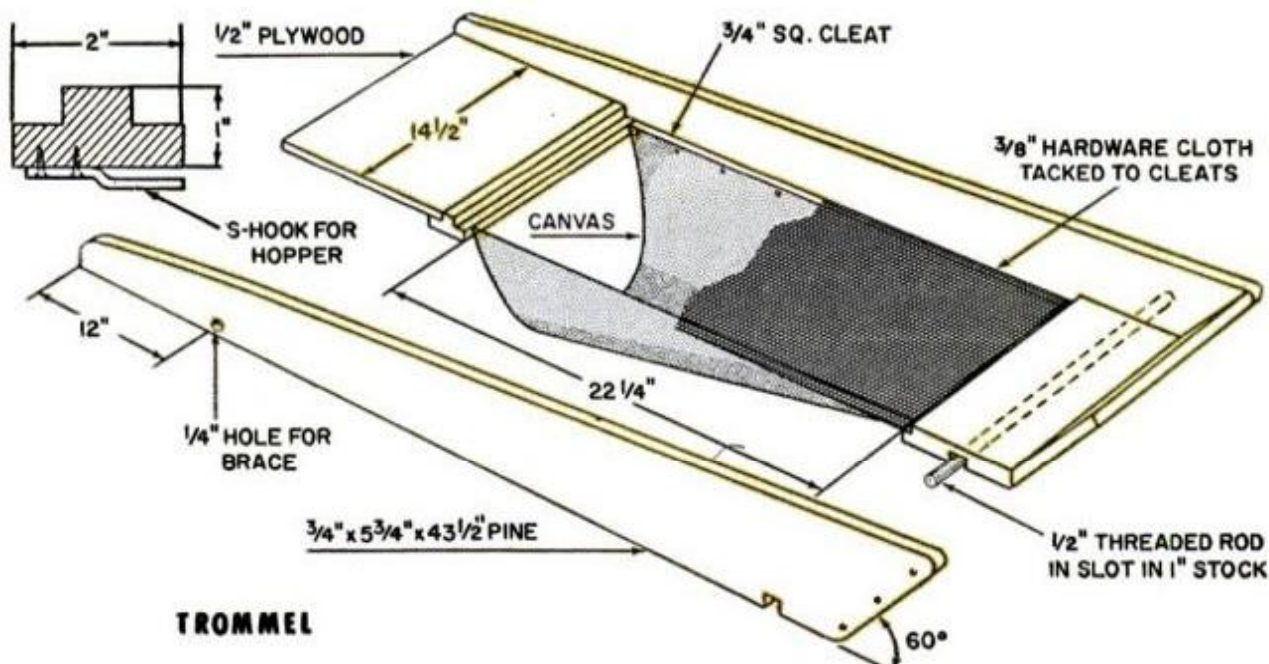

TIPS FROM READERS

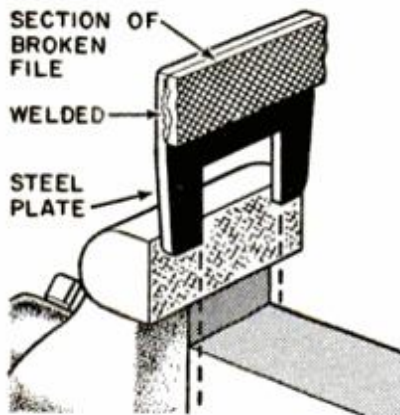

RENEW THE GRIP of worn-smooth vise jaws with two lengths cut from coarse-tooth file. Weld 'em to straddle plates, then slip units over sliding beam of vise



PROTECT EXPOSED bulbs in barn, shop or spray booth with "bottle jackets" which fit to twist-on caps installed between screw-shell ring and fixture

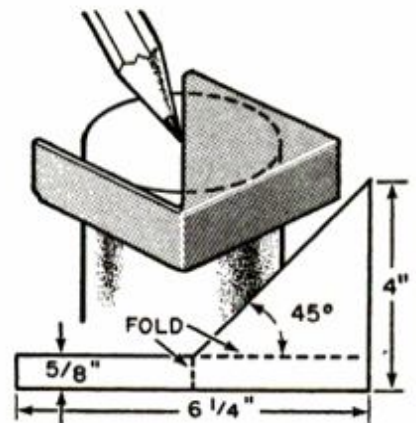

SELF-CENTERING center-finder locates the bull's-eye of all sizes of dowel stock. Make it any size from sheet metal—cut, bend, then use as shown above



"BLIND" INSIDE MEASUREMENTS are easy with this gadget—a bit of umbrella rib in channel, in which slides a length of coat-hanger wire bent as shown

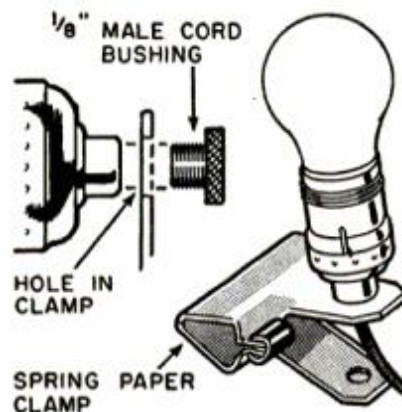

WORK LIGHT on extension cord uses a big spring paper clamp as a base. Light can also be clamped where you want it, or hung from the wall on a nail



SIMPLIFY READING boiler water gauge by backing it with a card bearing diagonal black lines. Refraction makes water line appear horizontal for easy reading

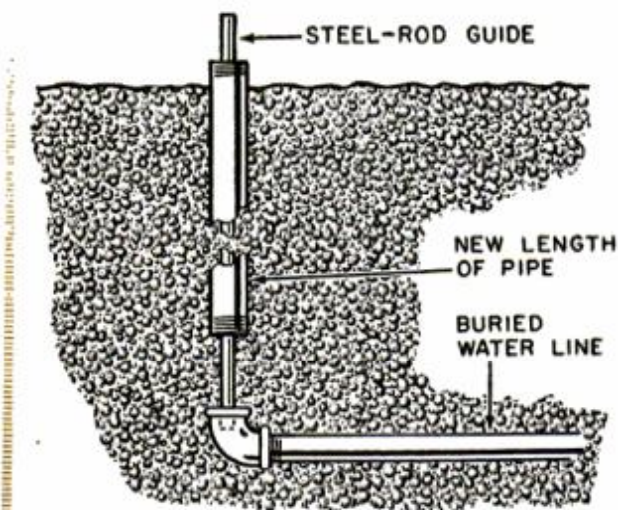

"Guide Rod" Saves Digging

How to replace a vertical buried water pipe which has frozen and burst—without digging? O.E. Hadwiger of Pueblo, Colo., solved this poser as follows: He removed the hydrant faucet, then thawed the pipe with hot water from his basement hose. He then dropped a 6-foot length of steel rod down the burst pipe till it bottomed in the elbow. Unscrewing the pipe and sliding it out over the rod, he simply slid a new length of pipe down the rod, which guided it straight to the buried elbow where he screwed it in place.

Hold It, Elmer!

HE'S ALWAYS READY to lend a helping hand and never complains if you burn his fingers. Actually, Elmer is a fully adjustable fixture for holding small work to be soldered, brazed or welded.

Elmer is made from a gooseneck-lamp base, some strap aluminum and three matched pairs of alligator clamps. After removing the shade, socket and wiring from the lamp, weld a $\frac{1}{4}$ -20 nut on the end of the neck, as shown below. The aluminum arms are bent in a vise. To form the short twisted pieces, clamp one end 1 in. deep in the vise, take a 1-in. grip on the other end with a wrench and twist.

Make the thumbscrews by cutting the head off a 1-in. stove bolt, running a wingnut up flush with the cut end and soldering it in place.—*Manly Banister*

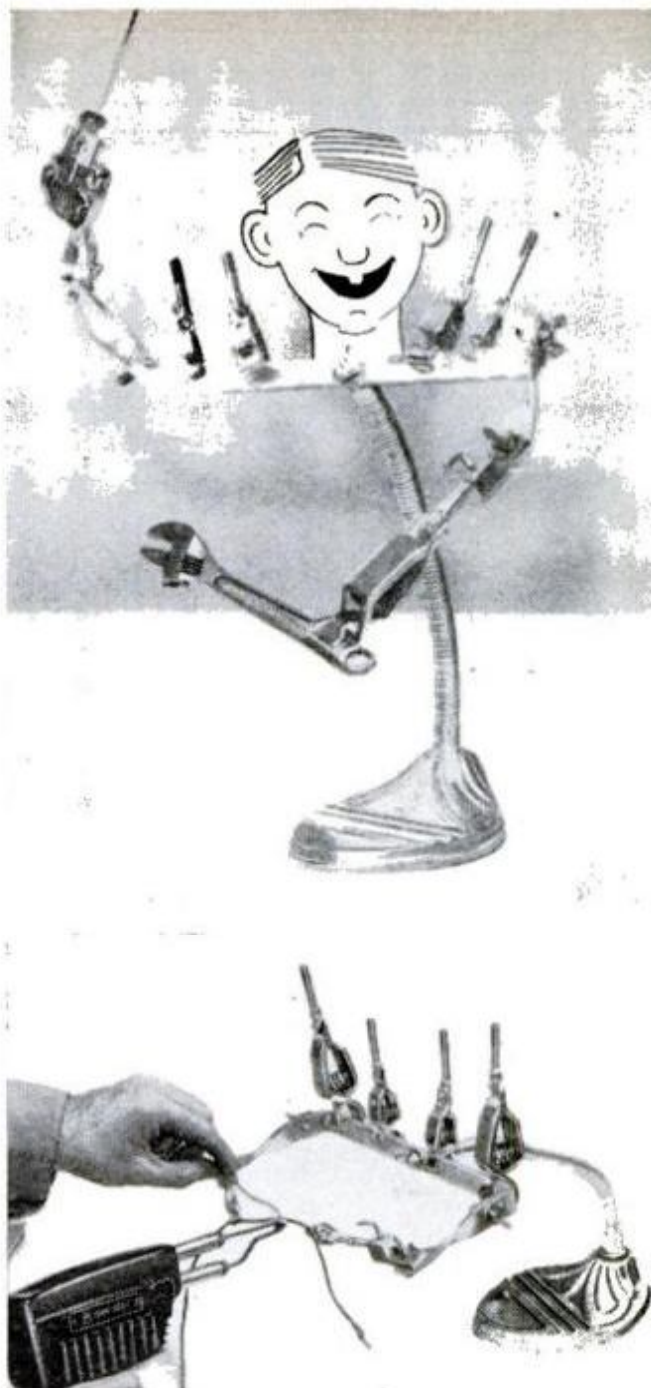
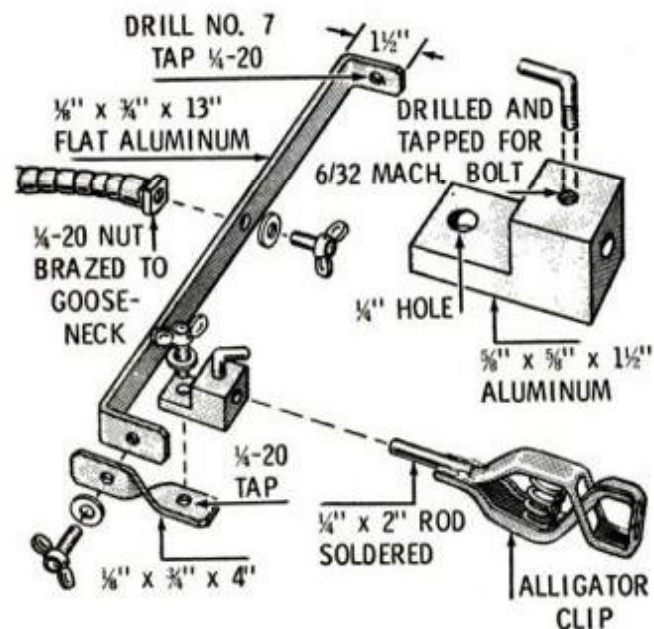

Three-Legged Horse

When you're constructing something simple, such as a sawhorse, it's only natural to stick to a standard, time-honored design. But I had a few ideas of my own for breathing new life into the old horse. First of all, I decided on a tripod base for maximum stability on rough ground or other uneven surfaces. This provided an unexpected fringe benefit—the vertical leg permitted close-in sawing without any interference. I made the top member of the horse from a 2 x 6, slotted to pass my saw blade when I'm ripping small pieces of stock.

To form the slot, I first drilled a 2-in.-diameter hole through the board approximately 15 in. from its end, then ran two saw cuts spaced 2 in. apart into the hole.

—*A. Barstad*

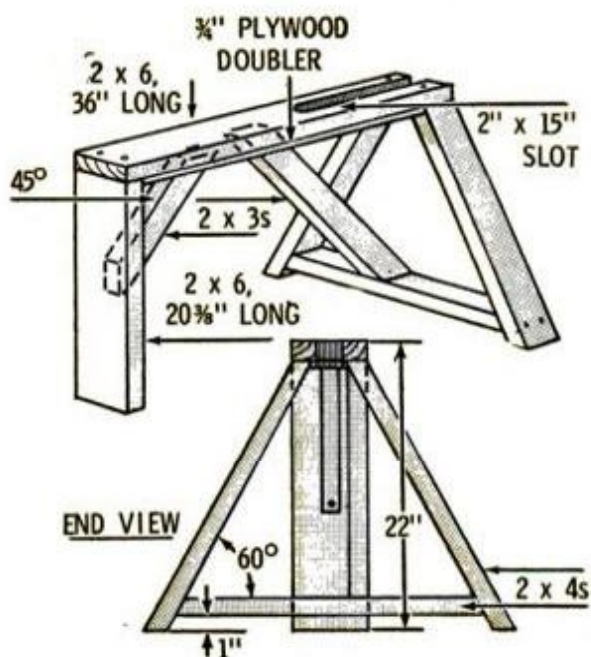

SOLUTIONS FOR MECHANICAL HEADACHES

AUTOMOBILE CLINIC

BY MORT SCHULTZ

Ammeter Running Amok?

I have power windows on my 1963 Chrysler Imperial. Every time I operate 'em my ammeter shows a charge. Shouldn't it read discharge?—Mel Rathjen, Portland, Ore.

Electric window motors are wired through the voltage regulator. When a load is put on the battery the current limit relay automatically steps up the amperage output. This will happen when you turn on your radio or heater too—and be glad it does.

Volt-Happy

I'm "going modern" and would like to know how to switch the 6-volt system on my car over to 12 volts. Seems to me most of the new accessories on the market these days are for 12-volt systems—Dave Pendle, Butte, Mont.

Dave, who needs it? You know what this switch-over will involve? You'll have to replace the battery, starter, voltage regulator, generator, condenser in the distributor, ignition coil and all lights. Figure up all the time, labor and money this will cost and you'll probably decide it would be simpler—and maybe cheaper—to go out and buy a car already equipped with a 12-volt system. As for those accessories: in most cases you'll find that a 12-volt accessory is also available for a 6-volt system.

Maligned PCV

Rough-idle has been dogging my '63 Chevrolet Impala. I've had everything tuned to perfection—plugs, points, timing, carburetor—and there aren't any vacuum leaks. Unhooking the positive crankcase ventilation (PCV) system is the only action which smooths out the idle, but I don't like to leave it off. Got any ideas?—Steve Karter, Brooklyn, N.Y.

I'd say your car's rough-idle is due to a too-rich fuel/air mixture. The engine runs like an old smoothie with the PCV disconnected because then more air is permitted to reach the manifold where it mixes with, and evens out, the gas mixture. The PCV's okay. Hook it back into the engine, then check out trouble spots that might be throwing the fuel/air mix-

ture out of whack. There's a good chance you'll find the trouble is caused by a high float level or by bad carburetor gaskets, especially where the air horn hooks in.

Descreeching Dodge Brakes

My 1963 Dodge gives out with a loud screech every time I hit the brakes. How can I eliminate this noise?—Ted Morris, Somerset, N.J.

Owners of Chrysler products seem to come up with this complaint more often than others. However, correcting this problem on 1963, '64 and '65 Dodges may not prove too difficult. The trouble may be found in the star-wheel adjuster assembly, specifically the flat washer between the adjuster socket and the face of the star wheel that was put on in production. Often replacing this washer with a wave-type washer will eliminate brake squeals.

This Bird's in a Nosedive

Listen to the troubles I'm having with my '65 Skylark Buick, then please advise (or lend me your crying towel):

1. Gas peddle throbs and pulsates at medium and high speeds.
2. At 10 to 15 mph the car vibrates on the driver's side as if it were strapped in a reducing machine.
3. At medium and high speeds the steering wheel quivers like a tuning fork.

Wheel balance and front-end alignment haven't helped. Can you?—Rocco L. Pignone, Pearl River, N.Y.

Maybe. There's a possibility that the nose angle of the drive shaft is off tilt. This could mean that the line from the power train to the differential is not straight, as it should and must be. I'd suggest you take your Skylark back to the dealer and have him check it for pitch. If you decide to tackle this job yourself, and discover that you'll have to tilt or flatten the nose of the car, do it by raising or lowering the transmission or by changing the pitch of the differential.

Galaxie Au Go-Go

I'm scared—and believe me, I've got a right to be. The accelerator pedal of my '63 Ford Galaxie XL500 with automatic transmission sticks to the floor whenever I press it all the way down. This happens

whether the car's at cruising speed or starting off from a standstill. If you've ever had the experience of passing someone, then letting up on the gas pedal only to have your car continue on its headlong, mad and merry way, you can appreciate why I'm pushing the panic button. No amount of tapping or kicking releases the pedal. The only way I can get it to pop out is by cutting the ignition. As far as I can tell there is no sticking or binding caused by the carpet or grommets between pedal and firewall. So what's up?—William E. Brown, Chattanooga, Tenn.

There are two primary causes for a jammed accelerator on any car. I suggest you check out both of 'em—fast!

First, get those motor mounts inspected. A broken or loose mount can throw the engine and transmission out of line so that the throttle will jam wide open.

Second, the accelerator linkage may not be properly set. The linkage may be riding up over the high-speed cam and sticking there. Get it set correctly.

Wants Her Caddy Spotless

I've got a beautiful '63 Cadillac. The only marks on it—and they're killing me—are soil spots on the vinyl-coated fabric covering the roof. Can I remove them? If so, how?—Paula Freed, Syracuse, N.Y.

Try erasing them first with a natural gum eraser. Spots which can't be erased can usually be washed away with plenty of lukewarm water and a mild detergent powder. Use a clean cloth or soft-bristle brush. If the dirt's really embedded, try rubbing the spot lightly with a moist cloth or sponge sprinkled with one of the "foamy" type cleansers from your kitchen. Then remove all traces of the cleanser by rinsing thoroughly with clear water. Never use volatile cleansers, harsh soaps, bleaching agents or a stiff-bristle brush.

Tale of a Comet

Just can't get the engine of my '62 Comet to idle down. Also, a too-rich fuel mixture is indicated by black smoke which billows out the exhaust. I've tried all the standard cures. What have I overlooked?—Jack Campbell, Dillon, S.C.

The carburetor, maybe. I've received more than one beef of this kind from owners of Comets having both the 144 and the 170 CID engine, and from owners of the Meteor with the 170 CID engine. Both cars seem to have a tendency to develop a blocked-up idle passage in the carburetor. Remove the carb air horn and inspect the passage. If you find some gook plugging it up, clean it out, then replace the air horn and reset idle speed to spec.

Service Tips

• **HEAR A HARD-TO-PINPOINT** scraping noise when you turn the steering wheel of your '64 F-85 Olds? Likely cause is insufficient lubricant on the horn contact brass ring. To repair the trouble it's suggested that the steering wheel, spring and turn-signal canceling cam be removed, and the brass ring and horn contact polished with No. 400 Wetordry sandpaper until smooth. Then clean the brass ring and contact thoroughly before applying lubriplate. If the ring doesn't polish up smooth, replace the canceling cam assembly.

• **FOR OWNERS OF PONTIACS** equipped with the Rochester 2GO carburetor, there's a new pump plunger which has been issued for it (Part No. 7031003), and which should be used if you replace the old one. It can be identified by its plastic tip and by the fact that it **doesn't** have a plunger ball check.

Also, the main metering jet size has been changed on this carburetor where it is used on cars with airconditioning. The new size (Part No. 7008661) is .061 inches instead of .060 inches (the size of the factory-installed jet), and is designed to provide slightly more fuel at idle and low speeds.

Each month Auto Clinic answers your questions on car repair. For a personal reply, please enclose 25 cents in coin to cover mailing and handling. Address questions to Auto Clinic, Popular Mechanics, 575 Lexington Ave., New York, N.Y. 10022.

You can get more miles per gallon

There are plenty of techniques for getting a better break from your fuel dollar; they range from mechanical adjustments to new driving habits

By Morton J. Schultz

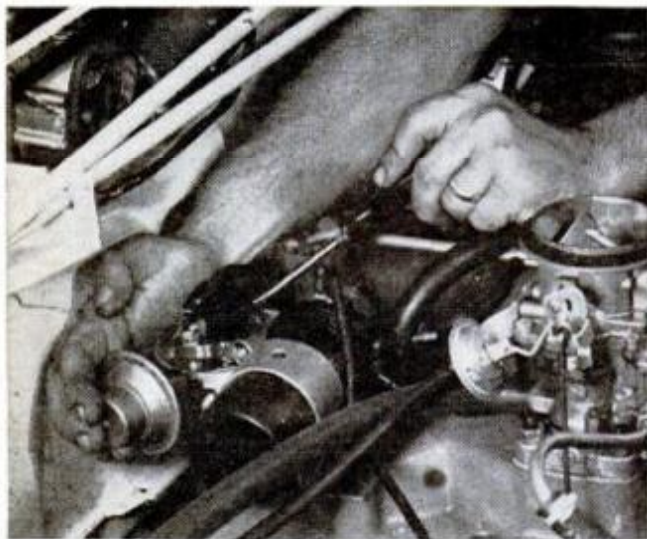

TEST distributor vacuum advance by moving breaker plate to full advance; plug opening with moistened finger. If plate moves when released, unit is faulty

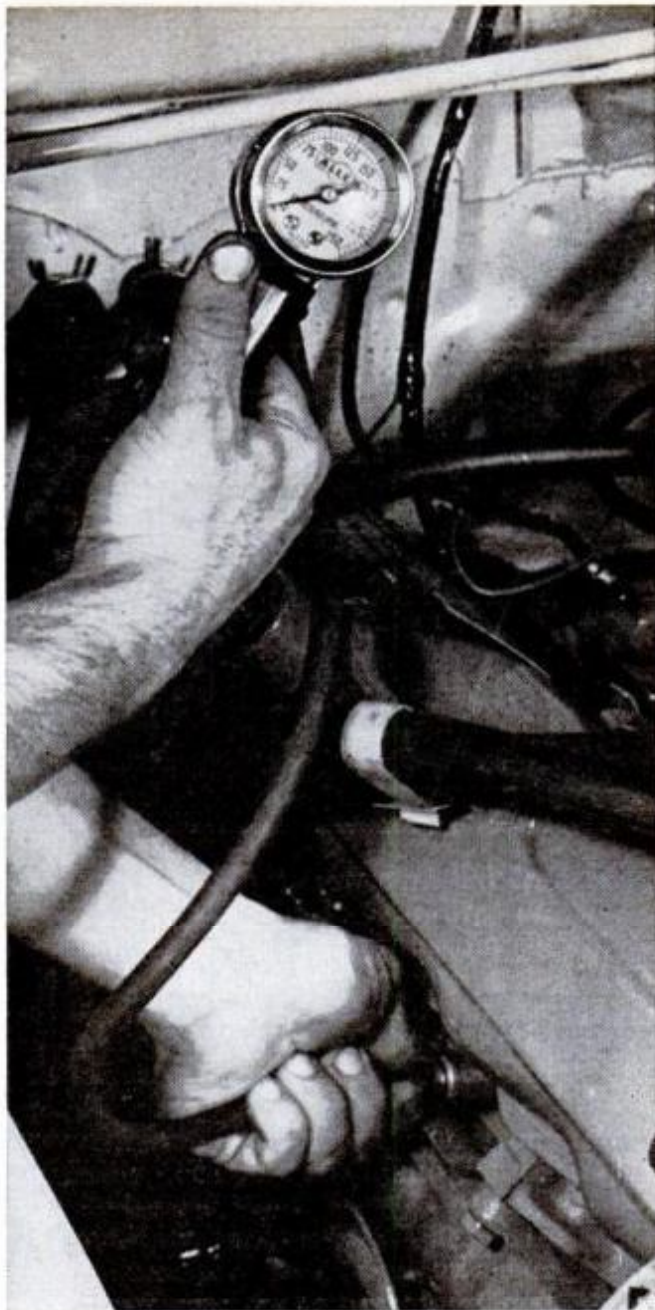

POWER ROBBERS inside the engine can be detected by conducting a compression test (shown above) and a vacuum-gauge test. Do both tests every 12,000 miles

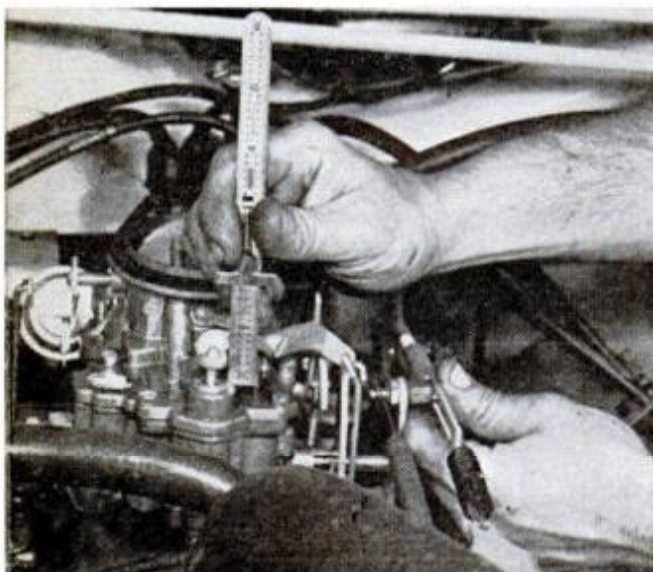

AN OUT-OF-WHACK accelerator pump stroke wastes gas by delivering too much fuel to engine. Measure the stroke, then adjust it according to specifications

WHAT do you find to be the major causes of excessive fuel consumption in modern cars," I asked 200 top mechanics in the New York metropolitan area.

Two answers stand out:

1. The way drivers drive.
2. Mechanical letdowns which rob the engine of power or add to the normal resistances a car must buck.

The experts also pointed out that many drivers whose cars are delivering quite satisfactory mileage are convinced they're driving "gas hogs"—simply because they employ a faulty method of calculating gas consumption.

Unless your car is mechanically perfect, and unless you're an expert driver, there's little doubt you *can* increase your miles-per-gallon. How much will depend on the

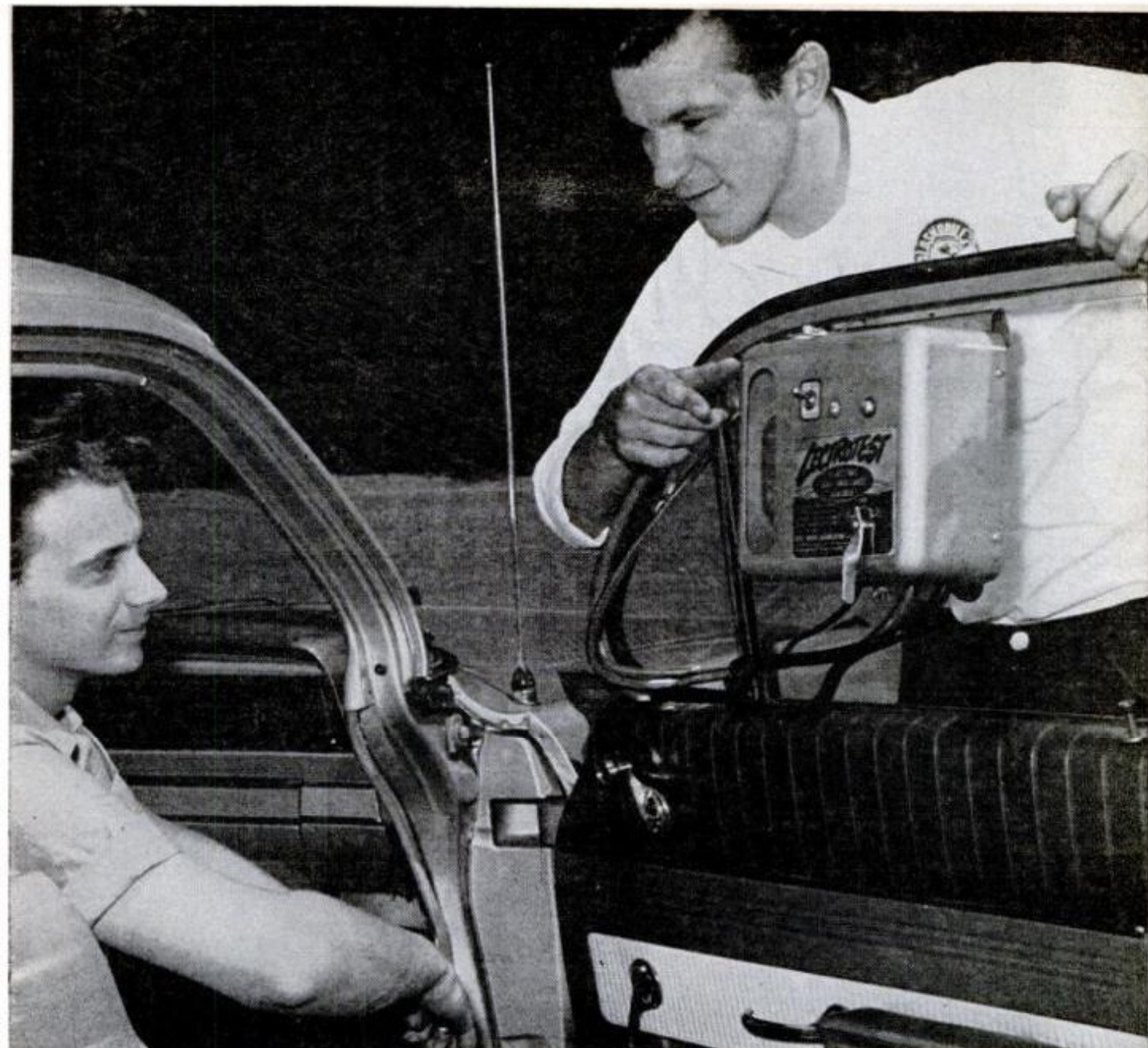

THE ONLY WAY to determine accurately how much gas a car is using is with a gas-per-mile gauge (shown fastened to door of car above). With gauge tapped into fuel system, a test run is made over a planned course

adjustments you make to your car—and the readjustment you make in your own driving habits.

I know. Right away some of you guys will ask, "Is it worth it?"

Well, from a mechanical standpoint I'd say it is; because the same conditions which reduce mileage are also those which rob your car of power and performance and lead to big repair bills.

As for a driver's ability—or willingness—to form new gas-saving driving habits . . . that's another matter. Some people will refuse to cut their highway speed by five miles an hour no matter how much gas they'd save.

Gas-miser tuneup

You must find out how much fuel your car is now using *with you driving*. A mile-

age test conducted by an expert will not show the same results that it will with *you* behind the wheel. However, having an expert drive the car after he observes your driving will give you the chance to get a comparison in mileage between his driving and yours. And he may offer you some good advice for improving your driving habits.

The *only way* to determine accurately how much gas a car is using is with a gas-per-mile gauge connected into the fuel system while driving over a *planned* test course. For those who might scoff at the above statement, let me quote what engineers of a leading national automotive service said recently about odometers as instruments for checking gas mileage:

"An odometer is not an accurate meter for recording engine use because engine

idle time is not recorded. Both speedometer and odometer rely on a cable driven by the transmission.

Thus, if the vehicle is not in motion, neither the speedometer nor the odometer can operate."

Now, here's the bombshell:

"Therefore, in consulting the numbers on the vehicle's odometer it is recommended that about 2000 miles be added to each 12,000 miles showing on the odometer to account for the time the engine has spent idling." (The italics are mine.)

In other words these engineers estimate that in 12,000 miles of driving some 2000 miles' worth of gasoline is wasted by the engine in idling! That's a lot of fuel, Jack.

Of course gas is wasted in other ways as well. There is no way to estimate, for example, how much gas you lose just by evaporation when the car is not used for some time. General engine fatigue as well as particular mechanical failures are important factors too.

Running a mileage test

According to my own rough estimate of the mileage on my car, I was getting an unsatisfactory 13 miles to the gallon. I decided to check this out a little more scientifically.

I took the car to a mechanic buddy of mine who has an accurate gas-per-mile gauge calibrated in tenths of a gallon. We tapped the gauge into the gas line between fuel pump and carburetor and conducted the so-called *bottle test*.

The car was taken on four different runs of equal distance. It was not allowed to sit still and idle except where traffic conditions and red lights forced natural stops. Readings on the corrected odometer were taken before and after each run.

The test course included (1) a drive at highway speed in one direction; (2) a drive over the same highway in the opposite direction (to equalize the effects of any head or tail winds); (3) a drive through a light-traffic urban area; and (4) a drive through a heavy-traffic business district.

Each run was conducted, where possible, at posted speed limits. The resulting readings were then added up and averaged to get the correct gas mileage.

The results of this test showed that my car was getting 18.2 miles per gallon—or 5.2 more miles per gallon than I had estimated—thus proving the unreliability and inaccuracy of those off-the-cuff estimates previously referred to.

This kind of test will cost you \$6 or \$7, but it's worth it—especially if you discover, as I did, that your car's not the gas burner you thought it was.

FUEL SYSTEM GAS ROBBERS

Beware of a fuel system that delivers more gas to an engine than it needs. Listen for faster-than-normal idling; look for black smoke from the exhaust pipe when car is started. Cause may be poor fuel-to-air ratio.

LOOK FOR

- High fuel-pump pressure
- Dirty air cleaner
- Too-rich choke adjustment
- Improper adjustments of:
 - idle setting
 - fast-idle screw
 - accelerator pump stroke
 - anti-stall dashpot
- Too-high carburetor float level
- Internal carburetor damage such as worn jets and faulty power valve
- Binding in the accelerator linkage



IGNITION SYSTEM GAS ROBBERS

You are not getting the full benefit from your fuel if a weak spark delivered to the cylinders fails to completely burn the gas. Unburned gasoline which reaches the cylinders is then lost through the exhaust pipe.

LOOK FOR

- Leaks in the high-tension cable
- A weak coil
- Worn, dirty, fouled or incorrectly gapped spark plugs
- Faulty ignition timing
- Incorrectly adjusted or worn distributor breaker points
- An inoperative distributor spark advance unit



A driver who wants to save gas keeps two "gas-gulping" facts in mind: (1) The more the accelerator pedal is hit, the more gas is wasted; (2) the more a car's engine is allowed to idle, the more gas is wasted. In other words, stop-and-go driving around town consumes much more gas than highway driving.

Here are some ways you can stretch your fuel dollar by using intelligent driving techniques. Try one or more of them for a week or two, then check your mileage again to see how much—or if—your fuel bills have been reduced.

- **Avoid needless idling.** Three minutes with the engine idling and the car standing still uses as much gas as driving one-half mile at 30 miles per hour. Repeat: *avoid needless idling.*

- **Use a steady foot on the accelerator pedal.** When starting from a standing stop, press the gas pedal slowly and steadily. Avoid jackrabbit starts—and stops, too. "Flooring it" and then backing off burns up gasoline which isn't needed for acceleration in the first place. Maintain steadiness of acceleration and de-acceleration at cruising speeds as well. Don't run up on the tail of the car ahead only to have to brake down because you can't go anywhere anyway.

- **Use correct passing procedure.** Never run up on the car ahead, slam down on the brakes, then hit the accelerator pedal

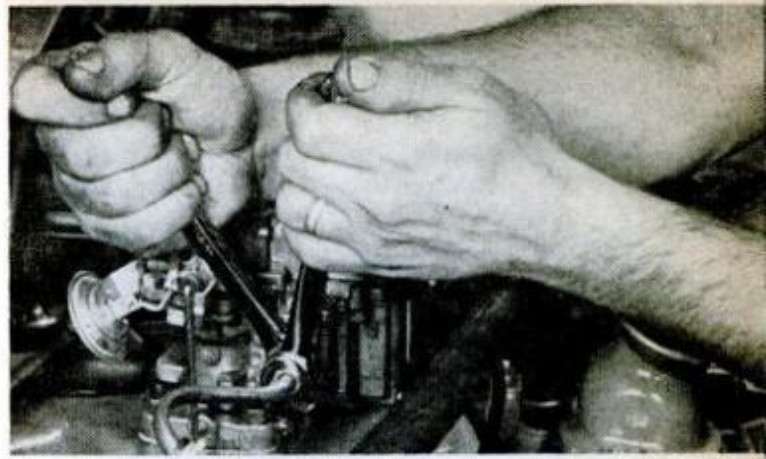

ANY LEAKAGE OF GASOLINE or loss by evaporation is wasteful. Check all gas lines and tighten up on any loose connections, especially around the carburetor

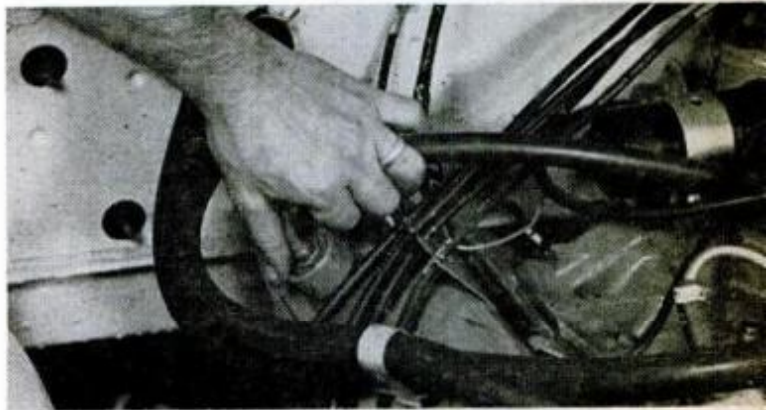

A CLEAN CRANKCASE VENT VALVE helps conserve gas. To clean or replace it, remove the cover and pull away vent line. Check manual before doing this job

ENGINE/POWER TRAIN GAS ROBBERS

The engine and power train are prime sources of fuel loss. Often the trouble can be traced to the valves. Regular maintenance and particular adjustments in this area can help save much fuel over a period.

LOOK FOR

- Compression loss
- Burnt or sticky valves
- Improperly adjusted valves
- A defective crankcase ventilation regulator valve
- A frozen manifold heat control valve
- A restricted exhaust system
- Improperly adjusted automatic transmission



AREAS OF GAS LEAKS

Leaks account for most of the gas that's lost before it reaches the engine. Stop leaks by battening down on connections and sealing up seams. The most likely places where leaks will occur are . . .

HERE—

- In the fuel line where it connects to the carburetor
- In the fuel line where it enters and leaves the fuel pump
- In the seams of the gas tank filler neck
- At the gas tank cap
- In the gas tank itself



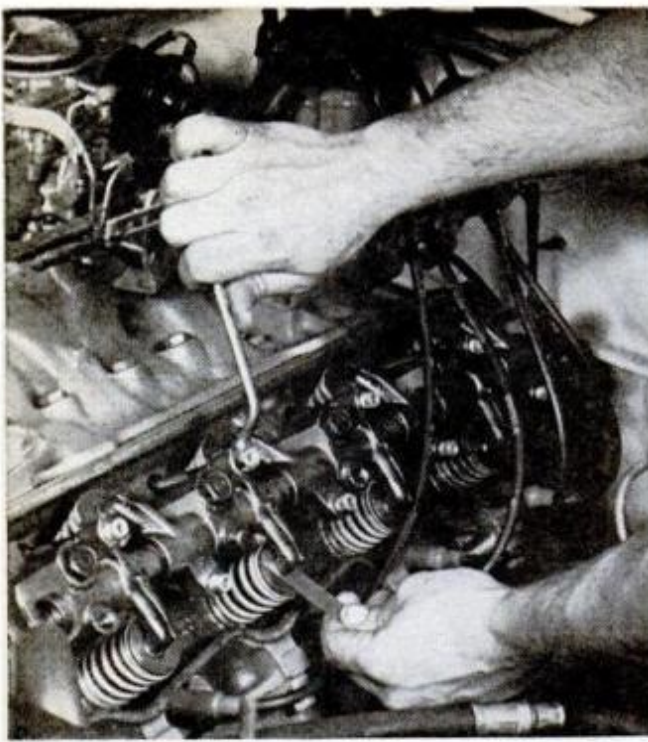

VALVE LASH of those cars with mechanical valve lifters should be checked periodically. So should the valve clearance of engines with hydraulic lifters

to pass. Start the pass well back of the car ahead to permit yourself a smooth swing out and in again.

- *Drive at moderate speeds.* Once the car shifts into driving gear, gas consumption increases as speed increases. Stay within posted speed limits; these are considered "moderate" as well as safe.

- *Don't brake unnecessarily.* Try to time traffic lights, for example, so you can keep rolling without stopping. You'll use more gas by stopping and starting again than if you can manage to coast to the light just as it turns green; then reapply a steady pressure on the gas pedal while you're still moving.

When you must stop, let your engine act as a brake. When approaching a stop sign, for instance, let up on the gas pedal at a sufficient distance from the sign to allow the engine to slow the car so only a minimum use of brakes is needed. This conserves not only gas, but also the brakes.

- *With a manual shift car, use your brakes instead of the clutch when waiting for a traffic light on an uphill grade.* "Riding" the clutch and revving the engine to keep from stalling wastes gas and increases clutch wear. Shift into neutral (or keep the clutch disengaged) and use the brake.

- *Never fill the gas tank to the top, especially in hot weather.* Gas expands as it heats up and may overflow a brimful tank. Always leave an air space of a few inches between the top of the gas and the top of the filler neck.

A car's not a greased rod moving through a vacuum. On the contrary, forces reacting against its forward motion act to hold it back. These forces (resistances) are both *natural* and *mechanical*.

In the first category are included such elemental forces as head winds, snow, mud—and hills (gravity).

A car's inherent mechanical resistances include the weight of the vehicle, friction generated by its movement through the air and the friction of the tires on the pavement.

Bucking all these resistances is engine go-power. A gas-efficient engine will overcome resistance by using a minimum amount of power. Just one mechanical flaw which reduces peak power means the engine must furnish just that much *more* power to overcome these forces. In generating this power the engine uses gas. So in your own attempts to increase gas mileage, bear the following two considerations in mind:

1. Reduce to a minimum those resistances over which you have control.
2. Maintain the car at peak mechanical efficiency so it can achieve maximum performance using minimum power.

Aim for peak efficiency

An important point in maintaining engine efficiency is to insure that no gas is lost by leakage because of a break in the sealed fuel system.

Tire pressure, too, is an important governing factor in fuel consumption. With less tire surface in contact with the road, less friction exists, thus less gas is consumed. This *doesn't* mean you should jam 45 pounds of air in your tires. However, slight overinflation—about five pounds over recommended pressure—is acceptable in most cases. *Underinflation* will substantially reduce tire life.

Wheels that are out of alignment are another cause of fuel-frittering friction. So is a hung-up brake that puts a drag on the wheels.

The mechanical failures that can rob your engine of power and cause it to waste gas are too numerous to discuss individually. We've done the next best thing by listing the most common causes in troubleshooting check-off charts on pages 185 and 186. If you discover your car is a gas-burner and are satisfied your driving habits are not at fault, spend a couple of Saturdays on the repairs and adjustments indicated on the check-off lists. The effort you put into this area of car maintenance now *may* pay off with a saving of \$100 to \$200 in gas and/or repairs over the next year's driving.

★★★

Make a Continuity Tester for Your Appliance Test Bench

WHEN AN APPLIANCE or motor quits, your first concern is whether it may be the cord, the switch or other part, and here's where a continuity tester lets you check out the path of electricity and finally pinpoint the trouble.

The tester shown at the right is made from a common two-prong rubber plug and a standard neon lamp which is pressed into the cord hole in the plug. Resistors are added to the neon lamp as a precaution against blowing a fuse should one of the probes be accidentally grounded.

In use, the tester is plugged into an AC outlet which causes the neon bulb to glow. The light stays on as long as the circuit is open and there is no continuity at the probes. When the light goes out, it shows that there is continuity.

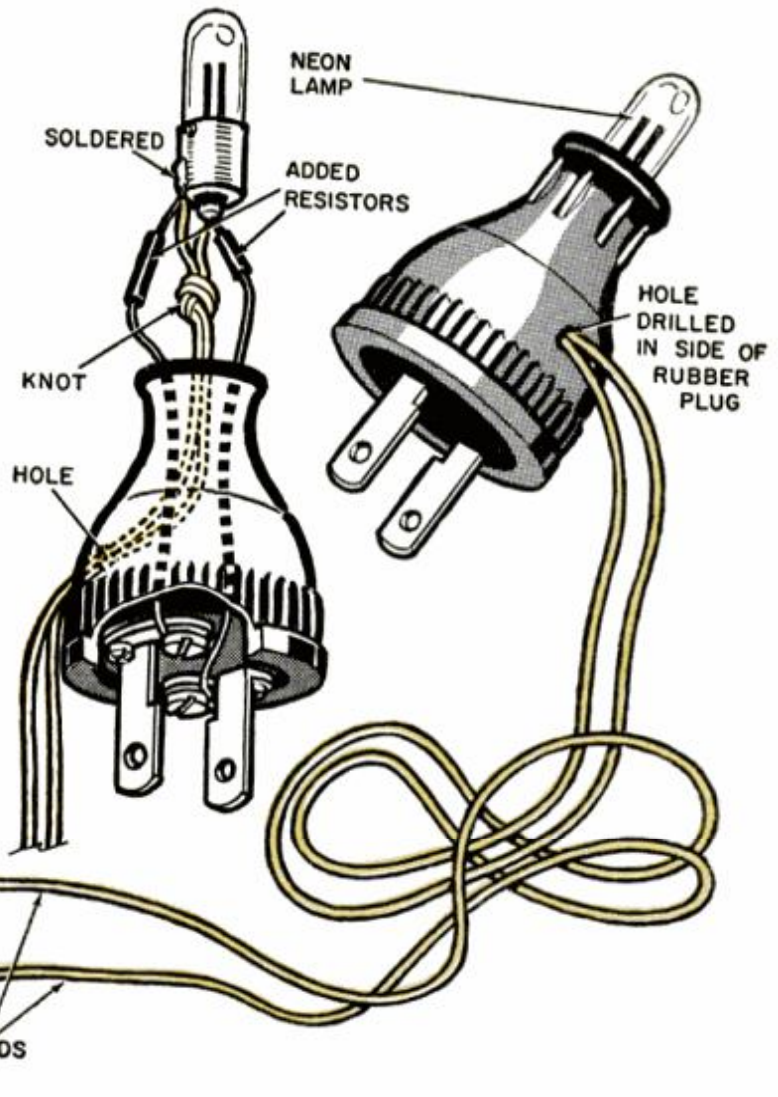

By Joseph Braunstein

This continuity tester differs from the one above in that it glows only when the electrical path is found broken, or interrupted. Both testers serve the same purpose but are simply made from different common electrical parts. This one is made from a plug-in neon night light which is taken apart and altered as indicated in the before-and-after wiring diagrams. Lamp-cord leads attached to the severed wire between the resistor and the neon lamp, are brought out through a hole made in the side of the plastic cover, after which the circular bottom is pressed back inside the cover and phone-tip probes are attached to the ends of the leads. You can obtain this particular night light at most any hardware or 5 and 10, but if you can't, you can order one for 39 cents from Signalite Co., Neptune, N. J.

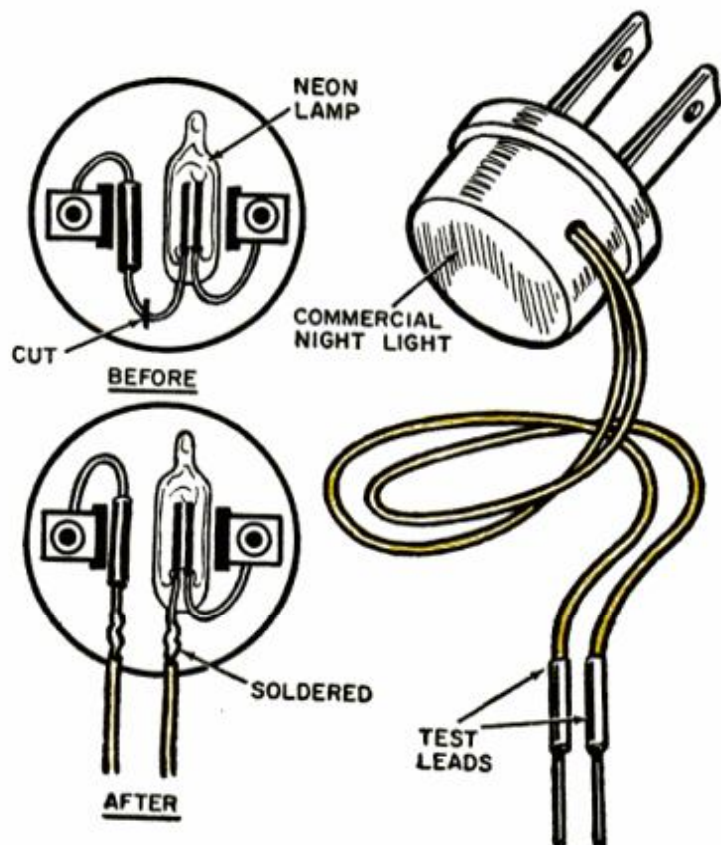

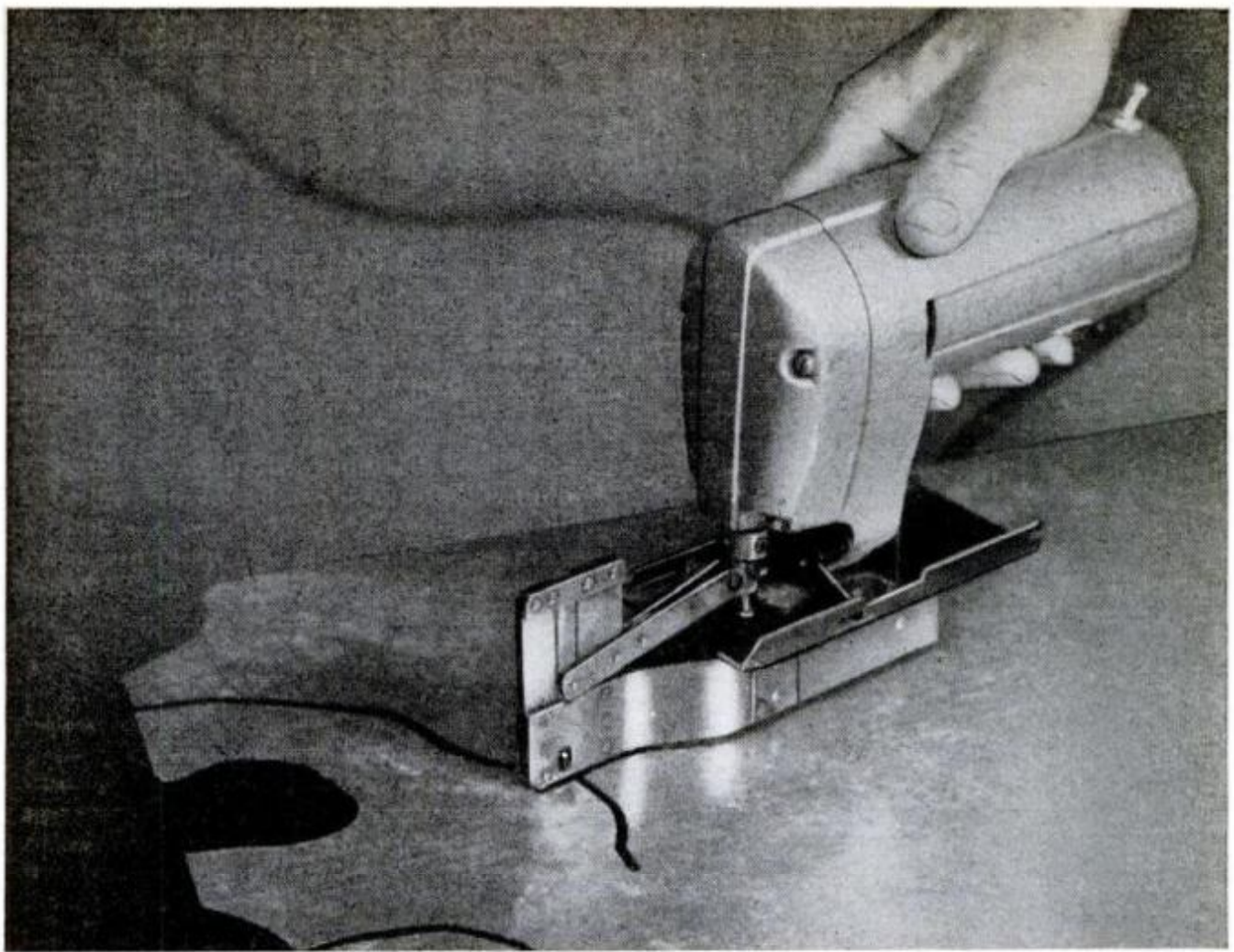

These shouldn't cost more than \$4 total. Such steel is accurately ground to size on all surfaces, which simplifies your work. You can get the wire for the two springs by unwinding larger springs, chosen for proper wire size from the assortment at your hardware store.

After cutting the two 6-in. pieces of $\frac{1}{16}$ -in. stock for the frame, lay out and centerpunch on one of them the locations of all rivet holes and the overlapping holes for the chip opening. Now clamp the two pieces tightly together to drill both at once. A little filing brings the chip opening to a smooth oval. Don't *bend* the sides yet—leave them flat. Though bends are indicated in the side-view sketch, far-left center, the dimensions given for these members are *before* bending.

Cut two cutter-bar guides from $\frac{1}{8}$ -in. steel and clamp the forward one to one frame side so that the factory-ground edges will be next to the bar, and at the bottom. Using the holes in the frame side as a template, drill the rivet holes through the guide. The rear edge of the guide covers half the chip opening, so scribe the opening outline on the guide and, after unclamping, arc out the excess with a round file—but be sure you don't file the $\frac{1}{16}$ -in. web at the bottom of the hole, as this forms one of your cutting edges.

Clean any oil from mating surfaces and rivet these three pieces solidly together. My rivets were nothing more than some 6d nails, pushed through the holes and snipped to the right length for "upsetting."

To form the cutter bar (from the same $\frac{1}{8}$ -in. die steel you used for the guides), study the sketches. Note there are two views: the left one has the piece turned enough to show perspective, while the right sketch is a straight-on edge view. The overall length of the blank is $3\frac{3}{4}$ in.—and if you cut it $\frac{9}{32}$ in. wide you'll have some leeway for filing the sawn edge smooth, and perfectly parallel with the factory-ground edge. The final width isn't critical as long as it is uniform from end to end within about .001 in.—not as difficult as it sounds, since as you file the cut side you check frequently with a hand micrometer after the saw-tooth marks disappear.

Slip the blank between the frame sides and snug it against the front guide. Place the rear guide tightly against the blank, drill the holes and rivet the guide in place. (For added rigidity, rivet a $\frac{1}{16}$ -in. strip across the tops as shown.) Remove the blank and slim it slightly by rubbing it lengthwise on a sheet of fine emery cloth laid on a flat surface. When you reinsert
[\(Please turn to page 200\)](#)

Metal Scriber from Pen

YOU CAN CONVERT that used-up ballpoint pen to a smart-looking pocket scriber having a retractable tungsten tip. Here's how:

Use a pen with a *metal*—not plastic—ink cartridge. Take the pen apart and remove the ballpoint with pliers. Then use a needle and heavy thread to clean ink from the cartridge. Crimp the shoulder of the cartridge to prevent the scriber—

a $\frac{3}{32}$ x $1\frac{3}{8}$ -in. length of tungsten—from slipping into the cartridge. Assemble the pen and check to see if the scriber retracts (you may have to grind it down). Disassemble the pen, remove the cartridge and dab some rubber cement into the cartridge neck. Re-insert the scriber and reassemble the pen. Crimp the neck of the cartridge as the point wears to maintain length of scriber.—*Mike Brenish*

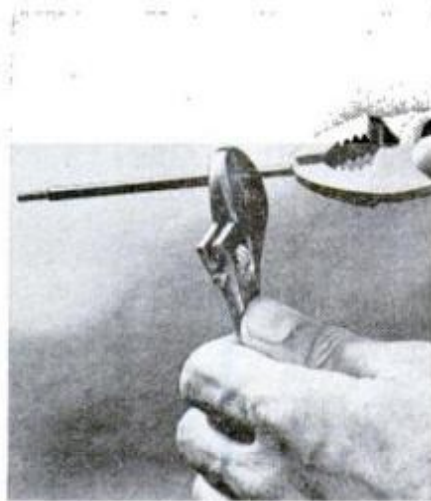
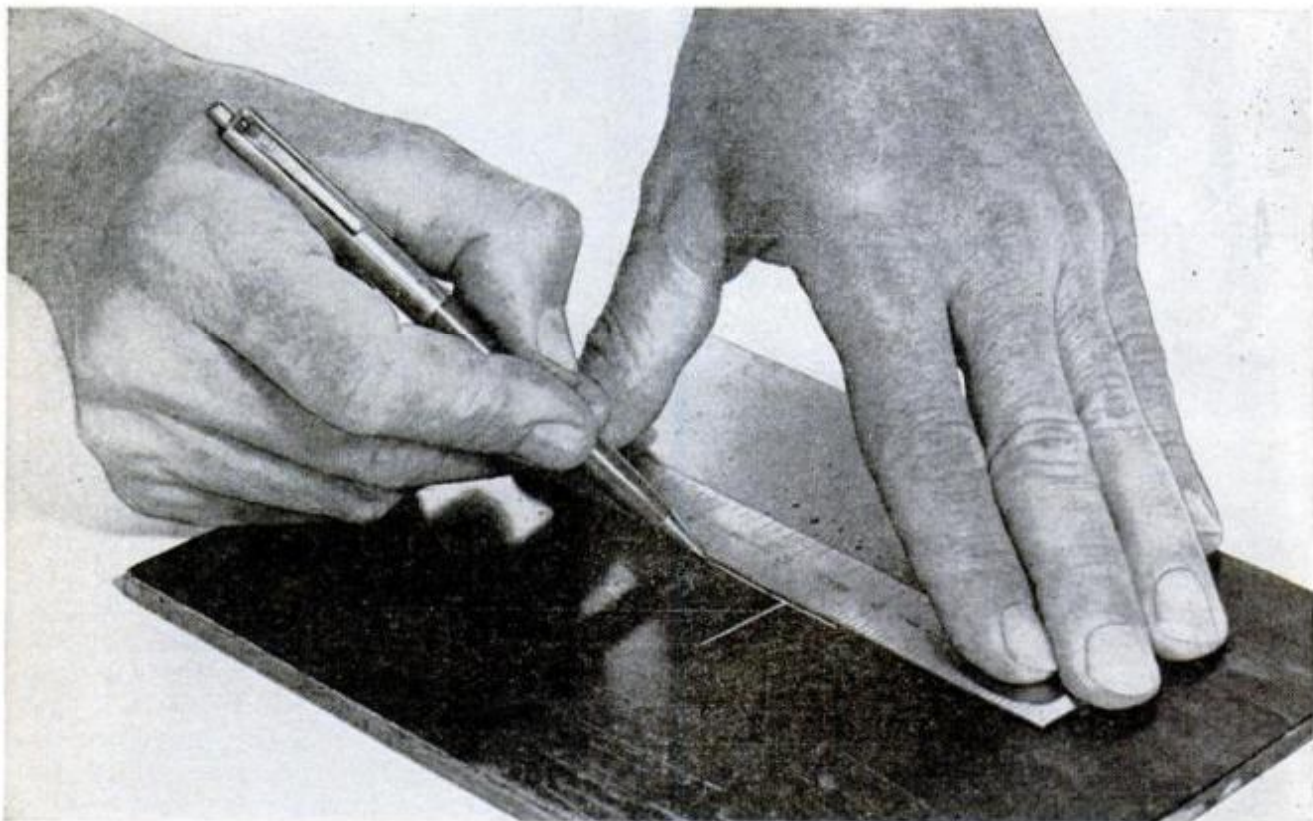

FIRST REMOVE METAL CARTRIDGE from ballpoint pen (left), and remove ballpoint with the aid of pliers and an adjustable wrench locked at the neck and shoulder of the cartridge. Next, obtain a $\frac{3}{32}$ x $1\frac{3}{8}$ -in. length of tungsten from a welding shop, grind a point on it, and insert the blunt end into the neck of the cartridge (center) after the latter has been dabbed with some rubber cement. Finally, enlarge the opening in the tip of the pen with a No. 17 drill bit (right) to accept the $\frac{3}{32}$ -in. dia. tungsten scriber

Pointing a Prick Punch

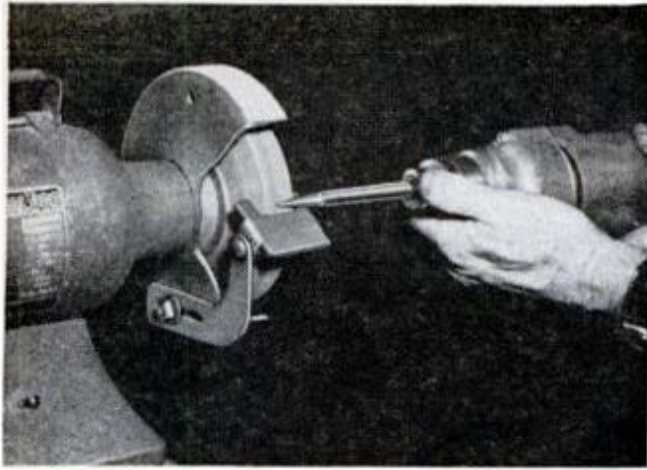

To put a new point on a prick punch, chuck it in a hand or power drill and hold the point against the grinding wheel at the desired angle. The double rotation of the drill and grinder speeds work and provides a perfect point.—*Wayne M. Judy*

Safety Spring for Chuck Key

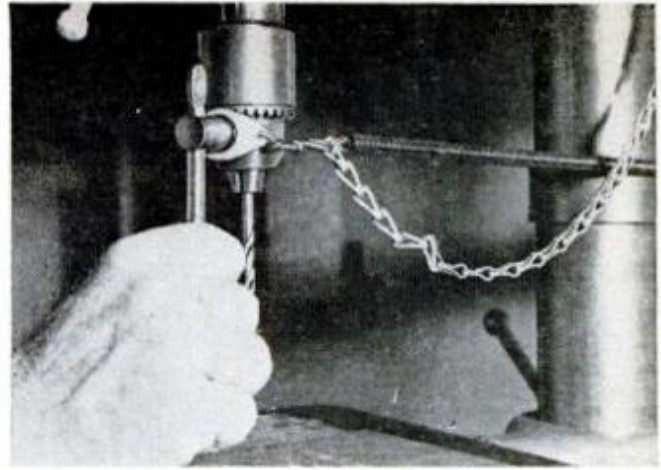

To avoid accidentally leaving your chuck key engaged when turning on the drill press, hang it from a length of screen-door spring. This will supply enough tension to pull it free after use. Hook the spring to a slip-fit yoke on the key.

Collet Spacer Sleeve

Work of nonstandard diameter can be made to fit any oversize collet by using a simple sleeve adapter. To make the split sleeve, turn and bore bar stock to the correct outside diameters to fit both work and collet. These diameters must be precisely concentric. Once all turning and boring is completed, split the sleeve with a hacksaw. Such sleeves work fine for turning out a limited run, and can prove to be lifesavers for precision second-operation lathe jobs.—*H. J. Gerber*

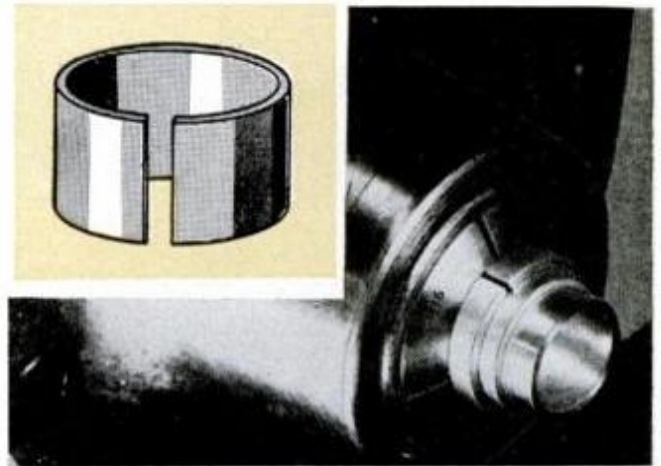

NEXT MONTH IN **SHOP** AND **CRAFTS**

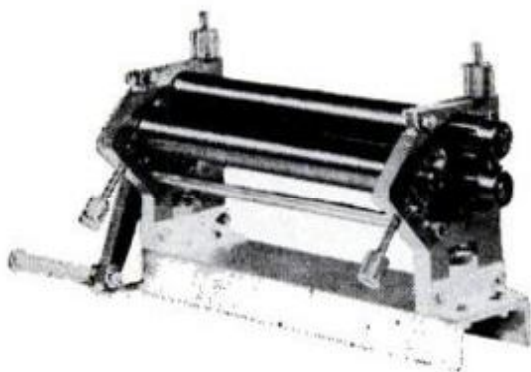

CARTS, CARTS, CARTS. Anything is handier if it's on wheels, so February's **PM** features a basic chassis that adapts to seven types of carts. It's a glamorous host cart with a built-in hot tray for tableside or party-buffet service. Alter the plans a bit and it's a bachelor's bar, instead. Or an equipment cart for cookout. Or three different outdoor work and storage counters: one for the Saturday Mechanic, one for pruning and potting, or one for yard sports

SHEET-METAL FORMER. You can turn out any cylindrical shape in your own workshop with the homemade slip-roll former shown at left. Great for custom tubing, drums or special parts. See the plans next month

WALL FASTENER GUIDE. Here's one you'll want to clip out and save—an easy-to-understand selector chart telling the perfect fastener for any hanging job, whether the wall is solid masonry or hollow-core. Complete in February

WIRELESS MIKE IN YOUR SHIRT POCKET

Microcircuits are the newest, hottest, tiniest

electronic devices around. Put

them to work for you in this

little license-free radio

transmitter. Use one of the

newest circuits and get four

transistors and associated re-

sistors in a package the size of an

ordinary transistor case. While you're

at it, try some experiments of your own

By John Potter Shields



TINY TRANSMITTER nestles in the palm of your hand. When not being used it is small enough to tuck away in any convenient pocket. Use of new microcircuit cuts down on the amount of wiring and reduces chances of error

A **TINY POCKET BROADCASTER** is a heap of fun and has a practical side, too. Use it for short-distance transmissions to a nearby standard AM radio receiver. Use it at parties to show your friends what they might sound like running through a soap commercial. Use it with a nearby portable radio and you have a public address system.

This wireless mike is built around a miniature microcircuit—a complete electronic circuit in a single-transistor case. To build the transmitter we have used four of the transistors in the unit and several resistors.

To assemble your own unit you'll need a 3 x 5-inch piece of perforated phenolic

board as a chassis. Use small brass eyelets or flea clips as tie points. The microcircuit is connected into the circuit through a special plug-in, 10-contact socket.

The antenna coil is fastened to the board by winding several turns of bare hookup wire (No. 20) around the metal end of the coil. Secure the wire with solder, pass the two ends through eyelets in the chassis board and solder in place.

After mounting all parts on the board and doublechecking the wiring, cement the chassis inside a plastic case. Depending on how carefully and compactly you build, you will be able to use a case that is 3 x 5 x 1 in. or smaller.

Since the unit draws little current, the

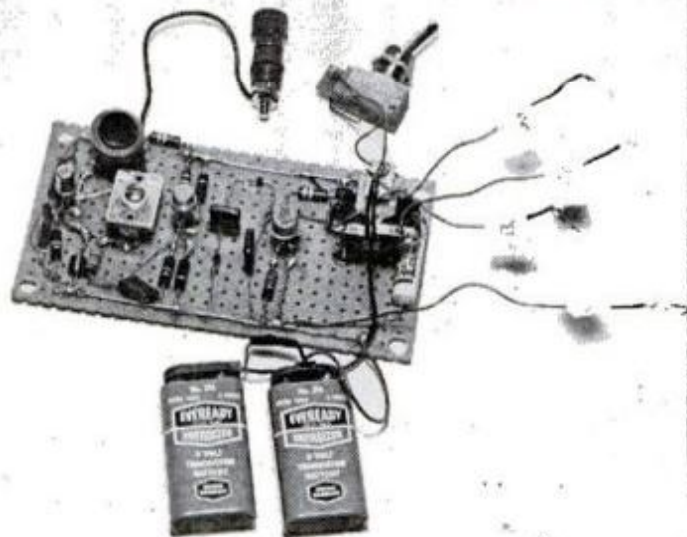
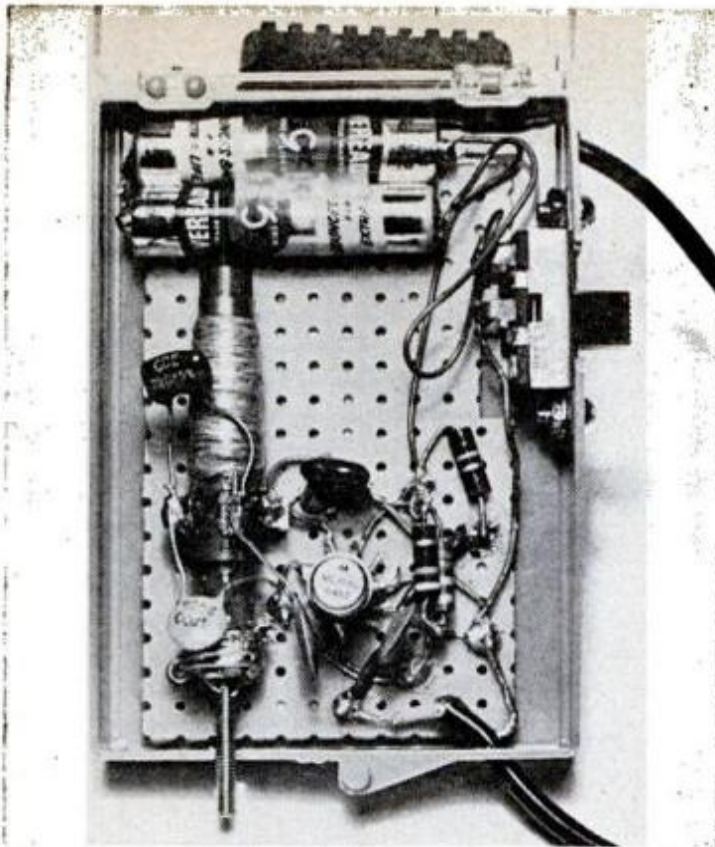

READY-TO-OPERATE UNIT is at top. Just close the lid of the case and you're ready to operate. Lower photo shows wired phenolic chassis ready to mount in case

two penlight cells that power it are cemented to the case. Use a contact cement so you can pry them loose for replacement when necessary.

To reduce the size of unit to a minimum you can use smaller batteries and a smaller antenna coil. This will take some experimenting on the builder's part, but can pay off with a matchbox-like transmitter.

After completing the unit you are ready to put it on the air. Place the wireless mike close to an AM radio and switch both sets on. Adjust the antenna coil on the transmitter so the tuning slug is about midrange. Now tune the radio through the lower end of the broadcast band (550-900

[\(Please turn to page 212\)](#)

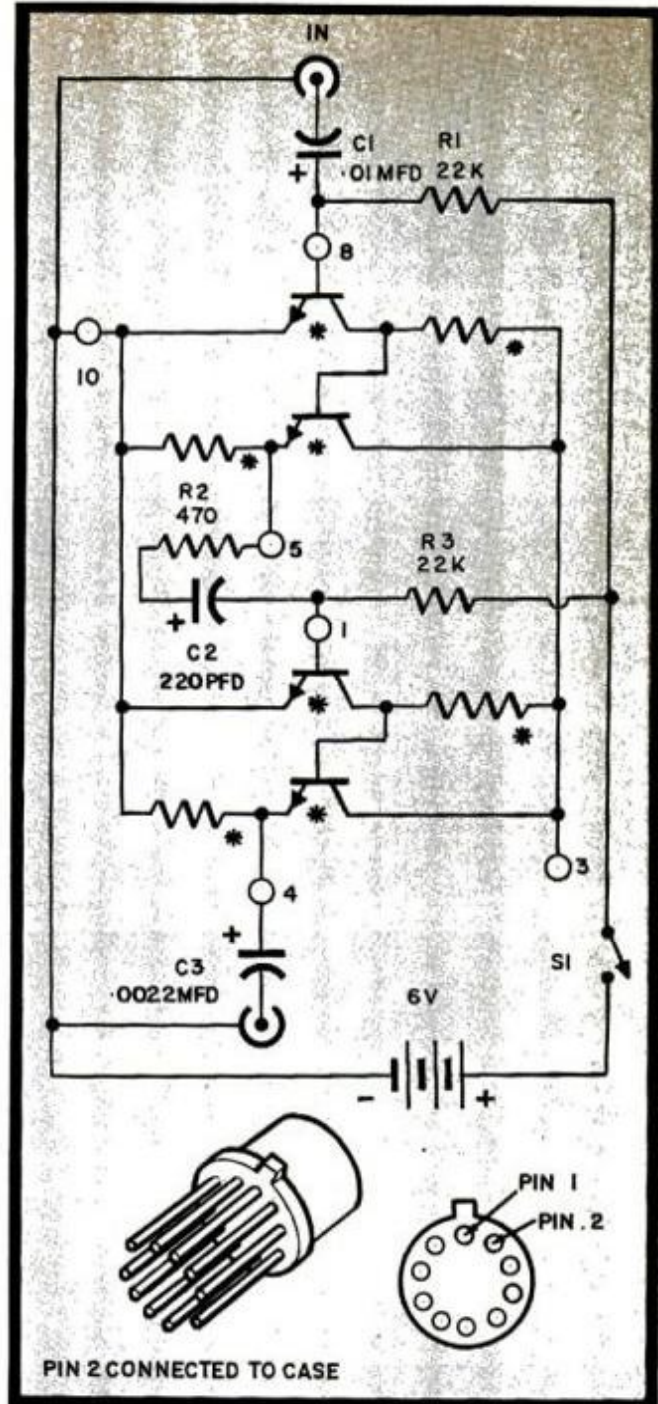

FOUR TRANSISTORS make the mike work. Numbers by circles in the circuit indicate terminal pins of the microcircuit. Check against pin layout diagram

PARTS LIST

Resistors

R1—22,000 ohms, 1/2-watt carbon

R2—470 ohms, 1/2-watt carbon

R3—22,000 ohms, 1/2-watt carbon

Capacitors

C1—.01 mfd disc ceramic

C2—220 pfd mica

C3—.0022 mfd disc ceramic

Miscellaneous

Microcircuit—Motorola MC-306

Microcircuit socket—Cinch 10-1C3

L1—Antenna coil (Olson L-73 or equiv.)

S1—s.p.s.t. slide switch

Battery—2 penlight cells (size AA)

Crystal microphone

Contact cement

Phenolic perforated board (3 x 5 in.)

Flea clips or brass eyelets

Plastic case, 3 x 5 x 1 in. (smaller if you use a smaller chassis)

Private ear for silent tv viewing

Wireless pickup brings TV or phono sound to your ears through an individual receiver without disturbing the rest of your family.

By Steven Hahn

SOONER OR LATER we all need a private wireless communications system for baby-sitting, paging people, listening to music while doing housework, or listening to the fights while Junior has to do his homework in the next room. Here's a little unit that can solve all of these problems, yet costs about \$3 per receiver.

The principle is audio induction. Any audio amplifier with a power output of 10 watts or more will serve as a transmitter. The antenna is a loop of wire strung around the area in which the receiver will be located. The receiver is an induction-type telephone pickup coil connected directly to a sensitive crystal earphone.

To get the best possible results from this system the amplifier output impedance must be matched to the antenna impedance. The antenna is strung around the area to be covered and can be nailed to the molding or placed under the rug. It is



made of ordinary single-conductor insulated wire. Since the impedance of such an antenna is the same as its electrical resistance use a length of wire that gives a match to the output transformer on your amplifier. If you check the table you will note that resistances are listed for several sizes of wire. For example, if you use 100 ft. of No. 10 wire, the total resistance is 2.7 ohms, a reasonable match to a 4-ohm transformer output.

If you find the wire you use does not match the transformer too well, you can still get proper matching with an inexpensive public address matching transformer.

With the 10-watt amplifier you can cover an area of about 20 x 40 ft. To cover larger areas, you'll need more power. Several possible loop arrangements are shown in the diagrams.

The receiver is a cinch. It uses no transistors or tubes, has no batteries and never

wears out. Solder and tape both leads.

In operation, the loop is connected to the amplifier and the amplifier turned on. The telephone pickup coil is carried so it sits vertically—in a man's shirt pocket. Amplifier volume is turned up until the signal can be heard in the receiver throughout the entire area to be covered.

The audio amplifier can be driven by a microphone, record player, radio or television set and has a thousand and one uses in every home. ★★★

RESISTANCE OF SINGLE-CONDUCTOR WIRE

Gauge	Resistance Per Foot (Ohms)
10	.0278
12	.0442
14	.0703
16	0.112
18	0.178
20	0.283
22	0.449
24	0.715

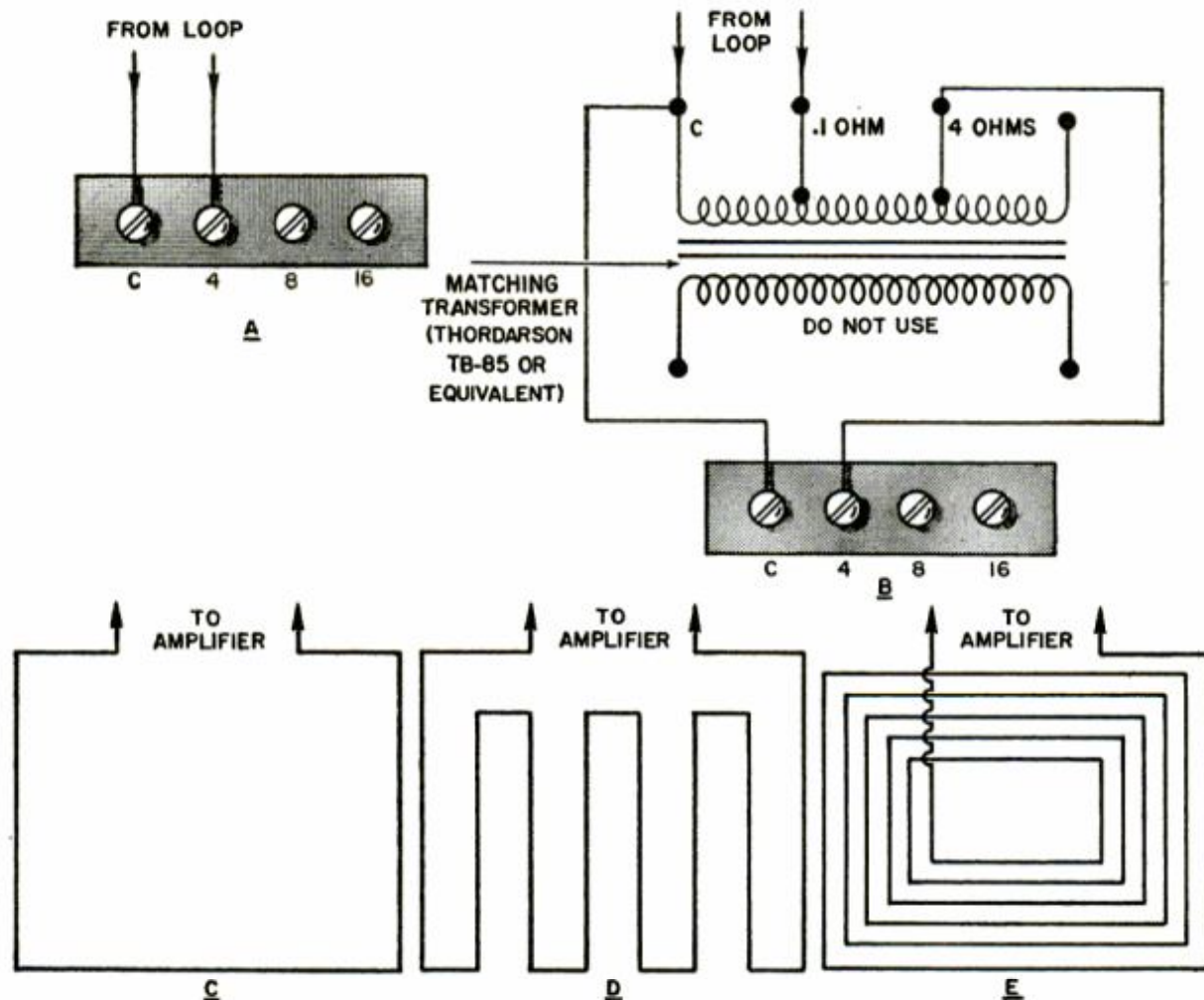

WIRING HOOKUPS for your private ear. Here's how to connect a loop to the 4-ohm output of your amplifier (a). If you don't have a 4-ohm loop you can use a matching transformer (b) to make a proper hookup. You can also wind a single loop (c) around the room or use an in-and-out loop (d). Best coverage of all is a spiral loop (e); obviously, an excellent arrangement to use under a rug

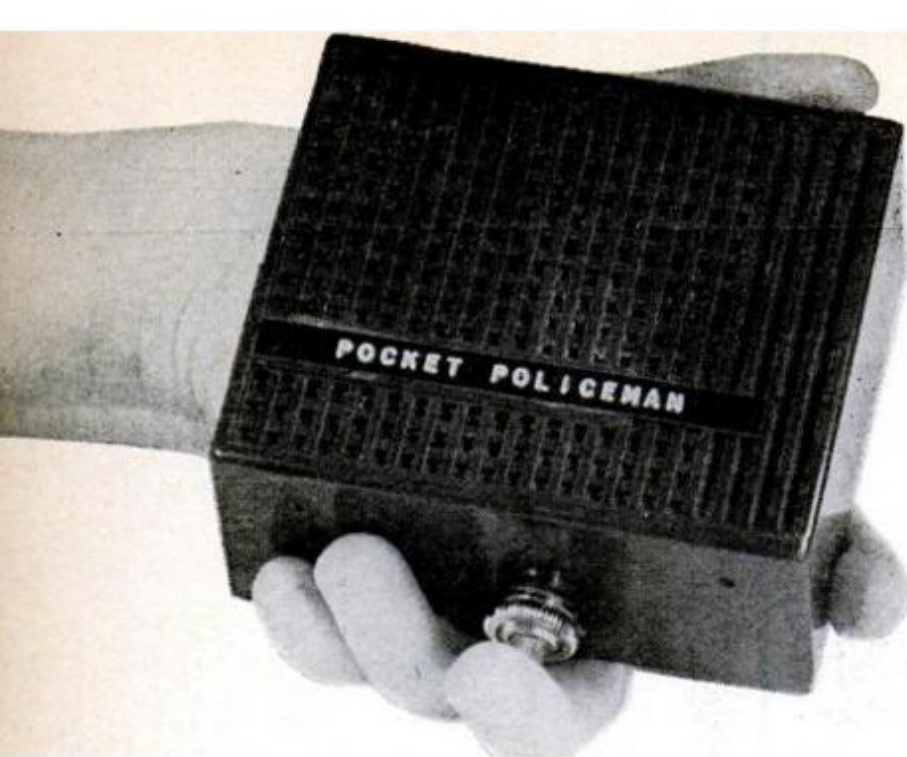

HAND-SIZE ALARM slips easily into pocket or purse. Pushbutton switch turns on its reassuring warble when you're in trouble

Pocket Policeman

Traveling deserted streets at night? Take this pocket alarm siren along. It offers an added measure of protection that will cost you less than \$10

FORCED TO WORK LATE? Must you travel sparsely settled areas at night? Let the Pocket Policeman help you. Its warbling alarm can deter the would-be assailant long enough for you to reach safety or arouse the attention of others.

Basically, the unit is a pocket-size alarm which simulates a police car siren. Two pushbutton switches control it. One turns the alarm on and off. The other varies the pitch of the alarm to give it a warble similar to that of a police siren.

If you need more volume than the unit

delivers, use a larger speaker. But keep in mind that this will reduce battery life. There are a minimum of parts and assembly should be no problem. Just follow the wiring diagram. Above all, make certain that the battery is wired correctly before turning the unit on.—*William S. Gohl*

PARTS LIST

- Cordover siren module SM-1
- Penlight cells, 2, 3 or 4
- Miniature speaker, 8-ohm
- Pushbutton switch, momentary contact
- Pushbutton switch, snap-action
- Case to suit, miscellaneous hardware

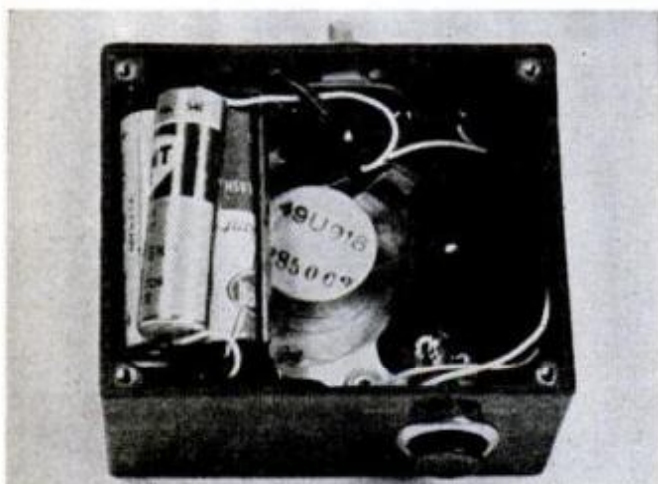

HEART OF THE ALARM is the electronic circuitry which is revealed when the case back is removed. Small components make the pocket-size unit feasible

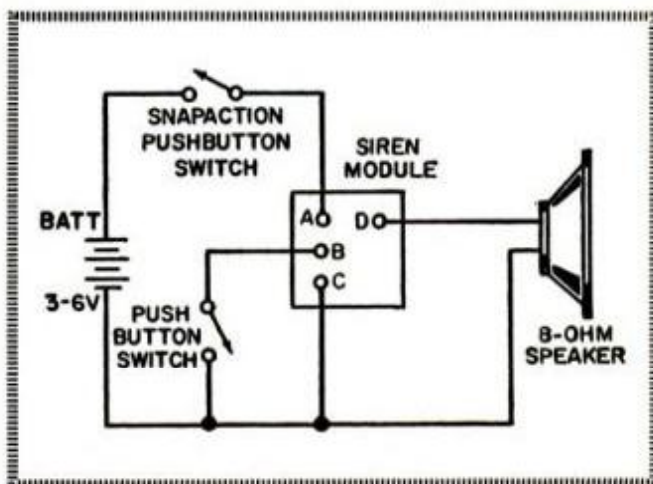

SIMPLE CIRCUIT makes alarm easy to assemble. Besides the semiconductor module there is only a speaker, two pushbutton switches and batteries to hook up

DISSTON

"Diss-Chrome" Circular Saw Blades have an edge on them all



"Diss-Chrome"® circular saw blades make any home workshop project easier. Cuts are cleaner and faster; work goes together neater.

There is a Disston "Diss-Chrome" blade style for any kind of cut—rip, cut-off, combination, planer, flooring and a special plywood blade. All popular sizes available with universal arbors for use with most bench or portable saws. Each

blade is hardened, tempered and chrome-plated to provide extra long life. Blades are individually packaged.

Add to your ability with Disston "Diss-Chrome" blades. Your hardware dealer stocks them and will help you select the right blade for your job. Or write: Hardware and Industrial Products Division, H. K. Porter Company, Inc., Porter Building, Pittsburgh, Pa. 15219.

Look for this new Disston Saw Blade Center at your dealers. It contains a full line of Disston quality circular saw blades, hack frames and blades. If your dealer doesn't have the blade center, ask him to order one for your convenience.



**HARDWARE AND INDUSTRIAL
PRODUCTS DIVISION
H. K. PORTER COMPANY, INC.**



(Continued from page 191)

it between the guides, there should be no bind. Now, in the factory-ground edge, carefully file the cutting notch, finishing the bottom edge with a triangular pattern-maker's file so that it slants slightly downward toward the rear and diagonally across the front. The side relief-tapers let the bar turn slightly in the kerf for curve cuts.

To form the stud that supports the stripper and its spring, trim the bottom inch of the blank down to $\frac{1}{8}$ -in. square, then file it round and thread the lower half. Bend the stripper by hammering a $\frac{1}{4}$ -in. strip of 18-ga. (.050 in.) steel around $\frac{1}{8}$ -in. die steel, and cutting to finished length.

The stripper spring must be very stiff. Make it by winding 11 turns of No. 18 spring wire (about .047 in. dia.) around the shank of a $\frac{1}{8}$ -in. drill. Try this: Clamp the drill in a vise with the starting end of the wire clamped in one of the flutes. After winding, grind both ends square. The finished spring should stand $\frac{3}{4}$ in. tall.

Drill your saw base

Now check the guide plate of your saw for spots to drill and tap holes for the machine screws that fasten the nibbler to the saw. Bend the frame sides to take advantage of these spots, rivet fastening brackets in place, then use them as marking templates for drilling the guide plate.

To make the operating lever, clamp the two sidepieces together and drill all holes through both at once. Rivet in the steel block (which is drilled and tapped for the adjusting screw) then bend the sides as shown. Cut two steel pins—one to form the lever's fulcrum, the other to attach the lever to the cutter bar—from the shank of a $\frac{7}{64}$ -in. drill. These should be long enough to protrude slightly on each side.

The rub plate provides a sliding surface on the saw chuck for the end of the lever. If you file a $\frac{1}{16}$ -in.-wide groove about halfway through the plate, you can make a stronger, simpler silver-solder joint.

The final step is to locate the hole in the cutter bar for the pin that joins it to the lever. This dimension is not given in our plans sketch since it can only be determined by trial assembly, as follows: Attach the lever (with its return spring) to the rear guide. The adjusting screw should project about five threads above the top of the lever. After a few tries, you'll be able to stop the saw with the ram at the exact top of its stroke. When the ram is in this position, the cutter bar should be at the bottom of its travel, with

the cutting edge $\frac{7}{16}$ in. below the bottom of the front guide. Slide it to this position and mark the location on the cutter bar through the hole in one side of the lever. After drilling the $\frac{7}{64}$ -in. hole squarely through the bar, widen it slightly with a small rat-tail file until, with the pin in place, there's no binding when the lever is operated by hand through its full travel. You can now test the cutter on cardboard or thin aluminum, but don't cut any hard metal until the cutting edges have been hardened and tempered. To accomplish this, just follow the directions supplied with the die steel. Normally, the procedure is this: Heat the area around the chip opening to a dull cherry red (1450-1500° F.) and quench in oil (plain SAE 20 or 30 is fine). Treat the lower part of the bar the same way, and temper by placing all treated parts in a kitchen oven heated to 550° F. for an hour.

Reassemble, and peen the lever pins lightly on both ends—just enough to keep them from working out. Oil the sliding surfaces and lever pins. Slip the stripper and spring on the stud and compress the spring with a nut until it's not quite solid when the ram has pushed the lever all the way down. (Tighten any more than this and you risk breakage: the motor exerts tremendous leverage on the cutter bar.)

Coddling Encouraged

Tender, loving care—and plenty of it—is one of the surest preventives of mental retardation in children. Dr. Reginald S. Lourie reported, during a recent three-day seminar on mental retardation in Washington, D.C., that 75 percent of all mentally retarded cases are caused by sensory deprivation resulting from lack of human attention during infancy. The theory is that the infant mind simply does not develop enough brain cells if it is left alone to organize sensations by itself.

Ancient Apeman Skull

A fossil skull unearthed by Chinese scientists has been declared the most ancient human of the apeman type so far discovered in the world. The well-preserved skull, found at Kungwangling, Lantien county in the Shensi province of China, belonged to a 30-year-old female who lived about 500,000 to 600,000 years ago.

Striking differences indicate its age. It is broader; has a frontal crest and an anterior nasal spine. It has a thicker cranial wall than other skulls found in China and Java and has a cranial capacity smaller than that of the Peking man and about equal to that of the most primitive type of Java man.

**Whatever the size of your job...
powerful parallel jaw grip
and tremendous leverage**

...yours with

CHANNELLOCK®

**the ORIGINAL
tongue and groove pliers**

The most versatile pliers ever made . . . so say hundreds of thousands of men who every year buy and use CHANNELLOCK, the *original* tongue and groove pliers. Try one, buy one and you'll agree that here is the all 'round handiest tool of them all. Be sure it's a *genuine* CHANNELLOCK . . . look for the trade mark on the handle and for the exclusive patented features shown above.

1. Patented Reinforcing Rib for ADDED STRENGTH WHERE YOU NEED IT!

2 1/2"

2. Patented Undercut Channels...SMOOTH-WORKING, CAN'T SLIP UNDER ANY LOAD!

7/8"

1/2"

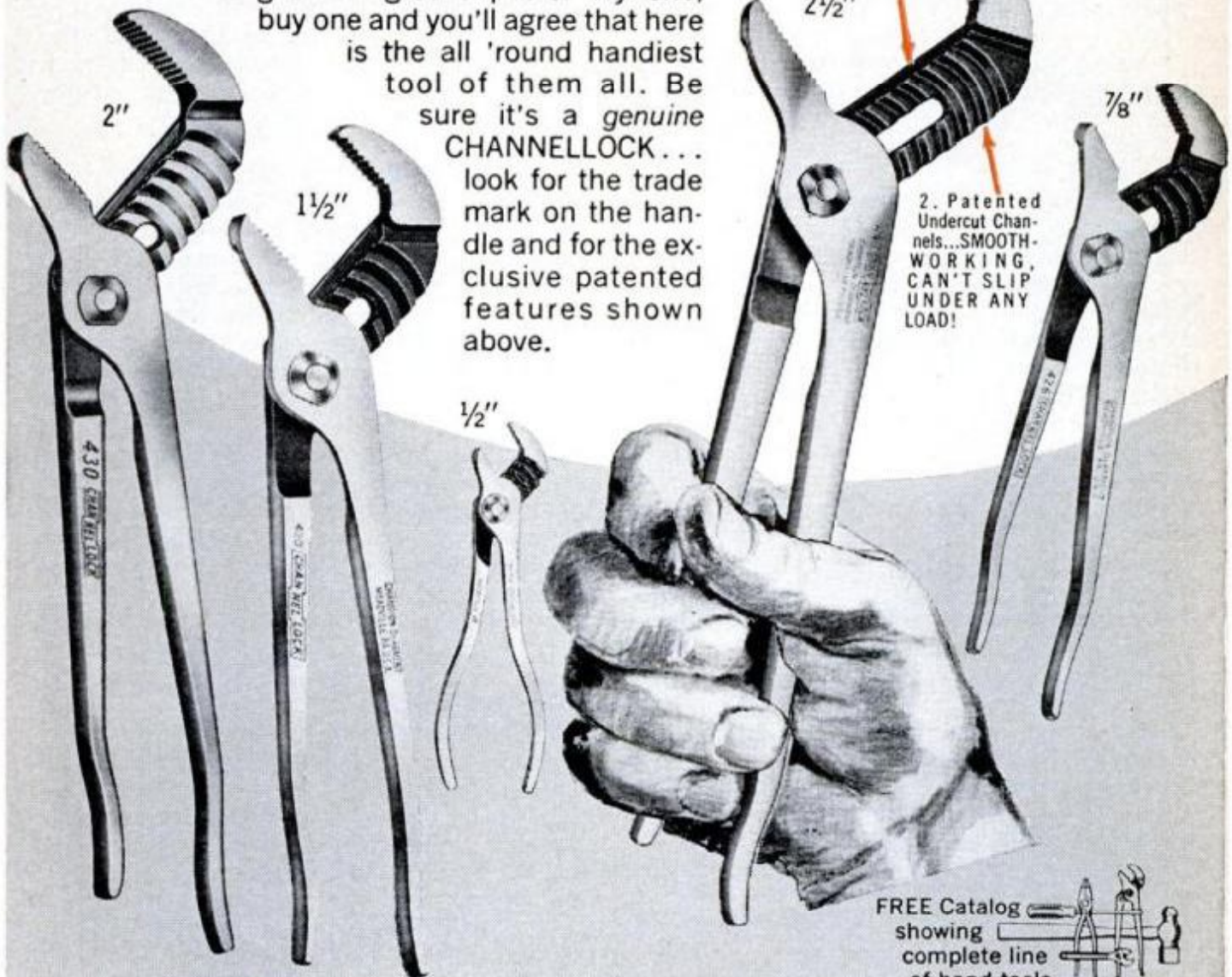

CHANNELLOCK, INC. Meadville, Pennsylvania
Formerly Champion DeArment Tool Co.

FREE Catalog showing complete line of hand tools . . . yours for the asking.

in the area where, later, you'll cut out the 17½-in.-long slot for the daggerboard.

Planking. A half bottom, side, half fore-deck and a side deck can be cut from each 4 x 10-ft. sheet of ¼-in. plywood. Clamp a plywood sheet to one side of the frame bottom and mark the bottom outline on the underside. Then remove the sheet and cut the half bottom slightly oversize; reclamp side pattern adjacent to side and mark side pattern adjacent to curve of bottom shape. Cut the side slightly oversize and lay scraps away to be used later for decking.

Now reclamp the side planking in place and mark it accurately, allowing just enough extra material for fairing. Also, mark the outlines of the chine, clamp and frame on the underside.

Remove the plywood, cut it to shape and drill small lead holes at intersections of frames with chines and clamps. These holes will provide a guide for driving planking screws. Coat the outside surfaces of the frame and the outlined areas of the plywood with glue. Place the planking in position and screwfasten it. Countersink the screws slightly so that surfacing compound can be used to hide screwheads. Clean off excess glue with a damp cloth.

When the glue has set, plane the plywood edge flush with the chine and attach the bottom planking, using the same procedure as you did with the sides. Be careful to stagger screws near the daggerboard slot so that they won't interfere with holes that will later be drilled for bedlog bolts. (This can be done by marking bolt positions on the lower keel prior to planking.) Trim off the edge of the plywood bottom so that it's flush with the side planking along the chine, and cover the joint with a ¼-in. x 1-in. rub rail to protect the plywood edge.

Carlins, beams and battens. Remove all screws holding the boat to the building form and lift the boat off. Turn the hull over and block it so that the hull is supported under frames 2 and 3.

Cut the seat support beam from 1 x 2 stock and position it on the after side of frame 3, just above the plywood gussets. Glue and screw it in place. The temporary crosspieces can now be removed from frames 2 and 3.

Cut the deck beam to length from 1 x 8 lumber and clamp it in position on the forward side of frame 2. Mark the shape of the deck beam, from full width of beam at center down to clamp top on each side. Also

off. Remove the deck beam and position the carlins, using frame 2 and transom top to locate them. Glue and screwfasten the carlins, using spacer blocks to keep them spaced equally from the clamp strip. Now saw off frame 3 extensions flush with the carlin and clamp.

Shape the deck beam, position it on frame 2 and secure it with glue and screws. Cut side-deck supports from ¾-in. scrap and fit under the spacer block. These supports will add stiffness to the planking and help the side decks support your weight if you have to hike out in heavy winds.

Notch the deck beam and stem frame for the 1 x 4 center deck batten. Glue and screw an 18-in. strip of 2 x 2 under the center deck batten below the mast step position. Then, run the 1 x 2 braces from this step support down to the stem knee and fasten in place. Also, fit the small knee under the center batten at stem.

Now fair the entire top of the boat, from stem to stern. Use a straight piece of wood to check the accuracy of your fairing between the clamp and deck batten, and between the clamp and carlin. Notch the deck beam and stem frame to accept 1 x 2 side deck battens, and glue and screwfasten these battens in place.

Daggerboard case. The daggerboard slot is ½ in. wide by 17½ in. long. Lay the slot out with pencil, centered on the keel 16 in. forward of frame 3. Use a ½-in. drill to make starter holes at each end of the slot, keeping the holes inside the overall slot dimensions. Then saw out the slot, using a small keyhole saw for starting and squaring the ends of the slot with a wood rasp.

Make the daggerboard case bedlogs from clear fir lumber, 1⅝ in. thick. Note that the ends are slightly angled. Clamp the log together in right and left-hand position and shape the bottoms of both bedlogs simultaneously to fit the keel. Then unclamp the logs and, keeping track of right and left log, cut a ⅜-in. x 1-in. rabbet along the top inside surface to accept the ⅜-in. side panels.

Drill bolt holes near the outside edge so that bolt heads will clear the lower keel when the case is installed. Since these holes should be drilled to countersink washers and nuts, first drill a small pilot hole, then drill the countersink hole for the washer and nut deep enough so that the nut will fit securely on bolt. Complete the hole with a ¼-in. drill.

Cut the side panels from ⅜-in. plywood and fasten them in the rabbets cut in the

[\(Please turn to page 204\)](#)



**60
SECOND
BONDING**

**No clamping
No cleanup**

new THERMOGRIP[®] electric glue gun

Fastest and easiest gluing method ever developed. Hot-melts solid glue. Bonds wood, pottery, leather, plastics, fabrics, practically any material—in 60 seconds. With glue sticks—plus white sealer sticks for all-purpose, instant-set, waterproof caulking.

\$7⁹⁵
list



So easy to use. Just insert Thermogrip glue sticks in rear of electric glue gun.



Push glue stick with thumb. Melted glue flows through tip. Apply glue to surface.



Press the glued surfaces together. In 60 seconds there's a permanent bond.

Use the Thermogrip Electric Glue Gun for hundreds of making, mending and caulking jobs.



See the Thermogrip Electric Glue Gun demonstrated at your hardware dealer.



B. B. CHEMICAL DIVISION

United Shoe Machinery Corporation

CAMBRIDGE, MASSACHUSETTS 02139

bedlogs with screws and glue, carefully avoiding the bolt holes in the log. Glue and screwfasten the end posts to one case side, and give inside surfaces of the case two or three good coats of spar varnish, avoiding surfaces yet to be glued. When the varnish has dried, glue and screwfasten the case together, keeping the bottom surfaces of the bedlogs level.

Carefully cut away approximately 1½ in. from each end post so that the posts will fit snugly into the daggerboard slot. Fit the cap supports between the seat beam and deck beam (but don't fasten them in position) and mark the top of the daggerboard case, which should be sawn off flush with the top of these cap supports.

With the daggerboard case still in position, mark the location of the bolt holes on the keel by tapping on a ¼-in. rod placed in the bedlog holes. Then remove the centerboard case and drill small pilot holes, carefully centered on the bolt-hole marks.

With these holes as your guides, use a underside of the planking for seating the bolt heads; then complete the holes with ¼-in. drill.

Saw off the top of the centerboard case as marked. Give all contacting surfaces, holes and bolt heads a good coating of waterproof glue, then place the centerboard case in position, drive the bolts in from underside and tighten up evenly all around. Clean off excess glue with a damp cloth.

Deck and cockpit. Now the cap supports can be glued and screwfastened in place on each side of the centerboard case. Use small blocks of wood of the same thickness as the case to space the supports at the seat beam and deck beam.

Cut the seat, notching the after edge of the ends to fit inside frame 3. Make seat knees from scraps of ⅜-in. plywood and fasten to the frame sides. Cut the daggerboard case cap to length so that it makes a snug fit between the deck beam and seat.

Locate and cut a ½-in. x 15½ in. slot above the opening in the daggerboard case. (If you would like to be able to remove the seat and cap, fasten them in place with No. 8 x 2-in. flathead wood screws set in finishing washers.)

Center the ¾-in. x 1¾-in. foredeck trim over the center deck batten, and glue and clamp it. This piece should extend forward of the stem and aft of the deck beam. Cut a small piece of ¾-in. x 1¾-in. material to fit between the cap and center deck trim.

The extended deck trim is cut on flush with this inside trim. Attach the ¾-in. x 1¾-in. stem trim so that it fits under the top deck trim and down over the lower keel. Then cut the top deck trim to match.

From ¼-in. plywood left over from the bottom and sides, cut two foredeck halves and two pieces of side decking. Glue and screwfasten these in place. Trim all around, and install half round molding all around the deck and inside the cockpit. (Molding can be made by ripping 1¼-in. dowel in half.) Glue and screwfasten this in place, and the hull is then ready for application of the finish.

You can assemble the remainder of the sailing equipment while you are waiting for the paint to dry on the hull. The rudder is made by gluing two pieces of ⅜-in. plywood back to back. Chamfer the edges and then apply several coats of spar varnish.

Do not drill a hole for the bolt that fastens the rudder to the tiller until you are ready to assemble the rudder on the transom. This hole is then located so that the tiller stop will positively prevent the tiller from rubbing against the top of the transom.

Cut the daggerboard from ⅜-in. plywood and place it in position in its slot to mark the top edge. Trim the top of the daggerboard with ¾-in. x 1½-in. strips, and drill a 1-in. hole for a finger grip. Smooth the edges and apply several coats of spar varnish.

Floorboards should be made so that they can be readily removed from the boat. The floor assembly shown on page 148 consists of three 1 x 4s fastened together with crosspieces. The floorboards can rest on strips fastened to frames 2 and 3. Small holding strips fastened to the frames above the floorboards with bolts and wingnuts will keep the floorboards in place.

Sailplan. The sailplan chosen for *Teacup* keeps costs to a minimum. A sail that fastens to the mast in a luff rope slot eliminates the expense of sail track; a loosefooted sail simplifies boom construction.

Since there are many small dinghy-class sailboats with sails of about 50 sq. ft., there seemed to be no point in designing an original sail if an existing design could be used. Furthermore, there are often good used sails available that can serve very satisfactorily on a training boat. A good used Dyer Dhow sail was found to satisfy the author's requirements completely, and the *Teacup's* sail plan was established. The only alteration required on the used sail was the removal of two grommets along the lower edge of the luff.

The holes were patched with sail tape. Thus, for \$30, the *Teacup* had a top quality dacron sail with many years of sailing life left.

If you decide to go the used-sail route, contact used-sail suppliers before you build the mast and boom so that you can alter the spars if you can't obtain a sail to these exact dimensions.

If you decide to buy a new sail, have a sailmaker make the sail to the Dyer Dhow specifications, but without luff grommets. (The author's sail was originally made by the firm of Ratsey & Lapthorn, Inc., City Island, N.Y.)

Mast material. Search through your lumber dealer's stock of 4-in. straight-grained fir flooring for two extra-straight pieces. After trimming away the tongue and groove, you'll have about 3 in. left. Cut 1/2-in. half-round grooves in each piece by running the board through the saw at an angle to the saw blade (use a tenoning blade if you have one). Remove about 1/16-in. of material from the groove to the edge to provide the 1/8-in. slot for the sail when the pieces are assembled. Cut a small glue-stop groove in each piece. Then sand and varnish the groove and slot, and glue the mast pieces together, being careful to keep the grooves aligned.

The mast can be rough-shaped on a bench saw and finished with a plane or belt sander. When you attain the smoothness, give it several coats of spar varnish, then attach fittings as shown on pages 150 and 151.

The boom is made from a 1 5/8-in. dowel. Shape one end to fit the gooseneck; attach an eyestay and drill a hole for fastening the sail clew at the other end. The boom is then ready for varnishing.

The mast step is cut from a small piece of hardwood. The hole in the mast step should be larger than the oak dowel set in the base of the mast so that the mast can move freely. A large brass washer between mast base and step will reduce wear on wood surfaces. For a sail of approximate dimensions shown on page 151, the mast-step hole should be positioned about 25 in. back from stem. Cut spray rails so that they extend out and aft from the after end of the mast step. The angles shown are approximate; you'll have to cut and try to get an exact fit.

Fittings. You can obtain hardware from a marine supply house, most of which provide catalogs for a small fee. The author selected mostly Wilcox-Crittenden brass and bronze fittings, primarily for their salty look. Stainless steel fittings can be used if you prefer, but the boat will

show off to best advantage if you remain consistent—choose all steel or all brass fittings.

Finishing. Many excellent marine paints and varnishes are available today. Check your local marine supply stores or paint suppliers to find out what seems to hold up best in your area.

The author selected a two-part epoxy paint for the hull. The wood should be primed with at least two coats of epoxy undercoat; apply epoxy finishing coats with a spray gun for best results. The decks, spars and other varnished surfaces were finished with several coats of a good marine varnish, carefully sanded between coats. ★★★

MATERIALS LIST

PLYWOOD (Ext. DFPA, A-A)

2 pc.—1/4" x 4' x 10'	Sides, bottom, decking
1 pc.—3/8" x 4' x 8'	Stem, transom, rudder, daggerboard

LUMBER

20 ft.—1 x 4	Frames
12 ft.—1 x 6	Frames
14 ft.—1 x 2 (white pine)	Temporary frame bracing
2 pc.—1 x 1 x 10'	For aligning frames
2 pc.—2 x 4 x 10'	Building form
(white pine)	
6 ft.—2 x 4 (white pine)	Building form crosspieces
1 pc.—3/4" x 4" x 10'	Keel
2 pc.—1 x 2 x 10'	Chines
4 pc.—3/4" x 1 3/8" x 10'	Clamps and carlins
2 pc.—3/4" x 1 1/8" x 10'	Bilge battens
1 pc.—3/4" x 1 3/8" x 10'	Lower keel
1 pc.—1 x 8 x 8'	Deck beam and seat
8 ft.—1 x 4	Center deck batten and daggerboard case cap
20 ft.—1 x 2 (white pine)	Side deck battens, cap supports, seat beam
1 pc.—3/4" x 1 3/4" x 5'	Deck and stem trim
2 pc.—1 1/4" diam. x 10'	Rip in half for molding
2 pc.—1/4" x 1" x 10'	Chine rub rails
1 pc.—1 3/8" x 5 5/8" x 2'	Bedlogs
3 ft.—1/2" x 2 1/2"	End posts daggerboard case
Assorted pieces of fir, oak	Knees, tiller, mast step, spray rails
2 pc.—3/4" x 3" x 15'	Mast
1 pc.—1 3/8" diam. x 8'	Boom

FASTENINGS

Flathead galv. or brass screws
 No. 7 x 1" for planking
 No. 10 x 2" for fastening chines, clamps.
 Other sizes as required
 Assorted brass or stainless steel bolts, washers, nuts
 Waterproof glue

RIGGING*

1 Set self-locking rudder fittings (#4601)
 1 Lightweight gooseneck (#6481)
 1 Stemhead plate, size 1 (#9893)
 2 Chainplates, 7 in. (#630)
 2 Finishing plates (#6301)
 2 Thru-deck fairleaders, size 1 (#993)
 1 Eyestay, size 1 (#275)
 40' Stainless steel cable, 3/32", 7 x 7, semi-flexible
 6 Stainless steel thimbles
 3 Stainless steel mast tangs, 3 in.
 1 Masthead sheave, 1 1/8" diam. x 3/8" thick
 1' Standard 3/8" track
 1 Becket block
 1 Eye block
 4 Halyard shackles
 40' 3/16" rope (halyard & traveler)
 25' 1/4" rope (main sheet)

*If you like brass and bronze fittings, Wilcox-Crittenden catalog numbers are given; these fittings can be obtained through many marine supply stores.

In Lockheed's case, this sort of problem was assigned to designer Henry Dreyfuss and his "human engineering" staff. The group came up with the recommendation that the number of ashtrays be cut to three per row of five seats, instead of the five now provided. That cuts cleaning time almost in half. Too, removable containers that can be replaced instead of cleaned are suggested. That also saves time.

Ten and twenty years from now the "average" passenger will be slightly larger than he is today, and so Dreyfuss recommends double or triple seats, with each space separated by arm rests, instead of the individual seats now used. Each passenger gets more room and yet the weight and size of the seating arrangement are reduced.

What's the fastest way to serve a meal, or even a snack, to a couple of hundred passengers? This is important because an SST would be in level flight for not much more than half an hour on a transcontinental trip.

One simple proposal by Dreyfuss is to pack a cold meal including a sandwich in a hinged container stored in a back pocket of each seat or that could be handed each passenger as he signs in, to be eaten at any time. Only a hot beverage would need to be served.

For more elaborate meals the Dreyfuss group suggests a mobile pantry supported on an overhead track and that can be pushed down the aisle. The narrow unit contains racks that hold prepackaged hot meals, together with beverage supplies. Similar mobile units would be used for cold beverages, magazines and even for housekeeping apparatus during turnaround time on the ground.

All engineers agree that the SSTs will be very much like present jets as far as passenger comfort is concerned. The greatest acceleration will be at the start of the takeoff run and will amount to less than half a G, the same as with present jets. The supersonics will climb at a steeper angle than most of today's transports; in fact, you'll remain in your seat until cruising altitude is reached.

Windows will be smaller and there won't be much to see in the harsh sunlight (the glare may be reduced by Polaroid screens), aside from the dark blue of the sky and the curvature of the horizon.

Earlier speculation that the ozone in high altitudes and even solar radiations could be dangerous doesn't seem to be proving true. It's pointed out that U-2 pilots who have flown above 60,000 feet

adverse effects. This has been the subject of a special study by the Lovelace Clinic, Albuquerque, N.M. However, ozone has been a problem in some electric circuits. For instance, it can produce arcing between an antenna and the structure. Such troubles are all solved by improved design.

400°F heat from friction

Aerodynamic heating remains the biggest bugaboo and accounts for a host of separate problems. The cabin skin, for instance, will heat to more than 400° F. from air friction. Passengers would actually cook like steaks if this heat seeped inside. This might have a bad effect on ticket sales, so a double-walled cabin is provided, with four inches of insulation between the walls and refrigerated air cooled as low as minus 30° F. circulating through small tubes in the insulation. Passengers and crew will be as comfortable as in today's jets. Similarly, the landing wheels will be contained in airconditioned compartments to preserve tire rubber.

Cabin windows will consist of an outer panel of thermalproof glass three inches thick, an air space and an inner panel. Windows are an expensive nuisance, structurally, and engineers would prefer giving passengers a view of the outside by television, but it's generally believed that passengers would object. So all SST designs are retaining windows.

How to prevent the fuel from overheating and boiling in a "hot" aircraft is another part of the problem. Besides, it's desired to keep the fuel so cool that it can be used as a heat sink to absorb heat from airconditioning and hydraulic systems. This is done in part by insulating the tanks against the heat and by using fuel from the outer wing tanks (which heat up the fastest) for takeoff and climb. Fuel for the rest of the flight will come from tanks buried deeper in the structure where they are better protected from heat.

Both U.S. designs call for a three-man flight crew even though five or six-man crews are the rule today for crossing the Atlantic. One reason is that the SSTs will be in the air for such short periods of time that relief personnel aren't needed. Another reason is that a navigator will no longer be carried: he's replaced by a black box, an inertial navigation system that tells the pilot where he is at all times. This is backed up by radar that shows landfalls and other terrain features.

Lockheed's cockpit mock-up offers a feature that is new to most pilots, though it's used on some military transports. In-

dials, some information is presented in the form of tapes that move up or down against calibrated backgrounds. The exhaust temperatures of the four turbines, for instance, can be shown by four tapes on a single background. A crew member can check the temperatures with a single glance instead of having to consult four different dials.

Meanwhile, General Electric and Pratt & Whitney are designing engines to power the transports. They'll be enormous engines—each one will develop 50,000 pounds of thrust. One company favors a turbojet with throttleable afterburner, and the other is researching a turbofan in which additional fuel is burned in the fan ducts for thrust augmentation.

\$27 million per plane

Today, Boeing and Lockheed have stepped up their research. They are completing details, developing tooling, and preparing proposals for building two prototype aircraft each and flying them for at least 100 hours of test flight. And they are starting construction of full-scale mock-ups. When this is all completed, a year from now, the next decision will be made: whether one design has won the competition or whether both designs should be carried farther.

It will be a big decision, for this next generation of passenger transports will be priced at around \$27 million each. In the next 20 years it's estimated there will be a worldwide market for close to 600 transports that cruise at 1800 mph or faster. If the United States doesn't lag in developing its designs, we can expect to get much, if not all, of that market. ★ ★ ★

Jonah May Join Navy

Jonah may join Julie and Jezebel in the Navy. Jonah is a new helicopter-towed submarine-listening device which is being tested for possible joining with veteran air-dropped sonobuoys Julie and Jezebel. The device is designed to eliminate the water noises generated when conventional listening gear is swept along at high speeds.

Two units make up Jonah—a large unit towed directly by helicopter and a hydrophone unit which trails out in the water behind the larger unit. The leading unit automatically pays out and pulls in the cable that's attached to the underwater "ear." While cable is being released, the second unit travels so slowly that very little noise is generated and lurking subs can be more easily detected. It's claimed that Jonah will enable air searches for subs at speeds up to 60 knots.



It won't cost you a cent to learn all the facts about using hand hacksaws, power hacks and band saws. That's what our 34-page booklet, "Sawology," is all about. Plenty of illustrations, plenty of clear descriptions, plenty of important facts every home craftsman should know about saws and their uses.

**JUST MAIL
THIS COUPON.
AS THE SIGN
SAYS, IT'S FREE.**



Name _____

Address _____

City _____ State _____ Zip Code _____



NICHOLSON



Nicholson File Company, Providence, Rhode Island
Files • Rotary Burs • Hacksaw and Band Saw Blades
Hole Saws • Ground Flat Stock • Industrial Hammers

(Continued from page 145)

killed by a light truck. The truck careened into a tree about 500 feet away, then raced off. State police, under Capt. Leo S. Daley, quickly amassed an imposing heap of evidence against the driver. His license number had been recorded by a witness. A rear-view mirror found at the scene matched a broken mounting on the truck. Paint embedded in the tree was proven to match that on the truck. Finally, a piece of bark found in the truck was shown to have come from the tree.

Still, the driver denied hitting the boy, and was making a good fight of it in court. However, two photographs brought a conviction. One showed that the truck's left front fender bore striations that matched the pattern of the corduroy pants the boy had been wearing. The other, even more dramatic, showed how a section of the pants fabric had been flattened by the impact of the bumper, except for one tiny square. It matched a hole in the bumper.

In a similar case, a woman killed by an auto was left lying in the street. A witness described the car in sufficient detail for police to identify the owner, a wealthy man who denied knowing of the accident.

The fatal injury was a penetrating fracture of the forehead, which investigators thought might have been made by the old-style projecting door hinges on the suspect's car. Infrared pictures were taken of the area of the car which was believed to have struck the woman. Sure enough, the photos revealed an imprint of the side of a human face. This imprint, invisible to the naked eye, was left by the natural grease of the woman's skin. When shown the pictures, the suspect confessed.

Bookies are booked

Infrared pictures play an important role in another phase of crime photography—detection of forged or altered documents. By photographing checks, wills, insurance policies and other papers under infrared or ultraviolet light, police can often detect erasures or spots where, for example, digits might have been inserted to raise the value of a check. Such techniques can also restore obliterated writing, as two Connecticut bookies found out.

These men, on hearing police arrive at their establishment, burned their betting slips in a fireplace. Much to their dismay, however, the police lab placed the ashes between sheets of glass and photographed them under infrared light, revealing the names of several nags running that day.

Another case of photographing the near-invisible led to the arrest of a thief in

Rochester, N.Y. A very faint set of his fingerprints was found in the dust on a suitcase lid. Since bringing out these prints with the usual dusting techniques would have destroyed them, police shot the prints on high-contrast film under low-angle light. Result: a clear set of prints.

Photography also serves the law by preserving "perishable" evidence. In Canada, two men robbed a loan company and, while maneuvering their car for a getaway, backed into a snowdrift to form an imprint of their license number. Officers spotted the imprint, clicked a camera and arrested the pair within two hours.

Color prints effective

At the moment, perhaps the biggest news in crime photography is the increasing use of color film. This medium, with its heightened realism, made its court debut rather humbly in 1943, when color photos helped convict a Denver butcher of trying to sell putrid meat. Today, police departments all over the country are switching to color film for mug shots.

In Los Angeles, a test showed that 75 percent of the victims who could not identify a black-and-white photo of a criminal were able to identify the same man in color prints.

A number of states now send color photos of all parolees to their parole officers, to discourage a parolee from sending a stand-in to report to the officer every month. And, in Washington, D.C., a pioneer in color mug shots, color-identity photos are now required on all drivers' licenses.

But Indiana lawmen once found that color film's realism can be a two-edged sword. When a mechanic was convicted of beating and slashing his wife and daughter to death, photos of the corpses were shown to the jury, along with shots taken during and after the autopsy. A higher court reversed the conviction on the grounds that the autopsy photos proved nothing pertinent to the case and were so gruesome as to be prejudicial to the defendant's rights. A new trial was ordered. For the most part, however, color pictures have gained wide acceptance in the nation's courts.

Where does crime photography go from here? There seems little doubt that it will find wider and wider application. For, as photography becomes easier, and cameras more mobile and less expensive, any police department, industrial plant or private individual can record solid evidence on film. Maybe it's unrealistic to say photography will put an end to crime. But we can say it's making it tougher and tougher to earn a dishonest day's pay. ★ ★ ★

Don't buy batteries—Save \$—Recharge them!

over and over up to 15 times or more
the **EVERLITE**—the best
charges more
than all the rest.

Only the New **EVERLITE**

- Charges 6 at one time.
- Charges 3 times faster.
- Charges all batteries.

Be prepared. Always have fresh batteries when you need them. The **EVERLITE** is the only charger made which charges all batteries, flashlight, lanterns, toys, radio, telephone, hearing aids, cameras—yes even mercury cells. Save money and have the convenience of fresh batteries always.

The **EVERLITE** is the best—the only charger built with a powerful magnetic energy winding. This power enables it to charge big lantern batteries and even car batteries. Also plays transistor radios on 115V. house current charging the batteries at the same time. **Charges all batteries better.**

Two models—the **EVERLITE 75** for all dry cell batteries up to 12 volts and the **EVERLITE 76** for all dry batteries plus a special charge for car batteries to assure fast starts on cold mornings. Simple, safe, fool-proof and unbelievably efficient. Plus into any 115 volt outlet. Guaranteed for one year. Send for your **EVERLITE** now—10 day money back guarantee.—You must be satisfied.

only \$6.95

New
Transistorized
Model
only
\$6.95



Free battery tester and adapter for special batteries included.
The **EVERLITE 75**—Send \$6.95 plus \$.65 for shipping.
The **EVERLITE 76** (including car battery kit)—Send \$8.95 plus \$.75 for shipping.

CONTOUR COPY

PATENTED

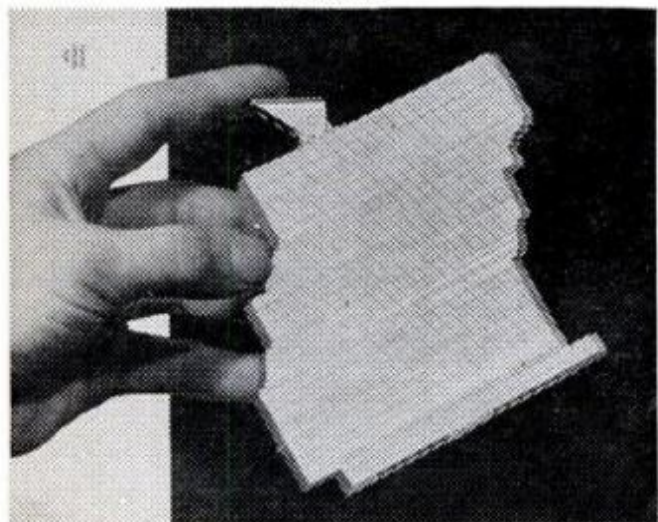

A PRECISION LIFETIME TOOL—\$6.90

Made of hardened aluminum alloy—will retain its accuracy indefinitely.

Size No. 1 is 4¼" x 4¼".....\$6.90
Size No. 2 is 7½" x 4¼".....\$9.90

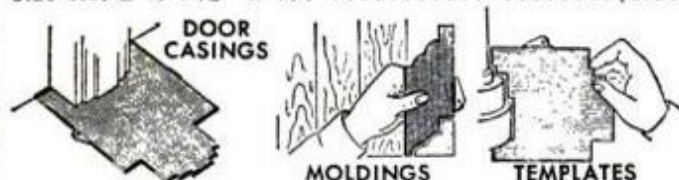

COPY ANY CONTOUR INSTANTLY Perfectly Accurate Every Time.

SAVES HOURS—SAVES MATERIAL. Can pay for itself on one job. The perfect tool for fitting in against door casings, bath fixtures, mouldings, pipes, sinks, masonry, etc. A real boon to pattern makers, sheet metal mechanics, tool makers and body men.

EASY TO USE—just push the gauge leaves against any contour and lock. A perfect template every time. Works against any surface or any material. Immediate delivery guaranteed.

Order now from **MASTER MECHANIC CO.**

Send \$1.00 deposit if you wish C.O.D. shipment.
All items guaranteed for 1 year plus 10 day moneyback guarantee.

Mail order to Master Mechanic Co. Dept. A16
Box A, Burlington, Wisc., or Box 98, Sarasota, Fla.

Send _____ EVERLITE 75 chargers \$6.95 ea. plus .65 shipping.
Send _____ EVERLITE 76 chargers \$8.95 ea. plus .75 shipping.
Send _____ No. 1 Contour Copies \$6.90 ea. plus .55 shipping.
Send _____ No. 2 Contour Copies \$9.90 ea. plus .65 shipping.

Name _____

Address _____

City _____ State _____ Zip _____

THE GREAT RELAXING BONANZA

(Continued from page 125)

Yoga, that physical philosophy, is booming. Turbaned teachers are happily instructing a growing group of eager pupils to cast off their worries through breathing, position and meditation. Once the butt of comedians' jokes, yoga is slowly achieving a sort of respectability. "I don't go for all that business of thinking beautiful thoughts," says a top corporation executive, "but the exercises are great for unwinding."



Other companies, alarmed by the skyrocketing rate at which their top executives are decommissioned by such tension-related maladies as high blood pressure, mental illness, ulcers and even alcoholism, have taken a long somber look and then put preventive programs into operation. Many firms will now foot the bill for relaxing courses, private gym membership, art lessons or even psychiatric help.

Still in the experimental stages, results of these programs have not yet been tabulated. "But if it works," explained a personnel manager, "it's a cheap solution to an expensive problem. Every time a department head conks out, it costs us a fortune in time for all the other people under him."

Newest gimmick is relaxation via long-playing records. Specially selected music is softly recorded by subdued orchestras of gentle string instruments. The musical style, known to Tin Pan Alley as "gutless," has no beat and less rhythm. Designed to induce sleep, 15 minutes of it would probably close the dance halls.

On the other hand, last July the Saun-

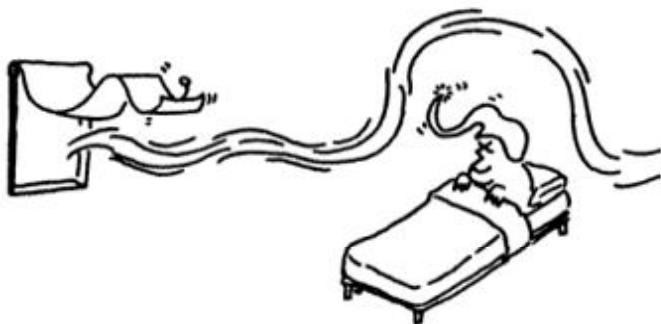

ders Recording Studio in New York got a frantic call that sent a recording crew

with full equipment to Times Square. The taped cacophony of screeching taxi brakes, police whistles, rumbling motors and auto horns was rushed via special messenger to a Catskill resort. A garment tycoon was going out of his mind with nothing but crickets outside his bedroom window.

Latest gadget to join the parade of the soothers are the home vibrators. Business, according to an industry spokesman, is boom-mm-ing. Many of these shakers are scaled-down versions of a device that's pretty common in better equipped barber shops. John Oster, largest and oldest manufacturer of small size units, has been selling them to tonsorial parlors for over 25 years. Preceded by a shave and followed by a hot towel, a vibrator massage treatment in the well-muscled fingers of an experienced barber is an utterly luxurious experience.

What's new about all this shaking is the fact that the vibrators have made a

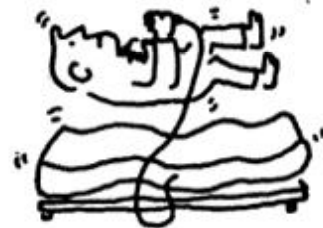

sales shift. Most of them are now being sold for home use in a rapidly expanding market that grossed over 30 million dollars last year. And if sales continue at the current pace, final tally for this year should be double that figure.

Although hand vibrator units proved to be quite popular, what really sparked the bonanza was the introduction of low-cost vibrator cushions. They take even less energy to use. If physical tension has left you in such a rocky and rattled state that you aren't up to running a massager over your aching neck or legs, just plug in the cushion, lean on it, stretch out or sit on it to localize the treatment.

The vibrator cushions are now sold in almost every department and chain drug store in the country with a list of claims that include relaxing, reducing, stimulating circulation and easing heart tension.

Most of this is bunk! At least that's the opinion of Owen K. Murphy, president of Niagara Therapy Mfg. Co., whose five factories pour out a torrent of hand mas-

(Please turn to page 212)

NEW

7½" Circular Saw—
shockproof*—
packed with the
power and speed
you need **\$3988**
for any job.



*Constructed of non-conductive miracle material, double insulated against electrical shock from product malfunction.

WORLD'S SAFEST SAW



NEW

¾" Variable Speed Drill—Electronic Trigger Speed Control gives you fingertip control for drilling wood, metal, plastics, and glass.

Only **\$2488**

Also ¾" Variable Speed Drill—\$2988



NEW

2-speed Jig Saw—gives you high and low cutting speed for problem materials. Base tilts 45° for added flexibility.

Only **\$2988**

Rockwell adds tools to Green Line

Here's a follow-up to the breakthrough introduction of Porter-Cable Green Line **SHOCK-PROOF** tools. Each new tool has 7 insulation barriers for maximum user protection. They are **breakproof**, too, with **failure-proof** motors. Saws, drills, sanders—your choice of 9 models. Mail coupon for full story.

Rockwell Manufacturing Company,
Power Tool Division
502L N. Lexington Ave., Pittsburgh, Pa. 15208

Please send me FREE brochure.

Name _____

Address _____

City _____ State _____ Zip _____



Rockwell
MANUFACTURING COMPANY

BUILD RESTORE ...anything of wood

LET Constantine's picture-packed Catalog & Manual help you build new furniture—refinish and restore beat-up cabinets, chests, tables, chairs, etc. See everything you need for better, easier woodworking. All materials plus plans, books, instructions. 60 glamorous woods in natural color. Hundreds of products found nowhere else. 8-ft veneers! Fabulous glue that needs no clamps. Tool bargains. Cabinet hdwe, etc. *Unsurpassed values since 1812.*



2,000

CRAFTSMAN PRODUCTS
World's Beautiful Woods & Veneers
Newest Workshop Tools & Materials
Wood Finishes — All Kinds
Lamp Parts — Upholstery Supplies
Period & Modern Furniture Hardware
Colonial Clock Kits — Cone Kits
500 Project Plans! Instructions!

Tear out ad. Mail with 25¢
for vast new CATALOG
Plus New "101 Project Ideas"

CONSTANTINE

2050 Eastchester Rd., Bronx N.Y. 10461 Dept. A-5

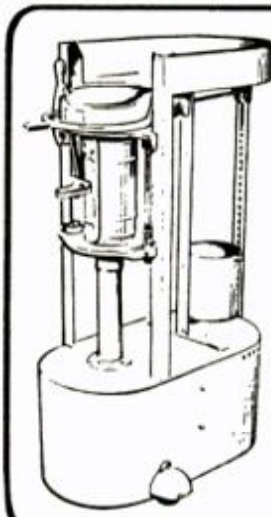

Turns CONCRETE into DRAIN TILE

This machine's a MARVEL. Costs less than \$500 and lets you make 100 or more top-quality tile per hour at a unit cost (including labor) of 4¢-5¢. Sell your tile at 10¢ to 15¢ each. Earn extra or full income making and selling a product that is in constant demand. Booklet with complete details free. Don't wait! Write for yours now.

CONCRETE MACHINERY

Box 99, Hickory 2, N. Car. 28601



ALUMINUM SIDING

Learn how you can earn up to \$1000.00 per sale, showing our quality aluminum siding on your home.

TO: ALUMINUM INDUSTRIES, Dept. P-16
KANSAS CITY 11, MISSOURI

Please send me complete information

My Name _____

Street _____

City _____ State _____

LICKITY WACO LOG SPLITTER

Splits Big Profits from toughest woods — Ends Splitting Drudgery with 18 ton hydraulic power!

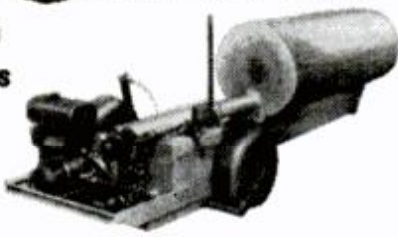

7 H.P. trailer unit squats under power to load logs without dead lift. Has 2 speeds, auto-shift, auto-stroke. 26" ram travel splits logs up to 34", any diameter — with extended frame and adjustable wedge splits up to 60". **NEW LOW COST** Economy model for farmers and small wood lots. Also ask about the 60L Series for logs up to 8½ ft. long—Details free.

Piqua Engineering Inc., Dept. P, Box 605, Piqua, Ohio

(Continued from page 210)

sagers, massage cushions and chairs with built-in action.

"We've spent over a million dollars so far on medical research," says Murphy, "and the end is nowhere in sight. Our Niagara Cyclo-Massage will help you unwind if you are tense, will banish ordinary physical fatigue and can give you a sustained feeling of well being, but it won't cure you of anything. Half the stuff on the market today is little more than a door buzzer stuffed into a cushion."

Biggest market for the Cyclo pads (as the massage cushions are known) comes from businessmen. The units are a standard fixture in the plush but nervous offices of such top corporations as U.S. Steel, United Air Lines and Burlington Industries. Arlene Francis, one of the busiest performers in the ulcer-producing television industry where heart attacks occur with ominous 13-week regularity, is firmly addicted to the habit. Also on the list are such nervous notables as King Ibn Saud, a handful of South American presidents, golfer Cary Middlecoff and several members of major league baseball teams.

The pills, potions and gentle persuaders have arrived just in time. The average guy, caught up in the tempo of a world wildly tense and growing more complex, feels a constant tug at his mental buttonholes. But, thankfully, there's a tonic for every twitch. ★★★

WIRELESS MIKE

(Continued from page 195)

kc.). Somewhere in here you will pick up the transmitter signal. It will sound like a whistle or a quieting of the radio's background noise. Speaking into the mike will produce a strong signal from the radio.

If this doesn't work, there may be a strong local station on the mike frequency. To avoid this problem set the radio to a vacant frequency at the low end of the band and adjust the antenna coil slug in the transmitter until you can transmit on that frequency.

A final tune-up of the radio and the antenna coil adjustment will give the best range and tone.

That's all it takes to build your wireless mike. It's a fast one-night project once you have all the parts together. ★★★

FREE SLIDE RULE

GIVES MATH ANSWERS IN A FLASH!

given with your first volume — Mathematics Made Simple

Fill the Gaps in your Family's Education
with the amazing **MADE SIMPLE**
Self-Teaching Encyclopedia

FREE
10 DAY
TRIAL
Examination

FREE
SLIDE RULE
with your
first volume

Become a MATH wizard!
Get the right answers in a
flash without paper or pencil!
Multiply, divide, square, cube, extract
square and cube roots as easy as pie!
Locate slide with handy carrying case.
A, B, C, D, E, F scales. Solves the
toughest math problems in a flash!

Your First **MADE SIMPLE SELF-TEACHING**
Encyclopedia Volume — Now Ready!

MATHEMATICS MADE SIMPLE!

Simple everyday mistakes in arithmetic, algebra,
geometry and trigonometry can cost you time,
money, job promotions and good school grades.

This handsome, expertly-prepared book covers:
short cuts to add, subtract, multiply, divide whole
numbers, fractions, decimals, algebraic expres-
sions, signed numbers; read and interchange frac-
tions, decimals, percentages; find the area of a
plot of land, room, etc.; ratio, proportion; algebraic
equations; definitions of mathematical expres-
sions; how logarithms simplify multiplication,
division; how slide rule makes figuring fast, easy,
accurate; axioms, theorems; constructing geo-
metric figures for everyday problems, solid geo-
metry; trigonometry to measure large or distant
objects; angle functions for practical problems;
representing quantities and sizes on graphs and
scales, combinations and permutations, probabi-
lity—and much more.

It clearly and quickly teaches you every-
thing you need to know about this subject.
There is no confusing language. You'll also
use this book often as a handy reference. If
completely satisfied after trial examination,
pay the special low introductory price of
only \$1.—a saving of 98¢ for this first volume.

Here is a brief description of set:

- | | | |
|--------------------------------------|---|--|
| 1. MATHEMATICS
Made Simple | 13. BUSINESS LETTER
WRITING
Made Simple | 25. ELECTRONICS
Made Simple |
| 2. ENGLISH
Made Simple | 14. ART OF WRITING
Made Simple | 26. ITALIAN
Made Simple |
| 3. EVERYDAY LAW
Made Simple | 15. BOOKKEEPING
Made Simple | 27. ECONOMICS
Made Simple |
| 4. PHYSICS
Made Simple | 16. RELIGIONS OF
THE WORLD
Made Simple | 28. CONTRACT
BRIDGE
Made Simple |
| 5. BIOLOGY
Made Simple | 17. SPANISH
Made Simple | 29. ANTHROPOLOGY
Made Simple |
| 6. CHEMISTRY
Made Simple | 18. SPELLING
Made Simple | 30. DRAFTING
Made Simple |
| 7. ASTRONOMY
Made Simple | 19. RAPID READING
Made Simple | 31. INTERMEDIATE
ALGEBRA AND
ANALYTIC
GEOMETRY
Made Simple |
| 8. ART OF
SPEAKING
Made Simple | 20. FRENCH
Made Simple | 32. ADVANCED
ALGEBRA AND
CALCULUS
Made Simple |
| 9. WORD MASTERY
Made Simple | 21. WORLD
LITERATURE
Made Simple | 33. LATIN
Made Simple |
| 10. PSYCHOLOGY
Made Simple | 22. AMERICAN
HISTORY
Made Simple | |
| 11. PHILOSOPHY
Made Simple | 23. WORLD HISTORY
Made Simple | |
| 12. TYPING
Made Simple | 24. ELECTRICITY
Made Simple | |

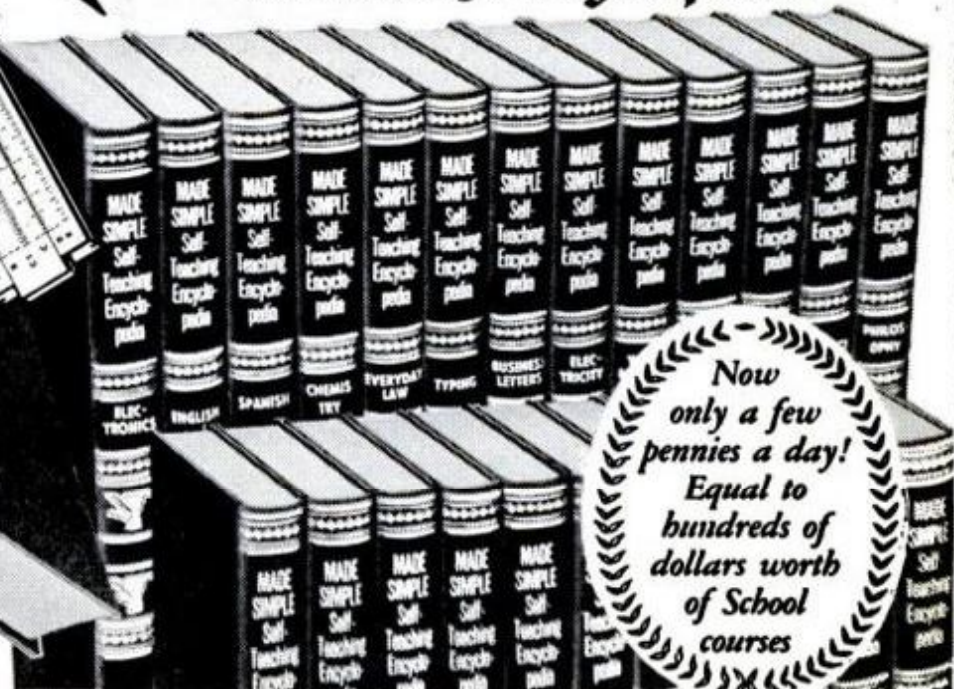

Now
only a few
pennies a day!
Equal to
hundreds of
dollars worth
of School
courses

New, Richly-Bound, Matched Library Volumes Use Everyday Situations to Teach Science, Business, Cultural and School Subjects; Assure Complete Mastery for Faster Job Advancement; Better School Grades, Richer, Fuller Living—In Just 15 Minutes a Day!

Now—the famous, proven **MADE SIMPLE** method offers you an education worth hundreds of dollars for pennies a day! Complete practical instruction in science, business and cultural subjects that you use every day for the children in school, mother at home, dad in his work and everybody in all their social contacts.

You can master these subjects in as little as 15 minutes a day, in weeks instead of years, with these books that are recommended by parents and noted educators for all age groups.

Learn Whenever You Want—Like Having Private Instructors in Your Own Home

This **MADE SIMPLE SELF-TEACHING** set is the only encyclopedia that makes important subjects part of your general knowledge instead of having to look in books to solve every problem. It covers practical, useful subjects in everyday language. It's like having private instructors in your own home. Learn at your own pace. No outside work, nothing else to buy. The books start from the beginning, assume no previous knowledge and lead you quickly and carefully through the entire subject. Prepared by experts for adults working without supervision, they also perfectly supplement classroom texts, which contain confusing technical language.

Beautiful Library Volumes Perfect for Learning, Brush-Up, Permanent Reference

Whether you want to learn for the first time, review subjects you forgot or use for ever-ready reference, you could find no better set or price. These handsome 7 1/4 x 10 1/2 inch, 24-carat gold imprinted, matched library volumes are not di-

gests or outlines. Every point is made absolutely clear by illustrations and simple step-by-step explanations, using everyday situations. No half-answers to confuse you, no cross-references to make you use several books to get information. All the books teach you naturally, without memorizing long lists of rules.

Complete Explanations, Simple Illustrations Make Every Point Clear—No Previous Knowledge of the Subject Required

Here's how complicated subjects are **MADE SIMPLE**. In **PHYSICS MADE SIMPLE**, you are shown this simple home experiment, which costs nothing. Hold one edge of a letter paper against your chin, just below lower lip, with the paper hanging over and down. Blow above the paper and it will rise as if pulled up in the air stream. This



simple principle makes airplanes fly and teaches us to make moving objects move quickly and easily. Other books give you Bernoulli's Law, molecular action and other confusing terms. By the time you got to the experiment, if there was one, you wouldn't understand it. Here you read a simple explanation, do the experiment and then learn the technical terms, so you learn naturally, by doing, without memorizing anything. This has worked for many people who thought they were more hopeless than you may think you are.

You would pay many times the price for much less beautiful and useful encyclopedias. But these books, with sample military and civil service tests, hundreds of illustrations, hundreds of safe, easy home experiments, thousands of pages of clear, concise, valuable instruction and self-tests with answers in the back, will be **USED, ENJOYED and ADMIRIED** by all your family and friends.

SEND NO MONEY!
MAIL ATTACHED CARD TODAY

for your **FREE SLIDE RULE** and
10 DAY FREE TRIAL RESERVATION

Get Your Reservation in Now While the Supply Lasts!

Just mail the card next to this ad (No Stamp Needed) to receive your **FREE** slide rule and to examine the first volume, **MATHEMATICS MADE SIMPLE**. With the volume will come invoice for \$1.00 as full payment, plus a few cents mailing charge—you save 98¢ on this first volume. Also you'll receive information on how to get your other beautiful volumes for only \$1.98 each plus a few cents mailing charge. There are no other charges. No minimum number of books to buy, no deposit in advance. Examine any book for ten full days in your home before deciding. Then either pay the bill or send any book back and owe nothing. You may cancel your reservation at any time. Fill in, detach and mail the card **NOW!** If the card is detached, just send your name and address to:

CADILLAC PUBLISHING CO., INC., Dept. A-664
Made Simple Self-Teaching Encyclopedia Div.
220 Fifth Avenue, New York, N. Y. 10001

(Continued from page 129)

the tree with a ski on either side. I had to pull it out: 369 pounds in deep snow. I would lift the track in the rear and fall back, moving it a couple of inches at a time. The temperature was below zero, but the sweat was running off me. I almost had it free when another competitor came roaring around the turn, I jumped aside, but he hit the machine, slamming it right back up against the tree. He kept going.

"Sportsman!" I shouted.

I went back to lifting, tugging, hauling and wondering what on earth I was doing out in the wilds of northern Wisconsin. When I first heard about the Hodag Marathon it seemed like the ideal way to learn about snowmobiles, the newest craze to take fire in winter sports. A race from Rhinelander to Eagle River. Great fun.

With a last gasp I freed the machine, got it started and rejoined the race. The worst, as they used to say in popular novels, was yet to come. The seat on the machine was wet and slick with snow. On almost every turn I'd slide off and land in a snow bank. At one turn I forgot to release the throttle and the machine went bouncing along, dragging me after it.

When I came rattling into Three Lakes, Wis., for a ten-minute break, it was like climbing out of a cement mixer. I was handed a cup of coffee, but I was still shaking so hard it all splashed onto the ground. I took a second cup through a straw with a woman holding the cup.

And to prove to you that my brains were totally scrambled, at Three Lakes I learned that I was making good time, so I was suddenly eager to get going. I didn't have a chance of winning, but I wanted to bear down on the final leg and make a respectable showing. No fool like an old fool!

Out of Three Lakes there was a long stretch of frozen swamp. It was wide open, so you could run at top speed, but there was a stiff crosswind blowing snow that caked on the goggles. Unable to see, I couldn't keep the skis in the tracks, and when one ski would suddenly dig into deep snow the machine would give a lurch and turn over. There were also numerous hummocks, and I went off these like a ski jump, slamming down on the far side with a bone-jarring jolt.

On this stretch I came across a girl who was stopped on the side of the trail. I slowed down. She was crying, her face buried in her gloves.

"Are you all right?" I asked.

"Oh, shut up, and leave me alone!" she snapped.

I can take a hint. I shoved off. There

was another place, a ditch, where you dropped straight down about 12 feet, hit the bottom and then roared right up the other side. And the worst was a logging road, a long washboard hill where you would sail off the top of one hump and slam right into the rise of the next one. It almost finished me. After 10 minutes, I stopped and just staggered around.

But then, believe it or not, I continued. And I was learning plenty about riding a snowmobile. In rough terrain you have to ride the handlebars, standing on the side running boards and taking the shocks with your legs. I was riding it like a sack of wheat and it was like being slammed against a brick wall for two hours. I also realized that if I hadn't been racing against time, this trip through the woods could have been exhilarating pleasure. The snowmobile will go almost anywhere, and when you get stuck, instead of manhandling it from the rear, you grasp the front of the skis, bouncing them around until they're downhill, and then use the engine to free the tread. It's easy when you're not exhausted. And these machines will take unbelievable punishment.

Competitor crashes head-on

On the final leg of the race I was running neck and neck with another snowmobile. We came down a swooping hill and up the other side, and at the top the trail narrowed. I got there first, but he kept coming alongside. Over the crest of the hill there was a sharp drop and the trail went to the left. I managed to stay with it, but he had jumped the crest and was airborne. He fell off in mid-air, and the machine crashed into a tree about six feet above the base. I slowed down, but even before I could stop he had his machine upright, it was still running, and he was plowing back to the trail.

Coming out of a stretch of woods, the course turned left and ran along a railroad bed. And there in the near distance was Eagle River. At this point I was totally exhausted. I was sitting on the seat, just hanging onto the handlebars, keeping the throttle pressed, my senses too numbed to think or feel.

But there's always a reserve of ham. When I came off the railroad tracks, and saw the crowds of people lining the main street, I was up on one knee, giving it all the throttle I could muster. In that little town you had the feeling that the whole world had gone snowmobile goofy. I came sliding and bouncing around the turn into the main street and gunned it to the finish line with classic style. And then someone said, "Congratulations, you finished."

Ah, well, you can't win them all. ★★ ★

Earn up to \$12,000 a year. Be your own boss.

Read about this business opportunity with the Shell Oil Company in your area.

SHELL is growing fast. We need men to manage our high-profit Shell service stations.

(Note: Previous experience with automobiles or service stations helps, but is not necessary. Many of our most successful dealers had no related experience before they joined Shell. Some of them now earn over \$12,000 a year.)

Would you like to be your own boss? Like to work to build *your* profits, instead of settling for a flat salary? If so, Shell offers you these advantages:

1. Shell stations pump more gasoline. Almost 50% more than the average station. Result: high-potential profits for Shell dealers.

2. You'll sell Super Shell, one of America's most popular gasolines. Sales of Super Shell gasoline are booming. That's because motorists know Super Shell contains Platformate, a mileage ingredient which helps them get *good* mileage. Result: high volume—and profits—for Shell dealers.

3. Shell trains dealers free. Shell teaches dealers the profit-proven methods of running a business. You'll learn—*free*—how to manage finances, sales and personnel. Result: higher profits for Shell dealers.

4. Shell helps you all the way. Shell representatives continue to help the dealer all through his career. They continually show him new ways to boost sales, cut costs. And Shell spends millions of dollars a year on advertising. Result: high profits for Shell dealers.

5. Shell's credit cardholders number in the millions. Credit cardholders buy more gasoline, tires and batteries than cash customers. And Shell has one of the largest groups of

credit cardholders. Result: millions of ready-made customers—and high profits for Shell dealers all across the country.

Can you qualify?

If you're interested in becoming a Shell dealer, we will want to ask you three important questions.

1. Do you agree that *customer service* is the most important factor in successful station management? Shell plans to give motorists the best service they've ever known. You should agree 100% with this goal.

2. Do you have managerial ability? Many men without technical training succeed in the service station business because they have *management know-how*. You must be able to put men and money to work for you.

3. Are you willing to invest in your own future? You will have to make a small investment in products and equipment to get started. Shell will help you arrange your finances but you must demonstrate faith in your own success by investing in your station.

We'll want to ask you other questions, too. But if you can answer "Yes" to the ones above, you're over the first hurdle.

MAIL THIS COUPON NOW TO

Shell Oil Company
Room 3420D, 50 West 50th St.
New York, N. Y. 10020



Yes, I want to know more about this business opportunity with Shell.

Name _____

Address _____

City _____ State _____

8 times more power to relieve pain of HEMORRHOIDS!

Soothing Nupercainal concentrates on pain!
Prolonged relief of pain, burning and
itching starts in minutes.

If you suffer from the misery of hemorrhoids, remember this about remedies you can buy for temporary relief. The leading "shrinking" preparation contains no anesthetic to relieve pain.

No wonder so many doctors recommend Nupercainal. Soothing Nupercainal relieves pain, itching, burning fast... gives prolonged relief... because it has *over eight times more pain-killing power* than the other most commonly-used topical anesthetic!

Nupercainal quickly puts raw nerve ends to sleep... thus puts pain to sleep. Lets you go about your business... relieved of the pain, burning and itching torment of hemorrhoids. Get Nupercainal Suppositories today—with free, handy pocket-pack. Start to live again, in comfort! (Ointment also available.)



Nupercainal®

Psoriasis sufferers

regain more
normal looking skin!

Whenever scales, redness, and itch of psoriasis occur, don't let them embarrass you—there is new hope. Medically-proven Mazon helps remove crusty scales without painful irritation, relieve itch and soreness fast; fades telltale redness; helps check formation of new scales! Mazon's vanishing cream formula is pleasant to use, disappears as you rub to help you regain smoother, more normal-looking skin. Don't spend \$4 or \$5 for psoriasis relief. Tried, proven Mazon is only \$1.25 at all drug-stores, without prescription. Satisfaction guaranteed or money back from Thayer Laboratories.

CLINIC FOR SICK CARS

(Continued from page 119)

if you bring the car back in two weeks.

Are they worth the cost? Yes, if you like your car to operate at close to peak efficiency and safety. How else can you find what's causing an engine to miss going up a hill at high speed? Without loading down the car with expensive equipment, the mechanic can only head for the nearest hill and hope to duplicate the complaining customer's driving conditions. He can't be under the hood and driving the car at the same time, and even if he could, he'd probably run out of hill long before he could trace the trouble.

For the skeptics who think they themselves can keep the family car running perfectly (and that included me in the beginning), I performed an experiment. I had noticed, over the two-month period of this assignment, a gradual deterioration in engine performance showing up on the charts. So, after the last test, I bought a set of sparkplugs and an ignition tune-up kit (points, condenser, rotor). That Saturday morning I installed them carefully and set gaps and dwell as best I could.

That Monday, I ran the car through the lane again and noticed a great improvement in performance, but also still some ignition "trouble." So I got a tune-up and the clinic repeated the power tests.

Road horsepower jumped from 68 to 73, with a peak reading of 75—a gain of 10 percent. Gas mileage went from 14 to 15 mpg, and the acceleration had returned.

Every one of the managers we talked to told us stories of mechanics from other local shops bringing in hard-to-find troubles that the diagnostic center equipment was able to find in minutes.

What about power-tuning? Theoretically, power-tuning can get the absolute top performance out of a car, but it can also open the door to problems. Power-tuning is simply adjusting the car to super-fine tolerances to squeeze out the last bit of power without modifications.

Most of the centers are willing to power-tune a car, at an extra charge, of course, and only with the customer's written approval. Adjusted for certain atmospheric conditions with a particular load of fuel, the settings could be way off when the weather changes or when you switch to a different gasoline. The clinic, naturally, does not want to be responsible for this.

The strictly stock automobile, of course, provides the best compromise between performance and reliability. The new diagnostic clinics will help you to stay *really* stock, getting out of your car all the power and efficiency that was built into it. ★★

WINTER TUNEUP

(Continued from page 155)

clear of carbon. Clean all soot from the muffler too. This is done by first removing the exhaust pipe; then the piston is moved to bottom dead center and the carbon scraped from the exhaust port.

Drive chain. All drive chains stretch in time. No motorcycle chain should ever have more than $\frac{3}{4}$ in. of free play. To tighten the chain, turn the drive-chain adjusting nut, which is located on the rear fork, to the right. If this fails to tighten the chain sufficiently, take the chain off and remove a link from it. Then replace it as before.

Brakes. Activate the front brake lever and the rear brake pedal. Both should move no more than $\frac{1}{2}$ in. before engaging. Brake adjustments are made by turning the front and/or rear adjusting nuts: clockwise to decrease brake lever and pedal travel; counterclockwise to increase travel.

The wheels should be pulled and the brakes serviced every 5000 to 10,000 miles. It's not that brake linings wear out—they usually last a good 60,000 miles—but the linings do glaze and cut down braking power. Remove this glaze with emery cloth or armature paper. Blow dirt from the brake drum area at the same time. Take this opportunity, too, to re-lubricate the wheel bearings.

Clutch. Activate the clutch lever. It should give $\frac{1}{4}$ to $\frac{1}{2}$ in. before engaging. If it doesn't, adjust the clutch by means of the clutch adjusting nut, the location of which will be identified in your manual.

Tightening and lubrication. Vibration is the enemy of safe, comfortable cycling, and harmful to the bike as well. With one exception all nuts and bolts on your cycle should be turned down as tight as possible. Head bolts are the exception. These must be torqued to specification (see your manual) with a torque wrench.

Apply grease or oil at every lubrication point. You'll find a lube chart in your manual. Bear the following points in mind when lubricating your motorcycle:

- Use only a hand grease gun; a high-pressure gun will blow seals.
- Carefully examine the rear of the engine for oil leaks. These are extremely dangerous as they can spew oil onto the rear tire and cause the bike to go into a skid. Engine leaks may be caused by a loose bolt or by a ruptured seal in the lower crankcase.
- Replace crankcase oil and keep a close check on its level. An undetected loss of a half quart of oil from a motorcycle can spell trouble. ★★

Carburetor gum can choke the life out of your engine

Remove it easily with **GUMOUT**

THE gasoline constantly being evaporated in your carburetor leaves a residue of varnish and gum. As this builds up, your carburetor has trouble "breathing." The symptoms are hard starting, stalling, rough idling, power loss, poor gas mileage.

Some premium grade gasolines now have an additive which, with continuous use, cleans the carburetor throttle plate area after about 5,000 miles. This is the roundabout, costly, time-consuming way to do the job. And the results are never complete.

GUMOUT is the right way to clean a carburetor. **GUMOUT** is a hard-working solvent you simply add to the gas tank. It goes to work instantly, removing harmful gum, varnish and moisture from your entire fuel system. Your carburetor *cleans itself* as you drive. **GUMOUT** does a fast, thorough cleaning job because it has a greater concentration of cleaning power than additives in premium gas.

By adding **GUMOUT** to your gas tank only three or four times a year, you'll get the performance your engine is designed to deliver, cut gasoline waste, and prevent a major cause of engine trouble. Get **GUMOUT** at your service station or auto supply store and let your carburetor clean itself!



GUMOUT

Cleveland, Ohio 44104

A New FREE BOOK for

MEN PAST 40

**Troubled With Getting Up Nights,
Pains in Back, Hips, Legs,
Nervousness, Tiredness.**

This new Free Book tells that if you are a victim of the above symptoms, the trouble may be traceable to Glandular Inflammation . . . a condition that very commonly occurs in men of middle age or past and is often accompanied by despondency, emotional upset and other mental and nervous reactions.

The book explains that, although many people mistakenly think surgery is the only answer to Glandular Inflammation, there is now a non-surgical treatment available.

NON-SURGICAL TREATMENTS

This New Free Illustrated Book tells about the modern, mild, Non-Surgical treatment for Glandular Inflammation and that the treatment is backed by a Lifetime Certificate of Assurance. Many men from all over the country have taken the NON-SURGICAL treatment and have reported it has proven effective.

The Non-Surgical treatment described in this book requires no painful surgery, hospitalization, anesthesia or long period of convalescence. Treatment takes but a short time and the cost is reasonable.

REDUCIBLE HERNIA | HEMORRHOIDS

Non-Surgical treatment for both Reducible Hernia and Hemorrhoids, the book explains, can usually be taken at the same time as treatment for Glandular Inflammation.

This new Free Book is fully illustrated and deals with diseases peculiar to men and women. It tells HOW and WHY New Modern NON-SURGICAL Methods are so successful today. Fill Out Coupon.



Excelsior Medical
Clinic, Dept. M 6150
Excelsior Springs, Mo.

Gentlemen: Kindly send me at once, your New FREE Book. I am interested in full information. (Please Check Box)

- | | |
|---|---------------------------------|
| <input type="checkbox"/> Glandular Inflammation | <input type="checkbox"/> Hernia |
| <input type="checkbox"/> Hemorrhoids | |

Name.....

Address.....

City..... State.....

NO LAND? BUILD ON AIR

(Continued from page 138)

Finally, it was discovered that far below the level of the street a piece of wood had become wedged in the two-inch air space separating one of the building's steel "legs" from the below-street railroad tracks. The bit of wood acted as a bridge through which track vibrations were transferred to the steel column. Eventually, the vibrations reached the wall next to the guest's bed. Removing the piece of wood solved the problem.

Today, most buildings occupying space that spans railroad tracks, subway beds and motor highways are insulated from the ground on which the traffic moves. Enormous lead, steel and asbestos "sandwiches" are put under support columns.

Air-rights construction really got rolling in New York around World War I, and within a decade Chicago followed suit. In 1927, the 25-story Daily News Building went up over the tracks of the Milwaukee R.R. And some years later the Chicago & North Western Ry. granted rights for the Sun-Times Building, the Merchandise Mart and other structures.

One of Chicago's larger recent air-rights projects is the \$100 million Gateway Center office building complex being constructed over the tracks entering the Union Station. It will occupy four city blocks, and three railroads will profit from use of this space. The Pennsylvania owns half of the rights; the Burlington and Milwaukee, a quarter each.

But the Illinois Central may have the

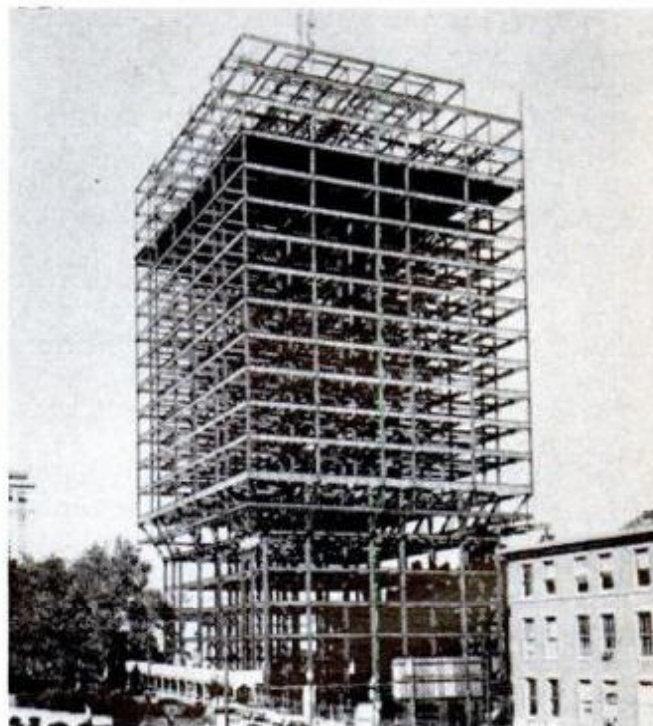

AIR RIGHTS and cantilever construction solved problem in erecting new Mercy Hospital in Baltimore

juiciest plum of all—51 acres of air rights over its tracks in the best possible location, right smack between Chicago's Loop and Lake Michigan. It's an air-rights builder's dream, the most valuable chunk of space in Chicago and perhaps in the world. Already the \$42 million Prudential Building is sitting atop the tracks, and a plush apartment building has been constructed to give tenants a gorgeous view of the lake on one side and Chicago's skyline on the other.

The rest of the property, though, is in a legal snarl at the present time, and a good many people including Illinois Central officials and real estate investors are watching the court battle.

Standing in the wings are drooling developers, ready to leap into action if the court rules in IC's favor. Proposed for this prize chunk of air rights are a batch of projects that would dwarf even New York's Rockefeller Center.

Here are some other interesting air-rights projects:

- In Baltimore, the three-story Hamburger apparel store recently built a 105-foot wing extending its second and third floors over Fayette St.

- In Buffalo, four stories of the new county public library will be built over downtown Allcott St. on seven 70-ton trusses, each 70 feet long.

- In Boston, the Massachusetts Turnpike runs under the new Prudential Center. And in Fall River, Mass., a municipal building complex has been proposed to bridge a new highway which will divide the town in two. ★ ★ ★

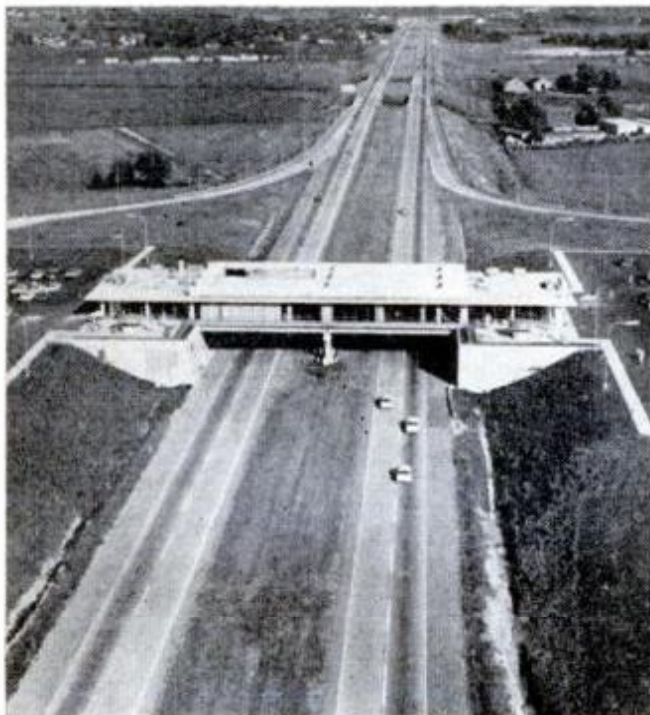

GOOD USE IS MADE of space above Illinois Tollway. Restaurants like this serve two-way traffic

GOVT. SURPLUS AND OTHER BARGAINS SAVE UP TO 90%



MOTORIZED TRANSFER PUMP

High volume. Delivers up to 700 gal. per hr. @ 35 PSI. Vane-type with carbon blades. Excellent for pumping water & oil base insecticides, transferring diesel fuels, gasoline, kerosene, solvents, etc. 24 V. D.C. motor. 1/4 H.P. 2500 RPM. 1 1/2" x 5" H x 4 1/2" W. Approx. GOV'T COST \$100. Tested prior to shipment, like new. \$21.50

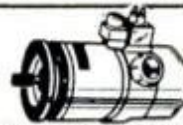

AC-DC GENERATOR rated 200 AMP

DC @ 24 to 30V. Also produces 1200 watts of AC current. Excellent for making your own arc welder. Also for lights and many cooking accessories. Size 14" L. x 6" dia. Tested prior to shipment. Shpg. wt. 55 lbs. Approx. GOV'T COST \$350. Special \$14.95

DC JET GENERATOR ARC WELDING KIT complete with GE Type CM Gen (30 V. D.C., 400 AMP, 3000 RPM: ampere rating is for continuous duty, intermittent amperage is 500 to 600 amps). Also 2 rheostats, 1 voltage reg., 1 voltmeter, 1 electrode holder, 1 welder's mask, 1 toggle switch, 10 lb. vacuum packed 3/8 in. welding rods, pair welder's gloves & spline coupling. All units guaranteed pre-tested. Wt. 110 lbs. Approx. GOV'T COST \$700. All items \$64.50



HEAVY DUTY MAGNET Fantastic power, will pull 125 lbs. on steel block. Excellent as underwater retriever. Picks up all ferrous metals. Dim. 4" x 2" x 1 3/4". \$7.95.



NEW! BIG 1966 CATALOG

Send 25c for amazing catalog with 1000's of bargains in hydraulics; electrical, marine, automotive items, etc. Order from ad. Prices FOB. 50% deposit for COD. Pls. include your zip code number. Satisfying mail order customers thru-out the world since 1945.

AIRBORNE SALES CO. Dept. PM166
8501 Stellar Dr. • Box 2727 • Culver City, Calif. 90231

Keeps Locks From Freezing



Puts an end to cold weather sticking and jamming. Easy to use, too. Handy squeeze dispenser lets you pinpoint a controlled jet of lubricant right where you want it.



Try these other special lubricants from Dixon: Chain Oil, Graphoil, Belt-Mate, Cable Lube, Slip Stick, Handy Home Oil. Available at hardware stores, service stations, locksmiths and auto part stores.

THE JOSEPH DIXON CRUCIBLE CO., Jersey City, N.J. 07303

(Continued from page 109)

perature wear, low-temperature rusting and deposits, high-temperature oxidation stability, high-speed cam and tappet wear and sludging and screen-clogging properties.

All Toronado steering linkage points should get a dose of multipurpose chassis lubricant every 12 months or 12,000 miles, whichever comes first. The four upper and lower ball joints require initial lubrication at 36,000 miles and thereafter every 12 months or 12,000 miles.

New fuel-metering design. In the new GM Quadra-Jet four-barrel carburetor (standard on some Chevrolets with the 327, the 396 and 427 engines on the Riviera, the Pontiac OHC Sprint Six, and the Olds Toronado, Cutlass 4-4-2 and Super Rocket engines), the primary and secondary sides of the carburetor differ in operation. The two small primary bores meter fuel through the venturi principle while the large secondary bores use an air-valve principle whereby fuel is metered in direct proportion to the air rushing through the secondary bores. Other V4 carbs only control the air flow through the secondary bores and rely upon the venturi principle to get the fuel into the air stream for mixing.

At a certain stage of primary throttle-plate opening (controlled by the accelerator pedal and engine load) primary bores can no longer meet the engine's fuel and air demands. At this point, the primary throttle lever, mounted at the side of the carburetor body and mechanically connected by linkage to the secondary throttle-plate shaft, begins to pull the secondary throttle plates open. Air rushing through the secondary bores creates low pressure beneath the air valve, and atmospheric pressure over the valve forces it open against slight spring tension.

Further opening of the air valve rotates a plastic cam attached to the center of the shaft and this cam pushes up a lever, raising the metering rods out of a fuel well. Fuel then flows from the float bowl into the secondary discharge nozzles and into the secondary bores. Increased engine speed increases air flow and the cam rotates still farther, permitting additional fuel to enter the engine as the tapered metering rods rise.

The factory sets the metering rods and no adjustment should be required unless they are damaged or bent. Air-valve flutter, which may occur from engine pulsations, is dampened by a dashpot piston operating in a fuel-filled bore in the carburetor body. The Quadra-Jet uses a

cleanable, sintered-bronze fuel-inlet meter with a pressure-relief spring, a closed-cell plastic float pontoon that is lighter than the conventional hollow-brass float and a float needle with a soft Viton, rubber-type tip, diaphragm-assisted to provide complete shutoff of incoming fuel if fuel-pump pressure should vary. In effect, fuel pressure counterbalances the float.

"Slushboxes" are simpler. Most automatic transmissions today can outthink most drivers. And they keep getting better—sometimes by the addition of another valve, sometimes by the removal of a unit. In the Chrysler TorqueFlite, the rear oil pump and the reverse blocker valve are eliminated from inside the case. New gating, for preventing accidental shifting into reverse while in forward motion, makes the hydraulically operated blocker valve unnecessary and improved front pumps and valve bodies have retired the rear pump.

Another transmission that has dropped the rear pump is the Turbo Hydra-Matic. The Powerglide is one of the few to retain this unit. Without the rear pump, push starts are impossible; but today's bumpers being little more than decorative tinfoil, jumper cables are a much better method to get yourself going again anyway.

Other power-train changes include the dropping of the conventional, leather-type rear axle pinion seal in the Dodge line. A "polycrylic" seal that has greater heat resistance and eliminates wick-like seepage is now used. And, to eliminate drive shaft vibrations, many new cars have constant-velocity universal joints, including Imperial, Lincoln Continental, Cadillac, some full-size Buicks and Toronado. These U joints cost much more than conventional cross-and-roller types, but they offer a smooth, vibrationless ride.

Plymouth and Dodge retain cross-and-roller joints, but they use a zero-degree drive line. This means the centerline of the engine and transmission is in a direct line with the centerline of the pinion gear in the rear axle. The result: less chance for driveshaft whip and smoother operation with changes in rear-axle up-and-down movement.

Another improvement for these two cars is new engine mounts. They're "tuned" to counteract drive line vibrations from rough roads at high road speeds, and they have been brought closer together so that the engine tends to roll more easily. Mounting life is at least triple that of earlier designs, say engineers.

All in all, the '66s promise to be the most trouble-free and maintenance-free cars ever. ★ ★ ★

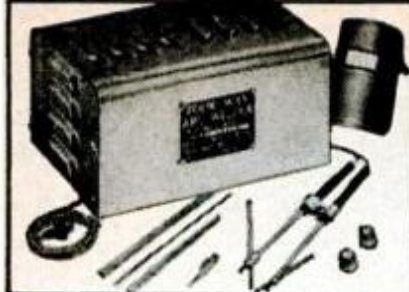

FOUR-WAY
BEST LOW COST
ARC WELDER
YOU CAN BUY
only \$14.95 Complete

WELD, BRAZE, SOLDER, CUT. Tops in performance and value. Ideal gift, educational, profitable, enjoyable. No experience needed. Use 3/8" welding rods and 1/4" carbons to make or repair auto bodies, fenders, trailers, boats, toys, furniture, farm equipment; garden tools, anything of metal. Operates on 110 V. line.
WORLD'S GREATEST WELDING VALUE. Over 500,000 in use by home owners, farmers, hobbyists, mechanics. **5-Year Unconditional Guarantee.** If inoperative will repair or replace without charge. **You Get: FULL FACE SHIELD,** heavy metal cabinet, ground clamp, 12 ft. of heavy duty welding cables, twin carbon arc torch, rod holder, carbons, welding and brazing rods, flux, solder, instructions. Order on **10-DAY UNCONDITIONAL MONEY BACK TRIAL.**
SEND ONLY \$2.00 and pay \$12.95 plus C.O.D. charges on delivery. or send only \$14.95 and we will ship prepaid. Order today.

FOUR-WAY WELDER CO. DEPT. W2-A
 1810 S. FEDERAL ST.
 CHICAGO, ILL. 60616

Piano-hinge top, two drawers and tote tray. 20x9x9 1/2 steel box in blue finish.
 At Hardware Stores or Write:
HUOT MFG. CO.
 555 N. Wheeler St.
 St. Paul 4, Minn.

Deluxe hip-roof tool-saver
HUOT TOOL BOX
 FOB \$18.00
 St. Paul
 Model 110



Print Your Own
 Cards, Stationery, Advertising, Circulars, labels, photo and movie titles, church work, tags, etc. Save money. Sold direct from factory only. Raised printing like engraving, too.
Own a Printing Business
 Print for Others, Good Profit. Have home shop. Junior press \$15; Senior \$35 up. We supply everything. Easy rules. Pays for itself in short time. Write now for free details.
KELSEY PRESSES, Z-37 Meriden, Conn.



Solves Repair Problems
 Durham's fills cracks and holes in plaster, wood and tile. Won't shrink or fall out. Economical, easy to use. Big 4-lb. can, only 1.60 at lumber, paint, and hardware dealers, or shipped direct postpaid in U. S. for \$2.00. Money-back guarantee. Order now. Donald Durham Co., Box 804-T, Des Moines, Iowa.

Shrinks Hemorrhoids
New Way Without Surgery
Stops Itch - Relieves Pain
 For the first time science has found a new healing substance with the astonishing ability to shrink hemorrhoids and to relieve pain - without surgery.
 In case after case, while gently relieving pain, actual reduction (shrinkage) took place. Most amazing of all - results were so thorough that sufferers made astonishing statements like "Piles have ceased to be a problem!"
 The secret is a new healing substance (Bio-Dyne®) - discovery of a world-famous research institute.
 This substance is now available in suppository or ointment form under the name Preparation H®. Ask for it at all drug counters.



EXPLORE... The Exciting
World of Electronic Kits
With This New FREE
1966 HEATHKIT Catalog!

Space-age fun at 50% savings! Build your own stereo/hi-fi, marine electronics, color TV, electronic organ, portables, ham radio, plus many more! No special skills, talents or tools needed! ... find out how simple it is. Tear out coupon for your Free Catalog now!

HEATHKIT

HEATH COMPANY, Dept. 17-1
 Benton Harbor, Michigan 49023
 Please send FREE 1966 Heathkit Catalog.

Name _____
 (Please Print)
 Address _____
 City _____ State _____ Zip _____
 CL-213R

Liquid
WRENCH
LOOSENS RUSTED NUTS, BOLTS, PARTS IN SECONDS
 at Service Stations, Auto and Hardware Stores



ROUTERMATIC
MAKES EVERY MAN
AN EXPERT
WOODWORKER
 Clamp this amazing tool to your electric drill and route, mortise, trim, shape, mitre and tenon like a professional cabinetmaker. Handles any job better by letting you take the tool to the work. Just like having an electric chisel. Routermatic is precision made, sturdy, lightweight. Use it once and you'll wonder how you ever got along without it. **ONLY \$6.95** including \$1.50 router bit. No C.O.D.'s. Can't be sold thru stores at this low price. Descriptive folder on request.
COMP-TOOL, Inc. 355 Prospect Rd., Ashtabula, Ohio

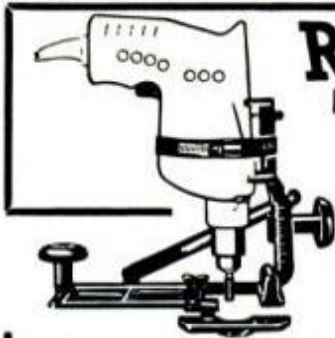

THREE HOTTEST ENGINES

(Continued from page 102)

lagged behind on every other test. Top speed range is from 138 to 145.

The Ford rode smooth and firm, thanks to the heavy-duty suspension. Overall, the ride was little different than in regular production models. In sharp curves there was some lean, but you never get the feeling that the car is tipping.

Except for the slow and heavy manual steering, the car was a pleasure to drive. Detents for each gear in the 4-speed transmission were positive and shifting was smooth. The manual clutch was soft, but it still had enough grab to handle the big torque of the engine.

A bit of skullduggery

This car had its defects, too. First of all, the engine stalled repeatedly, due to a high setting of the floats in the carburetors. Then the gears in the rear axle started to get noisy. Ford attempted to replace the rear end between the time I made acceleration runs and the next day when fuel economy tests were made. They wanted to put a 3.25 rear end in to replace the 4.11 that was used on acceleration tests. I vetoed the move.

Also, while the acceleration runs were in progress the shift linkage on the transmission was stretched to a point where shifting speed was severely affected. The transmission didn't want to go from gear to gear quickly, and it took some hard shoving to move the shift lever.

Of the three cars tested, I think the Ford suffered more from a poor combination of power, rear end ratios and tire size. The engine was just too much for the tires to handle. To get a good start from stop, the engine had to be cut way down or the tires would just sit there burying themselves in the asphalt. As a result, the Ford began its runs with the engine running at near stall speed.

The Dodge Coronet hemi that I drove weighed in at a surprisingly heavy 4419 pounds with all the equipment and crew aboard. Any big weight advantage Dodge may have started out with because of the intermediate size body was lost somewhere by adding heavy duty components. The car was beefed up with heavy duty springs and sway bar, special shocks, reinforced spring hangers, extra large police brakes, Sure Grip rear axle and a 5-clutch automatic transmission. Hemi buyers consider this the average equipment they want with the car.

The extra hard police tires and heavy duty suspension made the Dodge ride stiffer than Ford or Chevrolet. It actually

bordered on being harsh. But overall, the combination of the big engine and stiff ride made the Coronet a pleasurable car to drive. You have to keep in mind that the hemi is not only designed for cruising down the boulevard; it likes high speed and tight corners.

Dodge had TorqueFlite automatic transmission, using a special 5-clutch design that easily handles the power of the engine. It was easier to keep wheels from spinning off the line. And the transmission also eliminated some of the unsureness you get with manual shifting. Heavy duty components in the suspension and rear axle also got rid of another problem that seems inherent with high torque engines; speed-robbing wheel hop. The tires laid out a continuous strip of rubber.

Fastest family sedan?

While there was no available place to make speed runs at the top end, Dodge engineers assured me that the car I tested was capable of 145 miles per hour. And they said that's a conservative estimate.

Gas consumption at a steady 45 mph was a so-so 13.8 miles per gallon. Keep in mind that this mileage is impossible to duplicate in regular driving because of the constant speed of the car. Also, it is not quite the optimum mileage you can get under controlled conditions since the best economy readings are at 30-35 mph. However, all three cars were checked at the same rate of speed, and our figures are a valid comparison.

Speed times show the hemi makes the best use of its power in the passing ranges from 40-80 mph. It topped the other two cars in the 40-60 mph run at just under 3.1 seconds. For 60-80 mph it took 3.5 seconds, still ahead of Ford and Chevrolet. Combined times of 40-60 and 60-80 show the Dodge with a total of less than 6.6 seconds, while Chevy had 7 seconds and Ford 7.9.

In the quarter mile run Dodge took a tenth of a second longer than Chevy, but recorded an even 100 miles per hour, the highest of the three cars. A good indication of Dodge's power punch at high speed. Chevrolet's 427 was probably the most domesticated of the three cars I tested. The car wasn't slow, it just felt more like the family sedan than the other two. For one thing the suspension was not beefed up. Chevy had the same soft springs and shock absorber combination on the test car that it uses on its regular V8 sedans.

And the car was quiet. Power noise in the fastest acceleration runs was at about the level of a standard sedan. Exhaust noise was a trifle throatier though.

Unlike the Dodge and Ford, Chevrolet

has only one 4-barrel carburetor available with the 427, but it does the job in outstanding fashion. The extra gas mileage you get from the single carburetor is enough to convince me to stay way from more complicated setups. Besides, the top speed of this car is a rousing 142.5 miles per hour.

Economy champ

The Chevrolet got over 3 miles more on a gallon of gas than the next highest car. And these tests were run under almost identical conditions.

For those diehards who still want the extra punch of dual carburetion, the Chevy people tell me that custom performance shops are now offering multiple carburetor kits with special, high-capacity intake manifolds to fit the 427.

A word about clutches. It was surprising to note the softness of clutch action on Ford and Chevrolet; there was no heavy back pressure, no jerkiness. Still the clutches ran through more than five maximum acceleration runs with no noticeable loss in efficiency. No wonder the 4-speed boxes are so popular.

Extra equipment on the Impala test car comprised a 4-speed transmission, power brakes and steering, tachometer, AM/FM radio, tilt-and-telescope steering wheel, non-slip differential, power windows, viscous fan plus the regular SS model goodies. Total weight of the car in test was 4584 pounds including passengers and equipment.

I had a chance with the Chevrolet to see how these high powered cars behave on gravel roads. Believe me, it was an education. Those rear tires want to spin at the slightest pressure on the gas pedal. At any speed, and in practically any gear, that rear end is ready to come around and zip right past you.

Warranties changed

The auto companies have some screwy warranty rules for these cars, that depend on the corporate philosophy for racing. Ford will not warrant its engine at all, a realistic rule in light of the fact that almost all of the 427 engines it sells will end up in formal competition on the race-track. But the standard 24 and 24 warranty on the body is still good. I think Ford will even stand behind the engine, if you can prove it has had normal use.

Dodge will warrant its engine for 12 and 12. Chrysler people know that it would be foolhardy to give the usual 5 and 50 guarantee with the hemi, because these engines, by their very design, invite extreme use. If you race the hemi, though, (Please turn to page 228)

SEALS TUBS

DAP® KWIK-SEAL® Tub & Tile CAULK

Gives rubber-like, watertight seals around tubs, showers, lavatories, sinks. Caulks window and door frames; fills holes. Easy to apply. No silicones—no unpleasant odor. Takes paint. Money-back guarantee. Sold at leading hardware, building supply, paint and specialty stores.



DAP DAP INC., Dayton 31, Ohio
SUBSIDIARY OF Plough, Inc.

Save Money on WOOD

Hardwood Veneers . . . Hardware . . .
Wood Shop Supplies and Equipment
. . . Power Tools



Hardwoods, Fine Plywoods,
Inlays, Mouldings, Mosaic
Tile, Tools, Lamp Parts,
Upholstery Supplies

Your new MONEY SAVING wood and workshop buying guide now ready! 140 page. Full color! Your best "one stop" source for finest kiln dried domestic and imported hardwoods, veneers, plywoods, modern and traditional legs . . . over 1500 items.

STANLEY TOOLS at Discounts
Startling savings on top name power tools, hard to find cabinet hardware, lamp and upholstery supplies. New projects and kits. Enclose 35¢ to help pay mailing and handling costs. Mail coupon.

New Catalog
over 1500 items
Now Ready!

**CRAFTSMAN
WOOD SERVICE COMPANY**

2729 South Mary, Chicago, Illinois 60608. Dept. A-16
Rush new Craftsman WOOD Catalog. I enclose 35¢ to help pay mailing cost.

NAME _____
ADDRESS _____
CITY _____ STATE _____ ZIP _____
CODE _____

Sure beats smoking!



Enjoy Copenhagen: Place a small pinch between cheek and gum. No chewing.

United States Tobacco Company

BUILD YOUR OWN CAMPER AND SAVE!

Complete, easy to follow Camper Plans, instructions, materials list... **\$3.95**

PICKUP COVER PLANS with removable rear panel... **\$2.00**

EQUIPMENT CATALOG Refundable on first order... **\$1.00**



SATISFACTION GUARANTEED!

Send Check or M.O.—For Details Send Dime!

MAIL TODAY CAMPER COVER CATALOG

NAME.....

ADDRESS.....

CITY..... STATE.....

VIKING CAMPER SUPPLY 94-B Glenwood Ave. Minneapolis, Minn. 55403

RUPTURE!

An amazing Air-Cushion Invention allows body freedom at work or play. Light, neat, cool, sanitary. Durable, cheap. Day and night protection helps Nature support weakened muscles gently but surely. No risk. Sent on Trial! Write NOW for free Booklet and Proof of Results. All correspondence confidential.



Brooks Company, 346-C State St., Marshall, Mich.

NEW LIGHTWEIGHT TIRE GAUGE

Guaranteed accurate — and only **\$2.19 ppd.**

Send check or money order to:
JAY of Chicago
Dept. H, 919 N. Michigan Ave.
Chicago, Ill. 60611



ITALIAN SNUB NOSE AUTOMATIC

Identical duplicate in styling of automatic detective revolver. Fires 12-4.5 cal. blank cartridges in 10 seconds. Not a CO₂ or Pellet gun.

FREE—72 rounds of blank cartridges included. Perfect for sports, stage, etc. Illustrated gift carton.

FEDERAL 6652 N. Western/Chicago, Ill. 60645
Dept. GPM 1

FREE 72 ROUNDS OF BLANK CARTRIDGES

Postpaid Send cash, check or M.O. No COD's please.

Request **FREE** Catalog

\$4.98

THREE HOTTEST ENGINES

(Continued from page 227)

forget it. You can't expect anything from the company.

Chevrolet's racing ban has backed the division into a corner, to the benefit of the customer. Since Chevy officially doesn't go along with this racing business, it must take a head-in-the-sand attitude that the 427 is strictly for street use. As a result, the Chevrolet engine has the full warranty of 24 months or 24,000 miles, whichever comes first, just like any of its other cars. However, I think if you read the fine print on that warranty, you lose protection if the car is raced. ★★★

	Ford 7 Litre Galaxie	Chevrolet Impala SS	Dodge Coronet 440
Tires	8.15 x 15 Firestone	8.25 x 14 U.S. Royal	7.75 x 14 Goodyear
Rear axle ratio	4.11:1	3.31:1	3.55:1
Weight including equipment & passengers	4504 lbs.	4584 lbs.	4419 lbs.
Approximate suggested retail price of car	\$4725	\$4575	\$3500

	Ford 427 Galaxie	Chevrolet 427 Impala	Dodge Hemi Coronet
0-30	3.4 sec.	3.3 sec.	3.66 sec.
0-60	7.2	6.7	7.06
40-60	3.2	3.2	3.06
60-80	4.7	3.8	3.5
¼ mile	14.5	14.8	14.9
1.4 mile speed	98.4 mph	91.0 mph	100.0 mph
Fuel economy at steady 45 mph	11.4 mpg	17.65 mpg	13.8 mpg
Top speed	145 mph	142.5 mph	145 mph

Suboceanic Crisis

Future generations could find food for millions along the coastal areas of the world—if man hasn't by that time destroyed this lode with his wastes. Estuaries, where rivers flow into the sea, rank among the most naturally fertile areas for finfish and shellfish; yet these are the very places most beset by waste products.

In a talk before the National Audubon Society convention in Boston, John S. Gottschalk advocated a solution to the problem along four main courses: education, research, legislation and coordination. Mr. Gottschalk is director of the Bureau of Sports Fisheries & Wildlife of the U.S. Department of the Interior.

HOME WORKSHOP ARC WELDER!



**ELECTRIC
WELD BRAZE,
SOLDER, CUT
ALL METALS**



New 1966 Model

LIFETIME BURNOUT GUARANTEE—10 day money back

trial. Works on any 110 volt "Plug in". Welds up to 1/4" steel with 1/16" to 3/8" rods. **EXTRA** Special twin pressure type arc torch (shown) develops up to 10,000 deg. heat—**HAS A MILLION USES**—for **CARS—HOME—FARM—FACTORY**. No experience needed—**FREE** Welding book teaches **YOU**. Thousands of users. **SEND ONLY \$2.00** (cash, Ck, MO) and pay postman \$12.95 COD Postg. (r send \$14.95 for postpaid delivery in USA. **COMPLETE** ready to use with 12 ft. H.D. Cables, Arc torch rod holder, carbons, welding and brazing rods, flux solder, work clamp and full face mask. **FREE EXTRA** "Dark" eye goggles—if you order at once. **THIS BEST FOR THE MONEY** welder sold **ONLY** by **MIDWAY WELDER**, Dept. DPM-1, Kearney, Nebr.

For a Complete Book of Professional Secrets

Plus Illustrations
Of Products
And Prices Of
Over 300 Different
Molds You Can Use
To Make And Sell
Ornamental
Concrete Items . . .
SEND \$2.00



rushed to you by **FIRST CLASS MAIL**

CONCRETE MACHINERY COMPANY, INC.
839 Lenoir Rd. - P. O. Box 99 - Hickory 2, N. C.

ECONOMY DOES MORE **TRACTOR** KINDS OF JOBS



**MAN SIZE TRACTOR
AT GARDEN SIZE PRICE**

Powerful! America's big tractor value. Low price. Rugged, built-in quality. Easy to operate. 9 to 12 hp. **ALL GEAR DRIVE** incl. clutch, 3-spd. trans., diff., 176 to 1 reduction. Wt. 790 lb. 25 low-cost, quick-change tools for farm, lawn, snow, woodland. Write for **FREE CATALOG & dealer name**.

Engineering Products Co.
1005K-01 Anoka Ave., Waukesha, Wis.

You Can Own a 56' x 12' Mobile Home, King Size Lot and Utilities All For Only \$66⁶⁷ Per Month!
Situated On Four Lane U.S. #441-27 In The Heart Of The Citrus And Lake Section of Florida!



AD646070(F-2)

For low monthly payments with nominal down payment you can immediately move into a brand new, beautifully furnished two-bedroom Mobile Home on a 75'x125' lot, with superb water and septic tank. Pay like rent and then receive title to land, improvements and Mobile Home. Offer limited. Investigate before it is too late. For free booklet "Mobile Home Living in Florida", photos and information write:

ORANGE BLOSSOM HILLS INC. Dept. 519
2148 N.E. 164th Street, Miami, Florida 33162

UP YOUR BOATING SAFETY and FUN!

LEC-O-LIFT



Tilts and holds a motor in any position hydraulically

No other Lift has so many features:

- Manual or electric dash-board controls
- Improves riding performance under all loads and water conditions
- Drive up on sandy beach and back off. Allows full reverse under power at all times
- Drive through shallows without damage
- Motor releases upon hitting submerged objects



LEC-O-LIFT will take your boat anywhere it floats

WRITE FOR LITERATURE and PRICES

CASS SCREW MACHINE CO.

Lec-O-Lift Div., Dept. B-126—4748 France Ave. N. Minneapolis, Minn. 55429

PEEL OFF PAINT with KLEAN-STRIP



Heavy-Bodied wash type

- Fast, clean, safe
- No afterwash needed
- Non-flammable
- Refinish immediately

Regular for furniture work



THE KLEAN-STRIP CO., INC.
MEMPHIS 6, TENNESSEE

good glue never gets noticed

You're only aware of a glue-line when it fails. Use the right glue for the job and it won't let you down. **Weldwood® Plastic Resin Glue** makes a wood joint stronger than the wood itself. Glue it. Forget it. It's that good a glue.



U. S. Plywood Corporation
2305 Superior Ave., Kalamazoo, Mich.

LUXURY CAR

(Continued from page 99)

miles. Also, every car is dynamometer-tested for "50 miles," and each engine is run four hours before it's installed.

The body is remarkably rigid. It's made of steel, except for the hood and trunk, which are aluminum, and the doors, which are an aluminum-magnesium alloy to prevent corrosion. There's also a steel bar along the sides of the roof in case of a rollover.

The interior of our test car was appointed in fine leather, and the massive dash was carved from wood. The instrument layout was functional, and the steering wheel looked like a prewar Detroit part. Instruments included the ammeter, oil-pressure and water-temperature gauges. There were warning lights for low fuel, handbrake and battery discharge.

Rear seating was surprisingly confined, but the flat floor was an important plus. Rear passengers also had the convenience of folding picnic tables and footrests.

Driving the car was exhilarating, perhaps not even so much because of mechanical excellence as because of the Rolls image. Just looking down that long, straight expanse of hood gives one a feeling of power and status.

The big, 380-cu.-in. aluminum engine pulls the 211¾-inch, 4700-pound car easily. Rolls doesn't advertise horsepower, but there's plenty on tap. The four-speed automatic is positive, but not smooth.

Steering is moderately fast and fairly sensitive. Servo assist varies depending on effort required to move the driving wheels. Ride is unusually firm, even when the rear shocks are on the soft setting. At low speeds the ride is inferior to American luxury cars, but over really bad roads the suspension smooths out. Handling and cornering are markedly better than in the U.S. high-priced cars, especially when shocks are set at "firm."

Surprisingly, seat travel and rake adjustment are manually controlled. Standard features are power windows and a solenoid-operated gas-filler door. Other handy features are a single switch that controls fog, parking and headlights, a balanced control between front and rear radio speakers, adjustable front armrests, a dash socket that allows the battery to be charged without being removed, and a rear-window defroster consisting of hair-thin wires embedded in the glass.

Rolls also offers a long list of options: extra-wide rear seat, ladies' vanity, trunk picnic table, built-in bar. Even the shift lever can be switched from the right to the left side of the steering column.

But the big surprise is that a new Rolls model has been introduced. It wasn't available here at this writing, but on paper it promises to be an exciting, modern design. Called the Silver Shadow, it has sleek styling and four-wheel disc brakes. Independent suspension, long considered an unnecessary complication by Rolls, is now used. To hold an even keel regardless of load, an automatic hydraulic height control is fitted. Length, width and wheelbase are all smaller, but the engine remains unchanged. Price is yet to be announced.

The ultimate in luxury. Most impressive of our test cars was the "Grand Mercedes," the 600 sedan. The styling is boxy and functional and, with a jet-black finish such as our test car had, exudes an efficient Teutonic arrogance.

The dash is modern and businesslike. A tachometer and speedometer, both big and round, enjoy prominent positions, along with temperature and oil-pressure gauges. There's also an aurora borealis of colored warning lights for right and left generators, low hydraulic pressure, high ground clearance (when the air suspension is raised) and high beams.

Hydraulically operated accessories include trunk lid, shock adjustment all around from hard to soft, windows, seats, heat and vent flaps and automatic parking-brake release. Everything works in complete, almost ominous silence. Even the doors close automatically, with just a whisper.

Front seats have power adjustment fore and aft, up and down, and for angle. The rear seat reclines partially. These rich, leather-covered seats, incidentally, were probably the most comfortable we've tried.

One lever controls directionals, the two-speed wipers, headlight flasher and windshield *schpritzer*. A switch lets you select either the loud or the soft air horn. The loud one, which sounds like a rhinoceros in labor (only worse), should be used "only outside built-up areas," according to the owner's manual. We tried it on a few New York cab drivers. It's the only thing we've ever found that scares them.

Other interior features include a mirror that breaks on impact, a rear-window defroster with warning light, a steering wheel that telescopes, an aerial that automatically rises and retracts when the radio is switched on and off, all kinds of reading and courtesy lights and a vacuum-operated central door-locking system.

This destroyer weighs all of 5446 pounds, but its 386-cu.-in. double-overhead-cam V8, conservatively rated at 300 hp, pushes the car to 60 mph in just about 10 seconds. Mercedes claims a top speed of 127.4 mph. Perhaps this is optimistic, but

the car is definitely built for high-speed, long-distance cruising—as is indicated by the 29.6-gallon fuel tank.

It's hard to believe that such a heavy-weight could handle well, but it does. With shocks set at "hard," cornering approaches that of a sports car. And ride isn't objectionably firm. On soft setting, ride is close to perfect. The turning diameter is an amazing 39.5 feet. Even the Corvette needs more room.

The automatic transmission is exceptionally positive. And it can be overridden to hold second, third or fourth gear.

The last car on our list, a Jaguar 4.2 Mk X, listed for \$7950 as equipped. It had \$960 worth of options, including radio, white walls, power windows, tinted glass and airconditioning. We expected it would be a letdown after cars costing over twice as much. We were wrong.

Its styling was probably the handsomest. The interior was impressive, with a massive wooden dash, rich leather pleats and an array of toggles and gauges that would delight an astronaut. There's full instrumentation: tachometer, ammeter, oil-pressure and water-temperature gauges. And warning lights for ignition and for hand-brake and brake fluid level. Rear-seat passengers have two folding picnic tables.

The Jag is sporty first, luxurious second. It's the only car that offers a four-speed stick as well as an automatic. And there's that gleaming racebred 258-cu.-in. dual-overhead-cam Six with three carbs.

The three-speed-plus-torque-converter automatic is positive but, like the Rolls unit, not the smoothest. It offers some manual control. "L" locks in second or first, allowing a two-one shift but never an upshift into third.

The car isn't as quiet at speed as the others. Rear passenger room is skimpier, though still adequate for five passengers. Panel lights have no rheostat, just a two-way switch. Seats adjust manually, but do have a rake control. Even the aerial is manually operated, by a pencil-sharpener-like crank under the dash.

But that little Six cranks out over one hp per cubic inch, which gives acceleration almost as good as that of the Mercedes. One performance feature it shares with Mercedes is the standard-equipment, limited-slip differential. Cornering and general handling are unsurpassed by any of the other five cars.

Are these cars worth the extra money? It depends. If you can afford it, and if you appreciate luxurious, trouble-free transportation, the answer is a resounding yes. We found it hard to readjust to our own cars after our tests were over. Guess we're in the wrong (b)racket. ★★★

SAVE UP TO 85% **GOV'T SURPLUS and NEW EQUIP'T**

Send 25c For 3 Big Catalogs

**PUMPS
WELDERS
WINCHES
SURVEYING
TELEPHONES
HYDRAULICS
GENERATORS**

**ELECTRONIC
BINOCULARS
GEAR MOTORS
COMPRESSORS
SPEED REDUCERS
WEED SPRAYING
MANY OTHERS**



SURPLUS CENTER Dept. PM-016 Lincoln, Nebraska



Smoke **BOND STREET**
the pipe tobacco that stays lit



UNIMAT
the precision lathe and professional multi-purpose tool that lets hobbyists grind, polish, bore, mill and drill with no prior skill. For free literature, write American-Edelstaal, Inc., Dept. GA-6, 350 Broadway, New York, N.Y. 10013.

New! 2 LB. MAGNET lifts 125 LBS.

Revolutionary new non-electric magnet has twice the power of Alnico 5. Won't demagnetize. Full power lasts forever. No keeper needed. Pulls 125 lbs. on steel block. Wt. 2 lbs. / 4" x 2 1/2" x 1". No. X-125, \$8.95 postpaid.

ALNICO 5 BARGAINS / WE PAY POSTAGE / MONEY-BACK GUARANTEE

- No. RN75 Retriever assembly pulls 75 lbs. on steel block \$5.95
- No. HN25 Small assembly pulls over 25 lbs. on steel block \$3.95
- No. GP3 Electric guitar pickup rod, 3/16" dia. x 1" 10 for \$1.95
- No. GP5 Electric guitar pickup rod, 3/16" dia. x 1 1/2" 12 for \$3.95
- No. CM9 Superpowered rod, rounded ends, 1/2" dia. x 3" \$1.25
- No. MM30 Small bar, tumbled smooth, 1/4" x 3/16" x 1" 10 for \$1.00
- No. SC20 Science experiment & hobby kit. 10 assorted magnets \$2.00

SAMPLE PAIR SMALL HORSESHOE MAGNETS & NEW BARGAIN CATALOG 25c

MAGNA MAGNETICS 7777 SUNSET, LOS ANGELES, CAL. 90046 DEPT. M

IF YOU HAVE HERNIA

Get this NEW FREE BOOK

Tells how Rupture can be treated by a mild Non-Surgical method that is backed by a Life Time Certificate of Assurance. This treatment method has a long history of use and is recognized by Authorities today. Men and Women from all over the country have taken the Non-Surgical Treatment and reported it is effective. Why put up with wearing a griping, chafing, unsanitary truss?

Write today for this FREE BOOK. Tells How, explains Why more and more Rupture Sufferers are using Modern Non-Surgical Treatment Methods. Act Now. No Obligation.

EXCELSIOR MEDICAL CLINIC
Dept. E6129 Excelsior Springs, Mo.



Bob Jones boosted his salary 300%*. Could you do the same?

A few years ago, he was just another guy. Putting in long hours in a monotonous job. Barely able to make ends meet. No prestige. And no opportunity to get ahead.

But Bob Jones had determination. He looked around and saw other men being promoted. Men with no more on the ball than he had. Except for one thing. Specialized training that made them worth more to their employers.

So then and there Bob made up his mind to get out of the rut he was in. He read an ad for International Correspondence

Schools, and mailed the coupon. (The same coupon you see at the bottom of this page.) And though he didn't know it, he'd already taken his first step up.

Soon, Bob was busy studying in his spare time. Learning new skills, and applying them in his work. It wasn't long before he was offered a better job, with a fat increase in pay. Then came other promotions—and each time, more money. Bob Jones was starting to go places. The future was bright. Today, his salary has skyrocketed 300%!

Bob Jones' success story isn't unique. It simply proves what determination can do. You can do it, too, if you're even half as interested in making good. Pick the position you want, and I.C.S. will help you prepare for it. Just as it helped Bob Jones, and hundreds of thousands of others.

Clip this coupon now. Mail it at once. You'll receive 3 valuable booklets—free. They'll prove to you that Bob Jones' success story can be yours!

*The true story of Robert E. Jones, Houston, Texas. From the success files of I.C.S.

More than 7,000,000 men and women have already enrolled with I.C.S.

Clip coupon here—and take your first big step to real success! I.C.S., Scranton, Penna. 18515

Accredited Member
National Home Study Council

INTERNATIONAL CORRESPONDENCE SCHOOLS

Dept. 1448, Scranton, Penna. 18515

(In Hawaii: P. O. Box 418, Honolulu. In Canada: I. C. S. Canadian, Ltd. In other countries: I. C. S. World, Ltd.)

Yes, I want to know about how I can get ahead through I. C. S. Rush me FREE Success Kit with 3 valuable booklets: "How to Succeed," opportunity booklet on the field I've checked below, actual sample I. C. S. lesson. (Special WICS booklets for women.)

CONVENIENT PAYMENT PLAN.

ARCHITECTURE and BUILDING TRADES

- Air Conditioning Maint.
- Architecture
- Arch. Drawing & Design
- Building Contractor
- Carpenter-Builder
- Carpentry & Millwork
- Heating & Air Conditioning with Drawing
- House Planning, Interior Design
- Reading Arch. Blueprints
- Refrigeration, Air Conditioning

ART and DESIGN

- Commercial Art
- Interior Decorating
- Sign Painting & Design
- Sketching & Painting

AUTOMOTIVE

- Auto Mechanic-Technician
- Body Rebuilding, Refinishing
- Electrical Technician
- Engine Tune-Up
- Transmission Specialist

BUSINESS

- Accounting (Canadian)
- Advertising
- Business Administration
- Canadian Business Courses
- Cost Accounting
- Gen'l Accounting
- Industrial Psychology
- Managing a Small Store
- Practical Accounting
- Programming for Digital Computers
- Programming the 1401
- Public Accounting
- Purchasing Agent

- Real Estate Sales
- Retail Business Mgmt.
- Salesmanship
- Sales Management
- Traffic Management

CHEMICAL

- Analytical Chemistry
- Chem. Engineering
- Gen'l Chemistry
- Chem. Lab. Technician
- Plastics Technician

CIVIL ENGINEERING

- Civil Engineering
- Construction Eng'n'ng
- Highway Engineering
- Sewage Plant Op'r
- Structural Engineering
- Surveying & Mapping
- Water Works Operator

DRAFTING

- Architectural
- Drafting Technology

- Electrical and Electronic
- Mechanical
- Structural

ELECTRICAL

- Appliance Servicing
- Elec. Eng. Technician
- Ind. Elect. Technician
- Motor Repairman
- Practical Electrician
- Practical Lineman
- Reading Electrical Blueprints

ELECTRONICS

- Electronic Computers
- Electronics Fundamentals
- Electronics Technician
- General Electronics
- Industrial Electronics
- Practical Telephony

ENGINEERING

- (Professional)
- Chemical Civil

- Electrical Mechanical
- Math & Mechanics for Engineering

HIGH SCHOOL

- High School Business
- High School (Canadian)
- High School General
- High School Math
- High School Secretarial
- High School Vocational
- College Preparatory

LANGUAGES

(Edited by Berlitz)

- French German
- Italian Spanish

MECHANICAL and SHOP

- Gas and Electric Welding
- Industrial Engineering
- Ind. Instrumentation
- Machine Design
- Machine Shop Practice
- Quality Control

- Reading Shop Prints
- Tool Design

SECRETARIAL

- Clerk-Typist
- Professional Secretary
- Shorthand
- Stenographic Typist

STEAM and DIESEL POWER

- Power Plant Eng'n'ng
- Steam Engineering

SUPERVISION

- Foremanship-Sup'rv'n
- Personnel-Lab. Rel'ns

TV-RADIO

- Radio & TV Servicing
- Radiotelephone License

MISCELLANEOUS

- Textile
- Other (Please specify)

Name _____ (Please indicate whether Mr., Miss or Mrs.) Age _____

Address _____

City _____ State _____ Zip Code _____

Occupation _____ Employed by _____ I am a member of U. S. Armed Forces.

Working Hours _____ A.M. to _____ P.M. **Special Training Programs for Industry** Send me facts about special low rates.



TEST

Continuous testing makes the '66 Mercurys the most dependable outboards ever built

Lake X. 11,000 acres in central Florida. Stumps, logs, sandbars, water hyacinths and wire grass. Average July high, 91°. Humidity, 89%. Water can be glassy-smooth — or 7-foot waves. Lake X is the world's toughest marine proving ground. Tough—and honest. Run by Mercury people who believe only in facts. There's no compromise, no quarter. We'll run outboards day and night for weeks at full throttle ... over timed, measured distances ... hit sandbars at 40 mph to test the shocks ... plow through saw grass trying to clog the cooling system ... run into logs, run in the rain, run wide open and at trolling speed, beat motors, take them apart, tabulate, compare. When we're through, there's little we don't know about an engine. Same thing

happens at Mercury's Siesta Key, Florida, proving grounds. Tests are just as rough. Only this time the enemy is salt water, sandbars, oyster beds, rocks. This is how we test marine propulsion at Mercury, testing not only Mercurys, but other brands. This is how we know the score. It's one example of the plus you get with Mercury ... dependability *plus performance*. See what we mean at your Mercury dealer. 3.9, 6, 9.8, 20, 35, 50, 65, 95 and 110 hp.



MERCURY



Kiekhaefer Corporation, Fond du Lac, Wisconsin and Kiekhaefer Mercury of Canada, Ltd., Subsidiary of Brunswick Corporation

Fairlane has a smart answer to the great manual-vs.-automatic question:



Fairlane GT/A

Used to be if you wanted a manual shift (because you really enjoy bossing a car) and your wife wanted an automatic transmission, one of you had to lose. That was before Fairlane's hot new GT came up with its amazing automatic option, GT/A.

Fairlane GT/A solves the problem once and for all with a new kind of Sport Shift Cruise-O-Matic drive. The quadrant now reads "P-R-N-D-2-1" and the little woman can ignore everything below "D." Sport Shift will think for her . . . smoothly, efficiently, effortlessly . . . as Cruise-O-Matic always has (and for you too when you're lazy). But if you want to do what no conventional automatic can — think *ahead* — all it takes is one quick flick of the lever.

Pick "1" and you get First, nothing else. For inching along in the city, or crawling up the side of a mountain it's First all the way no matter how you accelerate.

Pick "2" and you get Second, nothing else. Great for downshifting before a hairpin corner, for saving your brakes on a mountain grade, for the crawl, sprint, crawl, sprint of heavy freeway traffic. And like First, Second hangs in there until you decide it's time for a change. In short, Sport Shift gives you the fun of manual shifting. The only thing that's missing is having to pump a clutch . . . and who needs that?

The only way to get the true meaning of Sport Shift is to slip behind the wheel of a Fairlane GT/A. That way you discover one of those rare situations in which you *can* have your cake and eat it too!



AMERICA'S
TOTAL PERFORMANCE CARS

FORD

MUSTANG • FALCON • FAIRLANE
FORD • THUNDERBIRD