

*Holiday special: 25 pages of great new gifts and projects!*

# POPULAR MECHANICS

DECEMBER 1965  
35 CENTS

*Electronic snoopers—now you can outwit them!*

*PM exclusive: fantastic coneless speaker!*

*Toronado: first cross-country test!*



***They Move!***

*Outdoor action displays —  
eyecatching, easy to build!*

*Corn*

# Miller High Life

*The Champagne of Bottle Beer*

Hint for holiday hosts: add the sparkle of special lightness . . .  
the flavor of old-world excellence . . . and the distinctive  
goodness of Miller High Life beer to your holiday season!

Enjoy the quality of Miller High Life —  
unequaled, unquestioned, unchanging.

Sparkling  
flavorful  
distinctive



Brewed only in Milwaukee for 110 years!

Where did the new Norelco Speedshaver ever get the idea that it could match shaves with a blade?



It's all in our head.



**(WHICH IS NOW MORE THAN 18% THINNER FOR 18% CLOSER SHAVES)**

The new Norelco Speedshaver® gives the *close* electric shave — so incredibly close that we dare to match shaves with a blade. And yet the Norelco shave is still the *comfort* shave. Because Norelco rotary blades gently stroke off whiskers. Never grab or pull. Never cut or nick. Norelco "Floating Heads" glide smoothly over every contour of your face.

There's also a pop-up trimmer that makes neat work of sideburns. Easy "flip-open" cleaning. Voltage selector. On/off switch. And a coil cord. All in all, more shaving features than any other electric shaver. We'll match the shave you get with the new Norelco Speedshaver against any electric shaver and win by a head. And then it's *en garde*, blades!



**Great first shaver.**  
The new Norelco "Flip-Top" Speedshaver. Now in bright maroon.



**Perfect second shaver.**  
Now at a new low price. The Norelco Cordless with drawstring pouch.

**Norelco®** The Close Electric Shave

©1965 North American Philips Company, Inc., 100 East 42nd Street, New York, New York 10017

**Other products:** Electric Housewares, Hearing Aids, Radios, Tape Recorders, Dictating Machines, Electronic Educational Kits, Medical X-ray Equipment, Electronic Tubes and Devic

**This One**

DEC. 1965



LCQY-CLR-4SRX

1

Материал, защищенный авторским правом



## Most useful tool to give or receive

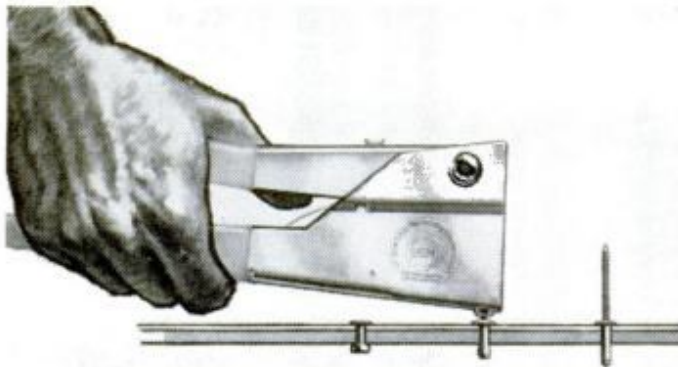

Year 'round and all around the house, you can fix or fasten many things better and faster with "POP" Rivets. Use them in place of screws, bolts, adhesives, soldering.

What a timely gift to "Open BEFORE Christmas." A "POP" Rivetool is ideal for making decorations, assembling toys, kits and other Christmas preparations.

Kit, in gay Christmas package, includes "POP" Rivetool that sets both  $\frac{1}{8}$ " and  $\frac{3}{16}$ " dia. rivets from one side—plus 3 boxes of rivets. A \$6.93 value at a happy holiday price of only \$5.95.

**ASK YOUR HARDWARE DEALER FOR A "POP" RIVET DEMONSTRATION**



**FASTENER DIVISION**  
**United Shoe Machinery Corporation**  
 Shelton, Connecticut 06485

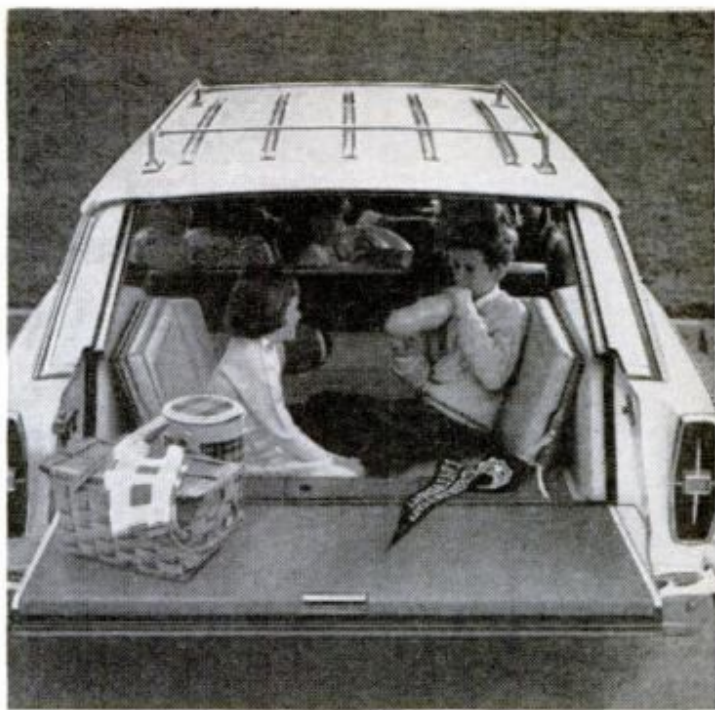

***Swings open for people...and swings down for cargo***



1966 Ford Country Squire

***New Magic Doorgate for all our 1966 wagons!***

Ford, Fairlane, and Falcon all offer this magically convenient invention for 1966—standard on all Ford and Fairlane wagons, optional on Falcon. Magic is the word for it. Reach for the door handle and it swings open like a door. Reach for the tailgate latch and, magically, it swings down like a tailgate. This is the kind of trail-blazing idea you'd expect from America's wagon specialist.

Yet Magic Doorgate is just a fraction of the 1966 news from Ford—builder of America's most popular wagons!

For 1966 there are 5 Ford, 3 Fairlane and 2 Falcon wagons to choose from. Fun for all the family. Beautiful enough to go anywhere. Smooth as a limousine. If you are in the market for a wagon this year—play it smart. Follow the wagonmaster. Ford!

AMERICA'S  
TOTAL PERFORMANCE CARS  
**FORD**  
MUSTANG • FALCON • FAIRLANE  
FORD • THUNDERBIRD

# POPULAR MECHANICS

## PM SPECIALS THIS MONTH!

- 76 COAST-TO-COAST IN THE '66 TORONADO**  
6000-mile diary of the front-end drive
- 70 OUTWIT THE ELECTRONIC EAVESDROPPERS**  
Spotting the snoopers that can invade your privacy
- 128 CHRISTMAS DISPLAYS THAT MOVE**  
Project-a-plans in action for your front yard
- 124 CHRISTMAS TOYS WITH A PURPOSE**  
PM selects 14 new, exciting and educational toys

## FEATURES OF SPECIAL INTEREST

- 82 Praise the Lord and Pass the Lug Wrench**
- 88 Master Modeler of Midget Guns**
- 92 Rescue in the Polar Ice Pack**
- 98 The Way-Out World of Antimatter**
- 104 Three Giant Steps to the Moon, Part 3**
- 110 Airplane/Glider**
- 118 Man-Made Comets**
- 120 Step Out with the Right Boot**
- 122 Leapin' Lizzies—40 mph in the Sand**

## FOR THE SHOP CRAFTSMAN

- 128 Christmas Displays That Move**
- 134 Batty Boxers**
- 136 Band of Angels from the Lathe**
- 139 Jeffrey Giraffe Clothes Horse**
- 140 Rainbow Star**
- 142 Three Christmas Dollhouses**
- 150 Audible Exposure Timer**
- 152 Speed Reducer for Metal Cutting**
- 158 The Secrets to Building Successful Stairs**
- 166 Shocks Shot? Service Them Yourself**
- 172 Band Grinder Smooths and Sharpens**
- 174 Tabletop Radio Goes Portable**

## REGULAR DEPARTMENTS

- |                                  |                                  |
|----------------------------------|----------------------------------|
| <b>8</b> Letters to the Editor   | <b>32</b> Aviation Jetstream     |
| <b>10</b> Science Worldwide      | <b>36</b> Coneless Loudspeaker   |
| <b>14</b> News from the Military | <b>69</b> Editor's Page          |
| <b>16</b> Homeowners' Clinic     | <b>116</b> New for Your Home     |
| <b>18</b> New Inventions         | <b>148</b> Solving Home Problems |
| <b>20</b> Career Barometer       | <b>156</b> Camera Buffs          |
| <b>24</b> What's New Outdoors    | <b>163</b> Shopping for Tools    |
| <b>26</b> Detroit Listening Post | <b>164</b> Automobile Clinic     |
| <b>30</b> New Products           | <b>175</b> New in Hi-Fi          |



# \$70,000.00 IN CASH PRIZES!

"Your \$1,200.00 check arrived this morning by Special Delivery. Thanks ever so much for your telephone call and prompt payment. It still doesn't seem possible. It's been a great thrill."

That's the way Emory Mead of Albany, N. Y., just one of our many big winners, reacted to receiving his cash prize. Dozens of men and women of all ages have cashed in as members of our exciting PUZZLE LOVERS CLUB.

Our Club winners got their cash awards for solving puzzles in their leisure time. Our Club also has awarded huge prizes for many other kinds of contests.

We've awarded cash in hundred-and-thousand-dollar units to retirees, sewing women, farmers, salesmen, war veterans, office workers, clerks, secretaries — people who never before dreamed of having the kind of money that movie stars make.

This announcement is an invitation to you, as a reader of this publication, to find out for yourself if you have the talent to win up to \$70,000.00 in cash. If you are over 18 and like to play word games of any kind, the information below may lead you to thousands of dollars in extra cash that you may use as you wish.

## YOU Can WIN Each Month!

Members of our Club win cash prizes at home, just by solving puzzles and entering Club contests. They turn an educational and enjoyable hobby into pure profit. You can too!

Your chief advantage in contests sponsored by our PUZZLE LOVERS CLUB is that you have only limited competition. Only members of the Club may compete and win.

In 1963 we offered our members \$35,000.00. We actually paid out more cash than we said we would—\$35,511.25, to be exact. In 1964, we again offered \$35,000.00. Again, we paid out more than we promised—\$40,778.11. And now we're offering our members \$70,000.00 in cash prizes. Most contest groups offer about \$4,500 or \$5,000 a year. Our Club gives you the opportunity to win double that every month!

As a member of our Club you will be eligible to enter every cash prize contest we sponsor and you'll get at least four new contests each month. You'll have three weeks to solve each set of contests. One week after the deadline, you'll receive a new copy of our **Puzzle Lovers Newspaper** with names and addresses of all winners, correct solutions, and your new puzzle contests. When YOU win, you receive your prize within two weeks.

### IT COSTS YOU NOTHING TO TRY OUR CONTESTS AND SEE IF YOU HAVE THE TALENT TO WIN

The coupon below will bring you, absolutely FREE, a sample copy of our **Puzzle Lovers Newspaper**, the only newspaper in the world exclusively devoted to contests (and it's published for members only). When your free copy of our newspaper arrives, sit down in a quiet place and read about our winners, our prizes, our contests. Try our stimulating word games to see if you can do them. You are under no obligation to enter our contests. If you do decide to go after our cash, there are no boxtops, no jingles to complete, nothing to buy.

Clip the coupon now and please be sure to print your name and address clearly. Then read about \$1,000.00 winners like Mrs. Belle Smith of Yakima, Wash. Discover how hundreds of other members cashed in just by doing our puzzles in their spare time. Find out all about this exciting and profitable hobby now. You may receive your first big prize in a few weeks.

**AFFIX THIS COUPON TO POSTCARD FOR FAST HANDLING OR MAIL IN ENVELOPE.**



"I still can hardly believe it," Mrs. H. C. Despain of Houston, Tex., wrote to us after receiving \$1,000.00 in cash as one month's winnings. She is a seamstress who works for a living.



Raymond Smith of Sacramento has won over \$900.00 in Club competitions. A retiree, Mr. Smith's first win was only \$25.00. Then, as he practiced solving our puzzles, he won much more.



"I was amazed to learn I won \$500.00," said Mrs. Florence Humphrey of Cincinnati. "The prize money came at a dandy time as I've had some debts to pay off. Thank you."

**WIN CASH  
MAIL NOW**

**PUZZLE LOVERS CLUB** Box 2, Prince Street Station, New York City 10012

Gentlemen,

Send me a free copy of your newspaper plus all details on your cash prize contests. I am under absolutely no obligation to pay anything. If I join the Club I may compete for all prizes and spend the cash I win any way I want.

PM-12

Name \_\_\_\_\_  
Address \_\_\_\_\_  
City \_\_\_\_\_  
State \_\_\_\_\_ Zip \_\_\_\_\_

**ENJOY YOURSELF IN YOUR OWN HOME AND WIN EXTRA CASH!**



KEEP PACE WITH SPACE AGE! SEE MANNED MOON SHOTS, SPACE FLIGHTS, CLOSE-UP!



# AMAZING SCIENCE BUYS

for FUN, STUDY or PROFIT



## 'FISH' WITH A WAR SURPLUS MAGNET

Go Treasure Hunting On The Bottom

Great idea! Fascinating fun and sometimes tremendously profitable! Tie a line to our 5-lb. Magnet—drop it overboard in bay, river, lake or ocean. Troll it along the bottom—your "treasure" haul can be outboard motors, anchors, fishing tackle, all kinds of metal valuables. 5-lb. Magnet is war surplus—Alnico V Type—Gov't. Coat—\$50. Lifts over 125 lbs. on land—much greater weights under water. Order now and try this new sport. Stock No. 70,571-H. 5 lb. Magnet .....\$12.50 Postpaid  
Stock No. 70,570-H. 3 1/2 lb. Lifts 40 lbs. ....\$ 8.75 Postpaid  
STOCK NO. 85,152-H . . . (lifts over 350 lbs).....\$33.60 F.O.B.



## SCIENCE TREASURE CHESTS

For Boys—Girls—Adults!

Science Treasure Chest—Extra-powerful magnets, polarizing filters, compass, one-way-mirror film, prism, diffraction grating, and lots of other items for hundreds of thrilling experiments, plus a Ten-Lens Kit for making telescopes, microscopes, etc. Full instructions included.

Stock No. 70,342-H .....\$5.50 Postpaid

Science Treasure Chest DeLuxe—Everything in Chest above plus exciting additional items for more advanced experiments.

Stock No. 70,343-H .....\$10.50 Postpaid



## MINIATURE WATER PUMP

Wonderful for experiments, miniature waterfalls, fountains, Christmas gardens, 110 gage railroad backdrops, hobbyists, labs, schools. Pumps continuous flow of water etc. Tiny (2 1/2" x 1 1/2") electric motor and pump ideal for hobbyists, labs, schools. Pumps continuous flow of water at rate of one pint per minute at a 12" head. With 2 D Batteries in series will pump to 24" high. Works in either direction. Stock No. 50,345-H .....\$2.25 Postpaid

## WOODEN SOLID PUZZLES

12 Different puzzles that will stimulate your ability to think and reason. Here is a fascinating assortment of wood puzzles that will provide hours of pleasure. Twelve different puzzles, animals and geometric forms to take apart and reassemble, give a chance for all the family, to test skill, patience, and best of all to stimulate ability to think and reason while having lots of fun. Stock No. 70,205-H .....\$3.00 Postpaid



## WAR SURPLUS ELECTRIC GENERATOR

Brand new Signal Corps Electric Generator for scientific experiments, electrical uses, demonstrations. Generates up to 90 volts by turning crank. Use in high impedance relays. Charge around and bring up night crawlers for bait or study. 2 Alnico Magnets alone worth original price. Wt. 2 lbs. Cost to Govt. \$15. Stock No. 50,225-H .....\$6.95 Postpaid



Same type generator, mounted, with light, as electricity demonstrator. Stock No. 50,365-H .....\$11.95 Postpaid

## HOME WEATHER STATION

New "Weather Station" is highly sensitive to weather changes. Consistent accurate thermometer to ± 2°C, barometer accurate to ± 25" and hygrometer to ± 5%. Foretells weather changes from 12 to 24 hours in advance. Hygrometer calibrated to percent relative humidity. Excellent for teaching weather phenomena and meteorological hobby work. Instrument mounted on handsome wood-grained wall panel 15 1/2" x 5 1/2". Meter cases heavily metalized—combines beauty and protection. Dials in etched aluminum, of high precision. Full instructions. Stock No. 70,607-H .....\$9.95 Postpaid



Bargains Galore! Hours of Fun! Only \$5

## NEW POPULAR SCIENCE FUN CHEST

Here are Edmund's 9 top selling science toys and curiosities in one fascinating, low-cost package. Perfect gift item. Amuse and delight young and old for hours or end. Educational, too! Teach basic science principles in a wonderful new fun way. Incl.: Solar Rayometer spins at 3,000 rpm; Albert the Bobbing Bird—runs continuously on thermal energy; Amazing Sealed Mercury Puzzle; Five 2-sided Ceramic Magnets; Big 3 1/2" Burning Glass in Zip-Lip Poly Bag; Magnetic Buggie and Spinning Ball—ball spins as dog approaches; Diffraction Grating; Rainbow Viewer; PIK-UP Ring (with Edmund TAK); Popular booklet, "Astronomy and You". All in die-cut storage box with complete instructions. Stock No. 70,787-H .....\$5.00 Ppd.



## Diagnose Hidden Trouble with Professional Stethoscope

Designed for use by physicians, this super-sensitive stethoscope is ideally suited for detecting faults in machines and engines, and in fluid, air and gas leakage. Dozens of uses in auto repair shops, labs, hobby, educational applications. Stock No. 50,270-H .....\$6.95 Postpaid



BARGAIN PRICE STETHOSCOPE—excellent value. No. 50,223-H .....\$2.95 Postpaid

Order by Stock No.—Send Check or M.O.—Money-Back Guarantee  
**EDMUND SCIENTIFIC CO., Barrington, New Jersey**

## MAIL COUPON FOR FREE CATALOG "H"

Completely new 1966 Edition, 148 pages Nearly 4000 Bargains.  
EDMUND SCIENTIFIC CO., Barrington, N. J. Please rush Free Giant Catalog "H".

Name.....  
Address.....  
City.....Zone.....State.....



## See the Stars, Moon, Planets, Close Up! 3" ASTRONOMICAL REFLECTING TELESCOPE

60 to 180 POWER! Famous Mt. Palomar Type! An Unusual Buy! See the Rings of Saturn, the fascinating planet Mars, huge craters on the Moon, phases of Venus, Equatorial Mount with lock on both axes. Aluminized and overcoated 3" diameter high-speed f/10 mirror. Telescope equipped with a 60X eyepiece and a mounted Barlow Lens. Optical Finder Telescope included. Hardwood, portable tripod. FREE with Scope: Valuable STAR CHART plus 272-page "HANDBOOK OF HEAVENS" plus "HOW TO USE YOUR TELESCOPE" BOOK. Stock No. 85,050-H .....\$29.95 Postpaid



4 1/4" Reflecting Telescope—up to 225 Power Stock No. 85,105-H .....\$79.50 F.O.B.

Superb 6" Reflector Telescope Up to 576 Power. Equatorial mount and Pedestal Base. Stock No. 85,086-H .....\$199.50 F.O.B.

## OPAQUE PROJECTOR

Projects illustrations up to 3" x 3 1/4" and enlarges them to 35" x 30" if screen is 6 1/2 ft. from projector; larger pictures if screen is further away. No film or negatives needed. Projects charts, diagrams, pictures, photos, lettering in full color or black-and-white. Operates on 115 volt, A.C. current. 8-ft. extension cord and plug included. Operates on 60 watt bulb, not included. Size 12" x 8" x 4 1/2" wide. Wt. 1 lb., 2 oz. Plastic case. Stock No. 70,199-H .....\$7.95 Postpaid



Fascinating New Kaleidoscope Insert. Same unit as above, but provides endless additional projects with everchanging kaleidoscope patterns. Stock No. 60,714-H .....\$10.00 Ppd.

## SOLVE PROBLEMS! TELL FORTUNES! PLAY GAMES! NEW WORKING MODEL DIGITAL COMPUTER

Actual miniature version of GIANT ELECTRONIC BRAINS Fascinating new see-through model computer actually solves problems, teaches computer fundamentals. Adds, subtracts, multiplies, shifts, complements, carries, memorizes, counts, compares, sequences. Attractively colored, rigid plastic parts easily assembled. 12" x 3 1/2" x 4 3/4". Incl. step-by-step assembly diagrams, 32-page instruction book covering operation, computer language (binary system), programming, problems and 15 experiments. Stock No. 70,683-H .....\$5.98 Ppd.



## WAR SURPLUS AMERICAN-MADE 7x50 BINOCULARS

Big savings! Brand new! Crystal clear viewing—7 power. Every optical element is coated. An excellent night glass—the size recommended for satellite viewing. Individual eye focus. Exit pupil 7mm. Approx. field at 1,000 yds. is 376 ft. Carrying case included. American 7 x 50's normally cost \$274.50. Our war surplus price saves you real money. Stock No. 1544-H .....Only \$78.40 Ppd.  
8 x 30 Binoculars—similar to above. Stock No. 963-H .....\$40.00 Postpaid  
7 x 35 American Made Binoculars. Stock No. 964-H .....\$55.00 Ppd.



## BUILD A SOLAR ENERGY FURNACE

A fascinating new field. Build your own Solar Furnace for experimentation—many practical uses. Easy! Inexpensive! Use scrapwood! We furnish instructions. This sun powered furnace will generate terrific heat—2000° to 3000°. Fuses enamel to metal. Sets paper aflame in seconds. Use our Fresnel Lens 11" sq. F.L. 19". Stock No. 70,533-H .....\$6.00 Postpaid



## EXPLORE THE FASCINATING WORLD OF MAGNETISM NEW 23 MAGNET VARIETY KIT

11 SHAPES! MANY COMPOSITIONS! Ever ripen tomatoes by magnetism—paint pictures using magnet as a brush and iron filings as paint? Surprising new ideas and uses for the bewildering forces of magnetism are continually discovered. Here, in one low-cost kit, you can learn and experiment with varied materials that obsoleted Magnetite—the natural magnetic ore. Terrific assortment includes ferrites, ceramics, flexible rubber, alnico in every shape imaginable—up to 20 lbs. pull. Sizes range from 3/4" x 7/16" x 7/16" to 3" x 3" x 3" Incl.: three—2 sided ceramic, flexible strip, alnico bar, ceramic alnico disc w/center hole, 2 lg. alnico cyl., sm. alnico cyl, flex. sheet, 2 baby alnico bar, 3-channel-type pole pieces for sm. ceramic magnets, bar magnet keeper, 2 disc magnet keepers, compl. info. and inst. (increase pull up to 5 times). Stock No. 70,780-H .....\$5.00 Ppd.



ORDER BY STOCK NUMBER SEND CHECK OR MONEY ORDER. SATISFACTION GUARANTEED.  
**EDMUND SCIENTIFIC CO., BARRINGTON, N. J.**

# LETTERS

TO THE EDITOR

## Bike Builder

I built the *Bicycle Built for Two* (page 176, Apr. '63 PM) in the vocational agriculture shop at my school.

One of the bikes cost me \$5 and the

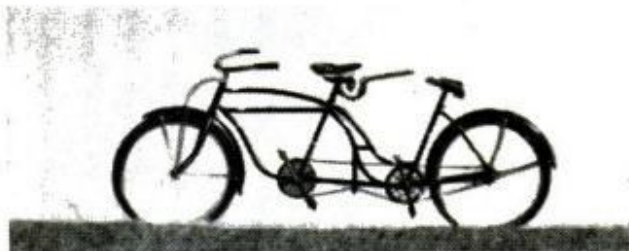

other was given to me. The other materials (paint, seat covers and so on) totaled about \$5.

Coin, Iowa

DAN RUNYAN

## Wax Bullets Indoors

In addition to the safety precautions mentioned in *Blast Away Indoors with Wax Bullets* (page 132, Oct. '65 PM), you should also mention that most of your readers would have to do their shooting in secret because almost every town in the United States has an ordinance against discharging a firearm within the city limits. Another example of stupid laws which govern firearms.

Carbondale, Ill.

R. G. SCHIFF

## Likes the Birdbath

That is a very well-designed engine (*Backyard & Birdbath R.R.*, page 118, Aug. '65 PM), and I intend to use it as the basis for constructing a 15-inch gauge locomotive which will be powered by a Renault car engine. I'll run it on a friend's track. I hope the designer will come up with a car to go with the locomotive.

London, Ont.

ERNEST J. SUTER

## Deft Diagnostician

I was more than pleased to receive an answer to my letter to your *Auto Clinic*. The local Chevrolet dealer was given your diagnosis of my problem. He changed the plunger on the carburetor and installed a new fuel pump. The car now runs well. I lived with this condition for two years, and you don't know how happy I am to have a car that doesn't cut out on hills.

Waterbury, Conn.

LOUIS PRIMUS

Thank you for your letter; your diagnosis was absolutely correct. The plunger of the accelerator pump was stuck. A new

pump has been put in, and I get the necessary acceleration.

New York, N.Y.

BORIS T. SAVICH

*And on and on go the letters to our solver of auto problems, Mort Schultz. If you have car troubles, see Auto Clinic for instructions on how to query Mort.*

## All the Good Features

A friend and I built PM-38 (page 140, Aug. '62 PM) and we found it to be the most stylish and best-performing boat made. It is the third boat I've constructed, and all the good features and shortcuts



I've been looking for are in PM-38.

I added a middle deck, rear seat and floor boards, and I modified the transom and fiberglassed the bottom and transom.

With a 40-hp engine, I get 35 mph in choppy water.

Thanks for the plans.

Oshawa, Ont.

BERT VANDER HEUVEL

## Not All There

I was about to attempt the *Leg Stool* (page 220L, Oct. '65 PM)—but I defy any do-it-yourselfer to complete a stool from the facts given in your article.

Obviously, the last minute insertion of the many "220" pages confused the issue. Would you kindly send me the complete article.

Holmdel, N.J.

ROBERT W. WEHRMAN

*Yes, the issue was confused—and we printed only half the story. Any reader who wants the full story (the other page, that is) can get it by writing to our Bureau of Information, Popular Mechanics, 575 Lexington Avenue, New York, N.Y. 10022*

THE EDITORS

# WHO ELSE WANTS A BIG RAISE IN PAY?

"My salary has increased 400% as a direct result of my LaSalle studies"



Rudolph Urbatis,  
Port Chester, N.Y.

"Salary more than doubled since enrolling"



William T. Black,  
Canoga Park, Calif.

"Income has increased 100 per cent since graduation"



James L. Yonning,  
Manhattan, Kansas

"I now earn three and a half times my former pay"

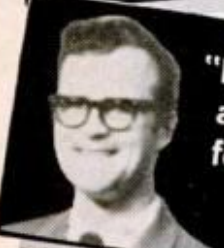

Robert Fisher,  
Holbrook, Ariz.

Stuck in a rut? Tired of your dead-end job? Here's proof you can step up to a high-salary position with prestige and security through LaSalle spare-time training.

JUST LOOK at these enthusiastic letters. Have you ever seen anything like them? They are just a few of many hundreds of similar statements in letters that come from LaSalle students week after week, month after month, year after year.

LaSalle students have one ambition in common — to get out of the ranks of the untrained and earn big money, prestige and security in a key job. Isn't that your goal too?

Without interfering with your present work — and by devoting only a little of your spare time — you too can prepare rapidly for advancement in the field of your choice through LaSalle home study. The cost is surprisingly low.

LaSalle has been an acknowledged leader in home education for more than half a century. It has provided training in business, high school and technical subjects to more than 1,000,000 ambitious men and women. Its distinguished faculty includes some of the country's most outstanding authorities. That is why your LaSalle diploma is a credential recognized and respected by employers.

Check the subject you are interested in — then send the coupon below for FREE booklet. No obligation. Mail to LaSalle, 417 South Dearborn, Chicago, Illinois 60605.

## LA SALLE EXTENSION UNIVERSITY

A Correspondence Institution • 417 South Dearborn, Dept. 48-044, Chicago, Illinois 60605

Please send me, without cost or obligation, FREE booklet and full information on the field I have checked below:

### ACCOUNTING

- Complete Accounting with CPA Training
- General Accounting
- Income Tax
- Accounting Fundamentals
- Auditing
- Controllership
- CPA Training
- Modern Bookkeeping

### BUSINESS MANAGEMENT

- Complete Business Management
- Credit and Collections
- Office Management
- Personnel Management
- Business Correspondence

### LAW COURSES

- Bachelor of Laws Degree
- Business Law
- Insurance Law
- Claim Adjusting Law
- Law for Police Officers
- Law for Trust Officers

### SALESMANSHIP

- Sales Management
- Complete Sales Training

### DRAFTING

- Basic Drafting
- Aeronautical Drafting
- Architectural Drafting
- Electrical Drafting
- Mechanical Drafting
- Structural Drafting

### REAL ESTATE

- Complete Real Estate
- Real Estate Brokerage
- Real Estate Management
- Real Estate Sales

### TRAFFIC AND TRANSPORTATION

- Complete Traffic Mgt.
- Transportation Law
- Rates and Tariffs
- Agency and Services
- Motor Truck Traffic

### STENOTYPE

- Machine Shorthand

### TECHNICAL COURSES

- Mechanical Refrigeration
- Air Conditioning, Refrigeration and Heating
- Diesel

### HIGH SCHOOL

- High School Diploma

### CAREERS FOR WOMEN

- Interior Decorator
- Dental Assistant
- Secretarial
- Accounting
- Bookkeeping
- Real Estate

Name..... Age.....

Address..... County.....

City & State..... Zip No.....

Occupation..... Working Hours..... A.M..... P.M.

321

BY JOHN F. PEARSON  
**SCIENCE**  
WORLDWIDE



# Portable Power Plant

**Want to quickly find  
hardware, paints,  
power tools, roofing  
materials...anything?  
Just let your fingers  
do the walking.  
Action-People do.**

**Human skin** quickly deteriorates when merely refrigerated and hard freezing often destroy its ability to survive when transplanted. But now two University of Pennsylvania scientists report the successful transplanting of skin stored for as long as 608 days.

Writing in the *Journal of the American Medical Association*, Drs. Ronald B. Berggren and Herndon B. Lehr describe soaking skin grafts in solutions of glycerol or the experimental drug DMSO (dimethyl sulfoxide) and then gradually cooling the tissue to temperatures as low as minus 385° F.

Out of 26 such transplants of patients' own skin, 12 were permanently successful, according to the researchers. Successful long-term storage eliminates the need for repeated skin-removal operations on patients requiring extensive surgical repair.

**A subzero slum**—that's what a New Zealand biologist says the Antarctic is rapidly turning into. Methods must be found, he says, to dispose of the rubble left behind by each expedition. Because decomposition is at a minimum in the cold temperatures, even litter from the expeditions of Scott and Shackleton (shortly after the turn of the century) can still be found.

**Ranger VII photos** of the moon are available. You can get a set of 200 in a bound volume for \$6.50. Send your order to the Superintendent of Documents, Government Printing Office, Washington, D.C. Ask for Catalog No. NAS 1.21:62.

**An oral contraceptive** for pigeons has been developed by a researcher at the University of Missouri. It's a chemical called diazacholestanol dihydrochloride that is put into grain fed to the birds. After the chemical has been part of the diet for 10 days, reproduction is completely prevented in most females for three to four months.

**Oil will flow over the Alps** early in 1967 if all goes well. Now under construction is a 300-mile pipeline that will zigzag through those formidable mountains. The 40-inch pipeline, said to be the largest in

[\(Please turn to page 12\)](#)

# EARN-WHILE-YOU-LEARN APPLIANCE REPAIR AND AIR CONDITIONING

## THESE TWO FREE BOOKS

CAN START YOU ON YOUR WAY TO:

- \* new high-pay skill
- \* business of your own
- \* spare time income
- \* savings on appliance repairs

### THIS NEW, SHORT EASY COURSE TRAINS YOU AT HOME

**THE BEST WAY TO GET AHEAD**  
is to make yourself better qualified than the next man. You can prepare quickly to do professional appliance servicing at home in your spare time.

**NEW EASY COURSE**  
shows you step-by-step professional methods for repair of all types of appliances...including air conditioning, even small gasoline engines, farm and commercial equipment.

**AMAZING PROFITS**  
in your spare time...in improved job opportunities...in a business of your own. You earn-as-you-learn professional methods of appliance repairs...are ready to start servicing appliances after only a few lessons.

**LOW COST TRAINING COVERS**  
everything...special equipment is included in your course at no extra cost.



APPLIANCE DIVISION, NATIONAL RADIO INSTITUTE  
3939 Wisconsin Ave., Washington, D.C. 20016



SEND FOR FREE BOOKS

**MAIL THIS COUPON TODAY!**

**Appliance Division, Department 600-125  
National Radio Institute  
3939 Wisconsin Avenue, Wash., D.C. 20016**

Send me the illustrated free book that tells about opportunities in Electrical Appliance Repair and details of NRI's new course—plus a sample lesson. I understand there is no obligation and no salesman will call.

Name ..... Age .....

Address.....

City ..... State ..... Zip Code.....

Accredited Member National Home Study Council

EVERY NEIGHBOR IS A CUSTOMER

**Earn \$5 An Hour**

during spare time in profitable

**LAWNMOWER  
Sharpening  
BUSINESS**

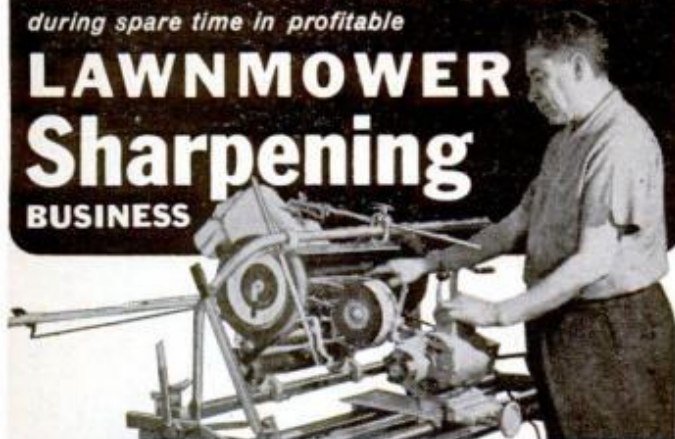

**Complete Shop in One Machine**

No experience needed to start—anyone can operate it—and it turns out professional jobs every time.



**Start Spare Time Business**

An ideal spare time business—alho many find it so profitable, they devote full time to it. For complete fact-filled booklet telling you how to start and how others have succeeded, send coupon. No salesman will call.

Foley Mfg. Co. 1207-5 Foley Bldg., Mpls., Minn. 55418

Send information on Lawn Mower Sharpening business.

Name \_\_\_\_\_

Address \_\_\_\_\_

City \_\_\_\_\_

State \_\_\_\_\_

Zip Code \_\_\_\_\_

**ARROW**  
ALL PURPOSE  
STAPLE GUN

T-50

**HEAVY  
DUTY**



Model  
T-50  
**\$12.50**

Uses 6  
Staple Sizes —  
1/4" to 9/16"  
and Ceiltile<sup>TM</sup>

OTHER  
MODELS  
FROM \$4.95

**SHOOTS A STAPLE  
WHEREVER YOU'D DRIVE A NAIL!**

**FASTER! CHEAPER! BETTER!**

for 1001 Home Improvement Fastening Jobs:  
Ceiling Tile, Insulating, Upholstering, Screening, etc.

Available at hardware, lumber, building supply,  
stationery and other retail outlets.

**ARROW FASTENER CO., INC.**

One Junius Street • Brooklyn 12, N. Y.

## SCIENCE WORLDWIDE

(Continued from page 10)

diameter in the Western world, will carry oil from Trieste to Ingolstadt in Bavaria.

**For better teeth, eat tortillas**—the chewy pancakelike food that's a staple below the border. Lack of severe tooth decay in many Guatemalans and Mexicans can be explained by the fact that the corn from which tortillas are made is soaked for a long time in limewater solutions or in water to which wood ash has been added. So reports a scientist at the Harvard School of Dental Medicine.

He says that the tortilla is high in calcium and phosphate and tends to accumulate in areas "which are poorly self-cleaning" such as the sides of molars in the jaw next to the cheek. Calcium phosphate and calculus deposits in these areas protect against decay.

**Room to spare.** NASA has invited proposals for experiments to pack aboard the manned Apollo mission. It seems there are about 17 cubic feet of free space left aboard the LEM (lunar excursion module), which is scheduled to make the moon landing in 1969.

**Biggest ship** in the world is about to go into service. She's the 150,000-ton Japanese tanker *Tokyo Maru*, built to carry oil from Persian Gulf ports to Japan. Her overall length is 1005 feet and she has a 155-foot beam.

**Four-eyed fish.** Trawling off the coast of Oregon, scientists came up with a rare Bathylchnops, a deep-sea fish that's well equipped to spot his enemies or his next meal. He has two sets of eyes, one placed above the other; one pair sights upward, the other down. A strong swimmer, the captured specimen measured 18 inches in length.

**Russian smoke** may not be as potent in the future if the work of a biologist named Illyin proves valid. He grafted tobacco plants onto tomatoes and found that, as a result, there was no nicotine in the leaves or branches of the tobacco plant.

**Aspirin can affect your hearing**—if you take enough of it. Arthritis patients and others who take unusually large doses of the drug often complain of ringing in the ears and loss of hearing. But, say Harvard University physicians who've studied the problem, the condition disappears soon after medication is stopped.

# COMET

LINCOLN-MERCURY DIVISION OF



COMET CYCLONE HARDTOP WITH OPTIONAL TWIN SCOOP GT HOOD

## ***For 1966: the big, new-generation Comets— our liveliest, roomiest driving machines ever.***

*This Comet looks  
the way it goes.  
Beautiful.  
And there are 13  
Comets like it.  
Sleeker. Roomier.  
Up to 8 inches longer.  
Sedans, convertibles,  
wagons, hardtops . . .  
from rakish 202's  
to hot new  
Cyclone GT's.  
All with a very  
special kind of luxury.*

*Plus the features and  
options you want most.  
Bucket seats.  
Four-speed floor shift.  
Or three-speed automatic.  
Or three-speed manual  
with full synch.  
Vinyl roof.  
Built-in air conditioning.  
Power steering,*

*power brakes,  
power windows,  
power everything.  
Including a new 390  
4-barrel V-8  
in the new  
Cyclone GT.  
Look into it. Closely.  
At your  
Mercury dealer's.*



***the big, beautiful performance champion***

NEWS FROM THE  
**MILITARY**  
 BY WILLIAM R. KREH



**winter...  
 it's wonderful!**

Evinrude's new SKEETER is here. Forecast: **Action!** And winter will seem to be about half as long as it used to.

For sportsmen, the SKEETER is the greatest thing since snowshoes. Take it ice fishing and hunting. Use it to haul gear — and game. If sporting blood runs in the family, you'll double your SKEETERING fun. Tow tobogganers and skiers. Take a family "snow safari" on scenic trails. Attend snowmobile derbies and rallies. Enjoy your country or lake cottage in winter as well as summer. While others are snow-bound, you can be fun-bound.

Choose from three models for 1966, including two new Wide-Track SKEETERS. All have new, automatic, torque-sensing drive for peak performance under any condition of load or terrain. Special winter-engineered 14 hp engine gives speeds to over 30 mph.

Let it snow! You can't go SKEETERING without it.

**SKEETER**  
 the snow vehicle that's built and backed by Evinrude!

**MORE INFORMATION — SEND COUPON!**

EVINRUDE MOTORS, 4357 N. 27th St., Milwaukee, Wis. 53216  
 Please send free 1966 Evinrude catalog plus SKEETER folder to:

Name.....  
 Address.....  
 City.....State.....Zip Code.....

**Six-foot antennas** now being tested aboard the USS *Canberra* and USS *Midway* give the Navy the capability for instant ship-to-ship and ship-to-shore communication through high-altitude "stationary" satellites, such as Syncom. Compared to the huge parabolic antennas, the shipboard satellite communication sets are almost miniature in size. The small sets provide both voice and teletype communications, unaffected by atmospheric conditions.

**A big pull** was accomplished recently when one of the Navy's new RH-3A helicopters tested its strength by towing a 1600-ton destroyer from a dead stop to speeds up to 5.3 knots. The 'copter, designed for mine countermeasures, will tow heavy gear through the water. The tests were to measure tensions against wind speeds.

**First cruise** of the Navy's newest aircraft carrier, the USS *America*, was electrifying—1400 amps. and 500 volts to be exact. The ship went through five hours of electrical jolts to reduce its permanent magnetic field through the deperming process.

In this operation, the *America* becomes, in effect, a large solenoid. Deperming cables wrapped around the vessel serve as the coil; the ship herself is the core. High-amperage current sent through the coil lessens, in turn, the ship's magnetic field and the effectiveness of magnetic sensing weapons. Eight miles of cable were wound around the 1047-foot carrier, circling the ship 83 times from bow to stern, making it the largest job now plying the high seas. One good yank and it would spin forever.

**Congress has cited** a Navy officer who found a way to save the government about \$4 million this year and more in the future. Cmdr. Richard F. Haley solved a problem presented by the military switch from 30-cal. small arms to 7.62-mm weapons, now standard for all NATO forces. This meant the Navy's M-1 rifles and light machine guns would become useless because of the curtailment in production of 30-cal. ammo. The Navy officer, however, developed a cheap method of rechambering existing weapons so they can fire the new ammunition.



# Make more money

## Move your savings to Southern California

Today, earn more money... more often... on your funds at World Savings. Strategically located on Wilshire Blvd. in the heart of thriving Los Angeles, World Savings is playing a key role in meeting the demands brought about by Southern California's dynamic growth.

*FREE BOOKLET... "Why Investors Look To California."*

*FREE GIFT... Colorful desk top world globe bank.*

---

*Open an insured savings account at  
WORLD SAVINGS and Loan Association  
1926 Wilshire Boulevard,  
Los Angeles 57-W, California.*

---

## WORLD SAVINGS

*Resources over \$200 million • Savings accounts are insured to \$10,000 by an agency of the U.S. Government • Interest is paid quarterly • Savings postmarked by the 10th earn from the 1st • Main Office: Lynwood, California • Airmail postage is paid both ways • Founded in 1927*



**WHEN OUR 4.85% CURRENT ANNUAL RATE IS COMPOUNDED DAILY AND MAINTAINED FOR A YEAR**

# HOMEOWNERS' CLINIC

BY W. CLYDE LAMMEY

## "Naturalizing" Driftwood

*What finish can I use on driftwood to retain the natural color? I've tried just about everything but still the wood darkens as soon as I apply the finish, and continues to darken afterward. Is there some special finish made for this purpose?—A.K., Fla.*

Any common finishing material will tend to darken the wood, mainly because the application of the liquid changes the reflective properties of the surface. There just isn't any practical way to entirely prevent this change. White shellac, certain of the synthetic clear finishes and paste wax applied as a first coat will probably least affect the shade of wood.

Another technique is to mix artist's colors to a tint matching the color of the wood as nearly as possible and then applying this mixture as a paste, rubbing it into the wood with a soft cloth. After this

has been allowed to thoroughly dry—two or three weeks—apply a sprayed-on semi-gloss finish. No high-gloss finish should be used unless for some special effect.

Or apply paste wax with a soft cloth, allow the wax to dry, then rub down with a fairly stiff bristle brush. More than one coat may be required.

## Re-affixing Tiles

*My basement rec room has an acoustical-tile ceiling. Some of the tiles have loosened at the corners and along the edges and dropped down below the adjacent surfaces. Is there any simple way to fix them?—L.G., S. Carolina.*

If the tiles have been stapled or nailed, or even cemented, it usually is possible to make a fairly satisfactory repair by re-nailing them using small finishing nails or brads. Assuming the tiles have been

## It's just like having TEN

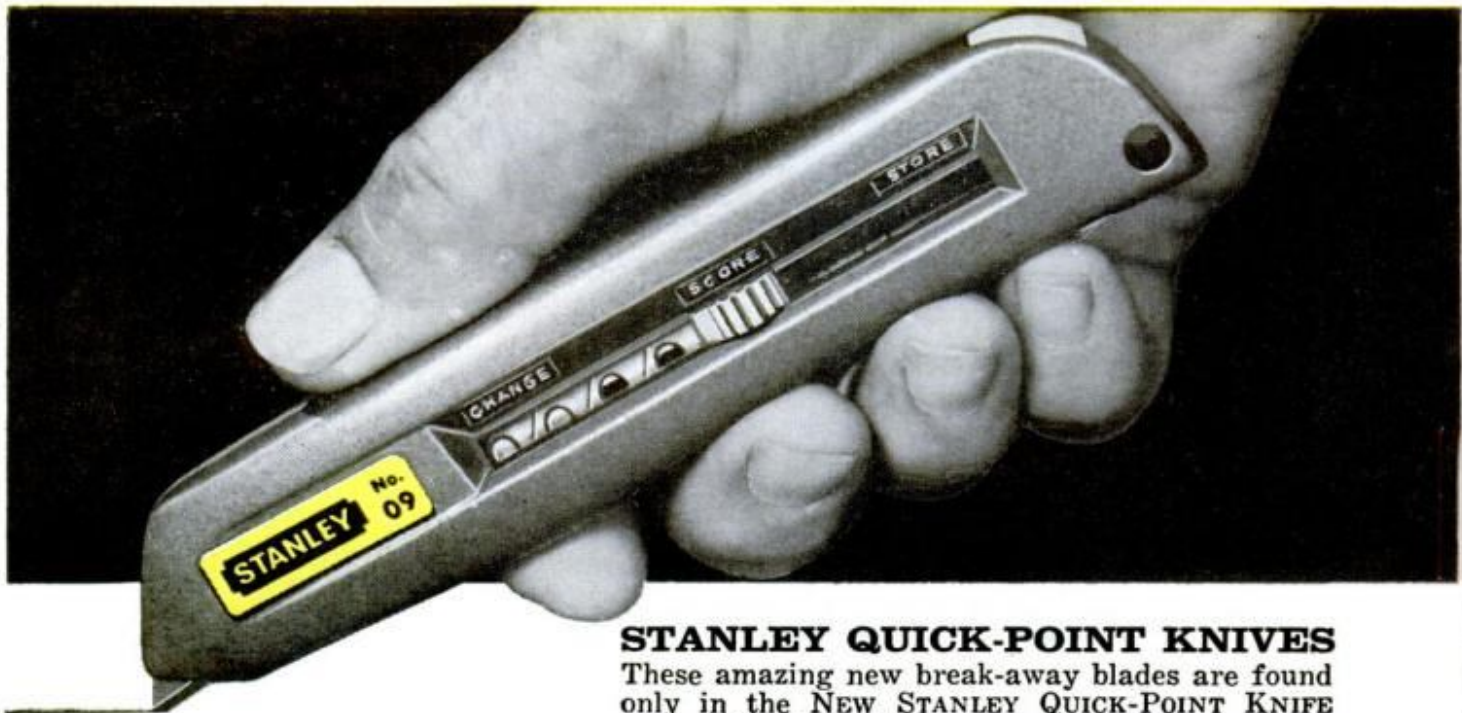

### STANLEY QUICK-POINT KNIVES

These amazing new break-away blades are found only in the NEW STANLEY QUICK-POINT KNIFE (No. 09). Ideal for scoring and general cutting. Quick, safe push button advances new ten-point break-away blade. You simply snap off old point, and have new point instantly. You can *change* blades, *store* blades without taking knife apart!

attached to furring strips, locate the latter by pressing a pin through the tiles at the joints. Then re-nail affected tiles at the joints, driving each nail only part way in and setting it with a nailset.

### Clean a Vase with Sand

*I have an old glass vase which I prize quite highly. I can clean the outside easily enough, but how do I get the dust and grime out of the inside?—G.S., Calif.*

If the cloudiness inside of vase is due to an accumulation of dust and other debris and not caused by long exposure to direct sunlight, then it may be possible to clean it satisfactorily by filling the vase about one fourth full of sharp, clean sand, then fill to half full with a fairly strong detergent solution and shake the vase vigorously, imparting a rotary motion while covering the mouth of the glass vase with one hand. It may be necessary to repeat the procedure several times to remove any remaining cloudiness.

### Whitening a Chest

*I have an old chest of drawers which I'm quite sure is oak. Originally the finish was light, but now it has become dark-*

*ened with dirt and grime. I'd like to remove this coating and then fill the wood with white. What kind of white should I use? White lead, white paint, or what?—W.H., Va.*

Once the old finish has been removed to the bare wood and the latter sanded super-smooth, coat the wood with an ivory, rather than a dead white paint. Apply this sparingly with brush or spray, then wipe it off across the grain with a clean, soft cloth until all the paint has been removed except that in the pores of the wood. Allow to dry thoroughly, then sand lightly and reapply another coating of the same paint and wipe off as before to continue to pack the pores of the wood as much as possible. When this has dried, sand again, removing a little more wood than before.

The purpose of this two-stage procedure is to level the painted surfaces of the wood. Otherwise depressions in the grain would be seen in oblique light and the job would have a cloudy appearance.

Finally, after allowing plenty of time for drying, spray-coat the surfaces with a dull varnish or a low-gloss lacquer and rub down with very fine steel wool. Properly done, this procedure will produce an attractive finish on oak.

## sharp knives on hand. Why?

Because there are  
ten sharp points  
per blade



Two ten-point break-away blades are provided with this quality Stanley Tool . . . *plus bonus blades* . . . two double-pointed reversible utility blades for heavy duty cutting all stored in magazine handle. Comfortable contoured handle is aluminum for light weight and high strength. Stanley Tools, Division of The Stanley Works, New Britain, Connecticut. Sold practically everywhere.

**STANLEY**®

THE TOOL BOX OF THE WORLD

SWORN STATEMENT FROM CHAS. LEMMING:

"After starting my own business

I've averaged

\$100<sup>00</sup>

A DAY

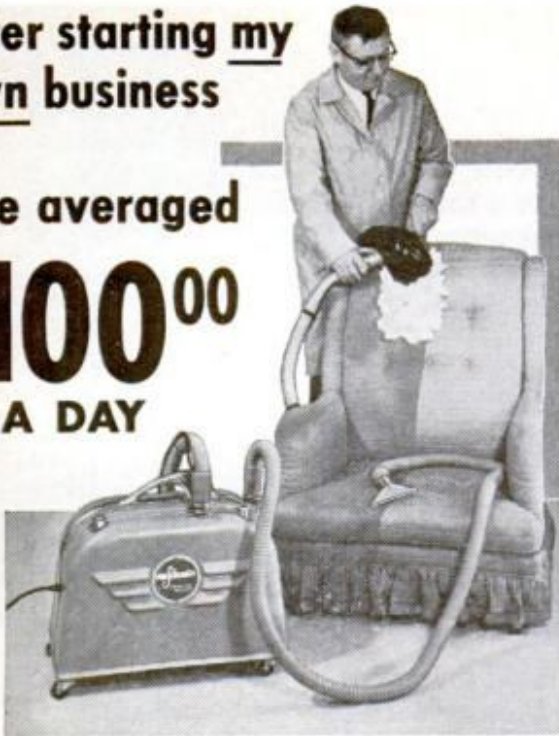

— most of it Clear Profit! "

*Here's your chance to start a money-making year 'round business of your own and make the success you've dreamed about*

• In a city of less than 50,000, Mr. Lemming started his own business after filling in coupon like one below. He averaged \$100 a day during first year, some days \$200. F. E. Doran grossed \$1050 in single month. Geo. Held grossed \$300 in one week.

How much you earn depends largely on you. No special skill, no large investment required for our electric upholstery cleaning machine. Start spare time until full time justified. Hire helpers as needed.

**NO SHOP NECESSARY** • You clean upholstered furniture on customers' premises—homes, hotels, motels, etc. Auto upholstery, too. No hauling; operate from your home. Watch business grow as satisfied customers tell friends. Supplies cost little, profits high. We will help you to start and work with you for your success. Training and consulting with experts is available at no extra cost.

**OURS IS NOT A LEASE ARRANGEMENT** • You are free to operate in an independent manner. You sign no contract. You own the detergent outright and are always your own boss...and every dollar you take in is yours to keep. You pay no fees, or dues, or royalties to anyone, and enough supplies come with it to return far more than your investment. Many earn the cost of the detergent in a week or two. It costs nothing to get details...write TODAY.

SEND COUPON TODAY

VON SCHRADER MFG. CO. W10 "D" PL., Racine, Wisconsin

Send at once (no obligation) your FREE booklet containing information about your ELECTRIC UPHOLSTERY DETERGENT and how I can start my own permanent, profitable business.

Name \_\_\_\_\_

Address \_\_\_\_\_

City \_\_\_\_\_ State \_\_\_\_\_ Zip Code \_\_\_\_\_

VON SCHRADER MFG. CO.

# FROM THE PATENT OFFICE **NEW INVENTIONS**

BY M. J. PEDERSEN

**Battery-powered "cigarette"** uses no tobacco and produces no smoke. A replaceable tip moistened with harmless, warmed chemicals could simulate the flavor of anything from root beer to rum. Receiving patent 3,200,819 for Herbert A. Gilbert, Beaver Falls, Pa., the smokeless cigarette also has medical potential. For example, asthma patients could be given internal medication through the lungs merely by moistening the tip with the medicine.

**An automatic tree farmer** that heats, irrigates and fertilizes an orchard won patent 3,200,539 for Marvin J. Kelly, Merritt Island, Fla. A series of pipes with discharge heads serve the two-fold purpose of gas burners and fluid nozzles.

**Burglar alarm** that telephones the police and automatically snaps pictures of the intruder earned patent 3,188,392 for Edward E. Ferrell, Sanford, Fla. Tripping an electric eye actuates the system and a tape recording tells the police what is happening and where.

**Golfers** may "read" the green using an optical viewing instrument that earned patent 3,186,092 for Charles S. Bertas, Covina, Calif. The slope of the green as well as little bumps between the ball and the hole can be estimated more accurately.

**Ultrasonic pencil** that makes a permanent, unalterable mark is capable of writing under all kinds of atmospheric conditions, and is the only known instrument capable of writing in space. Using no fluids or other substances, the pencil produces a mark by means of a metal rod vibrating at 20,000 cycles a second, which effects the reorganization of paper fibers. A three-watt transistorized generator supplies the power. Patent 3,202,133 went to Paul M. Platzman of Brookville, N.Y.

**Sleepy drivers** may be relieved by an automatic guidance system that takes over the wheel on a "magnetic" highway. Consisting of cables buried in the highway and equipment in the car to create a magnetic field and keep the car on course, the system earned patent 3,198,279 for Clark E. Quinn, Rochester, Mich.

# TUNE UP ELECTRONICALLY ANY CAR EVER MADE...

domestic or foreign; compact or limousine; 4 cylinder, 6 cylinder or 8 cylinder; 6 volt or 12 volt.

With New Improved Model BT-162

# DWELL TACHOMETER



**NOTE:**  
**GIANT 6 1/2"**  
**METER FOR**  
**EASY,**  
**ACCURATE**  
**READINGS**

At last a streamlined instrument designed to provide the most important services for "tuning up" any and every car ever made from a Model A Ford up to and including the current automatic transmission cars produced today. The Model BT-162 includes the very latest design Dwell Meter, working in conjunction with a dual range Tachometer and incorporating all modern improvements in circuitry design.

**Assure easy starts, optimum performance and maximum gas economy with Model BT-162.**

The Model BT-162 will perform the services specified below in addition to many other tasks too numerous to mention:

- Assure precise adjustments of points that are slightly worn or pitted.
- Indicate the most effective point setting without removing the distributor cap.
- Indicate the correct settings for external adjustment type distributors. (A feeler gauge cannot be used for making correct adjustments on this type of distributor since many manufacturers' specifications do not list the point gap in inches. They list only the dwell angle in degrees.)
- Insure maximum gas economy and quiet engine running. Read the exact RPM while the engine is in neutral position. Then adjust the carburetor in conformity with the car manufacturer's recommendations.
- To locate a "miss" you need only disconnect or "short" the spark plugs one at a time with the Model BT-162 switched to the Tachometer position.
- Cars with automatic transmissions function efficiently only if the fluid pressures are correctly maintained and since manufacturer's instructions always refer to RPM, the Model BT-162 (or an equivalent tachometer) is required to properly service automatic transmissions.

The Model BT-162 is the most complete unit in its price range ever produced. It comes absolutely complete, ready to use. Only .....

# \$29<sup>95</sup>

## **SEND NO MONEY WITH ORDER** **PAY POSTMAN NOTHING ON DELIVERY**

Try it for 10 days before you buy. If completely satisfied then send \$5.00 and pay the balance at the rate of \$5.00 per month until the total price of \$29.95 (plus small P.P. and budget charge) is paid. If not completely satisfied, return to us, no explanation necessary.

ACCURATE INSTRUMENT CO., INC.

Dept. D-433, 911 Faile St., Bronx, N.Y. 10474

Please rush me one Model BT-162. If satisfactory I agree to pay \$5.00 within 10 days and balance at rate of \$5.00 per month until total price of \$29.95 (plus small P.P. and budget charge) is paid. If not satisfactory, I may return for cancellation of account.

Name \_\_\_\_\_

Address \_\_\_\_\_

City \_\_\_\_\_ Zone \_\_\_\_\_ State \_\_\_\_\_

Save Money! Check here and enclose \$29.95 with this coupon and we will pay all shipping charges. You still retain the privilege of returning after 10 day trial for full refund.

# CAREER BY CREIGHTON PEET BAROMETER

**T**HERE'S STILL AN INDUSTRY in which a large percentage of tomorrow's top brass are starting at the bottom today. It's construction. An astounding number of big contractors began by climbing into a bulldozer, earth mover, road scraper, power shovel, dragline, or other heavy equipment to reach a solid future in their own construction business.

Running one of these monsters takes skill and judgment and pays about twice as much as driving a truck. Hourly rates run from around \$3 an hour in Kansas City to an average of \$6.42 in Alaska—the New York City average for power-shovel men being \$6.30. Overtime for weekends or holidays is usually time and a half to double time; however, in regions

where the ground freezes tight, heavy-equipment men may work only nine months a year. Formal education requirements may include a high school diploma.

In this field a man can buck automation without a college degree; heavy equipment itself is a kind of automation. More roads, dams and heavy construction jobs are completed every year with fewer men; one man controlling a big cat scraper can do a phenomenal amount of work in a day.

Running a roaring mass of machinery that can uproot trees or push over houses is far more complicated than running even the biggest truck. The work is taught at regular schools, the largest training about 1500 a year in California, Florida and

(Please turn to page 22)

JOB TITLE	CURRENT DEMAND	3-MONTH TREND	STATES WITH HIGHEST DEMAND				
Chemists, Biological	24	Demand down	N.J. 6	Pa. 2	Ohio 2	Wis. 3	Calif. 3
Chemists, Organic	52	Down slightly	N.J. 10	Ala. 11	Ohio 3	Minn. 4	Calif. 7
Chemists, Inorganic	7	Demand up	Conn. 3	Ala. 1	Mo. 1	N.M. 1	Calif. 1
Engineers, Metall.	47	Up slightly	D.C. 6	Pa. 4	S.C. 10	Ind. 6	Calif. 4
Engineers, Civil	524	Substantial increase	Conn. 31	N.Y. 53	D.C. 64	Calif. 161	Wash. 34
Engrs., Elect. & Electron.	949	Good increase	Conn. 45	D.C. 42	N.C. 58	Fla. 108	Calif. 333
Engineers, Industrial	426	Demand doubled	Conn. 27	N.J. 35	Miss. 21	Ill. 28	Calif. 109
Engineers, Mechanical	1,100	Very good increase	Conn. 62	Pa. 67	Fla. 62	Ohio 68	Calif. 281
Engineers, Aero.	560	Good increase	Pa. 11	Mo. 140	La. 17	Calif. 241	Wash. 120
Engineers, Mining	9	Demand steady	D.C. 3	Pa. 2	Fla. 1	Kan. 1	Colo. 1
Natural Scientists	106	Slight decrease	D.C. 23	Va. 5	Mo. 5	Calif. 8	Wash. 51
Draftsmen, Arch.	140	Demand tripled	Conn. 3	Mass. 3	Fla. 3	Mich. 4	Calif. 103
Draftsmen, Electrical	172	More than tripled	N.J. 2	Pa. 6	Fla. 6	Mo. 20	Calif. 126
Draftsmen, Mechanical	315	Good increase	Pa. 34	Wis. 35	Ohio 49	Mo. 10	Calif. 106
Draftsmen, all other	371	Very good increase	Conn. 16	D.C. 10	Miss. 20	Mo. 20	Calif. 226
Tool Designers	117	Good increase	Conn. 5	Vt. 10	Ill. 10	Calif. 6	Wash. 60
Lab. Tech. & Assts.	78	Some increase	Conn. 4	N.J. 6	Miss. 15	Ind. 13	Calif. 5
Sports Instr. & Officials	75	Demand doubled	Mass. 7	Vt. 21	N.Y. 9	Mich. 4	Colo. 25
Surveyors	25	Slight fall-off	Vt. 2	N.J. 2	Mich. 2	Iowa 5	S.D. 6
Techs., Engrs., Phys. Sci.	349	Very good increase	Va. 20	Ala. 56	Fla. 26	N.M. 10	Wash. 205
Tool Planners	9	Slight increase	Ohio 2	Ind. 7			
Systems Engineers	22	Slight increase	N.Y. 4	Pa. 1	Ill. 1	Mo. 15	Neb. 1
Programmers	303	Good increase	N.J. 19	D.C. 17	Mo. 11	Calif. 80	Wash. 115
Systems Analysts	87	Some increase	Conn. 3	D.C. 12	Mich. 4	Calif. 16	Wash. 35
Inspectors, Pub. Service	13	Demand doubled	Ohio 1	Tex. 1	Calif. 2	Alaska 1	Wash. 7

**PM's Career Barometer Chart**, above, gives the actual number of men currently needed for specific jobs. "Current Demand" figures are true as of our closing date. Check this chart each month and it will tell you where your talents are needed, and how badly. For names of actual employers represented by these listings, contact the state employment agency in the cap-

ital city of the state indicated. Mention that you saw this in **POPULAR MECHANICS**.

Today, with proper schooling, you can qualify for many of the job categories shown. For a list of accredited correspondence and residence schools, write to **POPULAR MECHANICS' Information Bureau, 575 Lexington Ave., N.Y. 10022**.

# Move Up Faster — Make More Money With N.T.S. "PROJECT METHOD" HOME TRAINING

Looking for your first real job in industry? Are you stalemated in a dead-end job? Or, are you being left behind because you're not up on new industry methods? Don't let technical progress — automation — pass you up. There's an N.T.S. Project Method training program to help you MOVE UP FASTER and MAKE MORE MONEY!

N.T.S., a leading technical school for more than 60 years, shop-tests every lesson and manual. Easy-to-follow lessons are fully illustrated so you can learn fast. Look over the big opportunity home study courses below. Choose your field! Check the coupon and mail it today! You'll soon be on your way to a high-paying new career!

## ELECTRONICS DIVISION

1. Electronics-TV-Radio Servicing and Communications
2. Master Course in Electronics-TV-Radio Advanced TV and Industrial Electronics
3. FCC License Course
4. Radio Servicing (AM-FM-Transistors)
5. Television Servicing (Including Color)
6. Stereo, Hi-Fi and Sound Systems
7. Basic Electronics
8. Electronics Math

Train yourself quickly for America's "big future" industry! BIG EQUIPMENT KITS come with many of the electronics courses — at NO EXTRA COST! NO KIT DEPOSITS REQUIRED — equipment is included with your tuition.

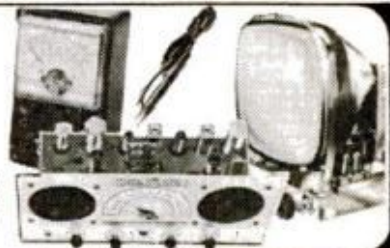

## AUTO-MECHANICS DIVISION

1. Automotive-Diesel Master Course
2. Automotive Mechanics
3. Diesel Mechanics
4. Engine Tune-up and Electricity

Eighty million cars and trucks need maintenance! Here's opportunity for you — in manufacturing, in sales and service — in your own auto repair business! VALUABLE TOOLS AND EQUIPMENT COME WITH ALL N.T.S. AUTO-MECHANICS COURSES! NO KIT DEPOSITS REQUIRED — NO EXTRA COST!

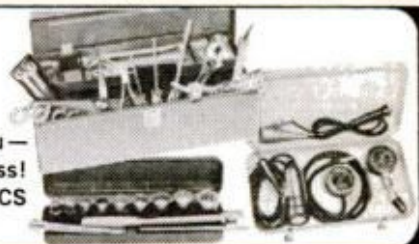

## AIR CONDITIONING — REFRIGERATION DIVISION

1. Air Conditioning-Refrigeration Servicing Course
2. Air Conditioning, Refrigeration & Electrical Appliances Master Course

Good income in installation & servicing homes, factories, schools, hotels & motels, office buildings, stores, cars, trains, buses and in servicing electrical appliances. The trained man in these fields is in demand! BOTH COURSES COME WITH BIG EQUIPMENT KITS AT NO EXTRA CHARGE. NO KIT DEPOSITS REQUIRED.



## HIGH SCHOOL AT HOME

National offers accredited high school programs. Take only subjects you need. Study at your own pace. Everything included at one low tuition. Check special High School box in coupon for full information and FREE catalog.



## HOME APPLIANCES DIVISION

1. Home Appliances Master Technician's Course. Prepares you quickly for a business of your own in all phases of major and small appliance work.
  2. Home Appliances Servicing Course. Prepares you for a part or full time job. Earn while you learn.
- No kit deposits required. No extra cost.

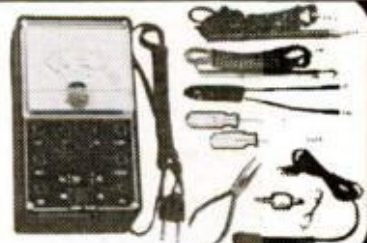

## Classroom Training at Los Angeles.

You can take classroom training at Los Angeles in Sunny Southern California. N. T. S. is the oldest and largest school of its kind. Check Resident School box in coupon for details.



## NATIONAL TECHNICAL SCHOOLS

WORLD-WIDE TRAINING SINCE 1905

4000 S. Figueroa Street, Los Angeles, Calif. 90037

YOU ENROLL BY MAIL UNDER N.T.S. "NO OBLIGATION PLAN." WE HAVE NO SALESMEN; THIS MEANS LOWER TUITION FOR YOU.

SEND FOR FREE BOOK & SAMPLE LESSON



Accredited Member  
National Home  
Study Council



## NATIONAL TECHNICAL SCHOOLS

WORLD-WIDE TRAINING SINCE 1905

### NATIONAL TECHNICAL SCHOOLS, DEPT. 201-125

4000 S. Figueroa St., Los Angeles, Calif. 90037

Please rush FREE BOOK AND SAMPLE LESSON on Courses in the Division checked below. No obligation — No salesman will call.

- |  |  |
|--|--|
| <input type="checkbox"/> ELECTRONICS Division    | <input type="checkbox"/> AIR CONDITIONING-REFRIGERATION Division |
| <input type="checkbox"/> AUTO-MECHANICS Division | <input type="checkbox"/> HOME APPLIANCES Division                |

HIGH SCHOOL Department

Name \_\_\_\_\_ Age \_\_\_\_\_

Address \_\_\_\_\_

City \_\_\_\_\_ State \_\_\_\_\_ Zip \_\_\_\_\_

Check here if interested ONLY in classroom training at Los Angeles.

# FREE!



## Trial lesson in **DRAFTING & DESIGN**

### LEARN AT HOME IN SPARE TIME

Check the want ads in any newspaper—SEE the big-pay opportunities open to you as a draftsman. What's more, you can learn this well-paid, prestige profession at home—quickly, easily! No special talent needed! Get complete, step-by-step Chicago Tech lessons in the mail, spend a few pleasant hours studying each week. In a short time you'll be a well-trained draftsman, ready to take your pick of many good jobs. Act now!

### FREE INFORMATION—MAIL COUPON TODAY!

Get FREE TRIAL LESSON plus information about C.T.C. practical training. Learn what successful Chicago Tech graduates say about high pay and opportunities in drafting. No charge, or obligation.

Est. 1904 Accredited National Home Study Council

## CHICAGO TECHNICAL COLLEGE

S-203 Tech Bldg., 2000 So. Michigan Ave.  
Chicago 16, Illinois

Mail me FREE Lesson with information about big opportunities in DRAFTING.

Name..... Age.....  
Address.....  
City..... Zone..... State.....

## CAREER BAROMETER cont'd

Texas. Such schools function all year, with new groups starting every other Monday. Classes run ten hours a day, five days a week. For about four weeks, a trainee gets technical instruction on construction, repair and operation of heavy equipment, with actual training on various machines.

Field training costs are about \$600 to \$1000. Some schools offer a study course. One such comprises 60 correspondence lessons and two or more weeks' training at the school. The apparent high cost is because schools must own or rent some 30 late-model machines, some costing \$50,000 and \$100,000. Veterans can take courses under the Veterans' Administration rehabilitation program. Students are accepted at 17, but some may be 50 or 60.

About 7 percent of starters are found to have insufficient judgment and coordination to operate machines, and they drop out. All schools emphasize safety, care and repair. Courses begin with classroom lectures, sometimes with chalkboard talks, again with cutaway models. One big school in North Carolina offers four courses:

No. 1—crawler tractor and bulldozer, and scraper, 3 weeks, 220 hours, \$795; No. 2—motor grader, 3 weeks, 220 hours, \$795; No. 3—cranes (clamshell, backhoe, dragline, shovel), 6 weeks, 440 hours, \$995; No. 4—construction equipment field mechanic (earth-mover maintenance and overhaul), 6 weeks, 440 hours, \$695.

For younger men, 53 conservation centers set up in 36 states under the Job Corps also offer training in use of heavy equipment. The program is free, supplying room, board and \$1 a day expense money. Students work on federal earth dams and other projects, but half their time is devoted to improving skills in reading, writing and math. Many are high school dropouts. Some 6000 boys are now enrolled.

For the next few years, there will be many more opportunities for heavy equipment operators in the West than in the East—chiefly in road and dam building.

Graduates receive diplomas; a good percentage find jobs quickly. Pay has been increasing every year and, not infrequently, contractors sweating to beat a deadline keep crews going seven days a week.

Among those who began as owner-operators of steam shovels 30 and 40 years ago, and now rank with the wealthiest of contractors, are James M. Slattery, New York; Frank M. Graves, Minneapolis, and George Brewster, Bogota, N.J. Among younger men, Karl T. Manzel, Pompano Beach, Fla., a heavy-equipment school grad, has a dozen pieces of equipment—and plenty of work. ★★★

**HOT SHOT  
HOT SHOT**

**Amazing New BENJAMIN  
30 30 CO<sub>2</sub> GAS  
BB CARBINE REPEATER**

—Packs a PUNCH that's so POWERFUL it will Drive STEEL BBs thru Both Sides of a 5 Gal. Steel Pail at close range! (26 ga. .018")

**\$18.00** Ask Dealer for Demonstration.  
**BENJAMIN AIR RIFLE COMPANY**  
896 Marion St., St. Louis, Mo. 63104

**FREE** Catalog Benjamin Single Shot and Repeaters—Cal. BB or 177 or 22. Also Special Hunting Knife Offer. Write today!

You're in for a thrill you'll never forget the first time you shoot HOT SHOT! The Hardest Shooting CO<sub>2</sub> Gun on the market—New Model 30 30 embodies features that also assure Flawless Performance: Permanent Alnico V Cast Magnet Shot Holder . . . a Positive, Jam-proof method of loading Ammo in firing position; Convenient, Positive Hammer Safety; 30-BB Mag.; 30 Shots per cartridge; Quality Built. Lightweight—Accurate—Field Tested—Lowest Shooting Costs—use Indoors/Outdoors.

**You Can DEPEND on BENJAMIN**





**MORE 1965 USAC AND  
NASCAR WINNERS  
USED PERFECT CIRCLE  
PISTON RINGS THAN ALL  
OTHER BRANDS COMBINED**

It happens year after year. Men who make their living at racing select their engine parts to assure peak performance from start to finish. When it comes to piston rings, they almost always choose Perfect Circle. And the

PC piston rings they use are not specially made for racing. They are standard sets — the same kind you can install! To maintain top engine efficiency in *your car*, insist on Perfect Circle next time you re-ring.

## **PERFECT CIRCLE**

**DANA PARTS  
COMPANY**



**DANA CORPORATION**

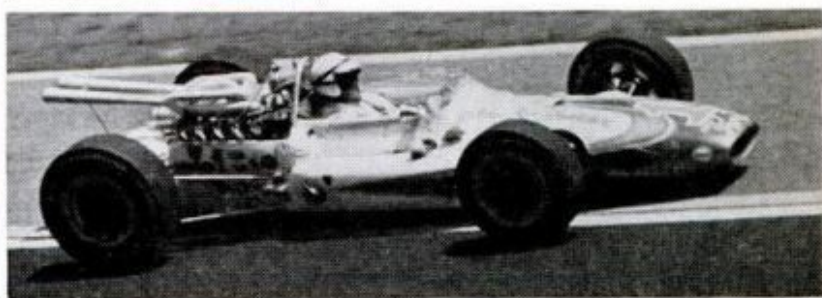
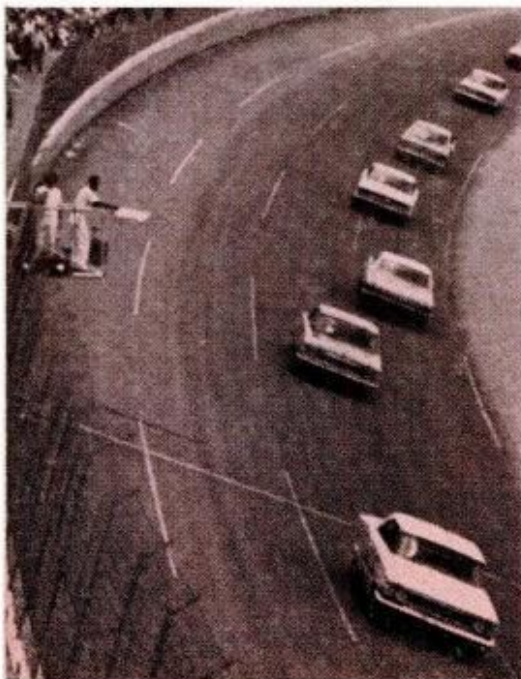

# LEARN BY DOING— Work On Late Model Cars and Equipment . . .



## Become a Professional **AUTO MECHANIC**

Take the giant step into an assured future with expert knowledge of Auto Mechanics and a Lincoln Tech Diploma. *Not Home Study.* You learn by actually working with live engines, automatic transmissions, power steering and brake systems, etc. and the latest electronic test equipment. 80,000 well paying jobs are open right now for Trained Auto Mechanics, Ignition Tune-Up and Automatic Transmission Specialists. The Lincoln Tech graduate is in demand because *he knows his business!* He has the solid foundation for rapid advancement to foreman, shop manager, fleet superintendent, factory representative or owner of his own business.

### FREE PLACEMENT SERVICE

Lincoln Technical Institute is recognized nationally for advanced teaching methods and personal guidance. Best of all . . . You can train in one of Lincoln Tech's resident schools located in principal cities throughout the United States.



New classes start every four weeks.  
Get all the facts *now!*

## LINCOLN TECHNICAL INSTITUTE

472 Market St, Newark, N. J. 07105

LINCOLN TECHNICAL INSTITUTE, SUITE 12-E  
472 MARKET STREET, NEWARK, N. J. 07105

Please send me full information on the Lincoln  
Tech Automotive School nearest my home.

I am interested in the course checked below:

- Automotive Mechanics
- Automatic Transmissions
- Ignition and Tune-Up

Name \_\_\_\_\_

Address \_\_\_\_\_

City \_\_\_\_\_ State \_\_\_\_\_

# WHAT'S NEW **OUTDOORS**

BY STUART JAMES

**When anti-pollution** becomes a problem that's news to me. The Du Pont plant in Victoria, Tex. keeps contaminants out of the Guadalupe River by using a series of ponds for evaporation and then pumps waste material into wells a mile deep. It was working without mishap until an army of nutria (a rodent) moved into the ponds and began destroying the pond walls and canal banks. Du Pont went back to nature to control nature. They imported four large alligators to patrol the disposal system.

**Russians** write to the U.S. to learn about revolutions. Gale Products received a request from Leningrad for copies of their booklet on choosing the best outboard motor props. Planning a long trip, perhaps?

**They oughta put wheels** on that thing, is the way novelist/sportsman Bill Butterworth reported to me on the Smith & Wesson .44 magnum revolver, after shooting it for a day, so I assumed it was a lot of gun. But I was still a bit skeptical when I was told that Los Angeles sportsman, Bob Petersen, used one to bring down a 1500-pound polar bear in Alaska this year. So they sent along this photo of Bob with his trophy. Personally I prefer a bazooka for this sort of game, but Bob did him in with five shots of the standard 240-grain bullet at 25 yards. But he did use both hands.



# - For Action, Security, Big Pay -

## WE CHALLENGE YOU TO TOP THIS JOB!

**Earn To \$15 An Hour ★ Work Part-Time Or Full-Time ★ Car Furnished — Expenses Paid ★ No Selling — No Previous Experience Needed ★ Only Average Education Required**

### NO OTHER CAREER OFFERS YOU A BRIGHTER FUTURE

Consider this fact. In the short time it takes you to read this page 1,100 accidents will take place. Over 440,000 will occur before this day ends. *These accidents must be investigated.* The law demands it. Yet in 4 out of 5 cities, towns and rural communities, no one has been trained for this vital work.

### KEEP PRESENT JOB UNTIL READY TO SWITCH

Step into this fast-moving Accident Investigation field. *Already* hundreds of men we have trained are making big money. Joe Miller earned \$14,768 his first year. A. J. Allen earned over \$2,000 in ten weeks. Robert Meier says "I'm now earning \$7.50 to \$15.00 an hour in my own business.. Universal's course is wonderful."

### FREE EMPLOYMENT HELP GIVEN

We CAN and WILL show you how to rapidly build your own full-time or part-time business. Or if you wish a big-pay job as Company Claims Investigator, our Placement Service will give you *real* assistance. Hundreds of firms needing men call upon Universal. *We place far more men in this booming field than any other individual, company or school.*



### EARN WHILE YOU LEARN

Write today. Let me show you how easy it is for you to get into this exciting new career in just a matter of weeks. No obligation. No salesman will call. Mail coupon or post card to me, M. O. Wilson, PM-12 Universal Schools, Dallas 5, Texas.

### Mail Now for FREE BOOK

M. O. Wilson, Dept. PM-12  
Universal Schools,  
6801 Hillcrest, Dallas 5, Texas

Please rush me your FREE BOOK on Big Money in The Booming Accident Investigation Field. I will be under no obligation — and no salesman will call upon me.

Name .....

Address .....

City ..... Zone ..... State .....



## You'll EARN CASH FAST as a CUSTOM UPHOLSTERER Start Making BIG MONEY RIGHT AWAY BE YOUR OWN BOSS!



### YOUR OWN BUSINESS

"Not long ago I was an auto mechanic. Now I operate my own upholstery shop and have more than doubled my income. UTS training has been invaluable."

— Paul M. DeVita

Do Custom Upholstering, Re-Upholstering, Make Slip Covers. Say "goodbye forever" to layoffs, shut-downs, dead-end, low-pay jobs. This clean, enjoyable, booming opportunity field can give you RIGHT AWAY a second income from spare-time work anytime, anywhere — open the way FAST to a high-profit business of your own... with NO INVESTMENT! BIG-PAY JOBS WAITING, too, if you want one.

### FREE BOOK GIVES EXCITING FACTS

Mail coupon to receive FREE 32-page Deluxe Illustrated Book and FREE Sample Lesson Sheets proving and showing how long-established, success-proved UTS Training AT HOME pays for itself. Earn as you learn! With this Accredited, State Licensed training you easily, QUICKLY build and slip cover new fine furniture you can keep, or sell for more than the course costs! Also you learn re-covering, re-upholstering to make old furniture new, handling of plastics, foam rubber, fireproofing. Only ACCREDITED COURSE to include all tools, new wooden frames, materials, fabrics, complete business-building aid, wholesale privileges... 32 Top-Wage, Top-Profit Skills... at no extra charge!



ALL TOOLS AND UPHOLSTERED PIECES YOURS TO KEEP OR SELL

**NO OBLIGATION — NO SALESMAN WILL CALL**  
Act now to LEARN FAST, EARN FAST, enjoy lifetime earning power and security in this thriving, big-money craft. Thousands we've trained now doing it — YOU CAN TOO! Let the coupon be your shortcut to a highly-paid, in-demand skill no machine can replace. Mail coupon NOW!

### UPHOLSTERY TRADES SCHOOL

(Division of Technical Home Study Schools)

Dept. 510-125, Little Falls, New Jersey 07424

Accredited Member National Home Study Council

**UPHOLSTERY TRADES SCHOOL,**  
Dept. 510-125,  
Little Falls, New Jersey 07424

Established  
1939

Please send me FREE book and FREE sample lesson sheets. No obligation—no salesman will call.

Name .....

(Please Print Plainly)

Address .....

City ..... State ..... Zip .....

DETROIT

# LISTENING POST

BY JIM DUNNE

## Merc Puts Horse Before Cart

Front drive for Mercury is scheduled for all big models in two years. A Ford man told us that the system is still too expensive for the Comet series, but that anything may happen as production brings costs down. Front drive would clearly set the big Mercury apart from the big Galaxies for the first time since the end of WW II. What will this do to competition? A GM engineer told us it would affect the whole Buick-Oldsmobile-Pontiac market, probably forcing more front-drive models from these divisions.

Buick is widely reported to be interested in front drive. But the hot rumor is that Cadillac will beat the other GM divisions. Cadillac significantly bought two Toronados just before introduction time last September. It's not normally done unless something big is in the wind. These cars obviously are being studied by engineers to see what parts they could use. Oldsmobile is happy, since it confirms the rightness of Olds' decision. An added bonus for Olds would be sharing of tooling cost.

## Fastback Cougar on the Way

Make way for Cougar, Mercury's version of the Mustang, coming next fall in a 2-plus-2 design. Rear-seat legroom and wheelbase should be four inches greater than the Mustang's. Hideaway headlights will remain fixed behind the vertical-bar grille; sections of the grille flap open when the lights are turned on, an innovation all Mercurys will soon have. The car will have an even longer hood than the Mustang's, and the rear end will be more severely chopped off. It will have a completely fresh look, with clean side sheet metal that is bellied out in the middle, as on the E-type Jaguar. Wheel openings will be flared. A vertical bar grille will decorate the fastback lines at the rear edge. Weight will be a little more than the Mustang's, and tires will be oversize for a low, solid look.

## Will Panther Pounce on Corvair?

Another answer to the Mustang—Chevrolet's Panther—is being designed with mixed emotions. When this car is introduced next fall, Chevrolet will have three cars—Corvair, Chevy II and Panther—all about the same size. Corvair could get the ax if Panther is a success, but GM insiders deny it. The industry is going to more car names, they say. One thing is certain: If the Corvair is to survive, it needs more power. You can't stalk tigers with 180 hp. So look for a rear-mounted V8 engine. I have seen two such research prototypes already. One Corvair had a small iron V8 mounted backwards in a body that was stock except for louvers in the rear fenders and a bulged-up fiberglass deck lid. The radiator sat behind the engine. The extra weight of the V8 was carried by firmer rear springs. A second, and more interesting, Corvair had GM's super-secret prototype diecast-aluminum V8. The radiator was up front, behind a functional grille. The most noticeable difference in outside appearance was oversize tires.

Prototype components of the Panther are now being tested in  
[\(Please turn to page 28\)](#)

From an AC Engineer's notebook:

*AC's full-flow design  
gives continuous filtration.*

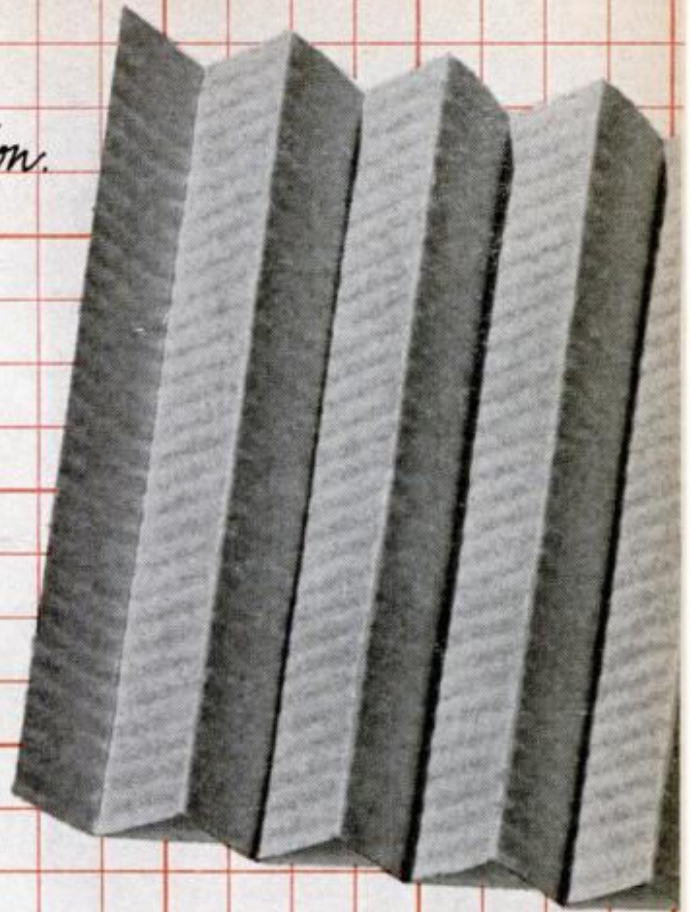
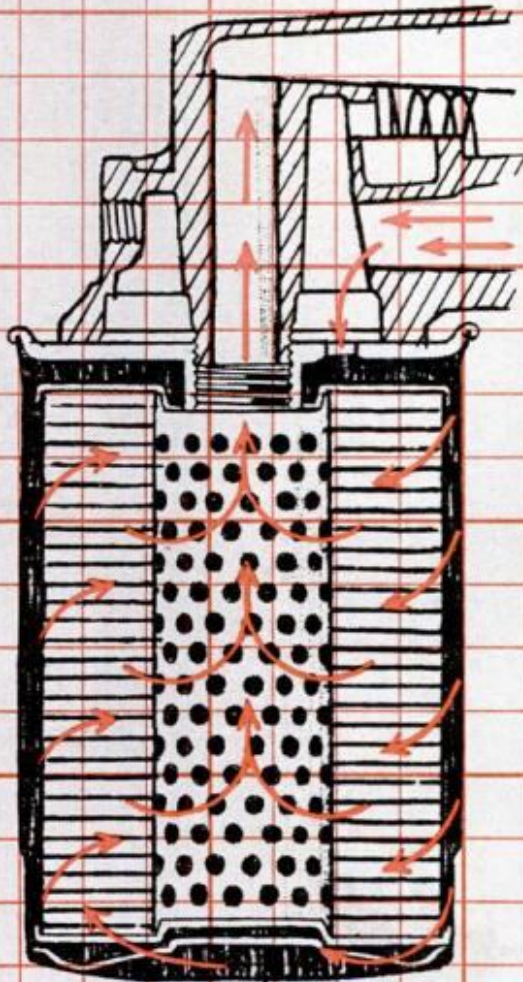

*AC's specially treated  
filter material  
assures maximum  
flow of clean oil.*

## Here's how the AC Oil Filter protects your engine against wear

The AC Full-Flow Oil Filter combines fast (600 quarts an hour\*) continuous filtration with greatest filtering efficiency. AC's specially processed filtering material assures resistance to acids, water and high operating temperatures. This process also adds strength and rigidity to the filtering material to help assure the same high degree of performance throughout its life. During the recommended service period, the AC Oil Filter effectively removes abrasive impurities that invariably result in engine wear. For more miles of top engine protection, always install a new AC Oil Filter when you change your oil.

\*Average recirculation time

AC SPARK PLUG DIVISION OF GENERAL MOTORS



**No Mess! No Guess! No Waste!**



**New QUIK-MIX EPOXY GLUE**  
comes pre-measured in handy  
**MIXER CUP** for super-strong joints

When you need an epoxy joint that absolutely must not fail, don't fool around with that messy tube stuff.

With tubes, you have to *guess* how much hardener to add. Guess wrong and you get a weak joint. But Quik-Mix Epoxy Glue in a mess-proof Mixer Cup gives you hardener and epoxy pre-measured and ready to mix. All you do is stir and apply. Buy Mixer Cups of Quik-Mix Epoxy Glue in hardware stores.

**Hang handy card with 2 cups on your pegboard.**

**2 Cups  
59¢**



A product of

**LOCTITE CORPORATION**

480 N. Mountain Rd., Newington, Conn. 06111

LISTENING POST continued

cobbled-up Chevy II bodies, which gives you an idea of the new car's size. Horsepower of either the Panther or the new Corvair could well reach 300. In fact, it would have to, to keep up with the competition.

Corvair is also playing with a special bucket-type front-seat design. Wings—actually padded shoulder-height extensions—are built into the seats to hold the driver during hard cornering. The sports car syndrome seems to be here to stay.

**No Topless T-Bird**

A four-door model will be among the all-new 1966 Thunderbirds. But a convertible won't be ready by next fall. The car should have many unique innovations, such as a rear window on the two-door that actually slides back into the "C" pillar instead of down into the wheel well. It still moves by crank or electric button. All models will do away with vent windows. The four-door won't be a hardtop; both front and rear doors will lock on the center post, as in the Lincoln. Wheelbase on the four-door model will be longer—perhaps as long as 119 inches—for more rear legroom. The main dashboard gauges will be housed in a semicircle in hooded pods, all facing the driver.

**Scissor-Frame Ragtop**

How do you store a convertible top? With cars getting lower, this has been bugging car stylists. When it is down, the top sits above the fender line, spoiling the lines of the car. Lincoln and Thunderbird licked this problem, but pay the heavy price of losing most of their trunk room. Now GM designers plan to store the metal framing directly behind the rear seat instead of stacking it above the wheel wells. The metal side rails would scissor in toward the middle. With top up, you can't tell the difference. Look for this on several GM models next fall, and for a similar design on Ford cars a few months later. (That's one reason the T-Bird convertible will be delayed.)

**Indy Engines for '67**

New Indianapolis engines are being prepared by Ford and Chevrolet. They'll be aluminum, and will be designed for the 1967 Indy three-liter rule. Ford's engine will be tested in Europe this year by Formula racing machines. Chevy's three-liter will be the division's first big racing move since GM banned racing activity two years ago. One owner who will get the Chevy engine for sure will be Texan Jim Hall, a man who has unofficially carried Chevy's racing colors during GM's official absence.

**START A BUSINESS**  
in your neighborhood

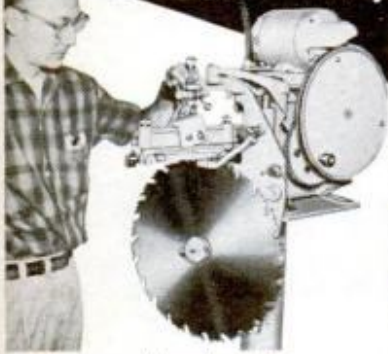

Sharpen Hand or Power Saw with the

**FOLEY SAW FILER**



**MODERN MOWER SHARPENER**

Precision-grind all hand and power lawn mowers—a perfect job every time.

Start your business in sparetime and make CASH PROFITS right away. No stock to carry, no selling involved, no experience needed—the Foley Saw Filer does every sharpening job **automatically!** Earn \$3 to \$6 an hour sparetime in your own garage or basement. Profit 90c on every dollar.

Best of all, every saw you sharpen, will be resharpened again and again—watch your repeat business grow! Add cash to your income now, while you build retirement security with the Foley Saw Filer.



**FREE BOOK** shows how you can make money as thousands of others have. Send coupon today. There's no obligation, and no salesman will call—so write today!

**Foley Manufacturing Co.**  
1243-5 Foley Bldg., Minneapolis, Minn. 55418  
Send for FREE book on Money-Making facts about the sharpening business.

NAME \_\_\_\_\_  
ADDRESS \_\_\_\_\_  
CITY \_\_\_\_\_ STATE \_\_\_\_\_ ZIP CODE \_\_\_\_\_



Pontiac Motor Division • General Motors Corporation

## Since when is a six a surprise? Starting right now.

So how does anybody turn a sweet, smooth, uninspiring six into an engine that goes around acting like a V-8? Brilliant engineering, mostly.

By putting the camshaft over the valves it operates, and connecting the two with a special cam follower pivoted on a zero-lash adjuster unit, the power-robbing weight of the pushrods, lifters, and rocker arms is eliminated. Zero-lash permits high rpm engine windup without valve float. Naturally, high rpm and low engine weight combine to produce a very agile power unit.

Our new six has only 15 cubic inches more displacement than the conventional pushrod engine it replaces, but 25 more horsepower. With the available sports package featuring a 4-barrel Quadrajet carburetor and split

manifold, horsepower is increased by 42 to 207 at 5200 rpm.

Simplicity of design is another feature of this revolutionary powerplant. The overhead cam is driven by a specially compounded, non-stretch neoprene timing belt reinforced with glass-fiber cords. The same belt drives an accessory sprocket, which in turn drives the distributor, fuel pump, and oil pump as one external drive assembly.

Of course, the only way to evaluate an engine like this is to connect it to a particularly sensitive piece of road machinery—like the Le Mans, Tempest Custom or Tempest on which it's standard—and drive it. The optional 207-hp sports package with heavy-duty shocks, springs, and stabilizer bar, and distinctive emblems and sport striping is available on the same

cars. You can read more about it in the special performance catalog available from your Pontiac dealer. Ask him for one. The tiger scores again!



**Wide-Track Pontiac/'66**



## HOMELITE XL CHAIN SAWS

save you time,  
money and labor!

If you have a home with trees — a campsite or a summer cottage — HOMELITE XL Chain Saws are for you!

Cut firewood, clear campsites, repair storm damage, take out diseased trees, prune shade trees — you can do all these jobs faster and easier with a HOMELITE XL because it's so light, so easy to handle. It will cut through 18" softwood in 17 seconds — 18" hardwood in 24 seconds!

Homelite XL starts quickly in any weather and gives you dependability, power, cutting speed . . . weighs as little as 12 lbs. 12 oz!\*

See your dealer today. He's in the Yellow Pages. Let him demonstrate any HOMELITE XL of your choice — then take it home and do the quickest job on wood you ever did. You'll soon see why the HOMELITE XLs are the fastest selling chain saws in the world!

FREE! Write for colorful, 8-page booklet, "Man's Guide to Woodcutting".

\*Less bar and chain



## HOMELITE

10212 RIVERDALE AVENUE  
PORT CHESTER, NEW YORK

A **Textron**  
DIVISION



Famous HOMELITE  
XLs — world's fastest  
selling chain saws.

## EXCITING NEW PRODUCTS

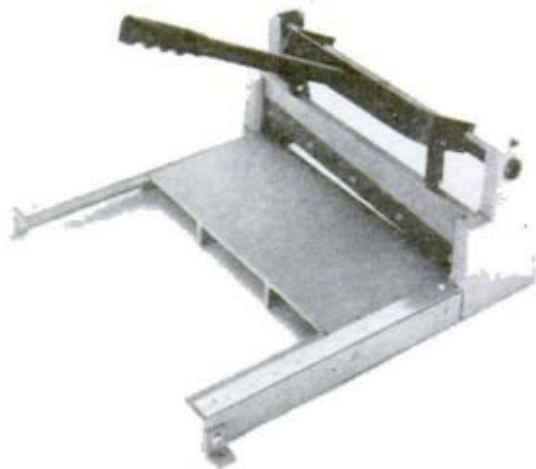

The hobbyist and home handyman can perform scores of jobs with the Accu Plate Cutter. It will accurately cut all vinyl or rubber tiles (to 12 in.), as well as copper, brass and aluminum sheet. \$84.95. By Accu Cutter Co., 70 Forest Dr., Jericho, N.Y.

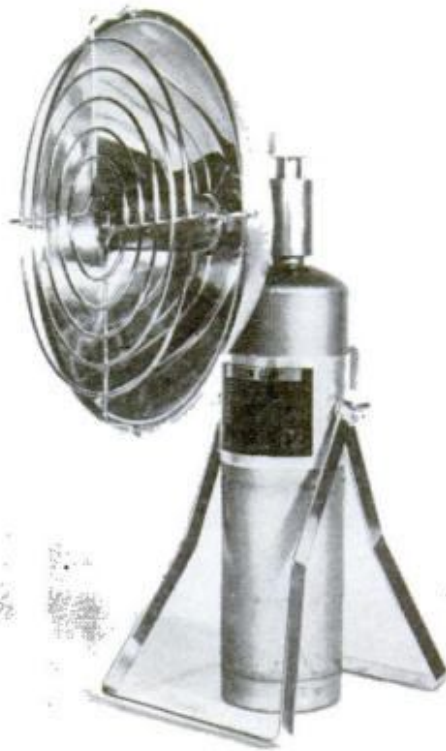

"Sun Gun" gives 14 hours' heat from a 13-oz. propane fuel cylinder. Use it for quickie heat in bathroom or garage. Take it camping. Its infrared heat is produced with complete oxidation. \$18.95. Made by Polyplastic Forms, Inc., Farmingdale, N.Y.



What if I'm laid off?  
 Will automation take my job?  
 How can I ever afford to retire?  
 Am I too old to change jobs?  
 Can I learn a new skill?  
 Could I succeed as my own boss?  
 How can I earn extra money fast?  
 Will my job ever pay more?



**FINDS 3-WAY  
 INCOME INSURANCE**

"I earned \$2,901.72 while learning locksmithing and now make \$5000 a year—doubling my income. Worries about layoffs, retirement, more money are over for me—thanks to the Locksmithing Institute Course!"—Stanley Nowak, Saginaw, Mich.



**MAIL  
 COUPON  
 NOW**

# Be a SKILLED LOCKSMITH

... and Solve ALL Your "FUTURE" Problems

No question about it... with Locksmithing YOU HAVE IT MADE! You'll do light, clean, fascinating work—take your choice of steady, high-pay job opportunities, or your own big-profit spare-time or full-time business! As a locksmith you have your own "built-in" pension plan. Say "goodbye" to layoffs, automation, slack times, forced retirement! **EARN MORE, LIVE BETTER** in good times and bad. **LOCKSMITHING IS SO EASY TO LEARN—EARN Extra Money RIGHT FROM THE START!** Regardless of age, education, experience, minor physical handicaps, fun and earnings begin **AT ONCE** as you learn quickly, easily at home to **CASH IN** on all kinds of locksmithing jobs. Experts guide you—locks, keys, parts, picks, special tools and equipment as well as complete fully illustrated lessons all supplied with course.

**FREE Illustrated Book, FREE Sample Lesson Pages Give Exciting Facts.** Find out how being a skilled Locksmith can put a quick end to your worries. Locksmithing Institute graduates now earning more, enjoying life. Send coupon **TODAY** for **FREE** illustrated book and sample lesson pages. No salesman will call. Only school of its kind. Licensed by N.J. State Dept. of Education, Accredited Member National Home Study Council.



**306** pieces of equipment  
**LOCKS, PICKS & TOOLS** supplied for use with course.

**LOCKSMITHING INSTITUTE, Dept. 110-125  
 Little Falls, New Jersey 07424**

Please send **FREE** Illustrated Book—"Your Big Opportunities in Locksmithing," complete Equipment folder and sample lesson pages—**FREE** of all obligation—(no salesman will call).

Name ..... (Please Print)  
 Address.....  
 City..... State..... Zip.....

**LOCKSMITHING INSTITUTE** Division of Technical Home Study Schools  
 Dept. 110-125, Little Falls, New Jersey 07424



## AUDEL GUIDES

- No. 8 Carpenters & Builders Guide, 4 Vols. 1900 pages... \$10.50
- No. 1 Auto Mechanics Guide. 1132 pages..... 6.00
- No. 15A Electric Library. 10 Vols. 5558 pages..... 25.00
- No. 2 Home Appliance Service Guide. 832 pages..... 6.95
- No. 14 Refrigeration & Air Conditioning Guide. 1090 pages..... 6.00
- No. 26 Masons & Builders Guide. 4 Vols. 1440 pages..... 10.50
- No. 6 Plumbers & Steamfitters Guide. 4 Vols. 1833 pages..... 10.50
- No. 3 Radio-TV Library. 2 Vols. 960 pages..... 9.50
- No. 12 Machinists & Toolmakers Handy Book. 1256 pages..... 6.95
- No. 10 Welders Guide. 606 pages..... 4.95
- No. 49 Outboard Motor & Boating Guide. 414 pages..... 4.00
- No. 4 Handy Book of Practical Electricity. 1052 pages..... 5.95
- No. 25 Blueprint Reading for Mechanics & Bldrs. 430 pgs.. 3.95
- No. 27 Electric Motor Guide. 1036 pages..... 5.95
- No. 11 Mathematics & Calculations for Mechanics. 672 pages..... 4.95
- No. 53 Foreign Auto Repair Manual. 592 pages..... 5.00
- No. 5 Truck and Tractor Guide. 908 pages..... 5.95
- No. 7 Painting & Decorating Manual. 592 pages..... 4.95
- No. 48 Gas Engine Manual. 468 pages..... 4.00
- No. 28 Oil Burner Guide. 420 pages..... 3.95
- No. 9 Diesel Engine Manual. 544 pages..... 6.00
- No. 29 Sheet Metal Pattern Layouts. 1152 pages..... 7.50
- No. 54 Programmed Basic Electricity Course. 272 pages... 4.00

**10 DAY FREE EXAMINATION. SEND NO MONEY.** We'll send you any Audel Guides for **FREE** trial. If you decide to keep the books you pay only \$3 per month under our easy-pay plan. Simply circle the books you want below and we'll send them at once. If you're not completely satisfied, return them to us.

**THEODORE AUDEL & CO.** - Since 1879 P-125  
 4300 W. 62nd St., Indianapolis, Indiana 46206

Please mail me for 10 days **FREE EXAMINATION** the books circled below. I agree to mail \$3 in 10 days for each book or set ordered, and to mail \$3 a month for each book or set, until I've paid the purchase price, plus shipping costs. If I'm not completely satisfied with my Audel Guides I may return them.

**MAIL  
 COUPON  
 TODAY!**

Name \_\_\_\_\_  
 Address \_\_\_\_\_  
 Employed by \_\_\_\_\_  
 1 2 3 4 5 6 7 8 9  **SAVE SHIPPING COSTS.** Check here if you enclose complete payment (plus sales tax, if any). We pay postage.  
 10 11 12 14 15A 25 26  I've bought Audel books before.  
 27 28 29 48 49 53 54

## ARE YOU MAKING ALL THE MONEY YOU CAN?

**U.S. DEPT OF  
 LABOR CITES  
 IMMEDIATE NEED FOR  
 SKILLED TECHNICIANS**

Prepare for the better paying jobs at the World's largest, most modern and best equipped Trade School. Greer's expert instruction and actual shop training teaches you how. Job placement aid and help in obtaining convenient living accommodations nearby. Resident training and Home Study courses. Over 100,000 successful graduates.



- AUTOMOTIVE MECHANICS
- AUTOMATIC TRANSMISSIONS\*
- MOTOR TUNE UP\*
- BODY & FENDER REPAIR\*
- DIESEL MECHANICS
- MACHINIST, TOOL & DIE\*
- REFRIGERATION & AIR CONDITIONING
- GAS & ARC WELDING
- HELIARC WELDING
- ENGINEERING DRAWING\*
- BLUEPRINT READING\*
- TWO YEAR AUTOMOTIVE AND DIESEL TECHNOLOGY\*
- TRUCK DRIVER TRAINING
- HEAVY EQUIPMENT OPERATORS
- CONSTRUCTION EQUIPMENT MECHANICS\*

NAME ..... Age.....  
 ADDRESS.....  
 TOWN..... STATE.....  
 \*Resident Courses Only.  Resident  Home Study

**GREER TECH** Est. 1902  
**INSTITUTE**  
 Box 2236 S. Michigan Ave., Chicago, Ill. 60616



## GIVE YOURSELF AN ALL-PURPOSE NICHOLSON FILE THIS CHRISTMAS

You probably won't get a Nicholson or Black Diamond file as a gift this year, so why not treat yourself to one?

Especially recommended this month is our Handy file—a combination single and double cut file with hang-up handle.

No matter what Nicholson or Black Diamond file you select, you'll want to be sure that you get the most out of it on the job. That's easily accomplished by sending for our free booklet, "File Philosophy." This is the booklet on files and their uses.

You can see the complete Nicholson or Black Diamond line at your local hardware store. Pick up some. They make great filing all year round.

 **NICHOLSON** 

Nicholson File Company, Providence, Rhode Island  
Files • Rotary Burs • Hacksaw and Band Saw Blades  
Hole Saws • Ground Flat Stock • Industrial Hammers



**Kit aircraft**, which don't exist on the U.S. market, may have their best chance for making a breakthrough with the unusual RF-3 reported on page 110.

In fact, the RF-3's designer, a Frenchman, isn't sure he can crack the American market unless he breaks it down into kit form. It would reduce the price if the buyer were obliged to put the aircraft together, and thus absorb some of the costs of shipping it from France.

At the moment, there are only a few gliders sold and sanctioned as kits here. No powered aircraft has received complete approval from the Federal Aviation Agency to be put together by the owner except as experimental aircraft.

So the RF-3, which is both airplane and glider, would be unique on three counts, an airplane, glider and kit all in one.

But it still has a long way to go. The certification process is long and often costly, and at least one American manufacturer told *PM* that he would challenge certification here of the modified Volkswagen engine now standard equipment on the RF-3 in Europe. Of course, he has an engine of his own, already certified, that he'd like to put on it instead.

But that's business, and that's one of the problems the French makers will have to face when attempting to introduce this altogether new aircraft in America.

The manufacturer, Alprovia, is now in the process of moving its operations to Germany. So it might be another year before any decision is made.



**RF-3 GLIDER-AIRPLANE.** Will it get here as a kit?

Cast your ballot for a successful future!

# 253 I.C.S. COURSES



I.C.S. is the oldest, largest correspondence school. Over 200 courses. Business, industrial, engineering, academic, high school. One for you. Direct, job-related. Bedrock facts and theory plus

practical application. Complete lesson and answer service. No skimping. Diploma to graduates. Send for the 3 free booklets offered here and find out how I.C.S. can be your road to success.

**ACCOUNTING**  
Accounting for Business Programmers  
Accounting (Canada)  
Auditing  
Business Law  
Cost Accounting  
C.P.A. Review  
Estate & Trust Accounting  
Executive Accounting  
Federal Tax  
General Accounting  
Industrial Accounting  
Junior Accounting  
Legal Accounting  
Office Accounting  
Personal Income Tax & Social Security  
Practical Accounting  
Public Accounting  
Small Business Accounting  
Starting & Managing a Small Bookkeeping Service

**ARCHITECTURE AND BUILDING**  
Arch. Drawing & Design  
Architecture  
Building Contractor  
Building Estimator  
Building Inspector  
Building Maintenance  
Carpenter-Building  
Carpentry & Millwork  
House Planning & Interior Design  
Mason  
Painting Contractor  
Reading Arch. Blueprints  
Review in Arch. Design & Practice  
Review of Mech. Systems in Buildings

**ART**  
Amateur Artist  
Commercial Art  
Commercial Cartooning  
Interior Decorating  
Oil Painting for Pleasure  
Show Card & Sign Prod.  
Show Card Writing  
Sign Painting & Designing  
Sketching & Painting

**AUTOMOTIVE**  
Automatic Transmission Specialist  
Automobile Body Rebuilding & Refinishing  
Automobile Electrical Tech.  
Automobile Engine Tune-Up

Automobile Technician  
Automotive Mechanic  
Diesel-Gas Motor Vehicle Engines  
**BUSINESS**  
Advertising  
Basic Inventory Control  
Business Administration  
Business Management & Marketing  
Business Management & Production  
Canadian Business Courses  
COBOL Programming  
Condensed Business Practice  
Direct Mail & Mail Order Advertising  
Industrial Psychology  
Magazine & Newspaper Advertising  
Managing a Small Store  
Marketing Research  
Marketing Research  
Modern Executive Management  
Office Automation  
Office Management  
Programming for Digital Computers  
Programming the IBM 1401 Computer  
Purchasing Agent  
Retail Business Management  
Retail & Local Advertising  
Retail Merchandising  
Retail Selling  
Systems and Procedures Analysis

**CHEMICAL**  
Analytical Chemistry  
Chemical Engineering  
Chemical Engineering Unit Operations  
Chemical Laboratory Tech.  
Chemical Process Operator  
Elements of Nuclear Energy  
General Chemistry  
Instrumental Laboratory Analysis

**CIVIL ENGINEERING**  
Civil Engineering  
Construction Engineering  
Highway Engineering  
Principles of Surveying  
Reading Highway Blueprints  
Sanitary Engineering  
Sewage Plant Operator

Structural Engineering  
Surveying and Mapping  
Water Works Operator  
**DRAFTING**  
Architectural Drafting  
Design Drafting  
Drafting Technology  
Electrical Drafting  
Electrical Engineering Drafting  
Electronic Drafting  
Introductory Mechanical Drafting  
Mechanical Drafting  
Pressure Vessel and Tank  
Print Reading  
Sheet Metal Layout for Air Conditioning  
Structural Drafting

**ELECTRICAL**  
Electric Motor Repairman  
Electrical Appliance Servicing  
Electrical Contractor  
Electrical Engineering (Power option or Electronic option)  
Electrical Engineering Tech.  
Electrical Instrument Tech.  
Industrial Electrical Tech.  
Power Line Design and Construction  
Power Plant Operator (Hydro or Steam Option)  
Practical Electrician  
Practical Lineman  
Reading Electrical Blueprints

**ENGINEERING (Professional)**  
Chemical Civil  
Electrical Mechanical  
Industrial Management for Engineers

**ENGLISH AND WRITING**  
Better Business Writing  
Free Lance Writing  
Introductory Tech. Writing  
Modern Letter Writing  
Practical English  
Short Story Writing

**HIGH SCHOOL**  
High School Business  
High School (Canada)  
High School College Prep. (Arts)  
High School College Prep. (Engineering & Science)

High School General  
High School Mathematics  
High School Secretarial  
High School Vocational  
**LANGUAGES**  
(Edited by Berlitz)  
French German  
Italian Spanish  
**LEADERSHIP**  
Basic Supervision  
Industrial Foremanship  
Industrial Supervision  
Personality Development  
Personnel-Labor Relations

**MATHEMATICS**  
Advanced Mathematics  
Mathematics and Mechanics for Engineering  
Mathematics and Physics for Engineering  
Mathematics & Physics for Technicians  
Modern Elementary Statistics

**MECHANICAL**  
Aircraft & Power Plant Mechanic  
Industrial Engineering  
Industrial Instrumentation  
Machine Design  
Mechanical Engineering  
Quality Control  
Safety Engineering Tech.  
Tool Design  
Value Analysis

**PETROLEUM**  
Natural Gas Production & Transmission  
Oil Field Technology  
Petroleum Production  
Petroleum Production Engineering  
Petroleum Refinery Oper.  
Pipeline Engineering

**PLASTICS**  
Plastics Technician

**PLUMBING, HEATING, AIR CONDITIONING**  
Air Conditioning  
Air Conditioning Maint.  
Domestic Heating with Oil & Gas  
Domestic Refrigeration Heating  
Heating & Air Conditioning with Drawing  
Industrial Air Conditioning

Industrial Heating  
Plumbing  
Plumbing & Heating  
Practical Plumbing  
Refrigeration  
Refrigeration & Air Conditioning  
Steam Fitting

**PULP AND PAPER**  
Paper Machine Operator  
Paper Making  
Pulp Making  
Pulp & Paper Engineering  
Pulp & Paper Making

**SALESMANSHIP**  
Creative Salesmanship  
Real Estate Salesmanship  
Sales Management  
Salesmanship

**SECRETARIAL**  
Clerk-Typist  
Commercial  
Legal Secretary  
Medical Secretary  
Professional Secretary  
Shorthand  
Stenographic  
Typewriting

**SHOP PRACTICE**  
Drill Operator  
Foundry Practice  
Industrial Metallurgy  
Lathe Operator  
Machine Shop Inspection  
Machine Shop Practice  
Machine Shop Practice & Toolmaking  
Metallurgical Engineering Technology  
Milling Machine Operator  
Multicraft Maintenance Mechanic  
Practical Millwrighting  
Reading Shop Prints  
Rigging  
Tool Engineering Techn'y  
Tool Grinder  
Toolmaking  
Turret Lathe Operator  
Welding Engineering Tech.

**STEAM AND DIESEL POWER**  
Boiler Inspector  
Industrial Building Engineer  
Power Plant Engineering  
Stationary Diesel Engines  
Stationary Fireman  
Stationary Steam Eng.

**TEXTILES**  
Carding  
Carding and Spinning  
Dyeing & Finishing  
Loom Fixing Spinning  
Textile Designing  
Textile Technology  
Textile Mill Supervisor  
Warping and Weaving

**TRAFFIC**  
Motor Traffic Management  
Railway Rate Clerk  
Traffic Management

**TV-RADIO-ELECTRONICS**  
Communications Techn'gy  
Electronic Fundamentals  
Electronic Fundamentals (Programed)

Electronic Fundamentals with Electr. Equip. Tr'n'g  
Electronic Instrumentation & Servo Fundamentals  
Electronic Principles for Automation  
Electronics and Applied Calculus  
Electronics Technician  
First Class Radiotelephone License

Fundamentals of Electronic Computers  
General Electronics  
General Electronics with Electronic Equip. Tr'n'g  
Hi-Fi Stereo and Sound Systems Servicing  
Industrial Electronics  
Industrial Electronics Engineering  
Industrial Electronics Engineering Technician  
Practical Radio-TV Eng'r'g  
Practical Telephony  
Principles of Radio-Electronic Telemetry  
Principles of Semiconductor-Transistor Circuits  
Radio Servicing with Equipment Training  
Radio & TV Servicing  
Radio & TV Servicing with Equipment Training  
Second Class Radiotelephone License  
Sound Systems Specialist  
Telephony, Electronics and Radio Communications  
TV Receiver Servicing  
TV Technician

Clip coupon—and take your first big step to real success! I.C.S., Scranton, Penna. 18515 Accredited Member, National Home Study Council

**INTERNATIONAL CORRESPONDENCE SCHOOLS** **I C S**

Dept. 1307, Scranton, Penna. 18515 (In Hawaii: P.O. Box 418, Honolulu. In Canada: I.C.S. Canadian, Ltd. In other countries: I.C.S. World, Ltd.)  
Without cost or obligation, rush me "HOW to SUCCEED," the opportunity booklet about the field I have indicated below, and a sample lesson.  
New! Special Package for Women! Special training programs for industry Convenient Payment Plan

Name of the course in which you are interested \_\_\_\_\_

Name \_\_\_\_\_ Age \_\_\_\_\_ Address \_\_\_\_\_  
(Please indicate Mr. Miss Mrs.)

City \_\_\_\_\_ State \_\_\_\_\_ Zip Code \_\_\_\_\_ Working Hours \_\_\_\_\_ A.M. to \_\_\_\_\_ P.M.

Occupation \_\_\_\_\_ Employed by \_\_\_\_\_  I am a member of U.S. Armed Forces.  
Send me information on special low rates.

## EXCLUSIVE PM REPORT

# FANTASTIC CONELESS LOUDSPEAKER! Turns doors into speakers! Fills swimming pools with sound...makes desks into speakers... washes your clothes! COSTS 38¢

... AND THAT'S JUST A BEGINNING. One New York discotheque operator spotting the prize-winning device at the First International Inventor's Show said he could make good use of it to turn his dance floor into one gigantic speaker. In this way the dancers could feel the rhythm of the music while they danced.

A schoolteacher mentioned she had such a large class that she must use microphones, amplifiers and speakers so that all can hear her. She pointed out that with the present system students in the rear of the room hear only very distorted sound and often are not sure what is going on. So, the school intends to erect plywood panels around the sides and rear of the room at ear level and attach a coneless speaker to each panel, making a loudspeaker that encloses the entire room.

If you hold a unit in the palm of his hand, a deaf person can feel the vibrations of music and speech—a great help in teaching such people how to dance and talk.

What does a coneless speaker look like? Just glance at the facing page. The unit on the bottom is the speaker. It is a mere 2 by 2 by 2 inches in size and rather easy to construct. Complete details of how to build your own will appear early next year.

To prepare the speaker, cement the bottom of the round metal disc to the surface you want to become a speaker. This can be a door, mirror, window, phonograph lid or any firm panel of wood, plastic or metal. Once it's in place, connect the unit to your sound amplifiers just as you would any ordinary speaker. Soundwise there's a top frequency limit of about 6000 cycles, but this is more than ample for an AM radio, children's phonograph, intercom and most public address systems.

Used in a car, the coneless speaker can be fastened to the rear of an inside door panel; thus, the entire door becomes a speaker. It has another great advantage over conventional speakers in this application. You don't have to worry about

(Please turn to page 38)

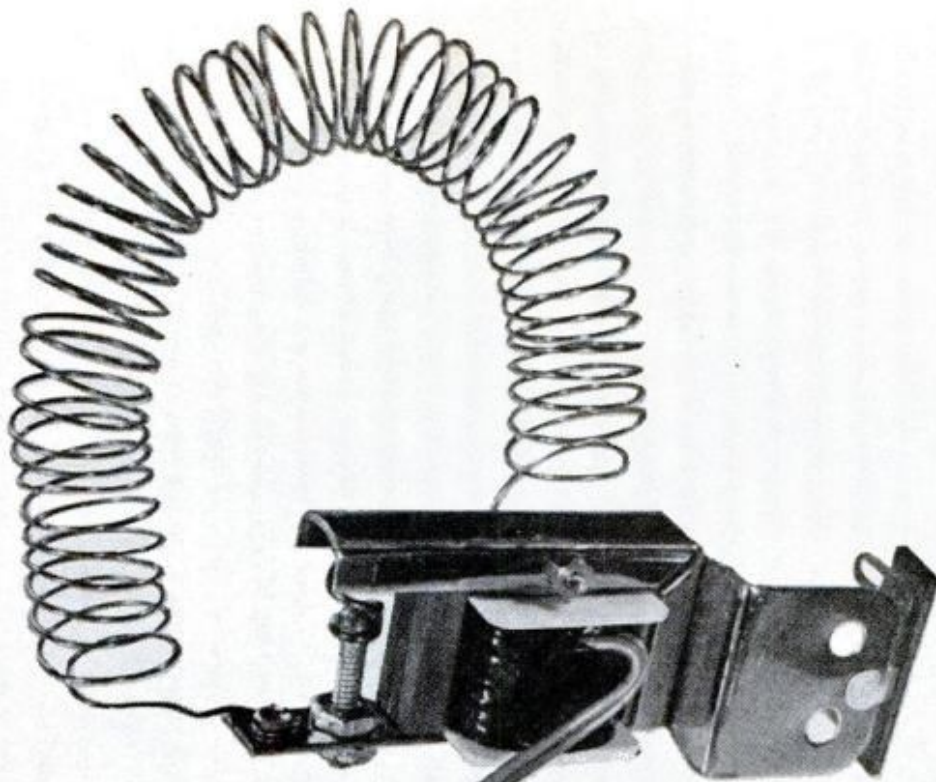

Reverberation unit

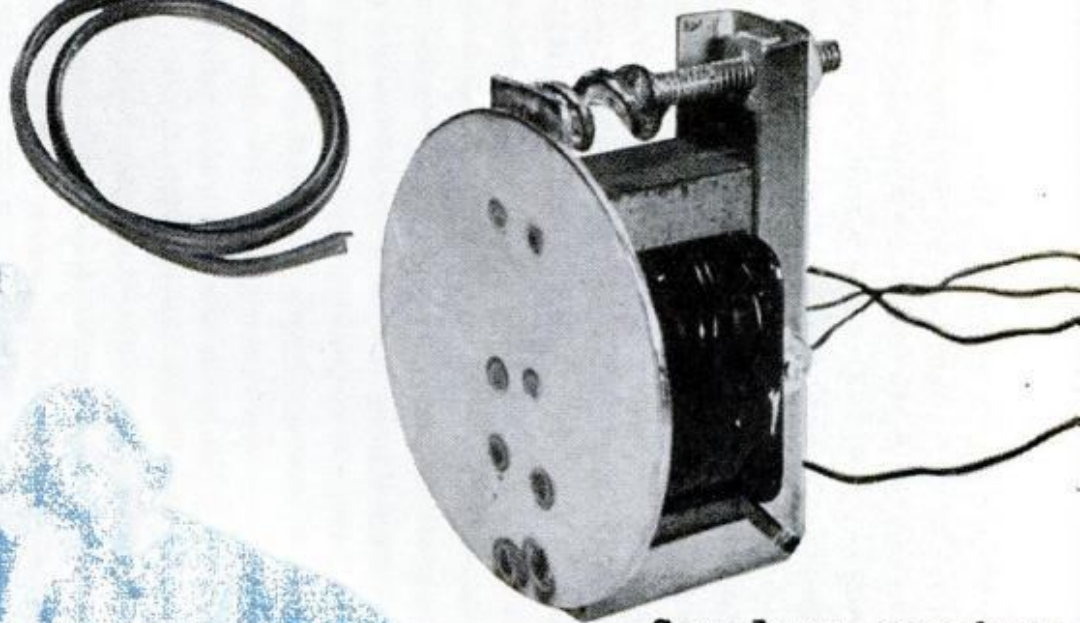

Coneless speaker



For every man's Dream Workshop!

**YOUR CHOICE**  
**\$19.88**  
EACH



### NEW 14-PIECE 3/8" DRILL KIT

The perfect gift for the handyman. Features a full-capacity 3/8" drill plus 3 drill bits, wire wheel brush, grinding wheel, 3 sanding discs, rubber

backing pad, wheel arbor, chuck key and holder. Packaged in custom-fitted carrying case. (Model U-125)



### NEW 16-PIECE JIG SAW KIT

An indispensable cut-up in a carrying case. This fine power tool is seven saws in one; a "dream" for any workshop.

Kit includes Jig Saw, 12 blades, wrench, wrench holder and custom-fitted carrying case. (Model U-153K)



### ORBITAL ACTION SANDER

Finish wood surfaces flawlessly with this compact, dependable sander.

Sands flush to walls, removes paint, buffs. "Orbital action" to sand with or against the grain.

(Model U-140) "Your Choice" power tools are available at all Black & Decker dealers.



expect the best from  
**Black & Decker**  
POWER TOOLS

Dept. D-125, Towson, Md. 21204

Enter the Black & Decker  
DREAM WORKSHOP SWEEPSTAKES  
1150 Fabulous Prizes  
See your dealer for entry forms

## CONELESS LOUDSPEAKER

(Continued from page 36)



**MINIATURE REVERBERATION UNIT** is in inventor William Ashworth's hand as he explains its use to PM editor. His automatic soldering iron is on table

moisture affecting the cone; there is none.

In fact, the unit is so waterproof that it can be operated under water as long as the connections to its coil are insulated. So fasten a coneless speaker to a board, connect it to an amplifier and submerge it in the nearest swimming pool, and you have an underwater sound system.

Washing clothes with sound is not new, but doing it with a coneless speaker is. Just cement the speaker to the side of an ordinary washbucket. Fill the bucket with water, soap and dirty clothes, and then feed low-frequency sound signals to the speaker. This agitates the water and gets the dirt out.

Who invented this amazing device? He's William Ashworth, born in Memphis and operating his lab in New Albany, Miss. Ashworth doesn't look or act very different from any other New Albany resident, but once you start talking with him you discover just how unusual a person he is. His lab is unusual too. It's not the ordinary corner of the basement affair that most inventors have. Instead it's a \$250,000 setup equipped with a machine shop for tool and die work, a woodworking shop, an elaborate electronics lab and a printing shop.

### Reverberator That's Different

While the coneless speaker may be the most fantastic device Ashworth has developed, he has quite a respectable string of other achievements, including 25 patents. One is a simple reverberation unit for hi-fi (shown at the top of page 37)

which is but a fraction of the size of existing units and operates on an entirely different principle. When it is used in a stereo amplifier it is not necessary to hook it up to a separate amplifier as is done with existing reverberation units. Instead it is coupled between the two stereo channels.

Also in Ashworth's patent file is a built-in indicator for a typewriter to tell the user that he's nearing the bottom of a sheet of paper. When ten lines from this end, a blue light is illuminated on the front of the typewriter. When one line away, a red light is activated.

Next on the list is a soldering iron equipped to feed solder right to the point that needs it. This differs from similar types on the market in that it holds a full pound reel of solder and is practically jamproof. Since you need only one hand to operate it, your other hand remains free to hold the part being soldered.

Then there's a light-actuated system which makes it possible to operate a television receiver by remote control with an ordinary flashlight. And, of interest to the man with a power-tool-equipped shop, there's a device that permits the use of three-phase motors on an ordinary single-phase a.c. line.

### What Comes Next?

Many new inventions are now being developed. Among those soon to emerge from the Ashworth lab is a telemetering device that automates meter-reading. The meter reader will no longer have to go from house to house. He simply drives down the block and reads the meters via radio waves.

For the automotive industry, there's a [\(Please turn to page 40\)](#)

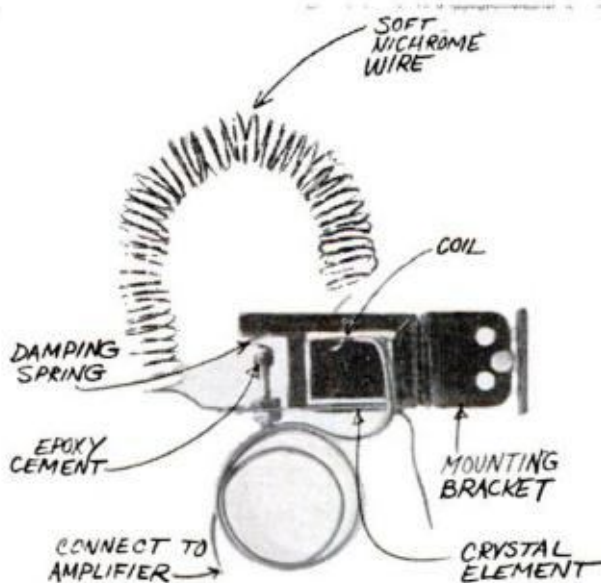

**MOST IMPORTANT PARTS** of the reverberation unit are identified by inventor's notes in this close-up view. It's an uncomplicated, easy-to-make device

For every man's Dream Workshop!

## NEW Black & Decker VARIABLE SPEED DRILLS AND KIT



**YOUR FINGER CONTROLS THE EXACT SPEED NEEDED FOR EVERY JOB.** The harder you squeeze the trigger, the faster it runs. Use slower speeds to start holes without skipping, or drill tile, or mix paint. Medium speeds for drilling metal and plastic. Fast speeds for drilling wood and powering accessories. No skipping or stalling! The Black & Decker exclusive Variable Speed Switch is built to space-age standards to eliminate erratic operation common to other make speed control drills. Geared rheostat switch for non-skip power. Solid state circuits and rectifier. Giant-size heat dissipator for cooler operation. Tested for over 50,000 cycles.

**1/4" DELUXE VARIABLE SPEED DRILL**  
Any speed from 0 to 2250 rpm. U-205..... **\$26.88**

**3/8" DELUXE VARIABLE SPEED DRILL**  
Any speed from 0 to 1000 rpm. U-225..... **\$31.88**

**1/4" Del. VARIABLE SPEED DRILL KIT**  
28 Pieces incl. U-205 1/4" Drill. U-213..... **\$31.88**



expect the best from  
**Black & Decker**

POWER TOOLS  
Dept. D-125, Towson, Md. 21204

Enter the Black & Decker  
**DREAM WORKSHOP SWEEPSTAKES**  
1150 Fabulous Prizes  
See your dealer for entry forms

## You Can Develop A Profitable Business on A Shoestring

Make \$5.00 an Hour in Your Own Home

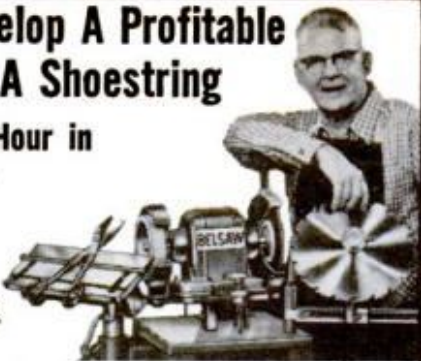

I wish there was space here to print the hundreds of letters received from men I've put in business with the Belsaw Sharp-All. With this precision machine you can sharpen all popular household, garden and shop tools easily and quickly. You need no previous experience . . . no inventory, no selling, no space to rent.

### I've Done It for 40,000 Men

I have been helping men get into this profitable business for over 30 years. I'll finance you to get started . . . give you all the instructions and help you'll need to really succeed. I'll keep you informed HOW others are making big cash profits every day. No obligation.

So don't delay. Send coupon for FREE book today.

STAN FIELD, President  
Belsaw Sharp-All Company  
716F Field Bldg., Kansas City, Mo. 64111



Name \_\_\_\_\_  
Address \_\_\_\_\_  
City \_\_\_\_\_ St. \_\_\_\_\_ Zip \_\_\_\_\_

## CONELESS LOUDSPEAKER continued

set of distributor points that can't drown out. The first time the points close, any moisture on them is burned off.

How does Ashworth get his ideas? "They just come to me," he says. "I often work out all details without even stepping over to a drawing board or workbench. Then I sit down and build the actual device."

The thing that makes his operation work so well, is that Ashworth, unlike most inventors, has no financial problems. He is backed by an unusually beneficial arrangement. The backer, who must remain anonymous, has financed the lab and pays operating expenses. When an invention is developed and sold or licensed, Ashworth and his backer share the proceeds on a 50-50 basis. More than one inventor has wished he could work in this fashion.

As a result of his experiences as an inventor, Ashworth has proposed that his state of Mississippi set up an inventors' council to solicit new inventions and ideas. He visualizes this organization as a clearing house to sift through ideas and inventions submitted to it and then attempt to interest manufacturers in any that are worthwhile. He also feels that the council should offer some reward to any person who produces a useful idea.

William Ashworth is a most unusual person. Yet he typifies that American ingenuity that has made the United States as great as it is.—Larry Steckler ★★



## Earn HIGH WAGES as a HEAVY EQUIPMENT OPERATOR

. . . and years of future security in the multi-billion dollar construction industry, in this country and *overseas*! Learn how at National, the original school of heavy equipment operation. For men ages 17 to 56. National is NOT a correspondence school. You train on school-owned diesel-engined machines at National's huge proving ground in North Carolina. Full 220 and 440 hour courses. Full-time Job Advisory and Counselling Director for the exclusive benefit of graduates. VA approved. Payment plans available. Write TODAY for FREE catalog. National School is a Member of American Road Builders Association Service and Supply Division.

Since National School was founded ten years ago, students from all 50 states and 28 foreign countries have been enrolled. Hundreds of graduates are now working in construction for higher wages than they ever made before.

**NATIONAL SCHOOL**  
**OF HEAVY EQUIPMENT OPERATION Dept. D-70**  
P. O. Drawer 1686, Charlotte, N. C.

Please send me FREE illustrated school catalog and complete information. I understand there's no obligation.

Name..... Age.....  
Address..... Phone.....  
City..... Zone..... State.....

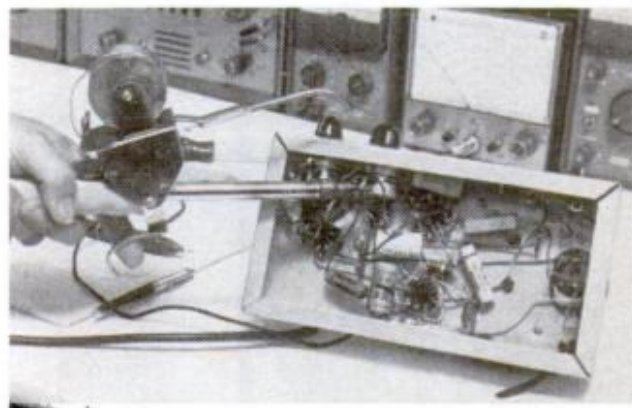

**THIRD-HAND SOLDERING IRON** in operation. As soon as the terminal reaches the proper temperature, a pull on the trigger will bring the solder into play



# 50¢ and this COUPON

AT FANTASTIC SAVINGS!



## KARATE

**BOXING! MUSCLEBUILDING! YOGA!  
STRONGMAN STUNTS! STRENGTH &  
ENDURANCE! HANDBALANCING! etc.**

**YOU GET ALL THESE!**

- 20 Illustrated KARATE blows
- SAVATE Foot Fighting
- SECRET NERVE Center and ANATOMY Charts
- 20 Lethal JUDO Throws
- 20 Terrific STRONGMAN STUNTS
- COMPLETE MUSCLE BUILDING Program
- Ancient YOGA Secrets
- HANDBALANCING Stunts
- Complete BOXING PROGRAM. All Picture Packed.
- No COD'S. Allow Three Weeks for Delivery!
- Canadian Orders & Foreign 75¢.

HOME GYM PLANS  
\*How to build your own gym 50¢ with order.

MAIL ORDER TODAY

Is All That Stands Between You and the Most Incredible Offer in the Entire Physical Culture World

THIS COURSE IS PACKED WITH INFORMATION ON BODY-BUILDING DEVELOPMENT CRAMMED WITH ILLUSTRATIONS AND COSTS ONLY 50¢. DEVELOP CONFIDENCE IN YOUR ABILITIES—POWER IN YOUR BODY—NEVER FEAR AGAIN! ACCEPT THE CHALLENGE WILL YOU BE SOMEBODY?  
20 SECTION PROGRAM COMPLETE WITH K-MAN DUMMY.

OXFORD STUDIO, 146 Blake St. (PM4) Mattapan, MASS. 02126  
Rush me your 20 section course.

Name.....  50c course  
 Address.....  1.00 with home gym  
 City.....State.....Zip.....  
 Be sure to include ZIP CODE on all mail.

OXFORD STUDIO, 146 BLAKE ST., PM4, MATTAPAN, MASS. 02126

## WE'VE GOT the FORMULA For Solving Your Problems

Planning to build your own garage? Need instructions to make a burglar alarm or beds? Want help on household hints or workshop projects? Looking for plans for a model clipper ship or child's car?

**SEND FOR YOUR FREE POPULAR MECHANICS SERVICE FILE**

More than 300 subjects covered in Popular Mechanics library of books, booklets, blueprints, and patterns are listed in this tremendous reference file. Here's the handy guide which shows you where to find the answers to almost any do-it-yourself problem.

POPULAR MECHANICS, Service Bureau PM12,  
575 Lexington Ave., New York, N. Y. 10022

Please send your free SERVICE FILE to:

Name .....

Address .....

City .....Zone.....State.....



# POPULAR MECHANICS SHOPPING GUIDE



## Secrets of Teaching Yourself MUSIC

Revealed in Your Home  
This Money-Saving Way

YES! Now you can teach yourself to play Piano, Guitar, ANY instrument in your spare time—even if you've never played a note in your life! Famous proven Course makes it simple as A-B-C. Pictured lessons show you how. No teacher. No scales. No boring exercises. Amaze friends by playing favorite music. Write today for FREE 36-page illustrated book. U.S. SCHOOL OF MUSIC, Studio A3012, Port Washington, New York 11050. (Est. 1898. Licensed N.Y. State Educa. Dept.) Tear out as a reminder.



## FREE GASKET MANUAL

Valuable Facts for those who value Top Performance:

- Rear End Gasket Installation Tips
- Correct Way to Install Pump Gaskets
- New Type Gaskets for Valve Covers
- Important Steps in Head Gasketing
- Metal Shim Gaskets
- How to Make Sure Gaskets Fit

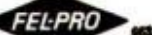

Division of Felt Products Mfg. Co.

32 pages of tips—hints—facts about gaskets and how to improve engine performance

Published as a service to the nation's mechanics, schools and car owners by Fel-Pro, Inc., one of the world's leading gasket manufacturers.

Write:  
**FEL-PRO, INC.**  
7452 N. McCormick Blvd., Skokie, Illinois  
Dept. PM-12



## THOUSANDS OF EXCITING TOOL VALUES!

Stanley, Millers Falls, Skil, Disston, Wiss, Dremel, Speedy

Sprayers, Plumb, Porter, Channellock, Bonney, Herbrand, Helios, Kennedy Boxes, Huot, Vise Grip, Ridgid and many other Nationally Advertised brands of Tools & Supplies too numerous to mention.

We Ship Coast To Coast At Prices Hard To Beat Send 25¢ today for our Big 148-page Tool Catalog.

**SILVO HARDWARE CO.**  
Dept. PM12, 107 Walnut St.  
Phila., Pa. 19106

## CAST A TOY ARMY



**POUR and PAINT**  
lead soldiers 2 1/4" tall  
in 3 action poses . . .  
up to 100 per hour . . .  
For FUN & PROFIT!

JUST LIKE DAD DID, ONLY BETTER!  
EXCITING KIT

Includes 3-soldier mold, clamp, handles, Electric stove, ladle. Only **10.00**  
Paints, brush, 18 pigs of casting metal. A world of fun. postpaid  
Add \$2 W. of Rockies, Canada, Mexico

## Fascinating WOODBURNING KIT

makes decorative gift items. Includes tie rack, coasters, hot plates, plaques, U/L approved Burn-Rite air cooled burning pen, coloring palette, brush, dishes; pattern transfer, sandpaper, color leaf foils. For hours of profitable fun, only 5.00.  
Add 75¢ for postage.  
Satisfaction guaranteed.



**HOME FOUNDRY** Dept. PM2  
1830 S. Washtenaw, Chicago 60608

## Stamp Your Name PERMANENTLY

reg. size Identify articles you own  
**\$3.95** ppd. **EVERSTAMP**



Hardened tool steel. Reg. Size 1/16" 15 letters max. last name only.

Names shown actual size  
**SMITH**

Large size 1/2" \$5.25  
10 letters max.

Stamp just about anything you own with one blow of a hammer. Made by the Henry A. Evers Co., Inc., makers of quality marking devices since 1898. Makes thousands of impressions. Send check or money order.

**HENRY A. EVERS CO., INC.**  
Dept. P 72 Oxford St., Prov., R. I. 02905

- TOOLS
- LUGGAGE
- BOOKS
- SPORTS EQT.
- PAINT BRUSHES
- PIPES
- GUNS
- FLASH-LIGHTS
- DRAFTING TOOLS
- PLUS HUNDREDS OF OTHER ITEMS



Tools are handy, orderly, safe hung magnetically on MAGNABAR. Holds any metal tool. Mounts easily on any wall. Hardwood natural finish. 1" wide by 12" long. Other lengths available.

Only **\$275 p.p.**

## TOOLS HANDY?

Keep your kitchen knives before your eyes with handsome, permanently magnetized MAGNAGRIP MARK X.



Only **\$349 p.p.**

Want information on other Magnagrip wife-savers? Guaranteed or money back. Send check to Dept. D

**PHOLON MAGNAGRIP COMPANY, INC.**  
East Longmeadow, Massachusetts

Are you a confused Santa Claus? If so, see **PM's** selection of educational Christmas toys on page 124.

Money Back Guarantee

## HEAVY DUTY-ARC WELDER

Five Year Guarantee

The New 1966 Model Heavy Duty 110 Volt Arc Welder works on any 110 volt house line. You can not buy a better welder anywhere at this low price. No experience necessary. Now anyone can braze, solder, cut and weld any metal up to 1/4" thick. Generates heat up to 10,000 degrees for cutting through steel plate, etc. **NOTHING ELSE TO BUY.** Comes complete with 12 ft. of heavy duty power cable, 1/16" and 1/8" welding and brazing rods, rod holder, twin carbon torch, helmet, instruction book, etc. **MONEY BACK GUARANTEE.** Try it for 10 days. If you are not completely satisfied we will immediately refund your money without question. **FULLY GUARANTEED FOR FIVE YEARS.** If inoperative, we will repair or replace it free of charge. **SEND ONLY \$2.00,** and when delivered, pay postman \$12.95 plus COD postage, or send \$14.95 and we will ship postpaid. Over 10,000 National Electric Welders are in use throughout the world. (For an extra large supply of rods, carbons and flux, send an additional \$2.00.)

Order Direct from factory: **NATIONAL ELECTRIC, Dept. PM-12, DELRAY, FLORIDA**



**ONLY \$14.95**

5 Day Home Trial



WORLD'S LARGEST DEALER

## "NEW SOUND" ACCORDIONS - SAVE 1/2\*

**42 NEW ELECTRONIC/STANDARD MODELS**  
\*SAVE 1/2 off retail prices of comparable accordions! 42 exciting new models—Standard, ELECTRONIC, Amplifiers, too! All famous makes. Try before you buy. Free Accessories, E-Z Terms. Trade-ins. Lifetime Performance Policy. Money back guarantee. FREE Color Catalogs and Importer-to-You Discount Prices. Rush coupon.

**ACCORDION CORP. of AMERICA, Dept. R-125**  
5535 W. Belmont, Chicago, Illinois 60641

**FREE**  
New Color Catalogs—Discount Prices

Accordion Corporation of America, Dept. R-125  
5535 W. Belmont, Chicago, Ill. 60641  
Send FREE Catalog of Accordions, Amplifiers—Discount Price List.

Name \_\_\_\_\_  
Address \_\_\_\_\_  
City \_\_\_\_\_ State \_\_\_\_\_  
 Check here if you have Trade-in

Here's the **EASY, Step-by-Step Way to**

# FIX 2,341 CAR MODELS!

Engines, Brakes, Transmissions, Rear Ends, Generators—Yes, All These Parts

**BRAND-NEW EDITION!**



Now—Whether You're a Beginner or Expert Mechanic — You Can "Lick" Almost Any Repair Job on Any Car built from 1958 thru 1965

YES, now you can fix practically ANY part of ANY car—quickly, easily, and right! From carburetor adjustment to a complete overhaul, it's easy when you have MOTOR's famous Auto Repair Manual. It's like having a staff of factory experts and MOTOR's field-trained engineers beside you, guiding you every step of the way. No wonder so many thousands of beginners and experts alike use this step-by-step, illustrated manual.

MOTOR's Manual "starts from scratch"—leads you through entire job with easy step-by-step directions, clear "how-to" pictures. Tells you WHERE to start, what TOOLS to use. You just CAN'T go wrong!

**3,800 Pictures! So Complete So Simple, You CAN'T Go Wrong!**

NEW, REVISED edition covers all you need to know to repair almost any car, 1958-1965, including all the new models! 1,325 Giant pages. 3,800 "This-Is-How" pictures lead you every step of the way. 457 "Quick-Check" charts — 55,000 essential repair specifications. Over 225,000 service and repair facts. Instructions and pictures so clear you can't go wrong!

Experts and beginners alike are amazed by the time and labor-saving methods!

**The "Meat" of 300 Official Shop Manuals**

The editors have put together the "know-how" from 300 Official Shop Manuals and "boiled it down" into one fully-illustrated easy-to-understand guide.

Here's ILLUSTRATED step-by-step guidance on Automatic Transmissions, Generators, Ignition, Carburetors, Fuel Pumps, Steering Gears, Rear End, Brakes, PLUS MUCH MORE.

**SEND NO MONEY**

**Try Book for 10 Days FREE**

Just mail coupon. (Attach it to postcard if you wish.)

Test book in your garage or shop. **GUARANTEED** to pay for itself in 10 days or you owe nothing. **MOTOR Book Dept., 250 West 55th St., New York, New York**

**OVER 5 MILLION COPIES SOLD!**

Try Book for 10 Days **FREE**

**Expert Raves About**



"Motor Book... Motor Manual is worth its weight in gold. I've done mechanic work for over 25 years. Motor has saved me many hours of brain-racking thinking."  
—R. Carter, N. Carolina (Mechanic)

**... So Does Beginner**



"In technical high school where I learned the auto mechanic's trade, Motor's Manual pulled me out of some rough spots. Now I'm in the Armed Forces, attached to motor pool."  
—W. Bekemerer, Missouri (Apprentice)

**Same Offer on MOTOR'S New TRUCK REPAIR MANUAL**

Covers all gasoline engines, plus Ford, GM, Cummins, Mack, Perkins, International diesels since 1955. Over 2,000 pictures! Check coupon for **FREE TRIAL**.

**Brand-New—Covers All These Makes**

- |               |          |             |
|---------------|----------|-------------|
| American      | Corvette | Mercury     |
| Barracuda     | Dart     | Meteor      |
| Buick         | De Soto  | Mustang     |
| Buick Special | Dodge    | Oldsmobile  |
| Cadillac      | Edsel    | Olds F-85   |
| Chevelle      | Fairlane | Plymouth    |
| Chevrolet     | Falcon   | Pontiac     |
| Chevy II      | Ford     | Rambler     |
| Chrysler      | Imperial | Studebaker  |
| Comet         | Jeep     | Tempest     |
| Continental   | Lancer   | Thunderbird |
| Corvair       | Lincoln  | Valiant     |
|               |          | Volkswagen  |

**MAIL COUPON NOW FOR 10-DAY FREE TRIAL**

**MOTOR BOOK DEPT., Desk 51Y  
250 W. 55th St., New York, N. Y. 10019**

Rush to me at once **MOTOR'S New AUTO REPAIR MANUAL**. If O.K., I will remit \$2 in 10 days, \$3 monthly for 2 months and a final payment of \$1.95 (plus delivery charges and sales tax, if any) one month after that. Otherwise I will return the book postpaid in 10 days.

Print Name..... Age.....  
Address.....  
City.....  
State..... Zip Code.....

Also send me for 10 days' Free Trial **MOTOR'S New TRUCK REPAIR MANUAL**. If O.K., I will remit \$11, plus delivery charge and sales tax, if any, in 10 days. Otherwise I will return book postpaid in 10 days.

Check box and save shipping charge by enclosing **WITH** coupon in envelope entire payment of \$9.95 for Auto Repair Manual (or \$11 for Truck Repair Manual) plus sales tax, if any. Same 10-day return-for-refund privilege applies.

ENGINE TUNE-UP SERVICE



## EARN \$1,000 A MONTH

### LEARN A TRADE YOU LIKE

Start as a mechanic in a good paying job; then advance to shop service manager. Many make \$1,000 a month and up. You learn fast in our shop because you learn with tools on real equipment. Some students earn part of their expenses while going to school.

### CHECK AND MAIL COUPON

- |   |  |
|---|--|
| <input type="checkbox"/> AUTO MECHANICS   | <input type="checkbox"/> AUTO BODY REPAIR        |
| <input type="checkbox"/> DIESEL MECHANICS | <input type="checkbox"/> AUTOMATIC TRANSMISSIONS |
| <input type="checkbox"/> GAS. ARC WELDING | <input type="checkbox"/> MOTOR TUNE-UP           |
| <input type="checkbox"/> HELIARC WELDING  |  |

Mail to: **AUTO-DIESEL COLLEGE**  
226 7th Ave., No., Dept. 86, Nashville, Tenn.

Please send without obligation free catalog

NAME \_\_\_\_\_  
(please print or write plainly)

ADDRESS \_\_\_\_\_

CITY \_\_\_\_\_ STATE \_\_\_\_\_

-  Transistor Radio with Battery \$1.96
-  17-Jewel Watch \$2.87
-  Derringer Pistol \$5.74

## HOME-IMPORT BUSINESS—Make Big Profits

New Drop Ship Plan offers you first day profits! Deal direct with overseas sources at prices shown. Dazzling bargains with no investment. Full or spare time. Write for FREE BOOK today to...  
**MELLINGER, 1554 S. Sepulveda, Dept. P25C, Los Angeles 25**



## Print Your Own

Cards, Stationery, Advertising, Circulars, labels, photo and movie titles, church work, tags, etc. Save money. Sold direct from factory only. Raised printing like engraving, too.  
**Own a Printing Business**  
Print for Others, Good Profit. Have home shop. Junior press \$15; Senior \$35 up. We supply everything. Easy rules. Pays for itself in short time. Write now for free details.  
**KELSEY PRESSES, 2-37 Meriden, Conn.**

## B.S. DEGREE IN 36 MONTHS

Small professionally-oriented college. Four-quarter year permits completion of degree in *Engineering* or *Business Administration* in three years. One year *Drafting* and *Design Certificate* program. Founded 1884. Rich heritage. Excellent faculty. Small classes. Well-equipped labs. New library. Residence halls. 300-acre campus. Graduate placement outstanding. Modest costs. Enter Jan., March, June, Sept. For Catalog And View Book, write Director of Admissions.

## TRI-STATE COLLEGE

4125 College Avenue • Angola, Indiana

## PROFESSIONAL TAX CONSULTANTS

### EARN BIG MONEY FASTER

Clean, dignified, high pay Tax Consultant Practice waiting for trained graduates. Busy tax season pays \$1,000 to \$3,000 for spare time work... leads to profitable year round Tax Service Business with monthly fees of up to \$50 per client. No previous experience. Low cost home training course shows you the way. Licensed by N. Y. Education Dept. and Accred. by Nat'l. Home Study Council. Write for FREE LITERATURE. No obligation. No salesman.

**NATIONAL TAX TRAINING SCHOOL, Monsey, N.Y.**

## REAL ESTATE BE A BROKER

**PAYS BIG! SEND FOR FREE, BIG, ILLUSTRATED CATALOG NOW!** Graduates report making substantial incomes. Start and run your own business quickly. Men, Women, all ages, learn easily. Course covers Sales, Property Management, Appraising, Loans, Mortgages, & related subjects. **STUDY AT HOME** or in classrooms in leading cities. **DIPLOMA AWARDED.** Write TODAY for FREE Booklet! Accredited Member National Home Study Council. (Established 1936)  
**WEAVER SCHOOL OF REAL ESTATE**  
3521-P Broadway Kansas City, Mo. 64111

FREE BOOK TELLS HOW

## '65 FORD OR DODGE



**\$999**  
ONLY

- '64 DODGE ----- \$699
- '64 FORD ----- \$699

Ex-taxicabs. Taxicab signs and markings removed. Present appearance no different than regular passenger cars.

## WRITE FOR FULL INFORMATION OR PHONE, WIRE OR VISIT PREMISES

Phone: Area Code 201 866-7500—N.Y.C.: 212 244-1580

**UNIVERSAL AUTO WHOLESALERS INC. Est. 1959**

LARRY SHANDEL, President

235-A Penhorn Ave., Secaucus, N. J. 07094  
Only 10 minutes from N.Y. off U.S. 1 & 9

Bank reference: TRUST COMPANY OF NEW JERSEY, 457 West Side Ave., Jersey City, N. J. 07304.

### make your own Gems 36.50 F.O.B.

The Gem Maker comes complete with all necessary equipment, including a super-charged diamond blade for sawing, and all the wheels for grinding, shaping and polishing; also complete instructions. The complete equipment as shown, less motor and belt for only \$36.50, f.o.b., Burlington, Wisconsin. Write today for information and literature.



**B&I MANUFACTURING CO.**  
Dept. P, Burlington, Wis.

## New Table Top Invention Puts You In... PROFITABLE RUBBER STAMP BUSINESS

Home Operators now make **\$9.20 AN HOUR** in Business once monopolized by a few big companies

Special rubber stamps bring high prices—cost only pennies to make on new, low-cost table top machine. Take 27 cents worth of material, make perfect stamps, the kind businesses and offices now buy by the dozen at \$1.80 each. Make up to \$9.20 an hour. Start in spare time in your own home. Run machine on kitchen table using ordinary electrical outlet. Make any kind of stamp. We'll send you free information without obligation about this established, highly profitable business. **We'll even help finance your start.** For free information send name and address today on a postcard to: Rubber Stamp Div., 1512 Jarvis Ave., Dept. R-2-PW Chicago 60626



# GROSSED \$1101<sup>35</sup> IN 4 WEEKS

*Some make more — some less...*

Many men have discovered how to be independent, to be free of layoffs and bosses. L. S. Mason grossed \$1101.35 in 4 weeks. T. N. Cochy averaged \$806 per month 12 months. H. Lemon says, "I netted \$133 in one 8-hour day." A father-son combination grossed \$44,000 their second year.

How much you earn depends largely on you, but we help you to start and work with you for your success. Training and consulting with experts is available at no additional cost. You need no special skill, no large investment. Start part-time if you wish. Hire helpers as needed.

**NO SHOP NECESSARY • Our PORTABLE ELECTRIC DETERGER sham-**

poos rugs, carpets right on customer's floor. Wonderful results bring you repeat business, large fees. So efficient and safe, it is used by largest hotels and railroads.

...

**OURS IS NOT A LEASE ARRANGEMENT**

You are free to operate independently. You sign no contract. You own the detergent outright and are your own boss... every dollar you take in is yours to keep. You pay no fees, or dues, or royalties, and enough supplies come with it to return far more than your investment. Many earn the cost of the detergent in a week or two. It costs nothing to get the details ... write **TODAY.**



## MAIL COUPON TODAY FOR FREE BOOK

**VON SCHRADER MFG. CO., • W10 "R" Pl., Racine, Wis.**

Without obligation send me **FREE** booklet about your **RUG DETERGER** and tell me how I can start my own permanent, profitable business.

Name \_\_\_\_\_  
 Address \_\_\_\_\_  
 City \_\_\_\_\_ State \_\_\_\_\_ Zip Code \_\_\_\_\_

## PROFIT IN YOUR SPARE TIME

**SMALL ENGINE REPAIR PAYS BIG!**

Outboard • Powermower • Chain Saw • Tractor  
**MAKE EXTRA MONEY** — or fix your own engines and **SAVE!** Illustrated, easy-to-learn Home Study Course qualifies you as expert. Free information. Write today!

**LINCOLN TECHNICAL INSTITUTE**  
 SUITE 12E, 472 MARKET STREET, NEWARK 5, N.J.



## PLANER • MOLDER • SAW!



Now you can use this **ONE power-feed** shop to turn rough lumber into moldings, trim, flooring, furniture... **ALL** popular patterns. **RIP... PLANE... MOLD...** separately or all at once with a one HP motor. Use 3 to 5 HP for high speed output. Low Cost... You can own this power tool for only **\$30.00** down payment.

Send postcard today for complete facts.  
**BELSAW POWER TOOLS, 906 Field Bldg., Kansas City 11, Missouri**

*You can make money in*

## WATCH REPAIR



**Learn at home the low cost Swezey Way**

Watch repairing pays up to \$6 an hour, part time watch makers report on survey. Unique and modern Swezey home study System starts you making repairs right away on Swiss and American watches. Professionally prepared training. No previous experience needed. Special tools provided for practice. Tuition only \$5 a month. Diploma Awarded. Free sample lesson and opportunity book give all facts. Write today. No obligation.

**CHICAGO SCHOOL OF WATCHMAKING**  
 Dept. 1125, Fox River Grove, Illinois 60021

### FREE BOOK and SAMPLE LESSON

CHICAGO SCHOOL OF WATCHMAKING  
 Dept. 1125, Fox River Grove, Illinois 60021  
 Please rush **FREE BOOK** and Sample Home Study Lesson.

Name \_\_\_\_\_ Age \_\_\_\_\_  
 Address \_\_\_\_\_  
 City \_\_\_\_\_ Zone \_\_\_\_\_ State \_\_\_\_\_

## SAVE ON WOOD

Imported & Domestic



**CABINET HARDWARE - VENEERS - TOOLS**  
*EVERYTHING for the Wood Shop*

**New 1966 Catalog Ready!**

**OVER 1500 ITEMS at MONEY SAVING PRICES!** Finest domestic and imported hardwoods... all dimensions. Hardwood veneers. Power tools at discount prices. Hardware, lamp parts, upholstery supplies, mosaic tile. Hard to find inlays, bandings, etc. Get new catalog... send name, address and enclose 35¢ to pay postage, handling.

**CRAFTSMAN WOOD SERVICE CO.** Dept. A-125  
 2729 S. MARY ST., CHICAGO, ILL. 60608

# EARN WHILE YOU LEARN DIESEL AUTO MECHANICS and AUTO BODY

**LATEST DIESEL FUEL PUMP  
CALIBRATING MACHINE**

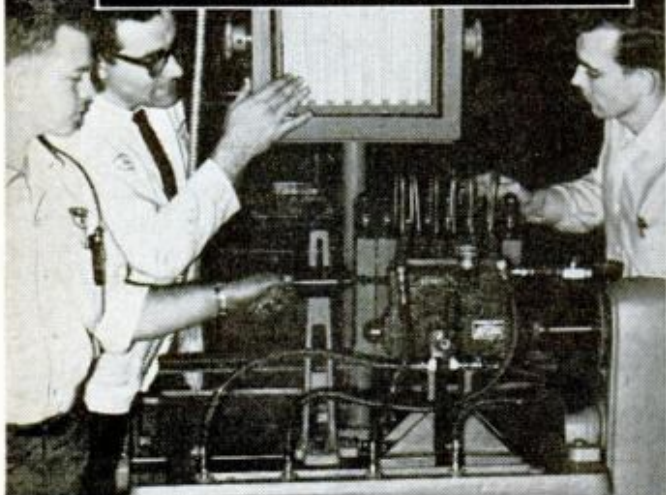

Prepare NOW for **BIG PAY JOBS** in industry or ratings, with **MORE PAY**, in the service.

96.4% graduates placed in big paying jobs! Start about \$5,000 a year . . . rapidly advance to \$10,000 a year. Earn to \$2,200 a month if you start your own business with 75% financing!

More **BIG PAY JOBS** than we can fill. Let us show you actual waiting list of Diesel dealers who have tried Bailey graduates, found them outstanding & keep coming back for more.

**Both DIESEL & AUTO training  
for PRICE OF ONE!**

See the most beautiful school in the country with best equipped modern shop.

Get free booklet showing step-by-step tour thru our big shops. See students as they Learn-By-Doing with Famous Bailey Method of training. Housing & part time jobs provided—national placement for graduates.

## BAILEY Technical SCHOOLS

1645 S. GRAND Dept. PM ST. LOUIS 4, MO.

**MAIL TODAY FOR FREE BOOKLET**

- DIESEL MECHANIC
- AUTO MECHANIC
- MASTER MECHANIC
- AUTO BODY



Name \_\_\_\_\_

Address \_\_\_\_\_

City \_\_\_\_\_ State \_\_\_\_\_

Telephone \_\_\_\_\_ Age \_\_\_\_\_

## ENROLL—EARN YOUR DEGREE

of Bachelor of Bible Philosophy (B.Ph.B.), Master of Bible Philosophy (M.Ph.B.), Graduate of Bible Philosophy (G.Ph.B.), Doctor of Metaphysics (Ms.D.), or Doctor of Divinity (D.D.). Chartered by State, Correspondence Courses only. Please write for **FREE BOOKLET**.

**AMERICAN BIBLE INSTITUTE**

Dept. PM, 408A W. 75th St., Kansas City, Mo. 64114

Two or four-wheel drive  
**JEEP or SCOUT**  
owners

## REPOWER

with V-8 or 6 Cyl. engines. **H.D. ADAPTORS** for TRUCK, CAR or COMPACT engines. Immediate del. Write, wire or phone **TODAY**. Free details.

**HOOSIER MACH. Prods. Co.**  
312 SE 6th Pendleton,  
Ph. 276-3442 Oregon

## NO JOB WORRIES

**PLASTEX INDUSTRY** needs manufacturers on small scale for big production of Lamps, Clock Stands, Art Goods, Novelties in Plastic Marble Imitation. No experience necessary. **Ure** material makes regular 10¢ store sellers. Moulds furnished for fast production. Small investment brings good profit. Big wholesale orders now being placed. Ambitious men have chance for real prosperity and job security. Our **NEW FREE** booklet will interest and benefit you.

**PLASTEX INDUSTRIES, Dept. A**  
3400 Third Ave. New York 56, N. Y.



## AUTOMATIC HUBS for your 4-WHEEL DRIVE!

**NOT EVEN A BUTTON TO PUSH** on these amazing Lock-O-Matic selective drive hubs that *automatically engage* the front wheels in 4-w.d., *automatically disengage* them for 2-w.d. They stop front drive drag, save gas, gears, tires in 2-w.d.—*automatically!* For **Lock-O-Matics**—or popular Warn® Locking Hubs—see your dealer.

**be happy—GO LOCK-O-MATIC!**

**WARN MANUFACTURING CO., INC.**  
9050-A Empire Way So. Seattle, Wash. 98118

\*Not made for some 4-w.ds.

TAPE THIS AD TO THE BACK OF YOUR TV SET

## ALL TV-RADIO RECEIVING TUBES

**\$1**  
ea.

ALL BRAND NEW, all at a flat discount price of only . . .

America's Greatest Source for Saving on High Tube Costs. Getting all Sets in Working Order.

- All Tubes 1st QUALITY MADE IN U.S.A.
- All Sold on Written 24-MONTH WARRANTY
- All Orders SHIPPED 1st CLASS SAME DAY REC'D.!



- If you know for sure which tubes are defective, order them @ \$1 each, plus 25¢ postage and handling on your entire order.
- If uncertain which tubes need replacing, send for our **FREE** leaflet "How To Save On TV-Radio Repair Costs." This valuable leaflet should be taped to back of your TV set, and kept handy . . . 'cause tubes are sure to go! Write today to, Dept. PM-125.

## UNIVERSAL TUBE CO.

Ozone Park, N. Y. 11417

# LAW FREE BOOK THE LAW TRAINED MAN

Write today for a **FREE** copy of illustrated law book, "THE LAW-TRAINED MAN," which shows how to earn the professional Bachelor of Laws (L.L.B.) degree through home study of the famous Blackstone Law Course. All necessary books and lessons provided. Moderate cost; convenient monthly terms. Write for **FREE** law training book today.

**Blackstone School of Law, 307 N. Michigan Ave.**  
 Founded 1890 Dept. 59, Chicago 1, Illinois

## 75 POWER TELESCOPE \$398

**NEW** 3 in one telescopes. 3 variable 25X 45X-75X magnification. Brass bound. 25 power for ultra bright images. 45 & 75 power for long range. Guaranteed to bring distant stars, moons, objects, sports 75 times closer.

Most powerful scope sold anywhere near this amazing low price. American made, 5 sections. Opens 36", closes 1 ft.; contains 4 ground & polished lenses. Can also be used as powerful compound microscope. Mass production enables us to offer telescope complete at \$3.98 postpaid. Money back guarantee.

**CRITERION CO., Dept. PBM-30, 331 Church St., Hartford, Conn.**

## DRAINS cellars, cisterns, wash tubs; \$8.95

**IRRIGATES - CIRCULATES - SPRAYS**

1,001 u-es. Stainless shaft. Won't rust or clog! Use 1/8 HP motor or larger... 3/4 HP for up to 2,400 GPH; 450 GPH 80' high; or 1,800 GPH from 25' well. 1" inlet; 3/4" outlet. Coupling included free. \$8.95.

**HEAVY DUTY BALL-BEARING PUMP.** Up to 3,200 GPH; or 3,000 GPH from 25' well. 1 1/4" inlet; 1" outlet. \$12.95

Postpaid if cash with order. **MONEY BACK GUARANTEE**

**Centrifugal and Gear Pumps in All Sizes**

**LABAWCO PUMPS, Belle Mead 7, New Jersey**

## LIKE TO DRAW?

In just weeks you can be on your way toward high-pay career or fascinating hobby in Painting, Advertising Art, Cartooning, Fashion, TV Art, etc. Learn at home, in spare time. **TWO** 22-pc. art outfits included. Only \$6.00 a month. Send for **FREE** Book. No salesman. Accredited National Home Study Council.

**WASHINGTON SCHOOL OF ART**  
 Studio 1412,  
 Port Washington, N.Y. 11050

## TELLS HOW TO SELL YOUR INVENTION

If you have an invention that you believe has merit, write us at once for copy of copyrighted booklet "How to Go About Selling Your Invention." We work with manufacturers, and booklet reveals present markets, qualities of a saleable invention, current royalty rates being paid by manufacturers. Booklet is **FREE**, is offered to encourage new ideas we might submit to manufacturers. Just send name (no drawings, please) to **Kessler Sales Corp., Dept. D-512, Fremont, Ohio 43420**

when it's time to think of college you should read this

## FREE CAREER BOOKLET

about engineering at

# MSOE



**MILWAUKEE MS-236**  
**SCHOOL OF ENGINEERING**  
 Dept. PM1265 1025 N. Milwaukee Street  
 Milwaukee, Wisconsin 53201

Tell me about an engineering career through residence study in:

Mechanical fields  Electrical fields

Name.....Age.....

Address.....

City, State.....

# FREE GIANT NEW CATALOG

**100's OF BARGAINS NOT IN ANY OTHER CATALOG**

**TUBES PARTS ETC. AT LOWEST PRICES**

**EVERYTHING IN HI-FI AND STEREO**

**SAVE UP TO 50% ON CHOICE KITS**

**TOP VALUES IN POWER & HAND TOOLS**

**SAVE ON CAMERAS FILM & PHOTO EQUIPMENT**

**100's OF BIG PAGES CRAMMED WITH SAVINGS**

## BURSTEIN-APPLEBEE CO.

Dept. PM, 1012 McGee, Kansas City, Mo. 64106

Rush me **FREE** 1966 B-A Catalog.

**SEND FOR IT TODAY**

Name .....

Address .....

City.....State.....

Please be sure to show your Zip No.....

# Own a Business

You now have an opportunity to double your income in your own business. A big 24-page book tells how others start in spare time—then expand to a full time operation. Gross hourly profit \$9.00—PLUS \$6.00 additional on each service man. Income unlimited.

In this business your service is Nationally Advertised. It's a business that's world-wide and endorsed by McCall's and Parents' Magazine. You need no experience—no shop. We show you how and finance you for all but a few hundred dollars. Easy to learn—easy to do—easy to build up to a good, steady volume on our 15 tested ways to get customers.

G. F. Monroe, after 12 months, sold his business for 10 times his cost. Leo Lubel sold his for \$7,116 more than he paid. L. Babbit writes, "I average \$2,600 monthly, part time." W. C. Smith earned \$650 in one week. Ed Kramsky said, "In two years I have two assistants, a nice home and real security."

This may be the opportunity of your life. Find out today before someone else gets your location. Mail the coupon now for full details and 24-page illustrated free book. No obligation. No salesman will call. Mail coupon now before it's too late to get territory.

### DURACLEAN COMPANY,

5-16D Duraclean Building, Deerfield, Illinois 60015

Please send me your 24-page illustrated book that tells how I can double my income in a business of my own. Everything you send me now is free and I am under no obligation. No salesman will call.

NAME.....

ADDRESS.....

CITY.....

STATE.....ZIP CODE.....



## Excitement! Security! Good Pay! CRIME DETECTION

**LEARN AT HOME IN SPARE TIME—START NOW!**  
Crime everywhere is on the rise! Learn now, in your own home, the profitable profession that enables you to track down criminals and bring them to justice! Hundreds of Identification Bureaus employ I. A. S. graduates . . . trained in finger printing, police photography, handwriting identification, firearms and investigation. Our 44th year! FREE "Blue Book of Crime" . . . packed with crime facts and the full story of famous I. A. S. training. State exact age. No salesman will call. Rush Coupon!  
*A Correspondence School Founded in 1916.*

**FREE**  
Blue Book  
of Crime  
**MAIL**  
COUPON

**INSTITUTE OF APPLIED SCIENCE, Dept. 1359**  
1920 Sunnyside Avenue, Chicago 40, Ill.  
Rush Blue Book of Crime . . . FREE!

NAME . . . . . Age . . . . .  
ADDRESS . . . . .  
TOWN . . . . . STATE . . . . .

## NEW CATALOG Hard-to-find tools

Exciting new tools rarely found in stores or other catalogs. For model makers, craftsmen, hobbyists, light industry. Superb quality tools that solve problems, make projects easier, more fun. Send 10¢ today (stamps or coin).

**BROOKSTONE COMPANY**

76 River Road Worthington, Massachusetts 01098



## TRANSEAL

**STOPS LEAKS  
IN AUTOMATIC  
TRANSMISSIONS**

at Service Stations, Auto and Hardware Stores

# ELECTRONICS

## COYNE ELECTRONICS INSTITUTE

A quarter million dollars worth of equipment. Non-Profit Institute—Est. 1899. Courses: Electronics • Electricity • TV-Radio • F.C.C. • Electronics Engineering Technology. Mail coupon or write for FREE BOOK, "Your Opportunities in Electronics." No Salesman will call.

**COYNE ELECTRONICS INSTITUTE** Educ. Serv. Dept. 95-S  
1501 W. Congress Parkway, Chicago, Ill. 60607

NAME \_\_\_\_\_ PHONE \_\_\_\_\_

ADDRESS \_\_\_\_\_ AGE \_\_\_\_\_

CITY \_\_\_\_\_ STATE \_\_\_\_\_

**"\$7,108<sup>50</sup> NEW!"**

**FIRST YEAR  
Cleaning-  
Repairing  
RADIATORS."**

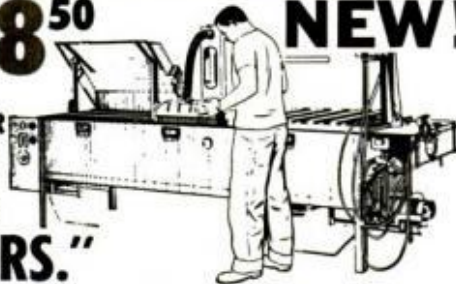

—Hank Konter, Newcastle, Wyo.

Make \$6,000-\$9,000 a year servicing auto-truck-tractor radiators with Inland's new 1-Piece Radiator Shop. Easy to do entire job—TEST, CLEAN and REPAIR radiators. Only 11' 7" long. Inland, world's largest radiator equipment manufacturer, trains you free. Small down payment starts you. Easy-pay plan lets you pay from profits. Proved merchandising assures volume. Profitable department for garage or service station. Many set up Radiator Shop in garage at home, make good money working evenings. Write.

**INLAND MFG. CO., Dept. PM-12, 1108 Jackson St., Omaha 2, Nebr.**



## Build This Beautiful Grandfather Clock

We show you how at price you can afford. Send only \$1.00 for complete plans and instructions plus information-packed catalog of clock movements, dials, blueprints and kits for constructing Grandfather, Grandmother, Terry and other fine clocks.

**MASON & SULLIVAN CO.**  
DEPT. PM OSTERVILLE, MASS.



## RAISE YOUR BOWLING SCORE?

You bet it will! Weighted glove increases bowler's score by providing him with a better follow-through caused by pendulum action of weights in glove. Made of Iranian Sheepskin leather. Available with weights from 3 to 8 oz.; sizes: Ex. Lrg., Lrg., Med., Sml. Colors: Blk., Wh., Flsh. Only \$5.95 ppd. (No c.o.d.'s)

**ROBIN B. STOKES, Dept. PM-12**  
107 Tudor Drive, Clark, N.J. 07066

Money back guarantee

## HYDRAULIC JACK REPAIRS



### Earn While You Learn at Home

Earn while you learn at home. Trained and qualified mechanics needed NOW to service inoperative hydraulic jacks. BIG opportunity for ambitious men. We show you HOW—in your basement or garage, spare time cash income in an expanding industry. Don't wait, ACT NOW! Get the facts.

Write for folder No. PM12 and free bonus offer.

**HYDRAULIC JACK REPAIR MANUAL CO.**  
P. O. BOX 50 • BLOOMFIELD, N.J.

## MAKE UP TO \$5<sup>00</sup> AN HOUR AT HOME

Let Me Prove It To You FREE!

I'll show you how Plastic Sealing and Laminating at home, spare time, can give you as much as \$5.00 each hour you operate. Table-top machine sets up anywhere. Easy. Fun. No experience needed. We furnish everything. We'll even help finance you. No house-to-house selling. Orders come by mail. Write for facts FREE. No salesman will call.

Warner Electric, 1512 Jarvis, Dept. L-2-PW, Chicago, Ill. 60626



## LEARN

## MEAT CUTTING



Train quickly in 8 short weeks at Toledo for a bright future with security in the vital meat business. Big pay, full-time jobs—HAVE A PROFITABLE MARKET OF YOUR OWN! Pay after graduation. Diploma given. Job help. Thousands of successful graduates. Our 42nd year! Send NOW for FREE catalog. No obligation. GI approved.  
**NATIONAL SCHOOL OF MEAT CUTTING, Dept. 50-B, Toledo 4, Ohio**

## HAVE FUN! WITH A HARMONOGRAPH

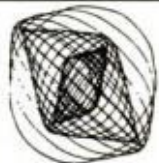

Make Beautiful Designs  
No two alike. Self-operating.

All metal. Material and workmanship guaranteed. \$3.95 postpaid, taxpaid, pen included. Send for literature.  
**GEORGE HANNEMAN, 8006 S. Atlantic Ave., Cudahy, Calif.**

## 1000 TRICKS 10¢

**AMAZE! ENTERTAIN! START NOW!**

**BIG EXCITING MAGIC & FUN  
CATALOG!** 160 Pages! Tricks,  
Jokes, Magic, Illusions, Secrets!  
Puzzles, Stunts, etc.! Rush name,  
address and only 10¢.

**VICK LAWSTON'S MAGIC DEN**

Dept. PM125 • 4018 N.E. Fifth Ave., Ft. Lauderdale, Fla.





# I-N-V-E-N-T-I-O-N-S

## WE NEED INVENTIONS

Sell your invention for cash—need money for Patent?—Are technical problems holding you back? Universal Inventions has helped inventors all over the world—just like yourself—why not you? Inventions provide the magic spring-board to sudden riches. REMEMBER, we either sell your invention or pay you a cash bonus. Write for details.

UNIVERSAL INVENTIONS, Dept. 13, Marion, Ohio

## BRONZE FOUNDRY



Since 1935  
Schools • Home Workshops • Inventors  
Make your own castings of aluminum, copper, bronze, silver. Foundry sets are available in six sizes, capacity 1½ lb. to 48 lb. of red brass. 2400 Deg. F. blast furnace included with each. Write for Free Circular.

KANSAS CITY SPECIALTIES CO. Dept. P-12, P.O. Box 193, Middleton, Wisc.



## NEW PATENTED BALL POINT PEN REJUVENATOR

If your pen has stopped writing, rejuvenate it so it will write. Millions of good pens are discarded everyday that are full of ink. Guaranteed. Instructions with rejuvenator. Ideal for schools, office, home, everywhere. A practical Xmas gift. \$1.00 postpaid.

OHNSTAD SPECIALTY COMPANY  
Box 756, Lawndale, California

## LEARN WELDING AT HOME WE SEND YOU A WELDER

A trade with a future—in demand everywhere. We have trained thousands—Men who earn up to \$4.50 an hour. Learn Arc, Heli-Arc and Gas Welding. We supply equipment that lets you earn while you learn. Practical lessons on brand new, industrial rated machines. Both arc and flame welding. On completion the equipment is yours. Set up your own shop or work in any shop on any job. Send today for full information.

AMERICAN INSTITUTE OF ENGINEERING & TECHNOLOGY  
1131 W. Fullerton Parkway, Chicago, Illinois

# FREE PLAN How to Start Your Own Business



Start a steady repeat CASH business in your basement or garage. Earn \$3 to \$6 an hour in your spare-time! Excellent profits in saw sharpening business! Automatic Foley Saw Filer, easy to operate, files combination saws, hand, band, and circular saws. No experience needed. H. C. Delbert wrote us: "Since I got my Foley Filer 5 years ago, I have averaged 4½ saws each day since I started."

Every saw you sharpen brings you more customers. "I rented a two-car garage and have all the work I can do," writes Charles H. Smith.

## FREE BOOK Shows How to Start

Fact filled booklet tells you how to start a sparetime business immediately; how to get new business; how to advertise. Rush coupon now; get "Money Making Facts" and details on Easy Payment Plan. No Salesman will call.

Send Coupon for FREE BOOK Money Making Facts

FOLEY MANUFACTURING CO.  
1216-5 Foley Bldg. Minneapolis 18, Minn.

Send FREE BOOK—"Money Making Facts", and Time Payment Plan.

Name \_\_\_\_\_

Address \_\_\_\_\_



# "JOHN F. KENNEDY" 1964-P MINT SETS

NOW... A GREATER GIFT THAN EVER—Unconditionally Guaranteed



The silver coins we have known will no longer be minted... the silver in the Kennedy half dollar reduced to 40%, no silver at all in quarters and dimes. We still have brilliant, uncirculated 1964 Sets, in sparkling plastic holders.

BIG STATE COIN CO. (Dept. A7D) • 1416 Commerce St. • Dallas 1, Texas

**295** 10 SETS  
27.50  
postpaid

Please send me \_\_\_\_\_ '64-P mint sets

NAME \_\_\_\_\_

STREET \_\_\_\_\_

CITY \_\_\_\_\_

STATE \_\_\_\_\_

CHECK  M.O.  C.O.D.

# LEARN TO EARN!

NO CORRESPONDENCE • NO HOME STUDY • CONTRACTOR OWNED • VA APPROVED



- Students train on the machines they will operate
- All training by fully qualified instructors
- Students live at the school

- Western's graduate students are readily accepted for employment
  - Many courses of study are offered
- WRITE TODAY FOR FREE SCHOOL CATALOG

# WESTERN SCHOOL

OF HEAVY EQUIPMENT OPERATION

Associate member of Associated General Contractors and A.R.B.A.

BOX 510 • WEISER, IDAHO

Dept. M-18

NAME \_\_\_\_\_

ADDRESS \_\_\_\_\_

CITY \_\_\_\_\_

STATE \_\_\_\_\_

# CLASSIFIED ADVERTISEMENTS

Rate: \$1.40 per word payable in advance each insertion. Minimum insertion ten words. To be inserted under the proper classification, copy must be in our office by the 15th of the second month preceding date of issue. The next available issue to place an advertisement in America's No. 1 Classified Section is February. The closing date is December 15. Send remittance and order to C. A. Martin, Popular Mechanics, 575 Lexington Avenue, New York, New York 10022.

## POPULAR MECHANICS

## CHRISTMAS GIFT SHOPPING

**JIFFY** Powered ice fishing drill. Easy. Spare parts service. More than 300 to choose from. Mailfeer-Selections, Box 505, Berkeley, California.

**MECCANO** Construction outfits all sizes. Spare parts service. More than 300 to choose from. Mailfeer-Selections, Box 505, Berkeley, California.

"SECRETS Of Successful Fishing." only 50c. LeRoy Burnette, 979 Brice, Lima, Ohio 45805.

**ADVANCED** Gifts info airmailed you free through Christmas. Roger Callender Co., 903 W. 9th, Spokane, Wash. 99204.



## AUTOMOBILES, MIDGET CARS

**KARTS** And profits. Sell \$1.00 rides on kart designed by track operator for public use and abuse at your own high-speed race track. Kart information, \$1.00. Track handbook, \$2.00. Salt Lake Sport, Box 15432, Salt Lake City, Utah 84115.

## AUTO SUPPLIES AND EQUIPMENT

**SAVE \$150!** Ring-valve job while driving, \$6.00 postpaid. Safe! Guaranteed! Many mechanics recommend. Motaloy, Grantham, Penna. 17027.

**JEEP** Parts! For military and civilian. At great savings. Largest inventory. Catalog for owners and dealers. Inquiries invited. American Auto Parts Co., 1830-PM Locust, Kansas City, Mo.

**JEEP** Owners—V8 conversions. Read Jeep Owners ad, page 46.

**AUTO** Welding repair training in world's largest non-profit welding school. Low tuition. Free booklet. Hobart Welding School, Box M-125, Troy, Ohio.

**ANTIQU**E Car pistons, gaskets, gears, valves, etc. Catalogue \$1.00. Antique Auto Parts, Milwaukee, Wisconsin 53204.

**COMPACT** Oil reclaiming plant. Plans, \$2.00. Details Free. Holcomb, Box 681, Pampa, Texas 79066.

**FOREIGN** Car parts. Discounts. Catalog. Box 7, Elmont, N.Y.

**\$100.00 WEEKLY** Spare time selling Banshee TS-30 transistor ignition systems. Big demand. Demonstration discount. Free colorful money making brochure. Slep Electronics, Drawer 178PS, Ellenton, Florida, 33532.

**SPINNING**, Snow, stuck, stranded! Newly invented Snomat arches snugly against spinning wheel, out of snow you go. Moneyback guarantee. Prepare now. Send \$1.50 (postpaid) Snomat, Box 617A, Franklin, Michigan.

**ESKIMO** Snow-ice steel tire traction mats, includes polypropylene rope, hooks, most practical gift, \$3.98 pair. Postpaid. Laval, 103 Commissioners East, Montreal, Canada.

**NEW** And used parts savings. Complete guaranteed service all model cars and trucks. Largest in west. Jeep and Army parts specialists. Shifting hubs for all front-end drive vehicles. \$27.50 up. Foreign parts. Fast service. Pioneer, 734 W. 13th Avenue, Denver, Colorado 80217.

**MODEL "A"** Ford Parts. List 25¢. Matco, Box 135, San Pedro, Calif. 90733.

**MAGIC**-Autoglass tint (16 oz. aerosol) \$5.00. 6 colors. Magic-quick release battery clamp, \$1.00. Exclusive Products Co., P.O. Box 12892, Tucson, Arizona.

**IGNITION**. Delta's Patented Mark Ten Capacitive Discharge Ignition System, the world's largest selling SCR Ignition, fits all cars. Easy assembled Kit \$34.95, assembled \$49.50. Acknowledged by engineers as the ultimate ignition system in feature articles in Popular Electronics, Electronics World, Electronics, and other engineering publications. Proven on thousands of cars, trucks, and boats. Connects to standard coil, no rewiring. Saves gas and 80% of ignition tuneups. Plugs last 5 times longer. Give you and your car a "treat," order your Mark Ten today. Satisfaction Guaranteed. Shipped postpaid. State Voltage & Polarity, Delta Products, Inc., P.O. Box 1147, Grand Junction, Colorado.

**HYDRAULIC** Jack repair kits and supplies. Catalog 35¢ (in coin). Hydraulic Jack Packing & Tool Co., P.O. Box 50, Bloomfield, N.J.

**NEW!!!** Harwood "neez-eez" adjustable automotive leg rest. Excellent gift for anyone who drives. Designed to provide lateral support for your accelerator leg. Eliminates cramps in your gas pedal foot or leg. "Neez-Eez" fits conveniently under any dash. Out of way when not in service. Yet ready for instant use. You'll enjoy driving comfort never dreamed possible. Send \$3.95 plus 65¢ postage and handling charges, make and year of car to: Neez-Eez, Box 394, Danvers, Mass.

**FIND** Good used cars! Spot danger signs in your own car. Valid, quick tests for brakes, transmission, clutch, rear end, engine. Gives repair cost estimates. Easy. No instruments. Written by engineer. Send \$2 to: Box 527, Wall St. Station, N.Y. N.Y. 10005.

**YUKON** Engine heater keeps engine warm all night or warms it up quickly before starting. Low priced. Particulars free. K&D, Box 1835-PM, Colorado Springs, Colorado 80901. (Service stations, dealers, write.)

**SEALER** For leaking automatic transmissions. Tru-Seal used by fleets. Moneyback guarantee, \$2.98 postpaid. General Laboratories, 2142 E. Hagert St., Phila., Pa. 19125.

**FAMOUS** Cars. Detailed color prints 11 x 14. Lotus-Ford, Cheetah, Ford G.T., Chaparral, Ferrari 275 LM, Corvette. \$1.00 each, any four \$3.00. Set of six \$4.00. Columbia Sales, 352 Wilson Avenue, Downsview, Ontario, Canada.

**CROSLEY**. New, used, parts. Discounts. Catalog. Box 7, Elmont, N.Y.

## AUTO TRAILERS

**BUILD** Aluminum pickup camper over-cab, hi-boy, lo-boy, blueprints, material, list, 3 models included, \$3.00. Bennett Custom Camper, 1500 S. Dallas, Auburn, Indiana 46706.

**TRAVELPAK** Cartopper camper, fits most cars. "Installation-service" distributorships available. Write Cartopper, Box 123PM, Napoleon, Ohio.

**PRE-Cut** pickup camper kits. Ready to assemble. Literature, 15¢. Snowy Mountain Campers, Lewistown, Montana.

**BUILD** Inexpensive compact bus camper unit; Volkswagens, Econoliners, Dodge, ChevyVan, Literature. Dot Campers, Box 67M, Saugus, California.

**PICKUP** Campers. Pre-cut kits. Blueprints. Supplies. Literature 10¢. Comstock Trailers, Parsons 4, Kansas.

**BLUEPRINTS**—Materials, prefabs—dealers wanted. Details, 25¢. Trailers, campers, Grove, Oklahoma, 74344.

**PICKUP** Camper, trailer or pickup-cover. Build yourself, save! Complete plans \$3.95 each. Bus conversion (and houseboat interiors) Drawings \$2.95. Equipment catalog, \$1.00 (refundable). Satisfaction Guaranteed. Details 10¢. Viking Camper Supply, 94-F Glenwood, Minneapolis, Minn. 55403.

## MOTORCYCLES, BICYCLES, MOTORSCOOTERS AND SUPPLIES

**BUILD** Motorbike from Bicycle! Plans, \$1.00: Go-Byk Industries, Rothsay, Minnesota 56579.

**HARLEY**-Davidsons — Used bargains. New, used parts, accessories, all models. Bulletin 25¢. Knuth's (Factory Dealer), 1753 Muskego, Milwaukee, Wis.

**KART** \$6, Minibike frame \$7, less engines. Engines \$5 up. Whizzer \$15. Three wheeled motorscooter \$30. Kart \$20. Volkswagen Chassis \$75. (Mailorder only.) Send 25¢. (35¢ for first class mailing) for directory-catalogue number 126, listing these and hundreds of other bargains, home-builders parts, plans, etc. Midget Motors Directory, Athens, Ohio.

**RECONDITIONED** Motorcycle motors. Large stock Indian Cushman Vespa Mustang NSU parts. Indian Motorcycle Sales, Kansas City, Missouri. 64127.



## AVIATION

BE A Government licensed aviation mechanic. Practical training. Free information. Aero Mechanics School, Municipal Airport, Kansas City 16, Missouri.

AIRBOAT-Snowplane propellers, plans, kits, supplies. Gauges throttles, spark plugs, gas-oil hose, oil coolers, primers, wrenches, switches, Tachometers, propeller hubs, engine mounts, conversion parts, fittings. 125-190 Lycoming engines, manuals, gaskets, parts. Catalog 25¢. Banks-Maxwell, Box 3301E, Ft. Worth, Texas 76105.

FREE Catalog aviation/space books Aero Publishers, Inc., 329 PM Aviation Road, Fallbrook, California 92028.

HOT Air balloon kit 10', \$4.00 pp. complete. U.S. Sportcraft, Box 847, Woodland Hills, California.

HOME BUILT. Real enclosed helicopter. 24 pages ideas, information, \$2.00. Build "executive" helicopter, drawings, specifications, \$1.50. Helicopter Development, Box PM147, Washington, New Jersey.



## BOATS

BOAT Plans, frame kits, full size patterns all prepared specially for amateurs. Send 50¢ for new catalog illustrating 55 proven designs including sail, inboards and outboards from 7' to 28'. Glen Designs, 9152 Rosecrans, Bellflower, Calif.

KAYAKS—One man \$16.50; two-man \$22.50; sailboat \$39.00. Exciting Sitka Kayak kits known world wide for speed and safety. Assembled in one afternoon. Free pictorial literature. Box 78-P, Brecksville, Ohio 44141.

CANOE Kits—Everything furnished in kit to make handsome, sturdy canoe. Canvas covered and can be Fibre Glassed. Easily assembled. From \$28.50. Free literature. Trailcraft, Box 51721, Glasco, Kansas 67445.

FULL Size, cut-to-shape boat patterns, blueprints, 7½-38 feet. Big new illustrated "Build a Boat" catalog of 64 designs, including catamarans, cruisers, runabouts, skiffs, outboard boats, sailing, racing, houseboats, 50¢. "How to Build a Boat" booklet, \$2.50. Cleveland Boat Blueprint Co., Box 18250, Cleveland, Ohio.

BETTER Bonding dynel fabric for lamination. Send for brochure. Noone Fabrics, 1495 Westport Turnpike, Westport, Conn. 06883.

BUILD Your own boat from our large-scale blueprints. Books of plans give how-to-build help. Hundreds of professional designs—motor, sail or auxiliary—for amateur builders. Free catalog. MoToR Boat-ing, 959 Eighth Ave., Dept. RS, New York 19, N. Y.

WORLD'S Finest boat kits! Frame kits! Models from 8' to 24'. Prams—skiffs—runabouts—cruisers. All leaders in styling and performance. Send 50¢ for catalog. \$1.00 for catalog plus boat building handbook. Custom Boat Designs, 1709-P Niagara Street, Buffalo, New York 14207.

BOAT Plans, world's largest selection. Frame kits and full size paper patterns. Designed for the amateur. Over 200 proven designs from all over the world. Fishing boats—cruisers—sailing—inboard and outboard hydroplanes. Send \$1.50 for catalog. \$2.00 for catalog plus boat building handbook. Custom Boat Designs, 1709-P Niagara Street, Buffalo, New York 14207.

SAILS Dacron. All types. Guaranteed. Bowen, 12 Jackmuir, Scarborough, Ontario, Canada.

200 BOAT Plans, \$1.00 up, kits. Catalogs: Powerboat \$1.00, Sailboat 40¢. Marinecraft, Box 161-M, Brighton 35, Mass.

FIBERGLASS Cloth and resin. World's finest cloth and non-run resin, at direct mill prices. Flotation foam. Complete line of plastics, silicon bronze and brass screws, save 60%. No sales tax. Boat Plans. Free catalogue. Freight prepaid. Stiles Boat Supply, Box 11P, Linden Ave., Mantua Hts., N.J.

BOAT Kits! Factory molded fiberglass or pre-assembled plywood. 50 models. 12' to 30'. Free catalog. Luger, Dept. BC-65, 9200 Access Road, Minneapolis 31, Minn.

## MARINE EQUIPMENT AND SERVICES

MARINE Conversions. Ford, Chevrolet. Jeep engines. Catalog 25¢. Lehman Manufacturing Company, 800 Elizabeth Avenue, Linden 4, N.J.

SAILS From Hong Kong, 50% discount. Chows, Box 529P, RFD #1, Northport, New York 11768.

FIBERGLASS Cloth, matt, polyester and epoxy resins. Lowest prices. Seifert's, Box 1206-M, Green Bay, Wisconsin.

NEW. Used, rebuilt marine motors. Marine conversions, fittings. Free catalog. Stokes Marine Supply, Dept. 24, Coldwater, Michigan.

## ATHLETIC AND BODY BUILDING COURSES

BAR BELLS, Exercise equipment, key to health, strength, physique, 25¢. Reading Barbell Co., West Reading, Pa.

POWERFUL Muscles fast! Free brochure! Universal, Box 4327-C, Northeastern, Dearborn, Michigan 48126.

UNUSUAL Strength stunt pictures, 40¢. Catalogue 10¢. Good Barbell, B-1495, Hendersonville, N. Car.

PHYSICAL Perfection courses guaranteed. Agents wanted. Mail 25¢ to Sid's, (PM-10 65), Southgate, California 90280.

"GIANT Arms." Dr. Young's, D.C. revolutionary discovery, \$2. Satisfaction or refund. Gaucho, Box 9309-S7, Chicago 90.

## SPORTING GOODS AND EQUIPMENT

BIG Money raising crickets and 12 inch African fishworms. Free literature. Carter Ranch, Plains, Georgia.

FREE! World's largest sporting goods discount catalog—86 pages of guns, ammo, scopes, reloading equipment, camping gear, fishing tackle and 1000's of items priced wholesale or below! Maryland Arms Company, Box 7888, Dept. PM, Baltimore, Maryland.

SWISS Exceptional sportsmen's watch, 17 jewels. Combining calendar, international time, diving, yacht racing watch. Only \$29.50. Free circulars. Impex Trade Company, Box 155, Department PM, Woodstock, New York 12498.

GOVERNMENT Surplus Bargains, in guns, ammunition, edged weapons, hunting, camping, fishing items. Write for giant free catalog. P & S Sales, Box 155, Tulsa, Oklahoma.



## FISHING, TACKLE, LURES

MOLDS For casting your own fishing sinkers. Free illustrated booklet. Reading Instrument Co., Box PM78, Reading, Penna.

FREE . . . Wholesale catalog. Beads. Spinners. Lure parts. Sinker molds. Jigs. Reels. Finnyports (ME), Toledo, Ohio 43614.

MOLDS For fisherman's sinkers, jigs, squids, casting and spinning lures. Free catalog. Sweet's Molds, Tonawanda 1, New York.

## EARTHWORMS, LIVE BAIT

SUCCESS For you! Raise fishworms and crickets. Write for free literature and our success story in Life Magazine. Let us teach you our secrets of success. Hybrid redworms 3000, \$5.95. Carter Redworms, Plains, Georgia.

RED Wigglers: Select breeders or fishing size \$3.50—1,000; \$14.25—5,000; bed-run \$9.95—10,000. Postpaid. Free folder "Growing Fishbait." Fain's Bait Farm, Box 56C, Edison, Georgia.

EARN Money raising fishworms for us! Exciting details free! Oakhaven—56, Cedar Hill, Texas.

HYBRID Redworms 1,000—\$3.00, 2,000—\$5.00, 5,000—\$8.00, 10,000—\$14.00. Bedruns 20,000—\$20.00. Postpaid with raising instructions. Brazos Bait Farms, Route 9, Waco, Tex.

MEN!—Women! Make money raising Bait for us at home. Wigglers, Warsaw 45, Indiana 46580.

## FROGS, FISH, REPTILES

FROG Raising. Young frogs and giant breeders. Stock your lakes, pond. Nu-Tex Frog Farm, Box 4029, Corpus Christi, Texas.



## HUNTING, GUNS, DECOYS

SHOTGUN Owners improve your score, bag more game with amazing optical night-sight. Free details. Nydar, Box 45-2125, Glenview, Illinois 60025.

ANTIQUE & modern military arms and equipment. largest selection of military goods in the East . . . guns, swords, edged weapons, hats, helmets, insignia, uniforms, books, medals and accoutrements. Large, fully illustrated Catalog—\$1.00. ZM Military Research Co., Inc., Dept. PM, 80 Nassau St., New York, N.Y. 10038.



## DOGS AND KENNELS

REG. German shorthair pups. Erwin Buckentine, Box 333, Arlington, Minnesota.

GUARANTEED Hunting hounds, reasonable. Catalog, 10¢. Clayco Kennels, Henrietta, Texas.



## GAME BIRDS

YOUR Ad in this space will be read by more than 1,400,000 active mail order buyers. Join the march to greater profits, place your products and services in front of them today with a small low cost classified ad. For further details, write: C. A. Martin, Dept. 15N, Popular Mechanics, 575 Lexington Avenue, New York, New York 10022.

## RABBITS—FUR BEARING ANIMALS

EARN \$10,000 Yearly raising Angora rabbit wool for us. Information 25¢ coin. American Angora Company, Malta 12, Montana.

RAISE Rabbits successfully by knowing facts. 48 page illustrated book describing 25 breeds. Housing, breeding, feeding, markets, marketing etc. 25 cents. American Rabbit Association, 36 Arba Building, Pittsburgh, Penn.

MINK. Free booklet, Book On Mink, \$1.00. Sno King Mink Ranch, Brigham City, Utah.

FREE List books, raising, marketing profitable rabbits, covies, Hamsters, Chinchillas, Diamond J Rabbitry, Colborne, Ontario, Canada.

RAISE Rabbits on \$500 month plan. Free details. White's Rabbitry, Mt. Vernon, Ohio.

### PETS—BIRDS, CATS, HAMSTERS, ETC.

HAWKS, Reptiles, raccoons, skunks, squirrels. Catalogue 25¢. Trails End Zoo, St. Stephens, S.C.

LIVE Seahorses, marine specimens, aquarium supplies. Illustrated catalog 15¢. Marine, Box 248-110, Dania, Florida.

MONKEYS \$10.00, mammals, birds, reptiles. Confidential wholesale list, \$1.00. Dale Logston, Box 682, Saint Joseph, Missouri 64502.

MAKE Money raising chinchillas, mink, rabbits, covies for us. Free catalog. Keeney Brothers, New Freedom 2, Penna.

### CAMPING EQUIPMENT AND TENTS

CAMPING Equipment, unusual selection. Morsan's own quality tents (200 styles) finer fabrics; sleeping bags (80 styles); every camping convenience imaginable. Free giant catalogue-guide-handbook. Morsan, 810-R Route 17, Paramus, New Jersey.

PAULIN Infra-red 5,000 Btu propane heaters. Demonstrators. Guaranteed same as new. Includes 14-oz. propane tank. Regular price \$24.95. Demonstrators only \$13.50. Postpaid. Limited supply. Send check or money order to Private Utilities, Inc., 1359 Yellowstone Road, Cleveland Hts. 21, Ohio.

### TRAVEL AND RESORTS

TELL The more than 1,400,000 avid readers of Popular Mechanics about your hotels, lodges and travel services. It costs very little to place your classified message in front of these hunters, fishermen, vacationers. For further details, write: C. A. Martin, Dept. 19N, Popular Mechanics, 575 Lexington Avenue, New York, New York 10022.

### ELECTRICAL SUPPLIES

LAMP Parts. Catalog, prices, wiring instructions. 50¢. Refunded first order. Gyro, 5208P N.W. 35 Ave., Miami 42, Fla.

METERS—Surplus, new, used, panel and portable. Send for list. Hanchett, Box 5577, Riverside, Calif.

APPLIANCE—Lamp parts. Wholesale catalogue, 25¢. SECO, 112 South 20th Street, Birmingham, Alabama.

LAMP. Electrical parts, wholesale. Thousands of items for repairing, converting. Catalog 35¢. Brown Lamp, Box 305, Clayton 5, Missouri.

### BATTERIES, GENERATORS

COMPLETE Rebuilding Manuals! Batteries \$3.00. Hydraulic jacks \$3.00. C.O.D. accepted. Bayer Publications, 938 Betty Avenue, Neenah, Wisconsin.

BATTERY Reconditioning kit, includes molds, material, complete instructions. The Battery Shop, P.O. Box 416, Palm Desert, Calif.

REPAIR Batteries, "for pennies!" Free details. Robert Patterson, Saint Croix Falls, Wisconsin.

ILLUSTRATED! Battery rebuilding manual. \$3.00. Supply catalog. 25¢. Battery charger repair manual. \$2.00. All for \$5.00 Postpaid. Capitol Battery Equipment, Box 7154, Montgomery, Alabama.

### ENGINES, MOTORS, DYNAMOS

REWIND Electric motors! Details free! Modern, Box 10025, Kansas City, Mo. 64111.

WINDING Data. 275 motors, single and three phase \$1.10. Data Company, 512 Kensington, Kansas City 24, Mo.

### MACHINERY, TOOLS AND SUPPLIES

FACTORY Prices! Brand new, first quality, fully guaranteed saw chain low as \$10.00; hardnose bars from, \$14.00. Big savings on parts, accessories for all makes of chain saws. Free catalog. Zip-Penn, Box 179NB, Erie, Pennsylvania 16512.

SPLIT Rocks—2000 degree kerosene torch, 99 practical uses. Destroys stumps, sprays, dries concrete. Free literature. Sine, PM2, Quakertown, Pa.

"SMALL Shop Supplies." Production—hobby. Machinist Tools, 1424 Barclay, Springfield, Ohio 45505.

LATHE 12" x 51" \$33. Alda Power Tools, 101 Masonic, San Francisco, Calif. 94118.

STANLEY, Millers Falls, Skil, Diaston, Wiss, Plumb, Channellock, Bonney, Herbrand, Ridgid, and hundreds of other nationally advertised brands at prices hard to beat. Send 25¢ for our big tool catalog today! Silvo Hardware, 107PM Walnut, Phila. 6, Penna.

MECHANICS' Gooseneck Inspection Light, \$3.95 ppd., with batteries. 11" long; tip will pass through  $\frac{7}{16}$ " hole. Dealers wanted. Hussman Products, Dept. PM, Gardnerville, Nevada 89410.

BUILDERS! Make rafter cutting easy! Free information. Emmert Products, Sycamore, Illinois 60178.

UNIQUE Tools: \$1.00, \$5.95. Stahl Mfg., 3166 Wadsworth, Saginaw, Mich.

SWISS Saw blades and frames for intricate, precise and very close detail operation on metal, wood, plastic, etc. Saw frame \$5.00, saws—60¢ doz., \$4.00 gr. The Rade Co., Importers, 4574 N. Mobile Ave., Chicago, Ill. 60630.

HARD-To-find tools. Superb quality. Catalog, 10¢. Brookstone, Worthington 19, Massachusetts.

BRONZE, Aluminum foundries, 5 sizes. Free information. Pyramid Products, Box 65, Fayetteville, Arkansas.

### WELDING, SOLDERING, PLATING

CHROME Plating equipment, supplies. All other finishes. Home workshop and production sizes. Send \$1.00 (refundable) for formulas, operating data, equipment guide and catalog. HBS Equipment Division L50, 3543 East 16th, Los Angeles, Calif. 90023.

FREE "Make Money, Have Fun With Cheap Welder." 25 cent coin for handling. Aqua-Jets Company, Florence, Kentucky.

FREE Catalog. Welders, kits. Build 350-ampere Welder. Plans, 25¢. Le Jay Manufacturing, Belle Plaine, Minnesota 56011.

FREE Catalog. welders, kits. 400-ampere welder from aircraft generator—Plans, 35¢. Dunbar, Chaska, Minnesota.

WELDERS, 150 Amperes. \$49.50. Paul Morris, 1070 Inner, Schenectady, N.Y. 12303.

### GOVERNMENT SURPLUS

GOV'T. Surplus. How and where to buy in your area. Send \$1.00. Surplus Information. Headquarters Building, P.M., Washington 6, D.C.

JEEPS \$53.90—Trucks, airplanes, thousands of other bargains selling at a fraction of their original costs to the taxpayer. For complete information on how to buy, and new 1966 sales directory, send only \$1.00 to U.S. Surplus, Box PM 92, Keego Harbor, Michigan.

JEEPS Have sold low as \$53.90 from U.S. Surplus. Bidders information and our over 400 item (order by mail) Surplus catalog, \$1.00. Quality Surplus, 422 (PM-12) Washington Building, Washington, D.C.

JEEPS \$62.50, autos, boats, thousands others available used direct from Government! Free exciting details! Global, Box 18216-PL, Indianapolis, Indiana 46218.

CHEEP Jeeps. Buy from Gov't. Full information, 25¢. Box 789PMTF, York, Penna.

WAR Surplus catalogue, generators, pumps, gearboxes, hydraulics, winches, motors, 25¢ stamps or coin. Trader, Box 8PMTF, Thomasville, Penna.

WAR Surplus bargain catalogue. Illustrated generators, blowers, pumps, gearboxes, hydraulics, winches, motors, etc. Send 50¢. Refundable on first order. Surplus Trader, Box 8TPPM, Thomasville, Penna.

JEEPS—Jeeps—jeeps. Direct from Government. Directory and our over 400 item (order by mail) surplus catalog, \$1.00. Quality Surplus, Dept. PM-12, 2546 W. Michigan, Indianapolis, Indiana.

LATEST FACTS concerning Government Surplus Bargains. Send dime or stamped envelope, Box 1563PM, York, Penna.

JEEPS—Typewriters—walkie-talkies—guns—boats—binoculars direct from Govt. for 2 or 3¢ on the dollar. Exciting details Free, Box 52PM, Thomasville, Penna.

JEEPS From \$52.50, typewriters from \$4.15, cars from \$31.50, walkie-talkies, guns, airplanes, boats. Typical "as is" bid bargains from Uncle Sam. Tremendous variety. Exciting free list. Write: Enterprises, Box 402-X5, Jamaica, New York 11430.

JEEPS From \$53.90, trucks from \$78.40, boats, typewriters, airplanes, sporting equipment, 100,000 Bargains, as is, direct from Government in your area. Complete sales directory and surplus catalog, \$1.00. Deductible first \$10.00 order. Surplus Service, Box 820-A, Holland, Michigan.

### HOBBIES AND COLLECTIONS

INTRODUCTORY Five military emblems and illustrated catalog, 25¢; Foreign Medal, 50¢; 10 Military decals 25¢. Hobbies, Box 71-S, Rockaway 94, New York.

EUROPEAN And Nazi uniforms, equipment, medals and badges, illustrated catalog, \$1.00. Der Alte Oberst, Box 1393, La Jolla, Calif. 92037.

ANY Child can and should have authentic legible postmarks. Start a new hobby by acquiring one for each of your children dated the day of birth. Now available plastic coated. Before their eleventh birthday 50¢. Older \$1.00 each. State particulars. Dated Postmarks, 2650 South Lynedale, Minneapolis 8, Minn.

AMERICAN Newspaper, complete, original, dated before 1880, \$1.50, 25¢ stamps brings catalogue. D. R. Spaight, Book-seller Tall Timbers 1, Maryland 20690.

50 JUNGLE butterflies \$2.00. Giant nature hobbies catalog 25¢. Collectors Wonderland, Box 1170, New York 8.



### STAMP COLLECTING

THOUSANDS Of worldwide sets and singles on approval. Highest quality! Cole, Box 223A, Buffalo, N.Y. 14221.

U.S. Bargain, 50 different 10¢, with beautiful worldwide approvals. Stamps, Kennebunk, Maine.

**GERMAN Commemoratives.** 10¢ with approvals. Schaefer, Box 1704, Washington 13, D.C.

**40,000 DIFFERENT.** Amazing new plan builds your collection systematically, country by country. As low as 50¢ weekly. Ware, Monroe 75, Conn.

**MILLION Foreign stamps!** 2¢ each! Send for thrilling, giant approvals! ABC Stamps, Box 6000-MB, San Francisco 1, Calif.

**FREE Surprise collection sent with approvals.** Gould, 1784 Union, San Francisco 94123.

**25 DIFFERENT United States Commemoratives** 1893 up 10¢. Approvals. K&B Stamp Company, Box 70, Brooklyn 23, New York.

**105 DIFFERENT U.S. Stamps.** 25¢ approvals included. Shelron, Box 187, Hempstead, N.Y.

**BREATH TAKING.** 50 Mint Monaco pictorials, multicolors. \$1.00. Approvals. Stamp Exchange, Box 103, Fairfield, California.

**50 YEARS Old.** fifteen different United States, over fifty years old—10¢ with approvals. Jaxon, Box 145-P, Brooklyn, New York 11230.

**PENNY Foreign stamps** neatly mounted in jumbo books in Scott order. Bullot Approval, 1454 Coney Is. Ave., Brooklyn 30, New York.

**"INVERTED Error,"** Dag Hammarskjold 5¢ with Approvals. Belmont Stamps, Washington, D. C. 20015.

**RUSSIAN Space set** 10¢. Russian approvals. Snedco, Box 68-P, Waldwick, N.J.

**50 DIFFERENT Old U.S. Revenue stamps** 50¢. Winchester stamps, Box 1592, Mansfield, Ohio 44907.

**PIPEX, Tipex, Cipex, Ashville.** Four miniature sheets used for \$1.00 if you ask for our bargain priced U.S. approvals. Triboro, 38 Park Row, New York, New York 10038.

**133 DIFFERENT Colorful stamps** 10¢ approvals. Krehl, 1708 Nebraska, Orlando, Florida.

**FREE! Congo triangle set!** Boy Scout beauty! 25 others, different. Approvals. Cambridge, Box 411, Cambridge, Ohio.

**100 OLD United States** between 1861 and 1935, \$1.00. Roush Stamps, 51 Chestnut, Mansfield, Ohio.

**225 STAMPS** For only 10¢! This mammoth value includes airmails, pictorials; stamps from strange countries cataloging up to 25¢ each! Also approvals. Mystic Stamp Company, Camden 80, New York.

**SELL Your surplus good grade stamps.** Write, describing fully what you have. Vanroy Shirr, Lebanon, Pennsylvania.

**500 DIFFERENT Stamps.** \$1.00. Smith, 508-A Brooks, College Station, Texas.

**PENNY Stamps!** 1000 Mounted in book at 1¢ each. Trust Stamp Company, P.O.B. 132-P, Jamaica, N.Y. 11435.

**ONE Pound value Geo. VI Bermuda,** plus 100 worldwide 10¢ approvals. Stevens, Box 105A, Homecrest Sta., Brooklyn 29, N.Y.

**60 DIFFERENT U.S. (30 commemoratives)** 25¢. No approvals. Seidenberg, Salem 169, Oregon.

**ABSOLUTELY Free** 50 worldwide. Request inexpensive approvals. University Stamps, P.O. Box 326, Pompano Beach, Florida 33061.

**AMAZING OFFER!** 200 United States stamps—including commemoratives, airmails, high denominations to \$1.00. Only 10¢ to approval applicants! Illustrated bargain lists free. Mystic Stamp Co., Dept. 80, Camden, New York.

**PENNY! Approvals!** Regardless catalogue! Kloster, 4164 52nd St., San Diego 5, Calif.

**163 WORLDWIDE.** 10¢. Also approvals. Siegel, Box 92-PM, Brooklyn 18, N.Y.

**64 PAGE U.S. and U.N. catalog** free. Stone, 260 Washington, Boston 8, Mass.

**FREE Stamp wallet** with approvals. Wide selection collections by countries. Clark, Box 28-C, Wilmette, Illinois.

**U. S. approvals.** Low prices. Eagle Stamps, Romine Ave., Pittsburgh 26, Penna.

**FREE Sample.** Interesting, illustrated, informative National Stamp News, Anderson, South Carolina 29622.

**FREE 25 Rockets** to new approval applicants. Tiquet, Box 1496, Denver 1, Colorado.

**INTRODUCING Our better United States approvals** we offer 15 United States stamps including Columbian, Bi-Centennials, famous American, airs, others: only 10¢. Ocean Stamps, Box 64-PM, Brooklyn 29, New York.

**1025 DIFFERENT.** \$1.30 with approvals. Klondike, 682 Jefferson, Elgin, Illinois.

**215 DIFFERENT U.S. commemoratives.** \$1.00 approvals. H. Holub, 18 East 198th Street, Bronx, N.Y. 10468.

**FREE Monaco nudes.** Approvals, Stamp Ranch, 902 Addison, Chicago 13, Ill.

**10 U.S. over sixty years old.** 10¢. Robert Gallup, Albany, New York 12201.

**UNITED States commemorative collection** containing 33 different—10¢. Approvals. White, 516-A Avenue L, Brooklyn 30, New York.

**FINE Stamps!** Large bargain lot, \$1. Giant Assortment, \$5. High Value Packet, \$3. Literature, coupons, free. Persile, 436 N.Y. Ave., Brooklyn 25, N.Y.

**COLORFUL Set** free Worldwide approvals. Gorfiz, Drawer 388PM, Park Ridge, Illinois.

**WOW! 1000 Different worldwide—valued** over \$20.00 only \$1.00 with quality approvals. Universal, Box 6, Kenosha 5, Wisconsin 53141.

**FLAGS.** 1944 U.S. mint set, (13) only \$1.25. Goldie McLain, 205 VanBuren, Pueblo, Colo. 81005.

**220 DIFFERENT U.S. commemoratives.** \$1.00. Rockefeller, 40 West Market, Red Hook, N.Y. 12571.

**ONLY 50¢ for 75 diff. U.S. comm.** Pittman, Box 125, Cottage Grove, Oregon.

**110 DIFF. U.S. comm., \$1.00.** Satisfaction guaranteed. Pittman, Box 125, Cottage Grove, Oregon.

**UNITED STATES price list.** 132 pages, price 30¢. Mark Hanna, 335 Fifth Ave., Pittsburgh 22, Pa.

**DEFECTIVE, Old U.S., 1/3 Scott.** Swarz, Box 373, Venice, Fla.

**ATTRACTIVE Triangle set free!** Request approvals. Cutlass, Box 235, Chicago 60645.

**MINT United States** on approval. Western, Box 1814P, San Leandro, California.

**SOUVENIR Sheets** Czechoslovakia 1937 plus Japan 1947, 10¢ with approvals, Kingman, 30 Empire, Yonkers, N.Y. 10704.

**MAKE Attractive plaques** from your extra stamps. Instructions 30¢. Blank plaques and instructions \$2.00. Vant Industries, Box 7724, Waco, Texas 76710.

**FREE! Two Russian Sets** and gift coupons with sensational foreign Approvals, 10¢ handling. Trio Stamps, Box 1806-MD, Grand Central Station, New York, N.Y. 10017.

**ATTRACTIVE—Mint Indonesian pictorials,** plus bargain catalogue featuring U.S. stamps, packets, accessories, 10¢ with approvals. Bydahl, Box 1293-ML, Seattle, Washington 98111.

**121 DIFFERENT Flag stamps** free. Approvals. W-B Stamps, Wilkes-Barre, Pa.

**THOUSANDS Bargain stamps** on approval, highest quality. J. R. Baker, Stamp Approvals, Box 748, Santa Barbara, California.

**FREE! 55 Triangles, rockets, others!** Colorful, low-priced approvals. L. Baird, PM-14, Box 8128, Portland, Oregon 97207.

**"OLD GLORY" in flaming colors!** U.S.A. flag giant beauty from Honduras. Enormous United Nations Mexican stamps. Plus strange gorilla issue. Duke of Windsor, Morocco lovely Macao flowers, wild buffalo stamps and others. 10¢ with approvals. Sunny Stamp, Fruitport 2, Mich.

**AMERICAN Historical collection!!** Enormous airmail diamond! Pres. Kennedy & movie star Grace Kelly, 1st USA spaceman Shepard, plus midget soldier. Latin Orchid issue, old St. Pierre Fisherman, etc. 10¢ with approvals. Roseland Stamps, Spring Lake 2A, Mich.

**WORLD'S Rarest stamp,** detailed reproduction free. Approvals. Hijop, Box 505, Norristown, Pa.

**SURPRISE Collection!** Exotic mint British Colonials, absolutely free with approvals. Viking, Great Neck 8, N.Y.

**CLEARANCE.** Forty different packets only \$1.00. Norge Company, Ho-Ho-Kus, N.J.

**217 DIFFERENT U.S. commemoratives** \$1.00. (Limit one) Carstamps, 739 Ordway, Freeport, Illinois.

**VATICAN Mint airmail set.** 5¢. Approvals. Donald Manning, Box 4107, Milwaukee, Wisconsin 53210.

**10 CHRISTMAS Stamps** of foreign lands 10¢. Approvals. Hohmann, 20S. Yacht Club, Treasure Island, Florida.

**1500 FOREIGN \$1.00.** 5000 \$3.00. 5000 USA—commemoratives, airs, high values, revenues, 19th Century, etc. \$3.00. No approvals. Meyers, 5321 Fleming, Richmond, California.

**AMAZING OFFER!** 200 United States stamps—including commemoratives, airmails, high denominations to \$1.00. Only 10¢ to approval applicants! Illustrated bargain lists free. Mystic Stamp Co., Dept. PM-12, Camden, New York.

**5 SETS mint,** including Triangles only 20¢ approvals. Wald Stamp Co., 3747 W. Belmont Avenue, Phoenix, Arizona 85021.

**1¢ SALE—Genuine United States Postage** Stamps, 100 different, \$1.00. No approvals. Calvin Marcum, Hopkinsville, Ky.

**225 DIFFERENT U.S. commemoratives,** \$1.00. Approvals. Gordon Davison, Henniker, New Hamp. 03242.

**U.S. MINT C7-9, C34-36** \$2.00. Cooper, Box 3751M, Oak Park, Mich. 48237.

**GIANT Stamp collection** including: Astronauts, Satellites, Moonrocks, Boy Scout issue, complete U.N. Set, recent Olympic and sports issues from many countries, etc. Plus big stamp dictionary and approvals. Everything, 10¢. Stampex, Box 47-RM, White Plains, N.Y.

**FREE! Big bargain catalog,** new edition listing thousands of bargains including U.S. & B.N.A. stamps, packets, albums, accessories and supplies. Plus selections of fine stamps from our approval service. Buy those you wish—return balance. Jamestown Stamp, Dept. E125PM, Jamestown, N.Y. 14701.

WOW! 110 all different Germany, 10¢ commemoratives, airmails, high values, big catalog, bargain lists plus selections of fine stamps from our approval service. Buy those you wish—return balance. Jamestown Stamp. Dept.—A125—PM, Jamestown, N.Y. 14701.

\$1.00 SPECIALS—1500 Worldwide; 400 U.S. high values, airmails; 225 U.S. commemoratives; 200 old U.S. Steele, Box 242-PK, Colorado Springs, Colorado 80901.

TEN Different nudes, 20¢. Approvals. Stamp Farm, 2M5, Oxford, Wisconsin.

U.S. Approval buyers only! \$2.80 buys very fine precancelled Huguenot-Walloo; set (cat. \$7.55), plus 50-different, when requesting our intriguing selections. Stamps Box 8, Lowell, Michigan 48331.

CLOSING Out tremendous old accumulation. Free lists. Alatalo, Maynard, Massachusetts 01754.

CANADA Sports complete, 10¢, Canada approvals. Valley Stamps, Little Valley, New York 14755.

5000 GRAB Bags! Dollar each. Satisfaction guaranteed. Catalogue. Stamps, 14980 Huntsville, Ontario, Canada.

JOHN Fitzgerald Kennedy, Panama's latest "Triangle" commemoratives—Free! Plus 101 bonus sets. Approvals. William Deems, 226 Race, Ravenswood, West Virginia 26164.

\$2.00 CONGLAMERATION Includes mixtures, packets, discontinued approvals. Norge, Ho-Ho-Kus, N.J.

FREE! U.S. Historical packet with penny approvals. Monjar, Cincinnati, Ohio 45211.

U.S. Mint specials! Flag set, complete \$1.00. 1¢, 2¢, 3¢ famous Americans (21 different) \$1.00. Free list. Brooks, 2601 Avenue "U", Brooklyn 29, N.Y.

## COINS, TOKENS, CURRENCY

CIVIL War specials: 1863 cent, \$1.75; 1863 civil war token, \$1.75; 1864 genuine confederate states of America \$10.00 bill, \$2.00. All three \$5.00. Raroca, 31 North Clark, Chicago 60602.

10 DIFFERENT Indian cents \$2.25. Hutchinson's, Box T-6256, Philadelphia, Penna. 19136.

RARE Silver Dollars, 1879, 80, 81 S mint \$3.00 ea. Uncirculated. New Catalogue, 50¢; Shultz, Salt Lake, Utah 84110.

25 BEAUTIFUL Coins from 25 countries. Mostly uncirculated. Terrific assortment. \$1.00 Hindley, Box 708, Aurora, Illinois 60507

TWENTY Page 1965 retail price list of USA and Canadian coins 10¢. Our retail selling prices on thousands of coins and coin collectors supplies. Bryson Incorporated, 612A White, Toledo 5, Ohio.

LARGEST Coin magazine. 288 pages, 50¢. Scrapbook, 7320-J Milwaukee, Chicago 31.

FOR Sale! 30 Lincoln cents before 1941, all different, \$2.00. Gene Carlton, Chandler, Okla. 74834.

"WORLD'S Safest Investment." New coins, 2500% profit, free details. George Shorey, Dept. 9-PM, 6215 Chef Menteur Hwy., New Orleans, La. 70126.

30 DIFFERENT Worldwide coins, \$1.00. Newcomers, Box 91, North Quincy, Mass. 02171.

40 PAGE Illustrated United States and Canadian coin list 10¢. Stoney, 260 Washington, Boston 8, Mass.

BUY, Sell, trade coins. Big discounts. Free list. Box 14377, Orlando, Florida.

NICE Liberty nickel plus picture price list of excellent condition coins, 50¢ ppd. Coins, 125 N. 19th St., Birmingham, Alabama.

FREE Price list, or add 15¢ postage for free coin album. Suburban Coin, 607-G Mesquite, Corpus Christi, Texas.

LINCOLNS: 22 Different "S" including rare 1955S, \$1.60. 28 different before 1940, plus odd 1960D small date, \$1.60. 10 different "S" Jefferson nickels, \$1.60. All three \$4.50. Harris, Box 1147-P, Oceanside, California.

3 BRAZIL Bills, 25¢, 5 Asia bills, 25¢. Jolie, Box 50M, Brooklyn, N.Y. 11224.

99.95% PURE Silver nuggets as released by U.S. Government in exchange for \$1.00 Silver Certificates, \$1.45 per pack, 3 \$4.00. Box 735, Arcadia, Calif. 91007.

10 DIFFERENT Indian cents plus 5 Foreign Coins, \$2.50. Kottke's, Box 428, Mankato, Minn.

TYPE Coins! Large cent \$2.00; copper-nickel cent \$1.75; 1/2-cent \$5.00; 2¢ copper \$2.00; 3¢ nickel \$2.00; 1/2-dime \$3.25; Liberty seated dime \$2.00; Quarter \$3.00; half \$4.50; bust half \$6.50; closeout list, 15¢. Nelson, 346-M, Rye, New York.

COIN Date guaranteed. Restores dates on worn nickels, \$1.00 bottle. Box 276F, Mooreville, N.C.

1966 CATALOG Now ready. 50¢ with refunding certificate. Hobby Sales, St. Paul, Minnesota 55116.

UNCIRCULATED \$20.00 Gold pieces, \$52.50. Pacific Coin, Box 274-M, Downey, California.

SILVER Dollars! Brilliant uncirculated, \$3.00 each. 1879-S, 1881-S, 1883-O, 1884-O, 1885-O, 1886-P, 1887-P, 1899-O, 1902-O, 1923-P. Stroud's Coins, Kinston, N.C.

BARGAINS—Brilliant proof sets: 1956 \$16.50, 1957 \$9.75, 1958 \$21.00, 1959 \$11.50, 1960 \$9.25, 1961 \$6.50, 1962 \$6.50, 1963 \$7.75, 1964 \$15.50. All nine \$99.50. General MacArthur set \$6.50. Gigantic bargain catalogue \$1.00. Bebee's, Incorp., 4514 North 30th, Omaha, Nebraska.

TEN Different Indian cents, \$1.99; five different silver dollars, \$7.95. Free price-list. Edel's, Carlyle, Illinois 62231.

XMAS Special: 23 different "S" mint Lincolns plus 1955S, \$1.70. 18 different, brilliant, uncirculated, \$1.50. Gemcoins, Box 8374, Minneapolis, Minn. 55416.

INVESTORS 1955 5 poor man's double die cent, BU \$2.95. International Investment Associates, Box 172, Hollywood, Calif. 90028.

WANTED! Half cents all dates. Pay \$10.00 each for EF/AU coins. Large cents, pay \$6.00 EF/AU. Indian pennies, pay \$1.00 before 1880, 15¢ after. "Gabby," 4565 170 St., Lawndale, Calif. 90260.

50¢ CALIFORNIA Gold pieces, 1849-1858, 75¢ each. Seven different \$3.50. 25—\$9.75. Silver dollars 1878-1899 \$1.75, unc. \$2.50, proof like \$3.50. Metropolitan Coins, 497 Lantz, Detroit, Michigan 48203.

FREE Coin supplies! Giant coin list 10¢ (refundable). Economy Sales, Mansfield, Massachusetts.

## ANTIQUES, RELICS, INDIAN GOODS AND CURIOS

ARROWHEADS, 10 for \$3.00. List free. Hyde's, Box 1788, Santa Fe, New Mexico.

HIGHLY Decorated Indian drum, tomahawk, 6 ft. whip, blow gun with darts, ceremonial dance bells on woolskin with dance lessons, Indian headdress, \$2.00 each or all 6 for \$10.00. Handmade by the Cherokee Indians. Very colorful—Free gift with \$10.00 order. Cherokee Krafts, 712 Valle Vista Drive, Dept. PM, Asheville, N.C.

TONS Of antique gun parts and supplies. All reproduction muzzle loading guns. Send \$1.00 for enlarged illustrated catalog No. 115. Dixie Gun Works, Union City 12, Tennessee.

ANTIQUES! Monthly magazine. Sample 25¢ or free circular. Antiques Journal, Uniontown, Penna. 15401.

SELLING 20,000 Ancient arrowheads, spearheads, etc. List free. Lear's, Glenwood, Arkansas.

## MODELS—SHIPS, TRAINS, PLANES, ETC.

ROCKETS: New illustrated catalog 25¢. Single and multistage kits, cones, engines, launchers, trackers, technical information, etc. Fast service. Estes Industries, Penrose 2, Colorado.

SHIP Model kits and fittings: clippers, frigates, etc. Catalog paint-tool list, book list, 35¢. Model Shipways, Box 85, Bogota, N.J.

LIVE Steam and gasoline model engine kits from \$8.20. Boilers, accessories. Robust, heavy duty materials. Pictured catalog, 50¢. HPK Models, Box 34, Centuck Station S, Yonkers, New York.

SHIP and yacht model fittings: Pine construction hull kits; blueprints. Send 50¢ for illustrated catalog. A. J. Fisher, Inc., 1002 Etowah Avenue, Royal Oak, Michigan 48067.

SHIP Models. Kits, fittings, plans, books, tools, engines, motors. Big illustrated catalog, 50¢. James Bliss & Co., Dept. SM, Route 128, Dedham, Mass. 02026.

STEAM Engines for operating toys and models. Free catalogue. O'Connor, Box 775, Baker, Oregon.

HARD-To-find tools for modelers, craftsmen. Catalog, 10¢. Brookstone, Worthington 20, Massachusetts.

LIVE Steam, gasoline engine castings kits. Fittings, accessories. Numerous ideas for Christmas gifts to delight the mechanical minded man or boy. Illustrated catalog, \$1.00. Coles' Power Models, Ventura, Calif.

STEAM Engines, castings & finished. Stuart, Crete, 6 hp compound, fittings, tools, boiler, pumps. Catalogue, \$1.00. New address, D. Live Steam Models, Box 306 S, Duncannon, Penna. 16115.

SLOT Racers! Trains! 25¢ brings 32 page bargain catalogue. Thousands of Lionel, Gilbert, Varney, Strombecker, Eldon, Aurora, Scalextrix, Revell, etc. Trains, all gauges, racers all sizes. Hobby Surplus, P.O. Box 1106M, New Britain, Conn.

BUILDING Materials, 1/4" & 1/8" scale, windows, doors, siding, roofing, lumber and structural shapes. Send 35¢ for catalog with samples. Small Sales Co., 6025 Martway, Mission, Kansas 66202.

## GAMES, TOYS, NOVELTIES

FREE Catalog, tricks, jokes, funny cards, 50 samples, 25¢. Donh-7K—Marks, Broadview, Illinois.

## MAGIC TRICKS, PUZZLES, JOKER NOVELTIES

FUN 'N Magic catalog, 10¢. 1,500,000 tricks, jokes, novelties, puzzles, disguises, books. Elbee 7408-P, San Antonio, Texas 78207.

NEW Edition, 1965 catalog, 500 tricks, only 10¢. Fastest same-day service to magicians for 40 years. Send 10¢ today. Douglas Magiland, Dept. 21, Dallas, Tex.

COMPLETELY Illustrated catalog, 84 pages, 25¢. Manhattan Magic, Box 334-M, N.Y.C. 11.

MAGIC Catalog! World's finest, 3000 tricks (408 pages) \$2.50. Beginners amateurs, professionals. Kanter's, A-200 South 13th St., Philadelphia, Pa. 19107.

**LATEST** Giant surprise catalog! 1000 Professional tricks, magic, jokes! Exciting! Thrilling! Only 10¢. Vick Lawton's Magic, Dept. PM65, 4018 N.E. Fifth Ave., Ft. Lauderdale, Florida.

**VENTRILOQUISM** For fun or money, new method, easy. R. Marlette, 554 Lynn Ct. Apt. A. Glendale Hgts., Ill.

**WORLD'S** Finest professional magic tricks. Joker's Novelities, Giant illustrated catalog 10¢. Top Hat, Evanston, Illinois.

**VENTRILOQUISM**—Practical home study course by professional teacher. Reasonable. Write for details. P. Stadelman, 1449 Fargo, Chicago 26, Ill.

**FREE** Bargain magic lists. Wisehart's, 3105 West Broad Street, Columbus, Ohio 43204.

**GIANT** Magic Catalog and free trick only 10¢. Write today. Mailmart, M1265, Box 616, White Plains, N.Y. 10602.

**BE A Magician!** Introductory catalog with free trick, only 35¢. Ireland Magic, 5082 Lincoln, Chicago, Illinois 60625.

**VENTRILOQUISM!** Information Free! Dummy Catalog 25¢. State age. Maher, Box 36, Kensington Station, PM-12, Detroit, Michigan 48224.

### BOOKS, PERIODICALS

**FREE** Catalog. Self-help books. Write Wilshire, 8721 Sunset, Los Angeles 69P.

**BOOKS** Successfully located! Atlantic Book Service, Cedar Street, Charlestown 29, Mass.

**PROPHET** Elijah coming before Christ. Wonderful book free. E. Megiddo Mission, Rochester, New York 14619.

**BOOKFINDERS!** All subjects. Send wants! Sydney Jaher, 175-45 88 Ave., Jamaica, N.Y. 11432.

**CHALLENGING!** Different! Unusual books! Free catalog. Ruby's, D-26, Paradise, Pennsylvania 17562.

**FREE** Catalog unusual books. Murry Company, Dept. 365, 3000 Truman, Kansas City, Mo. 64127.

**BOOKS**, Free general catalog, 100 pages. Text, vocational, educational, instructional subjects. Millions of volumes, new and used. Bargain prices. Books bought, Est. 1902. Long's College Book Co., Dept. PM, Columbus 1, Ohio.

**FIVE** Hundred thousand, out of print pocket novels, free catalog, Book Bin, 1247 Granville, Vancouver 2, B.C., Canada.

**NEW!** Special sentimental songs! Unusual. Particulars Free. Garrott's, East Cape Park, McClure, Ill. 62957.

**BOOKS** Published. Short runs. Low prices. D & D Company, 973 W. Exchange, Akron, Ohio.

**OUT-Of-print** books at lowest prices! You name it, we find it! Fast service. No obligation. International Bookfinders, Box 3003-PM, Beverly Hills, Calif.

### PLAYS, STORIES, MANUSCRIPTS

**WANT** Your book published? Learn how we publish, advertise, promote, distribute. Many successes. Free booklet PM. Vantage, 120 West 31, New York City.

**WANTED** Writers! Short stories, articles, books, plays, poetry. Will help place, sell your work. Write today, free particulars! Literary Agent Mead, Dept. 20A, 915 Broadway, New York 10, N.Y.

### BUSINESS OPPORTUNITIES

**RAISE** Rabbits on \$500 month plan. Free details. White's Rabbitry, Mt. Vernon, Ohio.

**HUGE** Profits! Mail order importing. Free information. ITIS-PM-12, Box 454, Hollywood, Calif. 90028.

**DOLLS!** Dolls! Dolls! We teach you to make, repair, dress and sell. Study at home. Earn while learning. Free booklet. Doll Hospital School Studio MC-125, 11826 San Vicente Blvd., Los Angeles 49, Calif.

**LEARN** Landscaping and the growing of plants. Start a profitable business part or full time. Free information without obligation. Lifetime Career Schools, Dept. MC-125, 11826 San Vicente Blvd., Los Angeles, Calif. 90049.

**SPARE** Time earnings. With your table-saw, bandsaw or jigsaw. Write: Workshop, A3800 Harney, Vancouver, Washington 98660.

**SELL** Advertising book matches. Write us today: we put you in business by return mail, handling complete line ad book matches in demand by every business right in your town! No investment; everything furnished free! Top commissions daily! Superior Match, Dept. MX-1265, 7530 S. Greenwood, Chicago 19, Ill.

**SIMPLE**. Pleasant, mailorder can net \$12,000 year. Write Rutward, 2610 Bryant, Columbia Station, Ohio.

**TO \$100.00** weekly! Mailing catalogs! Sample, instructions, 25¢. Costar, GPO Box 972-PM, New York 10001.

**BAKE** New greaseless doughnuts in kitchen. Stores buy output. Start spare time. Profit 29¢ dozen. Small appliance. Free recipes. Montgomery, 3605 South 15th, Minneapolis 7, Minnesota.

**FREE** "Franchise Profit Letter" tells how unique NFR service is helping thousands seeking profitable businesses. Write today. National Franchise Reports, W-528, 333 North Michigan, Chicago 1.

**SECRETS!** Secrets! Mail order success revealed by internationally famous expert who discovered how to make home business fortunes. Beginners: Get free copy "How to Make Money in Mail Order." Discloses free advertising, profitable products, everything! No obligation. Write Mailco, 1554 Sepulveda, Dept. P-70C, Los Angeles 25.

**PACKAGE** At home for profit! We supply everything. No "selling." Free home business details. HPC 807HPP, Sunset, Los Angeles 12.

**FREE** Facts and descriptive bulletin. Be an air conditioning, refrigeration, and heating serviceman. High pay, jobs open everywhere, operate your own service business, no school or correspondence necessary. Write Doolco, Trouble Shooter, 2016 Canton, Dallas, Texas.

**\$70.00 WEEKLY**—home, spare time. Simplified mail bookkeeping. Immediate income, easy. Auditax, 34741a, Los Angeles 90034.

**MAKE** \$46 From square foot plywood; jigsaw necessary. Free details. Woodart, Bridgewater, Mass.

**EARN** Money raising fishworms for us! Write: Oakhaven-38, Cedar Hill, Texas.

**IMPORT-Export** opportunity, profitable world-wide, mailorder business from home, without capital; or travel abroad. We ship proven plan, for no risk examination. Experience unnecessary. Free details. Melinger, P70C, Los Angeles 90025.

**PIANO** Tuning learned quickly at home. Tremendous field! Musical knowledge unnecessary. Information free. Empire School of Piano Tuning, Box 327, Shenandoah Station, Miami, Florida 33145. (Founded 1935).

**400,000 BARGAINS** below wholesale! Many free. Liquidations, job lots, single samples. Free details. Bargainhunters Opportunities, Box 730-A, Holland, Michigan.

**MAKE** Money from old tires. Operators clearing \$400 weekly. Equipment costs \$800. Get facts. S & S Patents, Inc., 3511 N. Lincoln, Chicago 13.

**READ** Progressive Mailtrade, the magazine that tells how to make money by mail. Quarter brings sample and special offer. Mailtrade, P.O. Box 357, Sheboygan, Wis. 53082.

**COPUBLISH** "Mail Sale Advertiser," leading mailorder paper. Copy and details 25¢. Vanroy Shirk, Lebanon, Pa. 17042.

**MAILORDER** Catalogs. No inventory required. Discounts 40% up, postpaid. Send 25¢ for 32 page sample catalog, featuring 150 unusual, fast-moving products and complete details. Satisfaction guaranteed. Gaylords, North Adams 7, Mass.

**BIG** Money raising fishworms and crickets. Free literature. Carter Farms, Plains, Georgia.

**\$400.00 MONTHLY** Raising giant fishworms. Soilless method. Charlie Morgan, Bushnell, Florida.

**COLORGLAZED** Concrete pottery made without molds. Patented method. Cemetery products, novelties, tiles. Basement leak-sealing. Money-making projects. Booklet, details free. Men only. National Pottery Company, Grand Rapids, Minnesota.

**INVESTIGATE** Fires, storm damage, accidents for insurance companies, pays up to \$1,000 a month, part or full time. No college necessary. Car furnished; expenses paid. We train you at home in spare time. Keep present job until ready to switch. Pick your location. Men badly needed now. Full information free. Write Liberty School, Dept. C-510, 1139 W. Park, Libertyville, Illinois.

**PROFITABLE** Catalog Mailorder Business! Vikari's, 835-PM, First Avenue, Salt Lake City, Utah 84103.

**START** Your own business on credit. Your own boss. Hundreds of dealers making \$100 to \$300 and more weekly. We supply stocks, equipment on credit. 300 home necessities. Sales experience unnecessary. Pleasant, profitable business backed by world-wide industry. Write Rawleigh, Dept. L-U-PPM, Freeport, Ill.

**WORLD'S** Largest wholesale supply. Buy from 7853 American, European, Japanese wholesalers. Tailormade suits from Hongkong. 123 dropship catalogs. Rock-bottom prices. Free details. International Buyers, 216-MM Jackson, Chicago 6, Ill.

**PLASTERCRAFT** Molds, liquid rubber, plasters, rocks, candle supplies. Catalog and manual free. Blue Rapids Supply, Blue Rapids, Kansas.

**I MADE \$40,000.00** year by mailorder! Helped others make money! Start with \$10.00—Free proof. Torrey, Box 3566-Y, Oklahoma City, Oklahoma 73106.

**FREE** Book "990 Successful, Little-Known Businesses." Work home! Plymouth-872P, Brooklyn, New York 11218.

**WANT** To make big money at home? \$10.00 profit in an hour possible with invisible mending. Make tears, holes disappear from clothing, fabrics. Steady year-round demand from cleaners, laundries, homes. Details free. Fabricon, 1585 Howard, Chicago 26, Ill.

**BUILD** Custom cases at home for profit. Get orders by mail. We supply materials, instructions, everything. Free home business details. Customcase, 805CPF, Sunset, Los Angeles 12.

**FREE** Booklet! Profitable, spare-time business bronzing, PearlKoting baby shoes! Complete set-up on credit. Kiktavi, Box 34861-B, Los Angeles, California 90034.

**YOUR** Own home business, interesting, profitable, different. Details free. Richey, 441 East Main, Greenville, Ohio 45331.

**IMPORT-Export** business made easy. Complete setup service. Not just instructions. Hermes, 152 West 42, New York City 10036.

**MONEY** In your mailbox. Save time, money, disappointments. Informative manual. 25¢ refundable. Modern Methods, Box 1203, Boulevard 1, California.

**EXTRA** Money making plastic signs at home, free details. Napco, Box 23485-P, Los Angeles, Calif. 90023.

**ADDRESSERS** And mailers needed. Send stamp for information. Lindbloom, 1508 West Erie, Chicago, 60622.

**MAILORDER** Laws. \$2.00. Kalvin Kahn, Attorney, 4504-D Pine, Philadelphia, Pa.

**VENDING** Machines. No selling. Operate a route of coin machines and earn amazing profits. 32-page catalogue free. Parkway Machine Corporation, 715 PMB Ensor Street, Baltimore 2, Maryland.

**SELL** Books by mail. 400% profit. Royal, Box 450-X, Cleveland, Ohio 44127.

**PROFITABLE** Home business projects! Free details! Practical Publications, Box 187-A3, Newark, Ohio 43055.

**FREE!** 128 Page illustrated catalog. More than 2000 name Brand items; below wholesale prices. Sell full or part time. Save hundreds of dollars on purchases for yourself! Watches, jewelry, cameras, radios, phonographs, tape recorders, appliances, housewares, cookware, hardware, power tools, luggage, musical instruments, sporting goods, toys, many others. 8 floors of Name Brands. Orders shipped within 24 hours. Continuous supply. Send for free catalog now! H. B. Davis Corp., Dept. PM, 145 West 15th Street, New York, N.Y. 10011.

**START** Profitable mail order. Easy instruction manual. \$2.00. Fuss, 3611 Hudson Parkway, New York, 10463.

**MAIL** Multi-colored catalogs printed with your address for big profits! Details. Sample 25¢ (refundable). Specialties, Box 148, Ypsilanti, Michigan 48197.

**NEWSPAPERS.** Sawdust. Tin-Cans. 200 uses. Instructions. \$1.00. Charles Company, 42-GPR, Norwood, Ohio.

**EARN** Money at home in spare time repairing all appliances, do housewiring, motor rewinding, electrical maintenance. We show you how. send 8 trouble shooting instruments, business getting materials, etc. Write for free book. Pay later plan. Advance Trades School, Dept. E-503, 5944 Newark, Chicago 60631.

**ARNOLD** Palmer offers you unequalled opportunity to profit from tremendous popularity of golf and power of Palmer. Highly profitable exclusive Palmer Golf Franchises available. Complete national program. Hefty profits—minimum investment. Write for details. Arnold Palmer Enterprises, Dept. CR, Pleasantville, New Jersey. Tel. 609-646-3500.

**SELL** Uncle Sam! Depression proof home business buying Old Gold. Successful plan shows how. Details free. Patton, Dept. PM-125, Box 283, Arlington Heights, Illinois.

**LIQUID** Molding rubber, free information. Chaney's, 5415-A San Jose Blvd., Jacksonville 7, Fla

**ABUNDANT** Capital. Details free. Sullivan's, Box 20266-B, Denver, Colorado 80220.

**1000** EMBOSSED Business cards \$2.99. Agents wanted. Eldee, Allendale, N.J.

**\$25.00-\$100.00** WEEKLY Possible. Addressing envelopes. Compiling names. (Longhand—typewriter) Details free. Superior, Box 721-A, Elkton, Maryland 21921.

**MAKE** Excellent profits selling new Delta ignition system. See our ad under "Auto Supplies & Equipment." Write today for details.

**MAIL** Baby catalogs to new mothers! Profitable! Northland Enterprises, Rhineland 3, Wis.

**BOOK** Match mail order business! No Selling! Lifetime commissions! Details, \$2.00. The Robinson Co., 15468 Hiway 80, El Cajon, Calif. 92021.

**DIFFERENT!** Outstanding profits from high quality mailorder businesses. Complete setup services; not just instructions. Hermes Co., 152 West 42, New York City 10036.

**CONCRETE** Facts: Cement artists make big money at home. Simple equipment. Experience unnecessary. Copyrighted methods. Easy to make unlimited cement pottery designs, bird baths, wishing wells, rustic gardens, patio items, etc., without molds. Formulated, chemical coloring, marbled glazing. Free illustrated brochure. Hollywood Cementcraft, 602 Athens, Altadena, California 91001.

**WE** Search the World over for the unusual, so that you may have something different to sell. Details free. Chandler's, Dept. 3125, Wailuku, Hawaii 96793.

**ALL** Types of businesses coast to coast. Over 350 local offices to serve you. Call or write for new free "Business And Income Property Bulletin." United Farm Agency 612-PM West 47th St., Kansas City, Mo. 64112. PLaza 3-4212.

**HOW** To win success in mail order. \$2.25 postpaid. Books, 734 Eldred, Erie, Penna.

**AUTO** Glass tinting dealerships \$100.00. Applicator, \$600.00 tints. Box 3661, El Paso, Texas.

**EARN** While learning cake decorating, home business. Free details. Chase, Dept. P-2859 Sidney St., St. Louis, Mo. 63104.

**MANUFACTURE** Statuary, bookends, wall plaques, molds, imitation marble. Profitable full or part-time business. Free details. Marbleizing Company, Box 170, Edwardsville, Illinois 62025.

**MAILORDER** Business at home. No merchandise inventory. Proof. Casey's, Box 1314-PM, Hollywood, Fla.

**CAPITAL** For small business loans. Credit available. Free details. National Counselor, Harlingen 17, Texas.

**THE** Secret of repairing and selling water heaters and softeners. No competition. Details \$2.00. Rudy, Box 7468, Robbinsdale, Minn.

**WE** Need Ginseng growers! \$3,000-\$20,000 annually. \$1.00 brings seeds and information. Glass's Ginseng Exchange, P.O. Box 1969, Springfield, Mass.

**HOME** Operated mailorder business! Everything furnished! American, Box 166D, NYC 10459.

**LEARN** Importing, exporting, manufacturer's representation. Imports below wholesale. Your products advertised Free in seven languages. 130 countries. Benko, Box 188-A, New York, N.Y. 10021.

**MOTEL** Management—approved home study course. Free booklet =109. Motel-Hotel Careers, Encino, California 91317.

**EUREKA!** Mail baby catalogs to new mothers. Fabulous profits. Details, catalog 25¢. Mail-O-Vend, 4158 Greeby St., Phila., 19135.

**VACUUM** Form at home! Mold plastic products for big profit. Fabulous new machineryless method. Free facts. Nationwide Plastics, Box 23321-MN, Los Angeles 90023.

**WORLDWIDE** Merchandise free brochure. Pat. 270 East 60th Street, Hialeah, Florida 33012.

**SELL** By mail. Interesting, profitable. Start small, grow big. Spare time, at home. free literature. Froner, P.O. Box 1624, Eugene, Oregon.

**MAIL** Baby catalogs to new mothers for big profits! Details, catalog 25¢. Volz-PM, Ypsilanti, Michigan.

**BASEBALL** Pitching machines and netting for batting ranges, leagues, home practice. Ideal part-time or retired business. Allstar, 9025 Sepulveda Blvd., Sepulveda, Calif.

**M.M.O.S.** Special—offers mail order opportunities, big mail, 35¢. Mundy, 440 W. 34th, New York 1, N.Y.

**OPERATE** Home mailorder business. Vosacek Printing, 4444AI Ute, San Diego, Calif. 92117.

**PROFIT** With Popular Mechanics' subscription plan. No investment, no experience needed. Earnings begin immediately when you obtain subscription for Popular Mechanics, Good Housekeeping and others. High commissions, bonus. No experience needed. Deal directly with the publisher. Write Popular Mechanics, Room 12-B, 250 West 55th St., New York 19, N.Y.

## MONEYMAKING OPPORTUNITIES

**CIGARETTES.** Make 20 plain or filter-tips for 9¢. Factory-fresh pipe tobaccos. Mild tropical flavored Philippine cigars. Facts free. Moberly, Box 904, Owensboro, Kentucky.

**EARN** \$240.00 a month at home, spare time, doing only two \$5.00 invisible mending jobs a day. Big money paid for service that makes cuts, tears disappear from fabrics. Steady demand. Details free. Fabricon, 1532 Howard, Chicago 26, Ill.

**BIG** Money raising fishworms and crickets. Free literature. Carter Hatchery, Plains, Georgia.

**NEW** Instant invisible mending. Learn in one hour, repair in five minutes. Make \$150.00 week. Literature free. Henson, P.O. Box 6136-6, Philadelphia, Pa. 19115.

**HOT** Money making line! Show line of business printing, advertising specialties, calendars. Watch orders pour in. All repeat items. Terrific commissions in full or spare time. No experience, no investment. Cash discounts to customers. Free bonus gifts to you. Free sales kits. Willens-David Lionel Press, Dept. W-27, Waukegan, Illinois.

**AMAZING** Successes through franchises! Become exclusive franchise holder your territory. Information rushed. National Franchise Reports, WP-528, 333 North Michigan, Chicago 1.

**MAKE** Plastic novelties for extra income. Low cost home training now available. Write for free booklet. Interstate Training Service, Dept. D-3, Portland 12, Oregon.

**WORK** Home, part-time, mailing our catalogs! Free details! Cam Company, Dept. 53, Verona, N.J. 07044.

**EARN** Big commissions full or part time. Show America's largest line low priced business printing and advertising specialties. Calendars in seasons. Big free sales kit samples hundreds items used daily by business people. Build profitable repeat business. Start right now. National Press, Dept. 19, North Chicago, Illinois.

**EASY** To start rubber stamp business at home in spare time. Make up to \$9.80 an hour without experience. Facts free. Write Roberts, 1512 Jarvis, Room CR-2-LW, Chicago 26.

**MEN** — Women! Start money-making plastic laminating business at home in spare time. Material that costs 11¢ brings back \$2.58. No canvassing or selling but mail orders bring in \$20 a day. Write for full particulars free. Rush name on postcard to Warner, Room CL-2-LW, 1512 Jarvis, Chicago 26, Ill.

**SHARP** \$\$\$ Opportunity! One low-cost machine sharpens—serrates knives, scissors pinking shears. Earn \$6-\$9 hourly in spare time. Professional results without experience. Free details. Beaver Machine, Box 121, Gardena, California.

**MAKE** Money writing short paragraphs! No tedious study! I tell you what to write, where and how to sell, and supply list of editors buying from beginners. Many small checks add up quickly. Write to sell, right away. Send for free facts. Benson Barrett, Dept. C-27-HA, 6216 No. Clark, Chicago 26.



**RAISE** Rabbits and fishworms on \$500 month plan. Free details. White's Rabbitry, Mt. Vernon, Ohio.

**CLIP** Items from daily newspapers. Get \$1.00 to \$5.00 each. Details free. Walter, Box 1023-P, Erie, Penna.

**FREE** Literature! Planned profits, all ages. Postal okay: Aladdin Research, Box 5183-L, Oakland, California 94605.

**WIN** Cold cash! Prizewinner sizzles with terrific contests, torrid tips, impertinence! Free sample! Box 11569, St. Petersburg, Fla.

**"NEW BOOKS"**. 80 ways to make extra money by mail. Lee, Box 252-P, Goleta, California.

**LEARN** The secrets of repairing junk batteries. "Fabulous Profits" at home. Details. The Batteryman, P.O. Box 416, Palm Desert, Calif.

**TYPISTS!** Typists! Typists! Work home. Steady income, Hamilton, Box 4-A, Astoria 5, N.Y.

**START** Your own home mailorder business, sparetime! Easy; fascinating; profitable! Alfano, 19-PM, Pine, Closter, New Jersey 07624.

**MEN—Women!** Sparetime opportunity. Secretarial homework. Refundable instructions, \$1.00. Interstate, 37 Besch, Albany, New York 12209.

**HAVE** Your own good paying, money-making business! Full, sparetime. Particulars free! Ashe's, Box 62-PM, Elmhurst, New York 11373.

**\$200.00 FROM** Sheet of plywood, 25¢ refundable. Novelties, 610 So. 24th, Elwood, Indiana.

**BOOKKEEPERS** Operate bookkeeping tax service. Universal, Box 664-M, Springfield, Missouri.

**SEASHELLS**. Shellcraft and jewelry supplies. Wholesale catalog 25¢, refunded first order. Our 31st year. Florida Supply House, Box 847M, Bradenton, Fla.

**BOOKS**, Folios, for homeworkers, hobbyists, writers. Ralph Underhill, Beebe, Arkansas 72012.

**"TYPING For Profit!"** Instruction manual, \$1.00. Satisfaction guaranteed. E-Liu Company, Box 4759, Chicago 60680.

**MOBILE** Home roof coatings. Guaranteed not to leak. Dealers needed. Aluminum Industries, Dept. PC-115, Kansas City 11, Missouri.

**VENDING** Machines. No selling. Operate a route of coin machines and earn amazing profits. 32-page catalogue free. Parkway Machine Corporation, 715 PMM Ensor Street, Baltimore 2, Maryland.

**DISC-JOCKEY**—\$10,000/year. Home Study. Box 3364, Anaheim, California.

**\$25.00—\$75.00 WEEKLY** Possible. Clipping Newspaper items. Complete instructions. \$1.00. Harvey's, Box 692, Elkton, Maryland 21921.

**INVEST** In coins, Fantastic Profits. Free details. Suburban Coin, 607-H Mesquite, Corpus Christi, Texas.

**WEAVE** Rugs, make good profits. No experience necessary! Free catalog, sample card, and low prices on carpet warp, rug filler, looms, parts, inexpensive beam counter. If you have loom—advise make, weaving width please. OR. Rug Company, Dept. X592, Lima, Ohio.

**JEWELRYCRAFT** For fun or profit! Details free! Write: Modern Craft, Box 3614-R, Cranston, R.I. 02910.

**YOU** Can become foreman, superintendent or general manager where you work; make more money! Instruction booklet, \$1.00. Ernmarr, Clermont, Florida 32711.

**DOLLAR** Ad agency. "200 Week Plan." Work home. Free details. Ad Market, Harlingen 4, Texas.

**BIG** Money raising Africans Brownose soilless method. Three Oaks Ranch, Dresden, Tenn.

**MAKE** \$5,000 Yearly spare time, raising mink, chinchilla, nutria, etc. Free booklet reveals proven plan. Write: Furs, Dept. E, Bewdly, Ontario, Canada.

**EARN** Big money fast! Take easy orders for Dwarf, Semi-Dwarf, Standard fruit trees, roses, ornamentals, \$1,000 profit in 60 days possible. World's oldest, largest nursery. Spectacular full-color selling outfit free. No investment. Stark, Desk 30166, Louisiana, Missouri 63353.

**HOBBYCRAFT** Supplies wholesale! Illustrated catalogue, 25¢. Paces, Box 279, Bradenton, Florida.

**BE** A radio announcer. Send for list, "500 U.S. radio stations hiring people with little or no experience." Only \$1.00. Command Productions, 1943 N.W. Irving, Portland, Oregon.

**1001 MONEYMAKING** Sources. Free literature. Columbus, 719 East Pike, Seattle, 98122.

**EARN** Money evenings, copying and duplicating comic cartoons for advertisers. Adservice, Argyle-1, Wisconsin.

## PROFITABLE OCCUPATIONS

**AUCTIONEERING**—Resident and home study courses. Auction School, Ft. Smith, Ark.

**VENDING** Machines. No selling. Operate a route of coin machines and earn amazing profits. 32-page catalogue free. Parkway Machine Corporation, 715 PMP Ensor Street, Baltimore 2, Maryland.

**INVESTIGATE** Accidents. Earn \$750 to \$1,400 monthly. Car furnished. Expenses paid. No selling. No college education necessary. Pick own job location. Investigate full time. Or earn \$8.44 hour spare time. Men urgently needed now. Write for Free Literature. No obligation. Universal, CPM-12, 6801 Hillcrest, Dallas 5, Texas.

**BECOME** Independent with your own franchise business. Thousands earning handsome incomes. Request interesting facts today. National Franchise Reports, PM-528, 333 North Michigan, Chicago 1.

**MAKE** Money writing short paragraphs. Information free. Barrett, Dept. C-27-HB, 6216 N. Clark, Chicago 26.

**CHROME** Plating. Instructions, equipment and supplies. Platers' Supply, P.O. Box 565, Lugo Station, Los Angeles, Calif.

**SHARPEN**—Scissors, pinkers. Inexpensive equipment, tools, supplies. Blackhawk's, Sheldahl, Iowa.

**FREE** Book "990 Successful. Little-Known Businesses." Work home! Plymouth-87P, Brooklyn, New York 11218.

**POLAROID** Camera owners! Earn immediate cash! Instructions, 25¢. Carstens, 406-PM South Second Street, Alhambra, California 91802.

**YOUR** Own sign shop—Signs, 1017 W. Mulberry, Springfield, Ohio.

**BAKE** New greaseless doughnuts in kitchen Sell stores. Free recipes. Michael, 3605 South 15th, Minneapolis 7, Minn.

**BIG** Money raising fishworms and crickets. Free literature. Carter Wormery, Plains, Georgia.

**RAISE** Pheasants on \$100 week plan. Little capital and space can make you independent. Free details. Great Central System, Columbus 1, Kansas.

**EARN** \$240.00 A month at home, spare time, doing only two \$5.00 invisible mending jobs a day. Big money paid for service that makes cuts, tears disappear from fabrics. Steady demand. Details free Fabricon, 1586 Howard, Chicago 26, Ill.

## SALESMEN—DISTRIBUTORS

**FREE** To salesman, descriptions and pictures 200 new, fast sellers for spare time cash or side line profits. No charge. Just send name, age, for sample copy Opportunity Magazine, 850 N. Dearborn, Dept. 17-G, Chicago, Ill. 60610.

**EARN** Extra money selling advertising book matches. Sample kit furnished. Matchcorp, Dept. PM-125, Chicago, Illinois 60632.

**SELL** Advertising book matches. Write us today, we put you in business by return mail; handling complete line ad book matches in demand by every business right in your town! No investment; everything furnished free! Top commissions daily. Superior Match, Dept. M-1265, 7530 S. Greenwood, Chicago 19, Illinois.

**ASTONISHING** Automatic toilet bowl cleaner, deodorizer. Works when toilet is flushed. Housewives buy on sight for every bathroom, at only \$1.98 each. Make up to \$10.00 in hour, spare time. Free sales kit. Merlite, 114 East 32nd, Dept. G71S, New York 16.

**HOT** Money making line! Show line of business printing, advertising specialties, calendars. Watch orders pour in. All repeat items. Terrific commissions in full or spare time. No experience. No investment. Cash discounts to customers. Free bonus gifts to you. Free sales kits. Willens-David Lionel Press, Dept. W-28, Waukegan, Illinois.

**BIG** profits selling automotive specialties to service stations, garages. Free wholesale price list. Inka Industries, 2401 Crocker, Houston, Texas 77006.

**LEARN** To sell the Holy Bible. We teach you how. For attractive profits, deal direct with publisher of 22 editions. Write Department PM, Bible Publishers, Box 5065, San Antonio, Texas 78201.

**\$1,000.00** a month for making dramatic 3-second demonstration of amazing Lightweight Presto Fire Extinguisher. New chemical used by Airforce snuffs out fires instantly. Only \$4.95. Terrific commissions. Millions want it. Free Kit. Merlite, 114 E. 32nd, Dept. P-66S, New York 16.

**SENSATIONAL** New longer-burning light bulb. Amazing free replacement guarantee—never again buy light bulbs. No competition. Multi-million dollar market yours alone. Make small fortune even spare time. Incredibly quick sales. Free sales kit. Merlite (Bulb Div.), 114 E. 32nd, Dept. C-73S, New York 16.

**\$1000.00** A Month. Show home owners how to save \$100.00 with 30 second demonstration of amazing Fuel Oil Activator. P.O. Box 15, N.Y., N.Y. 10003.

**QUALITY**—Swiss electric razors will sell on sight. Excellent profits, details—Reddy, 58 Oak St., Boston, Mass. 02136.

**NEGRO** People buy on sight. 100% profit. Nationally advertised cosmetics. Free sample offer. Valmor, Dept. HD, 2411 Prairie, Chicago 16.

**\$17,000 PLUS** New car as bonus for man over 40 in your area. Take short auto trips to contact customers. Write J. B. Dickerson, Pres., Southwestern Petroleum Corp., 534 N. Main, Ft. Worth 1, Texas.

**LONG** Needed invention. Man to contact service stations. Huge profits. Cyclo Mfg., 3816 Dahlia, Dept. 100, Denver, Colo.

**EARN** Big commissions full or part time. Show America's largest line low priced business printing and advertising specialties. Calendars in season. Big free sales kit samples hundred items used daily by business people. Build profitable repeat business. Start right now. National Press, Dept. 18, North Chicago, Illinois.

## AGENTS WANTED

**AMERICA'S** Biggest value wedding line! Big 40% profit showing wedding invitations and over 50 exciting accessory items. Ideal sideline for Christmas card, printing salesmen. Write for free display album. Elmcraft, Dept. EW-161, 7201 S. Cicero, Chicago, Illinois 60629.

**RAISE** Rabbits for us on \$500 month plan. Free details. White's Rabbitry, Mt. Vernon, Ohio.

**MAKE** Up to \$50.00 daily soliciting delinquent accounts. Terrific commissions. General Finance Co., Dept. LG-78, Pickwick Bldg., Kansas City, Mo. 64106.

**PRINTING.** Advertising salesmen—Excellent moneymaking sideline selling decalcomania name plates, small quantities. Automobile initials, sign letters. Free samples. Ralco, XL, Boston 19, Mass.

**YOUR** Own business—Used suits \$1.50; overcoats 65¢; mackinaws 35¢; shoes 12½¢; ladies coats 30¢; dresses 15¢. Enormous profits. Catalog free. Nathan Portnoy Associates, 2109-AA Roosevelt Road, Chicago 8, Ill.

**START** A business of your own selling Hertel Bibles. Full or part time. Age no handicap. For details write Ray Rush, Box 118P, Wichita, Kansas.

**IMPORTED** Original oil paintings, unbelievable low prices. Free brochure and details. Bavaria Co., Box 873, Detroit Lakes, Minn.

**AGENTS—300%** Profit selling genuine gold window letters; stores and offices. Free samples. Metallic Sign Letter Co., 1217-D West Newport, Chicago.

**ESTABLISH** Your own business. Low prices on used clothing, shoes, household goods. Unlimited profits. Free catalog. Northwestern Distributors, 2129 No. Western Avenue, Chicago, Illinois 60647.

## EMPLOYMENT INFORMATION

**FOREIGN** Employment. Construction, other work projects. Good paying overseas jobs with extras, travel expenses. Write only, Foreign Service Bureau, Dept. PM, Bradenton Beach, Florida.

**FOREIGN** Employment: South America, Africa, Europe, Australia, USA. Earnings to \$2,000.00 monthly. Construction, all trades, professions, occupations. Many companies pay fare, housing, benefits, bonuses. Write: Universal, Dept. A-2, Woodbridge, Connecticut 06525.

**DIRECTORY** Reports. Construction, aviation, shipping, oilfields, government, manufacturing, trucking, etc. foreign—stateside. Helpful information plus job-getting tips on preparing application letters. Unconditional money-back guarantee. Only \$3.00 (\$3.25 airmail) Research Services, Box 6768-PM, St. Louis, Missouri 63144.

**TREMENDOUS** Opportunities U.S.A.—Overseas. Choose jobs—locations—transportation. Free details. Occupations, International Airport, Box 100-C20, Jamaica 30, N.Y.

**BOOMING** Australia needs your skills! Government assisted passage. Details \$2.00. Irv Heyer, 2913 Chestnut, Costa Mesa, Calif.

**TREMENDOUS** Job opportunities. Foreign-U.S.A., construction, trucking, manufacturing, Government shipping, thousands more. Up to \$2,000.00 monthly! Money-back guarantee. Directory plus sample application form. Send only \$1.00 (\$1.25 Air Mail). Worldwide Opportunities, Box 730-A, Holland, Michigan.

## HELP WANTED

**MAKE** \$10 Hour at home Instructions and supplies 50¢ (refundable). American Company, 50th Department, 26 Jeannette, Belmont, Mass.

**APPLIANCE** Service men: National service company specializing in commercial gas equipment has openings—Boston, Chicago, Detroit, Philadelphia, Wash., D.C. for men with experience or mechanical aptitude. Permanent position, good opportunity. Gas Consumers Service, 103 Park Avenue, New York, N.Y. 10017.

**MAKE** \$280.00 getting just 10 growers to try Campbell's Plant Food. Sample free. Campbell, Rochelle 24, Illinois.

## FARMS—REAL ESTATE

**CANADIAN** Land, priced from \$4.00 an acre! Acquired through estate liquidations. Title guarantee, no mortgage, small monthly payments. Our lists describe finest properties in Canada. Best hunting, fishing locations, ideal for camps, cottages. Invest in Canada's minerals, farms and forests. Free descriptive booklet. Canadian Estate Land, 2788-P Bathurst Street, Toronto, Canada.

**CANADIAN** Vacation lands: Full price \$385.00, 40 acres, \$10 month. Suitable cottage sites, hunting, fishing, investment. Free information. Land Corporation, 3768-C Bathurst, Downsview, Ontario, Canada.

**GOVERNMENT** Lands low as \$1.00 Acre! Millions acres throughout U.S. Free details! Land Division, Box 26034-PL, Indianapolis, Indiana 46226.

**CANADIAN** Lands, seized and sold for taxes. Our 48th annual series of lists, describe many choice properties, situated from coast to coast, acquired by us through tax sale. Priced as low as five dollars per acre, guaranteed perfect title, small monthly payments, no mortgage. Beautifully situated hunting and fishing camps, where there is real sport; summer cottage sites, heavily wooded acreages. Now is the time to invest in Canada's minerals, forests and farms. Write today for free twenty page booklet with full explanation. Tax Sale Service, Room 301-D, 85 Bloor St., E., Toronto 5, Canada.

**400,000,000 ACRES** Government public land in 25 states. Some low as \$1.00 acre, 1965 report. Send \$1.00 National Land, 422PM12, Washington Building, Washington, D. C.

**FLORIDA** Campsites—deep in the heart of the great Ocala National Forest. Good hunting and fishing. Free maps and photos. Howard Vernor, DeLand, Florida, AD646369D

**FREE** Fall-winter catalog! Bargains galore! Coast-to-Coast! Low prices, easy down payments! Safe-Buy Real Estate Agency, 712-PM West Third, Little Rock, Ark. (Please include Zip Code)

**FREE!** 152-page real estate catalog! Over 1700 pictures! Farms, ranches, homes, businesses, vacation and retirement properties in 28 states coast to coast! United Farm Agency, 612-PM West 47th St., Kansas City, Mo. 64112. PLaza 3-4212.

**"CAL-ORE** Ranches" in Oregon's Rogue River Valley near Medford and Grants Pass. \$2995 to \$5995. Pay \$150 down, \$35 monthly. Free catalog. Cal-Ore Ranches, 1054PM South Riverside, Medford, Oregon.

**\$1 ACRE—Canadian** border—hundreds campsites, islands, farmlands, directly from tax authorities. (Non-profit). Lists, photographs mailed. Register, Room 203, 92 King St., E., Toronto 1, Canada.

**THE** Only "No-Risk Land Purchase Plan" in America—10 year money back guarantee on any Vacation, Retirement, or Investment homestead in Boiling Spring Lakes, the multi-million, 14,000-acre development on the Carolina Coast. All facilities, electricity, roads, shopping center, motel, golf course, country club, already in. Private ocean beach. ½-acre homesteads as low as \$435.00; \$5.00 down. Write for free literature. Boiling Spring Lakes, Southport 1-M, North Carolina 28461.

**CALIFORNIA** Land for investment. Virgin, undeveloped property still available inexpensively. Write: Sunset Valley, Department V-1, Box 48333, Los Angeles 48, Calif., for details.

**FLORIDA'S** Greatest homestead value. High, dry ¼ acre site, \$495. No money down. \$10 monthly, free photos. Write Dept. AI-12 Rainbow Park, Box 521, Ocala, Florida (AD-56067)

**ABANDONED** Timber Leaselands! Choice 640 acre Sportsmen's paradises still available—\$20.00 plus \$6.50 Taxes yearly. Maps, pictures, \$1.00 (Refundable). Director, Erindale 4, Ontario, Canada.

## FARM AND GARDEN EQUIPMENT

**YOUR** Ad in this space will be read by more than 1,400,000 active mail order buyers. Join the march to greater profits, place your products and services in front of them today with a small low cost classified ad. For further details, write: C. A. Martin, Dept. 43N, Popular Mechanics, 575 Lexington Avenue, New York, New York 10022.



## PLANTS AND NURSERY SUPPLIES

**WANT** Greatest cash crop working for you? Write Ginseng, Asheville 53, N. C.

## HOME CRAFTSMEN

**2512 PLANS.** Patterns, things to make, do. Fun. Profit. World's greatest selection. New catalog 10¢. Craftplans, 18250-A Harwood, Homewood, Ill.

**FREE** "Do-it-yourself" Leathercraft Catalog. Tandy Leather Company, 1001 Foch—Dept. H55, Fort Worth, Texas 76107.

**101 PATTERNS** Of smart gifts, novelties, shelves, action windmills plus "Make Money Jig Sawing." \$1.00. Mastercraft, 125M, 7041 Olcott, Chicago 60631.

**FREE!** Big 80 page Leathercraft catalog. 100's of new items! MacPherson Bros., Dept. K, 730 Mission St., San Francisco, Calif. 94103.

**SKIL-CRAFTS** New '65-66 catalog. Largest and finest selection of leathercraft, artist, hobby-craft supplies in the world. Free gift with first order. Send 50¢. Refundable with first order. Skil-Crafts, Box 105-P, Joplin, Missouri.

**PLANS.** Bird houses, feeders. Ready built houses and feeder. Illustrated catalog, 25¢ coin. Yeager, 1665 Linden, Homewood, Ill. 60430.

**WOODWORKING** Catalog and manual, 25¢. Plus free "101 Project Ideas." World's most beautiful veneers, lumber, plywood! Wood finishing, upholstery supplies. Furniture hardware, 2,000 needed workshop products. Constantine, 2051-T Eastchester Road, Bronx 10461.

**WALNUT,** Cherry, silver maple, gum stocks, squares lumber, picture frame moulding. Midland Lumber Company, Box 262, Savannah, Missouri.

**ROADSIDE** Business—6 plans—fast selling lawn furniture. \$1.00. Lafayette House, Box 434, Hampton, N.H. Dept. PM12.

**TRANSLUCENT** Plastic drawing board, 2 transparent plastic triangles, 2 retractable metal straight edges, only \$5.45 postpaid. Money Back Guarantee. Bonnie Lee Gifts, Box 17383, Dallas, Texas 75217.

**RESILVER** Old mirrors or make new ones. Kit #2 contains liberal amounts three solutions with simple instructions. \$4.95 ppd. Roccon Scientific Co., P.O. Box 778, Grand Prairie, Texas.

**HOBBYISTS** Electroplating kit, \$3.95 Postpaid. Details. Miniplating, Box 115, Mansfield, Mass.

**WOODWORKERS** — Home craftsmen! Catalog containing lamp parts, veneers, lazy susan bearings, Swiss movements, chair cane, folding metal legs, wooden legs, mouldings, furniture hardware, finishing materials, etc., only 15¢. Barap Specialties, Box 2044-DG, Chicago 60609.

**PLANS** for pool table with extra two-face top for table tennis and model railroad. Blueprints B1209 and building instructions \$3.50. Popular Mechanics Service Bureau, 575-M Lexington Ave., New York, N.Y. 10022.

## DO-IT-YOURSELF

**ORNAMENTAL Iron:** Direct from factory to you at wholesale prices, install yourself and save. Duley Steel Products, P.O. Box 351, Dexter, Mo. 63841.

**SAVE** On plumbing bills. Fully illustrated book. Covers repairs, stoppages and installations. Saves owner hundreds of dollars. Only \$2.00. Satisfaction guaranteed. Rex Publications, Box 3, Sunland, California.

**BUILD A** dependable pressure washer for cars & trucks. Send \$2.00 for details. Deco Mfg., Iowa Falls, Ia. 50126.

**FROM** The black forest of Germany! Unique do-it-yourself clock kit. A famous black forest clock comes with easy assembling instructions. Send \$4.95 to World-Wide Enterprises, Drawer #90, Southern Pines, North Carolina 28387. Money back if not satisfied.

**AUTOMATIC** Washer repair manuals for: Frigidaire, General Electric, Hamilton, Hotpoint, Kelvinator, Kenmore, Norge, RCA Whirlpool, Speed Queen, Westinghouse. \$2.50 ea. PPD. Refrigeration parts catalog, 50¢. Major Appliance, 13106 Caine Ave. (Dept. M), Cleveland 5, Ohio.

**FLUORESCENT** Tubes rejuvenated at no cost. Instructions \$1.00. Rejuvenators, 172 Bolton St., Portland, Me.

**EXERCISE** At home on build-it-yourself physical fitness equipment, including bicycle exerciser, rowing machine, belt massager, and abdominal board. Send \$2.50 for blueprints B1208 and instructions. Popular Mechanics Service Bureau, 575-K Lexington Ave., New York, N.Y. 10022.

**FREE** Check-list covering more than 300 classifications of projects, plans, instructions, service and repair information detailed in Popular Mechanics famous series of instructional booklets, books, patterns, and blueprints. List covers an extremely wide variety of do-it-yourself data on home remodeling, repair and improvement, hobbies, crafts, boating, games, lawn and garden, and hundreds of others. For your free copy of this helpful list, write: Service Bureau, Popular Mechanics, 575 Lexington Ave., New York 22, New York.

## ARTS AND CRAFTS

**MAKE** Figurines, plaques, lawn ornaments. Molds, plastercraft kits, liquid rubber. Sample and catalogue 10¢. Woolley Company, Box 29-B, Peoria, Illinois.

## BINOCULARS, TELESCOPES, MICROSCOPES, MAGNIFIERS

**BINOCULARS** Direct from manufacturer. Finest quality, tremendous savings! Request catalog, Koyu, 3860 Crenshaw Blvd., Los Angeles, Calif.

**BUILD** Your own reflector telescopes; complete kits: Mirrors, eyepieces, tripods. All other accessories, request free illustrated literature. Criterion Manufacturing, Dept. KPM-32, Hartford, Connecticut.

**BINOCULAR** Sale! Free color catalog 100 models \$9.95-\$250.00. Write, United, 9043 So. Western BCAT- 5908, Chicago 60620.

**ZEISS** Type 7 x 50 precision binoculars. Rush \$16.95. Gift Hunter, 35-20 24 St., Long Island City, N.Y. 11106.

**BUILD** Your own reflector telescopes: Complete kits: mirrors, eyepiece, tripods. Free catalog F describing other accessories sent on request. Also free brochure describing amazing line, world famous "Dyroscope" reflector telescopes. Criterion Manufacturing, Dept. KPM 33; Hartford, Connecticut.

**SCIENCE** Bargains! Lenses, telescopes, binoculars, microscopes, kits, parts, war surplus. Send \$1.00 for beginner's 10-lens kit with instruction booklet. Order Stock 2-CH. Request free 148 page Catalog CH. Edmund Scientific Co., Barrington, New Jersey



## CAMERAS AND EQUIPMENT

**PHOTOSTAT** Machine, model 4 continuous lights, 21" lens prism, dryer, etc., \$500.00. Nationwide Design & Drafting Corp., 3548 S. Grand, St. Louis, Missouri.

## PHOTO SUPPLIES

**TELL** The more than 1,400,000 avid readers of Popular Mechanics about your products and services. It costs very little to place your classified message in front of these proven mail order buyers. For further details, write: C. A. Martin, Dept. 50N, Popular Mechanics, 575 Lexington Avenue, New York, New York 10022.

## PHOTO FINISHING

A **FREE** Kodak roll returned with each black and white or Kodacolor developed and printed, fast service, lowest prices, guaranteed quality send for free mailers. Economy Photo Service, Dept. P. M., Box 1111, Albany 1, N.Y.

**FAST.** Hi-quality finishing. Kodacolor rolls: eight jumbo prints \$1.98. Twelve \$2.49. Twenty \$3.49. Reprints 15¢. Also low B&W prices. Custom Quality Studio, Box 4838-PM, Chicago 60680.

**BLACK.** Color films process. For \$1.00. 4x5 and 5x7 for \$1.00 each. Henry Turner, 520 Cleveland Ave., Schenectady, New York.

**COLOR** Movie Fans! 8 MM expertly processed for just \$3.10 including fresh Kodachrome film. All mailed back next day First Class. Craftsmanship guaranteed. Send exposed reel or request Free Mailers and Price List of complete services. Direct Mail Photo, Box 8352-PM, Pittsburgh, Pa. 15218.

## COLOR SLIDES

**NEW YORK** World's Fair, 1964 exclusive set 100 35mm, 2"x2" color slides. \$14.99 plus 28¢ postage. Biggest selection high quality slides available anywhere. Catalog free. Blackhawk Films, 423 Eastin-Phelan Bldg., Davenport, Iowa 52805.

**TRANSPARENCIES** Wanted! Learn free-lancing. American Color, Box 46372, Hollywood, California.

**NEW!** Hilarious comic title slides. Send dime for list. (Deductible first order). Colonial, 247A, Swarthmore, Pa.

## MOTION PICTURES AND SOUND EQUIPMENT

**16MM** Sound films features and shorts. Bedner, 5300 So. Talman, Chicago.

**8MM MOVIES.** 2"x2" Color Slides—biggest selection anywhere! World's Fair, railroad, antique automobiles, circus, World War II, Hollywood classics, travel, wild life and many others. 16mm, new, used films also. Big Blackhawk catalog free. Blackhawk Films, 424 Eastin-Phelan Bldg., Davenport, Iowa 52805.

**FREE** Catalog! Save on 8/mm.-16mm. film and supplies. Superior, 448 N. Wells, Chicago 10.

**CAPTURED** Nazi film. Guaranteed authentic. Sample 50¢. Sanford, Fairview, Pennsylvania.

**16MM** sound-projectors, films, new, used for sale. Free catalog, National Cinema, 71 Dey Street, New York City, N.Y.

**16MM** SOUND Shorts, cartoons, features. Cinemax Films, 10134 Perry Ave., Chicago, Ill. 60628.

**MOVIE** Film! Free catalog! ESO-R, 47th Holly, Kansas City 12, Missouri.

**16MM—Sound—silent—features—shorts—lists.** Free, send 10¢. Minot Films, Inc., Milbridge, Maine.

**HART** Industries buys used 8mm movies! 467 Parke, Birmingham, Michigan 48009.

**25 PAGES** 16MM Movie Bargains. Surprise Reel 1200', \$6.50. Gaines (PM) 14544 Vanowen. Van Nuys, Calif. 91405.

**8MM SPECIAL** Offer: 50' Old time comedies, cartoons, hunting, fishing, travel, \$1.25 each. Send \$5.00 for 5. Movieland, 6039-M Hollywood Blvd., Hollywood, Calif.

**5,000** 8-16 MM. Movie films. Free catalogues. International, Greenvale, N.Y.

## RADIO, TELEVISION AND HAM EQUIPMENT

**33¢** RADIO & TV tubes. Free list. Cornell, 4213-17 University, San Diego 5, California.

**GOVERNMENT** Surplus electronics, infra-red equipment. Catalog 20¢. Meshna, Nahant, Mass.

**BRAND** New tubes. World's lowest prices on radio, TV-industrial, special purpose tubes. Write for free parts catalog. United Radio, Newark, N.J.

**ALLWAVE** Radio Kit shortwave police etc. Tube and transistor included \$3.00. Headphones \$2.00. Ekeradio, Box 131, Temple City, Calif. Free information.

**FREE** 148-Page electronics catalog. Big 43rd Anniversary edition! Thousands of astounding buys on stereo hi-fi components, shortwave, citizens band, tape recorders, radios, parts, kits, everything you need at "wholesale low" prices. Write: Radio Shack, Box PM-12, 2727 W. 7th, Ft. Worth, Texas.

**KIT'S.** Diode radio \$1.25, transistor radio \$2.95, wireless transmitter \$3.95. Lectronix, Box 42, Madison Heights, Michigan 48071.

**HEADPHONES.** With soft foam earpads, easy adjustable head band. Send \$3.00 postage paid. Textape Co., 2601 Louise, Santa Ana, Calif.

**TIRED** Of TV commercials? Attach no gab. Control audio—video undisturbed. \$2.89 prepaid, money back guarantee. Pico Sales Co., 9040 W. Pico, Los Angeles, Calif. 90035.

**WORLD'S** Finest radios. Free catalog. Mini-tronics, 12513, 1983 Via Del Rio, Corona, California 91720.

**CITIZENS** Band catalog. All major brands and accessories. 10¢. Dealer inquiries invited. Knox Electronic, Dept. PM21, Galesburg, Ill. 61401.

## HIFI, RECORDS AND ELECTRONICS

**RECORDS!** Discounts on all LP's. Free details. Citadel Record Club, 545 Fifth Ave., Dept. 2, New York 17, N.Y.

**TAPE** Recorders, hi-fi components. Sleep learning equipment, tapes. Unusual values. Free catalog. Dressner, 1523 Jericho Tpke., New Hyde Park 3, N.Y.

**EXCLUSIVE** Free catalogue; extraordinary hard to find hobby party records. Record Suppliers, 300 Chelsea, Louisville, Kentucky 40207.

**FREE—Free—Free—Free—Free—Free—Free.** Send in for your Free one year subscription to Olson Electronics' fantastic value packed catalog, unheard of low, low prices on brand name speakers, changers, tubes, tools, stereo amplifiers, tuners, CB and other values. Credit plan available. If you have a friend interested in electronics send his name and address for a Free subscription also. Olson Electronics, Inc., 438 S. Forge St., Akron, Ohio 44308.

**NEW Mfrs B.S.R. record changers, UA15** model with stereo cartridge \$13 each. Parts guaranteed or units exchanged. Quantity discount. Changers, Box 144 Jerome Ave. Sta., Bronx N.Y. 10468.

**STEREO Tapes.** Save up to 60% (no membership fees, postpaid anywhere USA). Free 60-page catalog. We discount batteries, recorders, tape accessories. Beware of slogans "not undersold," as the discount information you supply our competitor is usually reported to the factory. Saxitone, 1776 Columbia Road, Washington, D.C. 20009.

**RECORD Cleaning, anti-static kit, \$2.00.** Fred Wortman, 8419 Oak, Kansas City, Missouri 64114.

**AMAZING** And truly different! Thirty great three minute stories on two long play albums. Each story a revealing wierd shocker! Be the life of the party—startle your friends. Ask for strange truths. Send \$3.98 to World-Wide Enterprises, Drawer #90, Southern Pines, North Carolina 28387. Money back if not satisfied.

**PROTECT Your records!** Two cleaning cloths, \$1.00. Towers, Lafayette Hill, Pa. 19444.

**McGee Radio Company.** Big 1966 catalog sent free. America's best values, hi-fi—amplifiers, speakers, electronic parts. Send name, address and zip code number to McGee Radio Company, 1901 McGee St., Dept. PM, Kansas City, Missouri 64108.



## **MUSIC AND MUSICAL INSTRUMENTS**

**POEMS** Wanted for new songs and records. Send poems. Five Star Music, 6M Beacon, Boston 8, Mass.

**GUITARS, \$11.95.** Electric double pickups with tremelo bar, \$49.95. Accordions, \$125.00. Concertinas, \$350.00. Drums pearl set, \$99.00. Wind instruments, \$39.95. Free catalogs. Melody Music, 4951 W. 95th St., Oaklawn, Ill.

**SONG** Ideas wanted. Write with active professional songwriters with publisher contacts. Records made. Share royalties. Send ideas—free examination. Songwriters' Associates, 236 W. 55th, N.Y. 19-P.

**ELECTRIC** Guitar kits, patterns, parts. Send 25¢. Kits, 3526 California, Peoria, Illinois.

**USED** Professional guitar, amplifiers, drums. Send 25¢. Hills, 3526 California, Peoria, Illinois.

**INCOME** Guaranteed two years for song-poems accepted! Free public releases! Castle's, 203PM West 46th Street, New York City 10036.

**PIANO** Self-Teaching Book. Includes popular, classical, harmony, theory, chords, scales. Price \$5.00. LaPont Publishing Company, Box 806-P, Franklin, Michigan 48025.

**SONGS, Songpoems:** Wanted for radio show. Hollywood Music Productions, 6425-B14, Hollywood Boulevard, Hollywood, California 90028.

**ACCORDION-O-RAMA.** Top brand accordions. Tremendous discounts. 120 bass. 5 switches for \$119.00. Trades accepted. Free brochure. Accordion-O-Rama, 874 Broadway, New York, N.Y. 10003.

**PLAYER** Piano books. Free catalog. Vestal Press, Vestal 11, N.Y. 13850.

**GUITARS!** Lowest prices, best deal in country. Famous brand catalogs free. Universal Guitars, 20 Clent, Great Neck, N.Y.

**SONGPOEMS** Wanted. Send poems for offer. Nashville Music Institute, Box 532-PM, Nashville, Tennessee.

**ACCORDIONS, Guitars, band instruments!** Save to 50%. Famous makes. Easiest terms. Trades accepted. Free home trial. Free discount catalog. Mention instrument. International Music Mart, 5535-R Belmont, Chicago 60641.

**SONGS** And song poems wanted. Royalties. Tin Pan Alley, Inc., 1650 Broadway, New York, N.Y. 10019.

**SONGS** Or song ideas wanted by new commercial recording company for release to disc jockeys and public. Preview Records, 6311-B Yucca, Hollywood, California 90028.

**SONG POEMS** Wanted! Collaborate with professional songwriters equally. Share royalties. Songwriters Contact, 1619-D. Broadway, New York 19.

**GRANADA, Jalisco, La Paloma, 50** favorite Spanish songs, \$1.00. Mondragon, 1305 Forrester, Albuquerque, N.M.

**VIOLIN** And guitar makers, send for latest Free catalogue of woods & accessories. International Violin, PM-12, 414 East Baltimore St., Baltimore 2, Md.

**WHO** Else wants songwriting success? Details free. Melody Writers, 2 Emma Street, Greenville, S.C.

**ACCORDION** Manufacturing, 6343-P South Ashland, Chicago, Illinois 60636. Piano Accordions, Chromatics, Hohners, Concertinas, Guitars. Wholesale catalogs free.

**POEMS** Wanted for musical setting and recording. Send poems. Free examination. Crown Music, 49-C West 32, New York 1.

**ELECTRIC** Guitars, amplifiers, whole-sale. Free catalog. Carvin, P.M.M. Covina, Calif.

**SONGWRITING** Services. Collaboration. Free details. Modern Music, Box 193-A, Bloomfield, Conn.

**FREE** Recording, your songpoem. For information send poems: Musicrest, 12044 Chandler Blvd., So. Hollywood, Calif.

**PRACTICAL** Violin making with patterns, \$2.00. Supplies, Chelsea Fraser, 2025 Stark, Saginaw, Mich.

**SWISS** Musical movements. Mechanical—electrical. Spielman, 131 West 42nd, New York 10036.

**FREE** Melodies, recording, good lyrics, songs. Send \$3 1-year membership card, details. Enclose self-addressed envelope. Songwriters' Cooperative, 972PM Broad, Newark 2, N.J.

**INSTANT** Musical knowledge guitar slide rule, \$1.00. Voglers' Box 661, Mt. Airy, N.C.

**GUITAR, Banjo** Making books, Plans, woods, necks, tools. List 15¢. Satinwood, 510 East 11th Street, New York 9, N.Y.

## **EDUCATION AND INSTRUCTION**

**AUTOSUGGESTION.** Sleep-learning headquarters! Tapes, records, books. Gigantic catalog free. Research Association, Box 24-PM, Olympia, Washington.

**PIANO** Tuning quickly learned with home study course. Diploma granted. American Tuning School, Gilroy, Calif.

**LEARN** Civil and criminal investigation at home. Earn steady, good pay. State age. Institute Applied Science, 1920 Sunnyside, Dept. 169, Chicago 40, Illinois.

**MASTER** Watchmaking at home. Free sample lesson. Chicago School, Dept. YY, Fox River Grove, Illinois 60021.

**USED** Correspondence courses and books sold and rented. Money back guarantee. Catalog free. (Courses bought.) Lee Mountain, Pisgah, Alabama.

**HIGH** School diploma at home. Licensed teachers. Send age, highest grade completed for free detail. No salesman will call. Southern States Academy, Professional Bldg., Dept. 16, Decatur, Ga.

**PENMANSHIP** Corrector. Improve poor penmanship quickly. Details free. Ozment, Box 665-34, St. Louis 88, Mo.

**COMPLETE** Your high school at home in spare time with 68-year-old school. Texts furnished. No classes. Diploma. Information booklet free. American School, Dept. X945, Drexel at 58th, Chicago 37, Illinois.

**MEN** Wanted. Earn \$125 a week and up. Master a trade with a future. Learn auto diesel mechanics in our shops. You learn with tools on real equipment. Earn while you learn. Many of our graduates earn \$125 a week and up. Write for free bulletin: Dept. 256, Auto Diesel College, Nashville 3, Tenn.

**OWN** Collection agency. "Little Gold Mine!" Franklin Credit, Roanoke, Virginia.

**LEARN** To drive tractor, trailer, trucks, buses. Short concentrated courses available. Write for free brochure. Driver Training Institute, 794 Bedford Ave., Brooklyn, N.Y. Ja 2-5080.

**LEARN** Auctioneering. Term soon. Free catalog. Reich Auction College, Mason City 15, Iowa.

**LEARN** Asleep or awake! Records, tapes, equipment! Free catalog! Drawer, PM-400, Ruidoso, New Mexico.

**BOOKKEEPERS.** Operate your own "Dollar-A-Week" system. Ellis, Box 200, Cedar Grove, North Carolina.

**INVESTIGATOR'S** Course. Credentials, diploma. Free information. Southwestern Institute Criminology, Box 201, Geronimo, Oklahoma.

**BE** A real estate broker. Insure security for yourself and your family. Study at home. Prepare for state examination. Write for free book today. Weaver School of Real Estate, 3519-P Broadway, Kansas City, Mo. 64111.

**PIANO** Tuning pays. Big money in spare time. Learn at home. No musical knowledge necessary. Phonograph, records, tools and instructions furnished. Electronic tuning also taught. Free catalog. Capital Tuning School, 3160 S.W. 16th Court, Ft. Lauderdale, Fla.

**SWEDISH** Massage. Foot technique. Post graduate. Home study. Residential. Diploma. Dr. Swanson's Illinois Licensed School, 3809-PL Alta Vista, Chicago 13.

**MISSOURI** Auction School. Free catalog! 1330-03 Linwood, Kansas City, Mo. 64109.

**FINGERPRINTING** Easily learned at home. Many job opportunities. Diploma awarded. Alabama School of Fingerprinting, Fairfield, Alabama.

**LEARN** To service oil burners. Free information. Mar-Lin Institute, Box 66095, Portland, Oregon 97266.

**IDEAS** How to get 'em! 30 step course with slide chart, \$5.00. Ritterby, 660 Pinecrest, Holland, Michigan.

**USED** Courses! Books! List 10¢. Smith's, 124 Marlborough, Salem, Mass.

**B.Sc. DEGREE** (Engineering) or College Entrance by home study. Send \$1 for 1966 prospectus. C.I.S.T. Suite 803, 263 Adelaide St., W., Toronto, Canada.

**LEARN** Landscaping and the growing of plants. Start a profitable business part or full time. Free information without obligation. Lifetime Career Schools, Dept. MC-125E, 11826 San Vicente Blvd., Los Angeles, Calif. 90049.

**LEARN** Special investigation. 20 Lessons, credentials, diploma, future. International Academy of Police Science, Oklahoma City, Oklahoma.

**GET** A British degree. Divinity, Philosophy, Radionics. 35 courses Prospectus free. Brantridge Forest School, USA Representative, Box 357, Lincoln, Montana.

**DETECTIVES**—Secret investigations. Experience unnecessary. Detective particulars free. George Wagner, M125 West 86th, New York 10024.

**FCC** License in 6 weeks. First class radio telephone. Results guaranteed. Elkins Radio School, 2603D Inwood, Dallas, Tex.

**FEDERAL** Income tax course. Details free. Taxmaster Systems, Box 1841, Orange, California 92669.

**TELEVISION:** Electronics: Appliance Repairing: Mailorder: (Low cost courses) Guaranteed. Brochure free. Mike Blizzard Company, Dept. PM-1, Linwood, N.J.

**EARN** College credits and degrees through correspondence, residence, and examinations. William Darren University. Fourteen North Central Avenue, Phoenix, Arizona 85002.

**DETECTIVE** Course. Free information. Universal Detectives, Box 8180-F, Universal City, California, 91608.

**PENMANSHIP** Book: Simplified. Improve your handwriting. Details free. T. Tevis, Chillicothe, Mo.

**WOODWORKING** And cabinetmaking course for beginning and advanced home craftsmen. Only complete low-cost home training program available. Write for free booklet. Interstate Training Service, Dept. G-3, Portland 12, Ore.

**REPAIR** Sewing machines. Easy. Profitable. Get most complete service manual ever published. Price \$6.25. Free information. Lincoln, Box 52, Hempstead, New York 11551.

**DRAFTING** Pays big money. Learn at home in your spare time! Revolutionary new method. Exciting work, wide open opportunity. Own your own drafting firm. Draftsmen needed everywhere. Train for world of tomorrow and dynamic future. Send for free book. Christy Trades School, Inc., Dept. D-7903, 3214 West Lawrence Avenue, Chicago, Illinois 60625.

**NEW** Home radio course only \$26.95. Tubes, components, tools, books included. Free literature. Edu-Kits, Department 635B, Hewlett, New York 11557.

**LEARN** Handwriting analysis. International, Box 700, 11749 Eldridge, Lakeview Terrace, Calif.

**JANITORS,** Custodians, cleaners make more money. Get a better job. Become a maintenance supervisor. Free homestudy information: Maintenance Training, 511-12th Niagara Falls, N.Y.

**BOOKS**—Thousands of titles, 15¢ each and up. Catalogs, 10¢. Midwest Mail Sales, 216-G West Jackson, Chicago, Illinois 60606.

**COMPLETE** Civil Service job guide, \$1.25. Lanich's, 734 Eldred, Erie, Penna.

**PROFITABLE** National Camera Repair School training at home! PM12, Englewood, Colorado.

**DRAFTING** (Electronic, Mechanical, Architectural, Art). Home courses \$25.00. Send \$2.00 first lesson. Prior, Inc., 23-09 169 Street, Whitestone 57, New York.

**MEN, Women**—Want Higher Pay? Take advantage of hundreds of well paying jobs in business and industry. Unusual training. Study courses at home while you work. Get literature. Aladdin Home Study Courses, Dept. B, 409 St. Louis, Springfield, Mo. 65806.

**MINISTERIAL** Home study course. Free qualifying examination. Soms, 5955 Powdermill Road, Kent, Ohio.

**SWEDISH** Massage and Physical culture pays big profits. Learn at home. Diploma. Free catalog. National Institute, Dept. E125, 307 North Michigan, Chicago 1.

## FOR INVENTORS

**PATENT** And invention development, by licensed professional patent engineer and U. S. Patent Office former examiner, and engineering specialists. Your inventions and ideas engineered for patent protection and commercial value. Inventions developed by us negotiated for cash or royalties with our nationwide contacts. Send for free protection "Invention Certificates" and further interesting, valuable patent information. George Spector, Licensed Professional Patent Engineer, Woolworth Building, New York.

**PROFESSIONAL** Patent searches, \$6.00, including official U.S. Patent Office copies of related U.S. patents! Prompt, dependable service. Certified, airmailed! For free "Invention Record Folio" and important patent information every inventor should have, write: United States Inventors Service Company, 1311 "G" Street NW, Washington 5, D.C.

**SAVE** High fees! Prepare your patent application yourself! New "Do-It-Yourself" patent kit now makes it easy! Free "Registration Form." Miss Blaine, 306A Carry Building, Washington 5, D.C.

**IMMEDIATE** Cash, for patent applications. Free patent searches. Write for details. Universal Patents, 184-D, Marion, Ohio.

**PATENT** Searches, including copies of related U.S. patents, \$6.00. Inventors, attorneys, manufacturers use my "world-wide" airmail service! "Invention Record" form and "Information Every Inventor Needs," sent free! Miss Hayward, 1029P Vermont, Washington 5, D.C.

**INVENTORS:** Save time and money. Prepare and file your own patent application. Our complete "Patent Kit" makes it easy. Includes detailed instructions and all necessary material. Only \$14.75. Money back guarantee. Don't delay. Send check or money-order today to National Inventors Service, 1244-19th Street, N.W., Washington, D.C.

**U.S. Patent Office** Searches, 234 Broadway, Room 3615, New York. Free invention certificates.

**TEST** Actual value unpatented inventions for \$10, safe and fast, satisfaction guaranteed, \$1 complete. Locke, 3913 Castro Valley Blvd., Castro Valley, Calif. 94546.

**TREMENDOUS**—Savings! Prepare your patent application yourself—easily, with our New "Patent Kit." Complete instructions, materials, sample application—send \$8.95 for immediate delivery. Money-back guarantee! Congress Invention Company, 210 McKim Building, Washington 5, D.C.

**INVENTIONS** Needed immediately for manufacturers. For additional information write Kessler Corporation, C-512-FI, Fremont, Ohio.

**INVENTIONS** Engineered. Patent office drawings made. Reasonable. Free booklet "How to Invent." Pen-Ink, 50 East 42nd Street, New York 17.

**INVENTORS** Apply for then sell your patents. Write: Creative, 3680 Fifth, San Diego 3, Calif.

**INVENTORS:** Your ideas and inventions (patented; unpatented) expertly searched and developed for commercial appeal and cash royalty sales to manufacturers by professional Invention Developer with excellent record of experience. B.S., Industrial Engineering; U.S. Patent Office former Patent Examiner; U.S. Government former Patent Adviser. Second decade of reliable service! Free "Invention Record" and Important Information. Airmailed! Write: Raymond Lee, Invention Developer 130-N W. 42nd, New York City 10036.

## INVENTIONS WANTED

**INVENTORS:** Protect your ideas! Free "Recommended Procedure." Washington Inventors Service, 422F, Washington Building, District of Columbia 5.

**WE** Either sell your invention or pay cash bonus. Write for details. Universal Inventions, 298-E, Marion, Ohio.

**INVENTORS** Wanted: Manufacturers need new items! Your inventions, ideas developed for cash/royalty sales. Free "Invention Record"; Information. Raymond Lee, 130-P W. 42nd, New York City 10036.

**INVENTORS** Needing Help with any problem, financial, development, securing manufacturer, obtaining patent. Write the organization that delivers action and results—not promises. Pioneer Invention Service, Dept. 83, 150 Broadway, New York 38, N.Y.

**IF** Your invention is adaptable to promoting we will contract for selling on cash or royalty. Free booklet outlines royalty rates, requirements. Kessler Corporation, C-512-IW, Fremont, Ohio.

**INVENTIONS** Wanted. Patented: unpatented. Tremendous manufacturers lists. Global Marketing Service, 2420G 77th, Oakland 5, California.

## MANUFACTURING

**LATHE** And drillpress work. Single or multipliable parts made to specification. Henry Meunier, 18022 Hubbell, Detroit, Michigan 48235.

**MODELS**—Small lot manufacturing. Metals, plastics, etc. Milburn, Burlington, Kentucky.

**INVENTORS** Services. Models, manufacturing, research. Consultants all fields available. William Parker, 32 Westminster, Worcester, Mass. 01605.

## BUY IT WHOLESALE

**100,000** PRODUCTS Wholesale! Terrific bargains! Wholesalers, 1265-MR Broadway, New York, N.Y.

**WORLD'S** Largest wholesale supply. Buy from 7853 American, European, Japanese wholesalers. Tailormade suits from Hongkong. 123 dropship catalogs. Rockbottom prices. Free details. International Buyers, 216-M Jackson, Chicago 6, Illinois.

**BARGAINS!** Buy wholesale and below. Name brands. Appliances, furniture, sports equipment, televisions, cameras, watches, jewelry, thousands more. Huge discounts to \$1,000.00 on new automobiles. All makes. Free details. Write today: Worldwide Bargainhunters, Box 730-A, Holland, Michigan.

**ELECTRIC** Guitars, amplifiers, wholesale. Free catalog. Carvin PMW, Covina, Calif.

**BARGAINS!** Buy wholesale! Save money! Free catalog! Norris, 273 Merrick, Dept. 115 Lynbrook, N.Y.

**SAVE \$\$\$\$\$\$\$** . . . Buy wholesale or below, thousands of items direct from U.S. and Foreign Manufacturers. Many items free! Write: Global, Box 18216-RZ, Indianapolis, Indiana 46218.

**POLYURETHANE** Plastic coating from manufacturer for paneling, cabinets, floors, boats. Gloss, Satin sheen, \$5.95 gallon postpaid. No COD. Auer Paint Inc., San Gabriel, California 91776.

**TRAIN** Sets \$136, Recorders \$6.70, Pistols \$5.74, Walkie-Talkies, Binoculars, Cameras. Buy from American, European, Japanese wholesalers. Exciting details free. Enterprises, Box 160-X9, Jamaica, New York 11430.

**NEW** 6-Color deluxe below wholesale catalog. Automobile catalog and others. Housewares, clothing, furs, furniture, appliances, refrigerators, washers, dryers, vacuum cleaners, polishers, cookware, dinnerware, strollers, cribs, radios, stereos, phonographs, recorders musical instruments, organs, typewriters, books, binoculars, luggage, sporting goods, bowling, golf, game tables, motor scooters, motor golf carts, power mowers, chain saws, boats, motors, bicycles, clocks, watches, diamonds, jewelry. Huge discounts, hundreds name-brand items. For free list (factory prices) postcard: Selbyco-5, Decatur, Illinois.

**FREE** Brochure storage-shipping boxes, tapes, polybags, labels. Allied Pkg., 88 Court, Paterson, N.J. 07504.

**WHOLESALE** Promotions every type merchandise. Amazing free catalog. Department 40, 100 North Green St., Baltimore, Maryland 21201.



**TREASURE. Gold, silver relics. Find them with new 1965 models. Free information. Rayscope, Box 715, North Hollywood, California.**

**TREASURE. Find gold, silver, relics with super, powerful Detectron locators. Free information. Detectron, Dept. 12-PM, P.O. Box 243, San Gabriel, California.**

**COMPLETELY** New prospecting technique developed by Relco. New transistor models detect buried gold, silver, coins, treasures. \$19.95 to \$129.50. Write for free catalog and "guide for beginners". Relco-A40, Box 10563, Houston 18, Texas

**SAVE!** Build transistorized treasure finder. Details free. Del Research, Box 347-B, Alden Manor, Elmort, N.Y.

**NEW. Coin locator!** Free literature! Howe, 811-C Kansas, Atchison, Kansas.

**FUN & Profit** finding treasure, relics with Transistor M-Scope. Booklet, interesting customer comments Free. Terms. Fisher Research, Dept. AX, Palo Alto, California.

**METAL** Detectors and kits, powerful, sensitive, light-weight, rugged. High-quality transistorized circuits, low cost. Electronic Development, Incorporated; 2538-M Colorado. Sarasota, Florida.

**METAL** Locator kits and assembled models from \$39.90. Terms. Transistorized models available. Free catalog. Electronic Applications, Dept. M, Box 6095, Alexandria, Virginia.

**POWERFUL** Metrotech locators detect gold, silver, coins, relics. Moneyback guarantee, terms. Free information. Underground Explorations, Dept. A, Box 793, Menlo Park, California.

### **PRECIOUS STONES AND MINERALS**

**GET** Free catalog no serious rockhound, gem cutter, jewelry maker, hobbyist or craftsman can be without. Full of bargains, exclusive items, low prices from largest suppliers and authorities in the field. Free new catalog just off the press, yours for the asking. Write Grieger's, Dept. C-12, 1633 E. Walnut, Pasadena, California.

**SEMI-Precious** uncut gems. Ten different for \$1.00. Request list 30. Prospectors Shop, 201 San Francisco, Santa Fe, New Mexico.

**JADE** Tie tack, rockhound catalogs. \$1.00. Dalley, Box 405C, Driggs, Idaho.

**DIAMOND.** Guaranteed genuine, natural, \$2.00. Apprx. Weight 1/4 carat. C & J Diamond Company, Box 97-M, Plainview, L.I., N.Y. 11803.

**20 DIFFERENT** Beautifully polished Agates and Jaspers. \$2.00. Phillips, Box 131-P, Banning, Calif.

**U.S. AND** foreign mineral specimens, lists 10¢. Minerals. Winston. New Mexico 87943.

**SPARKLING "Herklimer Diamond"** and apatite crystal with our catalog on Gems and Minerals. Send 50¢. T. L. Baskin & Sons, 732 Union Ave., Middlesex, New Jersey.

**AMETHYST** Dangle earrings. Gold plated screw or clip. \$2.25. Clark Lapidary 25 Ord St., San Francisco, Calif. 94114.

**EARTH** Science. Educational magazine. Subscription, \$2.50. Sample. 35¢. Box 550-PM, Downers Grove, Ill. 60515.

### **CARTOONING, COMMERCIAL ART, SHOWCARD & SIGN PAINTING, TATTOOING**

**SIGN** Painting. Fascinating system. Straley, 410 South Western, Springfield, Ohio.

**SIGN** Painting and art. Instructions, brushes, equipment, everything. Free catalogue. Kaufmann Supply, Centertown, Missouri.

**YOU** Can entertain with chalk talks. Catalog 10¢. Balda the Cartoonist, Oshkosh, Wis.

**LEARN** Sign painting at home. Free talent test. Ben Kerns, Box 812-PM, Greenville, S.C.

**LEARN** Profitable magazine cartooning. Free details. Hartman, Box 3097, Lincoln 10, Nebraska.

**ART** Lessons \$6.00 a month. Includes drawing, painting, advertising art, cartooning. Art kits (worth \$25) and materials. Assignments corrected with overlays, by mail, and returned to you. Write for free book. No obligation. Washington School of Art, Studio 148, Port Washington, L.I., N.Y.

**LIKE** To draw? Splendid opportunities in professional cartooning. Write for free catalogue. No obligation. National School of Cartooning, Studio-H, Box 8958, Cleveland 36, Ohio.

**DRAFTING:** Mechanical, architectural, electronic. Box 641, Los Alamos, New Mexico.

**CARTOONERAMA** Teaches you cartooning in a new, low-priced 24 lesson course. Free brochure. CPA, Box 263-9X, Branford, Connecticut.

**COLOR** Computer. Color mysteries simplified! Artists, Decorators, Designers find this handy device useful. \$2.00 Color Computer Kit, 2150-90 S. First, San Jose, Calif.

**How To** make money with simple cartoons. Everyone who likes to draw should have this book: Free. Send name, zip code. Cartoonists' Exchange, 912 Pleasant Hill, Ohio 45359.

### **ADVERTISING AGENCIES, ADV. SERVICE, MAILING LISTS**

**ADVERTISING** Ratebook leading newspapers, magazines, free. Chicago Advertising Agency, 28-E Jackson, Chicago 4.

**MAILING** Lists most all kinds 1000 \$5.00. Free folder. Your circulars mailed \$4.00 1000. Dixie Mailers, King, N.C.

### **TYPEWRITERS, DUPLICATORS, OFFICE EQUIPMENT**

**TYPEWRITER.** Adder, bargains. List 10¢. Columbus, 719 E. Pike, Seattle, 98122.

**OFFSET.** Letterpresses, varitypers, typewriters, mimeograph, multigraph machines. Bargains. DixieGraph, King, North Carolina.

### **RUBBER STAMPS AND OFFICE SUPPLIES**

**SIGNATURE** Stamp, \$2.88. Three lines. \$1.00. Catalog. Jackson's, 1433 Winnemac, Chicago, Illinois 60640.

**RUBBER** Stamps, marking devices, supplies. Free Catalog. Tabco, Tomkins Cove, New York 10986.

**FREE** Catalog: Rubber stamps, printing. Dowling Products, Dept. PMB5, Pittstown, N.J.

**SIGNATURE** Stamp, \$1.00. Three lines pocket, 50¢. 1000 gummed address labels, 50¢. Value House, 550-M Fifth Avenue, N.Y.C. 10036.

### **PRINTING, MULTIGRAPHING, MIMEOGRAPHING, GUMMED LABELS**

**100 PRINTED** 5 1/2 x 8 1/2 letterheads and 100 - 6 3/4 envelopes \$2.75. Price list free. Purple Enterprises, Box 16291-AM, Jacksonville, Florida 32216.

**OFFSET** Printing postpaid up to fifth zone. 1000 8 1/2 x 11 20 lbs. bond \$6.00. Write for price list. Biscayne Products, Box 346, New York 5, New York.

**FIRST** Quality printing—reduced prices. Selco Products, Danvers 37, Massachusetts.

**BUSINESS** Printing. Catalog Free. Bill's Press, 538-P Leffingwell, Kirkwood, Missouri 63122.

**1,000 THERMOGRAPHED** (raised letter) business cards, \$3.75. Free samples! Griffin, 322 West State, Ithaca, New York 14850.

**OFFSET** Printing—500—8 1/2 x 11's \$3.90. Postpaid to 7th Zone. Cisco's Duplicating, Atlanta, Illinois.

**AMAZING** Business printing values. Samples. Print Shop, Box 576, Greenville, R. I.

**YOUR** Sketch on stationery. BER, Box 530-P, North Hollywood, Calif. 91603.

**DISTINCTIVE** Business Cards—Catalog 10¢. Pace Card Company, Box 7, Flushing, New York 11352.

**1,000 GUMMED** Address labels, \$1.00. Walt's, Box 966A, South Bend, Indiana 46624.

**500 PORCELAIN** business cards, \$4.95. Eslick's Craft Studio, Delavan, Wisconsin.

**PRINTING.** Choose type faces. McDonald, 545 North Oakland, Pasadena, California 91106.

**BUSINESS** Cards thermographed engraved 1,000 \$4.10. postpaid, Goodall, 68-N Joost, San Francisco 94131.

**QUALITY** Printing: Lowest prices. samples. Dowling Press, PMB5, Pittstown, N.J.

**1000 NAME,** Address labels, \$1.00. Buyers. P.O. Box 565, South Laguna, California 92677.

**TERRIFIC** values — offset-letterpress printing. Free Samples. Chicke Press, Harvey, Illinois 60426.

**MIMEOGRAPHING.** Offset printing. Free samples. Pennway, Drawer 1340, Scranton, Penna.

**PRINTING—8** Page catalog—1 1/4¢: 5M 8 1/2 x 11. = 1/S, \$15.00. Free price list. Copen, 337 Butler Street, Brooklyn 1, N.Y.

### **PRINTING & RUBBER STAMP OUTFITS—SUPPLIES**

**MAKE** Your own self-molding rubber stamps and printing cuts. Flexirubber, Argyle 1, Wisconsin.

**RUBBER** Stamp presses, hydraulic operated, electrically heated. Sizes 5" x 8", 8" x 12", 10" x 15". Starting outfits, supplies. Printing presses. Type cases and cabinets. Custom Manufacturing, 1464-P East Commercial, Springfield, Missouri.

**DO** Your own printing. Save money. Simple rules. We supply everything. Print for others: good profit. Raised printing like engraving too. Have home shop. Details free. Kelsey Presses, V-11, Meriden, Connecticut.

**RUBBER** Stamp manufacturers supplies. New products. Low prices. Catalog. Jackson Supply, 1433 Winnemac, Chicago, Illinois.

**NEW** Type Catalog No. 11, 96 Pages. Send One Dollar. Deductible First Order. Acme Type, 732 Federal, Chicago, Illinois.

**RUBBER** Stamp outfits, supplies. Kiewiet, 2025 Barney Road, Kalamazoo, Mich.

**TYPE** And supplies for rubber stamp makers. New wholesale price list No. 3 free. Star Stamp Supply, 732 Federal, Chicago 5, Ill.

### **REMAILING SERVICE**

**SECRET** Receiving and remailing. Discreet and confidential. Remail 25¢ single. 8050 S. Main, Houston, Texas.

**SECRET** Mail receiving system. Hedgpath, 406-M South Second, Alhambra, California 91802.





Mrs. Jonscher

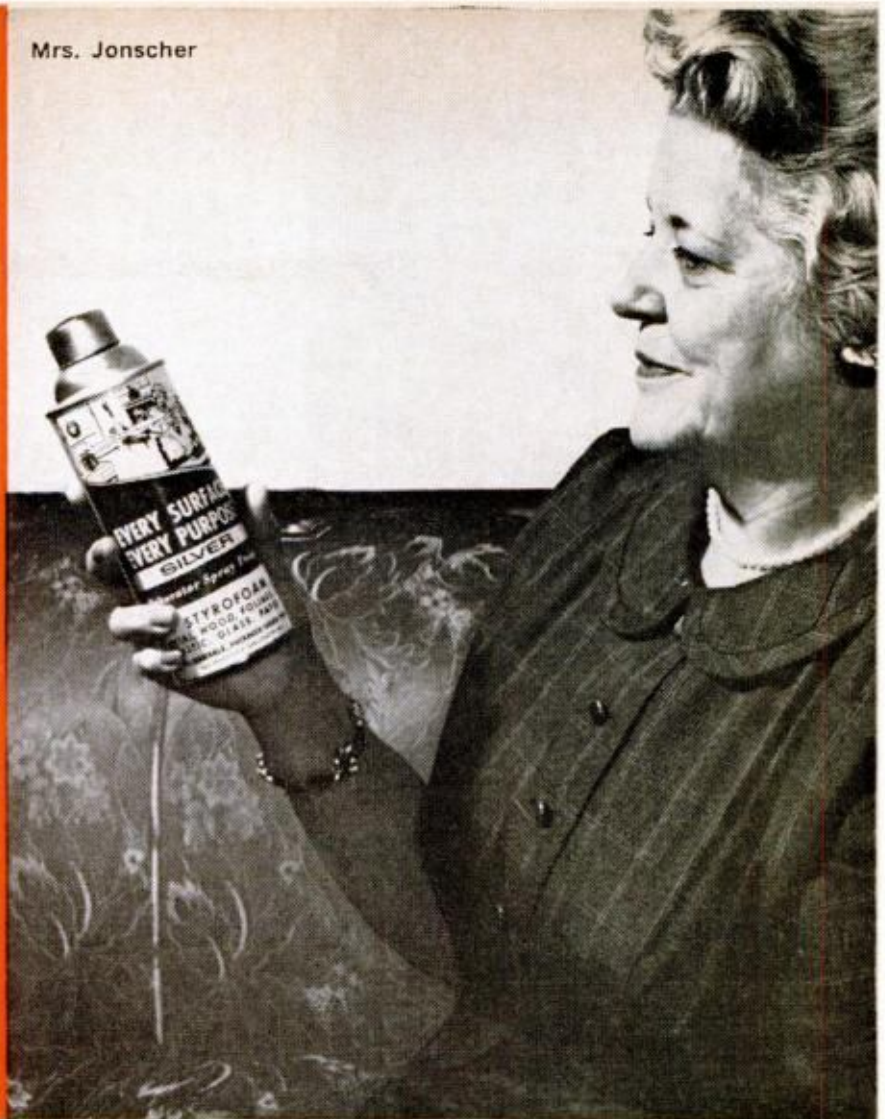

## DEKORATOR SPRAY ALUMINUM... it's the fast, easy way to decorate for Christmas

Users tell us *Dekorator* aluminum spray paint "works" on every surface from metal to styrofoam. Think what that includes—candles, fruit, rope, wood, paper, foliage, cloth, plastic, glass, Christmas trees, ribbon—and how it simplifies holiday decorating. Made with Alcoa® Pigment, *Dekorator* aluminum spray paint is made by Star Bronze Co., Alliance, Ohio.

Read what one user has to say. Helen C. Jonscher, prominent in Washington, D.C., club and charitable activities, writes, "I've found *Dekorator* aluminum spray paint to be completely versatile in many utility and decorative uses, both around the home and in the performance of committee work at clubs, church and hospital. Now, with the holidays upon us, *Dekorator Spray* will play a big role in preparing seasonal decorations of floral arrangements, styrofoam, etc."

Get a can today. You'll like it, too. Aluminum paint has great hiding power; it goes a long way. One coat covers even soiled or stained surfaces

(aluminum pigment is opaque). Aluminum paint is always bright and attractive; it looks clean—it's easy to keep clean. *Alcoa does not make aluminum paint*, but Alcoa Pigments are used in the best brands. Ask your dealer.

Aluminum Company of America  
895-M, Alcoa Building, Pittsburgh, Pa. 15219

Please send free booklet, *Painting With Aluminum*.

Name \_\_\_\_\_

Address \_\_\_\_\_

City \_\_\_\_\_ State \_\_\_\_\_ Code \_\_\_\_\_

Alcoa Brings You Action Drama At Its Best  
... "THE FBI," Sunday Evenings, ABC-TV



# Air-Cushion Commuters

Bob Grant



**COMING ABOARD** the Hovercraft at Oakland International Airport, these passengers will be whisked to downtown San Francisco in 15 minutes, a trip that could take as long as two hours during the rush hours on the freeways and bridges

**THE HOVERCRAFT**, first air-cushion passenger vehicle to operate commercially in America, is now in service between San Francisco International Airport, Oakland International Airport and downtown San Francisco.

Operating on a cushion of air at speeds up to 75 mph, the seven-ton craft makes the trip between the two airports in 15 minutes. Using radar, it is expected to make the trips in almost zero visibility

weather when helicopters are grounded. It carries 15 passengers.

Leased from Bell Aerosystems to the Port of Oakland and operated by SFO Helicopter Airlines, Inc., the Hovercraft can operate safely in four-foot waves. Extremely versatile, the British-built ground-effect machine can travel across land to pick up air passengers and then float like a boat to leave them at a dock in downtown San Francisco.



**MOVING EASILY FROM WATER TO LAND**, the air-cushion craft "flies" along at 60 mph with a full complement of passengers. The pusher prop in the rear is capable of driving the vehicle up to 75 mph

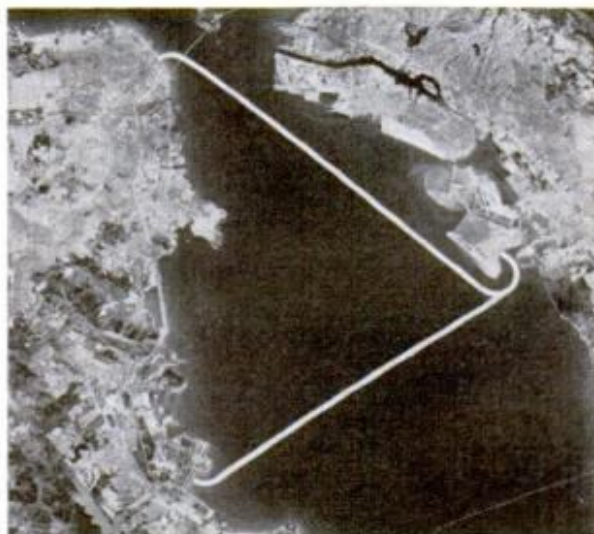

**SHORTCUT** between airports and downtown San Francisco is shown in aerial photo. White lines indicate route that is used by the Hovercraft. Using radar it can operate despite bad weather



1966 Chevrolet Fleetside pickup in big country near Dillon, Montana.

**America's  
most popular pickup  
is built for  
bigger things in '66!**



**'66 Workpower Trucks**

Here comes the pickup that people use most, and it's even more useable for '66!

There's more power this year—the famous Chevy truck Six is bigger than ever at 250 cubic inches, so that it can do more work. Or, if you want even more power, order a big 327 V8 for your  $\frac{1}{2}$ -,  $\frac{3}{4}$ -, or 1-ton Chevrolet. You can pick from thirteen models and a big variety of body sizes and power teams. You'll get double-strong construction and all of the other things that keep America's haulers sold on Chevy pickups! See your Chevrolet dealer. . . Chevrolet Division of General Motors, Detroit, Michigan.

# If she gives you a REMINGTON shaving system this Christmas, look what you get.

**A closer shave than any other electric shave.** 3 heads — not just 2. Thinnest made for the closest shave. Trims sideburns too.

**Extra power for comfort.** The most powerful motor in shaving. No pull or drag.

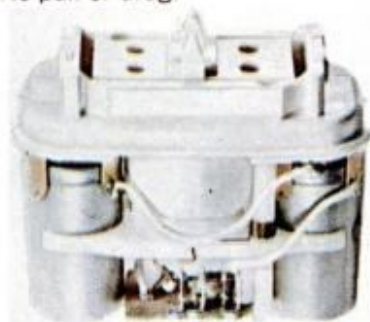

**Power console.** Stores and charges the shaver 24 hours a day.



**The little red light.**

An ingenious device. Tells you if the shaver is charging.

**Dial any voltage—home or abroad.** Same close shaves no matter where you travel.



Here's a cord in case you forget to recharge. Plug in, shave on the spot.

## Look what else you get.

That's why it costs a bit more. Cord/Cordless REMINGTON® LEKTRONIC V Shaver

REMINGTON *Lektro*



CORD / CORDLESS



**REMINGTON**  
ELECTRIC SHAVER • SPERRY RAND CORPORATION  
BRIDGEPORT, CONNECTICUT

Материал, защищенный авторским правом



# Makes a fine second car. Or a wonderful first truck.

Does the car-like ride of Ford pickups mean we've gone soft? Quite the contrary. Instead of one, we now have two I-beam axles up front, one for each front wheel, working independently. Shocks at one wheel don't get passed over to the other. Or to the driver. Husky radius rods hold wheel alignment too. Even the engines have big muscle: two husky Sixes have such punch, we had to develop a big new V-8 to keep ahead of them. So relax. Enjoy Ford's smooth ride. Just remember that under that velvet is a solid truck, with toughness where it counts. Very comforting.



Two front axles of forged steel I-beam make Ford's Twin-I-Beam suspension the most durable independent suspension in any pickup.

## FORD/66

# EDITOR'S PAGE

An age-old Eskimoan system of using sealskin bladders to move heavy objects across soft snow was applied to an experimental vehicle called the *Rolligon* some years ago. In place of wheels, a truck was equipped with inflated rubber bags resembling huge rollers. Army tests showed that it would roll through swamps, mud, snow and over the roughest terrain. What happened to the *Rolligon*? A sidelines spectator during experimental days was *PM* outdoors editor, Stuart James, and last summer he returned to California to find out. It is a complicated tale of disillusionment and financial disaster. But out of a dream of revolutionizing military transportation came a sand buggy, the *Terra-Tiger*, which Stu writes about in *Leapin' Lizzies* on page 122. "The design had changed completely," Stu explains, "but the basic principle was the same. Bill Albee, the original inventor, was no longer involved, but I'm sure he'd approve of how his machine turned out. I think he had the most fun during the earliest days when the bags were mounted on a jeep and he would go tearing around the Carmel beach. He was an adventurous, fun-loving guy with a keen sense of humor. I remember he once sent me a recipe for moose stew that began: 'Take one moose.'"



... **The most radical car** out of Detroit in many a year is the new Oldsmobile front-wheel-drive Toronado. Our two auto editors, Jim Dunne and Alex Markovich, could hardly wait to get their hands on a copy. When they did, they wouldn't let go. They gave it a real workout—6000 rugged miles from Detroit to San Francisco to New York. Their day-by-day report is on page 76. One big problem they ran into was an itchy right foot; the car is so smooth and stable that the speedometer kept creeping up on them. In fact, while returning the car to Detroit, they were stopped by a Pennsy Turnpike trooper. Luckily, he was so fascinated by the machinery that he forgot how he happened to be examining it. . . . **It was a shambles.** For a couple of days one fine week in mid-September, *PM*'s photo studio looked like a family reunion on Christmas morning. Children of staff members plus a big selection of this year's new toys fought for floor space with lights, tripods, cameras and a distraught photo crew. Out of the melee emerged the photos on pages 75 and 124. The kids

pounced first on a toy soda fountain and from then on it was a race to get the pictures before faces, shirts and floor dissolved in a monochromatic cherry-drink red. (Colorful, but it doesn't photograph well.) The worst casualty is yet to be suffered at the end of this month. It's an editor who had three children posing in the photos. Their three Christmas lists, he moans, exactly parallel the selection of toys in the studio. Every item—three times! If his young ones don't yield to sweet reason, he insists, he's going to survive 1966 only on an anti-poverty loan. . . . **Hydrofoil boats are old hat**, but during the Chicago boat show a few weeks ago our midwest editor found one that's making news. It's a 20-hp outboard foilboat, 12 feet long, and it looks like an outsize pumpkin seed. But it runs at a fearsome 40-plus mph. Pinch-hitting for boating editor Art Mikesell, midwest editor Cliff Hicks turned up at the Chicago Yacht Club for the first demonstration of this unusual speedster. Small craft warnings were flying, and Lake Michigan was kicking up such a chop that the designer wouldn't allow any test driving. So Cliff watched from the dock while the designer put the little pip-squeak through its paces. Results were fascinating. You'll read all about them next month.



# OUTWIT THE ELECTRONIC EAVESDROPPERS

Find and plug the hidden electronic ears that are giving away your most valuable secrets. Here are the ways to make your home and office secure again

By Larry Steckler





**I** COULD BUG YOUR OFFICE while you're sitting behind your desk. A few seconds, the time it takes you to turn and answer your phone, and I could have a mike installed under your desk or behind a bookcase. Give me five minutes alone and I'll have your phone tapped too, but I can do that without even entering your office.

"Shocking? Yes, but that's how easy it is to put your own ears into the most private business or personal conversations. Your car and home are just as easy to get at too. And long-range sensitive microphones can follow you through the park or out on the street. A microphone-carrying business acquaintance can make a record of luncheon conversations."

These startling statements were made to me during my very first day of investigations into the art of debugging—the art of preventing someone from listening in on your secrets. I had been talking with Richard F. Sirchie, president of Criminal Research Products in Conshohocken, Pa., and before looking into debugging I was trying to learn a bit about the procedures and equipment used in bugging.

Sirchie showed me some of the devices that are used for eavesdropping. He brought over a broom that had been standing in a corner of his office and stood it up on his desk. "Looks ordinary, doesn't it?" he remarked. "Dig through the straws and see what you can find."

I did, and uncovered a miniature mass of electronics. "That's a short-range FM transmitter," Sirchie explained. "It has been picking up every word of our conversation and passing it on to a tape recorder in the next room. Come on, let's take a look."

I followed him into the next room and watched as he rewound a tape

 **LONG-RANGE MICROPHONE** picks up conversations without the need to put a listening device in the tapped office. The same gadget can be used to listen in on talkfests in a parked car or out on the street. Connect it to a tape recorder and you'll get a permanent record





**BUG IN YOUR PHONE** might look like this one. It replaces the ordinary clear plastic insert (at right of photo) that belongs right under the mouthpiece



**TRANSMITTER IN A BROOM** is only one example of how a listening ear can be concealed in your office. Any piece of office furniture would work as well



**VIBRATION MICROPHONE** in hands of criminal research expert Bill Eaton picks up whispers through wall of room. It's small enough to carry in pocket

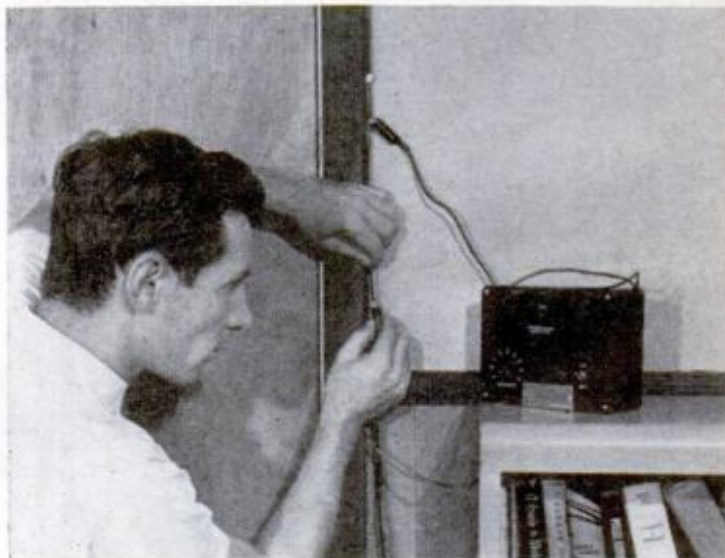

**CHECK FOR HIDDEN MIKES** with a "whistler," or audio tone generator. Bill Eaton shows how it's done. Unit turns mike into speaker emitting audible sound



**SNIFFER** finds transmitters hidden in conference room. Every inch of wall, floor and ceiling must be checked methodically or low-power bug might be skipped



**MIKE IN KEYHOLE** is demonstrated by Dick Sirchie. It's one effective way of listening in on whatever may be going on behind that securely closed door

recorder connected to an ordinary-looking FM radio. He pushed the playback button; there were our voices all over again.

"That's only one example," he pointed out. "Take this little job," indicating a tiny metal box about 1 by 1 by 1½ inches. "Stick a piece of two-sided tape to one surface of this box and you can conceal it almost anywhere. Just press it into place and it stays.

"The microphone is sensitive enough to pick up any normal voice within a 20-foot radius. The transmitter can relay that information up to a quarter-mile to a waiting receiver. And if you want to play it real safe, jack the receiver into a tape recorder that operates automatically whenever a voice comes through. You don't have to be there listening. Just pick up the tape once a day and run it through for a quick listen."

My next stop was in lower Manhattan to meet Emanuel Mittleman. He's the Wireless Guitar Co. and works out of a small office in an old loft building. He also showed me how easy it is to bug an office or home. He even demonstrated how Goldfinger could have outwitted James Bond by using one of his (Mittleman's) gadgets.

"Goldfinger used a radio disguised as a receiver to learn what cards were held by his opponent," Mittleman declared. "With my system there would be nothing visible. All you need are these two little metal discs (ordinary silver dimes with wire leads soldered to them) and this little receiver (a box about 2 by 3 by 1 inches). Space the discs about 2 inches apart, tape them to your arm, chest or leg and tuck the receiver away somewhere.

"Now your accomplice radios Morse code numbers to identify the cards in your opponent's hand. You 'hear' these signals as little electric shocks through your skin. Care to try it?"

I agreed. A few minutes later, I was wired for sound. Mittleman moved across the room with his transmitter and started sending. Each time he tapped the transmitter key, I received a minor jolt. It was easy to tell the dots from the dashes. I quivered longer when he sent a dash.

"Now here's a tricky one," Mittleman continued, holding up a small black box that looked much like all the others I had already seen. "This one hooks up to a telephone. It is normally turned off. However, call the bugged phone and when the connection is complete, but before the phone



**TOOT YOUR HARMONICA** and it can turn on remote microphone that has been connected to bugged telephone. Emanuel Mittleman developed this system

rings, you blow a special tone on a harmonica into the phone you are calling from. This prevents the phone from ringing and turns on the bug. Now you can listen to everything in the called office.

"Even better, you can complete a call to that office and after the party hangs up, blow the tone. Now your bug is on and again you can hear what is said about the call you just completed.

"This works, no matter where you call from. The only requirement is that you call via direct dialing—it won't work if there's a live operator on the line."

Next on the agenda was a range test of a little FM transmitter. Mittleman turned it on in his office. He also turned on a tape recorder and set it to play back a rather lengthy prerecorded reel of talk. Then he rigged his receiver, tuned it to proper frequency and invited me to take a walk.

We wandered down the elevator, out of the building and all the way to the Battery, about a half mile. The signal was still coming through loud and clear.

Mittleman pointed out, "Once one of these units is planted you can be almost anywhere in the neighborhood and listen in. There's little chance of being caught once the bug is placed. If it has been planted in a car, you don't even have to tail the car closely. If you miss a turn you'll notice the signal getting weaker, but because of the transmitter's range you still have time to do something about it."

Other types of listening devices I uncovered were even more interesting. There are microphones for listening through walls, doors, pipes and keyholes. There's even a bug to fit the telephone mouthpiece. If you look at your phone and unscrew the mouthpiece, you'll find a microphone. It belongs there. Now turn the phone over and dump out the microphone. Notice clear plastic housing that the mike fits? To bug your phone, this housing is replaced by a special unit with a built-in radio transmitter. If the inset in your phone is covered with electronic parts, it's been bugged.

This method isn't used very often. It's usually easier to get at lines to the phone than to the phone itself.

There are more exotic devices: microphones built into cufflinks, tiepins and wristwatches; radio transmitters built into a pack of cigarets and, most fascinating of all, the martini olive transmitter. This is a very ordinary-looking martini. The olive is the transmitter and the toothpick poked into it is the antenna. Its range is quite limited, less than 30 feet, but enough to pass your lunchtime chatter with a buyer or other firm member to competition.

Who uses bugs? If you ask them, no one does. But in real life almost every large industrial firm and government agency is on the user list. How extensive bugging has become is aptly shown by Arthur Whitman in a Feb. 1965 story in *Tape Recording* magazine:

"In 1962, a House committee reported that at least 5000 phones in Federal offices in Washington were bugged—not by Russians, but by American bureaucrats spying on each other. Not long ago, an official of the San Francisco Telephone Co. estimated that 10,000 firms in northern California alone monitor the calls of their executive employees without the executive's knowledge."

How do you protect yourself against bugging? The best way is to avoid saying anything you wouldn't want someone else to know. Naturally, this isn't very practical. So your next best procedure is to keep all business conversations private by conducting them in an area and over phone lines you know to be secure.

The how-to-do-it is a lot more difficult than you might imagine. It is next to impossible to tell that your phone has been tapped by listening. A modern tap does

[\(Please turn to page 206\)](#)

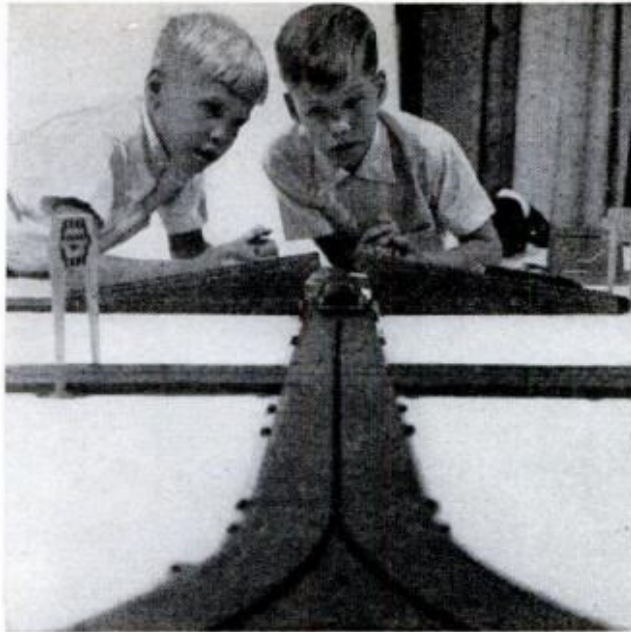

**Motorific Torture Track** puts these little cars through their paces hurtling through space, crashing through brick walls and bouncing through the spring test. Battery-powered cars scuttle around the setup turning left or right at the switch points. The Ideal Giant Detroit set is \$15. For four times the fun, add an extra car.



**Swinging Teens** will love the Tiger Guitar. It's a completely portable, amplified guitar that can go almost anywhere. The six-string instrument is good to look at and pleasant to listen to. Comes with shoulder harness, pick, music book and complete instructions for \$29.95 from Emenee. The amplifier has a 4-inch speaker and is battery-powered.

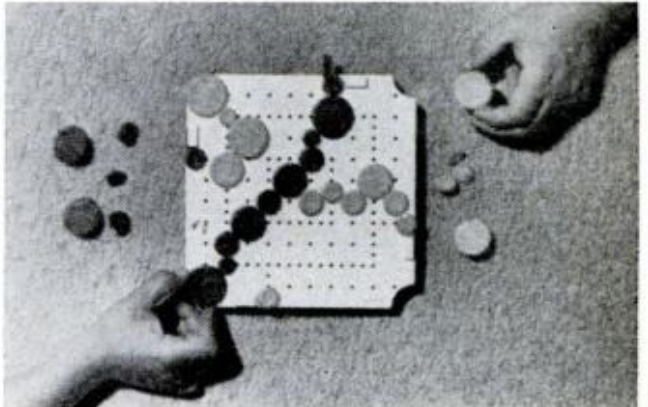

**Shifty Gears** is a true game of skill and mechanical know-how. Two, three or four players pit their wits against each other as they try to complete their train of gears before their opponents do. From Schaper, it costs \$2.



**Tricycles are out** when the V-Room X-15 pedals into sight. A new kind of pedal car, it's a jet on wheels as it banks, swoops, turns and steers with a joy stick. Rear wheels do the turning as the seat tilts. It's big enough for 8-year-olds, and small enough for 3-year-olds who are strapped into the adjustable bucket seat; priced at \$25 by Mattel.

# Coast to Coast in a TORONADO

In 6000 fast, rough miles, a few of the car's accessories acted up, but the sleek new Oldsmobile front-wheel drive proved that putting the cart behind the horse still works just fine

By Jim Dunne and Alex Markovich

**W**E'VE just put 6000 hard miles on an Oldsmobile Toronado, covering just about every road condition you can find anywhere in the country—mountains, desert, snow, high-speed freeways, rural trails, city traffic, the works.

It's been nearly 30 years since Detroit produced a front-wheel drive, so we decided this car deserved more than a routine shakedown drive. Our test started in Detroit, took us to San Francisco and back to New York.

The car's styling was a sensation; on the road, motorists gaped, often almost causing accidents. Wherever we stopped, we drew crowds of ogglers. But our main interest was in testing the machinery. Would that chain drive hold up? What about handling, ride, tire wear? Does a front-drive car really feel different? Here's a day-to-day report on what we learned.

*Friday:* We picked up the car in Detroit, with 266.4 miles on the odometer. Options include air conditioning, AM/FM station-seeking radio, power seat and windows, tinted glass, white walls, deluxe seat belts and GM's new air-injection system required in California. The standard Toronado base price is \$4617. Our Deluxe model with options lists at \$5761. It's a sleek, brutal-looking machine. Even when it's parked, it looks like it's crouching.

Tire wear could be an important consideration with front-wheel drive, so the first thing we do is measure tread depth. We'll check it at the end of our trip.

We start west across Michigan. Here are some first impressions: The flat floor (no driveshaft tunnel) gives acres of leg room. Rise is stiffer than usual. The firm suspension controls rearward weight transfer, helps front wheels to maintain traction. Hardly any wind noise with side windows closed. But severe buffeting when open.

Markovich finds spinning-barrel speedometer weird, hard to read. It stops his eye an extra second.

At gas stop in Buffalo, Mich., we get first taste of public reaction. It's 20 days before introduction date, and no one has seen the car. Crowd gathers. Everyone wants to see under hood, inside trunk. (This scene is repeated every time we stop throughout our trip).

Middle-aged woman: "They really got styling."

Station attendant: "Look at the size of that engine." He's the first to mispronounce car's name; calls buddy over to look at new "Tor-nay-do." Almost everyone calls it that.

Further observations: Flat floor makes it easy to slide across seat. With no vent-window frame in the way, there's clear side vision. Hood



San Francisco . . . with its precipitous hills proved no problem for the front-wheel drive. The car climbed inclines easily, without spinning its tires





**Detroit** . . . the starting point of our trip, was where we checked tire-tread depth. After 6000 miles, we rechecked and found wear was normal



**Wyoming** . . . gave us a chance to try out snow traction. No problem, even uphill. On the really steep, slippery hills, use reverse if all else fails

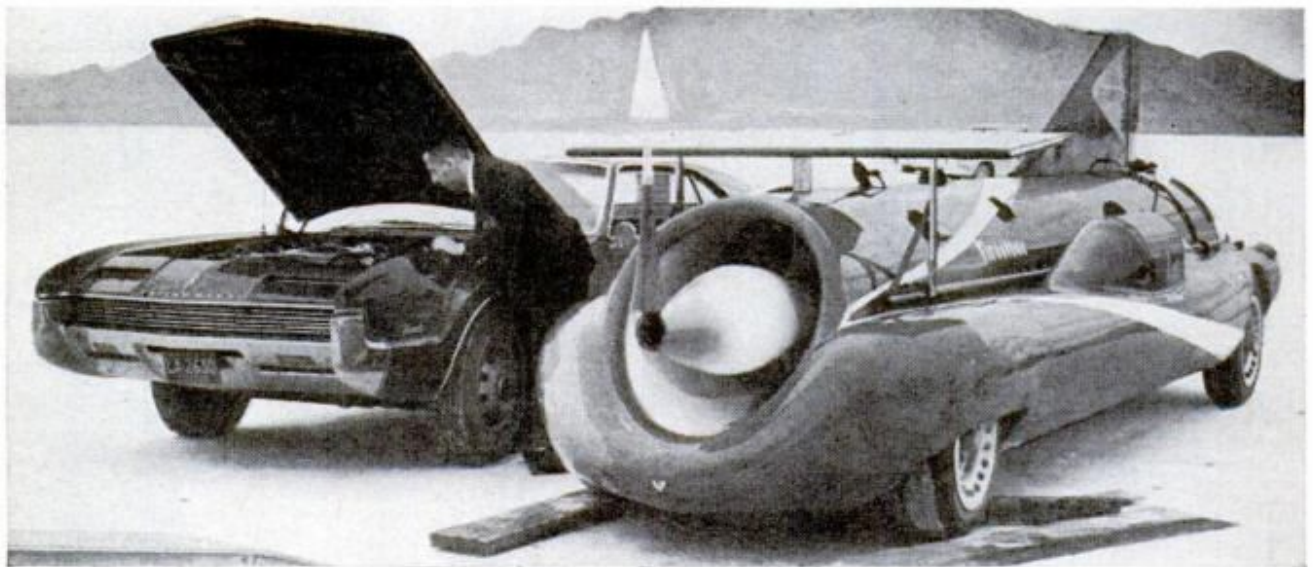

**Bonneville** . . . played host to two land-speed record contenders on day we were there. They were Art Arfons' jet-powered Green Monster (shown above) and the sleek and low Summers brothers' four-Chrysler-engined Goldenrod. Bad weather and minor mechanical problems kept speeds of both cars down

shakes over bumps. Brake pedal is low, also needs adjustment, but braking is powerful and progressive.

Swept-back dash adds more leg room. But Dunne misses a floor tunnel for resting his right foot. "That'll bother me the whole trip," he says.

A couple of bugs develop: Glovebox pops open on rough roads. At 399 miles, gas pedal falls off. We replace it, but it

won't stay on. We give up on it, use the rubber roller underneath.

After dark, we find lights too high, giving good view of tree tops. We stop overnight at Joliet, Ill., with odometer reading 581.5. So far, no big trouble.

*Saturday:* Stop for gas. Attendant spots Toronado script as he reaches for gas filler, does double-take. First check shows 11.7 mpg. We pump tires at 26 psi.



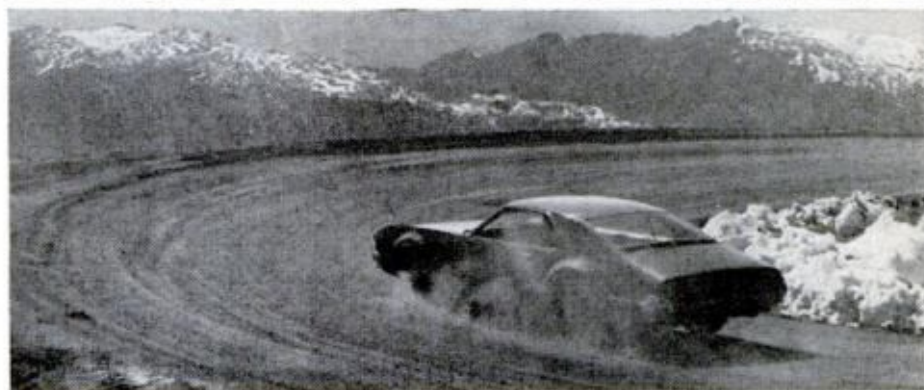

**Pikes Peak** . . . with its narrow hairpin bends proved car's fine handling. Lack of guard rail—with nothing visible over the edge but clouds—didn't help our peace of mind any. Climb to top of peak took us a half hour



**Bonneville** . . . race-car mechanics abandoned their streamliners to cluster around Toronado. They criticized unusually crowded engine compartment

We hold indicated 85 mph (actual 83), watching rear-view mirror for fuzz. Station-seeking radio is great in strange country. Automatically picks up local stations. Unpadded rubber covering on floor around pedals feels hard, and rubber is slipping out of frame. Satin-finish chrome on windshield wipers eliminates glare.

Ride smooths out at high speeds. No drive shaft vibration or mechanical noises,

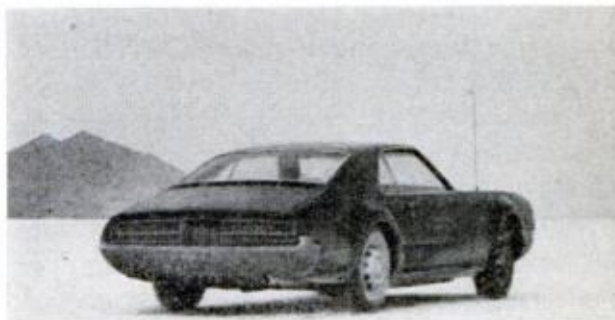

**Bonneville** . . . salt flats provided us with safe course for cornering tests and top-speed runs. Our corrected-speedometer times averaged 115.5 mph

even from the chain drive, are apparent. Handling is exceptional. Tight corners are safe at well over posted speed limits. Retracting headlights may be amusing, but in daytime they're useless for signaling other drivers.

People stare as we pass. Some speed up, pull alongside for a better look.

At Iowa City gas station, a '61 Olds station wagon follows us in. Driver says:



**Iowa** . . . is a rather unlikely place to spot Ferrari, but we found one. Struck by similarity of the rear-end lines, we posed the cars side by side

"I heard these jobs really handle. I stayed behind you for a way, but I was afraid to follow you through the corners." Gas mileage this leg is 12 even.

We're still impressed with the car's quietness. With windows up, we carry on normal conversation even at highest speeds. Plow-through ventilation is effective except that air is heated slightly even with temperature control closed. A minor adjustment should fix.

In Lincoln, Neb., station attendants are so excited they forget to wipe bugs off windshield.

From here our route is two-lane roads. Toronado gives us all the passing power we need. Passing gear ("S" range) is good to 80 mph.

Our night stop is North Platte, Neb. Odometer reads 1342.4.

*Sunday:* We start at 6:15 a.m., with temperature in low 40s. Weather is wet and windy. Bleaksville. Markovich plucks ice off aerial, recalls it was around 90° in New York when he left, three days before. But it's warm by the time we load our bags.

Crosswinds have hardly any effect on directional stability, even when a big semi passes from the opposite direction. The wipers cover a large area, but lift at 80 mph. Airfoil arms would help.

At gas stop in Castle Rock, Colo., we're up to 12.6 mpg. Attendants: "Boy, that's a fancy speedometer . . . looks real sharp . . . lots'a legroom in that Tor-nay-do . . . can you spin them front wheels?"

In Colorado—elevation 5500 feet and up—power drops off. We don't adjust carb,



**Utah** . . . cattle gave our brakes a workout when they wandered onto highway. Here we had to stop for flock of sheep. Brakes behaved quite well

since engine still has go—lots of it.

Pikes Peak is one of our major test sites. Race driver Bobby Unser ran a Toronado up the peak yesterday in a near-record time of 6:08. Our time is a cowardly 30 minutes. Handling is great.

It's a treacherous course, with narrow switchbacks and no guard rails. All you can see below is clouds. At the top, 14,110 feet up, the thin air slows us down as much as it does the car.

At the bottom of the hill, the gate-keeper, who's raced in hill-climbs, tells us he's driven the Toronado and loves its cornering. He says his racing buddies all like it too. "We've proved it can corner. It's a little underpowered and heavy for racing."

Our gas mileage suffers on the peak. We drop to 9.0 mpg.

We cross the Continental Divide after dark, start down western slope. Car whispers along downhill, and our ears are popping. We feel as if we're in a jet airliner making its landing approach.

Suddenly we're passed by a '65 Dodge Coronet. The driver seems intent on showing up our highly touted machine. About 100 yards ahead he barrels into a corner too fast, spins out and slides backwards 150 feet into a guard rail. The only damage is to his ego.

Our stop tonight is Montrose, Colo. Odometer reads 1978.9. Our gas mileage has picked up to 13.13.

*Monday:* We pull into a Provo, Utah, Olds dealership for 1000-mile checkup. Mechanics swarm over car. First one

[\(Please turn to page 208\)](#)



**Bugged** by burned-out lawn mower engines? Whirlwind rotary mowers, product of Toro Corp., Minneapolis, Minn., have a gimmick to kill this bug. Their 1966 Whirlwind line features the company's exclusive "Auto Oiler" as standard equipment. It's a funnel-shaped reservoir attached to the engine crankcase which makes engine maintenance simple. The operator simply fills the crankcase through the filler, then adds five extra ounces to the reservoir. Before each mowing he depresses the Auto Oiler plunger until the bubbles stop, which assures him that the crankcase is filled. The cherry atop this sundae is the Auto Oiler's transparent top, which shows when additional oil is needed. Toro is the first to incorporate an automatic oiler in its mowers.

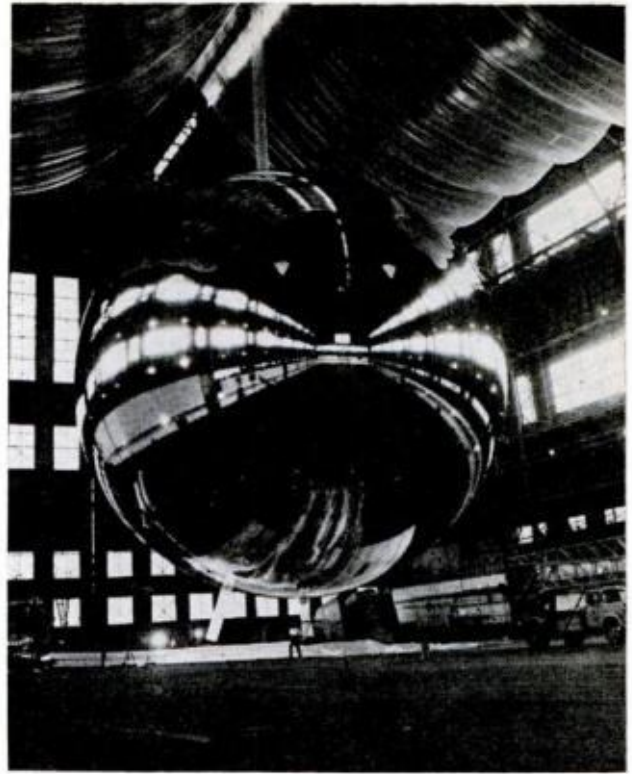

**Scheduled for launch** in 1966, another passive satellite undergoes inflation tests at Lakehurst, N.J. Named **Pageos** (for passive geodetic satellite), the 100-foot sphere will go into polar orbit at about 2300 miles altitude. Nearly identical to Echo I, it will be photographed by ground cameras to get precise data for locating points on Earth.

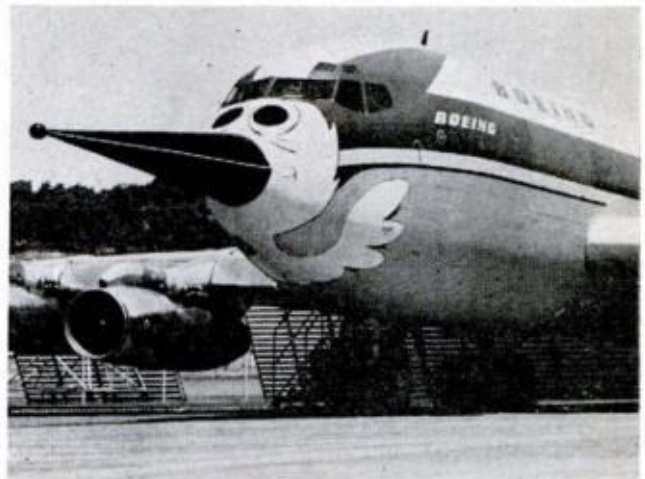

**Sticking its nose up to**, but not quite through, the sound barrier, this smiling bird is assisting engineers study low-speed flight characteristics of various supersonic transport designs. The nose is real—it contains response sensing systems—but the smile, while cute, is just paint. It was put on by people at Boeing where the plane was rigged with electronic equipment. The plane, incidentally, is the original prototype of Boeing's 707. It has been flying since 1954.

# Praise the Lord and Pass the Lug Wrench

*With a screwdriver in one hand and a bible in the other, a new breed of missionary repairs machinery to save souls*

By Keith Engh

**I**F YOU COULD FIX a broken fuel line of a 1937 Dodge truck with a leaf, a shoelace and a palm full of gumsap, you might qualify for one of the most challenging jobs in the world. You could join that small band of men who roam the rugged bush areas from Angela to Zanzibar repairing cars, trucks, airplanes, sanitation and power systems and a hundred other mechanical devices—often with little more than their imagination, their hands and whatever crude materials happen to be available.

You could be a missionary mechanic.

Envision these situations:

- You're in a remote section of South America. One of your responsibilities is to keep the crude equipment of a small hospital in working order. During surgery, there is a failure of the electric motor which operates the suction hose used to drain fluid from the patient's body. There is no auxiliary power and there's no time to work on the motor.

- Or, you're deep in the Congo bush and the old truck, almost as important to survival as your legs, is broken down. The fuel pump doesn't function because the diaphragms are shot. There are no replacements, no place to borrow and shipping time from the nearest supplier is six weeks.

- Or maybe it's elsewhere in Africa. You have been waiting almost a year for a shipment of tires. Finally, the tubes in the old set simply cannot be repaired any

more, but the truck still must be used.

If you could solve these three problems respectively: by pulling a truck or car up to the operating room window and connecting the suction hose with the intake manifold (as Dr. Paul Pendell did in the Cameroon); by making fuel-pump diaphragms out of monkey skins (as Theodore Couzzens did in Western Africa); and by riveting canvas, bamboo and old rubber hose into worn-out tires (as Dr. George Thorn did in another part of Africa)—you might qualify as a missionary mechanic.

It's not a job found in the classified ads. In fact, only in comparatively recent times have churches accepted for missions men who were mechanics or electricians and not primarily missionaries.

Twenty years ago, a doctor caring for the sick at a small, out-of-the-way mission post could be found operating in the fading light with a coal miner's lamp strapped around his head and later, with that same lamp, struggling half the night to get an antique autoclave back in working condition so his instruments could be sterilized.

But in the last few decades a more complete service to the sick, the hungry and the ignorant has been required to propagate the faith. Said one worker bluntly, "Plumbing may not be the way to man's soul, but it may allow him to live long enough for us to save it."

The number of trained missionary tech-



**PRIMITIVE CONDITIONS** at remote mission outposts make mechanics of missionaries, or missionaries of mechanics. Deep in the bush, old vehicles are almost as important to survival as legs and must be salvaged. Here mission workers attempt to pull bus through axle-deep mud with little more than rope and muscle

nicians is still small—some authorities say it is less than one percent of an estimated 100,000 missionary workers. And, though demand exceeds supply, it is unlikely that many do-it-yourselfers will find their way into African jungles to do God's work with a screwdriver and pliers. Still, the very circumstances under which they perform their jobs should be of interest to any nonprofessional who ever struggled with a home repair job.

What red-blooded man, for example, has never mused over some piece of junk and, even while his wife berated him for not getting rid of it, thought to himself: "That's sure to come in handy some day"? That's one of the first secrets of being a successful mechanic in the bush. He has to be something of a pack rat. "I never throw anything away," says one mission worker, "—not a wire spool, a bolt, not even a piece of scrap iron. Nothing."

Planning is another necessity. For us, an extra piece of TV antenna cable on hand may insure seeing the late late show; a missionary mechanic with a couple extra valves of the right kind could prevent a drastic power shutdown. (It might take eight weeks for a parts delivery by ship; at least a week and a half by air.)

Training native helpers—merely conducting a basic communication with them—is another difficulty. It's one thing to teach your son the principle of physics involved in a simple pump, but quite another matter to get a native to understand



**TRAINING NATIVES** to assume some of the mechanical work receives high priority. But translating technical terms into local dialects is often a problem

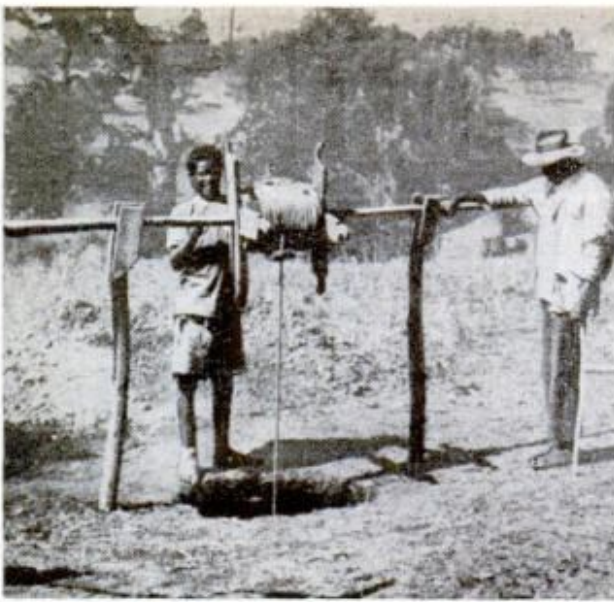

**OLD WELL** is as primitive as lowering bucket on rope. Even as basic a commodity as water must be gathered with rudimentary methods at some missions

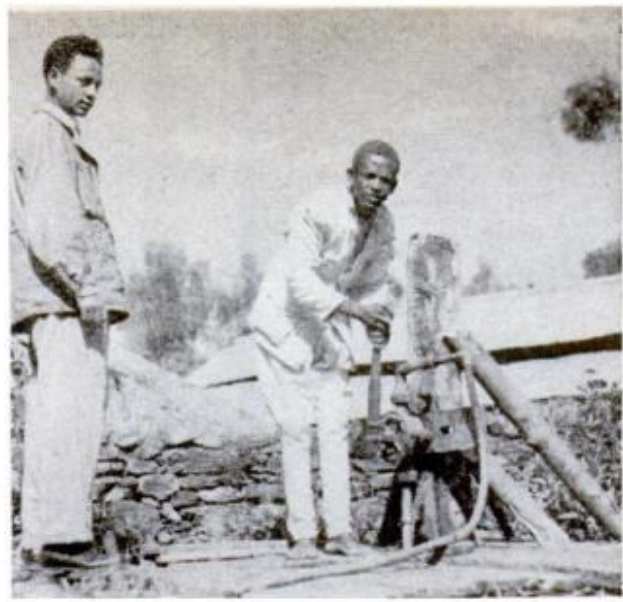

**NEW WELL**, while no beauty, is big step out of dark ages. Work was done by missionary mechanics with native help, and missions could use more of same

terms like *amperes* or *volts* when there is nothing in the elementary symbolism of his language to relate such foreign concepts.

A mechanic, like Swiss-born, self-taught Rene Ryter, teaching primitive industrial arts to a Bulu tribe in Africa would face this situation: the Bulu word closest in meaning to measurement is *vek*; the measuring device might be a stick or piece of string. The word closest to electricity is *zoian*, which describes nothing more finite than lightning or, sometimes, the supernatural power behind it. These are the only words that apply and it is almost impossible to reduce them to a definition of a specific unit of electric current. You have

to tell them to do this, do that and then this will happen.

The predominant condition of the missionary technician's life is economy. The simple desire of a homeowner to do it himself to save money is transplanted into necessity. No matter how ancient or crude, a device must be fixed because there is no money to buy a replacement, even if prices were reasonable—and they are not.

In the Cameroon, for example, the former French colony which got its independence in 1960, duty costs alone on American imports can double the price. An American doctor brought an International Traveload to haul stretcher patients. He



**TYPICAL SCROUNGING** operation used discarded cable spools as cooling tanks for diesel engines. Welded together, they formed 12-foot tanks. Steam pipe from engines entered bottom of tanks and, rising through water-filled tanks, the steam cooled as it rose, returning to engines from top of homemade, improvised tanks



**BRIDGE APPROACHES** are especially treacherous in bush. Here truck, loaded with valuable supplies in Cameroon, has slipped off road into ditch over stream. A difficult and awkward rescue operation even in civilized areas, it is near-tragic in mission territory. But truck is much too valuable to abandon in bush

figured he had invested about \$3500, but by the time it reached the mission hospital, the truck had cost him \$7000.

Thus, original costs, import duties and the related scarcity of basic equipment and spare parts make the missionary mechanic's job mostly patchwork. The theme can be identified in any recounting of some actual experiences of these men.

Floyd Allen, the first *bona fide* technician whom the Presbyterian Church accepted for field work, has served in the Cameroon since 1950. At Ebolowa, a mission post about 100 miles from the capital city of Yaounde, he is responsible for maintenance of a hospital, elementary

school, missionary residence and native workers' compound. Allen was raised in the depression and never finished high school. However, he worked as a welder, auto mechanic and nine years as a machinist, and he studied diesel engineering.

Despite a growing number of technicians being sent out, Allen and his jack-of-all-trades colleagues still carry the burden at most missionary outposts. Here are some of his accomplishments:

A dermatone is a medical device that looks something like a razor. Its oscillating blade is powered by a small motor through a rotating cable inside a flexible

[\(Please turn to page 184\)](#)



**SAVING BODIES** is duty to missionaries second only to saving souls and, in bush, some diseases have no equal in civilized society. In elephantiasis, patient's leg may swell to size of elephant's. Equipment in these remote areas inevitably breaks down and must be repaired on spot by new-breed missionary mechanic

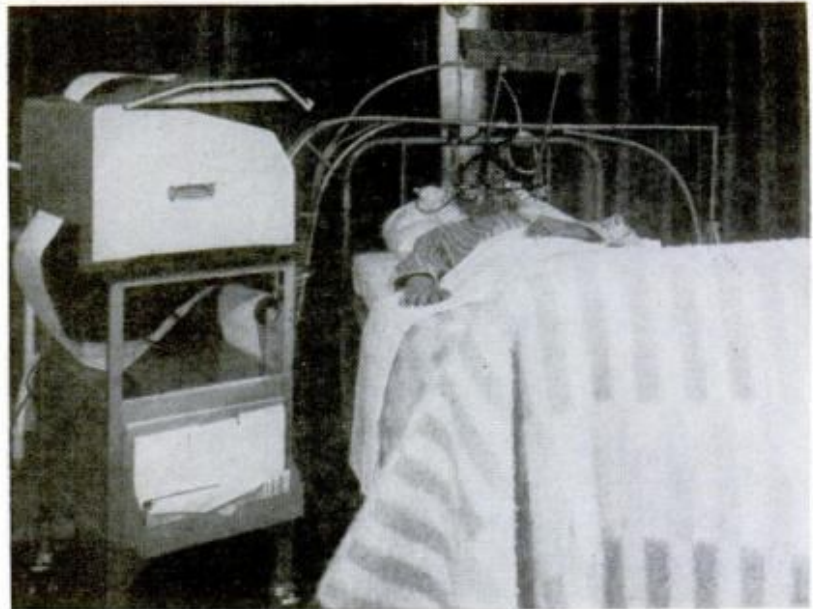
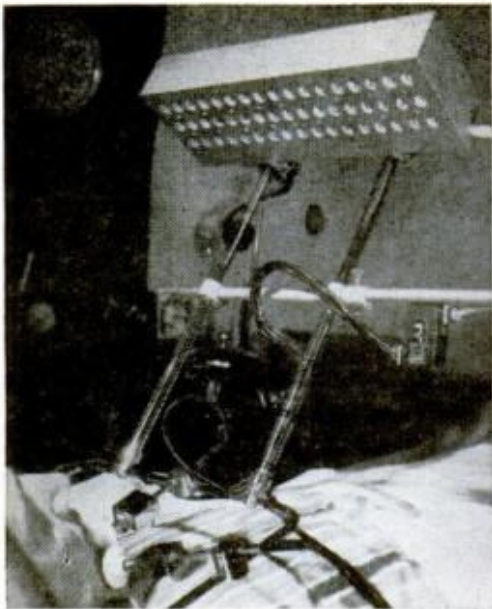

**He writes with light.** Able only to move his head, a polio victim in the Netherlands can put his thoughts on paper by using an electronic typewriter developed at a Dutch university. Three pressure switches, one at either side of the jaw and one directly in front of the chin, are the only controls. Pressure on one of the side switches causes letters on the keyboard to light in succession at the rate of 14 per second. When the desired letter lights, the patient hits the front switch with his chin, actuating the typewriter. If the "H" has just been printed and the man wants the "B," he presses the switch at his left, thus moving the "light" three spaces to left. If he had pressed the switch at his right, "B" would have been approached from the other direction, necessitating a complete circuit of the keyboard. The patient is capable of making from 40 to 50 jaw and chin touches per minute and can work for an hour at a time before tiring.



**Fold-up spectacles** have an adjustable bridge designed to fit any face. The arms grip the side of the head. When closed, the glasses are pocket-sized: four inches long, one inch wide, Tura, Inc., Great Neck, N. Y., maintains that their spectacles (\$20) may replace haughty lorgnettes.

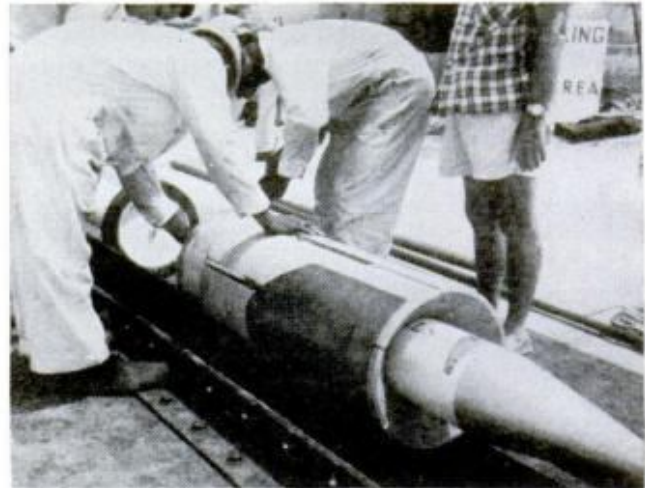
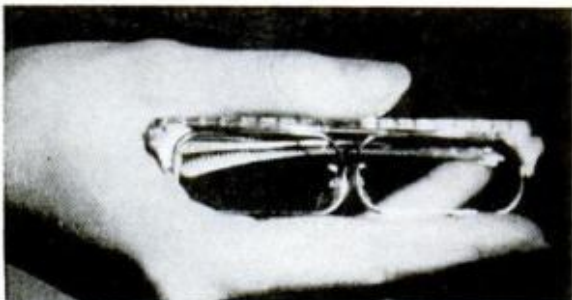

**Salvo into space.** Naval 16-inch guns now blast high-altitude research rockets into space in tests conducted by Canada's McGill University. Encased in wooden sabot for its passage through the gun barrel, the solid-propellant rocket ignites after leaving the barrel, as the casing breaks away.





**Wipeless windshield.** Motorists may benefit from a repellent that was developed for use on airliner windshields. It sheds rainwater so efficiently that near-perfect vision can be obtained without wipers in the rainiest weather. Perfected after 24 years of research by Dr. D. F. Stedman of Canada's National Research Council, Ottawa, it consists of a complicated silicone compound which is simply rubbed onto the glass surface and polished.

Pilots' vision is often distorted or blurred by heavy rain striking the windshield. This is especially dangerous during landing operations. Dr. Stedman claims that with the repellent, even the heaviest rain looks like tiny grains of pepper striking the glass. Called SPR (semi-permanent repellent), it looks like black shoe paste. When spread on the glass and subjected to friction, it molecularly combines with the glass. One coat may last for several months.



**Mom never looked like this.** What the well-dressed cook should wear is the theme for this mannequin prepared by Philippe Boucaud for the Paris antique dealers' exhibition. Copied from a 17th century engraving, the figure is draped with kitchen utensils of that period.



**Cake cutting easy as pie.** Taking the chore out of cutting cake for thousands of men at Anderson Air Force Base on Guam, T. Sgt. Claude Fedrick welded seven knives on two cross bars, so he cuts a large, flat cake with three motions, once lengthwise and twice across. The time-saving cake cutter is being adopted by a number of military installations.

# Master Modeler

*Working in a miniature machine shop, he turns out*

BY ED NANAS

**I**N THE DAYS before gunmaking became a factory operation, the only way an apprentice gunsmith could go into business for himself was to build an exact half-size replica of a pistol for his employer. The theory was that if the apprentice could produce a working miniature, exact in every detail to the full-size gun, he indeed had mastered the gunmaking art and was ready to strike out on his own.

Today, half and quarter-scale replicas of famous or unusual sidearms are collectors' items,

and modelmaking hobbyists have turned their talents and lathes back into the pages of history.

Raymond Stankiewicz builds 30 to 40 miniature models per year in the basement of his Bohemia, N.Y. home, the small guns bringing prices ranging from \$100 to \$1000. This appears to be lucrative, but it can take as long as 80 hours to build a half-scale model. He already has spent some 60 hours machining parts for a quarter-scale model of the very rare 1847 Colt-Walker pistol—and he's only halfway there!

"You can't rush a job," Stankiewicz claims. "One small slip and you may have to junk five hours' work. Generally, there are more than 23 parts in a gun. Each

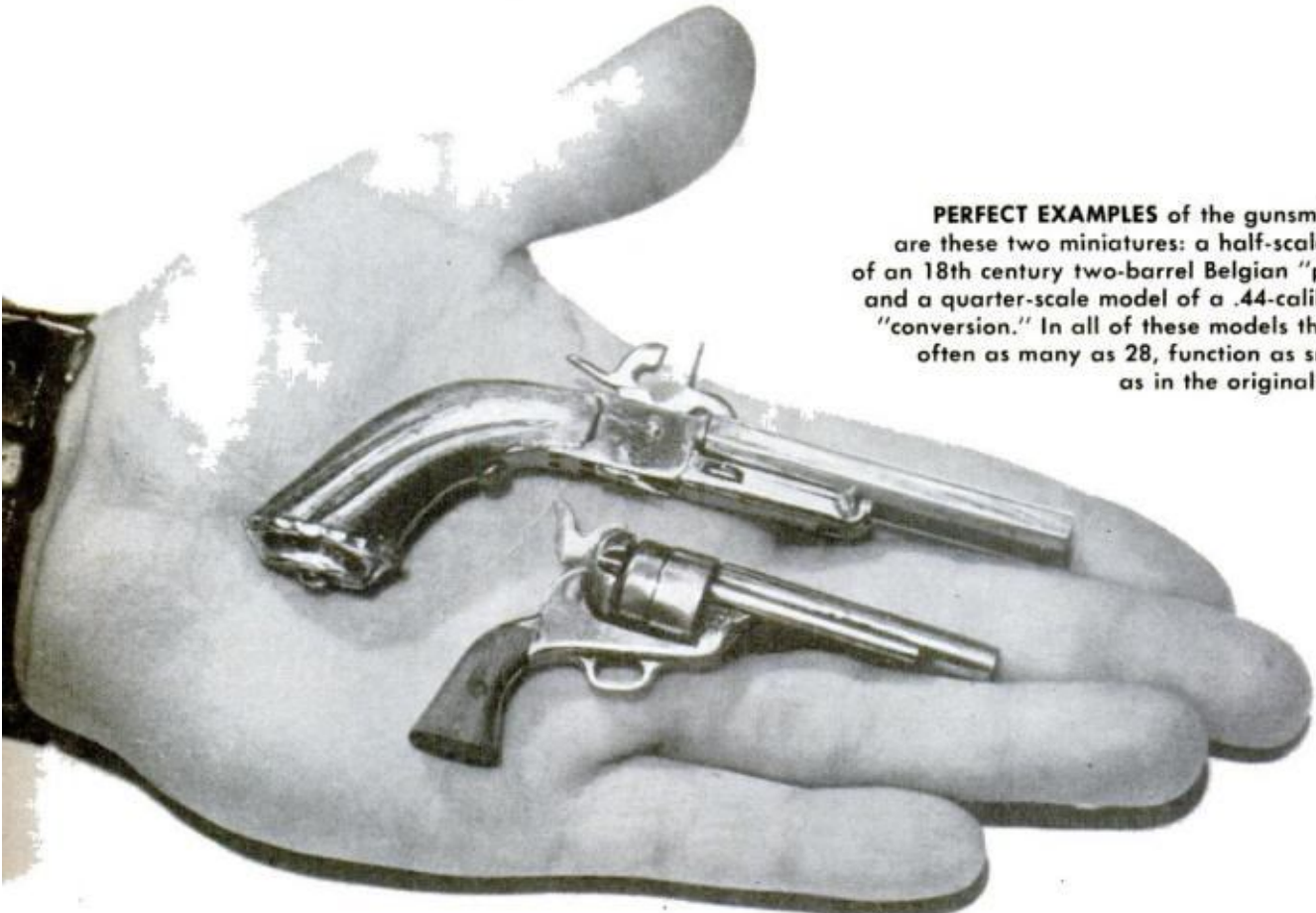
A black and white photograph showing a hand holding two miniature pistols. The hand is positioned palm-up, with the fingers slightly curled. The two pistols are resting on the palm. The larger one is a half-scale model of an 18th-century two-barrel Belgian "pin-fire" pistol, and the smaller one is a quarter-scale model of a .44-caliber Colt "conversion" revolver. Both are highly detailed and appear to be made of metal.

**PERFECT EXAMPLES** of the gunsmith's art are these two miniatures: a half-scale model of an 18th century two-barrel Belgian "pin-fire" and a quarter-scale model of a .44-caliber Colt "conversion." In all of these models the parts, often as many as 28, function as smoothly as in the original firearm

# of Midget Guns

*Lilliputian firearms to match fine antiques to the tiniest detail*

is a potential pitfall. The collector who gets your gun will strip it, go over it with a fine-tooth comb and settle for nothing less than perfection."

Perfection requires proper tools: small steel lathe, bandsaw with steel gear, table and jigsaws, drill press, buffing machine, calipers, micrometer, height gauge and jeweler's loupe (eyepiece) for optical fittings. While the initial investment may run the hobbyist close to \$1000, the tools can pay for themselves within a year if he sells part of his output.

The first step is to draft working plans or blueprints. If the mini-gunmaker can borrow an actual gun from a collector, a museum, a dealer or a manufacturer,



**PAINSTAKING ACCURACY** is necessary for a miniature to have value. In this case the gunsmith worked out mechanical details of an 1860 Army Colt by first making a full-scale model

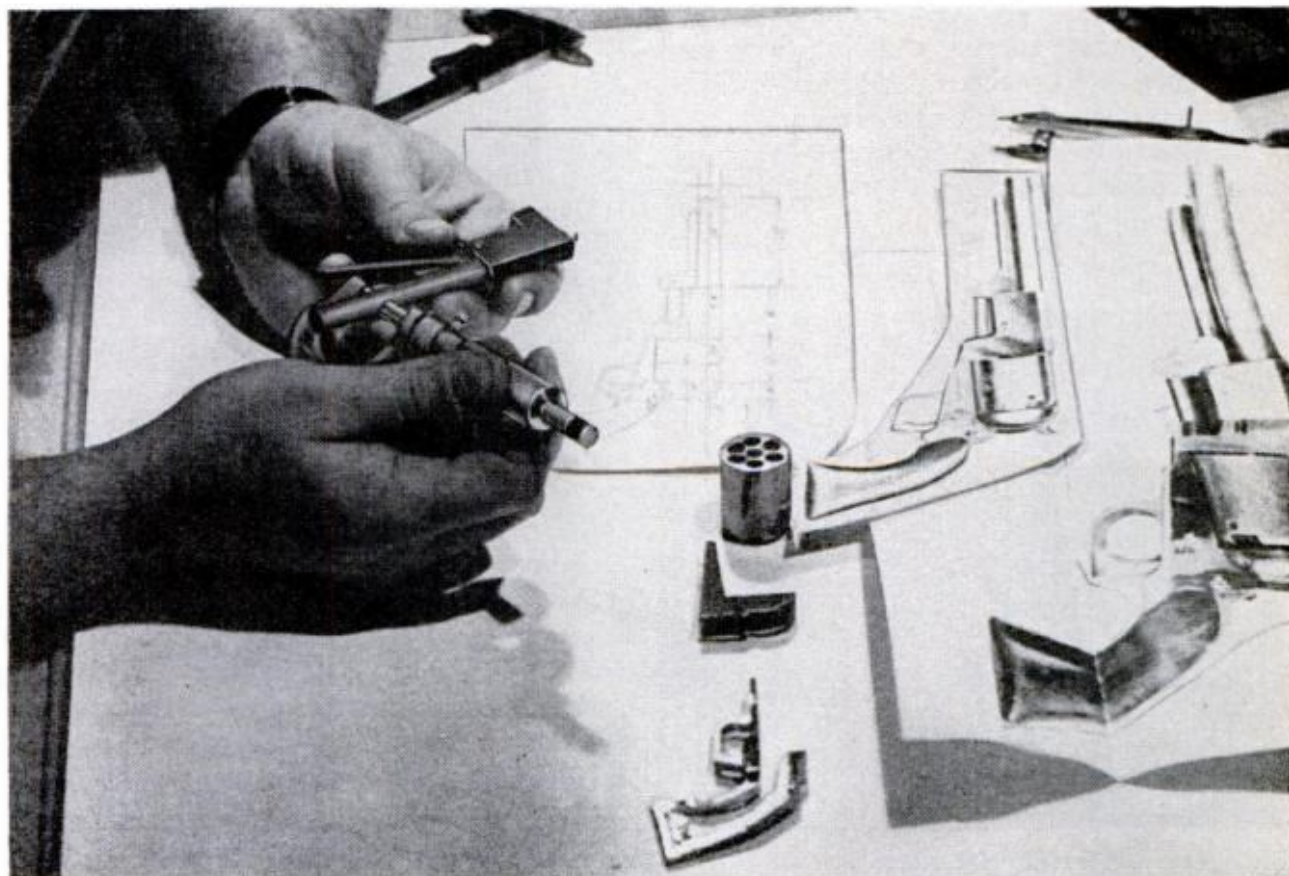

**WORKING FROM A CATALOG PHOTO** makes the job more difficult, but it is a common reference source for the modeler. In this case the enlarged photo is reduced to a scale drawing, then a detailed blue print

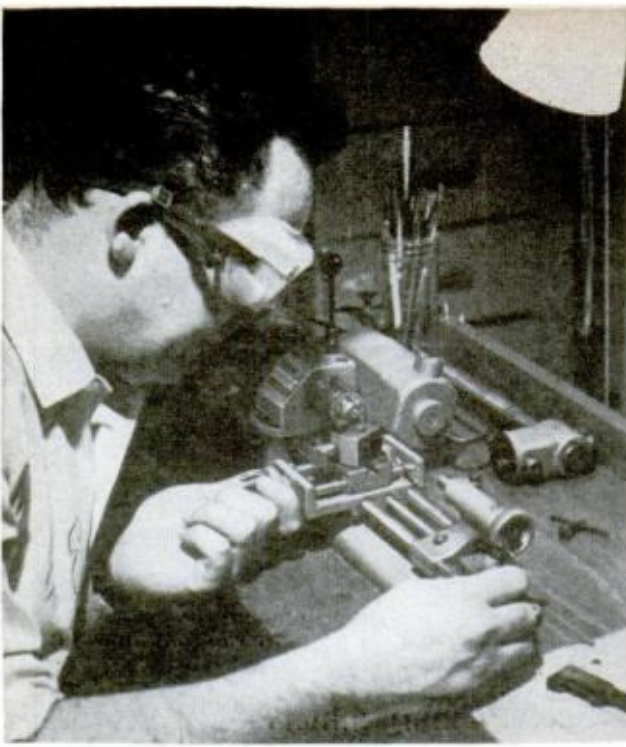

**PRECISION TOOLS** are vital to this art, where details are calibrated to thousandths of an inch, and a slight error in machining would cost hours of work

it is a simple matter to apply calipers and draw scaled plans. However, if the gun is a rarity, the collector is often reluctant to lend it or have it handled, but the owner or museum displaying such a gun will usually provide a modelmaker with actual-size photos. Otherwise the hobbyist must search through old gun magazines and libraries for pictures, plans, artist's sketches or verbal descriptions.

To scale a gun from photos or drawings, you need at least four pictures: top and back elevations and both sides. Often a



**BOON TO MODELMAKERS** is the Unimat, a multi-purpose power tool designed specifically for machining and drilling miniature parts with minute tolerances

sketch and photo of the actual gun will turn up discrepancies in detail. In such cases, the gunsmith accepts the photo.

After plans are drawn, the modelmaker must decide whether to use steel or brass stock. Steel must be used for quarter-scale models because small steel parts can better withstand stresses associated with machining and deburring. Also, steel miniatures bring higher prices.

Stankiewicz prefers brass for half-size models. It costs more than steel but is much easier to mill and drill. Brass poses another problem: its yellow color must be made to look like steel. To accomplish this, he has developed a bluing process using heat to draw a blue dye into the brass pores. When cleaned and polished, the metal parts take on an authentic and permanent steel-blue appearance.

All round stock is machined first; flat parts last. The barrel and cylinder are drilled, fluted and threaded as per plan. To comply with federal regulations, Stankiewicz does not drill through the barrel but leaves one fourth to three fourths of its length as solid metal. Otherwise the gun could be fired and a special gunmaking license would be required.

Milling and indexing the cylinder of a revolver ranks as a most difficult machining operation. And in most guns, the housing (part surrounding the cylinder) must be of one piece. This may involve long hours of hand filing and deburring.

Small parts, such as the trigger, hammer and hand, must be machined to ultraclose tolerances. It is not necessary to machine and thread screws since commercially available watchmakers' screws are ideal for miniature modelmaking.

Woodworking know-how is needed at handle-making time. African mahogany, which can be buffed to look like walnut, is most often used by Stankiewicz, who mixes stains to get color combinations closest to those in the original guns. Ivory, lemonwood and walnut are used occasionally.

A 29-year-old freelance tool designer and industrial modelmaker, Stankiewicz smiles at the idea of a modelmaker getting rich at his craft. He cites the example of an average job taking about 80 hours and selling for \$200. At best, this is \$2.50 an hour, not including materials.

"You have to face one thing," he says, "this is purely a labor of love." ★ ★ ★



**WITHOUT ALIGHTING FROM HIS CAR**, a customer can transact, by means of a two-way microphone, all regular banking business at one of 15 bulletproof teller booths

## Banking in the Garage



**ENTRANCE** to the world's largest motor bank, in Denver, Colo. It admits only customers on wheels

**DRIVE IN**, sit tight and complete your banking business without ever budging from your car. Such is the convenience provided at the Denver U. S. National Bank, the world's largest motor bank, where 15 cashier booths are expected to serve around a million cars a year.

Officers of the bank say they now give the best in modern banking anywhere. To give business a fillip, future plans call for a dining room and an auditorium where customers will be wined and dined and entertained.—*M. J. Pedersen*



**DESIGNED LIKE A HUGE GARAGE**, the ground floor caters only to motorists, who are directed by an automatic signal to booths open for business. Other floors have parking space in case of more involved business.



**SMASHING A PATH** through the antarctic ice, the *USS Glacier* reaches the *Polarhav*, a small sealer carrying supplies and a relief team to the Belgian antarctic expedition at King Baudouin Base.

# Rescue in the Polar Ice Pack

**MISHAPS PLAGUED THE RESCUE**, and ten days after reaching the stricken ship, the *USS Glacier's* only helicopter developed engine trouble and crashed on the ice, tearing off the tail and rotor blades.



# Slamming into a frozen no-man's land, we fought through 15-foot ice to reach a small "sealer," icebound for six weeks and carrying relief to an antarctic station.

By Capt. Edwin A. McDonald, USN (Ret.)

**W**HEN THE CALL FOR HELP came from the *Polarhav*, a small sealer carrying a relief party to the Belgian antarctic expedition at King Baudouin Base, the icebreaker, USS *Glacier* was in the Ross Sea.

Our orders, from Rear Adm. George Dufek, commander of the U.S. Naval Support Force in Antarctica: *proceed at once to give assistance*. This meant fighting through five thousand miles of polar sea, and in this austral summer of 1959, the ice in the Bellinghausen and Weddell seas was the worst on record.

The *Polarhav* had been within 30 miles of its destination when it was stopped by ice on Dec. 24. Capt. Sigmund Boe, Norwegian master of the *Polarhav*, had fought free many times only to be trapped again. Finally, low on fuel, he gave in to the ice and radioed for assistance. The drifting ice pack had carried the sealer 140 miles from the Belgian base when the *Glacier* moved into the ice on Feb. 2 and began the arduous task of smashing a path through the remaining 65 miles of solid ice.

We pushed steadily forward hour by hour, at first brushing the ice aside, and then, as it grew heavier, the full power of the 21,000-hp electric motors was brought to bear. The stem, a battering ram of eight-inch steel reinforced by a buttressed spine of four-inch plate, slammed into the ice; the bow of the ship rode up on the floes and crushed them with the full weight of 8500 tons.

Again and again the powerful icebreaker, newest and largest in the fleet of five, was brought to a shuddering halt so that she had to back off and repeatedly charge the ice, which not only stopped the advance, but clawed and gripped the sides. Sometimes the *Glacier* would slide up on a floe and hang there, unable to back off. Then the heeling system had to be used.

The *Glacier* has three huge tanks on each side of its squat, watermelon-like hull that hold 140,000 gallons of seawater. Powerful pumps throw the water from one side to the other in 80-second intervals, rocking the ship. And when the forward thrust is added the ship goes through the ice like a mammoth jackhammer.

Our progress was unbearably slow, and I was eager to make contact with the trapped sealer. I took off by helicopter from the *Glacier's* flight deck and was soon skimming across the hummocky ice. Finally, in the distance, 15 miles away, a small dot appeared in the vast expanse of ice. It resolved itself into a small red ship, and as we drew near I could see the evidence of her stay, the piles of rubbish encompassing her on all sides: boxes, tin cans, papers, all the refuse that is casually tossed aside to sink normally below the waves.

Capt. Francois Bastin of the Bel-



**CAPT. McDONALD** directed rescue



**SAVED FROM MONTHS OF DRIFTING** along with the massive ice shelf, the crew of the *Polarhav* lines the bow of the ship as they wait for the icebreaker to batter a path through the sea of 15-foot-thick ice

gian Air Force, leader of the expedition, and Capt. Boe greeted us and invited us aboard out of the subzero temperature for hot coffee.

In the ship's compact wardroom I learned how the Belgians had kept up their spirits during the long ordeal. On the way over in the helicopter I had seen them out on the ice stretching their legs. On the deck were carcasses of seals they had killed to feed their sled dogs. The coffee I supped so gratefully had been made from snow scraped off the ice. In leisure moments they had devised games and entertainment; for example, an election to the town

council of an imaginary Penguin Hollow which provided several days of high-blown oratory.

*Glacier's* speed, 1000 yards an hour at midday, decreased still further. Banging away with everything she had, the icebreaker inched forward. I tried not to think of what this punishment might do to mechanical and electrical systems. After dinner that evening, Cmdr. Joseph R. Houston, the commanding officer, reported that a blade on the port propeller had snapped when a chunk of ice had squeezed beneath the hull. How serious was the damage? Vibration did not appear too bad.

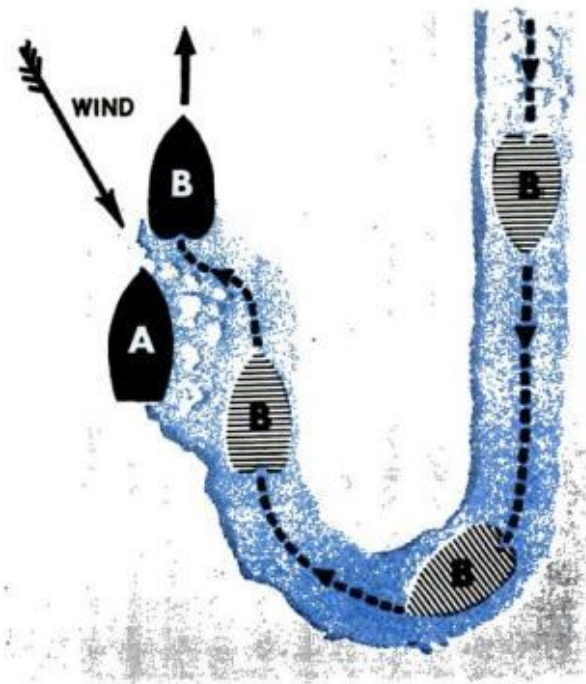
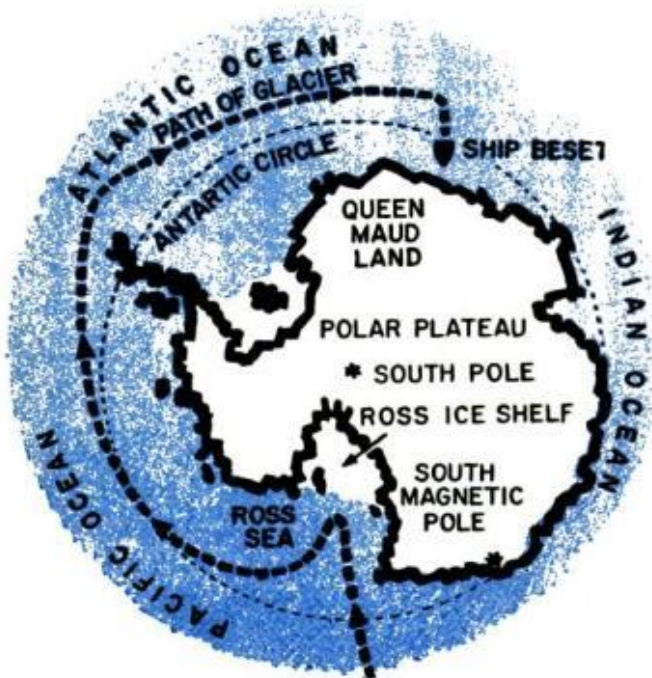

**ANSWERING THE DISTRESS CALL**, the USS *Glacier* left the Ross Sea and traveled 5000 miles through storm-tossed seas to the opposite side of Antarctica



We were committed and had to keep going. By morning of Feb. 4 we had closed the distance to the *Polarhav* to 3000 yards; by noon to less than 1000 yards.

That afternoon the *Glacier* finally pulled alongside. *Polarhav* crewmen swarmed the rigging, shouted, waved and dipped her flag. Caught by surprise, we blasted the whistle and ran up the proper formal response pennant. Even the sled dogs howled. It was a glorious occasion.

To reach the Belgian base now meant trying an end run, first to the outer fringes of the ice, then steaming eastward for 140 miles and finally plunging back into the ice pack to reach the ice shelves of the antarctic shoreline. It was late in the season. Ice conditions might suddenly worsen. Could we do it?

After the *Polarhav* was "broke-out," we hoped it would have sufficient power to keep going. When ice conditions are severe as they were here, and there is very little water area in which to displace the ice, a great deal of brash or loose ice is washed toward the bow of the following vessel. It may be unable to maintain headway. We might spend protracted periods freeing the offending ice by propeller wash or resort to towing.

We were fortunate in not having to rely on towing, a very slow and painstaking procedure in ice. The two ships did fairly well for 15 miles, but the weaker *Polarhav* frequently stopped against the ice rubble



**BUNDLE OF SLED DOGS** for use by the Belgian scientific expedition is unloaded from the *Polarhav*

left by the icebreaker. Each time, the *Glacier* backed down to wash the ice away with her powerful screw currents. It was slow going.

The weather, friendly for two days, now took a turn for the worse. An east wind built up to 40 knots. Snow swirled across the decks, covering everything. Visibility was reduced to zero. Ice floes driven together by the wind curled and buckled alarmingly along their edges. Soon, the sea was a mass of hollows and furrows as if plowed by some insane and drunken giant. Ship movement came to a halt. I ordered the ships to lie-to alongside one

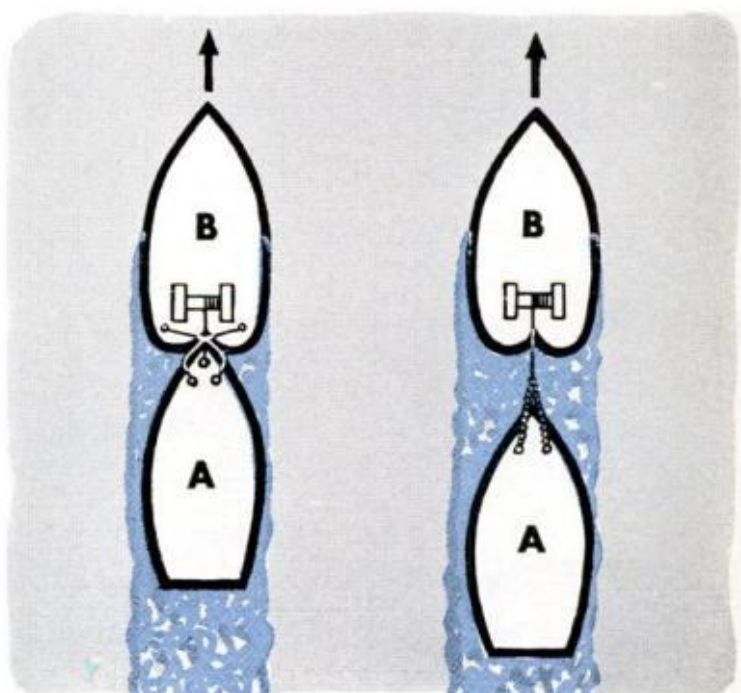
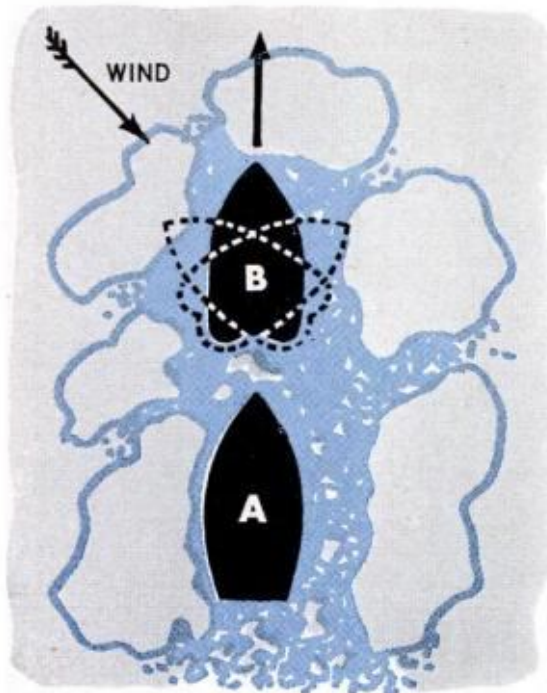

**FREING A TRAPPED SHIP**, the icebreaker (B), clear a channel to leeward taking advantage of the wind to drift the beset vessel into the channel

another. To keep going would only waste fuel and probably damage the ships.

Rear Adm. George Dufek anxiously read our dispatches in far-off New Zealand. A day or so later he directed a second icebreaker, the USS *Edisto*, to report to my command. Somewhat smaller than the *Glacier*, it had completed her mission of

relieving at Ellsworth, 1000 miles away.

We decided to transfer all cargo and expedition personnel from the *Polarhav* to the *Glacier*. Only one ship would then have to recross the pack to reach the King Baudouin base and the icebreaker, with its broken blade, would not be burdened with

[\(Please turn to page 196\)](#)

## **New outpost down under**

ANVERS ISLAND, off the west coast of the Antarctic Peninsula, is the site of the newest U.S. scientific station. This is known as the "banana belt," because, contrary to other areas of Antarctica, rock is exposed and the weather is relatively mild.

Named Palmer Station in honor of Capt. Nathaniel Palmer, an American seal hunter who explored the region in 1820-21, the headquarters will give scientists a chance to investigate an area rich in plant and animal life. It will bridge an important gap in worldwide coverage for the upper-atmosphere physicists, seismologists and geomagnetic observers.

About one-third of the way down from the northern tip of the peninsula and 25 miles offshore, Anvers Island is dominated by the centrally located massif of 9060-foot-high Mount Français.

So rich are the surrounding waters in fish that Dr. Waldo Schmitt of the Smithsonian In-

stitution trapped over 80 fish of the *Notothenidae* family in a single bottom drag. This bountiful fare attracts whales, seals and many kinds of sea birds, including five different kinds of penguins, three of them not found in the colder areas.

Glaciologists will be able to formulate important conclusions from the study of ice on the island, taking advantage of the confinement to simplify experimental conditions through the removal of variables associated with the more complex glacial systems.

Biologists will study antarctic insects. Small numbers of primitive flies, ticks, midges and springtails—the only land-dwelling animals in Antarctica—are found in this area. There are also algae, fungi, lichens, mosses, liverworts and three flowering plants in some locations.

During the long winter night, when the "banana belt" becomes the "frozen banana belt," Palmer Station will be staffed by five scientists from the National Science Foundation.



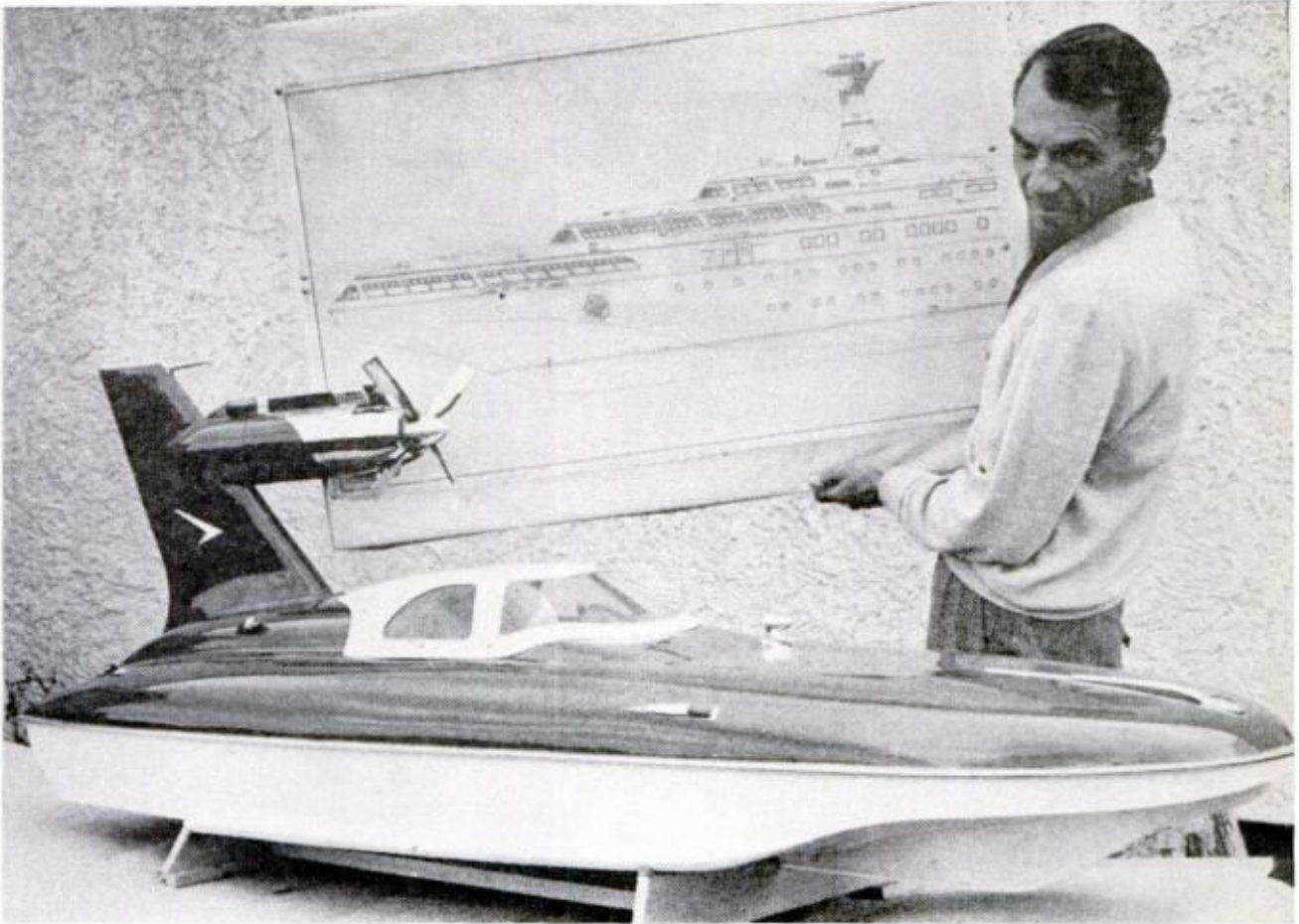

**Air-cushion boat.** Powered by a 10-cc motor, a test model air-cushion boat built by a German designer lifts at 10 miles per hour and has a top speed of approximately 60 miles per hour. The full-size boat will be powered by a 90-hp turboprop motor and carry two people. The designer, Dieter Jansen, Renning, West Germany, already has a second air-cushion boat on the drawing board a 500-passenger giant for operation on inland waters.



**Parkamometer.** To test the ability of new parkas to keep men warm, Air Force technicians devised this temperature-taking device. With it tucked inside the hood, subjects were exposed to temperatures of minus 80°F. Researchers found that the coldest air temperature in the hood was 50°F. and the coldest skin temperature 45°. The parkas passed the cold test.

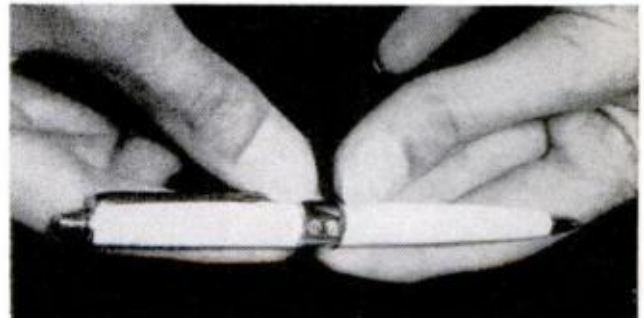

**Date reminder pen.** It will not be possible to forget the date with this new pen, because the center section is a small rotating calendar. Set the date each morning and leave the pen nearby all day. Made in Germany, it is ideal for both the home and office.

# Way-Out World of ANTIMATTER

Antiparticles—mirror-image counterparts of “normal” matter—exist. It’s even possible, say scientists, that there are antistars, antiplanets—and antipeople

WILLI WALLEB

MSA-OUT MOLIQ OF

By James R. Berry

**W**HATEVER IT WAS, it reached earth shortly after 8:00 a.m. on June 30, 1908. After cruising through the vast wastes of the universe for perhaps billions of years, it slammed into the atmosphere and flashed over the Tunguska River Basin in Siberia. Its wanderings ended about three miles above the forested peat bogs as it exploded with a force far greater than that of the biggest hydrogen bomb.

The blast momentarily bleached the ground white and was heard 500 miles away. Seismographs around the world noted the shock waves and Russia's Irkutsk Observatory recorded large disturbances of the earth's magnetic field. Strangely, despite the energy released, the explosion produced no mushroom cloud. A farmer 40 miles from the center of the blast reported: "I saw a ball of fire as heat almost burned my shirt off. I glanced down and when I looked up again the ball was gone. Then a rush of air threw me to the ground and knocked me unconscious."

Another curious thing: Investigators exploring the blast site found no crater or traces of meteorites. Possible cause of the event: a monstrous meteorite that completely evaporated.

"Or a chunk of antimatter smaller than a baseball," says Dr. Clyde Cowan, physicist at Catholic University in Washington, D.C. Along with Nobel prize-winner Willard Libby and astro-physicist C. R. Atluri, Dr. Cowan investigated the Tunguska explosion. Their conclusion, published last May, suggests that a lump of antimatter—matter with an atomic structure the exact reverse of ordinary matter—caused the blast.

"A piece of antimatter would explain why there wasn't a mushroom cloud," says Dr. Cowan. "All matter would have been consumed in the explosion. Of course, there are other reasons why we think antimatter could have been responsible."

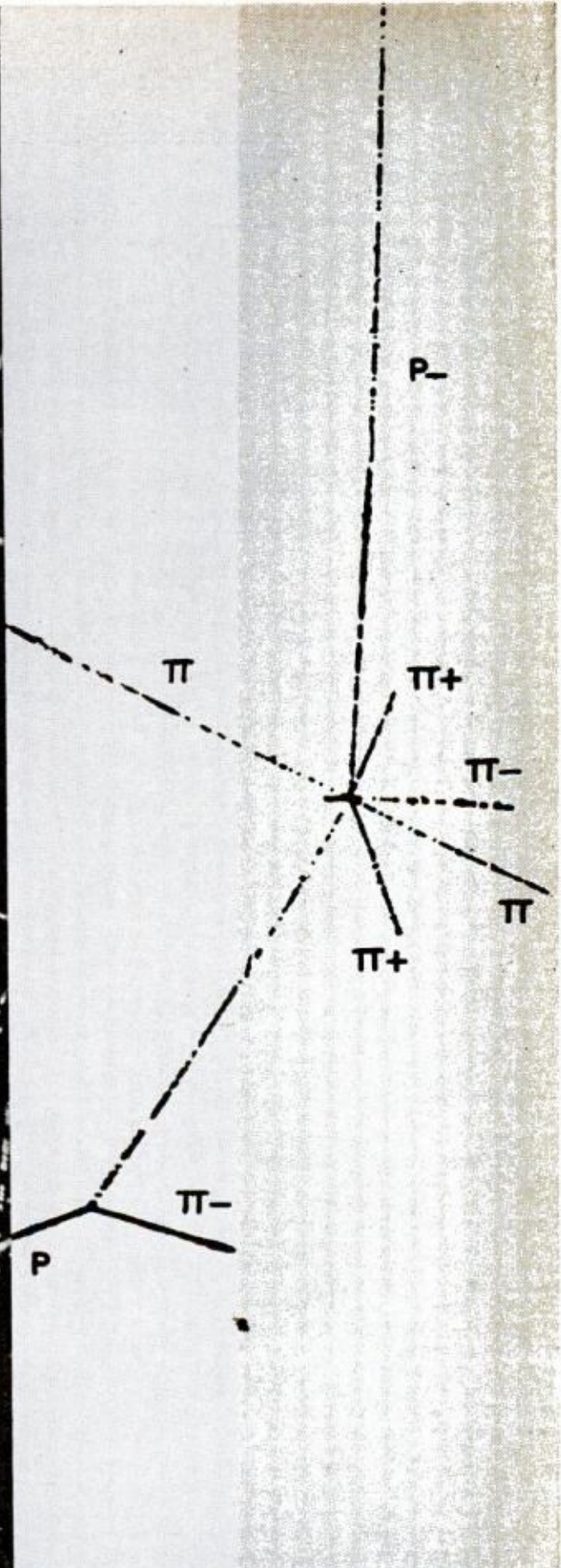
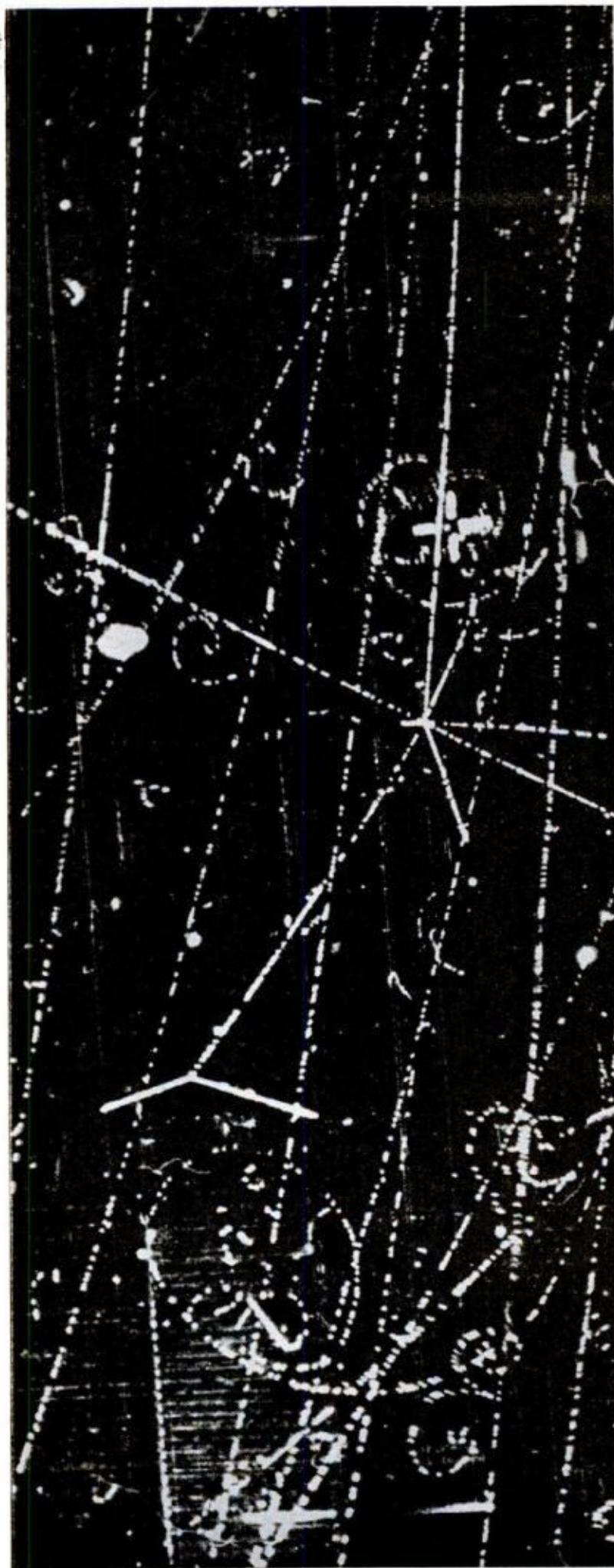

AND THEN THERE WAS NONE. Antiproton ( $P^-$  in diagram above) is destroyed when it crashes into proton of carbon nucleus, creating a "star of annihilation." Event was recorded (left) by tracks created in a propane bubble chamber in lab at the University of California

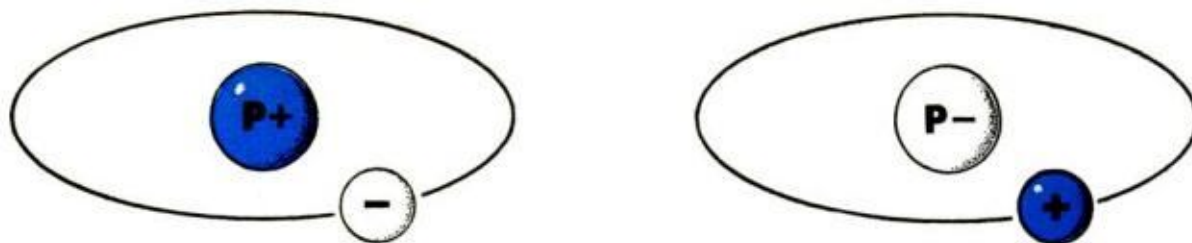

**OPPOSITES THAT WOULD DESTROY EACH OTHER:** hydrogen atom (left) and its antimatter counterpart. Instead of a proton in its nucleus, the anti-atom has an antiproton; instead of an attached electron, a positron. Though they have opposite charges, particles in the two atoms are held together by the same nuclear force

Dr. Cowan, a heavy-set man with white, crew-cut hair, led me to an instrument-jammed room in the basement of Catholic University's physics department. From under a desk he pulled out a cardboard carton filled with chunks of wood. Arranged on a table, they turned out to be two pie-shaped slices from a cross-section of tree trunk. "An antimatter explosion would increase the atmospheric level of carbon-14, a radioactive element absorbed by plant life," he explained. "We got this tree from Arizona, stripped off growth rings as far back as 1873, and tested a

sampling of rings for their carbon-14 content." I could see the chisel marks where the 1873 ring had been chopped from one side. "We did the same with another tree from California. In both cases the carbon-14 level was highest in 1909, the growth year after the Tunguska event."

The three scientists' theory that antimatter caused the blast is controversial. But it hasn't taken physicists by surprise. Actually, the first hint that matter might have a mirror-image counterpart came in 1927 with the work of Paul Dirac, a British physicist. As we know, in atoms, nega-



**DID A BOLT OF ANTIMATTER SNAP** these trees in Siberia's Tunguska River Basin and, according to eye witnesses make "even the light of the sun appear dark"? Scientists who investigated the mysterious explosion think that may be the case. The blast produced no atomic mushroom cloud and no trace of crater

tive electrons churn around a positive nucleus, and Dirac evolved equations that explained this and other properties in mathematical terms. But there was a hitch. The same equations led to the conclusion that positive electrons spun around negative nuclei. In short, antimatter.

Antimatter's existence seemed so preposterous that Dirac doubted his own conclusions. So did most other scientists, at least until 1932.

Early that year, Carl Anderson—an American physicist interested in the nature of cosmic radiation—photographed cosmic rays passing through a Wilson cloud chamber. On one of the pictures he found a trajectory that only an electron could make, but its curve was in the wrong direction. Same mass and speed: but opposite charge. It was Dirac's anti-electron. Anderson named his discovery the positron (from *positive electron*) and collected a Nobel prize for his work.

The positron's discovery started a scientific scramble for its atomic mate, the antiproton. "The antiproton's existence was very probable," recalls one scientist. "But probability wasn't enough. We needed definite experimental proof." To get such



**RING FOR YEAR** after Tunguska event had highest radioactive content in Arizona tree. That was determined by Dr. Clyde Cowan (right) and associates  
DEC. 1965

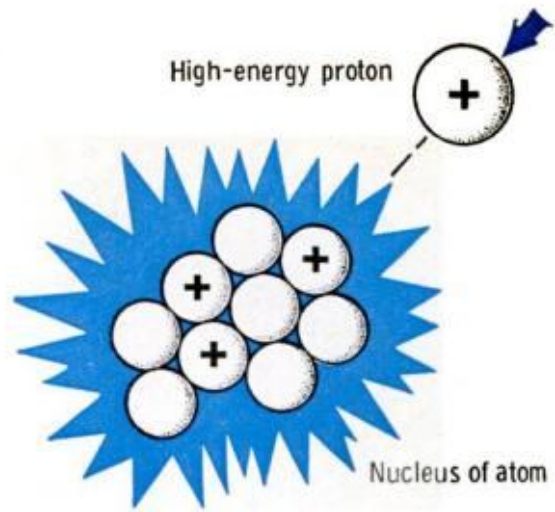

**BIRTH AND DEATH** of antimatter. Sequence begins when high-energy proton strikes proton in an atom

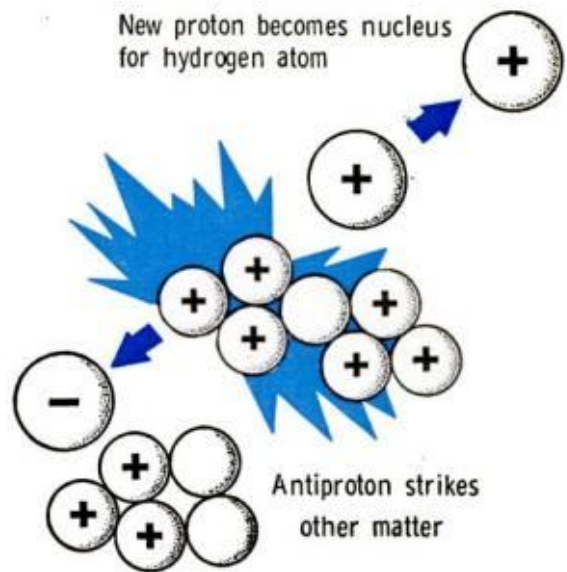

**IN VIOLENT COLLISION** energy is turned into particles: a new proton and its antimatter counterpart

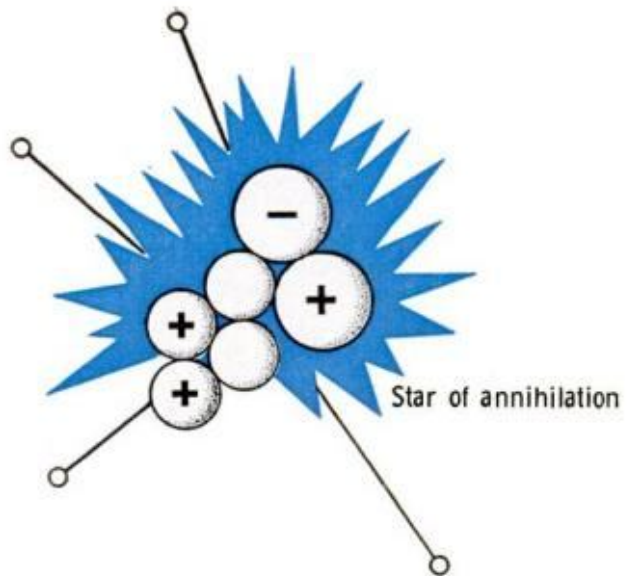

**NEWLY CREATED ANTIPROTON** lasts but a fraction of a second. It smashes into a piece of matter. The result: annihilation and a shower of atomic debris



**HISTORY WAS MADE AT BROOKHAVEN NATIONAL LABORATORY** last June. Proton "bullets" were whirled around half-mile-long underground track of synchrotron (indicated on photo) until they had speed enough to blast beryllium target. Among the spray of particles were antideuterons, the first ever created by man

proof, physicists looked to a newly invented machine, the cyclotron or atom smasher.

When high speed particles crash into target atoms, the atoms' nuclei splinter into dozens of various subatomic pieces. At the same time, some of the kinetic energy used in the bombardment materializes into new particles, a process that's the reverse of nuclear explosions. Physicists reasoned that by pounding a target in an atom smasher, some of the energy expended would become antiprotons, which would turn up in the rain of atomic debris. But there was a problem. Power.

The bigger a particle the more energy it takes to fabricate. Calculations showed that creation of an antiproton, with a weight nearly 2000 times that of a positron,

demands an energy burst equivalent to six billion electron volts (Bev). There wasn't an atom smasher that powerful around.

In 1954 scientists at the University of California, in Berkeley, convinced that heavy antiparticles could be created, designed and built an accelerator with a six-Bev output. Not everyone shared the scientists' optimism. One high-ranking physicist called the whole project nonsense and backed up his opinion with a \$500 bet.

He lost. In 1955 Emilio Segre and Owen Chamberlin, two Berkeley physicists, set up an elaborate detection system, revved up the new 385-foot doughnut-shaped particle accelerator, and zeroed in on a copper target with a power-packed torrent of

[\(Please turn to page 200\)](#)

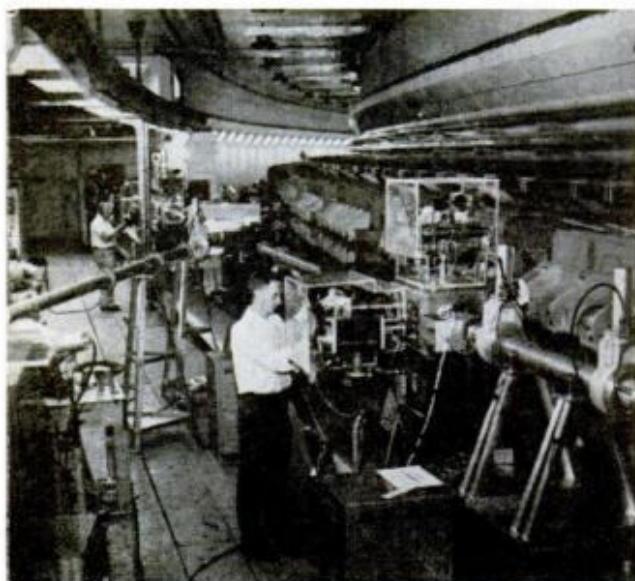

**INSIDE TUNNEL:** Proton beam is shot through pipe (seen at right) in which focusing magnets bend it into the orbit of the big synchrotron magnetic ring

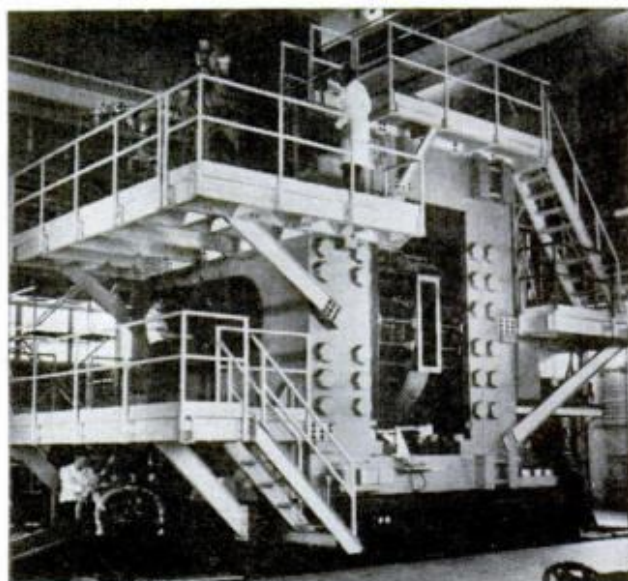

**PARTICLE BEAMS** pour from big ring into this liquid hydrogen bubble chamber. Photos of high-energy interactions are made via opening on lower platform





**Self-dumping log barge.** The largest vessel of its type in the world, the 370-foot **Straits Logger** can carry 9400 tons of logs and discharge them in one fell swoop. The barge tips when two big tanks above the waterline are flooded; it rights itself when they're drained. Both flooding and draining are accomplished through a 16-inch master valve. Loading is handled by two cranes mounted on 40-foot steel towers. Each crane has a 45-ton capability. Since it may require 20 hours to take on a full load the vessel is equipped with a mercury floodlight system to facilitate night operations. There are no crew quarters as the vessel is unmanned when towed from point to point. The barge was designed and built by the Yarrows Limited company of British Columbia, Canada, and is in use along the Pacific Coast of the U.S. and Canada.



**No strings attached.** In most shoes having eyelets, new "Ti-Bans" replace the lace. Made of elastic gores and fasteners, the stretch bands snap into place and you slip on the shoe. Mishawaka Rubber Co., Mishawaka, Ind., offers the tieless tennis shoe.

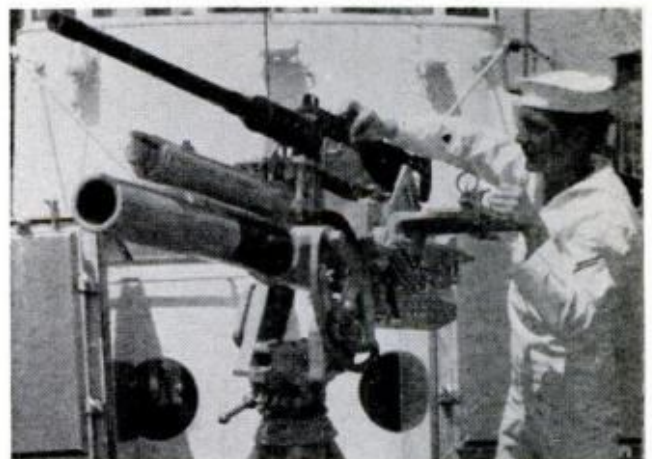

**Piggyback gun.** Devising a mechanism for mounting a 50-cal. machine gun on top of an 81-mm mortar, a Coast Guardsman gave his comrades a new double-action weapon for patrolling the shores off Vietnam. The weapon shown is on patrol-craft **Point-Grey**, now on duty near Vietnam.

# 3 GIANT STEPS TO THE MOON

Part 3

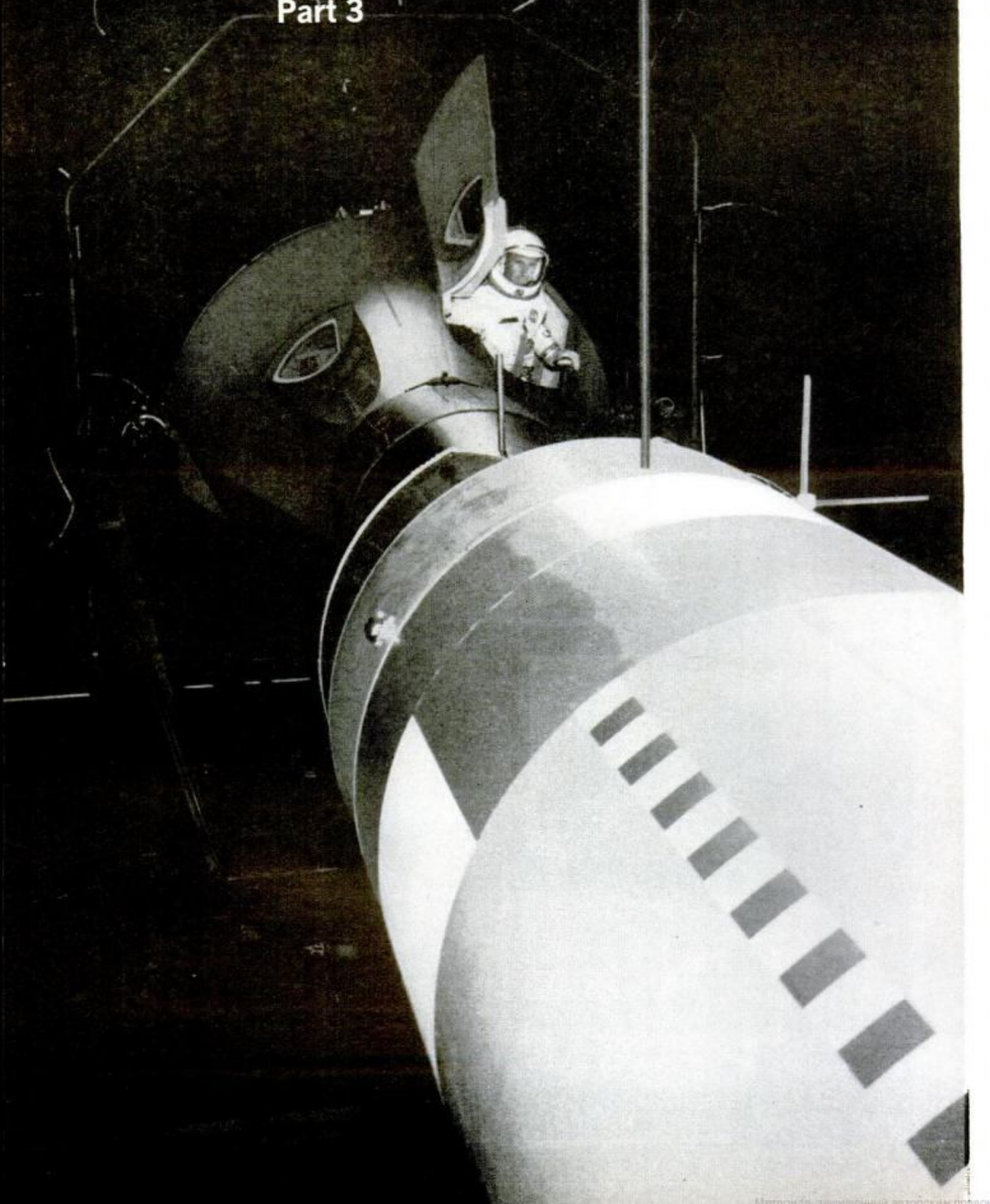

*Now astronauts no longer need spin in centrifuges. But they're crawling through jungles, climbing "moon" cliffs in Iceland and cramming for the toughest, most fantastic journey ever undertaken through space*

By Joseph N. Bell

**W**HEN YOU TALK WITH THE MEN who are going to do it—the moon pilots—they manage, somehow, to make it sound almost like a cakewalk, a trip to the corner grocery.

Alan Shepard, the first American in space, his newly won Navy captain's stripes tossed over a chair, can say: "We're just pushing the state of the art as far as we can, that's all. If you do any worrying, you do it before the flight."

Or Jim Lovell, who will pilot Gemini-Titan 7 and hopes to be the first man on the moon. A large, genial man, Lovell says: "I've been here since September of 1962 and haven't been up yet. That's a long time to wait. Everybody is anxious to fly. All of us are excited about the moon flight. It embodies, in microcosm, everything else we'll ever have to do in the manned space program."

Or Mike Collins, the only member of the third astronaut training group to be assigned crew status thus far (as back-up for GT-7). When Collins, a slim, animated man, talks of the moon flight, his eyes glow. "Worry? Why? The only people who worry are those who don't understand as much as they should about the equipment of their program. Our training is designed to give all of us complete information—and the confidence that goes along with it."

Is this bravado? Public relations? Whistling past the graveyard? I don't think so. It's simply a case of men of vast technical skill and knowledge talking about a mission in which they have absolute confidence.

How do you train a man to go to the moon—a journey unprecedented

**KEY TO GETTING BACK** from the moon is docking maneuver: coupling Lunar Excursion Module (LEM) with rocket that is orbiting moon. Spacemen then transfer to rocket and head for home. In photo, astronaut trains with the Gemini docking simulator



**DOCKING PROBLEMS** for training astronauts to solve are set up by computer. How the men do is closely monitored by technicians surrounded by instruments



**LAUNCH SPEEDS UP**, pulling astronaut skyward. Parasail training could come in handy if crew has to escape following an abort during booster phase



**NOT THE MOON**—but Iceland. The crater-pocked landscape of the eastern side of this island was used for geology training for our Apollo moon men

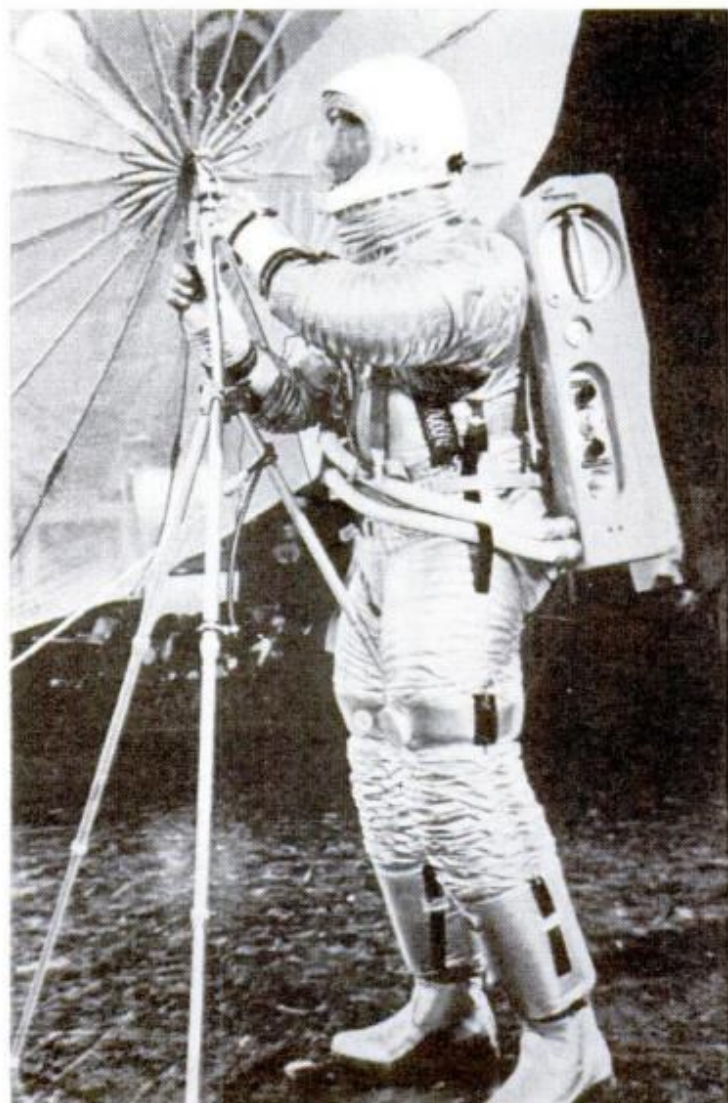

**FULLY SUITED AND FUNCTIONING** as he would on the moon, this space pilot erects an umbrella antenna that is used for S-band microwave communications



**ESCAPING FROM CAPSULE** at sea after splashdown is another skill requiring a lot of practice. Jim McDivitt (left) and Ed White are shown in action



**CONTROLS ON FULL-SCALE MODEL** allow astronaut to move spacecraft vertically and sideways in practicing simulated docking maneuver in darkened hangar

in human history and unparalleled by any existing conditions on earth? The answer is being sought daily in the cluster of buildings that make up the Manned Space Flight Center (MSFC, for short) on a Texas prairie about 20 miles southeast of Houston. Here, the people who will plant our standard on the surface of the moon are now being trained for that task.

Everything about the new MSFC—staffed by almost 5000 people—emphasizes the fact that it is the centerpiece of a slick, going concern. And nothing brings this point home more emphatically than the new training facilities aimed at preparing our pilots for a landing on the moon. Today's counterpart of that long-ago Mercury Project trainer—which was stuck away in one corner of a hangar full of airplanes when I saw it years ago—is the Gemini simulator, housed in a high-ceilinged, high-security building. Pilots are fed problems from a complex control center which can simulate almost any conceivable mechanical situation the pilot may encounter in space.

Here, a training instructor will say to a pair of practicing astronauts: "Okay, your yaw control is stuck. What're you gonna do about it?"

Or: "Okay, you have to abort. NOW!"

And the astronauts inside the trainer react. Now!

The Apollo simulator (presently being

built by Lockheed) won't be put in this place until the Gemini flights have been completed. When it is, some extra features will have been added. A large, boxlike affair is being constructed to fit over the simulator. Inside is a screen that will command the field of vision of the practicing astronauts. The screen will receive its picture from a camera mounted on a mobile frame in a cavernous, completely black room next door. Here, interstellar space will be reproduced and, as the pilot manipulates the simulator, the camera will also turn, giving him an accurate reproduction of what he will see as he maneuvers through space. The moon can be brought into this picture. So can the Earth. So can an Agena rocket, with which the astronauts must learn to rendezvous in preparation for the vital docking procedure on the moon flight.

A few doors away—in the largest laboratory building of the new space center complex—is the most ambitious new training device: the docking simulator. The room looks like the inside of a small blimp hanger, about four stories high and the length of a football field. It is completely dark. A pair of widely spaced tracks trisect the floor, providing rails for two giant frames that hover above the tracks on compressed air.

On one frame is mounted an exact replica of the Agena rocket; on the other is



**CHIPPING OFF SPECIMENS** of moon's surface will be one of the lunar explorers' prime objectives. Mock-up of a seismograph stands in the foreground



**USING LUNA-WALKER** stabilizing device, spaceman trudges up slope near McKenzie Pass, Ore., closely attended by members of medical and technical teams

the Gemini spacecraft. Above and around is the rich blackness of space, pocked by pinpoints of interstellar light. A computer in the next room can set the Agena and the spacecraft on any desired course; then the pilot must find the Agena with the stubby nose of the spacecraft, poke it into the gaping bay of the Agena, and lock it securely into place—like putting a cork into a funnel. This is the crucial step in the Apollo flight: a rendezvous and docking between the moon land craft (LEM) and the mother spacecraft hurtling in orbit about the moon.

There is an important difference between rendezvous and docking. Rendez-

vous involves getting close enough both in distance and in orbital pattern to the object sought to make docking—the actual physical contact between the two objects—possible. The first simulator offers problems in rendezvous, in which carefully computerized calculations must thrust the manned craft into a pattern that makes it possible for docking to take place.

(The failure of McDivitt and White to pull into close contact with their own jet-tisoned booster rocket on GT-4 was not so much a failure in docking as in rendezvous. When McDivitt cut loose from the rocket he slowed it down as he accelerated his spacecraft. Thus their orbital paths separated during the night, when McDivitt didn't want to get dangerously close, and by daylight they were too far apart to permit a close-up approach without rendezvousing—that is, adjusting the orbit of the spacecraft to the orbital path of the booster—for which McDivitt's ship wasn't equipped.)

Other training equipment at Houston is less exotic—but highly functional. A \$10 million centrifuge that will carry a three-man Apollo crew at one time in its oversized gondola is now nearing completion. (Astronauts have had to go to Johnstown, Pa., for their centrifuge training up to this time.) Helicopters and jet aircraft are available at a nearby airfield for the astronauts to maintain their normal flight proficiency. There is a regular training program on the choppers, while most of the jet time is logged on business trips on which the astronauts fly their own planes.

### Fence Is for Weeds

At the extreme edge of the Space Flight Center, a new training area has just been completed that will be used increasingly in the years ahead. Behind a huge circular wooden fence, the three principal types of terrain that pilots will likely encounter on the moon have been carefully reproduced for training exercises. One section is made up of rather large, jagged rock, another of pumice and a third of a volcanic slag. The fence is intended not so much for security as to keep out the unmoon-like Texas tumbleweed that kept rolling in.

The astronaut training program breaks down into three phases. The first, lasting about six months, consists almost entirely of classwork on space mechanics, mixed with occasional field trips to the companies

[\(Please turn to page 186\)](#)

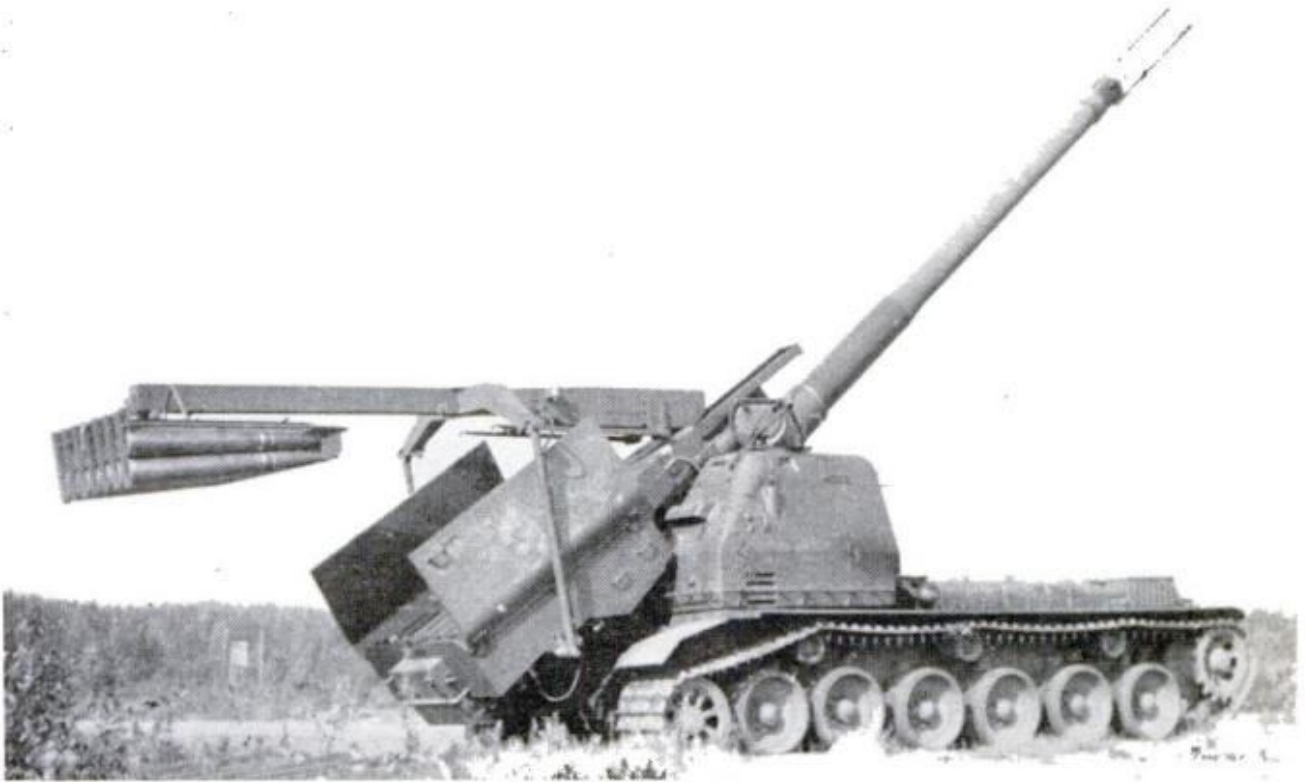

**Loads like a rifle.** Hoisting a 14-round clip into the magazine, a built-in crane loads a new Swedish self-propelled cannon. The cover of the magazine closes, the hoist fits into place and the gun is ready to fire. The gun can fire single rounds or all 14 rounds at the rate of about one round every three seconds. The magazine has seven drop compartments, each holding two rounds. A loading tray, suspended on rockers beneath the magazine, transports the rounds from the magazine to the ramming position. The tray and the rammer are operated by springs cocked by the recoil action of the gun. The cannon and its tracked carrier are operated by a crew of seven. Made by Bofors of Sweden, it has been purchased by the Swedish army.

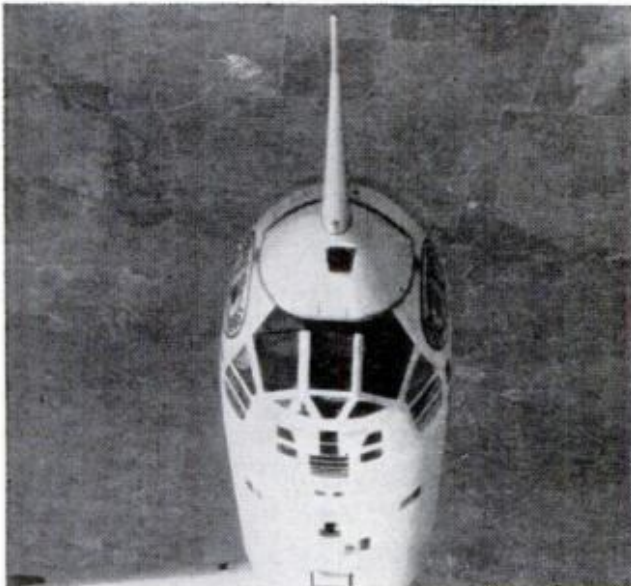

**Probe by proboscis.** Two Boeing B-52s have been equipped with 14-foot nose booms in low-altitude studies of turbulence. Sensitive instruments provide exact measurements of gusty flight conditions which may lead to design of new aircraft or modification of current models.



**Boo-aing!** Roadside posts that spring back into position after being struck can save local communities money ordinarily spent on repairing or replacing inflexible posts. There is a strong spring in the top section connected to the lower section by nylon-covered cables. The posts are made in Austria.

# I cut my engine at

I soared around without power for 30 pleasant minutes. It

By Kevin V. Brown

**A**S I LEVELED OFF at 9000 feet, I turned the aircraft toward the coast along the French Riviera. At the left I could see Cannes and its slim string of sandy beach, and directly ahead was the airport. Both looked inviting.

Reluctantly, I rolled the aircraft back toward the mountains behind me. I was warned to stay away from the coast for what I was about to do, and it only increased my feelings of loneliness. I could see no other aircraft in the sky around me. There was just myself and this weird bird, with the engine's hum up front and the wing's whistle around the canopy.

I checked the instruments again—for the umpteenth time—licked my lips, jockeyed the stick to test the controls, shuffled around in my seat and finally muttered, "Come on, buddy, quit stalling."

So, it had to come, down and dirty. I reached over to the left side of the instrument panel and for the first time in my flying career flicked the switch that cut the engine, with more than 9000 feet of air beneath me.

The hum quit, but the whistle came on louder, making me just a little queasier than I already was, but the prop kept windmilling. It was supposed to stop, they told me, but it seemed like it would go on forever. Finally, now that I had overcome my timidity and broken the barrier, I was getting cocky. I nosed up a little to reduce speed and, as the needle dropped toward 90 kilometers per hour, the prop slowed and finally, abruptly, it shuddered to a

stop in a diagonal position.

And there I was, at 2700 meters above the earth, with no engine. An intelligent man might ask why.

Well, there was this aircraft that the designer said was both an airplane and a glider. Not a powered glider, mind you—there are several of those around—but a real, sure enuf' aircraft that you could fly, cross-country if you like, as a bona fide airplane, or that you could, after cutting the engine, soar around in as a glider.

To our knowledge, there is nothing else like it on the market. So we decided to test it.

Its advantages are several. Since it can fly without an engine, it's a grossly safe training plane. As an airplane, it can perform exclusively as such, with outstanding economy and the added fillip of becoming, just for fun, a soaring plane. As a glider, it can take off under its own power, needing no tow plane or cumbersome substitute to get it airborne, and it can regain lost altitude while soaring by simply restarting the engine.

Called the RF-3 for its designer, Rene Fournier (his third model), it's produced at Gap, in southern France at the foot of the Alps.

Fournier, who looks like Adam, who was the oldest son on TV's "Bonanza," speaks no English, I speak no French, and Richard Thomas, our European correspondent who came along to translate, speaks no flying, as the saying goes. But, with some help from Fournier's lovely wife, who speaks some



# 9000 feet, then . . .

was my first flight in France's remarkable airplane-glider

fractured American and looks like a tall Elizabeth Taylor, we learned how it all began one evening at dinner.

Fournier is self-taught. He's had no formal training in aeronautical engineering, learning mostly by reading and doing.

"The idea just came to me," he said with a Gallic shrug, "to build an aircraft that was both airplane and glider. I read everything I could, then built it."

His first design, the RF-1, was conceived in 1958 and flew two years later. He tried one more model before going

**FRANCE'S UNIQUE RF-3 showing off its slim lines. Its pilot can take off under the craft's own power, fly for seven hours or shut off the engine in mid-air and glide**



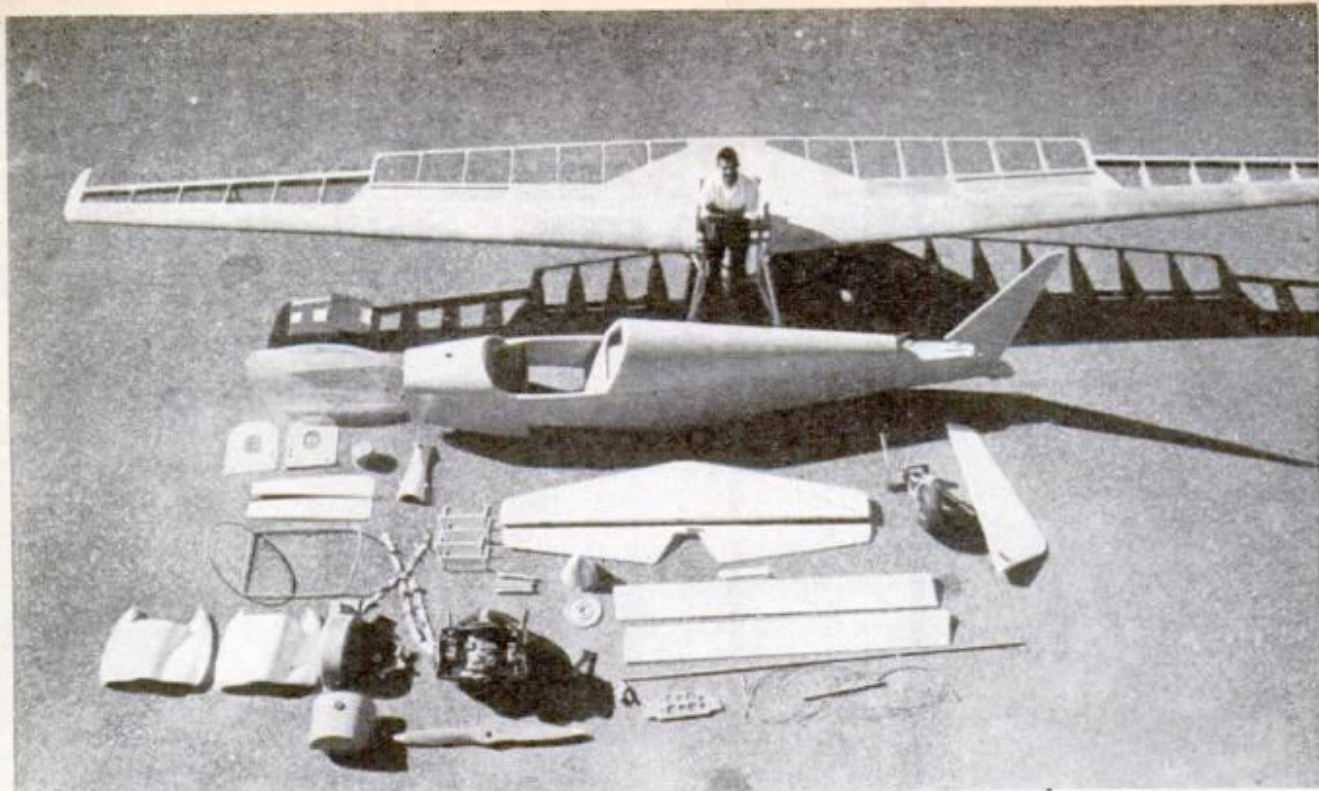

**RENE FOURNIER** stands amid bits and pieces of his airplane-glider which he hopes to market in kit form



**METICULOUS WORKMANSHIP**, exemplified by wet sanding of plywood fuselage, is boasted by RF-3 makers. Model is near-handmade version of original

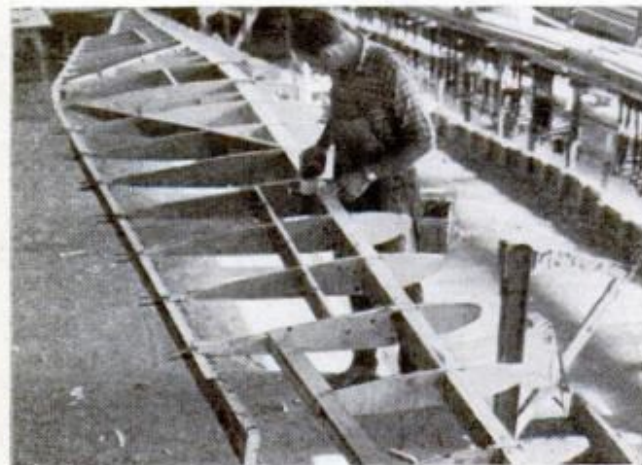

**HUGE WING**, spanning nearly 37 feet, is key part of RF-3. Much larger than wing on airplane of similar size, it gives glider an 18:1 ratio while soaring



**MAIN BEAM** of Canadian spruce is wing's backbone and largest individual piece of the RF-3. Even in kit form, beam would not be broken down for shipment

## CHARACTERISTICS AND PERFORMANCE

Span .....	37 ft.
Length .....	20 ft.
Empty weight .....	529 lbs.
Gross weight .....	770 lbs.
Engine, Volkswagen .....	39 hp.
Takeoff distance .....	426 ft.
Landing distance .....	328 ft.
Rate of climb .....	787 f.p.m.
Cruising speed .....	105 mph
Stalling speed .....	43 mph
Rate of minimum descent while soaring .....	23 f.p.m.
Lift-drag ratio .....	18:1
Fuel consumption at cruising .....	1.98 gal./hr.
Fuel consumption at reduced speed .....	.77 gal./hr.
Range .....	310 mi.
Service ceiling .....	18,000 ft.



into production with the RF-3, and has an RF-4 in design. This is the version he hopes to send to the United States.

"It will be basically the same aircraft," he said, toying with his salad. "The ailerons will be counterbalanced for more maneuverability; it will be stressed for aerobatics up to 9 Gs; and we hope to be able to ship it as a kit."

I asked if he could estimate a price.

"About \$5000 complete or \$2500 in kit form, with the wing covering, the painting and the assembling to be done by the owner. If we can get it certified in France and in the States, we may be able to start production by the end of 1966."

He pointed a fork at Thomas. "Make sure when he writes this he says it is an *avion-planeur*—an airplane/glider. It is not just a glider with a motor." He made that point several times.

It was late evening, but he escorted us through his factory which occupies about a hangar and a half at the small airport outside Gap. First, he showed us the wing structure, which seems to be the heart of his unique aircraft. And the heart of the wing is the long main beam of Canadian spruce which runs the entire span of nearly 37 feet. This is the one piece he refuses to cut up to accommodate the kit design.

"The kit is simply to save shipping costs," he explained. "But if we broke up the beam it would lose strength."

Except for some plastic around the engine and on the vertical stabilizer, the plane is mostly wood and fabric. It is very light (529 pounds empty) and requires only a 39-hp engine, a modified Volkswagen that produces 3600 rpm.

A unique feature of the engine is that it can be stopped and restarted in midair without a starter but with the aid of another RF-3 innovation, a decompressor. It works on the exhaust valves, reducing the engine compression and allowing the prop to windmill.

A distinctive part of its physical appearance is the landing gear—a retractable nose wheel and steerable tail wheel. Two loops of strong wire are attached on the underside of the wing on either side



COMTE D'ASSCHE checks out PM's aviation editor before his flight in RF-3. D'Assche is business associate of Fournier and member of Belgian nobility



**SPEED BRAKES** on upper panel are demonstrated by Fournier. Brakes serve to slow plane down and increase its rate of descent for picking landing spot

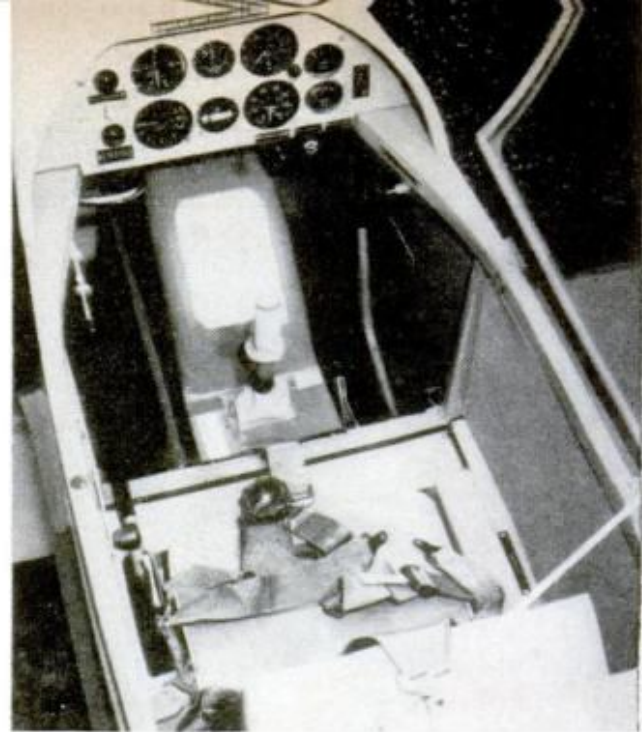

**RF-3 COCKPIT** shows compact but comfortable interior. Housing in center covers nose wheel when retracted. Handle for the speed brake is on pilot's left

to help stabilize the plane while taxiing.

Comte Antoine d'Assche, a member of Belgian nobility, is Fournier's partner, although he didn't use that word. The separation of duties was never explained, but it seems clear the count, who is an amateur sports flyer, is the businessman and Fournier the engineer.

We met the count at Cannes. He was vacationing on the Riviera and located an RF-3 that was owned by a flying club. (He and Fournier had sold their last complete craft just a week earlier.) We drove all day from Gap, through the twists and turns of the Alps, and I was ready for a bath and bed when we arrived but the count relaxed us. A tall, dignified man, he was both charming and gracious. But his major virtue was that he spoke beautiful English. He gave me my check.

The instrument panel includes the basic eight of speedometer, altimeter, rate-of-

climb indicator, tachometer, oil-pressure and temperature gauges, turn-and-bank indicator and floating compass. Leaning over my shoulder, Comte d'Assche explained the rest.

"Along your left seat is the speed-brake handle. Try it." I worked the handle and a row of slats rose vertically from the wing. "They can be locked in the full position or held in intermediate positions."

He continued around the cockpit, pointing out the throttle under the panel on the left, and warning lights for stalls and landing gear. "There is also a horn warning if you pull the throttle back to idle. So you're doubly warned."

The nose wheel itself was in a housing between my legs. "The handle is on the floor at the right. It locks up or down and the wheel is counterbalanced so there is no difficulty moving it."

[\(Please turn to page 180\)](#)

**AIRPLANE-GLIDER** is light enough (529 pounds) to be towed by one man. Note wire loops under wings

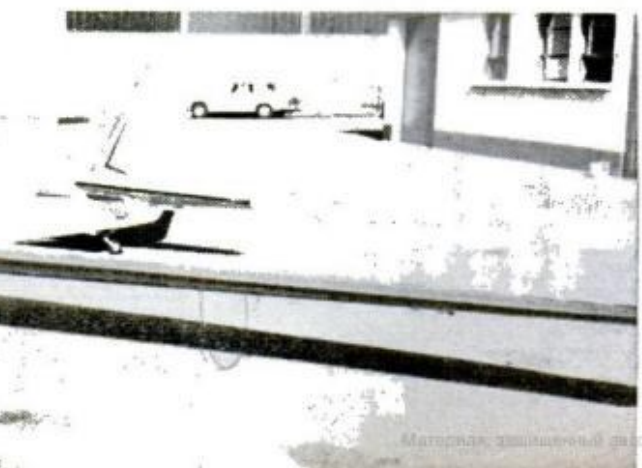



**Loggers' wagon train.** Experimenting with the extreme in highway hauling, Crown Zellerbach Canada Ltd., a wood pulp company, hitched together a train of five trailers loaded with 32-foot-long logs and hauled by a single 370-hp tractor for the seven-mile trip from the forest to the log dump. The caravan of 50,000 board feet of logs weighs 350,000 pounds.

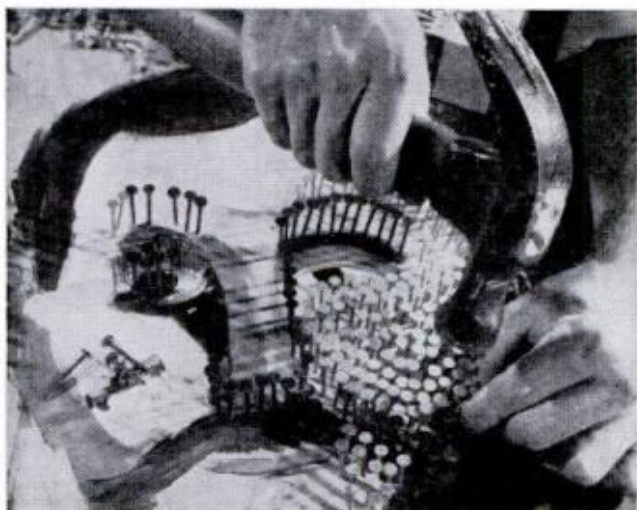

**Picture pounder.** When artist Adolph Garza bangs out a painting, he really does it. A student at Claremont Graduate School in California, Garza creates paintings with nails, hammering a variety of heads into a board. He uses finishing nails for details, Japanese roofing nails to fill in large black areas and aluminum nails to build up the highlights.



**Snow-going bike.** Mount an old bicycle frame on a pair of plywood skis and you've got a Jack Jumper, a midwest version of an old New England sport. The skis are two feet long and six inches wide, and when you sail down a snow-covered slope you steer with the front ski and balance with your feet.

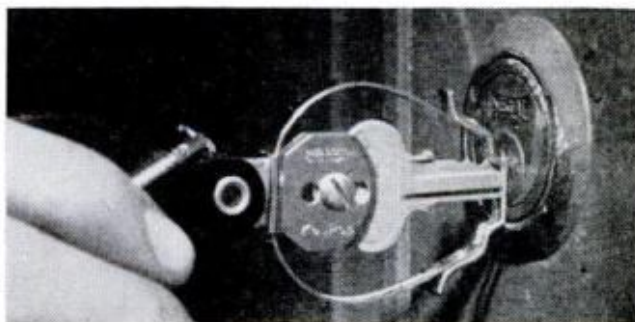

**Key on a spring.** There's no chance of leaving your key in the front-door lock if it's equipped with a Keypop—a spring device that automatically propels the key back into your hand the moment you let go of it. Keypop is easily attached to most keys.

NEW FOR  
**YOUR HOME**  
BY MARION MOREY



**MICROWAVE OVEN** cooks food in seconds without heating the oven. Unit fits on counter top, plugs in 110-volt circuit, operates by pushbutton or dial timer. About \$800. Litton Industries, Atherton Div., Chicago, Ill.



**VOICE SCRAMBLER** insures telephone privacy. Battery-powered instruments jumble voice, reconstituted only by a person with an identically coded scrambler. \$275. Hewlett-Packard, 943 Industrial Av., Palo Alto, Calif.

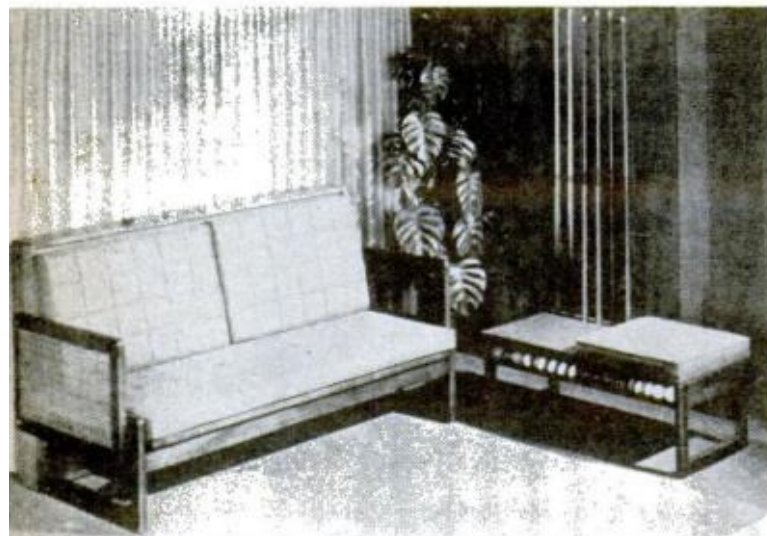

**FIRST IT'S A COUCH**, a Danish modern sofa with a 28 by 18 by 70-inch solid ash frame covered in rayon cotton and acetate with foam cushions. But that's only half the story . . . then it converts into a pool table. Inside the frame, a honeycomb-core bed, built-in floor levelers and an all-wool billiard cloth convert it into a 36 by 67-inch pool table. The dual-role piece comes with billiard balls, two cues, triangle, bridge attachment, chalk and rules. \$300. Sears, Roebuck & Co.

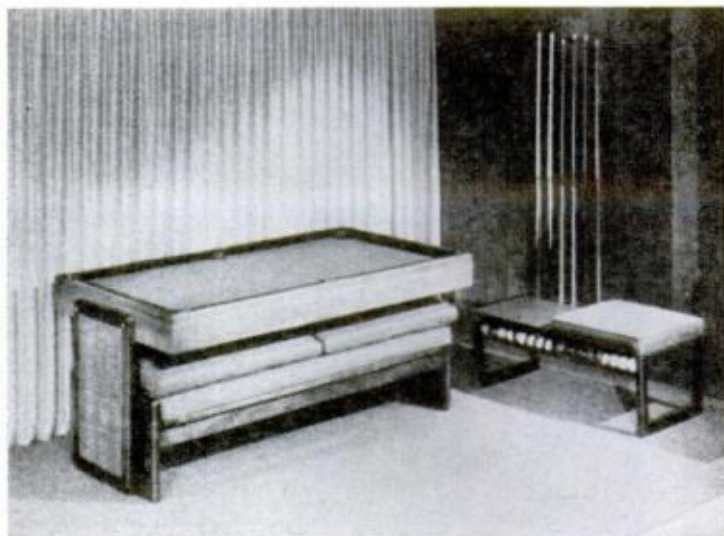

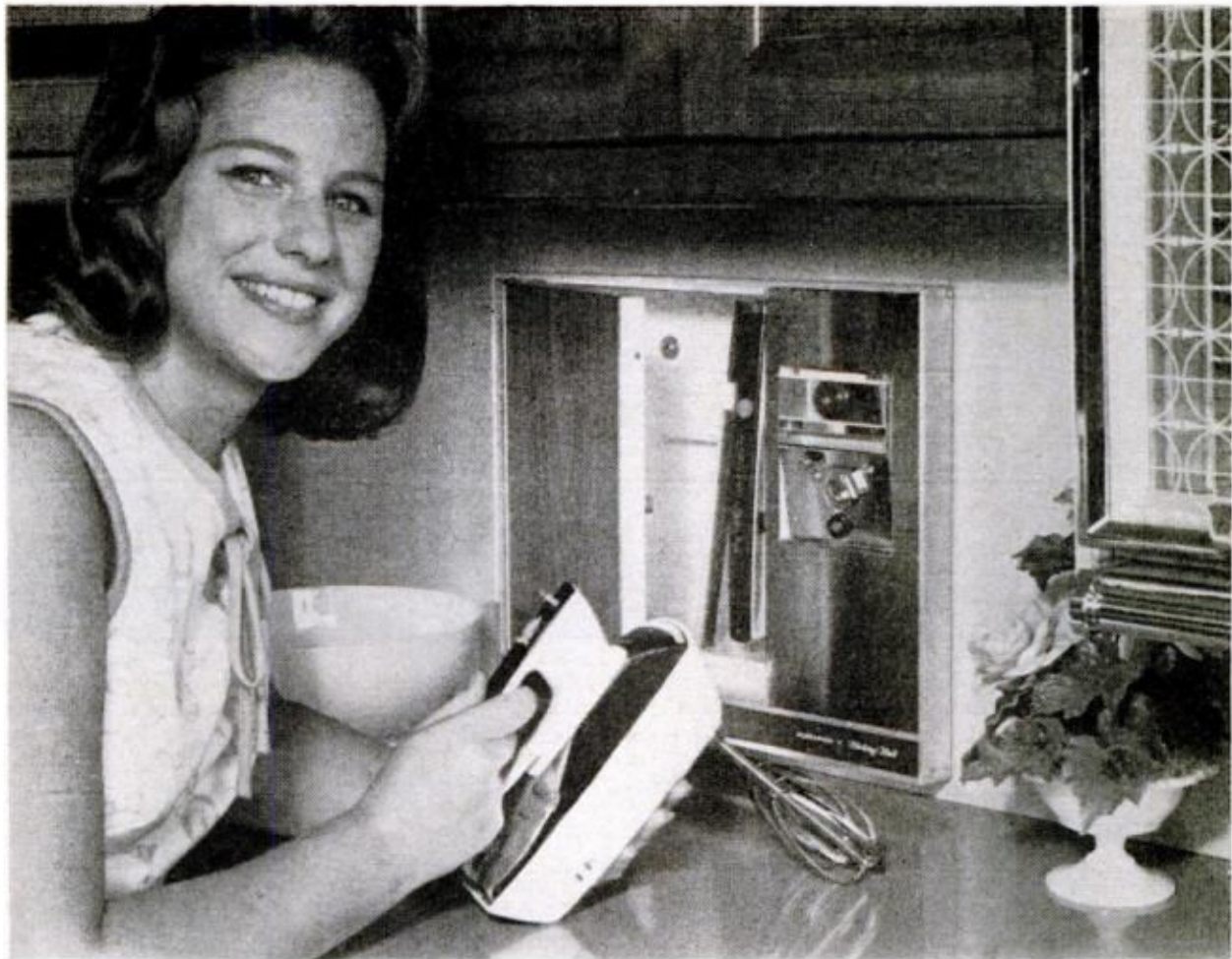

**APPLIANCE UNIT** screws to the wall or builds-in between studs. The 16 by 13-inch cabinet houses a hand mixer, electric knife and built-in commercial-type can opener. Also, there are two outlets below the cabinet door. In stainless steel with a walnut-paneled door, the "working wall" juts out just an inch and a half from the wall. Entire package; \$89.95 from Puritron Co., 15 Stiles St., New Haven, Conn.



**COFFEEMAKER** fits over cup, brews any kind of coffee right away. Cover grounds in self-contained filter, pour water up to brim; coffee filters into cup. \$2 from Perfex Products, 91E N. Franklin, Hempstead, N.Y.



**AUTOMATIC PET FEEDER** opens at pre-set times. Place food in removable inner bowl, close lid and set timer from one-half to twelve hours. Bowl holds three cans of food. \$14.95 at Hammacher Schlemmer, N.Y.



# Man-Made Comets

**ARTIFICIAL COMETS**, plying outer space around the clock, are man-made and man-launched. They are finding out what our astronauts may run into on their walks in space. Special optical equipment is used to film the behavior of these "comets," providing a record of the "events" that are invisible to the human eye

IF YOU WATCH the sky carefully at sunset, you may spot a curious colored light. It's not a rainbow—it's an artificially produced comet trailing a tail of metal vapor which is telling scientists about interplanetary plasma and solar winds.

The comets are actually metal barrels

filled with barium and strontium, which, when released, simulate ion cloud vapor. Rockets launch them as high as 130 miles, according to the experimenters at the Max-Planck Institute near Munich. Specially constructed cameras take stills and movies of the vapor trail.—*Marion Morey*

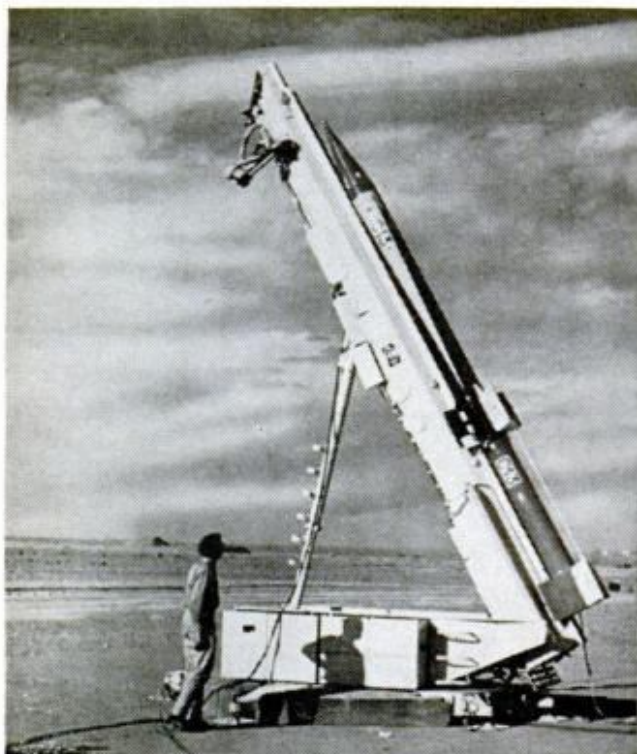

**DR. H. FOPPL** of the Max-Planck Institute observes a barrel-rocket about to be launched in the Sahara. Other tests were made near Munich and on Sardinia



**"COMET" IS MADE** from simple steel barrel like this. It is being filled with chemicals that later will form its tail. The reactions are controlled at launch sites





**Tag-along travel lodge.** Belgian bus travelers don't have to worry about hotel reservations; they just take their lodging along. The Mobilotel, a three-story travel trailer, is hauled behind the bus, and when the passengers stop for the night it has sleeping accommodations.

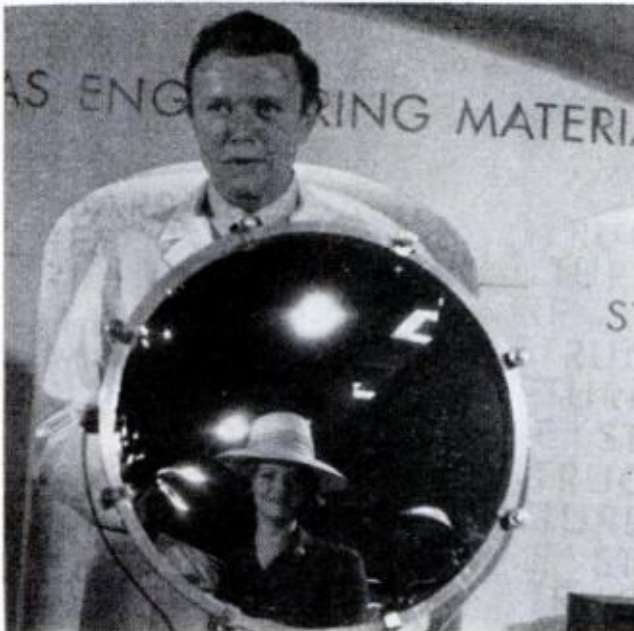

**Zoom mirror.** If you don't like the way you look in it, pump it up or deflate it. Curvature and optical characteristics are changed pneumatically. The mirror is made of aluminized Mylar plastic stretched across an airtight drum. The surface can be changed from convex (top photo) to concave—or vice versa—by letting out or adding air.

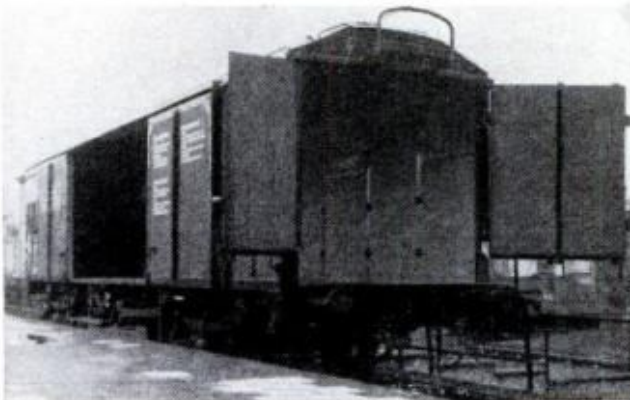

**End-loading freight car.** Box cars of this special design are used by the West German Federal Railway to haul freight that is too long to be loaded through the regular side doors. They often function as automobile transports. Autos are rolled up a ramp at the end of the box car and are rolled out again at the unloading point. Automobiles earmarked for sale in Denmark and England stay right aboard the end-door box car, which is carried by ferry.

# Step Out With The Right Boot

**SIGNS OF QUALITY** in a boot are a bellows-type tongue that extends above the boot top, and an added patch of leather to protect the instep. Superior chrome tanning is usually noted on manufacturer's label

**ALTHOUGH MOST BOOTMAKERS** contend that a full glove leather lining adds nothing to a boot but weight, it's a pretty sure indication that the rest of the workmanship is of very best quality



**T**OP QUALITY LEATHER that is properly tanned, superior construction and good oil treating—these are the things that go into a good boot to insure durability and comfort.

Ignore these qualities when buying a boot and you'll pay for it with wet, tired feet, and count your hiking miles in blisters.

The best boot leather is "full grain," which means that when the hide was tanned, only the hair was shaved off the outside. Lower grade hides are "corrected" by removing the thin outer layer of the skin to eliminate blemishes, scars and other imperfections. Unfortunately, when the tough outer surface is ground off, along with the blemishes, the leather loses much of its durability and water resistance. Since corrected leather has an artificial finish, it can often be detected by its unnatural gloss and smoothness. Full grain leather has a dull sheen. Another way to identify full grain leather is to look closely at the surface. If the hide wasn't corrected, you will be able to see the tiny pore holes. Often, too, full grain will be stamped as such; it's a quality mark.

The leather itself should be soft and supple to the touch. Chrome tanning and oil treating both contribute a great deal to the water resistance and durability of the material. Chrome tanning may be indicated by stamping on the leather or may be pointed out in literature or a sales tag on the boot. If it isn't, check along the exposed cut edges, such as at the eyelet facing. If the leather is chrome-tanned, you will probably be able to see a layer of greenish tinge just under the dye layer.

The best quick check for top quality oil treating is to take the boot and crease the leather sharply. With good oiled leather, this will produce a white streak along the point of the crease. The streak should vanish when you rub it lightly.

Where styling is concerned, the "right" boot depends on how and where you're going to use it.

The shoepac, made with watertight rubber bottom and leather upper, is designed for wet snow or shallow marsh. It is ideal for hunting, but for warm weather or long distance walking, it is uncomfortable. Unless a completely waterproof bottom is an absolute necessity, the disadvantages far outweigh the advantages.

An engineer boot is almost the opposite.

[\(Please turn to page 192\)](#)



**FULL MOCCASIN** boot has the vamp cut from a single piece of leather. This style, which has a full back stay, a heel and lug sole, and an eight-inch top, is ideal for hiking on rock and loose shale



**SEMI-MOCCASIN** style has the quarter extending down to the sole, and in this model triple stitching is a sign of quality. Wedge sole is ideal for walking in mud and also as a boating shoe



**RUBBER BOTTOM** and leather top makes the shoepac an excellent hunting boot when the hunter has to hike through mud and marsh. It is a warm boot and is the most waterproof of any style

# Leapin' Lizzies!

*It's just a motorized bucket seat on fat tires, but it's fun, it's fast and it flies through the air with the greatest of ease*

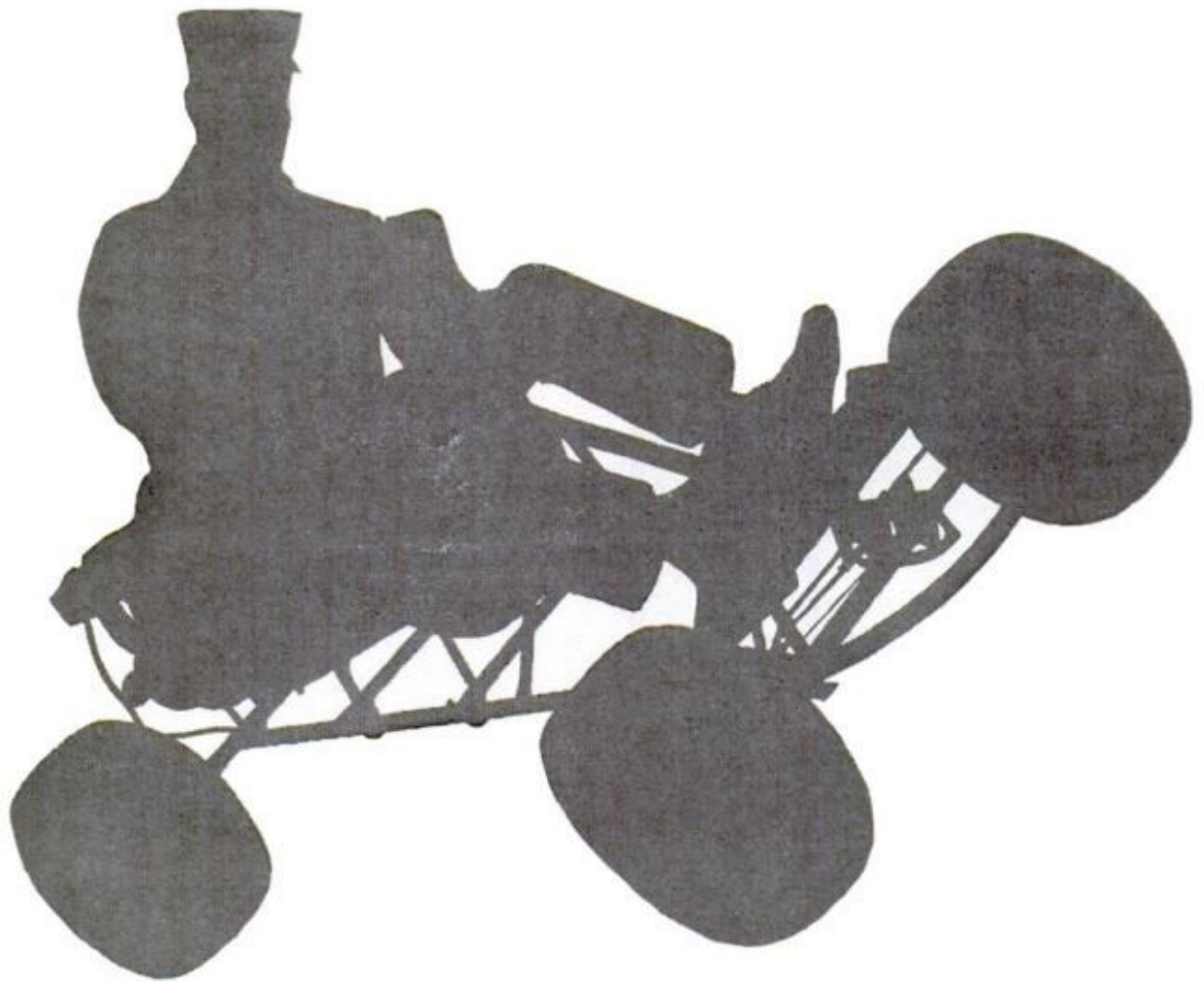

**T**HERE'S JUST SOMETHING about this little sand buggy that makes you act like a lunatic.

There were a dozen of us playing follow-the-leader on the sand dunes north of Monterey, Calif., and my total driving time was less than an hour, but I was suddenly struck by the "hell driver syndrome," and wanted to see how high and how far I could leap through the air.

Swooping down into the concavity of a wide, smooth dune, pressing hard on the throttle, I aimed straight for a four-foot hillock at the bottom. It was just like a ski jump. But I hadn't figured on the hillock being uneven. I was sailing through the air, and then I was doing a slow roll.

For a split second I was able to think, "You idiot, you're gonna break your neck," and then I landed with the buggy on top of me. The plastic bucket seat slammed into my back, and it hurt, but most of the impact was absorbed by the soft sand, and as soon as the dust settled I was on my feet.

It might seem like proving it the hard way, but this new sand buggy, the mechanical baby of a pair of Californians, is extremely safe to operate—even for a complete novice. It is quite a rig, and it is already sparking a new interest in the sport of dune riding.

Bob Emery and Rocky Bowersox designed the machine. Essentially it is a tubular steel frame that looks like an oversized go-kart. It's powered by a 6-hp Briggs & Stratton engine with a centrifugal clutch. The wide wheels are equipped with balloon-like Hi-Flotation tires. They call it the Terra-Tiger; it sails over sand with ease, and goes up and down steep hills like a mountain goat. A complete machine sells for \$595 from Terra Engineering, 271 Figueroa St., Monterey, Calif., but they also have a kit priced at \$475.

This is more fun than go-karting. It is exciting to race over the dunes and, on the flat, open beach jockeying for position at 40 mph, it feels like the main event at Daytona Beach.—*Stuart James*



**RUGGED STEEL FRAME** is welded at all joints so Terra-Tiger will withstand the jolts of high-speed game of hare and hounds in cross-country terrain



**RESPONSIVE STEERING ARM** and rear engine allow for sharp, sudden turns. Low, squat frame and wide tires give sand buggy amazing stability



**DRIVEN INTO THE SAND** by weight of the machine after turning over in the air, I didn't even lose my pipe, and the machine was untouched



# Christmas toys with a purpose

By Larry Steckler

**T**OYS SHOULD DO MORE than merely entertain. They should excite a child's imagination, encourage him to use his hands, think a little, learn a little. When these basics are combined with having fun a toy becomes important, quite a bit more than just something to keep the kids out from under foot while you sit back with the paper.

With this in mind I examined just about every new toy to be placed on the market this year. After careful testing, watching what the children did with them, the group was narrowed down to 14 really good, entertaining items. Several are mechanical, many are educational and all are fun. Here is a rundown on the new toys; I think you'll like them too.



1.



2.

**1.** What makes a cow go? Any child that builds Renwal's Visible Cow is sure to find out. Transparent hide reveals all anatomical details and it's a fascinating model to put together too. \$5.95

**2.** Learning the alphabet is fun with Mattel's The Bee Says. Point the bee at A, pull the Chatty Ring and the bee says "Apple, A". Children can select letters or let the bee pick them. \$6

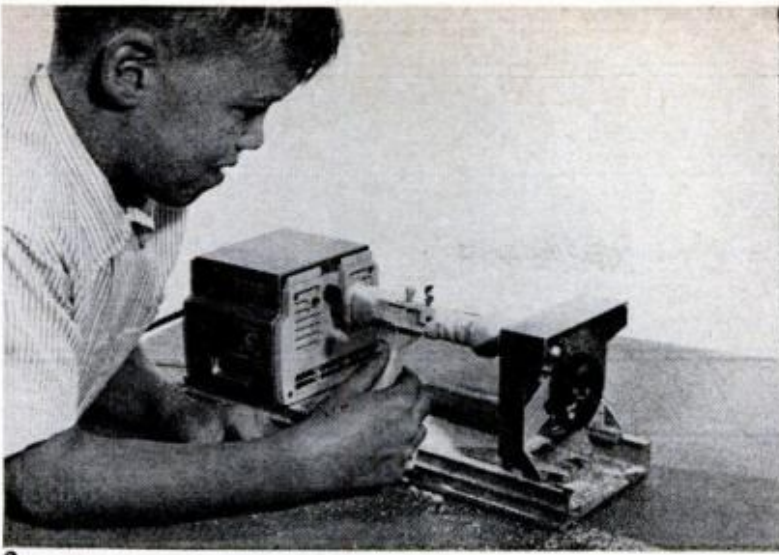

3.

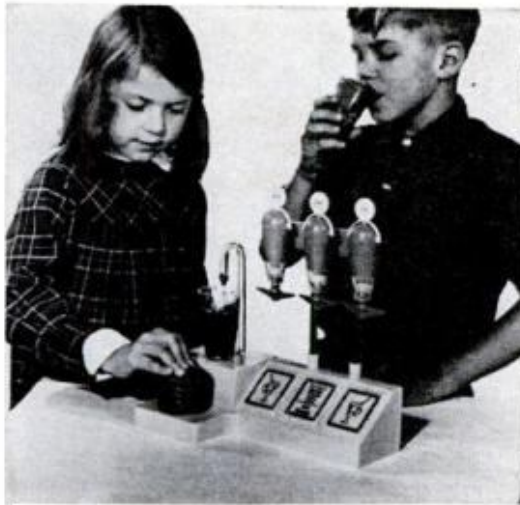

4.



5.

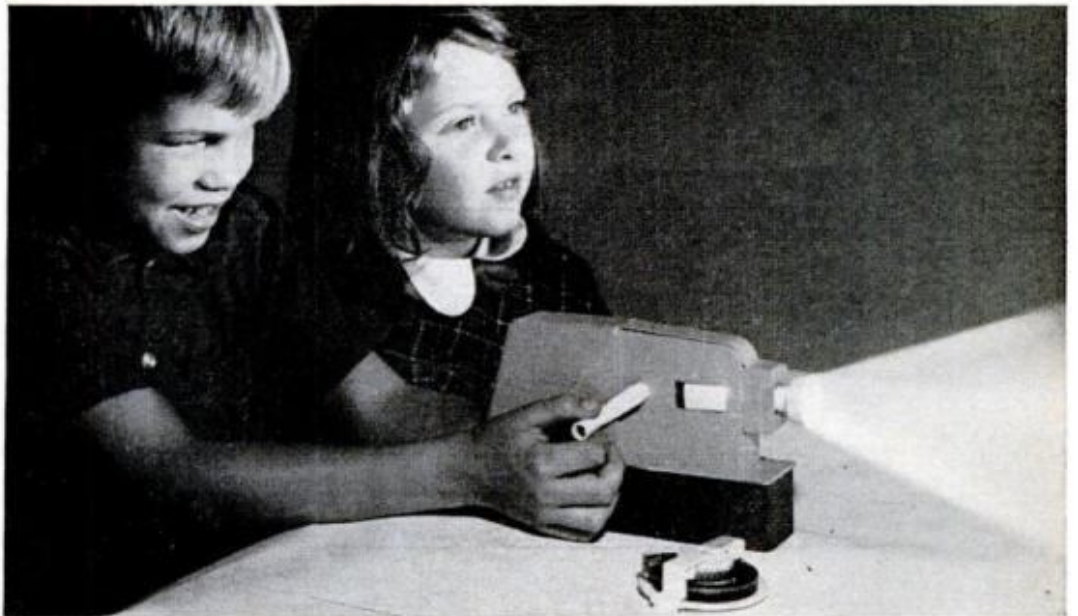

6.

**3.** Power shop for junior craftsmen is lathe, jigsaw, drill press and disc sander that really works. Runs on house current, machines pine. Dad may "borrow" occasionally. \$25 from Mattel

**4.** Have a soda at the Whiz Fizz Soda Fountain. Powdered flavoring is measured out automatically. Add a squirt of water from the fountain for grape, orange or cherry sodas. \$5 by Kenner

**5.** Look at the moon and see where astronauts expect to land. A. C. Gilbert's 80-power Astronomers Telescope 13214 brings the details to you. Precision focusing, tripod included. \$20

**6.** Cartridge-loading movie projector shows real 8-mm movies. Hand crank runs films forward or in reverse. These cartridges, containing six movies, come with Kenner's Easy-Show projectors. \$7



7.



8.



9.

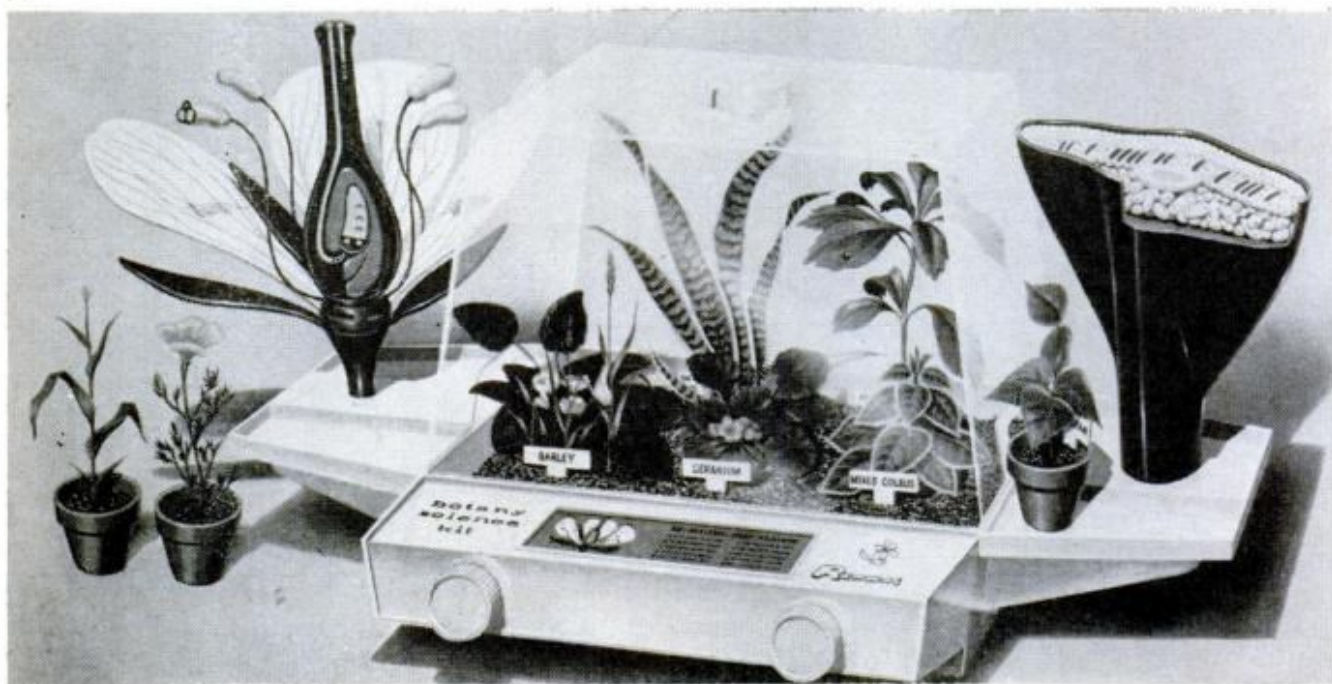

10.



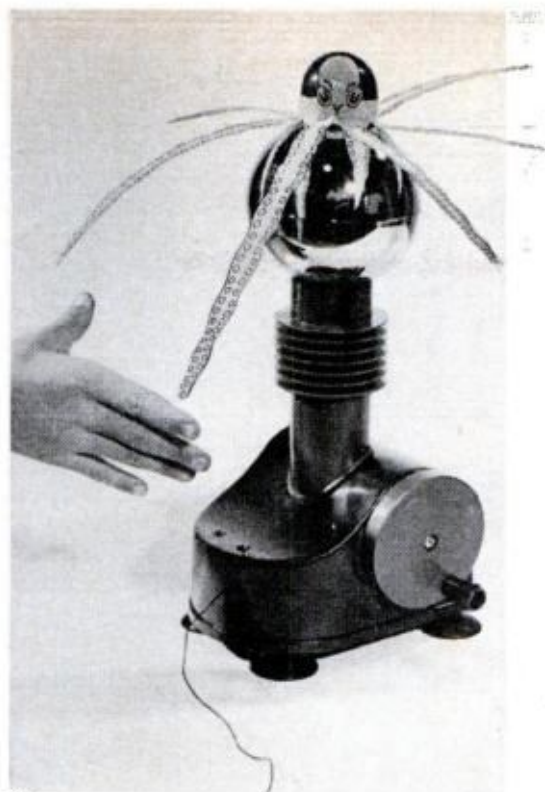

11.

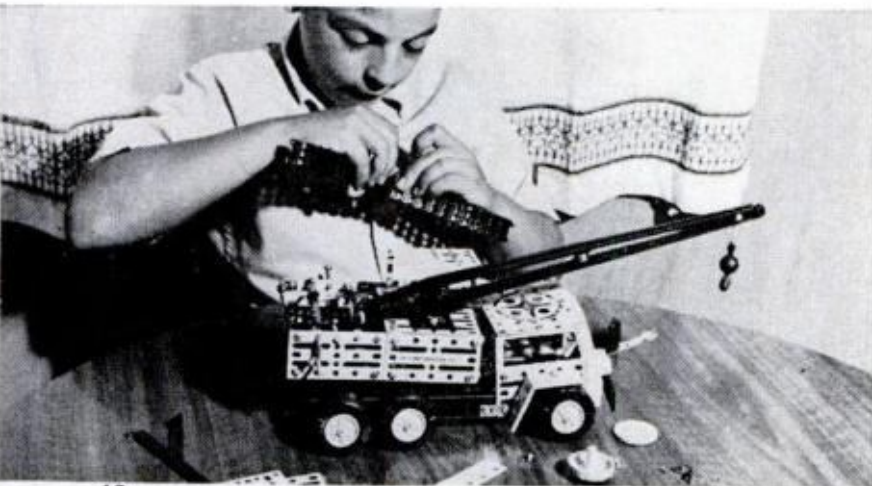

12.



13.



14.

**7.** Build a robot, monorail or rocket from the multishaped plastic construction elements in Halsam's Constructioneer sets. Four sets range from 100 to 503 pieces; \$2 to \$10

**8.** Roll the presses. You make your own type as you need it, on plastic tape and use plastic printing "plates". Mattel's Linoprinter has built-in permanent ink supply. \$19

**9.** Automatic drawing machine makes portraits, landscapes, cartoons. Set has animated figures, paper, pencils, erasers, Peerless Playthings' Draw-a-Matic. \$4.95

**10.** Your own greenhouse with growing living plants is part of Renwal's Botany kit. There are 3-D flower and leaf models. Teaching machine identifies specimens. \$9.95

**11.** Wiggling paper octopus is just one of many experiments you can perform with harmless static electricity. Turning the crank builds up operating voltages. \$6.95 by Renwal

**12.** Assemble roadbuilding equipment with the Erector Constructor. Makes five different vehicles: bulldozer, mobile crane, and dump truck among them. \$5.98 by A. C. Gilbert

**13.** Be a draftsman with Ohio Art's 3-D Draw, Draft, Design Set. Includes a drafting machine, drawing board, divider, compass, pencils, tape, eraser and even paper. \$4.95

**14.** Professor Wonderful's Wonder Lab comes into your home when your child tries his experiments on the kitchen table. Balls roll uphill, magnets float. \$4.98 by Gilbert





# ADD ACTION TO YOUR Christmas Displays

By David M. Swartwout

“BLAST OFF!” Santa cries *this* year; Gemini launches have made that “On Donder and Blitzen” stuff old hat. Even if you’re not space-minded, you can make *action* the theme of this season’s yard display. On these six pages, we offer you a choice of PM exclusives—and any of the three is sure to cop the prize for holiday decoration in your town.

The key to each is eye-catching movement. In this first display, it’s the foil rocket blasts, which twist and sparkle in the breeze, especially when spotlighted. The two designs that follow are actually motor-driven. All are quickly cut from hard-board, and require no more artistic skill than a child’s coloring book—the clip-out Project-a-Plans at far right give you full-size tracing outlines.

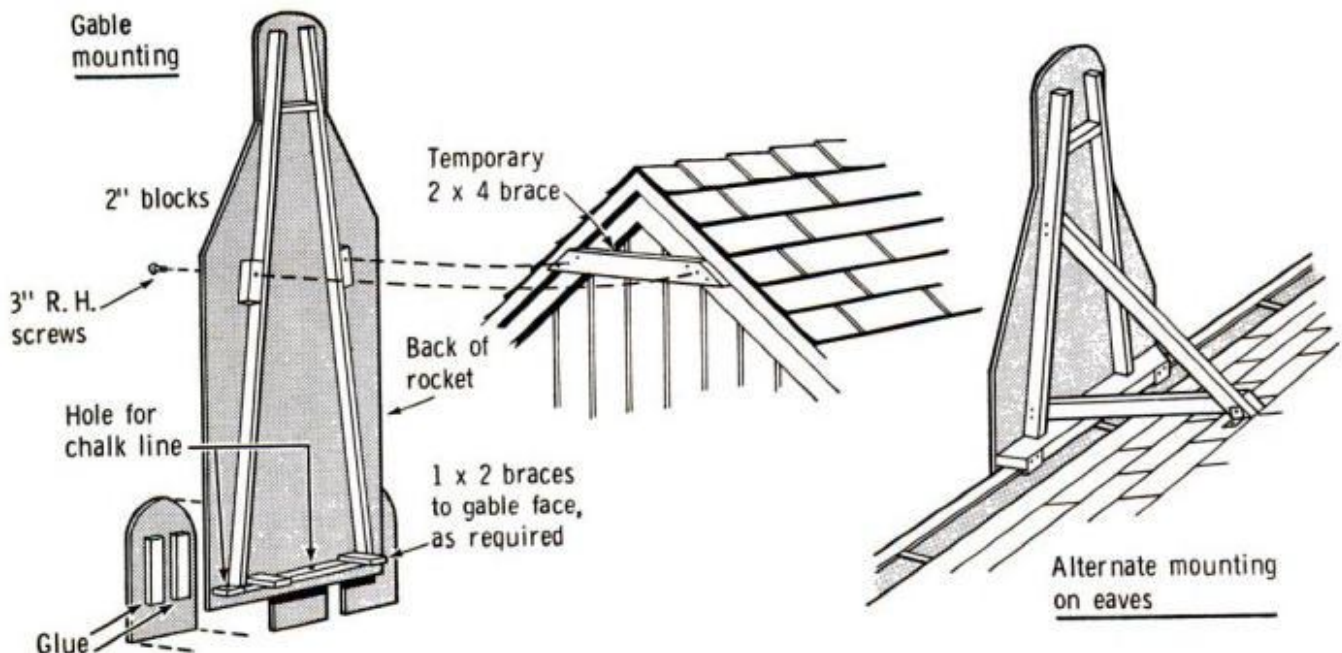
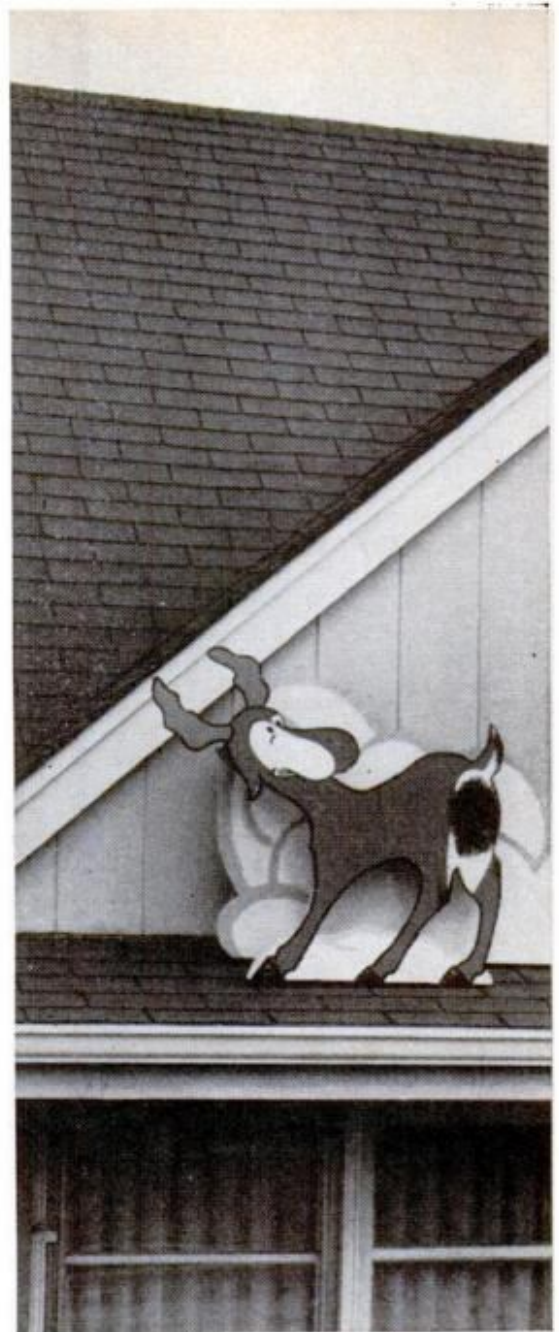

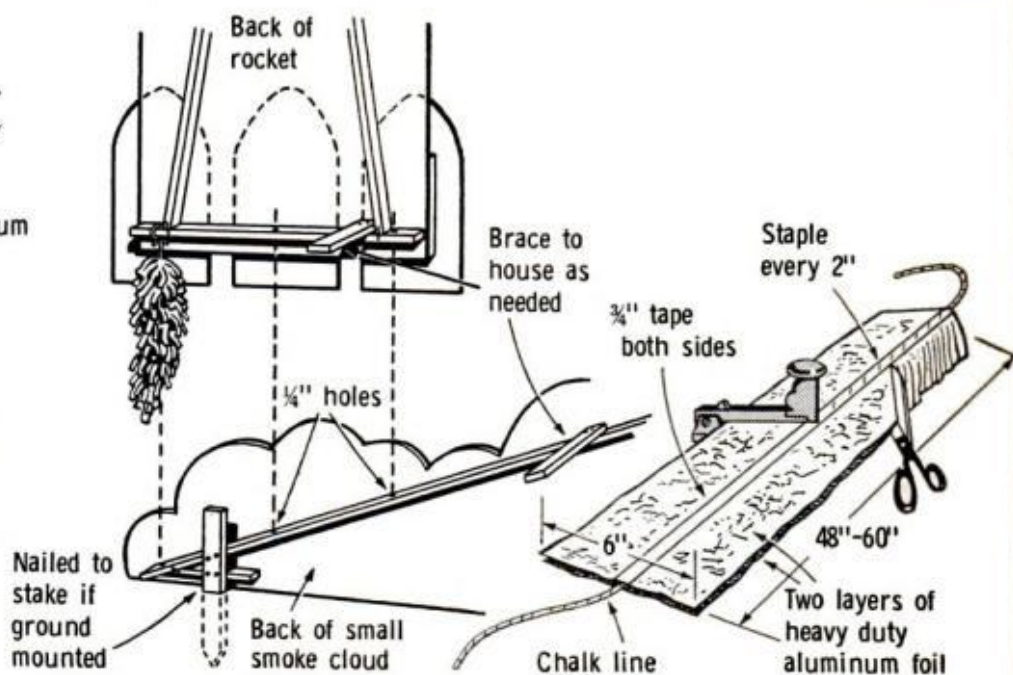
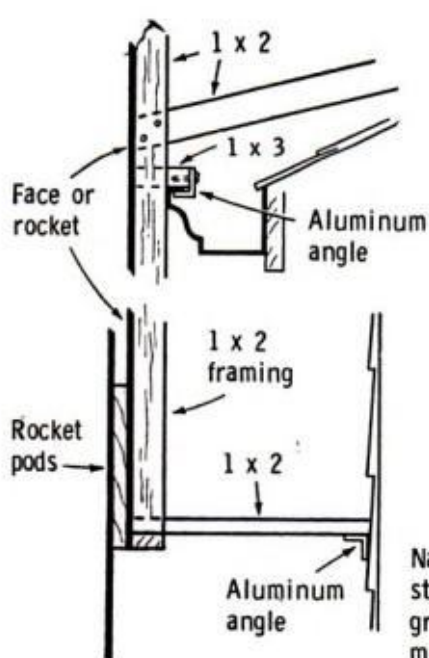
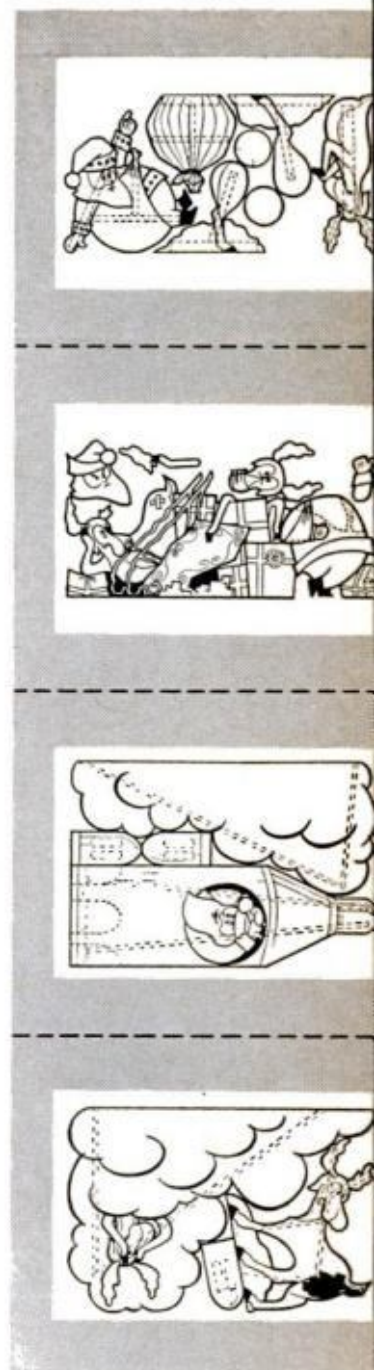

See reverse side

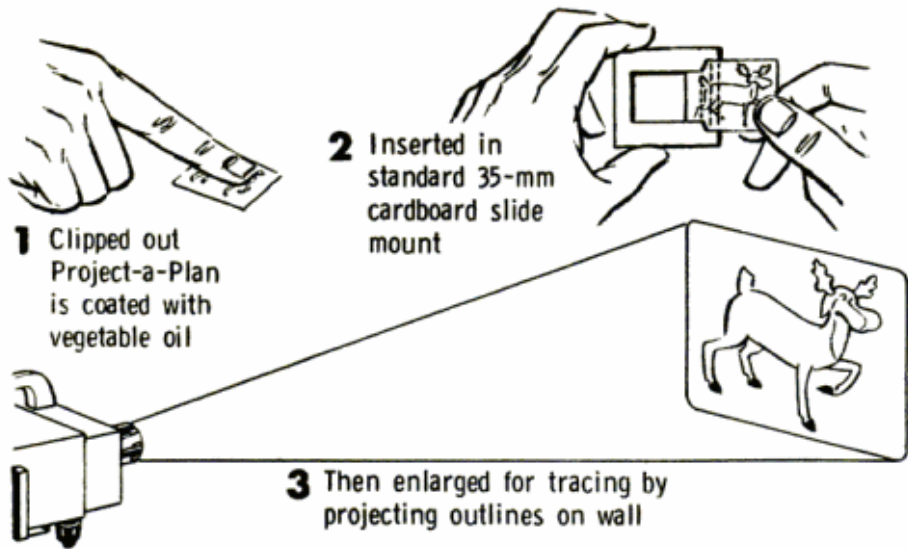

### How to use PM's Project-a-Plans

of page for

If you haven't used Project-a-Plan transparencies before, you're in for a real treat when it comes to enlarging patterns the easy way. It's as simple as 1, 2, 3. First you clip the one you want to enlarge right from the magazine page. Next you rub the front and back with a little vegetable oil to make the paper transparent. Finally, you insert the paper "film" in a regular 35-mm cardboard slide mount. You now have a black and white slide that can be used in any 35-mm slide projector which permits you to blow-up the pattern to any size you want by simply tracing off the projected outlines right on your material

Project-a-Plans

**THERE'S NO REST** for poor Comet at Christmas. Having delivered his bearded boss to a worthy home, the exhausted beast must now hoist him to the roof for the traditional chimney descent! The action's provided by a direct-drive motor tucked behind the reindeer. It should run from 12 to 15 rpm and produce 12 to 24 in./lbs. of torque. To anchor the reindeer and motor, you'll probably have to stake them to the ground, or weight them with stones or sand bags. Santa would be heavy enough to tug Comet off his feet on the return part of the cycle.

To keep Santa from twisting and scraping the side of the house, stretch two wires from the eaves gutter to the ground, passing them through screw eyes on the back of

**CUT, FOLD, TAPE** **YULE DISPLAYS**

#### TYPICAL LIFT MECHANISM

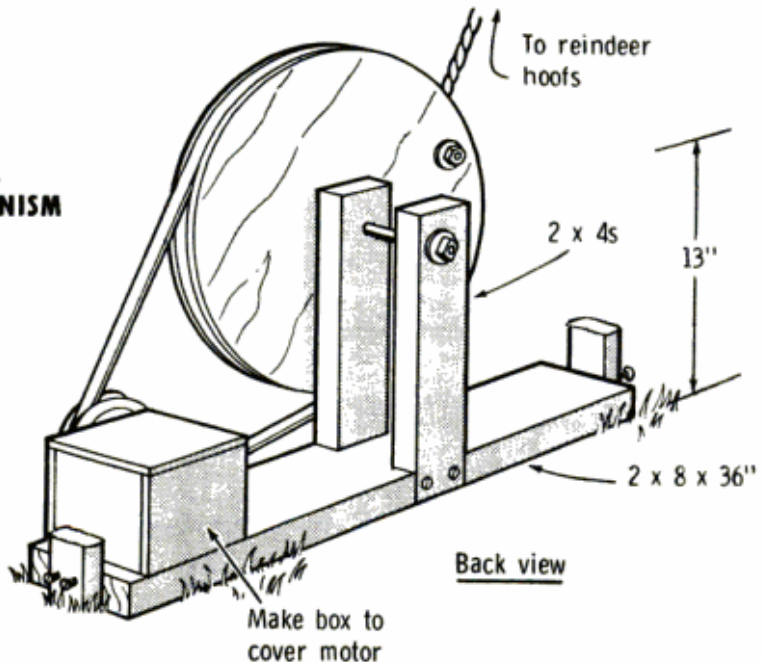
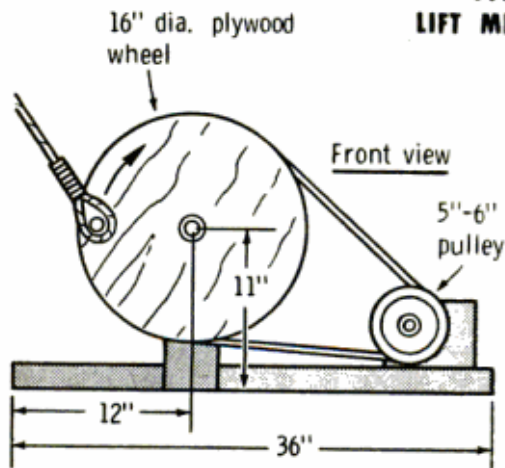

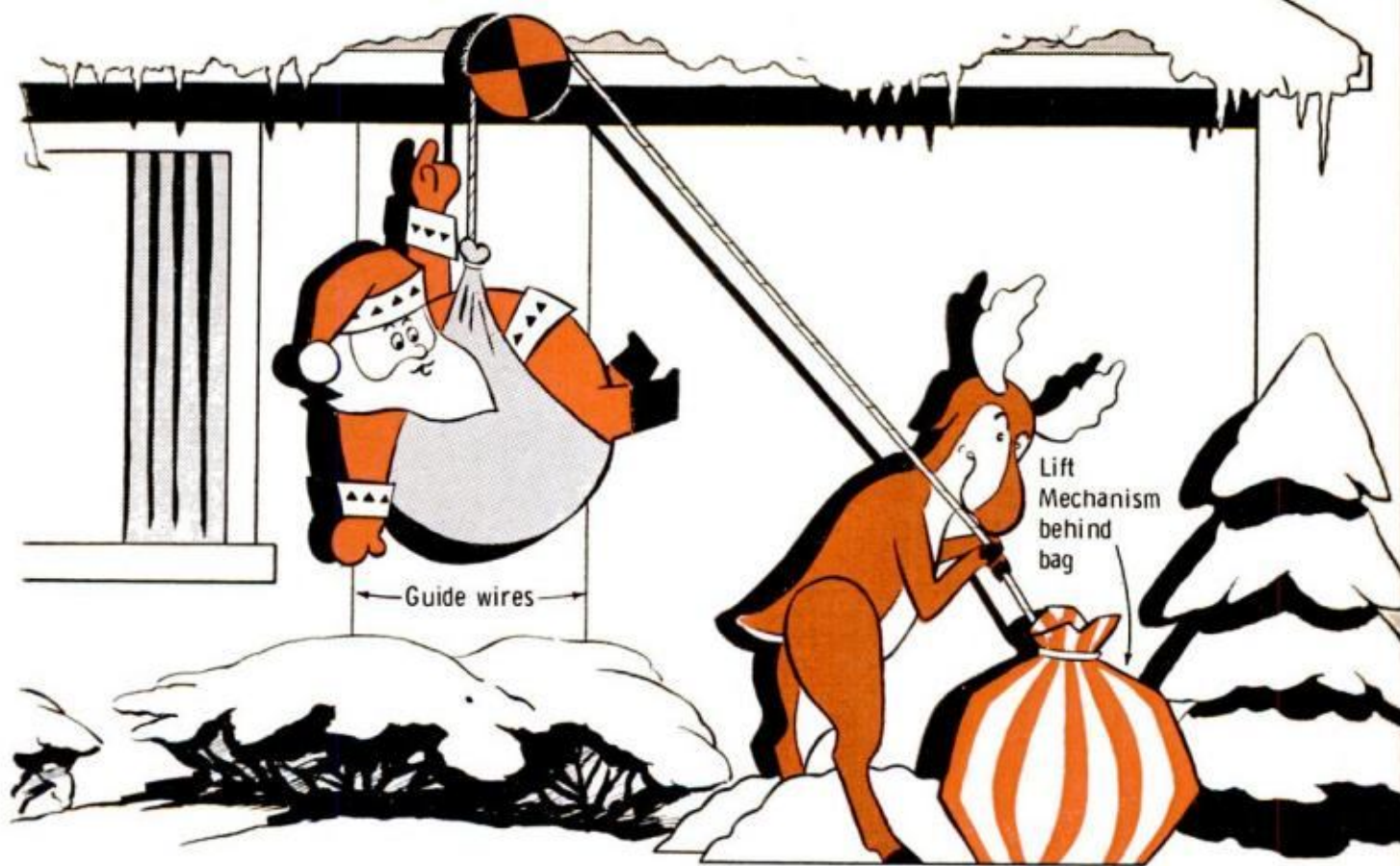

the Santa panel. Assembly of the finished units is a bit tricky. First locate the spot for the pulley (use a standard V-belt type, or make one from plywood) and create a bracket for the pulley that will attach to either the roof or the underside of your overhang, as shown. Now, set up the motor and reindeer so that the rope, when taut between motor and pulley, passes behind the hooves, where it can be stapled. The 16-in.-dia. pulley shown below will hoist the Santa about 14 in. As Santa drops back, he pulls Comet's pivoted

body upright for the next action cycle. The elements of each of the three display patterns are "stacked" for least-waste layout on 1/8-in. hardboard sheets, whether you project the clip-out design directly on white-primed board, or enlarge the graph-squared patterns presented on the next page. The parts for the rocket display fit neatly on two 4x6-ft. panels, while the other designs require one 4x8-ft. panel each. Attach the 1x2 stiffening framework, as indicated by the dotted lines on each pattern.

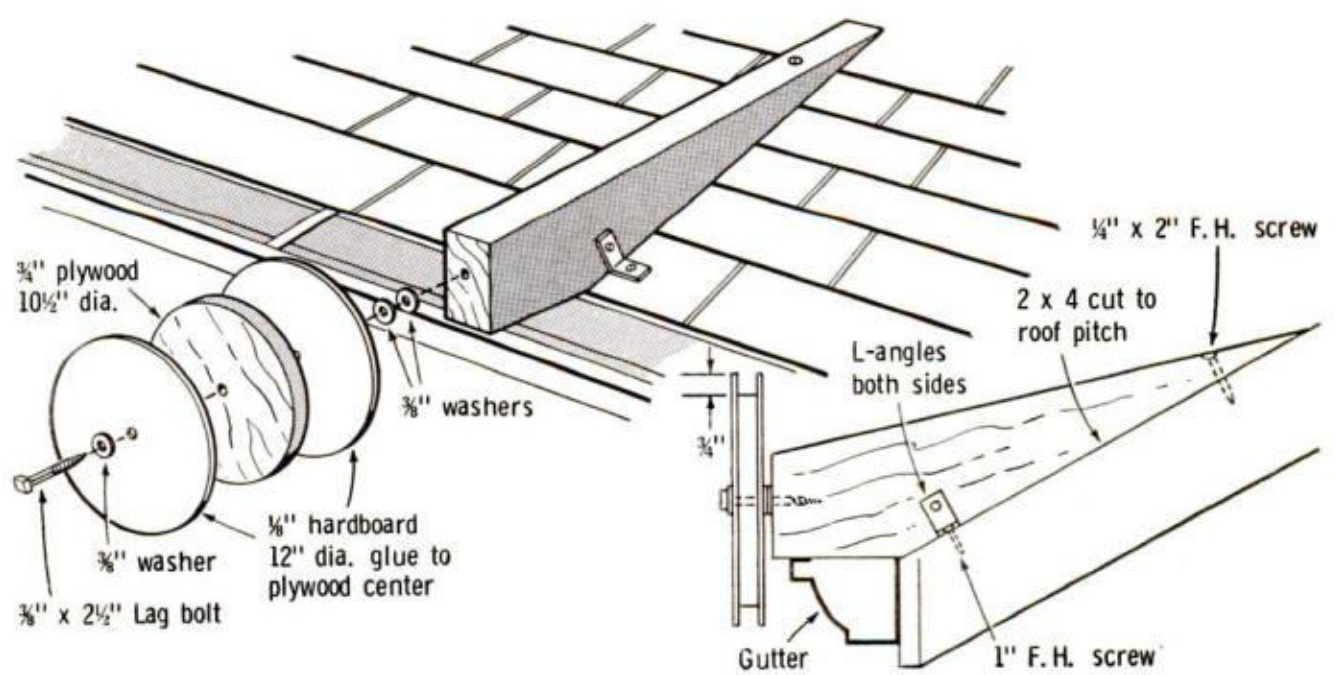

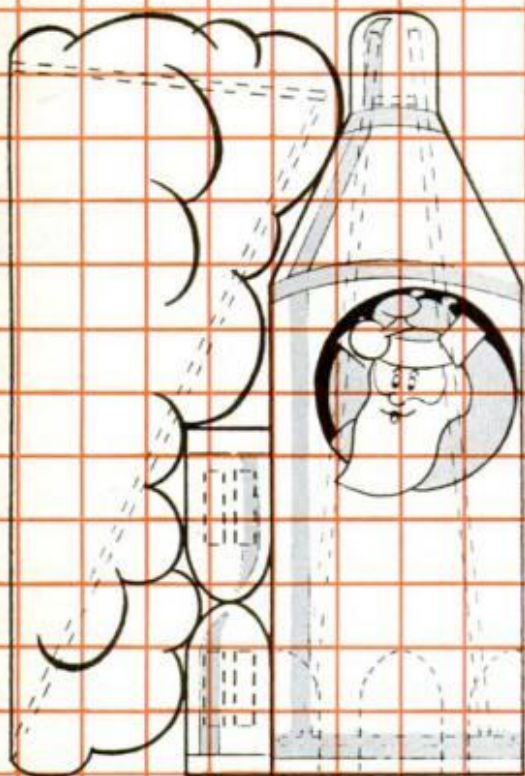
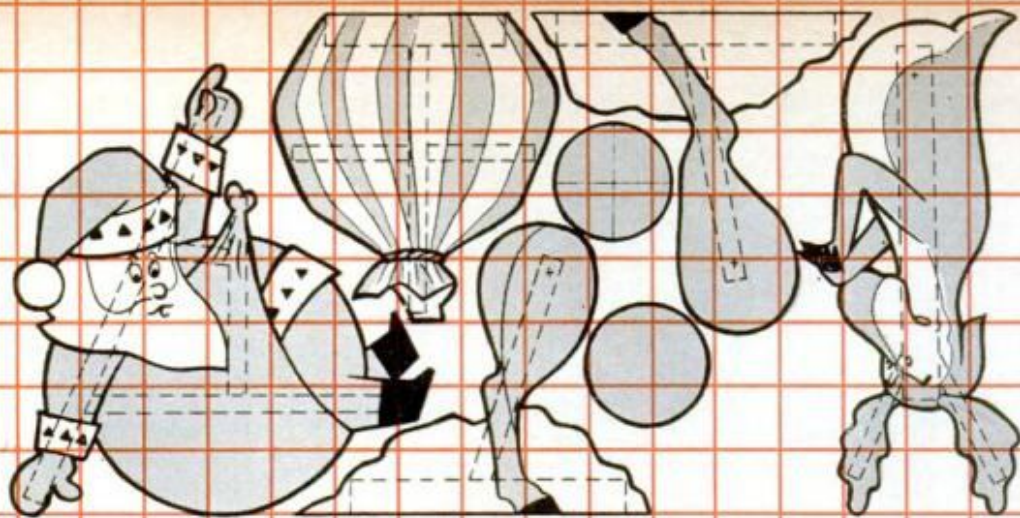

6" sqs.

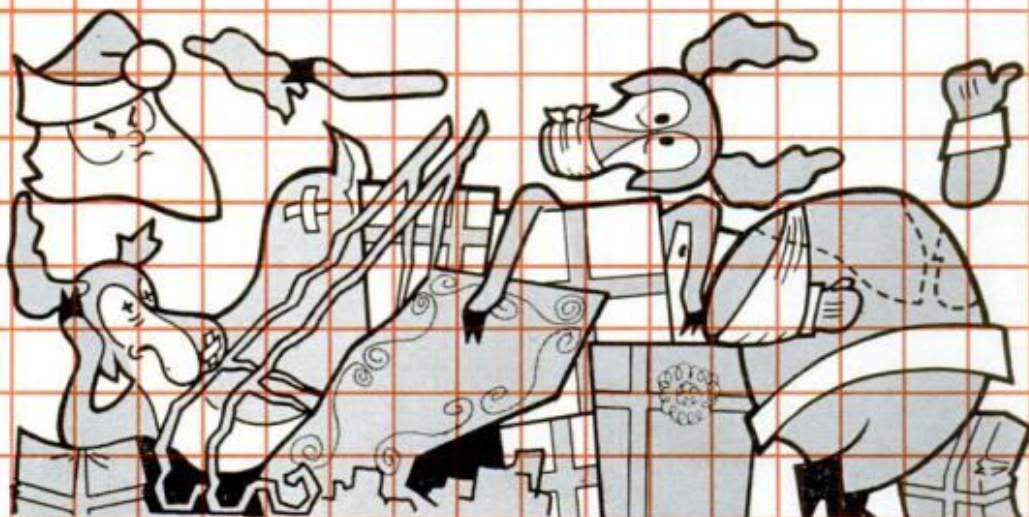
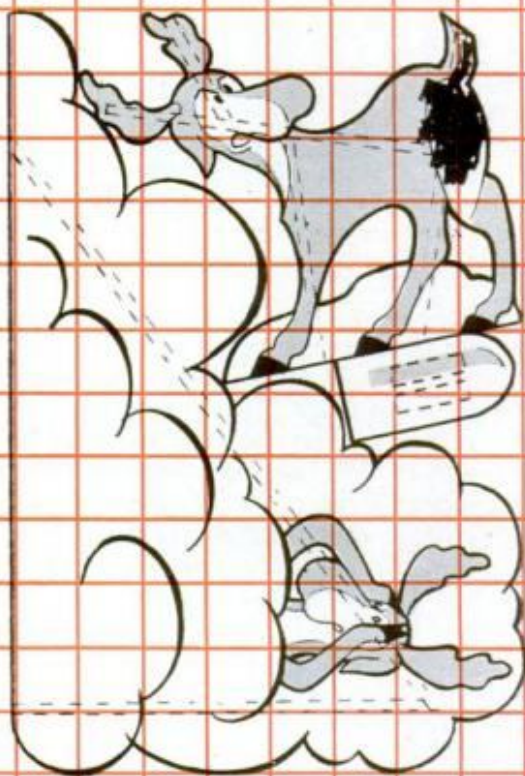



**ST. NICK HAS TANGLED** with modern traffic in the animated assembly above. Surrounded by the debris of his wrecked sleigh, he thumbs a ride to complete his rounds, while poor dazed Dancer ruefully attempts to fit his broken antler together and Cupid shakes his battered head. All three moving parts are run by a single shaded-pole, direct-drive, 12-to-20-rpm motor, as shown in the rear view, below. They're all linked to the plywood drive wheel by connecting rods made of hardboard or aluminum bar. Linkage will require some trial-and-error. Note corrugated fasteners at butt joints of framing.

\*\*\*

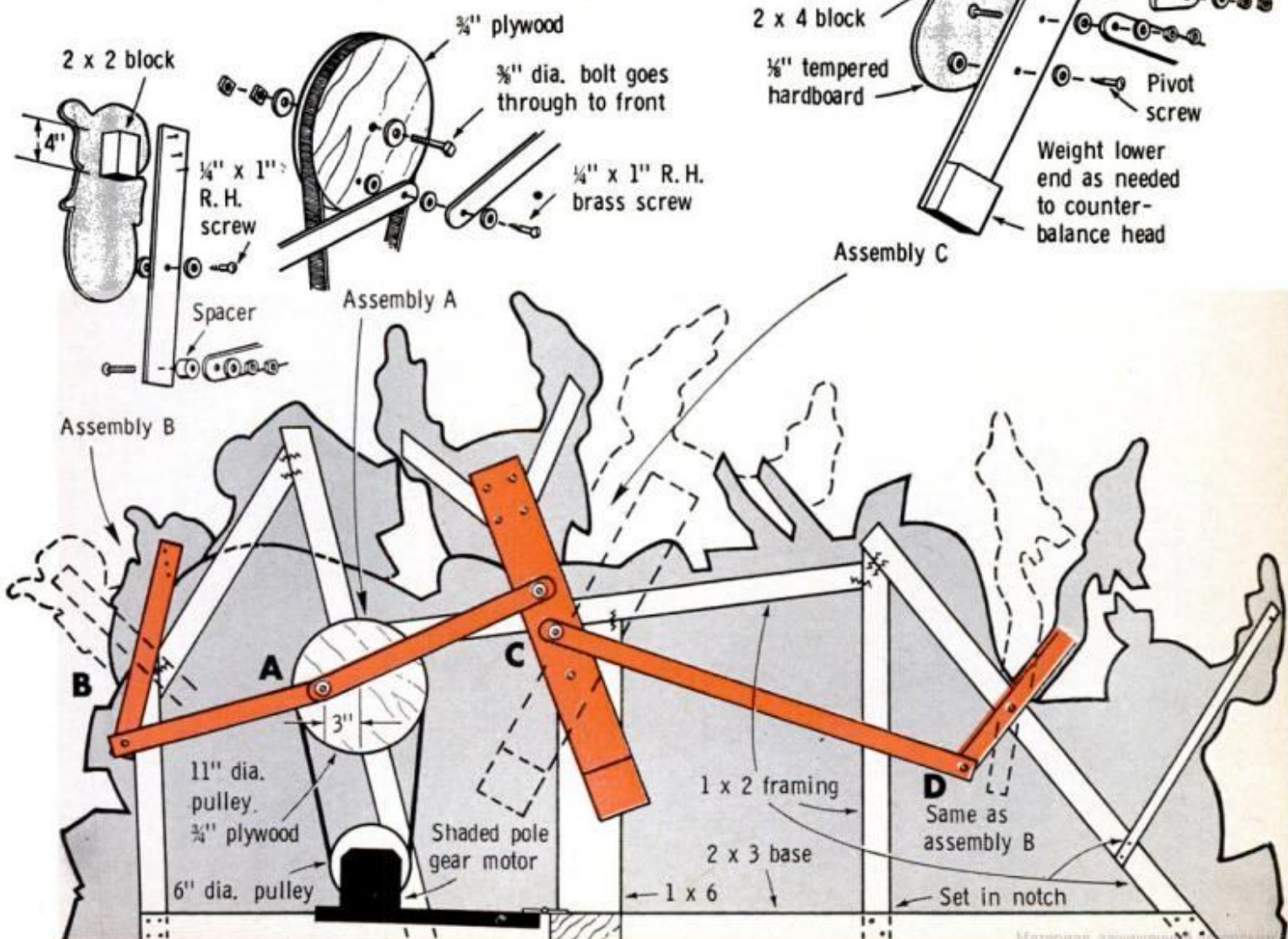

# Batty Boxers

By Willard and Elma Waltner

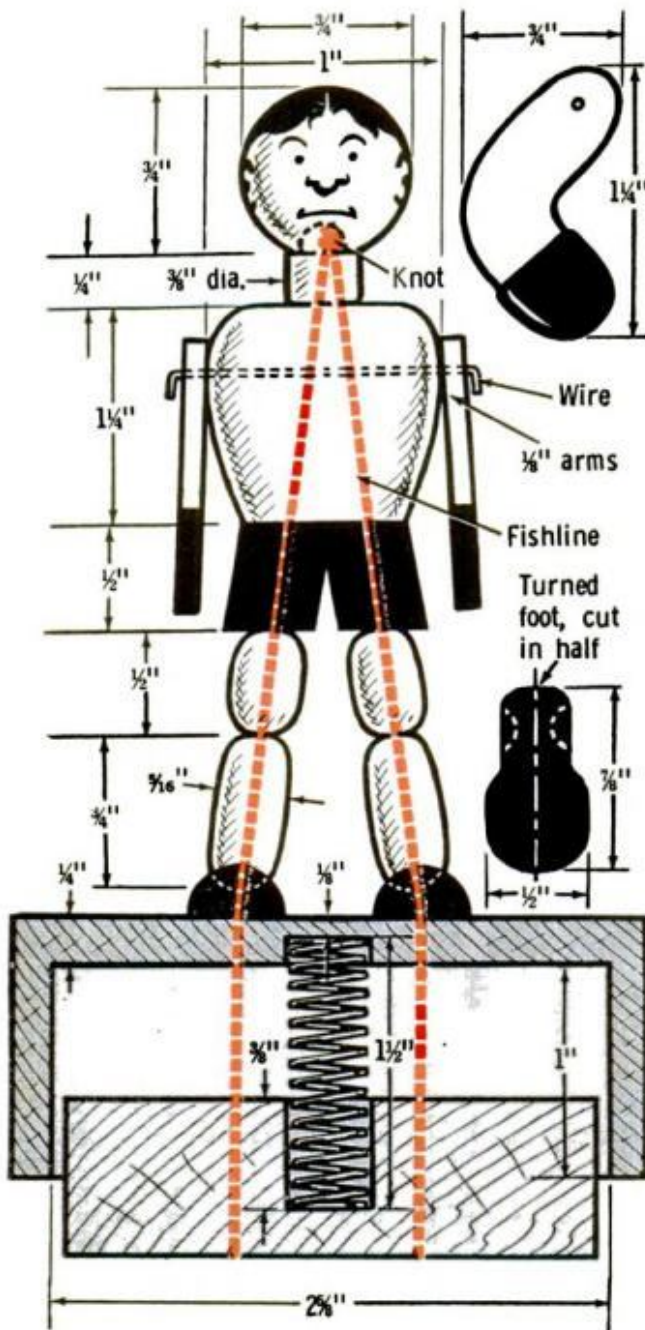

**I**T'S A KNOCKOUT, this battling boxers toy. By pressing the compression base at different points, you can produce anything from a cautious sparring match to an all-out slugfest.

Turn the parts as shown in the drawings, then drill holes in the body, legs and base for the stringing cord with which the figures are assembled. Fishing line works fine for this. Thread the line from the bottom, running the ends up through the compression block, base and figure and tying them off at the neck.

After gluing the head in place, attach the arms with pieces of piano wire passed through the body and bent to right angles at the ends, leaving enough space so that the arms swing freely. Finally, add the features and finish with clear varnish.

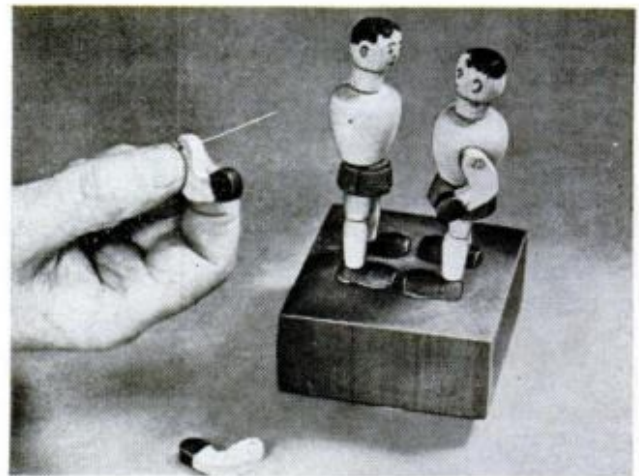

**SLUGGING POWER** for the boxers' arms is a matter of gravity. Mounted on pieces of piano wire which pass through the body, arms are held in place by right-angle bends in ends of the wire which allow enough clearance for arms to swing freely. Depressing disc causes fighter to lean, making arms swing



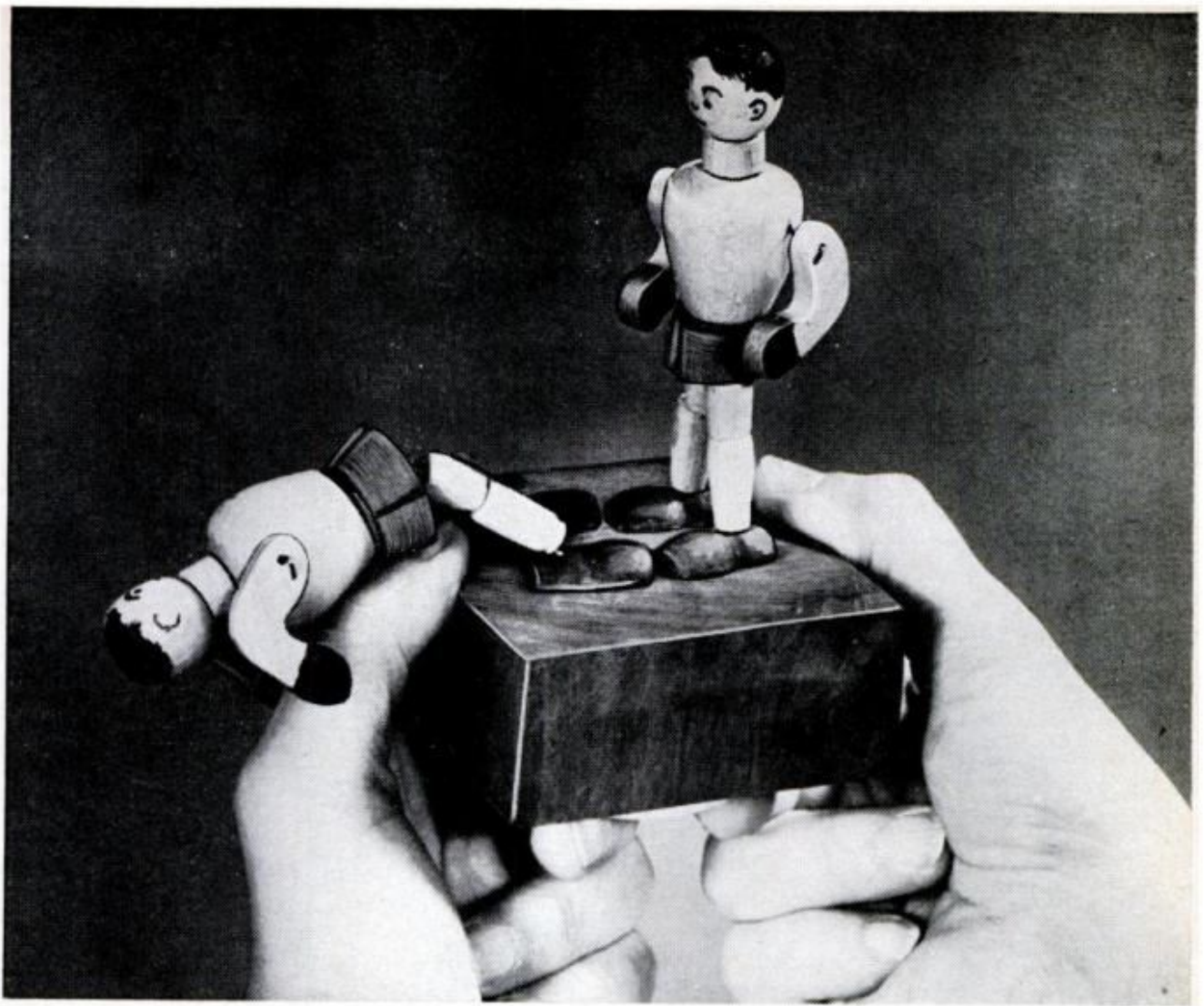

**KNOCKDOWN** is produced by depressing the compression disc immediately under one fighter. This relieves the spring tension on the stringing cord and causes the figure to collapse. Let go and he pops up

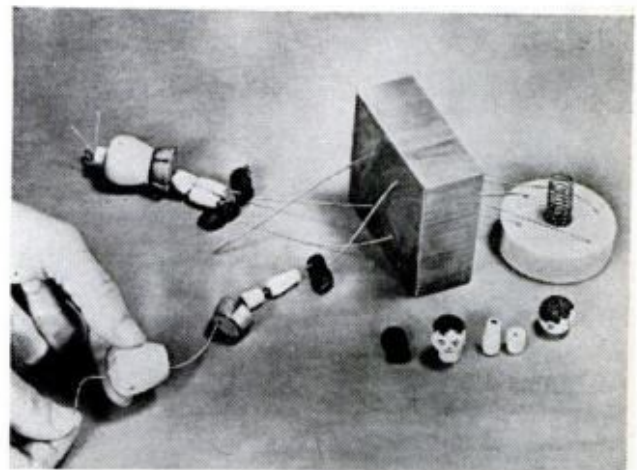
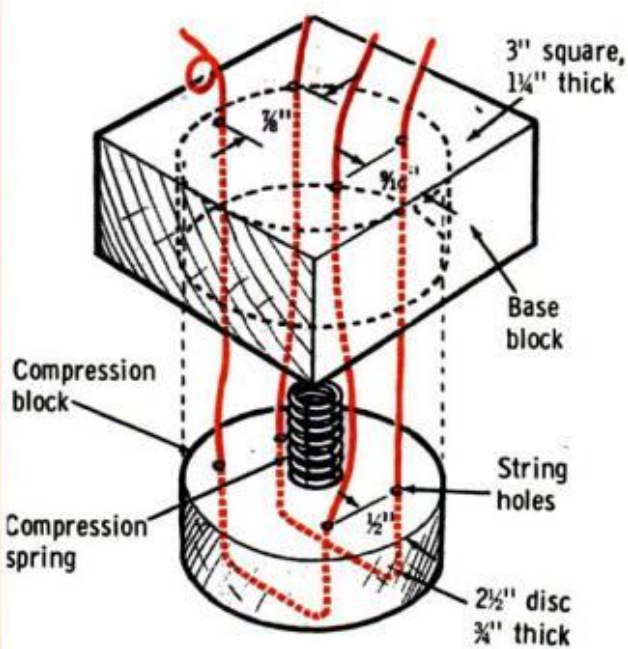

**THREADING** the parts of the fighter on fishing line may look like a cat's-cradle operation but is actually quite simple. Note that all the parts have been painted before this final assembly operation is started. Pull line tight, tie it and you're finished

# Band of Angels

*from the lathe*

By Willard and Elma Waltner

**A**N INTERESTING EXERCISE in novelty turning, this little band of stylized angels makes a handsome holiday display for coffee table or mantel.

Bodies, heads, arms and haloes are identical maple turnings; the instruments are walnut. Turn the heads in groups of three, connected by necks, then saw them apart. Turn the arms in sets of two, connected by hands. Saw these in half lengthwise,

using a fine blade in your jigsaw, then cut the two sets apart at the hands.

The drumsticks, fiddle bow and director's baton are all sections of round toothpick glued into holes drilled through hands.

After assembling the figures, seal with a coat of shellac and finish with two coats of brushing lacquer. Use gold paint on the haloes and glue them in place after you've finished the figures.

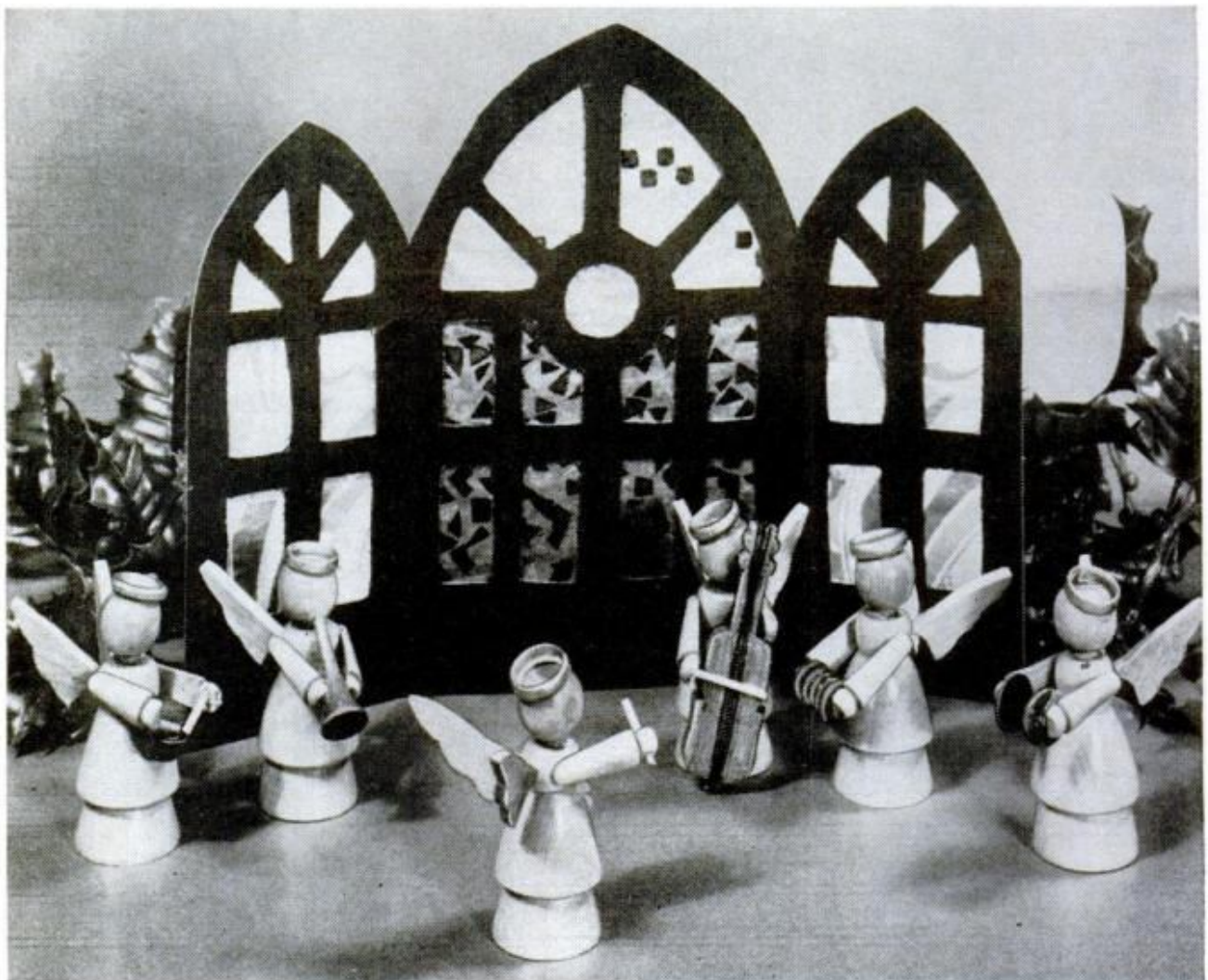

**GOTHIC WINDOW BACKDROP** is cut from cardboard and creased to stand upright. Windows backed with colored cellophane simulate stained glass

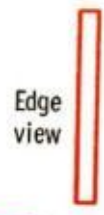
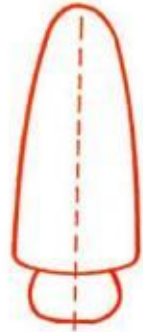
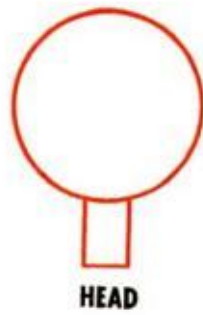
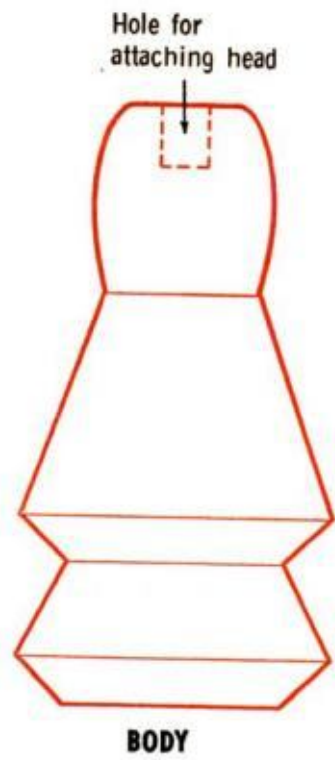

Full-size patterns for tracing

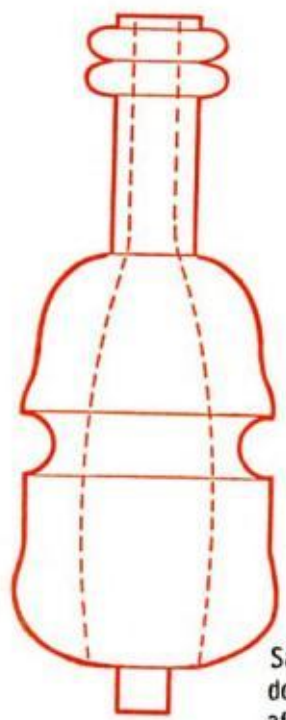

TO TURN HALOS, hollow out end of 3/4-in. round, leaving 1/8-in. thick wall, then cut off 1/8-in. ring

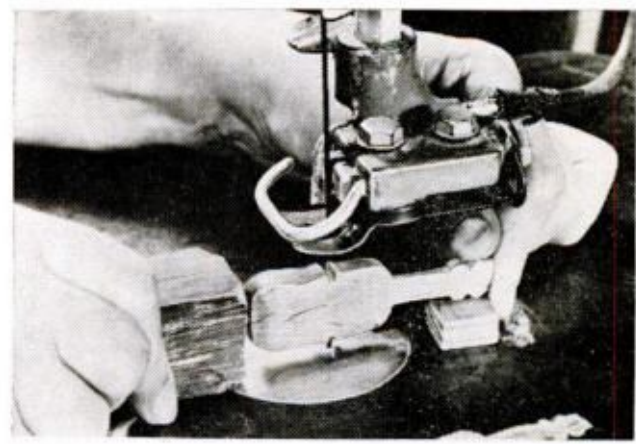
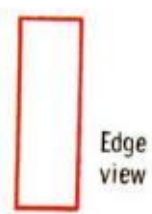
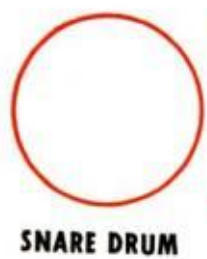

BASS FIDDLE is completed by sawing out center section of turning, indicated by dotted line in drawings

## Chimney Santa Holds Holiday Candy



Made from a 3-in.-dia., hurricane-lamp chimney, this novel glass Santa adds a colorful touch of Christmas cheer to any room in the house when filled with holiday candy. Press the large end of the chimney into a 1 in. x 4 in. x 4 in. Styrofoam block to form a  $\frac{1}{4}$ -in. depression, run a bead of

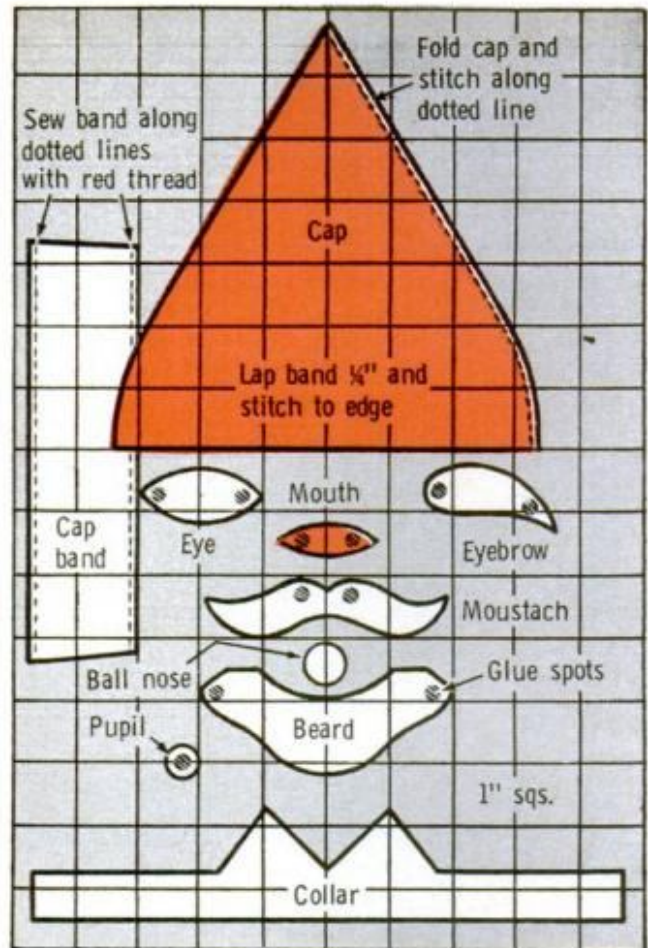

white glue around the bottom of this depression and glue the chimney in place. Cut out the felt parts, apply glue where indicated and position them on the chimney. Add the collar, tie (a  $\frac{1}{2}$ -in. red satin ribbon) and the bell-tasseled cap and Santa is finished.—*Gene Florida*



## Christmas Wall Collage

You can transform a barren wall into a festive Christmas display using box tops, metallic gift paper, ribbon and greeting cards. Just wrap each box top in metallic paper, taping the edges to the underside of the top, and paste a greeting card scene on the top. Next, make a hole in the middle of one edge with scissors, string a ribbon through it and tie a knot on the inside. Finally, mount the ribbon on the wall with double-faced cellophane tape and attach a bow near the top. For variety, use different size box tops and different color wrapping and ribbons. Interesting effects can also be achieved by offsetting the cards on the box tops. Six or seven box tops prepared this way will brighten up any wall. You'll find it a wonderful way of giving prominent display to cards you prize the most.—*Marion Morey*



PM IDEAS FOR  
CHRISTMAS

# Jeffrey Giraffe

By Steve Ellingson

**E**VER SEE MOPPETS who *liked* to hang their clothes up? Well, yours will when Santa leaves them this colorful "clothes horse"—which happens to be a giraffe. Dad can make it in a single evening with a bit of scrap wood, a handful of screws, glue, some paint—and a whisk broom tail that pulls out for a quick brush off.

Make full-size drawings of the parts, then trace them on your wood and cut out. Drill holes where indicated, then assemble as shown, using flathead screws and glue. Paint bright yellow. When dry, paint on the black enamel spots, eyes and mouth. If you want to work from a full-size pattern, see page 143 for ordering.



DEC. 1965

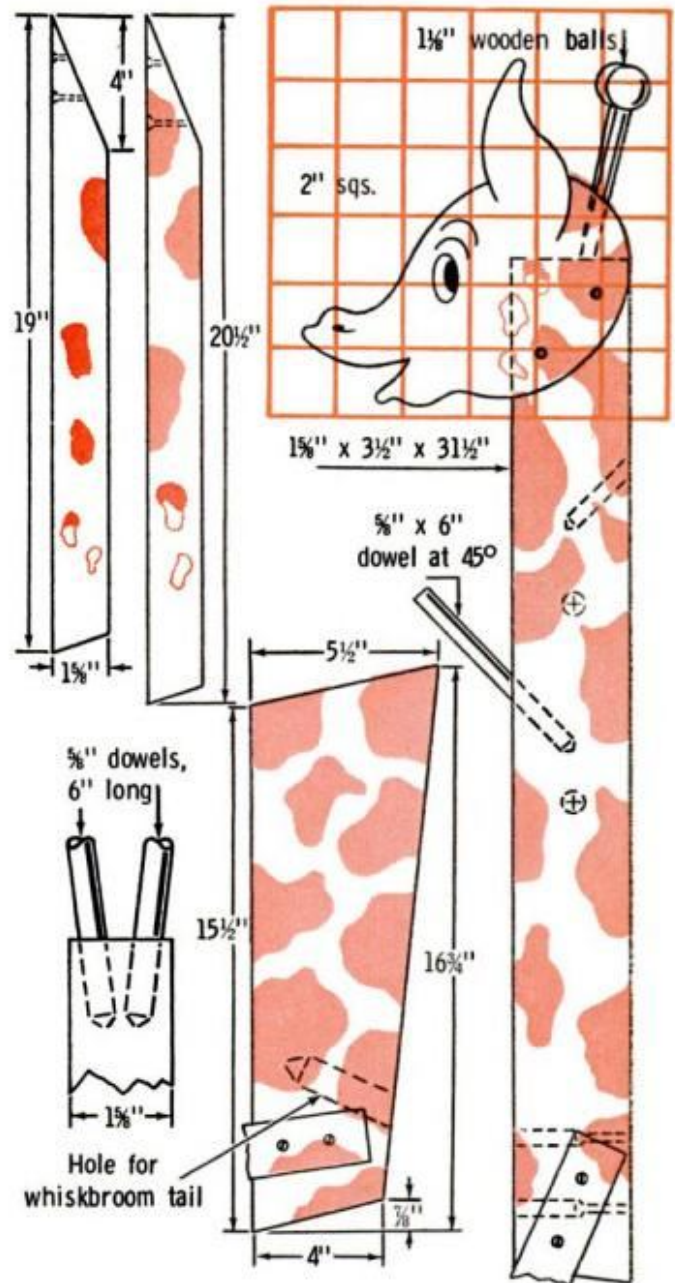
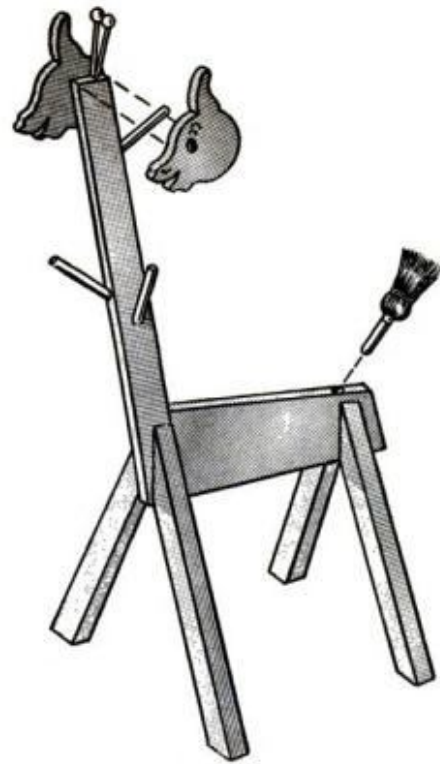

139

# Rainbow Star

Until recently, you couldn't have afforded to make this shimmering star of diffraction grating—the old type cost a king's ransom

By Willard and Elma Waltner

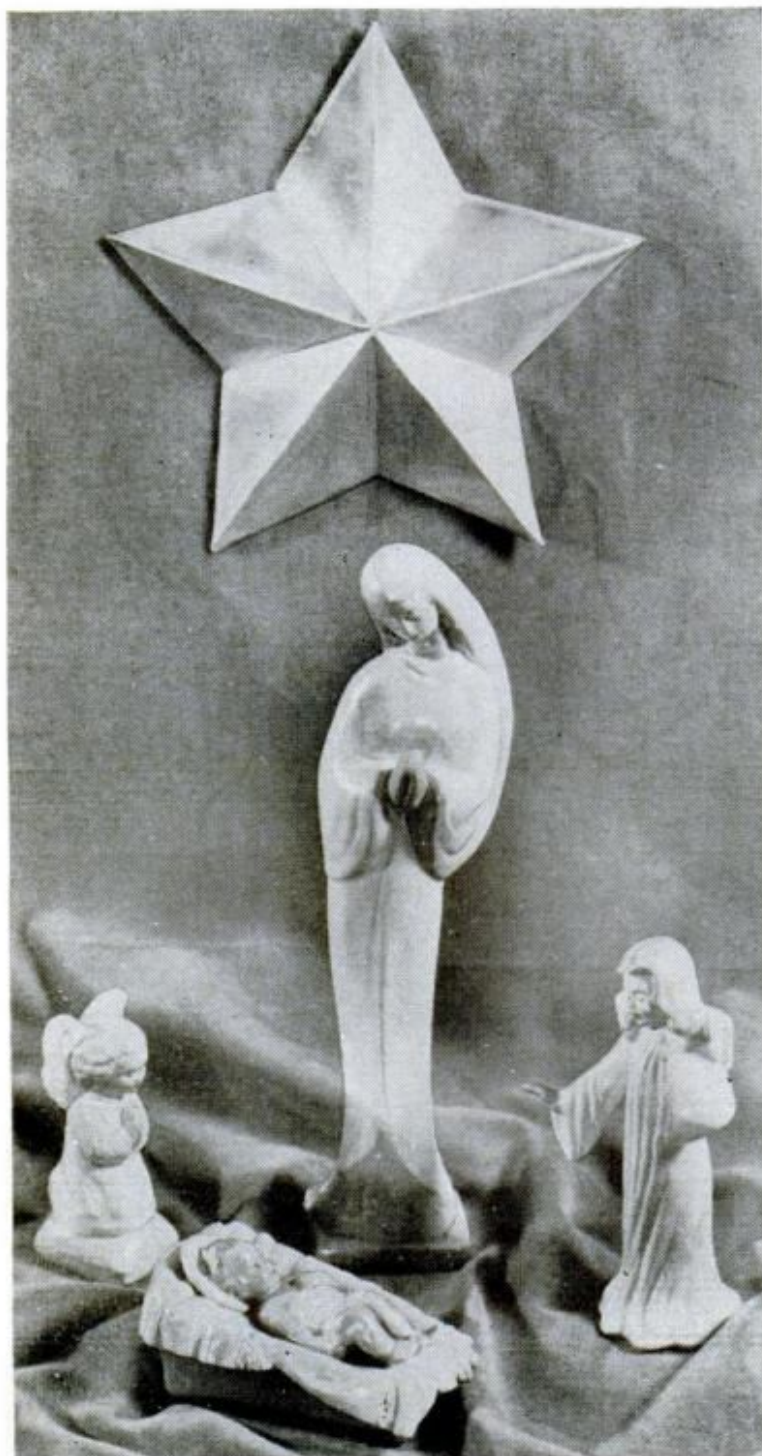

**O**NLY A COLOR MOVIE could capture the beauty of this shimmering Christmas star. Subtle rainbow hues dance across its silver surface as you move past. The secret is a material called diffraction grating. Original gratings were expensive glass panes in which thousands of parallel lines per inch had been etched. These lines caused light passing through the glass to break up into every color of the spectrum so that ever-changing rainbows were created as you moved the pane.

The material used for *this* project, however, is a low-priced, reflection-type replica on an aluminum-coated film that's easy to cut and fold. It has 13,400 grooves per inch to shatter the light into colors. You can order the required 8x11-in. sheet from Edmund Scientific Co., Barrington, N.J., 08007, for \$2.50 postpaid. While awaiting delivery, make the star's poster-board backing as shown at right.

When your diffraction grating arrives, use a china marking pencil to lay out the star right on the protective plastic sleeve. When you cut out the star, you discard the plastic on the back but fasten the matching front piece to the grating with transparent tape before creasing the flat shape to fit the poster-board form.

Fasten the grating star to the form with tape or cement, attach a thread to one of the points, and hang it where its cascading rainbows will contribute most to your holiday decor. Two smaller-size stars, taped back-to-back, make a beautiful tree ornament.

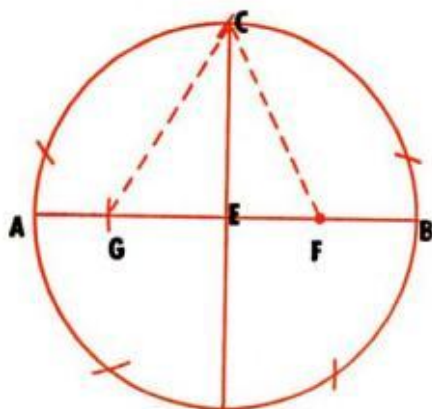

D STEP 1



STEP 2

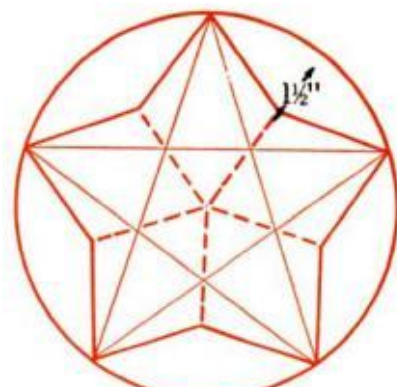

STEP 3

**LAYOUT—STEP 1:** Use compass to scribe 8-in.-dia. circle, then draw perpendicular mid-point diameters AB and CD; mark mid-point F on radius EB, set compass length CF and, with point at F, mark off G; set compass for length CG and strike five equidistant arcs around circumference. Step 2: Connect points. Step 3: "Fatten" star by drawing out lines outside basic shape, drawing radius lines halfway between points

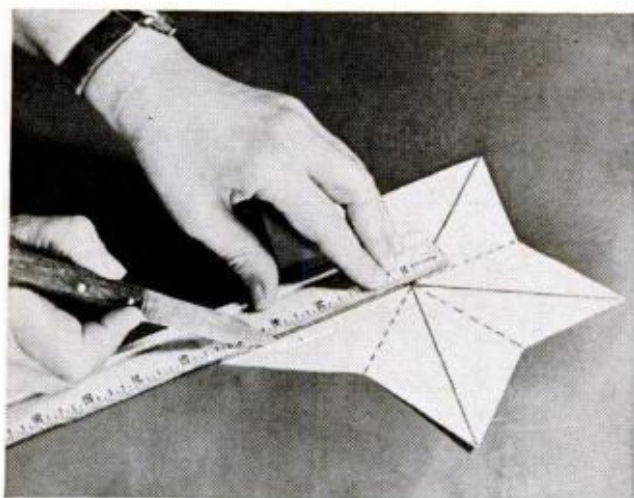

**SHARP KNIFE** and a straightedge are used to score from center to point-tip of star's cardboard backing. Dotted radial lines are scored on reverse side. Scoring aids creasing to three-dimensional shape, but trace pattern for future use while star is flat

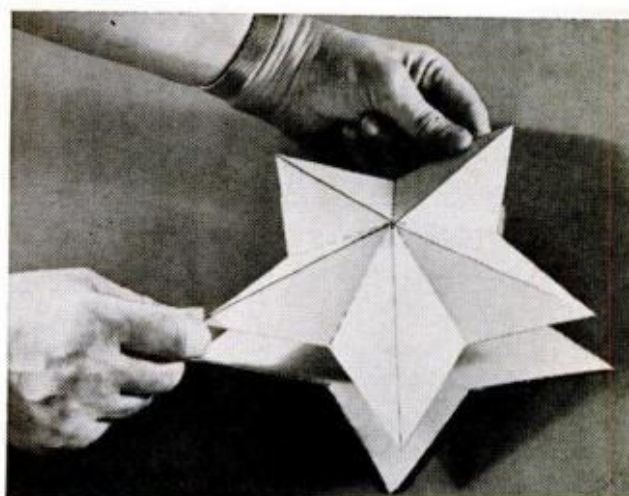

**FORM STAR'S "FACETS"** by bending flanking planes down from top scores and up from bottom ones. Set shaped star on cardboard and trace around it. Cut out new star and fasten it to back of shaped one, using cellophane tape along edges, to hold bends in place

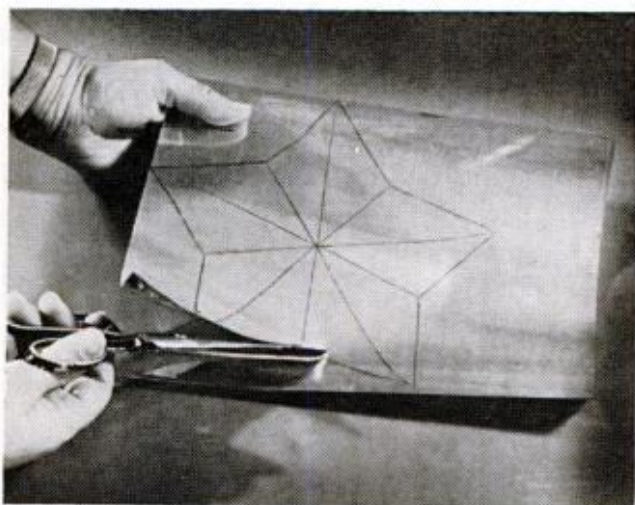

**MARK AND CUT OUT** identical design on protective plastic sleeve that encloses sheet of diffraction grating. (China marking pencil makes best lines.) Discard back plastic cutout, but tape front one to face of grating to hold the two pieces in alignment

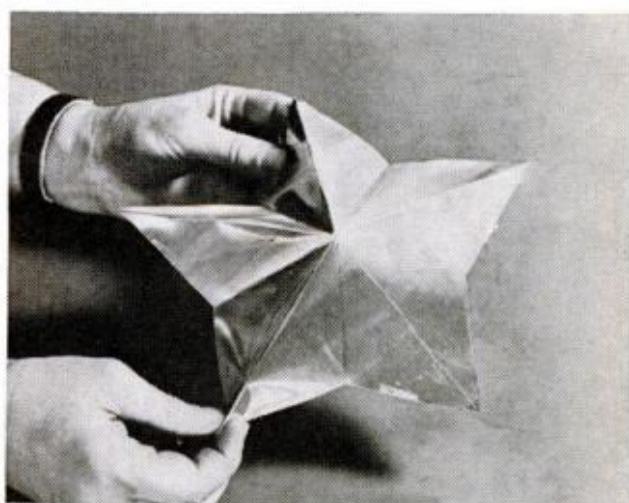

**DON'T SCORE** the diffraction grating—simply crease it along marked lines in the same manner as you shaped cardboard backing. Rub away any fold marks with clean cloth, and fasten star to backing, using cement or non-glossy invisible tape along all edges

# Christmas Dollhouses

ANY JUNIOR MISS will be delighted to set up housekeeping in one of the three miniature homes detailed on these six pages. Choose the one that best matches the temperament and tastes of the youngster you have in mind.

Some dollhousekeepers are fussier than their mothers about anyone *else* moving their furniture around. For this type, the hinged-box house on pages 144-5 may be best, since it folds closed between play sessions. But if your youngster prefers *shared* play, the "lazy Susan" model shown below should make a hit.

Accessible from all sides, its "atrium" arrangement lets several girls act out fantasies in separate rooms; then, for fresh

interest, they can turn the house to shift rooms, as with a revolving stage.

One 4x8 sheet of 1/4-in. plywood will give you the floor-disc, base, walls and roof sections, and a 2x4 sheet of 1/8-in. hardboard is plenty for the bearing plates. Tack roof cleats in place as shown; glue and brad all walls to each other and to the disc floor; then glue and brad the roof to the cleats. Fill roof "valleys" with wood putty and sand smooth before painting.

Drill a 1/4-in. hole through the center of the floor-disc, base and bearing plates, and run a 3/16 x 1-in. bolt down through the cap from a discarded spray can. This hides the bolt head and provides a planter for the tree.—Steve Ellingson

## 1 REVOLVING DOLLHOUSE

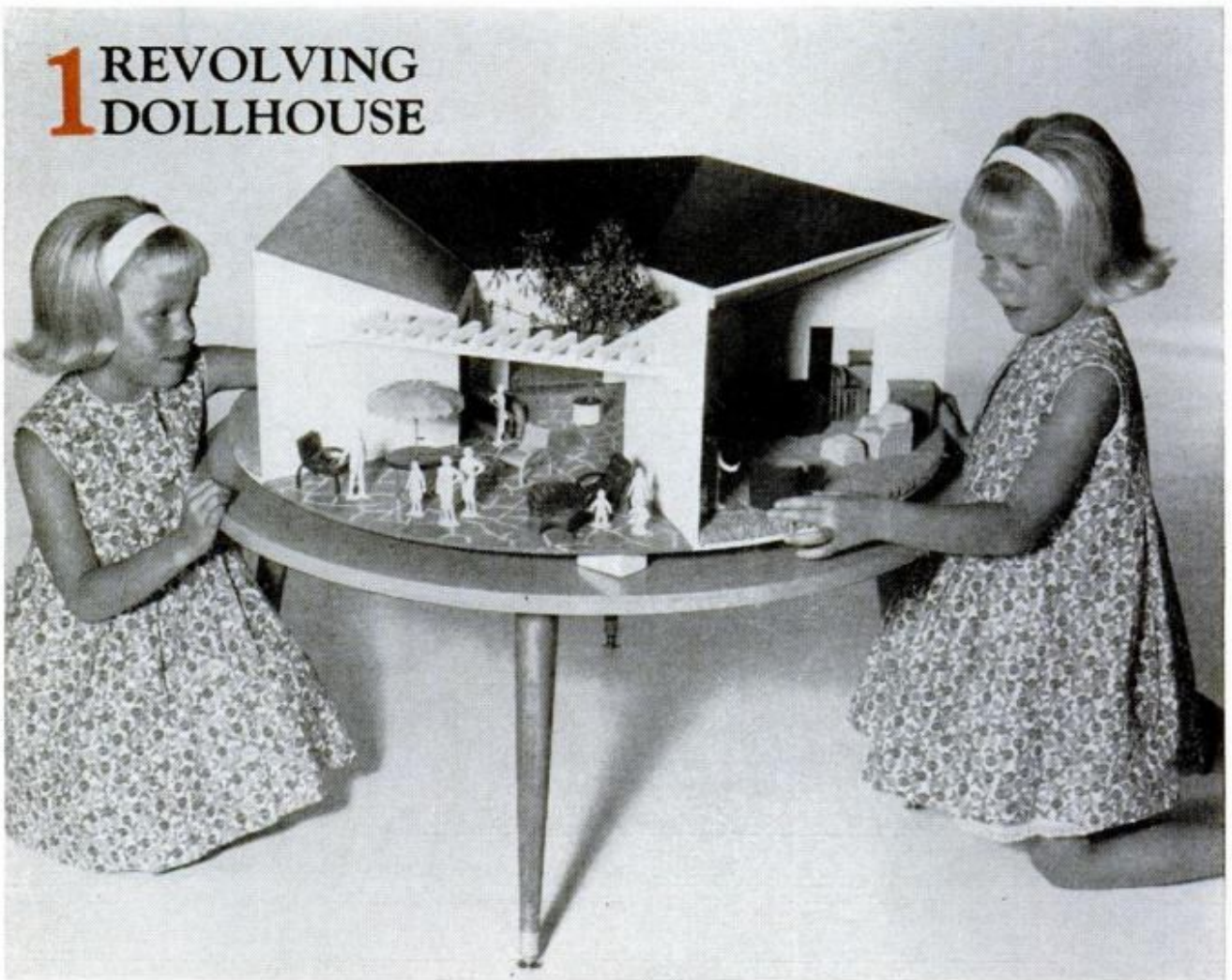



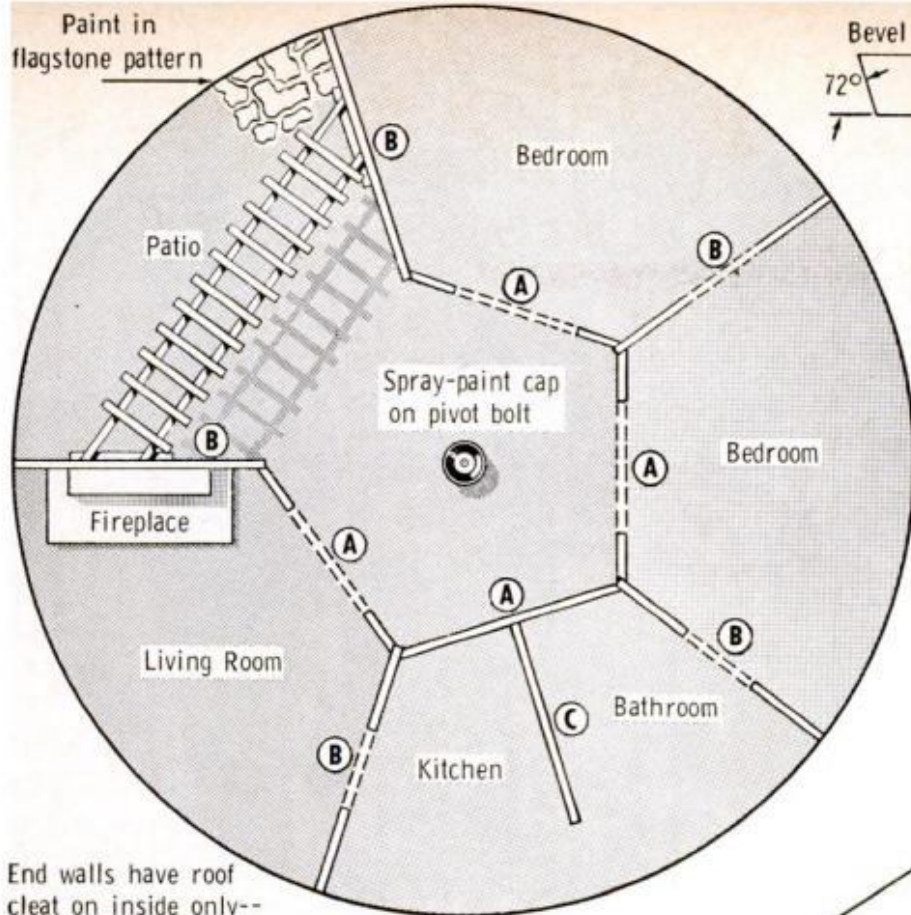

End walls have roof cleat on inside only--trellis cleat on other side

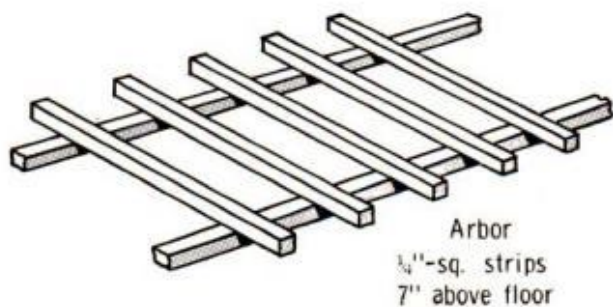
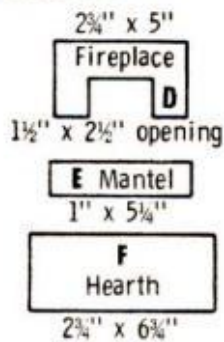
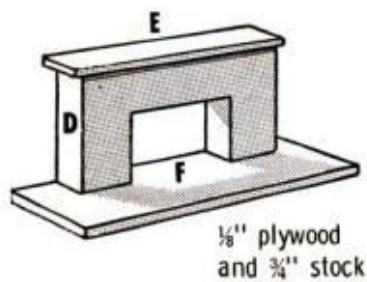

### PLANS AVAILABLE

Prefer to work from full-size patterns you can trace directly onto your stock? Of the gift projects shown in this issue, such a plan sheet is available for only this revolving dollhouse and the giraffe clothes tree on page 139. Write Steve Ellingson, Popular Mechanics Pattern Dept., Box 2383, Van Nuys, Calif., enclosing 50¢ for plan 113 (giraffe) or \$1 for plan 329 (revolving dollhouse).

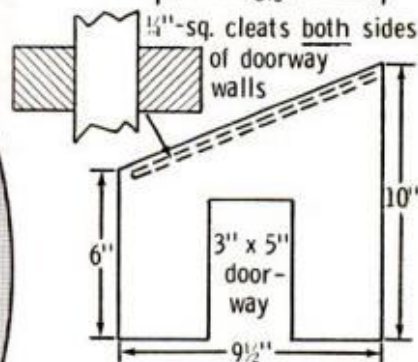
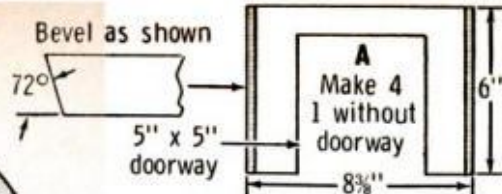

**B** Make 5 2 without doorway

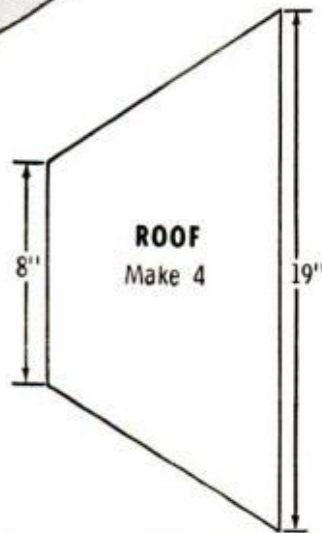
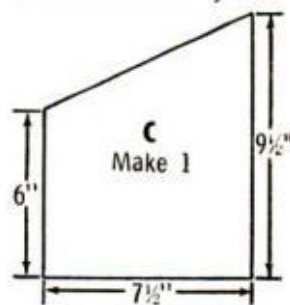

Glue rough face of 15" hardboard squares to platforms, wax 'pivot-bearing' faces liberally

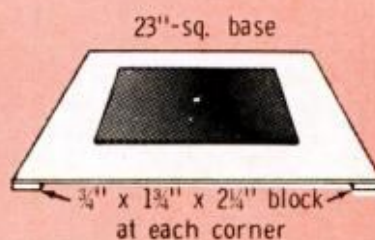

# 2 FOLDING DOLLHOUSE

HOMEMAKERS who prize their privacy will welcome a house that keeps snoopers from tampering with the rooms once the hinged side sections fold under the overhanging gable. There's even a secret attic in which summer furniture may be stored. When closed, the dollhouse occupies only 8 in. by 12 in. of floor or shelf space.

The best construction material—for both exposed and nailed edges—is ¼-in. pine, but you can substitute plywood. Apply glue to all butting surfaces during assembly, and attach the wings with four small brass hinges. Chimney, dormer and awnings are glued-on wood blocks.

In the model shown, windows and doors are dummies, with stencilled blue panes; but the ones at front and back may be cut out with a coping saw, if preferred, to permit peeking into the closed house. At least the gable window *should* be cut out, to provide a finger hole for tipping the triangle forward so it can be lifted out of its groove. Enlarge the graph-squared pattern for the other details on the facade.

The house is scaled for the tiniest doll furniture sold in most variety stores. Or you can make furniture from wood scraps. You'll probably want to build-in the kitchen counter, at least, and put a contact plastic on the floor.—Hi Sibley

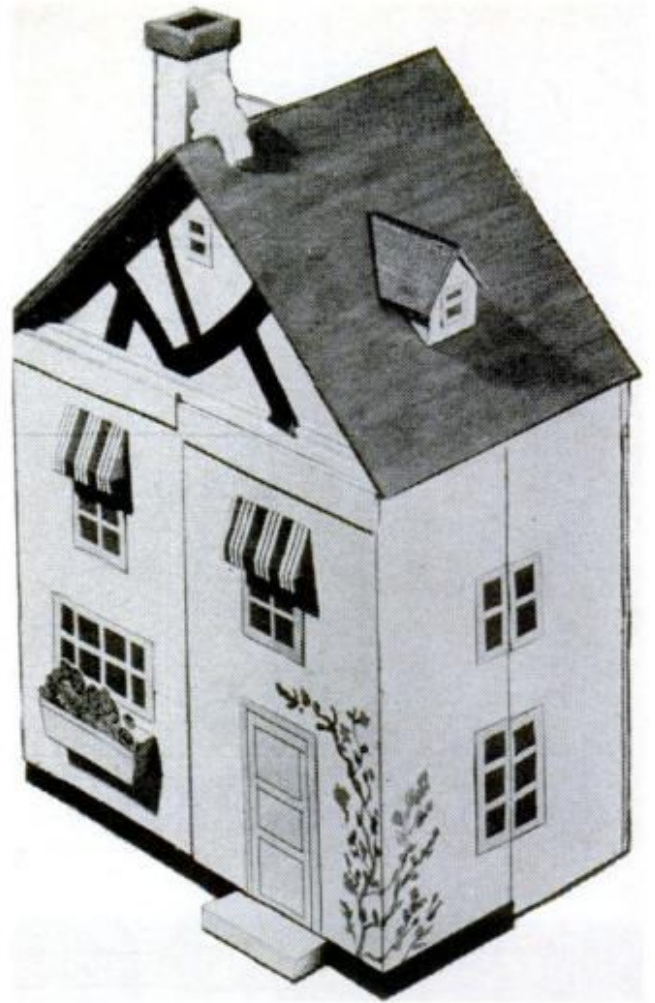

CUT,  
FOLD,  
TAPE

DOLL-  
HOUSES

Ornament lifts  
off to release  
attic triangle  
(See detail, right)

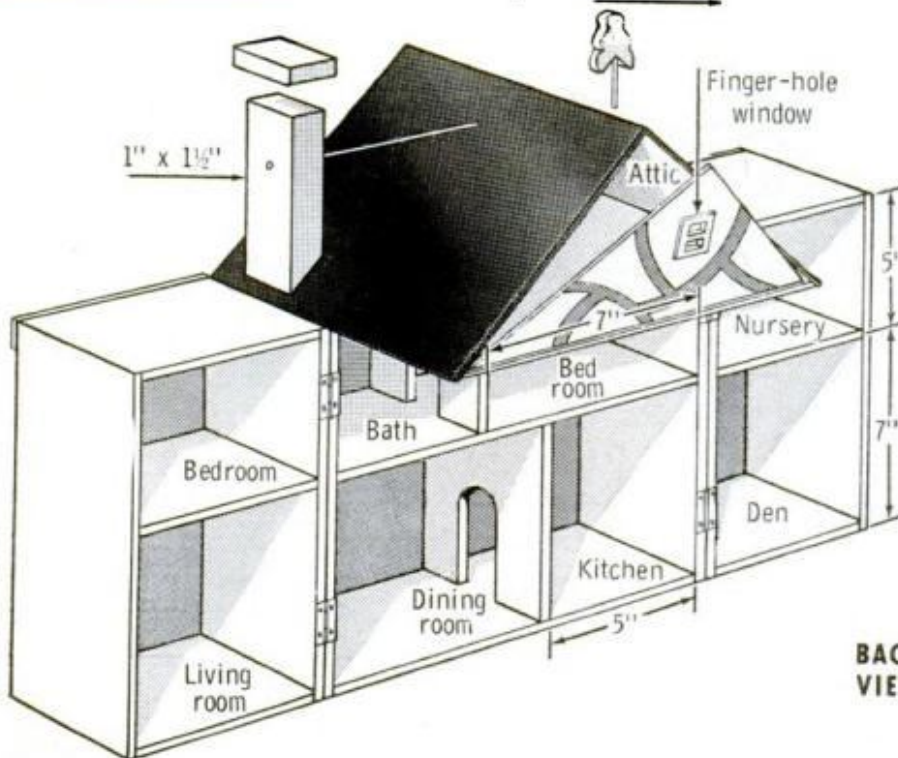

Drive nail into  
ornament, cut  
off head

Drill hole through  
roof peak

Groove  
attic floor

BACK  
VIEW

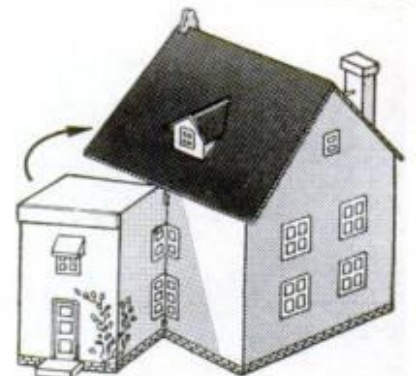

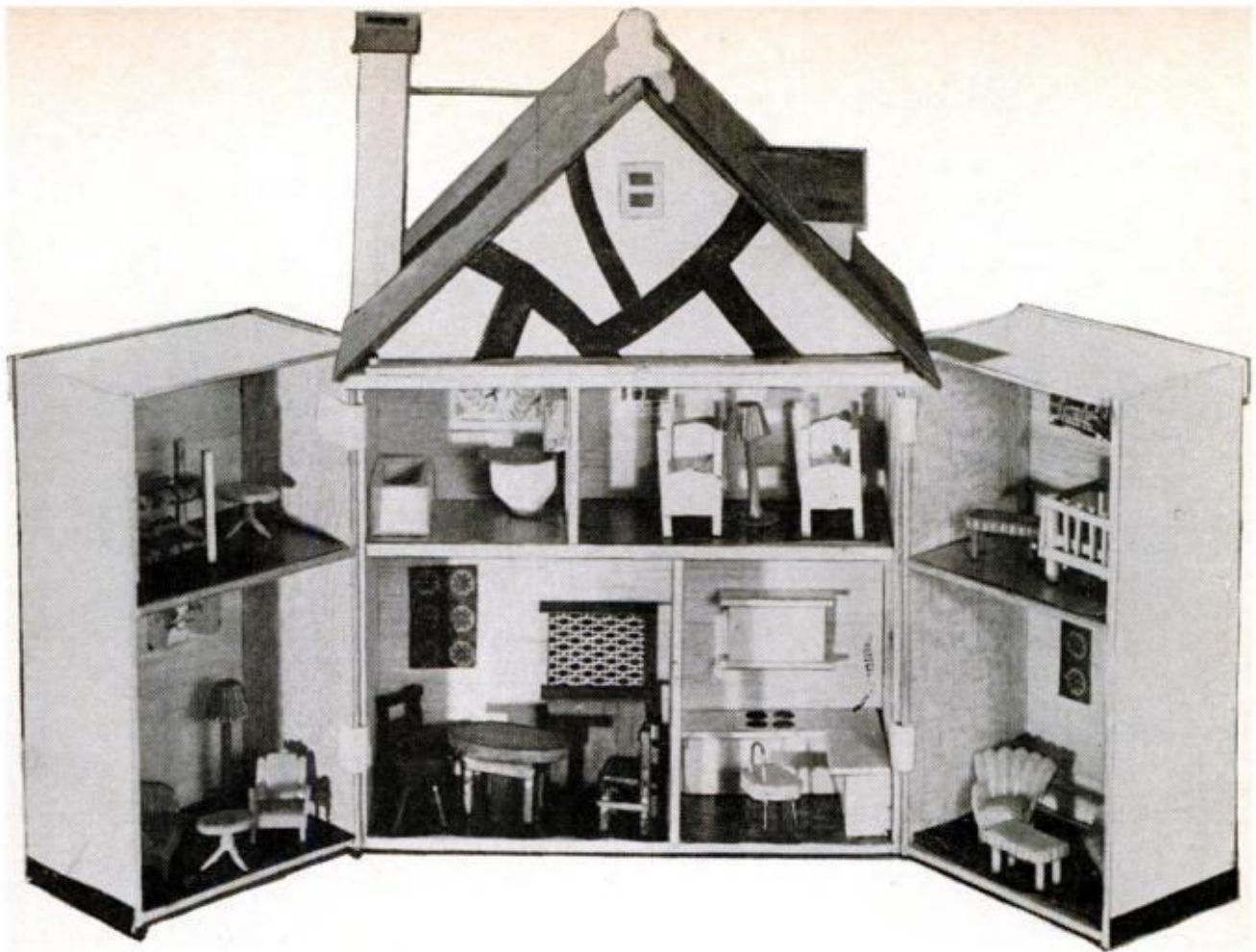

FRONT ELEVATION

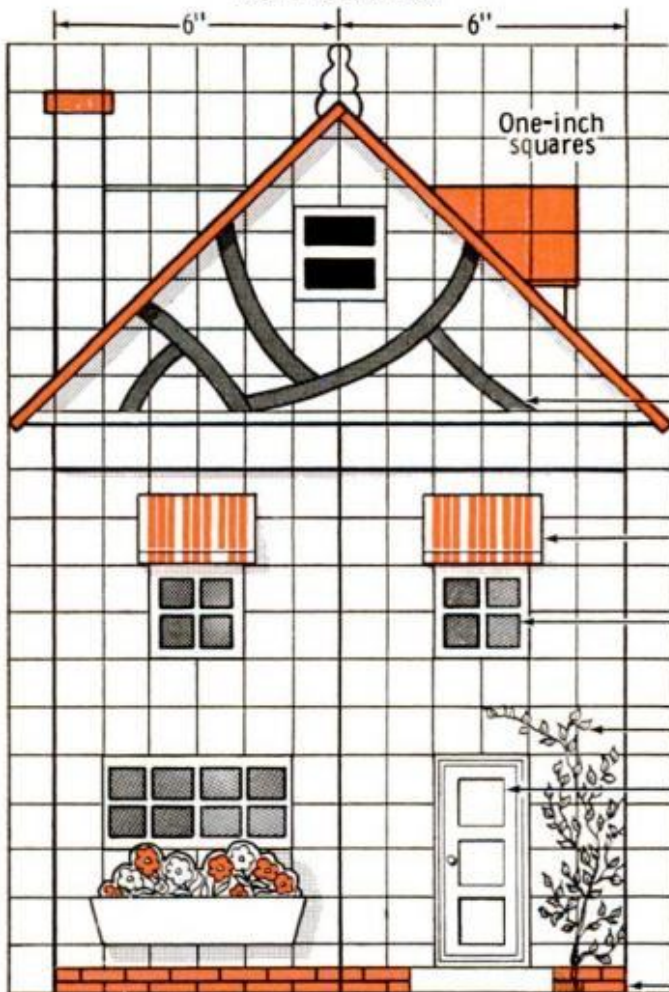

SIDE ELEVATION

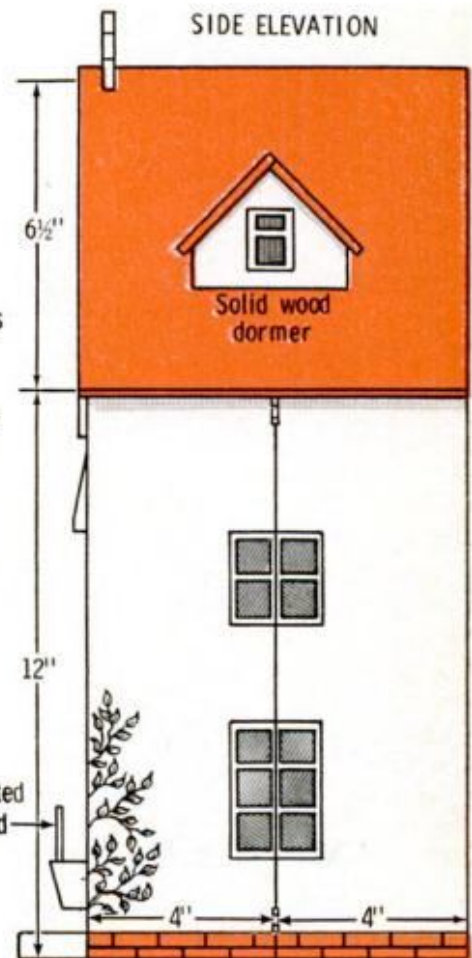

# 3 YOUR HOME IN REPLICA

WHEN YOUNGSTERS play "house," they become their parents in miniature. What could be more appropriate, then, than a dollhouse that's a scaled-down replica of the family home?

Exact plans, of course, can't be presented here. The best way to scale down your house is to photograph the front and side walls with a color-slide camera, shooting from a ladder to raise yourself level with the top of the ground-floor windows. Project these slides onto paper taped to a wall, moving the projector back and forth until the image matches a scale of, say, 1 in. for each foot your house really measures. Now, trace the outline of the wall, windows, doors and other details on the paper, to form a pattern.

Lay out a floor plan to the same scale, eliminating closets and halls, and cut the floor and walls from  $\frac{1}{4}$ -in. plywood.—*Dave Swartwout*

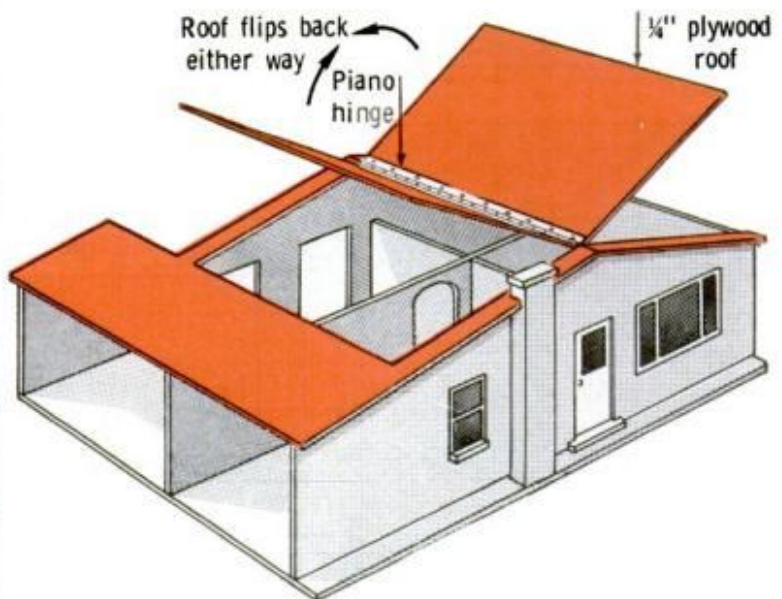
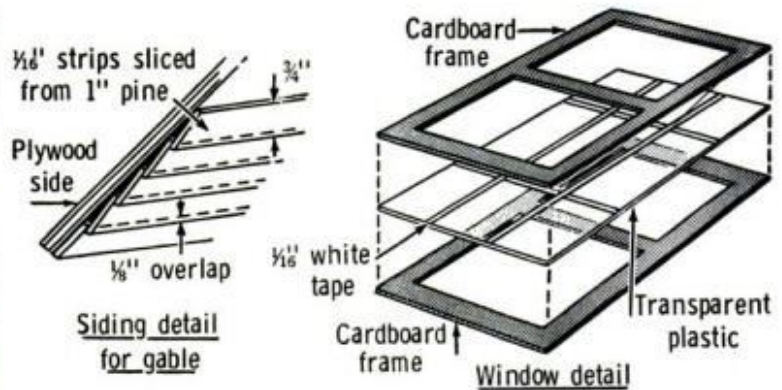
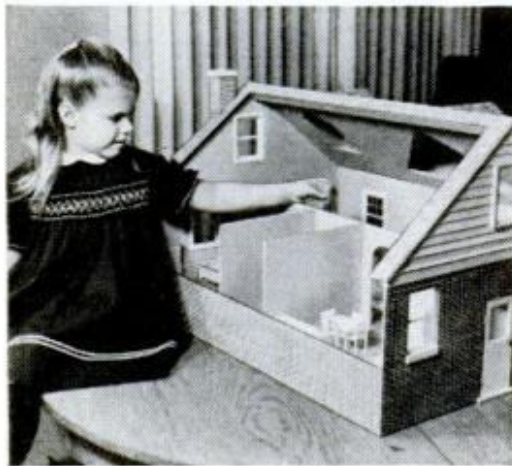
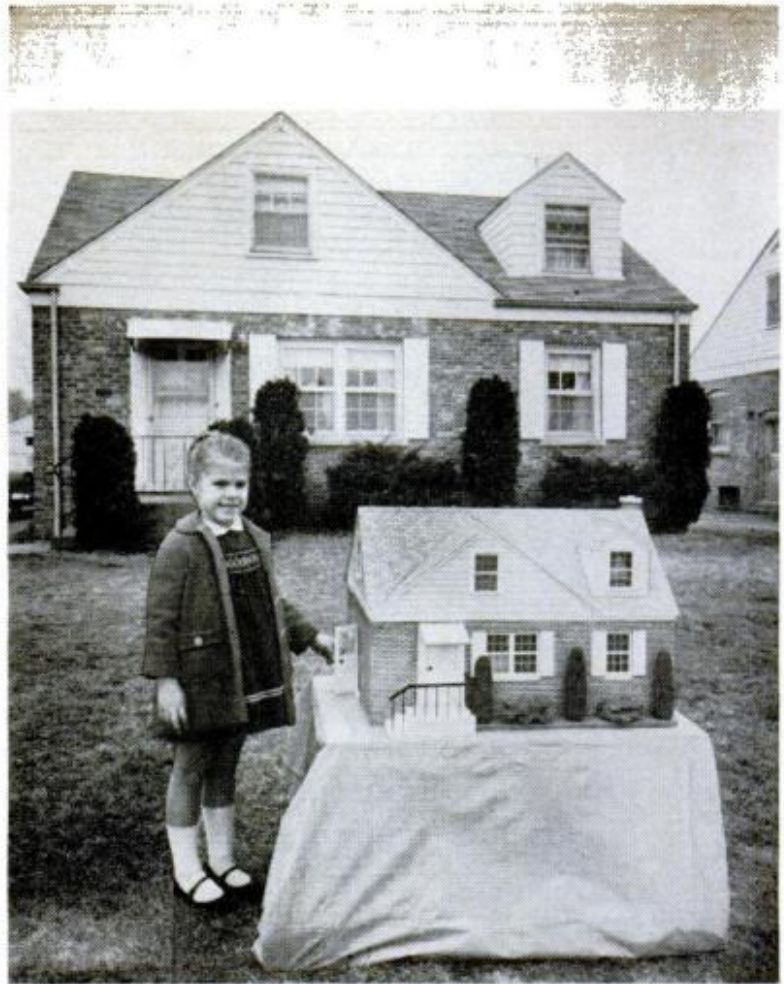

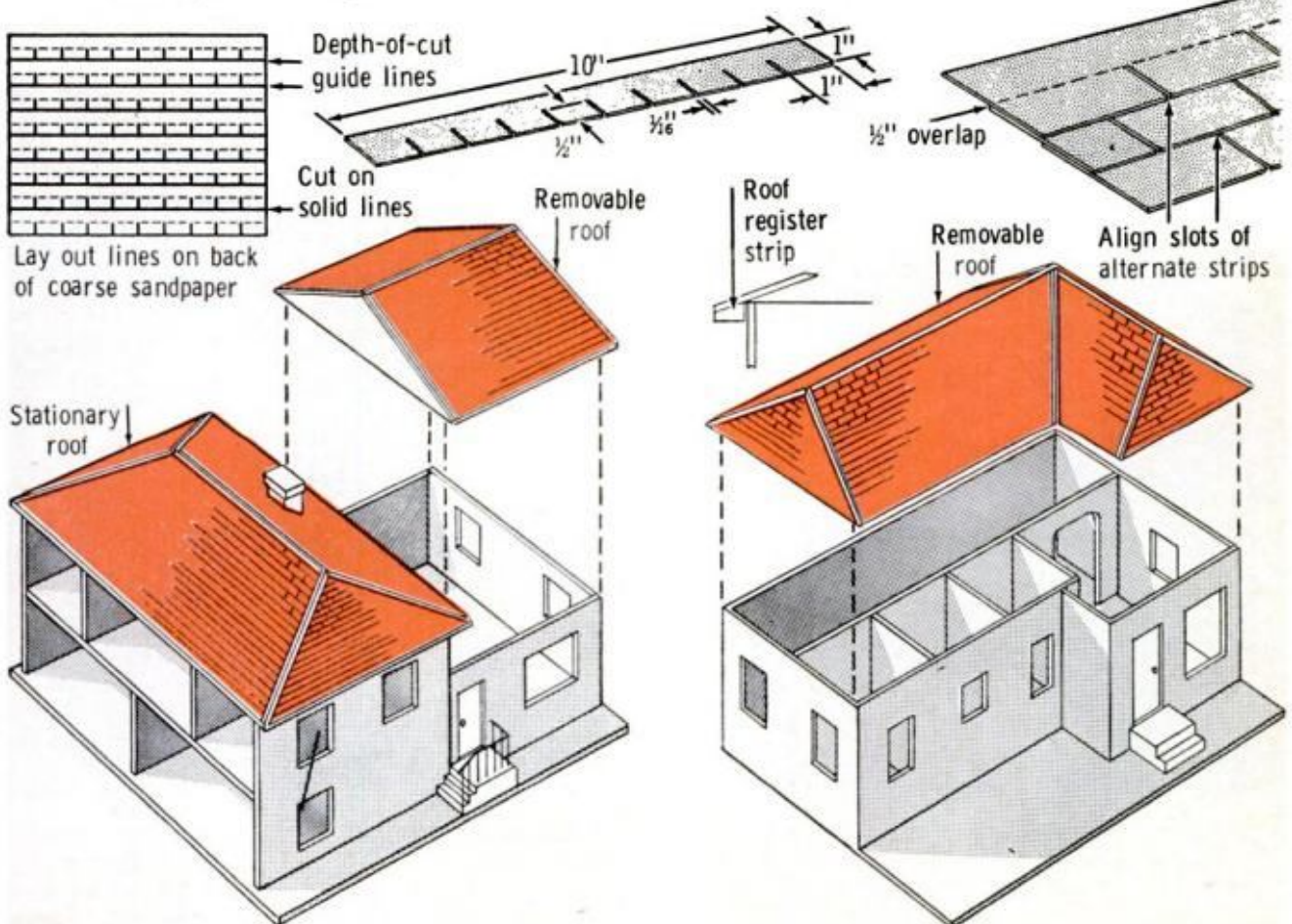
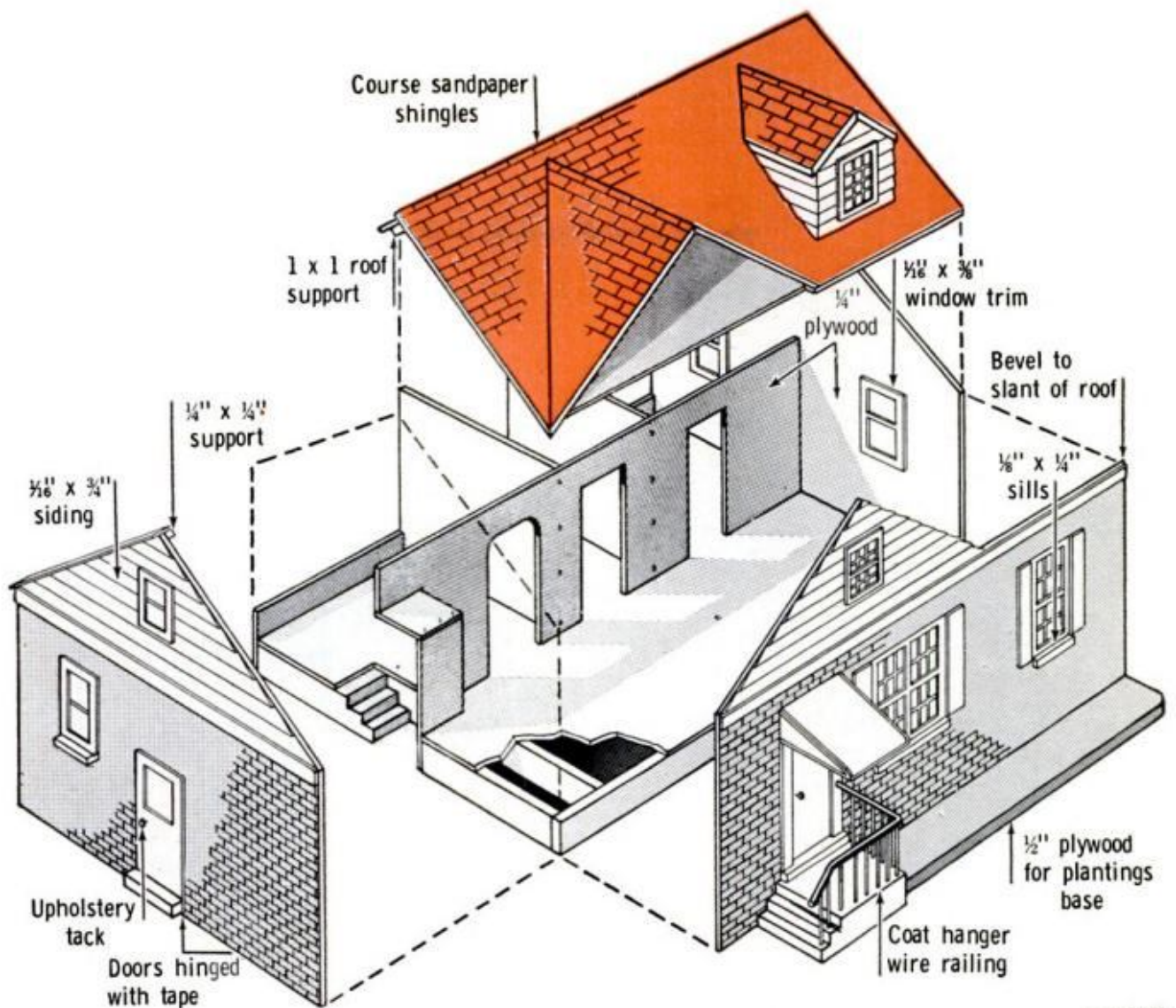

# SOLVING HOME PROBLEMS

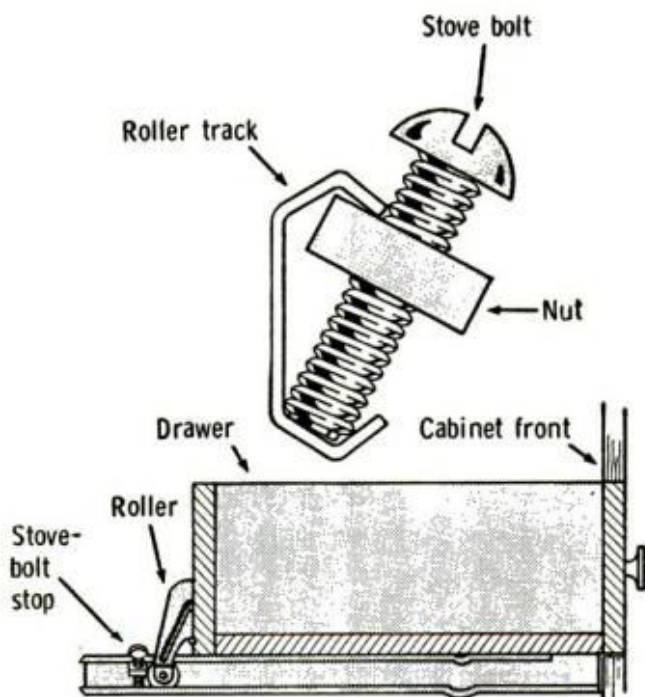

**DRAWER STOP** for home-made drawers using roller guides is an ordinary stove bolt and nut tightened inside the track to block the roller. It lets you stop odd length drawers flush with the front of cabinet

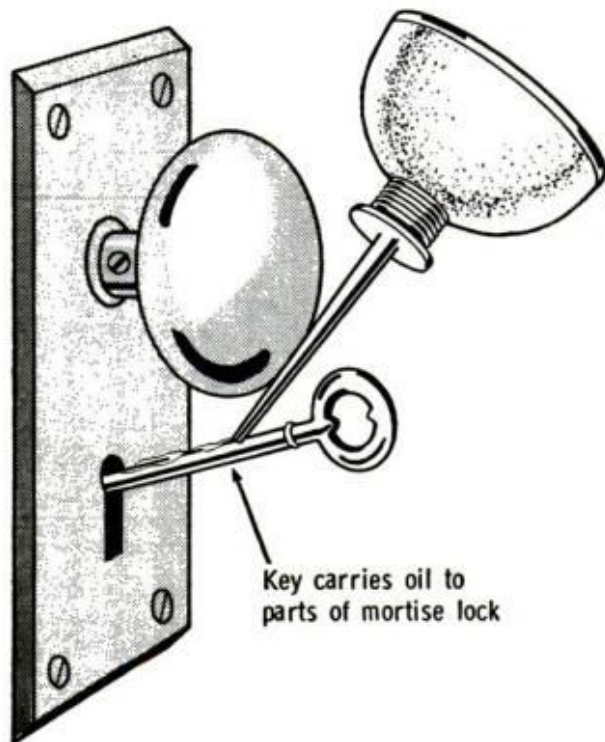

**TO OIL DOOR LOCK** efficiently without dripping oil on the door, insert the key in the lock and hold it at a slight angle, then apply a few drops of oil to the key shaft. It will flow right into the lock

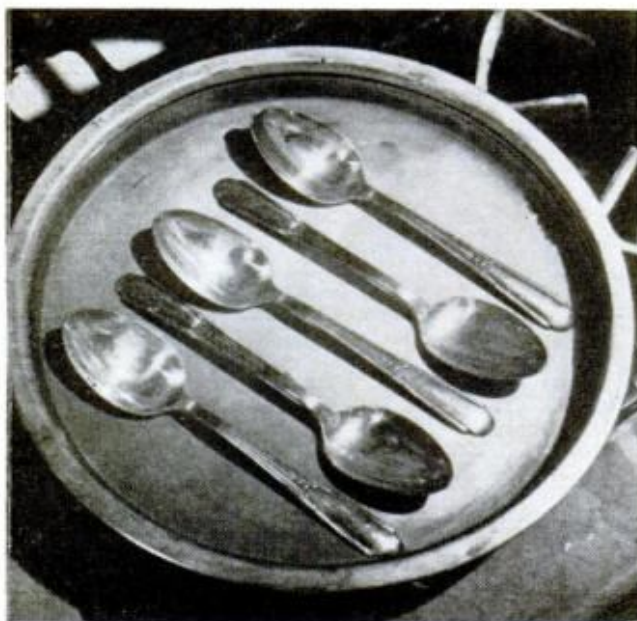

**TO CLEAN SILVER**, place it in an old aluminum pan and cover with cold water. Add several tablespoonfuls of salt, an equal amount of soap flakes and bring to boil. Then remove silver, wash and dry well



**TRIMMING TALL HEDGE** in a straight line is easy if you mount the trimmer on top of an upright support built to fit into your garden cart. Wheel it slowly along the hedge and you'll make a straight guide cut

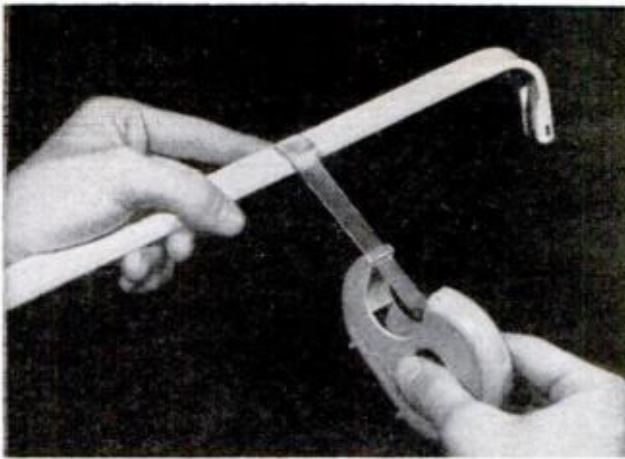

**CELLOPHANE TAPE** wrapped around the joint in a curtain rod will allow the curtains to slide smoothly over the joint, preventing the possibility of catching and tearing when curtains are pulled across it

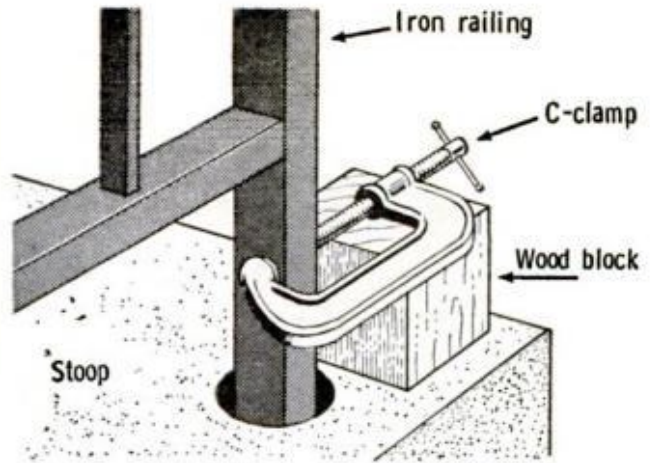

**WHEN INSTALLING** an ornamental iron railing on concrete steps, tighten a C-clamp on the post and use a wooden block to prop it at the desired height in the hole while you pour molten lead around base



**TO INSULATE** a beverage glass, wrap it with aluminum foil. This will not only trap the cold inside, but prevent the heat from your hand from being transmitted to the glass and warming an iced beverage

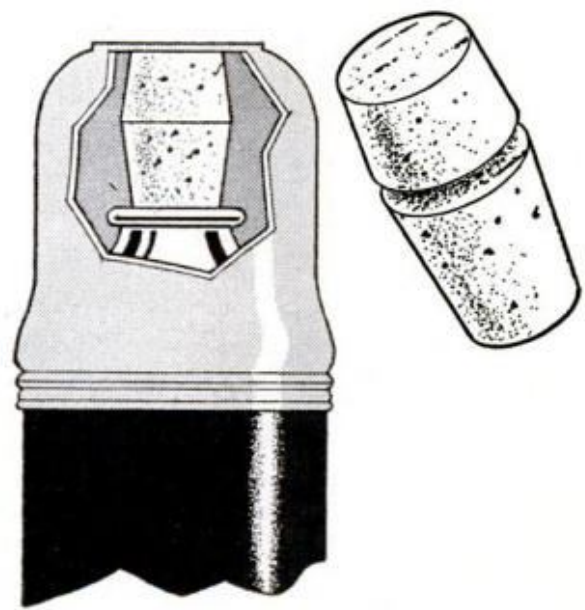

**IF YOU USE** a cork stopper in your vacuum bottle, cut a slice of cork from another stopper and glue it on top of the regular cork. When the top is screwed on, it will prevent stopper from loosening

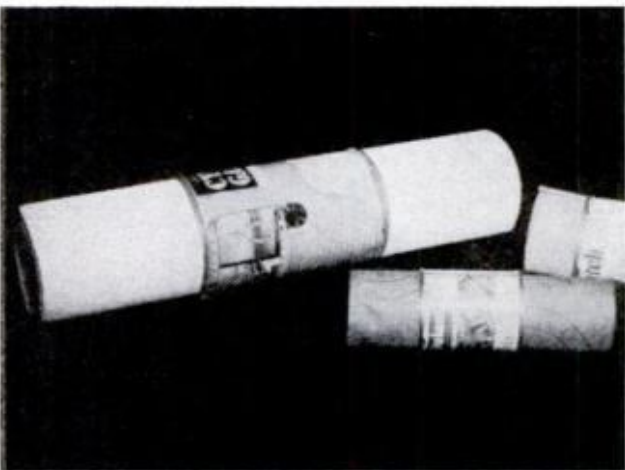

**STORAGE SLEEVES** for holding rolled materials can be made by cutting both ends out of tin cans. Unlike rubber bands or cord, this distributes compression over a wide area so it won't crimp the rolls

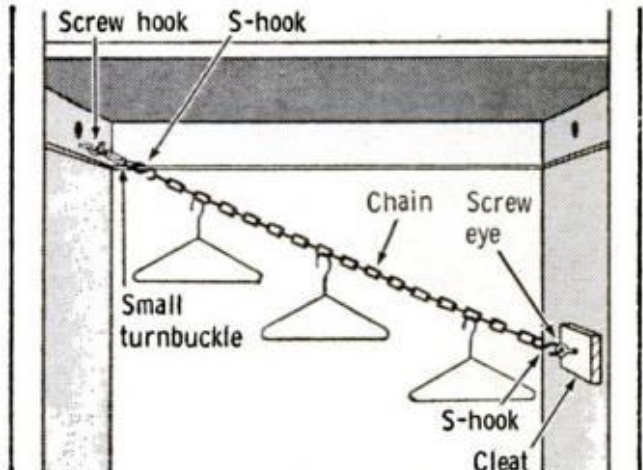

**CLOSET CHAIN** substituted for closet pole makes it practical for children of different ages to use the same closet. Locate the cleat to fit the reach of the smallest child and tighten chain with turnbuckle

# Audible Exposure Timer

No more squinting at a second hand or guesstimating dodging time. This timer counts, then turns off enlarger

By Hank Hilton



**MOUNT TIMER** on the wall next to your enlarger. With a cake-pan chassis, the handle flanges become mounting brackets

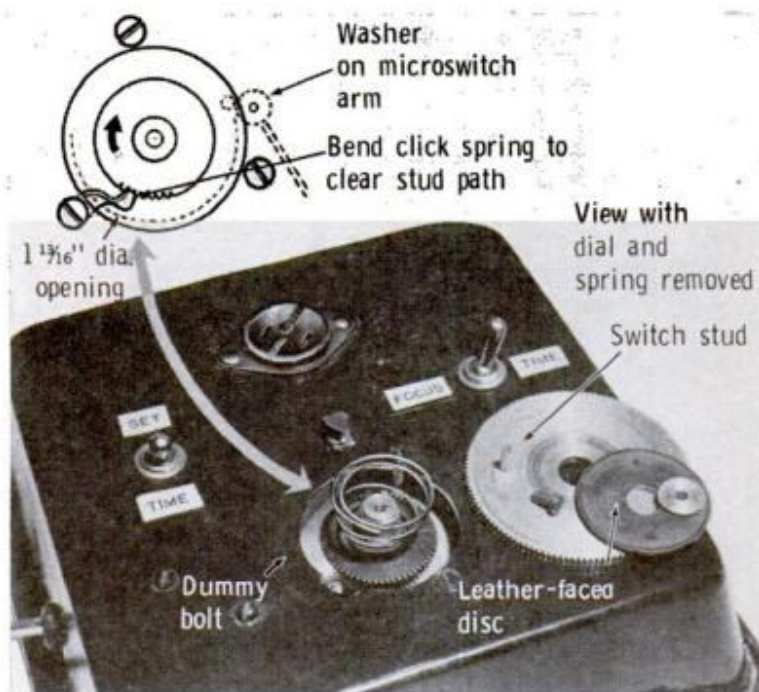

**EXTRA BOLT**, a dummy, gives the dial three-point bearing to keep it level when pressed down. Shaft sleeve shown was turned with shoulder for clutch disc, but may be a single diameter

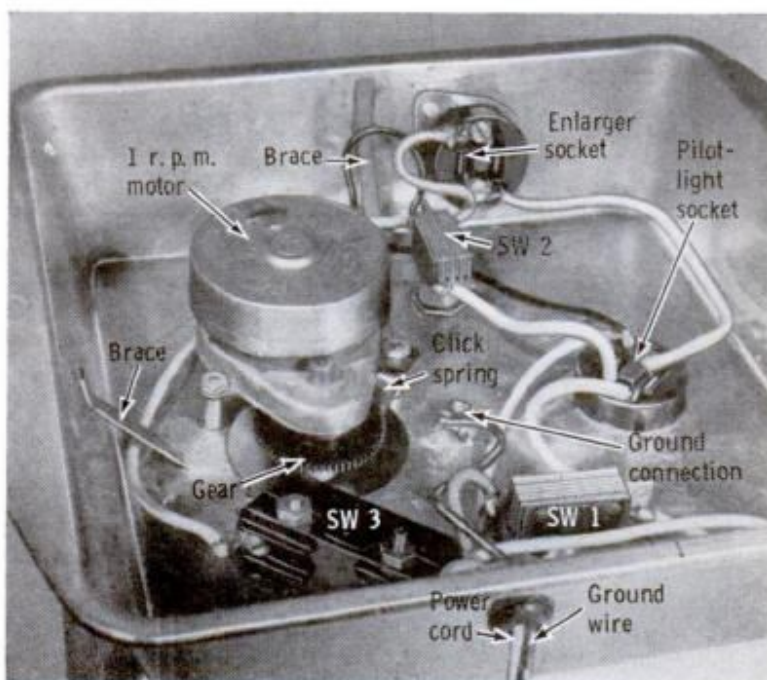
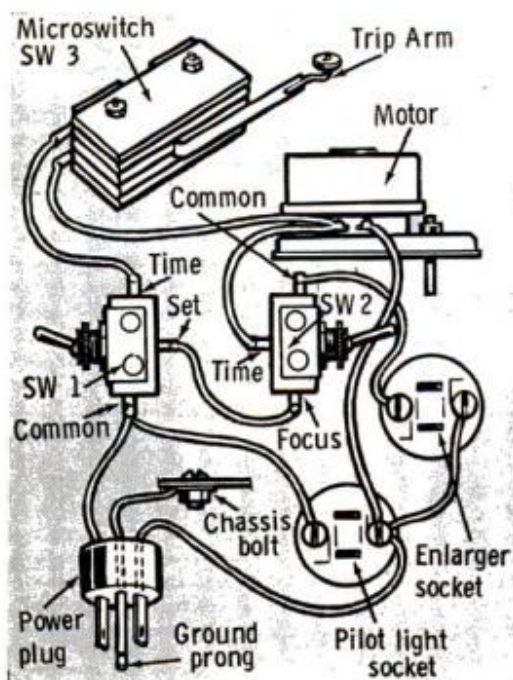

**WIRING DIAGRAM** and photo of inside of timer show the simple three-switch setup allowing precise control of exposure times. Click spring, secured to right-hand motor mounting bolt, trails on gear which turns with drive shaft. With a 60-tooth gear, the timer ticks off the seconds and eliminates need for clock-watching



**A**CCURATE as an electric clock, this motorized timer exposes prints to whatever second you dial. A simple clutch turns the calibrated timing dial. When a stud below the dial trips a microswitch, the motor stops and the enlarger or printer light goes out.

Since it clicks off the time in equal segments, the timer lets you count the clicks to time any dodging precisely without having to keep one eye on a clock. And there's no risk of untimed exposures, since the timer won't start again until reset.

The brains of the unit is a 115-v. synchronous motor with an output shaft that makes one revolution per minute. This will time intervals from one to 59 seconds—a good range for today's fast papers and enlargers. If you want to time exposures twice that long, buy a 1/2-rpm motor. Either one will cost about \$1.50.

Pressing on the dial releases the clutch, and the dial can be reset for the interval desired. One switch toggle immobilizes the motor while the dial is being set; another turns the enlarger on independently of the timer for focusing.

The clicking sound is made by a spring riding on a gear. This gear should be 1 in. to 1 1/4 in. in diameter and fairly thick. (Don't use a thin clock gear; it won't last.) A 60-tooth gear giving one click per second is ideal, but not absolutely necessary since the clicks need not indicate seconds.

A sleeve or shaft extension is made to fit the gear. You might use a thick-walled bushing, or build up the sleeve by soldering together pieces of telescoping tubing. Stock could also be chucked in a drill press or an electric drill and file-turned to a diameter that will be a tight drive fit in the gear.

Tap the upper end of the sleeve 6-32. If the gear isn't a secure fit, hammer over the bottom of the sleeve and solder the gear on. Tap for a setscrew above it.

The timing dial may be cut from 1/8-in. hardboard with a circle cutter. Enlarge the hole to a free fit on the shaft sleeve and file notches around the edge for a good grip, then drill and countersink a hole for the 4-40 switch stud on 1 3/16-in. radius. Finally, cut out the dial label on this page and paste it on the dial.

A small metal chassis, 4 in. x 6 in. or larger, or a 2-in. deep by 8-in.-square cake pan may be used to mount the parts. Cut a 1 13/16-in. hole in the top. Mount the motor with three bolts and nuts, using spacers cut from tubing. Two mounting lugs are provided; for the third, solder a bracket to the end of the motor case.

Check the direction in which the gear

(Please turn to page 190)

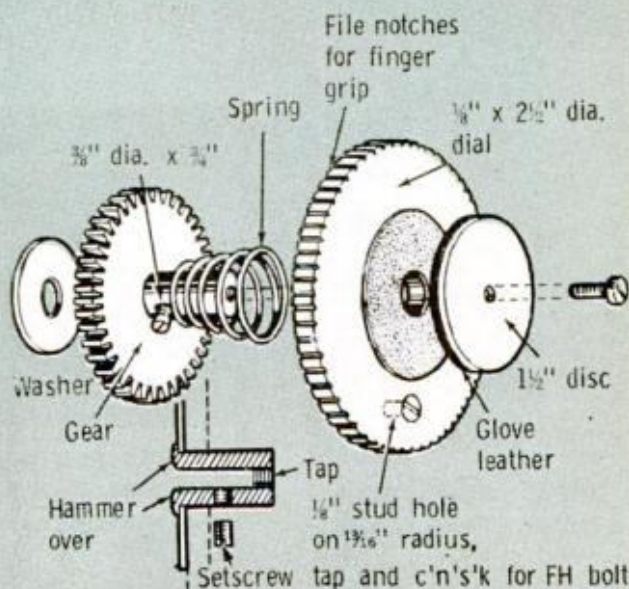
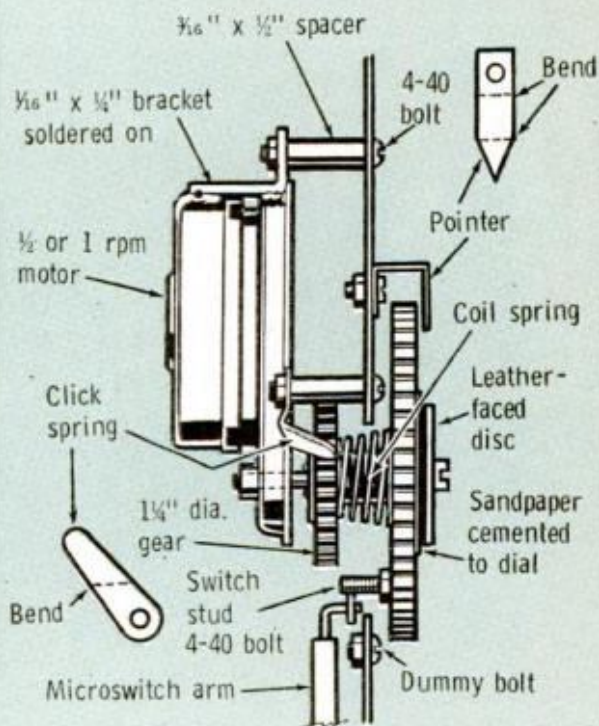
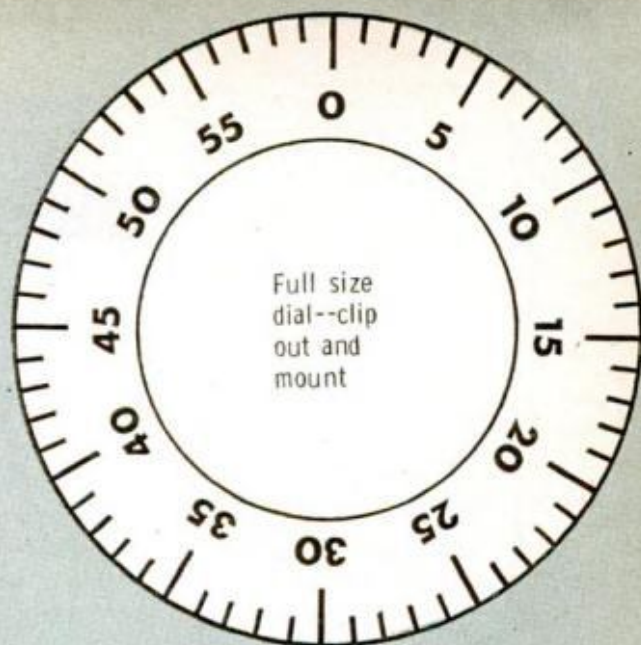

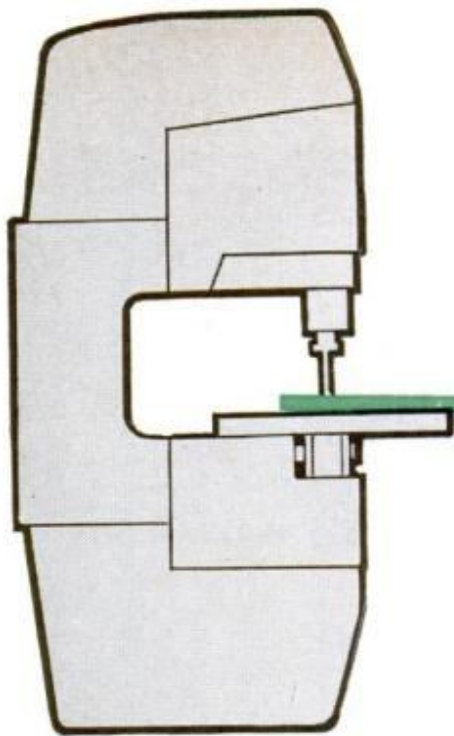

# Speed reducer for metal cutting

Dual-motor drive, plus worm-gear attachment, lets you switch quickly from high to low speed without changing a belt.

By Harold P. Strand

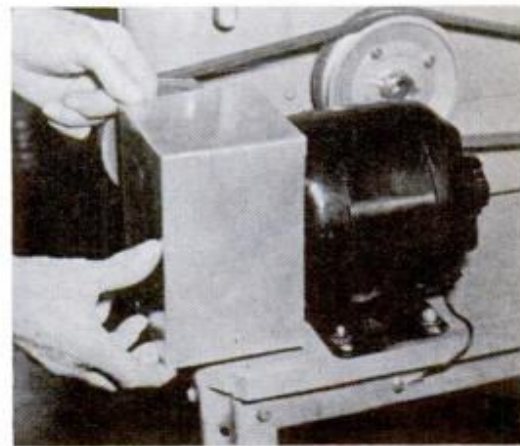
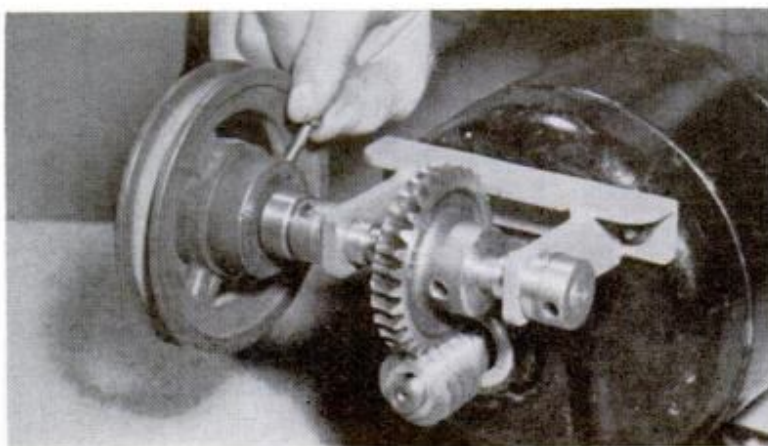
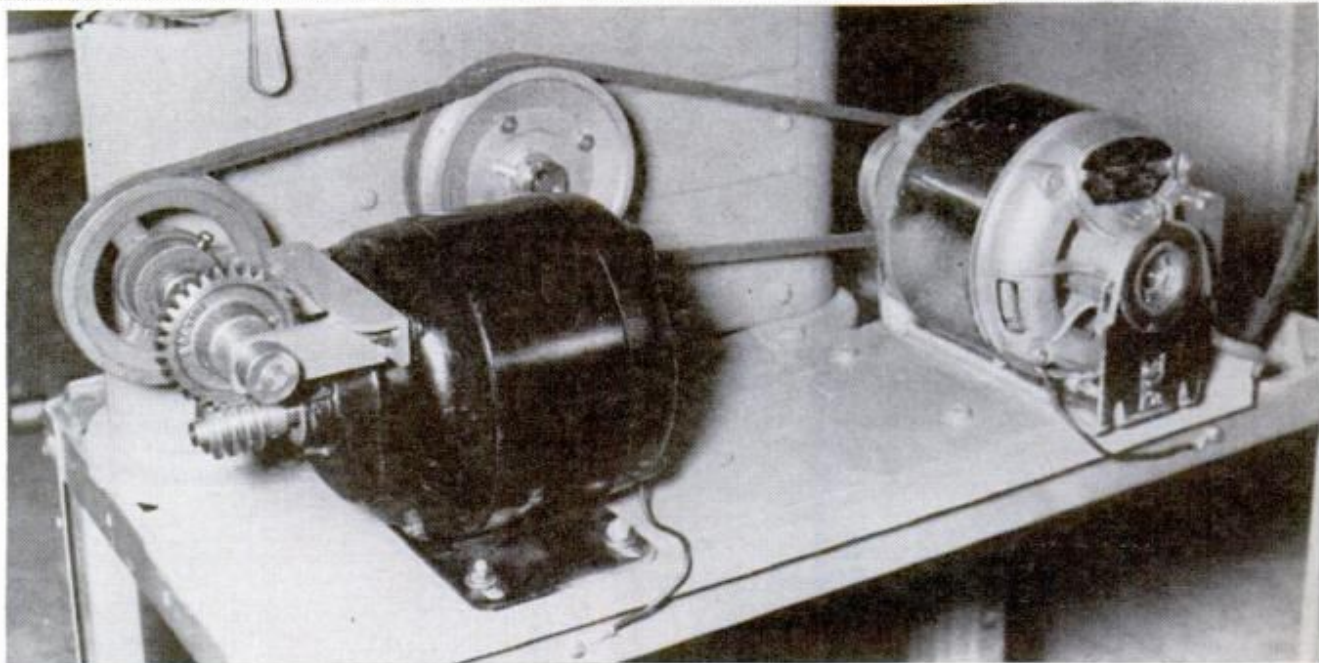

**THE DRIVE PULLEY ON THE JACKSHAFT** can be left belted to the bandsaw even when the geared drive is not in use. The pulley is engaged and disengaged by a removable pin inserted through the pulley hub. A safety cover of sheet metal can be made to enclose the exposed worm gears

**YOU JUST CAN'T SWITCH** to a metal-cutting blade and expect to saw steel with a wood-cutting bandsaw—the machine simply runs too fast. The high speed will ruin the blade and friction will heat up the work. But with a speed reducer to slow down the machine, your bandsaw will become twice as useful.

I rigged up the 30 to 1 reduction drive shown by attaching a worm-gear jackshaft to a second motor. The original motor still drives the saw for wood cutting, whereas the second one takes over for metal cutting. Each motor is controlled by its own switch, and aside from having to switch blades, the changeover from one speed to the other involves nothing more than the insertion or removal of a steel pin in an idler pulley on the worm-gear jackshaft.

Whether you can mount both motors exactly as I did depends upon the saw's

stand. If the saw is now driven by a motor mounted below, there's no reason why the motor cannot be left there. In any event, a second pulley for the second motor must be added to the drive pulley on the saw. However, since the saw's arbor is usually nothing more than a stub with little or no room for adding an extra pulley by its set-screw, the extra pulley has to be attached to the face of the saw's pulley with bolts and pipe spacers as detailed on page 154. With a 5 in. pulley on the saw, a 4-in. pulley on the jackshaft produced the proper speed for cutting metal.

As you see from the photos on the opposite page, the motor supports the jackshaft in that its bracket is bolted to the motor's tie bolts. The details show how the supporting bracket is welded up of flat steel and angle after its three parts are drilled for shouldered bronze bushings and slotted

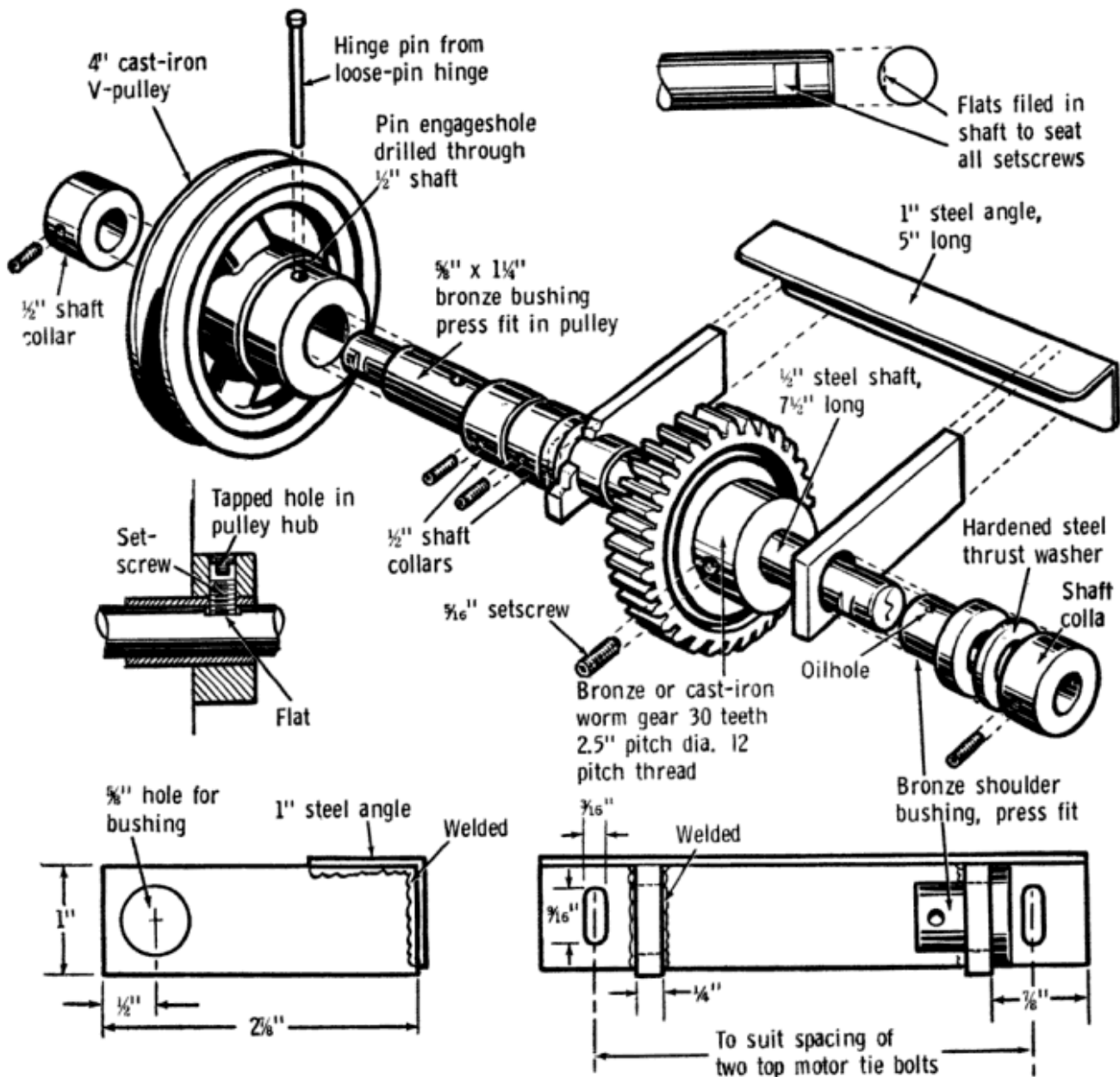

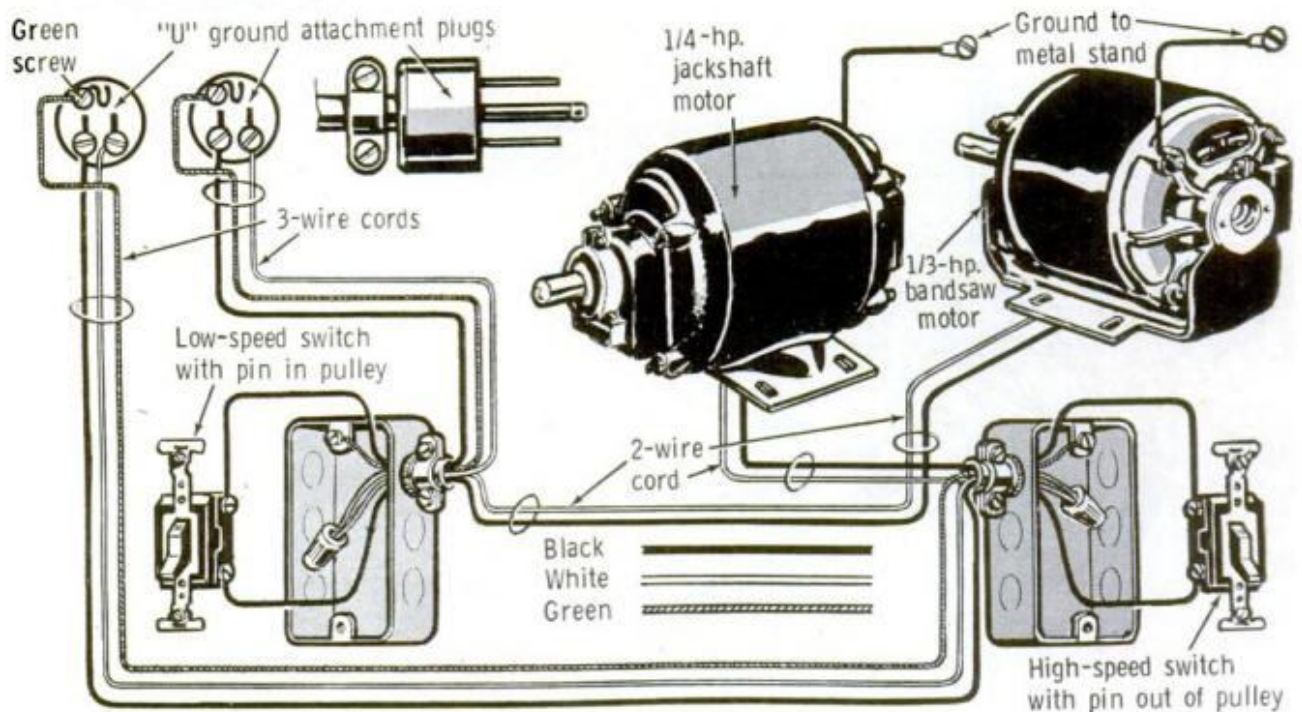
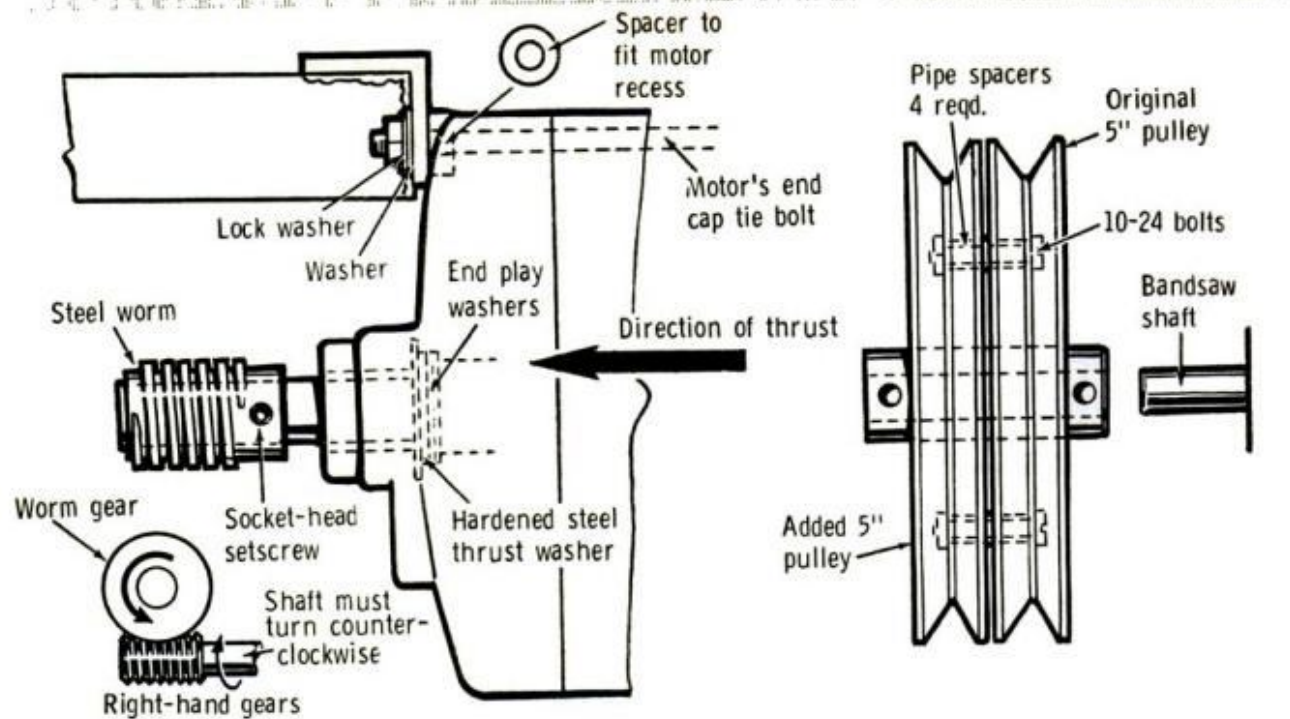

to suit the spacing of the motor tie bolts. The shaft must turn freely in the bushings.

The hub of the large worm gear is drilled, tapped and locked to the shaft with a  $\frac{3}{16}$  in. x 18 hollow-head setscrew and is held centered over its matching gear on the motor shaft by shaft collars placed on each side of the bracket's arms. Collars likewise are used to retain the free spinning V-pulley after the setscrew hole in its hub is aligned with a locking-pin hole drilled through the shaft. The locking pin should fit just tight enough to stay in place. The motor tie bolts are drawn up tight after the mating gears are in proper mesh and work smoothly. ★ ★ ★

#### MATERIALS LIST

- 1 pc.— $\frac{1}{8}$ " x 1" x 1" steel angle 5" long
- 2 pcs.— $\frac{1}{4}$ " x 1" x  $2\frac{7}{8}$ " mild steel—or length required for worm gear to clear motor end cap
- 1 pc.— $\frac{1}{2}$ " cold-rolled shaft  $7\frac{1}{2}$ " long
- 1 pc.— $\frac{3}{16}$ " steel pin  $1\frac{3}{4}$ " long
- 2 pcs.—Steel pipe spacers about  $\frac{5}{8}$ " O.D.,  $\frac{1}{4}$ " I.D.,  $\frac{1}{4}$ " long
- 1—4" dia. cast-iron V-pulley,  $\frac{1}{2}$ " hole
- 2—10-32 x  $\frac{3}{16}$ " hollow-head setscrews
- 1— $\frac{5}{16}$ "-18 x  $\frac{3}{8}$ " hollow-head setscrew
- 1—5" dia. V-pulley,  $\frac{1}{2}$ " hole
- \*—Bronze or cast-iron worm gear 30 teeth,  $2\frac{1}{2}$ " pitch dia.,  $\frac{1}{2}$ " hole (Bronze Cat. No. GR1051, cast iron G1051)—Iron Cat. No.
- \*—Worm gear to match, steel,  $\frac{1}{2}$ " hole (Cat. No. GH1056)
- \*2—Bronze shoulder bushings,  $\frac{1}{2}$ " I.D.  $\frac{5}{8}$ " O.D. (Cat. No. FB-810-8)
- \*4—Shaft collars,  $\frac{1}{2}$ " I.D. (Cat. No. SC50)
- 2—Hardened thrust washers,  $\frac{1}{2}$ " hole,  $\frac{3}{4}$ " O.D.
- \*1—Plain bronze bearing,  $\frac{1}{2}$ " I.D.,  $\frac{5}{8}$ " O.D.,  $\frac{1}{2}$ " long (Cat. No. B-810-12)
- \*These parts available from Boston Gear Co., Boston, Mass.

# TIPS FROM READERS



**MAKE YOUR OWN** oil-can opener and resealer from a piece of strap iron. Insert and solder a cut-down 60d nail with sharpened point in holes drilled through each end of the iron



**CHAISE LOUNGE PADS** tend to work into the springs at the ends of the supporting straps, then tear when being removed. Avoid this problem by wrapping the springs with plastic tape

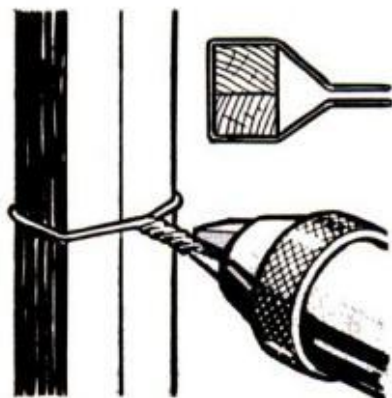

**A GOOD WIRE-TWISTER** that is seldom recognized as such is the chuck of an old hand brace. You simply tighten the chuck around the ends of the wire to be twisted, then turn the brace

DEC. 1965



**SOME HOME HANDYMEN** demand a "well-shod" ladder—for safety's sake. They keep the ladder from slipping on hard surfaces by sticking its "feet" in a pair of old tennis shoes



**WHEN ARE OPEN-END** wrenches "adjustable"? When the jaw of an open-end wrench is too big to fit a nut or bolt, a steel washer inserted as shown will "adjust" the jaw to a snug fit



**PREVENT DOWNSPOUT RUNOFF** from washing away your lawn and topsoil by sinking a discarded auto tire rim flush with the ground under the spout. Then fill the rim with coarse gravel



**OUTGOING MAIL** for the postman to pick up will be visibly and securely held to the mailbox if it's clamped in the jaws of a spring paper clip which has been bolted to the box



**FOR FASTER FUNNELING** and less back-up liquid, solder three 1/4-in. metal strips across spout joint as shown. This provides a vent between the funnel and the container that lets air escape



**YOU'LL GET MORE SERVICE** from your sawhorse with a couple of wood cleats nailed about 3/4 in. apart to hold short boards for edge-planing. Blocks nailed at slot ends serve as stop blocks

155

# NEW FOR CAMERA BUFFS

BY ROBERT B. BERGER

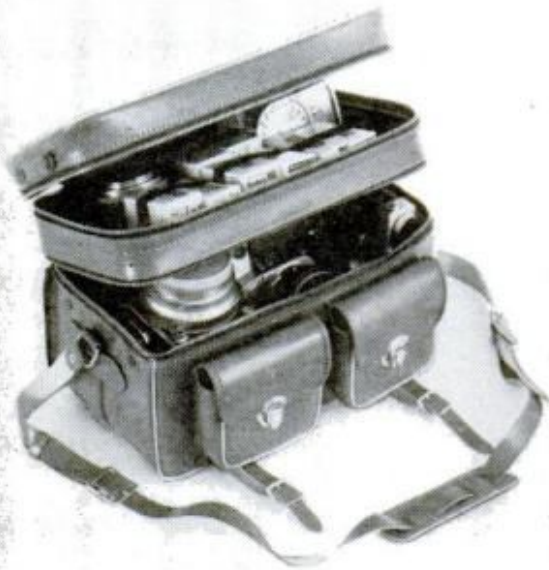

**Topdrawer gadget bags** boast an unusual feature—a 2-in. deep, separate upper compartment for film, flashbulbs, meter, filters and other small accessories. The bags are made of topgrain cowhide and are available in three sizes. Prices range from \$17.10 to \$26.79. Spiratone, Inc., 135-06 Northern Blvd., Flushing, N.Y. 11354.



**Moviemaking is easy** with the battery-powered Fujica Single 8. This 24-ounce camera uses a drop-in magazine which automatically sets the proper film speed for the built-in CdS meter. Further fool-proofing includes electric-eye exposure. Price is \$79.95. Ehrenreich Photo Optical, 623 Stewart Ave., Garden City, N.Y.



**Electronic flash exposure** is measured automatically by the Auto/Strobonar 660. A sensor on the left side of the flash lens detects light reflecting from the subject and cuts off the flash at the instant that proper exposure is achieved. The unit sells for \$129.50. Honeywell Photo Products, 4800 E. Dry Creek Rd., Denver, Colo.

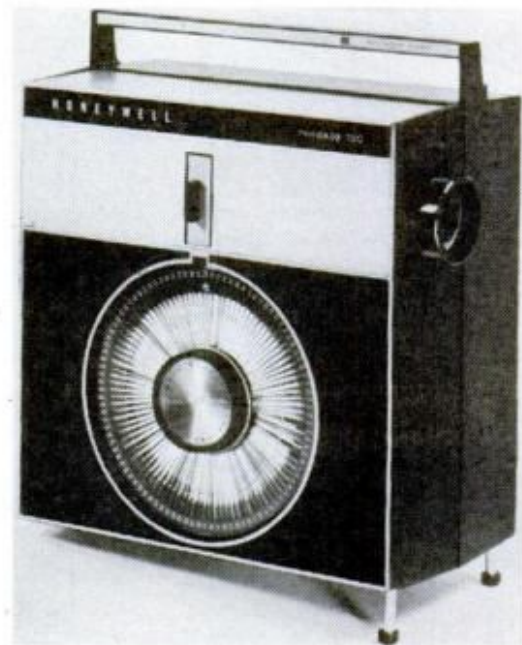

**Trouble-free slide shows** are assured when you use the Rondelle 100 projector. The unit is self-focusing and accepts 35-mm or super slides in either cardboard or plastic mounts. No mechanical changer is employed; slides are lifted magnetically and lowered by gravity. Priced at \$149.50, Honeywell, Denver, Colo.

## From Scrap—to Milk Can—to Lamp

FIVE 16½-in. lengths of 1⅝-in. scrap wood glued together and turned on a lathe produce this novel milk-can lamp base.

Rip the stock to 8-in. widths, then face-glue the pieces with furniture glue, and clamp. When the glue dries, square the ends by sawing an inch off each. Pencil the turning dimensions on the stock, then mark the end centers and make the small cross-cuts for the lathe spur and tail centers. Now clamp the piece in a vise and rough-round the edges with a rasp. Mount the piece in the lathe and turn it to the dimensions shown in the drawings. Sand smooth, then remove from the lathe. Now drill a ⅜-in. hole through the vertical center of the base and insert the threaded electrical pipe for socket and cord. Cut a shallow U-shaped groove in the base for the cord so the lamp will rest flat on the table.

—Robert Loveling

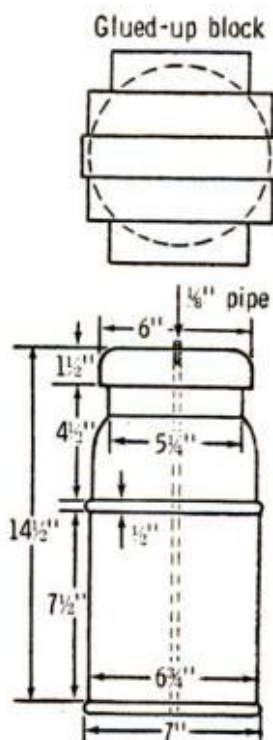

## Drilling for Partitions

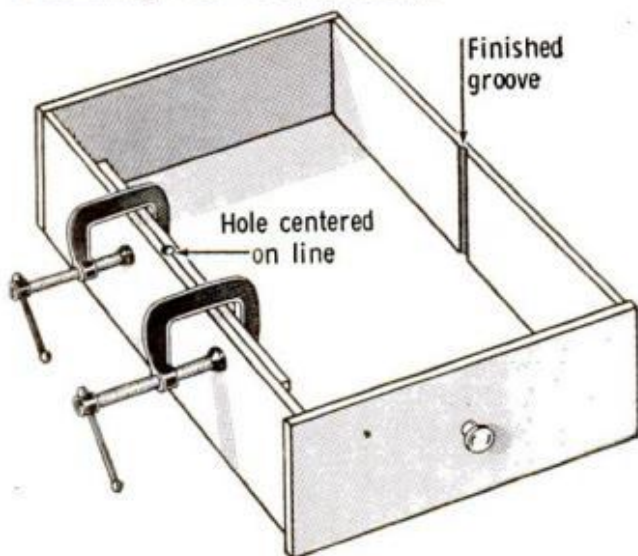

You can *drill* the grooves for partitions in a wooden drawer. Clamp a board to a side of the drawer, then mark the point for the partition's groove. Using a bit of the required size, drill down through the bottom of the drawer. Repeat this same procedure on the opposite side of the drawer. Round off the ends of the partition and slide it between the two grooves.

—Daniel Bousha

## Cut Tiles in Jig Time

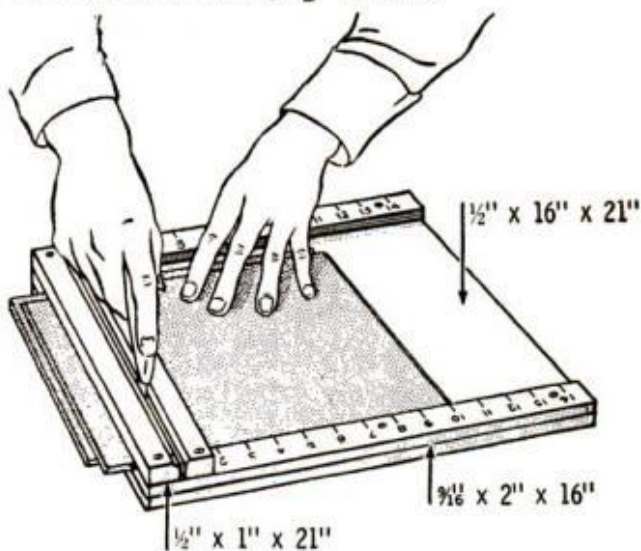

Border ceiling tiles measuring 12x12 or 16x16 in. are neatly cut to size with the aid of the jig shown above. The beveled hardwood guide strips permit clean, straight cuts by a utility knife. Markings at ⅛-in. intervals on both strips enable accurate measurements by a right- or left-handed worker. Make the jig 8 in. deeper to handle 12x24-in. tiles.

—Victor H. Lamoy

# Successful Stairs

By R. J. DeCristoforo

**T**HE SECRET IS PLANNING. Whether you're building a second-floor sun deck, remodeling an old two-story house, or are about to build a new one, there are facts and formulas you must know before you can provide a stairway properly scaled to the human stride.

A ramp or incline is, in many cases, the safest and easiest way to walk from one level to another. But since the maximum pitch for comfortable climbing is about 15°, ramps take so long to get there that they're impractical for cramped indoor space. So we use stairs that let us raise the pitch to 30 or 35°; the series of flat "pause platforms" greatly reduces the sense of struggling up a steep slope.

That 30 to 35° angle-from-horizontal is ideal, though stair pitch can be as little

as 20° or as great as 50°. An example of the former might be the vast staircase to a grandiose public building where the flats (called treads) are almost too wide to negotiate with a normal stride. You've probably encountered the 50° pitch—or steeper—in the attic stairs of old houses, where the vertical spaces between treads (called risers) are so great you tend to trip on the way up or pitch forward on the way down.

A good relationship between tread and riser is based on the length of an average person's climbing stride, and this runs somewhere over 16½ in. and under 18 in. Thus, the sum of one tread plus one riser should fall within this range. Proper riser height is around 7 in., so the tread should be 10 to 11 in. wide—not including the

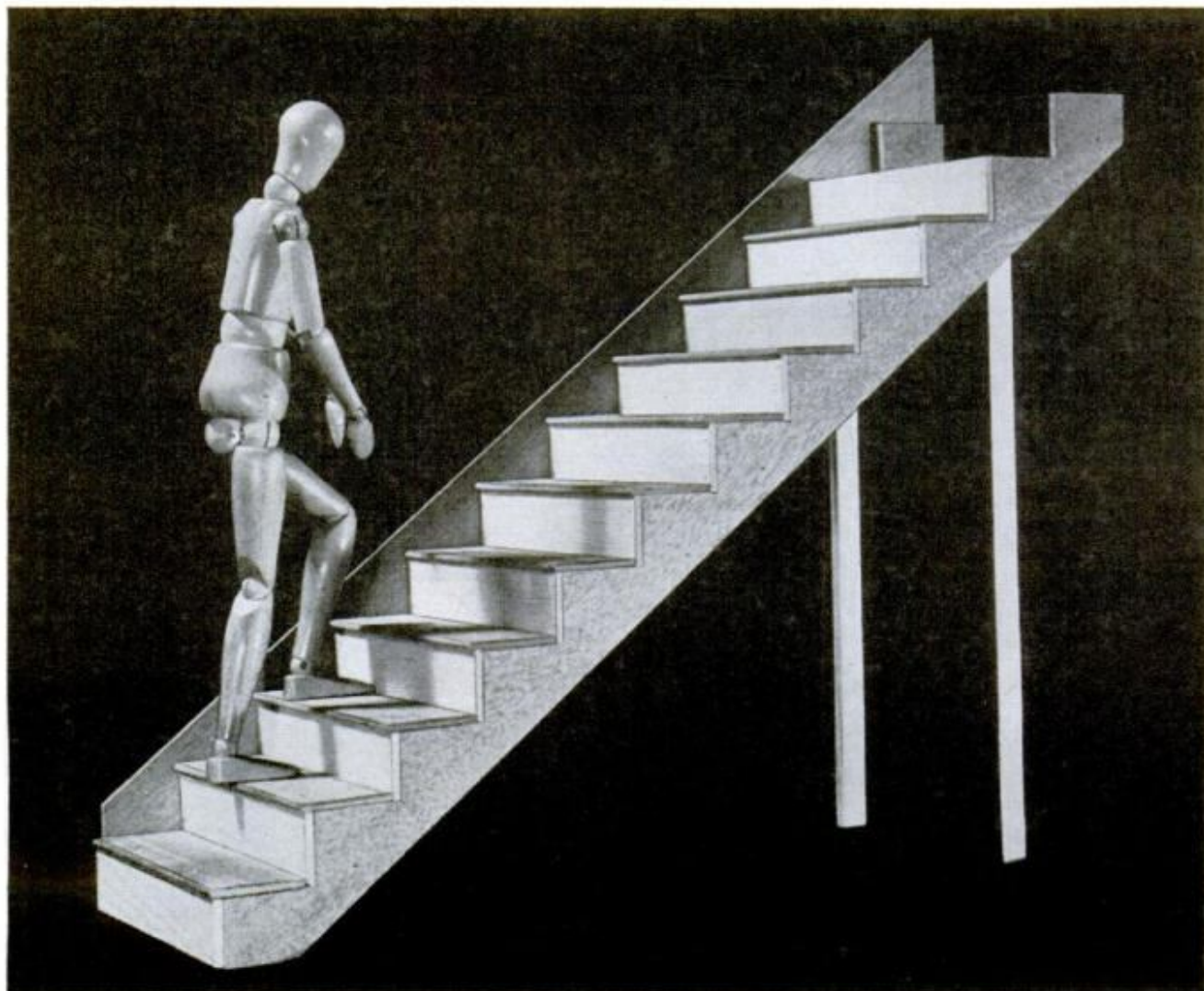



nosing (that part of the tread that projects beyond the riser and which should never exceed 1¾ in.).

In cases where you have no control over the pitch, and your stairway must be steeper than you'd like, you must increase the height of the riser and narrow down the tread. At 50°, for example, risers 9½ in. high and treads 8 in. wide still fall within the recommended "stride range." Carried beyond a certain point, though, you arrive at a situation where a ladder would be more practical than a stairway.

Okay, let's consider an actual installation. You know you've got to get from the lower floor to the one above; how can you do it best within the space you can spare for a stairway? Though the solution hinges on the application of a simple formula, a surprising number of professional builders duck the problem by calling in a "stair expert"—a fellow who probably knows no more than *you* will by the time you finish this article.

First: measure the vertical distance between the lower finished floor and the upper one, this is the *total rise*. Divide this by 7 (which represents the ideal *unit rise*) and you've got the number of risers you'll need. Ignoring any fraction, divide the total rise by this number to get the *actual* (as distinguished from the ideal) unit rise. Example: Total rise—8 ft.; 7 into 96 in. = 13.71; 13 into 96 = 7.384, the actual height of each of the 13 risers.

Now, to find a standard tread width,

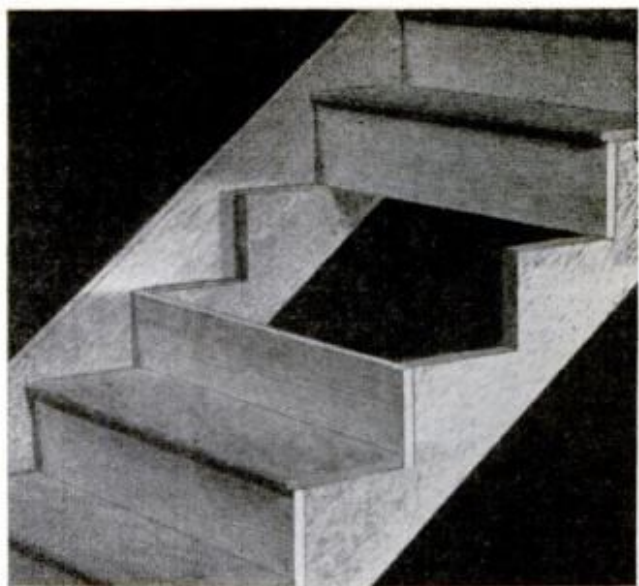

**ON WALL SIDE** of stairs, nail 1x12 into studs, then nail step-cut stringer to this and to studs, as shown where riser and treads are removed, above. Do this on both sides if stairway runs between walls

subtract the unit rise from 17½ in. This is the *unit run*. To find the *total run* (the actual length of floor space the stairway will require) multiply the tread width by the total number of risers, minus one—in the preceding example, 12.

Should you end up with an impractical total run for the space you've got, some compromise is in order. Better make a scale drawing based on the total rise and total run you have to work with—or even a scale model, like the one at far left.

Height Floor to Floor (H)	No. of Risers	Height of Risers (R)	Width of treads (T)	Total Run (L)	Well Width (W)
8'0"	12	8"	9"	8'3"	8'1"
	13	7⅞"	9½"	9'6"	9'2½"
	13	7⅞"	10"	10'0"	9'8½"
8'6"	13	7⅞"	9"	9'0"	8'3"
	14	7⅞"	9½"	10'3½"	9'4"
	14	7⅞"	10"	10'10"	9'10"
9'0"	14	7⅞"	9"	9'9"	8'5"
	15	7⅞"	9½"	11'1"	9'6½"
	15	7⅞"	10"	11'8"	9'11½"
9'6"	15	7⅞"	9"	10'6"	8'6½"
	16	7⅞"	9½"	11'10½"	9'7"
	16	7⅞"	10"	12'6"	10'1"

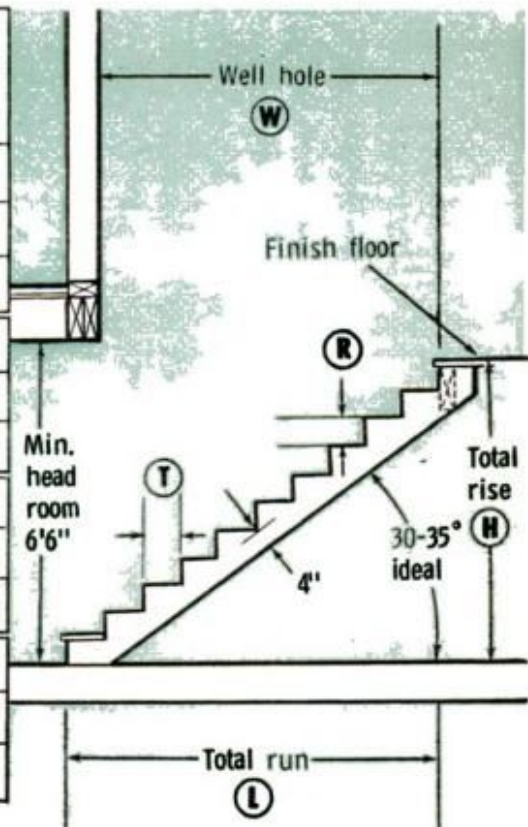

**DIMENSIONS UNDER "W"** are based on 6'6" minimum headroom in sketch. As headroom increases, so does well opening

## HOW TO LAY OUT STRINGERS FOR CUTTING

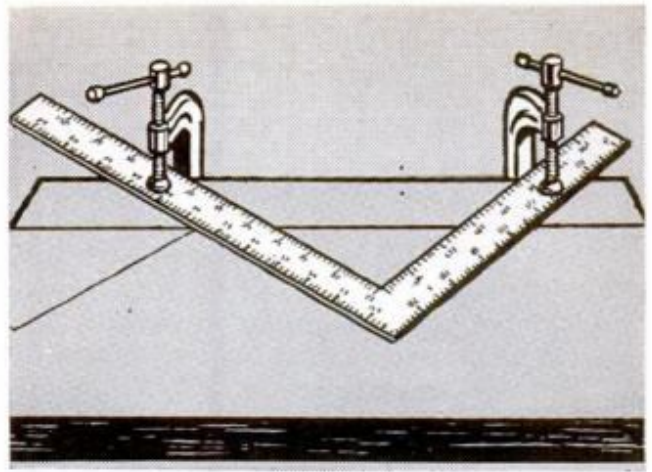
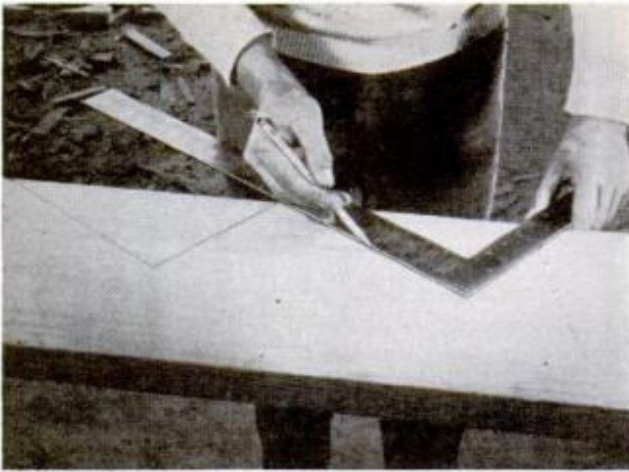

CUT,  
FOLD,  
TAPE

STAIR  
LAYOUT

**FRAMING SQUARE ASSURES RIGHT ANGLE** between risers and treads (left). Use tongue of square for unit rise, blade for unit run. For uniformity and speed, clamp the square to straight scrap stock as shown at right, then slide scrap snugly along edge of stringer to each new trace-around position

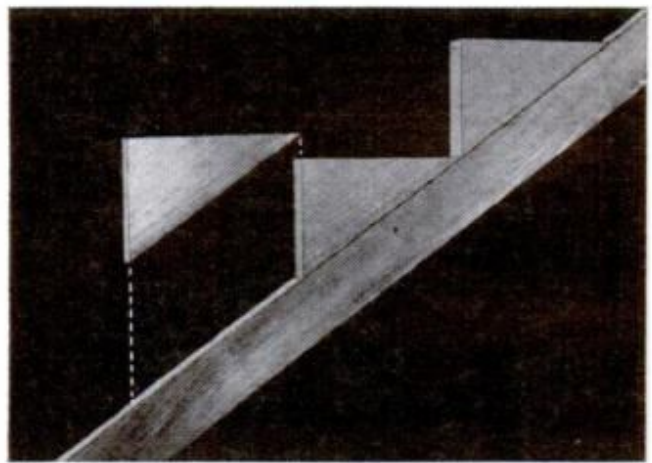
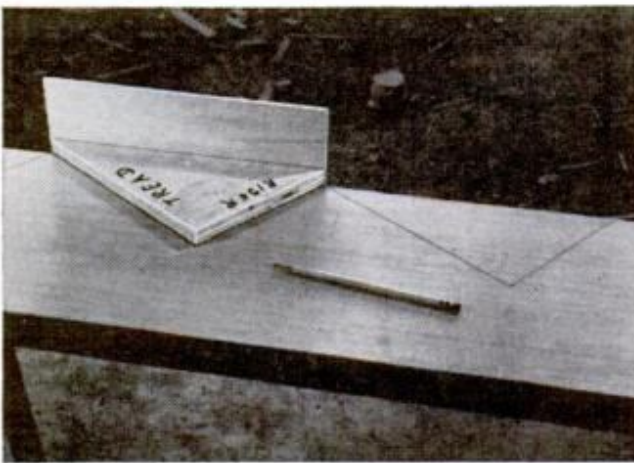

**STILL ANOTHER LAYOUT JIG** has a right-angle triangle with sides equal to tread width and riser height fastened to stop to form a T. Butt the stop against edge of stringer and slide it along to each position

**CARRIAGE-TYPE STRINGER** is built up of triangular blocks cut from 2x8 stock and nailed to 2x4. Cutting can thus be done on bench saw. In photo above, one block is lifted out of place for demonstration

## UNCUT STRINGERS FOR OPEN-RISER STAIRS

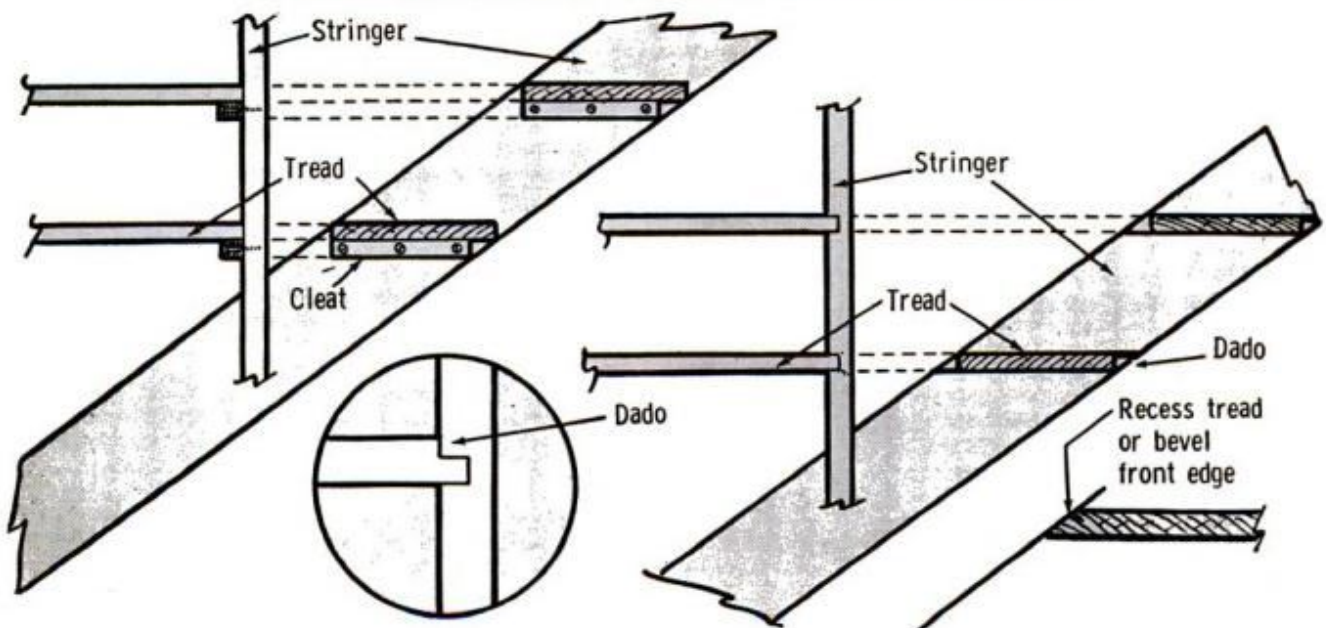

**NO SAWTOOTH CUTTING IS REQUIRED FOR STAIRS** without riser boards—often used for utility stairs in basements or attics—and for outdoor stairways, as to a sundeck. Treads are supported on cleats or in dados

Since you don't want to have to stoop as you climb your stairs, *headroom* is your next consideration. Measure along a plumb line dropped from the lowest ceiling point to the tread beneath. This distance should never be less than 6½ ft.—7 ft. is ideal wherever possible.

The *width* of the stairway depends on its intended use. For a single person at a time, it needn't be over 24 in.; for two people—walking together or passing in opposite directions—you'll need a width of 36 to 42 in. The minimum width isn't recommended for an inside stairway; remember, you'll have to move furniture up and down it. It's also possible that local building codes state a wider minimum.

The boards that are set at a ramp-like angle between upper and lower floors to *support* the treads are called stringers. Stringers are to treads what joists are to floorboards. Most often, they're notched into a sawtooth pattern to form bearing surfaces parallel to the floor. This pattern is laid out by means of an ordinary steel square, or one of the right-angle jigs demonstrated at left. The distance between the point of the "teeth" on the layout is called the "bridge" measure. To determine how long a stringer you'll need, multiply this figure by the number of risers.

Stringers are usually cut from 2x12 stock, using a handsaw—or a portable circular saw moved as far into each cut as possible, then followed with a handsaw. It's a good idea to clamp or nail the two stringer boards together and cut both at once, so they'll be identical. Other types of stringers are the uncut utility ones sketched at left, or the top-quality housed type, on the next page. The latter provides the squeak-free sturdiness and "finish" required for costly homes. Here the tapered grooves for the wedge-held treads and risers come factory cut in readymade stair kits.

When the steps run up between two walls, they're called close string stairs. If there's a wall on one side only, they're open string stairs, and should have a hand-rail along the open side. In some open-string applications in modern settings, such a hand rail would interrupt the "spatial flow," so the stairs are made extra wide and a rail is attached at the *wall* side, instead. Whether it's a wall-mounted rail or a balustrade running between newel posts, the proper height remains as shown in the sketch, next page.

So far, we've spoken in terms of the simple straight-run stair. In some cases you won't have enough wall or floor space to accommodate the full march of treads you'll need for a given rise. At such times, you must bend the stair, either around a

## ANCHORING STRINGER TOP

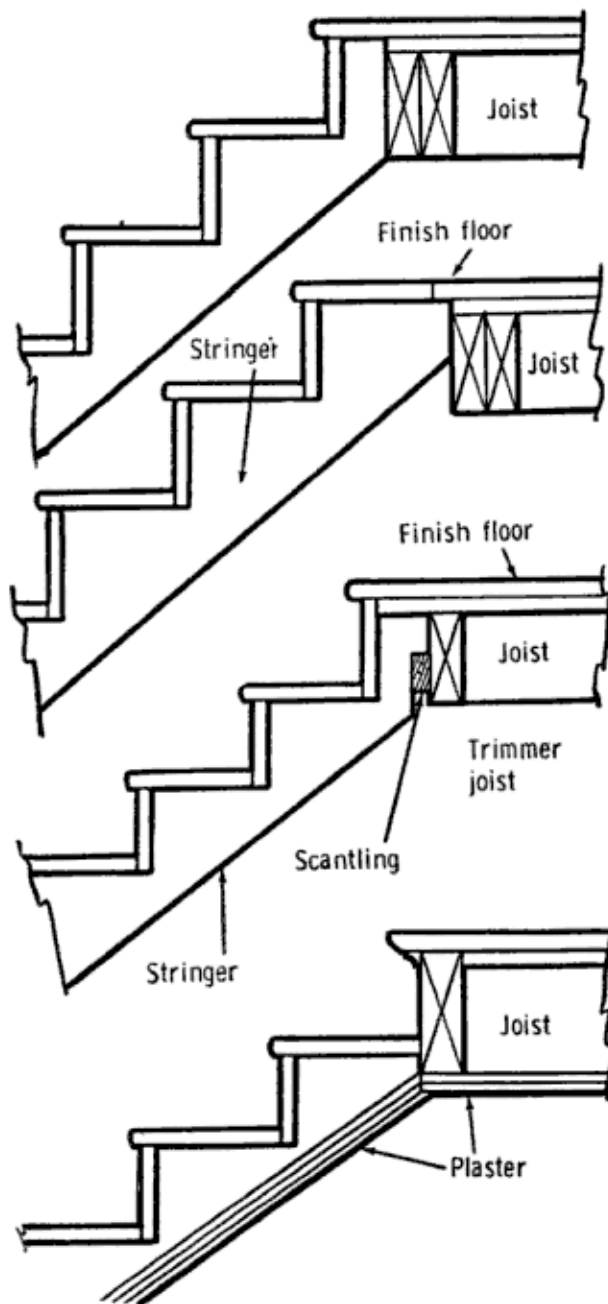

## NOSING DESIGNS

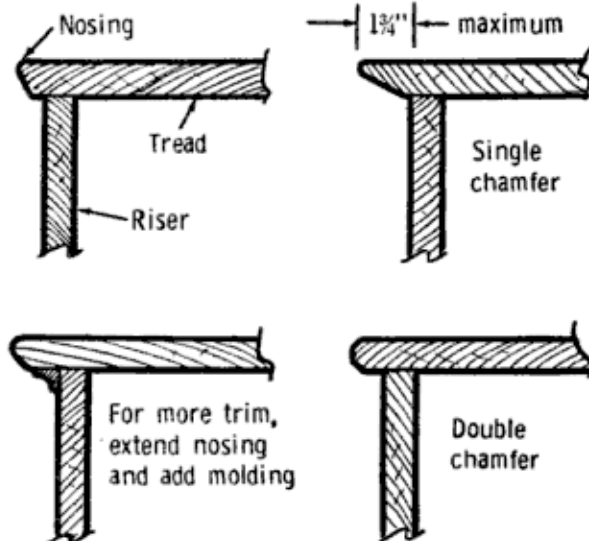

Note: Nosing width is not calculated in tread width when planning stairs

# STAIRS THAT TURN

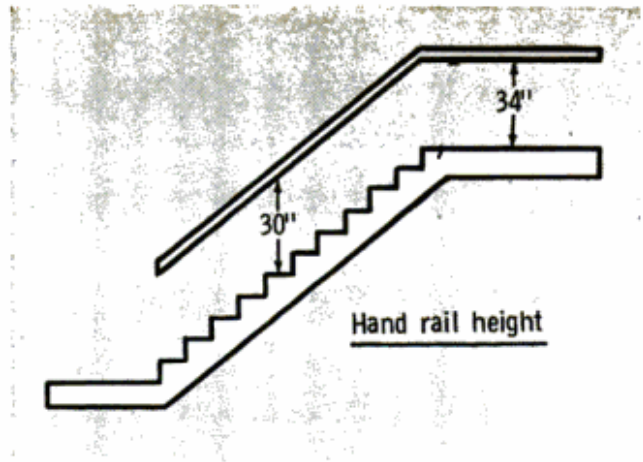
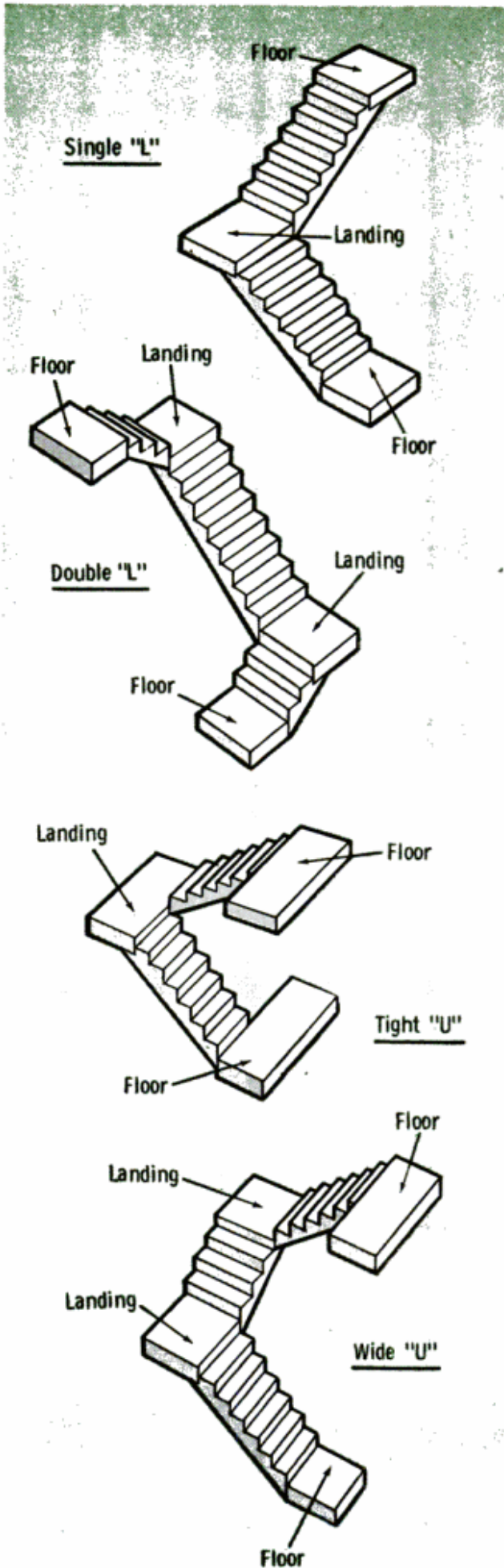

**OPEN STRING STAIRS** require continuous handrail to prevent stumbles and falls. For comfortable grip, height above tread is less than height above platform

corner to form an L, or completely back on itself to form a U. Samples of such stairs are sketched at left; note that the bend always involves a platform. Years ago, the high ceilings of vast Victorian homes taxed the capacity of stairways, and builders tried to squeeze maximum lift from them by having steps continue around turns, without a platform. This was done with pie-wedge treads that fanned around a corner by tapering down to nothing at the newel post. Such cramped, narrow treads—called "winders"—caused serious accidents when they were placed toward the top of a long flight. They're rarely used, today, and only near the base of a stairway.

Treads are usually 1 to 1¼-in.-thick hardwood. On utility steps 2-in. pine is often substituted. Outdoors, water run-off must be provided for. You can simply drill holes in the treads or use narrower boards, leaving ¼-in. gaps between them. ★★★

**HOUSED STRINGER** has ½-in. deep grooves on inside face of wall stringer. Treads and risers are wedged from behind and below, as shown, to assure tight fit

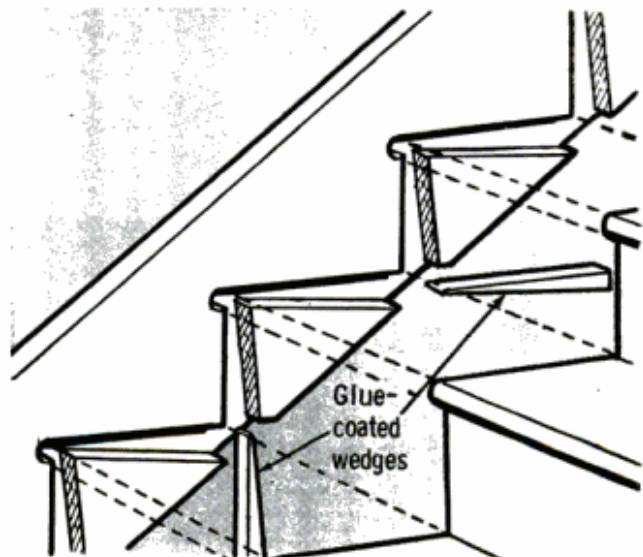

PM

# SHOPPING FOR TOOLS

BY RICHARD HOWE



**PUSH SLIDE** on Cage-Lok screw-holding drivers with automatic screw release permits guiding/removing screws from hard-to-reach locations. A pair with matching Phillips and slot heads costs \$3.95. Belknap Tool Co., 15016 Fenkell, Detroit, Mich.



**THE TOOL POOL** features 18-tools-in-6. It's milady's emergency fix-it kit and takes up just 14x18 in. on the kitchen wall. Tools include hammer, saw, pliers, screwdrivers. It's available from Wainwright Co., 2714 Chelsea Dr., Charlotte, N.C., for \$11.50 ppd.

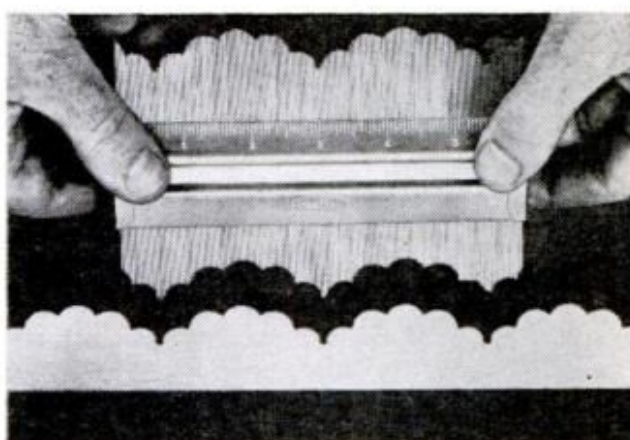

**175 ADJUSTABLE STEEL TEETH** enable the Copy-Cat Contour Gage to assume the outline of any irregular surface, which is then penciled on the stock to be cut. Listing for \$5, it's made by Coastal Abrasive and Tool Co., 42-33 Northern Blvd., L.I.C., N.Y.

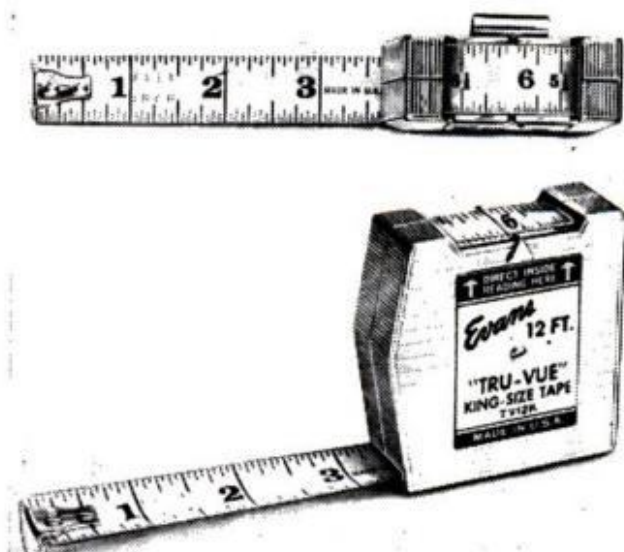

**"TRUE-VUE" TAPES** by Evans Rule Co. of Elizabeth, N.J., eliminate the necessity of mentally adding 2 in. when making inside measurements. Instead, the true measurement is read through a magnifying window on top of the case. Prices: \$1.60 to \$3.60

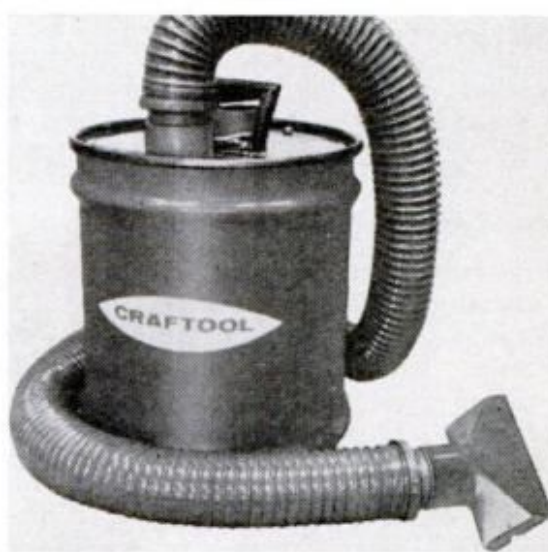

**MIGHTY-MINI** is Craftsman's rugged 5-gal. capacity vacuum—ideal for clean-ups around workshop, boat, patio, etc. Use it for spray painting, drying too. Its power-pac develops  $\frac{3}{4}$  hp. A special fitting permits use of all home-vacuum attachments. \$39.95

# SOLUTIONS FOR MECHANICAL HEADACHES

# AUTOMOBILE CLINIC

BY MORT SCHULTZ

## Stally Olds

*My '61 Olds starts easily, but then stalls out after I've driven it a couple of blocks. It's as if the car had run out of gas, yet the tank is full. You can rule out fuel pump, carburetor and associated parts; they've all been checked or replaced. It seems the gas just drains out of the sediment bowl. In half an hour the bowl fills up again—and I can drive another two blocks. Big deal! Please advise.—S. West Topeka, Kans.*

Somewhere between your fuel tank and carburetor a vacuum is being created which is pulling gas back out of the sediment bowl and preventing it reaching the carburetor. Check the filter in the gas tank. Chances are it's collapsing under pressure and causing the type of stalling you're experiencing.

## Grabby Clutch

*The clutch of my 3-speed stick shift '62 Buick Special is real grabby, but only when I start out with a cold engine. After about five miles of driving it settles down and performs smoothly. I used to blame the trouble on my inexperience with a stick shift, but now I think the car's at fault. Any ideas?—George Brice, Hollywood, Fla.*

Since shifting straightens itself out after a few miles, the trouble is due probably to oil leaking onto the clutch. As you drive, some of it burns off and shifting returns to normal. Look for signs of oil on the clutch plate. If the plate's badly scored, replace it. In any case: find leak, fix same.

## Wrong Guess

*I'd guess it was the water pump that was causing an up-front noise in my 1963 Ford Galaxie. So far I've installed three new water pumps, but the noise is still there. Also checked belt and fan alignment, belt tension, pulleys (for wear), etc. I'd appreciate your help.—Bobby P. Dunn, Dallas, Texas.*

Okay, Bobby, you pays your money and you takes your choice. But if the first new pump didn't work, how come you figured another, and then another, would? Don't feel too bad, though; this problem has

fooled many a good Ford mechanic.

I'll lay even money that your car is jiggling its marbles because of a little spring-loaded thrust button for camshaft end play which is hitting against the timing cover. Check it out by holding a long screwdriver on the cover while the engine is running. If the noise is coming from there, you'll feel it via vibration. A buddy of mine solved this particular problem by driving a small block of wood down between the water pump and cover. This put sufficient tension on the cover to eliminate the noise.

## Termites in the Pan?

*My 1959 Oldsmobile spouted a small hole in the bottom of the pan just as if a bug had eaten through it from the inside. Then another showed up on the bottom of the oil filter. Should I call an exterminator?—Clarence Oakley, Columbus, Ga.*

No, Clarence, just drop by your friendly service station. You don't say so, but I'll bet you don't drive that car too often or too far. A car that stands idle much of the time doesn't get a chance to heat up the oil sufficiently to keep acids from forming. These acids in the oil are the "bugs" that are perforating your pan and filter. There are two cures: (1) drive your car more often, or (2) change the oil more often—like every two months.

## Haunted Impala?

*Have you ever been driving along and suddenly everything on the car goes kaput? Ignition dies, headlights go out, radio fades away, horn won't honk. In a couple or three minutes everything returns to normal—except me. It's a '61 Chevy Impala that's givin' me the creeps. Maybe it's haunted.—Bill Klinger, New York.*

No. The trouble-making "ghost" in your car is probably the multiple connector located under the dash on the left side of the firewall. All wires to the dash radiate from this. If the connector is shorted, momentarily or just loose, you'll be driving a Twilight Zone car.

## Percolating in French

*What do you know about a Renault 4CV, 1960 vintage? When mine is stopped*

—after it's been well warmed-up—it takes a lot of cranking to fire it up again. Also, I've noticed that the carburetor, a Solex, bubbles fuel like a glass of French Champagne. My carburetor repair efforts have failed. Any ideas?—Don Peters, Baltimore, Md.

Re your carburetor, a simile with coffee rather than champagne would be more accurate since you've got a prime case of percolation. It's a Solex carb trait.

Get yourself a ¼-in. heat block to go between the manifold and the base of the carburetor. This will take the heat off the carb and put a stop to its bad imitation of a coffee pot.

### Fickle Minx

What do you do with a Minx—Hillman, that is—which is as fickle as any female

minx I've ever met. It starts fine, but begins coughing and sputtering after maybe ¾ of a mile. This goes on for maybe ½ mile more; then, it straightens itself out. New float, seat and valve, and new fuel pump have been installed. I've checked filter and lines, too. What have I overlooked?—Ernest Mauck, Albany, Calif.

Like you say, it's fickle. And as you'd do with any fickle gal, you look for something that's bothering her deep down. One possibility concerns the main metering jet. If you have a series 1 or 2 Minx, that jet should be a No. 90. If you have a series 3, it should be a No. 77. Maybe the guy who had the Minx before you didn't treat her right and switched jets. This'll make the gas vaporize too soon or too late, and it takes that ½ mile drive to straighten itself out.

---

## Service Tips

- **CHEVY'S CHANGED** the power steering pump drive belt for '64 and '65 Chevelles equipped with the 283 CID V-8 plant. It's 41¼ in. long and carries Part No. 3849258. The new belt, unlike the old one, can be firmly retightened when it stretches.
- **OWN A '65 PONTIAC V-8?** Then you just might have a shorted-out ignition wiring harness. Seems that some of these units slipped through that were routed the wrong way. It **should** be inboard of the spark plug wire bracket and held by a clip on the throttle-control cross shaft bracket. Otherwise it can be cut by the sharp edge of the rocker cover. It's spelled out for your Pontiac service department in 2 recent service bulletins.
- **THE WRONG CAPACITY FUSE** can leave you without music on a ride. Two types of radios that were installed in '64 Buicks (except Specials) could lead to this problem. There's the standard set (Sonomatic) and an optional set called the Wonder Bar. The Sonomatic takes a 2.5-amp fuse; the Wonder Bar, a 7.5-amp fuse. If a 2.5 is accidentally installed in the Wonder Bar—**pow!**—blown fuse, no music. So make sure you use the right fuse for the right set. The 2.5-amp fuse is marked with a red dot.
- **SUDDEN OIL SEAL FAILURES** in the crankshaft after new seals have been installed have cropped up in 1962 through 1965 Fords. The most likely cause is failure to do a careful cleaning job on the crankshaft surfaces contacting both front and rear seals. These surfaces should be cleaned with solvent to remove corrosion, sludge and varnish. They should then be polished with crocus cloth to get rid of burrs and sharp edges that could damage a new seal or cause premature wear. Before a new seal is installed, it and the contact surface of the shaft should be lubricated to prevent damage during installation, and to provide lubrication when the engine is first started.

---

Each month Auto Clinic answers your questions on car repair. For a personal reply, please enclose 25 cents in coin to cover mailing and handling. Address questions to Auto Clinic, Popular Mechanics, 575 Lexington Ave., New York, N.Y. 10022.

# Shocks Shot? Service

Shock absorbers can't be repaired, but they can be serviced—tightened, given new bushings, or replaced—and you can do it yourself

**N**ATURALLY it was during the zenith of last summer's heat wave that my old buddy, Thornton Barthelson, felt constrained to roust me out of a snore-filled hammock to tell me the latest bugaboo afflicting his "baby"—a beautiful big black '63 Buick.

"My shocks are shot," he announced in my ear.

"Your which are what?" I parried smartly, rubbing sleep out of my eyes.

"Shocks are shot. Shocks are shot. Speedometer says so. Just hit 20,000, y'know," growled Thorny.

Kissing my nap good-by, I proceeded to go in for a little growling myself.

"Look, T.B.," I pronounced with gentle malice, "the only way you'll convince me your shock absorbers are shot is to show me the bullet holes. All your speedometer says is that you've gone 20,000 miles. Sure, that's the accepted effective life of standard shocks. So what? The average American's life span is something like 68 years. Does that mean you're duty-bound to walk off a cliff on your 69th birthday?"

Anyway—yes, ol' Thorny wheedled me into examining his shocks and I found

Monroe Auto Equipment Co. photo



A GOOD EXAMPLE of bad shock absorbers is the bounced-up rear end of this car as it crosses a track



# 'Em Yourself!

By Morton J. Schultz

them to be in fine shape, and good undoubtedly for thousands of more miles.

Today the shock absorber replacement business is booming. In 1956 some 5.3 million were sold. Sales jumped to 17 million in 1964—an increase of over 300 percent in only eight years. It's interesting to note that during the same period the vehicle growth rate in the nation was only about 20 percent. These figures indicate that the general public has become increasingly aware of the importance of shock absorbers as they relate to both safety and driving comfort, and this new awareness is all to the good.

Any car owner can—and should—check out his shock absorbers occasionally; it's not all that difficult. A thorough examination of this element of your suspension system will serve to (1) reassure you as to your shocks' continued effectiveness, or (2) alert you to the fact that they're going bad.

The useful life of a set of shocks can range anywhere from 2000 to 50,000 miles. Ten miles of driving on back-country washboard roads, for instance, can do more damage to shocks than 1000 miles

of freeway driving. Moisture, dust and temperature are other factors affecting shock life.

## Recognizing Faulty Shocks

To ascertain the condition of your own shock absorbers you must test them. It would be easy to spot faulty shock absorbers if they went flat like a punctured tire. But shocks are coy. They wear out gradually. And because they do, a driver is subtly conditioned to accept whatever ride his car gives until the ride gets really bad.

Deteriorating shocks will advertise themselves by one or more of the following signs:

- Under-par steering control.
- Chassis noises and rattles.
- Skidding or loss of control on curves.
- Uneven or premature tire wear.
- A "too soft" or "too hard" ride.

Unfortunately, pinpointing shocks as the underlying cause of these symptoms will be difficult unless you're finely attuned to the difference in riding motion between a car with new shocks and one with an old, well-worn set. Also, these

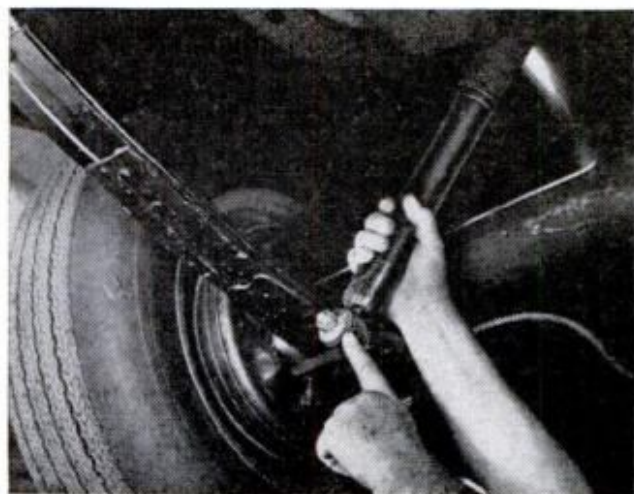

**TO DETERMINE IF A SHOCK** is firmly mounted, grab it as shown and try and shake it. If it's loose, tighten up on the mounting nuts. If the bushings are worn, replace them as described in the text

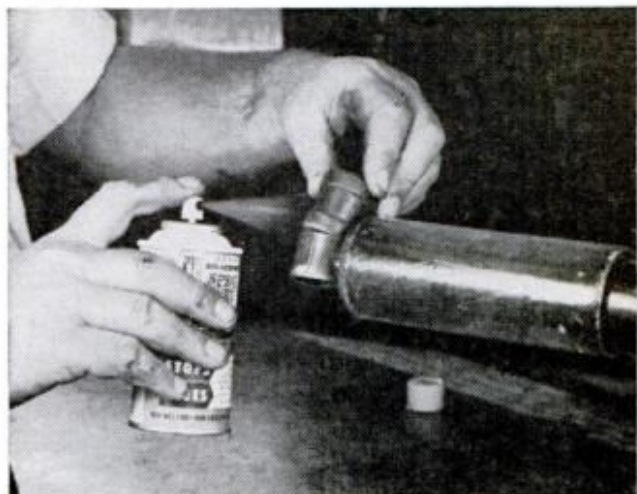

**WHEN INSTALLING NEW BUSHINGS**, spray them first with a silicone lubricant to facilitate working them into their seats. Never use a petroleum-base lubricant; it will cause the rubber to deteriorate

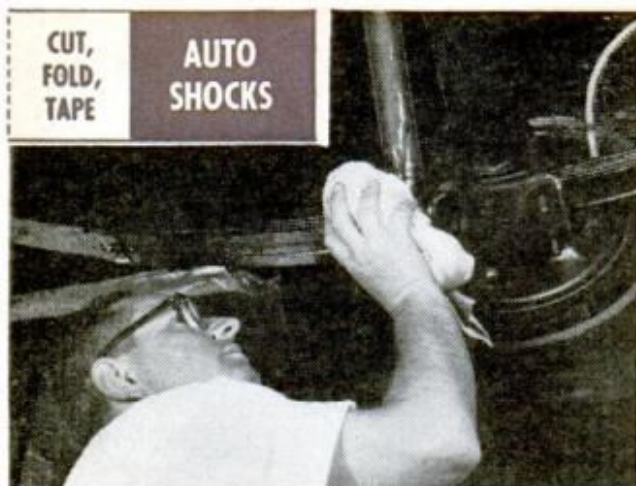

**FLUID LEAKING FROM A SHOCK** is easy to spot. Once this occurs the shock must be replaced. Wipe casing clean to be sure it is shock-absorber leakage, then replace shock—along with its left or right mate

same troubles can be caused by any one of a number of weak or worn parts in the steering or suspension systems, including a weak or broken spring, loose ball joints, defective wheel bearings or a bad idler. So don't rush into replacing a set of shocks just like—*snap!*—that. You may find you've spent a healthy chunk of money to no avail.

Shock absorbers are double-acting hydraulic devices. Double-acting simply refers to their damping action in two directions: on the rebound, when the shock absorber extends itself; and during compression, when the shock collapses.



**WITH CAR ON A FRAME-GRIP HOIST** that takes the weight off the wheels, removal of the lower end of the shock absorber will be made easier by jacking up the spring near the shock as shown in this photo

The relationship of rebound-to-compression load varies with the speed to which a shock absorber is subjected. In other words, a particular velocity results in a particular load on the shock. Normal operating pressures range from zero p.s.i. to 700 p.s.i. When subjected to really violent road shocks, the pressure can go as high as 5000 p.s.i.

Since shocks are filled with a carefully measured amount of fluid and sealed in manufacture, you can't reload them if they lose fluid; and you can't disassemble them to replace worn parts. The only first aid you can administer to a shock absorber is to replace worn rubber bushings and tighten loose mountings.

### How to Test 'Em

Practice the following three techniques for the care and coddling of your shock absorbers:

(1) *Keep aware of any changes in driving "feel."* If you detect any, check the shocks. If they're okay, check out the remainder of the suspension system—and the steering.

(2) *Inspect shocks every time the car is on a lift.* Look for fluid leakage; also for dents in the casings. The latter may signal damage to the internal valving. If so, the shock should be replaced.

To test a shock for stability, grab it and shake it (it shouldn't move—oh, maybe *very* slightly). If it's loose, tighten up the mountings. If this doesn't help, remove the shock, then bang out the old bushings and insert new ones. Admittedly, inserting new bushings can be a rough job. To ease this chore and make the new rubber bushings more pliable, spray them with a silicone lubricant. Then work the bushings into their seats. Note: Never apply a petroleum-base lubricant; petroleum attacks rubber and causes rapid deterioration.

(3) *Run a thorough inspection of your shocks when your car reaches 20,000 miles, then every 5000 miles thereafter.*

"How about that time-honored test of the used-car buyer—bouncing the car up and down?" you may ask.

Beautiful! And from my long experience with the breed I can say with absolute confidence: "Show me a car-bouncer and I'll show you a tire-kicker."

As a matter of fact this is a legitimate, if perfunctory, method of determining the general action of your shocks. Just jounce the car by hand or foot at each of its corners. A considerable amount of resistance should be felt at both the upward and downward thrusts of the car. However, I wouldn't bet a bowl of Himalayan yak-tail soup on the accuracy of this test.

# COMPONENTS AND ASSEMBLY OF A TYPICAL SHOCK ABSORBER

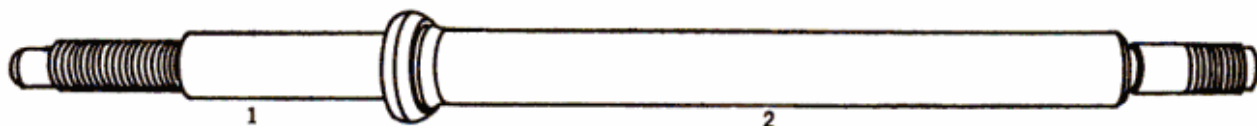

- 1. Mounting Section
- 2. Piston Rod
- 3. Seal Cover
- 4. Rod Seal
- 5. Seal Retainer
- 6. Seal Spring
- 7. Rod Guide
- 8. Pick-Up Washer

- 9. Intake Spacer
- 10. Star Spring
- 11. Intake Valve Disc
- 12. Piston
- 13. Rebound Valve Disc
- 14. Rebound Valve Disc Spacer
- 15. Rebound Spring Seat
- 16. Rebound Spring
- 17. Nut

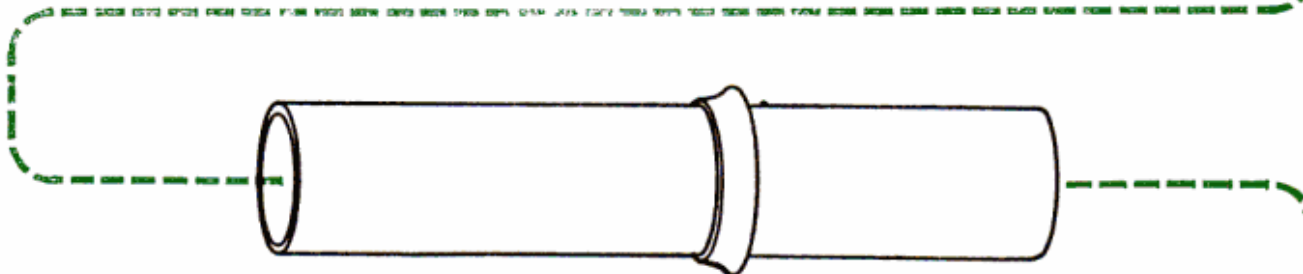
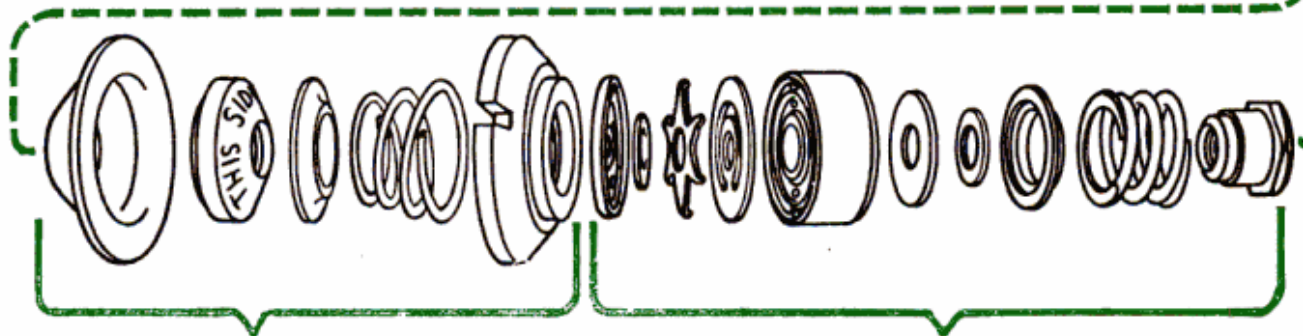

- 18. Pressure Tube
- 19. Baffle Ring
- 20. Compression Stem
- 21. Compression Valve Plate

- 22. Compression Valve Cage
- 23. Compression Valve Sleeve
- 24. Compression Valve Spring
- 25. Conical Replenishing Spring
- 26. Valve Retainer

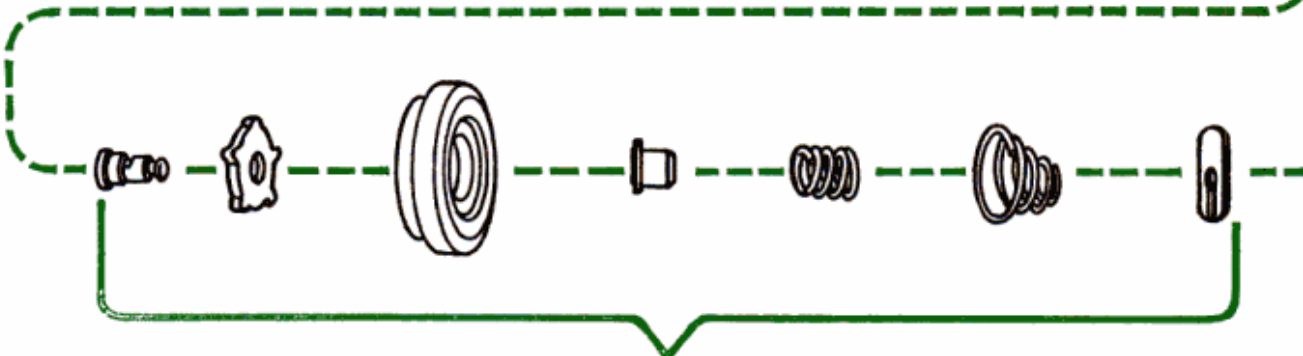

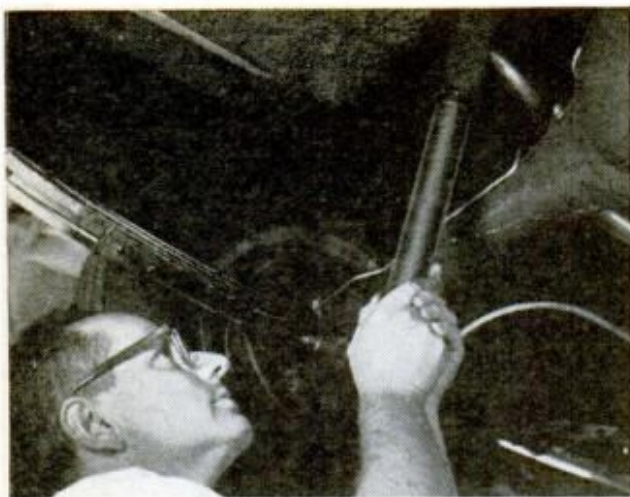

**SHOCKS CENTERED IN COIL SPRINGS** must be removed and bench-tested. Other types can be tested by removing shock from lower mounting, then forcing the shock in and out. If it moves easily, replace it

For one thing, interpreting the results takes experience. What might seem like sufficient shock resistance to you, *wouldn't* to a trained mechanic.

Another point: A strong spring could enable a bad shock to masquerade as a good one by resisting the bounciness that would show up in a road test.

### Service and Replacement

Shock absorber failure occurs in one of two ways: the seals rupture and fluid leaks out of the casing, or worn parts cause internal failure.

Fluid leaks are easy to spot. Once a shock begins to leak it must be replaced. Internal failure will make itself known by the "feel" of the ride.

To service or replace a shock, put the car on a lift, then clean all road dirt and grease from the upper and lower mountings. The toughest part of the job is removing the mounting hardware, especial-

ly if it has rusted. So give the mounting bolts and nuts a good shot of penetrating oil and let it soak in for several minutes. This will facilitate loosening the nuts with a wrench.

If your car is on a frame-grip lift that takes the weight off the wheels, removal of the lower end of the shock will be made easier by jacking up the spring near the shock.

Now compress the shock by hand as it hangs from the top mounting. This will require plenty of force if the shock is in good condition.

Front shocks that are mounted inside coil springs are the only type that must be removed from the car for testing. To test one of these, clamp it upright in a vise so the lower mounting is held firmly. Then force the shock in and out of the casing. Any erratic or low resistance indicates the shock is worn out and should be replaced.

### Replacement Shocks

The replacement shocks you buy are generally not the same as those originally on the car. Original factory shocks are built to give the softest ride. Replacement shocks are designed to give the best *control* to a car that has put many thousands of miles under its wheels. Thus replacement shocks will be found to be generally sturdier than the original units.

However, if you use your car to haul heavy loads—a boat or trailer, for example—you should consider installing the so-called *load-leveler* type shocks for greater control and easier handling. In any case, always buy well-known, brand-name replacement shocks which are marketed by such companies as Autolite, Monroe, Gabriel, Columbus, Delco and MoPar.

### Installation Tips

Here are some pointers to bear in mind when installing new shocks:

- Follow the manufacturer's installation instructions *to the letter*. Early failure can be expected in the form of broken shocks if they aren't mounted correctly.

- To avoid so-called *shock rattle* caused by air trapped in the working chambers, move each shock up and down a few times before mounting it. This cycling forces the air out of the chamber.

- Always replace old shocks in pairs—two in the front or two in the rear. Although only one of a pair of old shocks may be bad, chances are the one you *don't* yank won't match the performance of the new shock. Result: an unbalanced ride. Replacing shocks in pairs will equalize their damping effect. ★★ ★

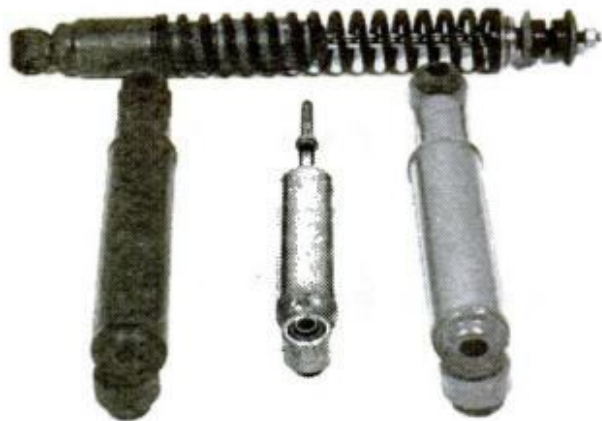

**FOUR TYPICAL REPLACEMENT SHOCKS** are pictured above. At the right is a Delco. The center unit is an Autolite rear shock, with an Autolite front shock at the left. At top is a Monroe load-leveler shock.

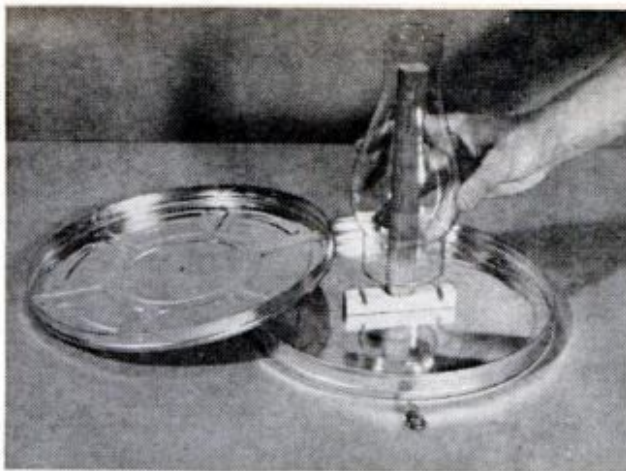

### Quickie Bird Feeder

You can make this feeder about as quickly as you can say whippoorwill—from a large film can (or two pie plates) a dowel and a lamp chimney. The chimney slips over a dowel attached to the bottom pan with a screw and rests in slots cut in a wooden block which hold it about  $\frac{1}{2}$  in. above the surface. This space allows seed to trickle out the bottom of the chimney. The top pan is secured to the dowel with a screw eye which also serves as a hook to hang the feeder.—*Joyce Patterson*



### Keeping Shell Boxes Dry

If you take extra boxes of shells out to the blind with you when duck hunting, place each box in a plastic bag and seal it with a piece of tape. While the new plastic shells are waterproof, the boxes are likely to come apart when exposed to moisture. Protecting them with plastic bags is a simple way to make sure that you don't end up with a pile of soggy cardboard boxes and pockets bulging with loose shells.—*Wayne M. Judy*

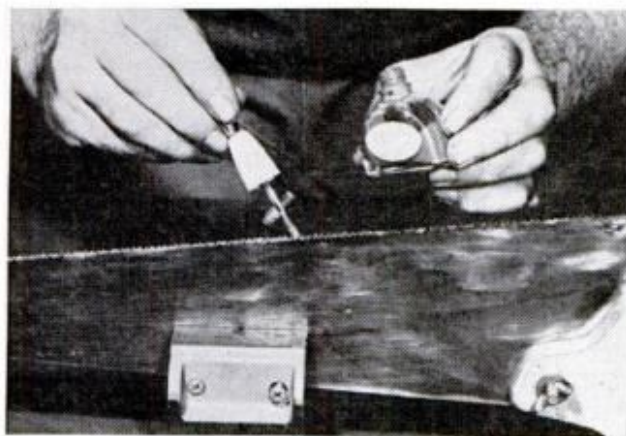

### Seeing Red When Filing

Red fingernail polish smeared on the teeth of a hand saw prior to sharpening will make it easier for you to keep track of which teeth have been sharpened. If the teeth are badly dulled, this also makes it easier for you to check on filing progress, since the nail polish will stay in the bottom of all pits or irregularities until they have been leveled. Give it a try the next time you find that your hand saw needs sharpening.—*Gilbert C. Close*

## Next month in shop and crafts

**Teacup—a basic-basic sailboat.** Not a sailing board, but a real hull. It's  $9\frac{1}{2}$  ft. of fun on the water for kids or adults, a **basic** boat both in handling and construction. With almost 5 ft. of beam, **Teacup** is stable and sturdy, a perfect beginner's boat. You'll find complete plans for this prambowed wonder in the January issue of **PM**

**Motorcycle tuneup: part 1.** January is the off-season for cycling in most parts of the country, so it's a perfect time to give your bike a thorough check-up. Next month's **PM** has an article on tuning light-weights with plenty of pro-type tips you won't find in your manual. If you want to get the most out of your bike, don't miss it

**Nibbler attachment for sabre saw.** Cutting at the rate of 3 in. per second, it zips easily through galvanized iron, auto-body sheet steel or aluminum. And you can make it in your shop. This ingenious attachment for your sabre saw makes smooth, clean cuts requiring little or no further finishing. You'll find all the plans in the January issue

# Band Grinder Smooths and Sharpens

ANYONE who can screw pipe fittings together can build this versatile workshop tool in a couple of evenings. And once you learn what it can do, you'll wonder why such a tool isn't on the market. It not only performs the normal function of a belt sander, such as de-burring, and sanding inside curves; it's the neatest sharpener you ever used to put a quick edge on knives, scissors, circular saw blades, twist drills or lathe tool bits.

By taking advantage of the natural sleeve fit of 1-in. pipe into 1 1/4-in. pipe, and of 5/8-in. shafting into 1/2-in. pipe, you avoid extensive machining, yet create a tool of surprising adjustability. The tracking pulleys can be moved in two directions for belts of different lengths and widths (up to 48 in. x 2 in.), and there's an automatic tensioning device that makes it easy to slip off one belt and insert a new one through the table slot, as shown below. Tilting the tool causes the belt to track.

The table tilts 20° to the back and 45° to the front, to permit you to set any cutting bevel you need. The belt backing plate stays rigidly vertical, aligned with the Plexiglas protractor tongue, as the table tilts. The normal 9-in. throat clearance can be increased to 14 in. by adjusting the bottom pipe extension back and the top pulley sleeve forward.

And you don't even tie up a motor. By swinging down the belt-tensioning arm, you can power other tools from the opposite end of a double-shaft motor without spinning the abrasive belt.

The table shown in the photos was salvaged from a sink cutout of 3/4-in. counter-top stock, then edged with a plastic laminate to match the top surface. The table can be raised—or removed altogether for large sanding jobs—by loosening the lock screw that bears against its vertical stem. This stem has a 1/4-in. cross-rod through it which cradles into notches at the top of the support sheath. The easiest way to accomplish this is to slip the rod into an overlong 1/2-in. pipe, drill a 1/4-in. hole through both, separate them, drive the 1/4-in. rod through the 5/8-in. stem and trim off the pipe right through the holes to form the notches. The stem is then permanently secured at right angles to the cross-shaft that runs under the table. The joint is made by concaving the end of the stem and tapping it to take a bolt inserted through the cross shaft. When the bolt is tight, check for squareness and weld.

The table pivots in two bearing sleeves consisting of short pieces of 1/2-in. pipe welded to mounting plates. When assembling the pivot mechanism, see that the 5/8-in. cross shaft running under the table extends slightly through the protractor mount that's bracketed to the table. Then, when the Plexiglas tongue is tightened against the end of the shaft with a small bolt into a tapped hole, it will sweep the protractor without binding. Note that the pivot shaft is anchored into a no-play position by means of two collars flanking the front sleeve, and cut from the same 1/2-in. pipe. These collars are secured by

## HOW THE BELT TENSIONER WORKS

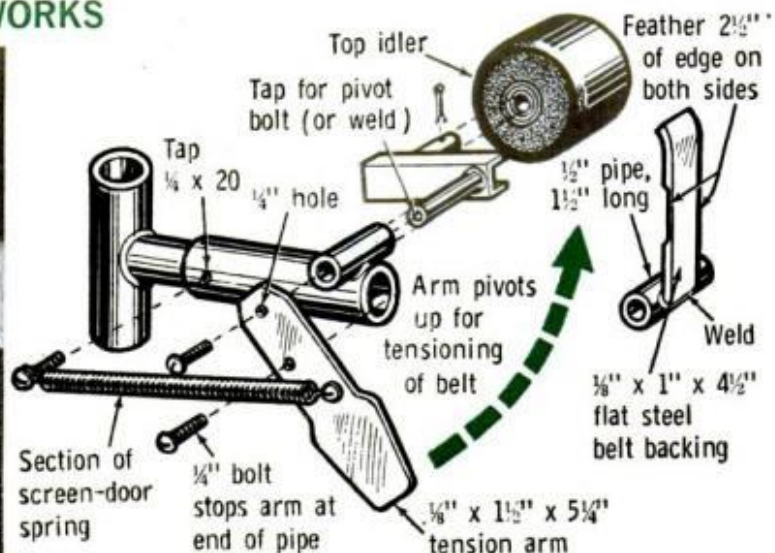
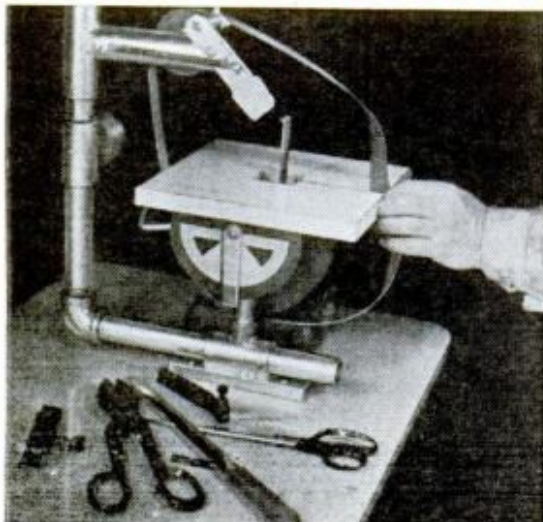

By William G. Waggoner

It operates much like a bandsaw, but drives a belt instead of a blade. It sharpens everything from scissors to twist drills and makes fast work of sanding and polishing.

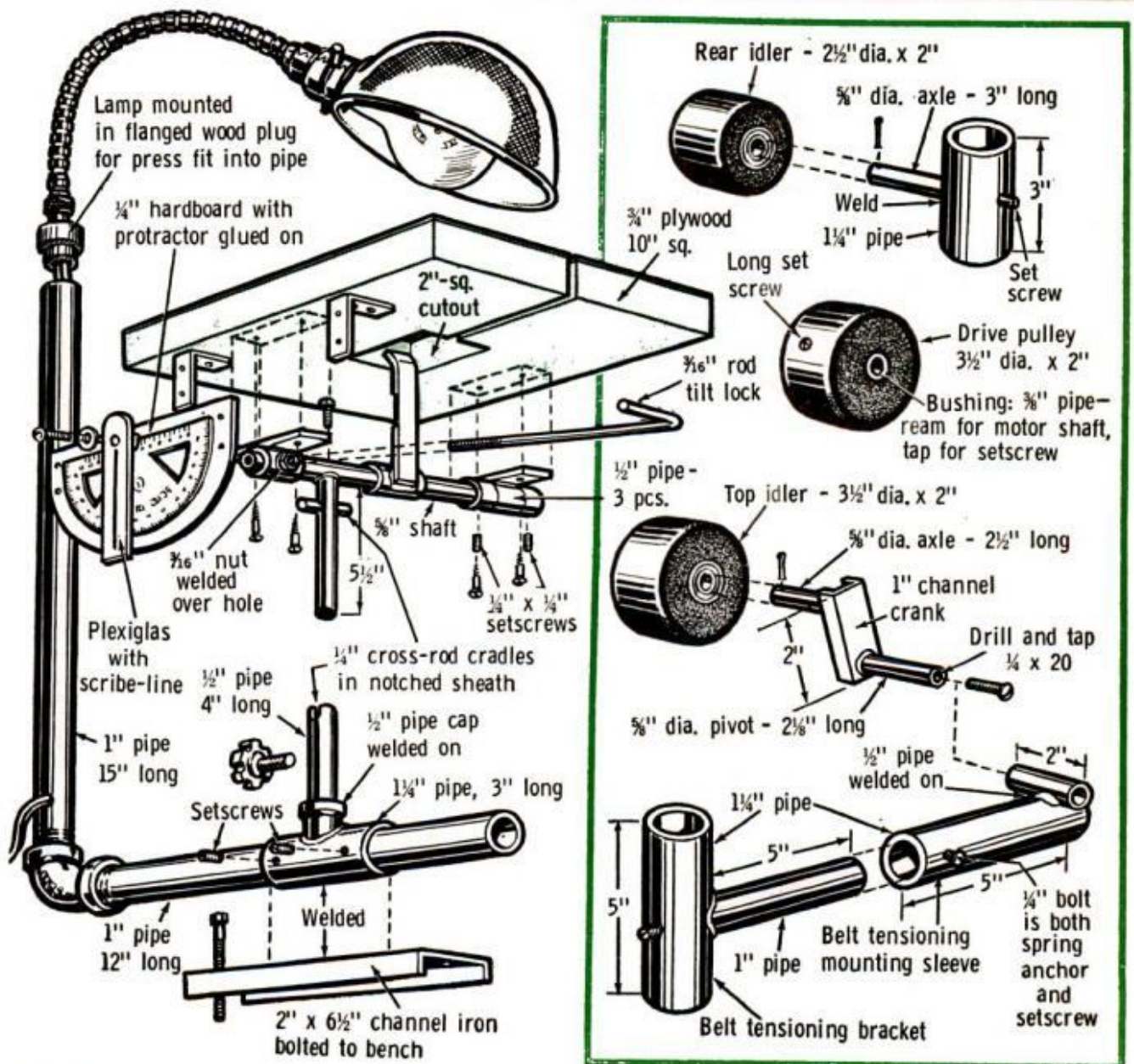

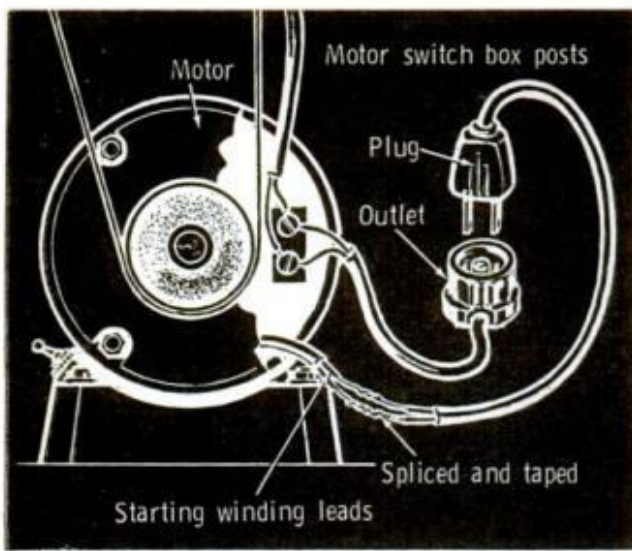

**OPTIONAL REVERSING** device lets you change direction of belt travel by reversing plug in socket mounted near on-off switch. Upward-moving belt is a boon for sharpening shears since it carries material away from cutting edges, leaves no burr to be honed

means of setscrews. The rear sleeve is equipped with a simple locking device. A  $\frac{3}{16}$ -in. rod is threaded on one end to match a heavy nut that's welded over a hole through the sleeve. For the sake of clarity, in the drawing this lock rod is projecting toward the *front* of the table. If you prefer, it can be attached at the back of the sleeve.

The adjustable-base connection consists of a channel plate to which a sleeve of  $1\frac{1}{4}$ -in. pipe is welded. A pipe cap is then welded to the top of this sleeve to form a socket for the vertical support sleeve.

The photos and captions tell you how to perform various sharpening operations. Circular saw blades can be sharpened without filing. The inside face of the belt backing plate is feathered to a knife edge at each side to give fine teeth access to the belt. Beveled teeth on combination blades are no problem, either. You just tilt the table to the proper angle. ★★

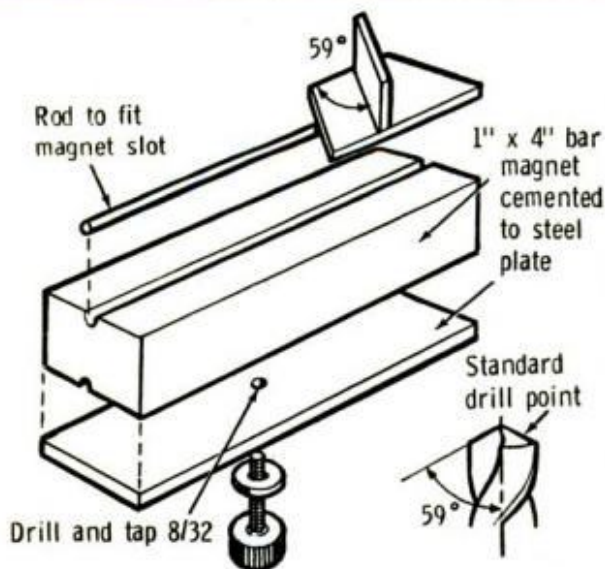

**PRECISE ANGLE** is important for "honed" bit sharpening. Fasten upright piece of flat steel to "bed" plate, as shown, either by welding or by drilling and tapping for screws. Rod, riding in magnet's slot, holds fence at proper angle as bit contacts belt

**LARGE TWIST DRILLS** are held snug against fence with fingers. Small ones can be held against edge of jig which has been cut to same angle as fence (below, left). Knurled-head bolt passes through table slot and is tightened in tapped hole to position magnet

**TURN JIG LENGTHWISE** and you can position it to serve as stop for setting perfect bevel on knives. Use magnet alone to support straight-edge tool (such as blade of shears) while edge is drawn across magnet against belt. Tilt table to proper bevel angle

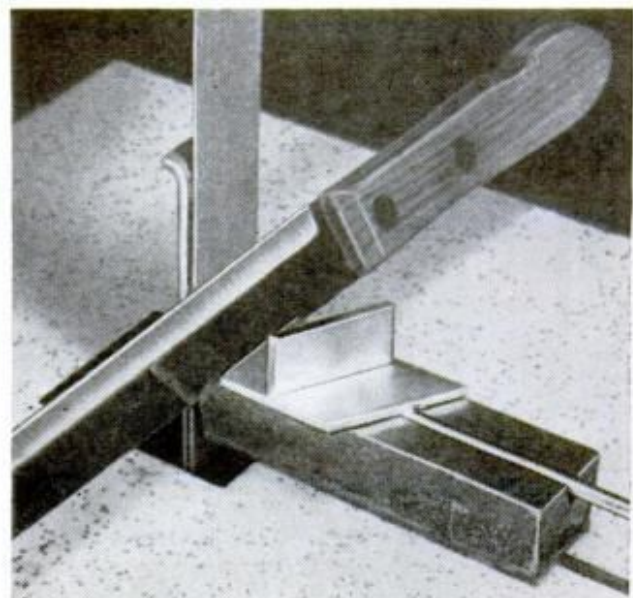
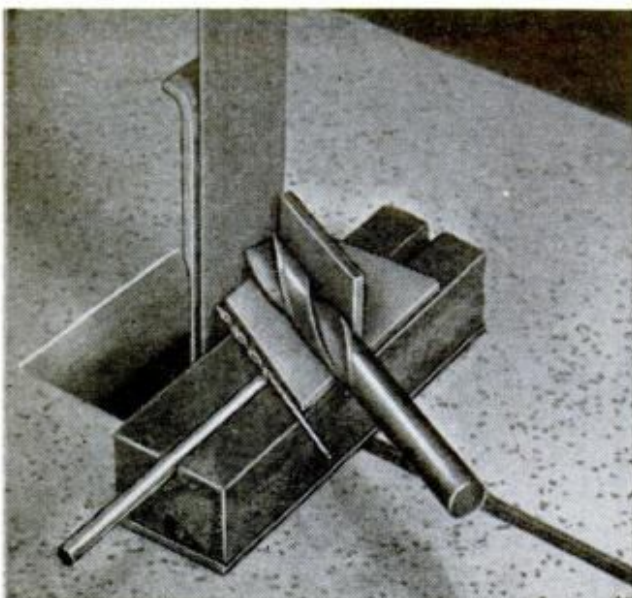



# new in HI-FI

**JUST ADD SPEAKERS** and you have a complete hi-fi stereo sound system. Benjamin Stereo 200 FM is an 18 x 16 x 9-in. package that includes Miracord automatic changer, FM stereo tuner, dual 18-watt amplifiers. \$339.50 from Benjamin Electronics, Westbury, N.Y.

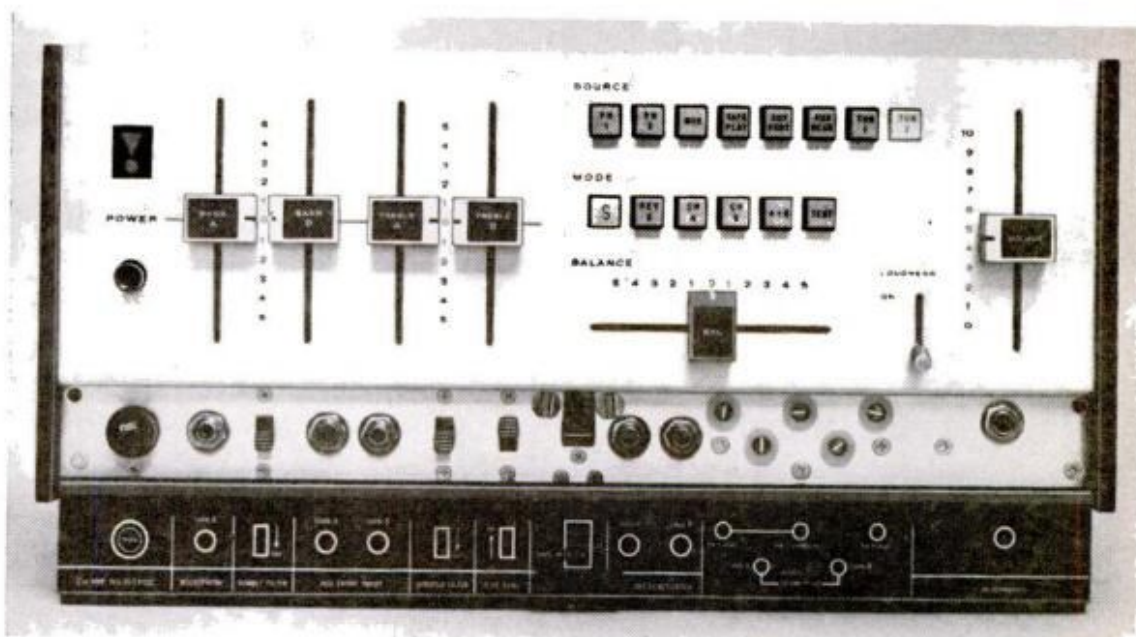

**PUSHBUTTONS AND STRAIGHT-LINE CONTROLS** make the JBL Graphic controller one of the best stereo preamplifiers available. With it you can control almost every conceivable function that exists in any stereo system, in the easiest possible way. Try it once and your present equipment will appear outdated. The SG-520 is made by James B. Lansing, Los Angeles, Calif.

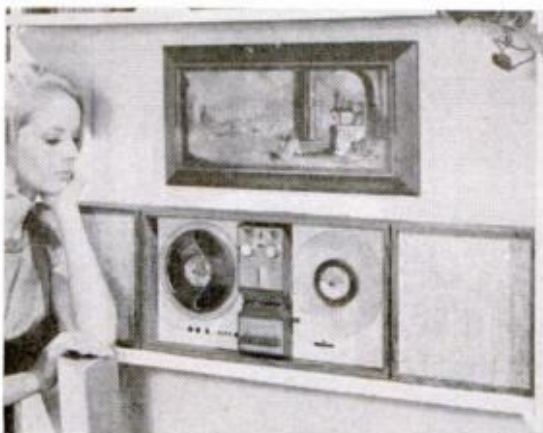

**TAPE RECORDER** on the wall is how this Wolensak model 5280 is being used. Keyboard control makes operation easy. Unit records in four-track stereo or monaural from any sound source, has two meters, four-digit counter, wing speakers, automatic shutoff; \$219.95

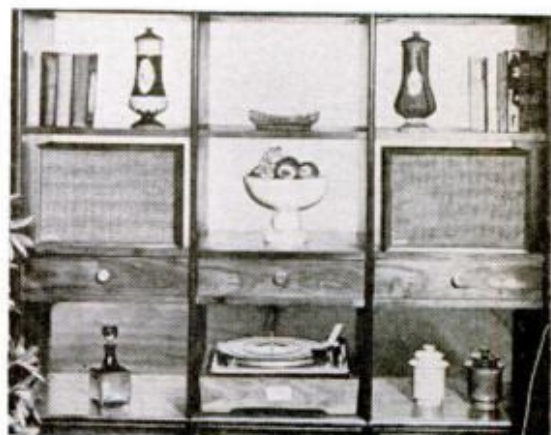

**MINIATURE BOOKSHELF SPEAKERS** that have a frequency response of 45 to 20,000 cycles but measure a mere 14½ x 10½ x 7¼ in. permit maximum flexibility in setting up your stereo system. The RM-1 handles 40 watts of audio, is a two-speaker system by Sonotone

# TABLETOP RADIO GOES PORTABLE

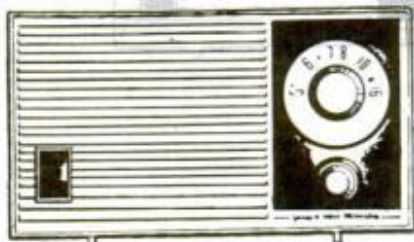

Look, no IF transformers! Where did they go? They've been replaced by some startling new electronic ceramic filters that cost less than the transformers, take up less space and work even better than standard circuits with transformers.

By Leonard J. D'Airo

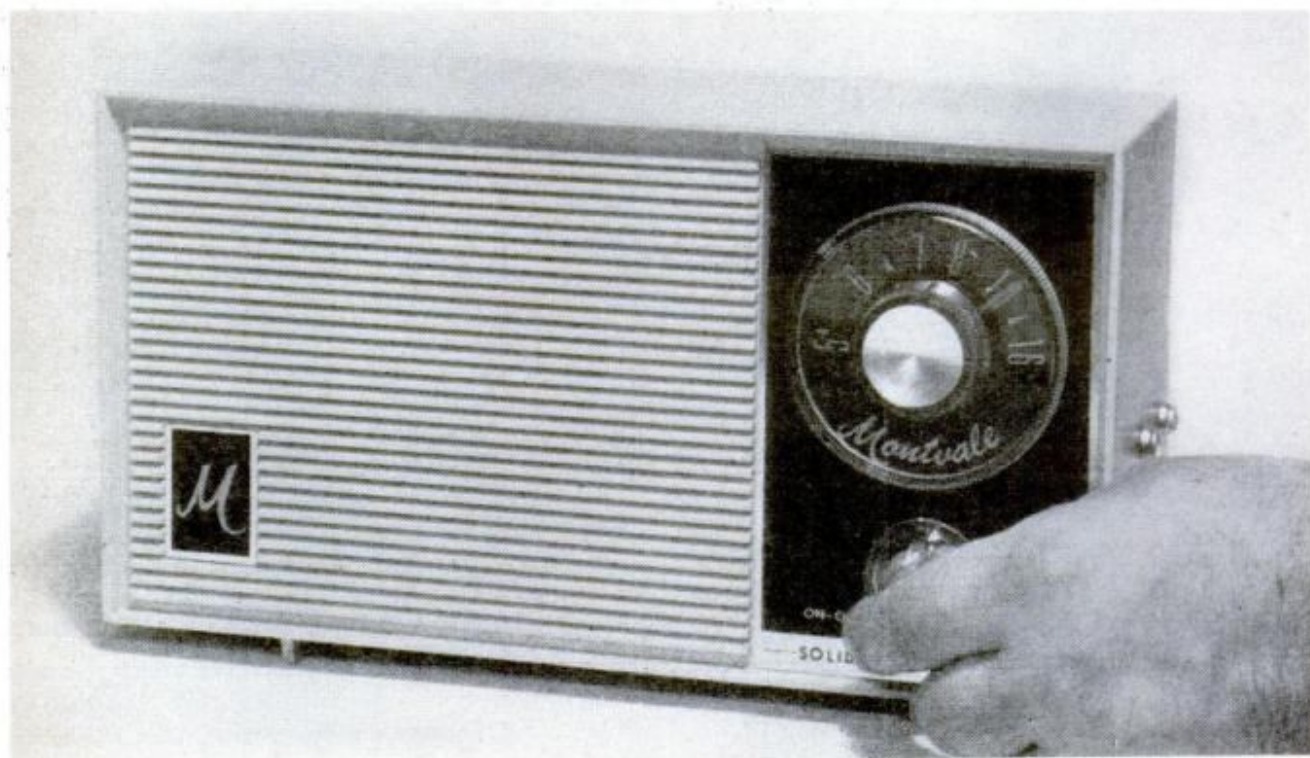

**STORE-BOUGHT LOOK** of completed radio is as good as appearance of the case you use. Old cases can often be found at surplus outlets or electronic supply houses. If you have an old, inoperative set on hand, use its cabinet

**A** NEW TWIST IN TRANSISTOR SETS is one which has two intermediate frequency (IF) stages and gets along just fine without IF transformers. Surprisingly, this radio performs just as well, if not better, than a conventional receiver. The secret is a ceramic filter element, known as a Transfilter, that takes the place of the IF transformers and couples the stages.

The radio, as pictured on the opposite page, makes an attractive tabletop set for the kitchen or bedroom. Add a handle and it becomes a portable unit for your outdoor use this coming spring.

Once again, you have several options as to the way to build this set. You can do the job from scratch, using parts you have on hand together with those obtained from your favorite parts supplier. If you prefer, you can buy a kit comprising the basic components, Transfilters, a printed circuit board and cabinet. Or, you can acquire the complete kit which contains all the parts you need. These kits are supplied by Techni-Kits (see the parts list on page 179 for details).

The Transfilter is a semiconductor device designed and developed by the Piezoelectric Div. of the Clevite Corp. It consists of a small, flat piezoelectric ceramic disc with plated silver electrodes on both faces. One face is completely plated, while the other has two electrodes: a dot (input) and a ring (output). The particular units used in this radio are designed to resonate at 455 kc., which makes them ideal replacements for standard IF transformers.

The radio has a six-transistor circuit, using three 2N274 drift-type transistors in the converter and IF stages and three 2N361 transistors in the audio driver and push-pull output stages.

Four 1.5-v. "D" cells connected in series form the 6-v. supply that powers the set. The current drain is low: 15 milliamperes (ma.) when idling (no

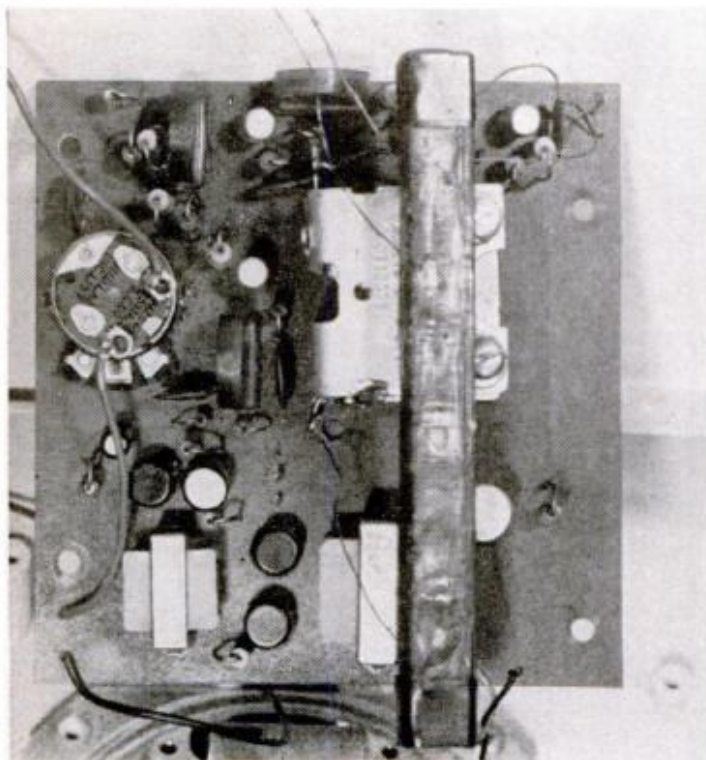

**TOP OF PRINTED CIRCUIT BOARD** as it appears when all the parts are in place. The complete lack of crowding is made possible by use of large case

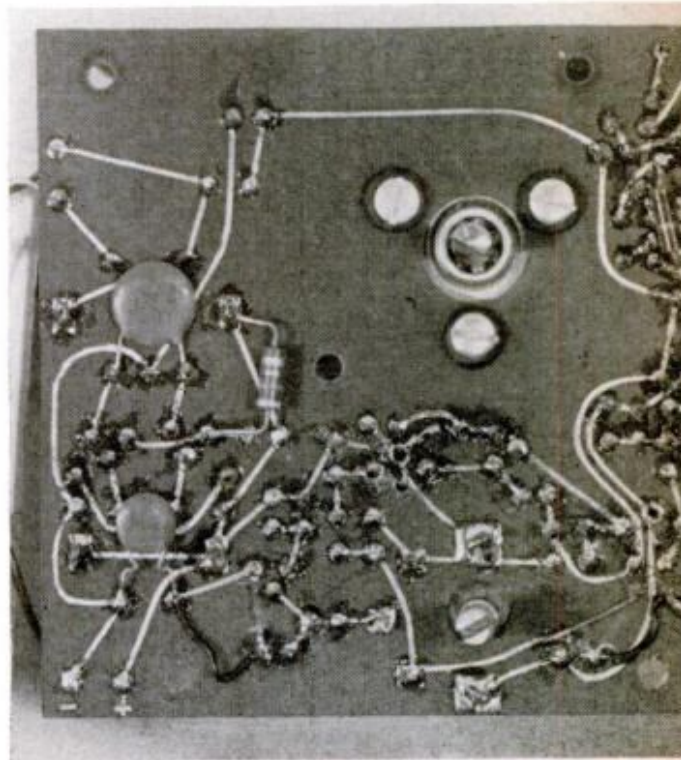

**WIRING SIDE OF CIRCUIT BOARD** shows how two ceramic capacitors are soldered in proper position. This greatly simplifies the job of wiring on board

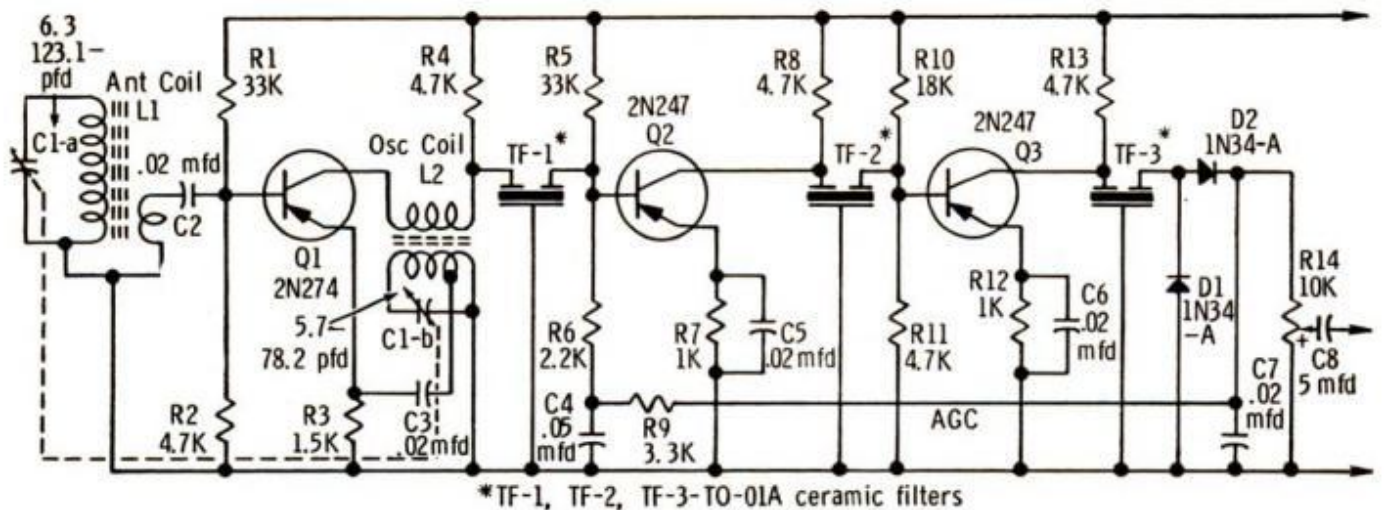

signal) and 180 ma. at full volume. With normal use, this means that a set of batteries will last nearly a year before requiring replacement.

I built my set in a surplus plastic cabinet I picked up at a local surplus store. You can use any similar type of cabinet or make your own. Minimum dimensions are 10 x 6 x 4 in.

No special layout is required; the circuit and components lend themselves to about any arrangement you desire. Just follow the standard practices of keeping your leads short and making good, clean solder connections.

### Before You Turn It On

Once you have put your set together, double check all wiring against possible errors. If you use the printed board, make certain that all components are mounted in the proper places. Then insert a 0-200-ma. meter in series with the negative battery lead. Set the radio volume to maxi-

imum and turn on the power. A check of the current reading should show not more than 20 ma. on the meter. If it's higher, either the wiring is wrong, off-value resistors have been used or the transistors are connected improperly or are defective. After any necessary corrections are made, you're ready to sit back and enjoy your handiwork.

Size does not limit the constructor as it would in a pocket portable, so a large speaker can be used. If you want to build a smaller set, use miniature components throughout, especially in place of the tuning capacitor, volume control, speaker and antenna coil. Obviously, a smaller battery is also a must. If you decide to do this, you should be able to come up with a really superior pocket radio. Should you design your own set this way, drop a line to *PM's* electronics editor. He'll be interested in hearing how your experimental set turned out. He might even run a story on it.

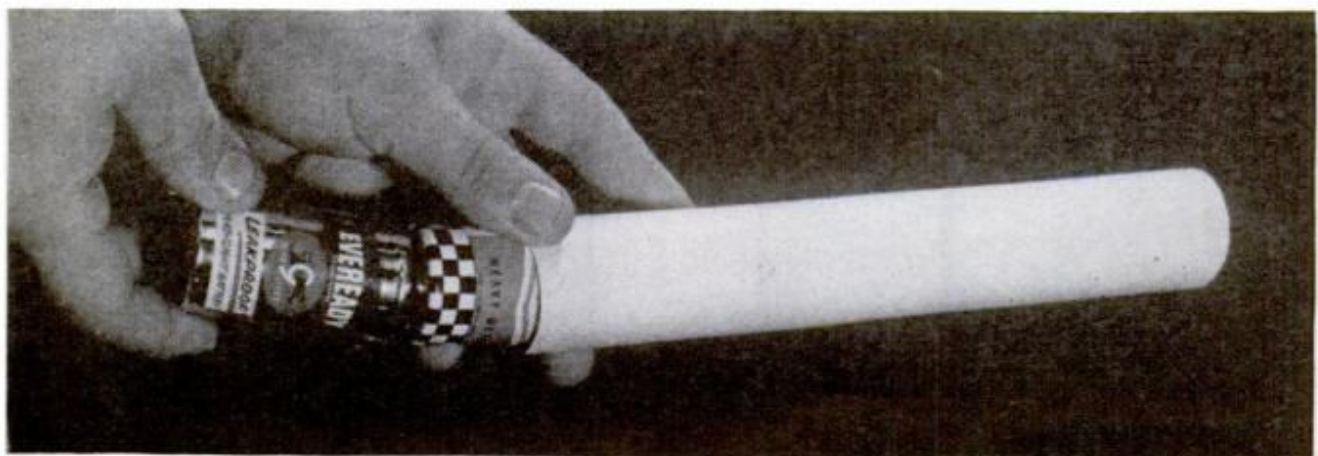

**SIMPLE BATTERY HOLDER** for the four "D" cells is made from plastic shower rod cover. Just cut cover a bit shorter than total length of the cells. Buy such covers at a hardware store; if not, use cardboard tubes to hold batteries

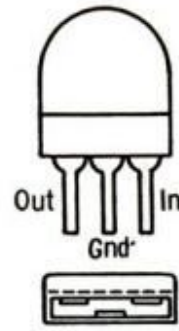
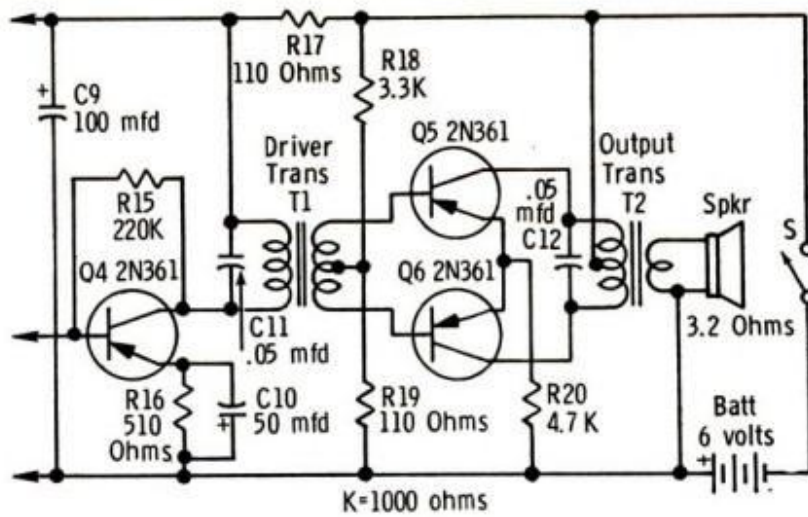

**CIRCUIT OF SET** includes a push-pull output stage for minimum distortion. Double check all connections before wiring any Transfilters into circuit. It's easy to hook up these elements wrong

For the technically minded, here is a brief listing of the important characteristics of the Transfilter radio. Compare them to those of existing commercial sets and see just how good a radio you'll wind up building.

Sensitivity for 100-milliwatt output:  
 600 kc. 175 microvolts/meter  
 1000 kc. 150 microvolts/meter  
 1400 kc. 100 microvolts/meter

Signal to noise ratio—14 decibels  
 Adjacent channel attenuation—15 decibels.  
 Band width at 6 decibels—12 kc.  
 Band width at 40 decibels—32 kc.  
 Automatic gain control (a.g.c.) figure of merit—58 decibels.  
 A.g.c. distortion—10 percent.  
 Harmonic distortion at full volume—8 percent.

Now go to work and build yourself a radio you can really be proud of. Use it in any and every room of your home and don't forget to show it to your friends. Happy listening.

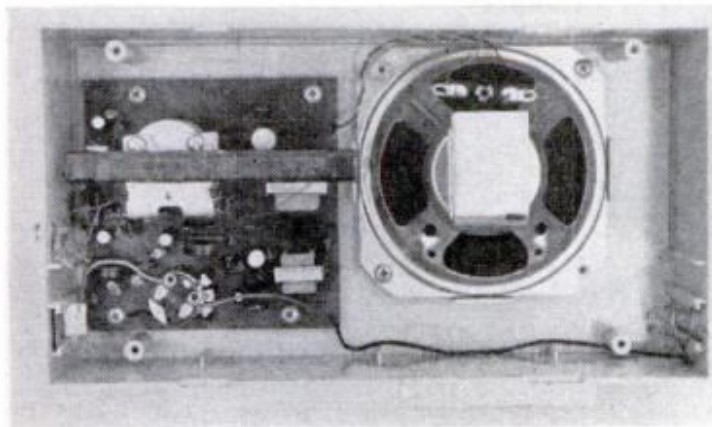

**INSIDE THE CASE**, showing exactly how the major parts are arranged. Large-size speaker was used to provide the radio with best possible sound quality

### PARTS LIST

#### Resistors:

- R1, R5—33,000 ohms, ½ watt, 10%
- R2, R4, R8, R11, R13—4700 ohms, ½ watt, 10%
- R3—1500 ohms, ½ watt, 10%
- R6—2200 ohms, ½ watt, 10%
- R7, R12—1000 ohms, ½ watt, 10%
- R9, R18—3300 ohms, ½ watt, 10%
- R10—18,000 ohms, ½ watt, 10%
- R14—Potentiometer, 10,000 ohms, audio taper, with s.p.s.t. switch
- R15—220,000 ohms, ½ watt, 10%
- R16—510 ohms, ½ watt, 5%
- R17, R19—110 ohms, ½ watt, 5%
- R20—4.7 ohms, ½ watt, 5%

#### Capacitors:

- C1—Tuning (Lafayette 32G1106 or equiv.)
- C2, C3, C5, C6, C7—.02 mfd., 75 v., disc ceramic
- C4, C11, C12—.05 mfd., 75 v., disc ceramic
- C8—5 mfd., 6 v., subminiature electrolytic
- C9—100 mfd., 12 v., submin. electrolytic
- C10—50 mfd., 6 v., submin. electrolytic
- L1—Antenna coil (Lafayette 32G4101 or equiv.)
- L2—Oscillator coil (Lafayette 32G4102 or equiv.)

TF-1, TF-2, TF-3—Ceramic filter (order from Techni-Kits; see below)

T1—Driver transformer (Argonne AR-113 or equiv.)

T2—Output transformer (Argonne AR-174 or equiv.)

D1, D2—1N34-A diode

Q1, Q2, Q3—2N247 transistor

Q4, Q5, Q6—2N361 transistor

Batt—Four 1.5 v. "D" cells in series

Speaker—3.2 ohms, 4-in.

Printed circuit board and cabinet (order from Techni-Kits; see below)

Kit of major parts, including Transfilters, printed circuit board and cabinet, \$12.95. Kit of all parts needed to build radio, \$24.95. Order either from Techni-Kits, 350 Broadway, New York, N. Y.

## AIRPLANE-GLIDER

(Continued from page 114)

Comte d'Assche also showed me the engine primer and elevator-trim handles, but there was one handle missing.

"Where's the decompressor?"

With some chagrin, he said, "Unfortunately, this flying club doesn't use this plane as a glider so, when they purchased it, they requested that it come without one. If you wish to soar and restart, you'll have to dive up to 210 kilometers per hour to turn the propeller."

*Sacre bleu!* With the decompressor, Fournier had told me, I'd need only 170.

The instruments, as I said, were all in meters and kilometers, but this actually became less of a problem than I first thought. Comte d'Assche gave me a basic check list, with recommended speeds for each attitude, and it was a simple task just to match the needles against the numbers on the dials regardless of what they stood for. For the balance of this report, however, I've translated all figures into American equivalents.

Comte d'Assche walked around to the nose, smiled and said, "Ready?"

I shrugged, "Ready as I'll ever be."

### A Day of Surprises

I primed the engine three strokes, nodded, and the count backed off to arms' length. I flicked the magneto switch and d'Assche spun the prop. The plane had been sitting for several days, so it took several turns. When it caught, it surprised me. It sounded like a motorbike, but I assume that's because it develops more rpm than airplanes I'm used to.

I closed the bubble canopy, which flips open to the right side, released the hand brake and started taxiing. Another surprise. It was rough. D'Assche held one wing part of the way, but when he waved and left, it dropped on the steel wire and I could both hear and feel it bumping over the ground and an occasional steel mat. I could tip it to the other wing by kicking rudder and turning the tail wheel, but it was the same thing. I think now that, since it was a first experience, I could have become used to it in time, but then I had the impression that if Americans got hold of it they would rig different, quieter supports or eliminate them.

In takeoff position, since I was on a grass strip to one side of the major runway, I needed no tower approval. I opened the throttle gradually, rolled 20 feet or more before the wings leveled, pushed the throttle all the way in, then concentrated on getting off the ground. The tail wheel seemed to stay on too

long, so I pushed the stick forward to build up speed, and at about 50 mph, I was airborne. From that point on, in spite of my lingering trepidation about cutting the engine, the flight became pleasant.

I turned away from the field, making almost a 270° climbing left turn, to get away from the coast and back toward the mountains. I kept the throttle full forward, concentrating on maintaining the recommended climbing speed of 62 to 68 mph. And more surprises. That little RF-3, with just a 39-hp engine, was oscillating in its climb between 720 and 980 f.p.m.

On the way up, I began getting the feel of the controls. The elevators were much more sensitive than the ailerons, or, to put it another way, there was much more stability in roll than in pitch. Fournier's comment that, in the RF-4 he was going to counterbalance the ailerons, came back. I think he's right. The huge wings account for some of the sluggishness in roll, but most pilots of powered aircraft would probably prefer more immediate response.

I leveled off from time to time to run tests, and again was surprised to find that, while climbing, I could only get 3100 rpm at full throttle, but had to cut back when cruising to maintain 3200 rpm. The peculiarities of this strange engine, I thought. At 3200, it averaged out to about 91 mph, somewhat less than called for.

At the time, I didn't care. The RF-3 was flying so smoothly, speed didn't matter. The bubble canopy, made of tinted Plexiglas, gave it excellent visibility in all directions. The wing was the only obstruction, but it was pure joy rolling lazily back and forth to see below.

I played with the nose wheel to see what difference it would make up or down, and I estimated about 5 mph in straight-ahead speed and 150 feet in rate of climb or descent.

I tried a few aerobatics, including a very pleasant loop, neither losing too much speed on the upside down nor gaining too much coming down, and a very sloppy slow roll—the sluggish ailerons, I thought. But, it's been a few years since I was proficient in aerobatics.

Finally, I tried the recommended slow speed for cruising, plus some stalls. The latter were quite mild. The stall warning light came on about 52 mph, shuddered at about 48 mph and finally, almost reluctantly, dropped through at about 46 mph. I had aileron control throughout. For minimum cruising, I cut back to 2200 rpm. It settled down at 57 mph and, trimmed up, seemed as if it could go on forever. Fournier claims seven hours.

Lastly, as I mentioned earlier, I cut the

(Please turn to page 183)



# Blast off in a **Bronco!**

**NEW 4-WHEEL DRIVE**—Bronco adds excitement to the going, wherever you go: through the woods for hunting, up to streamside for fishing, through snow, over beaches. Lots of oomph from a smooth six-cylinder powerplant and 4-wheel traction make it possible. Transmission is fully synchronized; you can downshift without stopping. Mono-Beam suspension with big radius rods makes coil springs practical: result—Bronco rides smoothly as a sedan. But how many sedans turn in a 34-foot circle? Or boast a protected underside? Try the Roadster, Wagon, or Sports Utility for a special kind of driving *fun*—on or off the road. At your Ford dealer's.



New  
fun one  
from **Ford**



**This is a GM Original:  
It comes in a GM car.**

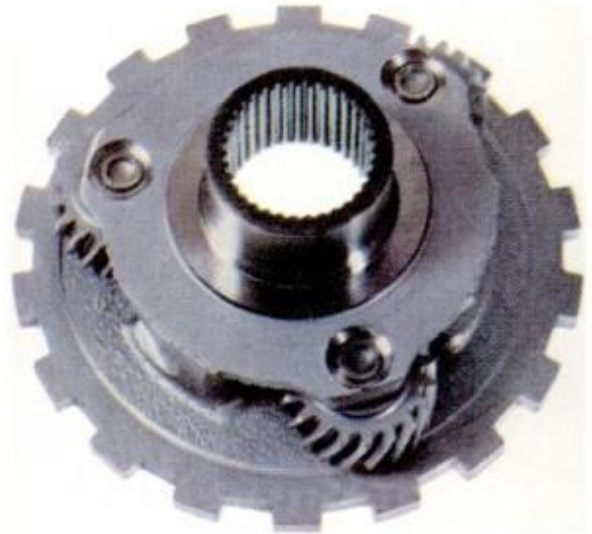

**This is a GM Replacement:  
It's one and the same.**

That's why this GM replacement not only looks like the planetary gear carrier that helps GM transmissions work smoothly. Like every GM replacement part, it *acts and is* just like the GM Original.

So whatever may need servicing on your car or truck—it's always best to replace a GM

Original with a genuine GM Replacement.

And when it's time for service, go where you know they use Genuine General Motors Parts. You'll know them by their easy-to-recognize, distinctive GM and United Delco packages. And you'll find them just about everywhere in the country.

## GENUINE GENERAL MOTORS PARTS



CHEVROLET • PONTIAC • OLDSMOBILE • BUICK • CADILLAC • GMC TRUCKS





## AIRPLANE-GLIDER

(Continued from page 180)

engine and went soaring. And I admit, I put it off as long as I could. Now, however, I can say it was a very pleasant experience. I tested the restart procedure twice before getting too cocky, however.

While soaring, I averaged between 62 and 68 mph while losing between 600 and 700 f.p.m. This rate of sink is considerably more than the 230 f.p.m. called for on the check list, but I suspect that figure is an absolute minimum while performed by an expert soaring pilot. I am not.

I tried the speed brakes at altitude, and the instruments showed only slightly more than twice the rate of descent at full brakes than without them. The last time I went soaring, in an American sailplane, the rate seemed drastically more.

The last restart went smoothly. I started into a dive around 4500 feet; the prop stood still for a long, long while; but, as the speed built up to about 125 mph, it finally began spinning. I lifted the nose to reduce speed, then flicked the switch. It caught and I was ready to go home.

With power on, the rate of descent seemed interminable. I finally dropped both the nose wheel and the speed brakes as I approached the field, still too high for the pattern, and in desperation dove down below 1000 feet, doing about 80 mph, much too fast for landing. I was doing 65 mph on the approach, speed brakes up, gear down, and knew I was too fast. The landing itself was sloppy, but well within the first half of the strip and within 500 feet from touchdown. In spite of excess speed, there was no sweat that I'd have to go around. I was depending too much on the speed brakes to compensate, however, when a slower approach of about 55 mph was called for.

As I left Cannes, I was convinced that Rene Fournier had made a significant breakthrough in aircraft design. His RF-4 with more aileron control, more aerobatic capability and, perhaps, more positive speed-brake control, should be better.

While it is not all things to all men, the RF-3 is the most versatile aircraft I've ever seen. Many airplanes can fly faster and farther, and many gliders can soar longer and higher.

But, as an airplane, it's a better glider than any other, and, as a glider, it's a better airplane than any other. And it's the only animal of *that* species.

Rene Fournier still has the tough road of certification to go down before his RF-4 is introduced here, but if he makes it, and the price is right, he should have no trouble finding a market. ★★★



# Silicone Rubber Sealants

## fix the things you couldn't fix before

General Electric's amazing silicone rubber sealants, first used in space capsules, repair and mend hundreds of things around the house. Bond securely to most materials. Ideal for gluing and caulking jobs, indoors and outdoors. Permanently flexible and waterproof, they won't shrink, crack, harden or leak.



"Used Silicone Clear Seal to waterproof worn golf shoes at sole line. Worked beautifully. Stays flexible." L. L. Lanna, Washington, Georgia. (Clear Seal is transparent, makes invisible repairs on fabric, leather, rubber and other materials.)

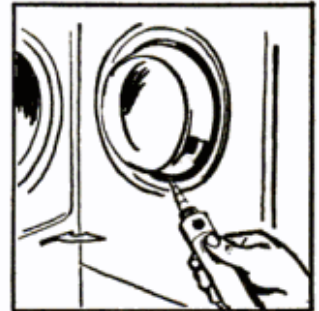

"Resealed a door gasket for my clothes dryer with Silicone Bath Tub Seal. No more leaks. Only adhesive that can stand the heat." William Jetter, Cincinnati, Ohio. (White Bath Tub Seal also caulks bathtubs and tile. Won't shrink, dry out or harden.)

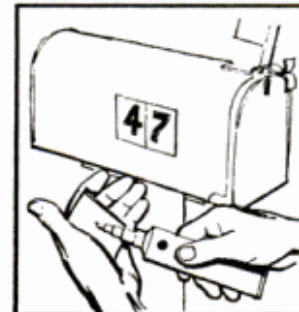

"Sealed house numbers to our rural mail box with Silicone Auto Seal. Now they'll never come off." William M. Smith, Dallas, Texas. (Black Auto Seal repairs convertible tops, cracked batteries and windshield gaskets.)

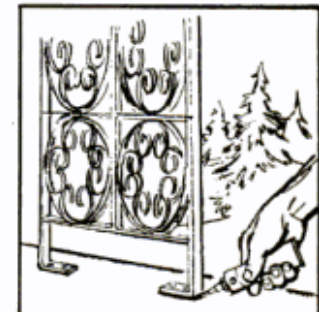

"Anchored a decorative metal column to our concrete porch floor with Silicone Metal Seal. Easier, faster and more economical than lag screws and anchors." L. M. LaBar, Bethlehem, Pa. (Metal Seal is also excellent for leaky rain gutters and storm windows.)



General Electric Silicone rubber sealants are available in 1 oz. and 3 oz. tubes for hundreds of large or small repair jobs. If you have used them for an unusual sealing job like those above, write and tell us. If we use your story in our advertising, we'll pay you \$10. All ideas submitted become property of General Electric. Just write Sect. B512162 Silicone Products Dept., General Electric Co., Waterford, N. Y.

GENERAL  ELECTRIC

## MISSIONARY MECHANIC

(Continued from page 85)

shield. The instrument has an important function in many parts of the primitive world because of the prevalence of elephantiasis, a disease which can literally make a patient's leg and foot resemble those of an elephant. The dermatone can shave off sheets of skin 3 to 40 thousandths of an inch thick so that a doctor can get at the diseased undertissue and then graft the skin back onto the limb.

The cable is about twice as heavy as a speedometer cable, but very sensitive. Usually, if broken, it would be replaced—in the Cameroon it must be repaired. Delicately, Allen must join the broken parts by silver brazing.

### One Challenge After Another

In another situation, a new power plant had to be built about a block away from the old shed. One problem was to move five diesel engines, each weighing about a ton. Allen found two huge old iron wheels, resembling those on giant tractors. They had been used a decade earlier by French railroads, with 40 to 50 natives pushing them through the bush to haul freight to the nearest station.

Allen built a crude axle from wood, welded together a kind of A frame and bolted it to rise vertically from the axle. He added a pulley and chain to obtain a mobile block and tackle, African style. Thus he was able to move the engines.

New cooling tanks were also needed for the engines. Normally, they come in one piece and look something like a smokestack that jumped ship. Scrounging through junk heaps, Allen found several large cores, or spools, left behind after World War II use as cable winders. Welded together, they looked like they were designed especially for the purpose.

There is a normal, but interesting, medical practice in the African bush of using French hypodermic needles with American syringes. French needles are cheaper, but American and French fittings are not the same. Adaptation is always necessary.

One doesn't picture a mechanic emerging from a diesel engine shop to tamper with delicate medical instruments—only in the Cameroon. But Allen would put both the American Luer-Lok steel-plunger syringe and the French needle on the lathe. He would cut the needle at a point where it tapered, then slip it into the American holder in place of the prescribed American needle. The fit had to be airtight. The process was completed with a tiny, but exacting, job of silver brazing.

Necessity and the need for reliability,

instead of a desire to tinker or customize, prompted Allen to rebuild his 1953 Plymouth station wagon.

The bush is everywhere in the Cameroon. Induced by heat, humidity and over 100 inches of rainfall each year, it will—if not constantly beaten back—gobble up open spaces and even houses. "If someone didn't make and keep a garden," says Allen, "it's bush. It's never very far off the road." And what roads exist are pock-marked with chuck holes.

Such conditions reduce drastically the life of springs, shocks and all suspension equipment, tailpipes, mufflers, oil pans and fuel lines. Allen decided to get his car higher off the ground.

He started with the back axle. After detaching the spring normally suspended underneath it, he welded a metal support block to the axle to hold the spring on top. This and larger tires added  $7\frac{5}{16}$  inches to the height. To compensate for front-wheel height, he machined four pieces of steel (two for spares) into adapters of proper height to insert each between a spindle bolt and the spindle itself. Then he brazed, welded and bolted the adapters to the spindles, and connected the lower spindle bolts at appropriate points on the adapters. This conversion was undertaken 12 years ago. The station wagon is still alive, even though Allen must operate it mostly in second gear.

The life and work of a missionary mechanic seems dominated by a special satisfaction. Partly, it's a sense of service, but it also seems to come from the challenge of the tasks themselves and an unabashed enjoyment in finding solutions. Allen remembers, "We just felt we weren't doing very much for other people, so we decided to try this for a while." After 15 years, he's learned that "It's no place to go for a vacation." Yet he's still at it and ready to go back for more.

For those readers who have not been inspired enough by this story to contact the World Council of Churches and apply for immediate placement in some remote corner of the earth (and perhaps attack a broken fuel line with a leaf, shoelace and gumsap), Allen has one final household hint that will work equally well in California or the Congo:

A bar of brown naphtha soap, rubbed on the surface repeatedly and evenly, can be built into an effective patch that will plug almost any leaky pipe found in the home. The treatment will last about a week—long enough to call a plumber or until the next weekend when you can try again to fix it yourself . . . and have time to apply more soap so it will hold until the plumber comes. ★★★

# DISSTON

## Christmas Specials

have an edge on them all



Disston D-95 Handsaw and FREE "Workbench" subscription. Highly polished 26" taper ground steel blade with carved walnut handle. 8-points.  
**Regular Price \$13.25**      **Christmas Special \$11.25**

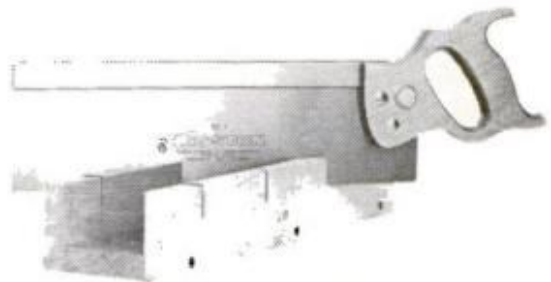

No. 4 Back Saw & FREE 12" hardwood Mitre Box. Steel back adds extra stiffness to 14" blade. Blade and back fit deeply into hardwood handle to insure rigidity and greater control.  
**Regular Price \$8.45**      **Christmas Special \$6.95**



Electric Shrub & Hedge Trimmer (D-99B). Natural grip gives balanced control in any cutting position. Ground steel blade and beveled teeth give no-skip trimming.  
**Regular Price \$44.50**      **Christmas Special \$39.95**

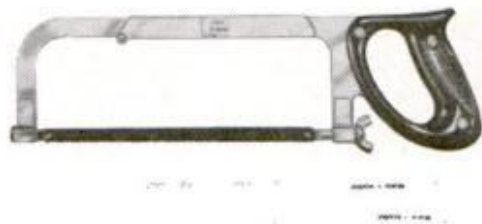

No. 368 professional quality Hack Saw Frame and Blade with two FREE Blades. Sturdy, nickel-plated steel frame. Steel handle faced with plastic grips. Adjustable for different blade lengths.  
**Regular Price \$3.82**      **Christmas Special \$3.50**



Nest of Saws (#101). Three interchangeable blades for wood cutting, fine tooth metal cutting and coarse tooth metal or wood cutting. Blades lock in 8 positions.  
**Regular Price \$3.88**      **Christmas Special \$3.49**



D-23 Handsaw and FREE #78 Chieftain Rule. Lightweight, 26-inch, 8-point saw of quality steel. Hardened, tempered and polished. Weatherproof hardwood handle.  
**Regular Price \$11.25**      **Christmas Special \$9.95**



**HARDWARE AND INDUSTRIAL  
 PRODUCTS DIVISION  
 H. K. PORTER COMPANY, INC.**

Your favorite retailer has these Disston Christmas Specials in stock now—shop early for best selection. For other product information write: Hardware and Industrial Products Division, H. K. Porter Company, Inc., Pittsburgh, Pennsylvania.

# GIANT STEPS TO THE MOON

(Continued from page 108)

that manufacture space hardware—plus proficiency work in conventional jet aircraft and helicopters.

The second phase—about a year in length—is general training applicable to any space flight to which the pilot might be assigned. During this period, the astronaut takes part in survival programs in jungle and Arctic areas so he will know how to sustain himself if forced down outside the scheduled impact area. He studies geology in the American Southwest and in Iceland, where rock formations resemble those on the moon. He practices water survival in the Gulf of Mexico. He is introduced to such space flight simulators as the centrifuge and weightless experiments in the K-135 aircraft that will background him for later, more specific training. He learns all spacecraft systems inside out.

## No Time for Dawdling

Finally comes specific crew training, after the astronaut is selected for a particular space flight mission. Crew selection (prime and back-up) is usually made six to eight months before a flight, about the time the spacecraft to be used is starting through its first tests at the manufacturing site. The crew that will fly it begins training by piloting these tests.

In the office of J.J. Van Boeckel, training program designer for the manned space programs, is a blackboard calendar filled with hieroglyphics in three different colors of chalk. Each color represents a crew, and the hieroglyphics spell out the training program for each crew.

What makes up a typical training week for a crew-assigned astronaut? During the week preceding and following my visit with him in Houston, astronaut Mike Collins' schedule ran something like this:

Monday and Tuesday: Simulator tests at McDonnell Aircraft, St. Louis

Wednesday: To Cape Kennedy for launch demonstration of Agena and GT-5 vehicle, both on launch pad

Thursday: Back to St. Louis to complete acceptance review of instruments on GT-7 vehicle

Friday: To Houston for office catch-up and pilot's meeting

Saturday: Egress training in Gulf of Mexico

Monday: Crew meeting in Houston with training officials to set up training schedule for following month

Tuesday: Make head molds for flight helmet. In evening, back to St. Louis

Wednesday and Thursday: Systems briefings from instructors at McDonnell, following by storage review in full flight gear (sample prob-

lem: where and how to stow 112 samples of urine that have to be brought back from the 14-day flight)

Friday: Back to Houston for work on simulators and exchange of information with other pilots on specialty areas.

These crew training programs are never static, mainly because each flight is, in itself, an exotic training mission.

"We built on Mercury in setting up the Gemini training program," says Van Boeckel, "and we'll build on Gemini in setting up the Apollo program. So far, there have been no parallels that didn't hold. Our biggest problem is to define the mission in very specific terms, then train for that particular mission."

(Although no one connected with MSFC would say so publicly, that careful equilibrium was disturbed only once: when instructions came from higher up—probably the White House—during the late stages of training for GT-4 to extend the mission to include a space walk (originally scheduled for GT-9) and attempted rendezvous. One succeeded; the other didn't.

In many respects, training for the Apollo crews will be as different from the training of Mercury pilots as the training of a modern-day jet pilot differs from pilot training early in World War II.

"We learn as we go," says Van Boeckel. "Each crew training program is based on experience and judgment, to a large extent obtained from the crew debriefing on the prior flight. Questions asked them tend to show up needs and shortcomings in the training program."

## G-Pull Not Bad

The GT-4 pilots, for example, repeated a conviction expressed by every other returning astronaut to date: that the gravity force (G-pull) on the flights, themselves, is simply no sweat and is well below the tolerance level. Therefore, the training time previously spent throwing the pilots around at high Gs on the centrifuge can—and will—be cut down considerably.

The biggest change in training techniques has come about through knowledge gained about zero G.

"We were once concerned," says Van Boeckel, "that two orbits of weightlessness might make a raving maniac of the pilot. Later, we were afraid that after the pilot orbited for several days, he would get so accustomed to zero G that it would be murderous when he hit the atmosphere again. Neither fear proved true. As a result of flight exposure, zero G was found to be a snap."

The only ill effect reported from zero G

(Please turn to page 188)

**Engine runs smoothly in desert heat!** This test proves quality of the cooling and air-conditioning

systems in Ford Motor Company cars. Keep the quality in your Ford-built car with Quality Car Care.



**Ford Motor Company builds quality in—  
Quality Car Care keeps it in**



**Special equipment**, like this stethoscope, helps Ford and Lincoln-Mercury Dealers to care for Ford-built cars. Add factory-trained mechanics, genuine parts, fair prices—that's Quality Car Care!



**Now, a check on the road!** Customer satisfaction is an important part of Quality Car Care, offered only by Ford and Lincoln-Mercury Dealers. They will make every effort to please you!

**Only at FORD and  
LINCOLN-MERCURY DEALERS**



# the Gift

that keeps tabs  
on everything



WINTER  
SUMMER  
SPRING  
FALL

Want a ROTEX Compact Labeler for Christmas? Draw a red ring around this ad and then leave the magazine where the rest of the family can see it.

The ROTEX Compact Labeler makes colorful, easy-to-read, self-sticking permanent labels which can help unscramble all the things families use. And the price is right! Christmas Gift Pack costs \$9.95, includes 3 rolls of tape plus 3 luggage/key tags. You'll find the ROTEX Labeler at hardware, stationery, department stores. Merry Christmas!

## ROTEX<sup>®</sup>

a division of Avery Products Corporation  
Los Angeles, California

## GIANT STEPS TO THE MOON

(Continued from page 186)

thus far in space flight debriefings was a comment from McDivitt that his helmet forced his hair to stand out in the wrong direction, causing him some discomfort until he took off his helmet.

How else has space flight training changed through experience? Here are some other examples:

- Heat chamber runs—to build resistance to cabin heat on re-entry—have been dropped. Space capsule heat is under control, and this training has been proven unnecessary.

- Training for pilot disorientation as a result of vibration, noise or tumbling action of the spacecraft has been dropped; flight experience shows it isn't needed.

- Psychologists no longer have a direct part in training. The main concern today is with physiological problems.

### If There's an Emergency

Crew training now places major emphasis on emergency procedures. If the flight is normal, much of the training is unnecessary. Van Boeckel estimates that 40 percent of the training time is spent on handling launch emergencies which never happened and, hopefully, never will.

One thing that hasn't changed is the absence of a formal physical training program. "We haven't found anybody yet who doesn't have enough motivation to keep himself in shape," says Shepard. The most popular physical activity for the pilots at Houston is handball, and strong rivalries have built up between the crews. (Jim Lovell insists that if White and McDivitt hadn't reneged on a solemn handball bet, Lovell and his partner, Frank Borman, would have taken the GT-4 flight instead of White and McDivitt.)

"In the early part of the program," says Shepard, "we trained men to fly in space; with Apollo pilots, much of our time will be spent on what to do after they get there."

As old training problems have fallen away or been de-emphasized, new ones—mostly relating to a landing on the moon—have arisen. Many of them grow out of the fact that the Apollo spacecraft will be carrying three men instead of two, considerably complicating storage and house-keeping. Thus, a large part of the Apollo crew training will consist of fully-suited astronauts working in the spacecraft they will actually fly, taking necessary items from their storage place, using them and replacing them to make sure this routine is possible and practical.

A group of astronauts were taken to a

craggy part of Arizona that rather closely resembled the moon's surface from above. There were no trees, roads or structures that could give the pilots an idea of relative size. The astronauts were put in helicopters with safety pilots and provided goggles that cut down the light to simulated earthshine on the moon. The altimeter was covered and each pilot was told to "bring it in."

All of them found it extremely difficult to estimate their altitude or the size of the panels on the ground. Without the safety pilots, a half-dozen astronauts would have cracked up by letting down into peaks they thought were much farther away. As a result of these training tests, it was decided to make the moon landing in sunshine, with the sun at 15° angle to the LEM so the moon pilots can use their own shadow for navigation and altitude estimation.

### Incredibly Complex 'Routine'

Astronaut Mike Collins summed up the problem of training for a moon flight. "If you look at it a step at a time," he told me, "it seems almost routine. You say to yourself, 'Heck, we've done that before' . . . or 'That doesn't seem too complicated.' The LEM touches down and that may be a little tricky, but not too tough—almost like bringing in a helicopter. And then, on leaving the moon, we're up against the same launch problems we've always had.

"Each one of these things doesn't seem difficult by itself, but when you string them together in a series, it becomes an incredibly complex job. I don't worry about the hazards of space any more. The thing I worry about is not knowing my spacecraft enough. That's why we train; a highly trained crew doesn't worry."

Which astronauts are most likely to go to the moon? This, of course, is paramount in the thoughts of every space pilot. Deke Slayton, who is in charge of all flight crew operations, told me: "Sure, I've given some thought to Apollo crews. I have to think five or six years ahead all the time." But none are being named now and they probably won't be for several years.

Despite the utter seriousness of their task, the astronauts still maintain a sense of humor. Proof of this rests on the desk of astronaut John Young: a corned beef sandwich on rye bread, carefully encased in glass for use as a paperweight, mute evidence of the row over Young's smuggling such a sandwich aboard his Gemini flight. Right now, Young is hoping to eat the first corned beef sandwich on the moon. And the chances are pretty good he might do just that. ★ ★ ★

# 10¢ says you have **BEAUTIFUL HANDS**

**under all that grease, grime,  
paint, shoe polish, etc.**

**Take this coupon to your grocer and find out!**



**This coupon worth 10¢ off the purchase  
of Boraxo Waterless Hand Cleaner in  
the new Pressurflo Container.**

Mr. Dealer: For prompt reimbursement for this coupon, send it to BORAXO, Box 1475, Clinton, Iowa. We will pay you 10¢, plus 2¢ for handling, provided coupon is redeemed only on Boraxo Waterless Hand Cleaner, and invoices showing your purchase of sufficient stock to cover coupons presented for payment can be shown on request. Coupons are non-transferable and redeemable only through Boraxo retailers. Coupon is void if use is taxed, restricted or prohibited by law. Any sales tax must be paid by customer. Cash redemption value 1/20 of 1¢. 20 Mule Team Products Department, U.S. BORAX & CHEMICAL CORPORATION.

PM-12-63

# Test your automotive I.Q.



When this instrument reads 1260, what does it tell you?



What does this symbol stand for?

The battery hydrometer reports the state of your car battery's charge. 1260 means it's fully charged. The life preserver stands for Quaker State Motor Oil—the best engine life preserver for your car. It's refined only from 100% Pure Pennsylvania Grade Crude Oil. Quaker State keeps your car on the road, out of the repair shop. So keep your car running young. Always ask for Quaker State Motor Oil by name.



QUAKER STATE OIL REFINING CORPORATION  
OIL CITY, PENNSYLVANIA

## AUDIBLE EXPOSURE TIMER

(Continued from page 151)

turns and shape a click spring from thin phosphor bronze or clock spring stock so that it can be mounted under one of the motor-mounting lugs to trail on the gear teeth as they move. Solder a wire leg to the end of the microswitch arm and a small washer on the upright bend, as shown in the drawing. File the threads off most of the switch stud.

Drill oversize holes for Micro Switch mounting bolts to permit adjustment. Set the switch so that the dial stud trips it with a minimum of dial travel.

Cement a leather disc to a metal or hardboard disc to fit over the dial, and cement a similar-size sandpaper disc to the top of the dial. Seat the spring on the gear, push the dial down on it and fasten the leather-faced disc over it, leather down, with a 6-12 screw.

If the toggle switches aren't marked, identify the common terminal (the one that can be switched to either of the other two) with a continuity tester, meter or series lamp.

Be sure to ground the timer to eliminate any risk of shock. If your darkroom has a three-hole receptacle, wire the ground prong of a matching plug to a bolt on the chassis. With a two-hole receptacle, run a separate wire alongside the power cord to a chassis ground. At the other end of the ground wire, fasten an alligator clip. Connect this to a water pipe or BX cable when you plug in the power cord.

With Switch 1 at "Set," Switch 2 will turn on the enlarger light at "Focus." Always flip Switch 1 to this position before resetting the dial. The motor will start and the enlarger light will go on when this switch is flipped to "Time." ★★★

### PARTS LIST

Synchronous 1 rpm motor.  
Single-pole, double-throw toggle switches (2).  
Leaf-type Micro Switch, normally on, flush mount 115-v. sockets (2).  
Gear, 30 to 80 teeth, 1" to 1¼" dia.  
Dial, ⅛" metal or hardboard disc.

#### Miscellaneous:

Chassis, sleeve stock, spiral coil spring, spring bronze or steel, line cord and plug, alligator clip, night-light socket with red bulb (to light dial), 4-40 and 6-32 screws, tubing for spacers, nuts and washers.



**Don't buy batteries—Save \$—Recharge them!**  
**over and over up to 15 times or more**  
**the EVERLITE—the best**  
**charges more**  
**than all the rest.**

Only the New EVERLITE

- Charges 6 at one time.
- Charges 3 times faster.
- Charges all batteries.

Be prepared. Always have fresh batteries when you need them. The EVERLITE is the only charger made which charges all batteries, flashlight, lanterns, toys, radio, telephone, hearing aids, cameras—yes even mercury cells. Save money and have the convenience of fresh batteries always.

The EVERLITE is the best—the only charger built with a powerful magnetic energy winding. This power enables it to charge big lantern batteries and even car batteries. Also plays transistor radios on 115V. house current charging the batteries at the same time. **Charges all batteries better.**

Two models—the EVERLITE 75 for all dry cell batteries up to 12 volts and the EVERLITE 76 for all dry batteries plus a special charge for car batteries to assure fast starts on cold mornings. Simple, safe, fool-proof and unbelievably efficient. Plus into any 115 volt outlet. Guaranteed for one year. Send for your EVERLITE now—10 day money back guarantee,—You must be satisfied.

only \$6.95

New  
**Transistorized**  
**Model**  
**only**  
**\$6.95**



Free battery tester and adapter for special batteries included.  
 The EVERLITE 75—Send \$6.95 plus \$.65 for shipping.  
 The EVERLITE 76 (including car battery kit)—Send \$8.95 plus \$.75 for shipping.

**COPY ANY CONTOUR INSTANTLY**  
**Perfectly Accurate Every Time.**

**SAVES HOURS—SAVES MATERIAL.** Can pay for itself on one job. The perfect tool for fitting in against door casings, bath fixtures, mouldings, pipes, sinks, masonry, etc. A real boon to pattern makers, sheet metal mechanics, tool makers and body men.

**EASY TO USE—**just push the gauge leaves against any contour and lock. A perfect template every time. Works against any surface or any material. Immediate delivery guaranteed.

**Order now from MASTER MECHANIC CO.**

Send \$1.00 deposit if you wish C.O.D. shipment.  
 All items guaranteed for 1 year plus 10 day moneyback guarantee.

**CONTOUR COPY**

PATENTED

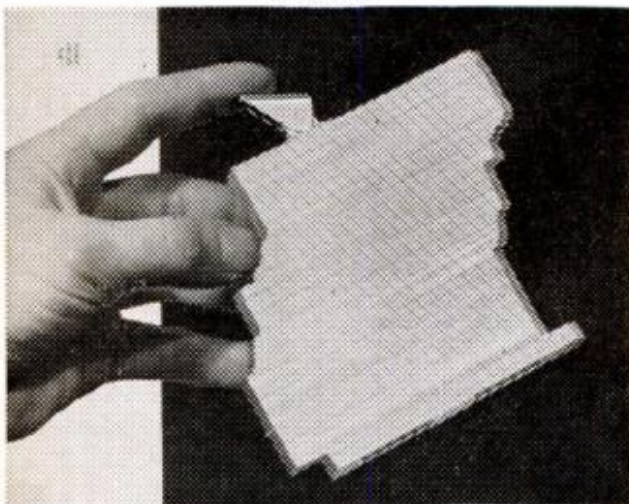

**A PRECISION LIFETIME TOOL—\$6.90**

Made of hardened aluminum alloy—will retain its accuracy indefinitely.

Size No. 1 is 4¼" x 4¼" ..... \$6.90  
 Size No. 2 is 7½" x 4¼" ..... \$9.90



Mail order to Master Mechanic Co. Dept. A125  
 Box A, Burlington, Wisc., or Box 98, Sarasota, Fla.

- Send \_\_\_\_\_ EVERLITE 75 chargers \$6.95 ea. plus .65 shipping.
- Send \_\_\_\_\_ EVERLITE 76 chargers \$8.95 ea. plus .75 shipping.
- Send \_\_\_\_\_ No. 1 Contour Copies \$6.90 ea. plus .55 shipping.
- Send \_\_\_\_\_ No. 2 Contour Copies \$9.90 ea. plus .65 shipping.

Name \_\_\_\_\_  
 Address \_\_\_\_\_  
 City \_\_\_\_\_ State \_\_\_\_\_ Zip \_\_\_\_\_

**Bore 35 standard holes  
with just one tool**

**New IRWIN  
Expansive Bit**

**lets you dial your size**

Just turn the dial and you're set to go with this new Irwin Expansive bit. No hunting for the size you need. Fits all hand bit braces. Clean, fast, accurate boring action from  $\frac{7}{8}$ " to 3"—35 standard hole sizes in all!

And what a really fine precision tool to own. It's drop-forged from special bit steel, heat treated full length, machined for accuracy and sharpness, highly polished, too. Two cutters supplied with each bit. Model No. 21 with  $\frac{5}{8}$ " to 1 $\frac{3}{4}$ " boring range also available. Ideal for home handyman, professional woodworker, or farm. See your independent hardware dealer soon.

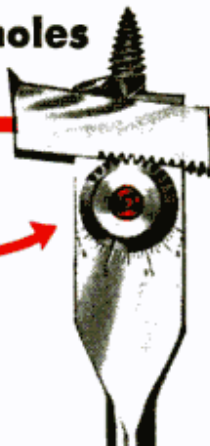

**No. 22  
Micro  
Dial  
only  
\$4.20**  
 $\frac{7}{8}$ " to 3"  
boring  
range

**IRWIN**

Wilmington, Ohio

the original solid  
center auger bit  
screw drivers  
screw driver bits

**GOVT. SURPLUS AND OTHER BARGAINS SAVE UP TO 90%**



**HIGH SPEED TURBINE BLOWER**

Designed for operating at speeds up to 50,000 RPM. Has large volume output with delicately balanced turbine blades. Air driven. Can be adapted for motor drive, or as blower, exhaust, fan, super-charging mechanism, etc. Approx. GOV'T COST \$649. Wt. 12 lbs. Like NEW. **\$5.95**

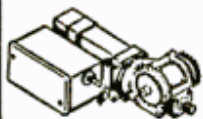

**GEAR HEAD MOTOR**

A truly versatile, compact, heavy duty geared motor. Turns 65 RPM under load & up to 120 RPM no load. Develops 150 In. - Lbs. equally well on 12 V or 24 V.D.C. Has dual 9/16" drive shaft. 173 to 1 reduction. Excellent for use as a small boat winch, garage door closer, toy cars, etc. 10" L x 3 1/4" H x 6 1/2" W. Tested prior to shipment. Approx. GOV'T COST \$125. Now **\$12.50**



**HEAVY DUTY BATTERY WINCH**

Rugged, deluxe winch with ball bearing construction throughout motor & gear train. High gear reduction. Rated cap 3000 lb. pull. Contains reversible switch. Rugged 3/8" plate steel mounting base with outrigger support. 22" L x 9" W x 8" H. Handles 250' of 1/4" cable. Built for 12 V battery operation; also operates on 6 V. at reduced cap. & speed. A must for Scouts, Jeeps, Trucks, Boat loading trailers, etc. Shpg. wt. 80 lbs. Approx. GOV'T COST \$490. NEW. 90-day guarantee. Model E-D **\$79.50**



**ELECTRIC PUMP WITH CONTROL SWITCH**

For boats, campers & trailers. Output 200 GPH. Can be used in fuel or water. 1/2" pipe bronze inlet. 12 or 24 V.D.C. Explosion proof motor. Shpg. wt. 9 lbs. Complete with wiring diagram. Approx. GOV'T COST \$200. NEW **\$10.95**



**NEW! BIG! 1965 CATALOG**

Send 25c for amazing catalog with 1000's of bargains in hydraulics; electrical, marine, automotive items, etc. Order from ad. Prices FOB. 50% deposit for COD. Pls. include your zip code number. Satisfying mail order customers thru-out the world since 1945.

**AIRBORNE SALES CO.** Dept. PM1265

8501 Stellar Dr. • Box 2727 • Culver City, Calif 90231

**STEP OUT WITH THE RIGHT BOOT**

(Continued from page 121)

Its loose-fitting upper and absence of laces make it cool and quite comfortable. In some styles, with extra heavy leather in the quarters, it's an ideal solution to the problem of poisonous snakes. Its main disadvantage for general purpose use is that the design is such that it gives little support for negotiating rough terrain.

By far the most popular all-around boot design is the bird shooter. Whether it is beefed up for foot support and called a climbing boot, cut low and called a boat shoe, made in a lightweight model and called a hiking boot, the basic design is all the same.

Almost all bird shooters have what is called "moccasin toe" construction, meaning that the toe piece is a separate piece of leather sewn to the vamp to form a more comfortable boxlike toe shape. On the very high quality boots you will find the toe piece joined to the vamp with an overlap type of construction.

The finest boots you can buy have what is called a true moccasin vamp. This means that the vamp is cut from a single piece of leather and runs from one edge of the toe piece down the side, all the way across the bottom, and back up the other side. The imitation moccasin also has a one-piece vamp, but it only extends down from the toe piece to the mid-sole where it is sewn or "welted" to the sole.

There are also full and semimoccasin types. The full style has a vamp running back to the heel; the semimoccasin extends only a bit behind the front edge of the quarter. In the semi-, the quarter comes all the way down to the sole. The full style has two advantages. It is more watertight and more comfortable, because the seam that joins the quarter to the vamp is up along the side of the boot.

Top-line boots will have stitched reinforcing at the stress points where the toe piece is joined to the vamp and quarter. Good boots have a sturdy rivet here.

Another mark of a good boot is a backstay that runs all the way from the heel to the top of the back of the boot. Double or triple stitching is important here also. A pull loop at the top of the backstay is of no particular value except with a pair of hard-to-get-into boots.

The type of sole on a boot should depend mostly on the use you intend for the boot. The wedge sole is popular for upland game shooting where much of the walking may be in muddy fields. While the completely flat bottom is less likely to collect mud, it is heavier and gives

(Please turn to page 194)

New from Ford Motor Company

# A station wagon tailgate that's a door that's a tailgate

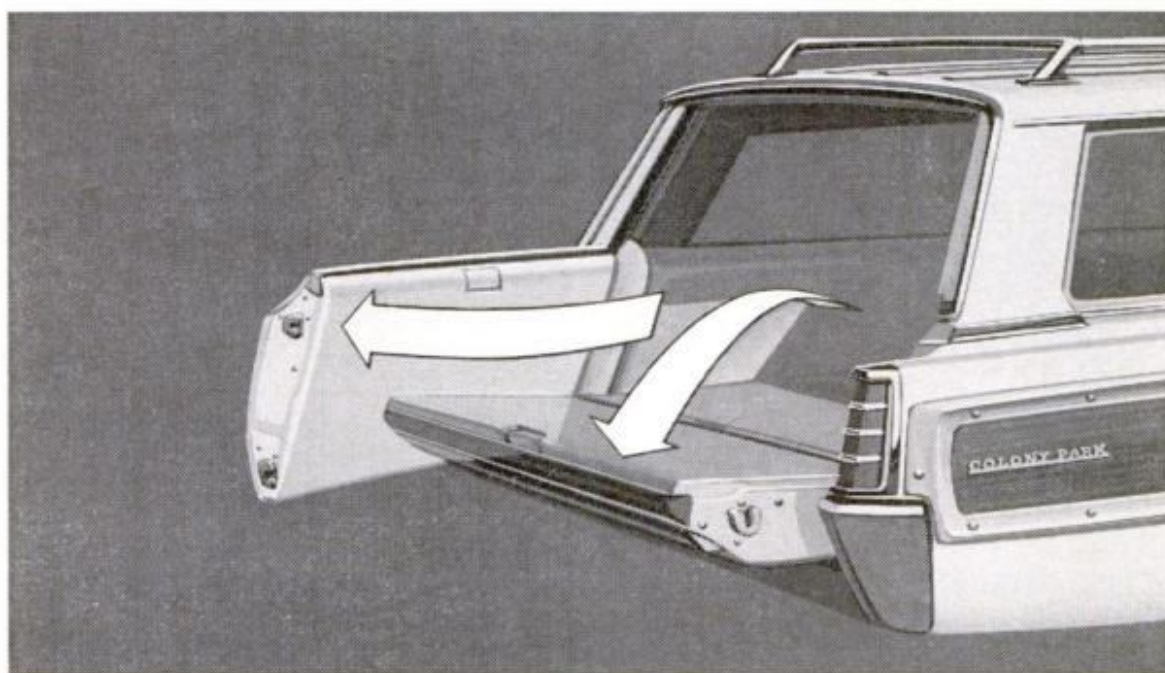

Ford Motor Company, America's automotive innovator, has come up with the year's brightest idea for its '66 station wagons. It's a dual-action tailgate that lowers for loading or swings open like a door for extra-easy passenger access. Secret of the unique feature — available with all Falcon, Ford, Fairlane, Comet and Mercury wagons for '66 — is Ford-developed patented hinges. One hinge has twin pins for lateral or vertical pivoting action. Another is a door hinge that "unhinges" when tailgate is used in conventional manner. And a third hinge functions as both a hinge and a door latch! Whether you're loading lumber, parcels, or a carload of kids, Ford's exclusive door-and-tailgate doubles the pleasure of owning a wagon. See this great new feature, and the best wagons yet, at your Ford or Lincoln-Mercury dealer's now.



MUSTANG • FALCON • FAIRLANE • FORD • COMET • MERCURY • THUNDERBIRD • LINCOLN CONTINENTAL

**You've cleaned your carburetor, adjusted your spark gap and checked your timing.**

**Now let's get serious about instrumentation.**

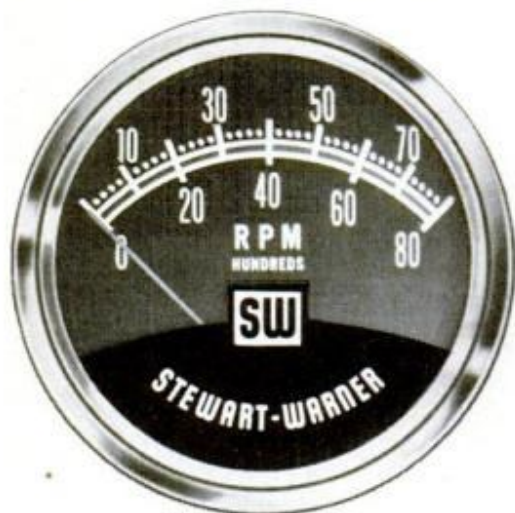

Your engine comes out of the shop in top tune—but how can you keep it that way?

Your answer is Stewart-Warner instruments, the fast, accurate way to keep tab on engine efficiency. Stewart-Warner has electric and mechanical tachometers; speedometers; pressure, temperature and vacuum gauges; ammeters; voltmeters. Whatever your instrument need, Stewart-Warner can supply it. And you can choose from handsome S-W face dial designs like the ones below.

See your Stewart-Warner dealer. He's serious about instrumentation. No wonder. He has the most complete line in America.



**STEWART-WARNER**  
**INSTRUMENT** DIVISION

Dept. C-125, 1840 Diversey Pkwy., Chicago, Illinois 60614



**STEP OUT WITH THE RIGHT BOOT**

*(Continued from page 192)*

slightly less traction on slippery surfaces. Hikers like a heeled boot because of the increased grip and lighter weight and, to them, mud is rarely a problem. Both of these sole styles are designed for extensive walking, so good models of either should have most of the sole flex between toe and front of the arch. To check, pick the boot up and bend the sole.

A boot that is to be used for climbing or hiking on rock or loose shale should have a lug sole. Metal calks are useless because they skid on the rock. Climbing boots should also have a considerably stiffer and less flexible sole, as should a general-purpose work boot.

Another point of support that is very important to check is the counter. This is the cuplike stiffener in the rear of the boot. It serves as sort of a cradle for your heel. A good counter will feel quite rigid when you squeeze the heel of the boot and it should extend about two inches up the back of the boot.

Heights, measured from the floor to top of the back of the boot, run from 6 to 18 inches, although 8 or 9 inches is about standard for a hunting boot. Super-tall models are good for snake country. Climbing boots run 6 to 9 inches and boat shoes are usually 6 inches.

A low boot isn't much good in country where there are low weeds, sand, or small loose stones. Anything less than 8 inches in this kind of country means spending half your time dumping out the garbage.

During the past few years, several manufacturers have introduced insulated styles of leather boots. For the most part these are quite effective for use in temperatures down to about the zero mark. Since the construction of an insulated boot is almost identical to that of an uninsulated model, boot quality can be analyzed on the same basis for both. The only drawbacks to insulated boots are that, once you get them wet, they take forever to dry out and they are quite a bit heavier than conventional models.

Weight, incidentally, is quite an important factor if you are going to be covering a lot of ground in your boots. The average pair of lightweight nine-inch bird shooters weighs about three pounds. A heavy pair of insulated boots can weigh four or more. If you figure the number of steps involved in ten miles of deer hunting that extra half pound per boot suddenly mounts up to the fact that you have lifted an extra, and possibly unnecessary, five and a half tons during your day of hunting.—Pat Snook

★★★

# McCulloch electrifies the fishing world!



## World's first lightweight 7½ with Golden-Touch™ electric starting!

Here's the break you fishermen have been deserving for a long time—a lightweight, compact outboard that's ready to go at the touch of a button. It actually takes all the work out of fishing. And its revolutionary direct-coupled starter is a generator, too. No gears to jam. Keeps your battery fully charged for running lights or other electric powered conveniences. Naturally, it's got all the other great McCulloch outboard features. A weedless propeller, for instance. A twist-grip throttle. A full forward-neutral-reverse gearshift. And Bail-a-Matic® that automatically bails up to 120 gallons per hour to keep your boat dry. Runs on economical 40/50:1 or 100:1 fuel mix. And even has a ShallowWater

Drive® position to let you run in as little as 6 inches of water. □ The 7½ electric weighs only 53 lbs. It stands just 35 inches high, only 11 inches of which peek over the transom. If you want the rest of the 7½'s vital statistics, see your McCulloch outboard dealer. He's the man who can show you the entire McCulloch line, from the 75 to the new air-cooled 4 h.p.

**MCCULLOCH**   
**OUTBOARDS • CHAIN SAWS**  
LEADERSHIP THROUGH CREATIVE ENGINEERING  
6101 W. CENTURY BLVD., LOS ANGELES 45, CALIFORNIA

# BOND STREET

*The Pipe Tobacco  
That Stays Lit!*

Bond Street keeps burning because of its Old English cut—a combination of flakes for even-burning and cubes for slower-burning. You'll like its aroma of fine domestic and imported tobaccos, too.

## Secrets of Ideal Puffing



Easy does it—the hard puff is harsh on the tongue. A short, easy draw is best. And don't blow through your pipe to keep it lit. It can cause hot spots.

*Like a good wife, a pipe is a friend and companion for life.*  
HERMAN MELVILLE



A product of Philip Morris Inc.

## RESCUE IN POLAR ICE PACK

(Continued from page 96)

a difficult escort job. All hands turned to, shifting some 340 tons of cargo. In the wind and snow, it was back-breaking, chilling work. Sometimes we thought we would never get warm again.

One night I was awakened by an excited messboy shouting, "Wake up, sir, wake up! Our helicopter's crashed on the ice." Throwing on my clothes, I rushed to the bridge. The orange-red machine lay inert on the ice pack about a mile distant. The tail had been torn off and the rotor blades were broken and bent. Three figures clustered about the wreckage which meant the crew was unhurt. It was plain that the helicopter would never fly again.

On Feb. 12, the last of the cargo came aboard, including 2 Sno-cats, 950 drums of fuel, 20 very dead and ripe seals, 5 dogs and 2 parakeets. Most of this we stowed topside—the *Glacier* looked like a floating supply dump. Behind their supplies came the Belgians: 22 expedition members and 3 observers, each with personal gear. We put them wherever we had a spare bunk.

### Winds Change Picture

Soon after the transfer the wind moderated to a gently five-knot breeze and the ice pressure gradually relaxed. At 10 p.m. the ships got underway and early the next morning one of the *Edisto's* helicopters flew over to replace the one we had lost. With helicopter aloft to spot open places, we soon worked our way into a series of leads or channels through the pack. The ships steamed merrily along, *Polarhav* like a small, lively puppy at the heels of a giant Saint Bernard.

That evening we decided that the *Edisto* should escort the *Polarhav* to the edge of the pack directly north of King Baudouin base and remain there while the *Glacier* made its run in with the Belgians. They soon disappeared in the lowering fog as we headed forward.

We moved along easily. The storm which had caused so much difficulty had almost the opposite effect here. It had scattered the pack in all directions. Constant fog and snow, however, made it impossible to take a fix on the sun or stars. Somewhere ahead lay the ice shelf, the 100-foot cliffs of marble-like glacial ice that guard most of Antarctica. Finally, they showed up in the fog ahead. Somewhere along this shelf was the indentation where the Belgians had landed supplies and men the previous year. Now we had to find it.

We had some charts and Capt. Boe, who had been there the year before, gave us a few hints. Neither did much good. Great

## ROUTERMATIC

**MAKES EVERY MAN  
AN EXPERT  
WOODWORKER**

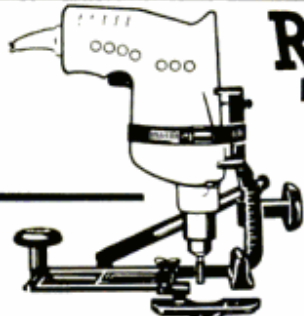

Clamp this amazing tool to your electric drill and route, mortise, trim, shape, mitre and tenon like a professional cabinetmaker. Handles any job better by

letting you take the tool to the work. Just like having an electric chisel. Routermatic is precision made, sturdy, lightweight. Use it once and you'll wonder how you ever got along without it. ONLY \$6.95 including \$1.50 router bit. No C.O.D.'s. Can't be sold thru stores at this low price. Descriptive folder on request.

**COMP-TOOL, Inc. 355 Prospect Rd., Ashtabula, Ohio**

pieces of the shelf had broken off as icebergs, so changing the topography that charts were useless.

Finally, wind blowing off the continent swept the fog away. The *Glacier* sent up rockets. Those on shore soon spotted them and gave us radio directions. In a couple of hours we steamed into Leopold Bay, which, to our surprise, was free of bay ice. Only then did we realize our good fortune in being lost. At 2 o'clock that afternoon, a Belgian Sno-cat and crew had been four miles out on the bay ice trying to sight us. Shortly afterward, they had returned to their camp eight miles from the shelf edge. If they had lingered, they would have met disaster. If we had arrived earlier, we would certainly have lost vehicles, cargo and, maybe, men. Fate, this time, had been kind.

### Anchors Torn Loose

A little huddle of men and dogs in the lowering darkness waited for the *Glacier* to tie up. As gale-force winds struck the ship, deadmen (timbers) that served as anchors were torn loose from the snow. The Belgians then suggested an alternate unloading site in an adjoining bay.

On arrival at the new location, the ice-breaker had spent 16 hours punching out a channel. Then she turned around so that her bow pointed seaward for a quick get-away. Thick snow and 40-knot winds prevented unloading for 24 hours, but Capt. Bastin was busy. He had leaped ashore while the *Glacier* was nuzzling ice in King Leopold Bay. For eight hours he groped his way about in a Sno-cat, crawling through crevassed areas to mark out a safe route with oil drums and bamboo stakes. Late Feb. 17, he appeared alongside the ship: cold, weary, but triumphant.

The next morning, cargo began going over the side in spite of falling snow and indifferent visibility. *Glacier's* personnel lifted the supplies off the deck while the eager Belgians dragged them away on sleds.

Now that the unloading was near an end, a few of us accepted a Belgian invitation to visit the base and climbed aboard Sno-cats. We found it in tip-top condition, warm and snug, and completely buried in the snow. As in many antarctic camps, we got in through a hole in the roof.

Shortly after dinner that evening, Feb. 22, the *Glacier* hauled in her ice anchors and pulled slowly out of the ice. As long as we could see, a small group stood on the ice waving. Behind them lay the white and frozen continent, beautiful but treacherous, that was to be their home for a year—until another ship would return to pick them up. ★ ★ ★

## The most useful gift you can give or receive



# Weller® DUAL HEAT SOLDERING GUN KIT



ELECTRICAL REPAIRS



METAL MENDING



HI-FI KIT BUILDING



HOBBIES AND CRAFTS

**Be sure it's a Weller.** More Weller soldering guns are sold than all other makes combined. Unmatched for value, features and performance.

**Heats fastest.** Reaches full soldering temperature faster than any other soldering gun. No waiting.

**Trigger-controlled dual heat.** A Weller exclusive. Two trigger positions let you switch instantly to high or low heat to suit the job.

**Kit includes:** Weller 100/140 watt dual heat gun, 3 soldering tips, tip-changing wrench, flux brush, soldering aid, solder, break-proof plastic case. Model 8200PK. **\$895** list

**WELLER ELECTRIC CORP., Easton, Pa.**  
WORLD LEADER IN SOLDERING TECHNOLOGY

# Set!



**ENDURO \$30**  
Over 13' of track

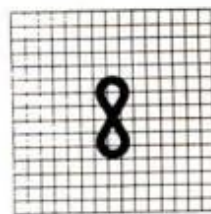

Layout size: 2½' X 6'



**GRAN TURISMO \$40**  
Over 13' of track

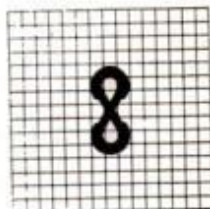

Layout size: 3' X 6'



**EUROPA \$55**  
Over 22' of track

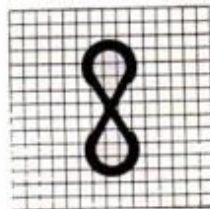

Layout size: 4' X 10'



**ATLANTICA \$60**  
Over 27' of track

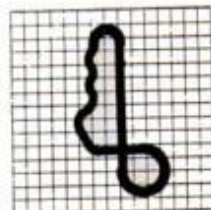

Layout size: 7' X 13'



**AMERICANA \$100**  
Over 25' of 4-lane track or over 50' of 2-lane track

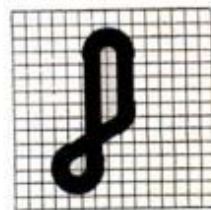

Layout size: 7' X 13'

# Ready!

Five minutes after you open the box of one of these precision-engineered Revell Home Raceway Sets, you're racing with all of the performance, thrills and skills of a commercial raceway. Snap the track together, plug in the electric power pack and controllers, get set with the completely assembled, high powered cars...and go! There's a lifetime of racing fun ahead of you, because the Revell Raceway is just the start of a complete Revell System—expandable with a whole series of quality interchangeable components and accessories: straight and curve tracks, chicanes, lane changers, cars...any kind of layout is possible, even converting a two lane course to four lanes! And, new special apron sections not only make 1/32 racing more exciting and realistic, but you can race the same big 1/24 GTO's you use on the commercial raceways on the Revell Home Raceway. Send for more information about these Revell Sets—and get ready

**Revell**  
Authentic Kits

for challenging, professional racing on your Home Raceway! **Revell, Inc.**, 4209 Glencoe Ave., Venice, California

See the Revell Home Raceway System in the new Howard Hawks-Paramount release "Red Line 7000".

PM



# Go!



Revell's Atlantica Set—\$60

## NEW RIGID® UTILITY VISE

gives you 7 extra-value features

Choice of 3", 3½", 4"  
and 5" Jaw Widths

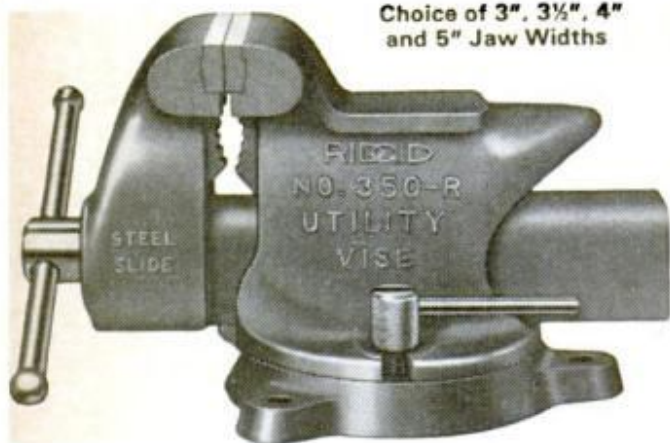

Swivel base swings full 360°. Base clamp gives solid support across full base. Clamp handle swivels on ball joint for fast adjustment. 3 jaws give slip-proof grip on pipe. Anvil surface is extra large. Large, strong slide-support-horn permits heavy-duty use. Hardened jaws are cast in place . . . can never come loose.

BUY THESE EXTRA HANDY RIGID® UTILITY  
VISES AT YOUR DEALER

**RIGID®**

The Ridge Tool Company, Elyria, Ohio, U.S.A.

# Patches Walls

DAP® VINYL-  
PASTE  
SPACKLING

No mixing—ready to use. Patches cracks, holes, joints in plaster and wall-board. Fills even deep holes quickly, easily. Creamy smooth, fast drying, easy sanding. Takes paint. Sold at leading hardware, building supply, paint and specialty stores.



**DAP®** DAP INC., Dayton 31, Ohio  
SUBSIDIARY OF *Plough, Inc.*

## ANTIMATTER

(Continued from page 102)

protons. Particles rained from the target like rice at a wedding. Among them were antiprotons, an average of four for every hour of operation. Accompanying the antiprotons was a Nobel prize for the two scientists.

The antiproton's discovery led the way to other antiparticles, including the antineutron and such exotic specimens as the antisigma positive, the antineutrino, the antilambda, and the anti-xi neutral. But even as physicists amassed the collection a nagging doubt persisted. Unearthing the antimatter equivalent of subatomic particles was a startling achievement. But it was no proof that antimatter *atoms* existed.

### Breakthrough at Brookhaven

Then, last June, came the announcement that anti-atoms had been manufactured. A team of physicists headed by Columbia University's Dr. Leon Lederman used the 30-Bev synchrotron at the Long Island (N.Y.), Brookhaven National Laboratory to bombard a beryllium target with a beam of protons. Amid the bevy of particles appeared antideuterons—anti-atoms each with an antiproton firmly wedded to an antineutron by the same mysterious force that binds ordinary atomic nuclei together.

The discovery confirmed a bizarre possibility voiced by Dirac 35 years earlier: that somewhere in the universe exist entire antimatter worlds that are the alter egos of our own. Such antiworlds would contain antigalaxies flying apart like those in our own cosmos. Antiplanets would revolve around antistars, and the heavens would be peppered with antimeteorites, comets and dust. Antipeople living on antiplanets are another real possibility. To such people, negative charges would be positive and all magnetic polarities would be reversed, in terms of earth, of course. To antipeople, *we* would be the antimatter.

One notion, that antimatter holds the key to antigravity, doesn't pan out. "This idea has been looked into," says Dr. Lederman, "and it seems that antimatter has the same kind of gravitation we do."

If an antiworld really exists, contact with any part of it, no matter how brief, would spell disaster. Outward characteristics of antimatter and matter are identical. On an antipланet water would turn to steam, tides would ebb and flow, and falling bodies would accelerate just as they do on earth. But, because of reversed electrical properties, a clash between matter and antimatter results in total annihilation of

(Please turn to page 202)

champing at the bit  
for a really cool pipe?

LIGHT UP A

*Kirsten*

Kirsten's patented Duralumin Radiator stem not only produces a cooler draw, but condenses out harsh and harmful tobacco impurities. Moisture easily is removed with a flick of the exclusive Kirsten valve. Featherweight Sportsman model features premium imported Mediterranean briar and hand-finished vulcanite bit. Order yours by mail today. Just \$7 Postpaid.

**SEND FOR YOUR FREE CATALOG**

20 pages of full-color illustrations of all the Kirsten models up to \$18.50

**KIRSTEN PIPE CO., Inc.**

Dept. 12,  
P.O. Box 5227  
Seattle, Wash. 98107



**you and your boy**

Share a Dremel Moto-Shop. You get close to your boy when you team up with this versatile jig saw. It's ideal for hobby projects, home maintenance jobs.

But don't be deceived. Moto-Shop is not a toy. It's a dad-size tool — a craftsman's tool. Yet it's so simple to operate a small boy can master it in minutes. Completely safe, too. Moto-Shop weighs only 10 lbs. — you can store it on a closet shelf.

**DREMEL MOTO-SHOP**

Big capacity! 15" throat — cuts 1 3/4" wood, light metal, tile, plastics • Ball bearing motor • Table tilts 45° • Saws in any direction • No belts or pulleys. **Model 571 Jig Saw** with disc sander (as shown), \$33.95. **Model 572 Deluxe Jig Saw** with disc sander, grinding wheel, wire and cloth buffing wheels. Plus 30" flexible shaft and 12 piece accessory set for grinding, drilling, routing, carving, \$49.95.

*Ask your power tool dealer for a demonstration or mail coupon for free literature.*

**WHY STRUGGLE**

Why struggle with old fashioned Wheel Wrenches? The new patented\* Levermaster facilitates wheel changing.



A



B

For increased leverage, step on it (A); then spin nuts off by hand (B). The Levermaster is plated and has wheel cover removal and jack handle features. State nut size and send \$2.90 money/postal orders.

**H. Leps Dists. Co., Room 505, 60 Esther Lorrie Drive  
Rexdale, Ontario, CANADA.**

\*Patented U.S.A., Canada, U.K.

**DREMEL MFG. CO.**  
Dept. 905-L, Racine, Wis.

Please send me your free catalog on Dremel power tools

Name \_\_\_\_\_

Address \_\_\_\_\_

City \_\_\_\_\_ State \_\_\_\_\_

**Sure beats smoking!**



Enjoy Copenhagen: Place a small pinch between cheek and gum. No chewing.

United States Tobacco Company

**BUILD** REFINISH RESTORE  
**...anything of wood**

LET Constantine's picture-packed Catalog & Manual help you build new furniture—refinish and restore beat-up cabinets, chests, tables, chairs, etc. See everything you need for better, easier woodworking. All materials plus plans, books, instructions. 60 glamorous woods in natural color. Hundreds of products found nowhere else. 8-ft veneers! Fabulous glue that needs no clamps. Tool bargains. Cabinet hdwe, etc. *Unsurpassed values since 1812.*

**2,000 CRAFTSMAN PRODUCTS**  
 World's Beautiful Woods & Veneers  
 Newest Workshop Tools & Materials  
 Wood Finishes — All Kinds  
 Lamp Parts — Upholstery Supplies  
 Period & Modern Furniture Hardware  
 Colonial Clock Kits — Case Kits  
 500 Project Plans! Instructions!

Tear out ad. Mail with 25¢ for vast new CATALOG Plus New "101 Project Ideas"

**CONSTANTINE**  
 2050 Eastchester Rd., Bronx N.Y. 10461 Dept. T-5

MAIL AD

**ANTIMATTER**

(Continued from page 200)

both substances with pure energy as the product. Disintegration is 100 percent efficient. Atom for atom, a matter-antimatter explosion delivers a wallop thousands of times stronger than a hydrogen bomb.

**Magnetic Bottles for Storage**

The violence of such a reaction makes antimatter the ultimate in stored fuel, ideal for jobs like driving spaceships or rocket probes across interstellar distances. Recent work in handling plasma—scorching hot gases—with magnetic fields gives a clue how antimatter might someday be contained. Isolated in magnetic bottles, antimatter could be stored until a pulsating electromagnetic field slowly nudged it into a reactor chamber.

Right now there's no absolute proof that antimatter inhabits the universe. But there is strong supporting evidence, including discoveries about a principle called parity. Parity implies that, because nature is inherently symmetrical, particles shoot out of a decaying radioactive element at random, preferring neither the left nor right-hand side. In 1956 a Columbia University physicist, Chien-Shiung Wu, tested the idea using radioactive cobalt-60. Shock waves from the experiment's results are still echoing through the field of physics. Wu discovered that certain types of breakdown particles *do* prefer darting out to one side, indicating that matter is endowed with an innate handedness. And antimatter? Theoretical physicists have shown that it has the opposite handedness. To be symmetrical, nature would consist of two universes: one right-handed, the other left-handed. One of matter, the other of antimatter.

Another principle—called the particle-antiparticle conjugation symmetry—adds more evidence supporting antimatter's existence. Simply put, this law holds that when nature creates a particle, its equivalent antiparticle materializes at the same time. Consequently, when the material composing our universe appeared, as much antimatter showed up too. If the theory is correct, how did the two substances separate before destroying one another?

Dr. Maurice Goldhaber, director of Brookhaven National Laboratory, offers this model of how it might have happened: The mass of the entire universe was at first contained in a single particle called the universon. Like a radioactive element that splits into particles and antiparticles, the universon broke into the cosmon and anticomon, each shooting apart from the other

(Please turn to page 204)

**You can't buy a Mudhog. You can own the machine that made it!**



MUDHOG? A well-known pump used by the construction industry. UNIMAT? The world famous multi-purpose machine that lets you make precision replicas of the most intricate objects!



UNIMAT is a complete miniature machine shop only 16" long. Amazing versatility is the secret to its success. It's a precise lathe which in seconds converts to a vertical milling machine, drill press, surface grinder and more ready to go to work on anything made of metal, plastic or wood. Model railroad and slot car equipment, hobby gear, gas and steam engines, machine castings—UNIMAT'S many uses are limited only by the imagination!

UNIMAT operates with the accuracy of expensive toolroom equipment (.0005") at just a fraction of the cost. Basic UNIMAT sells for \$139.50 and includes lots of extras. It's so easy to use... and takes up so little space. *No experience is necessary.*

To find out more about UNIMAT, just drop a card in the mail for free illustrated literature. To discover its complete personality, send \$1.00 for "Miniature Machining Techniques"—a 40 page photo packed manual.

American-Edelstaal, Inc., Dept. GL-5, 350 Broadway, N.Y.C. 10013.

# THIS IS THE SUNGLASS THE ASTRONAUTS WEAR

You won't find these sunglasses in stores. Thru exclusive arrangement we are able to offer these sunglasses worn by our spacemen. Their lenses are guaranteed to be 100% distortion-free. If you want your eyes to have the ultimate in high quality protection, follow the example of the astronauts and wear these True-View lenses of neutral grey for accurate color identification. They are furnace hardened by a special process. The 12K gold-filled frames have contoured end pieces stylishly encased in translucent Saflon for safe, comfortable fit.



## GEMINI STORY FOLDER FOR GIFT GIVING

We've printed a little explanatory folder so you can use these glasses as gifts.

### PRESCRIPTION LENSES

Send us your single-vision prescription and we will deliver, in about ten days, Astronaut Sunglasses ground to that prescription by a licensed optician for \$22.50 postpaid. Send Bi-focal or Tri-focal prescription for quotation. Also available in Hunters' Yellow (Dawn to Dusk haze-free lenses) ground to prescription at same prices.

The prices at the right are post-paid. If you wish shipment by first class mail please add 50¢ per unit.

- \$12.95 ppd.
- 2 for \$11.95 ea.
- 3 for \$10.95 ea.
- 6 for \$ 9.95 ea.

MEREDITH/COUNTRY CLUB CO.—Dept. Melvarie, 210 W. 8th St.—Kansas City, Mo. 64105



120 RECORDS  
In  
Only 17 INCHES

End Searching and Clutter. Records you want right at your fingertips. Complete with heavy-duty punch. All albums easily numbered and indexed.

TABLE MODEL  
(or Wall Mounted)

\$12.95 plus \$2.00 postage

- Remove Record, Not Album
- Protects Album Covers
- Protects Records
- Rapid Finding of Records

FLOOR MODEL (Not Shown) \$15.95 plus \$2 postage



© 1965  
Kaufman Adv. Co.  
Kansas City, Mo.

## MUSTANG HORN

For Any  
Car or Boat

New electronic development imitates the sound of wild mustang stallion. For either 6 or 12 volt (specify).

WHINNIES like  
a WILD  
MUSTANG!

Write for  
Free Catalog  
Bull Horns  
Lion Roars  
Kik-Steps

- \$14.95
- \$14 ea. for 2
- \$12 ea. for 6

All Prices Postpaid



AEROSOL  
\$1.95  
ppd.

Unretouched photo of saw shows half sprayed with KOVOK still clean. Unsprayed half is rusted.

METAL  
PROTECTION  
POWER

Invisible KOVOK prevents rust on tools, parts. Protects guns, cameras, motors. Harmless to all materials.



\$5.95  
ppd.  
Add  
60¢  
for  
Air  
Mail



MERRY  
CHRISTMAS  
for  
YOUR DOG

Or Any Dog You Know

Complete with black belt, gold buckle, hat and beard. Made from 100% cotton flannel by quality coat manufacturer.

MAKES A BRIGHT RED HIT

Wonderful fun and hilarity for all size dogs from toys to collies. Comes in sizes 8 to 20. Measure from collar to base of tail in inches.

WEAR IT YEAR AFTER YEAR

## STICK ANY PAINT to ANY SURFACE

SPAD is a revolutionary new adhesive layer which will stick to any metal, wood, glass, concrete, tile, plastic . . . no matter how slick. Just spray, dip or paint on SPAD, let dry, then paint with ANY kind of paint. No more acid etching, pickling, sanding or slippery surfaces.

### PREVENTS RUST

SPAD turns any paint into a rust preventive paint. And it displaces moisture. You don't have to wait for surfaces to dry.



Jumbo  
Aerosol  
\$4.95  
Gal. Can  
\$10.95  
ppd.

MEREDITH/COUNTRY CLUB CO.—Dept. Melvarie  
210 W. 8th St.—Kansas City, Mo. 64105 Phone 816 221 3562

Please Rush Merchandise  
As Follows:

\_\_\_\_\_  
\_\_\_\_\_  
\_\_\_\_\_  
\_\_\_\_\_

Name \_\_\_\_\_

Address \_\_\_\_\_

City \_\_\_\_\_ State \_\_\_\_\_ Zip \_\_\_\_\_

## ANTIMATTER

(Continued from page 202)

at tremendous speed. The cosmon subsequently decayed into particles that compose the atoms in our universe.

And the anticosmon? Statistically, it would have had the same chance of forming galaxies, solar systems, and other celestial bodies as the cosmon. But it may be decades before anyone knows if it did. Reason: Astronomers can't distinguish between light emitted from antimatter and that radiated by ordinary matter.

But observations can spot the energy released from a collision between the two substances. And such confrontations may already be a matter of record.

### Comet or Anticomet?

In early 1963, for instance, Dr. Robert Richardson of Los Angeles' Griffith Observatory noticed a comet he was tracking suddenly veer off course and become a thousand times brighter. One explanation Dr. Richardson offers: He was observing an anticomet passing through a meteor field.

Mutual annihilation of matter and antimatter would account for other puzzlers, too. The galaxy Messier 87 is one of them. Jutting out of Messier 87's globular body is a luminous streak generating powerful radio signals that astrophysicists can't account for. One noted astronomer, Fred Hoyle, claims this bright jet might be a cloud of antimatter captured from an antigalaxy. Quasars are another stickler. These stellar objects are so far away they can barely be seen with the most powerful telescopes. Yet, the quantity of radio energy that they radiate has astrophysicists baffled. An instance of a crash between galaxies and antigalaxies? Privately, many scientists say it's likely.

Such a likelihood raises a possibility once found only in extravagant science fiction adventures. That somewhere in the far reaches of the universe scientists on an antiplanet are busily exploring the nature of a strange, newly discovered substance. The name of that substance: matter. ★★★

### New Ocean-Bottom Map

A new map of the land beneath the sea from Nova Scotia to Florida may help geologists detect such underwater resources as sand and gravel beds, and oil, gas, manganese, phosphorite and potash deposits.

Nearly two million sounds were made in the coastal waters to create the map, drawn at the scale of one inch to 16 miles, reported Dr. William T. Pecora, director of the U.S. Geological Survey.



## Fruit is for jelly (and beginning pipesmen)

Revelation is for pipe smokers who're tired of sweet, syrupy blends. You get the rich *naturally* mellow flavor of five great tobaccos. It's a taste you can stick with all day long.

## Revelation is for the experienced pipe smoker.



A product of Philip Morris Inc.

### SAW SHARPENING IS EASY

Super Filer No. 11 joints and sharpens circular saws 6" to 10" with all teeth correct in height, depth, pitch, bevel. When file hits steel roller, teeth are finished. Saw runs true with no side pull. Includes 8" file. \$9.95 PPD.

"TRU-CIRCLE" sawset \$2.95 ppd.

### GEM MAKING KITS



**NEW!** Combination CABOCHON UNIT =63.

A. D. MCBURNEY Dept. A125, 1610 Victory Blvd., Glendale, Calif.

FREE  
LITERATURE

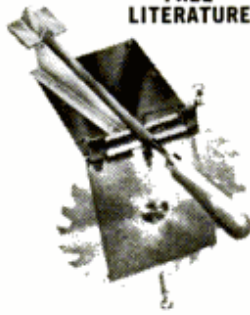

It saws-grinds-polishes. Delivers complete. \$77.25 ppd. less motor. Includes belt. Nothing on market like it at near its low price.



**FOUR-WAY**  
**BEST LOW COST**  
**ARC WELDER**  
**YOU CAN BUY**  
**\$14.95**  
 Complete

**LIFE-TIME BURN-OUT GUARANTEE—10-DAY MONEY BACK TRIAL.**  
**WELD, BRAZE, SOLDER, CUT.** Tops in performance and value. Ideal gift, educational, profitable, enjoyable. No experience needed. Use 1/8" welding rods and 1/4" carbons to make or repair auto bodies, fenders, trailers, boats, toys, furniture, farm equipment; garden tools, anything of metal. Operates on 110 V. line.  
**WORLD'S GREATEST WELDING VALUE.** Over 500,000 in use by home owners, farmers, hobbyists, mechanics. **Life-time burn-out guarantee.** You Get: **FULL FACE SHIELD,** heavy metal cabinet, ground clamp, 12 ft. of heavy duty welding cables, twin carbon arc torch, rod holder, carbons, welding and brazing rods, flux, solder, instructions. Order on 10-day unconditional money back trial.  
**SEND ONLY \$2.00** and pay \$12.95 plus C.O.D. charges on delivery.  
 or send only \$14.95 and we will ship prepaid. Order today.

**FOUR-WAY WELDER CO.**

DEPT. W2-N  
 1810S. FEDERAL ST.  
 CHICAGO, ILL. 60616

STATEMENT OF OWNERSHIP, MANAGEMENT AND CIRCULATION (ACT OF OCTOBER 23, 1962; SECTION 4369, TITLE 39, UNITED STATES CODE). 1. Date of filing: October 1, 1965. 2. Title of publication: Popular Mechanics. 3. Frequency of issue: monthly. 4. Location of known office of publication: 575 Lexington Avenue, New York, N. Y. 10022. 5. Location of the headquarters or general business offices of the publishers: 959 Eighth Avenue, New York, N. Y. 10019. 6. Names and addresses of publisher, editor, and managing editor. Publisher: The Hearst Corporation, 959 Eighth Avenue, New York, N. Y. 10019. Editor: Walter Ian Fischman, 575 Lexington Avenue, New York, N. Y. 10022. Business manager: Joseph F. Kern, 575 Lexington Avenue, New York, N. Y. 10022. 7. Owner: The Hearst Corporation, principal office, 100 West Tenth Street, Wilmington, Delaware 19899. All of the stock of The Hearst Corporation is held by the following Voting Trustees, namely: Richard E. Berlin, 959 Eighth Avenue, New York, New York 10019; Harold G. Kern, 5 Winthrop Square, Boston, Massachusetts 02106; G. O. Markuson, 959 Eighth Avenue, New York, New York 10019; Charles Mayer, Third and Market Streets, San Francisco, California 94103; William Randolph Hearst, Jr., 959 Eighth Avenue, New York, New York 10019; Randolph A. Hearst, Third and Market Streets, San Francisco, California 94103; David W. Hearst, 270 North Canon Drive, Beverly Hills, California 90210; Frank Massi, 959 Eighth Avenue, New York, New York 10019; and Herbert W. Beyea, 410 Park Avenue, New York, New York 10022, under Voting Trust Agreement dated as of February 20, 1964; the beneficial owners of the stock deposited under the aforesaid Voting Trust are The Hearst Foundation, Inc., the William Randolph Hearst Foundation, William Randolph Hearst, Jr., Randolph Apperson Hearst, David Whitmire Hearst, George Hearst, John Randolph Hearst, Jr., Joanne Hearst Betancourt, William Randolph Hearst II and Deborah Hearst. 8. Known bondholders, mortgagees, and other security holders owning or holding 1 percent or more of total amount of bonds, mortgages or other securities: None. 9. Paragraphs 7 and 8 include, in cases where the stockholder or security holder appears upon the books of the company as trustee or in any other fiduciary relation, the name of the person or corporation for whom such trustee is acting, also the statements in the two paragraphs show the affiant's full knowledge and belief as to the circumstances and conditions under which stockholders and security holders who do not appear upon the books of the company as trustees, hold stock and securities in a capacity other than that of a bona fide owner. Names and addresses of individuals who are stockholders of a corporation which itself is a stockholder or holder of bonds, mortgages or other securities of the publishing corporation have been included in paragraphs 7 and 8 when the interests of such individuals are equivalent to 1 percent or more of the total amount of the stock or securities of the publishing corporation. 10. This item must be completed for all publications except those which do not carry advertising other than the publisher's own and which are named in Sections 132.231, 132.232, and 132.233. Postal Manual (Sections 4355a, 4355b, and 4356 of Title 39, United States Code). A. Total no. copies printed (net press run): Average no. copies each issue during preceding 12 months, 1,576,750; single issue nearest to filing date, 1,674,000. B. Paid circulation—1. Sales through dealers and carriers, street vendors and counter sales: Average no. copies each issue during preceding 12 months, 420,577; single issue nearest to filing date, 396,800. 2. Mail subscriptions: Average no. copies each issue during preceding 12 months, 990,647; single issue nearest to filing date, 1,042,817. C. Total paid circulation: Average no. copies each issue during preceding 12 months, 1,411,224; single issue nearest to filing date, 1,439,617. D. Free distribution (including samples) by mail, carrier or other means: Average no. copies each issue during preceding 12 months, 10,833; single issue nearest to filing date, 10,689. E. Total distribution (Sum of C and D): Average no. copies each issue during preceding 12 months, 1,422,057; single issue nearest to filing date, 1,450,306. F. Office use, left-over, unaccounted, spoiled after printing: Average no. copies each issue during preceding 12 months, 154,693; single issue nearest to filing date, 223,694. G. Total (Sum of E & F—should equal net press run shown in A): Average no. copies each issue during preceding 12 months, 1,576,750; single issue nearest to filing date, 1,674,000. I certify that the statements made by me above are correct and complete. Joseph F. Kern (Signature of business manager).



**GRINDS**      **POLISHES**  
**DRILLS**      **SHARPENS**  
**CARVES**      **DEBURRS**

No. 2  
 Moto-Tool Kit  
 Illustrated

**MOTO-TOOL**  
**THE POCKET SIZE MACHINE SHOP**

Handiest tool you'll ever own. Does fine detail work with pin point accuracy. Eliminates time consuming hand work. Gets into places difficult to reach with larger tools. 27,000 RPM. Collet sizes 1/8", 3/32" and 1/16". An industrial favorite since 1936. Wt. 13 oz.

**NO. 2 MOTO-TOOL only** ..... \$19.95  
**NO. 2 MOTO-TOOL KIT with 23 accessories in steel case** ..... \$29.95

**NEW HEAVY DUTY NO. 3 MOTO-TOOL**

New high torque motor designed for hard industrial use. Same features as No. 2 plus 50% increase in power.  
**NO. 3 MOTO-TOOL only in steel case** ..... \$29.95  
**NO. 3 MOTO-TOOL, 23 accessories, steel case** .. \$37.95

SEE YOUR DEALER OR WRITE FOR CATALOG  
 Dremel Mfg. Co. • Dept. 115-L • Racine, Wis.

**3.95**



No. 77

**OPEN-ZUM**

A gleaming stainless steel wall unit that will punch open beer, beverage and juice cans, also includes a built in bottle opener. Open-Zum now in use on planes of famous airline. Attractively packaged, excellent gift.

For kitchen cabinet, bar, boat, galley.

**HYDE TOOLS**

Write for Free Catalog  
 SOUTHBRIDGE, MASS., U.S.A.  
 Send check or money order for immediate delivery by mail.

## A New **FREE BOOK** for

# MEN PAST 40

**Troubled With Getting Up Nights,  
Pains in Back, Hips, Legs,  
Nervousness, Tiredness.**

This new Free Book tells that if you are a victim of the above symptoms, the trouble may be traceable to Glandular Inflammation . . . a condition that very commonly occurs in men of middle age or past and is often accompanied by despondency, emotional upset and other mental and nervous reactions.

The book explains that, although many people mistakenly think surgery is the only answer to Glandular Inflammation, there is now a non-surgical treatment available.

## **NON-SURGICAL TREATMENTS**

This New Free Illustrated Book tells about the modern, mild, Non-Surgical treatment for Glandular Inflammation and that the treatment is backed by a Lifetime Certificate of Assurance. Many men from all over the country have taken the NON-SURGICAL treatment and have reported it has proven effective.

The Non-Surgical treatment described in this book requires no painful surgery, hospitalization, anesthesia or long period of convalescence. Treatment takes but a short time and the cost is reasonable.

### **REDUCIBLE HERNIA | HEMORRHOIDS**

Non-Surgical treatment for both Reducible Hernia and Hemorrhoids, the book explains, can usually be taken at the same time as treatment for Glandular Inflammation.

This new Free Book is fully illustrated and deals with diseases peculiar to men and women. It tells HOW and WHY New Modern NON-SURGICAL Methods are so successful today. Fill Out Coupon.



Excelsior Medical  
Clinic, Dept. M 6150  
Excelsior Springs, Mo.

Gentlemen: Kindly send me at once, your New FREE Book. I am interested in full information. (Please Check Box)

- Glandular Inflammation       Hernia  
 Hemorrhoids

Name.....

Address.....

City..... State.....

## ELECTRONIC EAVESDROPPERS

(Continued from page 74)

not produce clicks, crackles or hollow sounds. They do not affect normal operation of your phone in any way.

The only way to be certain that your phone is safe is to check the entire line before each call. Again this is not practical. The practical solution is to use "scramblers." These electronic devices fit the mouthpiece and earpiece of your phone. A matching unit is used by the party at the other end. The scrambler mixes up your conversation by changing tones according to a preset code. The matching unit decodes the scrambled signal.

According to Richard Sirchie, "I start by looking for hidden radio transmitters with an electronic 'sniffer.' This is a wide-range field-strength meter. If it detects a radio transmitter it tells me.

### **Inch by Inch Bug Hunt**

"To use it, I scan all walls, floor and ceiling of the room inch by inch. This check must be methodical. Low-power bugging transmitters are easy to miss.

"Next I check for hidden microphones feeding a tape recorder. These devices can be hidden in walls, a nearby room or a lamp. All require wires to connect them to the recorder. To find the mikes, I use a 'whistler,' an electronic tone generator. I scout the conference room and nearby areas for wires. Every time I see a set of wires I connect the whistler to them. Then, leaving it connected, I go back to the room. If a mike was connected to those wires it will now be emitting a high-pitched whistle. If I don't hear anything I know those wires are safe and go look for more.

"After checking all wires in the area I can be reasonably certain it is safe. Now all I will worry about are bugs those attending the meeting may bring with them."

Bugging and debugging can turn into a rather exciting game—the bugger trying to outwit the debugger and vice versa. There is only one important point to remember: Even the safest sanctuary can be bugged. To be certain of security you must check before each use of a conference room. Above all, beware of the public room or street. Check your office now. Odds are, if you hold a responsible position, one in ten that it's already bugged.

Another important point. Once you've found a bug, don't assume you're safe. Chances are if someone has planted one, he's also protected himself by planting a second and possibly a third.

I hope you never have occasion to play the game yourself, but if you do be sure to consult an expert—or you'll lose. ★★ ★



# CUT-TO-FIT HOMES SAVE LABOR COSTS UP TO 100%

Save labor cost up to 100%, reducing completed home cost. You can assemble any of 57 designs from easy-to-follow plans. No measuring or cutting . . . every piece precision machine pre-cut and marked. **BUY DIRECT FROM MILL.** Eliminate all between overhead, profit and labor

costs. Nothing to plan or figure. Complete with all lumber, hardware, paint, nails, glass, roofing, etc. Sterling Home quality material throughout. Freight paid most areas. Write today. Send 25c for illustrated, color catalog, floor plans and details.

**CHOICE OF 57 DESIGNS**

**PRICED FROM \$2295 UP**

Prices do not include carpentry labor, heating, lighting, plumbing and masonry materials. FIVE EASY-PAYMENT PLANS,

**THIS HOME \$6535**



**INTERNATIONAL MILL & TIMBER CO.** Bay City, Michigan, DEPT. PM125

## THAW FROZEN PIPES SAVE MONEY • MAKE MONEY NO FIRE HAZARD • NO DIGGING

Ends tearing up floors, walls and costly service calls. Can pay for itself on a single job. Handles copper pipe up to 45 ft. lengths 30 ft. of 1 1/4" iron pipe. Portable, anyone can operate. Simply attach cable to pipe and plug into any 110V outlet. Complete with 30 ft. of cable, clamps & instructions. Model P250 at your dealer or Order Direct. Send only \$10 and pay \$69.50 balance plus C.O.D. charges on delivery or send \$79.50 and we will ship prepaid.



**\$79.50 Prepaid**

**TRINDL PRODUCTS LTD.**

Dept. T2-N  
1807 S. Clark St.  
Chicago, Ill. 60616

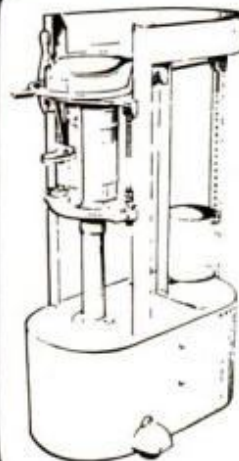

Turns **CONCRETE** into **DRAIN TILE**

This machine's a MARVEL. Costs less than \$500 and lets you make 100 or more top-quality tile per hour at a unit cost (including labor) of 4¢-5¢. Sell your tile at 10¢ to 15¢ each. Earn extra or full income making and selling a product that is in constant demand. Booklet with complete details free. Don't wait! Write for yours now.

**CONCRETE MACHINERY**

Box 99, Hickory 2, N. Car. 28601



## CARRY YOUR KEYS ON A KEY-BAK® KEY REEL

KEY-BAK is worn on the belt. It reels back your keys, keeps them safe, handy and out of your pocket. Pocket-watch size steel case, chrome-plated. Patented reel. 24" long stainless steel chain. Ruggedly built. Factory guaranteed. Many MILLIONS now in use. At Retail or Postpaid

**\$295**

Buy KEY-BAK at your hardware or key shop or send to Dept. A

WEST OF MISSISSIPPI  
**LUMMIS MFG. CO.**

2242 E. Foothill Blvd. Pasadena, Calif.

EAST OF MISSISSIPPI  
**CTL COMPANY**

1710 W. Stewart Ave. Wausau, Wis.

WITH DIP BASKET

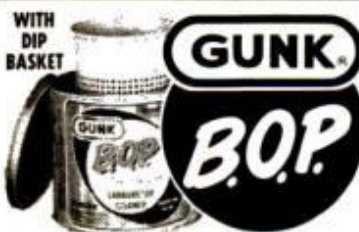

## DO-IT-YOURSELF CARBURETOR AND SMALL PARTS CLEANER

AT SERVICE STATIONS, AUTO & HARDWARE STORES

**Hey Kids!**

**NEW GAS ENGINES \$25**

Amazing directory tells where to buy discount mini-bike, kart parts etc.!

RUSH \$2 for directory or send 25c for brochure describing new edition!

**BARGAINS, PO BOX 4408, DEPT. PM CHICAGO, ILL. 60680**

**FREE! BONUS COUPONS!** with directory order Mini-Bike Plans...\$1 Racing Kart Plans...\$1 OVER 100 BARGAINS!



## Sensational, All Purpose, New 6 in 1 EMCO-STAR

**Instant Change-over**

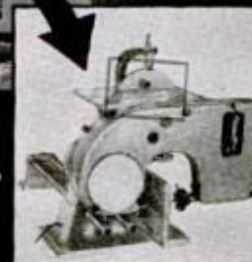

6" Band saw  
8" Circular Saw  
7" Disc Sander  
8 1/2" Jig Saw  
2" Belt Sander  
Saber Saw

## Complete shop for home & industry

New EMCO-STAR is the fastest change-over machine ever. Switch from band saw to Circular saw, then to sander, instantly.

## Check these exclusive EMCO-STAR features:

✓ The only combo-machine that gives you band saw and jig saw as part of the basic unit ✓ Convenient size ✓ Compact enough for portable use ✓ Ball-bearing equipped throughout ✓ Add wood lathe and molder with low cost attachment ✓ Many accessories available ✓ Precision-built by the makers of multi-purpose UNIMAT. Write for catalog: American Edelstaal Inc., Dept. GE-LS 350 Broadway, N.Y.C. 10013.

**\$189** complete

or **\$33** down **\$14.50** mo.



**BE WARM  
WHILE**

**YOU WORK WITH**

**Jon-E WARMERS**

*Gives Heat Without Flame*



Work outside? Forget the cold! Just put one or two Jon-E Warmers to work. Slip these flameless "personal radiators" into your pockets and stay warm and comfortable all day regardless of freezing weather. A Jon-E can keep you warm all day on only one filling of Jon-E Fluid.

Insist on the genuine Jon-E. Never wears out. American-made. Fully guaranteed.

Standard size—\$3.95 Giant size—\$4.95

Lights cigarettes, too!

Jon-E Fluid lights fast, longer lasting.

8 oz. can—49¢

16 oz. can—79¢

**ALADDIN LABORATORIES, INC.**

620 So. 8th St., Minneapolis, Minn.



## TORONADO

(Continued from page 80)

they've seen. But we can't get service. The manager doesn't have instructions for the car yet.

Still going downhill, we chalk up 14.5 mpg at Salt Lake City. On to Bonneville.

The salt flats offer us a chance to check top speed. Our two-way run indicates 115 and 120 mph on the speedometer (later corrected to 113 and 118). But the altitude robs about 15 percent of our power.

The flats offer a safe handling course. We lay out a fast slalom run and go through at about 80 mph. We notice a mild change in handling through corners with power on and power off, ranging from marked understeer to just about neutral steering. Car controllable at all times.

In Elko, Nev., three cowboys pass in front of us. Dunne, a homespun student of psychology, says, "Watch these guys look." He pulls the switch, and the lights roll out with a soft gasp. The cowboys stop dead in their tracks, hypnotized.

With 2736.5 miles on the odometer, we stop for the night at Winnemucca, Nev. Three men standing on second-floor balcony of the motel almost fall over the rail trying to get a look.

*Tuesday:* This morning we start hearing a strange whirring noise in the engine compartment, mostly when we lift up on the throttle. Our first thought is the chain drive. We make a check; it seems to be vibration in throttle linkage.

We get our best mileage on this part of the trip: 14.8 in Fernley, Nev., 14.2 in Reno.

We stop at Harrah's Automobile Museum in Reno, take special note of '37 Cord front-wheel-drive. One girl there criticizes the ashtray. It's too far from the driver. What's more, there's no vent window for flicking ashes.

At the California border inspection station. (Please turn to page 210)



**New York** . . . crowds were the most curious. All through Times Square, passers-by shouted questions. This was the end of our coast-to-coast trip

**NOW!** Write, sketch, doodle  
in Living Color!



Special Introductory Offer

**\$1.96 value...ALL FOUR-ONLY \$1.00**

Fabulous Pentel four-pen set of four colors: black, red, blue and green. Write on any surface—paper, glass, plastic. Colors flow smoothly from special point. No leaking or bleeding. More than 3 miles of writing pleasure. Four pens come to you post-paid in handsome pocket case. Send \$1.00 for your four-color Pentel set and FREE catalog of outstanding values.



**MODI**

P.O. Box 9411  
Nashville, Tenn. 37204

**SAVE UP TO 85%**

**GOV'T SURPLUS and NEW EQUIP'T**

Send 25¢ For 3 Big Catalogs

**PUMPS  
WELDERS  
WINCHES  
SURVEYING  
TELEPHONES  
HYDRAULICS  
GENERATORS**

**ELECTRONIC  
BINOCULARS  
GEAR MOTORS  
COMPRESSORS  
SPEED REDUCERS  
WEED SPRAYING  
MANY OTHERS**

**SURPLUS CENTER** Dept. PM-125 Lincoln, Nebraska

**NOW! WARN OVERDRIVE gives 'Jeeps' more Go!**

New approved accessory cuts engine RPM 33% at any speed, reduces noise, vibration so you can drive your Jeep 4-w.d. comfortably at freeway speeds. Amazing synchromesh OD lets you shift up or down, on the go, anytime, in any gear, at any speed. Adds six forward speeds, two reverse. At Jeep dealers, or write us.

**WARN SALES CO., Inc.**  
9050-A Empire Way South  
Seattle, Washington 98118

**YOUR OWN BIKE**  
**\$119.50 to 179.50**

Even Mom'll go for this one—costs less, runs for just pennies (nearly 100 miles on a gallon of gas). And it's American made! It's the popular CAMPUS BIKE!

**FOX**

Literature FREE • Parts Catalog \$1.00  
Box 797PM • Janesville, Wis. 53546

**AUTOMATIC RETOOTHER**  
MAKES NEW PROFITS

for **HAND SAWS**

Cuts new teeth in 50 seconds—any size 4 to 16 points. Old teeth fall off as chips. Easy to operate. A perfect job.

**BURR MFG. CO.**  
8933 VENICE BLVD.  
LOS ANGELES 34, CALIF.

Send For Free Literature

**IF YOU HAVE HERNIA**

**Get this NEW FREE BOOK**

Tells how Rupture can be treated by a mild Non-Surgical method that is backed by a Life Time Certificate of Assurance. This treatment method has a long history of use and is recognized by Authorities today. Men and Women from all over the country have taken the Non-Surgical Treatment and reported it is effective. Why put up with wearing a griping, chafing, unsanitary truss?

Write today for this FREE BOOK. Tells How, explains Why more and more Rupture Sufferers are using Modern Non-Surgical Treatment Methods. Act Now. No Obligation.

**EXCELSIOR MEDICAL CLINIC**  
Dept. E6129 Excelsior Springs, Mo.

DEC. 1965 209

**NEW DREMEL ELECTRIC ENGRAVER**

with solid carbide engraving point.

**Permanently marks any material**

This new compact Dremel permanently engraves names or identification numbers on steel, copper, brass, silver, aluminum, glass, wood, plastic. Handy for marking tools, personal and business valuables, jewelry, industrial tools and dies — anything requiring permanent identification. Weighs only 7 ozs. Exclusive calibrated stroke adjustment regulates depth of engraving. Solid carbide engraving point. Diamond points also available.

See your dealer or write for literature.

Model 290 with molded storage case... **\$14.95**

**DREMEL MFG. CO.**  
Dept. 85-BL • Racine, Wisconsin

**NOW FOR THE FIRST TIME AT THIS RIDICULOUSLY LOW PRICE \$5.95**

22 Cal. Blank Cart. 6 Shot Revolver  
No Permit Required

Imported from ITALY

**"BLACK VENDETTA"** Latest model, not a toy. Gun is of solid steel construction. Lightweight and perfectly balanced. Fires 6 rounds in 2 seconds! Double or single action. Precision crafted. 5 1/2 inches long. Ideal for stage, sporting events, boating, protection. Revolver \$5.95, deluxe leather holster \$2.25. Send cash, check or M.O. and save C.O.D. charges. \$1.00 deposit with C.O.D. orders.

**BIG THREE ENT. INC.** 1109 Sixth Ave., New York 36, N.Y. Dept. PM-125

Not sold to Calif. or N.Y. res.

**FILLS CRACKS AND HOLES**

**FIX IT QUICK!**

No muss—no fuss with easy-to-use Plastic Wood. Resists grease and water.

For surest results always use GENUINE

**PLASTIC WOOD**

Handles like putty—hardens into wood!

Материал, защищенный авторским правом

## 8 times more power to relieve pain of **HEMORRHOIDS!**

Soothing Nupercainal concentrates on pain!  
Prolonged relief of pain, burning and  
itching starts in minutes.

If you suffer from the misery of hemorrhoids, remember this about remedies you can buy for temporary relief. The leading "shrinking" preparation contains no anesthetic to relieve pain.

No wonder so many doctors recommend Nupercainal. Soothing Nupercainal relieves pain, itching, burning fast... gives prolonged relief... because it has *over eight times more pain-killing power* than the other most commonly-used topical anesthetic!

Nupercainal quickly puts raw nerve ends to sleep... thus puts pain to sleep. Lets you go about your business... relieved of the stabbing pain, burning and itching torment of hemorrhoids. Get Nupercainal Suppositories today—with free, handy pocket-pack. Start to live again, in comfort! (Ointment also available.)



**Nupercainal®**

Now...helps solve  
denture wearers'  
3 biggest problems



Today science offers a *proven* way that (1) helps keep your dentures from slipping or dropping; (2) keeps dentures more comfortable; and (3) makes it easier to eat and chew with your false teeth. The one discovery that does *all 3* is **FASTEETH** Powder. **FASTEETH** helps hold teeth in place. Makes you feel more secure. You can laugh or speak without embarrassment. It cushions tender gums. Checks denture breath. Get **FASTEETH** Powder at drug counters everywhere.

## TORONADO

(Continued from page 208)

tion, our trunk is checked. "Keen," says the inspector. "But the spare is hard to get out with the trunk loaded."

We get an extra thorough inspection. "Look at the room with that cutaway dash. Got rid of the floor hump too."

Early this afternoon we reach San Francisco. Mileage is 3138.5.

*Wednesday:* The car is drawing crowds everywhere we stop. One passerby says, "Looks like a space car." Another chimes in, "All it needs is wings."

Nob Hill proves out the car's hill-climbing ability. The front drive, with its 60-40 weight distribution, doesn't hurt traction. The handbrake holds. This is as steep a hill as you'll find anywhere.

Before heading back east, we stop at Oldsmobile to get our overdue 1000-mile check. We get VIP treatment.

Their headlight-aiming procedure is unique. The mechanic paces off seven long steps from the garage wall, hops back half a step, and tells the other mechanic to park it *right there*. The lights are flashed on the two-tone wall and adjusted at the line where the colors meet. Not very scientific, but it works. We get a new accelerator, the glovebox door is adjusted, and all the vital fluids are checked.

### Quiver Corrected—Almost

The underhood vibration proves to be in the transmission interrupter switch, mounted on the throttle linkage. It is replaced, but the noise is still there.

As we head east through Sacramento, noise gets worse. We stop overnight at Reno. Our mileage reads 3385.1. Gas consumption dropped from 14.0 in San Francisco to 9.5 in the mountains; now it's up again to 11.8.

*Thursday:* It's taking Dunne a while to get used to the new accelerator pedal. Markovich still prefers the rubber roller. But with pedal on, Dunne no longer misses a transmission hump. Flat floor makes distance riding extra comfortable.

We gas up at Elko, Nev. "Hot damn, what a rig!" says the attendant. "So that's the new Tor-nay-do."

Across Nevada and Utah, we're getting 12.0 to 13.4 mpg. At gas stop in Little America, Wyo., a teenager admires the car, but asks, "How'll it be towing a trailer?" We explain that in a heavy car such as this the front drive should be no problem.

Incidentally, throughout our trip a problem keeps cropping up. Dunne brought along a pillow, but every time he falls asleep, Markovich forgets to watch route signs. Dunne miraculously

wakes up at junctions, keeping us from getting lost. "I can see I won't be getting much sleep on this trip," he grumbles.

At 4213.2 miles we pull into Rawlins, Wyo. to spend the night.

**Friday:** A group of people stand around the car as we get to it. One asks, "Does this Tor-nay-do really handle as well as it's supposed to?" We assure him it does.

He peers under the hood and says, "It's almost as bad as my '63 Olds. It took me a couple of weeks to find my sparkplugs."

It's down to 38° this morning, and we have trouble keeping the engine idling. Choke doesn't set properly. But once we start running, the heater percolates within minutes.

As we drive through Rawlins, three black cats cross our path within 15 minutes. Bad omen? On the outskirts of town, a little old lady on a bicycle stares at us too long, nearly crashes.

Something we've appreciated throughout the trip is the little pocket shelf at the top of the dashboard. It's handy for holding odds and ends. Speaking of the dash, we can't praise it enough. All gauges are easily visible through the steering wheel and controls are within easy reach. One gripe: The horn bars, recessed in the dished steering wheel, are hard to find.

About 25 miles out of Laramie, Wyo., with Dunne driving, we pass a sign welcoming us to Colorado. "Hey," Dunne exclaims, "we've been going south instead of east." Markovich chuckles diabolically. Dunne is unhappy; but after the ribbing Markovich has taken about route signs, he's ecstatic. Dunne mumbles about black cats.

### Through Snow in the Rockies

In northern Rockies we check out traction in snow on a rutted, uphill trail. Front drive pulls through where a conventional car would bog down.

Gliding down the eastern slope of the Rockies, Dunne suddenly exclaims, "Oh gosh, I'm up to 100!" He slows down, but a few minutes later, without realizing it, he's back up to 95. Markovich has noted it too; the car is deceptively smooth.

Brakes act well. Little fade, even during severe use in mountain driving. As we cross into Nebraska, glove box starts popping open again.

Our night stop is Des Moines, Iowa; the odometer reading 5097.1. Today's mileage ranges from 12.3 to 13.3.

**Saturday:** On bumpy Iowa roads, Dunne feels front shocks are a little too soft. "On certain bumps they don't return right away," he says. But we've never bottomed, even on the worst roads.

(Please turn to page 212)

## NEW DYNAMIC MARK 88 INDUSTRIAL TRANSFORMER ARC WELDER

IDEAL GIFT—EDUCATIONAL, PROFITABLE, ENJOYABLE

ANYONE CAN WELD, BRAZE, CUT, SOLDER, HEAT ON STEEL, BRASS, ALUMINUM, AND OTHER METALS.

Build and repair anything of metal. Tremendous time and money saver. **THIS IS ALL BRAND NEW, PROFESSIONAL ARC WELDER!** Rugged metal cabinet, baked Hammer-oid finish, ideal for home, shop, farm and industrial use. Expert work on your **FIRST** job. **POWERFUL** glass insulated transformer welds 1/2" metals with 3/8" rods, 4 heat settings, 20 to 80 amps. Operates on 110 Volt AC house line fused for 30 amps. Complete, ready-to-use—full head shield, electrode holder, ground clamp, cables, solder, assorted rods and simplified welding manual. Double-protection guarantee: 10-day money-back trial plus full 5-year warranty on materials and workmanship. **Order today: ONLY \$47.50 (220V at \$49.50).**



SEND ONLY \$600

Only \$47.50 Complete. Send only \$6.00. Pay balance plus C.O.D. charges on delivery.

**EASY PAY PLAN**—Write for easy pay plan. **LOW** down payment—pay as you weld and earn. Welder Details **FREE**

**DYNAMIC WELDER CO.**

DEPT. D2-N  
1808 S. FEDERAL ST.,  
CHICAGO, ILL. 60616



**FREE**  
72 ROUNDS  
OF BLANK  
CARTRIDGES

**ITALIAN  
SNUB NOSE  
AUTOMATIC**

**\$4.98**

Identical duplicate in styling of automatic detective revolver. Fires 12—4.5 cal. blank cartridges in 10 seconds. Not a CO<sub>2</sub> or Pellet gun.

**FREE**—72 rounds of blank cartridges included. Perfect for sports, stage, etc. Illustrated gift carton.

Request  
**FREE**  
Catalog

**FEDERAL** 6652 N. Western/Chicago, Ill. 60645  
Dept. GPM 11

**SEALMASTER**

# FLAPPER

## TANK BALL



QUIET, POSITIVE ACTION . . . SEALS AUTOMATICALLY. READY TO INSTALL

**STOPS WATER WASTE**

**AT HARDWARE STORES**

WORLD'S FINEST CORED SOLDER

## ERSIN MULTICORE 5-CORE SOLDER



**BUY IT AT  
RADIO-TV  
PARTS STORES**

**EASY DISPENSER  
ONLY 69¢**

OVER  
300  
DIFFERENT

MOLDS

you can use to  
make and sell

YOUR OWN  
ORNAMENTAL  
CONCRETE ITEMS



Get  
The Full Story



SEND \$2.00

CONCRETE MACHINERY COMPANY, INC.  
839 Lenoir Rd. - P. O. Box 99 - Hickory 2, N. C.

## TORONADO

(Continued from page 211)

Markovich, a foreign-car owner, likes the firm ride.

A pimply-faced young station attendant on the Ohio Turnpike asks the top speed. Told our Bonneville results, he isn't impressed. "My Ford does over 120," he says.

Another attendant walks up, asks him: "What did you say could beat this?" "I didn't say anything," says Pimples, looking pleadingly at us. "Honest."

At a gas station in Pittsburgh, Pa., an attendant asks, "What is it?" He thought it was a hand-built job. We spend the night in Pittsburgh, with 5931.1 miles on the clock. We still haven't had a back ache, though we have just completed our third straight 800-plus-mile day. You can drive this car coast-to-coast in less than four days and still like it.

*Sunday:* The Pennsy Turnpike is a ball. Lots of curves to show off handling. We detour off the New Jersey Turnpike at Newark to get a car wash. There, we hit some of the roughest roads of the whole trip. The car's ride borders on being harsh. On to New York.

### New Yorkers Agog

In Times Square, each time we stop we're mobbed. Everyone wants to know what it is, how much it costs, how fast it'll go. Markovich drops Dunne at a Manhattan hotel and hooks a fifth wheel to the car to calibrate the speedometer and do acceleration, mileage and braking runs.

The speedometer is unusually accurate—just two mph high anywhere from 30 mph on up to top speed. The odometer is 0.7 percent high. From rest to 60 takes 9.4 seconds shifting manually. 9.6 if you let the box think for itself. From 40 to 60 takes 4.6 seconds, from 50 to 70 takes 5.6.

Steady-speed fuel mileage is 15.61 mpg at 60 mph, 17.42 at 40. With odometer correction, our gas for the trip averaged 11 mpg—552.1 gallons for 6189 miles.

The brakes are effective, though discs would be still better. Fade is noticeable after the second panic stop from 60 mph; by the seventh stop it is pronounced.

Our tire tread-wear check shows that after 6000 miles, front tires averaged 38 percent tread loss, the rear tires 7.5 percent. With the recommended 6000-mile rotation, tire wear should be more than satisfactory for this size car.

All in all, we're sorry to part with the car. Dunne is driving it back alone to Detroit, where he'll return it to Oldsmobile. But the way he was talking when he left, he may go via Mexico City.

## NEW WESTERN HAIG

.12 CALIBER  
SPECIAL FACTORY  
OFFER!



\$300  
post-paid

### USES POWDER CHARGE

This small bore gun shoots .12 cal. lead bullets fired by small 4.4 mg. powder charge. Not a CO<sub>2</sub> gun! You'll like the handsome lines, grip, and balance. Western in style, but patented ball and cap action allows this low price. 9 3/4" steel barrel cased in knurled styrene stock, overall 13 1/2". Develop pistol form, accuracy at a fraction of cost of large caliber pistols. Comes with 50 lead bullets. Satisfaction guaranteed. Send \$3 to: Haig Mfg. Co., P.O. Box 4-X, Alhambra, Calif. 91802

## FOR HOLIDAY DECORATIONS

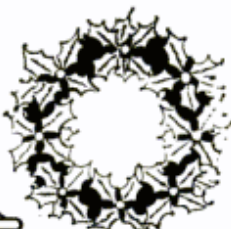

SPRAY  
PAINT

IF YOU PRIZE IT...KRYLON-IZE IT

ALL FAMOUS BRANDS! **FARM TRUCK AUTO** **TIRES!** AT LESS THAN WHOLESALE

SAVINGS NEVER LESS THAN 50% up to 70% OFF REG. PRICE!

HEADQUARTERS for ALL SPORT CAR TIRE SIZES

FREE - SEND FOR YOUR FREE CATALOG - FREE!

RELIABLE TIRE DIST., 1111 Chestnut St., Camden, N. J.

## BASEMENT TOILET FLUSHES UP



TO OVERHEAD SEWER OR SEPTIC TANK.  
NO DIGGING UP FLOORS.

Write  
McPHERSON, INC. BOX 15133 TAMPA, FLA.

**Don't put up with bad-tasting water!**

**SEND FOR FREE 16 PAGE BOOKLET**

You can eliminate excess chlorine, sulphur, other bad tastes or odors from home drinking water. Simple. Inexpensive. Write: Cuno Engineering Corporation, Meriden, Conn.



**CUNO® AQUA-PURE® filters**



**1001 USES! WELDWOOD® FLEXIBLE WOOD-TRIM®**



**PROFESSIONAL LOOK TO PLYWOOD PRODUCTS**

Beautiful wood veneer, paper-backed, in handy 1" & 2" rolls 8' long, for edging plywood. Also, decorate lamp shades, book ends, do inlay work, etc. Apply with Contact Cement or Presto-Set® White Glue. Oak, birch, African mahogany, walnut, fir, Korina®. At lumber, paint, and hardware dealer's. United States Plywood, Dept. PM12-65, 2305 Superior Ave., Kalamazoo, Michigan.

**300 POWER.....**



**Complete Telescope Lens Kit**

only **\$3.98** postpaid

Conquer Space, Explore the Universe, Planets, Moon craters, New Stars etc. Complete Lens Kit consists of 80 Inch focal length ground and polished objective lens, eyepiece lenses for 50 POWER, 100 POWER, 150 POWER, 200 POWER, 250 POWER, 300 POWER, and all necessary lens fittings. Easy to make from simple step by step instructions. (Tripod and mount not included.) Money back guarantee.

**BUSSE SALES CO., Hartford, Conn., Dept. PM-87**

**BUILD YOUR OWN CAMPER AND SAVE!**

**ALSO TRAILER OR PICKUP-COVER**

Complete, easy to follow plans, instructions, material list... **\$3.95 ea.**

Bus Conversion and Houseboat Interiors drawings..... **\$2.95**

EQUIPMENT CATALOG—\$1.00 (Refundable on first order)



Satisfaction Guaranteed! Send Check Or M.O.—For Details Send Dime.

**VIKING CAMPER SUPPLY** 94-B Glenwood Av., Minneapolis 3, Minn.

**130,000 CANDLE POWER FLAME THROWERS**



Fits all 4 light systems—bright sockets. American made for American cars. 65,000 candle power in each sealed beam unit. Over 2½ times as bright as the factory stock brights. Lets you really see where you are going.

**\$995 pair**

Prepaid U.S.A. No C.O.D. please

**WARREN AUTOMOTIVE** Box 401 Skokie, Illinois 60076

Piano-hinge top, two drawers and tote tray. 20x9x 9½ steel box in blue finish.

At Hardware Stores or Write:

**HUOT MFG. CO.** 555 N. Wheeler St. St. Paul 4, Minn.

Deluxe hip-roof tool-saver

**HUOT TOOL BOX**

FOB \$ **18.00** St. Paul



Model 110

**DRILL GLASS!**

WITH THE "Blue Borer"



Make handsome lamps from old bottles. Do custom lamp making. This is a professional tool. 7.16" in dia. Exact size for doing the job. Fits ¼" drill chuck.

Blue Borer and instructions for drilling holes in glass. \$2.95 p.p. **MAGUIRE'S STUDIO.** 207 Butler Ave., Dept. PM-4, Providence 6, R. I.

**BILL TROUBLES?**

**NOBODY REFUSED UP TO \$9,000.00**

**BAD CREDIT • NO PROBLEM • NOT A LOAN CO.**

**SEND YOUR NAME FOR FREE APPLICATION**

**ATLANTIC ASSOCIATES - DEPT. 43**

**144 WESTMINSTER ST., PROVIDENCE 3, R. I.**

**ELECTRIC ARC WELDER \$14.95!**

**MAKE—REPAIR MOST ANYTHING MADE OF METAL!**

**LIFETIME BURNOUT GUARANTEE—10 day money back trial!**

Works on 110 volt plug in 10 WAYS! WELDS, BRAZES, SOLDERS, CUTS, MELTS most ALL metals! HEATS, SOFTENS, LOOSENS, THAWS, BENDS most ANYTHING. COMPLETE READY TO USE WITH face mask, clamps, arc torch, rod holder cables—and supply of welding, brazing carbon, solder rods, flux

and ARC WELDING INSTRUCTION BOOK—Tells how YOU can use for CARS—HOME—FARM—SHOP or FACTORY all 10 WAYS—NO EXPERIENCE NEEDED!

**SEND ONLY \$2.00** (cash, ck. M.O.) and pay postman \$12.95 plus COD postage or send \$14.95 for PP del. in USA. **BEST WELDER FOR THE MONEY IN THE WORLD. FREE!** EXTRA "Hellers" dark goggles if you order from this ad. Sold ONLY by **MIDWAY WELDER, Dept. DPM-12 Kearney, Nebraska.**



**MAN-SIZE! NOT A TOY!**

10 & 12 hp, all-gear drive

Mows lawn up to 60" swath ... handles tough jobs others can't. Sized for bigger tools, extra leg room. Automotive clutch, transmission, and differential — no belts. Implements for mowing, dozing, gardening, snow. Own the best, at modest cost! Write for catalog.



**ECONOMY TRACTOR**

1005-K12 Anoka Avenue Waukesha, Wisconsin



**MOTOR-MEDIC**

- REDUCES ENGINE WEAR
- MAKES OIL LAST LONGER
- STOPS OIL BURNING

At Service Stations and Auto Supply Stores

**FREE!**

Learn how you can buy used engines \$15 up, new engines \$30 with FREE confidential list and coupons when you order your plans

• **BUILD THIS MINI-BIKE!**

Plans reveal step by step details!

• **BUILD A RACING KART!**

Complete frame for less than \$10!



**RUSH \$2 for plans (indicate type) or send 25¢ for brochure describing plans: PLANS, Box 478, Dept. PM12, Denver, Colo.**

**Shrinks Hemorrhoids  
New Way Without Surgery  
Stops Itch — Relieves Pain**

For the first time science has found a new healing substance with the astonishing ability to shrink hemorrhoids and to relieve pain — without surgery.

In case after case, while gently relieving pain, actual reduction (shrinkage) took place.

Most amazing of all—results were so thorough that sufferers made astonishing statements like "Piles have ceased to be a problem!"

The secret is a new healing substance (Bio-Dyne®)—discovery of a world-famous research institute.

This substance is now available in suppository or ointment form under the name Preparation H®. Ask for it at all drug counters.

**DANA ANDREWS, Star of Stage, Screen and TV... Reports on AMERICA'S MOST REMARKABLE BUY IN PROFESSIONAL QUALITY POWER TOOLS...**

DANA ANDREWS... Star of "CRACK IN THE WORLD" in Technicolor—a Paramount Release—writes... "Like most people, I guess, I sure had my doubts about how anyone could sell machines that are supposed to do so much... for so very little. I was never more pleasantly surprised! Every claim for them—and more—is true. Putting them through the most rugged workouts, has convinced me that the AMCO people know something no other manufacturer in America has been able to find out. These machines are, without question, a most remarkable buy in professional quality power tools."



BUY DIRECT FROM OUR FACTORY

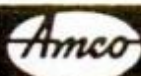

**POWER TOOLS**

SAVE AS MUCH AS

**80%**

**REVOLUTIONARY PATENTS DECREASE COSTS, INCREASE EFFICIENCY**  
Full scale power tools of heavy duty 100% cast iron and steel. Streamlined design reduces weight, cuts material and production costs. Special patents provide added efficiency, accuracy, savings. Parts made, assembled, tested and packed right in our own factories, shipped direct... save store profits.

**8" TILT ARBOR  
POWER  
SAW**  
**\$14.95**

f.o.b. factory. Wt. 25 lbs.

Includes completely assembled cast iron and steel 8" tilt arbor power saw with ground cast iron table... less blade. If desired, RIP FENCE for easier work alignment, \$3.50 additional

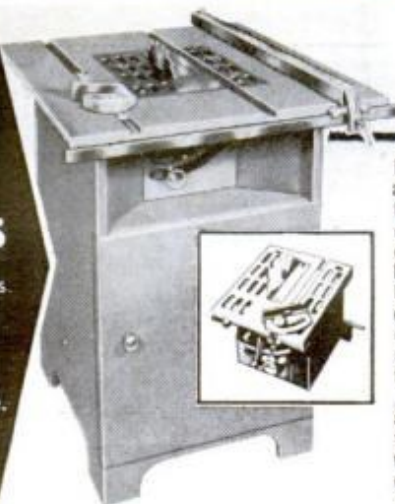

**DOES WORK OF \$75 BENCH SAW** as is. Converts easily to equal any \$300 floor model cabinet units! Crosscuts, rips, mitres, cuts compound angles, dadoes, makes coves and mouldings. **FREE CABINET BASE PLANS** Use as portable bench saw as received (inset photo)... or transform easily and inexpensively into floor model (as shown) guar. to do work of floor models costing \$300. **FREE plans**... sheet of 3/4" plywood and 3-4 hours are all you'll need. Use your AMCO saw for cutting. Plans provide 27" x 24" work surface, 33" height, pullout sawdust bin, tool storage compartment. **10-YEAR FULL SERVICE GUARANTEE\***

**BLADE TILTS... TABLE STAYS LEVEL**  
• Locks securely at any angle to 50°, raises, lowers 0"-2 1/4" • Patented tilt mechanism, accurate etched scale • Patented motor mount takes std. 1/4 h.p. or larger motor, keeps belt tight, assures perfect alignment at any angle, transmits full power • Takes std. blade, saw insert removes to take dadoe heads, cutters, etc. (not incl.) • Accurate mitre gauge assembly • Ground spindle • Enclosed steel base • "Compo" bearings • Accessories available at factory prices • RIP FENCE, if desired for easier work alignment: Std. size (for bench saw) \$3.50; larger fence (for cabinet base, as ill'd.) \$4.50.

**6" SWING  
3-FT. LATHE**  
**\$9.85**

f.o.b. factory

Optional Faceplate for turning bowls, trays, lamp bases, rosettes, etc. \$2.50



Complete as shown

**DOES THE WORK OF \$40 UNITS**—Sturdy all cast iron power tool turns wood or plastics with the precision and speed of machines selling for 4 times as much: Tubular steel bed, ball thrust cup center, spur center, T-Rest assembly, lever action tail stock, 2 speed pulley. Fits any motor.

**10-YEAR FULL SERVICE GUARANTEE\***

**FULL 22" LONG, 4 1/4" JOINTER-PLANER**  
**\$19.95**

F.O.B. Factory Complete as shown

100% precision ground cast iron and steel.

**UNCONDITIONAL 10-DAY MONEY BACK GUARANTEE**

You must be fully satisfied. If not, return in 10 days, freight collect. Money refunded in full, no questions asked.



**DOES WORK OF \$60 UNITS**  
Now, at little more than a hand tool price, a guaranteed professional quality precision machine which does same work as skilled hand planing... much faster, more accurately. Make accurate glue joints; rabbeting cuts for doors, window frames, table drawers; square taper cuts for chair legs; accurate beveling.

• Precision ground cast iron tables, adjustable for depth of cut • Rigid cast iron base • New patent-pending design holds clearance between knives and tables at any depth • Rabbett depth 3/8" • Hardened, ground high speed steel knives • Patent-pending fence adjustable to any position, any angle 0°-50° • Patent pending lift-off guard (nothing to loosen!) • Balanced steel cutter head.

**10-YEAR FULL SERVICE GUARANTEE\***

**OR**  
**1/2 HP ELECTRIC MOTOR**

SPECIAL AMCO PRICE (when purchased with any unit in this ad)

**\$12.95**

f.o.b. factory If purchased separately, \$18.95



**SPECIAL LIMITED TIME ONLY**

Brand new factory-fresh motors for use with any of the units on this page. Limited quantity purchase... first come, first served. Wt.: 17 lbs.

**FULL SERVICE 1-YEAR WARRANTY\*** Otherwise, as described below

**MAIL COUPON TODAY!**

AMERICAN MACHINE & TOOL CO., Dept. PM-125, Royersford, Pa.

Please send me the units checked. Payment in full enclosed \$... or \$3 deposit each item enclosed, balance C.O.D.

**I MUST BE FULLY SATISFIED OR WILL RETURN UNIT WITHIN 10 DAYS FOR FULL REFUND.** No questions asked.

- 8" Power Saw at \$14.95
- Jointer-Planer at \$19.95
- Long Rip Fence #354C at \$4.50
- Lathe at \$9.85 with Standard Rip Fence #354 at \$3.50 faceplate \$12.35
- 1/2 hp Motor:  \$18.95  \$12.95 (purchased with other item)
- Belt Sander at \$14.95
- Disc Sander at \$7.95
- Mitre gage at \$1.95

NAME .....  
ADDRESS .....  
CITY ..... ZONE/ZIP ..... STATE .....

**PRECISION 4"x36" BELT SANDER**  
**\$14.95**

f.o.b. factory Wt. 15 lbs.

Optional Disc Sander incl. disc, bracket, ground cast table (tilts 0-45°): \$7.95 add'l. Mitre gauge: \$1.95 add'l.



**DOES WORK OF \$50 SANDERS**  
After 23 mos. of design and testing, AMCO offers the world's most talented belt sander at a fraction of the usual cost.

Heavy cast sander incl. 4" x 36" sanding belt, V-pulley drive, multi-purpose drive spindle for 1/4" shank acc'ssy tools. Changes from horizontal to vertical sanding in secs. Uses 1/3 hp or larger motor.

**10-YEAR FULL SERVICE GUARANTEE\***

**\*10-YEAR FULL SERVICE GUARANTEE** Any part or parts of any AMCO power tool which may become inoperative for any reason within ten years after the purchase date will be repaired or replaced by the factory without cost to the purchaser. Your only cost: for postage.



# You can see how great Handi-Van is from the back. But the most important thing is on the front.

Handi-Van's body and frame are unitized. And the heavy-gauge steel has extra resistance to corrosion. Rugged construction like this saves money. Also, low initial price and economical operation give you a van that'll help you make money every year you own it.

The three letters up front—GMC—are what we want you to remember. Handi-Van is built, sold and serviced by truck people. GMC truck people. Yet Handi-Van's price is low. Right down with the others.



Handi-Van can turn inside a 38-ft. circle. Lets you scoot out of packed traffic and deliver your goods where and when promised.

Look at all the space. Handi-Van measures 211 cu. ft. inside. That'll hold over a one ton payload, 2,200 lbs. to be exact.

The engine is a 6-cylinder, 120 h.p. engineering gem. If you want more muscle you can specify a 140 h.p. work horse.

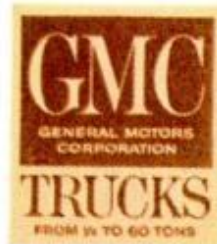

# Chesterfield People:

They like a mild smoke, but just don't like filters. (How about you?)



Henry Silver is a retail druggist in Pennsylvania

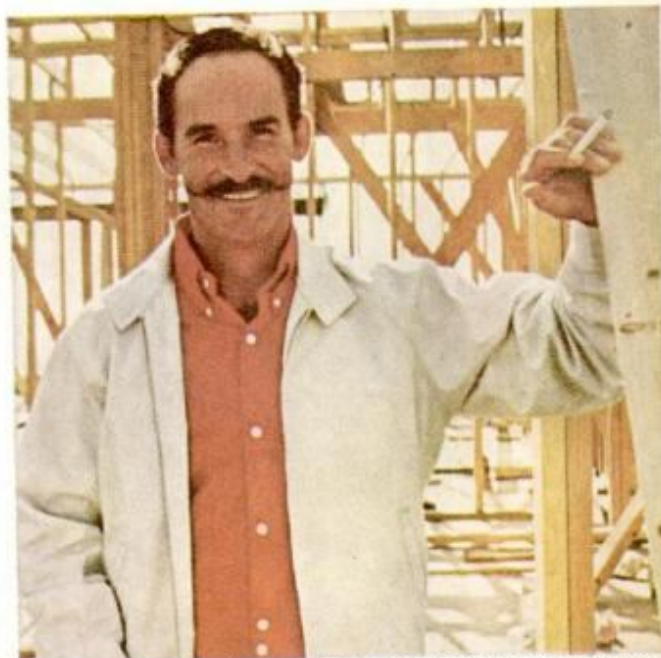

Lloyd Van Vorse heads carpentry at new home sites in California



Robert Thomas arranges transportation at a Nevada hotel



Chesterfield People get the taste that satisfies. Do you?

If you like a mild smoke, but don't like filters, try today's Chesterfield King—mild-est-tasting Chesterfield in 53 years. Vintage tobaccos—grown mild, aged mild, blended mild. Made to taste even milder through longer length. They satisfy!

**CHESTERFIELD KING** tastes great...tastes mild!