

Instant Skiing—How It's Done

POPULAR MECHANICS

DEC. 1964
35-CENTS

Speed Carnival at Bonneville

Buyer's Guide to
Household Batteries

Thief-Proof Car Switch

New Christmas
Project-a-Plans



Build a
SAUNA BATH
In Your Basement

Material, защищенный авторским правом

Most men think this GMC pickup costs a lot more than it really does. Can you blame them?



A printed circuit replaces the tangle of wires behind the instrument panel. It's a GMC exclusive.

A double-roofed steel cab. Others? A single steel roof.

A husky wood floor that is quiet and long lasting. None of that annoying drumming and rusting.

In-line six engine. More torque, more cooling and lubricating capacity than most competitive engines.

Progressive leaf rear springs that automatically adjust to the load.

*Based on manufacturers' suggested retail prices, the GMC in-line six model pictured above is never priced more than \$49 over comparable competitive base models. Often the difference is less.

Three letters that stand for three important things. Built by truck people. Sold by truck people. Serviced by truck people.

Four headlamps. Most other pickups have just two.

Only GMC offers a proven total suspension system that always gives a smooth ride even with maximum loads.

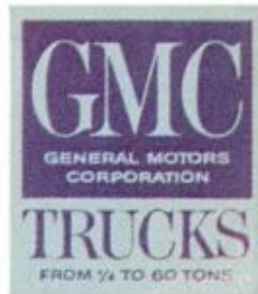

The truth is its price is only \$49* more than others.

Nothing
comes
closer
than
this

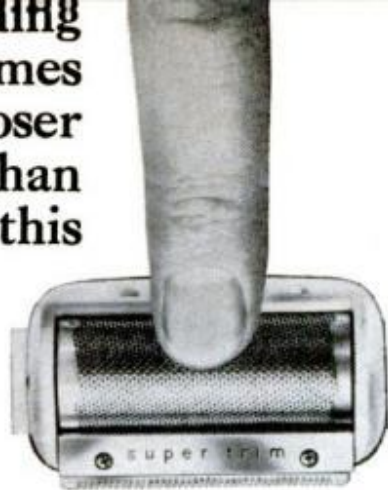

trims
better
than
this



or
gives
better
value
than
this
Ronson
"200"

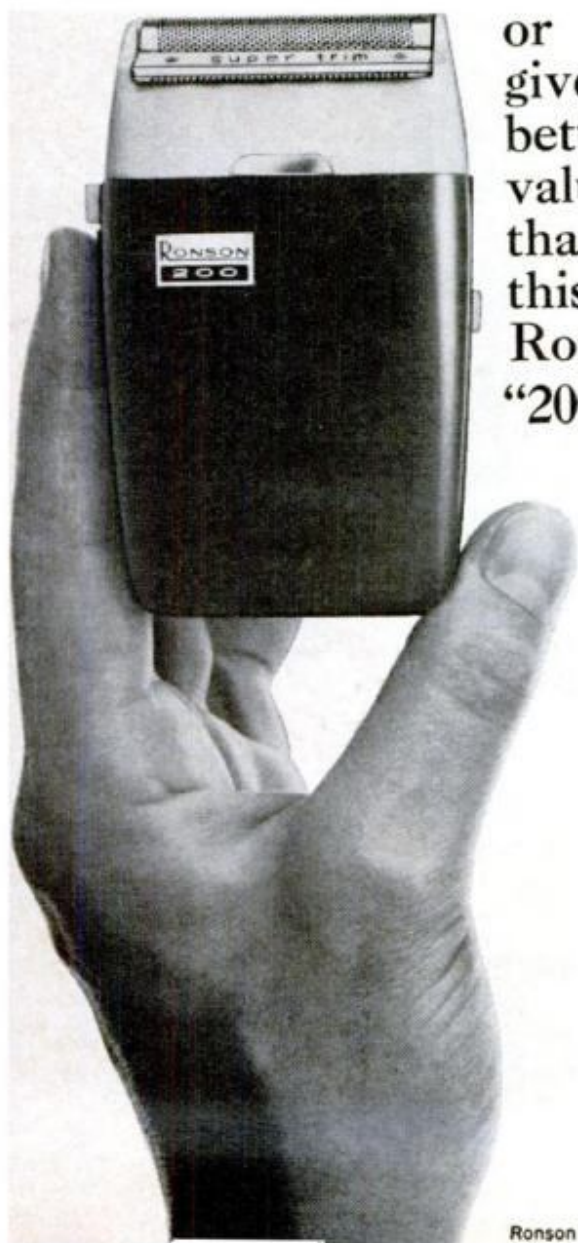

From Every Point of View ...America's Best Shaving Buy!

Tough beards! Wiry beards! Twice-a-day beards! Nothing shaves 'em faster, smoother, *closer* than the new Ronson "200" Electric Shaver! A sun-up to bedtime kind of shave . . . because no shaver but the Ronson has the "Miracle Cutter" —32 blades *micro-honed* for super-sharpness. Blades that get *closer* to the base of your beard through Ronson's exclusive "Micro-Thin" shaving screen, the thinnest made! And no other shaver has "Super-Trim" . . . man-size clippers that trim a sideburn or a mustache straight, clean, and neat! Both shaving screen and cutter are instantly and easily replaceable. And the Lexan case is unbreakable. The Ronson "200" with automatic power cleaning adds up to the finest electric shaver value in the world today! Get a free demonstration at your Ronson dealer's, and find out why . . .

The Ronson "200" Shaver is the closest friend your face ever had

BY THE MAKER OF FAMOUS RONSON LIGHTERS



Ronson Corp., Woodbridge, New Jersey,

— automatically better

also available in Canada

TOMORROW'S FORECAST:

HEAVY SNOW, GUSTY WINDS,
FREEZING RAIN, ICY ROADS



(SOUNDS LIKE MG WEATHER)

Winter takes a holiday—when you drive an MG Sports Sedan. Consider: front-wheel drive. This puts power into the *steering* wheels (where it belongs), sends the car arrow-straight to where you aim it. It puts weight over the driving wheels (where it works for you), delivers remarkable trac-

tion, even on super-slick surfaces. Consider: fluid suspension. No springs, no shocks here! Instead, a rugged sealed-in system gives you superlative road-holding ability. Result: your MG Sports Sedan holds steady in crosswinds... steps sure over snow and ice.

There is no safer winter car. You say you don't want one? Then don't take a chance—stay home.



FOR OVERSEAS DELIVERY AND OTHER INFORMATION, WRITE: THE BRITISH MOTOR CORP. / HAMBRO, INC., DEPT. J-7, 734 GRAND AVENUE, RIDGEFIELD, NEW JERSEY

DISSTON a welcome addition to any workshop



**DISSTON D-38
DIAL-A-POWER DRILL.**
Variable speed $\frac{3}{8}$ " drill with constant power from 600 to 2000 rpm. Slim profile for close work. Reg. \$69.95.
Christmas Special, \$62.94.



FOLDING CAMP AND PRUNING SAW WITH KITCHEN SAW.
Curved, single-edge saw with folding hardwood handle. Kitchen saw of nickel-plated steel, blade of stainless steel. Reg. \$6.70.
Christmas Special, \$5.98.



HACKSAW FRAME WITH 3 BLADES.
Nickel-plated steel frame. Adjusts for all blades and to 4 cutting positions. \$3.92 value.
Christmas Special, \$3.50.



DAGGER ELECTRIC SABER SAW.
Cuts wood, metal and plastic. 2.75 amps, 3600 strokes per minute. Metal carrying case. \$64.26 value.
Christmas Special, \$54.50.



DISSTON R-1 HANDSAW AND FREE COPING SAW.
Natural hardwood handle with curved handgrip. 8 point, crosscut. No. 10 Coping Saw included free. \$6.86 value.
Christmas Special, \$5.96.



ELECTRIC HEDGE TRIMMER AND FREE SHRUB RAKE.
Lightweight, with hardened steel blade. 115-volt AC-DC motor. Shrub rake included free. \$48.08 value.
Christmas Special, \$44.50.

DISSTON D-100 HANDSAW. Ground, chrome-nickel alloy steel blade. Walnut handgrip set in diecast aluminum frame. 8 points to the inch, crosscut. Reg. \$11.95.
Christmas Special, \$10.76.

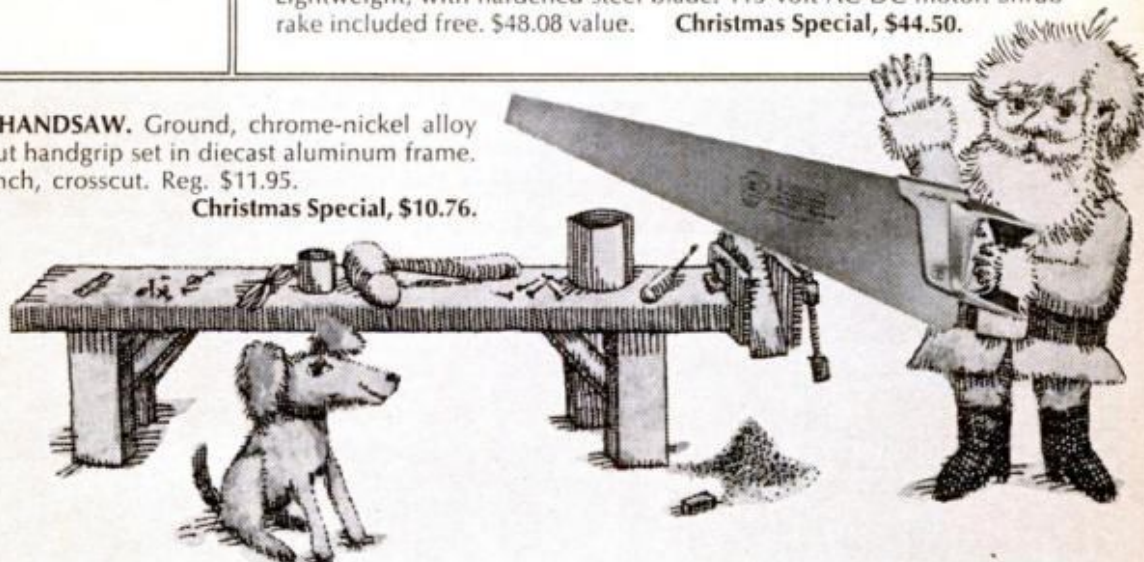

This One



CX3P-H8W-BDU6

PORTER

**HARDWARE AND INDUSTRIAL
PRODUCTS DIVISION**

H. K. PORTER COMPANY, INC.

POPULAR MECHANICS®

DECEMBER 1964
VOL. 122 NO. 6

575 LEXINGTON AVE.
NEW YORK, N.Y. 10022

INTERNATIONAL EDITIONS • AUSTRALIAN • SPANISH • CARIBBEAN • FRENCH • DUTCH

Features of Special Interest

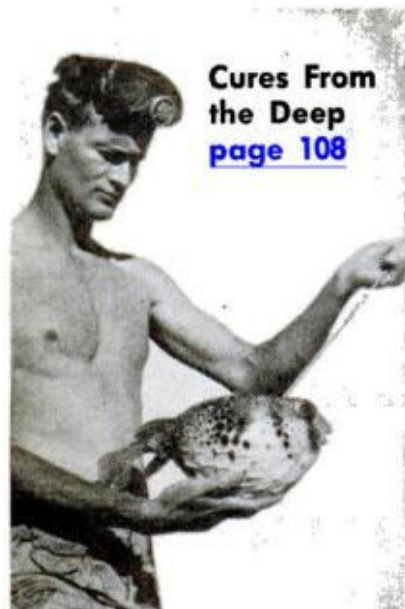

Cures From
the Deep
page 108

Bonneville Speed Carnival: How the World Land Speed Records Fell Like Rain . . .	69
Choice New Toys for Christmas . . .	74
Spotlight on a Wanderlust Bus . . .	77
First Metal Plane Anyone Can Build . . .	80
Driving Ford's Fabulous Turnpike Truck . . .	86
Which Household Battery Is Best for You? . . .	90
Double-Decker Station Wagon . . .	96
X Raying Our Giant Missiles . . .	98
Instant Skiing the Parallel Way . . .	100
Therapy from the Sea . . .	108
High Living in a Stilt House . . .	114
Madhouse Behind the Mailbox . . .	118
Foil the Car Thief . . .	176
Record Changer Plays 80 Tunes . . .	176
Multivider—Electronic Slide Rule . . .	178

For the Workshop Craftsman



Tile on Tile
page 136

Build a Basement Sauna Bath for the Family . . .	124
Christmas Door Decor Project-a-Plans . . .	130
Tips on Tiling over Old Floor Tile . . .	136
Piggy Bank Squeals on Thief . . .	140
Project-a-Plan Gifts for Christmas . . .	142
Coffee Table Rises Up for Dining . . .	146
Plant Tier to Brighten a Corner . . .	153
Cigar Humidor for Your Coffee Table . . .	154
Portable Folding Lectern . . .	156
Controlling Your Car's Distributor, Part I . . .	158
Multi-Adjustable Drilling Jig . . .	166
Heat Treating Steel in the Home Shop . . .	170

Regular Departments

Over the Editor's Desk . . .	10	New on the Market . . .	32
News from the Services . . .	12	Shopping for Tools . . .	34
Science Worldwide . . .	14	What's New for Your Home . . .	122
Noteworthy New Inventions . . .	16	New for Camera Buffs . . .	148
Sidelights on Aviation . . .	18	Solving Home Problems . . .	150
Clinic for Homeowners . . .	20	Auto Clinic . . .	164
Detroit Listening Post . . .	28	Shop Short Cuts . . .	168
Items from All Outdoors . . .	30	New in Electronics . . .	180

NEXT MONTH: 1965's snazzy cars are taken apart and put together by an expert mechanic who analyses their faults and virtues. January PM also carries a hot report on a new whispering engine, a rundown on latest ice fishing gadgets, an adventure with a frost-fractured airline, plus does and don'ts for hanging your own wallpaper.

PORTUGUESE • DANISH • SWEDISH

DON DINWIDDIE
Editor

RICHARD E. DEEMS
President, Magazines Division

JOSEPH F. KERN
Publisher

RICHARD F. DEMPEWOLFF
Executive Editor

JOHN A. LINKLETTER
Managing Editor

Published by Hearst Corp., **RICHARD E. BERLIN**, Pres.

WAYNE C. LECKEY . . . Shop Crafts Managing Editor

CLIFFORD B. HICKS . . . Midwest Editor

520 N. Michigan Ave., Chicago, Ill. 60611

THOMAS E. STIMSON . . . Western Editor

3460 Wilshire Blvd., Los Angeles, Calif. 90005

HENRY NEHRBASS . . . Art Director

KEVIN V. BROWN . . . Aviation Editor

ED NELSON . . . Automotive Editor

LARRY STECKLER . . . Electronics Editor

ALFRED W. LEES . . . Home Workshop Editor

ARTHUR MIKESSELL . . . Boating Editor

JOHN F. PEARSON . . . Science Editor

STUART JAMES . . . Outdoors Editor

ALEX MARKOVITCH . . . Associate Auto Editor

FRANK X. SMITH . . . Production Editor

ART MAHER, ROBERT BERGER . . . Associate Editors

MURRAY COOPER . . . Art Editor

LEO WEEKS . . . Assistant Art Director

FRANK P. FRITZ . . . Chief Photographer

GARRY WINTER . . . Book Editor

ADDRESS COMMUNICATIONS TO: 575 Lexington Ave., New York, N.Y. 10022. For additional sources of information on the articles in this issue, or the name and address of the manufacturer of a particular product, write to Bureau of Information, *Popular Mechanics* for free "Where-to-Find-It-List."

L. PARK BENJAMIN, Advertising Director

ADVERTISING OFFICES: New York: 575 Lexington Ave., MUrray Hill 8-8500; Chicago: 520 N. Michigan Ave., 527-2400; Detroit: General Motors Bldg., TRinity 5-8711; Cleveland: Hanna Bldg., 1422 Euclid Ave., PRospect 1-0456; Los Angeles: 3460 Wilshire Blvd., DUmkirk 2-8458; San Francisco: 1206 Hearst Bldg., YUkon 2-0823.

SUBSCRIPTION SERVICE: Mail all subscription orders, changes of address, correspondence concerning subscriptions, and Postmaster notices of undeliverable copies to *Popular Mechanics*, 250 West 55th St., New York, N.Y. 10019.

Popular Mechanics is published monthly by The Hearst Corporation, 57th St. at 8th Ave., New York, N.Y. 10019. U.S.A. Richard E. Berlin, President; George Hearst, V-Pres.; Richard E. Deems, President of Magazines; Fred Lewis, Executive V-Pres. of Magazines; John R. Miller, V-Pres. and Gen. Mgr. of Magazines; G. Harry Chamberlaine, V-Pres. for Research and Marketing; William S. Campbell, V-Pres. and Director of Circulation; Joseph F. Kern, V-Pres. for *Popular Mechanics*; Frank Massi, Treasurer; R. F. McCauley, Sec'y. Single copy in the United States and Canada, 35 cents. Subscription prices: United States and Possessions, \$4.00 for one year; \$7.00 for two years; \$10.00 for three years. Canada, add \$0.50 for each year. Pan American Postal Union countries, add \$1.00 for each year. All other countries, add \$2.00 for each year. When changing address, give old address as well as the new, with postal-zone number, if any, and allow six weeks for change to become effective. Second-class postage paid at New York, N.Y., and at additional mailing offices. Authorized as second class mail by the Post Office Department, Ottawa, and for payment of postage in cash. Registered as Second Class matter at the Post Office at Mexico, D.F., Mexico, June 20, 1950. ©1964 by The Hearst Corporation. All rights reserved. Printed in U.S.A.

Sam Hanks,
Indianapolis "500"
champion and
driving safety
expert says—



"Monroe front Load-Leveler® stabilizing units give me the same kind of car control that helped me win at Indianapolis."

"Monroe front Load-Leveler® stabilizing units give road-hugability you'd never think possible with your present car. They give you better control and add safety and enjoyment to driving. And they help hold wheels in alignment, save tire wear, and protect front-end parts in the bargain."

Have a set installed today in just 30 minutes where you have your car serviced.

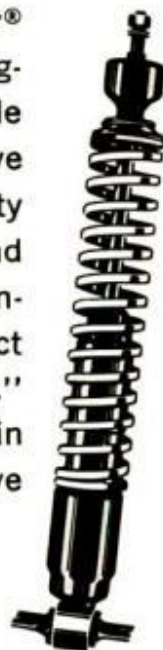

World leader on highway and speedway

MONROE AUTO EQUIPMENT COMPANY • Monroe, Mich.
In Canada, MONROE-ACME, LTD., Toronto, Ont.
In Mexico, MEX-PAR, Box 28154, Mexico City

600 hp Gas Turbine Powers Ford Motor Company's Experimental Superhighway Giant

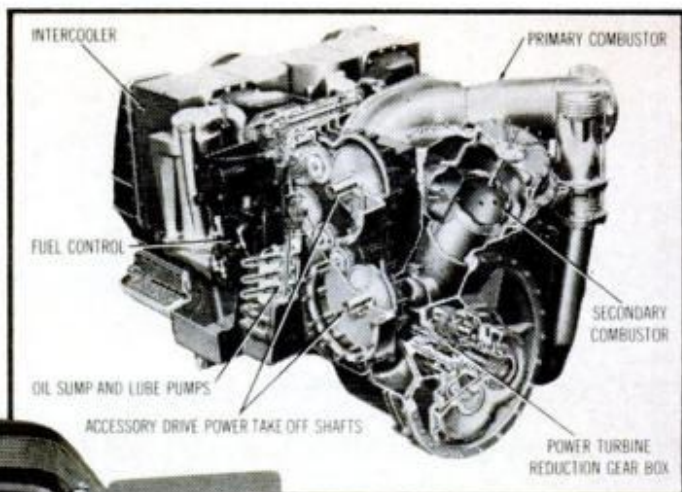

Ford Motor Company anticipates the highways of the future with this experimental tractor-trailer forecasting a new era in coast to coast big payload hauling. Powered by a Ford-developed supercharged 600 hp gas turbine, the rig has a range of 600 miles—a cruising speed of 70 mph. The power plant is virtually two engines in one. It can operate with only half of the engine running and develop 45 hp for refrigeration or other requirements. At the push of a reset button the full 600 hp is available.

The independently mounted two-man cab—with over six feet of headroom—is designed

for long-distance, non-stop operation. Equipment includes a fold-away table, lavatory, toilet, oven, refrigerator, TV for the co-driver and a heating and air conditioning system. Controls are similar to a conventional truck, and easily mastered by any truck driver. The superhighway truck's 70 mph cruising speed makes it compatible with the normal traffic flowrate of passenger cars. Other unique features are its odorless exhaust and extremely quiet operation.

Truly, here's a look at tomorrow—and another example of the spirit of progress you find in every Ford-built product.

FORD-BUILT MEANS BETTER BUILT



MUSTANG • FALCON • FAIRLANE • FORD • THUNDERBIRD
COMET • MERCURY • LINCOLN CONTINENTAL

MOTOR COMPANY

POPULAR MECHANICS



LA SALLE EXTENSION UNIVERSITY

A Correspondence Institution • 417 South Dearborn, Dept. 36-017, Chicago, Illinois 60605

Please send me, without cost or obligation. FREE booklet and full information on the field I have checked below:

ACCOUNTING

- Complete Accounting with CPA Training
- General Accounting
- Federal Income Tax
- Accounting Systems
- Auditing Procedure
- Controllership
- CPA Training
- Modern Bookkeeping

LAW COURSES

- Bachelor of Laws Degree
- Business Law
- Insurance Law
- Claim Adjusting Law
- Law for Police Officers
- Law for Trust Officers

SALESMANSHIP

- Sales Training

REAL ESTATE

- Complete Real Estate
- Real Estate Brokerage
- Real Estate Management
- Real Estate Sales

TRAFFIC AND TRANSPORTATION

- Complete Traffic Mgt.
- Rates and Tariffs
- Agency and Services
- Motor Truck Traffic

STENOTYPE

- Machine Shorthand

TECHNICAL COURSES

- Auto Body Repair
- Refrigeration
- Air Conditioning
- Diesel
- Welding
- Motor Tune-up

HIGH SCHOOL

- High School Diploma
- Vocational Course

CAREERS FOR WOMEN

- Dental Assistant
- Secretarial
- Accounting
- Bookkeeping
- Real Estate

BUSINESS MANAGEMENT

- Complete Business Management
- Credit and Collections
- Office Management
- Personnel Management
- Business Correspondence

DRAFTING

- Basic Drafting
- Electrical Drafting
- Mechanical Drafting
- Architectural Drafting
- Structural Drafting
- Aeronautical Drafting

Name.....Age.....

Address.....County.....

City & Zone.....State.....

Occupation.....Working Hours...A.M....P.M.

Canadian Residents, write: LaSalle, Box 1001, Montreal 3, Quebec

322

If you had mailed this coupon a year ago, your salary could be way up too!



WHY NOT MAIL IT TODAY?

Look at these enthusiastic letters. Have you ever seen anything like them? There are hundreds and hundreds more that pour in from LaSalle students week after week, month after month, year after year.

Do you know that many graduates attribute their increases in income largely to their LaSalle training?

All LaSalle students have one ambition in common—to get out of the ranks of the untrained and earn big money, prestige and security in a key job. Isn't that your goal too?

Without interfering with your present work—and by devoting only a little of your spare time—you too can prepare rapidly for advancement in the field of your choice through LaSalle home study. The cost is surprisingly low.

LaSalle has been an acknowledged leader in home education for more than half a century. It has provided training in business, high school, and technical subjects to more than 1,000,000 ambitious men and women. Its distinguished faculty includes some of the country's most outstanding authorities. That is why your LaSalle diploma is a credential recognized and respected everywhere.

Check the subject you are interested in—then send the coupon above for FREE booklet. No obligation.

"My salary has increased 400% as a direct result of my LaSalle studies"

Rudolph Urbatis,
Port Chester, N.Y.



"Salary more than doubled since enrolling"

William T. Black,
Canoga Park, Calif.



"Income has increased 100 per cent since graduation"

James L. Yanning,
Manhattan, Kansas



"I now earn three and a half times my former pay"

Robert Fisher,
Holbrook, Ariz.



LA SALLE EXTENSION UNIVERSITY

A Correspondence Institution • 417 S. Dearborn, Chicago, Illinois 60605

ACCOUNTING
Accounting
Cost Accounting
Federal Tax
General Accounting
Junior Accounting
Practical Accounting
Public Accounting

ARCHITECTURE AND BUILDING
Architectural Drawing & Designing
Architecture
Building Contractor
Building Estimator
Building Inspector
Building Maintenance
Carpenter-Builder
Carpentry & Millwork
House Planning & Interior Design
Mason
Painting Contractor
Reading Arch. Blueprints
Review in Arch. Design & Practice
Review of Mech. Systems in Buildings

ART
Amateur Artist
Commercial Art
Commercial Cartooning
Illustrating
Interior Decorating
Painting for Pleasure
Show Card & Sign Production
Show Card Writing
Sign Painting & Designing
Sketching & Painting

AUTOMOTIVE
Automatic Transmission Specialist
Automobile Body Rebuilding & Refinishing
Automobile Electrical Technician
Automobile Engine Tune-Up
Automobile Technician
Automotive Mechanic
Diesel-Gas Motor Vehicle Engines

AVIATION
Aircraft & Powerplant Mechanic
Introductory Aero-Engineering Technology

BUSINESS
Advertising
Basic Inventory Control
Business Administration
Business Correspondence
Business Law
Business Management & Marketing
Business Management & Production
Canadian Business Management
Condensed Business Practice
Industrial Psychology
Managing a Small Store
Marketing
Modern Executive Management
Office Management
Programming for Digital Computers
Programming the IBM 1401 Computer
Purchasing Agent
Retail Business Management
Statistics and Finance
Systems and Procedures Analysis

CHEMICAL
Analytical Chemistry
Chemical Engineering
Chemical Engineering Unit Operations
Chemical Laboratory Tech.
Chemical Process Control Technician
Chemical Process Operator
Elements of Nuclear Energy
General Chemistry
Instrumental Laboratory Analysis

CIVIL ENGINEERING
Civil Engineering
Construction Engineering
Highway Engineering
Principles of Surveying
Reading Highway Blueprints
Reading Structural Blueprints
Sanitary Engineering
Sewage Plant Operator
Structural Engineering
Surveying and Mapping
Water Works Operator

DRAFTING
Aircraft Drafting
Architectural Drafting
Electrical Drafting
Electrical Engineering Drafting
Electronic Drafting
Introductory Mechanical Drafting
Mechanical Drafting
Pressure-Vessel and Tank Print Reading
Sheet Metal Layout for Air Conditioning
Structural Drafting

ELECTRICAL
Electric Motor Repairman
Electrical Appliance Servicing
Electrical Contractor
Electrical Engineering (Power option or Electronic option)
Electrical Engineering Tech.
Electrical Instrument Tech.
Electrical Power-Plant Engineering (Steam option or Hydro option)
Industrial Electrical Tech.
Industrial Telemetering
Power Line Design and Construction
Practical Electrician
Practical Lineman
Reading Electrical Blueprints

**CAST
YOUR
BALLOT
FOR
A
SUCCESSFUL
FUTURE!**

236 I.C.S.

Special in-plant training programs for industry

Low rates for members of the United States Armed Forces



I.C.S. is the oldest, largest school of its kind. Over 236 courses for men and women. High school, business, secretarial, interior decorating, engineering. One for **you**. Direct, job-related. Bedrock facts and theory plus practical

application. You learn from experts. Diploma to graduates.

Clip and mail the coupon **now**. You'll receive, absolutely **FREE**, 3 valuable booklets that have helped thousands. But don't delay. Cast **your** "ballot" today!



ENGINEERING (Professional)

Chemical
Civil
Electrical
Industrial Management for Engineers
Mechanical

ENGLISH AND WRITING

Better Business Writing
Introductory Technical Writing
Modern Letter Writing
Practical English
Short Story Writing

HIGH SCHOOL

High School Business
High School College Prep. (Arts)
High School College Prep. (Engineering & Science)
High School General
High School Mathematics
High School Secretarial
High School Vocational

LANGUAGES

(Edited by Berlitz)
French
German
Italian
Spanish

LEADERSHIP

Basic Supervision
Industrial Foremanship
Industrial Supervision
Personnel-Labor Relations
Supervision

MATHEMATICS

Advanced Mathematics
Mathematics and Mechanics for Engineering
Mathematics and Physics for Engineering
Modern Elementary Statistics
Value Analysis

MECHANICAL

Industrial Engineering
Industrial Instrumentation
Machine Design
Mechanical Engineering
Quality Control
Safety Engineering Tech'I'gy
Tool Design

PETROLEUM

Natural Gas Production & Transmission
Oil Field Technology
Petroleum Production
Petroleum Production Engineering
Petroleum Refinery Operator

PLASTICS

Plastics Technician

PLUMBING, HEATING, AIR CONDITIONING

Air Conditioning
Air Conditioning Maintenance
Domestic Heating with Oil & Gas
Domestic Refrigeration
Gas Fitting
Heating
Heating & Air Conditioning with Drawing
Plumbing
Plumbing & Heating
Plumbing & Heating Contractor
Plumbing & Heating Estimator
Practical Plumbing
Refrigeration
Refrigeration & Air Conditioning
Steam Fitting

PULP AND PAPER

Paper Machine Operator
Paper Making
Pulp Making
Pulp & Paper Engineering
Pulp & Paper Making

RAILROAD

Car Equipment Fundamentals
Motive Power Fundamentals
Railroad Administration

SALESMANSHIP

Creative Salesmanship
Real Estate Salesmanship
Sales Management
Salesmanship
Salesmanship & Sales Management

SECRETARIAL

Clerk-Typist
Commercial
Professional Secretary
Shorthand
Stenographic
Typewriting

SHOP PRACTICE

Foundry Practice
Industrial Metallurgy
Machine Shop Inspection
Machine Shop Practice
Machine Shop Practice & Toolmaking
Metallurgical Engineering Technology
Patternmaking
Practical Millwrighting
Reading Shop Blueprints
Rigging
Tool Engineering Tech'I'gy
Toolmaking
Welding Engineering Technology
Welding Processes

STEAM AND DIESEL POWER

Boiler Inspector
Industrial Building Engineer
Power Plant Engineering
Stationary Diesel Engines
Stationary Fireman
Stationary Steam Engineering

TEXTILES

Carding
Carding and Spinning
Cotton Manufacturing
Dyeing & Finishing
Loom Fixing
Spinning
Textile Designing
Textile Engineering Technology
Textile Mill Supervisor
Warping and Weaving
Wool Manufacturing

TRAFFIC

Motor Traffic Management
Railway Rate Clerk
Traffic Management

TV-RADIO-ELECTRONICS

Communications Techn'I'gy
Electronic Fundamentals
Electronic Fundamentals (Programmed)
Electronic Fundamentals with Electronic Equipment Training
Electronic Instrumentation & Servo Fundamentals
Electronic Principles for Automation
Electronics and Applied Calculus
Electronics Technician
First Class Radiotelephone License
Fundamentals of Electronic Computers
General Electronics
General Electronics with Electronic Equip. Trng.
Hi-Fi Stereo and Sound Systems Servicing
Industrial Electronics
Industrial Electronics Engineering
Industrial Electronics Engineering Technician
Practical Radio-TV Eng'r'g
Practical Telephony
Principles of Radio-Electronic Telemetry
Principles of Semiconductor-Transistor Circuits
Radio Servicing with Radio Equipment Training
Radio & TV Servicing
Radio & TV Servicing with Radio Equip. Trng.
Second Class Radiotelephone License
Sound Systems Specialist
Telephony, Electronics and Radio Communications
TV Receiver Servicing
TV Technician

COURSES

Clip coupon—and take your first big step to real success! I.C.S., Scranton, Penna. 18515

Accredited Member, National Home Study Council

**FREE! THE I.C.S. SUCCESS KIT!**

Three valuable booklets sent to you free when you mark and mail the I.C.S. coupon. No obligation.

1. "How to Succeed"—A new, exciting booklet that lets you evaluate yourself and your future in an entirely different way!
2. Complete catalog outlining job opportunities and outlook in your field of interest.
3. Sample lesson to demonstrate the success-proved I.C.S. method of spare-time study.

INTERNATIONAL CORRESPONDENCE SCHOOLS ICS

Box 256, Scranton, Penna. 18515
(In Hawaii: P. O. Box 418, Honolulu. In Canada: I.C.S. Canadian, Ltd., Montreal.)

Without cost or obligation, send me "HOW to SUCCEED," the opportunity booklet about the field I have indicated below, and a sample lesson.

Course in which I'm interested: _____
(Select from listing above)

Your name _____ Age _____

Address _____

City _____ State _____ Zip Code _____

Occupation _____ Working hours _____ a.m. to _____ p.m.

Employed by _____

Over the Editor's Desk

Stair Chair

I built the *Chair That Climbs the Stairs* (page 119, August PM) and it works very well.

When I built this one, I put a 12-volt solenoid and ignition switch in the system so one must have a key to operate it. Otherwise, it would be easy for a child to



move the lever and get into the cable. I also put a guard over the spool to protect anyone from becoming caught in the cable.

Thank you for the very excellent plans. I have had PM every month for over 25 years.

Grantsburg, Wis.

CLAYTON G. RETZER

Rough, Too, in the Good Old Days

In your article *Shin-Bustin' Polo* (page 108, July PM), the authors state, "Cycle polo, unknown a short time ago, is catching on."

I beg to differ; back in 1929 my brother was considered the champion motorcycle poloist of the United States.

Lansdale, Pa.

FRANK E. MANSON

And it was a rough sport then, too, according to a clipping Reader Manson enclosed from the July 5, 1929, Philadelphia Public Ledger. The article tells how Harry Manson, captain of the Philadelphia Ramblers motorcycle team, was seriously burned when a gasoline leak set his clothing afire.

Marine Listener

After I had bought parts and put them in my radio (\$5 Conversion Puts AM Radio on Marine Band, page 172, July PM), I was pleased very much by the way the additional circuit works.

I have been receiving many radiotelephone conversations from the San Francisco area. Five dollars is little for the pleasure I have had.

Big Basin, Calif.

BARNEY TRIGEIRO

St. Louis Revisited

In the December, 1963 issue, Midwest Editor Cliff Hicks reported on the construction of "The Incredible Gateway Arch," America's mightiest national monument. The 630-foot Arch is under construction in St. Louis.

The article pointed out that if construction crews made an error of just $\frac{1}{64}$ inch in pouring the foundation of either of the two mighty legs of the Arch, the legs would fail to meet high in the sky when it was time to slip the keystone section into place.

Editor Hicks recently returned to check on the progress—particularly that $\frac{1}{64}$ -inch. The legs now are more than halfway to their meeting point 630 feet in the air. Construction is slightly behind schedule

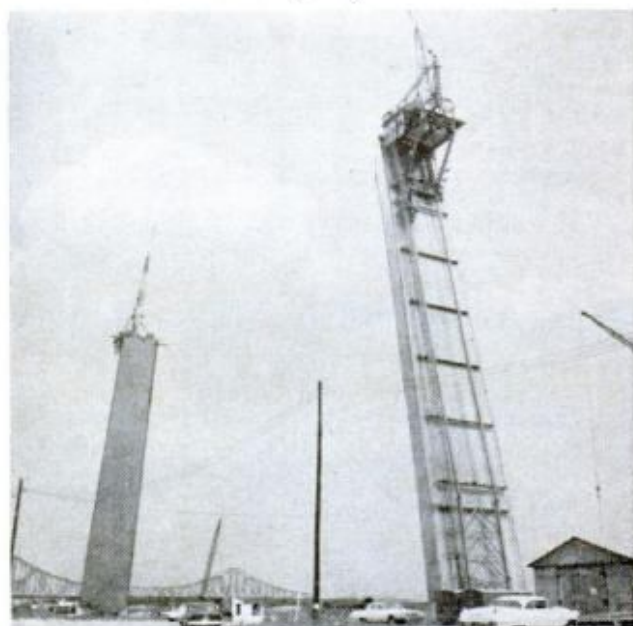

because work was stopped for a few weeks while engineers checked on that $\frac{1}{64}$ -inch, along with every other factor involved, to make sure that one of the tallest and most unique of all man-made structures will be absolutely safe. As a result of this re-evaluation, only a few minor changes were made in construction plans, and there is every indication that if you visit St. Louis on an as-yet undetermined date in the summer of 1965 you can see the mighty derricks hoist the keystone into place.

The Editor

POPULAR MECHANICS

Need a better job? Want to own a business? LOOK INTO AIR CONDITIONING AND REFRIGERATION FIRST!

Skilled men are in big demand in the air conditioning and refrigeration field. Industry leaders say that 20,000 mechanics must be trained each year. Here's why: During a 12-year period, production quadrupled. Only one other industry grew so fast. Last year, over 3 million air conditioning units and 5 million refrigerators and freezers were produced. Over 150 million units are in use. It takes skilled men to install, service and repair such equipment. They are well paid. They work steady. Why don't you qualify for one of the better-pay jobs? CTI trains you at home in spare time. For complete information, send coupon. No obligation.

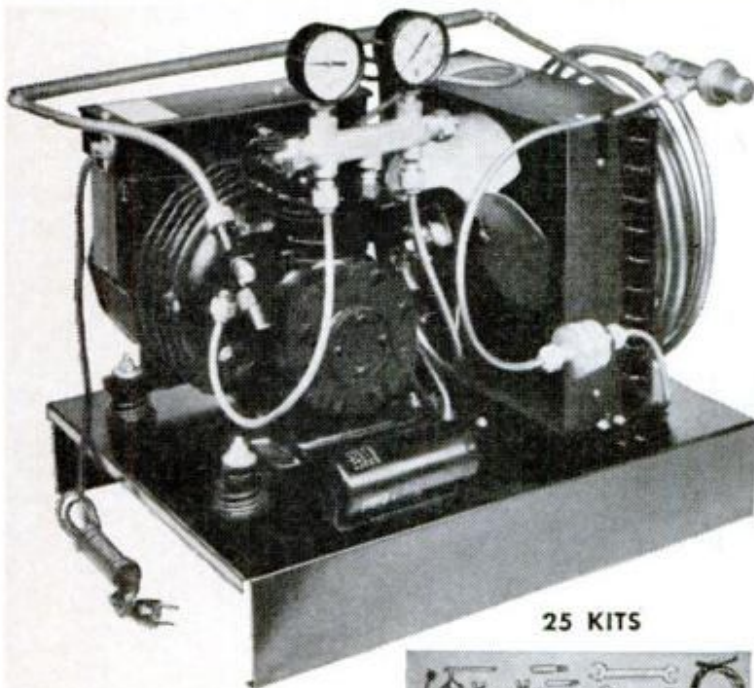

25 KITS

Above—This is how your heavy-duty refrigeration system will appear after it is built. All parts are new and late model. A work project accompanies each kit. Right—You also get mechanic's tools, including wrenches and flaring tubes; also gauges, propane torch.



An easy course — Written especially for beginners

You don't need a formal education, not even a grade school diploma. You don't need previous experience. All we ask is that you can read and write, and be willing to devote a few hours a week to training. If you have ambition, and can finish what you start, you can earn a CTI diploma.

You train at home — Build a complete refrigeration system

In addition to easy, illustrated lessons, CTI sends 25 kits of parts and tools to build a complete, operating refrigeration system. As you assemble your unit, you get practical experience and gain confidence. You become familiar with parts and their functions. You develop skill in using tools. On completing training, you can convert your system into an air conditioner, freezer or refrigerator (from plans we provide). CTI makes home your training center.

Many earn money while learning

Since the CTI course includes training with real equipment, many students start service work soon after enrolling. They go out on their own, or get a part-time job with a local dealer. Some arrange with food stores, taverns, restaurants, etc., to handle maintenance. Numerous students pay part or all of their tuition through spare-time earnings.



Recommended highly by students

"I operate my own sales and service shop. As a student I made more than the course costs."—Ray Ball, Kan.
 "... I have started a refrigeration business of my own. The prospects are good."—John Brooks, Ariz. . . .
 "The refrigeration course is excellent. I have had two pay raises."—Paul Zeleski, Ill. . . . "I am now working in the refrigeration field—for the man who advised me to take your course."—G. R. Fontenot, La. . . . "I have my own shop—earn about 60% more than when I enrolled."—David Fonseca, Pa. . . . "My income has doubled. I service in people's homes."
 —Donald Minner, California

Mail coupon for 3 free booklets



Investigate the opportunities available in air conditioning and refrigeration. Find out how easily you can train yourself for a better job, more pay or a business of your own. Discover how you can earn money as you train. Fill out and mail coupon today.

Commercial Trades Institute
Chicago 26, Illinois

Accredited Member National Home Study Council

COMMERCIAL TRADES INSTITUTE
1400 GREENLEAF AVENUE
CHICAGO, ILLINOIS 60626

DEPT. R-353

Without cost or obligation, mail me 3 valuable FREE booklets: *Success in Air Conditioning and Refrigeration*; *Lesson Samples*; and *Proof from Graduates*.

Name _____ Age _____

Address _____

City _____ Zone _____ State _____

Test your automotive I.Q.



Recognize this device?



What does this symbol stand for?

Ring compressor (top) is used to insert piston in cylinder. The life preserver is the symbol of Quaker State Motor Oil—the finest engine life preserver! Made only from 100% pure Pennsylvania Grade Crude Oil, Quaker State keeps your car on the road—out of the repair shop. Always ask for Quaker State Motor Oil—it keeps your car running young.



QUAKER STATE OIL REFINING CORP., OIL CITY, PA.



Sidelights from the SERVICES

By William R. Kreh

Ever wonder if a pilot really can "fly by the seat of his pants," as the old saying goes? Well, apparently he can, according to Dr. H. Strughold, a specialist in aeromedicine. He decided to find out if a pilot really does receive aid in the form of "gravity reports" from nerve impulses transmitted through his posterior. Dr. Strughold injected his backside with novocaine and when said sitter was completely anesthetized, he went aboard an airplane.

The pilot took off and performed a number of slow rolls, loops and other aerobatics. As the doctor sat on his frozen posterior and rolled around the sky, he discovered he had lost all ability to orient himself. Even though, in the course of other medical experiments, he had piled up many hours of aerobatic flying without undue discomfort, Dr. Strughold proved that when he lost his anchor of gravity, i.e., the seat of his britches, the psychological effect produced was one of fear, nausea and absolute disorientation.

Lead bricks—5000 of them—were flown recently to the Navy's Arctic Research Laboratory as part of a federal study to determine how much nuclear fallout has contaminated the food of Alaskan Eskimos and Indians.

The bricks are being used to shield the natives from outside radiation—particularly cosmic rays—while a sensing device measures the radioactive materials that have been absorbed into their bodies over a period of time.

Are birds the answer to ambush detection problems in Vietnam? Apparently the Army's Limited Warfare Laboratory thinks they could be. Pentagon officials have confirmed that a commercial firm has been awarded a \$175,000 contract to study Army findings that birds are able to detect the presence of humans and signal this recognition to other humans. Further details are classified, the Pentagon says.

A revolutionary electric generator has been developed by the Army. The device converts the heat of a gasoline flame directly to 150 watts of electricity. The silent generator has no moving parts, can operate four hours on less than a gallon of gasoline and weighs only 30 pounds.

Try a HEAT-PAL 2-in-1 stove AT OUR RISK!

See for yourself how much its superior performance means to you. Heat-Pal stoves guarantee more heat, more safety, more convenience than any comparable stove. They have been used and tested around the world. Now we want you to try and enjoy one this winter.



For Camps, Cabins, Tents. Heat-Pal provides instant, safe heat.



Cooks Complete Meals—You can't cook better at home.



**Heat-Pal Stoves Keep Cabins, Tents, Boats Warm
Cook Food Perfectly—Provide Safe Heat Anywhere**

Heat-Pal stoves give maximum heat with maximum safety! They produce this heat almost instantly—as soon as you light them—and you can regulate the heat by an outside volume control. They double as cook stoves, too.

Heat-Pals burn safe inexpensive denatured alcohol or alcohol solvent—you buy it in any hardware store—anywhere. This fuel goes into a special burner, which is crammed with absorbent non-flammable material. Heat-Pals don't burn the raw fuel, though. They burn vaporized fumes. Safest method known. There is no liquid to spill or leak. Tip Heat-Pal over and no fuel escapes.

A Field & Stream Magazine report says, Heat-Pal is so safe... "it will burn safely even though lying on its side."

Your Heat-Pal will warm you—cook for you—in tents, cabins, boats, trucks, cars or station wagons. Will keep you warm and comfortable anywhere.

There are three Heat-Pal models: *Regular Heat-Pal: Red lacquered finish, upper part heavy-duty spun aluminum, has carrying strap for easy transport. Approximately 9" x 11 1/4" x 9". Weight 5 lbs. Delivers 3600 BTU's per hour. Runs up to 20 hours on 1 1/2 pints of fuel. Price \$19.95.* *Heat-Pal 5000: Same construction but larger size: 9" x 13 1/4" x 9". Weight 7 lbs. Delivers 5,000 BTU's per hour. Runs up to 30 hours on 2 3/4 pints of fuel. Price \$27.95.* *Boat Heat-Pal: Same specifications as Regular Heat-Pal but made of heavy gauge aluminum enamelled in boat blue, all working parts of brass or stainless steel. Can't rust ever. Price \$24.95.*

Add \$1 PP & Hdlg per stove. Use coupon to order.

Electric Motor & Battery Warmer CAR STARTS FAST IN COLDEST WEATHER

Amazing new "Electromatic" gives you continuous, automatic protection—guarantees that you start motors instantly—in coldest weather. Cars, trucks, tractors, generator or pump motors never freeze or balk with this protection. Just put this on your



Only \$4.95 plus 35c PP & Hdlg.

motor, plug it into any line and you can forget freeze troubles. It keeps motor warm, protects battery, keeps crankcase oil, gas line and engine block warm and protected. Saves time, temper—and costly repairs. Operates for pennies a month—unfailingly! Waterproof and acid-resistant. Ready to serve you every winter—in coldest weather for years and years. 15" x 24" with UL approved cord. Only \$4.95 plus 35c PP & Hdlg.

PERMANENT MATCH

Lights Up to 10,000 Times. Ingenious match lasts for many years. Just pull it out of its slim case, strike on the side... it's lit! Replace into case to extinguish. Guaranteed to light up to 10,000 times. Only 1 1/2" high, feather-light. Metal construction. Has its own small ring for easy attachment to any key chain. You always have a light in any weather. Only 69¢, 2 for \$1.25

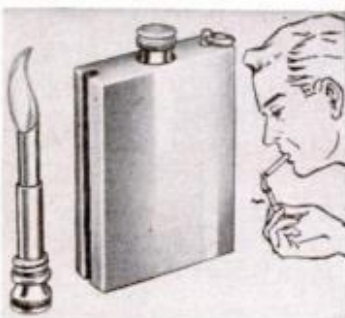

EMPIRE MDSG. CO., Tuckahoe, N. Y.



CHESSMEN OF ANCIENT ROME

This new chess-set design has remarkable beauty—striking design—delicately faithful detail. And its size is impressive. Yet, the price of a complete set starts at only \$5.95!

Meticulously fashioned after the classic sculpture of Rome. The King is Augustus; the Queen, Livia; the Bishop, Cicero; the Knight, a mounted Roman Soldier; the Rook, a Forum column; the Pawn, a Roman foot soldier. They are Styrene, in Alabaster White and Granite Gray. All with felted base.

CLASSIC SET: King 4 1/8" high; Queen, 3 7/8"; all other chessmen in proportion. Included with set are a 15 7/8" square chessboard and 16-page booklet, giving historic outline of each chessman and basic rules for chess. **\$5.95** plus \$1 PP & Hdlg.

STANDARD SET: Same as above, but all pieces heavily weighted **\$9.95** plus \$1 PP & Hdlg.

DELUXE SET: King, 4 7/8" high; Queen, 4 1/2"; Bishop, Knight and Rook, App. 4 1/8"; Pawn, 3 1/8". Heavily weighted and felted. Included are folding playing board, 16 1/2" square and Chess Booklet. In leatherette case, with 2 lift-out trays. **\$14.95** plus \$1 PP & Hdlg.

SPECIAL GOLD & SILVER SET: Same size as above, but Hand-Antiqued gold and silver figures; extra-heavily weighted and felted. Included are black-and-gold 16 1/2" board & Chess Booklet. In elegant green Morocco leatherette presentation case. **\$25.00** plus \$1 PP & Hdlg.

Heavy-Duty Portable Garage

12x25 Ft. Protects Cars, Boats, Trucks From ALL WEATHER

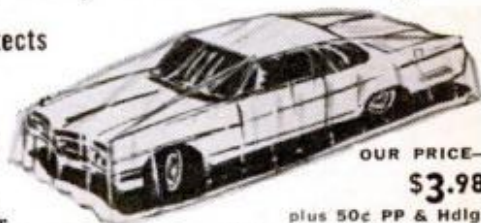

OUR PRICE—**\$3.98**

Slips onto any car or boat instantly to give you all-weather protection. Made of heavy-gauge durable, clear plastic. Waterproof, weatherproof, resists tears and scuffs. Huge 12x25 ft. size fits every make of car, station wagons, panel trucks, etc. Protects in coldest weather. Tested to 60 deg. BELOW ZERO! Folds easily when not in use—stores in trunk compartment. Saves cost of rust, repairs, repainting—useful for outdoor furniture, garden tools, etc. Now take your car or boat protection wherever you go. AND SAVE MONEY! Also available: Double-weight plastic with 6 tie-down grommets—\$5.95 plus 70¢ pp & hdlg. 9 x 12 Tarp with 4 grommets, \$2.49 plus 35¢ pp.

MAIL THIS HANDY ORDER COUPON

EMPIRE MDSG. CO., Dept. PM-1264
125 Marbledale Rd., Tuckahoe, N. Y.
Please send items listed below (or listed on the attached sheet) on a satisfaction guaranteed basis. I enclose pay't of \$.....

Name.....
Address.....
City..... State.....



Christmas trees from the freezer. If you bought your tree at a supermarket and it's between three and four feet high, chances are it came from the freezer vaults of Roy Halvorson in Duluth, Minn. His company ships to cities throughout the country and exports to Central and South America.

The trees are black spruce, which grow in northern Minnesota, Halvorson told *Popular Mechanics*. They're cut in the spring and fall, then coated with a preservative and frozen.

Fish are built all wrong for fast swimming, according to some scientists, and supposedly can't do any better than 25 to 30 m.p.h. But a Los Angeles zoologist, Dr. Vladimir Walters, has clocked a hooked tuna at 46 m.p.h. He read the speed from a simple rig that recorded how fast the line was coming off the reel.

Discovery of a new nuclear fragment was recently credited to an international team of physicists and engineers working at the European Center for Nuclear Research in Switzerland. Named the *epsilon* particle, the fragment has a mass approximately four-fifths that of the nuclear building blocks, protons and neutrons, and is the sixteenth member of the family of nuclear particles called mesons to be identified.

Mystery in the Indian Ocean. Russian and British research vessels report finding huge areas—as large as 75,000 square miles—covered by millions of dead fish. Scientists have arrived at this explanation: Mineral-rich but oxygen-poor deep water rises and promotes the growth of plankton (minute organisms). As the plankton dies and decomposes, it uses up more oxygen, causing fish to asphyxiate.

Scientists at Cornell University report that they've been able to keep whole eggs fresh for more than two years. Their method: pack the eggs under high vacuum and store them at 40 degrees F.

For a lot of guests, or for someone with a real yen for hard-boiled egg, British food experts have produced a composite egg a foot long. The yellows of eight eggs are boiled in a 12-inch-long cylinder. The resulting stick of yellow is placed on end in another cylinder and the whites are poured around it. Another boiling and you have a big sausage-shaped egg that's handy for slicing.

An antenna described as the "free world's most advanced radio communications instrument of its kind" has been installed at Tyngsboro, Mass. The 120-foot aluminum saucer is said to be capable of detecting a quarter-inch metal sphere 1000 miles in space.

Super snooper. It's now possible to measure TV audiences without contacting a single viewer. A California firm has developed an electronic device that can detect the tiny signals that are emitted by television receivers. Installed in a truck, the device can quickly tell which houses have TV turned on and which channels are being watched.

Doctors at New York's Albert Einstein College of Medicine are doing research on the feathers of a rare African bird, the loerie. It seems that the loerie is not "color fast"—the red in its feathers washes off. After a rain, it takes several days for the bird to get his color back.

The red pigment is closely related to the red of hemoglobin, which gives color to human blood. Experiments with the loerie red may help explain the nature of nutritional blood ailments.

Sign of the times. One *PM* editor recently renewed an accident insurance policy that provides coverage for air travel. In addition to the usual exclusions involving such things as suicide and war, he noted a new one: "This policy does not cover loss caused by or resulting from travel or flight in any vehicle or device for navigation beyond the earth's atmosphere."

By adding a TV attachment to an electron microscope, engineers at RCA have developed an instrument capable of magnifying an image two million times. Under such magnification, a one-inch paper clip would appear 32 miles long. Standard electron microscopes can magnify objects 200,000 times.

John F. Pearson
Science Editor
POPULAR MECHANICS

GET READY FOR THE SPACE and SCIENCE ERA! SEE SATELLITES, MOON ROCKETS



AMAZING SCIENCE BUYS

for FUN, STUDY or PROFIT

AUTOMATICALLY SHOWS TIME, TIDES, POSITION OF SUN, MOON, STARS



NEW SPILHAUS SPACE CLOCK

19 READINGS AT A GLANCE
3-DIALS—COMPLETELY-ILLUMINATED

Startling scientific achievement, yet completely practical and functional. Designed for the space age by world renowned scientist, Dr. Athelstan Spilhaus, Dean of Technology, University of Minnesota. Handsome conversation piece—constantly up-to-date encyclopedia of the sky. The Spilhaus Space clock has beautiful fruitwood case and 3 illuminated sky-blue dials. Blends with decor of any home, office, club room, classroom, museum, display window, hotel, etc.

Large dial shows sun position, daily sun rise and set, moon position, moon rise and set, phase of moon, low and high tide time, current stage of tide, day and month of year, current position of stars in sky, time of star rise and star set, relationships of sun, moon and stars, sidereal or star time. Left dial shows local time. Right dial shows world time including major U.S. cities and Universal (Greenwich) time. Operates on house current—requires only one simple setting for any geographic location. Measures 16" high x 11 1/2" wide x 4 1/2" deep. Presentation plaques available.

Stock No. 1202-H, Shp. Wt., 12 lbs. \$195 F.O.B. (+ \$5 F.E.T.)
SPECIAL 220-V., 50-cycle motor—illuminated dials
Stock No. 1203-H (Foreign orders deduct tax) \$215 F.O.B. (+ \$5 F.E.T.)

SCIENCE TREASURE CHESTS

For Boys—Girls—Adults!



Science Treasure Chest—Extra-powerful magnets, polarizing filters, compass, one-way-mirror film, prism, diffraction grating, and lots of other items for hundreds of thrilling experiments, plus a Ten-Lens Kit for making telescopes, microscopes, etc. Full instructions included.

Stock No. 70,342-H \$5.00 Postpaid

Science Treasure Chest DeLux—Everything in Chest above plus exciting additional items for more advanced experiments.
Stock No. 70,343-H \$10.00 Postpaid

OPAQUE PROJECTOR

Projects illustrations up to 3" x 3 1/2" and enlarges them to 35" x 30" if screen is 6 1/2 ft. from projector; larger pictures if screen is further away. No film or negatives needed. Projects charts, diagrams, pictures, photos, lettering in full color or black-and-white. Operates on 115 volt, A.C. current. 6-ft. extension cord and plug included. Operates on 60 watt bulb, not included. Size 12" x 8" x 4 1/2" wide. W. 1 lb., 2 oz. Plastic case.



Stock No. 70,199-H \$7.95 Postpaid

FASCINATING NEW KALEIDOSCOPE INSERT. Same set as above, but provides endless additional projects with everchanging kaleidoscope patterns.
Stock No. 70,714-H \$10.00 Ppd.

BUILD A SOLAR ENERGY FURNACE

A fascinating new field. Build your own Solar Furnace for experimentation—many practical uses. Easy! Inexpensive! Use scrapwood! We furnish instructions. This sun powered furnace will generate terrific heat—2000° to 3000°. Fuses enamel to metal. Sets paper aflame in seconds. Use our Fresnel Lens 11" sq. F.L. 19".

Stock No. 70,533-H \$6.00 Postpaid

WOODEN SOLID PUZZLES

12 different puzzles that will stimulate your ability to think and reason. Puzzles, animals and geometric forms to take apart and reassemble, give a chance for all the family, young or old, to test skill, patience.

Stock No. 70,205-H \$3.00 Postpaid

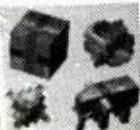

SOLVE PROBLEMS! TELL FORTUNES! PLAY GAMES!

NEW WORKING MODEL DIGITAL COMPUTER

ACTUAL MINIATURE VERSION OF GIANT ELECTRONIC BRAINS



Fascinating new see-through model computer actually solves problems, teaches computer fundamentals. Adds, subtracts, multiplies, shifts, complements, carries, memorizes, counts, compares, sequences. Attractively colored, rigid plastic parts easily assembled. 12" x 3 1/2" x 4 3/4". Incl. step-by-step assembly diagrams, 32-page instruction book covering operation, computer language (binary system), programming, problems and 15 experiments.

Stock No. 70,683-H \$5.00 Ppd.

WAR SURPLUS ELECTRIC GENERATOR

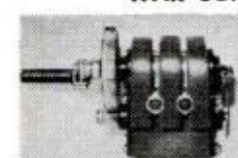

Brand new Signal Corps Electric Generator for scientific experiments, electrical uses, demonstrations. Generates up to 90 volts by turning crank. Use in high impedance relays. Charge ground and bring up night crawlers for bait or study. 2 Alnico Magnets alone worth original price. Wt. 2 lbs. Cost to Govt. \$15. Stock No. 50,225-H. \$6.95 Pstpd. Same type generator, mounted, with light, as electricity demonstrator.

Stock No. 50,365-H \$11.95 Postpaid

ORDER BY STOCK NUMBER. SEND CHECK OR MONEY ORDER. SATISFACTION GUARANTEED.
EDMUND SCIENTIFIC CO., BARRINGTON, N. J.

See the Stars, Moon, Planets Close Up!

3" ASTRONOMICAL REFLECTING TELESCOPE



60 TO 180 POWER!
Famous Mt. Palomar Type!
An Unusual Buy!

See the Rings of Saturn, the fascinating planet Mars, huge craters on the Moon, phases of Venus. Equatorial Mount with lock on both axes. Aluminized and over-coated 3" diameter high-speed f/10 mirror. Telescope comes equipped with a 60X eyepiece and a mounted Barlow Lens. Optical Finder Telescope included. Hardwood, portable tripod. FREE with Scope: Valuable STAR CHART plus 272-page

"HANDBOOK OF HEAVENS" plus "HOW TO USE YOUR TELESCOPE" BOOK.
Stock No. 85,050-H \$29.95 Postpaid
4 1/4" REFLECTING TELESCOPE—Up to 255 Power.
Stock No. 85,105-H \$79.50 F.O.B., Barrington, N.J.

WAR SURPLUS AMERICAN-MADE 7x50 BINOCULARS

Big savings! Brand new! Crystal clear viewing—7 power. Every optical element is coated. An excellent night glass—the size recommended for satellite viewing. Individual eye focus. Exit pupil 7mm. Approx. field at 1,000 yds. is 376 ft. Carrying case included. American 7 x 50's normally cost \$274.50. Our war surplus price saves you real money.
Stock No. 1544-H Only \$74.80 Ppd. (tax incl.)
6 x 30 Binoculars—similar to above.
Stock No. 963-H \$33.00 Postpaid (tax incl.)
7 x 35 American Made Binoculars.
Stock No. 964-H \$60.50 Ppd. (tax incl.)



HOME WEATHER STATION

New "Weather Station" is highly sensitive to weather changes. Consistently accurate thermometer to ± 2%, barometer accurate to ± 25% and hygrometer to ± 5%. Foretells weather changes from 12 to 24 hours in advance. Hygrometer calibrated in percent relative humidity. Excellent for teaching weather phenomena and meteorological hobby work. Instrument mounted on handsome wood-grained wall panel 15 1/2" x 5 3/4". Meter cases heavily metalized—combines beauty and protection. Dials in etched aluminum, of high precision. Full instructions.
Stock No. 70,607-H \$9.95 Postpaid



MAKE YOUR OWN POWERFUL ASTRONOMICAL TELESCOPE



Kits contain mirror blank, tool, abrasives, diagonal mirror and eyepiece lenses. You build instruments ranging in value from \$75.00 to hundreds of dollars.

Stock No.	Diam.	Mirror Thickness	Price
70,003-H	4 1/4"	3/4"	\$ 7.50 ppd.
70,004-H	6"	1"	11.95 ppd.
70,005-H	8"	1 3/8"	19.50 ppd.
70,006-H	10"	1 3/4"	30.75 f.o.b.
70,007-H	12 1/2"	2 1/8"	59.95 Barrington

MINIATURE WATER PUMP



Wonderful for experiments, miniature waterfalls, fountains, HO gauge railroad backdrops, etc. Tiny (2 1/2" x 1 3/4") electric motor and pump ideal for hobbyists, labs, schools. Pumps continuous flow of water at rate of one pint per minute at a 12" head. With 2 D Batteries in series will pump to 24" high. Runs 48 hrs. on battery. Works in either direction. Self-priming. Stock No. 50,345-H \$2.25 Postpaid

'FISH' WITH A WAR SURPLUS MAGNET

Go Treasure Hunting On The Bottom

Great idea! Fascinating fun and sometimes tremendously profitable! Tie a line to our 5-lb. Magnet—drop it overboard in bay, river, lake or ocean. Trawl it along the bottom—your "treasure" haul can be outboard motors, anchors, fishing tackle, all kinds of metal valuables. 5-lb. Magnet is war surplus—Alnico V Type—Gov't. Cost—\$50. Lifts over 125 lbs. on land—much greater weights under water. Order now and try this new sport.
Stock No. 70,571-H. 5 lb. Magnet \$12.50 Postpaid
Stock No. 70,570-H. 3 1/2 lb. Lifts 40 lbs. \$ 8.75 Postpaid
Giant 15 lb. Magnet Feat. Oct. POP. MECH
"3RD HAND FOR SHOP CHORES"



STOCK NO. 85,152-H . . . (lifts over 250 lbs) \$33.60 F.O.B.

MAIL COUPON FOR FREE CATALOG "H"

Completely new 1965 Edition, 148 pages.
Nearly 4000 Bargains.

EDMUND SCIENTIFIC CO., Barrington, N. J.
Please rush Free Giant Catalog "H".

Name
Address
City Zone State

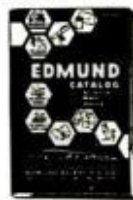



automatic adjustable wrench

Jaw locks automatically under turning pressure ■ Only automatic adjustable wrench with the magic "Golden Knurl" ■ No levers ■ No gadgets ■ No need to reset ■ No jaw creep ■ Proto guaranteed *professional tool* quality ■ All sizes

Buy from hardware stores
and auto parts stores.

©CLIK-STOP is a registered Trade Mark
of Pendleton Tool Industries, Inc.

Noteworthy New INVENTIONS

By M. J. Pedersen

A ship on a collision course with another moving object, can be warned automatically by a relatively inexpensive radar modification which was awarded patent 3,149,325 for John F. Kellogg of Bethesda, Md. When two objects are moving in straight lines so as to reach the same point at the same time, the angles between the paths of the objects and a line joining the objects remain constant, regardless of the relative speeds and directions as long as these do not change. In such an event, an alarm is tripped by the new device.

Space vehicle changes its shape so it can travel at the high speeds necessary to reach orbit or at the much slower speeds for controlled flight and landing. It unfolds sections into a winged configuration. The vehicle earned patent 3,147,936 for Earl J. Mercille, Creve Coeur, Mo.

A free-piston hydraulic pump that could be used to power automobiles is not mechanically connected to convert the power it generates into useful work, as in the transmission of most automobiles. Its power is used directly; the free piston engine is linked to a hydraulic pump in a single interacting unit. Receiving patent 3,145,660 on his invention, Dr. Vannevar Bush of Belmont, Mass., says that a free piston is more efficient than conventional engines and operates on cheaper fuel.

Spotting decoys surrounding a bomb-carrying missile to confuse detection and tracking instruments can be accomplished by a laser light beam. The usual decoy being an inflatable balloon with a reflective coating, the intense coherent light from a laser has sufficient energy to knock it off course. This deflection can be detected by noting the changes in frequency of the reflected light beam. Rodger C. Finvold of San Diego, Calif., received patent 3,150,363 for the system.

A hydrofoil attachment for boats, comprised of a frame with a pair of side rails extending parallel to the sides of the boat hull and a means for connecting it to the hull, was awarded patent 3,150,626 for Finn T. Irgens, Milwaukee, Wis.

ARROW
ALL PURPOSE
STAPLE GUN T-50

HEAVY DUTY

Model T-50
\$12.50

Uses 6
Staple Sizes —
1/4" to 9/16"
and Ceiltile

OTHER
MODELS
FROM \$4.95

**SHOOTS A STAPLE
WHEREVER YOU'D DRIVE A NAIL!**

FASTER! CHEAPER! BETTER!
for 1001 Home Improvement Fastening Jobs:
Ceiling Tile, Insulating, Upholstering, Screening, etc.

Available at hardware, lumber, building supply,
stationery and other retail outlets.

ARROW FASTENER CO., INC.
One Junius Street • Brooklyn 12, N. Y.

TUNE UP ELECTRONICALLY ANY CAR EVER MADE...

domestic or foreign; compact or limousine; 4 cylinder, 6 cylinder or 8 cylinder; 6 volt or 12 volt.

With New
Improved
Model BT-162

DWELL TACHOMETER



NOTE:
GIANT 6 1/2"
METER FOR
EASY,
ACCURATE
READINGS

At last a streamlined instrument designed to provide the most important services for "tuning up" any and every car ever made from a Model A Ford up to and including the current automatic transmission cars produced today.

The Model BT-162 includes the very latest design Dwell Meter, working in conjunction with a dual range Tachometer and incorporating all modern improvements in circuitry design.

Assure easy starts, optimum performance and maximum gas economy with Model BT-162.

The Model BT-162 will perform the services specified below in addition to many other tasks too numerous to mention:

- Assure precise adjustments of points that are slightly worn or pitted.
- Indicate the most effective point setting without removing the distributor cap.
- Indicate the correct settings for external adjustment type distributors. (A feeler gauge cannot be used for making correct adjustments on this type of distributor since many manufacturers' specifications do not list the point gap in inches. They list only the dwell angle in degrees.)
- Insure maximum gas economy and quiet engine running. Read the exact RPM while the engine is in neutral position. Then adjust the carburetor in conformity with the car manufacturer's recommendations.
- To locate a "miss" you need only disconnect or "short" the spark plugs one at a time with the Model BT-162 switched to the Tachometer position.
- Cars with automatic transmissions function efficiently only if the fluid pressures are correctly maintained and since manufacturer's instructions always refer to RPM, the Model BT-162 (or an equivalent tachometer) is required to properly service automatic transmissions.

The Model BT-162 is the most complete unit in its price range ever produced. It comes absolutely complete, ready to use. Only

\$29⁹⁵

Specifications

The Model BT-162 provides three dwell angle scales; 0 to 45 degrees, 0 to 60 degrees, and 0 to 90 degrees. The three dwell angle ranges specified above make this instrument suitable for making accurate dwell angle adjustments on all 4 cylinder, 6 cylinder, and 8 cylinder cars, both foreign and domestic.

The dual range tachometer is extremely versatile since it provides both a low range of 0 to 1000 RPM, necessary for making precise carburetor adjustments and the high range tachometer, 0 to 5000 RPM suitable for making all other tests at high engine speeds.

SEND NO MONEY WITH ORDER
PAY POSTMAN NOTHING ON DELIVERY

Try it for 10 days before you buy. If completely satisfied then send \$5.00 and pay the balance at the rate of \$5.00 per month until the total price of \$29.95 (plus small P.P. and budget charge) is paid. If not completely satisfied, return to us, no explanation necessary.

ACCURATE INSTRUMENT CO., INC.

Dept. D-380, 911 Faile St., Bronx, N.Y. 10474

Please rush me one Model BT-162. If satisfactory I agree to pay \$5.00 within 10 days and balance at rate of \$5.00 per month until total price of \$29.95 (plus small P.P. and budget charge) is paid. If not satisfactory, I may return for cancellation of account.

Name _____

Address _____

City _____ Zone _____ State _____



**ONLY
12½ POUNDS**



NEW HOMELITE SUPER XL-12

Here is the perfect combination of light weight and super power . . . the best saw yet for clearing land, building cabins, cutting fence posts or firewood. Pick it up. Weighs only 12½ pounds less bar and chain. Try it. Feel its power. Cuts 15" softwood in 15 seconds, 15" hardwood in 20 seconds. Fells trees up to 4 ft. in dia.

The Super XL-12, rugged and perfectly balanced, has a new, more powerful engine, plus a new muffler to smother noise. Added, of course, are all the famous Homelite professional features that make it easier to start, run, control and operate regardless of cutting position.

With its flush-cut handle, you can cut flat with the ground. You can have 12" to 24" straight blades, 14" plunge cut bow, or clearing bar. Consult your yellow pages for names of your nearest dealers.

FREE! Write for your copy of colorful, 8-page booklet, "Man's Guide to Woodcutting".



HOMELITE A Textron
DIVISION 
10212 RIVERDALE AVE., PORT CHESTER, N.Y.

Sidelights on

AVIATION

The build-it-yourself airplane described in the story beginning on page 80 was designed by John Thorp who, if nothing else, is an honest man—blunt, but honest. He claims a maximum of nine Gs for his all-metal T-18 monoplane, but hastens to point out that this means a six-G limit load. Most designers and/or manufacturers of new airplanes would simply say "it's aerobatic up to nine Gs" and stop.

Thorp, in his blunt but honest way, plows right ahead. (His blunt letter to us started out, "Apparently no one has explained to you the significance of six-G limit load and nine-G ultimate . . .")

Well, now that you mention it . . .

Here's Thorp's explanation: "Theoretically, a structure . . . which was designed to carry nine Gs without breaking would start showing permanent deformation at two-thirds of its breaking strength (six Gs). Hence, if we design for six Gs limit . . . we could theoretically pull six Gs as many times as we want without hurting the structure. If we exceed six Gs (say seven) in some maneuver . . . we would not expect the structure to break, but we would expect to find permanent deformation in the structure when we got down. Maybe the structure would be repairable—maybe not.

"If, in a pinch, we were called upon to pull nine Gs under the same conditions we would expect the airplane to stay together, but we would know for sure that when we got down it would be so bent up that it probably would not be worth repairing. If we exceeded nine Gs, the structure would have every right to a catastrophic in-flight failure.

"Hence, we can maneuver as much as we want up to six Gs without hurting anything. The ultimate strength of the same structure would be nine Gs."

Any questions?

Incidentally, as the story indicates, only one T-18 had been completed at the time of writing, but by the time this issue hits the mails and the newsstands a few more may be flying. We expect to have a follow-up report on these other planes—each one built by a different maker—to see how closely their performances match the first completed version.

Kevin V. Brown
Aviation Editor

POPULAR MECHANICS

Should you have a Driver's License before you own a Strombecker?

Talk about realism and you're talking about Strombecker model road racing! Ask any Strombecker team driver and he'll tell you that the action begins and ends with official 1/32 scale Strombecker racing—with 200 mph speeds, head-on, skill demanding competition—split-second decisions—and all the accurate detailing and authentic racing excitement you can ask for.

Strombecker is America's first, finest and fastest model road racing. Choose from four basic sets and build a family hobby with 18 International Grand Prix racing machines; such as, the Lotus MK XIX, Porsche RS61, Lotus Ford and GT competition cars; automatic lap counters; track lights and buildings and every other pit and track accessory you can ask for.

A driver's license? Take a Strombecker for a fast turn at your dealer—and you be the judge!



STROMBECKER®



Formula I Racing Set for Family Fun and Racing Realism features 500 mile Indy Racer and Cooper Formula I. Features pre-wired terminal track, 2 rheostat throttles with brake, automatic starting flagmen, lap counter and enough track to build a huge 206" competition circuit!



STROMBECKER TOOL KIT
Gift box of most popular hobby tools, beautifully designed and crafted. Includes: Hobby Knife, set of 3 screwdrivers, 2 saws, criss-cross tweezers and needle-nose pliers. Only \$4.95.



CORDLESS POWER DRILL
Designed for perfect hand control. Complete drill kit includes 2 drills, sanding drum, de-burring tool, and router. 1001 uses for all hobbyists. Gift Boxed, only \$3.95.

Join the Strombecker Racing Club. Send 50c for year's subscription to Table Top Topics, racing tires, decals and membership card.

Mail to: Strombecker Corporation
Dept. XX-1
4646 West Lake Street
Chicago, Illinois 60644

NAME _____ AGE _____
ADDRESS _____
CITY _____ STATE _____ ZIP CODE _____

STROMBECKER CORPORATION

DECEMBER 1964

19

FREE!

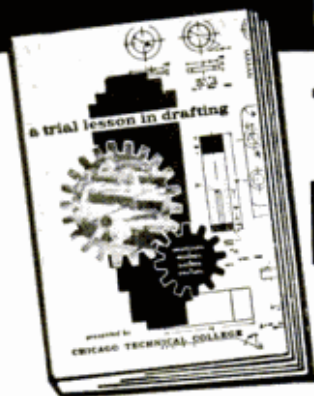

Trial lesson in **DRAFTING & DESIGN**

LEARN AT HOME IN SPARE TIME

Check the want ads in any newspaper—SEE the big-pay opportunities open to you as a draftsman. What's more, you can learn this well-paid, prestige profession at home—quickly, easily! No special talent needed! Get complete, step-by-step Chicago Tech lessons in the mail, spend a few pleasant hours studying each week. In a short time you'll be a well-trained draftsman, ready to take your pick of many good jobs. Act now!

FREE INFORMATION—MAIL COUPON TODAY!

Get FREE TRIAL LESSON plus information about C.T.C. practical training. Learn what successful Chicago Tech graduates say about high pay and opportunities in drafting. No charge, or obligation.

Est. 1904 Accredited National Home Study Council

CHICAGO TECHNICAL COLLEGE

S-202 Tech Bldg., 2000 So. Michigan Ave.
Chicago 16, Illinois

Mail me FREE Lesson with information about big opportunities in DRAFTING.

Name..... Age.....
Address.....
City..... Zone..... State.....

CLINIC FOR HOMEOWNERS

Q I have fairly long runs of cold-water pipe in my basement. The pipe sweats badly during the warmer months. It's installed in such a way that it would be difficult or impossible to use a wrapping material. Is there any other way of coating the pipes or any material that can be applied like paint?—N.R., W.Va.

A There are materials that can be applied in a manner similar to painting to prevent the condensation that is causing the trouble. Inquire of your local hardware or building materials dealer. If they do not stock the item they can order for you. There also is a relatively new foam-like material that comes in an aerosol (pressurized) container which is said to be quite effective. Be sure to follow manufacturer's instructions when applying any of these products.

Q I have acoustical tile ceilings in two small rooms. I have warm air heating and directly over the registers the tiles are discolored with what I suppose is dust and grime. How does one clean them? Also, can the tiles be painted?—R.G., Mo.

A In general, acoustical tiles can be cleaned by sponging with a mild soap solution. This should remove any discoloration from the sources you mention. Be careful not to get the surface of the tiles too wet and rub only lightly, using a large artificial sponge with a flat face. The tiles can be repainted with any of the common inside paints without appreciably affecting the acoustical properties. Thin the paint to an easy brushing consistency and be careful to apply evenly and without filling any of the holes in the tiles.

Q In my older home a partition has been removed to make a larger living room. The ceiling is sagging rather badly where this partition was taken out. How can I un-sag it?—G.N., N.Mex.

A Ordinarily, such a condition calls for a major repair job, but it may be possible to level the ceiling with jacks and install a large beam to carry the weight. The beam must be of adequate size and

HOT SHOT
HOT SHOT

**Amazing New BENJAMIN
30 30 CO₂ GAS
BB CARBINE REPEATER**

—Packs a PUNCH that's so POWERFUL it will Drive STEEL BBs thru Both Sides of a 5 Gal. Steel Pail at close range!
(26 ga. .018")

You're in for a thrill you'll never forget the first time you shoot HOT SHOT! The Hardest Shooting CO₂ Gun on the market—New Model 30 30 embodies features that also assure Flawless Performance: Permanent Alnico V Cast Magnet Shot Holder . . . a Positive, Jam-proof method of loading Ammo in firing position; Convenient, Positive Hammer Safety; 30-BB Mag.; 30 Shots per cartridge; Quality Built. Lightweight—Accurate—Field Tested—Lowest Shooting Costs—use Indoors/Outdoors.

\$16.95 Ask Dealer for Demonstration.
BENJAMIN AIR RIFLE COMPANY
896 Marion St., St. Louis, Mo. 63104

FREE Catalog Benjamin Single Shot and Repeaters—Cal. .22 or .177 or .22. Also Special Hunting Knife Offer. Write today!

You Can DEPEND on BENJAMIN

must be solidly supported at each end. After installation it can be boxed with clear material to make it more attractive and finished to match the woodwork in the room. If you proceed in this fashion, support the jacks on a beam at the first floor and then use 4 x 4 extenders from each jack to another 4 x 4 beam at the ceiling. This setup should be placed so that it does not interfere with installation of the permanent beam. When raising the ceiling turn the jacks up uniformly and only a fraction of an inch of lift at a time.

Q I have an old piano I'd like to refinish. I think the wood is mahogany as what appears to be veneer is chipped in one or two inconspicuous places and the chips appear to be mahogany. Shall I spray-paint it or take the old finish off and refinish in natural color?—O.F., La.

A It should prove attractive either way. We would take off the old finish first, as some old pianos were made up in very beautiful woods on all exposed parts. Take off all the removable panels and use a paste-type paint remover on all fixed vertical surfaces. Remove all the piano hinges and be especially careful not to get any of the remover on the strings, mechanism or keys. Then sand and refinish all exposed parts with a sealer and two coats of semi-flat varnish, rubbing down between coats with very fine steel wool. Rub the last coat glass-smooth. If the wood is not especially attractive in the grain, then you can refinish with any of the newer multicolored finishes of the brush-on type, or those supplied in aerosol (pressurized) containers. When using any of these finishing materials be sure to provide adequate ventilation. Also, read and follow all instructions for use.

Q I have some fairly old books I'd like to make more presentable. The covers are worn and rather shoddy but are not yet "dog-eared". Is there any way I can brighten them up a bit, using enamels, or what?—R. P., N. H.

A You do not mention the bindings so we assume they are still in reasonably good condition. If the bindings are loose, broken or otherwise damaged, you have a job for the bookbindery. Otherwise you can do a fair job of renewal by going over the books with a damp cloth dipped in soapy water to remove grime. Allow to dry and apply a light coating of a quick drying clear finish, such as fixative which comes in a spray can.

DECEMBER 1964

Perfect match for file users:



Nicholson files and Nicholson's booklet—

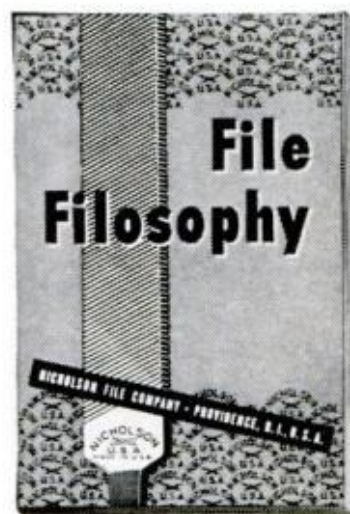

For best results use both!

Learn how to get the most out of your files and rasps by reading Nicholson's special booklet, "File Philosophy." It's yours, free. Just fill in the coupon below.

And for the finest files and rasps, ask your local hardware dealer for the Nicholson brand.

NICHOLSON FILE COMPANY
Dept. PME, Providence, Rhode Island 02904

Please send me a free copy of "File Philosophy."

NAME _____

ADDRESS _____

CITY _____ STATE _____ ZIP CODE _____



NICHOLSON



Files • Rotary Burs • Hacksaw and Band Saw Blades
Hole Saws • Ground Flat Stock • Industrial Hammers

Ronson introduces the

(Complete with large-

Burns for hours on butane gas. Adjusts from pinpoint to



STARTS LOG FIRES.



MELTS ICE.



STARTS CHARCOAL FIRES.



REMOVES PAINT.

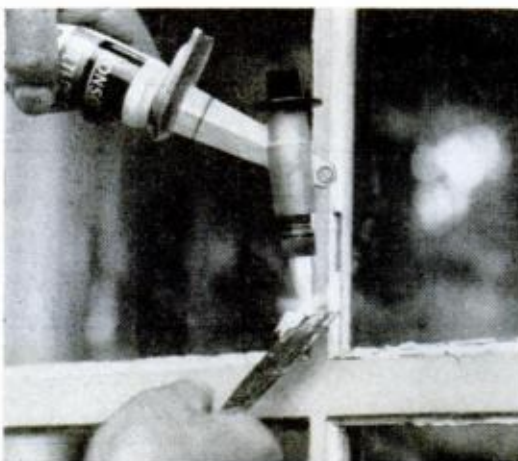

SOFTENS PUTTY.



FOR HARD-SOLDERING METALS SUCH AS THIS METAL CHAIR.

O.K. You own a hammer, a chisel, a screwdriver—a lot of good, hardworking tools.

So when something at your house needs fixing, you're ready, willing and able to go to work.

Or are you?

Ever try to thaw a frozen water pipe with that hammer? Or unstick a cracked floor tile with that screwdriver?

Or chip ice off the front steps with that chisel?

Humiliating, isn't it?

(Not having the right tool at the right time can make you feel about as self-sufficient as an old-maid schoolteacher fixing her first flat tire.)

But now Ronson has a new torch that can do all those

things. And more.

You don't have to be a handyman to put it to work. It starts charcoal and log fires quickly. It burns leaves and caterpillar nests. You can even use it to put a nice brown meringue on Baked Alaska!

It weighs less than 13 ounces. Much smaller than other leading torches, it takes very little storage space. It's as compact and easy to handle as a flashlight.

A blast from this torch can spot-kill a weed faster than you can yell "Crabgrass!"

A broken wire fence needs mending?

This torch can do a perfect soft-solder job in less than a minute.

It can hard-solder a 1/2" copper tube to a brass elbow in just a few minutes.

It can help remove old paint.

Soften old putty.

Fix a kid's toy.

Help refinish furniture.

Sweat copper tubing.

(Whew!)

Loosen rusted pipe fittings and connectors. (Just try to get in and around pipes and fittings with a larger torch.)

Free frozen nuts and bolts.

And even stand up like a laboratory burner.

(This comes in handy when you need both hands free.)

How did Ronson put this new torch together?

We used butane gas, and the

Varaflame Torch. \$4.95.*

(size butane Multi-Fill.)

blow torch flame. Lightweight. Compact. Easiest to handle



BURNS OUT WEEDS AND CATERPILLAR TENTS.



FOR LAYING OR PICKING UP ASPHALT FLOOR TILES.

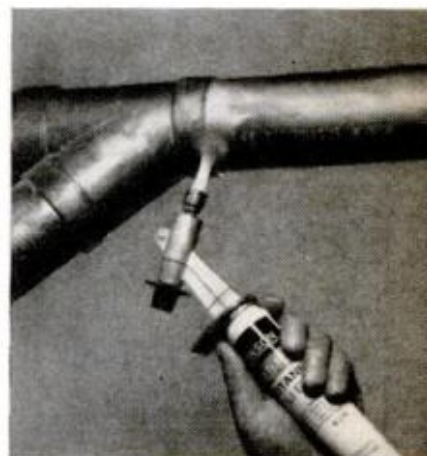

SWEATS AND THAWS PIPES



SOFT-SOLDERS BROKEN TOYS.



FOR BENDING GLASS TUBING AND OTHER LABORATORY USES.



COMES APART EASILY FOR STORAGE.

same Ronson Multi-Fill® injector that fuels our gas lighters.

(The Multi-Fill injector lasts for hours, but when it runs dry, you can buy a new one almost anywhere in town.)

And we developed an entirely new kind of torch head.

It snaps onto the Multi-Fill injector. You don't have to be a professional plumber to use it.

A fingertip knob controls the flame precisely. You get the bluest flame possible. The steadiest pinpoint flame. (The steadier and bluer the flame, the more intense the heat, the faster the job gets done.)

And you won't have to take this torch apart to clean it between jobs. It's completely self-

cleaning. It just won't clog.

Now.

Where can you get your hands on the new Ronson Varaflame Torch?

Anywhere hardware is sold. The price, complete with large-size, 76 gram Ronson butane Multi-Fill injector, just \$4.95.*

Isn't that a small price for this amazing torch?



RONSON®
Varaflame
Butane Torch

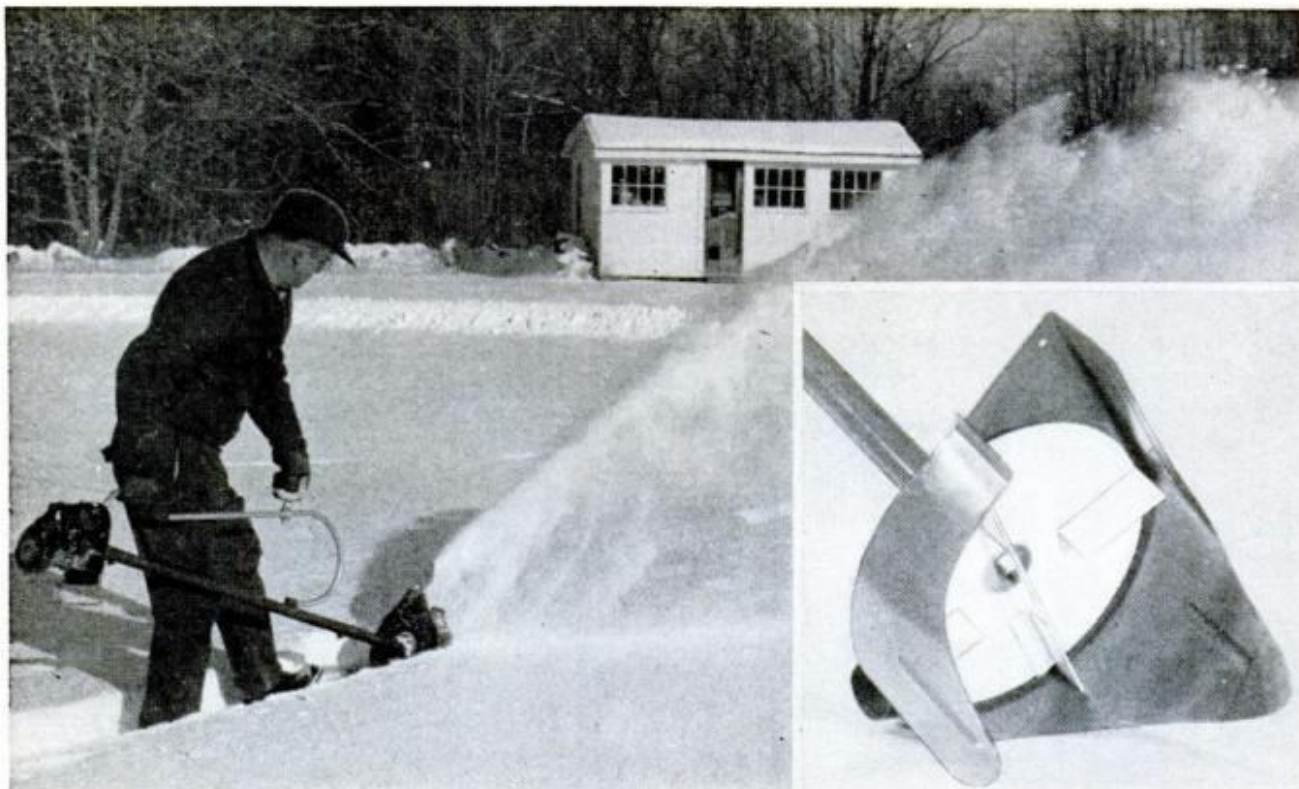

ONE OF THE NEATEST MECHANICAL TRICKS WE'VE SEEN in a long time is the marketing of a complete line of gasoline-powered tools which operate off a single detachable engine. Loosening a screw permits detachment of the $\frac{3}{4}$ -hp engine from one tool for use on another. The power snow shovel above is the first of the line. Weighing only 18 lbs., it can be used on stairways, narrow walks, roofs and other places a conventional blower won't go. It clears a 10-in. path. Price is \$49.95, plus \$69.95 for the engine. Manufacturer, Polaris Power Pole, Inc., King St., W. Hanover, Mass., plans on eleven other attachments, including a lawn mower, grass trimmer, generator, sickle mower, and even a small outboard motor called a Power Oar

NOW MAKE BATHROOM REPAIRS THAT REFUSE TO WEAR OUT

—with an amazing, virtually indestructible new sealer and glue that's as easy to use as toothpaste

Amazing new SILASTIC® brand Bathtub Caulk won't crack, chip, shrink, crumble, dry out or wear out—for years! Just squeeze it on and it dries into an elastic seal of silicone rubber. Use it to seal cracks between tub and tile, tub and floor, washbasin and tile. Or use it to glue on towel racks, soap dishes, loose tiles—even glass door-knobs. Every home should have a tube handy. At all hardware and paint supply dealers — U. S. and Canada.



SILASTIC BATH TUB CAULK
from **Dow Corning** . . . the silicones people

Move Up Faster — Make More Money With N.T.S. "PROJECT METHOD" HOME TRAINING

Looking for your first real job in industry? Are you stalemated in a dead-end job? Or, are you being left behind because you're not up on new industry methods? Don't let technical progress — automation — pass you up. There's in N.T.S. Project Method training program to help you MOVE UP FASTER and MAKE MORE MONEY!

N.T.S., a leading technical school for more than 60 years, shop-tests every lesson and manual. Easy-to-follow lessons are fully illustrated so you can learn fast. Look over the big opportunity home study courses below. Choose your field! Check the coupon and mail it today! You'll soon be on your way to a high-paying new career!

ELECTRONICS DIVISION

1. Electronics-TV-Radio Servicing and Communications
2. Master Course in Electronics-TV-Radio Advanced TV and Industrial Electronics
3. FCC License Course
4. Radio Servicing (AM-FM-Transistors)
5. Television Servicing (Including Color)
6. Stereo, Hi-Fi and Sound Systems
7. Basic Electronics
8. Electronics Math

Train yourself quickly for America's "big future" industry! BIG EQUIPMENT KITS come with many of the electronics courses — at NO EXTRA COST! NO KIT DEPOSITS REQUIRED — equipment is included with your tuition.

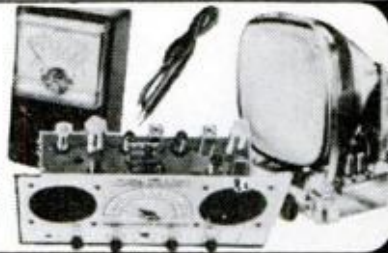

AUTO-MECHANICS DIVISION

1. Automotive-Diesel Master Course
2. Automotive Mechanics
3. Diesel Mechanics
4. Engine Tune-up and Electricity

Eighty million cars and trucks need maintenance! Here's opportunity for you — in manufacturing, in sales and service — in your own auto repair business! VALUABLE TOOLS AND EQUIPMENT COME WITH ALL N.T.S. AUTO-MECHANICS COURSES! NO KIT DEPOSITS REQUIRED — NO EXTRA COST!

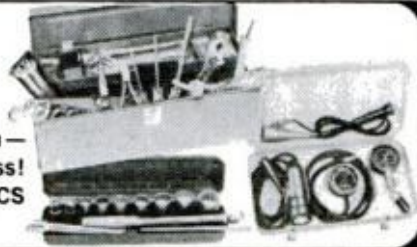

AIR CONDITIONING — REFRIGERATION DIVISION

1. Air Conditioning-Refrigeration Servicing Course
2. Air Conditioning, Refrigeration & Electrical Appliances Master Course

Good income in installation & servicing homes, factories, schools, hotels & motels, office buildings, stores, cars, trains, buses and in servicing electrical appliances. The trained man in these fields is in demand! BOTH COURSES COME WITH BIG EQUIPMENT KITS AT NO EXTRA CHARGE. NO KIT DEPOSITS REQUIRED.



HIGH SCHOOL AT HOME

Learn easily. New modern method. National also offers accredited high school programs for men and women. Take only subjects you need. Study at your own pace. Latest approved textbooks — yours to keep — everything included at one low tuition. Check High School box in coupon for information.



HOME APPLIANCES DIVISION

1. Home Appliance Technician's Course

This complete course prepares you quickly for a business of your own or important jobs with manufacturers, distributors and retail sales service. You can earn while you learn by repairing appliances for friends and neighbors. TOOLS AND EQUIPMENT INCLUDED WITH COURSE AT NO EXTRA CHARGE.



Resident Technical Training at Los Angeles

You can take classroom training in our famous Resident School at Los Angeles in Sunny Southern California. N.T.S. is the oldest and largest school of its kind. Associate in Science Degree also offered in our Resident Program. Check Resident School box in coupon for full details.



NATIONAL TECHNICAL SCHOOLS

WORLD-WIDE TRAINING SINCE 1905

YOU ENROLL BY MAIL UNDER N.T.S. "NO OBLIGATION" PLAN. WE HAVE NO SALESMEN; THIS MEANS LOWER TUITION FOR YOU.

SEND FOR FREE BOOK & SAMPLE LESSON



CHECK ONE ONLY

Accredited Member National Home Study Council



NATIONAL TECHNICAL SCHOOLS

WORLD-WIDE TRAINING SINCE 1905

NATIONAL TECHNICAL SCHOOLS, DEPT. B-124

4000 S. Figueroa St., Los Angeles, Calif. 90037

Please rush FREE BOOK AND SAMPLE LESSON on Courses in the Division checked below. No obligation — No salesman will call.

- | | |
|--|--|
| <input type="checkbox"/> ELECTRONICS Division | <input type="checkbox"/> AIR CONDITIONING-REFRIGERATION Division |
| <input type="checkbox"/> AUTO-MECHANICS Division | <input type="checkbox"/> HOME APPLIANCES Division |
| <input type="checkbox"/> HIGH SCHOOL Department | |

Name _____ Age _____

Address _____

City _____ State _____ Zip _____

Check here if interested ONLY in Resident Training at Los Angeles.

This Christmas, give from the **TURNER "GIFT CENTER"**

and get your Free "How to Do it" booklet at leading hardware stores and departments (see stores on opposite page)

6297

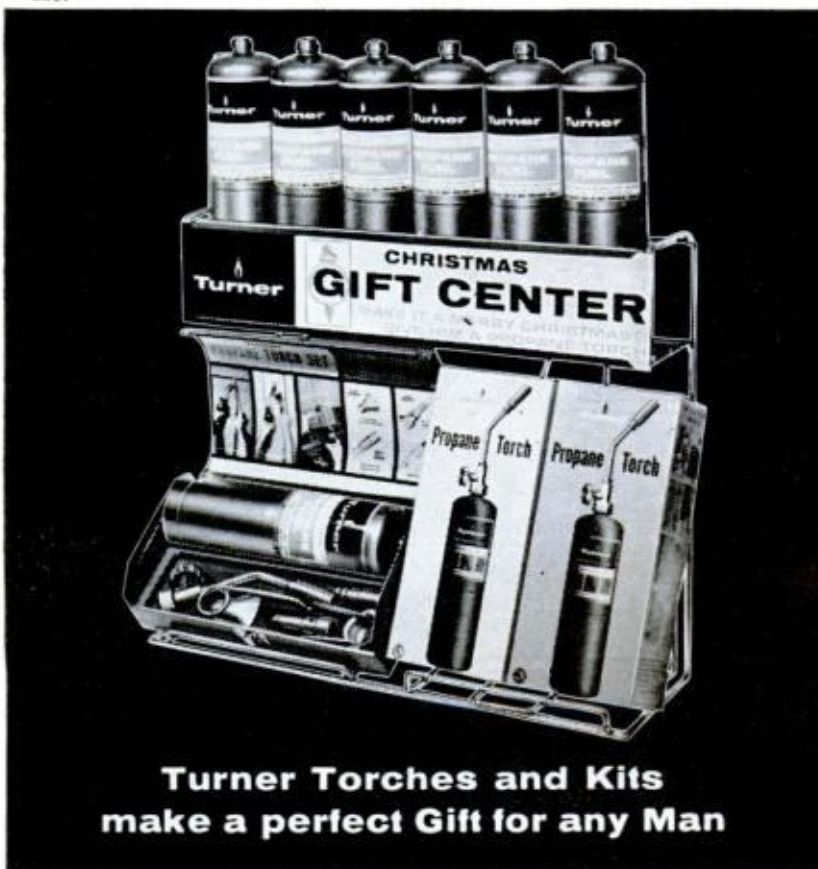

Turner Torches and Kits make a perfect Gift for any Man

Shop at the "Turner Fixit and Gift Center" for every man or family on your list (women, too!)

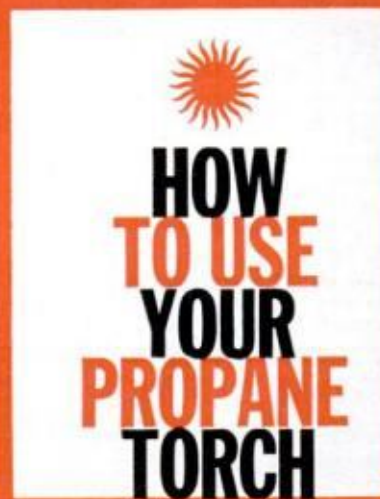

This informative booklet will show you many ways to do more jobs easily with the heat of a Turner Torch. It's yours absolutely free when you visit one of the hardware dealers shown on the opposite page.

Learn how to:

**SOLDER • REPAIR GUTTERS
BRAZE • SOFTEN PUTTY
SOFTEN ASPHALT TILE
REMOVE RUSTY NUTS**
and scores of other useful ways to use a Turner Torch.



PROPANE TORCH KIT in metal chest. Includes torch, flame spreader, soldering tip, heavy duty burner head and spark lighter.



PORTABLE PROPANE RADIANT HEATER burns 16 hours or more on two tanks of fuel (included.) Perfect for every outdoor use.



PROPANE CAMP LANTERN gives light equivalent to two mantel lanterns or a 125 watt bulb.



PROPANE TORCH complete with disposable fuel tank.



"TWIN TRAVELER" PROPANE CAMP STOVE lights easily, cooks as clean and quickly as a kitchen stove.

Turner Corporation

Sycamore, Ill. 60178
Turner Products Ltd.
Toronto, Can.

Computers' Computer Secretary

Computers are behaving more like human beings every day. In related developments at Purdue University:

- One computer has "hired" another computer as its personal secretary.

- Computers across the country soon may be linked into a network that will enable any one of the machines to pick the brains of all other computers in the net.

The "secretarial computer" schedules appointments for the biggest computer on the Purdue campus. The "secretary" collects problems from human researchers, and discreetly asks its "boss" every few minutes if it is prepared to take on some outside work. If the answer is affirmative, the master computer accepts the problems, makes its computations, and feeds the answers back to its "secretary." The smaller computer then sorts out the answers and routes them to printout typewriters located in various departments on campus.

By efficiently scheduling the big computer's operations, the smaller one permits its "boss" to perform several times as much work. It interrupts the master's electronic cerebrations about once every three minutes to ask whether it is prepared to accept and solve new problems before going on with the work it then has in progress.

Eventually the master computer at Purdue will be linked to another at Indiana University 100 miles away; if this experiment proves satisfactory, these two masters then may be linked to other computers in laboratories all across the country. The computers then can talk to each other, drawing on memory systems anywhere in the computer network for facts and figures needed for computations. In such a case "secretarial" computers will schedule questions so the master computers will not be interrupted during long-distance "conferences" or other important work.

Mountain Haze Caused by Plants

That blue haze of the Blue Ridge Mountains and the hazy days of summer are caused partly by the fragrance of plants, according to Drs. R. Rasmussen and F. W. Went of Washington University, St. Louis.

Although the blue-gray haze hanging over cities may be largely gasoline vapors, the scientists found that most of the common volatile substances in the air (isoprene, alpha-pinene, beta-pinene, limonene and myrcene) derive from the odors which make plants smell. Man uses them as turpentine and in perfumes. Concentrations of these volatiles vary, rising during the day and decreasing during night.

DECEMBER 1964

Get your FREE Turner "How to Do it" Booklet at any of these "Gift and Fixit Centers"

CONNECTICUT

All Moores Auto Stores

Bridgeport

Hawley Hdw. Co.

Canaan

Fuller Hdw.

Hartford

Bidwell Hdw.
Greenspon's Inc.

Milford

Diamond Hdw.

Norfolk

Norfolk Hdw.

South Norwalk

Klaff's

Torrington

Burritt's Hdw.
W. H. Morrison

West Hartford

Anderson & Hammerlind

Winsted

Park Place Hdw.
Highland Hdw.

DELAWARE

Wilmington

Almar Hdw.
Bronstein Hdw.

MAINE

Biddeford

Biddeford Maine Hdw.

Waterville

Waterville Hdw.

MARYLAND

Annapolis

Boulevard Hdw.
Fischer's Hdw.
Economy Auto Supply
Hill & Dale Hdw.
Kelly Hdw.
Northwood Hdw.
Rep. Hdw.

Baltimore

Charing Cross

Essex

A. Bilke & Son

Lonsdone

Lonsdone Hdw.

Middle River

Middle River Supply

Pasadena

United Hdw.

Pikesville

Pikesville Hdw.
Akehurst Hdw.

Pimlico

Pimlico Hdw.

MASSACHUSETTS

Boston

Reliable Hdw.

Brookline

Highland Hdw.

Falls River

J. O. Neill Co.

Greenfield

Prestige Lmbr.

Framingham

White Hdw.

Keene

Spencer Hdw.

East Longmeadow

Kelly-Fradit Lmbr.

N. Andover

Roberts Hdw.

Norwood

Norwood Hdw.

Northampton

Hampshire Supply

Salem

Zina Goodell

Springfield

Vadnair

Wilbraham

Hdw. Center

Wollaston

J. MacFarland & Son

Ware

Green Acres Supply

Worcester

Stone & Berg Lmbr.

NEW HAMPSHIRE

Dover

Dover Hdw.

Keene

Spencer Hdw. Co.

Lebanon

Dulac's

Manchester

J. J. Moreau & Son

NEW JERSEY

Glassboro

Glassboro Hdw.

PENNSYLVANIA

All Moores Auto Stores

Chester

Marchliks Hdw.

Conshohocken

Conshohocken Variety

Germantown Pike

Fairview Village
Fairview Bldg. Supply

Norristown

Cottonaro Hdw.

Philadelphia

Blumberg Hdw.
Bridge Hdw.
Ce Mar Hdw.
P. Cohen Hdw.
E. C. Fisher Hdw.
C. Hughes Hdw.
Jacobs Hdw.
S. Jacobs Supply
Katzen Hdw.
S. Kravitz Hdw.
Reinbult Hdw.
H. Rush Hdw.
Watson Hdw.

Shenandoah

Neetzow & O'Hearn Co.

Upper Darby

Dees Variety
Upper Darby Boat Hdw.

RHODE ISLAND

Newport

J. O'Connell

Providence

City Hall Hdw.
Harris Lmbr. Co.

VIRGINIA

All Moores Auto Stores

Hampton

J. P. Blythe, Inc.



Coming: A Brand-New Suspension for Mustang, and a Long, Long Wait for a Chrysler Turbine

Ford's Total Performance program will include a new goody for the '66 Mustang—an optional independent rear suspension. This will give a more comfortable ride and better cornering on rough road surfaces. Cost: about \$200.

Our don't-believe-everything-you-hear department will now explode two rumors circulating in Auto Land:

- **Chrysler** is *not* building hundreds of gas-turbine cars for sale to the public. A total of 50 has been made. So far, 34 have been lent to 97 private individuals for three months at a time, to test public reaction. The remaining 16 are used for promotional purposes. There are no marketing plans.

- **Chrysler** won't have an entry in the next Indy 500 race. A new engine formula is due in '66, and it wouldn't pay Chrysler to develop an engine that would be obsolete after a year.

Speaking of Indianapolis, Ford will soon sell its 255-cube Indy racing engine to all comers. This hairy V8 has dual overhead cams, injection and a set of headers that looks like Medusa's hairdo. Before you run to order one, stop at the bank and withdraw a cool 15 gees.

Smarting from many oval-track and drag-strip defeats at the hands of the **Dodge and Plymouth** hemispherical-head V8s, **Ford** has been developing its own hemi. But now it turns out this engine will not be legal in **NASCAR** (National Association for Stock Car Auto Racing) events next year. NASCAR president Bill France recently ruled that engines must be of production design, thus eliminating hemi heads, high risers and overhead cams. They're so expensive that only factory teams could afford to compete. And squeezing out the private owner would hurt the sport. Wheelbase and displacement specs remain the same. Any internal modifications may be made.

Ford and Chrysler are dropping their rally activities abroad. Though Ford has been moderately successful, and Chrysler somewhat less so, the cost is staggering and the amount of publicity in this country practically nil. What's more, Ford was competing with its own English-made

Ford Cortina in the foreign contests.

A dual-gap spark plug for auto engines has been proposed by a Stanford University electrical engineer. The conventional spark plug, explains Dr. George H. Barry, is a compromise between high- and low-speed efficiency. "Rich fuel mixtures, as in full-throttle operation, ignite with any spark, however small," he said. "Lean mixtures, under part throttle, demand a bigger spark and wider gap." His plug would have two spark gaps—designed so the spark always jumps the wide gap if possible. If it can't, then it jumps the narrow gap.

A production goof has resulted in at least 100,000 new '64 and '65 cars collecting dust in lots. They can't be sold because they have no seats! The primary seat supplier to Detroit miscalculated. Now they're working three shifts a day, seven days a week to catch up.

Is overdrive worthwhile? A Californian writes us complaining that the economy benefits of overdrive are lost when manufacturers automatically include a lower axle ratio. But it's not that bad. This year's **Chevy Biscayne** and **Bel Air** sedans are typical examples. With a three-speed manual box, the rear-axle ratio is 3.07. With overdrive it's 3.70. But in overdrive, the transmission ratio drops to 0.7, giving the same effect as running in non-overdrive high with a 2.59 axle—certainly an economy ratio.

Speaking of axle ratios, **Mercedes-Benz** says the sluggishness I complained of (*Spotlight on Mercedes-Benz 190 Diesel*, p. 32, Sept. PM) is gone. The 3.9 axle has been replaced by a 4.1 unit.

The Defense Dept. keeps trying to warn us about "surplus" Jeep bargains. "Chances are," said one colonel, "that anyone who collects cash in advance for \$35 bargains in unused surplus Jeeps is a swindler or swindler's victim."

Department catalogs say candidly that many Jeeps for sale seem in poor condition. Often major parts are missing.

Automotive Editor

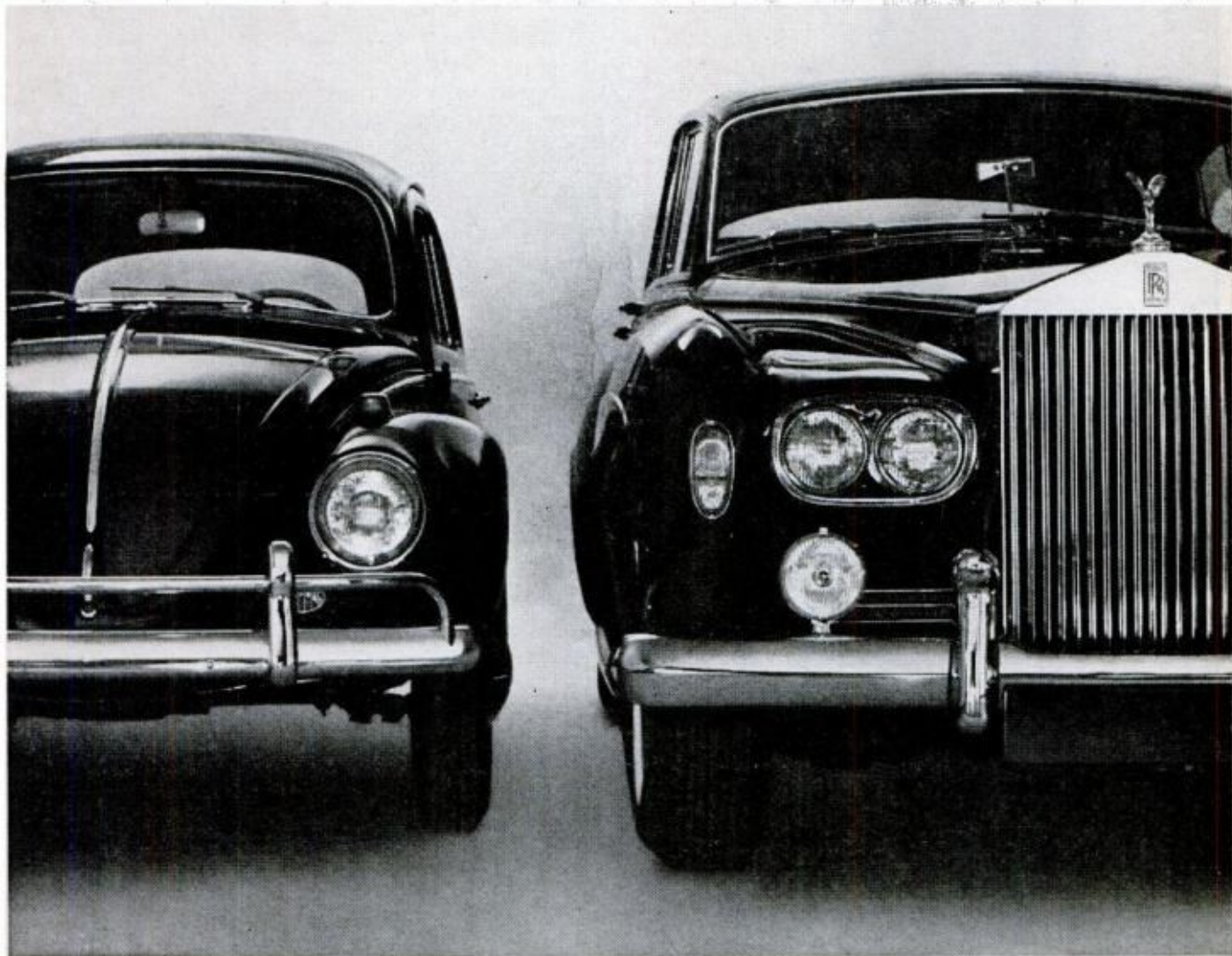

Millions of cars the world over, including Volkswagens and Rolls-Royces, come equipped with silvery-plated Champions

Again in 1965, Champions will be installed by more of the world's car makers than the next two brands of spark plugs combined—because Champions have no equal for all-around performance. Why settle for less in your car?

P.S. For dependable power all winter, install new silvery-plated Champions now!



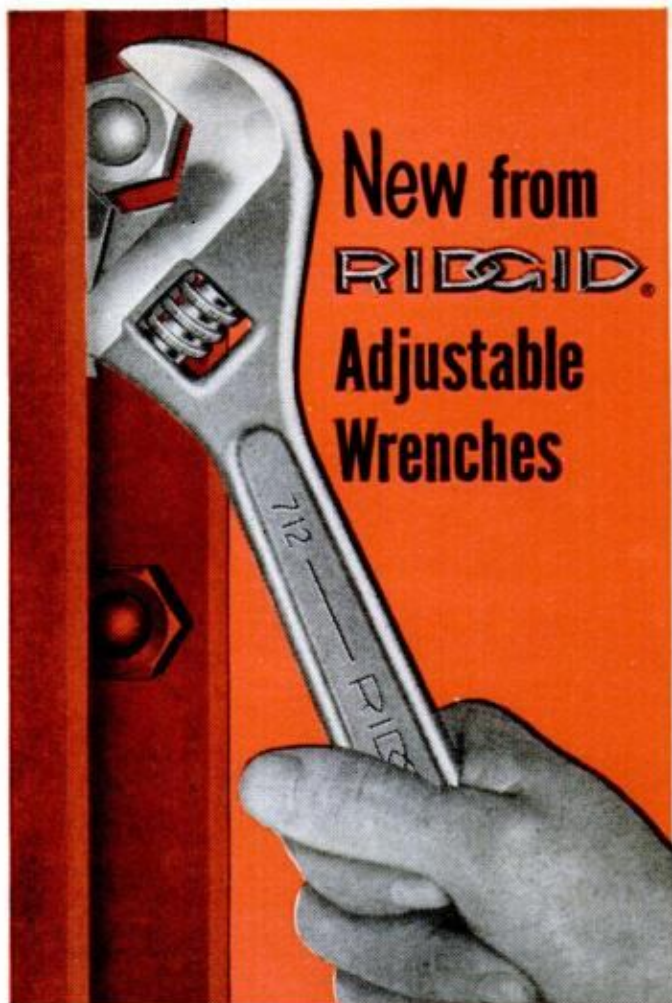

New from
RIDGID
Adjustable
Wrenches



7 Sizes, 4" through 18" Lengths

...with Thin Heads for Fast Work in Close Quarters!

Made of special alloy steel, these new **RIDGID** Adjustable Wrenches are selective induction hardened for extra toughness . . . long service life. Sparkling *chrome plated* finish stays new looking for years. You'll like the fast, easy, one-hand adjustment. When properly tightened, jaw stays tight . . . will not slip. Comfort-grip, forged, I-beam handle has handy hang-up hole.

See and buy them at your Dealer's. For your convenience, he maintains a complete selection of **RIDGID** Work-Saver Tools and parts.

RIDGID®

The Ridge Tool Company, Elyria, Ohio, U.S.A.

Items from All Outdoors

Learning to ski in a week is possible by a new teaching method described in an article on page 100. Walter Foeger, the man who devised the system, has written a book about it: *Skiing for Beginners*. It is published by Ronald Press. For more detailed information about where the system is taught, write to: Walter Foeger, Jay Peak, North Troy, Vt.

Ice fishing, a growing mania in the U.S., will be the subject of an article in next month's *PM*. While gathering material for the article I was in Winona, Wisconsin, a small town that bills itself as the Ice Fishing Capital of the World. In particular, I was interviewing Ronnie McKee, veteran ice fisherman, raconteur and saloon keeper, and it was Ronnie who introduced me to Mrs. Marie Aska of Rockford, Ill. and her recipe for barbecuing fish on a spit. This recipe, alone, was worth the trip. It is best with a large-size bass or lake trout. When the fish is cleaned, you wrap it with cheesecloth and bind it with cord. It is put on the spit, and while it is turning, it is *liberally* basted with melted butter. When the flesh flakes at the touch of a fork it is done. The cheesecloth is a charred coating that is easily peeled away.

What's new for outdoors is a folding saw for campers with a 21-inch blade that goes through eight-inch logs with ease. I used it last summer and found it extremely stable, and easy to fold and unfold. It sells for \$5.95 from Savage, Inc., Elverson, Pa. . . . And also for campers is a unique can of aerosol cooking fuel that contains its own stove. The cap on the can is inverted, wire legs are pulled out, and it becomes a single-burner stove that will hold a coffee pot or medium-sized pan. It is called Redi-fire. A 10-ounce can sells for \$1.69, and it is made by Turtle Wax, Inc., 1800 No. Clybourn Ave., Chicago, Ill. . . . For shooting enthusiasts with a child ready for his first shotgun, the Ithaca Gun Co. of Ithaca, N.Y. is offering an excellent booklet on basic gun training for \$1. The author is Gerald A. Stoltenberg, and he writes about his own son's initiation to shotgun shooting.

STUART JAMES

Outdoors Editor

POPULAR MECHANICS

CLIP AD TO GET FREE GIFT!

For an exciting Christmas and years of fascinating fun...

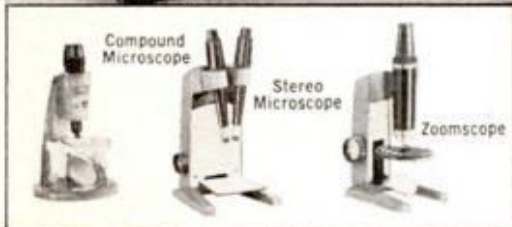

NEW genuine Award-Winning* BAUSCH & LOMB MICROSCOPE SETS

- Here's an exciting different way to have loads of FUN while you LEARN... by seeing a whole new world of amazing things invisible to the human eye.
- These microscopes won't be junk in a few weeks... but are ruggedly built to take a beating and stay operating like new.
- Same microscopes as officially approved and being used by leading schools nationally.
- You'll be proud to own one of the only microscope sets to carry the "Bausch & Lomb" name... world-famous for microscopes used by scientists everywhere.
- Designed by leading optical engineers... to give you for the first time professional laboratory image quality in a hobby microscope.
- Sets are chock-full of micro-science materials, specimens and experiments developed by leading science consultants.
- Write for full-color catalog 31-2094. (See address below.)

FREE!



(of extra cost) when you buy your Bausch & Lomb Microscope Set: two slides with two exciting specimens on each... retail value \$3.00. Just clip this ad and take to

store. Get sales slip showing store name, address, model number purchased. Mail sales slip and ad, with your name and address, to Bausch & Lomb Inc., 19112 Bausch St., Rochester, N. Y. 14602. Offer good only until Dec. 15, 1964.

*1964 MASTER DESIGN AWARD WINNER

SEE THEM AT LEADING TOY AND HOBBY STORES

- For Action, Security, Big Pay -

WE CHALLENGE YOU TO TOP THIS JOB!

Earn To \$15 An Hour ★ Work Part-Time Or Full-Time ★ Car Furnished — Expenses Paid ★ No Selling — No Previous Experience Needed ★ Only Average Education Required

NO OTHER CAREER OFFERS YOU A BRIGHTER FUTURE

Consider this fact. In the short time it takes you to read this page 1,100 accidents will take place. Over 440,000 will occur before this day ends. *These accidents must be investigated.* The law demands it. Yet in 4 out of 5 cities, towns and rural communities, no one has been trained for this vital work.

KEEP PRESENT JOB UNTIL READY TO SWITCH

Step into this fast-moving Accident Investigation field. *Already* hundreds of men we have trained are making big money. Joe Miller earned \$14,768 his first year. A. J. Allen earned over \$2,000 in ten weeks. Robert Meier says "I'm now earning \$7.50 to \$15.00 an hour in my own business... Universal's course is wonderful."

FREE EMPLOYMENT HELP GIVEN

We CAN and WILL show you how to rapidly build your own full-time or part-time business. Or if you wish a big-pay job as Company Claims Investigator, our Placement Service will give you *real* assistance. Hundreds of firms needing men call upon Universal. *We place far more men in this booming field than any other individual, company or school.*



EARN WHILE YOU LEARN

Write today. Let me show you how easy it is for you to get into this exciting new career in just a matter of weeks. No obligation. No salesman will call. Mail coupon or post card to me, M. O. Wilson, PM-12 Universal Schools, Dallas 5, Texas.

Mail Now for FREE BOOK

M. O. Wilson, Dept. PM-12
Universal Schools,
6801 Hillcrest, Dallas 5, Texas

Please rush me your FREE BOOK on Big Money In The Booming Accident Investigation Field. I will be under no obligation — and no salesman will call upon me.

Name

Address

City

Zone

State



New on the Market

LONG-LIVED SNOW TOOLS: Ace snow pusher and snow shovel (inset) are made of stainless steel with specially heat-treated wear strips. Manufacturer says the working edges of these tools outlast those of competitive tools. Pusher sells for \$6, shovel for \$5. Made by the Union Fork & Hoe Co., Columbus, Ohio

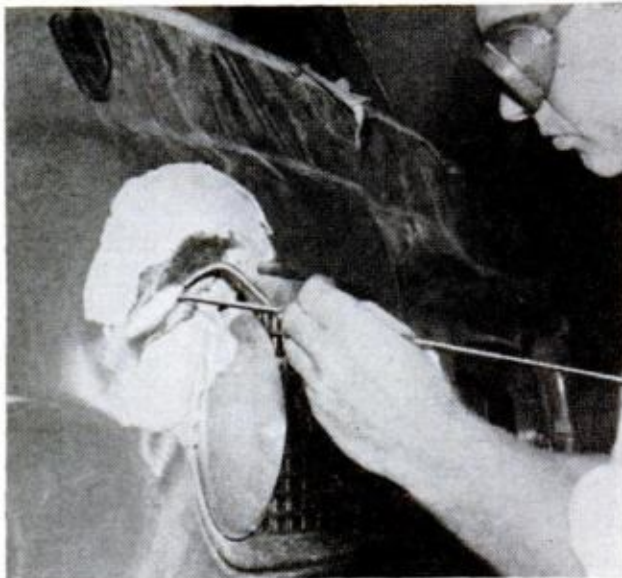

PROTECT FINISHES, GLASS, rubber, etc. from welding heat. Weld-Dun is a foamy paste made by mixing two compounds. You spread this paste around the area to be welded. Said to confine heat no matter how hot welding becomes. Costs \$3 for trial kit. Aceto Chemical Co., 40-40 Lawrence St., Flushing 54, N.Y.

AUTOMATIC REGISTER, the Homart 600, has a sensing element (bottom photo) that reacts to temperature of the air passing through it. For cooling, it opens wide. For heating, it closes, sending air in a wide pattern over the walls (top photo). Costs \$6.50, from Sears, Roebuck & Co., 925 South Homan Ave., Chicago, Ill.

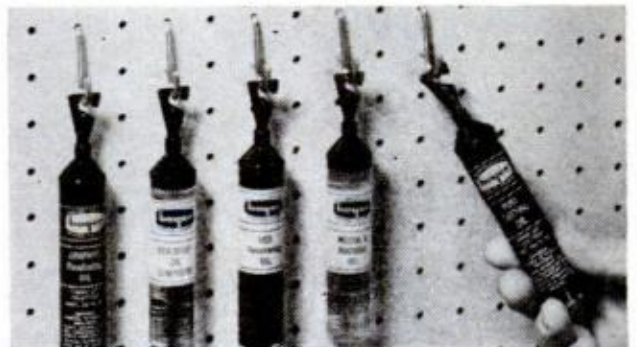
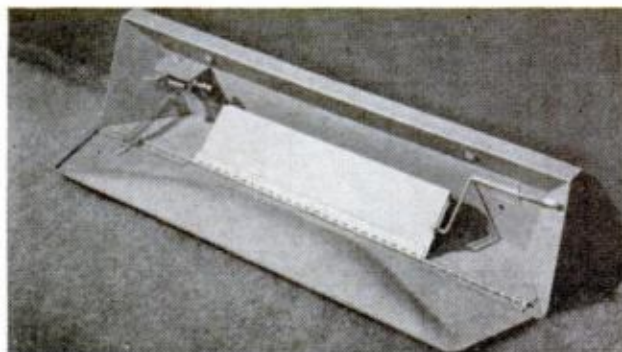

OIL AT YOUR FINGERTIPS: Clear plastic tubes containing various types of oil—general purpose, penetrating, rust cutting, graphited penetrating and neatsfoot—have hook-like tops to permit hanging on nails or hardboard hooks. Hang-Up Oilettes cost 29¢ each. Boyer Chemical, Box 1279, Evanston, Ill.



ADHESIVE TAPES perform many repair jobs around the house. No. 357 plastic-coated tape (\$1.98 for 60 ft. roll) seals ducts, patches dryer exhausts, repairs auto seats. No. 330 aluminum foil tape (\$2.98) seals gutter leaks, repairs garbage cans and car bodies. Johns-Manville, 22 E. 40 St., New York 16, N.Y.

POPULAR MECHANICS

Share great moments with other great guys



Get a new set of wheels in the Army. Ten feet across or scooter size, there are more wheels in the Army than in any other organization in the Free World. Some are an adventure to drive, others take you to adventure—and, if you want, you can learn what makes each one roll.

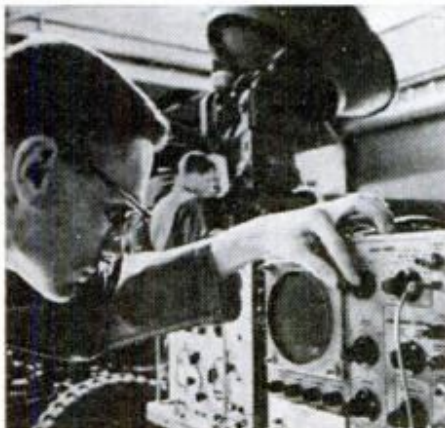

Experts are made, not born. And the Army makes the best. Army schools teach hundreds of different specialties. If you qualify, you can sign up for the one you want before you enlist.

It's different from your home town. And who wouldn't expect it to be? After all, one of the reasons you join the Army is to see the world of differences.



You're not alone in today's action Army. Every experience you have is shared with other great guys. Regular guys who are learning, earning, growing, going, serving our Country, developing themselves. Just as you are.

But the wonder of these experiences is yours alone. No one can tell you how great it feels to master a difficult specialty like computer programming, missile repair, electronics, or construction. No one can live the excitement of landing in a foreign country for you. No one can know what *your* great moments in the Army will be. But you can be sure your life in today's Army will be full of great moments. Enough to add up to a great life.

Talk to your local Army recruiter. Let him tell you what the Army can do for you... and what you can do for the Army. Let him help you to that great moment, the moment you realize that...if you're good enough to get in, a proud future can be yours in today's *action*

Army

Shopping for Tools

WIRELESS VOLTAGE TESTER tells you if electricity is present in an outlet, plug, etc. You insert the tip into the plug and press the pocket clip on the tool's handle. If the line is hot, a tube inside the transparent handle lights up. Priced at \$1.29 to \$1.98. Marfree, Inc., 17620 James Cousin St., Detroit, Mich.

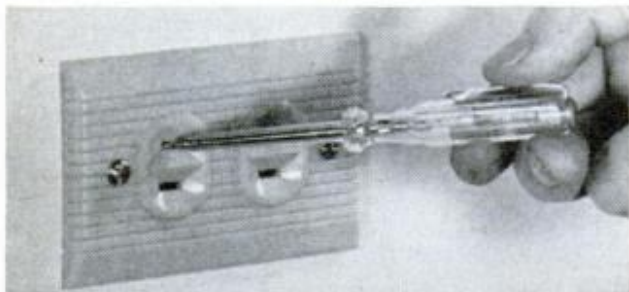

THREE TAPS IN ONE: The Multi-Tap is a screwdriver-type tool which cleans or cuts any of three thread sizes most commonly found in gutters, electrical fixtures, junction boxes. Removable shank can also be used with tap wrench. Costs \$2.25. North County Mfg. Co., 2175 Canyon Drive, Ocean Side, Calif.

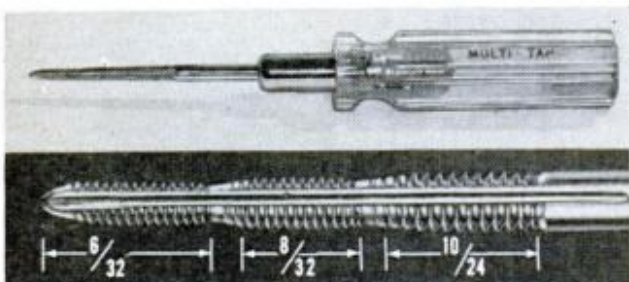

FASTEST ORBITAL SANDER on the market, according to the manufacturer, is the No. 330 Speed-Bloc. Its 12,000 5/64-in. orbits per minute give a smooth, swirl-free surface, and its 4 1/8 x 4 1/2-in. pad fits into corners that would be too tight for other sanders. PM editors found the shape and balance of this tool ideal for easy one-hand operation. Costs \$55. Rockwell Mfg., 400 N. Lexington Ave., Pittsburgh, Pa.

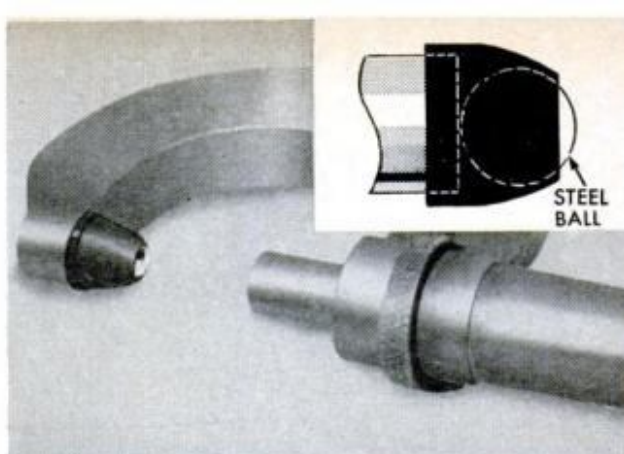

MEASURE THICKNESSES of tube walls and other curved surfaces by placing the Neo Ball Adapter on the anvil of your micrometer. Consists of a steel ball of known diameter in a neoprene socket. To measure, you hold ball against inside of tube wall, then read micrometer as usual. Subtract ball diameter from reading for final result. Price is \$1.50. Neo Ball Co., 669 MacArthur Avenue, Redwood City, California

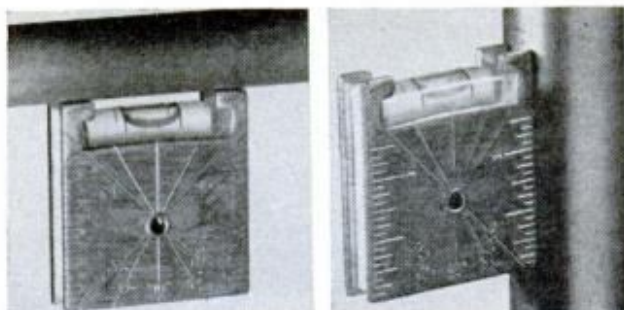

MAGNETIC LEVEL, Model A 23, holds itself on any horizontal or vertical iron or steel pipe for fast checking of levelness or plumb. Particularly handy when a pipe line is very close to ceiling, as it will cling to the pipe's underside. Retail for \$1.25. Made by Piggyback Level Company, Jutland, New Jersey

ELECTRIC-ZIP SCREW DRIVER drives and removes right- or left-hand screws with slotted or Phillips heads. You place tip of tool on screw, and, with motor turned on, press downward. The driving bit engages screw head. Whole operation takes seconds. In trying this tool, we found its 100-1 reduction gears delivered an impressive amount of torque. \$29.95. Portable Electric Tools, 1200 E. State St., Geneva, Ill.

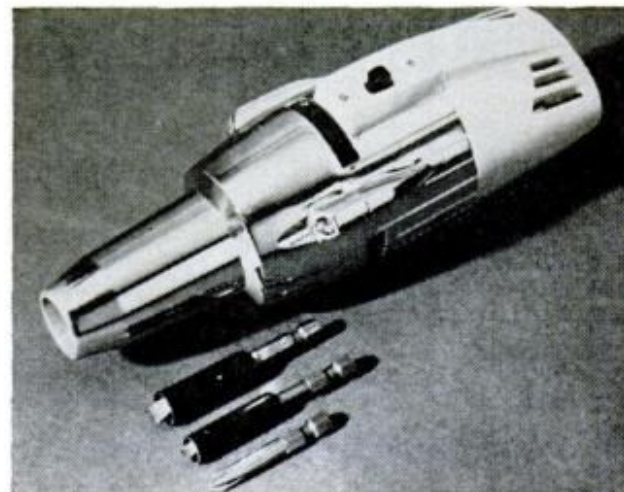

DREMEL MOTO-SHOP

Compact, Portable Power Workshop

First practical multi-purpose workshop designed for the whole family. Moto-Shop is a compact, portable unit — five power tools in one: jig saw, disc sander, buffing wheel, bench grinder, flexible shaft machine. Ideal for hobby crafts, home maintenance. Completely safe! Sets up anywhere — cuts 1 3/4" wood, metal, plastic. Dremel Moto-Shop has a ball-bearing rotary motor . . . outperforms heavier, more expensive jig saws. See your power tool or hobby dealer today. Write for *free* Moto-Shop catalog.



DREMEL MFG. CO. Dept. M-114
Racine, Wisconsin

Model 571 (jig saw with disc sander) . . . \$33.95
Model 572 (all attachments shown) . . . \$49.95

4002



LET **Jon-E**
KEEP YOU
WARM WHILE
YOU WORK!



Forget the misery of cold weather outdoor work. Just slip one or two Jon-E Warmers into your inside pockets and stay warm all over, all day.

These "personal radiators" give comforting flameless heat all day long on only one filling of Jon-E Fluid.

Insist on the genuine Jon-E. Never wears out. American-made. Fully guaranteed.

At sporting goods counters everywhere. Standard size—\$3.95 Giant size—\$4.95 Use fast lighting, long lasting Jon-E Fluid; 8 oz. 49¢, 16 oz. 79¢

ALADDIN LABORATORIES, INC.
620 So. 8th St., Minneapolis, Minn.



GET INTO ELECTRONICS

V.T.I. training leads to success as technicians, field engineers, specialists in communications, guided missiles, computers, radar, automation. Basic & advanced courses. Electronic Engineering Technology and Electronic Technology curricula both available. Assoc. degree in 20 mos. B.S. obtainable. G.I. approved. Start Feb., Sept. Dorms, campus. H.S. graduate or equivalent. Catalog.

VALPARAISO TECHNICAL INSTITUTE
DEPARTMENT D, VALPARAISO, INDIANA



START A BUSINESS

in your neighborhood



Sharpen Hand or Power
Saw with the

FOLEY SAW FILER



MODERN MOWER SHARPENER

Precision-grind all hand and power lawn mowers—a perfect job every time.

Start your business in sparetime and make CASH PROFITS right away. No stock to carry, no selling involved, no experience needed —the Foley Saw Filer does every sharpening job **automatically!** Earn \$3 to \$6 an hour sparetime in your own garage or basement. Profit 90¢ on every dollar.

Best of all, every saw you sharpen, will be resharpened again and again—watch your repeat business grow! Add cash to your income now, while you build retirement security with the Foley Saw Filer.



FREE BOOK shows how you can make money as thousands of others have. Send coupon today. There's no obligation, and no salesman will call—so write today!

Foley Manufacturing Co.
1216-4Foley Bldg., Minneapolis, Minn. 55418
Send for FREE book on Money-Making facts about the sharpening business.

NAME _____
ADDRESS _____
CITY _____ STATE _____ ZIP CODE _____



Popular Mechanics Shopping Guide

"Doodits"



It's a super strength magnet; attached to one surface, it will hold most anything made of steel in its mighty little fist. Unique and practical "doughnut" shape permits attachment to wood, fibre, paper or cloth. Only genuine "DOODITS" have super strength — more than twice the magnetic power found in units of comparable size (3/4" x 1/4"; 1/4" hole).

Package of 5 units 98¢ postpaid. (Directions and dozens of suggested uses on package)

Famous MAGNABAR—the all-purpose magnetic strip in natural hardwood finish. 12" length \$2.75 — postpaid.

DEALER INQUIRIES INVITED
PHELON MAGNAGRIP CO., INC.
Dept. P-5 East Longmeadow, Mass.

Secrets of Teaching Yourself MUSIC

Revealed in Your Home
This Money-Saving Way

YES! Now you can teach yourself to play Piano, Guitar, ANY instrument in your spare time—even if you've never played a note in your life! Famous proven Course makes it simple as A-B-C. Pictured lessons show you how. No teacher. No scales. No boring exercises. Amaze friends by playing favorite music. Write today for FREE 36-page illustrated book. **U.S. SCHOOL OF MUSIC, Studio, 3012, Port Washington, L. I., N.Y.** (Est. 1898. Licensed N. Y. State Educa. Dept.) Tear out as a reminder.

SHARPENING !!!

Turns Your Time Into Cash

Men everywhere are making as much as \$6.00 per hour hollow grinding knives, scissors, clippers, saws, tools, surgical instruments, etc. with TREYCO outfits. Your friends, neighbors, beauty shops, hobbyists, markets, restaurants, hospitals—EVERYBODY—needs sharpening service. Be independent, own your own business. Start for \$39.95—factory-to-you. Manual furnished. Write for Free Booklet, "The Turning Point in Your Life." No salesman will call. **Write TREYCO PRODUCTS**
381 Niagara St., N. Tonawanda, N.Y.

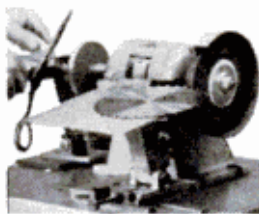

Stamp Your Name PERMANENTLY

\$3.95
ppd.

Identify articles you own



Hardened tool steel 3" long. Up to 15 letters. Last name only.

Name shown actual size

DIE TOOL

Comparable to a \$9.00 die tool, now available at this special price.

- TOOLS
- LUGGAGE
- BOOKS
- SPORTS
- EQT.
- PAINT BRUSHES
- PIPES
- GUNS
- FLASH-LIGHTS
- DRAFTING TOOLS
- PLUS HUNDREDS OF OTHER ITEMS

Metal • Wood • Plastic • Leather, etc.

Stamp just about anything you own with one blow of a hammer. Made by the Henry A. Evers Co., Inc., makers of quality marking devices since 1898. Makes thousands of impressions. Send check or money order.

HENRY A. EVERS CO., INC.
72 Oxford St., Providence, R. I. 02905

For more information on articles in this issue . . . Write

Service Bureau, Popular Mechanics,
575 Lexington, New York 22,
New York 10022



FREE GASKET MANUAL

Valuable Facts for those who value Top Performance:

- Rear End Gasket Installation Tips
- Correct Way to Install Pump Gaskets
- New Type Gaskets for Valve Covers
- Important Steps in Head Gasketing
- Metal Shim Gaskets
- How to Make Sure Gaskets Fit

32 pages of tips—hints—facts about gaskets and how to improve engine performance

Published as a service to the nation's mechanics, schools and car owners by Fel-Pro, Inc., one of the world's leading gasket manufacturers.

Write: **FEL-PRO, INC.**
7452 N. McCormick Blvd., Skokie, Illinois



Dept. PM-12
Division of Felt Products Mfg. Co.

Money Back Guarantee

HEAVY DUTY-ARC WELDER

Five Year Guarantee

The New 1965 Model Heavy Duty 110 Volt Arc Welder works on any 110 volt house line. You can not buy a better welder anywhere at this low price. No experience necessary. Now anyone can braze, solder, cut and weld any metal up to 1/4" thick. Generates heat up to 10,000 degrees for cutting through steel plate, etc. **NOTHING ELSE TO BUY.** Comes complete with 12 ft. of heavy duty power cable, 1 1/2" and 3/8" welding and brazing rods, rod holder, twin carbon torch, helmet, instruction book, etc. **MONEY BACK GUARANTEE.** Try it for 10 days, if you are not completely satisfied we will immediately refund your money without question.—**FULLY GUARANTEED FOR FIVE YEARS.** If inoperative, we will repair or replace it free of charge. **SEND ONLY \$2.00,** and when delivered, pay postman \$12.95 plus COD postage, or send \$14.95 and we will ship postpaid. Over 10,000 National Electric Welders are in use throughout the world.

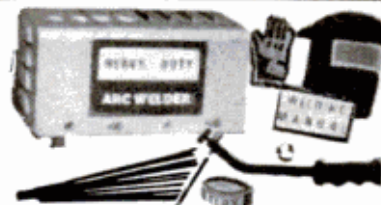

ONLY \$14.95

Order direct from factory; NATIONAL ELECTRIC, Dept. PM-12, DELRAY, FLORIDA

5 Day Home Trial



WORLD'S LARGEST DEALER

"NEW SOUND"

ACCORDEONS—SAVE 1/2*

42 NEW ELECTRONIC/STANDARD MODELS
*SAVE 1/2 off retail prices of comparable accordions! 42 exciting new models—Standard, ELECTRONIC, Amplifiers, too! All famous makes. Try before you buy. Free Accessories. E-Z Terms. Trade-ins. Lifetime Performance Policy. Money back guarantee. FREE Color Catalogs and Importer-to-You Discount Prices. Rush coupon.

ACCORDION CORP. of AMERICA, Dept. R-124
5535 W. Belmont, Chicago 41, Illinois

Accordion Corporation of America, Dept. R-124
5535 W. Belmont, Chicago 41, Ill.
Send FREE Catalog of Accordions, Amplifiers—Discount Price List.

FREE
New Color Catalogs—Discount Prices

Name _____
Address _____
City _____ State _____
 Check here if you have Trade-in

What if I'm laid off?
 Will automation take my job?
 How can I ever afford to retire?
 Am I too old to change jobs?
 Can I learn a new skill?
 Could I succeed as my own boss?
 How can I earn extra money fast?
 Will my job ever pay more?



\$250 EARNED WHILE TRAINING PAYS FOR COURSE AND EXTRA EQUIPMENT FOR HIS OWN SHOP

"I wanted another occupation to help me in my part time business of speedometer repair. While taking the course I was able to earn enough to pay for the course and extra tools, books and key blanks besides for the full time shop I intend to open soon."

Jacob A. King,
 Hereford, Texas.



MAIL COUPON NOW

Be a SKILLED LOCKSMITH

... and Solve ALL Your "FUTURE" Problems

No question about it... with Locksmithing YOU HAVE IT MADE! You'll do light, clean, fascinating work—take your choice of steady, high-pay job opportunities, or your own big-profit spare-time or full-time business! As a locksmith you have your own "built-in" pension plan. Say "goodbye" to layoffs, automation, slack times, forced retirement! **EARN MORE, LIVE BETTER** in good times and bad. **LOCKSMITHING IS SO EASY TO LEARN—EARN Extra Money RIGHT FROM THE START!** Regardless of age, education, experience, minor physical handicaps, fun and earnings begin **AT ONCE** as you learn quickly, easily at home to **CASH IN** on all kinds of locksmithing jobs. Experts guide you—locks, keys, parts, picks, special tools and equipment as well as complete fully illustrated lessons all supplied with course.

FREE Illustrated Book, FREE Sample Lesson Pages Give Exciting Facts.

Find out how being a skilled Locksmith can put a quick end to your worries. Locksmithing Institute graduates now earning more, enjoying life. Send coupon **TODAY** for **FREE** illustrated book and sample lesson pages. No salesman will call. Only school of its kind: Lic'd. N.J. State Dept. of Education, Acc'td. Member National Home Study Council.

Est. 1948

LOCKSMITHING INSTITUTE Division of Technical Home Study Schools
 Dept. 110-124, Little Falls, New Jersey



306 pieces of equipment
LOCKS, PICKS & TOOLS supplied for use with course.

LOCKSMITHING INSTITUTE, Dept. 110-124, Little Falls, New Jersey

Please send **FREE** illustrated book—"Your Big Opportunities in Locksmithing," complete Equipment folder and sample lesson pages—**FREE** of all obligation—(no salesman will call).

Name _____ (Please Print)
 Address _____
 City _____ Zone _____ State _____



Build Your Own Business While Still Employed

It's true. Without giving up your regular job—without losing a single pay check—you now have an opportunity to double your income in your own business. A big 24-page book tells how other men do it—then expand to a full time operation. Gross hourly profit \$9.00—PLUS \$6.00 additional on each service man. Income unlimited.

Your service is Nationally Advertised, world-wide and endorsed by McCall's and Parents' Magazines. Carpet and upholstery cleaning. Also 5 other superior on location services. You need no experience. We show you how and finance you for all but a few hundred dollars. Easy to learn—easy to do—easy to build up to a good, steady volume because we show you 15 tested ways to get customers.

G. F. Monroe, after 12 months, sold his business for 10 times his cost. Leo Lubel sold his for \$7,116 more than he paid. L. Babbit writes, "I average \$2,600 monthly, part time." W. C. Smith earned \$650 in one week. Ed Kramsky said, "In two years I have two assistants, a home and security."

This may be the opportunity of your life. Find out today before someone else gets your location. Mail coupon now for details and 24-page illustrated free book. No obligation. No salesmen will call. Mail coupon now while territories are open.

DURACLEAN CO., 4-16D Duraclean Bldg., Deerfield, Ill. 60015

DURACLEAN COMPANY,
 4-16D Duraclean Building, Deerfield, Illinois 60015

Please send me your 24-page illustrated book that tells how I can double my income in spare time, in a business of my own. Everything you send me now is free and I am under no obligation. No salesmen will call.

NAME _____
 ADDRESS _____
 CITY _____ STATE _____ ZIP CODE _____

DECEMBER 1964

ELECTRONICS

COYNE ELECTRONICS INSTITUTE

A quarter million dollars worth of equipment. **Non-Profit Institute—Est. 1899. Courses: Electronics • Electricity • TV-Radio • F.C.C. • Electronics Engineering Technology. Mail coupon or write for FREE BOOK, "Your Opportunities in Electronics." No Salesman will call.**

COYNE ELECTRONICS INSTITUTE Educ. Serv. Dept. 94-S
 1501 W. Congress Parkway, Chicago, Ill. 60607

NAME _____ PHONE _____
 ADDRESS _____ AGE _____
 CITY _____ STATE _____

1965 Catalog of 2900 Novelties

- Gas Powered Jet Engine \$1.50 complete
- Electrostatic Generator 75c
- Precision Midget Camera \$1.00
- 250 Power Telescope Lens Kit. \$3.50
- Smoke Bombs. Dense clouds. 10 for \$1.00
- Fireworks Fuse. 26" length. 20c. 3 for 50c
- Sun Battery & Photocell. New, surplus. 50c
- Live Chameleon. Changes color. 75c each
- Radio Mike. Broadcast thru any radio. \$2.50
- Electric Motor. Import bargain. 35c. 3 for \$1.00
- Real Midget Gun. 2" long. Fires blanks. \$1.50
- 6-shot Revolver. Shoots .22 cal. blanks. \$4.95
- Imported Stiletto Knife. (Quick opening) \$2.50
- Balanced Throwing Knife. 10". \$1.00 set of 3, \$2.75
- Felt Emblems for Shirt, Sweater. Any team, animal. 25c ea.
- Calendar Girl Cards. Reg. deck. 53 playmates. Color. \$1.95
- Carbide Cannon. Loud Blast. \$4.95. Carbide Ammo 45c
- Hypno-matic Disc. Hypnotize fast. 65c
- 6-ft. 4-ply Leather Whip \$1.98. 10-ft. \$3.29
- 100X Opaque Projector, Enlarger, Copier. Electric. \$4.98

New Send 10c for amazing catalog of novelties, live animals, scientific supplies, hobbies, funmakers, planes & boats, looms, magic tricks, joke articles, unusual seeds, gadget timesavers, cameras, optical goods, projectors, movies, lucky jewelry, religious novelties, disguises, musical instruments, stamps, coins, puzzles, fortune tellers, radios, auto & bike accessories, telescopes, magnifiers, compasses, banks, smokers' gadgets, artists' supplies, printing sets, engines, motors, snickers, knives, billfolds, guns, rifles, sports, books, games, plants etc. Send 10c.

JOHNSON SMITH COMPANY Dept. 575 Detroit 7, Mich.

Материал, защищенный авторским правом

Assemble the finest instrument your money can buy

NEW ALL-TRANSISTOR Schober®

ELECTRONIC ORGAN

New Recital Model
compares musically
to instruments
costing 4 times
the price!



meets AGO specifications



PIPE ORGAN VOICING—separate, distinct—32 in Recital Model. LIBRARY OF STOPS™ Kit feature adds extra plug-in voices

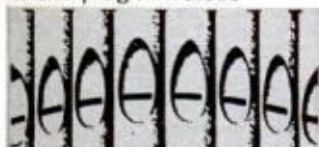

PIPE ORGAN TONE—all four families of pipe tone in all models

plus **FULL THEATRE AND CHURCH VOICING, PERCUSSION,** many other quality features!

How is it possible to acquire the skill needed to build a splendid organ—without any previous knowledge of electronics or music?

While the complete organ is a complex instrument, Schober Organ kits are specially designed for do-it-yourselfers. Printed circuitry eliminates a lot of the work and makes errors almost impossible. Many parts come preassembled. You simply follow detailed illustrated instructions for easy assembly, then place in assembled and pre-finished cabinet.

You save costly factory assembly, retail store markup—put every penny into fine musical parts. You enjoy the finest instrument your money can buy.

Schober Organ kits cost as little as \$550 in kit form, and you may spread this cost by ordering in sections.

THE *Schober Organ* CORPORATION
NEW YORK, N. Y. 10023

SEND FOR FREE CATALOG WITH FREE "SAMPLER" RECORD

The Schober Organ Corp., Dept. PM-14
43 West 61st Street, New York, N. Y. 10023

- Please send me without cost or obligation FREE SCHOBER ORGAN Booklet describing models. FREE 7-inch "sampler" record included.
- Enclosed find \$2 for high-quality LP 10" SCHOBER RECORD DEMONSTRATING all three models with different music (\$2 refunded with purchase of first kit).

NAME _____

ADDRESS _____

CITY _____ STATE _____ ZIP NO. _____

B.S. DEGREE IN 36 MONTHS

Small professionally-oriented college. Four-quarter year permits completion of degree in *Engineering* or *Business Administration* in three years. One year Drafting Design Certificate program. Founded 1884. Rich heritage. Excellent faculty. Small classes. Well-equipped labs. New library. Residence halls. 200-acre campus. Graduate placement outstanding. Modest costs. Enter Jan., March, June, Sept. For Catalog And View Book, write Director of Admissions



TRI-STATE COLLEGE

4124 College Avenue • Angola, Indiana

MONEY IN WORMS

Success for you! 5000 of our hybrid red wiggler fishworms produce 5,000,000 in one year using our successful method of worm raising. Read our success story in LIFE MAGAZINE, Dec. 28, 1959 issue. Let us teach you our secrets of success. Write today for FREE INFORMATION on how to raise and sell fishworms and crickets.

Special Today—Hybrid Red Wigglers—3000—\$5.95, 5000—\$8.95, 10,000—\$16.95. Postpaid.

CARTER WORM RANCH, PLAINS, GEORGIA



G E A R S

In Stock — Immediate Delivery

Gears, speed reducers, sprockets, thrust bearings, flexible couplings, pulleys, etc. A complete line is carried in our Chicago stock. Can also quote on special gears of any kind. Send in your blueprints and inquiries.

Send for Complete Catalog No. 10
CHICAGO GEAR WORKS
440-50 N. Oakley Blvd., CHICAGO 12, ILL.

STATEMENT OF OWNERSHIP, MANAGEMENT AND CIRCULATION (ACT OF OCTOBER 23, 1962; SECTION 4369, TITLE 39, UNITED STATES CODE). 1. Date of filing: October 1, 1964. 2. Title of publication: Popular Mechanics. 3. Frequency of issue: monthly. 4. Location of known office of publication: 575 Lexington Avenue, New York, N. Y. 10022. 5. Location of the headquarters or general business offices of the publishers: 959 Eighth Avenue, New York, N. Y. 10019. 6. Names and addresses of publisher, editor and managing editor. Publisher: The Hearst Corporation, 959 Eighth Avenue, New York, N. Y. 10019. Editor: Don Dinwiddie, 575 Lexington Avenue, New York, N. Y. 10022. Business manager: Joseph F. Kern, 575 Lexington Avenue, New York, N. Y. 10022. 7. Owner: The Hearst Corporation, principal office, 100 West Tenth Street, Wilmington, Delaware 19899. All of the stock of The Hearst Corporation is held by the following Voting Trustees, namely: Richard E. Berlin, 959 Eighth Avenue, New York, New York 10019; Harold G. Kern, 5 Winthrop Square, Boston, Massachusetts 02106; G. O. Markuson, 959 Eighth Avenue, New York, New York 10019; Charles Mayer, Third and Market Streets, San Francisco, California 94103; William Randolph Hearst, Jr., 959 Eighth Avenue, New York, New York 10019; Randolph A. Hearst, Third and Market Streets, San Francisco, California 94103; David W. Hearst, 270 North Canon Drive, Beverly Hills, California 90210; Frank Massi, 959 Eighth Avenue, New York, New York 10019, and Herbert W. Beyea, 410 Park Avenue, New York, New York 10022, under Voting Trust Agreement dated as of February 20, 1964; the beneficial owners of the stock deposited under the aforesaid Voting Trust are The Hearst Foundation, Inc., the William Randolph Hearst Foundation, William Randolph Hearst, Jr., Randolph Apperson Hearst, David Whitmire Hearst, George Hearst, John Randolph Hearst, Jr., Joanne Hearst Herndon, William Randolph Hearst II and Deborah Hearst. 8. Known bondholders, mortgagees, and other security holders owning or holding 1 percent or more of total amount of bonds, mortgages or other securities: None. 9. Paragraphs 7 and 8 include, in cases where the stockholder or security holder appears upon the books of the company as trustee or in any other fiduciary relation, the name of the person or corporation for whom such trustee is acting, also the statements in the two paragraphs show the affiant's full knowledge and belief as to the circumstances and conditions under which stockholders and security holders who do not appear upon the books of the company as trustees, hold stock and securities in a capacity other than that of a bona fide owner. Names and addresses of individuals who are stockholders of a corporation which itself is a stockholder or holder of bonds, mortgages or other securities of the publishing corporation have been included in paragraphs 7 and 8 when the interests of such individuals are equivalent to 1 percent or more of the total amount of the stock or securities of the publishing corporation. 10. This item must be completed for all publications except those which do not carry advertising other than the publisher's own and which are named in Sections 132.231, 132.232, and 132.233, Postal Manual (Sections 4355a, 4355b, and 4356 of Title 39, United States Code). A. Total no. copies printed (net press run): Average no. copies each issue during preceding 12 months, 1,530,167; single issue nearest to filing date, 1,572,000. B. Paid circulation—1. To term subscribers by mail, carrier delivery or by other means: Average no. copies each issue during preceding 12 months, 935,075; single issue nearest to filing date, 915,600. 2. Sales through agents, news dealers, or otherwise: Average no. copies each issue during preceding 12 months, 429,619; single issue nearest to filing date, 427,000. C. Free distribution (including samples) by mail, carrier delivery, or by other means: Average no. copies each issue during preceding 12 months, 9,502; single issue nearest to filing date, 8,618. D. Total no. of copies distributed. (Sum of lines B1, B2 and C): Average no. copies each issue during preceding 12 months, 1,374,196; single issue nearest to filing date, 1,351,248. I certify that the statements made by me above are correct and complete. Joseph F. Kern (Signature of business manager).

Here's the **EASY, Step-by-Step Way to**

FIX 2,700 CAR MODELS!

Engines, Brakes, Transmissions, Rear Ends, Generators—Yes, All These Parts

BRAND-NEW EDITION!

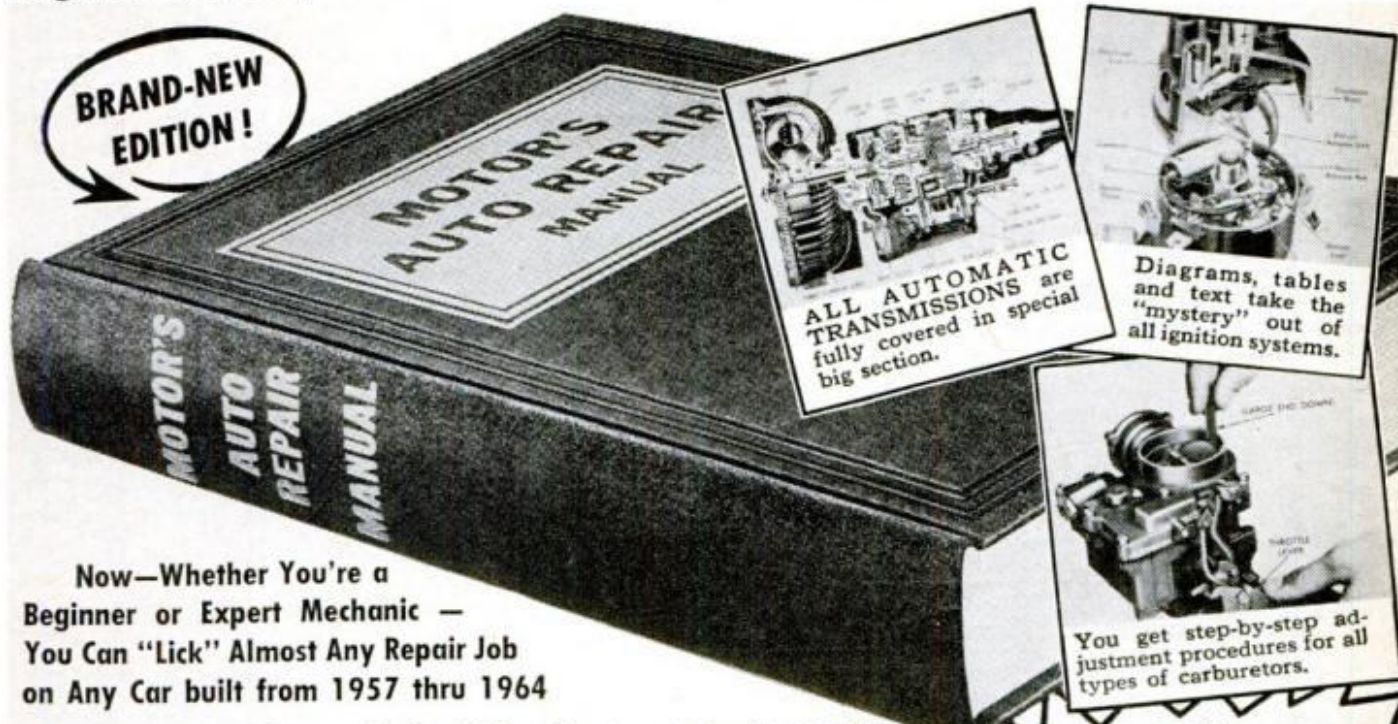

Now—Whether You're a Beginner or Expert Mechanic — You Can "Lick" Almost Any Repair Job on Any Car built from 1957 thru 1964

YES, now you can fix practically ANY part of ANY car—quickly, easily, and right! From carburetor adjustment to a complete overhaul, it's easy when you have MOTOR's famous Auto Repair Manual. It's like having a staff of factory experts and MOTOR's field-trained engineers beside you, guiding you every step of the way. No wonder so many thousands of beginners and experts alike use this step-by-step, illustrated manual.

MOTOR's Manual "starts from scratch"—leads you through entire job with easy step-by-step directions, clear "how-to" pictures. Tells you WHERE to start, what TOOLS to use. You just CAN'T go wrong!

3,800 Pictures! So Complete So Simple, You CAN'T Go Wrong!

NEW, REVISED edition covers all you need to know to repair almost any car, 1957-1964, including all the new models! 1,280 giant pages. 3,800 "This-Is-How" pictures lead you every step of the way. 457 "Quick-Check" charts — 55,000 essential repair specifications. Over 225,000 service and repair facts. Instructions and pictures so clear you can't go wrong!

Same Offer on MOTOR'S Revised AUTO ENGINES & ELECTRICAL SYSTEMS

1,300 Big pictures. Clear text explains how parts work; principles involved; design; construction; maintenance. Covers all parts of engines & entire electric system. For FREE trial, check coupon.

Brand-New—Covers All These Makes

- | | | |
|---------------|----------|-------------|
| American | De Soto | Mercury |
| Buick | Dodge | Meteor |
| Buick Special | Edsel | Monterey |
| Cadillac | Fairlane | Oldsmobile |
| Chevelle | Falcon | Olds F-85 |
| Chevrolet | Ford | Plymouth |
| Chevy II | Galaxie | Polara |
| Chrysler | Imperial | Pontiac |
| Comet | Jeep | Rambler |
| Continental | Lancer | Studebaker |
| Corvaair | Lark | Tempest |
| Corvette | Lincoln | Thunderbird |
| Dart | | Valiant |

Experts and beginners alike are amazed by the time and labor-saving methods!

The "Meat" of 191 Official Shop Manuals

The editors have put together the "know-how" from 191 Official Shop Manuals and "boiled it down" into one fully-illustrated easy-to-understand guide.

Here's ILLUSTRATED step-by-step guidance on Automatic Transmissions, Generators, Ignition, Carburetors, Fuel Pumps, Steering Gears, Rear End, Brakes, PLUS MUCH MORE.

SEND NO MONEY

Try Book for 10 Days FREE

Just mail coupon. (Attach it to postcard

if you wish.) Test book in your garage or shop. **GUARANTEED** to pay for itself in 10 days or you owe nothing. **MOTOR Book Dept., 250 55th St., New York, New York**

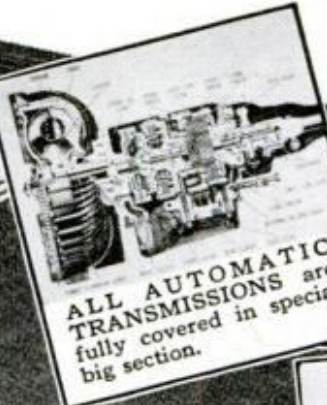

Try Book for 10 Days FREE



Expert Raves About Book . . .
"Motor Manual" is worth its weight in gold to any mechanic. I've done mechanic work for over 25 years. Motor has saved me many hours of brain-racking thinking."
—R. Carter, N. Carolina



. . . So Does Beginner
"In technical high school where I learned the auto mechanic's trade, Motor's Manual pulled me out of some rough spots. At present, I'm in the Armed Forces, attached to motor pool."
—W. Bekemerer, Missouri

MAIL COUPON NOW FOR 10-DAY FREE TRIAL

MOTOR BOOK DEPT., Desk 41Y
250 W. 55th St., New York, N. Y. 10019

Rush to me at once **MOTOR'S NEW AUTO REPAIR MANUAL**. If O.K., I will remit \$2 in 10 days, \$3 monthly for 2 months and a final payment of \$1.95 (plus delivery charges and sales tax, if any) one month after that. Otherwise I will return the book postpaid in 10 days.

Print Name.....Age.....

Address.....

City.....

State.....Zip Code.....

Also send me for 10 days' Free Trial **MOTOR'S Revised AUTO ENGINES and ELECTRICAL SYSTEMS**. If O.K., I will remit \$3 in 10 days, \$2 monthly for 2 months, and a final payment of \$1.50 (plus delivery charges and sales tax, if any) one month after that. Otherwise I will return book postpaid in 10 days.

Check box and save delivery charges by enclosing WITH coupon in envelope entire payment of \$9.95 for Auto Repair Manual for \$8.50 for Auto Engines & Elec. Systems) plus sales tax, if any. Same 10-day return-for-refund privilege.

MAKE \$30 TO



\$100 A DAY

Some make more, some less

MAKE BIG MONEY • With an easily operated, highly efficient WALL WASHER, H.D. Hart makes \$30 to \$100 every day he works. E. Goss took in more than \$10,000 in one year. C.H. Jones wrote, "I made a net profit of \$1200 on one job." And no wonder — this machine washes walls 6 times faster and better than by hand and with no mess — no drop cloths needed.

Your Money-Making Opportunity • We want more men to go into this profitable business for them-

We help you to start your own all-year business

selves and enjoy independence — freedom from layoffs and bosses. Customers everywhere — homes, offices, schools, churches, hotels, etc. How much you earn depends largely on you, but we help you to start and work with you for your success. What you take in is mostly profit. No need to rent shop or office; operate from home. Can start spare time until full time is justified.

Ours is NOT a lease arrangement • You are free to operate in an independent manner. You sign no contract. You own the detergent outright and are always your own boss...and every dollar you take in is yours to keep. You pay no fees, or dues, or royalties to anyone, and enough supplies come with it to return far more than your investment. Many earn the cost of the detergent in a week or two. It costs nothing to get the details...write TODAY.

FREE BOOK! MAIL COUPON TODAY

VON SCHRADER MFG. CO.
W10 "W" Pl., Racine, Wisconsin

Send at once (no obligation) your **FREE** booklet containing information about your WALL WASHING MACHINE and how I can start my own permanent, profitable business.

Name _____
Address _____
City _____ Zone _____ State _____

◀ Lose No Time — Send Coupon Today for All the Facts

MACHINE Casts Metal

Steady production of beautiful 2 1/4" figures for FUN and PROFIT.

MAKES TOY SOLDIERS, 100 an hour!



only \$15
post paid
Add \$2 if W. of Rockies;
Add \$3 outside U.S.



ELECTRIC! AUTOMATIC!

Ready to Operate. Includes 3-man Commando mold, several poses, mold handles, 24 pigs of metal, paints, brush, smoking candle, all instructions, only \$15

ELECTRIC HAND CASTER

This big outfit has electric stove, ladle, 18 pigs metal, mold for 3 World War II action soldiers and all other accessories above... \$10

Add \$1.50 W. of Rockies;
\$2.50 outside U.S.

EXTRA MOLDS

3 Knights of the Round Table \$3
Cannon Mold, Wheels Roll... \$3
Add \$1.00 W. of Rockies

HOME FOUNDRY

1826 S. Washtenaw,
Chicago, Ill. 60608



\$10

REAL ESTATE BE A BROKER

PAYS BIG! SEND FOR FREE, BIG, ILLUSTRATED CATALOG NOW! Graduates report making substantial incomes. Start and run your own business quickly. Men, Women, all ages, learn easily. Course covers Sales, Property Management, Appraising, Loans, Mortgages, & related subjects. **STUDY AT HOME** or in classrooms in leading cities. **DIPLOMA AWARDED. Write TODAY for FREE Booklet!** Accredited Member National Home Study Council. VA Approved. **WEAVER SCHOOL OF REAL ESTATE (Est. 1936)** 3521-P Broadway Kansas City 11, Mo.

FREE BOOK TELLS HOW

when it's time to think of college you should read this **FREE CAREER BOOKLET** about engineering at

MSOE

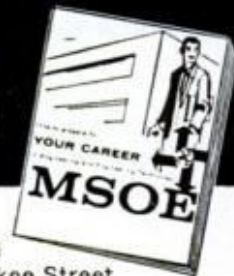

MILWAUKEE MS-221 SCHOOL OF ENGINEERING
Dept. PM-1264, 1025 N. Milwaukee Street
Milwaukee, Wisconsin 53201

Tell me about an engineering career through residence study in:

Mechanical fields Electrical fields

Name.....Age.....

Address.....

City, State.....

SANDING BELTS



Dozen		Dozen	
1x42 Mead, etc.	\$2.95	4x21 3/4 Skil, etc.	\$4.95
2x17 1/2 Burgess	2.95	4x27 Porter Cable, etc.	5.50
2x21 Porter Cables, etc.	2.95	4 1/2 x 26 Skil-Thor, etc.	5.50
2 1/4 x 21-5/16 Skil, etc.	3.50	4x36 Hammond, etc.	6.95
3x18 All Makes	3.50	4x37-13/16 Atlas, etc.	6.95
3x21 Porter Cable, etc.	3.95	4x54 Porter Cable, etc.	9.50
3x23 3/4 Skil, Thor, etc.	3.95	4x52 1/2 Walker Turner	9.50
3x24 Porter Cable, etc.	3.95	6x48 Delta-Sears, etc.	11.95
3x27 Porter Cable, etc.	3.95		

- 1—All Belts Cloth Backed—Brand NEW.
- 2—Please Specify for Wood, Metal, Etc.
- 3—On orders of 4 dozen or more DEDUCT 10% from above prices.
- 4—Belts shipped assorted. Fine, Medium, Coarse, or specify grits desired.
- 5—**MONEY BACK GUARANTEE.**
- 6—All other sizes available at lowest prices—PLEASE INQUIRE. Include 45¢ for postage and handling: Send check or money order. DEALERS INQUIRIES INVITED.

JACKSON TOOL CORP.

28-09 Jackson Ave., Dept. PM., L. I. City 1, New York



EARN BIG MONEY

LEARN APPLIANCE REPAIRING

Learn at home in your spare time. How to fix appliances using Christy Electronic Trouble Tracer, what to charge, how to operate your own fix-it shop. Make \$5-6 per hour in kitchen or basement. Pay later from earnings.

Send for
**FREE
BOOK**

CHRISTY TRADES SCHOOL

Dept. A-6303, 3214 W. Lawrence Ave., Chicago 60625

NO JOB WORRIES

PLASTEX INDUSTRY needs manufacturers on small scale for big production of Lamps, Clock Stands, Art Goods, Novelties in Plastic Marble Imitation. No experience necessary. 1/2c material makes regular 10¢ store sellers. Moulds furnished for fast production. Small investment brings good profit. Big wholesale orders now being placed. Ambitious men have chance for real prosperity and job security. Our NEW FREE booklet will interest and benefit you.

PLASTEX INDUSTRIES, Dept. A
3400 Third Ave. New York 56, N. Y.



You can make money in

WATCH REPAIR

Learn at home the low cost Sweazey Way

Watch repairing pays up to \$6 an hour. part time watch makers report on survey. Unique and modern Sweazey home study System starts you making repairs right away on Swiss and American watches. Professionally prepared training. No previous experience needed. Special tools provided for practice. Tuition only \$5 a month. Diploma Awarded. Free sample lesson and opportunity book give all facts. Write today. No obligation.

CHICAGO SCHOOL OF WATCHMAKING

Dept. 1124, Fox River Grove, Illinois, 60021

FREE BOOK and SAMPLE LESSON

CHICAGO SCHOOL OF WATCHMAKING
Dept. 1124, Fox River Grove, Illinois, 60021
Please rush FREE BOOK and Sample Home Study Lesson.

Name _____ Age _____
Address _____
City _____ Zone _____ State _____

94.6% OF BAILEY GRADUATES ARE EMPLOYED AT TOP PAY IN THE FIELDS WHICH THEY WERE TRAINED!



DIESEL-AUTO MECHANICS DESPERATELY NEEDED!

We have a far greater demand for our students than we can fill!

We can show you an actual waiting list of leading companies throughout the world who have tried Bailey graduates — found them outstanding, and are coming back for more!

Bailey Graduates are Successful . . . RECEIVE BIG PAY — HAVE SECURE FUTURE!

The Famous Bailey Course prepares you for BOTH Diesel and Gasoline Mechanics.

This is a **must**-due to the advent of using Diesel principles, such as 'Fuel Injection' on passenger cars . . . use of gasoline engines for starting Diesel engines, etc. You learn all this at Bailey in the amount of time ordinarily required to learn just one of these subjects, **ALL FOR THE PRICE OF ONE.**

Don't be satisfied with a 'futureless', one-type job — learn how you can make **big money** now!

Write today for Free Booklet that takes you on a step-by-step camera tour through our spacious, modern shops — See Bailey students in action as they Learn-by-doing with the Famous Bailey Method of training!

We provide you with housing and part time jobs while in school, plus nation-wide placement service for graduates.

BAILEY Technical SCHOOLS

1634 S. GRAND

ST. LOUIS 4, MO.

MAIL TODAY!

Please mail immediately this free booklet without obligation.

FREE BOOKLET



Name _____
Address _____
City _____ State _____
Telephone _____ Age _____

Big Profits in UPHOLSTERY

Get Your Share... FAST!

EARN BIG MONEY **3** **NEW EASY WAYS**

1. Be your own boss, make up to 85% profit on every job.
2. Start earning right away while learning at home in sparetime - keep furniture you build, or sell for hundreds of dollars.
3. Today's home and office upholstery, re-upholstery, slipcover boom make it easy to say "goodbye" to layoffs and take your pick of steady big-pay jobs.

LEARNING EASY AS A B C

Your own two hands are all you need. UTS experts and simple instructions do the rest. You get all tools, new wooden frames, materials, fabrics, business tips, wholesale privileges, decorating magic at no extra charge whatsoever! LEARN FAST, EARN FAST. Thousands we've trained now doing it. Find out how you can, too.

MAIL COUPON TODAY

UPHOLSTERY TRADES SCHOOL, Dept. 510-124
(Division of Technical Home Study Schools)
Little Falls, New Jersey

Please send me FREE book, "Your New Way to a Successful Career," and FREE sample lesson pages. No obligation - no salesman will call.

Name _____
(Please Print Plainly)

Address _____
City _____ Zone _____ State _____

FREE
Deluxe Illustrated Book and
FREE
Sample Lesson Pages Give Proof - Show How



Tools - Equip. To Keep or SELL

BE A RADIO ANNOUNCER

Men & Women • Learn from real radio announcers—the Columbia way in only 6 months. Our announcers teach you with special recorded courses and texts. How to get your first job. Many announcers earn \$175 a week and more. Hundreds of job openings for announcers. A home study course. Send for free sample recorded lesson.



COLUMBIA SCHOOL OF BROADCASTING
DEPT. 12, 4444 GEARY BLVD., San Francisco

75 POWER TELESCOPE \$398

25X-45X-75X

NEW 3 in one telescopes, 3 variable 25X-45X-75X magnification. Brass bound. 25 power for ultra bright images 45 & 75 power for long range. Guaranteed to bring distant stars, moons, objects, sports 75 times closer.

Most powerful scope sold anywhere near this amazing low price. American made, 5 sections. Opens 36", closes 1 ft.; contains 4 ground & polished lenses. Can also be used as powerful compound microscope. Mass production enables us to offer telescope complete at \$3.98 postpaid. Money back guarantee.

CRITERION CO., Dept. PBM-23, 331 Church St., Hartford, Conn.

DRAINS collars, cisterns, wash tubs; \$8.95

IRRIGATES - CIRCULATES - SPRAYS

1,001 uses. Stainless shaft. Won't rust or clog! Use 1/2 HP motor or larger... 3/4 HP for up to 2,400 GPH; 450 GPH 80' high; or 1,800 GPH from 25' well. 1" inlet; 3/4" outlet. Coupling included free. **\$8.95.**

HEAVY DUTY BALL-BEARING PUMP. Up to 5,200 GPH; or 3,000 GPH from 25' well. 1 1/2" inlet; 1" outlet. **\$12.95** Postpaid if cash with order. **MONEY BACK GUARANTEE**

Centrifugal and Gear Pumps in All Sizes
LABAWCO PUMPS, Belle Mead 7, New Jersey

1000 TRICKS 10¢

AMAZE! ENTERTAIN! START NOW!
BIG EXCITING MAGIC & FUN CATALOG! 160 Pages! Tricks, Jokes, Magic, Illusions, Secrets! Puzzles, Stunts, etc.! Rush name, address and only 10¢.



FREE MAGIC TRICK GIVEN
House of 1000 Mysteries • Dept. PM124 • Monroe, Conn.

POLYSEAMSEAL®

TUB CAULK • TILE ADHESIVE
Pure White • Elastic Permanent

Sticks like glue! 101 Household Uses!

L. W. FERDINAND & CO., INC., SIMSBURY, CONN.



IF YOU HAVE HERNIA

it is important that you Get this **NEW FREE BOOK**

This New **FREE** Illustrated Book tells how Rupture can be treated by a mild **NON-SURGICAL METHOD** and **THAT THE TREATMENT** is backed by a Lifetime Certificate of Assurance.

The book explains that, although many people have not heard of, or have been misinformed about the non-surgical treatment, it has a long history of use and is recognized by authorities today.

Many men and women from all over the country have taken the **NON-SURGICAL TREATMENT** and have reported it has proven effective.

Write today for this New Free Book that tells **HOW** and explains **WHY** more and more sufferers are using **MODERN NON-SURGICAL** Methods of treating their ruptures. Act Now. No obligation.

EXCELSIOR MEDICAL CLINIC
Dept. E. 6137 Excelsior Springs, Mo.

NEW CATALOG WOOD

Everything for the Craftsman
Over 1,500 Items
Finest Domestic and Imported Woods...
Kits... Ornaments...
Tools... Special Hardware... Tile.
LOW MONEY - SAVING PRICES
Stanley Power Tools
—Big Discounts!



Workshop Supplies, Equipment
Send for Craftsman's NEW 132-page catalog... get big discount prices on Stanley Power tools! Finest kiln-dried domestic and imported woods, wood and metal legs, ornaments. Over 1,500 items! Big values on tools, craftsman hardware, Mosaic Tile, upholstery supplies, lamp parts. **Glue injector.** Send 25¢ to help pay postage and handling. Craftsman Wood Service, Dept. A12 2729 S. Mary St., Chicago 8, Ill.

CRAFTSMAN WOOD SERVICE CO., Dept. A-12
2729 South Mary Street, Chicago 8, Illinois

Enclose find 25¢. Rush new CRAFTSMAN Wood Catalog.

NAME _____
ADDRESS _____
CITY _____ ZONE _____ STATE _____

MAIL COUPON NOW!

For your own use or resale for profit.

1964 FORD CUST. \$899
DODGE 330



FANTASTIC BARGAINS

Ex taxis... no different than regular passenger cars

You read it right - 1964 models. Quantity limited. Act fast. Also 1963 cars at big bargain buys. Phone now, wire or write Larry Shandel, Universal Autos, 990 Newark Ave., Jersey City, N. J. DEPT F
Phone: 201 - HE 5-8400, in NYC: CO 7-4440.

TELLS HOW TO SELL YOUR INVENTION

If you have an invention that you believe has merit, write us at once for copy of copyrighted booklet "How to Go About Selling Your Invention." We work with manufacturers, and booklet reveals present markets, qualities of a saleable invention, current royalty rates being paid by manufacturers. Booklet is **FREE**, is offered to encourage new ideas we might submit to manufacturers. Just send name (no drawings, please) to **Kessler Sales Corporation, Dept. D512, Fremont, Ohio**

**Career in
ELECTRONICS?** 

Train at home with RCA Institutes, one of America's leading Electronic Schools. Lab work with first lesson. No installment payments required. (Licensed by N. Y. State Education Dept.) Send for free 64-page book.

RCA Institutes, Inc.
A Service of RCA
Dept. PM-D4
350 W. 4th St., N.Y. 14, N.Y.

Two or four-wheel drive
JEEP or SCOUT
owners

REPOWER
with V-8 or 6 Cyl. engines.
H. D. ADAPTORS for TRUCK, CAR or COMPACT engines. Immediate del. Write, wire or phone TO-DAY. Free details.
HOOSIER MACH. Prods. Co.
312 SE 6th Pendleton, Oregon
Ph. 276-3442

ENROLL-EARN YOUR DEGREE
of Bachelor of Bible Philosophy (B.Ph.B.), Master of Bible Philosophy (M. Ph. B.), Graduate of Bible Philosophy (G. Ph. B.), or Doctor of Metaphysics (Ms. D.). Chartered by State. Correspondence Courses only. Please write for FREE BOOKLET.
AMERICAN BIBLE INSTITUTE
Dept. PM, 408A W. 75th St., Kansas City, Mo. 64114

the going's great!
WARN HUBS
ON YOUR 4-WHEEL DRIVE

Stop front end drag, save gas, gears
These famous hubs save gas, gears, tires, engine, improve performance, reduce maintenance costs, increase vehicle life by disengaging the front drive in 2-w.d.—automatically, or with manual controls. To get the most from your 4-w.d. under all conditions, install Warn Hubs. That's what the majority of 4-w.d. owners do. Write, or see your dealer.
Warn Mfg. Co., 9050-A Empire Way S., Seattle, Wash. 98118

640 ACRES OF WILDLIFE - \$20

\$20 plus \$6.00 taxes yearly gets you a 640 acre wildlife domain near Canadian border. Untamed paradises! (Abandoned timber leaslands.) Extensive choice of these exclusive lakeland campsites, accessible by road, teeming with wildlife, including bear, moose, deer, muskie, northern pike, ducks, geese. Send \$1 (refundable) for maps, pictures, Gov't. regulations, official application blank to: Director, O.S.C.A., Room 597, 56 Church, Toronto 1, Canada. Add 50¢ for rush air mail

Dr. Grabow Golden Duke

only filter pipe with a justomatic stem!

Needs No Breaking-In!



\$495
DISPOSABLE FILTER Ajustomatic Screw Stem

Imported, hand-shaped briar. Other Dr. Grabow Duke Filter Pipes — \$1.95 to \$3.95.

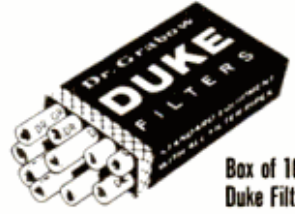

Box of 10 Duke Filters, 10¢

For FREE Information Booklet, Write to:
DR. GRABOW Pre-Smoked Pipes, Greensboro, N.C.

LEARN TO EARN!



NO CORRESPONDENCE OR HOME STUDY TRAINING

Home study does not make a good operator. Our students are taught on the machines on actual construction jobs by qualified instructors. This means they are better qualified and more readily accepted for immediate employment by contractors.

• CONTRACTOR OWNED - V.A. APPROVED
Western School is the only contractor owned and operated school in the world. These are the men who eventually hire heavy equipment operators. Write today for FREE information on how you may enroll in one of Western School's many courses.

WESTERN SCHOOL
OF HEAVY EQUIPMENT
OPERATION

Dept. M-12
Box 510
Weiser, Idaho



WRITE TODAY FOR FREE SCHOOL CATALOG

Associate member of Associated General Contractors and A.R.B.A.

DISCOVER EXCITING PROFITS Hidden in America's Mountain of Broken Electrical Appliances



EARN \$3 TO \$5 AN HOUR
spare time, full time — learn at home

400 million Appliances are in American homes right now. 76 MILLION MORE are bought each year. People need them fixed, good times or bad. YOU make good money repairing them in your basement, garage, even on your kitchen table. No experience needed!

FREE BOOK TELLS YOU HOW

24-page FREE BOOK tells about "Appliance Boom" — how you can cash in on it. FREE SAMPLE LESSON shows how simple our instruction is — how NRI can quickly prepare you for profitable future — how you even get, AT NO EXTRA COST, your own Appliance Tester Kit worth \$32.50.

Get FREE Book and FREE Sample Lesson now. Mail coupon below, letter or postcard. No salesman will call.

NATIONAL RADIO INSTITUTE, Appliance Division
Dept. 600-124, Washington 16, D.C.
Send Free Book, Free Appliance Repair Course Lesson. Am interested in:
 Spare Time Earnings My Own Business
 Better Job

Name.....
Address.....
City.....Zone.....State.....

Accredited Member National Home Study Council



Earn HIGH WAGES as a HEAVY EQUIPMENT OPERATOR

... and years of future security in the multi-billion dollar construction industry, in this country and *overseas!* Learn how at National, the original school of heavy equipment operation. For men ages 17 to 36. Amount of previous education no barrier. National is NOT a correspondence school. You train on school-owned diesel-engined machines at National's huge proving ground in North Carolina. Full 220 and 440 hour courses. Full-time Job Advisory and Counselling Director for the exclusive benefit of graduates. VA approved. Payment plans available. Write TODAY for FREE catalog.

Since National School was founded nine years ago, students from all 50 states and 28 foreign countries have been enrolled. Hundreds of graduates are now working in construction for higher wages than they ever made before.

**NATIONAL SCHOOL
OF HEAVY EQUIPMENT OPERATION Dept. D-59**
P. O. Drawer 1686, Charlotte, N. C.

Please send me FREE illustrated school catalog and complete information. I understand there's no obligation.

Name..... Age.....
Address.....
City..... Zone..... State.....

Print Your Own

Cards, Stationery, Advertising, Circulars, labels, photo and movie titles, church work, tags, etc. Save money. Sold direct from factory only. Raised printing like engraving, too.

Own a Printing Business
Print for Others, Good Profit. Have home shop. Junior press \$15; Senior \$35 up. We supply everything. Easy rules. Pays for itself in short time. Write now for free details.
KELSEY PRESSES, Z-37 Meriden, Conn.

LEARN MEAT CUTTING

Train quickly in 8 short weeks at Toledo for a bright future with security in the vital meat business. Big pay, full-time jobs — HAVE A PROFITABLE MARKET OF YOUR OWN! Pay after graduation. Diploma given. Job help. Thousands of successful graduates. Our 41st year! Send NOW for FREE catalog. No obligation. GI approved.
NATIONAL SCHOOL OF MEAT CUTTING, Dept. 50-N, Toledo 4, Ohio

BILL TROUBLES?

NOBODY REFUSED UP TO \$9,000.00
BAD CREDIT • NO PROBLEM — NOT A LOAN CO.
SEND YOUR NAME FOR FREE APPLICATION
ATLANTIC ASSOCIATES — DEPT. 43
144 WESTMINSTER ST., PROVIDENCE 3, R. I.

Build This Beautiful Grandfather Clock

We show you how at price you can afford. Send only \$1.00 for complete plans and instructions plus information-packed catalog of clock movements, dials, blueprints and kits for constructing Grandfather, Grandmother, Terry and other fine clocks.
MASON & SULLIVAN CO.
DEPT. PM OSTERVILLE, MASS.

EARN MORE be a TAX CONSULTANT

Our students earn lucrative fees in 3 month busy tax season preparing income tax returns in spare time—and operate profitable Business Tax Service yielding steady monthly fees of \$10-\$50 per client, year 'round. Enjoy professional standing in dignified full or part time home-office business. No experience necessary. We train you at home and help you start. Write today for free literature. No agent will call. Licensed by N.Y. Education Dept.
National Tax Training School, Mansey V-20, N.Y.

PROFIT IN YOUR SPARE TIME

SMALL ENGINE REPAIR PAYS BIG!

Outboard • Powermower • Chain Saw • Tractor
MAKE EXTRA MONEY — or fix your own engines and SAVE! Illustrated, easy-to-learn Home Study Course qualifies you as expert. Free information. Write today!

LINCOLN TECHNICAL INSTITUTE
SUITE 12E 472 MARKET STREET, NEWARK 5, N. J.

HYDRAULIC JACK REPAIRS

Earn While You Learn at Home
Earn while you learn at home. Trained and qualified mechanics needed NOW to service inoperative hydraulic jacks. BIG opportunity for ambitious men. We show you HOW—in your basement or garage, spare time cash income in an expanding industry. Don't wait, ACT NOW! Get the facts.
Write for folder No. PM-12 and free bonus offer.

HYDRAULIC JACK REPAIR MANUAL CO.
P. O. BOX 50 • BLOOMFIELD, N. J.

BUILD, DRIVE TIGER-MITE SCOOTER

Fun to build and drive, inexpensive. Safe, powerful, quite family fun... gasoline scooter. Order: Specs & plans \$2.00 Glossy photo, brochure, decal \$1.00 Completed Scooter \$59.95. SEND COUPON TODAY

TIGER INDUSTRIES
Box 413P, Laguna Beach, Calif.
Name.....
Address.....

NEW STROMBECKER CORDLESS POWER DRILL

Only \$3.95

10,000 rpm
on 2 "C" batteries.
With 2 drills, router,
de-burrer, sanding drum. 1001 uses in
every home—for every hobby! At hobby depts.

STROMBECKER CORP.

4646 W. Lake St./Chicago 60644

BRONZE FOUNDRY

Since 1935

Schools • Home Workshops • Inventors

Make your own castings of aluminum, copper, bronze, silver. Foundry sets are available in six sizes, capacity 1 1/2 lb. to 48 lb. of red brass. 2400 Deg. F. blast furnace included with each. Write for Free Circular.

KANSAS CITY SPECIALTIES CO. DEPT. P-12
MARYSVILLE, KAN.

MAKE UP TO \$5.00 AN HOUR AT HOME

Let Me Prove It To You FREE!

I'll show you how Plastic Sealing and Laminating at home, spare time, can give you as much as \$5.00 each hour you operate. Table-top machine sets up anywhere. Easy. Fun. No experience needed. We furnish everything. We'll even help finance you. No house-to-house selling. Orders come by mail. Write for facts FREE. No salesman will call.

WARNER ELECTRIC, 1512 Jarvis, Dept. L-2-PP, Chicago 26, Ill.



NOW! DENTISTS HELP
OVERCOME THE SHOCK
OF NEW FALSE TEETH—
WITH **FASTEETH**

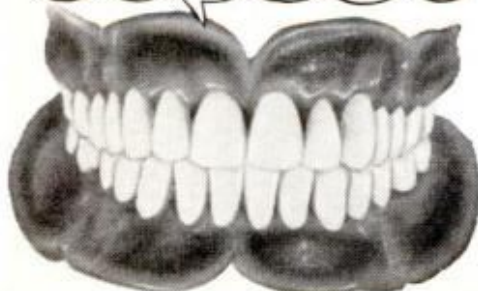

When false teeth get on your nerves many dentists give special **FASTEETH** powder. It helps hold teeth in place—helps keep them from slipping or dropping down when you talk—makes you feel more secure. **FASTEETH** cushions tender gums so you can bite harder and eat easier, faster with greater comfort. **FASTEETH** helps you laugh and speak more clearly without embarrassment. **FASTEETH** is alkaline (non-acid). Checks "plate odor" (denture breath). At drug counters everywhere.

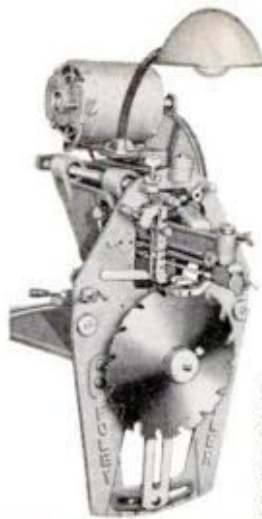

EARN
\$3 TO \$6
AN HOUR
in sparetime

Here's a practical way to increase your income and build security for your family. Earn extra money every week sharpening saws with a Foley Automatic Saw Filer. You can actually build your own business with it—without special training or previous experience.

TURN YOUR SPARE TIME INTO CASH. Make from \$3 to \$6 an hour evenings, week-ends. Start in your basement or garage. No canvassing. "I advertised in our local paper and got in 83 sales"—says M. L. Thompson. Every saw you sharpen with the Foley Filer brings you more customers. Hundreds are making extra money this sure, fast, easy way. You can too.

FREE BOOK SHOWS YOU HOW TO START

"Money Making Facts" explains how you can get business from home owners, farmers, carpenters, schools, factories, etc., how to build your business and expand—every step of the easy way. Don't wait. Mail coupon now for this exciting book and easy pay plan. No salesman will call.

MAIL COUPON FOR FREE BOOK

FOLEY MANUFACTURING CO.
1243-4 Foley Bldg., Minneapolis, Minn. 55418
Rush free book, "MONEY MAKING FACTS", and details on easy pay plan.

Name _____
Address _____
City _____ State _____



AUDEL SKILL-BUILDING GUIDES

- | | | |
|---------|---|---------|
| No. 3 | Radio-TV Library, 2 Vols. 1024 pages..... | \$ 9.50 |
| No. 52 | Domestic Compact Auto Repair Manual, 832 pages.. | 5.95 |
| No. 53 | Foreign Auto Repair Manual, 592 pages..... | 5.00 |
| No. 54 | Programmed Basic Electricity Course, 272 pages... | 4.00 |
| No. 13 | Wiring Diagrams for Light & Power, 320 pages.... | 4.00 |
| No. 1 | Auto Mechanics Guide, 1132 pages..... | 6.00 |
| No. 8 | Carpenters & Builders Guide, 4 Vols. 1845 pages... | 10.50 |
| No. 2 | Home Appliance Service Guide, 882 pages..... | 6.00 |
| No. 14 | Refrigeration & Air Conditioning Guide, 1090 pages. | 6.00 |
| No. 49 | Outboard Motor & Boating Guide, 414 pages..... | 4.00 |
| No. 10 | Welders Guide, 588 pages..... | 4.95 |
| No. 43 | Do-it-Yourself Encyclopedia, 2 Vols. 1000 pages... | 8.95 |
| No. 4 | Handy Book of Practical Electricity, 1052 pages... | 5.95 |
| No. 25 | Answers on Blue Print Reading, 430 pages..... | 3.95 |
| No. 7 | Painting & Decorating Manual, 592 pages..... | 4.95 |
| No. 34 | Q&A for Electricians Examinations, 272 pages..... | 3.00 |
| No. 11 | Mathematics & Calculations for Mechanics, 672 pgs. | 4.95 |
| No. 12 | Machinists & Tool Makers Handy Book, 1256 pages | 6.95 |
| No. 28 | Oil Burner Guide, 420 pages..... | 3.95 |
| No. 6 | Plumbers & Steam Fitters Guide, 4 Vols. 1833 pages | 10.50 |
| No. 15A | New Electric Library, 10 Vols. 5000 pages..... | 25.00 |
| No. 26 | Masons & Builders Guide, 4 Vols. 1440 pages..... | 10.50 |
| No. 27 | Electric Motor Guide, 1036 pages..... | 5.95 |

7 DAY FREE EXAMINATION. SEND NO MONEY. We'll send you any Audel Guides for FREE trial. If you decide to keep the books you pay only \$3 per month under our easy-pay plan. Simply circle the books you want below and we'll send them at once. If you're not completely satisfied, return them to us.

THEODORE AUDEL & CO. • Since 1879 P-124
4300 W. 62nd St., Indianapolis 6, Ind.

Please mail me for 7 days FREE EXAMINATION the books circled below. I agree to mail \$3 in 7 days for each book or set ordered, and to mail \$3 a month for each book or set, until I've paid the purchase price, plus shipping costs. If I'm not completely satisfied with my Audel Guides I may return them.

MAIL COUPON TODAY!

Name _____
Address _____
Employed by _____

1	2	3	4	6	7	8	10	11
12	13	14	15A	25	26	27		
28	34	43	49	52	53	54		

SAVE SHIPPING COSTS. Check here if you enclose complete payment (plus sales tax, if any) with order. We pay postage. Same return privilege.

You Can Develop A Profitable Business on A Shoestring

Make \$5.00 an Hour in Your Own Home



I wish there was space here to print the hundreds of letters received from men I've put in business with the Belsaw Sharp-All. With this precision machine you can sharpen all popular household, garden and shop tools easily and quickly. You need no previous experience . . . no inventory, no selling, no space to rent.

I've Done It for 40,000 Men

I have been helping men get into this profitable business for over 30 years. I'll finance you to get started . . . give you all the instructions and help you'll need to really succeed. I'll keep you informed HOW others are making big cash profits every day. No obligation.

So don't delay. Send coupon for FREE book today.

STAN FIELD, President
Belsaw Sharp-All Company
715F Field Bldg., Kansas City, Mo. 64111



Name _____
Address _____
City _____ St. _____ Zip _____

WANTED! TRAINEES!

At School At Home

Send for SAMPLE LESSON and FREE Aptitude Test today. Study at School or at Home. You can EARN while you LEARN!

Allied Institute of Technology, Dept. PM-124
1338 S. Michigan Ave., Chicago, Ill.

Please send me FREE information about the courses I have checked and Allied's Industrial Co-op Placement Service.

Name _____ Age _____
Address _____
City _____ County _____ State _____

Get into one of these important fields:

- MACHINIST TRADE
- TOOL-DIE MAKING
- DRAFTING
- TOOL DESIGNING
- INDUSTRIAL ENGINEERING
- AIR CONDITIONING REFRIGERATION
- AUTO MECHANICS

NOW! WARN OVERDRIVE gives 'Jeeps' more Go!



New approved accessory cuts engine RPM 33% at any speed, reduces noise, vibration so you can drive your Jeep 4-w.d. comfortably at freeway speeds. Amazing synchromesh OD lets you shift up or down, on the go, anytime, in any gear, at any speed. Adds six forward speeds, two reverse. At Jeep dealers, or write us.



WARN SALES CO., Inc.
9050-A Empire Way South
Seattle, Washington 98118

"\$33,000 LAST YEAR" OPERATING AUTO RADIATOR SHOP



-Mercier Bros., Lowell, Mass.

"1,100 radiators repaired in last 7 months," reports Mercier Bros. as volume soars . . .

and the market is still growing! Modern V8's and 6's produce more heat than older engines. . . cooling system pressures are higher. . . yet radiators are smaller. Tests show 83% of all year-old autos, trucks, tractors need radiators cleaned - neglect endangers engine life, brings major repair bills. Inland's Flo-Test Machine diagnoses radiator condition - customer SEES his radiator is plugged - OK's cleaning. Inland-owners satisfy customers by performing needed cooling system service, replacing worn hoses, belts, water pumps, thermostats, etc.; average up to \$45 per job!

Profits Immediate - Investment Modest

Inland - world's largest mfr. of radiator servicing equipment - offers you complete package: equipment, supplies, 96-page Operating Manual, FREE FACTORY TRAINING for repairman (enables him to train others). Proved merchandising assures volume. Pay-As-You-Profit purchase plan. Act now - establish your own Cooling System Shop:

- Set up a side-line business, hire manager.
- Be the owner-operator.
- Makes a profitable dept. for established business.
- Start "part time" and build a profitable future.

WRITE FOR FREE 32-PAGE BOOKLET - "Blueprint for Profits" . . . describes equipment, prices, purchase plan, includes owner letters.

INLAND MFG. CO., Dept. PM-12, 1108 Jackson, Omaha 2, Nebr.

make your own Gems 3650 F.O.B.

The Gem Maker comes complete with all necessary equipment, including a super-charged diamond blade for sawing, and all the wheels for grinding, shaping and polishing; also complete instructions. The complete equipment as shown, less motor and belt for only \$36.50, f.o.b., Burlington, Wisconsin. Write today for information and literature.

B & I MANUFACTURING CO.
Dept. P, Burlington, Wis.



LEARN CRIMINAL INVESTIGATION at home

Prepare for an exciting job, good pay, security! We teach you **at home in spare time**. Learn Finger Printing, Firearms Identification, Criminal Investigation, Police Photography. Low cost; easy terms. Over 800 Bureaus of Identification employ our graduates! Write for famous "Blue Book of Crime" - **free!** State age, please. (A Correspondence School Since 1916).

Institute of Applied Science
1920 SUNNYSIDE AVENUE • DEPT. 1359 CHICAGO 40, ILLINOIS

Shrinks Hemorrhoids New Way Without Surgery Stops Itch - Relieves Pain

For the first time science has found a new healing substance with the astonishing ability to shrink hemorrhoids and to relieve pain - without surgery.

In case after case, while gently relieving pain, actual reduction (shrinkage) took place.

Most amazing of all - results were so thorough that sufferers made astonishing statements like "Piles have ceased to be a problem!"

The secret is a new healing substance (Bio-Dyne®) - discovery of a world-famous research institute.

This substance is now available in suppository or ointment form under the name Preparation H®. Ask for it at all drug counters.



**ALL TOP BRANDS
50-70% REDUC.**

Spec. Imp. 120 B, 5 Sw. \$119

Write for **FREE BROCHURE M**
ACCORDION-O-RAMA
874 Broadway, N. Y. 3, N. Y. (cor. 18 St.)

Make Rubber Stamps for BIG PAY



Need more money? Earn \$30-\$50 a week, spare time, at home making rubber stamps for offices, factories, individuals. Hundreds of uses. Hundreds of prospects—everywhere. Right in your own community. Turn out special stamps for names, addresses, notices, prices, etc., in minutes with table-top machine. We furnish everything and help finance you. Write for free facts. No salesman calls.

Rubber Stamp Div., 1512 Jarvis Ave., Dept. R-2-PP, Chl. 28

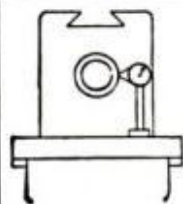

**—Improve Machinist's Skills—
MACHINE TOOL
RECONDITIONING**

& the Art of Hand Scraping (6th printing)
Now get information, ideas & know-how from this time-tested, instructive book. Send today for free folder describing illustrated manual for machinists.

MACHINE TOOL PUBLICATIONS
215-P Commerce Bldg., St. Paul, Minn. 55101

\$50,000 a YR. POSSIBLE

Become a finance broker part or full time

PO Box 482 Desk 3D
Okla. City, Okla.

Ra-Mar

**BASEMENT
TOILET FLUSHES
UP**



TO OVERHEAD SEWER OR SEPTIC TANK.
NO DIGGING UP FLOORS. INSTALLS EASY. Write

McPHERSON, INC. BOX 15133 TAMPA, FLA.

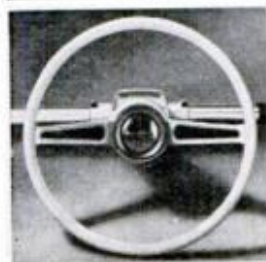

RIDE-GUIDE STEERING

Effortless rack-and-pinion steering. No ropes, cables or pulleys. Standard, deluxe or Captain's wheels.

**QUICKSILVER
ACCESSORIES**

At your MERCURY outboard dealer

© 1964, Kiekhaefer Corporation, Fond du Lac, Wisconsin, and Toronto. Subsidiary of Brunswick Corporation

LAW FREE BOOK



Write today for a **FREE** copy of illustrated law book, "THE LAW TRAINED MAN," which shows how to earn the professional Bachelor of Laws (LL.B.) degree through home study of the famous Blackstone Law Course. All necessary books and lessons provided. Moderate cost; convenient monthly terms. Write for **FREE** law training book today.

Blackstone School of Law, 307 N. Michigan Ave.
Founded 1890 Dept. 59, Chicago 1, Illinois

DIRECT FROM FACTORY

Compact Scooter, Rugged, Quality Unit. 10"-12" wheel choice. You save by assembly. Adult and young adult use.

- A1 complete less motor 10" . . . 59.95
- A2 complete with 3 HP motor . . . 99.95
- A3 frame only with bars . . . 29.95
- A12 3 1/4 HP chr. bars, 12" twist grip . . . 129.95
- A12B complete 12" less motor . . . 89.95

THE DORR CO.

Dept. C-3, 2924 4th Ave. S., Minneapolis, Minn. 55408



ENGINE TUNE-UP SERVICE

EARN \$1,000 A MONTH

LEARN A TRADE YOU LIKE

Start as a mechanic in a good paying job; then advance to shop service manager. Many make \$1,000 a month and up. You learn fast in our shop because you learn with tools on real equipment. Some students earn part of their expenses while going to school.

CHECK AND MAIL COUPON

- AUTO MECHANICS
- DIESEL MECHANICS
- GAS, ARC WELDING
- HELIARC WELDING
- AUTO BODY REPAIR
- AUTOMATIC TRANSMISSIONS
- MOTOR TUNE-UP

Mail to: **AUTO-DIESEL COLLEGE**
226 7th Ave., No., Dept. 86, Nashville, Tenn.

Please send without obligation free catalog

NAME _____
(please print or write plainly)

ADDRESS _____

CITY _____ STATE _____

**LAFAYETTE RADIO ELECTRONICS
ALL-TRANSISTOR WALKIE-TALKIE**

Ideal for Short-Range Communications

- Great Fun for Kids too—At a Price Even They Can Afford
- Complete with Built-in Antenna, Transmit Crystal, Battery, Plastic Carrying Case • Imported



10⁹⁵ each **2 for 21.00**

HA-70 **FREE!** NEW 1965

**LAFAYETTE CATALOG NO. 650
OVER 500 Pages**

Mail the coupon for your **FREE** catalog!

LAFAYETTE Radio ELECTRONICS
Dept. LL-4 PO Box 10
Syosset, L. I., N.Y. 11791

- Rush my free 1965 Lafayette Catalog
- Send me.....HA-70 Walkie-Talkies, shipping charges collect. I am enclosing \$.....

Name.....

Address.....

City..... State..... Zip No.....



Designed for Pilots

*GV-60: \$125 \$995

Now you can own the same high quality sunglasses currently being issued to U.S. Air Force Pilots. Neutral grey "TRUE-COLOR" lens; 1/10 12 karat gold filled frame. Deluxe leather case included at no extra cost. Mfg. by: THE AMERICAN OPTICAL CO. For airmail delivery—add 25¢. Sorry—no C.O.D.'s.



PILOTS SUPPLY COMPANY

P.O. Box 242, Coraopolis 5, Pennsylvania



FREE

MUSCLE BUILDING INFORMATION

Sensational New Isometrics

Less Time—Less Effort—Better results

BODY-TONE, Box 638, North Miami 61, Fla.

Plan Your Future Now

PREPARE FOR THE BETTER PAYING JOBS



Skilled men are needed in every part of the country. Earn top pay in established shops or start your own business. Greer's expert instruction and actual shop training teaches you how. Quick, easy courses using the latest tools and equipment. Resident training, and Home Study courses offer training in many fields without leaving your present work.

Job placement aid and help in obtaining convenient living accommodations nearby. Contact GREER'S FREE JOB PLACEMENT SERVICE when you enroll if you wish part time or full time employment assistance. Write today.

CHECK JOB YOU WANT AND RUSH THIS COUPON

- | | |
|---|--|
| <input type="checkbox"/> AUTO MECHANICS | <input type="checkbox"/> GAS AND ARC WELDING |
| <input type="checkbox"/> AUTOMATIC TRANSMISSIONS* | <input type="checkbox"/> HELIARC WELDING |
| <input type="checkbox"/> MOTOR TUNE UP* | <input type="checkbox"/> ENGINEERING DRAWING |
| <input type="checkbox"/> BODY & FENDER REPAIR* | <input type="checkbox"/> BLUE PRINT READING* |
| <input type="checkbox"/> DIESEL MECHANICS | <input type="checkbox"/> HEAVY EQUIPMENT OPERATORS |
| <input type="checkbox"/> MACHINIST, TOOL & DIE* | <input type="checkbox"/> CONSTRUCTION EQUIPMENT MECHANICS* |
| <input type="checkbox"/> REFRIGERATION | |
| <input type="checkbox"/> AIR CONDITIONING | |

Please send me free booklet on the trade checked—no obligation.

NAME _____ AGE _____

ADDRESS _____

TOWN _____ ZONE _____ STATE _____

*Resident Course Only. RESIDENT HOME STUDY

GREER TECH Est. 1902
INSTITUTE

Box M 2236 S. Michigan Ave., Chicago, Ill. 60616

PROTECT YOURSELF!

TEAR GAS

NO PERMIT REQUIRED

TEAR GAS GUN OUTFIT

This all-steel, .22 cal. TEAR GAS gun shoots 6 times as fast as you can pull the trigger. Also fires blanks for alarm, or dog training, and flares for emergencies. Complete with 6 tear gas shells and instructions.



BLUE STEEL \$9.98
CHROME \$11.98

TEAR GAS PENS

This handy size chrome pen shoots the new powerful .38 spec. MAGNUM cartridge. Will halt an attacker—in his tracks, renders him helpless while you summon aid!



Complete with 2 shells... \$9.98
As above, two shot with 2 shells... \$11.98
.22 cal., single shot with 3 shells... \$4.98

- | | | |
|--------------------------------------|--|---|
| <input type="checkbox"/> Gun \$9.98 | <input type="checkbox"/> Pen \$9.98 | <input type="checkbox"/> .38 Shells .75 ea. 20 for \$13.50 |
| <input type="checkbox"/> Gun \$11.98 | <input type="checkbox"/> Pen .38 Cal. 2 shot \$11.98 | <input type="checkbox"/> .22 Shells .15 ea. 100 for \$13.50 |
| <input type="checkbox"/> Pen \$4.98 | <input type="checkbox"/> Gun Holster \$2.00 | <input type="checkbox"/> .22 FLARES 6 - \$1.50 |

TEAR GAS DEVICES CO. • 136 A MADISON AVE. • ST. LOUIS, MO. 63122

Pre-Paid in U.P.S. areas, Others Express Collect (NO C.O.D.'s) Send Check.

A New FREE BOOK for

MEN PAST 40

Troubled With Getting Up Nights, Pains in Back, Hips, Legs, Nervousness, Tiredness.

This new Free Book tells that if you are a victim of the above symptoms, the trouble may be traceable to Glandular Inflammation... a condition that very commonly occurs in men of middle age or past and is often accompanied by despondency, emotional upset and other mental and nervous reactions.

The book explains that, although many people mistakenly think surgery is the only answer to Glandular Inflammation, there is now a non-surgical treatment available.

NON-SURGICAL TREATMENTS

This New Free Illustrated Book tells about the modern, mild, Non-Surgical treatment for Glandular Inflammation and that the treatment is backed by a Lifetime Certificate of Assurance. Many men from all over the country have taken the NON-SURGICAL treatment and have reported it has proven effective.

The Non-Surgical treatment described in this book requires no painful surgery, hospitalization, anesthesia or long period of convalescence. Treatment takes but a short time and the cost is reasonable.

REDUCIBLE HERNIA | HEMORRHOIDS

Non-Surgical treatment for both Reducible Hernia and Hemorrhoids, the book explains, can usually be taken at the same time as treatment for Glandular Inflammation.

This new Free Book is fully illustrated and deals with diseases peculiar to men and women. It tells HOW and WHY New Modern NON-SURGICAL Methods are so successful today. Fill Out Coupon.



Excelsior Medical Clinic, Dept. M 6150
Excelsior Springs, Mo.

Gentlemen: Kindly send me at once, your New FREE Book. I am interested in full information. (Please Check Box)

- | | |
|---|---|
| <input type="checkbox"/> Glandular Inflammation | <input type="checkbox"/> Hernia Hemorrhoids |
|---|---|

Name _____

Address _____

City _____ State _____

CLASSIFIED ADVERTISEMENTS

Rate: \$1.40 per word payable in advance each insertion. Minimum insertion ten words. To be inserted under the proper classification, copy must be in our office by the 15th of the second month preceding date of issue. The next available issue to place an advertisement in America's No. 1 Classified Section is February. The closing date is December 15. Send remittance and order to C. A. Martin, Popular Mechanics, 575 Lexington Avenue, New York, New York 10022.

POPULAR MECHANICS

AUTOMOBILES, MIDGET CARS

SAVE \$1,000 on 1965 model automobiles. Guaranteed. No gimmicks. Lists, details \$1 cash. National Sales, Box 297, Barbourville, Kentucky.

AUTOMOBILE literature, antique thru modern; catalogs, photos, manuals. Monthly bulletin. Free information. Enthusiasts, Box 451B, Mt. Clemens, Mich. 48044.

GLIDDEN Tour; Antique cars climb Pikes Peak. For color slides, photos, write, 35-Slides, Green Mt. Falls, Colorado 80819.

"MOTOMART Bulletin," since 1953. antique auto classifieds, 3¢ word. Box 6293, Marietta, Georgia.

1963 FORDS \$795.00 . . . Other makes below wholesale. Also huge discounts on all new cars! Complete information \$1.00. Opportunities Unlimited, Box 730-A, Holland, Michigan.

AUTO SUPPLIES AND EQUIPMENT

TRANSISTORIZED Ignition systems. Electrotone's newest, improved, foolproof. (SS-1: \$29.95. SS-2: \$39.95.) Free illustrated catalog, technical data, complete specifications of unique design. Prompt delivery. Satisfaction guaranteed. Doron Enterprises, Inc., Dept. PS, Box 7214, Chicago, Illinois 60680.

ANTIQUE Car Pistons, Gaskets, Gears, Valves, etc. Catalogue \$1.00. Antique Auto Parts, Milwaukee, Wisconsin 53204.

FOREIGN Car parts. Discounts. Catalog. Box 7, Elmont, N.Y.

CROSLY. New, used, parts. Discounts. Catalog. Box 7, Elmont, N.Y.

JEEP Parts! For military and civilian. At great savings. Largest inventory. Catalog for owners and dealers. Inquiries invited. American Auto Parts Co., 1830-PM Locust, Kansas City, Mo.

NEW And used parts at savings. Complete guaranteed parts service for all models cars and trucks. Largest in the west. Jeep and Army parts specialists. Shifting hubs for all front-end drive vehicles. \$27.50 and up. Foreign car parts. Fast service. Pioneer, 734 W. 13th Ave., Denver, Colo.

BUILD Yourself! 200 MPG carburetor, V-8, six, etc.! Complete patent drawings, Description, \$5.00. F. Schwab, Lakeville, Ind. 46536.

AUTO Welding repair training in world's largest non-profit welding school. Low tuition. Free booklet. Hobart Welding School, Box M-124, Troy, Ohio.

FREE Literature. Repair your leaking automatic transmission with simple patented attachment. Voor, Box 49, College Point, N.Y. 11356.

RING-Valve job while driving, \$6.00 postpaid. Guaranteed! Nothing like it! Many mechanics recommend! Motaloy, Grantham, Penna. 17027.

AUTOMATIC Headlight dimmer. Similar to Cadillac. Easily installed. \$29.95 Moneyback guarantee. Free literature, Cherry Radio, 1430 Belfield, Philadelphia 19140.

WHEEL Balancers \$10.95, \$14.95 Bubble Levels, \$7.95 Suspension-type (heavy duty) \$24.95. Guaranteed. Weights 5¢ up. Hundreds satisfied users. Jacobsen Mfg., Box 6143C, Seattle, Washington 98188.

HYDRAULIC jack repair kits, parts and supplies. Catalog 25¢ (in coin). Hydraulic Jack Packing & Tool Co., P.O. Box 50, Bloomfield, N.J.

DYNALOW Reverse repair. Quick, easy, instructions \$4.95 postpaid. Langelands Transmissions, 1600, Terrace, Muskegon, Mich.

REVOLUTIONARY Instrument saves gasoline dollars! Details free. Highley, 13805-PM Congress Drive, Rockville, Maryland 20853.

SUPERCHARGERS \$10.00. Build from discarded vacuum cleaner. Complete plans \$2.00. Superchargers, 7907 Lovers Lane, Dallas, Texas.

GUARANTEED Champion Autolite, AC plugs, points, condensers. Delivered Complete \$3.19. Give year, model. Murray Sales, 8189 Heather, Fontana, Calif.

MOBILE Hydraulic floor cranes 1000 lb., disassembles, ideal engine pulling or machine shop. Reasonable. Free Brochure. Air Technical Industry, Mentor, Ohio.

NEW Car carpeting! 2 yard cuts \$1.60. Minimum order 25. White, Box 307, Rossville, Ga.

START In 40° below zero. Simply pour VX-6 into car battery. Guaranteed starts for life of car. \$2.98 postpaid. Eastern Enterprises, P.O. Box 176, Ringwood, N.J.

NEED Automobile dealer's mailing lists? Completely "cleaned," lists new or used car dealers available immediately. Any franchise, any state. Typed on perforated gummed mailing labels. 100 @ \$2.00; 250 @ \$4.00; 500 @ \$7.75; 750 @ \$11.50; 1000 @ \$15.00. Payment please. No C.O.D.'s. Reference: Dun-Bradstreet. "Continental," Dep't. P.M., P.O. Box 5217, Gulfport, Florida 33737.

NEED "Master Keys" for automobiles? Attention: Auto dealers, banks, finance companies, wreckers, repossession, police agencies etc.; keys to fit all Fords, Lincolns, Mercurys \$2.00; Chevrolets, Pontiacs, Cadillacs, Oldsmobiles \$3.00; Ramblers, Americans \$2.00; Plymouths, Chryslers, Valiants, Desotas \$3.00. Postpaid. Payment please. No C.O.D.'s. Our references: Dun-Bradstreet—Central Plaza Bank, Auto Key Supply Co., 2854—60th Street (N), Dept. P.M., St. Petersburg, Florida 33710.

"AUTOBOOKS"—104 page illustrated catalogue—antique, classic, sports, racing car books. 25¢. Mark, Layton, N.J.

DYNAGLAZE. Best auto polish. \$2-can, \$22.50-case 12. Postpaid. Resell \$3-can. National, Box 7112, Washington, D.C. 20004.

NEW! Dual inside mirror. Two mirrors, one above another, angled in 10 x 4 1/4 chromed frame. Rear and side vision. 21 inch mirror range. Guaranteed. \$7.95. Make, year to: Duo, Box 72, Cleveland 21, Ohio.

JEEP Owners—V8 conversions. Read Jeep Owners ad, page 43.

AUTO TRAILERS

TRAILERS: All kinds—boat, box or camping. Also: All parts to build your own. Send 25¢ for catalog. Norjack, 616 S. 108th St., Milwaukee, Wis.

PICKUP Camper, trailer or pickup-cover. Build yourself, save! Complete plans \$3.95 each. Equipment catalog \$1.00 (refundable). Details 10¢. Viking Camper Supply, 94-F Glenwood, Minneapolis, Minn. 55403.

TRAVEL Trailers, Pickup campers, truck covers, working plans, materials available. Details 10¢. DuPage Coach—Box 86, Wood Dale, Illinois.

PICKUP Campers. Pre-cut kits. Blueprints. Supplies, literature 10¢. Comstock Trailers, Parsons 4, Kansas.

CAMPING Travel trailers, 6 complete plans, etc. \$1.00. Kamcraft, Box 1153, Milwaukee 1, Wis.

MOTORCYCLES, BICYCLES, MOTORSCOOTERS AND SUPPLIES

RECONDITIONED Motorcycle motors. Large stock Indian Cushman Vespa Mustang NSU parts. Indian Motorcycle Sales, Kansas City, Missouri. 64127.

BE A BSA Motorcycle dealer! Some choice territories still open for ambitious men who want their own motorcycle business. Enjoy your favourite hobby, be independent in a business that gives you the financial rewards of your work and selling ability. Nominal investment required. (Offer open only in area where we do not now have a dealer.) Write: BSA Incorporated, Dept. PM, 639 Passaic Ave., Nutley, N.J.

CUSHMAN Eagle \$25. Go Kart \$15. Minibike \$15. less engines. Gasoline engines \$3 up. Whizzer engine \$8. (Mail order only). Send 25¢ (35¢ for First Class Mailing) for Directory-Catalogue Number 121 listing these and hundreds of similar bargains, homebuilders parts, plans, etc. Midget Motors Directory, Athens, Ohio.

MOTORCYCLE Parts. Closing out, New, Used. List 25¢. Ballak, 811 N. 9th, St. Louis 1, Mo.

BUILD Motorbike; motorscooter, go-cart; Plans . . . \$2.00 each: Go-Byk Industries, Rothsay, Minnesota.

MINI Bike plans \$2.00. H. Irvin, 1509 N. 9th, Fresno, California 93703.

HARLEY-Davidsons — Used bargains. New, used parts, accessories, all models. Bulletin 25¢. Knuth's (Factory Dealer), 1753 Muskego, Milwaukee, Wis.

AVIATION

FREE Catalog of aviation books from all publishers. Save time and money! Aviation Book Headquarters (PM), 565 W. Glenoaks, Glendale, California 91202.

BE A Government licensed aviation mechanic. Practical training. Free information. Aero Mechanics School. Municipal Airport, Kansas City 16, Missouri.

FREE 48 Page catalog of aviation and space books. Aero Publishers, Inc., 329 Aviation Rd. (PM), Fallbrook, Calif. 92028.

AIRBOAT-Snowplane propellers, plans, kits, supplies. World's lowest prices on gauges, throttles, spark plugs, gas-oil hose, oil coolers, primers, tachometers, hubs, engine mounts, conversion parts, fittings. 125 H.P. Lycoming engines, gaskets, parts. Catalog 25¢. Banks-Maxwell, Box 3301E, Ft. Worth, Texas 76105.

AMAZING New low-cost books include official Government manuals on flying fighters, bombers, airliners. Details free. Morgan Books, Box 20754-PM, Dallas, Texas.

RAMJET Helicopter. Build inexpensively. Plans only \$1.00. Richard Frank, 5807 Victoria, Riverside, California.

HOMEBUILT. Real enclosed helicopter. 24 pages ideas, information. \$2.00. Build "executive" helicopter drawings, specifications. \$1.50. Helicopter Development, Box PM147, Washington, New Jersey.

BATTERIES, GENERATORS

BATTERY Reconditioning kit, includes molds, material, complete instructions. Battery Shop, 18182 Vierra, Salinas, California.

REPAIR Any battery instantly! Free details. R. Patterson, St. Croix Falls, Wisconsin.

COMPLETE Rebuilding Manuals! Batteries \$3.00. Hydraulic Jacks \$3.00. C.O.D. accepted. Bayer Publications, 938 Betty Avenue, Neenah, Wisconsin.

ELECTRICAL SUPPLIES

LAMP. Electrical parts, wholesale. Thousands of items for repairing, converting. Catalog 35¢. Brown Lamp, Box 305, Clayton 5, Missouri.

TIME Switch kit, 30A contact, 2 pair trippers, motor operates 120/240 vac. \$2.75. TDN Enterprises, Box 7265, Milwaukee, Wis. 53213.

LAMP Parts. Catalog, prices, wiring instructions. 50¢. Refunded first order. Gyro, 5208P N.W. 35 Ave., Miami 42, Fla.

WELDING, SOLDERING, PLATING

CHROME Plating equipment, supplies. All other finishes. Home workshop and production sizes. Send \$1.00 (refundable) for formulas, operating data, equipment guide and catalog. HBS Equipment Division L50, 3445 Union Pacific Avenue, Los Angeles 23, Calif.

A.C. WELDERS. Oil protected. \$49.50. Morris, 1070 Inner, Schenectady, New York 12303.

MACHINERY, TOOLS, SUPPLIES

MACHINIST. Small shop supplies. Campbell Tools, 1424 Barclay, Springfield, Ohio.

SUCTION Blowers, flexible pipe, pipe cutoff fittings, shavings attachments for Delta Unisaw, 6" Jointer, 14" Band Saw, Rex Mfg., Box 253, Fontana, Calif.

MODELMAKERS Drill Press—precision built, Jacobs 1/4" chuck—motor—variable speed foot switch, \$28.50. Microm Company, 2822-A Halladay, Santa Ana, California.

STANLEY, Millers Falls, Skill, Disston, Wiss, Plumb, Channellock, Bonney, Herbrand, Ridgid, and hundreds of other nationally advertised brands at prices hard to beat. Send 25¢ for our big tool catalog today! Silvo Hardware, 107PM Walnut, Phila. 6, Penna.

ENGINES, MOTORS, DYNAMOS

GM "N" Injectors Wanted. Standard parts and fuel pumps Series 51-53-71-110-567. Packard, 2093 E. 19th St., Cleveland, Ohio 44115.

REWIND Motors yourself. Complete instructions. \$1.00. Lewis Manufacturing, Howell, Michigan.

BUILD Growler yourself. Complete plans, instructions \$1.00. Natural Color Printing, 155-A North Franklin, Hempstead, New York.

WINDING Data. 275 motors, single and three phase \$1.10. Data Company, 512 Kensington, Kansas City 24, Mo.

GOVERNMENT SURPLUS

JEEPS—\$62.50. Typewriters—\$4.15, cars—\$32.78, guns, walkie-talkies, binoculars, televisions. Typical surplus prices. Exciting details free. Enterprises, Box 402-X13, Jamaica 30, New York.

GOVERNMENT Surplus, how to buy in your state at tremendous savings. Directory gives all details. Catalog with pictures, prices of over 400 surplus items included. Send \$1.00. Quality Surplus, 422 PM-12, Washington Building, Washington, D.C.

GOV'T. Surplus. How and where to buy in your area. Send \$1.00. Surplus Information. Headquarters Building, P.M., Washington 6, D.C.

JEEPS \$64.50 . . . Boats \$6.18 . . . Typewriters \$4.15 . . . Airplanes, Sporting Equipment, 100,000 Bargains typically like these direct from government in your area. For complete directory and surplus catalog Send only \$1.00. Surplus Service, Box 820-A, Holland, Michigan.

JEEPS \$64.50, airplanes \$75.20; boats \$6.18. Many others direct from U. S. Government. For complete "Directory" and catalog send \$1.00 to Quality Surplus, PM12, Box 22038, Indianapolis 22, Indiana.

FREE Surplus catalog. Thousands of amazing values never before offered at amazing savings. Be the first to receive this different type of surplus catalog. A must for everyone!!! Request your free copy today! Surplus World, P.O. Box 785, Dept. D, Rochester, New York 14603.

JEEPS Low as \$62.50, Autos, Boats, many others. Buy direct from Government! Send \$1.00 for "How to Buy in Your State" and "1965 Directory." Surplus Disposal, 2230-PL Wisconsin, Washington, D.C. 20007.

GOVERNMENT Land available in many states at fabulously low prices! "Your Opportunities in Government Land" plus "Land Opportunity Digest." Send \$1.00. Land Disposal, 2230-RY Wisconsin, Washington, D.C. 20007.

GUARANTEED Facts concerning Government Surplus Bargains, \$1.00. Surplus, Box 8 PM, Thomasville, Penna.

OFFICIAL Government surplus. Jeeps \$59.50, Electronics, cars, guns. Typical prices. Over 1281 items. Free advise service! Pictures! Guaranteed finest Directory catalog available! \$1.00. U.S. Surplus, Box 4495, Fresno, Calif.

GOVERNMENT Surplus. Complete sales directory \$1.00. Surplus Publications, Box 45781, Los Angeles 45, California.

BOATS, OUTBOARD MOTORS

BUILD Your own boat from our large-scale blueprints. Books of plans give how-to-build help. Hundreds of professional designs—motor, sail or auxiliary—for amateur builders. Free catalog. MoToR Boating, 959 Eighth Ave., Dept. RS, New York 19, N. Y.

BOAT Plans, frame kits, full-size patterns prepared specially for amateurs. Send 50¢ for new 80-page catalog illustrating over 50 build-it-yourself power boats from 7' to 28'. Glen Designs, 9152 Rosecrans, Bellflower, Calif.

FULL Size, cut-to-shape boat patterns, blueprints. 7 1/2-38 feet. Big new illustrated "Build a Boat" catalog of 64 designs, including catamarans, cruisers, runabouts, skiffs, outboard boats, sailing, racing, houseboats. 50¢. "How to Build a Boat" booklet. \$2.50. Cleveland Boat Blueprint Co., Box 18250, Cleveland, Ohio.

BOAT Kits! Factory molded fiberglass or pre-assembled plywood. 50 models, 12' to 30'. Free catalog. Luger, Dept. BC-64, 9200 Access Road, Minneapolis 31, Minn.

30 H.P. Outboard motors or powerheads. Brand new 1963's \$185.00. Write: Motors, P.O. Box 111, Perry, New York.

FIBERGLASS Cloth and resin. World's finest cloth and non-run resin, at direct mill prices. Flotation foam. Complete line of plastics, silicon bronze and brass screws, save 60%. No sales tax. Free catalogue. Freight prepaid. Stiles Boat Supply, Box 11P, Linden Ave., Mantua Hts., N.J.

SITKA Kayaks—Known World wide for speed and safety. Assembled in one afternoon. Sitka Jr. one-man 10 ft. boat (\$16.50); Sitka Sr. two-man 14 ft. boat (\$22.50). Also Sitka Sr. Sail Attachment—lee boards, rigging and 29 sq. ft. sail—only \$16.50. Most exciting boat kits on the market! Free pictorial literature: Box 78-P, Brecksville 41, Ohio.

BOAT Plans, kits, catalogs! Powerboat, large \$1.00, condensed 60¢, Sailboat 40¢. Marinecraft, Box 161-M, Brighton 35, Mass.

NEW, Used, rebuilt marine motors. Marine conversions, fittings. Free catalog. Stokes Marine Supply, Dept. 24, Coldwater, Michigan.

FIBERGLASS Boat covering. Wholesale prices. Free literature and sample. Seifert's, Box 1206-M, Green Bay, Wis.

FREE 64-Page catalogue. Marine engines, kits, equipment. Star Marine, Berkeley 10, California.

MARINE Conversions. Ford, Chevrolet, Jeep engines. Catalog 25¢. Lehman Manufacturing Company, 800 Elizabeth Avenue, Linden 4, N. J.

SPORTING GOODS, GUNS, FISHING, SKIN DIVING, ARCHERY

BIG Money raising crickets and 12 inch African fishworms. Free literature. Carter Ranch, Plains, Georgia.

MOLDS For fisherman's sinkers, jigs, squids, casting and spinning lures. Free catalog. Sweet's Molds, Tonawanda 1, New York.

BAYONET Hunting knives \$2.98 M.O. Berman's, Box 116, Toledo 1, Ohio.

GOVERNMENT Surplus Bargains, in guns, ammunition, edged weapons, hunting, camping, fishing items. Write for giant free catalog. P & S Sales, Box 155, Tulsa, Oklahoma.

MOLDS For casting your own fishing sinkers. Free illustrated booklet. Reading Instrument Co., Box PM78, Reading, Penna.

AMAZING Centrifugal Force weapon. Ancient hunting weapon "rediscovered," powerful, deadly. More impact than hi-power rifle. Rush \$2.98. Thrust Products, 303 11 St. S.E., Washington, D.C.

JUDO, Karate supplies, accessories 19 page catalog 15¢. Nozawa Trading, 232 East Second Street, Los Angeles 12, Calif.

FISHERMEN, Send \$2.00 for three proven weedless lures. Weedless Bait Company, Aitkin, Minnesota.

NEW "Home-Finder" compass. Unique memory dial. Details free. Jeret, Box 1357, Sarasota, Florida 33577.

FISHERMEN—Look! New transistorized sonic calls catch fish to you. Provides more fun—sport—thrills. Pocket size. Ideal gift. Guaranteed. Free details. Tenn-Dixie Sales, Dept. PM, 4002 Martin Mill, Knoxville, Tenn.

FISHERMEN! Amazing electronic fish call attracts fish to bait. \$12.95. Edco, P.O. Box 2007PM, Decatur, Ill. 62526.

GUN Suppliers' handbook, reference directory, \$1.00. Box 6293, Marietta, Georgia.

SKI Rack—Savings to \$18.00. Materials cost \$3.50. Theft proof. Fits automobile roof or trunk. Assemble in one evening. Plans, instructions—\$1.00. Ray's Racks, 68 Fairfield Avenue, Holyoke, Massachusetts.

FREE—Wholesale catalog. Beads. Spinners. Lure parts. Sinkers molds. Jigs. Reels. Finny sports (ME). Toledo 14, Ohio.

ATHLETIC EQUIPMENT, BODY BUILDING COURSES

60 SECONDS daily for perfect physique. Scientific exercises without equipment. Complete course \$2.00. Sheridan House, Box 413, Hollywood, California.

ISOMETRIC RACK, \$7.00 threaded pipe and fittings. No holes to drill, unique leverage locking bar. Hand assemble and knockdown in seconds. Plans and instructions \$2.00. Iso-Rak, 94 W. Salome Ave., Akron 10, Ohio.

"GIANT Arms." Dr. Young's. D.C. revolutionary discovery. \$2. Satisfaction or refund. Gaucho, Box 9309-S7, Chicago 90.

BAR BELLS. Courses, equipment. Catalogue 10¢. Good Barbell, B-1495, Hendersonville, N. Car.

BARBELLS. Exercise equipment. Key to health, strength, physique. 25¢. Reading Barbell Co., West Reading, Pa.

CAMPING EQUIPMENT AND TENTS

TENT And camping equipment specialist. Send for 96 page catalogue. Morsan, 810-R Route 17, Paramus, New Jersey.

BINOCULARS, TELESCOPES, MICROSCOPES, MAGNIFIERS

BINOCULAR Sale! Free Color Catalog 100 models \$9.95-\$250.00. Write United, 9043 So. Western, BCAT 4908, Chicago, Ill. 60620.

BUILD Your own reflector telescopes, complete kits; mirrors, eyepieces, tripods. Free catalog F describing other accessories sent on request. Also free brochure describing amazing line world famous "Dy-nascope" reflector telescopes. Criterion Manufacturing, Dept. KPM 21, Hartford, Connecticut.

HI Power binoculars 95¢ pr., 2 for 1.50, comparable models selling for \$4.95. Research Products & Publications, Box 235a, Brea, Calif.

SCIENCE Bargains! Lenses, telescopes, binoculars, microscopes, kits, parts, war surplus. Send \$1.00 for beginner's 10-lens kit with instruction booklet. Order Stock 2-CH. Request free 148 page Catalog CH. Edmund Scientific Co., Barrington, New Jersey.

EARTHWORMS, CRICKETS, FROGS

SUCCESS For you! Raise fishworms and crickets. Write for free literature and our success story in Life Magazine. Let us teach you our secrets of success. Hybrid redworms 3000, \$5.95. Carter Redworms, Plains, Georgia.

EARN Money raising fishworms for us! Exciting details free! Oakhaven—56, Cedar Hill, Texas.

HYBRID Redworms 1,000—\$3.00, 2,000—\$5.00, 5,000—\$8.00, 10,000—\$14.00. Bedruns 20,000—\$20.00. Postpaid with raising instructions. Brazos Bait Farms, Route 9, Waco, Tex.

RAISE Rabbits and fishworms on \$500 month plan. Free details. White's Rabbitry, Mt. Vernon, Ohio.

FREE Literature. Big money raising African Nightcrawlers, Redworms. Three Oaks Ranch, Dresden, Tennessee.

MEN! Women! Make money raising bait for us at home. Red Wigglers, Warsaw 45, Indiana.

FARMS, FARM LANDS, REAL ESTATE

CAROLINA Coast. ¼ acre homesites as low as \$435.00. \$5.00 down, with 10 year, money back guarantee and free life insurance. In a 14,000 acre Paradise in the Pines. 50 fresh-water lakes, 4,000 acre hunting preserve, golf course, country club, shopping center, motel, already built. Only minutes to private ocean beach. For free details write Boiling Spring Lakes, Southport 1-V, North Carolina 28461.

\$5 MONTHLY Buys 5 acres. Near town, good building site, excellent fishing. Price \$125.00. Free list. Box 425-P Carthage, Missouri.

400,000,000 ACRES Government Land Available in 25 states. Some low as \$1.00 acre. 1964 report. Send \$1.00. National Land 422, PM-12, Washington Building, Washington, D.C.

FLORIDA Campsites—deep in the heart of the great Ocala National Forest. Best hunting and fishing. Free maps and photos. Howard Vernor, DeLand, Florida, AD63052(1-2)

\$1 ACRE—Canadian border—hundreds campsites, islands, farmlands, directly from tax authorities. (Non-profit). Lists, photographs mailed. Register, Room 203, 92 King St., E., Toronto 1, Canada.

FLORIDA Water Wonderland—Homesites, cottagesites, mobilesites, campsites. Established area. \$390 full price. \$5.00 month. Swimming, fishing, boating, hunting. Write, Lake Weir, Box 38BK, Silver Springs, Florida. Ad 6-1070-(F-1).

THUNDER Bay Village, Alpena, Michigan. Complete 18 room club house, fishing, swimming, hunting, riding, golf. Homesites, Cottagesites, Mobilesities, Campsites, \$695 ¼ acre, \$7 month. Bloch Brothers 7, Waterford, Michigan.

ABANDONED Timber Leaselands! Choice 640 acre Sportsmen's paradises still available—\$20.00 plus \$6.50 Taxes yearly. Maps, pictures, \$1.00 (Refundable). Director, Erindale 4, Ontario, Canada.

TRAILER Park—Rental lots! Free brochure! Worth investigating. R. Schuler, Rt. 1, Box 415, Deland, Florida.

CANADIAN Vacation tracts. Price \$75—\$10 month. Tax free. Suitable cottage sites, camping, hunting, fishing, investment. Free maps, information. Land Sales Corp., 206-D Bloor Street, West, Toronto 5, Canada.

CANADIAN LANDS, seized and sold for taxes. Our 47th annual series of lists, describe many choice properties, situated from coast to coast, acquired by us through Tax Sale. Priced as low as five dollars per acre, guaranteed perfect title, small monthly payments, no mortgage. Beautifully situated hunting and fishing camps, where there is real sport; summer cottage sites, heavily wooded acreages. Now is the time to invest in Canada's minerals, forests and farms. Write to-day for free twenty page booklet with full explanation. Tax Sale Service, Room 301-D, 85 Bloor St., E., Toronto 5, Canada.

OWN A brand new nationally known 56' x 12' completely furnished mobile home plus big 75' x 125' Florida lot including water, sewerage, landscaping. All for payments of only \$66.67 monthly. On Highway 441. Electricity, phones, churches, schools, shopping. World's best fishing! No obligation. Write, Orange Blossom Hills, Drawer D, Miami, Florida 33160-C.

GOVERNMENT Land available in many states. Some low as \$1.00 acre! "Your Opportunities in Government Land" plus "Land Opportunity Digest" with current listings, send \$1.00. Land Disposal, 2230-PL Wisconsin, Washington, D.C. 20007.

MONTANA—18 Tracts from 2½ to 15 acres. Fishing, hunting, cabin sites and campsites on beautiful Yaak River in Montana Rockies; \$50.00 down and \$25.00 a month. Mountain Empire Company, Box 203-P, Libby, Montana.

CALIFORNIA Land for investment. Virgin, undeveloped property still available inexpensively. Write: Sunset Valley, Department L-1, Box 48333, Los Angeles 48, California for details.

FREE! Big illustrated catalog. Top value coast to coast! Farms, ranches, homes, businesses, waterfront, recreation, retirement, properties. United Farm Agency, 612-PM West 47th St., Kansas City, Mo. 64112. PLaza 3-4212.

GOVERNMENT Land available in 25 states for individuals as low as \$1.00 acre. Complete report send \$1.00. Public Land, 1196K11, National Press Building, Washington, D.C.

BIG. Free Fall-Winter catalog! Bargains galore! Low prices, easy down payments! Safe-Buy Real Estate Agency, 712-PM West Third, Little Rock, Ark.

CANADIAN Vacation lands: Full price \$385.00. 40 acres, \$10 month. Suitable cottage sites, hunting fishing, investment. Free information. Land Corporation, 3768-C Bathurst, Downsview, Ontario, Canada.

PETS—DOGS, BIRDS, HAMSTERS, ETC.

HAWKS. Reptiles, raccoons, skunks, squirrels. Catalogue 25¢. Trails End Zoo, St. Stephen, S.C.

LIVE Seahorses, marine specimens, aquarium supplies. New illustrated catalog 25¢. Box 626-110, Dania, Florida.

MAKE Money raising chinchillas, mink, rabbits, cavies for us. Free catalog. Keeney Brothers, New Freedom 2, Penna.

RACING Homer Pigeons \$5.00 Pair. Game fighting chickens \$10.00 pair. William Meders, Bedford Road, Cumberland, Md.

PETS. Hamsters, mice, rabbits, squirrels, chipmunks, guinea pigs, skunks, raccoons. Picture catalog twenty-five cents. Moore's Hamster Ranch, Shepherdstown 25, West Virginia.

RABBITS—FUR BEARING ANIMALS

RAISE Rabbits on \$500 month plan. Free details. White's Rabbitry, Mt. Vernon, Ohio.

RAISE Rabbits successfully by knowing facts. 48 page illustrated book describing 25 breeds. Housing, breeding, feeding, markets, marketing etc. 25 cents. American Rabbit Association, 36 Arba Building, Pittsburgh, Penn.

EARN \$10,000 Yearly raising Angora rabbit wool for us. Information 25¢ coin. American Angora Company, Malta 12, Montana.

MINK Raising information free. Lake Superior Mink Farm, Inc., Superior EE1, Wisconsin.

BOOKS, PERIODICALS, PICTURES, POSTCARDS

SAVE TO 84% on books. Free Catalogue. Discount Reader's Service, M-5435 Upland Way, Philadelphia 19131.

PROPHET Elijah coming before Christ. Wonderful book free. E. Megiddo Mission, Rochester 19, New York.

OUT-Of-print books at lowest prices! You name it, we find it! Fast service. No obligation. International Bookfinders, Box 3003-PM, Beverly Hills, Calif.

BOOKFINDERS! All subjects. Send wants! Sydney Jaher, 175-45 88 Ave., Jamaica, N.Y. 11432.

BOOKS Successfully located! Atlantic Book Service, Cedar Street, Charlestown 29, Mass.

STAY Alive! Learn survival secrets now! Recognized authorities. Details free. Adobe Hacienda, Route 3, Glendale, Arizona.

FREE Paperback catalogue. Great savings New York Paperback—Record Club, 4 N. West 43rd Street, New York City 10036.

MOST Air-minded readers get our free catalogs. Do you? Morgan Aviation Books, Box 20754-PM, Dallas, Texas.

IMPROVE Your memory using easy to learn methods. Free details. Snyder, 55130 Belair Street, Osceola, Indiana 46561.

BOOKS, Free general catalog, 100 pages. Text, vocational, educational, instructional subjects. Millions of volumes, new and used. Bargain prices. Books bought. Est. 1902. Long's College Book Co., Dept. PM, Columbus 1, Ohio.

BOOKS: Civil service, self-improvement, hobbies, automobiles, gardening, etc. Free literature. Drobnek's, 5604-D Haddon, Baltimore, Maryland 21207.

HOMEOWNERS — Save money. Know your legal rights. Protect your home. Read new book, "The Legal Adviser On Home Ownership." Free brochure. Institute of Legal Knowledge, Box 121-AE, Garden City, N.Y.

"**SECRET** Of bowling strikes"!!! Free brochure. Machado, Box 16186, San Francisco, California.

FREE Catalog. Self-help books. Write Wiltshire, 8721 Sunset, Los Angeles 69P.

MAGIC TRICKS, PUZZLES, JOKER NOVELTIES

COMPLETELY Illustrated catalog, 84 pages, 25¢. Manhattan Magic, Box 334-M, N.Y.C. 11.

CATALOG, trick 10¢. 1,500,399 tricks, jokes, novelties, puzzles, disguises. Elbee, 7408-P, San Antonio, Texas 78207.

MAGIC Catalog! World's finest. 3000 tricks (408 pages) \$2.50. Beginners amateurs, professionals. Kanter's, A-200 South 13th St., Philadelphia, Pa. 19107.

VENTRILOQUISM! Information Free! Dummy Catalog 25¢. State age. Maher-PM12, Box 36, Kensington Station, Detroit 24, Michigan.

1000 LATEST Professional tricks, jokes, magic! New deluxe jumbo edition! Hot off the press! 164 pages thick! Bigger-better than ever! Special! Now only 10¢. Lawston's Magic Den, Dept. PM112C, Monroe, Conn.

BE A magician! Two booklets explaining sixty-eight tricks plus large professional catalog \$1.00. Magic, Inc., 5082 Lincoln, Chicago, Illinois 60625.

500 TRICKS. Douglas famous magic Catalog, only 10¢. Fastest service to magicians for 40 years. Douglas Magicland, Dept. 51, Dallas, Texas.

GAMES, TOYS, NOVELTIES

GAMES Inventors! We are interested in new and novel child and adult game ideas. Nationally-known game manufacturing and marketing firm. Send for details. Hagglund and Associates Research, Dept. A, 650 Ottawa Ave. N., Minneapolis 22, Minnesota.

FREE Brochure! Special gifts, unusual toys. Gaskill Enterprises, 2810 East Walnut, Des Moines 17, Iowa.

HUNDREDS Unusual novelties, gifts. Wholesale catalog 10¢. Dohn, AA-3 Marks, Broadview, Illinois.

STAMP COLLECTING

200 DIFFERENT Stamps, 25¢. Smith, 508-A Brooks, College Station, Texas.

50 DIFFERENT Old U.S. Revenue stamps 50¢. Winchester Stamps, 45 Winchester Rd., Mansfield, Ohio.

FREE Sample. Interesting, illustrated, informative. National Stamp News, Anderson, South Carolina 29622.

100 OLD United States between 1861 and 1935. \$1.00. Roush Stamps, 51 Chestnut, Mansfield, Ohio.

225 STAMPS For only 10¢! This mammoth value includes airmails, pictorials; stamps from strange countries cataloging up to 25¢ each! Also approvals. Mystic Stamp Company, Camden 80, New York.

SELL Your surplus good grade stamps. Write, describing fully what you have. Vanroy Shirk, Lebanon, Pennsylvania.

60 DIFFERENT U.S. (30 commemoratives) 25¢. No approvals. Seidenberg, Salem 169, Oregon.

AMAZING OFFER! 200 United States stamps—including commemoratives, airmails, high denominations to \$1.00. Only 10¢ to approval applicants! Illustrated bargain lists free. Mystic Stamp Co., Dept. 80, Camden, New York.

FREE Monaco nudes. Approvals. Stamp Ranch, 902 Addison, Chicago 13, Ill.

U. S. approvals. Low prices. Eagle Stamps, Romine Ave., Pittsburgh 26, Penna.

INTRODUCING Our better United States approvals we offer 15 United States stamps including Columbian, Bi-Centennials, famous American, airs, others: only 10¢. Ocean Stamps, Box 64-PM, Brooklyn 29, New York.

UNITED States commemorative collection containing 33 different—10¢. Approvals. White, 516-A Avenue L, Brooklyn 30, New York.

UNITED STATES price list, 132 pages, price 30¢. Mark Hanna, 335 Fifth Ave., Pittsburgh 22, Pa.

U.S. Mint specials! Flag set, complete \$1.00. 1¢, 2¢, 3¢ famous Americans (21 different) \$1.00. Free list. Brooks, 2601 Avenue "U", Brooklyn 29, N.Y.

THOUSANDS Of worldwide sets and singles on approval. Highest quality! Cole, Box 223A, Buffalo, N.Y. 14221.

PENNY! Approvals! Regardless catalogue! Kloster, 4164 52nd St., San Diego 5, Calif.

U.S. Bargain, 50 different 10¢, with beautiful worldwide approvals. Stamps, Kennebunk, Maine.

FREE U.S. catalog, mint Farley Parks #756-65. Rare with gum. \$4.00 singles; \$15.00 blocks. Simmy Co., 40 Court, Boston, Mass.

FREE! 50 Turkey, 10¢ handling. Approvals. Berchtold Stamps, Troy, Ohio.

FREE! Congo triangle set! Boy Scout beauty! 25 others, different. Approvals. Cambridge, Box 411, Cambridge, Ohio.

GERMAN Commemoratives, 10¢ with approvals. Schaefer, Box 1704, Washington 13, D.C.

5000 STAMP Grab bags! \$2.00 each. Pictorials, sets, etc. Bargain list. Satisfaction or refund. Stamp Service, 1498-M4, Huntsville, Ontario, Canada.

FREE Stamp wallet with approvals. Wide selection collections by countries. Clark, Box 28-C, Wilmette, Illinois.

KENNEDY Memorial set. Mint. Colombian multicolored air mail. Pictures late President. Free! With approvals. Philatelic, 78-S, New Paltz, N.Y. 12561.

40,000 DIFFERENT. Amazing new plan builds your collection systematically, country by country. As low as 50¢ weekly. Ware, Monroe 75, Conn.

MILLION Foreign stamps! 2¢ each! Send for thrilling, giant approvals! ABC Stamps, Box 6000-MB, San Francisco 1, Calif.

FREE Surprise collection sent with approvals. Gould, 1784 Union, San Francisco 94123.

1500 FOREIGN \$1.00. 5000 \$3.00. 5000 USA—commemoratives, airs, high values, revenues. 19th Century, etc. \$3.00. No approvals. Meyers, 5321 Fleming, Richmond, California.

VATICAN Price list. Jeller, 1111 Westlawn Dr., Falls Church, Virginia.

GIANT Stamp Collection, including astronauts, satellites, moonrockets, boy scout issue, complete U.N. set, many Olympic and sport issues, etc., plus big stamp dictionary and approvals. Everything, 10¢! Stampex, Box 47-RM, White Plains, N.Y.

ATTRACTIVE Set free. U.S. Worldwide approvals. Gorliz, Drawer 388PS, Park Ridge, Illinois.

170 DIFFERENT U.S. commemoratives \$1.00. Carstamps, 739 Ordway, Freeport, Illinois.

20 DIFFERENT U.S. Commemoratives 1893 up 10¢ appr. K&B Stamp Co., Box 70, Bklyn., 23, N.Y.

FREE! 222 Worldwide, 25¢ handling. Penny approvals. Jung, 1601 North Stanley, Los Angeles 90046.

1025 DIFFERENT Stamps \$1.00. Approvals. Klondike, 682 Jefferson, Elgin, Illinois.

UNITED STATES Stamp album, 96 pages, fully illustrated for postage stamps with stories of the men, women and places that have made America's history plus starter collection of 50 stamps and special offers to inspect. \$1.00. Palmer, P.O. Box 86-SM3, N.Y. 34, N.Y.

FIPEX, Tipex, Cipex, Ashville. Four miniature sheets used for \$1.00 if you ask for our bargain priced U.S. approvals. Triboro, 38 Park Row, New York, New York 10038.

105 DIFFERENT U.S. Stamps, 25¢, approvals included, Shelton, Box 187, Hempstead, N.Y.

U.S. Stamps. Giant discount catalog—30¢. Raymax, 37-VZ Maiden Lane, NYC 38.

BREATH TAKING. 50 Mint Monaco pictorials, multicolors. \$1.00. Approvals. Stamp Exchange, Box 103, Fairfield, California.

CLEARANCE. Twenty different packets 50¢. No approvals. Norge, Hohokus, N.J.

FREE! Giant Bargain Catalog—New Edition listing thousands of bargains including U.S. and B.N.A. stamps, packets, mixtures, albums, accessories and supplies; sent with beautiful approvals. Jamestown Stamp, Dept. E-124PM, Jamestown, N.Y.

INTERNATIONAL Auto Race Set 10¢. Approvals. Gertrude O'Loughlin, 10B Hillside, Avenue, Newport, Rhode Island 02843.

FREE New mint Paraguay Olympics, also approvals. Alpaughco, Highbridge, N.J.

TEN Triangles showing Planes, Fruits, Flowers, and insects: Plus 50 diff. Foreign 10¢ with request for our 2¢ Foreign Approvals. Merle Timm, Duerr Road, Orchard Park, N.Y. 14127.

WOW! 110 All Different Germany 10c! Zeppelins, Semi-Postals, Airmails, High values, etc. Giant Catalog, bargain lists included with beautiful approvals. Jamestown Stamp, Dept. A-124PM, Jamestown, N.Y.

12 HITLERS. Mint set. 10c. Approvals. Galleries, Box 35291, Los Angeles 35, California.

25 LARGE Czechoslovakian commemoratives. 10c. Approvals accompany. Kohns, 9060 Santa Monica, Los Angeles 69, California.

12,000 PENNY Approvals waiting for you. Many from exotic countries, pictorials airmails, new issues. Tibury, Box 862, Newark 1, N.J.

210 DIFFERENT U.S. Commemoratives. \$1.00. Rockefeller, 40 West Market, Red Hook, N.Y. 12571.

"OLD GLORY" in flaming colors! U.S.A. flag giant beauty from Honduras. Enormous United Nations Mexican stamps. Plus strange gorilla issue. Duke of Windsor. Morocco lovely Macao flowers, wild buffalo stamp and others. 10c with approvals. Sunny Stamp, Fruitport 2, Mich.

STAMPS Free! New issues, new countries, triangles, rockets, Olympics, Scouts, birds, flowers, animals. Also old Canadian and U.S. stamps. Plus complete illustrated Canadian stamp catalog. Send 10c for mailing. Gray Stamp Co., Dept. PM, Toronto, Canada.

CANADA Sports complete 10c. Canada approvals. Valley Stamps, Little Valley, New York 14755.

FREE 50 Rocket stamps to approval buyers. Howard Davison, Suncook, New Hampshire.

FIRST Day cover approvals! Included free, valuable airmail cover. Myers, Coopersburg, Penna.

INDONESIA 50 Different 20c. Over \$3.00 Cat. Approvals. HJOP, Box 505, Norristown, Pa.

50 YEARS Old, fifteen different United States, over fifty years old—10c with approvals. Jaxon, Box 145-P, Brooklyn, New York 11230.

307 WORLDWIDE Different 25c. Sensational approvals. Niagara Stamps, St. Catharines 201, Ont.

25 LARGE American commemoratives 10c. Accompanying approvals. Free perforation gauge. Linstamps, St. Catharines 101, Ontario.

100 DIFFERENT Free! 1/4c Upwards British Commonwealth or world approvals. Bush, Newlyn Way, Poole, England.

100 DIFFERENT Stupendous worldwide 10c. Attractive approvals. Linstamps, St. Catharines 401, Ontario.

USED Foreign stamps on approval. L. Traviss, 13 N. Racine Avenue, Chicago, Illinois.

100 BRITISH Commonwealth 10c. Accompanying approvals. Niagara Stamp Co., St. Catharines 501, Ont.

4 UNITED States mint plate blocks \$1.00. Cooper, 3751M, Oak Park, Mich. 48237.

TWO Mint Mexico (cat. 65c) airmails, 25c with foreign approvals or 100 used U.S. large comms \$1.10. William Landon, 729 South Pearl St., Denver, Colorado.

10 DIFFERENT Civil War United States and representative confederate stamps, illustrated pricelist, approvals, Minuteman, 19 Deering, Lexington 73, Mass.

PRICELISTS For U.S. stamps and h'neless albums, Free. U.S. special: 19 Mint Champions \$1.50. Smith Box 83-PM (Rugby), Brooklyn, N.Y. 11203.

AUSTRALIA 50 Different 10c, 100 different 25c. Farrell, Box 119, Jerome Station, New York 10468.

55 DIFFERENT U.S. commemoratives 25c. Approvals. Derzis, Box 4073, Baltimore, Md. 21222.

135 DIFFERENT U.S. commemoratives \$1.00: 200 \$1.75; 245 \$2.50; 100 mint \$4.00. Southard, 1025 Clearwater Road, Largo, Florida.

AMERICAN Historical collection!! Enormous airmail diamond! Pres. Kennedy & movie star Grace Kelly, 1st USA spaceman Shepard, plus midget soldier, Latin Orchid issue, old St. Pierre Fisherman, etc. 10c with approvals. Roseland Stamps, Spring Lake 2A, Mich.

PENNY Foreign stamps neatly mounted in jumbo books in Scott order. Bullof approval, 1454 Coney Is. Ave., Brooklyn 30, New York.

ABSOLUTELY Free 50 worldwide. Request inexpensive approvals. University Stamps, P.O. Box 326, Pompano Beach, Florida 33061.

START Approval business—Details 25c! Steele, 116-M So. Nevada, Colorado Springs, Colorado 80902.

WEST GERMANY, buy direct! 1000 mixed comms \$12.00, 150 different \$5.00. Kiloware, many comms, 1 kg \$6.00, postpaid. Bills or US Postal Money Order, please. Dipl. Ing. Springmann, 4800 Bielefeld, Detmolderstr. 129, West Germany.

CLOSING Out tremendous old accumulation. Collections, lots, miscellaneous. Lists free. Alatalo, Maynard, Massachusetts, 01754.

\$30 WEEKLY—Part time, placing stamp racks in local stores. Full details. Flint Stamp, 93 Frost, Fall River, Mass.

PORTUGUESE! 25 different free. Approvals. Elkhart, Box 33, Elkhart, Ind.

35 YEARS Collecting, accumulating; 100 from collection plus 100 from accumulation \$2.00. Rhodenizer, 157 Elizabeth, St. John's, Newfoundland.

FREE—Mint pair = 1058 with \$2.00 order of U. S. mint commemoratives 3c, 4c & 5c from = 960 to date face plus 1c each. Rabb, 16678 Cruse, Detroit, Mich. 48235.

1,000 WORLDWIDE Stamps \$1.00. Marshall, 721-P North Franklin, Colorado Springs, Colorado 80903.

NEW ZEALAND, latest bicolored 1964 Christmas Service. Commemoratives free! Approvals. William Deems, 226 Race, Ravenswood, West Virginia 26164.

"INVERTED Error," Dag Hammarskjold 5c with Approvals. Belmont Stamps, Washington, D. C. 20015.

OLD U.S. space-fillers, 1/2 Scott. Karl Swartz, Malden Bridge, New York.

COINS, TOKENS, CURRENCY

GIANT Illustrated catalog listing hundreds of bargains in coins and supplies, only 50c. Rarcoa, 31 North Clark, Chicago 2.

FREE Coin supplies! Giant coin list 10c (refundable). Economy Sales, Mansfield, Massachusetts.

U.S. Coins wanted. Free buying list available. Bedrin, 250 Fulton, Hempstead, N.Y.

"COINS MAGAZINE" is world's largest seller! Latest coin prices, 1 year \$5.00; Special 3 months \$1.00. Water St., Iola, Wis. 54945.

"NUMISMATIC NEWS," the coin collectors' Bible, lists coin values, 1 year \$3.00; Special 6 issues \$1.00. Water St., Iola, Wis. 54945.

10 DIFFERENT Indian cents \$2.25. Hutchinson's, Box T-6256, Philadelphia, Penna. 19136.

10 DIFFERENT Lincolns before 1921 \$1.00. 20 before 1931 \$1.50. Eugene Carlton, Chandler, Okla. 74834.

100 LINCOLNS 1909 up, \$4.50. No two alike. Earl Sprague, Kingston Drive, Muskego, Wisconsin.

HIGHEST Prices paid immediately for coins. Send 10c for 1964 Buying prices. Wilmot's, 1067 Bridge St., Grand Rapids 4, Mich.

25 BEAUTIFUL Coins from 25 countries. Mostly uncirculated. Terrific assortment. \$1.00. Hindley, Box 708, Aurora, Illinois.

COIN Date guaranteed. Restores dates on worn nickels. \$1.00 bottle. Box 276F, Mooreville, N.C.

UNCIRCULATED 1935 pony express silver commemorative medal \$1.00. Coin lists free. Sayers, 1000 Unaka, Johnson City, Tennessee.

RARE Silver Dollars, 1879, 80, 81 S mint \$3.00 ea. Uncirculated. New Catalogue, 50c; Shultz, Salt Lake, Utah 84110.

10 DIFFERENT Indian cents, bargain lists, \$2.25. Hobby Sales, St. Paul 16, Minnesota.

BARGAINS—Coins, supplies. Large list, 10c (refundable). Ron Farley, Metamora, Illinois.

SILVER Dollars, uncirculated, \$2.50 each. 10 different \$22.50, 20 different \$60.00. Sam Sloat, Highpoint, Westport, Conn.

YOUR Choice Indianhead cents, Liberty Nickels, or barber dimes. Five \$1.25, Ten \$2.50. All different. Fred Lewis, Wall, So. Dak.

LINCOLNS! 22 Different "S" including rare 1955S, \$1.60. 28 different before 1940 plus 1960D small date, \$1.60. Harris, Box 1147, Oceanside, California.

RARE And unusual Alaskan tokens. Free list. Write Santa Claus House, North Pole, Alaska.

COINS, Foreign -- starter sets -- ideal gifts. 10 different—\$1.00, 20—\$2.75, 30—\$5.00. Banner's, 307 Comstock Road, Ithaca, New York.

RECORD Your coin collection and transactions. Space for all information, 8 1/2 x 11 punched sheets, 12 sheets \$1.00, 50 sheets \$3.50. ReKord-ReKount, Box 68, Niagara Falls, New York 14302.

10 INDIANHEADS \$2.90; 12 V-nickels \$3.15; 10 Morgan dimes \$3.50; 10 Morgan quarters \$7.50; 10 Morgan halves \$12.50. All different! Fairway, 121-M, Rye, N.Y.

COIN Bargains galore. Illustrated lists 10c (refundable). Hutchinson's, Box P-6256, Philadelphia 36, Pa.

TRUNKFUL 25,000 Indian-Lincoln cents mixed (from the 1920's and older). Will pack "grab-bag" style. 400 mixed \$25.00, sample bag of 20—\$2.00. Mrs. Fischer, Box 5490, Sherman Oaks 4, Calif.

UNSORTED Foreign currency, one and two dollar packages Sutton's, Box 7023, Louisville 7, Kentucky.

4 BARBER Dimes \$1.00. 8 Buffalo nickels \$1.00. Doktor, 5028 W. Pico, Los Angeles, Calif. 90019.

SAN FRANCISCO Lincolns! 25 different—\$2.50. 250 mixed—\$6.25. Everything postpaid! Molzan, 3228 Fruitvale Avenue, Oakland, California 94602.

BEAUTIFUL Official large bronze medals (Boxed with historical list): Alaska, Hawaii, Civil War Centennial, Golden Gate Bridge, U.S.S. Enterprise, each \$4.75, President Kennedy Inaugural \$8.95, 1964 proof set \$18.50, Carver 1/2 \$2.50, 1965 books: Guidebook \$1.75, Bluebook \$1.00, World Coins \$4.00. Bebee's, Inc., Omaha, Nebraska 68111.

COIN Investment service. Details, latest report, 50¢. Coins, Box 913G, Port Jervis, N.Y.

FIVE Different Indian cents—\$1.00. Four different Liberty nickels—\$1.00. John Gardner, Box 408, Colorado Springs, Colorado.

SILVER—Two brilliant uncirculated Mexican silver dollars \$1.00. Cogburn, Box 1294, Vidor, Texas 77662.

TWENTY Page 1965 retail price list of USA and Canadian coins 10¢. Our retail selling prices on thousands of coins and coin collectors supplies. Bryson Incorporated, 612A White, Toledo 5, Ohio.

LINCOLNS: 50 Different before 1940, plus uncirculated Kennedy Half, \$1.98 plus 25¢ postage. Mickey, Box 82, Brooklyn, N.Y. 11229.

WORLD Coins. Each uncirculated set contains complete current coinage. Bulgaria (4) \$1.50, Canada (6) \$4.00, Guatemala (5) \$2.50, Hong Kong (4) \$3.50, Iran (4) \$3.00, Ireland (8) \$3.50, Jamaica (2) \$4.00, Mexico (6) \$1.50, Norway (7) \$1.50. MWC, Box 8202, Phila., Pa. 19103.

LARGEST Coin magazine. 288 pages, 50¢. Scrapbook, 7320-J Milwaukee, Chicago 31.

ANTIQUES, RELICS, INDIAN GOODS, CURIOS

SELLING 20,000 Ancient arrowheads, spearheads, etc. List free. Lear's, Glenwood, Arkansas.

TONS Of antique gun parts and supplies. All reproduction muzzle loading guns. Send 50¢ for thick illustrated 11th anniversary catalog. Dixie Gun Works, Union City 12, Tenn.

SIX Arrowheads from six states, \$2.00. George Smith, 9825 Conway Drive, Indianapolis, Indiana 46236.

ARROWHEADS 10 for \$3.00. List free. Hyde's, Rosemar Rd., Parkersburg, W.Va.

HOBBIES AND COLLECTIONS

AMERICAN Newspaper, complete, original, dated before 1880, \$1.50. 25¢ stamps brings catalogue. D. R. Spaight, Book-seller, Tall Timbers 1, Maryland 20690.

WORLD'S Largest moth \$1.98. Marden House, Box 3213-A, Seattle 14, Washington.

FIVE Military emblems and illustrated catalog, 25¢; 30 different 50¢; Foreign medal 50¢; add 10¢ postage. Hobbies, Box 71-M Rockaway 94, New York.

EUROPEAN And Nazi uniforms and equipment, medals and badges, all authentic and reasonably priced. Catalog with 600 illustrations \$1. Der Alte Oberst, Box 1393, La Jolla, Calif.

50 JUNGLE butterflies \$2.00. Giant nature hobbies catalog 25¢. Collectors Wonderland, Box 1170, New York 8.

PRECIOUS STONES, MINERALS

EARTH Science. Rockhound's National Magazine. Subscription \$2.50. Sample 35¢. Box 1357-PM, Chicago 90, Ill.

U.S. Foreign minerals. Price lists 10¢. Minerals, Winston, N. Mex. 87943.

GET Free catalog no serious rockhound, gem cutter, jewelry maker, hobbyist or craftsman can be without. Full of bargains, exclusive items, low prices from largest suppliers and authorities in the field. Free new catalog just off the press, yours for the asking. Write Grieger's, Dept. C-12, 1633 E. Walnut, Pasadena, California.

SEMI-Precious uncut gems. Ten different for \$1.00. Request list 30. Prospectors Shop, 201 San Francisco, Santa Fe, New Mexico.

PHOTO FINISHING, CAMERAS, PHOTO SUPPLIES

COLOR Movie Fans! 8 MM expertly processed for just \$3.10 including fresh Kodachrome Film. All mailed back next day First Class. Craftsmanship guaranteed. Send exposed reel or request Free Molders and Price List of complete services. Direct Mail Photo, Box 8352-PM, Pittsburgh, Pa. 15218

TWO Beautiful B&W prints from each picture on roll—8 exposure 45¢; 12 exposure 60¢. One color print each on 8 exposure Kodacolor \$2.25; 12 exposure \$3.25. Lens Photos, Dept. J-4, Janesville, Wisconsin.

A FREE Kodak roll returned with each black and white or Kodacolor developed and printed, fast service, lowest prices, guaranteed quality send for free mailers. Economy Photo Service, Dept. P. M., Box 1111, Albany 1, N. Y.

INDIVIDUAL Custom processing—All photographic services! B & W Color. Special! Ektachrome-X processed at ASA 500.—Personal Service. Peters and Company, Box 351T, Jamaica, New York 11431.

FAST, Hi-quality finishing. Kodacolor rolls: eight jumbo prints \$1.98. Twelve \$2.49. Twenty \$3.49. Reprints 15¢. Also low B&W prices. Custom Quality Studio, Box 4838, Chicago 80.

FREE 64 Page photographic supply and accessory catalog. Central Camera Company, Dept. 1-2-12 230 South Wabash Ave., Chicago, Illinois 60604.

QUALITY Enlargements! Five 5x7's or three 8x10's from negative, \$1.25. Waltham Studio, 536 Fourth, San Diego, Calif. 92101.

CHRISTMAS Special! Enlargements from negatives! 5 x 7—\$.25, 8 x 10—\$.50, 11 x 14—\$1.25, wallet—25—\$1.25. Coventry, Derby, New York.

QUALITY Enlargements! Five 5x7's or three 8x10's from negative, \$1.25. Waltham Studio, 536 Fourth, San Diego, Calif. 92101.

CHRISTMAS Special! Enlargements from negatives! 5 x 7—\$.25, 8 x 10—\$.50, 11 x 14—\$1.25, wallet—25—\$1.25. Coventry, Derby, New York.

NEW Automatic electric eye F:2.8 camera. Half price. Dunne, 7707 Chappel, Chicago.

AMAZING Values, film users write, Chai Photo Supply Co., 14-03 Berdan Ave., Fair Lawn, N.J.

MOTION PICTURES AND SOUND EQUIPMENT

MOVIE Film! Free catalog! ESO-R, 47th Holly, Kansas City 12, Missouri.

FREE Catalog! Save on 8/8mm.-16mm. film and supplies. Superior, 448 N. Wells, Chicago 10.

TREMENDOUS Selection 16mm sound movies. Gaines (PM) 14544 Vanowen, Van Nuys, Calif.

8MM CLASSICS. Fairbanks, Keaton, others—50¢ introductory offer \$1.00. Free catalog also 16MM sound films. Entertainment Films, 850 7th Ave., NYC.

FILM Collectors! Scintillating silent classics, 8mm, 16mm. Movie-drome, 219 Lake, Bayhead, N.J.

16MM sound-projectors, films, new, used for sale. Free catalog, National Cinema, 71 Dey Street, New York City, N.Y.

COLOR SLIDES

PHOTOGRAPHS And transparencies wanted. To \$500.00 each. Valuable information free—write Interfoto, Box 74607, Hollywood 90004.

WORLD'S Fair—Eight Color Slides \$1.00. Catalog included. Eddings—8PM Roberts, Corning, New York.

TRANSPARENCIES Wanted. Up to \$500.00 each. For information write American Color, P.O. Box 46372, Hollywood 46, Calif.

BUSINESS OPPORTUNITIES

MAKE \$46 From square foot plywood: jigsaw necessary. Free details. Woodart, Bridgewater, Mass.

PIANO Tuning learned quickly at home. Tremendous field! Musical knowledge unnecessary. Information free. Empire School of Piano Tuning, Box 327, Shenandoah Station, Miami, Florida 33145. (Founded 1935).

READ Progressive Mailtrade, the magazine that tells how to make money by mail. Quarter brings sample and special offer. Mailtrade, P.O. Box 357, Sheboygan, Wis. 53082.

EARN Money raising fishworms for us! Write: Oakhaven—38, Cedar Hill, Texas.

COPUBLISH "Mail Sale Advertiser," leading mailorder paper. Copy and details 25¢. Vanroy Shirk, Lebanon, Pa. 17042.

BIG Money raising fishworms and crickets. Free literature. Carter Farms, Plains, Georgia.

\$400.00 MONTHLY Raising giant fishworms. Soilless method. Charlie Morgan, Bushnell, Florida.

PLASTERCRAFT Molds, liquid rubber, plasters, floccs, candle supplies. Catalog and manual free. Blue Rapids Supply, Blue Rapids, Kansas.

WORLD'S Largest wholesale supply. Buy from 679 American, European, Japanese wholesalers. Tailormade suits from Hongkong. 123 dropship catalogs. Rock-bottom prices. Free details. International Buyers, 216-MM Jackson, Chicago 6, Ill.

WANT To make big money at home? \$10.00 profit in an hour possible with invisible mending. Make tears, holes disappear from clothing, fabrics. Steady year-round demand from cleaners, laundries, homes. Details free. Fabricon, 1585 Howard, Chicago 26, Ill.

VENDING Machines. No selling. Operate a route of coin machines and earn amazing profits. 32-page catalogue free. Parkway Machine Corporation, 715 PMB Ensor Street, Baltimore 2, Maryland.

LIQUID Molding rubber, free information, Chaney's, 5415-A San Jose Blvd., Jacksonville 7, Fla.

SELL Champion, AC, Autolite spark plugs. Reconditioned, electroplated, guaranteed 10,000 miles. 100% profit. Free sample. Lee Plugs, 1608-A Roberts, Houston 3, Texas.

OPERATE Home mailorder business. Vosack Printing, 4444AI Ute, San Diego, 17, Calif.

RAISE Rabbits on \$500 month plan. Free details. White's Rabbitry, Mt. Vernon, Ohio.

PROFITABLE Catalog mailorder business! Vikari's, 468-PM, Third Avenue, Salt Lake City, Utah 84103.

HUGE Profits! Mail order importing. Free information. ITIS-PM-12, Box 454, Hollywood, Calif. 90028.

DOLLS! Dolls! Dolls! We teach you to make, repair, dress and sell. Study at home. Earn while learning. Free booklet. Doll Hospital School, Studio MC-124, 11826 San Vicente Blvd., Los Angeles 49, Calif.

MANAGE Motel or resort. Men, women, couples can make high salary plus apartment. Pick your own location with our employment assistance. Learn at home. Free Booklet. Motel Managers Training School, Dept. PMC-124, 612 So. Serrano, Los Angeles 5, Calif.

LEARN Landscaping and the growing of plants. Start a profitable business part or full time. Free information without obligation. Lifetime Career Schools, Dept. MC-124, 11826 San Vicente Blvd., Los Angeles, Calif. 90049.

AMAZING Manufacturing opportunity. Free list of manufacturing formulas. Presler Oil Company, Fostoria 16, Ohio.

SPARE Time earnings. With your table-saw, bandsaw or jigsaw. Write: Workshop, A3800 Harney, Vancouver, Washington 98660.

SELL Advertising book matches. Write us today; we put you in business by return mail, handling complete line ad book matches in demand by every business right in your town! No investment; everything furnished free! Top commissions daily! Superior Match, Dept. MX-1264, 7530 S. Greenwood, Chicago 19, Ill.

IMMEDIATE Profits with no capital or experience. Take orders for all magazine subscriptions. Friends and neighbors are your prospects. Write now for complete, free kit. McGregor Magazine Agency, Dept. CB4, Mount Morris, Illinois.

"HOW To Establish Your Own Successful Mail Order Business," new information packed, 24 page booklet free. Direct Mail Guides, Inc., PM-C12, 4227 Herschel Building, Dallas, Texas.

FREE Book "990 Successful, Little-Known Businesses." Work home! Plymouth 772P, Brooklyn 4, New York.

BOOKKEEPERS. Accountants. Operate a bookkeeping service. Part or full time. Amazing simplified system. Wonderful money-making opportunities. Complete information free. National Bookkeeping Service, 301 West Armour, Kansas City 11, Mo.

OPERATE Home mailorder business. L&D Printing, 106 Cumberland, Lawrence, N.Y.

GUARANTEED Market! Earn sparetime cash raising fishworms for us, or cash in big on nationwide bait boom! We teach you how, buy your crop while you get established. We paid Baugh \$322.96, Mrs. Dufrechou \$195.84 for sparetime work. (Many others). Start backyard, garage, basement. If interested in extra cash or fulltime home business, write today for exciting free details! Oakhaven-38, Cedar Hill, Texas.

SIMPLE. Pleasant, mailorder can net \$12,000 yea. Write Rutward, 2610 Bryant, Columbia Station, Ohio.

COLORGLAZED Concrete pottery made without molds. Patented method. Cemetery products, novelties, tiles. Basement leak-sealing. Money-making projects. Booklet details free. Men only. National Potteries Company, Grand Rapids, Minnesota.

SELL Books by mail. 400% profit. Royal, Box 450-X, Cleveland 27, Ohio.

MAKE Money mailing mothers our postcards. Particulars free. Wesley, Western Springs, Illinois.

FREE Booklet! Profitable, spare-time business bronzing. Pearl-kotting baby shoes! Complete set-up on credit. Kiktavi, Box 34861-BY, Los Angeles, California.

TO \$100.00 weekly! Mailing catalog! Sample, instructions, 25¢. Costar, GPO Box 972-PM, New York 10001.

BAKE New greaseless doughnuts in kitchen. Stores buy output. Start spare time. Profit 29¢ dozen. Small appliance. Free recipes. Montgomery, 3605 South 15th, Minneapolis 7, Minnesota.

VENDING Machines can make you an excellent spare time income. Small investment gets you started. Write for our free catalogue. Vendall Distributing Co., 1820 E. 38th St., Minneapolis 7, Minn.

STOP Throwing away boxtops! They're worth money! Some, 25¢! Inquire: "Box-tops-MB", Cedar Hill, Texas.

MAKE \$50.00 daily! Sell air operated vacuum cleaners to service stations for \$19.50. Your cost \$9.50 postpaid. Free details. Inka Industries, 2409-M Crocker, Houston 6, Texas.

INVESTIGATE Fires, storm damage, accidents for Insurance Companies. Pays up to \$1,000 a month, part or full time. No college necessary. Car furnished; expense paid. We train you at home in spare time. Keep present job until ready to switch. Pick your location. Men badly needed now. Full information free. Write Liberty School, Dept. C519, 1139 W. Park, Libertyville, Illinois.

400,000 BARGAINS below wholesale! Some free. Liquidations, job lots. Free details. Bargainhunters Opportunities, Box 730-A, Holland, Michigan.

HOME Manufacturing opportunities. Money-makers. Amazing literature. Ideal, 179-P, Park Ridge, Illinois.

PROFITABLE Mail order business. Be independent. Details free. Ideal, Box 357-DM, Valley Stream, N.Y.

IMPORT-Export opportunity, profitable world-wide, mail-order business from home, without capital; or travel abroad. We ship proven plan, for no risk examination. Experience unnecessary. Free details. Mellinger, Dept. M70C, Los Angeles 25.

DIRECT Rock bottom wholesale sources! Buy for pennies! Sell for dollars! Free Details, Joric, Dept. 40C, Box 6751, Portland, Oregon 97266.

76 MILLION Prospects! Immediate profits! Selling Champion, AC, Autolite spark plugs. Precision reconditioned, silvery-plated, guarantee 10,000 miles. Up to 308% profit. Free samples, details. Indy 500 Spark Plug Co., 4620 Braeswood, Houston, Texas 77035.

HOW And where to raise capital Details free. Financial, Box 785-PM, Springfield, Missouri 65801.

FREE Copy money-making mail order newsletter Address Newsletter, 3207-PM Southern Hills, Springfield, Missouri 65804.

CONCRETE Facts: Cement Artists make big money. Home Shop—Simple Equipment—Copyrighted Methods and Formulas. Make. Color and Marble Glaze beautiful Cement Pottery without molds. Wishing Wells, Bird Baths, Waterfall, Rustic Garden and Patio items. For free illustrated Brochure, write Hollywood Cementcraft, 602 E. Athens St., Altadena, California 91001.

ESTABLISH Your own home operated, profitable business! Particulars free! MacMillan, 2020-C Marlowe, Lakewood, Ohio 44107.

BIG Profits! Consignment selling. Full, sparetime. Others work for you. Particulars free. Unicis, Box 735-WP, Norwalk, Conn. 06852.

PROFESSIONAL Termite control! First time opportunity to join this easy big pay business. Write Sterling Co., 1112 W. 4th, Santa Ana, Calif.

FREE Information about franchises. Go into business for yourself. 98% are successful. Write today for interesting facts. American Franchise Reports, Box 74852-C, Los Angeles 90004.

NEWSPAPERS. Sawdust. Tin-cans. 200 uses. Instructions \$1.00. Charles Company, 42-GPR, Norwood, Ohio.

BIG Money, in spare time businesses. Free details: Worldcraft, Greenhills 6723, Nashville 12, Tenn.

HOW And where to raise cash to start a business. American Advisor, Box 48337-D, Los Angeles, 90048.

FREE "Franchise Profit Letter" tells how unique NFR service is helping thousands seeking profitable businesses. Write today. National Franchise Reports, W-528, 333 North Michigan, Chicago 1.

BECOME Tax consultant. Our students earn \$1,000-\$3,000 every tax season preparing returns evenings. State approved. National Tax Training School, Monsey V-2, New York.

\$140.00—Day's homework! (Proof!) No experience! Ideagraphy, R6, Wellsboro, Pa. 16901.

SENSATIONAL Profits in importing. Free information. Limrite, 2360-62, San Miguel, Salinas, California 93901.

FIVE Basic laws for complete success and satisfaction. Free details! Bischoff, Montmorenci Road, Ridgeway, Penna. 15853.

FREE Merchandise! 400,000 bargains below wholesale. Goldmine, Box 183-A, Bloomfield, New Jersey.

SENSATIONAL Method gives you peace, power, plenty. Free details. Martin, 1948 Pennington Road, Trenton, New Jersey.

SECRETS! Secrets! Mail order success revealed by internationally famous expert who discovered how to make home business fortunes. Beginners: Get free copy "How to Make Money in Mail Order." Discloses free advertising, profitable products, everything! No obligation. Write Malco, 1554 Sepulveda, Dept. M70C, Los Angeles 25.

PACKAGE At home for profit! We supply everything. No "selling." Free home business details. HPC, 807HPF Sunset, Los Angeles 12.

BUILD Custom cases at home for profit. Get orders by mail. We supply materials, instructions, everything. Free home business details. Customcase, 805CPF Sunset, Los Angeles 12.

RETIRE Securely now regardless of age or sex. Free details. Croswell, Box 304-C, Fort Morgan, Colorado 80701.

EARN \$300.00 Week retarding growth of trees, grass, shrubs. Franchise information 25¢. Denford, PO Box 5002, Va. Beach, Virginia.

NEW Instant invisible mending. Learn in one hour, repair in five minutes. Make \$150.00 week. Literature free. Louis Rosenstein, P.O. Box 6136-6, Philadelphia, Pa. 19115.

REPAIR Hydraulic jacks. Details free. Write: Hydraulic Parts Supply, Box 3645, El Paso, Texas.

CHECK Protector. Best seller by mail. Write: Goodall, 68-M Joost, San Francisco 94131.

HOW To raise \$1500 business capital. Directory gives sources and methods. Free details. Counselor, Harlingen 17, Texas.

FREE Facts and descriptive bulletin. Be an air conditioning, refrigeration, and heating serviceman. High pay, jobs open everywhere, operate your own service business, no school or correspondence necessary. Write Doolco, Trouble Shooter, 2016 Canton, Dallas, Texas.

"MAILORDER—Stop looking!" Get your own catalog! Methods, 1804-FD, Lafayette Hill, Pennsylvania, 19444.

LEARN Motel management. Thousands of locations for men, women, couples to make high salary plus apartment. Enjoy real security. Learn at home 8 weeks. Write today for free folder P-11. Motel-Hotel Careers, Inc., P.O. Box 337, Inglewood, Calif.

HOW I made \$50 day operating Ad Market. Free details. Ad Market, Harlingen 1, Texas.

BIG Mail, catalogs, mail order magazines. \$1.00. Lincoln, Box 1018M, Southgate, Mich.

IMPORT-EXPORT business made easy. Complete setup service; not just instructions. Hermes, 152 West 42, New York City 10036.

BELOW Wholesale! 350,000 items. Free lists. Bevco, 363 Sam, Johnstown, Pa. 15902.

RADIO Mail order. \$50,000 in one month possible. No cost percentage plan. Walthay, Box 53-M, Los Angeles 90032.

IMPORT Hospital supplies. Full details. Pallas, 3823 Behrwald, Cleveland 44109.

C.B. Radio's, equipment, quality, guaranteed American made. From \$77.00. Excellent spare time earnings. Minimum investment \$150.00. G.M.P., Box 55, Millersville, Md.

IMPORT Export represent manufacturers. Details 10¢. Benko, Box 188-A, New York 21, NY.

GOLD, Silver, Bronze plastic 3-D products! You produce, profit at home. Fabulous new machineryless method. Free Facts. Nationwide Plastics, Box 23321-EF, Los Angeles 90023.

IMPORT For fun or profit. Details free. Dunlap, 1037 Madison, Grand Rapids, Mich. 49507.

HOW And where to raise cash to start a business. American Advisor, Box 48337-D, Los Angeles 90048.

MAILORDER Business started with \$10.00. Free information. Lennon—Box 176 PM, Midland Park, New Jersey 07432.

HOW To operate Home Importing Business. Free details. Livingston, Box 5332, North Charleston 1, South Carolina 29406.

MAILORDER. Net \$10,000 year without investment. Budget, Box 501P, Monterey Park, California 91754.

BETTER Yourself! Success, money, pleasure. Start your own business! No gimmicks or gadgets to sell. Details free. Bolden Enterprises, Box 519-M, Bristol, Pa.

AMAZING New guide! "How To Acquire An Adequate Income For Life." Free brochure! Mann, D-226, Hillsdale, New Jersey 07642.

MOLD Statuary, pottery, tiles, novelties—5¢ materials makes dollar sellers! Particulars free. Marbeilizing Service, Edwardsville, Illinois.

YOUR Own auto parts business! No investment. Full or spare time. Profit opportunities kit free. C. B. S., Tarentum 25, Pennsylvania.

START Your own business on credit. (U.S. only) Your own boss. Hundreds of dealers making \$100 to \$300 and more weekly. We supply stocks, equipment on credit. 300 home necessities. Sales experience unnecessary. Pleasant profitable business backed by world-wide industry. Write Rawleigh, Dept. L-U-PPM, Freeport, Ill.

\$70.00 WEEKLY—home, spare time. Simplified mail bookkeeping. Immediate income, easy. Auditax, 34741a, Los Angeles 34.

PROFIT With Popular Mechanics' subscription plan. No investment, no experience needed. Earnings begin immediately when you obtain subscription for Popular Mechanics, Good Housekeeping and others. High commissions, bonus. No experience needed. Deal directly with the publisher. Write Popular Mechanics, Room 12B, 250 West 55th St., New York 19, N.Y.

MONEYMAKING OPPORTUNITIES

VENDING Machines. No selling. Operate a route of coin machines and earn amazing profits. 32-page catalogue free. Parkway Machine Corporation, 715 PPM Ensor Street, Baltimore 2, Maryland.

EARN \$240.00 a month at home, spare time, doing only two \$5.00 invisible mending jobs a day. Big money paid for service that makes cuts, tears disappear from fabrics. Steady demand. Details free. Fabricon, 1532 Howard, Chicago 26, Ill.

BIG Money raising fishworms and crickets. Free literature. Carter Hatchery, Plains, Georgia.

AMAZING Successes through franchises! Become exclusive franchise holder your territory. Information rushed. National Franchise Reports, WP-528, 333 North Michigan, Chicago 1.

EASY To start rubber stamp business at home in spare time. Make up to \$9.80 an hour without experience. Facts free. Write Roberts, 1512 Jarvis, Room CR-2-LL, Chicago 26.

EARN \$1000.00 month operating Bookkeeping Tax Service. Details free. Universal Bookkeeping, Box 664, Springfield, Missouri.

MAKE Plastic novelties for extra income. Low cost home training now available. Write for free booklet. Interstate Training Service, Dept. D-3, Portland 12, Oregon.

MAKE Money writing short paragraphs! No tedious study! I tell you what to write, where and how to sell, and supply list of editors buying from beginners. Many small checks add up quickly. Write to sell, right away. Send for free facts, Benson Barrett, Dept. C27-X 6216 Clark, Chicago 26.

MEN—Women! Start money-making plastic laminating business at home in spare time. Material that costs 11¢ brings back \$2.58. No canvassing or selling but mail orders bring in \$20 a day. Write for full particulars free. Rush name on postcard to Warner, Room CL-2-LL, 1512 Jarvis, Chicago 26, Ill.

495¢ PROFIT Selling mailorder manuals. Details Free. Rutward, 180 Bryant, Columbia Station, Ohio.

RAISE Rabbits and fishworms on \$500 month plan. Free details. White's Rabbitry, Mt. Vernon, Ohio.

EARN Money evenings, copying and duplicating comic cartoons for advertisers. Adservice, Argyle 1, Wisconsin.

MINK Raising information free. Lake Superior Mink Farm Inc., Superior, EE1, Wisconsin.

START Your own home mailorder business, sparetime! Easy; Fascinating, profitable! Alfano, 19-PM Pine, Closter, New Jersey.

PAINT Signs for yourself—others! Easy with our letter patterns, supplies. Also "Raised Letters." Paulow, Crystal Falls, Michigan 49920.

WE Purchase items you make at home for us. Send stamp for details. Wolfe Specialties, Box 171, Center Line, Michigan 48015.

EARN Big commissions full or part time. Show America's largest line low priced business printing and advertising specialties. Calendars in season. Big free sales kit samples hundred items used daily by business people. Build profitable repeat business. Start right now. National Press, Dept. 19, North Chicago, Illinois.

START Big-pay business at home in spare time. No experience needed to operate little table-top machine for bronzing baby shoes. Make \$5.46 profit on every pair. Full particulars free. Send postcard to Mason, 1512 Jarvis, Room CM-2-LL, Chicago 26, Ill.

MAKE \$2-\$5 an hour, enjoy fascinating hobby, searching common coins. Send 25¢ for instructions and buying list. Sam Sloat Highpoint, Westport, Conn.

LEARN The secrets of repairing junk batteries. "Fabulous Profits" at home. Details. Batterymen, Prunedale P.O., Salinas, California.

UNUSUAL Moneymaking opportunities. Free literature. Eaton's, 708PM Gold, Centralia, Wash. 98531.

HOW To win prize sweepstakes, drawings, contests. Lesson \$1.00. Winner, Box 304, Columbia City, Indiana 46725.

INCREASE Your income in your own franchised business. Banish unemployment fears forever. Investigate today, write American Franchise Reports, Box 74852-B, Los Angeles 90004.

CAPITAL Available. Easy, proven sources. Details free. American Advisor, Box 48337-C, Los Angeles 90048.

MAKE \$5,000 yearly, sparetime, raising mink, chinchilla, nutria, etc. Free booklet reveals proved plans. Write: Furs, 588 Mt. Pleasant Road, Toronto 2, Canada.

"TAPE Recording for pleasure & profit." Tremendous home study course jam-packed with hundreds of money-making ideas using a tape recorder! Guaranteed! \$4.95 plus 30¢ postage. Hammer Enterprises, Asheboro 1, N.C.

NET \$12,000.00 Yearly. Mailorder classified advertising. Details. Watkins Company, Leesville, South Carolina.

MAKE Figurines, plaques, lawn ornaments, molds, plastercraft kits, liquid rubber. Sample and catalogue 10¢. Wooley Company, Box 29-B, Peoria, Illinois.

TO \$100.00 weekly. Mailing catalogs. Sample, instructions, 25¢. House, 1810D Romaine, Columbia, S.C. 29210.

RETIRE Securely now regardless of age or sex. Free details. Taylor Service, Grayville 32, Illinois.

RETIRE Now, without money! Ordinary people with ingenuity smart-money knowledge, become financially secure. Free information. Southwest Sales, Box 542, Cleburne, Texas.

MONEY-MAKING Opportunity fastest-growing outboard motor manufacturer offers lucrative service franchises. Invest less than \$200. Service School training. Manuals provided. Write, Engine Division, The West Bend Company, Hartford, Wisconsin.

WORLD'S Zaniest crosswords. Win \$1,000.00 and die laughing. Details free. Prizewinner, 1315 Central, St. Petersburg, Fla.

CAPITAL Available. Easy proven sources. Details free. American Advisor, Box 48337-C, Los Angeles, 90048.

PROFITABLE OCCUPATIONS

EARN \$240.00 A month at home, spare time, doing only two \$5.00 invisible mending jobs a day. Big money paid for service that makes cuts, tears disappear from fabrics. Steady demand. Details free. Fabricon, 1586 Howard, Chicago 26, Ill.

SHARPEN Scissors, pinkers, clippers. Inexpensive machines, supplies. Blackhaws, Sheldahl, Iowa.

VENDING Machines. No selling. Operate a route of coin machines and earn amazing profits. 32-page catalogue free. Parkway Machine Corporation, 715 PMP Ensor Street, Baltimore 2, Maryland.

INVESTIGATE Accidents. Earn \$750 to \$1,000 monthly. Men urgently needed. Car furnished. Expenses paid. No selling. No college education necessary. Pick own job location. Investigate full time. Or earn \$8.44 hour spare time. Write for Free Literature. No obligation. Universal, C-PM-12, 6801 Hillcrest, Dallas 5, Texas.

FREE Book "990 Successful, Little-Known Businesses." Work home! Plymouth 77P, Brooklyn 4, New York.

MAKE Money writing short paragraphs. Information free. Barrett, Dept. C27-XA, 6216 No. Clark, Chicago 26.

WHOLESALE Magazine subscriptions. Highest commissions! Bonus! Box 151MA, Freshmeadows, N.Y. 11365.

BECOME Independent with your own franchise business. Thousands earning handsome incomes. Request interesting facts today. National Franchise Reports, PM-528, 333 North Michigan, Chicago 1.

CHROME Plating. Instructions, equipment and supplies. Platers' Supply, P.O. Box 565, Luzo Station, Los Angeles, Calif.

YOUR Own sign shop—Signs. 1017 W. Mulberry, Springfield, Ohio.

BAKE New greaseless doughnuts in kitchen. Sell stores. Free recipes. Michael, 3605 South 15th, Minneapolis 7, Minn.

RAISE Pheasants on \$100 week plan. Little capital and space can make you independent. Free details. Great Central System, Columbus 1, Kansas.

START Your own franchised business. International franchising opportunities available. Thousands have found profitable businesses. Act now—valuable details rushed. American Franchise Reports, Box 74852-A, Los Angeles 90004.

OPERATE Restaurant or diner. Free booklet reveals profitable plan. Write Restaurant Business School, Dept. EC-124, 1920 Sunnyside, Chicago 40, Illinois.

FREE Information. Huge profits. Invest in ordinary coins. Stacey's, 531 North 53rd Place, Mesa, Arizona 85201.

OPERATE Profitable mail order business from home. Free booklet. Hagemann, 604 Suntime, St. Louis 25, Mo.

MONEY To make money with. Free details. Counselor Reports, Harlingen 5, Texas.

\$200 POSSIBLE Weekly operating Ad Market. Free details. Ad Market, Harlingen 4, Texas.

BETTER Yourself! Become a professional Accident Investigator earning up to \$1,000 monthly operating own business. Or as company adjuster with car furnished, expenses paid. Home training in spare time. College unnecessary. Claim Investigators urgently needed. Free employment help. Send for free information. United Schools, Dept. 2811, 1626 Glendale, Orlando, Florida.

BIG Money raising fishworms and crickets. Free literature. Carter Wormery, Plains, Georgia.

AGENTS WANTED

ESTABLISH Your own business. Low prices on used clothing, shoes, household goods. Unlimited profits. Free catalog. Northwestern Distributors, 2129 No. Western Avenue, Chicago 47, Illinois.

RAISE Rabbits for us on \$500 month plan. Free details. White's Rabbitry, Mt. Vernon, Ohio.

MAKE Up to \$50.00 daily soliciting delinquent accounts. Terrific commissions. General Finance Co., Dept. LG-74, Pickwick Bldg., Kansas City, Mo. 64106.

SALESMEN Make big profits selling "do-it-yourself" sign kits to merchants. Information free. Signmakers, Inc., Dept. PM4, Box 6626, Denver 16, Colorado.

ELECTRONIC Fish Lure—Big Profits—Details Free. Parketta, 4719 "B" Street, Philadelphia, Pennsylvania 19120.

PRINTING. Advertising salesmen—Excellent moneymaking sideline selling decalomania name plates, small quantities. Automobile initials, sign letters. Free samples. Ralco, XL, Boston 19, Mass.

AGENTS—300% Profit selling genuine gold window letters; store and offices. Free samples. Metallic Sign Letter Co., 1217-D West Newport, Chicago.

AGENTS To handle quality merchandise. Liberal commissions, minimum cash investment, fully refundable upon return of samples and sales kit. Further information write. Telephone Equipment Co., Inc., Oxford, Miss. 38655.

EXOTIC Earrings! Details free. Pair, \$1.00. Ohga, PM-561, Sigakenkusatu, Japan.

YOUR Own business—Used suits \$1.50: overcoats 65¢; mackinaws 35¢; shoes 12½¢; ladies coats 30¢; dresses 15¢. Enormous profits. Catalog free. Nathan Portnoy Associates, 2109-AA Roosevelt Road, Chicago 8, Ill.

SALESMEN—DISTRIBUTORS

IF You're interested in making money in selling, see the hundreds of exceptional opportunities in Salesmen's Opportunity Magazine. Send name for your copy, absolutely free. Tell us what you're selling now. Opportunity, 848 N. Dearborn, Dept. 17, Chicago 10, Illinois.

DISTRIBUTORS Wanted. Stainless razor blades. Buhl, Box 34, Princeton, Florida.

SELL Advertising book matches. Write us today, we put you in business by return mail; handling complete line ad book matches in demand by every business right in your town! No investment; everything furnished free! Top commissions daily! Superior Match, Dept. M-1264, 7530 S. Greenwood, Chicago 19, Illinois.

EARN Big commissions full or part time. Show America's largest line low priced business printing and advertising specialties. Calendars in season. Big free sales kit samples hundred items used daily by business people. Build profitable repeat business. Start right now. National Press, Dept. 18, North Chicago, Illinois.

\$1,000.00 a month for making dramatic 3-second demonstration of amazing Lightweight Presto Fire Extinguisher. New chemicals used by Airforce snuffs out fires instantly. Only \$4.95. Terrific commissions. Millions want it. Free Kit, Merlite, 114 E. 32nd, Dept. P-66D, New York 16.

SENSATIONAL New longer-burning light bulb. Amazing free replacement guarantee—never again buy light bulbs. No competition. Multi-million dollar market yours alone. Make small fortune even spare time. Incredibly quick sales. Free sales kit. Merlite (Bulb Div.), 114 E. 32nd, Dept. C-74D, New York 16.

SELL Business cards. Unlimited market. 20% Commission. Catalogue \$1. (Refundable!) M T L Printing, Box 947, Chicago, 60690.

EARN Cash commissions plus free gifts. Sell matchbook advertising. Sales kit furnished. Matchcorp, Dept. PM-124, Chicago 60632.

MAKE Big money taking orders for stark Dwarf fruit trees. Everybody can now grow giant size apples, peaches, pears, in their yards. Also shade trees, shrubs, vines, roses, etc. Outfit free. Stark Bro's, Desk 30165, Louisiana, Missouri.

EMPLOYMENT INFORMATION

JOBS. Ships \$100.00 weekly. Beginners, men, women. Seaman's Service, Box 41M, New York 21, New York.

DIRECTORY Reports. Construction, aviation, shipping, oilfields, government, manufacturing, trucking, etc. foreign—stateside. Helpful information plus job-getting tips on preparing application letters. Unconditional money-back guarantee. Only \$3.00 (\$3.25 airmail) Research Services, Box 6768-PM, St. Louis, Missouri 63144.

TREMENDOUS Job Opportunities. Foreign-U.S.A., construction, trucking, manufacturing, government, shipping, thousands more. Up to \$2,000.00 monthly! Directory plus application forms. Send \$1.50 (\$2.00 air mail). Satisfaction guaranteed. Worldwide Opportunities, Box 730-A, Holland, Michigan.

YOUR Skills needed in booming Australia. Government-assisted passage, if qualified. Details \$1.00. Gladys Klein, 2932 Royal Palm, Costa Mesa, California.

GLOBETROTTER'S Newsletter, 25¢. Current job, travel information. Frank Klein, 2932 Royal Palm, Costa Mesa, California.

DIRECTORY Of Foreign-U.S.A. job possibilities. Most occupations. Up to \$1600.00 monthly. Often free transportation. Benefits. Money back guarantee. Send \$1.50 (\$2.00 airmail). International Employment, PM-12, Box 22038, Indianapolis 22, Indiana.

FOREIGN Employment information. High wages, travel. Write Gordon Green, Dept. 5, 926 Harlan, San Leandro, Calif.

FOREIGN U.S. employment: Big construction projects. All Trades. Salaries up to \$1,600 monthly, with travel expenses, extras. Write only: Foreign U.S. employment bureau: Dept. 521, The State Building, Portland, Maine.

TREMENDOUS Opportunities—U.S.A.—Overseas—choose jobs—locations—transportation—free details. Occupations, International Airport, Box 100-C9, Jamaica 30, N.Y.

MERCHANT Marine, Men and women. Top wages. Travel. Information. Captain, Box 501-P, Reading, Massachusetts.

FOREIGN—U.S.A. Excellent employment. All-year jobs hiring. Direct placement. Transportation. Family relocation. Fast service. Global, Box 286-A, Oroville, California.

CIVIL Service opportunities. For you, now! Free details: Publications, Greenhills 6723, Nashville 12, Tenn.

YOUR Resume professionally RE-written. Send present resume and \$15. Executive Resumes, Dept. P, 744 Broad Street, Newark 2, N. J.

FOREIGN Employment. Construction, other work projects. Good paying overseas jobs with extras, travel expenses. Write only. Foreign Service Bureau, Dept. PM, Bradenton Beach, Fla.

MUSIC AND MUSICAL INSTRUMENTS

POEMS Wanted for musical setting and recording. Send poems. Free examination. Crown Music Company, 49-C West 32 Street, New York 1.

ELECTRIC Guitars, amplifiers, wholesale. Free catalog. Carvin, PMM, Covina, Calif.

GUITAR, Banjo Making books, Plans, woods, necks, tools. List 15¢. Satinwood, 510 East 11th Street, New York 9, N. Y.

ACCORDION-O-RAMA, 874 Broadway, New York 3, N. Y. Tremendous discounts. Top brands. Free brochure.

ACCORDIONS, Guitars, drums. Wholesale prices. Free catalogue. Allied, 406 East 189th Street, Bronx, New York 10458.

POEMS Wanted for musical setting and recording by America's largest song studio. Send poems. Free examination. Five Star Music Masters, 6-M Beacon, Boston 8, Mass.

SONG Ideas wanted. Write with active, professional songwriters with publisher contacts. Records made. Share royalties. Send ideas—free examination. Songwriters' Associates, 236 W. 55 St., N.Y. 19-P.

ITALIAN Accordions Manufacturing. 6343P, So. Ashland, Chicago 36, Illinois. Piano, Chromatics, Hohners, Concertinas. Wholesale catalogs free.

1964 ACCORDION Organ combination. Wholesale, Free Catalog, Accordion Import Center, 7120 Galli Dr., San Jose, Calif. 95129.

PIANO Self-Teaching Book. Includes popular, classical, harmony, theory, chords, scales. Price \$5.00. LaPont Publishing Company, Box 606-P, Franklin, Michigan 48025.

USED Professional guitars, amplifiers, drums. Hills, 3526 California, Peoria, Illinois.

PLAYER Piano books. Free catalog. Vestal Press, Vestal 11, N.Y. 13850.

SONGPOEMS Wanted. Send poems. Free examination. Hollywood Song Productions, 10885 Los Alamitos Blvd., Los Alamitos, California.

BANJO Resonators, Parts, necks, rings. J & D, Box 112, Paramount, Calif.

SONGPOEMS Wanted. Send poems for offer. Nashville Music Institute, Box 532-PM, Nashville, Tennessee.

SWISS Musical movements. Mechanical, electrical. Spielman, 131 West 42nd, New York 10036.

ACCORDIONS. Guitars, band instruments. Save 1/2. Famous makes, free home trial. Easy terms. Trades. Free discount catalogs. Mention instrument. International Music Mart, Dept. R, 5535 Belmont, Chicago 41.

VIOLIN And guitar makers: Send for latest free catalogue of woods and accessories. International Violin, 414 PM East Baltimore St., Baltimore 2, Md.

SONGPOEMS Wanted: Collaborate with professionals. Share royalties. Hollywood Music Productions, 6425-B2 Hollywood Blvd., Hollywood, Calif.

PROTECT Songs, poems. Copyright information etc. \$1.00. Rasco, 306 Sipsey, Prichard, Ala.

PRACTICAL Violin making with patterns. \$2.00. Supplies. Chelsea Fraser, 2025 Stark, Saginaw, Mich.

AMAZING Offer: We can get your songs recorded by famous artists!! This offer made only to legitimate songwriters who have lead sheets or demos. Write for info to: International Record Prod., 126 W. 42 St., N.Y. 36.

FREE Catalogue 2500 unusual extraordinary hobby, educational, party records. Rose's Records, 300 Chelsea, Louisville, Kentucky 40207.

SONGS, Poems, collaboration, publication. Details, Newart, Box 693, Syracuse, N.Y.

RECORDS! Discounts on all LP's. Free details. Citadel Record Club, 545 Fifth Ave., Dept. 2, New York 17, N.Y.

RADIO, TELEVISION AND ELECTRONICS

BRAND New tubes. World's lowest prices on radio, TV-industrial, special purpose tubes. Write for free parts catalog. United Radio., Newark, N.J.

TAPE Recorders, hi-fi components. Sleep learning equipment, tapes. Unusual values. Free catalog. Dressner, 1523 Jericho Tpke, New Hyde Park 3, N.Y.

TAPE Recorders. Save 30-60% on stereo tape. Free 50 page catalog. Saxitone, 1776 Columbia Road, Washington, D.C. 20009.

MC GEE Radio company. Big 1965 176 page catalog sent free. America's best values. Hi-fi—amplifiers—speakers—electronic parts. 1901 McGee Street, Dept. PM, Kansas City 8, Missouri.

RECORDS To tape: stereo monaural: 4-track, 2-track; 7 1/2 IPS, 3 3/4 IPS, free tape and price list; William Baumann, 557 North 17th Street, Milwaukee, Wisconsin 53223.

33 1/2 RADIO & TV tubes. Free list. Cornell, 4213-17 University, San Diego 5, California.

LOW Price kits. Hi fi. Hobbyist, Experimenter etc. Write Brandwein, 306 W. 100 St., NYC. 10025.

FREE Electronics catalog. Tremendous bargains. Electrolabs, Department C-614B, Hewlett, New York 11557.

WALKIE-Talkies communicate with friends, business associates, up to 5 miles. Service, construction, business, hunting, boating, fire dept., police. Free details. Sheirr Electronics Lab., 1182 Keniston Ave., Dept. 2C, Los Angeles, Calif. 90019.

ELECTRONICS Slide rule! A new, professional rule designed to solve electronic and usual slide rule problems quickly and accurately. Has special scales for solving reactance and resonance problems, locates decimal points, lists many electronic formulas and conversion factors for instant reference. A 10" all-metal rule made specially by Pickett & Eckel. Complete with handsome top grain leather case and illustrated, 123 page self-training course. An ideal gift for technicians, engineers, students, hobbyists, etc. Only \$14.95. Satisfaction guaranteed. Available only from Cleveland Institute of Electronics, Dept. PM-101, 1776 E. 17th St., Cleveland, Ohio 44114.

FREE! Tape recording handbook. Sarkes Tarzian's Galaxie tape. Pofe, 1716-PM Northfield, Muncie, Indiana.

ASTOUNDING Government Surplus illustrated electronics catalog 10¢. Meshna, Nahant, Mass.

SCIENCE & CHEMISTRY

ROCKETS! Flight kits, testing equipment. Catalog 25¢. Rocket Development Corporation, Box 522-P, Richmond, Indiana.

AMAZING New book of science experiments, formulas, and catalogue of laboratory supplies. Only 35¢. National Scientific Co., 13 So. Park Avenue, Dept. PM-12, Lombard, Illinois.

232 PAGE Catalog \$2.00. Laboratory Materials, 1330 Hyde Park Blvd., Chicago 15, Illinois.

ROCKETS: New illustrated catalog 25¢ Single and multistage kits, cones, engines, launchers, trackers, technical information, etc. Fast service. Estes Industries, Penrose 7, Colorado.

CHEMICALS And apparatus for industrial, analytical, and private laboratories. Catalog 35¢. Dept. M-50, Biological Supply Co., 1176 Mt. Hope Ave., Rochester 20, N.Y.

YOUNG Chemists, large variety of chemicals and laboratory apparatus available. Illustrated catalogue 35¢. Sheard Science Supplies, Columbus, Wisconsin.

GET Expendables kit free. Details, catalog 25¢. Laboratory Sales, Box 161-A, Brighton 35, Mass.

ROCKETS Solid fuel powered models. Supplies, cones, propellants. Sample waterproof fuse sent with new illustrated catalog 25¢. Central Rocket Company, Wau-paca 89, Wisconsin 54981.

64 PAGE Science catalog in color: Kits, microscopes, experiments, supplies—solar motor only \$1.49—etc. Lowest prices. Send 25¢ to Schoolmasters Science, 3666 So. State, Ann Arbor, Michigan.

ILLUSTRATED Catalog: Chemistry, mineralogy, biology 25¢. Tracey Laboratories, Evanston, Illinois.

WUMCO Chemical Company. Chemicals and chemical apparatus. Catalog—25¢. Booklet of experiments—50¢. Box 681, Reading, Pennsylvania.

CONTACT Explosive: Explodes with touch of feather. Handled safely wet. Powerful. Ideal for jokes. Applies like paint. Made from household chemicals. Complete instructions \$1.00. Franks Scientific Company, P.O. Box 1192, Corinth, Miss.

UNDERWATER Fuse 3/32" diameter, 25 feet \$1.00 postpaid. Rigley, Box 138-F, Addison, Mich.

FREE Science catalog. Chemicals, glassware, physics, biology. Frey Scientific, 273 Orange, Mansfield 1, Ohio.

CHEMICALS, Apparatus, Biology, Catalog 35¢. Mid-States Scientific, 7053 N. Clark, Chicago, Ill.

UNUSUAL Chemistry books, courses, kits! Rare chemicals, cheap! Catalog 25¢. NSC, Box 11133, Palo Alto, Calif.

FORMULAS, PLANS, ETC.

LATE. Modern manufacturing formulas. List free. Moon Chemical, Martville, New York.

FORMULAS—All kinds. Amazing big catalog. 10¢. Kemixal, Park Ridge, Ill.

FREE Folders fully describe our many hundreds of formulas and plans for home-work and profitable small-business enterprises. Western Chemicals, Box 19718-C, Los Angeles 90019.

FREE Formula book. 96 pages! Bell, 210 Pine, Melbourne, Florida.

FOR Proof of what you can do in specialty manufacturing get our literature. It's free! Miller, Chemist, 1517-P, Tampa, Florida.

PLASTICS

PLASTIC Embedders, jewelry workers. We have everything. Findings, moulds. New catalog 25¢. David Co., 20 Garden St., Dept. M, Providence 3, R.I.

BOXES, Plastic. 200 sizes. Free list. Althor, 2301 Benson Ave., Brooklyn, N.Y.

FREE Brochure on new casting resin. Cat. 25¢. Castacast Corp., Box 555, Palo Alto, California.

NOW! Laminating sheets and supplies. Burr, 7645 Oakland, Kalamazoo, Michigan 49002.

NEW Liquid casting plastic clear colors. Embed real flowers, butterflies, photos, coins. Send 25¢ for two handbooks. "How to Cast Liquid Plastics" and "How to Make Extra Money at Home." Castolite, Dept. 101P, Woodstock, Illinois.

EXPORT — IMPORT

AT Last! Switzerland's fabulous Vito-Rapid electric shaver—\$5.95 postpaid. Two year guarantee. Universal Associates, Box 550, Colorado Springs, Colo.

GOVERNMENT Loans how and where to get. The U.S. Government will lend you up to \$350,000.00 for business purposes. Also export-import loans and insurance. For complete information send \$1 to Box 7414, Dallas, Texas.

BUY IT WHOLESALE

ELECTRIC Guitars, amplifiers, wholesale. Free catalog. Carvin PMW, Covina, Calif.

NEW 6-color deluxe below wholesale catalog. Automobile catalog and others. Furniture, clothing, housewares, appliances, refrigerators, freezers, washers, dryers, televisions, radios, luggage, binoculars, hi-fi, stereo, phonographs, recorders, cameras, projectors, musical instruments, sporting goods, toys, tools, typewriters, watches, jewelry. Huge discounts on thousands of name brand items. For free specimen list of actual factory prices—postcard: Selbyco —5, Decatur, Illinois.

BARGAINS! Buy wholesale! Save money! Free catalog! Norris, 273-AH Merrick, Lynbrook, N.Y.

FREE! Name brands catalog! Your own high profit business. Sell name brands, full or part time. No inventory, no investment. More than 2,000 name brand items; lowest wholesale prices. Watches, jewelry, cameras, hi-fi, stereo radios-phonos, appliances, housewares, hardware, power tools, luggage, musical instruments, garden equipment, sporting goods, toys, many others. 8 floors of name brands. Million dollar inventory. Orders shipped complete in 24 hours! Send for free, beautifully illustrated catalog now! Separate wholesale price list. H. B. Davis Corp., Dept. PM, 145 W. 15 St., New York 11, N.Y.

USED And new watches \$2 up. Free list. Southern Watches, 5-PM So. Wabash, Chicago 3.

BARGAINS! Buy wholesale and below! Appliances, furniture, sports equipment, television, cameras, watches, jewelry, thousands more. Name brands. Also new cars at huge discounts up to \$1,000. All makes. Free details. Worldwide Bargain Hunters, Box 730-A, Holland, Michigan.

100,000 PRODUCTS Wholesale! Terrific bargains! Wholesalers, 1265-MR Broadway, New York, N.Y.

TRAIN SETS—\$1.36, Pistols—\$5.74, Hair Dryers—\$1.40, Walkie-Talkies, Binoculars, Watches. Buy from 685 American, European, Japanese Wholesalers. Exciting Details Free. Enterprises, Box 160-X7, Jamaica 30, New York.

400,000 ITEMS, Details free. Pat, 270 E. 60th St., Hialeah, Fla. 33012.

WORLD'S Largest wholesale supply. Buy from 679 American, European, Japanese wholesalers. Tailormade suits from Hongkong. 123 dropship catalogs. Rockbottom prices. Free details. International Buyers, 216-M Jackson, Chicago 6, Illinois.

SPECIAL SERVICES

NEW! Easy tax bookkeeping records for small business. Avoid tax messes! Order today. \$9.95 postpaid. Oneida, 509-A Fifth Avenue, New York.

WE Permanize (Plastic Laminate) to protect forever your photos, awards, documents, passes, clippings, announcements, identification cards, papers, etc. Send \$1 with each item. Guaranteed, item returned immediately. King's, Box 3295 Grand Central Station, Glendale, California.

PORTABLE Cases. Designed, manufactured your specifications. Free estimates, brochure. R. Durst (CCA), Waynesboro, Penna.

LOCATING Service! Any item or product. Jake Barraco, 478 Gardner, South Beloit, Illinois.

ARCHITECTURAL Drafting service home builders—lumber dealers—realtors—we will take your rough sketches and make finish drawings from them. Absolutely professional results! Engineering Services, Box 2933, Fort Wayne, Indiana.

EDUCATIONAL AND INSTRUCTION

SWEDISH Massage. Foot technique. Post graduate. Home study. Residential. Diploma. Dr. Swanson's Illinois Licensed School, 3809-PL Alta Vista, Chicago 13.

PENMANSHIP Corrector. Improve poor penmanship quickly. Details free. Ozment, Box 665-34, St. Louis 88, Mo.

MEN Wanted. Earn \$125 a week and up. Master a trade with a future. Learn auto diesel mechanics in our shops. You learn with tools on real equipment. Earn while you learn. Many of our graduates earn \$125 a week and up. Write for free bulletin: Dept. 256, Auto Diesel College, Nashville 3, Tenn.

AIRLINE Careers. Adventure! Prestige! Four-week course, men 18-35. Airline-trained teachers. Free placement service. 20th year. Catalog B. McConnell Airline School, 1030 Nicollet, Minneapolis, Minnesota.

LEARN Asleep or awake! Records, tapes, equipment! Free catalog! Drawer PM-697, Ruidoso, New Mexico.

GET A British degree. Divinity, Philosophy, Radionics. 35 courses. Prospectus free. Brantridge Forest School, "Lodge" Brantridge Forest, Balcombe, Sussex, England.

BOOKKEEPERS. Operate your own "Dollar-A-Week" system. Ellis, Box 200, Cedar Grove, North Carolina.

PIANO Tuning pays. Big money in spare time. Learn at home. No musical knowledge necessary. Phonograph, records, tools and instructions furnished. Electronic tuning also taught. Free catalog. Capital Tuning School, 3160 S.W. 16th Court, Ft. Lauderdale, Fla.

MISSOURI Auction School. Free catalog! 1330-03 Linwood, Kansas City, Mo. 64109.

WANT A diesel career? Higher pay? Advancement? We can help you qualify! Complete diesel, tractor and heavy equipment and Cummins diesel engine shop-method home-training courses available. Write today. Interstate Training Service, Dept. B-3, Portland 12, Oregon.

USED Courses! Books! List 10¢. Smith's, 124 Marlborough, Salem, Mass.

FCC License in 6 weeks. First class radio telephone. Results guaranteed. Elkins Radio School, 2603D Inwood, Dallas, Tex.

WOODWORKING And cabinetmaking course for beginning and advanced home craftsmen. Only complete low-cost home training program available. Write for free booklet. Interstate Training Service, Dept. G-3, Portland 12, Ore.

MANAGE Motel or resort. Men, women, couples, can make high salary plus apartment. Pick your own location with our employment assistance. Learn at home. Free booklet. Motel Managers Training School, Dept. PMC-124A, 612 So. Serrano Los Angeles 5, California.

OWN Collection agency. "Little Gold Mine!" Franklin Credit, Roanoke, Virginia.

HIGH School diploma at home. Licensed teachers. Send age, highest grade completed for free details. No salesman will call. Southern States Academy, 235 Ponce de Leon, Decatur, Georgia.

WRITE Well. With amazing new penmanship book. Details free. T. Tevis, Chillicothe, Mo.

HOW To train horses. A book everyone who likes horses or ponies should have. Free. No obligation. Simply address Beery School, Dept. 11012-C, Pleasant Hill, Ohio.

SPEAK. Sing with power. Self-training records. Canfield, 2018-A Fifth Avenue South, Minneapolis 4, Minnesota.

TRIGONOMETRY New invention, simplicity itself. Details. Ken Swayze, Box 772, Imperial Beach, California.

SWEDISH Massage and Physical culture pays big profits. Learn at home. Diploma. Free catalog. National Institute, Dept. E124, 307 North Michigan, Chicago 1.

LEARN Auctioneering. Term soon. Free catalog. Reisch Auction College, Mason City 1, Iowa.

WRITERS Wanted for magazines, Television, newspapers, motion pictures. Easy to learn home-study course shows you how to write and sell stories. Free lesson, revealing book, aptitude test, confidential directory of publishers that pay profits. Write: Palmer Institute, 941-AZ-N, Highland, Hollywood 38, California.

NEW Experimental offer, limited time. Learn special investigation, free information. International Academy of Police Science, Box 314, Oklahoma City, Oklahoma.

AUTOSUGGESTION. Sleep-learning headquarters! Tapes, records, books. Gigantic catalog free. Research Association, Box 24-PM, Olympia, Washington.

SECRET Investigations. Experience unnecessary. Investigators particulars free. George Wagner, M125 West 86th, New York City 24.

MONEY BACK GUARANTEE—C.I.S.T.—The World Wide Institute of Home Study—34 global centres—260 courses—Engineering, Electronic, Academic and Commercial—send for your FREE 100 page copy of "Career Opportunities" today—No salesman will call. C.I.S.T., 624 Garden City Building, 263 Adelaide St. W., Toronto, Canada.

PROFITABLE National Camera Repair School training at home! PM5, Englewood Colorado.

DETECTIVE Training. Robert B. Phillips, Sr., Founder, Former Govt. Special Agent. For free information write to 1917F North Kenneth Ave., Chicago, Ill.

FINISH High School at home. No classes. Texts furnished. Diploma awarded. If 17 or over and have left school, write for free information and booklet. Wayne School, Dept. 36-509, 417 S. Dearborn, Chicago, Illinois 60605.

LEARN Technical metaphysics—The ancient masters method of healing. Easy to learn, inexpensive. For free details write to: Premier College of Technical Metaphysics, P.O. Box 95, Ucluelet, B.C., Canada.

COLLEGE Diplomas can be obtained, from famous universities, thru spare time home study. Details \$1.00. Academic Advisory, Box 118, Ridgewood, New Jersey.

PIANO Tuning quickly learned with home study course. Diploma granted. American Tuning School, Gilroy, Calif.

LEARN Civil and criminal investigation at home. Earn steady, good pay. State age. Institute Applied Science, 1920 Sunnyside, Dept. 169, Chicago 40, Illinois.

BE A real estate broker. Insure security for yourself and your family. Study at home. Prepare for state examination. Write for free book today. Weaver School of Real Estate, 3519-P Broadway, Kansas City, Mo. 64111.

ROSICRUCIAN Secret Teachings are offered to those who seek to use them for the perfection of their inner faculties and in the mastering of the daily obstacles of life. The Rosicrucians, an international group of thinking men and women, will be happy to send a Free copy of the fascinating book, "The Mastery of Life," to those who believe worthiness and sincerity determine the right for one to have such knowledge. Let this book guide you to the conservative plan whereby you may widen your scope of Personal Power. Simply address your request to Scribe E.R.Z., The Rosicrucians, San Jose, California 95114.

HIGH Grades and a giant vocabulary! Satisfaction or refund. \$1.00. Reilly, Box 7393-V, St. Louis, Mo. 63177.

RADIO Course only \$14.95. Free catalog. Edu-Kits, Department 613B, Hewlett, New York 11557.

HEAVY Equipment repair. 640 page illustrated book, gives basic instruction, helps train good mechanics. Includes questions and answers. Satisfaction guaranteed. \$12.50. Northcastle Books, Dept. PM, 212 Bedford Road, Greenwich, Conn.

DETECTIVE Training, home study, credentials. Civil Investigative Training, P.O. Box 249, Lockhart, Florida.

TEST Your ability to pass a Civil Service examination. Prats, 1712 Michigan Ave., Kenner, La.

ATTEND The nation's finest. Write Galion Welding School, Galion, O.

MATHEMATICS For shop or office. Study at home. Belton School, 8842 Grand, River Grove, Ill.

EARN Valid college degree by examination and/or instruction through correspondence. Bretton Woods University, 3936 East 10th Street, Indianapolis, Indiana.

MASTER Watchmaking at home. Free sample lesson. Chicago School, Dept. YM, Fox River Grove, Illinois.

SKELETONS—Human. Excellent for study or teaching. Details 15¢. Friedmann, 1225 Jefferson, Vandalia, Illinois.

SHORTHAND In four days. 2 book set \$2.98 postpaid. National, Box 7112, Washington, D.C. 20004.

FOREIGN Language aid. 300 household words on adhesive labels. Specify, French, German, Spanish \$1.00. Labels, Box 102, Lathrup, Michigan 48037.

ABC'S Of bookkeeping \$1.98 postpaid. National, Box 7112, Washington, D.C. 20004.

INVESTIGATOR'S Course, Credentials, diploma. Free information. Southwestern Institute Criminology, Box 201, Geronimo, Oklahoma.

PLAYS, STORIES, MANUSCRIPTS

WANT Your book published? Learn how we publish, advertise, promote, distribute. Many successes. Free booklet PM, Vantage, 120 West 31, New York City.

ADVERTISING AGENCIES, ADV. SERVICE, MAILING LISTS

ADVERTISING Ratebook leading newspapers, magazines, free. Chicago Advertising Agency, 28-E Jackson, Chicago 4.

MAILORDER Thermodynamics. Tangible, intangible merchandise, services. Passion Flower, P.O.B. 7001, Cleveland, Ohio.

FREE! Redhot book, "More Profit From Your Advertising." Includes best mailorder magazines, newspapers. Adservice, 11730 NW 22 Court, Miami, Florida 33167.

MAILING Lists most all kinds 1000 \$5.00. Free folder. Your circulars mailed \$4.00 1000. Dixie Mailers, King, N.C.

MAILORDER Record Book, 30 pages. Records inquiries, orders, advertising expense, etc. Most complete. Just send dime for postage and handling. C. A. Martin, Popular Mechanics, 575 Lexington Ave., New York, N.Y. 10022.

TYPEWRITERS, DUPLICATORS, OFFICE DEVICES

OFFSET, Letterpresses, vartypers, typewriters, mimeograph, multigraph machines. Bargains. DixieGraph, King, North Carolina.

RUBBER STAMPS AND OFFICE SUPPLIES

FREE 32 Page rubber stamp catalog. Signature stamps \$3.50. Youngers Stamp Shop, Princeton, Iowa.

POCKET 3 lines \$1.00. Office stamps \$1.50. Free catalog. Specialty, 8464 Manhattan, Detroit, Mich. 48211.

FREE Catalog: Rubber stamps, printing. Dowling Products, Dept. PMB4, Pittstown, N.J.

RUBBER Stamps, 3 lines, \$1.50. Free catalog. Tabco, Tomkins Cove, New York.

STAMP Makers' supplies. Lowest prices. O'Brien's, 421 Jackson, Toledo, Ohio 43604.

STAMPS, Business cards, stationery embossers. Evero, Box 9233, Phoenix, Arizona 85020.

THREE Line quality rubber stamp, 90¢. Script or block type. Rex, Aliquippa, Pennsylvania, 15001.

CARTOONING, COMMERCIAL ART, SHOWCARD & SIGN PAINTING, TATTOOING

LEARN Profitable magazine cartooning. Free details. Hartman, Box 3097, Lincoln 10, Nebraska.

YOU Can entertain with chalk talks. Catalog 10¢. Balda the Cartoonist, Oshkosh, Wis.

SIGN Painting. Fascinating system. Straley, 410 South Western, Springfield, Ohio.

ART Lessons \$6.00 a month. Includes drawing, painting, advertising art. Art kits (worth \$25) and materials. Assignments corrected, with overlays, by mail and returned to you. Write for free book. No obligation. Washington School of Art Studio 14X12, Port Washington, L.I., N.Y.

SIGN Painting—Instruction, brushes, equipment, paint. Free catalogue. Kaufmann Supply, Centertown, Missouri.

"HOW To Make Money With Simple Cartoons"—A book everyone who likes to draw should have. It is free; no obligation. Simply address Cartoonists' Exchange, Dept. 912, Pleasant Hill, Ohio.

LEARN Profitable, fascinating tattooing. Illustrated information \$1.00. Zeis, 2220-C Delcy Drive, Rockford, Illinois.

PAINT Signs! Using patterns! Trial alphabet \$1.00. Harwell's, PM-1264, Byrdstown, Tennessee.

LETTERING—Learn professional tricks! Speed methods! Free literature. Harris, P.O. Box 1567-R, Portland 7, Oregon.

ARTISTS And photographers—sell your pictures—to \$500.00 each. Free information. Write Amerpic, Box 1469, Beverly Hills, California.

LEARN Sign painting at home. Free talent test. Ben Kerns, Box 812-PM, Greenville, S.C.

PRINTING, MULTIGRAPHING, MIMEOGRAPHING, GUMMED LABELS

BUSINESS Printing. Catalog free. Bill's Press, 538-P Leffingwell, Kirkwood, Missouri 63122.

AMAZING Business printing values. Samples. Print Shop, Box 576, Greenville, R. I.

QUALITY Printing: lowest prices. Samples. Dowling Products, Dept. PMB4, Pittstown, N.J.

250—8 $\frac{1}{2}$ x11 HAMMERMILL Letterheads \$2.75, 250 envelopes \$2.50. Samples. Patton, Box 248R, South Haven, Mich.

PRINTING—8 Page Catalog—1 $\frac{1}{2}$ ¢ Free Price List. Kopen, 288 Atlantic Avenue, Brooklyn 1, N.Y.

OVERNIGHT Offset, 8 $\frac{1}{2}$ x11, 100—\$2.20, 1000—\$5.50. F.O.B. Oliverprint, Romeo, Michigan.

MIMEOGRAPHING, Offset printing. Free samples. Pennway, Drawer 1340, Scranton, Penna.

STENCILS. Name and address or message \$1.95 maximum, 4 lines $\frac{5}{8}$ " characters (22 each line). Special Merry Christmas & Happy New Year, \$1.00. Ideal gift. Jeldell, P.O. Box 3381, Anaheim, California.

MANUFACTURE Rubber stamps of printing and drawings. \$14.95 outfit. Don's, 741 18th, Boulder, Colo.

250 BUSINESS Cards \$1. Distributing Company of America, Box 10023, Phoenix, Arizona.

OVERNITE Offset printing 1000 8 $\frac{1}{2}$ " x 11"—\$6.50. Postage extra. Evergreen, 9420 Trumbull, Chicago 42.

PERSONALIZED Stationery, \$2.50. Samples 10¢. Columbus, 719 East Pike, Seattle 98122.

1,000 BUSINESS Cards, embossed, \$3.95; two-color, \$4.95. Others. Samples, Decals. Bixler, 752 Benson, Frankfort, Kentucky 40601.

500 ZIP Code name and address labels 50¢. Postpaid. Printed with your name and address or any message up to 3 lines. So practical—use on envelopes, checks, stationery, etc. Order now! Clayton Company, 509—21st Avenue, San Francisco, California 94121.

FREE Gift with 1000 executive embossed business cards, \$4.49. Samples, (other printing bargains). Weaver, Dept. 41C, 3524 Northeast 118, Portland, Oregon 97220.

QUALITY Offset printing, 24 hour service. Your copy, 8 $\frac{1}{2}$ x11, 1,000—\$5.50 F.O.B. N.Y.C. Write for our complete price list. Biscayne Products, Box 346, New York 5, N.Y.

PRINTING & RUBBER STAMP OUTFITS & SUPPLIES

RUBBER Stamp outfits, supplies. Kiewiet, 2025 Barney Road, Kalamazoo, Mich.

MAKE Your own self-molding rubber stamps and printing cuts. Plexirubber, Argyle 1, Wisconsin.

RUBBER Stamp presses, hydraulic operated, electrically heated. Sizes 5" x 8", 8" x 12", 10" x 15". Starting outfits, supplies. Printing presses. Type cases and cabinets. Custom Manufacturing, 1464-P East Commercial, Springfield, Missouri.

90% PROFIT Rubber stamps. Complete outfit, \$99.95. Duckman, Avoca, Ark.

DO Your own printing. Save money. Simple rules. We supply everything. Print for others; good profit. Raised printing like engraving too. Have home shop. Details free. Kelsey Presses, V-11, Meriden, Connecticut.

PRINTING Presses, type, supplies, lists 5¢. Turnbaugh Service, Mechanicsburg, Pa.

HARD Type for rubber-stamp making, printing. Introductory offer 10 or 12 pt. 20th Century Medium Caps or L.C. \$2.50. Free catalog. Barco Type, 232 Evergreen, Bensenville, Ill.

FOR INVENTORS

PATENT Searches, including copies of related U.S. patents, \$6.00. Inventors, attorneys, manufacturers use my "world-wide" airmail service! "Invention Record" form and "Information Every Inventor Needs," sent free! Miss Hayward, 10299 Vermont, Washington 5, D.C.

U.S. Patent Office Searches, 234 Broadway, Room 3615, New York. Free invention certificates.

INVENTORS: Your ideas and inventions (patented; unpatented) expertly searched and developed for commercial appeal and cash royalty sales to manufacturers by professional Invention Developer with excellent record of experience. B.S., Industrial Engineering; U.S. Patent Office former Patent Examiner; U.S. Government former Patent Adviser. Second decade of reliable service! Free "Invention Record" and Important Information, Airmailed! Write: Raymond Lee, Invention Developer, 1606C Bush Bldg., New York City 36.

PATENT And invention development, by licensed professional patent engineer and U.S. Patent Office former examiner, and engineering specialists. Your inventions and ideas engineered for patent protection and commercial value. Inventions developed by us negotiated for cash or royalties with our nationwide contacts. Send for free protection "Invention Certificates" and further interesting, valuable patent information. George Spector, Licensed Professional Patent Engineer, Woolworth Building, New York.

INVENTORS—If you have an invention for sale, patented or unpatented, write for free brochure outlining manufacturer's requirements, Royalty rates. Kessler Corporation, C-512-F1, Fremont, Ohio.

AMAZING Guide: Sell your inventions. Excellent results. Galleon, 27 School, Boston, Mass. 02108.

PATENT Searches—48 hour airmail service, \$6.00, including nearest patent copies. More than 200 registered patent attorneys have used my service. For free invention protection forms, write Miss Ann Hastings, P.O. Box 176, Washington 4, D.C.

BETTER Patent services: profit from patents with good sales values and effective market protection by patent. I help inventors to have both at low definite fees: free self protecting forms give you security in disclosure; patents filed for \$200.00 up; foreign patents filed at very low cost. Forty years successful practice. Joseph O'Brien, Patent & Development Engineer, R 1127, Munsey Building, opposite U. S. Patent Office Washington, D.C. Patent searches made for \$7.50, with references.

PROFESSIONAL Patent searches, \$6.00, including official U.S. Patent Office copies of related U.S. patents! Prompt, dependable service. Certified, airmailed! For free "Invention Record Folio" and important patent information every inventor should have, write: United States Inventors Service Company, 1311 "G" Street NW, Washington 5, D.C.

SAVE High fees! Prepare your patent application yourself! New "Do-It-Yourself" patent kit now makes it easy! Free "Registration Form." Miss Blaine, 306A Carry Building, Washington 5, D.C.

INVENTIONS WANTED

INVENTIONS Wanted. Patented; unpatented. Tremendous manufacturers lists. Global Marketing Service, 2420G 77th, Oakland 5, California.

INVENTIONS Needed immediately for manufacturers. For additional information write Kessler Corporation, C-512-1W, Fremont, Ohio.

INVENTORS Wanted: Manufacturers need new items! Your inventions, ideas developed for cash royalty sales. Free "Invention Record"; Information, Raymond Lee, 2114B Bush Building, New York City 36.

MANUFACTURING

WIRE Forming progressive dies, send print, part sketch, short run turning. B. L. Tool & Die, 413 26th St., Union City, N.J. B. Lindberg, prop.

MODELS—Small lot manufacturing. Metals, plastics, etc. Milburn, Burlington, Kentucky.

MODELS—SHIPS, TRAINS, PLANES, ETC.

SHIP Models. Kits, fittings, plans, books, tools, engines, motors. Big illustrated catalog 50¢. James Bliss & Co., Dept. SM, 342 Atlantic Avenue, Boston 10, Massachusetts.

TRAIN Bargains: 25¢ brings catalogue of 2000 Gilbert, Lionel, Atlas, etc. Bargains—all gauges. Also Strombecker, Aurora, Eldon and other slot racer parts. Hobby Surplus, P.O. Box 1106M, New Britain, Conn.

ROCKETS: New illustrated catalog 25¢. Single and multistage kits, cones, engines, launchers, trackers, technical information, etc. Fast service. Estes Industries, Penrose 2, Colorado.

ALL American, steam engines, tractors, boilers, fittings, castings. Catalog manual \$1.25. Tiny Power, Junction City, Oregon.

AMAZING Adaptor! Sprayer converts your model engine to air-compressor, many uses. (only \$5.95) Send 25¢ for details. G. Hobby Products, Dept. C, 271 E. 10 St., N.Y.C.

SHIP Model kits and fittings: clippers, frigates, etc. Catalog paint-tool list, book list, 35¢. Model Shipways, Box 85, Bogota, N. J.

LIVE Steam models. Castings and machined kits. Marine, walking beam, mill engines, boilers. From \$7.45. Pictured catalog 40¢. H. P. K. Models, Box 34, Centuck Station K, Yonkers, New York.

LIONEL Trains bulletin 10¢, catalog 25¢. Mack Bros., 2043 Chicago Ave., Chicago 60622.

CIRCUS Wagon kits, catalog 35¢, animals, wild, domestic, cat. 50¢. "Old West" wagon kits, lit. 10¢. Walters, 207-PM French, Utica, New York, 13502.

WHITE Heat V, trophy winning, miniature racing hydroplane. Blueprints, kits, engines, propellers, fittings for this, other radio controlled boats. Free literature for stamped, self-addressed envelope. Ocutura Models, 8148 N. Milwaukee Ave., Niles, Illinois 60648.

SHIP and yacht model fittings: Pine construction hull kits; blueprints. Send 50¢ for illustrated catalog. A. J. Fisher, Inc., 1002 Etowah Avenue, Royal Oak, Michigan, 48067.

HOME CRAFTSMEN

PLANS. Bird houses and feeders. Illustrated catalog 25¢ coin. F. Yeager, 1665 Linden Road, Homewood, Illinois.

WOODWORKING Catalog and manual 25¢. World's most beautiful veneers, lumber, plywood! Wood finishing, upholstery supplies. Furniture hardware. Tool bargains! 2,000 needed workshop products. Constantine, 2051-T, Eastchester Road, Bronx 10461.

FREE "Do-It-Yourself" Leathercraft Catalog. Tandy Leather Company, Box 791-Y51, Fort Worth, Texas.

FREE! Big 80 page Leathercraft catalog. 100's of new items! MacPherson Bros., Dept. K, 730 Mission St., San Francisco, Calif. 94103.

SKIL-CRAFTS New '64 catalog. Largest and finest selection of leathercraft, artist, hobby-craft supplies in the world. Free gift with first order. Send 50¢. Refundable with first order. Skil-Crafts, Box 105-P, Joplin, Missouri.

KNOCKDOWN Cedar chests, also over fifty kits. Catalog 25¢. Giles Kendall Co., Huntsville 2, Alabama.

MAGNETIC Door and drawer latches. Automatic towel holders. Thermometers. Novelties. Grand H Specialties, Boston 14, Mass.

BUILDING Materials— $\frac{1}{4}$ " & $\frac{1}{8}$ " scale windows, doors, siding, roofing, lumber and structural shapes. Send 35¢ for catalog with samples. Small Sales Co., 8008 Floyd, Dept. PM, Overland Park, Kansas.

WOODWORKERS—Home craftsmen! Catalog containing lamp parts, veneers, lazy susan bearings, Swiss movements, chair cane, folding metal legs, wooden legs, mouldings, furniture hardware, finishing materials, etc., only 15¢. Barap Specialties, Box 2044-BO, Chicago 60609.

WALNUT. Cherry, silver maple, gun stocks, squares lumber, picture frame moulding. Midland Lumber Company, Box 262, Savannah, Missouri.

2512 PLANS. Patterns, things to make, do. Fun. Profit. World's greatest selection. New catalog 10¢. Craftplans, 18250-A Harwood, Homewood, Ill.

PLANS For pool table with extra two-face top for table tennis and model railroad. Blueprints B1209 and building instructions \$3.50. Popular Mechanics Service Bureau, 575-M Lexington Ave., New York, N.Y. 10022.

DO IT YOURSELF

BUILD Your own tractor plans. Free information. Eltraco, Department A, Camp-tonville, California 95922.

ELECTRIC Wiring, home course. Particulars 25¢. Felco, Box 532, Santa Rosa, Calif. 95403.

BUILD All metal wood lathe, stand. Blueprints \$1.00. Plans, Box 298-A, Excelsior, Minnesota.

GIFTS Hobbys mending free sample. Write: Mend Master, 4408 Sillman, Dayton, Ohio 45440.

EXERCISE At home on build-it-yourself physical fitness equipment, including bicycle exerciser, rowing machine, belt massager, and abdominal board. Send \$2.50 for blueprints B1208 and instructions. Popular Mechanics Service Bureau, 575-K Lexington Ave., New York, N.Y. 10022.

FREE Check-list covering more than 500 classifications of projects, plans, instructions, service and repair information detailed in Popular Mechanics famous series of instructional booklets, books, patterns, and blueprints. List covers an extremely wide variety of do-it-yourself data on home remodeling, repair and improvement, hobbies, crafts, boating, games, lawn and garden, and hundreds of others. For your free copy of this helpful list, write: Service Bureau, Popular Mechanics, 575 Lexington Ave., New York 22, New York.

WATCHES, OLD GOLD, JEWELRY

HIGHEST Cash—Gold, jewelry, diamonds, silver, platinum. Mail articles. Free information. Chicago Gold & Precious Metals, 6 E. Monroe, Dept. 1558, Chicago 3.

WANTED. Gold, silver, platinum, scrap (any form), coins. Information free. Wilmot's, 1067 Bridge St., Grand Rapids 4, Michigan.

WATCH And clock repairing books. Free catalog. North American, Box 77-AZ, Fox River Grove, Illinois.

WATCHES Overhauled \$4.00. Prompt service. A.M. Watch Repair, 10625 Chardon, Ohio.

MINIATURE Grandfather clock \$4.00 postpaid: Gitta, 23 Railroad, Maynard, Mass. 01754.

OF INTEREST TO WOMEN

HAND Operated sewing machine. Zig-zags, bastes, blind or straight stitches. Handy for vacations, visits, or home use. Fits in purse. \$4 to: Heavrin's Warehouse, Muldraugh, Kentucky.

NYLONACE 40 yards \$1.00. Buttons 800—\$1.00. Schaefer, Drummondville, Quebec.

GUARANTEED Printed stationery! Catalog, free offer! Baldridge, 105A W. Payne, Olney, Texas 76374.

AMAZING! New! Invisible thread. 2 spools 50¢, 6 spools \$1.00. Ber-Lop Company, 1877 East 12th Street, Brooklyn 29, New York.

LADIES! Buy rare perfume direct from Paris! Save over 30%! Two full drums only \$3.98 postpaid. Manlon H. Rissler Company, Route 2, New Holland 11, Penna.

50 DIFFERENT Mallorder publications—\$1. Menski, Box 1167, Memphis 3, Tenn.

ROUT Rapists with revolutionary new weapon. Free details. Branvold, 6725 Ran-chito, Van Nuys, Calif. 91405.

WOMEN! Make big money at home. \$10.00 profit in an hour possible with invisible mending. Make holes, tears disappear from clothing, fabrics. Steady year-round demand from cleaners, laundries, homes. Details free. Fabricon, 1533 Howard, Chicago 26, Illinois.

HOUSEWIVES. Teachers, students, office workers. If you need extra cash each week but household or other duties prevent you from taking a part-time job, learn how you can earn by accepting orders to Popular Mechanics, Good House-keeping and all other magazines. No experience needed. Write Popular Mechanics, Room 12W, 250 West 55th St., New York 19, New York.

TREASURE FINDERS

TREASURE. Gold, silver relics. Find them with new 1965 models. Free information. Rayscope, Box 715, North Hollywood, California.

NEW. Coin locator! Free literature! Howe, 811-C Kansas, Atchison, Kansas.

POWERFUL Metrotech locators detect gold, silver, coins, relics. Moneyback guarantee. Terms. Free information. Underground Explorations, Dept. A, Box 793, Menlo Park, California.

METAL Locator kits and assembled models from \$39.90. Terms. Transistorized models available. Free catalog. Electronic Applications, Dept. M, Box 6095, Alexandria, Virginia.

GOLD. Treasure, coin locator \$2.00 complete. Guaranteed. Treasures—3, Ashland, Oregon.

TREASURE. Find gold, silver, relics with super, powerful Detectron locators. Free information. Detectron, Dept. 12-PM, San Gabriel, California.

FUN & Profit finding buried treasure, relics with transistor M-scope. Booklet, interesting customer comments free. Terms. Fisher Research, Dept. AX, Palo Alto, California.

NEW Supersensitive transistor models detect buried gold, silver, coins. Kits, assembled models. \$19.95 up. Underwater models available. Free catalog. Relco-A40, Box 10563, Houston 18, Texas.

TREASURE Hunters, prospectors, beach-combers: pin-point exact location buried coins, relics, gold, silver with powerful metal locators. Free literature. Write: Goldak, Dept. B10, 1544 W. Glendoaks, Glendale, California 91201.

REMAILING SERVICE

CONFIDENTIAL New York City mail address \$3.00 month. Remails 25¢. Details free. Birnhan, 152 W. 42, New York City 36.

HAWAII Secret unadvertised address, receiving-forwarding. \$3.00 monthly. Remails 25¢ each. Souvenirs, postcards. Coe, Box 984, Kailua, Hawaii 96734.

INTERNATIONAL Remailing, Domestic 25¢. West, 22P Spruce Drive, Wilmington, N.C. 28403.

REMAILING 25¢. Monthly \$3.00. Details. Acosta, Box 4327, Tampa, Fla. 33607.

CONFIDENTIAL. Permanent. Bonded Notary Public. Remail 25¢ single. Mail forwarding Service, 8050 S. Main, Houston, Texas 77025.

MIAMI Remails 20¢. Monthly rates. Marie, Box 1266, Coral Gables, Florida.

SECRET Mail receiving system. Hedg-peth, 406-M South Second, Alhambra, California 91802.

NORWAY. Reairmail \$1. Regular 50¢. Adana, Box 168, Voss, Norway.

HOLLYWOOD Remailing 25¢. Monthly \$3.00. Paris, Montreal, Roux, 1350N, Citrus, Hollywood 28, Calif.

SECRET Mail! Confidential service system! Cox, 84 Chestnut, Saugus, Massachusetts 01906.

GREATER Kansas City area remails 25¢. Hubbard, Box 1, Paola, Kansas.

SEATTLE, Tacoma—30¢ per letter. Hitchcock, 417 North E. Tacoma.

ARIZONA Remails, 25¢, \$3.00 monthly. Marc, P.O. Box 125, Phoenix 85001.

FOREIGN Mail addresses, remailing, postcards, hotel stationery, souvenirs. Free brochure. Worldwide Mail Service, Box 1736, Denver 1, Colorado.

PROMPT Remails! 20¢, 2 months, \$4.00, 1 year, \$20.00. Todd, Box 416, Morgantown, W. Va.

ENGLAND, Confidential, reairmails, \$1.00. Sawyer, 61 West Parade, Rhyl, Flint.

PERSONAL

ONLY \$44.00 monthly repays \$1008.46 (thirty payments). Borrow \$100-\$1000 entirely by airmail. Write today. Bankers Investment Company, 67-A, Hutchinson, Kansas 67501.

BORROW \$1,233 Airmail! Repay \$54 for twenty-nine months. State licensed. Postal Finance, Dept. 17-H, Kansas City 1, Kansas.

AMAZING Gifts for mother and baby. Catalog free. Michael Boros, 822 Park Ave., Plainfield, N.J.

NEED Money? Borrow \$100-\$1000 by mail. Confidential, repay in 24 months. Free loan application. World Finance Co., Dept. TW-144, 620 Symes Bldg., Denver 2, Colo.

RUPTURED. Relief and comfort. No understraps, elastic or steel. Write Hand-Lock Products, Preston 4, Ont., Canada.

BIBLE Questions answered. Stamped envelope. Bylon, 17167 Bentler, Detroit, Michigan 48219.

INSTANT Spanish. Actual conversation. Free sample lesson. Ray, 68 River Route, Dept. L-1, Kingman, Arizona 86401.

SUBCONSCIOUS Conditioning remakes personality while you sleep. Free details. Sleep-Learning, Box 24N, Olympia, Washington.

YOU Can locate missing persons. Detailed professional Police Guide Now. \$1.95. Fuchs, Box 299, Valley Stream, N.Y.

WIPE Out all debts, clear credit. Proof free; American Advisor, Box 48337-B, Los Angeles, 90048.

HOME I.Q. test. Know your I.Q. Free sample. Test Center, Box 139, Fresh Meadows, N.Y. 11365.

LOANS By mail, \$100-\$1000. Anywhere. Confidential. Write Union Finance, Dept. PM, 222 W. Osborne, P.O. Box 7457, Phoenix, Arizona.

BORROW \$100 to \$1000 by mail. Quick, easy, private. No co-signers. Repay in 30 small monthly payments. For the amount you want write today to Dial Finance Co., 410 Kilpatrick Bldg., Dept. 12-001, Omaha, Nebraska 68102.

BIBLE Errors? Many! Send for free references. Frank Battle, Box 647-B, Dover, N.J.

HEMORRHOIDS—Strain relief. External device. \$6.87. Dr. Charles Hudson, Drawer 680, Easton, Pennsylvania 18043.

PRIVATE Address, remails 25¢, information dime. Horton, 68 Kensington, Greenville, South Carolina 29609.

DEBTS Pressing? Free yourself of debt. Clear credit. Free details. National Counselor, Harlingen 7, Texas.

FREE Catalog of quality gifts for that special occasion. Modern Items Co., 332 N. 81st, Seattle, Wn. 98103.

WIPE Out all debts—clear credit—Proof free; American Advisor, Box 38337-B, Los Angeles 90048.

INVESTIGATORS. Free brochure, latest miniature electronic surveillance equipment. Ace Electronics, 11500-P NW 7th Ave., Miami 50, Florida.

WANTED—MISCELLANEOUS

STAMP Collections, accumulations. Eagle Stamp Co., 2221 Romine, Pittsburgh 26, Penna.

FOR SALE, MISCELLANEOUS

BUY Direct from Hong Kong & Japan! Catalog, prices and information \$1.00. Phillips, P.O. 709, Arkadelphia, Arkansas.

AUTOMATIC Rafter computer. Dial hip, common, jack lengths instantly. Free literature. \$4.95 postpaid. Satisfaction guaranteed. Emmert, Box 221, Sycamore, Illinois 60178.

100 YEAR Calendar, \$1.00 ea. Keith's, 1319 North Sugar, Lima, Ohio.

HEARING Aid batteries wholesale. Free list. Habs, Box 51, York, Penna.

CHEMICALLY Cured rubber sealant—6 ounce navy kit for sealing windows, tanks, and boats. Special offer 6 units for \$3.90, regularly \$3.50 each. Box 931, Fort Lauderdale, Florida.

PAINTINGS—Original—From 9.95. Free literature. Northwestern, 639 Gough, San Francisco 2.

LOOKING For distinctive gifts? Direct from Mexico. Rush free booklet. Ledoux, Box 11126, Oakland 76, California 94611.

MISCELLANEOUS

YOUR Name sent to 1000 importers, publishers, mailers, wholesalers, etc. on our mailing list. Year \$1.00. Dixie Mailers, King, N. Car.

HEARING Aids \$28.95. Free trial. Terms. Cary-B Sales, Inverness, Fla.

BOOKS On antiques and their prices. Free circular! P. Warman Publishers, Uniontown, Penna.

RECEIVE Gifts, samples, magazines, catalogs, opportunities. 10¢. Directory, Adkins, Texas 78101.

CESSPOOLS. Septic tanks restored to newness by miracle crystal pellets. Free literature. Electric Sewer Cleaning Co., Aliston 34, Mass.

ORNAMENTAL Iron designs. Book of 1600 beautiful, practical designs for railings, columns, etc. Free literature. Cunningham, 3881 South 3200 West, Salt Lake City, Utah 84119.

LOANS By mail, \$100-\$1000. Anywhere. Confidential. Write Union Finance, Dept. PM, 222 W. Osborne, P.O. Box 7457, Phoenix, Arizona.

SEND Us wool for blankets. Free Literature. El Dorado Woolens, Eldorado, Texas.

BIRTH Certificates, Marriage Certificates, Diplomas! 2 blank forms \$1.00. Sample 10¢. Standard Forms, Box 7228-M, Washington 4, D.C.

GET Rid of debts—Immediate action. American Advisor, Box 48337-A, Los Angeles 90048.

FREE Wholesale catalog! 100,000 products. Tremendous discounts! Taylor Distributors, Newton 2, New Jersey.

CARVED Conquistador statue. Mexico. Over foot tall, \$5.00. Importes Internacionales, Box 6092, San Diego, Calif. 92106.

SUN-POWERED Cardboard cookstove. Reusable. \$4.98. Clevia, Box 8282, Lexington, Kentucky.

FREE Denture cleaner with denture repair kit \$3.98, or professional reliner kit \$4.98. Money back guarantee. Send M.O., check or cash. Homadent Company, Box 771P, Wayne, N.J.

TERRIFIC Values! Books—all subjects! Free lists. Hallows, 14 Drexel, Cahokia, Illinois.

CAPITAL. Finance, loans, grants, cash to start a business. Free details. Counselor, Harlingen 19, Texas.

ASTONISHING! New! Gift shopping Idea. Unbelievable—wholesale prices—membership—with full color illustrated catalog. Send \$1.00. Casa De Oro Gifts, P.O. Box 7394, Mobile, Alabama.

NEW Jiffy-Outs

End Broken Screw and Bolt Problems

\$3.98 ppd

Broken screws and bolts come out in a jiffy! Drill hole in broken screw or bolt shank. Insert Jiffy-Out. Left hand thread removes screw or bolt in a jiffy. Kit includes: • 3 Jiffy-Outs • 3 drills • 1 wrench

Taprite Screw Assortment
SEE YOUR DEALER or send check or money order to:

CAMCAR SCREW & MFG. CO.
Dept. J, 600 18th Ave., Rockford, Ill.

a **Textron** company



DEALER INQUIRIES INVITED

ALL PURPOSE GLUE KIT \$1.00

POST PAID

LEECH ADHESIVE

LEECH GLUE KIT contains Adhesives for wood, paper, fabrics, rubber, glass, leather, pottery—regular size packages \$1.00 postpaid. Send your Dealer's name and address.

LEECH PRODUCTS, INC., HUTCHINSON, KANSAS

GEM MAKING KITS

NEW! Combination CABOCHON UNIT #63
It saws-grinds-sands-polishes
Delivers complete with:
1-6" Diamond Saw Blade
1-6" 100 grit grinding wheel
1-6" 220 grit grinding wheel
1-6" felt polishing buff
1-pulley . . . oilite bearings
\$77.25 ppd, less motor - includes belt. Nothing on market like it—at near its low price.

MODEL A (not shown)
Complete Gem Making Kit for the beginner - \$37.50 ppd, accessories included.
Write for literature:

A. D. McBURNEY - Dept. A124, 1610 Victory Blvd., Glendale, Calif. 91207



**Theodore Sturgeon, noted science fiction writer, says:
 "When it's fix—not fiction—I use Duro-Plastic Aluminum"**

Winner of the International Fantasy Award, writer Theodore Sturgeon says: "Whether it's fixing toys for my children or making repairs around the house, I find Duro-Plastic Aluminum the most versatile and effective fix-it product in my workshop. It saves time, money and peace of mind."

There are thousands of satisfied users like Mr. Sturgeon. Here's why: A good aluminum putty like Duro-Plastic Aluminum is made with Alcoa® Powders. It fills, seals, solders—adheres to virtually any surface. This means you can make hundreds of quick, economical repairs in your home, car or boat.

Users report that aluminum putties adhere to metal, wood, concrete, glass, even hard plastics—are not affected by water, oil or gasoline—can be burnished to a high luster, or painted.

Duro-Plastic Aluminum, a product of Woodhill Chemical Company, Cleveland, Ohio, is stocked by dealers everywhere. Try a tube today. You'll be back for more.

Alcoa does not make aluminum putties, but Alcoa Aluminum Powders are used in the best brands. For more information, send coupon.

Aluminum Company of America
 870-M Alcoa Building, Pittsburgh, Pa. 15219
 Please send more information about fillers and sealers made with Alcoa Aluminum Powders.

Name _____
 Address _____
 City _____
 State _____ Code _____

Alcoa Brings You America's Finest News Show...
 THE HUNTLEY-BRINKLEY REPORT, on NBC-TV



★ NOW HEAR THIS —
SPECIAL CHRISTMAS OFFER
FROM HALLICRAFTERS ★

FREE
HEADSET
WORTH \$5.00

when you buy
the famous S-120
4-band short wave/AM receiver
for just \$69.95!



hallicrafters

Dept. 7, 5th & Kostner Aves.
Chicago, Ill. 60624
Send details of headset offer and
16-pg. FREE booklet immediately.

Mail coupon
today for
details of
offer plus
FREE 16-page
booklet
on SWL!

NAME _____

ADDRESS _____

CITY _____ STATE _____ ZIP _____



Can do DOZENS of Fastening Jobs in Home
and Shop FASTER • EASIER • BETTER

"POP" RiveTool and "POP" Rivets replace adhesives,
nuts and bolts, screws, brazing, soldering, ordinary
rivets. You set rivets in seconds without
anvil or hammering — from one side
only — and make neat, professional
fastenings every time.

Great NEW "POP" RiveTool Kit
features new RiveTool with interchange-
able nosepieces for setting 1/8" steel or
aluminum and new 3/16" aluminum
"POP" Rivets. Spring-return handles
feature comfort-proved design and slid-
ing button lock. ONLY \$5.95 with "POP"
Rivets and back-up plates.



FASTENER DIVISION
United Shoe Machinery Corporation
2262 River Road, Shelton, Conn.

See Your Local Hardware Dealer for a Free Demonstration

REVOLUTIONARY NEW PATENTED
**ADJUST-A-BOX
WRENCH**

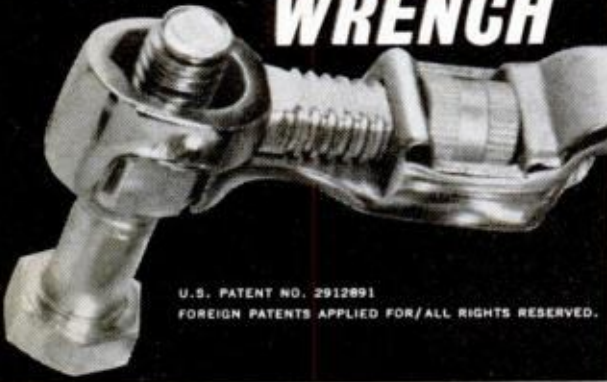

U.S. PATENT NO. 2912891
FOREIGN PATENTS APPLIED FOR/ALL RIGHTS RESERVED.

A COMPLETE SET OF BOX WRENCHES IN A SINGLE TOOL
Patented adjustable box wrench with non-slip 4 sided
grip fits all hex nuts... U.S. and foreign sizes. Does
work of 8 double-end wrenches or more than 16 sockets.
Needed by anyone who uses tools.

MADE
IN
U.S.A.

TRY ADJUST-A-BOX TODAY AT HARDWARE,
AUTO SUPPLY STORES... WHEREVER TOOLS ARE SOLD!

8" model adjusts from 1/4" to 1".....\$3.98
10" model adjusts from 3/8" to 1 1/4".....\$5.95
12" model adjusts from 7/8" to 1 3/4".....\$7.95

Adjust-A-Box wrenches are drop forged...chrome plated...fully guaranteed by

NEFF ENTERPRISES, INC.

1575 West Rialto Avenue, San Bernardino, California 92410

CUT-TO-FIT HOMES SAVE LABOR COSTS UP TO 100%

Save labor cost up to 100%, reducing
completed home cost. You can assemble any of 57
designs from easy-to-follow plans. No measur-
ing or cutting... every piece precision ma-
chine pre-cut and marked. **BUY DIRECT
FROM MILL.** Eliminate all between
overhead, profit and labor

PRICED FROM \$2295 UP

Prices do not include car-
pentry labor, heating,
lighting, plumbing and
masonry materials.
FIVE EASY-PAYMENT PLANS,

THIS
HOME
\$6535



costs. Nothing to plan or figure. Complete with all lumber,
hardware, paint, nails, glass, roofing, etc. Sterling Home
quality material throughout. Freight paid most areas.

Write today. Send 25c for illustrated, color catalog,
floor plans and details.

**CHOICE OF
57 DESIGNS**

INTERNATIONAL MILL & TIMBER CO. Bay City, Michigan, DEPT. PM124

POPULAR MECHANICS



THIS IS A GM ORIGINAL

(It comes in a GM car)



THIS IS A GM REPLACEMENT

(It goes with GM service)

You can't tell the difference—and neither can your GM car or truck.

You see, GM replacement bearings are like *all* GM replacement parts.

They're built to the tough specifications of the people who built the original. They're built by those same people to fit and work just like the original. And they're built to help GM cars

and trucks keep their genuine GM performance longer.

If that makes sense, doesn't it also make sense to ask for genuine General Motors parts next time you go in for service? You can find them in their distinctive new GM or United Delco packages in most service outlets and just about anywhere you drive in the country.

GENUINE GENERAL MOTORS PARTS



CHEVROLET • PONTIAC • OLDSMOBILE • BUICK • CADILLAC • GMC TRUCKS

United
Delco





YOUR CHOICE OF THESE TOP GIFT VALUES. NEW 26-PIECE BLACK & DECKER U-123 3/8" DRILL KIT for the previous price of the drill alone. Powerful 3/8" drill with true double reduction gears for tough jobs at home, in the shop, on the farm. Drives all 3/8" B&D accessories. Includes 3 drill bits, wire brush, arbor, rubber pad, lambswool pad, 15 sanding discs, grinding wheel, handy steel case. **\$19.88***

No. 1 Man Gifts from Black & Decker...

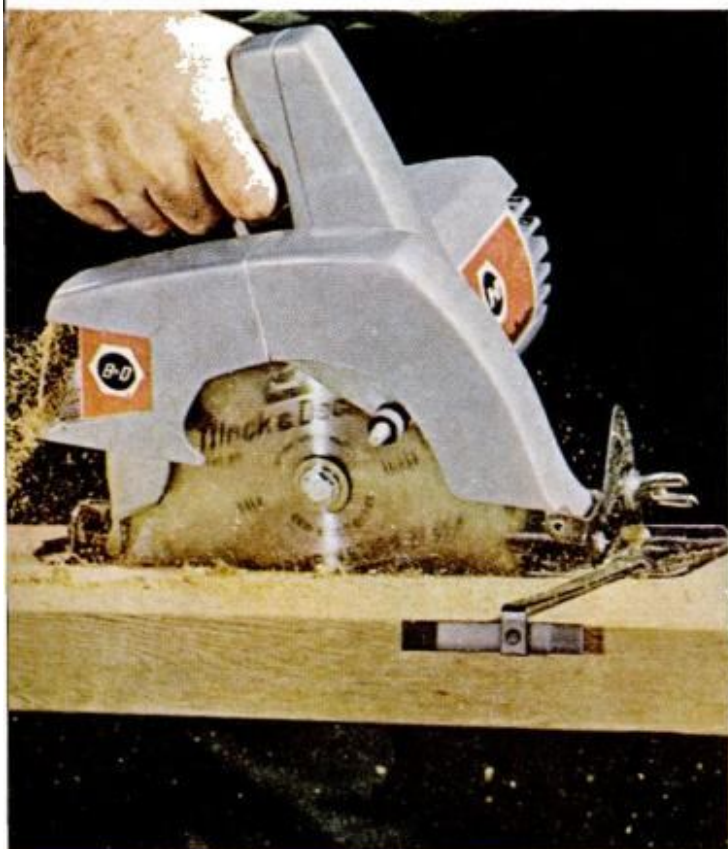

NEW BLACK & DECKER U-130 is a full 7 1/4" saw for the price of a 6 1/2". 4,400 RPM. 9 Amps. Rugged aluminum housing. King-size shoe. **\$29.88*** Over-size fan. Perfect heft. Rip fence.



GREAT NEW BLACK & DECKER U-202 DELUXE 1/4" DRILL. Needle bearing for more go, long life. Powers all B & D 1/4" accessories. (B & D Drill Accessory Kit—22 pieces for only \$3.98.) **\$14.88***

*At most stores. Prices slightly higher in Canada. Ask about convenient terms. For nearest Black & Decker dealer, check Yellow Pages under "Tools—Electric." Or write: Black & Decker, Dept. D-124, Towson 4, Maryland. защитный авторским правом



ALL NEW BLACK & DECKER U-140 SANDER. Sands flush front or side—in corners. 25 square inches sanding surface. Less vibration. Runs cool. Dustless attachment optional. **\$19.88***

NEW BLACK & DECKER U-151C JIG SAW KIT at low price. Saws circles around anything in its class—in wood, metal, plastics. Handy steel case, 3 blades, wrench. **\$19.88***

..make you an Instant Expert

ALL NEW DeWALT MODEL 1100 HOME SHOP HAS EVERYTHING, BUILDS ANYTHING. "See my new right arm!" says Johnny Unitas. The DeWalt Home Shop finishes a room and furnishes it with built-ins, tables, cabinets—the works. It's a cinch to operate. More fun. Saves you hundreds of dollars, too. Yet this new DeWalt has the features, accuracy, rigidity, versatility you'd expect only from DeWalt. Complete free Be-A-Pro Instruction Course. Ask about trades, terms and specials.

WIN A FREE FORD MUSTANG. It's easy. See your DeWalt dealer for full details—and be sure to get a demonstration of the new DeWalt Home Shop **\$159.95*** at this amazing low price.

WHAT'S THE LAST WORD IN WORKSHOP DESIGN? This is it — a 16-page booklet with complete plans as actually shown in the "House of Good Taste" at the New York World's Fair. Just send 50¢ to Black & Decker, Dept. D-124, Towson 4, Maryland.



Johnny Unitas, Baltimore Colts



Expect the best from
Black & Decker®

NEW FROM MARX! MOTOR SOUNDS!

PLUS 25 OTHER REAL-LIFE FEATURES
IN THE WORLD'S BIGGEST
ROAD RACING LINE!



ZAZOOM™
THE SOUND OF POWER



Now the Road Race Sets That Look Like Real,
Race Like Real . . .

SOUND LIKE REAL!

Control the sounds with your Marx pistol grip throttle. Make your racers idle, rev, go full blast. That's only one of 25 new, real-life features from Marx. There are brand-new cars with authentic styling, sleek lacquered finish and real-looking drivers; cars with operating headlights and Ackerman Steering. There are eight kinds of special track: Jump Chicane, Turnout 1/32nd, Turnaround Drag Strip 1/32nd, HO Wiggle Obstacle, 90-degree Crossover 1/32nd Tracks. Marx has built dozens of engineering improvements into the world's biggest Road Racing line.

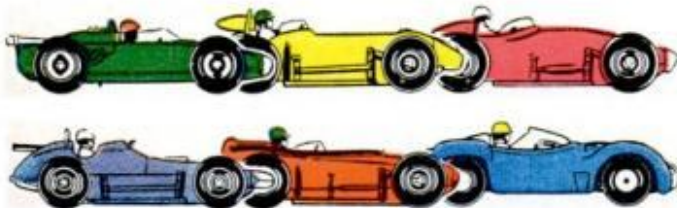

MARX OFFERS BIGGEST SELECTION OF HO AND 1/32nd RACING CARS

All the greatest racers on the road are available in Marx Road Racing Sets. The list includes Wilard Battery Special 1/32nd, Watson Special 1/32nd, Birdcage Maserati 1/32nd, Ferrari GT 1/32nd, Thunderbird HO, Sting Ray HO, Harvey Aluminum Special HO and many more.

CHECK THESE EXCLUSIVE NEW FEATURES —

- Real Ackerman Steering for better, more accurate handling
- 5 geared power train for smoother, more realistic operation
- Bodies painted in detail, with chrome-like trim
- Electro-matic racing: control 2 cars on 1 track

Every Marx car is solidly built to take a real beating and go back for more. And it's road-tested before it's packed.

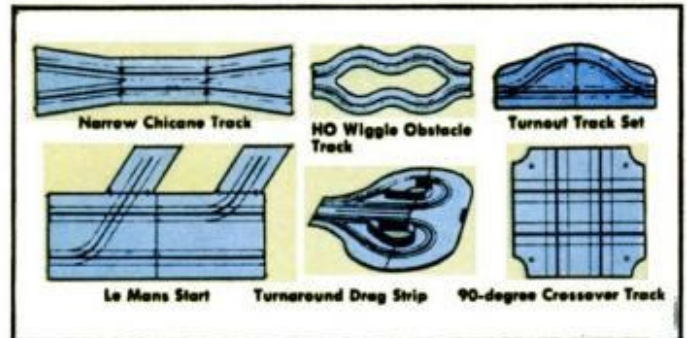

Dozens of Track Combinations
Big Feature of Marx Road Racing

Re-create famous courses like Le Mans, Indianapolis, Monza, Watkins Glen, Sebring with Marx track. All track has a special high-traction finish and quality screw-down terminals. Just look at the special feature track you can choose from.



Hi-Voltage Power Pack included in every set

Every power pack is UL Approved

New Calibrated Pistol Grip Throttle for more positive control
Throttle down from 500 scale miles per hour with smooth, realistic action.

Marx adds to your racing fun with a full line of accessories
• figures • bridges • trestles • guard rails

YOU GET MORE FROM **MARX**... WORLD LEADER IN ELECTRIC ROAD RACING AND SPEEDWAYS

Here's the story on the racing weeks that really were—when world land speed records fell like rain in history's wildest, hairiest . . .

SPEED CARNIVAL AT...

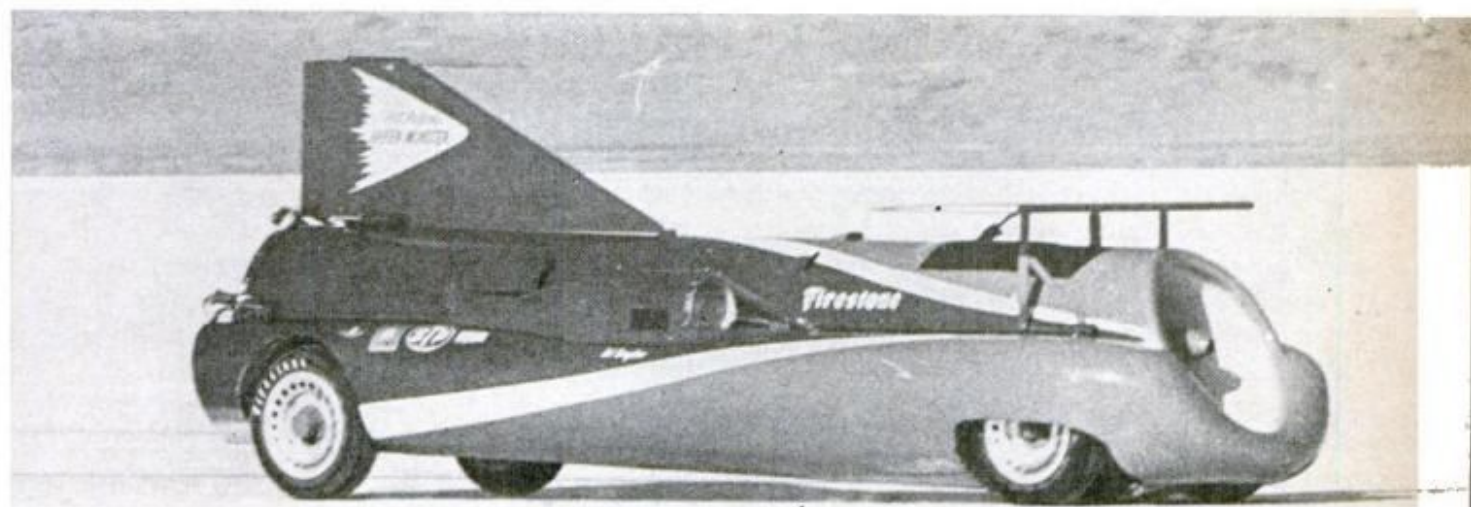

BONNEVILLE

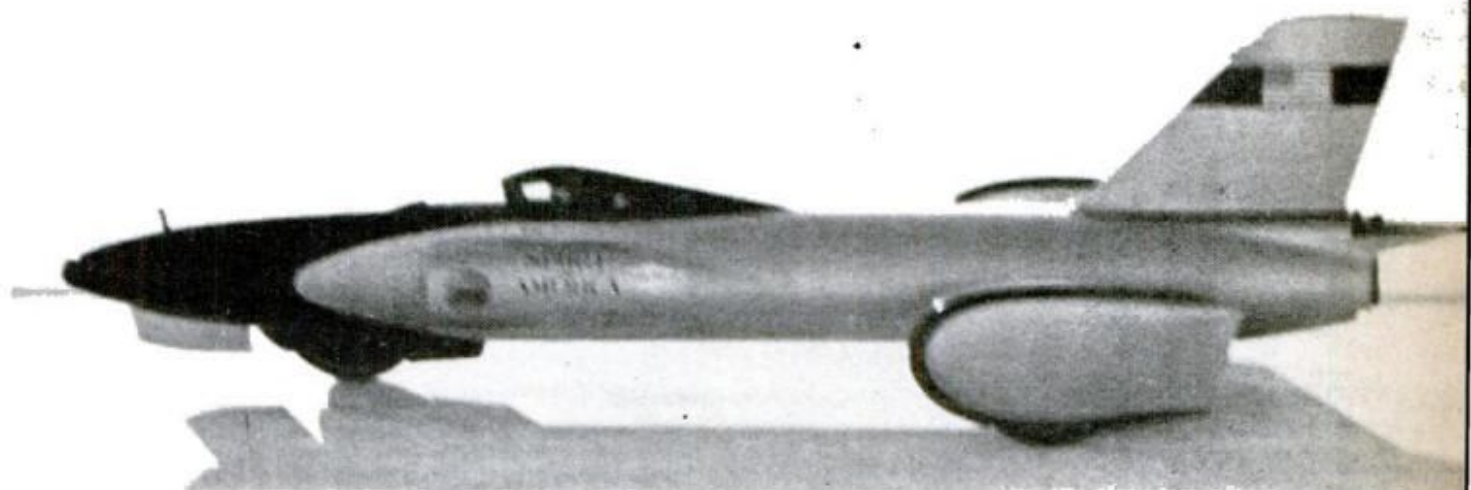

TOP, ART ARFONS' *Green Monster* setting a new world land speed record of 536.71 m.p.h. Below, Breedlove's *Spirit of America* on its way to a record of 526.28 m.p.h., which Arfons later broke. At one point, Arfons topped 610 m.p.h.

By
C. P. Gilmore

THEY WERE THE WILDEST WEEKS in racing history. The big jets roaring across the salt at Bonneville broke the world's land speed record so many times they're still picking up the pieces.

First out of the box was the *Wingfoot Express* driven by Tom Green of Wheaton, Illinois, and built by Green and Walt Arfons of Akron. On Friday, October 2, *Wingfoot* smashed Craig Breedlove's 1963 record—407 miles per hour—with an average two-trip speed of 413 m.p.h. But Tom and Walt held the record for just three days. The following Monday, Art Arfons, Walt's brother, hurtled across the salt in his snub-

nosed *Green Monster* to peg the record at 434. That record lasted ten days. Then Craig Breedlove of Los Angeles, smoking across the Utah desert in his sleek *Spirit of America*, lost his steering and both braking parachutes, plowed across a quarter mile of mud and shallow water, smashed a telephone pole into kindling, climbed a 12-foot embankment, and flew through the air 50 feet before coming to rest under 18 feet of water. But he walked—or swam, to be more accurate—away unscratched.

The ride was spectacular in more ways than one. Flashing across the salt with only partial control, Breedlove managed to clock a record 538.89 miles an hour through the measured mile. With the 513 he had chalked up on his previous run, his average was 526.28. (Timers get the official speed by averaging elapsed time through the mile on two runs, then calculating speed from average time. It gives a slightly different answer than averaging the speeds directly.)

Arfons Comes Back

The climax came on Tuesday, October 27, when Art Arfons set out to beat Breedlove again. The salt was rough—still chewed up by Breedlove's wild ride. To cut down on the amount of rough salt he would have to navigate, Art decided to limit his acceleration to a two-mile stretch before entering the measured mile. A warmup run of 462 Tuesday morning convinced Art the *Monster* would handle on the rough salt.

The first record-assaulting run began at 1:07 p.m. as the big car started with a roar. "Then," said Humpy Wheeler, Firestone's representative at the trials, "there was a tremendous boom, like a jet going through the sound barrier. A huge tongue of flame shot out of the tailpipe. We thought the car had exploded."

It had. But not the way they feared. To get up to speed in the two miles he had allowed himself, Art had fired the first stage of his four-stage afterburner. (He never used the other three.)

A camera had been rigged in the right cockpit (Art drives from the left) and a small wire came out under the canopy. Air got under the slit caused by the wire and ripped the canopy off. With no other troubles on the run, official time was 515.98.

The gaping hole left where the canopy had been had to be covered before the re-

turn run. But the canopy was shattered. And the return run, to be official, had to start within one hour. Frantic crew members bolted an aluminum plate over the hole. When it was in place, Art still had 12 minutes.

Again, the big jet roared, and Art laid a heavy foot on the throttle. "I just made up my mind I wasn't going to make another run," he said. "This would be the one."

It was a hairy ride. "When I slipped it into burner," says Art, "it literally picked the car off the ground. It felt like I was in a tornado." Crew members nearest the track said they saw daylight under all four wheels as the *Monster* slammed over the rough salt.

Art went into the measured mile at about 500, accelerated all the way through, and estimates he came out doing a fantastic 610. That's when the right rear tire blew.

Art's tires, especially designed for his car by Firestone, were tested only up to 600 miles an hour. He went faster.

"I let one chute go right away," says Art, "and it ripped off. Then I waited until I slowed down to 400 to let the other one go. I lost about half of it, but it slowed me OK."

Some 4½ miles from the point where he lost the tire, the new world's champion rolled to a stop. He had no trouble controlling the car after the world's first 600-m.p.h. blowout. "She was just right," said Art. "She rolled in a straight line. When the tire blew, it bent the axle, and the wheel started dragging on the frame when the car slowed down to around 200. But it held straight."

"I knew I had it after the run," says Art. So we just waited for the official time. It was worth waiting for. Time on the run was a staggering 559.18 through the measured mile. With the first run, Art's average time—and the new world's record—was 536.71 miles an hour.

The tremendous carnival of speed this year at Bonneville is all the more remarkable in view of the fact that record-breaking runs have been few and far between in the past. The late John Cobb's record 394, set in 1947, stood for 17 years. Finally, just over a year ago, Breedlove squeaked out a 407 average to take the crown. Then suddenly this year, the salt was crowded with record breakers. In 25 days, the world's record changed hands four times

[\(Please turn to page 72\)](#)

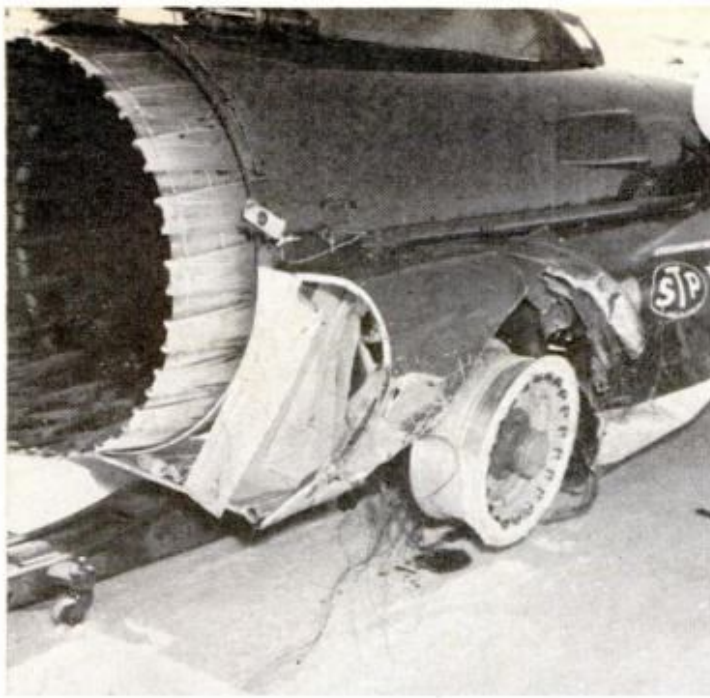

LIKE A BULLET, 3-inch bolt left on salt blew Arfons' tire at 500 m.p.h., causing this damage. Art kept the power on for control, then halted the car safely



ARFONS gets tucked in for record run. His Green Monster with afterburners can put out 17,500 pounds of thrust, compared to Breedlove's 5700 pounds

THE DRINK BREEDLOVE HIT at 160 m.p.h. Note tail of racer protruding from water at left. This year Breedlove's three-wheeler had smaller nose fin. Engine was the same, but it had been tuned for about 500 more pounds of thrust

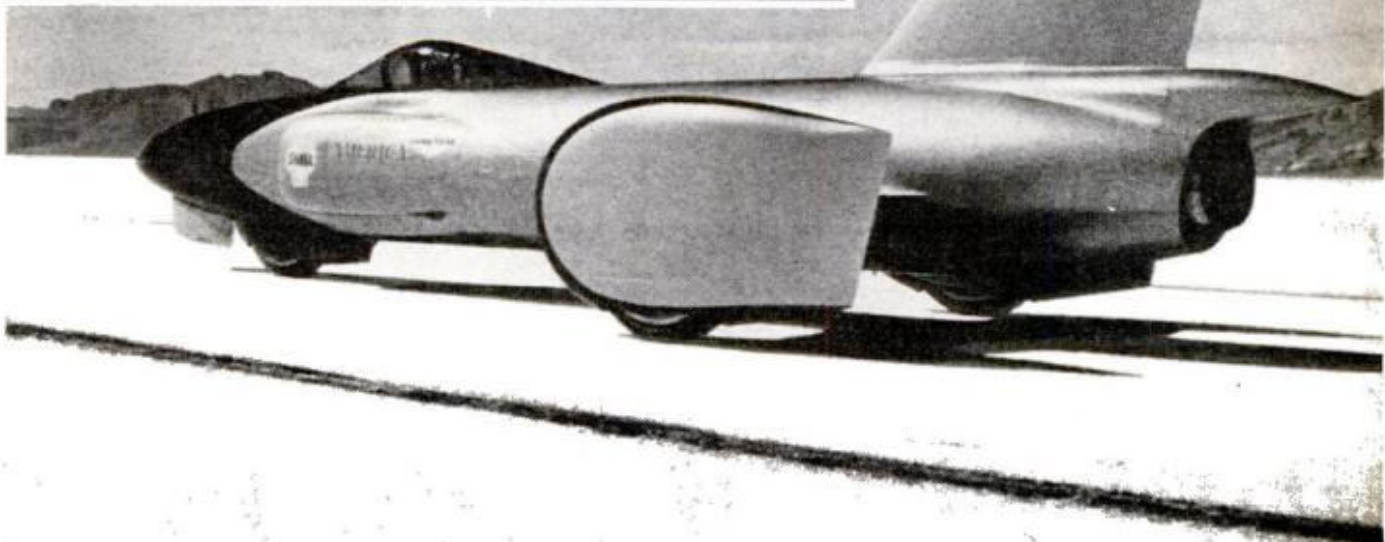

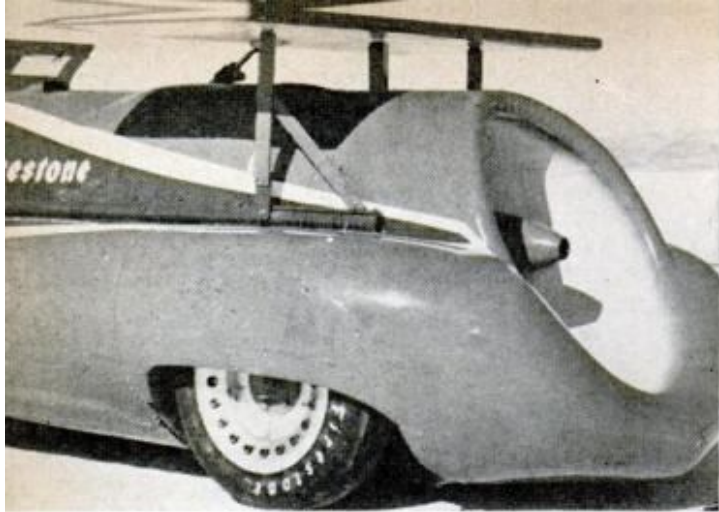

TOO MUCH WEIGHT on front end and small wing on Arfons' racer supplies lift; if nose rises, suspension link makes wing supply aerodynamic down pressure

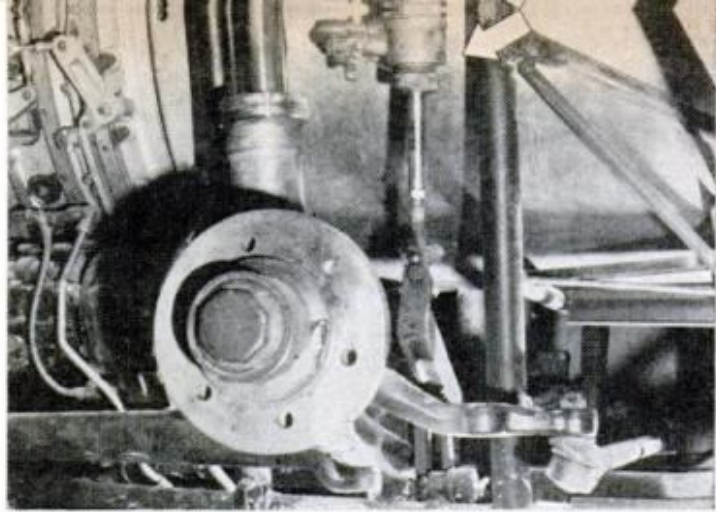

HOW SUSPENSION links to Arfons' wing, keeping front tire loading relatively constant at all speeds. Hydraulic cylinder moves wing when front end lifts

and was shoved upward a staggering 129 miles an hour.

Art, the final winner, paradoxically, was plagued with tire trouble on both of his record assaults. First trouble came on October 7. Art had set a new record with his 434 run two days earlier, and was now out to beat his own record. The airspeed indicator was sitting on 500 m.p.h. when the *Monster's* right rear tire exploded. Later, engineers found a three-inch long bolt near the blowout spot which, they reasoned, the tire had hit. "Hitting a piece of metal at that speed," said Firestone engineer Bob Martin "is just like firing a bullet into the tire."

The tire, with more than 250 pounds of pressure and thousands of pounds of centrifugal force straining to tear it apart, blew up as though it were packed with dynamite. In the process, it ripped a gaping hole in the car's sheet metal skin and put Art on the sidelines for major repairs.

I was watching the *Monster* from a plane above the track when the tire let go. Art said he felt a lurch. But from the air, the car didn't appear to waver. "It dropped on the right rear corner and started wandering to the right," Art told me. "I left the power on long enough to get things straightened out. I eased out of the power then, and I corrected and started back to the left. Then I knew I had control, so I put out the second chute." (The first one had been kicked out of its compartment by the force of the exploding tire, and had shredded in the 500-m.p.h. slipstream.)

When my plane landed minutes later, I drove back along the salt and inspected the three-and-a-half mile furrow Art's naked wheel had plowed in the salt be-

fore he could get the car stopped. For the most part, it was as straight as the black guide lines laid out by surveyors to keep cars on course. Since the tire blew just as the car entered the measured mile, speed dropped rapidly and official time was a relatively slow 331.

Breedlove's out-of-control run—packed with enough close calls to raise hackles on

MONSTROUS J-79 JET used by Art Arfons is the only one in civilian use. Movable vanes circling inside of tailpipe automatically adjust for optimum thrust

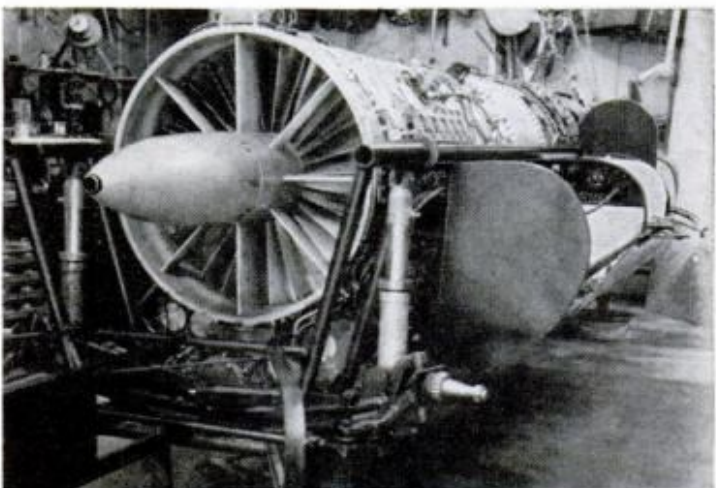

a brass statue—also ended without injury. But it was rugged while it lasted.

"I was just two miles off the starting line when I lost my steering," says Craig, "and the car started to pull very hard to the right. I think something broke in the steering linkage to the front wheel, although we haven't found out for sure what. I kept my foot on it, and I had the wheel as hard as I could turn it to the left. It's a butterfly type, and it was almost upside down. I think I was still getting some steering from the fin on the nose, and that's probably what held it.

"Anyhow, the car was holding, and I just kept thinking to myself 'Stay with it, stay with it.' I wanted that 500 bad. When I got into the mile it started pulling out to the right again and the fin wasn't holding it. I backed my foot off the throttle until I cleared the mile.

Chutes Gone, Brakes Fail

"I came out going about 550. I hit the parachute button and the chute tore loose from the car. The thing I didn't know was

that both chutes had come out and torn off. I let the car slow down for another two miles—about 13 seconds—and then I punched the emergency button. Nothing happened. I was in trouble.

"I looked at the brake pedal and I knew it wouldn't work. I said, 'Well, that's all you've got, go ahead and punch on it.' I stepped down and it went right to the floor. Even if they'd worked, the brakes would have burned up in seconds. They are designed for 30,000 foot-pounds torque. At my speed I was developing about 10,000,000 foot-pounds. But we found out later that the brake pucks never touched the discs.

"I thought about getting out of the car, but I was going 480 miles an hour. I thought to myself, 'Don't be ridiculous. You get out there and you'll lose your balance.'

"I thought the dip at the end of the course would flip me. And I was trying to get lined up so I wouldn't hit any of the telephone poles in the first row. When I

[\(Please turn to page 190\)](#)

BREEDLOVE USES LONG BUILDUP to reach measured mile between 5 and 6-mile markers. When chutes failed, he was still going 488 m.p.h. at 8-mile marker. Arfons, with more power, reaches top speed in about 3½ miles

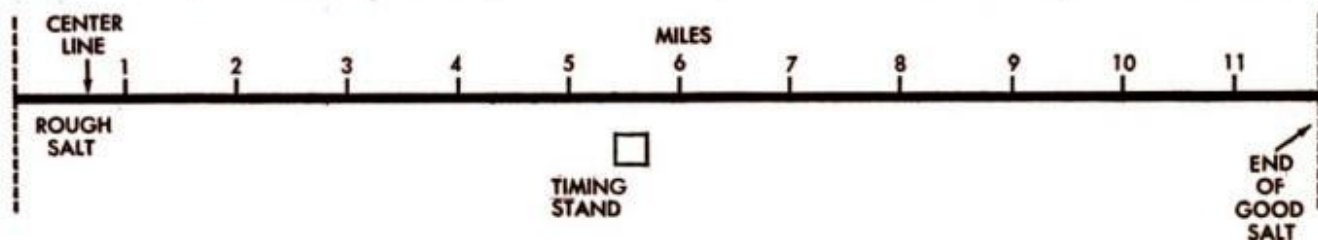

AS HE TOLD PM READERS he would last June, Tom Green did break the 1963 record of 407 with a new 413 m.p.h. record October 2, in this *Wingfoot Express*. But Art Arfons and Breedlove promptly topped Tom with four new records



Some Choice New TOYS FOR CHRISTMAS

Santa's toy shelf was handy so we took a quick look around. Here's a glimpse of some of its contents

There we were in Santa's workshop surrounded by toys. Big ones, small ones, short ones, tall ones—and we had to make a decision. Which ones did we think were best? We tried them out and learned what made them tick. Finally we made our selection. Here are nine toys, new this year, that we judged best—best to play with, best to have fun with, best to learn from. No doubt your youngsters will be as delighted as the children in these pictures.

FIRE CHIEF HELMET has a built-in transistorized sound amplifier, turns any youngster into a volunteer fireman. Amplifier and speaker are hidden behind shield. Hand mike is attached to the brim. Price is \$3.98 at Texaco stations



MOLD AN ARMY with Formex 7 Military Casting Set. Ordinary light bulb melts plastic. Pour into molds and dip into cooling tank to harden. The finished toys can be recast if desired. Extra kits offer other molds and additional plastic for casting. Priced at \$8 from Emenee Industries

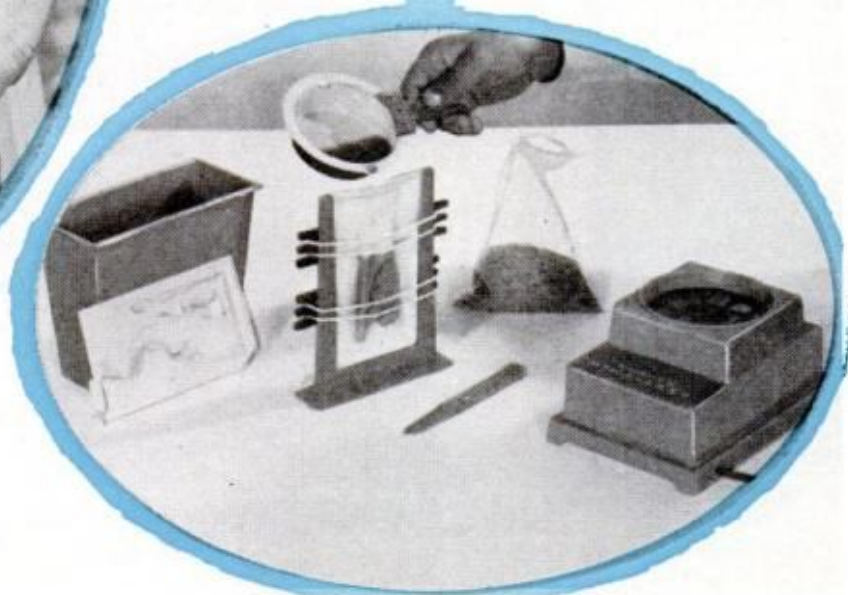

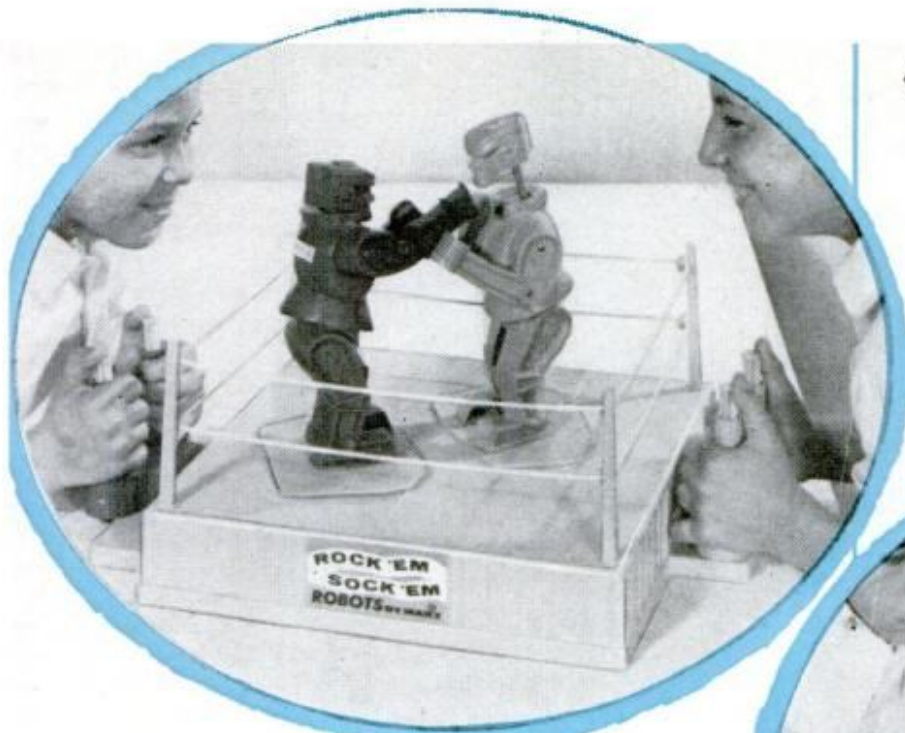

ROCK-EM SOCK-EM ROBOTS toy lets kids spar without hurting anything but the plastic jaws of the two boxers. Hand operated controls move boxers around ring and trigger rights and lefts to the jaw. It takes a good clout to knock a head loose and win. \$12.98 by Marx

YOUNG PRINTERS will while away the hours with the Big Press flatbed printer. It turns out anything from business cards to novelty sayings and slogans and letterheads. Complete with all accessories. \$18 by Ideal Toy



LITTLE GIRLS CAN BAKE delicious pies, cakes, biscuits, pizza and pretzels with the Easy Bake Oven. Cooking heat provided by two 100-watt light bulbs. Cooks in 6 to 16 minutes. \$15.95 by Kenner

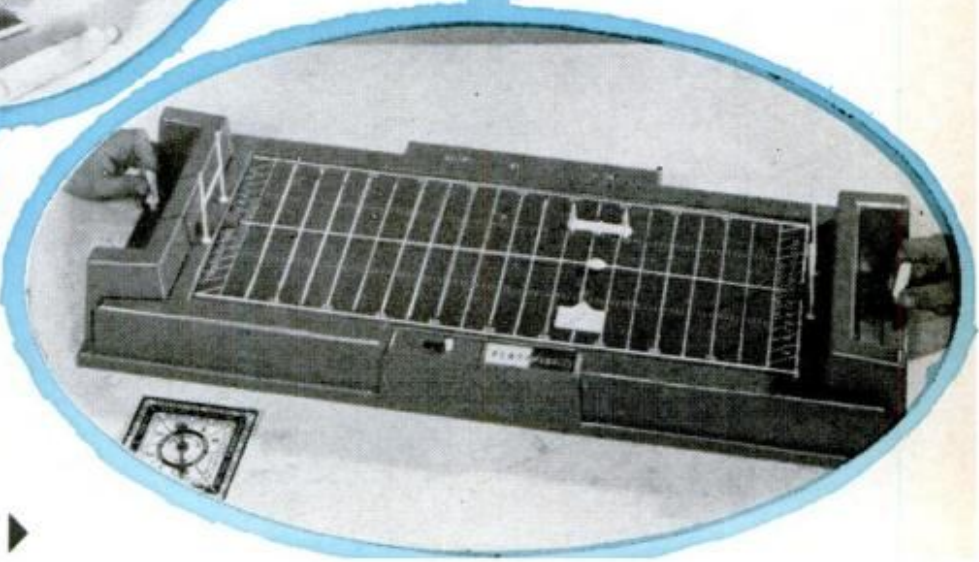

ELECTRIFYING football action: Spin for kickoff and runback, then electric power takes over as teams run ball back and forth to a touchdown. Players try various plays to win. Two batteries required. \$14 from Kenner

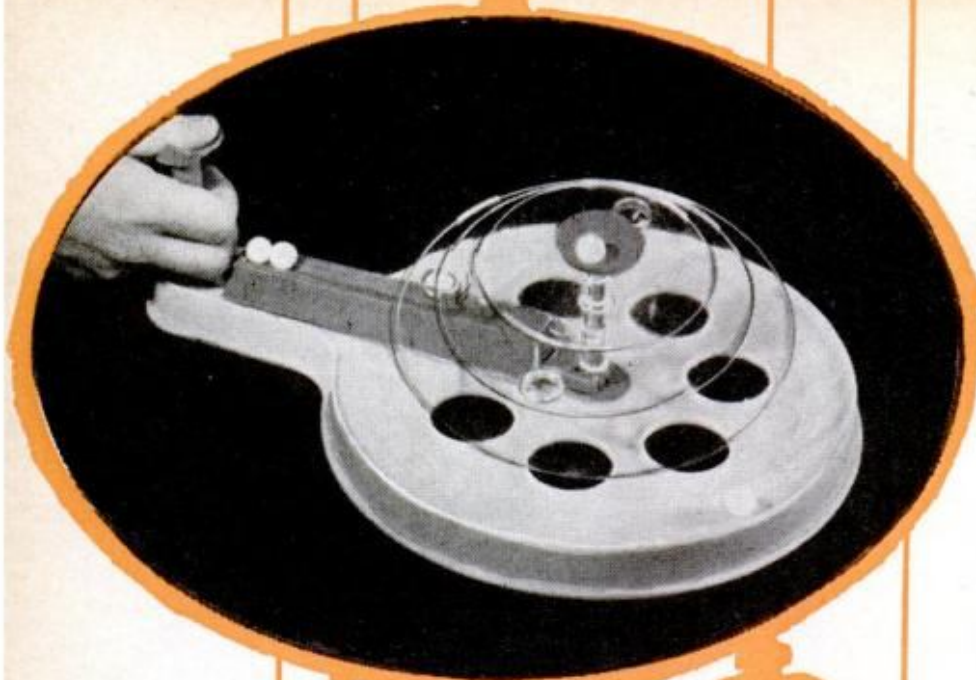

ASTRO TRAINER puts a fine edge on reflexes and coordination as you try to maneuver the marble from the top platform to a safe landing on the base. If one marble becomes easy, try two at a time. \$4 from Emenee, Ind.



PUSHBUTTON MARIONETTE takes the kinks out of the strings. Piano-key type operation makes it easy for children to animate marionettes. Eight different puppets for girls and boys. \$3.98 by Knickerbocker Toy Co.

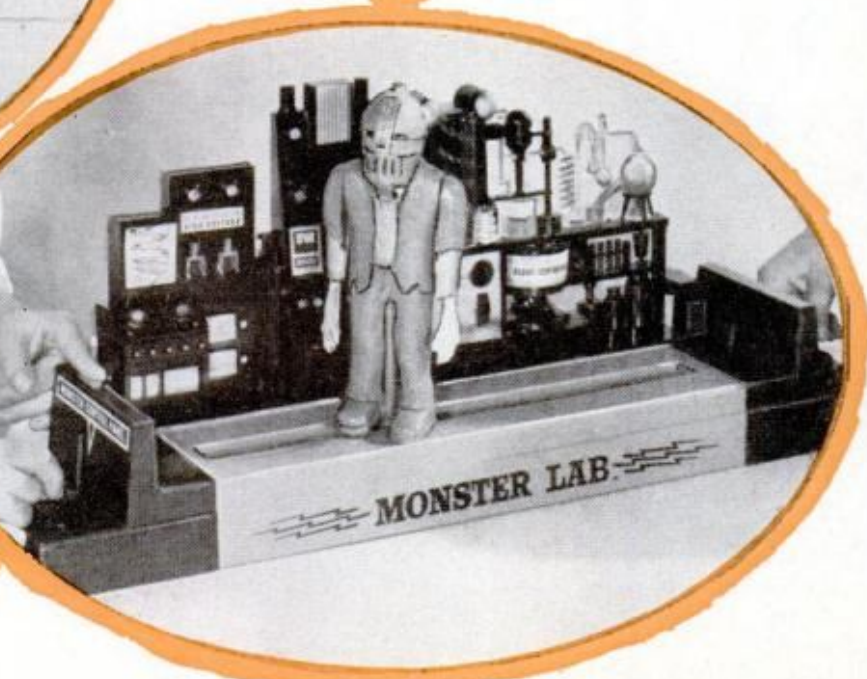
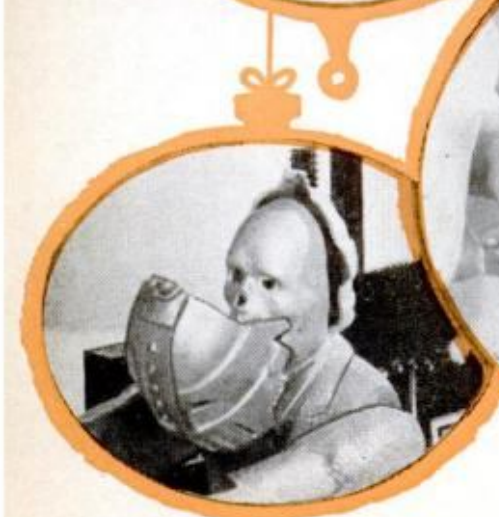

OPPONENTS try to keep the monster away from their end of the Monster Lab as button controls make him walk back and forth. If he reaches either end of lab, he raises his arms, emits a growl and mask over his face drops off. \$16, by Ideal

Spotlight on a New Wanderlust Bus

Are you itching to travel? This all-season cruiser lets you bring your home along with you

By Ed Nelson

THERE'S A TOUCH OF WANDERLUST in most of us, a dream of roaming aimlessly with family or friend. More and more, this vagabond life is becoming available—comfortably—through the many new self-propelled homes on wheels.

I tried a long weekend in the Clark Cortez, one of the finest. It's by no means the biggest; it has only a 120-inch wheelbase and a Chrysler Corp. 225-cube Six. But neither my friend nor I found any important areas in which it was short-changed. There's ample room for two, adequate room for two adults and two or three kids. And one long weekend is not enough vagabonding, you'll find. I'm ready to go again.

Cortez equipment includes a refrigerator, water heater, double sink, stove, toilet and shower. It's a year-round camper. In winter, the regular car heater is more than adequate while you're driving. Overnight, a 17,000-B.T.U. rear heater keeps

OVER-ALL LENGTH is only 225 inches—shorter than that of several large passenger cars. The 140-hp. Six allows 70-plus m.p.h. Sitting directly over the front wheels, driver has an excellent view through panoramic windshield



your family warm as toast.

The drawers under the kitchen counter have flush pushbuttons instead of handles, so your helpmate isn't clipped around the hips while you roll along. My companion wasn't a versatile cook, so I can't report on the oven and broiler. But the bacon and eggs were tasty.

Two rubber-covered wire racks holds dishes and pots neatly on edge. A chromed framework above the three stove burners keeps pots from sliding. It's hinged to swing out of the way for oversized pans, but when we camped on an incline we found it wouldn't stay up. The incline also frustrated the gravity operation of the refrigerator, so the morning juice was warm.

Our Cortez had nine individually controlled, recessed ceiling lights, and two gas lamps (replaced with electric dittos in later models). I prefer the gas; the electrical system carries a heavy load as it is—lights, a good radio and a water pump. Every morning I had ample starting current, but the situation might have been different in the dead of winter.

If you're where the auxiliary 110-volt system can be hooked up, two double outlets are activated, one in the washroom and one over the dining-room table.

The shower, toilet and washroom are all in a closet-sized area. The first use of the shower is an eerie experience. The entire room becomes the shower stall. After your shower, you can swing the door open until it latches across the hall to form a screen, for privacy when the whole family is along. Gals will appreciate the large mirror in this area, which is also a sliding closet door. But I wonder how long the thin plastic bathroom floor will hold up.

For rough roads, foam rubber is called for in the refrigerator. Our eggs suffered a 50-percent mortality rate.

Some foam stripping would be handy along the edges of the sliding closet doors to provide tension. The lock pin tends to vibrate out of place, allowing the doors to bang back and forth. We improvised with a scrap of old inner tube.

The Cortez' eight-foot width takes getting used to. The two outboard mirrors help. At 70 (a practical cruising speed), handling is stable and solid—the result of 3½ tons of body and frame. I'm still amazed that the little Six handled that weight so well. Much of the credit belongs



CORTEZ is sure-footed even on poor back roads. Well-controlled ride lets your wife cook while you are driving. Suspension is independent all around



WHILE MY FRIEND peeled onions for a disreputable-looking stew, I was enjoying the radio up front. There's plenty of upper and lower storage space

to the Clark four-speed transaxle. Its gear ratios are 23.80, 12.84, 7.48 and 4.44 to one—equivalent to transmission ratios of 5.36, 2.86, 1.71 and 1.00 to one with 4.44 conventional rear axle. All forward gears are synched, but linkage is mushy. Shifting up to third, I often overshot the wide gate. There was no gear clashing, because reverse is far to the right and down, but a heavier spring in the gate would help.

Front-wheel drive allows a low, flat floor and low center of gravity—which means little lean on corners. Power brakes are standard. So is power steering; with

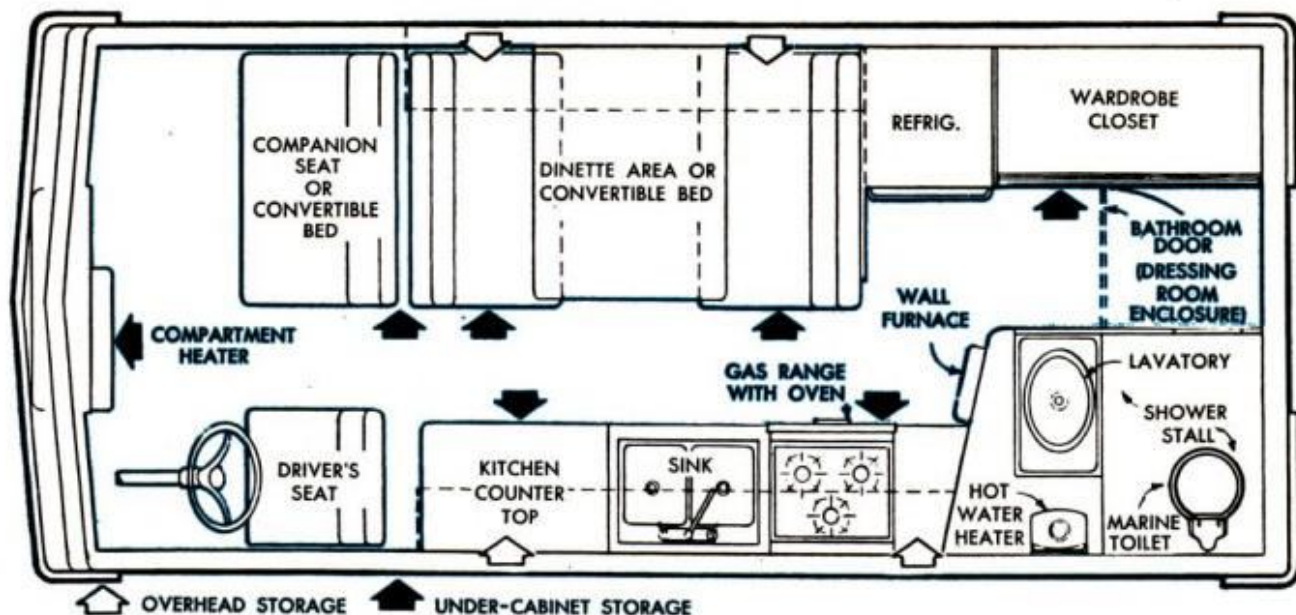

INTERIOR IS FUNCTIONALLY DESIGNED to squeeze maximum convenience into a minimum of space. Kitchen facilities are grouped directly behind the driver's seat. Behind them is bathroom. All windows are fitted with curtains



TWO DOUBLE BEDS fold out in ingenious over-under fashion. Interior lights are individually controlled so you can work or read while the kids sleep



FOR DINING, beds turn into benches and companion seat, and hinged table is raised. Trouble is, stopping for groceries means less mileage covered

4000 pounds on the front axle, you'd have a merry time without it.

The driver's seat proved amazingly comfortable. The seat back has a firm lower section that gives excellent support—something like the seats in the Volvo 1800S, the best ones I know of.

The gas tank holds 25 gallons of regular. With something this massive you can't expect great fuel economy; we got 10.14 m.p.g. over 554.4 miles of turnpike and back-road driving. The 30-gallon water tank drains into a holding tank of the same size, which is easy to empty.

What are the chances of running out of water? I found out, after thoroughly soaping up in the shower—and before rinsing off. I had to dress and drive off to find a well. A water-level gauge would be handy.

All in all, the Cortez adds up to real quality. There's handsome paneling, excellent fittings, wall-to-wall carpeting and much more. If I had \$8619 to spend, this would be a fine place for it.

In some places you can rent one for about \$150 a week and 12 cents a mile. Sure, that's expensive, but who wants to be a cut-rate vagabond? ★★★

FLIGHT TESTING THE ...

First All-Metal Plane

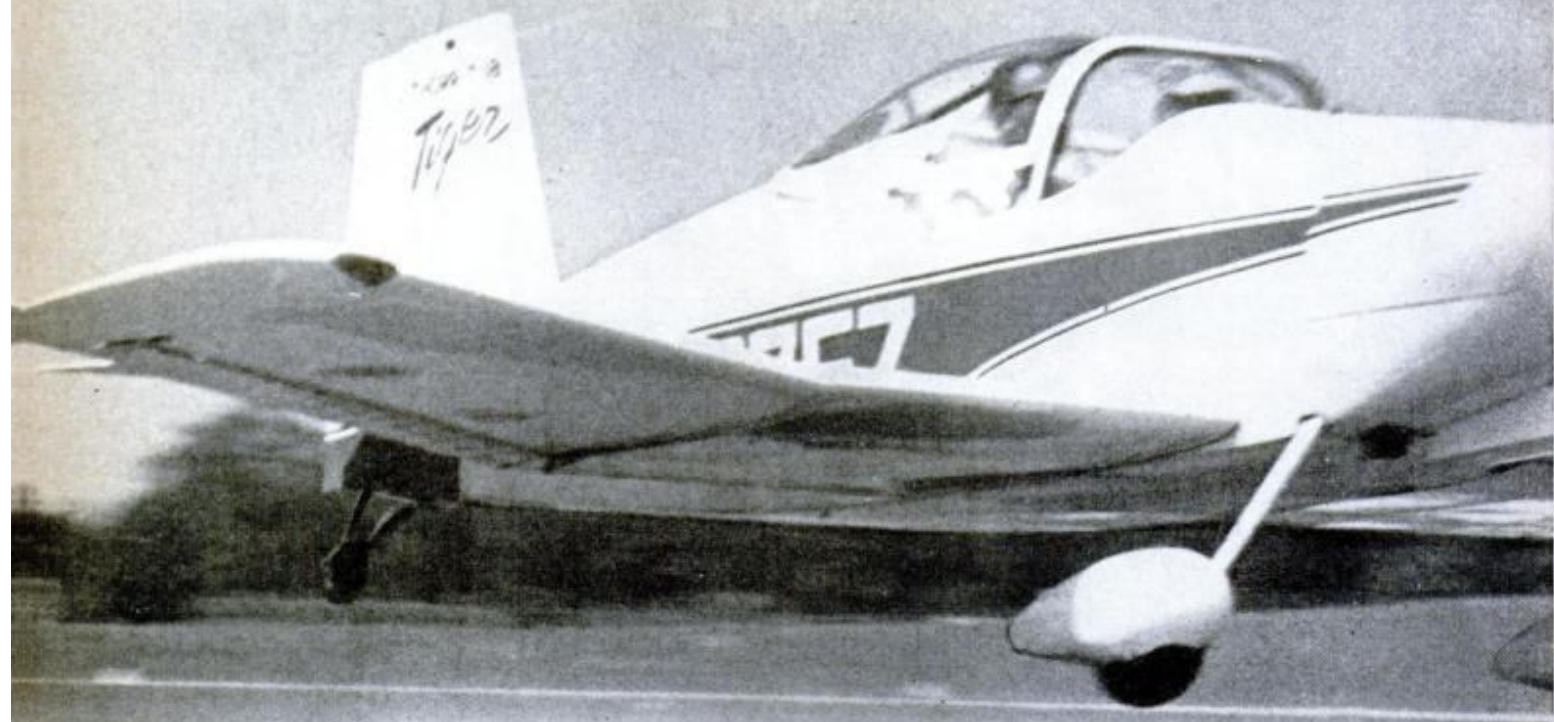

FIRST T-18 built is a swifty. Bill Warwick cruises above Rockford, Ill., indicating 167 m.p.h. straight and level at 75-percent power. Warwick, who had never built a metal airplane before, completed the craft in one year



Anyone Can Build

- A beginner can do it
- Needs only simple tools
- Speeds up to 200 m.p.h.
- Costs less than \$3000

By Kevin V. Brown

LETTERS TO THE EDITOR follow definite patterns. Most respond to stories that have appeared in the magazine, offering additional information, asking for additional information or rebutting information contained in a story.

Some letters, however, come in "from left field." Completely unsolicited, they ask about subjects that have never been covered by any magazine, and often about things that don't even exist. A few, of course, come from crackpots—"Why don't you do a story on a fur-lined gizmo?" Most do not.

One of the most consistent of the sensible requests we've had "from left field"

T-18 TAKES OFF in less than 1500 feet, climbs at 1500 feet per minute. Note distinctive gull outer-wing sections and craft's tubular-steel landing gear

COMPLETELY AEROBATIC, T-18 probably will outperform most amateur-built planes, and open new era of all-metal aircraft constructed in workshops



in recent years is to do a story on a small airplane that a beginner could build in his workshop, easily and inexpensively, and fly just for fun. And, as all editors know, for every man who writes, there are hundreds more who only think about it.

Well, for all those who wrote and for those who only thought about it, we believe we've found what you've been looking for. It's called the T-18—"T" for John Thorp who designed it, and 18 for his eighteenth model. It's a two-place, low-wing, all-metal plane that anyone can build, with simple tools, for less than \$3000. And it's a real speedster.

These are its features:

—It's all-metal. Most amateur-built

planes are wood-and-fabric which, without exceptional care (including hangar parking), have limited life spans. Some say about three years. Theoretically, an all-metal plane should last forever.

—It has a simple design. Thorp calls it "irreducibly simple." The number of parts have been held to a minimum, and are designed to be made with minimum shop equipment. Everything that could be eliminated, without sacrificing structural integrity, was left off for easier building.

—It can be made with simple tools. A major reason most amateurs build wood-and-fabric planes is that they can't handle metal, or afford the necessary jigs and riveting equipment. The T-18 needs no

Thorp T-18

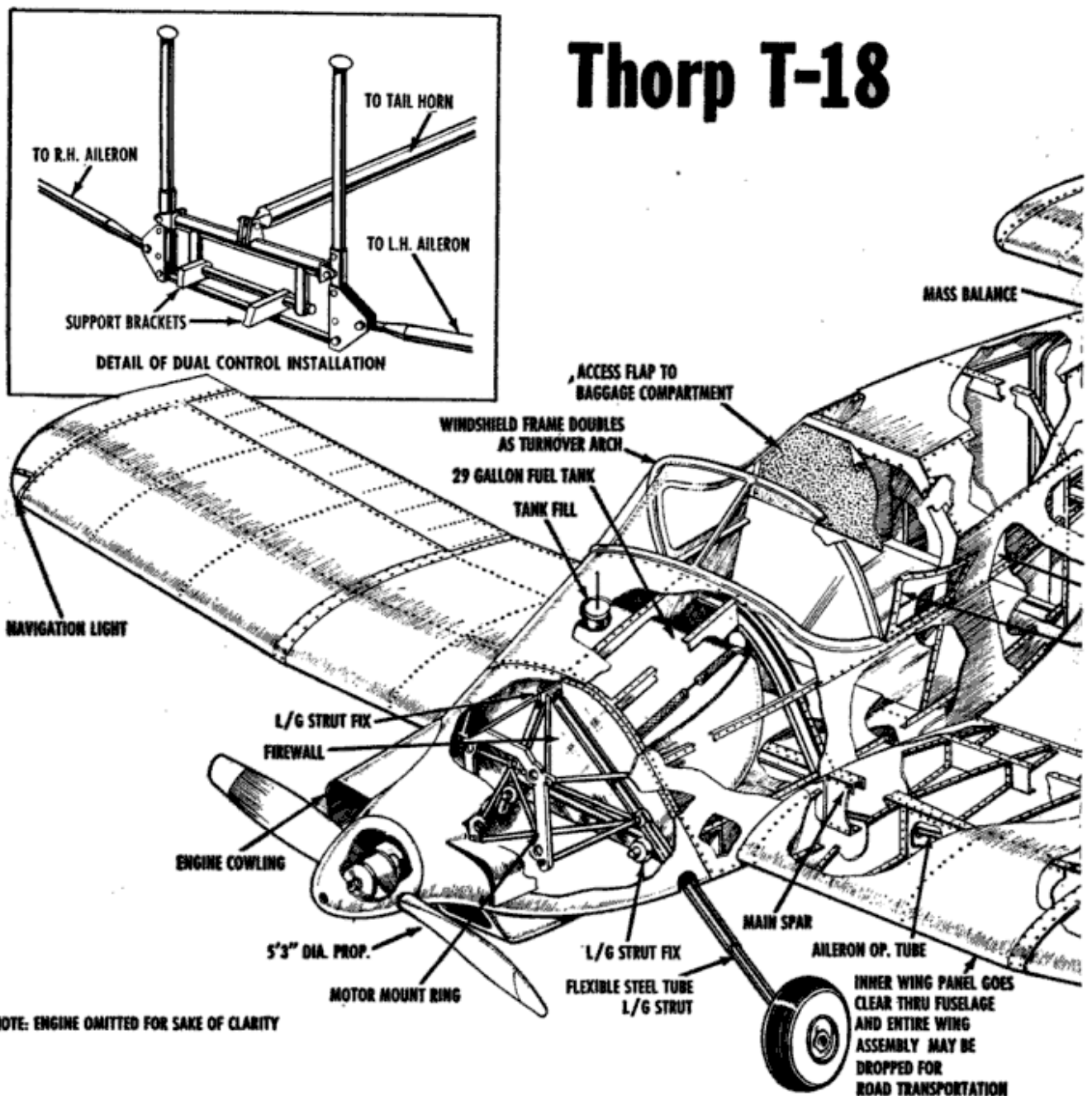

jigs and can be put together with a hand-held "pop" riveter.

—It's aerobatic. At gross weight it is stressed to six Gs (nine Gs maximum).

—The wing is removable. It can be unbolted and dropped off whole (it takes about 30 minutes), then the plane can be towed home and stored for the winter.

—Its performance is outstanding. Highly maneuverable, its specifications call for speeds from 130 m.p.h. to 200 m.p.h., depending on engine size and refinements in configuration. Its basic design can accommodate engines up to 205 horsepower.

—Its cost is comparable to wood-and-fabric homebuilts. Thorp estimates an average of \$3000, although at least one has

been built for \$2000. Some wood-and-fabric planes have been brought in for less, but all-metal planes run considerably more, as much as \$10,000.

Thorp's basic claims are that the T-18 will be "simpler and cheaper to build than any other airplane," and that it may "open up a whole new era of useful homebuilt transportation." Wood-and-fabric devotees have already challenged the simplicity, and the expense is still to be proved. But he may be right about its usefulness as transportation. Most homebuilts are one-place runabouts in the 100-m.p.h. class. The T-18 is a two-place, all-metal swifty that can easily hack it cross-country.

In any case, it's the first all-metal plane

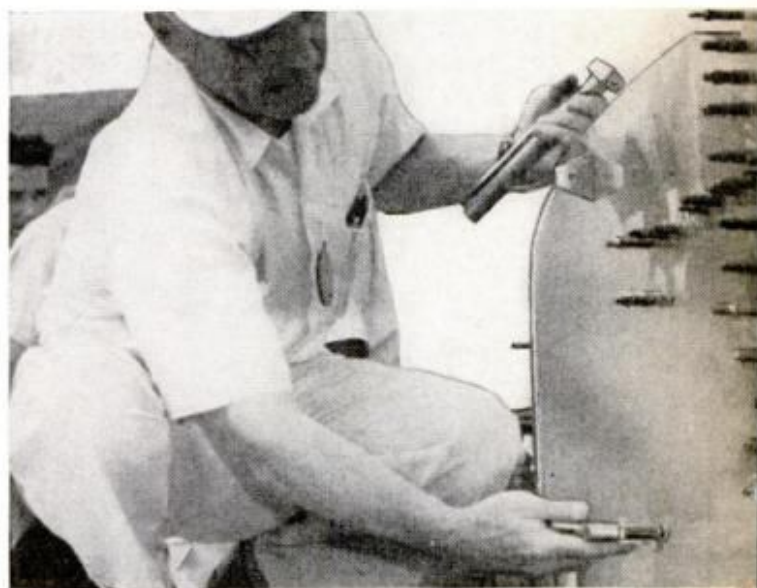
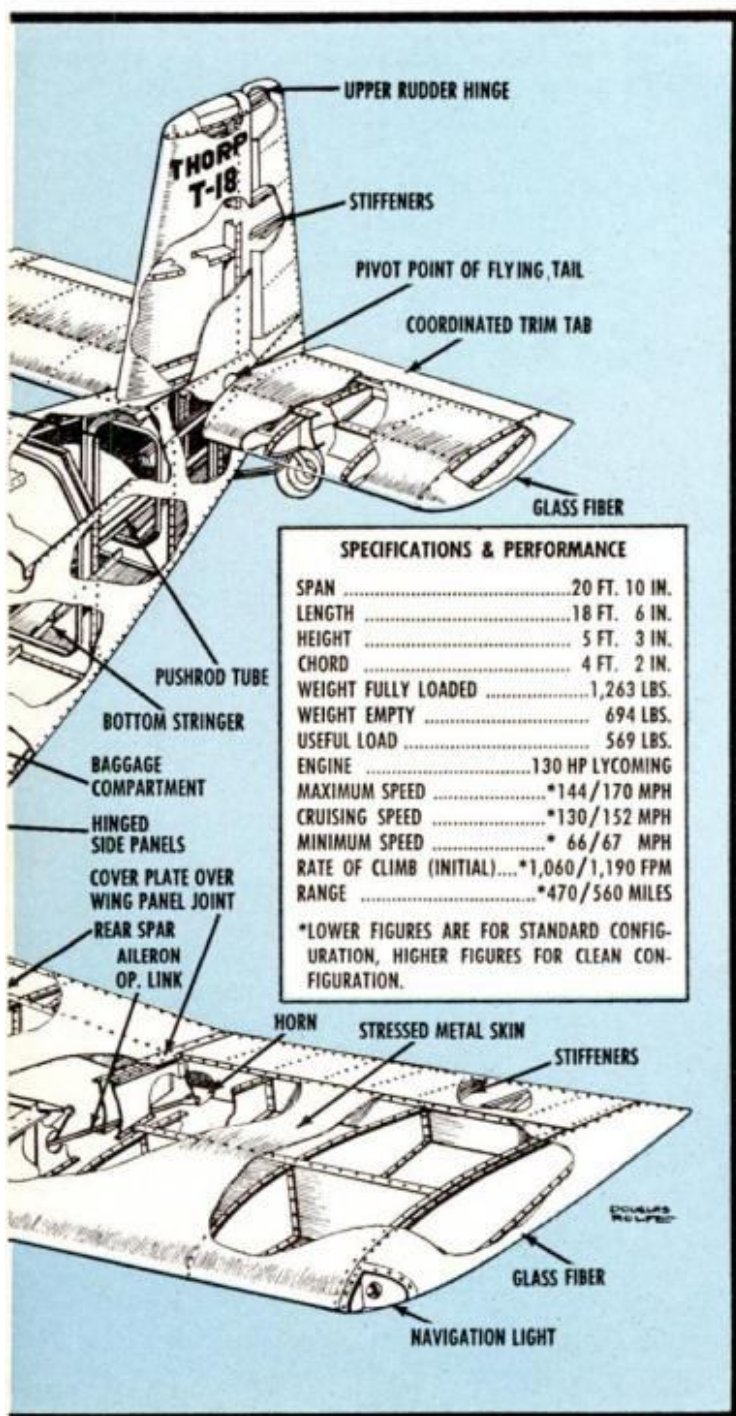

JOHN THORP demonstrates Cleco method of holding parts in place, eliminating jigs usually used in metal work. Parts are then fastened with pop rivets

POP RIVETER secures parts together permanently. T-18 is so designed that holes are drilled together so they will match up even if slightly off center

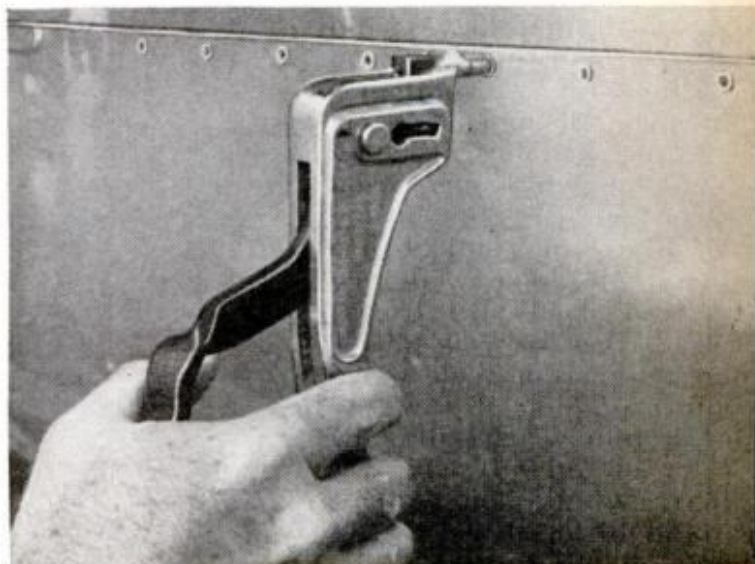



'FLYING TAIL', designed by Thorp, is all elevator without usual horizontal stabilizer. Bill Warwick was first of 150 T-18 builders to finish his plane



LANDING GEAR, another innovation, is shaped like an "A" and secured to fuselage behind the engine. This part, and others, can be purchased by beginners

being built on a mass basis by amateurs. Even at this writing, Thorp has not completed the blueprints, yet nearly 150 home-builders had enough faith in him as a designer to buy plans (at \$125 per set) before a T-18 had ever flown. In fact, one of these men was the first to finish and fly a T-18, and this is the plane we tested.

Our verdict: Whether or not it's as simple to build as some men might prefer, it is being done and by beginners. And, once in the air, it's a hot little airplane.

Just who is John Thorp and what are the theories behind this "irreducibly simple" airplane? Well, he lives in Burbank,

FAA INSPECTOR checks another T-18 before approving it for flight. All amateur builders must contact Federal Aviation Agency when building planes



Calif., and he has been designing aircraft since 1932. He's up to number 18 now and, along the way, amateurs may remember his *Little Dipper* and *Sky Scooter* (*PM*, October, 1964). Commercially, he was involved in the preliminary designs of the Lockheed-Vega PV-2 and Piper *Cherokee*, among others. He also designed what he calls the "flying tail" and what Piper calls a "stabilator"—an elevator without a horizontal stabilizer. There's one on the T-18.

This starkly simple do-it-yourself plane is based on several innovations. All of the parts that are made from flat sheets—the skin, ribs and bulkheads, for instance—are completed while flat, cut to size and the holes drilled before flanging the edges, wherever necessary.

Further, Thorp uses "matched hole" tooling in which parts that will be riveted together, or have identical rivet patterns (like the two sides of the fuselage), have their holes drilled together, two or more parts at a time. So patterns are laid out only once. Not only does this speed up the work, but it insures that the holes will match up even if slightly off-center. If they were drilled together, they will be off-center together, so perfectly aligned.

Then, when all the parts are finished, they can be put together "like an Erector set," sub-assemblies first, followed by whole assemblies. The parts are held in place with Cleco fasteners, then riveted with a hand-held "Pop" riveter. No jigs, no heavy riveting equipment. Best of all,

[\(Please turn to page 198\)](#)

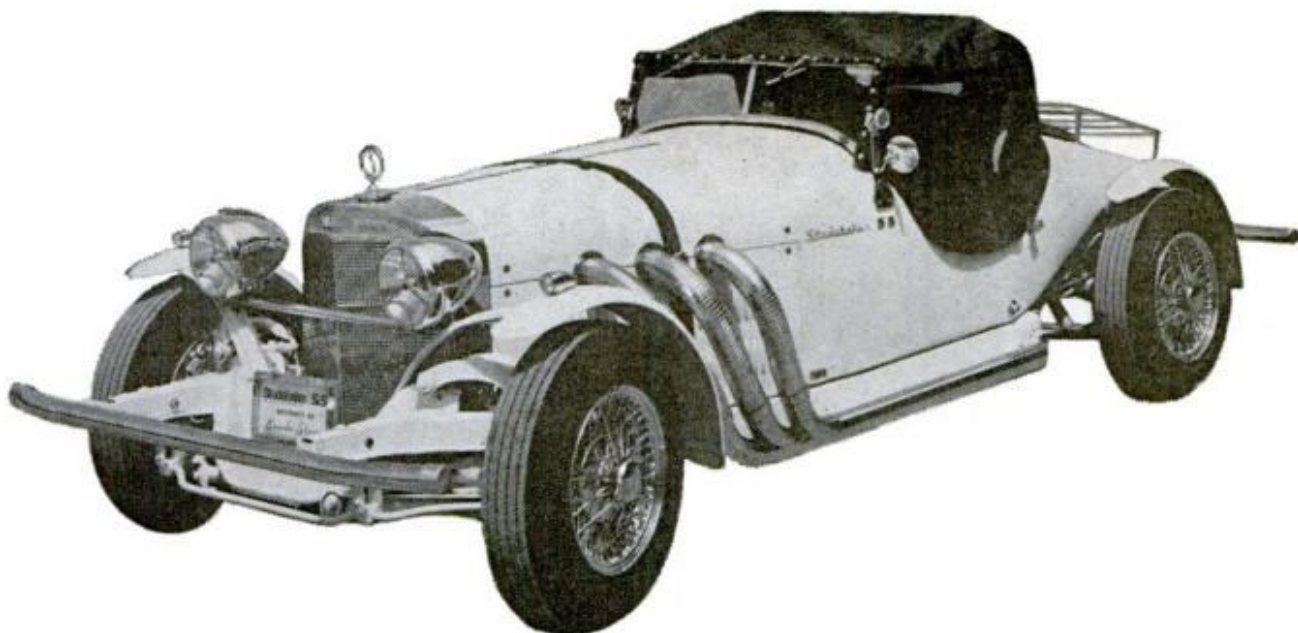

If the '65s Don't Suit You, Try This

Out of the past comes today's version of one of the hairiest sports cars ever built, the Mercedes SSK. But this is no \$30,000 restoration job; it's the \$6000-plus SS Excalibur, redesigned and built by

Brooks Stevens. It's more than a dream, too. They're available for purchase as what Stevens calls "contemporary classics." The engine is Corvette's and the chassis is Studebaker's.

An Inside Job

Tagging lobsters to study their migratory habits has been impossible in the past, because a lobster sheds its skin as it grows.

But now a University of Rhode Island professor is placing a plastic-covered metal tag behind the lobster's eye. It stays in place after molting, and is detected in the recaptured lobster by an electronic tunnel.

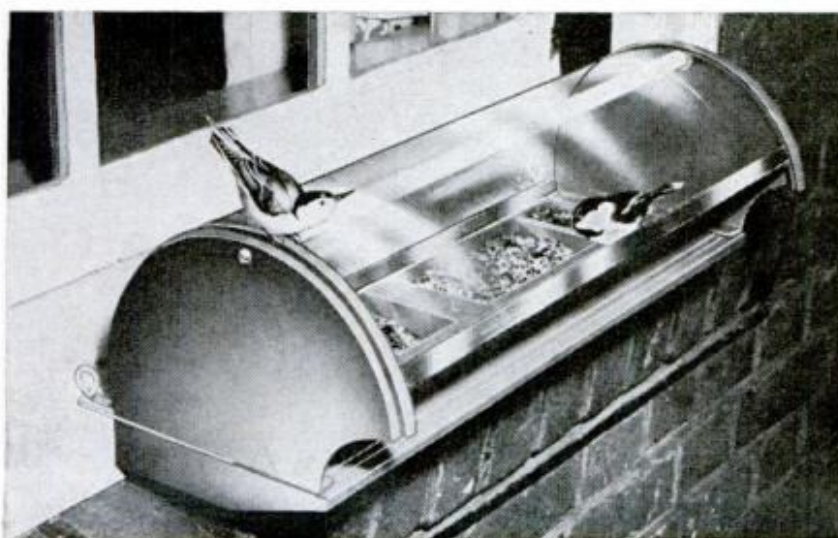

Snack Bar for Birds

A new wild-bird feeder features a transparent roll-top roof over a partitioned tray and landing platform. It measures 8 by 18½ inches and attaches to window sill or can be hung. It is designed to discourage the patronage of free-loading pigeons.

The feeder is made by Duncraft, Penacook, N.H., and costs \$7.95.

Driving Ford's FABULOUS TURNPIKE TRUCK

A gas turbine cruises this brute at 70 m.p.h., and the driver can enjoy all the comforts of home

By Alex Markovich

THE MONSTER was straight ahead of us, stretched out to its full length—an awesome 95 feet. As we drove closer, I watched Everal Kirby's face. His rugged, craggy features were frozen in disbelief.

It isn't easy to surprise Kirby with a new truck; a driver for Consolidated Freightways, he's been pushing trucks of all kinds for 41 years. Since starting at 15 in a four-cylinder, chain-driven White with solid tires, he's logged three million truck miles. Among his many awards, this brawny 240-pounder was Ohio champ at the annual American Trucking Association Roadeo from 1953-1957 and in 1962 and 1963—and national champ in 1956.

Kirby shook his head, still staring at the truck. "I don't believe it," he said slowly, a trace of a drawl lingering from his West Virginia boyhood.

Before going to the Ford test track, we were briefed by engineers. The truck wasn't a production prototype. It was more Ford's working prediction of what trucks would be like in the 1970s, when more than 40,000 miles of superhighways would link 90 per cent of our cities with more than 50,000 population. With terminals near the exits, a double-bottom or twin-trailer truck would never leave the turnpike except to pick up or drop trailers. At the terminals, trailers would be hitched to small tractors for local delivery.

On such super roads, a modern truck could safely do 70 m.p.h.—which would make a gas turbine the ideal power plant.



AIR-CYLINDER-OPERATED DOOR opens and electrically powered ladder swings down for easy entry. Cab is slightly pressurized and free of engine fumes

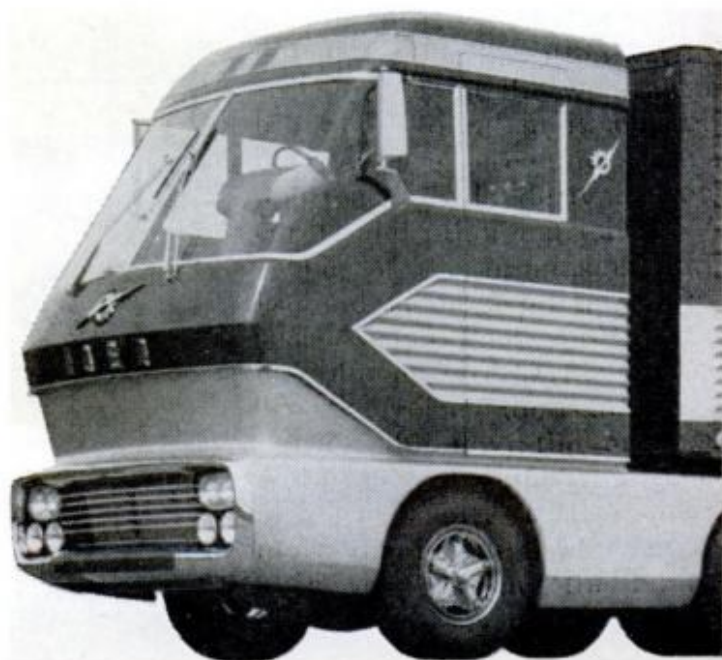

POPULAR MECHANICS



TURBINE TRUCK DWARFS FORD'S BIGGEST DIESEL. Fiberglass cab was built in two sections because of low ceiling. On today's roads, clearances are a problem. In some states, special permit is needed before driving through

CLEAN CAB STYLING AND SKIRTS ON TRAILERS cut down air turbulence, making it safer for passenger cars to pass. Brakes are failsafe; if the air pressure drops below a certain point, the brakes lock automatically

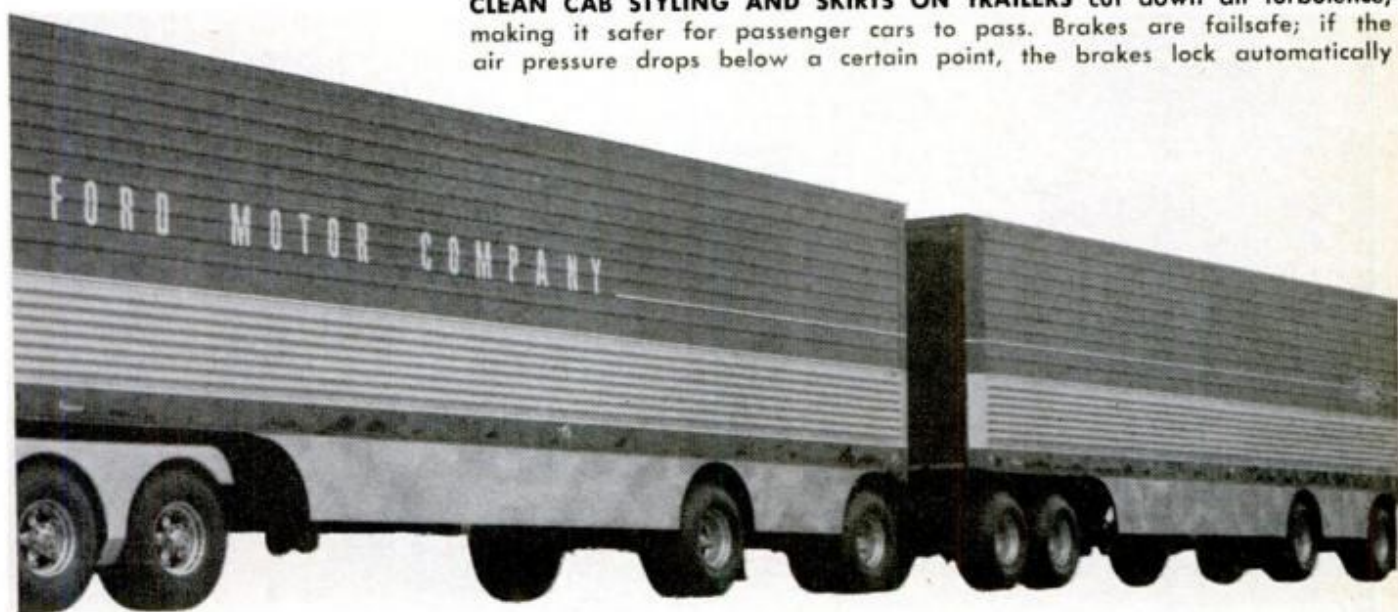



TV SET IN FRONT OF CO-DRIVER has vertical slats so driver's attention isn't distracted. Separate co-driver's air-conditioning control is at the right



KIRBY CHECKED OUT REFRIGERATOR, found it empty as Mother Hubbard's. Three spiggots serve refreshments. Stylists had field day with decorative map

DRIVER CAN SHIFT MANUALLY WITH DASH SWITCH or let Allison five-speed box work automatically. Turbine tachs are above windshield. Immense tinted windshield had slight distortion at bends, but provided a panoramic view





CONTOURED LOUNGE FOR CO-DRIVER proved very comfortable. It was built to recline, but later welded in fixed position because of elusive prototype rattle



FORD'S TURBINE is virtually two engines in one, producing 45 hp. for running accessories or, with supercharging section triggered, the full 600 hp.

The turbine is inefficient at low speeds, but at high speeds efficiency approaches a diesel's. Further, a turbine weighs only about a third as much, which means the truck can haul about 2000 pounds more pay load. At 70, the Ford truck can pull a gross combined weight of 170,000 pounds.

We pulled up near the monster and got out of the car. One of the engineers pulled a switch on the cab; the door swung open and a ladder slid down. We climbed up.

The cab is immense. It has a wide, flat, carpeted floor and enough headroom for Kirby to uncoil to his full six-foot-six-inch height. In fact, the cab, towering 13 feet above the ground, resembles a loaf of bread standing on end. It's mounted over the 600-hp. engine and is independently suspended on four leaf springs.

After watching a quick demonstration of the controls, Kirby slid into the driver's seat and pulled the adjusting lever. The seat glided back—a little too far even for Kirby. He moved it slightly forward again. "You know," he said, "none of the truck manufacturers ever think of the tall driver's comfort. All my life I've been sitting in a cramp. And on the run from Richfield, Ohio, to St. Louis I drive 530 miles at a stretch. This is the first truck I've ever been in where I have *more* than enough legroom."

He glanced approvingly at the futuristic instrument console sprouting from the floorboards, then looked out through the vast expanse of windshield. "Isn't that

view lovely," he said. "When you're driving you can never see too much. But with all this glass, isn't heat a problem?"

"Wait'll the air conditioning is on," the engineer volunteered. "You can make it as cold in here as you want."

Kirby flicked the master switch. The burners went on and the turbine wheels began spinning with a soft, high-pitched whistle that gradually reached a muted peak. The needles on the tachs above the windshield climbed quickly. At the same time, cool air flooded the cabin.

Kirby twisted the electric shift knob to Low and stepped on the large, treadle-like accelerator. There was a lag of a couple of seconds, then the mammoth was rolling. It gathered speed quickly.

I asked Kirby about that lag. "With a full load, you get that in any truck," he answered. "In fact, this job gets rolling faster, it seems to me."

We felt an upshift to Second. Then Kirby twisted the shift knob to "4," which allows shifts to Third, Fourth and Fifth. "This sure beats my 15-speed gearbox," he said. "You've got to double clutch, and every time you shift the revs drop way down. Here you don't even let up on the gas."

The speedometer was registering 40. "The speedo is slow," the engineer said. "We're doing about 50." From our height, it seemed more like 30.

Engine noise was hardly louder than at

[\(Please turn to page 197\)](#)

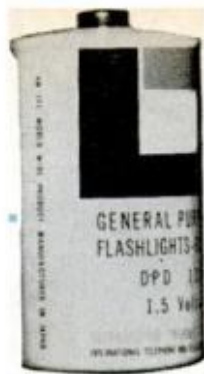

PM SHOPPING GUIDE

Which Battery Is Best

Flashlight dead? Transistor radio "motorboating?" Toys won't work? Here's how to match new dry cells to the job.

By Larry Steckler

BATTERIES have become an important part of everyday life. You'll find them in your electric toothbrush, the emergency flashlight in the car, powering the motor in your movie camera, giving life to your transistor radio or portable TV, and keeping the kids' toys going. But when it's time to replace a set of run-down batteries, your problems are just beginning.

Take the "standard" D cells that fit your flashlight—there are endless types to choose from. There are high, low and medium output zinc-carbon cells. There are steel-jacketed leakproof types, cardboard-jacketed leakproof types and no-jacket, not-leakproof types. Then there are alkaline, mercury and rechargeable nickel-cadmium batteries. Prices in this assortment of types vary from a low of seven cents for the imported, not-leakproof battery to six dollars for the rechargeable ones.

There are three basic demands we make on batteries: The amount of power needed, the length of time the power is required and the storage life of the battery. For example; we may want a little power for a prolonged period of time as in transistor radios. We may need medium power for continuous use in toys, movie cameras or other motor-driven devices. Or we may require high power for short intervals, as for firing flashbulbs. We also want standby

time. We want to be able to store batteries, leave them standing idle, and still have them deliver full power on demand.

These are factors that determine the best battery for a particular job. Figure 1 shows what happens in a transistor radio. You'll note that the mercury battery gives the lowest cost of operation. And this is true even though the mercury type costs as much as an alkaline dry cell and three times as much as a zinc-carbon dry cell.

However, if the same chart were drawn for a flashlight that is used every day, the zinc carbon cell would come out ahead. Draw a similar chart for flashguns and the alkaline cell would lead.

As a general rule, mercury batteries are excellent where low power is required for prolonged periods of time. This is why mercury types are found in hearing aids, electric watches and transistor radios. They also have the ability to pack a lot of electricity into a small package and are used in almost all subminiature electronic devices. For extra power capacity, special silver-mercury cells are made.

Fig. 1—Despite their higher initial cost, mercury batteries give the lowest operating cost when they're used in a low-power drain transistor radio circuit

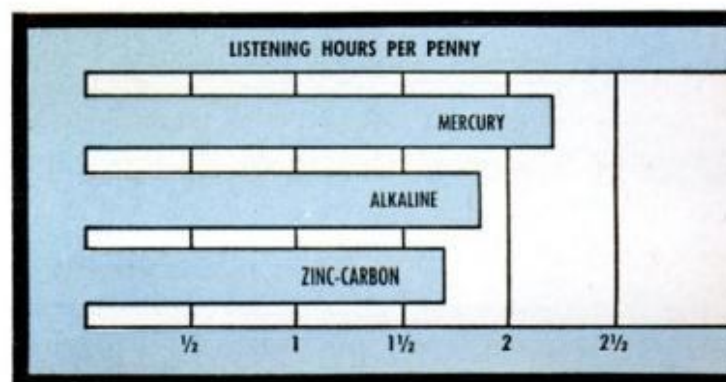

POPULAR MECHANICS

for You...

Alkaline cells are at their best where high power is required for intermittent short periods of time. The cell recuperates rapidly. This makes them extremely useful in motorized devices or for firing flashbulbs or strobe lights.

Zinc carbon cells have a moderate life, but are available almost anywhere. They are made in three basic categories—general purpose, photoflash and transistor applications. Each should be used for the purpose specified. Do otherwise and you shorten their life.

In Fig. 2, we compare the hours of service various types of batteries can be expected to deliver. Again the application illustrated is a transistor radio. Obviously, if long life in a low-power circuit is required, mercury batteries are best.

If we change the application and draw this same chart for a high-current motor, the alkaline cell would take the lead.

Try to draw high current from a mercury cell and you shorten its life drastically. Zinc-carbon cells don't stand a chance here—the high power drain kills

Fig. 2—Measure hours of service and you'll find that both mercury and alkaline types come out ahead of zinc-carbon batteries when used in a transistor radio

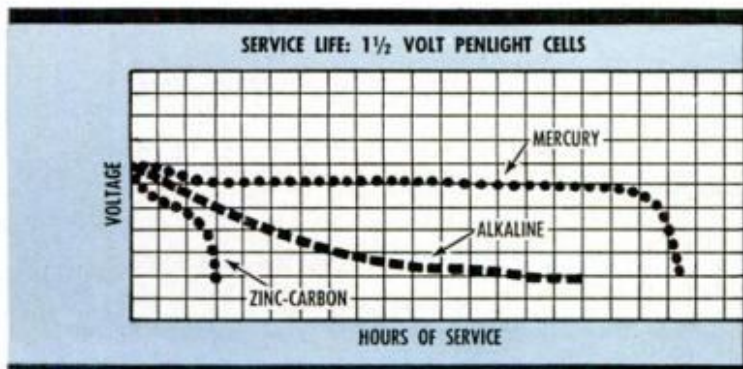
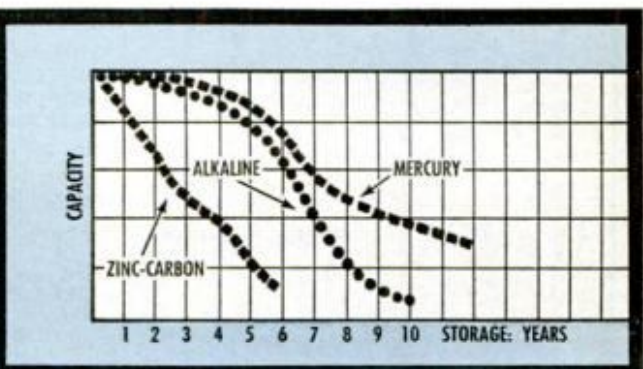

Fig. 3—Shelf life is an important characteristic. It tells you how long you can store idle batteries and still have them work when they are needed



them fast. They may be inexpensive and readily available, but for high power use, alkaline is best.





Figure 3 compares the shelf or standby life of various batteries. Again the mercury cell comes out on top. It can stand idle up to eight years and still deliver 50% of its original power. In less than two years a zinc carbon cell is almost dead. So, if standby power in an emergency radio is required, mercury is best. Note too that alkaline cells have a good shelf life. For this reason they make good standby power for the flashlight in your car.

Going back to Fig. 2 for a moment, notice that this chart also shows the comparative voltage stability of the battery

over its useful life. Both the zinc-carbon and the alkaline drop steadily. However, mercury cell voltage remains relatively constant until it reaches its final hours. Here's another reason why mercury batteries are used in watches and clocks and in the new cadmium-sulfide light meters.

What about leakage? We've all seen what happens when an over aged zinc carbon cell splits and corrosive electrolyte oozes out all over the inside of a flashlight. You usually end up throwing out the flashlight. Leakproof cells help, but I can show you many a leakproof cell that has split and oozed. In a transistor radio this can be fatal; electrolyte can ruin the copper-printed circuit board.

Alkaline cells are much more resistant

WHERE TO USE THEM		
Use	Battery Type	Pros and Cons
Clocks, Watches 	Mercury	Long, constant-voltage life gives accurate timekeeping with minimum of battery changing. Excellent resistance to leakage
	Alkaline	Voltage curve not constant, could affect timekeeping accuracy. Not available in subminiature sizes used in watches
	Zinc-carbon	Voltage curve not constant. Not available in subminiature sizes. Tendency to leak which could damage mechanism
	Nickel-cadmium	Not suitable. Life too short before recharging
Flashlights 	Zinc-carbon	Excellent for everyday watchman-type service where it can give lowest-cost operation. Replacements are readily available
	Alkaline	Good for rarely-used emergency flashlight in car or home. Long shelf life (see Fig. 3). High current output. Little chance of leakage
	Nickel-cadmium	Very useful around the house where a.c. line voltage available for recharging. Needs recharge after using
	Mercury	Use when long standby life is mandatory. Comparatively high current drain of flashlight will rapidly run down battery
Hearing Aids 	Mercury	Best bet. Provides long-term power in these low-current circuits. Minimum replacement
	Alkaline	Not available in subminiature button-type sizes often used
	Zinc-carbon	Not available in subminiature sizes. Short useful life. Leakage may damage device
	Nickel-cadmium	Not practical. Short useful life before recharging. Might not last eight hours
Cadmium-sulphide light meters 	Mercury	Long, constant-voltage characteristic with minimum battery changing makes this best
	Alkaline	Voltage does not remain constant. Not available in sub-miniature sizes
	Zinc-carbon	Not available in subminiature sizes. Voltage does not remain constant. Tends to leak
	Nickel-cadmium	Voltage does not remain constant. Short useful life before recharging
Flashbulbs 	Alkaline	High power keeps firing bulbs in sync. Long shelf life ideal. Leakage not a problem
	Zinc-carbon	Shorter life but readily available. Change every eight months no matter how much or how little used. Leakage can damage equipment
	Nickel-cadmium	Short life before recharging
	Mercury	Not recommended. Lacks high-current capability. Life short and erratic in this application
Movie camera	Alkaline	Excellent choice. Provides high, fairly constant power. Good storage life. Little leakage

to leakage and mercury cells almost never leak. However, it's a good policy to remove the batteries from any equipment that will stand idle for any length of time.

The rechargeable nickel-cadmium cells are a world to themselves. They keep you tied to an a.c. outlet for recharging, but if you recharge after each use, they last indefinitely. Be sure not to let the battery go completely dead. If it does, it can never be fully charged again.





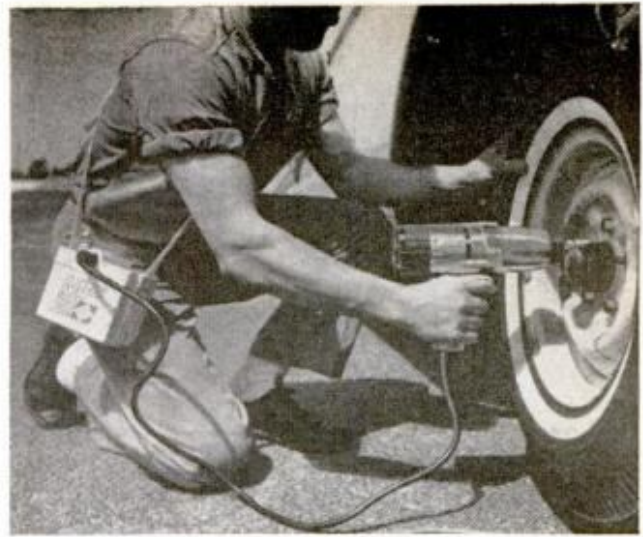

Zinc-carbon, alkaline and mercury batteries are rechargeable, too. Several rechargers for these units are on the market. Also a new rechargeable alkaline battery has been announced by Eveready.

When recharging these batteries, remember that a battery that has gone dead from



NEW SEALED EXIDE lead-acid wet-cell may soon replace more costly nickel-cadmium types. The new rechargeable device holds more power and is less expensive

WHERE TO USE THEM

Use	Battery Type	Pros and Cons
Movie camera (cont.) 	Mercury	Second choice. High current required by some motors can reduce life. Much better voltage stability than alkaline (see Fig. 3). Practically no leakage
	Zinc-carbon	Can be used, but leakage can damage camera. Short life, rapid voltage drop, readily available
	Nickel-cadmium	Short life before recharging needed. Rapid voltage drop. Ties user to a.c. outlet
Strobe 	Nickel-cadmium	Permits a.c. and battery operation. Indefinite life if recharged after each use
	Alkaline	High power. Little leakage possibility. Rapid recycling. Long storage life
	Zinc-carbon	Short life. Leakage may damage equipment. Readily available in emergency
	Mercury	Not recommended. High power drains can reduce life of battery
Tape recorder 	Alkaline	High current for motors. Fairly stable voltage output. Reasonably long shelf life
	Mercury	Long flat voltage output means better speed regulation. However, high current drain from motor may shorten life
	Zinc-carbon	Short life. Leakage may damage recorder. Rapid voltage drop. Easily available
	Nickel-cadmium	Good only for short periods of operation before recharging
Toys 	Alkaline	Longer life and better performance because of high-current potential
	Zinc-carbon	Low cost per unit, but life can be very short. Leakage can damage toy. Readily available
	Mercury	Not recommended. High current drain can shorten battery life
	Nickel-cadmium	High cost can be prohibitive in this use
Transistor radios 	Mercury	Longest life, best performance and lowest end cost. (see Fig. 1)
	Alkaline	Good in sets requiring high power (e.g. table models). In pocket sets won't last as long as mercury, but costs as much
	Zinc-carbon	Readily available, but life is short and end cost high. Leakage can damage receiver
	Nickel-cadmium	Very costly. Practical if only short periods of operation are required before recharging
Transistor portable TV 	Nickel-cadmium	Permits battery or a.c. operation. Indefinite life if recharged after each use. Usable life after recharging may be as little as 2 or 3 hours. Light weight for size
	Mercury	All three expensive, non-chargeable and heavy for this application
	Alkaline Zinc-carbon	

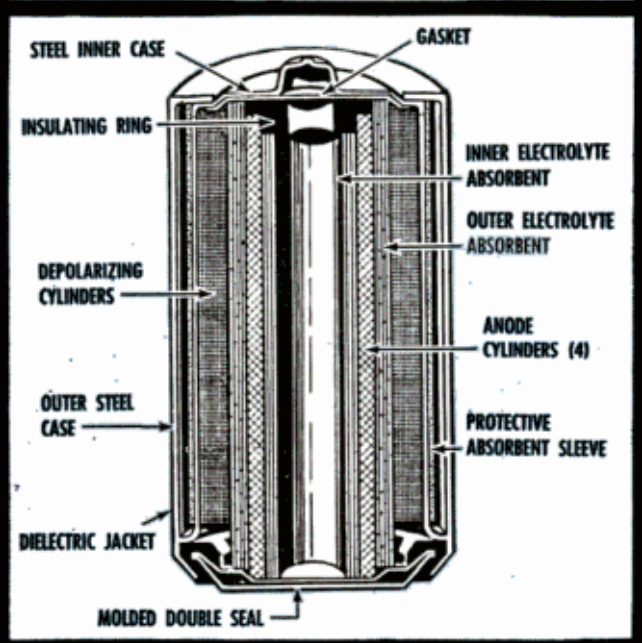
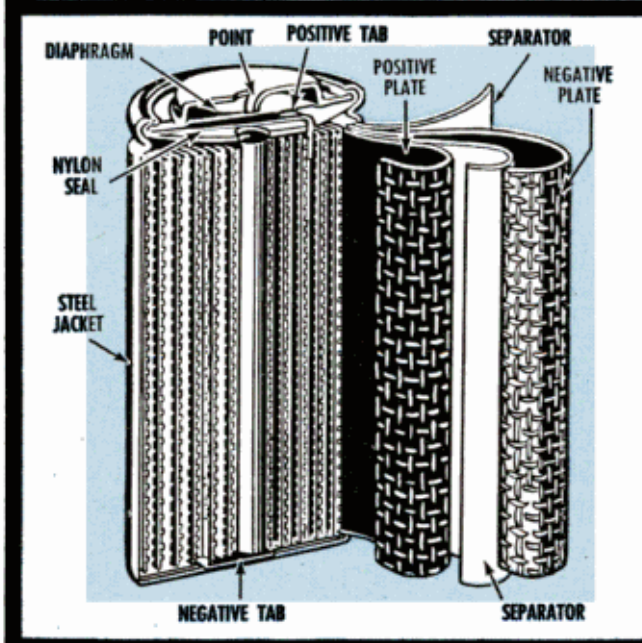
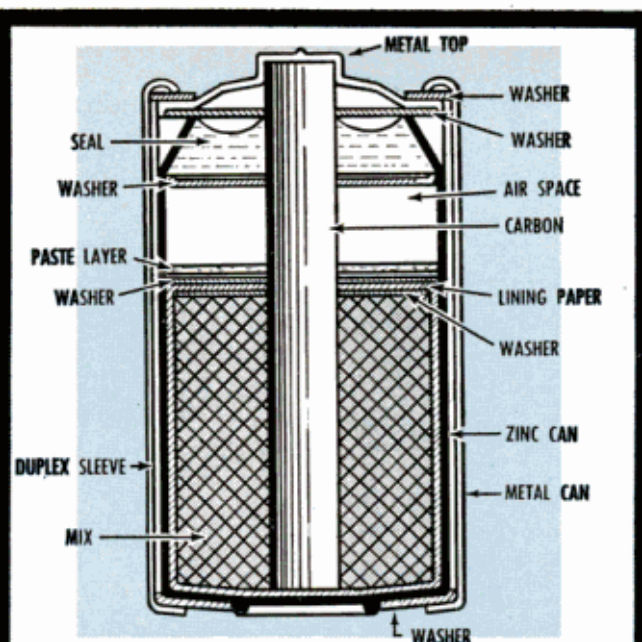
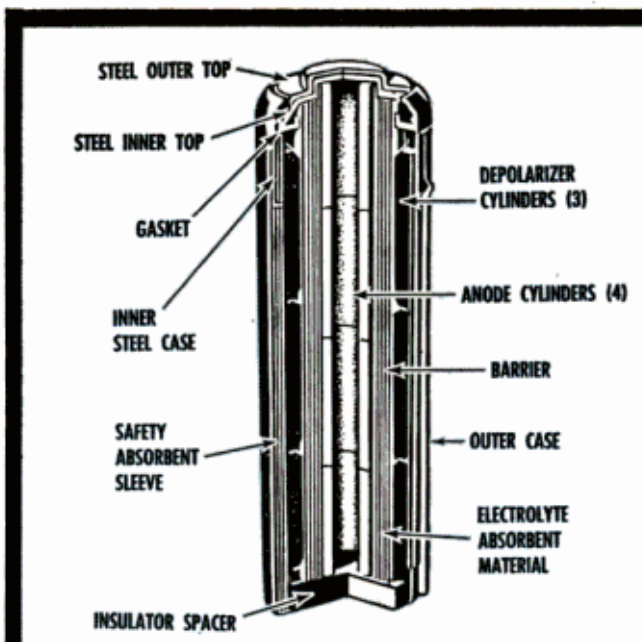

CUTAWAY VIEWS of the four major battery types showing their internal structure. Cylindrical mercury cell is in the upper left. To its right is a standard zinc-carbon battery. On the lower left is a rechargeable nickel-cadmium type and to its right an alkaline battery. All Four types are dry cells

sitting around cannot be recharged and you shouldn't let a battery go completely dead before recharging. When recharging you'll be able to use that zinc-carbon cell about two more lifetimes, the alkaline five to ten lifetimes and the mercury 50 lifetimes. Charging must be slow and steady (usually overnight). A fast or overlong charge may cause the cell to explode.

Now for some final tips. If you want to extend the life of zinc-carbon batteries during storage, keep them cold. The colder the better. This slows down the electrochemical action, prolonging shelf life.

Wherever you keep or use zinc-carbon cells, replace them every eight months whether they have been used or not. This

will insure you against dead or weak batteries when you need them. This is especially true for your flashgun. Weak batteries may fire the flash, but the firing time may be late and the bulb won't sync with the shutter.

Looking into the future, there's a new Mallory battery coming that won't have a storage problem. It is not even charged until you are ready to use it. You'll turn a thumbscrew before use to release the electrolyte and activate the cell. But it's experimental and won't appear on the market for some time.

For more battery data, you can purchase detailed manuals from Burgess, Mallory, RCA, and Union Carbide (Eveready). ★★



Coffee—Anywhere

Supplying hot coffee any time and any place, a new coffee pot carries its own heating fuel.

Porta-Perk is distributed by Teeco Products, Inc., Anaheim, Calif. Retail price is \$13.95; extra fuel cans cost 69 cents apiece.

Two endless rubber-belt sidewalks at the San Francisco International Airport carry passengers from the United Air Lines ticket area to the flight gate, a distance of 450 feet.

The electrically driven Speedwalk Passenger Conveyors were developed by Stephens-Adamson Manufacturing Co., Aurora, Ill.

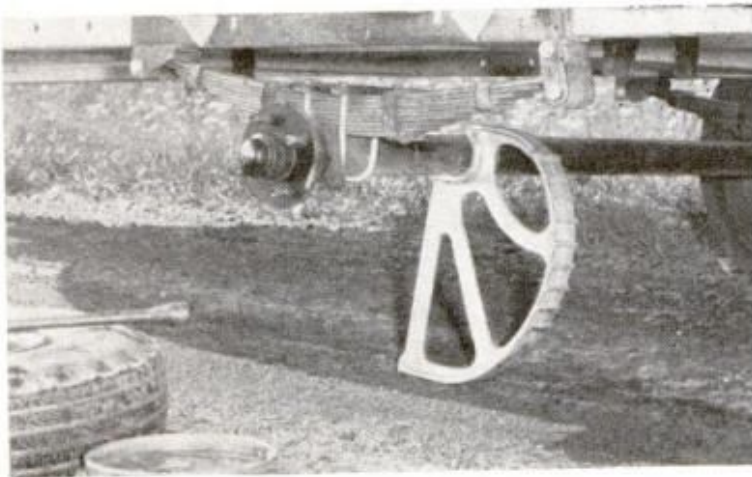

Roll-On Trailer Jack

The ingenious design of a new trailer jack makes it possible to elevate a wheel by just pulling the trailer forward on it. Called Kwik Lift, it's available in a two-ton \$9.95 model which fits wheels from 8 to 16 inches and a four-ton \$19.95 size for wheels from 12 to 16 inches, f.o.b. Conlan-Sieloff Industries, Box 372, Bloomfield Hills, Michigan.



Steam Cycle

A loud hiss, a cloud of vapor, and Lenord Washburn is off on his steam-powered motorcycle.

The frame and wheels are Harley Davidson. A butane-burning 1902 Toledo automobile steam engine, running at a normal pressure of 180 pounds, supplies the power—far more than that of a conventional cycle engine. Gobs of torque make a clutch and transmission unnecessary. A droll touch is a valve-operated steam whistle.

Washburn, who lives in Rubidoux, Calif., spent \$650 and 14 months building the hefty 850-pound machine, which is about 250 pounds lighter than a conventional machine.

The photo shows Washburn "fueling up" with water.

Double-Decker Station Wagon

This split-level sleeper, once a Detroit stocker, provides a lofty outlook to highway cruising

By Alex Markovich

THE CLOSEST THING on wheels to John Swanberg's zany split-level sleeper is a transcontinental Sceni-Cruiser bus.

A Minneapolis trucking firm employee, Swanberg made his first sleeper conversion five years ago on a Dodge sedan. He was so pleased with the results that as soon as he got his next car—the six-cylinder Chevrolet sedan shown here—he went to work chopping off the roof, rear window and rear deck lid. He added a second, raised floor pan, an all-steel superstructure and three seats—one facing backward—that fold into two full-length beds. Finally came matching carpeting, upholstery and the wraparound windshield and tinted side windows that curve up over the top.

With help from Minneapolis Honeywell engineers, Swanberg designed a micro-

switch system with lighted pushbuttons in the upstairs areas. A touch of the proper button turns on a rear radio speaker, reading or indirect floor lights, an exhaust fan or windshield wipers.

There's been only one mechanical change to Swanberg's rig: He installed station wagon springs to compensate for the 350 pounds of added 16-gauge steel and glass. While his sleeper may look top heavy, he claims its handling isn't noticeably different from a regular Chevrolet Six sedan. Acceleration is, of course, somewhat slower. The only dimensional change is in the increased height—about 14 inches.

Swanberg says the conversion is possible on any full-size car since each one is a custom job. With his son's help, this one took a summer's spare time. Cost: \$1500 over the original price of the car.

A JUNIOR-SIZE TRANSCONTINENTAL BUS is this turnpike sleeper, the spare time project of a Minneapolis trucking firm employee. The conversion was based on a standard Chevrolet six-cylinder sedan. It adds only 350 pounds weight

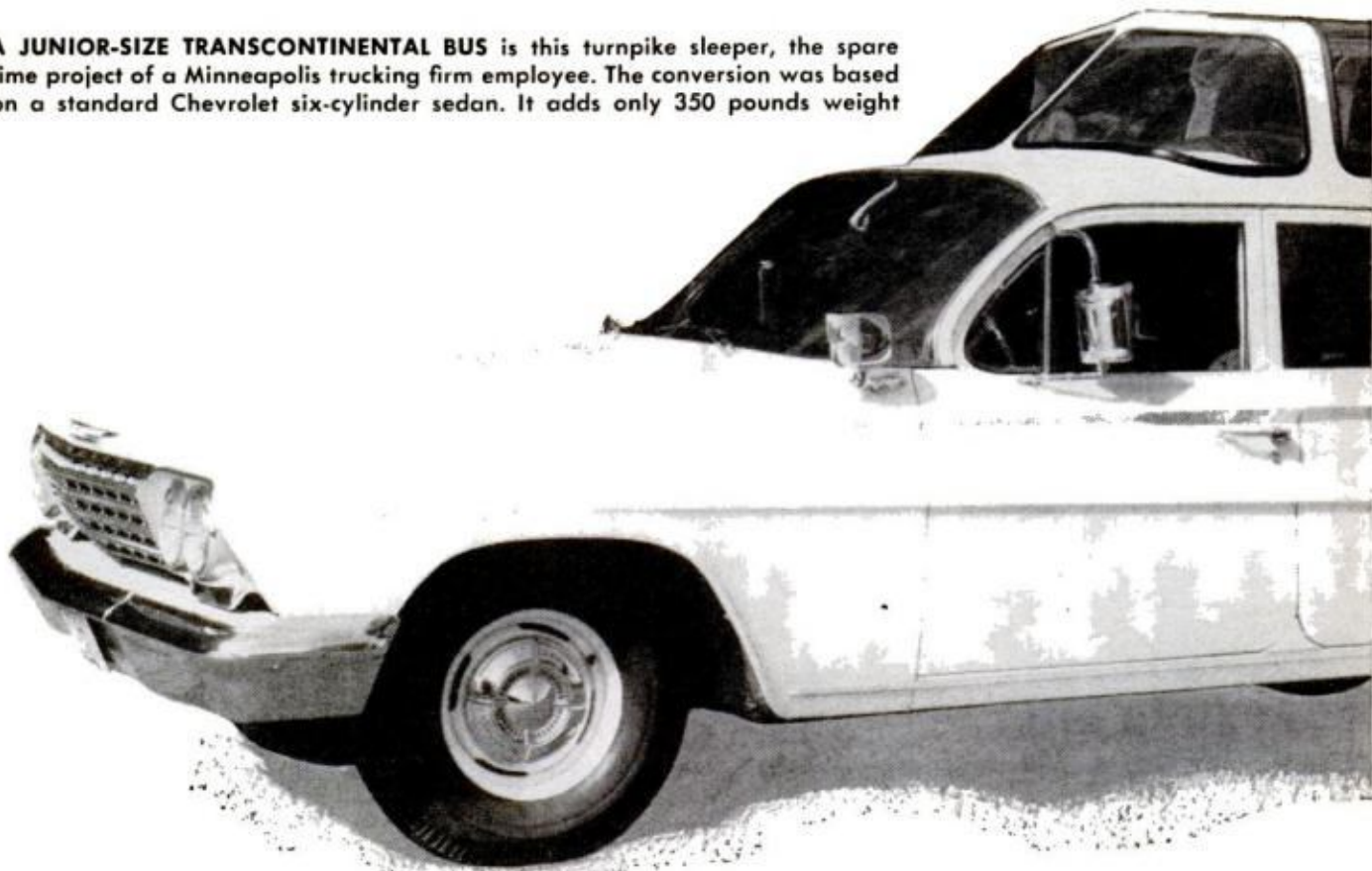

A. TINTED WINDOWS of the split-level sleeper curve up and nearly meet at the top. Occupants of the full-length beds sleep under the stars. For day-time travel, the two beds become comfortable reclining seats

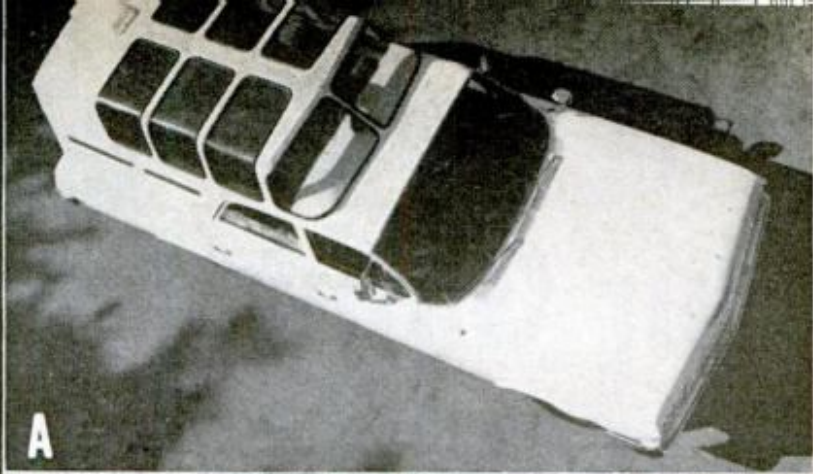

B. HALF OF THE TEAM that built the turnpike sleeper, Roy Swanberg, is shown checking his route from the driver's seat. View is from the upper level. The Swanbergs report there's no change in handling characteristics

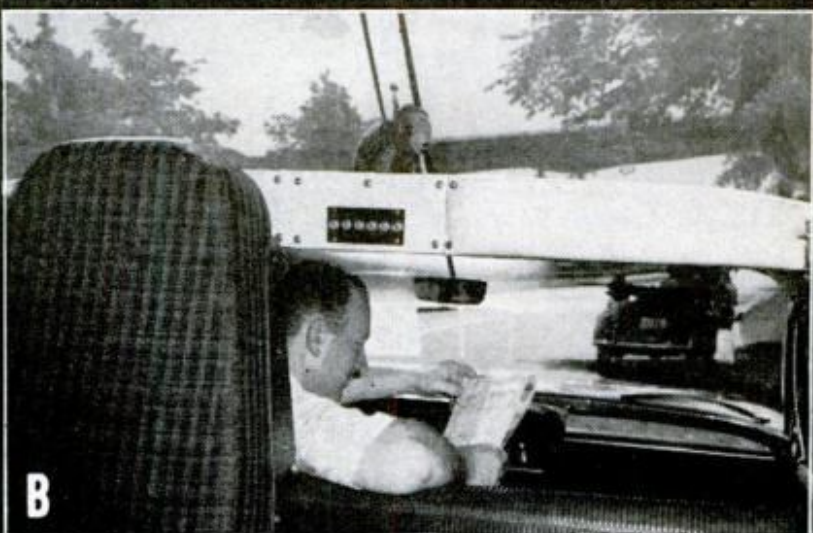

C. A LIGHT TOUCH ON one of a bank of micro-switches controls overhead reading or indirect floor lights, an exhaust fan, special windshield wipers, even a remote speaker for the radio. It lets owners camp "in transit"



D. GLASS EXPANSE atop the "upstairs" section of the sleeper, although tinted, can let in lots of sun—and heat. But curtains snap in place easily. Removing them at night gives illusion that you're bedding down outdoors



X Raying Our Giant Missiles

By Frank Tinker

A MISSILE is of no value if it's not ready to go. To guard against possible failure, our ICBMs are put through regular countdowns as they stand in their concrete silos. The countdowns stop just short of actual launch.

Another check is a constant monitoring system. If a red light shows on a control panel in the underground launch center, the particular weapon is immediately taken out of service. If the trouble is too complex for local repair, the missile is shipped to a central maintenance shop.

One such center is at Hill Air Force Base in Utah. Minuteman missiles from sites in Montana, Wyoming and North Dakota are flown intact to Hill in huge C-130 cargo planes.

The main diagnostic tool at this center is the largest X-ray machine in the country. It can pierce the heavy metal case of the Minuteman and reveal if the solid propellant has developed a flaw such as a crack or void.

The machine can transmit 12,000 Roentgens and take pictures through eight inches of lead. (About 150 Roentgens will usually prove fatal to a human being within an hour.) To produce the tremendous energy required, a linear accelerator—Linac—is used. Electrons shot into one end are hustled along the main tube until they near the speed of light. They smash into a metal target and X rays are emitted from the force of the collision.

Exposures are governed by a radicon, a computer that determines the exact amount of radiation being received by the missile. Though over 500 pictures are required to inspect Minuteman's first stage alone, such a probe can be completed in 20 hours.

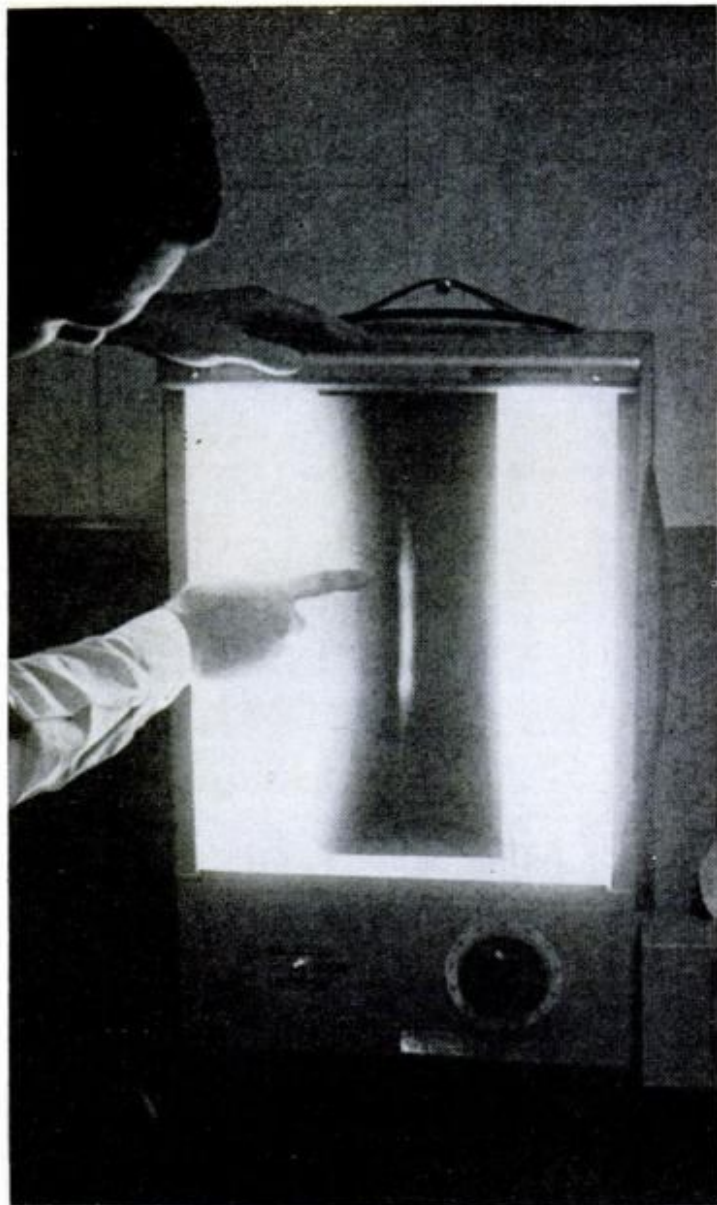

A SERIOUS FLAW, a separation in the propellant, shows up clearly on X-ray film. Such a separation could cause an explosion when the missile is fired

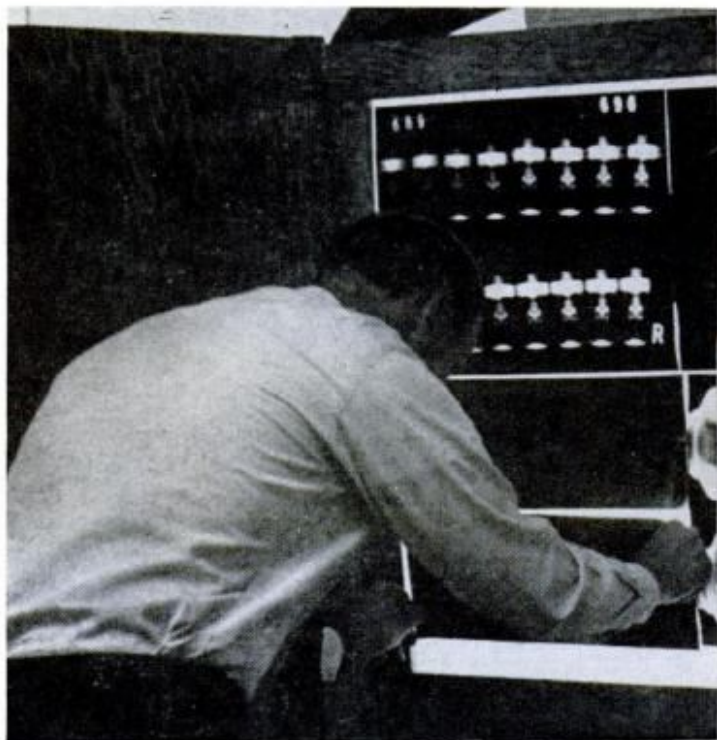

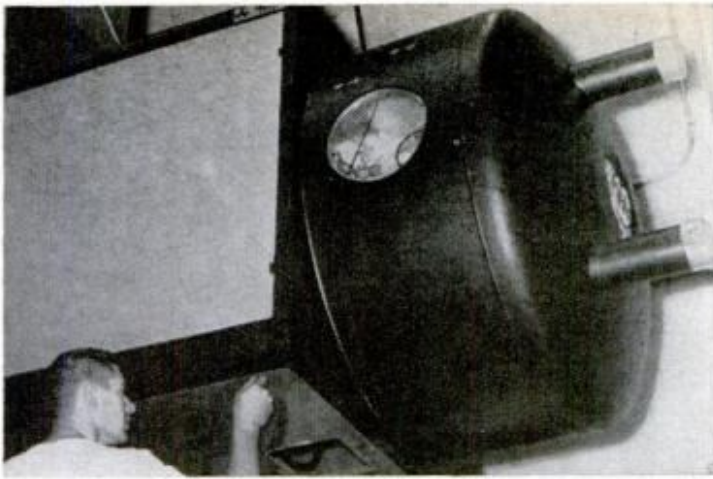

ROUND MIRROR in head of 24-million electron volt machine reflects an aiming light on target. Head can be rotated independently of accelerator tube

LOADED Minuteman first stage sits in front of big film holder. Alarm bells will warn crewmen 30 seconds before the powerful machine is turned on

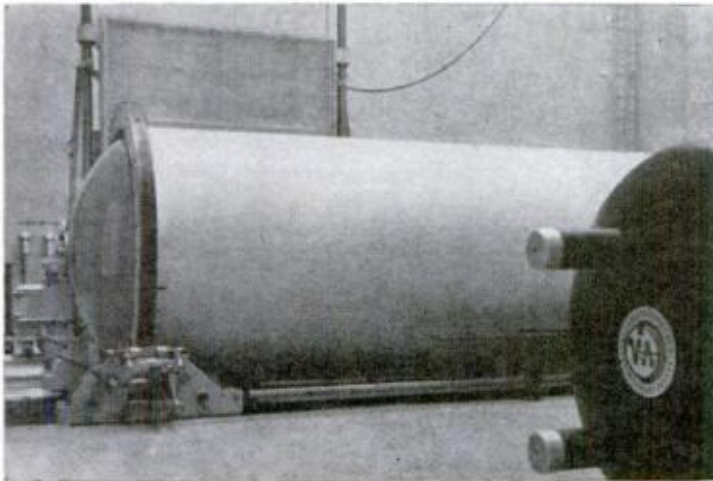

SERIES of films of missile components is studied by technician (below). By comparing X rays, the expert can quickly spot deviations from norm

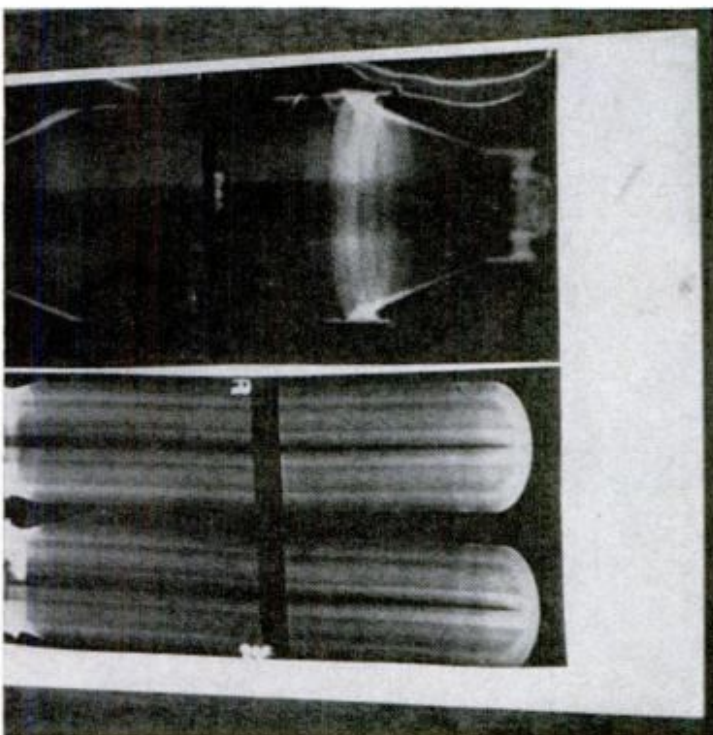

DECEMBER 1964

Ride a Steel Horse

Wild horseflesh isn't always available to rodeo performers. So they practice on what they succinctly call a "phony bucker."

The device consists of an empty oil drum suspended by ropes from four solidly planted poles; an ordinary western saddle is cinched to the drum. With an energetic "puller" yanking and swinging on each rope, the simple apparatus is transformed into a bucking monster.

Though they're college boys shown here taking their lumps, even veteran riders say there's nothing phony about the "phony bucker."



99



...You Can

WALTER FOEGER, controversial director of the ski school at Jay Peak, Vt., has eliminated the snow plow and stem turn in his unusual teaching method

THE PROOF is in the skiing, and the student in the photo executes a parallel christie with perfect form on the seventh day of instruction at Jay Peak



Ski Parallel in 7 Days

It's tough, and critics damn it, but this system has revolutionized ski instruction

By Stuart James

PM outdoors editor

IT'S IMPOSSIBLE! I don't care what you say, it takes at least five years to ski parallel, and I think this whole system is a phony gimmick!"

I had been talking to a friend at the American Alpine Club, and the mere mention of a new method of teaching skiing was enough to send her into an angry tirade.

Last spring I received a letter from a ski instructor in Aspen, Colo., and he wrote: "Be careful what you say about the Foeger system. There is great opposition to this method all through the West."

At the center of what appears to be a storm in the small world of skiing is Walter Foeger, a stocky, bombastic Austrian skimeister, who conducts his ski school at Jay Peak, Vermont, with the zeal and fanaticism of an athletic evangelist.

The cause of the furor is simple. Recognizing that the ultimate aim of almost all skiers is to ski parallel (skiing with both skis close together at all times), Foeger devised a method to teach parallel technique from the very first time on skis, totally eliminating the snow plow, the plow turn and the stem turn, the absolute basics being taught in almost every other ski school.

"What do I care what they say about me!" Foeger exploded with indignation, when I talked with him at Jay Peak. "The snow plow is ridiculous! It is old fashioned. These people are against progress." He stormed around in the small area behind his desk, intermittently stopping to pound a fist on the desk, jab the air with his finger, scowl and shake his head. "I call my method Natur-Teknik, because it is the natural way to ski. Anyone with normal coordination can learn to ski parallel in seven days. I guarantee this, or I give the money back. You will see what I mean. You will see!"

And I did see. I spent two weeks at Jay Peak. I enrolled in a class under instructor Tom Emrich and was introduced to the Foeger system. It was an exciting experience.

The Foeger school is no place for a "snow bunny." The instructors and students take their skiing seriously—almost obsessively—and from the beginning it is hard work. Jay Peak has the atmosphere of an Olympic training camp, and the instructors work their classes with all the charm and finesse of a Marine drill sergeant. This Spartan dedication permeates everywhere, and you hear nothing but *parallel*. You practice it all day, talk about it at lunch and dinner, argue about it around the fire at Dave Allen's Jay Barn Village, and I even dreamed about it, Tom Emrich's shouts invading my sleep—*Keep them together! Bend your knees! Relax! Just relax! Keep those skis together! No, no, no.*





KICK TURN: Make secure platform with uphill ski. With poles to the rear, kick downhill ski up on tail, let it fall as shown, then bring uphill ski to bear

Oh, how can you be so clumsy? Dumkopf!"

The criticism I heard was limited to claims that the system was too physically gruelling, and a high incidence of minor injuries (sprains and pulled muscles) was blamed on the exhaustion of the students. A student who dropped out after only three days told me: "I came up here to have fun. This place is run like a concentration camp."

It is tough, but it gets results.

The instruction begins with standing and walking on skis, how to hold the poles, the step turn, how to get up after a fall, climbing a slope with the sidestep and the herringbone step. It is much the same as a conventional class, except that there is no snow plow. There is considerable stress placed on the execution of the kick turn, for the simple reason that it will speed up the classes when they get on the slopes.

Schussing (going straight downhill without checks or turns) on a gentle slope winds up the first day, and in this exercise the skier develops balance by bending down to pick up gloves on the trail, and lifting the tails of alternate skis.

Skating exercises start the second day, pushing off with one ski and then the other, improving the balance and getting the feel of using the edges. Then comes the traverse on a gentle slope. With the skies close together, the uphill ski leading slightly, the uphill shoulder well forward so that the upper half of the body is turned downhill, the skier glides across

the slope and comes to a stop. It is all very pleasant and simple—and then you head for the T-bar lift and the terror sets in.

As the beginners take their positions at the lift, take the T-bar from the attendant, and are then jerked off their feet and tumbled into the snow, you hear the first groan from the instructor. It might be comical—except that you're the one being dragged up the hill upside down.

It takes time, but the class manages to get to the top of the intermediate slope. The drop-off looks awfully steep, and as you look around at the others in the class, you know they all have the same thought: *I hope he doesn't really expect me to go down there.*

He doesn't, and there is a general sigh of relief that brings a laugh. One after another the class traverses from side to side, stopping at each side, making a kick turn, then traversing to the other side.

I have neglected mentioning the falls, but there are a lot of them. They jar the bones. Time after time you push yourself up, and by the time you reach the bottom and break for lunch, you feel as though you've been dragged down the mountain on your back.

The afternoon begins with hopping exercises. With the skis close together, you lean well forward, bend the knees, and then hop up, lifting the tails. With a ski pole stuck in the snow as a pivot point, you face it with the ski tips close to it, and

BASIC EXERCISE on flat ground. With skis together, leap up and forward to lift the tails, jumping from side to side to get natural feel of the hip action

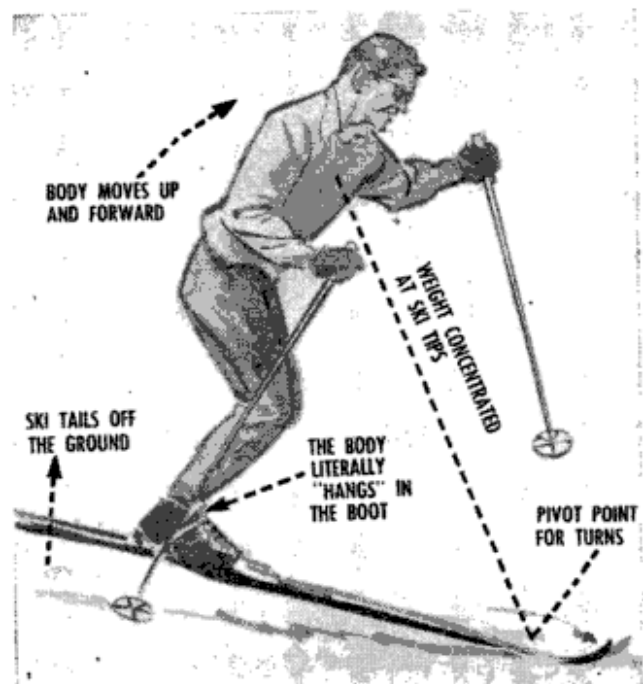

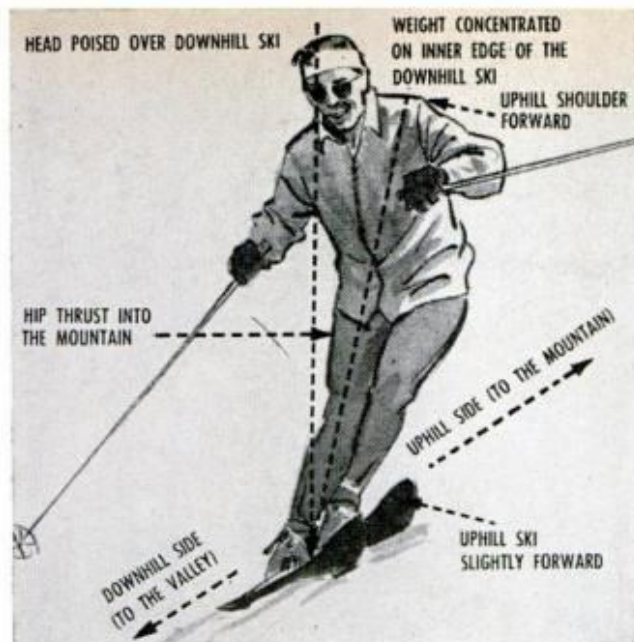

COMA POSITION in the traverse illustrates how leaning out from the mountain places the weight on the inside edge of the downhill ski for greater control

jump around it. Next, you jump to left and right.

On a gentle traverse you practice hopping, displacing the unweighted tails downhill until the skis turn to the mountain.

Then you go to the top of the intermediate slope again, and now you traverse, using the hop technique to stop. The traverses are now longer and steeper—the falls are more frequent and harder. But you are beginning to feel confidence in your ability to control the skis on steep and difficult ground.

The third day you begin side sliding. Standing at the top of a vertical drop, you assume the traverse position. By pushing off with the poles and tilting the skis so they are flat against the snow surface, you begin to slide sideways. You are leaning out from the mountain and trying to keep the tips facing slightly downhill. In this exercise you learn that as you lean the body out and place the weight on the downhill ski, the tails of the skis tend to slide downhill.

Feels Like Skiing

Next step is the turn to the mountain, and for the first time you feel as though you are really skiing.

In the traverse position you angle down and across the slope. As you pick up speed, you go into a crouch, weighting the downhill ski to make a solid platform. You jump up and forward, unweighting the skis. Then you come down on the inner edge of of

the downhill ski, thrusting your hips into the mountain, and thrusting down and out with the heel on the downhill ski. The tails slide out and you come to a stop. When you execute this turn after a fast run directly down the fall line, it is an exhilarating feeling.

The fourth day is spent perfecting the turn to the mountain on a variety of terrain, and to stress the importance of keeping the weight on the downhill ski, you learn to execute it while wearing one ski.

Making the downhill turn is the finale. You prepare on a gentle slope using the hop technique to bring the skis into and over the fall line. Then you go on the intermediate slope.

In a relaxed position you traverse the slope. You crouch to weight the skis, then you leap up to unweight them. The weight is on the front of the skis. You thrust the heels into the mountain, moving the tails uphill. At the same time you bring the downhill shoulder forward and twist the body from the waist up. The skis slide over the fall line, still turning. You come down on the outside ski, planting the edge, and you are in the traverse for the next downhill turn.

That's it, the Foeger method. I saw, without exception, every student who went through the full seven days of instruction making linked parallel turns down an intermediate slope. The proof is in the skiing—and this system works. ★★

IN ANOTHER VIEW of the traverse, the knees point in the direction of traverse, hip is thrust to the mountain, and upper half of body faces the fall line

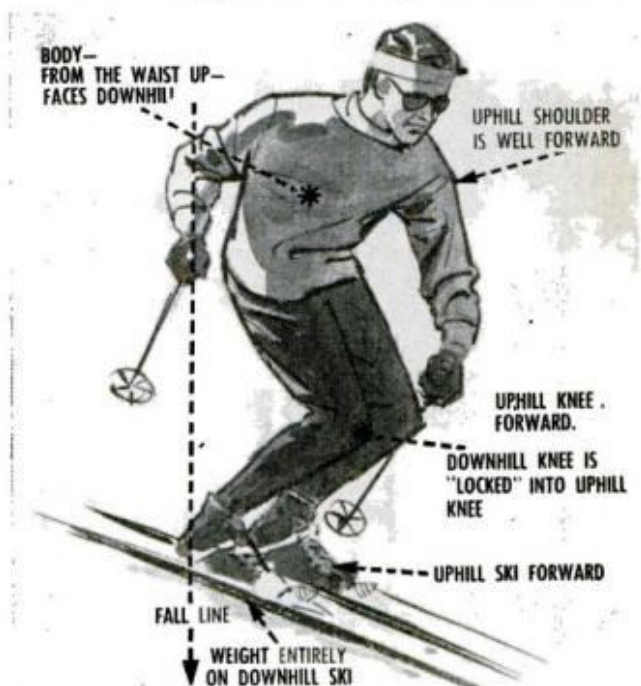

A. Side Sliding

BODY in traverse position, the skis are unweighted by upward rise

SKIS are flattened to start slide sideways, tips angled downhill

SLIGHT crouch with hip thrust to the mountain weights downhill ski

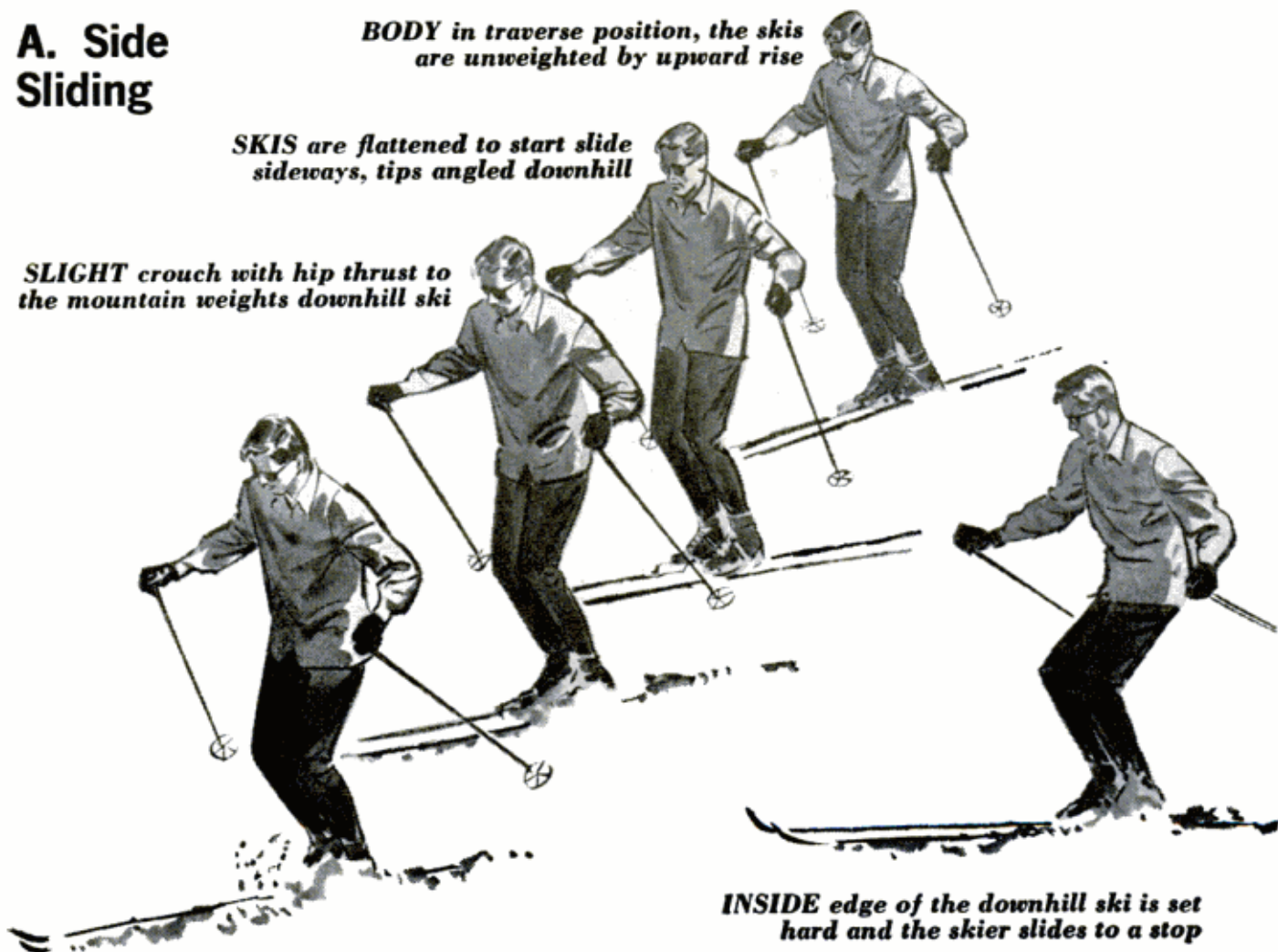

FULL weight on inside edge downhill ski stops sideslip

INSIDE edge of the downhill ski is set hard and the skier slides to a stop

A. Side Sliding

This maneuver teaches edge control and gives the beginner confidence in handling the skis. It is executed on a relatively steep slope. The skier stands with both skis across the fall line. With the uphill shoulder and the uphill ski forward, he unweights the uphill ski, and tilts the downhill ski sideways (flat against the snow surface) so that he starts to slide sideways down the hill. At the same time, the ski tips are angled slightly downhill. The beginner will find that the skis have a tendency to turn uphill in the slide, and that he can check up the slide by edging the skis (turning them so the inside edges cut into the snow). By sliding backwards, vertically and forward, the skier begins to realize that he can—after all—control the cumbersome slats on his feet, and he has experienced the practical application of edge control, one of the most important points in parallel skiing.

B. Turn to the Mountain

This maneuver incorporates the traverse, unweighting the skis, edging and side sliding. In the traverse position the skier angles across the slope. The uphill ski and the uphill shoulder are forward. The skier goes into a crouch. For just a split second the weight is transferred to the uphill ski. The skier comes out of the crouch quickly, practically leaping up and forward. The tails are unweighted and the weight is concentrated at the front of the skis. The tails start to drift downhill automatically. The skier comes down hard on the downhill ski. The body is in the extreme coma position, the hip thrust into the mountain. As he edges the downhill ski, the heel thrust slides and tails of the skis further downhill. There is a certain amount of side sliding, but the edging serves as a brake and the skier comes to a smooth stop facing uphill. With this one maneuver he can manage most trails.

B. Turn to the Mountain

TRAVERSE in slight crouch, uphill arm and ski forward, upper body facing downhill

DEEP crouch. Weight concentrated on inside edge of the downhill ski

RISING up and forward unweights the ski tails and starts turn at the tips

DOWNWARD crouch begins as the tails begin to slide downhill

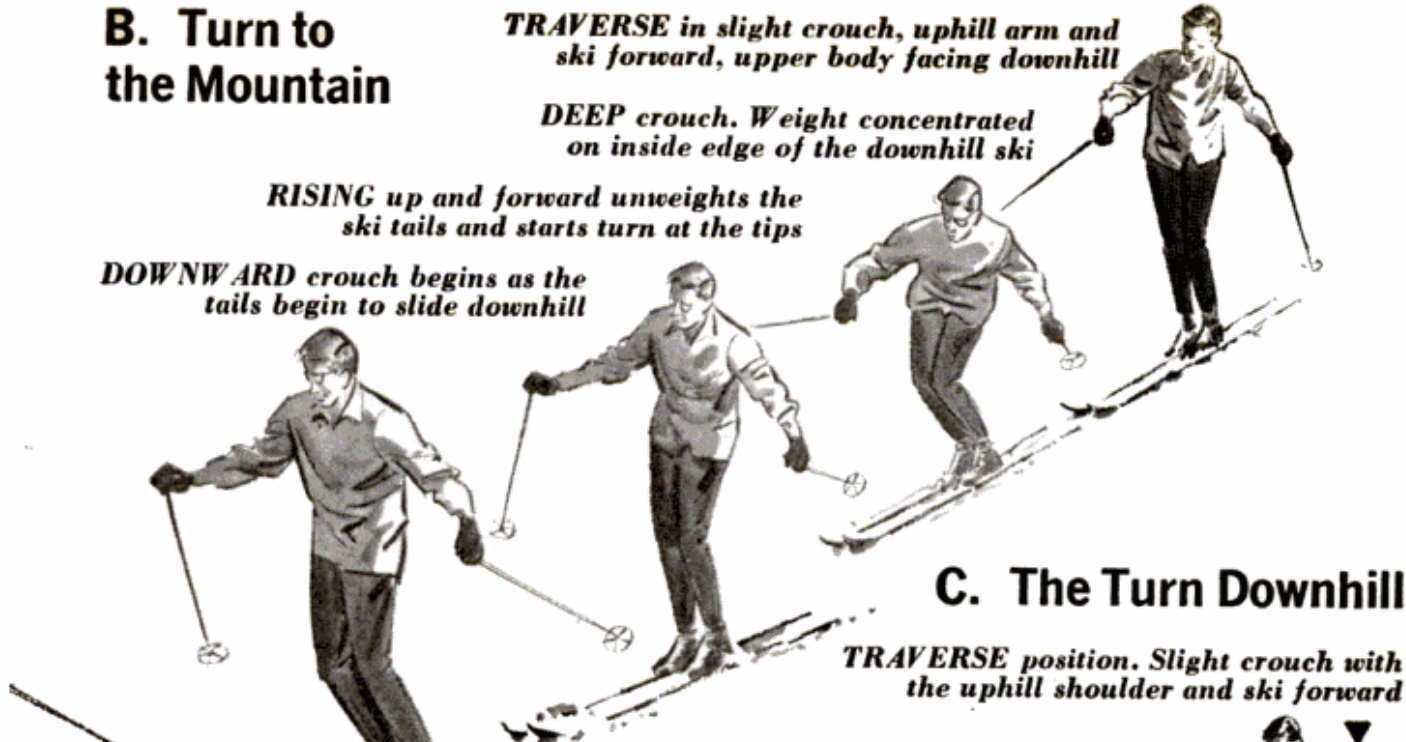

C. The Turn Downhill

TRAVERSE position. Slight crouch with the uphill shoulder and ski forward

DOWNWARD motion centers weight on inside edge of the downhill ski

RISING up and forward. Hop unweights tails, skis start into the fall line

PIVOTING on tips of skis, downhill shoulder comes forward

WEIGHT on pivot point, tails sliding over fall line, inside ski is forward

DOWNHILL ski is edged as the platform for the traverse preparatory to the subsequent downhill turn



C. The Turn Downhill

This is the maneuver that will allow the beginner to make linked turns down a mountain. The skier is traversing in relaxed position. Uphill shoulder and uphill ski are leading. He goes into a crouch, weighting the skis, and in the next instant he leaps up and forward. The tails are now unweighted and the weight is concentrated at the front of the skis, creating a pivot point. As he comes down the heels are thrust uphill, turning the skis into the fall line. In this same heel-thrusting movement, the downhill shoulder is thrust forward, twisting the body from the waist up (this is also called the reverse shoulder movement), and accentuating the pivoting of the skis on the tips and the sliding out of the tails. Once over the fall line, what was previously the downhill ski is advanced slightly. The skier returns to a crouch, weighting the new downhill ski, and traverses for the next turn.



Keep Them In Their Place

This child-size safety belt is a harness so complete it's almost impossible for a youngster to wriggle out. Adults control the release. The rig comes in two sizes, one for children 1 to 4 and one for those age 3 to 5. The safety belt is sold for about \$11 by Chrysler dealers.

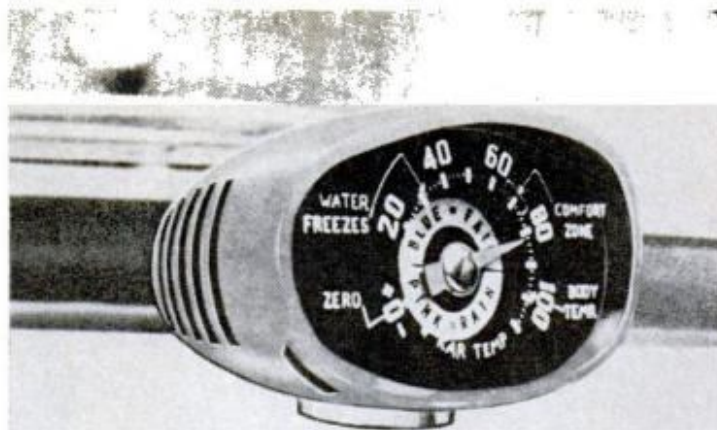

How Cold Is It?

For those who are curious about the weather, the Weather Guide has both a thermometer and a humidity-sensitive color disc that helps estimate what changes are coming. Dial can be inverted for under-dash mounting. Price is about \$4. By Kar Temp Co., Ruxton, Md.



Swept-Forward Wings

Said to be the only airplane with wings swept forward, the German-made Hansa Jet will do an estimated 550 m.p.h. The forward sweep, the makers claim, will allow the jet to land in short fields, even unpaved airports with grass strips.



He Drives on Two Wheels

Balancing cars on two wheels is old hat to French stunt driver Jean Sunny. He's been developing the act for 12 years. His longest run was 60 miles, from Paris to Chartres. His Simca 1000 has reinforced shocks and a locked differential.

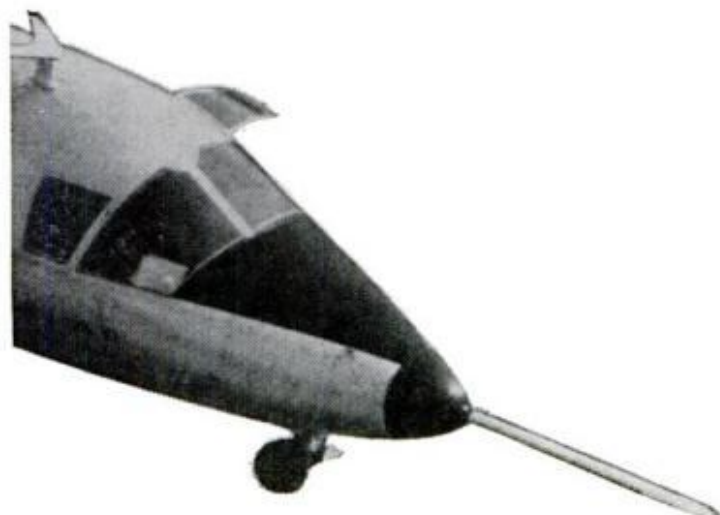
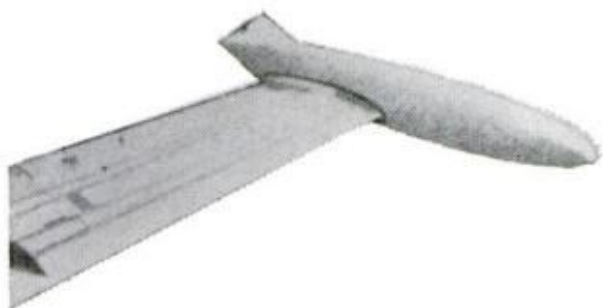

Rudder-Brake for Big Ships

Stopping distance for big ships is cut sharply with a new "water wing" rudder, according to the Japanese engineers who developed it. The rudder appears conventional (photo immediately below) until its two leaves, hinged at the rear vertical edge, swing out (other photos) to slow forward motion with parachutelike effect.

The wings normally remain folded until they are activated from the bridge. They're also said to increase maneuverability at low speeds.

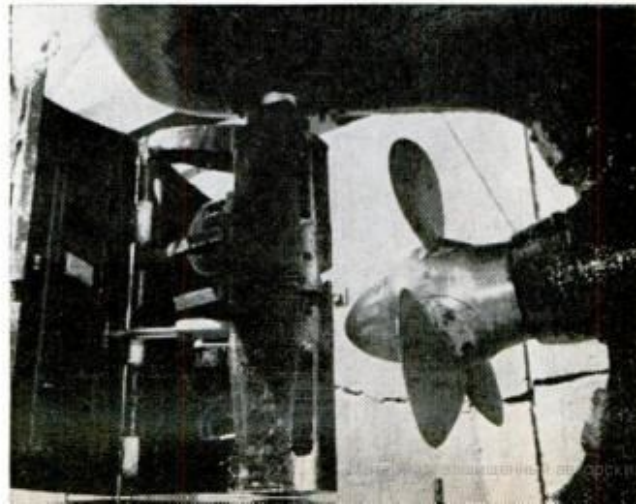
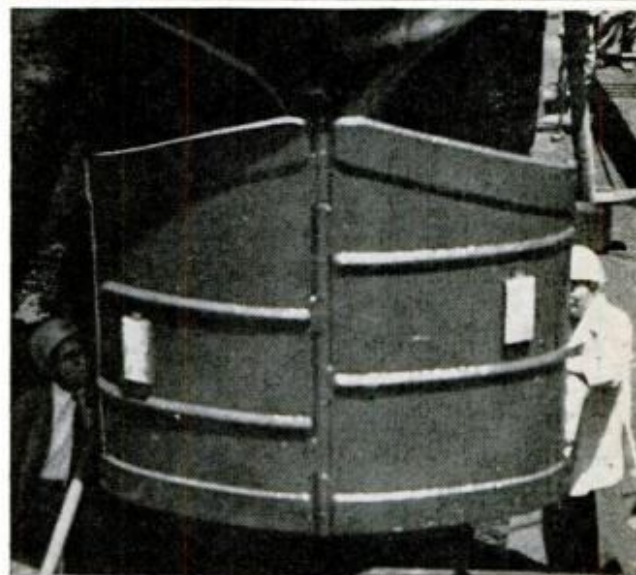
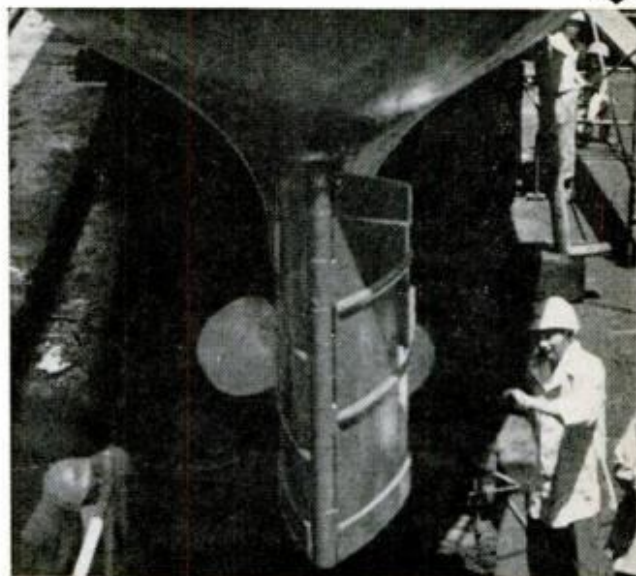

BRUCE W. HALSTEAD, physician and skilled diver, hunts the seas for toxic fish such as this porcupine (right), captured in waters off Wake Island

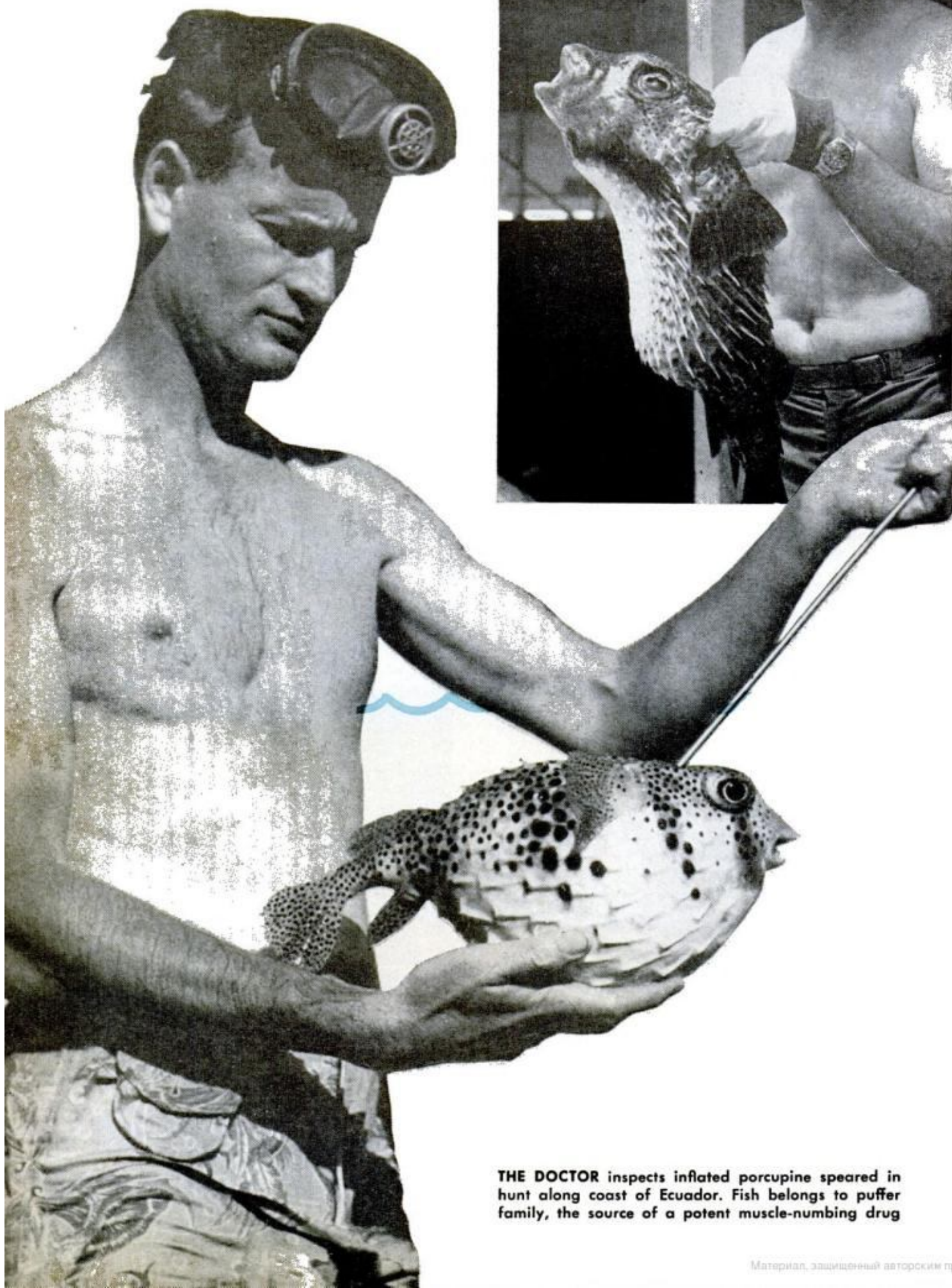

THE DOCTOR inspects inflated porcupine speared in hunt along coast of Ecuador. Fish belongs to puffer family, the source of a potent muscle-numbing drug



EVAPORATOR is used by bacteriologist John Sieburth to extract moisture from Sargassum weed, which contains an antibiotic and is plentiful in Atlantic



IN LAGOON of Palmyra Island, 1000 miles south of Hawaii, Halstead uses steel hook to pry loose coral samples. Some corals have antibacterial property

Therapy from the Sea

Nature's medicine chest is opening to reveal potent new chemicals for fighting viruses, heart disease and a host of other ailments

By James R. Berry

MAN'S ANCESTRAL HOME—the sea—has long been a source of remedies for illnesses. Millenniums ago the Chinese prescribed seaweed preparations for dropsy, abscesses and menstrual disorders. In India, an ancient treatment for bronchitis is an algal solution called gillurka-tutta, and Polynesians have traditionally used seaweed to hasten the healing of cuts.

But despite the long history of medicinals from the sea, scientific sifting of the oceans' extraordinary pharmaceutical potential has only begun. "So far, we've studied less than one percent of all the

sea organisms we *know* contain biologically active materials," estimates Dr. Bruce Halstead, one of the nation's foremost biomarine investigators. But the pace is picking up; a new medical field, marine pharmacology, is fast turning the sea into nature's most promising medicine cabinet.

Here, for example are some of the discoveries that have been made:

- Dr. John Sieburth, marine bacteriologist at the University of Rhode Island, isolated a potent antibiotic from the Sargassum weed, a plant growing in the Sargasso Sea.

- Scientists at the World Life Research

PACIFIC HAGFISH (below) has three hearts and is the source for a cardiac pacemaker. The fish is examined by Dr. David Jensen, a heart researcher

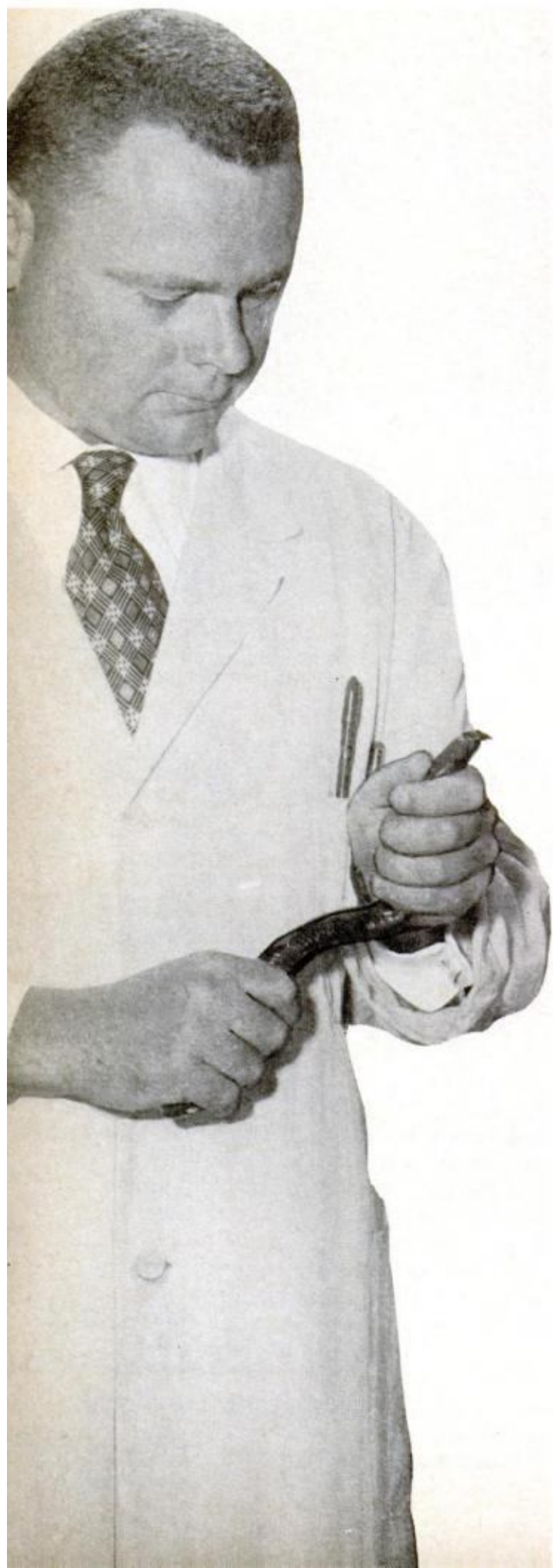

HALSTEAD and colleague bring in moray eel in Red Sea. This is a pugnacious, carnivorous fish that's frequently found near reefs and coral formations

Center, a California organization studying marine life, found a compound in the poison of sea snakes that greatly reduces the coagulating time of blood.

- At Marine Colloids, a New Jersey firm making commercial products from algae, researchers extracted a drug from brown sea kelp—it's called sodium alginate—that can rid the body of strontium 90.

In another instance, research on the Pacific hagfish at Scripps Institute of Oceanography in San Diego has resulted in what may become a startling new treatment for some heart disorders. The hagfish is a 1½-foot long, eel-like animal with 12 pairs of gills and two rows of horny teeth. Dr. David Jensen, a specialist in heart research, became interested in yet a stranger characteristic of the animal—three hearts, one of which has no nerve connections to the rest of the body.

Dr. Jensen wanted to know what kept the hagfish's nerveless heart beating. Months of painstaking work gave him the answer: a powerful biochemical pacemaker he named *eptatretin*. When injected into dogs and other laboratory animals with damaged cardiac nerve centers, eptatretin jolted the heartbeat back to normal for hours at a time. According to the American Heart Association, which sponsored much of Dr. Jensen's work, eptatretin is viewed as a possible drug to regularize the heartbeat of people with faulty cardiac nerves. This drug may eventually mean that pills instead of implanted electronic pacemakers will keep hearts with damaged nerves going.



AT NEW YORK'S AQUARIUM, research associate Sophie Jakowska isolated an antibiotic from sponge. She is shown testing the drug on infected mice

Another important center for marine investigation is the Lamont Geological Observatory at Palisades, N.Y. I recently visited the observatory's marine laboratory, where I met Dr. Paul Burkholder, chairman of the biology programs and a scientist with several pharmaceutical discoveries to his credit.

In 1944, when he was at Yale University, Dr. Burkholder and his fellow researchers found a germ killer, usnic acid, in the lichen—a composite organism consisting of a fungus and an alga. (That drug is now prescribed for tuberculosis and some serious skin infections.) Later, working with a Venezuelan soil sample, he isolated a mold that produces chloromycetin, a drug that's now synthesized and used to treat typhus and typhoid fever.

Though it was years ago that Burkholder turned his attention to the sea, he still marvels at the wealth and variety of life to be found in it. Currently, he and his staff are screening some 60 potential pharmaceuticals derived from seaweeds, corals and other marine life.

One of the organisms under study at Lamont is the "red tide." During certain seasons, a one-celled plant called *Gonyaulax* blooms off Florida and other coastal areas, covering thousands of acres of sea. During the day, the organism tints the water red; at night it phosphoresces with an eerie beauty. It also secretes a poison more deadly than strychnine.

"I was studying the biology of Phosphorescent Bay in Puerto Rico and came across a bloom of red tide," Dr. Burkhol-



PUFFER FELL VICTIM to Dr. Halstead's spear on lagoon floor. Fish's poison—tetrodotoxin—is said to be the second most powerful biotoxin known

der explained. "I wondered if that species of *Gonyaulax* contained antibiotics and I looked into it out of scientific curiosity."

To collect the plant, he bought 15 large plastic garbage pails and filled them with sea water scooped up from the bloom of red tide. After several hours the water was poured off, the thin film of sludge containing the organism collected, and the pails refilled. About 3000 gallons later, Burkholder had one pound of *Gonyaulax*. When smeared onto germ colonies growing in gelatin—a favorite food of bacteria—the organism polished off many kinds of disease microbes.

At the Lamont laboratory, Burkholder separated the different organic compounds in the *Gonyaulax*, any one of which could have been the antibiotic factor, by a technique called column chromatography. He and his staff first dissolved the pound of red tide in chloroform. Then they wet the ends of slides covered with silica gel, an inert and absorbent powder, with the solution. As the liquid was gradually absorbed by the powder, several chemical compounds, their rates of molecular attraction to the silica being different, dropped out along the way to form narrow bands.

Burkholder tested each band on microbe colonies. Those bands that killed germs were put through the chromatography technique again, separating the active elements even more distinctly. After the process was repeated several times, Burkholder had as much antibiotic as can be stacked on a pinhead. "And we're still



A SCIENTIST at the National Institutes of Health in Maryland discovered that the body juices of red abalone (shown) contain a strong antiviral agent

trying to purify the drug even more with other laboratory techniques," he told me. "Gonyaulax has pigments and fatty substances that make it especially hard to separate."

He led me to a waist-high, slate-covered laboratory table. Nestled among test tubes, flasks and other glassware was a row of six-inch-long slides covered with silica gel. Burkholder pointed to one and told me to take a look.

I saw several faint, pastel-colored bands spaced along the slide's length.

"We've found three different antibiotics in this species of red tide," Burkholder told me. "We've got two of them pretty well isolated. But we haven't pinned down the third, the one that stops *Candida albicans*." He referred to a pathogenic yeast that infects about 40 percent of women in maternity wards. It affects mouth and vaginal tissues and is debilitating, which can lead to serious secondary infections.

More Sea Snooping

"Our present knowledge is like a drop in the sea compared with what remains to be discovered about the biology, chemistry and pharmacology of marine organisms," says Dr. Burkholder. "In order to provide stockpiles of miracle drugs from salt-water vegetation and fishes, we will need to generate new knowledge and perhaps develop new methods."

Laboratories in various parts of the

country have joined the hunt for marine pharmaceuticals—and have found them. At the National Institutes of Health in Bethesda, Md., for example, investigation of abalones, clams and oysters have turned up one of the most sought-after substances today—an antiviral compound. Few drugs prove effective against viruses; and those that exhibit any potency are soon nullified by fast-developing resistant strains. So, any discovery in this area is most important.

Dr. C. P. Li, specialist in viral biology, first discovered that body juices of the abalone and related shellfish contain a strong antibacterial agent, which he named paolin I. Further research revealed that the fluids of these shellfish had another factor—designated paolin II—that killed many different viruses. Now, both paolins are being exhaustively tested on laboratory animals.

Repels Cancer and Sharks

Other important finds have been made at the New York Aquarium's marine laboratory. One, a drug isolated from the toxin of sea cucumbers and called holothurin, is practically a pharmacy in itself. This chemical has kept mice infected with cancer cells alive for 18 months, about their normal life span. Control groups died of the disease within two weeks. In addition to its anticancer properties, holo-

[\(Please turn to page 188\)](#)

ANOTHER EEL speared for eventual testing and investigation. Catches are wrapped in paper, frozen and flown back to laboratories in the United States





Rarin' Renault

The little French lamb's turning into a lion. Economy was the strong point for Renault's Dauphine. The R-8 had more spunk. Now here's the R-8 1100 with aluminum head, hemi chambers and 10.4:1 compression. (The engine is shown at right.) Speed of 100 m.p.h. is claimed.

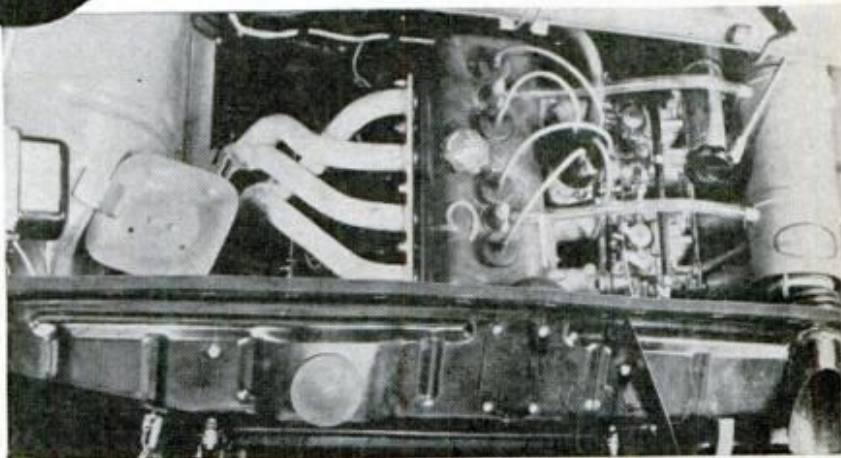

Piggy-Back Fuel Tank

Borrowing an idea from American transport systems, the British Railways are "leap-frogging" fuel tanks carrying up to 4000 gallons.

The tank can be transferred from train to truck or ground or back again in four minutes. A sideloader does the transferring with complete precision.



Quick-Thaw Gun

Plugged into a car's cigarette lighter socket, a new defroster melts frost and ice from the windshield. Warm air, moving at 1800 feet per minute, quickly clears a windshield even in five-degree weather, according to the manufacturer. Priced at \$7.95, it's made by A. G. Busch & Co., 6138 Northwest Highway, Chicago 31.

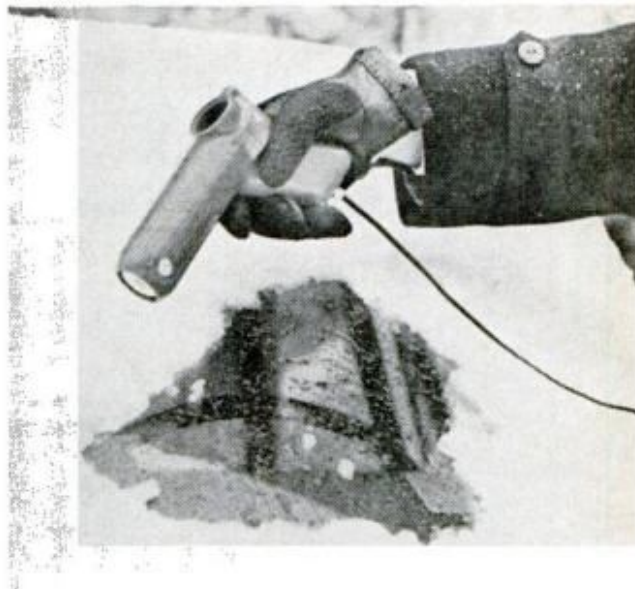

High Living On Stilts

By Merle E. Dowd

PRIMITIVE MAN once built his home on stilts to protect his family from the marauding beasts of the jungle. Today, many Americans are returning to this method of house construction, but for entirely practical Twentieth Century reasons.

Two of the main reasons are: (1) adaptability to problem building lots and; (2) savings of up to 10 percent. Often the two are combined.

Problem lots are those difficult building sites that have been bypassed because of added expense that would be required for grading and foundation work. But often

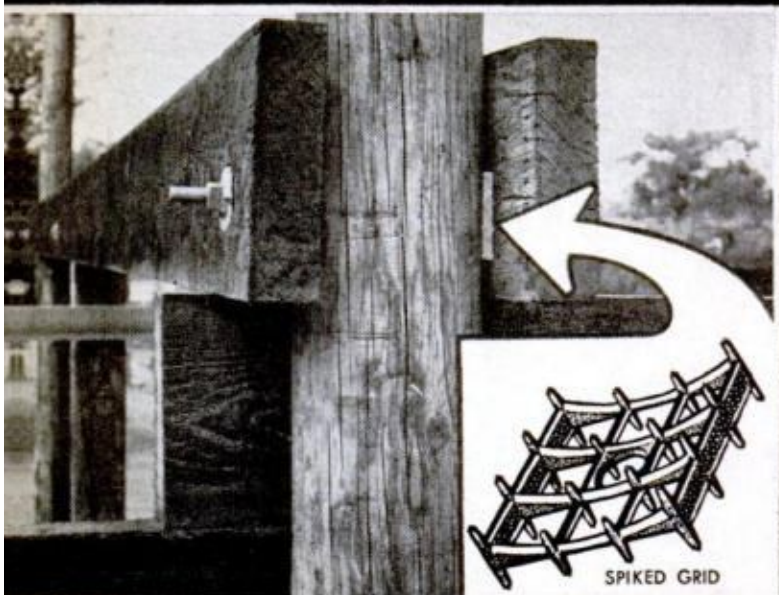
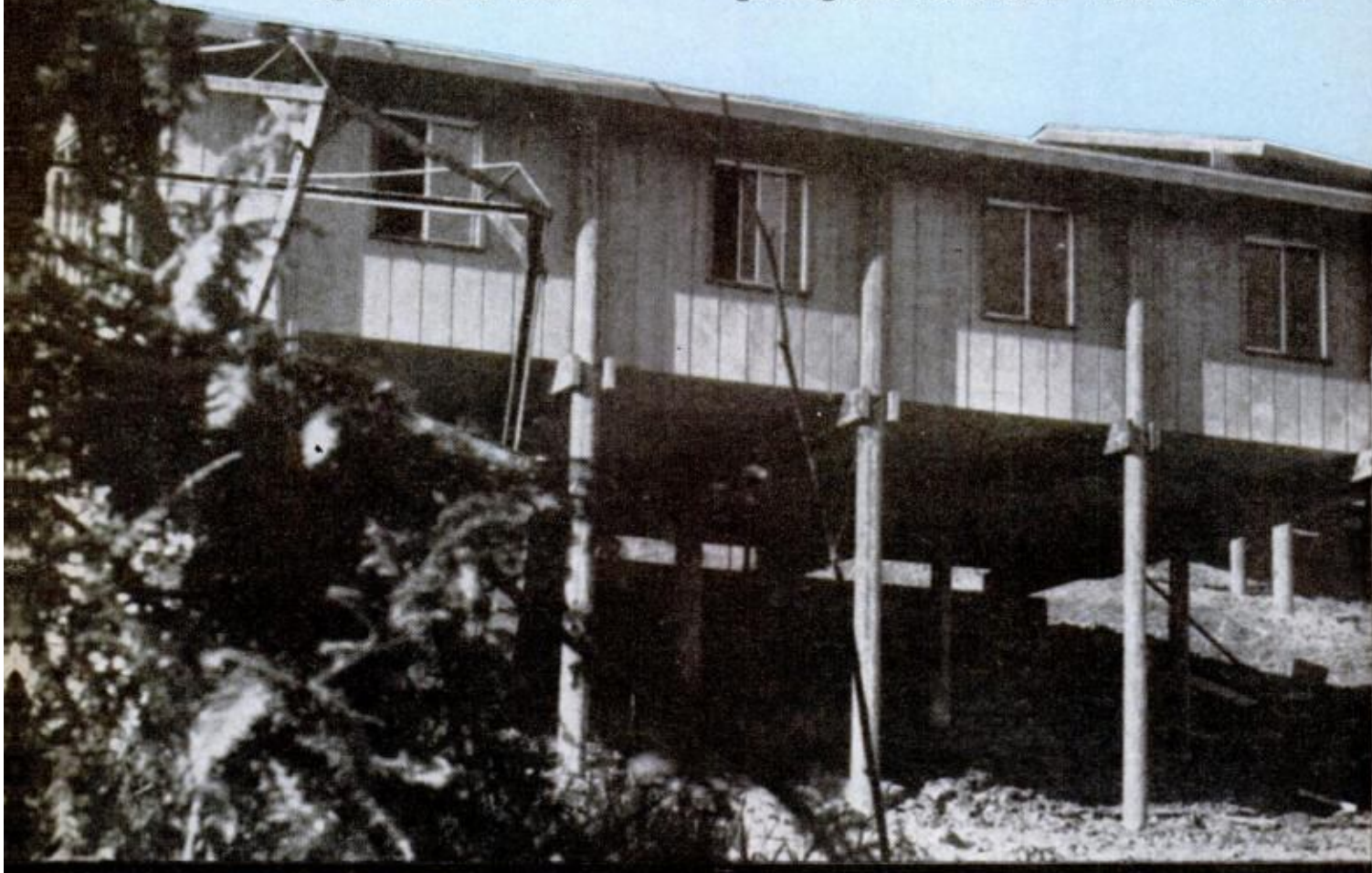

they command a sweeping view, are near a city center or are on choice waterfront land. Pole-type construction converts these lots into prime building sites.

For an idea of how this is done, look at the houses below. Building them on conventional foundations would have involved digging away part of the hill, building a retaining wall under the front of each house, or a combination of the two. With poles, all the builder had to do was sink them into the ground, and vary their lengths to conform to the slanting terrain. On swampy land, where conventional

foundations might involve pumps, underwater form-work, etc., all he'd have to do is drive the poles down to firm bearing.

But . . . how long will the poles last? Probably a hundred years or more, say the experts. Poles used for house construction, are generally "Chemonite" treated with salts of arsenic (to kill insects such as termites) and copper (to kill fungi that cause decay). These odorless salts are forced into the wood under pressure by means of an ammoniacal solution, and will not leach out. Test poles so treated in 1927 are still sound. ★ ★ ★

HILLSIDE HOMES in Marin County, Calif., sell for up to \$1500 less than their Federal appraisals for certificate of resale value. They are framed with poles like those used in farm sheds. Note how foundation poles run up to roof to form the basic wall structure. The walls are prefab stress-skin panels

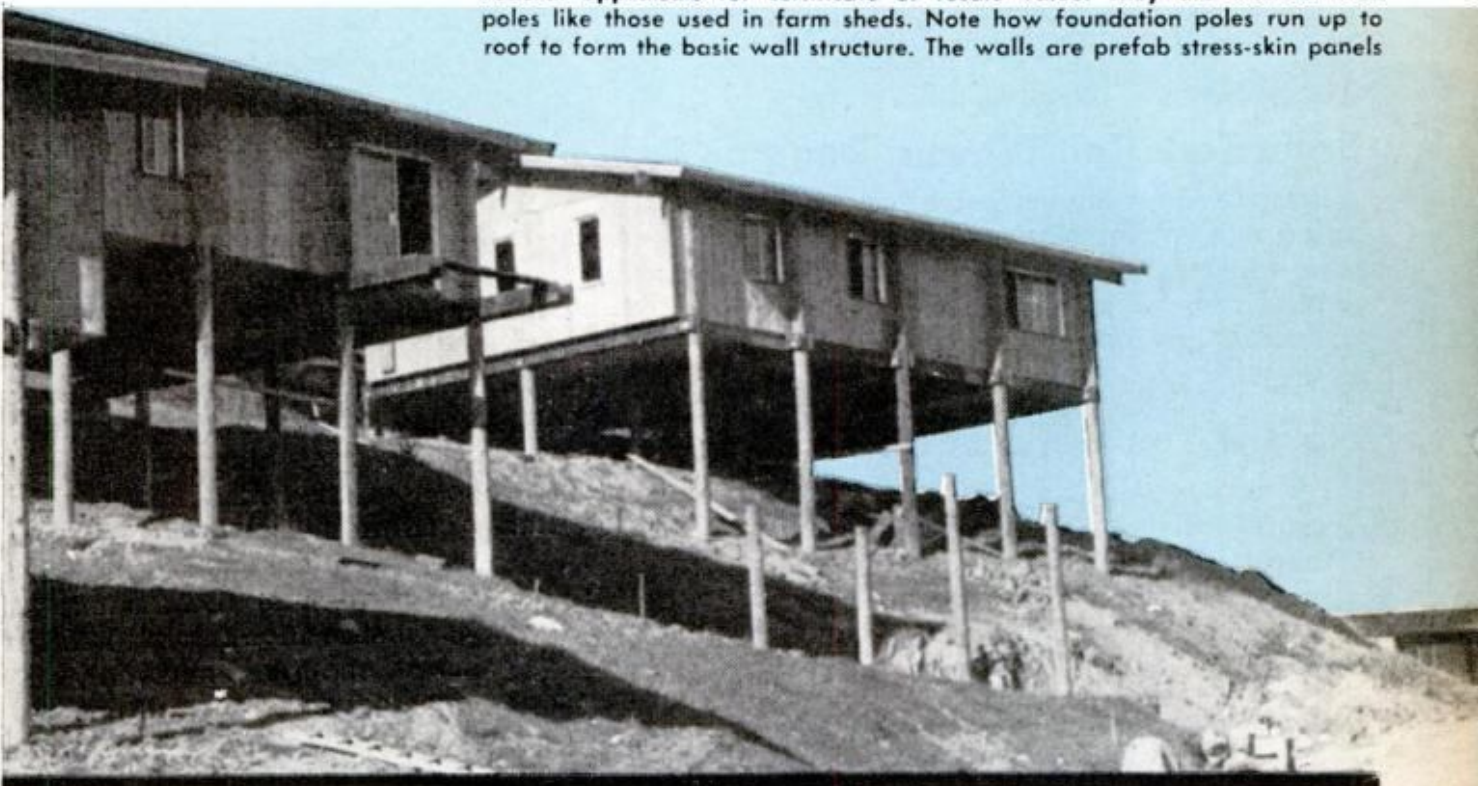

FLOOR BEAMS of stilt houses are generally bolted to the foundation poles (far left), which rest on concrete pads buried 6 to 8 feet under ground. Timber connectors (inset) strengthen joints

STRIKING INTERIOR (center) is natural asset of stilt house. Roof beams, also bolted to the poles, create a dramatic cathedral ceiling. Poles themselves add pleasing accent to the walls

IN BEACH HOUSES, pole foundations raise structure above hurricane-driven floods. Space under floor is often used as a carport. Walled in, it may become a storage room or quick-change booth



Brain Tests Tell When a Dog's as Sick as a Dog

Long used on human patients to record brain activity, an electro-encephalograph is now being employed by an English vet to detect brain disorders in dogs.

Needles are inserted into the dog's skin

and wires attached (left). Impulses from the animal's brain are then recorded on a graph and read by the doctor (right). Dr. Phyllis Croft of London has spent three years developing the technique.

Now, If You Get a Battleship and Run It into the Truck . . .

It's not highway tragedy. It's a Rambler dealer's answer to crash tests staged by Connecticut police, in which big cars were driven into small ones. Supposedly, they proved small cars dangerous—but critics said they didn't take handling, braking,

and angle of impact into account. Battenfield Motors, Amarillo, Tex., ran a 10-ton truck into a Cadillac, Buick and Rambler broadside and head-on at 25 m.p.h. Their finding: All the cars sustained comparable damage.





Mover Picks Up a Tree—Roots and All

Cutting around the roots with a blade, a new machine then lifts an entire tree, all in one operation.

The English-made unit, a tractor shovel with the blade mounted on it, can lift up



to 17,000 pounds. It replaces the laborious method of transplanting trees by trimming and cultivating the roots up to 18 months before, then lifting and wrapping them. Cost savings are about 80 percent.

Escape Capsule

Future submariners will escape from extreme depths in one-man capsules, if current Navy experiments work out. Made of wound glass filaments, the capsules can be stored one inside the other to save space. Each will be 65½ inches long.

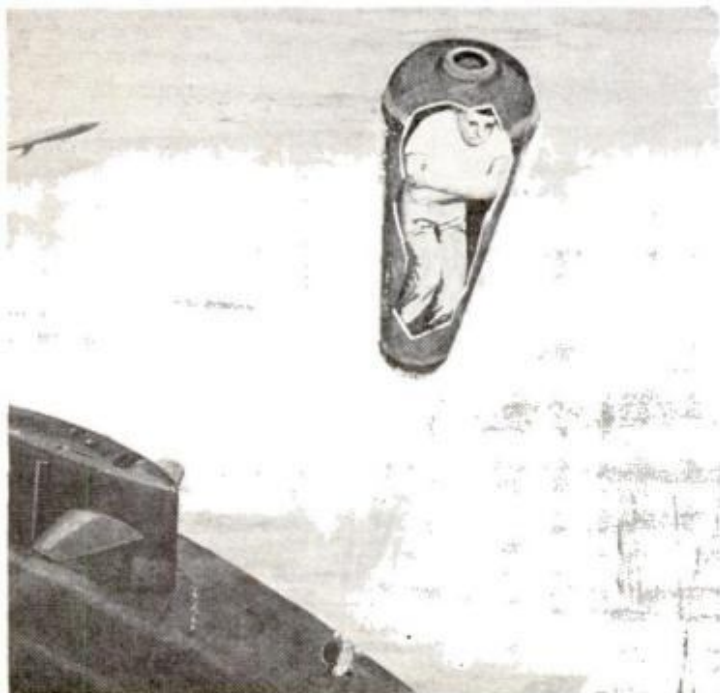

DECEMBER 1964

Cool Seat

Air can circulate around a driver's body when he uses a porous seat cover that's equipped with an electric fan. The fan plugs into the car's lighter socket. Priced at \$12.95, the cover is sold by Hammacher Schlemmer, 145 East 57th, New York.

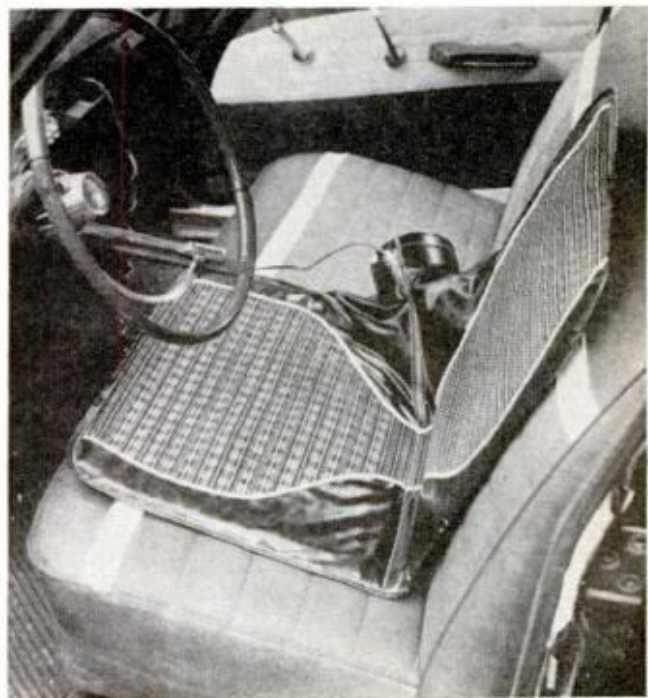

117



ADVERTISERS have been known to create pandemonium in parcel post when they mail transistor radios tuned to the station carrying their sales message

MaDHOUSE Behind the Mailbox

Thieving crows, ice cream mailed parcel post, oddball collectors—they're just routine for a postman

By Robert A. Kelly

FOR THE U.S. POST OFFICE and its long-suffering letter carriers, it's a mad, mad, mad, mad, mad world down in stampville.

Normally, of course, things run pretty smoothly in Postmaster General John A. Gronouski's Post Office Department, and efficiency is the byword, despite that automated post office in Providence, R.I., which (until frantic adjustments were made) happily accepted Christmas Seals as proper postage!

Along with the daily avalanche of mail, Uncle Sam has to contend with zany (and often impossible) requests, freakish mechanical breakdowns and a host of fractured postal regulations.

Much of the madness is touched by a

SAVING STEPS, a postal employee made chutes of fruit juice cans to send sorted mail to a lower floor



kind of mechanical genius. Like maybe the musical packages which crop up from time to time. Certain advertisers—always looking for a new way to get their message across to prospective buyers—hit upon the idea of actually mailing small, transistor radios to themselves! Not only were the radios turned on, they were tuned to the particular radio station carrying the advertiser's message. In this way, hundreds and maybe thousands of people (especially the "captive" postal employee) had to listen. The packages were kept in circulation by their owners as long as possible by mailing them again and again. The advertisers were warned to cease and desist or face penalties.

Another clever craftsman realized that a little scissors work on the new John F. Kennedy Commemorative five-cent stamp could well produce two halves *each* looking very much like a regular-size five-cent stamp. Some actually got through before the alarm was sounded by the department.

On the other hand, people are occasionally *too* anxious to obey postal regulations. A rural carrier in Huckabay, Tex., found that a post supporting the boxes of three different families was violating regulations by being nine inches too tall. This made it awkward for him to place mail in

the boxes without leaving his automobile. So he left a form in each box requesting that the post be lowered the appropriate nine inches. Next time around, he found that all three had complied—the post had been lowered 27 inches

Even postal employees themselves occasionally surprise the department. Take Chicago postal worker John Sestak who, applying some mechanical ingenuity, created a Rube Goldbergian device which increased mail sorting efficiency by a full 30 per cent.

Clerks sort mail by placing it in "cases," a sort of pigeon hole rig. Before Sestak's idea, clerks lost 12 minutes each hour removing mail from the fully packed pigeon holes. Sestak simply knocked out the back of the holes and connected individual chutes made of one-gallon fruit cans from the nearby cafeteria. Mail then tumbled down the chutes to a lower floor, into a bin already separated by destination. A crazy idea, but one with a happy ending for the Post Office.

A couple of Brooklyn pot lids gave the Post Office a new safety gimmick aimed at saving children's lives. Due to the shape of postal trucks, there are "blind spots" into which the driver cannot see. Unfortunately, children often are attracted to the mail trucks and occasionally play in these

AIR MAIL ran amok when a shipment of ladybugs got loose in an airliner and swarmed over passengers

SLEET OR RAIN won't stay a courier of the mail, but one was delayed when a crow stole a letter from a box



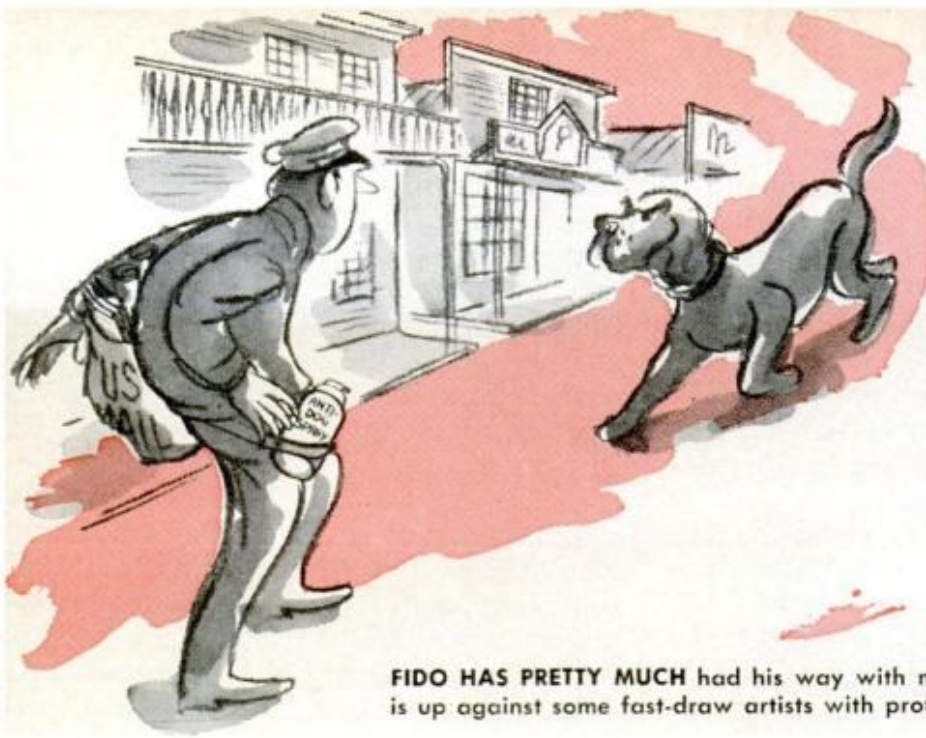

FIDO HAS PRETTY MUCH had his way with mailmen in the past, but now he is up against some fast-draw artists with protective pepper-filled aerosol cans

blind areas—right against the front bumper or fender, for example.

While drying dishes one night, a postal employee noticed the excellent, reflective qualities of a pot lid and suggested to his superiors that similar metallic discs could be attached to the front and rear of the trucks in such a manner that all blind spots could be made visible to the driver. The idea appealed and a Brooklyn manufacturer won the order for 20,000 stainless steel discs and brackets. From pot lids to life savers, and all from one way-out idea.

One day not too long ago, a postal worker was casually instructed to take a batch of mail from one location in Washington, D.C.'s General Post Office over to that section handling New York City mail—his instructions were simply “take this load over to New York.” Imagine his supervisor's surprise, some hours later, upon receiving a long-distance telephone call from New York City's Postmaster inquiring “why in the world such a small packet of routine mail had been especially trucked all the way to New York City?”

To the dismay of the USPO, Americans apparently will ship anything through the mails . . . prickly bushes, live alligators, ashes of the deceased, stove grates and ice cream included. Recently, a New York City post office was disconcerted when a crated beehive split open on a loading platform. After everyone found cover, the Humane Society was called to put down the invaders.

However unwarranted, politics do enter postal life in one way or another. An obvious partisan wrote the department suggesting that all postage stamps in all denominations carry portraits of Democratic presidents. Postage *due* stamps, he added, should carry the portraits of Republican presidents!

Not everyone is as politically motivated, but many people are extremely observant and this often serves to keep the Post Office Department on its toes. Complained one man, “The signature of George Washington in the American Credo Series is not exactly true!” A check revealed that he was correct. A stamp designer had attempted to make George's signature a little more legible.

Unfortunately for some of us, postal regulations prohibit the return of stamps once they've been purchased. This upset a woman who bought 200 Whooping Crane Commemorative stamps with which to mail her daughter's wedding invitations. After buying them, she realized that the crane belongs to the stork family. The implication of a shotgun wedding was more than she could take.

Recently, George Washington was assigned to a place of honor on the basic five-cent stamp replacing James Monroe. Reaction, at least from one furious citizen, was rapid. Said the correspondent, doing away with the Monroe stamp could mean only one thing—scuttling of the Monroe

[\(Please turn to page 186\)](#)



Poor Man's Rolls

A touch of luxury for the average motorist is the Rolls Royce aluminum Six now available in the English-made Vanden Plas Princess R. It develops 175 horsepower from 238.5 cubic inches for 112-m.p.h. top. U.S. price: about \$5600.

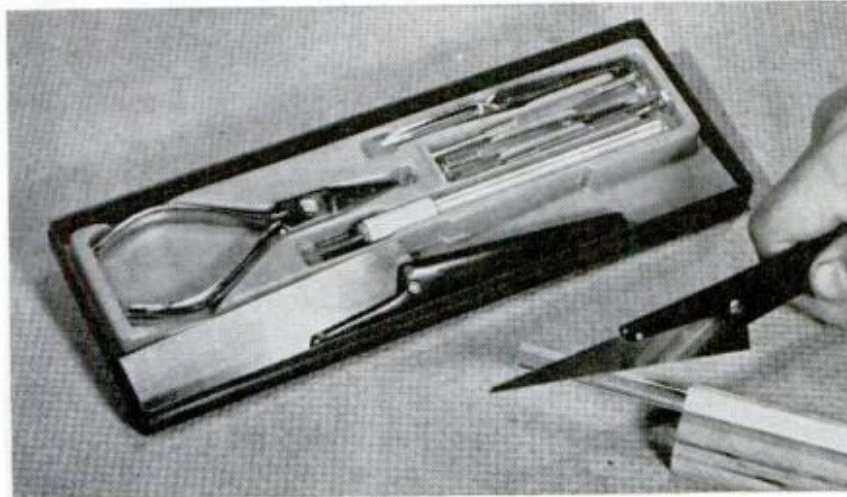

Precision Tool Kit

A new hobbyist's kit contains tools designed for precision work. It includes self-gripping crisscross tweezers, three swivel-head screwdrivers, two miniature saws, needle-nosed pliers and an interchangeable-blade knife. No. 7300 kit sells for \$4.95. It's made by Strombecker Corp., 600 N. Pulaski Rd., Chicago, Ill.

Filing by Television

When magnetic video tape is used to replace file folders, a secretary can almost enjoy filing. Ampex's Videofile system does just this and will soon be used by NASA.

Each page of a document is televised and recorded on video tape. At the same time an identification code is added to the tape on an auxiliary track. When the file is needed, the identification code is fed into the device. It then automatically finds the proper section of tape, plays it back and prints it out on an electronic printer.



New for Your Home

RUG SHAMPOOER won't soak carpeting. Shampoo is released by handle trigger onto rollers which dry foam above rug. Nylon brushes work foam into rug as third roller keeps machine level, \$14.95. By Bissell, Grand Rapids, Mich.

MOUSE TRAP sets and empties so that you never touch a varmint. Mouse steps on platform, triggers trap and you press tail-end to eject him. Of finished steel, two traps are \$1.25 from Ewing Co., 1621 E. 17th St., Santa Ana, Calif.

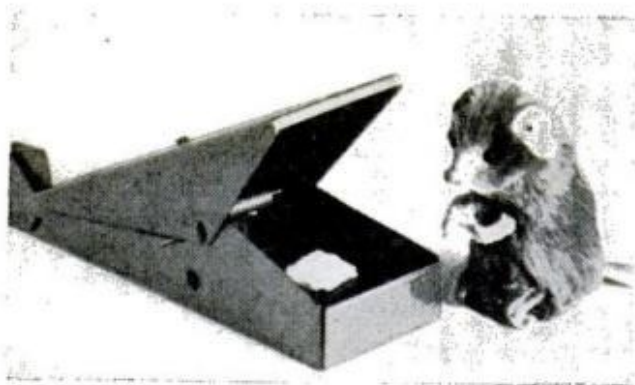

INDOOR BARBECUE cooks electrically using quartz, a permanent element, not charcoal. Spit and char-bar unit attaches to 15 by 26-inch wall space, plugs into 115-volt outlet. Prices start at \$170. Purcarb Inc., 137 W. 25th St., N.Y., N.Y.

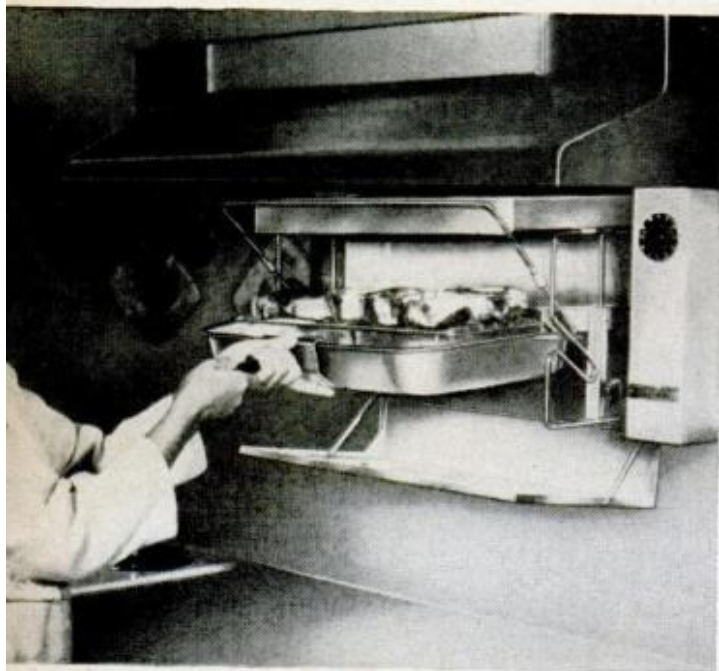

WASHER works like concertina; squeeze for woolens, swing to and fro for lingerie. Polyethylene 6 by 12-inch unit is convenient for camping or travel. Available for \$4.98 from Beh Housewares, 1150 Broadway, New York, N.Y.

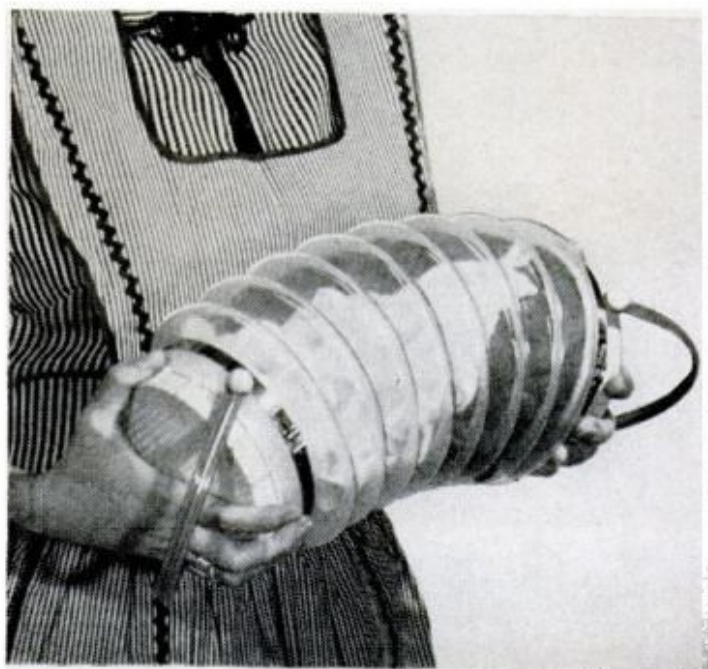

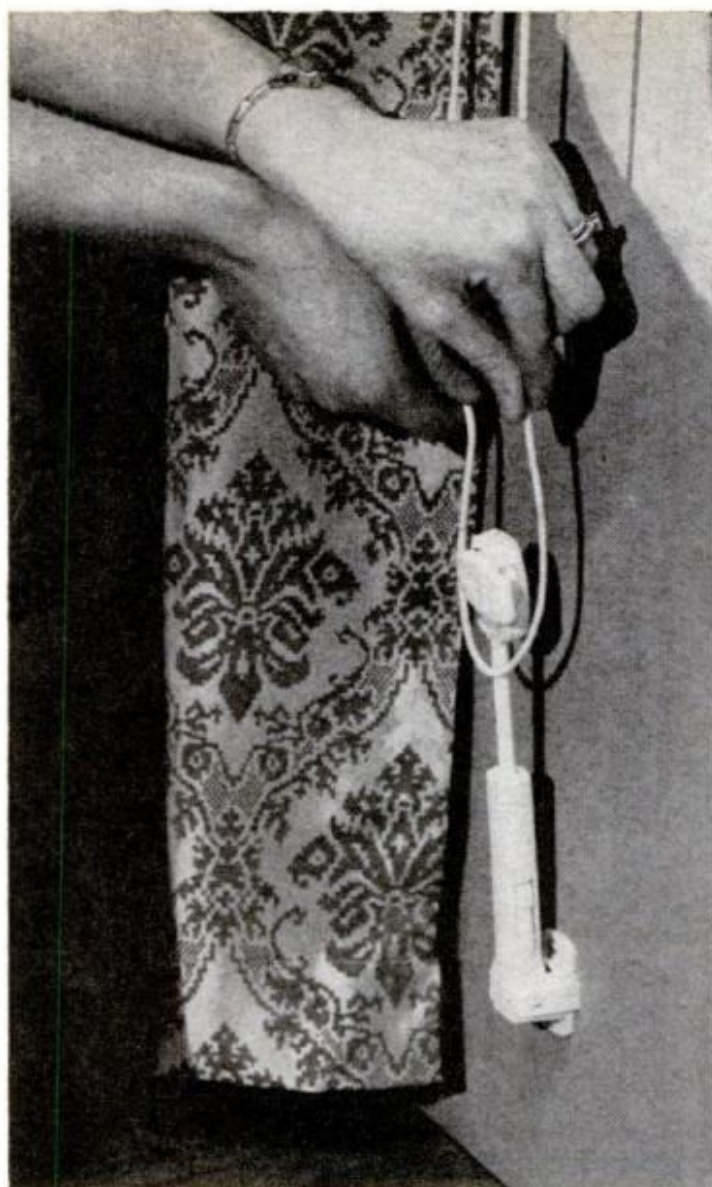

DRAPERY PULLEY keeps traverse cords taut. Tension lock holds pulley head upright, fully extended, while cords are slipped into place. White plastic item installs on wall or floorboard, costs about 60 cents. The Graber Co., Middleton, Wis.

CONTROL BOX HOLDER for electric blankets, sheets or pads adapts to any style bed. Platform brings dial within easy reach and lowers for neat bed make-up. Price of aluminum holder: \$2.95. By Sinton's, P.O. Box 847, Sonoma, Calif.

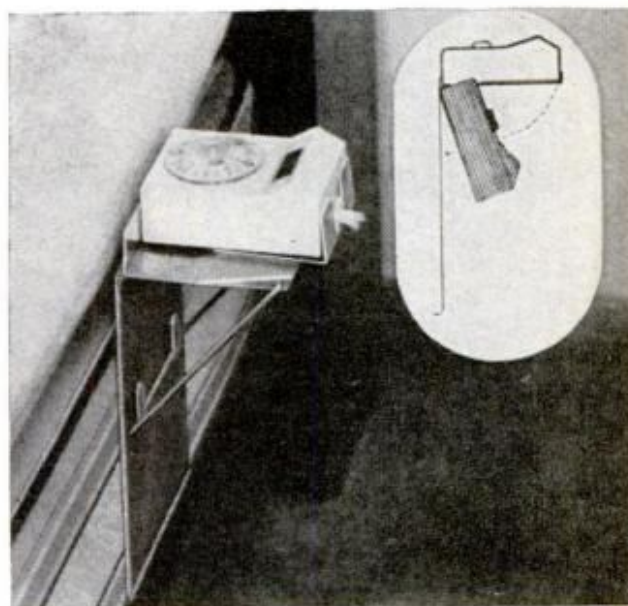

CLOCK TABLE reminds guests when it's time to leave. Mechanism under 18-inch-high walnut table runs on year-long batteries, needs no winding. Drinks sit on clock face (15-inches across). \$75 from Hammacher Schlemmer, N.Y., N.Y.

FIREPLACE prefabricated from hearth to chimney top installs anywhere. All-metal, 46 inches wide, unit needs no mortar, masonry or footings. Front opening model costs \$300-350 installed. By Majestic Co., Erie St., Huntington, Ind.



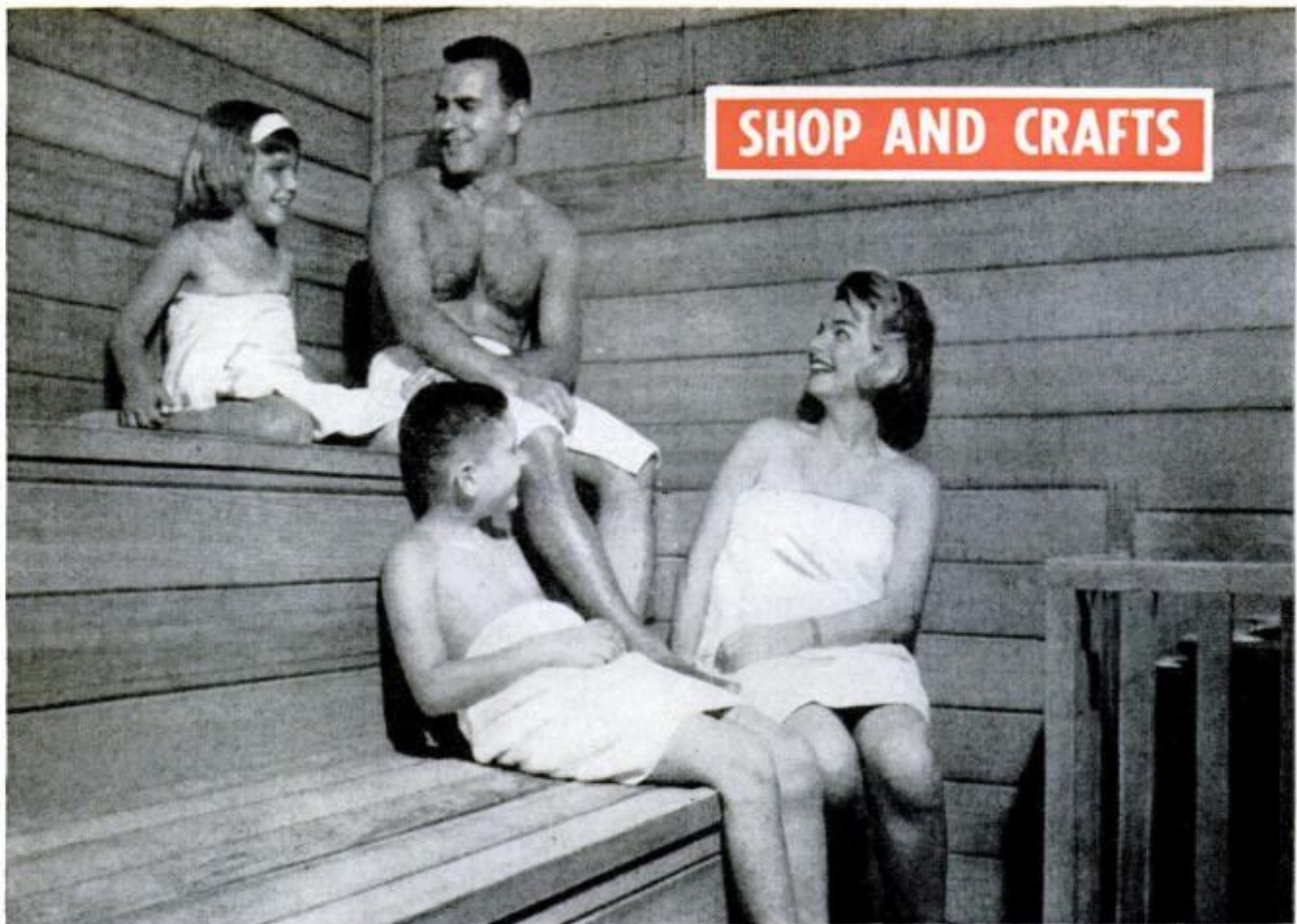

Viking Sauna Corp. photo

BUILD A FAMILY SAUNA

Once you've tried this modern version of the ancient Finnish dry bath, you'll know why the sauna is sweeping America. It's not an out-of-reach luxury if you build your own

THE SWIMMING POOL has lost out as the big status symbol for American home owners. To be a master of on-upmanship today, you've got to show off a sauna. Never seen one? Well it's a specially-heated, redwood-lined room that you sit in to sweat.

"Oh, no!" you might protest. "I've tried steam baths. It's no treat to squat in a blinding cloud of hot vapor, with the air so thick you can hardly drag it into your lungs! That's for people who have to lose fat fast, and will put up with the discomfort."

Ah, but there's a world of difference between a Finnish bath and a Turkish one! There's no steam in a sauna (pronounced sow-nuh)—in fact, you deliberately keep humidity to an absolute minimum (5-10 per cent) to encourage perspiration. With the air so dry, you can up the heat to 175° and more without that sweltering sensation, and still breathe free and easy. And,

though the heavy sweating certainly melts off excess fat (some people shed three pounds per session), the sauna isn't mainly a reducing device. It's a relaxer . . . a toner . . . a cleanser.

The Scandinavians have known the secret for years—though they've always made a bigger production out of it than most Americans are likely to. They whip their bodies with leafy birch twigs and sometimes toss in a bone-jolting massage. And the classic topper for a Scandinavian sauna session is to jump naked into the nearest ice-pool or snow bank. Perhaps such "torture" elements explain why the rest of the world has been slow to share this Nordic enthusiasm. But Finnish athletes have kept insisting upon sauna facilities in their Olympic Games quarters, and competing sportsmen have given it a try and carried the message home. As a consequence, there's a sauna boom, today. Dry heat rooms are being installed in

resorts, health clubs, beauty parlors, military bases and private homes.

Once you try it, you'll see why. The profuse sweating clears the pores far more deeply than the most vigorous soap-and-water scrubbing, bringing a healthy glow to your skin. The greatly-increased body temperature burns out germs (much as a high fever does, but without the danger or discomfort), melts away tension, and increases blood circulation (as with heavy exercise, but without the exhaustion). The result: your body is simultaneously invigorated and wrapped snugly in a deep sense of well-being. After your first sauna bath, you'll swear that you've never been more profoundly relaxed, even with a potent tranquilizer!

Perhaps the strangest sensation of all is the way the stored body heat *insulates* you from cold. That's why the Scandinavians can tumble in that snow bank. If you're the type who inches into ocean surf or a cold lake, you'll be amazed how little a cool post-sauna shower or swim will shock your body.

Sauna baths are equally beneficial when taken first thing in the morning to prepare you for the day, at the end of the day's work, or just before bed. And because the heat inspires complete relaxation, the sauna room's an ideal family-conference spot—and a great place to chat with friends, once you shed your initial inhibitions about shedding your clothes. No tight clothing (such as bathing suits) should be worn in a sauna; where modesty dictates, a towel tucked loosely around the body is the accepted costume.

The special boon for the home owner who's handy with tools is that a sauna is an ideal do-it-yourself project. Few people would want to risk introducing the



Simpson Timber Co. photo

A SAUNA doesn't have to be in the basement. If your home is without a basement, you can still enjoy the relaxation of a sauna by converting a spare closet

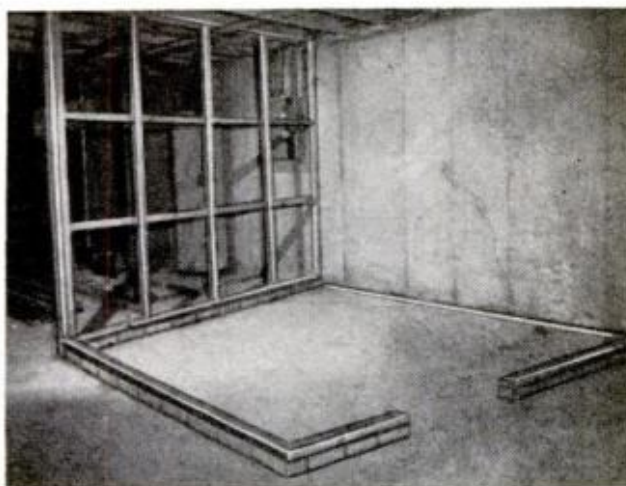

IF BUILDING AREA includes a window, it can be used to ventilate the sauna after using. Hinged cover backed with insulation of redwood should cover it

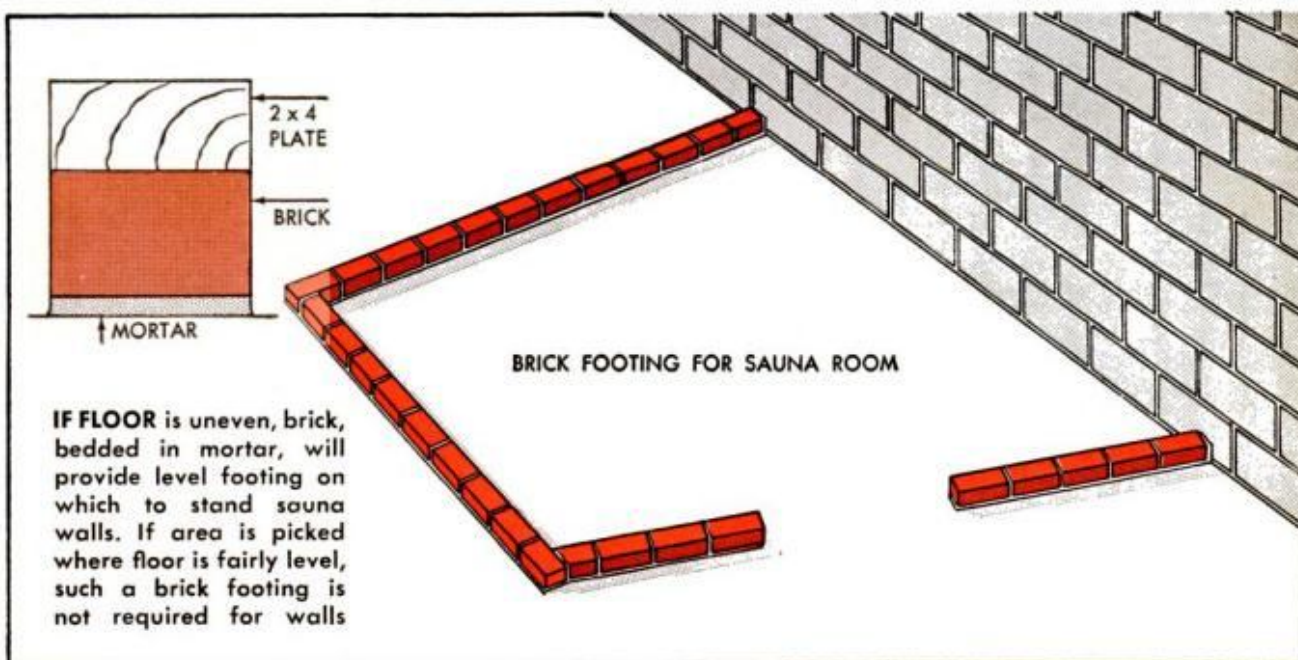

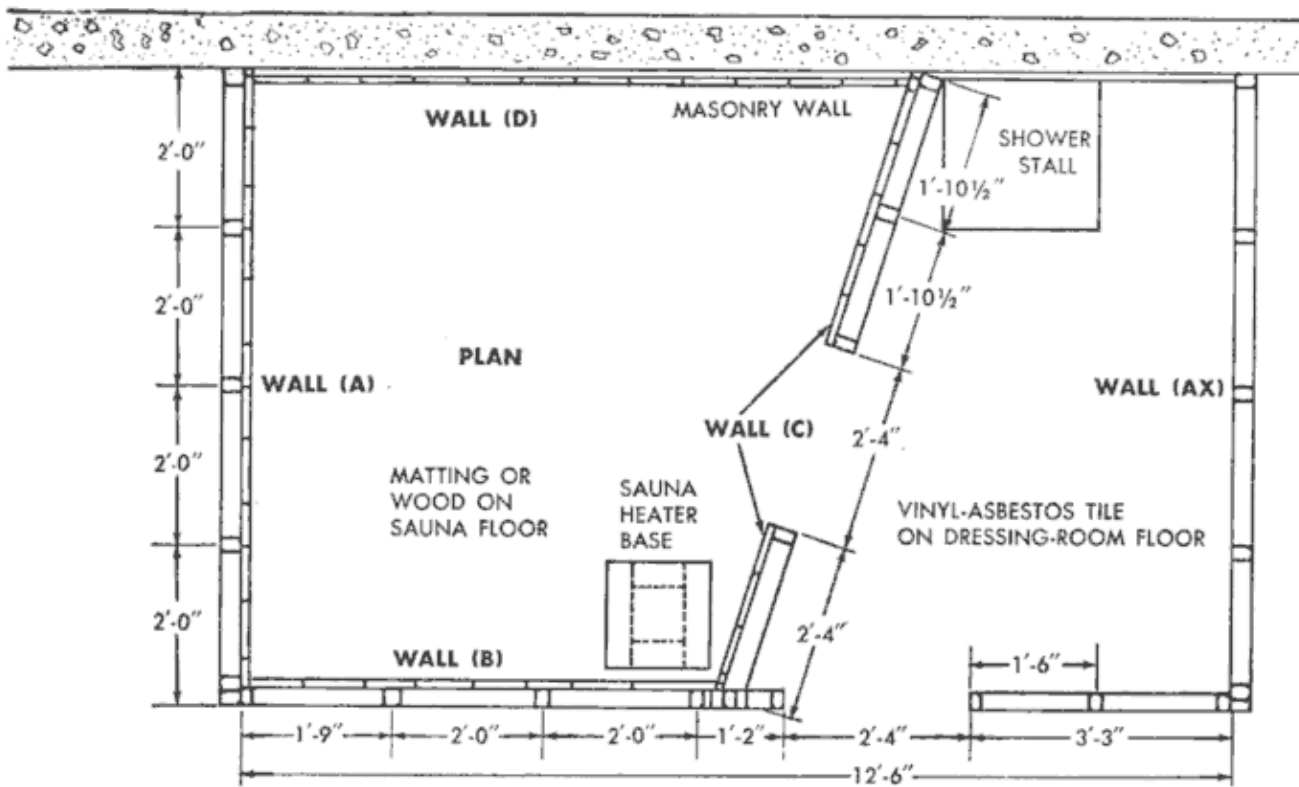

sodden air of a steam room into their homes, and installation costs would be sky-high. With an electrically-heated sauna, however, no flues or plumbing are involved. You can install one anywhere you can hook into 220-volt current. (And there's a gas heater on the market for homes that are strictly 110.)

Your sauna room can be tucked into an unused basement corner, or built as a separate structure in the back yard (a cabana, if you have a pool). The basementless "House of Good Taste" on display at New York's Worlds Fair has a sauna built into the garage. The room can be a simple box as small as 4x6 ft., or an elaborate suite including the heat room, a full bath and a lounge complete with TV, hi-fi and bar.

If you're in a hurry for that first bath, there's even a ready-made plug-in "solitaire" model that looks like a phone booth.

The room is faced with redwood or red cedar since they're poor heat-conductors; they keep walls and benches cool enough for comfort and their insulating qualities contribute to the economy of sauna operation. Blind nailing is recommended for assembling the benches—sitting on hot nail heads isn't fun. Use aluminum, stainless steel or hot-dipped galvanized nails throughout to avoid stains.

You don't apply any finish. Redwoods are far more durable than anything you can coat them with. Thus your sauna room is virtually maintenance free; you don't even have to scrub it down, since the heat

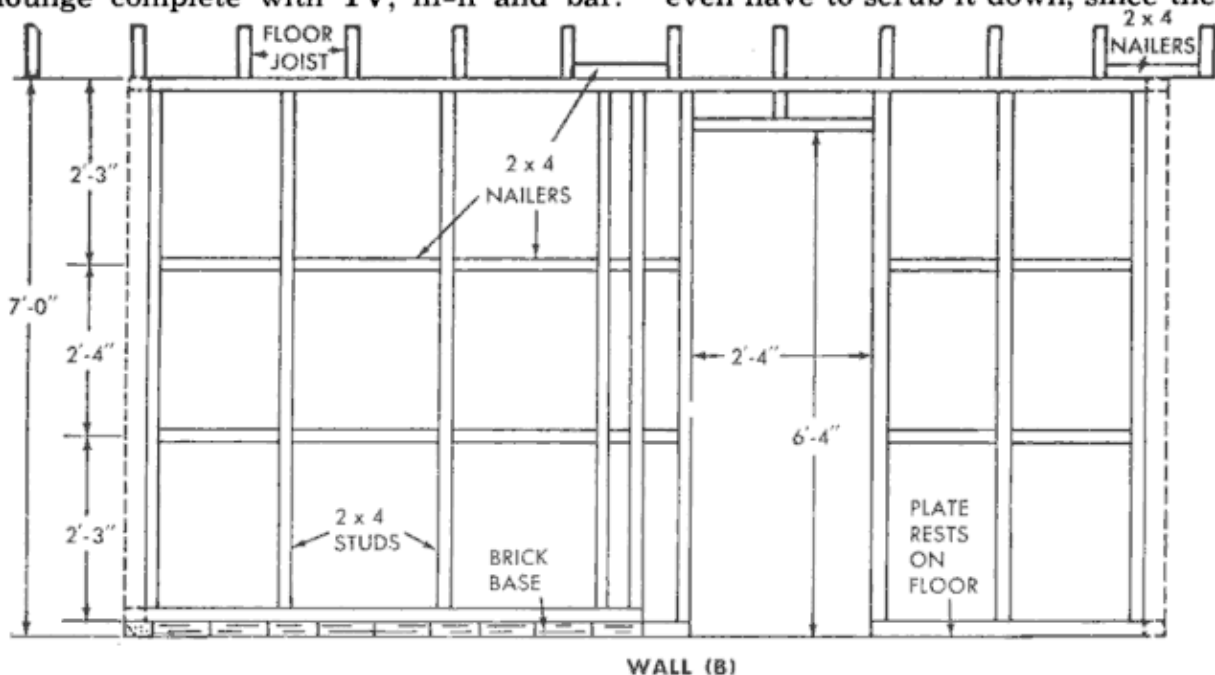

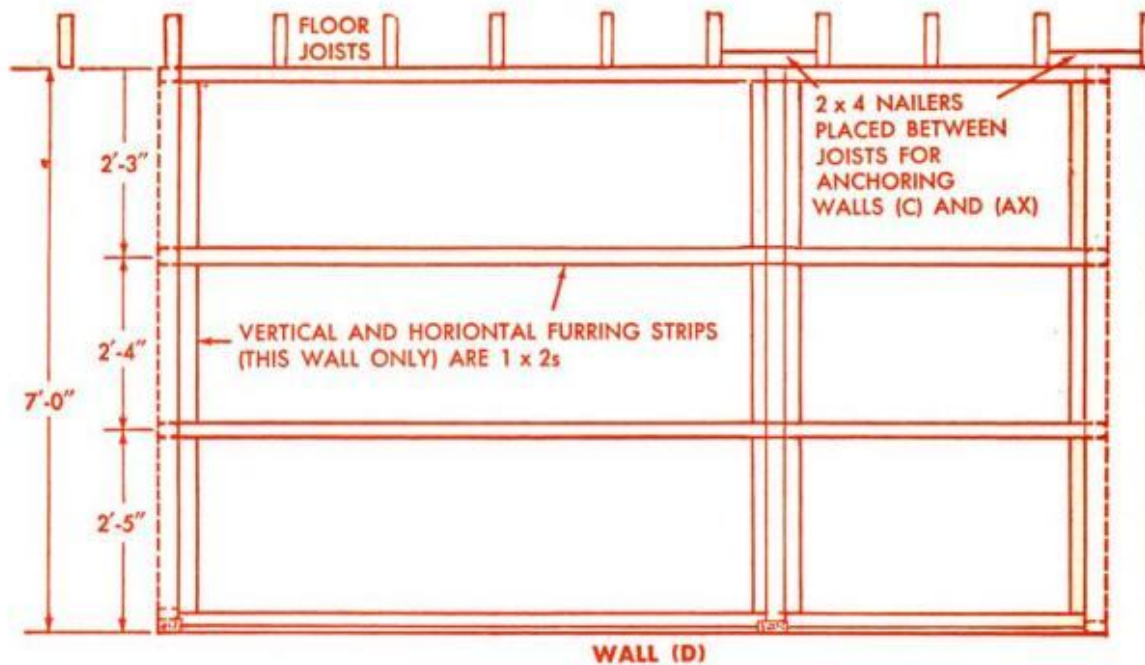

makes the sauna self-sterilizing.

Exterior windows are rarely incorporated into sauna construction, because of loss of privacy and complication of framing. So you'll need a vented exhaust fan to suck out the hot air and to encourage circulation of fresh air after each use. Some of the commercial heaters have this feature built in; you've taken care of air circulation when you vent the heater to the outside.

Your biggest investment, incidentally, will be the sauna heater or stove. It would be impractical to design an efficient unit yourself. Most stoves have provision for holding a batch of stones; they radiate heat, and retain it after the heater shuts off. Because of this—and the redwood—

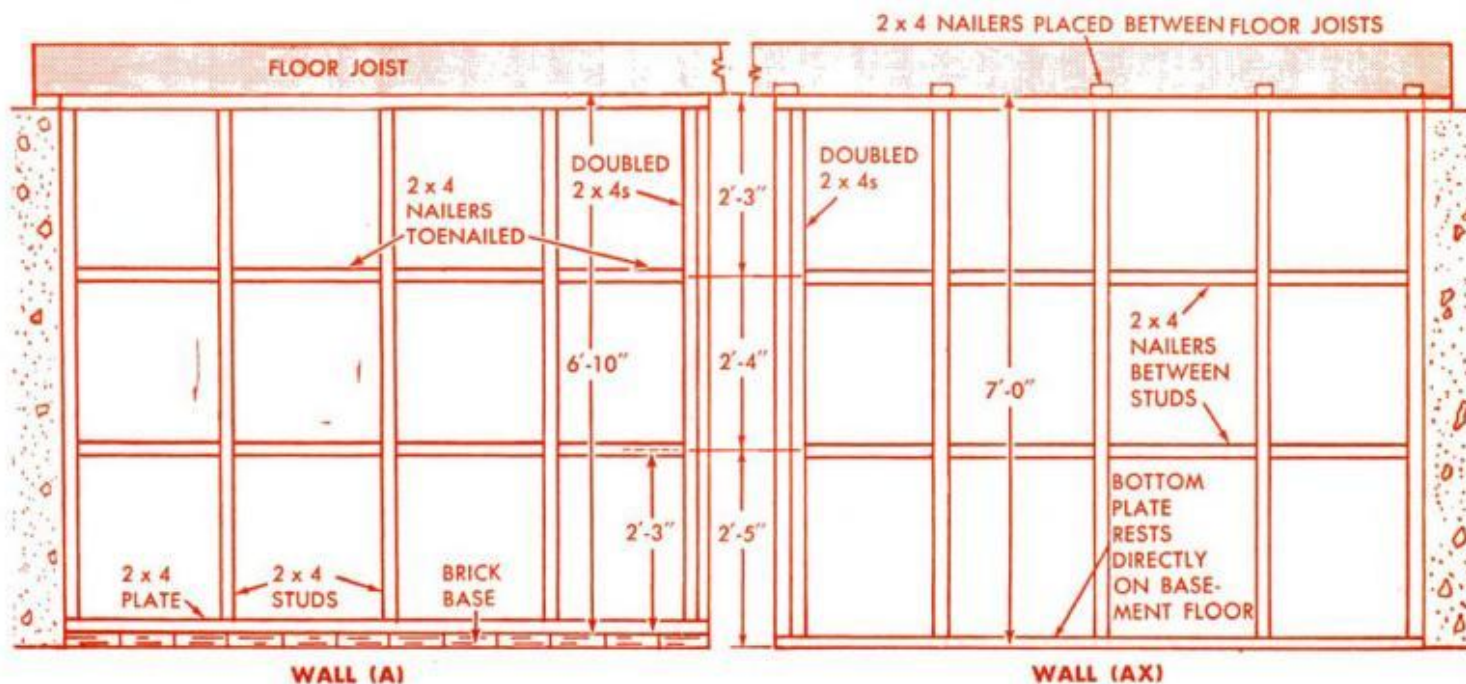
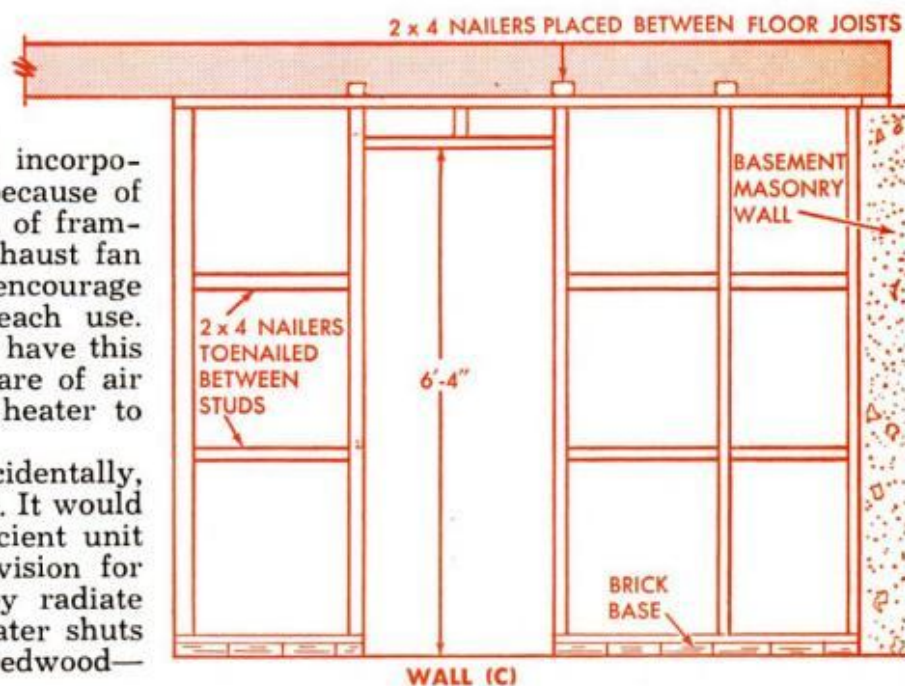

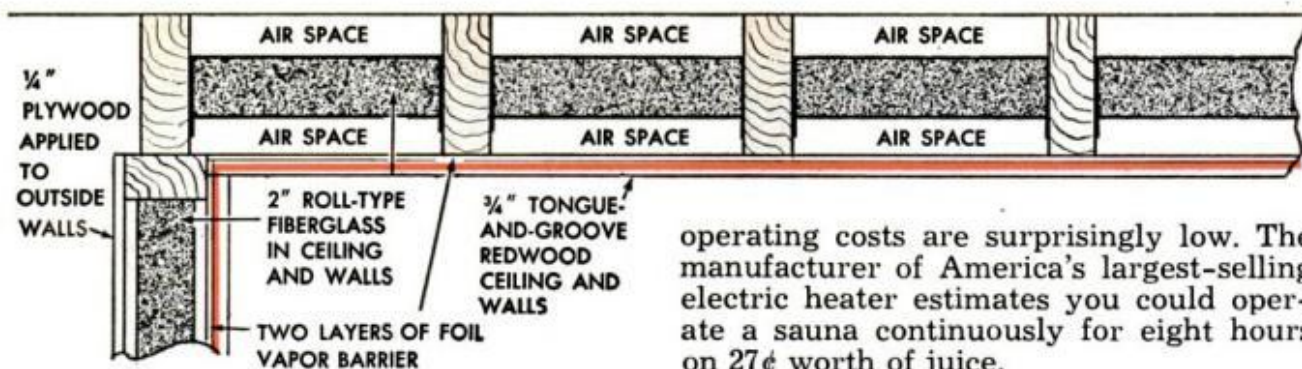

SECTIONAL VIEW through walls and ceiling show how spaces between joists and studs are filled with insulation and covered with foil vapor barrier before applying tongue-and-groove cedar or redwood lining

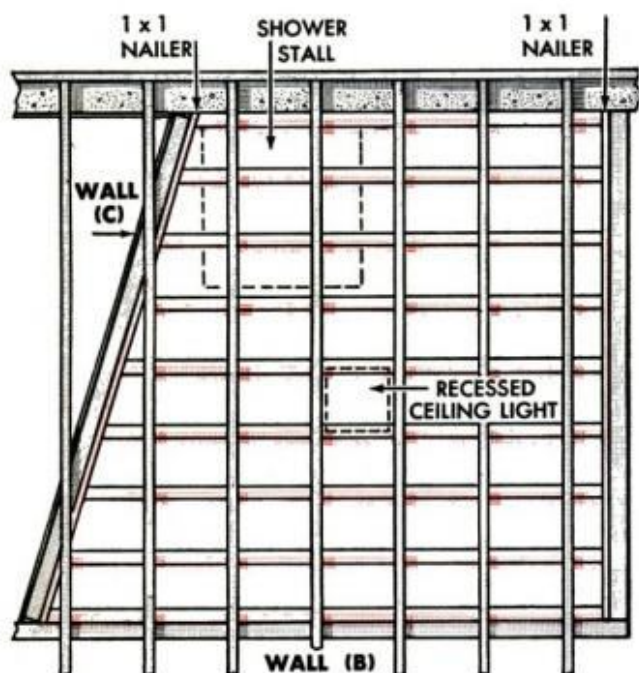

1 x 3 FURRING STRIPS NAILED TO UNDERSIDE OF FLOOR JOISTS FOR INSTALLING TILE

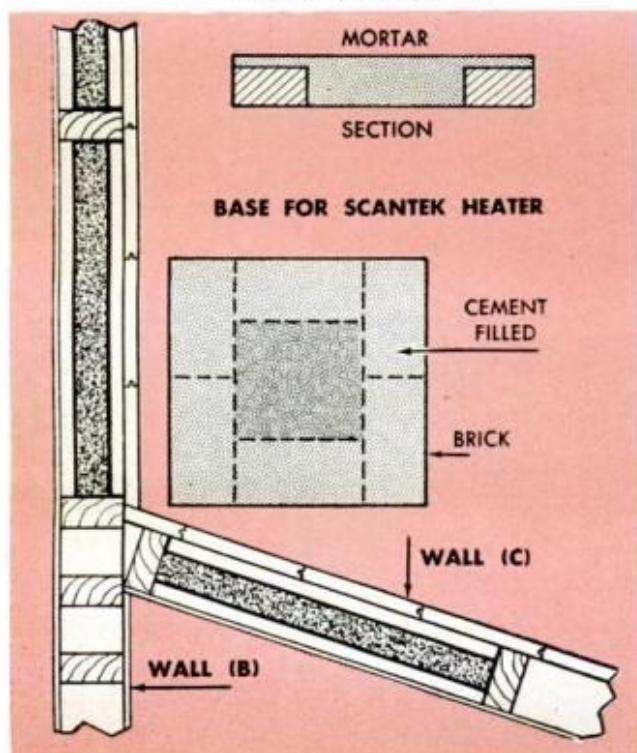

operating costs are surprisingly low. The manufacturer of America's largest-selling electric heater estimates you could operate a sauna continuously for eight hours on 27¢ worth of juice.

The bath itself can be as simple as a 15-minute stint in the heat room, followed by a shower. But for full benefits—both physically and emotionally—follow the procedure recommended on page 129. Don't take a sauna bath after exhausting physical exertion, or heavy eating or drinking. Rest first in such cases. Remember: the body works hard in a sauna and shouldn't be asked to tackle additional jobs—such as digestion—simultaneously.

While a sauna room need not be any specific size, a 6 x 8 ft. one will accommodate a family of four nicely and heat easily. In the case of a basement sauna, overall size is determined somewhat by the overhead floor joists since it simplifies construction if the walls are aligned to bear on the joists. The sauna plans presented here include an adjoining shower and dressing room. While this adds to the convenience of the sauna, it's optional of course, since the shower in an upstairs bath can take over. Whether you build this sauna or one of your own design, you frame

VIKING SAUNA HEATER—a Swedish import—heats room to 200° in 15 minutes, shuts off until needed to maintain temperature. It includes a dehumidifier



the walls like any wall in your house, using 2 x 4 studs and plates. By using the foundation wall for one wall (or two walls when you pick a corner) you'll cut your framing costs and construction work. If the floor is pretty uneven, a footing of bricks, bedded in mortar, will start you off with a level surface on which to stand the walls. On the other hand, if the spot you've picked is fairly level, you can forget the brick footing and rest the walls directly on the floor. A plumb bob, dropped from the floor joists, will locate the walls so they'll be directly below. You can't raise the walls as separate preassembled units since you wouldn't be able to wedge them in place. So with the bottom plate resting on the floor, or the brick footing, as the case may be, only the upper plate can be spiked to the ends of the studs beforehand. The lower ends of the studs have to be toenailed to the bottom plate after the wall is up. Where the basement wall is a part of the sauna, horizontal and vertical furring strips must be attached to it so you'll have something to nail to when applying a foil vapor barrier and the kiln-dried cedar or redwood lining. Special masonry nails designed to be cemented to

[\(Please turn to page 184\)](#)

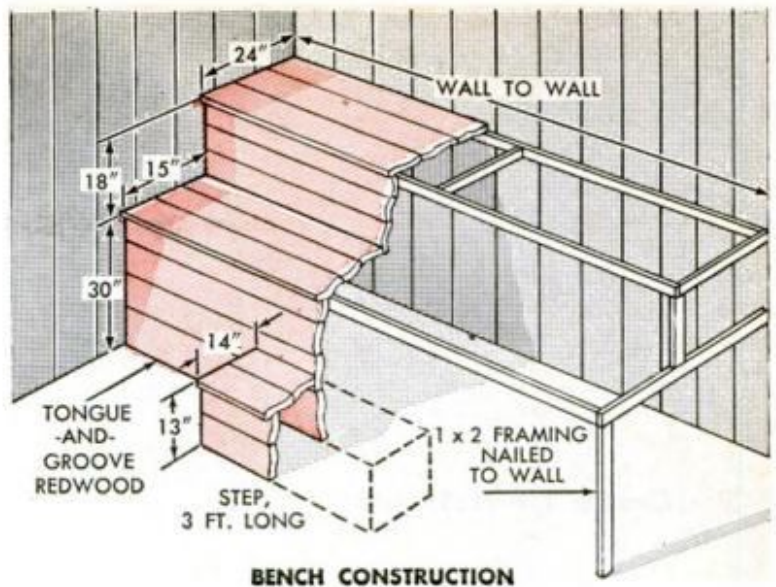

HOW TO SAUNA-BATHE

1. **SWITCH ON HEATER**, let sauna heat to 175° or more, then disrobe and enter. Sit or recline on one of the benches. If your sauna has two, start out on lower one, move up after few moments for increase in temperature. Do not exercise or smoke. First bath should last 8-10 minutes. (With experience you'll probably extend this)
2. **TAKE A SHOWER**—cold, if the idea doesn't make you flinch, or as cool as is comfortable. (A dip in a pool is the ideal alternate). Relax for 10-20 minutes
3. **STEP BACK** into heated sauna and relax completely. Since you'll start perspiring at once, you need stay only 5-10 minutes for maximum benefits
4. **TAKE LONG, COOL SHOWER** to bring down body temperature, then settle back for at least 20 minutes of peace

SCANTEK SYSTEM employs two units to heat room in one-half to one hour. Infra-red heater, left, supplies radiant heat. Electric stove, right, has inner and outer steel skin with heating elements between and stones in center. Lid is raised for rapid heat gain, closed to store heat and reduce electrical consumption

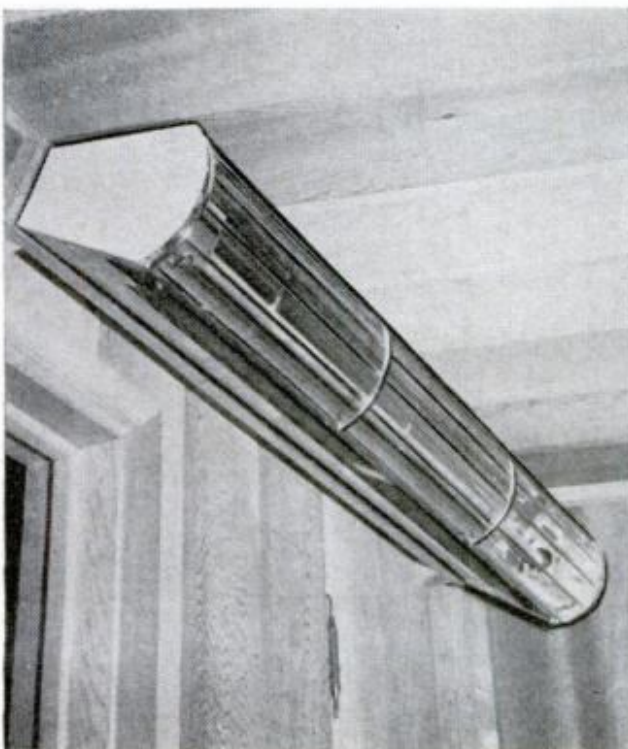

Christmas DOOR DECOR

By Dave Swartwout

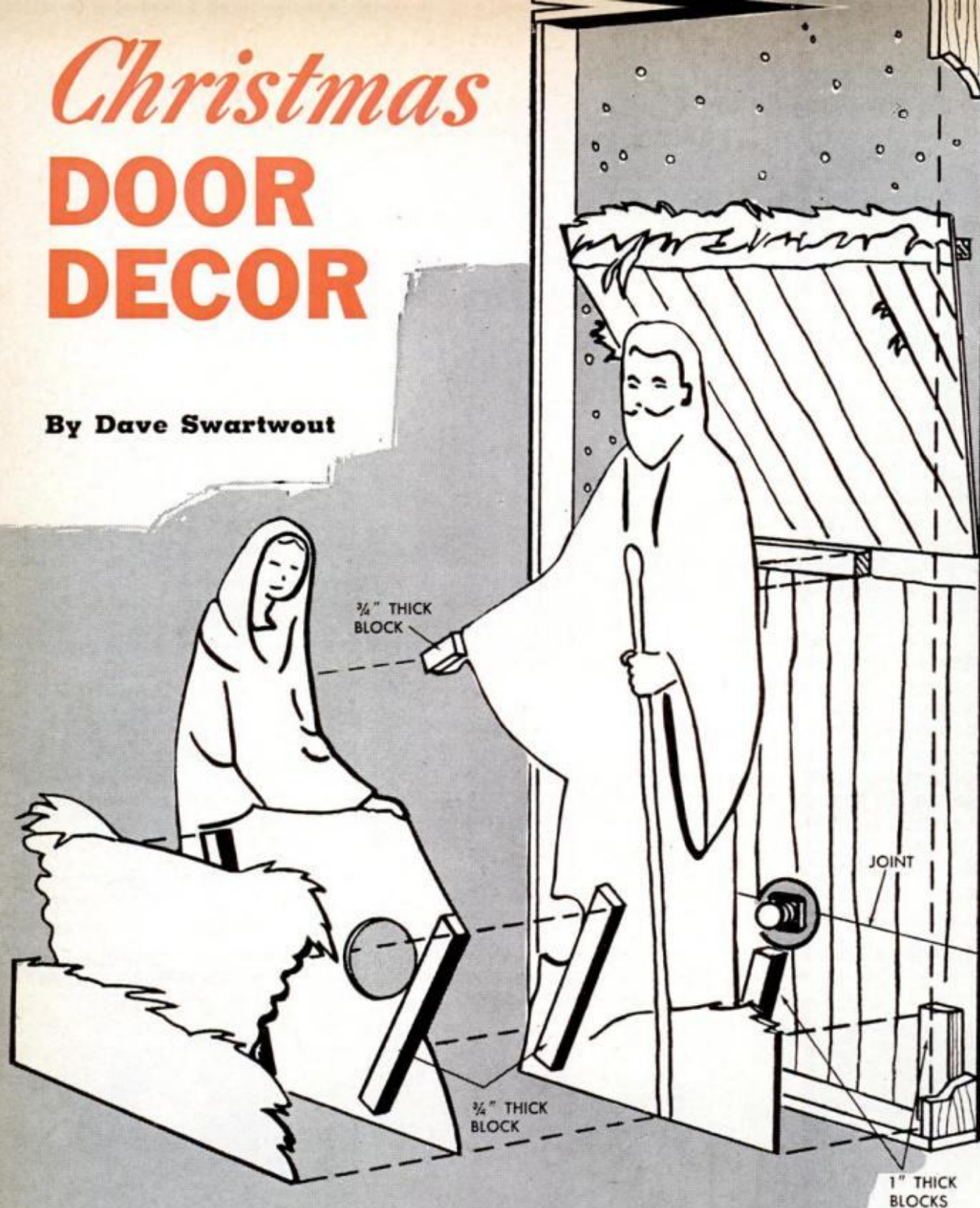

LIGHTING YOUR DISPLAY is the last step in construction. Just attach a small socket to a round hard-board plate that can be fastened to the back of the box with screws. Run the cord up the inside of the box and out to a porch outlet, tying it to the hinge pin to hold it in place when the door is open or closed

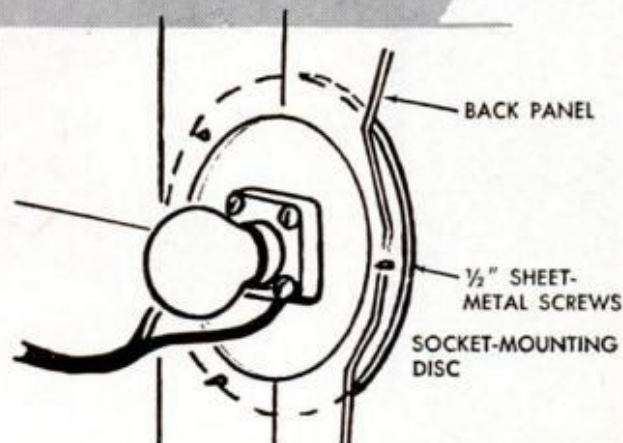

HERE'S something different in Christmas cutouts for adding the holiday spirit to your home. Two are holly-framed shadow boxes made to fit your storm door in place of the glass insert. A third, a high-hatted Santa with a blinking red nose, attaches to the outside of the door. Project-a-Plans—an exclusive PM method of enlarging patterns—make it easy to “blow up” the figures of all three displays to fit your particular door. (For those who don't own a slide projector, we've duplicated each pattern on graph squares.)

First, measure your screen door to determine the size to

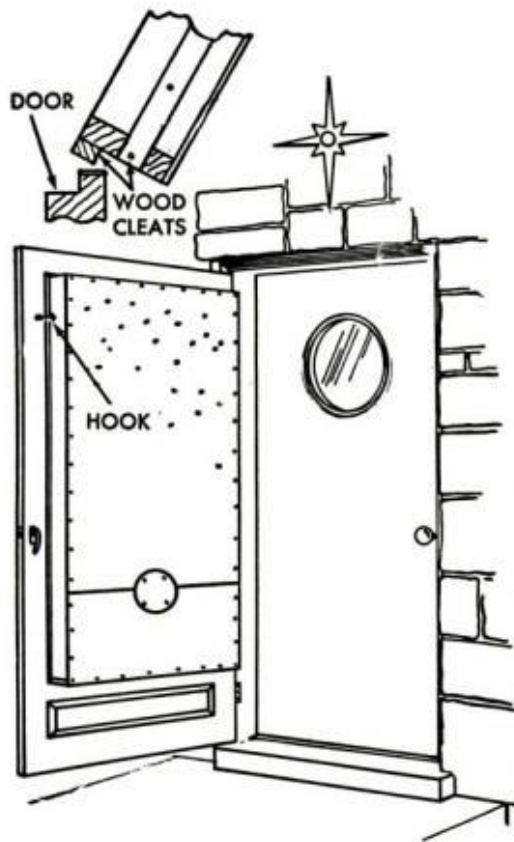

PROJECT-A-PLANS, below, are paper transparencies designed to fit standard 35-mm slide mounts. Before inserting in mount, coat both sides with vegetable oil to make the paper more transparent for a sharper image of patterns

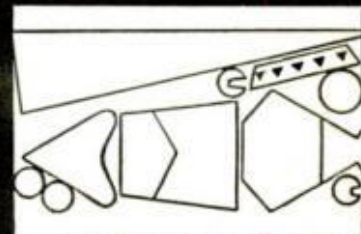
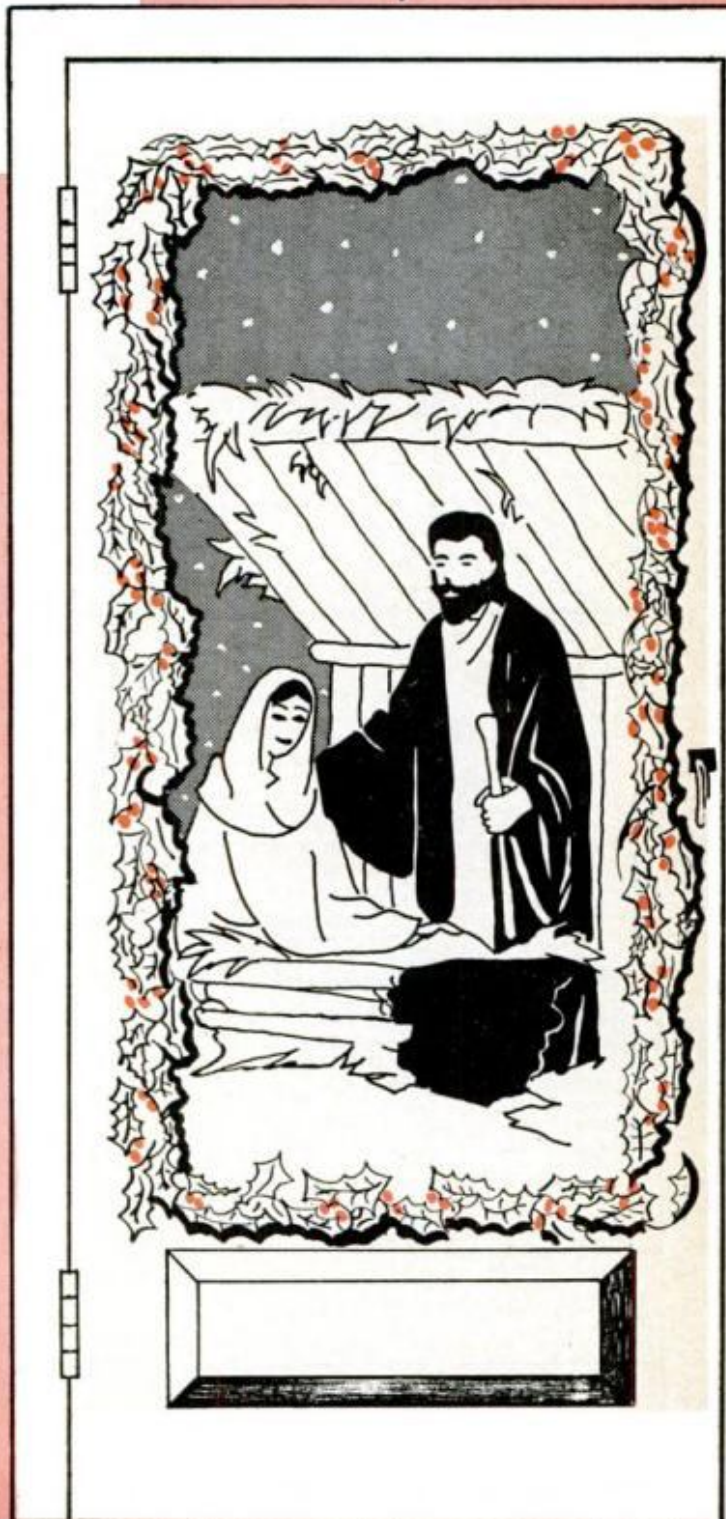

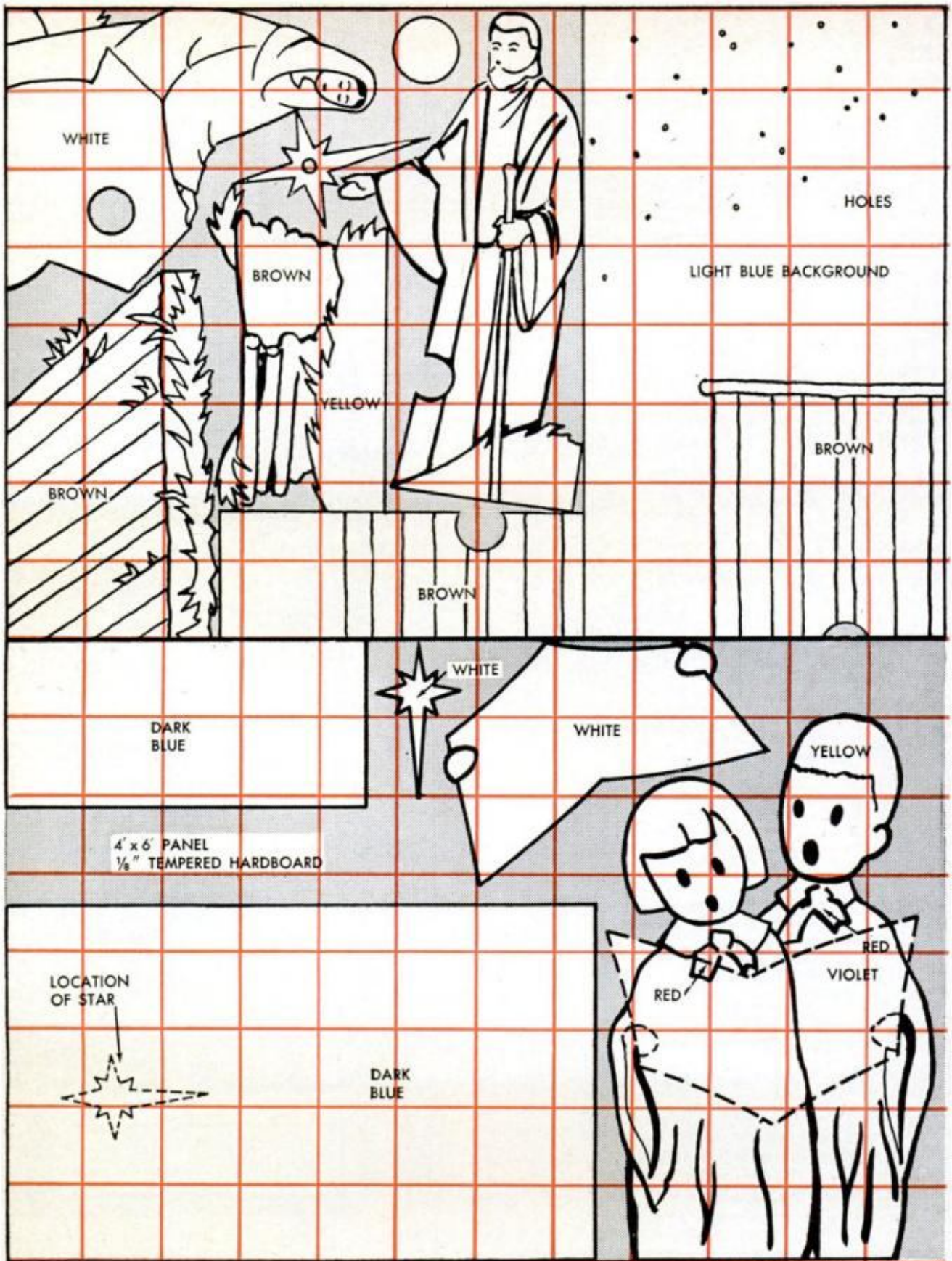

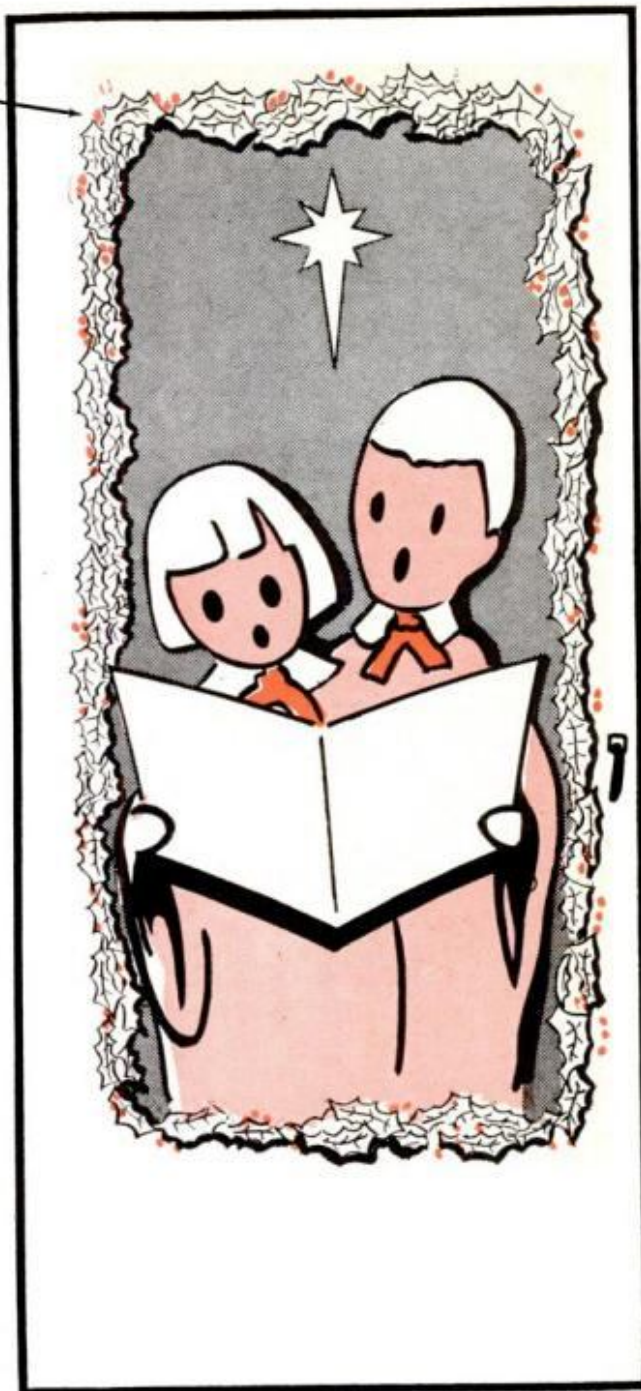
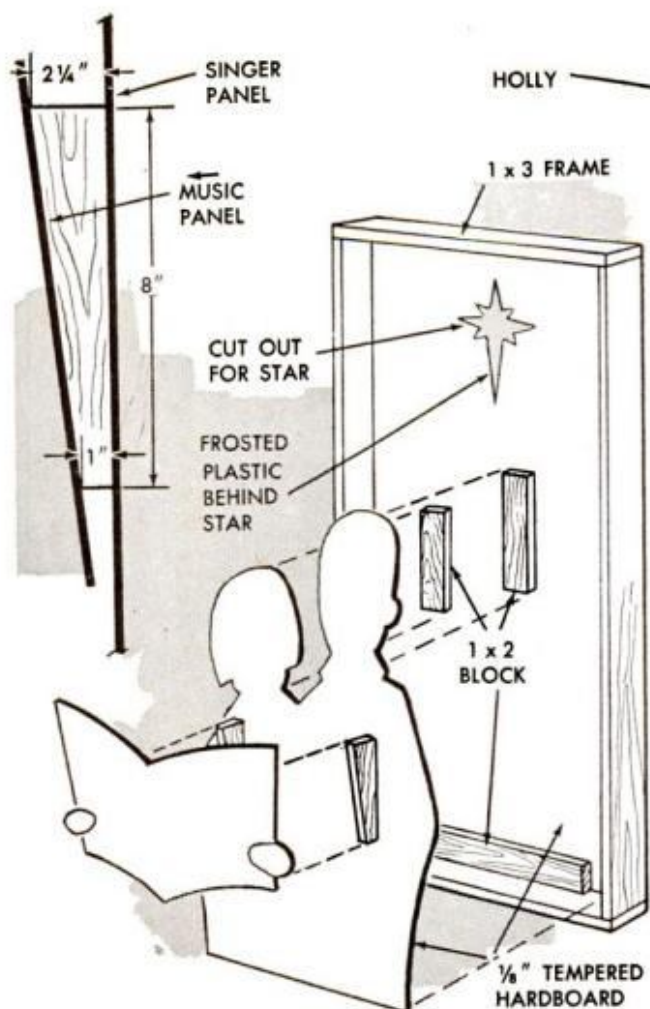

make your display, and build the background box, using $\frac{1}{8}$ -in. tempered hardboard framed with either $\frac{1}{2}$ -in. plywood or 1 x 4 stock. Next, cut cleats to fit the rabbets of the opening in the door and mount these along the edges of the box with glue and nails. The regular catches which hold the screen or stormwindow in place are strong enough to secure the display to the door, but it's a good idea to

PROJECT-A-PLANS IN COLOR

FULL-COLOR PROJECT-A-PLAN transparencies, already mounted for use in any 35mm projector, can be ordered now for prompt delivery. These slides save you the trouble of preparing your own, and give a sharper image in easy-to-copy colors. Order by number: Santa #101, Carolers #102, Nativity #103, enclosing \$1.00 for each or \$2.50 for all three. Other Project-A-Plans of our 1962 and 1963 Christmas cutouts (samples below) are also available. Address Project-A-Plan, Popular Mechanics, 575 Lexington Ave., New York, N.Y. 10022

MECHANICS



5 Christmas Costumes
For Your Home with New
Project-a-Plans for Easy Enlarging



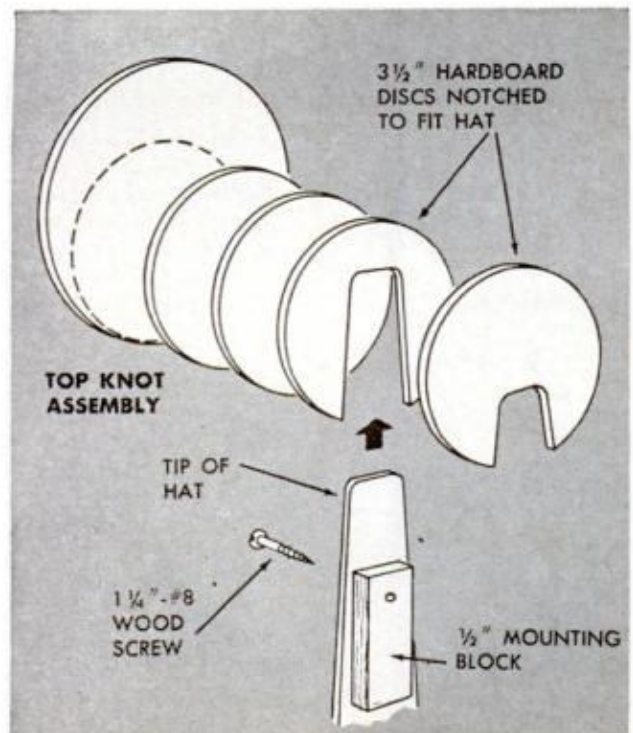
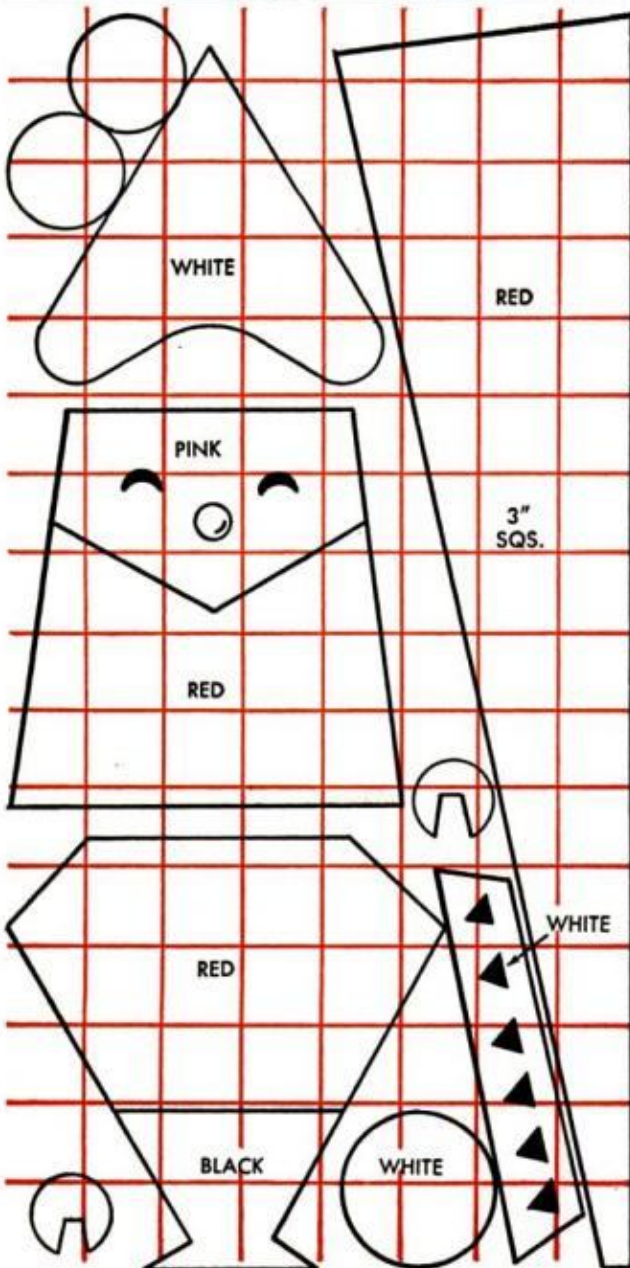
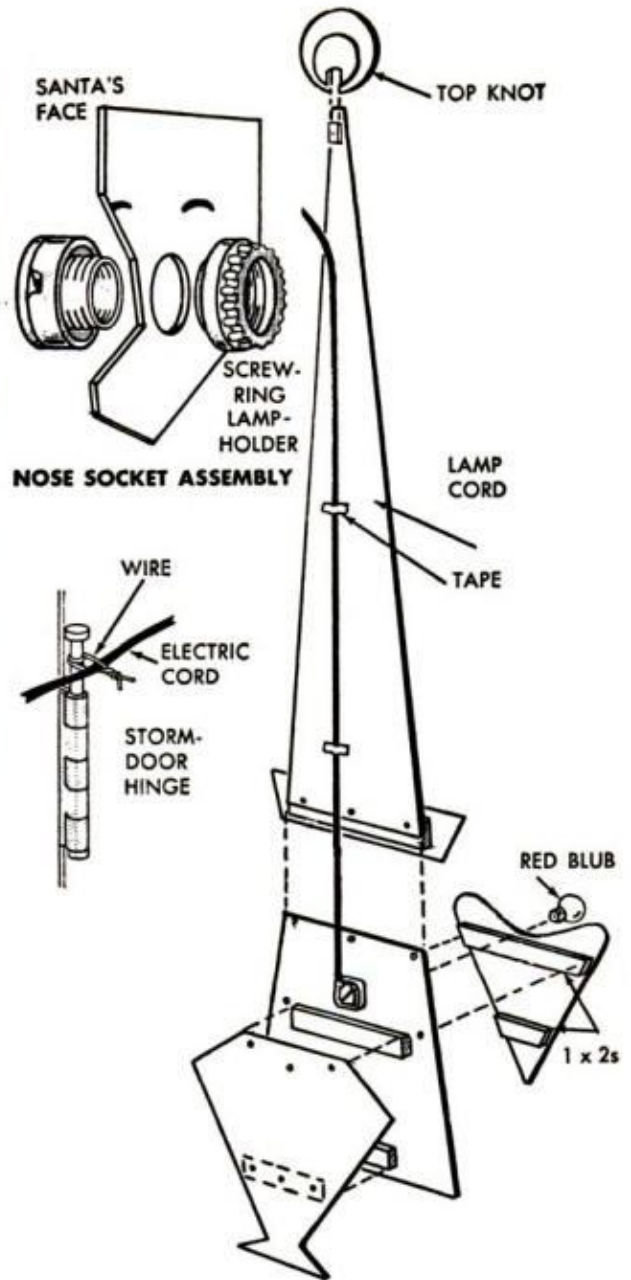
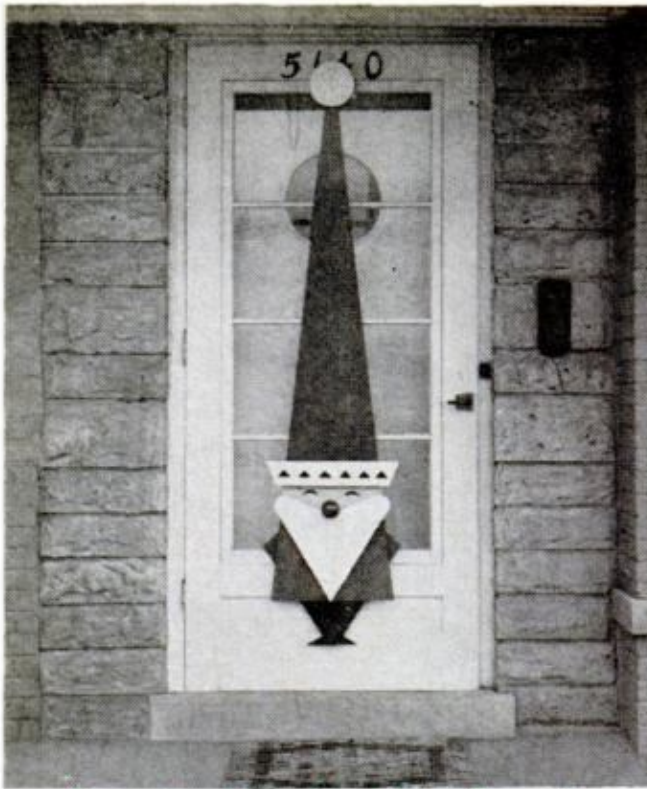

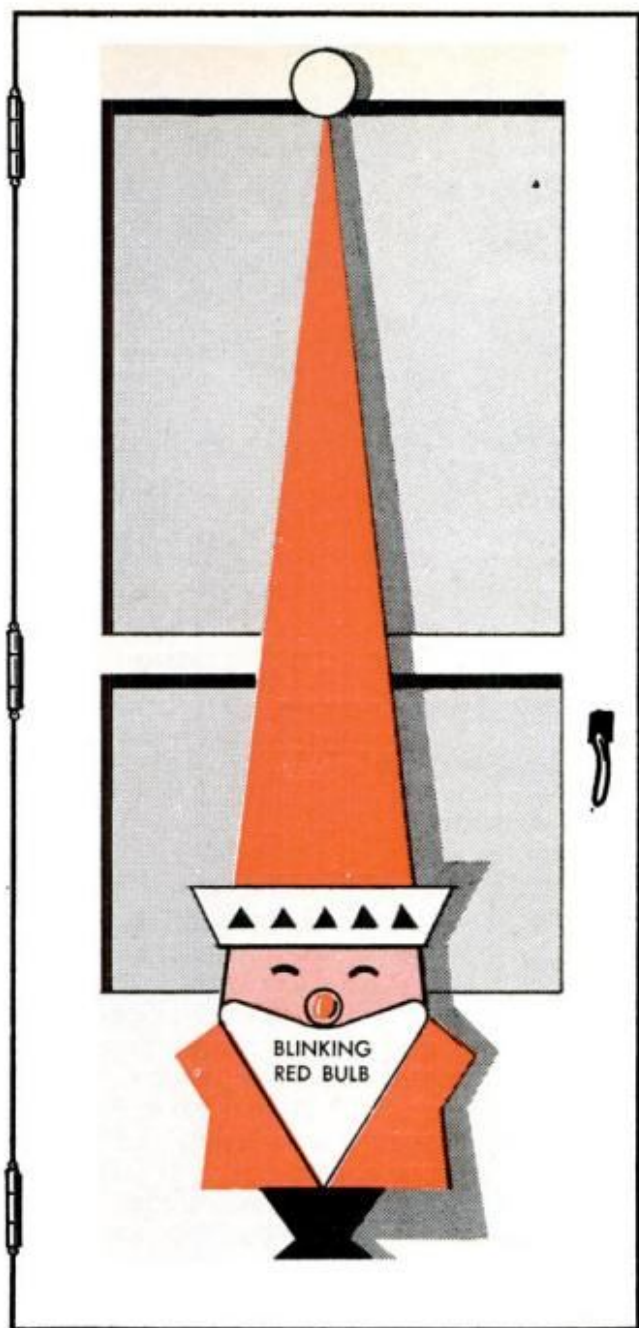

add screen hooks near the top.

Before cutting the figures, mark out an area the size of the box on the panel to be cut, then set up the projector so that the back-panel image fits this area and trace the pattern for the back. You can usually trace the other figures without moving the projector.

Cut the various shapes out with a sabre-saw or jig saw and give them an undercoat of outdoor enamel. When dry, you can paint the separate areas with quick-drying enamels. Finally, assemble the inserts with glue and brads. Put cut-outs or holes in the back panel only if your main door has a glass insert.

If your storm door is metal, you'll have to make the box a bit shallower and bolt it to the face of the door. Use 1/8-in. aluminum bolts with aluminum washers, two each at the top and bottom. After Christmas, just tighten the bolts in place.

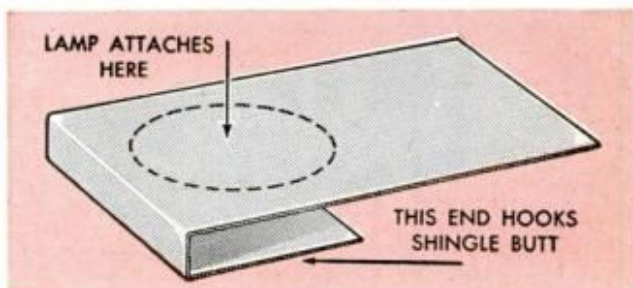
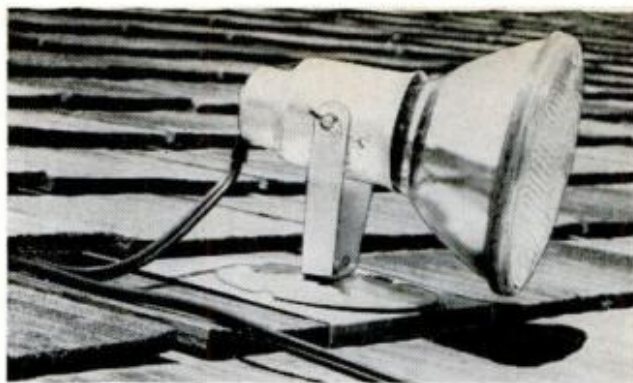

Roof Mounted Floodlight

Light up an outdoor Christmas display this season or brighten up your lawn parties next summer. This floodlight can be moved anywhere on your roof in minutes, since it clips to the shingles. It's just an ordinary outdoor swivel fixture on a standard box-mounting plate soldered to a clip made by folding a strip of galvanized sheet metal. For asphalt shingles, make clip thinner.—*Bob Gilmore*

Make Your Own Yule Lights

With clip-on adapters called "Add-a-Tap," you can turn any standard two-strand extension cord into a string of Christmas lights. Simply clip the taps to the cord, plug in adapter sockets and add colored bulbs. Such homemade lights are ideal for decorating outdoor Christmas trees, and by fitting them with Japanese lanterns you can use them for summer patio parties.—*Joseph Braunstein*

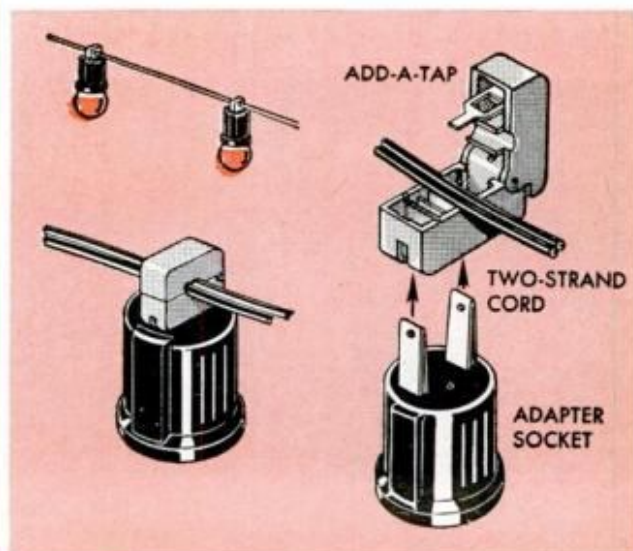

DON'T PULL IT UP— RETILE OVER THE OLD

Leaving the old tile right where it is and covering it with a special underlayment, saves work and actually gives a better base for your new floor

By Steven J. Howard

WHEN REPLACING a worn-out tile floor, it makes sense to lay the new tile over the old. You'll save the time-consuming chore of pulling up the old tile, and the new floor will be every bit as good as if you'd stripped the floor right down to the wood or concrete.

The trick in laying tile over tile is *not* the actual installation, which anybody with a little practice can do. It's in the proper preparation of the old surface and, most important, in knowing what materials to use.

Taking things logically, you could divide the job into four steps: (1) selecting the tile, (2) preparing the surface, (3) marking off the floor, and (4) laying the new tile.

TO PREPARE SURFACE, fill all cracks, gouges and dents with a compound called "floor patch and crack filler." Flatten bumps in old tile by nailing them down

Selecting the Tile. The most popular types of floor tile on the market today are asphalt, vinyl asbestos and vinyl.

Asphalt tile is the least expensive, but it offers a somewhat limited selection as far as color and patterns are concerned. It's not resistant to grease, so it's not the best choice for the kitchen floor.

This tile is used primarily in direct contact with concrete, such as in a basement recreation room, since the asphalt, asbestos and plastic filler in the tile resist the natural moisture which permeates concrete. (But no tile, including asphalt, will stay on a concrete floor that has water actually pushing up through it.)

Asphalt tile comes only in $\frac{1}{8}$ -in. thickness and 9 x 9-in. squares. It sells gener-

FILE ALL EDGES of the underlayment on top and bottom. This will remove all burrs, which could show through your new floor as unsightly bumps and ridges



ally for 5¢ to 10¢ a tile in carton lots.

Vinyl-asbestos tile, which is grease resistant, is perhaps the most popular of all since it comes in a variety of patterns and colors, and is reasonably priced. It is also easy to lay because some of its adhesives do not have to be troweled on, but can be brushed and even rolled. These adhesives, by the way, dry clear so that any excess which might seep up between the cracks doesn't mar the appearance of the floor.

Vinyl-asbestos tile is available in $\frac{1}{16}$, $\frac{3}{32}$ and $\frac{1}{8}$ -in. thicknesses, and in 9 x 9 and 12 x 12 in. squares. Prices run from about 12¢ per tile to 19¢.

Vinyl tile is the most expensive of all, running from 18¢ a tile to about \$3. It offers the widest range of patterns and colors, and also of sizes. Popular thicknesses run $\frac{1}{16}$ in., .080 gauge and $\frac{1}{8}$ in. You can get vinyl tile in practically any size up to 16 x 36 in., although the more popular sizes for home use are 9 x 9, 12 x 12, and 9 x 18 in.

In laying vinyl tile, which is grease resistant, you must use a waterproof vinyl-tile adhesive, which has to be troweled on.

A word about *cork tile*, which, although losing favor, is still fairly popular. It should only be used in light traffic areas, where it will be subjected to little wear, since it's hard to maintain. It sells for about 35¢ to 38¢ a tile.

Preparing the Surface. Before doing anything, fill up all gouge marks and large cracks with a spackling compound made for this job called floor patch and crack filler (photo, opposite page). This material strengthens the area and will prevent a spike heel or furniture leg from popping into it again.

There's a minor difference of opinion

FOR A SMOOTH FLOOR, allow $\frac{1}{64}$ in. for expansion between sheets of underlayment. Also, stagger the seams to avoid having four edges meet in one spot



DECEMBER 1964

TILE ESTIMATING			
Square Feet	Number of Tile Needed		
	9" x 9"	12" x 12"	9" x 18"
1	2	1	1
2	4	2	2
3	6	3	3
4	8	4	4
5	9	5	5
6	11	6	6
7	13	7	7
8	15	8	8
9	16	9	8
10	18	10	9
20	36	20	18
30	54	30	27
40	72	40	36
50	89	50	45
60	107	60	54
70	125	70	63
80	143	80	72
90	160	90	80
100	178	100	90
200	356	200	178
300	534	300	267
400	712	400	356
500	890	500	445
600	1068	600	534
700	1246	700	623
800	1424	800	712
900	1602	900	801
1000	1780	1000	890

Tile Waste Allowance	1 to 50 sq. ft. 14%	
	50 to 100 sq. ft. 10%	100 to 200 sq. ft. 8%
	200 to 300 sq. ft. 7%	300 to 1000 sq. ft. 5%
	Over 1000 sq. ft. 3%	

SECURE UNDERLAYMENT with 4d cement coated, annular ring or similar nails, spaced on 4-in. centers. Some underlayments come with spacing printed on





UNDERLAYMENT GRADE HARDBOARD cuts readily with standard power and hand saws. As shown above, a sabre or scroll saw is ideal for cutting the material to fit columns, corners, casings, and the like

among flooring experts concerning what type of underlayment to use—plywood, ordinary hardwood or a not-too-widely publicized product called underlayment grade hardboard. After listening to all arguments and working with one type of material, I have to agree with Harry Whitt, co-owner of Whitt Brothers Flooring in Middlesex, N. J.: "I don't advise the use of ordinary hardboard—the type you buy in a lumber yard. Tempered hardboard is too hard, and it's difficult to drive a nail so its head is flush with the

board. Naturally, any nailheads sticking up will show as bumps through the tile. On the other hand, untempered hardboard is too soft and could 'give' under a spike heel too readily."

"As for choosing between underlayment grade hardboard and plywood, it's pretty much of a toss-up, although the underlayment grade does come in 3 x 4 and 4 x 4-ft. sizes, which are easy to handle. Also, underlayment hardboard is usually marked off so you know where each nail should go. Cost of the two materials is about the same."

Underlayment grade hardboard might not be available in your lumber yard. However, most floor tile establishments stock it.

Why use underlayment at all? Tile "gives" in relation to the material beneath, which expands and contracts with changes in temperature and humidity. This offers the possibility of wide cracks opening between the tiles. Furthermore, according to Whitt, there is yet to be developed a floor adhesive which permits two tile materials of the same or different composition to adhere properly to one another.

If you've ever tried to remove floor tile, you'd know why this is not recommended. Removing floor tile that's been in place for several years is rough and takes time—too much time.

"A tiled area of 100 square feet," Whitt told us, "would take the average homeowner two days to clear—and that's not including the time it would take him to prepare the subfloor and lay the new tile. The old tile has to be heated and then scraped, and there's danger that you could damage the subfloor."

THE BEST WAY TO FIND WHERE TO START

STEP 1: Find the center of both end walls and mark floor mid-point by snapping chalk line between marks

STEP 2: Before spreading adhesive, lay two perpendicular rows of tile to determine how they will fit

STEP 3: Measure distance from last tile to wall. Space must be no less than 2 in., no more than 8 in.

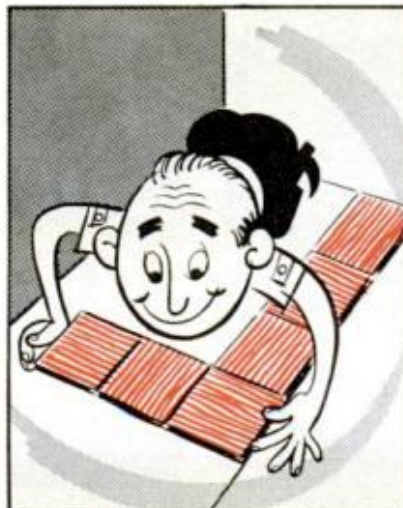

"By using the underlayment method, though, a man can completely retiling the floor in from 6 to 8 hours—and it's a whale of a lot easier."

Marking Off the Floor. First, estimate how much tile you'll need. To make things easier, measure the square footage of the room. Then consult the chart on page 137.

Here's an example of how to use the chart. Suppose your room size is 253 square feet and you plan to use 9 x 9-in. tile. First find the number of tiles needed for 200 square feet (356 tile); then the number needed for 50 square feet (89 tile); then the number needed for 3 square feet (6 tile). The total is 451 tile.

But you must allow for waste—in this case, 7 percent. Thus, 7 percent of 451 is 32 extra tile. In other words, you need a total of 483 tile to do the room.

Tile is generally boxed 80 to a carton. Most floor tile dealers will split a carton for you, but buy a few extra anyway in case you have to replace a tile or two in the future.

To mark the floor, measure off the center point of the room's opposing end walls.

Hammer in a tack at the center point at one end of the room and tie a string to it that's been rubbed in chalk. Line the string up with the other center mark and snap a chalk line between marks (step 1, page 138). This is the line on which the initial row of tile will be laid. After the chalk line is made, remove the string and pull out the nail.

Lay down two test rows of tile perpendicular to each other starting from the center of the room, using the chalk line as a guide (step 2). Measure the distance between the wall and the last tile to it (step 3). This distance should not be less than 2 in. or more than 8 in. If it is either, readjust the center line parallel to the wall so the last tile is about 4½ in. from the wall. The idea is to avoid having a strip of tile less than 2 in. wide along the walls at either side.

Laying the Tile. Pick up the test tile and pour some adhesive on the floor—enough to spread over half the room.

I recommend using the clear adhesive where possible since you can see the center line through it when it has set enough to lay the tile. Whichever adhesive you use, however, note on the label whether it is combustible or not, and take the necessary precautions dictated by common sense—putting out pilot lights, not smoking while you work, etc.

It matters little whether you trowel, brush or roll the adhesive on. The key word is **THIN**. Use the adhesive sparingly to avoid excess from coming up through

(Please turn to page 196)



A. APPLY MASTIC over about half the floor. Be careful to spread it as thinly as possible, to minimize the possibility of adhesive coming up between the tile

B. WORK FROM CENTER of room laying first row of tile along the center line, which remains visible through clear adhesive. Pyramid tile for even seams



C. MARK BORDER TILE for cutting by laying a tile on last full row. Lay a second tile over it, butted against wall; mark first tile using second as straight edge





PIGGY BANK

SQUEALS ON THIEF

TRY to filch a coin or bill from Mrs. Tattletale and you'll be greeted with a loud squeal of protest. Her guarding voice is a buzzer which sounds off when tiny mercury switches, tucked inside her body, are tilted the least bit. Even picking her up will scare off would-be "borrowers" which will lessen the temptation to dip into a vacation kitty.

The buzzer, which should be 1½-volt, and no more than 2 in. in diameter, was taken from a bicycle horn. Power is from two 1½-volt penlight dry cells. Note that the dry cells are connected in series, and that the bottom one stands in a hole in the cork, which also plugs the bank's access hole. A 1-in. pipe clamp under the coin slot protects the batteries from being damaged by falling quarters and half-dollars.

The three mercury switches are glued in "down-hill" grooves filed in the sides of a ¾-in. thick triangular wood block, 1½-in. long. To make the switches as sensitive as possible, find out by trial-and-error how close to horizontal the switches can be installed without activating the buzzer. The more gradual the incline of the switches, the more quickly they'll respond to movement. The switch block, and the buzzer, are cemented in place with epoxy.

Wire the circuit according to the diagram on the opposite page. After testing, cover the buzzer and switches with heavy mastic to prevent the coins from shorting the circuit. Make sure the mastic is the type that dries; some kinds remain tacky. The cork holding the dry cells is cemented in place last, after final sanding and painting. To empty the bank (months later), just break out the cork. You can replace it with a new one when you start the next fund.

—Tommy Thomas

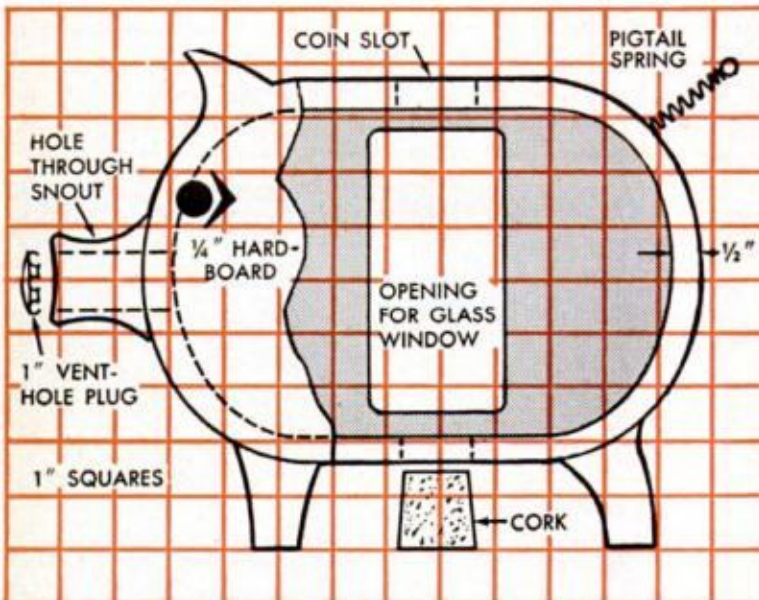

THE PIG consists of four rings cut from ¼-in. wood and glued together like a sandwich. Note that the two outer rings are provided with feet. Sides of the body are cut from ¼-in. hardboard or plywood, the snout being cut separately. The optional window is held in place with contact cement. Drill the hole for the cork and the one through the snout after the rings are glued together. A vent-hole plug is inserted in the snout

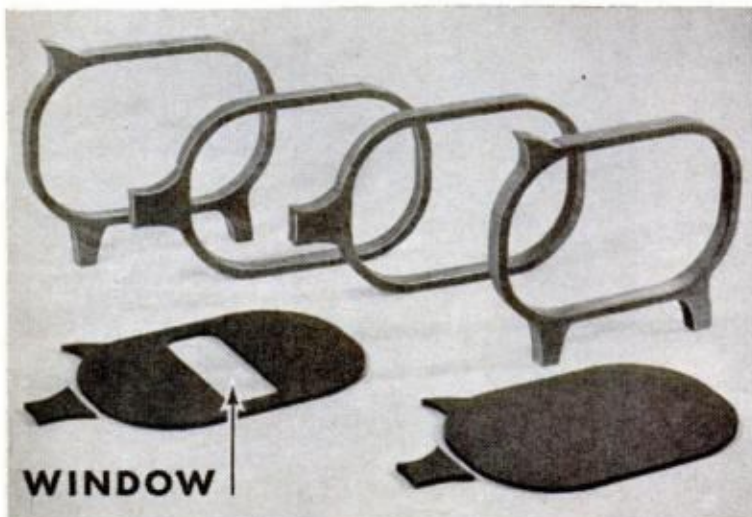

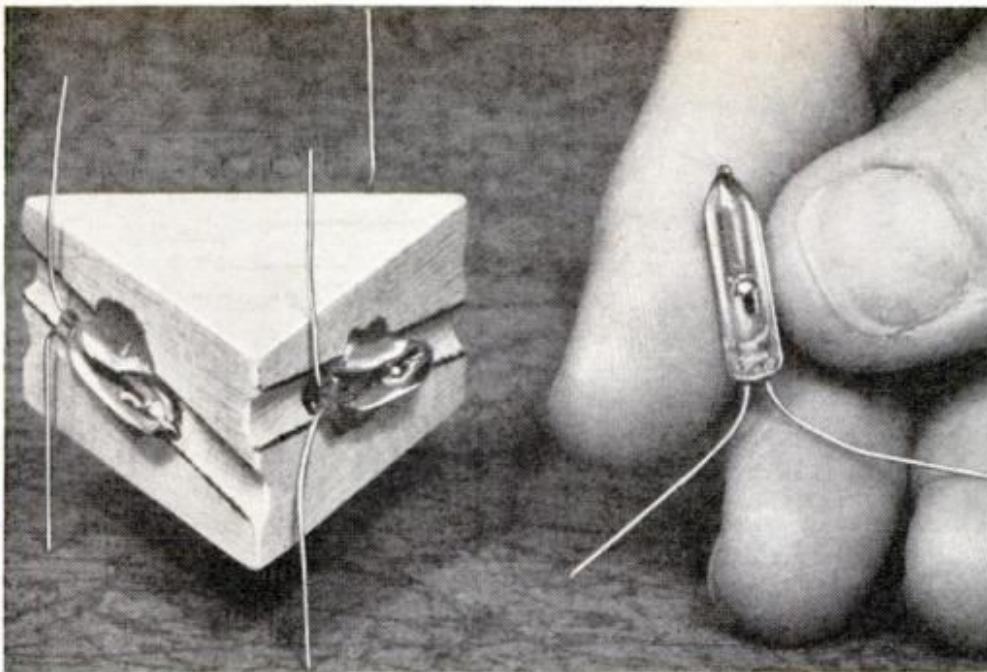

SEE REVERSE

MOUNT MERCURY SWITCHES with epoxy, making sure the longer of the wires inside each switch is on top. Cement block inside body with one of the switches forward

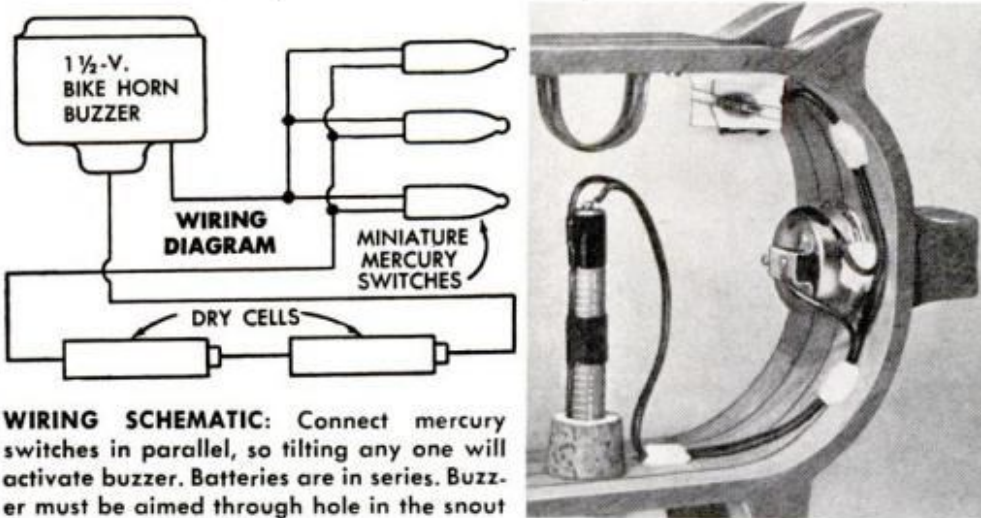

SIDE OF PAGE

WIRING SCHEMATIC: Connect mercury switches in parallel, so tilting any one will activate buzzer. Batteries are in series. Buzzer must be aimed through hole in the snout

HEAVY BLACK MASTIC or roofing cement prevents coins from shorting circuit or damaging the buzzer and switches. Connecting wires are tacked to body with epoxy

FOR CLIP-OUT

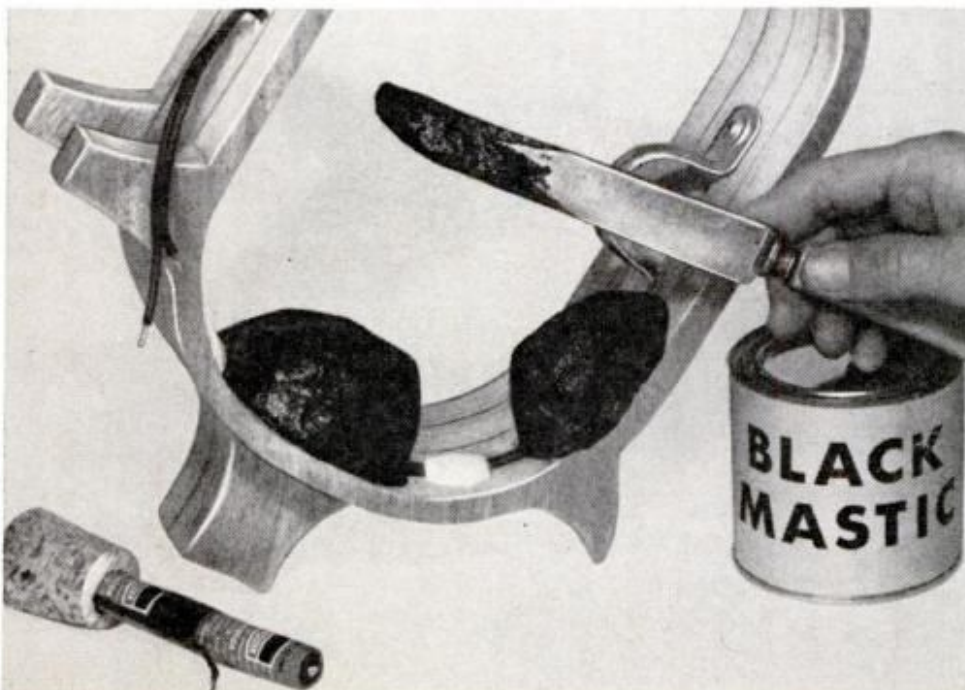

PROJECT-A-PLANS

Gifts You Can

By David M. Swartwout

BELIEVE IT OR NOT, from the five Project-a-Plan patterns shown at the left, you can come up with at least 30 different gift ideas, including coasters, trivets, wall plaques, cutting boards, books ends and pin-up boards. Actually, from these five basic designs, project possibilities are endless and you'll find many other places where these clever patterns can be used for decoration and useful novelties.

The Project-a-Plan system makes pattern enlarging easy. Just tape a sheet of paper to the wall, then set up the projector a short distance away and focus it on the paper. Measure the projected image to make sure that it's the size you want for the project of your choice. If not, move the projector to change the image size. The pattern may then be outlined on paper and transferred to the wood with carbon paper. The chart on page 144 gives suggested sizes, though you may prefer to vary them.

THE CLIP-OUT Project-a-Plan transparencies at the left make it a snap to enlarge the patterns to the size you want. They're designed to slip in a standard slide mount for projecting full size with any 35mm slide projector. Coating the paper with vegetable oil will make it more transparent, for a brighter projected image. The height dimensions shown apply only for use as trivets

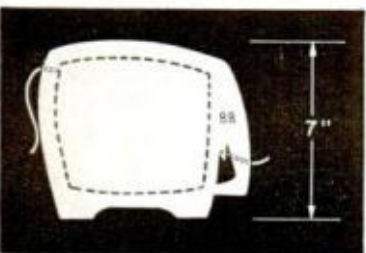
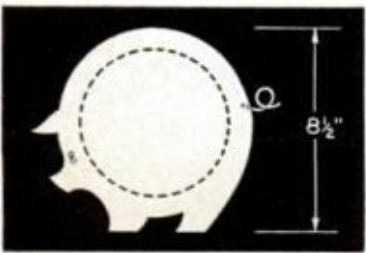
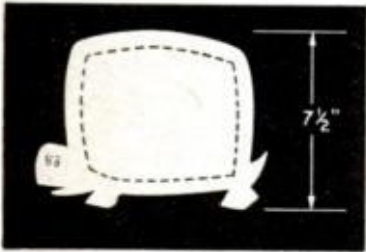
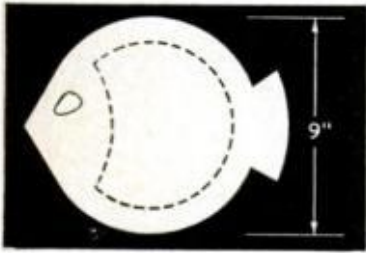
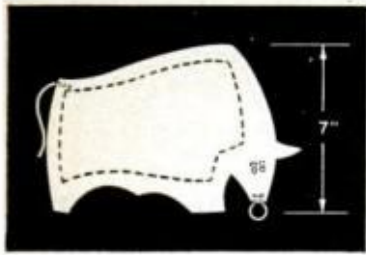
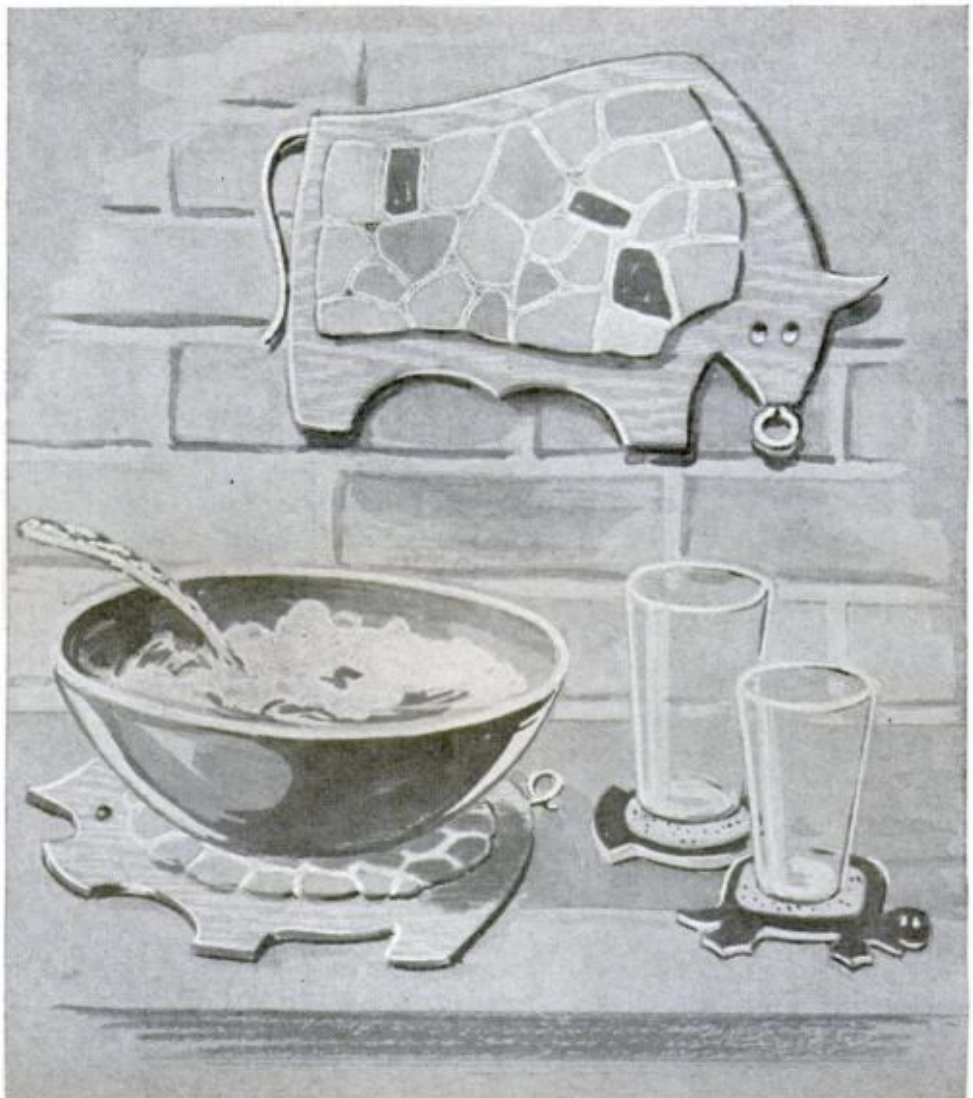

Make for Christmas

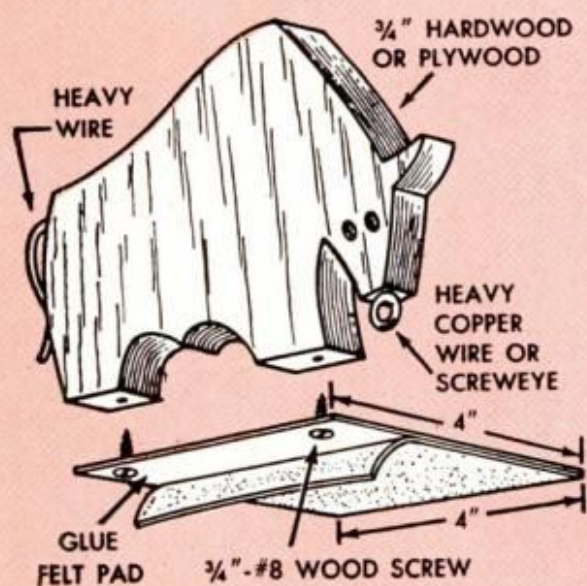

BULL BOOK END is a handsome addition to a boy's room. Or make a set to match whatever design you pick for the bulletin board. The square sheet-metal base should be felt padded to prevent marring furniture

CONTACT CEMENTING the bulletin-board cork calls for a special technique. First, coat both surfaces with cement and allow them to dry. Then lay a sheet of wax paper over most of the bonding surface. Position the cork, press down as you withdraw paper

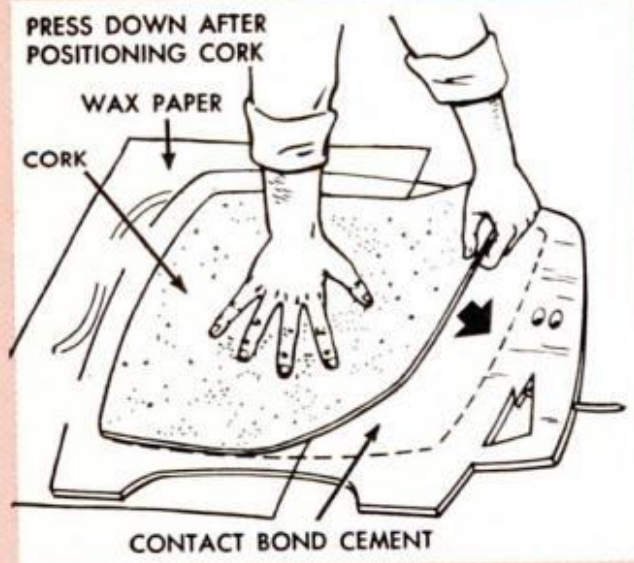

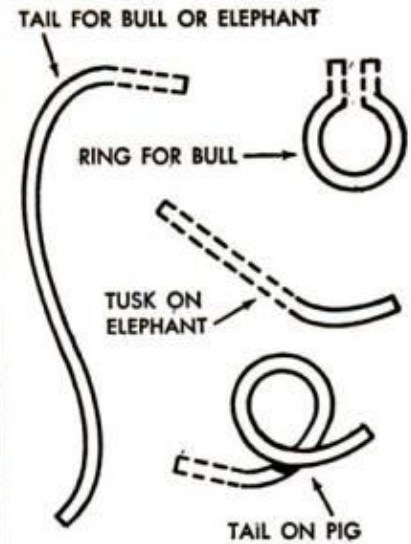
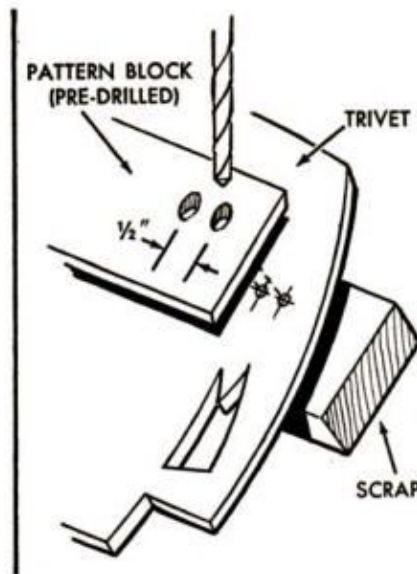
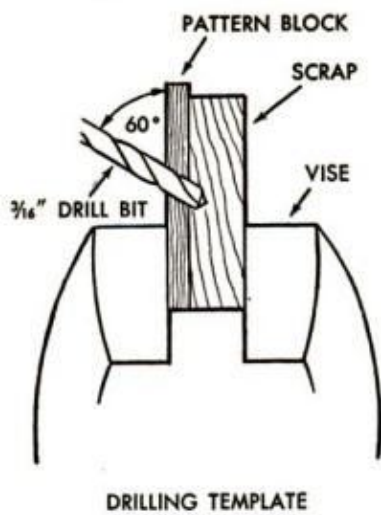

For trivets, coasters and wall plaques $\frac{1}{4}$ -in. hardwood plywood is best. The pin-up boards require $\frac{3}{8}$ -in. plywood and the cutting boards should be made from 1-in. solid stock, preferably maple or other hardwood. The thinner stock can be cut to shape with a jigsaw or even a coping saw; the heavier material used for the cutting board and book ends can be handled best on a bandsaw. After cutting, the edges should be sanded and the top surface outlined for the placement of tile, cork or linoleum.

Copper wire is used for the trimmings, such as the bull's tail and the elephant's tusks. An extra inch should be allowed so that the wire can be firmly inserted in a hole drilled in the edge of the cutout. The drawings at the top of the page will guide you in bending the wire and drilling the

holes for the eyes, which have an especially realistic appearance when angledrilled with the pattern block.

Tile, base glue and grout are standard items at most hobby shops. Sheet cork may be obtained at many auto supply and department stores. Very small tile should be used for the coasters, or if you prefer, a disc of $\frac{1}{16}$ -in. cork may be used instead. Center panels for the pin-up boards can be made from insulating cork or linoleum.

A natural finish with either varnish or shellac is attractive, or the wood may be stained and when dry, rubbed with paste wax. To avoid possible contamination of food, the cutting board should not be finished with any sort of paint or stain. If a finish is wanted, rub the smooth-sanded face with vegetable oil, and clean after each use with a damp cloth. ★ ★ ★

SUGGESTED SIZES FOR VARIOUS USES

	Fish	Bull	Turtle	Elephant	Pig
Coaster	3"	3½"	3½"	3"	3"
Trivet	9"	7"	7½"	7"	8½"
Wall Plaque	9"-12"	9"-14"	9"-14"	9"-14"	12"
Cutting Board	10"	10"	10"	10"	10"
Pin Up Board	18"	16"	18"	18"	18"
Book Ends	5"	5"	5"	5"	5"



FIRST STEP when working with mosaic tile is to find the most pleasing arrangement of pattern and color. Special attention should be given to each border tile to make certain that it fits neatly inside the lightly penciled dotted line

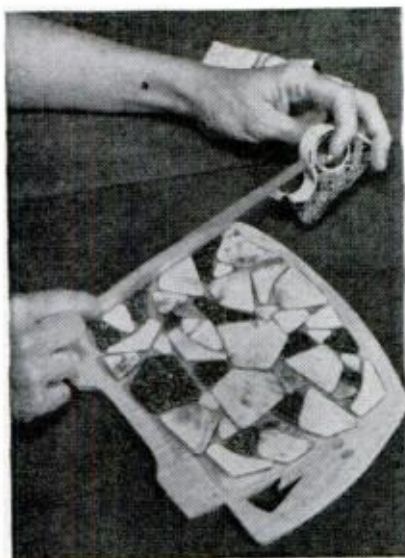

CELLULOSE TAPE or masking tape applied in a criss-cross pattern will keep tiles from shifting while glue is applied to the back. Leave the tape in place for at least 24 hours to give base glue plenty of time to dry thoroughly

AFTER TAPING tiles together invert the assembly and apply a quick-setting base glue to the underside. Then lift the board and press it down onto the glued tile. Flip unit face up between palms



DECEMBER 1964



ANY OF THE FIVE animal cutouts lend themselves to novel tile-covered trivets, the turtle being particularly appropriate. The five simple steps for applying the mosaic tile to the plywood cutout within a border outline are shown at left and below

WHEN GLUE has dried, remove tape and apply liberal coat of grout. The mixture should be about as thick as toothpaste. Work the grout into all cracks, then squeegee excess off surface of tile

LET GROUT SET about 30 minutes then wipe the surface with a damp rag to remove any bits of grout that may remain on the tile. When the grout is completely dry, polish carefully with a clean, soft cloth



145

HI-LO TABLE



By Steve Ellingson



**Faced with a space problem?
Here's a table that plays two
roles to relieve a crowded room**

THE APARTMENT DWELLER or small home owner can't stretch his under-sized rooms. But he can make the most of his available space by choosing dual-purpose furniture such as this combination dining and cocktail table. The secret behind its double life is a unique leg design that permits instant adjustment of height.

Building the table isn't difficult, but if your toolkit is limited or if you have no convenient place to work, you may find it best to lay out the work on a sheet of hardwood veneer plywood and have the lumber yard or a cabinet shop do the cutting for you. In most cases only a nominal charge will be made for such work.

For strength, all joints are glued and nailed. Care in setting the nailheads and in filling holes with a matching wood putty will pay dividends when the table

is completed. A roll of matching wood tape conceals the exposed plywood edges.

To correctly locate the first set of bullet catches in the 16-in. leg stop and in the narrow (16 $\frac{1}{4}$ -in.) leg assembly, start by placing the bullet part of the catches in the ends of the 16-in. stop. Next, fasten the strike plates to the inside of the legs to engage the bullets. The bullets of the second set are positioned on the outside of the narrow leg assembly directly above the 2 $\frac{1}{2}$ -in. leg stops. The strike plates are placed on the inside of the wide (18 $\frac{1}{8}$ -in.) leg assembly.

If you prefer to work from a large plan which includes an actual size leg pattern ready for tracing, send \$1.00 to Steve Ellingson, Popular Mechanics Pattern Dept., Box 2383 Van Nuys, Calif. and ask for plan #314.

MATERIAL LIST

- 1 panel $\frac{3}{4}$ " x 4 ft. x 8 ft. hardwood veneer plywood
- 24 ft. $\frac{3}{8}$ " x $1\frac{1}{4}$ " matching door molding
- 1 1" x 36" dowel
- 1 $\frac{5}{8}$ " x 36" dowel
- 8 1" x $\frac{3}{4}$ " x brass butt hinges
- 16 ea. #6 x $\frac{3}{4}$ " and #6 x $\frac{1}{2}$ " FH wood screws (for leg assembly and drop leaf hinges)
- 4 $\frac{1}{4}$ " bullet catches and plates
- 4 Corner braces with #8 x $\frac{1}{2}$ " screws
- 2 Elbow catches and screws
- 40 ft. 1" flexible wood trim (and contact cement)

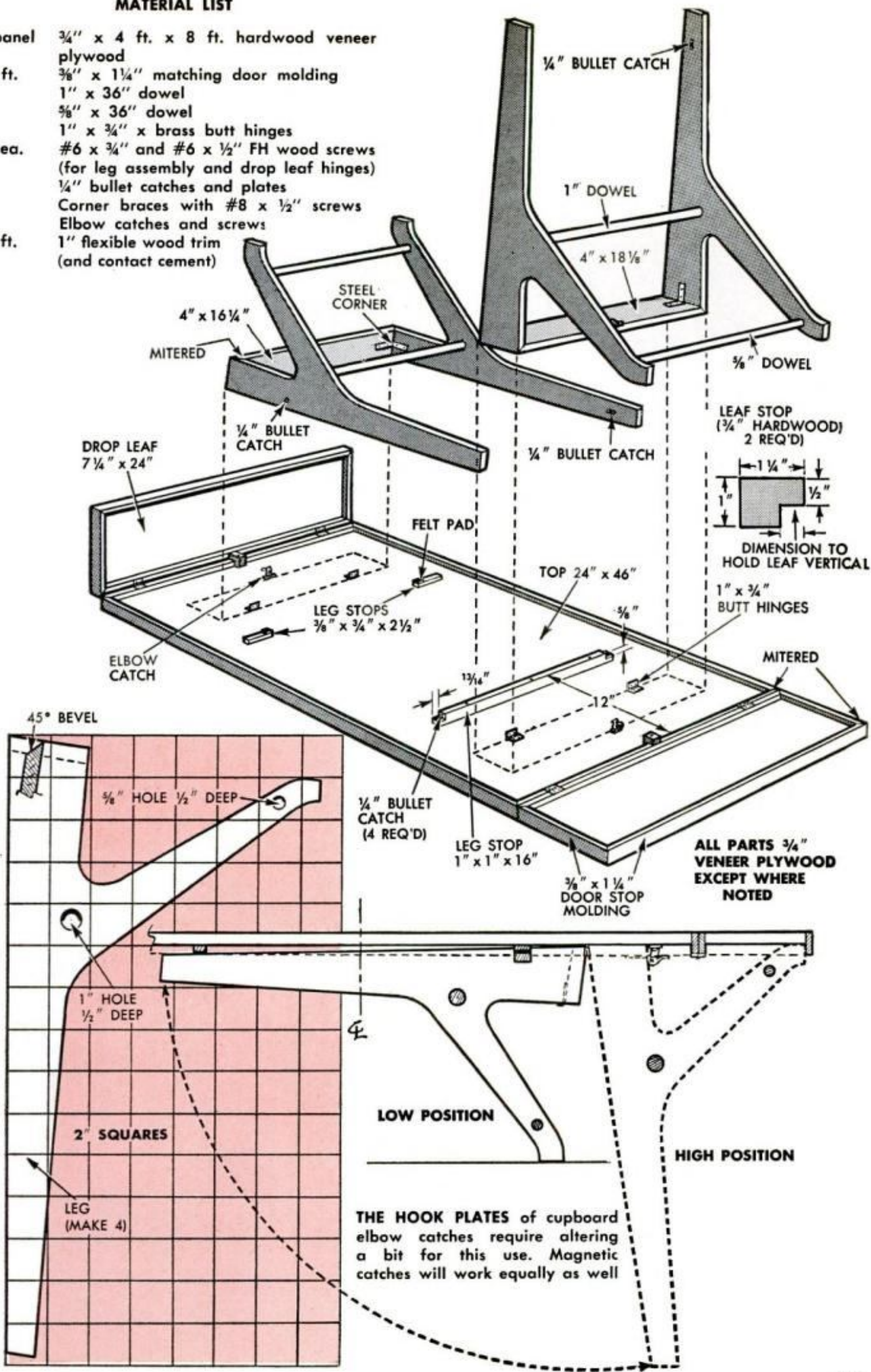

New for Camera Buffs



600-MM F:8 TELEPHOTO LENS sells for only \$129.85. Focuses from 33 ft. to infinity, and is said to have a resolving power of 200 lines per millimeter. For 35-mm single-lens reflexes. Equipped with a tripod socket at its center of gravity. Considering the low price, we were very impressed with the sharpness of black-and-white shots made with this lens. Sterling-Howard, Box 236 South Sta., Yonkers, N.Y.

DARKROOM HINTS

CLEAN YOUR FERROTYPE TINS with non-scratching cake-type kitchen cleanser. Apply the cleanser gently with a damp cloth, then buff with a clean, dry cloth. Finally, rinse the tins thoroughly with hot water and stand them on edge to dry. This method is also effective on the glass from contact printing frames

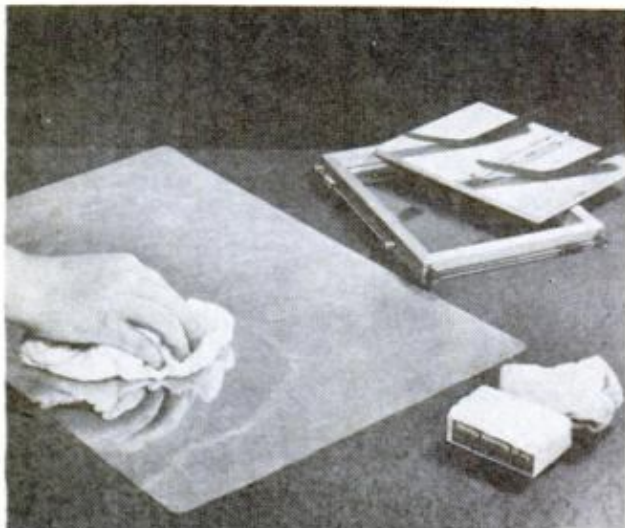

SPACE-SAVING TRAY RACK: Conventional racks for drying darkroom trays are effective, but take up a lot of room under your table. If your darkroom is a bit cramped, make a tray rack by cutting grooves at a compound angle into a block of wood measuring $1\frac{1}{2} \times 4 \times 18$ in. The dimensions and spacing of the grooves will depend on the size of your trays. To use, mount the block over your sink and hang the trays by hooking one edge of each tray into a groove

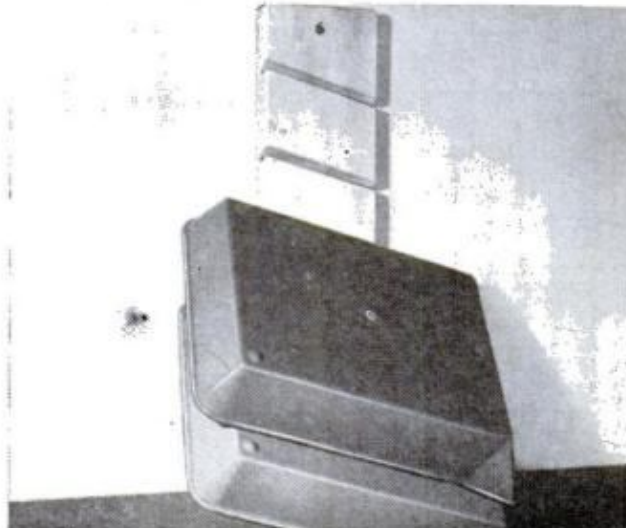

YEM-55 EXPOSURE METER uses a highly sensitive CdS cell. Clearly printed scales read from ASA 3 to 12,000 at exposures of 60 sec. to 1/2000, and apertures of F:1 to F:32. On-off switch minimizes battery drain. We tried this meter and found it rivals others costing almost twice as much. Retail for under \$25, with mercury battery, cord and leather case. Yashica, 50-17 Queens Blvd., Woodside 77, N.Y.



LATEST EDITION of "Pocket Photo Data Book" contains 160 pages of valuable information, such as exposure indexes for current foreign and domestic films, flash and flood guide numbers and depth-of-field scales. Also gives formulas and instructions for 25 negative developers, 29 paper developers, 10 fixing baths, 9 replenishers, 6 stop baths, 27 paper toners. The loose-leaf volume sells for \$3.95. From Morgan & Morgan, Inc. 101 Park Ave., New York 17, N.Y.

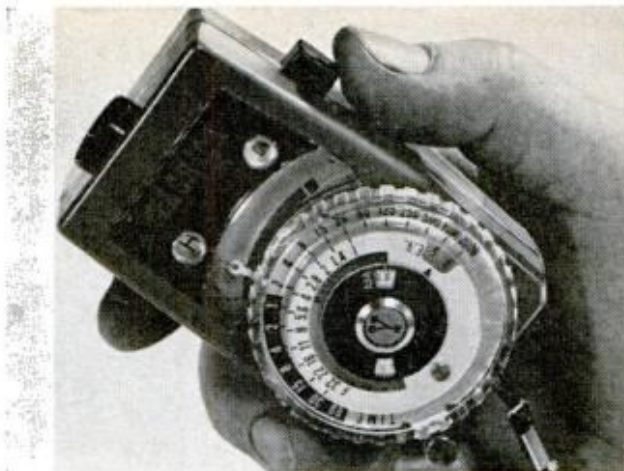

TAKE A PICTURE A SECOND with the Instamatic 150, motorized camera that employs the drop-in, cartridge system of loading. After loading the camera, you wind the spring-drive motor. As you take each shot, the motor advances the film, then winds off film after the last shot. About \$29.95, including film, flash bulbs, batteries and compact carrying case. Eastman Kodak, 343 State Street, Rochester 4, N.Y.

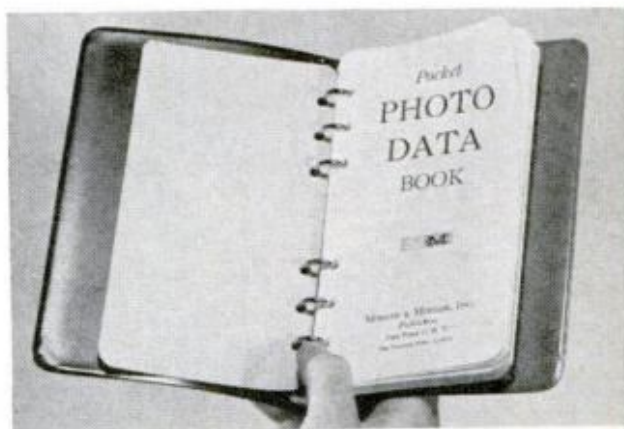

FAST, EASY CARTRIDGE OPENER: When opening a 35-mm cartridge, pry off one flange with a can opener. With the non-reloadable cartridges now used for many films, this method is much more effective than the usual technique of rapping one end of the cartridge on a table. With reloadable cartridges, you have to be careful not to bend the flange. But you'll find the opener prevents the flange from popping off onto the floor, to be lost or stepped on and ruined

DUSTPROOF SQUEEGEE HOLDER: Even a squeegee that looks clean can harbor dust that will scratch your negatives severely. To avoid this, mount a jar upside-down on your darkroom wall. The spring action of the squeegee will hold it in the jar, keeping it safe from stray dust. On most walls, a good way to mount the jar would be with two loops of wire secured to the wall by drywall anchors or toggle bolts. Brick or block walls require masonry anchors

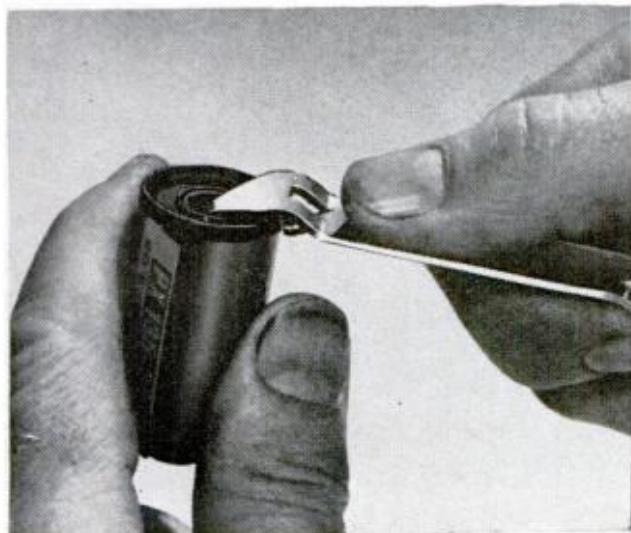



HOME PROBLEMS

APPLIANCE CORD is usually stored by coiling it around the appliance and twisting the plug under the last coil to hold it tight. An easier way is to cement a pair of magnets from a magnetic catch to the plug. These will hold it flat against metal

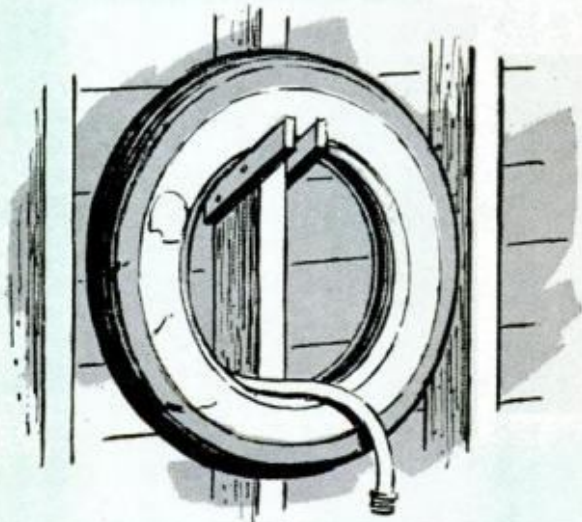
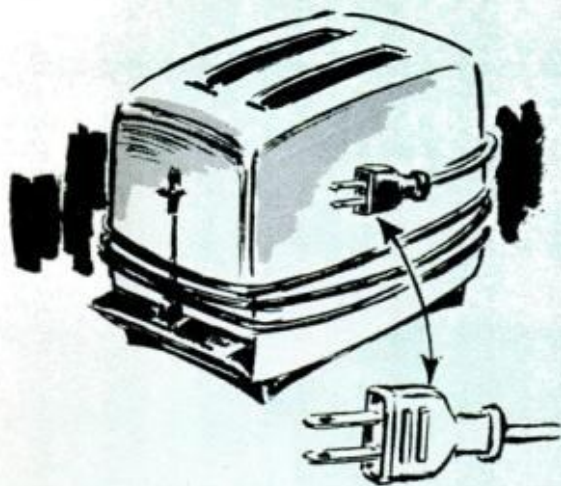

HOSE HOLDER that can be rolled easily from place to place is just an old tire casing. It's a real space-saver for off-season storage, since an 8:00 x 14 tire will hold as much as 75 ft. of hose. If you're cramped for storage space, give this idea a try

IF YOU BEND the handle of a medicine spoon so that it sits level, you'll be able to put the spoon down while you replace the stopper in the bottle or pick up the baby to give him his medicine. Keep this no-spill spoon in the medicine chest



SCRATCHING WALL for your cat will save the drapes and furniture. Just mount a piece of carpeting on the end of a kitchen counter and train the cat to restrict his scratching to that spot. Most cats will prefer this wall to a commercial scratching post

SIMPLEST METHOD of storing an ironing board is to hang it by the legs from a pair of wire coat hooks. Bend the upper part of each hook to prevent the board from slipping off. The two lower hooks come in handy for hanging brooms, mops, dust pans, etc.

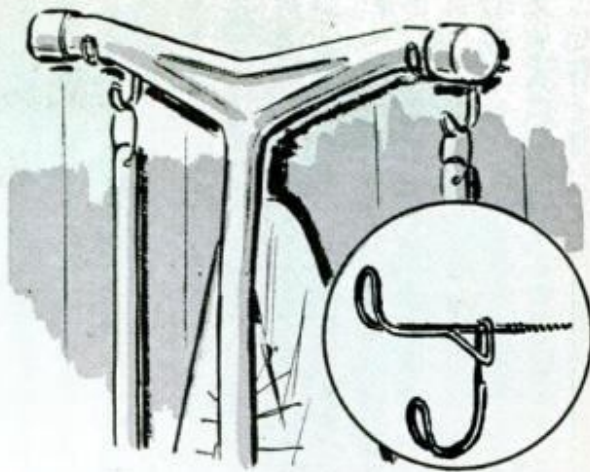

PREVENT PIRACY around your feeding station by hanging bells over the tray, as shown at left. Small birds will slip between the bells and feed undisturbed, but squirrels or large birds will hit the bells and be frightened off by the noise

WHEN YOU RUN OUT of vases for large flowers, you can make extra ones in a hurry by washing the labels off fruit juice cans and perforating the tops with a beer-can opener. To doll them up, give them a coat of quick-drying enamel or cover with wallpaper



SHAPING SHEATH for old brushes holds the bristles together and prevents them from splaying outward after cleaning. Make it by folding a sheet of stiff plastic to fit the brush and stapling side. place it on brush by slipping it down the handle

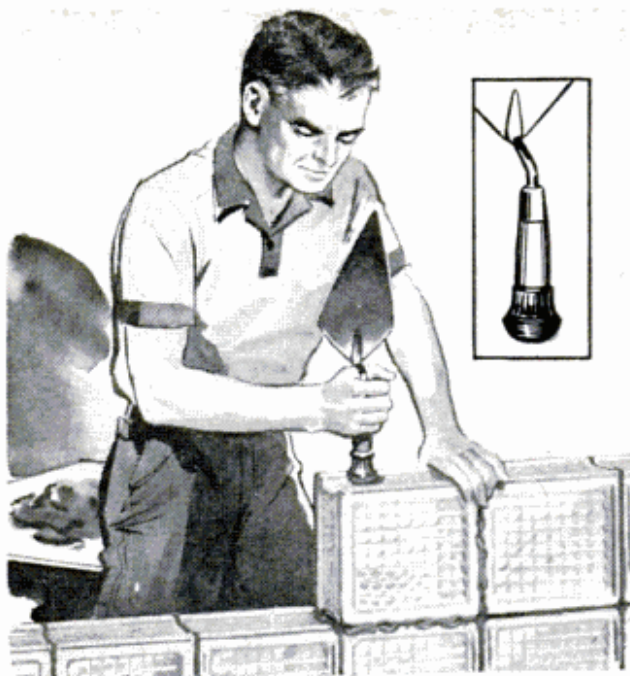

Crutch Tip Cushions Handle

When laying structural glass blocks, one mason found that with a rubber crutch tip on the end of his trowel handle he didn't have to be so careful in tamping the blocks in the mortar bed. Cushioned by the rubber tip, there no longer was the chance of chipping the glass as there was with the plain hardwood handle. In some cases, it may be necessary to trim down the end of the handle a bit so the crutch tip can be forced tightly over the end.

—Victor Lamoy

It's difficult to do a thorough cleaning job in most kitchens because the appliances are so close to one another that there's not enough room to reach between with a mop or vacuum cleaner. You'll find cleaning easier if you use a long handled auto windshield snow brush.

The paper-like bark of a dead birch tree is a perfect kindling for starting a campfire. It burns even when damp, making it possible to build a fire under adverse conditions. Bark should never be stripped from living trees.

After applying varnish remover and giving it time to work into the finish, sprinkle the surface with some fine sawdust. This will absorb the thick, gummy residue and greatly facilitate removal of the finish with a scraper or brush.

Safeguarding Your Home Against Moisture Damage

Much has been said and written about the moisture problem in homes of modern construction and of the damage it does during the colder months. But where does this moisture come from?

According to the Paint, Varnish and Lacquer Mfgs. Asso. each member of the family contributes about 2 oz. of water vapor per hour to the moisture in your home merely by perspiring and breathing normally. When you shower-bathe in water warmed to average shower temperature you add nearly a half pound of vapor. The average tub bath contributes somewhat less. Washing the tableware and utensils used in preparing and serving three average meals can raise the vapor content of the air by as much as a half pound. Cooking the three meals can add as much as five pounds when gas is used as fuel. Laundering for a family of four or five can add another five pounds or so, much, much more if you dry the laundry with an unvented automatic dryer. There are, of course, other sources, such as the moisture from a damp unvented crawl space and unvented heaters that burn concentrated fuels. But it is those sources enumerated that usually produce the greatest concentrations of water vapor in homes tightly constructed and insulated without proper moisture barriers. Of course, much of the moisture produced

dissipates slowly by various escape routes to the drier air outside without appreciably damaging the structure. But the vapor can penetrate most common building materials and wherever and whenever it becomes entrapped in walls and ceilings, when cooled to the dew (condensation) point it can cause quite rapid deterioration of building materials and blistering and peeling of protective paint applied to wood siding.

Yet even in homes that are constructed without the usual safeguards against moisture damage, there are several simple steps that can be taken to prevent, or at least minimize, the possibility of damage. Merely closing the bathroom door and opening a window will dissipate excess water vapor resulting from tub bathing or showering. You can do the same in a kitchen or you can install a ventilating fan and operate it during or after the preparation of meals. Opening a window in the laundry room will lower the vapor content of the air resulting from laundering. Painting the room side of all outside walls with two coats of an oil-base enamel will serve as a fairly effective vapor barrier. You can, of course, paint or apply wallpaper over the enamel. You can reduce the output of your furnace humidifier or shut it off for certain periods. Any unvented gas or oil heater should be properly vented to the outside.

PLANT TIER

BRIGHTEN a corner where you are with a pole tier of colorful plants. By supporting the shelves on a single free-standing pole wedged between floor and ceiling, you can place plants in a sunny corner of a porch or a bare corner of living room.

For my pole I used a unit called Timber Topper. This is a 1 $\frac{5}{8}$ -in. wooden pole which has a spring-loaded top to bear against the ceiling. You'll need to cut off the pole itself 3 in. short of your floor-to-ceiling height. I fitted the pole with three shelves, but more can be added.

If you nest the shelf patterns, three can be cut from a 2 x 4-ft. sheet of plywood with a minimum of waste. Each shelf is attached to the pole by a 2 $\frac{1}{4}$ -in. locking screw which is driven through the edge of a square block fastened to the underside of the shelf. To bore the large hole through both shelf and block you'll need a hole saw or a fly cutter. Both of these tools work best in a drill press—particularly the fly cutter—but you can use a hole saw in a portable electric drill. Note that the hole should be made slightly larger (1 $\frac{3}{4}$ -in.) than the diameter of the pole so the shelves will slide in place freely. To wedge the pole against the ceiling, first tack the soft pad that comes with it to the bottom, slip the spring-loaded top onto the pole, and push it in place so it's straight up and down. If your hardware or lumber dealer don't stock spring loaded poles, you can order one from the Brewster Corp., Old Lyme, Conn. for \$2.28.—*L. D. LaBarge*

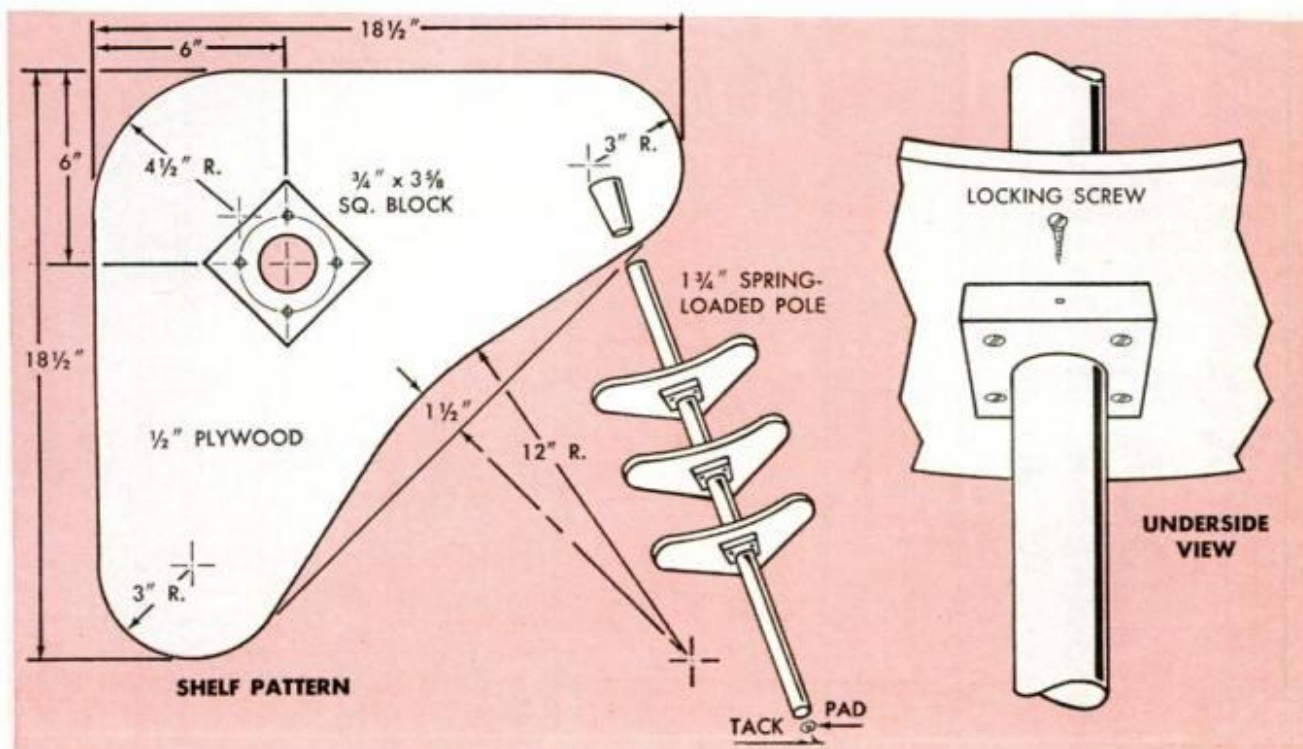

HAVE A CIGAR FROM THIS HUMIDOR BEAUTY

By John Burroughs

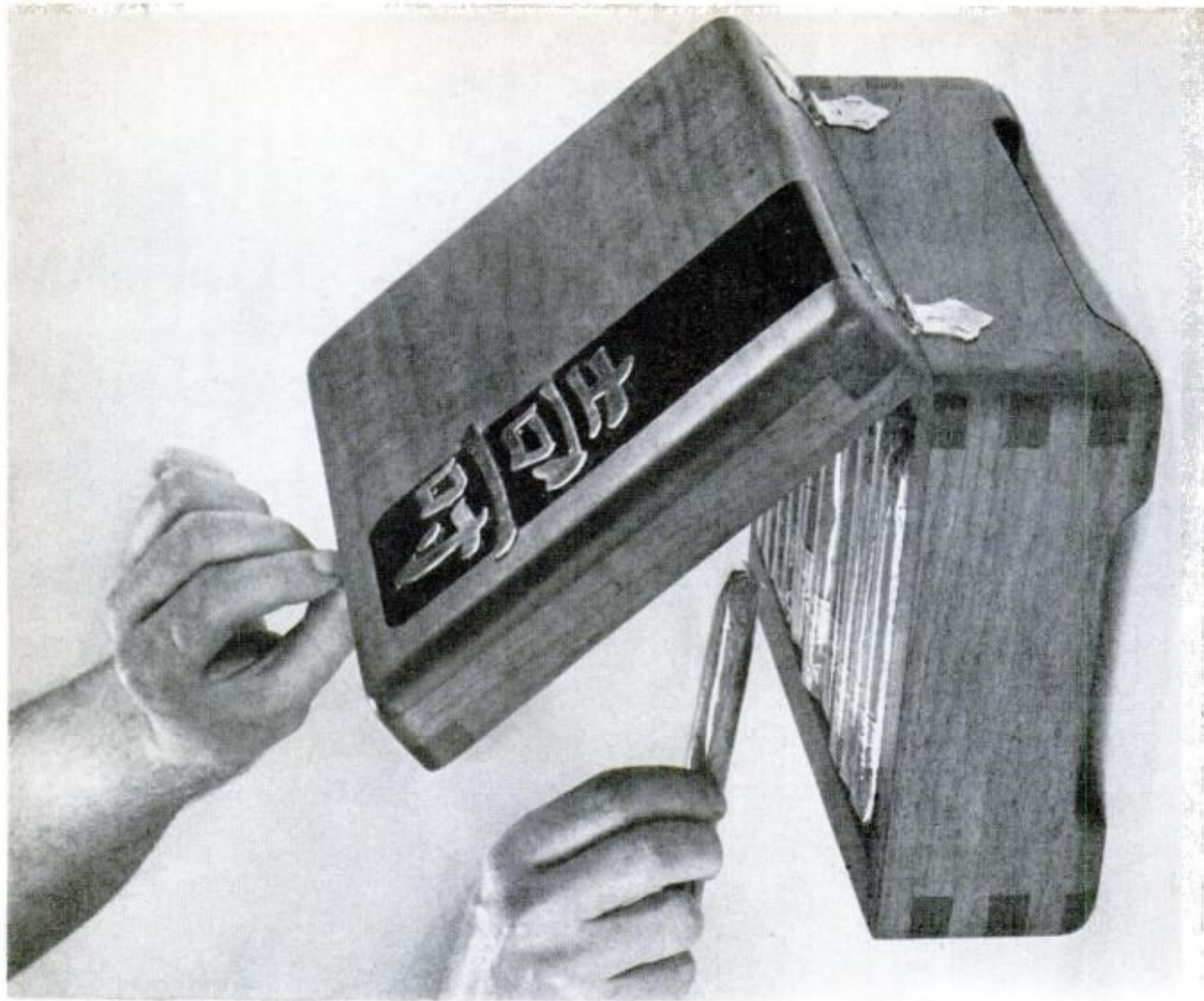
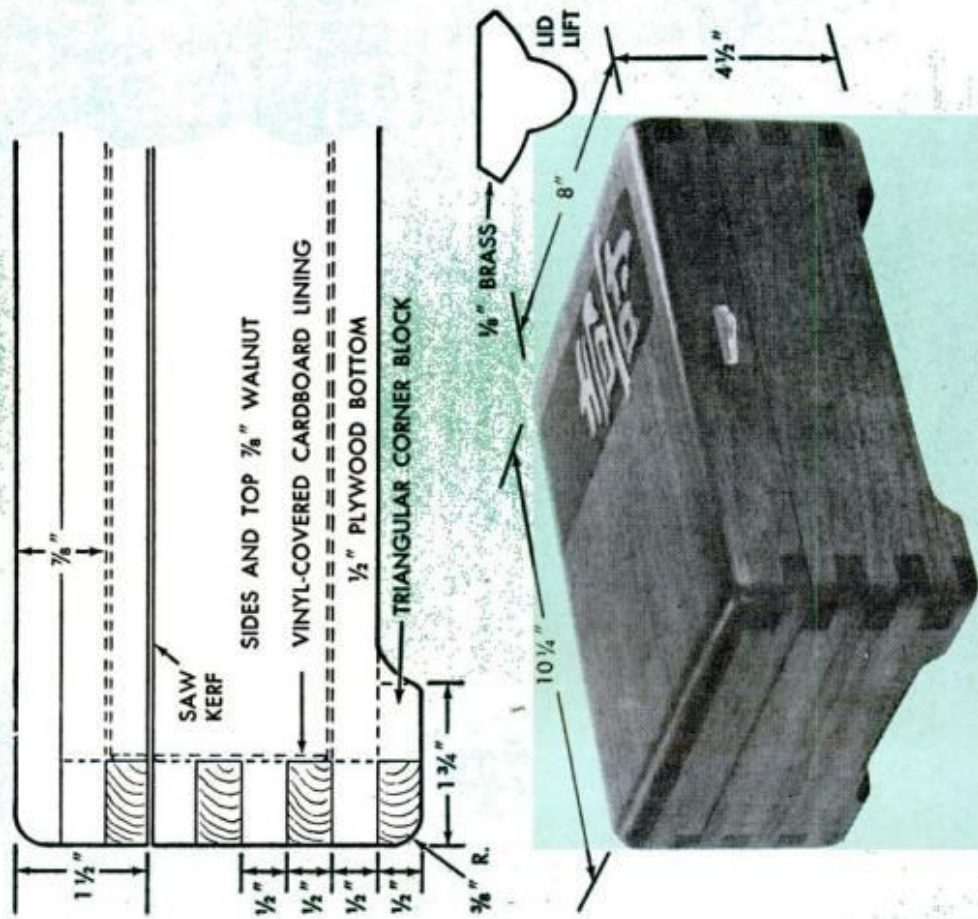

YOUR SMOKING PLEASURE takes on an extra puff of elegance when you reach for your favorite cigar from this humidor beauty. Made of rich walnut or mahogany, hand-rubbed to a fine finish, and topped off with a polished brass ideograph, it's stunning enough to grace the finest coffee table and please the most discriminating smoker. As a gift it's doubly appropriate, since the oriental character on the lid wishes the recipient "long life."

Cut the top and sides of the humidor from thoroughly seasoned $\frac{7}{8}$ -in. stock. The dimensions shown are for 6-in. cigars. For longer or shorter smokes, vary the front-to-back dimension.

To make sure the lid fits neatly and accurately, assemble the humidor as a bottomless box and saw the lid free with a table saw. Start by rabbeting all four edges of the top piece to take the side members. Then cut the corner finger joints with a backsaw or fine-toothed blade on a table saw. To assure accuracy, lay out the fingers with a steel rule and scribe the lines with a sharp penknife.

Assemble the top and sides with white glue. After the glue dries, round the corners and top edges to a $\frac{3}{8}$ -in. radius, sand the entire box smooth, then cut the lid off. Next, sand the lid and box glass-smooth with progressively finer grades of garnet paper and finish with spar varnish or a low-luster urethane.

Now attach the lid by means of solid brass hinges, and inset the $\frac{1}{2}$ -in. plywood bottom, which is supported by small triangular corner blocks of walnut glued inside the legs. Jigsaw the ideograph for the lid from heavy sheet brass, using the character printed in color as a full-scale pattern. File the lid handle from $\frac{1}{8}$ -in. brass. After polishing, coat both brass pieces with clear lacquer and epoxy in place.

Finally, line the box with black leather-grained vinyl upholstery fabric cemented to light cardboard, and give the hardwood several coats of paste wax.

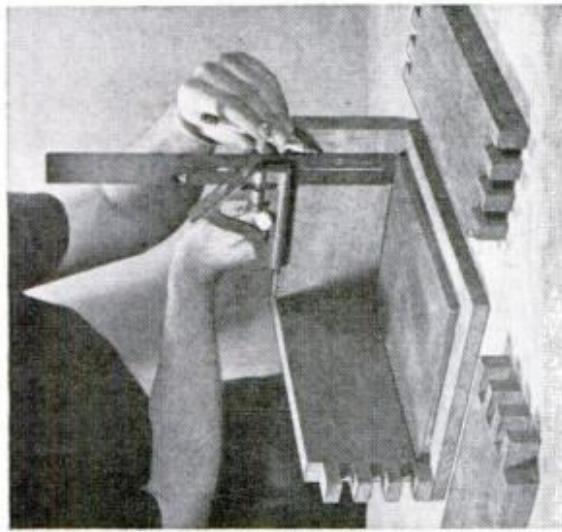

FOR PERFECT JOINT at last corner, match depth of handcut notches to rabbet on lid

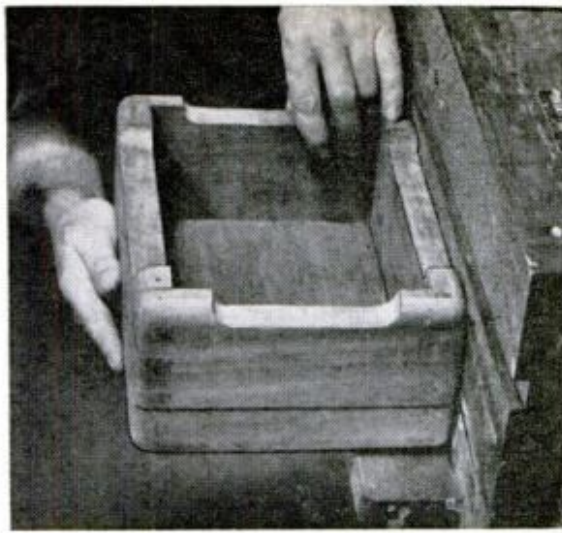

TO CUT LID from the assembled humidor, use a fine-toothed blade and feed slowly

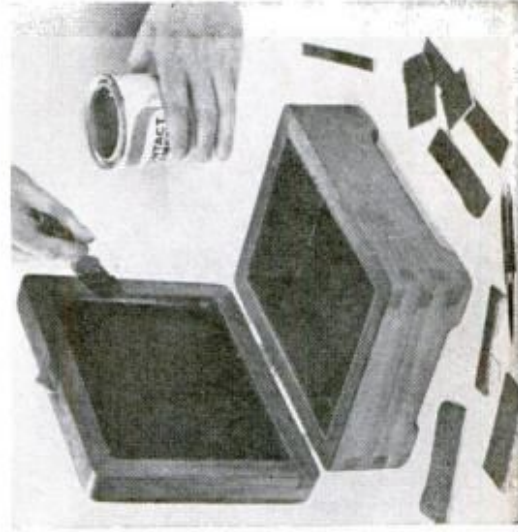

BLACK VINYL lining, put in with contact cement, helps prolong freshness of the cigars



BLACK BACKGROUND of high-gloss enamel accents decorative oriental character on lid

FOLDING LECTERN

IT NEVER SEEMED TO FAIL. Every time a club asked me to give a talk, the meeting was held in a restaurant or hall that had no lectern. This can be disconcerting to anyone with a written speech, since it means either juggling a handful of pages or hunching over a low table to search for one's place. Now I take my own lectern along. It's as easy to carry as a briefcase, and can be set up in seconds on any table or desk.

The drawings below show how to cut and assemble the parts. The sides are 1/2-in., the legs 3/4-in. pine; the bearing blocks are 3/4-in. maple. The top panel, which sets in 1/2-in. rabbets, is a 16 1/2 x 19 1/2 piece of 1/4-in. hardboard. The front leg unit folds over the rear one, and one friction clamp holds both in place.

Due to the spread position of the legs, my lectern has withstood the heavy thumping of some pretty heavy handed speakers, despite its light weight. And the slight incline of the top has proved excellent in that it permits me to glance repeatedly at my notes without losing eye contact with my audiences.

—P. L. Stotler

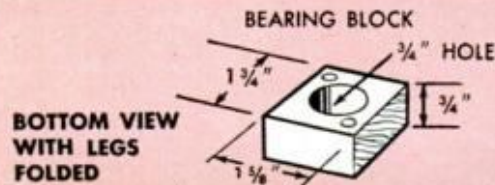

BOTTOM VIEW WITH LEGS FOLDED

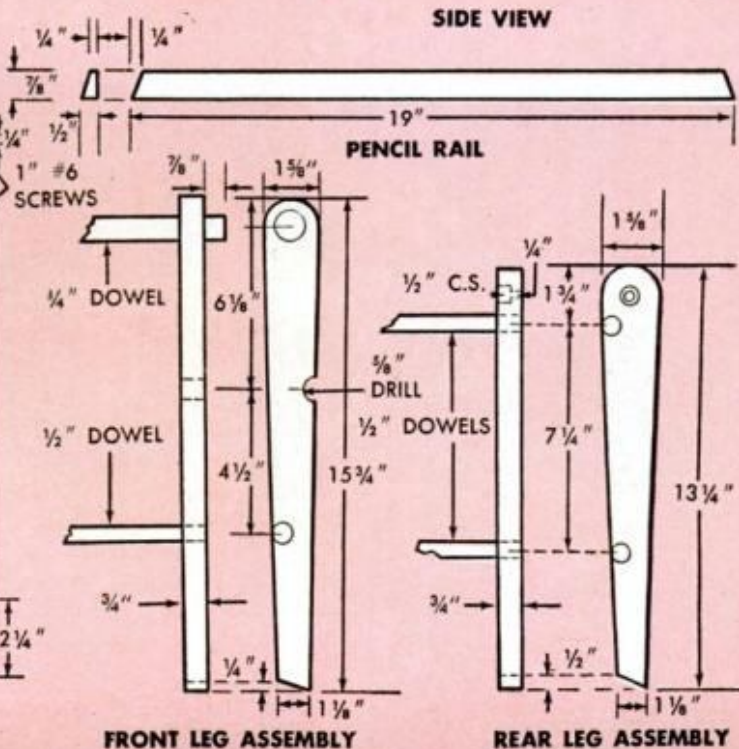
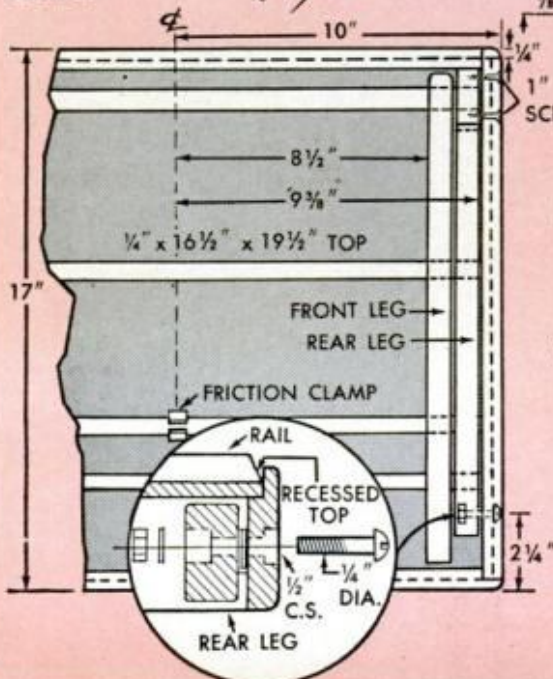
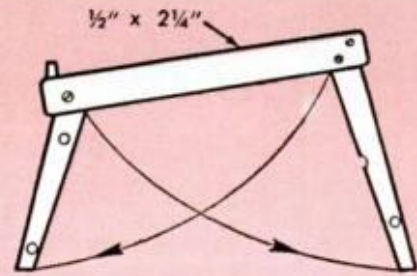

Scoring Glass with Radial-Arm Precision

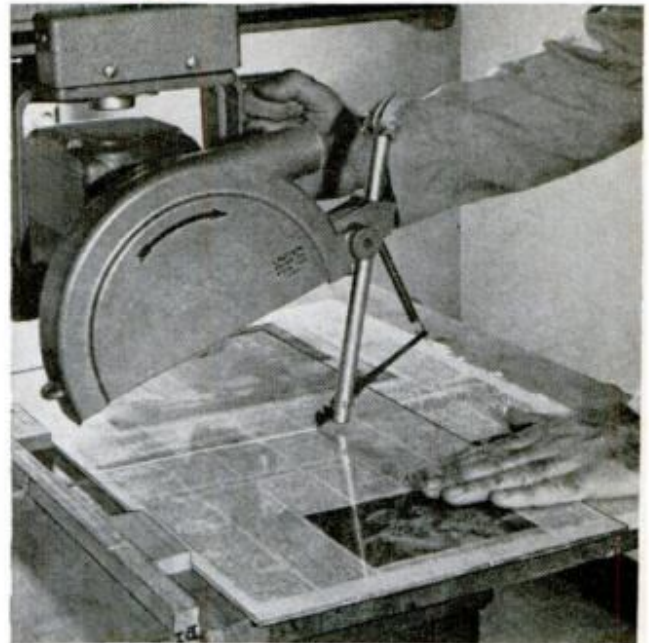
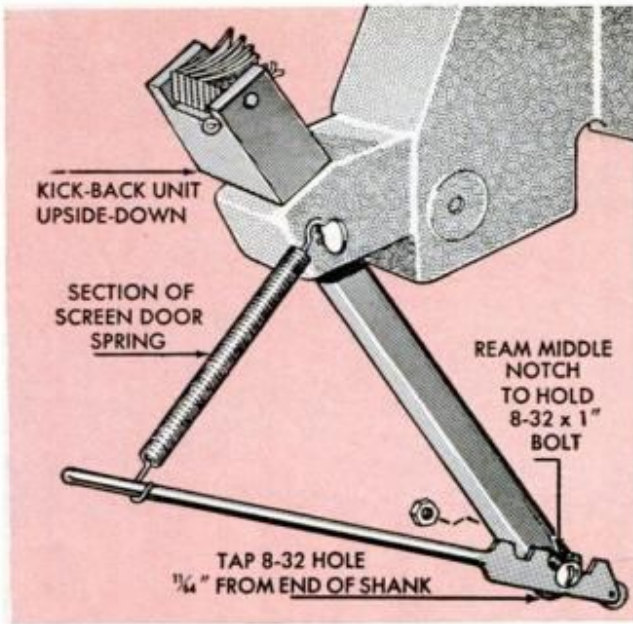

With the blade removed from your radial-arm saw and a glass cutter attached to the inverted kickback rod, you can score glass as neatly and squarely as you'd saw a board. And where an angle cut is required, the machine's settings save fussing with protractors and straight edges. In fact, you can cut glass scraps into tiny geometrical shapes that would be next to impossible by hand.

To attach the cutter, simply drill and tap a hole at the end of the kickback rod

for a bolt to fit a notch in the cutter, and add a section of screen-door spring to make the cutter bear on the glass.

Lower the saw arm so there's just enough tension on the spring to score the glass, then press down on the back of the cutter and slide the glass under it. The newspaper cushioning shown in the photo is optional, but you'll probably need the spacer blocks against the fence to bring the cutting wheel to the edge of the glass. Simply pull the motor for an even score.

Screen Door Catches Make Your Garage Door Weathertight

Upward-acting garage doors that are equipped with low-headroom tracks often give a poor weather seal at the top where the edge of the door fits loosely in the tracks. I found that roller-action screen door catches mounted across the door opening—one for every four or five feet of span—made the door fit snugly when closed. As shown in the detail, the catches are mounted on wood blocks screwed to the lintel so the base of each catch is inclined about 30 deg. from vertical. The upper roller of each catch is tripped by the top edge of the door when the door is lowered, which simultaneously snaps the bottom roller against the inner face of the door to hold it snugly against weatherstripping applied across the top.

—Thomas H. May

When polishing your car with paste wax or cleaner, a fast way to bring up a high gloss is to buff with a strip of felt cut from an old hat. Place the felt in a soft-faced sanding block, or wrap it around a kid's blackboard eraser. Works on both enamel and chrome.

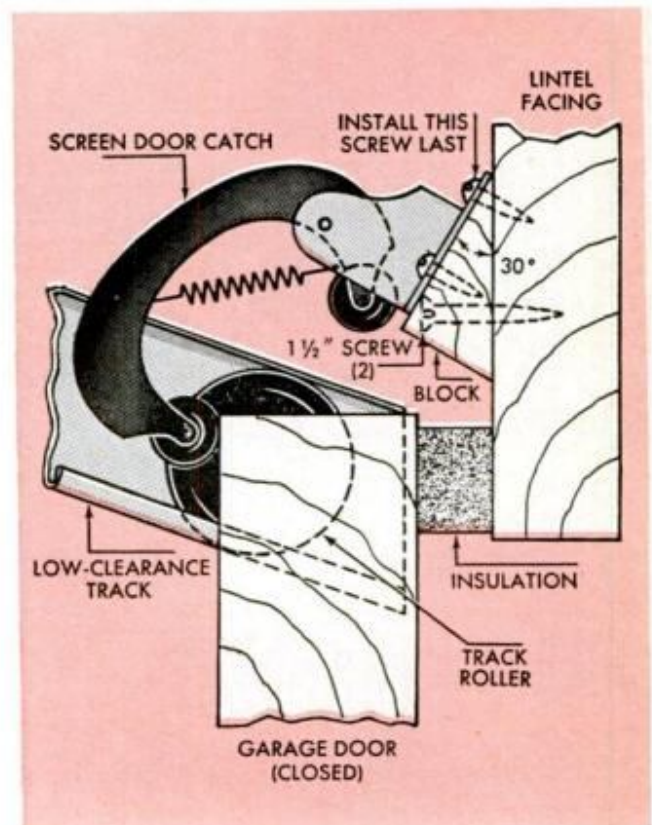

PART 1

CONTROLLING YOUR CAR'S CONTROL CENTER

By Morton J. Schultz

That octopus under your hood is well-named: the distributor is the nerve-center of your car, distributing precisely-timed sparks to each cylinder in turn

WHAT'S THE CAR OWNER on the facing page got in mind as he hunches over that fountain of cables in his stalled car? It depends on how well he knows his distributor. If he regards it as a troublesome stranger, his impulse may be to strangle it. Or maybe he's just awed by its mysterious power and is trying to "read" it, like a crystal ball. But let's hope that gesture of his expresses confidence that his skilled hands can control this vital unit—once he learns what it does, and how. This article, and one to follow next month, will supply that information.

Without doubt, the distributor in your car has more to say about the operation of the engine than any other unit in the automotive power train.

It's the car's nerve center. Not only does it help produce the hot sparks needed to ignite the fuel mixture, but it also has full control over delivery of those sparks. If you doubt its importance, just scan this list of troubles it will cause if permitted to malfunction—

- It can prevent the engine from starting or make it hard to start.
- It can cause the engine to misfire at any speed, or to stall.
- It can prevent the engine from put-

ting forth its maximum power at any speed, or make it idle rough.

● It can cause internal engine damage by producing knocks or pings, or by inducing backfire.

But the biggest "problem" of all posed by a distributor is the fear it inspires in the hearts of many ardent and capable do-it-yourself auto mechanics. They look upon this black object as a Pandora's box full of mystery and misery for those who dare to open it. And strange-sounding words like vacuum advance, centrifugal advance, dwell, cam angle, capacitance, induction, primary and secondary—all of which surround the distributor like pawns protecting the sanctity of the king—don't help matters.

I'm not exaggerating. I've had capable amateurs tell me either "I'm a do-it-yourself mechanic up to—but never including—the distributor" or "I'll tackle it, with misgivings, but I don't understand the first thing about it."

Yet, they admit—and rightly so—that you can't mention the word *tuneup* without including the word *distributor* in the same breath. It's like saying Gilbert without Sullivan. So, obviously, an educational campaign is overdue, where distributors

THAT FAT SPARK each cylinder needs is produced by the chain of components shown in simplified wiring diagram below and stylized "close-up" of the coil at right. The primary (low-voltage) circuit—colored cables, below—includes battery, ignition primary coil, breaker points and condenser. Secondary (high voltage circuit) includes coil's core, distributor cap and rotor, and all leads from cap to spark plugs

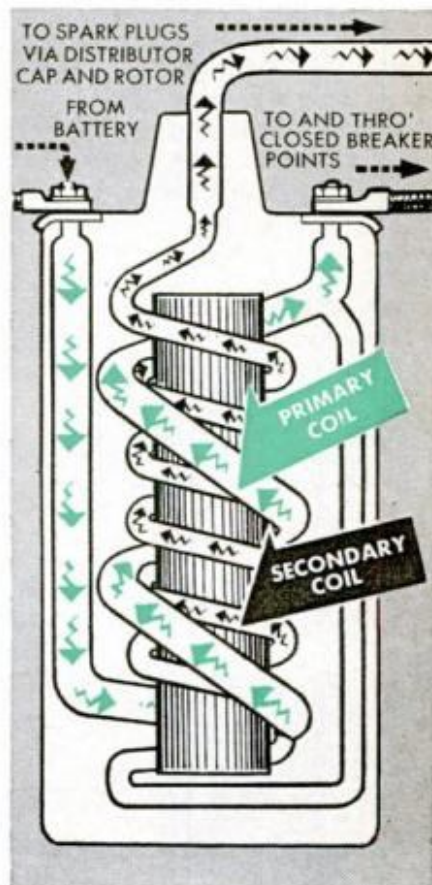
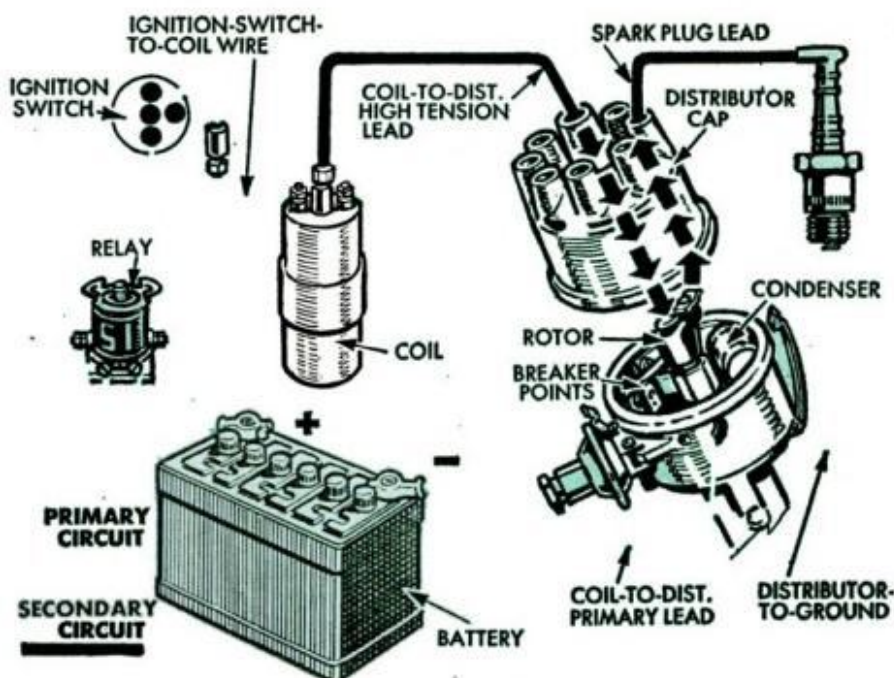

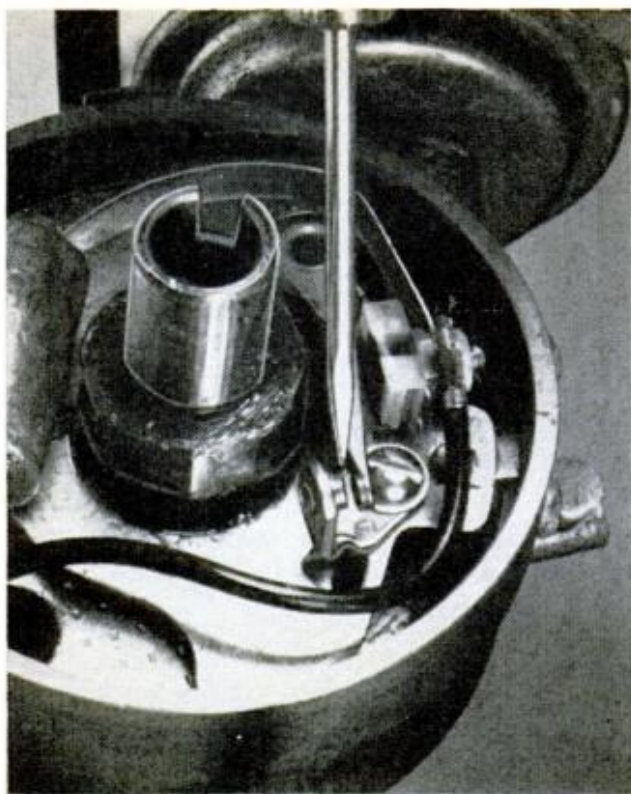

DISTRIBUTOR POINTS determine whether low-voltage current flows smoothly through coil or is forced to jump windings. Points—forced open here—open and close as result of rotation of distributor shaft

are concerned. Knowledge helps two ways:

For those of you who do-it-yourself, distributor functioning isn't really that much of a mystery and, provided you have the correct equipment, you can and should work on it yourself.

For those of you who aren't do-it-yourselfers but are interested in keeping the buggy in top-notch running shape, knowing how the distributor operates and what can happen to it will (1) enable you to know when the distributor is probably at the root of a problem; and (2) permit you to describe and pinpoint the trouble area for your mechanic.

CAP AND ROTOR are two secondary-circuit parts of distributor. Rotor is two-pronged affair. Center part picks current off as it enters cap from coil; rotating end clip passes current to each plug in turn



In the first article, we'll deal with the functioning of an ignition system, focusing on the distributor as its most important part. If we seem to devote too much space to what-it-does, remember that if there's one part of a car you *can't* work on without first understanding its function, that part is the distributor. We'll get into repair and tuning next month.

The basic makeup of distributors and, for that matter, of ignition systems, hasn't changed much in 50 years. Yes, we know all about transistorized ignition and the promise it holds for trouble-free ignition (see our *Saturday Mechanic* piece in the Sept. '63 issue). But this promise is in the future since transistorized ignition is still optional equipment on new cars, and most people aren't ready to pay good money to buy something that does a job done by something else they've already paid for. So, we doubt if one car in 5000, today, is equipped with transistorized ignition.

To study an automotive ignition system, you've got to think of it in terms of two circuits: a primary (low voltage) circuit and a secondary (high voltage) circuit. And when you consider the makeup and functioning of the distributor in relation to that ignition system, it's easier to understand and trouble-shoot if you separate its parts into these two families—that is, whether the part's associated with the primary or with the secondary circuit.

The diagram on page 159 breaks the system into its two ignition circuits. Parts are considered "primary" when they handle none of the high voltage induced in the system. Most of them do, however, have a direct hand in the production of this high voltage.

The secondary ignition circuit consists of the secondary winding in the coil, the coil-to-distributor high tension lead, the distributor rotor, the distributor cap, the high tension wires going from the distributor to the spark plugs, and the spark plugs themselves.

All these are carriers and passers of high voltage, but not one has anything to do with the actual production of that voltage.

Here's how these parts work to produce and deliver the nice fat spark you need to run the engine:

When you turn on the ignition switch, current (6 or 12 volts of it, depending on your car) goes from the battery, through the switch and into the primary winding of the coil. The coil is actually two coils in one, as shown in the stylized "x-ray" on page 159. The outer (primary) coil is composed of heavy wire (usually No. 18) that's wrapped around the inner coil a few hundred turns. The inner (secondary)

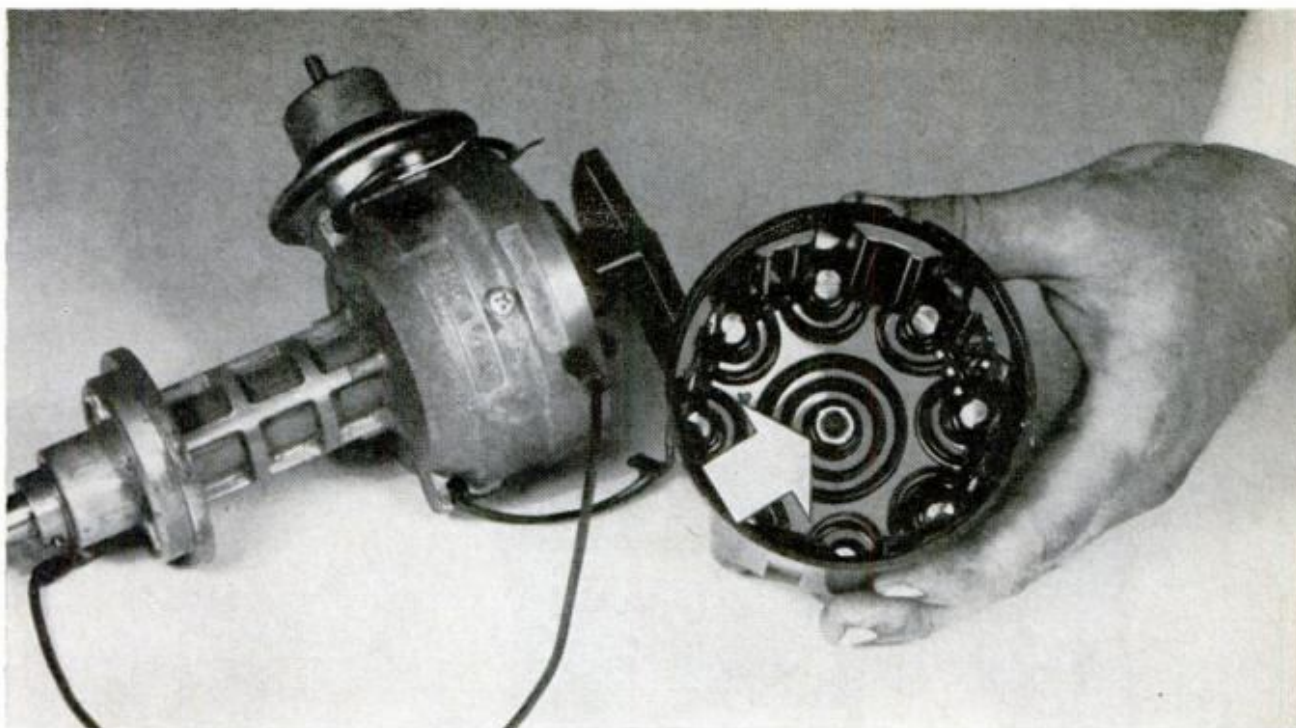

INSIDE OF CAP (right) is an in-and-out unit, like rotor (left). Current flows through center electrode (arrow), passes through rotor then back out of cap through one perimeter contact after another as rotor spins

coil is composed of fine wire (usually No. 38) that's wrapped around a core of soft iron many thousands of turns.

As low-voltage current comes from the battery into the primary winding of the coil, it continues to flow through the coil via this winding, into the distributor by means of the coil-to-distributor primary lead, through the breaker points, to ground, and then back to the battery.

Nice, orderly march, isn't it? But it depends on one important condition—the *distributor points must be closed*.

Once these points open, breaking the circuit, the magnetic field that's built up in the coil, as electrons march through, rapidly collapses.

The once relatively small voltage (6 or 12 volts) suddenly finds itself stepped up to a higher voltage, *induced* to jump from the primary into the secondary winding of the coil, and then *transformed* into still higher voltage.

Those words *induced* and *transformed* are significant. The coil, in reality, is a transformer that steps up low voltage into high voltage by self-induction—in other words, by pulling low voltage electrons from the heavy primary wire into the fine secondary wire. This induction results when the magnetic field collapses, which occurs when the circuit is broken. The field collapses *inward* toward the soft iron core of the coil, spring-boarding electrons from one wiring circuit to the one below it.

According to electrical theory, when a counter-voltage is induced from one winding to another, the collapsing magnetic field across the windings is about the same

value for each turn. Thus, since the secondary coil has many more turns than the primary, the voltage in the secondary will assume a proportionate increase.

Assuming a turn ratio of 100:1, the secondary voltage will go at least 100 times higher than the primary voltage.

When the breaker points open, causing the field to collapse across the primary, this action creates an immediate step-up in voltage in the primary of some 200 volts. As this still relatively small voltage is induced into the secondary, it increases in value 100 times. Thus, the voltage that begins to flow through the secondary wiring is in the neighborhood of 20,000—and that's hot enough to jump the gap of a spark plug and fire a fuel mixture.

The high voltage pours out of the coil

DISTRIBUTOR SHAFT on some models has tang at end, like this one, that fits into slot in camshaft. Other types have gear. Either way, shaft rotates to open and close breaker points and to spin the rotor

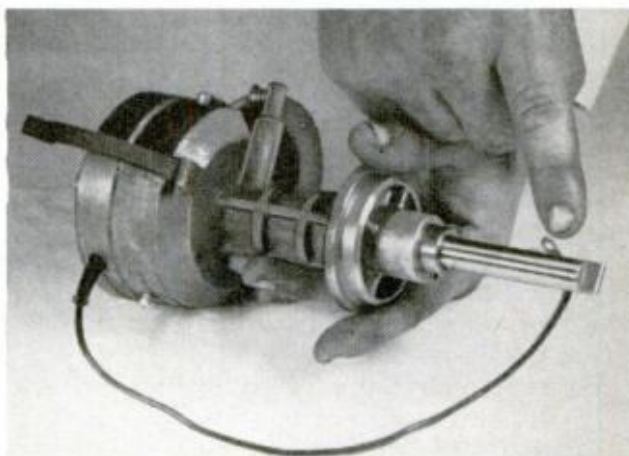



CONDENSER SNUGGLES against rotor shaft. It's a decoy for left-over current when breaker points snap open, prevents arcing which could burn up points

and to the center tower of the distributor cap through a high tension lead. Here, the spinning rotor picks it off and carries it to each distributor tower, in turn, where a metal contact again picks it off and shoves it through a high tension wire to a spark plug.

When the points open, the voltage built up in the primary before it collapses across the secondary can jump the relatively slight gap between the points. If this arcing, as it's called, were allowed to happen, the points would soon become ruined because of the searing heat.

So, a condenser (merely an insulator) is added and connected across the points. To the electrons, it looks like a detour to the point gap; but it turns out to be a one-way street, and the electrons pour into it before they can get to the point gap. By the time the waylaid electrons find out they've been duped and reverse themselves, the plug has fired, the contact points are closed and the electrons are again marching in orderly fashion to ground.

When you consider how fast and how frequently all this happens, you begin to wonder why distributors don't fail more often. For example, if it has taken you 10 minutes to read to this point, and you'd been traveling in a car that was going 60 miles an hour, the breaker points in the distributor would have opened and closed 100,000 times and the rotor would have handled a cumulative voltage equivalent to one trillion volts!

So that's how the system *should* work. Now let's consider what can be done if it *doesn't*. Whatever you've read else-

where, you can't properly repair and tuneup an automotive ignition system without certain basic pieces of test equipment.

This is no place for a "Kentucky windage" approach. Ignition has to be smack on the beam for the following reasons:

- Only by correct ignition tuneup can you get maximum power output from your car.

- Only by correct ignition tuneup can you expect to run your car in the most economical fashion—and this includes getting full wear from parts such as plugs and breaker points—plus every possible mile from a gallon of gas.

- Only by correct ignition tuneup can you extend the life expectancy of your car. The internal operation of that engine depends as much on ignition as on anything else, and serious damage can be done to pistons, valves, and associated parts if ignition tuning is botched.

By proper repair and tuneup, I don't refer to emergency repair. In an emergency, of course, your only interest is to get started and rolling, and any gimmick that enables you to do this is OK. You'll find a run-down on emergency ignition repair in the August 1964 issue of *PM*, page 146.

Now, what constitutes a correct repair and tuneup ignition procedure? First, the time element is an important factor.

You should check and test, and replace *known* malfunctioning parts at least *every 10,000 miles*. Note that I said "known" malfunctioning parts. The only parts, in the entire system which definitely need replacing every 10,000 miles are the distributor breaker points. But simply replacing them and setting them with a feeler gage is not enough. There's a lot more to doing this job right, as we'll see next month.

As to what test equipment you need for tuneup and repair, logic and discretion must be used or you can find yourself in a financial nightmare. In some cases, you're better off simply replacing a part rather than buying a piece of test equipment to test it. For example, replacing a condenser every 10,000 miles, which costs about 85¢, is a lot wiser than buying a condenser tester for maybe \$20 or \$30.

However, there are several pieces of equipment you can't do without. These are—

- A dwell/tach meter. This is a dual-purpose device. If you now own a separate tachometer, you can buy the dwell meter itself, or vice versa. The dwell portion has just one purpose—to indicate the number of degrees of rotation through which the distributor cam moves to open and close the points. The tachometer portion of the

tester is used to indicate engine speed while performing your tests, and permits you to adjust that speed for performing the test according to specification.

A good dwell/tach meter can be bought for about \$50. A separate dwell meter sells for about \$25 to \$35, and a separate tach goes for about \$35 to \$40.

● A timing light that permits you to set ignition timing and determine the number of degrees advance of the distributor. Try to tune up a car without one. A good timing light will cost in the neighborhood of \$12 to \$15.

● A voltmeter to detect resistance by measuring voltage drop between any two points in the ignition circuit, and to measure available voltage at any point in the circuit, is nice to have, but not absolutely necessary. As you'll see in next month's article, you can judge the availability of voltage without a voltmeter by observing the condition of a spark or by use of a troublelight. However, a voltmeter will give an accurate reading—the other two won't. A good voltmeter will cost about \$15 to \$25 (volt-ammeter combinations like the one at right run \$35 to \$45).

In next month's article, we'll go right through ignition repair and tuneup from beginning to end, showing you how to handle this equipment, and other procedures, such as replacing points.

Modern distributor design makes that job less tricky than it used to be. You no longer have to worry about the spring tension, for example. And, if you wish, you can probably get by without setting the gap of new breaker points.

Today's points are one-piece sets that are machine-calibrated at the factory. Although it's a good idea to check gap as a precaution, all you have to do to replace points is remove the old ones and drop a new set in.

But, as with anything automotive, easy or hard, you can't do much unless you know procedure and, especially, what pitfalls to watch out for. True, it's simple, but only one mistake can make an otherwise fine tuneup job go sour within the first hundred miles of travel.

Furthermore, it never hurts to know the tricks of the trade that permit you to test and tune without need for professional equipment. Several of the tricks we'll demonstrate next month have never before been publicized—and the garage men who let us in on their professional secrets are now smoking good cigars.

Whether you actually try these yourself, or pass the tips along to your mechanic, you'll find the information will take still more of the mystery out of that octopus beneath your hood. ★★★

TESTING'S A CINCH WITH THIS EQUIPMENT



VOLTMETER (OPTIONAL)

Материал, защищенный авторскими правами

AUTO CLINIC

Q My 1961 Rambler with aluminum block engine has had its spark plugs and ignition wires replaced twice in a few thousand miles because the car bucks badly in low speeds, especially under a pull and on a rainy day. It runs well in high speeds and pleasant weather. My dealer is stymied—suggests I try you.—J.S.B., N. J.

A There's a couple of things to look into. First, you say the ignition wires have been replaced, but I'm wondering if they were replaced with the regular resistor-type which the car used as original equipment or with a copper type. There have been numerous reports of resistor-type wiring breaking down when there's moisture in the air, causing the problem you describe.

If the wire angle doesn't prove out, I'd look for a sticky valve condition. One of those valves might be hanging up in wet weather. As a matter of fact, Rambler has issued a heavier valve spring for aluminum blocks to alleviate the problem.

Q I always set my own timing and want to check something out with you regarding my 1962 Valiant with 225 CID engine. The shop manual says to set timing at $2\frac{1}{2}^\circ$ BTDC. The timing plate, though, has four lines on it. The bottom one's marked "0" and the third line is marked "10." The others aren't numbered, but I assume they'd represent 5° and 15° . Would $2\frac{1}{2}^\circ$ BTDC be between the "0" line and the one I assume to be the 5° line?—G.O.W., Ind.

A Right you are. Why another little line wasn't included and marked $2\frac{1}{2}^\circ$, so people wouldn't have to guess at the specified timing is a \$64 question.

Q Volkswagen mechanics seem adverse to giving information. Can you tell me if an interested owner, such as myself, can consult any manual that gives particulars about the VW engine and other areas?—D.P., Fla.

A You're in luck. Volkswagen only recently came out with a brand new publication that's being sold at VW dealers throughout the nation. It

gives complete details concerning the entire car. It's called "Owner's Service Manual, VW 1200." The publication deals only with the sedan from 1961 through 1964. Charge for the book depends on who's selling it. We got prices ranging from \$3 to \$5 a copy.

Q I have a terrific growl, noticeable particularly at low speeds, but also at other times, coming from the front of my 1959 Chrysler New Yorker. Mechanics have replaced the idler puller bearing, the bearing in the air conditioner compressor, and two bearings in the generator. Still, the growl continues. I'd be grateful for any hint as to where the trouble lies.—J.H., Texas

A With a growl like this, one of the first things to check is the water pump. Just take the fan belt off the pump and run the car for a few seconds without it. If the growl is coming from the water pump, there will be no noise.

Monthly Service Tips

★ Chevy Corvette convertible owners (1963 and 1964) who desire to have the softtop replaced with a hardtop can have their wish by installing roof panel assembly 3838439. The assembly comes unpainted, so it can be sprayed to match the color of the car. For installation instructions, see Chevrolet Service News No. 5 (May 1964).

★ If you've been having trouble with your 1963 or 1964 Studebaker stalling during warm up and hard starting at temperatures of from 50° to 70° , you'll be glad to hear that a new automatic choke thermostatic coil and cover assembly, cover gasket, and choke piston lever are available to eliminate the problem. Part number for the coil and cover assembly is 1563427; for the new gasket, 1563428; for the lever, 1563445.

As a service to Popular Mechanics readers with problems relating to their cars or to driving in general, we invite you to submit your questions for answering through this column or by mail. Address Auto Clinic, Popular Mechanics Magazine, 575 Lexington Avenue, New York, N. Y. 10022, enclosing a stamped, self-addressed envelope.



FOR THE MOTORIST

Flashing Masks Tire

When repainting car wheels, you can protect the tires from overspray by using metal flashing as a shield. A strip 4-in. wide and about 5-ft. long is adequate. The flashing, obtainable at lumber yards, is bent into a circle of the same diameter as the wheel. The ends of the strip may be clamped with a locking plier wrench, which also serves as a handle to hold the shield in place with one hand.—*L. Campbell*

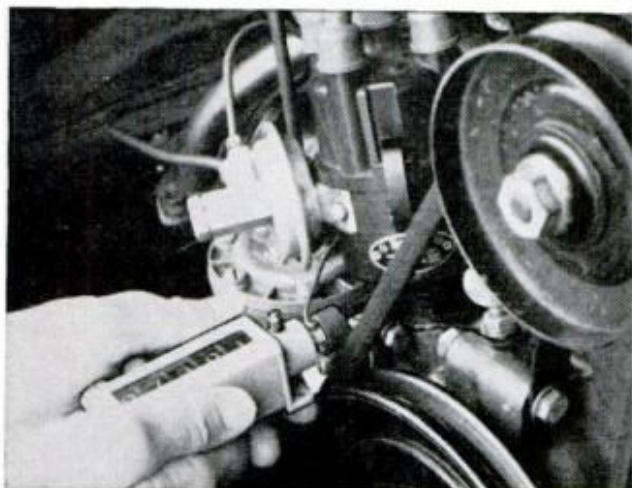

Count Those Revs

Car owners who do their own tune-up work often need a tachometer. This may be improvised with a four- or five-digit rotary counter fitted with a rubber wheel. Hold the wheel against the generator belt; then turn the belt one revolution and note the number on the counter dial. Start the engine and allow it to reach normal temperature, then zero the counter and hold the wheel against the belt for one minute. To determine r.p.m. divide the number shown after one revolution into the number indicated by the counter after one minute of running time.—*R. Micals*

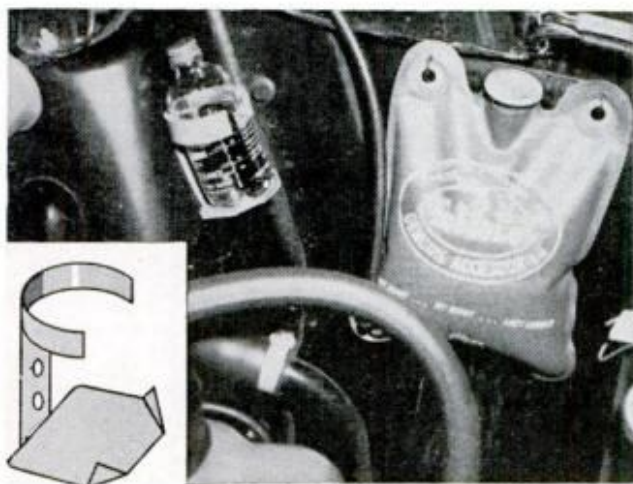

No More Freeze-Ups

An under-the-hood bracket that holds a bottle of anti-freeze fluid for the windshield washer is a handy accessory. The bottle is not likely to break, as it might if kept in the trunk or glove compartment—and there's less chance of forgetting to add the fluid to the washer water. After forming the bracket from sheet metal as shown in the drawing, it should be lined with felt to prevent rattling. The bracket is fastened with self-tapping screws to a convenient spot on the firewall, preferably near the reservoir.—*W. Rudolph*



Lost Cap Comes Back

Hub caps on most late model cars are expensive. I know—I had to replace one that I lost on a recent vacation trip. After that, I decided that if I ever lost another cap, a simple precaution would make it possible for the finder to return it. On the inside of each hub cap I printed the words; "Finder please notify," followed by my name, address and telephone number. As an inducement, I indicated that a reward would be paid. A felt tipped marking pen, or a china marking crayon makes it easy to do a neat lettering job.—*Andrew Vena*

MULTI-ADJUSTABLE DRILLING JIG

The turret revolves, the platform slides, the pressure screw clamps tight on any stock up to 4 in. thick

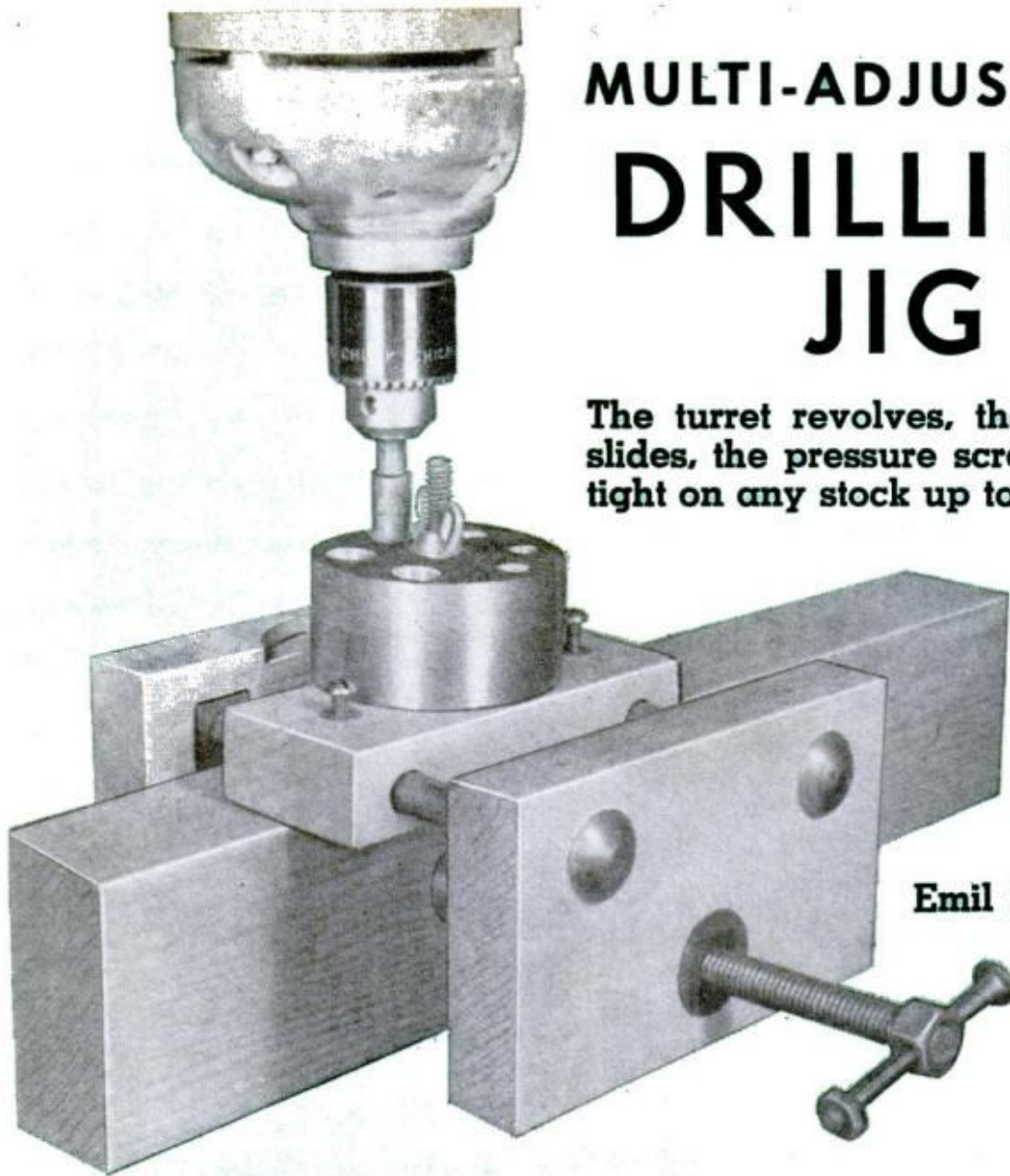

By

Emil P. Kushner

ASSEMBLE THREE hardwood blocks and a steel cylinder with a few bolts, and you've ended the grief of trying to drill true holes at precise locations. Two of the blocks position the jig on the work with a vise-jaw action. The third serves as a sliding platform for further adjustment of the rotating cylinder, which is pre-drilled to present a choice of guide holes for bits of six different diameters.

The jig is especially handy when drilling holes for dowel joints with a hand brace or portable electric drill. Such holes must be in perfect alignment and at exact right angles to the edges joined. The same goes for bolt holes in critical assemblies. This versatile jig ends the guesswork.

Cut the vise-jaw blocks and brad them face-to-face temporarily, in order to drill $\frac{3}{8}$ -in. holes for the carriage bolts through both at once. Separate the blocks, drill the 1-in. hole to recess the nut, then, using the same center, drill a $\frac{3}{8}$ -in. hole

on through the block to pass the tightening screw. Place the nut in the recess and pack steel paste or epoxy around it to fill the hole flush. Before this sets, thread the rod into the nut and through the block, to assure alignment.

In the corresponding face of the second block, chisel two square recesses around the holes, deep enough to seat the nuts you'll use on the carriage bolts. These are held in place by press-fit.

Now, using either jaw block as a template, drill the carriage-bolt holes through the edges of the sliding hardwood block. Wrap sandpaper around a $\frac{1}{4}$ -in. dowel and relieve these holes enough to provide a sliding fit on the bolts. Cut the chip recess in the undersurface, then drill the $\frac{1}{4}$ -in. hole for the square-head bolt, and chisel a square recess for its head. Drill the holes for the locking bolts and counterbore to recess their nuts, which, like the rod's nut, are anchored in steel paste or epoxy.

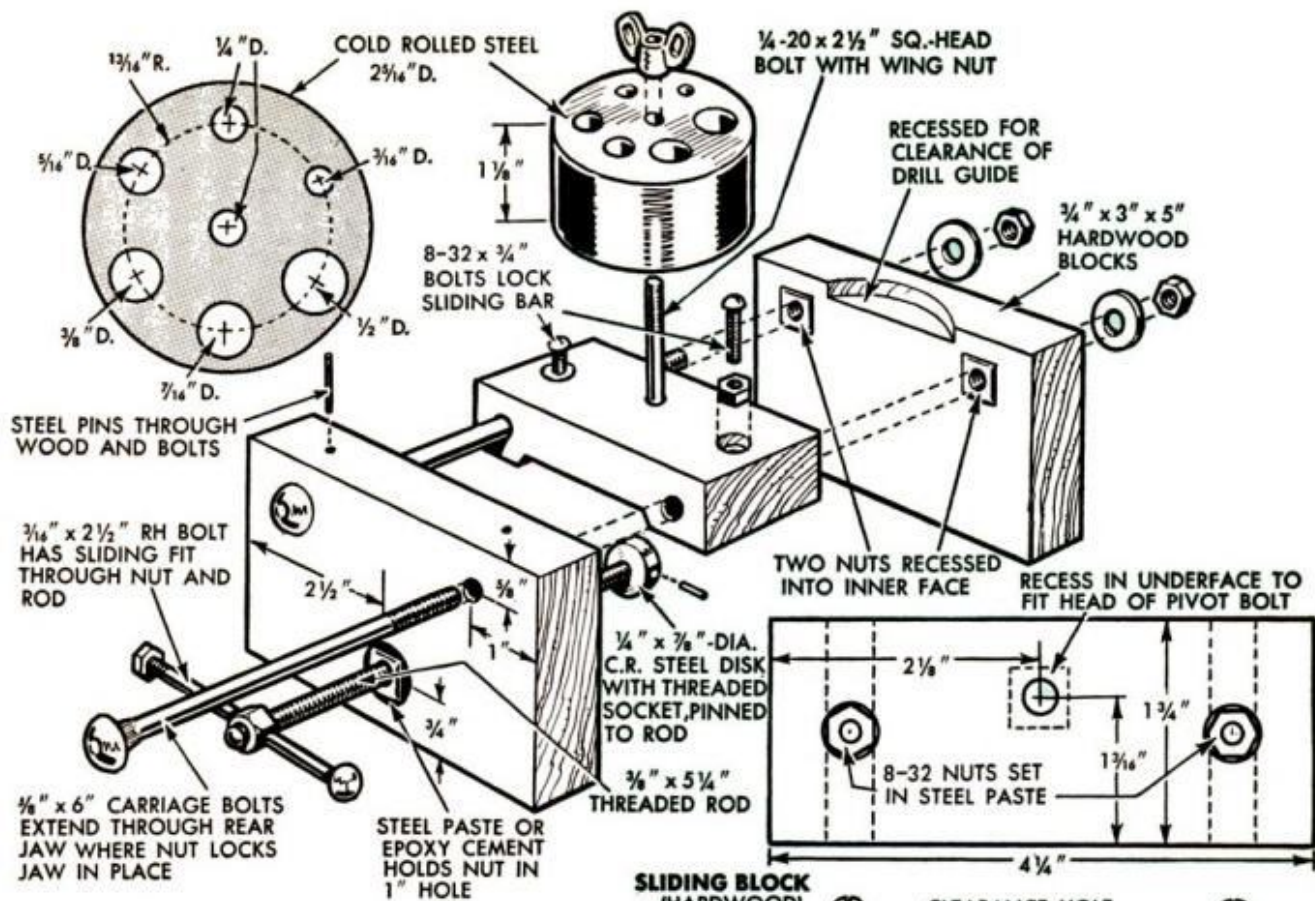

FOR PRECISION WORK, all hardwood blocks must be squared and bolt holes carefully aligned; holes in steel cylinder must be square with bottom face. Since nuts would have to be pried out of rear block to permit adjustment of space between jaws, pressure-plate screw is used

Drive the carriage bolts through the front jaw-block, ending with a sharp blow to sink the square shoulder into the wood. Drill holes down through the bolts from the top edge, to take steel pins. Slide the platform block onto these bolts, then turn on two square nuts before sliding on the rear jaw. Adjust the nuts until the two

DRILL BIT is inserted in hole of matching diameter, which has been positioned so bit will clear edge of sliding bar and center over layout mark on work

jaws are parallel when the nuts are snug in their recesses.

After bolting the steel guide to the sliding block, you can mark the upper edge of the rear block for cutting the circular gain. This allows the cylinder to lap the jaw when you're drilling small holes on narrow stock, with the jig compressed. ★ ★

ANGLE DRILLING is done by tilting jig until jaw ends align with sliding T-bevel set for desired angle. Clamp jig tight, hold steady while drilling

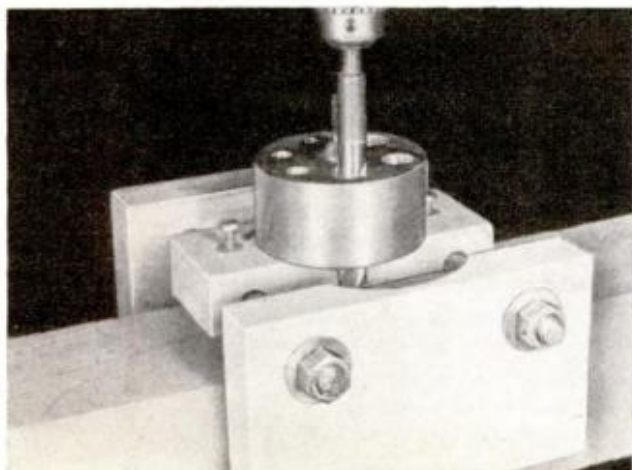

SHOP SHORT CUTS

Rock It for Accuracy

Measuring inside diameters to thousandths of an inch can be tricky with a telescoping gauge—especially if the compression spring is weakened with long use. For greater precision, place the gauge in the tube or hole with its handle at an angle to the axis (1st Position, left). After the gauge expands, snug the knurled ring, rock the handle upward past the axis and back down.—*H. J. Gerber*

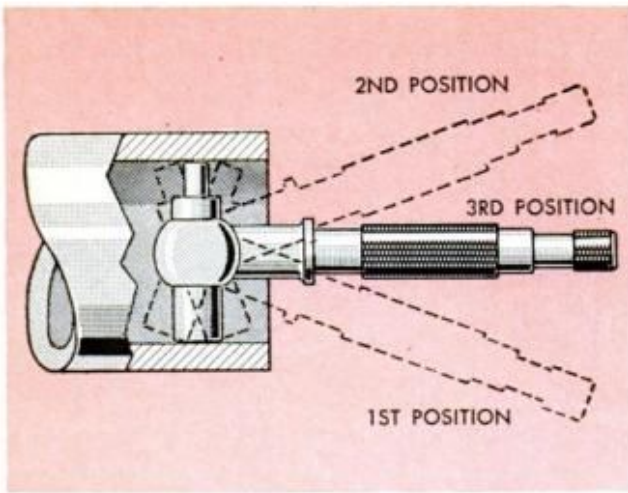

For Nuts and Bolts

A 12-compartment muffin tin serves as both a sorting and storage tray for nuts, bolts and small parts. A lid of 1/8-in. hardboard is hinged to one long edge; light chain holds it upright. For quicker selection or sorting, a sample from each corresponding bin can be glued to a label stuck to the underside. Or, if it's a bolt, turn it through to protrude slightly and trim flush on top. To attach the hinges to the hardboard cover and to the muffin pan, use short aluminum rivets.

—*W. G. Waggoner*

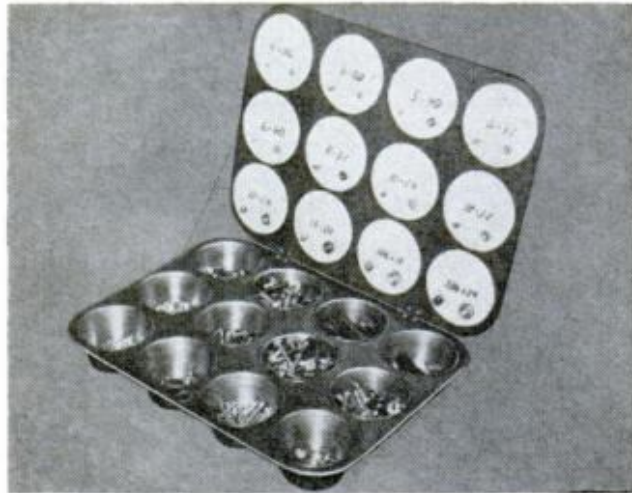

Jig Lends A Hand

Trying to keep two pieces of wire or light rod in perfect alignment while manipulating solder and soldering iron can be pretty frustrating. Fortunately, there's an easy way to handle this tricky job. A simple jig can be made by screwing two spring-type clothespins to the beveled edge of a block of scrap wood. The jig holds the work firmly in the desired position and lets you concentrate on applying the solder. Note that one leg of each pin must be shortened to permit attaching it with a screw.—*Daniel Bousha*

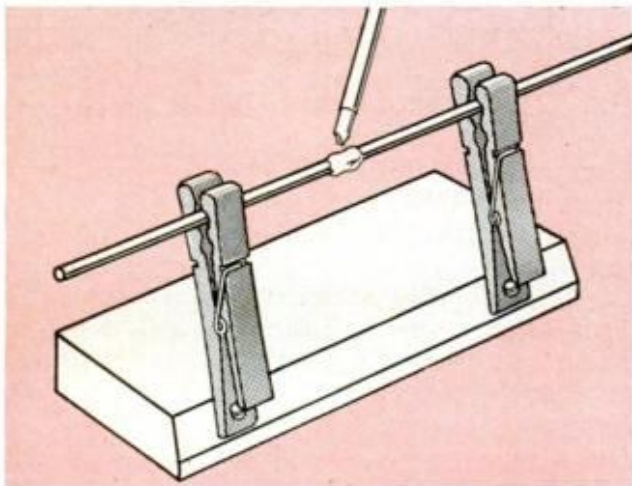

Marking In Tight Spots

A ball-point pen cartridge is handy for marking holes in situations like the one shown. The thickness of the block and the small diameter of the hole make it impossible to mark the work with a conventional pencil. The cartridge, on the other hand, is slender enough to make nearly a full-size tracing of a hole as small as 1/4-in. dia. The cartridge may be fitted with a dowel handle to make it comfortable to hold, if you have a lot of such marking to do. Hold the cartridge at a slight angle as you mark around the hole.

—*W. B. Burton*

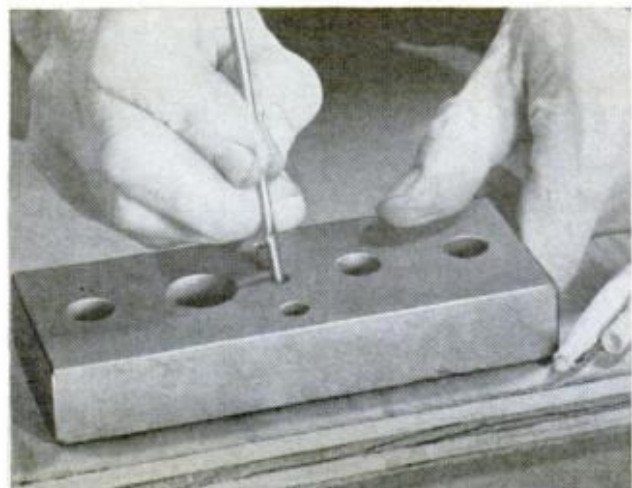

Shadow Box Displays Prized Keepsakes

BABY SPOONS and other pieces of treasured family silver become a colorful conversation piece when displayed against the red velvet that covers the back of this picture-frame shadow box. The rich red texture adds sparkling contrast to the silver to make it a handsome decoration.

The sides of the box are $\frac{1}{4}$ -in. plywood, the back is carton cardboard. While the depth and size will of course depend on the number of items to be displayed, the overall size of the box should be a bit smaller than the outside dimensions of the frame. Fasten the glass in the frame with brads and hinge the frame to the box at the top, so it can be opened. Line the inside with velvet; and attach the silver with loops of elastic cord pulled through the back.

—Gerald and Frank Callahan

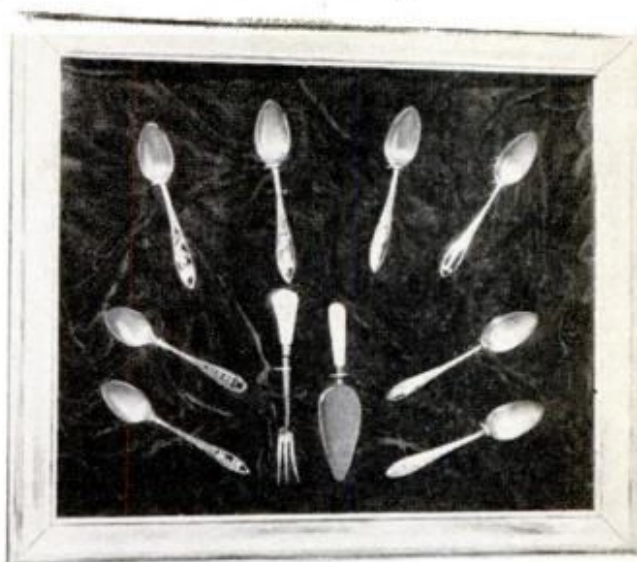

YOUR FINE SILVER won't tarnish if you insert a piece or two of camphor inside lower corner of frame



CORRUGATED CARDBOARD is cut to fit the back of the box, then items to be displayed are arranged on cardboard and locations for elastic loops are marked



SPREAD GLUE generously inside box, then press velvet in place. The material should be gathered as shown rather than stretched taut. Trim off excess

NEXT MONTH IN SHOP AND CRAFTS

- ★ **REAR-PROJECTION CABINET.** It looks like a luxurious TV console with a giant 20 x 24-in. screen, yet this handsome piece of furniture is actually a rear projector screen for showing your slides. When not in use, it serves as a storage cabinet for your projector and slide magazines. You'll find detailed how-to-build-it plans in the January *PM*
- ★ **PLUG-IN POWER CONTROL.** Utilizing a new semiconductor device, this simple control unit makes it possible to dial any speed for your electric drill or sander, any heat for your soldering iron or shop heater, any light intensity for your living-room lamps or photofloods. No cumbersome in-the-wall box, just plug the compact control unit into any handy 110-v. outlet. Watch for the plans for this bargain \$12 project in next month's issue
- ★ **\$3.00 COPYING MACHINE.** How many times have you needed copies of important correspondence or legal papers? Next month, *PM* brings you plans for a low-cost machine which makes exact copies of any 8½ x 11-in. document for less than one cent each. It's a simple project that will probably pay for itself during the first year of use. Watch for it in January
- ★ **GRINDING YOUR OWN GEMSTONES.** Beginners in the fascinating hobby of making gemstones should make a special note to get the January *PM*. It contains an easy-to-understand article describing the construction of a basic grinder-polisher which can handle all the common grinding, sanding and polishing operations. All you need is \$11 and a $\frac{1}{4}$ -hp. motor

HEAT TREATING IN THE HOME SHOP

By Manly Banister



What's the difference between hardening and tempering? What's the best temperature for these jobs—and for forging? Can you "read" a heat rainbow? Not sure of the answers? Then read on

SNAP! goes your favorite chisel or screwdriver or wrench. It needn't mean a sad waste of fine steel. If you've got a corner of your shop set up for heat treating, like the outfit shown above, that broken metal will be a challenge. Soften it by annealing; forge it into a new tool, then bring back its toughness by re-hardening and tempering.

And that's only a start. You can buy your own drill rod or tool steel and create new tools, tailor-made for a job at hand.

Heat treatment of alloy and high carbon steels needn't be a chore fraught with bewildering technicalities. Strip away the complex graphs and the metallurgist's fancy jargon and you'll find that the basics of heat treating are easy to master. And you won't have to make a big investment in equipment. The largest item in that line-up above is a homemade oven!

As for safety, only common-sense precautions are necessary. Concrete patio blocks under and behind the oven and blast furnace serve as fire protection. And since the gas flames will burn the oxygen out of the air of a closed room, you'll want a window or two you can open.

The steels listed in the chart at right should cover any job you're likely to tackle. We've selected them, from the many varieties of steel available, as being most useful to the home craftsman or job shop operator. An alloy steel results when one or more *additional* metals are included in the melt. Carbon is not properly an alloying material, but when added to the melt in varying amounts from 0.10% (1010 steel) to 1.5% (High Carbon) it increases the hardness proportionately. These steels are designated as Low Carbon (hot- or cold-rolled steel) and High Carbon (tool

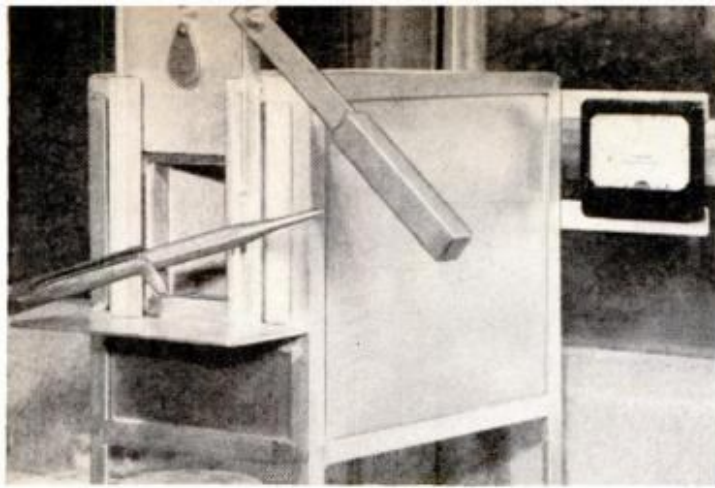

OCTAGON BAR of high-carbon tool steel is withdrawn from preheating oven when pyrometer indicates temperature of 1200° F. Gradual preheating avoids thermal shock from too-rapid heating in blast furnace

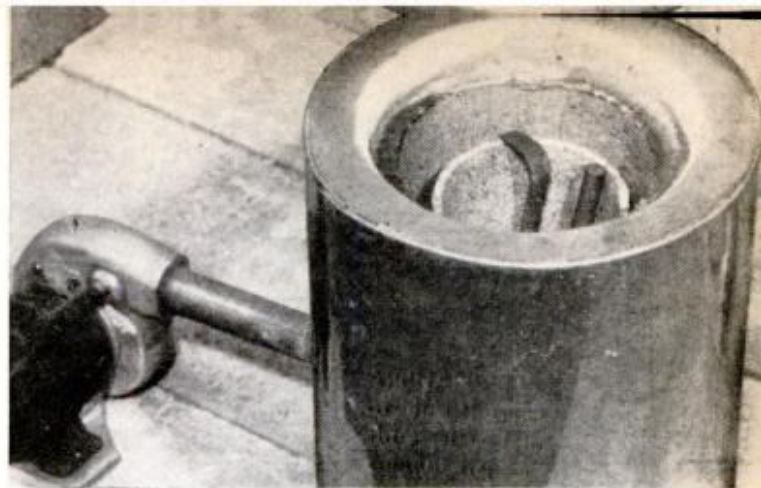

PREHEATED STEEL has just been transferred to blast furnace. Crucible keeps direct flame from metal, preventing burning and decarburization. Glowing steel looks black because of superheated furnace

steel, drill rod). Only High Carbon steels can be hardened by heat treating. When the Low Carbons need toughening up, you accomplish it through "case hardening," as shown at right.

In the alloys, manganese is added to make steel easier to forge, to increase the strength and depth of hardness, and to reduce the distortional effect of quenching. Molybdenum increases strength and hardness, too—as well as reducing temper brittleness—but it also raises the temperature required for forging. Chromium in steel is a third way to increase strength and hardness; it provides a hardening effect

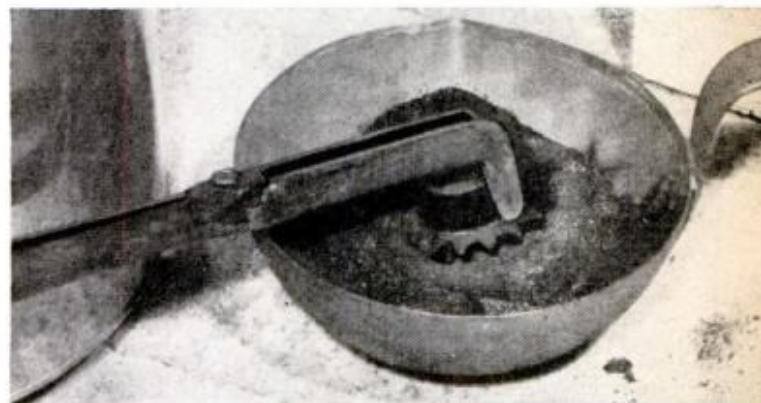

RED-HOT SPROCKET is dipped in carburizing (case-hardening) compound, which sticks to it as sprocket is returned to furnace. After compound melts over surface, procedure is repeated before quenching

THESE STEELS ARE BEST FOR HOME WORKSHOP USE

Temperatures for:

Type of Steel	Characteristics	Forging	Normalizing	Annealing	Quenching	Drawing	Sample Uses
AISI* C-1040 SAE** 1040	An open hearth, medium carbon (0.30-0.50%) fine-grained, manganese alloy steel. Good machining and forging qualities	2250°- 1900° F.	1650°- 1750° F.	1500° F.	1550° F. Oil or water	400°- 1200° F.	Shafts, pins, bolts, bushings, machine parts, rollers, etc.
AISI A-4142 SAE 4140 Annealed	A chromium-molybdenum-manganese alloy, 0.40-0.45% carbon. Easily fabricated, forged, machined, welded and heat treated. Resists fatigue, abrasion and impact	2200°- 1900° F.	1600°- 1650° F.	1500° F.	1550° F. Oil	400°- 1200° F.	Boring bars, wrenches, small tools, shafts, axles, cams, bolts, connecting rods, pins, hammers, mandrels, ratchets, rollers, gun barrels, etc.
AISI C-1075/ 1090 High Carbon	A general utility steel where toughness plus hardness is required	1900°- 1600° F.	1600° F.	1450° F.	1450°- 1500° F. 10% Brine or water	300°- 550° F.	Forged tools, blacksmiths' tools, cold chisels, pinch bars, crow bars, cold cutters, hardies, swages, anvils, etc.
AISI C-1095 SAE 1095 Drill Rod	0.90-1.05% carbon, possessing good stiffness and toughness as supplied — without heat treating. Highly finished surface, no decarburization. Heat treats very hard	---	1650° F.	1450° F.	1475° F. Oil 1450° F. Water or 10% brine	300°- 550° F.	Small shafts, dowel pins, scribes, small machine parts, punches, rollers, arbors, lead screws, etc.
S-5 Tool Steel ASM Classification I11C (Omega Tool)	Hardness with great ductility for shock resisting parts. Subject to decarburization if held too long at forging temp.	1900°- 1650° F. Cool slowly	1500°- 1600° F. After forging cool in ashes	1450° Cool slowly to 800° for best machining	1625°-50° Oil (pref.) 1550°- 1600° F. Water	400°- 650° F.	Chipping chisels, rivet sets, punches and other tools subject to heavy impact
AISI W-1 Tool Steel ASM Classification IA	A carbon tool steel for high wear resistance, cold cutting qualities, and high impact resist.	2000°- 1500° F.	---	1450° F. Cool in dry ashes or in furnace	1450° F. Water or brine (1 lb.) salt gal.	300°- 550° F.	Punches, rivet sets, cold forming tools, shop hand tools, arbors, forming tools, carbon steel lathe centers

*AISI: American Iron and Steel Institute

**SAE: Society of American Engineers

MAKING A CHISEL WITH A HOMEMADE BURNER

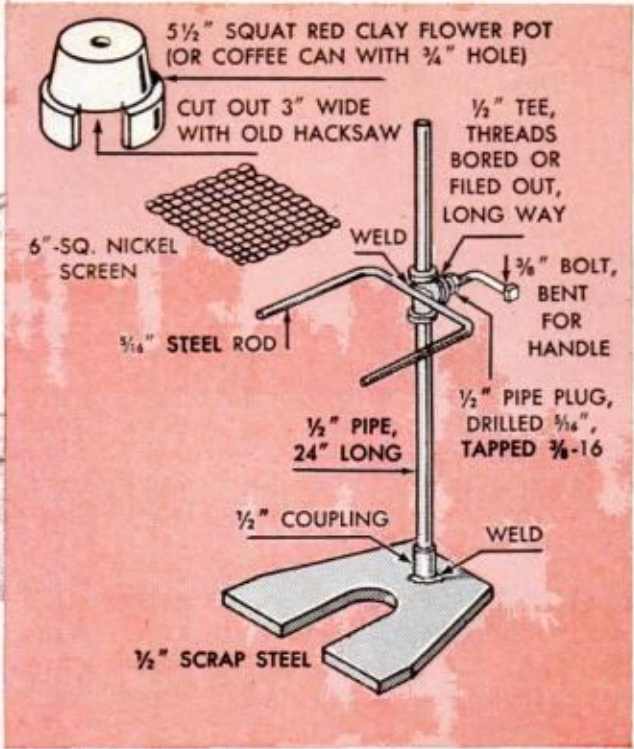
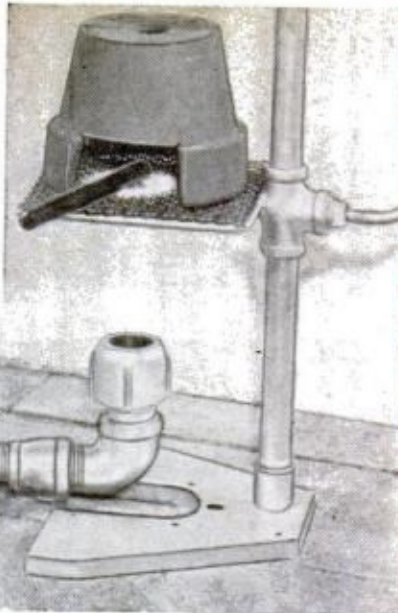

1. Burner is made of standard pipe fittings, plus Eclipse nozzle. 1-in. size gives good blast of heat at 15 lbs. air pressure, works well at 3 to 5 lbs. Photo shows tool steel being heated for forging

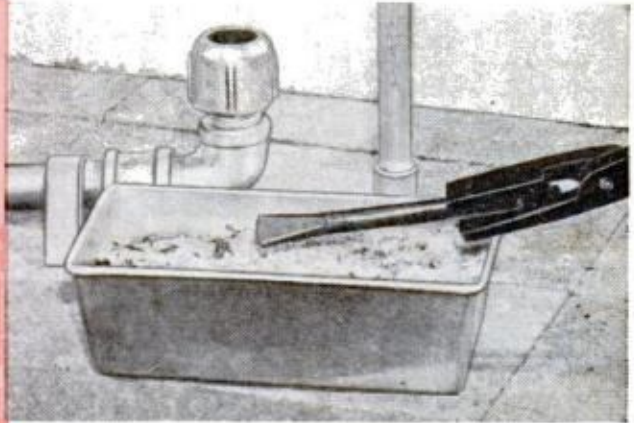
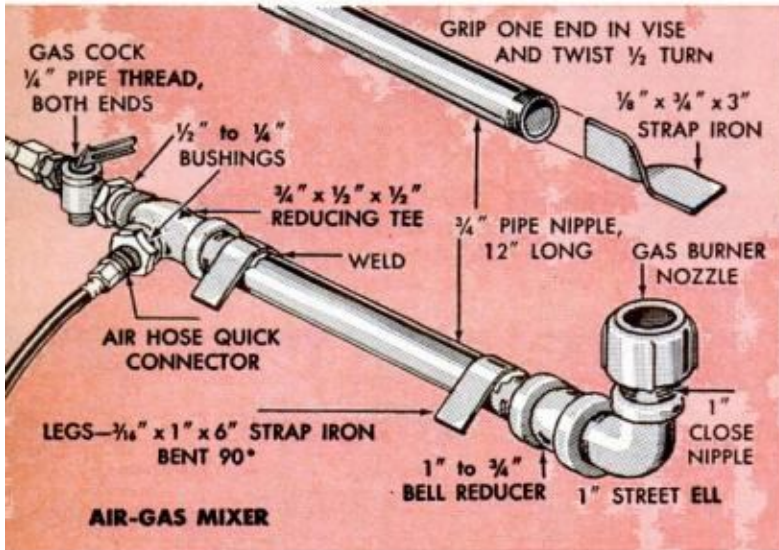

2. After forging on anvil, chisel blank (1/2-in. rod W-1 tool steel) is reheated to annealing temperature and buried in dry ashes for slow cooling. Blacksmith's tongs let you handle hot steel

3. When cooled to room temperature, flat is ground to shape, but end is left square-blunt through hardening and tempering, as steel is now too soft to hold edge. Final grinding is detailed in inset below

4. Tempering is done on top the oven where you can watch colors run down polished blade toward blunt tip. Each color appears at base of flat; when ranged as in sketch, quench and grind

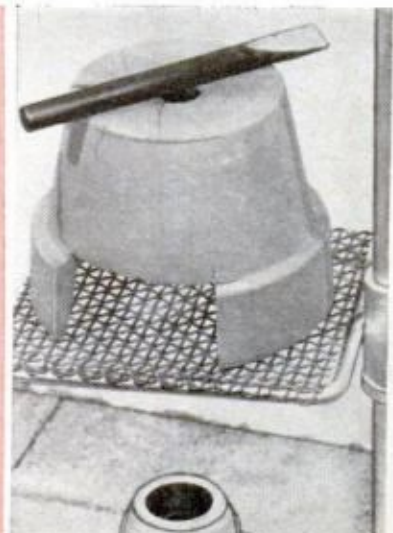
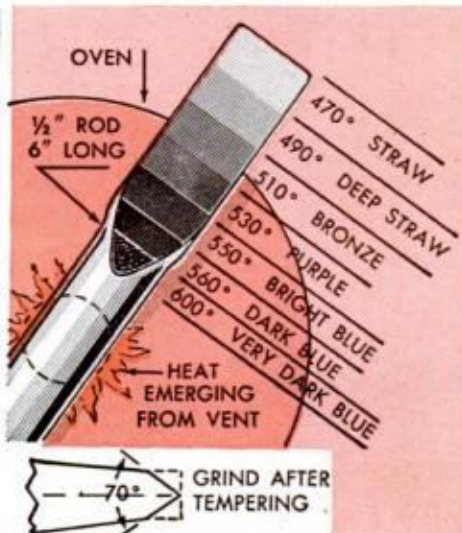
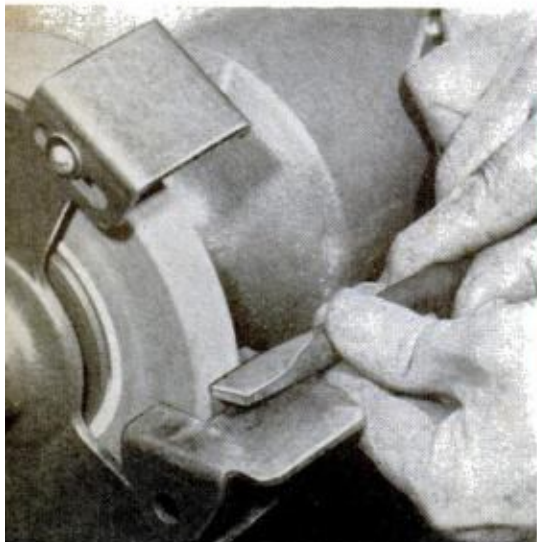

OTHER ITEMS YOU CAN MAKE

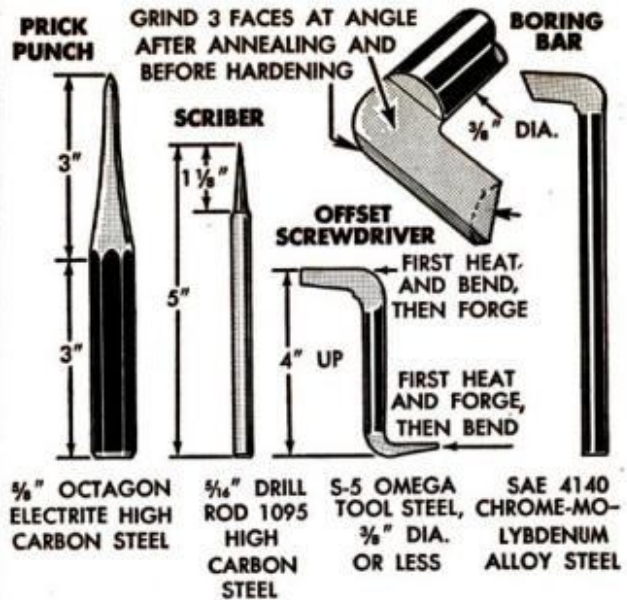

similar to High Carbon steel.

Blacksmith-type heat treating requires the least amount of equipment—a small forge, or an oxy-acetylene, acetylene or LP torch. But you'll find a homemade gas burner of the type detailed on the facing page comes in handy. You can make it yourself, using a commercial 1 or 1 1/4-in. nozzle (see product list, page 175). When ordering, specify whether you want it for manufactured, natural or LP gas. Air is supplied by a compressor at 3-5 lbs. pressure (or up to 15, for a really hot flame). Don't have one? Then hook the burner up to a small blower or even to the exhaust of a vacuum cleaner. (You'll probably need an air cock to regulate the flow.) The air-gas mixer is nothing more than a foot-long pipe with a twist of strap iron driven into each end. Twist the two pieces in opposite directions, then hammer their ends broad enough for a drive fit.

The flower-pot oven helps retain the heat when you're heating work in it, for forging; and the pot's hole "focuses" the heat when you're tempering work on top the oven. Don't worry if the pot develops a crack; this won't affect its efficiency.

The chisel being made in the steps at left is shown above with other finished homemade tools. The bushing is 1040 machinery steel, quenched in oil and drawn at 400° in a kitchen oven. The sprocket was case-hardened at 1650° and quenched in brine (no tempering required). The prick punch and scribe were machined on a lathe, then finished to a high polish with a file and emery before being heated to hardening temperature, quenched in brine, and drawn at 300°. The offset driver was forged, annealed, and rough-ground to shape (note that the sequence differs for opposite ends). The boring bar was heated and bent, annealed, ground to

HEAT COLORS OF GLOWING STEEL

Color	Temp. °F.	Notes
Dark Red	1100°-1300°	
Cherry Red	1350°-1450°	Carbon steel is hardened at temperatures from 1350°-1550°
Bright Cherry Red	1500°-1650°	
Orange Red	1700°-1850°	
Salmon Red	1900°	Alloy steel is hardened at temperatures from 1450°-1950° F.
Yellow	2000°-2250°	
Yellow White	2300°-2450°	High speed steels are hardened at temperatures from 2250°-2400° F.
White	2500° up	

TEMPERING COLORS OF STEEL

Color	Drawing Temp. °F.*	Suggestions for Use:**
Faint Yellow	300°	Scribers, cutting tools, cams, rollers, bushings, etc.
Light Straw	400°	
Light Straw	425°	
Straw (Yellow)	470°	Razor steel, cold chisels, screwdrivers, punches and dies, boring bars, mandrels, shafts, axles, arbors, etc.
Deep Straw (Yellowish Brown)	490°	
Bronze (Purple Brown)		
Bronze (Purple Brown)	510°	
Purple	530°	Woodworking tools
Bright Blue	550°	Lead screws, nuts, bolts, hammers, wrenches, etc.
Dark Blue	560°	Knives and springs
Very Dark Blue	600°	Saw steel, hack saw blades, etc.
Glow black-ish red in dull light	700°-850°	Tool steel spring temper (700°-800° F.)
Glow very dark red	900°-1000°	

* Draw (temper) 1 hour per inch of thickness (or fraction) at indicated temperature.
** Use this column as a guide only. Let experience determine whether a higher or lower drawing temperature is to be preferred for the particular application.

Carbon steel tempering range: 300°-1050° F.
High speed steel tempering range: 350°-1100° F.

MAKING A PREHEATING/TEMPERING OVEN

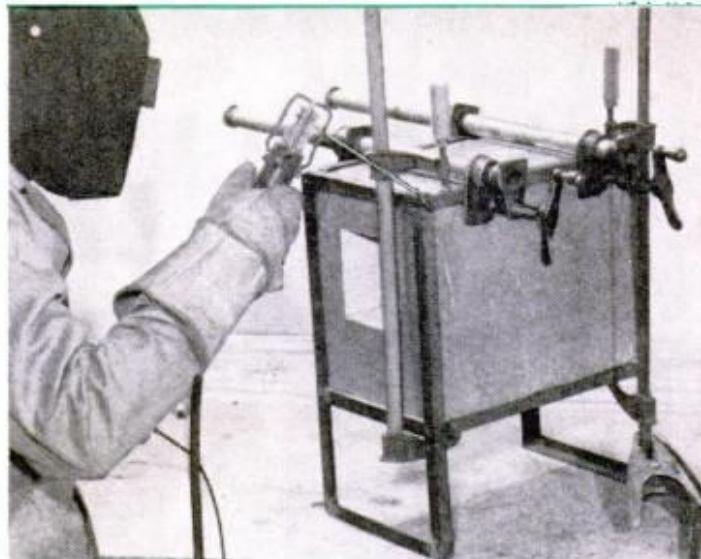
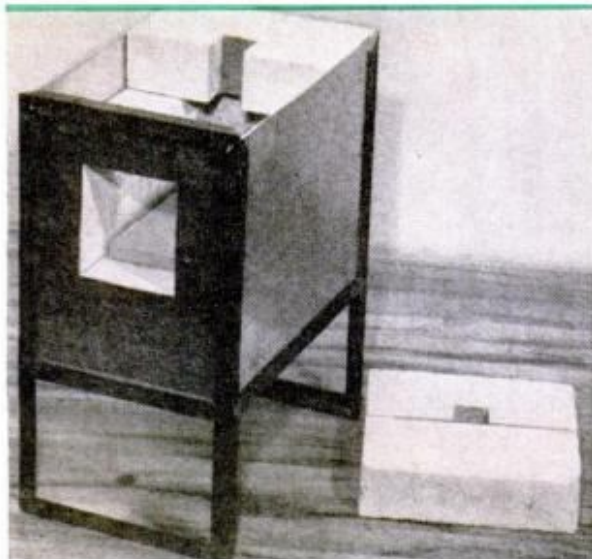

ASSEMBLY STARTS with angle-iron frame, then sheet steel bottom and sheet metal sides are set in. Fire bricks are stacked inside to form lining (left) with two of top bricks notched to create vent holes. Matching holes are cut in sheet metal top before it is laid over bricks and top rails are clamped in place for welding (right)

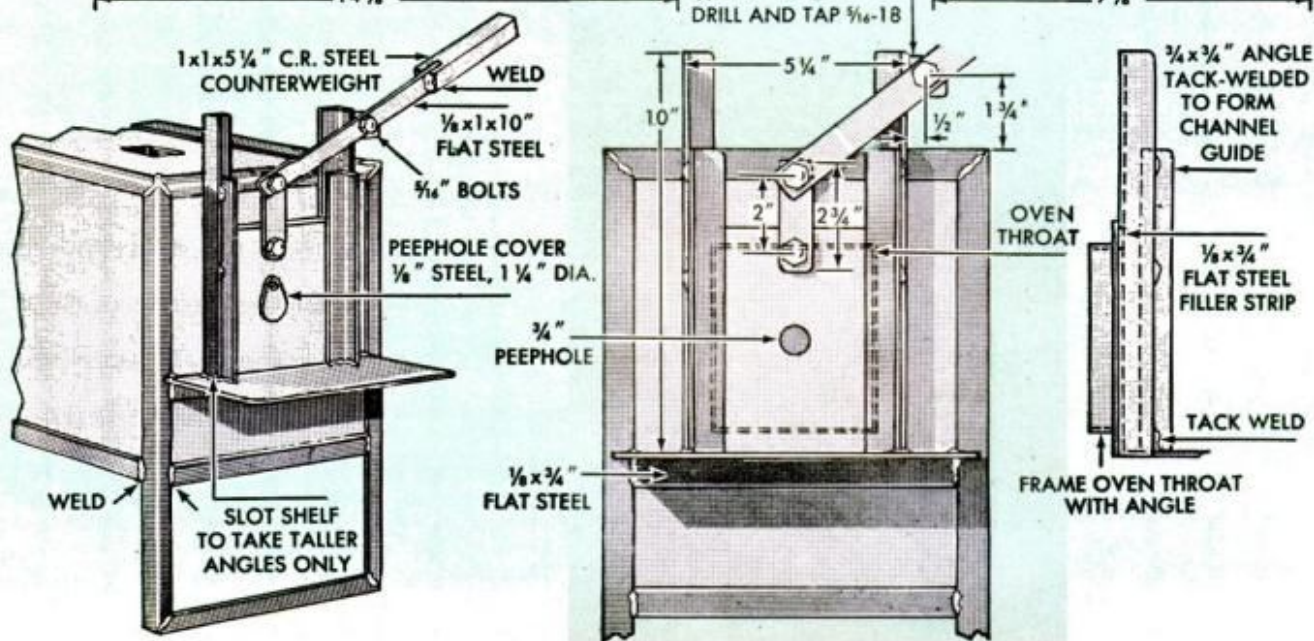
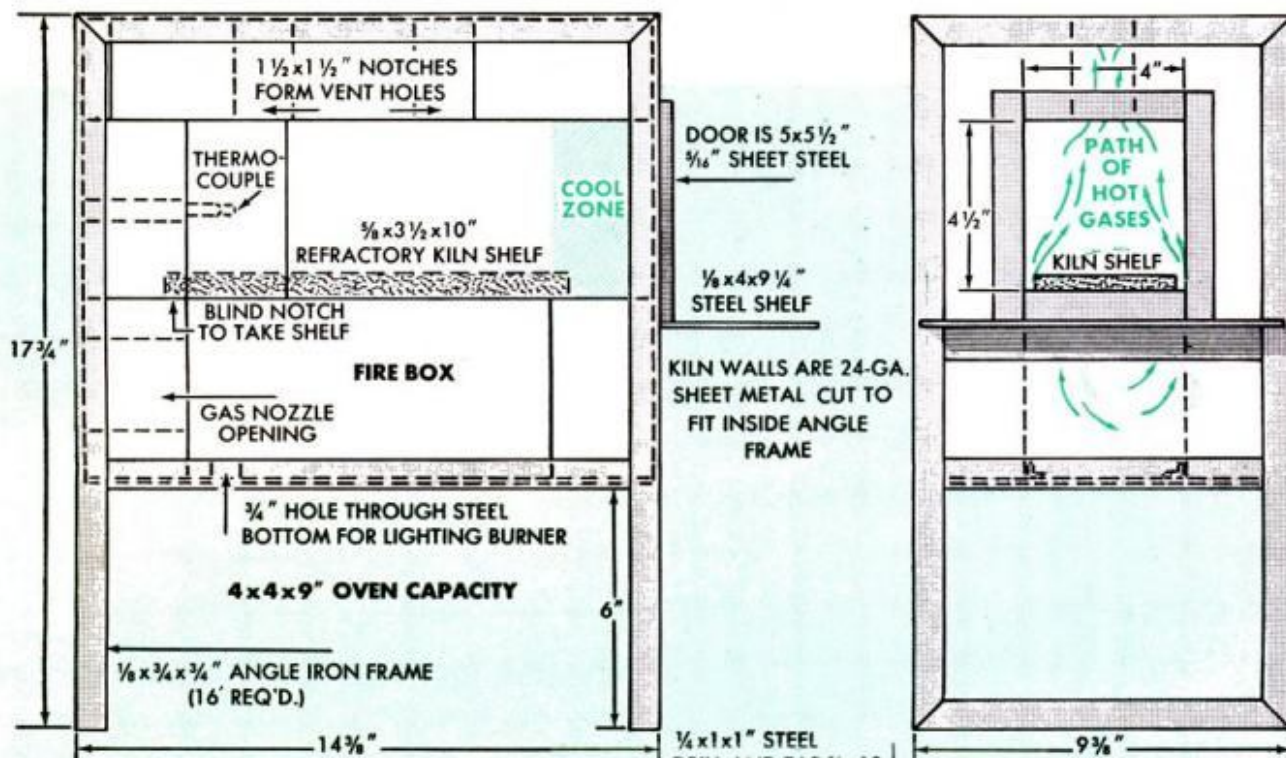

WITH A VENTURI NOZZLE GAS BURNER

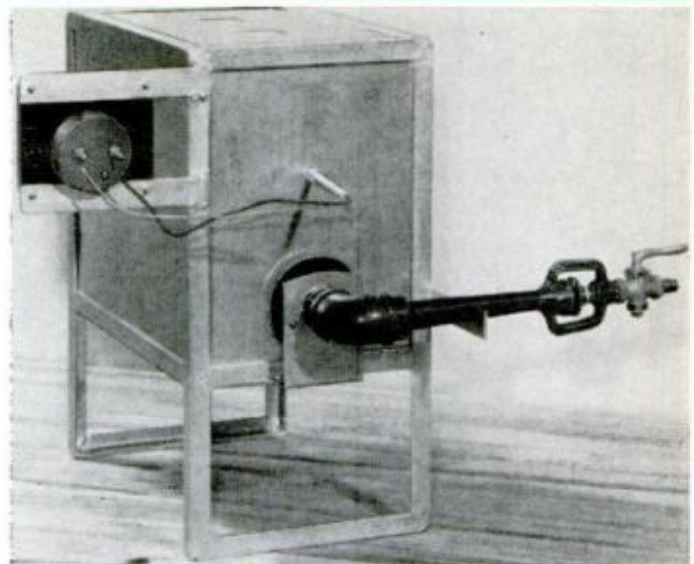
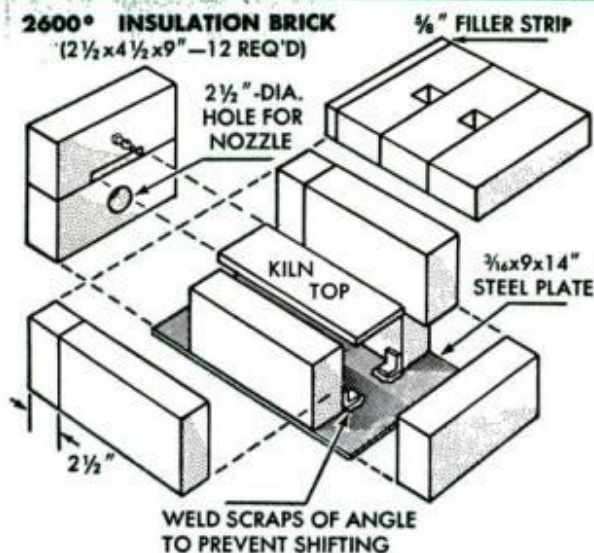

KILN SHELF "floats" within brick lining. There must be a gap of at least $\frac{1}{4}$ in. along each side for adequate draw. Thermocouple brick is notched to fit over shelf. Rear view, right, shows plus and minus thermocouple leads attached to matching terminals of pyrometer—also how Venturi burner nests in two brackets for easy removal

shape (any angle that provides cutting clearance is okay for the three flat faces). Then both these tools were hardened, quenched in oil, and drawn at 400° . After final quenching, those tools that required a sharp edge were finish-ground and polished with emery cloth.

But how about that big homemade oven? Its construction is detailed on these pages. You'll find it very effective for preheating work to the required 1200° F. before placing it in the blast furnace. The Venturi burner uses gas at atmospheric pressure, so needs no blower. The nozzle shown has a 90° angle burner, and a capacity of 25,000 BTU per hour. It lets you regulate and hold temperatures by throttling the gas supply. You can also control heat by moving the sheet-metal damper disc toward or away from the oven's back wall (the bracket provides an inch of space for this), or by partially covering the flues.

There's no trick to welding up the angle-iron-and-sheet-metal oven with its brick lining, as shown in the two top photos, facing page. But the angle-iron throat frame should be welded *in place* for a good

(Please turn to page 192)

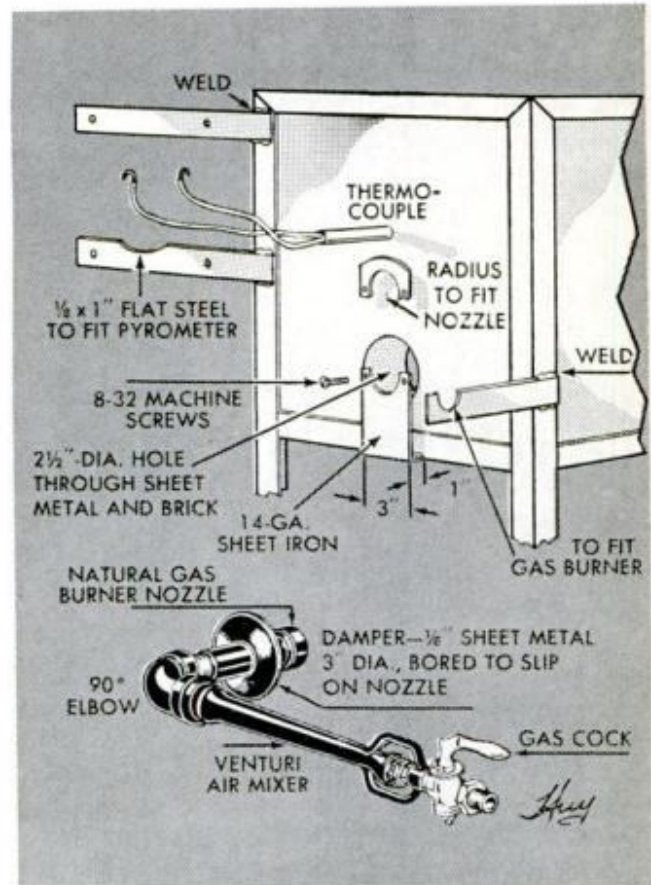

WHERE TO BUY THE PRODUCTS MENTIONED

ITEM	SAMPLE SOURCE	STOCK NO.	PRICE
1" or 1 1/4" Eclipse Stick-Tite Nozzle	Industrial gas burner dealer; check GAS BURNERS in yellow pages	Approx. \$2.00
1" "Buzzer" Venturi Nozzle	Charles A. Hones, Inc., 2473 So. Grand Ave., Baldwin, L.I., N.Y.	VNB100	18.50
Blast furnace	Kansas City Specialties Co., Marysville, Kans.	Complete range of sizes	
Pyrometer	Edmund Scientific Co., Barrington, N. J.	70,408	26.00
Thermocouple		40,478	3.75
Case hardening compound	Kasenit Co., Mahwah, N. J.	1-lb. can	

Foil the Car Thief

By Warren Roy

Add a toggle switch to the ignition system wiring and make your car too much trouble to take

THIS YEAR some 400,000 cars will have been stolen in the United States. And if you aren't careful, one of them may be yours. About 30 percent of all stolen cars

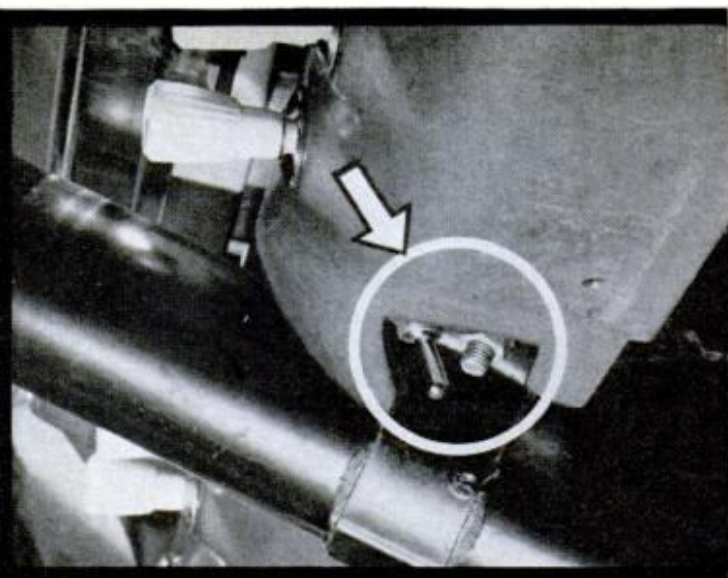

ONE PLACE to hide the toggle switch after you have it wired in series with the ignition switch is under dash. Recess it enough to make it hard to see

are never seen again, and while you may be insured, the inconvenience can be a real headache.

The two most common car theft methods entail the thief's getting into your car and under the dash. Many times getting into the car means only opening the door. You'd be surprised how many people don't

Changer for 80 Records

It works like a jukebox, plays both sides of every record, holds 40 discs in interchangeable racks

WE'VE GOT ONE COMPLAINT when it comes to long-playing records—you can't select individual pieces from individual records unless you do it manually. This defeats the purpose of that automatic record changer. The other choice is to listen to a lot of unwanted music, just so you can hear the one or two bands of music you really care for.

But this doesn't have to be a problem any longer. The other day we saw a new record changer that can play up to 40 seven-inch records, on both sides, auto-

matically. It's just like putting a jukebox in the home. But this one is completely portable and self contained. It even stores 40 records.

Made by Gerinvex in Switzerland, the Discomatic will play either 33 $\frac{1}{3}$ or 45-r.p.m. records. As you can see in the photos records are held vertically and played.

IF 40 RECORDS aren't enough, just lift out the rack you're finished with and slip a new one into place. You can't have too many records for this changer

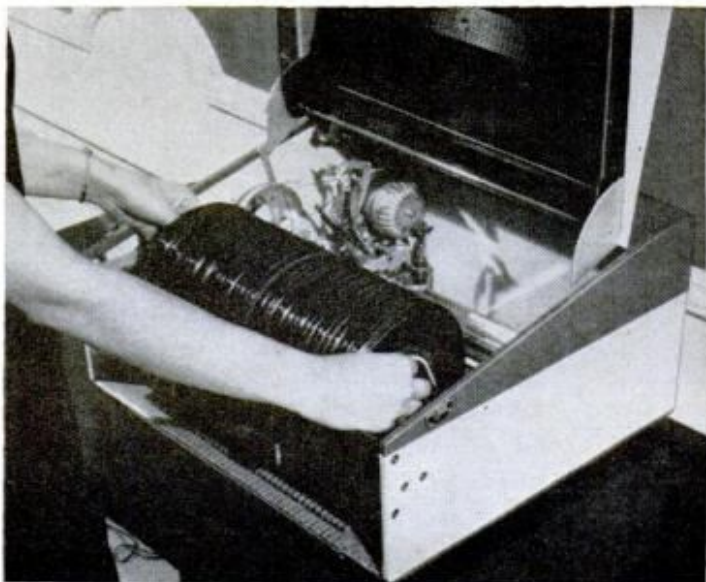

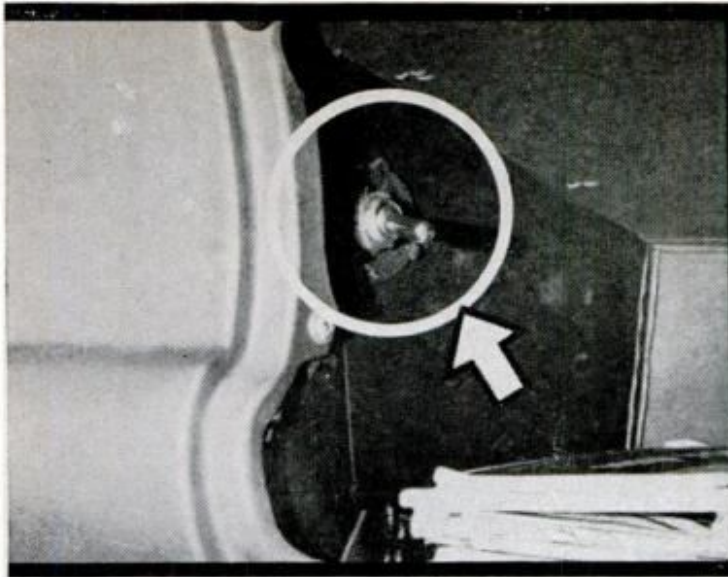

INSIDE the glove compartment is an even better hiding place. Not only does it put the switch out of sight, but the compartment can be locked

bother to lock their cars. Once in the car it's under the dash with a jumper wire to circumvent the ignition switch. The real pro goes one better. He removes the entire ignition lock cylinder and replaces it with a new one—one he has a key for.

Thefts of both these types can often be prevented by simply adding a con-

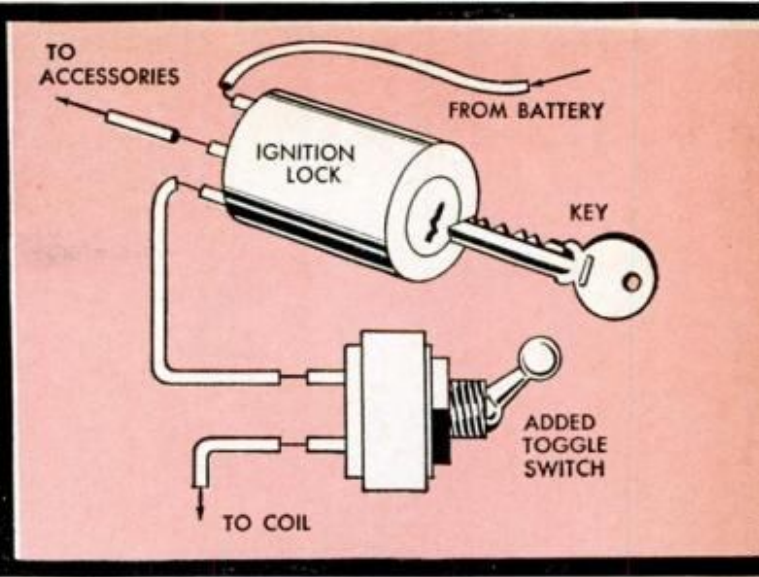

ADDING the switch is easy, but you may have to poke around until you locate the proper lead from the ignition switch. Ask your mechanic for help

cealed toggle switch in series with the ignition switch. Locate the added switch in some out-of-the-way place—in the glove compartment, under the seat, or under the dash.

When you leave the car, flip the switch and the ignition system is disengaged no matter what is done at the ignition switch.

The single pickup arm has one cartridge with two opposing diamond needles. One needle gets the left side of the disc, the other one gets the right side.

The record rack may be lifted out of the changer and another rack of 40 records put in its place. Each record slot is numbered, and title sheets are supplied for

PUSH THE BUTTONS to select the music you want to hear. Index sheets fit into sliding drawer under pushbuttons. Plastic cover protects against dust

each rack. A series of 80 pushbuttons lets you pick the tunes you want to hear. A lever on the front of the unit allows for cancelling all previous selections.

Discomatic will soon be available in kit form for around \$100. It will also appear in portable phonograph versions. It is being imported by the Lehara Corporation.

HERE'S WHAT the basic mechanism looks like. We've put one record in the play position. The pushbutton selector system and automatic reset lever are in front

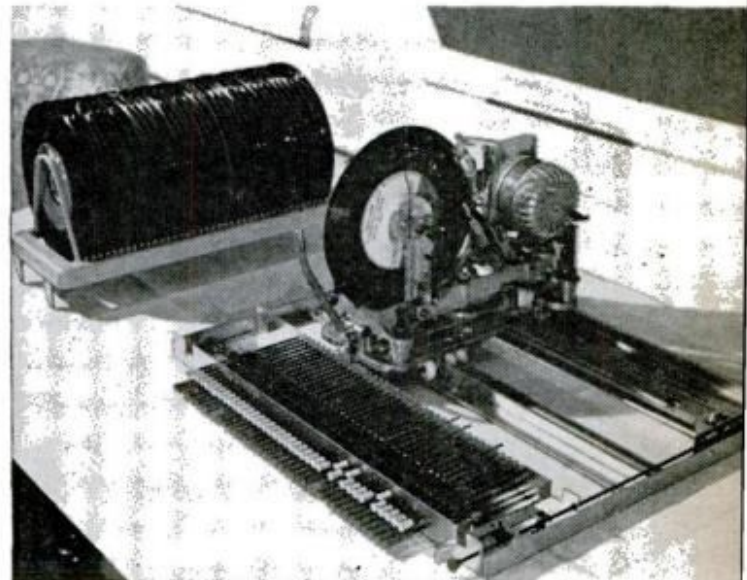
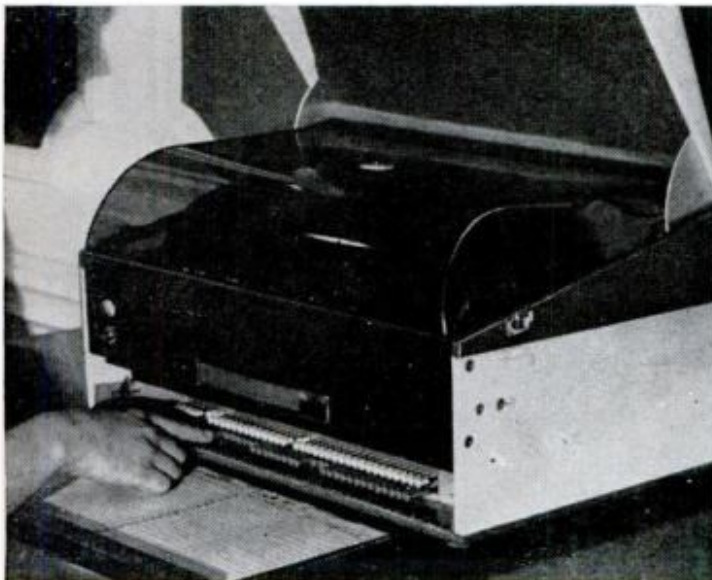

The Multivider-

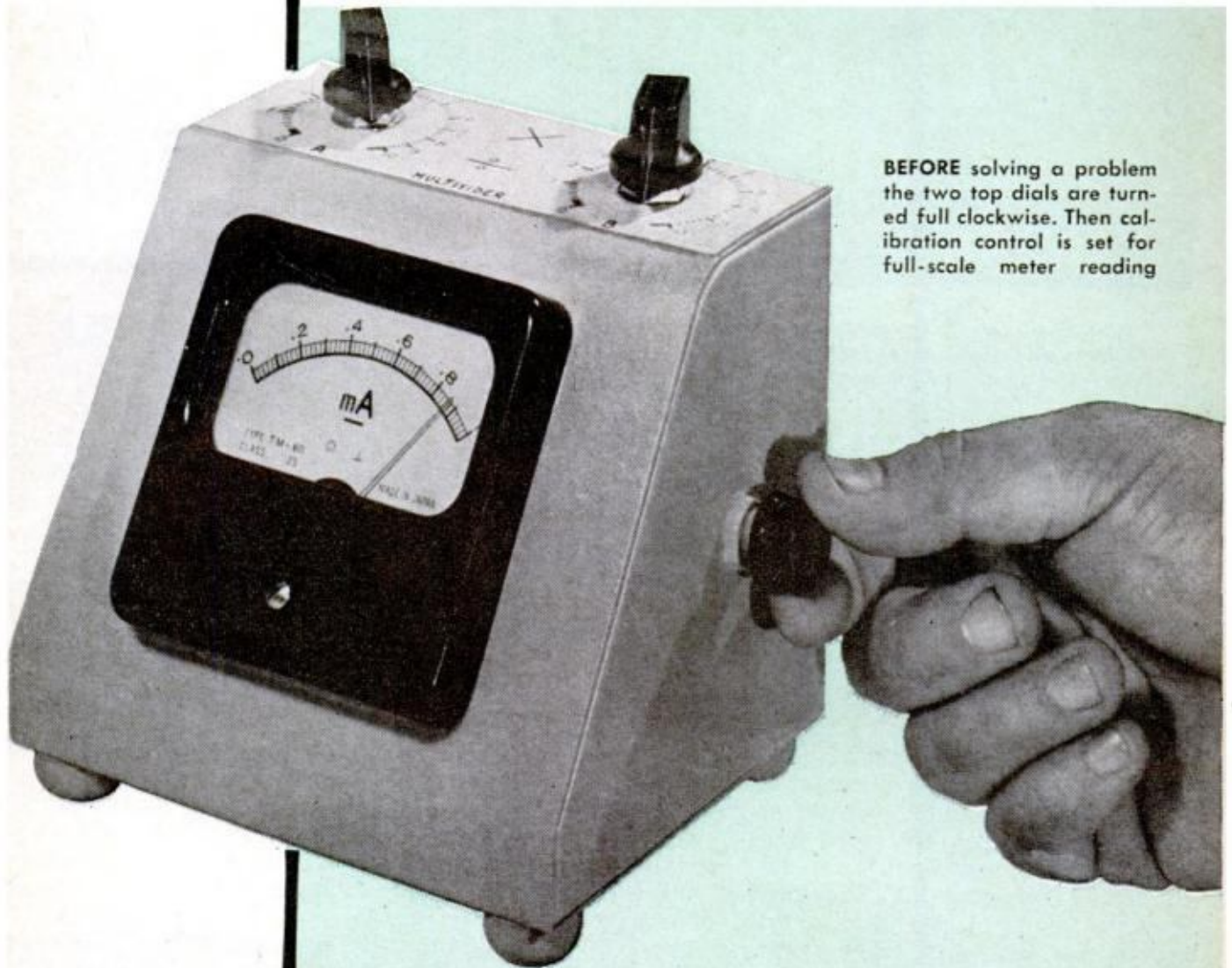

BEFORE solving a problem the two top dials are turned full clockwise. Then calibration control is set for full-scale meter reading

PICTORIAL DIAGRAM shows how the six electronic components are interconnected. Wiring is simple and can be completed in a very short time. Don't rush and you'll be right the first time

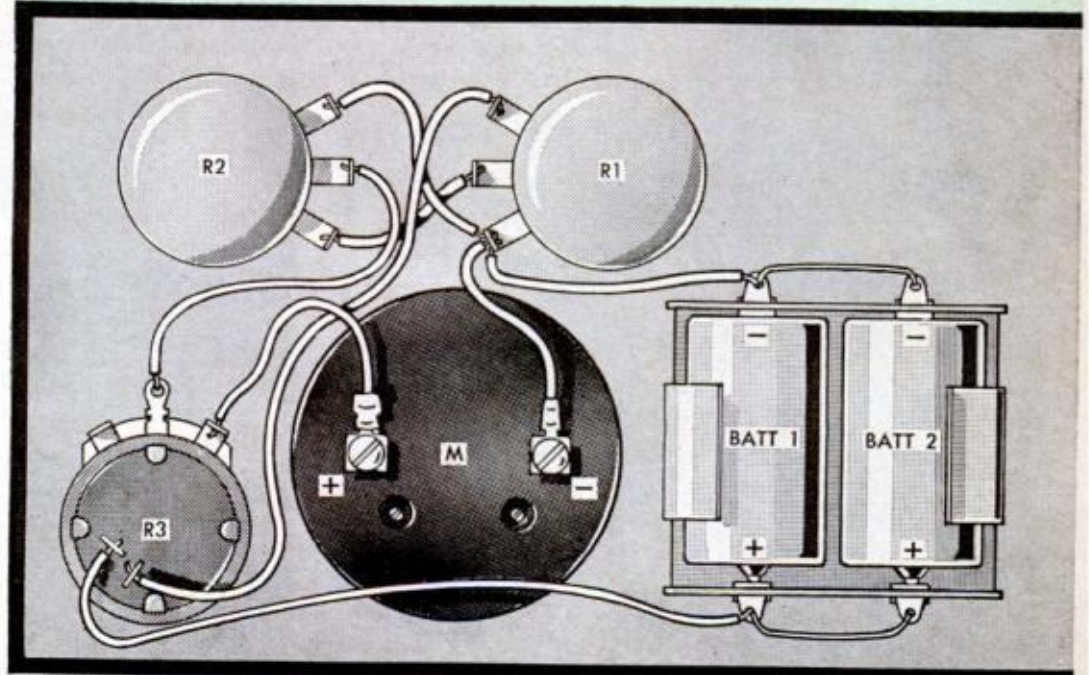

Electronic Slide Rule

*\$10 analog computer multiplies and divides.
Put your own together in less than two hours*

ONE OF THE SIMPLEST of computers, the Multivider has only six parts. The settings of R1 and R2 represent the first two quantities of a problem, while the meter reading represents the third.

Construction is simple; just follow the pictorial to be sure wiring is correct. The case is already punched for the meter.

To calibrate the unit, take a piece of white paper and cut holes in it for the potentiometer shafts. Mount it atop the meter case, fastening it in place with the potentiometer mounting nuts. Now turn on the unit and set R1 and R2 fully clockwise. Then adjust R3 until the meter needle is at the high end of the scale on the 1. Then turn the left-hand control all the way to the left and the meter will read zero.

Now advance the left-hand control until the meter needle is on the first small division. Mark this point at the tip of the control knob with a short line on the paper scale. Continue this until you come to the first heavy line on the meter scale (between 0 and .2). Mark this point with a heavy long line and label it 1. Continue

marking the scale using short lines for the small divisions and long heavy lines for the numbered divisions. When you reach 10, leave the control in that position and turn the other control to zero and use the same procedure to calibrate it.

To multiply 5 times 6 set the left control to 5 and the right one to 6. Read the answer off the meter, as 30 (the meter dial will read 3, but as in using a slide rule the decimal place is known).

To divide 10 by 2 reverse the procedure. Set the left control to 2. Adjust the right control until the meter reads .1 (10, again as for a slide rule). Read the answer on the scale of the right control—5.

PARTS LIST

- R1, R2—50 ohms, 4 watts, wirewound, linear taper potentiometers (IRC Type WPK-50)
- R3—5000 ohms, linear taper potentiometer with slt switch (Mallory U14 with US-26 switch)
- M—0-1 ma. 3-inch meter (Lafayette TM-60)
- BATT1, BATT2—1.5 volt C cells (RCA VS-335)
- Meter Case (Premier ASPC-23)
- Battery bracket (Lafayette MS-174)
- Pointer knobs (2) Lafayette KN-42)
- Standard knob (1) Lafayette KN-39)

FOR the electronically minded try working from the schematic and double check all wiring against the pictorial diagram at the left

HERE'S the setup for a sample multiplication problem 5×7 . The answer as shown on the meter dial is the expected 35

THIS TIME it's division; $10 \div 2$. Set 2 on left control. Rotate right control till meter reads 10. Read answer, 5, on right

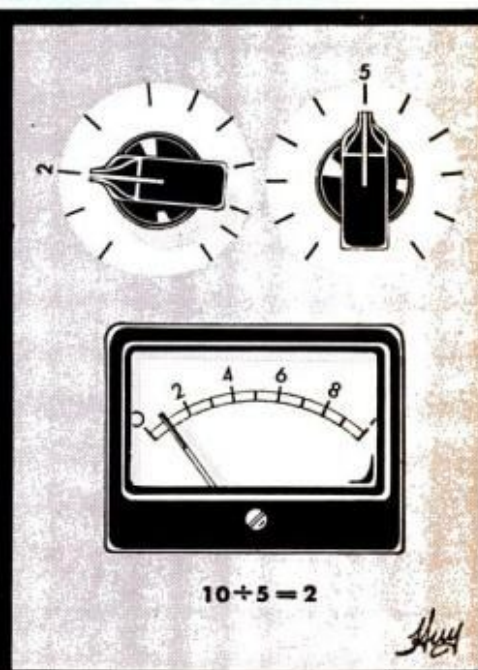
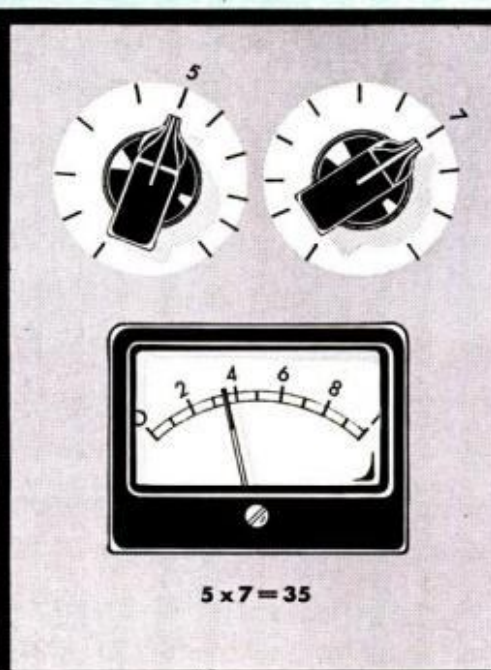
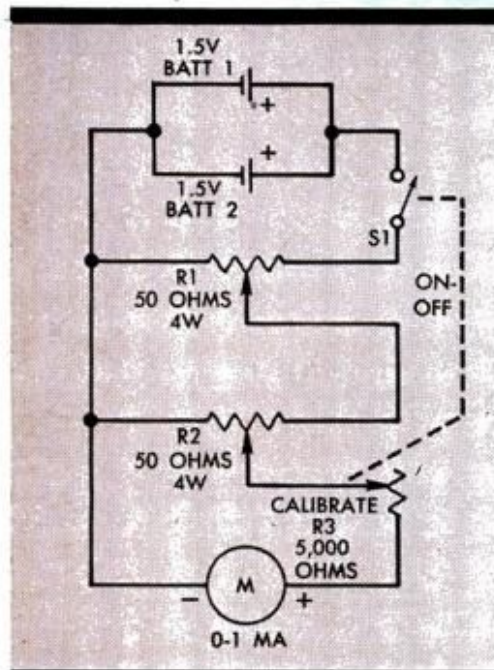

New in Electronics

TUNE IN THE TOWER when you use this converter to turn your AM radio into an Aircraft Band Receiver. To use it, turn on both radio and converter, place the converter next to the radio and adjust tuning. It's surprising how much there is to listen to. \$14.95 from Skyway Radio Inc., New Castle, Delaware

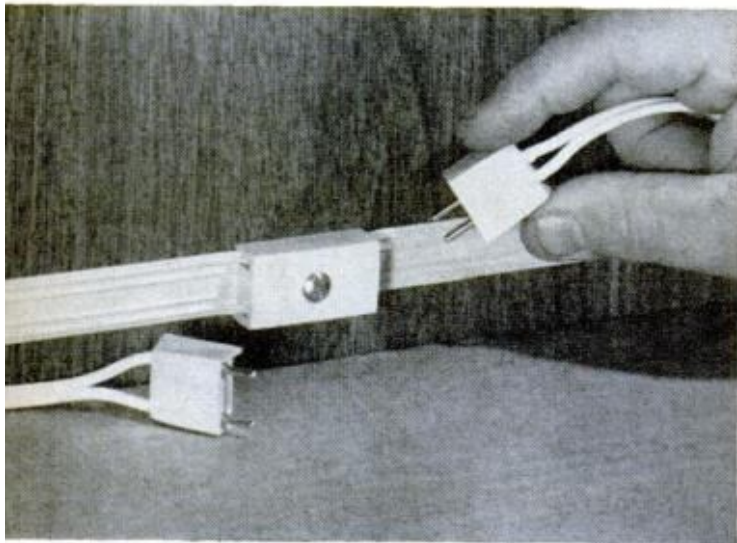

EXTENSION STEREO SPEAKERS are easy to hook up when you use Scotchflex audio cable system 800. 4-wire flat cable sticks to most surfaces, and stereo speakers plug right into the convenient connectors. 3M Company, 2510 Hudson Rd., St. Paul, Minn.

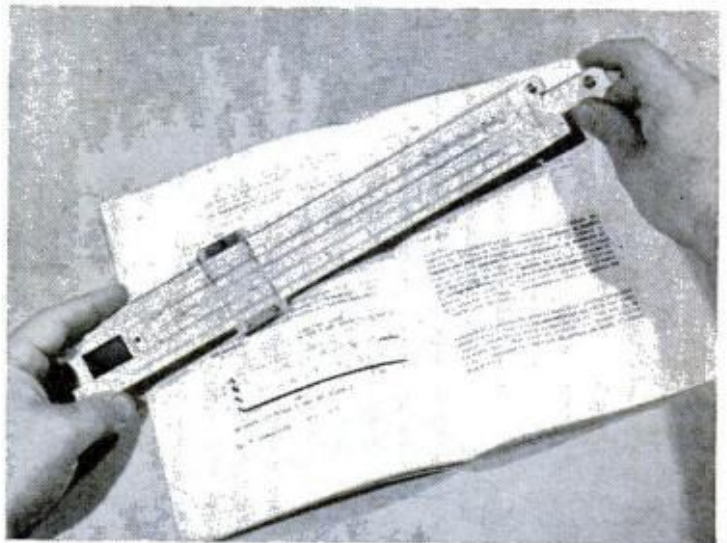

SLIDE RULE FOR ELECTRONICS makes quick work of most any electronics mathematics. Equipped with special scales not found on other rules and accompanied by a 123-page manual, it's an excellent electronics help. Cleveland Institute of Electronics, Cleveland, Ohio

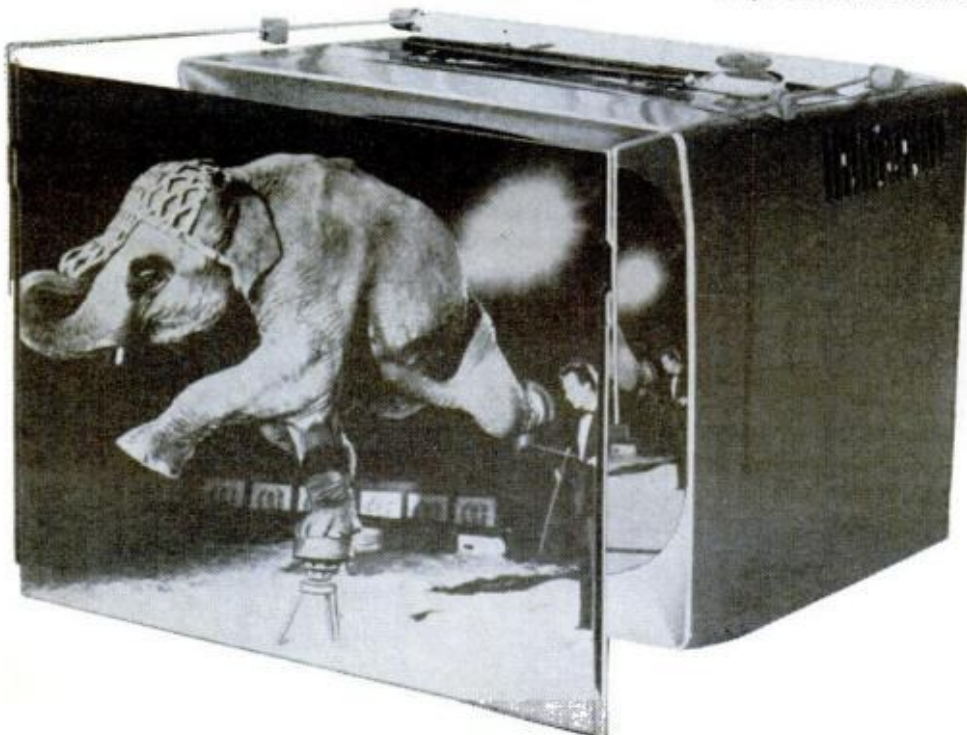

TV SCREEN MAGNIFIERS are back. Eight models from an 8-inch screen unit to a giant 31-inch screen unit are available. All add about a third to the existing screen size. They're made by impressing Fresnel rings into a clear sheet of 1/4-inch plastic. Scope Giant Co., 8447 Wilshire Blvd., Beverly Hills, Calif.

- Front wheels operate independently, each on its own axle
- Front axles are forged steel I-beams
- Forged radius rods secure axles to frame siderails

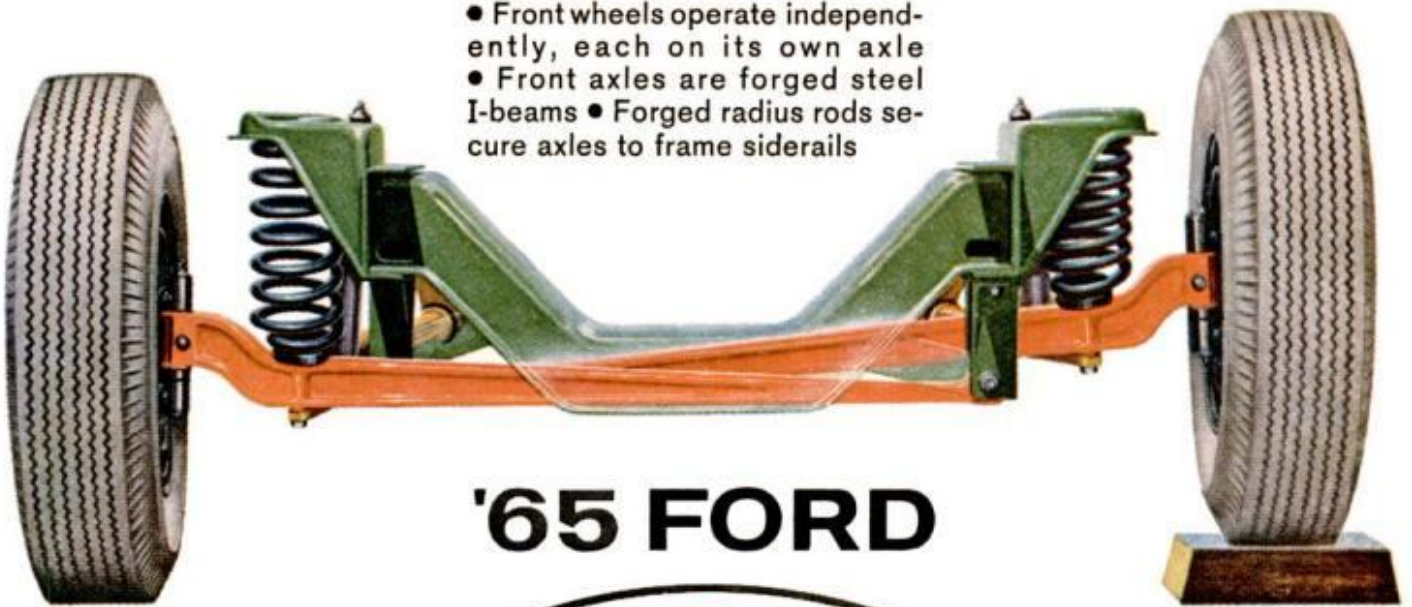

'65 FORD



PICKUPS
BUILT TO LAST LONGER

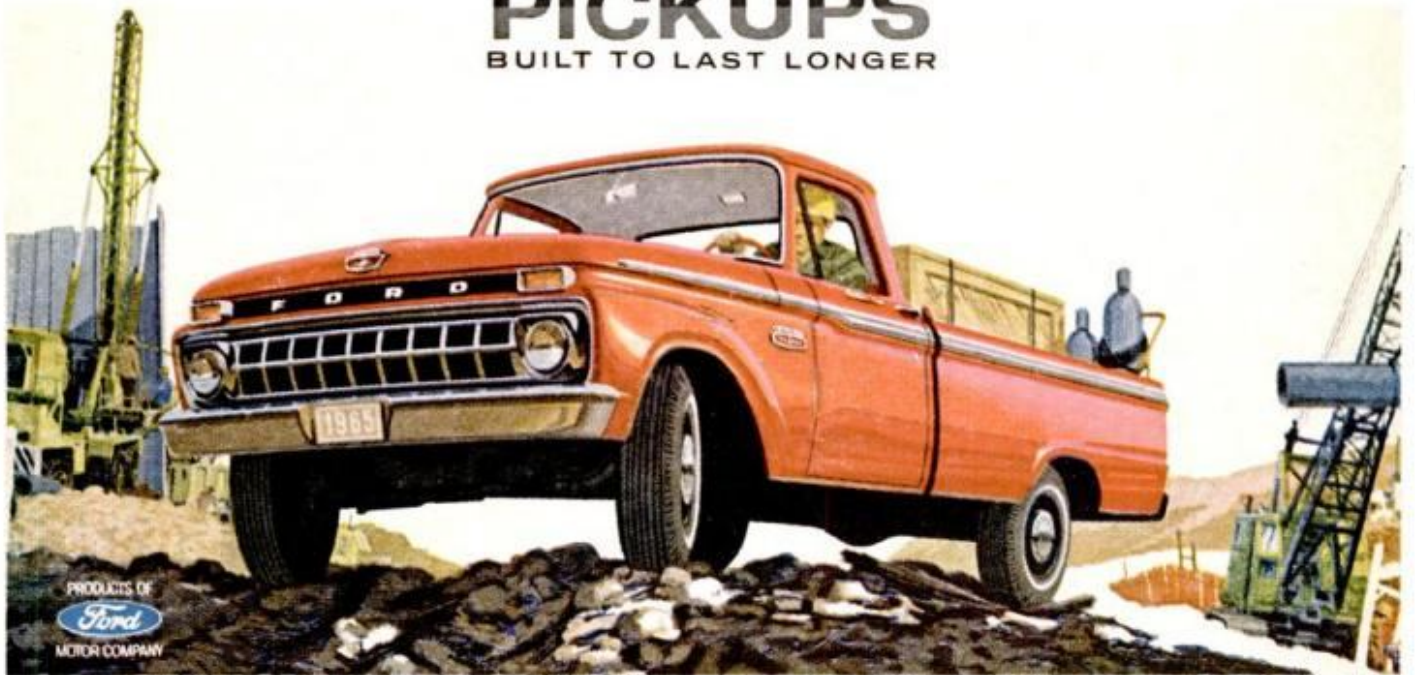

Two independent front axles share the shocks, smooth the road!

That's right, Ford's revolutionary new Twin-I-Beam suspension has two front axles to share the roughest abuse! And because of drop-forged I-beam construction—like the big trucks use—they'll really stand up! Moreover, both axles have I-beam radius

rods to hold wheel alignment, cut tire wear and reduce front-end maintenance! But you get more than toughness. Independent action smooths away road shocks . . . gives you a wonderful new feel of control. Try it soon at your Ford Dealer's!



3 all-new engines! New economical 240 cu. in. Six is standard. Or take your choice of two optional engines: 300 cu. in. Big Six or 352 cu. in. V-8, most powerful engines ever offered in Ford pickup trucks!



NEW! The world's safest



***SHOCKPROOF**—Constructed of non-conductive Cyclocac. Double insulated against electrical shock to conform with all Electrical Safety Codes.

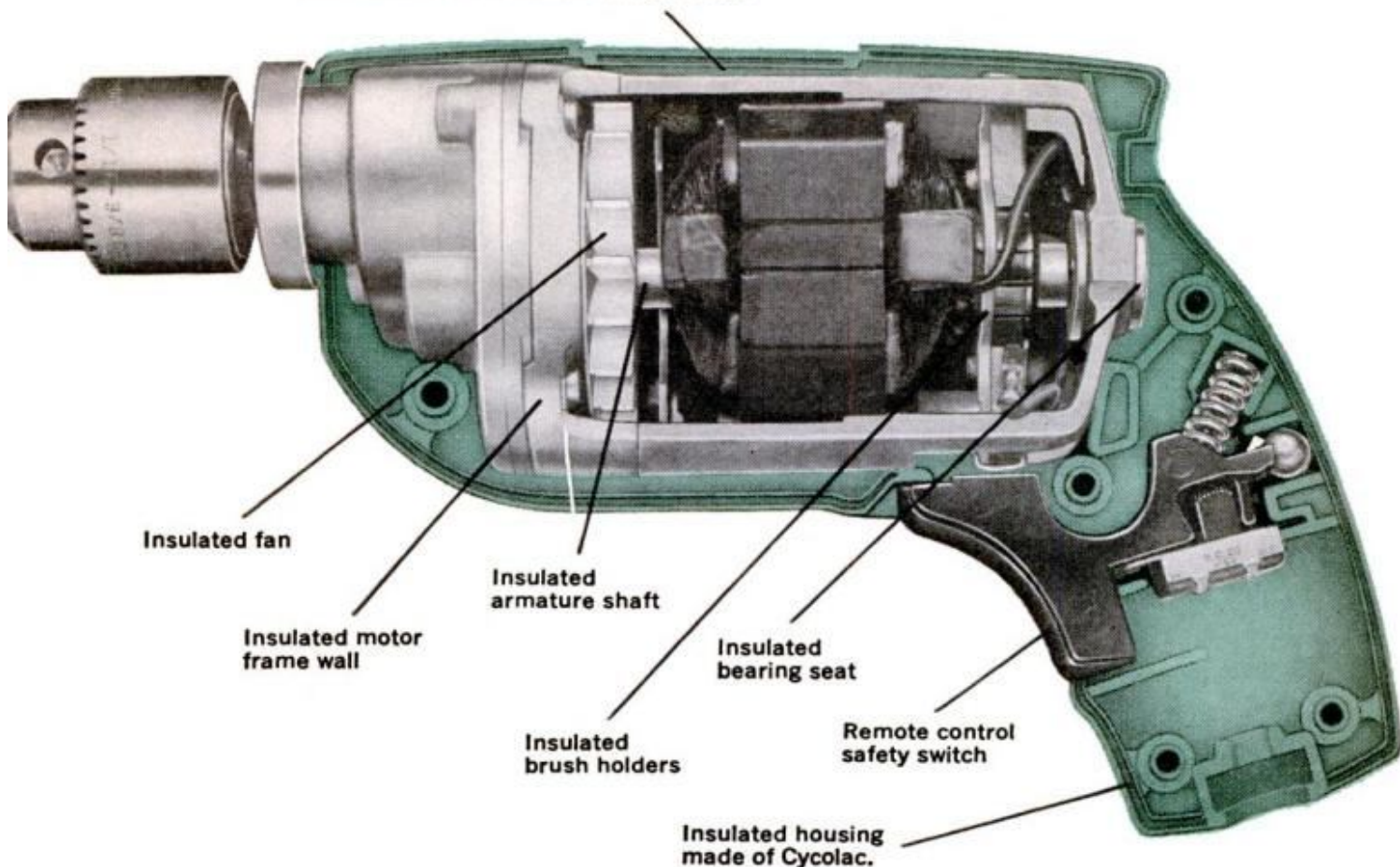

power tools by Rockwell Porter-Cable

You've never seen anything like these Porter-Cable tools! They give you qualities that, up to now, you couldn't buy in any tool at any price. These tools are:

Shockproof*—Total insulation assures complete user protection against electrical shock. No three wire plug or adapter needed. Use anywhere with confidence.

Breakproof—Housings of amazing new CYCOLAC® are so tough, they're unconditionally guaranteed against breakage—FREE replacement.

Failure Proof—All motors are protected with high temperature insulation, they last longer, won't burn out from overload.

These tools are industrially rated, have the power and convenience features of tools costing much more.

Available through December 31, 1964 at these introductory prices: 1/4" Drill—\$14.88,

Reg. T.M.—Marbon Chemical Div., Borg-Warner

3/8" Drill—\$19.88, Jig Saw—\$22.95, Finishing Sander—\$22.95. Drills and saw available in kit with accessories—about \$10 more.

Look for your Rockwell Porter-Cable dealer in the Yellow Pages or write—

POWER TOOL DIVISION
502M N. Lexington Ave.
Pittsburgh, Pa. 15208

Gentlemen:

Please send me

Complete literature

Name and address of my nearest dealer

Name _____

Address _____

City _____ State _____ Zip Code _____



Rockwell
MANUFACTURING COMPANY

Buy the Green Line for safety.



Never before has an advanced camera been so automatic. Loading, exposure settings for daylight or flash, and film advance are all auto-

matic. Built-in rangefinder. 1/250 shutter. Built-in, pop-up flash holder. **KODAK INSTAMATIC 800** Camera, with $f/2.8$ lens, less than \$130.

1964 KODAK Gift



Superb gift for family movies! Drop-in cassettes eliminate in-camera film threading, make loading easy. Battery drive winds film. Electric eye adjusts lens aperture automatically. **KODAK Electric 8 Automatic Camera**, with fast $f/1.6$ lens, less than \$80. **KODAK Electric 8 Zoom Camera**, with $f/1.6$ zoom lens, pistol grip, cassette, carry straps . . . less than \$160.

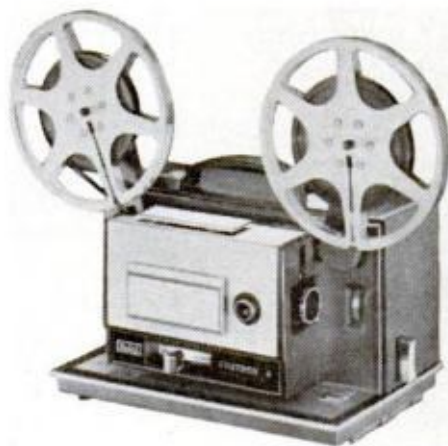

Shows movie "stills" as brilliantly as color slides. Dual air jets cool film, let you project stills brighter than ever to give you a fascinating new look at movie action. Slow motion and reverse action let you add interest, humor, pace. **KODAK CHEVRON 8 Projector, Model 10**, with $f/1.2$ lens, less than \$190. With $f/1.0$ lens or $f/1.2$ zoom lens, less than \$215.



Wonderful way to start someone out in photography. Camera loads instantly. No threading, no settings to make, no focusing needed. Has built-in, pop-up flash holder. **KODAK INSTAMATIC 100 Outfit**, with camera, film, flashbulbs, flashguard, wrist strap, and batteries, less than \$18.



Can't make a mistake. Electric eye automatically sets exposures outdoors. Dim-light signal in viewfinder warns you to switch to flash. Film advance is automatic, too. **KODAK INSTAMATIC 400 Outfit**, less than \$60. **KODAK INSTAMATIC 300 Outfit** has camera with same electric eye, manual film advance, less than \$50.



KODAK INSTAMATIC Camera convenience—RETINA Camera precision. Smart, new, continental styling, electric-eye exposure control and single-stroke, rapid film-advance lever. Multispeed shutter to 1/500. **KODAK INSTAMATIC 500 Camera**, with $f/2.8$ lens, less than \$95. Smart new **KODABLITZ Flashholder** (cordless) shown on camera, less than \$7.

Guide for Men



Sophisticated gift! Fast $f/2.8$ lens, shutter speeds from 1 second to 1/500, coupled rangefinder, pop-up flash holder, new transistorized flash circuit. A beautiful 35mm camera with smart continental design and finish, and broad picture-taking capacity. **KODAK RETINA IIF Camera** . . . less than \$125.



Give the pleasure of jam-free slide shows. Spillproof tray holds 80 slides. Projects slides automatically or by remote control. Finest projector Kodak has ever made—in a slimmer, lighter model. **KODAK CAROUSEL 800 Projector**, with 3-, 4-, or 5-inch lens, less than \$150. New zoom lens also available. Other **CAROUSEL Projectors** from less than \$90.

EASTMAN KODAK COMPANY
Rochester, N.Y.

Prices subject to change without notice.

Kodak
TRADEMARK

The important glue.

For important gluing jobs like:

repairing leather book bindings cleanly, fixing wood drawer joints quickly, velvet-lining jewelry boxes richly, making paper Christmas decorations neatly, assembling model airplanes soundly, mending wooden shoes strongly, mounting album pictures, building shadow box Indian villages about any project you can



United States
Plywood. Protection
Products Division.
Kalamazoo, Michigan.

This is *Maji-Buckle*™ Seat Belt

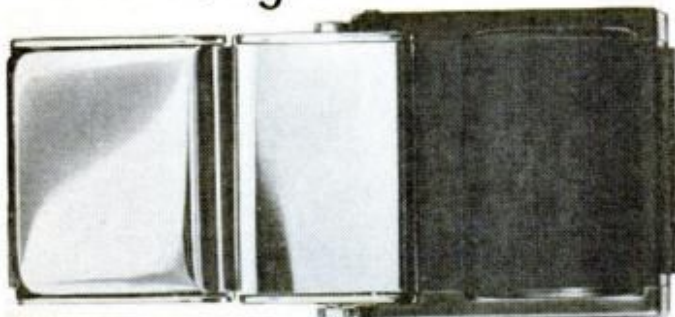

**You've sat on, then dragged
from under, then untangled,
then finally adjusted-to-fit... your
last seat belt.**

World's first auto seat belt that adjusts *automatically* to fit when used, that retracts into a tight neat roll when not used. Fits any car. Meets all S.A.E., G.S.A. specs. Specify black, gray, blue, red, green or fawn. Send \$14.95 each to Spring Division, Borg-Warner Corp. Dept. E, P.O. Box 419, Melrose Park, Illinois 60161.

Build a Family Sauna

(Continued from page 129)

the concrete with mastic can be used to hold the furring in place. Such nails are spaced about 2 ft. apart, in rows, and the furring is impaled on the protruding nail points by rapping the strips with a hammer and then clinching the nails.

Spaces between the 2 x 4 studs and the overhead floor joists are filled with 2-in. blanket-type fiberglass insulation which is stapled to the studs and joists in the conventional manner. After this you cover all four walls of the sauna, plus the ceiling, with two layers of aluminum foil to form a vapor barrier. Before the insulation and foil are applied, however, 2 x 4 nailers must be installed between the wall studs so you'll have something to nail the redwood or cedar boards to. If you plan to recess a light in the ceiling, which should be a weather-proof fixture, do it before you nail the redwood to the joists. After bringing in a connection for the sauna heater, you can line the walls with redwood, applying the boards vertically and nailing at the top and bottom and to the 2 x 4 nailers. Blind nailing the 6-in. tongue and groove redwood is preferred over surface nailing. Here the nails are driven at an angle through the tongue of each board (using a nailset to avoid banging up the tongue) so they are hidden by the succeeding board. The walls of the adjoining shower room can be lined with any kind of panel board, the ceiling can be furred for 12-in.-sq. tile. Outer wall covering can be the same as that used to panel the shower room. The shower stall is simply a commercial unit.

Low or High Benches

The redwood benches in the sauna can be single or double tier. In some saunas you'll find them left open underneath, but by boxing them in as shown, you can cut down on the cubic area to heat. Some saunas are fitted with wooden floors, others are covered with fiber matting. One or the other should be added to keep you from doing an Irish jig on the hot concrete. The door leading to the sauna is built up around a 2 x 4 frame, faced with redwood on the inside, filled with fiberglass insulation and covered on the outside with 1/4-in. plywood. A wooden turnbutton can be used to hold it shut; any metal lock would soon become too hot to handle.

The sauna detailed here was designed for the Scantek heating system but, of course, can be used with other heaters. Whatever heater you use, a picket guard fence should be erected around it to keep anyone from touching it. ★★★

POPULAR MECHANICS



What an experienced gift giver did with \$46 for Christmas

Put his \$46 down on a bright, new Holiday-red Harley-Davidson M-50.

Gave it to his best elf, wished him more fun than even elves are up to. Show us one elf, from here to the North Pole, who wouldn't gladly work off the balance (\$179).

If you have some exceptionally deserving "elves" in your home, you can buy the M-50 outright for only \$225 f.o.b. Milwaukee. Or, ask your Harley-Davidson dealer about a gift certificate. Low-cost insurance readily available, ask your Harley-Davidson dealer for details.

HARLEY-DAVIDSON

Madhouse Behind the Mailbox

(Continued from page 120)

Doctrine as an obvious first step toward a "get soft with Cuba" policy.

Americans constantly flood the Post Office Department with requests for all kinds of commemorative stamps to be printed. Recent suggestions have included requests for new stamps to be issued in praise of such items as Elvis Presley, dinosaurs, tobacco, hamburgers, the totem pole, a champion hog caller and the completion of the 3000th swimming pool in Palm Springs, Calif.

One woman asked that a Battle of Gettysburg commemorative stamp be based on portraits of Lincoln, Grant, Lee and her grandfather, an aide to Jeb Stuart.

Addresses Like Parlor Game Clues

One of the reasons the letter carrier must know his route so well is the "unusual" addressing often found on the envelope. The Post Office (taking it calmly) delivered a letter from a Texas woman addressed, "Downtown furniture store, run by two brothers who look alike, across the street from dime store, appliance store at one end of street, dry goods store at other, Gulfport, Miss."

And on and on . . . a Des Moines, Iowa, man became very upset about stamps he had ordered for mailing church notices. He refused to accept Devil's Tower National Monument Commemoratives.

"People waste a lot of time," wrote a California man, "in arranging stamps right side up." He suggested that stamps be designed "upside down proof" so that they can be affixed at random.

Among many kinds of stamp collectors in the United States is an inner-sanctum group called the Pre-Cancel Society, one of whose aims is to be first-on-the-scene when a new stamp is issued.

Of course, when a new stamp is issued, the Post Office holds a traditional "first day ceremony" in the appropriate city. Atchison, Kansas, birthplace of Amelia Earhart, for example, was the first-day-city for a commemorative stamp honoring the famous aviatrix. On the same day, the Kansas Pre-Cancel Society—recognizing an opportunity when it saw one—held its annual meeting in Atchison.

Once aloft on a commercial airliner, one might believe that the U.S. mails are protected from the unusual. Not so! A while back, 20,000 ladybugs on their way from the West Coast to New England (where they were to attack the aphid problem) managed to break loose from their crate and concentrate on passengers instead.

The department's "front-line soldier,"

the letter carrier, is not exempt from odd-ball happenings. In Mankato, Minn., a rural carrier looked over his shoulder and saw a crow pry open a box and fly off with a letter. It was recovered.

And in San Jose, Calif., someone tried out a new idea in credit services. The carrier found a note in the mailbox ordering postage stamps and accompanied by a credit card. It didn't work.

When it comes to danger, however, the ordinary dog creates the greatest threat to the letter carrier's life and limb.

Funny, yet ironic, was the cartoon recently carried in a national magazine. It showed executives of a dog food company in conference over a new product they felt would dominate the market. It was a biscuit in the shape of a letter carrier.

The dog, as every postman knows, is *not* man's best friend. Mailmen, of course, have been attacked by everything from goats to roosters. In Philadelphia, one homeowner posted a sign reading "Bad Cat." But it's still Fido who has the reputation.

When the National Association of Letter Carriers meets in convention, casual conversation usually drifts to a familiar topic—dog bites. America's beloved dogs chew on 7000 postmen a year and cost the government about \$1,000,000.

Turnabout for a Hairless

One postman, fed up with being attacked, reportedly took the classic reprisal against the breed by biting back. According to a Washington correspondent for a Newark, N.J., newspaper, letter carrier John Doherty bit a Mexican hairless in suburban Silver Spring, Md., after it had repeatedly nipped at his heels.

The Post Office Department, equally fed up with the high cost of medical and legal treatment following 7000 dog bites, is striking back with an anti-dog weapon, an aerosol bomb containing an extract of cayenne pepper which besieged letter carrier can squirt in the faces of their foes. The sprayed dog slinks away with only his ego damaged.

Then there was the man who had a stamp cancelled on his forehead. Actually, as a Pre-Cancel Society member, he had just purchased an Earhart stamp at the post office. After being told that postal regulations require that stamps be affixed before they can be cancelled, he pasted the Earhart stamp on his brow, thrust his head inside the cage and said, "Cancel!" The clerk complied with a handstamp.

Standing in line behind him, waiting to buy stamps, was a young woman. "Is this unusual?" she asked the postal worker. Told that it was, she said, "I think I'll have one too!" ★★★

360 HP TURBINE FOR VOLKSWAGEN

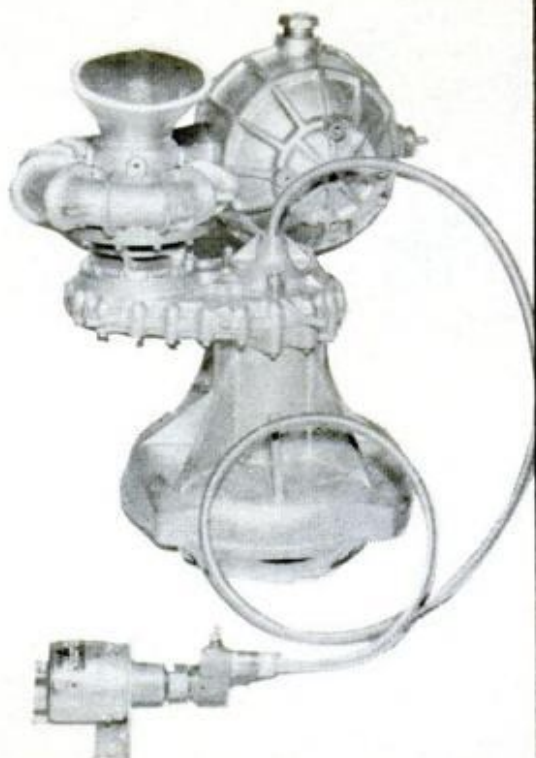

**BOLT IN REPLACEMENT
138 MPH TOP SPEED
1 YEAR GUARANTEE
PROMPT DELIVERY**



124 M.P.H. 10.2 SEC. E.T.

TURBONIQUE, INC., P. O. BOX 8641, ORLANDO, FLA.

\$1.00 Encl. For new 28 page catalog, prices. \$2.00. Send 33 1/3 rpm recording of operating noises. \$5.00. Send technical manual. \$5.00. Send 8 mm. x 50 ft. color demonstration film, or \$10.00. Send everything. All money refunded first order.

Name _____

Address _____

City _____ State _____

Therapy From the Sea

(Continued from page 112)

thurin is a nerve blocking agent and an anticoagulant. As a bonus, it's a possible shark repellent.

The Aquarium's laboratory was the scene of another significant discovery: ectyonin, a broad-spectrum antibiotic found in the red-beard sponge by Dr. Sophie Jakowska.

"Water around sponge beds usually stays fresh and clear even though sponges die," says Dr. Jakowska, research associate at the Aquarium. "We suspected that the sponges kept the colonies pure by secreting chemicals that prevented decay germs from growing. Such chemicals might make useful antibiotics, so we decided to investigate."

Power of the Red Beard

Dr. Jakowska tested extracts from various species of sponge on germ colonies growing in gelatin. Several sponges—the heavenly sponge, fire sponge and bleeding sponge, for example—were deadly to a few kinds of disease bacteria. But the red-beard sponge wiped out many, including those responsible for penicillin-resistant staphylococcus infections, tuberculosis, trench-mouth and some bladder disorders. The drug finally extracted from the red-beard sponge—ectyonin—is still being looked into for its action against other microbes and for possible side effects on persons using it.

Deep Secrets of Trade

How long before marine drugs reach your medicine cabinet? Only the country's pharmaceutical companies have the money and manpower to give a prospective drug the years of screening demanded by the U.S. Food and Drug Administration before tests are conducted on human beings. And these companies are as talkative as clams. In the highly competitive pharmaceutical trade, details of any progress with new drugs are guarded like a formula for turning lead to gold. There are rumors that some marine drugs are now being tested—or ready to be—in hospitals. But exactly which ones, if any, have reached the finish line isn't public information.

No one in the field doubts that when marine drugs start flowing from the oceans, a new era in therapy for human ills will begin. "The sea is a gigantic pharmacy," says one biomarine scientist. "All you have to do is go to the right shelf for treatment of a particular illness. The research going on now is showing us what shelf to go to." ★★★

NEW DYNAMIC MARK 88 INDUSTRIAL TRANSFORMER ARC WELDER

ANYONE CAN WELD, BRAZE, CUT, SOLDER, HEAT ON STEEL, BRASS, ALUMINUM, AND OTHER METALS.

Build and repair anything of metal. Tremendous time and money saver. **THIS IS ALL BRAND NEW, PROFESSIONAL ARC WELDER!** Rugged metal cabinet, baked Hammer-oid finish, ideal for home, shop, farm and industrial use. Expert work on your **FIRST** job. **POWERFUL** glass insulated transformer welds 1/2" metals with 3/8" rods. 4 heat settings, 20 to 80 amps. Operates on 110 Volt AC house line fused for 30 amps. Complete, ready-to-use—full head shield, electrode holder, ground clamp, cables, solder, assorted rods and simplified welding manual. Double-protection guarantee: 10-day money-back trial plus full 5-year warranty on materials and workmanship. **Order today: ONLY \$47.50 (220V at \$49.50).**



SEND ONLY \$600

Only \$47.50 Complete. Send only \$6.00. Pay balance plus C.O.D. charges on delivery.

EASY PAY PLAN

Write for easy pay plan. **LOW** down payment — pay as you weld and earn.

DYNAMIC WELDER CO. DEPT. D2-N
1808 S. FEDERAL ST., CHICAGO, 60616

NEW "SPEEDLOK"® SANDING DISC



Locks on in seconds. No bolts or nuts in center of disc. Rugged industrial quality outlasts ordinary paper discs 20 to 1. Works on wood, metal, plastic, marble. Great for removing old paint. Speedlok Kit fits 1/4" drill. (includes pad and 2 each coarse, medium and fine discs). Satisfaction guaranteed. Send \$3.95, check or money order to Speedlok®, P. O. Box 425, Northridge, Calif.

U. S. PATENT 3,149,442

Christmas problem-solver for indoorsmen and outdoorsmen

Whether you give it or get it, this high-quality ten-power telescope satisfies all sorts of Christmas needs. Ideal for use in country or city, Balscope Ten focuses by a turn of the eyepiece, weighs no more than the average flashlight, fits into a glove compartment. Use it for trips, sports events, nature study. There's a handy belt holster for only 98¢ extra. Made to American standards of quality by America's most respected optical craftsmen, here's an ideal gift for anyone you know... including yourself! At sports, optical and photo stores. Bausch & Lomb Incorporated, Rochester, New York 14602.



HIGH-PERFORMANCE \$9.95 10-POWER TELESCOPE

BAUSCH & LOMB



DECEMBER 1964

1 will get you 7

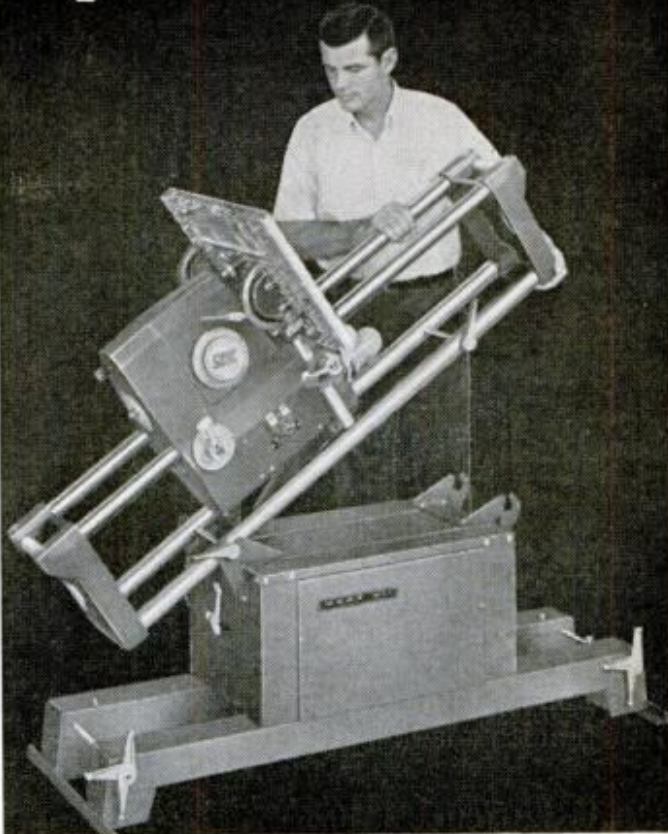

Put your money on MARK VII and get 7 power tools in 1 compact unit.

Put "zing" into your life with a SHOPSMITH. There's a lot of pardonable pride built into furniture and home improvements you make. Save money and enjoy an exciting hobby, too!

SHOPSMITH gives you "the most": a 10" table saw, exclusive horizontal boring machine, 16 1/2" drill press, 34" lathe, 10" disc sander, professional shaper and built-in vacuum to clean up while you work.

Original Variable Speed Drive lets you dial correct speed for any job instantly. Write for catalog and names of dealers.

Send coupon for your lucky sweepstakes number. Check winners' list at your dealer's to see what you've won!



Dept. K-12, Interstate 75, Cincinnati, Ohio 45215
Rush my lucky Magna Sweepstakes number:

NAME _____ (Please print clearly)

ADDRESS _____

CITY _____ STATE _____ ZIP _____

Offer void where prohibited by law.

Speed Carnival at Bonneville

(Continued from page 73)

hit the dip, the nose wheel went 68 feet through the air, but the car was still on the ground and I was really moving. Only now I was heading for the second row of telephone poles.

"I threw the fin as hard as I could to the right, and the car started veering gradually. If I had had steering, maybe I could have spun it. But maybe it was better this way. I might have flipped it instead. Then I was headed exactly for this pole. It was a dead hit—impossible to miss. I closed my eyes and stuck my head down just before I hit, waiting for that real sick feeling you get when you get swatted hard. And I heard a little thump and opened my eyes and there was no pole. I was still there and the car was still going. The left rear axle fairing had splattered the pole in a million pieces but it hardly did anything to the car. I haven't figured it out. I don't know whether God moved the pole or what happened.

"Then I hit water about four inches deep and this slowed me down a great deal. I saw the embankment coming, and I thought 'This is going to flip me for sure.' I was doing about 200 when I hit it, and the car glanced off and sailed through the air about 50 feet. When I was up in the air, I saw that I was going into the water. So I threw the canopy off while still in midair, and the car hit the deep water at about 160 m.p.h.

"When the water started pouring in, I pulled my harness and started out. But I was stuck. I finally realized my air mask was still plugged in and I ripped it from my face just as it pulled me under to eye level. I thought 'Oh my God, I got through all that and now I'm going to drown.'"

Breedlove swam ashore and waited. "When I saw them coming," he said, "I waved to show I was all right. You know, our crew of eight had donated a lot of time gratis—a bunch of guys who believed in something. We all went to school together, and the last election was the first time we'd voted. President Kennedy was kind of our hero. You know, he said, 'Ask not what your country can do for you, but what you can do for your country.' This was what we felt we could do—bring the land speed record title back to the United States. That's why we call this car we built the *Spirit of America*. It sounds corny, but that was the spirit in which we did it. And when that car went down and I turned and saw just the fin and the American flag sticking out—that was really it—beautiful. Then I had to let them know I was okay."

The cars at the Bonneville free-for-all

this year—like the drivers—were terrific performers despite their troubles. Two machines in particular—Breedlove's *Spirit* and Arfon's *Monster*—were outstanding. While both are capable of bettering 550 m.p.h., they are designed along diametrically opposed principles. *Spirit* is slim and elegant, like a jet fighter without wings. She's designed to slip through the air as smoothly as an eel through oil, and develops maximum speed for every pound of thrust. She is relatively low-powered, with a 5700-horsepower J-47 jet engine.

Monster, on the other hand, has the graceful lines of a sawed-off stove pipe and gets her speed by brute force: 17,500 jet-powered horses are harnessed under her skin. She'll win no beauty contests ("I didn't make her to look pretty," said Art) but she took off like a startled gazelle when Art stomped on the throttle.

Rumor got around this summer that Breedlove had recently upped the power of his J-47 by adding afterburner or water injection. Neither was used, although water injection was available on standby. Breedlove says the car has always had the ability to exceed 500 miles an hour. He just hasn't used it before. "This business is a little bit like Russian Roulette," he told me, "except each time you put more bullets in the gun." He didn't go faster than 407 last year "because I didn't see anybody that was going to come close to it, and it's very dangerous."

Three changes were made in Breedlove's car before this year's run. First, the steering linkage was strengthened (it still may not have been strong enough, since linkage failure probably caused the loss of steering in the last run). Second, the nose fin was made smaller. And third, streamlining of the rear axle housing fillets were improved. Breedlove also had a new engine this year, identical to the one it replaced. It had, however, been tuned to operate at high exhaust gas temperatures and r.p.m. which means it will furnish up to 500 lbs. more thrust than the static sea level rating of 5200 lbs. for the old engine.

Art Arfon's car was the most powerful racing vehicle ever built. Art managed to get a J-79 jet—the only one released by the military as surplus so far—which delivers 10,000 pounds of thrust straight, 17,500 with afterburner. "The J-79 drives an F-104 faster than 1600 miles an hour," Art told me in Akron last July. "It will push nine tons straight up and hit the speed of sound. I could put it in my bus," he said, referring to the rebuilt city bus used to haul his racing cars around, "and break the sound barrier."

But power is only one ingredient in building a race car. Control is the other.

Breedlove's car is designed like an arrow. The high tail and rear axle fairings act like feathers and hold it straight at high speeds.

Arfons, however, figured his greatest problem would be the tendency of the front end to leave the ground. His solution was a small, horizontally pivoted wing mounted over the nose (see photos). Also, for better directional control, Art linked a small rear rudder to the steering. Early trials showed that it wasn't needed, so it was disconnected and bolted in place.

After his 500-mile-an-hour blowout, I asked Art how much speed he thought was built into his car. "I believe," he said, "it would still handle at 600. If the course was smooth, I wouldn't mind trying it." His run on the 27th proved the point.

Says Breedlove of the *Spirit*: "I think we had the potential to go into the high 500s and possibly 600 miles an hour. We didn't really find out on that last run (officially clocked at 539) because I stepped down on the throttle too fast and got a compressor stall. Then I took my foot off the throttle once during the mile when the car started to drift off course." *Spirit's* top speed, unfortunately, will never be known. The car, says Craig, has had its last run. He plans to repair it and keep it for its historic value as the first car to break 400, then 500.

Mach 1 Racer

Breedlove still discusses his record run with considerable humility. I noted that he'd disappeared Wednesday night after the run, and asked where he went. "I wanted to be by myself," he said. "I drove down to Nevada and stopped and looked at the stars and things, you know. I was thinking I was the luckiest guy in the world to still be alive, and I kept trying to figure out how that pole got out of the way . . ."

Meanwhile, the *Spirit's* pilot is already planning his next racer. "We learned a lot from this one," he says, "and our next car will be practically unbeatable." How fast will that be? Breedlove, reportedly, is working on a car to break Mach 1—the speed of sound.

Art, on the other hand, says he is satisfied with *Monster*. She'll go, he says, faster than he'll ever push her. (The J-79, he says, would drive a properly designed car 1000 mph. *Monster*, however, isn't designed to break the sound barrier.) This winter, he plans to hook one of his 1700-hp Allison aircraft engines to a tire-testing machine so Firestone can build and test 700-mph tires for his next run.

Next year should be quite a season.

★★★



EVINRUDE'S NEW SKEETER IS HERE ...and winter is fun again!

Meet Evinrude's newest fun-making machine, the SKEETER. It transforms idle winter days into hours of fun-filled activity with family and friends.

■ The versatile SKEETER cruises over snow or ice, tows skiers and tobogganers.

You'll use it for hunting, ice-fishing, photo trips and family "snow safaris." ■ Its smooth, 14 hp engine takes hills in stride — gives speeds of over 30 mph. Every fourth cleat on the drive track is an ice cleat for extra traction on slippery surfaces. ■ See and try the new SKEETER — the advance-design snow vehicle with Evinrude quality through and through.

Commercial uses? Yes! Ranching and farming, lumbering, surveying, trapping, conservation work, rental fleets at ski hills, resorts, clubs.



SEND COUPON!

**EVINRUDE
SKEETER**

EVINRUDE MOTORS,
Non-Marine Products Division
6169 N. 64th St., Milwaukee, Wis. 53218
Please send me FREE COLOR BROCHURE
and name of nearest SKEETER dealer.

Name.....

Address.....

City.....State.....Zip Code.....

EVINRUDE MOTORS • Milwaukee, Wis. Division of Outboard Marine Corp.

Heat Treating in the Home Shop

(Continued from page 175)

fit. Then weld on the flat steel cross-brace and weld the bottom flange of the throat frame to it. Next, add the two tall door-slide angles and weld a filler strip between them, across the top flange of the throat frame. Add the steel shelf, notch-welding it to the door-slide angles, then set the shorter slide angles on top this shelf and tack-weld them to the taller angles. Before slipping the door in place, coat all oven parts with a high-heat aluminum paint.

The insulation brick can be bought from an industrial supply house (at around 50¢ per brick for the 2600° grade)—or from a fire-brick dealer. You should be able to build the oven for \$10, not counting the cost of the burner, pyrometer and thermocouple. And the burner is installed so you can remove it easily for paint burning, singeing, welding pre-heat, or other jobs.

The pyrometer is a must for exacting work, but you can get adequate results by learning to recognize the colors of heated steel. The glowing colors of "red hot" steel are given with their corresponding temperatures in the smaller chart on page 173. The tempering colors are given in the second chart; unlike the first list, these colors don't give off light, but are caused by oxides forming on the polished surface, starting with pale yellow at about 400° F. As the temperature rises, the colors change, passing through straw, bronze, purple and various shades of blue. By using these charts you can do as the blacksmith does: When the pre-hardened work turns the tempering color desired, quench it immediately.

Tempering in a Kitchen Range

Better results can be had, however, by heating the hardened steel to the tempering temperature listed in the second chart and holding it there for one hour per inch of thickness (minimum time, one hour). The kitchen range, gas or electric, is ideal for this, as it provides thermostatically-controlled temperatures up to about 600° F. Many professional job shop operators buy an electric range on the second-hand market and use it for all their tempering needs. If you do this, make sure the oven thermostat is in working order.

Before you attempt any hardening and tempering, you should know what happens to the steel during such processes. As steel is heated, a change occurs in its internal structure. At a point called "the critical temperature," the change is completed and the properties of the steel become different from what they were in the cold state. The critical temperature varies with differ-

ent compositions of steel, but it is always in the glowing state and the steel becomes soft, ductile and non-magnetic. You can tell when the critical temperature has been passed by holding a compass near the hot steel; the needle should not deflect. Quenching temperature is only slightly higher than the critical, so you can determine this with a fair degree of accuracy by touching a bar magnet briefly to the glowing steel. When it no longer sticks, the work is ready to be quenched.

In the slow cooling of steel, the carbon separates out as carbides, and the cooled product is soft and easily filed or machined. This process is called "annealing." When cooling is rapid, as in quenching, the carbon does not have time to separate and the internal structure of the steel changes into a product supersaturated with carbon. This makes the steel very hard and brittle. In the tempering process, some of the temper is drawn by re-heating the steel to a degree lower than its critical temperature, further changing the internal structure by precipitating some of the carbon in the form of carbide. Steel gains in ductility and loses hardness with increase of tempering temperature. It is necessary, therefore, to choose a tempering temperature at which hardness and ductility are balanced to best serve the purpose for which the steel is to be tempered (see third column in Tempering Colors chart).

Why Pre-Heat Steel?

To avoid stresses and thermal shock, the work must be heated slowly and evenly. It should be put into the cold pre-heating oven and the temperature brought up to 1200° F. in not less than a half hour. In forge work, steel is pre-heated at the edge of the flame area, then moved over for final heating. If using a high temperature heat treating furnace or a blast furnace, the work is transferred when it reaches a dull red glow (1200° F.), then brought up to the final temperature for forging or hardening, which can be determined from the glowing color of the metal.

Forging is, of course, the act of hammering hot steel to shape on an anvil or block of steel. Proper hammering improves the steel by compressing its structure. The chart on page 171 indicates that alloy steels require a higher forging temperature than carbon steel. Forging temperatures are given as maximum and minimum. Forging at temperatures lower than the minimum risks cracking or damaging the internal structure of the steel.

Tool steels must be cooled slowly after forging to prevent air-hardening. Bury the work in dry ashes or mica and leave it

(Please turn to page 194)

The ORIGINAL one-fill plastic WOOD FILLER

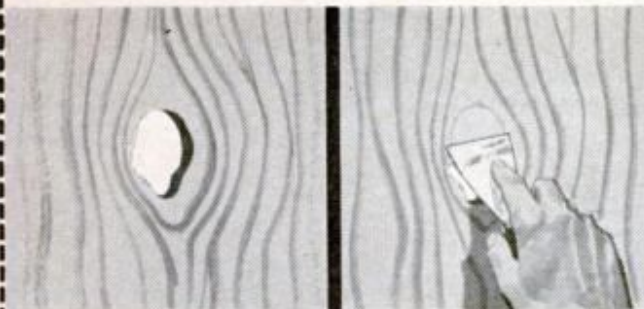

DURATITE® plastic • waterproof WOOD DOUGH

Molds like dough—hardens into wood you can sand, saw, drill, nail, stain, paint, varnish. Gives fast "one-time" fills in deeper holes. Hides defects in wood, furniture, paneling. 9 colors. Sold at hardware, paint, building supply stores.

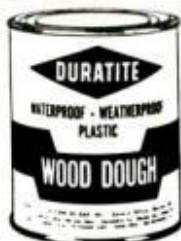

DAP INC., DEPT. MD, DAYTON 31, OHIO
SUBSIDIARY OF *Plough, Inc.*

ALL FAMOUS BRANDS! **FARM TRUCK AUTO** **AT LESS THAN WHOLESALE**

TIRES! SAVINGS NEVER LESS THAN 50% up to 70% OFF REG. PRICE!

HEADQUARTERS for ALL SPORT CAR TIRE SIZES
FREE - SEND FOR YOUR FREE CATALOG - FREE!

RELIABLE TIRE DIST., 1111 Chestnut St., Camden, N. J.

IDEAL CHRISTMAS GIFT FOR ANY MAN

BEST LOW COST ELECTRIC WELDER MONEY CAN BUY ONLY \$14.95



SEND ONLY \$2.00

You Get: **FULL FACE SHIELD**, heavy metal cabinet, ground clamp, 12 ft. of heavy duty welding cables, twin carbon arc torch, rod holder, carbons, welding and brazing rods, flux, solder, instructions.

SEND ONLY \$2.00. Pay \$12.95 plus C.O.D. charges on delivery or send only \$14.95 and we will ship prepaid. Order today.

FOUR-WAY WELDER CO.

DEPT. W2-N, 1810 S. FEDERAL ST., CHICAGO, 60616

**5-YEAR GUARANTEE
10-DAY MONEY BACK TRIAL. WELDS, BRAZES, SOLDERS, CUTS ANYTHING OF METAL**

No comparison for performance and value. No experience needed to make or repair auto bodies, fenders, trailers, boats, furniture, farm equipment, garden tools, anything of metal. Use up to 1/8-in. welding rods and 1/4-in. carbons on up to 1/4-in. metal. Operates on any 110 V. line. **WORLD'S GREATEST WELDING VALUE.** Over 500,000 in use by home owners, farmers, hobbyists, mechanics. **5-Year unconditional guarantee.** Order on 10-day moneyback trial, if not satisfied return for refund.

WARNING LIGHTS ARE NOT ENOUGH!

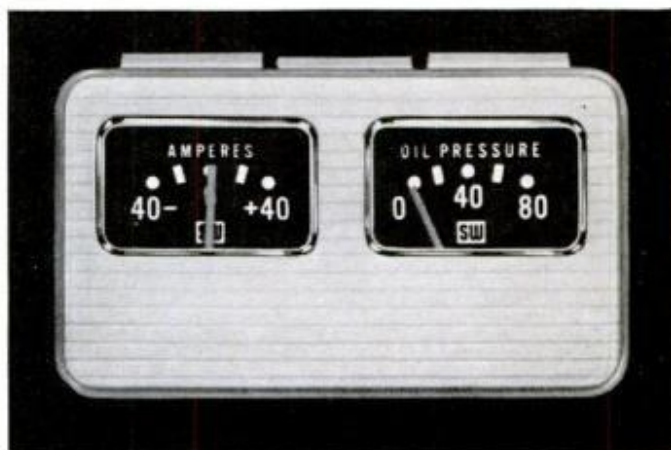

Give a "2-in-1" gauge panel that helps stop engine trouble at the start!

The Stewart-Warner "2-in-1" Gauge Cluster — the perfect Christmas gift for someone who really cares about cars. Points out the first sign of engine system trouble, so immediate action can prevent more serious problems. No guesswork . . . no sudden "warning light confusion."

Handsome compact unit features an ammeter and an oil pressure gauge. Fits all cars. Mounts independently in a variety of positions. Ask your dealer to show you the Stewart-Warner "2-in-1". . . Santa's choice — from the most complete line of automotive instruments in America.

STEWART-WARNER 
INSTRUMENT DIVISION

Dept. C-124, 1840 Diversey Parkway, Chicago, Ill. 60614

Save Over \$400!

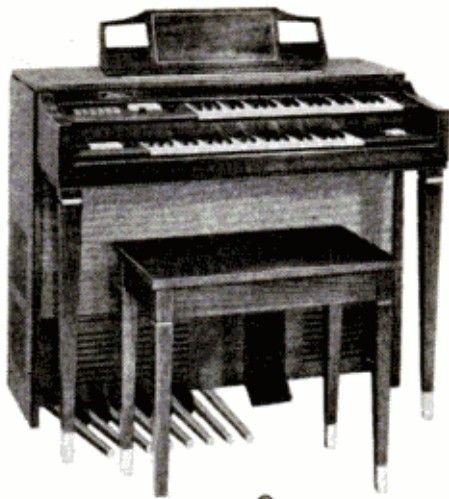

New Heathkit®/Thomas "Coronado" All-Transistor Organ

• 17 beautiful organ voices • Two full-size 44 note keyboards • Built-in 2-speed Leslie plus 2-unit Main speaker systems • 28 notes of melodious chimes for hundreds of chime variations • 13-note heel & toe pedalboard, range C thru C • Reverb for concert hall realism • New stereo chorus for exciting "stereo" effects • Sustain on keyboards & pedals for variety of special effects • Color-tone Attack & Repeat Percussion for additional voice effects • Treble accent for brilliance • Manual balance • Pedal volume • Expression pedal • Headset outlet to play without disturbing others • 75 watt peak power amplifier • Vibrato for warmth & beauty • 5-year warranty on tone generator boards . . . the heart of the organ • Luxurious full-bodied walnut finished cabinet, hand-crafted & completely assembled • Includes matching bench • Only \$125 dn., as low as \$27 mo.

This new beauty has every feature imaginable for complete playing versatility. It's truly a "professional" organist's dream with a "beginner's" simplicity. And famous Heath "Engi-nuity" has reduced it to a simple-to-assemble kit for unmatched savings . . . over \$400! Tear out & mail coupon for full details.

Kit GD-983, organ & matching bench, 290 lbs. . \$849.00

Hear It Yourself!

Send 50c with coupon & receive a 7", 33-1/3 rpm demonstration record. You'll convince yourself!

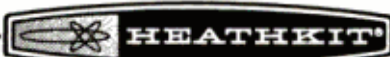

HEATH COMPANY, 17-12-1

Benton Harbor, Michigan 49023

- Enclosed is \$849.00. Please send Kit GD-983 Organ.
- Enclosed is 50c. Please send Demo Record No. GDA-983-2.
- Please send Free 1965 Heathkit Catalog.

Name _____
(Please Print)

Address _____

City _____ State _____ Zip _____

Prices & specifications subject to change without notice. CL-191R

Heat Treating in the Home Shop

(Continued from page 192)

there until it reaches room temperature. Steel is often "normalized" after forging—heated to normalizing temperature and air-cooled. It is then annealed to relieve the stresses caused by air cooling—that is, brought slowly up to annealing temperature and cooled in ashes, or in the furnace with the gas shut off and the cover on.

If the work requires grinding after forging, this is done immediately after annealing. Machining is also taken care of at this stage. Heavy machining can cause stresses that should be relieved by heating the work slowly in a tempering oven set at 900–1100°; then turn off the gas, shut the damper, plug the flues and let oven and work cool slowly together.

Hardening vs. Tempering

The work is now ready for hardening and tempering, the history of which goes back to ancient times when the process was known only to a chosen few and performed virtually as a magic rite. Today, the biggest mystery to most of us is: Exactly what is the *difference* between hardening and tempering?

Steel is first hardened by heating it to the proper temperature (as listed on page 171, then rapidly cooled by plunging it into a bath of oil, water or brine maintained at a temperature between 60° and 100° F. This makes the steel hard and brittle—full of "temper" which must be "drawn" to make the steel less hard, but tougher. This is done by re-heating the work to another specified temperature and holding it there for at least an hour, then quenching it again.

The process of heating the steel for hardening is the same as already detailed for forging, except that the quenching temperature is considerably lower. The quenching medium may be water, brine, or oil (cottonseed oil, SAE 20 motor oil, or one of the high-flashpoint oils manufactured particularly for quenching). If a given steel can be quenched in either oil or water, oil is preferred as it is less drastic in action, minimizing the risk of cracking the work through too-rapid cooling. For somewhat the same reason, a 10 per cent brine solution is preferred to water. The dissolved salt (12 oz. to 1 lb. and promotes more rapid cooling for a harder case on the quenched steel. Stir the quenching medium vigorously before plunging in the hot metal, and keep it agitated while the work is immersed.

Remove the work immediately from the quenching medium—before it has cooled

to room temperature, which means as soon as it stops quivering (about 200° F.). Place it at once in the tempering oven (kitchen range) which has been preheated to the proper tempering temperature. (Second chart, page 173.) Quenched steel allowed to reach room temperature may crack.

The hardening-tempering procedure can be summarized as follows: Heat the work slowly and evenly in an oven to 1200° F., then transfer to the hardening fire; quench, then transfer the work to the tempering oven immediately and let it soak for a minimum of 1 hour at the proper drawing temperature; quench again, in the same medium used for hardening.

Hardening Low Carbon Steel

As stated earlier, low carbon steels must be put through a process of "case hardening" in which carbon is introduced into the skin of the metal through a carburizing process. This gives the steel a hard, abrasion-resistant case with a tough, ductile core. A case hardening compound (such as Kasenit) can be sprinkled on steel brought to a temperature of 1650° F., or the hot steel can be dipped or rolled in the stuff. Either way, the work is then returned to the furnace for several minutes to give the compound a chance to penetrate. A deeper case can be had by dipping the work a second time while still hot and returning it to the furnace for several minutes. It is then quenched in water. No further treatment of low carbon steel is required.

Cast or tool steel can also be case hardened to bring out its limit of hardness and to prevent cracking. Heat the work to a light yellow (about 2000° F.) and dip in the compound. Leave it there until it cools to the correct quenching temperature, then plunge into cold water. Follow by tempering at the correct heat for the job the piece must do, as listed in the chart. ★★

Fish Eyes for Research

Deep-sea fishermen are helping medical science in research on the human eye by preserving the eyes of fish they catch and sending them to the Retina Foundation in Boston. Scientists there hope to discover, among other things, why the cornea of a shark's eye shows little or no swelling following injury.

While they prefer the eyes of the shark, other fish orbs are valuable, too. These include tuna, swordfish, marlin, the larger cod and some striped bass. The eyes must be at least an inch in diameter. Tuna eyes, incidentally, are larger than whale eyes.

The foundation has available leak-proof cardboard containers, with special instructions for packing and handling.

Regardless Of What You Pay For Other Color TV...

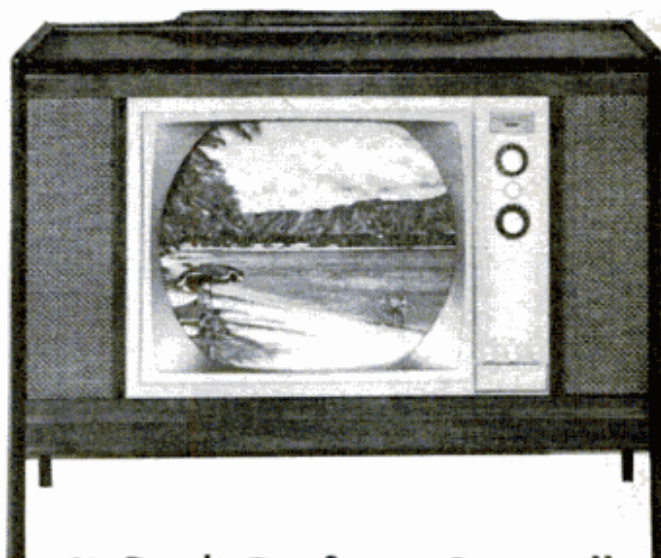

It Can't Perform As Well As This Heathkit® Does For As Little As \$399!

Why? Exclusive Heathkit Features!

For example, *all* color sets require periodic adjustments to maintain peak picture performance. The Heathkit All-Channel, High Fidelity 21" Color TV is the *only* set with "built-in servicing facilities" for perfect picture adjustments. Heath's simple-to-follow instructions & detailed color photos show you exactly what to look for and how to achieve it . . . quickly, easily! Results? Beautiful true-to-life color pictures day in and day out . . . and *no* costly color TV service calls. It's easy to build, too . . . takes around 25 hours, and no special skills or knowledge needed!

But Don't Take Our Word For It!

See the recent articles on the Heathkit GR-53A in *Popular Electronics, Radio-TV Experimenter, Popular Mechanics, Science & Mechanics, Radio-Electronics, and Popular Science*. And here's what just one Heathkit color TV owner, Mr. J. I. Newton, Chapel Hill, North Carolina says: "My friends tell me the color is better than they have seen on sets costing \$895, and I must say I agree."

Only Color TV You Can Install 3 Ways!

1. In Heathkit Deluxe Walnut Cabinet (illustr. above), Model GRA-53-7, 85 lbs. \$115.00
2. In Heathkit walnut-finished hardboard cabinet, Model GRA-53-6, 52 lbs. \$49.00
3. In a wall, bookshelf, or custom cabinet!

Tear out the coupon & order your Heathkit TV now!

Kit GR-53A, chassis, tubes, mask, VHF & UHF tuners, mounting kit, speaker, 127 lbs. \$399.00



HEATH COMPANY, Dept. 17-12-2

Benton Harbor, Michigan 49023

In Canada: Daystrom, Ltd., Cooksville, Ontario

Enclosed is \$ _____, plus shipping.

Please send Model(s) _____.

Please send FREE 1965 Heathkit Catalog.

Name _____
(Please Print)

Address _____

City _____ State _____ Zip _____

Prices & specifications subject to change without notice. CL-194

Retile Over Old Floors

(Continued from page 139)

the joints once the tile is laid. If you use a trowel (photo A, page 139), make sure you get the notch size recommended on the can of adhesive for your size tile.

When the adhesive dries, you can begin laying the tile, starting on the chalk line (photo B). Do not step on the adhesive, even when it is dry. By the way, you'll know the clear adhesive is dry when it loses its color. Black adhesive won't stick to your fingers when it's ready to take the tile. If any adhesive comes up between the tile, remove it while still fresh with fine steel wool.

Here's an easy way to fit border tile (photo C). Put a loose tile over a tile in the installed row. Take another loose tile and lay it on the first loose tile, butting it against the wall. Use its outer edge as a guide to mark the first loose tile, then, cut along the mark.

Vinyl asbestos tile can be cut straight across by scoring with a plasterboard knife and snapping it, or by heating it over the stove and cutting with a scissor. If you have to make irregular cuts, the tile is heated and cut with scissors. On warm days, however, the heating opera-

tion might not be necessary since the tile could be soft enough for cutting.

Vinyl tile doesn't have to be heated. Just cut it with scissors.

There's one other hint that might come in handy. It concerns the movement of heavy appliances, such as refrigerators. If you put a square of carpeting, nap down, beneath each corner of the appliance, you can slide it easily in any direction, even over the edge of newly laid tile.

Now, in years to come, suppose a gouge or two appears in one of the tile and you want to replace it with a spare you kept on hand. Just take a propane torch and heat the tile which, at the same time, loosens up the adhesive beneath. Be careful not to harm the tile around it, though. Remove the damaged tile and lay the new tile into the softened adhesive. ★★★

Sticky-fingered doughnut eaters may become a thing of the past, thanks to a Marine inventor. Maj. Albert L. Protz has perfected a doughnut on a stick and has patented the idea. It's been tried before, he says, but no one has ever found a way to make the doughnut cling to the stick without falling apart. A special deep-frying machine he perfected does it.

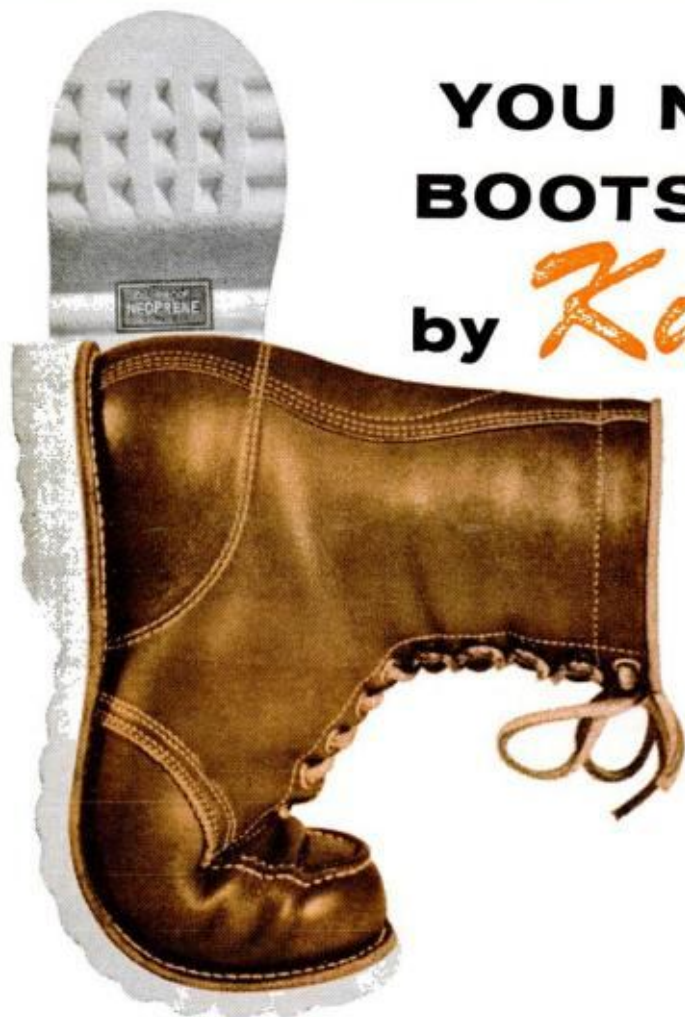

YOU NEVER WORE BOOTS LIKE THESE by *Kushins*, INC.

The first boots that don't need breaking in—that feel *right*, first time you lace them up. The reason is *flexibility*. Kushins built these boots with a *cemented* sole—no nails. And the sole is flexible crepe made of Du Pont Neoprene synthetic rubber.

The identifying word "Neoprene" always means added flexibility—and extra wear. Even under the worst conditions, Neoprene far outlasts ordinary sole and heel materials.

Always look for "Neoprene" on the soles and heels of shoes you buy.



Better Things for Better Living . . . through Chemistry

Ford's Turnpike Truck

(Continued from page 89)

idle. We talked without raising our voices. "In my truck I only have 220 horses under me and it's much louder," Kirby said. "But this steering wheel bothers me." It was a small, passenger-car type, mounted nearer to vertical than is usual in a truck. "The steering feels too sensitive. Maybe if the wheel was bigger. . . ."

We were at the end of the straightaway and into the banked curve. Kirby steered part way up the bank. The cab springs kept us practically upright. The Fruehauf trailers behind us also hardly leaned, thanks to air suspension. The ride got choppy in the corner because of changes in steering geometry, then smoothed out in the straight. "Hardly any bouncing," Kirby said. "Much better than my truck."

He paused. "You know, I think I might even get used to that steering wheel."

After a few more laps around the track, Kirby stepped on the retarder pedal; this fills the transmission torque converter with fluid for braking. Then he pushed the brake pedal and we stopped.

He stood up in the cab. "There's plenty of room to walk around in here," he said. "Nice flat floor. In our trucks there's always a hump or a bulge here and there."

He looked at the back wall of the cab, at the oven and refrigerator. "It's a driver's dream. Even a kitchen in here."

"Mind if I try driving her?" I asked.

With damp fingers I twisted the shift control. As I stepped on the gas, the turbine wheels revved up. "Time lag on take-off isn't important in a truck like this," the Ford engineer said. "The kind of use it's designed for, it'd probably never see a red light." And then we were off.

I was very much aware of the width of the truck. I preferred not even to think of the length. But visibility was superb. Steering didn't take any more muscle than a big, manual-steering passenger car.

Kirby, meanwhile, was checking out the TV set, the kitchen and toilet facilities and the reading lights. "There's only one thing I don't like," he told the engineer. "This reclining seat for the co-driver feels fine, but the sunlight will come in through the windshield and keep him awake. In our trucks the bunk is behind the driver, and there's a curtain to keep out the light."

This was the only criticism I heard Kirby make—and stick to.

I stopped and pulled a switch in the cab, and once again the door swung open and the ladder slid down. We climbed out and walked back toward the car. Kirby kept looking back at the truck. "I hate to walk away from it," he said. ★ ★ ★

7.95
19.95
23.95
24.95

PLA. Plastic Wall
Ceramic Hardwood 9x
Walnut Mosaics 12x12
Fancy OPEN SUNDAVE in in 3

UNITE

DUCTS

Dept. Store
(Oakton)
SP 4-0778
comfort
9-9, Sun. 10-2

RANCE

30c sq. ft.
2-4 yr.
Ed. Smith after 9

Machinery and Equipment For Sale

TOOL ROOM SURPLUS PRECISION LATHE, 3 x 6.9" cap., machines hard metals, all materials to .0005" accuracy; w. 3 Jaw precision chuck, cross feed, tool post, tailstock, 9-spd. drive, built-in motor, drill chuck, operating manual, post for inst. conversion to sensitive vertical drill press, also use as vert. mill and surface grinding machine. ONLY \$139.50. Call Ed Smith after 9 . . .

bik. stallion. Been shown. Also gentle FU 8-1140

Buy. Bargain quarter- Exc. Also

Used by 100,000
4 years or more
CALL MONDAY

ATTENTIO

1964 Auto. of
2 yrs. Clear,
AIR-CON'
24-HR. S

CARRIER
omp. 8.4
\$269.50

AIR-CONC
yourself
hp. rev

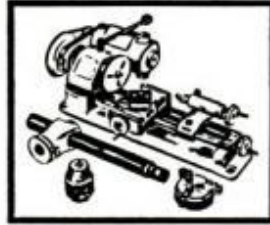

If you saw this ad in your home-town paper, you'd know it was one of the best buys ever offered. Yet this is actually the regular price of a new Unimat . . . the most versatile power tool in the world! Over 20,000 of these machines are now in use in shops, labs, and home work-

shops all over the U.S. Inexpensive accessories make Unimat even more useful for such jobs as sawing, slitting, thread cutting, indexing, polishing, buffing. Unimat machines metal, wood and plastics with high accuracy. Drop a post card in the mail today. You'll receive complete brochures, power tool information free. No salesman will call.

Write:
American Edelstaal Inc. or Canadian Edelstaal
Dept. G-L4, 350 Broadway 47 Granger Ave.
New York 10013 Scarborough,
Ontario, Canada

THE MOST VERSATILE POWER TOOL IN THE WORLD!

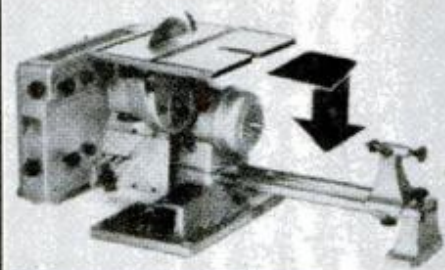

Multi-Matic 8 is a radically new breakthrough in power tool design. At upper left you see a Multi-Matic

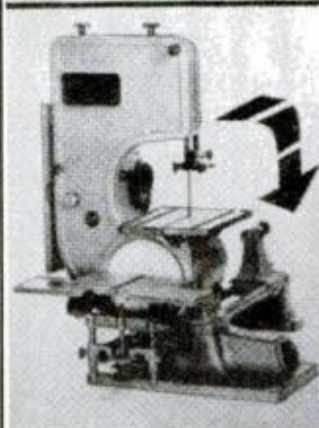

8 running in the horizontal position. You have a powerful 8-inch circular saw. Next to it ready to use instantly is a belt sander. On the right is a 9 x 36" wood lathe. Built into the head is a saber saw and fast cutting jig saw. Either sets up in seconds. On any job, you flip a switch to select high or low speed.

Swing the frame up as the arrows show. Effortless and it takes only seconds. Your band saw now operates, or you can use the 7-inch disc sander, the molder, the horizontal drill, and the power grinder. Yet the complete Multi-Matic 8 stores in less than 4 square feet. No workshop space is too small and no woodworking job too big! Multi-Matic 8 is portable too. With motor built in, wired and ready to run, price is only \$269.50.

See Multi-Matic 8 in action at your local dealer. Send a post card for free literature. No salesman will call unless you say so.

Write today to:
AMERICAN EDELSTAAL INC. Dept. GG-L4 350 Broadway, New York 10013

All Metal Plane You Can Build

(Continued from page 84)

riveting becomes a one-man job. Standard aircraft riveting requires two men, plus an expensive compression gun, and you must countersink the frame and dimple the skin metal. "Pop" rivets can be installed by one man with one hand.

There are no compound curves on the T-18, only simple bends. On the wing panels, for instance, the skin is wrapped around from the trailing edge, over the leading edge and back to the trailing edge. The fuselage is almost hexagonal in cross-section, and its skin sections are bent slightly from the cockpit area down toward the tail. And so it goes.

The raw materials, with some exceptions, are easily available. The plane is mostly aluminum—sheet for the skin, frame and ribs, and plate for the fittings.

Other specialized parts, if the builder doesn't have the skill or equipment for making them, can be purchased. Aluminum extrusions are used for the main wing beam and fuselage longeron, and steel tubing for the A-frame landing gear and cockpit roll bar. Either glass-fiber or metal can be used for the cowling, fuel tank, and tips of the wings and tail assembly. Except for the A-frame, the only other welding necessary is at the base of the control stick and rudder pedals or, if metal, the fuel tank.

Thorp insists that a really skilled amateur could build the entire T-18 himself, purchasing only the raw materials and the extrusions, plus the usual items bought over the counter by all homebuilders—engine, wheels, brakes, instruments and radio equipment.

As for shop tools, Thorp suggests a band saw and a drill press, plus these hand-held tools: an electric drill with bits and disc sander, a tin snips, Whitney punch, Cleco pliers and fasteners, and "pop" riveter. Optional equipment includes a set of files for smoothing cut or drilled edges, and a brake for making sharp bends. Welding, as noted, can be sent out. So can the small amount of milling necessary. And that's it.

The T-18's basic design is built around a 130-hp. Lycoming engine with a "dirty" configuration—cowling that exposes the cylinders, exposed rivets and an open cockpit. Some of the refinements that would clean it up, adding an average of 5 m.p.h. each to the speed with the same power, include a sliding canopy, a pressure cowling to cover the engine, flush rivets, wheel pants and gear fairing. The canopy seems mandatory. Thorp flew in the first T-18 during its early test flights and reported, "It was going so fast, it

nearly sucked us out of the cockpit." He's working on a design now.

Also, larger engines will boost speed according to horsepower. As a rule of thumb, the T-18 will give about a mile-per-hour in speed for each horsepower, slightly more with smaller engines and slightly less (because of the extra weight) with larger engines. For instance, the recommended 130-hp. engine will give, in the "cleaned up" configuration, 150 m.p.h. cruising. The one completed T-18 has a 180-hp. engine and is averaging 170 m.p.h. at 75-percent power. The T-18 design, incidentally, is built around Lycoming engines; the mounts would have to be changed for other makes.

First T-18 Built

The completed T-18, which we flew, is the work of Bill Warwick of Torrance, Calif. He lives near Thorp and finished it, without complete plans, by verbal advice from the designer. In addition to the large engine, Warwick has a heavy controllable-pitch propeller on it, plus a large battery starter and radio equipment which runs his empty weight above 900 lbs.—about 200 lbs. more than the specs on the "basic" plane with the small engine. However, the extra horses plus a canopy pressure cowl, flush rivets and wheel pants made up most of the loss in speed.

Warwick had built two wood-and-fabric planes before the T-18, but had never handled metal and admits to "throwing away a few parts" before getting them made right. He says, with a lot of scrounging, it cost him only \$2000. After he finally completed it last summer, and it was inspected and approved by the Federal Aviation Agency, he flew it to the annual get-together of the Experimental Aircraft Association at Rockford, Ill. That's where we caught up with him, and it was appropriate enough because Paul Poberezny, EAA president, first told us about the T-18. We've been chasing it ever since.

Rockford was beautiful, the day we flew with Warwick—hot and muggy, but beautiful. So it was a relief to get in the air. We started down the 4400-ft. paved runway smoothly, accelerating steadily, and the T-18's tail came up almost immediately. About a third of the way down, indicating 100-m.p.h., the T-18 lifted off.

We carried 27 inches of manifold pressure at 2700 revolutions per minute on takeoff but, climbing out, we cut back slightly. Warwick had only 70 hours on the plane and hesitated to use full throttle too long. Even so, we continued climbing at 1500 feet per minute, indicating 110 m.p.h. Warwick says he has had it up to

(Please turn to page 200)

Model
65



*Always have fresh hot batteries
when you need them.*

The Everlite is the only battery charger that will recharge all types of dry cell batteries up to 12 volts including flashlight (all sizes), lantern, hot-shot, telephone, ni-cad, mercury, hearing aid, radio, tape recorder, toys and camera batteries. The Everlite is so powerful (charges 3 times faster) that with the addition of the model 66 kit it can boost auto batteries to assure fast starts on cold mornings.

The Everlite is practically non-breakable, simple and foolproof—any child can use it with absolute safety. Plugs into any 115v. AC outlet. Can't overcharge, can't burn out, guaranteed for 1 full year.

Don't Buy Batteries Save \$—Recharge Them!

- \$5.95** • Charges 6 batteries at once
- factory price • Charges *all* types of batteries
- Charges 3 times faster

You will save real money by using the Everlite battery charger plus the convenience of always having fresh batteries when you need them. You'd have to pay \$17.85 for competitive models including all the attachments necessary to even approach Everlite performance—and then you still wouldn't have the power or ability to charge 6 batteries at one time.

TRANSISTOR RADIOS—The Everlite will play all battery powered transistor radios on 115v. house current and at the same time charge the batteries, keeping them in top shape for portable operation. It will also play transistorized tape recorders and phonographs and recharge their batteries in the same way.

Order at once for fast delivery. **FREE** battery tester included with every Everlite. A terrific Xmas gift—highly useful and completely new and different.

Send \$5.95 (plus 55¢ postage) for each model 65 Everlite. Send \$7.95 (plus 55¢ postage) for each model 66 Everlite Battery Charger including car battery booster kit. Send \$1.00 deposit for C.O.D. shipment. Send orders to nearest office.

EVERLITE* World's THRIFTIEST Light Plants

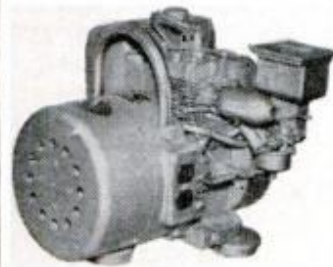

**The Champion —
1200 watts, 115
volts AC for only
\$139.95.**

Unbelievable but true—Brand new production methods now make possible world's finest design in a service free alternator light plant at this unprecedented price. Plant puts out a steady 1200 watts of 115 volt AC power to run power tools, oil burners, pumps, TV, or anything that requires up to 1200 watts. Powered by a rugged 3 HP, 4 cycle, easy start gas engine with 1 year factory warranty. Complete with carry handle and shock mounts. Why fool with short life 2 cycle plants when you can buy this rugged top quality machine at our factory price.
Item # 1265—wt. 65 lbs.
The Champion \$139.95

® Trade-Mark Registered. Special models for public utilities—Approved for Civil Defense.

HEATING AND VENTILATING FAN

(Item 10) Easily installed in furnace pipes. Forces even heat to all rooms. Over range removes kitchen smoke and odors. Powerful, continuous duty motor. 110-120 v. AC. Mount in wall or ceiling to ventilate any area. Quiet, super-efficient fan moves huge volume of air. (400 to 600 CFM.)

8" Pipe, wt. 5 lb. \$6.85
9" Pipe, wt. 6 lb. \$7.85
10" Pipe, wt. 7 lb. \$8.85
12" Pipe, wt. 8 lb. \$9.85

HEAVY DUTY FAN. Semi-enclosed motor, suitable for spray booths, restaurant exhausts, poultry houses, etc.

10" Fan, wt. 8 lbs. (Item 10E) \$11.95
12" Fan, wt. 10 lbs. (Item 10D) \$12.95



STANDARD DIAL PHONES WITH BELL

Western Electric and other late model dial phones same as used by all telephone companies. Ideal as extensions on any system. Easy to connect. Several may be connected on one line. Easily modified for private inter-com system. Cost \$40.00 new—guaranteed excellent condition.
ITEM 855 NC. Wt. 8 lbs. **\$7.45**



MODERN WALL DIAL PHONE

A modern compact dial phone which hangs on the wall out of the way. Easy to install.
Item #1266, Wt. 8 lbs., Wall Phone \$9.45

Send 10¢ for 100 page Catalog **FREE** with order. Prices f.o.b. factory. Money back guarantee.

Briggs & Stratton—Clinton New Gas Engine Sale

Never before and perhaps never again—this offer of brand new genuine Clinton and Briggs & Stratton engines including 1 yr. factory warranty at less than cost. Perfect power for scooters, tractors, mowers, generators, pumps, sprayers, etc. We bailed out 3 big factories who needed cash and the savings are yours while quantities last. Act fast.



Clinton 2 1/2 hp, Mdl. 500 — Re-coil starter Std. 5/8 shaft w. keyway—ready to go. Reg. price \$49.50 Special (item 1002)

\$29.95

2 for \$59.50
6 for \$176.50



Briggs & Stratton 2 hp, Mdl. 60101 Rope start, std. 5/8 shaft w. keyway, Sturdy 4 cycle power.

Regular price \$49.80 Special (item 106a)

\$29.75

2 for \$58.90
6 for \$175.50

\$69.95

5 3/4 hp.

Briggs

&

Stratton

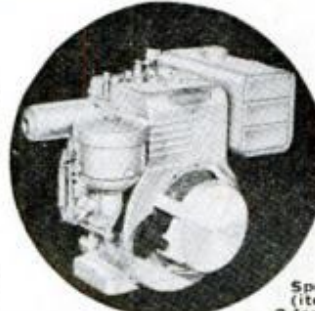

Briggs & Stratton 5 3/4 hp, Mdl. 143302. Recoil start. Std. 1" shaft w. keyway, and adjustable governor — a rugged big engine ready to tackle any job.

Regular price \$92.60 Special (item 1059) ... **\$69.95**

2 for \$135.00, 6 for \$375.00

2 3/4 h.p. Clinton—34.95

Model 400, rugged 4 cycle model. Alum. Block, castiron cylinder Rope start—5/8" std. shaft

Item 1107 34.95

2 For 69.95

3 1/2 h.p. Clinton—39.95

A big engine with big power. Model 406, 4 cycle, rope start, 3/4" std. shaft.

Item 406 39.95

2 for 77.50



Remember these engines are absolutely perfect and standard and under factory warranty. Money back guarantee. Order now while stocks are complete. Factories—we buy new engines.

MASTER MECHANIC MFG. CO.

Dept. A-124

Box A, Burlington, Wis.

Box 65, Sarasota, Fla.

Send orders to nearest office.

All Metal Plane You Can Build

(Continued from page 198)

2100 f.p.m. and held it steady. Like, wow!

We leveled off at 3000 feet altitude, cutting back to 23 inches at 2400 r.p.m. The first thing you notice straight and level is the stubby wing—not so much the gulled-up outer sections, but the stubbiness of the wing itself. It spans 20 feet, and knock off three feet for the cockpit, that leaves about eight feet on each side. Hardly enough for a grown man to lie down on.

The cockpit incidentally, is small but not uncomfortable. It might become so on long flights, however. The stick control comes up between the knees, and on sharp turns you have to move the knees.

Our speed built steadily until it came to rest just above 170 m.p.h. We kept it there a few minutes while Warwick "trimmed" it up. The T-18, as an "irreducibly simple" airplane, has no built-in trim control. With Warwick's big engine, it needs back pressure for takeoff and climb and forward pressure for cruise. He has rigged a Rube Goldberg spring, attached to the floor board, which he slides up the stick for nose-down trim and down for nose-up. Without it, he could get arm-weary. Some kind of internal trim is also on Thorp's agenda.

Warwick's T-18 stalls at about 68 m.p.h., and very sharply. There's no warning. Just vroom! The nose drops, and in Warwick's plane to the left. He says one of his wings is twisted slightly, accounting for the "lefty" quirk. Thorp, however, says that the sharp stall will probably be characteristic of all T-18s unless he designs a warning "shudder" into it.

Its hotness shows up best in maneuvers. It is extremely responsive on the controls, especially the ailerons—probably those gull outer sections. The T-18 rolls—like "right now"—and the elevator (or "flying tail") control is good. Climbing turns, and rolling into flat tight turns, are a real joy.

Warwick, understandably, had never really opened up on his T-18 with so few hours on it, so it had never been put through its aerobatic paces. But the feel is there. It wants to move.

Straight and level, there won't be too many amateur-built planes that will keep up with the T-18, power for power. One indication is that when we went up to shoot aerial pictures of Warwick's plane, the only two-place chase plane we could find that could stay in front of it was a Steve Wittman *Tailwind*, long the amateur's standard for speed.

We never went above 4000 feet at Rockford, but Warwick says he has had his T-18 up to 11,000 feet without laboring it.

Coming back to the airport, the T-18's hotness again was evident. We entered the pattern at 130 m.p.h. indicated, turned onto the final approach at 120 m.p.h. and touched down at 90. That's pretty warm for a small airplane. Warwick claims that his air-speed indicator reads "high" at low speeds and guesstimated that we were closer to 75 m.p.h. That's still warm. However, Warwick has no flaps. There are none called for in the basic design.

Otherwise, the landing—again, in about a third of the runway—was rough, but not uncomfortable. The A-frame gives a little, but doesn't bounce the plane.

Hot Little Plane

In sum, we found nothing radically wrong with the T-18 on our test flight, and much to recommend it. The canopy is a necessity, and we'd strongly advise elevator trim and flaps. The sudden stalls may bother some, but there's nothing about them—nor any of the other T-18's hot characteristics—that an intelligent pilot can't handle. In fact, we know some intelligent pilots who would be tickled to death to have a plane as hot as the T-18.

Whatever problems it has seem to be on the ground. We talked with Warwick and some of the other T-18 builders (there were about 50 of them at Rockford, and most of them went up with Warwick).

Warwick, for one, is quite happy. He likes the T-18's distinctive looks, that "leaning forward" configuration and gull wings, and he is very high on its maneuverability and speed. He mentioned specifically its great aileron control, good pitch control and absence of torque or yaw. In fact, he claims he can make turns with his feet off the rudder pedals. The landings, he said, are consistently solid, neither too mushy nor too hard. But he flies from paved airports regularly, and said sod fields may give "stiff" touchdowns. Considering the short takeoff and landing roll at Rockford (less than 1500 feet on a paved runway), the T-18 seems suitable for small fields, especially with flaps.

Some of the other T-18 builders, naturally, had more to say about its construction problems, especially the beginning builders. Metal was the big nemesis. They were surprised, and a little discouraged, to find how easily it would warp, "run" and rip on them, and they wish now that they had taken a basic course in metalworking before starting.

Thorp's answer is that each piece made in the workshop should be considered expendable—if at first you don't succeed, throw it away and try it again.

Also, the beginners recommend a basic

(Please turn to page 202)

SURPLUS SALE

GOVT. SURPLUS
EXCESS INVENTORY
BANKRUPT STOCK



AC WORM WINCH

• =319 Ball Bearing Oil Bath Worm Gear. 1500 lbs. Cap. 3/4 h.p. 115-volt motor. Holds 80 ft. 1/2" cable. Reversible. Wt. 64 lbs. Does work of units



=200 \$84.50

12-VOLT GEAR MOTOR

• =564 powerful 12-volt battery reversible 350 RPM 1 1/2 h.p. Make cars, winches, lifts, reels, etc. Wt. 36 lbs. Govt. Cost \$295.00



\$18.95

WAR SURPLUS HYDRAULIC BUYS

• Save 70%. Build loaders, presses, snow lifts. Hundreds of items (see catalog). =175 Hydraulic 12-volt motor pump—\$18.49; =42 Hand Hydraulic 1000 lb. Pump—\$11.95; =55 Hydraulic Cylinder 2" bore x 30" stroke—\$24.91; =110 Hydraulic 1500 PSI 3.5 GPM Pump—\$21.90; Catalogs shows valves, filters, cylinders, etc.

#716 DIAL TELEPHONE

• Use as extension to main phone or for private. Instructions, 8 lbs. Repolished perfect \$7.95. Cost \$30.00. Same except not cleaned or polished



\$5.91

12-VOLT ICE AUGER

• =138-X. Fish thru ice in winter. Run on 12-volt battery. Powerful. Also use for post holes. (Specify ice or earth auger). Wt. 45 lbs. Govt. Motor cost \$275



\$69.50

ELECTRONIC BUYS

• \$110 Automatic Phone Switch... \$12.91
• \$75 Automatic Motor Code Unit... \$3.95
• \$45 Variable Voltage 115-V Trans... \$2.39
• \$14 Hi Volts. 10,000. Spark Coil... \$3.91
• \$9 5-Gang Aircraft Switch... \$9.99
• \$4000 Telephone Amplifier Sys... \$13.91

AIR COMPRESSOR EQUIPMENT

• Make your own outfit for painting tires, shop use, etc. Save to 60%. Compressor \$19.95; Govt. Tank \$4.95; Gauge \$1.75; Spray Gun \$10.50; Auto Switch \$4.35; Air Regulator \$3.95; Motor Outfit \$79.50.



FIRE-BURGLAR ALARM SYSTEM

• =1135-A provides both fire-burglar protection. Foolproof lock-up type. Consists master relay-control unit. Fire-burglar sensors, wire, etc. 115-volt AC. Does work of =300 sys-tems. Wt. 7 lbs. \$24.95



SPECIAL OF THE MONTH!

DUMB WAITER

• =342. Install your own elevator. Easy to build your own cage and guide. Consists motor driven ball bearing worm winch 1000 lbs. cap. with 115 volt 1/2 h.p. Motor holds load when stopped. Drum holds 45 ft. cable. Complete elevator winch unit. Wt. 60 lbs. A four star \$89.90 buy



EXAMPLE BARGAINS IN CATALOGS

• S240 3 to 1 Clutch-reducer Transmission \$ 69.50
• S 29 115-V 12 RPM 1/15 h.p. Motor \$ 11.76
• S500 Automatic Pilot Control Gyroscope \$ 12.47
• S 35 Power (30 amp. 115-V) Time Switch \$ 8.91
• S450 Switchboard 12-line Telephone \$ 79.50
• S435 Generator 3000 W-115-V 60c. \$147.90

Send 25c stamps for THREE War Surplus Mechanical-Electrical Catalogs:

- 1) Govt. Mechanical Catalog
- 2) Electronic Import Catalog
- 3) Warehouse Clearance Catalog

*All items f.o.b. Lincoln.

SURPLUS CENTER

Dept. 814, LINCOLN, NEBR.



FOR HOLIDAY DECORATIONS



KRYLON
SPRAY PAINT

IF YOU PRIZE IT...KRYLON-IZE IT



WORKS
IN
SECONDS



Loosens Rusted Bolts
nuts, screws, "frozen" parts!

LIQUID WRENCH

Loosens rusted studs, bolts, battery terminals, mufflers and all other parts. Cleans guns, rods, reels and sports equipment. Harmless to all metals.

35¢

AT HARDWARE AND AUTOMOTIVE SERVICE STORES

THE POCKET SIZE MACHINE SHOP Dremel MOTO-TOOL

Handiest tool you'll ever own. Moto-Tool's high speed (27,000 rpm) is ideal for precision grinding, drilling, polishing, carving, engraving, deburring, sharpening. Does fine detail work with pin-point accuracy. Eliminates time consuming hand work, gives the finished job a professional look. Weighs only 13 oz. — handles easily as a pencil. Fastest, most powerful tool of its kind. Widely used by tool and die makers, model builders, gunsmiths, repair men, schools.



No. 2 Moto-Tool only.....\$19.95
No. 2 Moto-Tool Kit..... 29.95
(Incl. No. 2 Moto-Tool & 23 assorted accessories in steel case)

NEW HEAVY DUTY NO. 3 MOTO-TOOL

New high torque motor designed for industrial use. Same features as No. 2 plus 50% increase in power. Weighs only 18 oz. Complete with 1/8" and 3/16" collets and finger grip in steel case... \$29.95
No. 3 Moto-Tool Kit, with 23 acc. in steel case... \$37.95

SEE YOUR DEALER OR WRITE FOR CATALOG
DREMEL MFG. CO. DEPT. 114M, RACINE, WIS.

EVERY NEIGHBOR IS A CUSTOMER

IN PROFITABLE
MOWER
SHARPENING
BUSINESS

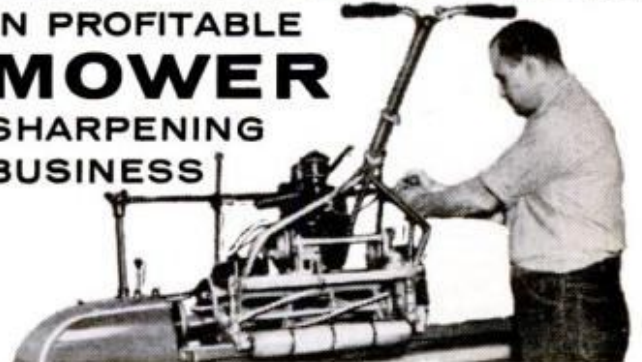

EARN \$5 AN HOUR

Earn extra cash right from the start—average \$5 an hour. The Foley Lawn Mower Sharpener is a complete shop in one machine. No experience is needed to start—anyone can operate it, and turn out professional-like jobs. All operations are done quickly, easily and accurately.

Start Sparetime Business

An ideal sparetime business—altho' many find it so profitable, they devote full time to it. For complete fact-filled booklet telling you how to start and how others have succeeded, send coupon. No salesman will call:



FOLEY MFG. CO., 1207-4 Foley Bldg., Mpls. 18, Minn.
Send booklet on Lawn Mower Sharpening business.

Name _____
Address _____
City _____ Zone _____ State _____



Professionals use
Red Devil



PUTTY KNIVES

and other painters' tools

Red Devil Tools.

Union, N. J.



4733

ELECTRIC ARC WELDER \$14.95!

MAKE—REPAIR MOST ANYTHING MADE OF METAL!

LIFETIME BURNOUT GUARANTEE—10 day money back trial!



Works on 110 volt plug in 10 WAYS! WELDS, BRAZES, SOLDERS, CUTS, MELTS most ALL metals! HEATS, SOFTENS, LOOSENS, THAWS, BENDS most ANYTHING. COMPLETE READY TO USE WITH face mask, clamps, arc torch, rod holder cables—and supply of welding, brazing carbon, solder rods, flux and ARC WELDING INSTRUCTION BOOK—Tells how YOU can use for CARS—HOME—FARM—SHOP or FACTORY all 10 WAYS—NO EXPERIENCE NEEDED! **SEND ONLY \$2.00** (cash, ck, M.O.) and pay postman \$12.95 plus COD postage or send \$14.95 for PP del. in USA. **BEST WELDER FOR THE MONEY IN THE WORLD. FREE: EXTRA "Helpers" dark goggles if you order from this ad. Sold ONLY by MIDWAY WELDER, Dept. DPM-12, Kearney, Nebraska.**



OVER
300
DIFFERENT

MOLDS

you can use to
make and sell

**YOUR OWN
ORNAMENTAL
CONCRETE ITEMS**



Get
The Full Story



SEND \$2.00

CONCRETE MACHINERY COMPANY, INC.
839 Lenoir Rd. - P. O. Box 99 - Hickory 2, N. C.

All Metal Plane You Can Build

(Continued from page 200)

course in reading blueprints. Thorp's drawings, they say, are excellent but a bit much for a novice.

The extrusions caused the most confusion. They are not stock items, and no metal manufacturer will make up special dies to form them without a minimum order of about 300 lbs. of extrusions—enough for twenty T-18s.

Thorp's solution is that twenty T-18 builders should band together and order the extrusions en masse. One T-18 man, in fact, ordered the dies on his own and sold the extra extrusions to other T-18 men to get his money back.

Texas T-18 Club

There were some complaints about the tools necessary, but Thorp sees nothing exotic about them and feels they can easily be absorbed in the estimated cost of \$3000.

One group in Texas has solved some of their problems by forming a T-18 club and dividing the work. One man makes all the skins, another man the fittings, another man the formed parts, and so sharing their individual skills.

Ironically, some of the complaints were about what wasn't on this "irreducibly simple" airplane. As the Detroit auto manufacturers learned when they built compacts, customers responded with: "Yes, but we want *luxury* compacts."

The most common luxury asked for at Rockford was a retractable landing gear. For this, Thorp said, the wing would have to be redesigned. It's a tail-wheel plane now because the A-frame main gear is forward of the wing (so the wing can be removed) and forward of the center of gravity. To make either a tricycle gear or retractable gear would cause changes.

All in all, none of the problems in building the T-18 seem insurmountable, and it all hinges on Thorp's definition of "irreducibly simple." He insists that if it were made any simpler it would be unsafe to fly.

It's *Popular Mechanic's* considered opinion that the T-18 is probably the easiest-to-build all-metal plane ever designed. It could be recommended even if its performance were ordinary. And it's not. Once built, the T-18 will take off into a class of its own, because it will out-fly almost any amateur-built plane in the air today. And, with proper construction and care, it should last a lifetime.

So for those men who were looking for a good little plane they could build in their workshop, and are willing to put in the necessary labor and suffer the inevitable mistakes, this is it. ★★★

BUY GREAT NECK HAND TOOLS

... for long-lasting performance

Precision Balanced NAIL HAMMER



One-piece, forged steel, rubber-cushioned, no-slip grip



GREAT NECK SAW MFRS., Inc.

MINEOLA, N. Y. — SEE YOUR LOCAL STORE

WOOD CATALOG & MANUAL

See 2,000 products for better wood-working in Constantine's big, new picture-packed Catalog-Manual. Over 60 woods in full color. Largest selection. Everything for woodworkers. Plans, kits, hdwe. Glue that needs no clamps! Unsurpassed values! Send 25¢ toward mailing vast catalog. Est. 1812

World-Wide Headquarters—Woods, Veneers, Finishes, Tools, Upholstery, Etc. 2,000 Products for Craftsmen

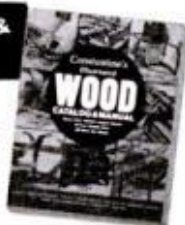

CONSTANTINE 2050 Eastchester Rd., Bronx N.Y. 10461 Dept. T-5

BUILD-IT-YOURSELF CATALOG

Start today! Save up to 50% when you build your own scooter, mini-bike or kart! Big new catalog contains plans, specifications, parts list, prices... engines, brakes, clutches, wheels, helmets — everything you need to start building now, in your own home! Enjoy hours of low cost fun! Order your plans today!



SEND ONLY \$1.00 TODAY

Go **Kart** Box 797P • Janesville, Wis.

AUTOMATIC MAKES NEW PROFITS

RETOOTHER

for HAND SAWS

Cuts new teeth in 50 seconds—any size 4 to 16 points. Old teeth fall off as chips. Easy to operate. A perfect job.

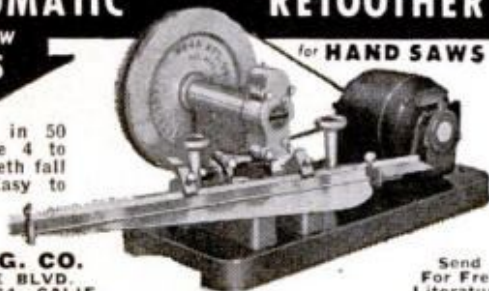

Send For Free Literature

BURR MFG. CO.
8933 VENICE BLVD.
LOS ANGELES 34, CALIF.

BUILD YOUR OWN CAMPER AND SAVE!

ALSO TRAILER OR PICKUP COVER

Complete, easy to follow plans, instructions and materials list.

\$3.95 ea.

EQUIPMENT CATALOG—\$1.00 (REFUNDABLE ON FIRST ORDER)



SEND CHECK OR M.O.—FOR DETAILS SEND DIME!
VIKING CAMPER SUPPLY 94-B Glenwood Av., Minneapolis 3, Minn.

Man-size
ECONOMY
ALL-GEAR-DRIVE
TRACTOR
at garden-size price

Bigger, more powerful than ordinary garden tractors. For farm, lawn, woodland. Easy to operate. Rugged, built-in quality. 9-12 hp. ALL GEAR DRIVE incl. clutch, 3-spd. trans., diff., 175 to 1 reduc. No belts in drive-train. Wt. 750 lbs. 25 low-cost quick-change tools. Write for FREE CATALOG and dealer name.

ENGINEERING PRODUCTS CO., 1005 K-12 Anoka Ave., Waukesha, Wis.

GOVT. SURPLUS AND OTHER BARGAINS SAVE UP TO 90%

DC JET GENERATOR Rated 400 AMPS continuous duty @ 30 V. D. C. 3000 RPM up. Will produce up to 600 AMPS at 48 V. for intermittent periods. A truly fine gen. that will make an excellent welder. Mfg. by G. E. Approx 16" L 7" dia., shpg. wt., 80 lbs. complete with wiring diagram. Approx Gov't cost \$464. Special, limited quantity **\$39.95.**

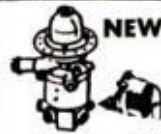

NEW ELECTRIC PUMP WITH CONTROL UNIT

For boats, campers & trailers. Output 200 GPH. Variable rheostat with on & off switch controls output of pump. 1/2" pipe thread into bronze impeller housing. 12 V.D.C. Explosion-proof const. Shpg. Wt. 9 lbs. Complete with wiring diagram. Approx. GOV'T COST, \$200. NEW, **\$10.95**

160-1 MOTORIZED REDUCTION

GEAR Excellent for making your own winch or hoist, for beaching boats or as a golf cart or electric car drive unit, 1000's of other uses. Contains DC motor, clutch and reduction gear box. Easily reversible, wiring diagram furnished. Hi-torque runs on 6, 12 or 24 V.D.C. Turns approx. 75 RPM @ 12 v. Shpg. wt. 50 lbs. Approx. Gov't cost \$300. Like new, tested prior to shipment. New low price **\$17.50.**



HEAVY DUTY BATTERY WINCH

Rugged, deluxe winch with ball bearing construction throughout motor & gear train, 225-1 gear reduction. Rated cap. 3000 lb. pull. Contains heavy-duty reversing switch. Rugged 3/8" plate steel mounting base with outrigger support. 22" L x 9" W x 8" H. Handles 250' of 1/4" cable. Built for 12 V. battery operation; also operates on 6 V. at reduced cap. & speed. A must for Scouts, Jeeps, Trucks, Boat loading trailers, etc. Shpg. wt. 80 lbs. Approx. GOV'T COST \$490. NEW, 90 day guarantee. Model E-D. **\$75.00** plus Fed. Tax of **\$4.50.**



NEW! BIG! 1965 CATALOG

Send 25¢ for your copy of this new and amazing catalog containing 1000's of bargains in hydraulics, electric precision tools, marine items, automotive etc. for hobbyist or industrial. Order from this ad. All prices FOB Culver City, Calif. 50% deposit for COD. Send check, cash or money order.

AIRBORNE SALES CO. DEPT. PM1264

8501 Stellar Drive • Culver City, Calif., Box 2727

OUTDOORSMEN • DOCTORS • EMERGENCY WORKERS • FARMERS • CAMPERS • MOBILE

300 WATTS OF STANDARD AC ELECTRICAL POWER ANYWHERE!

The **POWERMAKER \$44.95**

Run Tools, TV, Hi-Fi, Etc. • 120 Volts, 60 Cycles • Only 12 Pounds
12 Volt Battery Powered

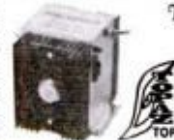

TOPAZ INCORPORATED 3802 Houston St. San Diego, Calif 92118

Shipped anywhere U.S.A. \$2.50 • California residents add 4%.

DISASTER AREAS • TRAILER • PLANE • SALESMEN • BOAT • CAR • DOCTORS

CAMP • POLICE & FIRE • AMBULANCE • SPORTING EVENTS • FAIRS • RADIO AMATEURS

EVERY MAN WHO WORKS WITH WOOD NEEDS THIS ROUTERMATIC



Clamp this amazing new tool to your electric drill and you're ready to route, mortise, trim or shape wood to precision tolerances. Mortises for hinges made in seconds. Inside shapes and inlays are easy. Handles any kind of routing better by letting you take the tool to the work. Make mortise and tenon joints including mitre joints for picture frames. Perfect for fluting lathe work. Router-matic is a precision made tool, sturdy, light weight, portable. Once you've used it you'll wonder how you ever got along without it. Only \$6.95 including \$1.50 router bit. We can't sell thru stores at this low price. Fully guaranteed or money back. If you're skeptical write for descriptive folder.

COMP-TOOL, Inc.

355 Prospect Road Ashtabula, Ohio

**PHIL RIZZUTO . . . Radio Network Sportscaster and Former Yankee Shortstop
DISCOVERS A RICHLY REWARDING NEW NATIONAL PASTIME!**

"There's a new indoor pastime I'd been introduced to recently that has me wondering where it's been all my life. Until I outfitted the basement of my new home with a set of American Machine power tools, I had no idea how much fun it could be to make things out of wood—nor how easy it can really be. I am constantly amazed with the accuracy, speed and ease with which I can now make useful and beautiful things for the house, for the kids—and for my own pleasure and convenience. I don't know how they do it, but the remarkable low cost of these professional quality tools has taken nothing away from their ability to do a job."



BUY DIRECT FROM OUR FACTORY



POWER TOOLS SAVE AS MUCH AS 80%

**8" TILT ARBOR
POWER
SAW**

\$14.95

f.o.b. factory. Wt. 25 lbs.

Includes completely assembled cast iron and steel 8" tilt arbor power saw with ground cast iron table . . . less blade. If desired, RIP FENCE for easier work alignment, \$3.50 additional

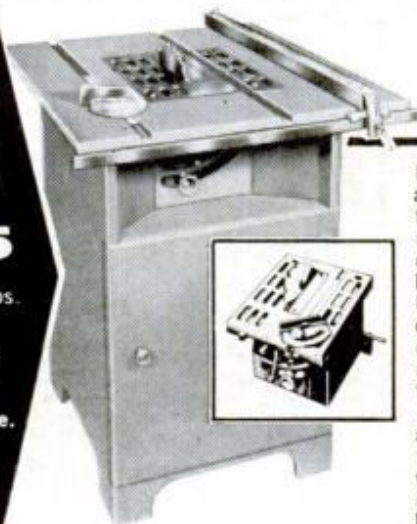

REVOLUTIONARY PATENTS DECREASE COSTS, INCREASE EFFICIENCY

Full scale power tools of heavy duty 100% cast iron and steel. Streamlined design reduces weight, cuts material and production costs. Special patents provide added efficiency, accuracy, savings. Parts made, assembled, tested and packed right in our own factories, shipped direct . . . save store profits.

DOES WORK OF \$75 BENCH SAW as is. Converts easily to equal any \$300 floor model cabinet units! Crosscuts, rips, mitres, cuts compound angles, dadoes, makes coves and mouldings. **FREE CABINET BASE PLANS**

Use as portable bench saw as received (inset photo) . . . or transform easily and inexpensively into floor model (as shown) guar. to do work of floor models costing \$300. FREE plans . . . sheet of 3/4" plywood and 3-4 hours are all you'll need. Use your AMCO saw for cutting. Plans provide 27" x 24" work surface, 33" height, pullout sawdust bin, tool storage compartment. **UNCONDITIONAL 10 YEAR GUARANTEE**

BLADE TILTS . . . TABLE STAYS LEVEL

- Locks securely at any angle to 50°
- raises, lowers 0"-2 1/4"
- Patented tilt mechanism, accurate etched scale
- Patented motor mount takes std. 1/4 h.p. or larger motor, keeps belt tight, assures perfect alignment at any angle, transmits full power
- Takes std. blade, saw insert removes to take dado heads, cutters, etc. (not incl.)
- Accurate mitre gauge assembly
- Ground spindle
- Enclosed steel base
- "Compo" bearings
- Accessories available at factory prices
- RIP FENCE, if desired for easier work alignment: Std. size (for bench saw) \$3.50; larger fence (for cabinet base, as ill'd.) \$4.50.

**6" SWING
3-FT. LATHE**

\$9.85

f.o.b. factory

Optional Faceplate for turning bowls, trays, lamp bases, rosettes, etc. \$2.50

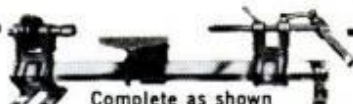

Complete as shown

DOES THE WORK OF \$40 UNITS—Sturdy all cast iron power tool turns wood or plastics with the precision and speed of machines selling for 4 times as much. Tubular steel bed, ball thrust cup center, spur center, T-Rest assembly, lever action tail stock, 2 speed pulley. Fits any motor. **UNCONDITIONAL 10 YR. GUARANTEE**

FULL 22" LONG, 4 1/4"
JOINTER-PLANER

\$19.95

F.O.B. Factory Complete as shown

100% precision ground cast iron and steel.

**PROVED BY
MORE THAN
500,000
USERS**



DOES WORK OF \$60 UNITS

Now, at little more than a hand tool price, a guaranteed professional quality precision machine which does same work as skilled hand planing . . . much faster, more accurately. Make accurate glue joints; rabbeting cuts for doors, window frames, table drawers; square taper cuts for chair legs; accurate beveling.

- Precision ground cast iron tables, adjustable for depth of cut
- Rigid cast iron base
- New patent-pending design holds clearance between knives and tables at any depth
- Rabbet depth 3/4"
- Hardened, ground high speed steel knives
- Patent-pending fence adjustable to any position, any angle 0°-50°
- Patent pending lift-off guard (nothing to loosen!)
- Balanced steel cutter head.

UNCONDITIONAL 10-YEAR GUARANTEE.

OR
**1/2 HP
ELECTRIC MOTOR**

SPECIAL AMCO PRICE (when purchased with any unit in this ad)

\$12.95

f.o.b. factory if purchased separately, \$18.95

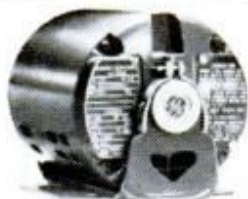

SPECIAL LIMITED TIME ONLY

Brand new factory-fresh motors for use with any of the units on this page. Limited quantity purchase . . . first come, first served. Wt.: 17 lbs. **FULL 1-YEAR WARRANTY**

PRECISION 4"x36"
BELT SANDER

\$14.95

f.o.b. factory Wt. 15 lbs.

Optional Disc Sander incl. disc, bracket, ground cast table (tilts 0-45°): \$7.95 add'l. Mitre gauge: \$1.95 add'l.

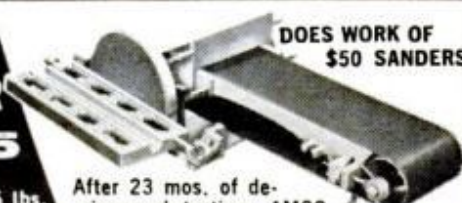

DOES WORK OF \$50 SANDERS

After 23 mos. of design and testing, AMCO offers the world's most talented belt sander at a fraction of the usual cost. Heavy cast sander incl. 4" x 36" sanding belt, V-pulley drive, multi-purpose drive spindle for 1/4" shank acc'ssy tools. Changes from horizontal to vertical sanding in seconds. Uses 1/3 hp or larger motor. **UNCONDITIONAL 10-YEAR GUARANTEE**

MAIL COUPON TODAY!

AMERICAN MACHINE & TOOL CO., Dept. PM-124 Royersford, Pa.

Please send me the units checked. Payment in full enclosed \$. . . or \$3 deposit each item enclosed, balance C.O.D.

I MUST BE FULLY SATISFIED OR WILL RETURN UNIT WITHIN 10 DAYS FOR FULL REFUND. No questions asked.

- 8" Power Saw at \$14.95
- Jointer-Planer at \$19.95
- Long Rip Fence = 354C at \$4.50
- Lathe at \$9.85 with
- Standard Rip Fence = 354 at \$3.50 faceplate \$12.35
- 1/2 hp Motor: \$18.95 \$12.95 (purchased with other item)
- Belt Sander at \$14.95
- Disc Sander at \$7.95
- Mitre gage at \$1.95

NAME
ADDRESS
CITY ZONE/ZIP STATE

10 DAY MONEY BACK GUARANTEE

You must be satisfied or money refunded.

AMERICAN MACHINE & TOOL COMPANY

Dept. PM-124 Royersford, Pa.

Buy Below Wholesale



JEWELLED

CALENDAR WATCH \$2³³
WITH-OUT BAND
movement. Full styling. Time and date, too. Sweep hand, gift case, stainless back, water resistant, and magnetic. METAL EXPANSION 11c.

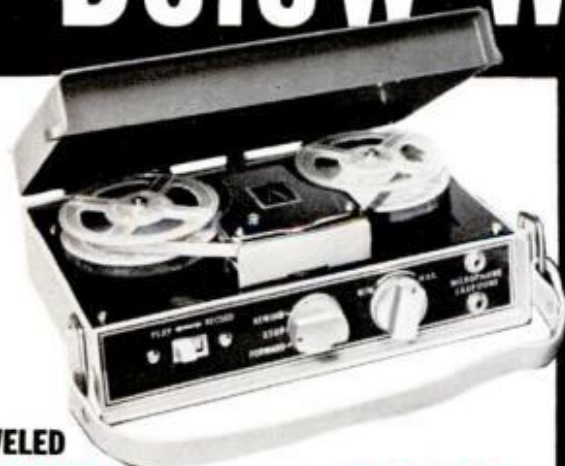

4-TRANSISTOR TAPE RECORDER \$6⁷⁰

Complete with powerful built-in dynamic speaker. Records—Plays Back—Erases—Re-winds. Includes microphone, battery, tape, reels, etc.



ELECTRIC RAZOR \$1⁷⁰

Product of Swiss craftsmanship... Shaped to shave the heaviest beard. Maker guarantees for 2 full years. With cord, head guard and brush.



DOGGIE RADIO \$3¹⁰

Soft cuddly pup has transistor radio cleverly concealed inside. Nose is control button. Luxurious leather-like vinyl coat.



Fabulous 2-Piece KNIT SUIT ONLY \$4⁵⁰

- Fine wool.
- Beautifully tailored abroad.

DERRINGER PISTOL \$5⁹⁹



Beautiful blued finish. Double barrel fires two shots. Product of West Germany's precision craftsmanship.

- Short cut plan guides you step by step
- Previous experience unnecessary
- Start without investment in merchandise
- Start anywhere—city, town, rural area



I SHOW YOU WHAT TO DO —HOW TO DO IT

B. L. Mellinger, Jr., Famous World Trader, says: "I reveal secrets of Import-Export that have made a fortune for me. My plan gives you hundreds of overseas suppliers—opportunities for thousands of exciting imports."

DO NOT ORDER FROM US
Plan shows where to get buys like these for big profit sales. Prices shown are direct from suppliers abroad.

START YOUR OWN BUSINESS HOME IMPORT

with DAZZLING BARGAINS like these..

AMAZING NEW PLAN STARTS YOU FAST

Thousands of amazing import bargains can lead you to opportunities far beyond your wildest dreams. Start now at home, spare or full time. Cash in now without previous experience or capital investment. Pocket cash even before ordering merchandise! Sparkling imports bring first day profits. Beginners—make your first import transaction 10 minutes after you receive my drop ship plan. Bargains go fast to stores, premium users, to friends and others.

... And, these are only a few of the hundreds of import bargains you can get to make fantastic profits of 200% and more... here are examples of other high profit imports:

BLACK FOREST CLOCK	\$.63	TEAKWOOD CHEST	\$.90
ELECTRIC TRAIN SET	1.50	WINDBREAKER JACKET	1.40
CIGARETTE LIGHTER21	STAR SAPPHIRE RING	6.00
ELECTRIC CARVING KNIFE	1.50	ELECTRIC HAIR DRYER	1.37
8mm MOVIE PROJECTOR	2.80		

Products subject to availability, price fluctuation

SEND NO MONEY...RUSH THIS AIR MAIL REPLY CARD for FREE BOOK, FREE DETAILS

FREE DETAILS ABOUT IMPORTS CENTS SENT FREE

Chesterfield People:

They like a mild smoke, but just don't like filters. (How about you?)



Charles Feingarten, art gallery director, Illinois



James S. Thompson, optical physicist, California



Richard N. Pudge, mining engineer, Nevada



If you like a mild smoke, but don't like filters, try today's Chesterfield King—mildest-tasting Chesterfield in 52 years. Vintage tobaccos—grown mild, aged mild, blended mild. Made to taste even milder through longer length. They satisfy!

CHESTERFIELD KING tastes great...yet it smokes so mild!