

PREVIEW: THE '64 CARS

# POPULAR MECHANICS

AUG. 1963  
35 CENTS

CORD'S BACK—AND WE DROVE IT!

EIGHT GAMES FOR BOATERS

DETECTING BOOTLEG  
H-BOMB TESTS



Build a  
SCOOT-CAR  
12 MPH on Two Wheels





When  
a  
cigarette  
means  
a lot...

## get Lots More from L&M

more body in the blend... there's a special rich-flavor leaf—and more of it—among L&M's choice tobaccos.

more flavor in the smoke... every puff is heartier, for L&M has more longer-aged, extra-cured leaf than even some unfiltered cigarettes.

more taste through the filter... and L&M's filter is the modern filter—*all white*, inside and outside—so only pure white touches your lips.



**It's the rich-flavor leaf that does it!**





Agajanian—Willard Battery Special sets new "Indy" record of 143.137 mph with silvery-plated Champions

Parnelli Jones wins Indianapolis "500" with  
Champion Spark Plugs! Men who live power and  
performance insist on Champions. Why settle for  
less in your car?



To feel new power in your car, instantly, install new Champions now and every 10,000 miles

AUGUST 1963



**only one  
wagon has  
"DRIVEPOWER"\***

Conventional wagons put horse-  
power only at the rear . . . only  
2-wheel power . . . only push.



'Jeep' Wagoneer puts horse-  
power front and rear . . . 4-wheel  
"Drivepower" . . . push and pull.

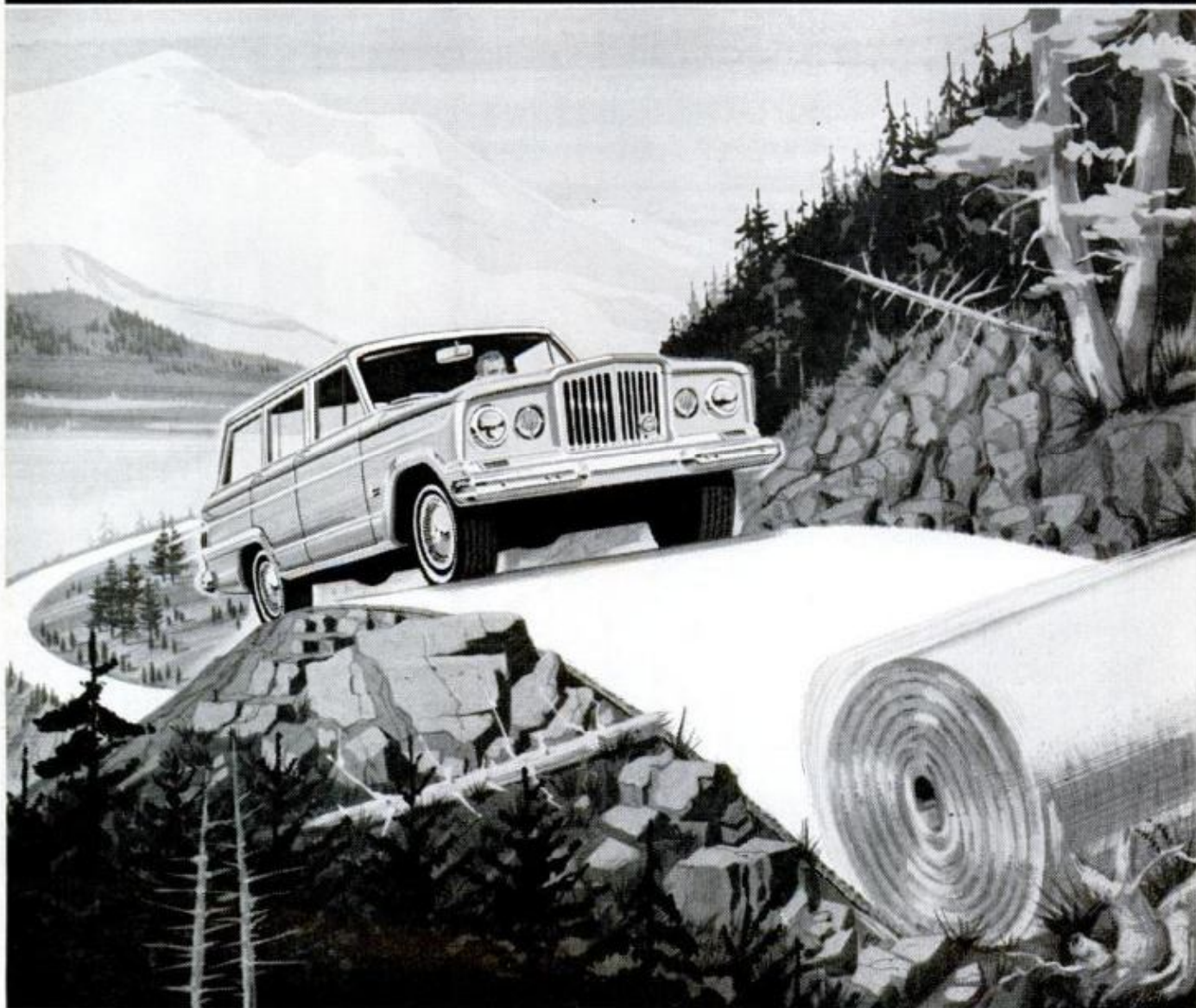

**go the Wagoneer road!**

Where there's no road, Wagoneer station wagon makes one. Just hit the "power bolt" . . . the lever that shifts from 2-wheel to 4-wheel drive . . . and pour on the "Drivepower". Go Wagoneer™-ing. Cut out of traffic. Go over hills, through mud, sand or snow. Discover the greater traction, greater driving safety of "Drivepower". Try the new automatic transmission, power options, and quiet highway ride. See your 'Jeep' dealer and shift into greater safety with Wagoneer—the only family wagon with "Drivepower".

**KAISER Jeep CORPORATION** Toledo 1, Ohio

\*"Drivepower" is Wagoneer station wagon's new, improved and exclusive 4-wheel drive system.

**ALL NEW 'JEEP' WAGONEER**





## Firestone's Farm & Commercial Truck Tire Tread and Shoulder Above the Others *(And priced below them, too!)*

The Firestone Farm & Commercial truck tire is priced so low, you'll think the price tag is wrong. But don't let the low price fool you. There are mile-adding extras in the new Farm & Commercial tire. Longer-lasting Diene Rubber in the Farm & Commercial tread adds many extra, low-cost miles. A cooler running tire shoulder design helps keep your tires on the road long after other tires are worn out.

On the farm, on highways or city streets, Shock-Fortified Nylon cord bodies and torque-toughened Diene Rubber work together to produce the money-saving miles you need. Every Firestone Dealer or Store has the right tire for you—it's available in all popular sizes. If you like, simply charge them or buy on easy terms. And remember, *you know what you're getting when you buy Firestone.*

# Firestone

YOUR SYMBOL OF QUALITY AND SERVICE

AUGUST 1963



SHBQ-GR3-RTKS

3

Материал, защищенный авторским правом



# POPULAR MECHANICS®

AUGUST 1963  
VOL. 120 NO. 2

INTERNATIONAL EDITIONS • AUSTRALIAN • SPANISH • CARIBBEAN • FRENCH • DUTCH

## Features of Special Interest



Deep Sub Rescue  
page 69

Sub Rescues—Four Miles Deep	69
Preview of the 1964 Cars	77
Next Year: The Classic Cord Returns	82
Detecting Bootleg H-Bomb Tests with "Black Boxes"	86
Mechanized Billy Goat	92
Pushbutton Eating Center	96
Surfboard Speedometer	99
He Makes Accidents Obsolete	101
Eight Games for Boaters	106
New Hydrostatic Drive for Cars	112
How to Buy a Good Used Camera	118
Music-Box Alarm Clock	176
Two-Mile Boat Horn	178

## For the Shop Craftsman

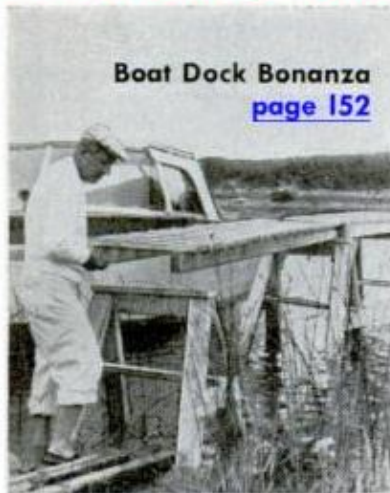

Boat Dock Bonanza  
page 152

Wind-Rotor Model Sailing Ship	124
Perking up a Plain-Faced Exterior	128
Lawn Cabana	131
Back-Yard Schooner for Children	136
Building a 12-m.p.h. Scoot-Car	138
Bleach-Bottle Bonanza	146
Tips on Buying or Building Docks, Piers and Floats	152
Trouble Shooting Auto Starters	158
Auto Clinic	162
Keeping Your Car up to Par	163
Folding Camp Stool	164
How to Stay Alive on a Ladder	166
Build a Wood Lathe for \$10.67	170
Magnifying Thickness Gauge	174

## Regular Departments

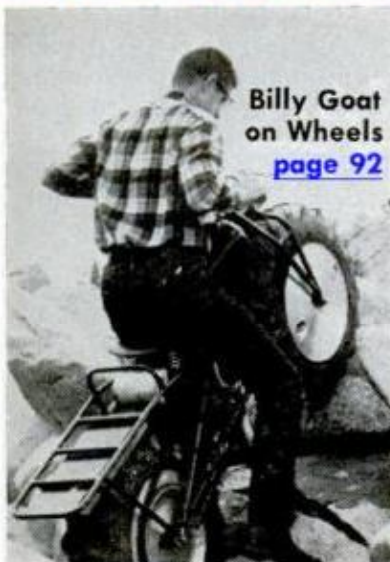

Billy Goat  
on Wheels  
page 92

Over the Editor's Desk	6
Science Worldwide	11
Items from All Outdoors	14
Sidelights from the Services	16
Spotlight on the Ford Pickup	20
Sidelights on Aviation	26
Detroit Listening Post	28
Tune in on the Inventors	30
Worth Writing For	41
What's New for Your Home	122
Solving Home Problems	134
New on the Market	145
What's New for Shutterbugs	150
Shopping for Tools	165
Electronically New	180
Clinic for Homeowners	184



**NEXT MONTH — Practical Home Improvers:** Tired of living in a carbon-copy home? September PM shows ways to convert to a distinctive exterior. Also, in a 42-page remodeling section are 21 week-end home-improvement specials, plus a beginning course in home-remodeling basics that every man should have handy—and lots more

**PORTUGUESE • DANISH • SWEDISH**

Published by Popular Mechanics Company

**RICHARD E. BERLIN**  
President

**RICHARD E. DEEMS**  
Executive Vice-President

**JOSEPH F. KERN**  
Publisher

**DON DINWIDDIE**  
Editor

**RICHARD F. DEMPEWOLFF** . . . . . Executive Editor  
**JOHN A. LINKLETTER** . . . . . Managing Editor  
**WAYNE C. LECKEY** . . . . . Shop Crafts Managing Editor  
**CLIFFORD B. HICKS** . . . . . Midwest Editor  
 740 N. Rush St., Chicago 11, Illinois  
**THOMAS E. STIMSON** . . . . . Western Editor  
 Suite 1003, 3460 Wilshire Blvd., Los Angeles 5, Calif.  
**HENRY NEHRBASS** . . . . . Art Director  
**KEVIN V. BROWN** . . . . . Aviation Editor  
**JAMES R. WHIPPLE** . . . . . Automotive Editor  
**LARRY STECKLER** . . . . . Electronics Editor  
**ALFRED W. LEES** . . . . . Home Workshop Editor  
**ARTHUR MIKESSELL** . . . . . Boating Editor  
**FRANK X. SMITH** . . . . . Production Editor  
**STUART JAMES, JOHN P. McNEEL**  
**ED NELSON, ARTHUR J. MAHER,**  
**ROBERT B. BERGER** . . . . . Assistant Editors  
**MURRAY COOPER** . . . . . Art Editor  
**LEO WEEKS** . . . . . Assistant Art Director  
**FRANK P. FRITZ** . . . . . Chief Photographer  
**J. C. BONFIGLIO** . . . . . Director, Bureau of Information

**L. PARK BENJAMIN** . . . . . Advertising Director

**ADDRESS COMMUNICATIONS TO:** 575 Lexington Ave., New York 22, N.Y. For additional sources of information on the articles in this issue, or the name and address of the manufacturer of a particular product, write to Bureau of Information, Popular Mechanics for free "Where-to-Find-It-List."

**SUBSCRIPTION SERVICE:** Mail all subscription orders, changes of address, correspondence concerning subscriptions, and Postmaster notices of undelivered copies to Popular Mechanics, 250 West 55th St., New York 19, N.Y.

**ADVERTISING OFFICES:** New York: 575 Lexington Ave., MUrray Hill 8-8500; Chicago: 740 N. Rush St., WHitehall 4-0100; Detroit: General Motors Bldg., TRinity 5-8711; Cleveland: Hanna Bldg., 1422 Euclid Ave., PRospect 1-0456; Los Angeles: 3460 Wilshire Blvd., DUmkirk 2-8458; San Francisco: 111 Sutter St., YUkon 2-0823.

Published monthly by Popular Mechanics Company, 575 Lexington Ave., New York 22, N. Y. Richard E. Berlin, President; Richard E. Deems, President of Magazines; Fred Lewis, Executive V-Pres. of Magazines; John R. Miller, V-Pres. and Gen. Mgr. of Magazines; Joseph F. Kern, V-Pres.; G. O. Markuson, Treasurer; R. F. McCauley, Secretary. Single copy in the United States and Canada, 35 cents. Subscription prices: United States and Possessions, \$4.00 for one year; \$7.00 for two years; \$9.00 for three years. Canada, add \$0.50 for each year. Pan-American Postal Union countries, add \$1.00 for each year. All other countries, add \$2.00 for each year. When changing address, give old address as well as the new, with postal-zone number, if any, and allow six weeks for change to become effective. Second-class postage paid at New York, N. Y., and at additional mailing offices. Authorized as second class mail by the Post Office Department, Ottawa, and for payment of postage in cash. Registered as Second Class matter at the Post Office at Mexico, D.F., Mexico, June 20, 1950. ©1963 by Popular Mechanics Company. All rights reserved. Printed in the United States of America.

# BACKSTAGE at PM . . .

We have yet to hear whether Midwestern cornfields have become one big concert hall as a result of our story in the May issue, *Growing Corn to Music*. (In the story, Midwest Editor Clifford Hicks told of George Smith's experiments in Normal, Ill. which indicated that corn yields can be increased as much as 17 percent when music is piped to the fields).

But from the South there comes a new—and quieter—way to make your corn behave differently.

It's with light. Red light, for instance, makes plants grow lean and tall, while blue light makes them grow squat. Violet light makes a plant bend, while yellow-orange spurs photosynthesis, seed germination and flowering.

Under a deep-red light, the corn plants virtually halt flowering and seed germination, while green light seems to have little effect at all on plant growth.

This new light on corn growing comes from the Department of Agriculture field station at Watkinsville, Ga., where 288 lamps in a "growing room" duplicate all degrees of sunlight.

It looks as if musical score and lighting are going to become as important on the farm as they are on Broadway.

As editors, we'll admit that we have a number of special problems (keeping you happy is number one). But seldom do we consciously take stock of how we're doing "dignitywise." So it shook us up a bit when one reader, responding to a readership survey, branded our *Editor's Desk* column of readers' letters as "childish," and suggested that we drop it to "keep up the dignity of the magazine."

We took a dignified look around the office, observed the editors in shirt-sleeves, and pondered the whole thing.

But, dignified or not, we concluded that we'll keep the forum open so that readers can sound off with a "that's great," or "that's awful." Your letters make this business a two-way exchange of ideas. And that, whether dignified or not, can be helpful for both of us!



# Over the Editor's Desk

## Tandem Bike Builders

Thanks for the article on how to build a tandem bike (page 176, April PM). I

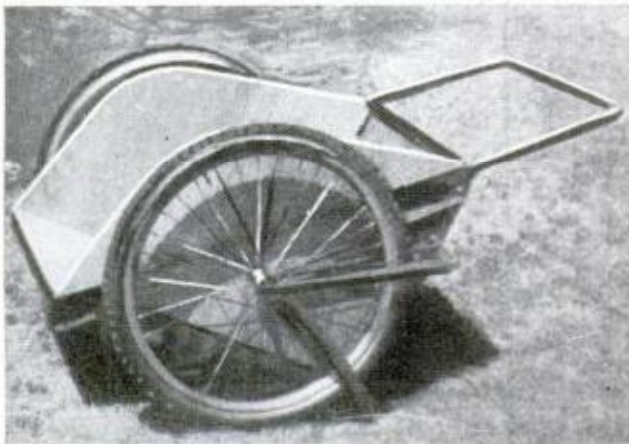

made mine from two girl's bicycles at a cost of \$8.

Since we have more grass than snow in Phoenix, I used the extra wheels and parts to make a grass buggy. By raising the handle up and over, the cart dumps easily. (And my boys now want a pony to pull the cart like a chariot.)

Phoenix, Ariz. WILLETT C. MUNSIL

Just a few lines about the fine article on making a tandem bike. I got by on \$5.78 for mine. By luck, my chain fit perfectly, so I eliminated the chain tensioner. Works fine.

I have read and enjoyed your fine magazine for years. Keep up the good work. New Philadelphia, Ohio T. J. LEHMAN

## Fastest Nonrecord

*I Water Ski 106 MPH* (page 126, March PM) is an exciting article, but contains some inaccuracies.

The author refers to the 106-miles-per-hour record set by Harold Peterson as one that still stands in APBA (American Power Boat Association) ledgers. The fact

is that APBA has nothing whatever to do with water skiing.

New York, N.Y. RALPH J. IANUZZI

Author Jack Speirs reports that Mr. Peterson believed his wild slide across water was an APBA record because it was set at a drag-boat race sanctioned by APBA and sponsored by a club that's a member of APBA and timed by a man who's an official APBA timer. But Mr. Ianuzzi, public relations chairman for the APBA, is right—it isn't an APBA record, because they don't keep such records. The important thing is, can anyone top it?

## An Old Saw for Pondering

During lunch hour the other day, we were discussing *Home Workshop Tools You'll See Tomorrow* (page 106, April PM) when someone happened to notice a handyman named Chen sawing a new desk top with a pull saw that cuts on the upstroke. Mr. Chen's saw, which dates back about 1000 years, has rip teeth on one side and crosscut on the other, a convenience the students at Illinois Institute of Technology's Institute of Design might well ponder.

A.P.O., San Francisco, J. G. CARPENTER, LCDR, USN  
R. J. ELLIOTT, LT, USN  
Calif. V. L. THOMPSON, MNC, USN

Okay, Navy, we'll pass along the word on Mr. Chen's saw, and they'll probably ponder it well. We think they did some dandy pondering on that batch of futuristic tools you saw in April.

## Air-Car Fans

Recently our 12-year-old son, Dan, made an air car from your plans (page 160, Jan. 1962 PM). He used balsa wood and cardboard tubes to make the model.

He did some experimenting with it and found that it tended to follow the downhill

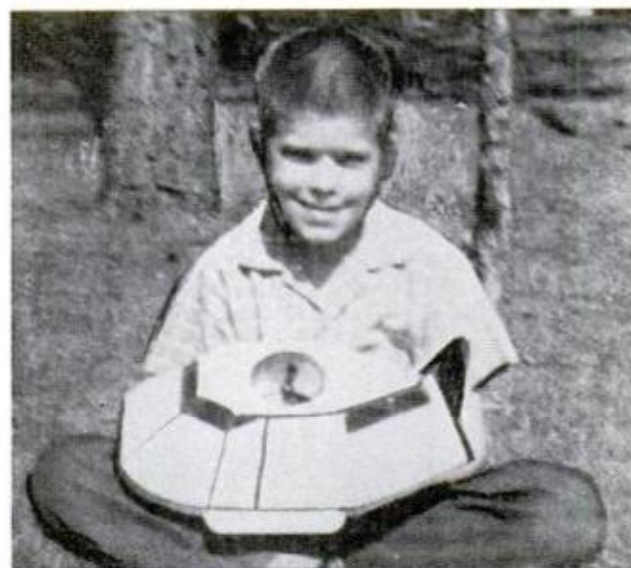

(Please turn to page 8)

POPULAR MECHANICS



# Great NEW Idea from CTI

...to help you get and hold a fine job  
(or start a business of your own) in  
**Air Conditioning and Refrigeration!**

"Practice" Your Way  
to Bigger Pay!



Here Is Your  
"Training Shop"



REAR  
VIEW

EXCLUSIVE  
CTI FEATURE!

## 25 KITS WITH SHOP PROJECTS

Illustrated above is a view of the new CTI condensing unit, fully assembled. This is a commercial-type, heavy-duty, 1/4 h.p. unit. You build it from 25 kits of parts (and with tools) that CTI sends without extra cost. In addition, CTI includes 25 Shop Projects, which simulate the kind of problems you are likely to encounter in the field. After assembling your condenser, you may then build an air conditioner, freezer, refrigerator or milk cooler.

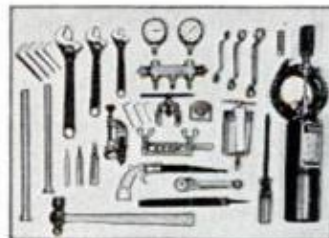

### Tools Are Included

You receive wrenches, tube flaring tools, hammer, tubing, fittings, gauges and many other items used by the experienced mechanic. Everything is of professional quality. Best of all, CTI trains you to use tools with speed and skill.

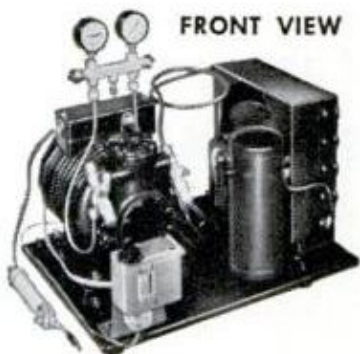

FRONT VIEW

## Go in Business



Because air conditioning and refrigeration is expanding so rapidly all over the nation, opportunities to go in business are plentiful. Many CTI graduates have accomplished this high aim. Start in a small way, from your own home, and gradually expand. In time you may wish to add a sales division. Manufacturers offer attractive franchises, including merchandising aids, to ambitious, qualified men.

## You learn by practicing with operating equipment

Thousands once learned this rewarding craft just by completing home study lessons. But CTI goes a step farther—and an important step it is! CTI also sends you 25 kits of tools and parts. You build these parts into an operating unit. It's a practical method because you get experience as you train.

## Earn Cash in Spare Time

Soon after enrolling, many CTI students earn money in spare time. Some handle servicing on a monthly fee basis for food stores, restaurants, taverns and office buildings. Many work part time at local dealers. Quite a number of CTI students have a full-time business going by the time they graduate. CTI kit training gives you the practice and experience you need to step from lesson study to actual field work.

## 3 FREE BOOKLETS

Get complete information—read it—and then decide. The facts are free. Mail coupon for 3 opportunity booklets. Act today.



### PROOF FROM GRADUATES

CTI has prepared a fascinating, new booklet called "Proof from Graduates." In their own words, CTI graduates tell you how training has helped them to better jobs, higher pay, or a business of their own. Send coupon for your copy.

COMMERCIAL TRADES INSTITUTE CHICAGO 26, ILLINOIS  
Accredited Member National Home Study Council

MAIL  
COUPON  
TODAY

### COMMERCIAL TRADES INSTITUTE

1400 GREENLEAF AVENUE DEPT. R-224  
CHICAGO 26, ILLINOIS

Send me your 3 free booklets: Success in Air Conditioning & Refrigeration, Proof from Graduates, and Lesson Samples.

NAME \_\_\_\_\_ AGE \_\_\_\_\_

ADDRESS \_\_\_\_\_

CITY \_\_\_\_\_ ZONE \_\_\_\_\_ STATE \_\_\_\_\_





# RIDGID

... the  
Drop Head Threaders  
that give you  
Easy-to-Reverse  
Dies ...

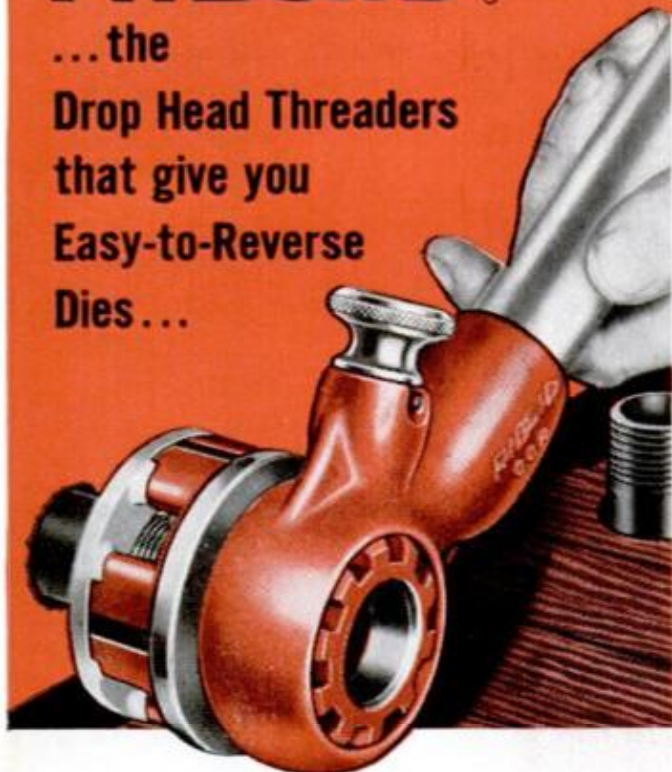

## You can thread right up to a wall ... even thread close nipples!

You'll like these extra-handy reversible **RIDGID** Dies. Granted, this feature is primarily for emergency use. But when it's needed, it's needed badly. Dies are easily reversed with a screw driver. Then you can thread right up to a wall. What's more, it's the fast, sure way to recut bruised or battered threads.

Light and easy to carry, **RIDGID** Drop Head Threaders are extra-rugged for long service-life. Heads lock in . . . can't fall out until released. Reversible ratchet action gives fast, easy threading and back-off, even in tightest spots. For guaranteed accuracy . . . each set of **RIDGID** long-wearing dies is fully work-tested before shipment. Straight thread dies available.

### Your Choice of Exposed or Enclosed Ratchet Designs

3 Exposed Ratchet Models: OO-R for  $\frac{1}{8}$ "-1"; 111-R for  $\frac{1}{8}$ "- $\frac{1}{4}$ "; 12-R for  $\frac{1}{8}$ "-2"

2 Enclosed Ratchet Models: O-R for  $\frac{1}{8}$ "-1"; 11-R for  $\frac{1}{8}$ "- $\frac{1}{4}$ "

See them at your Dealer's. For your convenience, he maintains a complete stock of **RIDGID** Work-Saver Tools.

# RIDGID

The Ridge Tool Company, Elyria, Ohio, U.S.A.

slope on an inclined plane and that weights caused it to move in the direction of the weighted side.

Cartersville, Ga.

MRS. EARL GEER

*Even the big ones we've been in tend to follow a downhill slope and move in the direction of a weight that causes them to tilt. (Some are steered by tilting.) If Dan can get his air car to move up a steep slope, he's got something!*

Here's an air car that I constructed. Among the changes I made is a plastic covering over the car's body and an ex-

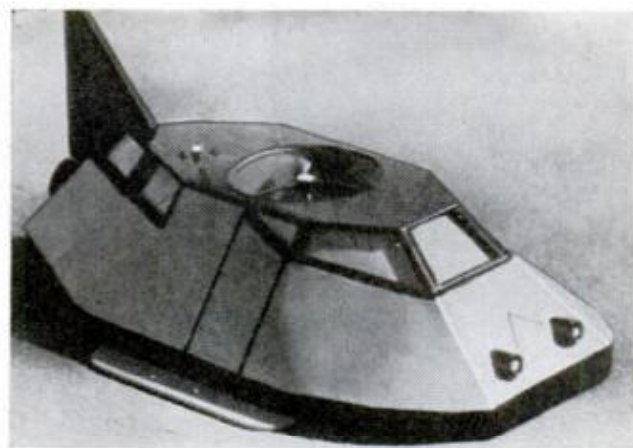

tended needle valve coming out of the front of the car.

I have had hours of fun building it and flying it. I hope that you continue to print similar plans of flying models.

New York, N.Y.

NICHOLAS DOUSMANIS

## Roughriders Are Safer?

Just happened to read your June auto reports, and I have a few words on cars.

People have been lulled into a peaceful, deathdealing bliss by the luxury of modern autos. There is no vibration or other annoying indication of movement.

I like to feel the little tremor in the wheel that lets me know what is going on underneath me. I like to have a sufficient lack of cushioning between myself and the frame of the car so that I can tell when something is going wrong, like a flat tire, or loose front-end connections.

I'd suggest comparing accident statistics to see how sports-car drivers stack up alongside luxury-car drivers. Sports-car drivers must learn to drive the car; the car doesn't drive them.

I contend that people have lost the knack of proficiently handling a car, sacrificing this knack for luxury and comfort. Point Mugu, Calif.

TIM O. RUSSELL

*What about it, luxury-car drivers—do you feel you are losing your touch?*

*The Editor*

POPULAR MECHANICS



"YOU'RE NOTHING  
BUT AN  
ECONOMY NUT"



"I CAN'T HELP IT.  
AUTOLITE  
MADE ME THAT WAY"



**OBVIOUSLY, CLEAN SPARK PLUGS SAVE GAS. THE PROBLEM IS TO KEEP THEM CLEAN.** Spark plugs seldom wear out. They foul out. Slow speed city driving loads them up with unburned fuel and other deposits. The plugs short out. Your gas goes out the exhaust pipe. To solve this problem, Autolite engineers developed a new kind of spark plug. The Autolite Power Tip. The spark plug that actually cleans itself

while you drive. The spark plug with the longer firing tip that uses the heat of engine combustion to burn fouling deposits away. Drive in the city? Notice that a gallon of gas doesn't go as far as it used to? Guess what. You've got 'em. Deposits. If you're in no hurry to meet 'em again, just drive in and ask your dealer for Autolite Power Tip, the thrifty, long-lasting spark plug that actually cleans itself while you drive.

SPARK PLUGS • BATTERIES • SERVICE PARTS



**AUTOLITE**

THE NAME TO REMEMBER WHEN YOU CARE FOR YOUR CAR

PRODUCTS OF  MOTOR COMPANY

AUGUST 1963

9



GET READY FOR THE SPACE and SCIENCE ERA! SEE SATELLITES, MOON ROCKETS CLOSE-UP



# AMAZING SCIENCE BUYS

for FUN, STUDY or PROFIT



## See the Stars, Moon, Planets Close Up! 3" ASTRONOMICAL REFLECTING TELESCOPE

Photographers! Adapt your camera to this Scope for excellent Telephoto shots and fascinating photos of moon!

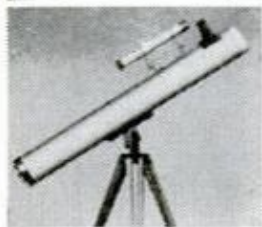

**60 TO 180 POWER:**  
Famous Mt. Palomar Type!  
An Unusual Buy!

See the Rings of Saturn, the fascinating planet Mars, huge craters on the Moon, phases of Venus. Equatorial Mount with lock on both axes. Aluminized and over-coated 3" diameter high-speed f/10 mirror. Telescope comes equipped with a 60X eyepiece and a mounted Barlow Lens. Optical Finder Telescope included. Hardwood, portable tripod. FREE with Scope: Valuable STAR CHART plus 272-page

"HANDBOOK OF HEAVENS" plus "HOW TO USE YOUR TELESCOPE" BOOK.

Stock No. 85,050-H ..... \$29.95 Postpaid  
4 1/4" REFLECTING TELESCOPE—Up to 255 Power.  
Stock No. 85,105-H ..... \$79.50 F.O.B., Barrington, N.J.

## BUILD A SOLAR ENERGY FURNACE

A fascinating new field. Build your own Solar Furnace for experimentation—many practical uses. Easy! Inexpensive! Use scrapwood! We furnish instructions. This sun powered furnace will generate terrific heat—2000° to 3000°.

Fuses enamel to metal. Sets paper aflame in seconds. Use our Fresnel Lens—14" diameter . . . f.1. 14".

Stock No. 70,130-H . . . . . Fresnel Lens . . . . . \$6.00 Postpaid

11" Sq. Fresnel Lens F.L. 19" slight second

Stock No. 70,533-H . . . . . \$4.75 Postpaid

## LARGE SIZE OPAQUE PROJECTOR

Ideal for photographers, this low-cost unit projects 3 1/2 ft. sq. image at 6 ft.—7 1/2" ft. sq. image at 12 ft. Projects photos, drawings, sketches, clippings, any opaque copy up to 6" x 6"—larger pieces in sections. Lenses are 2 plano-convex, 3 1/2" dia. mounted in 5 1/4" barrel. Projector is 11 1/2" high, 13 1/4" wide, 9" front to back, pressed steel in black wrinkle finish, bakelite handle. Uses two 200 watt bulbs—not included. Complete with side platform to hold illustrations, 6 ft. elec. cord, heat resist. plate glass mirror.



Stock No. 80,066-H . . . . . \$42.00 Postpaid

## WAR SURPLUS AMERICAN-MADE 7x50 BINOCULARS

Big savings! Brand new! Crystal clear viewing—7 power. Every optical element is coated. An excellent night glass—the size recommended for satellite viewing. Individual eye focus. Exit pupil 7mm. Approx. held at 1,000 yds. is 376 ft. Carrying case included. American 7 x 50's normally cost \$274.50. Our war surplus price saves you real money.

Stock No. 1544-H . . . . . Only \$74.80 Postpaid (Tax included)

6 x 30 Binoculars—similar to above and a terrific bargain.

Stock No. 963-H . . \$33.00 Postpaid (Tax inc.)



## MINIATURE WATER PUMP

Wonderful for experiments, miniature waterfalls, fountains. Christmas gardens, HO gage railroad backdrops, hobbyists, labs, schools. Pumps continuous flow of water etc. Tiny (2 5/8" x 1 3/4") electric motor and pump ideal for hobbyists, labs, schools. Pumps continuous flow of water at rate of one pint per minute at a 12" head. With 2 D Batteries in series will pump to 24" high. Works in either direction. Stock No. 50,345-H . . . . . \$2.25 Postpaid

## MINIATURE SUBMERSIBLE WATER PUMP FOR HOBBIES, EXPERIMENTS

Sturdily built, self-priming, electric water pump. Ideal for science classes, advertising exhibits, miniature waterfalls, fountains, etc. Operates under water on 8 to 20V AC. At 20V, pumps 1 pint per minute at 12" head. Spare valve, spring and instructions included. Plastic, 2 1/2" lg., 1" dia.; wt. 1 1/4-oz.

Stock No. 60,307-H . . . . . \$2.98 Postpaid

Order by Stock No.—Send Check or M.O.—Money-Back Guarantee

**EDMUND SCIENTIFIC CO., Barrington, New Jersey**

## MAIL COUPON FOR FREE CATALOG "H"

New! 1000's of Bargains 164 Pages

EDMUND SCIENTIFIC CO., Barrington, N. J.

Please rush Free Giant Catalog "H"

Name .....

Address .....

City..... Zone..... State.....



## 'FISH' WITH A WAR SURPLUS MAGNET Go Treasure Hunting On The Bottom

Great idea! Fascinating fun and sometimes tremendously profitable! Tie a line to our 5-lb. Magnet—drop it overboard in bay, river, lake or ocean. Troll it along the bottom—your "treasure" haul can be out-board motors, anchors, fishing tackle, all kinds of metal valuables. 5-lb. Magnet is war surplus—Alnico V Type—Gov't. Cost—\$50. Lifts over 125 lbs. on land—much greater weights under water. Order now and try this new sport.

Stock No. 70,570-H. 3 1/2 lb. size ..... \$ 8.75 Postpaid  
Stock No. 70,571-H. 5 lb. Magnet ..... \$12.50 Postpaid  
Stock No. 70,572-H. 7 1/2 lb. Magnet ..... \$18.75 Postpaid  
Stock No. 85,152-H 15 lb. size lifts 250 lbs. \$33.60 FOB

## ASTRO-COMPASS AND TRANSIT

War surplus! Astro Compass alone cost Gov't. \$75. We have added a Sighting Level to improve versatility. Hundreds of uses in carpentry, brick laying, foundation work, grading, irrigation or drainage. Much below cost of ordinary surveying instruments. Ideal for do-it-yourselfers, 10 1/4" high, 6" long, 4" wide. Adjustable leveling platform—2 spirit levels for aligning—also spirit level in sighting attachment. Tremendous bargain.

Stock No. 70,267-H . . . . . \$19.95 Postpaid

## BIOLOGICAL FUEL CELL AMAZING "BUG-BATTERY" GENERATES ELECTRICITY WITH BACTERIA



New Biological Fuel Cell Fascinates science classes and home experimenters. Waste organic material impregnated with bacteria, when fed an activator solution, produces electrical current. Generates approx. 6-volts at 40 milliamps, will operate most 6-volt transistor radios. Easily assembled kit includes: 12 plastic cylinders (approx. 3 3/4" high x 2" diam.) with anodes, cathodes, hardware, connecting wire and enough organic material and activator to produce full potential. (First cell is still running after 6 mos.) Also includes bulb and holder, demonstration electric motor, switch, whirling disc and instructions.

Stock No. 70,617H . . . . . \$21.50 Postpaid

Fuel Cell only—does not include motor, switch, whirling disc.

Stock No. 70,616H . . . . . \$17.95 Postpaid

## OPAQUE PROJECTOR

Projects illustrations up to 3" by 3 1/2" and enlarges them to 35" x 30" if screen is 6 1/2 ft. from projector; larger pictures if screen is further away. No film or negatives needed. Projects charts, diagrams, pictures, photos, lettering in full color or black-and-white. Operates on 115 volt, A.C. current. 6-ft. extension cord and plug included. Operates on 60 watt bulb, not included.

Size 12" x 8" x 4 1/2" wide. Weight 1 lb., 2 oz. Plastic case with built-in handle.

Stock No. 70,199-H . . . . . \$7.95 Postpaid

## DIAGNOSE HIDDEN TROUBLE WITH PROFESSIONAL STETHOSCOPE

Designed for use by physicians, this super-sensitive stethoscope is ideally suited for detecting faults in machines and engines, and in fluid, air and gas leakage. Dozens of uses in auto repair shops, labs, and for hobby and educational applications.

Stock No. 50,270-H . . . . . \$6.95 Ppd.

BARGAIN PRICE STETHOSCOPE—excellent value

Stock No. 50,223-H . . . . . \$2.95 Ppd.

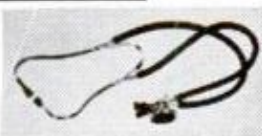

## WOODEN SOLID PUZZLES

12 Different puzzles that will stimulate your ability to think and reason. Here is a fascinating assortment of wood puzzles that will provide hours of pleasure. Twelve different puzzles, animals and geometric forms to take apart and reassemble, give a chance for all the family, young or old, to test skill, patience, and, best of all to stimulate ability to think and reason while having lots of fun. Order yours now.

Stock No. 70,205-H . . . . . \$3.00 Postpaid



## SOLAR CELL SET HARNESES POWER OF THE SUN

Conduct spell-binding experiments, experience endless fascination in converting sunlight into electricity to power small motors, amplifiers, make light meters, densitometer, burglar alarms, etc. Used experimentally to drive cars, power boats. Low price set includes SILICON SOLAR CELL and SUN BATTERY (Produces .2 to .45V 10-16 milliamps) SELENIUM SOLAR PHOTOCELL (lower power) and 112-page Handbook of Projects, demonstrations, experiments, etc. Also incl. CADMIUM SULPHIDE PHOTO CONDUCTIVE CELL (light sensitive resistor) which generates electricity to turn lights on in the evening, open doors, count traffic, etc., etc.

Stock No. 60,291-H . . . . . \$7.95 Postpaid

ORDER BY STOCK NUMBER. SEND CHECK OR MONEY ORDER. SATISFACTION GUARANTEED.  
**EDMUND SCIENTIFIC CO., BARRINGTON, N. J.**





**The uproar** over the so-called hallucinatory drugs continues. One such drug, LSD-25, which has been undergoing research as a possible tool in psychiatric therapy, is now being widely bootlegged in large cities and on some university campuses, according to a recent article in the *Archives of General Psychiatry*. The use of these illusion-producing drugs has been roundly condemned by medical and psychiatric authorities. They cited the disagreeable and often dangerous side effects, especially among psychologically disturbed persons.

The hallucinatory drugs, such as LSD-25 and mescaline, produce a state of mind described as "all-powerful, godlike." But indiscriminate use, experts say, can result in mental illness and even death. One dose of LSD-25, which stands for lysergic acid diethylamide, could cause a latent psychotic person to disintegrate mentally, says Dr. Roy R. Grinker, chief editor of the *Archives*.

**Could an astronomer** on Mars detect life on earth? Not with our present astronomical equipment, says Carl Z. Sagan of the Harvard University Observatory. Of 80,000 photos of the earth taken from Tiros satellites, only one showed a possible indication of biological life, he said.

Martian astronomers might be able to see light reflections from some large cities and, conceivably, light from atomic explosions, but these would not be conclusive proof that such a being as man lived on the earth, says Prof. Sagan. (Tiros vehicles orbit between 350 and 600 miles up. At its closest approach, Mars is still some 35 million miles from the earth.)

**Chromosome analysis**, a technique for spotting genetic deficiencies in the laboratory, can reveal whether or not a parent is likely to have a mongoloid child. This disorder is the result of abnormalities in the chromosomes, the cell parts that transmit hereditary traits from parent to child.

Normal human cells contain 46 chromosomes. Mongoloid children either have

cells containing one extra chromosome or a greatly enlarged one. By chemical treatment and microscopic examination of a parent's blood cells, scientists can tell whether either parent has enlarged chromosomes. If so, the chances are one in three that a child born to them would be mongoloid. (A few mongoloid children are born to normal parents as a result of a random error in cell division just before the moment of conception.)

**How Korean women divers** are able to stay underwater for several minutes at a time in water that's as cold as 50 degrees is being studied by Korean and American physiologists. So far, the study has shown that the women have coarse, heavily pigmented skin with a thick underlayer of fat. They produce more body heat than the average person, and for longer periods of time. In winter, their basal metabolic rate is 40 percent above normal.

**Flounder a la AEC.** You may someday dine on fresh, unfrozen fish a month or longer after it's caught. The Atomic Energy Commission has developed a radiation bath to keep fish fresh from four to six weeks without refrigeration. The fish, says the AEC, keeps in flavor, and the radiation has no harmful effect on diners. A \$60,000 fish irradiator is being built in Massachusetts to test the bath's commercial possibilities.

**Italy** is getting into the space game with a new twist—satellites within satellites. Italian scientists are preparing such vehicles for launching next year from a Texas Tower in the sea off East Africa to achieve orbit around the equator.

The project is designed to study air drag along the orbital path, a measurement considered extremely difficult but highly important by American scientists. An inner satellite will orbit independently shielded from drag, while the outer element will be subject to the tenuous pull of atoms and molecules in the high-altitude air. Comparisons between the two will be radioed back to earth.

**America's Mt. Everest team** may have brought back data that will prove that much of the tritium contained in rainfall comes from the sun. Climbers collected 40 samples of glacial ice for Nobelist Dr. Willard F. Libby who believes solar flares, as well as cosmic rays, are a source of tritium fallout. Everest's annual frozen rains are followed by dust storms which mark the layers of each year's ice formation. Dr. Libby's theory would be vindicated.

(Please turn to page 12)



# RCA introduces a new easy way to learn electronics at home

Learn faster, remember more with this revolutionary new "learning method!" And RCA Institutes is first to bring it to you! Forget all your old ideas about learning! The newest method, RCA "Autotext", uses the latest scientific development in the field of home training! RCA "Autotext" is a system of programmed instruction that helps you learn more quickly with less effort.

Complete Home Training Course using new RCA "Autotext" now available! "Introduction to Electronics" gives you the advantages of RCA "Autotext" plus Experiment lessons, service practice lessons, and all the kits you need! Send for complete information now and FREE SAMPLE Home Training lesson!

Wide Choice of Home Training Courses in Electronics! In addition to "Introduction to Electronics" RCA Institutes offers this complete selection of Home Training Courses:

- Electronic Fundamentals
- TV Servicing
- Color TV
- Transistors
- Electronic Drafting
- Communications Electronics
- FCC License Preparation
- Mobile Communications
- Automation Electronics
- Computer Programming

RCA Institutes Liberal Tuition Plan affords you the most economical possible method of home study training! You pay for lessons only as you order them. If you should wish to interrupt your training for any reason, you do not owe one cent!

Classroom Training Available in New York City, Los Angeles, and Cherry Hill (near Camden) New Jersey. Check "Classroom Training" on the coupon and information will be rushed to you.

SEND FOR FREE ILLUSTRATED BOOK TODAY! SPECIFY YOUR CHOICE OF "AUTO TEXT", HOME TRAINING, OR CLASSROOM TRAINING!

RCA INSTITUTES, INC., Dept. PM-83  
A Service of Radio Corporation of America  
350 West 4th St., New York 14, N. Y.  
Pacific Electric Bldg., 610 S. Main St.,  
Los Angeles 14, Calif.



THE MOST TRUSTED NAME  
IN ELECTRONICS

RCA INSTITUTES, INC., Dept. PM-83  
350 West 4th St., New York 14, N. Y.

Rush me FREE information about "Autotext"  
Home Training \_\_\_\_\_, Classroom Training (Choice of  
City) \_\_\_\_\_, No salesman will call.

Name .....

Address .....

City..... Zone.... State.....

CANADIANS: Take advantage of these RCA Institutes Home Study Courses at no additional cost. No postage, no customs, no delay. Fill out coupon and send in envelope to: RCA Victor Limited, 5581 Royalmount Ave., Montreal 9, Quebec.

## Science Worldwide

(Continued from page 11)

cated if the glacial layers show a marked increase in tritium content coinciding with years of high sun-spot activity. Dr. Libby will be looking for a tritium concentration of one atom in a billion billion atoms of glacial water.

Heartbeats of whales may explain mysterious thumping noises detected by electronic gear in the Atlantic and Pacific. A Bell Telephone Laboratories official recently reported that scores of pulsing thumps have been recorded in the sea off New England. The sounds move at speeds of a few knots in random fashion, suggesting a biological source. He noted a similarity of timing between the thumps and the pulse rates recorded in an electrocardiogram of a diving finback whale.

Machines haven't made man obsolete, at least not yet. One champion of man's usefulness in the space age, a government scientist, put it this way: "Human limbs have extremely rapid feedback control coupled with infinitely variable power out-put and are guided by sensitive multi-channel sensors." Makes a man proud to be human.

Secrets from the deep may be revealed with a new instrumented submarine buoy developed in Norway. Several such buoys will be anchored at various depths in the North Atlantic between the Faroes and Shetland islands. Designed for pressure at depths of 3200 feet, the cylinder-shaped buoys will store tape-recorded data for at least two months on the force and direction of deep ocean currents, water temperatures and salinity. Recordings must be retrieved for study, but next year an attempt will be made to transmit data direct to shore from the buoys.

Worn-out uranium may help eliminate the smog problem. The AEC reports that depleted uranium could be used as a catalyst in devices attached to automobiles to rid their exhausts of smog-producing elements. Tests show that uranium does the job satisfactorily.

You win, grandma. An old saying had it that you cured a sty on the eye by rubbing a gold ring over it. Now, it seems, the saying is more than an old wives' tale. Researchers at Mayo Clinic tried the treatment on hundreds of staff members and patients suffering from sties. In 92 percent, the swelling disappeared. The clinic researchers came up with a scientific reason:



Chlorine is one of the few substances capable of dissolving gold in microscopic quantities. There's just enough chlorine in salt tear crystals to form traces of gold chloride, basis of many eye medications.



**TV in the hole.** Electronics researchers have designed two television cameras that can be lowered into boreholes to give geologists a worm's-eye view of what's happening underground. The cameras show what rock fractures look like, what minerals are present, why recovery of oil is poor, or how drilling bits are lost.



**Large residues** of DDT and other insecticides have been found in sharks, tuna and other ocean fish, a mystery scientists can't explain. Some fish had concentrations of up to 200 parts per million, well above the government limit of 10 ppm or less for most edible meats.



**Crabgrass**, noxious weeds and hungry insects would most likely make up man's visible world following nuclear war. Trees, flowers, vegetables, shrubs and other plants would probably be wiped out. This cheerful prospect has been described in recent studies made at Brookhaven National Laboratories which indicate that

foliage plants are not nearly so resistant to radiation damage as had been thought. Pine trees are the most sensitive and can be killed by a steady diet of 20 to 30 roentgens of radiation a day. Hardy grasses and weeds, however, can withstand several thousand roentgens a day.



**Don't live on a mountaintop** if you want to be smart, seems to be what experiments at a two-mile-high laboratory have demonstrated. In tests at the University of California's White Mountain Research Station, it's been shown that the brain matures more slowly in young animals taken to great heights. Tests indicated that the brains were delayed in maturing both among mountain-born animals and those taken to high altitudes soon after birth. Scientists say lack of oxygen may delay the growth of nerve fibers in the brain.



**A mechanical "mother's heartbeat"** to lull babies to sleep has been developed by a Japanese company. The battery-operated device throbs audibly, and when placed in the crib will give an infant a sense of security that entices sleep, the firm says.

John P. McNeel  
Science Editor

## NEW...BETTER WAY TO HANG TOOLS ON PEG-BOARD

*DELRIN\* fixtures will not drop out when tools are removed*

These exclusive Delrin plastic fixtures for 1/8" Peg-Board—products of Masonite and Du Pont research—bring you new advantages for easy, secure tool storage. Here's why:

- ✓ Positive stabilization—better than any other fixtures
- ✓ Can be inserted easily in four directions, not just one, as with other fixtures
- ✓ Pleasing Delrin neutral color—won't tarnish or corrode
- ✓ Great strength—yet light in weight
- ✓ Smooth plastic—won't scratch or cut user—won't damage panel or chip paint



**MASONITE**  
*shows the way!*

\*Delrin is a registered trademark of E. I. du Pont de Nemours & Co. (Inc.)  
Masonite and Peg-Board are registered trademarks of Masonite Corporation



### MAIL COUPON FOR SAMPLES AND LITERATURE

Masonite Corporation  
Dept. PM-8, Box 777, Chicago 90, Ill.  
Please send me two sample Delrin Peg-Board fixtures—full-color Peg-Board idea booklet. I enclose 10¢.

Name \_\_\_\_\_

Address \_\_\_\_\_

City \_\_\_\_\_ Zone \_\_\_\_\_

County \_\_\_\_\_ State \_\_\_\_\_



# Items from All Outdoors

**Rent camping equipment** for a week before you buy. You don't have to take a \$500 plunge for gear just because the family has been needling you to take them on a camping trip.

In almost every city and town in the U.S. you can find equipment rentals. A good 10 by 10-foot tent will rent for about \$22 for one week. Four sleeping bags and air mattresses will cost about \$34. A two-burner gas stove is about \$4.50, and a gas lantern is about \$3.75. Your total expenditure is about \$64.25, and you'll have a chance to make certain that you really enjoy camping. Many sporting-goods dealers will also apply 90 percent of the rental cost to the purchase price of the equipment if you decide to buy after your trial.

**New Mexico** continues to lead the country in active planning for the future of hunting. We reported some months ago that their Department of Fish and Game was having great success with imported

Barbary Sheep (several hundred hunting permits issued last year), Siberian ibex and francolin hens.

We have now been notified that they will import eight kudu and eight oryx (long-horned antelope) from Africa as a basic breeding stock. There is little doubt that within 10 years New Mexico will be the country's hunting paradise.

**Husbands who object** to the lacquer women now use on their hair will appreciate the report from several lady campers that the stuff attracts droves of insects despite application of insect repellent.

**Unusual game cookery** is a hobby with us, and here's one we tried recently. *Marinated Rattlesnake*: Cut the head from rattler, hang until well drained, then skin. Prepare a sauce with ¼ tsp. of ground pepper, a dash of nutmeg and the juice of four oranges and one lemon. Cut the meat into one-inch chunks and marinate in the sauce for three hours. Remove the meat, drain and wipe dry. Salt and dip chunks in egg, roll in bread crumbs and sauté until brown. It tastes like chicken or tuna.

STUART JAMES  
Outdoors Editor



## Now! HOLLEY ANNOUNCES switches and ignition parts for all cars and trucks

Now you have a one stop source for switches and ignition parts built to fit any popular make or model car or truck . . . designed *exactly* to meet Holley's quality standards and priced right. Get all the facts on why Holley parts are the most efficient and economical to get with and stay with!

The parts you see are just a few of the many new performance-improved products continually coming to you from Holley.

Look to Holley for "Quality Service Parts"



HOLLEY CARBURETOR COMPANY,  
Warren, Michigan K/S-1

POPULAR MECHANICS



# BE THE MAN IN DEMAND

## Train at home for a high-paying job in one of these 4 major fields

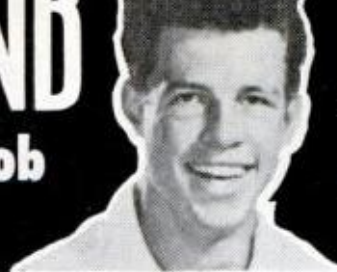

**N.T.S. TRAINED  
TECHNICIANS ARE  
HIGHER PAID ...  
MORE RESPECTED ...  
CONFIDENT  
OF SUCCESS**

START NOW in one of these "Big 4" Industries, and be among the most sought after technicians in America. As an N.T.S. Trained Technician you can enjoy higher pay, rapid promotion, lifelong security.

### N.T.S. TRAINS YOU RIGHT, FAST AND EASY!

Incomplete, "short-cut" training limits your earning power, even disqualifies you for top-pay jobs. N.T.S. gives you everything in *All Phases* ... to qualify you for any job in your field ... for greater profits the year round.

### BETTER, MORE COMPLETE, LOWER COST TRAINING

N.T.S. Home Training is proved and tested in N.T.S. Resident School Shops and Laboratories — the oldest, largest school of its kind in the world. You learn *all phases*, and receive everything you need — Lessons, Manuals, Diagrams, big professional Kits with parts, tools, instruments for experimental, repair, service, troubleshooting projects. Yet N.T.S. Training costs less; only 1 Low Tuition. Other schools make several courses from the material in each of our Master Courses.

## ELECTRONICS TELEVISION AND RADIO

YOU ARE NEEDED in All Phases of ELECTRONICS TELEVISION - RADIO ... Servicing, Communications, Broadcasting, Manufacturing, Automation, Radar and Micro Waves, Missile and Rocket Projects, plus all the other high-pay branches of this vigorous Industry. N.T.S. Shop-Tested Home Training gives you ONE MASTER COURSE ... at ONE LOW TUITION ...

**INCLUDES RADIO SET, TV SET, MULTITESTER.**



## AUTO MECHANICS AND DIESEL

TAKE YOUR CHOICE ... be a successful all-around mechanic in cars, trucks and heavy-engines. Or specialize in your favorite field ... Tune-Up, Automatic Transmissions, Farm Mechanics, Trucks and Buses, Stationary Installations, Foreign Cars, or get into Auto Air Conditioning, Engine Rebuilding, Diesel, and other high-pay fields, or go into business for yourself.

**INCLUDES SOCKET SET, ANALYZER, TOOLS.**



## AIR CONDITIONING

**REFRIGERATION  
ELECTRICAL  
APPLIANCES**

FUTURE BRIGHT FOR TRAINED MASTER TECHNICIANS ... over 30,000 new Technicians must be trained annually. You are needed to help service and repair the 50 million air conditioners, refrigerators and electrical appliances that will need fixing this year alone. You can go places in your own business or with a manufacturer, dealer, distributor or department store. With All-Phase training, your earning power is unlimited!

**INCLUDES TESTER, GAUGES, TOOLS.**

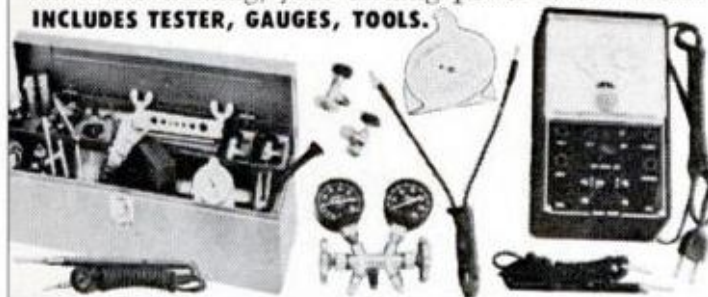

## HOME APPLIANCE TECHNICIAN'S COURSE

MILLIONS OF HOME APPLIANCES NEED FIXING ... Every home is your market for Full-Time career or spare-time "Second Income." All you need is a workbench, spare time and N.T.S. Home Training. Costs less than \$1.50 per week. Repair any home appliance—from toasters, electric irons to washing machines and even room air conditioners — right in your own workshop. Or take a high-pay job with appliance manufacturer or large service company.

**INCLUDES TOOLS, PROFESSIONAL TESTER, SOLDERING SET.**



## NATIONAL TECHNICAL SCHOOLS

WORLD-WIDE TRAINING SINCE 1905



### NATIONAL TECHNICAL SCHOOLS

WORLD-WIDE TRAINING SINCE 1905  
4000 So. Figueroa St., Los Angeles 37, Calif.

Accredited Member  
National Home Study Council

### RESIDENT TRAINING AT LOS ANGELES

If you wish to take your training in our famous Resident School in Los Angeles — the oldest and largest school of its kind in the world — check special box in coupon.

SEND FOR **FREE BOOK** (fully illustrated) and **ACTUAL LESSON**

ACTUAL LESSON



**NO OBLIGATION  
NO SALESMAN  
WILL CALL**

**CHECK ONE**

**National Technical Schools, Dept. B-83  
4000 S. Figueroa St., Los Angeles 37, Calif.**

Please rush FREE Book and Actual Lesson checked below. No obligation. No salesman will call.

- Electronics — TV — Radio
- Auto-Mechanics & Diesel
- Air Conditioning, Refrigeration & Electrical Appliances
- Home Appliance Technicians Course

Name \_\_\_\_\_ Age \_\_\_\_\_

Address \_\_\_\_\_

City \_\_\_\_\_ Zone \_\_\_\_\_ State \_\_\_\_\_

Check here if interested ONLY in Resident Training at L.A. High school home study courses also offered. Check for free catalog.





## Sidelights from the SERVICES

By William R. Kreh

**Hay-fever sufferers** may be in for some relief, thanks to the Navy's Polaris submarines. A 13-pound "spin filter demister" developed to keep air super clean on Polaris subs may be marketed commercially for attachment to room air conditioners. The device uses spinning disks to collect mists, pollens, bacteria and dust particles as small as 20 millionths of an inch in diameter. It has proved to be 99-percent efficient.

**"Bikini"** is the name given a new lightweight reconnaissance drone being tested by the Marine Corps. It was so named, the Corps says, because of "its simplicity and ability to cover strategic areas."

**Quiet, too!** Five goats, known as "vegetation specialists," are keeping the grass trimmed on bunkers containing hundreds of tons of explosives at Otis Air Force Base, Mass. The goats' job is too dangerous for lawn mowers, which might touch off an explosion.

**A sure-fire secret-eater** is now at work in the Pentagon. It's a paper-hungry, pulp-making machine known as Somat and it has replaced the military's old method of burning classified papers. Somat takes the classified documents and turns them into a soggy gray matter that looks like a batch of cereal that's been soaking all night. The machine can devour 500 pounds per hour.

**Black-widow spiders** have lost their place in the Army. Their webs, once widely used for cross-hairs on bomb sights and other optical instruments, are being replaced by extremely fine lines etched into glass with a newly developed process.

**Dropping dynamite** in the ocean is helping the Navy unlock the mystery of the way sound travels in water 4000 feet deep. Temperature and density of the sea at this depth is apparently ideal for long-distance transmission of sound throughout the ocean. To find out more about it, Navy planes are dropping explosives at various points in the Atlantic from Bermuda to Great Britain. Sounds of the explosions are "tracked" by underwater hydrophones located in various spots throughout the Atlantic.

**Army scientists** say they have tracked down several chemicals that would protect troops against nuclear radiation but they cause such severe side effects that they can't be used.

**Dishpan hands** are on their way out of the fleet. The Navy has perfected an automatic scullery that will completely take over the clean-up detail in mess halls. Sailors can dump traysful of left-overs, dirty dishes, soiled silverware, bones, milk cartons and toothpicks into it. Within minutes, the trays, dishes and silverware are washed, sterilized, dried, sorted and stacked, and the waste is ground up and either flushed out the ship's sewerage system or powdered and stored for later disposal. The machine can take care of the mess gear for 900 men in just an hour.

**It's the bark, not the bite** that counts in Air Force sentry dogs, so it's okay if the canines have their teeth extracted. Some of the dogs sent for training have been found to have worn, broken or missing teeth and there was some question whether they should be sentry dogs. But USAF higher-ups ruled that a sentry dog's primary function was to alert its handler and act as a psychological deterrent to intruders and that its ability to attack and hold an intruder was secondary.

**Veteran soldiers** say a Fort Knox, Ky., corporal may have hit on a new wrinkle for standing inspections. He finds that putting his boots in the refrigerator puts a hard shine on them and makes them "stand tall" without wrinkles.

**An Army biologist** has patented a method of putting glass windows in animals. His device, a window made of nonirritating tentallium, can be inserted into laboratory animals to permit observation and photography. The window can be inserted wherever a scientist wants to make an observation, and it can stay in the animal for extended periods without harm.

**Booms to the rescue.** The sonic boom, considered an irritant by many, led to the rescue of an Alaskan bush pilot recently. The pilot, forced down by a snowstorm, used his radio to contact the nearest Air Force station. Using radio fixes taken on the downed plane, an F-102 jet flew five-minute courses supersonically over predetermined routes. The downed pilot, on hearing the resulting boom from each flight, relayed the time of the boom to the Air Force radio dispatcher. By triangulation, it was then possible to pinpoint on a map the exact location of the pilot.



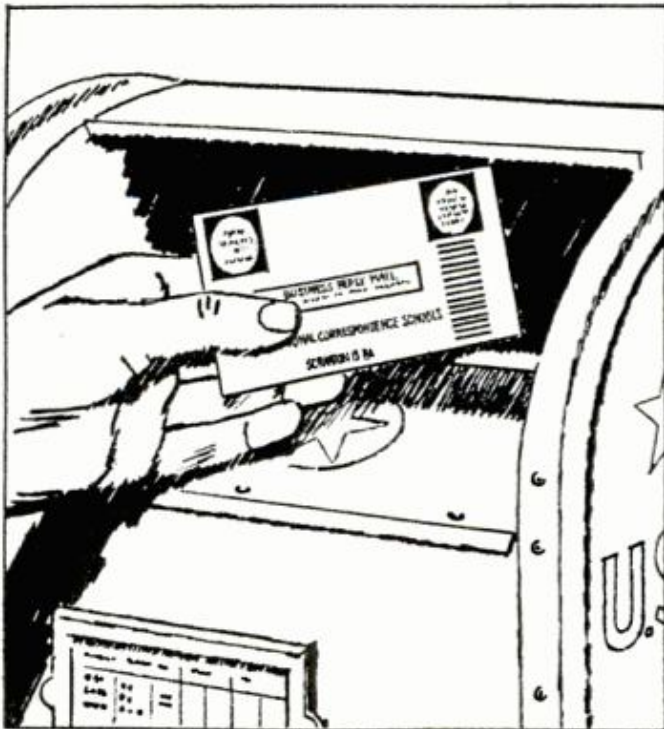

**Easy** If you're after the "good life" for yourself and your family, you'll never find an easier—or better—first step than filling in our card or coupon and sending for the free I.C.S. Success Kit.



**Tough** To be sure, you must be willing to devote some of your leisure time to mastering skills that will give you the power to demand more money and prestige in the business world.



**Worth it!** But we have testimonials from thousands of successful graduates with new jobs, higher salaries, happier families who are living proof that it's worth it!

INTERNATIONAL CORRESPONDENCE SCHOOLS

**I C S**

SCRANTON 15, PENNSYLVANIA

Accredited Member Home Study Council

Mark and mail our postcard or coupon today!

INTERNATIONAL CORRESPONDENCE SCHOOLS

Box N6752H, Scranton 15, Penna.

(In Canada: I. C. S. Canadian, Ltd., Montreal.

In Hawaii: P. O. Box 418, Honolulu)

Please rush me my FREE Success Kit containing 3 valuable booklets.

Name \_\_\_\_\_ Age \_\_\_\_\_

Street \_\_\_\_\_

City \_\_\_\_\_ Zone \_\_\_\_\_ State \_\_\_\_\_

Field of interest \_\_\_\_\_

Employed by \_\_\_\_\_

Working hours \_\_\_\_\_ A.M. to \_\_\_\_\_ P.M.

Special low rates to members of U. S. Armed Forces!





## Spotlight on the

# Versatile Ford Pickup

*For those who master it, this truck offers power, economy and the capacity for varied assignments*

By Ed Nelson

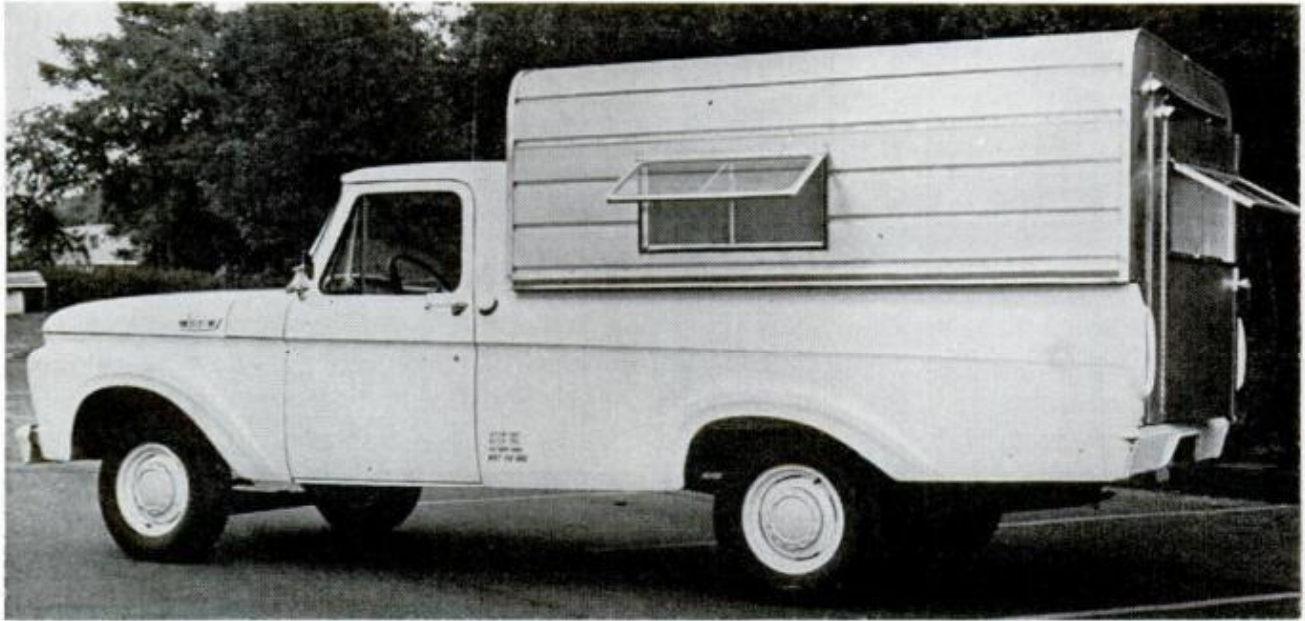

**ALTHOUGH IT'S SPACIOUS**, a camper body doesn't look ungainly on the 8-foot box of Ford's half-ton pickup. *PM* found it behaves well on the road, too

**F**ORD's F-100 half-ton Styleside pickup truck is a working buggy that'll take you almost anywhere you want to go. With optional extra-duty springs like the 1350-pound units on *PM*'s test vehicle, you can bring more along than you're likely to want. The bulk of a camper body is handled easily.

But don't expect a soft-riding passenger car with a box at the rear. The firm suspension emphasizes the F-100's descent from Ford's truck line. Seat belts would improve the comfort and safety over rough surfaces, where it's possible for you to be bounced clear of the seat. A surface rough enough to make the F-100 bottom, however, is hard to imagine. And, happily, there's lots of headroom.

The standard, 223-cubic-inch, 135-horsepower Ford in-line Six handles the pickup's weight (3389 pounds empty) with impressive ease through a medium-duty transmission, 11-inch clutch and 3.73:1 rear axle. Although the three available three-speed manual transmissions all are tagged *Synchro-Silent*, only the standard-duty gear box has synchromesh Low. The heavy-duty clutch is paired with a heavy-duty spring that calls for extra effort by any light-duty drivers.

Automatic transmission is available (priced at \$243.40), but the F-100 still wouldn't be the housewife's dream. A relatively small turning circle makes it maneuverable, but she'll still

[\(Please turn to page 22\)](#)



# It is now easier than ever to start a business of your own

## Free Book Tells How

Shows the way to start in spare time without giving up your job—how to build to a profit of \$250.00 for a 40 hour week in a one man operation—(more if you hire others to do the work)—how we finance nearly three-fourths of total cost and let you pay the balance out of profits. Yes, it's easier to start and it's easier to succeed because of the backing and the "know how" given you by our company. Send your name for this free book which shows you the way to independence in a Franchise business which you own outright.

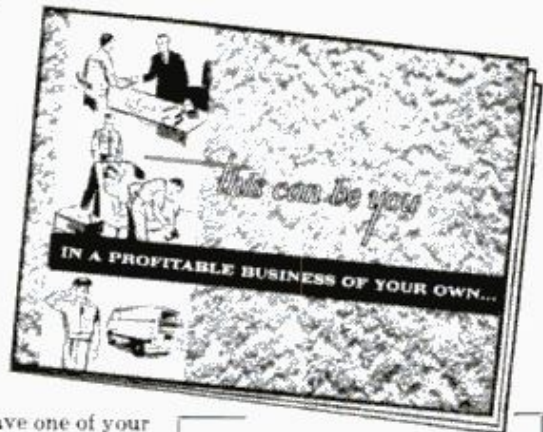

Grant Mauk

In the past, many men started businesses of their own—and failed. Some entered businesses that were already on the decline. They were as foredoomed to failure as a buggy-whip salesman. Some had no talent for the businesses they entered. Most of them worked for someone else and had no experience in business management.

Today, all that has been changed by reputable Franchising firms. Our Franchise business is one that has been tried, and tested, and proved by the parent company. It is one that has been shown to have an enormous and a growing market. It is a business that has been brought to a high level of success by many other men. The kinks have been eliminated. The methods and plans that lead to success have been clearly charted. When an ambitious man is given the equipment and training he needs, and follows the plans laid out for him by the parent company, success is the logical result.

There are many kinds of Franchise businesses. Many require investments as high as \$50,000. The profits they pay depend on how well the owner follows instructions.

We have a Franchise business that does not require a large investment. In our business you can get started for a few hundred dollars. We finance the rest of the investment for you and let you pay it in monthly payments so small that the profits on just one job a month could cover your payment. The overall investment is small by comparison with many other Franchises—yet the potential is \$250 a week net profit. That's for a one man operation. If you have two or three or more men working for you, the potential increases accordingly.

A small dealer just starting and doing his own service should gross \$180 profit from 20 hours service in a week. If he uses 30% for advertising, etc., he nets a clear \$125. If he services 40 hours, net profit is \$250.

With only two men working for him a 35 hour week brings the owner \$420.00 gross profit. Allowing 20% for advertising, etc., (since he has time to sell) he clears \$335.

What is this business? It's one of the fastest growing businesses in America today. It includes six different services that you perform for the housewife right in her home. No office or shop is needed. No investment in real estate. No problems of finding a good location. In fact, if you have a telephone at home and a car with space in the trunk—you have everything you need except the things we furnish. Your business comes to you on the telephone and in personal calls following up leads generated by National Advertising and by your own local Direct Mail Plan which we furnish. You quote your prices to

the housewife, do the job, or have one of your men do it and collect the money on the spot.

What are these services? The first and most important is the cleaning of carpets, rugs, and upholstered furniture by a revolutionary modern process known as the "Absorption Method." The work is done right in the customer's home. No scrubbing with harsh motor-driven rotary brushes. No soaking with gallons of water. An Aerated Foam loosens the greasy, atmospheric dirt and holds it in suspension until it is removed. A test conducted by an impartial laboratory showed that machine scrubbing in the home removed less than half as much dirt as was removed by the Absorption Method.

Five other services add to your income. With portable power equipment you spray furniture and carpets with a product that retards soiling. You remove stubborn spots like magic. You spray another liquid to make fabrics flame resistant. You mend small damages such as cigarette burns and moth holes, often saving the owner the price of new furnishings. And finally, you deep spray fabrics with a moth killing liquid on which you can give a company guarantee for six full years.

As owner of a business, you have the opportunity to make more money than you could hope to make working for someone else. Also, should you wish to sell, you are building a business with a cash value. When an arm injury made it necessary for Al Svitak to sell after operating his dealership only 17 months, he sold to a prospect supplied by Duraclean at a price 50% above his original investment. G. F. Monroe sold his Texas Dealership after 12 months for ten times his cost. Leo Lubel, after 30 months, sold for \$7,116 over cost. When our Franchise owners want to sell, we help them find buyers.

It's all explained in this free book. Pictures and descriptions show you how the work is done; how to start without giving up your present job; how to build to full time operation through plans worked out for you.

If you are tired of working for others, tired of jumping from one proposition to another; if you have good health, energy, and ambition; if you have a real yearning for independence in a business you own, send for this book. If you have thought that starting your own business would be difficult or expensive, or risky, this book will open your eyes. With our plan it is easier than ever for you to become master of your own destiny in a business you own.

There is no obligation, no charge. No salesmen to high pressure you. Send for this book now. Read it. Then decide if you want to take the next step toward independence.

### OPPORTUNITIES TO FIT YOUR OWN AMBITIONS

The Duraclean Franchise is so flexible that it can be fitted to your own ambitions. As a one man business and based on the rates in our National Price Guide you can make a net profit of \$6.00 an hour—\$240.00 for 40 hours of servicing.

Ward Whitebeek wrote "I have made as much as \$225.00 in one day." L. Lawson says: "In September, working alone, jobs totaled \$1,475." L. Canaday wrote: "\$1,571 in a single month."

If you wish, you can operate as the head of a multi-crew business with others doing the service work.

This increases the profit opportunity as the owner of a business can make as much as \$6.00 an hour gross profit on every hour each employee works. Even after paying him a good hourly wage, the owner can clear \$325.00 a week for himself with only two men on his staff.

Ed Kramsky wrote, "In my second year I now have two assistants, a nice home, and real security for my family." And, E. Davis reported "Gross income increased \$17,660 this year."

So, no matter at what level you have set your sights, here is a Franchise that is worth careful investigation. Send your name now for the Free Book that tells all angles of the business.

### Send name for FREE BOOK

Grant Mauk, President  
3-168 Duraclean Building, Deerfield, Illinois

Dear Mr. Mauk: Please mail a copy of your Free Book telling how I can get a Duraclean Franchise started in spare time without giving up my present income, and how I can build a one man business with a potential of \$250.00 a week net profit. No charge. No obligation. And, no salesman is to call on me. After reading your book I will let you know my decision.

Name \_\_\_\_\_ Age \_\_\_\_\_  
Address \_\_\_\_\_  
City \_\_\_\_\_ Zone \_\_\_\_\_ State \_\_\_\_\_

GRANT MAUK, President; 3-168 Duraclean Building, Deerfield, Illinois



# FREE!



## Trial lesson in **DRAFTING & DESIGN**

### LEARN AT HOME IN SPARE TIME

Check the want ads in any newspaper — SEE the big-pay opportunities open to you as a draftsman. What's more, you can learn this well-paid, prestige profession at home — quickly, easily! No special talent needed! Get complete, step-by-step Chicago Tech lessons in the mail, spend a few pleasant hours studying each week. In a short time you'll be a well-trained draftsman, ready to take your pick of many good jobs. Act now!

### FREE INFORMATION—MAIL COUPON TODAY!

Get FREE TRIAL LESSON plus information about C.T.C. practical training. Learn what successful Chicago Tech graduates say about high pay and opportunities in drafting. No charge, or obligation.

Est. 1904 Accredited National Home Study Council

## CHICAGO TECHNICAL COLLEGE

K-201 Tech Bldg., 2000 So. Michigan Ave.  
Chicago 16, Illinois

Mail me FREE Lesson with information about big opportunities in DRAFTING.

Name..... Age.....

Address .....

City..... Zone..... State.....

**Remodeling your home?** Don't pick up a hammer until you see the September PM, with its roundup of the latest time-saving building materials.

## \$6.44 AN HOUR IN YOUR OWN BUSINESS



### STEP INTO THIS BOOMING \$19 BILLION A YEAR INDUSTRY

Hundreds of accidents and losses will happen this year in your community.

We'll show you how to investigate and adjust these losses for insurance companies, railroads, government offices. You buy NO tools or equipment. You do NO selling. You need NO prior

experience or higher education. And you can operate out of your own home. Right now independent Accident Investigators average \$6.44 an hour. We'll train you quickly to do the same. Start part-time if now employed. Fill the need for an Accident Investigation specialist in your area. Colorful booklet explains everything. Absolutely no obligation on your part. No salesman will call. Write TODAY for FREE Booklet.

UNIVERSAL SCHOOLS, PM-8, 6801 Hillcrest, Dallas 5, Texas

## Spotlight on the Ford Pickup

(Continued from page 20)

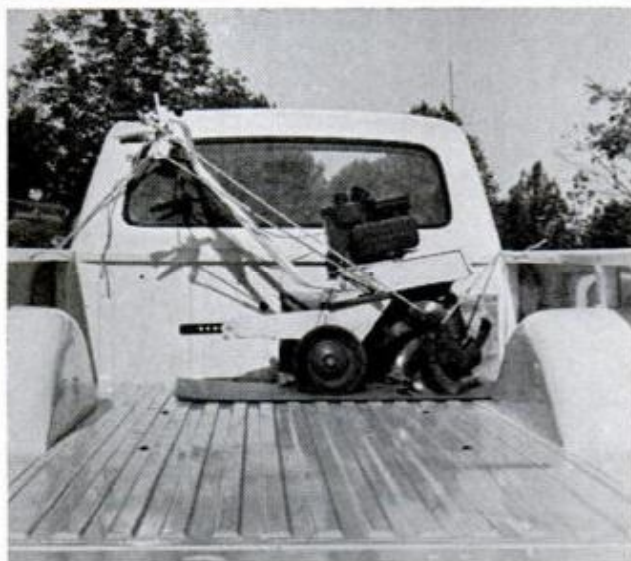

**SWING-UP REAR ASSEMBLY** of the Sportsliner camper (above) gives access for larger loads. But for the greatest capacity, the open box still is preferable

find it stiff work winding the truck into a tight parking hole. And power steering isn't available.

From its prompt, powerful start right up through highway speeds, the noise level is kept well under control. The cab is comfortable, the driving position good. Your throttle foot tires less than in many plushier passenger cars. The throttle is thrifty, too. Our test vehicle was brand new and far from broken in, but we got just a hair under 18 m.p.g. on Regular gas.

PM's long-legged test drivers found the cab comfortable once the seat was moved to full rear. It's also wide—58 inches worth—and the springs are deep, as they'd have to be. There's ample room for three adults in the seat, and the cab floor is high enough to avoid any drive shaft hump.

Getting up into the cab is a two-step climb, of course. But even for some of

(Please turn to page 24)

POPULAR MECHANICS





## The racing profession's seal of approval

### Why Racing "Pros" Prefer Perfect Circle Rings—the piston rings to install for championship performance in any engine

The PC emblem has long been a familiar sight on winning race cars. It rides with racing "pros" who specify Perfect Circles, "pros" who can't risk using rings that give anything less than full power, full time. That's why Perfect Circles are the track favorite.

Look at the record: more than 80% of the Indianapolis meets since 1922 have been won by PC-equipped cars. More major USAC events and NASCAR competitions are won by drivers using Perfect Circle

rings than any other piston ring brand.

What's the difference between PC "racing" rings and those you can buy? Nothing. They are *identical*, from the specially-selected metals to the solid chrome surface. They are *identical* in design and manufacture, in the long life, fit and dependability that assures new-car power and economy.

Here's another engine tip: to prevent costly oil loss through valve guides, always install Perfect Circle Valve Seals, or have them installed, when you re-ring.



## PERFECT CIRCLE

**PISTON RINGS • CYLINDER LINERS • PRECISION CASTINGS  
TURBINE BLADES AND WHEELS • ELECTRONIC PROGRAMING EQUIPMENT  
SPEED CONTROLS • HAGERSTOWN, INDIANA**

Plants and Subsidiaries: HAGERSTOWN, RICHMOND, NEW CASTLE, TIPTON AND RUSHVILLE, INDIANA  
THE PERFECT CIRCLE COMPANY, LTD., DON MILLS, ONTARIO, CANADA • SCHELLEN'S TRUE CORPORATION,  
IVORYTON, CONNECTICUT • PERFECT CIRCLE INTERNATIONAL, FT. WAYNE, INDIANA • PERFECT  
CIRCLE HOLLAND N.V., THE HAGUE, NETHERLANDS • Factories, Affiliates and Licensees in MEXICO,  
ARGENTINA, AUSTRALIA, BRAZIL AND FRANCE



# Add-a-room IDEAS



## NEW 36-page booklet shows how you can find "room for improvement" with plywood

Cramped for space? Need a family room? Bedroom or bath? This valuable new booklet tells you how to add space—whether it's a single room or a whole new wing—to almost any kind of house. Developed by modernizing experts, these practical, good-looking designs can add livability and resale value to your home. Each one calls for simple, straightforward plywood construction for a quality job at lowest possible cost. Booklet includes before-and-after color pictures, floor plans and decorating ideas. Gives you tips on materials, wiring, plumbing—plus useful information on financing.



Mail Coupon Today for Valuable  
Full-Color Remodeling Booklet

Douglas Fir Plywood Association  
Tacoma 2, Wash. Dept. PM

I enclose 10¢. Please send me  
the Add-a-room Idea Book.

Name \_\_\_\_\_

Address \_\_\_\_\_

City \_\_\_\_\_ Zone \_\_\_\_\_ State \_\_\_\_\_

## Spotlight on the Ford Pickup

(Continued from page 22)

the ladies, this might be less of a problem than swiveling into today's compacts. The F-100's step is enclosed by the door so it'll never be snow- or ice-covered. And the sill extends into the cab area before meeting the second step, giving you a split-level floor effect that is fine for storing empty Coke bottles on a trip.

Vision through a panoramic windshield and wrap-around rear window is excellent. Unless you're carrying a bulky load, there's no chance for a little Isetta to sneak up from a "blind" side.

With the basic truck, there's no rear bumper to protect your neighbor's grille as you back to park, but the body is shaped so you can see the left rear corner through the standard outside mirror.

The floor of the box is 27.2 inches off the ground, nearly as high as the kitchen table and quite a lift for a heavy load. The trunk lip on many a passenger car, however, is close to that height. And the F-100 has 7.2 inches of road clearance to the differential housing. Our test truck had the 8-foot box on a 122-inch wheelbase.

### Camper Wring-Out

With the increasing popularity of lightweight camper bodies on pickups, *PM* wanted to know the effect on roadability. The answer: practically none.

For our test we chose an Aeromotive camper—the Sportsliner from Custom Accessory Sales of Columbus, Ohio. This is only one of many that fit the F-100 series Fords. Inside headroom is fine if you're seated, yet the unit doesn't stick up so high the driver feels extra wind drag. The truck's stability isn't impaired, even in a cross-wind, and road noise is, if anything, muffled by that package of dead air behind you.

Fitting a camper involves several hours' work lining it up, driving good-size self-tapping screws, and fitting the filler panels that adapt the cover for various truck boxes. Two men can lift the Sportsliner camper, and the completed unit is solid. With the truck box already welded to the cab, the final combination is rugged and rattle-free. The camper costs \$302.38 F.O.B., Columbus.

Once the camper has been fitted to the truck, removal and re-installation is simple. For any except very heavy loads, standard transmission and springs are fully adequate for truck or camper. You'll have an economical and versatile vehicle that can handle about any normal family job.

Stripped, the F-100 pickup costs \$2015.24. Options brought our total to \$2388.99. ★★



# Here's Why More Mechanics Use MOTOR than Any Other Car Repair Manual

**3,200 Pictures, Step-by-Step Instructions Show YOU, too, How to Fix 33 Car Makes — 2,519 Car Models Built Since 1955!**

OVER 4 MILLION COPIES SOLD!

**WANT TO FIX CARS FAST?** It's easy! Just do it the way most pros do — with MOTOR's Manual. Yes, more pros use MOTOR's "Auto Repairman's Bible" than any other car repair manual — because MOTOR's Manual shows you *exactly* what to do, *how* to do it. You breeze through tough repair jobs in less time, with less effort. Whether simple adjustment or complete overhaul — just look it up in the index, then follow clear *pictured* step-by-step instructions.

### New Edition Bigger Than Ever!

You get the "meat" of 191 Official Factory Manuals — showing you how to fix practically every part on 2,519 models built between 1955 and 1963! Over 1,300 double-size pages — 3,200 pictures — over 30,000 repair specs — 285 "Quick-Check" charts — over 225,000 service and repair facts. **EVERYTHING** you need to fix cars *fast, easy, right* the first time you try.

Giant **TROUBLE-SHOOTER** section spots 2,300 car troubles right away; tells you where to look in Manual pages to fix them. So clear and complete you **CAN'T** go wrong, even if you're a beginner. And top-notch mechanics will find new shortcuts that will save time, money, wear and tear. No wonder MOTOR's Manual is used in so many schools, by the Armed Forces, and by hundreds of thousands of mechanics. No wonder over **FOUR MILLION COPIES** have been sold!

### SEND NO MONEY

Use Manual **FREE** for 10 Days

We're so convinced MOTOR's Manual must save you time, energy, and money that we'll send you the 1963 edition to use **FREE** for 10 days. If it doesn't pay for itself on the very first job, return it and you owe nothing. You don't risk a penny. Rush coupon *today* to MOTOR Book Dept., Desk 318, 250 West 55th St., New York 19, N. Y. (Schools, Bookstores; Write for Discounts.)

**FREE 10-DAY TRIAL**

### FIX ALL THESE CARS

American	Corvair	Imperial	Oldsmobile
Buick	Corvette	Jeep	Olds F-85
Buick	Dart	Lancer	Plymouth
Special	De Soto	Lark	Polaris
Cadillac	Dodge	Lincoln	Pontiac
Chevrolet	Edsel	Mercury	Rambler
Chevy II	Fairlane	Mercury	Studebaker
Chrysler	Falcon	Metzger	Tempest
Comet	Ford	Mercury	Thunderbird
Continental	Galaxie	Monterey	Valiant
		Nash	

### Some 10-Day FREE OFFER on Brand-New 1963 TRUCK REPAIR MANUAL

Covers 98% of all trucks, 1952 through 1963, including all new economy models. Over 2,000 illustrations; 300,000 facts. Easy to use. Covers all gasoline engines, plus GM, Cummins, Mack, Perkins, International diesels. Over 900 pages. For 10-day FREE Trial, check box in coupon.



### GREAT HELP TO BEGINNERS

"All I do is read the instructions. Haven't had any trouble yet. A great help to beginners."  
—Joe Disabato, Altoona, Pa.

### MOST PRIZED "TOOL" IN SHOP

"Been using MOTOR Book since before World War II. It's most prized 'tool' in entire shop. Have used other manuals but none so complete and easy to understand as MOTOR's. The finest source of auto info."  
—Wm. C. Hale, Dallas, Texas



### MORE WORK, MORE MONEY

"Manual has helped me. Speeded up jobs and put extra dollars in my pocket more often. The book is worth the price."  
—Eddie Sinabria, Bronx, N.Y.



### BEST WHEN IN DOUBT

"Find my Manual more and more useful with each problem. Book is best when you are in doubt about any job concerning automobiles."  
—John W. Baker, Earle, Arkansas



### SAVES TIME, SAVES MONEY

"Manuals have saved a lot of time, considerable amount of money. They are an ever-present help — equipment I can't do without."  
—H. D. Hartman, Baltimore, Md.



### NOW HAS OWN SHOP

"After I received MOTOR Manual my work improved. Now I have a shop of my own, and repair cars very quickly."  
—S. Scott, Valdosta, Ga.



### CAN OVERHAUL ANY CAR

"Since using MOTOR I can overhaul any car. Before I got MOTOR I didn't know anything. Now I know a lot about every car. Can't be without it."  
—W. Harold, Julesburg, Colo.



### NEVER A "BUM STEER"

"My work covers all makes and models of cars, trucks. All of us here use MOTOR at one time or another. It's never given us a bum steer."  
—Guss Evans, Warren, Ariz.



### THE MECHANIC'S RIGHT HAND

"Since using MOTOR have yet to find a job I can't handle. Helped me do tough jobs, also cut my time on other jobs. Truly the mechanic's right hand."  
—V. Mulligan, Nuttings Lake, Mass.



### MAIL COUPON NOW FOR 10-DAY FREE TRIAL

(Attach to Postcard for Fast Action)

MOTOR Book Dept.

Desk 318,  
250 West 55th St.,  
New York 19, N. Y.

Name.....Age.....  
(please print)

Address.....

City.....Zone.....

State.....

Rush to me at once

**MOTOR's 1963 AUTO**

**REPAIR MANUAL.** If O.K.,

I will remit \$2 in 10 days,

\$3 monthly for 2 months and

a final payment of \$1.95

(plus 45¢ delivery charges

and sales tax, if any) one

month after that. Other-

wise, I will return the book

postpaid in 10 days.

Also send me for 10 day Free Trial **MOTOR's 1963 TRUCK REPAIR MANUAL.** If O.K., I will remit \$1, plus delivery charge and sales tax, if any, in 10 days. Otherwise, I will return book postpaid in 10 days.

Check here and **SAVE 45¢** delivery charge by enclosing **WITH** coupon in envelope entire payment of \$9.95 for Auto Repair Manual (or \$11 for Truck Repair Manual) plus sales tax, if any. Refund guaranteed.





**Baby airliners** for light-traffic, short-haul routes may help solve the financial problems of local-service airlines. An 18-passenger plane, capable of 300 m.p.h. for runs of up to 500 miles, has been proposed by a local-airlines association. The plane would be able to land and take off on runways of 3500 feet or less.

**Emergency landing areas** capable of supporting fully loaded jet aircraft can be located from the air by a new method of measuring soil hardness. A rocket projectile, called a penetrometer, is fired from cannons mounted in high-speed jets. The depth of penetration into the ground is governed by soil hardness, and a deceleration switch in the penetrometer measures the impact. Set at a certain level, a bulb in the tail of the penetrometer lights up if the impact is greater than this level.

The Air Force, which is conducting the tests, estimates that there are thousands of flat land surfaces throughout the world

that could support a big jet in an emergency, but the effort of sending land crews in to survey each area is prohibitive.

**Apparent-motion machines** have been found more accurate and much faster for studying aerial-reconnaissance photos than the traditional methods of overlays and side-by-side. Apparent motion involves blinking two photos alternately on the same screen. The photos could be before-and-after shots of the same area to determine military build-ups.

The study, conducted by the Boeing Company, showed that apparent motion was up to 42 times faster than side-by-side. The pictures, taken at different times, are projected alternately on the same screen. Changes seem to flicker on the screen, or swell or shrink.

**When evacuating Indians** by helicopter from a flooded area in Alberta recently, the Royal Canadian Air Force discovered they evacuated 30 percent more than actually lived there. They then discovered some of the Indians were recrossing the river to get another ride.

Kevin V. Brown  
Aviation Editor



## HOW TO ADD WEEKS TO YOUR HUNTING SEASON!

Add a Bear hunting bow to your gun rack, and enjoy a *second* hunting season: the bowhunting season!

You get an extra opportunity to bag a buck. To sharpen your woodsmanship and stalking ability. And, like a good gun, Bear Bows have balance, craftsmanship and design. If you can shoot a gun, you can easily learn to handle a Bear Bow.

Bear Hunting Bows . . . Kodiak®, Kodiak Magnum and Grizzly® . . . have brought down small game and trophy big game alike. See them today, at your Bear Dealer's. Or write for free color catalog.

Designed for hunters by the world's greatest bowhunter  
—Fred Bear.

**Bear** ARCHERY COMPANY  
Dept. PM-8 • Rural Route One • Grayling, Michigan





**In today's world...**

## **What does it take to feel like a man?**

It takes *action* to feel like a man. Takes *pride*, too, and good, skillful *training*. Join the modern Army's Combat Arms program and you'll have all three.

**Pride?** In Combat Arms it makes no difference whether you select Infantry, Armor, or Artillery. You'll be proud of any one of them. And you'll end up proud of yourself, too.

**Action?** In today's modern Army it's *go* all the way. Every unit is smooth, fast, and flexible. And every day brings fresh, new challenges. It takes real men to cope with them.

**Training?** In today's world nothing but skilled hands and minds will do. The whole Army is like a huge, well-oiled engine—with men and machines closely interlocked. It takes *men* to fit into this kind of picture. And the Army *makes* men like this—technically skilled, competent, confident.

If you qualify you can receive extensive training in other areas like: missiles, motor mechanics, electronics, engineering—or any of 150 other fields. Find out how to feel like a man in today's fast-changing world. See your local Army recruiter today!





By Jim Whipple



## Look for Some More Fords in Indy's Future. Turbine Car Races 24 Hours on Kerosene

Jim Clark's second place at Indianapolis has shaken up the racing trade more than a little. Driving a radically different sort of car with a modified aluminum passenger car engine that used pushrod valve gear and ate pump gas—he moved at one time to within 5 seconds of winner Parnelli Jones.

Jones' car, which posted the highest average speed ever, 143.137 for the 500 miles, was a classic Offenhauser-powered solid-axle car driven on the ragged edge.

Some observers were of the opinion that had it not been for the oil that Jones' car spilled on the track, or the fact that several drivers made it possible for Parnelli to pass during the yellow flag caution laps (after an accident), Clark might have caught him and won the race. This is one of those fascinating "ifs" that will keep the fans arguing all winter.

Several items are not iffy, however. One is that the days of the four-cylinder, methanol-fueled overhead camshaft Offenhauser engine are numbered. Next May 30th, a whole flock of genuinely Detroit based engines could be on Indy's grid.

Nothing could make this more certain than the story going the rounds recently that a group of sponsors of the Offy-powered roadsters have banded together and are putting pressure on Indy's governing body USAC (United States Auto Club), to prohibit cars weighing less than 1500 pounds from entering the race. This would mean that the Ford-Lotus, Mickey Thompson's cars and other new lightweight designs could not run. The reason: Offy roadster owners have large amounts of money tied up in cars like this year's winner, the Agajanian-Willard Battery Special, and they have a feeling that next year, the lightweight Ford-Lotuses et al. could fill a lot more of the first 10 places than the Second and Seventh that they copped this year. In effect, if the rumor is true, the Status Quo boys are saying, "You can't race your fast cars here, this race is for slow cars!"

A quicker way to kill interest in the Memorial Day spectacle can't be imagined, and we can't see Indy's owner, Tony Hulman, putting a stopper in the path of prog-

ress just as the track regains its former status as the U.S. auto industry's most exciting and colorful proving ground.

We think that there's more than one Ford in Indy's future.

Traditional patterns of engineering are being challenged all over the map this year. Recently a BRM (British Racing Motors) car, powered by a turbine designed and built by the Rover Motor Co. of Solihul, England, placed Seventh overall in the 24-hour race at LeMans, France.

Although not officially scored because of its unique engine, the Rover-BRM finished ahead of everything but the fabulous Italian Ferraris, the cars which have carried development of the piston engine to what may well be its limit.

Rover's turbine performed beautifully, just 10 miles-an-hour slower than the winning Ferrari's 118 m.p.h.

What does it prove? Basically that the turbine can compete in performance and durability with the piston engine and do so on more economical fuels. The Rover raced on kerosene.

Chrysler's newest turbine (p. 26, July '63 PM) has yet to win a race, but the important thing here is that they have discovered that it can be produced quickly and at a price competitive to that of piston engines. A figure of \$350 for the power plant in full production was judged as "a reasonable expectation" by one engineer. Reason for the confidence in such down-to-earth prices is Chrysler's use of non-exotic materials and methods of manufacturing the critical high speed and high temperature parts. For example, turbine wheels, rotating at 46,000 r.p.m. at 1800° F., are made of a low-cost iron alloy by investment casting (wax molds).

Most auto engineers agree that the turbine has several corners to get around before it reaches volume production, while the piston engine is healthier than ever.

Is Our Face Red Department. In the June 1963 Listening Post (page 82) we mentioned only two overhead valve V8s of 10 years ago, Olds and Cadillac.

In addition, Studebaker, Lincoln, Buick, Chrysler, Dodge and DeSoto had overhead valve V8s back in '53.





# NOW YOU CAN SOLVE "TOUGH" MATH PROBLEMS LIKE THIS!

$$47892 \times 39421 = ?$$

AS EASY AS  $1 + 1 = 2$

GET A BETTER JOB WITH HIGHER PAY, SECURITY IN THIS ATOMIC AGE!

This man is multiplying numbers that should ordinarily produce the answer in about 4 minutes. The answer appears on his blackboard in less than 15 seconds flat! Yet he knows little about math! As a matter of fact he failed arithmetic in school. Read on to discover the fantastic new method that even a child can learn easily in just a few short hours—at home . . .

Yes, in just hours you can turn into a "math wizard" even though you know little about arithmetic! Surprise your friends with your "E-Z MATH" ability . . . enjoy job security and advancement . . . a better job . . . Increase your self-confidence and prestige—all through amazing new "E-Z MATH".

The world is moving fast these days. In good times and bad the ability to handle mathematical problems in our age of electronics, automation and nuclear science is becoming more and more necessary for promotion on the job and for higher pay. If you don't think you have what it takes—and if you believe that "math" is beyond your power—then you're in for the biggest surprise of your life!

For now you CAN learn to DIVIDE, MULTIPLY, ADD and SUBTRACT figures not only quickly and easily—but also in a FRACTION of the time the average person requires! You can actually solve such tough problems as multiplying a 5-figure number by a 7-figure number in your head without ever touching pencil to paper . . . or dividing 836791 by 284, for example, in exactly 15 seconds—even if you "flunked" math in school!

The secret of success in "math" is NOT laborious study and wearisome practice—but, on the contrary, knowledge of SPECIAL SHORT CUTS, LITTLE-KNOWN METHODS of calculation and arithmetical "tricks" that take the work and gamble out of figuring. These methods—so new and radical that they have not yet been incorporated in our school systems—take but a few hours to learn. Yet they permit you to OUT-THINK and OUT-FIGURE the average high school and college graduate who hasn't had the benefit of these amazing methods! You can even BEAT AN ELECTRIC CALCULATOR in answering many problems!

## Sharpen Your Brain Power— with Short-Cut "E-Z MATH"!

Imagine being asked to divide 38634 by  $89\frac{1}{2}$ —and rattling off the answer absolutely correctly in 7 seconds! Or—multiplying 369.34 by 982.7 and coming up with the correct result in 11 seconds! Or adding 29 numbers each with 6 digits—and supplying the right total every time! People will GASP at your fabulous lightning-quick mind. You'll be able to JUGGLE numbers . . . do STUNNING TRICKS . . . amaze your friends and boss—and be a "master mind"!

With a knowledge of "E-Z MATH" you no longer need be puzzled by such every-day figuring as computing interest charges on installment purchases . . . division, multiplication and addition of fractions . . . adding long rows of numbers with 100% accuracy . . . adding and subtracting fractions from whole numbers—plus many, many other practical and valuable pointers you will use daily to your advantage. The few hours you spend with this course will really pay off. Numbers are the basic instrument of all scientific and technical work. The man or woman who can use "math" is rewarded, recognized quickly, moves ahead in his job faster and more surely!

## Order Today on No-Risk Free Home Trial!

Send for "E-Z MATH" today on our no-risk money-back guarantee: use the book for 30 days . . . prove to your own satisfaction how far a knowledge of "E-Z MATH" can advance you in business and social life. If you don't agree that this is the best investment you've ever made . . . if your family and friends aren't AMAZED by your new ability—return the book for full and prompt refund.

CAN YOU SOLVE THESE EVERY-DAY BUSINESS AND SOCIAL ARITHMETIC PROBLEMS IN THE TIME ALLOWED? YOU CAN DO THEM EASILY EVEN WHEN BLINDFOLDED—AFTER YOU'VE READ "E-Z MATH"!



Blindfold yourself and have someone call the following numbers to you as you add them:

- 739
- 463
- 906
- 785
- 642

(Solve in 6 seconds) ?

$$\frac{9864372}{8146} = ? \quad (\text{Solve in 9 seconds})$$

$$\frac{4}{7} \times \frac{9}{4} = ? \quad (\text{Solve in 4 seconds})$$

1 3/4 % interest per month amounts to what percentage yearly? (Solve in 4 seconds)

$$367 \times 75 = ? \quad (\text{Solve in 3 seconds})$$

## WHAT IS "E-Z MATH"?

"E-Z MATH" is based on an amazing new method of working with numbers—easier to learn and remarkably faster and more accurate than you ever dreamed possible when you took math in school. You'll be shown the newest way of reading numbers—just as though they were words—and of adding and subtracting them almost at a glance—INSTANTLY! You'll be shown a unique new technique for adding hundreds and even thousands of numbers without ever making a mistake . . . yet now on you'll whiz through all figuring problems without wasting your valuable time—through income tax, checking grocery lists, homework—as fast as a calculator. You'll never again dislike or avoid numbers—you'll actually ENJOY using them to get ahead in business!

## WHAT THEY SAY:

"My 10-year old had nearly always failed arithmetic with old-method arithmetic. Then he found my copy of 'E-Z MATH'. Now in less time than you can put the numbers on a blackboard, he can multiply 8391726547 by 12. It's amazing and incredibly easy. I use it myself on my job and my wife uses it to check grocery lists."

A Father for which I compliment you. It's the best I have ever seen. Pupils' marks seem to be climbing as a result. Should help in any job. Excellent for home tutoring use."

—SCHOOL PRINCIPAL

"Thank you! Thank you! Thank you! All our children are using your system too, and it is terrific. My husband and I are using it—and it works! My husband has already received a job advancement with tremendous boost in pay. Best investment we have ever made!"

—HOUSEWIFE

"My employee, Joe Malone, asked for a better job. I recommended he read 'E-Z MATH'. Now that he can do 'tough' problems easily, I've promoted him to head of his department with a \$35 weekly increase in pay. I now suggest all employees read 'E-Z MATH' if they want to get ahead in their jobs."

Business Executive

## MAIL NO RISK FREE HOME TRIAL COUPON NOW!

E-Z MATH PROGRAM DEPT. R-82  
285 Market St., Newark, NEW JERSEY

OK! Prove to me that "E-Z MATH" can bring me higher pay, prestige and social advancement! Rush book to me postpaid in plain wrapper for 30-day free examination and use. If I don't agree with everything you say about "E-Z MATH"—I may return book for prompt refund. I am enclosing \$2.98 as payment in full.

NAME \_\_\_\_\_ AGE \_\_\_\_\_  
(Please Print)

ADDRESS \_\_\_\_\_

CITY \_\_\_\_\_ ZONE \_\_\_\_\_ STATE \_\_\_\_\_

E-Z MATH PROGRAM  
© Entire contents copyright 1963

DEPT. R-82, 285 Market St.  
Newark, NEW JERSEY



## BUILDING CONSTRUCTION OFFERS RICH REWARDS

Over 300,000 jobs open in Building Construction most years. Over 1 million homes are built. Pay is high. Be a craftsman, blueprint reader, estimator, supervisor... or a contractor. New easy CTI course trains you at home. Earn cash while training. Mail coupon for free facts.



COMMERCIAL TRADES INSTITUTE, Dept. C-133  
1400 GREENLEAF AVE. • CHICAGO 26, ILL.

NAME \_\_\_\_\_ AGE \_\_\_\_\_  
ADDRESS \_\_\_\_\_  
CITY \_\_\_\_\_ ZONE \_\_\_\_\_ STATE \_\_\_\_\_



## MY SPARE TIME HOBBY MAKES ME \$5<sup>00</sup> an hour CASH PROFIT

—Grover Squires



### START YOUR OWN SPARE TIME BUSINESS

You can turn your spare time into Big Cash Profits with your own COMPLETE SHARPENING SHOP... Grind saws, knives, scissors, skates, lawn mower blades... all cutting edges. Your Own Cash Business with no inventory... right at home... no experience needed.

FREE BOOK tells how you can start your own spare time business while you are still working at your regular job. Low Cost — time payments only \$15.00 a month. Send coupon today.



BELSAW SHARP-ALL CO. 714 Field Bldg., Kansas City 11, Mo.  
Send Free Book "LIFETIME SECURITY". No obligation.

Name \_\_\_\_\_

Address \_\_\_\_\_

City \_\_\_\_\_ State \_\_\_\_\_

## For a Complete Book of Professional Secrets

Plus Illustrations  
Of Products  
And Prices Of  
Over 300 Different  
Molds You Can Use  
To Make And Sell  
Ornamental  
Concrete Items...

SEND \$2.00

rushed to you by FIRST CLASS MAIL



CONCRETE MACHINERY COMPANY, INC.  
839 Lenoir Rd. - P. O. Box 99 - Hickory 2, N. C.

## Tune in on the Inventors

Aircraft powered by the sun and capable of flying 1000 miles per hour at altitudes up to 300,000 feet could result from patent 3,089,670 granted to Elmer G. Johnson of Fairborn, Ohio. Solar power would be trapped in an accordionlike device beneath a rectangular wing. Needing no fuel, the plane could fly indefinitely.

The irate golfer who flubs a birdie no longer has to wrap an expensive niblick around a tree to relieve his feelings. Instead, he can let fly with a simulated "breakable" golf club, patented for just such crises by Ashley Pond III of Taos, N.M. Described in patent 3,087,728.

Rotary lawn mowers can be sharpened in seconds by inserting a new sharpener through a hatch opening and letting the mower's motor do the work. Patent 3,085,387 went to Will M. Harper, Monroe, La.

Photographers can mount their own slides with a motor-driven (or manually operated) binder that does the job in less than 10 seconds. It can also be adapted for binding other types of material. Patent 2,528,754 was granted to Dallas H. Johnson, Avon, Ohio.

For bumbling parkers, patent 3,088,431 describes a device that indicates the position of the front wheels of an auto directly on the dashboard. Inventor Martin Brownshield, Dobbs Ferry, N.Y., designed it to help drivers park in tight quarters.

An automobile that converts into an airplane—using the same power plant—earned patent 3,090,581 for Einar Einarson of Farmingdale, N.Y. For air travel, stabilizers and wings are put in place and road wheels are raised. The craft has removable propellers fore and aft. On the highway, wings and stabilizers are removed and front and rear hoods drop down to give it a conventional auto appearance.

An antisubmarine airborne rocket invented by three China Lake, Calif. men sports a small parachute for slowing the missile down before it hits the water, thus reducing malfunctions. The weapon is said to be smaller and simpler to make than conventional torpedoes. Patent 3,088,403 went to James T. Bartling, Orville J. Saholt and Bernard Smith.



# WHAT ALL car owners, even HOT RODDERS, want to know about UNDER CAR CARE

FREE "HAPPIER DRIVING"

PAMPHLET TELLS ALL!

You're looking at the underside of things that make it safe and more fun to drive your car. That's true whether you're a hot rodder on a drag strip... a "500" Mile racer... or Mr. or Mrs. Typical American Car Owner! Bear "Under Car Care" makes driving more fun and it's safer, too!

Bear Wheel Alignment, both front and rear, makes steering easier; doubles the mileage. Bear Balancing ends vibration fatigue. You get a smooth ride. Bear Brake Service makes stops sure, safe, with no hard pedal to get you leg-weary! Lots more facts you ought to know are in the Free Bear pamphlet "Happier Driving." Mail coupon or look for the service center displaying the sign of the



FREE!  
MAIL  
COUPON



## BEAR.



Mechanics... Shop Owners... Car Factory Engineers... Students from all over the world come to the BEAR SCHOOL. It is the only one in the world devoted exclusively to the science of Under Car Care.

MAIL THIS COUPON with your name and address to BEAR MFG. CO., Dept. PM-3, Rock Island, Illinois

I'm interested in having you send to me FREE of cost or obligation:

"HAPPIER DRIVING" PAMPHLET  
 BEAR SERVICE AS A BUSINESS OPPORTUNITY  
 BEAR SCHOOL FACTS

Copyright 1963 Bear Mfg. Co.

627

## If You Want to Make up to \$1,000 a Month

Mail this Certificate NOW with name and address

Get FREE Details of Amazing Light Bulb with No-Time-Limit Free Replacement Guarantee

Tear out this certificate, mail with name, address to learn how you can make up to \$50 and more in a day, spare or full time, introducing sensational longer-burning Merlite Light Bulbs in your area. Simply say... "Once you buy Merlite Bulbs, you never again have to buy light bulbs." Friends, neighbors, others order 12 to 24 and more at a time on astounding Free Replacement Guarantee without time limit! **FREE SALES KIT!** Everything you need to start making good money first day. Rush your name and address with this Certificate—TODAY!

MERLITE INDUSTRIES, Bulb Div., 114 E. 32nd., N.Y. 16, Dept. C-15K  
In Canada: Mopa Co., Ltd., 371 Dowd St., Montreal 1, P. Q.



## FREE CATALOG!



Just out... Corcoran's all new 1963 Fall-Winter catalog. Our largest selection ever of hunting, fishing and camping equipment.

Send for your free copy. See hundreds of items — all field-tested by Corcoran. Includes boots, clothing, hunting equipment, tents and dozens of other specialties.

**CORCORAN, INC.**  
BOX PM-83, STOUGHTON, MASS.

## YOU WILL NOT LOSE YOUR KEYS WHEN YOU CARRY THEM ON A

# KEY-BAK



KEY-BAK is worn on the belt. It reels back your keys; keeps them safe, handy, and out of your pockets. Pocket-watch size. Polished chrome finish. 24" long stainless-steel safety chain reaches all locks. Ruggedly built for years of use.

**\$2<sup>95</sup>** at retail or postpaid

Buy KEY-BAK at your hardware or key shop or send today to:

**FACTORY GUARANTEED INDEFINITELY!**

West of Mississippi  
**LUMMIS MANUFACTURING CO.**  
2242 E. Foothill Blvd.  
Pasadena, Calif.

East of Mississippi  
**CTL COMPANY**  
1710 W. Stewart Ave.  
Wausau, Wis.

OVER THREE MILLION KEY-BAKS HAVE BEEN SOLD



# America's Oddest Export: Mysterious Ginseng Root

AMONG THE EXPORTS in which America leads the world, the strangest is one of man's oldest home remedies, the ginseng root. Ginseng has been used for centuries by the Chinese and other Asian peoples as a cure-all and aphrodisiac.

The ginseng plant is found wild through much of the Northeast—particularly in the Appalachian Mountains—and in the Midwest. Mountaineers and farmers have been digging 'seng since the early 1700s when it was found here by a missionary to China who was paying a visit to America.

The term "ginseng" comes from the English translation of the Chinese ideograph for the plant, which means "image of a man." Often, roots are found in a manlike shape, but contrary to legend,

these are no more valuable than other roots.

Fall is the best time of year to dig 'seng, after its thick clump of berries ripen, although many root hunters take it in spring and summer also. It's usually found in wooded and brushy areas, burned-over forests and even along abandoned fence rows. Roots must be carefully cleaned and dried to avoid breakage.

The Red takeover in China reduced the 'seng market somewhat, but Thailand, Korea and Hong Kong take most of our crop—with some going to Chinese Americans.

Prices for wild root run from about \$21 to \$27 a pound, \$6 to \$10 for cultivated root, according to the William J. Boehner Co. of New York, which exports about a third of the \$2,000,000 annual crop.

**GINSENG PLANTS** usually have two to four prongs, sometimes more. Each prong has five dark-green leaves, two of which are smaller than the others. The red berries bring up to \$24 a pound. The Chinese often prepare 'seng by boiling it, or they grind it up for use as a condiment. Since the war, West German firms have taken some ginseng for use in pills, face creams, aspirins, elixirs and vitamins

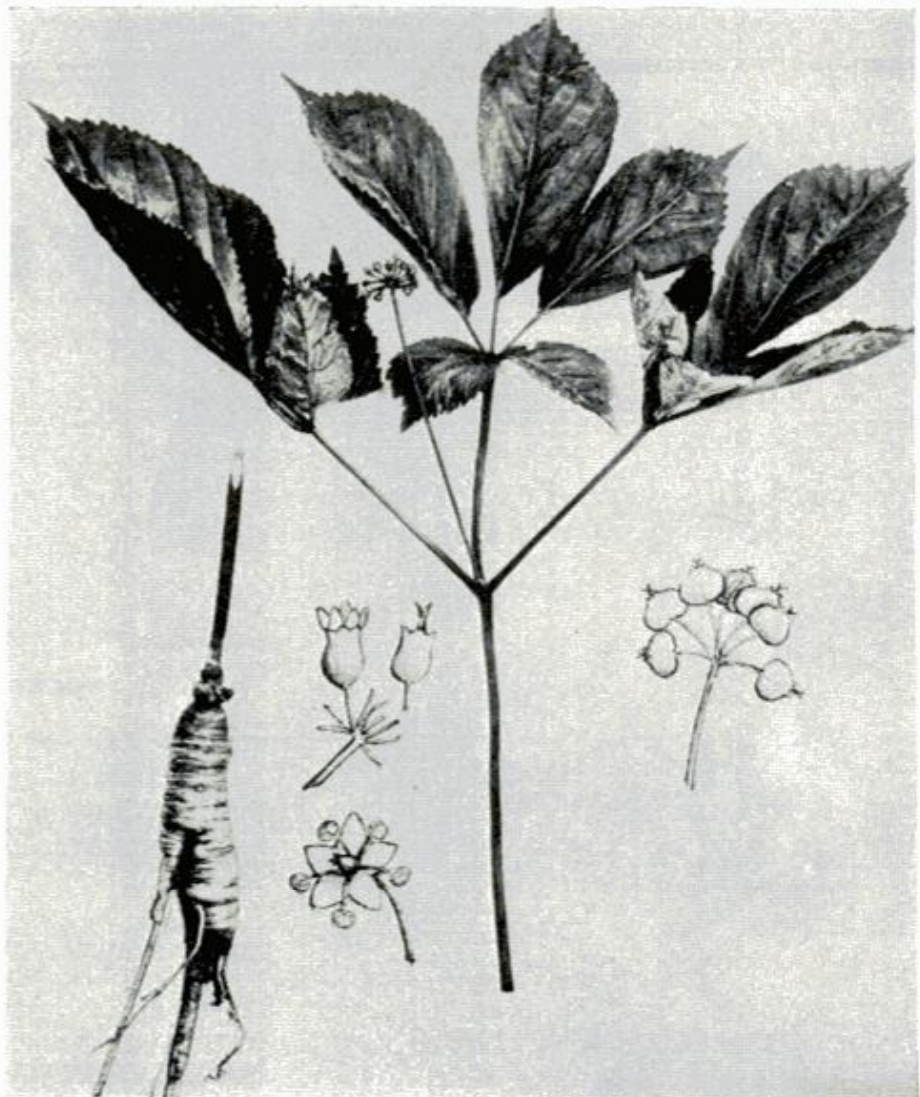



# JEEP OWNERS

RE-POWER NOW WITH A V-8 OR 6 CYL. ENGINE — USE FORD—CHEV.—MERCURY—GMC—PONT—STUDE—DODGE OR PLYMOUTH In Jeeps, Jeepsters, Sta-Wgn, trucks, Kaiser & H. J. cars. Conversion Kits \$45.35 to \$56.90. Want fast action? Give us full information, send \$15.00 Dep. and we will ship correct kit. Bal. COD. Send full amount for prepaid shipment. Wire, phone or write today. Details FREE.

**HOOSIER MACHINE PRODUCTS CO.**

312 S. E. 6th St. Phone 276-3442 Pendleton, Oregon



## MANUFACTURE this BEAUTIFUL OUTDOOR FIREPLACE in YOUR OWN BACKYARD

\$4.00 worth of sand and cement produces this attractive fireplace. Sells on sight from \$60 to \$80. Easy to start your own profitable business in your backyard. No experience necessary. Big profits. Exclusive manufacturing territories. Write immediately for full details. General machines sold to U.S. Government. Dealer inquiries invited.

**GENERAL ENGINES CO., INC.** Dept. MF 83 Rt. 130 Thorofare, N. J.

**"OK" SAY FOUR WHEEL DRIVE OWNERS**



## WARN HUBS STOP 2-WHEEL DRIVE DRAG—

Save gas, gears, tires

Warn Hubs on your 4-w.d. give it double-duty value thru economical free-wheeling 2-w.d. with added pep, speed and handling ease; plus normal 4-w.d. — automatically with Warn Lock-O-Matics, manually with Locking Hubs. See your dealer.



**WARN MFG. CO., INC.**

Riverton Box 6064-A2, Seattle 88, Wash.



## DISCOVER EXCITING PROFITS Hidden in America's Mountain of Broken Electrical Appliances

### EARN \$3 TO \$5 AN HOUR

spare time, full time — learn at home

400 million Appliances are in American homes right now. 76 MILLION MORE are bought each year. People need them fixed, good times or bad. YOU make good money repairing them in your basement, garage, even on your kitchen table. No experience needed!

### FREE BOOK TELLS YOU HOW

24-page FREE BOOK tells about "Appliance Boom" — how you can cash in on it. FREE SAMPLE LESSON shows how simple our instruction is — how NRI can quickly prepare you for profitable future — how you even get, AT NO EXTRA COST, your own Appliance Tester Kit worth \$32.50.

Get FREE Book and FREE Sample Lesson now. Mail coupon below, letter or postcard. No salesman will call.



**NATIONAL RADIO INSTITUTE, Appliance Division**  
Dept. AH-3, Washington 16, D.C.

Send Free Book, Free Appliance Repair Course Lesson. Am interested in:

Spare Time Earnings  My Own Business  
 Better Job

Name.....

Address.....

City..... Zone... State.....



Accredited Member National Home Study Council



## FATTEN YOUR WALLET WITH WATCH REPAIRING

Opportunities for full or part time earnings are the best in years

If you are always short of cash, watch repairing offers a sure way to add to your income. Trained, part time repairmen report earnings of \$5-\$6 an hour. You can start these dollars coming your way if you prepare yourself now. Skilled watch repairmen are in short supply and getting scarcer.

In these uncertain times, it's good job insurance to know a second trade like watch repairing. Strikes occur. Layoffs happen. Automation wipes out jobs overnight.

## CHICAGO SCHOOL OF WATCHMAKING

WILL TRAIN YOU AT HOME IN YOUR SPARE TIME

The unique Sweazey System teaches you to repair Swiss and American watches step by step. No previous experience needed. Diploma awarded. Tuition? Just \$5 a month—a fraction of what it would cost to attend school in person. Send today for a free sample lesson. No obligation whatever. No salesman will call.

**CHICAGO SCHOOL OF WATCHMAKING**

Founded 1908

**FOX RIVER GROVE, ILLINOIS**



Sickness strikes and savings vanish. Retirement comes all too soon.

That's why a knowledge of watch repairing will stand you in good stead. It gives you a second income you can fall back on at any time. It's a light, clean trade needed everywhere watches are sold. It eases money and retirement worries for you can work at it all your life. Age is no barrier. And if you want a business of your own, it will lead you quickly to it.

## FREE SAMPLE LESSON

● CHICAGO SCHOOL OF WATCHMAKING  
● Dept. 183, Fox River Grove, Illinois  
● Please rush FREE SAMPLE LESSON and full information to tell me how I can learn watch repairing at home.

● NAME..... AGE.....

● ADDRESS.....

● CITY..... ZONE..... STATE.....



# LEARN MORE-EARN MORE WITH MODERN AUDEL GUIDES

YOURS FOR FREE EXAMINATION—SEND CARD AT RIGHT ▶

## AUDEL'S DOMESTIC COMPACT AUTOS



Repairs Service Manual

## Now Ready! ANOTHER AUDEL GUIDE

Designed to provide serviceman, owner and operator with information on maintenance and repairs of domestic compact cars. Will serve as a ready reference guide for experienced serviceman and do-it-yourself car owner alike. Covers repairs and accessories. Illus. Approx. 800 pgs. \$5.95.

Circle No. 50 In Coupon

## AUDEL'S PAINTING and DECORATING MANUAL



Just off press! Practical, modern guide for painters, apprentices, home owners & all paint users. Illus. 585 Pgs. \$4.00

Circle No. 7 In COUPON

## AUDEL'S MATHEMATICS and CALCULATIONS in MECHANICS

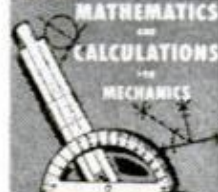

Study or reference. First principles thru all phases. Emphasis on mech. and eng. problems. Indexed. 550 Illus. 672 Pgs. \$4.00

Circle No. 11 In COUPON

## AUDEL'S WELDERS GUIDE

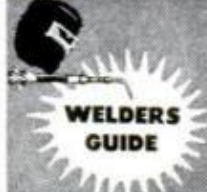

Concise, practical guide to operation & maintenance of all welding machines. A must for all welders. Illus. 608 Pgs. \$4.00

Circle No. 10 In COUPON

## AUDEL'S MASONS and BUILDERS GUIDE



Four practical vols. Last word on construction for bricklayers, stonemasons, cement workers, etc. 2067 Ill. 1100 Pgs. Set \$9

Circle No. 26 In COUPON

## AUDEL'S RADIOMANS GUIDE

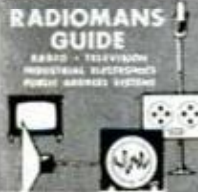

Authentic, concise treatment of practical radio problems for engineers, service-men & amateurs. 400 Ill. 1088 Pgs. \$5.00

Circle No. 3A In COUPON

## AUDEL'S ANSWERS ON BLUEPRINT READING



Secrets of blueprint reading, step-by-step in easy stages. All types covered. None other like it! Illus. 448 Pgs. \$3.00

Circle No. 25 In COUPON

## AUDEL'S ELECTRIC MOTOR GUIDE



Entire subject in every detail. 31 Chapters. 617 diagrams, hook-ups and drawings. Indexed. Illus. 1000 Pgs. \$5.00

Circle No. 27 In COUPON

## AUDEL'S CARPENTERS and BUILDERS GUIDE



Four all-inclusive vols. Modern construction for carpenters, builders, and all woodworkers. 3700 Ill. 1600 Pgs. Set \$9

Circle No. 8 In COUPON

## AUDEL'S TELEVISION SERVICE MANUAL



Practical guide to installation, trouble-shooting & repairing. Inc. color systems. 18 Chapters. 225 Illus. 500 Pgs. \$5.00

Circle No. 3B In COUPON

## AUDEL'S PLUMBERS and STEAM FITTERS GUIDE

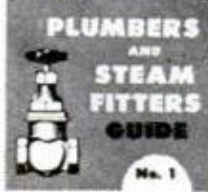

Four vols. of ready reference for plumbers, steam fitters, gas fitters, sheet metal workers, etc. 3642 Ill. 1670 Pgs. Set \$9

Circle No. 6 In COUPON

## AUDEL'S HOUSE HEATING GUIDE



Complete guide for heating, ventilating and air conditioning workers. 57 Chapters trade secrets! 910 Illus. 966 Pgs. \$5.00

Circle No. 41 In COUPON

## AUDEL'S HOME APPLIANCE SERVICE GUIDE



How to fix elec. refrigerators, washers, ranges, toasters & all other gas & elec. appliances. 500 Illus. 864 Pgs. \$6.00

Circle No. 2 In COUPON

## AUDEL'S NEW ELECTRIC LIBRARY



Ten all-inclusive volumes. Complete electrical encyc. Questions & answers & trial tests for study. 9000 Ill. 5000 Pgs. Set \$22.50

Circle No. 15A In COUPON

## AUDEL'S TRUCK and TRACTOR GUIDE



A guide for mechanics, drivers, trouble-shooters, etc. Both gas & diesel. 78 Chapters. Indexed. Illus. 1376 Pgs. \$5.00

Circle No. 5 In COUPON

## AUDEL'S Refrigeration & Air Conditioning Guide

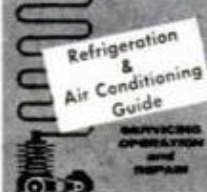

Four books in one. Modern systems & machines. Inc. quick freezing, water coolers, etc. Indexed. Illus. 1360 Pgs. \$6.00

Circle No. 14 In COUPON

## AUDEL'S OIL BURNER GUIDE

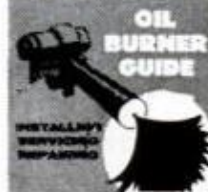

New practical work on all domestic & industrial oil burners. Inc. elec. hook-ups & wiring. Indexed. 320 Illus. 416 Pgs. \$3.00

Circle No. 28 In COUPON

## AUDEL'S GAS ENGINE MANUAL

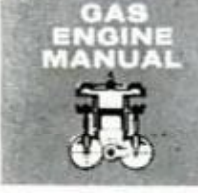

Brand new title! Construction, operation and repairs on all types of modern gas engines. Illus. 467 Pgs. \$4.00

Circle No. 48 In COUPON

## AUDEL'S OUTBOARD MOTOR & BOATING GUIDE



Just off press! All phases of outboard motor repairs and maintenance. An essential boating tool! Illus. 400 Pgs. \$4.00

Circle No. 49 In COUPON

## AUDEL'S DO-IT YOURSELF ENCYCLOPEDIA



Two vols. New, giant home repair and project guide. Step-by-step plans and charts. Alphabetized. Illus. 1000 Pgs. Set \$8.95

Circle No. 43 In COUPON

## AUDEL'S AUTO GUIDE



Ready guide for mechanics, stnnts. & car owners. Theory, construction and servicing of modern cars. Illus. 1132 Pgs. \$6.00

Circle No. 1 In COUPON

### ADDITIONAL IMPORTANT TITLES

The following Audel Guides are all the best in their fields, written in clear simple fashion, all lavishly illustrated. Circle the numbers wanted on the POST CARD at right. All books are sent for FREE EXAMINATION.

- No. 4 HANDY BOOK OF ELECTRICITY, 1052 Pages..... \$5.00
- No. 9 DIESEL ENGINE MANUAL, 640 Pages..... 4.00
- No. 12 MACH. & TOOLMAKERS HANDBOOK, 1250 Pages..... 6.00
- No. 13 WIRING DIAGRAMS (Light & Power), 304 Pages..... 2.50
- No. 29 SHEET METAL PATTERN LAYOUTS, 1152 Pages..... 7.50
- No. 30 SHEET METAL WORKERS HANDBOOK, 448 Pages..... 3.00
- No. 31 MECHANICAL DRAWING GUIDE, 192 Pages..... 2.50
- No. 32 MECHANICAL DRAWING & DESIGN, 410 Pages..... 3.00
- No. 34 ELECTRICIANS EXAMINATIONS, 272 Pages..... 2.50
- No. 35 ELECTRIC POWER CALCULATIONS, 480 Pages..... 3.00
- No. 36 ELECTRIC DICTIONARY, 9,000 Terms..... 3.50
- No. 37 POWER PLANT ENGINEERS GUIDE, 1568 Pages..... 6.00
- No. 38 ENGINEERS & FIREMANS EXAMS, 544 Pages..... 3.50
- No. 40 PUMPS, HYDRAULICS, AIR COMP., 1248 Pages..... 6.00
- No. 42 MILLWRIGHTS & MECH. GUIDE, 1248 Pages..... 6.00
- No. 44 NEW MECHANICAL DICTIONARY, 712 Pages..... 6.95
- No. 45 MAGIC OF LANDSCAPING, 128 Pages..... 1.49
- No. 46 WATER SUPPLY & SEWAGE, 436 Pages..... 4.00
- No. 47 GUIDE TO CREATIVE PHOTOGRAPHY, 416 Pages..... 3.95



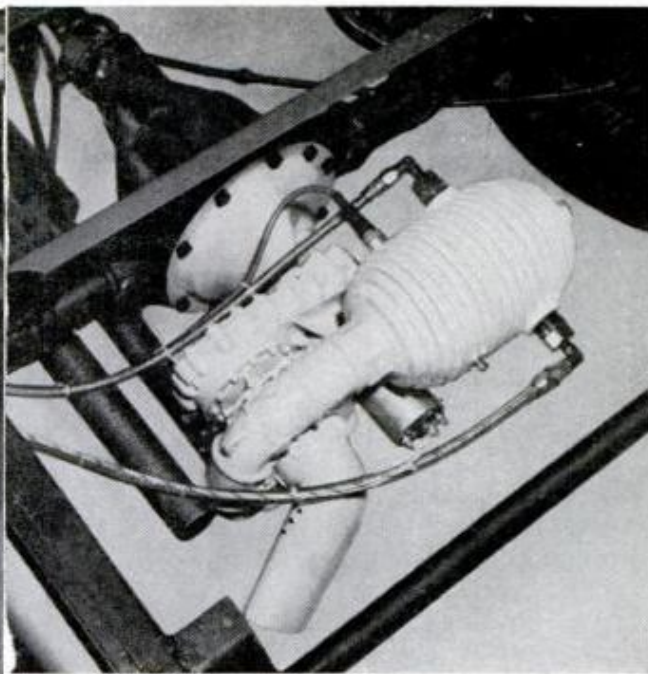
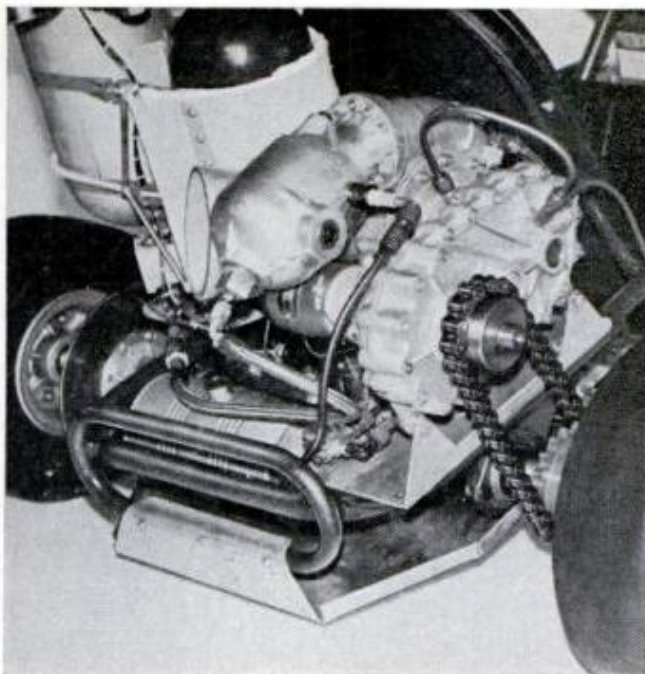

## Short-Snort Turbine Gives Extra Kick

Half a dozen different turbine engines are now available to add from 45 to 360 horsepower directly to your car's rear axle whenever you call for it.

Installation of the supplemental Microturbo engines is hardly more than a bolt-on operation. Just remove the differential inspection plate and bolt the turbo in its place. Then hook up a tank of turbine fuel, the spark plug wiring, and—for the 1/4-second starting cycle—a five-pound CO<sub>2</sub>

bottle of oxygen. A one-way Borg-Warner sprague clutch passes the turbine's power to its own pinion gear and on to the differential ring gear.

The manufacturer, Turbonique Incorporated of Orlando, Fla., says its Micros can be adapted for almost any fuel. As built, they use Thermolene, a special, nitrate-based mixture now costing about 15 cents a pound. Microturbos also are available in kit form or as a group of castings.

## What Comes Next—Plastic Igloos?

With foam-flotation at bow and stern, a new 17-foot fibreglas kayak tips the scales at only 70 pounds. It's designed to be cartopped to the water, and includes ample under-deck storage space for overnight

camping gear. Complete with double paddle, adjustable seat and footrest, this updated Eskimo runabout sells for \$279 F.O.B. Graves Yacht Yards, 6 Beacon St., Marblehead, Massachusetts.





# Hacksaws Are Getting More Versatile

Too often, when a manufacturer claims to have improved a hand tool, he's merely given it a new shape or jazzed up the finish. But three unusual hacksaws by Dreier Bros., Inc., 7301 S. Woodlawn Ave., Chicago 19, Ill., are actually more versatile than conventional models. For example, the Challenger (photo, right) and Jab Saw (center) will both cut flush with the work surface—something you can't do with most hacksaws. In addition, we found the Jab Saw excellent for cutting plaster and gypsum-board, and both it and the Low Boy model (bottom) will get into places that are impossible to reach with a standard saw. Prices: Challenger, \$4; Jab Saw, \$3.50; Low Boy, \$2.75.

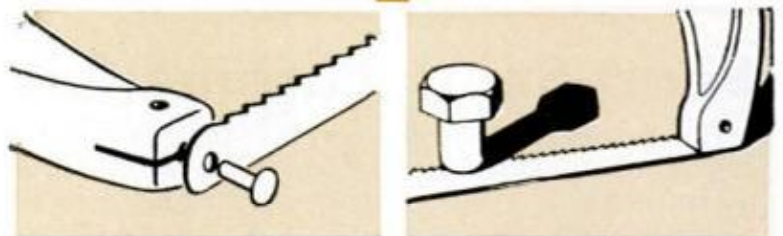
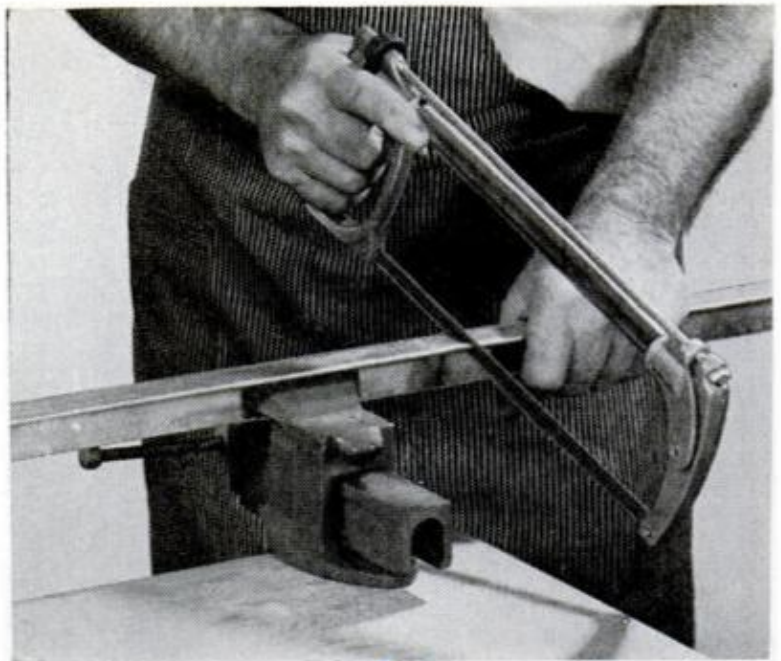

**CHALLENGER BLADE** turns 90 deg. for flush cuts. Model also has adjustable tension wheel, blade storage in frame

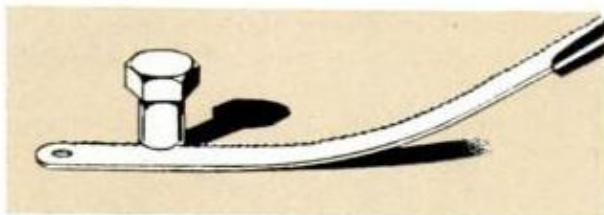

**BESIDES CUTTING FLUSH**, as shown, Jab Saw is ideal for work in tight corners. Also doubles as keyhole saw

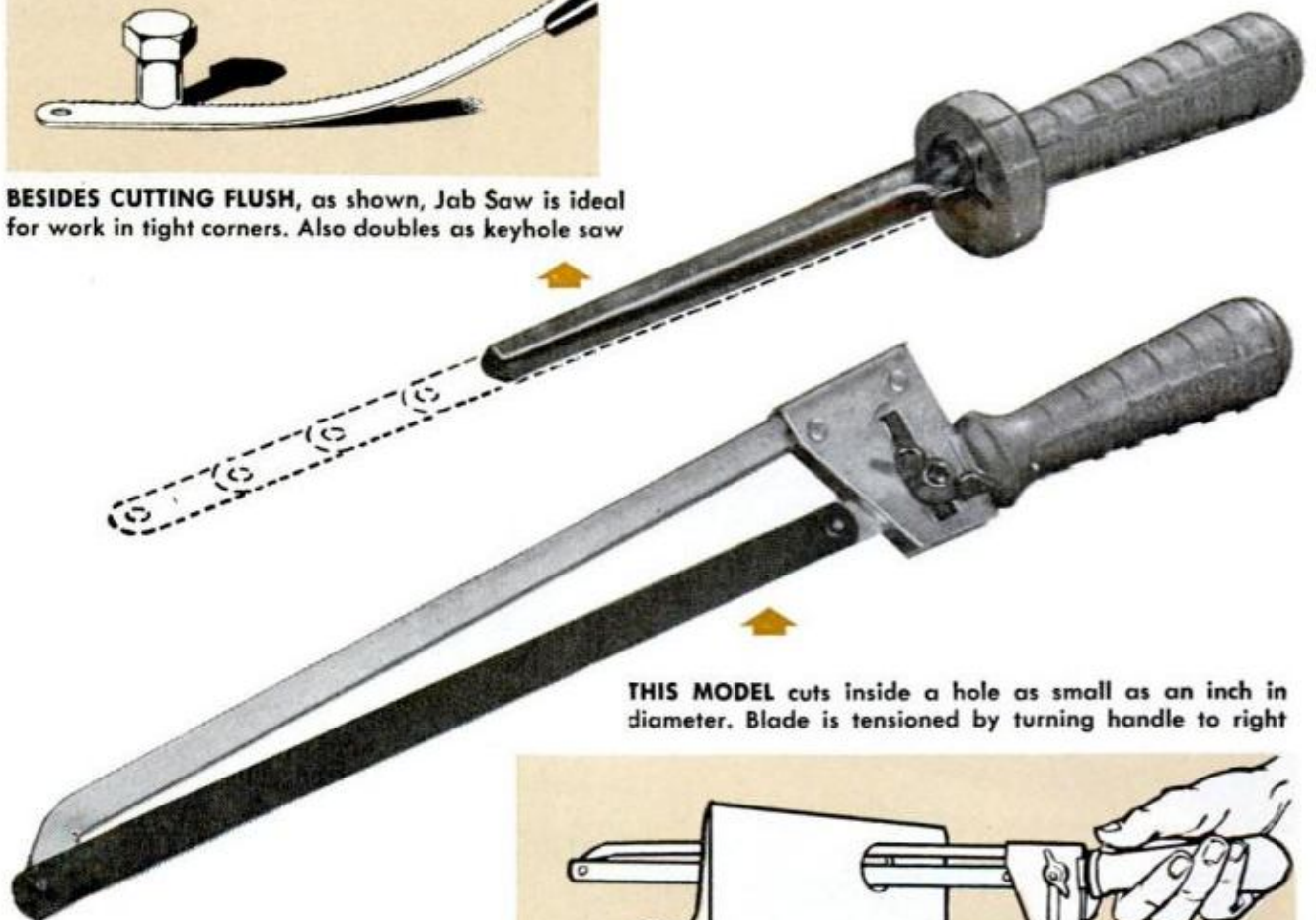

**THIS MODEL** cuts inside a hole as small as an inch in diameter. Blade is tensioned by turning handle to right

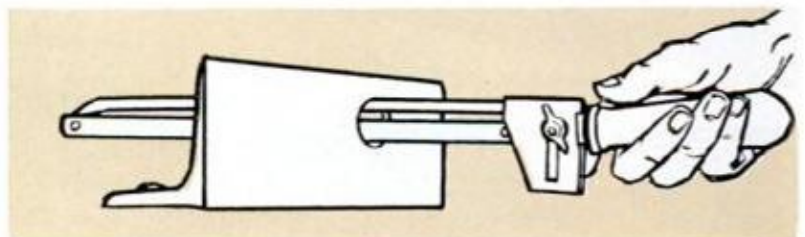





**"I'M MAKING \$1000 MORE A YEAR**

**—and I'm just getting started!"**

says William E. Myers, Jr., Philadelphia

"... I am now making my full income from Locksmithing. It's more than \$1000 a year higher than before. All my thanks to your Locksmithing Institute Course."



**306**

pieces of professional equipment

Supplied for use with course.

Professional Equipment includes  
**LOCKS—PICKS—PARTS—KEYS  
SPECIAL TOOLS & SUPPLIES**  
all FREE for use with course.

# Be a LOCKSMITH

**Train at HOME—Earn While You Learn.** Add 50%-100% to YOUR INCOME with easy spare time earnings. Cash in on the nation-wide shortage—trained locksmiths in great demand! Quickly step into a big pay opportunity job or start a high-profit shop of your own.

**Earn Extra Money RIGHT AWAY!** All Master Locksmiths Special Tools, Equipment and Supplies furnished for use with course.

Age, education, minor physical handicaps don't matter in this growing trade. You can quickly qualify as a skilled locksmith. It's like a fascinating hobby. Study at home as little as one hour a week. Gain practical experience through complete well-illustrated lessons. Do real jobs on car locks, house locks, padlocks and safe locks, under the guidance of experts. **FREE Illustrated Book, write now.**

**LOCKSMITHING INSTITUTE.**  
(Div. Technical Home Study Schools)  
Dept. 108-3, Little Falls, New Jersey

**MAIL COUPON for FREE ILLUSTRATED BOOK**

For a future as your own boss or in a high-pay job, write now for **FREE Illustrated Book.** Only school of its kind. Licensed by State of New Jersey. Approved for Veterans.

Acc'd Member Nat'l Home Study Council.

**MAIL COUPON NOW**

**LOCKSMITHING INSTITUTE, Dept. 108-3  
Little Falls, New Jersey**

Please send **FREE Illustrated Book**—"Your Big Opportunities in Locksmithing," complete Equipment folder and sample lesson pages—**FREE** of all obligation—(no salesman will call).

Name.....  
Address.....  
City.....Zone.....State.....  
(Please Print)



## BIG Throwing Knife \$1.00

**PIERCES METAL**  
Specially weighted & balanced point zeroes right into bull's eye with a wallop! Positive accuracy! Deep penetration! Easy throwing! Hard hitting! Excellent for hunting game, self-defense, fun. Cutlery steel, double edge. Big 10" long. Leather handle. You must be delighted or your money back. Price Postpaid \$1.00. Leather Sheath 50c. Professional Knife Throwing Book 25c.

## Imported Stiletto Knife

**OPENS WITH FLICK OF FINGER and LOCKS INTO POSITION**  
Prevents blade from snapping shut when in use. Push button release. Convenient pocket size, yet rugged. Fine quality, polished nickel-steel razor-sharp blade. **PIERCES METAL.** Narrow, tapered stiletto blade with thick rigid backbone for heavy duty use. Fine outdoor knife for sportsmen and emergencies. Comfortable handle. Safety guards. **Pop. \$2.50**  
**JOHNSON SMITH & CO., Dept. 325, Detroit 7, Mich.**

**\$1,000 DOWN PUTS YOU IN BUSINESS**  
balance on easy terms

**EARN \$10,000**

**A YEAR OR MORE**  
Own a **Tastee-Freeze Drive-in**

Year 'round business. Sell Tastee-Freeze soft ice cream products, hot dogs, hamburgers, french fries, shakes. No experience needed. We train you. Information **FREE.**



**TASTEE-FREEZE, 4311 W. Belmont, Chicago 41, Dept. PM**

**A Unique Sparetime BUSINESS Opportunity**

**Pays for itself out of profits in 90 days**

**2 Blades + 30 Minutes = \$60.00 a Month**

Circular saw blade sales are booming. And every blade sold needs to be sharpened sometime. Take advantage of this opportunity by finding out about the extraordinary profits available in saw sharpening. New Foley Grinder sharpens circular saws 5" to 44" in diameter. Every community and suburb needs this important service.

**NO EXPERIENCE NECESSARY!!**

No need to be a mechanical wizard to operate! Precision Foley Grinder and easy instructions make anyone an expert overnight. Men, everywhere, are averaging \$6 an hour in their sparetime with this low cost machine.

**MINIMUM DOWN PAYMENT!!**

Get information with all of the facts plus how to start your own business for a modest down payment. (Equipment will pay for itself out of profits in 90 days by sharpening only 2 blades a day.) Write, today, to:

**FOLEY MANUFACTURING COMPANY**  
816-3 Foley Bldg., Minneapolis 18, Minn.



# EARN \$10,000 A YEAR

LET ME PROVE to you that the average starting salary of our graduates is \$4,300.00 per year.

After becoming familiar with the industry their salary usually increases to \$6,000.00 to \$7,000.00 per year.

When they become specialists, or part of management, they can earn \$8,000.00 to \$10,000.00 a year . . . and more!

WHY WORK FOR LOW PAY—or worry about losing your job?

WE CAN QUICKLY TRAIN YOU to enter one of these rapidly growing BIG-PAY fields:—

- DIESEL—AUTO MECHANICS
- AIR CONDITIONING SERVICING
- REFRIGERATION SERVICING
- HEATING EQUIPMENT SERVICING
- ELECTRONIC TECHNICIAN

## SUCCESS INSURANCE

LET ME PROVE to you that, due to our special, exclusive SUCCESS INSURANCE PROGRAM, we are successful in placing **BETTER THAN 98% OF OUR GRADUATES** in the field for which they are trained.

**EARN WHILE YOU LEARN.** We provide you with a part time job and housing while in school.

MAIL TODAY! Free booklet, no obligation.

WRITE FOR FREE BOOKLET

CHECK SUBJECT OF YOUR CHOICE IN BOX ABOVE.

Your Future  
IN  
AIR CONDITIONING  
REFRIGERATION  
& HEATING

**BAILEY**  
Technical Schools

Your Future  
in  
DIESEL and  
AUTO  
MECHANICS

1634 S. Grand, St. Louis 4, Mo.

Name \_\_\_\_\_ Age \_\_\_\_\_  
Street \_\_\_\_\_  
Town \_\_\_\_\_ Zone \_\_\_\_\_ State \_\_\_\_\_  
Telephone \_\_\_\_\_



C. W. BAILEY, PRES.

# REAL ESTATE BE A BROKER

**PAYS BIG! SEND FOR FREE, BIG, ILLUSTRATED CATALOG NOW!** Graduates report making substantial incomes. Start and run your own business quickly. Men, Women, all ages, learn easily. Course covers Sales, Property Management, Appraising, Loans, Mortgages, & related subjects. **STUDY AT HOME** or in classrooms in leading cities. **DIPLOMA AWARDED.** Write TODAY for FREE Booklet! Accredited Member National Home Study Council. VA Approved. **WEAVER SCHOOL OF REAL ESTATE** (Est. 1936) 3521-P Broadway Kansas City 11, Mo.

FREE BOOK TELLS HOW

## GET INTO ELECTRONICS

V.T.I. training leads to success as technicians, field engineers, specialists in communications, guided missiles, computers, radar, automation. Basic & advanced courses. Electronic Engineering Technology, an ECPD accredited Technical Institute curriculum. Assoc. degree in 29 mos. U.S. obtainable. G.I. approved. Start Sept., Feb. Dorms. campus. H.S. graduate or equivalent. Catalog.

**VALPARAISO TECHNICAL INSTITUTE**  
DEPARTMENT D. VALPARAISO, INDIANA



## A BUSINESS OF YOUR OWN REPAIR HYDRAULIC JACKS



Earn while you learn at home. Millions of jacks in gas and auto-service stations, truckers, body-shops, riggers, factories, farms need servicing. We show you HOW — easy step by step directions and what tools to use. EARN UP TO \$5 an hour, in spare time, in your basement or garage. Start your own business NOW! Write for folder PM8 and free bonus offer

**INSTITUTE OF HYDRAULIC JACK REPAIR**  
P. O. BOX 50 • BLOOMFIELD, N. J.  
A Correspondence School Licensed by N. J. Bd. of Ed.



## ACCORDIONS UP TO 1/2 OFF

Save up to 1/2 off retail prices of comparable accordions

- 5-DAY FREE TRIAL •
- Buy DIRECT from world's Largest Exclusive Dealer! Compare our Importer-to-You prices! •
- See how you save! Over 80 models—finest genuine Italian makes! New, easier terms! 5-Day Free Home Playing Trial with satisfaction 100% assured. Bonus Gifts Free. Rush name and address for FREE Color Catalog and direct Importer-to-You prices—FREE. Write TODAY! •
- Accordion Corporation of America •
- 2003 W. Chicago Av., Dept. R-83, Chicago 22 •

## PROFIT IN YOUR SPARE TIME



### SMALL ENGINE REPAIR PAYS BIG!

Outboard • Powermower • Chain Saw • Tractor  
**MAKE EXTRA MONEY** — or fix your own engines and SAVE! Illustrated, easy-to-learn Home Study Course qualifies you as expert. Free information. Write today!

**LINCOLN TECHNICAL INSTITUTE**  
SUITE 8-E, 472 MARKET STREET, NEWARK 5, N. J.

## 75 POWER TELESCOPE 25X-45X-75X \$3.98

**NEW** 3 in one telescopes, 3 variable 25X, 45X-75X magnification. Brass bound. 25 power for ultra bright images 45 & 75 power for long range. Guaranteed to bring distant stars, moons, objects, sports 75 times closer.



Most powerful scope sold anywhere near this amazing low price. American made, 5 sections. Opens 36", closes 1 ft.; contains 4 ground & polished lenses. Can also be used as powerful compound microscope. Mass production enables us to offer telescope complete at \$3.98 postpaid. Money back guarantee. **CRITERION CO., Dept. PBM-12, 331 Church St., Hartford, Conn.**

## FREE OUTFIT STARTS YOU IN BIG MONEY SHOE BUSINESS!



Run your own profitable 'shoe store' business from home! Represent fast growing million dollar firm in spare or full time. We give you—**FREE**—complete Starting Outfit that makes you **\$217.00 EXTRA each month for just 2 easy orders a day.** You feature 195

fast-selling dress, sport, work shoe styles for men and women. Air-cushion shoes, many other special features! Sizes 2 1/2-15—widths AAAA to EEEE. Draw on 200,000 pair stock. Also horsehide jackets. Start now selling to friends, folks where you work. Rush postcard for FREE Outfit!

**MASON SHOE, Dept. F-47, CHIPPEWA FALLS, WIS.**



# POPULAR SHOPPING

**Computers** are now basic to many fields from architectural planning to payroll computation. "Careers in Electronic Data Processing," a 16-page illustrated booklet, discusses what it takes to get into computer work, various jobs at the research, engineering, management, marketing and maintenance levels, and the people involved in these areas. Write to the Project on Information Processing, Box PM 210, Montclair State College, Upper Montclair, N.J., for your free copy.

**Pesticides** are both a concern and a benefit: their power not only protects us from hunger and disease, but also endangers our wildlife. "Agricultural Chemicals—What They Are/How They Are Used," a 65-page booklet published by the Manufacturing Chemists' Assoc., 1825 Connecticut Ave., N.W., Washington 9, D.C., discusses the uses of chemicals in agriculture, public health and conservation . . . with emphasis upon legal controls and proper use of a variety of both pesticides and growth regulators. A special section is devoted to biological pest control. Selected references are indexed. You may obtain a copy for 25 cents—or free if requested on organization letterhead.



**Mufflers** can affect gasoline consumption and horsepower output. "Your Muffler, Your Car and You," a free, 16-page pamphlet, tells what mufflers do, how they are constructed and why good muffler condition may improve car economy or even save a life. Copies are available from the Walker Manufacturing Co., Dept. PM, Racine, Wis.

**Radio hobbyists:** build and operate your own station with the help of a new book, "Understanding Amateur Radio," published by the American Radio Relay League, Dept. PM, West Hartford, Conn. 16 chapters explain and diagram the workings of receivers, antennas, transmitters, etc., and how to build them. The author, George Grammer, technical director of the ARRL, also includes a chart of operating signals. Cost of the 313-page book is two dollars.

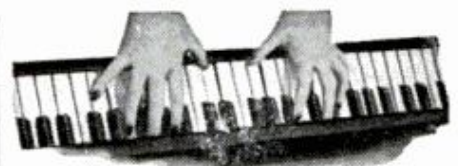

## BE YOUR OWN MUSIC TEACHER

ANY INSTRUMENT

even if you don't know a single note now!

Now it's EASY to learn ANY instrument. No boring exercise. Even if you don't know a single note now you can play delightful pieces—from your FIRST lesson! BY NOTE. Make amazing progress. No special "talent" needed. Learn at home in spare time, without a teacher. Low cost! Soon you can play popular music, hymns, classical and any other music. Over 1,000,000 students, all over the world. **FREE BOOK.** Send this ad with your name and address filled in below today, to: **U. S. SCHOOL OF MUSIC, Studio A308, PORT WASHINGTON, L.I., N.Y.**



(No obligation, no salesman will call. Licensed by N.Y. State Education Dept.)



Name .....

Address .....

City..... Zone.... State.....

Free "Information on patents" . . .  
Write

Service Bureau, Popular Mechanics,  
575 Lexington, New York 22, New York.

## LEARN MEAT CUTTING AT NATIONAL Pay After Graduation

The steady dependable trade of Meat Cutting taught easily in 8 short weeks. YOU LEARN BY DOING under actual meat market conditions in big modern school at Toledo.

For beginners or men with experience. Get a profitable store of your own. Remember, PEOPLE MUST EAT! Big pay jobs. Free employment help. Thousands of successful graduates.

Buying, cutting, percentage, pricing, advertising, selling, etc. A complete retail meat education. National School established 40 years. Get National training now. Pay your tuition in easy monthly payments after you graduate. Send coupon for FREE 40 page school catalog—TODAY. G.I. approved.

**National School of Meat Cutting, Inc., Dept. 50-W, Toledo 4, Ohio**

Send me your FREE school catalog on National Training at Toledo in Meat Cutting, Meat Merchandising and Self-Service Meats. No obligation. No salesman will call.

Name \_\_\_\_\_ Age \_\_\_\_\_

Address \_\_\_\_\_

City \_\_\_\_\_ State \_\_\_\_\_

Approved for Veterans



# ELECTRONICS

Train in the new shop-labs of the world famous  
**COYNE** ELECTRICAL SCHOOL on a  
 quarter of a million dollars  
 worth of equipment. Est. 1899—Non-Profit Institute.  
 Courses: Electronics • Electricity • TV-Radio.

Use this coupon to get our free book  
**"YOUR OPPORTUNITIES IN ELECTRONICS"**  
 COYNE ELECTRICAL SCHOOL Educ. Serv. Dept. C3-S  
 1501 W. Congress Parkway, Chicago 7, Ill.

NAME \_\_\_\_\_  
 ADDRESS \_\_\_\_\_  
 CITY \_\_\_\_\_ STATE \_\_\_\_\_

Unlike most other schools, we do not employ salesmen.



## Earn HIGH WAGES as a HEAVY EQUIPMENT OPERATOR

... and years of future security in the multi-billion dollar construction industry, in this country and *overseas!* Learn how at National, the original school of heavy equipment operation. For men ages 17 to 56. Amount of previous education *no barrier*. National is NOT a correspondence school. You train on school-owned diesel-engined machines at National's huge proving ground in North Carolina. Full 220 and 440 hour courses. Full-time Job Advisory and Counselling Director for the exclusive benefit of graduates. VA approved. Payment plans available. Write TODAY for FREE catalog.

Since National School was founded eight years ago, students from all 50 states and 28 foreign countries have been enrolled. Hundreds of graduates are now working in construction for higher wages than they ever made before.

**NATIONAL SCHOOL  
 OF HEAVY EQUIPMENT OPERATION Dept. D-43  
 P. O. Drawer 1686, Charlotte, N. C.**

Please send me FREE illustrated school catalog and complete information. I understand there's no obligation.

Name..... Age.....  
 Address.....  
 City..... Zone..... State.....

## New Table Top Invention Puts You In... **PROFITABLE RUBBER STAMP BUSINESS**

Home Operators now make  
**\$9.20 AN HOUR** in Business once monopolized by a few big companies

Special rubber stamps bring high prices—cost only pennies to make on new, low-cost table top machine. Take 27 cents worth of material, make perfect stamps, the kind businesses and offices now buy by the dozen at \$1.80 each. Make up to \$9.20 an hour. Start in spare time in your own home. Run machine on kitchen table using ordinary electrical outlet. Make any kind of stamp. We'll send you free information without obligation about this established, highly profitable business. **We'll even help finance your start.** For free information send name and address today on a postcard to: Rubber Stamp Div., 1512 Jarvis Ave., Dept. R-2-J, Chicago 26



worth  
writing  
for...

## DRAINS cellars, cisterns, wash tubs; \$7.95 IRRIGATES - CIRCULATES - SPRAYS



1,001 uses. Stainless shaft. Won't rust or clog! Use 1/8 HP motor or larger . . . 3/4 HP for up to 2,400 GPH; 450 GPH 80' high; or 1800 GPH from 25' well. 1" inlet; 3/4" outlet. Coupling included free. \$7.95.  
**HEAVY DUTY BALL-BEARING PUMP.** Up to 5,200 GPH; or 3,000 GPH from 25' well. 1 1/4" inlet; 1" outlet. \$12.95  
 Postpaid if cash with order. **MONEY BACK GUARANTEE**

Centrifugal and Gear Pumps in All Sizes  
**LABAWCO PUMPS, Belle Mead 7, New Jersey**

## DON'T QUIT SMOKING

... Before Giving My Pipe a Trial!

New principle that contradicts every idea you've ever had about pipe smoking. I guarantee it to smoke cool and mild hour after hour, day after day, without rest without bite, bitterness or sludge. To prove it, I'll let you try a new Carey Pipe. Send name today for my FREE complete trial offer. Write to: **E. A. CAREY, 1920 Sunnyside Ave., Dept. 252-J, Chicago 40, Ill.**

## MONEY IN WORMS

Success for you! 5000 of our hybrid red wiggler fishworms produce 5,000,000 in one year using our successful method of worm raising. Read our success story in LIFE MAGAZINE, Dec. 28, 1959 issue. Let us teach you our secrets of success. Write today for FREE INFORMATION on how to raise and sell fishworms and crickets.

**Special Today—Hybrid Red Wigglers—3000—\$5.95. 5000—\$8.95. 10,000—\$16.95. Postpaid.**

**CARTER WORM RANCH, PLAINS, GEORGIA**

send  
for  
FREE  
BOOK  
TODAY



Transistor  
Radio with  
Battery  
\$1.96

17-Jewel  
Watch  
\$2.87

Derringer  
Pistol \$5.74

## HOME-IMPORT BUSINESS—Make Big Profits

New Drop Ship Plan offers you first day profits! Deal direct with overseas sources at prices shown. Dazzling bargains with no investment. Full or spare time.

Write for FREE BOOK today to...  
**MELLINGER, 1554 S. Sepulveda, Dept. K258, Los Angeles 25**

## Shrinks Hemorrhoids New Way Without Surgery Stops Itch - Relieves Pain

For the first time science has found a new healing substance with the astonishing ability to shrink hemorrhoids and to relieve pain — without surgery.

In case after case, while gently relieving pain, actual reduction (shrinkage) took place.

Most amazing of all — results were so thorough that sufferers made astonishing statements like "Piles have ceased to be a problem!"

The secret is a new healing substance (Bio-Dyne®)—discovery of a world-famous research institute.

This substance is now available in *suppository or ointment form* under the name *Preparation H®*. Ask for it at all drug counters.



## 1001 USES! WELDWOOD® FLEXIBLE WOOD-TRIM®



**PROFESSIONAL LOOK TO PLYWOOD PROJECTS**  
Beautiful wood veneer, paper-backed, in handy rolls, 8' x 1", for edging plywood. Also, decorate lamp shades, book ends, do inlay work, etc. Apply with Contact Cement or Presto-Set<sup>3</sup> Glue. Oak, birch, African mahogany, walnut, fir, Korina<sup>2</sup>. At lumber, paint, and hardware dealer's. United States Plywood, Protection Products Div., Dept. PM8-63, 2305 Superior Ave., Kalamazoo, Mich.

## NEW CATALOG OF 49 BOATS... ONLY 50¢ BOAT PLANS • PATTERNS • FRAME KITS

All specially prepared for amateurs!

Power & Sail... Runabouts, Cruisers, Ski Boats, Catamarans & Dragsters. MAIL 50¢ to:

**GLEN L** 9152T ROSECRANS, BELLFLOWER, CALIF.

## New Jet Engine Burns Gasoline



Powerful continual thrust for models, experiments, thrills! Operates by itself or drives model car, boat, plane, etc. **LOWEST PRICED GAS ENGINE.** Ram jet principle. No moving parts. Easy starting. Runs on regular gas. About 6" long. Use two for double power. **\$1.50** (2 for \$2.75.) Complete, Each

**JOHNSON SMITH CO., DEPT. 325, DETROIT 7, MICHIGAN**

## MAKE MORE MONEY Become a Master UPHOLSTERER!!



Make Custom Furniture or Reupholster Chairs, Divans, Footstools for BIG MONEY in spare or full time. Make Slip Covers, Drapes, Cushions. We give you EVERYTHING: 1) Home Training covering ALL PHASES, 2) All TOOLS to practice AT ONCE, 3) Practical Job Projects and FREE supplies, materials to build \$300 worth of furniture—yours to keep or sell! Write TODAY for Big FREE Upholstery Career Kit: 32 pg. Book: Workshop Project: Business Plan Guide. ALL THREE FREE! MODERN UPHOLSTERY INSTITUTE, DEPT. U47, FALLBROOK, CALIFORNIA.

## WANT MORE MONEY? GET INTO PHOTOGRAPHY



Coast-to-coast, high-paying jobs in photography are waiting for people with the "know-how" to fill them. You can quickly, easily qualify at home with the world-famous NYI Learn-by-Doing Method. Write today for free catalog. Also resident training in N. Y. Our 53rd Year. Approved for Veterans.

**NEW YORK INSTITUTE OF PHOTOGRAPHY**  
Dept. 49 10 West 33 St. New York 1, N. Y.

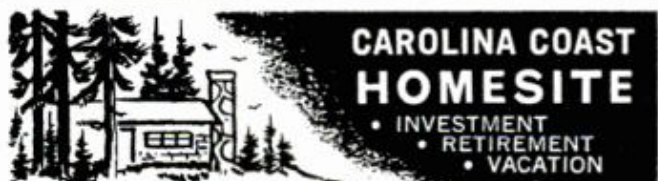

## CAROLINA COAST HOMESITE

- INVESTMENT
- RETIREMENT
- VACATION

- Cooled by Ocean Breezes in Summer
- Warmed by Gulf Stream in Winter

**\$10 Down \$10 Month**

14,000 Acre Development on Highway 87! ... 50 fresh-water lakes for boating, swimming, fishing, water-skiing! 4,000 acres for private hunting! Shopping center, Motel, and all facilities available NOW—right on property. Electricity, water system, 47 miles of roads already in. Championship golf course, ultra-modern country club, boat ramp, park and picnic areas. Only minutes to Atlantic Ocean. Developed by multi-million dollar firm listed on Stock Exchange. Over 4,000 homesites already sold. Write for full details today. No obligation.

**REEVES Broadcasting & Development Corp.**  
Boiling Spring Lakes 42, North Carolina



# RUPTURED

## YOU CAN NOW BE FREE FROM TRUSS SLAVERY

Surely you want to THROW AWAY TRUSSES FOREVER, be rid of Rupture Worries.

Then why put up with wearing a griping, chafing truss the balance of your life? If you do, it will not be through necessity but through choice on your part—for most reducible Ruptures can be corrected **NON-SURGICALLY.**

## NON-SURGICAL TREATMENTS

The resultful **NON-SURGICAL** treatments of reducible Rupture used by the Excelsior Medical Clinic, require no painful surgery, hospitalization, anaesthesia or long periods of convalescence.

Thousands of satisfied patients from hundreds of communities have come here to be successfully treated. The treatments are so dependable that every patient accepted for treatment is given a **Lifetime Certificate of Assurance.** Treatments usually take but a short time and the cost is reasonable.

## Do Something TODAY

The Excelsior Medical Clinic has recently published a New Free Book, fully illustrated, on how neglect of Rupture, Rectal-Colon Disorders or Glandular Inflammation often results in expensive surgery.

It shows **HOW** and **WHY NON-SURGICAL** treatment methods are so successful today. Fill out Coupon below for your **FREE** Copy.

### RECTAL-COLON DISORDERS GLANDULAR INFLAMMATION

These disorders, if not corrected, may gradually grow worse and often require painful surgery. The **NON-SURGICAL** treatment of these disorders is fully explained in our Free Book.



**EXCELSIOR MEDICAL CLINIC**  
Dept. H6150  
Excelsior Springs, Mo.

Gentlemen: Kindly send me at once your New **FREE** Book. I am interested in full information. (Please Check Box)

- Glandular Inflammation       Hernia  
 Rectal-Colon

Name \_\_\_\_\_

Address \_\_\_\_\_

City \_\_\_\_\_ State \_\_\_\_\_



## JOBS WAITING FOR ALLIED GRADUATES SPACE PROGRAM NEEDS MEN

Certified Courses

**DRAFTING** ALL BRANCHES

**TOOL & DIE MAKING** DESIGN

**AIR CONDITIONING** HEATING & REFRIGERATION

**AUTO MECHANICS**

**AUTOMATIC SCREW MACHINES**

Allied training is the basis for tremendous opportunities in the many vital industries of the Space program. No previous experience or higher education required.

Mail coupon today for free bulletin.

**ALLIED INSTITUTE OF TECHNOLOGY, Dept. PM-83**  
1338-42 So. Michigan Ave., Chicago 5, Illinois

RESIDENT  HOME STUDY  
 Industrial Engineering  Drafting  Auto Mechanics  
 Tool & Die Making-Design  Air Conditioning  
 Auto. Screw Machine

Name \_\_\_\_\_ Age \_\_\_\_\_  
Address \_\_\_\_\_  
City \_\_\_\_\_ County \_\_\_\_\_ State \_\_\_\_\_

## A Complete Miniature Machine-Shop!

Metal - Plastics - Wood

- Turns • Threads • Bores
- Drills • Mills • Grinds
- Polishes • Buffs • 900-7200 rpm • 16" of bench space

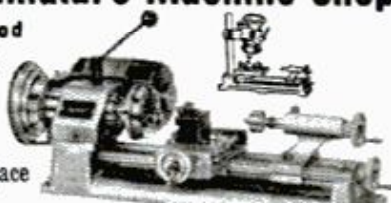

BASIC UNIMAT:

\$139.50 (includes high-efficiency motor). WRITE FOR FREE CATALOG.

AMERICAN EDELSTAAL, INC., DEPT. G-H, 350 BROADWAY, N.Y. 13, N.Y.

# "\$33,000 LAST YEAR"

## OPERATING AUTO RADIATOR SHOP



-Mercier Bros., Lowell, Mass.

"1,100 radiators repaired in last 7 months," reports Mercier Bros. as volume soars . . .

and the market is still growing! Modern V8's and 6's produce more heat than older engines . . . cooling system pressures are higher . . . yet radiators are smaller. Tests show 83% of all year-old autos, trucks, tractors need radiators cleaned - neglect endangers engine life, brings major repair bills. Inland's Flo-Test Machine diagnoses radiator condition - customer SEES his radiator is plugged - OK's cleaning. Inland-owners satisfy customers by performing needed cooling system service, replacing worn hoses, belts, water pumps, thermostats, etc.; average up to \$45 per job!

**Profits Immediate - Investment Modest**

Inland - world's largest mfr. of radiator servicing equipment - offers you complete package: equipment, supplies, 96-page Operating Manual, FREE FACTORY TRAINING for repairman (enables him to train others). Proved merchandising assures volume. Pay-As-You-Profit purchase plan. Act now - establish your own Cooling System Shop:

- Set up a side-line business, hire manager.
- Be the owner-operator.
- Makes a profitable dept. for established business.
- Start "part time" and build a profitable future.

WRITE FOR FREE 32-PAGE BOOKLET - "Blueprint for Profits" . . . describes equipment, prices, purchase plan, includes owner letters.



INLAND MFG. CO., Dept. PM-8, 1108 Jackson, Omaha 2, Nebr.

worth  
writing  
for . . .

## TRAIN AT HOME FIX any TV or RADIO



### MAKE UP TO \$5 AN HOUR

Start soon fixing sets for friends and neighbors in spare time. Be ready for a full-time business of your own when you graduate. Rapid growth of color TV, stereo hi-fi, home and car radios, PA systems, other electronic equipment means higher earnings for the trained Technician. Low monthly payments include special training equipment. NRI is oldest, largest school of its kind. For FREE Catalog, write NRI, Dept. 3HA, Washington 16, D.C.

## LITTLE PUMP DOES 1000 BIG JOBS

QUICKLY DRAINS CELLARS AND POOLS  
FILLS TANKS • IRRIGATES • SPRAYS



Pumps up to 5000 GPH. Up to 60 ft. head. Threaded, 1 1/4" intake, 1" discharge. Rust-free aluminum castings. Superior design. Top quality. Fits any motor. Satisfaction guaranteed or money Standard Model refunded. Send check or M.O. \$1 deposit on C.O.D.'s. Flexible drive coupling \$1 extra. **895** ppd.

Heavy Duty Ball Bearing Model. \$12.95 ppd.  
AMERICAN MACHINE & TOOL CO., INC.

Dept. PM-83, Royersford, Pa.

## Planning

to improve,  
remodel,  
modernize your home?

## NOW IS THE TIME TO DO IT

See your local lumber and building supply dealer displaying this symbol.

OFFICIAL

POPULAR  
MECHANICS

HOME IMPROVEMENT  
REMODELING PROGRAM

DEALER

It's your assurance that he has the ideas and know-how to help you make your home a better and happier place in which to live, work and play.



# START YOUR OWN MONEY MAKING BUSINESS

Clean rugs on customers' floors — upholstery in their homes — even painted walls — with highly efficient electric machines which are making big money for others and giving them independence. Write today for complete information. It's FREE!  
**VON SCHRADER MFG. CO., Dept. 810 "R" Pl., Racine, Wis.**

## MEN WANTED

**Earn \$125 Per Week and up AUTO DIESEL MECHANICS**

Master a trade with a future — learn Auto-Diesel mechanics in our shops. You learn with tools on real equipment. Earn while you learn. Many of our graduates earn \$125 per week and up. No previous experience necessary. Day and night courses. Approved for veterans.

Write for free bulletin  
**AUTO-DIESEL COLLEGE**  
 226 7th Ave., N., Dept. 92  
 Nashville 3, Tenn.

## BE A LANDSCAPE CONTRACTOR

**LEARN MODERN LANDSCAPING** for exciting hobby or profit. Thousands of spare or full time money making opportunities. Start a profitable business — we show you how. Study and earn your certificate at home.

Write today for Free Book.  
**LIFETIME CAREER SCHOOLS**  
 Dept. M-83  
 11826 San Vicente Blvd.  
 Los Angeles 49, Calif.



## Learn Profitable Profession in few months at Home

**MEN AND WOMEN, 18 TO 60**

\$4.00 to \$5.00 for 1-hour treatment is the established charge for a skilled operator. Easy to learn and do. Diploma awarded. Open your own office or earn good income from Doctors, Hospitals, Clubs and other health or recreational centers. Wonderful part-time profession. Low monthly payments. Write today for free Anatomy Charts and catalog. No obligation.

**ANDERSON SCHOOL OF SCIENTIFIC MASSAGE**  
 Dept. J1, Princeton, Illinois



## make your own Gems 36.50 F.O.B.

The Gem Maker comes complete with all necessary equipment, including a super-charged diamond blade for sawing, and all the wheels for grinding, shaping and polishing; also complete instructions. The complete equipment as shown, less motor and belt for only \$36.50, f.o.b., Burlington, Wisconsin. Write today for information and literature.

**B&I MANUFACTURING CO.**  
 Dept. P, Burlington, Wis.



## INSTALL BURGLAR ALARM SYSTEMS... BIG PROFIT HOME BUSINESS

**Protect men's shop Gross Profit \$188**  
**Protect Flooring Co. Gross Profit \$411**

The burglar alarm service profits need more explanation. 100 clients pay \$6,000 to \$12,000 a yr. Get details.

Start spare time. No mechanical experience or costly equipment. Expert shows beginners way to big profits installing in stores, homes. Big demand. Write for FREE PLAN now.  
**NASCO, 11071 Massachusetts, Dept. K258, Los Angeles 25, Calif.**

## Follow Science with Model Rocketry

"Blast off" ... into the exciting world of this new space-age hobby

**BUILD AND FLY YOUR OWN MODELS!**

**ASTRON-SCOUT ROCKET KIT... \$2.00**  
 easy to assemble... climbs 1200 ft.  
 • 3 engines • instructions • catalogue

New fact-filled, illustrated catalogue 25c  
 Nose cones, tubes, engines, launchers, etc.

**ESTES INDUSTRIES**  
 Penrose 15 Colorado



# KARATE!

**20 COURSE HOME STUDY PROGRAM**

## JUDO

**BOXING! MUSCLEBUILDING! YOGA! STRONGMAN STUNTS! STRENGTH & ENDURANCE! HANDBALANCING! ETC.**

YOU GET ALL THESE COURSES! \*20 illustrated KARATE blows \*SAVATE foot fighting \*secret NERVE CENTER and ANATOMY charts \*20 lethal JUDO throws \*20 terrific STRONGMAN STUNTS \*Complete MUSCLE-BUILDING course \*Ancient YOGA secrets \*HANDBALANCING stunts \*Complete BOXING course. Secrets of ENDURANCE \*WRESTLING holds \*WEIGHTLIFTING \*TENSION-FLEX COURSE \*HEALTH & FITNESS EXERCISES \*KEEP FIT PROGRAM \*K-MAN Karate Dummy Chart. No C.O.D.'s. Canadian 75c. YOU GET THE LOT.

**ONLY 50¢**

Free K-Man Practice Dummy showing attack points.

**COMPLETE HOME GYM PLANS**—Build gym equipment: vault horse, rowing machine, etc. Convert basement, garage to gym. ONLY 50¢ with courses. Total \$1.00 compl.

**OXFORD STUDIO, 44A-17 Bromfield, Boston, Mass.**

NAME (print) ..... **50¢ PROGRAM**  
 Address ..... **\$1.00 with GYM**  
 City ..... State .....

# High School at Home

## MANY FINISH IN 2 YEARS

No classes. No time wasted going to and from school. Progress as fast as your time and abilities permit. Standard H.S. texts supplied. Thousands enroll each year in this 66-year-old school. Send for FREE descriptive booklet.

**AMERICAN SCHOOL, Dept. HC 45**  
 Drexel at 58th St., Chicago 37, Ill.

Without obligation, please send FREE descriptive booklet.

Name \_\_\_\_\_  
 Address \_\_\_\_\_

Accredited Member **NATIONAL HOME STUDY COUNCIL**

# AIRMAIL STAMPS ONLY 10¢!



Fabulous collection of all-different genuine Airmail Stamps from remote corners of the world — Africa, Europe, Exotic Orient, everywhere! World's Largest Airmail, Flying Doctor, Bomber, \$2.00 Helicopter, many others. PLUS Collection of thrilling Space-Age stamps... Sputniks, Jets, fantastic Moon Rocket stamps. Both of these remarkable collections — containing stamps worth up to 25¢ each! — for only 10¢ to cover mailing costs. Extra: Illustrated Bargain Catalog and an attractive selection of stamps on approval.

**Jamestown Stamp Co. Dept. F83PM, Jamestown, New York**  
**RUSH my Airmail Collection and other offers.**  
 I enclose 10c for mailing costs.  
**PLEASE PRINT**

Name.....  
 Address.....  
 City &  
 State.....



# EARN WHILE YOU LEARN CUSTOM UPHOLSTERY & SLIP COVERS



## Make Big Money In Spare Time

You can earn right off, in your own home, while learning Custom Furniture Upholstery and Professional Slip-Cover making. Enjoy steady work, well-paid job, big profits as your own boss. Booming fields also offer ideal opportunity for husband-and-wife. **YOU GET ALL MATERIALS AND SUPPLIES** with UTS complete easy home study training—make beautiful chairs, lovely slip-covers, to keep or sell. Send for Big Free Illustrated Book. At home become skilled, professional custom upholsterer, make slip-covers like professional decorator.

Accredited member N.H.S.C. No obligation. No salesman.

**MAIL COUPON TODAY**

**EARN  
BIG  
MONEY**

**Upholstery Trades School, Dept. RM-318  
Little Falls, New Jersey**

Please send me Big FREE Book about  
 Upholstery & Slip Covers     Slip Covers Only

Name .....

Address .....

City..... Zone..... State.....

check if Korean Veteran

**STOP DREAMING...  
START DRAWING!**

New system brings amazing results inexpensively, quickly. See for yourself.

**BOOK FREE.** No obligation.

Continental Schools, Inc., Dept. E-179

4201 S. BROADWAY, LOS ANGELES 37, CALIF.



## BUILD, FLY ONE-MAN COPTER

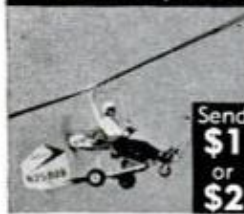

Fun to build, inexpensive, easy to fly. Factory kits available. Order 3-view drawings, specs, photo of Gyro-Copter \$2 or motorless Gyro-Glider \$1. Send coupon today.

Send  
**\$1**  
or  
**\$2**

**BENSEN AIRCRAFT CORP., Dept. PM-83**

Raleigh-Durham Airport, Raleigh, N. C.

NAME

ADDRESS

811

**WANT TO BE  
A LOCAL Brikcrete\*  
MANUFACTURER?**

\*Guaranteed to Contain No Clay

High income can be earned operating a Brikcrete plant, because Brikcrete — world's most modern masonry — gives more value for less cost to building owners without sacrifice of profits. Huge savings by local production makes possible low prices and high income potentials.

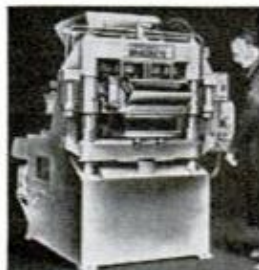

## Choice Territories Open

Broad markets are waiting because Brikcrete is popular for every type of residential, commercial and industrial construction. Ultra modern in design, size, proportion. Cost less than lumber. Wide color range. Combines all the features that make for large consumer acceptance. More local plants are needed. Exclusive privileges in franchise-protected territories. Mark-up averages 100% on basic cost. Machine available on long-term payments. Write for Brikcrete Book No. 2 and tentative reservation of territory.

W. E. Dunn Manufacturing Co., 402 W. 25th, Holland, Mich.

worth  
writing  
for...

## engineering degree in 27 months

College graduates have higher income, advancement. Major corporations visit us regularly to interview and employ seniors. **BACHELOR OF SCIENCE DEGREE IN 27 MONTHS** in Electrical, Mechanical, Aeronautical, Chemical, Civil Engineering. **IN 36 MONTHS** a B.S. Degree in Business Administration (General Business, Accounting, Motor Transport Administration majors). One-year Drafting-Design Certificate Program. Small classes. More professional class hours. Well-equipped labs. Campus. Modern dorms. New library. Moderate costs. Founded 1884. Enter September, January, March, June. Write J. E. McCarthy for Catalog and "Your Career in Engineering and Commerce."

**TRI-STATE COLLEGE**

483 College Avenue  
Angola, Indiana



## NEW CATALOG for CRAFTSMEN!

Workshop  
Supplies and  
Equipment, Kits  
Power Tools, Special  
Hardware  
**All at Money  
Saving Prices**

**WOOD..**

Get our new 132-page FULL COLOR Catalog. Finest domestic and rare imported hardwoods. Legs, mouldings, ornaments, mosaic tile, lamp parts, glue injector, upholstery supplies. Over 1,500 items. New project ideas and plans. Discounts on Stanley Tools. Send 25c for postage, handling.

**CRAFTSMAN Wood Service, Dept. A-8, 2729 S. Mary St., Chicago 8**

## LEARN FIBERGLASSING at Home in Spare Time

Interstate's complete home training course in Plastics Fabrication teaches fiberglassing, plastic molding, casting, laminating, internal carving, etc. Shows how to make hundreds of salable articles of plastic. Professionally prepared. Special materials furnished. Send postcard for FREE booklet.

**INTERSTATE TRAINING SERVICE**

Dept. C-3, Portland 12, Oregon



## ALVA ALLEN Swaine Power Punch Presses 1 to 150 Ton Capacity

Complete line of Punch Presses in hundreds of different style and model combinations. Write for FREE literature on presses and complete line of punch Press accessories as—Feeds, Punch Units, Dies, etc.

Alva Allen Industries, Dept PM, Clinton, Mo.

## FREE "How To Start Your Own MAIL ORDER BUSINESS"

Work from your home. We supply top-notch mail order catalogs imprinted with your name and address. Simply mail out to prospects and all orders come directly to you. We carry all stock and drop-ship for you. Write today for details and free booklet. No obligation.

**STATILE CO., MAIL ORDER DIVISION, MONTVALE 36, N. J.**

## RIDE 'EM ANIMAL CUTOUTS

Here for your youngster is PM's own **PROJECT-A-PLAN NO. 2**, on transparent film for less trouble and more fun. Camel, elephant, and horse patterns that can be projected easily on wood or cardboard, cut out and used as quick-change play-mounts. 75 cents to **READER SERVICE BUREAU, POPULAR MECHANICS, 575 Lexington Avenue, New York 22, N. Y.**



## New! WARN OVER-DRIVE for 4-wheel drives

**JEEP  
and  
SCOUT**

Highball on the hiway at top legal speeds — save gas, engine with lower RPM's. Use any gear, anytime, on the go. Increase speed, power ranges. Reduce noise, vibration. Easy to install in P.T.O. access.

Unconditionally guaranteed. Write for details, price, dealer's name.



**WARN SALES CO., Inc.**  
Riverton Box 6132-A • Seattle 88, Wash.

## Don't Neglect Slipping

# FALSE TEETH

Do false teeth drop, slip or wobble when you talk, eat, laugh or sneeze? Don't be annoyed and embarrassed by such handicaps. FASTEETH, an alkaline (non-acid) powder to sprinkle on your plates, keeps false teeth more firmly set. Gives confident feeling of security and added comfort. No gummy, gooey, pasty taste or feeling. Get FASTEETH today at drug counters everywhere.

The New spine-chiller  
by the author of

## WHAT EVER HAPPENED TO BABY JANE?

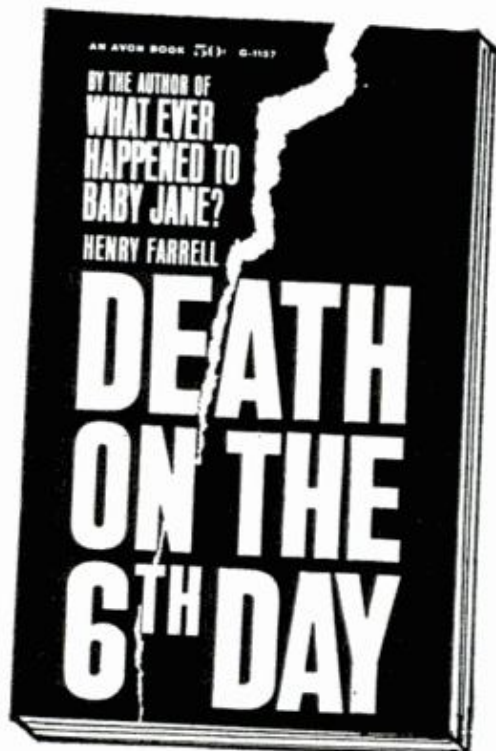

An Avon Book G1157 50¢

Available wherever paperback books are sold; or send 50¢, plus 10¢ per copy for mailing costs, to: Avon Book Division, Dept. M, 572 Madison Ave., New York 22, N. Y.

## FREE Key Machine

Kind master locksmiths use. Sells for \$125, but yours FREE with Locksmithing Course



## You Can Learn To Be A LOCKSMITH

in your spare time

There's a big demand for skilled locksmiths. You can earn big money either full or part-time in your own home. Be your own boss; earn steady, year 'round income with no layoffs. The BELSAW INSTITUTE training, recommended by professional locksmiths, teaches you to make keys, open and repair locks on homes, cars and buildings. Easy, step-by-step illustrated lessons complete with all tools and supplies. We tell you how to get servicing jobs, how much to charge, how to earn while you learn and how to build a secure cash profit business.

Mail Coupon for FREE Book Today!

BELSAW INSTITUTE, 104 Field Bldg., Kansas City 11, Mo.  
Send FREE book, "Keys To Your Future!"  
No obligation. No salesman.

Name.....

Address.....

City..... State.....

My name is Charles Atlas. I can't promise you'll win the title of "World's Most Perfectly Developed Man" as I did. But I do believe I can make a powerful He-Man of you -- in a very short time. You can prove it to yourself -- at my risk. My big free book tells how to do it.



**FREE BOOK** Mail coupon now for free 32-page book. Tells how I can give you "Stand-Out" muscles — how "Dynamic Tension" can make you a new man — confident, popular, successful. Rush coupon to me personally: **CHARLES ATLAS, Dept. 88, 115 E. 23 St., N.Y. 10.**

**CHARLES ATLAS, Dept. 88,  
115 East 23rd St., New York 10, N. Y.**

Dear Charles Atlas—Here's the Kind of Body I Want:

(Check as many as you like)

- |   |   |
|---|---|
| <input type="checkbox"/> Broader Chest, Shoulders | <input type="checkbox"/> More Powerful Arms, Grip |
| <input type="checkbox"/> More Weight, Solid       | <input type="checkbox"/> More Powerful Legs       |
| <input type="checkbox"/> Slimmer Waist, Hips      | <input type="checkbox"/> Better Energy, Sleep     |

Send me, absolutely FREE, a copy of your famous book showing how "Dynamic Tension" can make me a new man. 32 pages, crammed with photographs, answers to vital questions, and valuable advice. No obligation.

Name..... Age.....  
(Please Print or Write Plainly)

Address.....

City..... Zone..... State.....

In England send to: Charles Atlas, Chitty St., London W. 1



**ENGINEERING  
SCIENCE  
MATH**

**B.S. DEGREE  
IN 36 MOS.**



**U.S. NEEDS 50,000 NEW ENGINEERS EVERY YEAR**

EARN ACCREDITED B.S. DEGREE in Science or Engineering in 36 months — year-round program optional. 27-month engineering diploma also available. *Classes start September, January, March, June.* QUALITY EDUCATION. Graduates employed throughout U.S. and foreign countries. Government approved for veteran training. Students from 50 states, 40 countries, 20 buildings; dorms, gym. Campus. New library and laboratories. Employment help provided. **SAVE TIME AND MONEY.** Write for catalog and complete information.



**Indiana Institute of Technology**

formerly Indiana Technical College

1612 E. Washington Boulevard, Fort Wayne 2, Indiana

Please send free information on accredited B.S. Degree programs in Engineering and Science as checked:

- |   |  |
|---|--|
| <input type="checkbox"/> Aerospace Engineering  | <input type="checkbox"/> Mechanical Engineering    |
| <input type="checkbox"/> Chemical Engineering   | <input type="checkbox"/> Metallurgical Engineering |
| <input type="checkbox"/> Civil Engineering      | <input type="checkbox"/> Physics                   |
| <input type="checkbox"/> Electrical Engineering | <input type="checkbox"/> Chemistry                 |
| <input type="checkbox"/> Electronic Engineering | <input type="checkbox"/> Mathematics               |

Name \_\_\_\_\_

Address \_\_\_\_\_

City \_\_\_\_\_ State \_\_\_\_\_



**Excitement! Security! Good Pay!**

## CRIME DETECTION

**LEARN AT HOME IN SPARE TIME—START NOW!**

Crime everywhere is on the rise! Learn now, in your own home, the profitable profession that enables you to track down criminals and bring them to justice! Hundreds of Identification Bureaus employ I. A. S. graduates . . . trained in finger printing, police photography, handwriting identification, firearms and investigation. Our 44th year! FREE "Blue Book of Crime" . . . packed with crime facts and the full story of famous I. A. S. training. State exact age. No salesman will call. Rush Coupon!

*A Correspondence School Founded in 1916.*

**FREE Blue Book of Crime MAIL COUPON**

**INSTITUTE OF APPLIED SCIENCE, Dept. 135-C**  
1920 Sunnyside Avenue, Chicago 40, Ill.  
Rush Blue Book of Crime . . . FREE!

NAME \_\_\_\_\_ Age \_\_\_\_\_  
ADDRESS \_\_\_\_\_  
TOWN \_\_\_\_\_ STATE \_\_\_\_\_

# MEN PAST 40

**Afflicted With Getting Up Nights,  
Pains in Back, Hips, Legs,  
Nervousness, Tiredness.**

If you have these troubles, particularly getting up nights, then your condition may be traced to Glandular Inflammation . . . a constitutional disease. Neglect of this condition often leads to premature old age and sometimes incurable conditions.

The Excelsior Medical Clinic has a New Free Book that tells how thousands of men have been successfully treated here at Excelsior Springs for Glandular Inflammation by **NON-SURGICAL Methods.** They found soothing relief and a new outlook on life.

This Free Book may prove of utmost importance to you. Write Today. There is no obligation.

Excelsior Medical Clinic, Dept. 86140, Excelsior Spgs., Mo.



## 12-TRANSISTOR 2-WAY WALKIE TALKIE



Superb citizens band performance. Lightweight. Model HE-100L features squelch and separate microphone and speaker. No tests or license required. Crystal receive and transmit. With leather case, earphone, telescoping antenna, batteries and crystals. Send \$39.95 for one, or 2 for \$78.88 plus \$1.50 postage. (we refund excess).

Lafayette Radio, Dept. LH-3, P.O. BOX 88, Syosset L.I., N.Y.

# SHORTHAND IN

Famous **SPEEDWRITING** shorthand, 120 words per minute. No strange symbols; no machines; uses ABC's. Learn at home or through classroom instruction. Low cost. 700,000 graduates. For business and Civil Service. **TYPING AVAILABLE.** 40th Year. Schools in 113 cities. Write for **FREE** booklet.

# 6 WEEKS

**Speedwriting**  
Dept. 1508-3  
55 W. 42 St., N. Y. 3, N. Y.

## Train Now For BIG Pay Jobs!

**EARTHMOVING  
EQUIPMENT  
OPERATOR**

**HEAVY EQUIPMENT  
REPAIR-REBUILDING**

**Greer**  
**TECHNICAL INSTITUTE**  
Atten. P. H. Hutch, Box 368, Braidwood, Ill.

Get ready for a man's job in the booming road and construction industry. Operate cranes, "dozers," earth-movers, etc. Train "on the job" in 5 to 13½ weeks. Classes start weekly; reserve space now. Approved for vets. Complete catalog and reservation facts **FREE.** Write today!

## BUY FACTORY DIRECT!

**WREN**  
Send 25c for brochure  
Many Models



**MINI-BIKE! \$99.95**

\$10.00 Down  
\$6.00 a Month  
Complete with  
Clinton 2½ H.P.  
engine

Order Now!  
Bird Engineering, Box 427, Dept. PM-W-8 Omaha, Nebr.

Would You Like to Make **\$1,000 A MONTH?**



That's what Stanley Hyman made selling the amazing new Presto Fire Extinguisher! Many others "cleaning up"—so can you! Amazing tiny new extinguisher ends fires fast as 2 seconds. **Guaranteed for 20 years!** Sells for only \$4.95. Write for Free sales kit.



Merlite Industries, Inc., Presto Div.,  
114 E. 32nd St., Dept. P-15K, New York 16, N. Y.

## NO JOB WORRIES

**PLASTEX INDUSTRY** needs manufacturers on small scale for big production of Lamps, Clock Stands, Art Goods, Novelties in Plastic Marble imitation. No Experience necessary. 1/2¢ material makes regular 10¢ store sellers. Moulds furnished for fast production. Small investment brings good profit. Big wholesale orders now being placed. Ambitious men have chance for real prosperity and job security. Our NEW FREE booklet will interest and benefit you.

**PLASTEX INDUSTRIES, Dept. A**  
3400 Third Ave. New York 56, N. Y.





# LAW FREE BOOK THE LAW TRAINED MAN

Write today for a FREE copy of illustrated law book, "THE LAW-TRAINED MAN," which shows how to earn the professional Bachelor of Laws (LL.B.) degree through home study of the famous Blackstone Law Course. All necessary books and lessons provided. Moderate cost; convenient monthly terms. Write for FREE law training book today.

**Blackstone School of Law, 307 N. Michigan Ave. Dept. 50-C, Chicago 1, Illinois**  
 Founded 1890



## BARBELLS

**100 POUND SET \$12.80**

Extra Plates Only 12c Pound

140-Pound, CHROME DELUXE Barbell-Dumbbell set only \$19.80. This is our feature set and is the finest ever manufactured.

Training with adjustable weight is the BEST way to keep fit; the ONLY way to develop great strength and a perfect body. As the oldest and best equipped barbell company, BUR gives value and prices no one can equal.

**SEND FOR FREE CATALOG**  
**BUR BARBELL CO.**  
 Lyndhurst 9, New Jersey



**ASK FOR HASTINGS**

**PISTON RINGS  
 OIL FILTERS  
 CASITE ADDITIVES**

Best \$ you can spend on your car

## EARN MORE be a TAX CONSULTANT

Our students earn lucrative fees in 3 month busy tax season preparing income tax returns in spare time—and operate profitable Business Tax Service yielding steady monthly fees of \$10-\$50 per client, year 'round. Enjoy professional standing in dignified full or part time home-office business. No experience necessary. We train you at home and help you start. Write today for free literature. No agent will call. State Approved Course.

**UNION INSTITUTE, Lakewood, C-20, New Jersey**



## Little Champ

LIST \$495

ECONOMICAL FAMILY CAMPER

Sleep in protected comfort

Easily sleeps four

Tent expands living area for extended stays

Write for complete information

LIST with tent \$595

**Champion Home Builders Co. DRYDEN, MICHIGAN**



## NEW HI-FI PERFORMANCE

The Exciting NEW MODEL 422 BENJAMIN CO<sub>2</sub> 10-SHOT SEMI-AUTOMATIC .22 PELLET PISTOL

**\$24.00**

EFFICIENT—SAFE—DEPENDABLE—CONVENIENT  
 Famous BENJAMIN Quality

AT LAST—an Amazing New Handgun that incorporates the Characteristics Wanted for Serious Training, Plinking and Match Competition—Indoors and Outdoors—at LOWEST SHOOTING COSTS! Handsome, Dynamic, Mechanically Reliable, MODEL 422 combines Traditional BENJAMIN PEAK POWER and ACCURACY with Incredible Firing Speed—Smooth JAM-PROOF ACTION (no ramrod for cleaning pistol bore required)

WITH EXTRA MARGIN BENJAMIN'S Unique DOUBLE SAFETIES

Press Trigger Safety "OFF"

Release Hammer Safety as Illustrated.

Use Benjamin H-C Pellets in Model 422 for Accurate, Jam-Free Shooting.

**BENJAMIN AIR RIFLE CO. 896 MARION ST., ST. LOUIS 4, MO.**

KEEPS SHOOTING & SHOOTING & SHOOTING & SHOOTING AS FAST AS YOU CAN SQUEEZE THE TRIGGER!

FREE Write today! Complete Catalog Benjamin Rifles & Pistols—Single Shot & Repeaters—BB or 177 or 22. Also, Special Offer on Hunting Knives.

# SAVE and be SAFE



## MOTT Hammer-Knife MOWER

**SAVE YOUR MONEY**—get not only four machines in one (Renovates turf, Mows lawns, Shreds weeds, Mulches leaves)—but get long lasting industrial type construction.

**SAVE YOUR LAWNS**—Renovating (vertical mowing) thins dense disease harboring mats. Regular mowing prevents tall stemmed plants from reseeding themselves. Shredding knocks the stuffing out of crabgrass and broad leaved plants. Mulching adds valuable humus to the soil.

**SAFE IS THE WORD** for this mower. Not a reel. Not a rotary. It's a FLAIL. It lets objects lay and withstands the shock of hitting them. The secret is the light weight free swinging flail blades. Proven by over 14 years use in Industrial, Public Works and Military mowing.

Write for the FREE SAFETY booklet — "The Story of the Shoe"

**MOTT CORPORATION**  
 507 Shawmut Ave., La Grange, Ill.

## NEED MONEY?

IT'S EASY TO BORROW FROM US - BY MAIL!

Borrow \$100 to \$600 without collateral or co-signers. Confidential. Repay in small monthly amounts. Tell us how much you need now.

**SEND THIS TODAY** Send me Application for National Loan By Mail.

Name.....

Address.....

.....

**NATIONAL LOANS**  
 Div. Bankers Investment Co.

Dept. 61K, 101 S. Tejon, Colorado Springs, Colorado

## MIX MORTAR OR CONCRETE

**AS FAST AS YOU CAN USE IT!**

Only drill-powered mixer on market. Low friction makes your 1/4" drill ample power for thorough mix. Support-drive mechanism fits inside for compact storage. Send cash, check or M.O. to:

**MIXIE, P.O. Box 158, MOORESVILLE, IND.**

**\$10.00**  
 Delivered

(Excluding Drill)  
 Anywhere in U.S.A.  
 Weight: 8 LBS.



PAT. APP. FOR



# LEARN

CUT OUT



- AUTO MECHANICS
- DIESEL MECHANICS
- BODY & FENDER REPAIR\*
- GAS, ARC WELDING
- HELIARC WELDING
- DRAFTING
- REFRIGERATION
- AIR CONDITIONING

- MACHINIST-TOOL & DIE\*
- AUTOMATIC TRANSMISSIONS\*
- HEAVY EQUIPMENT OPERATORS
- MOTOR TUNE-UP\*
- CONSTRUCTION EQUIPMENT MECHANICS\*

## \$ EARN MORE MONEY \$

Skilled men are needed in every part of the country. Earn top pay in established shops or start your own business. Greer's expert instruction and actual shop training teaches you how. Quick, easy courses using the latest tools and equipment. Resident training, also Home Study courses which leads you to practical training in our school without leaving your present line of work. Job placement aid and convenient living accommodations are yours while training. Contact GREER'S FREE JOB PLACEMENT SERVICE when you enroll if you wish part time or full time employment assistance.



### TECHNICIAN COURSES\*

- DIESEL AUTOMOTIVE TECHNICIAN—21 MONTHS
- REFRIGERATION & AIR COND. TECH—17 MONTHS
- WELDING TECHNICIAN—14 MONTHS

Please send me free booklet on the trade indicated at no obligation.

NAME \_\_\_\_\_ AGE \_\_\_\_\_

STREET \_\_\_\_\_

TOWN \_\_\_\_\_ ZONE \_\_\_\_\_ STATE \_\_\_\_\_

\*RESIDENT COURSE ONLY RESIDENT  HOME STUDY

**GREER SHOP** Established  
**TRAINING** 1902

BOX # 2236 S. Michigan Ave., Chicago 16, Ill.

After all these years, is the love affair over between Volkswagen owners and their beetles? See what they say about them now in the September PM owners report.

## Ambitious Young Men

You can have a fascinating job with splendid opportunities for advancement and high earnings

Due to a program of expansion, we need young men to train for executive jobs, both in traveling and in branch offices throughout the country. No special educational requirements are necessary. We train you and you then create your own future with us!

You will be interviewed in your own area by one of our nation-wide group of representatives.

Fill out the coupon below and mail today. Start your success career NOW!

**Periodical Publishers' Service Bureau, Inc.**  
Dept. 1-M, Sandusky, Ohio

Have your representative contact me. I am interested in the opportunity you offered.

Name .....

Address .....

City ..... RR No. or Zone ..... State .....

# WE'VE GOT the FORMULA



## For Solving Your Problems

Planning to build your own garage? Need instructions to make a burglar alarm or bunk bed? Want help on plumbing or television repairs? Looking for plans for a model clipper ship or child's dollhouse?

### SEND FOR YOUR FREE POPULAR MECHANICS SERVICE FILE

More than 600 subjects covered in Popular Mechanics library of books, booklets, blueprints, and patterns are listed in this tremendous reference file. Here's the handy guide which shows you where to find the answers to almost any do-it-yourself problem.

**POPULAR MECHANICS, Service Bureau**  
575 Lexington Ave., New York 22, N. Y.

Please send your free SERVICE FILE to:

Name .....

Address .....

City ..... Zone ..... State .....



**WORLD'S  
BEST  
WANT-AD  
MEDIUM**

# CLASSIFIED ADVERTISEMENTS



Advertisements in this section \$1.35 per word, each insertion, minimum 10 words, payable in advance. To be inserted under proper classification, copy must be in our office the 18th of the second month preceding date of issue  
F. W. Johnson, Manager, Classified Advertising  
Popular Mechanics, Classified Adv. Dept., 740 Rush St., Chicago 11, Illinois

## YOU'LL PROFIT

By reading and answering the classified ads in this section. Hundreds of opportunities for you to make and save money

### AUTOMOBILES, MIDGET CARS

**KART** Wheel bargain. New hands 10" front with high-speed bearings; 12" rear with keyway. Wheels, tires and tubes \$36.00 set. Wheels only \$20.00 set. Mitchell Mfg. Company, Monett, Missouri.

**FORDS** Cost less in Pittsburgh. Delivery anywhere in U.S.A. Write for details. Bernard Schroll, 5835 Baum Blvd., Pgh. 6, Pa.

**OLD** Auto catalogs; reprints; hobby club. Enthusiasts, Box 451B, Mt. Clemens, Mich.

### AUTO SUPPLIES AND EQUIPMENT

**WILD** Bumper strips, labels! Strange, startling, unconventional. Crazy Labels, Box 15-B, Olympia, Washington.

**"TAP-A-DIM"** Headlight dimmer. Truckers, travellers, tap on horn button flicks beam. Horn on split second delay (night), foot dimmer unaffected. 12 volt, \$39.95 postpaid, complete instructions, Pringle Electronics, Box 737, Leesburg, Fla.

**AMAZING** New invention is guaranteed to rid cooling system of rust and damaging metallic particles. No more rusty water. Furnish make and year when ordering. \$4.98 ppd. Rust-O-Tractor, 1109 Treat, Adrian, Mich.

**CRANKSHAFT** Grinder, hand operated. Makes bearings fit without taking engine apart. \$5.00. Literature. L. D. McGee, 719 Cascade, Wenatchee, Wash.

**DRIVE** Car, 16 ways to save money. Save gas, oil, tires, battery. Details free. A. Spencer, Mokena, Ill.

**CROSLY** And foreign car parts. Discount Club, Box 7B, Elmont, N. Y.

**RING-Valve** job while driving, \$6.00 postpaid. Guaranteed! Nothing like it! Many mechanics recommend! Motaloy, Grantham, Penna.

**JEEP** Parts! For military and civilian. At great savings. Largest inventory. Catalog for owners and dealers. Inquiries invited. American Auto Parts Co., 1830-PM Locust, Kansas City, Mo.

**NEW** And used parts at savings. Complete guaranteed parts service for all models cars and trucks. Largest in the West. Jeep and army parts specialists. Newest type shifting hubs for all jeep and all military and latest production front end drive vehicles. \$27.50 and up. Also, foreign car parts. Write, Pioneer Auto and Truck Parts Co., 734 W. 13th Avenue, Denver 17, Colo.

**PARTS.** Model "A." List 25¢. (Refundable) Matco, Box 135, San Pedro, Calif.

**ANTIQUE** Model pistons, gaskets, gears, valves, etc. Antique Auto Parts, Milwaukee 4, Wisconsin.

**HYDRAULIC** Jack repair parts. "Sava-Jack" genuine metal replacement parts; "Econo-Pak" bulk items; Jackmaster repair kits, catalog 25¢ in coin. Hydraulic Jack Packing & Tool Co., P.O. Box 50, Bloomfield, N. J.

**CRAZY** Customizing! Newest craze! Free info. Sample, 25¢. Craft, 3008-M Montrose, Chicago 18.

**GRANCO** FM Car radio converters \$36.00. Motorola transistorized ignition systems \$37.00. Shipped prepaid. Send for car radio price sheet. Nash Distributors, 207 Tulpehocken Ave., Elkins Park 17, Pa.

**AUTO** Shop welding repair training in world's largest non-profit welding school. Low tuition. Free booklet. Hobart Welding School, Box M-83, Troy, Ohio.

**FREE** Circular automotive accessories. Lesters, K1, Box 10, Franklin Square, N. Y.

**BUY** Tires wholesale! Dunlop, Cooper—auto, truck, farm, trailer, sports car—tires, tubes. Return ad for free catalog. Factory Tire Sales, 4875 Stevens Creek, Santa Clara, California.

**PERSONALIZED** Car plaque. Your name. Gleaming brass, 2 3/4" x 1", with self-adhesive back. \$1.00. Michael Oberaitis, 13902 Rugby Rd., Cleveland 10, Ohio.

**FREE** "Economy Driving Handbook." Write: Western Pioneer, Box 2246-E, Idaho Falls, Idaho.

**CONVERTIBLE** Owners—Rear window discolored? Replace in minutes with Instant Window. Kit includes heavy gauge clear window, snaps, clips, detailed instructions. Do disassembling top. Send \$14.95 we ship prepaid. Satisfaction guaranteed. Tee-Boyd, Wildwood, N.J.

**SPARK** Plugs—Champion, AC, Autolite. Reconditioned. Guaranteed 10,000 miles or money back. \$3.92 for box of 8. State make, year, type engine. Midwest Sales Enterprises, 2432 Ridge Court, Lawrence, Kansas.

**RING-VALVE** Job while you drive. Highly recommended. Guaranteed. \$6.00 postpaid. Tidewater Motaloy, 1367 Ray, Norfolk 2, Virginia.

**JEEP** Owners—V8 conversions. Read Jeep Owners ad, page 33.

**CAR-Call** AM-FM frequency converter. Monitor police and fire calls—receive your base transmissions on auto radio. Plug-in installation. Crystal-controlled single frequency no-drift reception. State frequency. \$29.95 each. Pennsylvania residents 5% sales tax. Send check with order (we pay postage) or we'll ship C.O.D. Car-Call unconditionally guaranteed. Electrosonics, Dept. PM, 150 Burnside Street, Philadelphia 27, Penna.

**TRANS-NITION** 260/1 coil, manual special \$8.50. Anderson Engineering, Wrentham, Massachusetts.

**SPARK** Plugs. Matched set of factory reconditioned plugs, unconditionally guaranteed 10,000 miles. We send same brand as original equipment or you specify Champion, Autolite or AC only. Eight cylinder set \$1.88, six \$1.41. We pay postage when money accompanies order. COD's accepted. Specify your car's make, year and number of cylinders. Auto Products, 1600-A Channel Avenue, Memphis 6, Tennessee.

### AUTO TRAILERS

**BUILD** Camping travel trailers. Illustrated circulars 25¢. Kamcraft, Box 1153 Milwaukee 1, Wisc.

**PICKUP** Camper. Build yourself. Save! Complete plans \$7.50. We have materials, equipment. Details 10¢. Viking Camper Co., 14123-F Holly Road, Hopkins, Minn.

**APARTMTS** For pickups, also special camper unit for automobile. Write for special delivery offer. Sloat Mfg. Co., 111 West Lowden, Ft. Worth, Texas.

**PICKUP** Campers. Pre-cut Kits. Blueprints. Supplies. Literature 10¢. Comstock Trailers, Parsons, Kansas.

### MOTORCYCLES, BICYCLES, MOTORSCOOTERS AND SUPPLIES

**BUILD** Your own cart, trail or Mini Cycle frame for less than \$10! Save 50%! Buy kits, parts at discount prices! Plans with information only \$2 each. Money back guarantee. Cycle-Cart, Dept. PM8, 3518 W. Cahuenga Blvd., Los Angeles, California.

**SCOOTER-BIKE.** Parts to convert bicycle frame \$4.95; wheels, clutches, engines discount priced. Plans \$2.00 refundable. Gilliom Manufacturing Co., St. Charles 22, Missouri.

**BMW** Motorcycles, shaftdrive. U. S. distributor Butler & Smith, Inc., 160 West 83rd St., New York 24, New York.

**HOMEBUILT** Motorbike from bicycle. Plans \$1.00: GO-Byk Industries, Rothsay, Minnesota.

**BANKRUPT** Motorcycle bargains. Wholesale parts, new, used. Directory 35¢. Bunico, 146-5G, Covington, Virginia.

**SPEED** cams for motor scooters. 3/4 midgets, Cushman's, Whizzers, Continentals, Mustangs, etc. \$15.00—your core. 50¢ for auto catalog. Weber Speed Equip., 310-B So. Center, Santa Ana, Calif.



**HARLEY-Davidsons** — Used bargains. New, used parts, accessories, all models. Bulletin 25¢. Knuth's (Factory Dealer). 1753 Muskego, Milwaukee, Wis.

**RECONDITIONED** Motorcycle motors. Large stock Indian Cushman Vespa Mustang NSU parts. Indian Motorcycle Sales, Kansas City 27, Missouri.

**GO CART** \$15, Minibike \$15, Doodlebug \$15, less engines. Whizzer engine \$5, others \$3 up. Isetta \$80. (Mailorder Only.) Send 25¢ (35¢ for first class mailing) for Directory-Catalogue Number 114, listing these and hundreds of other bargains, homebuilders parts, plans, etc. Midget Motors Directory, Athens, Ohio.

**NEW Mini-bike, go-kart catalog** with 6 parts diagrams. Send 50¢. Jerry Staver, Box 511-M, Janesville, Wisconsin.

## AVIATION

**HOME BUILT Helicopters:** Booklet of design, materials, \$2.00. Drawings, specifications of "executive" \$1.50. Helicopter Development, Box 4057-PM8, Newark 12, New Jersey.

**ADVERTISE** in Aviation Shopping Guide 10¢ per word. Wandal Enterprises, 2030 Prairie, Pueblo, Colorado.

**GYROCOPTER** Blades. Solid aircraft spruce. Vancraft, 7246 North Mohawk, Portland 3, Oregon.

**PROPELLERS.** Plans, supplies for airboats, snowplanes, 125 H.P. Lycoming, 150 H.P. Continentals \$125.00. Hubs, parts, gauges, throttles, spark plugs, wires, hose, oil coolers, gaskets, magnetos, switches. Catalog 25¢. Banks-Maxwell, Box 3301E, Ft. Worth 5, Texas.

## BATTERIES, GENERATORS

**REBUILD Batteries!** Complete manual \$3.00; Hydraulic Jack Repair manual \$3.00; Chrysler Corp. alternator guide \$3.00. C.O.D. accepted. Bayer Publications, 938 Betty Avenue, Neenah, Wisconsin.

**WINDMILL** Generators; kits \$19.00 up; catalog \$1.00 refundable. Richcraft Engineering, Sterling, Virginia.

**BATTERY** Reconditioning kit, molds, instructions. Old batteries like new. Battery Shop, 96 Vierra, Salinas, Calif.

## ELECTRICAL SUPPLIES

**WHOLESALE**—Lamp, appliance parts. Free information. SECO, 112 South 20th Street, Birmingham 3, Alabama.

**NATIONAL** Electric code. Do wiring safely and legally. Send \$2.00. Code A, Box 451, Nice, Calif.

**LAMP.** Electrical parts, wholesale. Thousands of items for repairing, converting. Catalog 35¢. Brown Lamp, Box 305, Clayton 5, Missouri.

**LAMP** Parts. Catalog, prices, wiring instructions. 50¢. Refunded first order. Gyro, 5208P N.W. 35 Ave., Miami 42, Fla.

## WELDING, SOLDERING, PLATING

**FREE** Catalog, welders, kits. Build 350-ampere welder using aircraft generator, plans 25¢. Dunbar, Minneapolis 8, Minn.

**FREE** Welder catalog. Kits, build 350-ampere welder using aircraft generator, plans 25¢. LeJay, Minneapolis 31, Minnesota.

**PRODUCTION** Welders, \$69.50, \$39.50. Paul Morris, 1070 Inner, Schenectady 3, New York.

**CHROME** Plating equipment, supplies. All other finishes. Home workshop and production sizes. Send \$1.00 (refundable) for formulas, operating data, equipment guide and catalog. HBS Equipment Division L50, 3445 Union Pacific Avenue, Los Angeles 23, Calif.

**ACETYLENE** Welding outfits new \$69.50; used \$50.00. Arcwelders \$69.50; Eagle Welding, Dept. PM, 5085 Broadway, Chicago 40.

**ARC** Welder manual. Only 50¢. Regular \$1.00 value. Tells how to weld every job. Emerson Electric, 8100 Florissant, Dept. PM-8, St. Louis, Missouri.

**SOLDER** Aluminum permanently with your propane torch and A-LUM-ITE. Send \$1.00 today for ½ lb. A-LUM-ITE and guaranteed instructions. United Welding Service Co., R.D. #2, Franklin, Penna.

## MACHINERY, TOOLS, SUPPLIES

**MACHINIST** Tools factory direct. Campbell Tools, 1424 Barclay, Springfield, Ohio.

**MACHINISTS.** Toolmakers chests. List free. Cepuder, 4715 Spencer, Lisle, Ill.

## ENGINES, MOTORS, DYNAMOS

**DIESEL** Injector parts and fuel pumps wanted. GM51-53-71-110. Bares, 2093 East 19 Street, Cleveland 15, Ohio.

**MOTOR** Rewinding simplified! Details free. Modern, Box 8573, Kansas City 14, Mo.

**REWIND** Motors yourself. Complete instructions, \$1.00. Lewis Manufacturing, Howell, Michigan.

**WINDING** Data. 275 motors, single and three phase \$1.10. Data Company, 512 Kensington, Kansas City 24, Mo.

## GOVERNMENT SURPLUS

**FREE** War surplus catalogue when you order our directory! Jeeps \$178, airplanes \$159, boats \$7.88, generators \$2.68, typewriters \$8.79 typical government surplus sale prices. Buy 10,001 items wholesale, direct. Full details, 627 locations and procedure \$1.00. Surplus, Box 208-PM1, Etners, Penna.

**SURPLUS** offerings from WW I, WW II, Korean War, souvenirs of many nations available from the house with the greatest variety and largest stock of genuine government surplus in America. Fascinating catalog 50¢. Kaufman Surplus and Arms Corp., 623 Broadway, N.Y.C. 12, N.Y.

**GOVERNMENT** Surplus: Boats, airplanes, power tools, diving equipment, sporting goods. Everything imaginable. You buy direct. "Locations and Procedures" plus "Profits from Surplus" only \$1.00. Satisfaction guaranteed. Tangent, Dept. A8, Box 6091, Dallas 22, Texas.

**JEEPS** \$89.00. Guns, boats, airplanes, thousands items low as 1¢ on dollar direct from government. Complete "Directory" \$1.00. Satisfaction guaranteed. U.S. Surplus, Room 160-M4, 333 West First, Dayton 2, Ohio.

**GOVERNMENT** Surplus. What, where, how. Thousands items! Depots nearby you! Complete guide \$1.00 to Surplus Board, Box 152-B, Chicago 17, Ill.

**JEeps** \$64.50, airplanes \$75.20, boats \$6.18. Many others direct from U.S. Government. For complete "Directory" send \$1.00 to Quality Surplus, Box 22163, PM8, Indianapolis 22, Indiana.

**JEeps** \$178, airplanes \$159, boats \$7.88, generators \$2.68, typewriters \$8.79, are typical government surplus sale prices. Buy 10,001 items wholesale, direct. Full details, 627 locations and procedure, only \$1.00. Surplus, Box 789, PM8, York, Penna.

**GOV'T** Surplus. How and where to buy in your area. Send \$1.00. Surplus Information. Headquarters Building, P.M., Washington 6, D. C.

**JEeps** \$111.68, boats \$6.20, airplanes, walkie talkies, guns, cameras, thousands of items typically at 90% savings or better. For complete information send \$1.00 to Surplus Service, Box 820, Holland 1, Michigan.

**JEeps** \$160.83. Typewriters \$4.15. Radios \$2.65. Televisions, recorders, guns, watches, binoculars. Typical surplus prices. Exciting details free. N.Y. Enterprises, Box 402-X7, Jamaica 30, New York.

## BOATS, OUTBOARD MOTORS

**10' RUNABOUT.** Unsurpassed sailing, rowing, outboarding. Streamlined kit, unbelievably inexpensive. Interesting free literature. Goliath, 222-A East Eleventh, Columbus 1, Ohio.

**ENGINE** Kits. Assemble your own boat motor. Chev., Pontiac, Buick—most others. No experience necessary. Save ½ to ¾. Catalog 25¢. Dept. C, Star Marine Engine Works, Berkeley 10, Calif.

**BUILDING** OR buying a new boat? Need new boating equipment? Send \$1.00 to Boat Owners Buyers Guide, Suite 1417, 205 East 42nd St., New York 17 for latest illustrated, 290 page catalog of boats, kits, gear. Lists specifications, prices, products of over 2000 manufacturers.

**FIBERGLASS** Canoe kits—\$37.50! At last, you can assemble your own genuine, top quality fiberglass canoe. Amazing new design of outboardman-size, fourteen-foot Chippewa fiberglass canoe is tested and proven for ideal canoeing, rugged quality, and perfect safety. Exciting project! No special tools or experience needed. It's easy, fast, and fun. Limited introductory offer only \$37.50 complete. You save hundreds. Satisfaction guaranteed. Write now for free literature. Chippewa Canoes, B-1, Barberton, Ohio.

**BUILD** Your own fiberglass pontoon boat. Free illustrated circular. Wentworth's Products, P. O. Box 143, Dept. PM, Muskegon, Michigan.

**150** PLANS, patterns, kits. Catalogs: Powerboat 50¢. Sailboat 40¢. Marinecraft Box 161-M, Brighton, Mass.

**INBOARD** Outboard engine 7½ HP for hydrokarts and boats to twelve feet \$159.50. Fiberglass hydrokart hulls only \$99.50. Complete marine hardware. ASK 5525 Chicago Ave., Chicago 51, Ill.

**BOAT** Light. Waterproof, shines under water. It floats. 40,000 CP., \$8.95 ppd. Free literature. Edlyn Co., Box 362, Collingdale, Pa.

**FIBERGLASS** Cloth, Matt, polyester and epoxy resins. Lowest prices. Selfert's, Box 1206-M, Green Bay, Wis.

**ELECTRIC** Outboard motors direct from factory. Whisper quiet. Run on 6 or 12 volt batteries. \$104.50. Freight prepaid in U.S. Free folder. City Engineering Co., Inc., 3547 Massachusetts, Indianapolis 18, Ind.

**FIBERGLASS** Cloth and resin. World's finest cloth and non-run resin, at direct mill prices. Flotation foam. Complete line of plastics, silicon bronze and brass screws, save 60%. Free catalogue. Freight prepaid Stiles Boat Supply, Box 11P, Linden Ave., Mantua Hts., N.J.

**NEW.** Used, rebuilt marine motors. Marine conversions, fittings. Free catalog. Stokes Marine Supply, Dept. 24, Coldwater, Michigan.

**MARINE** Conversions. Ford, Chevrolet, Jeep engines. Catalog 25¢. Lehman Manufacturing Company, 800 Elizabeth Avenue, Linden 4, N. J.

**BUILD** Your own boat from our large-scale blueprints. Books of plans give how-to-build help. Hundreds of professional designs—motor, sail or auxiliary—for amateur builders. Free catalog. MoToR Boat-In-G, 959 Eighth Ave., Dept. RS, New York 19, N. Y.



**FULL Size, cut-to-shape boat patterns, blueprints, 7 1/2-38 feet.** Big new illustrated "Build a Boat" catalog of 64 designs, including catamarans, cruisers, runabouts, skiffs, outboard boats, sailing, racing, houseboats, 50¢. "How to Build a Boat" booklet, \$2.50. Cleveland Boat Blueprint Co., Box 1651, Cleveland, Ohio.

**BOAT Plans, frame kits, full-size patterns prepared specially for amateurs.** Send 50¢ for new 80-page catalog illustrating over 40 build-it-yourself power boats from 7' to 28'. Glen Designs, 9152 Rosecrans, Bellflower, Calif.

**SAVE On fiberglass, plastics and chemicals for the hobbyist, boat owner and professional.** Buy direct from factory distributor. 38" chrome finished glass cloth 67¢ yd. Mat \$1.80 yd. Fresh resin \$5.69 gal. Plexiglas mill ends 75¢ lb. Colored \$1.25 lb. Free instructions. Starr Sales Co., 1321 East Pacific Coast Highway, Wilmington, California.

**KAYAKS.** One man \$16.50; two man \$22.50. Exciting Sitka kayak kits, known world wide. Free pictorial literature, Box 78P, Brecksville 41, Ohio.

### **SPORTING GOODS, GUNS, FISHING, SKIN DIVING, ARCHERY**

**JAP Rifle** altering to 30-06. \$6.00. Japshells \$3.95. Catalog 10¢. T. P. Shop, West Branch 11, Mich.

**FISHERMAN'S Dream book free!** 170 pages. Sweetest pocket size catalog ever! Do-it-yourself stuff galore: for making: nets, turtle traps, landing nets, rods, lures, sinkers, plastic worms, flies, fish smoking rig. Here's everything including latest rods, reel 'n' gadgets. Send card: Netcraft Co., Dept. PMM, Box 5510, Toledo 13, Ohio.

**FREE For sportsmen!** Newest edition of the famous Corcoran catalog. Largest selection ever of hunting, camping and fishing equipment. All items field-tested. Boots, clothing, fishing tackle, tents, gun cases, sleeping bags. Dozens of specialties. Write Corcoran, Dept. PM-83-C, Stoughton, Mass.

**FREE Wholesale catalogue.** Hunting or Fishing. Parker Distributors, 1 Penn Place, Dept. PM-863, Pelham Manor, N.Y.

**CAPS For sportsmen, baseball type.** 100% virgin wool flannel Pre-shrunk, water repellent, rubberized unbreakable peak, reinforced front panels for longer life. All sizes. Navy, royal, scarlet, maroon, black, kelly. Price \$1.95. Hildebrand Mallorders, 845 Riverside Drive, New York 32, N.Y.

**GUNS!** 10,000 antique, modern arms, armour, gunaccessories! Giant 120 PP. bargain catalog \$1.00. Agramonte's, Yonkers, N. Y.

**SEND For free 1963 exclusive list of antique, military, modern firearms & ammo.** Write Box PM or visit our headquarters arsenal, Globe Firearms, 30 Front Street, New York, N.Y.

**MOLDS—For casting your own fishing sinkers.** Free illustrated booklet. Reading Instrument Co., Box PM78, Reading, Penna.

**FREE—Wholesale catalog.** Beads. Spinners. Lure parts. Sinker molds. Jigs. Reels. Pinnysports (ME), Toledo 14, Ohio.

**BIG Money raising crickets and 12 inch African fishworms.** Free literature. Carter Ranch, Plains, Georgia.

**MOLDS For fisherman's sinkers, jigs, squids, casting and spinning lures.** Free catalog. Sweet's Molds, Tonawanda 1, New York.

### **ATHLETIC EQUIPMENT, BODY BUILDING COURSES**

**"SECRET Fighting Arts of The World."** Gilbey, \$3.75 plus 15¢ postage. Also have other books on boxing, judo, karate, wrestling, etc. Catalog 15¢. Combat Sports Service, Box 482A, Worcester 1, Mass.

**DEADLY Kungfu Karate "Iron Poison"** hand fighting. Break bricks in 100 days \$5.00. Free brochure. Oriental Book Sales, P.O. Box 1183, Oakland 4, Calif.

**BAR-BELLS.** Courses, equipment. Catalogue 10¢. Good Barbell, B-1495, Hendersonville, N. Car.

**ISOMETRIC Contractions:** Ultraefficient musclebuilding method; equipment, long workouts unnecessary. Complete principles, exercises \$2.00. Isometricks, 1604 O'Farrell, San Francisco, California.

**BUILD A mighty body.** \$1.00. Champagne's, Box 15322, Baton Rouge, Louisiana.

**BARBELLS.** Exercise equipment. Key to health, strength, physique. 25¢. Reading Barbell Co., West Reading, Pa.

**WEIGHT Exercising equipment.** Free literature. Ed Jubinville, Holyoke 9, Mass.

**PHYSICAL Perfection.** Reducing, gaining, muscles, longevity. Mail 25¢ for all 4 courses, guaranteed, to Sids System, (PM-M-63), 8421-C Evergreen, Southgate, California.

**OUTSTANDING Physical development!** Any age. New guaranteed discovery uses only a rope! Strength, health, muscles. Gain—reduce. Free information. Roperise, 4834 Art. San Diego 15, California.

**"GIANT Arms."** Dr. Young's, D.C. revolutionary discovery. \$2. Satisfaction or refund. Gaucho, Box 9309-S7, Chicago 90.

### **CAMPING EQUIPMENT AND TENTS**

**CAMPING Equipment, tents (300 styles—most erected on display).** Send 25¢ for new giant catalogue-handbook-camp site directory. Morsan Tents, 810-R, Route 17, Paramus, New Jersey.

### **BINOCULARS, TELESCOPES, MICROSCOPES, MAGNIFIERS**

**DYNASCOPE—Amazing world-famous reflector telescope.** Request free brochure. Criterion, Dept. DP-7, Hartford, Connecticut.

**BUILD Your own reflector telescopes:** Complete kits, mirrors, eyepieces, tripods, all other accessories. Request free illustrated literature. Criterion Manufacturing, Dept. KPM-4, Hartford, Connecticut.

**BINOCULARS, Folding—Ground Lens Center Focus \$2.50.** Mal Co., Box 73, Brooklyn 30, N.Y.

**SCIENCE Bargains!** Lenses, telescopes, binoculars, microscopes, kits, parts, war surplus. Send \$1.00 for beginner's 10-lens kit with instruction booklet. Order Stock 2-CH. Request free 144-page Catalog CH. Edmund Scientific Co., Barrington, New Jersey.

### **PLANTS**

**HOW To build a garden pool.** Complete instructions \$1.00—refundable on filter order. Miracle Filter Co., Box 9128, Long Beach 10, Calif.

### **EARTHWORMS, CRICKETS, FROGS**

**AZTEC Red wigglers.** Texas' largest worm grower. Satisfaction guaranteed. Circle J Farms, Box 4056P, Waco, Texas.

**SUCCESS For you!** Raise fishworms and crickets. Write for free literature and our success story in Life Magazine. Let us teach you our secrets of success. Hybrid redworms 3000, \$5.95. Carter Redworms, Plains, Georgia.

**HYBRED Redworms.** 1000—\$3.00, 2000—\$5.00, 5000—\$8.00, 10,000—\$14.00. Bedruns—\$1.00. In 20,000 orders only. Postpaid. With raising instructions. Brazos Bait Farm, Route 9, Waco, Texas.

**MEN!—Women!** Make money raising bait for us at home. Free details. Red Wigglers, Warsaw 45, Indiana.

**EARN Money raising fishworms for us!** Exciting details free! Oakhaven—56, Cedar Hill, Texas.

**FROG Raising.** Young frogs and giant breeders. Stock your lakes, pond. Nu-Tex Frog Farm, Box 4029 Corpus Christi, Texas.

**HYBRID Redworms.** 2,000—\$3.95, postpaid. Mrs. William Lee, Salem, Iowa.

### **FARMS, FARM LANDS, REAL ESTATE**

**FREE All new Strout summer catalog.** Over 3700 farms, homes, ranches, vacation, retirement and business opportunities described. Nationwide coverage. World's largest, 63 years service. Write Strout Realty, 7-CJ S. Dearborn, Chicago 3, Ill.

**CAROLINA Coast.** Large 1/4 acre, high, dry, heavily-wooded homesites in beautiful Boiling Spring Lakes only \$10 monthly. Full price \$395. Fishing, swimming, boating on 50 freshwater lakes. Hunting on 4,000 acre private preserve. Championship golf course, ultra-modern country club, motel, shopping center. Located on two state highways only minutes from ocean. Money back guarantee. Developed by Reeves Broadcasting and Development Corporation, listed on American Stock Exchange. Over 4,000 homesites already sold. Free literature. Write Art Greene, Boiling Spring Lakes 1-I, North Carolina.

**FARM With lake!** Picturesque 180-acre Missouri place going for only \$1,500 down! Has five-acre fishing lake, creek! Good grazing land, 55 tillable acres. Big 4-room electric-lighted house with over 1,200 sq. ft. floor space. Broiler setup for 4,000 birds. On blacktop, 8 miles town. Disability forces sale for only \$10,000 with \$1,500 down! Big free illustrated Summer catalog, bargains coast to coast! United Farm Agency, 612-PM West 47th St., Kansas City 12, Mo. Plaza 3-4212.

**NEW Homes from \$35 per month.** Nothing down, custom constructed on your lot. Over 88,000 built. Free information and illustrated brochure. Jim Walter Corporation, Box 9128, Dept. PM-8, Tampa, Florida. 212 branch offices to serve you.

**IDAHO Homesites in the air-conditioned, unspoiled center of the hunting and fishing paradise!** World record Kamloop trout! Beautiful lakes, mountains, forests surround North Idaho 1/4 acre homesites at Pine Tree Ranch! Live, work, play, retire or vacation in this outdoor wonderland! 40 minutes paved highway convenience to big city, 15 minutes to intermediate city! \$10 down. Write for free full color brochure and information. Pine Tree Ranch, Western Builders Co., Dept. 20, N. 5523 Alberta, Spokane 16, Wash.

**IDEAL Summer climate.** Fishing, golf, saddle horses available. Diversified entertainment. Skiing in winter. Building lots from \$600. Beautiful homes from \$12,500. Terms. Free brochure. Valley of Roan, P. O. Drawer 6, Bakersville, N. Y.

**FLORIDA.** 2 1/4 acres, Gulf Coast area: 50 ft. elevation; \$795.00; \$15.00 down and month. Russell Hancock, Realtor, Brooksville, Fla.

**FLORIDA Campsites—deep in the heart of the great Ocala National Forest.** Abundance of game, best fishing. Warranty deed. Unrestricted—pitch tent, park trailer, build lodge. Free maps and photos. Howard Vernor, DeLand, Florida, AD60088(Q-O).

**\$5 MONTHLY Buys 5 acres.** Near town, good building site, excellent fishing. Price \$125.00. Free list. Box 425-P Carthage, Missouri.

**CANADIAN Vacation lands:** Full price \$385.00, 40 acres, \$10 month. Suitable cottage sites, hunting fishing, investment. Free information. Land Corporation, 3768-C Bathurst, Downsview, Ontario, Canada.



**CANADIAN Lands**, seized and sold for taxes. Our 46th annual series of lists, describe many choice properties, situated from coast to coast, acquired by us through Tax Sale. Priced as low as five dollars per acre, guaranteed perfect title, small monthly payments, no mortgage. Beautifully situated hunting and fishing camps, where there is real sport; summer cottage sites, heavily wooded acreages. Now is the time to invest in Canada's minerals, forests and farms. Write to-day for free twenty page booklet with full explanation. Tax Sale Service, Room 301-D, 85 Bloor St., East, Toronto 5, Canada.

**FREE Strout catalog**. The original property catalog of values in farms, homes, businesses, ranches. Nationwide. Over 450 offices. 32 states. 63 years service. World's largest. Write Strout Realty, 7-CJ S. Dearborn, Chicago 3, Ill.

**FLORIDA Lake living**. Homesites near everything. Established area. \$390 full price. \$5.00 month. Information write: Lake Weir Shores 7, Silver Springs, Florida Ad 6-1070-(F-0).

**\$1 ACRE—Canadian Border**. Hundreds campsites, islands, farmlands directly from tax authorities. (Non-profit.) Lists, photographs mailed. Bureau, 56 Churches, Toronto 1, Canada.

### FARM MACHINERY AND SUPPLIES

**3 HP Hoeling machine**. Hoes between plants, rows. Depth adjustable. Self propelled for tired tiller wrestlers. Month trial. Year warranty. Discount. Autohoe, West De Pere 22, Wisconsin.

### PETS—DOGS, BIRDS, HAMSTERS, ETC.

**LIVE Seahorses**, marine specimens, aquarium supplies. Illustrated catalog 10¢. Marine Life, Dept. 110, Box 626, Dania, Florida.

**HAWKS**, reptiles, raccoons, skunks, squirrels. Catalogue 25¢. Trails End Zoo, St. Stephen, S. C.

**PETS**, hamsters, mice, rabbits, squirrels, chipmunks, guinea pigs, skunks, raccoons. Picture catalog twenty-five cents. Moore's Hamster Ranch, Shepherdstown 25, West Virginia.

**MAKE Money raising chinchillas**, mink, rabbits, cavies for us. Free catalog. Keeney Brothers, New Freedom 2, Penna.

**DESCENDED Baby skunks**, \$9.99. Monkeys, rodents, cats, birds, snakes, list 10¢. Animal World, Elwood, Kansas.

### RABBITS—FUR BEARING ANIMALS

**NEW ZEALAND White rabbits**, cavies. Free information. John Miller, Mill Run Pennsylvania.

**EARN \$10,000 Yearly raising Angora rabbit wool** for us. Information 25¢ coin. American Angora Company, Malta 12, Montana.

**RAISE Rabbits on \$500 month plan**. Free details. White's Rabbitry, Mt. Vernon, Ohio.

**RAISE Rabbits successfully by knowing facts**, 48 page book. 38 illustrations describing 25 breeds. Housing. Breeding. Feeding. Markets and Marketing. Bulletin etc. 25 cents. American Rabbit Association, 36 ARBA Building, Pittsburgh, Penna.

### PROFITABLE OCCUPATIONS

**BARGAINS! Buy wholesale! Save money!** Free catalog! Norris, 273DP Merrick Road, Lynbrook, N. Y.

**INVENTION Pays**. Write for free list product possibilities. Box 841, Norristown, Pa.

**INVESTIGATE Auto accidents**. Pays up to \$750-1,000 a month. Investigators needed everywhere, part or full time. Car furnished; expenses paid. No selling. Meet interesting people. We train you spare time at home in weeks. Hold present job until ready to switch, or start own investigating business. Free information. No obligation. Liberty School, Dept. C-95, 1139 West Park, Libertyville, Illinois.

**AUCTIONEERING—Home study course**. Diploma granted. Auction School, Ft. Smith, Ark.

**BAKE New greaseless doughnuts** in kitchen. Sell stores. Free recipes. Michael, 3605 South 15th, Minneapolis 7, Minn.

**BECOME Independent with your own franchise business**. Thousands earning handsome incomes. Request interesting facts today. National Franchise Reports, PM-528, 333 North Michigan, Chicago 1.

**BIG Money raising fishworms and crickets**. Free literature. Carter Wormery Plains, Georgia.

**EARN \$240.00 A month at home**, spare time, doing only two \$5.00 invisible mending jobs a day. Big money paid for service that makes cuts, tears disappear from fabrics. Steady demand. Details free. Fabricon, 1586 Howard, Chicago 26, Ill.

**SHARPEN Scissors, pinkers, clippers**. Inexpensive machines, supplies. Blackhaws, Sheldahl, Iowa.

**CHROME Plating**. Instructions, equipment and supplies. Platers' Supply, P.O. Box 565, Lugo Station, Los Angeles, Calif.

**VENDING Machines**. No selling. Operate a route of coin machines and earn amazing profits. 32-page catalogue free. Parkway Machine Corporation, 715 PMP Ensor Street, Baltimore 2, Maryland.

**FREE Report: "609 Unusual, Successful Businesses"**. Box 1001-PT, Evanston, Ill.

**INVESTIGATE Accidents**. Earn \$750 to \$1,000 monthly. Men urgently needed. Car furnished. Business expenses paid. No selling. No college education necessary. Pick own job location. Investigate full time. Or earn \$8.44 hour spare time. Write for free literature. No obligation. Universal, CPM-8, 6801 Hillcrest, Dallas 5, Texas.

**INCOME Unlimited in homework of your choice**. Free details. Write: Mr. Davellas, Spring Arbor, Michigan.

**WHOLESALE Magazine subscriptions**. Highest commissions. Bonus! Qualified Agencies, 451JA, Kingston, Brooklyn 25, N.Y.

**REMAIL System**. Kit \$3.00. Labrie, 3364 Station C, Ottawa 3, Canada.

**INVESTIGATE Automobile accidents**. Earn up to \$1,000 monthly. Investigators urgently needed by insurance companies. Car furnished, expenses paid. Free employment help. Or, open your own profitable business full or spare time earning \$6 hour. College unnecessary. Free booklet and sample lesson, no obligation. United Schools, C828, 1626 Glendale, Orlando, Florida.

**YOUR Own business with limited capital**. You can make a fortune as I did in vending machines. I will show you how. Wiltons, 5426 South Willow Dr. Houston 35, Texas.

**FORTUNES in naturalistic "Beauty Stone"** and strange new building plastics. Waterproof, fireproof, durable, economical. Write Bays Laboratory, Oklahoma City 9.

**PIZZA Shops needed everywhere**. Free details. Box 274, Indianapolis, Ind.

**START A magazine subscription business**. Earn generous commissions on Popular Mechanics, Good Housekeeping and all others. Best commissions, bonus, all material sent free. No experience needed. Write Popular Mechanics, Room 8-P, 250 West 55th St., New York 19, N. Y.

### BOOKS, PERIODICALS, PICTURES, POSTCARDS

**BOOKFINDERS!** All subjects. Send wants! Jaher Book Service, 183 Hazelwood Drive, Westbury, N. Y.

**BOOKS**, Free general catalog, 100 pages. Text, vocational, educational, instructional subjects. Millions of volumes, new and used. Bargain prices. Books bought. Est. 1902. Long's College Book Co., Dept. PM, Columbus 1, Ohio.

**BOOK Hunters!** Send wants! Atlantic Book Service, Cedar Street, Charlestown 29, Mass.

**FREE Catalog**. Self-help books. Write Wilshire, 8721 Sunset, Los Angeles 69P.

**NATIONAL Geographic magazines**, 1888-1960, any issue. Periodical Service, Box 465-PM, Wilmington, Delaware.

**BRITISH Book bargains—Any subject**. Catalogues free. Transatbooks, Wantagh, N. Y.

**BOOKS Located!** Aardvarks Worldwide Booksearch, Box 668-PM, San Diego 12, California.

**PROPHET Elijah coming before Christ**. Wonderful book free. E. Megiddo Mission, Rochester 19, New York.

**OUT-Of-print books at lowest prices!** You name it, we find it! Fast service. No obligation. International Bookfinders, Box 3003-PM, Beverly Hills, Calif.

**Publish Your book!** Join our successful authors: All subjects invited. Send for free appraisal and detailed booklet. Carlton Press, (Dept. PMT), 84 Fifth Avenue, N.Y.C. 11.

**PAPERBACKS**, Magazines. Catalogue 10¢. Ajay Sales, Box 5796, Pikesville 8, Md.

**FOR Moneymaking, educational, entertaining books write:** Roland, 3728-SP3 Wilton, Chicago 13.

### MAGIC TRICKS, PUZZLES, JOKER NOVELTIES

**500 TRICKS**, Douglas famous 120-page Catalog, only 10¢. Fastest service to magicians for 40 years. Send 10¢ today. Douglas Magicland, Dept. 51, Dallas, Texas.

**1000 LATEST Tricks, jokes, magic!** New de luxe giant edition! Hot off press! 160 pages thick! Bigger, better than ever! Special for August! Only 10¢! Free trick too! House of 1000 Mysteries. Dept. PM8C-63, Monroe, Connecticut.

**VENTRILOQUISM For fun or money**. New method. Easy. R. Marlette, 1570 Glen Ellyn Rd., Glen Ellyn, Ill.

**PROFESSIONAL Catalog**, 175 pages, 25¢. Williams, 900 Plymouth, Ellwood City, Penna.

**WORLD'S Finest professional magic**. Joker novelties. Giant illustrated catalog 10¢. Top Hat. Evanston 12, Illinois.

**WORLD'S Finest magic catalog**, \$2.50 (\$2.00 magic included free). 3000 tricks, pocket, stage (408 pages). Kanter's, M-200 South 13th, Philadelphia 7.

**BE A Magician!** Introductory catalog with free trick, only 35¢. Ireland, 109-F North Dearborn, Chicago 2.

**CATALOG #20**, free trick, 25¢. 1,500,399 tricks, jokes, novelties. Elbee, 7408-P, San Antonio 7, Texas.

**FREE Illustrated list cards**, coins, magic. Berten, 9420 Trumbull, Chicago 42.

### GAMES, TOYS, NOVELTIES

**BEAUTIFUL**, Unusual, inexpensive gifts. Satisfaction guaranteed. Send for free catalog. Edward Guzman, 2816-P Ambler Place, Las Vegas, Nev.



GET Laugh gags, tricks, novelties wholesale. Sell friends. 50 gag samples 25¢, free catalog. Dohn-VP-Marks, Broadview, Illinois.

**GAMES** Inventors! We are interested in new and novel child and adult ideas. Nationally-known game manufacturing and marketing firm. Send for details. Haglund and Associates Research, Dept. 650, Ottawa Ave. N., Minneapolis 22, Minnesota.

### ANTIQUES, RELICS, INDIAN GOODS, CURIOS

**DELIGHTFUL** Ornament. Unique letter opener. Full head and body hand carved African paper knives \$1.95. Mangels, Box 34, Brentwood, Maryland.

**SELLING** 20,000 Ancient arrowheads, spearheads, etc. List free. Lear's, Glenwood, Arkansas.

### COINS, TOKENS, CURRENCY

**CURIOUS** Coins and odd paper money from seven countries! Yours for only 10¢. \$100,000 Confederate "money" facsimile bonus for promptness. Other interesting offers on approval. Littleton Coin Co., Littleton MI, N. H.

**NUMISMATIC** Boobos! 10 different Lincolns VF/BU for \$1.25. S. Levinson, Box 557, No. Hollywood, Calif.

**PROOF** Sets 1959 \$4.45. 1960 Small-Date (Rare) \$24.95 postpaid. M. B. Distributing Company, P.O. Box 224, Burbank, California ZIP #91503.

**UNCIRCULATED** Silver dollar on key chain, our choice of date, boxed (\$3.50 value) \$2.50. Sumberg Enterprises, Box 21, Malden 48, Mass.

**100 FOREIGN** Coins \$2.95. 2 Mexican silver dollars \$1.00. Johnson, Box 6350M, Phoenix 5, Arizona.

**LINCOLN** Cents for sale 10¢ each: 1910, 1911, 1916, 1917-D, 1918-D, 1919-D, 1919-S, 1920-D, 1920-S, 1923, 1927-D, 1928-D, 1929-D, 1929-S, 1930-D, 1930-S, 1935-D, 1935-S, 1936-D, 1937-D, 1937-S, 1939-S, 1942-S, 1948-S, 1949-S, 1954-S. John Gardner, Box 408, Colorado Springs, Colorado.

**FOREIGN** Crowns, Thalers, List free. World Circuit, P.O. Box 465, San Francisco 1, Calif.

**POPE** John Vatican set \$5.00. Rare 1885-CC uncirculated dollar \$19.00. 1961, 1962, 1963 proof sets—each \$2.85. Bargain lists coins, supplies 25¢. Bebee's, 4514 North 30th, Omaha 11, Nebraska.

**\$40.00 EACH** Paid for certain Indian head pennies. Send 25¢ for list. Nowak, 3021 W. Hayes, Seattle 99, Wash.

**INDIAN** Head cents, 20 different \$6.00. Allen's, Westerville, Ohio.

**FORTY** Frisco nickels assorted \$3.25. Alcenter, Box 606, Lamirada, California.

**TRUNKFUL** 25,000 Indian-Lincoln cents mixed (from the 1920's & older.) Will pack "grab-bag" style. 400 mixed \$25.00, sample bag of 20—\$2.00. Mrs. Fischer, Box 5490, Sherman Oaks, 81, Calif.

**WOW!** "Rare" silver dollars! Beautiful! Brilliant! Uncirculated! Low prices! 1903-O only \$25.00! 1862-O \$8.00! 1898-O, 1899-O, 1900-O, 1901-O, 1902-O, 1904-O, only \$2.00 each! 1882-O \$7.00. 1883-O \$3.00. 1885-O \$3.00. 1889-O \$3.00. 1879-S, 1880-S, 1881-S, 1882-S, 1885-S, 1921-S, \$3.50 each! 1883-S \$10.00. 1886-S \$16.00. 1887-S \$5.00. 1898-S \$15.00. 1902-S \$25.00. 1903-S \$75.00. 1935-S \$20.00. 1883-CC \$12.00. 1887-P 3.50 1891-P \$3.50. 1892P \$6.00. 1902-P \$2.00. 1903-P \$2.00. 10% discount on orders over \$50.00! Thousands of other coins! Rush your order, and get your free price list! Silver Center, Box 3293-M, San Francisco 19, California.

**LINCOLN** Cents: 23S, 24S, 21S-P 16S-D, 17S-D, 18S-D, 19S-D, 20S-D, 25S-D, 25S-D, 29S-D, 30S-D, 28S-D, 27S-D, 5S-S, 54S-P, 32D, 33P, 39S-D, 49S. Good to fine, complete lot \$8.50. Rolls 55S \$12.50 fine to x fine.—49S \$3.50 roll. Berry, Box 1241, Orange, Calif.

**LINCOLNS**, 22 different "S" \$1.45. 30 different before 1940 \$1.45. Huge pricelist included. Harris, Box 586G, Cupertino, California.

**ILLUSTRATED** Coin catalog \$1.00 post-paid. Antioch, Box 11073-PM, Kansas City 19, Missouri.

**35¢ BRINGS** Bargain list plus Indian cent. PDS, 114P Nassau, Massapequa, New York.

**COIN** Bargains galore. Illustrated lists 10¢ (refundable). Hutchinson's, Box 6256, Philadelphia 36, Penna.

**40 PAGE** Illustrated United States and Canadian coin list 10¢. Stoney, 260 Washington, Boston 8, Mass.

**INDIANS**, Lincoln, Liberty nickels. List 10¢. Evans, Box 9912d, Atlanta 19, Ga.

**LARGEST** Coin magazine, 288 pages, 50¢. Scrapbook, 7320-J Milwaukee, Chicago 31.

**35 DIFFERENT** Lincoln cents S/D only before 1942. album, 2 bargain catalogs, \$3.95. Hobby Sales, St. Paul 16, Minn.

**GIANT** Illustrated catalog listing hundreds of bargains in coins and supplies, only 50¢. Rarcoa, 31 North Clark, Chicago 2.

**TWENTY-Four** page 1963 retail price list of USA and Canadian coins 10¢. Our selling prices on thousands of coins and coin collectors' supplies. Bryson Incorporated, 612A White, Toledo 5, Ohio.

**FREE** Coin supplies! Giant coin list 10¢ (refundable). Economy Sales, Mansfield, Massachusetts.

**BARGAIN** List! U. S. coins, accessories. Stamp please. Hugh's, Hickory, N. C.

**GOLD** Coins. Foreign and American. List 5¢. Cook, Box 181, Jackson 5, Mississippi.

**10 DIFFERENT** Lincolns before 1921 \$1.00. 20 before 1931 \$1.50. Eugene Carlton, Chandler, Okla.

**50¢ BRINGS** 3-scarce Lincolns, including 1954, and new bargain price list #7. Kenwood Coins, 6513 Langdale Road, Baltimore 6, Md.

**CATALOGUE**: 34 pages, all U.S., Canadian coins and supplies, 25¢. Harold Ball, 2614 Calhoun, Ft. Wayne, Ind.

**RARE** 1878 CC mint dollar \$5.00. 100pp. coin catalogue 50¢. Shultz, Salt Lake 10, Utah.

### HOBBIES AND COLLECTIONS

**AMERICAN** Newspaper, complete, original, dated before 1880. \$1.50. 25¢ stamps brings catalogue. D. R. Spaight, Bookseller, Tall Timbers 1, Maryland.

**50 JUNGLE** Butterflies, 30 oriental seashells, 20 gem-stones, each \$2.00. Giant collectors wonderland pricelists 25¢. Haas, Box 1170, New York 8, N.Y.

**WORLDWIDE** Sea treasures! Less than 10¢ each. Literature free! Thornton, 5103 Londonderry, Orlando, Florida.

**COLLECTORS** Matchbook covers, 100 different unused, \$1.00. Catalog 25¢. Helene Edelman, 1311-C East 84, Cleveland 3, Ohio.

### STAMP COLLECTING

**209 DIFFERENT** Stamps 25¢. Exciting collection includes beautiful Monaco set plus Antarctic Explorers, South Africa Gold Mine, many more. Grand total 209 stamps, all genuine, all different. You also get 88 flags of the world and midget encyclopedia of stamp collecting. All this for only 25¢ to introduce our bargain approvals. Satisfaction guaranteed. Send 25¢ today. Ask for Lot FO-49, Zenith Co., 81 Willoughby St. Brooklyn 1 N.Y.

**SMASHING** Collection free. Includes triangles early United States, rockets, sports, British Colonies, high value pictorials, etc. Complete collection plus big illustrated magazine, all free. Send 10¢ for postage. Gray Stamp Co., Dept. PM, Toronto, Canada.

**NO Gimmicks**. No gadgets. No giveaways. Just attractive approvals at attractive prices. Sunny Stamps, Apopka 2B, Florida.

**327 WORLDWIDE** Different 25¢. Bargain approvals. Niagara Stamps, St. Catharines 201, Ontario.

**100 WORLD** Wide stamps 25¢. Approvals. Eureka, Box 35334, Los Angeles 35, Calif.

**25 LARGE** American commemoratives 10¢. Accompanying approvals. Free perforation gauge. Linstamps, St. Catharines 101, Ontario.

**103 DIVERSIFIED** British Commonwealth 10¢. Approvals included. Crown Stamps, Virgil 601, Ontario.

**QUEEN** Elizabeth on stamps. A beautiful collection of 50 different stamps from 22 countries—all bearing the portrait of the Queen of England, 10¢ with approvals. Capital Stamp Co., Ferrysburg 2A, Michigan.

**20 DIFFERENT** commemoratives 1893 up 10¢. US approvals. K&B, Box 70, Bklyn 23, N. Y.

**FREE** Collection, 50 different, topicals, U.S. comm., diamond, triangle, with approval selection. Carpenter, Box 310, Claremont, Calif.

**ISRAEL** Packet 10¢ with approvals. Iray, Box 114, Boston 34, Mass.

**U.N.** Postal set. Among world's prettiest. Only 10¢. Approvals. Welles, Box 1246-R, NYC 8.

**ONLY 10¢!** Get this new valuable North American collection, all-different postage stamps of Greenland (North Pole), St. Pierre, Newfoundland, Canada—Eskimos, Indians, scarce 1867 Confederation, 1862 British Columbia & Vancouver Is. Cent., Nova Scotia, Northern Territories, United Nations, U.S. Stamps—19th Century, first plane, steam boat, pony express, etc. Also, complete Colonial & Civil War Issues, many others. Plus full color flag stamps of 87 foreign countries. Extra! Bargain catalog: "How to Recognize Rare Stamps"; other exciting stamp offers on approval. Send 10¢ for handling. Kenmore, Milford EF-504, New Hamp.

**DAG** Hammarksjold "inverted Error" 5¢ with approvals. Belmont Stamps, Washington 15, D.C.

**LOWER** Priced approvals. U.S., Foreign. Stamps, Box 737, Memphis 1, Tennessee.

**FREE!** Giant bargain catalog. New Edition listing thousands of bargains including U.S. and B.N.A. stamps, packets, mixtures, albums, accessories and supplies; sent with beautiful approvals. Jamestown Stamp, Dept. E83PM, Jamestown, N.Y.

**FOUR** Weird insect triangles, American spaceman, 25 others, 5¢. Approvals. Blanchard, 73 Washington, Suffern, New York.

**UNITED STATES** Commemoratives, 100 different, mint, \$3.50. Used \$9.95. Golden's, 6721 Eastwood, Philadelphia 49, Penna.

**300 DIFFERENT** Given free with approvals. Particulars. Windsor Stamps, P.O. Box 735, Santa Clara, California.

**WOW!** 110 all different Germany 10¢! Zeppelins, semi-postals, airmails, high values, etc. Giant catalog, bargain lists included with beautiful approvals. Jamestown Stamp, Dept. A83PM, Jamestown, N.Y.

**"RARITY"** Project mercury first day covers unaddressed. Cape Canaveral cancellation, February 20th 3:30 P.M. 1962. Was Port Canaveral officially. \$3.00 each. Send self-addressed envelope. Henry Dowless, 227 E. 6th Ave., Tallahassee, Florida.



**FREE!** Surprise "mystery" packet. Premiums. Approvals. Dancer, 75-P46, Mansfield, Ohio.

50 YEARS old. 15 different United States stamps at least 50 years old 10¢ with low priced United States approvals. Jaxon, Box 145-P, Bklyn. 30, New York.

**SPORTS.** Animals, rockets etc. on worldwide approvals. Packets from which to select the stamps you want—1¢ each and up. Surprise collection to new accounts, 10¢ handling. Boser Stamps, Yaphank, New York.

**GERMANY** "Nazi war swastika—Hitlers" collection—Free! Approvals. William Deems, 226 Race, Ravenswood, West Virginia.

50 FREE stamps: Approvals. Allman, 620 West 47th, North Little Rock, Arkansas.

**SERIOUS Collectors:** Defective old U.S. approvals. K. Swartz, Malden Bridge, New York.

1500 FOREIGN \$1.00. 5000 \$3.00. No approvals. Meyers, 5321 Fleming, Richmond, California.

**AMERICAN** Historical collection! Enormous George Washington beauty, F. D. Roosevelt diamond, giant U.S.A. flag commemorative, plus midjet soldier, Latin orchid issue, old IFNI overprint, etc. 10¢ with approvals. Roseland Stamps, Spring Lake 2A, Mich.

U.S. Bargain. 50 different 10¢, with beautiful worldwide approvals. Stamps, Kennebunk, Maine.

**HELIGOLAND** Stamp free. Approvals. W-B Stamps, Wilkes-Barre, Penna.

**EXTRAORDINARY!** Free! 20 different Finland to those requesting approvals. Rosenbert, Box 1303, Chicago 90.

500 FINE Mixed U.S. 15¢. Wright, Box 753M, Hagerstown, Md.

**QUALITY** Approvals. Geo. L. C. Scheirer, P.O. Box 441, Gaithersburg, Md.

\$1000.00 AMERICAN Stamp \$1.40. King, 330 Alexander, Kampos, British Columbia, Canada.

**LOOK!** 50 better stamps from fifty countries! (25¢) Money saving catalog included! Ewing, 2133 Lunt, Chicago 45.

100 DIFFERENT Foreign stamps with catalog value of \$20.00, only \$1.50. No approvals. Lee Stamps, 4546 South Park Drive, Metairie 20, La.

200 DIFFERENT Germany 10¢ to approval applicants. Rothschild, 3112-76th Ave., Washington 28, D.C.

**FLAG** Stamp free with U.S. or worldwide approvals. Gorkiz, Box 265, Park Ridge, Illinois.

**WORLDWIDE.** 50 all different, absolutely free just to introduce our incomparable approvals. Kent Stamp Company, GPO Box 87, Brooklyn, N. Y.

**VATICAN** Xmas set 35¢. Approvals. Baricks, Box 7154, Detroit 2, Mich.

500 DIFFERENT includes pictorial. 35¢. Approvals. Knopp, Box 1381, Bristol, Conn.

**FREE!** Congo triangle set! Boy Scout beauty! 25 others different Approvals. Cambridge, Box 411, Cambridge, Ohio.

**UNITED** States price list, 116 pages, price 25¢. Mark Hanna, 335 Fifth Ave., Pittsburgh 22, Penna.

**SAN MARINO**—25 different only 25¢! Worldwide approvals included. Cole, Box 223-A, Buffalo 21, N. Y.

15 PLEASANT Offers plus valuable tips. Write; Bileski, Station B, Winnipeg, Canada.

150 DIFFERENT U.S. stamps 25¢. Approvals. Winchester Stamps, 45 Winchester Rd. Mansfield, Ohio.

215 DIFFERENT Worldwide 25¢. Iceland, French Colonies, etc.! Approvals. Bobb's, Box 3045, St. Louis 30, Missouri.

**PENNY!** Approvals! Regardless catalog! Kloster, 4164—52nd Street, San Diego 5, California.

U. S. approvals. Low prices. Eagle Stamps, Romine Ave., Pittsburgh 26, Penna.

200 STAMPS. 25¢ With approvals. Smith, 508A Brooks, College Station, Texas.

**FREE!** 222 worldwide. 10¢ handling. Penny approvals. Jung, 1601 North Stanley, Los Angeles 46.

U.S. Mint specials! Flag set, complete \$1.00; 1¢, 2¢, 3¢ famous Americans (21 different), \$1.00. Free list. Brooks, 2323 Avenue X, Brooklyn 35, New York.

80 DIFF. U. S. stamps includes 19th Century commemorative. High values. Plus 1943 flag stamp of occupied nations. All for only 25¢. Approvals included. Willett Co., Box 338-C, Yorktown Heights, N. Y.

**UNITED** Nations 15th anniversary sheet with first day cancel, as commemorated by Russia. Free! While they last, with approvals, Philatelics, R-J, New Paltz, N. Y.

**STAMP** Collecting outfit, includes, packet worldwide stamps, package hinges, watermark detector, millimeter gauge. Everything 10¢ with approvals. Loraine Brown, Marion, Michigan.

**INTRODUCING** Our better United States approvals we offer 15 United States stamps including Columbian, Bi-Centennials, famous American, airs, others: only 10¢. Ocean Stamps, Box 64-PM, Brooklyn 29, New York.

**UNITED** States commemorative collection containing 33 different—10¢. Approvals. White, 516-A Avenue L, Brooklyn 30, New York.

**PENNY** Approvals. Thousands. Bargains for pennies. Gifts with purchases. Penny Stamps, Orange, California.

100 OLD United States between 1861 and 1935. \$1.00. Roush Stamps, 51 Chestnut, Mansfield, Ohio.

**FREE** Monaco nudes. Approvals. Stamp Ranch, 902 Addison, Chicago 13, Ill.

60 DIFFERENT U. S. (30 commemoratives) 25¢. No approvals. Seidenberg, Appleton, Wisconsin.

225 STAMPS For only 10¢! This mammoth value includes airmails, pictorials: stamps from strange countries cataloging up to 25¢ each! Also approvals. Mystic Stamp Company, Camden 80, New York

**SELL** Your surplus good grade stamps. Write, describing fully what you have. Vanroy Shirk, Lebanon, Pennsylvania.

**AMAZING OFFER!** 200 United States stamps — including commemoratives, airmails, high denominations to \$1.00. Only 10¢ to approval applicants! Illustrated bargain lists free. Mystic Stamp Co., Dept. 80, Camden, New York.

701 U.S.A. 25¢ (plenty commemoratives). Request approvals. Horace Gatewood, Winston-Salem, N. C.

21,000 ALL Different, only pennies a day using our systematic payment plan. Details free. Sjoquist, 1435 Cherrydale, San Jose 25, California.

**FREE!** 50 Turkey, 10¢ handling. Approvals. Berchtold Stamps, Troy, Ohio.

**MILLION** Foreign stamps! 2¢ each! Send for thrilling, giant approvals! ABC Stamps, Box 6000-MB, San Francisco 1, Calif.

**FREE!** When you buy our foreign approvals you receive absolutely free stamps equaling your purchase. Coast, 1609 S. Park, Santa Ana, California.

**GIANT** Approvals. Thousands different 1¢ and 2¢ each. Wahl's Stamp Exchange, 7008P Farragut, Chicago 31, Ill.

**FREE** Stamp wallet with approvals. Wide selection collections by countries. Clark, Box 28-C, Wilmette, Illinois.

**TRADE** Your duplicates. (Toward foreign approvals.) Write: VPT, Box 98, Newton Highlands 61, Mass.

80,000 DIFFERENT. Amazing new plan builds your collection systematically, country by country. Only 50¢ weekly. Free details. Ware, Monroe 75, Conn.

**FREE** Sample. Interesting, informative, illustrated. National Stamp News, Anderson, South Carolina.

**HAWAII.** Three old classics 20¢ with worldwide approvals. Hawaii Stamp, 280 Lewers, Honolulu 15, Hawaii.

25 COLUMBIA 20¢. Approvals included. Reed, Box 980, Chicago 90, Illinois.

U.S. Mint imperforate parks \$2.40. Approvals. Bill Egleston, Clearfield, Utah.

**UNUSUAL** Old U.S. defectives. Bargain prices. K. Swartz, Malden Bridge, New York.

**FREE!** 33 Greenland! Ghana! Ruanda! others. Approvals. Keating, 2520-P Boulevard, Jersey City 4, New Jersey.

## PRECIOUS STONES, MINERALS

**SEMI-Precious** uncut gems. Ten different for \$1.00. Request list 28. Prospectors Shop, 201 San Francisco, Santa Fe, New Mexico.

**EARTH** Science. Rockhound's National Magazine. Subscription \$2.50. Sample 35¢. Box 1357-PM, Chicago 90, Ill.

**GET** Free catalog no serious rockhound, gem cutter, jewelry maker, hobbyist or craftsman can be without. Full of bargains, exclusive items, low prices from largest suppliers and authorities in the field. Free new catalog just off the press, yours for the asking. Write Grieger's, Dept. C-12, 1633 E. Walnut, Pasadena, California.

**OPALS:** Precious. Fiery! 10 ready to set \$6.00. Free pricelists. Apartado, 80 Sanmiguel, d'Allende, Gto, Mexico.

**ENJOY** Thrill. Discover gold. Instructions, ore, \$1.00. B&R, 299 Madison Ave., N.Y. 17.

**COPY** Your color slides by attaching slide duplicator to your camera. Information free. Electron Development Co., Box 1743, Springfield, Illinois.

**HAWAII.** Art studies. Samples \$1.00. Avery, Box 8261, Honolulu 15, Hawaii.

**FREE** Brochure of world's largest selection of colored slides. Entertaining! Educational! Write: Tricolor, P.O. Box 123-M, So. Windsor, Conn.



**TRANSPARENCIES** Wanted. Up to \$500.00 each. For information write American Color, P.O. Box 46372, Hollywood 46, Calif.

### PHOTO FINISHING, CAMERAS, PHOTO SUPPLIES

**PHOTOGRAPHY** For pleasure or profit. Learn at home. Practical basic training. Long established school. Free booklet. American School of Photography, 835 Diversey Parkway, Dept. 345C, Chicago 14.

**FREE!** Send now for photographic bargain book. Dept. 1-K-8, Central Camera Company, 230 So. Wabash Ave., Chicago 4, Illinois.

**SLIDES** From your negatives, photos. Color or b&w. Ten, \$3.00. 35-Slides, Green Mtn. Falls, Colorado.

**A FREE Kodak roll** returned with each black and white or Kodacolor developed and printed, fast service, lowest prices, guaranteed quality send for free mailers. Economy Photo Service, Dept. P. M., Box 1111, Albany 1, N. Y.

**COLOR** Movie fans! Low cost—high quality processing our specialty, 8mm. just \$1 (or \$3 with fresh film). Mailed back next day. Craftsmanship guaranteed. Send exposed reel or request free mailers and price list of complete photo-finishing services. Direct Mail Photo, Box 8352-PM, Pittsburgh 18, Penna.

**FAST, Hi-quality finishing.** Kodacolor rolls: eight jumbo prints \$1.98. Twelve \$2.49. Twenty \$3.49. Reprints 15¢. Also low B&W prices. Custom Quality Studio, Box 4838, Chicago 80.

**12 EXPOSURE** Roll 70¢. Wallet 25 for \$1.00. Mail in Photo, Box 707, Lowell, Mass.

### MOTION PICTURES AND SOUND EQUIPMENT

**FREE!** Six-months subscription to Blackhawk Bulletin—most extensive listing of 8mm. movies and 2"x2" color slides available anywhere! Blackhawk Films, 314 Eastin-Phelan Bldg., Davenport 5, Iowa.

**SWAP 8MM, 16MM** with others. Details 10¢. Box PM-224, Pasadena, Calif.

**16MM** sound-projectors, films, new, used for sale. Free catalog. National Cinema, 71 Dey Street, New York City, N.Y.

**8mm SILENT** Films. 16mm sound films. Bedner, 5300 So. Talman, Chicago.

**5,000 8-16 MM.** Movie films. Free catalogues. International, Greenvale, N. Y.

**MOVIE** Film! Free catalog! ESO-R, 47th Holly, Kansas City 12, Missouri.

**FREE** Catalog! Save on 8/8mm.-16mm. film and supplies. Superior, 448 N. Wells, Chicago 10.

### MUSIC AND MUSICAL INSTRUMENTS

**VIOLINMAKERS.** Repairers, headquarters: Woods, supplies, string instruments, including guitars. Wholesale pricelists. Write: International Violin Co., 414-P E. Baltimore St., Baltimore 2, Maryland.

**BUILD** your own Hawaiian Guitar. Simple. Full size plans \$2.00. Craftline, Box 1892, Glendale, California.

**SONGWRITERS.** With publisher contacts, need song ideas—in any form. Share royalties. Songs composed, recorded, promoted. Free examination. Send now! Songwriters' Associates, 236 West 55th Street, N.Y. 19-P.

**NEW 45 RPM** phonograph records! Fifteen different \$1.00. Return for full refund within fifteen days if not enthusiastic! Leary, 223 East Hennepin, Minneapolis 14, Minn.

**SONGPOEMS** Wanted! Collaborate with professional songwriters equally. Share royalties. Songwriters Contact, 1619-D Broadway, New York 19.

**SONGPOEMS** Wanted. Send poems for offer. Nashville Music Institute, Box 532-PM, Nashville, Tennessee.

**USED** Professional guitars, amplifiers, drums. Write: Music, 1215 War Memorial, Peoria, Ill.

**ACCORDIONS.** Guitars, chord organs! Famous makes. Free home trial. Easy terms. Trades. Free catalogs. Mention Instrument. International Music Mart, Dept. R. 2003 Chicago Avenue, Chicago 22.

**RECORDS!** Discounts on all LP's. Free details. Citadel Record Club, 545 Fifth Ave., Dept. 2, New York 17, N. Y.

**SONGWRITERS.** With publisher contacts, want song ideas. Share royalties. Send poems, free examination: Songwriters' Associates, 1650 Broadway, N.Y. 19-P.

**POEMS** Wanted for musical setting and recording by America's largest song studio. Send poems. Free examination. Five Star Music Masters, 630 Beacon Building, Boston.

**POEMS** Wanted for musical setting and recording. Send poems. Free examination. Crown Music Company, 49-C West 32 Street, New York 1.

**ACCORDION-O-RAMA.** 874 Broadway, New York 3, N. Y. Tremendous discounts. Top brands. Free brochure.

**SONGPOEMS** And songs wanted! Mail to: Tin Pan Alley, Inc., Box 405, Radio City Station, New York 19, N. Y.

**ELECTRIC** Guitars, amplifiers, wholesale. Free catalog. Carvin, P.M.M. Covina, Calif.

**ITALIAN** Accordions Manufacturing, 7600-M Cottage Grove, Chicago 19, Illinois. Piano, Chromatics, Hohners, Concertinas. Wholesale catalogs free.

**GUITAR** Self-instruction books, chords, melodies. Special \$1.00. Hrudka, Box 950, Chicago 90, Ill.

**GUITAR.** Banjo Making books, Plans, woods, necks, tools. List 15¢. Satinwood, 510 East 11th Street, New York 9, N. Y.

### RADIO, TELEVISION AND ELECTRONICS

**DIGITAL** Computers simplified: Basic, concept level introduction, clearly illustrated. \$3.00, 25¢ postage. Advent Editions, P.O. Box 124E, Sarasota, Florida.

**MANY** Transistor radios distance reception. Particulars 50¢ coin. Lindle, Box 1093, Abilene, Texas.

**GOVERNMENT** Surplus radios, parts. Picture catalog 10¢. Meshna, Malden 48, Mass.

**FIX** Your own TV. Save 80%! Send for free illustrated chart showing how! We'll include giant electronics catalog. Zalytron, 461 Jericho Turnpike, Mineola, N.Y.

**SAVE** Dollars on radio, TV-tubes, parts at less than manufacturer's cost. 100% guaranteed! No rebrands, pulls. Request bargain bulletin. United Radio, 1000-M, Newark, N. J.

**TAPE** Recorders hi-fi components. Sleep learning equipment, tapes. Unusual values. Free catalog. Dressner, 1523 Jericho Tpke, New Hyde Park 3, N. Y.

**BATTERY** Eliminator for transistor radio. Battery charger for 9 Volt battery. Complete kit \$3.30. Leiman Distributors Co., Box 147, Brooklyn 18, N. Y.

**RECORDING** Tapes. Free sample. Mail 25¢ (handling). Towers, Lafayette Hill, Penna.

**RADIO** Electronics course only \$14.95. Includes all tubes, parts, tools, instructions. Write for full information. Edu-Kits, Dept. 587B, Hewlett, N. Y.

**COMPLETE** Prerecorded tape inventory. Free tape recorder discount catalog. Saxitone, 1776 Columbia Road, Washington 9, D. C.

**FREE!** Comprehensive new hi-fi/stereo catalog. Full color illustrations, specifications, exciting savings to 75% on hundreds of name brands. Components, systems, kits, recorders, speakers, accessories. Address: "PM" I F A, 17640 Burbank Boulevard, Encino, Calif.

### BUSINESS OPPORTUNITIES

**\$10.00 IN** An hour spare time at home possible with amazing "Magic Wonder Method" invisible reweaving. Details free. IRI, Dept. P-1, 8411 La Mesa Blvd., La Mesa, Calif.

**PROFITABLE** Catalog mailorder business. Vikari, 468-P Third Avenue, Salt Lake City 3, Utah.

**SIMPLE.** Pleasant mail-order can net \$12,000 year. Write Rutward, 2010 Bryant, Columbia Station, Ohio.

**\$200.00 MONTHLY.** Spare time. With tablesaw, bandsaw or jigsaw. Write. Holiday House, A3800 Harney, Vancouver, Washington.

**"HOW To Sell Book by Mail!"** Money-making system. Details free. American Distributors, Box 409-P, Niles, Michigan.

**FREE** "Franchise Profit Letter" tells how unique NFR service is helping thousands seeking profitable businesses. Write today. National Franchise Reports, W-528, 333 North Michigan, Chicago 1.

**HOW** And where to obtain capital. Reliable Service, Rome City, Ind.

**BIG** Money raising fishworms and crickets. Free literature. Carter Farms, Plains, Georgia.

**TO \$100.00** Weekly. Sparetime, home operated mailorder business. Successful beginner's plan. Everything supplied. Lynn, 10420-M National, Los Angeles 34.

**BAKE** New greaseless doughnuts in kitchen. Sell stores. Free recipes. Montgomery, 3605 South 15th, Minneapolis 7, Minnesota.

**MAKE \$46** From square foot plywood: jigsaw necessary. Free details. Woodart, Bridgewater, Mass.

**\$400.00** MONTHLY Raising giant fishworms. Soilless method. Charlie Morgan, Bushnell, Florida.

**PLASTERCRAFT** Molds, liquid rubber, plasters, flocks, candle supplies. Catalog and manual free. Blue Rapids Supply, Blue Rapids, Kansas.

**WORLD'S** Largest wholesale supply. Buy from 679 American, European, Japanese wholesalers. Tailormade suits from Hongkong. 123 dropship catalogs. Rock-bottom prices. Free details. International Buyers, 216-MM Jackson, Chicago 6, Ill.

**11,000** NEW Prospects daily. Baby record books, shoes, albums. Sell mailorder. Use our literature. Write: No-Co-Ro, Capitola, Calif.

**COLORGLAZED** Concrete pottery made without molds. Patented method. Cemetery products, novelties, tiles. Basement leak-sealing. Money-making projects. Booklet, details free. Men only. National Potteries Company, Grand Rapids, Minnesota.

**WANT** To make big money at home? \$10.00 profit in an hour possible with invisible mending. Make tears, holes disappear from clothing, fabrics. Steady year-round demand from cleaners, laundries, homes. Details free. Fabricon, 1585 Howard, Chicago 26, Ill.



**EARN Money** raising fishworms for us! Write: Oakhaven—38, Cedar Hill, Texas.

**RAISE Rabbits** on \$500 month plan. Free details. White's Rabbitry, Mt. Vernon, Ohio.

**STOP Throwing away boxtops!** They're worth money! Some, 25¢! Inquire: Box-tops-MB, Cedar Hill, Texas.

**BUY Direct** from factories. Appliances, cameras, watches! Free details! Cam Co., 436 P.M. Bloomfield Ave., Verona, N. J.

**COPUBLISH Mail Sale Advertiser**, leading mail order paper. Details, latest copy, dime. Vanroy Shirk, Lebanon, Penna.

**MAKE Money** from old tires. Operators clearing \$400 weekly. Equipment costs \$800. Get facts, S & S Parents, Inc., 3511 N. Lincoln, Chicago 13.

**MAKE Durable** building plastic easily. Waterproof. Fireproof, economical. Bays Laboratory, Cedaredge, Colorado.

**VENDING Machines**. No selling. Operate a route of coin machines and earn amazing profits. 32-page catalogue free. Parkway Machine Corporation, 715 PMB Ensor Street, Baltimore 2, Maryland.

**LIQUID Molding** rubber, free information. Chaney's, 5415-A San Jose Blvd., Jacksonville 7, Fla.

**\$70.00 WEEKLY**—home, spare time. Simplified mail bookkeeping. Immediate income—easy. Auditax, 34741A, Los Angeles 34.

**SELL Champion, AC**. Autelite spark plugs. Reconditioned, electroplated, guaranteed 10,000 miles, 100% profit. Free sample. Lee Plugs, 1608-A Roberts, Houston 3, Texas.

**OPERATE Home** mailorder business. Vosacek Printing, 4444A Ute, San Diego, 17, Calif.

**AMAZING Manufacturing** opportunity. Free list of manufacturing formulas. Presler Oil Company, Fostoria 16, Ohio.

**NEW Company**. Big potential. Terrific ground floor opportunity. Like money in bank. Terry-O, Box 588-F, Hicksville, N.Y.

**WORK At home** packaging merchandise. Very profitable. No selling. Everything supplied. Details free. HBE, 1043-P West Grand, Chicago 22.

**OWN Your own Western Auto** store. Over 3,800 now operating. Minimum investment \$14,000. Free training. No retail experience necessary. For complete details write G. M. Wilson, Room 951, Western Auto, 2107 Grand, Kansas City, Missouri. (Indicate geographical area preferred.)

**REFILL Propane** hand torch cylinders. Thousand % profit! McCarthy, 2232 Wisconsin, Washington 7, D. C.

**SELL Greeting cards**. Make extra money. Christmas, all occasion assortments, stationery, gifts, jewelry, name imprinted Christmas cards. Experience unnecessary. Salable samples on approval. Free catalog. Write Hedenkamp, 361 Broadway, Dept. PM-86, New York.

**PIANO Tuning** learned quickly at home. Tremendous field! Musical knowledge unnecessary. Information free. Empire School of Piano Tuning, Champaign, Ill. (Founded 1935).

**FREE Details!** Importing, world trade, mail order. Jaydee, Box 1054, Decatur, Georgia.

**MAILORDER'S Best**. Guaranteed successful methods! Ashco, 1608 Nelson, Chicago 13, Illinois.

**MAILORDER Pays big!** Tested, proven, home moneymaking opportunity! Everything furnished. Mann, 266-PM, Hillsdale, New Jersey.

**HANDY With tools?** Your own house repair business. High income. Banish unemployment fears forever. Amazingly easy. Full or part time. Free information. House Doctor, 2809-p Balasco, Fort Worth 7, Texas.

**MAKE Money** making leathers. 1148 ideas. Free information. Tandy Leather Co., Box 791-M4, Fort Worth, Texas.

**\$50 SPARE Time**. Details 25¢. Raymar, Box 602P, Lynwood, Calif.

**NEW Formulas** for profit. Manufacture your own product. List free. Johnston, Box 6284-P, Marietta, Georgia.

**DOLLS! Dolls! Dolls!** We teach you to make, repair, dress and sell. Study at home. Earn while learning. Free booklet. Doll Hospital School, Studio MC-83, 11826 San Vicente Blvd., Los Angeles 49, Calif.

**OPERATE Profitable** home mail-order business. Sparetime. Get lifetime repeat orders. Write Wayne's Service, 3016-J Channing, Washington 18, D. C.

**MANUFACTURE Imitation** quarried stone and patio blocks. Free booklet. Forms Inc., 554 W. Adams St., Chicago 6, Illinois.

**MANAGE Motel** or resort. Men, women, couples can make high salary plus apartment. Pick your own location with our employment assistance. Learn at home. Free booklet. Motel Managers Training School, Dept. PMC-83, 612 So. Serrano, Los Angeles 5, Calif.

**MAKE Money**, operating home mail-order business. Free information. McWilcof, Box 3435, Milwaukee 6, Wisconsin.

**SIX Beautiful Colour** prints of African lions, elephant, giraffe, etc by famous game hunter. Size 8 1/4" x 11", all different. Send \$1 for sample set to Continental Distributors, Box 3411, Johannesburg, S. Africa.

**MAIL-ORDER home** business. Get free Copy. "Make Money in Mail-Order." Mailco, 1554 S. Sepulveda, Dept. K708, Los Angeles 25.

**POOL Tables** wholesale. Profit from national craze. Distributors, dealers, territory given Tournament Manufacturing, 6605 Tireman, Detroit, Michigan.

**MAIL Order** beginners. Start small, grow big. Write R. Johnson, 1598 A. East 94th, Cleveland 6, Ohio.

**AMAZING New home** plastics business! Up to \$10.00 hour if you qualify. Pleasant, easy. No selling. Secrets revealed in free plan. NPC, Box 23321-PE, Los Angeles 23.

**\$100.00 WEEKLY** Possible spare time. "Radar Sentry" warns motorists speed traps ahead. Watco, 11091 Prince Lane, Cincinnati 41, Ohio.

**OPERATE Profitable** remail service from home. No selling or experience necessary. For details and plan send one dollar to cover cost. Mercury, Box 2021, Fort Myers, Florida.

**EXPORT-Import** opportunity, profitable, world-wide mail-order business from home, without capital; or travel abroad. Established world trader ships instructions for no-risk examination. Experience unnecessary. Free details. Mellinger, K-708, Los Angeles 25.

**PROFITABLE Mail** order business. Be independent. Details free. Ideal, Box 357-BE, Valley Stream, N. Y.

**LEARN Landscaping** and plant growing. Start a profitable business part or full time. Free information without obligation. Lifetime Career Schools, Dept. MC-83, 11826 San Vicente Blvd., Los Angeles 49, Calif.

**MAKE Money** from newspaper clippings. Some clippings worth dollars. Details free. Harvey, 29068-CN, Thornton 29, Colo.

**MERCHANDISE** Wanted. With good mail order sales power. Also drop ships. National or foreign firms. Orlando Segarra, 1115 Elizabeth Avenue, Elizabeth, New Jersey.

**BIG Money maker!** Custom upholstery, auto trim, slip covers, drapes offers tremendous spare-full time earnings to men, women, all ages. No experience required. We furnish everything: Easy home instruction, tools, supplies to build \$300 in beautiful furniture, yours to keep-sell! Send for big free illustrated book. Modern Upholstery Institute, Dept. U-48, Fallbrook, Calif.

**MIMEOGRAPH** And ruler can mean financial independence. Details free. The Graphic Garret, 210-C Fifth Avenue, New York 10.

**SELL Advertising** book matches. Write us today; we put you in business by return mail handling complete line ad book matches in demand by every business right in your town! No investment; everything furnished free! Top commissions daily! Superior Match, Dept. MX-863, 7530 S. Greenwood, Chicago 19, Ill.

"**HOW To Raise** Capital to Make Money". Free details. Advance Publishing, 4455-P N.W. 7th St., Miami 44, Florida.

**SELL Products**. Mailorder. 400% profit. Work home. Catalogue free. International, 6347 Parnell, Chicago 21, Illinois.

**\$34.70 TWO Hours** manufacturing concrete products. No selling. Castings #3, Box 1721, Rapid City, South Dakota.

**REPAIR Hydraulic** jacks. Easy, profitable. Write: Hydraulic Parts Supply, 3000 Mountain, El Paso, Texas.

**KLONDIKE Kenny's**. Free information on catalogs, money order plans, self-help, books, folios, bargains. Kenny's Place, Larchwood, Iowa.

**ARCHERY** Mail. Garden golf. Games. Super crowds. Large income. Brockway, Box 6624, Portland 66, Oregon.

**TAXES!** Learn to prepare returns. Spare time. Lucrative. Write Union Institute, Lakewood C-2, N.J.

**BIG Money**. Operate your fix-it shop. Service and repair all household appliances. Fix irons, fans, toasters, refrigerators, automatic washer-dryers, vacuum cleaners, automatic dish washers, etc. Know how they work, what can go wrong, and then how to fix them. Be able to do house wiring, commercial wiring; how to rewind motors of all sizes, sharpen mowers, skates, saws; where to buy spare parts wholesale; how to get business, what to charge. A tremendous money making opportunity for a mechanically inclined man (or family). Free book. Christy Trades School, A-4303, 3214 W. Lawrence, Chicago 25.

**RAISE Fishworms, crickets;** illustrated instructions, both \$1.00. Stoners, Chattanooga 6, Tennessee.

**NEW**. Easy and amazingly profitable business of your own manufacturing enormously popular sculpture reproductions. Minimum investment. prompt returns, unlimited potential. Details free. Bob Wade Associates, P. O. Box 12-115, Sarasota, Fla.

**REAL Opportunity** for distributors, dealers, reps, route men, direct salesmen. Electronic TV/FM power cord antenna, filter, booster line. Sample \$6.95. Electro Dynamics, Dept. PM 101, P.O. Box 3177, Ft. Worth 5, Texas.

**IDEAL Mail** order item. Check protector \$1.00. Circulars available. Goodall, 68-N Joost, San Francisco 12.

**MAIL Order**. Sell to new mothers. Free facts. Munroe, 1000 Lariat, El Paso 15-A, Texas.

**LET Modern** mail order methods make more money for you. Information free. Rush postcard. Aronheim, 554-B Fifth Avenue, New York 36, N.Y.

**LIQUID Rubber**, plaques, figurines, plastercraft supplies. Sample, details free. Lavin Novelties, Box 296J, Leavittsburg, Ohio.

**OPERATE** Paying mailorder business! Ashe Company, 45-C Calumet Road, Holyoke, Mass.



EARN \$6,000. selling rugs at home. Free samples. Box 67, Boston 26, Mass.

RE-CAST Junk batteries into new. Latest achievements. Battery Laboratories, Bayou LaBatre, Alabama.

RADIO Advertising (nationally) without investment. Copyrighted! Details \$1. Melro, 1982, Salt Lake City 10.

HOME Mailorder business. Details. DeHoven's, Box 414, Chicago 17, Illinois.

76 MILLION Prospects! Immediate profits! Selling Champion, AC, Autolite spark plugs. Precision reconditioned, silver-plated, guaranteed 10,000 miles. Up to 308% profit. Free samples, details. Indy 500 Spark Plug Co., 4620 Braeswood, Houston 35, Texas.

SALESMEN Earn \$20.00 to \$50.00 per day selling 7-day collection statements and bookkeeping instructions. Get details. Beaver's Mail Order Business, Box PM467, Roxboro, N.C.

MONEYMAKING Home businesses. Free literature. Wayne, Department E, Box 1222, Pawtucket, R. I.

QUICK Money by mail plan \$2.00 or dime for details. Money back guarantee. Ellsworth, 11278 San Mateo Dr., Loma Linda, Calif.

OUTSTANDING Mailorder business. Brochure free. Danbros Enterprises, 4917 Park Heights, Baltimore 15, Maryland.

MAKE \$32 From 49¢ piece vinyl. Free details. A-1834 Edgeland, Louisville 4, Ky.

DOLLARS In minutes! New home business. No skill or investment. Sells self. Complete business operation book; \$3.00. Research-Development Co., Box 4051, Newark 12, New Jersey.

Auto Wrecking business. Big profits. 16 years—\$5,000. KV, Victoria, Va.

BRONZE Baby shoes. Genuine electroplating process. Equipment, mountings, instructions. Send \$1.00 for valuable book "Your Guide To Success" bronzing baby shoes, plus complete catalog. Hollywood Bronze Supply, Dept. B60, 3445 Union Pacific Avenue, Los Angeles 23, California.

PAINT murals for profit. Earn \$10-\$15 per hr. No art exp. needed. New projection method. Paint \$100 murals for "pennies" in paint. Huge demand from bars, builders, homes, etc. Free success plan. Associated Muralists, Dept. E-8C, 135 Vesta, Reno, Nevada.

## MONEYMAKING OPPORTUNITIES

EXPERIENCE Unnecessary. Make money with any camera. Fifty proven methods. Information free. Photoplan 222 East Eleventh, Columbus 1, Ohio.

MAKE \$5,000 yearly, sparetime. raising mink, chinchilla, nutria, etc. Free booklet reveals proved plans. Write: Furs, 588 Mt. Pleasant Road, Toronto 1, Canada.

MAKE Money gathering wild roots, herbs, weeds, leaves, tree seeds, flowers plants! Over 200 varieties! Buyers listed for all you can ship! Easy! Pleasant! World wide! Free book, bonuses available! Rush! Allain; 69-P Hollis, Worcester 01610 Mass.

MAKE Money from newspaper clippings. Some clippings worth dollars. Details free. Harvey, 1402-NC, Englewood, Colorado.

THRILL to money in your morning mail! Simple operation. Everything furnished. Details 10¢. Crandall, 607 Ohio St., South Bend, Indiana.

APPLIANCE Servicing. Complete guide \$7.00. Guild Book, Box 471, Norwood, Mass.

AMAZING! Brand new, home money opportunity. Details free. Vista, 1230 Purcell, Cincinnati 5, Ohio.

FREE Advertising for mailorder items. Branvold, 5718 Troost, North Hollywood, California.

EARN Money oil coloring photographs at home. Hollywood Enterprises, 1023 N. Hyperion, Los Angeles 29, Calif.

EXTRA Money making plastic novelties, jewelry, floating and photo key chains. Catalog 25¢. David Co., 20 Garden St., Providence 3, R. I.

FREE 1964 earthworm raising plan for beginners. Lee Earthworm Research, Marshall, Texas.

Learn Machine engraving! Enjoy profitable, home; nameplate engraving business. Write: Desco, 4329-GP Woodman, Van Nuys, Calif.

\$5.00 PROFIT on \$6.00 sale! Sample details, 25¢. Hamilton's, Box 1374, Las Cruces, New Mexico.

DOLLAR-MAKER "Tips" book. Over 1000 tips. Free details. Wayne, Department D, Box 1222, Pawtucket, R. I.

SELL Bodi-Gard. Amazing new chemical. Squirt in face of muggers, rapists, hoodlums. Temporarily blinds, disables them. Stains face red for identification. Retail \$1.95, sample \$1.50, 4 for \$3.50, postpaid. Money-back guarantee. Bodi-Gard, 443 West 50th St., New York 19, N.Y.

FREE Sample wholesale price list. Work from your home. Billow Co., P.O. Box 104, Florissant, Mo.

QUICK Money by mail plan \$2.00 or dime for details. Money back guarantee. A. Carithers, Box 136 P-M, Inkster 4, Michigan.

\$300,000.00 IN Prizes! Where? Write Spence, Box 11569, St. Petersburg 33, Fla.

DOUBLE Your money with bonds. \$3 booklet explains. "Bonds", 620-A So. Inglewood, Inglewood, Calif.

BIG Profits selling imports! List and sample, send \$1.00 to Holly Hill House, PO Box 3191, Tacoma 99, Wash.

BE Sharp. Do sharpening. Make money sharpening knives, scissors, saws, tools. Big profits. Treco hollow grinding outfit \$34.95. Write for free book. Treco Products, N. Tonawanda 15, N.Y.

BECOME A Notary Public! Win extra income, prestige, business contacts. Details free. Stationers Exchange, P.O. Box 617, Kilgore, Texas.

HUSBANDS & Housewives wanted! Big money. Spare or full time cake decorating and candy making. Turn your kitchen into a gold mine. No age, education limits. Complete instruction. Learn and earn at home. Write for free facts. Candy and Cake, Dept. D-743, Fallbrook, Calif.

MAKE Money at home by mail, full time, spare time, without investment. Write: Mid America Sales, Box 597-B, Topeka, Kansas.

AMAZING Plan brings quick cash by mail. Details 10¢. Fisher, Lime Springs, Iowa.

CIGARETTES. Make 20 plain or filter-tip for 9¢. Factory-fresh pipe tobaccos. Mild tropical flavored Philippine cigars. Facts free. Moberly, Box 4027, Owensboro, Kentucky.

YOUR Own, easy-to-start, home mail-order business, sparetime. Fascinating; profitable! Information free. Alfano, 19-PM, Pine, Closter, New Jersey.

LEARN The secrets of repairing junk batteries, generators, starters, profitable, easy, at home. Free particulars. Batteryman, Prunedale Station, Salinas, Calif.

VENDING Machines. No selling. Operate a route of coin machines and earn amazing profits. 32-page catalogue free. Parkway Machine Corporation, 715 PMM Ersor Street, Baltimore 2, Maryland.

EARN \$240.00 a month at home, spare time, doing only two \$5.00 invisible mending jobs a day. Big money paid for service that makes cuts, tears disappear from fabrics. Steady demand. Details free. Fabricon, 1532 Howard, Chicago 26, Ill.

SEASHELLS. Shellcraft and jewelry supplies. Wholesale catalog 25¢, refunded on first order. Our 29th year. Florida Supply House, Box 847M, Bradenton, Fla.

MAKE Plastic novelties for extra income. Low cost home training now available. Write for free booklet. Interstate Training Service, Dept. D-3, Portland 12, Oregon.

BAKE New greasless doughnuts in kitchen. Sell stores. Free recipes. Melvin, 3605 South 15th, Minneapolis 7, Minn.

EASY To start rubber stamp business at home in spare time. Make up to \$9.80 an hour without experience. Facts free. Write Roberts, 1512 Jarvis, Room CR-2-H, Chicago 26.

MINK Raising information free. Complete. Lake Superior Mink Farm, Superior, EE1, Wisconsin.

BIG Money raising fishworms and crickets. Free literature. Carter Hatchery, Plains, Georgia.

AMAZING Successes through franchises! Become exclusive franchise holder your territory. Information rushed. National Franchise Reports, MP-528, 333 North Michigan, Chicago 1.

MAKE Money by obtaining permission to ship guaranteed hosiery on free trial. Earn up to \$1.25 per sale. Send for free outfit. No obligation. M. C. Lege & Co., P.O. Box 241, Atlanta 1, Georgia.

WE Buy items you make for us. Send stamp for details. Wolfe Specialties, Box 171, Center Line, Michigan.

MAKE It big! Sell mailorder manuals. Tremendous market, profits. Free details. Rutward Publications, Columbia Station, Ohio.

MEN — Women! Start money-making plastic laminating business at home in spare time. Material that costs 11¢ brings back \$2.58. No canvassing or selling but mail orders bring in \$20 a day. Write for full particulars free. Rush name on postcard to Warner, Room CL-2H, 1512 Jarvis, Chicago 26, Ill.

LEARN The art of professional poodle grooming. Easy, profitable, home business. Write Poodle Shop, 3777 Sierra, Clovis, California.

START A profitable subscription business in spare time! We need men and women (young and old) as representatives for all leading national magazines. Liberal commissions in all subscriptions. Supplies free. No experience needed. Send this ad with your name and address to: Popular Mechanics, Room 8-O, 250 W. 55th St., New York 10, N. Y.

## EXPORT — IMPORT

RADIOS At discount prices. Portable 2, 6, 8, 10 transistor models, \$3.95, \$7.95, \$11.95, \$14.95 respectively. Includes carry case, batteries, ear-phone. Gift boxed. Guaranteed finest quality. Shipped directly from Japan. Herman's, 777 W. First, Azusa, Calif.

JAPAN: Mail-order 26 page catalogue; dolls, novelties, business information, manufacturers' addresses, \$1.00; Japan Trade Directory, 1000s product illustrations, \$3.00; Tourist Guide, \$1.00. Send cash. Clarence Yamagata, 814 Toginbiru, Marunouchi, Tokyo.

NEWEST Japanese imports. Price list available. Bill's Services, Box 96, Dorothy, N.J.

FABULOUS Gifts from around the world. Holly Hill House, PO Box 3191, Tacoma 99, Washington.

## SCIENCE & CHEMISTRY

EXPERIMENTER'S Handbook free with bigger discounts catalogue. Now only 20¢. Hagenow Laboratories, Manitowoc, Wisconsin.



**BUDGET** Priced chemicals, apparatus, Biology. Catalogue 25¢. Mid-States Scientific, 7053 N. Clark, Chicago, Ill.

**ROCKETS:** New illustrated catalog 25¢. Single and multistage kits, cones, engines, launchers, trackers, technical information, etc. Fast service. Estes Industries, Penrose 7, Colorado.

**CHEMICALS** And apparatus for industrial, analytical, and private laboratories. Catalog 35¢. Dept. M-50, Biological Supply Co., 1176 Mt. Hope Ave., Rochester 20, N. Y.

**ILLUSTRATED** Catalog: Chemistry, mineralogy, biology 25¢. Tracey Laboratories, Evanston, Illinois.

**UNUSUAL** Chemistry books, courses, kits! Rare chemicals, cheap! Catalog 25¢. NSC, Box 11133, Palo Alto, Calif.

**AMAZING** New book of science experiments, formulas, and catalogue of laboratory supplies. Only 35¢. National Scientific Co., 13 S. Park Avenue, Dept. PM-8, Lombard, Illinois.

**CATALOG** 25¢. Free expendible kit with \$10.00 order. Laboratory Sales, Box 161-A, Brighton, Mass.

**NEW!** Low cost laboratory apparatus. Chemicals. Catalog 25¢. United Scientific Corp., Waupaca, Wisconsin.

## PLASTICS

**NEW** Liquid casting plastic, clear, colors. Embed real flowers butterflies photos, coins. Send 25¢ for two handbooks, "How to Cast Liquid Plastics" and "How to Make Extra Money at Home." Castrolite Dept. J-101, Woodstock, Illinois.

**EMBEDDING.** Casting secrets free. Sample 25¢. Crystal, 4350-B N. Whipple, Chicago 18.

**PLASTIC** And supplies for laminating. Colamco, 12 Center, New Haven, Conn.

**BOXES.** Plastic. 200 sizes. Free list. Althor, 2301 Benson Ave., Brooklyn, N. Y.

**NATCOL** Resins are best for casting and laminating. Catalog 25¢. Natcol Plastics, Box 227, Redlands 3, California.

## FORMULAS, PLANS, ETC.

**ONE-Way** glass and hundreds more simple homework money-making formulas are described in our free brochures. Western Chemicals, Box 19718-C, Los Angeles 19, Calif.

**FORMULAS**—All kinds. Amazing big catalog, 10¢. Kemixal, Park Ridge, Ill.

**LATE.** Modern manufacturing formulas. List free. Moon Chemical, Martville, New York.

**FORMULAS** For latest money-making discoveries. New! Good! Valuable literature free! Miller, Chemists, 1517-D, Tampa, Florida.

## AGENTS WANTED

**SELL** Greeting cards. Make extra money. Christmas, all occasion assortments, stationery, gifts, jewelry, name imprinted Christmas cards. Experience unnecessary. Salable samples on approval. Free catalog. Write Hedenkamp, 361 Broadway, Dept. PM-86, New York.

**FREE** Sample. Beautiful curios! Sell on sight. Apartado 9036, Mexico City.

**AGENT** Wanted. Supply gift shop, motel, drug, with gift line. Gift Parade, Box 18453, Kearns, Utah.

**BUY** From factories! Appliances, cameras, watches, etc! Free details! Cam Company, 436-PJ Bloomfield Ave. Verona, N.J.

**PRINTING.** Advertising salesmen—Excellent moneymaking sideline selling decalcomania name plates, small quantities. Automobile initials, sign letters. Free samples. Ralco, XL, Boston 19, Mass.

**YOUR** Own business—Used suits \$1.50; overcoats 65¢; mackinaws 35¢; shoes 12½¢; ladies' coats 30¢; dresses 15¢. Enormous profits. Catalog free. Nathan Portnoy Associates, 2109-AA Roosevelt Road, Chicago 8, Ill.

**AGENTS**—300% Profit selling genuine gold window letters; store and offices. Free samples. Metallic Sign Letter Co., 1217-D West Newport, Chicago.

**MAKE** Most extra cash with world's biggest line Christmas cards, wrappings, gifts. Introduce friends, neighbors to 150 Christmas, Everyday box assortments, 600 big money-making novelties. Pocket up to 50% profit plus liberal bonus. Free giant color catalog. Buy on credit. Arrow Greetings, 513 Fourth Ave., S., Dept. 83-G, Minneapolis, Minn.

**MEN!** Women! 60% profit on cosmetics. Famous nationally advertised Hollywood cosmetics pay 60%. Make \$25 day up. Hire others. For free samples, details, write Studio Girl, Glendale, California, Dept. 23J38.

**WILL** You test new items in your home? Surprisingly big pay. Latest conveniences for home, car. Send no money. Just your name. Kristee 112, Akron, Ohio.

**CHRISTMAS** Cards. Business and personal. Earn really big commissions selling medium and high-priced cards with customer's name imprinted. Free sample album. Process Corp. (Our 42nd Year), 3434 S. 54th Ave., Chicago 50, Ill.

**NEW** "Magic Knife" slices frozen foods, even bone! Guaranteed 5 years. More than double your money in 30 days with no risk! Rush postcard for free profit details, special starting assortment discount offers. Dalo, Dept. S602K, 4333 N. Pulaski, Chicago 41, Ill.

**ESTABLISH** Your own business. Low prices on used clothing, shoes, household goods. Unlimited profits. Free catalog. Northwestern Distributors, 2129 No. Western Avenue, Chicago 47, Illinois.

**EXOTIC** Earrings! Details free. Pair, \$1.00. Ohga, PM471, Sigakenkusatu, Japan.

**MAKE** \$50.00 selling 25 boxes of our personalized Christmas cards. 49 exclusive designs. Free album. No obligation. Write: Elmcraft, 5930 So. Western, Dept. EC-7, Chicago 36, Ill.

**THREADED** Needles. Sew instantly. No threading. Five needles already threaded with 48 inch colorless nylon thread. Blends with most colors. Neatly packaged. Travelers' necessity. Nothing else like it. Agents biggest moneymaker. Write for free sample offer. R-U-Company, P.O. Box 569, Chicago 90, Ill.

**HOUSE** to house salespeople earn big money selling Princess imported jewelry. Individually designed. A few sales a day will pay you \$100 or more weekly with promotion possibilities as district manager. Write: Tousana Company, 3517 W. Franklin Blvd., Dept. P, Chicago 24, Illinois.

**SELL** On sight! Amazing sunglass invention for glasswearers. Separate lenses, positive pneumatic suction attachment. Assorted styles. Write Sunline, 5506 Nettie Rd., Jacksonville 7, Fla.

**FREE** Oil portrait sales kit. Details. Lakeside Products, Spring City, Tenn.

**MAKE** \$50.00 daily! Sell air operated vacuum cleaners to service stations for \$19.50. Your cost only \$9.50 postpaid. Free details. Inka Industries, 2409-M Crocker, Houston 6, Texas.

**BIG** Profits. Stamp social security plates, key protectors. Sample 50¢. Catalog free. General Products, Dept. PM8, 11 No. Pearl, Albany 7, N. Y.

**WANT** A satisfying new career? Sell the world's most useable Bible. Positions open for men or housewives. Supplies furnished free. National company, in business 30 years. Free company insurance, weekly pay. Full or part time. International Book Company, Box 118M, Wichita, Kans.

## BUY IT WHOLESALE

**DIRECTORY:** 100,000 low cost imports, \$2.00. Details free. Deevaughn, Box 507, Kelso, Washington.

**TOOL** Catalog. Send 25¢. Silvo Hardware, 107-PM Walnut, Phila. 6, Penna.

**APPLIANCES,** Toys, tools, catalogs, 25¢. Scott's Wholesale, 412 Valentine Street, Anderson, S. C.

**BUY** Direct from factories. Appliances, watches. Catalog, 25¢. Holliday, 914 Burnside Rd., Sharon Hill, Pa.

**ICE** Picks. Dozen \$1.72. Halsey Mfg. Co., Evansville 12, Ind.

**BARGAINS!** Buy wholesale! Save money! Free catalog! Norris, 273DE Merrick Road, Lynbrook, N.Y.

**350,000 BARGAINS!** Free merchandise! Write: Goldmine, 240-B, Planetarium Station, New York City 24.

**FREE!** Name brands catalog! Your own high profit business. Sell name brands, full or part time. No inventory, no investment. More than 2,000 name brand items; lowest wholesale prices. Watches, jewelry, cameras, hi-fi, stereo radios-phonos, appliances, housewares, hardware, power tools, luggage, musical instruments, garden equipment, sporting goods, toys, many others. 8 floors of name brands. Million dollar inventory. Orders shipped complete in 24 hours! Send for free, beautifully illustrated catalog now! Separate wholesale price list. H. B. Davis Corp., Dept. PM, 145 W. 15 St., New York 11, N. Y.

**NEW** Deluxe below wholesale catalog. Automobile catalog and others. Furniture, clothing, housewares, appliances, refrigerators, freezers, washers, dryers, television, radios, luggage, binoculars, hi-fi, stereo, phonographs, recorders, cameras, projectors, musical instruments, sporting goods, toys, tools, typewriters, watches, jewelry. Huge discounts on thousands of name brand items. For free specimen list of actual factory prices—postcard: Selbyco, Decatur 15, Illinois.

**USED** And new watches \$2 up. Free list. Southern Watches, 5-PM So. Wabash, Chicago 3.

**BUY** Direct from factories! Appliances, cameras, watches! Free details! Cam Company, 436PA Bloomfield Ave., Verona, N.J.

**WORLD'S** Largest wholesale supply. Buy from 679 American, European, Japanese wholesalers. Tailormade suits from Hongkong. 123 dropship catalogs. Rockbottom prices. Free details. International Buyers, 216-M Jackson, Chicago 6, Illinois.

**LARGEST** Wholesale supply source in U.S. Furniture, clothing, electric appliances, housewares, auto accessories, tools, sporting goods, farm equipment, hobby supplies, bargain merchandise, world imports. Free details. Associated Wholesalers, Box 52-DX, Burlington, Iowa.

**ELECTRIC** Guitars, amplifiers, wholesale. Free catalog. Carvin PMW, Covina, Calif.

## SALESMEN—DISTRIBUTORS

**AUTOMOTIVE:** German formula engine conditioner. Improves viscosity, checks excessive oil consumption, boosts compression, money back guarantee. Dealer merchandise starter kit \$5.95. Naylor Sales, 618 E. Irving Blvd., Irving (Dallas) Texas.

**BEST** Sales item since hoola hoop. Areas going fast. Details free. Reedco, 7907PM Blackshear, Dayton, 24, Ohio.

**150% PROFIT** Selling aerosol products. Egyptian, Box 168C, Anna, Ill.



**SENSATIONAL** New longer-burning light bulb. Amazing free replacement guarantee—never again buy light bulbs. No competition. Multi-million dollar market yours alone. Make small fortune even spare time. Incredibly quick sales. Free sales kit. Merlite (Bulb Div.), 114 E. 32nd, Dept. C-74K, New York 16.

**\$5,000 FOR** Part of your free time. Your own business. Free selling outfit. Opportunity to profit 8 ways including cash commissions, monthly bonus, bonds, free insurance. Age no barrier. Full time or part-time. No obligation. Write Ortho-Vent, 1138 Brand Road, Salem, Va.

**MAKE** Extra money selling advertising matchbooks. Free catalog and sales outfit. Matchcorp, Dept. PM-83, Chicago 32.

**MAKE** Big money taking orders for Stark dwarf fruit trees. Everybody can now grow giant size apples, peaches, pears in their yards. Also shade trees, shrubs, vines, roses, etc. Outfit free. Stark Bro's, Desk 30184, Louisiana, Missouri.

**RUN** Spare time greeting card-gift shop at home! Show friends samples new 1963 Christmas. All-occasion greeting cards, gifts! Take orders, earn to 100% profit. No experience needed. Try without cost! Special fund raising plans for organizations. Rush name for samples on approval. Regal Greetings, Dept. 101, Ferndale, Michigan.

**\$1,000.00** A Month for making dramatic 3-second demonstration of amazing light-weight Presto fire extinguisher. New chemical used by Airforce snuffs out fires instantly. Only \$4.95. Terrific commissions. Millions want it. Free kit, Merlite, 114 E. 32nd, Dept. P-66K, New York 16.

**SELL** Advertising book matches. Write us today: we put you in business by return mail; handling complete line ad book matches in demand by every business right in your town! No investment; everything furnished free! Top commissions daily! Superior Match, Dept. M-863, 7530 S. Greenwood, Chicago 19, Ill.

**SALESMEN!** Earn triple profits with Tri-truck, the revolutionary new hand-truck that sells on sight! Big commissions, S & H green stamps, retirement bonds. Rush your name for free information to Jet Tool Sales Co., Lemon Grove, California.

**UP** to \$400 weekly. Advertising space salesmen. Christy, Waukomis, Okla.

**PROSPECTS** Everywhere! Sell lighted religious pictures. Details free. C-V, 514 Beecher, Louisville 15, Kentucky.

**FROM** \$2.50 to a millionaire possible selling "Liquid Glass Auto Polish"! Details: Volz Ypsilanti, Michigan.

**SELL** Portraits painted on silk and canvas. Send photo/\$5. Toyo Oil Portraits, 855 Seijo, Setagayaku, Tokyo, Japan.

**SIGNS**, Stakes, flags, pennants, etc. L. A. Sign, 4503 Eagle Rock Blvd., Los Angeles 41, Calif. Free catalog.

**IF** You're interested in making money in selling, see the hundreds of exceptional opportunities in Salesmen's Opportunity Magazine. Send name for your copy, absolutely free. Tell us what you're selling now. Opportunity, 848 N. Dearborn, Dept. 17, Chicago 10, Illinois.

**EARN** Big commissions full or part time. Show America's largest line low priced business printing and advertising specialties. Big free sales kit samples hundreds items used daily by business people. Build profitable repeat business. Start right now. National Press, Dept. 8, North Chicago, Illinois.

## EMPLOYMENT INFORMATION

**AMAZING** Method! Foreign-U.S.A. employment, all occupations, unlimited opportunities. Free details. Meyer, Box 3371, St. Paul 1, Minn.

**YOUR** Skills are needed to help build Australia. Government-assisted passage. Details \$1.00. Irving Heyer, 316 Cypress, Santa Ana, Calif. 92701.

**"RITING** Resultful Resumes". How to book about resume writing. \$2.95 copy postpaid. Resumes printed. Fast service. Free price list. Star Letter and Offset Service Inc., 207 Somerset Street, North Plainfield, New Jersey.

**OVERSEAS**—U.S.A. employment opportunities. Construction, aviation, government, clerical, etc. Many high paying jobs, transportation and per-diem provided. Special section, California, Hawaii, Africa, Australia. Satisfaction assured. For complete report send \$2.00: Tropical Research, P.O. Box 45163, Los Angeles 45, California.

**FLORIDA** And Bahamas job opportunities. 500 new listings daily. Guaranteed results. For details send \$1.00 to Gold Coast Service, P.O. Box 4493, Miami Beach 41, Fla.

**\$1.00 FOR** Classified section New Orleans-Los Angeles newspaper. Harvey, 4529 Lake Villa, Metairie, La.

**JOBS**, Ships, \$100.00 weekly. Beginners, men, women. Seamans Service, Box 17-M, Brooklyn 8, N. Y.

**WORK** For the U.S. Government. Send \$1.00 for next five monthly issues containing announcements of Federal job examinations. Good pay plus fringe benefits. Civil Service Reporter, 330 Newbury Street, Boston 15, Massachusetts.

**MERCHANT** Marine. Men and women. Top wages. Travel. Information. Captain, Box 501-P, Reading, Massachusetts.

**DIRECTORY** Reports. Construction, aviation, shipping, oilfields, government, manufacturing, trucking, etc. Foreign-stateside. Helpful information plus job-getting tips on preparing application letters. Unconditional money-back-guarantee of satisfaction. Act today. Only \$1.00. (\$1.25 airmail). (C.O.D.'s accepted). Research Services, Meramec Building, St. Louis 5-PM, Missouri.

**FOREIGN** Employment job possibilities up to \$1600 monthly in Europe, Africa, Asia, South America. Free transportation. Construction workers, clerks, hundreds of occupations men, women. Complete information, proper application form sent promptly. Satisfaction guaranteed. Send \$2.00 (\$2.25 airmail) (C.O.D.'s accepted) to: Jobs, P.O. Box 50512, Dept. E, New Orleans 50, Louisiana.

**FOREIGN** Employment. Construction, other work projects. Good paying overseas jobs with extras, travel expenses. Write only: Foreign Service Bureau, Dept. PM, Bradenton Beach, Florida.

**OUTDOOR** Jobs available, high school graduates. Good pay, pleasant work. Federal, state, private agencies. Instructions and lists, \$2.00. Outdoor Enterprises, Argyle (1), Wisconsin.

**JOBS** Galore! All trades. Los Angeles classifieds \$2.00. Baker, 129 Cooper, Santa Ana, Calif.

## SPECIAL SERVICES

**INVENTIONS**, New ideas—We finance, manufacture, market. Sunnyside Finance, 2424 W. Montrose Avenue, Chicago, Illinois.

**INFORMATION** On anything. Ferguson Research Specialists, 59 Lent Ave., Hempstead, N.Y.

**WHAT** Can I do for you in New York. Harding, Box 111, New York City 28.

**RESEARCH** Specialists will prepare manuals, courses, reports effectively, reasonably. L'Aurea, Central Valley, New York.

**PATENTS** Skillfully prepared for maximum commercial value, with useful product development. High record of success in proving and claiming patentability. Valuable market service. Patent prepared for a fee as low as \$200.00. Send for self-protecting record of invention forms free. Patent search with valuable engineering report \$10.00. Foreign patents filed at low cost. Thirty years established. Joseph O'Brien Patent and Development Engineer, 132 Nassau St., New York 38, N. Y.

## EDUCATIONAL AND INSTRUCTION

**COMPLETE** Your high school at home in spare time with 66-year-old school. Texts furnished. No classes. Diploma. Information booklet free. American School, Dept. XC45, Drexel at 58th, Chicago 37, Illinois.

**NEW** Self-teaching course in memory helps you achieve greater success in business and social world. Free booklet. Memory Studies, 835 Diversey Parkway, Dept. 343C, Chicago 14.

**GOOD** Paying jobs open! Operate, repair heavy earth moving equipment! Learn "on the job" operating latest cranes, bulldozers, earth carriers! V.A. approved. Free catalog. Write H.P. Hutch, Greer Technical Institute, Braidwood, Illinois.

**OIL** Coloring photographs. A fascinating hobby or profitable sideline for those with artistic talent. Learn at home. Easy simplified method. Free booklet. National Photo Coloring School, 835 Diversey Parkway, Dept. 343C, Chicago 14.

**WRITE** Well: New penmanship book. "Ornamental and Business Writing." Details free. T. Tevis, Chillicothe, Mo.

**LEARN** Civil and criminal investigation at home Earn steady, good pay. State age. Institute Applied Science, 1920 Sunnyside, Dept. 16C, Chicago 40, Illinois.

**SWEDISH** Massage and physical culture pays big profits. Learn at home. Diploma. Free catalog. National Institute, Dept. E-83, 450 East Ohio, Chicago 11.

**PROFESSIONAL** Investigators. Home study. Lapel pin, certificate, future. Box 41197-F, Los Angeles 41, California.

**MASTER** Watch making at home. Free sample lesson. Chicago School, 2328-YU, Milwaukee, Chicago 47.

**FREE** Education yours from many trade schools, high schools, colleges, correspondence schools. Full facts, \$1.95. Beaumont, Star Route, Huntington, Massachusetts.

**FREE** High School and diploma at home or in class; other free education and training. Complete manual of free schools, \$1.95 Brookstone, Worthington 50, Massachusetts.

**LEARN** Auctioneering. Term soon. Free catalog. Reisch Auction College, Mason City 1, Iowa.

**PHOTOGRAPHY**: Earn big money. Travel. Own your own studio. Learn at home in your spare time. Write for big free book. School of Modern Photography, Dept. C-883, Little Falls, New Jersey.

**FCC** License in 6 weeks, first class radio telephone. Results guaranteed. Elkins Radio School, 2603D Inwood, Dallas, Texas.

**Get into politics!** New folio tells how. Details 25¢. Realfacts, Box 137, Bronx 51, New York.

**INVESTIGATOR** Training. Free booklets. Complete home study plan. Certificate. National Detective Academy, Box 374M Garden Grove, Calif.

**BUSINESS** Administration degree through correspondence. Associated Universities, Phoenix 16, Arizona.

**PIANO** Tuning pays. Learned easily at home. GI approved. 59th year. Free booklet. Niles Bryant School, Dept. P, 3731 Stockton, Sacramento 20, Calif.

**FREE** Sleep-learning catalog. Fletcher, 2407 PM Catherine, Dallas 11, Texas.

**HIGH** School diploma at home. Licensed teachers. Send age, highest grade completed for free details. No salesman will call. Southern States Academy, Station E-16, Atlanta, Ga.

**PIANO** Tuning quickly learned with home study course. Diploma granted. American Tuning School, Gilroy, Calif.



PIANO Tuning pays. Big money in spare time. Learn at home. No musical knowledge necessary. Phonograph, records, tools and instructions furnished. Electronic tuning also taught. Free catalog. Capital Tuning School, 3160 S.W. 16th Court, Ft. Lauderdale, Fla.

USED Courses! Books! List 104. Smith's, 124 Marlborough, Salem, Mass.

MISSOURI Auction school. Free catalogue. 1330 Linwood, Kansas City 9-x3, Missouri.

LEARN Fascinating, profitable invisible reweaving at home. \$10.00 earnings in an hour possible making tears, holes disappear from clothing, fabrics. Steady demand from cleaners, laundries, homes. Details free. Fabricon, 1534 Howard, Chicago 26, Illinois.

INVESTIGATOR'S Course. Credentials, diploma. Free information. Southwestern Institute Criminology, Box 201, Geronimo, Oklahoma.

PENMANSHIP Corrector. Improve poor penmanship quickly. Details free. Ozment, Box 665-34, St. Louis 88, Mo.

SWEDISH Massage. Foot technique. Post graduate. Home study, Residential. Diploma. Dr. Swanson's Illinois Licensed School, 3809-PL Alta Vista, Chicago 13.

USED Correspondence courses and books sold and rented. Money back guarantee. Catalog free. (Courses bought.) Lee Mountain, Pisgah, Alabama.

WOODWORKING And cabinetmaking course for beginning and advanced home craftsmen. Only complete low-cost home training program available. Write for free booklet. Interstate Training Service, Dept. G-3, Portland 12, Ore.

BOOKKEEPERS. Operate your own "Dollar-A-Week" system. Ellis, Box 200, Cedar Grove, North Carolina.

LEARN Asleep or awake! Records, tapes, equipment! Free catalog! Drawer PM-697, Ruidoso, New Mexico.

MEN Wanted. Earn \$125 a week and up. Master a trade with a future. Learn auto diesel mechanics in our shops. You learn with tools on real equipment. Earn while you learn. Many of our graduates earn \$125 a week and up. Write for free bulletin: Dept. 256, Auto Diesel College, Nashville 3, Tenn.

LEARN While asleep with your recorder, phono. Details, catalog free. Sleep-Learning, Box 24-PX, Olympia, Wash.

AEROSPACE Technology. 2 1/2 year courses aimed directly at important technician's positions in the critical Aerospace and Electronics industries. Request Catalog P. Academy of Aeronautics, LaGuardia Airport, Flushing 71, New York.

INVESTIGATOR Training Robert B. Phillips, Sr., founder. Former U.S.A. Government special agent. For free information write to: 1917-P North Kenneth Avenue, Chicago 39, Illinois.

OWN Collection agency. Little gold mine! Franklin Credit, Roanoke, Virginia.

BE A real estate broker. Insure security for yourself and your family. Study at home. Prepare for state examination. GI approved. Write for free book today. Weaver School of Real Estate, 3519-P Broadway, Kansas City 11, Mo.

### PATENTS FOR SALE

NEED Inventions, projects, etc., financed? Send \$2.00 to EJK Enterprises, P.O. Box 702-P, Tucson, Ariz., for list of finance firms.

REVOLUTIONARY Baby walker assures free walking within predetermined safe limits. Invaluable to persons in regaining leg strength. Will negotiate rights. Vidal, 99 Woodmount, Toronto 6, Canada.

### PLAYS, STORIES, MANUSCRIPTS

WANTED: Short stories, books, articles, plays of all descriptions for sale to publishers, producers. Free literature! Literary Agent Mead, Dept. 26A, 915 Broadway, N.Y.C. 10.

WRITERS. Bid rejection slips "good-bye". Sell without publishers. Tested money-making ideas. Free details. Write-shoppe, Box 9217, San Diego 9, California.

WANTED: Writers. We have the market. Send stamp. National Research Service, West Frankfort, Illinois.

WANT Your book published? Learn how we publish, advertise, promote, distribute. Many successes. Free booklet PM. Vantage, 120 West 31, New York City. Or 6253 Hollywood Blvd., Hollywood 28, Calif.

### ADVERTISING AGENCIES, ADV. SERVICE, MAILING LISTS

FREE! Redhot book. "More Profit from Your Advertising." Lists—best mailorder magazines, newspapers. Adservice, 516-H, Cornelia, Chicago 13.

HOW To get free advertising. 600 magazine directory \$3.00. Musselman, Box 2766H, Kalamazoo, Mich.

MAILORDER Record Book. 30 pages. Records inquiries, orders, advertising expense, etc. Most complete. Just send dime for postage and handling. F. W. Johnson, 740RB Rush St., Chicago 11.

ADVERTISING Ratebook leading newspapers, magazines, free. Chicago Advertising Agency, 28-E Jackson, Chicago 4.

AMAZING New Book—"Profits From Classified Advertising." Tells how and what to advertise. Be sure to read this book before you invest one cent in advertising. Write for your copy now. F. W. Johnson, Classified Advertising Manager, Popular Mechanics, 740-PR Rush St., Chicago 11, Illinois.

### TYPEWRITERS, DUPLICATORS, OFFICE DEVICES

NEW Typewriters \$39.00. New mimeographs \$16.95. Linco, 5117 East 22nd, Tulsa 14, Okla.

### RUBBER STAMPS AND OFFICE SUPPLIES

EXCELLENT! Three line pocket stamp, 75¢. Ruby's, D-26, Paradise, Pennsylvania.

RUBBER Stamps 25¢ up. Free lists. Leon's, Box 1103, Portsmouth 5, Virginia.

EMBLEM Stamps, 50¢. Business, trade or lodge. Morgan, 239 1/2 W. Amerige, Fullerton, Calif.

QUICKY Name and address pocket stamp \$1.00. Kirk Enterprises, 470 27th Street, San Francisco, Calif.

FREE Booklet. Indexed rubber stamps. Dowling Products, Dept. PM83, Pittstown, N.J.

CATALOG: Rubber stamps, printing, photostamps. Martin, 1425 Major, Jefferson City, Missouri.

FREE 32 Page rubber stamp catalog. Signature stamps \$3.50. Youngers Stamp Shop, Princeton, Iowa.

POCKET 3 Lines \$1.00. Office stamps \$1.50. Free catalog. Specialty, 8464 Manhattan, Detroit 11, Michigan.

### CARTOONING, COMMERCIAL ART, SHOWCARD & SIGN PAINTING, TATTOOING

ART Lessons—\$6.00 a month. Includes drawing, painting: commercial art: Art kits (worth \$25) and materials. Assignments corrected, with overlays, by mail, and returned to you. Write for free book. No obligation Washington School of Art, Studio 148, Port Washington, L.I., N.Y.

LEARN Profitable, fascinating tattooing. Illustrated information \$1. Zeis, 2220-C Delcy, Rockford, Illinois.

"HOW To Make Money with Simple Cartoons". A book everyone who likes to draw should have. It is free; no obligation. Simply address Cartoonists' Exchange, Dept. 98, Pleasant Hill, Ohio.

WANTED Cartoonist. Amateurs, professionals. Over 200 markets. Information free. Cartoon Markets-4-83, 11620 Lansdowne, Detroit 24, Michigan.

YOU Can entertain with chalk talks. Catalog 10¢. Balda the Cartoonist, Oshkosh, Wis.

LEARN Sign painting at home. Free talent test. Ben Kerns, Box 812-PM, Greenville, S.C.

LEARN Sign painting with fascinating system. Straley, 410 S. Western, Springfield, Ohio.

LEARN Profitable magazine cartooning. Free details. Hartman, Box 3097, Lincoln 10, Nebraska.

### PRINTING, MULTIGRAPHING, MIMEOGRAPHING, GUMMED LABELS

EXECUTIVE Prestige quality business printing. Lowest prices! Samples. Professional Printers, Box 3177, Ft. Worth 5, Texas.

BUSINESS Printing reasonable. Samples. Lodgepole Press, Box 443, Bettendorf, Iowa.

250 8 1/2x11 LETTERHEADS, #10 Envelopes, \$2.89 each. Fred, Box 623, Independence, Mo.

OFFSET, 1000 8 1/2x11, \$7.75 postpaid. 1000 gummed personalized name and address labels \$1, postpaid. Ramsbottom Printing, Box 237P Kirksville, Missouri.

QUALITY Business & personal. Fast service. Fair prices. Bestprint Dayton, Virginia.

250 8 1/2x11 HAMMERMILL letterheads \$2.75. 250 envelopes \$2.75. Samples. Patton, Box 248C, South Haven, Mich.

OFFSET Printing. Reasonable. Free estimates, samples. Lakeside Press, Park Rapids, Minn.

CHOOSE Type faces. Samples. McDonald, 545 North Oakland, Pasadena 4, California.

OVERNITE Offset, 8 1/2x11, 16 lb. white or colored Bond: 100—\$3.45; 1000—\$5.95; 5000—\$17.95. Also business cards, letterheads, envelopes, labels, etc. Free samples rushed! Print 17033 Miles, Cleveland 28, Ohio.

1000 BUSINESS Cards, raised letters \$3.75 postpaid. Samples. Routh, PM-8, 3910 Kipling, Greensboro, N.C.

MIMEOGRAPHING, Offset printing. Free samples. Pennway, Drawer 1340, Scranton, Penna.

YOUR Photographs printed on stationery, circulars, postcards, etc. Free samples! Print, 17034 Miles, Cleveland 28, Ohio.

OFFSET-Letterpress printing. Free samples rushed. Chicke Press, Harvey, Illinois.

OVERNITE Offset printing 1000 8 1/2" x 11"—\$6.50. Postage extra. Evergreen, 9420 Trumbull, Chicago 42.

AMAZING Business printing values. Samples. Print Shop, Box 576, Greenville, R. I.

OFFSET Printing, economical, top quality, letterhead, envelopes, forms. All types rubber stamps. Request catalog. Overnight Service, 912 Bob Wallace, Huntsville, Alabama.

1500 ADDRESSED Labels \$1.00. Sturdevant, 6207 Cambridge Ave., Cincinnati 30, Ohio.

PRINTLIKE, Overnite mimeographing. Reasonable. Samples. Scherer, 168 West Harrison, Chicago 5.



## PRINTING OUTFITS AND SUPPLIES

TYPE CASES. Manufacturer. Catalog. King McKay Company, 23179 Telegraph, Southfield, Michigan.

PRINTING Presses, type, supplies. Lists 5¢. Turnbaugh Service, Mechanicsburg, Penna.

MAKE Your own self-molding rubber stamps and printing cuts. Plexirubber. Argyle 1, Wisconsin.

RUBBER Stamp presses, hydraulic operated, electrically heated. Sizes 5"x8", 8"x12", 10"x15". Starting outfits, supplies. Printing presses. Custom Manufacturing, 1464-P East Commercial, Springfield, Missouri.

DO Your own printing. Save money. Simple rules. We supply everything. Print for others; good profit. Raised printing like engraving too. Have home shop. Details free. Kelsey Presses, V-11, Meriden, Connecticut.

RUBBER Stamp outfits, supplies. Kiewit, 2025 Barney Road, Kalamazoo, Mich.

BUY Postpaid rubber stamp materials. Free Press. Duckman, Avoca, Arkansas.

ILLUSTRATED Silk Screen Printing. Instructions with Supply Sources. \$2.00. George Shine, Box 162-A, Springfield 1, Massachusetts.

HARD Type for rubber stamp making, printing. Introductory offer 10 or 12 pt. 20th Century Medium caps or L.C. \$2.50. Free catalog. Barco Type, 232 Evergreen, Bensenville, Ill.

MAKE Rubber stamps. Complete outfit \$99.95. Terms. Duckman, Avoca, Ark.

NO Mimeo, circulars for pennies equipment \$3.98. Luby's, P.O. Box 784, Calexico, Calif.

## MANUFACTURING

MECHANICAL Parts, devices. Small to medium, made, repaired reasonable. Ebbin, 2129 Thomas, San Diego 9, Calif.

MODELS — Small lot manufacturing. Metals, plastics, etc. Milburn, Burlington, Kentucky

## MODELS—SHIPS, TRAINS, PLANES, ETC.

CASTINGS And finished steam-gas engines from simple oscillating to triple expansion. Finest materials and fittings. Catalogue \$1.00. Denison Live Steam Models, PM 1606 Denison, Cleveland 9, Ohio.

SHIP Models. Kits, fittings, plans, books, tools, engines, motors. Big illustrated catalog 50¢. James Bliss & Co., Dept. SM, 342 Atlantic Avenue, Boston 10, Massachusetts.

SHIP Model kits. Clippers, galleons, liners; Operating power boats for radio control; Send 25¢ for catalog. Ideal, 19 West 18 Street, New York 11, N. Y.

SHIP And yacht model fittings; blueprints. Send 50¢ for illustrated catalog listing hundreds of items. A. J. Fisher, Inc., 1002-1 Etowah Ave., Royal Oak, Mich.

ROCKETS: New illustrated catalog 25¢. Single and multistage kits, cones, engines, launchers, trackers, technical information, etc. Fast service. Estes Industries, Penrose 2, Colorado.

SHIP Model kits and fittings: clippers, frigates, etc. Catalog paint-tool list, book list, 35¢. Model Shipways, Box 85, Bogota, N. J.

"WHITE HEAT V" radio-controlled model hydroplane featured June 1962 Popular Mechanics. Full size plans, patterns, accessories and engine available. Literature for stamped addressed envelope. Oc-tura Models, 8144-P No. Milwaukee, Niles 48, Illinois.

MODEL Steam engines, ready to run. Sheridan air rifles. Catalogue 25¢. Gun Shop, Baker, Oregon.

## HOME CRAFTSMEN

WOODWORKERS, Home Craftsmen! Catalog containing lamp parts, veneers, lazy susan bearings, Swiss movements, chair cane, folding metal legs, wooden legs, finishing materials, etc., only 10¢. Barap Specialties, Box 2044-D, Chicago 9.

SWISS Musical movements, experimental special. 3—one tune, 1—two tune, wind-up. \$7.50. Regular \$12.00 will prevail after August. Tunes our choice. Walters, 207-PM, French, Utica 4, New York.

FOUNDRYETTE 2400" F., 1½ to 48 lb. capacity. Descriptive circular, send 10¢ for postage. Kansas City Specialties Co., Dept. P-8, Marysville, Kans.

101 PATTERNS Of smart gifts, novelties, shelves, action windmills plus "Make Money Jig Sawing". \$1.00. Mastercraft, 85M, 7041 Olcott, Chicago 31.

12 JIGSAW Wall patterns. Instructions \$1.00. Miniatures 25¢. Silhouette Workshop, 36 Linnaean Street, Cambridge 37, Mass.

CARPENTER 5 pocket nail aprons, 8 oz. Canvas. Double Strand Sewing, Metal Grommets, Nylon Cord Ties, \$1.50 postpaid. Gregg's Workshop, 5446 N. Moody Ave., Chicago 30, Ill.

2477 PLANS. Patterns, things to make, do. Fun. Profit. World's greatest selection. New catalog 10¢. Craftplans, 18250-A Harwood, Homewood, Ill.

SAVE: Raw picture frame molding, all species, all styles. We will miter corners. Bauerle Cabinet Works, Inc., Hammond, Louisiana.

PLANS For pool table with extra two-face top for table tennis and model railroad. Blueprints B1209 and building instructions \$3.50. Popular Mechanics Service Bureau, 740-M Rush St., Chicago 11, Illinois.

PICTURE Frame moulding, squares and lumber. Kiln dried walnut, cherry, silver maple. Midland Lumber Company, Box 262, Savannah, Mo.

SKIL-CRAFTS New 62-63 catalog. Largest and finest selection of leathercraft, artist, hobbycraft supplies in the world. Free gift with first order. Send 50¢. Refundable with first order. Skil-Crafts, Box 167-P, Joplin, Missouri.

WOOD Screws. Non-corrosive flat head aluminum assortment \$1.00. Flat head stainless assortment \$1.25. Postpaid in plastic box. Joart Specialty Co., Box 3007, Elmira, N.Y.

FREE "Do-It-Yourself" leathercraft catalog. Tandy Leather Company, Box 791-N49, Fort Worth, Texas.

## DO IT YOURSELF

SWIMMING Pool. Build yourself. Low cost. Illustrated plan, instructions. Free details. Technical Associates, 8040 N. 8th, Phoenix, Ariz.

FREE Check-list covering more than 500 classifications of projects, plans, instructions, service and repair information detailed in Popular Mechanics famous series of instructional booklets, books, patterns, and blueprints. List covers an extremely wide variety of do-it-yourself data on home remodeling, repair and improvement, hobbies, crafts, boating, games, lawn and garden, and hundreds of others. For your free copy of this helpful list, write: Service Bureau, Popular Mechanics, 575 Lexington Ave., New York 22, New York.

EXERCISE At home on build-it-yourself physical fitness equipment, including bicycle exerciser, rowing machine, belt massager, and abdominal board. Send \$2.50 for blueprints B1208 and instructions. Popular Mechanics Service Bureau, 740-K Rush St., Chicago 11, Illinois.

HEAT Your home from your hot water tank. Thermostat controlled. It's quiet, safe, clean, healthful, economical, and easy to install. Complete installation plan and instructions \$2.00. Heart Heating Co. 3769 Promontory St., San Diego, 9 California.

MAKE Loose screws stay put. New packing holds screws in metal, plastic, wood, etc. Easy to apply. \$1.00 postpaid. Free sample. Striker Enterprises, 1107 Southport, Lisle, Ill.

PLANS—Mobile home additions. Build-it-yourself. Two 10'x10' finished rooms with closets, entranceway, and carport; specify flat or hip roof style \$20.00. Garage and patio 13'x40'; specify flat or hip roof style \$15.00. Plans complete with material lists and specifications for frame or masonry construction. Duplicate sets \$5.00 each. Custom designs by request. Write today. Travelport Industries, Box 458, New Matamoras, Ohio.

## OF INTEREST TO WOMEN

NEW Musical imports from Switzerland. Wonderful gifts for baby and all occasions. Free information. Import House, 614-B East Little Creek Road, Norfolk 5, Virginia.

LEARN Expert cake decorating, candy making. Free details on home instruction method. Candy & Cake, Dept. D-781, Fallbrook, Calif.

"VACUUMIZING Attachment" keeps food fresh and from spoilage longer. Sample 2 dollars. Animarko Manufacturing, Box 1452, Wichita, Kansas.

MAKE Money. Sell amazing calorie control charts. Free information. Samples 25¢. Box 863, Burbank 3, Calif.

NO Woman dares be without "Does Your Wife Know?". Protect yourself and children! Don't be left in embarrassing circumstances! Rush just \$2.00 for your copy of this 56-page complete record book. (Literature free) Satisfaction guaranteed. Scoop Wainscott, Box 275-PM, Branchville, Maryland.

CANDLEMAKING & decorating. Fascinating hobby. Great business! Learn fascinating molding, dipping, creating & decorating candles for year-round demand—holidays, birthdays, weddings, anniversaries. All events. Spare time fun & extra income now; expand to colorful candle shop later. No age limit. Write for free facts on home instruction method. Candle Institute, Dept. X-32, Fallbrook, Calif.

LEARN Expert cake decorating, candy making. Free details on home instruction method. Candy & Cake, Dept. D-742, Fallbrook, Calif.

OVERWEIGHT? Lose pounds in one month! No starving, exercises, drugs! Success guaranteed plan. \$2.00 postpaid. Brugenheimer Company, Box 158-H92, Lexington, Massachusetts.

SEL Fine fabrics. Get yours wholesale. Box 863, Norwalk, Conn.

WOMEN! Make big money at home. \$10.00 profit in an hour possible with invisible mending. Make holes, tears disappear from clothing, fabrics. Steady year-round demand from cleaners, laundries, homes. Details free. Fabricon, 1533 Howard, Chicago 26, Illinois.

## FOR THE HOME

HEAT Homes, cottages. Save dollars. New idea. Free information. Bonanzavilla, Rt. 1, Box 290, Manassas, Va.

## WATCHES, OLD GOLD, JEWELRY

GOVERNMENT Ordnance wrist watches—used, as is. Waltham \$3.95; Elgin \$4.95; Bulova \$5.95. In good running order \$1.00 additional. While they last. Cash must accompany order. Joseph Bros., 5-P South Wabash, Chicago 3, Ill.

WATCH And clock repairing books. Free catalog. North American, 2320-AH, Milwaukee, Chicago 47, Illinois.

HIGHEST Cash. Gold, jewelry, diamonds, silver, platinum. Mail articles. Free information. Chicago Gold & Precious Metals, 6 E. Monroe, Dept. 5358, Chicago 3.



**CASH** Immediately for old gold, jewelry, gold teeth, watches, diamonds, silverware, spectacles, platinum, mercury. Free information. Rose Industries, 29-A East Madison, Chicago 2.

**CASH** For gold scrap, rings, jewelry, dental gold. Free information, or send items now for cash airmailed immediately. King Ramsey, 1001 West 21st, Odessa 1, Texas.

**WATCHES** Lowest wholesale, free brochure. Davidson's, Box 3247, Phoebus, Va.

## TREASURE FINDERS

**EXCITING** Adventure locating hidden loot, treasure, relics, etc., with powerful electronic M-scope locator. Lightweight. Guaranteed. Very easy terms. Send for free booklet, interesting customer reports. Fisher Research, Dept. AY, Palo Alto, Calif.

**TREASURE.** Find gold, silver, relics with super, powerful Detectron locators. Free information. Detectron, Dept. PM-8, San Gabriel, California.

"**TREASURE** Hunter's Bibliography", lists all known books, authors, publishers. Every enthusiast needs this reference: \$2.00. Shelby, Box 4266-E, Saticoy, California.

**GUARANTEED** Metal, treasure and water locator only \$3.00. Robbins-2, 57 Scott, San Francisco 17, Calif.

**EXPLORE** Underground, years ahead transistor Metrotech locators detect gold, silver, coins, relics. Information free. Underground Explorations, Dept. A, Box 793, Menlo Park, California.

**SUPERSENSITIVE** Transistor treasure finders. \$19.95 up. Kits available. Free catalog. Reiko, Box 10563, Houston 18, Texas.

**NEW** Coin locator! Free literature. Howe, 811-C Kansas, Atchison, Kansas.

**METAL** Locator kits and assembled models from \$39.90. Terms. Transistorized and underwater models available. Free catalog. Electronic Applications, Dept. M, Box 6095, Alexandria, Virginia.

**TREASURE.** Gold, silver, relics. Find them with new 1963 models. Free information. Raytron Box 715, North Hollywood, California.

## RAZORS

**GENUINE** German blades. Fit any double edged razor. Only \$2.95 per 100 prepaid. The Import Shop, 1502 Cherokee Place, Bartlesville, Oklahoma.

## PERSONAL

**INVESTIGATORS.** Free brochure, latest subminiature electronic listening devices. Ace Electronics, 11500-P NW 7th Ave., Miami 50, Florida.

**INVENTIONS** Wanted. Patented: unpatented. Tremendous manufacturers lists. Global Marketing Service, 2420 77th, Oakland 5, California.

**BIBLE** Questions answered. Stamped envelope. Bylon, 17167 Bentler, Detroit 19, Michigan.

**DEVELOP** Mind power, personality while asleep. Details free. Research Association, Box 24-N, Olympia, Washington.

**BORROW** \$100 to \$1000 by mail. Quick, easy, private. No co-signers. Repay in 24 small monthly payments. For the amount you want write today to Dial Finance Co., 410 Kilpatrick Bldg., Dept. 8-214, Omaha 2, Nebraska.

**LEARN** Real Spanish fast. Guaranteed results. Introductory lesson 25¢. Trader, Box 3488-PM8, Ridgecrest, California.

**RUPTURED.** Relief and comfort. No understraps, elastic or steel. Write Hand-Lock Products, Preston 4, Ontario.

**NEED** Money? Borrow \$100-\$1000 by mail. Confidential, repay in 24 months. Free loan application. Budget Finance Co., Dept. MB-173, 317 So. 20th, Omaha 2, Nebraska.

**WILLS!** 60 page booklet explains will-making, plus five blank will forms, complete only \$1.00. Standard, Box 1046, Santa Monica 11, California.

**LOANS** By mail, \$100-\$600. Anywhere. Confidential. Write Union Finance, Dept. PM, 323 E. Camelback, Phoenix, Arizona.

**PROFESSIONAL** Voice training at home. New scientific method. Quick positive results. Feuchtinger Voice Clinic, 6308 N. Lakewood Ave., Chicago 26.

## REMAILING SERVICE

**HOUSTON-NASA** Area. Prompt remails 25¢ single. \$3.00 monthly. Confidential receiving-forwarding. Tremaco, Box 5277-H, Houston 12, Texas.

**PARIS,** France reairmails \$1.00. 2 postcards \$1.00. Services Ltd., P.O. Box 369, St. Prest, France.

"**ECUADORIAN** Registered re-airmails \$1.00. Confidential and reliable. Leon, Box 360, Guayaquil, Ecuador, So. America."

**REMAIL** 30¢. Monthly \$3.00. Labrie, 3364 Station C, Ottawa 3, Canada.

**SECRET** Mail receiving system. Hedgpath, 406-M South Second, Alhambra, California-91802.

**CONFIDENTIAL** Remails 25¢ single, \$3.00 monthly. Box 4327, Tampa 7, Florida.

**WASHINGTON** Remails, 25¢, \$2.00 monthly. Confidential. Redick, Box 1082, Washington 13, D.C.

**MEXICO** Remails 35¢. Questions answered 25¢. D. H., 34 Resaca Blvd., Brownsville, Texas.

**REMAILS** 25¢, \$3.00 monthly. LAMA, 6017 S. 117 Pl. Seattle, 78.

**MEXICO:** Reliable services. Remailing \$3.00 monthly. Ramcke, Correo Chapalita, Guadalajara, Mexico.

**HAWAII** Secret address. Receiving-forwarding 25¢, \$3.00 monthly. Postcards. Coe, Box 984, Kailua, Hawaii.

**MIAMI BEACH** Remails 25¢: 5 for \$1.00. Monthly \$3.00. National, P.O. Box 678-A, Miami Beach 39, Florida.

**CONFIDENTIAL** New York City mail address \$3.00 month. Remails 25¢. Details free. Birnhan, 152 W. 42, New York City 36.

**LOS ANGELES.** Hollywood, San Fernando Valley—25¢ single; \$3.00 monthly. Confidential, 10437P Lanark, Sun Valley 3, California.

## WANTED—MISCELLANEOUS

**U.S. Coins.** Paying 15¢ each for Indian pennies, 1950 nickels, Lincoln cents dated 1931, 1932, 1933. 5¢ each penny dated 1909 through 1915, 1921 through 1924. Complete buying list 50¢. Coins, 3726 7th., Riverside 1, California.

**OLD** Auto catalogs, manuals, MoToR, ATJ magazines, auto mascots, Boyce motometers. Top prices paid. Sheldon Lewis, 154-62 71st Ave., Flushing 67, N.Y.

**QUICKSILVER.** Platinum, silver, gold. Ores analyzed. Wholesale Terminal, Norwood, Mass.

**STAMP** Collections, accumulations. Eagle Stamp Co., 2221 Romine, Pittsburgh 26, Penna.

## FOR SALE—MISCELLANEOUS

**CANNON** Fuse 3/32" diameter, waterproof. Burns under water, 10 ft., \$1.00; 25 ft. \$2.00; ppd. Will Zeller, Hudson, Mich.

**HEARING** Aid batteries wholesale. Free list. Habs, Box 51, York, Penna.

**USED** Industrial work clothes. Shirts 79¢. Pants 98¢. Coveralls \$1.49. Assorted colors, sterilized, laundered. Give size, color. Post paid. P.O. Box 502, Greenville, S. C.

**TEMPLE** Snugglers ends annoyance of slipping eye glasses. 75¢ for 3 sets. Klein Enterprises, 1902 Webster Rd., Orchard Pk., N.Y.

**AUSTRALIAN** Mulgawood souvenirs. Catalog and sample air mailed \$2.00. Phillips, Box 1393-K, G.P.O., Adelaide, South Australia.

## TOBACCO

**CIGARS.** Tobaccos. Save! Free list. Tobacconist, 220 N. Clark, Chicago 1.

## MISCELLANEOUS

**HEARING** Aids only \$28.95. Free trial, terms. Write: Cary-B-Sales, Inverness, Fla. Also small rooted shrubbery.

**ATTRACTIVE** Charcoal sketches made from your favorite photos. 11" x 14" each \$3.95. Satisfaction guaranteed. Free information. Val-art, P.O. Box 1205-SA, Harlingen, Texas.

**NEWSPAPER** Clippings, box tops, labels, wrappers, used books, magazines. Reasonable rates. Write: R. Costello, 639 W. 43rd Place, Chicago 9, Illinois.

**ALL-Purpose** permanent super-powered magnets. 1001 uses. Home, office, workshop, auto. Each magnet 3/4" x 1". Set of 4, 75¢. Lesters, Box 10, Franklin Square, N.Y.

**SEWER** Cleaning machines. Free literature. All Clear, 3040 Matthews Ave., Bronx 67, N. Y.

**N. J. Area** newspaper ad clip service. Jos. Koker, Bx. 121, Closter, N.J.

**FIVE** Original homespun poems. Clean. Not fifth. Send \$1.00. Wamack, 307 East 11th Street, Ashland, Ohio.

**SUPER** Memory overnight! Success guaranteed! Bijou, Box 1727-M, Hollywood 28, California.

**GRAB** Bag, fabulous item monthly, \$12 year. 6 months \$7. Myles, 18670 Ventura, Tarzana, California.

**CONTEMPLATING** California? Send \$1 cash to Orientation, Box 618, Los Altos, California, for helpful pamphlet by former Easterner.

**RECEIVE** Gifts, samples, magazines, catalogs, opportunities, 25¢. "Directory," Adkins, Texas.

**SIGNS:** Indoor or outdoor type. Aluminum, brass, bronze. Send for brochure. R. T. A. Service, Box 522, New York 8, N. Y.

**TROPICAL** Ceylon offering attractive gift parcels consisting beautiful rare curios, antimony, semi-precious stones, silverware, etc. Ten dollars upwards. Remittance only through banks. William Trading Company, Box 698, Colombo, Ceylon.

**LOANS** By mail, \$100-\$600. Anywhere. Confidential. Write Union Finance, Dept. PM, 323 E. Camelback, Phoenix, Arizona.

**FREE** Catalog—Gifts, novelties. Handy House, 214 Main, Hackensack, N. J.

**LONGHORNS.** Genuine Steer Horns. For mounting 4-6 foot spans. Longhorns, Laclede 10, Missouri.

**CESSPOOLS,** Septic tanks restored to newness by miracle crystal pellets. Free literature. Electric Sewer Cleaning Co., Allston 34, Mass.

**FREE** Wholesale catalog! 100,000 products. Tremendous discounts! Taylor Distributors, Newton 2, New Jersey.

**CIGARETTES**—Make 20 plain or filter tip for 9¢. Facts free. Moberly, Box 785, Owensboro, Kentucky.

**SEND** Us wool for blankets. Write Eldorado Woolens, Eldorado, Texas.

**BOOKS** On antiques and their prices. Free circular! P. Warman Publishers, Uniontown, Penna.

"**STAMMER, Stutter, No More.**" (Dr. Young.) Write: Gaucho, Box 9309-S7, Chicago 90.



## Ancient Waterworks

A water system built in ancient times by the Indians has been discovered on an island off the California coast. No date for the system has been determined, but Indians inhabited San Nicolas Island as early as 4000 years ago, radiocarbon dating indicates.

The ingenious water system, which may have supported 2000 people, was fed from a small spring percolating through a sandstone bluff. A series of channels, one 38 feet long, were dug out at the foot of the bluff to collect water seeping over a sandstone shelf. Peck marks indicate that the system was built with stone tools.

## Microbes May Test Drugs

Protozoa, a simple, single-celled organism, may make future drugs safer for man to use. Researchers have found that thalidomide, the drug which causes malformations in unborn babies, inhibits the growth of some protozoa. Thus, they think, these minute, cheaply produced organisms could be used to evaluate a drug's toxicity before trying it on higher species of animals.

No one knows why thalidomide causes malformations in babies, but if it has the same effect on man as it has on protozoa, the drug probably interferes with cellular oxidation at the beginning of life.

## Anemic Spacemen?

Our superbly conditioned astronauts might possibly return from long space voyages as anemic weaklings, NASA experiments suggest. The disability could result from lack of nitrogen in the voyagers' oxygen supply.

Tests conducted with a group of volunteers in simulated space conditions showed that the men developed anemia but otherwise remained healthy. The volunteers were exposed to pure oxygen in an altitude chamber during four two-week periods. The tendency to anemia, according to a Republic Aviation scientist, could represent "potentially serious or disabling" conditions on long space flights.

During the tests, four groups of volunteers put in a 10-hour day performing some 683 physiological and psychological tests; they were monitored around the clock by medical experts in space environment and the life sciences. Health and morale among the four groups remained high despite the development of anemia. Further studies of the effects of a pure oxygen atmosphere are necessary, the Republic scientist reported.

AUGUST 1963



## It reigns where it pours

Mac's No. 13 Radiator Rust Inhibitor has no equal. It positively prevents rust in all automobile cooling systems ... mixes with any type of anti-freeze. And it keeps your cooling system clear for an entire year. Your service station man is ready to pour when you say when.

**MAC'S SUPER GLOSS CO., INC.**  
Los Angeles 42, Calif., Cincinnati 26, Ohio



## "Otter-torium" Shows Otters as Eaters

VISITORS to Florida's Weeki Wachee Springs are treated to a primitive wildlife hunting ritual by naturalist John Hamlet's feeding tank for otters.

Established as a display point for jungle cruise boats, the "otter-torium" is a large glass tank at the edge of an otter refuge. An electrically operated ferris wheel with

16 buckets of live fish is triggered into motion by a radio signal from an approaching boat. The wheel dumps a bucket of fish into a pipe running into the otter tank. Scentsing the fish, the otters dive into the tank just as the cruise boat arrives, and begin their hunt before the eyes of the tourists.



**NATURALIST** (top left) makes adjustment on radio-controlled ferris wheel that dumps fish into glass tank where otters feed (top right). The refuge (below) is on the bank of the Weeki Wachee river in Florida







## New aluminum engine enamel—now in a spray can

Here's another first from "Seymour of Sycamore," America's oldest spray paint manufacturer. Packaged in the familiar aerosol container, which they originated, it's the new engine enamel that has met with such enthusiasm and acceptance by users.

Seymour recommends this highly heat-resistant aluminum engine enamel for all surfaces except the exhaust manifold. Made with Alcoa® Pigments, it's a genuine enamel, according to Seymour, not a lacquer. Users say it dries in 10 minutes, dust free. Now you can dress up the power plant without the usual muss and splatter.

Today, spray aluminum is standard equipment in thousands of home workshops. It's available in several types—including colors. Aluminum paint is durable; a tough film of metal resists wear, cuts the maintenance nuisance. It has great hiding power: one coat covers soiled or stained surfaces (aluminum pigment is opaque).

*Alcoa does not make aluminum paint, but Alcoa Pigments are used in the best brands. Available in either spray cans or conventional containers, brands like Seymour's are at dealers everywhere. Send for our booklet.*

Aluminum Company of America  
1705-H Alcoa Building, Pittsburgh 19, Pa.

Please send your free booklet,  
*Painting With Aluminum*

Name \_\_\_\_\_

Address \_\_\_\_\_

City \_\_\_\_\_ Zone \_\_\_\_\_ State \_\_\_\_\_



Entertainment at Its Best . . . ALCOA PREMIERE  
Presented by Fred Astaire . . . Thursday Evenings, ABC-TV





because  
it's  
**completely furnished**  
when you buy it . . .

# *instant living*

**begins the moment you move in!**

Imagine setting up housekeeping in a spacious, 3 bedroom home . . . *with only dishes, linens and silverware.* That's all it takes in a New Moon mobile home, because everything else . . . from kitchen appliances to living room furniture . . . is provided for you! Here's *instant, ready-to-go living* . . . all for **LESS** than the cost of furnishings alone in the average home.

*Write for free folder or see New Moon homes at any of the nation's more than 500 dealers.*

6318

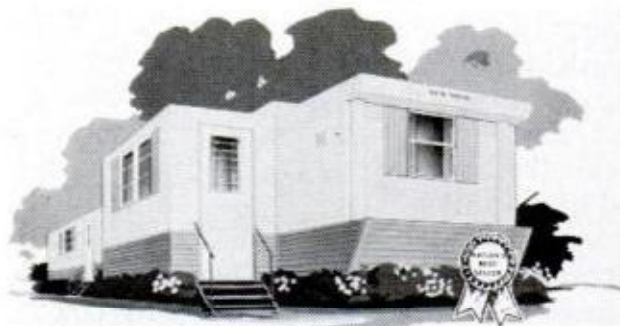

**NEW MOON**® HOMES INC.

Dept. 79 /7808 Carpenter Freeway /Dallas, Texas



# Sub Rescues-Four Miles Deep

*Stunned by the Thresher disaster, the Navy is rushing to develop a family of buglike vessels that will snatch men from death under the sea*



By S. David Pursglove

**O**VER THE NEXT FIVE YEARS, the U.S. Navy will build a fleet of the weirdest looking vessels ever imagined. Experimental models of eerie, crablike metal and plastic monsters are even now far beyond the drawing board stage. They are as unlike conventional surface vessels as space craft are unlike ordinary aircraft.

Their mission will be to probe the abysses of the deepest ocean floors. And they will attempt to answer two of the Navy's toughest problems: How to rescue men from a stricken submarine beyond present rescue range of 1300 feet *and* how to raise a crippled sub from



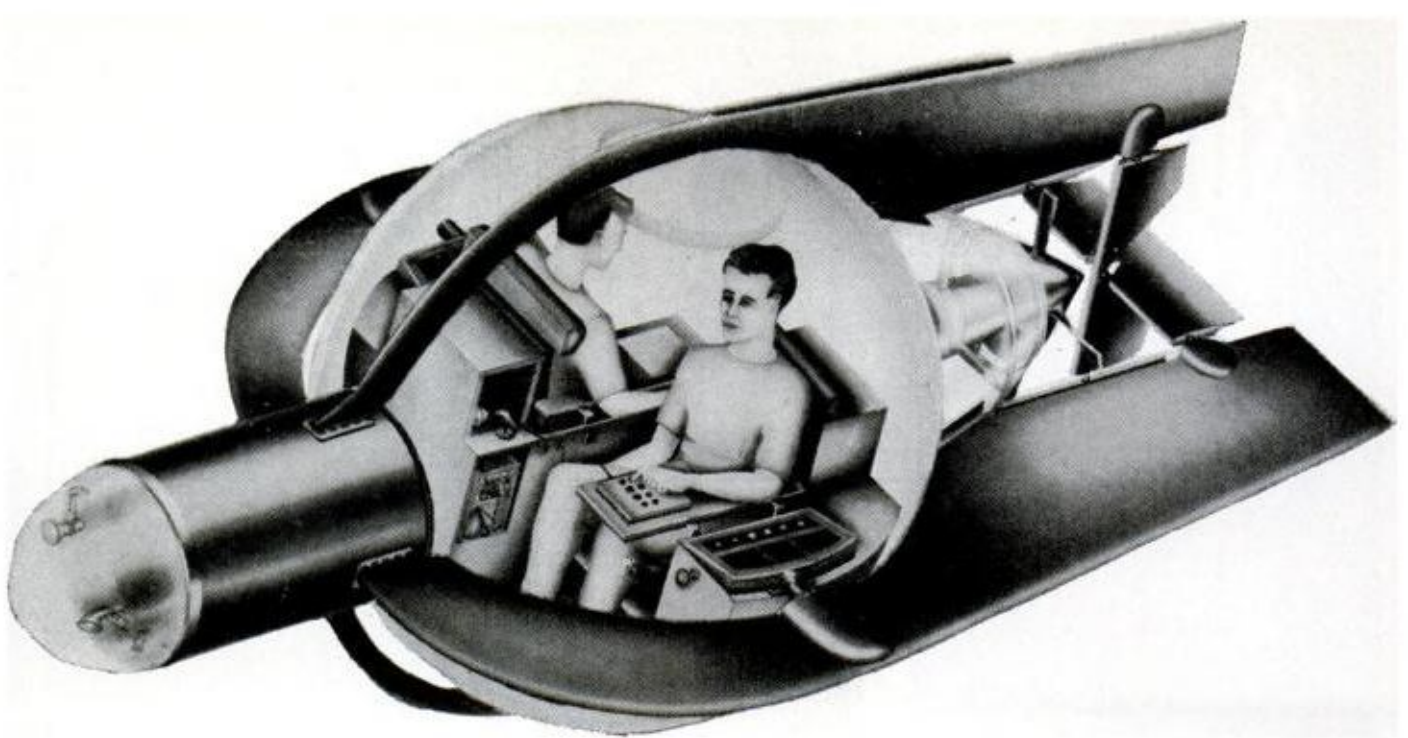

**PLEXIGLASS SPHERES** for deep-diving research submarines are now undergoing tests by Naval Ordnance. They would give full visibility down to 2000 feet

any depth, especially if it carries Polaris nuclear warheads. Future subs are expected to operate below 20,000 feet.

It took the USS *Thresher's* 129 officers, enlisted men and civilians lying dead on the Atlantic floor to jolt the Navy into resuming research on the art of rescuing sub-

marine crews and salvaging sunken hulls.

Two weeks after the *Thresher* disappeared in 8400 feet of water, Navy Secretary Fred Korth ordered Rear Adm. Edward C. Stephan, the Navy's chief oceanographer, to form a committee to look at America's present sub rescue and

**STEINKE HOOD** permits submariners to breathe while popping rapidly to the surface in a "blow and go" escape; it also blocks cold water from their eardrums

**McCANN RESCUE CHAMBER**, which will hold nine men and two operators in its upper compartment, is winched down to a disabled sub's escape hatch

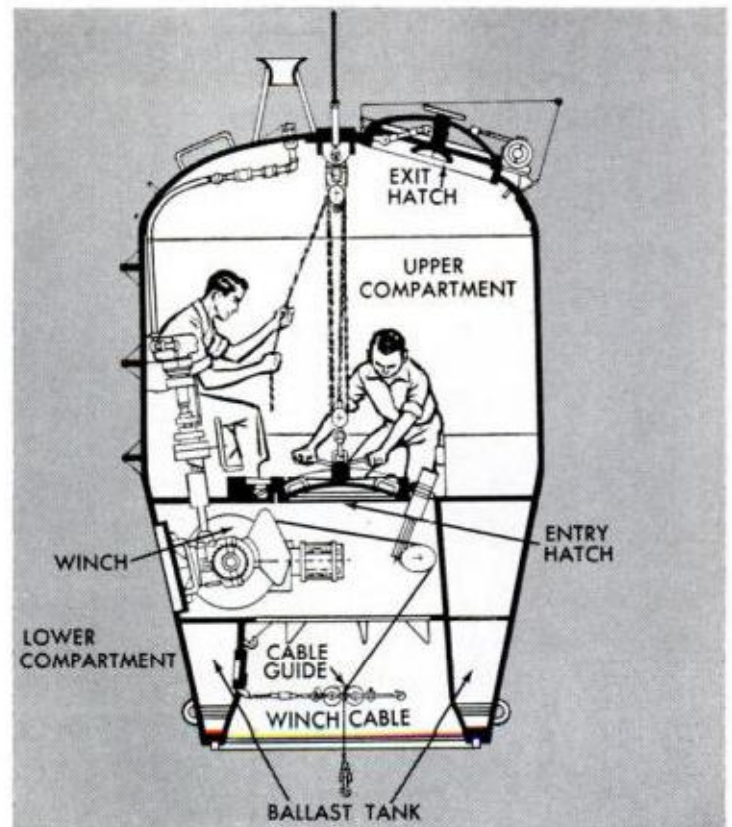

POPULAR MECHANICS







chores as retrieving missiles and nose cones from space craft.

Present diving capabilities of our nuclear subs are still classified information. Nobody knows at what depth the *Thresher* was crushed by underwater pressure. Her sister ship, the new USS *Jack*, will dive deeper than any other submarine in the world, according to the Navy. But it's safe to say that it won't go anywhere near the depths planned for the next generation of submarines. These, says the Navy, will lurk 20,000 feet beneath the surface.

The U.S. has never built any kind of vessel that could reach a crippled sub at 20,000 feet. The European-built bathyscaph *Trieste*, now owned by the U.S., has been to 35,800 feet. But *Trieste* can only descend and look. It cannot rescue men, nor can it salvage a submarine. It has been called a "good deep-sea yo-yo." Once down it can maneuver very little, and it cannot oper-

ate effectively in a current of more than one mile per hour.

Mare Island Naval Shipyard is now putting the finishing touches on a new bathyscaph float that will have a two-to-three-mile lateral range on the ocean floor. A two-man sphere will have a four-inch diameter viewing port, and it will also transmit TV pictures to the surface. Two mechanical arms will be able to pick up objects from the ocean floor and deposit them in an outboard basket. For shallow and intermediate depths it will use a lightweight chamber, but for deep-sea areas it will use the six-inch-thick steel sphere cut from the *Trieste*.

But even this 'scaph will not have a rescue capability. That will have to wait until a deep-diving rescue vehicle now being studied by the Navy comes off the ways. This craft will be a cross between

[\(Please turn to page 202\)](#)

**MOBOT V**, the undersea oil-well robot, could probably be used in sub-rescue work. It is surface-controlled, has motorized arms, is fairly maneuverable

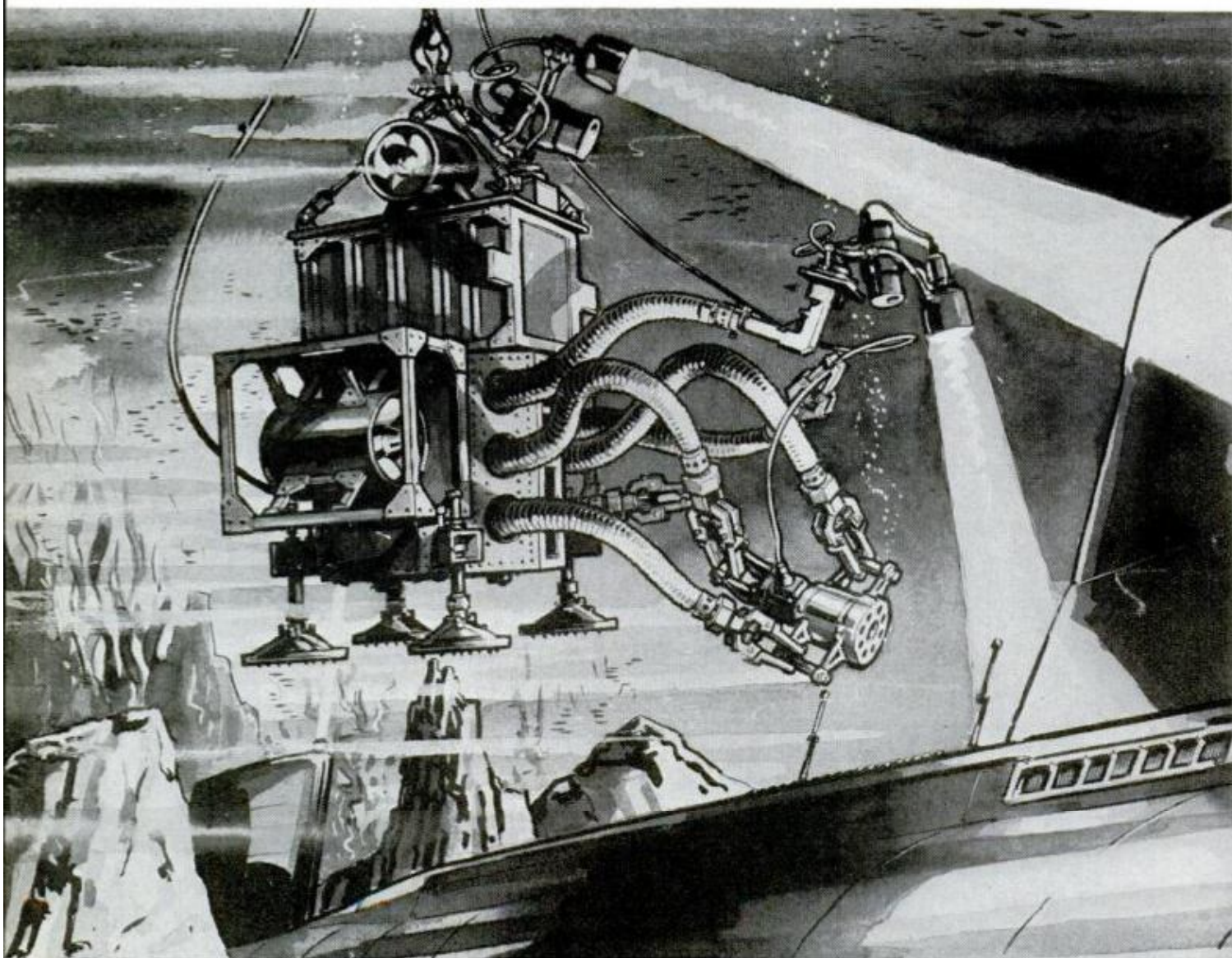



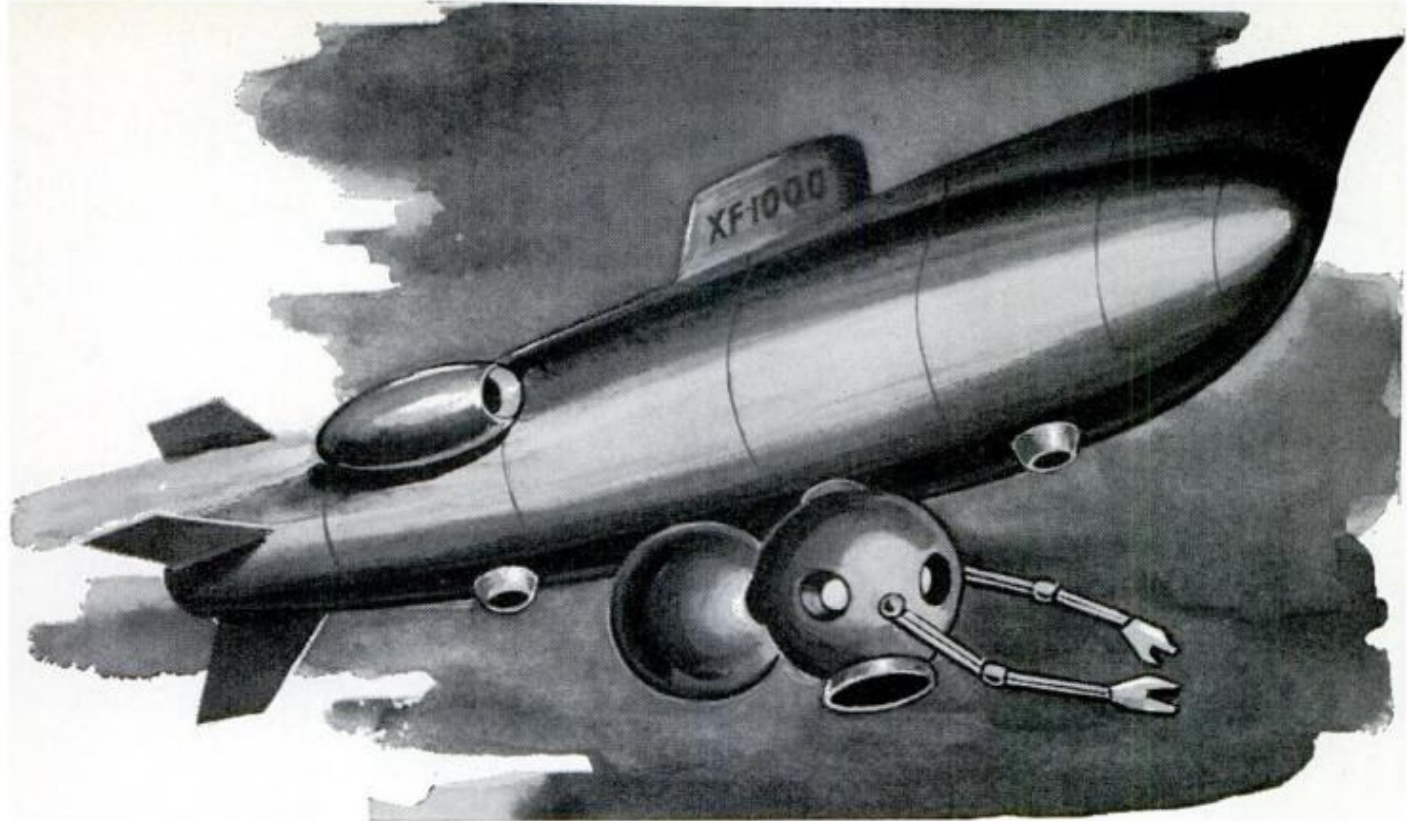

**PROPOSED DEEP-SEA RESCUE** vessel is similar to *Trieste* but more useful. It has mechanical arms for attaching salvage cables, a sphere for personnel

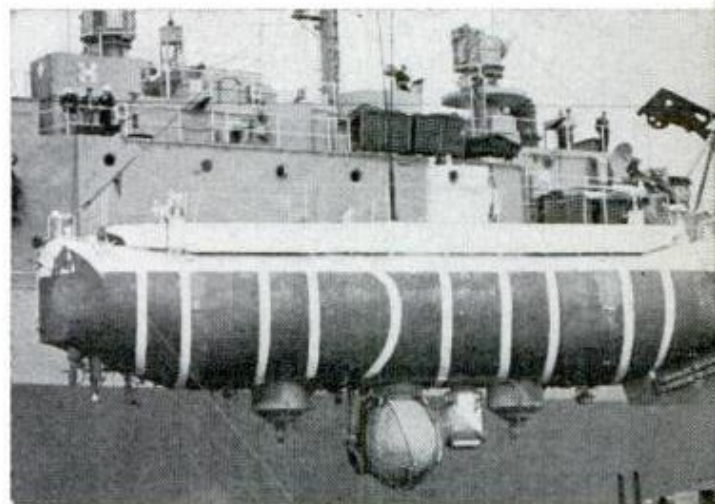

**THE TRIESTE** can only descend and look; it can't rescue men or salvage a sunken submarine. Built in Europe but owned by the U.S. Navy, it has been down to 35,800 feet

**SUB-RESCUE SHIP**, the *Florikan* (ASR 9), has a McCann Rescue Chamber near the stern and positioning buoys amidships; these are anchored around sunken submarines





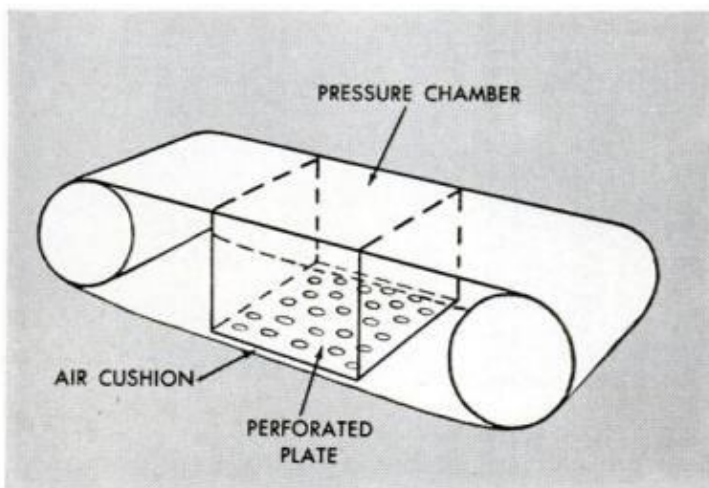
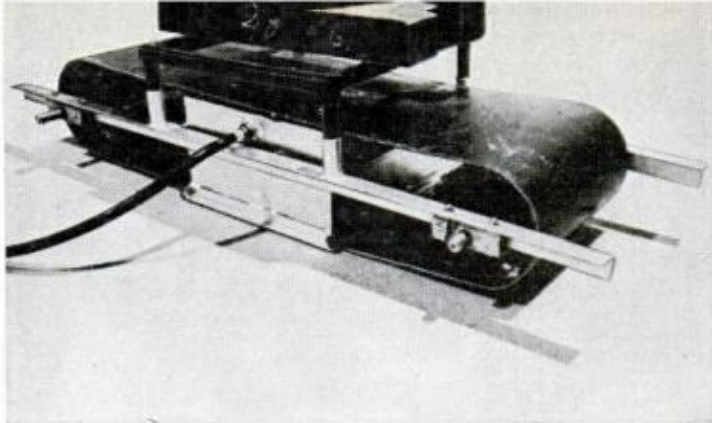

**USE OF AN AIR CUSHION** to support a crawler tractor's load makes the tractor cheaper to build and easier to maintain, says the inventor of Air Track. Dr. William Bertelsen, Neponset, Ill., reports that a model (above) supports 500 pounds with an air pressure of 10 p.s.i. Air from the chamber forms a cushion between track and load; a full-size machine would generate its own air and provide its own propulsion.

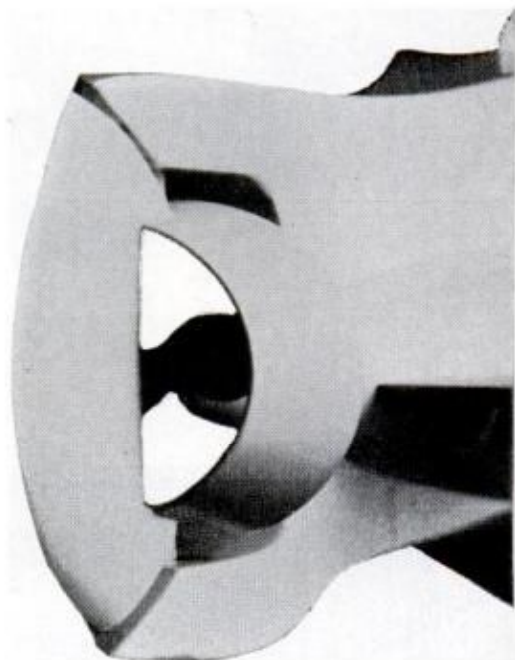

**ELEVEN-INCH TV** is truly portable. The 12 $\frac{3}{4}$ -pound set operates off house current and uses standard vacuum tubes. It's designed by General Electric to fit into the bookcase. Measuring only 10 $\frac{3}{8}$  by 14 by 9 $\frac{7}{8}$  inches, it has a 60-square-inch screen. Price is \$99.95.



**RAMBLING WRECK.** Now used as a trainer for antisubmarine air crews, the fuselage of a Grumman Tracker is actually the reclaimed portion of a plane that crashed.

Its cockpit and electronic equipment was still in good condition so it was refurbished, installed on a roof near a classroom, and rigged with equipment that projects mock maps and targets on a radar screen so the trainees can fly simulated missions.



**SIGHT-SEEING SUBMARINE** is now under construction for the 1964 exposition at Lausanne, Switzerland. The 40-passenger submarine will take visitors on a tour of the underwater flora and fauna of Lake Lemman. It will dive to a depth of more than 1000 feet, and has 20 windows on each side for viewing. Designed by Dr. Jacques Piccard of the famous balloon and diving-sphere family, the Mesoscapha will make 14 underwater excursions daily.

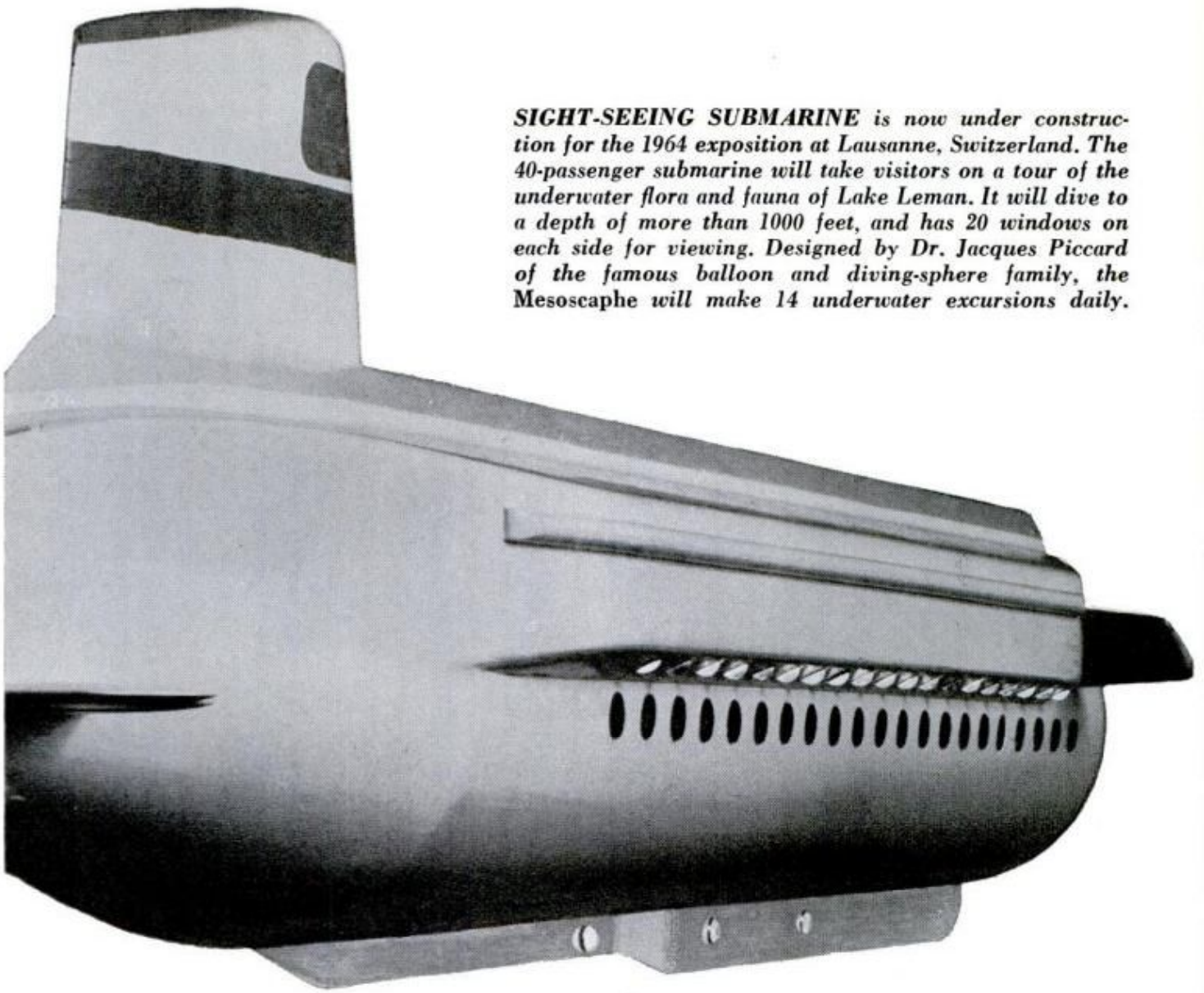

AUGUST 1963



75



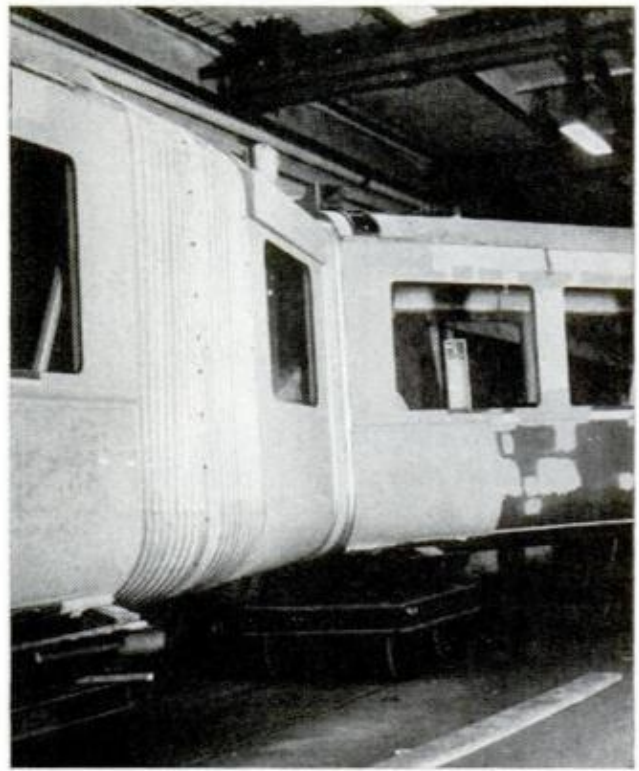

### West Germans Add Accordion Pleats to Rail Car

Passenger cars for a suspension rail line between two West German cities are being built in three sections. The center "turntable" section enables the elongated new

car to negotiate sharp turnarounds.

A prototype for the air-conditioned, 195-passenger cars was made from sections of conventional suspended rail cars.

### Small Four-Place Helicopter Has Tandem Rotors

Built to bridge the gap between small two-place helicopters and the larger four-place helicopters, the new Jovair 4 is said to be the only small machine with tandem

twin rotors. It seats four, and each passenger has a door. Its controls can be adjusted to duplicate the feel of the large tandem-rotor controls on the larger helicopters.





*Weary of wild guesses? Here's a factual preview of*

## *What You'll Find In the '64 Cars*



1964 COMET will have same wheelbase but this completely new skin with bladelike front fender tips suggests the familiar Lincoln theme

**S**OMETIMES you can't tell good rumors from bum rumors without an up-to-date score card.

Let's take the good rumors first. Yes, the 1964 cars will have fewer unitized bodies and fewer aluminum engines. Yes, the four cylinder engine is dying off, and more oomph will be put into bigger (but not necessarily the hottest) engines. Yes, many cars will grow in length, and some long-needed improvements in transmissions have been made.

Chevrolet will add a between-size, new 115-inch wheelbase car with a new V8 engine to power it. And that "vista-cruiser" roofline for Buick Special wagons will indeed be a sight for sore eyes.

And the bum rumors, which ones are they? Well, despite what you may have read elsewhere, Chrysler



The new car sketches on these and the following pages show basic changes you can expect to see on many of the 1964 cars. Don't expect the sketch details to be hairline precise. Trim can be altered or a final choice of brightwork between two competing configurations can be made even as this is being written. But the essential changes are here and detailed information about them is given in the accompanying text.

WAGON "Vista-Dome" for Buick Special (Olds F-85 may also have it)

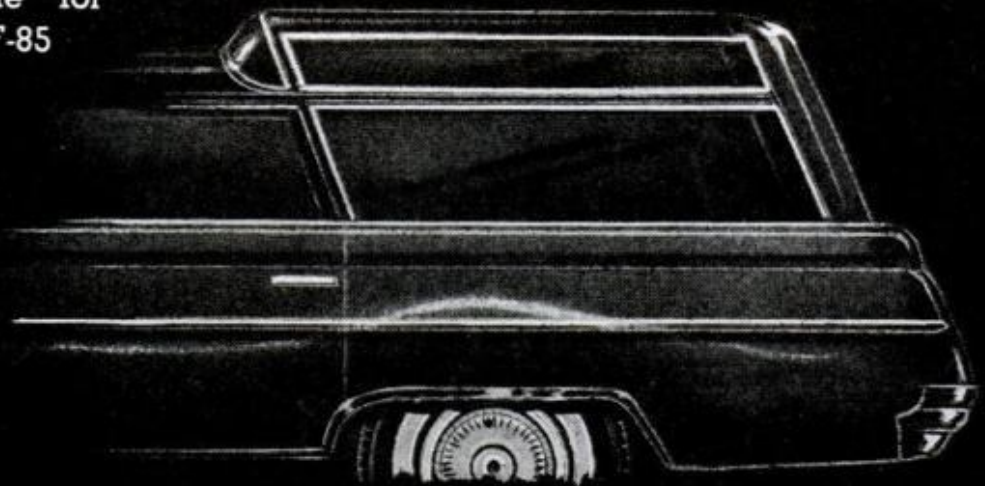

Corporation lines *will not* abandon torsion bars. Chevrolet *will not* drop the Corvair. Buick *will not* have a convertible model of the Riviera. And Ford *will not* bring out the lightweight sports Mustang to compete with Corvette's Sting Ray. At least, not in 1964, Ford people insist.

We do not, by the way, know the name of the new mid-size Chevrolet, and the only guess we'll make concerning it is

that none of the names you've seen so far are correct. The people at Chevrolet delight in fooling the name guessers.

From reports we've received, we doubt if any of the 1964 styles will really startle you. The bread-and-butter lines of the Big Three will show that same take-no-chances-blend of styling themes borrowed from each other that has been the trend for the last several years.

**GLUING WINDSHIELDS** in place with Thiokol polysulphide, instead of the old rubber gasket-and-glass method, will be commonplace on many 1964 models. It saves about \$8 per car, may reduce number of strain breaks and water leaks

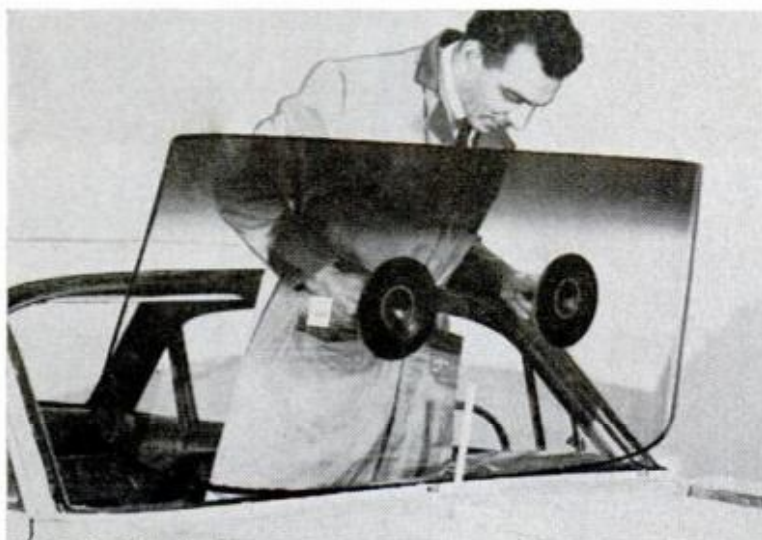

Kent Industries, Inc.

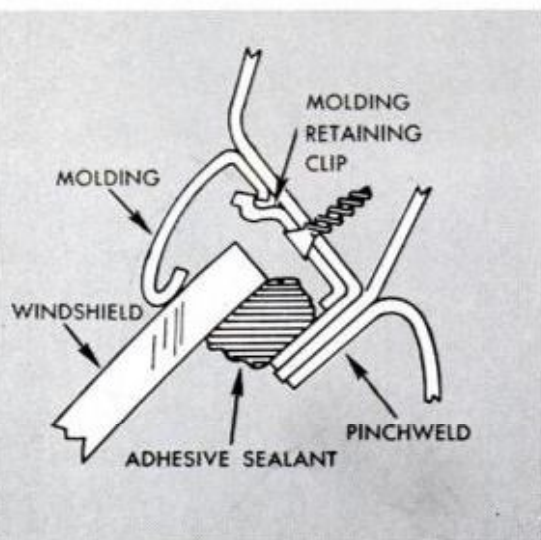



**CHEVROLET** may have contrasting side panel, more headlight framing emphasis

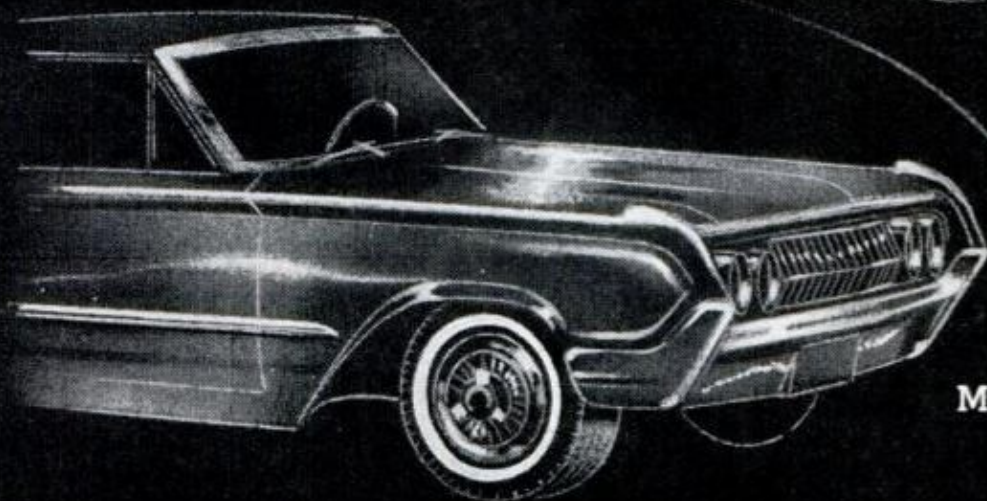

**MERCURY** will sport a prowlike front with fishhook bumpers à la 1963 T-Bird

Here and there, though, there will be some pleasant innovations in styling. The Studebaker Avanti's new grille, for example, will eliminate the old Avanti's armored-car approach. The new Rambler American is reported to be a masterpiece of miniaturizing the Rambler Classic. But more on that later.

Those who've seen the new Thunderbird say that the old banana contours are gone

**EXPECT** a pod-type drive control speedminder such as this to be available as an option on the 1964 Thunderbird and perhaps also on the Ford Galaxie

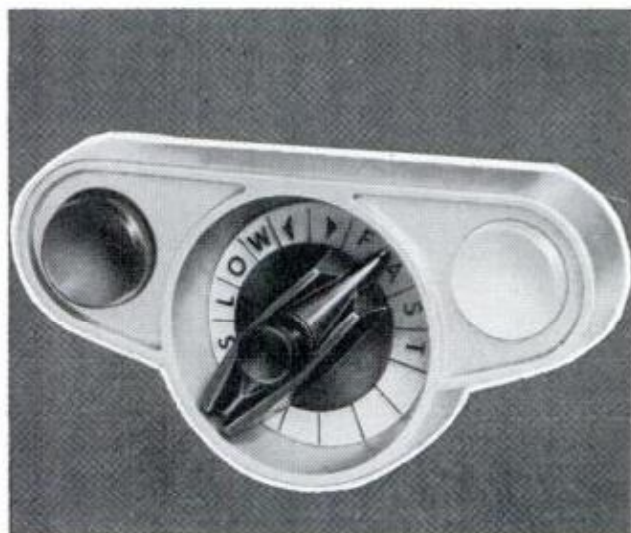

and in their place are squarer corners and sharper edges reminiscent of the 1958-60 models. And there's a nice rear-end treatment which has bumpers framing rectangular tail lamps looking a lot like Ben Franklin spectacles.

Chrysler's Imperial is also reported to be more pleasurable to behold. Designer Elwood Engle has come up with a fine blend of rectangles crisply reminiscent of the Lincoln, which Engle also designed. The jutting fender extensions are gone, however, along with Imperial's "ill-at-ease" separately mounted headlights. But Engle couldn't resist adding a dummy tire-mount bulge in the rear deck, a little flatter on top but otherwise like the old Lincoln Continental.

And now, suppose we focus down on a car-by-car comparison of the changes in store for '64.

**CHEVROLET.** Because General Motors is reverting in 1964 to the old A,B,C, body shell game of making several cars use the same basic body, the new 115-inch wheel-base Chevrolet will share body, frame and suspension components with the BOP compacts—Buick Special, Olds F-85 and Pontiac Tempest. Of course, there will be





**STUDEBAKER** will use new chambered pipe exhaust system (shown above behind a conventional exhaust). The new pipes eliminate need for large muffler by distributing silencing chamber bumps over length of pipe. Idea is for gas pressure to go through, sound waves to be trapped. Should be less costly and take less space underneath

different grilles and front and rear quarter panels for each of the four cars, just as there are among the current BOP compacts which have been sharing their frames and suspensions. The 115-inch wheelbase of the new Chevrolet will fit nicely between the 110-inch wheelbase of the Chevy II and the 119-inch wheelbase of the large Chevrolet.

The new V8 developed for Chevrolet's new car will have about 260 cubic inches of displacement and weigh 84 pounds less than the current small Chevrolet engine known as the "283". The lighter weight makes sense in a smaller car, as proper weight distribution is being jeopardized by too much heavy iron up front in some of the new performance compacts.

**DODGE** will have more squared-off body lines on same 119-inch wheelbase



**STUDEBAKER AVANTI** will acquire a grille

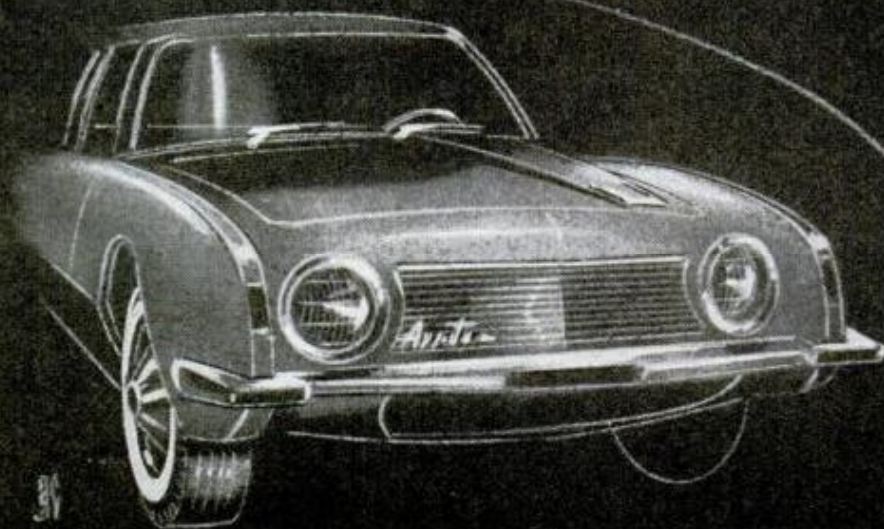



Chevy II will share the new engine, and this not only will spread production costs over a broader base, but give both of them a more potent competitive weapon against the lightweight V8 Ford brought out in mid-1963 for its Fairlane and the peppier Falcon series. Ford's new V8 is currently accounting for 30 percent of Ford Motor Co.'s engine production.

Out of the Chevrolet lineup goes the 90-hp. four-cylinder engine designed for Chevy II, at a time when fuel economy seemed to be an appealing theme in the marketplace. This four-cylinder engine, which currently goes on only one percent of Chevrolet production, will not be completely interred, however. Chevrolet will ship the tooling for it to their new assembly plant in Argentina,

Chevy II styling will change little, with a reorganization of grille and trim doing the job of helping Junior to spot the new model easily. Larger Chevrolets may get the same surface redo with greater trim emphasis around headlights and a contrasting side band on at least one model.

Corvair will show more appearance change than it has shown since it came out in 1960, but the basic body shell will remain the same. A power boost, supposed

to be less costly and more practical than the turbocharger, is rumored for the Corvair Monza.

Corvette Sting Ray's sales volume of around 18,000 in 1963 is high enough to warrant a switch from slow-production fiberglass to steel for the body, but they won't do it for the 1964 model year. Why should they? The body shell was all new this year and is selling handsomely, so only enough trim changes to identify the new model will be made.

Chevrolet will be in the engine business for sure in 1964, because Pontiac Tempest is dropping its "half-eight" four-cylinder engine in favor of a much modified version of Chevrolet's, 140 hp. 230-cu. in. Six. This engine is reported to have a single, overhead camshaft to simplify valve operation and give potentially greater power.

The camshaft has a unique belt drive which uses a synthetic rubber belt built on steel wire cord—a type of belt used for similar non-slip work in industrial power transmission applications.

**PONTIAC, OLDSMOBILE, BUICK.** Biggest changes at GM outside of Chevrolet are the Pontiac Tempest, Olds F-85 and Buick Special. All will get new sep-

[\(Please turn to page 198\)](#)



**CHRYSLER'S IMPERIAL**  
will have a strong  
Continental flavor

**FORD'S FALCON**  
will be sculptured  
like Ford Cortina  
for a longer look

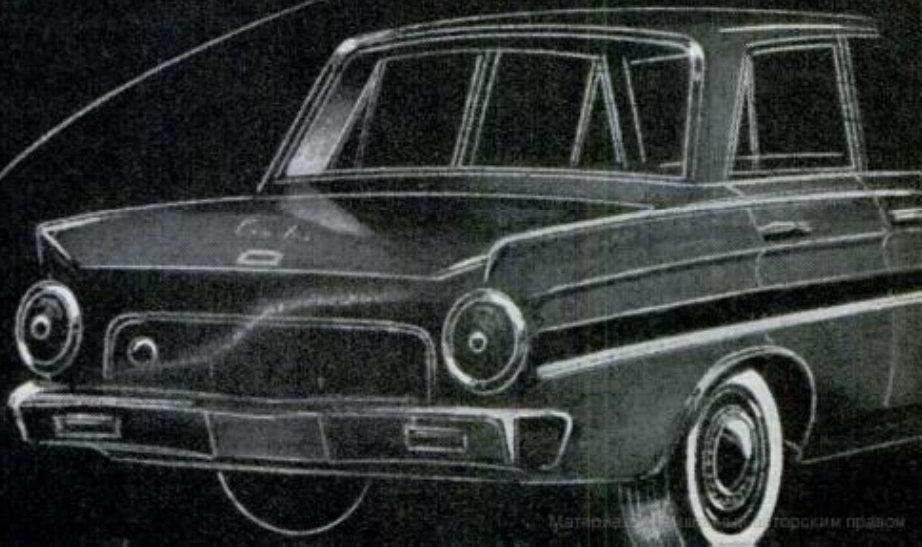



# RETURN OF THE CLASSIC *Cord*

*You haven't been able to buy a new Cord for 26 years. Next year you will. Here are details on how it will compare with its classic forebears*

**By Harris Edward Dark**

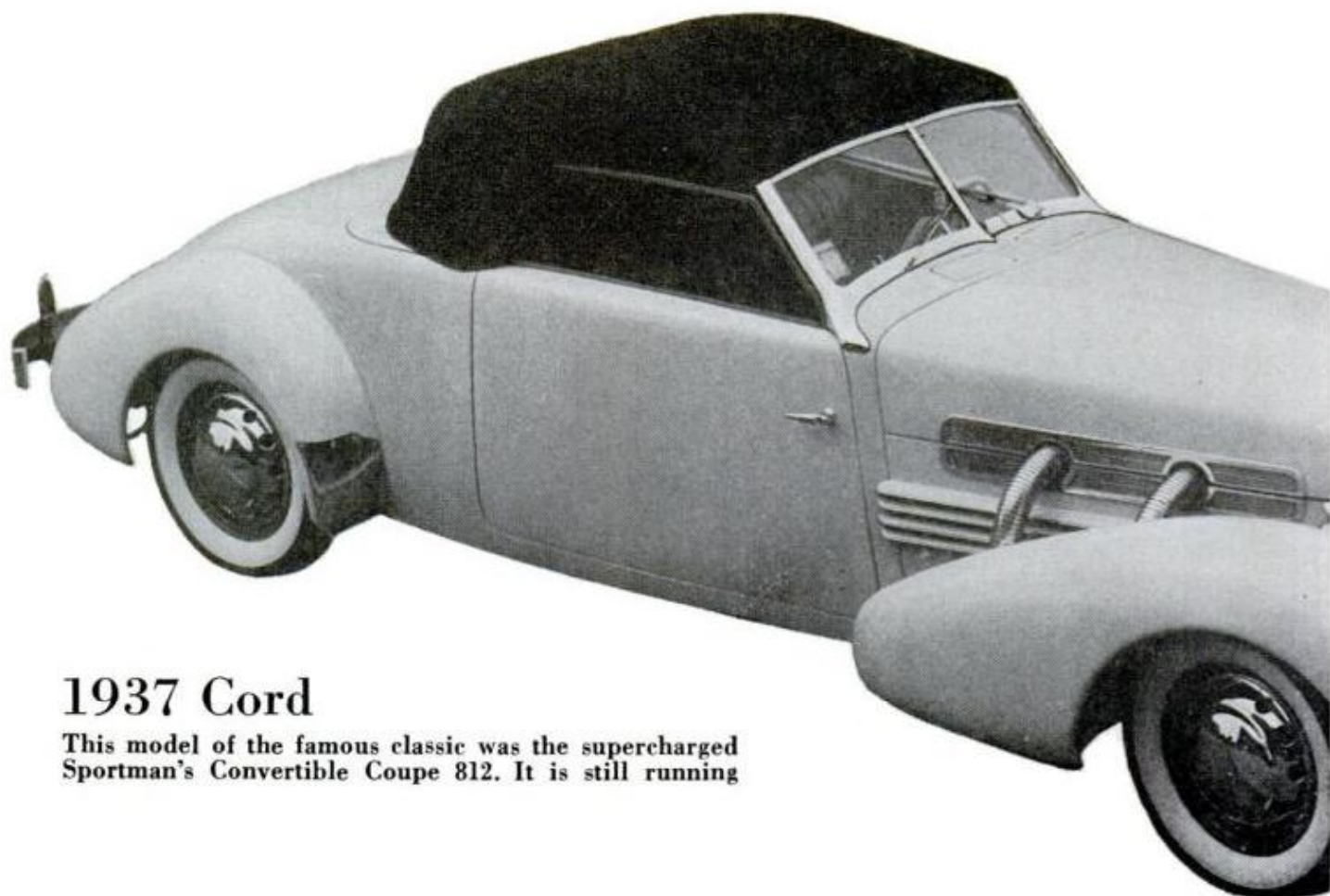
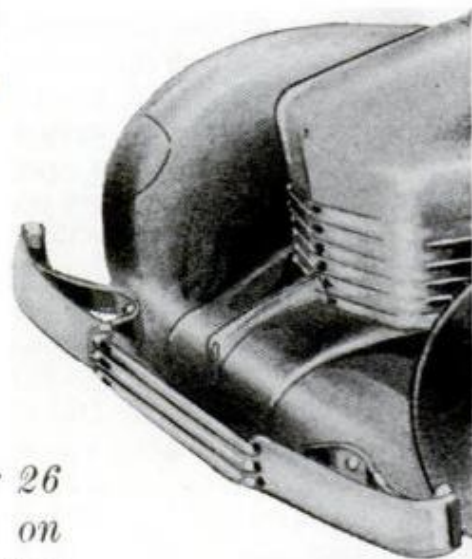

## **1937 Cord**

**This model of the famous classic was the supercharged Sportman's Convertible Coupe 812. It is still running**





## 1964 Cord Sportsman

Next year's Cord will have the same classic lines as the original, but it will be on a 25 percent smaller wheelbase

**I**T ISN'T EASY to resurrect a legend, but there are still men who will try it, thanks be.

One of them is Glenn Pray, president of the Auburn-Cord-Duesenberg Company of Tulsa, Oklahoma. And the legend he is breathing fresh life into is that of the famous Cord car of the 1930s—the one with the classic lines and such pleasant innovations for its day as front-wheel drive and fold-out headlights.

Over 3000 of these Cords were made in the Thirties and two-thirds of them are still in operation today, lovingly cared for by one of the most dedicated group of owner-fans any old car ever had. Glenn Pray knows this well. At one time, he personally owned 13 old Cords and, long before he purchased the Auburn-Cord-Duesenberg Company, he had decided that the old Cord was the greatest car ever made.

Small wonder, then, that Pray is planning to bring out a 1964 model of the Cord, to be called the Cord Sportsman 8/10.

I was the third person to drive the first stripped prototype of this 1964 car, the first 100 of which are scheduled for delivery to customers by March, 1964.

Keep in mind that the 1964 Cord 8/10 will not be a carbon copy of its forebear, the 1937 Cord 810. True, nearly all the old, great contours are there. You can recognize the rectangular hood and handsome wrap-around louver lines from the prize-winning old-timer designed by Gordon Miller Buehrig, now a senior

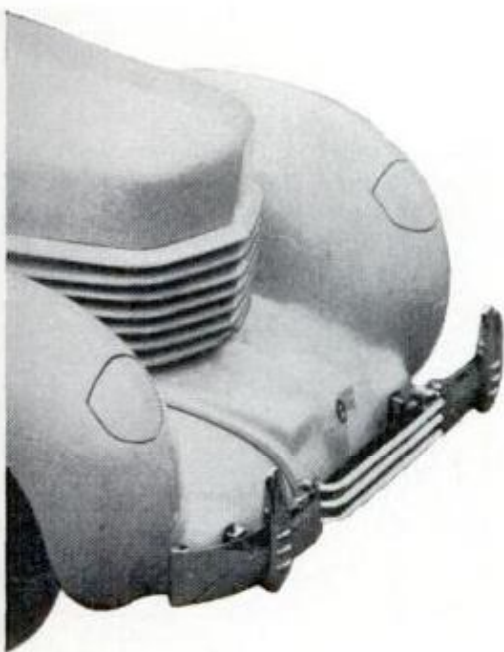



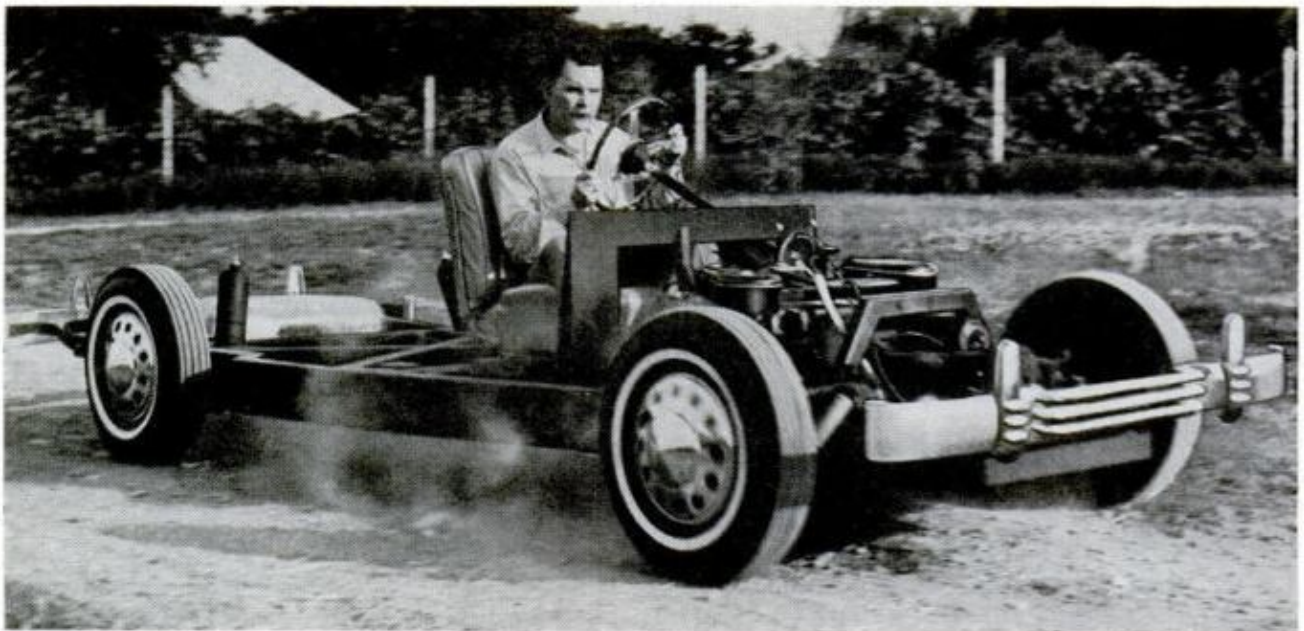

**AUTHOR DARK TRYING** out 1964 Cord chassis-engine prototype near Tulsa. Front-wheel drive gave good control over fast cornering runs on this gravel

design engineer with the Body Structures Department of Ford Motor Company's Engineering Research Staff.

You're also likely to do a double-take when you see the retractable headlights. Or the windshield made of two flat pieces set back at a rakish 45-degree angle. It still spells motion, even at a stop sign.

If you have a good memory for profiles, though, you'll notice that the rear quarter panel on the new Cord has been shortened, and the rear axle has been brought forward almost to the plane of the rear glass. The result is a wheelbase on the 1964 Cord which is only 100 inches, or exactly eight-tenths the 125-inch wheelbase of the 1936 Cord 810. Hence the model designation 8/10 for the new Cord, whose width remains almost the same, but whose height, length and body lines are scaled

down accordingly to match the smaller wheelbase of the new model.

#### Cornering the New Cord

Front-wheel drive—so prized by old Cord fans—will still be featured on the new Cord, however. And I got the message on what it will mean to new Cord owners from the chassis prototype which I drove. Granted, a prototype drive is not the best way to test a car. For one thing, gravel from country roads can clobber you when you have no fenders. But the ability of this Cord prototype to pull its way around on fast cornering and to work its way out of spins on gravel roads was testimony enough to the value of its front-wheel drive. It should have no trouble matching the reputation of the old Cord 810 as a car

[\(Please turn to page 204\)](#)

**PLOTTING** the new Cord against the outlines of an old Cord. The new model will be smaller and nimbler, with less overhang and less unsprung weight

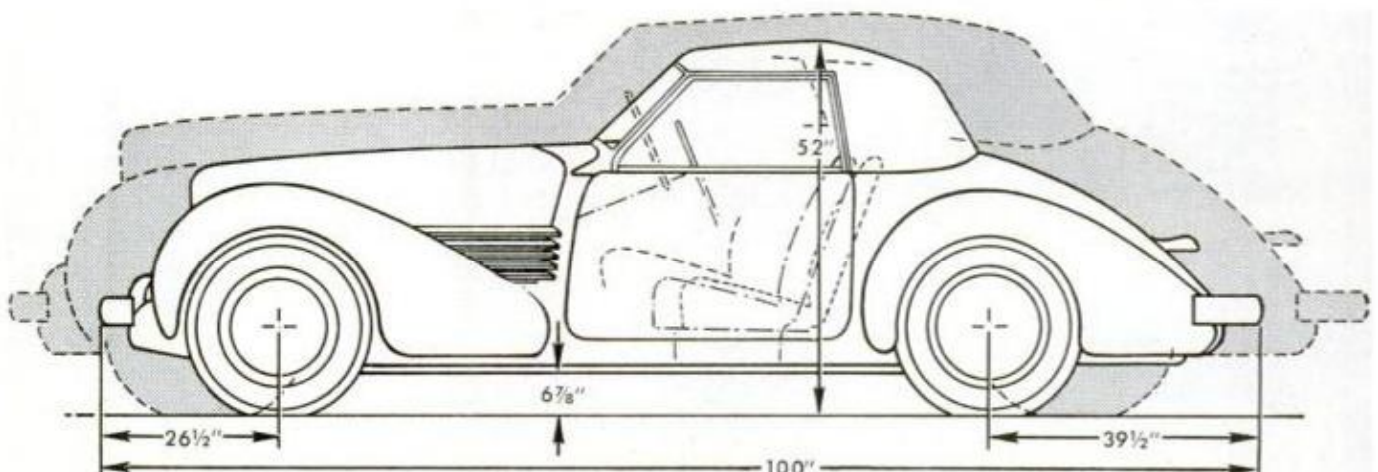



## Buses Built for Bicycles

Designed to keep cyclists out of mile-long Dartford Tunnel near London, five double-deck buses will operate a shuttle service through the tunnel. The bus has a bottom section as storage for 30 bikes, and the cyclists will ride in the top of the bus. The service begins late this year.

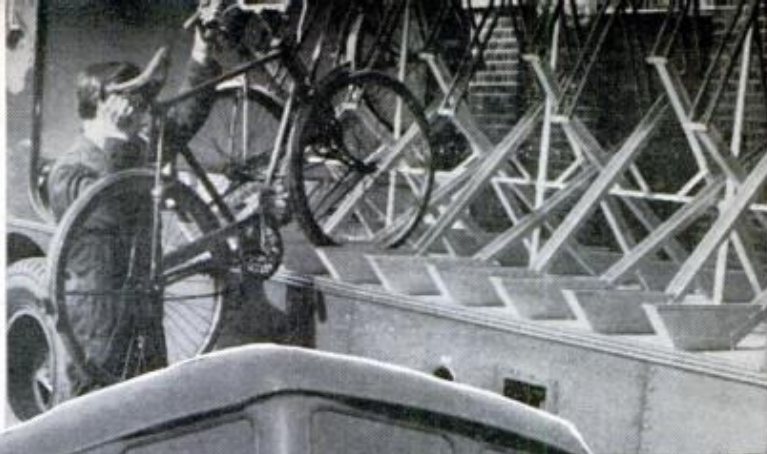

## Kit for Emergency Living

Operating entirely on LP gas, an "existence kit" contains a thermoelectric generator for lights, radio, television, stove and heater. Assembled by the LP Gas Council, the kit costs about \$1000.



## Adjustable Lawn Sprinkler

Water pressure on adjustable jet nozzles supplies rotary action for Sky Jet lawn sprinkler. Made by Nelson Mfg. Co., Peoria, Ill., a five-place dial gives it a wide variety in sprinkling patterns.



# The Riddle of the BLACK BOXES

*Can nuclear bomb tests ever be effectively policed? Will the so-called "black boxes" the diplomats argue about work and, if so, how well?*

By S. David Pursglove

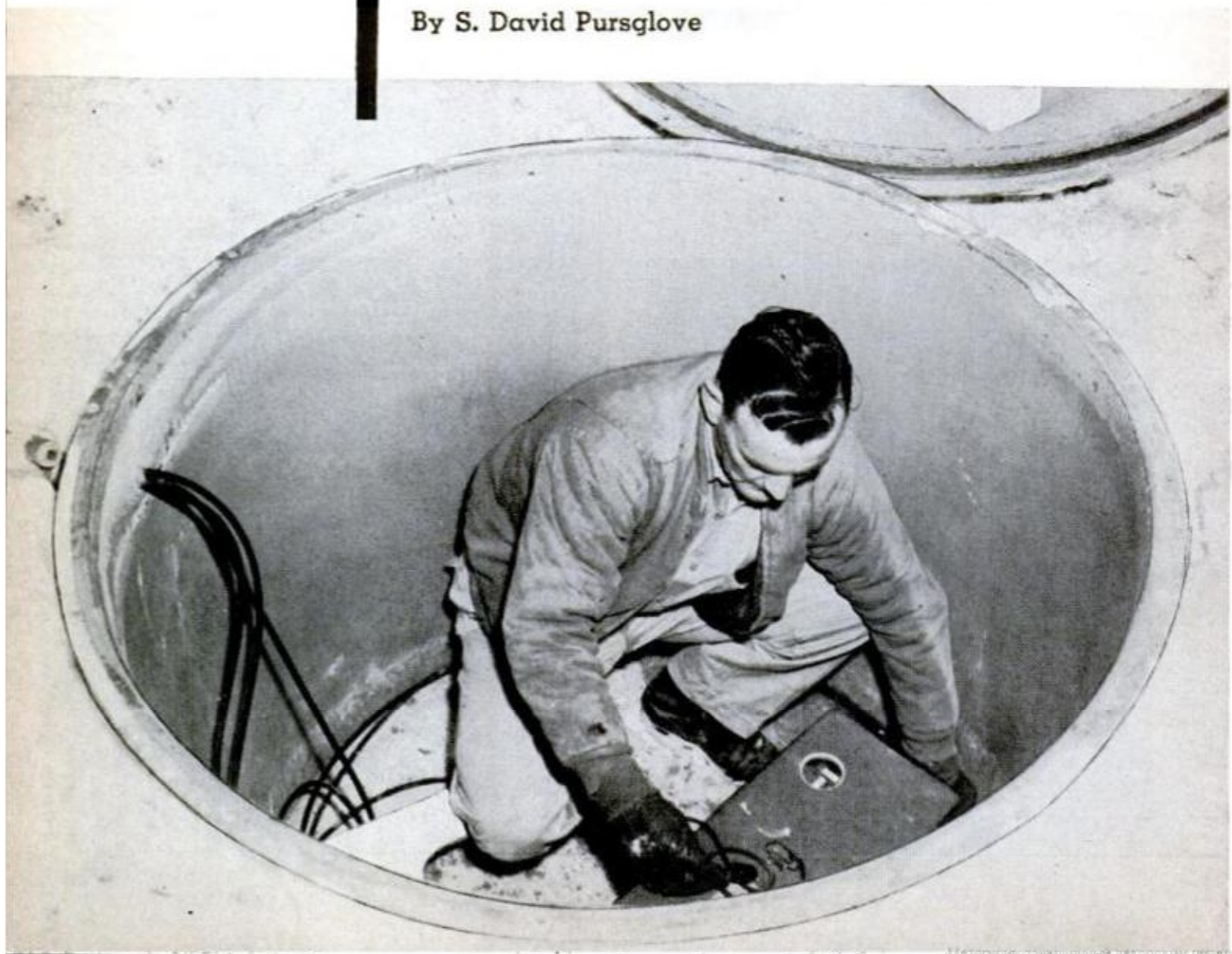



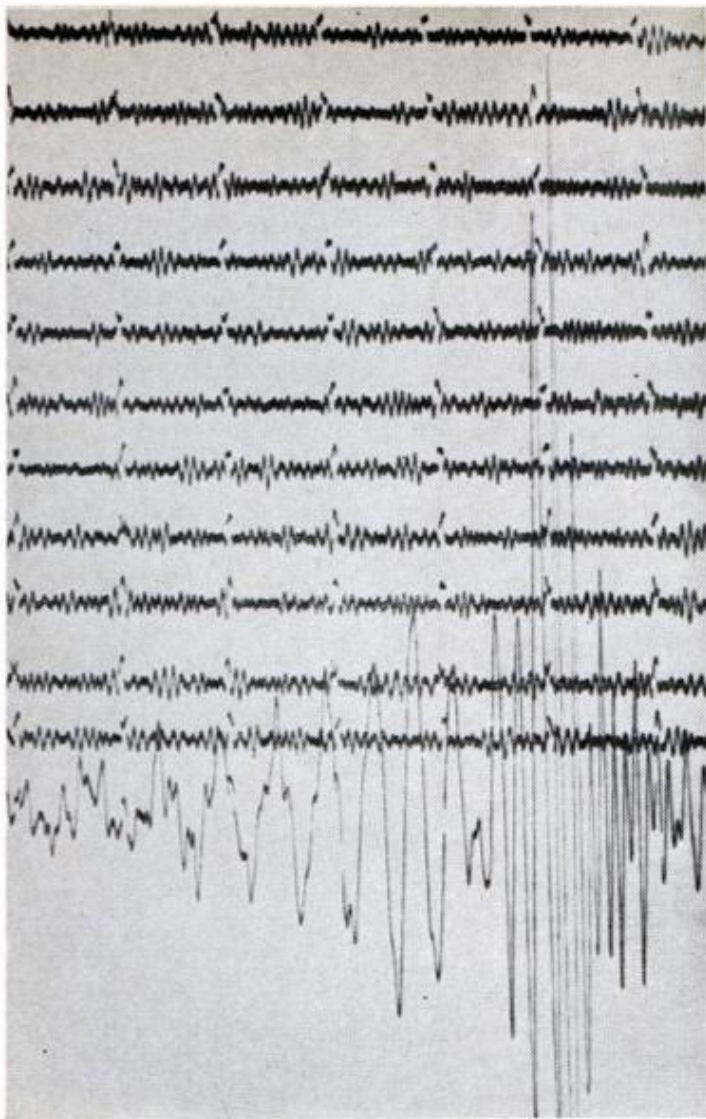

**BIG BLAST** of the Reds' 57-megaton Arctic test in 1962 showed up on seismogram, above, as giant squiggle so violent that the scribed curve went completely wild at the end of the stylus recording strip

**SEISMOGRAPH CELLS** at manned sites like Cumberland Plateau Observatory, left, monitor nuclear blasts and earthquakes all over the world. Below, vertical level is adjusted in a vault at Uinta



**B**URIED in a shallow hole near the edge of the Fort Sill Military Reservation in Oklahoma is a small metal box about the size and shape of a home freezer chest. Few people have ever seen it because its presence has been a secret. In the box are batteries, fuses and an amplifier. There is also a seismometer that detects the faint tremors that travel thousands of miles through the earth from the scene of an earthquake—or an underground nuclear weapons test.

This small chest is the original "black box." It was built under the \$120,000,000 "Vela-Uniform" research program that took off five years ago when American scientists estimated that it would take as many as 25 manned seismic stations on Russian soil to make certain no nuclear blasts went undetected. Since that time, a number of things have happened. Recently, experts at the U.S. Arms Control and Disarmament Agency indicated that as few as seven unmanned stations inside Russia could enforce a test ban treaty!

The obvious question is: Why do we need only seven now? Have our detection devices improved by a factor of three or more in that short time?

Part of the answer may, indeed, lie in our new "black box"—a term freely used by Russian and American diplomats and newspaper reporters, and thoroughly deplored by Senator John O. Pastore, chairman of the Joint Committee on Atomic Energy, who calls it a "non-existent figment of the public's imagination."

The committee and its technical staff don't mind at all discussing "unmanned nuclear detection stations," "seismic vaults" or "unmanned seismological observatories."

"Just don't call them black boxes," it pleads, contending that the expression gives an erroneous impression that we now have small, portable devices that can detect underground blasts almost anywhere in the world. Not so, says the committee. Any unmanned detecting station, it insists, will be a major device of "bank vault" size, constructed underground and filled with seismometers, timers, recorders, amplifiers and power sources.

Well, then what about that device in Oklahoma? Seismologists in the know call it the "SIE box." Its manufacturer, Southwest Industrial Electronics Division of Dresser Industries in Houston, Texas, won't talk about it, but the Defense De-



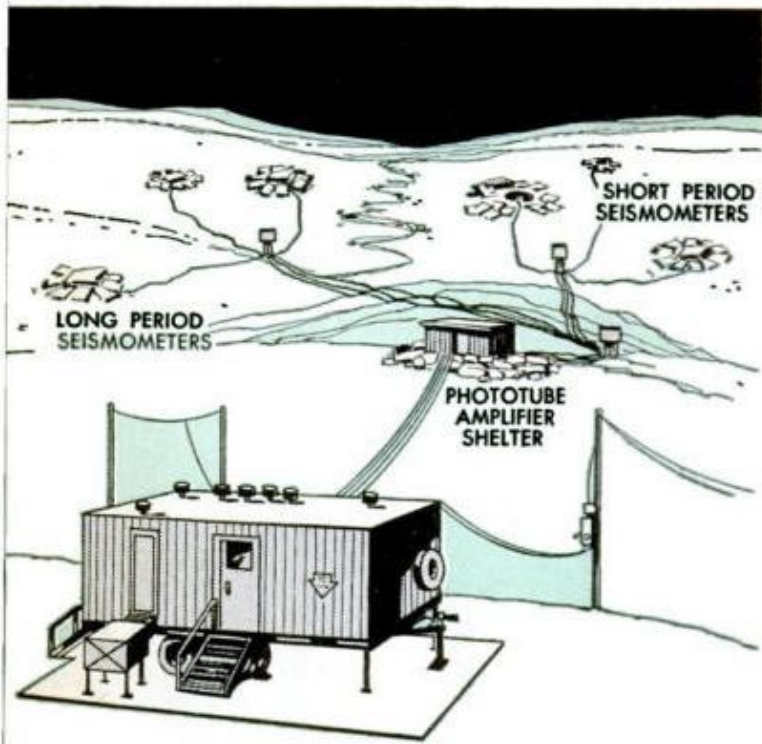

**MOBILE** seismic stations are manned, play an important role in detecting sneak tests. Each has three vaults. Van carries timers, amplifiers and recorders

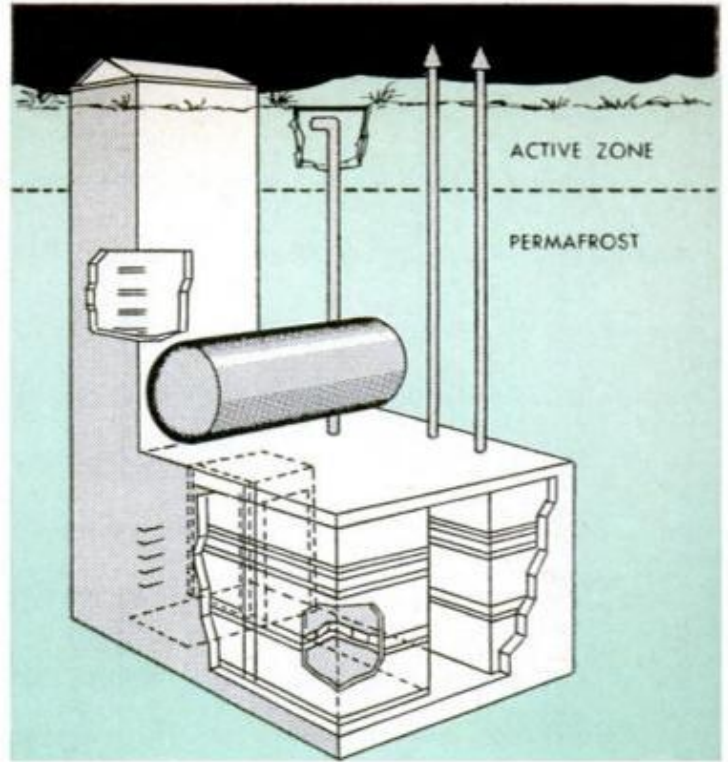

**UNMANNED VAULT** proposed for national detection net inside U.S. would consist of an underground room, eight by ten feet, filled with gear (right)

partment's Advanced Research Projects Agency (ARPA) will. It is a dark gray sheet-steel chest about three feet by three feet by four feet. The lid is sealed with a waterproofing compound to protect the delicate contents.

Those contents are mostly batteries, 400 pounds of them. The remaining 100 pounds include a simple vertical seismometer, an amplifier and a signal demodulator.

Nothing fancy, the seismometer is the

usual small coil attached to a pendulum suspended by a spring between permanent magnets. As the shock of a distant earthquake (or nuclear explosion) jerks the earth's crust up and down almost imperceptibly, the magnets move with it. But inertia holds the pendulum and coil momentarily fixed. As the magnets move past the coil, a small, slightly changing electrical current feeds into the amplifier. It transmits its signal over ordinary leased

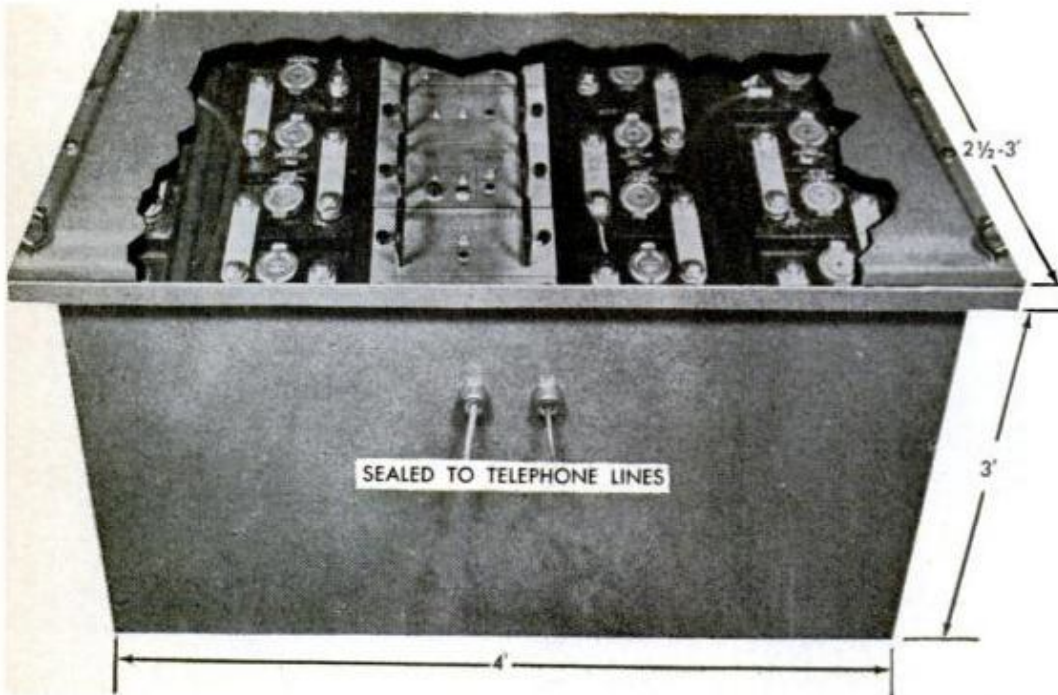

**BLACK BOX** seismic cell buried in Oklahoma is an unmanned unit and possible prototype for use inside Russia if test ban treaty is signed. Unit weighs 500 pounds, contains seismometer, batteries, recorder, controls



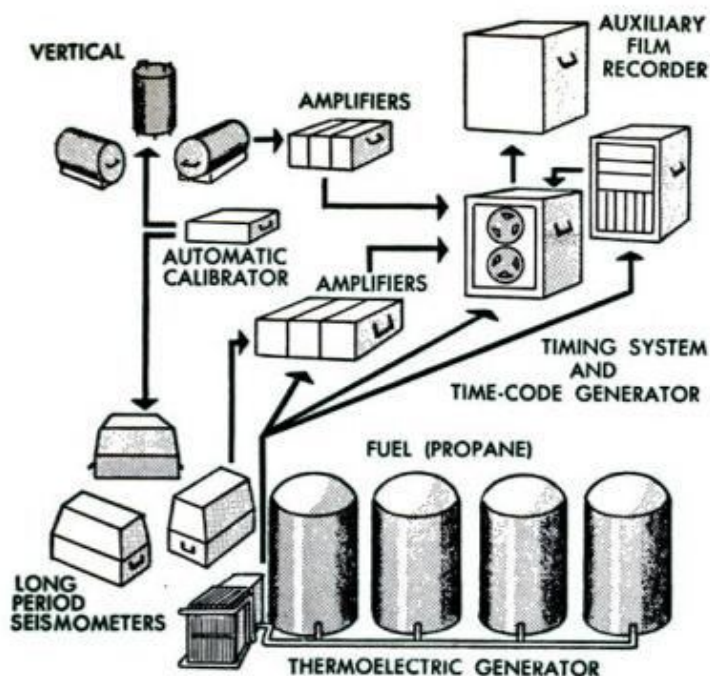

**GIANT** unmanned vault at left would contain all the equipment shown here. Though not for use in Red territory, it would serve in the net elsewhere

telephone lines to recorders and other equipment in a small, ranch-style house several miles away. (The house also happens to be the central recording building of ARPA's Wichita Mountains Seismological Observatory.)

Defense Department scientists cannot tell all they know, but they admit that the black box has spotted most underground "events" that a conventional seismometer should detect, including the first large French nuclear test in the Sahara over 6000 miles away.

The Oklahoma black box was built partly to prove that the components of that kind of a system can operate reliably for at least six months without human attention. It was also meant to prove that an unmanned station is tamperproof. The signal demodulator varies the frequency of the unit's output according to a complex built-in code. Only we (or a control commission) would know the key. A technician routinely monitoring the signals from many boxes would immediately spot any tampering, such as reversing the telephone leads; or slipping a spurious signal onto the line in place of the genuine one.

At present, the box is marking time. Its initial job has been done and the engineers have turned the power down to the lowest operating level—too low to spot many



**SUBMARINE BLACK BOX** has most elements of manned station, including (below) power, recorder, timer, detector. It could surround an enemy's shores

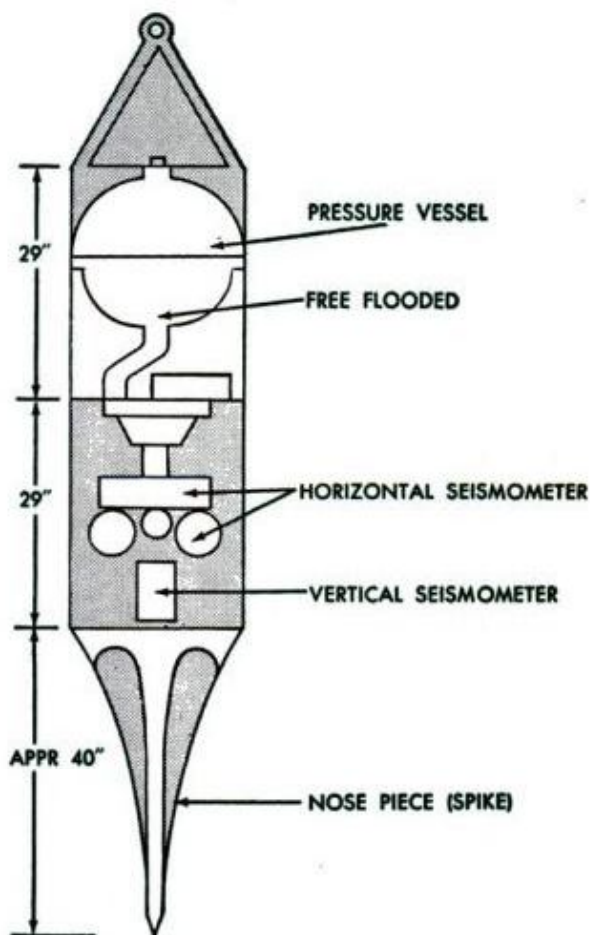



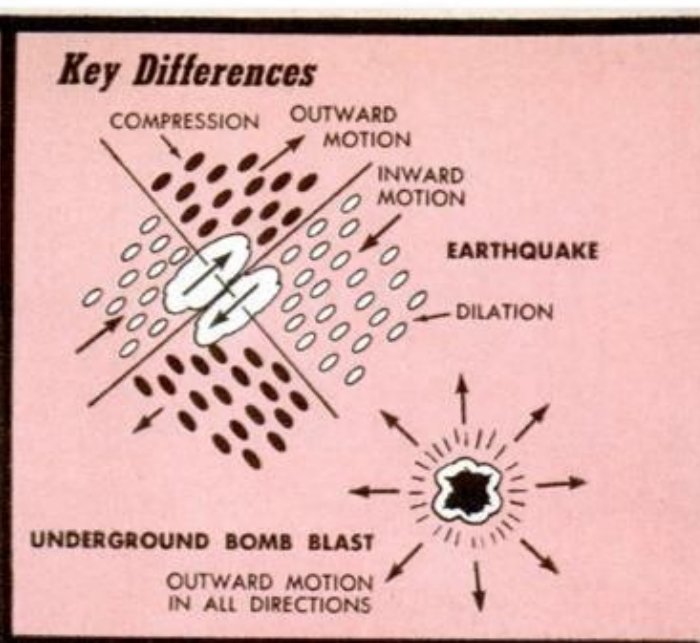
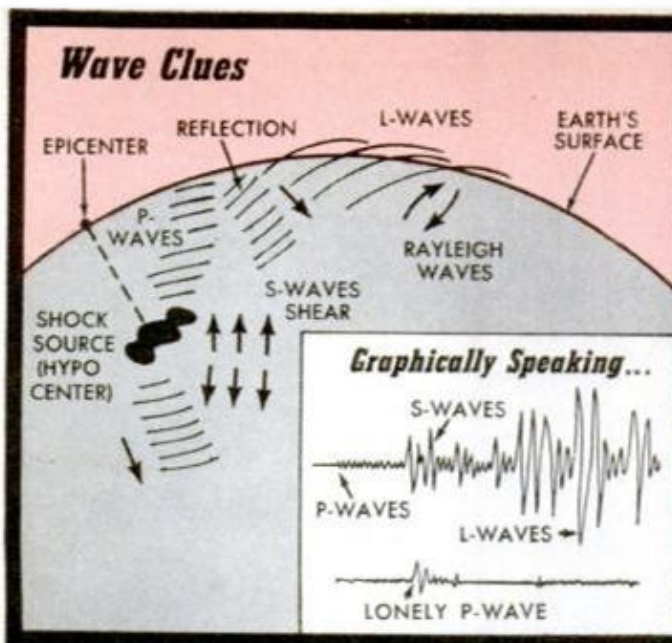

**SHOCK WAVES** from natural or nuclear disturbances come in many types, above left. Inset shows how seismic detector records them. Diagram at right shows how earthquake disturbances differ from patterns of nuclear blasts

tests. It's there in case of need, but it doesn't figure prominently in current detection systems.

But the U.S. isn't waiting for the Russians to agree to a black-box detection network inside their borders. We have already built, and are continually adding to, a worldwide system of seismological stations and observatories, ringing the Red homeland and satellite countries. Some are manned by our allies.

Newest item in our bag of detection tricks is an underwater seismic station developed for ARPA by Texas Instruments, Inc. Besides a short period vertical seismometer, it also contains two short period horizontal seismometers, one pointing east and west, one pointing north and south. A transducer detects pressure changes caused by blasts in water. A long metal nose couples the underwater black box firmly with the earth.

Some underwater stations transmit data acoustically to surface ships. Some transmit through cables. But others are completely self-contained stations in that they contain timers and recorders. They make and store ready-to-use seismograms. When an event needs to be checked, a ship hauls up the underwater station and examines the tape for clues.

Underwater black boxes can be ringed around a potential enemy's coast without his knowledge. There is often less background seismic noise on the ocean floor, and they can be placed close enough to

detect the important initial waves, called first motion waves, from a man-made blast. This calls for detectors in every direction within 6000 miles around an event.

Underwater secrecy complicates the cheater's problem of trying to pick a spot for a bootleg test, decide what size bomb he dares detonate, and determine whether he should test in granite, dry sand or a spacious cavern. ARPA's director, Dr. Jack P. Ruina and the Arms Control office's Dr. Franklin A. Long, believe that a high-quality manned station network combined with underwater stations would

**MANNED** stations in U.S. are set up in geometric arrays of multiple seismic units like these to cancel local noise as well as to catch any "spoofing"

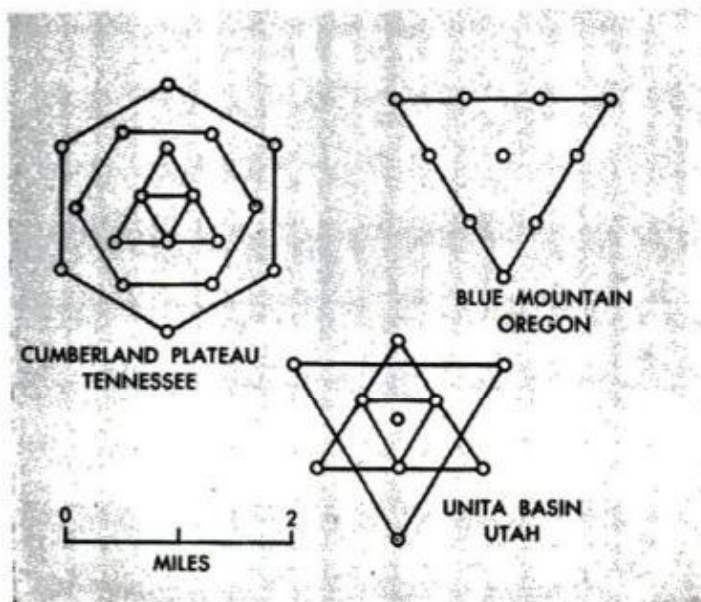



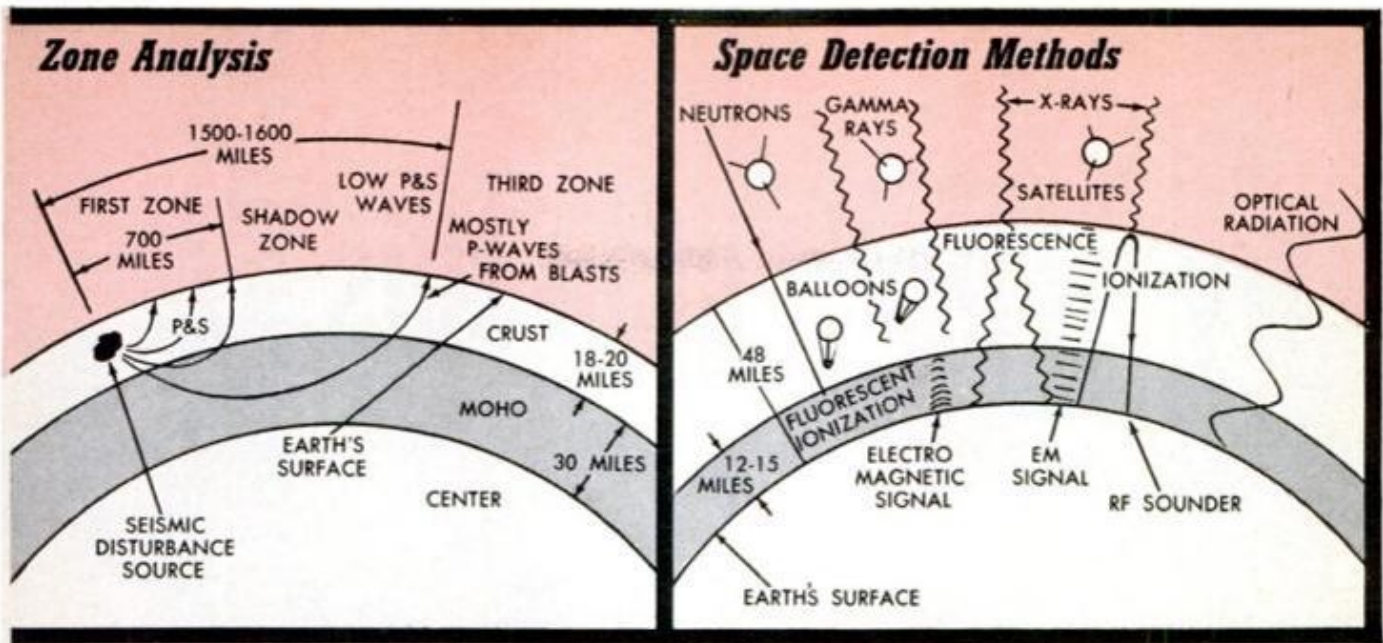

**SEISMIC DETECTION** depends on what kind of wave shows up where. Diagram above left shows which waves turn up in various zones outward from epicenter. Sketch at right diagrams the methods of detecting space blasts

be enough to make a nation think twice about violating a possible treaty.

So far, underwater black boxes have worked well. Operating at points near Catalina Island off California, in the Arctic Ocean, near Bermuda, in the Gulf of Mexico and off Hawaii, they have recorded at least five small blasts from our Nevada test site and a number of natural quakes. Have they recorded any Russian tests? Neither ARPA nor the Arms Control people will say publicly, but scientists say it's almost certain that they have.

Actually, seismological devices are not

the only safeguards we have against sneak Russian tests. One of the most effective is ARPA's High Altitude Sampling Program (HASP) which sends U-2 aircraft to more than 70,000 feet to strain out microscopic bits of radioactive dust for analysis. An instrument known as the microbarometer measures the acoustic waves monitored from blasts and earthquakes. Besides this aerial check, photoelectric cell devices are detecting the slightest pulse of light from above-ground nuclear shots thousands of miles away. And if we ever sus-

[\(Please turn to page 196\)](#)

**EARTHQUAKE AREAS** are ideal spots to conduct sneak tests. The map shows seismic areas and earthquake percentages encountered in the area of Russia

**CONTROL CENTER** at Uinta Basin Observatory records on drum graphs vertical and horizontal disturbances from quakes and blasts around world

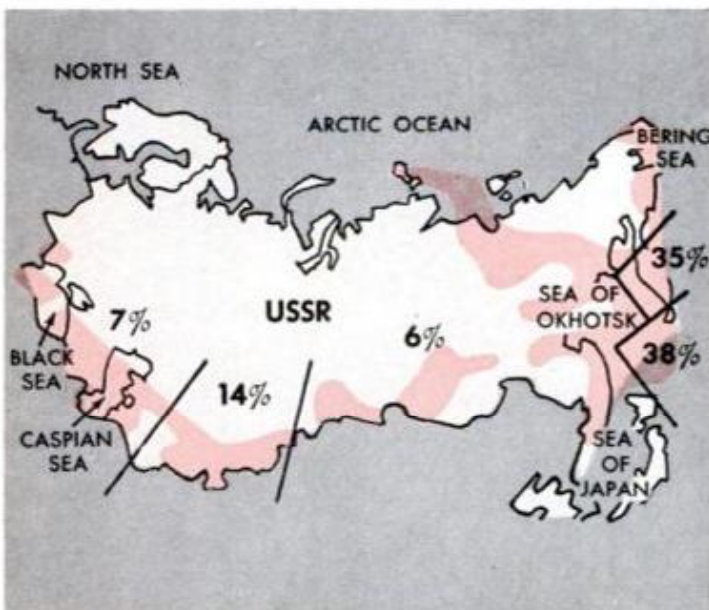



# Try to stop this ...

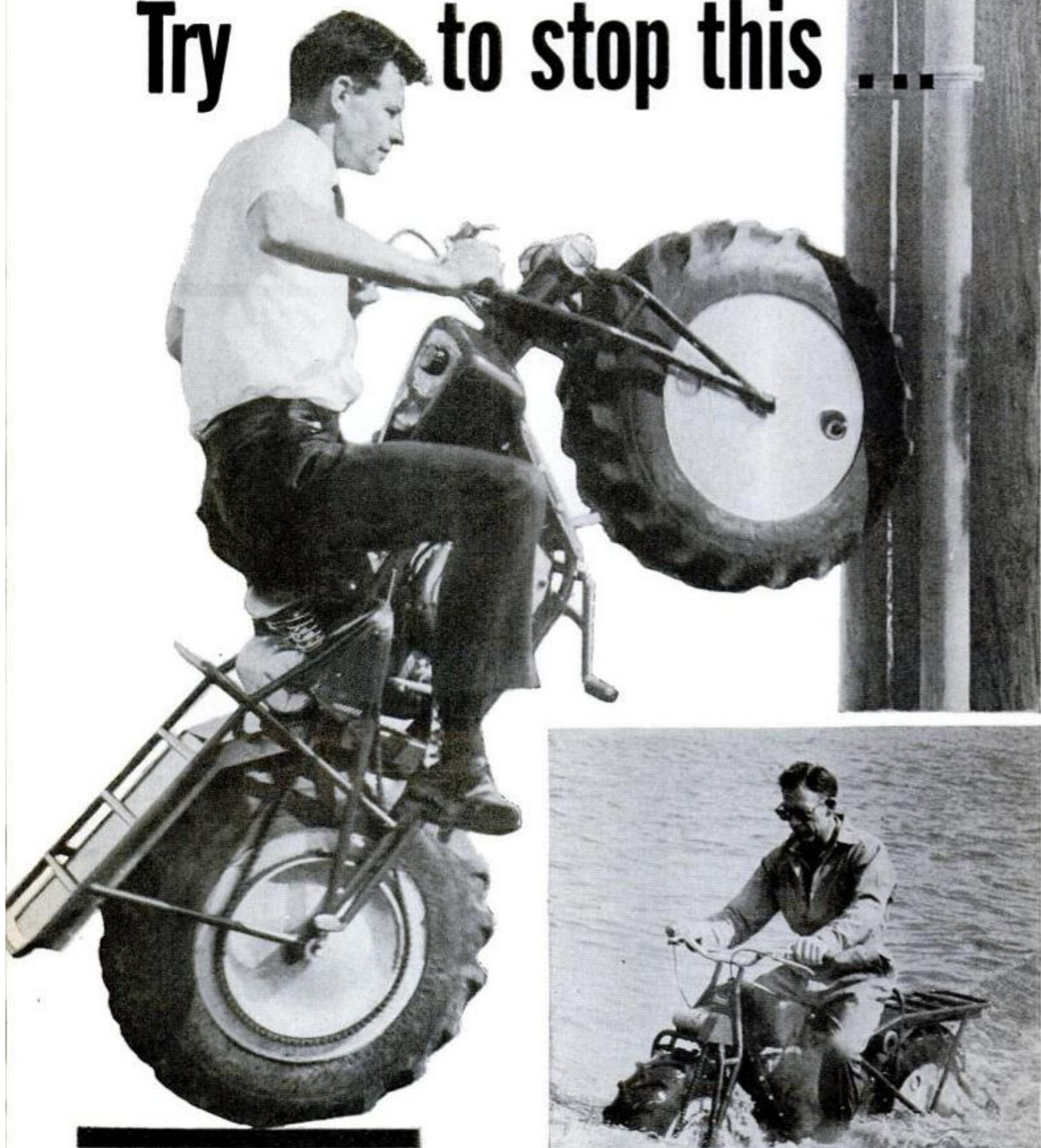

**POWERHOUSE ON WHEELS**, the Trailbreaker has front and rear-wheel chain drive, enabling it to climb walls and plow through 15-18 inches of water

92



POPULAR MECHANICS



# MECHANIZED BILLY GOAT

*This lugging fool with two-wheel drive climbs rocks, plows through mud and water, and comes as close to a go-anywhere bike as any we've seen*

By Thomas Stimson

**A**N AMAZING MOTORCYCLE that crawls part-way up phone poles, swims in water and wades through swamps, is the latest thing in rugged off-trail vehicles.

This motorcycle is a climbing fool and can ascend grades in excess of 45 degrees from a standing start, carrying loads of up to 400 pounds.

It creeps down the same grades at low speed under complete control and without locking the wheels. It crawls over enormous boulders and fallen trees instead of

around them. It can tow a fire hose up the stairs of a building, all the way to the top floor. It weighs less than 200 pounds, yet is so buoyant it floats in water.

A rider can plow through water a foot and a half deep all day long and merely get his feet wet. If the water is up to his hips, he can dismount and steady the vehicle in an upright position while it floats, then give it enough throttle to literally pull him along while he walks on the bottom. For still deeper water he can do one of two things: tow the floating

**CLIMBING OVER BOULDERS** is child's play at low speeds. Feet are used for balance, and the footrests swing up to allow clearance of difficult objects

**HEAVY CLEATS** on the large tires afford excellent traction when the Trailbreaker roars through mud that would hopelessly bog down ordinary vehicles







**CYCLE WHEELS** are actually airtight drums, enabling vehicle to be floated in deep water. Fitted with outrigger pontoons, it maneuvers like a boat with driver on the seat

machine behind a boat or canoe or, with the right equipment, extend a couple of outriggers having air bags or foam floats at their ends, then mount his seat and actually ride across the water. The deep-cleated tires are fairly efficient paddle wheels for water propulsion.

This fabulous machine was developed by a company that seemingly shouldn't be in the motorcycle business at all. The "Trailbreaker" is a product of the Nethercutt Industrial Corporation, Sylmar, Calif., a subsidiary of a concern that manufactures cosmetics. Five years and several hundred thousand dollars went into the vehicle's development. It lists at \$695.00.

The reasons why it performs the way it does can be told in a few words: both the

wheels are powered instead of just the rear wheel; it has a fluid drive instead of a clutch; the engine is mounted high in the frame to give 15 inches of ground clearance; and each wheel is an airtight aluminum flotation drum. The big tires also contribute to buoyancy.

#### High-Altitude Carburetor

The motorcycle is powered with a 10-horsepower one-cylinder, two-cycle West Bend engine equipped with an aircraft-type carburetor that works in any altitude and needs only adjustment for extreme altitude. A spark-arrestor exhaust is used in dry brush where there is fire danger.

The three-speed transmission (81:1, [Please turn to page 187](#))

**DESIGNED FOR WILDERNESS TRAVEL** where roads are nonexistent, cycle resembles two-wheeled tractor. Extra gas can be carried in the two wheel drums.

**CLIMBING THE TAILGATE** of a truck is just one of the Trailbreaker's acrobatic feats. In low gear, it can be driven off the truck in exactly the same manner

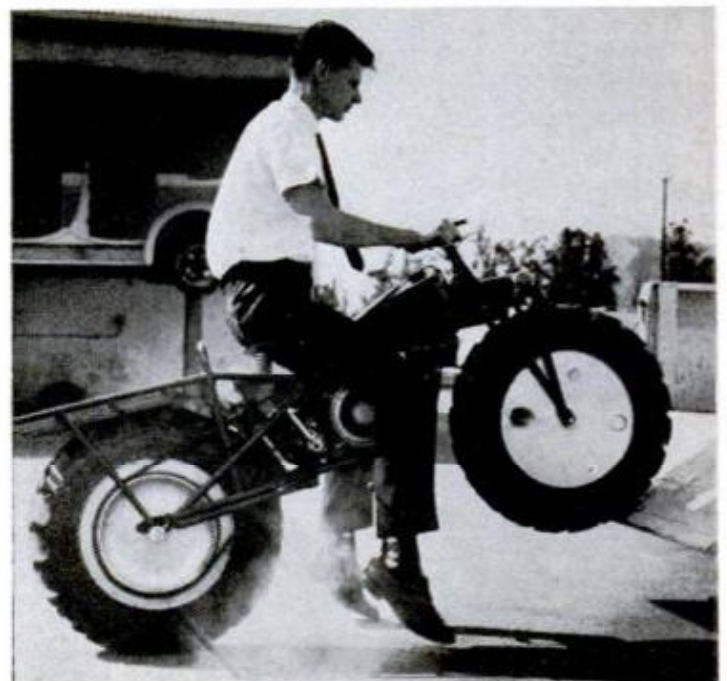





### Blotters Soak Up Swamps

Silt land in Belgium is being reclaimed by driving specially prepared strips of blotting boards—multilayered with space between the layers—deep into the soft ground. The water seeps in and, by gravity alone, flows down the boards to a lower level, thus making the topsoil suitable for such projects as a canal-side dock.

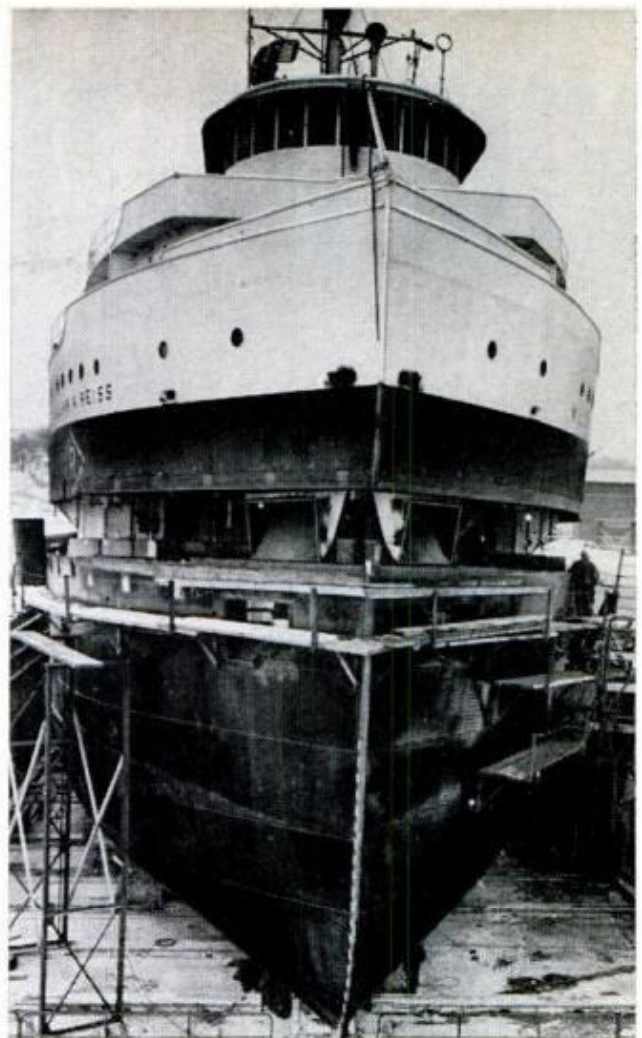

### Lakes Ship Grows a Bit

The Great Lakes steamer *William A. Reiss* was recently sliced neatly in two, horizontally, to add 7½ feet of height and about 4000 tons capacity. A special cutting machine split the ship from stem to stern. Sixty-ton jacks lifted the 1500-ton upper deck, as Manitowoc Shipbuilding Co. spliced in new plates to cover the gap.

### Sidecar for Cyclists

Made to fit on standard bicycles, a sidecar makes a three-wheeler out of a two-wheeler and adds a seat for a passenger or groceries and packages.

There are three models to fit 20, 24 and 26-inch bicycles, and custom-made models for newsboys or sidewalk vendors.

The sidecars are made of sheet metal and are lacquered to match the bicycle. They list at \$59.95. Sold through retail outlets, they are manufactured and distributed by Mohs Seaplane Corp., 2355 University Ave., Madison 5, Wis.

AUGUST 1963





# Pushbutton Eating





# Center

*Just push a button and this home-made diner sets the table for six. After the meal, it washes and dries the dishes, disposes of the garbage and provides storage for all the tableware*



**DINER COUNTER**, made by engineer John Lenz for his home, is a combination table-dishwasher-disposal unit. Sides come off easily for servicing

**PUSHBUTTON PANEL** gives fingertip control over the lights, dishwashing action and the disposal unit. Circular dial times the four washing cycles

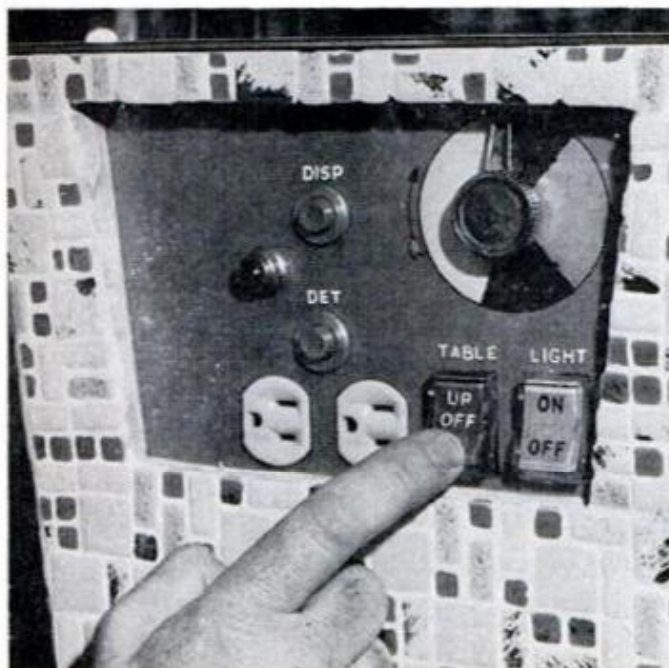

**YOU FLICK A SWITCH** on the end of the "diner" counter and two table leaves fold down with dishes and silverware already in place for a meal.

When mealtime is over, you dial an electric switching mechanism to activate a dishwasher, press a garbage disposal button and—presto!—all the drudgery is removed from kitchen cleanup. Even your dining table is all set for the next meal.

This housewife's dream was designed and built in his spare time by a suburban engineer in Minneapolis. In fabricating the "mechanical waitress" (actually a combination dining counter-dishwasher-disposal unit), John Lenz used standard components wherever possible for reliability, such as switches, pushbutton controls, timers and, of course, the dishwasher and disposal unit. But many elements are of his own design.

Table leaves on each side of the counter provide place-settings for a family of six. Each setting has a plastic plate, salad bowl and dessert dish permanently fastened to an aluminum holder with epoxy glue. A glass and cup are separate pieces which fit in special slots in the metal holder for washing and storage. A metal basket holds silverware. The aluminum holders make a handy unit for carrying a meal into the TV room or outdoors.

At clean-up time, the holders, with cups, glasses and silverware attached, are lined up on the table leaves, with pots and pans in between. Table leaves close up and the holders slide down into slots so they won't tip over when the dishwasher is turned on.

Dishes, pots and pans get a thorough scouring in four separate washing cycles, with food waste being flushed out through the disposal unit in the first five-minute flushing with soapy water. Next, high-velocity pressure hoses spray suds against the dishes during a 15-minute washing cycle. (Garbage can be disposed of at any



time by dumping waste into the top window; press a button and it's gone.)

After rinsing in two separate two-minute hot-water rinses, the dishes are dried with warm air from a screened intake under the table. Rubber gaskets around table leaves prevent leakage.

Despite the four washing cycles, total water consumption amounts to only 12 gallons per washing. Lenz achieved this economy by having water pumped through the spray tube over and over again. A 1000-watt electric heating element in the tube keeps the water at 180 degrees.

The neatly-designed counter has top and side surfaces of Formica, with the end finished in plates of mosaic tile. The table interior is of fibreglas coated with epoxy paint. A window in the table top

permits a full view of the washing cycle, which is illuminated with interior lights. End and sides come off for servicing.

Tiny precision switches, made by Minneapolis-Honeywell, control the automatic table counter and provide built-in protection against mishaps. For instance, the dishwasher cannot be switched on unless the table leaves are closed tight.

Operated by cams on an electric timer, various switches control the 1/3-hp. motor to open and close the table leaves, drive the spray pump, spin the fan, rotate the spray tubes and run the disposal unit.

Other switches keep the water level in the tub constant, open and close the drain, and shut off the electric heating element if it gets too hot. Switches also dispense detergent during the wash cycles. ★★★

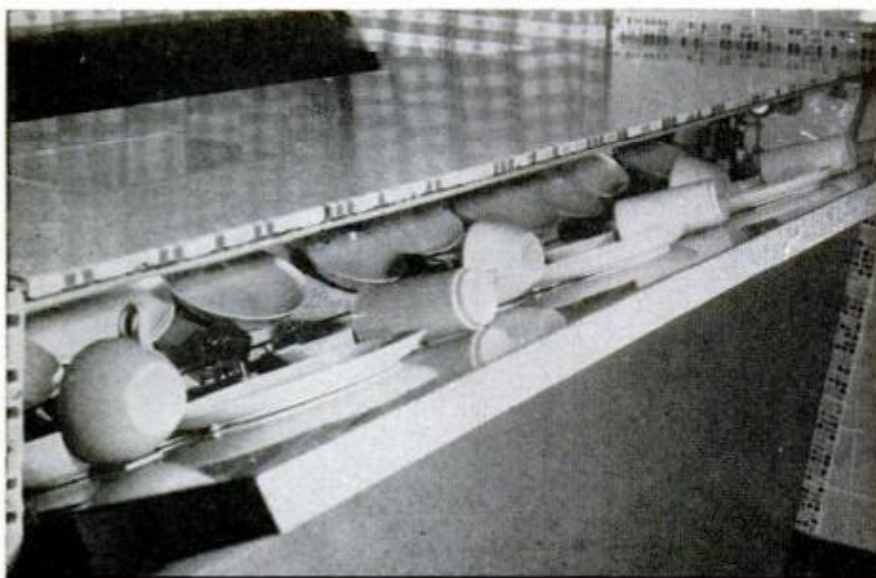

**TABLE LEAVES** on both sides of the counter fold down at the touch of a button, with place settings ready for use. Diagram, below, shows dishwashing and disposal equipment inside the counter. Despite four cycles, the unit uses only 12 gallons of water

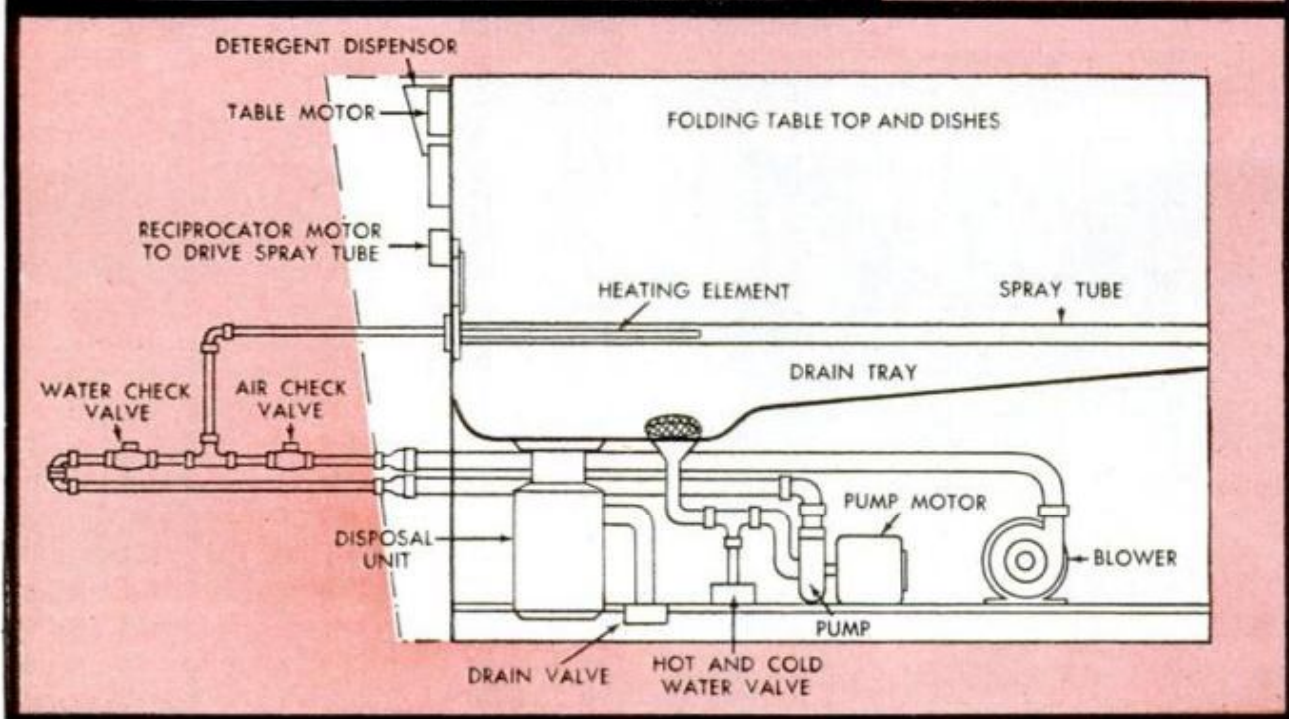



## Surfboard Speedometer

Recessed in the foredeck of a surfboard, a speedometer operates on water pressure against an opening in the board's fin. It gauged the maximum speed on eight-foot waves at Oahu, Hawaii, to be 20 miles per hour.

The device was designed by surfer Bob Shepherd.

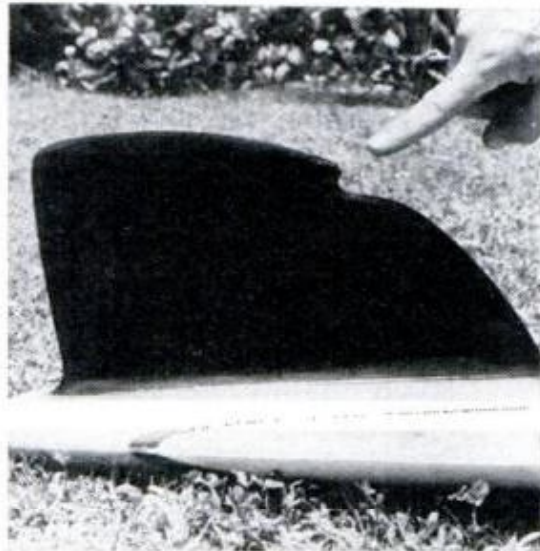

## Circular Movie House Puts Audience Inside the Picture

Seated in swivel chairs so they can follow the action, West German movie audiences will soon be sampling movies-in-the-round. A spherical movie house is being built with a 360-degree wraparound screen that will give audiences the illusion they're in the middle of the action.

A spherical reflecting mirror will hang above the audience like a huge lighting

fixture (below, right). Viewers are seated around the perimeter of the globe. The inventor, Adalbert Baltes (below, left), has devised a special camera for shooting 360-degree pictures. These are projected onto the reflecting mirror.

Named the Cinetarium, Baltes' invention is now being built in an amusement center in Hamburg.







### Table for Those Who Can't Wait to Get to the Office

A collapsible car table, which folds under the dashboard when not in use, can be quickly set up for typing chores or for picnics while you're traveling. The Belgian designed Piccolo-Table fits into almost any make of car, is stain- and scratch-resistant, and provides a rigid

work surface about 12 by 16 inches.

In use, all you do is slide it up, hook on collapsible legs and fit it into the glove compartment. (Individual fittings may vary slightly due to different locations of glove compartments.) In Belgium, the table sells for about \$12.75.

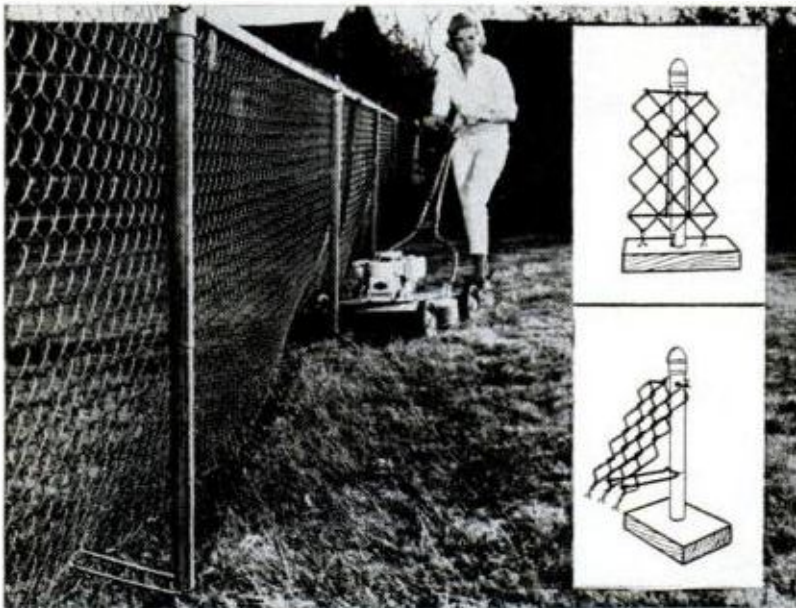

### Trim Borders

You can skip hand trimming along fence borders with a new fitting that lets lawn mowers do the job.

The device, called Trim-Aid, consists of two metal arms attached to a sliding ring. The arms lock the fence against the post (top inset), but hold the bottom of the fence away from the post when the ring is moved downward (bottom inset).

Trim-Aids sell for 69 cents each. They're made by Fence Trim-Aid Manufacturing Co., Tulsa, Okla.

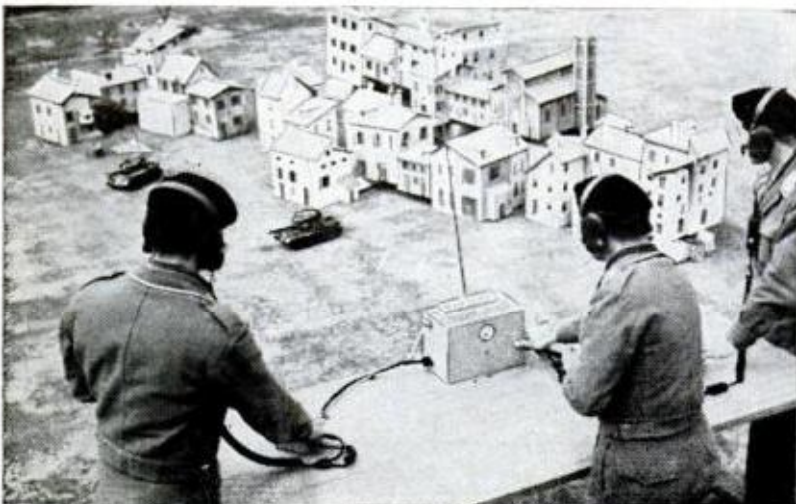

### Miniature War Games

Officer candidates in the Italian Armored Troops School learn tank tactics with radio-controlled miniatures in a Lilliputian-size village.

Cadets, who have an over-all view from the edge of the tiny town, receive orders over headphones. Using remote controls, drivers maneuver the tanks into firing position, while gunners direct the fire of rotating turrets.





# He Makes Accidents Obsolete

*Frank Crandell's hazard hunters explode aerosols, put shoes on machines, listen to rocks talk —so that your life will be safe*

**By Myron Stearns**

**A** HORRIFIED YOUNGSTER with a squealing sneaker caught between step and sidewall of a descending escalator in a Cincinnati department store weeps with relief as the moving stair comes to a jolting stop. One inch more and his trapped foot would have been mangled in the steel fingers of the comb-plate at the bottom.

A shopper cart, laden with Junior and a week's groceries, slips from the grip of a busy mother as she guides it from a supermarket to her parked car. The runaway heads down an incline toward traffic. As though by magic, it stops before rolling three feet.

Sandhogs at the head of a giant tunnel project suddenly are ordered out of the area by their crew boss. A day later,

**GEOPHONE** that listens to the rocks "talk" is a sort of stethoscope for mining engineers. With it, miners and tunnelers can hear dangerous stress noises and predict cave-ins before they happen



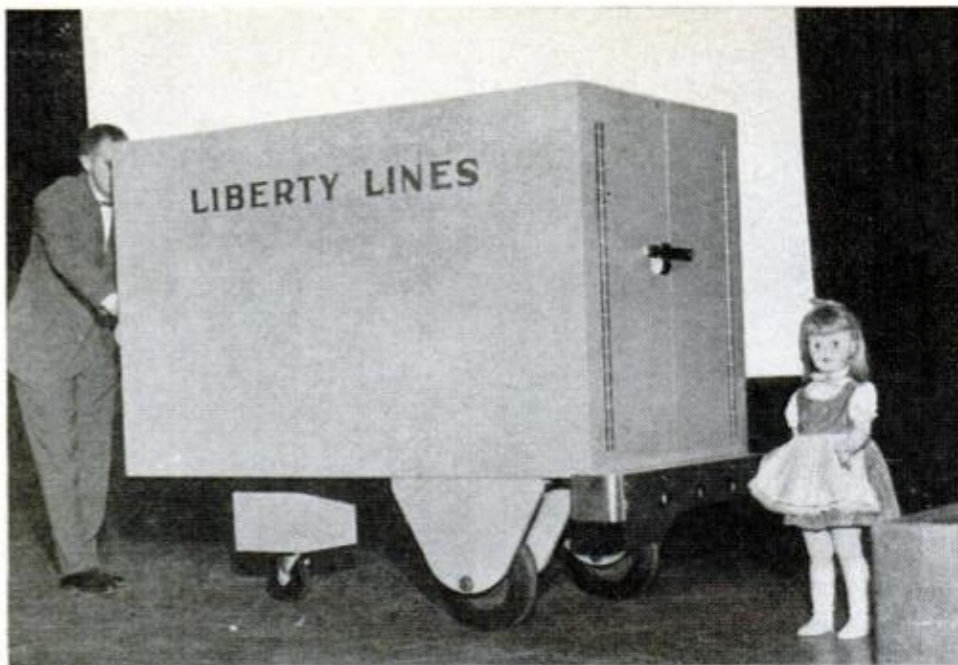

**SONAR EYES** for truck drivers, another hazard hunter "first," detects people or objects behind a backing vehicle with a reflected sonic signal. It warns the driver in the cab with a visual or audible warning read-out

hundreds of tons of rock crash from a collapsing roof to the spot where they'd been working.

Each of these seemingly unrelated and miraculous escapes from tragic disaster has happened—some of them many times. And they are far from miracles. They are accidents that were foiled by shrewd design. The thing they have in common is the inspiration of a hearty, six-foot New Englander named Frank J. Crandell. For it was Crandell and his staff that stopped the escalator, halted the cart and got the rocks to tell that they were about to fall.

For 25 years, Crandell has served as chief engineer of Loss Prevention for one of America's big-risk insurance companies, Liberty Mutual. His secret is a brand new approach to safety. Instead of exhorting people to be careful, he uses design and foresight to eliminate the *cause* of accidents. Working under him, spread across the country, are some 400 safety engineers who call themselves "hazard hunters". Their job is to scout the activities of 70,000 policyholders, sniff out situations that spawn accidents and eliminate them.

Chief Hazard Hunter Crandell works out of a small office in his company's Boston headquarters, or at a sprawling laboratory on an 86 acre tract in nearby Hopkinton. Here, crews of technicians build and experiment with a vast assortment of accident prevention schemes and devices. In a concrete-walled enclosure, rubber-garbed scientists work to eliminate hazards in the handling of radioactive

isotopes. Down the hall, engineers build a finger-guard for a factory machine. Here and there mock-up vehicles bristle with strange devices. In a soundproof chamber, a rickety loom is rebuilt to muffle its noise and, perhaps, eliminate cases of deafness attributed to it by some weavers.

"I want you to listen to this brick," Crandell said to me recently in his office. A moment later I discovered that the brick, lying on his desk, illustrated his whole approach. He fastened it to an amplifier that can multiply sound 300,000 times. He had me put on an earphone. Then, with a small iron clamp such as you find in home workshops, he twisted the screw and squeezed the brick. Into my ears came a sound like frying fat! Crandell told me it was caused by the molecules in the brick adjusting themselves to the new pressure.

Similarly squeezed by the pressure of a mountain above it, he pointed out, different kinds of rock—in a tunnel roof, for instance—give off individual sounds: limestone, like rain on a window pane; shale, like the creaking of timbers; basalt, low-pitched tones like chime doorbells.

To detect this microseismic language of rock under strain, Crandell spent 15 years developing his "geophone"—a sort of stethoscope for mining engineers. Long, sensitive "listening" probes are inserted in drill holes in suspect rock. The highly amplified sounds emitted by rocks under increasing or changing pressure, lets a



POINT LIGHT SOURCE poised above circular glasstop table travels around miniature road system as student steers, accelerates or brakes it with controls in mock-up car, below. Whatever light illuminates . . .

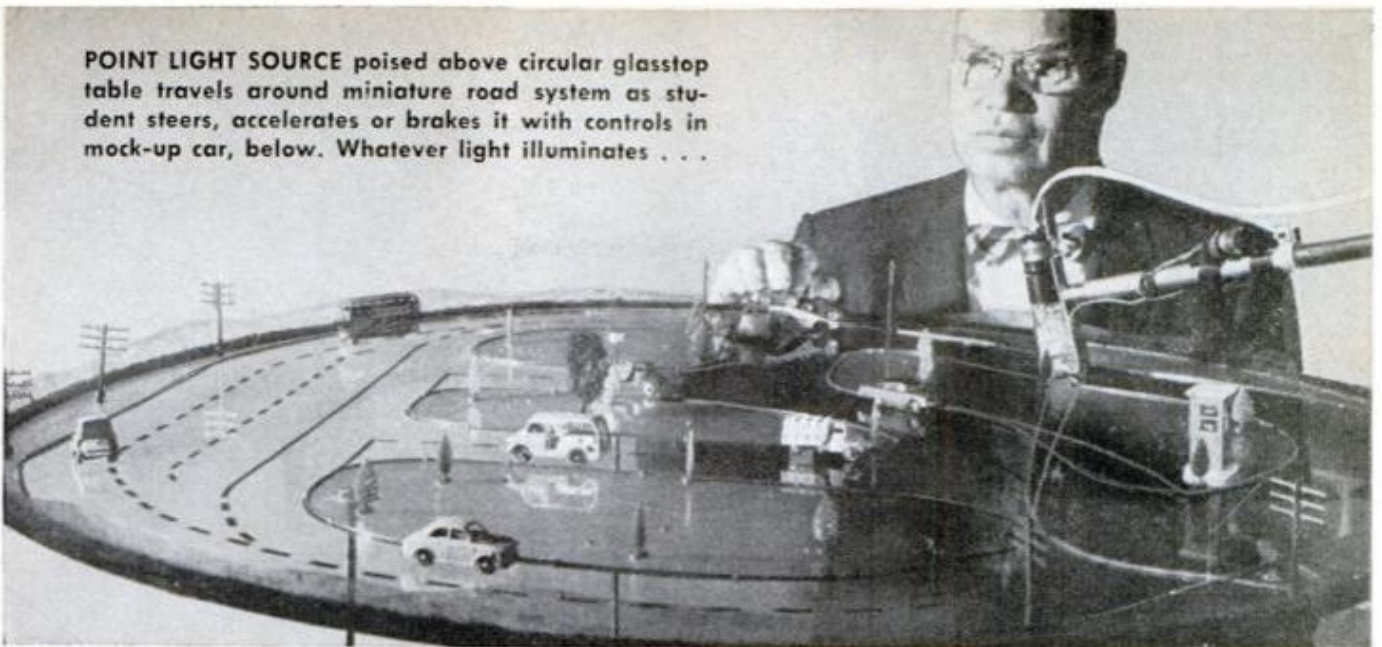

listener detect imminent rock falls or cave-ins *before they occur*. An early detector during construction of a 27-mile section of the Delaware Water Gap supply tunnel for New York City predicted 72 rock falls in advance.

Translating the geophone's odd noises takes an expert, but he doesn't have to be on the scene. At a dam site in Northern Canada, contractors were worried about a high rock wall that looked dangerous. Crandell sent geophones to them, had them make tapes of "rock talk" and then play the results to him over the telephone. There was noise, all right. But it turned out that it came from tension created by steel cables the men had strung to hold the cliff up. Once the cables were cut, the rocks relaxed and stopped "talking". And they stayed put.

Today Crandell's portable geophone is saving lives in Swedish and Australian as well as United States' mines, and in countless miles of tunnel construction. It is also being used in the labyrinthine galleries under the city of Paris, to see whether or not there is danger of city buildings caving in over them.

What prompts anyone to invent such a thing? "Falling rock is the number one killer in mining and tunneling," Crandell reveals. "Before the geophone, crews would whack a mine roof with an iron bar. If it rang, it was good, if it sounded dull, it was bad. What miners called 'popping rocks' was a sure sign of trouble—and usually too late to avoid disaster.

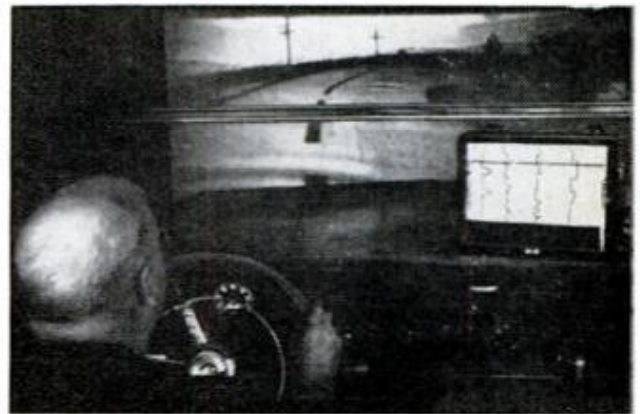

. . . is projected in semi silhouette on screen in front of mock-up's windshield, creating illusion that the make believe car is moving along roadway.

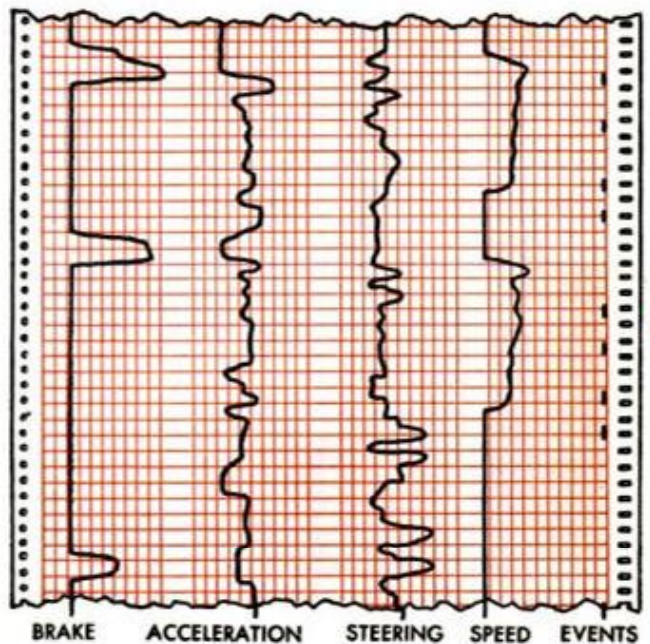

PERFORMANCE chart records steering, braking, acceleration. Sudden moves register as "events" (right), point out flaws when compared with norm



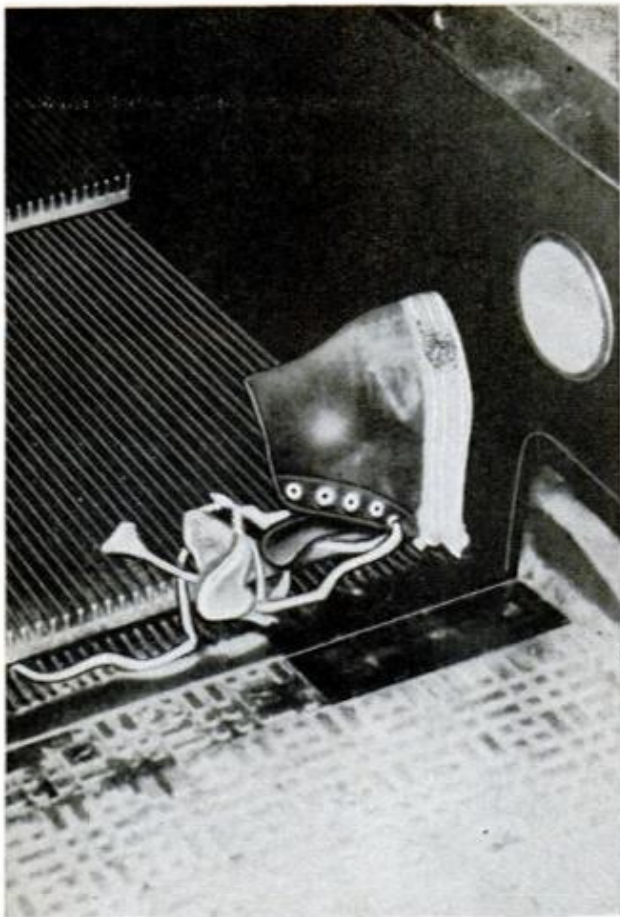

During an early tunnel job on the Pennsylvania turnpike, Crandell and an inspector went into the diggings to recommend supports for what he'd diagnosed as a bad section of roof the day before. "Just as we arrived," he recalls, "tons of rock thudded to the floor, crushing five men. We were so close, stones peppered our hard hats.

"That accident got me thinking," he says. "And you don't turn off your brain on weekends. I was lying in a hammock one Sunday snapping a piece of wood lathe between my fingers. I noticed that long before it broke, the fibers made crackling sounds. I wondered if maybe rock made noises long before it collapsed under tension, and whether a sensitive enough instrument could be devised to hear them."

Crandell is a man who seldom lets a thought pop up without grabbing it and converting it into action. And when it moves, it usually goes someplace. In high school he'd captained the baseball and hockey teams and played everything else in sight—to the point where his highest mark in the entrance exams for Massachusetts Institute of Technology was 17. Undismayed by family headholders, he

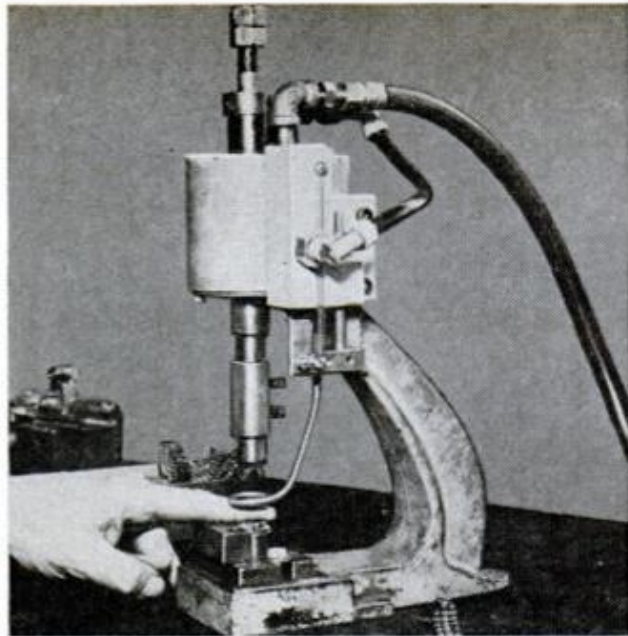

**FINGER-SAVER** for watchmakers punch press consists of a simple loop guard devised by hazard hunters. Guard stops the punch from ramming downward when an operator's finger is in the target area

**SAVED FOOT** of youngster whose sneaker caught in escalator graphically illustrates efficiency of automatic cut-off switch designed by hazard hunters. Victim's foot here was removed without a scratch

dove into an extra year of study, tried again, and this time the lowest mark he received was 96.

To this day, almost anything he really tackles goes down. Once he'd made up his mind to lick rockfall disasters, something had to happen. He slogged through underground warrens with a variety of instruments, testing them all, then visited manufacturers to find more.

Out of these experiments, the geophone was born, and it has exceeded even the inventor's wildest expectations. Modern versions of it predict earth slides and avalanches on the West Coast. In a language of "clicks" and "tunks" the new instrument, called a seismitron, can detect earth movement smaller than the diameter of a hydrogen atom.

Though much of his work is industrial, many of Crandell's safety projects touch you and me. Some time ago, his hazard hunters turned up the fact that a remarkable number of people were tangling with revolving doors. Since you can't educate millions of people to stop pushing, hazard hunters concentrated on the doors. Thorough investigation proved that accidents almost never happened when the doors

[\(Please turn to page 192\)](#)

POPULAR MECHANICS



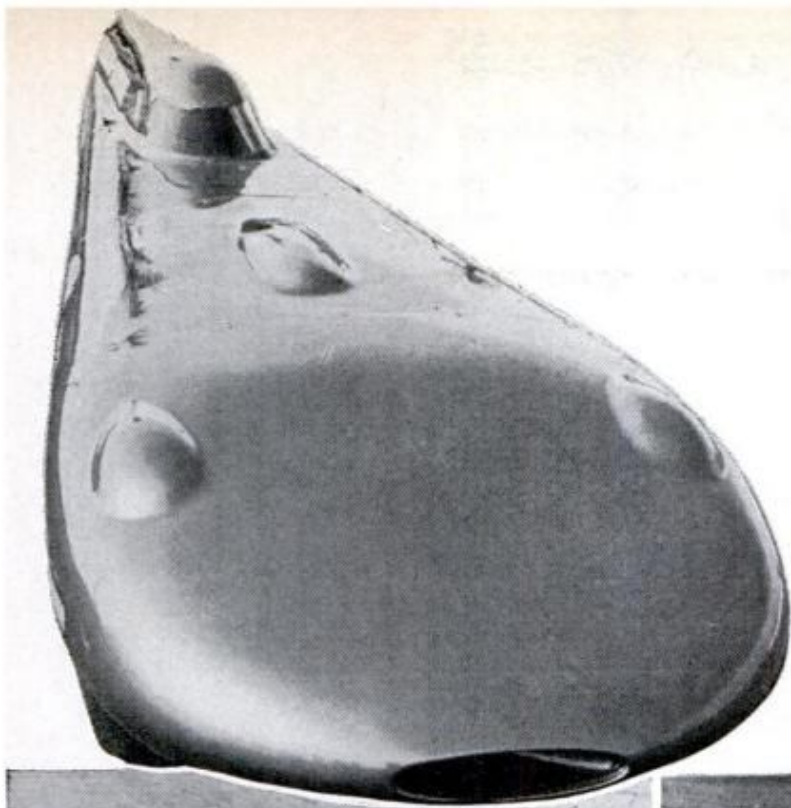

## Speedy Brothers

The Summers Brothers Special, built and owned by two California brothers, is gunning for a speed record on the Bonneville, Utah, salt flats.

The SBS has made a one-way run at 323.87 m.p.h., but was unable to complete its return run in the required time. Bob (the driver) and Bill Summers use a bored-out, super-charged, alcohol-fed 1955 Chrysler engine in their speedster. They say the 744-h.p. rig weighs only 2150 pounds.

The car is a four-wheeler. Hood blisters make room for the GMC 6-71 blower and for springing action by the wheels.

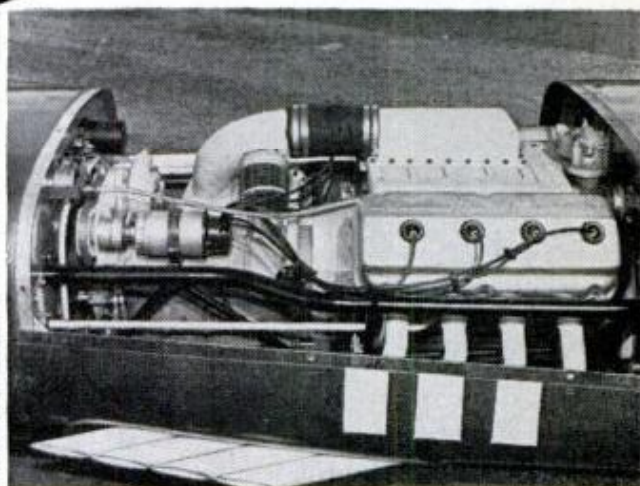
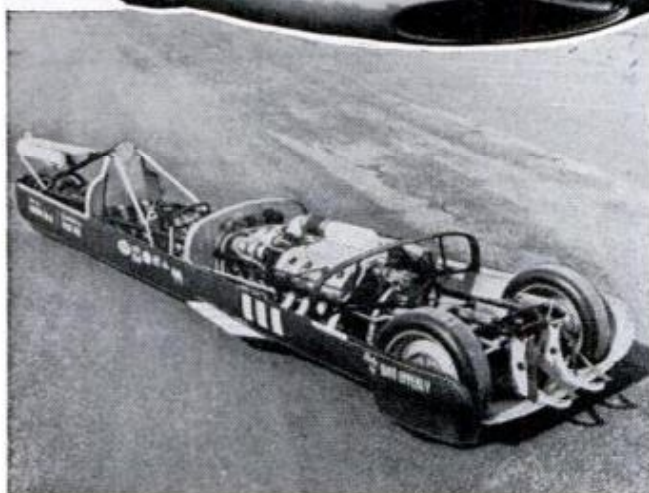

## Missile Patient

"Dental" care for a 103-foot Titan II missile was recently required at Davis-Monthan Air Force Base near Tucson, Ariz.

A tiny drift pin broke off in a hard-to-reach hole in the ablative skirt of the rocket engine. No machine shops could handle such a delicate job, so Dr. Robert Ratcliffe, a dentist, was called in to perform the extraction.

With a portable dental drill, he completed the job—after breaking several drill bits on the hard metal. The skirt, designed to resist heat during firing, is part of the second stage of the ICBM missile being prepared for operational duty at the base.





# Games for Boaters

*Tired of the same old Sunday afternoon cruises? Then try some fun-filled, skill-building water games*

By Patrick K. Snook

**M**ANY BOATING CLUBS are solving the problem of those midsummer what-do-I-do-with-my-boat-now doldrums by borrowing ideas from sports-car clubs.

Predicted-log competition, a nautical adaptation of the automobile rally, has picked up thousands of fans over the past couple of years and is already a red-letter date on many club calendars. However, few people have heard of a more recent but equally appealing borrowing, the boaters' "gymkhana."

A sports car gymkhana is run on a twisting road course marked off into sections with flags or pylons. Actually, it's just a series of tests—acceleration, braking, backing, driving through a narrow slot, etc.—and the winner is determined by timing each contestant's run, then subtracting any penalties picked up along the way.

Boaters have taken this general idea, added a few special wrinkles of their own and come up with a number of games which are ideal for livening up your midsummer outings. Turn the page for complete rules and instructions on eight of these games.

**POP-AND-RUN**, right, is a modern version of *Moby Dick* using balloons instead of whales. While many variations are possible, basic idea is to pop all of the balloons

**HIGHBALL HANDICAP**, below, is a real test for a pair of skillful boat drivers. Run too close together and you'll break the beach ball, thus disqualifying your team

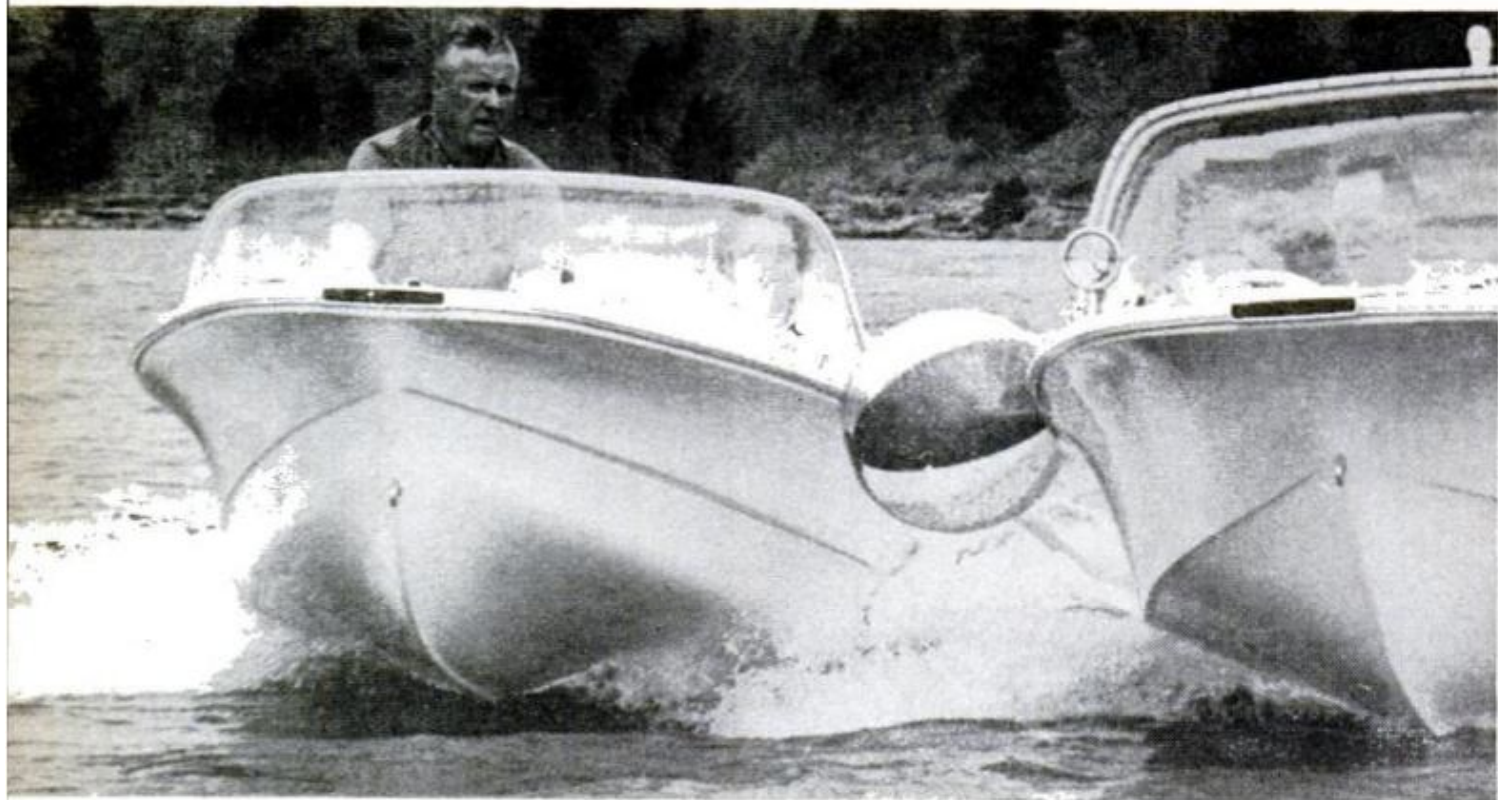



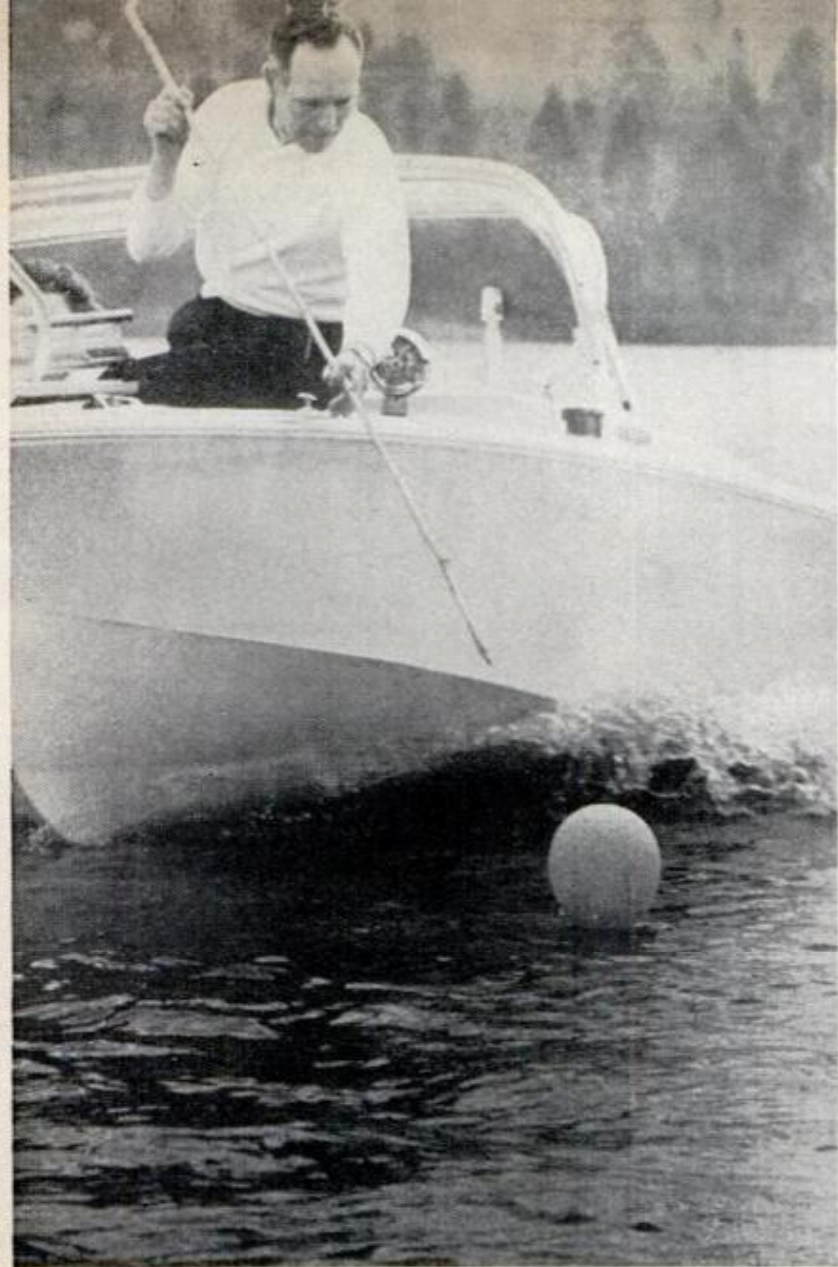

**PLUG CHECK**, an easy dock-side contest, is particularly good for the gals, though everyone who uses an outboard motor should know how to do it

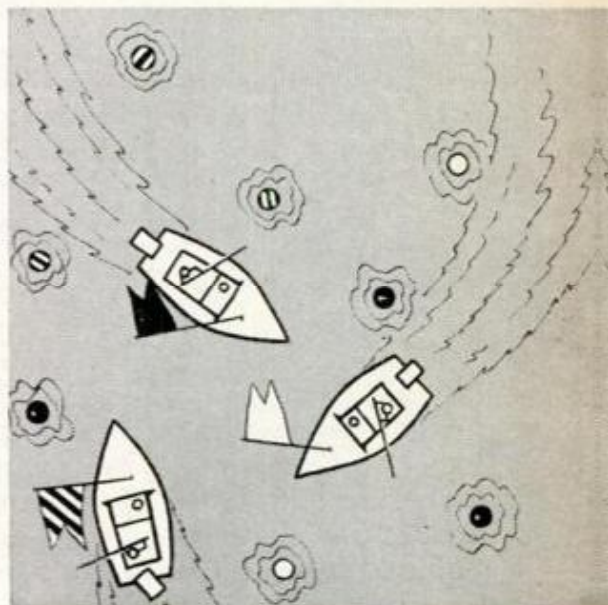

**IN CROWDED WATER**, balloon popping can be dangerous. With this, and every other event, make sure that you have enough open space for safe maneuvering

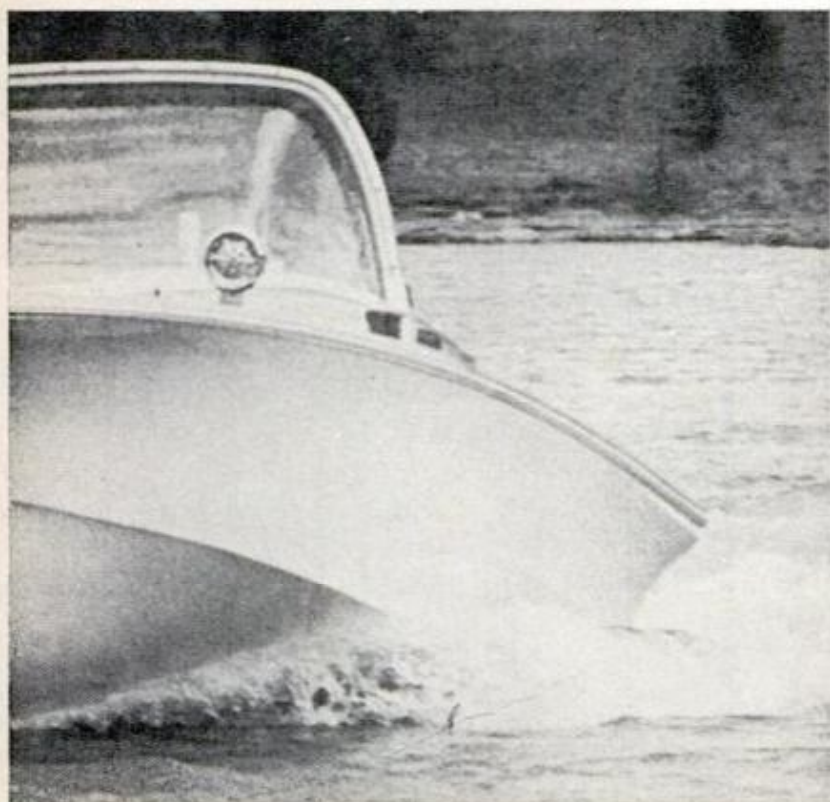

**SHEAR-PIN SWITCH** clocks a contestant's speed at pulling up and locking the engine, removing the shear pin, then putting the engine back in running condition



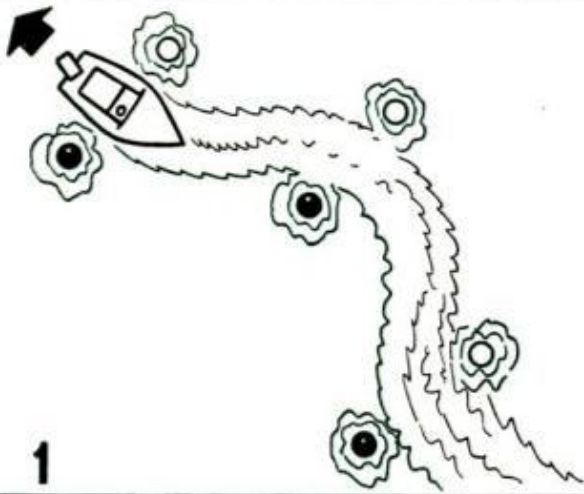

1

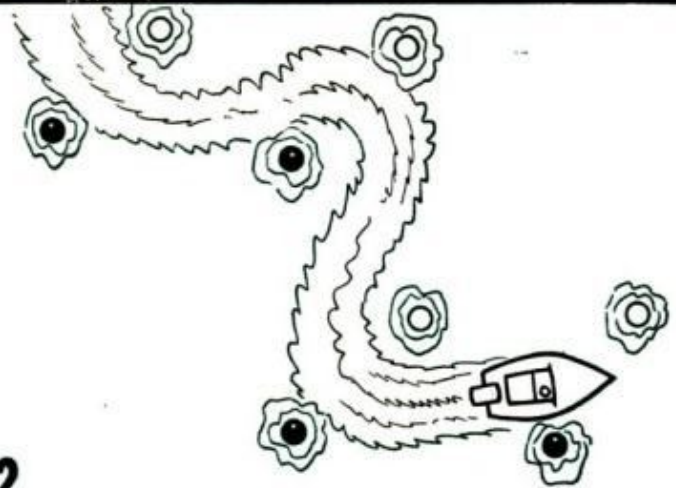

2

**SLALOM.** Use anchored balloons or plastic bleach bottles to mark off a twisting slalom course. These should be located in pairs so that they form "gates" through which the boat must pass. For a fast course, make the gates wide and locate them farther apart; if you want to make things more difficult, use narrow gates spaced only a boat length or two apart.

The actual event is run against time, with the contestant idling up to the first gate and pouring on the power at a signal from the starter. Over-running the markers or leaving the course earns a time penalty, and the fastest time wins.

For a little extra excitement, try a flying start on a tight course and increase the penalty times.

**BACKING SLALOM.** Reverse maneuvering requires a considerable amount of skill, particularly in close quarters, so a slalom variation based on this aspect of boat handling is a real test and has a great deal of spectator appeal.

The competing craft is brought up to the starting gate and shut down. When the starter's flag drops, the contestant must fire up the engine, turn the boat around and back through the course. As in a regular slalom, over-running a marker or leaving the course is a penalty offense.

**TAG-ALONG SLALOM.** Here's one that requires two boats. You can use the same basic slalom course, but the gates should be wider and the turns less severe.

Tie a 10-foot length of very light cord or ribbon between the transom of the lead boat and the bow of the number-two craft. After positioning the boats at the starting gate, both engines must be shut off. Then, at the starter's signal, each driver starts

his engine, and the boats make a follow-the-leader run through the course.

The object, of course, is to make the fastest time without breaking the string between the two boats. This can be quite a challenge, particularly while accelerating. Snapping the ribbon means disqualification for the team.

**HIGHBALL HANDICAP.** This is a tough one, and like the "tag-along," requires two boats. The boats take up a position some distance from the starting line and get under way, running side by side. Next, a large plastic beach ball is positioned between the inside gunnels. This is a little tricky, and several false starts are par for the course.

When the team has the ball set, they signal the starter and head through the starting gate. Once on the course, the ball cannot be touched. Fastest time wins,

**FIRST MATES** can be a big help, and many of the clubs are organizing events for husband-and-wife teams





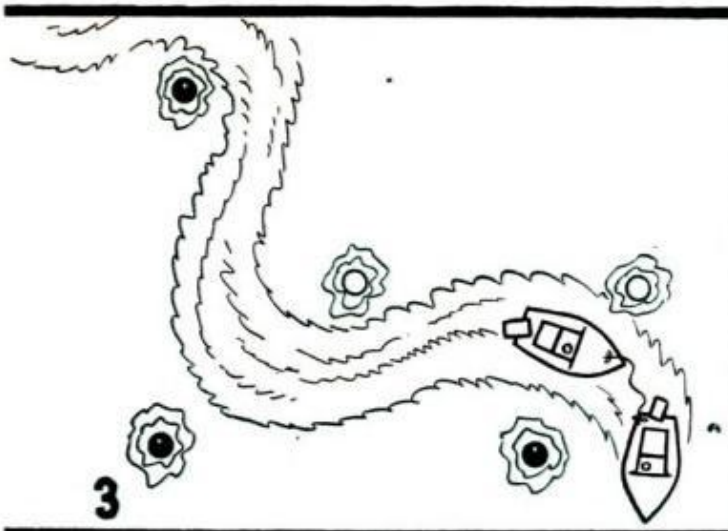

1. **BACKING SLALOM** looks simple, but you'd be surprised at the number of experienced boaters who go off course or over-run markers

2. **STRAIGHT SLALOM** is an ideal game because you can vary speed of course by changing the width of gates and spacing between them

3. **TAG-ALONG SLALOM**, a great test of driving skill, requires a pair of boats to run through the course at approximately the same speed

and dropping or breaking the ball disqualifies the team.

It's a good idea to have an adequate supply of balls on hand if you plan to try this one.

**QUICK PICK-UP.** This event tests skill in close-in maneuvering and the use of a boat hook. A number of bleach bottles are scattered about 100 yards apart, and at the starter's signal, each team (one driver and one hook-handler) retrieves the bottles.

Interesting variations? Number the bottles and pick them up in sequence. Or paint them different colors and start the teams together, each one picking up only one color.

**POP-AND-RUN.** All you need is a good supply of balloons and some lightweight poles sharpened on one end. Either set the balloons adrift or anchor them with stones and lengths of light string. The object is

to break all the balloons and get back to the starting line in the fastest time. See "quick pick-up" for possible variations.

**PLUG CHECK.** In this dock-side game, the contestant must remove the shroud, disconnect a spark-plug wire, remove the plug and hold it over his head, then reverse the procedure and wind up by starting the engine. With tyros, better stop at the plug-over-head point to make sure that the plugs don't go back in cross-threaded.

**SHEAR-PIN SWITCH.** Same idea as the event above. However, heaving the engine up requires a little muscle, so this should be a men-only competition (or husband-and-wife teams, with mother doling out the tools and shouting encouragement).

And so it goes. You can probably come up with at least as many game ideas of your own. Have fun! ★★★

**RACING THROUGH** the wide starting gate, two boats enter the twisting course for a tag-along slalom run. If that ribbon snaps, they're out of the race

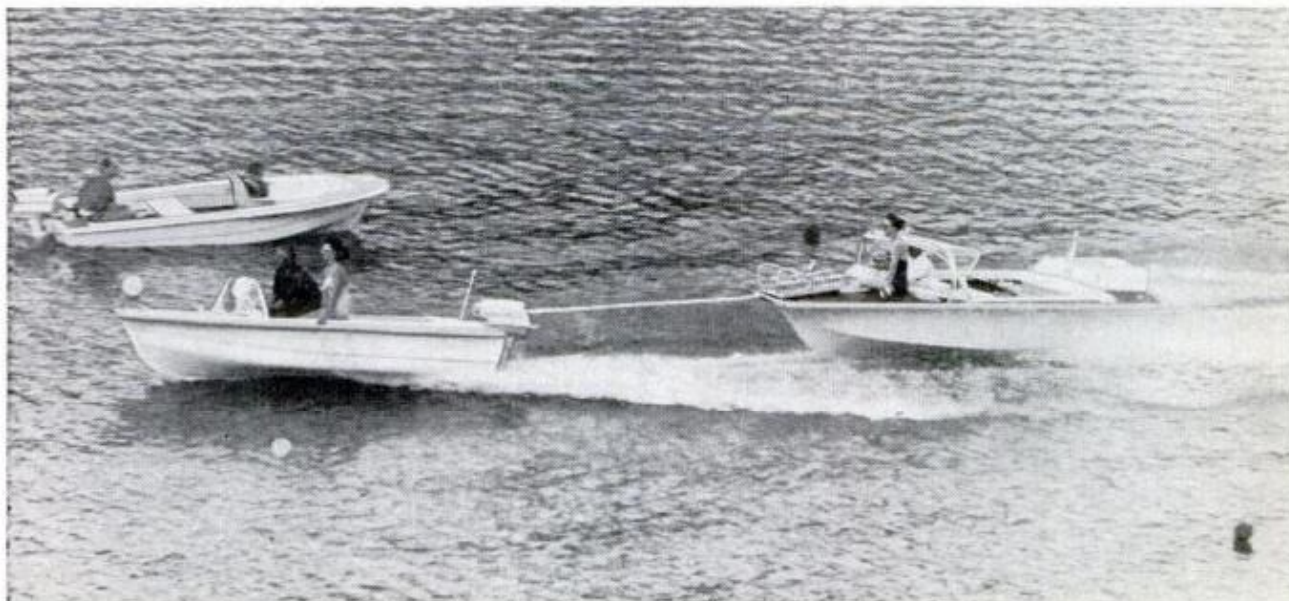





**STEPPING OVER SLUSHY GUTTERS** with ease, a secretary in London, England, keeps her feet dry with her own invention, a step-over umbrella. A metal ferrule fitted on the end of her umbrella includes a metal bar that folds out (inset) to form the puddle-jumping step, then folds flat again.



**"DISAPPEARING" OVEN** is a counter-height unit that has sides which fold away when not in use and a "door" formed by an air curtain blown from ducts at the edge of the oven. The American Gas Assn. uses the oven in tests designed to add speed to cooking.

110



**ELECTRONIC AMPLIFICATION** of sound, taken directly from an instrument's strings by a transducer, does away with the instrument's traditional sound-body and improves its quality, say Les Barcus and John Barry. Above is their electronic guitar beside a conventional guitar.

Their *Violectra*, shown above right with an Italian Mezzadri violin, sells for \$795. The *Violectra* can be played directly into earphones for practice, below right or directly into a recorder.

**SUN-BATHING CAPSULE** for use on cool or windy days is made of ultraviolet transmitting plexiglass. The lightweight unit can be carried. The heat of the sun's rays is retained in the capsule, making sunbathing possible in 50-degree temperatures. It's manufactured by Fabor Robison Productions, Inc., 2609 W. Olive St., Burbank, Calif.

POPULAR MECHANICS





**FOUR CAN SLEEP** in a collapsible extension added to British Motor Corporation's Mini car or van by Wildgoose Worthing Ltd. Despite the extra weight, the car still gets 40 miles per gallon, says the maker. The Wildgoose conversion costs about \$1120—about the price of the Mini car itself.

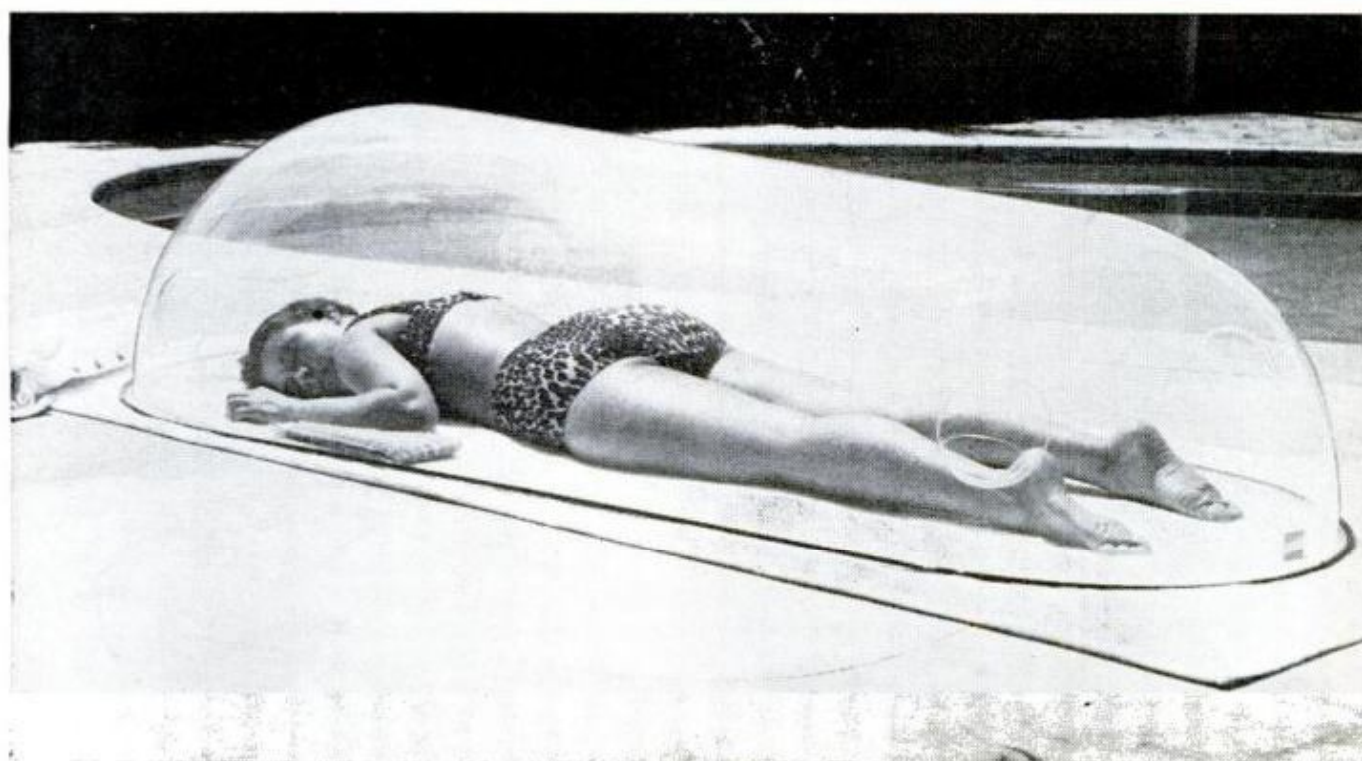



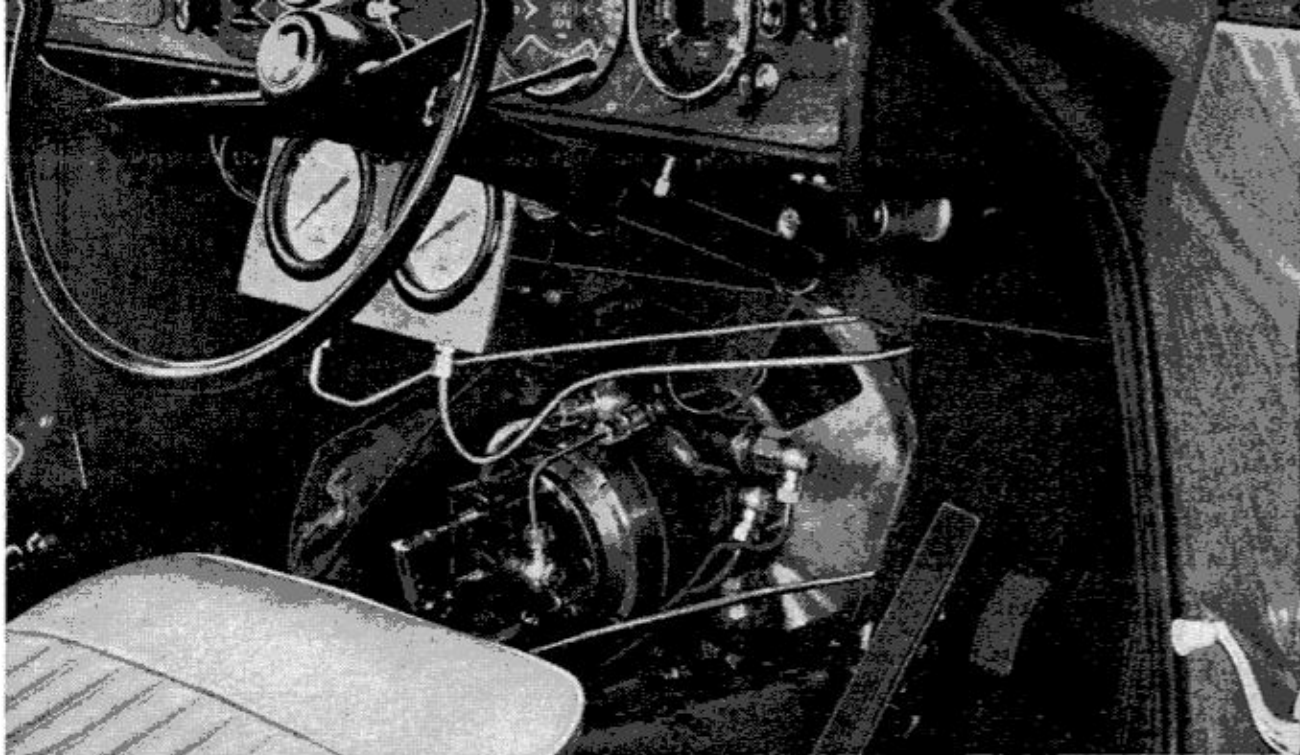

# Hydrostatic Drive

*Tomorrow's cars may boost drive efficiency, yet discard the gearbox, clutch and even the brakes*

**By Jay Arthur**

**I**MAGINE A CAR that always operates at peak engine efficiency, getting the most usable power from the least gas whether tooling along an expressway at 70 m.p.h. or inching up a mountainside. Picture it not only stopping on a dime, but giving you change. You'd never need brake linings or drums, transmission grease or repairs. Sound crazy?

The prototype of such a car is operating now in Scotland. It was created at Britain's National Engineering Laboratory. The unorthodox performance comes from its hydrostatic transmission. There is no mechanical gearing or gearbox, no differential, no drive shaft. In fact, this hydrostatic-drive car doesn't even need a rear axle. Its four-cylinder gasoline engine is connected to an oil pump that, in turn, is linked by oil lines to hydraulic motors that drive the wheels.

A swashplate eliminates the usual crankshaft and connecting rods for moving pistons back and forth in their cylinders. This is a round, smooth-surfaced disk pivoted at its center. On a common axis with the disk, the pump (or motor) pistons rotate with their circular cylinder block just as bullets do in a revolver cylinder. As the cylinder block rotates, the pistons' outer ends bear on the plate. Ramp action forces them to stroke in and out and pump oil as they travel. Oil pressure from the drive pump goes to corresponding motor pistons. They pass against the tilted motor swashplate, forcing their cylinder block to turn, thus turning the wheels. Increasing the pump swashplate's angle from vertical makes piston strokes longer, as they ride a steeper ramp.

In contrast, mechanical gears work in step. The ratio you choose is dictated by steps available. With the hydrostatic's



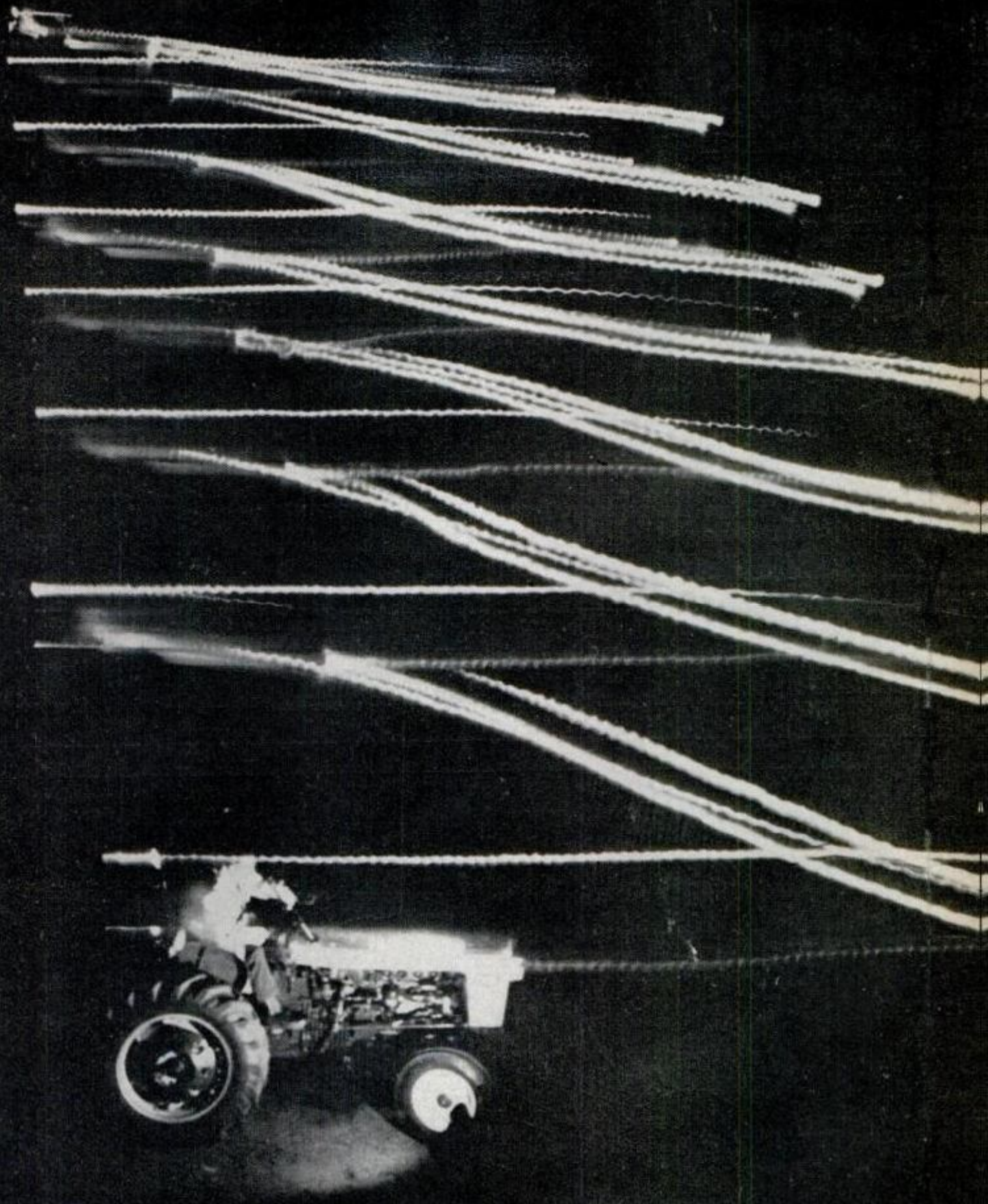

**HYDROSTATIC** tractor's ability is demonstrated in this night photo showing immediate change from forward to reverse using the transmission for the braking system



continuously variable displacement, you get an infinite variety of ratios.

Hydrostatic transmission alone is less efficient than a stepped cogwheel mechanical box alone, but with the latter you can't hold the engine at its best speed. And you need all of the usual drive train with its frictional and inertial losses. For example, to send three-quarters of engine power through the transmission at all ground speeds, a conventional tractor would need an unlikely 29 gear steps. Contrast that with a hydrostatic system that holds the engine at peak-power speed with any load.

You "downshift" the hydrostatic by reducing pump displacement for instant, variable braking with no gears to strip. A zero-angle (i.e. vertical) swashplate locks driven motor pistons with standing oil pressure. Wheels stop cold. By reversing the pump you go into reverse.

Britain's NEL has demonstrated hydrostatic's fast, positive braking and reversing. They use a Triumph Herald sedan, with transmission and drive replaced by three dual-purpose hydrostatic units and their oil lines. The engine crankshaft drives the pump unit; two hydraulic motors in the trunk drive rear wheels through non-variable reduction gears. For

more economy, the NEL hopes to combine swashplate tilt with the throttle on a single control.

Donald Firth, designer of the NEL system, says that a car built around it can locate the engine anywhere at any angle. You'd eliminate the transmission tunnel, mount hydrostatic motors on the wheels.

International Harvester's Carl Meile used wheel-mounted radial hydro motors on two experimental tractors. The drive train, from clutch to rear axle and brake drums, was replaced. The motors' pistons operated against the edges of a cam instead of the face of a swashplate. A load governor was designed to match speed ratios to loads. Transmission efficiency was only 79 percent, but I-H men, limited to off-the-shelf components, got tractor efficiency close to standard. With full power available, work was faster. The hydrostatic's advantages showed dramatically on a turbine tractor.

The NEL talks of transmission efficiencies on its Herald of up to 85 percent, and Firth thinks we could get hydrostatic cars "perhaps in as few as three years." Detroit is leery now, but when the British succeed with a commercially practical vehicle, you can be sure U.S. car builders won't be lagging far behind. ★★★

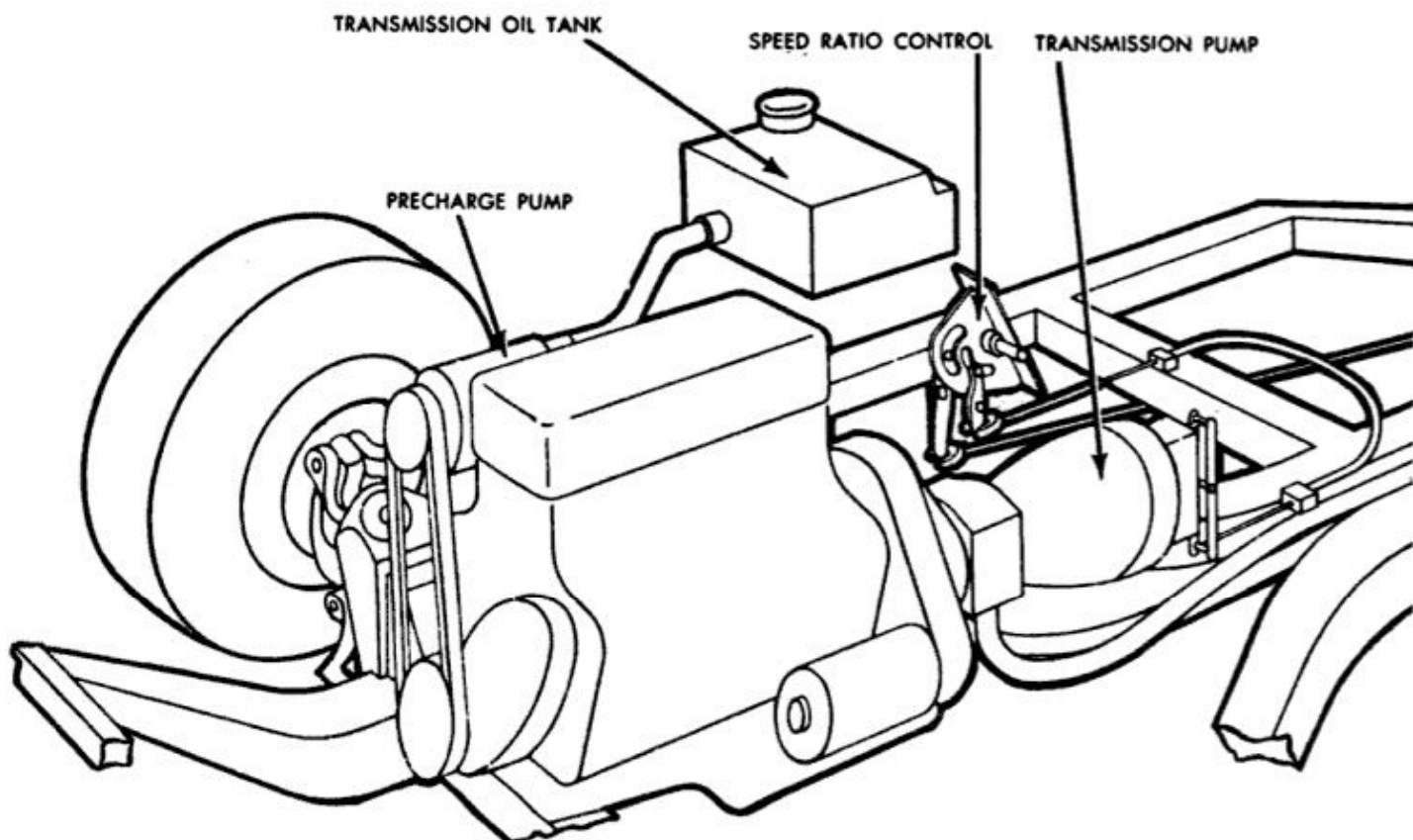



**SMALL HYDROSTATIC** motors are mounted in the trunk of the NEL's test Triumph. They're counterparts of the drive unit, but are considered motors since they're driven by the pump's action

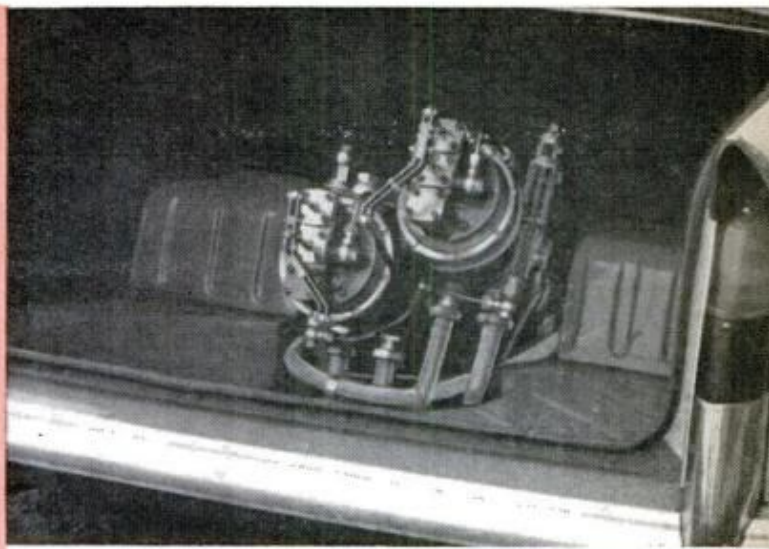

**OPERATION** of one hydrostatic pump-motor combination is shown in this simplified diagram. Depending on the pump swashplate's angle, piston displacement varies to control action at the motors

**LAYOUT** of the test hydrostatic-drive Triumph shows how the drive pump replaces the usual transmission and is linked by oil lines to driven hydrostatic motors in the car's trunk

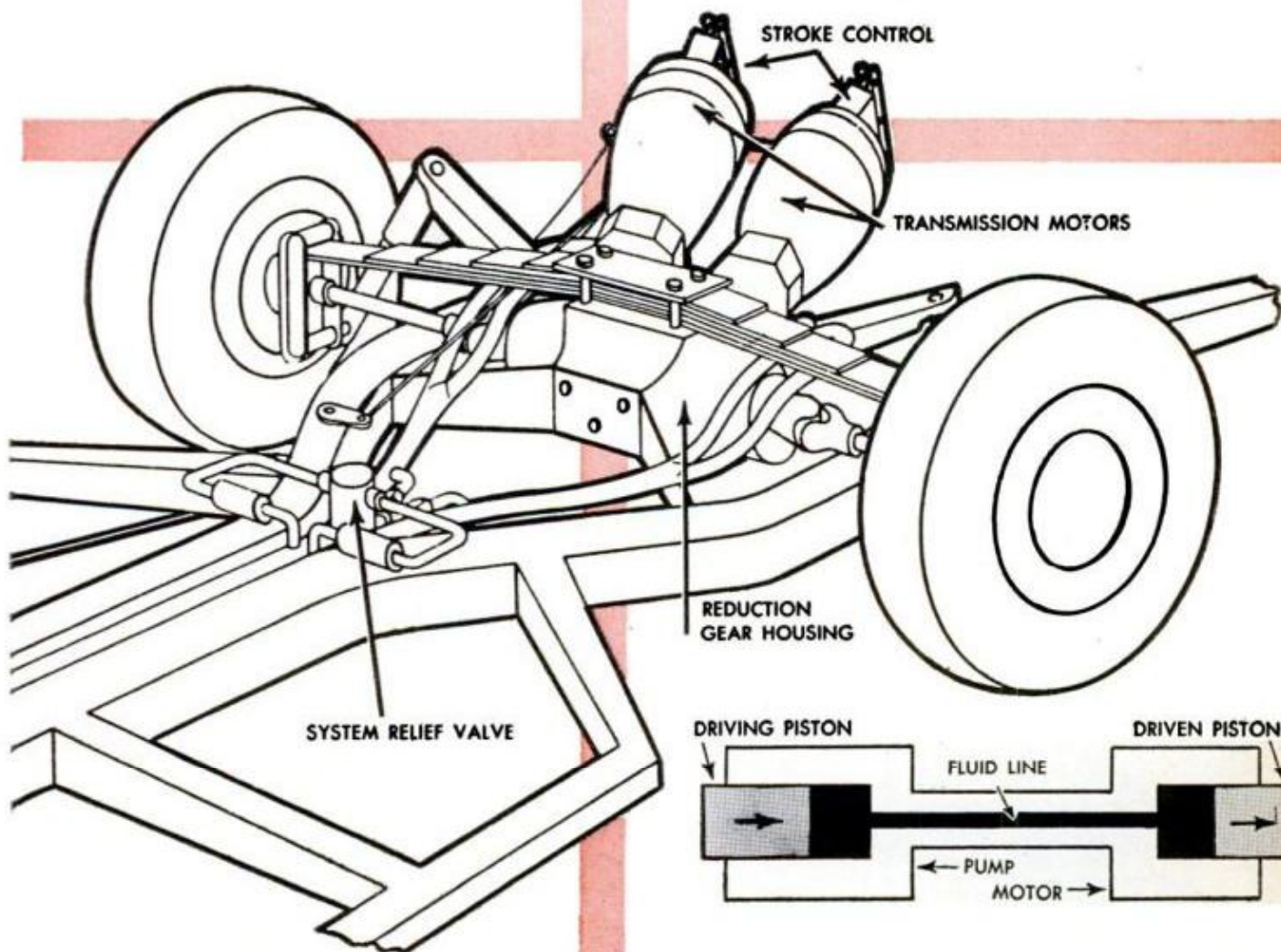
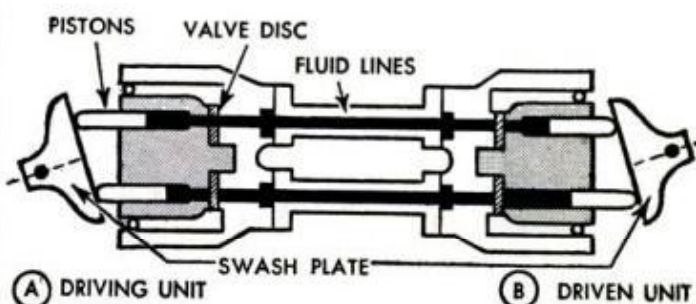





**MOORING BUOY** that's made of fiberglass and polyurethane foam never needs repainting, won't rust and can't sink, even if punctured. Called "Everfloat," the buoy comes in many colors and sizes, and is a product of the Glasspar Co., 19101 Newport Blvd., Santa Ana, Calif.



**CAP WITH A "POCKET"** is for carrying valuables, cigarettes and credit cards when you're in a bathing suit or other pocketless attire. The cork-billed floating cap has a detachable waterproof pouch that snaps into the crown. It was specifically designed for boaters by Official International Outboarders, Ltd., Box 646, St. Louis, Mo. Price: \$4.95..







**TRIPLE-DECK DRIVING RANGE** accommodates three stacks of budding golfers in Japan. Built in the heart of Tokyo, on the grounds of an abandoned Buddhist temple, the range has 50 stations on each deck. There is no danger of any of the drives from the upper decks hitting the golfers on the lower decks because of deck overhang.

AUGUST 1963

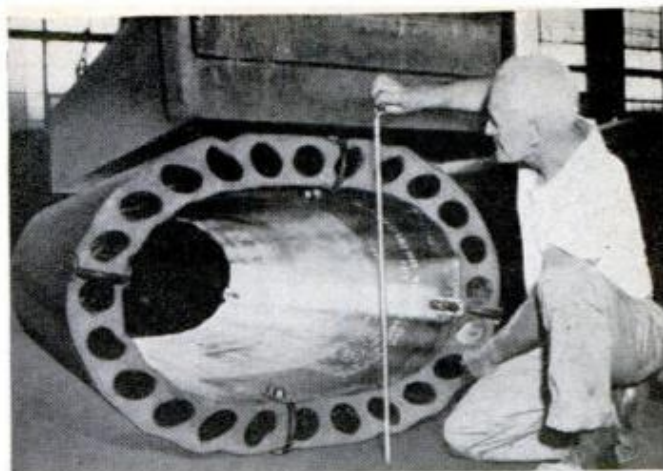

**SHIP FENDERS** on U.S. Navy tenders will eliminate collision danger to nuclear submarines being refueled at sea. The tenders will wear huge rubber cushions developed by B. F. Goodrich Co. Weighing 2200 pounds, the massive fenders deflect only 12 inches under a 22,000-pound load (photo).



**KNIFE WITH A VIEW** combines a monocular field glass with a five-inch hunting knife. Made of Solingen steel, the Tele-Optic knife has a non-slipping hard rubber handle. Embedded in the handle is a double-lens two-power scope. A flap on the sheath protects the scope when not in use. The hunting knife is priced at \$3.95 from Leon Zakian Co., 58 Engle St., Englewood, N.J.

117



# Buying a Good Used Camera

*Ten basic checks, in the store and at home,  
to spot quality trade-ins on the dealer's shelf*

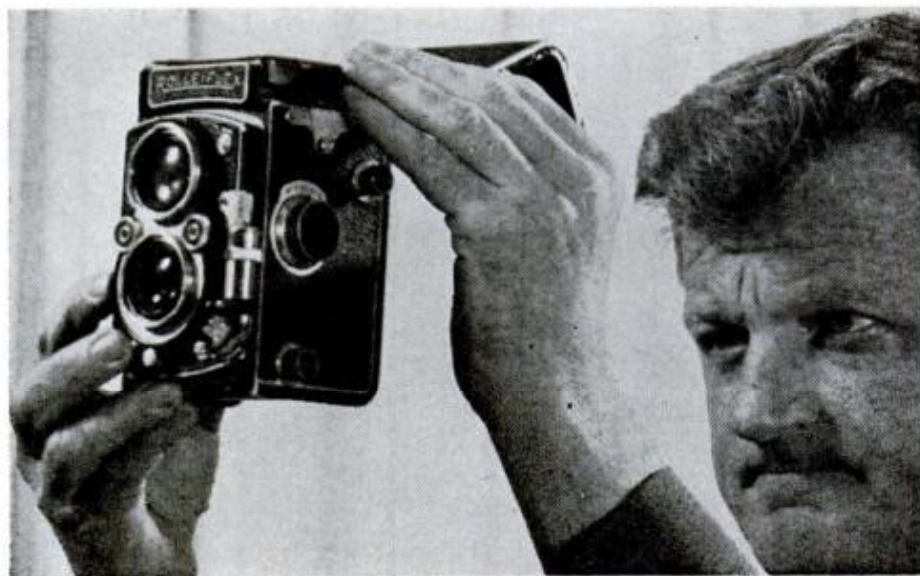

By C. H.  
Crandall

**BEST CHECK** is looking through back of camera and through lens as you set aperture and shutter at each of their settings to test for consistency

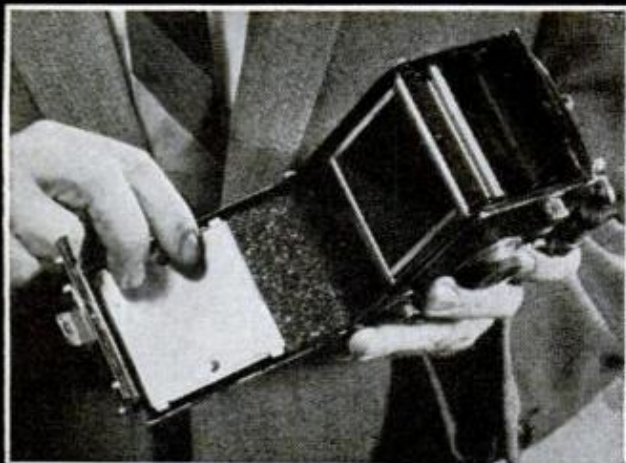

**OPEN BACK** of camera and examine insides. Pressure plate should be firm though not stiff, rollers should spin easily and interior should be reasonably clean. Inside appearance of camera is actually more important than the outside

**ROLL FILM** through camera to test winding mechanism, both with back open and closed. If film comes out with wrinkled edges, it is not winding properly, could cause fogged edges on your negatives or it could even tear the roll



**P**HOTOGRAPHERS are probably the world's most notorious gadgeteers. Every new gimcrack deserves a tryout. This built-in inability to resist new-model cameras, plus the introduction more than a decade ago of good, low-priced models—notably Japanese—has produced the greatest turnover of cameras in history.

Many photo stores, as a result, have genuine bargains on their used-camera shelves. And a used camera is not necessarily an abused camera. However, buying any used precision instrument involves a certain amount of risk, so the wary buyer can minimize the risk by applying a few simple checks, some in the store and some at home during the customary trial period.

Before even going to shop, however, decide what you want the camera for—black-and-white prints, color prints or color slides—and how much you can spend. The first will help establish the size. The 35-mm. camera is certainly the most popular for color slides, and the 35-mm. and 2¼-square cameras are the most common for all-around work. Larger sizes, especially the press and studio types, are for specialized work and should not concern the average snapshotter. Whether you want a rangefinder (with which you focus through a special viewer) or a reflex (with which you focus through either

the actual lens or a duplicate of it) is a matter of personal choice.

1. *Check the appearance.* It has some bearing on previous use, but a shabby-looking camera can still be functionally sound. However, severe dents may mean the camera has been dropped, jarring the mechanisms. Corrosion may extend to working parts. An accumulation of dirt and debris or scratches may mean severe misuse. Burred screw heads indicate an amateur mechanic has been meddling.

2. *Open the back.* The working parts are all inside and your most important checks will be made there. A clean inside is a good sign, no matter how shopworn the outside. Twirl the rollers and test the pressure plate (see photo). Both are important for proper feeding of film.

3. *Look through lens* with shutter on "bulb" to open the lens. Then hold it toward a light and look through it for nicks, scratches, discoloration or disfiguration. (Ignore small air bubbles you'll find on most lenses.) While it's open, move the lens' aperture to each of its f-stops. The iris blades should move in unison and form a symmetrical opening (usually hexagonal) at each stop, and each opening should be half (or double) the size of the one next to it.

4. *Next*, with the aperture wide open, close the shutter and run a similar test.



**REMOVE THE LENS** on cameras with interchangeable lenses and examine separately for dents and scratches. Then replace and remove several times to check snugness of fit. Poor fit could cause light leaks or focusing problems

**BUILT-IN METER** can be checked against name-brand meter. Camera meters are usually much smaller and less sensitive than hand-held meters, but the readings obtained should be within ½ stop or so to be of any effective use



**BUILT-IN ATTACHMENTS** can be tested in store. Flash units, bulb or strobe, can be fired at the counter. To check synchronization, look through the lens through back of camera to see if the flash fires while the shutter is open

**CAMERAS WITH BELLOWS** need a special check. Small penlight should be inserted inside bellows to check for light leaks. Even one small pinhole could fog every picture. Also check bellows' adherence to body and lens board

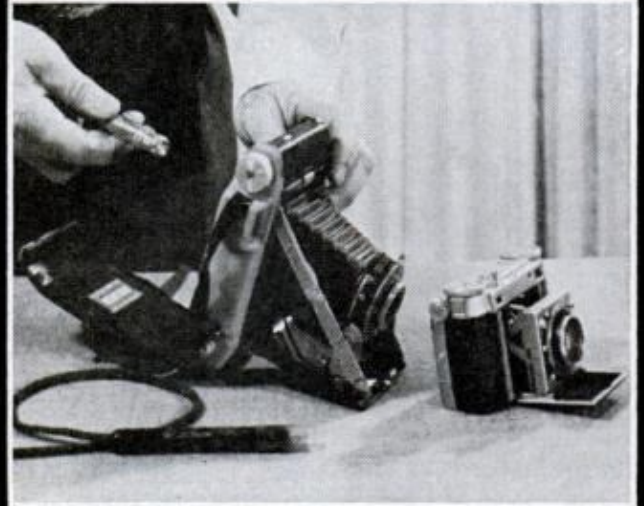
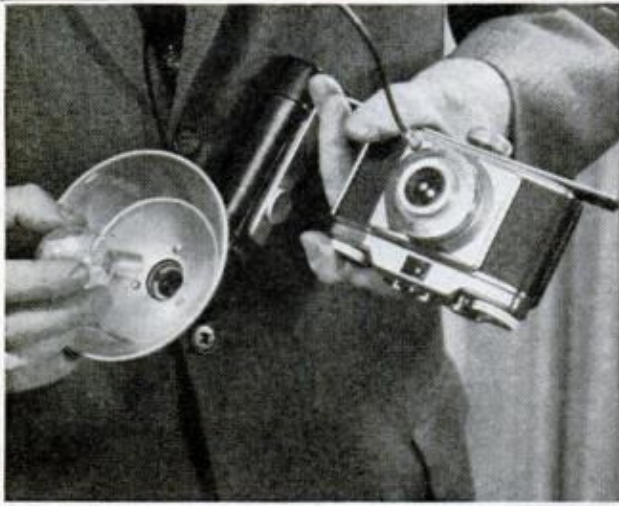

With the camera toward the light, cock and fire the shutter at each of its speeds, up and down the scale. It should look and sound consistently faster (or slower) than each previous setting. **Repeat the test.**

If the blades on either the iris or shutter stick, or in severe cases flop loose, move on to the next camera. The advantage of these through-the-back checks are that you check the lens, the aperture and shutter—the three most important parts of the camera—as well as the cocking and shutter-release mechanisms.

5. *Remove the lens.* If the camera has interchangeable lenses, the aperture and shutter tests outlined above can be done separately. Also, by removing the lens you can examine it for burred threads or for nicks in the mount or scratches on the glass. Shake it and listen for loose elements or bits of glass. When replacing, check snugness of fit.

6. *Run film through the camera.* Bring or buy a roll of outdated film and load it in the camera. With the back still open, run it through once, cocking and firing the shutter and advancing the film one frame at a time. It should ride over the rollers (or sprockets) easily. Rewind it and, with the back closed this time, run it through again. If there is any problem about the film riding up over the grooves

**CAMERA LENS** is perhaps most important—and expensive—item on camera. Working mechanism can be repaired, but a scratched lens is practically useless. The tiny bubbles found in most lenses are harmless





**TAKE SOME PICTURES.** This is the most practical test of all, because it's what the camera is for. Take a few closeup portraits and long-shot scenics, and make prints to check the results for sharpness and shutter accuracy

**BRICK WALLS** or any other flat, detailed surface is excellent for testing the sharpness of lens on a plane, from corner to corner of the frame. These tests should be made with a tripod to eliminate any camera movement

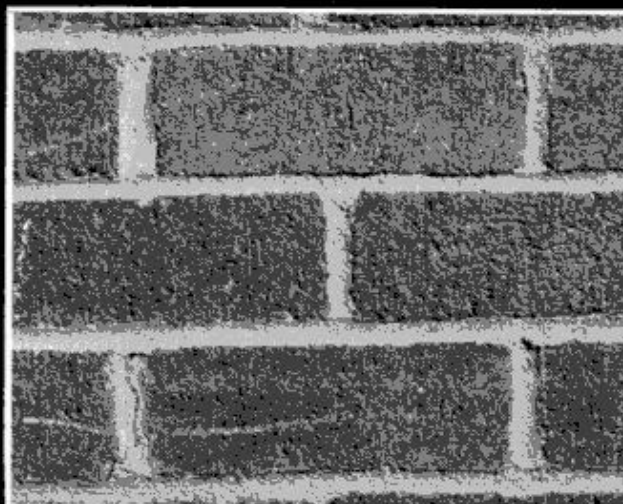

it is meant to run in, or winding sloppily, film may tear.

7. *Check the accessories.* Some cameras have built-in accessories or attachments and, since they are part of the purchase price, they should be tested, too. Flash attachments are quite common, and can be tested readily in the store by borrowing or buying a few bulbs and firing them. If the camera is synchronized for electronic flash, borrow a strobe unit (or bring your own) and test-fire that, too. Built-in exposure meters can easily be tested against another meter.

8. *Check the focus.* This is especially important on rangefinder cameras, where you depend almost completely on the focusing mechanism for sharp focus. Check it for telltale play. On reflex cameras you depend primarily on your eye. On either, however, it's a good idea to double check both the nearest and farthest ranges of the lens. Most normal lenses will focus down to within 3½ feet or so. Do it, and measure off the distance carefully with a tape. Then, with the clerk's permission, step out on the street and focus on something distant, at least 100 feet away. The footage scale on the lens should be on the infinity mark. If both the near and far focus line up accurately with the footage scale, the range in between should be accurate.

9. *Get a trial period.* Most reputable stores will give some form of trial period during which you can take the camera home and actually try it out. The most common is a 10-day trial, which gives you time to test with actual film.

10. *Take pictures.* Use the trial period for some systematic testing especially of the sharpness of the lens and the accuracy of the shutter, plus the intangible of whether you enjoy working with the camera. (Some personal dislikes, not apparent in the store, show up during shooting sessions.) Test the lens by taking closeup portraits as well as pictures of a flat surface with lot of detail, such as brick wall or a newspaper taped to a wall. If possible, use a tripod to eliminate movement, and take pictures at both the widest and smallest apertures. The portraits will tell you how fast the focus falls off from front to rear and the flat-surface pictures will tell you how well it holds up from center to edges. In addition, take scenic long shots to test the lens at infinity.

To test shutter consistency, take a series of pictures of the same subject at all shutter speeds, adjusting the aperture each time to keep the same exposure (i.e., 1/25 at f:22, 1/50 at f:16, 1/100 at f:11, etc.). If the shutter is way off on one of the speeds, it will show up in this series. ★★★



# New for Your Home



**SALT AND PEPPER SHAKER** "buoys" of plastic with napkin-holder base may be hung on boat bulkhead or used on table. Black enamel base model costs \$3.95; mahogany base, \$4.95. By Lister Industries, 141 E. 44th St., N.Y. 17, N.Y.

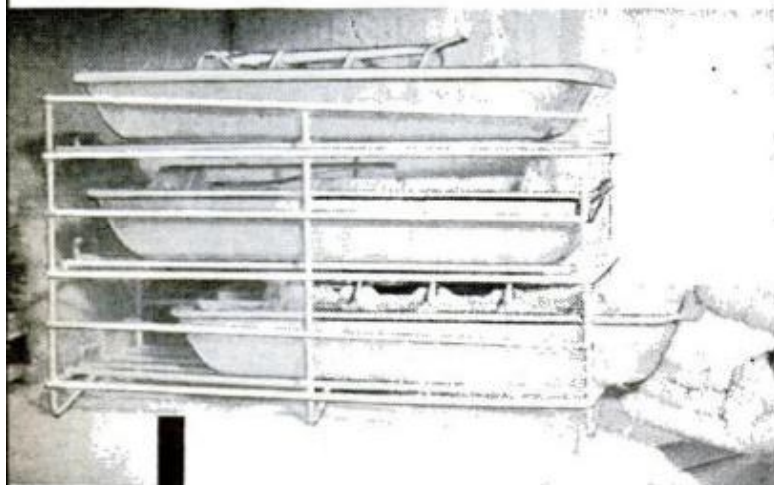

**ICE-CUBE-TRAY RACK** stacks 3 full-size trays for easy access in freezers over 8 inches high. Chrome-plated rack costs \$3.20; Stewart's, 433-61 St. N., St. Petersburg, Fla.

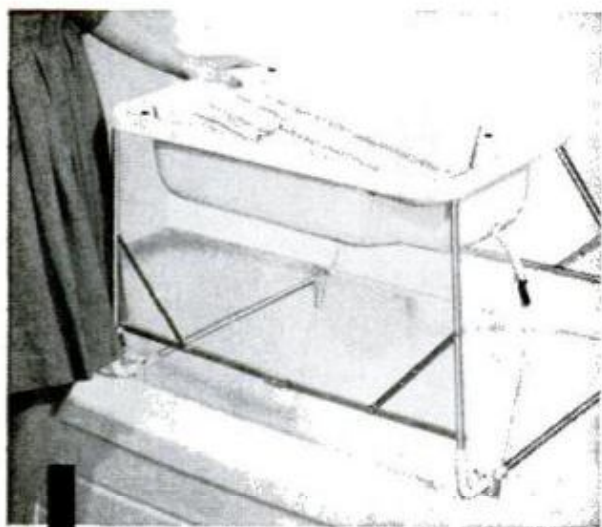

**BABY'S BATHTUB** of polystyrene with steel frame locks safely onto standard bathtub, uses big tub's faucet and drain. Price: \$12.95; Century Prod., 3510 Chatham, Cleveland, Ohio



**UPHOLSTERY FOAM SHAMPOO** and sponge applicator unit cleans color-fast fabric and leather, dries within an hour. 14-ounce aerosol can will clean two chairs or a sofa. Cost is \$1.49 from Bissell, Inc., Grand Rapids, Mich.



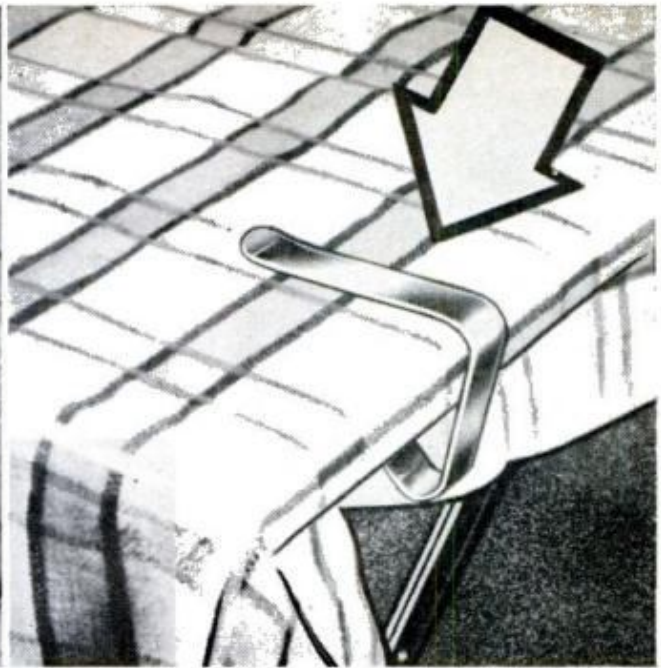
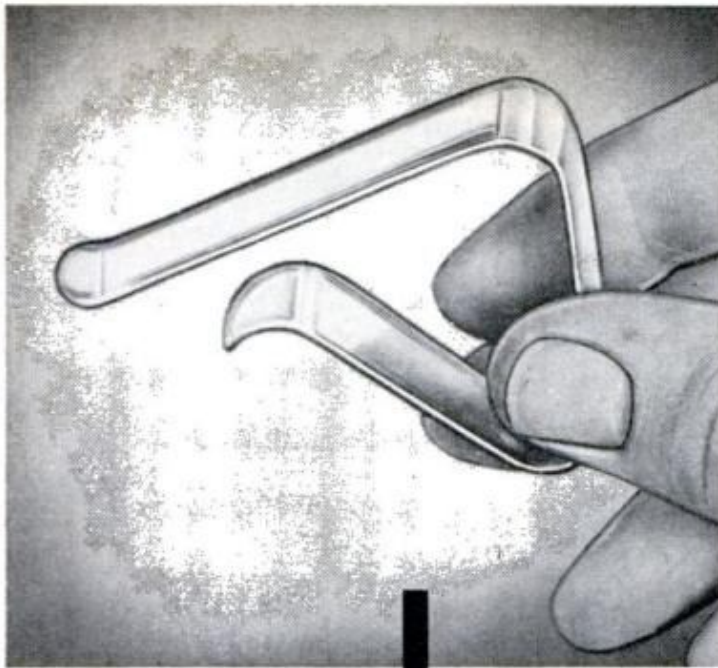

**PICNIC CLIP** of spring steel, one-half inch wide, bends into position and instantly holds down cookout gear, foiling the wind. To secure a tablecloth or napkin, the flat leaf goes on top with the angle section underneath. For paper plates, the angle section goes on top. Set of six costs \$1 postpaid from W. Perusse, P.O. Box 81, De Kalb, Ill.

**PLASTIC-BAG SEALER** unit of heater, wheel, lubricant, mat and stand heats to 265 degrees F. and operates by rolling wheel over ends of bags. Complete kit costs \$12.95. Made by the Harwil Co., 1009 Montana Ave., Santa Monica, California



**VIEW THE NEST** through a one-way mirror without being seen by the birds. Plastic wren nest attaches to window glass with special tape, needs no maintenance. Price per nest: \$2.98, from Vu-A-Nest Co., Box 21, Granite City, Ill.





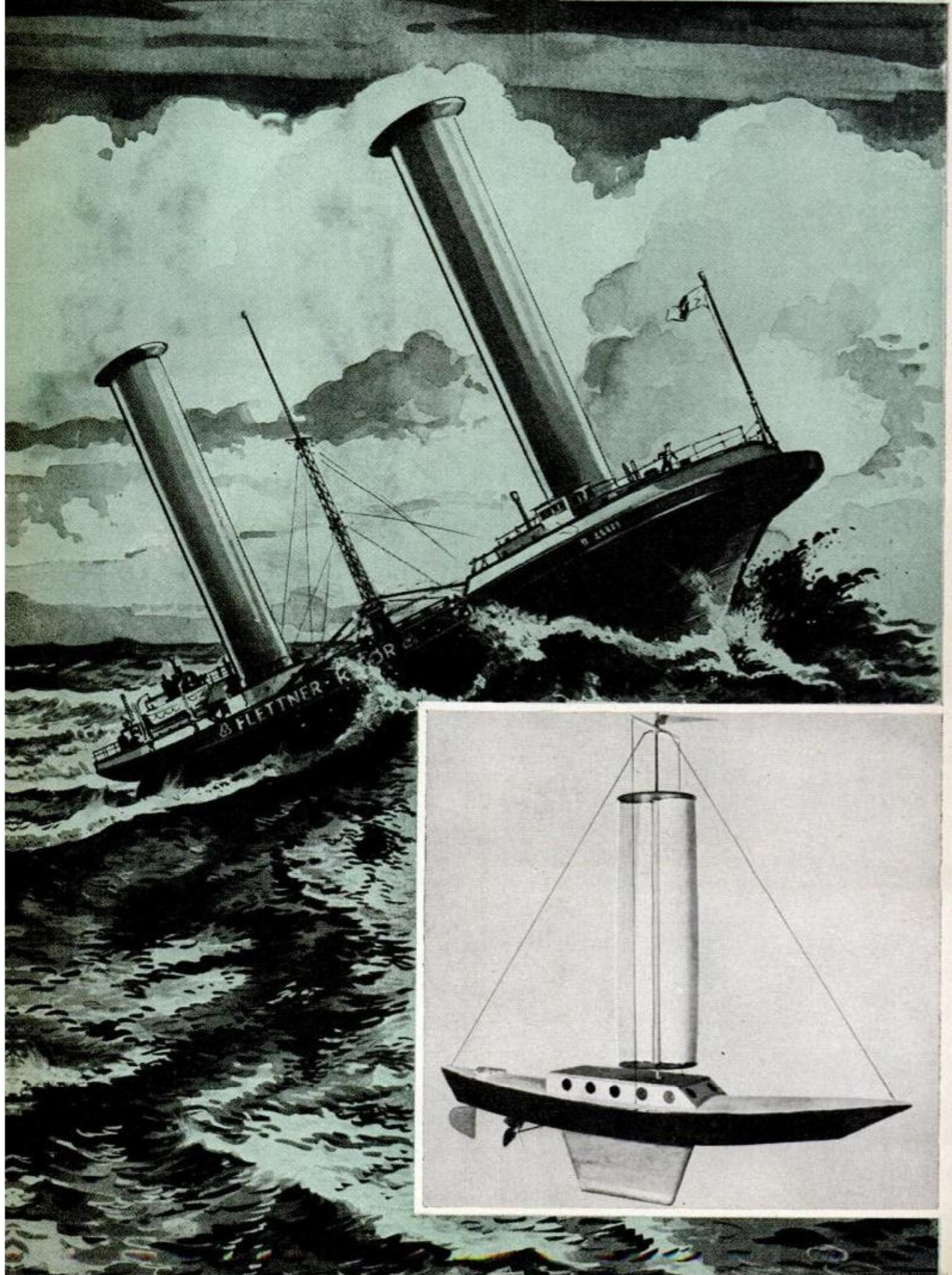



# ROTOR-SAILING SHIP

By Roy L. Clough, Jr.

ANTON FLETTNER'S famous rotor ship *Buckau* was propelled by spinning drums upon which the wind acted to produce thrust. While it required a small motor to spin these rotors, the main source of power was the wind harnessed through the Magnus effect—if a drum is set to spinning in a wind, a thrust vector is produced at 90 deg. from wind impingement.

Unlike the original rotor ship, this little model uses an unpowered modified rotor which also provides rotary shaft power to spin an underwater propeller. It's actually a Magnus windmill that will spin regardless of the wind direction.

The thrust produced by the rotor is in direct proportion to the speed at which it turns. However, you will note that this rotor has been loaded with a rather large propeller which holds down its speed, since the propeller thrust must be greater than the rotor thrust. The reason for this is actually quite simple.

When the model has the wind on its port beam, the thrust of the clockwise rotor is dead ahead, but when the wind is on the starboard beam, the rotor thrust is toward the rear of the ship. In the first instance, the rotor thrust is added to the propeller thrust, but in the second it is subtracted. Thus, the greater prop thrust makes it possible for the model to tack either way, though it is fastest with the wind from port.

The graceful little hull will go together as easily as a box if you allow the cement to dry well between assembly steps. Solder the "shaft-log" bearing into a bit of tin-can stock and cement it into the hull. The deep keel (pine) should be cemented and nailed to the hull. Drill an undersized lead hole in this and drive in the  $\frac{1}{8}$ -in. wire mast. Ballast can be a length of old shafting, solder, babbitt or type metal. About 24 to 30 oz. will suffice.

To shape the vanes of the rotor, soak the balsa until it's pliable, then bind the two sheets around a  $2\frac{1}{4}$ -in. mailing tube which you have covered with wax paper. When dry, you can make minor dimensional corrections by springing them slightly during assembly. Next, roll up a tube of stiff paper, soak it well in model airplane dope and mount it between the rotor end disks on locating plugs. Finally, glue the curved vanes in place.

It's particularly important that the gearing and shaft in the power train work

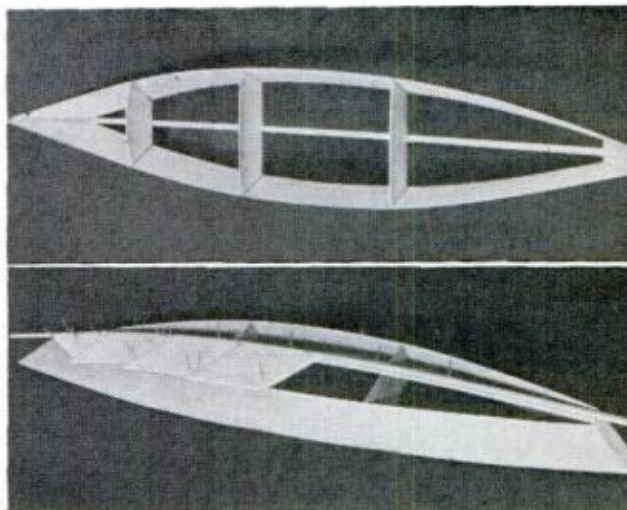

TWO SIDES should be attached at stem and stern block, then sprung apart so that bulkheads may be inserted. Pin guide strip to keel so that different sections of bottom planking may be aligned easily

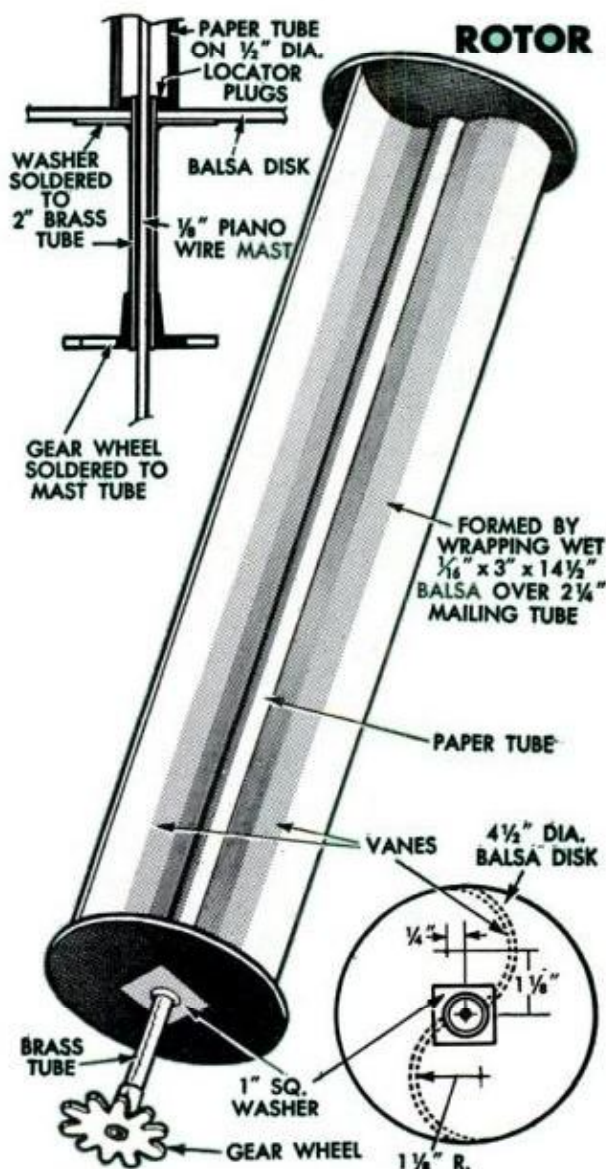



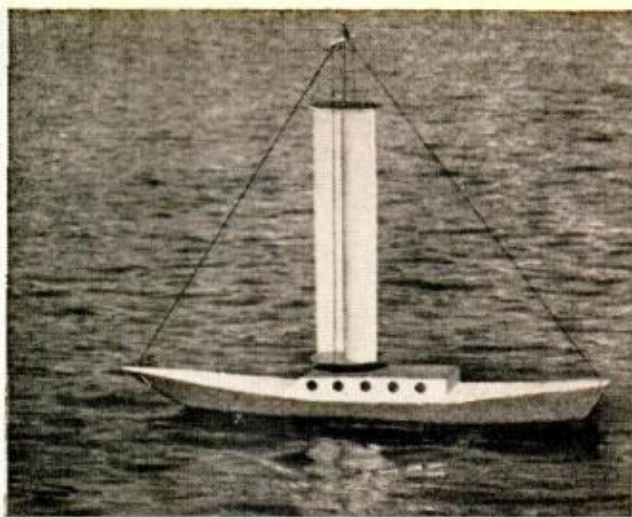

**ROTOR SAILER** makes best speed when wind is on the port beam. At varying angles in front of the wind, speed will vary with thrust vector resultant

freely. Flattened egg-beater gears were used in the model illustrated, but many similar gears would have worked just as well. Be careful to align the cross member which supports the upper part of the propeller shaft. This should mesh perfectly with the gears. You can adjust the location of the rotor gear by slipping washers or bits of tubing over the rotor mast so that this gear engages the prop shaft gear favorably. The shaft log bearing may be very loose and still not leak water, since a couple of drops of lubricating oil will be enough to keep the water from entering.

Make a trial assembly before permanently mounting the parts. The cabin roof should be spot-cemented in several places so that it may be removed easily in case adjustments are necessary. ★★★

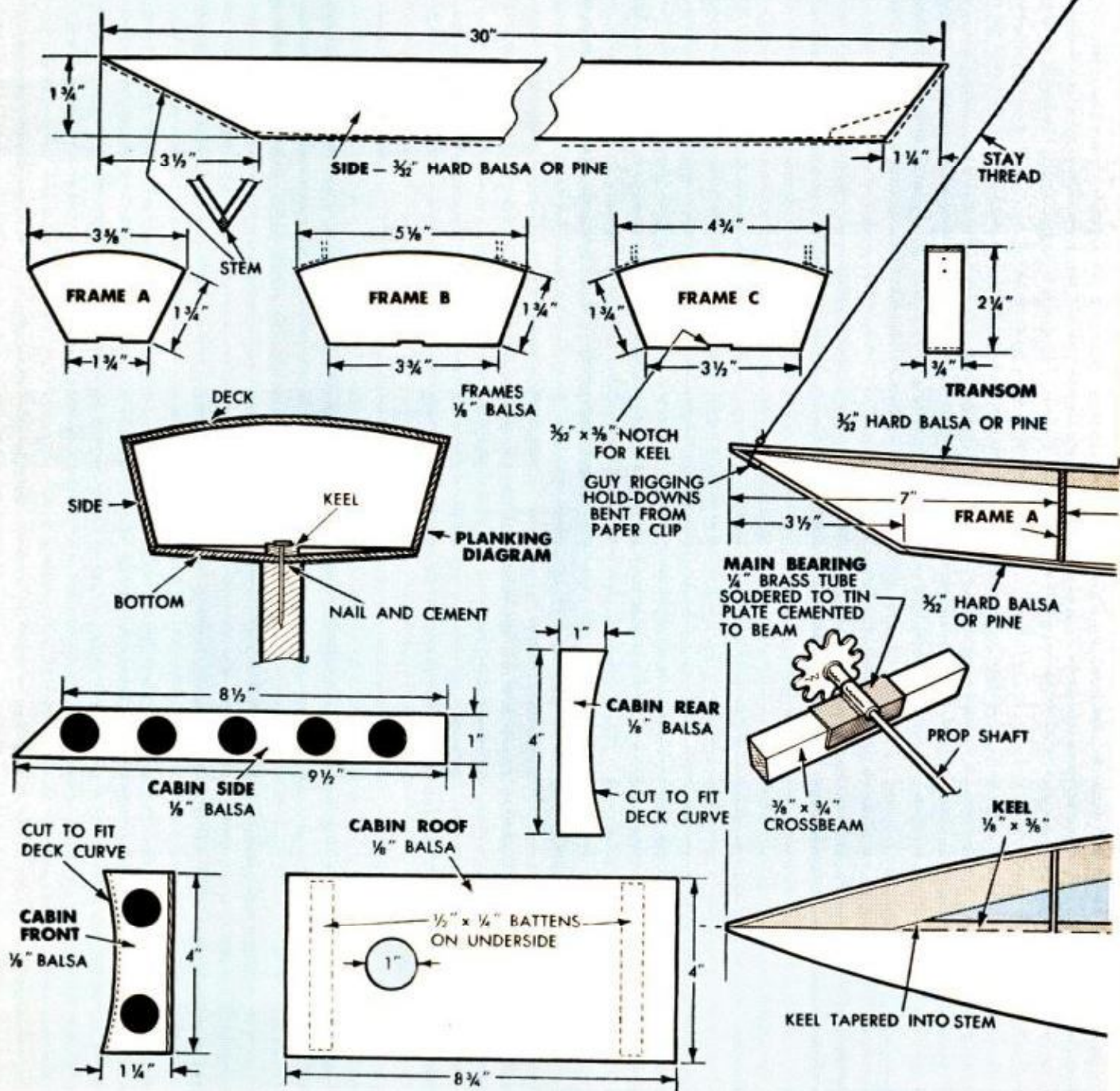



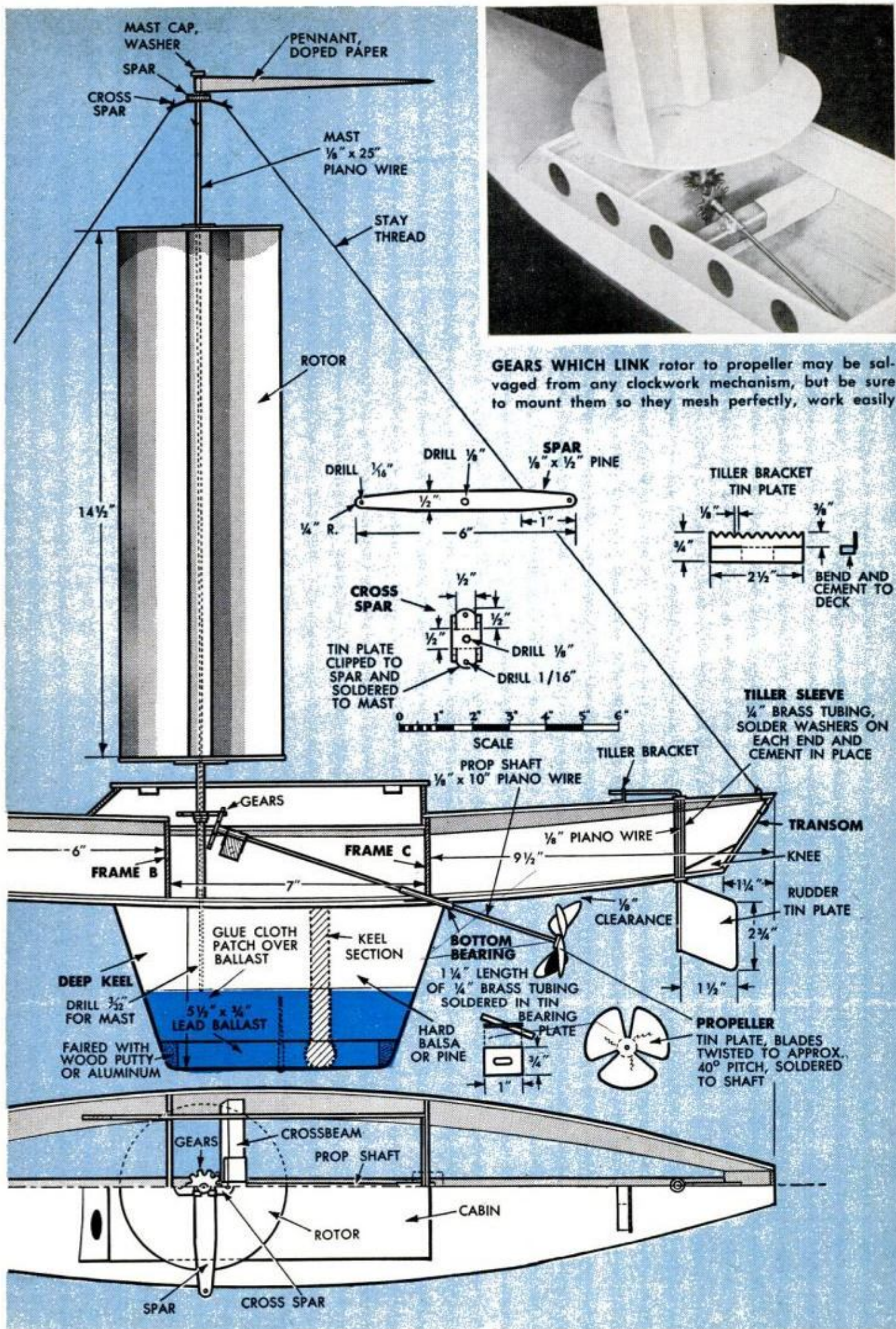

GEARS WHICH LINK rotor to propeller may be salvaged from any clockwork mechanism, but be sure to mount them so they mesh perfectly, work easily



# PERK UP THAT

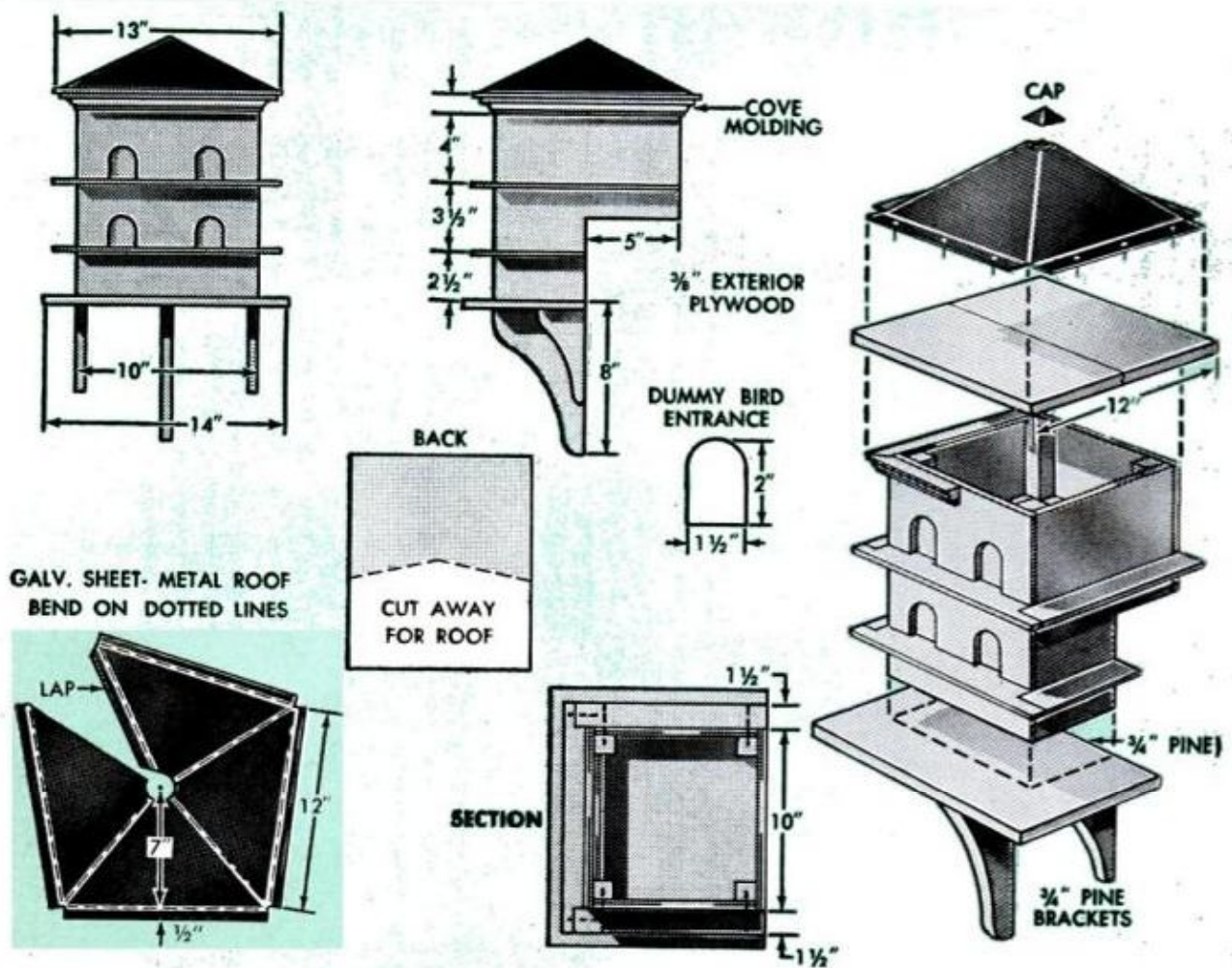
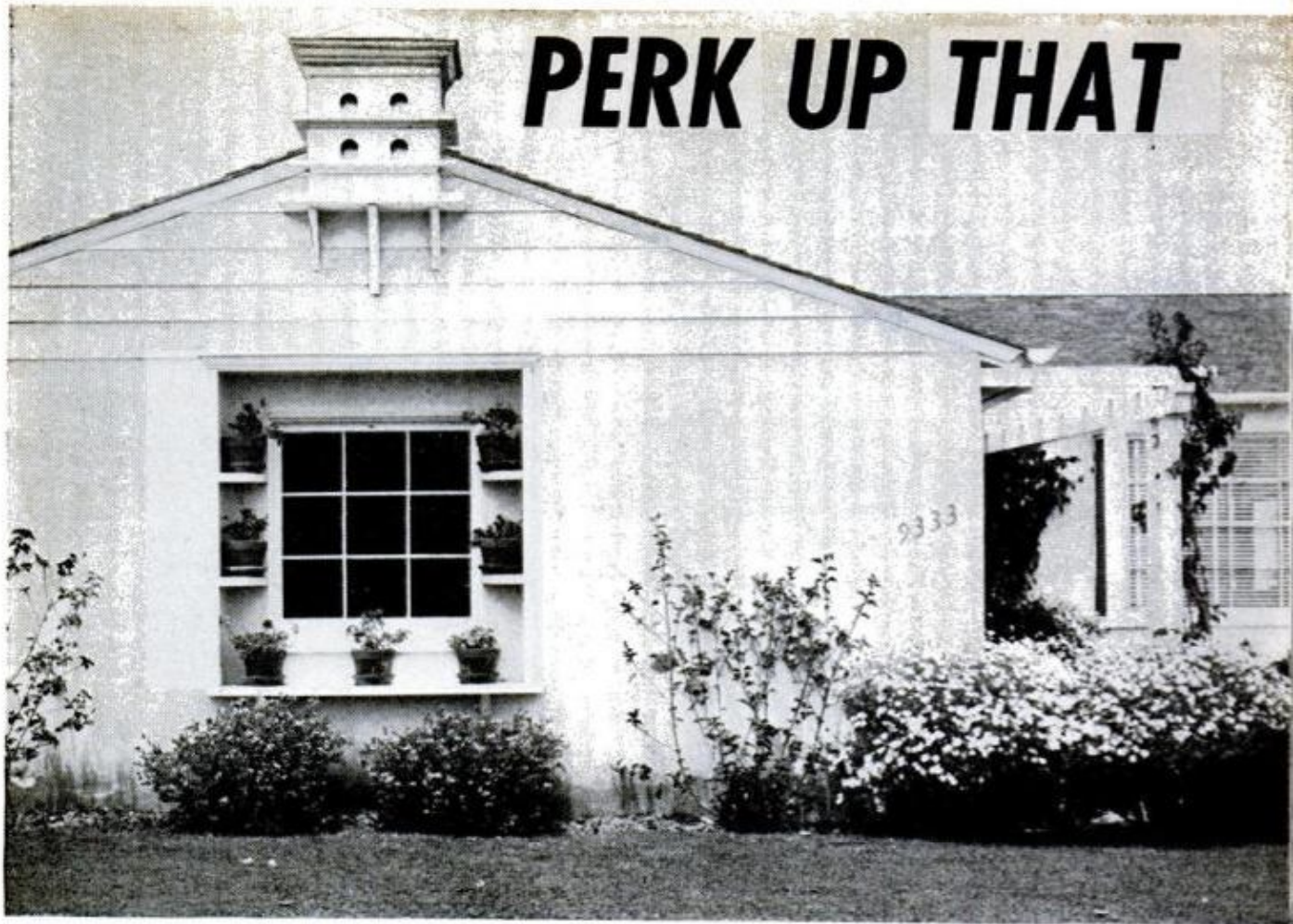



# PLAIN WALL

RELIEVING the plain outward appearance of a home often can be done with a few simple embellishments, and a good example is shown in the photo at the left. Without the birdhouse cupola and the shadow-box window shelf, you can picture how plain looking this wall would be. Yet with the addition of these two face-lifting items the house takes on a distinctive individuality.

The cupola is a dummy affair and made to only look like a birdhouse since the entrances are actually boarded up. The shadow-box window shelf simply frames the existing window and is merely hung over it like a picture frame. In each case, the dimensions given must be adapted to suit individual requirements. The back of the cupola, for example, must be cut to match the pitch of the particular roof. Likewise, the size of the window determines the over-all size of the shadow-box frame. Stock lumber and molding can be used for both items. If you use plywood, be sure it is the exterior type. The roof can be copper or galvanized.—Hi Sibley

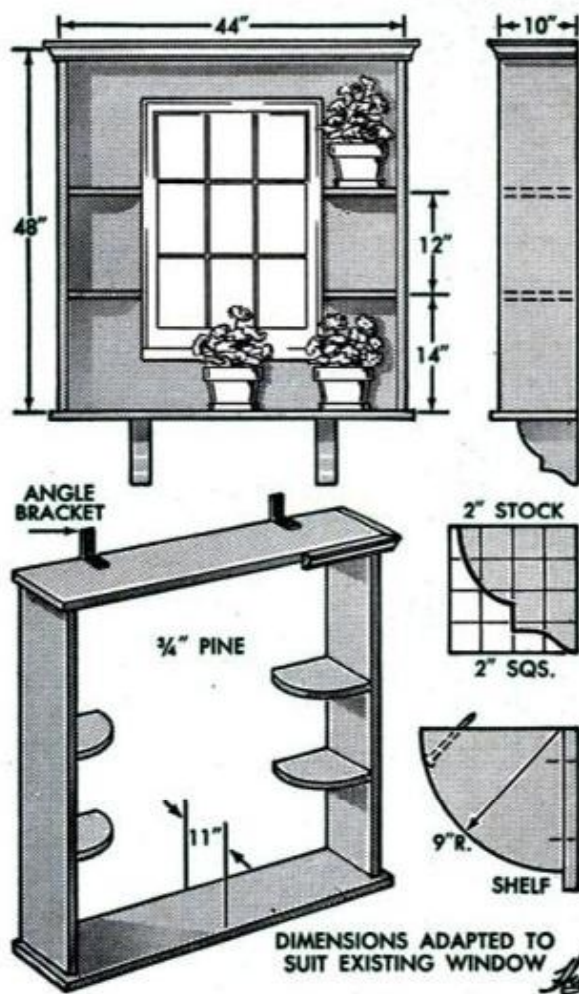

## Pint-Size Rake

Cutting down a bamboo rake to 5 or 6 teeth made the handiest tool I ever had for raking out between shrubs. I simply cut away the outer teeth and retwisted the original wire lacing to hold the remaining teeth intact.—P. Casperson

## Less Briquets

The average size barbecue grill is fine for a large cookout, but when grilling a steak or two, the large fire bed is a waste of fuel. Here is where you can make good use of a narrow notched ring formed from a strip of sheet metal to confine the fire.





# Easel Caddy Holds Cleaner Attachments

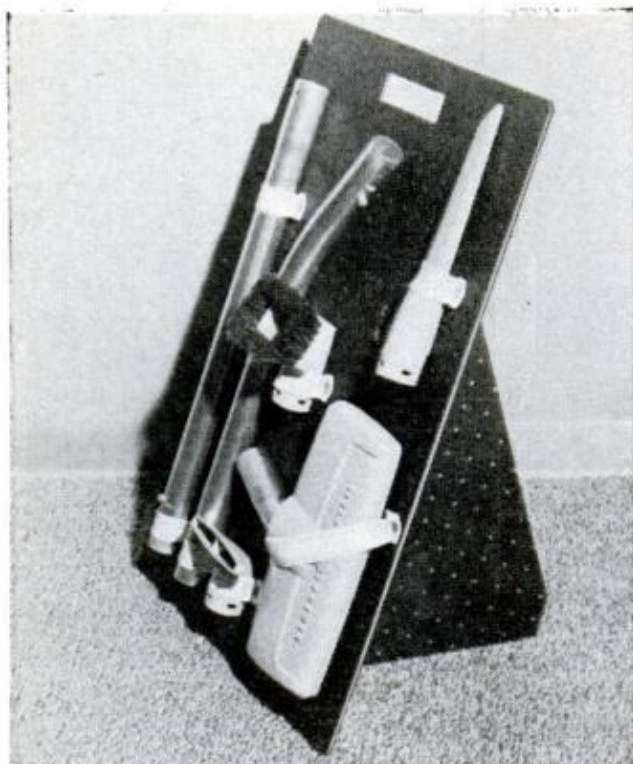

Here's a handy low-cost rack for vacuum-cleaner attachments that can be hung in the broom closet when not in use. On cleaning days, your wife can take the whole rack with her from room to room, standing it up by just folding out the hinged brace in the rear. Thus, every at-

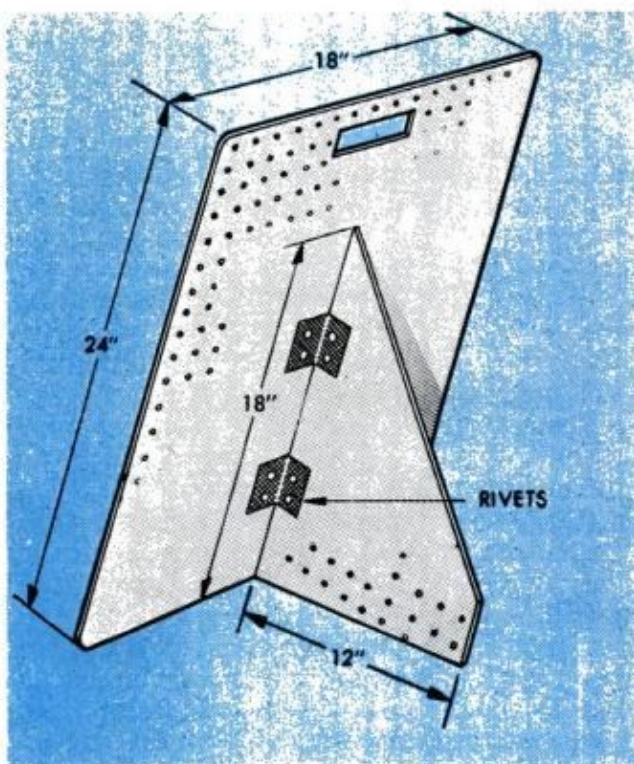

tachment is always handy, ready for instant use. It's an easy one-hour project. Just rivet elastic-webbing slings to the perforated hardboard to hold the attachments, and use rivets to mount the hinges. A slot at the top serves as a built-in handle.—*Barbara B. Paine*

## Flat 3-D Trellises Are Designed to Fool the Eye

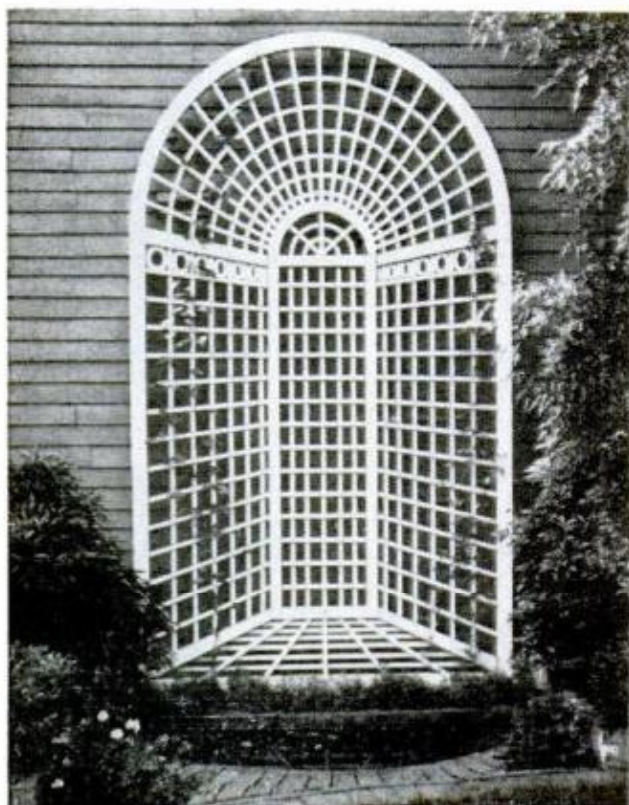

You'd think that you could walk right through these 3-d trellises but actually they are flat structures fastened to the side of the house. After making a full-scale paper pattern, 2x2-in. stock is cut and assembled to form the framework. The 1-in. lattice strips of the arch are spaced to create an optical illusion. The other trellis is made with 1½-in. strips tapered and spaced to fool the eye. Lap joints assure rigid construction.

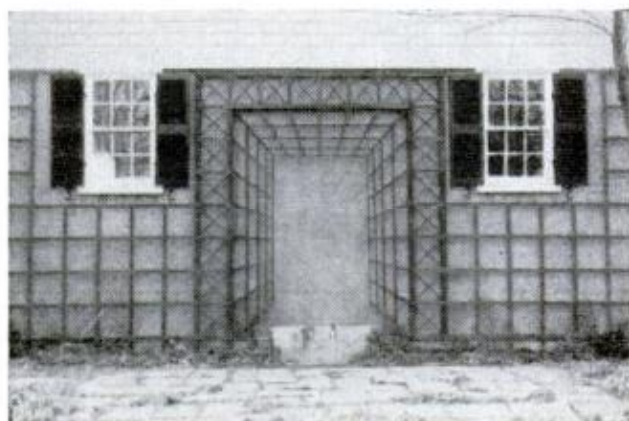



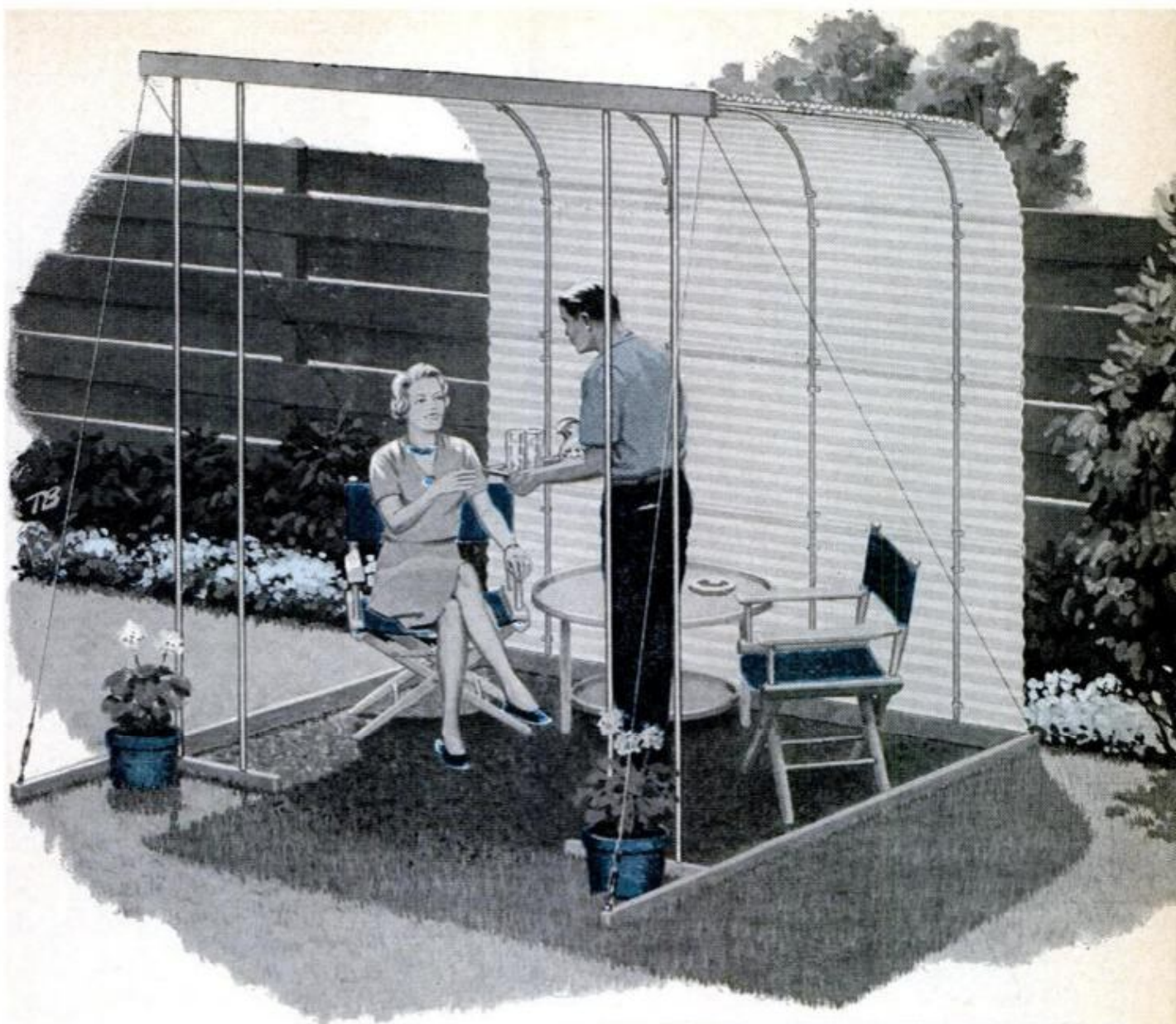

# LAWN CABANA

**W**ANT TO GET AWAY from it all to the peace and quiet of the back yard? This attractive cabana will shelter you from a hot afternoon sun and provide a delightful spot to relax, away from household din.

It's light enough to pick up and move about and park where you want it, and it can be made as festive as you want by covering it with colored fiberglass or aluminum. Best of all, the whole thing comes apart so you can put it away for the winter. The pipe supports merely rest in holes bored in the 2 x 4 framework, and pipe clamps permit the corrugated panels

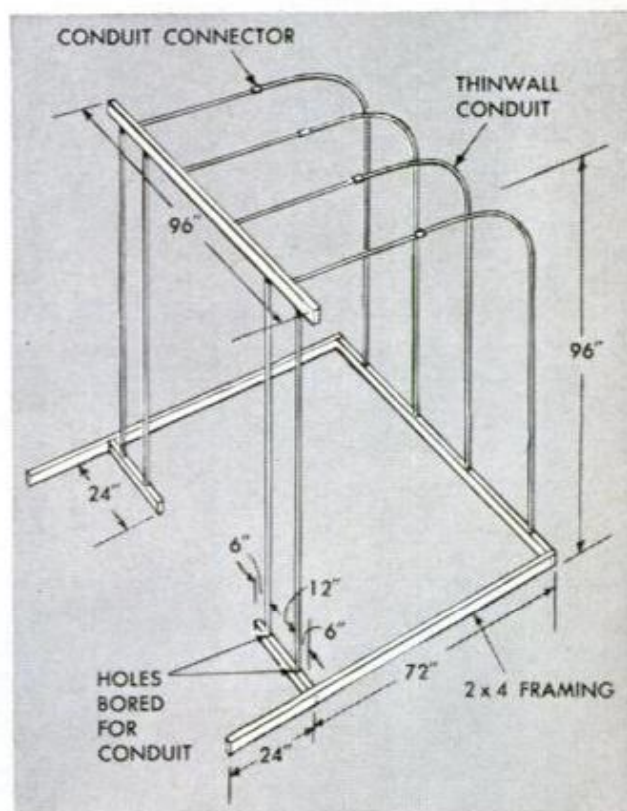



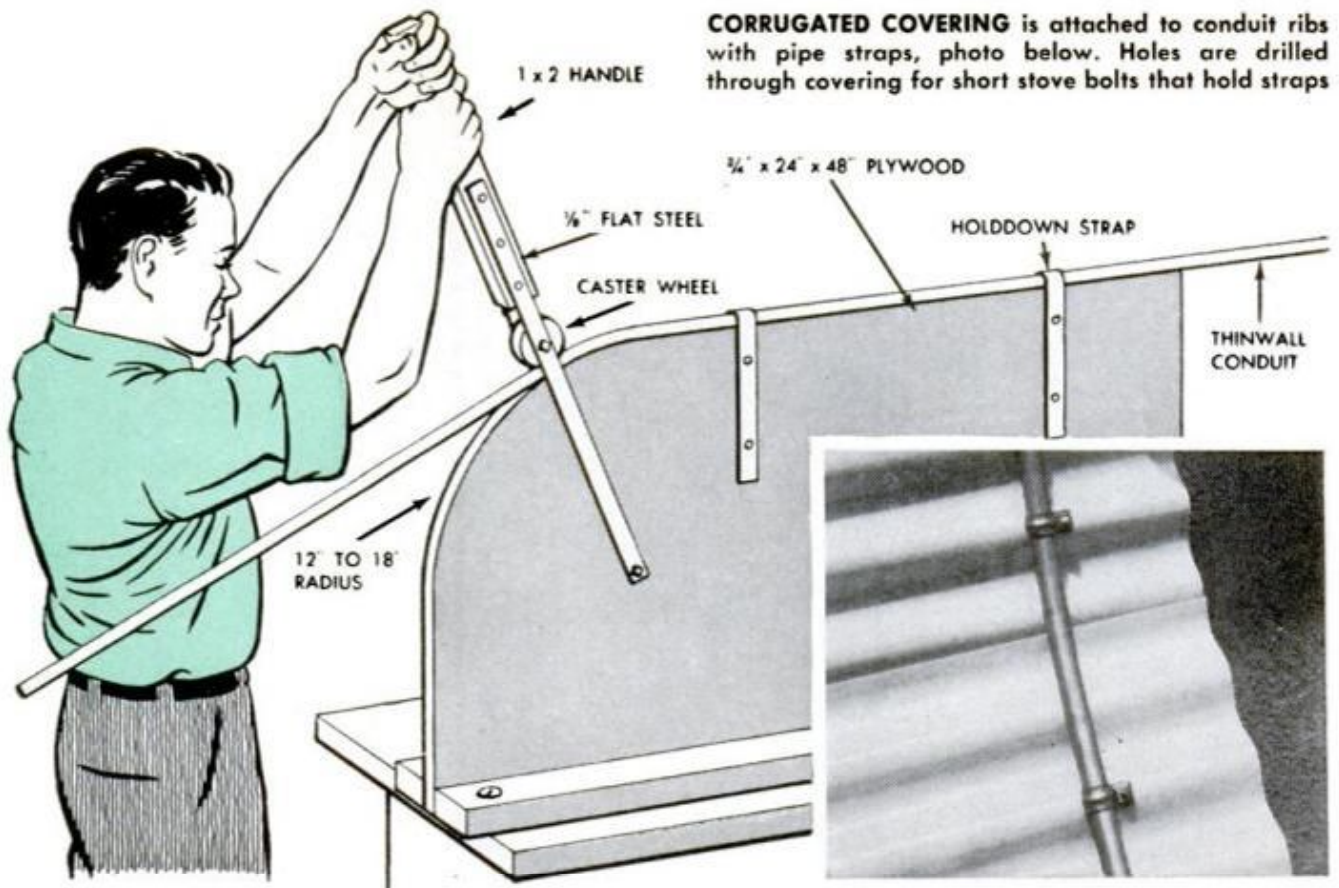

**CORRUGATED COVERING** is attached to conduit ribs with pipe straps, photo below. Holes are drilled through covering for short stove bolts that hold straps

to be removed. Stakes, turnbuckles and guy wires hold it together and keep it from blowing over in a strong wind.

It's a simple thing to make. The pipe supports are formed from standard 10-ft. lengths of 1/2-in. thinwall conduit, and the base is nothing but 2 x 4s set on edge. The four front poles are cut 8 ft. long and the 2-ft. leftovers are coupled to full 10-ft. lengths to form the four bowed ribs.

You can bend the ribs with a borrowed conduit bender, but a jig like the one shown above makes it a simple matter to bend all four ribs exactly alike. The important thing in making the jig is to be sure that the caster-fitted handle is pivoted at the exact center of the radius

point, and that there is snug clearance under the caster for the conduit. In bending each length, a mark is made on the conduit at the point of bend and aligned with a similar mark made on the jig. The 15-deg. springback you will get when the tubing is removed from the jig will give you the desired 75-deg. bend. Regular thinwall connectors are used to join the 2-ft. extensions to the short ends of the curved ribs.

Seven sheets of 26-in.-wide corrugated fiberglass or aluminum are required to cover the cabana. Holes for short 1/4-in. stove bolts are made in the panels at the crest of the first or second corrugations, 3/4 in. to one side.—*Mac L. Olds*

## Loop of Emery Cloth Puts Keen Edge on Pencil Sharpener

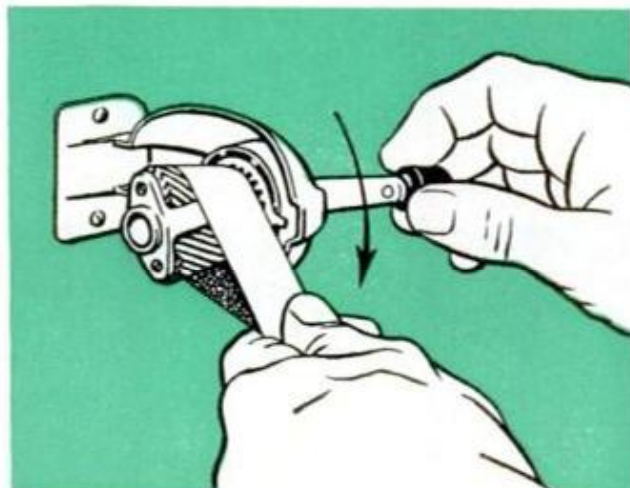

If you've noticed that your pencil sharpener doesn't give the clean-cut point it did when new, you can touch up the roller blades without removing them. Simply remove the shaving container and loop a strip of emery cloth over the cutters in the manner shown. Then crank the sharpener in a reverse direction as you move the cloth back and forth across the blades. A few times across is all it takes to whet the cutting edges.—*Michael Ligocki*

**Cane chair seats** can be made taut again by sponging bottom with vinegar solution, 2 tablespoons of vinegar to 1 qt. of water.



## Screw-Cap Brushes

Where you have daily intermittent use for paints, shellacs or oils, you have the twin problems of keeping the materials from drying out and the brushes in workable condition. You can solve both by punching a hole through the screw tops of the jars to take the brush handles. Cut a disk of wood of a diameter near that of the screw top, center drill and cement the two together. Slip the brush handle into the hole and adjust so the brush is immersed in the liquid when the top is in place.—*Jack Eisner*



## Holder for Tube Cement

I got tired of replacing the cap each time when using a tube of quick-setting cement just in order to set it down. So I made a holder from a block of wood which would let me stand the tube upright after each use. As you see, I simply cut a groove across the block in which to rest the end of the tube. To make it still handier, I drove a headless nail in the holder so I would have a way of getting the cement to flow should it dry in the end of the tube while left open.



## Triangle of Many Angles

A protractor will serve as a triangle of infinite angles when used in conjunction with this simple guide. Placed against the T-square, the guide supports the protractor at two points, and by using the edge of the guide as a reference point, the protractor can be set for drawing lines at any angle from 0 to 90 degrees by merely rotating it on the guide. To make one you simply cut a piece of thin plastic perfectly square and then jigsaw it after scribing around the protractor to mark the two arcs.

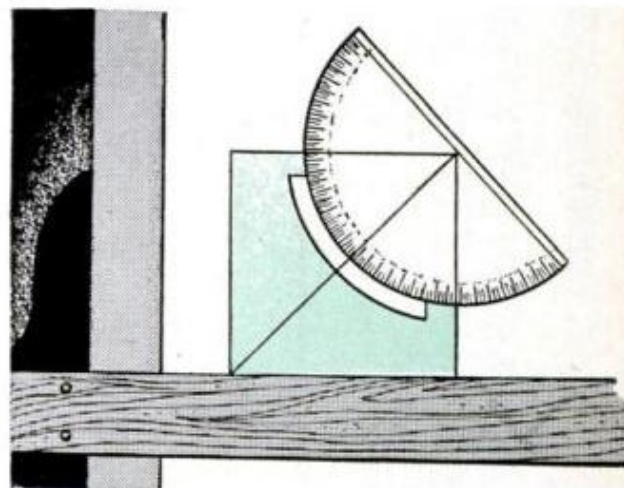

## Toolbox Dolly

You're sitting, or maybe standing, holding parts together with one hand while trying vainly to move that toolbox within easier reach. It won't budge—too heavily loaded with tools. This predicament is easily avoided by making a ball-bearing dolly for the box, using a piece of 1/2-in. plywood and four ball casters. Cut the plywood to the same measurements as the bottom of the toolbox. It can be used as a dolly or fastened to the toolbox with sheet-metal screws.—*Edward J. Kolb*

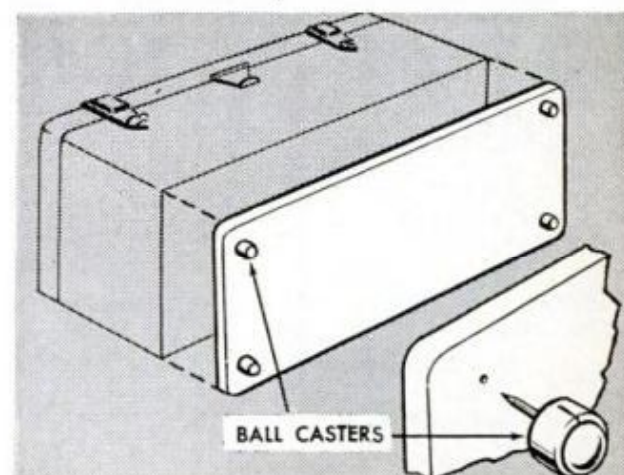





# Solving

## HOME PROBLEMS

**IF YOUR WIFE** does a lot of sewing and saves the scrap pieces of material to use for patches, suggest that she organize these in a "scrap" book. Simply mount the pieces in a large scrapbook with cellophane mending tape. The book can also hold samples of fabric which she has stored away for later use

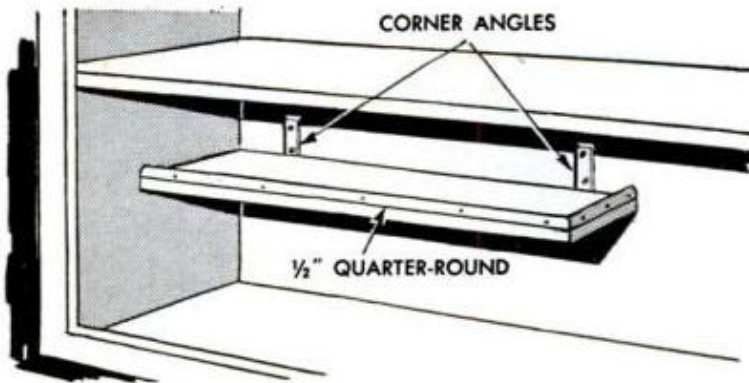

**NEED EXTRA SPACE** in a kitchen cabinet? Add a small auxiliary shelf for tumblers, cups, etc., and you'll double the capacity of that part of the cabinet. Hang it with angle irons

**MAKE A TOOL** for cleaning the blades of a kitchen mixer by cutting a shallow slot in a plate scraper. Slip this over a blade and you can clean both surfaces in one easy stroke

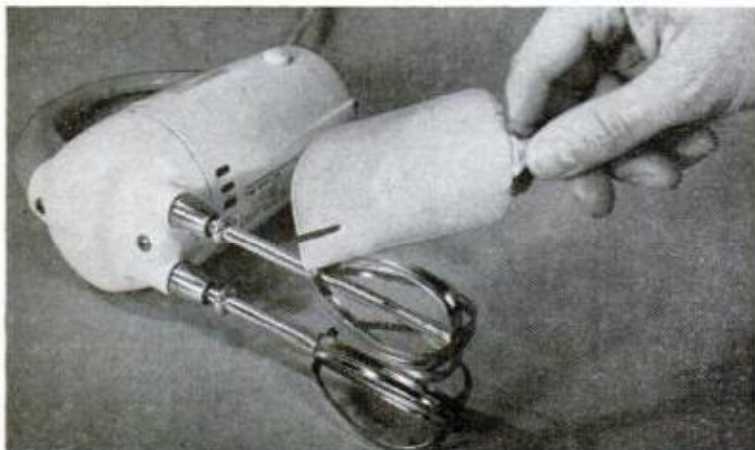

**MOST PEOPLE** use small felt pads on the bottoms of cigarette boxes, lamps and ash trays which might scratch polished surfaces. Plastic rubber works just as well and is much easier to apply. Put a dab at each corner or a bead around the edge

**CEREAL CARTON** makes a dandy sandwich case for picnics, because the foil or wax-paper will protect sandwiches and keep them from drying out. Just fold the lining down and close the flaps. Such a carton also works fine as an emergency lunch box





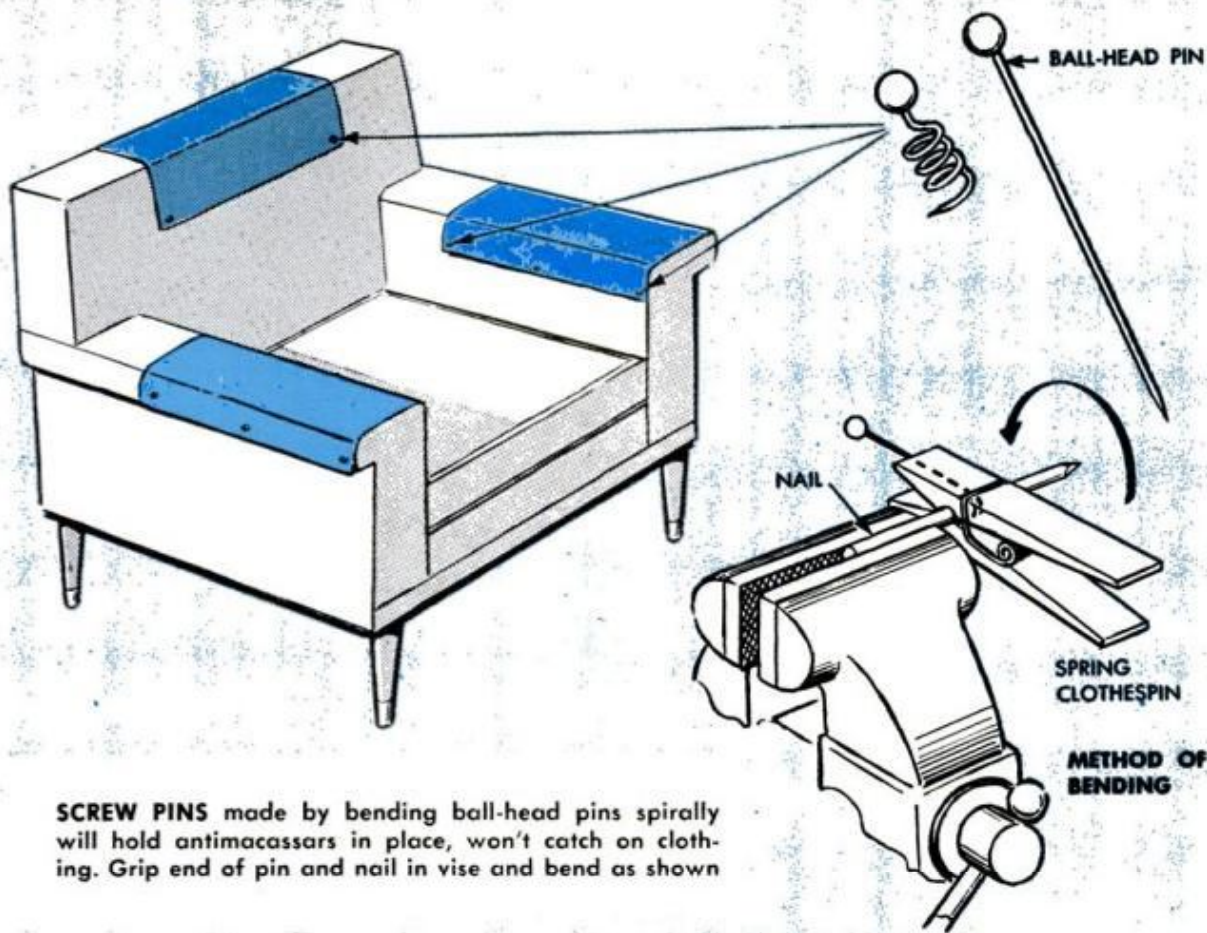

**SCREW PINS** made by bending ball-head pins spirally will hold antimacassars in place, won't catch on clothing. Grip end of pin and nail in vise and bend as shown



**HERE'S ANOTHER TIP** for the seamstress. Spools, even when placed upright, are often accidentally knocked over so that they roll off the table. To avoid this, lay the spool on its side in the handle of your scissors

**SQUEEZING** the last drop of glue or toothpaste from an "empty" tube is easy if you have a pencil handy. Just place the tube on a flat surface and run the pencil from bottom to top, pressing it down firmly

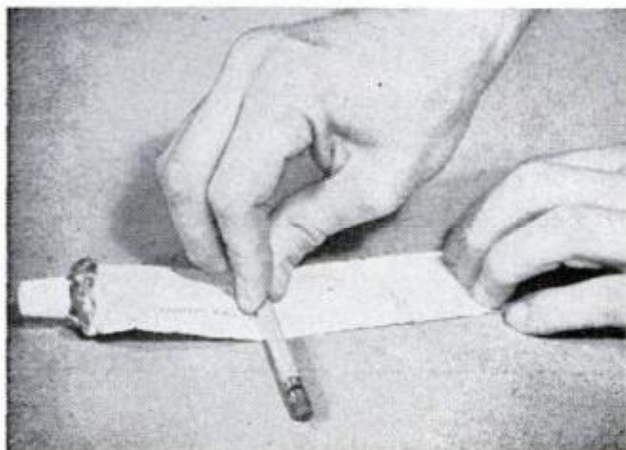

**TO GET A GRIP** on a stubborn jar cap, stretch two rubber sealer rings over it. These will provide a no-slip grip for your hand, enabling you to concentrate your efforts on twisting the reluctant cap





# SHIP AHOY, MATEY!

WITH A CARGO of cookies and a crew of kids, this back-yard sloop is ready to set sail. It's made mostly from exterior plywood with stock lumber being used for the supporting members and other parts.

Begin by nailing the "deck" to the crossbeams. As indicated in the drawing, the mast and crosstree are made of 2x4s. Since the crosstree will see considerable service as a crow's nest, be sure that the 2x4s are bolted solidly to the mast.

Next, fit the topmast to the aft edge of the main mast, nailing it to both the mast and the aft crosstree member. Bevel the top of both masts and center a screw eye on each beveled face to attach halyards.

The mast is anchored by inserting it through a hole in the deck and bolting it to the 2x4 bracing underneath. Additional blocking, nested around the base of the mast as shown, provides extra rigidity.

Erect the bridge by nailing two 2x2 cleats across the main deck, adding side panels and a plywood transom. Bolt the wheelpost in place before nailing down the bridge deck.

Make the ship's wheel by sandwiching 1x1 spokes between plywood disks. Nail the spokes to the 18-in. disk, so that 4 in. of each projects beyond the edge. Rasp these projections round before adding the 8-in. disk. Drill the wheel and the post for a 1/4-in. bolt.

Paint the sloop before outfitting with sails and rigging. Pass the flag cord through the topmast screw eye without knotting; the kids will enjoy running the flag up the mast. Tie the forward bow-sail clothesline to the main-mast screw eye; the back line merely ties into this.

Cut sheeting to the size of the sail outlined by the ropes, pinning the two long edges over them. The hems may be sewn by hand with the sail in place or the lines may be untied and the sail removed for machine sewing.

The dowels, used as rungs in the rope ladders, are marked for drilling and cutting by tying the two ropes temporarily in place and holding each dowel in position for marking.—*F. N. Stephany*



## No More Fish Stories

Wet hands and a wiggling fish usually result in a story about the one that got away. You can avoid such disappointments by keeping the fish in the landing net while you disengage the hook. Simply close your hand around the outside of the net to get a firm grip on the fish while you remove the hook.—*John Krill*

## Saw It Square

Keeping a handsaw exactly perpendicular to the work is difficult when cutting wide stock. Solve this problem by sawing a 1 x 12 x 18-in. board halfway through. The cut *must* be at right angles to the face and edge. Use the kerf as a saw guide by starting the cut in the usual way. Then hold the board over the saw as shown.—*A. C. Cashion*





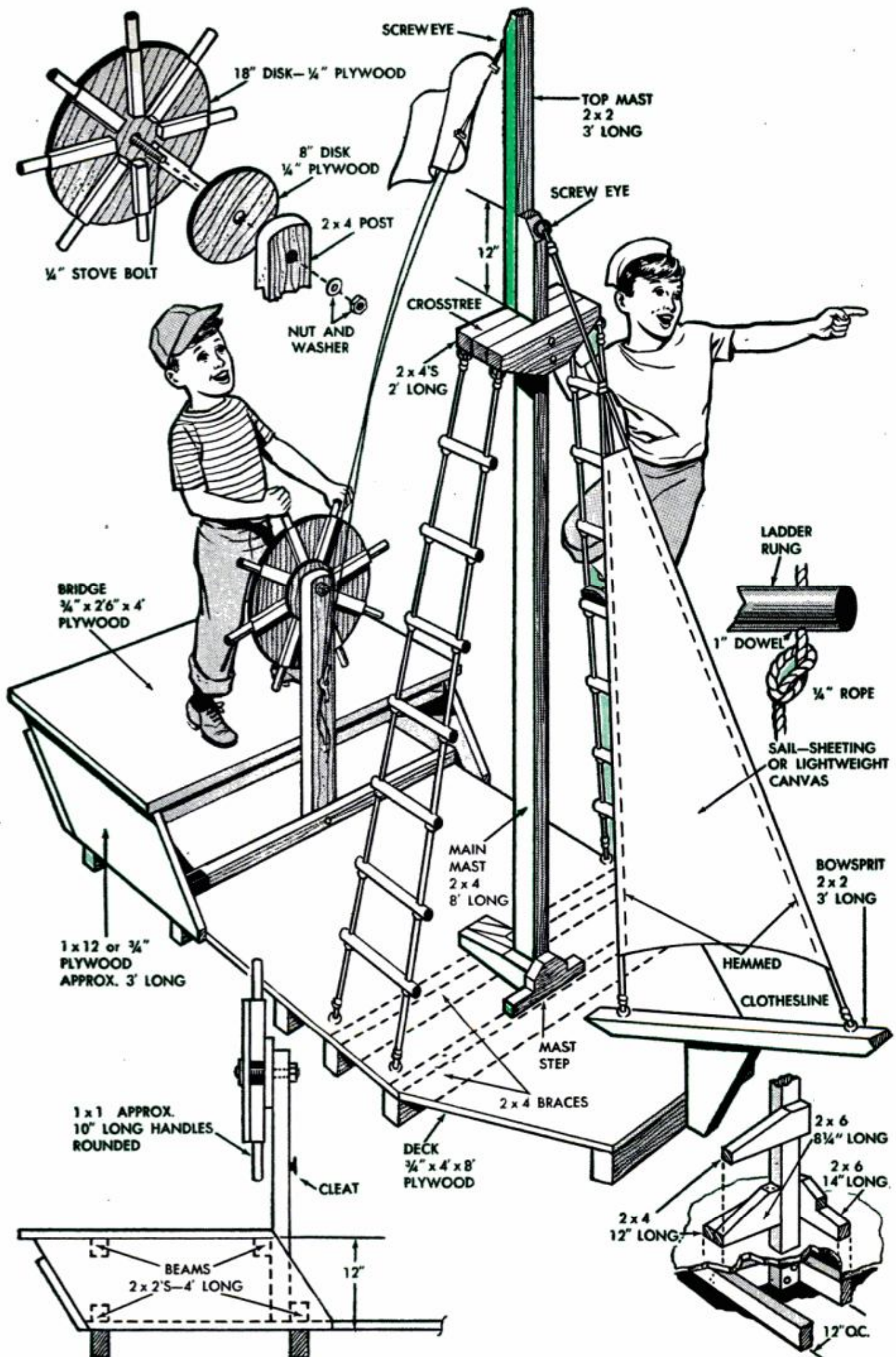



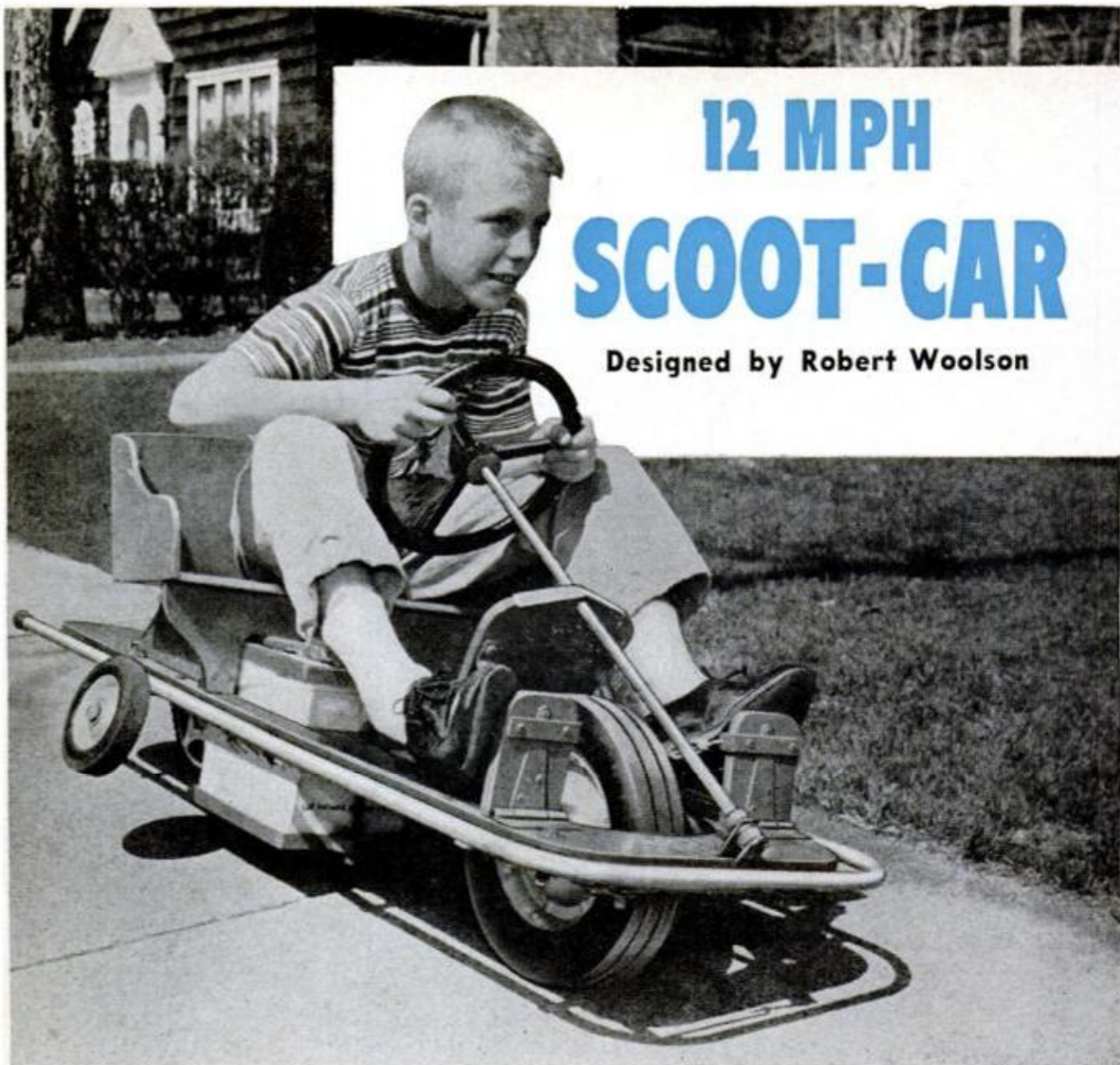

# 12 MPH SCOOT-CAR

Designed by Robert Woolson

**A novel positive steering gear, two forward speeds and a brake that stops on a dime make this sidewalk special a safe vehicle for young hotrodders**

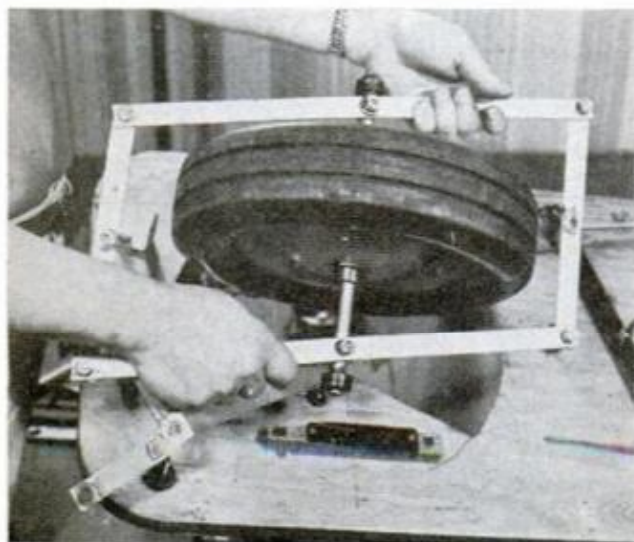

**O**NE full battery charge readies Scoot-Car for hours of fun. Cornering wheels, one on each side of the chassis, give the driver sure stability from a standing start, and a near top speed of 10 to 12 miles per hour puts the car up on two wheels where it steers and controls like a car, but rides like a speedy low-slung scooter.

When cornering, the car leans over on one or the other of the outrider wheels, enabling the driver to keep safe, full control when turning. Power and brake ap-

**PARALLEL-ARM** steering gear, assembled, being placed in position. Shorter pivot links are bolted to the deck, using washers and locknuts for free movement



plication are controlled by pedals with strong return springs. Release the power pedal, hit the brake hard and Scoot-Car stops within its length of four feet.

**Caution:** While Scoot-Car is a safe toy mechanically, there are precautions to observe in riding it. When operating it for the first time, the immediate reaction to tipping is to take the feet off the pedals and plant them on the ground. With the car in motion, this can pitch the rider forward. The outrider wheels, of course, make tipping over impossible, and after a few trial spins, the rider will overcome the tendency to brace himself and will keep his feet on the pedals.

Looking over the details you will see that Scoot-Car is most unusual in design, has a unique parallel-arm steering gear and a positive roller-chain drive from an

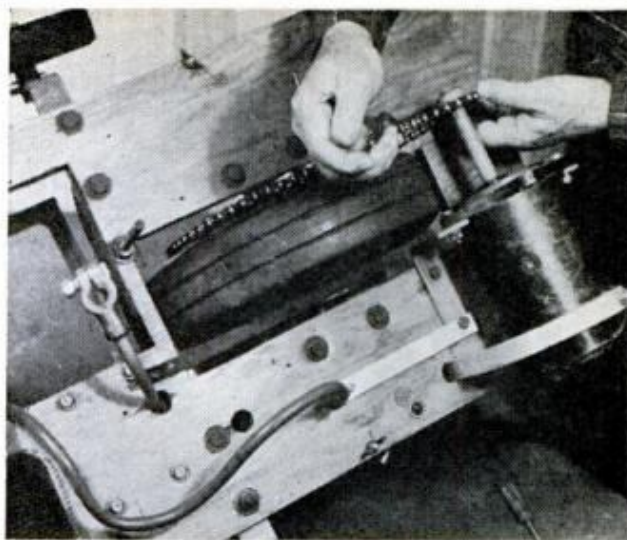

**ROLLER-CHAIN** assures positive drive from motor to ground wheel. Slack in chain should not exceed  $\frac{1}{2}$  in. Note position of the ground and power straps





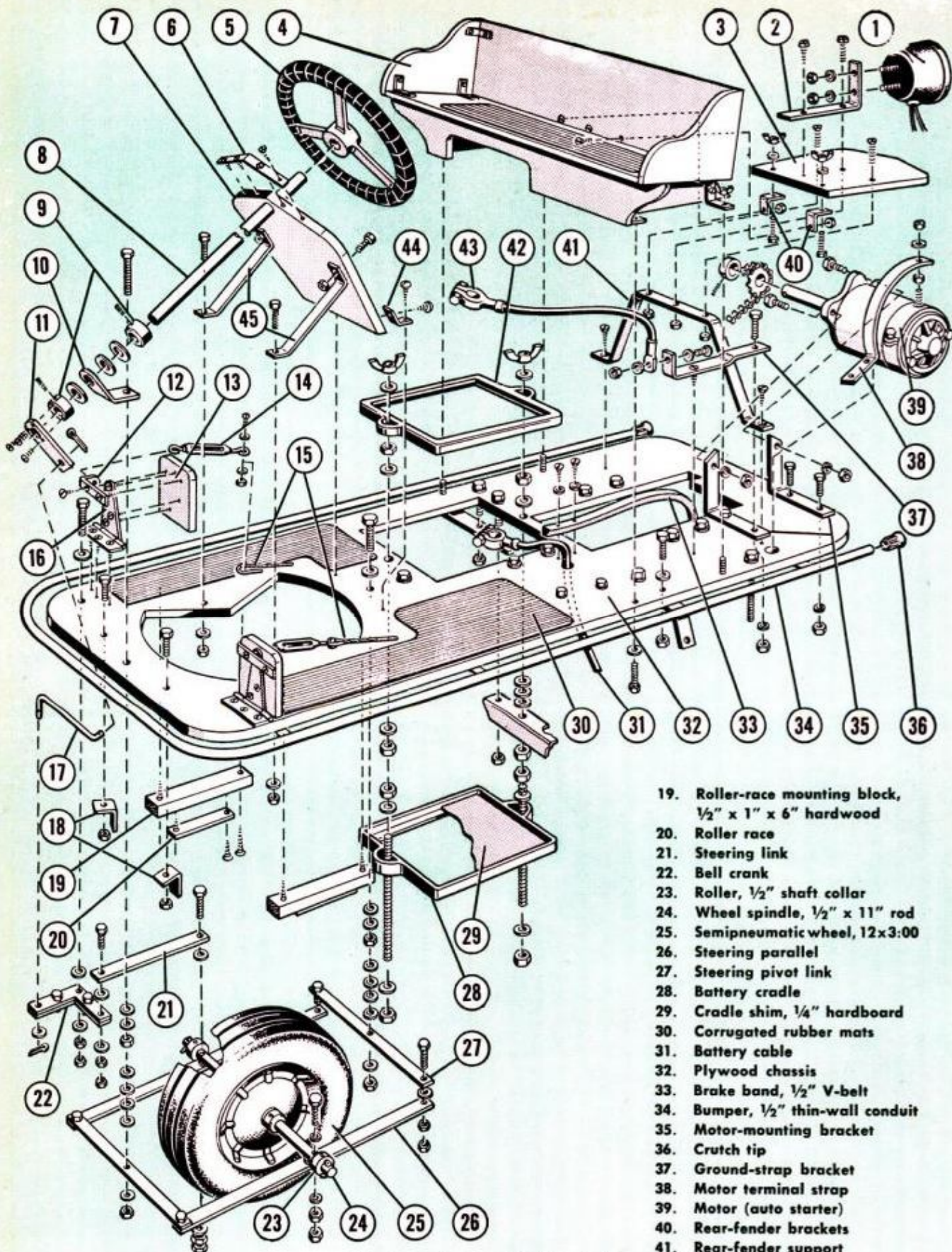

1. Taillight (optional)
2. Taillight bracket
3. Rear fender
4. Seat
5. Steering wheel
6. Front-fender trim (1/8" x 1/2")
7. Front fender
8. Steering post, 1/2" x 25" rod
9. Shaft collar, 1/2" dia.

10. Lower bearing, steering post
11. Steering arm
12. Cable bracket
13. Drive pedal
14. Turnbuckle
15. Drive and brake cables
16. T-hinge, 3" leaf
17. Tie rod, 1/4" steel rod
18. Steering limit bracket, 1/8" x 1" flat steel

19. Roller-race mounting block, 1/2" x 1" x 6" hardwood
20. Roller race
21. Steering link
22. Bell crank
23. Roller, 1/2" shaft collar
24. Wheel spindle, 1/2" x 11" rod
25. Semipneumatic wheel, 12x3:00
26. Steering parallel
27. Steering pivot link
28. Battery cradle
29. Cradle shim, 1/4" hardboard
30. Corrugated rubber mats
31. Battery cable
32. Plywood chassis
33. Brake band, 1/2" V-belt
34. Bumper, 1/2" thin-wall conduit
35. Motor-mounting bracket
36. Crutch tip
37. Ground-strap bracket
38. Motor terminal strap
39. Motor (auto starter)
40. Rear-fender brackets
41. Rear-fender support
42. Battery cradle
43. Battery cable
44. Fender bracket
45. Fender brace
46. Semipneumatic wheel, 6 x 1:50
47. Wheel bracket
48. Chassis cross brace
49. Control rod (pedal to switch)
50. Drive and brake cables
51. Return spring







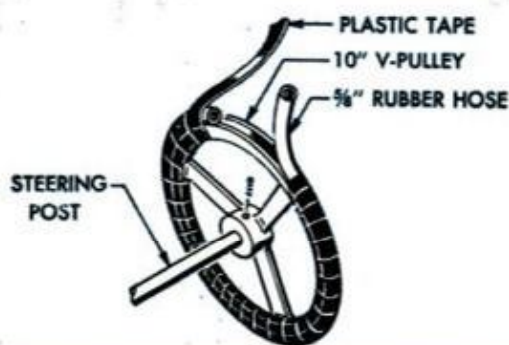
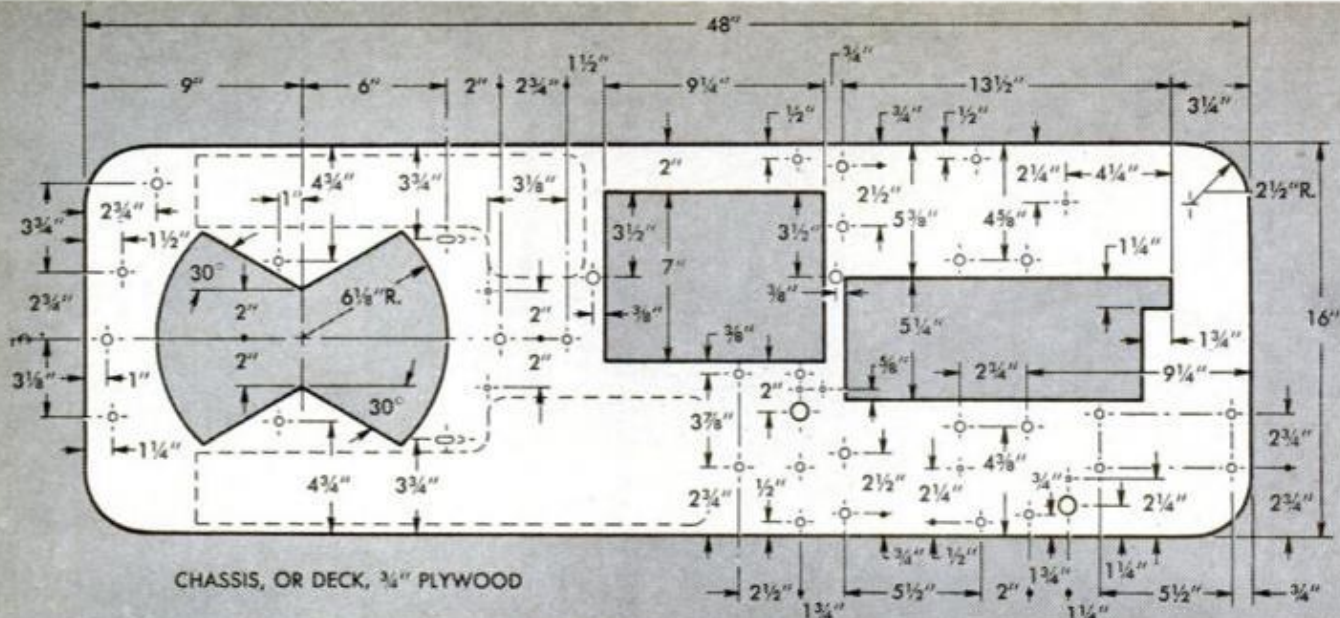

auto-starter motor. Throughout the construction, full use is made of standard, readily available parts and materials wherever possible. For example, the steering wheel is a 10-in.-diameter spoked V-pulley, wrapped with electrician's tape over a length of hose set into the V-rim of the pulley. This makes a neat, attractive wheel of just the right size.

Make the plywood chassis (part No. 32), first cutting the three openings for front and rear wheels and battery cradle as the first step. These openings should be cut just inside the pattern lines and then smoothed out to the lines with a wood rasp. Round corners slightly and sand smooth. Round the corners of the chassis to the radius indicated and sand all edges. Then lay out the hole pattern and centermark the location of holes with an awl. All smaller holes indicated are  $\frac{1}{4}$ -in. in diameter. Those for the battery-cradle studs are  $\frac{3}{8}$  in. in diameter to take  $\frac{3}{8}$ -in. threaded rod. Holes taking the rear-wheel bearing bolts are  $\frac{7}{16}$  in. in diameter and the two largest holes indicated take the battery cable and motor-terminal strap and are each  $\frac{3}{4}$  in. in diameter. The two holes, indicated as elongated, take the brake and power-control cables and are drilled  $\frac{1}{4}$  in. in diameter and at as steep an angle as possible, then enlarged with a round file so that the cables clear without binding. Dotted lines on the chassis indicate the position of the rubber foot mats.

Next comes installation of front and rear wheels. Take the front wheel first and begin by noting closely the relationship of the parts. The parallels and the pivot links are of flat steel (also often referred to as band iron) and are cut to length and drilled as detailed. The front wheel is centered on its spindle with shaft collars, and the outer ends of the spindle are car-

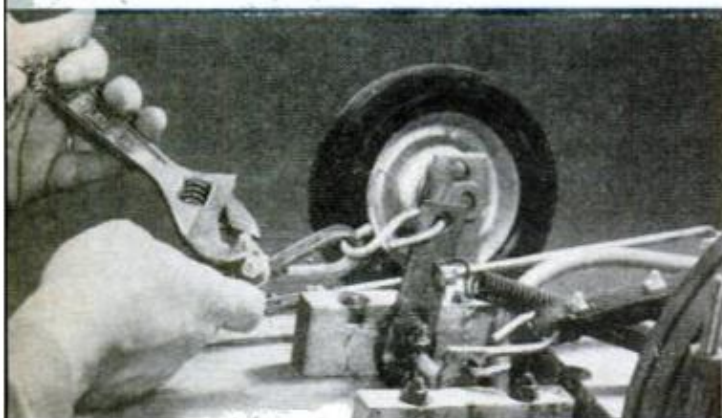

**BRAKE CABLE** is attached to brake rocker with cable eye and clamp. Note end of the brake band

**FREE END** of V-belt brake band is bent back on itself to form a loop taking one eye of an S-hook

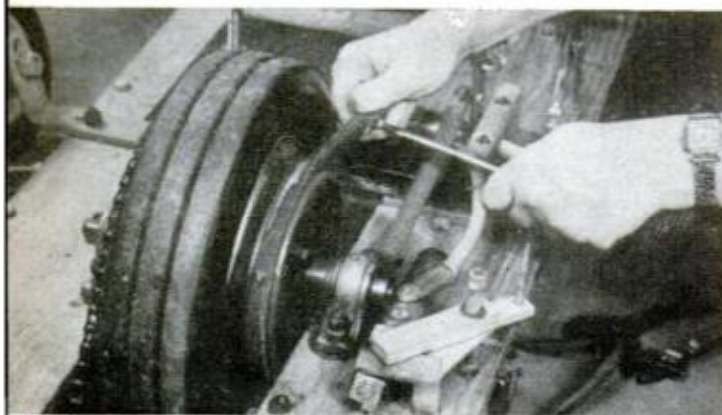



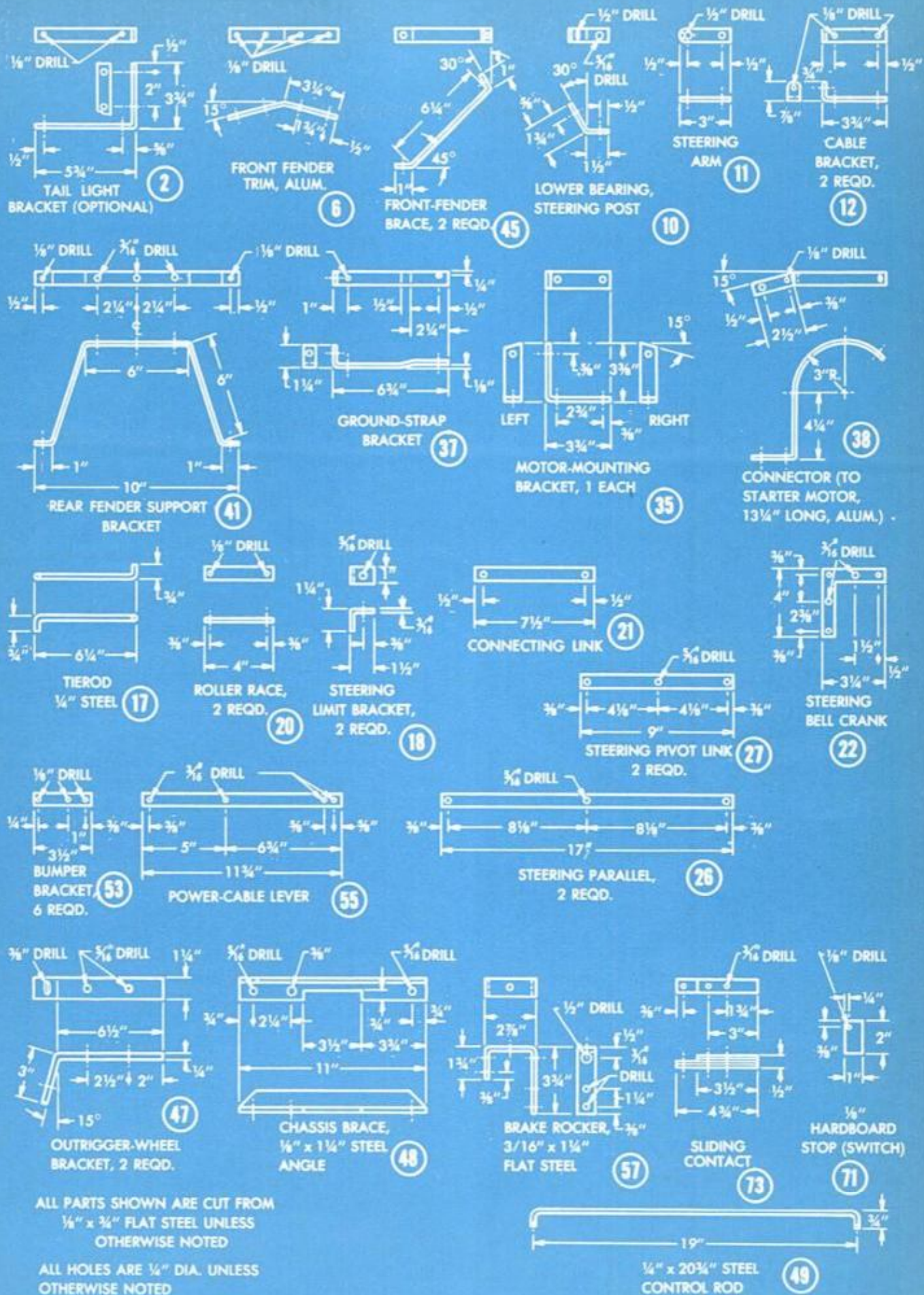

ALL PARTS SHOWN ARE CUT FROM 1/4" x 3/4" FLAT STEEL UNLESS OTHERWISE NOTED

ALL HOLES ARE 1/8" DIA. UNLESS OTHERWISE NOTED



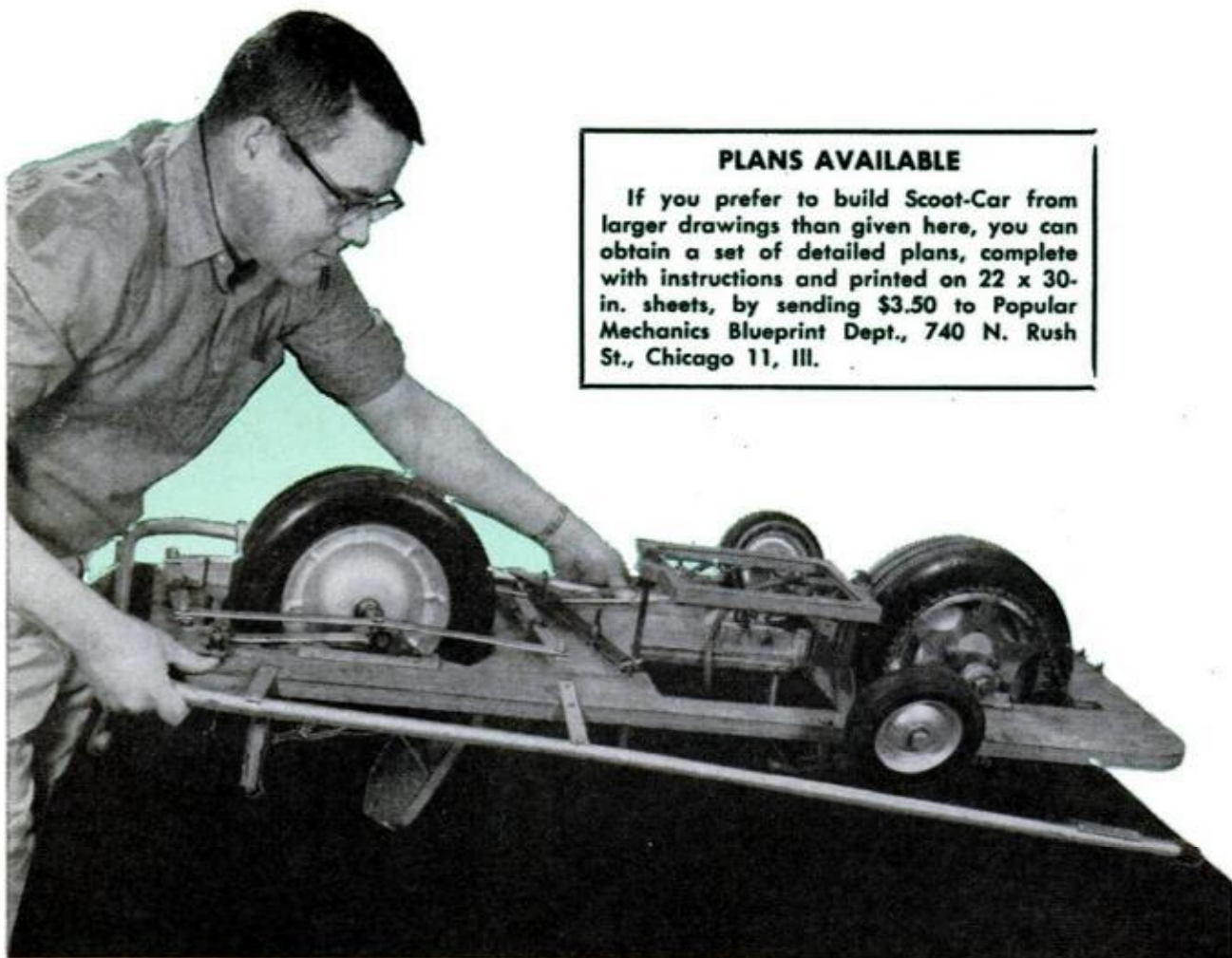

#### PLANS AVAILABLE

If you prefer to build Scoot-Car from larger drawings than given here, you can obtain a set of detailed plans, complete with instructions and printed on 22 x 30-in. sheets, by sending \$3.50 to Popular Mechanics Blueprint Dept., 740 N. Rush St., Chicago 11, Ill.



**LOWER HALF** of battery cradle, or carrier, is held in place by jam nuts. Be sure the nuts are tight

**TURNBUCKLES** provide adjustment on both power and brake cables. Adjustment is made after assembly



ried on rollers, which are  $\frac{1}{2}$ -in. shaft collars cotter-pinned on the shaft. The spindle is drilled just inside the collars (rollers) to take the  $\frac{1}{4}$ -in. capscrews which hold the parallels to the shaft. One screw is longer to take the steering link. Spacer washers are placed between the joining parts and all screws carry additional washers and locknuts to permit free movement. In the assembly, the rollers on the ends of the wheel spindle ride on races made as shown. Each consists of a mounting block of hardwood and a facing of flat steel, and the two units are attached to the underside of the deck with wood screws. The pivot links are bolted to the underside of the deck and the steering, or connecting, link attaches to the bell crank. The latter is bolted to the underside of the chassis and the free arm takes the lower end of the tie rod when assembled. The upper end of the tie rod is attached to the steering arm on the lower end of the steering post. The steering arm is riveted to a shaft collar which provides a hub and a means of attaching to the steering post.

Now comes the rear wheel which is attached to the deck with two pillow-block bearings and carries the driven sprocket and brake drum. Notice especially the rear-wheel assembly. The brake drum is

[\(Please turn to page 188\)](#)



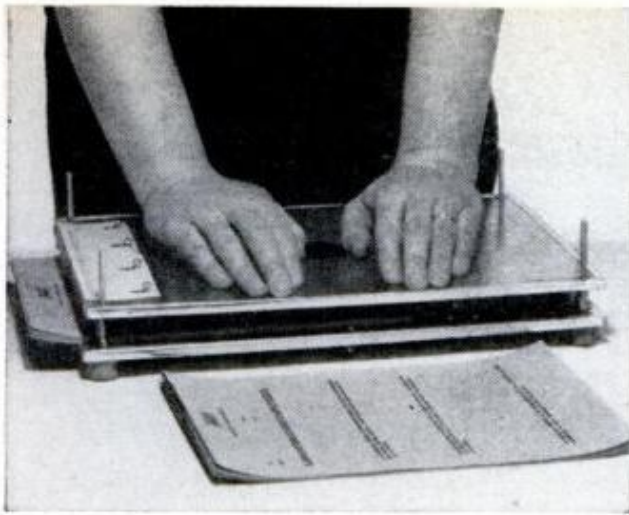

**SIMPLE MIMEOGRAPH** sells for only \$19.95 (post-paid). Yet, PM editors who tried it got results comparable to those produced by higher-priced models. Uses standard mimeograph stencils, takes paper up to 8½x14 in., which makes it ideal for small offices, clubs, etc. Up to 150 copies are possible on one inking. Absey Prods., 1186 Broadway, N.Y. 1, N.Y.

**CALKING COMPOUND** comes in a pressure can that simplifies application. The odorless vinyl-base material is said to give a waterproof seal around bathtub, shower, sink, even windows. Sells for \$1.45 a can, at dealers. Pecora, Inc., 300-400 W. Sedgley Avenue, Philadelphia 40, Pa.



**VARATHANE WHITE** is a liquid plastic coating that gives a hard tile-like finish. Resists chemicals, moisture, weathering. Said to outlast varnish 2-to-1. Ideal for bathrooms, showers. Can be tinted. Costs \$12.95 a gal. Flecto Co., Incorporated, P.O. Box 84, Station A, Berkeley 2, Calif.



**THIS KEYLESS LOCK** will appeal to travelers and people who live alone. Holds securely shut, from inside, any hinged door that has a latch. Simple to operate. Goes on, comes off in seconds—with no tools. Price: \$1.98 postpaid, with plastic case. Write Cornelia Sales Company, Cornelia, Ga.

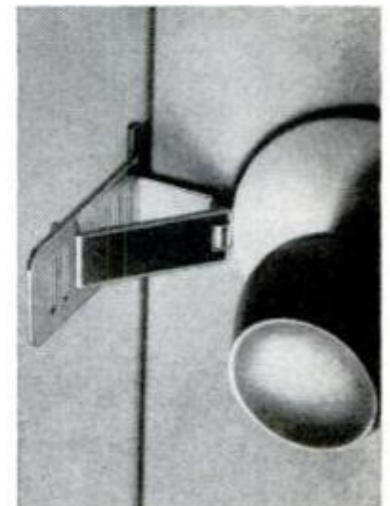

**SELF-CLEANING FEATURE** is built into current line of Turbocone power mowers. With motor running, you run water in and the blades clean themselves. Mowers have 3-hp., 4-cycle engines and are said to have improved, smooth-cutting blades. Six models offered. Jacobsen Mfg. Co., 1721 Packard Ave., Racine, Wis.

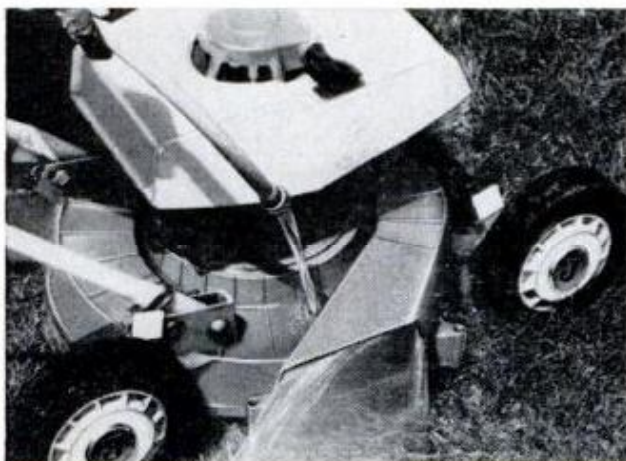

**NEW PLASTIC PEG-BOARD FIXTURES** are more versatile and have more holding power than any others we've seen. They hold securely, even horizontally or upside-down, which makes it possible to "nest" irregular-shaped objects. Cost 39¢ to \$1.98 a pack, at dealers. Masonite Corp. 29 N. Wacker Drive, Chicago, Ill.

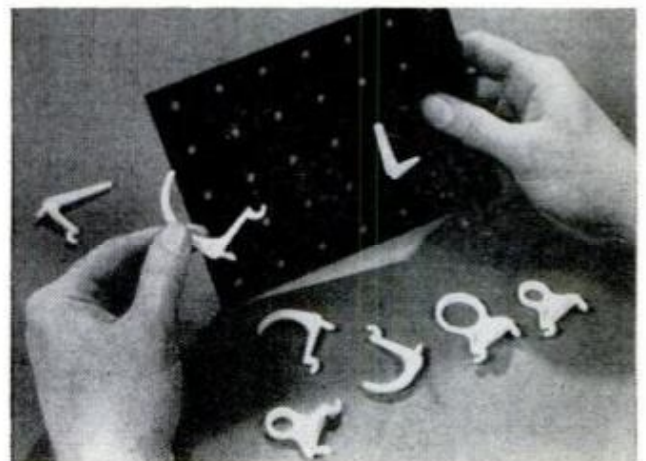





1. PIGGY BANK. Cut coin slot in 1/2-gal. bleach jug, glue on plastic ears and tail, then add plastic-foam legs

## BLEACH-BOTTLE BONANZA

By Willard and Elma Waltner

2. GIANT FUNNEL



3. CANDLESTICK



4. CLOTHESPIN JUG







5. SAILBOAT for the pond or the bathtub



6. PLANTER finished with metallic paint

THE SKY'S THE LIMIT on projects involving plastic bleach jugs and detergent bottles. When empty, these no-rust, easy-to-cut containers have a limitless potential for project use. Most of the items shown here are self-explanatory. The candlestick, Fig. 3, is made by cementing the tops of two detergent bottles together, mouth-to-mouth, then running a dowel through the necks and wrapping it with cord. To make the clothespin jug, Fig. 4, cut an opening in the front and slit the handle to hang on a line. Ballast the boat, Fig. 5, with a little sand, pouring melted paraffin over this to hold it in place.

7. PICNIC SET brightened up with decals



8. SCOURING-PAD CUP



9. SUPER SCOOP



10. TOOL CADDY





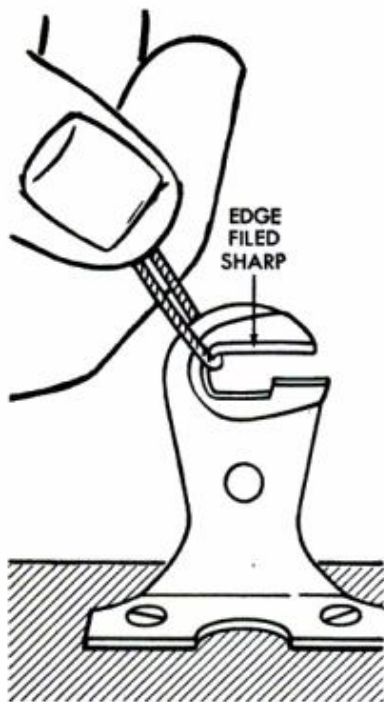

### String Cutter

To convert a window-shade bracket into an efficient string cutter, file the edges of the slot to a knife edge and mount the bracket on a wall or door handy to your work table. To use it, simply loop the string where you want to cut it and pull the loop over the sharp edge. Tell your wife about it; she might like one in the kitchen.



### Brush Clamp

When storing a small artist's brush in a bottle of solvent, you can prevent the bristles from touching the bottom by slipping a clip-type hairpin over the brush handle. The pin lying across the mouth of the bottle will hold the brush suspended at any height and thus avoid the possibility of damaging the bristles on the bottom.

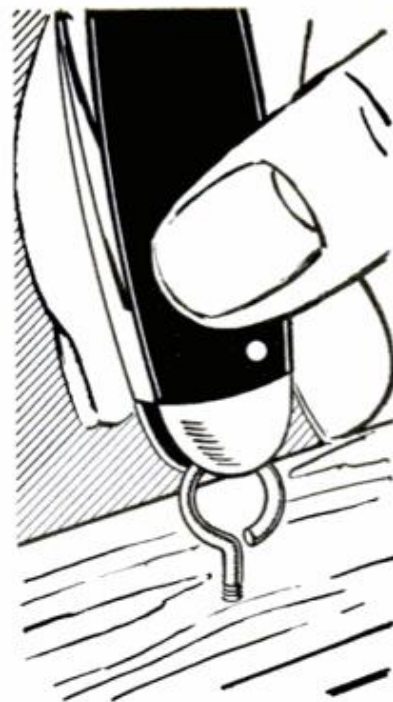

### Hook Driver

Having trouble driving screw eyes or small cup hooks in cramped space? Try using the handle of your pocketknife, as shown above. First, drill a lead hole to avoid putting unnecessary strain on the knife handle. Then, after starting the hook with your fingers, use the slot in the end of your pocketknife to turn it in the rest of the way.

## NEXT MONTH IN SHOP AND CRAFTS

**WHEN THE JOB CALLS FOR FRAMING.** Here's a two-part article that should be required reading if you're planning a remodeling job that involves modifying the basic skeleton of your house. Solid facts on how to cut openings for doors or windows, the right way to enclose a basement stairway, how to "fur" a wall, plus ideas galore on how to solve many other common remodeling problems—you'll find it all in the September *PM*.

**TWO-IN-ONE CAMPER BOAT.** Next month, *PM* brings you complete plans for a 10½-ft. johnboat designed with the camper in mind. Remove five bolts and it comes apart in two pieces—an 8-ft. pram and a 2½-ft. bow locker which can be packed with provisions and camping gear. Just bolt the locker in place and head upstream. When you set up camp, remove it again and you have a sturdy camp chest and an 8-ft. fishing boat.

**TRANSISTORIZED IGNITION.** Everybody's heard about it, but few people know the complete story. How many different types are there? If the idea is so good, why isn't it standard equipment of the '64 cars? What about the kits being advertised today? If you want all the startling facts on this revolutionary ignition system, see the September *PM*.

**MOBILE LEAF BURNER.** It won't be long before those autumn leaves start to fall, but you can be ready for them with this handy leaf burner. Basically just a steel drum mounted on a two-wheeled chassis, it has an ingenious hopper system which allows you to empty ashes from the bottom without tipping the drum. You'll find full how-to-build-it plans in Sept.



## FOR CAMERA BUGS

### Towel Bar Stores Trimmer

If you need a way to keep your photo trimmer handy at all times, without taking up valuable space on your darkroom table, fasten an ordinary towel bar to the wall a few inches above the table. The trimmer rests neatly behind the bar, occupying only a few inches of space.—*G. E. Hendrickson*

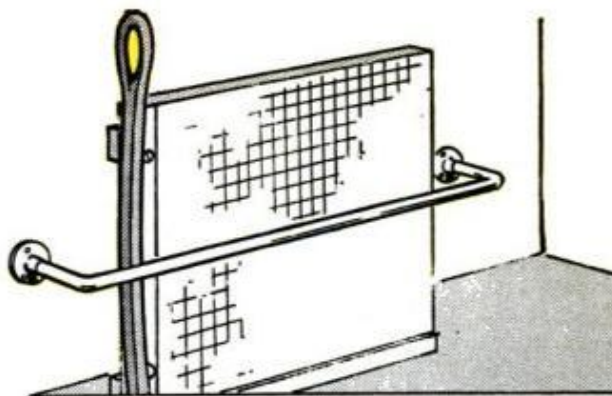

### Is That Developer Still Good?

Too often, amateur photographers forget how many rolls of film have been run through a batch of developer, and don't know the solution is exhausted until they ruin a roll or two. You can avoid this by putting a rubber band around the neck of your developer bottle every time you process a roll. This will tell you, through experiment, when it's time to mix a new batch.—*Wayne Floyd*



### Tape Identifies Film

By putting a strip of adhesive or masking tape around the slide handle of a film holder or magazine, you can tell which type of film is inside, and there'll be less chance of using the wrong film when working rapidly. Color the tapes with crayon or paint—say, blue for one type of color film, red for another, plain white for black-and-white.

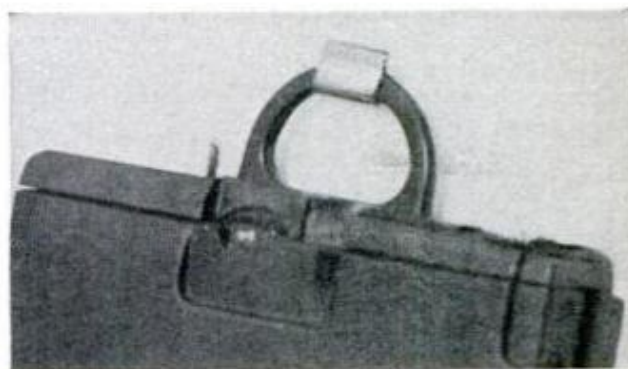

### Self-Standing Ferrotypes Plates

Bowed outward to fit the notches on this strip of plywood, a pair of ferrotypes plates can stand by themselves, saving you a lot of shelf space. Also, the bowed surfaces will cause the prints to pop off as they dry. The strip is  $\frac{3}{4}$  in. wide, and made of  $\frac{1}{4}$ -in. exterior plywood. Distance between the notches must be  $\frac{3}{4}$  in. less than the length of the plates.

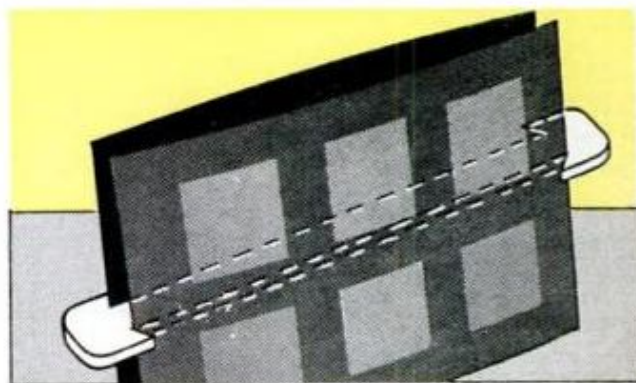

### Gadget Bag from Attache Case

An attache case makes a convenient case for your camera and equipment if you divide it into compartments. Make the partitions from sheet plastic,  $\frac{1}{8}$ -in. hardboard or similar material, and pad the inside of each compartment with foam rubber. This type of case is handier than standard gadget bags, as it keeps your equipment separated in compartments.

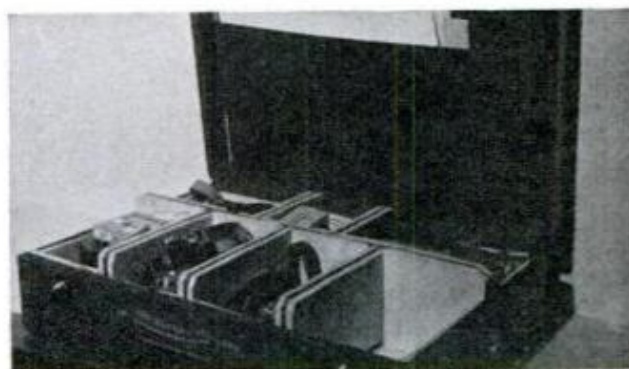



# New for Shutterbugs

**MODERATELY PRICED** selenium exposure meter rivals some cadmium sulphide models in range and versatility. Reads from F:1.4 to F:22, ASA 3 to 1600, 30 sec. to 1/1000 sec. and 8, 16, 32 and 64 frames per second. Sells for \$15.90; case, booster cell extra. E. Leitz, Inc., 468 Pk. Ave. South, N.Y. 16, N.Y.



**YOU CAN SAVE 30 PERCENT** on the price of Anscochrome color film by buying it on this 8-roll bulk reel. Comes in a light-tight box which feeds the film into cartridges. Retail for \$10.75. Reusable cartridges are priced at 8 for \$1.20. Ansco, Binghamton, N.Y.



**NIKONOS 35-MM CAMERA** operates under water with no special housing. Features include interchangeable Nikkor lenses, special easy-access controls. Shutter speeds are 1 sec. to 1/1000 sec. Costs about \$160 with 35-mm lens. Nikon, Inc., 111 5th Ave., N.Y., N.Y.



**TELEPHOTO BOOSTER** works with Spiratone lenses, as well as some other makes using the T-mount system. Almost doubles the power of the lens without altering its focusing scale. Works only with single-lens reflex cameras. Costs \$15 if bought with a telephoto, \$20 if purchased alone. Spiratone Inc., Dept. PM, 135-06 Northern Boulevard, Flushing 54, N. Y.

**NEW 4X5 PRINTER** is half the size of other models. Its double platens assure fast, accurate print alignment. Costs \$8.95. Yankee Photo Prods., 3349 Union Pacific Avenue, L. A. 23, Calif.



**HIGH-SPEED PRINT WASHER** gives hypo-free prints in 20-25 minutes. It's made of plastic, needs no special plumbing connection, and has no moving parts. Priced at \$49.50 with splash cover and hose. Richard Manufacturing Co., 5914 Noble Ave., Van Nuys, Calif.







### Photog's Safety Harness

Have you ever tried to aim and focus a camera while balanced precariously on a vehicle moving at high speed? It's not only dangerous, but the pictures taken under such conditions seldom turn out exactly as you would have liked.

When assigned to take some waterskiing pictures, photographers from the Eastman Kodak Co. devised a novel safety harness which makes it possible to get studio quality action shots with a minimum of risk. Basically just a window-washer's belt with an extra pair of ropes, this harness features a four-point mounting which enables the photographer to brace himself while facing in any direction by just leaning his weight back against any two of rope or belt guys. Such a harness would work equally well in an open car or on the back of a truck, and in an emergency, could be made entirely of rope.



### Weakened Spring Clamps

If the spring clamp on your photo lamp has lost its grip, notch the ends of a wood block and slip a flat rubber band around it. Then just force this block up between the springs when mounting.

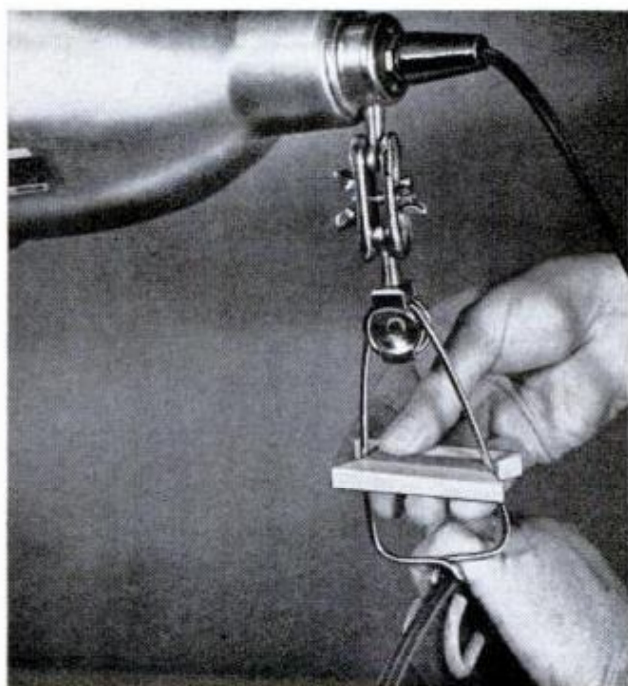

AUGUST 1963

### Emergency Lamp Stand

When you need an extra photo-lamp stand in a hurry, dig that Christmas tree stand out of the attic and mount a 1-in. dowel or broom handle in it. You'll find that it works like a charm.—Ken Patterson



151



# Buying or Building DOCKS, PIERS and FLOATS

By George Daniels

**W**ANT TO DOUBLE the fun value of your lake-front vacation hide-away? A new boat dock or diving float will turn the most ordinary waterfront cottage into a private shore club. Whether you build, assemble from pre-fab units or purchase a ready-to-use structure, the cost will probably be less than you expected and you'll make it up in the increased resale value of your cottage.

If the idea of just dropping a ready-made unit into the water sounds tempting, you can get a 20-ft. floating dock 40 in. wide for about \$150. Add another \$50 and you'll have enough for a similar size all-steel pier with adjustable legs which adapt to any bottom contour. These are just a couple of examples from the almost limitless variety of waterfront equipment that is available commercially. If you know what you want and aren't particularly concerned about cost, you can probably buy it ready-to-use.

However, you'll save money by building your own pier or float. The lumber used in such units (especially piers) should be rotproofed and borer-proofed by pressure treatment with pentachlorophenol or creosote. While you probably won't find this at most lumberyards, it's available on special order. Cost may run anywhere from a third more to double that of untreated lumber, but it's definitely worth every penny.

As for flotation, you can buy enough polystyrene foam to support close to half a ton for less than \$30, and it will last indefinitely without paint or maintenance. If your budget is tight, three 55-gal. oil drums will do about the same job for around \$10, if you don't mind seasonal painting and occasional replacement. A good compromise here might be galvanized drums which cost slightly more, but last longer and require less maintenance.

Piers built from scratch can cut costs

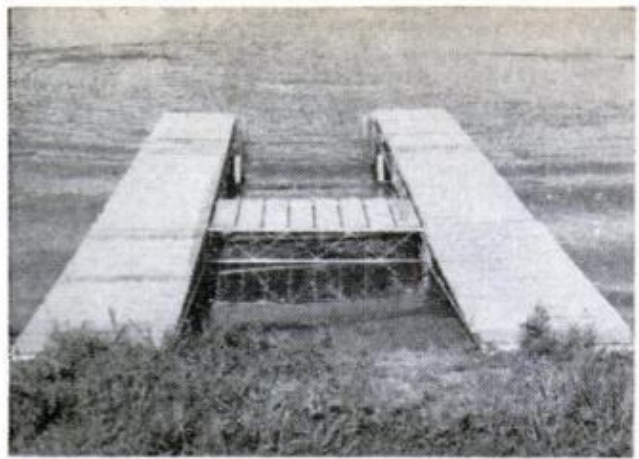

**TWIN DOCKS** connected by a crosswalk form an H-unit with boat slip in center. Note roller-type bumpers on either side of slip which keep boat from rubbing

## FOAM FLOAT

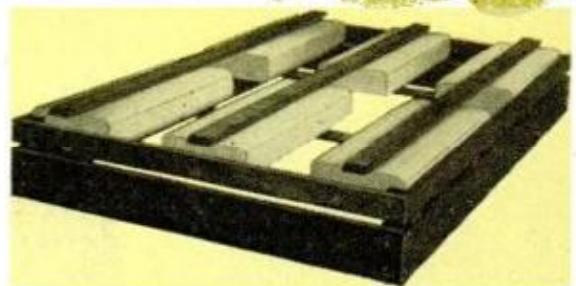
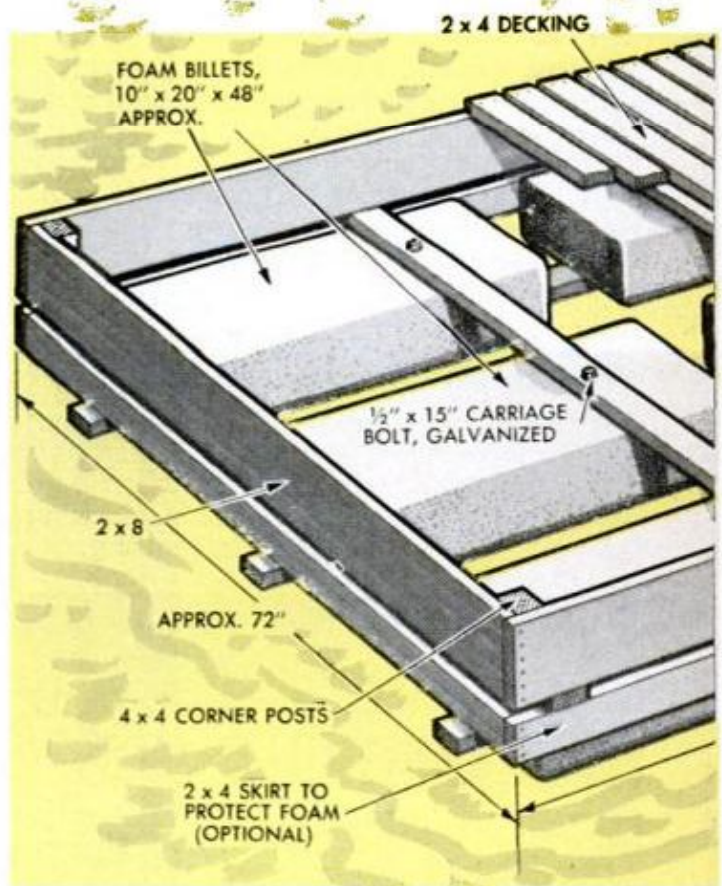



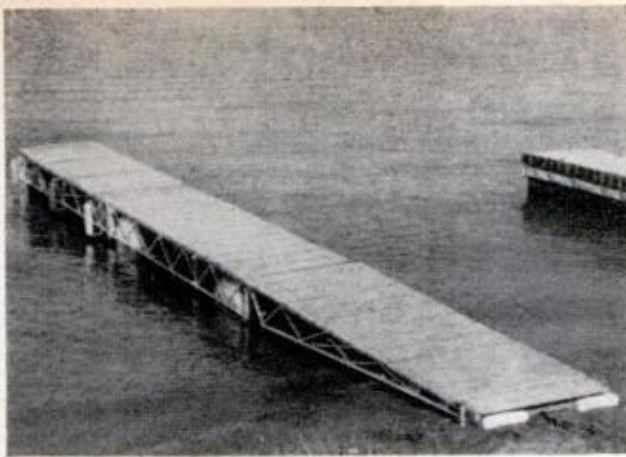

**BUDGET-PRICED** floating dock for sheltered waters uses pre-fab steel trusses with brackets designed to hold oil drums. A 10-ft. section sells for \$63

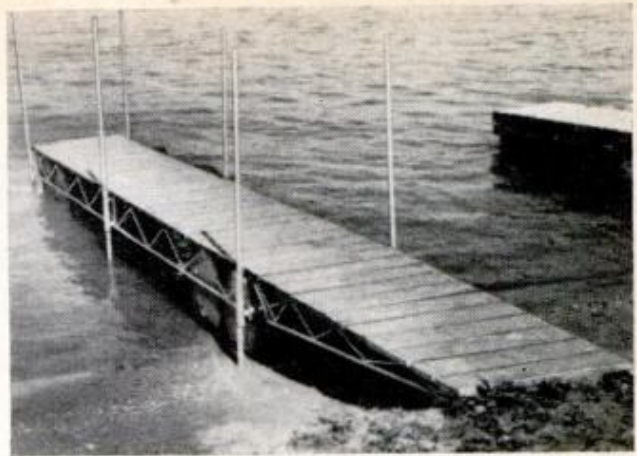

**PIPE PILINGS** hold this floating dock in line. If water level changes, oversized sleeves ride up or down the pipes, allowing the float to rise or fall

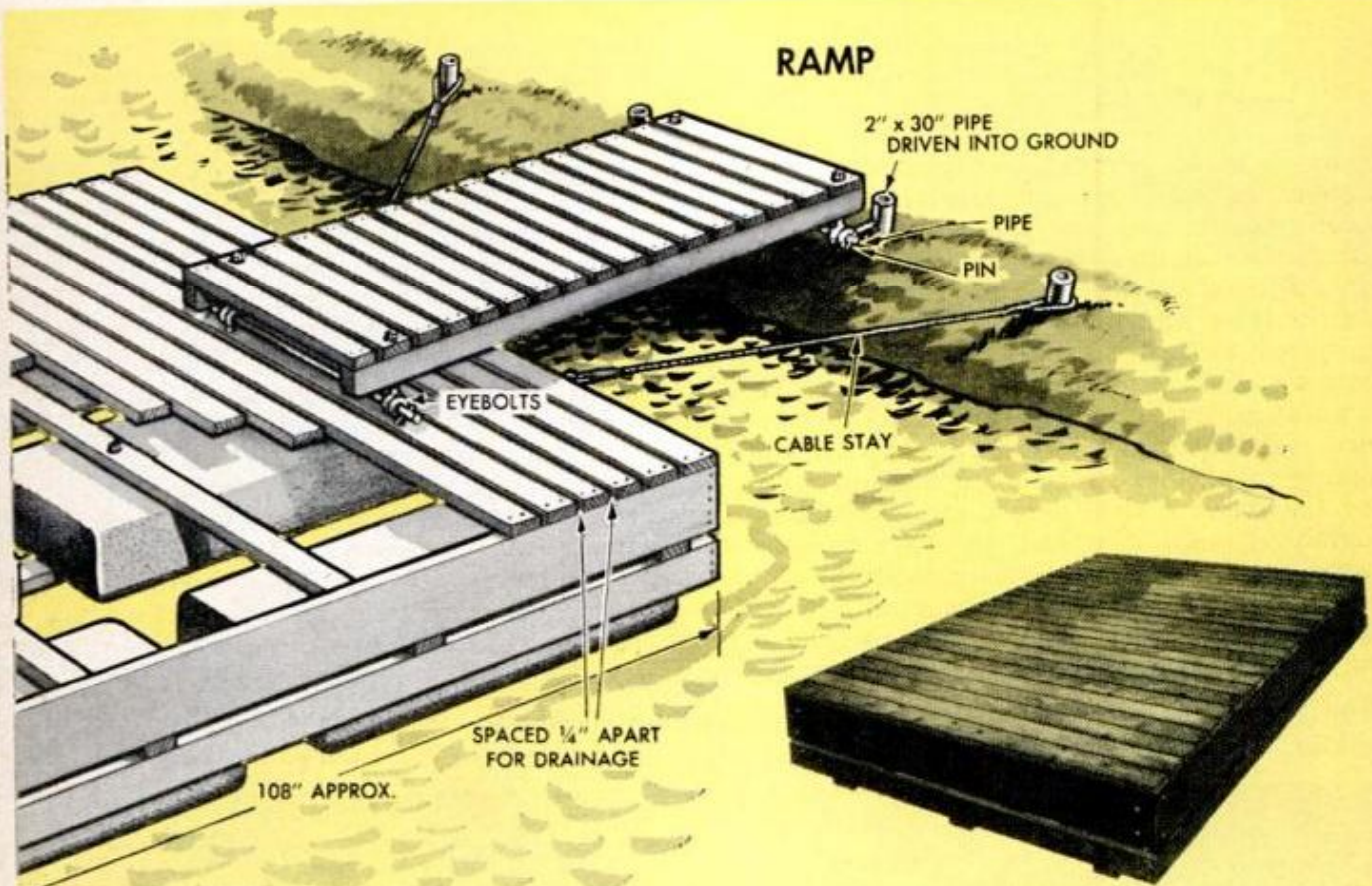

**ONE OFF-BEAT** danger with foam flotation—homeless muskrats will occasionally riddle it with tunnels

**IF YOU LIVE** in muskrat country, protect the upper surface of foam planks with galvanized chicken wire

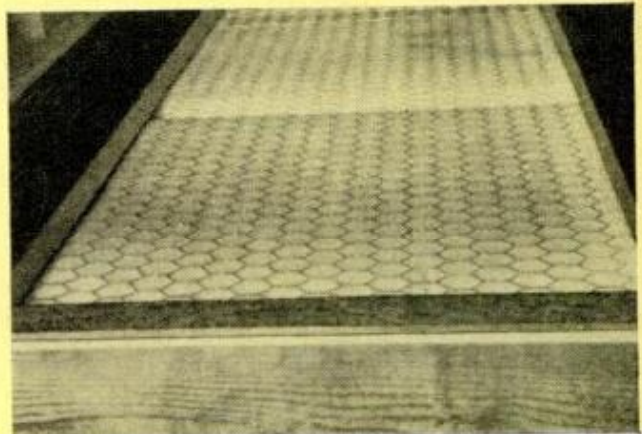



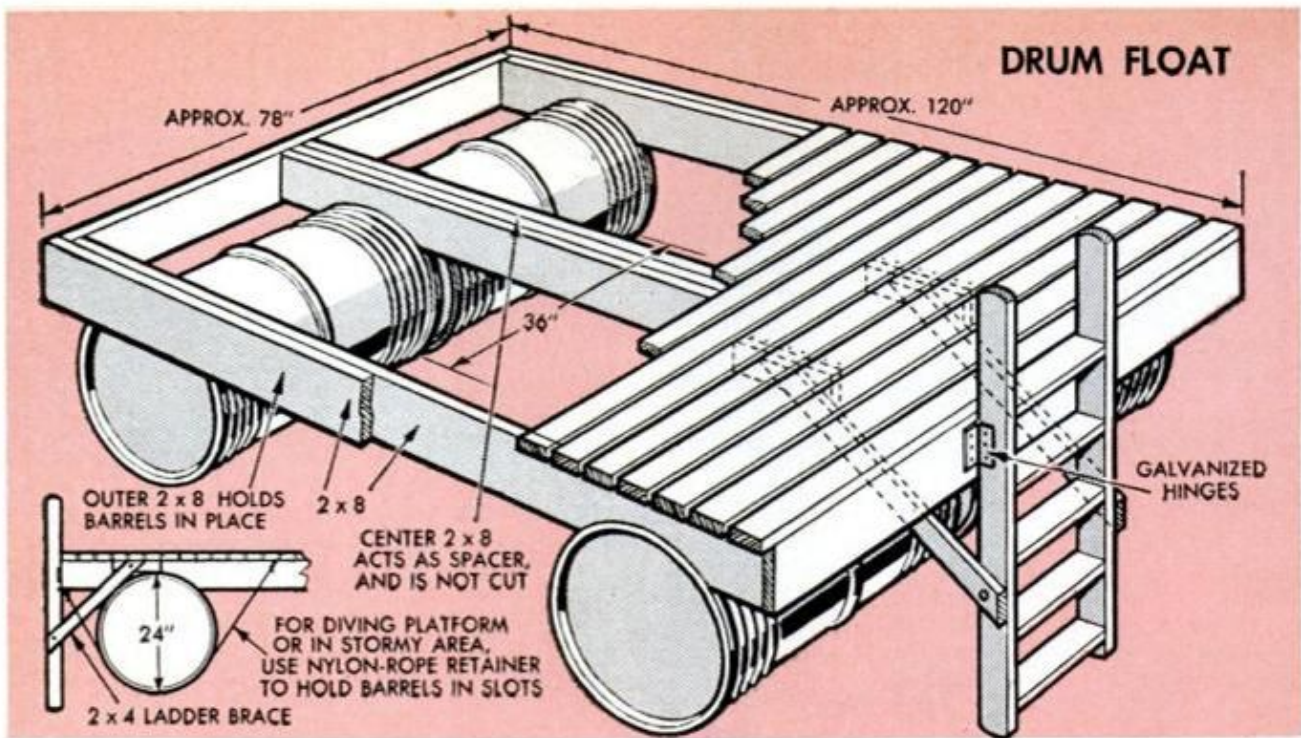

from 30 to 50 percent, but plan on days instead of minutes for assembly work. Ready-made and pre-fab piers rest on tubular or channel-form metal legs which are adjusted to the bottom contour.

One type has an 8 x 8-in. metal foot designed to rest on the bottom; another terminates in a spiral auger bit that is actually screwed into the bottom by slipping a rod through a hole in the upper end. (You can buy this permanent type for use with home-built piers. With adjustable-height crossbar, prices per pair range from \$12.50 for 4-ft. height to \$20.50 for 12-ft., all with 3-ft. gap between legs.)

**There are a number** of methods of driving homemade pilings. Simple pipe pilings

**TRESTLE DOCK**, the ultimate in simple low-cost construction, is perfectly adequate for sheltered waters

can be sledge-hammered from an anchored boat. Wood pilings should have a square pyramidal point, like that of a soldering iron, for easier penetration; you can either "work" them into the bottom by tilting back and forth while applying pressure, or "bore" them in by drilling a hole near the top of each one for a hardwood dowel so that it can be turned.

In the fall, leg-type piers should be removed from the water. Driven pilings can remain in place, though you may wish to remove the walkways. If the water level varies after ice has formed around the piers, this may tend to loosen them. You can minimize this effect by placing a few large rocks near the piling bases;

**MAKE WALKWAY** by nailing 1 x 5s over 2 x 4s. Stagger 2 x 4 locations so sections can be bolted together





## FIGURING FLOTATION

When planning your float, you can estimate how much weight it will support from two factors: the weight of the lumber and the buoyancy of the flotation units. Douglas fir, the lumber you're most likely to use for framework and decking, weighs about 34 lbs. per cubic foot. Thus, a 2 x 12 will have a running foot weight of around 4¼ lbs.; a 2 x 8 a little less than 3 lbs.; a 2 x 6 just over 2 lbs.; and a 2 x 4 slightly more than 1¼ lbs. Estimate total weight from your lumber bill. As for buoyancy, a cubic foot of polystyrene foam weighs only about 2 lbs., yet it will support about 60 lbs. (though designers usually figure 55 lbs. to allow a safety factor). The popular 10 in. x 22 in. x 9-ft. foam plank can hold over 800 lbs. On the other hand, a pair of 55-gal. oil drums will support about 770 lbs. in addition to their own empty weight of 50 lbs. each so flotation is about equal

when the water level drops these rocks will break through the ice, loosening its grip on the pilings so that they won't be pulled out of the bottom.

**Floats**, both home-built and ready-made, usually use either foam or drum flotation. An ordinary 55-gal. oil drum weighs about 50 lbs. empty and will support approximately 385 lbs. While prices vary, you can figure on around \$3.50 for a standard drum and about \$5 for a galvanized one. Galvanizing almost doubles the life of the drum so that some last up to eight years. A 10 x 22 in. plank of polystyrene foam 9 ft. long replaces two drums and lasts indefinitely with no maintenance.

**TO ASSEMBLE**, first put trestles in place, then bolt walkway sections to each other and to the trestles



AUGUST 1963

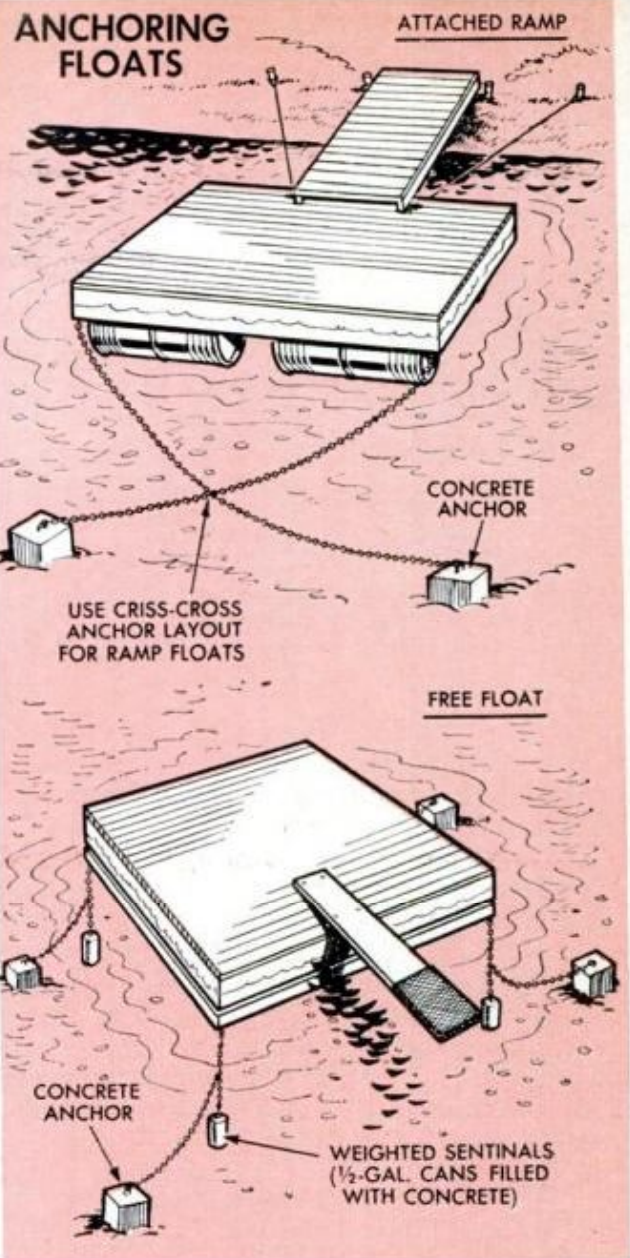

**WEIGHT OF DOCK** is enough to keep it from floating, but keep walkway high above surface to play safe



155



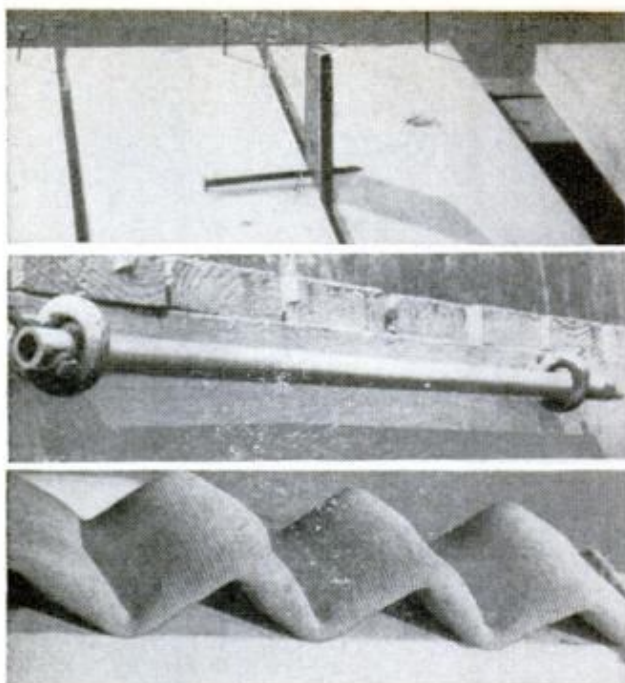

**THREE TIPS** on dock building: Spacer board (top) will speed up the job of nailing deck planking, assure even spacing; To cut costs, use large galvanized eyebolts and galvanized pipe (middle) to hinge ramp to float; Worn-out firehose (bottom) makes a perfect dock bumper, so check with your local fire department to see if any will be put on the market soon

It can't rot, and marine borers won't touch it. While this foam costs more than twice as much as comparable drum flotation, its advantages are obvious.

**Polystyrene foam** has only two natural enemies: muskrats and seagulls. The best insurance against muskrats is described on p. 155. As for the gulls, they won't actually eat the foam, but they do get a big kick out of pecking holes in it. However, paint the exposed portions of foam a brilliant orange and gulls won't touch it.

More dangerous to polystyrene foam are its man-made enemies—oil, gas, in-

dustrial chemicals and other solvents floating on the surface of the water. To protect the foam, build a wooden skirt that extends beneath the waterline all the way around your float. This will block out the harmful surface film. In areas of heavy contamination, you'll probably be better off using drums or ready-made metal pontoons. Or you might check on Dow's Tyrilfoam buoyancy billets, which are designed to resist this solvent damage.

**Two home-built floats** shown on the preceding pages illustrate the general construction methods used with both types of flotation. While these small landing or diving floats may not suit your purposes, you can easily vary the dimensions to make narrow docks or large-area fun floats.

Anchoring a float is basically like anchoring a boat, but there are a couple of special rules to keep in mind. A float linked to a pier ramp should have two anchors at the outer end with the lines crisscrossed to insure lateral stability. A free float requires four anchors with the lines radiating out from the corners instead of crossing. And since the water around a float is a heavy-traffic area,

### SAMPLE PRICES, READY-TO-USE AND PRE-FAB UNITS

ITEM	SOURCE	PRICE
3' x 19" pre-fab steel pier with 8' end platform, decked with fiberglas	Aqua-matic Piers, Inc. Milwaukee, Wis.	\$300
3' x 19" pre-fab steel pier with 8'-8" end platform, nonskid pebbled steel deck, baked marine enamel finish (additional 3' x 8' sections cost about \$57)	Standard Steel Products Mfg. Co. Milwaukee, Wis.	\$200
40" x 8' sectional pier, galvanized steel rod frame, plywood deck	Pasconi Systems, Inc. Cambridge 39, Mass.	\$125
3' x 10' sectional pier, galvanized square tube stringers, auger-tipped legs, wood deck, one pr. 6' legs	Indiana Galvanizing & Mfg. Co. Muncie, Ind.	\$76
32" x 8' sectional all-aluminum pier, bottom pads on legs	Alumidock Div., Metallic Ladder Corp. Randolph, N.Y.	\$98
Aluminum truss ramp, supports 2000 lbs., rubber-tired wheels at float end, lengths from 12 ft.	Alumidock Div., Metallic Ladder Corp. Randolph, N.Y.	From \$250
20" x 20" aluminum pontoons in lengths from 15' to 26'	Kiekhaefer Corp. Special Prod. Div. Fon du Lac, Wis.	From \$160
Prow section for pontoon above, used in building party barge	Kiekhaefer Corp., Special Prod. Div. Fon du Lac, Wis.	\$65
7' to 10' sectional float, steel truss construction, redwood deck, designed for use with 55-gal. oil drums, can also be used with foam. (Sold without flotation.)	Indiana Galvanizing & Mfg. Co. Muncie, Ind.	\$54 to \$76
10" x 20" x 9' polystyrene flotation planks	Gilman Bros. Gilman, Conn.	\$23

**NOTE:** Since space limitations make it impossible to include a complete list of products and manufacturers here, consult your marine dealer for further information.



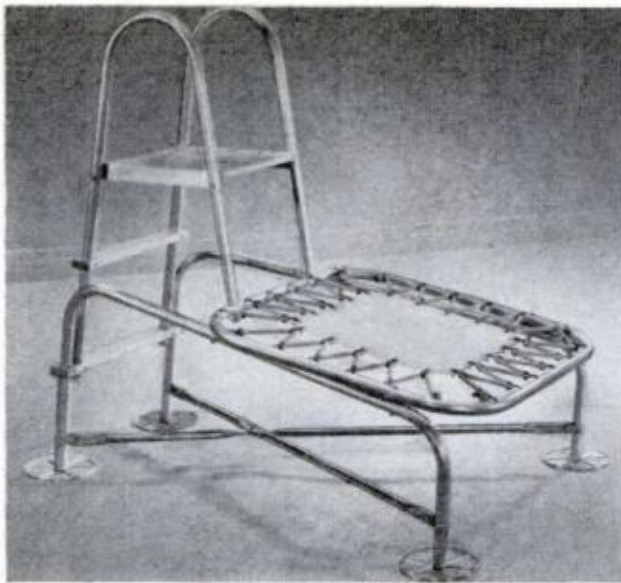

**BIG BOUNCE** for a small diving float is possible with these two space-saving units. Trampoline, above, sells for \$129.50. Springboard, right, uses torsion spring action of legs, needn't be fastened to dock



lines must be deep enough to be out of the way of boat props and springboard divers, so rig weighted sentinels to them.

To cut costs, you can cast your own 18-in. concrete-block anchors in scrap-wood forms, embedding an eyebolt in the concrete before it sets. Each one of these will weigh more than 300 lbs., so your four-anchor free float will be safely hitched to the bottom with more than half a ton of concrete.

Most commercial docks and floats have non-skid walkways. You can get the same

effect by finishing with a weatherproof coating (Seaprene, or similar) sprinkled with non-skid grit, available from any large paint supply house. The best tool for spreading this grit? A salt shaker.

Accessories for piers and floats range all the way from boarding ladders and springboards to benches where the non-boaters in your family can relax in the sun. If you're thinking big, you might consider a pier-linked float dock which can double as an outboard-powered party barge, a real "boat dock." ★★★

## Make Your Own Mushrooms

All you need to make the economy mushroom anchor shown below is a discarded water tank and a large eyebolt. Just cut the bottom off the tank and attach the eyebolt to it.—*R. Beach*



AUGUST 1963

## Trailer Your Motor Amidship

When trailering, your outboard will be a lot safer in the boat than on the transom. To make this possible, clamp or bolt a 2 x 6 athwartships above the trailer axle and clamp motor to this.—*Jackson Hand*

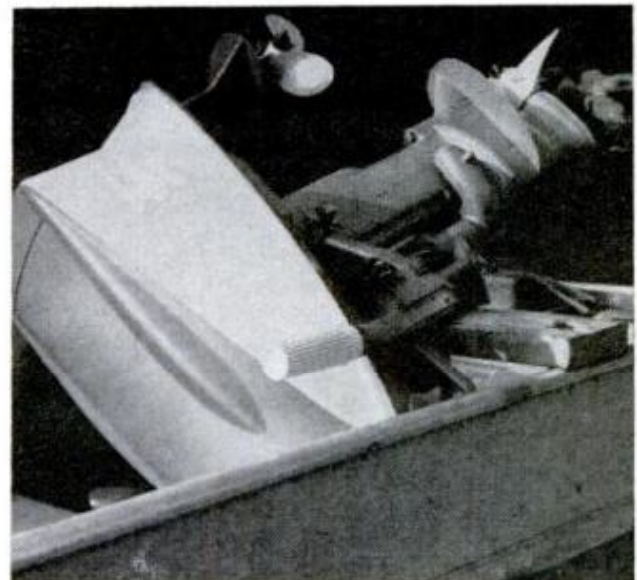

157



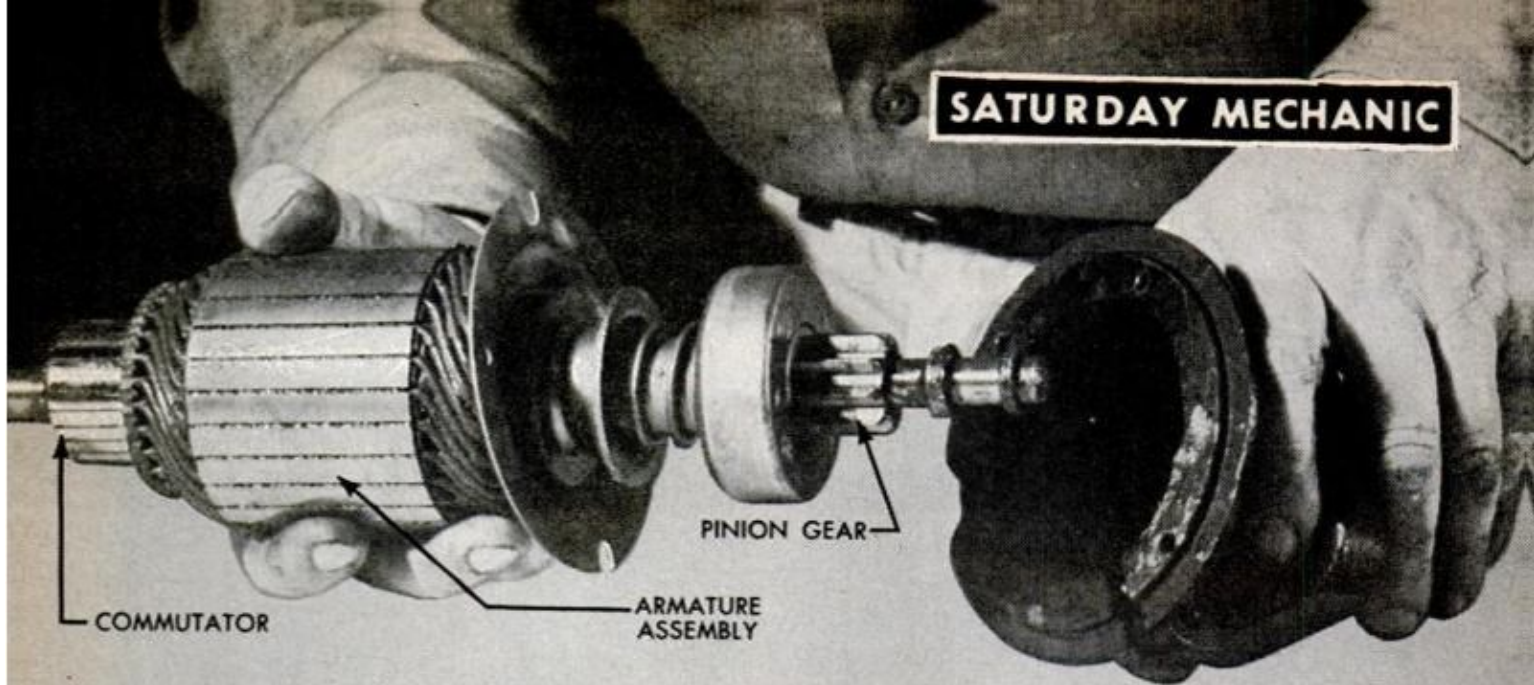

# THE MOTOR THAT STARTS THE MOTOR

By Morton J. Schultz

**T**O MANY AUTOMOBILE OWNERS, the starter is still a mystery. Few know how it works, still fewer care so long as it *does* work. Consequently, when anything resembling a starter malfunction occurs, most car owners run to a professional mechanic.

Of course, the services of a mechanic may be required since the problem could be inside the starter, but usually you can

save yourself time and money by first checking various conditions yourself. Keep in mind that a starter seldom goes bad internally. Usually, what appears to be a starter malfunction is merely a bad connection, a shorted cable, a faulty switch, or a weak battery—troubles that you can easily handle.

You should also keep in mind that the starter is part of the car's charging system

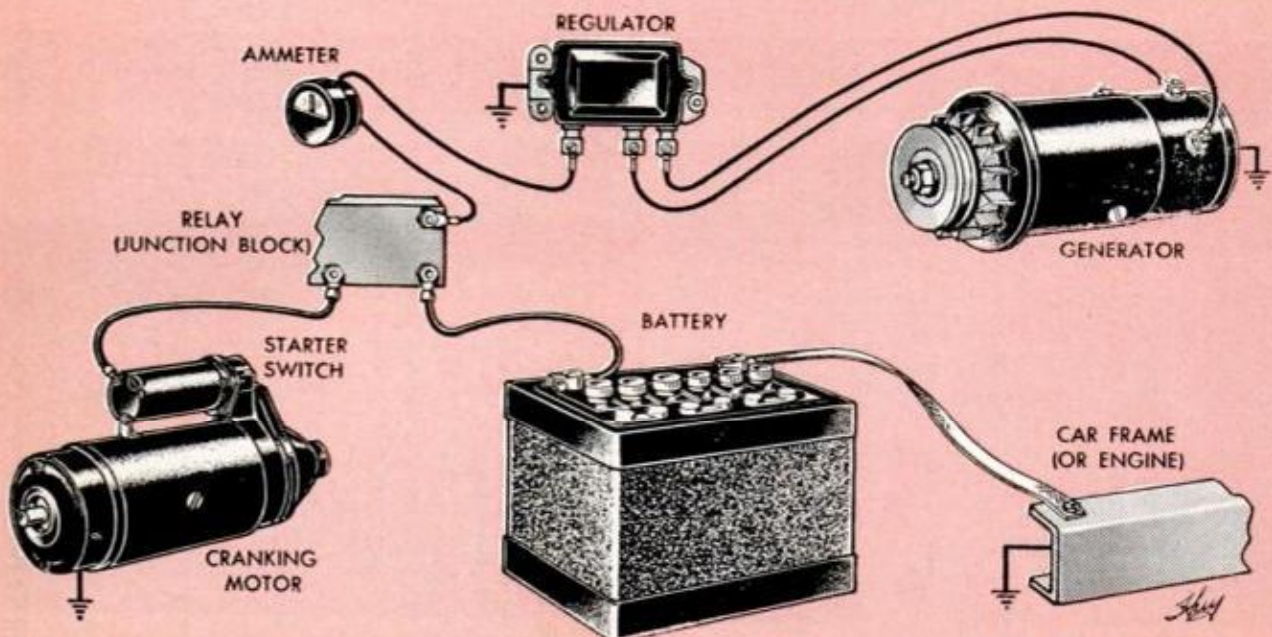



and all parts of that system—particularly the battery, but also the generator (or alternator) and regulator—must be in good shape for all other parts to work well.

The purpose of this low-voltage, direct-current electric motor we call the starter is to convert electrical energy into mechanical energy. This mechanical energy must be produced at a torque high enough to crank the engine. Thus, for its size, the starter provides a very high horsepower and is capable of operating under a great overload for the short intervals needed to fire the engine.

● Basically, there are only two types of starters used in late-model cars: overrunning clutch-drive starters and Bendix drive starters. Major differences between the two are the types of switches used in the battery-starter circuit and the types of internal control used to disengage the starter from its cranking position once the engine begins to fire. The type of switch used dictates the type of internal control.

### Bendix Drive Starters

Bendix drive starters employ an electromagnetic switch that has only one job: closing the circuit between battery and starter so as to provide the necessary current for the starter to operate.

Overrunning clutch drive starters employ a solenoid switch, or a combination solenoid and relay switch that has two functions. It, too, provides sufficient current for the starter, but it also has the job of pushing the starter pinion gear into mesh with the flywheel. It is this pinion gear that rotates and turns the flywheel. The flywheel then rotates the crankshaft, causing the engine to start. In Bendix drive starters, meshing of pinion and flywheel is achieved by inertial action.

● As indicated above, the switch in an overrunning clutch starter could be just a plain solenoid; a solenoid and relay where the two are separated one from the other, with the relay located on a fender or the firewall; or an integrated solenoid-relay where the relay is built right into the solenoid. However, the integrated solenoid-relay switch has seen only limited use and has not been employed in cars since 1955.

No matter what type of solenoid starter switch is used on your car, the solenoid itself will always be mounted on the starter, as is the magnetic switch of Bendix drive starters.

If just a solenoid is used, the cable from the "hot" side of the battery is connected directly to the solenoid. The relay you may have in conjunction with the solenoid is nothing more than a junction box for connecting the cable from the "hot" side of



**BATTERY CHECK** using hydrometer is made by drawing a small amount of electrolyte out of each cell

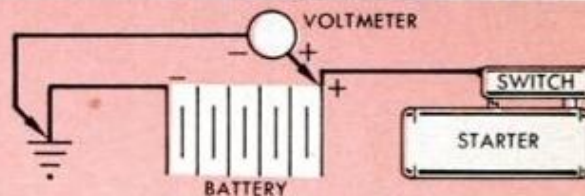

**TO TEST GROUNDED** side of starter circuit, connect one lead of voltmeter to "hot" side, the other lead to ground, as shown in photo and sketch above. To test "hot" side, connect one lead to battery's ground post and the other lead to starter switch (photo and sketch below). All examples are for negative-grounded car

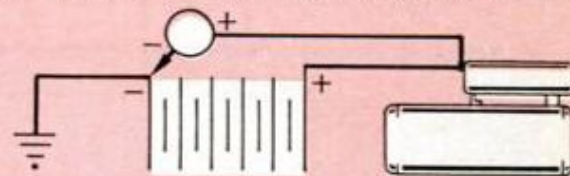



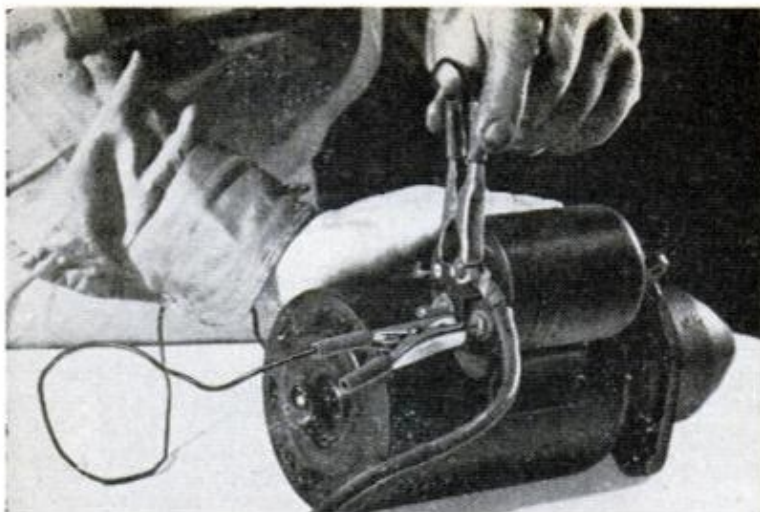

**JUMPER CABLE** between the contact and control terminals of this 12-v. starter makes it possible to determine whether or not the starter switch is defective. If the starter spins when the engine is cranked, the trouble might lie in ignition switch or inside starter

the battery, the cable from the solenoid, and other wires such as the one going to the car's ammeter.

Chrysler-built cars, with the exception of Plymouth, use an overrunning clutch starter with a solenoid and relay switch (Plymouth employs a Bendix drive starter with a magnetic switch); most cars made by General Motors use overrunning clutch starters with a simple solenoid switch (Buick, however, employed a solenoid and relay switch in models after 1951); and Ford-built cars use a Bendix drive starter with a magnetic switch.

● Since an overrunning clutch starter is a bit more difficult to understand, we will explain its operation first. But keep in mind that, with the exception of the operation of the switch and the action of the internal disconnect control, both overrunning clutch and Bendix drive starters operate basically the same, and both are basically the same in appearance.

When you turn on the ignition switch, the battery releases a small amount of electrical energy that flows to the solenoid. This charge forces a shaft to pop from the solenoid and strike a plunger. When activated, the plunger forces the starter pinion gear to engage the flywheel. The movement of the plunger also closes a

switch inside the solenoid to complete the battery-starter circuit. When this is done, the starter is allowed to receive a large electrical dose from the battery.

To convert this electrical energy into the mechanical energy needed to rotate the flywheel, the starter functions the same as most electric motors. Brushes feed the electrical energy to the commutator at the end of an armature assembly. This electricity sets up a magnetic field, which causes the armature to rotate.

The armature, in turn, is attached to a drive shaft at the end of which is the pinion gear engaged with the flywheel. Constant rotation of the armature causes everything ahead of it—drive shaft, pinion gear, flywheel and crankshaft—to spin.

But this rotation *cannot* continue once the engine is running or else the starter could burn up, and the pinion gear and flywheel could chew each other up. So, the solenoid again controls the action.

When the engine begins to run and you release the ignition switch, several things happen. Current to the solenoid is cut off. This causes a strong return spring inside the solenoid to pull the solenoid plunger back, releasing the pinion gear from its mesh with the flywheel. The circuit between the battery and starter is also

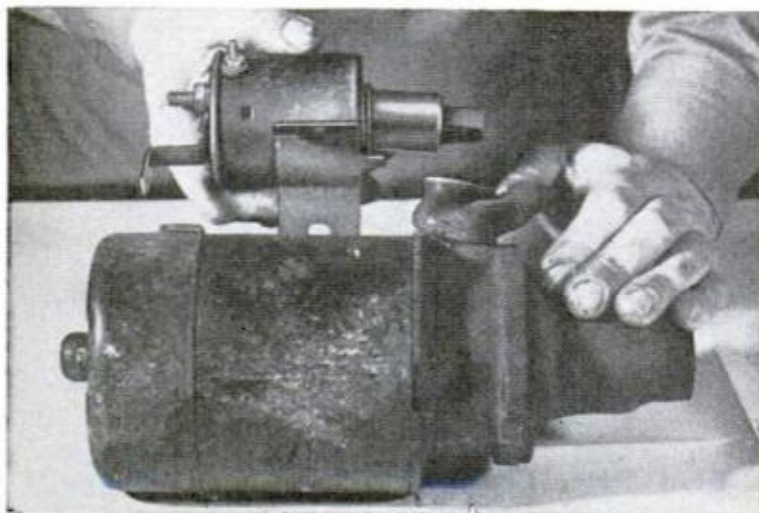

**STARTER SWITCH** mounted on starter motor housing may be either solenoid or magnetic type. Failure of the starter to spin, one of the more common starter problems, is caused by a defective switch, so check this switch carefully before dismantling the starter



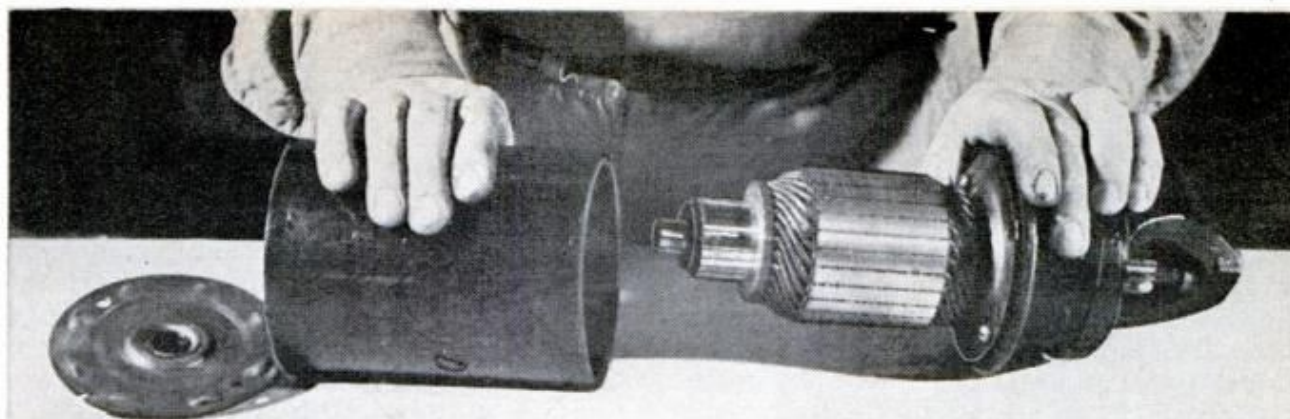

**TO GET INSIDE** starter, simply remove bolts holding the cover plate and slide the starter out of the case

broken and the starter becomes a dormant part of the car, having no further function to perform until it is needed once again to start the engine.

● Bendix drive starters with their magnetic switches operate essentially the same way, except for the manner in which the pinion engages the flywheel and is forced to disengage when the engine starts.

When the magnetic switch closes, causing current to flow from the battery to the starter, the armature shaft accelerates very rapidly. Instead of turning the pinion, however, this action forces the pinion *forward* along the spiral splines of its sleeve to mesh with the flywheel. In other words, the Bendix drive starter uses the inertia of the pinion and high starting speed of the armature shaft to move the pinion into engagement with the flywheel.

When the pinion becomes fully meshed with the flywheel, its forward motion stops and the pinion is locked to the rotating armature shaft. With all starter parts locked together, the rotation of the armature is actually the force that turns the flywheel and crankshaft.

But when the engine starts, the pinion begins to rotate faster than the armature shaft. As a result, it spins itself back and out of mesh with the flywheel.

● If starter operation is sluggish, chances are in your favor that the trouble is not in the starter, but is instead a weak battery or excessive resistance in the starter circuit—problems you can iron out yourself.

Start at the battery, checking each cell with an accurate, temperature-tested hydrometer. (Incidentally, whenever such a specific gravity test is made, the engine should be at normal operating tempera-

ture.) If hydrometer readings show that a battery is less than fully charged, have it charged and see if this doesn't solve the problem. If not, test the starter circuit with a voltmeter.

A battery that is less than about  $\frac{3}{4}$  charged often denotes trouble in the generator or regulator, especially if you know the battery is in good condition. The generator (or alternator) and regulator should be checked before further starter tests are made.

● Starter circuit tests measure the voltage drop produced by defective circuit condition. Conditions that cause high resistance and poor cranking include faulty terminal connections and defective cables.

To make sure the engine doesn't start during the tests, pull the primary lead wire from the center tower of the distributor or from the coil.

● First, check for voltage drop across the grounded side of the circuit. Hook the proper voltmeter lead to the "hot" battery terminal. If your car is negative grounded, the *positive* lead of the voltmeter is connected to this terminal, which is positive; if positive grounded, the *negative* lead of

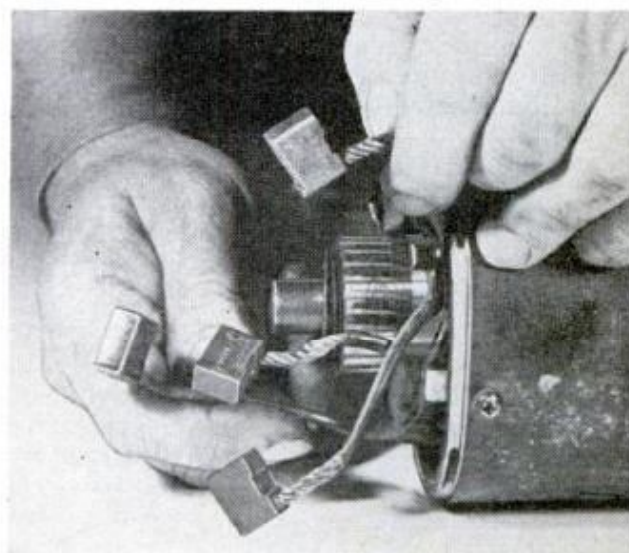

**MOST STARTERS** have four brushes which may be held in place by any of several different means, a spring clip or inset pin being the most common. They are easily removed but replacement entails soldering



the voltmeter is hooked to the terminal, which is negative.

Connect the other voltmeter lead to ground on the vehicle frame or engine (the bolt head where the battery ground cable is connected will suffice). Now, crank the engine.

The voltmeter should read at least 9.0 v. for a 12-v. charging system and 4.5 v. for a 6-v. charging system. A reading less than this indicates excessive resistance in the ground circuit, since you know the battery is in good condition—you've just checked it.

Remove the ground cable where it connects to the battery and to ground on the engine or frame. Clean the terminals with a brush saturated with a cleaning solvent, and clean the battery post and the area to which the grounded end of the cable is attached on the frame or engine block.

Replace the cable and rerun the test. If the reading still shows lower than 9.0 v. for a 12-v. system or 4.5 v. for a 6-v. system, the ground cable is damaged internally and should be replaced.

● Now, test the "hot" circuit. Hook the correct lead of the voltmeter to the battery's ground terminal, and connect the other lead to the solenoid or magnetic switch on the starter. Make this connection

where the cable going to the starter is attached to the switch.

Again, crank the engine. If the reading is under the minimums given above, do the cleaning job already described. Rerun the test to see if a proper reading is now obtained. If not, replace the cables.

If no resistance in the circuit is apparent and the battery is in good condition, the solenoid or magnetic switch should be checked next. Testing these switches is also in order if another common problem occurs—failure of the starter to spin.

● To check the switch on a Bendix drive starter, you must first determine the type of magnetic device the starter possesses. There are four kinds: magnetic switches with ignition bypass terminal (these are used in cars with 12-v. charging systems); switches with a single control terminal and an internal ground; switches with a single control terminal and an external ground; and switches with two control terminals.

Switches used on 12-v. starters (with the exception of Studebaker) and switches with a single control terminal and an internal ground are checked the same way. Connect a jumper across the switch from the terminal to which the cable is con-

(Please turn to page 186)

## AUTO CLINIC

**Q** Is there any way to repair an outside rear-view mirror that has become loose and rattles?—A.M., Penna.

**A** Take the mirror from the car and lay it flat, glass side up. Trickle some transparent windshield glass sealer around the edge of the glass, so it runs between the glass and the frame. Let it set for a while to form a secure bond. One type of sealer you can use is manufactured by Minnesota Mining and Manufacturing Company and is called Clear Auto Glass Sealer.

**Q** I recently had to replace several spark-plug cables because the cables had become separated from their terminals. What can cause this?—J.M.P., Va.

**A** The cause is probably the last man who removed the cables from the plugs. You can no longer just pull cables from plugs. The boot encasing today's resistance-type plug adheres to the plug insulator, and any pulling ac-

tion will cause damage. The proper way to separate the cable is to grasp the boot at its base above the spark plug shell. Then, with a rotating motion pull gently to break the adhesion.

**Q** Is there anything to do about an annoying window rattle on my 1962 Rambler without disassembling the door?—W.J.S., N.J.

**A** There is one fix you can try. Get a length of ordinary TV antenna wire. Then, with the window down, push the wire into the channel. This should shim up the channel and make a snug fit between the window and the channel. The antenna wire, since it is plastic coated, makes a good track for the window. If the wire's too wide to enter at any point, shave a small amount of plastic from one side.

As a service to the readers of Popular Mechanics in solving problems relating to their cars or to driving in general, you are invited to submit your questions for answering either through this column or by mail. Address Auto Clinic, Popular Mechanics Magazine, 575 Lexington Avenue, New York 22, New York.



# Keeping Your Car Up To Par

**ONE EASY WAY** to locate a head-gasket leak on V8s having separate top radiator hoses is to remove both of the hoses and take out the thermostats. Next, remove the fan belt so that the water pumps won't operate and fill the block with water to the top of the head. Then start the engine, and while it is idling look for bubbles along the gasket line

**WHEN OVERHAULING** older-type L-head engines, one of the ever-present problems is keeping dust, carbon particles and other debris out of the valve guides. A small twist of clean cloth or tissue paper will do the job, if you can keep it in place. However, a simpler and surer solution is to select a common carriage bolt that will just drop down into the guide

**BEFORE TIMING** an engine having timing marks on the vibration damper, be sure to remove the fan belt. The engine will idle safely without it for a short time, and this allows you to reach down with the timing light to pinpoint marks without risking a painful injury. With the belt connected, your finger might be caught between the pulley and the belt

**ON SOME V8 ENGINES** the front cylinders tend to run cooler than others in the two banks. This can result in fouled plugs, a rough idle and possibly a persistent miss in one or two cylinders. To correct this tendency without the risk of damage to the engine, install plugs of a somewhat higher heat range in cool cylinders. Also, check the thermostat

**TO PREVENT THEFT** of your spare tire from the trunk, pass a length of chain through the center of the wheel and around a brace in the trunk, then padlock the ends together. The same basic idea works especially well in securing the outside-mounted spares found on many small trucks, and may also be used to protect a toolbox, passing chain through handle



AUGUST 1963

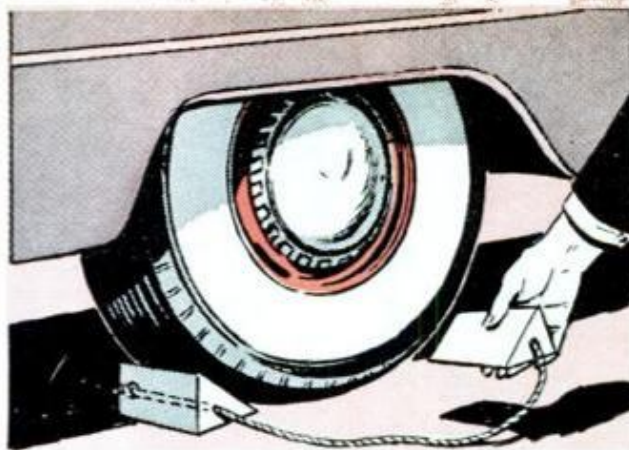

**DOUBLE INSURANCE** in the form of two wooden wedges will prevent your car from rolling when it's up on a jack. For easier storage, thread them on a short piece of rope and tie a knot in each end. If you ever have occasion to block both wheels, as on a particularly steep grade, simply untie one of the knots and pull off a wedge to block the other wheel

**WHEN ENGINE COOLANT** is drained for any reason, it's not possible to get all of it back into the cooling system because of the closed thermostat. To avoid loss of time running the engine to open the thermostat, remove a hose at the heater. Then you can pour all the coolant back into the system without unnecessary delay. Be sure to replace the hose

**ODOMETER CABLES** that break off short can be removed by turning a sheet-metal screw into the broken end. Once this is done, you can grip the screw head with pliers and pull the cable out. Old cables coated with hardened lubricant are always difficult to remove, so squirt a little penetrating oil into the open end to loosen it before you begin the job

**AN INCONVENIENCE** when using a conventional tire pump is the lack of a gauge to let you know when the correct pressure has been reached. You can remedy this by installing a small pressure gauge in the pump hose. Just screw the gauge connection into the side arm of a tee and screw hose nipples into the other two arms, then clamp the ends of hose to them





# CAMP STOOL

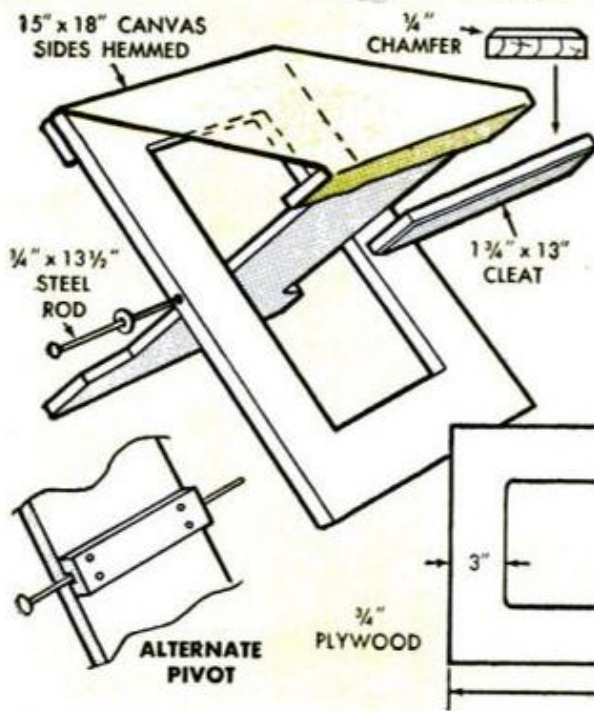
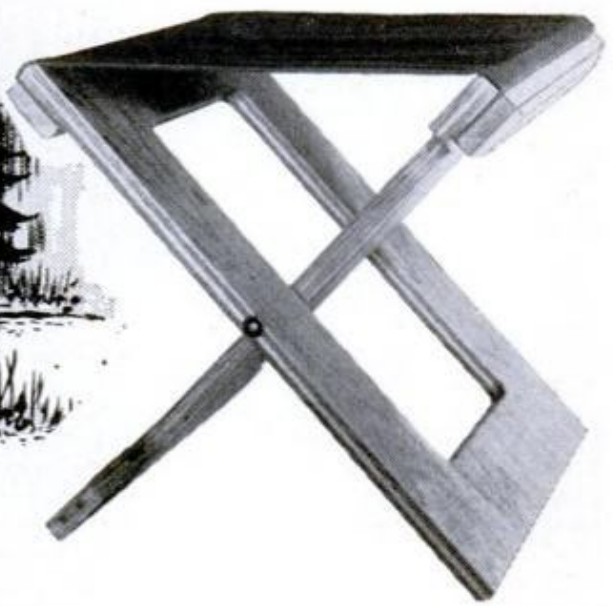

If, like most outdoorsmen today, you feel a camp is incomplete without all the comforts of home, you'll want to make one of these folding stools for every member of your party. They weigh only a few pounds, and three or four of them take up little room in your car. Make the legs from exterior plywood, the cleats from 1 x 2 and the seat from canvas or duck.—*E. V. Traylor*

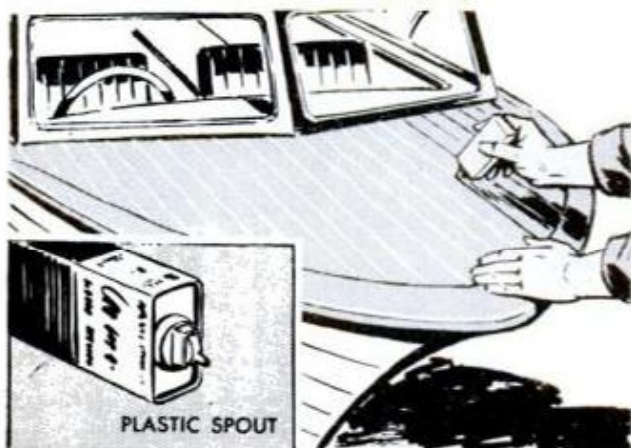
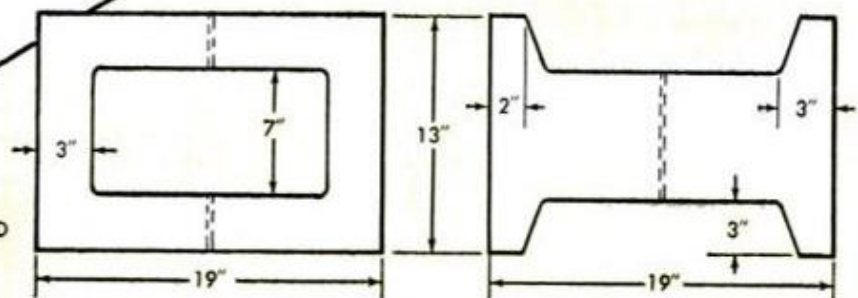

## Improved Striping Tool

Many a boat owner has ruined a good paint job by doing a poor job of striping the deck planking. But masking for each individual stripe is difficult and time consuming. Solution? Make a striping tool from an empty lighter fluid can—preferably the type with a fold-down plastic spout. Fill with marine enamel, thinned to flow freely through the spout. Then, while squeezing the can gently, move the spout at a uniform rate of speed along the plank joints.—*E. Dahlgren*



# Shopping for Tools



**STANDY** is an adjustable stand that will hold a propane torch at any angle while you hold the work, the brazing rods or the solder. It's safer than the usual run of improvised stands, and comes equipped with a flint gas lighter. Made of heavy-gauge satin-finish aluminum. Priced at \$1.98. Silver King, 1529 Youngs Avenue, Aurora, Illinois

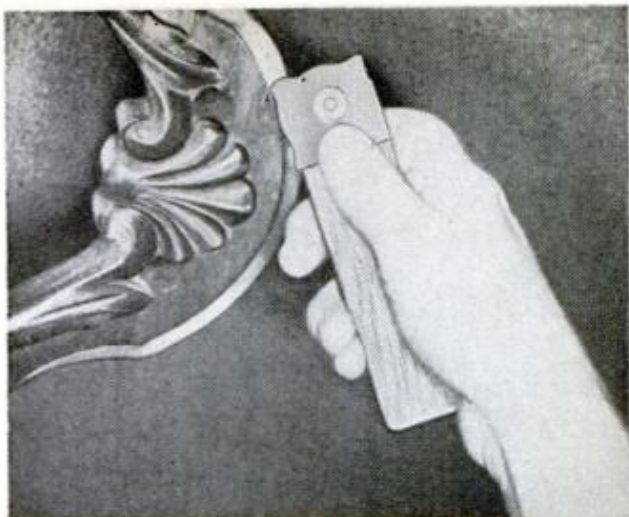

**VERSATILE SCRAPER** is said to be ideal for cleaning carvings and other difficult surfaces before refinishing. Two blades offer a wide variety of concave, convex and straight edges. Pressed wood handle is finished to resist acids and paint removers. Costs \$2.50 postpaid. Extra pair of blades is \$1.25. Dept. PM, Carl F. Maute Co., Box 27, Williamsville 21, N.Y.



**NEW VINYL-GRIP CHISELS** were specifically designed for geologists and rock hounds. Model ERC-8 is 8 in. long, has a 1¼-in. cutting edge. ERC-12 is 12 in. long, has a ½-in. cutting edge. Prices are \$1.50 and \$1.35, respectively. Estwing Manufacturing Co., Rockford, Ill.

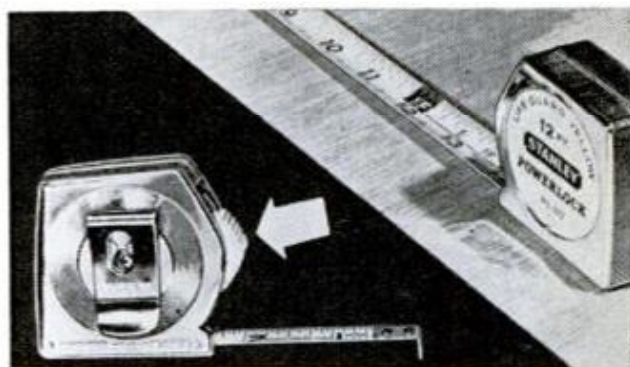

**POWERLOCK PLASTIC-COATED TAPE** locks in extended position, freeing your hands to make notes, etc. It's equipped with a convenient belt hook. Made in ½- and ¾-in. widths, lengths up to 12 ft. Prices start at \$1.59. The Stanley Works, New Britain, Conn.

**UTILITY CHAIN WRENCH** fits ⅝- to 4-in. pipe. Operates in either direction without having to be removed or refastened. Needs only ¾-in. clearance. Chain is 15¼ in. long, and can be lengthened. Handle is 12¾ in. long. At dealers only. Ridge Tool Co., Elyria, Ohio

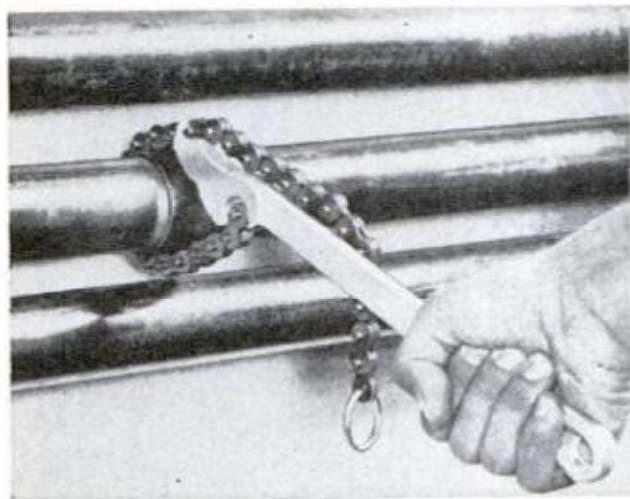

**SLIK WRENCH** has no adjusting screw. You slide it open, put it on the work, slide the movable jaw against the work. Jaw's wedge action maintains a tight fit as you push against it. Price: \$2.98. Empire Mds. Co., 140 Marbledale Road, Tuckahoe, N.Y.

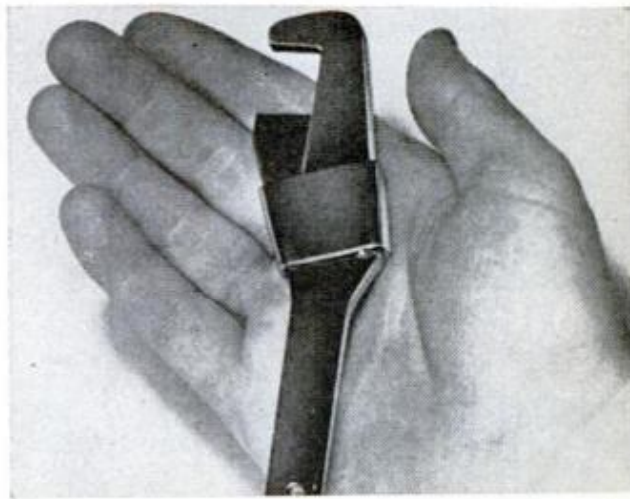



# HOW TO STAY ALIVE ON A LADDER

By Bernard Gladstone

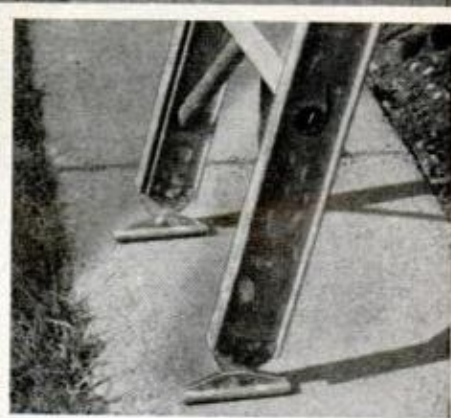

**PLANT IT FIRMLY.** Rubber-faced feet keep metal ladders from slipping. On soft ground, lay plank for footing



*No home accessory looks so harmless—yet has greater accident potential. But if you're savvy, you're safe*





**FOR ROOF PERCH**, lay ladder flat, hooking brackets over ridge (inset). This simplifies climbing up and down, gives you choice of levels from which to work

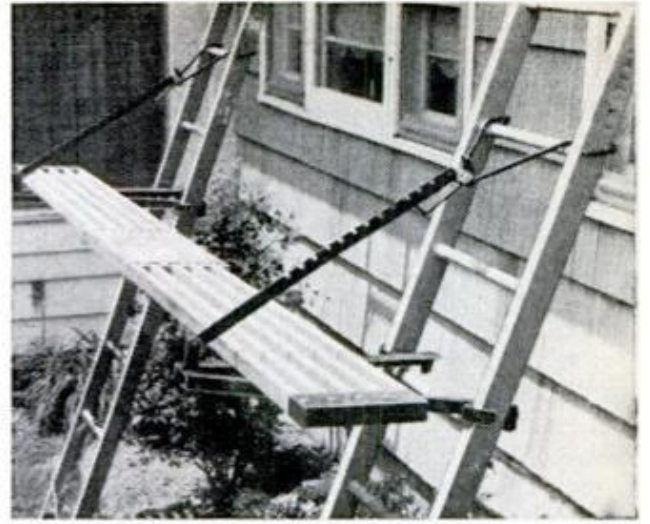

**PAIR OF RENTED JACKS** lets you rig scaffold to save a lot of ladder moving. At low heights, as here, take extension ladder apart to avoid renting second one

**WHAT GOES UP** must come down—but not always at the same speed. To make sure *you* will always come down a ladder the way you went up—a step at a time—never forget two rules:

- Don't climb anything but a top-quality ladder which you know is in good repair.
- When using any type of ladder, be sure to follow established common-sense rules on setting it up and working from it.

Before you use a ladder—especially one that's rarely used or one you've borrowed or rented—inspect it carefully. Check rungs or steps to see if any of them show signs of cracking or splitting. It also pays

to test all metal braces under the rungs with a wrench to make certain they're tight. An easy way to test the rungs on a tall ladder is to lay the ladder flat and bounce lightly on each rung with your full weight. Next, stand the ladder in its working position to see if it wobbles or shakes excessively. At the same time, inspect all pivots, locks and other hardware.

If you're buying a new ladder, don't let price alone determine your selection. Even with a small step ladder this can be foolhardy. Remember that more injuries are caused by falls from a three or four-foot height than by falls from a tall extension

**MULTI-PURPOSE LADDER** leads three lives: Left, it's a double-climb stepladder with rungs up back as well as treads up front; runged section extends to convert to small extension ladder (center) or comes off for use as separate straight ladder; adjustable feature lets you offset back (right) for steps or sloping ground

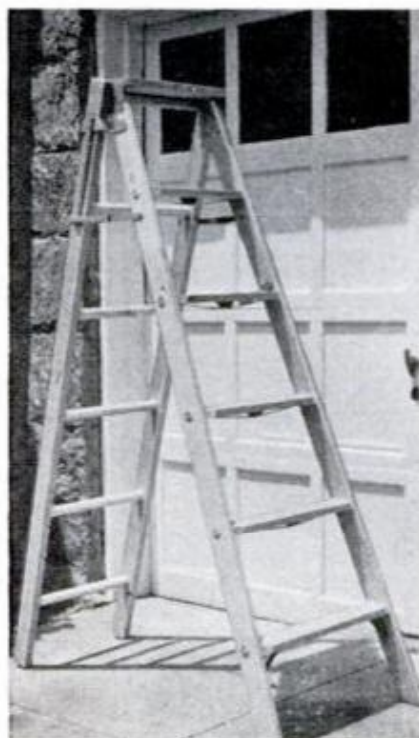



ladder. Since a good ladder will last many years, the few dollars saved is hardly worth the increased risk inherent in a "bargain" of inferior quality. Check the ladder before you buy it. The side rails should be free of knots or other defects.

To preserve a new wood ladder, coat it with a clear penetrating wood sealer or spar varnish before you expose it to the weather. Never use paint—an opaque finish may hide cracks so they'll be difficult to spot later on. It's good precaution to lubricate all hardware at least once a year, and spray exposed metal with a clear plastic or lacquer to prevent rusting. Ladders of magnesium or aluminum need no special maintenance (except for lubrication of pivots), but they should be permanently equipped with rubber-faced safety feet to prevent slipping on hard surfaces. Such metal ladders are lighter and easier to handle than comparable wood ladders, but be very careful when using them near power lines.

Before climbing to any height on a ladder, mount a step or two and bounce lightly up and down to see if there's any sign of shifting or sliding. When positioning a tall extension ladder against the side of a house, one obvious caution is to avoid resting the top end against a windowpane or screen. If you must place the ladder in a spot where a window is located, nail a wide board across the opening first, and rest the ladder against this. If it's not practical to nail the board in place from inside the window, nail it across the upper end of your ladder, instead, before you raise it. To keep the top of an extension ladder from marring a freshly-painted surface, wrap the ends in heavy rags, or

slip a pair of old wool socks or work gloves over them. Be sure to scrape all mud or grease off your shoes before you start up.

When climbing, descending or working from any ladder, always face *toward* it, never away from it. While climbing, hold on with both hands. Try to tuck tools in your pockets or clip them to your belt to leave your hands free. Where quite a load of tools and supplies is needed, climb the ladder first, then haul the load up with a light rope. You can keep most items in a pail hooked onto a rung. While working, hold on with at least one hand. If a two-handed job makes this impractical, hook one leg through a rung.

For certain jobs, a long working platform is more convenient than working from a single ladder. The quickest way to rig up a simple scaffold is to rent a couple of ladder jacks. At relatively low heights such as the setup shown on the previous page, you have the option of mounting such jacks on the *inside* of the ladders, as well, for an underslung platform closer to the wall. Though ladder jacks are made in various styles, the safest type is the kind that hooks onto the ladder rails rather than the rungs. You can also rent an adjustable extension plank of the kind shown, or just use 2x10 or 2x12.

If a ladder must be placed in front of a door, either lock the door shut or tie it open so that no one can come charging through and slam into the ladder while you're on it. If you're working indoors—particularly on polished-tile or hardwood floors—you can keep a ladder from slipping (or marring the floor) by fastening a piece of rubber heel or a split section of hose to the bottom of each leg. ★★★

## HOW TO CARRY A LADDER

**HORIZONTAL TOTE** is safest if you're moving a long ladder any distance. Lift ladder at mid-point for best balance and rest rail on shoulder to minimize strain. For short hauls, as along wall, right, lift vertically to clear ground, steady top with highest practical grip.

Try only on level ground and watch for overhead branches or wires







1. Working alone? No problem, if you butt the foot of the ladder against the wall, then lift other end



2. Raise ladder until end is head-high, grasp top rung as shown and "walk hands" toward the building

## HOW TO RAISE A LONG LADDER...

3. Continue walking ladder—shifting hands from rung to rung as you move forward—until ladder is vertical
4. Ladder can now be moved where it's needed or, if you've raised it at right point, just bring foot out
5. For safest climbing angle, distance from wall to foot should be equal to one-fourth of ladder's height



## ... AND HOW TO ADJUST IT AFTER IT'S UP

**NEVER REACH TO SIDES** more than comfortable arm's length; stand straight on rungs (left) and don't strain overhead. Raise extension to add needed height (center) by pulling down on rope; spring-loaded bracket hooks over rung (inset). To lower, tug rope till hook is free. Pivoting bar closes hook so it will jog past rungs on way down. To shift ladder sideways (right) tip its top over two or three feet, move foot in line





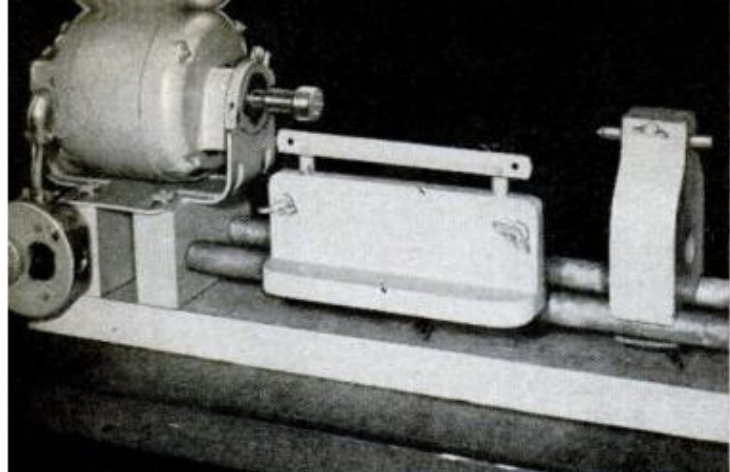

**HEADSTOCK** of this low-cost lathe is direct-drive, capacitor-starting motor mounted on blocks which are glued and screwed to 2 x 6 base. Note ends of clamp-tightening levers below tailstock and toolrest

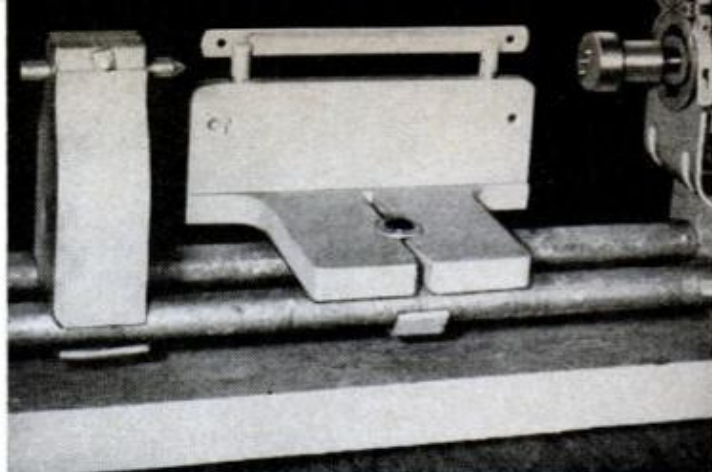

**TOOLREST** held firmly to the ways by means of clamp plates can be adjusted to different heights by loosening a pair of wingnuts. Shorter 5-in. toolrest is mounted on single post, is also adjustable

# I Built This Wood Lathe

By E. R. Haan

**I**T TOOK me approximately 12 hours to build this simple wood lathe. Powered by a 1/4-hp. motor, it has a faceplate capacity of about 8 1/2 in. and will take work up to 34 in. between centers. Tailstock and toolrest are clamped securely by means of lever-operated bolts, thus eliminating the need of a wrench.

In spite of the low cost and simplicity of this shop-made tool, it's a practical lathe that will handle most common wood-turning jobs and a good one for the beginner. Since materials costs vary, you probably won't duplicate the \$10.67 it cost me. But whether you pay \$10 or \$12, it's a bargain.

A switch on or near the motor will be an extra convenience. On some motors, you can fit a small 110-v. toggle switch to the plate of the connection box to extend inside. This wasn't practical with the

motor that I used, so I mounted a regular switch in an outlet box and attached this to one of the motor-support blocks. I also placed a fuse in the circuit.

One other item that I had to buy was a spur center. The one shown in the photos was purchased from a mail-order house and is designed to fit a 5/8-in. unthreaded arbor. In order to make this fit the 1/2-in. motor shaft, I added a fiber sleeve having a 1/16-in. wall, then drilled two holes to allow setscrews to pass through the sleeve.

● Start construction with the base and ways, shown in the drawing below. After sawing the three blocks to size, bore holes to take the 3/4-in. pipe ways snugly. If at all possible, bore these holes (and all others mentioned here) on a drillpress since this assures greater accuracy than hand boring. After boring the blocks, glue and screw them to the 2 x 6 base.

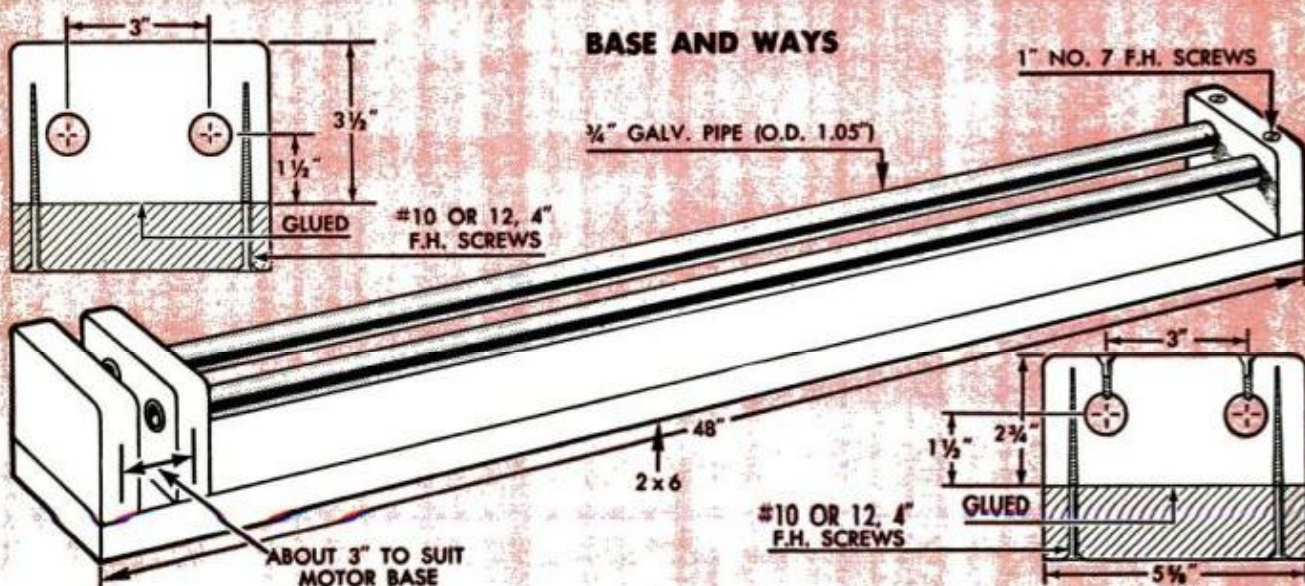



Wood	—	\$ 1.70
Pipe	—	78
Hardware		1.49
Spur Center		1.20
Motor		5.50
		<u>\$10.67</u>



for **\$10.67**

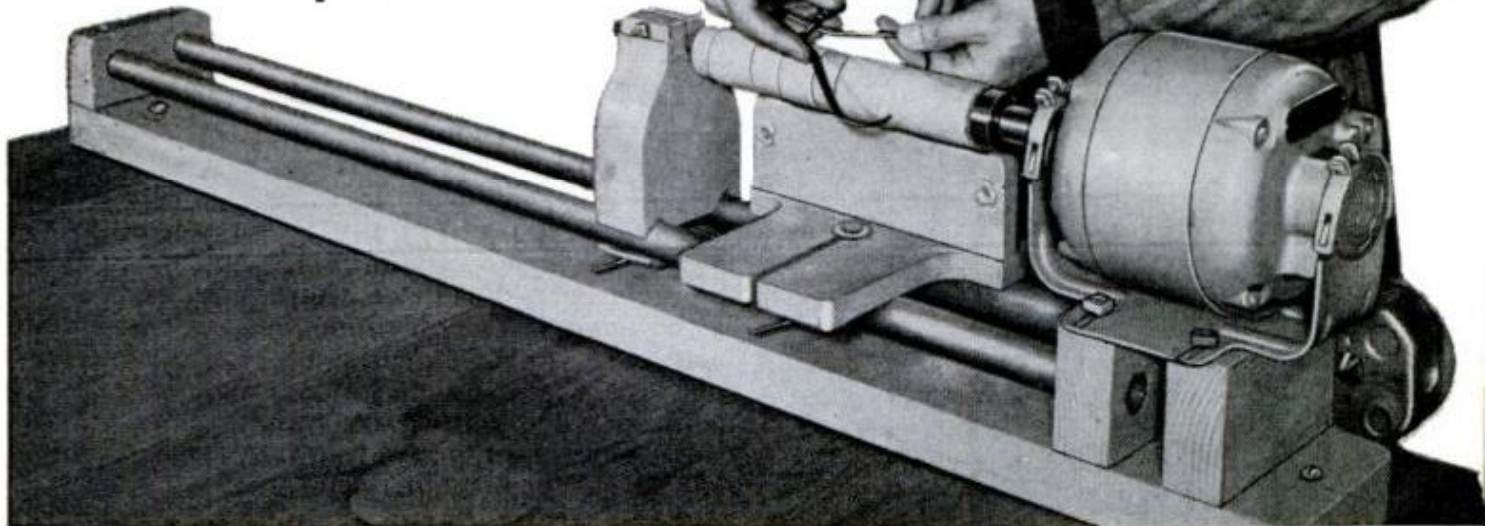

The 4-in. wood screws extend almost all the way through the blocks to prevent them from splitting crosswise along the grain if subjected to stress. Drill pilot and body holes for these screws before driving them home. A little soap on the threads

will make driving them much easier. Drill a small hole in the end of each pipe to take the end of the 1-in. screw which is used to lock the pipe in place.

● The tailstock is of sandwich construction, consisting of three thicknesses of

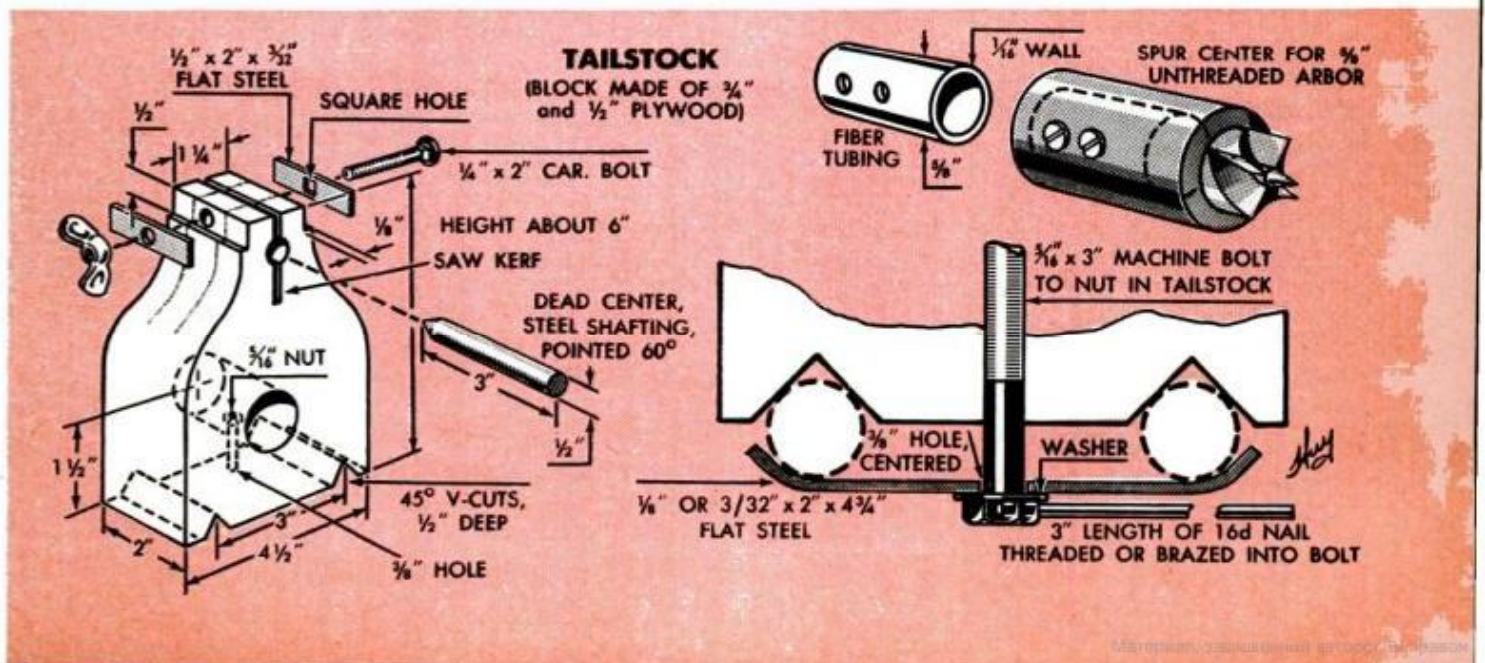



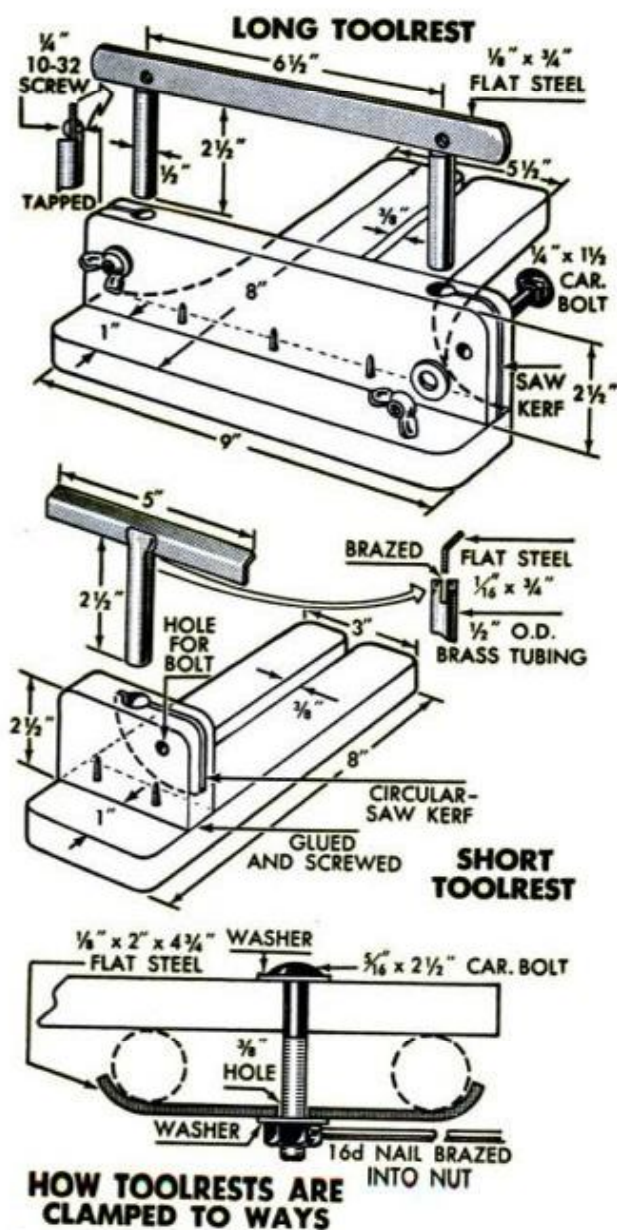
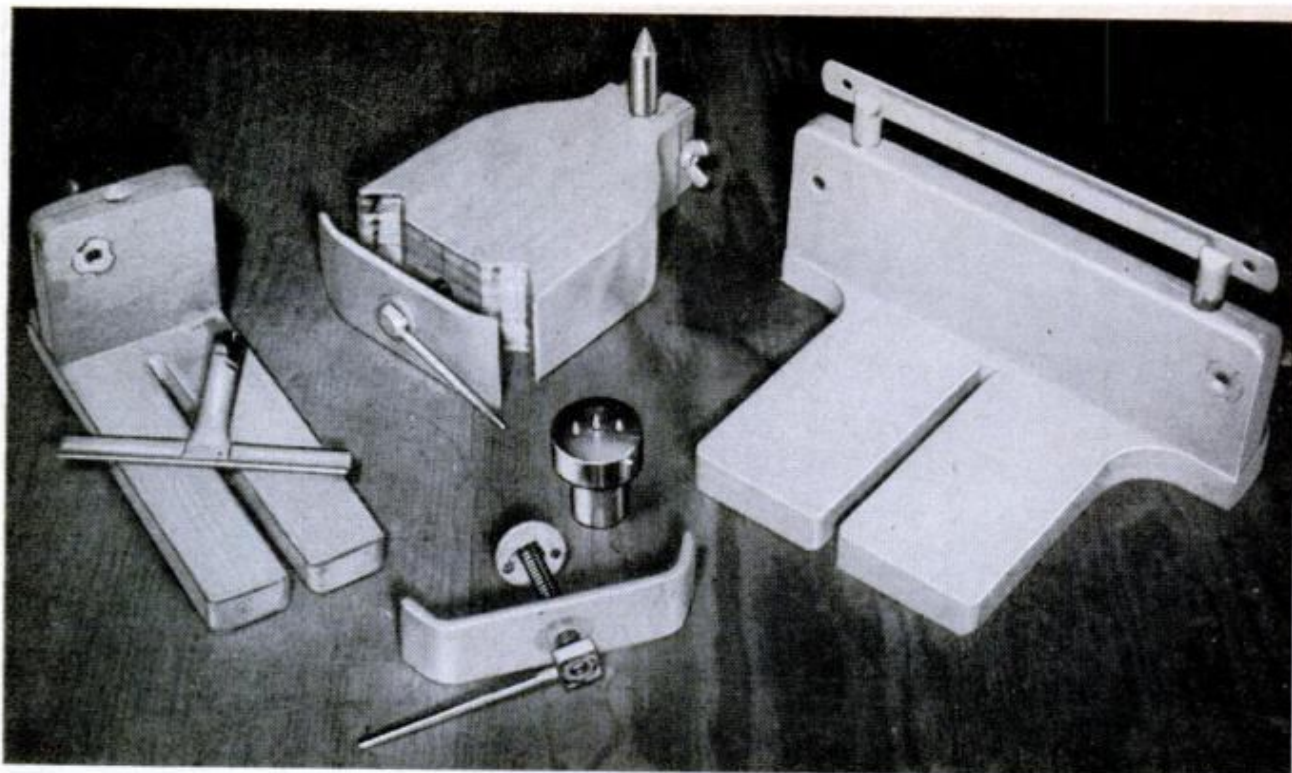

**TAILSTOCK AND TOOLRESTS** all use the same type of clamp plates to secure them to the ways. Levers are actually 16d. nails attached to bolt heads or nuts, making it easier to tighten or loosen clamps

plywood (two  $\frac{3}{4}$ -in. and one  $\frac{1}{2}$ -in.). After applying glue, clamp these pieces together and allow the glue to dry overnight. In cutting the block to shape, use a circular saw for straight cuts and a band saw for curved cuts, if you have access to these tools. It's especially important that you cut the 45-deg. notches accurately. After drilling the  $\frac{3}{8}$ -in. hole for the clamping bolt, bore a  $1\frac{1}{4}$ -in. crossing hole so that you can insert the nut.

The dead center must be in perfect alignment with the motor shaft. To mark the location of the hole that takes the dead center, set the motor in place temporarily and put the tailstock on the ways against the end of the motor shaft. After drilling this hole, make a saw cut down through the middle of it. Finally, cut notches for the steel plates and install the carriage bolt and wing nut.

Cut the steel clamp plate and bend the ends up to an angle of about 45 deg., then drill a hole in the center for the machine bolt. To make the lever that turns this bolt, drill the head to take a length of 16d. nail. Either thread or braise the nail in the hole.

● The toolrests have the same type of lever-operated clamp as the tailstock, except that a carriage bolt is used instead of a machine bolt. Construction, detailed at the left, is somewhat simpler than that of the two other units, and requires no special explanation. ★★★



## SHOP SHORT CUTS

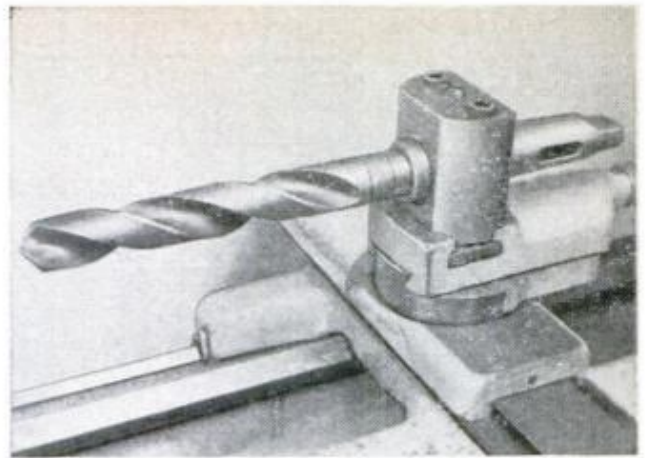
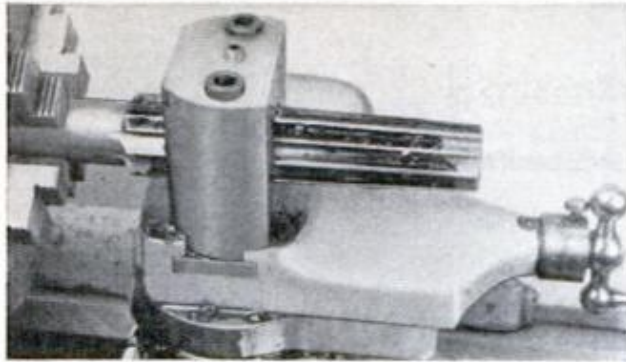

### Toolpost "Chuck" Holds Large Morse-Taper Twist Drills

When other machines in the shop were tied up with rush jobs one machinist came up with a method of mounting a large twist drill on a small lathe for accurate drilling of big holes. Precision twist drills above  $\frac{1}{2}$  in. diameter usually come with taper shanks and must be carried in a Morse-taper sleeve. First machine (rabbet) a steel block to drop into the T-slot on the compound. Then counter-bore the block to seat two socket-head screws,

the latter turning into tapped holes in a clamping plate which slides into the T-slot. Next, clamp the block on the compound and drill and ream for the taper sleeve as in the left-hand photo. Finally, drill and tap the block to take a socket setscrew which locks the taper sleeve. This completes the setup pictured in the right-hand photo, which permits use of the lead screw to feed big drills for precise drilling of chucked workpieces.—H. J. Gerber

### Bench Top Arbor Press

Teamed with the simple weldment pictured, your bench vise can serve as a powerful arbor press for seating pulleys, enlarging sleeves and similar parts in press fits on spindles and shafting. The weldment consists of a steel base, a vertical plate and two brace plates welded to form a platen which is slotted to take the spindle or shaft. A second platen seats against the end of the vise slide. The platen is bolted to the bench top back of the vise and in line with the slide. Photo pictures a typical setup.

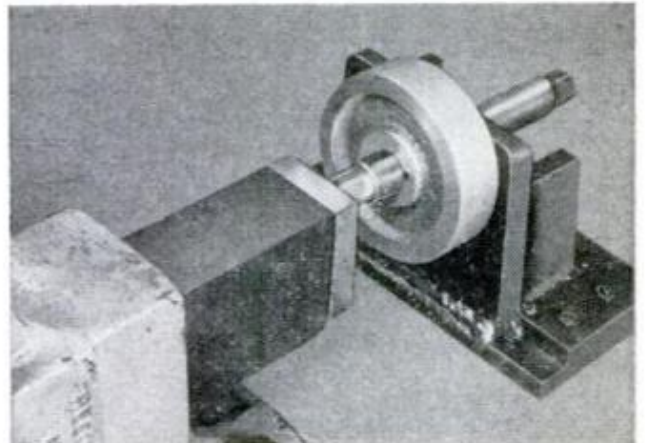

### Pipe Cleaner Works Fast

However odd this contrivance may appear, it will clean the rust off a length of pipe or shafting in minutes, or less! It consists of a heavy sprocket and a loop of heavy roller chain, the sprocket fitted to the spindle of a belt-driven grinder head. All you do is lay the length of pipe in the chain loop, start the grinder and slide the pipe along, turning it uniformly as you go. Move the pipe about half its length, stop the grinder, reverse the pipe and proceed as before. Wear goggles for protection.

**Avoid unnecessary handling** of roller and ball bearings. Even though oiled, perspiration from fingers can cause rusting.

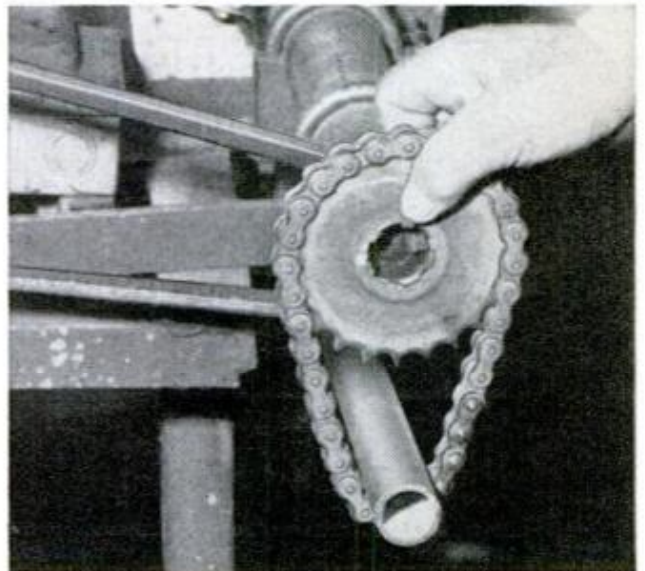



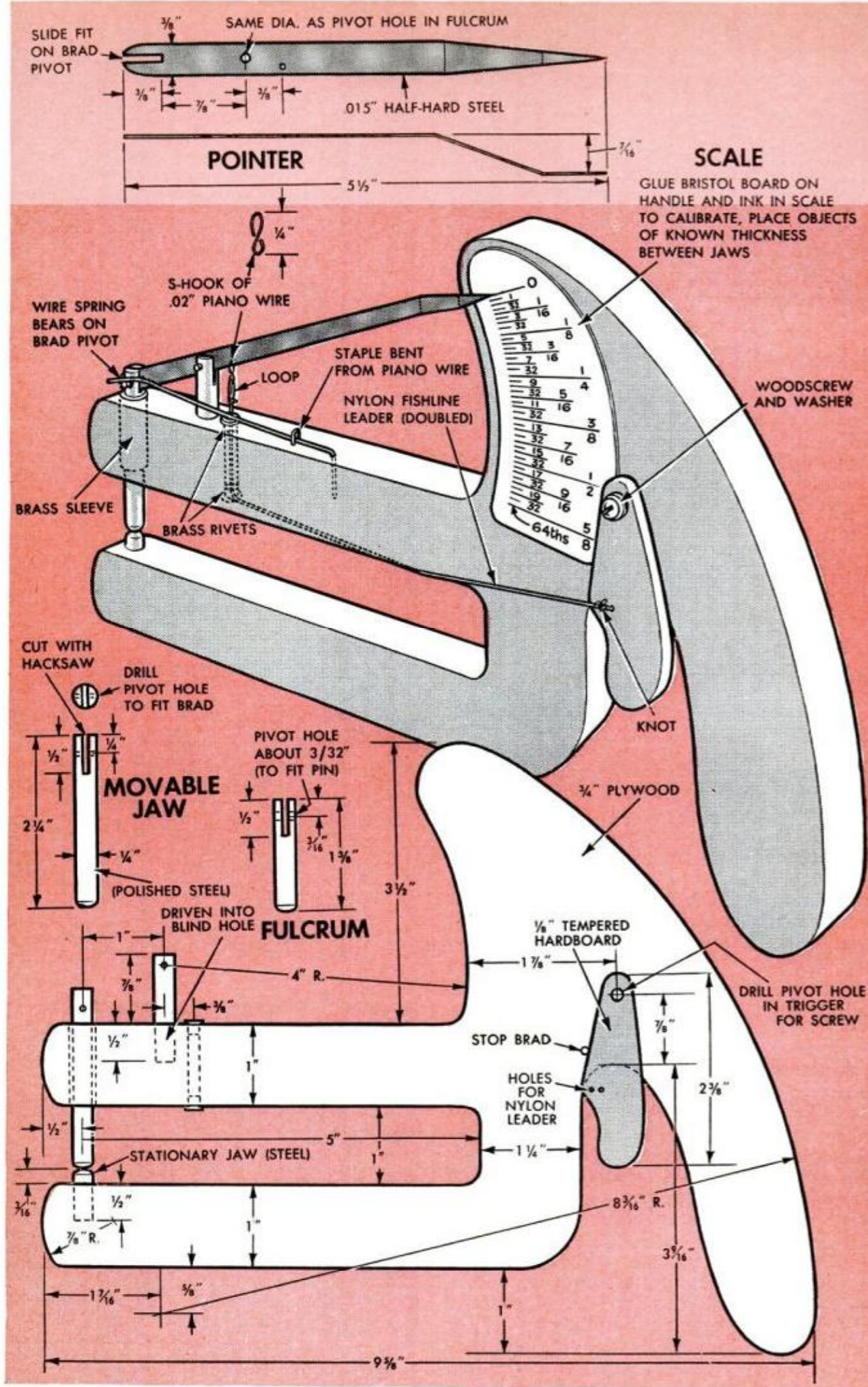



# 4x Magnifying THICKNESS GAUGE

By E. R. Haan

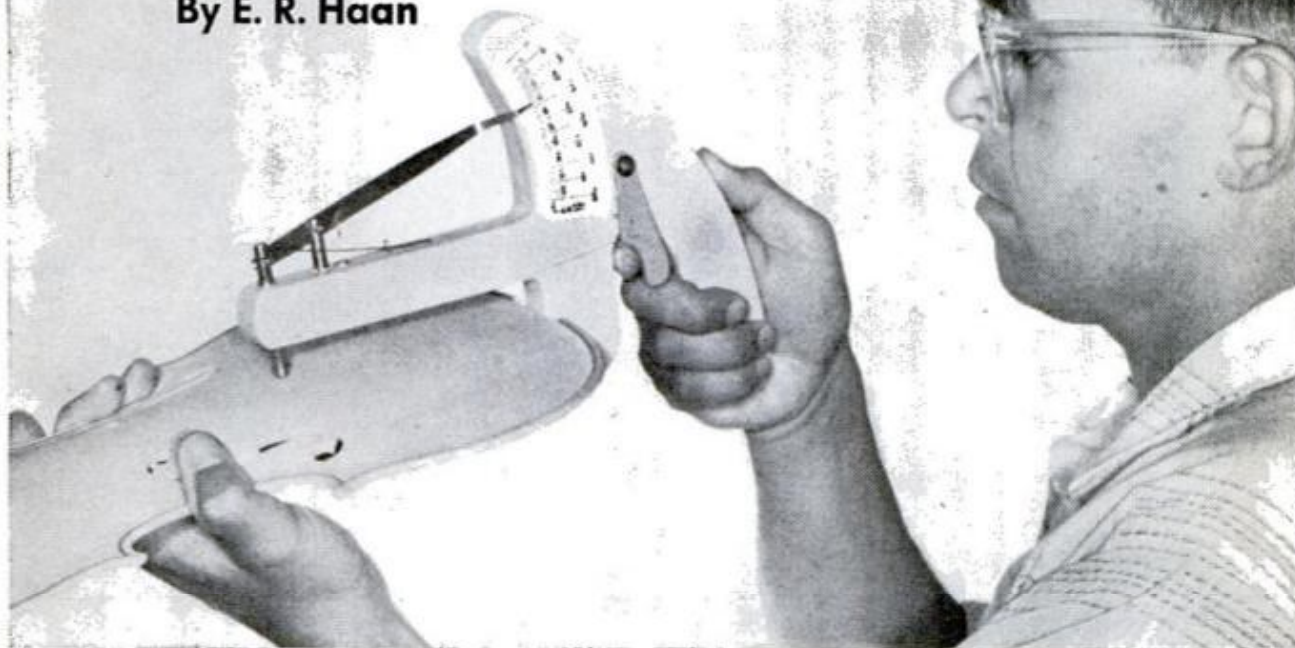

**No eye strain with this pistol-type gauge that lets you take instant readings down to 1/64 in.**

**M**EASUREMENTS are instantly visible on the large, easy-to-read scale of this direct-reading, low-cost thickness gauge. With a jaw capacity of  $\frac{5}{8}$  in. and throat clearance of 5-in., it's particularly valuable for those exacting jobs where the work is thicker near the edges than at the point being measured. In such cases, ordinary machinist's calipers are useless, since to remove the calipers from the work for determining the measurement, the jaws must be opened and in doing so, the original setting is lost.

When making this gauge, it's especially important that the surface of the movable jaw be true throughout, so that it will slip up and down in the sleeve with a minimum of friction. If you dress this jaw down in a drillpress by filing it, use a fine-tooth file and keep it moving up and down as the work rotates. After filing, use emery and crocus cloth to produce a high polish.

Pivot pins must fit exactly in the slot and hole in the pointer and in the holes in the jaw and fulcrum so as to avoid play. Slots in the pointer, movable jaw and fulcrum should be cut with a thin metal-cutting saw. After cutting, smooth the sides of the slots with a thin flat needle file, followed by emery cloth glued

over a piece of tin. The slots must have smooth sides or the action of the gauge will be jerky.

It's best to select the pivot brad and matching twist drill first, then make the slot and pivot hole to fit it exactly. The same applies to the brad and pivot hole in the fulcrum.

An L-shaped spring of .035-in. piano wire will apply just enough downward pressure on the upper jaw to assure positive closing. Force the short end of the spring into the plywood with a pair of pliers, then bend the other end down a trifle so that it will exert pressure in line with the jaw axis.

Calibrate the scale after assembling the thickness gauge. To do this, just slip objects of precise known thickness between the jaws ( $\frac{1}{32}$  in.,  $\frac{1}{16}$  in., etc.) and mark the location of the pointer on the scale. After the main divisions have been marked, you can subdivide these into equal spaces. Divisions at the top of the scale will be slightly smaller than those lower down, since the pointer assumes a more acute angle as it rises.

Mark the scale with India ink and coat it with clear shellac or lacquer, then finish the wood with enamel. ★★★





# Wake Up to Your Song



*Or start breakfast coffee perking with this \$10 music-box alarm clock-timer*

**I**F YOU'RE TIRED of having the same old raucous alarm clock awaken you each morning, then you need this easily made "variety" alarm clock by your bedside.

Most of the time it will gently rouse you with a tinkling music-box tune. But whenever you get to bed extra late and feel you'll need something more urgent, just switch to the high-powered buzzer to be sure you won't over-snooze.

Or plug in a bedside radio, or even a percolator to lure you awake the next morning with the aroma of coffee brewing.

If you have to rise at night and don't want to disturb the family, a flashing light will wake you quietly. The heart of this talented timer clock is a Telechron clock mechanism that can be set to operate any electrical device at any preset time. By hooking it up



**GIVE THE MUSIC-BOX** alarm clock a finish that matches your bedroom decor. Socket on top is for appliances to be controlled. Switch on front turns off buzzer

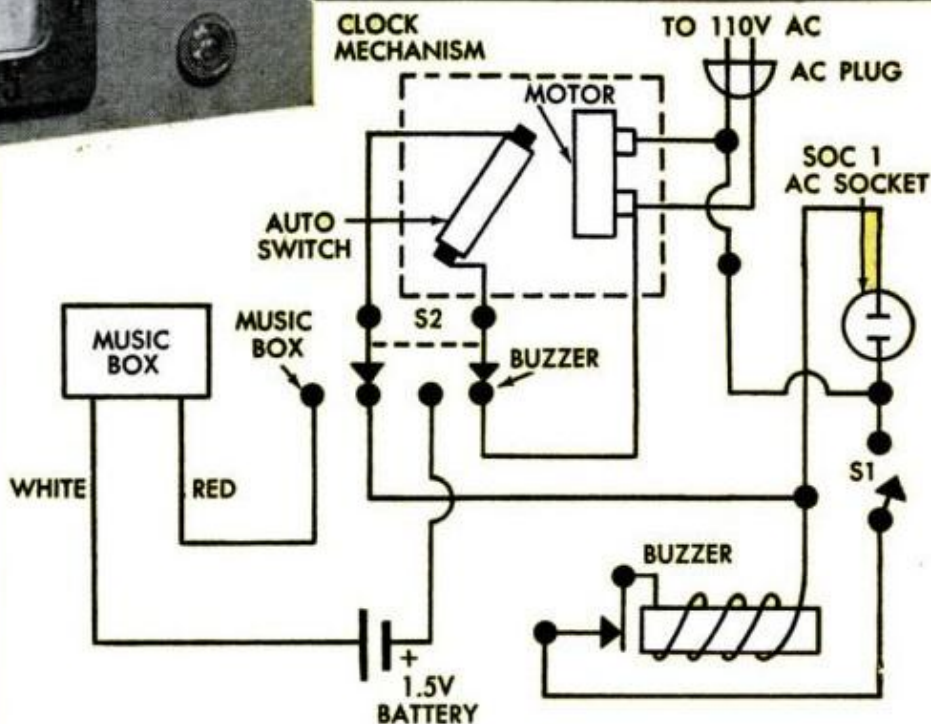

**IN WIRING THE** circuit, make sure the red lead from the music box goes to the positive end of the battery



to an electric music-box movement, you'll have as pleasant a sleep-interrupter as can be found anywhere.

My unit has a homemade hardboard housing,  $6\frac{3}{8} \times 4\frac{1}{2} \times 3\frac{1}{4}$  inches, which is about as small as you can make and get all the parts in conveniently. It is cemented together with white glue, a side at a time. After the glue has set firmly, cut all the necessary holes.

I used epoxy cement to fasten the clock mechanism in place and at the same time to hold the music box and 115-volt outlet, too. If you have a dab or two of epoxy left over, put it on the buzzer mounting screws to prevent them from loosening.

The *s.p.s.t.* switch on the clock is rated at 1650 watts, but this rating is reduced here because the wiring goes through a 690-watt *d.p.d.t.* switch. If you need the full 1650-watt rating, get a *d.p.d.t.* toggle switch that can handle the load safely.

Wiring is straightforward. Follow the simple schematic and make sure the red wire from the music box goes to the positive end of the battery. If it doesn't, the music-box motor will run backwards and may ruin the movement.

For the rest of the wiring (*including that going from the clock coil to the wall plug*) use number 16 wire, though number 18 will do. Remember, besides supplying power to the clock, this wiring must

also carry the load for whatever is plugged into the timer socket for control.

Most anything electrical can be plugged into this alarm clock to suit your own special needs.

To set up a light alarm, use an ordinary table lamp plugged into the timer outlet. But insert a flasher button from the hardware store between the bulb and the lamp socket. For daytime alarm use, select a red bulb; for night use, choose a white one.—Tommy Thomas

#### PARTS LIST

- \*Telechron timer-switch clock mechanism (MS-793)
- \*Electric music-box movement (MS-763)
- \*115-volt a.c. electric buzzer (EL-86)
- Heavy-duty *d.p.d.t.* toggle switch
- Vent hole plug, 1-inch (pkg of 4)
- Manganese alkaline battery (Mallory type Mn-1300)
- 115-v. female socket (Amphenol type 61-F1)
- Battery holder for 1 D-cell
- S.p.s.t.* toggle switch with wire leads
- Hardboard, paint, white glue, epoxy cement, 115-volt male plug, rubber feet, flasher button, nuts and bolts
- \*These parts are specialty items obtainable from Lafayette Radio, 111-A Jericho Turnpike, Syosset, LI, N.Y. The proper catalog number is given.

**ONCE ALL THE PARTS** are mounted, the case gets somewhat crowded. Before fastening anything down, lay out all the parts inside the case, so you'll be sure of getting everything in and properly located

**CROSSBAR** made from a strip of wood, metal or plastic should be fastened across the rear of the clock mechanism as shown. It will support adjustment shaft to reduce strain and keep it from breaking

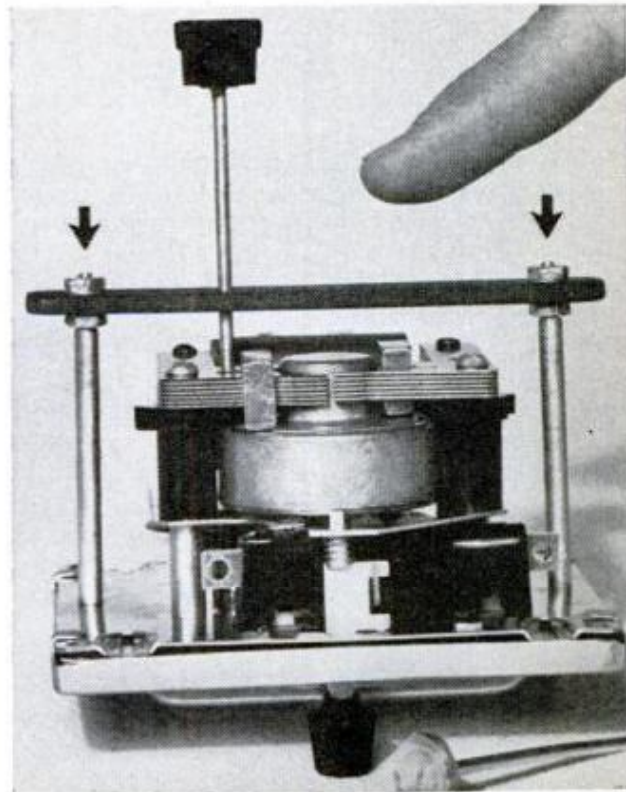
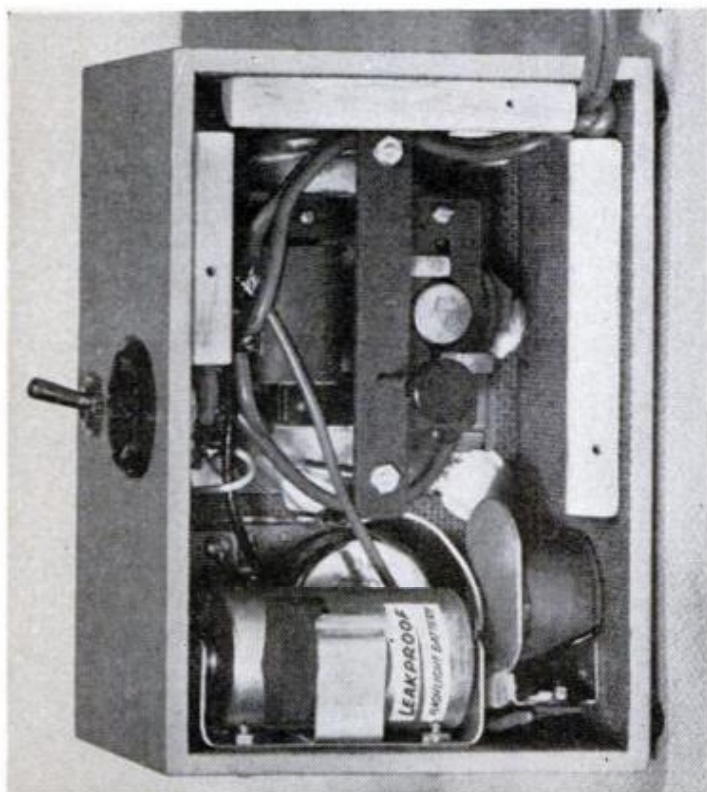



# 2-Mile Boat Horn

*For signaling or emergency warning, make this dual-tone, battery-powered horn for your boat for about \$20*

By Len Buckwalter

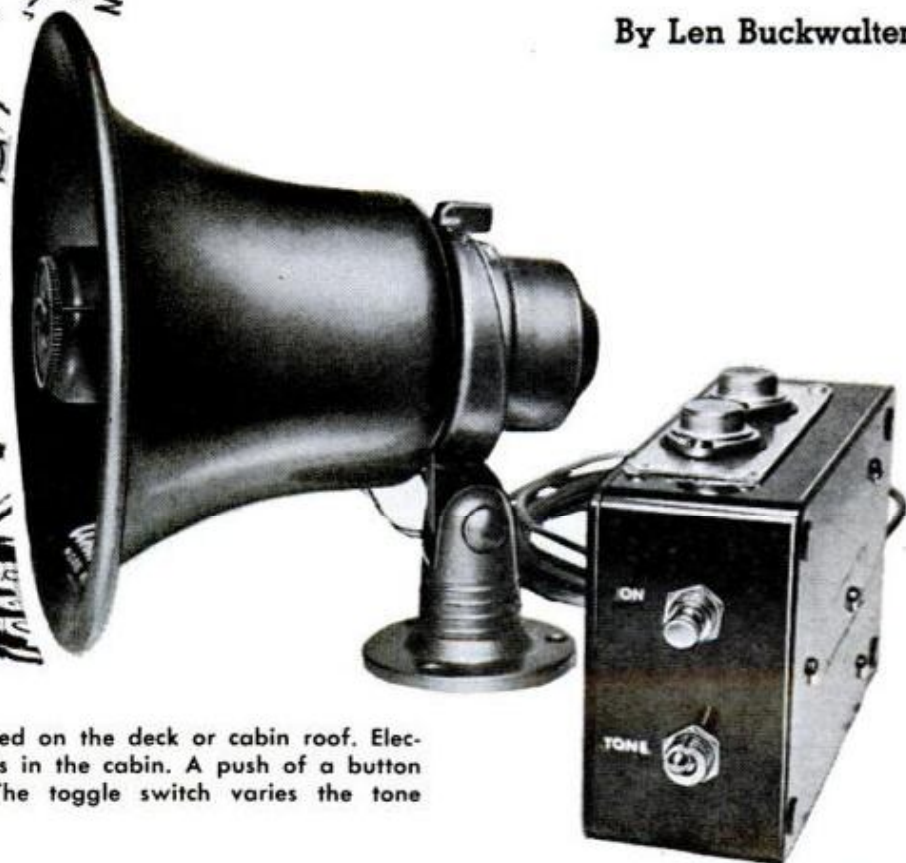

**HORN-TYPE SPEAKER** is mounted on the deck or cabin roof. Electronics-packed plastic case goes in the cabin. A push of a button sounds the horn's warning. The toggle switch varies the tone

**F**ORGET ABOUT corroding contacts, heavy solenoids and high battery drain—this transistorized boat horn eliminates such problems.

Relying on electronic action, rather than mechanical, the device is one of the most efficient ways to convert battery power into a loud blast of sound. It works in powered craft with 6- or 12-volt electrical systems or aboard a sailboat with the addition of a small battery pack. You can put it together in two or three evenings at a cost of about \$20 including the speaker.

The electronic horn is built around a 2-transistor circuit. When the button is pressed, the transistors instantly begin a flip-flop action that drives current around the circuit in a series of fast-moving pulses. Fed to the horn speaker, the pulses are turned into a loud steady tone. The horn tone can be easily changed by a flick of the tone switch. Depending on the situation, the horn can sound a mid-range tone for normal use or a piercing, high-pitched tone as an attention-getting alarm.

## PARTS LIST

- R1, R2—220 ohms, 1/2 watt, 10% carbon resistors
- C1, C3—4 MFD, 50 volts, miniature electrolytics
- C2—2 MFD, 15 volts, miniature electrolytics
- J1, J2, J3, J4—binding posts (2 red, 2 black)
- Q1, Q2—2N307 (or Lafayette SP-147)
- S1—spst toggle switch
- S2—spst normally open pushbutton switch
- T1—audio output transformer: primary 48 ohms, ct; secondary 3.2 ohms; 6 watts (Lafayette AR-503 or equivalent)
- Spkr—3.2 or 8-ohm horn-type speaker
- Miscellaneous: Bakelite case 6 1/4 x 3 3/4 x 2 inches with matching front panel; 2 solder lugs; transistor heat sink, 1 1/2 x 4 1/2 x 1/4 inch cut from aluminum scrap; four No. 6 fiber washers, extruded shoulder type; two mica or composition insulators for mounting transistors (Cinch-Jones 2W-1); two 5-lug terminal strips with a center-lug mounting foot



The horn electronics are built into a plastic instrument case. The best place to begin is at the transistor heat sink. The metal case of both transistors must not contact the aluminum heat sink. If they do, the transistors will be shorted together and the horn won't work. Special insulators (specified in the parts list) are sandwiched between the transistors and the heat sink. Be sure there are no rough spots on the heat sink that might puncture the insulator and cause a short circuit. The nuts and screws that hold the transistors down must also be insulated. This is done with fiber-shoulder washers. Wires are soldered directly to the emitter and base terminals of the transistors. The collector connection, which is the metal case of the transistor itself, is made by placing a solder lug under one of the mounting screws.

There is one potential trouble spot in the circuit that should be eliminated before using the horn. These are the mounting screws that hold the 5-lug terminal

strips to the case. The heads of these screws are exposed. Since they are not "ground," but have live circuit voltage on them, a short could develop if they happen to contact a metal surface. (There is no shock hazard—voltages are far too low.) The remedy is simple: countersink the screw heads or cover them with plastic electrical tape. The transistor cases are also live, but covering them would interfere with proper heat dissipation. Just be sure not to let the cases touch any nearby metal after the unit is mounted. You'll find the difference in performance when using 6-volt or 12-volt power is loudness of sound—lower voltage, shorter range.

Hook up for power through a fuse block and insert a 1-amp. fuse. If there is no block in your boat, install an automobile type line fuse in the positive power lead.

To use the horn on a boat that does not have a power supply, make up a battery pack of two 6-volt batteries in series. Use Burgess F4BP's. They should last through the boating season. ★★★

**CLOSE-UP** view of the case with its cover removed. Both operating switches are at the right, horn and power terminals are all on the left end

**DOUBLE-CHECK** all wiring before using the horn, and be sure battery polarity is right. If not, you are likely to burn out both power transistors

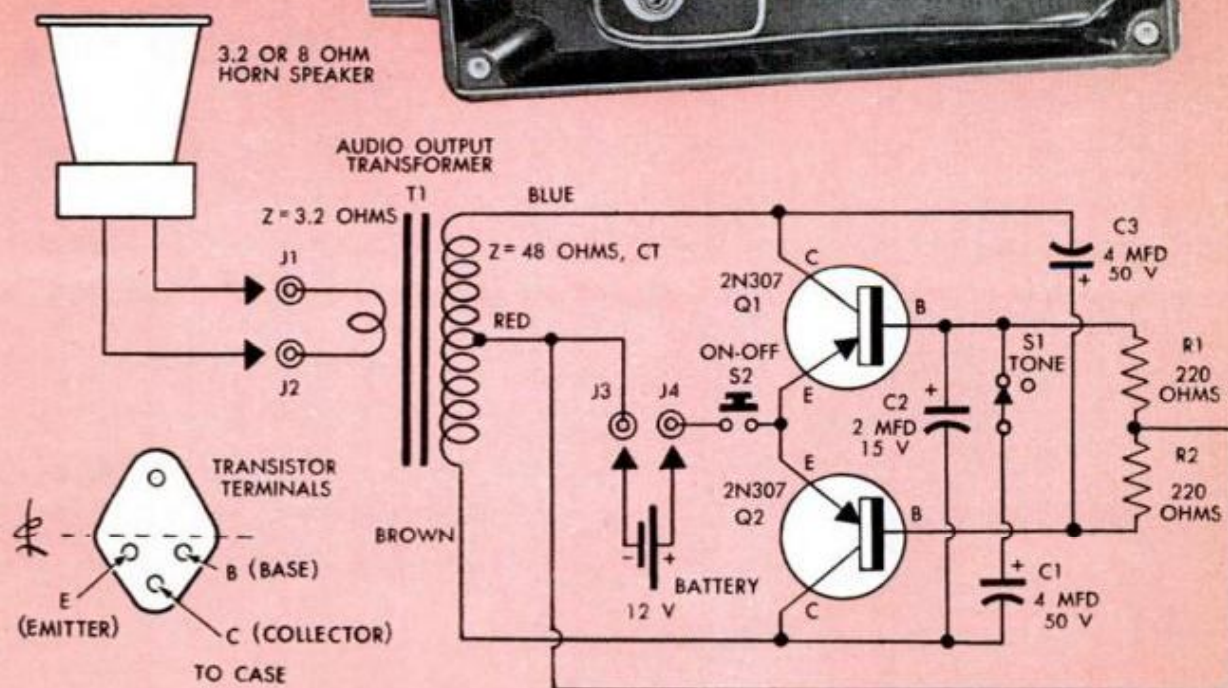
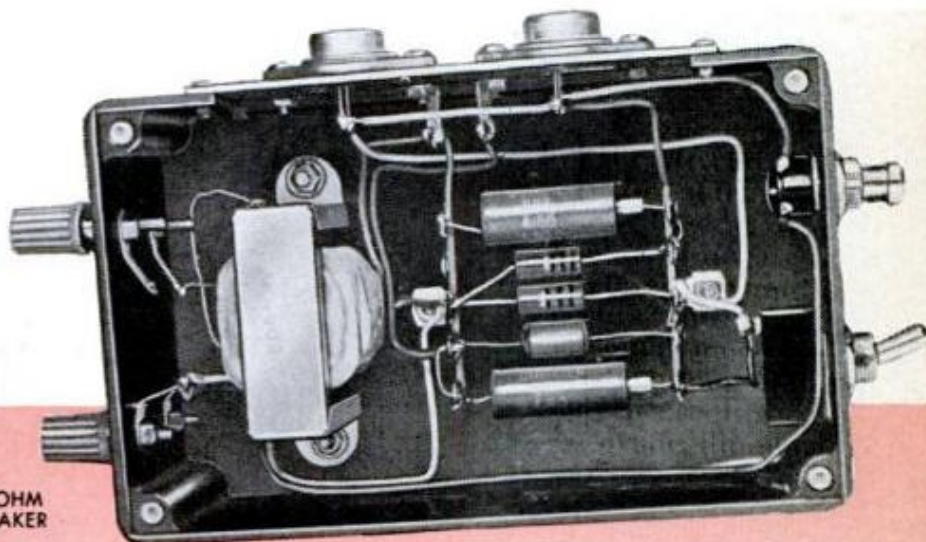



# New in Electronics

**FLASHLIGHT BATTERIES** can last from eight to 50 times longer when you recharge them after each use. Slip them into this plug-in charger overnight. It will rejuvenate almost all 1.5-volt cells—zinc carbon, alkaline or mercury types. Dynamic Instrument Corp., Plainview, New York. \$5.95

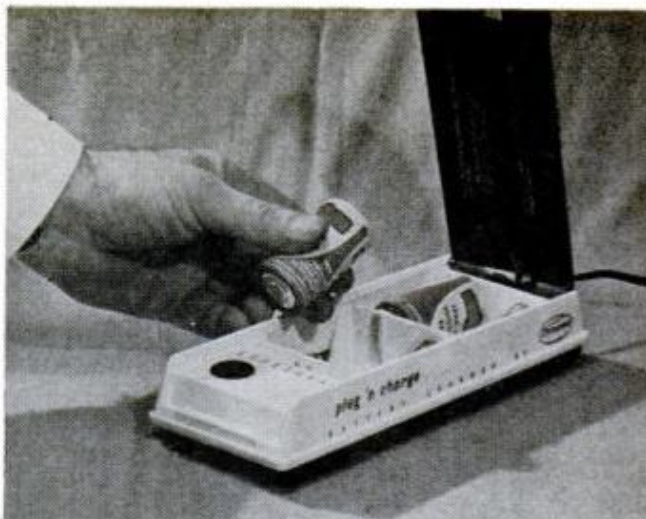

**DUAL-PURPOSE RECORD PLAYER** can be used as either an automatic record changer or a single-play turntable. All you do is insert the proper spindle. Adjustable counterweight sets stylus pressure. Garrard Type A, Mark II, \$79.50. Sold by British Industries, Port Washington, New York

**MULTIPURPOSE LIGHT DIMMER** works in reverse. As it gets dark, lights are turned up automatically. Additional manual control lets you set the light level when you're at home. Alluralite can handle up to 500 watts of incandescent lighting. \$29.95, Fasco Industries, Rochester, New York

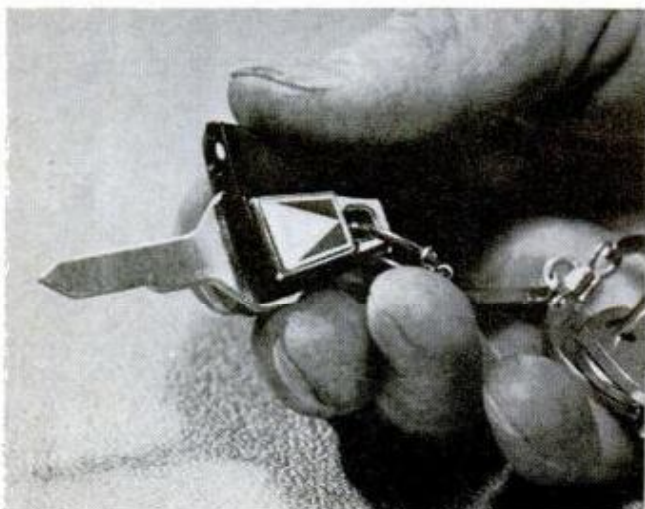
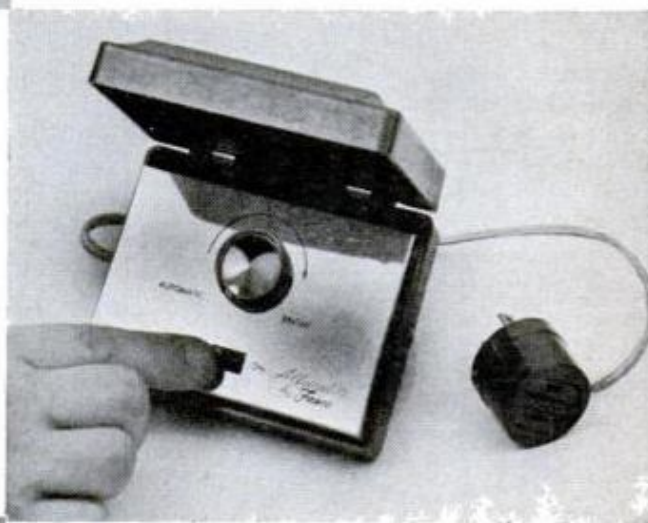

**KEYHOLE GROPING** can be reduced with this Key Beam, which uses tiny silver energy cell. Squeeze the key holder and a microminiature lamp lights. It should give up to two years service before a new 34-cent battery is needed. \$2.95, from Flex Electric Inc., Long Island City 1, N. Y.



# AC Spark Plugs give you full gasoline power

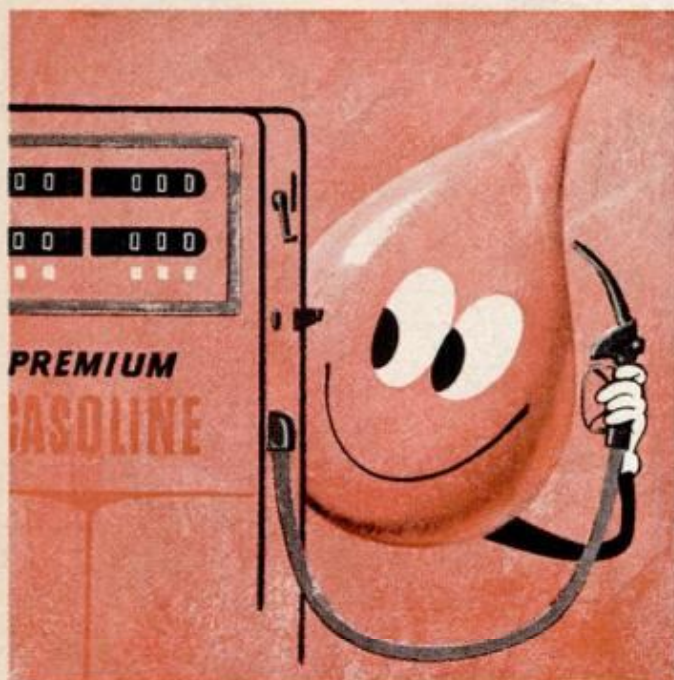

Today's gasolines are refined to give top mileage, peak power. Ideal mates for AC Fire-Ring Spark Plugs because . . .



ACs unleash maximum gasoline power with a full-bodied spark; give full power longer because they're self-cleaning.

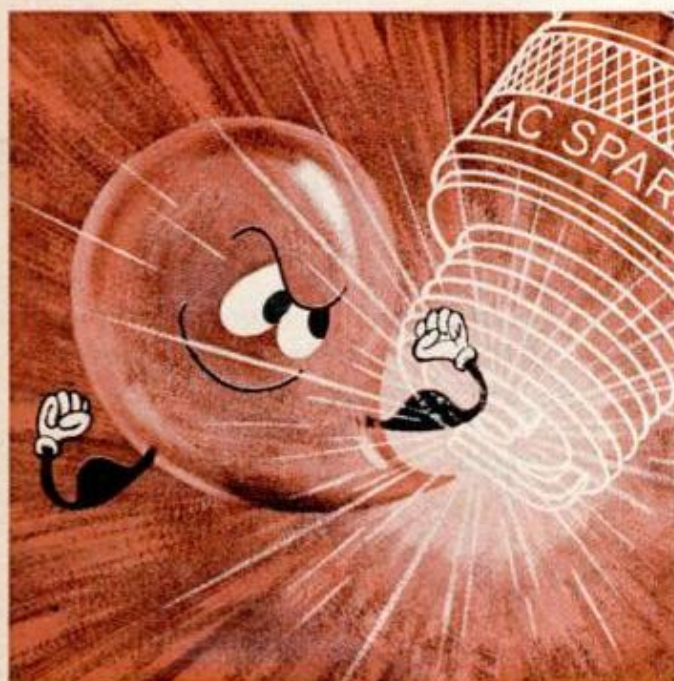

AC's exclusive Hot Tip design heats faster to burn off power-robbing deposits . . . puts the big punch in your gasoline.



To get all the power you pay for at the pump —team up your favorite gasoline with new AC Fire-Ring Spark Plugs.



## FIRE-RING SPARK PLUGS

AC SPARK PLUG THE ELECTRONICS DIVISION OF GENERAL MOTORS





Fast, drop-in loading with new KODAK DUEX 8 Cassette

## *New KODAK Electric 8 Zoom Camera*

# **Gives you the drop on**

***New fast loading, plus battery drive and electric eye keep you always ready to shoot!***

You don't miss any action with this camera. It uses regular 8mm film—in the handy new KODAK DUEX 8 Cassette which just snaps into the camera. At the end of the first 25 feet, flip the cassette over! You're set to go again in seconds! Preload several cassettes and you can shoot roll after roll of action!

**No winding!** Four powerful batteries

drive the film steadily, silently through the camera. Viewfinder signal tells when it's time to replace batteries.

**Zoom smoothly** from wide-angle view to telephoto close-up . . . and see the zoom right in the big viewfinder. Electric eye automatically keeps the  $f/1.6$  lens adjusted to the light. For special effects, you can lock the lens at any setting, or set the meter for more or less exposure than normal, when desired.

You can shoot at regular 16 frames per second or frame by frame for special titling

**Kodak**  
TRADE MARK

**EASTMAN KODAK COMPANY,**

Enjoy Walt Disney's "Wonderful World of Color" Sunday evenings, NBC-TV



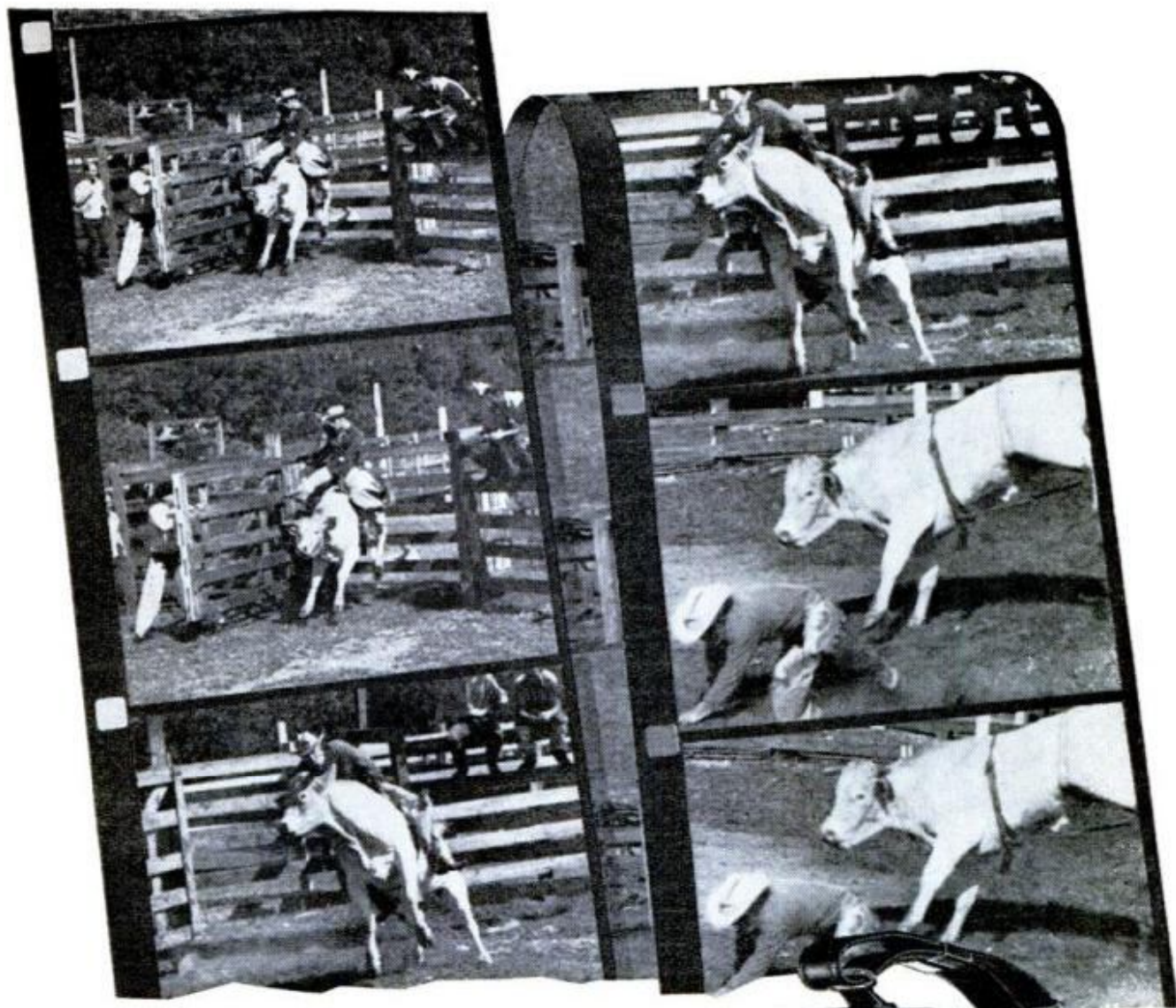

## *any action!*

and animation effects. Built-in filter lets you use the same roll of KODACHROME II Film, Type A, indoors and outdoors.

Be ready for any action. See the fast-shooting new KODAK Electric 8 Zoom Camera soon at your Kodak dealer's. With pistol grip, hand strap, shoulder strap, and one cassette, less than \$150. Batteries extra.

For brilliant color, sharp detail, load with KODACHROME II Film! And for convenient direct-mail processing of your films, use KODAK Prepaid Processing Mailers. Available at your Kodak dealer's.



Rochester 4, N. Y.

*Price subject to change without notice.*





# CLINIC FOR HOMEOWNERS

**Q** My lawn is getting rather thin with a few bare spots, and although I've applied a fertilizer I think it needs reseed-ing. I'm told this can be done better in fall than in spring. But how? Do I just sow the seed over the existing lawn, working it into the bare spots, or is there some better way?—L. A., Kan.

**A** Yes, you can proceed as you suggest with a reasonable chance of getting a catch of new grass, assuming, of course, that the remainder of the growing season is favorable. If we can judge correctly from your description of the present condition of the lawn, it needs cultivation, that is, a stirring of the top soil to permit water and added plant food to penetrate more readily to lower levels. This can best be done with a lawn spiker, a tool you can usually rent from your hardware dealer. This unit, weighted to penetrate about 1½ to 2 in., does an excellent job of loosening the soil without injuring the grass. Go over the entire lawn with this unit before seeding and applying fertilizer. Then sow seed uniformly, apply fertilizer and follow with a second spiking to work the seed into the soil. Treat spots with a somewhat heavier seeding. Then, unless rain follows immediately, water lightly. Continue watering at intervals unless frequent rains add ample moisture.

**Q** I have an old heirloom upright piano I'd like to refinish. Tone is still good but the case appears to have some light-colored wood with an artificially-grained finish which is now grimy, dark colored and scratched here and there. How should I go about refinishing to make the instrument more presentable?—M. G., N. Dak.

**A** Probably the best procedure is to give the whole case a thorough sanding to remove the "grime" and scratches and then apply an undercoater and two or three coats of colored enamel. Sanding is going to take time as a thorough job will be essential to get a smooth surface over which to apply the finish coats. It is best to first remove the keyboard and then all the panels that are removable and work on the panels separately. There's no need to remove all the original finish. A smooth surface is all that is necessary. Once you get a smooth surface you're ready for the paint job. The first coat should be a white or tinted shellac enamel.

This will serve as a primer or base coat. Although you can apply the base coat and finish coats with a brush, you'll get a better job with a sprayer. Usually you can rent a sprayer from your local paint dealer. Take special pains to get a uniform base coat. Hit all the edges and corners first, then finish the large surfaces with uniform, sweeping strokes, making sure you get full coverage at all points. Allow to dry four to six hours, then follow with the finish coats in the desired color and using the same application technique. Old ivory or bone-white semi-gloss enamel makes an excellent finish for an old piano.

**Q** During the warm weather, damp spots appear on the plaster above my bathtub at the end where the faucet comes through the wall. The spots appear above the faucet. I've searched everywhere for a leak—in the piping and in the roof above the point. I can find no indication that either the roof or the pipes are leaking. My bath is not tiled and if something is not done soon the plaster will be badly damaged. Any suggestions?—W. L., N. J.

**A** You do not say, but we assume you have a shower head. A slow, drop-at-a-time leak in the shower head line is a possibility that might give little evidence, even on a close examination. There is another possibility. If you take warm showers in the summer this seems unlikely, but if you take cold showers then condensation on the pipes may be a cause. There must be an access door or opening, possibly in a closet, directly back of the shower head. If you examine the shower line through this opening at any time the shower is being used, or shortly thereafter, you may find the pipe covered with condensate. This could drip from the horizontal run of the pipe at the point where it passes through the wall, and, of course, could be the cause of the damp spots you see on the room side of the wall. If this is the case, then a wrapping (of material made especially for the purpose) covering the entire length of pipe within the wall is the cure.

As a service to Popular Mechanics readers in solving the hundreds of problems pertaining to a home—inside or out—you are invited to present your problems to The Clinic Editor for his helpful advice. Address your questions to The Clinic Editor, Popular Mechanics Magazine, 575 Lexington Ave., New York 22, N.Y.



# DREAM KITCHEN?



**YOUR BUILDING  
SUPPLY DEALER  
IS YOUR BEST  
ONE-STOP SOURCE FOR  
COMPLETE, RELIABLE  
HOME IMPROVEMENT SERVICES**

Your local building supply dealer has carefully built a solid reputation for providing top value in all types of home improvement services. Whether you "Do-It-Yourself"—or have him do it—the long-established building supply dealer in your community is your best one-stop source for • **COMPLETE HOME IMPROVEMENT SERVICES** • **EXPERIENCED HOME IMPROVEMENT GUIDANCE** • **ALL THE LATEST, BEST BUILDING MATERIALS, TOOLS, HARDWARE, PAINT** • **TOP VALUE . . . BUDGET TERMS.**

## LOOK FOR THIS BANNER

*Building Supply dealers displaying this banner are participating in a new customer-satisfaction program sponsored by their industry's leading magazine, Building Supply News. Buy where this banner is displayed. It's your assurance of quality and service at a fair price.*

**SHOP  
HERE  
FOR**



**HOME  
IMPROVEMENT  
SERVICE**



We feature the best in Building Materials, Paint, Hardware, Tools

Prepared as a public service by Building Supply News, Cahnern Publishing Co., Inc.





IMITATED  
...BUT  
NEVER  
EQUALLED

**CHAN NEL LOCK**

When you buy a Channellock, you get two exclusive patented features you can't get in any other adjustable plier:

- ① Smooth-working, machined, undercut channels. The tighter you grip, the tighter they lock.
- ② Reinforcing rib for added strength when you put the muscle to a job.

Only Channellock—the original tongue and groove plier—has these features.

Be sure you're getting the genuine Channellock . . . look for the trademark on the handle. Your choice of five jaw capacities: 1/2, 7/8, 1 1/2, 2 and 2 1/4 inches.

Write for catalog showing our complete line of pliers. Champion DeArment Tool Company, Meadville, Pennsylvania.

## The Starter Motor

(Continued from page 162)

nected (the control terminal) to the contact terminal. Crank the engine. If the starter spins, the magnetic switch is OK, and the fault lies in the ignition switch or inside the starter.

● To check 12-v. Studebaker starters and magnetic switches with a single contact and an external ground, connect a jumper from the switch-control terminal to ground. On magnetic switches with two control terminals, disconnect the wires from both terminals. Then, connect two jumpers—one from the "hot" side of the battery to one of the switch terminals, and another from the other terminal to ground.

In either case, crank the engine. If the starter turns, the switch is in good condition and the fault lies in the ignition switch or inside the starter. If this test shows the switch to be defective, you can easily remove the switch and replace it.

### Checked by a Jumper

Solenoid switches without relays and those with separate relays are checked by connecting a jumper from the "hot" side of the battery to the control terminal of the solenoid. Crank the engine. If the starter turns, the switch is OK, and the trouble lies with the ignition switch or inside the starter.

The last common trouble is a starter motor that spins, but does not crank the engine. This can happen to any starter, whether it is an overrunning clutch type or a Bendix type. The cause is a defective drive or broken teeth in the flywheel. In any event, this is usually a job for a professional mechanic.

If the source of starter difficulty isn't detected by these circuit and switch tests, the starter must be removed from the car for bench test and repair. This job is usually one for a mechanic.

A thing to keep in mind if you take your car to a mechanic, is what we said before: a starter seldom goes bad internally. Many times, starter troubles can be cleared up by taking the starter apart and cleaning it. Any dirt inside the motor will cause resistance, resulting in less than full output.

If a starter malfunction is caused by bad brushes or poor brush contact, it would pay to have the starter repaired by replacing the brushes. Major damage, such as shorts in the field windings, broken pinion gear teeth, bad bearings or thrown solder from the armature, will mean a big repair bill. In these cases, it may be worthwhile to simply buy a new or rebuilt starter. ★★★



## Mechanized Billy Goat

(Continued from page 94)

45:1 and 25:1) together with the fluid coupling allows any speed selection ranging from zero to 25 m.p.h., and the transmission can be shifted from one range to another at any speed. Throttle and brake are hand-operated. The machine has an overrun mechanism for positive steering that allows the front wheel to travel farther than the rear wheel when making a tight turn. The chain drives are self-lubricating and have 10 times the strength actually needed.

The fuel tank carries an eight-hour supply. If the wheels are not to be used for flotation, they may be used to carry extra fuel or even drinking water. Each wheel drum has four and a half gallons capacity, and the two wheels can carry enough fuel for five days' operation. A small plastic squeeze pump is used for transferring fuel.

### Look, Ma, No Springs

The vehicle has no springs and its low-pressure (5 pounds) 6.70-by-15 tires serve both as suspension and as shock absorbers. The tires are spread to a seven-and-one-half-inch tread and impose no more than two pounds per-square-inch pressure on the ground. This light "footprint" doesn't tear up the surface and allows positive steering even when traversing a hillside of snow or sand.

The Trailbreaker was designed strictly as a remote-area vehicle, for cross-country travel whether or not there are any trails. It can be licensed for road use by installation of an alternator, lamps and other required equipment, available in kit form. Only now on the market, many uses are already being suggested for it. Farmers and irrigators can traverse soft ground with it. Timber cruisers could more than triple their operations, using a paint spray from a pump operated by the engine to mark the trees that are to be cut. Fences, power lines and pipelines can be patrolled without the need of maintaining trails.

It would be ideal for military use. It can operate in areas where the Jeep would be useless, and would make any armed patrol more mobile. It could be used for guerrilla attack, actually bringing back the cavalry on modern motorized lines.

Nethercutt's customers are suggesting new uses for the machine every day. But it may prove most popular as a hill-climbing vehicle for hunters and fishermen. The company's usual customer seems to have only one stipulation when he orders a Trailbreaker—"It must be delivered before the opening of deer season!" ★★

AUGUST 1963

## Markwell's famous L3 "BLUE TACKER"



Handles  
every  
tacking job!

Markwell  
Patent  
# 2,265,361

The "professional" tool for all home projects: ceiling tile, insulation, screens, upholstery, wall plank, weather stripping, etc.

FREE SERVICE whenever needed! See your lumberyard or hardware dealer. Write for FREE booklet "TACKING TIPSTER."

Uses 12 different styles and sizes of staples (instantly interchanged) for every indoor and outdoor tacking job

**Markwell**® Mfg. Co., Inc.

Dept. 2308, 424 West 33rd St., New York 1, N. Y.

(Quality Tacking Tools Since 1919)

## Speedy Sprayer

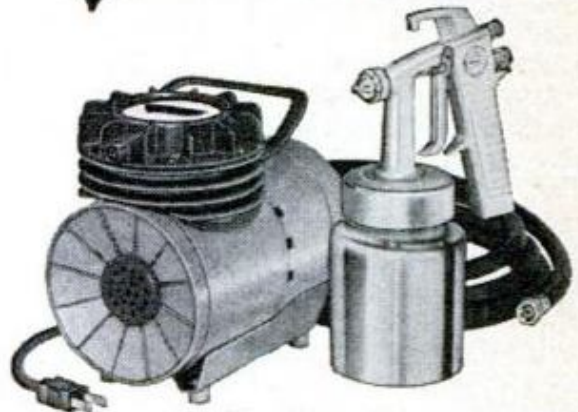

### Tool of a dozen uses!

Motorized! Ready to plug in and spray! Use it to paint anything, from a toy to a house. Does an hour's painting in just minutes. Pays for itself on the first big job. Also use it to spray insecticides, weed killers, liquid fertilizer; vacuum, tire inflator, etc. A real professional tool needed in every work-shop. Ask for Speedy Sprayer "Compact" No. 404. **\$39<sup>95</sup>**

Slightly higher Denver West.

Write for "How to Spray" booklet and catalog.

**W. R. BROWN CORP.**

*Specialists in Portable Sprayers Since 1921*

2635 N. NORMANDY AVE., CHICAGO 35, ILL

187



## 12-M.P.H. Scoot-Car

(Continued from page 144)

a V-pulley which slips onto the wheel spindle to which it is locked with its set-screw and additionally locked by a cap-screw long enough to permit the threaded end to enter a hole drilled in the hub of the rear wheel. On the opposite side of the wheel a smaller V-pulley, with the rim cut away as indicated, serves as a spacer and a hub for the driven sprocket. It is locked to the hub of the rear wheel in the same manner as the brake drum. The brake band is a length of  $\frac{1}{2}$ -in. V-belt, one end of which is attached to the top face of the deck with two wood screws. The other end is doubled back on itself to form a loop around an S-hook, the latter attaching to the short arm of the brake rocker.

The brake rocker is carried on a shaft supported in hardwood bearings bolted to the underside of the deck. The brake-return spring attaches to the long arm of the rocker and to one of the pillow-block bearing bolts. The second S-hook attaches to the long arm of the rocker and to a cable eye which connects to the  $\frac{3}{16}$ -in. wire cable from the brake pedal. Note that turnbuckles are provided on both brake and power cables for adjustment.

### The Control Rod

The power-control cable reaches from the turnbuckle to one end of a pivoted lever. The other end of the lever connects to the control rod, part No. 49. The free end of the control rod is bent at right angles, drilled and cotterpinned to the sliding contact, part No. 73. The lever is returned by a spring, one end of which is hooked to a bracket screwed to the underside of the deck, see parts No. 51 and 52. The resistor, which is the carbon core from a dry cell, is mounted in brackets, parts No. 74 and 75, and is drilled and tapped for three  $\frac{1}{4}$ -in. flat-head screws and two  $\frac{1}{4}$ -in. capscrews, the latter holding it in place between the brackets. Drilling and tapping must be done with care, the tap holes being drilled slightly oversize so that the tap cuts only a 50 to 60-percent thread. One screw of the three shown takes the end of the battery cable, the other two, which are contacts through the resistor, are fitted with squares cut from  $1/16 \times \frac{1}{2}$ -in. flat steel and center-counter-sunk to take the heads of the screws flush. In the off position the spring-loaded sliding contact arm contacts an insulating strip of hardboard, part No. 71, which is attached to the ground strap. This type of switch (in effect a rheostat) prevents heavy current surges and reduces arcing

in the control switch to the minimum.

The motor-mounting brackets are made right and left and are so placed that the regular mounting lugs on the motor can be utilized as fastenings. Note especially how the aluminum ground strap from the motor terminal is bent so that it passes through the large hole in the chassis, the lower end being held in place by the bolt on which the sliding contact pivots. It will be noted that there is an L-shaped retainer attached to one of the brackets supporting the resistor. This has been lowered in the photo for clarity. It has, however, been replaced by a large washer, part No. 76. This retainer prevents the insulator, part No. 71, from swinging out of position.

### Seat of Plywood

All parts of the seat except the risers are made from  $\frac{3}{8}$ -in. plywood and all parts are joined with  $1 \times 1 \times \frac{1}{2}$ -in. steel corner angles which are readily available. Care must be taken when locating the front and side risers to see that the holes in the attaching corner angles register with those in the deck to which the seat is attached with bolts and wing nuts. Note also that the inner end of the rear fender is attached to the back of the seat with corner angles, small bolts and wing nuts. The front fender is bracketed and braced to the deck and serves not only as a front-wheel fender, but also as a support for the steering post, or column. The brake and power pedals consist of a 3-in. T-hinge and a pedal, or pad, of plywood, and a bracket which takes one eye of the turnbuckles. The hinge leaves are attached to the deck with wood screws.

The bumper is a length of  $\frac{1}{2}$ -in. thin-wall conduit and is held in place with six flat-steel brackets screwed to the underside of the platform with wood screws and to the thin-wall conduit with self-tapping screws or sheet-metal screws. Rubber crutch tips are slipped on the open rear ends of the bumper. It may be attached either before or after the cornering wheels are in place. These wheels are carried at an angle of 15 degrees on heavy outrigger brackets bolted to the deck. Finally, install the steel-angle brace.

All that remains are installation of the battery cradle, the 6-v. battery and the foot and seat mats which are cut from corrugated-rubber stair treads and cemented to the deck. The taillight can be of the type pictured and detailed and wired into the power circuit, or you can use a battery-powered bike headlight and cover the lens with red cellophane. Also, you'll probably need to do some adjusting of the brake and power-cable turnbuckles to get the controls working right. ★★



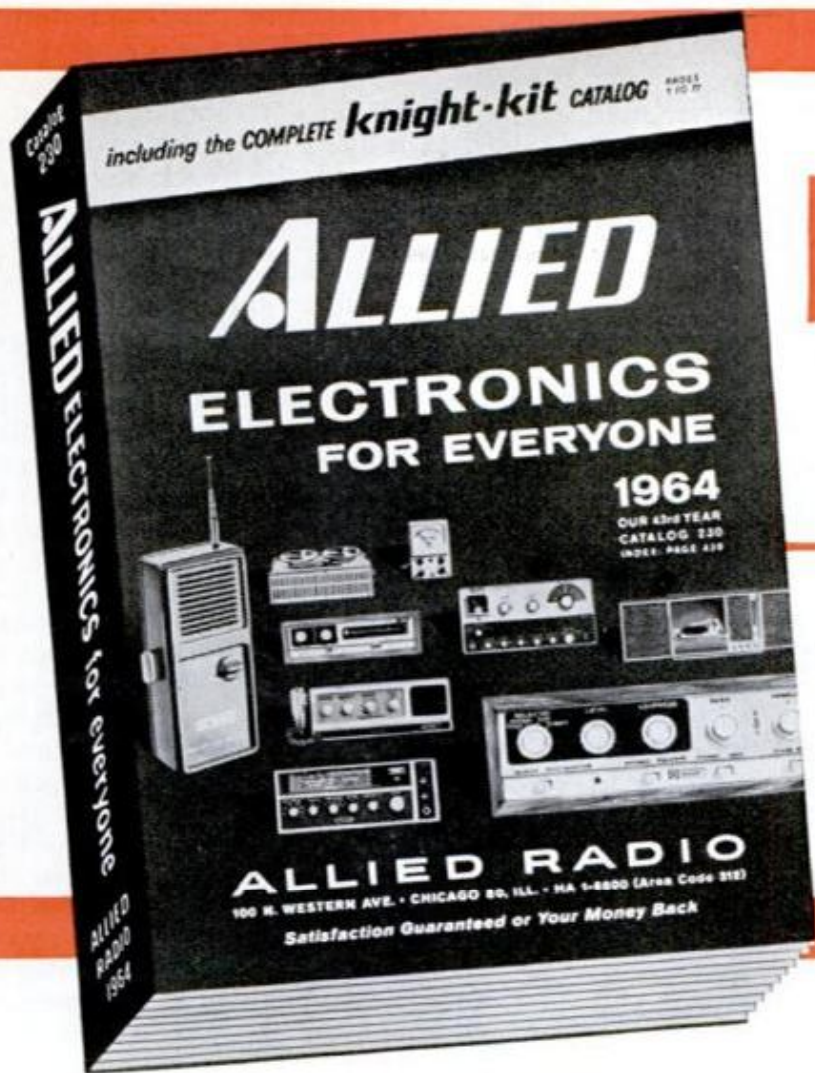

# FREE

send for  
it today!

world's  
largest  
electronics  
catalog

mail coupon for your money-saving

## ALLIED 444-PAGE 1964 CATALOG

**BIGGEST SELECTION—  
BIGGEST SAVINGS ON:**

- Everything in Stereo Hi-Fi
- KNIGHT® Super-Value Hi-Fi
- Citizens Band 2-Way Radio
- Tape Recorders & Tape
- Latest FM-AM & AM Radios
- Phonographs & Accessories
- Ham Station Equipment
- P.A. Systems, Intercoms
- Test & Lab Instruments
- TV Tubes & Antennas
- Parts, Tubes, Transistors,  
Books, Tools, Hardware

**NO MONEY DOWN:**

Now! More Buying Power with  
Your Allied Credit Fund Plan!

*satisfaction guaranteed or your money back*

**ALLIED RADIO**  
The World's Largest Electronic Supply House

over 100 great build-your-own **Knight-Kits**®  
see what's new and best in **stereo hi-fi**  
save on the very latest in **CB radio**  
top buys in **tape recording**  
everything in **ham radio**

**SEND FOR YOUR COPY TODAY**

ALLIED RADIO, Dept. 6-H  
100 N. Western Ave., Chicago 80, Ill.

Send FREE 1964 ALLIED Catalog

Name \_\_\_\_\_  
PLEASE PRINT

Address \_\_\_\_\_

City \_\_\_\_\_ Zone \_\_\_\_\_ State \_\_\_\_\_





## He Makes Accidents Obsolete

(Continued from page 104)

turned less than 12 times a minute. Once this was established, technicians simply designed a drag brake to keep the door from turning faster than that.

Not all problems are solved so easily. The escalator trick took some doing. That project began when hazard hunters reported that among 300,000 claims that Liberty is called on to settle each year, a number were for injuries on moving stairways. Many, particularly agonizing, were for the torn feet of children.

"That's the kind of accident that gnaws at your insides until you've licked it," Crandell says. "We soon discovered that most victims were little boys from four to six years old, that they nearly always wore sneakers and that it always happened on the way *down*. Experiments soon showed us why. By tucking a toe into the crack between the apron and the edge of a moving step, the sneaker sole is forced back against the next riser and makes a lovely squeal. The fact that the foot is already caught doesn't bother the youngster yet. The foot is comfortable and the friction makes it feel warm. But at the bottom, as the riser slides down to nest, friction wedges the foot further and further down. Ahead are the awful comb-plate teeth, where the treads disappear beneath the floor. Then it's too late. The result is a horribly mangled foot. In a typical case, three toes and part of a boy's foot had to be amputated."

### Foot-Saver Switch

Out at Hopkinton, technicians went to work. First they found that an escalator can be stopped in 11 inches without throwing people off their feet. So, about one foot from the comb-plate, Crandell had them equip each side of the escalator with an automatic pressure-switch that shuts off the power the instant anything—such as the edge of a sneaker or shoe—contacts it. Today, most escalator manufacturers incorporate the switch in their product.

In some instances policyholders themselves come to Liberty with their problems. That's what happened in the case of the shopper carts. Several New England based supermarkets were having trouble with runaway carts bumping into moving cars, creating havoc and, occasionally, panic when a toddler was perched in one. Hopkinton engineers solved the problem with a braking mechanism that would go "on" whenever the cart was unattended. A push or pull on the handlebar released it. No more runaway carts.

Dozens of tricky accident preventers

like that pour from the Hopkinton brain factory every year. To eliminate accidents resulting from delivery men jumping on and off vehicles, Crandell had ignitions wired to prevent the driver from starting his motor until the truck door closed.

To prevent drivers from slipping and falling in winter, he brought heat from the engine to keep the steps warm. Now ice can't form on them.

Multiple reports of ugly accidents in loading docks and construction excavations, when heavy trucks backed up and crushed unwary workmen, succumbed to an easy solution: trucks were equipped with a loud buzzer that sounds off automatically the moment the truck backs.

### Sonar Back-Up Alarm

A more sophisticated version of this howler is a device designed to alert the driver, instead of frightening everyone within earshot to immobility. Actually a tiny sonar set, it operates on the same principle as a bat's homing equipment. Sensing elements on the rear of the van send out ultra-sonic impulses. The signals, reflected by any object closer than 20 feet behind the backing truck, are picked up, amplified, and shot through circuits to trigger a "blip" on an instrument dial in the cab. The device can be set up to sound an alarm at any desired distance within the 20 feet. Developed by Research Director Allen L. Cudworth at the Hopkinton Research Center, it is still undergoing field trials. But it works.

Since the nature of industry makes it susceptible to accidents, much of Crandell's attention is focused on this area.

Safety inspection, Crandell believes, has little value in industry when it becomes routine. For all his objectivity, the chief hazard hunter rumbles with quiet anger when discussing some needless tragedy, and his eyes grow thoughtful as he counts the lives that might have been saved by common sense and a little foresight.

"You have to keep alert for accidents that have never happened before," he says. Though hard-put to keep up with new hazards introduced by bigger bulldozers, taller cranes, more gigantic projects, faster and faster machinery, these are the things that keep Crandell and his hazard hunters in business. The installation of giant, high-speed looms in an old New England mill result in a nifty new safety device. When he first saw the looms, Crandell warned the owners that they were too much for the ancient walls. He knew that high-speed looms had recently collapsed two old German mills—one with a loss of 14 lives. The Yankee mill owners didn't

(Please turn to page 194)



# Handy Shopping Guide to Series E U.S. SAVINGS BONDS



Makes an ideal gift for graduations, birthdays, communions, bar mitzvahs or any occasion when you want to be especially nice to someone. Including yourself. Sells for **\$18.75**



This one is tailor-made for the investment of bonuses, tax refund, and other windfalls. At maturity it grows into a tidy \$200 nest egg, yet costs only **\$150.00**



Grandfathers can give one of these Bonds to eight grandchildren (or eight of them to one grandchild) in any one year without having to pay the gift tax, because the outlay per Bond is only **\$375.00**



Lots of businesses buy these as a good safe investment for company surplus funds. Also ideal for widows who suddenly find themselves with a large insurance check. Per Bond, **\$750.00**

Actually there are 7 denominations, but all U.S. Savings Bonds have these things in common:

They're one of the most widely held investments in the world—owned by tens of millions of American families. They're replaceable in case of loss. They return \$4 at maturity for every \$3. They're cashable at any time. They help make your individual future, as well as your country's future, secure. Buy the ones that fit your budget—at your bank, or through the Payroll Savings Plan where you work.

Help yourself while you help your country  
**BUY U.S. SAVINGS BONDS**



*This advertising is donated by The Advertising Council and this magazine.*



**paileys** NEW! For HOBBYISTS • MODELEER • MD • SURGEON • LAB • etc.

22  10  
24  11  
21  12  
23  15  
20 

**STAINLESS STEEL SCALPEL HANDLES and BLADES**

Accurately shaped, perfectly tempered and precision balanced with nine different blade shapes and choice of two handles — standard or slender. Standard handle takes blades 20, 21, 22, 23 and 24 — slender handle takes blades 10, 11, 12 and 15 (specify type blade and handle). Blades are interchangeable and come 6 per pac. Blades are made of finest quality Sheffield surgical steel. Use for carving, cutting, biology, surgery, etc.

**SAVE!** Scalpel Set — Pac of 6 blades & handle... **2.95** Extra Blades — Specify type...6 for **100 PAC**

 **NEW BANDAGE SCISSORS**

Finest stainless steel or nickel chrome scissors. Made for cutting bandages but excellent for use by children, etc. Choice of two sizes.

5-1/2" Stainless **2.89** 5-1/2" Nickel **1.29**  
7-3/4" Stainless **3.89** 7-3/4" Nickel **1.69**

**DENTAL PICK ASSORTMENT**

An assortment for the hobbyist! Points include hooks, chisel, scrapers, etc. Ideal for working on wood, leather, clay, etc. Stainless steel... 6" long. 6 different heads!

**6 FOR \$2.49**

 **NEW SENSITIVE STETHOSCOPE**

A Ford type stethoscope. Ideal for Doctor or the mechanic to listen for engine sounds, etc. Metal parts chrome plated. New, top quality.

**2.98 EA.**

**SAVE on LAMPS FOR HOME • SHOP OR OFFICE**

Now a drafting light or desk light at a price anyone can afford. Newly adapted from a Swedish design... ideal for drafting table, office desk, etc. Precision made and balanced. Reflector will swing to light desk or table up to 6 ft. long x 3 ft. wide. Extension arms are fully universal with surgical steel springs for counterbalance with finger-tip movement. Finished in baked enamel.

**No. ID-118 — MECH LYTE** — Gives light for work bench, shop, etc. Gray finish only... **9.95**

**No. ID-118B — COOL LYTE** — Insulated lamp hood reduces heat. Ideal for draftsman, artist, etc. Colors: gray, brown or black (specify)... **10.95**

**No. ID-FL1 — 2-Tube FLOURESCENT LYTE** — **19.95**

Takes two 15 watt fluorescent tubes.

**No. ID-MAG 1 — ILLUMINATED MAGNIFIER** **28.95**

Has 5" dia. lens. Power of 3 diopters. 13" focal lgth. For stamp or coin collectors, etc. Circline bulb not included.

 **MECH LYTE**  
**COOL LYTE**  
**PRECISION STEEL ARMS FULLY UNIVERSAL**  
**MAGNIFIER**

 **25 TO 1 WORM GEAR DRIVE**

**9.95** No. GB-202

For use with 7/32" dia., 12 spline flex shaft on input. Output is 3/8" dia. x 3/4" long shaft at right angle to input. Ball bearing mounted.

**NAVY WADE SUIT**

Made to top Gov't specs from from rubberized heavy duty canvas. All seams vulcanized. Has built-in rubber gloves and boots. Available as overall (with shoulder straps) or coverall type. Sizes: Small, Medium or Large.

No. CWS-1 (Coverall) — **12.95**  
No. CWS-2 (Overall) — **9.95**



 **U. S. ARMY KNIFE-BAYONET**

Ideal for skin diving or hunting knife, or for collectors. Has 6-1/2" steel blade — double edged for 3" from the point. Handle is laminated leather. Overall lgth. 11-5/8". **2.98**

 **PERISCOPE PRISM**

Made of finest optical glass. Bends light rays 90°. Can be adapted to lens, lights, etc. Size: 5" x 1". **ONLY... 1.95**

 **260 PAGES of Amazing BARGAINS** — Government Surplus, Factory Closeouts and hard-to-find items of all kinds. NOW — special bargains in U.S. Army, Navy, Airforce and Industrial Surplus. Order NOW and SAVE up to 85%!

**Only 50c** TO COVER HANDLING & MAILING. Your 50c will be refunded with your first order of \$1.00 or more.

**TO ORDER:** Send check or M.O. 1/2 dep. w/ C.O.D.s. P.O.s accpt'd from D&B. Firms rated F2½ or better. Items sent freight or postage col'ct.

**paileys** 2263 E. VERNON AVE., Dept. PM83 LOS ANGELES 58, CALIFORNIA

## He Makes Accidents Obsolete

(Continued from page 192)

believe him. Two weeks after they started rolling, a 152-foot crack showed up in walls thick enough to have held up a medieval castle. Crandell was called back.

To solve that one, engineers made slippery plastic shoes for the machines, allowing them to move back and forth without taking the building with them.

There's plenty of hazard hunting left for the future, as Crandell and his men view it. Out at Hopkinton, dozens of new projects are under way all the time. "We know," says Crandell, "that some people can create accidents where none would exist. But they're not the only victims."

### Aerosol Barrage

"Right now our warehouses are full of aerosol bombs. Pressures are always dangerous and we have a lot to learn about aerosols for this reason. Recently, a youngster took a can of spray to make snow on a Christmas tree. Ironically, the label read 'Merry Christmas'. He put the can in hot water to perk it up, shook it, and lost his jaw and one eye when it exploded."

Today at Hopkinton, aerosols of all kinds are being exploded deliberately to see what happens. Though hazard hunters point out that the industry's record has been excellent, as far as the public is concerned, they admit that the problem is like lightning—no one knows where it will strike. When standard aerosols were thrown on a fire at Hopkinton, some cans were found 300 feet away. Twice, the steel tailgate of a pick-up truck 150 feet from the fire was ruptured by the impact of empty 12-ounce cans. Having found a potential cause for trouble, the safety engineers are on the trail of an answer for it.

In the basement of his laboratory, Crandell has built an "unprogrammed" automobile driving simulator unlike any other known. In it a student can look through the windshield and steer himself down any road he wishes in the panorama projected in front of him. If he steps on the gas, the view through the windshield moves faster. When he hits the brake, the view stops with him. He can steer off the road, crash into other vehicles. As he goes along, a stylus measures his reactions. "We think we can learn a lot," says Crandell, "by measuring and counting the steering reversals a student makes while driving."

Crandell believes that current driver training stops short of the most important instruction. "Everyone is taught to drive under ideal conditions," he says. "No one gets any real experience in how to handle a car in a crisis situation."



Consequently, he's going to build a "skid school" in an unused parking lot beside the lab. "We'll run a line from the hydrant through a supply of liquid soap," he reveals, "and slick down the entire blacktop lot. Then we'll take trainees out in cars and deliberately throw them into skids. We'll teach them how to come out of a skid. It's easy when you know how."

If you think Frank Crandell is fooling, think again. His "Alertomatic" device evolved out of the same sort of wild experimentation. This incredible gadget, designed to keep sleepy night drivers on their toes, is a real Rube Goldberg—but it works. A dashboard light goes on intermittently. The driver turns it off by tapping the horn. If he doesn't tap, the horn blows by itself. If that doesn't wake him, the ignition goes off and on, jogging him. If he's still dozing, it kills the engine.

### Crash-Cushioned Car

Hopkinton is full of experimental cars. Most famous is "Survival Car II," featuring 24 modifications including roll bars, immovable seats, whiplash preventers, harnesses and a fire-extinguisher system. According to the hazard hunters, it would be almost impossible to be seriously injured in a crash in that vehicle.

More than anything else, Crandell would like people to pick up his ideas and use them. He knows they would pay off in lives saved. In one year, Liberty returned \$41,500,000 to policyholders on a total premium business of \$350,000,000. On one 30-mile tunnel job, the contractor's premium was reduced from \$2,410,000 to \$1,723,000, largely through use of the geophone.

Whatever happens, Frank Crandell can look back on one of the most productive and worthwhile lives that man has known. A contracting career of his own—including construction of a Chilean railroad, work in New York subways, a Westchester County development and a parkway bridge—he considers incidental. He says his real work began with hazard hunting.

He won't talk much to strangers about his wife, a busy, practicing physician, or his married daughter and two grandchildren. His private life is a private affair.

Ask him about his future plans and he may tell you about the schoolboy who came to see him in order to find out what a safety engineer does. "I told him some stories about our projects," says Crandell. "Then he asked, 'What do you do in here?'"

"I solve problems," I told him.

"And what do you do when all the problems are solved?" he wanted to know.

"I didn't tell him in so many words," says Frank Crandell, "but I'm not worried about that gaunt possibility." ★★★

**Bore 35 standard holes with just one tool**

### New IRWIN Expansive Bit

lets you dial your size

Just turn the dial and you're set to go with this new Irwin Expansive bit. No hunting for the size you need. Fits all hand bit braces. Clean, fast, accurate boring action from 7/8" to 3"—35 standard hole sizes in all!

And what a really fine precision tool to own. It's drop-forged from special bit steel, heat treated full length, machined for accuracy and sharpness, highly polished, too. Two cutters supplied with each bit. Model No. 21 with 5/8" to 1 3/4" boring range also available. Ideal for home handyman, professional woodworker, or farm. See your independent hardware dealer soon.



**IRWIN**

Wilmington, Ohio

the original solid center auger bit  
screw drivers  
screw driver bits

## Planer • Molder • Saw!

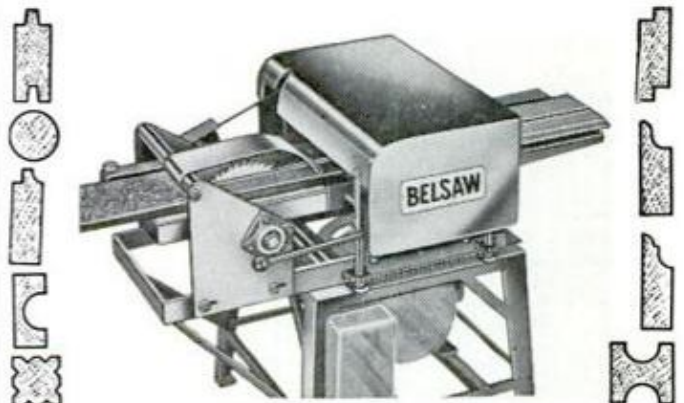

Now you can use this ONE power feed shop to turn rough lumber into high-value moldings, trim, flooring, furniture... ALL popular patterns.

**RIP...PLANE...MOLD...** separately or all at once by power feed... with a one horsepower motor. Use 3 to 5 HP for high speed commercial output.

**LOW COST...** You can own this MONEY MAKING POWER TOOL for only ..... **\$3000** down payment

Send coupon today

**BELSAW POWER TOOLS** Field Bldg., Kansas City 11, Mo.  
Send me complete facts on the MULTI-DUTY Power Tool. No obligation.

Name \_\_\_\_\_  
Address \_\_\_\_\_  
City \_\_\_\_\_ State \_\_\_\_\_



## The Riddle of the Black Boxes

(Continued from page 91)

pect the Reds of testing nuclear bombs millions of miles out in space, high flying satellites can be lofted to monitor results.

While these watchdogs and the underwater black boxes are filling a large hole in our detection system, the brunt of our nuclear blast intelligence depends on huge manned seismological stations, the first of which was the Wichita Mountains site. Others are on the Cumberland Plateau in Tennessee; Tonto Forest in Arizona, and stations near Baker, Oregon, and Vernal, Utah. The Arizona station will be a test bed for new equipment and ideas.

### Giant Seismic Centers

These observatory complexes feature 10 to 100 seismometers of all types tended by crews of six to 20 men plus mobile data-gathering units. Photomultiplier tubes magnify signals from the seismometers and record them on magnetic tape, while a pencil of light traces them on film. The tape or film is marked continuously by a timer that is never more than one-tenth of a second away from true Greenwich time. The tape is fed into a large room full of permanent storage reels, perhaps after first recording its data in a fast computer. The film is processed in a high-speed darkroom and, in a little more than 10 minutes, displays its picture.

The sensitivity of a single detection station still depends more on clever location of proven equipment than it does on souped-up instruments.

Our underwater stations are one of the fruits of recent research. So are our "deep-hole" units. Project Vela-Uniform scientists found that deep wells are usually very quiet, seismically speaking. Two seismometers in deep wells may do the work of 10 or more surface units. A new triaxial seismometer replaces several units formerly operated simultaneously to spot the direction of a seismic wave. Radar-type scopes display the direction and size of underground events for visual study; computer systems rapidly sum up the recorded signals of a wave as it passes across an array of many seismometers.

More important, ARPA and ACDA scientists now have had enough experience with signals from planned nuclear tests so that they can interpret data with greater confidence than, say, five years ago.

Recent improvements have made our seismometers only a little more sensitive. But scientists have developed better ways of using them. Groups of the units, for instance, used in new geometric patterns, have increased the over-all efficiency of

observatories. Seismometer arrays, usually 10 instruments, now are arranged so that local background noise, such as rail and highway traffic and even wind-caused seismic noises cancel each other out. Signals from distant underground blasts are analyzed by computers. The large "summed" signal from a far blast or quake now stands out more clearly.

Though all this improves our ability to spot distant seismic events, the identification of quake or nuclear test is still a ticklish question.

Most earthquakes push some ground away from the epicenter (the spot on the earth's surface directly above the deep center of the quake, or hypocenter) and cause some ground to fall toward it. Thus, some seismic stations will record first motions away from the source, and others will record first motions toward the source. Shock waves from a man-made explosion, on the other hand, always travel away from the center of the blast.

Stations must be extremely sensitive (have high signal-to-noise ratios) to spot that first motion reliably. But, when monitors learn that an underground event registered both compression and rarefaction waves, they know it was a quake.

### Quakes Vs. Bombs

A better technique is to examine the record traced by the waves that reflect from the earth's surface directly above the event before beginning their cross-country travels. These indicate the depth of the seismic event clearly. Scientists agree that any event 40 or more miles deep is a quake, not a man-made blast.

Some shock waves push the earth at a seismic station up and down, others rock it back and forth. The total movement may be just a few microns (the smallest registered motion was about 20 microns in diameter). Not much movement, but it can be detected and measured.

Four different types of seismic shock waves come from quakes or bomb blasts. In the order they reach a seismometer, they are: P-waves, or "pressure waves", move through the earth away from, and then reflect back toward the shock source—like sound waves traveling through air. S-waves, or "shear waves", move by producing motions back and forth across the wave's traveling direction. They move at a slower pace than P-waves but go farther. L-waves travel horizontally over the earth's surface rather than through dense underlayers, and don't go as far as either P- or S-waves. "Rayleigh waves" move vertically, at right angles to the direction of travel.

When a dozen or more clues in a given



blast fail to identify the event as a quake, then our monitors suspect an underground blast. At this point, in our proposed test ban treaty enforcement plan, the U.S. Arms Control and Disarmament Agency would call for certain information from the Central Intelligence Agency, the Defense Department's Intelligence Agency, the U.S. Geological Survey and the Coast & Geodetic Survey.

### "Spoof-Proofing"

The ACDA will prepare a "travel folder" containing everything the contributing agencies know about the suspicious blast. If it is over or near a city, the event will be ruled out. Earthquakes happen under cities, but people don't test atomic bombs there. If the blast comes from a known weapons test area, or from a remote territory, the agency will call for more intelligence reports.

But most scientists and diplomats discount the possibility of "spoofing" a detection system. The fact of an explosion cannot be hidden. A nation conceivably could try to cover a small blast in one location with a larger blast in another location. If carefully phased, this would hide a small test from a single detecting station but would give it an even bigger seismic kick to wonder about. Small charges planted between test sites and detection stations would confuse the seismic records, but only those of surface waves. Test detection relies much more on deep earth waves.

The experts know that a better way of hiding nuclear tests would be to conduct them in areas where earthquakes are common. Tremors emanating suddenly from a region of low seismic activity, like Kansas, would arouse suspicion. But nuclear blasts in the Kurile Islands and the Kamchatka Peninsula of the USSR's Pacific coast, where over 70 percent of that nation's earthquakes take place, could be distinguished from quakes only by a large complex network of stations.

### Islands Unstable

A few manned stations in Japan would do the trick under good conditions. But seismic conditions in Japan are among the worst in the world. The islands are perched on an unstable, constantly shifting rim of crust material jutting up from the Pacific Ocean floor.

Hence, the proposal to plant underwater black boxes all around the peninsula. These devices, less than 10 feet tall and two feet in diameter, lack only one component of the large manned stations and the unmanned vaults: they have no device for recording the very low fre-

quency waves that take many seconds to pass a station. But even this item is now under development.

The larger "seismic vaults", containing long period seismometers, are what the Arms Control agency would build in the USSR if someday a test-ban treaty is signed. Data from the sealed vaults would supplement information from our own network outside Russia.

The ticklish question of whether seven on-site inspections annually inside the Soviet Union would be enough to prevent cheating remains. Many scientists believe seven (or even less) would do the job. They don't guarantee that every test would be spotted. They think that most of the very small tests would be missed or at least remain in doubt. But on-site inspections, they say, would at least slow the nuclear arms race considerably.

### Our Detection "Specs"

To be on the safe side, the Arms Control group actually would operate at least 15 manned stations, plus the underwater stations necessary to fill in the gaps.

Here is what could be expected from the agency's system:

- Detect one-kiloton blasts detonated in granite. (The Hiroshima bomb was equal to 20 kilotons—20,000 tons of TNT.)
- Detect a two to six-kiloton test in the rocky volcanic soil at the Nevada test site.
- Detect a 10 to 20-kiloton test in loose, sandy, dry alluvium.

This looks like the Russians could get away with tests of small, battlefield-size weapons. However, ARPA points out that these are the figures for reliable detection of every test in the size range and the Reds know that we would detect a few smaller tests. Also, there are only two suitable alluvial areas in the USSR. These could be given special attention.

The figures quoted above are for tamped tests of weapons well coupled with the earth. What about "decoupled" tests of weapons suspended in huge caverns?

According to ARPA, such tests would be costly and time-consuming. Test ban violators would have to dig out a cavern 360 feet in diameter to muffle a 10-kiloton blast; 770 feet for a 100-kiloton explosion. The U.S. took three years to conduct decoupled tests in Mississippi.

That briefly is the black box story. But the Joint Committee on Atomic Energy may be right after all. There may really be no black box. Dr. Charles C. Bates, director of Project Vela-Uniform, stopped the writer in a Capitol corridor one day recently. "About that black box," he began. "You know it's not really black. It's more of a dark gray." ★★★



don't leave us behind

# WHEN YOU MOVE!

Postal regulations require that you pay extra postage on all magazines forwarded to you at a new address. Copies will not be forwarded free, and we cannot replace lost copies.

To insure delivery at your new address PLEASE NOTIFY US NOW, OR SURELY 6 WEEKS IN ADVANCE OF YOUR MOVING. Write in old and new address below, if possible include the address label from your last issue. Thank you.

Please mail this form today to:

**Popular Mechanics**  
Subscription Department  
250 West 55th Street  
New York 19, N. Y.

ATTACH LABEL HERE  
or  
write old address below

## Old Address

Name \_\_\_\_\_ *Please Print*

Address \_\_\_\_\_

City \_\_\_\_\_ State \_\_\_\_\_  
zone

Magazine \_\_\_\_\_

**Be sure to give us your**

## New Address

Name \_\_\_\_\_ *Please Print*

Address \_\_\_\_\_

City \_\_\_\_\_ State \_\_\_\_\_  
zone

Magazine \_\_\_\_\_

## Preview of the '64 Cars

(Continued from page 81)

arate frame bodies which will be several inches longer, but fit the same 115-inch wheelbase the new Chevrolet will have.

### Convertible Mice

The increased size of 115-inch wheelbase was not as much of a factor in the change from unit construction to separate frame and body for these cars, as was the increasing popularity of convertibles. Have you ever heard the mice that live between the windshield and top of a *unitized* convertible?

Buick Special and the Olds F-85 will have a new cast-iron version of their compact V8, and displacement is expected to be upped to about 300 cu. in. from the 215 cu. in. being used on the current engine. Both cars will share the Buick Special's V6 and Tempest will continue its own optional 326-cu. in. V8.

In addition to abandoning its slant Four engine, Pontiac Tempest is expected to drop its controversial transaxle in favor of a forward-mounted transmission and driveline.

### Big Transmission News

New transmissions are, by the way, one of the big 1964 stories, both at GM and Ford. GM is phasing in a new automatic made up of three-speed planetary gearing and controls derived from the present Hydramatic plus a new torque converter. It won't replace all Hydramatics at once, but look for it in the full-size lines as a replacement for the unpopular three-speed Hydramatic in current use. The new (for GM) transmission offers a nice balance between performance and economy, with the torque converter filling in smoothly between the gear ratio steps. Expect to see it first on the Buicks, later on Pontiacs and Oldsmobiles.

The BOP compacts and the new intermediate Chevrolet may adopt a revised version of the transmission now used on the Buick Special.

Oldsmobile is expected to add a new series in '64, one that will fall between the Dynamic 88 and the Super 88. It will use the basic 88 body shell, but have a very hot engine and some fancy identifying trim.

### General Motors' A, B, Cs

Technically, GM will return in 1964 to the old A,B,C body shell system it used in the mid-Fifties. Expensive but out-of-sight stampings such as some of the cowl, floor pan and inner door structures are interchangeable between lower and higher price GM cars, though the outsides will



look quite different, of course. This is GM's big cost-cutting secret. Currently, you can replace your Cadillac windshield at a Chevy dealership for \$50 less. Door handles on an Olds 98 and a Corvair are currently interchangeable. But few people know these things.

For 1964, the B shell will range through all GM lines except Cadillac, the A shell is for intermediate compacts and the new mid-range Chevrolet, and the C shell is for the likes of Cadillacs, Oldsmobile 98s and Buick Electras.

The hiked-up, glass-sided "vista-dome" for the Buick Special (and perhaps other wagons on the BOP compact shell) will add about six inches of height to the wagon, and will probably have a sliding roof section like that on this year's Studebaker Wagonaire.

**FORD, FALCON, COMET, MERCURY, LINCOLN.** The 1964 Falcon no longer looks as if Paul Bunyan sat on the front end by mistake. Body lines stretch closer to bumpers and are straighter, cleaner and crisper, giving an impression of increased length and width, although Falcon's wheelbase will remain 108 inches. Look for an important suspension change here that will improve the ride.

The new Comet (see drawing) changes sheet metal substantially below the window lines, acquiring some of the more mature aura of Mercury and Lincoln in the process. Fairlanes get a new grille and side sheet metal face-lift and a thicker application of chrome trim. Galaxies acquire an even more solid "medium-price" look. Mercury will drop the 116-inch wheelbase Meteor (or perhaps use its name to designate one of the Comet models).

Ford is bringing back a three-speed plus torque converter transmission to fit between the Cruise-O-Matic used by the big Galaxie and Mercury V8s, and the simple two-speed automatic used by Falcon and Comet Sixes. The latter will eventually phase out as production of the new automatic takes over.

Falcon and Fairlane will have the large 289-cu. in. Fairlane V8 available as a power option.

### Race-Tested Improvements

Thunderbird, Lincoln and eventually all larger Fords will switch to the 15-inch wheel and profile tyrex tire which has done well in stock car racing. This will mean 38 percent better work life, 20 percent higher skid resistance and fewer balancing problems at the factory. The low profile design keeps the car's height the same, while the larger wheels permit better circulation of air around brake drums,

(Please turn to page 200)

AUGUST 1963

Take a TIP from the  
AUTO MAKERS...USE

# BAR'S LEAKS

Specified by cooling system engineers at auto factories ... then every 5,000 miles... stops engine block and gasket leaks... inhibits rust, scale... lubricates water pump seal... protects all metals, rubber, plastic... does not clog... use with anti-freeze, new or old... neutralizes acid.

U.S. Pat. 2580719  
U.S. Pat. 2935189  
Can. Pat. 901547

LIST PRICE \$7.00

Available: at car dealers, auto goods stores, service stations.

POUR INTO YOUR CAR RADIATOR

USED IN 4 OUT OF 5 CARS ON THE ROAD TODAY

FRE-BAR, INC., P.O. Box 65, Holly, Michigan

Factories: San Jose, Calif.; Springfield, Mo.; Ft. Worth, Texas; Minneapolis, Minn.; Taylor, Mich.; Morrisville, N.Y.; Harrisburg, Pa.; Logansport, Ga.; Blytheswood, Ontario

GOVT. SURPLUS AND OTHER BARGAINS SAVE UP TO 90%



### NEW! ELECTRIC PUMP WITH CONTROL UNIT

For boats, campers & trailers. Output 10 to 200 gal. an hr. Variable rheostat contains on & off switch and controls output of pump. 1/2" pipe thread into bronze impeller housing. 12 V.D.C. Radio noise filter. Explosion-proof const. Shpg. Wt. 9 lbs. Complete with mounting instructions & wiring diagram. Approx. GOVT. COST \$200. NEW. \$10.95.



### DELUXE ELECTRIC STORAGE BATTERY WINCH

A ruggedly built, heavy-duty winch with ball bearing construction throughout motor and gear train. 225-1 gear reduction. Rated cap. 2500 lbs. Contains heavy duty enclosed forward, neutral & reverse switch. Rugged 1/4" plate steel mounting base with outrigger support. Dims. 22" L. x 9" W. x 8" H. Handles 250' of 1/4" cable. Built for 12 V. battery operation: will also operate on 6 V. at reduced cap. & speed. A must for scouts, jeeps, trucks, boat loading trailers. Shpg. wt. 80 lbs. Approx. GOVT. COST \$490. New. Model E-D. \$75.00

\*Lighter duty & remote control models also available from \$55.00. Write for spec sheet.



### CORNELIUS AIR COMPRESSOR

Ideal for filling underwater diving tanks, air horn tanks, etc. Three stage USAF air compressor. Has built-in 1/2 HP, 27 V. DC electric motor and adjustable cut-out switch. Develops 1500 PSI or may be reset to 2000 PSI. Delivers .4 CFM. Approx. GOVT. COST \$375. Like NEW. \$32.95

## BIG NEW 1963 CATALOG!



Send 25c in coin for amazing new catalog with 1000's of surplus bargains in hydraulics, electrical, precision tools, marine items, automotive, etc. for hobbyists or industrial. Or order from this ad and receive a free copy. All prices F.O.B. Culver City, Calif. 50% dep. for C.O.D. Send check, cash or money order. Order today!

**AIRBORNE SALES CO. INC. DEPT. PM863**

8501 Stellar Drive • Culver City, California

199



# DYNAMIC INDUSTRIAL TYPE TRANSFORMER WELDER

WELD-CUT-BRAZE-SOLDER-HEAT  
IRON-STEEL-BRONZE-BRASS  
ALUMINUM AND OTHER METALS



Professional Electric Arc Welder. Ideal for Home, Shop, Farm or Industrial use. The handiest tool in your workshop. Weld, Braze, Solder, Cut, Bend all metals. Do expert work on your first job. Build or repair Boats, Trailers, Auto Bodies, parts, fenders, metal and ornamental iron furniture, fixtures, farm equipment, garden tools, bicycles, toys, etc. Operates on any properly wired 110 V. A.C. line. Complete with helmet, arc torch, electrode holders, flux, rods, cables, instruction book. **FULL YEAR GUARANTEE.** 10 day money back trial. **ONLY \$38.50 f.o.b.**

**Only \$38.50 f.o.b.** Send only \$6.00 check or m.o. Pay postman balance plus charges. **EASY PAY PLAN.** Low down payment. Pay as you weld.

**DYNAMIC WELDER CO.** 1808 SOUTH FEDERAL STREET  
Dept. D2-H, CHICAGO 16, ILL.

# NO.1 for boating fun!

**ALUMA**Craft

**ALPEX**

BOATS, CANOES,  
TRAILERS

FIBERGLAS BOATS

write for **FREE Catalog**

**ALUMA CRAFT** BOAT DIVISION • **ALPEX CORP.**

1519 Central Ave. N.E., Minneapolis 13, Minnesota

## DO AWAY WITH UNSIGHTLY ANTENNAS

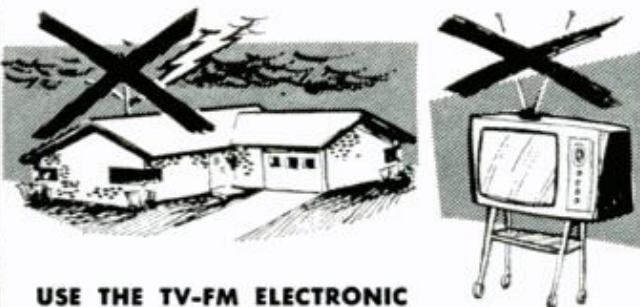

### USE THE TV-FM ELECTRONIC POWER CORD ANTENNA MODEL 2-C

DELIVERS EXTRA PICTURE POWER needed for crisp, bright, snow-free pictures and static free sound. Field proven for remote area reception.

USES ENTIRE HOUSE WIRING and outside power lines for antenna signal reception with protective line isolation.

INSTALLATION SIMPLE. Remove old antenna from set, install the Power Cord Antenna in its place, simply plug into wall outlet.

- Does not consume any power. Shock proof (child safe) Eliminates any Fire, Storm, Shock and Lightning Hazards.
- No moving parts—nothing to wear out, repair or adjust. Pre-tuned and Omni-Directional.
- Perfect for Color, B/W, portable TV; VHF and FM Stereo.
- Ideally suited for apartment house—motel—hotel installations. Eliminates costly wiring, master outside antennas and coupling devices.
- Built-in "Interference Arrestor" and "Precision Clarifier".
- Complete **SATISFACTION GUARANTEED** or your money back.

Send for Yours Direct—

**ELECTRO DYNAMICS**

ONLY **6<sup>95</sup>** EACH

Plus 14c Tax

P. O. Box 3290—Dept. PM 101

2724 Tillar St., Fort Worth, Texas

Edison 2-5545

## Preview of the '64 Cars

(Continued from page 199)

which should reduce brake fade.

Many engine changes at Ford also reflect racing experience. They include wider, thinner webs for connecting rods on high performance engines; these should improve fatigue life substantially. A race-developed counter-balancing mechanism will be applied to all distributor rollers to cut down on the high-speed vibration that can throw off spark timing and intensity.

It was also found that the valves and pistons on Ford race engines actually contacted each other at r.p.m.'s of 6500 or more, so 1964 Ford's engines will have a pad and increased clearance on these parts. Rib locations in the blocks have also been moved closer to the seals to help prevent the deflection that sometimes causes these to blow out, particularly on high mileage engines.

**CHRYSLER.** We've already mentioned the big styling news at Chrysler—the redo of the Imperial. Styling changes on Plymouth, Dodge and regular Chryslers can generally be described as of the "safe" variety that today represents a blend of the main-line models of GM, Ford and Chrysler products.

But rear windows on Chrysler cars will increase somewhat in size for better vision. And there are signs of tampering with that rear T-bird-like greenhouse panel by having some interesting notches and curves cutting into the near sacred parallelogram.

Dodge and Plymouth Divisions sincerely mourn the fact that a past management ordered the disposal of tooling used for the 283-cubic inch V8 first used on the 1953 Dodge. This would be just what they need for power option on the Valiant and Dart. But, lacking this, there may be no V8 for these cars in 1964.

Rumor has it, though, that Chrysler is working with feverish haste to complete a lightweight cast-iron V8 of the 250 to 300-cubic inch range for the bottom engine on Plymouth and Dodge, as well as an option for the Dart and the Valiant.

**RAMBLER.** The dumpy Rambler American has been transformed for 1964 into a cleverly scaled-down Classic, according to those who've seen it. Wheelbase will be at least six inches longer, but all of that won't be reflected in over-all length. This will make the American a full six-passenger, Falcon-sized sedan, as it moves the rear seat up from between the wheel wells to widen it. Look for a long-overdue line of Rambler Classic hardtops.

Rambler has let tooling for an all new 6-cylinder engine, but it won't be ready



until the 1965 model season. Aside from the aircooled Corvair, Rambler will be the only maker to continue offering an aluminum engine block. Chrysler quietly phased out its option on the six-cylinder one this year. Pontiac, of course, dropped its current model, and, for '64, Buick Special and Olds F-85 will replace their troublesome aluminum blocks with all-cast iron.

Aluminum blocks were not so troublesome from a consumer's standpoint as from that of the manufacturer. GM aluminum blocks were permanent-mold castings and there was a tendency to porosity which required too high a percentage of them to be subjected to an expensive sealing operation. Also, the material was erratic in density, a condition that raised hob with such expendable, but expensive tools as drill bits and reamers. But aluminum usage in other parts such as transmission cases, axle housings and radiators will at least make up for the loss of light-weight aluminum engines.

**STUDEBAKER.** There will be a Loewy-restyled Studebaker next year in several forms, all about five inches lower, and they may or may not carry the Lark designation. They will have a novel muffler-less exhaust piping system (see photo) whose width will be no more than three inches at any point. This solves space problems underneath.

The Avanti will not only acquire a grille to relieve the plain line front end, it will sport a dress up job on its interior which will include the application of walnut veneer to the instrument panel.

All Studebakers will move up finally to the 6000-mile oil and grease change interval which neatly fits a twice-a-year cycle for average annual mileage. ★★

### Short, Happy Life

A new sub-atomic particle, the phi meson, was recently discovered by teams of physicists from the University of California, Syracuse University and Brookhaven National Laboratory.

The new particle has an extremely brief life, so brief it's unbelievable to anyone except a physicist. It exists for no more than two ten-thousandths of a billionth of a billionth of a second.

Phi mesons owe their existence to K mesons, and vice versa. When hydrogen atoms were bombarded by K mesons, particles flew off that were found to be phi mesons. And what happens to phi mesons after their incredibly brief lives? They break up into pairs of K mesons. The whole thing sounds faintly cannibalistic, but that's nuclear physics.

AUGUST 1963

## GIGANTIC SURPLUS SALE!

**COMPACT LEVEL** Item #829. New leading make. Light weight. Ideal for contractor, surveying, farm contouring, utility co. etc. 8" 8-pr. scope. Telescopes down to 3 1/2". 1 3/8" level vial. Horiz. circle 3 1/2" divided & numbered every 10° to 180°. Includes telescope, tripod, plumb bob. Wt. 9 lbs. List \$46.50. SALE. **\$29.95 FOB**



**COMPACT LEVEL-TRANSIT** Item #832. Big instrument performance. Ideal for interiors, excavations, etc. Accurate for leveling, aligning, plumbing. Vertical arc graduated both ways, 0 to 45°. Same spec. and equipment as above. Wt. 11 lbs. List \$67.50. SALE. **\$39.95 FOB**

### GAS ENGINE ELECTRIC STARTER

Item #515. Genuine Fairbanks-Morse starter with 12-v dry battery. Adapts to Clinton, Briggs, Cushman, etc. engines up to 4 h.p. Press button, engine starts instantly. 12-to-1 gear reduction. Wt. 25 lbs. List over \$50. SALE. **\$18.95 FOB**



### FREE CATALOG

64 illustrated pgs. 100s items, electronics, pumps, tools, etc. Save to 70%.

**SURPLUS CENTER**  
DEPT. 822 LINCOLN, NEBRASKA

### EXCLUSIVE DOUBLE-BEARING HEAVY DUTY PUMPS

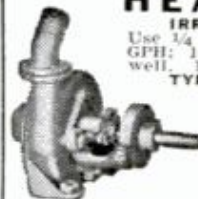

IRRIGATE • DRAIN • CIRCULATE • SPRAY  
Use 1/4 HP motor or larger. . . 1 HP for up to 5,200 GPH; 1,000 GPH 60" high; or 3,000 GPH from 25' well. 1 1/4" inlet; 1" outlet. Stainless shaft.  
**TYPE X**—2 oil-less bronze bearings. **\$10.95**  
Won't rust . . . . .  
**TYPE XB**—Ball bearing model. **\$12.95**  
Best for belt drives. . . . .  
Postpaid if cash with order.  
Don't delay—send for yours today!  
**MONEY BACK GUARANTEE**  
Centrifugal and Gear Pumps in All Sizes  
**LABAWCO PUMPS, Belle Mead 2, N. J.**

## REPAIR ANYTHING

STICKS LIKE A  
**Leech**  
CEMENTS • GLUES • ADHESIVES

FOR EVERY PURPOSE  
ASK YOUR DEALER

LEECH PRODUCTS, INC.  
HUTCHINSON, KANSAS

## SEALS CRACKS

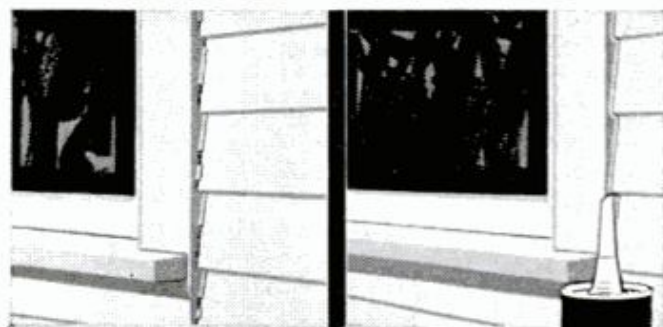

... stops heat loss and drafts

**DAP CAULK**

Nation's best-selling caulking. Fills cracks and joints to seal out air, dirt, water, insects. Keeps heat in.

DAP INC., DEPT. 37, DAYTON 31, OHIO





## Operation Sub Rescue

(Continued from page 72)

an improved bathyscaph and the present McCann Rescue Chamber, now carried by the four sub-rescue ships on the West Coast and five on the East Coast.

With the present chamber, the skipper of a crippled sub releases the hatch above the sub's escape trunk and a small buoy pops to the surface trailing a thin cable. The rescue ship fastens the escape chamber, carrying two operators, to the cable and winches it down to the sub. Over the escape hatch, the operators manipulate ballast and adjust water in many small tanks until the chamber is sealed in place. Then compressed air blows water from the lower chamber and from the sub's escape trunk. As many as nine men can be hauled to the surface at a time.

### Cables Limit Chambers

Diving chambers are limited to about 1300 feet because of currents and the cable capacity of the vehicle's winch. Another limitation is the length of cable on the messenger buoy. A submarine built to carry two reels of cable (for fore and aft escape trunks) 20,000 feet long, or even 8400 feet long, would have to be "nearly as big as a battleship."

The proposed combination bathyscaph-rescue chamber would be self-propelled and highly maneuverable to enable it to find a sub and mate with its escape hatch.

Ultimately, the Navy hopes to develop new materials capable of withstanding greater underwater pressures. Ultra-strong titanium, for example, would permit construction of larger crew and passenger spheres for rescue operations. The present cost of titanium, \$8 per pound, is prohibitive; submarine steel plate, HY-80, costs only 25 cents per pound. A new steel, which the Navy hopes will cost only a little more than HY-80, is now being developed by the United States Steel Corporation especially for the new deep-diving submarines now on the drawing boards. Called HY-130, it will withstand pressures of 130,000 pounds per square inch. HY-80's strength is 80,000 pounds.

Titanium is notoriously difficult to fabricate and HY-80 is nearly as stubborn. Adm. Ralph K. James, chief of the Bureau of Ships, says of HY-80, "We don't construct submarines, we blacksmith them." The Navy hopes HY-130 will be much easier to work with.

Steel and fibreglas-laminated "sandwiches" similar to safety glass may one day replace conventional steel plate. It will provide extra strength and improved heat and sound insulation.

Navy designers would like to test the use of lithium as the buoyant material in a rescue bathyscaph's float. The *Trieste's* float is filled with aviation gasoline to bring it back to the surface after ballast is dumped. Lithium is the lightest of the solids, only slightly heavier than hydrogen and many times lighter than gasoline.

Deep-diving craft able to operate well below the depths of our present sub fleet (published estimates are 1000 to 1500 feet) are already under construction. These are mostly research craft, ocean explorers rather than rescue and salvage vessels. One is a prototype for future combat subs, the super-secret *Dolphin*, which will operate at about 6000 feet, or 4700 feet deeper than the crew could be rescued.

Another big step away from bathyscaph-type vessels is a small, two-man craft named *Alvin*. Designed by General Mills for the Office of Naval Research, the 20-foot craft will operate at 6000 feet, deep enough to explore all parts of the continental shelf. It will operate at six knots and be fully maneuverable.

### Aluminum Diver

Also under construction is a heavy aluminum deep diver that will cruise at 3.8 knots, 15,000 feet under the waves. The *Aluminaut* is being built for Reynolds Metals Company, but will be leased by the Navy for use by the Woods Hole Oceanographic Institution.

Westinghouse Electric is putting the finishing touches on the *Deepstar* which will maneuver with a three-man crew at 3½ miles per hour at 12,000 feet. It was designed by French undersea explorer Capt. Jacques-Yves Cousteau. It will be powered by two shaftless propellers; varying the speed of either propellers will turn *Deepstar* on a dime.

Before a dive, ballast on *Deepstar* is adjusted so that it is neutrally buoyant. High-speed pumping of a small amount of heavy mercury from a rear tank to a forward tank points the vessel down. Pumping to the rear tank points it up. This lets *Deepstar* climb over hill and dale of the ocean bottom. For a rapid climb to the surface, the pilot releases magnetically attached weights for positive buoyancy.

The most unusual undersea research vehicle in the works is a very small, two-man "utility" submarine designed at Naval Ordnance Test Station in California. This is a five-foot plexiglass sphere with a wall four inches thick. If durability tests confirm the designers' theories, it will provide almost unlimited visibility for its crew at 2000 feet. The plastic chamber would be replaced by a steel sphere for operation down to 10,000 feet.



Although observers say the Navy won't let the absence of deep-sea rescue capability slow its plans for ultra-deep diving subs, nobody will admit a willingness to write off crews of submarines disabled below 1300 feet simply as casualties of the cold war. The Bureau of Ships works as hard as its limited funds permit to make sure that men can be rescued.

Heroic divers proved some years ago that there is a better way for a man to escape from a sub sunk in shallow water (if a McCann chamber is not handy) than to climb slowly up a cable, breathing in the well-known Momsen Lung.

### "Blow and Go"

Careful studies and pure, nerveless guts proved a new "blow and go" method. Crew members enter a submarine's escape trunk and pressurize extremely rapidly, then step through the escape hatch and pop rapidly to the surface, exhaling and expanding air from the lungs steadily as they rise. "Blow and go" is safe down to 450 feet.

A hood developed recently by submariner Harris E. Steinke permits the wearer to breathe if he feels it is necessary, although all submariners can hold their breath longer than it takes to pop up from 450 feet. The hood keeps cold water away from ruptured eardrums.

Techniques for rescuing men have occupied the Navy's attention far more than salvaging sunken subs. Low-key consideration has been given a few salvage ideas such as a collapsible pontoon, similar to a parachute, that could be carried down to a sunken submarine and filled with piped air to raise it. But studies show that even if a sub sank in shallow water, and very few do, it would cost much more than the sub is worth to raise it. Up to now the Navy has been satisfied, if the men can be rescued to leave the sub on the bottom.

However the U.S. State Department is not, and for sound diplomatic reasons. After the nuclear-powered *Thresher* went down, the Soviet Union squeezed a lot of propaganda mileage out of a nuclear reactor lying on the floor of the Atlantic.

The State Department, with the blessing of the White House, has urged the Navy full speed ahead on a deep ocean salvage program. It fears that a similar sinking, say in the crowded Mediterranean, would provoke a world uproar if we could not raise the sub. Especially if, instead of carrying only a power reactor, the sub also carried 16 Polaris nuclear warheads.

Finally, says the State Department, who would be the bad guys and who would be the heroes if the Soviet Union could come along and raise that submarine while we watched helplessly? ★ ★ ★

AUGUST 1963

# SHOOT A STAPLE WHEREVER YOU'D DRIVE A NAIL!



Available at Hardware, Building, Lumber and Stationery Dealers Everywhere.  
ARROW FASTENER CO., INC. 1 Junius St., Brooklyn, N. Y.

## EVERLITE\* World's THIRTIEST Light Plants

(Item 869-12T)



### NEW TRANSISTOR ALTERNATOR REPLACES GENERATOR

Now a Service Free Light Plant built with a transistorized alternator. Offers 30% greater efficiency—more power for less fuel. Ferrite service life—no brushes to arc and burn. No more commutator to wear, no collector ring trouble. And best of all it costs no more to "go modern with Everlite." Thrifty 1200 watt, 115v. AC plant powered by a rugged easy starting 4 cycle engine—leader priced. Model 869-12T. Wt. 65 lbs. as illustrated ..... **179.50**  
f.o.b. factory

\*Trade-Mark Registered. All sizes available—can finance. Write for catalog. Special models for public utilities—Approved for Civil Defense. Write

**MASTER MECHANIC MFG. CO., Dept. A-863 Burlington, Wis.**  
Southern Customers Write to Dept. A-863, Box 65, Sarasota, Florida



## KING MIDGET "WORLD'S MOST EXCITING LOWEST PRICED CAR"

Drive it for 75c a week. Rider Agents Wanted. Send 25c for 32 page book, full details, dealer price. Or send \$1 (refunded first order) for this plus Service and Repair Manual and 16 5x7 photos of car and factory.

**MIDGET MOTORS CORP., Athens 1, Ohio**

# Outlasts Varnish 2 to 1

New miracle clear plastic finish dries dust-free in minutes, needs no sealer, goes on any kind of wood—inside or outside. Gives tougher, longer-lasting protection for patio furniture, siding, doors, cabinets, floors, paneling, tables, boats. Glass-like finish resists



alcohol, boiling water, food acids. Won't darken, crack or peel. Odorless. Non-toxic. Gloss or Satin finish. For free brochure and nearest FLECTO VARATHANE dealer, contact:

**Flecto Company Inc., Box 84-PM, Sta. A, Berkeley 2, Calif.**  
**Flecto Coatings Ltd., 7304 Buller Ave., Burnaby, B.C.**

203



# The Return of the Classic Cord

(Continued from page 84)

**ENGINE** for the new Cord will be the same 102-horsepower, 145-cubic inch plant used on the Corvair Monza Spyder. The Corvair turbocharger, which raises horsepower to 150, will be an option on the Cord. So will the Monza 4-speed stick, as an option for Power glide

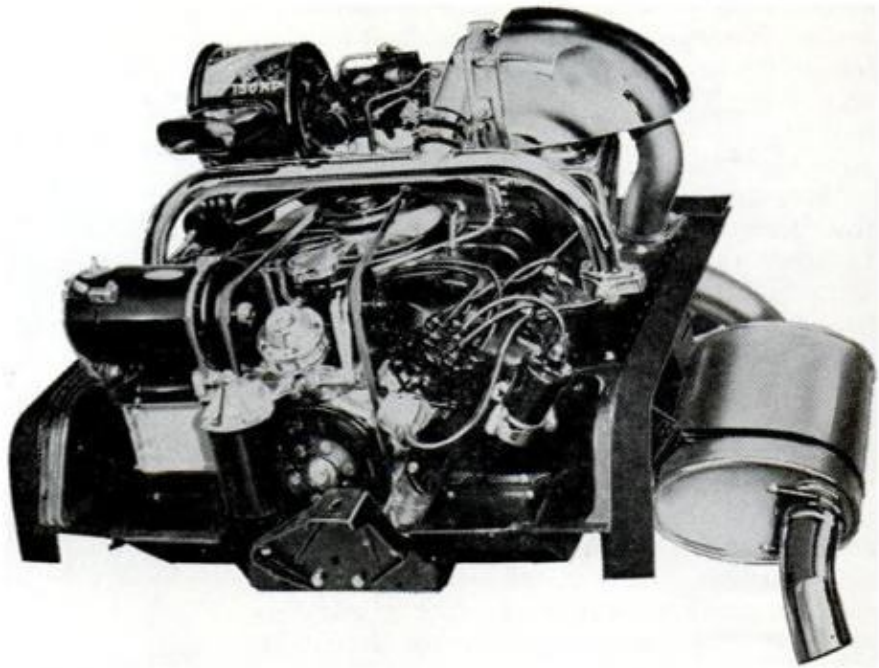

whose front-wheel drive enabled it to make good time safely on icy roads.

What about the rumor that a front-powered car on a steep incline throws so much weight rearwards that the pulling wheels lose their traction? It was true that the very first Cord—the L29 introduced in 1929—had hill-climbing troubles because its engine was set too far back from the front wheels. The 810 Cord introduced in the Thirties corrected this problem, however. With plenty of weight on its drive wheels, it was a climbing son-of-a-gun. So is the grandson-to-be, the 1964 Cord prototype I drove.

## Ditch Testing

In fact, despite some prototypical ailments, such as a right front torsion bar that needed more tension and rear springs that were a bit too stiff, my test chassis sat well, rode well, climbed in and out of ditches with ease, and certainly seemed to

maintain the correct amount of weight on each wheel. The front driving wheels were not hard to steer, as some might imagine, and there should be no need for conventional power steering on this car.

The prototype was bereft of body, of course, but adding the 280-pound body to the 1440-pound chassis-engine combination will not materially affect the 55 percent front, 45 percent rear weight distribution planned for this car. This is almost exactly the same weight distribution as on a 1937 Cord 812 although total weight of the new Cord will be some 1700 pounds less than the 4000-plus pound weight of the old Cord.

The smaller wheelbase and substantial weight reduction certainly make the new Cord more maneuverable than its classic daddy. Circles can be turned in 36 feet, as opposed to the 42-plus feet required for the 1937 Cord. And zero-to-60 mile-per-hour acceleration runs can be logged in

**1964 CORD** will have same interior dimensions as the old Cord, but be about an inch narrower outside, eight inches lower and about 29 inches shorter

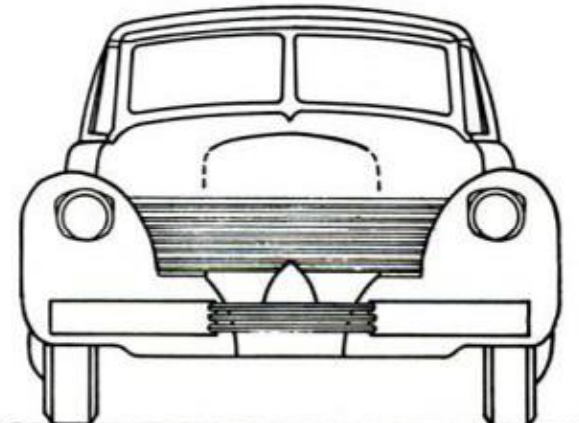



less time. Where it took a 1937 Cord somewhere between 13 and 21 seconds (depending on whether it was supercharged or not) to make it from standstill to 60, my unblown prototype Cord repeatedly made it in a few tenths of a second on either side of 10 seconds.

### Engine for the New Cord

What kind of power plant is responsible for times like these. The old Cord used an L-head V8 Lycoming which was rated at 125 hp. at 3500 r.p.m., or 170 hp. with supercharger. The lighter 1964 Cord will have the same opposed six-cylinder, 145 cu. in. engine used by the Corvair Monza Spyder. It is rated at 102 hp. unblown, or 150 with its optional turbocharger. When coupled with the new Cord's weight reduction, it should work the same improvement on fuel mileage that it does on acceleration.

In case our mention of the Corvair engine startled you, perhaps we should note right now that Glenn Pray is not planning to compete with the miles of market surveys, drawing boards, dies, smokestacks and erupting production lines that represent the giant mass producers of automobiles in this country. His new Cord Sportsman will be a limited production car, incorporating most of the old classic outlines but using, insofar as possible, tested, off-the-shelf conventional parts supplied by other auto manufacturers.

Thus, in addition to the Corvair engine, the new Cord will have a standard Powerglide automatic transmission or, as an option, the same four-speed stick shift used on the Monza Spyder. Cords with Powerglide, such as the prototype we drove, will have the control lever mounted in the center of the instrument panel which, by the way, is where the shift lever on the old L29 Cord was. Cords with stick shift will be controlled by a stick suspended from under the instrument panel.

### Heat Out the Dents

One feature of the new Cord that is definitely not an off-the-shelf item will be its plastic body shell, which will be vacuum-formed for Cord by U.S. Rubber Company out of their Expanded Royalite. This is basically a laminate made up of a low density, expanded ABS plastic resin core sandwiched between two layers of high density, solid ABS plastic resin.

U.S. Rubber Company representatives claim it has, for its weight, greater rigidity and impact resistance than fiberglass or steel. It can be readily patched with epoxy, and any dents made in it can be easily removed by the application of hot air at

(Please turn to page 206)

AUGUST 1963

## ELECTRIC WELD - BRAZE & CUT

REPAIR MOST EVERYTHING MADE OF METAL  
BEST WELDER MADE FOR THE MONEY!



Includes full face shield, extra arc goggles, ground clamp, twin carbon arc torch, welding rod holder, supply of welding and brazing rods, solder, flux and full supplies. PLUS ARC WELDING INSTRUCTION BOOK! ONE YEAR GUARANTEE—10 DAY FREE TRIAL. Now you can make or repair metal parts for cars, home, farm, garden, shop or factory. Works on any 110 v. house plug-in. CUT, MELT, BRAZE, SOLDER OR WELD MOST ANY METAL!

SEND ONLY \$2.00 (cash, ck, mo) and pay postman only \$12.95 plus COD postage or send \$14.95 for postpaid delivery. Every EXPERIMENTER, MECHANIC, INVENTOR, CAR OR HOME OWNER NEEDS THIS SMALL WELDER. ORDER YOURS NOW! Ideal gift. MADE ONLY BY: MIDWAY WELDERS CO., Dept. DPM-8, KEARNEY, NEBR.

### Permanent Sealer

Ready to use—no mixing required  
Sticks tight on any surface

- metal
- wood
- aluminum
- tile & concrete

49¢, 98¢ tubes & cartridges  
W. J. RUSCOE CO.  
Akron 1, Ohio

### Print Your Own

Cards, Stationery, Advertising, Circulars, labels, photo and movie titles, church work, tags, etc. Save money. Sold direct from factory only. Raised printing like engraving, too.

**Own a Printing Business**  
Print for Others, Good Profit. Have home shop. Junior press \$15; Senior \$35 up. We supply everything. Easy rules. Pays for itself in short time. Write now for free details.  
KELSEY PRESSES, Z-37 Meriden, Conn.

### At Last a New Amazingly Simple GAS TURBINE JET ENGINE

Build from easy to follow plans. Length 15", Dia. 8½", Wt. 15 Lbs. Fuel—Gasoline or Kero.

'Scream Demon' develops 20 H.P. Ideal project for serious-minded hobbyists, scientific and industrial arts classes. Make on 9" metal cutting lathe with milling attachment. For use on small racing boats, midget cars, etc. Full size assembly drawings with critical dimensions, bill of material and photos. Price \$5.00. No C.O.D.

SAVOY SCIENTIFIC, Box 1398, SANTA MONICA, CALIF.

Works in Seconds!

### Loosens Rusted Bolts nuts, screws, "frozen" parts!

## LIQUID WRENCH

SUPER-PENETRANT

BONUS USE: Add to crankcase to quiet noisy valve lifters... remove gum, sludge deposits!

THEN ADD...

### MOTOR-MEDIC

EXTRA LUBRICATION... SMOOTHER PERFORMANCE

Both at leading dealers everywhere!

205



# GUNK®

removes grease and grime **FAST**



from: power mowers  
 ● engines ● machinery  
 ● cement floors  
 ● kitchen walls  
 ● ovens ● implements  
 ● exhaust ducts  
 ● paint brushes  
 ● furnace filters  
 ● barbecue grills

AT AUTO SUPPLY, FARM & HARDWARE STORES

**GUNK® Laboratories, Inc.**  
 5829 W. 66th, Chicago 38, Ill.



### LIFE-LONG SERVICE

GERSTNER CHESTS last and last. Free catalog to tool-makers, machinists and other craftsmen.

**GERSTNER TOOL CHESTS**  
 483 Columbia St., Dayton 7, Ohio

## HYDE TOOLS

Finest Quality Fix-Up Paint-Up Tools

**WRITE FOR FREE CATALOG**

**HYDE TOOLS, SOUTHBRIDGE, MASS.**



ALL FAMOUS BRANDS!

# TIRES!

FARM TRUCK AUTO

AT LESS THAN WHOLESALE

SAVINGS NEVER LESS THAN 50% up to 70% OFF REG. PRICE!

HEADQUARTERS for ALL SPORT CAR TIRE SIZES

FREE • SEND FOR YOUR FREE CATALOG • FREE!

**RELIABLE TIRE DIST., 730 Morgan Blvd., Camden 4, N. J.**

# POLYSEAMSEAL®

TUB CAULK • TILE ADHESIVE

Pure White • Elastic  
Permanent



Sticks like glue! 101 Household Uses!



**BUY GREAT NECK HAND TOOLS**  
 . . . for long-lasting performance

**Precision Balanced  
NAIL HAMMER**



One-piece, forged steel, rubber-cushioned, no-slip grip

**GREAT NECK SAW MFRS., Inc.**  
 MINEOLA, N. Y. — SEE YOUR LOCAL STORE

## The Return of the Classic Cord

(Continued from page 205)

500°F. It is currently being used for truck engine covers, hood and fender assemblies, and in the first plastic travel trailer body. It is also being tested by Ford Motor Company in an experimental one-piece automobile body weighing only 120 pounds.

The corrosion-proof nature of the Royalite body fits in with the Auburn-Cord-Duesenberg Company's plans for keeping their new Cord as maintenance-free as possible. They have to, for the simple reason that they will have no network of dealerships equipped to provide special service for their new car.

So Cord officials are making sure that your friendly mechanic around the corner can take care of the Cord without any additional training. The stock parts approach—all of them of American manufacture—should help insure this. So should the fact that a complete service manual will come with every car and replacement parts will be deliverable from the Cord plant in Oklahoma by air express. Incidentally, the Auburn-Cord-Duesenberg plant did not spring up recently just for the purpose of making the 1964 Cord. For 26 years it has been conducting a going business supplying replacement parts for all the old classic Cords.

### Two-Section Frame

Other features of the new Cord which will ease servicing problems are a box-type frame with X-members which is made in two sections, so that the front half can be removed in one man-hour for quick servicing of the power plant and front drive unit. With few exceptions, a single size bolt ( $\frac{3}{8}$  National Coarse) is used throughout the chassis. And every line for electrical, gas or brake components will break at the firewall to simplify servicing of any of them.

At present, Cord plans to produce only one basic model, the convertible coupe shown on pages 82 and 83, with an optional hardtop shell. Company officials are setting up for a production rate of 2000 units a year, and the early months of production will be devoted to filling the orders of those who were on the waiting list as of June 1963. Shortly thereafter, however, orders can be taken from new, would-be buyers. Such as you, for example, if you are interested.

And what would you have to pay for this classic-line legend reborn? Somewhere between \$4000 and \$5000, depending on options.

Is it worth it? Well now, that depends on the strength of your dreams. ★★★





doubled since enrollment with LaSalle and due to my fine training is still growing."

—William T. Black,  
Canoga Park, Cal.



study I could not qualify as controller of a concern with millions of assets and sales. Thanks to LaSalle."

—Walter Zielke,  
Bridgeman, Mich.

the course I got a job in Accounting. I now earn times my former pay as a service station attendant."

—Robert Fisher,  
Holbrook, Ind.

*Regardless of previous experience or*

# LaSalle trains you at home in the fastest-growing profession

*Students report up to 56% increase  
in income the first year*

**A**CCOUNTANTS make big money — and there are more jobs available today in Accounting than there are trained people to fill them.

The Accountant is the control center of modern business. The financial functioning of every department depends on his information and skills. You can step up to this privileged position through LaSalle training.

**Training duplicates  
actual on-the-job-experience**

You can take LaSalle Accounting training at home, in your spare hours, without any previous bookkeeping experience. You set your own pace; you are neither hurried nor slowed. LaSalle's distinguished faculty starts you at the beginning; explains every basic Accounting principle and method; gives you actual Accounting problems with your work; shows you exactly how accountants on the job handle these problems. Your training is complete, practical, and enjoyable. You are thoroughly prepared for practically every Accounting task you may handle in the business world.

Your career could not be in more experienced hands. For more than half a century, LaSalle has been a world leader in business training, with over 1,000,000 students. More than 5,500 CPAs have trained with LaSalle. A LaSalle diploma is a credential recognized and respected by America's biggest companies.

**Mail card for Free Booklet**

If you are truly seeking a more rewarding job, higher pay, and all the good things that come with success, you owe it to yourself to read LaSalle's famous booklet "Opportunities in Accounting." With it you will receive a free sample lesson in Accounting which will demonstrate how LaSalle makes home study interesting and practical. Mail card today to LaSalle, 417 South Dearborn Street, Chicago 5, Illinois.

**Accounting offers you**

- ✓ **HIGH INCOME**
- ✓ **RAPID PROMOTION**
- ✓ **LIFETIME SECURITY**
- ✓ **DIGNITY AND PRESTIGE**

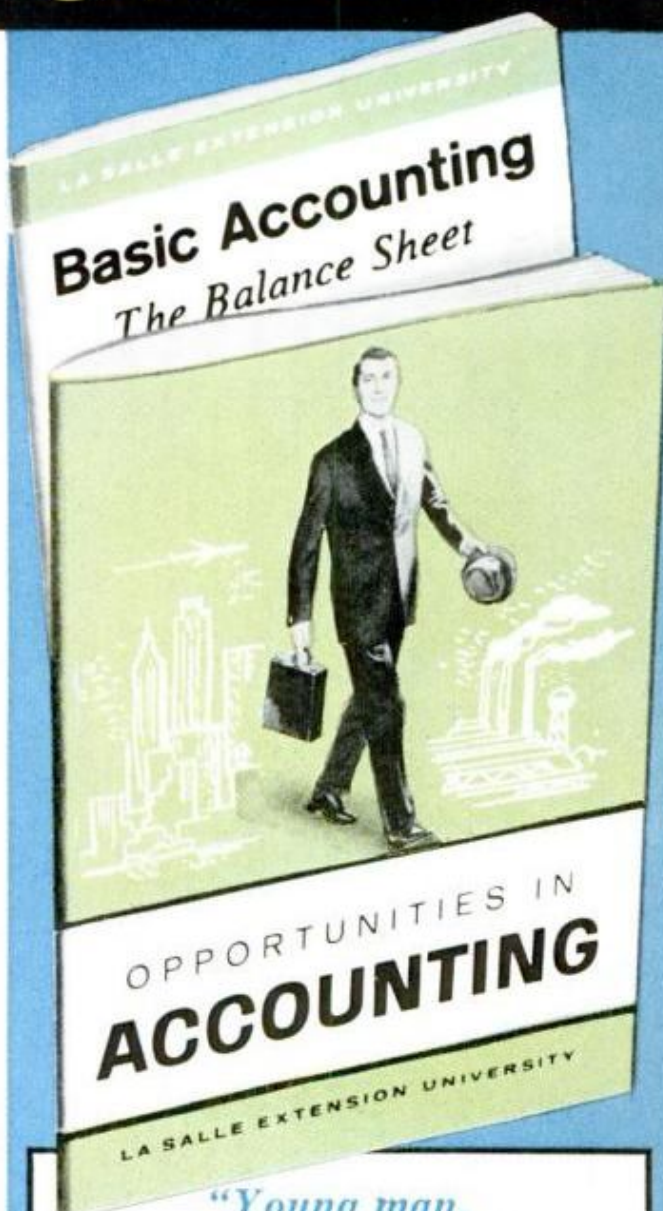

*"Young man,  
be an Accountant!"*

"The whole profession makes good money. According to a recent survey of 1,700 chief executives of listed companies, more of them started in finance and accounting than in any other department."

—ESQUIRE MAGAZINE

"The tremendous growth of the accounting profession is still accelerating: the profession expects to pick up an additional 40,000 CPAs by 1970."

—FORTUNE MAGAZINE



# Get Lucky

the taste to start with...the taste to stay with



The taste of a Lucky spoils you for other cigarettes. This famous taste is the best reason to start with Luckies... the big reason why Lucky smokers stay Lucky smokers. How about you? Get the taste you'll stay with. Get the fine-tobacco taste of Lucky Strike.

© A. T. Co.

*Product of The American Tobacco Company — "Tobacco is our middle name"*