

Home Fix-It Center Built in Any Wall

# POPULAR MECHANICS

JUNE 1963  
35 CENTS

Complete Battery-Powered  
Stereo in a Suitcase

CADILLAC and VALIANT  
Owners' Reports

AMAZING  
**B-70**  
Military Monster  
or Supersonic  
Transport?



HOW SILENT WAS SPRING  
in One Pesticide-Drenched Town?

# Get Lucky

the taste to start with...the taste to stay with

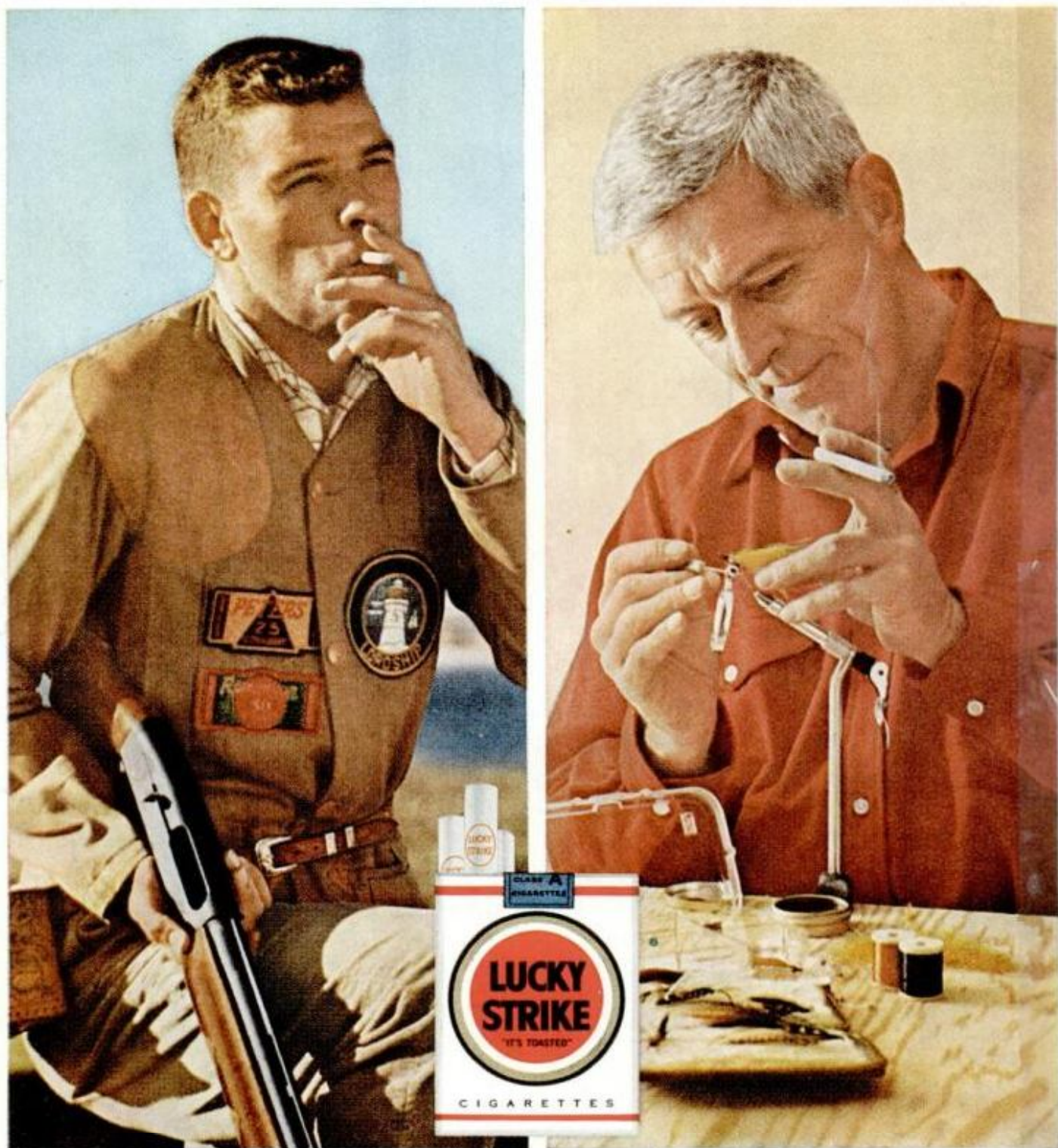

The taste of a Lucky spoils you for other cigarettes. This famous taste is the best reason to start with Luckies...the big reason why Lucky smokers stay Lucky smokers. How about you? Get the taste you'll stay with. Get the fine-tobacco taste of Lucky Strike.

© A. T. Co.

Product of *The American Tobacco Company* — "Tobacco is our middle name"

Материал, защищенный авторским правом



Super Hi-Miler (at left) vs. comparably priced truck tire (at right) after typical accelerated, high-speed, overloaded, 50,000-mile test on same equipment, over same roads, with same driver.

# yes, outwears! yes, any other!

## Goodyear's New Super Hi-Miler truck tire

**yes!** Super Hi-Miler is made with TUF SYN—toughest, longest-wearing synthetic rubber in Goodyear history. And it's been proved over millions of highway miles!

**yes!** A new wide-tread pattern lengthens Super Hi-Miler life. Tread wear is distributed over much greater area to reduce *rate* of wear and increase mileage.

**yes!** Super Hi-Miler beats tire-killing heat. Dual-compounded tread has a resilient inner tread to cut heat buildup. Open shoulder grooves dissipate heat further.

**yes!** There's longer wear in compact continuous ribs, too. No small segments to squirm and scuff away mileage. Deeper outer grooves for extra traction, extra safety.

**yes!** Super Hi-Miler rides with a new "muted sound" for less "rumble" at high speeds on the road. Variable zigzag tread segments are acoustically engineered. Listen!

**yes!** Goodyear's new Super Hi-Miler with TUF SYN rubber outwears any other truck tire of its kind. Save with Super Hi-Miler truck tires! Goodyear, Akron 16, Ohio.

# GOODYEAR

Hi-Miler, Tufsyn—T.M.'s The Goodyear Tire & Rubber Company, Akron,

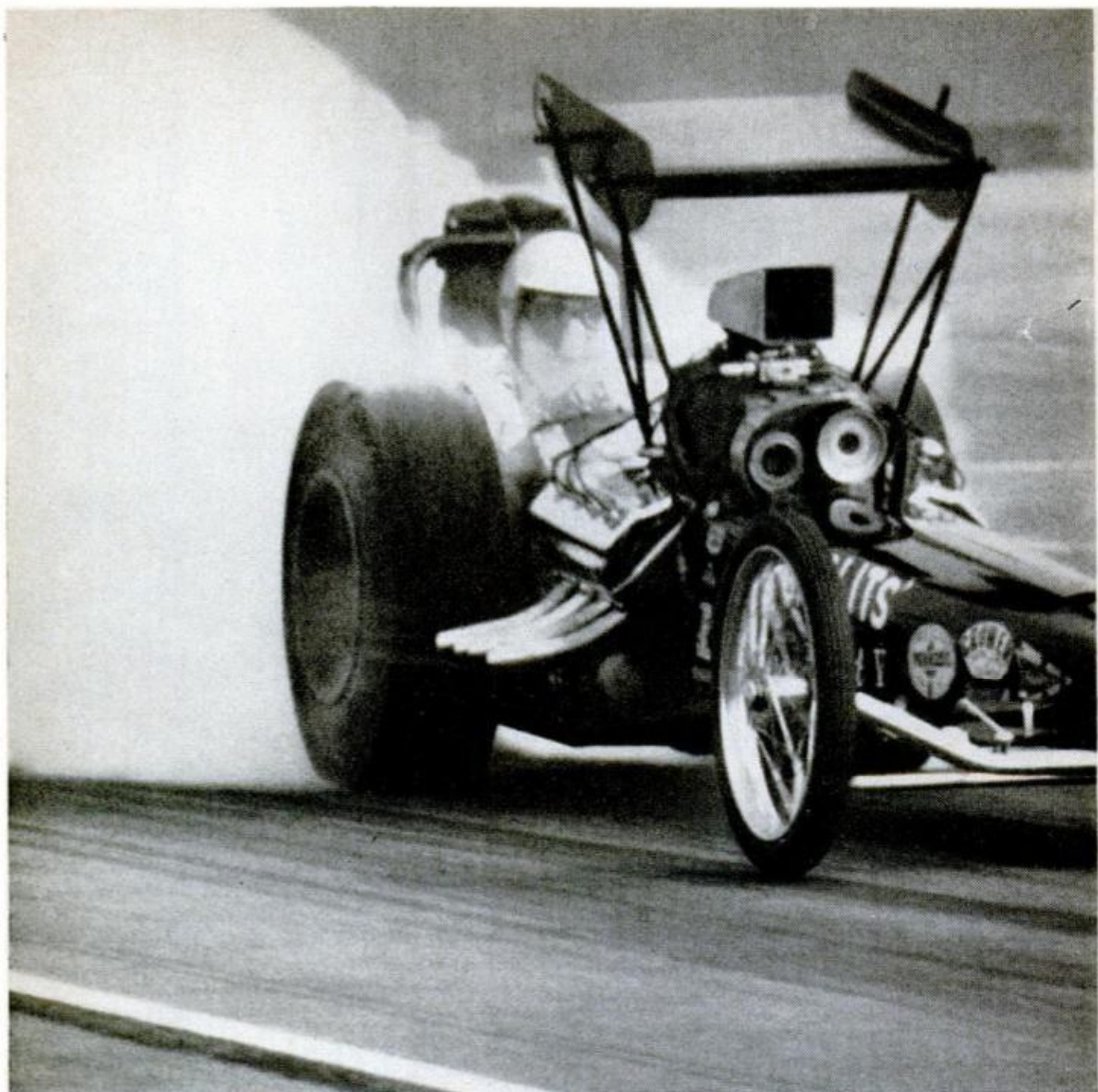

Don Garlits' Dodge-powered dragster, sparked by Champions, wins Top Fuel Eliminator at the NHRA Winternationals, Pomona, California

The overwhelming majority of men  
who design, build or race  
engines use Champion spark plugs.  
Why settle for less in your car?

New Champions can give your car 26% more power...instantly!  
On the average, that's what you can get with new Champions  
if you haven't changed spark plugs in 10,000 miles or more!



**CHAMPION**



**like father**

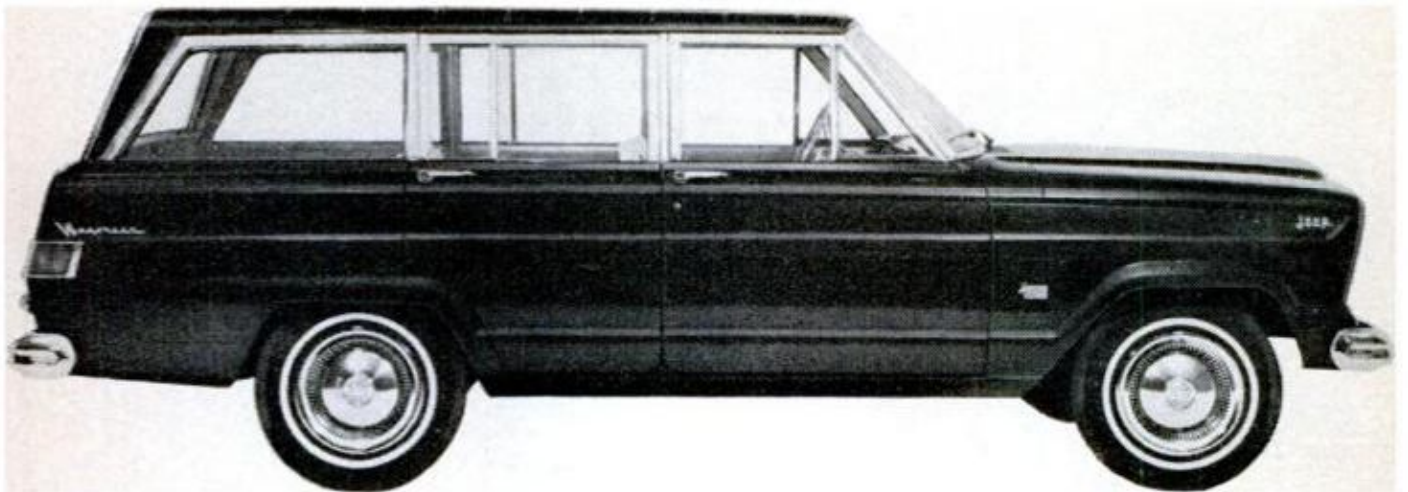

**love son**

**For every man who ever fell in love with a 'Jeep'** — a new kind of family station wagon has been born. The 'Jeep' Wagoneer. It's the first station wagon ever built to offer the comfort, silence, speed and smoothness of a passenger car — plus the traction and safety of 4-wheel drive.

It's sheer pleasure to drive. Simple too. One lever puts you in 4-wheel drive. So at a second's notice you can shift into greater safety... from wheel-spinning in mud or snow... from skids on slick surfaces... from getting stuck or going out of control on the highway or off!

The Wagoneer really makes a demonstration worthwhile. It'll be your most exciting 30 minutes behind the wheel in 1963. By the way, 2-wheel drive models available too.

**7 exclusive features that turned the 'Jeep' into a family station wagon:** 1. Automatic Transmission.\* 2. Independent Front Suspension.\* 3. Both Power Steering and Power Brakes.\* 4. Easy-To-Enter Doors open wider than other wagons. 5. New Tornado-OHC Engine. ("OverHead" Cam) Gives more horse power on less gas. 6. More useable cargo area. High and Wide. 7. New 'Jeep' 4-Wheel Drive. Quiet. Simple one-lever shift. See your 'Jeep' Dealer today.

**KAISER Jeep CORPORATION** Toledo 1, Ohio

\*Optional on the 'Jeep' Wagoneer and not available on any other 4-Wheel Drive Wagon.

shift into greater safety **NEW 'JEEP' WAGONEER** the family wagon with 4-wheel drive

This One



G53J-N8G-FSUG

# POPULAR MECHANICS®

JUNE 1963  
VOL. 119 NO. 6

INTERNATIONAL EDITIONS • SPANISH • CARIBBEAN • FRENCH • PORTUGUESE

## Features of Special Interest



Little Valiant,  
Big Splash  
page 90

The Amazing B-70—Supersonic Transport? . . . . .	67
Out of This World Life Detectors . . . . .	72
Owners Report on Their 1963 Cadillacs . . . . .	78
How Silent Was Spring in One Pesticide-Drenched Town? . . . . .	85
Sculptured French Water Towers . . . . .	89
The 1963 Valiants: What Their Owners Like and Dislike About Them . . . . .	90
The Chesapeake's Porpoising Highway . . . . .	94
Commuter Scooter . . . . .	96
Taking the Panic Out of Braking . . . . .	98
A-Power: Creeping Giant . . . . .	100
PM Shopping Guide: Backpacks and Frames . . . . .	106
Swirl-Chamber Engine Runs on What's Handy . . . . .	110
Stereo in a Suitcase . . . . .	116

## For the Workshop Craftsman

3-D Pantograph  
page 164

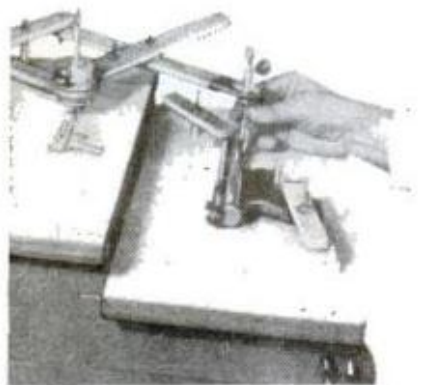

Fix-It Center Built in Any Wall . . . . .	122
Model Boat That Rides on Stilts . . . . .	128
Sectional Screens: Privacy for Your Patio . . . . .	134
PM Tests the New Propane Spray Paint . . . . .	136
Make Your Own Outdoor Party Lamps . . . . .	138
Merry-Go-Spin for Small Fry . . . . .	144
Fisherman's Drift Sock Sea Anchor . . . . .	146
Build Yourself a Rollaway Darkroom . . . . .	148
Folding Kayak for \$15 . . . . .	152
Keep the Fuel Flowing with Fuel Pump Care . . . . .	158
A 3-D Pantograph for Your Shop . . . . .	164
Make Your Own Pole Saw for Pruning . . . . .	168
Trinket Boxes Made from Napkin Rings . . . . .	169
Brazing and Hard Soldering Tips . . . . .	170

## Regular Departments



Pick the  
Right Pack  
page 106

Over the Editor's Desk . . . . .	10
Sidelights on Aviation . . . . .	14
Items from All Outdoors . . . . .	16
Sidelights from the Services . . . . .	20
Science Worldwide . . . . .	24
Spotlight on the Falcon Sprint . . . . .	28
Worth Writing For . . . . .	32
Detroit Listening Post . . . . .	82
What's New for Your Home . . . . .	114
Electronically New . . . . .	121
Shopping for Tools . . . . .	137
New on the Market . . . . .	145
What's New for Shutterbugs . . . . .	147
Solving Home Problems . . . . .	156
Auto Clinic . . . . .	163
Clinic for Homeowners . . . . .	180

**NEXT MONTH—Way-out Boat Designs** will be on the water this summer, and you'll find many of them in July *PM*—along with owners ratings of their Olds F-85s, a report on family style rock climbing, an inside story about what it takes to win a Mobilgas Economy Run by *PM's* auto editor, who placed second. Don't miss it

DANISH • SWEDISH • DUTCH

Published by Popular Mechanics Company

RICHARD E. BERLIN  
President

RICHARD E. DEEMS  
Executive Vice-President

JOSEPH R. BUELL JR.  
Publisher

DON DINWIDDIE  
Editor

RICHARD F. DEMPEWOLFF . . . . . Executive Editor  
JOHN A. LINKLETTER . . . . . Managing Editor  
WAYNE C. LECKEY . . . Shop Crafts Managing Editor  
CLIFFORD B. HICKS . . . . . Midwest Editor  
740 N. Rush St., Chicago 11, Illinois  
THOMAS E. STIMSON . . . . . Western Editor  
Suite 1003, 3460 Wilshire Blvd., Los Angeles 5, Calif.  
HENRY NEHRBASS . . . . . Art Director  
KEVIN V. BROWN . . . . . Aviation Editor  
JAMES R. WHIPPLE . . . . . Automotive Editor  
LARRY STECKLER . . . . . Electronics Editor  
ALFRED W. LEES . . . . . Home Workshop Editor  
ARTHUR MIKESELL . . . . . Boating Editor  
FRANK X. SMITH . . . . . Production Editor  
STUART JAMES, JOHN P. McNEEL  
ED NELSON, ARTHUR J. MAHER . . Assistant Editors  
MURRAY COOPER . . . . . Art Editor  
LEO WEEKS . . . . . Assistant Art Director  
FRANK P. FRITZ . . . . . Chief Photographer  
HEINZ P. SCHLICHTING . . . . International Editor  
Ritterstrasse 26, Karlsruhe/Bd., Germany  
L. PARK BENJAMIN . . . . . Advertising Director  
J. C. BONFIGLIO . . . . . Director, Bureau of Information

ADDRESS COMMUNICATIONS TO: 575 Lexington Ave., New York 22, N.Y. For additional sources of information on the articles in this issue, or the name and address of the manufacturer of a particular product, write to Bureau of Information, Popular Mechanics for free "Where-to-Find-It-List."

SUBSCRIPTION SERVICE: Mail all subscription orders, changes of address, correspondence concerning subscriptions, and Postmaster notices of undelivered copies to Popular Mechanics, 250 West 55th St., New York 19, N.Y.

ADVERTISING OFFICES: New York: 575 Lexington Ave., MUrray Hill 8-8500; Chicago: 740 N. Rush St., WHitehall 4-0100; Detroit: General Motors Bldg., TRinity 5-8711; Cleveland: Hanna Bldg., 1422 Euclid Ave., PRospect 1-0456; Los Angeles: 3460 Wilshire Blvd., DUmkirk 2-8458; San Francisco: 111 Sutter St., YUkon 2-0823.

Published monthly by Popular Mechanics Company, 575 Lexington Ave., New York 22, N. Y. Richard E. Berlin, President; Richard E. Deems, Executive Vice-President; Fred Lewis, Vice-President and General Manager; John R. Miller, Vice-President; Joseph R. Buell, Jr., Vice-President; G. O. Markuson, Treasurer; R. F. McCauley, Secretary. Single copy in the United States and Canada, 35 cents. Subscription prices: United States and Possessions, \$4.00 for one year; \$7.00 for two years; \$9.00 for three years. Canada, add \$0.50 for each year. Pan-American Postal Union countries, add \$1.00 for each year. All other countries, add \$2.00 for each year. When changing address, give old address as well as the new, with postal-zone number, if any, and allow six weeks for change to become effective. Second-class postage paid at New York, N. Y., and at additional mailing offices. Authorized as second class mail by the Post Office Department, Ottawa, and for payment of postage in cash. Registered as Second Class matter at the Post Office at Mexico, D.F., Mexico, June 20, 1950. ©1963 by Popular Mechanics Company. All rights reserved. Printed in the United States of America.

CHECK ALL

5

- 1 INSIDE CORNER
- 2 OUTSIDE CORNER
- 3 INSIDE ROUND
- 4 OUTSIDE ROUND
- 5 CONVEX SURFACE

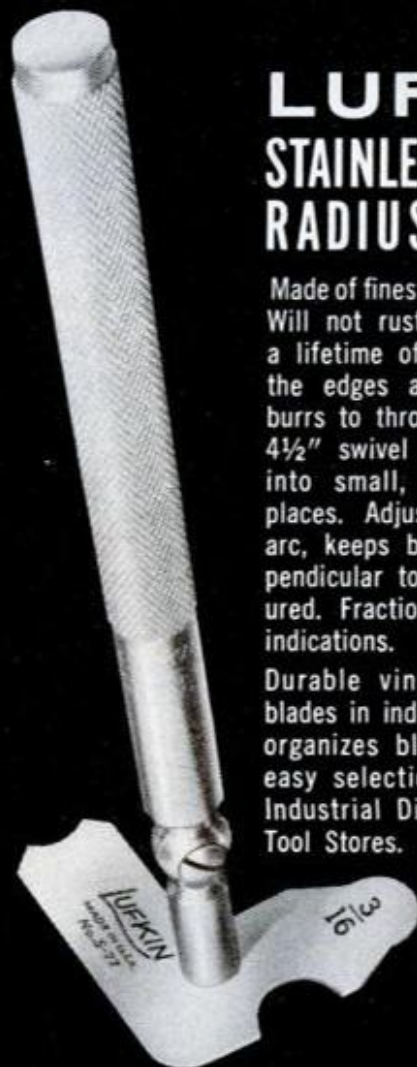

**LUFKIN  
STAINLESS STEEL  
RADIUS GAGES**

Made of finest stainless steel. Will not rust. Hardened for a lifetime of accuracy. And the edges are ground. No burrs to throw readings off. 4½" swivel holder reaches into small, out-of-the-way places. Adjusts over 180° arc, keeps blade edge perpendicular to surface measured. Fractional or decimal indications.

Durable vinyl case holds blades in individual pockets, organizes blades for fast, easy selection. At leading Industrial Distributors and Tool Stores.

New leader in precision tools...

**LUFKIN**  
SAGINAW, MICHIGAN



## IS the Spyder's thrust just so much hot air?

A rhetorical question if ever we posed one. Sure, the Corvair Monza Spyder\* uses hot exhaust gas to power its turbo-supercharger. Gets 150 hp as a direct result. But hot air alone does not a Spyder make. This is no bolt-on firecracker with a short, loud life-span. We beefed up that 145-cubic-inch air-cooled Corvair power plant to take the extra stress in its stride. Added super-alloy exhaust valves. Redesigned the exhaust valve guides for excep-

tional heat dissipation. And put in a more rugged crankshaft. Then added heavy-duty connecting rods and chrome-plated upper piston rings. Result: performance every bit as reliable as it is potent—and that's plenty. There's something very solid about the Monza Spyder—and that isn't hot air.... Chevrolet Division of General Motors, Detroit 2, Mich.

**CORVAIR SPYDER**

**CHEVROLET**

\*Spyder equipment and radio as shown optional at extra cost.



# People who live in green houses shouldn't use anything but Dutch Boy Latex House Paint.

And that goes for people who live in blue houses. And red houses. And houses in light, delicate colors like beige, or off-white. Why? Because Dutch Boy Latex House Paint holds its color. Stays fresh and bright.

The reason is this.

Dutch Boy Latex House Paint is made with exclusive 100% pure acrylic resins and permanent, light-proof pigments. And that means you get a paint job that's incredibly resistant to the three main causes of damage to paint. Moisture. Oxidization. And sunlight. Add this to the fact that, with this exclusive formulation, there's no chalking to mask the color and it's easy to see why Dutch Boy Latex House Paint really retains its color. In fact, it does it so well you can even come back and touch up years later and not see the difference.

Think what this means in maintenance. To keep your house looking good all the time you simply touch up the worn spots when they need it. In other words, you may never have to paint your whole house at one time again.

And color retention isn't all you get from this remarkable paint. Being latex, it brushes on more easily. Covers almost any surface—wood, st. no., even galvanized iron. You can stop when you like, start where you like, because it doesn't show landmarks. It's quicker drying, too. You get a weathertight, bug-free coat in just a couple of hours. Brushes, equipment and people all clean up with soapy water.

Want to know more?

Call your Dutch Boy dealer. He has thirty new 1963 colors in stock right now. You'll find him in the Yellow Pages.



A product of National Lead Company.

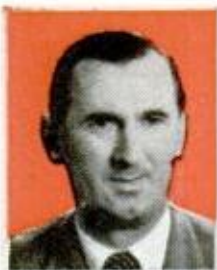

"Without the opportunity to study I could not qualify as controller of a concern with millions of assets and sales. Thanks to LaSalle." — Walter Zielke, Bridgeman, Mich.



"I am pleased to say that I am now Traffic Supervisor with Johns-Manville. I owe much to your course in Traffic and Transportation." — J. E. Saunders, Natchez, Miss.



"My salary has more than doubled since enrollment with LaSalle and due to my fine training is still growing." — William T. Black, Canoga Park, Cal.



"Salary is double what I earned when I enrolled. At 52, I feel that a new life is beginning, thanks to the opportunity you offered." — Robert Hughes, CPA, Costa Mesa, Cal.

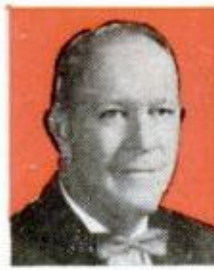

"My selection for my position was based primarily on the fact that I held LaSalle's LL.B. Degree." — William F. Hornbeck, Cheyenne, Wyo.



Mrs. Elieptine McGill, Brooklyn, N.Y. is mother of 5 children: "I cannot tell you how much LaSalle has done for me. The business education I received is put to good use."

## Why more than 20,000 men in LaSalle's career

**Which one of these famous La Salle training programs interests you?**

### LA SALLE SCHOOL OF ACCOUNTING

Training in one of the most highly paid professions in the business world today—leading to positions as General Accountant, Auditor, Controller, Tax Specialist, CPA.

### LA SALLE SCHOOL OF LAW

The Law-trained man has become the indispensable man in the world of business. LaSalle offers training leading to the LL.B. degree, also specialized Law courses.

### LA SALLE SCHOOL OF TRAFFIC & TRANSPORTATION

Training in one of the most exciting and profitable careers in modern industry, leading to managerial positions in the shipping of goods all over the world.

### LA SALLE SALES TRAINING

Many of today's corporation heads have come straight from the sales department. LaSalle offers courses in Basic Selling Principles and Techniques, as well as Sales Executive Training.

### LA SALLE SCHOOL OF BUSINESS MANAGEMENT

Training for executive careers, including Advertising and Marketing, Production Management, Financing, Credit and Collections, Office Management, Foremanship.

*LaSalle also offers home study courses in such high-pay technical fields as Refrigeration, Air Conditioning, Diesel, Drafting and others, plus High-School Diploma courses. Choose from the complete list in the coupon provided on the opposite page.*

LA SALLE students live in every state in the Union, in every part of the world. They are to be found in every occupation you can think of. Yet all of them have one goal in common; to advance from a hum-drum, insecure job to a prestige position with high pay and unlimited future.

They enroll with LaSalle because they can train for advancement without interfering with their regular work and without the loss of a single day's pay. They study in spare time—at home—during hours that suit their convenience. They pace themselves as they wish—always under expert and attentive supervision.

The direct practical results of LaSalle home study—in terms of pay increases, promotions, and broadened opportunity—are truly remarkable, as student reports show. Many are able to pay for their training out of the extra money they earn the first year.



*As a LaSalle home-study student, you are a class of one . . . you set your own hours, at your convenience.*

**If you are ready to move ahead, LaSalle offers you a choice of profitable studies**

If your present job is just a dead-end street—if you are ready to get started on a program of self-advancement, LaSalle can help you achieve your highest ambitions.

LaSalle offers you training in an attractive choice of today's best paid, fastest growing fields. The demand for qualified people in each of these fields is at an all-time high. Many fine jobs are actually going begging. Salaries keep growing; promotions are rapid. And LaSalle graduates are eagerly welcomed—for good reasons.

LaSalle Extension University, a correspondence institution since 1908, has become a world



"Without the opportunity to study I could not qualify as controller of a concern with millions of assets and sales. Thanks to LaSalle." — Walter Zielke, Bridgeman, Mich.



"I am pleased to say that I am now Traffic Supervisor with Johns-Manville. I owe much to your course in Traffic and Transportation." — J. E. Saunders, Natchez, Miss.



"My salary has more than doubled since enrollment with LaSalle and due to my fine training is still growing." — William T. Black, Canoga Park, Cal.



"Salary is double what I earned when I enrolled. At 52, I feel that a new life is beginning, thanks to the opportunity you offered." — Robert Hughes, CPA, Costa Mesa, Cal.

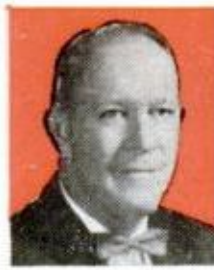

"My selection for my position was based primarily on the fact that I held LaSalle's LL.B. Degree." — William F. Hornbeck, Cheyenne, Wyo.



Mrs. Eleptine McGill, Brooklyn, N.Y. is mother of 5 children: "I cannot tell you how much LaSalle has done for me. The business education I received is put to good use."

## Why more than 20,000 men in LaSalle's career

**Which one of these famous La Salle training programs interests you?**

### LA SALLE SCHOOL OF ACCOUNTING

Training in one of the most highly paid professions in the business world today—leading to positions as General Accountant, Auditor, Controller, Tax Specialist, CPA.

### LA SALLE SCHOOL OF LAW

The Law-trained man has become the indispensable man in the world of business. LaSalle offers training leading to the LL.B. degree, also specialized Law courses.

### LA SALLE SCHOOL OF TRAFFIC & TRANSPORTATION

Training in one of the most exciting and profitable careers in modern industry, leading to managerial positions in the shipping of goods all over the world.

### LA SALLE SALES TRAINING

Many of today's corporation heads have come straight from the sales department. LaSalle offers courses in Basic Selling Principles and Techniques, as well as Sales Executive Training.

### LA SALLE SCHOOL OF BUSINESS MANAGEMENT

Training for executive careers, including Advertising and Marketing, Production Management, Financing, Credit and Collections, Office Management, Foremanship.

*LaSalle also offers home study courses in such high-pay technical fields as Refrigeration, Air Conditioning, Diesel, Drafting and others, plus High-School Diploma courses. Choose from the complete list in the coupon provided on the opposite page.*

LA SALLE students live in every state in the Union, in every part of the world. They are to be found in every occupation you can think of. Yet all of them have one goal in common; to advance from a hum-drum, insecure job to a prestige position with high pay and unlimited future.

They enroll with LaSalle because they can train for advancement without interfering with their regular work and without the loss of a single day's pay. They study in spare time—at home—during hours that suit their convenience. They pace themselves as they wish—always under expert and attentive supervision.

The direct practical results of LaSalle home study—in terms of pay increases, promotions, and broadened opportunity—are truly remarkable, as student reports show. Many are able to pay for their training out of the extra money they earn the first year.



*As a LaSalle home-study student, you are a class of one . . . you set your own hours, at your convenience.*

**If you are ready to move ahead, LaSalle offers you a choice of profitable studies**

If your present job is just a dead-end street—if you are ready to get started on a program of self-advancement, LaSalle can help you achieve your highest ambitions.

LaSalle offers you training in an attractive choice of today's best paid, fastest growing fields. The demand for qualified people in each of these fields is at an all-time high. Many fine jobs are actually going begging. Salaries keep growing; promotions are rapid. And LaSalle graduates are eagerly welcomed—for good reasons.

LaSalle Extension University, a correspondence institution since 1908, has become a world

# Over the Editor's Desk

## Now Try Rockets

The Fairchild C-123 (page 110, April PM) may be built at the present time by Fairchild, but actually was designed, originally built and flown at West Trenton, N.J. The original of this plane was a glider during World War II built by Chase Aircraft Co., located at Mercer Airport, West Trenton.

When I worked on the plane at Chase in 1954, it had already been a glider, piston-type aircraft and a jet. It was the only plane at that time capable of all three types of flying. It has also been a twin-engine and four-engine plane. In different stages of its development.  
Freedom, N.Y.      ROBERT C. STREEPER

## Generating Arguments

"The alternator and generator do the same job," states your author, Morton Schultz (*Getting to Know Your Alternator*, page 174, March PM). Are we changing our terminology?

Strictly speaking . . . rotating a conductor in a magnetic field is mechanical generation. Whether alternating current or direct current is produced is beside the point.

St. Petersburg, Fla.      WALTER M. RENNICK

"Sure," comments writer Schultz, "an alternator is an a.c. generator, and the d.c. job is a d.c. generator—and whatever instrument produces an electric current is a generator. To differentiate between the two, the automotive industry calls the a.c. device an alternator and the d.c. device a generator. I guess it's just one of those things we have to live with."

In the picture caption at the top of page 175, I found a false statement: "Rotor of alternator does same job as generator's armature. Other half of alternator assembly is stator . . . that corresponds to generator field coil."

The rotor of an alternator is similar to the field coils of a generator, and the stator of an alternator is similar to the armature of a generator.

Philadelphia, Pa.      WALTER D. BECKER

Author Schultz says many mechanics and trade journals servicing the automotive industry compare the alternator and generator as we did, and stated that the rotor is comparable to the generator's armature.

Mechanically speaking, the rotor of the alternator corresponds to the generator's armature, and the stator corresponds to the generator's field. Just as the armature revolves within the field in a generator, the rotor revolves within the stator. So, depending on how you look at it, everybody is right.

## Crayfish Chasers?

I have a crayfish problem. I have tried to divert water from several small springs on my lot to a storm sewer by means of a rock-and-gravel-filled ditch, but crayfish burrow into the ditch and dam up the water so that it soaks my yard. I have tried to kill crayfish with methyl alcohol, frying grease, oil and other substances—with no success. Do you have any suggestions?

South Charleston, W. Va.      GARY L. BAKER

Our suggestion is this: We'll ask a group of experts (our readers), and you'll hear of a dozen ways to get rid of the crayfish. First, though, are you sure you don't want to start a bait shop?

## We're in His Budget

About three months ago I picked up a copy of your magazine. I read through that issue, and I have been saving my allowance for the next copy every month. You have a very fine magazine, so keep up the good work.

North Royalton, Ohio      RALPH FORESTEK

We'll try. And you keep up your good work to qualify for that allowance.

## Bring Back Paul Bunyan

Your story *They Won't Bury Paul Bunyan* (page 123, April PM) was very interesting yet a bit sad. I know you can't stop progress, so they are fighting a losing battle for the work they love.

I may be called old fashioned today because I am not looking forward to a push-button computer that will fix a defective TV receiver for me. Though always trying to think up new ideas myself, may they always provide easier and more work for the trades—not take them over.

Malden, Mass.

PETER LEGON

## There's a Long, Long Trail

I was most disturbed by your article *Fat-Tire Scooter for Sportsmen* (page 151, April PM) in that you are very unsportsmanlike in recommending it for use in wilderness and mountainous areas. What are you trying to do—destroy the few remaining back country areas that are left?

Why can't you power mongers keep out

(Please turn to page 12)

This story actually happened. The man's name has been changed and this is not his photograph, but the facts are true.

## "Your name is on the list"



Doug Mott was not surprised. The recession was on and the assembly line where he worked was almost at a standstill.

And then, strangely, the boss began to smile. "You know how the Engineering Department sends us blueprints and then we have to send them back for revision because they just aren't practical to produce?" Doug nodded . . . wondering. "That's waste . . . and we can't allow it to continue. That's why we thought that if we had a man who knew assembly and production — and drafting, too — he could act as liaison man between engineering and production. You know production, Doug . . . and you're studying drafting with I.C.S. You've got a *new* job. Congratulations!"

Doug Mott now heads a drafting room. But he will never forget the day his name was on the list to be laid off.

Good times or bad, I. C. S. training sets a man off from his fellows, puts him on the road to promotion. You can start on that road by filling out the coupon *now!*

Clip coupon here—and take your first big step to real success! I.C.S., Scranton 15, Penna.

Accredited Member  
National Home Study Council

# INTERNATIONAL CORRESPONDENCE SCHOOLS

Box N0752F, Scranton 15, Penna.

(In Hawaii: P. O. Box 418, Honolulu. In Canada: I.C.S. Canadian, Ltd., Montreal.)

Without cost or obligation, rush me **FREE Success Kit**, with 3 valuable booklets: (1) How to Succeed; (2) opportunity booklet about the field I've checked below; (3) Sample I. C. S. Lesson.

### ARCHITECTURE and BUILDING TRADES

- Air Conditioning
- Architecture
- Arch. Drawing
- Building Contracting and Estimating
- Carpentry & Millwork
- Heating
- House Planning
- Painting
- Plumbing

### ART and DESIGN

- Commercial Art
- Fashion Illustrating
- Interior Decorating
- Magazine Illustrating
- Show Card & Sign
- Painting
- Sketching and Painting

### AUTOMOTIVE

- Auto Body Rebuilding
- Auto Electric Technician
- Automobile Mechanic
- Engine (Gas & Diesel)
- Engine Tune-Up

### Transmission Specialist

- Aero Engineering
- Aircraft Drafting
- Aircraft Mechanic

### BUSINESS

- Accounting
- Cost Accounting
- Public Accounting
- Bus. Administration
- Executive Training
- Marketing
- Personnel-Labor Relations
- Programming for Digital Computers
- Purchasing Agent
- Real Estate
- Salesmanship
- Sales Mgmt.
- Small Business Mgmt.
- Traffic Mgmt.

### CHEMICAL

- Analytical Chemistry
- Chem. Engineering
- General Chemistry

- Lab. Technician
- Nuclear Energy
- Plastics
- Pulp, Paper

### CIVIL ENGINEERING

- Civil Engineering
- Construction Engr.
- Highway Engineering
- Reading Structural Blueprints
- Sanitary Engineering
- Structural Engineering
- Surveying & Mapping

### DRAFTING

- Architectural
- Electrical and Electronic
- Mechanical
- Sheet Metal

### ELECTRICAL

- Elec. Appliance Servicing
- Electrical Engineering
- Elec. Eng. Technician
- Elec. Motor Repairman
- Industrial Electronic Technician

- Industrial Telemetering
- Instrument Technician
- Practical Electrician
- Practical Lineman

### ELECTRONICS

- Automation
- Basic Electronics
- Electronic Computers
- Electronics Technician
- Hi-Fi Stereo and Sound Systems
- Industrial Electronics
- Ultrasonics

### ENGINEERING (Professional)

- Chemical
- Civil
- Electrical
- Mechanical

### ENGLISH and WRITING

- Better Business Writing
- Introductory
- Technical Writing
- Short Story Writing

### Practical English

### HIGH SCHOOL (Diploma)

- High School General
- High School Math
- High School Secretarial
- High School Vocational
- College Preparatory

### MECHANICAL and SHOP

- Gas and Electric Welding
- Industrial Engineering
- Industrial Instrumentation
- Machine Design
- Machine Shop Practice
- Mechanical Engineering
- Reading Shop Blueprints
- Tool Design
- Toolmaking
- Safety Engineering

### SECRETARIAL

- Clerk-Typist
- Professional Secretary

- Shorthand
- Stenographic
- Typist

### STEAM and DIESEL POWER

- Boiler Inspector
- Power Plant Engineering
- Stationary Diesel Engineering
- Steam Engineering

### SUPERVISION

- Foremanship—Suprv'n
- Personnel—Lab. Ref'ns

### TV-RADIO

- Radio and TV Servicing
- Radio-Telephone License
- TV Technician
- Practical Radio-TV Engineering

### MISCELLANEOUS

- Railroad
- Textile
- Other (please specify)

Name \_\_\_\_\_ Age \_\_\_\_\_ Sex \_\_\_\_\_  
 Home Address \_\_\_\_\_  
 City \_\_\_\_\_ Zone \_\_\_\_\_ State \_\_\_\_\_  
 Occupation \_\_\_\_\_  
 Employed by \_\_\_\_\_ Working Hours \_\_\_\_\_

**Special low rates to members of U. S. Armed Forces!**

of the wild country and leave it to the fellow who is willing to get there under his own foot power? What solace is left to man when the call of the wild is replaced by the sound of the putt-putt?

Sandy Springs, Ga. D. E. DOLAN

*But it's going to be a long walk for both of us if we decide to go after bighorn sheep.*

### The Chair? Here's Where

In *Chair Helps Disabled Stand* (page 139, Jan. PM), you stated that our firm produces the electrically operated chair. The producer of this chair is Rise-O-Matic Chair Co., 2294 Scranton Road, Cleveland, Ohio. The chair is unknown to us and is not delivered by us.

Vlotho, Germany WILHELM MEYER Co.

*That's right—and we're sorry that we told folks to look in Germany for this helpful chair when they could buy it right in Cleveland, Ohio. The erroneous information came to us from a news agency; a sharp tap on the wrist to them.*

### Solace ex Machina

I found *Look What Those Knuckleheads Are Doing* (page 135, Jan. PM)

amusing as well as comforting. My interests lie in the field of finance, and it has occurred to me that I might be in competition with an IBM machine when seeking employment. I am glad to find that it would be rather improbable for machines to replace human beings in all types of business positions.

Holland, Mich. ROBERT B. RAATJES

*Well, we're comforted, too, and we'd bet our quill pens that machines will never replace everybody. Besides, what robot editor would have dared print such an expose of his own kind?*

### How's the Driver Holding Up?

I have a 1936 two-door Ford which I have driven 1,050,000 miles. The original motor has been replaced six times, each engine having been overhauled at about 100,000 miles to give another 50,000.

I believe this must be some sort of record. Can you verify?

Atlanta, Ga. BOYD TAYLOR

*We don't keep actuarial tables of that sort, so right now you're our international grand champion at keeping 1936 Fords out of the junk yard. Let's see what our readers have to say about piling up more than a million miles on a particular car.*



## for good measure

...**Stewart-Warner Custom Gauges.** They give you the precise information you need to detect and correct engine-system problems before they get serious. No guesswork and no 'warning light confusion.'

Whatever you need in an automotive gauge, rely on Stewart-Warner to supply it. The S-W "2 in 1" Gauge Cluster (above), for example, is a handsome combo unit that features an ammeter and an oil pressure gauge... fits all cars. Other popular Stewart-Warner gauges include: the S-W *Motor-Minder*, a favorite of

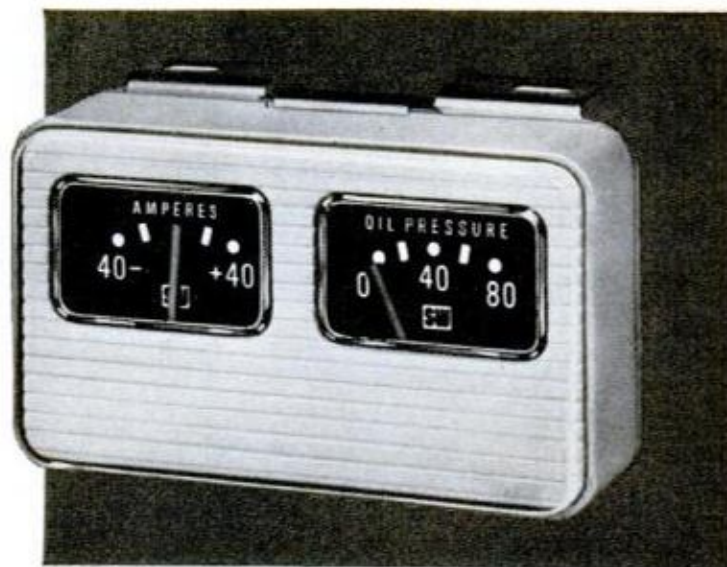

mechanics for checking engine performance ...and the S-W *Volt-Guard*, a special gauge for checking battery condition, generator and voltage regulator. Ask your dealer about the full-line of reliable Stewart-Warner Custom Gauges... from the most complete line of automotive instruments in America.



INSTRUMENT DIVISION  
**STEWART-WARNER**  
CORPORATION

Dept. C-63,  
1840 Diversey Pkwy.,  
Chicago 14, Ill.

POPULAR MECHANICS

Important news for the inexperienced man who needs a short cut to a better job, more money and greater security.

# AMAZING NEW HOME TRAINING PLAN IN AIR CONDITIONING AND REFRIGERATION

... the exclusive CTI Learn-and-Practice method which enables many students to earn money in spare time — as they train for a top-pay job or their own business

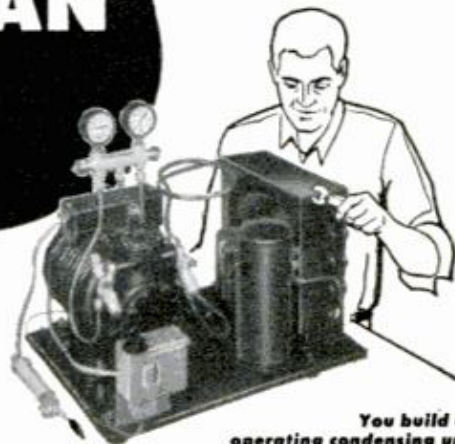

You build an operating condensing unit

This Is Your "Home Training Shop"



REAR VIEW

25 Kits  
20 Shop Projects

## Learn by Practicing—Get Experience

The new CTI semi-sealed condensing unit. You build this heavy-duty commercial-type unit from 25 kits that CTI sends without extra cost. You complete 20 Shop Projects. After assembling unit, you may then build an air conditioner, freezer, refrigerator or milk cooler.

## Mechanic's Tools

You get wrenches, tube flaring tools, hammer, tubing, fittings, gauges and other items used by the experienced mechanic. Everything is of professional quality. Best of all, CTI trains you to use tools with speed and skill.



"A demand for many thousands of additional mechanics who can install, maintain, and repair air-conditioning and refrigeration equipment is expected in the 1960s," the U.S. Dept. of Labor reports. "The use of air-conditioning in offices, stores, and theatres is increasing tremendously. In homes, the number of centrally installed air conditioning units doubled between 1957 and 1960." The growth of refrigeration in food preservation and in the manufacture of synthetic rubber, oil, high-test gasoline, medicine and drugs is also stressed by the Labor Dept. Want to be a mechanic in this great-growth field? Find out how—by mailing coupon below for complete information! No obligation.

## Easy and Interesting Course

CTI's exclusive home study course is expertly written, clearly illustrated, easy to understand. It offers up-to-date knowledge and includes kits of tools and parts that you assemble into a working unit. It provides job experience projects which help you put knowledge to practical use. It's prepared especially for men who've had no previous experience. You'll enjoy CTI lessons.

## Go in Business—Be the Boss

Opportunities to go in business are available because air conditioning is one of America's two fastest-growing industries. Start in a small way working from your home, and gradually expand. In time, you may want to add a sales division. Manufacturers offer attractive franchises and aids to ambitious and qualified men. Many CTI graduates report they are starting repair shops.



## Make Money as You Train

Many CTI students earn money in spare time. Some handle servicing for food stores, restaurants, taverns, etc., on a monthly fee basis. Others work part time with local dealers. Many make service calls to homes on their own.



## Graduates Praise Training

"I started my own business. Earn from \$800 to \$900 a month."—Dale Landsberger, Okla. "Have gone into trucking refrigeration. My wages have tripled."—James Wiest, Minn. "I quit my \$75 a week job and am now making \$120 a week in a refrigeration shop."—Roy Goldsworth, Wyo. "Am a repair man and earn \$200 a month over what I used to."—Albert Baum, Ill.

## Over 50,000 Graduates

CTI is one of the nation's largest home study institutes and has graduated over 50,000 men. CTI is the only school in this field that sends parts-kits to build real equipment.



## FREE! THREE VALUABLE OPPORTUNITY BOOKLETS

Investigate your opportunities for a better-pay job or your own business in an industry that has grown by 400% the past 12 years. Just fill out and mail coupon and we'll send our school catalog, lesson samples and a booklet of testimonials from grateful graduates. Act today.

CLIP COUPON BEFORE YOU TURN THIS PAGE—MAIL TO CTI TODAY

COMMERCIAL TRADES INSTITUTE CHICAGO 26, ILLINOIS  
Accredited Member National Home Study Council

COMMERCIAL TRADES INSTITUTE  
1400 GREENLEAF AVENUE DEPT. R-200  
CHICAGO 26, ILLINOIS

Send me your 3 free booklets, Success in Air Conditioning and Refrigeration; Lesson Samples; and Proof from Graduates. No obligation.

NAME \_\_\_\_\_ AGE \_\_\_\_\_

ADDRESS \_\_\_\_\_

CITY \_\_\_\_\_ ZONE \_\_\_\_\_ STATE \_\_\_\_\_



Three radical aircraft have been proposed recently for three different uses.

The Air Force hopes to develop a space plane that could take off from a runway under its own power, fly into orbit like the X-20 *Dynasoar* (which will be boosted into space by a *Titan III* missile) and land again. The plane could be used for intercepting, inspecting and even destroying suspicious satellites. It would be propelled into space by ramjet engines.

A British scientist has offered plans for building a semiorbital bomber that would fly 25 times the speed of sound at altitudes up to 250,000 feet. It would combine a ramjet and turbojet power plant, plus retractable wings so it could fly like a missile during its ultrahigh-speed flights. It could reach targets several thousand miles away in less than half an hour.

The Air Force also is studying the concept of an endurance airplane—one that stays aloft for as much as eight days without refueling. It would have low-

level capabilities to sneak in under radar defenses, plus highly sophisticated decoy devices to counter radar when operating at higher altitudes. Its ability to stay aloft so long, and literally hide in the sky, would reduce the possibility of its being destroyed on the ground. The Air Force isn't telling how it plans to keep it up for long periods, but apparently it will be with increased refinement of conventional fuels and power plants rather than exotic chemicals or new engines.

Small airfields in small communities are getting increased attention.

Depressed areas have found, to their delight, that new airports not only increase local interest in flying but are also a major attraction for new industries. Several small cities that built airports in recent years have lured new plants into the area, increasing employment.

Now the government, via the Federal Aviation Agency, is taking increased interest. It recently published a booklet on starting and managing an airport, available (for 25 cents) from the U.S. Government Printing Office, Washington 25, D.C.

Kevin V. Brown  
Aviation Editor



## MISSING SOMETHING?

The most important part of this plier is missing . . . the half stamped with the name CRESCENT. If you've purchased pliers or any other hand tool lately without looking for the name CRESCENT on the handle, you've been missing something, too. You've missed the satisfaction of owning and using the tools that are the trademark of master craftsmen throughout the world. CRESCENT tools are made better to work better and last longer. They cost a little more, and they're worth it. Ask for CRESCENT tools by name at your hardware store.



CRESCENT TOOL COMPANY, JAMESTOWN, NEW YORK A Division of Crescent Niagara Corporation



# BE THE MAN IN DEMAND

## Train at home for a high-paying job in one of these 4 major fields



N.T.S. TRAINED  
TECHNICIANS ARE  
HIGHER PAID...  
MORE RESPECTED...  
CONFIDENT  
OF SUCCESS

START NOW in one of these "Big 4" Industries, and be among the most sought after technicians in America. As an N.T.S. Trained Technician you can enjoy higher pay, rapid promotion, lifelong security.

### N.T.S. TRAINS YOU RIGHT, FAST AND EASY!

Incomplete, "short-cut" training limits your earning power, even disqualifies you for top-pay jobs. N.T.S. gives you everything in *All Phases*... to qualify you for any job in your field... for greater profits the year round.

### BETTER, MORE COMPLETE, LOWER COST TRAINING

N.T.S. Home Training is proved and tested in N.T.S. Resident School Shops and Laboratories — the oldest, largest school of its kind in the world. You learn *all phases*, and receive everything you need — Lessons, Manuals, Diagrams, big professional Kits with parts, tools, instruments for experimental, repair, service, troubleshooting projects. Yet N.T.S. Training costs less; only 1 Low Tuition. Other schools make several courses from the material in each of our Master Courses.

## ELECTRONICS TELEVISION AND RADIO

YOU ARE NEEDED in All Phases of ELECTRONICS TELEVISION- RADIO... Servicing, Communications, Broadcasting, Manufacturing, Automation, Radar and Micro Waves, Missile and Rocket Projects, plus all the other high-pay branches of this vigorous Industry. N.T.S. Shop-Tested Home Training gives you ONE MASTER COURSE... at ONE LOW TUITION...

INCLUDES RADIO SET, TV SET, MULTITESTER.



## AUTO MECHANICS AND DIESEL

TAKE YOUR CHOICE... be a successful all-around mechanic in cars, trucks and heavy-engines. Or specialize in your favorite field... Tune-Up, Automatic Transmissions, Farm Mechanics, Trucks and Buses, Stationary Installations, Foreign Cars, or get into Auto Air Conditioning, Engine Rebuilding, Diesel, and other high-pay fields. or go into business for yourself.

INCLUDES SOCKET SET, ANALYZER, TOOLS.



## AIR CONDITIONING REFRIGERATION ELECTRICAL APPLIANCES

FUTURE BRIGHT FOR TRAINED MASTER TECHNICIANS... over 30,000 new Technicians must be trained annually. You are needed to help service and repair the 50 million air conditioners, refrigerators and electrical appliances that will need fixing this year alone. You can go places in your own business or with a manufacturer, dealer, distributor or department store. With All-Phase training, your earning power is unlimited!

INCLUDES TESTER, GAUGES, TOOLS.



## HOME APPLIANCE TECHNICIAN'S COURSE

MILLIONS OF HOME APPLIANCES NEED FIXING... Every home is your market for Full-Time career or spare-time "Second Income." All you need is a workbench, spare time and N.T.S. Home Training. Costs less than \$1.50 per week. Repair any home appliance—from toasters, electric irons to washing machines and even room air conditioners—right in your own workshop. Or take a high-pay job with appliance manufacturer or large service company.

INCLUDES TOOLS, PROFESSIONAL TESTER, SOLDERING SET.



## NATIONAL TECHNICAL SCHOOLS

WORLD-WIDE TRAINING SINCE 1905



### NATIONAL TECHNICAL SCHOOLS

WORLD-WIDE TRAINING SINCE 1905

4000 So. Figueroa St., Los Angeles 37, Calif.

Accredited Member  
National Home Study Council

### RESIDENT TRAINING AT LOS ANGELES

If you wish to take your training in our famous Resident School in Los Angeles — the oldest and largest school of its kind in the world — check special box in coupon.

SEND FOR FREE BOOK (fully illustrated) and ACTUAL LESSON



NO OBLIGATION NO SALESMAN WILL CALL

CHECK ONE

National Technical Schools, Dept. B-63  
4000 S. Figueroa St., Los Angeles 37, Calif.

Please rush FREE Book and Actual Lesson checked below. No obligation. No salesman will call.

- Electronics—TV—Radio
- Auto-Mechanics & Diesel
- Air Conditioning, Refrigeration & Electrical Appliances
- Home Appliance Technicians Course

Name \_\_\_\_\_ Age \_\_\_\_\_

Address \_\_\_\_\_

City \_\_\_\_\_ Zone \_\_\_\_\_ State \_\_\_\_\_

Check here if interested ONLY in Resident Training at L.A. High school home study courses also offered. Check for free catalog.



# FREE!



## Trial lesson in **DRAFTING & DESIGN**

### LEARN AT HOME IN SPARE TIME

Check the want ads in any newspaper — SEE the big-pay opportunities open to you as a draftsman. What's more, you can learn this well-paid, prestige profession at home — quickly, easily! No special talent needed! Get complete, step-by-step Chicago Tech lessons in the mail, spend a few pleasant hours studying each week. In a short time you'll be a well-trained draftsman, ready to take your pick of many good jobs. Act now!

### FREE INFORMATION—MAIL COUPON TODAY!

Get FREE TRIAL LESSON plus information about C.T.C. practical training. Learn what successful Chicago Tech graduates say about high pay and opportunities in drafting. No charge, or obligation.

Est. 1904 Accredited National Home Study Council

## CHICAGO TECHNICAL COLLEGE

G-201 Tech Bldg., 2000 So. Michigan Ave.  
Chicago 16, Illinois

Mail me FREE Lesson with information about big opportunities in DRAFTING.

Name..... Age.....

Address .....

City..... Zone..... State.....

**Need a patio grill?** July PM tells how to build a combination backyard planter, yard light and lift-out barbecue grill.

## **\$6.44 AN HOUR** IN YOUR OWN BUSINESS



### STEP INTO THIS BOOMING \$19 BILLION A YEAR INDUSTRY

Hundreds of accidents and losses will happen this year in your community.

We'll show you how to investigate and adjust these losses for insurance companies, railroads, government offices. You buy NO tools or equipment. You do NO selling. You need NO prior experience or higher education. And you can operate out of your own home. Right

now independent Accident Investigators average \$6.44 an hour. We'll train you quickly to do the same. Start part-time if now employed. Fill the need for an Accident Investigation specialist in your area. Colorful booklet explains everything. Absolutely no obligation on your part. No salesman will call. Write TODAY for FREE Booklet.

UNIVERSAL SCHOOLS, PM-6, 6801 Hillcrest, Dallas 5, Texas

## Items from All Outdoors

Fishing theorists are at it again. After a year-long survey of fishing off the Atlantic coast, three biologists of the Sandy Hook (N.J.) Marine Laboratory claim that time of day, cloud cover, and wind velocity and direction have nothing to do with good or bad fishing. The only factor they could link to increased catches was a day of predominantly low barometric readings. This should cause some controversy among the fishermen who take out their gear only on odd-numbered Tuesdays, during certain phases of the moon, or when the wind is from the south. It also brings to mind a theory voiced by some disgruntled commercial fishermen: Fish strike in the middle of breakfast and in the middle of dinner.

Fur trapping was the subject of an item in our February column, and the response shows that it is still a lively occupation. We learned that three Rutgers University students are paying their way through school partly by trapping and selling pelts. Mrs. W. B. Marshall of Flushing, N.Y., informed us that the Caldwell (Ohio) *Journal* regularly carries an ad for a dealer who buys raw furs "at top prices." Mr. Frank Sampson of the Missouri Conservation Commission informed us that nearly 7½ million pelts were taken in the U.S. in 1961. An interesting sideline: upon investigation by a national magazine, a midwest pressure group campaigning against trapping as inhumane turned out to be backed by a large commercial fur farm eager to stop competition.

Live bait anglers with the problem of keeping a minnow full of life while using a sinker can sweeten their line and end their trouble. To weight the line, put a double loop about six inches above the bait, then fasten a cube of sugar in the loop. You have enough weight for a good 60-foot cast, and when the sugar dissolves in the water, the minnow swims freely.

Water depth is important to fishing, and sometimes difficult to figure. Mr. Jay Carter of Butler, N.J., marks the anchor line of his boat with adhesive tape every two feet for fast, easy sound.

**STUART JAMES**  
Outdoors Editor

POPULAR MECHANICS

SCOUT is the registered trade mark for a vehicle manufactured exclusively by International Harvester Company.



**The SCOUT helps earn get-away money...**



**and takes you where the sport is**

You can keep the SCOUT busy all week earning money for you: hauling tools, equipment, merchandise or people. Pushing, pulling, winching heavy loads, or plowing snow.

Then go anywhere with the SCOUT. The same 4-cyl. 93 hp. COMANCHE® engine that worked all week for pennies (with rear-wheel or all-wheel-drive) will make play out of woods and fields. The SCOUT's frame stands up to the jolts of rough terrain.

Full-length tops in steel or vinyl enclose 78½ cu. ft. of play-or-pay-load space . . . or choose a hard or soft top for the cab. If you want to go sportier, you can get a four-passenger bucket seat model.

There's all sorts of special equipment to keep your SCOUT busy the year around. So for the vehicle you can enjoy every day at work or play, get the SCOUT. See your INTERNATIONAL Dealer or Branch.

THE  
**Scout**  
BY INTERNATIONAL®   
International Harvester Company

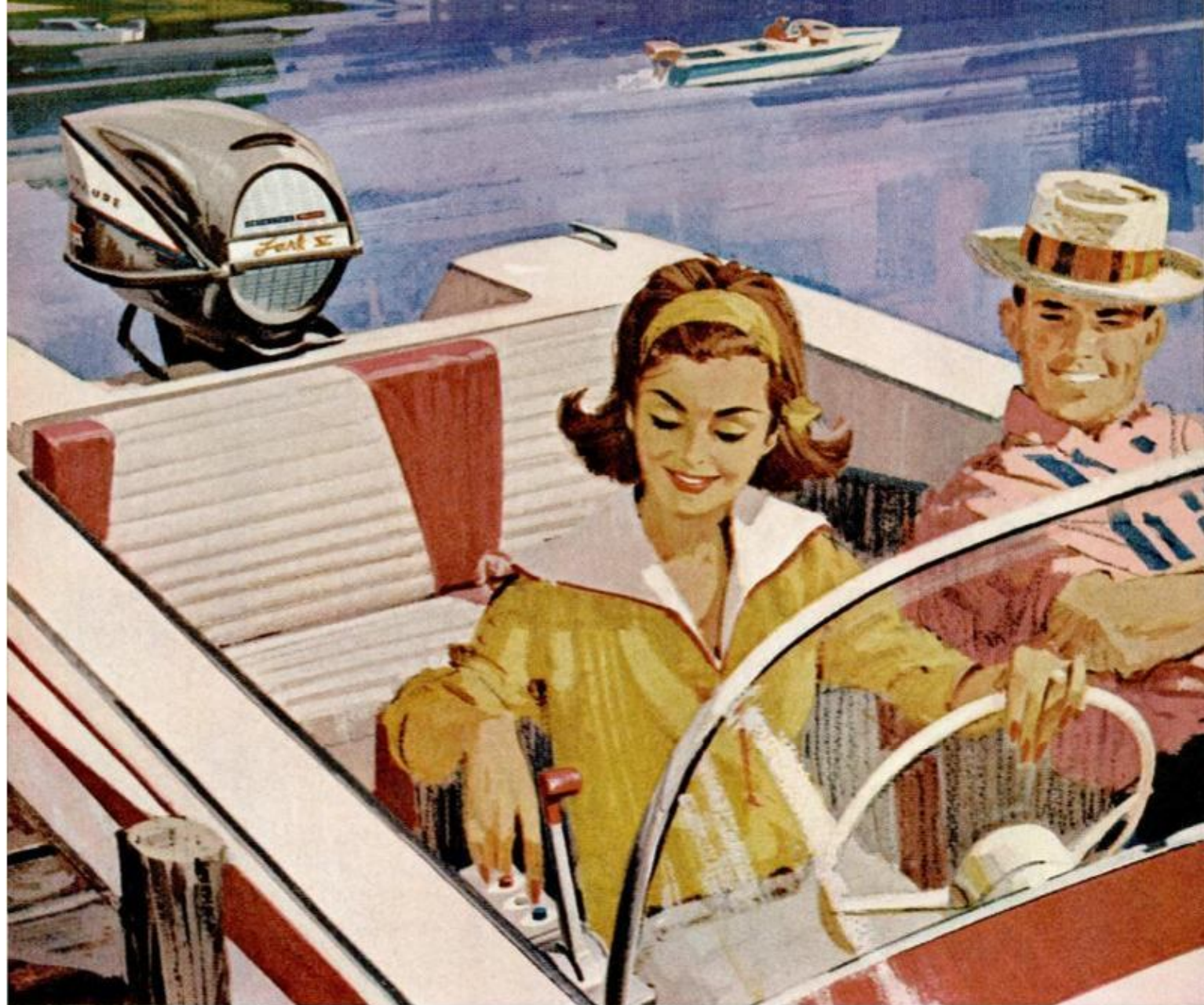

## NOWADAYS—you just push a button to go across the lake

Click.

You're underway. Just feed the gas and steer.

Can anybody do it?

Nope. Just Evinrude owners. And their wives. And families. And friends. You never saw so many friends!

How does it work?

Simple. The control box up front has a throttle lever and three buttons — forward — neutral — reverse. The buttons are connected by sealed wire to an electric clutch which drives the propeller.

Can you depend on it?

Completely! Everything is electric just like flipping a light switch. Nothing to get out of order except the button switches themselves. And we test them for 1,000,000 cycles. That's the equivalent of 50 years'

operation. After that, you may have to buy new buttons.

Suppose you want to stop at a dock.

Slow down. Ease up on the gas. Pick out a spot. Forget about the throttle. You won't need it for docking.

Click — you're in neutral, Click — you're in reverse (for braking). Click — you're in neutral again, ready to tie up.

Suppose you goof?

Click.

Nobody will ever know — the hand is quicker than the eye.

Ask your Evinrude dealer for a FREE catalog. Look him up in the Yellow Pages.



# EVINRUDE

FIRST IN OUTBOARDS  
DIVISION OF OUTBOARD MARINE CORPORATION



## ***What does it take to feel like a man?***

It takes action to feel like a man. Takes pride and courage. But in today's modern world *it also takes training. Technical training.* Ask any mechanic. Ask any missile man.

In today's modern Army all units are fast-moving. Flexible. Men and machines are closely interlocked. And since the machines are complex, men have to be extra skilled to handle them. The Army *makes* men like this—technically skilled, competent, confident.

You can be expert in areas like engineering, missiles, electronics, motor mechanics—or any of 150 other fields!

And of course, if you are qualified, you can receive extensive training in other fields like Combat Arms—Infantry, Armor or Artillery. You will be proud to be a member of any one of them. And you'll end up proud of yourself too. Find out how to feel like a man in today's fast-changing world. See your local Army recruiter today.

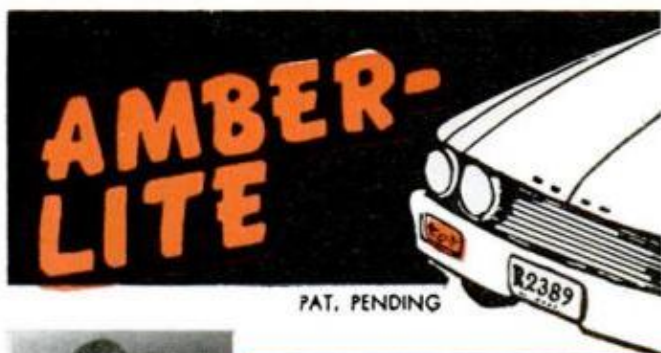

"I have installed Amber-Lite lens conversion in my car. Be smart, be safe and bring your car up to date too."

*Bob Cousy*

BOB COUSY

### BE SAFE . . . BRING YOUR CAR UP-TO-DATE NOW!

- AMBER COLOR TURN SIGNALS HAVE BEEN RECOMMENDED BY THE SOCIETY OF AUTOMOTIVE ENGINEERS (S.A.E.) AND ARE STANDARD ON ALL 1963 MODELS.
- AMAZING LOW PRICE FOR COMPLETE **AMBER** LENS CONVERSION KIT FOR THE TURN SIGNALS ON YOUR CAR!

**only \$1.00 per set**

- CONVERT YOUR OLD FASHIONED WHITE DIRECTIONAL SIGNALS NOW TO NEW, SAFER, AMBER COLOR.
- **AMBER-LITE** CONVERSION IS NOW AVAILABLE FOR ALL U.S. CARS 1955-1962 AND FOR ALL YEARS AND MODELS OF VOLKSWAGENS.
- EASY TO INSTALL IN A FEW MINUTES!

**FREE!**

**AMBER-LITE** PM-6 will ship 4 CONVERSION SETS to you for the price of 3. You get a set for one car absolutely FREE!

**AMBER-LITE**

P.O. BOX 62  
BOSTON 32, MASS.

GENTLEMEN: I enclose \$..... for.....sets for the following car(s):

MAKE ..... YEAR .....  
MAKE ..... YEAR .....  
MAKE ..... YEAR .....  
MAKE ..... YEAR .....

PLEASE RUSH MY ORDER TO:

NAME .....  
STREET .....  
CITY ..... STATE .....

**AMBER-LITE** Pays Postage and Handling.



## Sidelights from the SERVICES

By William R. Kreh

Glass masts have joined plastic armor in the Navy. A forest of glass masts, some of them 80 feet high, are being installed aboard the USS *Wright* which is being converted to a floating command ship for high-level military leaders. The glass masts will eliminate interference with the electronic transmission of communications and radar gear that steel masts generate. "Macks"—combination masts and stacks—already have made their appearance in missile cruisers. They have plastic armor to protect them from heat and cold. Had the tower-like structures been made of metal, the differences in heat during the day and night would cause the macks to expand and contract, throwing electronic gear out of alignment.

Saltiest flight suit in the Navy is probably owned by Lt. R. J. Wallace. He got his back recently three months after he had jettisoned it near Puerto Rico. The suit was found drifting, boots up, near Brunswick, Maine, after making the 1100-mile drifting trip home.

Tooting their horns is easier now for some youngsters who wear teeth braces at Fort Knox, Ky. One of the boys' father, an Army dentist, designed a variation of a football player's protective mouthguard that the kids could wear to allow them to play brass instruments while wearing dental braces. Usually, young musicians have to lay aside their horns until the dental work has been completed.

Jets for snowplows were used recently at a snowbound air base in Japan. When stubborn ice and snow near arresting cables at the ends of runways created safety hazards, the air base commander remembered how the hot exhaust blast of an F-100 jet fighter plane is angled toward the runway, so he had four of the supersonic fighters park with tails pointed at the snow. Then power was applied. The gases, moving up to 500 m.p.h. soon blasted the icy hazard away.

Champion title-holder this month is the man who works for the Department of Defense as the Deputy Special Assistant to the Assistant for Space Office, Deputy Director, Research and Engineering (Tactical Warfare Programs).

**SENSATIONAL OFFER TO POPULAR MECHANICS' READERS**

**60 P.C. PROFESSIONAL SOCKET WRENCH & TOOL SET**  
**DO ANY JOB BETTER — FASTER — EASIER!**

IDEAL FOR CAR, HOME, FARM,  
 BOAT, SHOP, ETC.

SAVE HUNDREDS  
 OF DOLLARS PER YEAR

HANDY TOTE BOX

**BIG-JOB  
 11-Pc. 1/2" DRIVE  
 SOCKET SET**

**1/2" L-HANDLE  
 AND EXTENSION**

**\$9.95**  
 COMPLETE  
 60-Pc.  
 SET

**REVERSIBLE  
 RATCHET**

**HANDY  
 8 PIECE  
 1/4"-DRIVE  
 SOCKET SET**

SAVE  
 ON ALL  
 REPAIRS

**HUSKY 11-Pc.  
 3/8" DRIVE  
 SOCKET SET**

**INCLUDED! 21 PIECE INTERCHANGEABLE  
 SCREW DRIVER & SOCKET SET**

**3/8" RATCHET**

**3/8" L-HANDLE**



The handiest tool you've ever used. For those hard-to-get-at places. Complete with right, left, and rigid ratchet.

THIS SET ALONE  
 REGULARLY  
 SELLS FOR  
**\$5.95**

**8 Pc. SET  
 BOX END  
 &  
 OPEN END  
 WRENCHES**

COMPLETE WITH  
 CARRYING CASE!  
 STOWS EASILY IN YOUR  
 GLOVE COMPARTMENT,  
 TOOL OR TACKLE BOX.

NOW FOR THE FIRST TIME a quality tool set to handle any job at a price so low to please every one. Whether you're a mechanic—a garage or farm worker—a gas station owner—or a handyman, you'll find this tool set is a real time and work saver. Can save you hundreds of dollars on repairs of all kinds.

YOU GET EVERYTHING SHOWN! HEAVY DUTY 11 Pc. 1/2" DRIVE SOCKET SET with 15/16" - 7/8" - 3/4" - 11/16" - 5/8" - 7/16" - 1/2" - and 9/16" sockets, 1 reversible ratchet, 1 L handle and extension • HUSKY 11 Pc. 3/8" DRIVE SOCKET SET with 5/8" - 7/16" - 1/2" - 7/16" - 13/16" - 3/4" - 11/16" and 9/16" sockets, 1 reversible ratchet, 1 L handle and extension • UTILITY 8 Pc. 1/4" DRIVE SOCKET SET from 1/4" to 7/16" sockets • VERSATILE 8 Pc. BOX END AND OPEN END WRENCH SET • COMBINATION 21 Pc. INTERCHANGEABLE SCREW DRIVER AND SOCKET SET with the right, left, and rigid ratchet that makes it a breeze to reach those hard to get at places.

FREE TRIAL OFFER! USE THIS SET FOR 10 DAYS and SEE FOR YOURSELF. If for any reason you are not 100% satisfied, return the set for a full refund.

**NIRESK DISCOUNT SALES** A DIVISION OF NIRESK INC. **CHICAGO 11**

**MONEY BACK GUARANTEE!**

**NIRESK DISCOUNT SALES, Dept. BGX18  
 Chicago 11, Illinois**

Please rush 60 pc. SOCKET WRENCH AND TOOL SETS at \$9.95 each on MONEY BACK GUARANTEE.

Name \_\_\_\_\_

Address \_\_\_\_\_

City \_\_\_\_\_ Zone \_\_\_\_\_ State \_\_\_\_\_

I enclose \$9.95 plus 50c for postage and handling for each set.

I enclose \$1.00 deposit. Ship C.O.D. plus postage and C.O.D. charges.



because  
it's  
**completely furnished**  
when you buy it . . .

# *instant living*

**begins the moment you move in!**

Imagine setting up housekeeping in a spacious, 3 bedroom home . . . *with only dishes, linens and silverware.* That's all it takes in a New Moon mobile home, because everything else . . . from kitchen appliances to living room furniture . . . is provided for you! Here's *instant, ready-to-go living* . . . all for **LESS** than the cost of furnishings alone in the average home.

*Write for free folder or see New Moon homes at any of the nation's more than 500 dealers.*  
6318

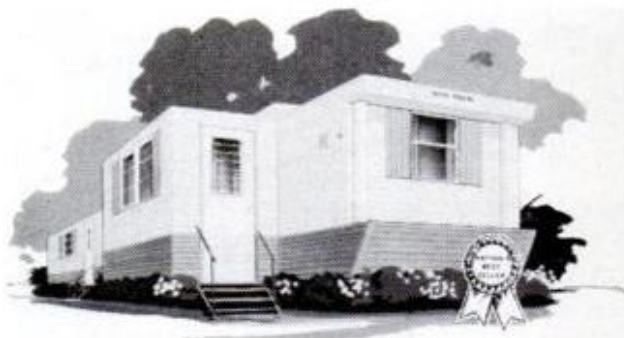

**NEW MOON** HOMES INC.

Dept. 79 / 7808 Carpenter Freeway / Dallas, Texas



# WILDCAT!



*The name fits. WILDCAT! Sleek, sure-footed, muscles of steel . . . and terrible tempered. Only full-size luxury sports job with Advanced Thrust engineering, WILDCAT tracks arrow-straight, corners tight, handles with caliper precision. Front buckets and center console with tach and Turbine Drive selector stick are standard in the eye-popping WILDCAT convertible and 2-dr. sport coupe. Like to try your hand at taming one? There's a willing WILDCAT waiting at your Buick dealer's now.*

Buick Motor Division also presents: Buick Special/Skylark/LeSabre/Electra 225/Riviera

**'63 BUICK  
WILDCAT**

**ANATOMY OF A WILDCAT!** Engine: 90° V-8 valve in head. Displacement: 401 cu. in. Maximum hp: 325 @ 4400 rpm. Compression: 10.25:1. Bore and stroke: 4.1875 x 3.64. Carburetor: one 4-bbl. downdraft. Valves: hydraulic lifter type. Rear axle: hypoid semi-floating. Gear ratio: 3.42. Transmission: automatic torque converter type. Brakes 12" Duo-Servo, finned aluminum up front. Advanced Thrust engineering for straight tracking, flat cornering.



**In communities drenched** with poisonous insecticides, the voices of spring are absent, wrote Rachel Carson in the best-selling *Silent Spring*. *PM's* Midwest Editor, Cliff Hicks, examined one such community, Sheldon, Ill., and came up with the chilling report on page 85. Hard evidence of damage to wildlife continues to turn up. Latest to report is the Cranbrook Institute of Science in Bloomfield Hills, Mich. In a letter to *PM*, Naturalist Walter P. Nickell said farmers in the Michigan counties of Monroe and Lenawee have picked up the dead bodies of more than 500 rabbits, squirrels, pheasants, mice, songbirds and barnyard chickens following the spraying of 80,000 acres with dieldrin in an effort to eradicate an infestation of Japanese beetle.

**If you want to see** the July eclipse of the sun in its totality, better pack your bags and head for Alaska, Canada or Maine. Due July 20, the eclipse will be total about 10 a.m. south of Fairbanks; at about noon near Great Slave Lake, and about 4:45 p.m. in Bar Harbor. (Times are standard). A partial eclipse will be seen over the rest of the U.S., except Hawaii.

**Kidney-stone removal** may become routine for astronauts returning from space trips. Scientists say excess calcium builds up in the body when weightlessness reduces skeletal needs.

**Birth ratios** among Japanese caught in the atomic bombings of Hiroshima and Nagasaki show at least one deviation from the normal, says a report recently released by the Atomic Bomb Casualty Commission. In the 18 years since the blast, males exposed to radiation have shown a tendency to produce more sons than daughters; females to bear more daughters. No increase in birth malformations or mutations has been detected in a study of 70,000 pregnancies in Hiroshima. Lifelong studies are being conducted of some 20,000 persons who were either in the blast or born of parents receiving radiation.

**Irradiated food** on supermarket shelves appears to be just around the corner. Recently, the Food and Drug Administration gave its OK to bacon irradiated by the Army, the first clearance for food treated with nuclear energy. Advantage of the process is that radiation kills organisms that cause spoilage and decay, thus could dispense with the need to refrigerate some foods. Fruits and fish for instance, could be brought to market quickly with their freshness unimpaired—and they'd remain fresh for longer periods.

**Dimple doctor.** Dr. Khoo Boo-Chai, a Singapore plastic surgeon, reports a booming business in creating dimples for Chinese females. It's a simple operation, he says. An incision is made in the cheek lining inside the mouth over the spot chosen for the dimple. A facial muscle is tied to the skin to form a depression in the cheek and that's it.

**Capturing asteroids** to make use of their raw materials may be only a few years off, says an astronomical scientist in a recent issue of *Astronautics and Aerospace Engineering*. They could either be captured and propelled into an earth orbit, he said, or they could be brought back to earth for mining—chiefly for nickel and iron. Asteroids range in size from one to 500 miles in diameter, and sometimes pass close to the earth in their orbit of the sun.

**Radio stars** are the most powerful objects yet found in the sky, says the California Institute of Technology. In a recent survey of the sky, it studied 24 radio stars ranging in distance from 13 million to five or six billion light years from the earth. The strongest star in the group has the power of 20 billion suns, or 40 billion billion billion watts.

**Here's a new excuse** for slow-starters in the morning. A British medical journal says that elderly thin persons sometimes have trouble getting their eyes open in the morning and it's possible this "morning stiffness of the eyelids" is due to rheumatism.

**Measles** may be on the way to extinction. Two types of measles vaccines have recently been licensed, one "live" and one "killed." The live-virus vaccine, which should be in plentiful supply by fall, is recommended by the Public Health Service, except in special circumstances. One injection alone is necessary, experts say, but they suggest an accompanying shot of gamma globulin to reduce reactions.

(Please turn to page 26)

GET READY FOR THE SPACE and SCIENCE ERA! SEE SATELLITES, MOON ROCKETS CLOSE-UP



# AMAZING SCIENCE BUYS

for FUN, STUDY or PROFIT



See the Stars, Moon, Planets Close Up!

## 3" ASTRONOMICAL REFLECTING TELESCOPE

SEE AND PHOTOGRAPH SUN'S ECLIPSE JULY 20TH.

Be visually safe and use Edmund's Combination Sun Projection Screen and Camera Holder.

Stock No. 70.162-H .....\$9.95 Postpaid



**60 TO 180 POWER!**  
Famous Mt. Palomar Type!  
An Unusual Buy!

See the Rings of Saturn, the fascinating planet Mars, huge craters on the Moon, phases of Venus, Equatorial Mount with lock on both axes. Aluminized and over-coated 3" diameter high-speed f/10 mirror. Telescope comes equipped with a 60X eyepiece and a mounted Barlow Lens. Optical Finder Telescope included. Hardwood, portable tripod. FREE with Scope: Valuable STAR CHART plus 272-page

"HANDBOOK OF HEAVENS" plus "HOW TO USE YOUR TELESCOPE" BOOK.

Stock No. 85.050-H .....\$29.95 Postpaid

4 1/4" REFLECTING TELESCOPE—Up to 255 Power.

Stock No. 85.105-H .....\$79.50 F.O.B., Barrington, N.J.

## BUILD A SOLAR ENERGY FURNACE

A fascinating new field. Build your own Solar Furnace for experimentation—many practical uses. Easy! Inexpensive! Use scrapwood! We furnish instructions. This sun powered furnace will generate terrific heat—2000° to 3000°. Fuses enamel to metal. Sets paper aflame in seconds. Use our Fresnel Lens—14" diameter . . . f.1. 14".

Stock No. 70.130-H .....Fresnel Lens .....\$6.00 Postpaid

11" Sq. Fresnel Lens F.L. 19" . . . slight second

Stock No. 70.533-H .....\$4.75 Postpaid



## STUDENT MICROMETER SET

'OLD-WORLD CRAFTSMANSHIP' STANDARDS

Set of 3—English make—sturdy, dependable. Closest tolerance of many inexpensive micrometers tested—with accuracy of plus or minus .003". 1" outside micrometer measures to 1"; 2" outside model from 1" to 2"; combination 1" and 2" depth instrument up to 1" and from 1" to 2"

with 2 shafts supplied. Packed in functional, protective vinyl case. Full instructions.

Stock No. 63-333-H .....\$9.95 Postpaid

## SOLAR CELL SET HARNESES

POWER OF THE SUN



Conduct spell-binding experiments, experience endless fascination in converting sunlight into electricity to power small motors, amplifiers, make light meters, densitometer, burglar alarms, etc. Used experimentally to drive cars, power boats. Low price set includes SILICON SOLAR CELL and SUN BATTERY (Produces .2 to .45V 10-16 milliamps) SELENIUM PHOTO CONDUCTIVE CELL (light sensitive resistor) which generates electricity to turn lights on in the evening, open doors, count traffic, etc., etc.

Stock No. 60.291-H .....\$7.95 Postpaid

## WAR SURPLUS AMERICAN-MADE 7x50 BINOCULARS

Big savings! Brand new! Crystal clear viewing—7 power. Every optical element is coated. An excellent night glass—the size recommended for satellite viewing. Individual eye focus, Exit pupil 7mm. Approx. field at 1,000 yds. is 376 ft. Carrying case included. American 7 x 50's normally cost \$274.50. Our war surplus price saves you real money.

Stock No. 1544-H . . . Only \$74.80 Postpaid

(Tax included)

6 x 30 Binoculars—similar to above and a terrific bargain.

Stock No. 963-H . . \$33.00 Postpaid (Tax inc.)

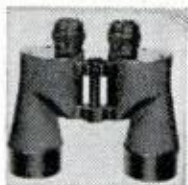

## MINIATURE WATER PUMP

Wonderful for experiments, miniature waterfalls, fountains, Christmas gardens, HO gage railroad backdrops, hobbyists, labs, schools. Pumps continuous flow of water etc. Tiny (2 5/8" x 1 3/4") electric motor and pump ideal for hobbyists, labs, schools. Pumps continuous flow of water at rate of one pint per minute at a 12" head. With 2 D Batteries in series will pump to 24" high. Works in either direction. Stock No. 50.345-H .....\$2.25 Postpaid



## MINIATURE SUBMERSIBLE WATER PUMP FOR HOBBIES, EXPERIMENTS

Sturdily built, self-priming, electric water pump. Ideal for science classes, advertising exhibits, miniature waterfalls, fountains, etc. Operates under water on 8 to 20V AC. At 20V, pumps 1 pint per minute at 12" head. Spare valve, spring and instructions included.

Plastic, 2 1/2" lg., 1" dia., wt. 1 1/4-oz.

Stock No. 60.307-H .....\$2.98 Postpaid

ORDER BY STOCK NUMBER SEND CHECK OR MONEY ORDER. SATISFACTION GUARANTEED

EDMUND SCIENTIFIC CO., BARRINGTON, N. J.

## 'FISH' WITH A WAR SURPLUS MAGNET

Go Treasure Hunting On The Bottom

Great idea! Fascinating fun and sometimes tremendously profitable! Tie a line to our 5-lb. Magnet—drop it overboard in bay, river, lake or ocean. Troll it along the bottom—your "treasure" haul can be out-board motors, anchors, fishing tackle, all kinds of metal valuables. 5-lb. Magnet is war surplus—Alnico V Type—Gov't. Cost—\$50. Lifts over 125 lbs. on land—much greater weights under water. Order now and try this new sport.

Stock No. 70.570-H. 3 1/2 lb. size .....\$ 8.75 Postpaid

Stock No. 70.571-H. 5 lb. Magnet .....\$12.50 Postpaid

Stock No. 70.572-H. 7 1/2 lb. Magnet .....\$18.75 Postpaid

Stock No. 85.152-H 15 lb. size lifts 250 lbs. \$33.60 FOB



## ASTRO-COMPASS AND TRANSIT

War surplus! Astro Compass alone cost Gov't. \$75. We have added a Sighting Level to improve versatility. Hundreds of uses in carpentry, brick laying, foundation work, grading, irrigation or drainage. Much below cost of ordinary surveying instruments. Ideal for do-it-yourselfers. 10 1/4" high, 8" long, 4" wide. Adjustable leveling platform—2 spirit levels for aligning—also spirit level in sighting attachment. Tremendous bargain.

Stock No. 70.267-H .....\$19.95 Postpaid

## LARGE SIZE OPAQUE PROJECTOR

Ideal for photographers, this low-cost unit projects 3 1/2 ft. sq. image at 6 ft.—7 1/2 ft. sq. image at 12 ft. Projects photos, drawings, sketches, clippings, any opaque copy up to 6" x 6"—larger pieces in sections. Lenses are 2 plano-convex. 3 1/2" dia. mounted in 5 1/4" barrel. Projector is 11 1/2" high, 13 1/4" wide, 9" front to back, pressed steel in black wrinkle finish, bakelite handle. Uses two 200 watt bulbs—not included. Complete with side platform to hold illustrations, 6 ft. elec. cord, heat resist. plate glass mirror.



Stock No. 80.066-H .....\$42.00 Postpaid

## OPAQUE PROJECTOR



Projects illustrations up to 3" by 3 1/2" and enlarges them to 35" x 30" if screen is 6 1/2 ft. from projector; larger pictures if screen is further away. No film or negatives needed. Projects charts, diagrams, pictures, photos, lettering in full color or black-and-white. Operates on 115 volt, A.C. current, 6-ft. extension cord and plug included. Operates on 60 watt bulb, not included.

Size 12" x 8" x 4 1/2" wide. Weight 1 lb., 2 oz. Plastic case with built-in handle.

Stock No. 70.199-H .....\$7.95 Postpaid

## NEW MINIATURE TAP SET

CUTS SMOOTH INSIDE THREADS



These superior tools cut inside threads quickly, smoothly. Used for innumerable small items. Knurled steel, chuck type handle with torque hold provides firm, steady leverage. 5 tap & drill sizes; O-80NF, =56 or 3/64; 1-72NF, =53; 2-56NC, =50; 3-48NC, 47; 4-40NC, =43.

Stock No. 60.340H .....\$4.95 Postpaid.

## WOODEN SOLID PUZZLES

12 Different puzzles that will stimulate your ability to think and reason. Here is a fascinating assortment of wood puzzles that will provide hours of pleasure. Twelve different puzzles, animals and geometric forms to take apart and reassemble, give a chance for all the family, young or old, to test skill, patience, and, best of all to stimulate ability to think and reason while having lots of fun. Order yours now.



Stock No. 70.205-H .....\$3.00 Postpaid

Order by Stock No.—Send Check or M.O.—Money-Back Guarantee  
EDMUND SCIENTIFIC CO., Barrington, New Jersey

## MAIL COUPON FOR FREE CATALOG "H"

New! 1000's of Bargains 164 Pages

EDMUND SCIENTIFIC CO., Barrington, N. J.

Please rush Free Giant Catalog "H"

Name .....

Address .....

City..... Zone..... State.....



# Do it all easily, quickly with a SWINGLINE STAPLE GUN

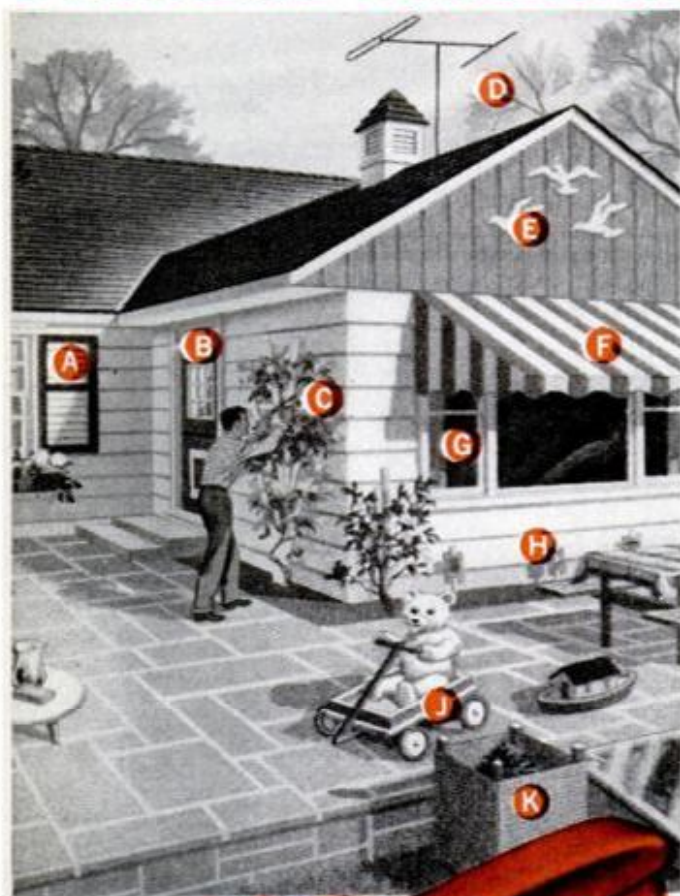

ONLY  
\$4<sup>95</sup>  
4



- Push-button loading
- Built-in extractor
- Handle lock
- Rugged, heavy-duty steel construction
- Load indicator
- Open channel takes 2 staple sizes: 1/4" and 5/16"
- At better hardware, department, stationery stores

A Swingline Staple Gun makes immediately possible—and easy—all those time-consuming, hard-to-do chores both inside and outside your home.

- (A) Repairing shutter slats
- (B) Weather-stripping
- (C) Fastening plants, vines to trellis
- (D) Television antenna wire
- (E) Outdoor decorations
- (F) Awnings
- (G) Screening
- (H) Markers for seeding
- (J) Repairing toys
- (K) Burlap covers

**FREE!** Send for booklet on how to do many stapling jobs.

## Swingline<sup>®</sup> INC.

Long Island City 1, N.Y.  
World's Largest Manufacturer of Staplers for Home and Office

## Science Worldwide

(Continued from page 24)

Merck & Co. was first in the field with the live vaccine, other firms are following suit. The shots are good for regular measles only, a Merck spokesman told PM, not German measles.

**No cavities from candy?** Generations of children will think they've been led up the garden path if the report of a dental researcher at the University of Oregon is true. He says a nine-year study of the diets of 37 youngsters fails to show any relationship between sugar consumption and tooth cavities in the group.

**Liver disorders**, recently reported from different areas of the U.S., may be due to a new anesthetic, halothane. Now in use about five years, halothane has been administered to some 10 million people. Doctors like it because, unlike other anesthetics, it won't explode or burn. But evidence of liver damage has mounted, according to the New England Journal of Medicine. One 16-year-old girl was operated on for a deep wrist cut; six days later she was dead and an autopsy found four-fifths of her liver destroyed.

**Clear and warmer** for the next 350 years, following by increasing cloudiness, rain and snow, with a few thousand feet of ice spreading over most of the northern hemisphere by the year 12,000. That's the long-range weather forecast made by a group of scientists studying the weather over the past few thousand years. They believe they've discovered a cycle of alternating cold spells, ice ages and warm spells—such as we're having now. Some think that unless we can invent a way of interrupting this vast movement we'll be in a bad way in about 10,000 years.

**Grandma's been right** all these years. Scientists have finally confirmed what people have been saying for generations—aching joints can foretell weather changes. A Pennsylvania university scientist put several arthritic people into special sealed rooms where humidity, barometric pressure and temperature could be changed at will. Test subjects were little affected by any changes until pressure was lowered and humidity raised, the two weather changes that take place before a rain storm. Then, all but one of the patients felt familiar twinges in aching joints.

John P. McNeel  
Science Editor

POPULAR MECHANICS



**Best  
performance  
under the  
sun...**

## **...comes from ACs under the hood**

A tune-up and new AC Fire-Ring Spark Plugs will help your car deliver top performance during the hot weather months ahead. One big reason is AC's self-cleaning Hot Tip design. It heats faster to burn away fouling deposits . . . cools faster to help prevent preignition. AC's self-cleaning action can help improve engine power and economy mile after mile. Get your car tuned now with a new set of AC Fire-Ring Spark Plugs for the best performance under the sun.

AC SPARK PLUG  THE ELECTRONICS DIVISION OF GENERAL MOTORS

JUNE 1963



**FIRE-RING  
SPARK PLUGS**



# Spotlight on the *Falcon Sprint*



*Holman & Moody join Ford in producing a hot, slam-bang, 100-plus m.p.h. Falcon*

By Jim Whipple



**FRESH FROM ITS FEATS** in the Monte Carlo Rally of 1963, Falcon Sprint #221 blasts off complete with road lights, tow hooks, 235 hp. V8 and 15-inch wheels

**T**HE PUSSY CAT is now a tiger. We got a clue when we drove the new 164 hp. Falcon Sprint V8 with four-speed stick. (That's the stock model, not the 235 hp. Monte Carlo car shown above). More of the message came through as we listened to eyewitness reports of Swedish rally driver Bo Ljungfeldt's record-breaking drives over Alpine black ice in the special sections of the Monte Carlo Rally at the wheel of the more powerful 235 hp. Falcon V8.

Ljungfeldt's car was one of three specially prepared for the Monte by the renowned stock car set-up shop of Holman and Moody in Charlotte, N.C. These are very special Falcons indeed, with hopped-up versions of the 260 cubic-inch Fairlane V8, disc brakes, quick steering and heavy duty suspension to set them apart from the "ready-to-wear" Sprint V8 hardtops now in the showrooms.

Our curiosity fully aroused, we arranged for a test at Ford's Dearborn proving grounds, the very spot where we first previewed the Falcon in 1959 when it was a docile little economy car.

Recalling that early Falcon with its genuine, 25 mile-per-gallon economy and milktoast performance, we found car No. 221, a Monte Carlo "combat veteran," in shocking contrast.

Holman and Moody's Falcon Sprint is

loaded for bear. It's got the same 260 cubic-inch Fairlane V8 Carroll Shelby uses in his Cobras.

The Cobra engine uses a four-barrel carburetor, special manifold, and a 9.2 to 1 compression cylinder head with intake and exhaust valves enlarged from 1.59 to 1.72 inches and from 1.39 to 1.45 inches respectively. The camshaft gives greater valve lift and longer duration of opening via solid lifters.

In this semi-race tune the V8 can crank out 235 horsepower all day at 6000 r.p.m. The engine is coupled to the Borg-Warner four-speed full synchromesh floor stick transmission via a heavy duty clutch with pedal pressure that would put a bulldozer to shame.

Gear ratios are close and on the hot side, at 2.20, 1.64, 1.31 and 1.0 to 1 for the forward ratios (stock ratios are 2.73, 2.04, 1.51 and 1.0 to 1 for 1st, 2nd, 3rd and 4th).

The stock Falcon axle housing is strong enough to take all this torque which is poured to the wheels via Thornton limited slip gearing with a 4.5 to 1 ratio. This is not much lower than the standard Sprint V8's 3.25 to 1 ratio as the Monte Sprints are equipped with 6.70 x 15 tires on 5½ inch rims.

At idle the engine makes a sizeable clamor, but when you let in the clutch

*(Please turn to page 30)*

# ONLY ARMSTRONG TIRES CAN SAVE YOUR LIFE

with "Ounce of Prevention" Safety Discs!



## PATENTED SAFETY DISCS KEEP TREAD OPEN, READY TO GRIP!

Just as discs in fist (above, left) keep fingers apart, over 1,000 Safety Discs in each Armstrong Tire keep tread's gripping edges apart, always ready to grip the road, no matter how hard you brake! But fingers of fist **without** discs (above, right) can squeeze shut. That's why ordinary tires **without** Safety Discs can squeeze smooth under braking pressure, and lose their grip. So, get Armstrong Tires' patented extra safety, at no extra cost!

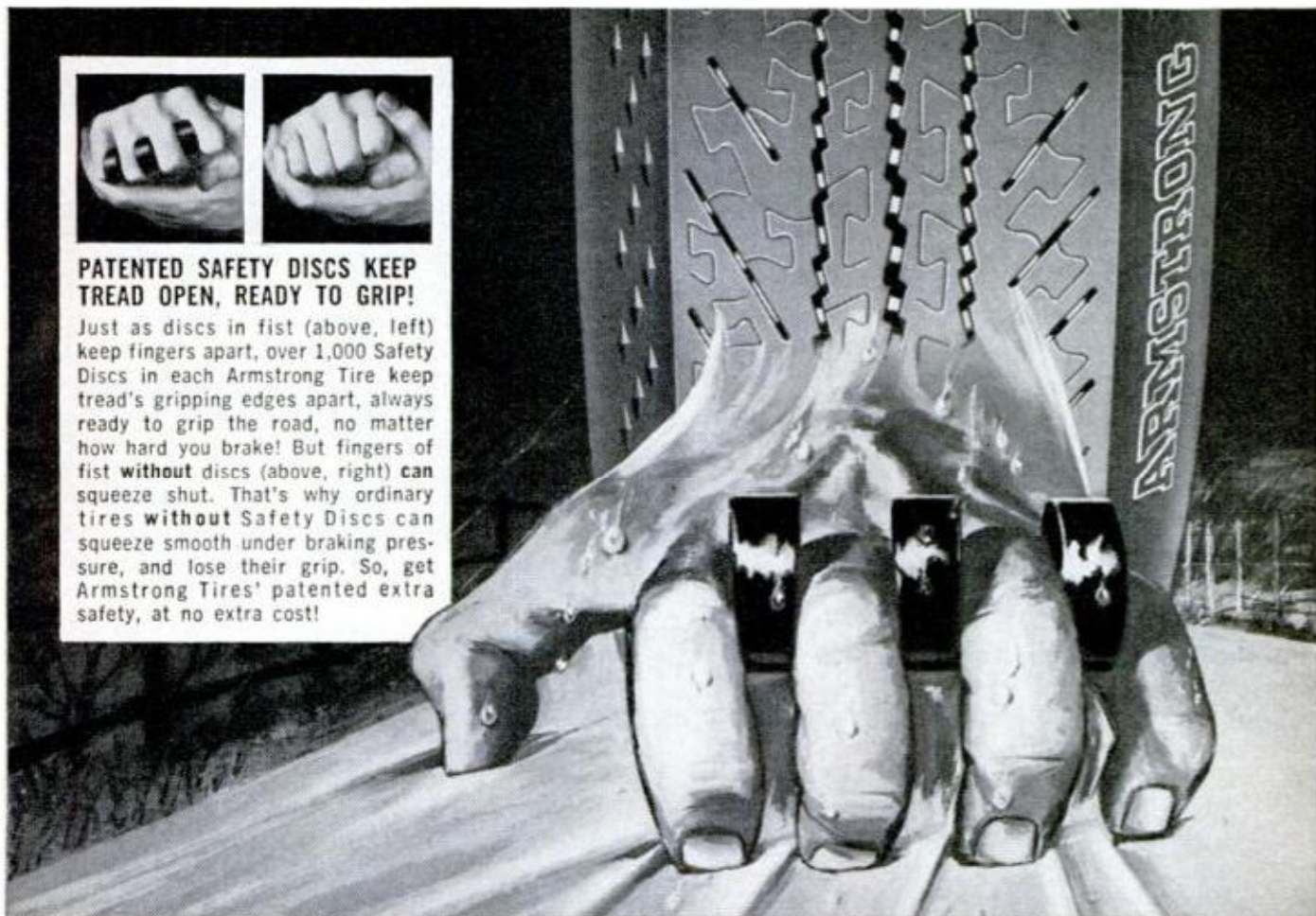

Armstrong's Exclusive Wide-Track tread design doubles the width of the outer ribs — doubles the rubber where tires wear most!

## PLUS! up to 10,000 MORE SAFE MILES with WIDE-TRACK TREAD DESIGN!

Which part of a tire wears out first? Take a look at your own tires. You'll find the *outer tread ribs* take most of the punishment. That's why ordinary tires, with narrow outer ribs, so often disappoint you on mileage. To prevent this mileage loss, Armstrong engineers developed the Wide-Track Tread.

This exclusive design doubles the width of the outer ribs — doubles the rubber where tires wear most — to give you up to 10,000 more safe miles than ordinary tires. Get Armstrong's Wide-Track tread design, and get extra mileage at no extra cost! See the Yellow Pages for your Armstrong dealer.

The Armstrong Rubber Company, West Haven, Conn.  
Des Moines, Iowa • Natchez, Miss. • Hanford, Calif.

**You can't buy a better tire . . . to save your life . . . than Armstrong!**



Build these **8** patio projects  
yourself with **SAKRETE**<sup>®</sup>  
... for less than **\$99\***

For hours of fun and relaxation all summer long . . . there's nothing like a patio. You can build your own for less than \$99—with SAKRETE Concrete and Mortar Mixes. You'll have fun making your own patio blocks, planter boxes and flower bed edging with pre-mixed SAKRETE. Do a little at a time . . . start and stop any time . . . for SAKRETE stores indefinitely until you add water. High strength, easy to use, economical, no waste. Get SAKRETE today at your lumber, building material or hardware dealer.

\*Approximate cost of materials in most areas for this 10' x 12' patio project.



**FREE** booklet of cement building and repair projects. See your dealer or write SAKRETE, Inc., Dept. PM, Box I, Cincinnati 17, Ohio.

**SAKRETE**<sup>®</sup>  
concrete and  
mortar mixes



SAKRETE IS A REGISTERED TRADE MARK OF SAKRETE INC. © 1963

## Spotlight on the Falcon Sprint

(Continued from page 28)

and hose fuel to the Cobra V8 it sounds like an old-fashioned propeller-driven fighter on full-throttle takeoff. The car surges forward with an incredible blast of torque. Surprisingly, there's very little wheelspin or tire chirp. The leaf springs at the rear are heavy duty and act almost like torque arms.

Estimating acceleration was a bit vague since the conventional speedometer had been blacked out. Its place was taken by a tachometer and a console of engine gauges.

One of the Ford Rally Team mechanics who rode with us estimated our speed on the Ford oval at over 106 m.p.h., using the tachometer as a guide.

We judged that the 0-60 run was accomplished in the area of 6 seconds.

At high speed the car felt like a concrete battering ram or a cast-iron sled. It is dead solid on the road, with no tendency to float, drift or swerve. It just goes straight ahead, never bobbing, never sliding out on the curves, and when it's time to stop, the braking system with Bendix discs up front and oversize (11 instead of 10 inch) drums on the rear, coupled with a power booster, brings the car down **right now** with no struggle.

Steering is accurate and precise, just the way you'd want it in rallying or road racing, but a far cry from the easy-steering Falcon you knew on Main Street. Holman & Moody cut the steering ratio from 4.64 turns down to 2.25 lock to lock. Turning No. 221 at low speeds is much like trying to wrestle a cast-iron cookstove down a dry cement sidewalk.

It's a tribute to the sturdiness of the stock Falcon's unitary body-frame structure that no special reinforcements were needed. However, the suspension is modified with heavier coil and leaf springs.

### Combat Vehicle Vs. What You Can Buy

Set up as No. 221 was for the Monte, a Falcon Sprint would be too much of a "combat vehicle" for most people, even conditioned sports car drivers.

However with some modifications such as the Cobra-tune engine, heavy duty suspension and shock absorbers, plus the disc braking system, stock option four-speed transmission and beefed up clutch, you'd have a bargain basement Ferrari Gran Turismo that would be more fun to drive than anything you've ever held the wheel of. With the special order items delivery would be a bit of a wait and the price tag might crowd \$3500 for the full treatment on the Sprint hardtop. ★★



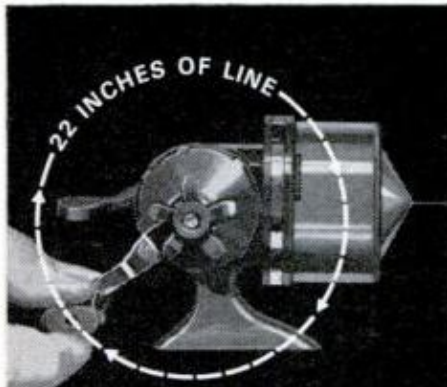

**YOU'LL RETRIEVE LINE FASTER**  
because of high 4-to-1 gear ratio,  
oversize handle, low line friction.

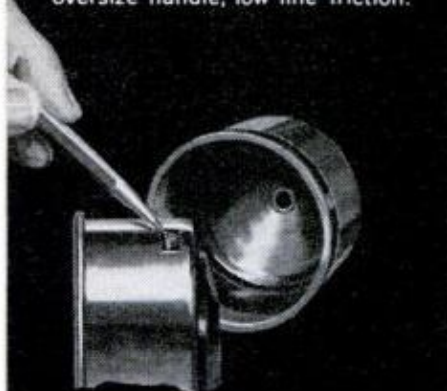

**YOUR LINE WILL LAST LONGER.**  
Pulley-like pickup pin lets line roll  
on spool, reducing wear.



**YOU'LL CLEAN IT EASIER.**  
Quick take-apart without tools for  
that rare cleaning and oiling.

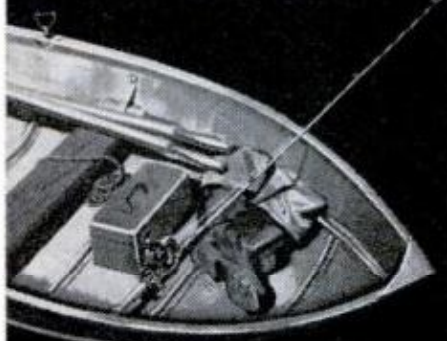

**YOU'LL GET LONGER LIFE.**  
Anti-rust "space-age" materials  
resist impact, abuse, and wear.

# NEW #420 REEL BY TRUE TEMPER



*so much more fun to fish with*



*so much more trouble-free*



*lands so many more fish*



*you'll never want any other  
closed-face spinning reel!*

**\$15.00\***

**TRUE TEMPER**  
ADDS SCIENCE TO FISHERMAN'S LUCK

1623 Euclid Avenue - Cleveland 15, Ohio

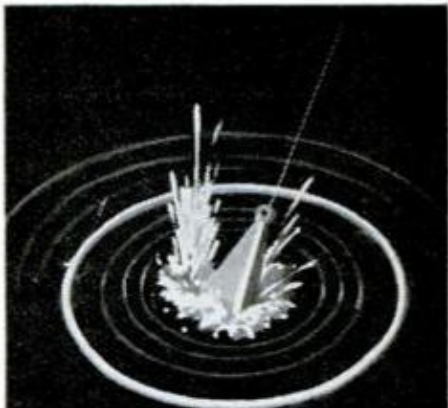

**YOU'LL CAST MORE ACCURATELY.**  
Oscillating spool lays line down  
evenly to spin off cleanly.



**YOUR DRAG SETTING IS Surer.**  
Controlled at the handle — not  
the spool. Control is uniform.



**YOU'LL PICK UP LINE QUICKER.**  
Pin circles track inside shroud for  
positive pickup of even loose line.



**YOU'LL CONTROL IT BETTER**  
because of precise, functional de-  
sign. "Palming" is comfortable.

\*Manufacturer's suggested retail price—not necessarily price charged at retail stores. Available throughout U. S. and Canada.

# POPULAR SHOPPING

**Back-yard pools**, planned with common sense, may expand your home recreation facilities reasonably. "Build A Pool," a new book by Norman Foster, gives concise how-to facts on pool excavation, layout, plumbing, filtering and decking. Construction details are clearly diagrammed, trouble spots cited and remedies offered. Published by Technical Associates, P.O. Box 3292, Scottsdale, Arizona, the book costs \$2.95.

**Car racers, boat owners and home mechanics:** "Gasket Installation Manual," a 36-page booklet recently published by Fel-Pro, Inc., 7450 N. McCormack Blvd., Skokie, Ill., details many new designs and materials in gaskets—hand, valve, manifold and pump types—with step-by-step procedures for their installation. Avoid gasket failure by pin-pointing the right gasket for the job with your free copy of this manual.

"**First Aid for the Family**," a series of eight articles on the most common emergencies, tells what to do and what not to do until the doctor comes. Care of shock, poisoning, burns, cuts, bone injuries and radiation are covered; one article deals only with first-aid supplies. The series costs 15 cents from The American Medical Assoc., 535 N. Dearborn St., Chicago 10, Ill.

worth  
writing  
for...

**Pruning** may increase the yield and health of your favorite plants. "How to Prune for Better Flowers, Shrubs, Trees and Fruits," a 42-page booklet, contains four clearly illustrated sections describing what you can hope to accomplish by careful pruning at the right times, with the proper tools—whether you manage delicate rose bushes or hardy evergreens. Copies are 25 cents each from J. Wiss & Sons Co., Newark 7, N.J.

**Tent and trailer tourists:** "Campground Guide for 1963-64," a 134-page glove-compartment-size book, gives exact locations and facilities for thousands of public campgrounds throughout Canada and the U.S., including Yukon Territory, all accessible by auto. Made to be used in conjunction with road maps, the book includes check lists for equipment needed. Cost per copy is one dollar postpaid from the publisher, Campgrounds Unlimited, Blue Rapids, Kansas.

**Intriguing hobby** gets you in a bind: "Hand Bookbinding: A Manual of Instruction," by Aldren Watson, gives step-by-step descriptions of traditional methods of fine binding. Illustrations demonstrate projects from a simple folded folio to a four-signature book. Advanced section includes techniques on three-quarter bindings. The edition is six dollars from publisher, Reinhold Book Division, 430 Park Ave., N.Y. 22, N.Y.

**Garbage disposal troubles?** Freezer on the fritz? A new book, "How to Repair Major Appliances," by Ernest Tricomi, offers 224 pages of tips on the installation, operation and repair of all types of home equipment. Eleven chapters explain how and why clothes dryers, air conditioners and other machines work so readers can figure out what and where to fix. The \$3.95 book (MAJ-1) is available from Howard W. Sams & Co., Indianapolis 6, Ind.

**Be cool!** Select the right air conditioner for your comfort with the help of "Room Air Conditioners," a 12-page pamphlet published by the National Better Business Bureau, Dept. A, 230 Park Ave., New York 17, N.Y. At ten cents a copy, the text describes types of units available, installation, wiring requirements and servicing.



## PLAY RIGHT AWAY!

Piano, Guitar, ANY Instrument

**PLAY** real tunes on ANY instrument right from the start—even if you don't know a single note now! Amazing course lets you teach yourself at home, in spare time. No boring exercises. You play real notes. Make rapid progress. Easy as A-B-C. Low cost. Over 1,000,000 students.

**FREE BOOK** describes this famous course in full. See how easy learning music can be. No obligation. Write TODAY to:  
**U. S. SCHOOL OF MUSIC,**  
Studio A-306  
Port Washington, L.I., N.Y.  
(Est. 1898) Licensed N. Y. State  
Dept. of Education. Tear out as reminder.



## NEW SHEET METAL TOOL!



### GAY BLADE CLIP-SHEAR

Shears, clips, notches, nibbles, perforates. Shears a straight line thru any length of material. Makes locking joints, fastens two pieces together, locks corners of boxes, trays, etc. No burrs, no rough edges, no distortion. Bolts to bench, or can be carried to job and held with 'C' clamp. Size 3x5x1 1/2 inches overall. Weight 5 lbs. Write for illustrated brochure. Only \$18.75 postpaid, money back guarantee.

**TRADOR MANUFACTURING COMPANY**  
TOOL DIV.  
873 W. 15th St., Newport Beach, Calif.

## How Convenient and Comfortable Are the '63 Cars?

Find out the truth with this **FAC-TUAL CHART** from *Popular Mechanics*, including handy servicing information send 25¢ to **Comfort-Convenience Index Popular Mechanics, Bureau of Information, 575 Lexington Avenue, New York 22, New York.**

POPULAR MECHANICS

**PROFESSIONAL'S PRIDE.** Black & Decker's U-337 7¼" Professional Heavy-Duty Saw has superior M-L wire for increased overload burnout protection. All ball bearings. Accurate depth and bevel adjustments. Built for continuous power sawing.



**ALL MUSCLE, ALL "GO."** Black & Decker's U-136 6½" Utility Saw (like other B&D saws) has triple-dipped armatures for greater dependability, durability. Sawdust ejector. Your best saw buy for quality, power, accuracy. Saws from under \$50.

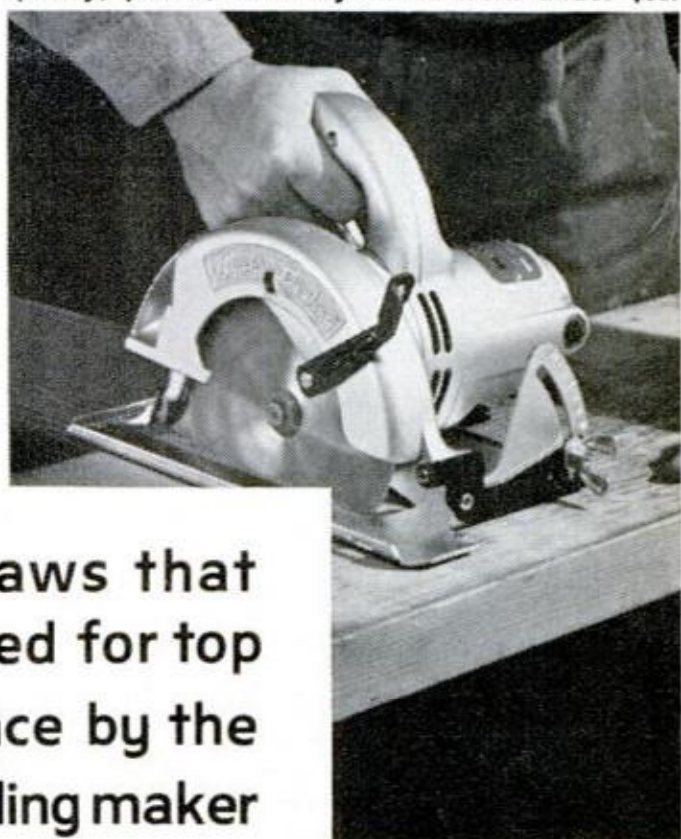

Pick the saws that are powered for top performance by the world's leading maker of power tool motors.



**Black & Decker**®

MAKER OF THE WORLD'S FIRST CORDLESS POWER TOOLS  
**Master Power**    **DEWALT**  
AIR TOOLS                  POWER TOOLS

CHECK YELLOW PAGES "Tools-Electric" for the nearest B&D dealer. Send 25c for 180-page book, "How to Choose and Use Power Tools" to: The Black & Decker Mfg. Co., Dept. D-063, Towson 4, Md.



**CYCLOID ACTION.** Black & Decker's U-351 Professional Jig Saw has fast, extra-smooth cutting power. Blade teeth cleared on each stroke. Nylon shoe insert. Tilting shoe for bevels up to 45°. Four blades, rip fence, circle-cutting guide included.

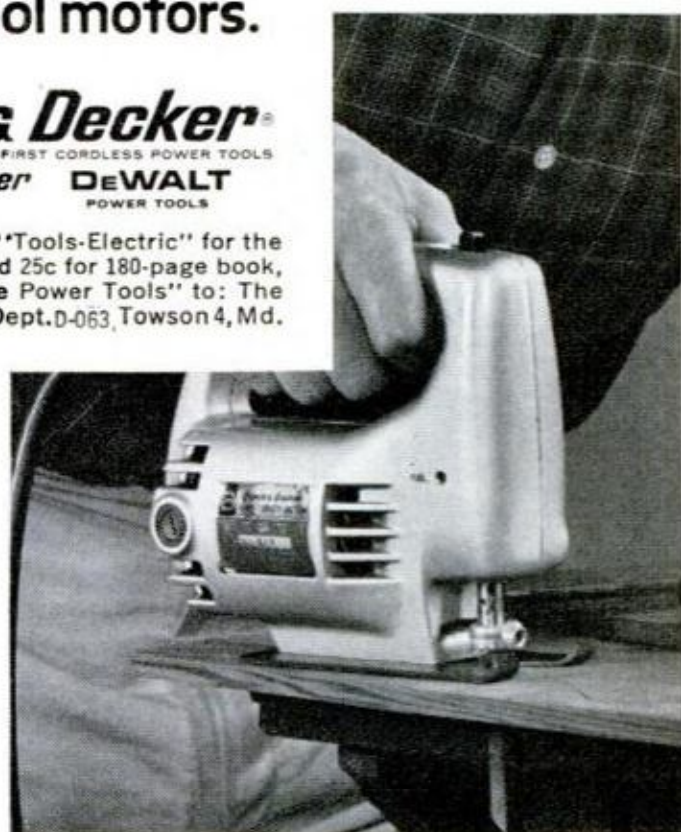

**HIGH ON PERFORMANCE—LOW ON PRICE.** Black & Decker's U-151 Utility Jig Saw handles like a sports car—makes straight, curved or irregular cuts effortlessly in wood, metal, plastic. Perfect balance and control. Jig saws from under \$24.

# GOOD JOBS IN BUILDING CONSTRUCTION

AND HOW TO GET THEM



Be a Specialist, Foreman, Superintendent or Contractor

You know that building workers are among the highest-paid in the world. Yet, there are tens of thousands of good jobs waiting for trained men. Not only for craftsmen, but for men who can read blueprints, estimate, purchase and supervise. Foremen, superintendents and inside specialists are in demand. No wonder! Over 1 million homes are built each year, over \$20 billion spent on remodeling! Let CTI train you at home for success in Building Construction. Easy course teaches every phase, including contracting. Earn as you train.

MAIL COUPON TODAY for free booklet. Find out how you can break into this top-pay, secure field.

COMMERCIAL TRADES INSTITUTE Dept. C-95  
1400 GREENLEAF AVE. • CHICAGO 26, ILL.

Send valuable booklet, *Your Future in Building Construction*.

Name \_\_\_\_\_ Age \_\_\_\_\_

Address \_\_\_\_\_

City \_\_\_\_\_ Zone \_\_\_\_\_ State \_\_\_\_\_

## BUILD, FLY ONE-MAN COPTER



Fun to build, inexpensive, easy to fly. Factory kits available. Order 3-view drawings, specs, photo of Gyro-Copter \$2 or motorless Gyro-Glider \$1. Send coupon today.

BENSEN AIRCRAFT CORP., Dept. PM-63  
Raleigh-Durham Airport, Raleigh, N. C.  
NAME \_\_\_\_\_  
ADDRESS \_\_\_\_\_

# ENGINEERING

HOME STUDY or RESIDENT

**DRAFTING** ALL BRANCHES

**TOOL & DIE** DESIGNING & MAKING

**AIR CONDITIONING** HEATING & REFRIGERATION

**AUTO MECHANICS**

IMPORTANT FACTS FOR YOU TO KNOW

- Allied is endorsed and approved by Industry, U.S. Government and State educational agencies.
- Allied's Honor Roll of successful placements will assure you of your own future.
- Allied trained men are in great demand and are essential in this era of automation.

Check (X) and send for free information on the course of your choice.

ALLIED INSTITUTE OF TECHNOLOGY, Dept. PM-63,  
1338-42 S. Michigan Ave., Chicago 5, Ill.

Name \_\_\_\_\_ Age \_\_\_\_\_

Address \_\_\_\_\_

City \_\_\_\_\_ County \_\_\_\_\_ State \_\_\_\_\_



# JEEP OWNERS

RE-POWER NOW WITH A V-8 OR 6 CYL. ENGINE — USE FORD—CHEV.—MERCURY—GMC—PONT—STUDE—DODGE OR PLYMOUTH In Jeeps, Jeepsters, Sta-Wgn, trucks, Kaiser & H. J. cars. Conversion Kits \$45.35 to \$56.90. Want fast action? Give us full information, send \$15.00 Dep. and we will ship correct kit. Bal. COD. Send full amount for prepaid shipment. Wire, phone or write today. Details FREE.

HOOSIER MACHINE PRODUCTS CO.  
312 S. E. 6th St. Phone 276-3442 Pendleton, Oregon

# START YOUR OWN MONEY MAKING BUSINESS

Clean rugs on customers' floors — upholstery in their homes — even painted walls — with highly efficient electric machines which are making big money for others and giving them independence. Write today for complete information. It's FREE!

VON SCHRADER MFG. CO., Dept. 610 "R" Pl., Racine, Wis.

**"OK" SAY FOUR WHEEL DRIVE OWNERS**

**WARN HUBS STOP 2-WHEEL DRIVE DRAG— Save gas, gears, tires**

Warn Hubs on your 4-w.d. give it double-duty value thru economical free-wheeling 2-w.d. with added pep, speed and handling ease; plus normal 4-w.d. — automatically with Warn Lock-O-Matics, manually with Locking Hubs. See your dealer.

used by the majority of 4-w.d. owners

**WARN MFG. CO., INC.**  
Riverton Box 6064-A2, Seattle 88, Wash.

# WINDOWS STICK? DRAWERS STICK? ZIPPERS STICK? USE ELMER'S SLIDE-ALL

Now spray away sticking and binding in 101 places with Elmer's Slide-All, the dry-spray lubricant. Use it on drawers, doors, zippers, bicycle chains. Not oily, it won't stain. Try it. A product of The Borden Chemical Company, 350 Madison Avenue, New York 17, New York. (Available in Canada.)

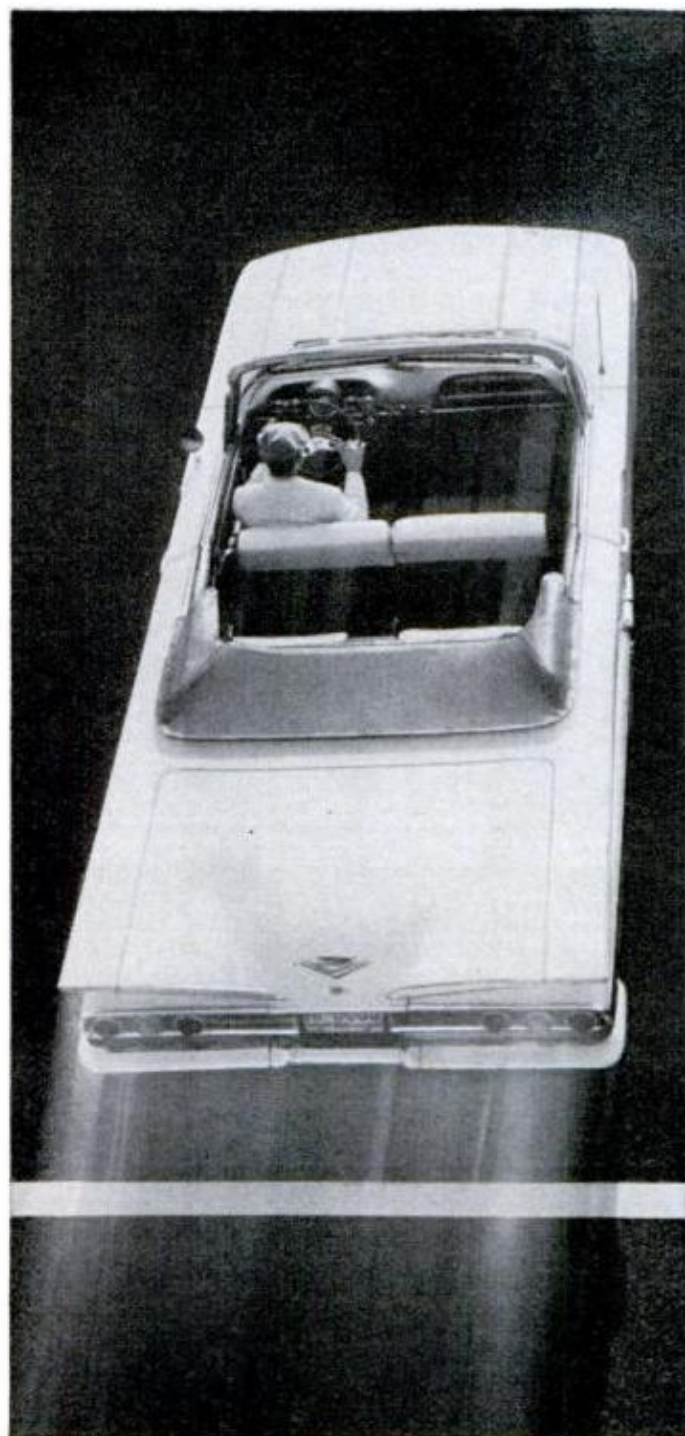

Go...

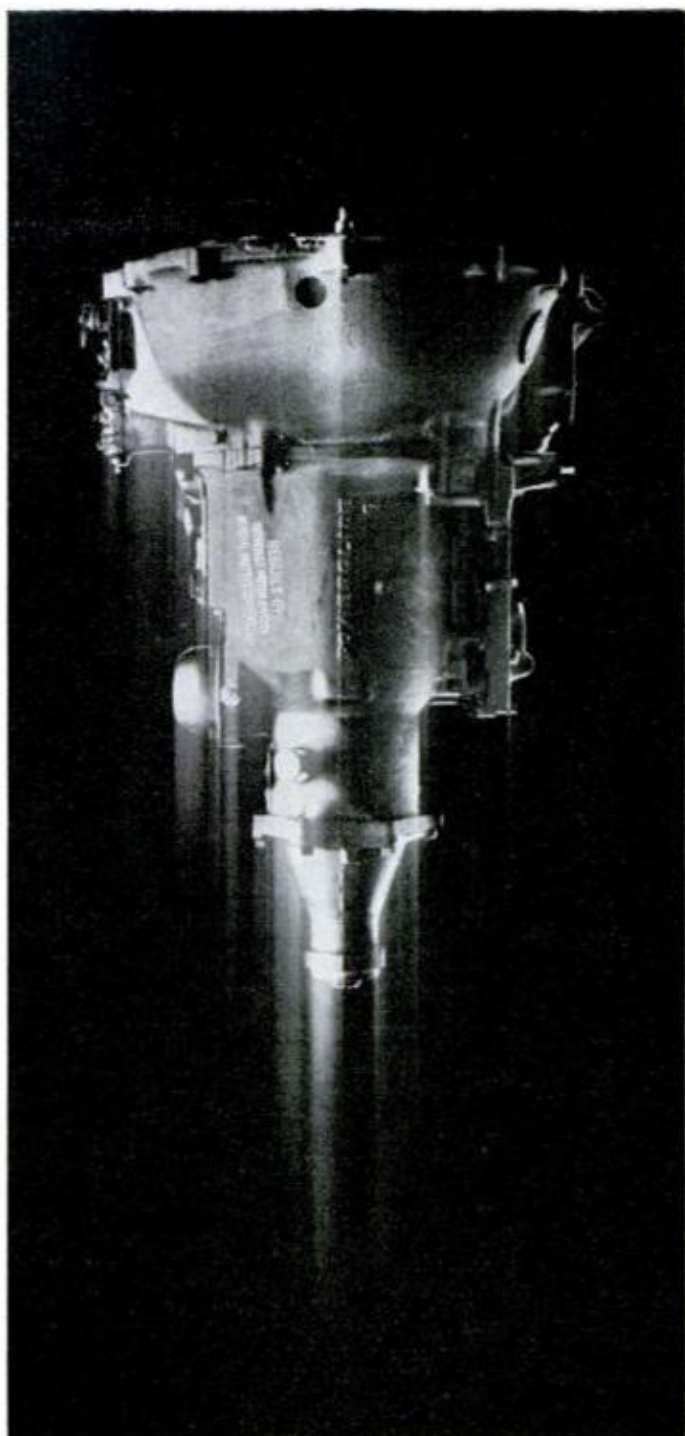

smoother

**When you want new car getaway in your Chevrolet, ask for GENUINE CHEVROLET REPLACEMENT PARTS**

Takes less than half a day to restore your Chevrolet's smooth, instant response with a factory-rebuilt automatic transmission. But prompt, efficient service is just part of the story. You'll know exactly what the cost will be *before* it's installed. And you can be sure of long trouble-free service because it's rebuilt to Chevrolet's quality standards to fit and work right in your Chevrolet. Ask for rebuilt automatic transmissions and other Genuine Chevrolet Parts by name—at your Chevrolet dealer's and at leading independent garages and service stations. . . . Chevrolet Division of General Motors, Detroit 2, Michigan.

LOOK FOR THIS SIGN



**IT PAYS TO KEEP YOUR CHEVY THE CHEVY-EST**

**94.6% OF BAILEY GRADUATES ARE EMPLOYED AT TOP PAY IN THE FIELDS WHICH THEY WERE TRAINED!**



**DIESEL-AUTO MECHANICS DESPERATELY NEEDED!**

We have a far greater demand for our students than we can fill! We can show you an actual waiting list of leading companies throughout the world who have tried Bailey graduates — found them outstanding, and are coming back for more!

**Bailey Graduates are Successful . . . RECEIVE BIG PAY — HAVE SECURE FUTURE!**

The Famous Bailey Course prepares you for **BOTH Diesel and Gasoline Mechanics.**

This is a must—due to the advent of using Diesel principles, such as 'Fuel Injection' on passenger cars . . . use of gasoline engines for starting Diesel engines, etc. You learn all this at Bailey in the amount of time ordinarily required to learn just one of these subjects, **ALL FOR THE PRICE OF ONE.**

Don't be satisfied with a 'futureless', one-type job — learn how you can make **big money** now! Write today for Free Booklet that takes you on a step-by-step camera tour through our spacious, modern shops — See Bailey students in action as they Learn-by-doing with the Famous Bailey Method of training!

We provide you with housing and part time jobs while in school, plus nation-wide placement service for graduates.

**BAILEY Technical SCHOOLS**

1634 S. GRAND ST. LOUIS 4, MO.

**MAIL TODAY!**

Please mail immediately this free booklet without obligation.

**FREE BOOKLET**



Name.....  
 Address.....  
 City..... State.....  
 Telephone..... Age.....

worth writing for . . .

**GET INTO ELECTRONICS**

V.T.I. training leads to success as technicians, field engineers, specialists in communications, guided missiles, computers, radar, automation. Basic & advanced courses. Electronic Engineering Technology, an ECPD accredited Technical Institute curriculum. Assoc. degree in 29 mos. U.S. obtainable. G.I. approved. Start Sept., Feb. Dorms, campus. H.S. graduate or equivalent. Catalog.

**VALPARAISO TECHNICAL INSTITUTE**  
 DEPARTMENT D, VALPARAISO, INDIANA



*Repair any watch*

**. . . SWISS OR AMERICAN**

Unique, modern Smeazey System starts you making repairs right away. Develops skill step by step at home in spare time. Tuition \$5 monthly. Diploma awarded. Free sample lesson. No obligation.

**CHICAGO SCHOOL OF WATCHMAKING**  
 2330 Milwaukee, Dept. 163, Chicago 47, Ill.



**ELECTRIFY** PLAYER PIANOS  
 PUMP ORGANS

**YOU CAN QUICKLY END TIRESOME FOOT-PUMPING**  
 With a Compact Low-Cost Lee Silent Suction Unit



EASY TO INSTALL  
 FULLY GUARANTEED  
 1000'S IN USE



write to  
**LEE MUSIC MFG. CO.**  
 Box 595, Tujunga, Calif.

**HUNT YEAR 'ROUND**



Enjoy new thrills of hunting! At last an inexpensive way to capture game without harm. If it is closed season you can release it, if it is a pest you can destroy it! Also handy for personal protection.

ORDER BY MAIL — USE THIS COUPON

**TEAR GAS GUN OUTFIT** This all-steel, .22 cal. TEAR GAS gun shoots 6 times as fast as you can pull the trigger. Also fires blanks for alarm or dog training. Complete with 6 tear gas shells and instructions.  
 BLUE STEEL ..... \$ 9.98  
 CHROME ..... \$ 11.98

**"GAME FLUSHER" PENS** This handy size chrome pen shoots the new powerful .38 spec. MAGNUM cartridge. Will flush game out of the deepest holes. Powerful enough to even stop a Bear! Complete with 2 shells . . . \$9.98 Same as above in .22 caliber with 3 shells . . . \$4.98

- Gun \$9.98
- Pen \$9.98
- .38 Shells .75 ea. 20 for \$13.50
- Gun \$11.98
- Pen .38 Cal. 2 shot \$11.98
- .22 Shells .15 ea. 100 for \$13.50
- Pen \$4.98
- Gun Holster \$2.00
- .22 Blanks 100 for \$1.25

**TEAR GAS DEVICES CO., ST. LOUIS 22, MISSOURI**

**Rush!** Enclosed is check. (No. C.O.D.'s)

NAME.....  
 ADDRESS.....  
 CITY..... ZONE..... STATE.....

# The few minutes it will take you to read this important announcement can save you hundreds of dollars and hours of time in car repairs!

**N**OW at last even beginner mechanics can fix almost any part of 2,519 car models fast, easy, right the first time you try — thanks to MOTOR's new 2-in-1 Auto Repair Manual and trouble-shooter that spots 2,300 car troubles for you immediately . . . leads you to the exact repair needed . . . then shows you how to do every job quickly, with crystal-clear pictures and step-by-step directions. Every job is easy as A-B-C.

No guesswork. This giant illustrated guide tells you where to start; what tools to use. Leads you easily and quickly through the entire operation — from a simple carburetor adjustment to a complete transmission overhaul.

## Everything You Need to Know Right At Your Fingertips

This **BIG, NEW REVISED** Edition covers everything you need to know to repair practically any car model from 1955 thru 1963, including all the new compacts. Over 1,300 giant pages (each almost a foot high!). 3,200 "This-Is-How" pictures — clear drawings, diagrams, cut-away photos — make every step **EASY**. 285 "Quick-Check" charts — more than 30,000 essential repair specifications. Over 225,000 service and repair facts. Instructions and pictures are so **COMPLETE**, so **CLEAR** — you **CAN'T** go wrong!

### FIX ANY OF THESE MAKES—FAST!

1955-1963—including all new compacts

American	De Soto	Meteor
Buick	Dodge	Monterey
Buick	Edsel	Nash
Special	Falcon	Oldsmobile
Cadillac	Ford	Olds F-85
Chevrolet	Fairlane	Plymouth
Chevy II	Galaxie	Polaris
Chrysler	Imperial	Pontiac
Comet	Jeep	Rambler
Continental	Lancer	Studebaker
Corvair	Lark	Tempest
Corvette	Lincoln	Thunderbird
Dart	Mercury	Valiant

### Same FREE 10-Day Trial on MOTOR'S New TRUCK REPAIR MANUAL

Covers 98% of all trucks, 1952 thru 1963, including all new economy models. Over 2,000 illustrations; 300,000 facts. Covers all gasoline engines, plus GM, Cummins, Mack, Perkins, International diesels. Over 900 big pages. For **FREE** Trial, check proper box in coupon.

Even a green beginner can do a good job. And if you're a top mechanic, you'll be amazed at the time-saving procedures.

### The "Meat" of 191 Official Shop Manuals

Engineers from each automobile plant in America worked out these time-saving procedures for their own motor car line. Now the editors of MOTOR have gathered together this wealth of "KnowHow" from 191 Official Shop Manuals, "billed it down" into crystal-clear terms in one big handy book!

This giant guide makes every operation easy as A-B-C! Eliminates trial and error—saves you work and money.

### Pays for Itself the First Time You Use It

MOTOR's Manual will more than pay for itself the first time you use it! Here's **ILLUSTRATED** step-by-step guidance you need to service and repair all types of Engines. Fuel Pumps. Standard and Transistorized Ignition. Generators. Alternators. Voltage Regulators. Starting Motors. Brakes. Power Steering. Universals. Dash Gauges. Automatic Transmissions—**AND MUCH, MUCH MORE**. Used by schools, service stations, the U.S. Armed Forces.

### Try this book at our risk

Just mail coupon. (Attach it to postcard for fast action.) We'll send manual to your home or shop. **TRY** it for 10 full days **FREE**! See for yourself what a time-saver it is. If this book doesn't pay for itself in the first 10 days, just return it and pay nothing, owe nothing. **MOTOR Book Dept., Desk 316, 250 W. 55th St., New York 19, N. Y.** (Schools, Bookstores: Write for discounts.)

**USED BY U.S. ARMY & NAVY AND THOUSANDS OF SERVICE STATIONS AND REPAIR SHOPS**

**OVER  
4,000,000  
COPIES  
SOLD**



**TRY BOOK  
FREE  
FOR 10 DAYS**

### MAIL COUPON NOW FOR 10-DAY FREE TRIAL (Attach to Postcard for Faster Action)

#### MOTOR BOOK DEPT.

Desk 316, 250 W. 55th St., New York 19, N. Y.

Rush to me at once **MOTOR'S New AUTO REPAIR MANUAL**. If O.K., I will remit \$2 in 10 days, \$3 monthly for 2 months and a final payment of \$1.95 (plus 45¢ delivery charges and sales tax, if any) one month after that. Otherwise I will return the book postpaid in 10 days.

Print Name.....Age.....

Address.....

City.....Zone.....State.....

Also send me for 10 days' Free Trial **MOTOR'S New TRUCK REPAIR MANUAL**. If O.K., I will remit \$11, plus delivery charges and sales tax, if any, in 10 days. Otherwise I will return book postpaid in 10 days.

**Check box and save 45¢** delivery charge by enclosing WITH coupon in envelope entire payment of \$9.95 for Auto Repair Manual (or \$11 for Truck Repair Manual) plus sales tax, if any. Same 10-day return-for-refund privilege.



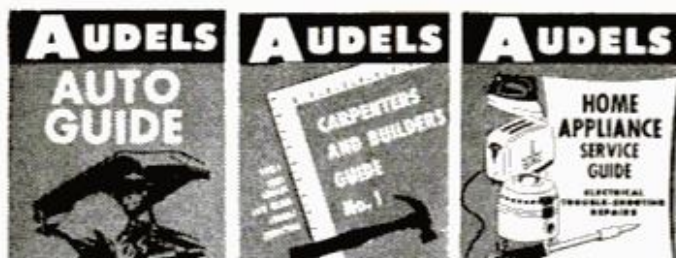

Ready guide for mechanics, students, & car owners. Theory, construction and servicing of modern cars. Illus. 1132 Pgs. \$6.00  
Circle No. 1 in COUPON

Four all-inclusive vols. Modern construction for carpenters, builders, and all woodworkers. 3700 Ill. 1600 Pgs. Set \$9  
Circle No. 8 in COUPON

How to fix elec. refrigerators, washers, ranges, toasters & all other gas & elec. appliances. 500 Illus. 864 Pgs. \$6.00  
Circle No. 2 in COUPON

No. 11	MATHEMATICS MADE EASY. 672 Pages	4.00
No. 14	REFRIGERATION & AIR CONDITIONING. 1360 Pages	6.00
No. 26	MASONS & BUILDERS GUIDES. 4 Book Set	9.00
No. 43	DO-IT-YOURSELF ENCYCLOPEDIA. 2 Book Set	8.95
No. 44	NEW MECHANICAL DICTIONARY. 712 Pages	6.95
No. 48	GAS ENGINE MANUAL. 480 Pages	4.00
No. 49	OUTBOARD MOTORS & BOATING GUIDE. 400 Pages	4.00

**7-DAY FREE EXAMINATION**  
SEND NO MONEY—Pay the postman nothing! We'll send you any of the Audel Guides for FREE examination. If you decide to keep the books you pay for them under our easy-pay plan of only \$2 a month.

**HERE IS ALL YOU DO**  
IT'S EASY TO ORDER: In the No-Risk Mail Order Coupon below draw a circle around the number of Guides you want. We will send them to you at once. If you are not completely satisfied, return the books to us.

**MAIL THIS COUPON TODAY!**

THEO. AUDEL & CO. — Self Improvement Publishers Since 1879 P6  
49 W. 23rd Street, New York 10, N.Y.

Please mail me for 7 days' FREE EXAMINATION the books I have circled below. I agree to mail \$2 in 7 days on each book or set ordered, and to further mail \$2 a month on each book or set ordered until I have paid the purchase price, plus shipping costs. If I am not completely satisfied with my Audel Guides I may return them.

NAME \_\_\_\_\_  
ADDRESS \_\_\_\_\_  
EMPLOYED BY \_\_\_\_\_

1 2 8 11 14       Check Here for Free Complete Catalog  
36 43 44 48 49

**SAVE SHIPPING COSTS!** Check here if you enclose complete payment with order. We pay postage charges. You have some return privilege.

## how you can make money FILING SAWS

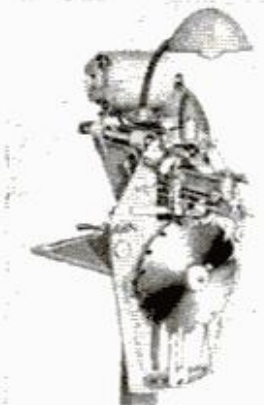

Have you ever thought about owning and operating at home a little business that you could work at when you felt like it? Not a big shop with high rent, overhead, and a payroll to worry about, but a small one-man business you could handle yourself in spare time? With the Foley Automatic Saw Filer you can quickly set yourself up in a business like that. All around you there are hundreds, even thousands of saws in daily use—saws that must be sharpened regularly.

**Earn BIG PROFITS for Lifetime Security!**  
The free Foley Plan Book shows how you can sharpen the saws in your community, and make steady cash profits in this essential service. It tells how to start, how to build, how to keep business coming in every week, and how to make up to \$6.00 an hour in spare time. Automatic filing machine requires no previous experience or special skill, for expert workmanship. Send postcard today for your free copy, with full details about how to get established with little capital and little space at home. No salesman will call. Everything will be mailed free, and you will not be under the slightest obligation.

**FOLEY MANUFACTURING COMPANY**  
616-3 FOLEY BLDG. • MINNEAPOLIS 18, MINN.



**NEW CATALOG for CRAFTSMEN!**

**WOOD..**

Workshop Supplies and Equipment, Kits Power Tools, Special Hardware **All at Money Saving Prices**

Get our new 132-page FULL COLOR Catalog. Finest domestic and rare imported hardwoods. Legs, mouldings, ornaments, mosaic tile, lamp parts, glue injector, upholstery supplies. Over 1,500 items. New project ideas and plans. Discounts on Stanley Tools. Send 25c for postage, handling.

**CRAFTSMAN Wood Service, Dept. A-6, 2729 S. Mary St., Chicago 8**

**75 POWER TELESCOPE \$3.98**  
25X-45X-75X

**NEW** 3 in one telescopes, 3 variable 25X-45X-75X magnification. Brass bound. 25 power for ultra bright images 45 & 75 power for long range. Guaranteed to bring distant stars, moons, objects, sports 75 times closer.

Most powerful scope sold anywhere near this amazing low price. American made, 5 sections, opens 36", closes 1 ft.; contains 4 ground & polished lenses. Mass production enables us to offer telescope complete at \$3.98 instead. Money back guarantee.

**CRITERION CO., Dept. PBM-10, 331 Church St., Hartford Conn.**

**AGCORDIONS UP TO 1/2 OFF**

Save up to 1/2 off retail prices of comparable accordions

**5-DAY FREE TRIAL:**  
Buy DIRECT from world's Largest Exclusive Dealer! Compare our Importer-to-You prices! See how you save! Over 30 models—finest genuine Italian makes! New, easier terms! 5-Day Free Home Playing Trial with satisfaction 100% assured. Bonus Gifts Free. Rush name and address for FREE Color Catalogs and direct Importer-to-You prices—FREE. Write TODAY!

**Accordion Corporation of America**  
2003 W. Chicago Av., Dept. R-63, Chicago 22

**1001 USES! WELDWOOD® FLEXIBLE WOOD-TRIM®**

**PROFESSIONAL LOOK TO PLYWOOD PROJECTS**  
Beautiful wood veneer, paper-backed, in handy rolls, 8' x 1", for edging plywood. Also, decorate lamp shades, book ends, do inlay work, etc. Apply with Contact Cement or Presto-Set® Glue. Oak, birch, African mahogany, walnut, fir, Korina®, At lumber, paint, and hardware dealer's. United States Plywood, Protection Products Div., Dept. PM 6-63, 2305 Superior Ave., Kalamazoo, Mich.

**22 FT. PARACHUTE**  
22 ft. Circ. **\$2.95**  
Bright orange color—complete with white rayon shroud lines. The cloth is worth more than the price of the chute! Use them for covers, children's play tents, shrub protection, lawn furniture covers, drag chutes, boat anchors, etc.

**16 PANEL NYLON—\$6.95**  
40 ft. Circ—14 ft. Across plus 50c Ppd. & Hdg.  
Pure white nylon with nylon shroud lines! Use them for drag chutes, drop-cloths, dust covers, tents, clothing, draperies, etc. Terrific buy!

**BOAT WHISTLE** Only **\$2.95**  
Chrome Plated  
Sounds like a steam job when you blow it. Heavy triple-plated chromium over brass. Made in West Germany. Has 3 pipes and safety-chain lanyard with attachment on end to hook onto any button, or nail. 6" long. 1 1/2" diam. Ideal for small boats and power boat owners. Only \$2.95. Two for \$5.70.

**EMPIRE MDSG., 140 Marbledale Rd., Dept. PM 663, Tuckahoe, N.Y.**



**BIG BOOM**  
**\$450**  
**CARBIDE CANNON**

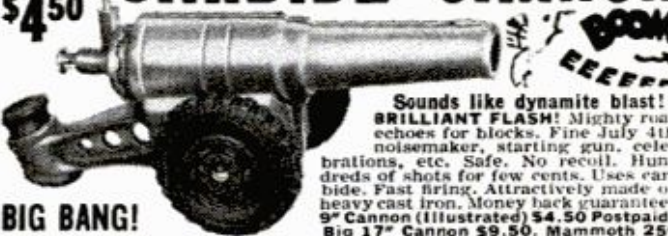

**BIG BANG!**  
 Cannon \$13.95. Ammunition 39¢ tube (500 shots), 3 tubes \$1.10.  
**JOHNSON SMITH CO., DEPT. 277, DETROIT 7, MICH.**

Sounds like dynamite blast! **BRILLIANT FLASH!** Mighty roar echoes for blocks. Fine July 4th noisemaker, starting gun, celebrations, etc. Safe. No recoil. Hundreds of shots for few cents. Uses carbide. Fast firing. Attractively made of heavy cast iron. Money back guarantee. 9" Cannon (illustrated) \$4.50 Postpaid. Big 17" Cannon \$9.50. Mammoth 25" Cannon \$13.95. Ammunition 39¢ tube (500 shots), 3 tubes \$1.10.

## TIRED OF WORKING FOR SOME ONE ELSE?

Send name for wonderful Free Book. Shows how to start your own business in spare time while holding job—how to build. We finance you for all but a few hundred dollars. Nat'l. advtg. brings you prestige and work. Write—**GRANT MAUK, 3-166, Duraclean Bldg., Deerfield, Illinois**

## Train Now For BIG Pay Jobs!

**EARTHMOVING EQUIPMENT OPERATOR**      **HEAVY EQUIPMENT REPAIR-REBUILDING**

**Green TECHNICAL INSTITUTE**

Get ready for a man's job in the booming road and construction industry. Operate cranes, "dozers," earth-movers, etc. Train "on the job" in 5 to 13½ weeks. Classes start weekly; reserve space now. Approved for vets. Complete catalog and reservation facts FREE. Write today!

Atten. P. F. Hutch, Box 368, Braidwood, Ill.

## REAL ESTATE BE A BROKER

**PAYS BIG! SEND FOR FREE, BIG, ILLUSTRATED CATALOG NOW!** Graduates report making substantial incomes. Start and run your own business quickly. Men, women of all ages, learn easily. Course covers Sales, Property Management, Appraising, Loans, Mortgages, and related subjects. **STUDY AT HOME** or in classrooms in leading cities. Diploma awarded. Write TODAY for free booklet! No obligation. Approved for World War II and Korean Veterans.

**WEAVER SCHOOL OF REAL ESTATE (Est. 1936)**  
 3521P Broadway      Kansas City, Mo.

## A Complete Miniature Machine-Shop!

**Metal - Plastics - Wood**

- Turns • Threads • Bores
- Drills • Mills • Grinds
- Polishes • Buffs • 900-7200 rpm • 16" of bench space

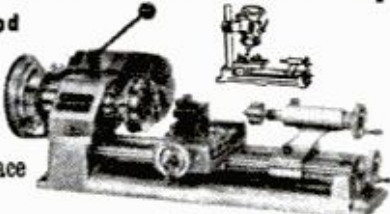

**BASIC UNIMAT:**  
 \$139.50 (includes high-efficiency motor). WRITE FOR FREE CATALOG.

**AMERICAN EDELSTAAL, INC., DEPT. GF, 350 BROADWAY, N.Y. 13, N.Y.**

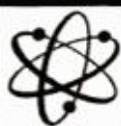

## ELECTRONIC ENGINEERING TECHNOLOGY

Associate of Science Degree • 24-months course

Professional technical career opportunities open to young men and women in broad range of activities: communications, computers, radar, aviatlional and navigational aids, industrial controls, guided missiles, etc. 15-week trimesters in Miami. Write today for FREE BULLETIN.

**EMBRY-RIDDLE AERONAUTICAL INSTITUTE**  
 (Founded 1926) a non-profit institute of higher education  
 Dept. B, Miami, Florida

Name .....  
 Address .....  
 City ..... Zone .... State .....

3-PM-63

## Dr. Grabow Continentals



The Dr. Grabow Symbol of Quality

World's Finest Imported Briar

Starfire ... \$ 4.95  
 Viscount ... \$ 5.95  
 Eldorado ... \$10.00  
 Pipes shown available in all three price ranges.

Dr. Grabow Pipes need no breaking in. They are mechanically pre-smoked and ready for you to enjoy the most in rich, sweet, cool, satisfying smoking.

Write for free booklet  
 Dr. Grabow Pre-Smoked Pipes • Greensboro, N. C.

Learn sand casting. See the basic steps in casting small items in home workshop molds in the July PM.

## GARDENCRETE CENTER



### A New Business Opportunity for Men of Modest Capital

Gardencrete Center denotes a new wayside industry, covering the making and selling of decorative masonry. It sparks latent possibilities into practical opportunities. Opens up new horizons for a business potentially huge but long neglected. It is a low-investment franchise operation, with exclusive privileges in protected territories. A timely business with fascination, interest, and opportunity for expansion. Markets are broad; profit possibilities are generous. Practically every home owner is a prospective customer. No experience or special building required. We supply complete equipment, as well as manuals covering manufacturing and selling. Thousands of good territories are available, but those who act quickly get the choice of the select.

Write at once for prospectus "The Gardencrete Center Idea".

W. E. Dunn, Manufacturing Co.  
 726 Ottawa Avenue  
 HOLLAND, MICHIGAN

Bird Baths  
 Lawn Seats  
 Flagstones  
 Screen Blocks  
 Flower Boxes  
 Vases & Urns  
 Brick & Stone for building  
 Planters  
 Walks  
 Patios  
 Etc.



**MY SPARE TIME HOBBY  
MAKES ME  
\$5<sup>00</sup> an hour  
CASH PROFIT**

— Grover Squires

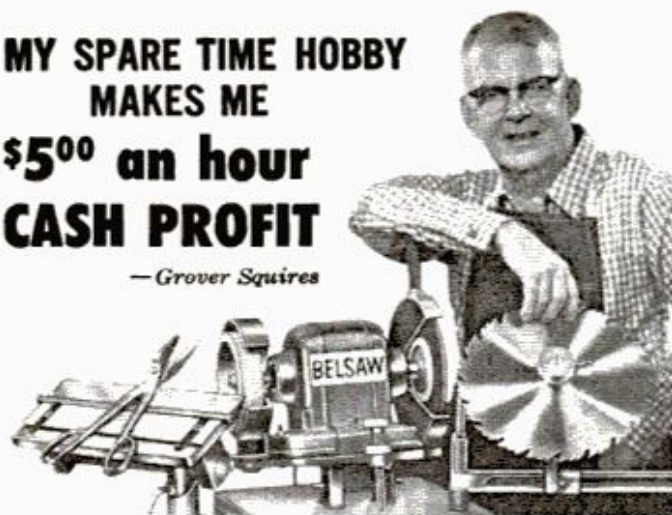

**START YOUR OWN SPARE TIME BUSINESS**

You can turn your spare time into Big Cash Profits with your own **COMPLETE SHARPENING SHOP** . . . Grind saws, knives, scissors, skates, lawn mower blades . . . all cutting edges. Your Own Cash Business with no inventory . . . right at home . . . no experience needed.

**FREE BOOK** tells how you can start your own spare time business while you are still working at your regular job. Low Cost — time payments only \$15.00 a month. Send coupon today.



**BELSAW SHARP-ALL CO.**, 713 Field Bldg., Kansas City 11, Mo.

Send Free Book "LIFETIME SECURITY". No obligation.

Name

Address

City  State



**Earn HIGH WAGES as a  
HEAVY EQUIPMENT OPERATOR**



. . . and years of future security in the multi-billion dollar construction industry, in this country and *overseas!* Learn how at National, the original school of heavy equipment operation. For men ages 17 to 56. Amount of previous *education no barrier.* National is **NOT** a correspondence school. You train on school-owned diesel-engined machines at National's huge proving ground in North Carolina. Full 220 and 440 hour courses. Full-time Job Advisory and Counselling Director for the exclusive benefit of graduates. VA approved. Payment plans available. Write **TODAY** for **FREE** catalog.

Since National School was founded eight years ago, students from all 50 states and 28 foreign countries have been enrolled. Hundreds of graduates are now working in construction for higher wages than they ever made before.

**NATIONAL SCHOOL  
OF HEAVY EQUIPMENT OPERATION** Dept. D-41  
P. O. Drawer 1686, Charlotte, N. C.

Please send me **FREE** illustrated school catalog and complete information. I understand there's no obligation.

Name  Age

Address

City  Zone  State



**Would You Like to Make \$1,000 A MONTH?**



That's what Stanley Hyman made selling the amazing new **Presto Fire Extinguisher!** Many others "cleaning up" — so can you! Amazing tiny new extinguisher ends fires fast as 2 seconds. **Guaranteed for 20 years!** Sells for only \$4.95. Write for **Free** sales kit.



Merlite Industries, Inc., Presto Div.,  
114 E. 32nd St., Dept. P-15H, New York 16, N. Y.

**EXCLUSIVE DOUBLE-BEARING  
HEAVY DUTY PUMPS**



**IRRIGATE • DRAIN • CIRCULATE • SPRAY**

Use 1/4 HP motor or larger . . . 3 HP for up to 5,200 GPH; 1,000 GPH 60" high; or 3,000 GPH from 25' well. 1 1/2" inlet; 1" outlet. Stainless shaft.

**TYPE X-2** oil-less bronze bearings. **\$10.95**

Won't rust . . . Best for belt drives. **\$12.95**

**TYPE XB**—Ball bearing model. **\$12.95**

Postpaid if cash with order.

Don't delay—send for yours today!

**MONEY BACK GUARANTEE!**

Centrifugal and Gear Pumps in All Sizes  
**LABAWCO PUMPS, Belle Mead 2, N. J.**

**EMBLEMS-LETTERED JACKETS**



New! Illustrated catalog featuring emblems & lettered sportswear personalized with your name, the name of your team, club, school, or team. Buy direct & save.

RUSH TO TODAY FOR DISCOUNT CATALOG. **National** DEPT. M-101  
1777 PASSAIC ST. NEWARK 6, N. J.

**T/SHIRTS • SPORTSWEAR**

**HOW ABOUT A PERSONAL  
TOUR INSIDE THE '63 CARS?**

Send for an exciting and thorough report of features and statistics on Detroit's latest, including a reliable service check list, yours for only 25¢. Write **Comfort-Convenience Chart, Popular Mechanics Reader Service Bureau, 575 Lexington Avenue, New York 22, New York.**

**MAGIC MAIL PLAN  
that comes with this Little Machine  
CAN MAKE YOU \$5<sup>00</sup> AN HOUR**



The machine is turning out a job that will bring operator \$2.58, by mail. Material cost, only 11c!

Write today for free facts about the newest and most fascinating of all new home operated businesses. For the first time, a simplified machine brings the fabulous profits of Plastic Sealing and Plastic Laminating within reach of the small operator. Anyone can learn to operate it with a few minutes practice. Then—with our **MAGIC MAIL PLAN**—can get mail orders pouring in daily with cash in every envelope.

**No Canvassing or Selling**

Fill orders at home in spare time to start. Then expand to full time business. We even supply circulars to bring back cash and orders. Rush name for all the facts you need to start. A postcard will do. No charge.

**WARNER ELECTRIC CO., Dept. L-2-F**  
1512 Jarvis, Chicago 26, Illinois

# "\$7,108.50 First Year SERVICING RADIATORS!"

— Hank Konter, Newcastle, Wyo.

Make good money servicing auto-truck-tractor radiators with new Inland 1-Piece Radiator Shop. Easy to test-clean-repair radiators. Inland, world's largest radiator equip. mfr., trains you free. Small down payment starts you. Easy-pay plan lets you pay from profits. Proved merchandising assures volume. Profitable dept. for garage or service station. **WRITE for Free Book.** INLAND MFG. CO., Dept. PM-6, 1108 Jackson, Omaha 2, Nebr.



NEW!

## Luger Fiberglass or Plywood **BOAT KITS** Save You Money!

**FREE 64 PAGE Full Color Boat Kit Catalog**

Save \$1000 to \$2500 on 18'-20'-22' LUGER LUXURY CRUISERS . . .

Save to \$500 on speedy 14' or 16' Molded Fiberglass Runabouts! *Over 50 Models!* Easily assembled by anyone with ordinary tools. Every part and every section comes pre-cut, pre-assembled or precision molded from factory. Just put sections together! Many models take only one or two evenings to complete. Easy Terms! 3 Years to Pay! *Money Back Guarantee!* Rush name, address for big full color catalog—64 pages—FREE! Write

**LUGER BOAT KITS, Dept. B-63**  
9200 Access Road, Minneapolis 31, Minn.



## BARBELLS

140-Pound, CHROME DELUXE Barbell-Dumbbell set only \$19.80.

This is our feature set and is the finest ever manufactured.

Training with adjustable weight is the BEST way to keep fit; the ONLY way to develop great strength and a perfect body. As the oldest and best equipped barbell company, BUR gives value and prices no one can equal.

**SEND FOR FREE CATALOG**

**BUR BARBELL CO.**  
Lyndhurst 9, New Jersey

**100 POUND SET**

**\$12.80**

Extra Plates Only 12c Pound

**BRAND NEW—7 x 50 BINOCULARS!**  
Zeiss-type precision lenses; coated for color-correct, sharp, fresh viewing! Excellent for boating, fishing, hunting, vacationing, etc. . . . In fact, for anyone that wants big, clear, long range viewing at modest cost. Sturdy die-cast aluminum frames. Dual eye center focus. Carrying case included.

**ONLY \$16.95 postpd.**  
Money Back Guarantee. Send check or M.O. Ga. residents add 3% state tax.

**H. R. AUVIL ENTERPRISES**  
RR1 WARNER ROBINS, GA.

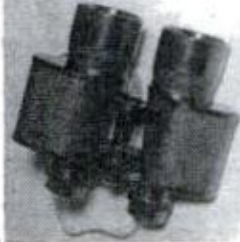

# MEN PAST 40

**Afflicted With Getting Up Nights,  
Pains in Back, Hips, Legs,  
Nervousness, Tiredness.**

If you have these troubles, particularly getting up nights, then your condition may be traced to Glandular Inflammation . . . a constitutional disease. Neglect of this condition often leads to premature old age and sometimes incurable conditions.

The Excelsior Medical Clinic has a New Free Book that tells how thousands of men have been successfully treated here at Excelsior Springs for Glandular Inflammation by **NON-SURGICAL Methods**. They found soothing relief and a new outlook on life.

This Free Book may prove of utmost importance to you. Write Today. There is no obligation.

Excelsior Medical Clinic, Dept. B6140, Excelsior Spgs., Mo.

JUNE 1963

## MANUFACTURE THIS BEAUTIFUL CONCRETE OUTDOOR FIREPLACE

Right In Your Own Backyard

**\$4.00 Worth of Sand & Cement produces this Attractive Fireplace.**

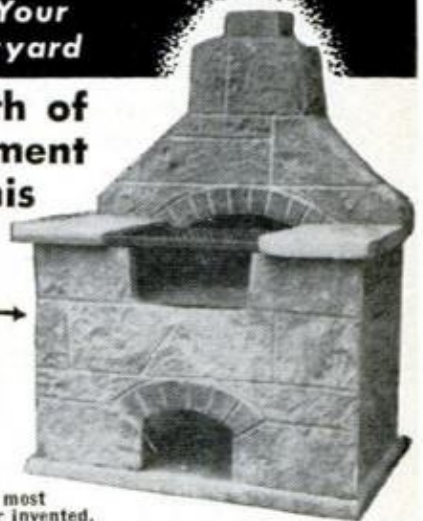

**Sells on Sight from \$60. to \$80. Easy to start your own Profitable Business.**

The General Fireplace Molds and Process are the most amazing and foolproof ever invented. Simple to operate. Two men can produce five fireplaces a day.

### BIG DEMAND!!

Sell all you produce to Department Stores, Homeowners, Parks, Nurseries and Picnic Groves. Fireplaces sell on sight. No experience necessary. We supply full operating instructions and equipment plus the know-how that spells **BIG PROFITS**. This is an outstanding opportunity for men of vision and small capital to get into a busy rich paying field. Don't delay, be the only exclusive manufacturer in your own home town. Mail coupon at once for full details as to how you can reserve your territory. **Molds sold only on exclusive franchise.**

**GENERAL ENGINES CO., Inc., Dept. MF-63**  
ROUTE 130, THOROFARE, N. J.

Mr. Tor of Philadelphia writes: Sold 250 in first 4 months. Selling to Sears Roebuck, John Wanamaker, and Gimbel Bros. in Philadelphia area.

Name \_\_\_\_\_  
Address \_\_\_\_\_  
City \_\_\_\_\_ Zone \_\_\_\_\_  
State \_\_\_\_\_

# ELECTRONICS

Train in the new shop-labs of the world famous  
**COYNE ELECTRICAL SCHOOL** on a quarter of a million dollars worth of equipment. Est. 1899—Non-Profit Institute.  
Courses: Electronics • Electricity • TV-Radio.

Use this coupon to get our free book  
"YOUR OPPORTUNITIES IN ELECTRONICS"  
COYNE ELECTRICAL SCHOOL Educ. Serv. Dept. A3-S  
1501 W. Congress Parkway, Chicago 7, Ill.

NAME \_\_\_\_\_  
ADDRESS \_\_\_\_\_  
CITY \_\_\_\_\_ STATE \_\_\_\_\_

Unlike most other schools, we do not employ salesmen.

## NO.1 for boating fun!



BOATS, CANOES,  
TRAILERS

FIBERGLAS BOATS

**write for FREE Catalog**  
**ALUMA CRAFT** BOAT DIVISION • ALPEX CORP.  
1519 Central Ave. N.E., Minneapolis 13, Minnesota

# RCA introduces a new easy way to learn electronics at home

Learn faster, remember more with this revolutionary new "learning method!" And RCA institutes is first to bring it to you! Forget all your old ideas about learning! The newest method, RCA "Autotext", uses the latest scientific development in the field of home training! RCA "Autotext" is a system of programmed instruction that helps you learn more quickly with less effort.

Complete Home Training Course using new RCA "Autotext" now available! "Introduction to Electronics" gives you the advantages of RCA "Autotext" plus theory lessons, service practice lessons, and all the kits you need! Send for complete information now and FREE SAMPLE Home Training lesson!

Wide Choice of Home Training Courses in Electronics! In addition to "Introduction to Electronics" RCA Institutes offers this complete selection of Home Training Courses:

- Electronic Fundamentals
- TV Servicing
- Color TV
- Transistors
- Electronic Drafting
- Communications Electronics
- FCC License Preparation
- Mobile Communications
- Automation Electronics
- Computer Programming

RCA Institutes Liberal Tuition Plan affords you the most economical possible method of home study training! You pay for lessons only as you order them. If you should wish to interrupt your training for any reason, you do not owe one cent!

Classroom Training Available in New York City, Los Angeles, and Cherry Hill (near Camden) New Jersey. Check "Classroom Training" on the coupon and information will be rushed to you.

SEND FOR FREE ILLUSTRATED BOOK TODAY! SPECIFY YOUR CHOICE OF "AUTO TEXT", HOME TRAINING, OR CLASSROOM TRAINING!

RCA INSTITUTES, INC., Dept. PM-63  
A Service of Radio Corporation of America  
350 West 4th St., New York 14, N. Y.  
Pacific Electric Bldg., 610 S. Main St.,  
Los Angeles 14, Calif.



THE MOST TRUSTED NAME  
IN ELECTRONICS

RCA INSTITUTES, INC., Dept. PM-63  
350 West 4th St., New York 14, N. Y.

Rush me FREE information about "Autotext"  
Home Training \_\_\_\_\_, Classroom Training (Choice of  
City) \_\_\_\_\_ No salesman will call.

Name .....

Address .....

City..... Zone.... State.....



worth  
writing  
for . . .

## LAW FREE BOOK THE LAW TRAINED MAN

Write today for a FREE copy of illustrated law book, "THE LAW TRAINED MAN," which shows how to earn the professional Bachelor of Laws (LL.B.) degree through home study of the famous Blackstone Law Course. All necessary books and lessons provided. Moderate cost; convenient monthly terms. Write for FREE law training book today.

Blackstone School of Law, 307 N. Michigan Ave.  
Founded 1890 Dept. 50-A, Chicago 1, Illinois

## LEARN FIBERGLASSING at Home in Spare Time

Interstate's complete home training course in Plastics Fabrication teaches fiberglassing, plastic molding, casting, laminating, internal carving, etc. Shows how to make hundreds of salable articles of plastic. Professionally prepared. Special materials furnished. Send postcard for FREE booklet.

INTERSTATE TRAINING SERVICE  
Dept. C-3, Portland 12, Oregon



Do It Yourself  
and Save

New Beauty,  
Strength and  
Quality for '63

ADJUSTABLE  
Railings  
and Columns

DEMAND GENUINE *Versa* PHOS-FUSED

IMITATED BUT NEVER DUPLICATED  
SEE YOUR LUMBER OR HARDWARE DEALER

Write for Free Bonus Certificate and How to Plan Ideas

VERSA PRODUCTS COMPANY  
LODI 27, OHIO • TIFTON 2, GA.

## LITTLE PUMP DOES 1000 BIG JOBS

QUICKLY DRAINS CELLARS AND POOLS  
FILLS TANKS • IRRIGATES • SPRAYS



Pumps up to 5000 GPH. Up to 60 ft. head.  
Threaded, 1 1/4" intake, 1" discharge. Rust-  
free aluminum castings. Superior design. Top  
quality. Fits any motor. Satisfac-  
tion guaranteed or money Standard Model  
refunded. Send check or M.O. \$1  
deposit on C.O.D.'s. Flexible  
drive coupling \$1 extra. **895** ppd.

Heavy Duty Ball Bearing Model . . \$12.95 ppd.  
AMERICAN MACHINE & TOOL CO., INC.

Dept. PM-63, Royersford, Pa.

## For a Complete Book of Professional Secrets

Plus Illustrations  
Of Products  
And Prices Of  
Over 300 Different  
Molds You Can Use  
To Make And Sell  
Ornamental  
Concrete Items . . .

SEND \$2.00



rushed to you by FIRST CLASS MAIL

CONCRETE MACHINERY COMPANY, INC.  
839 Lenoir Rd. - P. O. Box 99 - Hickory 2, N. C.

## PARKWAY ANTHRAFILT POOL FILTER KIT

- 10-Gallon Tank with Bolt-on Cover
- Epon Phenolic Lining
- 30 lbs. Anthrafil Filter Media
- 3 Super Flex Hoses
- Aluminum Pump
- Heavy Duty Brass Strainer
- Uses Your Own 1725 RPM 1/3 or 1/4 H.P. Motor\*
- Assembles in Minutes with Instructions and Fittings

RSA100

**29<sup>88</sup>**  
List  
49.95

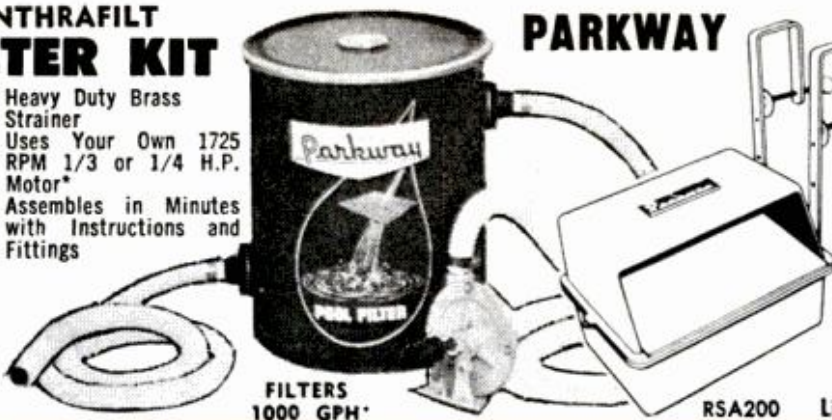

FILTERS  
1000 GPH\*

PARKWAY

## AUTOMATIC TOP POOL SKIMMER

Easily attaches to intake hose of filter for automatic skimming action. Cleans floating and surface debris. High impact poly-styrene and poly-propylene floating weir with amazing "living hinge", removable leaf strainer, adjustable anodized aluminum support brackets.

Dealer  
Inquiries  
Invited

RSA200

List 14.95

**11<sup>95</sup>**

Send Check or M.O., Sorry, No C.O.D. • All Prices F.O.B. S. Plainfield, N.J.  
PARKWAY INDUSTRIES BOX 123 DEPT. PM S. Plainfield, N.J.

## How To Hold

# FALSE TEETH

More Firmly in Place

Do your false teeth annoy and embarrass by slipping, dropping or wobbling when you eat, laugh or talk? Just sprinkle a little FASTEETH on your plates. This alkaline (non-acid) powder holds false teeth more firmly and more comfortably. No gummy, gooey, pasty taste or feeling. Does not sour. Checks "plate odor" (denture breath). Get FASTEETH today, at drug counters everywhere.



## LEARN MEAT CUTTING

Train quickly in 8 short weeks at Toledo for a bright future with security in the vital meat business. Big pay, full-time jobs—HAVE A PROFITABLE MARKET OF YOUR OWN! Pay after graduation. Diploma given. Job help. Thousands of successful graduates. Our 40th year! Send NOW for FREE catalog. No obligation. GI approved. NATIONAL SCHOOL OF MEAT CUTTING, Dept. 50-U, Toledo 4, Ohio

send  
for  
FREE  
BOOK  
TODAY



Transistor  
Radio with  
Battery  
\$1.96

17-Jewel  
Watch  
\$2.87

Darringer  
Pistol \$5.74

## HOME-IMPORT BUSINESS—Make Big Profits

New Drop Ship Plan offers you first day profits! Deal direct with overseas sources at prices shown. Dazzling bargains with no investment. Full or spare time. Write for FREE BOOK today to... MELLINGER, 1554 S. Sepulveda, Dept. K256, Los Angeles 25



## Excitement! Security! Good Pay! CRIME DETECTION

LEARN AT HOME IN SPARE TIME—START NOW!

Crime everywhere is on the rise! Learn now, in your own home, the profitable profession that enables you to track down criminals and bring them to justice! Hundreds of Identification Bureaus employ I. A. S. graduates. . . trained in finger printing, police photography, handwriting identification, firearms and investigation. Our 44th year! FREE "Blue Book of Crime" . . . packed with crime facts and the full story of famous I. A. S. training. State exact age. No salesman will call. Rush Coupon! A Correspondence School Founded in 1916.

FREE  
Blue Book  
of Crime  
MAIL  
COUPON

INSTITUTE OF APPLIED SCIENCE, Dept. 135-A  
1920 Sunnyside Avenue, Chicago 40, Ill.  
Rush Blue Book of Crime . . . FREE!

NAME.....Age.....  
ADDRESS.....  
TOWN.....STATE.....

Earned \$2,000 While Training!



Says ROBERT N. MILLER, Oakland, N. J. "I became a locksmith when a back injury forced me to give up my job as a truck driver. Now I own a successful mobile locksmithing shop."

# Be a LOCKSMITH



Add 50%-100% to YOUR INCOME with easy spare time earnings. Cash in on nationwide shortage . . . in good times and bad. Quickly step into a big-pay opportunity job—high profit shop of your own.

Earn Extra Money RIGHT AWAY! All Special Tools, Supplies Furnished.

Age, education, minor physical handicaps don't matter in this growing trade. You can quickly qualify as a skilled locksmith. Study at home as little as one hour a week. Gain practical experience through well-illustrated lessons. Do real jobs on car locks, house locks, padlocks and safe locks, under guidance of experts.

FREE Illustrated Book

For a future as your own boss or in a high-pay job, send for FREE book and sample lesson pages. Only school of its kind. Lic. State of N. J. Accredited Member N.H.S.C. Vet. App'd. Locksmithing Institute (Div. of Tech. Home Study Schools), Dept. 106-3, Little Falls, N. J.

**306**  
pieces of  
equipment—  
Locks, Picks,  
Tools & Parts  
**SUPPLIED**

for use with  
course.

MAIL COUPON NOW!

Please send, without obligation, FREE Book, "Big Money in Locksmithing," and Sample Lesson Pages. No Salesman will call.

LOCKSMITHING INSTITUTE  
Dept. 106-3  
Little Falls, New Jersey

Name.....  
(Print here)

Address.....

City.....Zone.....State.....

Check if Veteran

## PROFIT IN YOUR SPARE TIME



SMALL ENGINE REPAIR PAYS BIG!

Outboard • Powermower • Chain Saw • Tractor  
MAKE EXTRA MONEY — or fix your own engines and SAVE! Illustrated, easy-to-learn Home Study Course qualifies you as expert. Free information. Write today!

LINCOLN TECHNICAL INSTITUTE  
SUITE 6-E, 472 MARKET STREET, NEWARK 5, N. J.

# You Can Still Finish HIGH SCHOOL Graduate Now!



What does a High School Diploma mean to you? Increased earning power? A wider choice of respected careers? Faster promotions? A richer, fuller life? **All this—and more—can be yours more easily than you think.** You "attend" high school at home, in spare time... study at your own pace. Take only the subjects you need for your Diploma. Expert instructors guide you, step by step. It's easy. It's fun.

**Latest, Approved Textbooks—Yours to Keep.** You build a fine library to use and enjoy for a lifetime. Everything included in one low tuition.

Send for Free "Opportunity Book" Now!  
**YOU ENROLL BY MAIL**  
No salesmen means lower costs for us, lower tuition for you.

**National Schools**  
HIGH SCHOOL DEPARTMENT  
Santa Barbara at Figueroa  
Los Angeles 37, Calif.  
Accredited Member—  
National Home Study Council

HIGH SCHOOL AT HOME • HIGH SCHOOL AT HOME

**National Schools**  
HIGH SCHOOL DEPARTMENT Los Angeles 37, Calif.

Please send Free High School Opportunity Book Dept. SB-63

Name \_\_\_\_\_ Age \_\_\_\_\_

Address \_\_\_\_\_

City \_\_\_\_\_ Zone \_\_\_\_\_ State \_\_\_\_\_

## LEARN UPHOLSTERY

in your spare time run your own business AT HOME

**FREE BOOK with sample lessons**

**With Course You Make**

**SLIPPER CHAIR**

**CLUB CHAIR**

**OTTOMAN**

**PLUS SLIP COVERS**  
Yours to Keep or Sell

**BE YOUR OWN BOSS**  
Earn more from the start in spare time. STOP worrying about layoffs, enjoy a steady growing income and lifetime independence in the booming field of Custom Furniture Upholstery. Right off, you start upholstering with the tools, complete frames, fabrics and materials included with your N. Y. State-approved UTS Home Study Course. You learn skilled professional custom upholstery, reupholstery, furniture finishing, repairs, how to make valuable custom slip covers, cushions and draperies **EARN WHILE YOU LEARN**, in your spare time AT HOME... the UTS easy way. **FREE ILLUSTRATED BOOK—FREE SAMPLE LESSON** Get ready for well-paid job and big profits, from steady work, as your own boss, running your own business.

**MAIL COUPON NOW FOR FREE BOOK!**  
**VET APPV'D. ACC'DT. MEMBER NHSC**

**UPHOLSTERY TRADES SCHOOL, Dept. RH-310, P.O. Box 102, Cooper Station, New York 3, N.Y.**

Please send me **FREE** book, "Your New Way to a Successful Career," and **FREE** sample lesson. No obligation—no salesman will call.

Name \_\_\_\_\_ (Please Print Plainly)

Address \_\_\_\_\_

City \_\_\_\_\_ Zone \_\_\_\_\_ State \_\_\_\_\_

Check if Korean Veteran

worth writing for...

## engineering degree in 27 months

College graduates have higher income, advancement. Major corporations visit us regularly to interview and employ seniors. **BACHELOR OF SCIENCE DEGREE IN 27 MONTHS** in Electrical, Mechanical, Aeronautical, Chemical, Civil Engineering. **IN 36 MONTHS** a B.S. Degree in Business Administration (General Business, Accounting, Motor Transport Administration majors). One-year Drafting-Design Certificate Program. Small classes. More professional class hours. Well-equipped labs. Campus. Modern dorms. New library. *Moderate costs.* Founded 1884. Enter September, January, March, June. Write **J. E. McCarthy** for Catalog and "Your Career in Engineering and Commerce."

**TRI-STATE COLLEGE** 463 College Avenue  
Angola, Indiana

## NO JOB WORRIES

PLASTEX INDUSTRY needs manufacturers on small scale for big production of Lamps, Clock Stands, Art Goods, Novelties in Plastic Marble imitation. No Experience necessary. 1/2¢ material makes regular 10¢ store sellers. Moulds furnished for fast production. Small investment brings good profit. Big wholesale orders now being placed. Ambitious men have chance for real prosperity and job security. Our NEW FREE booklet will interest and benefit you.

**PLASTEX INDUSTRIES, Dept. A**  
3400 Third Ave. New York 56, N. Y.

## Little Champ

**LIST \$495** **ECONOMICAL FAMILY CAMPER**  
Sleep in protected comfort  
Easily sleeps four  
Tent expands living area for extended stays

**LIST with tent \$595**  
Write for complete information

**Champion Home Builders Co. DRYDEN, MICHIGAN**

Automation hits the lawn. A permanent underground lawn sprinkler has timing and sensory devices that trigger it at the proper time. See it in July PM.

## BE A BRIKCRETE MANUFACTURER

**B-28**  
\* Truly — No Clay

**More Local Plants Needed**  
As a local manufacturing opportunity, Brikcrete has much to offer. Local markets are supplied by local plants using local materials and labor. Savings in freight and distribution enable low selling prices, high income potentials. Plants operate in franchise-protected territories with exclusive privileges. For men of modest capital, machinery is available on long-term payment.

Because Brikcrete gives so much more for so little it is the preferred masonry for homes, schools, motels practically every kind of residential, commercial, and industrial construction. A lower-than-lumber selling price still permits 100% or more mark-up on basic production costs. And Brikcrete has quality appeal because it is outstanding in design, proportion and color. That is why market possibilities are so broad. Write or wire for **Brikcrete Book No. 2.**

**W. E. Dunn Manufacturing Co.**  
402 W. 25th, Holland, Mich.

# TRAIN AT HOME FIX any TV or RADIO



MAKE UP TO \$5 AN HOUR

Start soon fixing sets for friends and neighbors in spare time. Be ready for a full-time business of your own when you graduate. Rapid growth of color TV, stereo hi-fi, home and car radios, PA systems, other electronic equipment means higher earnings for the trained Technician. Low monthly payments include special training equipment. NRI is oldest, largest school of its kind. For FREE Catalog, write NRI, Dept. 3FA, Washington 16, D.C.

## GUITARS **Big Discounts** BUY DIRECT! Famous Brands

E-Z TERMS  
5-Day FREE Trial

SAVE! BIG DISCOUNTS! Nationally advertised guitars. Over 100 models, all styles, for students and professionals. Low as \$19.95! DIRECT from Wholesaler-to-You. Easy Terms, low as \$5.00 down! FREE Home Study Course and Bonus Gifts! Discounts on banjos, mandolins, ukes. Satisfaction or money back. Free Color Catalogs, low discount prices. Write: **GUITAR WORLD, Dept. R-63**  
2003 W. Chicago Ave., Chicago 22, Illinois



## FREE "How To Start Your Own MAIL ORDER BUSINESS"

Work from your home. We supply top-notch mail order catalogs imprinted with your name and address. Simply mail out to prospects and all orders come directly to you. We carry all stock and drop-ship for you. Write today for details and free booklet. No obligation.

STATILE CO., MAIL ORDER DIVISION, MONTVALE 8, N. J.

## A BUSINESS OF YOUR OWN REPAIR HYDRAULIC JACKS



Earn while you learn at home. Millions of jacks in gas and auto-service stations, truckers, body-shops, riggers, factories, farms need servicing. We show you HOW — easy step by step directions and what tools to use. EARN UP TO \$5 an hour, in spare time, in your basement or garage. Start your own business NOW! Write for folder PM-6 and free bonus offer

**INSTITUTE OF HYDRAULIC JACK REPAIR**  
P. O. BOX 50 • BLOOMFIELD, N. J.  
A Correspondence School Licensed by N. J. Bd. of Ed.

## DO MORE PLANING JOBS WITH LOW COST BELSAW



Exclusive MONEY-MAKING Features: Full 12 1/4" x 6" capacity • Power feeds at 14' to 34' a minute • Provides for Grinding Knives in the Cutter-head • Attachments for Jointing, Rabbering, Tongue, Matching, Groove. Convert low cost rough lumber into high priced stock. Easy to make flooring and popular patterns. Send Today for FREE Literature and Prices.

Belsaw Machinery Co., 2053 Field Bldg., K.C. 11, Mo.

## Shrinks Hemorrhoids New Way Without Surgery Stops Itch — Relieves Pain

For the first time science has found a new healing substance with the astonishing ability to shrink hemorrhoids and to relieve pain — without surgery.

In case after case, while gently relieving pain, actual reduction (shrinkage) took place.

Most amazing of all — results were so thorough that sufferers made astonishing statements like "Piles have ceased to be a problem!"

The secret is a new healing substance (Bio-Dyne®)—discovery of a world-famous research institute.

This substance is now available in suppository or ointment form under the name Preparation H®. Ask for it at all drug counters.

JUNE 1963

# LEARN



- AUTO MECHANICS
- DIESEL MECHANICS
- BODY & FENDER REPAIR\*
- GAS, ARC WELDING
- HELIARC WELDING
- DRAFTING
- REFRIGERATION
- AIR CONDITIONING
- MACHINIST-TOOL & DIE\*
- AUTOMATIC TRANSMISSIONS\*
- MOTOR TUNE-UP\*

## \$ EARN MORE MONEY \$

Skilled men are needed in every part of the country. Earn top pay in established shops or start your own business. Greer's expert instruction and actual shop training teaches you how. Quick, easy courses using the latest tools and equipment. Resident training, also Home Study courses which leads you to practical training in our school without leaving your present line of work. Job placement aid and convenient living accommodations are yours while training. Contact GREER'S FREE JOB PLACEMENT SERVICE when you enroll if you wish part time or full time employment assistance.



- TECHNICIAN COURSES\***
- DIESEL AUTOMOTIVE TECHNICIAN—21 MONTHS
  - REFRIGERATION & AIR COND. TECH—17 MONTHS
  - WELDING TECHNICIAN—14 MONTHS

Please send me free booklet on the trade indicated at no obligation.

NAME \_\_\_\_\_ AGE \_\_\_\_\_

STREET \_\_\_\_\_

TOWN \_\_\_\_\_ ZONE \_\_\_\_\_ STATE \_\_\_\_\_

\*RESIDENT COURSE ONLY RESIDENT  HOME STUDY

## GREER SHOP TRAINING

Established 1902  
BOX F, 2236 S. Michigan Ave., Chicago 16, Ill.

20 COURSE  
HOME STUDY  
PROGRAM

## KARATE!



**JUDO** BOXING! MUSCLEBUILDING! YOGA!  
STRONGMAN STUNTS! STRENGTH & ENDURANCE! HANDBALANCING! etc.

YOU GET ALL THESE COURSES! \*20 illustrated KARATE blows \*SAVATE foot fighting \*Secret NERVE CENTER and ANATOMY charts \*20 lethal JUDO throws \*20 terrific STRONG-MAN STUNTS \*Complete MUSCLE-BUILDING course \*Ancient YOGA secrets \*HANDBALANCING stunts \*Complete BOXING course. Secrets of ENDURANCE \*WRESTLING holds \*WEIGHTLIFTING \*TENSION-FLEX COURSE \*HEALTH & FITNESS EXERCISES \*KEEP FIT PROGRAM \*K-MAN Karate Dummy Chart. No C.O.D.'s, Canadian 75c. YOU GET THE LOT.

ONLY 50c

COMPLETE HOME GYM PLANS—Build gym equipment: vault horse, rowing machine, etc. Convert basement, garage to gym. ONLY 50c with courses. Total \$1.00 compl.

OXFORD STUDIO, 44A15 Bromfield, Boston, Mass.

NAME (print) \_\_\_\_\_ \$50c PROGRAM

Address \_\_\_\_\_

City \_\_\_\_\_ State \_\_\_\_\_ \$1.00 with GYM

## PARADOX SELF PRIMING PUMP



LITTLE IN SIZE—BIG IN PERFORMANCE



It pumps as little as one drop—as much as 30 gallons in a minute. Will deliver 18 G.P.M. through 50 ft. of 3/4" hose.

\$99.50

**PUMP**—centrifugal type. Only one moving part. Light weight—8 lbs. in aluminum—10 lbs. in bronze. Impeller, cast bronze. Seal, mechanical type. Self priming from low lift by adding water into discharge. **ENGINE**—two cycle easy to start. Rugged recoil type starter. Three ring piston. Demand type diaphragm carburetor. Extremely active throttle governor.

**DEALER TERRITORIES OPEN! MARINE AND SPORTING GOODS LINES ALSO AVAILABLE. WRITE TODAY!**

**ROYAL DISTRIBUTORS** 256 E. CENTRAL AVE. LA HABRA, CALIF.

## NEW AEC 77 transistorized ELECTRONIC IGNITION



- Increases engine power up to 10%
- Assures fast starts at low rpm
- Full power at high rpm
- Up to 20% more mpg
- Prevents fouled plugs
- Increases spark plug life 3 to 5 times over normal
- Insures 75,000 mile breaker point life
- Gives instant starting in sub-zero weather
- Eliminates frequent tune-ups
- Simple 20 minute installation.

In conventional ignitions, high voltage at the spark plugs falls off from 28,000 volts to 13,000 volts as engine speeds increase. The result is a weak spark causing incomplete combustion, fouled plugs, loss of power, and poor gas mileage. AEC 77 Transistor Ignition increases and maintains high voltage at 30,000 volts to guarantee a strong "hot" spark for complete combustion, delivering full engine power beyond 10,000 rpm, and up to 20% more mpg.

**WORLD CHAMPION RACING DRIVER, PHIL HILL, USES AEC 77 . . . reports "AEC 77's strong spark can make up for worn points and spark plugs. It will make your car run smoother at all speeds and appreciably improve its performance and economy."**



AEC 77's use quality components such as General Motors Delco type 2N1100, high voltage, 15 ampere transistors, and Motorola type 1N2836B, 50 watt zener diodes . . . while others use two low voltage transistors in series with two 1 watt zener diodes, that can cause synchronization problems and premature failures. Every Transistor 77 (400:1) Ignition Coil is epoxy-oil impregnated and hermetically sealed for maximum insulation and cooling . . . while others use tar filled coils that cannot handle the power loads AEC 77 delivers.

Proven in over 2,000,000 miles of testing, AEC 77 is so dependable in performance, design, and engineering, that every unit is registered and guaranteed for 3 full years.

### FREE TRANSISTOR TUNE UP METER

Available only from Automotive Electronics Co. . . . at no extra cost . . . with every AEC 77 system ordered.



#### COMPLETE DO IT YOURSELF KIT!

AEC K4 - Negative Ground only . . . \$32.95

#### NEED COILS & BALLAST RESISTORS ONLY?

Transistor 77 (400:1) Ignition Coil . . . \$11.95

Ballast Resistor - (.5 ohm-90 watt) . . . \$ 1.25

#### COMPLETE FACTORY WIRED SYSTEMS!

AEC 77 with (400:1) Ignition Coil

6/12 volt systems . . . \$39.95

AEC 77 Positive Ground for British Cars only

6/12 volt . . . \$54.95

#### ORDER NOW

Please add 75c for postage and handling!

AEC, 387 PARK AVE. SOUTH, NEW YORK 16, N.Y.

**AUTOMOTIVE ELECTRONICS CO.**  
387 Park Ave. South, N. Y. 16, N. Y.

NAME .....

ADDRESS .....

CITY..... ZONE..... STATE.....

AEC-77 For Negative ground cars 6/12v \$39.95

AEC-77 For Positive ground cars 6/12v \$54.95

K4 Kit \$32.95  400:1 Coil \$11.95  Ballast \$1.25

FREE BROCHURE on AEC units. **PM-6**

worth  
writing  
for . . .

**make your own Gems 36<sup>50</sup>**  
F.O.S.

The Gem Maker comes complete with all necessary equipment, including a super-charged diamond blade for sawing, and all the wheels for grinding, shaping and polishing; also complete instructions. The complete equipment as shown, less motor and belt for only \$36.50. F.O.S., Burlington, Wisconsin. Write today for information and literature.

**B & I MANUFACTURING CO.**  
Dept. P, Burlington, Wis.

**12-TRANSISTOR 2-WAY WALKIE TALKIE**

Superb citizens band performance. Lightweight. Model HE-100L features squelch and separate microphone and speaker. No tests or license required. Crystal receive and transmit. With leather case, earphone, telescoping antenna, batteries and crystals. Send \$39.95 for one, or 2 for \$78.88 plus \$1.50 postage. (we refund excess).

Lafayette Radio, Dept. LF-3 P.O. BOX 88, Syosset L.I., N.Y.

**MEN WANTED**

Earn \$125 Per Week and up  
**AUTO DIESEL MECHANICS**

Master a trade with a future — learn Auto-Diesel mechanics in our shops. You learn with tools on real equipment. Earn while you learn. Many of our graduates earn \$125 per week and up. No previous experience necessary. Day and night courses. Approved for veterans.

Write for free bulletin  
**AUTO-DIESEL COLLEGE**  
226 7th Ave., N., Dept. 92  
Nashville 3, Tenn.

**INVENTORS**

If you have an invention that you believe has merit, write us at once for copy of copyrighted booklet "How to Go About Selling Your Invention." FREE—Just send name.

**Kessler Sales Corporation • Dept. D-56 • Fremont, Ohio**

**ENGINEERING  
SCIENCE  
MATH**

**B.S. DEGREE  
IN 36 MOS.**

**U.S. NEEDS 50,000 NEW ENGINEERS EVERY YEAR**

EARN ACCREDITED B.S. DEGREE in Science or Engineering in 36 months — year-round program optional. 27-month engineering diploma also available. Classes start June, September, January, March. QUALITY EDUCATION. Graduates employed throughout U.S. and foreign countries. Government approved for veteran training. Students from 50 states, 40 countries. 20 buildings; dorms, gym, Campus. New library and laboratories. Employment help provided. SAVE TIME AND MONEY. Write for catalog and complete information.

**IT** **Indiana Institute of Technology**  
formerly Indiana Technical College

1612 E. Washington Boulevard, Fort Wayne 2, Indiana

Please send free information on accredited B.S. Degree programs in Engineering and Science as checked:

<input type="checkbox"/> Aerospace Engineering	<input type="checkbox"/> Mechanical Engineering
<input type="checkbox"/> Chemical Engineering	<input type="checkbox"/> Metallurgical Engineering
<input type="checkbox"/> Civil Engineering	<input type="checkbox"/> Physics
<input type="checkbox"/> Electrical Engineering	<input type="checkbox"/> Chemistry
<input type="checkbox"/> Electronic Engineering	<input type="checkbox"/> Mathematics

Name \_\_\_\_\_

Address \_\_\_\_\_

City \_\_\_\_\_ State \_\_\_\_\_



**If You Want to Make up to \$1,000 in a Month**  
 Mail this Certificate NOW with name and address

Get FREE Details of Amazing Light Bulb with  
**No-Time-Limit Free Replacement Guarantee**

Tear out this certificate, mail with name, address to learn how you can make up to \$50 and more in a day, spare or full time, introducing sensational longer-burning Merlite Light Bulbs in your area. Simply say... "Once you buy Merlite Bulbs, you never again have to buy light bulbs." Friends, neighbors, others order 12 to 24 and more at a time on astounding Free Replacement Guarantee without time limit! **FREE SALES KIT!** Everything you need to start making good money first day. Rush your name and address with this Certificate—TODAY!

MERLITE INDUSTRIES, Bulb Div., 114 E. 32nd., N.Y. 16, Dept. C-15H  
 In Canada: Mopa Co., Ltd., 371 Dowd St., Montreal 1, P.Q.

**Model B-2  
 2 Ton**



**ALVA ALLEN Swaine  
 Power Punch Presses  
 1 to 150 Ton Capacity**

Complete line of Punch Presses in hundreds of different style and model combinations. Write for FREE literature on presses and complete line of punch Press accessories as—Feeds, Punch Units, Dies, etc.

\$107.50  
 job  
 less  
 Motor

Alva Allen Industries, Dept PM, Clinton, Mo.

**\* NOW! EARN BIG MONEY IN \*  
 \* CARTOONING AND COMMERCIAL \* ART \***



Now you can enter this highly-paid field quickly and easily. Learn in your own home, in spare time. No previous training or art ability required. Own your own business—urgent demand for artists everywhere! Earn 100% profit on all drawings—we show you how!

→ illustrated book **FREE!**

Continental Schools, Inc. Dept. E-157 4201 S. Broadway, LOS ANGELES 37, CALIF.



**MASONS!**  
 Send today for free catalog  
 of Masonic & Eastern Star  
 books and rituals

**EZRA A. COOK PUBLICATIONS, INC.**  
 P. O. Box 796 Dept. A-18 Chicago 90, Ill.

**MONEY IN WORMS**

Success for you! 5000 of our hybrid red wiggler fishworms produce 5,000,000 in one year using our successful method of worm raising. Read our success story in LIFE MAGAZINE, Dec. 28, 1959 issue. Let us teach you our secrets of success. Write today for FREE INFORMATION on how to raise and sell fishworms and crickets.

Special Today—Hybrid Red Wigglers—3000—\$5.95. 5000—\$8.95. 10,000—\$16.95. Postpaid.

**CARTER WORM RANCH, PLAINS, GEORGIA**

**New Table Top Invention Puts You In...  
 PROFITABLE RUBBER  
 STAMP BUSINESS**



Home Operators now make **\$9.20 AN HOUR** in Business once monopolized by a few big companies

Special rubber stamps bring high prices—cost only pennies to make on new, low-cost table top machine. Take 27 cents worth of material, make perfect stamps, the kind businesses and offices now buy by the dozen at \$1.80 each. Make up to \$9.20 an hour. Start in spare time in your own home. Run machine on kitchen table using ordinary electrical outlet. Make any kind of stamp. We'll send you free information without obligation about this established, highly profitable business. **We'll even help finance your start.** For free information send name and address today on a postcard to:  
 Rubber Stamp Div., 1512 Jarvis Ave., Dept. R-2-F, Chicago 26

# RUPTURED

## YOU CAN NOW BE FREE FROM TRUSS SLAVERY

Surely you want to **THROW AWAY TRUSSES FOREVER**, be rid of Rupture Worries.

Then why put up with wearing a griping, chafing truss the balance of your life? If you do, it will not be through necessity but through choice on your part—for most reducible Ruptures can be corrected **NON-SURGICALLY**.

### NON-SURGICAL TREATMENTS

The resultful **NON-SURGICAL** treatments of reducible Rupture used by the Excelsior Medical Clinic, require no painful surgery, hospitalization, anaesthesia or long periods of convalescence.

Thousands of satisfied patients from hundreds of communities have come here to be successfully treated. The treatments are so dependable that every patient accepted for treatment is given a **Lifetime Certificate of Assurance**. Treatments usually take but a short time and the cost is reasonable.

### Do Something TODAY

The Excelsior Medical Clinic has recently published a New Free Book, fully illustrated, on how neglect of Rupture, Rectal-Colon Disorders or Glandular Inflammation often results in expensive surgery.

**RECTAL-COLON  
 DISORDERS  
 GLANDULAR  
 INFLAMMATION**

These disorders, if not corrected, may gradually grow worse and often require painful surgery. The **NON-SURGICAL** treatment of these disorders is fully explained in our Free Book.

It shows **HOW** and **WHY NON-SURGICAL** treatment methods are so successful today. Fill out Coupon below for your **FREE** Copy.



**EXCELSIOR MEDICAL CLINIC**  
 Dept. H6150  
 Excelsior Springs, Mo.

Gentlemen: Kindly send me at once your New **FREE** Book. I am interested in full information. (Please Check Box)

Glandular Inflammation       Hernia  
 Rectal-Colon

Name \_\_\_\_\_  
 Address \_\_\_\_\_  
 City \_\_\_\_\_ State \_\_\_\_\_

*transistorized ignition system*

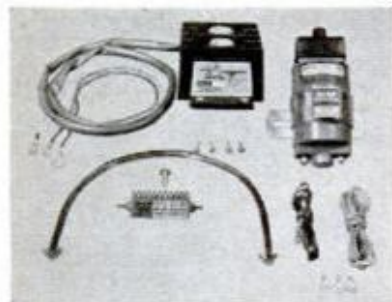

TS-30  
"Banshee"

**ADVANCE STYLING AND DESIGN**

Complete Banshee Systems are available in the following models:

- 30 KV Output with F-250T Coil, 250:1 turns ratio, neg. ground ..... \$39.95
- 45 KV Output with F-400T Coil, 400:1 turns ratio, neg. ground ..... 44.95
- 55 KV Output with F-500T Coil, 500:1 turns ratio, neg. ground ..... 49.95
- Banshee TS-30 with F-500T, positive ground ..... 59.95
- Free Color Brochure

TESTED • APPROVED • FULLY GUARANTEED ONE YEAR

SLEP ELECTRONIC COMPANY, Automotive Division  
P.O. BOX 178-PM1, Ellenton, Florida Ph. (813) 722-1843

Name .....  
Address .....  
City ..... State .....  
YEAR ..... MAKE ..... MODEL .....

**MOWER TIRES SMOOTH?**

Restore full traction with

**Replace-a-Treads**

With Replace-a-Treads you can restore original traction power to worn-out, slipping power mower tires ... at less than half the cost of new tires or wheels. Installed quickly, simply, without removing mower wheels. Complete instructions on package. Fits all standard tires from 8 1/2" to 11" dia. ... treads up to 1 1/8" wide ... reel type power and hand mowers.

**Tough tread gives long wear!**

Made of same tough tread rubber used in passenger tires. Outlasts original mower tires by far. Won't leave black marks on walks or drives. Only \$3.95 a pair at your favorite hardware store, garden center, mower repair shop or service station.



TPA-2003  
only \$3.95 a pair

The Gates Rubber Company 999 South Broadway Denver 17, Colorado

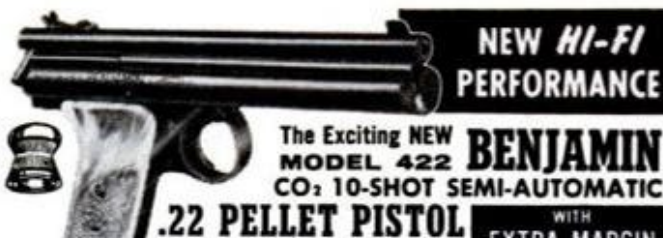

**NEW HI-FI PERFORMANCE**

The Exciting NEW **BENJAMIN MODEL 422 CO<sub>2</sub> 10-SHOT SEMI-AUTOMATIC .22 PELLET PISTOL**

\$24.00

Ask Dealer for Demonstration

EFFICIENT—SAFE—DEPENDABLE—CONVENIENT Famous BENJAMIN Quality

AT LAST — an Amazing New Handgun that Incorporates the Characteristics Wanted for Serious Training, Plinking and Match Competition — Indoors and Outdoors — at LOWEST SHOOTING COSTS! Handsome, Dynamic, Mechanically Reliable, MODEL 422 combines Traditional BENJAMIN PEAK POWER and ACCURACY with Incredible Firing Speed — Smooth JAM-PROOF ACTION (no ramrod for cleaning pistol bore required)

WITH EXTRA MARGIN BENJAMIN'S Unique DOUBLE SAFETIES



**KEEPS SHOOTING & SHOOTING & SHOOTING & SHOOTING AS FAST AS YOU CAN SQUEEZE THE TRIGGER!**

**FREE** Write today! Complete Catalog Benjamin Rifles & Pistols — Single Shot & Repeaters — BB or 177 or 22. Also, Special Offer on Hunting Knives. **BENJAMIN AIR RIFLE CO. 896 MARION ST., ST. LOUIS 4, MO.**

**INSTALLING FLOOR TILE?**

Remove Adhesive, Stains, Scuffs in a Jiffy. Professional Looking Work with



**MY-KO TILE CLEANER & ADHESIVE REMOVER**

Write for free sample and name of floor covering dealer.

**MY-KO CHEMICAL CORP.**  
1255 N. 6th St., Milwaukee 12, Wis.

**KILLS USING NO CHEMICALS GASES, ETC.**

- MOSQUITOES • MOTHS, MILLERS
- FLIES, GNATS • FISH FLIES, ETC.

OVER 1/4 ACRE HANGS ANYWHERE

No insect recovery. Guaranteed. Beautiful outdoor lighting. Plug into any 110 volt socket. NO AREA CONTAMINATION Safe, beautiful. Complete with fly attractor. Dead insect catcher. Cord. Directions. Etc. Low cost. SING SING BUG CHAIR, INC. BOX P3708, OAK PARK 37, MICH.



WEIGHT 12 LBS. BOX SIZE 15 X 15 X 18

**Need a playroom in the basement? Patio in the backyard? New kitchen?**



Your local lumber and building supply dealer offers quality materials and workmanship for these and hundreds of other home improvement jobs. . . Visit him now.

1963 is Home Improvement Year

**BORROW MONEY YOU NEED FROM US BY MAIL**

B-I-C Cash-By-Mail Loans—\$100.00 to \$600.00 easy to arrange—easy to repay on 24-month schedule. No co-signers or security needed. **DON'T DELAY — MAIL COUPON** Please send me, by return mail, Application Form for B-I-C Cash-By-Mail Loan. I understand this request does not obligate me in any way.

Name.....  
Address.....

**B-I-C LOANS**  
Div. Bankers Investment Co.  
Dept. 70 100 S. WALNUT, HUTCHINSON, KANSAS



# CLASSIFIED ADVERTISEMENTS



Advertisements in this section \$1.35 per word, each insertion, minimum 10 words, payable in advance. To be inserted under proper classification, copy must be in our office the 18th of the second month preceding date of issue  
 F. W. Johnson, Manager, Classified Advertising  
 Popular Mechanics, Classified Adv. Dept., 740 Rush St., Chicago 11, Illinois

## YOU'LL PROFIT

By reading and answering the classified ads in this section. Hundreds of opportunities for you to make and save money

### AUTOMOBILES, MIDGET CARS

OLD Auto catalogs; reprints; hobby club. Enthusiasts, Box 451B, Mt. Clemens, Mich.

### AUTO SUPPLIES AND EQUIPMENT

FACTS! No gimmick. Save Money! Get an extra 3 to 6 miles more on a gallon of gasoline, with your present automobile. Simple information and a triple screen for your carburetor. Need no tools to install. Send \$2. today. Leonard E. Simmons & Company, 1736 West 63rd Street, Chicago 36, Illinois.

DRIVE Car. 16 ways to save money. Save gas, oil, tires, battery. Details free. A. Spencer, Mokena, Ill.

CROSLLEY And foreign car parts. Discount Club, Box 7B, Elmont, N. Y.

RING-Valve job while driving. \$6.00 postpaid. Guaranteed! Nothing like it! Many mechanics recommend! Motaloy, Grantham, Penna.

JEEP Parts! For military and civilian. At great savings. Largest inventory. Catalog for owners and dealers. Inquiries invited. American Auto Parts Co., 1830-PM Locust, Kansas City, Mo.

NEW And used parts at savings. Complete guaranteed parts service for all models cars and trucks. Largest in the West. Jeep and army parts specialists. Newest type shifting hubs for all jeep and all military and latest production front end drive vehicles. \$27.50 and up. Also, foreign car parts. Write, Pioneer Auto and Truck Parts Co., 734 W. 13th Avenue, Denver 17, Colo.

PARTS, Model "A." List 25¢. (Refundable) Matco, Box 135, San Pedro, Calif.

BATTERY Chargers. Home type. Electrotrone's famous line. Wholesale prices. Same day delivery. Free catalog. Doron Enterprises, Inc. Box 7214, Chicago 80, Ill.

CRAZY Customizing! Newest craze! Free info. Sample 25¢. Craft, 3008-M Montrose, Chicago 18.

SCIENTIFIC Night driving glasses. Men's, women's, clip-ons. \$2.49. G. Winans, 144 W. 9th Avenue, Conshohocken, Pa.

ANTIQUE Model pistons, gaskets, gears, valves, etc. Antique Auto Parts, Milwaukee 4, Wisconsin.

HYDRAULIC Jack repair parts. "Sava-Jack" genuine metal replacement parts; "Econo-Pak" bulk items; Jackmaster repair kits, catalog 25¢ in coin. Hydraulic Jack Packing & Tool Co., P.O. Box 50, Bloomfield, N. J.

AUTO Shop welding repair training in world's largest non-profit welding school. Low tuition. Free booklet. Hobart Welding School, Box M-63, Troy, Ohio.

BIG MONEY! Nationally known miniature oil refinery for cars, trucks. Saves 90% of engine lubrication cost. 15¢ cartridge guarantees perfect lubrication. Never change oil. Prolongs motor life. Distributors wanted full or part time. Box 393, Santee, Calif.

SHOP Manuals 25¢ up! List 10¢. Manager, Box 8573, Kansas City 14, Mo.

LIQUID Glass auto polish. Guaranteed permanent. Can \$2.50. Harte's, Decatur, Michigan.

NOW—The ignition system of tomorrow for your car or truck today! Kar-Life Transistor Ignition System eliminates frequent ignition tuneups, replacement of points, plugs, condenser. Improves engine performance, idle, acceleration, gas mileage. Makes starting easier. Saves you hundreds of dollars. Unconditional money-back guarantee. For all makes, years, models. Lowest priced on the market! Write for free literature. Whitney, 1919 PM-6, Archer, Chicago 16.

CHROMED Wheels (4). Reversed. \$79.50 exchange. \$99.50 outright. Any Kar, 205 So. Arnaz Dr., Beverly Hills, California.

JEEP Owners — V8 conversions. Read Jeep Owners ad, page 34.

### AUTO TRAILERS

TRAVEL Trailer shell models. Exterior complete. Vacation now—finish interior later. Save half. Literature 20¢. Doe-Wah-Jack Travel Trailer Co., Box 147, Dowagiac, Michigan.

APARTMETS For pickups, also special camper unit for automobile. Write for special delivery offer. Sloat Mfg. Co., 111 West Lowden, Ft. Worth, Texas.

PICKUP Campers. Pre-cut Kits. Blueprints. Supplies. Literature 10¢. Comstock Trailers, Parsons, Kansas.

PICKUP Camper. Build yourself. Save! Complete plans \$7.50. We have materials, equipment. Details 10¢. Viking Camper Co., 14123-F Holly Road, Hopkins, Minn.

### MOTORCYCLES, BICYCLES, MOTORSCOOTERS AND SUPPLIES

BUILD Your own cart, trail or Mini Cycle frame for less than \$10! Save 50%! Buy kits, parts at discount prices! Plans with information only \$2 each. Money back guarantee. Cycle-Cart, Dept. PM6, 3518 W. Cahuenga Blvd., Los Angeles, California.

MOTORIZED Your bicycle. Complete plans \$1.00. Go-Byk Industries, Fergus Falls, Minnesota.

SCOOT'R-BIKE. Parts to convert bicycle frame \$4.95; wheels, clutches, engines discount priced. Plans \$2.00 refundable. Gilliom Manufacturing Co., St. Charles 26, Missouri.

DISCOUNT! Mini-bikes \$59.96, karts \$79.60. Pictures, specifications, parts catalog 25¢. Universal, 3551 West 25th, Chicago 23.

IMPORTED Motorcycles. 2—22 h.p., \$159.95 up. Photos, specifications, 25¢. Michaels Motorcycles, Absecon, N.J.

BMW Motorcycles, shaftdrive. U. S. distributor Butler & Smith, Inc., 160 West 83rd St., New York 24, New York.

MINIBIKE \$15, go-cart \$15, servicycle \$25, less engines. Engines \$4 up. Moped \$30. Vespa \$50, Harley \$25, Isetta \$175. (Mailorder only). Send 25¢ (35¢ for first class mailing) for Directory-Catalogue Number 113, listing these and hundreds of similar bargains, homebuilders parts, plans etc. Midget Motors Directory, Athens, Ohio.

RACING Bicycles, accessories, apparel. Adult tricycles. Catalog 25¢. Cupertino Bike Shop, 10080 Randy Ln., Cupertino, Calif.

BANKRUPT Motorcycle bargains. Wholesale parts, new, used. Directory 35¢. Bunico, 146-5G, Covington, Virginia.

MINI-BIKE, Go-kart parts, accessories, frames, engines. Send 25 cents for 32 page catalog. Jerry Staver, Box 511-M, Janesville, Wisconsin.

SPEED cams for motor scooters, 3/4 midgets, Cushmans, Whizzers, Continentals, Mustangs, etc. \$15.00—your core. 50¢ for auto catalog. Weber Speed Equip., 310-B So. Center, Santa Ana, Calif.

MOTORCYCLE Parts, new, used, list 25¢. Ballak, 811 N. 9th, St. Louis 1, Mo.

HARLEY-Davidsons — Used bargains. New, used parts, accessories, all models. Bulletin 25¢. Knuth's (Factory Dealer), 1753 Muskego, Milwaukee, Wis.

RECONDITIONED Motorcycle motors. Large stock Indian Cushman Vespa Mustang NSU parts. Indian Motorcycle Sales, Kansas City 27, Missouri.

### AVIATION

MAGNETO Point synchronizer. Visual and oral indication of dual magneto point adjustment. Plans \$2.00. Brochure free. Rogers Books, Box 3212, Fresno 66, California.

"FLIERS Or killers? Homebuilt helicopters". Ex-manufacturer pulls no punches. Complete report, \$2.95. Shelby, Box 4266-B, Saticoy, California.

**GYROCOPTER** Blades. Solid aircraft spruce. Vancraft, 7246 North Mohawk, Portland 3, Oregon.

**HOMEBUILT Helicopter handbook** \$1.00. Directory \$1.00. Urshanair, Box 250, Santee, California.

**PROPELLERS** For airboats, snowplanes, icesleds. Beautiful colors. Boat kits, mounts, worlds best. 25¢ for catalog. Aerial Propeller Co., Box 692, Greenville, Texas.

**PROPELLERS.** Plans, supplies for airboats, snowplanes, 125 H.P. Lycoming, 150 H.P. Continentals \$125.00. Hubs, parts, gauges, throttles, spark plugs, wires, hose, oil coolers, gaskets, magnetos, switches. Catalog 25¢. Banks-Maxwell, Box 3301E, Ft. Worth 5, Texas.

### BATTERIES, GENERATORS

**BATTERY** Reconditioning kit, molds, instructions. Old batteries like new. Battery Shop, 96 Vierra, Salinas, Calif.

### ELECTRICAL SUPPLIES

**WHOLESALE**—Appliance, lamp parts. Free parts listings. SECO, 112 South 20th Street, Birmingham 3, Alabama.

**NEW Fluorescent work light.** Completely portable. Use like drop-cord. Brighter, safer, more economical. Write for details. Mech-Lite, Box 163, Ft. Atkinson, Wis.

**LAMP.** Electrical parts, wholesale. Thousands of items for repairing, converting. Catalog 35¢. Brown Lamp, Box 305, Clayton 5, Missouri.

**LAMP Parts.** Catalog, prices, wiring instructions, 50¢. Refunded first order. Gyro, 5208P N.W. 35 Ave., Miami 42, Fla.

### WELDING, SOLDERING, PLATING

**PRODUCTION Welders,** \$69.50, \$39.50. Paul Morris, 1070 Inner, Schenectady 3, New York.

**CHROME** Plating equipment, supplies. All other finishes. Home workshop and production sizes. Send \$1.00 (refundable) for formulas, operating data, equipment guide and catalog. HBS Equipment Division L50, 3445 Union Pacific Avenue, Los Angeles 23, Calif.

**DO Your own plating!** With this inexpensive kit you can gold and silver plate in your home or shop at a fraction of the cost of commercial plating. Texas electroplaters have been in use for many years. A rich finish is produced with finest materials. Pure 24K gold, pure silver and nickel are furnished. Complete Texas electroplater to plate 125 square inches with 24K gold, same amount with silver and same amount with nickel. Special \$15.00. Complete kit to plate silver, \$5.40; Brass, \$5.40; Nickel, \$5.40. All sets complete. All you need is 2 cheap batteries. Instructions included. Low cost extra supplies always available. No experience necessary. Make money—save money. Order your plater now. Quick service. Postpaid. Texas Plater's Supply Co., 7220 Lancaster, Dallas 16, Texas.

**ARC Welder manual.** Only 50¢. Regular \$1.00 value. Tells how to weld every job. Emerson Electric, 8100 Florissant, Dept. PM-6, St. Louis, Missouri.

**SURPLUS Heavy duty 110 volt arc welder.** Brand new. Braze, solder, weld and cut up to 1/2" steel plate. Complete with 1/16" and 1/8" rods, helmet, gloves, instruction book, etc., \$18.95 postpaid. Fully guaranteed for five years. Try it for 7 days, if not completely satisfied, money refunded. National Surplus, Box 678-A, Miami Beach 39, Florida.

### MACHINERY, TOOLS, SUPPLIES

**MAKE** World's best grass cutter with axe handle. You'll see. Patented tool steel blade, wire, fasteners \$2.00 postpaid. Sinclair's, Centerville, Louisiana.

**LARGEST** Stocks of bargain new cutting tools in England. Send for free list. G.P. Engineering Tools Ltd., 313 New North Rd., London, N.I. Cables: Gepetra Londonni.

### ENGINES, MOTORS, DYNAMOS

**REWIND** Motors yourself. Complete instructions, \$1.00. Lewis Manufacturing, Howell, Michigan.

**WINDING** Data. 275 motors, single and three phase \$1.10. Data Company, 512 Kensington, Kansas City 24, Mo.

**OPERATE** 3-Phase motors from single phase. Plans \$1.00. Donald Howell, Barnesville, Ohio.

**REWIND** Motors yourself! Details free! Modern, Box 8573, Kansas City 14, Mo.

### GOVERNMENT SURPLUS

**JEEPS** \$111.68, boats \$6.20, airplanes, walkie talkies, guns, cameras, thousands of items typically at 90% savings or better. For complete information send \$1.00 to Surplus Service, Box 820, Holland 1, Michigan.

**GOV'T** Surplus. How and where to buy in your area. Send \$1.00. Surplus Information, PM, Headquarters Building, Washington 6, D. C.

**JEEPS.** Air conditioners, guns, boats, airplanes, thousands items low as 2¢ on dollar direct from U.S. Government. Complete "Directory" \$1.00. Satisfaction guaranteed. U.S. Surplus, Room 160-M2, 333 West First, Dayton 2, Ohio.

**10,000 GOVERNMENT Bargains.** Directory. Buying procedure. 60 cents. Surplus, Mountain View, Oklahoma.

**JEEPS** \$160.83. Typewriters \$4.15. Radios \$2.65. Televisions, recorders, guns, watches, binoculars. Typical surplus prices. Exciting details free. N.Y. Enterprises, Box 402-X7, Jamaica 30, New York.

**BOATS,** \$6.18, **JEEPS,** \$97.50. Typewriters, \$4.15. Trucks, Tractors, Guns, and other bargains from U.S. Government. For latest directory send \$1.00. National Surplus, Box 185-PM2, Eatontown, New Jersey.

**SURPLUS?** Accurate, up-to-date information. \$1.00. Stratford Publications, Machias, New York.

**JEEPS** \$111.26. Boats \$6.38. Typewriters \$4.17. Thousands items direct from government in your area. Complete "Guide" \$1.00. Surplus Information, 1402-C, Englewood, Colorado.

**GOVERNMENT Surplus:** How and where to buy in your area, only \$1.00. Surplus Terminal Building, Box 2272-PM6, Fort Worth, Texas.

**GOVERNMENT** Surplus sales information—"Procedure-Directory" 50¢. Industrial, Box 770-B, Hoboken, N.J.

**SURPLUS:** Jeeps, boats, airplanes, parachutes, etc. Instructions, \$1.00. Towers, 2800 W. Ledbetter, Dallas 33, Texas.

**FREE!** You can get hundreds of big illustrated government surplus catalogues absolutely free. Full information sent first class mail for only two dimes (or stamps). Honour, Box 52M, Thomasville, Penna.

**GOVERNMENT** Surplus sales bulletin—"Directory-Procedure," 50¢. Surplus, Box 425 PM, Nanuet, New York.

**BUY** Surplus direct in your area. Complete details, plus "Profits from Surplus", \$1.00. Tangent, Box 6091-A6, Dallas 22, Texas.

**JEEPS** \$111.68, airplanes \$75.20, boats \$6.18. Many others direct from U.S. Government. For complete "directory" send \$1.00 to Quality Surplus, Box 23, Dept. PM6, Greensburg, Pennsylvania.

**JEEPS** \$68.11, airplanes \$75.20, boats \$6.18. Many others direct from U.S. Government. For complete "directory" send \$1.00 to Quality Surplus, Box 22163, PM6, Indianapolis 22, Indiana.

**JEEPS** \$111.68, airplanes \$75.20, boats \$6.18. Many others direct from U.S. Government. For complete "directory" send \$1.00 to Quality Surplus, 4544 East 14 Street, Dept. PM6, Oakland 1, California.

### BOATS, OUTBOARD MOTORS

**FIBERGLASS** Your boat. Dynel or fiberglass cloth 50" wide \$2.50 yard. Resin and hardener \$2.50 quart (quart covers one yard cloth). Color, your choice, 40¢/quart unit. Thinner, cleaner 85¢/pint. Cash with order. Dipcraft, 4830 Hatfield St., Pittsburgh 1, Pa.

**10' RUNABOUT** Unsurpassed sailing, rowing, outboarding. Streamlined kit, only \$22.95. Interesting free literature. Runabout, 222-A East Eleventh, Columbus 1, Ohio

**HUNDREDS** of used outboard motors 10 to 75 H.P. in lots of 10. Wholesale prices. C & S Outboard Marine, Int'l Falls, Minn. Ph. 283-3456

**CANOE** Kit trailblazer 15'. Precut, easy assembled, complete \$34.95. Free literature. Trailcraft, Box 392, Concordia, Kansas.

**FLORIDA** Pier-boats. Assemble your own. Request free illustrated circular. Wentworth's Products, P.O. Box 143, Dept. PM, Muskegon, Michigan.

**FIBERGLASS** Cloth, matt, polyester and epoxy resins. Lowest prices. Seifert's, Box 1206-M, Green Bay, Wis.

**PLANS,** Patterns, kits, Catalogs: Powerboat 50¢. Sailboat 40¢. Marinecraft, Box 161-M, Brighton 35, Mass.

**11 1/2' SAIL-FIN** Kit and 57 sq. ft. sail \$67.50 complete. Literature 10¢. Box 78, Brecksville 41, Ohio.

**ELECTRIC** Outboard motors direct from factory. Whisper quiet. Run on 6 or 12 volt batteries, \$104.50. Freight prepaid in U.S. Free folder. City Engineering Co., Inc., 3547 Massachusetts, Indianapolis 18, Ind.

**NEW 1962** Scott Outboard motors. Clearance. 3 1/2 H.P. \$99.50; 7 1/2 H.P. \$198; 14 H.P. \$258; 28 H.P. \$318; 44 H.P. \$378. 1961—75 H.P. electric generator \$558. 1962—75 H.P. \$638. We ship anywhere or hold on our layaway plan. Factory warrantee. Electra Marine, (Dept. M) 1427 Broadway, Brooklyn, N. Y. Tel. 212-GL5-0122.

**HYDROKARTS.** Fiberglass hulls. Complete line marine hardware. Aqua Speed Kart, 5525 Chicago Ave., Chicago 51, Ill.

**MARINE** Conversion equipment, gears, accessories—Chevrolet, Ford, Buick, others. Catalog 25¢. Star Marine Engine Works, 2920—7th Street, Berkeley, California. Dealer inquiries invited.

**10' KAYAK** kit and paddle \$19.50, literature 10¢. Box 78, Brecksville 41, Ohio.

**FIBERGLASS** Cloth and resin. World's finest cloth and non-run resin, at direct mill prices. Flotation foam. Complete line of plastics, silicon bronze and brass screws, save 60%. Free catalogue. Freight prepaid Stiles Boat Supply, Box 11P, Linden Ave., Mantua Hts., N.J.

**BUILD-it-yourself** boat plans 8 to 32 feet. Send for information: C. W. Horst, 6515 Earl Avenue N.W., Seattle 7, Wash.

**NEW,** Used, rebuilt marine motors. Marine conversions, fittings. Free catalog. Stokes Marine Supply, Dept. 24, Coldwater, Michigan.

**MARINE** Conversions. Ford, Chevrolet, Jeep engines. Catalog 25¢. Lehman Manufacturing Company, 800 Elizabeth Avenue, Linden 4, N. J.

**BUILD** Your own boat from our large-scale blueprints. Books of plans give how-to-build help. Hundreds of professional designs—motor, sail or auxiliary—for amateur builders. Free catalog. MoToR Boat-ing, 959 Eighth Ave., Dept. RS, New York 19, N. Y.

**FULL Size, cut-to-shape boat patterns, blueprints, 7 1/2-38 feet. Big new illustrated "Build a Boat" catalog of 64 designs, including catamarans, cruisers, runabouts, skiffs, outboard boats, sailing, racing, houseboats, 50¢. "How to Build a Boat" booklet, \$2.50. Cleveland Boat Blueprint Co., Box 1651, Cleveland, Ohio.**

**BOAT Plans, frame kits, full-size patterns prepared specially for amateurs. Send 50¢ for new 80-page catalog illustrating over 40 build-it-yourself power boats from 7' to 28'. Glen Designs, 9152 Rosecrans, Bellflower, Calif.**

### **SPORTING GOODS, GUNS, FISHING, SKIN DIVING, ARCHERY**

**FOCUS** On target, split image hunting rangefinder instantly shows true range for deadly accuracy every shot. Perfect for varmints. Also golf and archery models. \$9.95 up. Free literature. Federal Instrument, 92-60P, Queens Blvd., Rego Park 74, N.Y.

**CAPS** For sportsmen, baseball type. 100% virgin wool flannel Pre-shrunk, water repellent, rubberized unbreakable peak reinforced front panels for longer life. All sizes. Navy, royal, scarlet, maroon, black, kelly. Price \$1.95. Hildebrand Mallorders, 845 Riverside Drive, New York 32, N.Y.

**FISHERMAN'S Dream** book free! 170 pages. Sweetest pocket size catalog ever! Do-it-yourself stuff galore: for making: nets, turtle traps, landing nets, rods, lures, sinkers, plastic worms, flies, fish smoking rig. Here's everything including latest rods, reel 'n' gadgets. Send card: Netcraft Co., Dept. PMM, Box 5510, Toledo 13, Ohio.

**CATCH** Bass without trying? Amazing silent fisherman does it for you! Delayed action, unique transfer from device to your own rod or cane pole does the trick. For exciting results build several. Quick, easy, inexpensive. Detailed plans, instructions \$2.00. Druid Products Co., Box 310G, Northport, Ala. Patent applied for. Additional information 20¢.

**GUNS!** 10,000 antique, modern arms, armour, gunaccessories! Giant 120 PP. bargain catalog \$1.00. Agramonte's, Yonkers, N. Y.

**SEND** For free 1963 exclusive list of antique, military, modern firearms & ammo. Write Box PM or visit our headquarters arsenal, Globe Firearms, 30 Front Street, New York, N.Y.

**RID** Lakes of turtles. Information, diagrams, how to make repeating turtle trap. Easy. New. Copyright reserved. Easily moved. \$1.00. Traps, 2400 West 5, Owensboro, Kentucky.

**SKINDIVERS.** Send \$1 for discount catalog. All popular brands. Jabarb, Box 6844, Towson 4, Maryland.

**SKINDIVERS!** Start your own business. Buy name brands wholesale. Send \$1.00 for dealer price list, catalogs and full details. Discount Divers Supply, P.O. Box 1701, Hammond, Indiana.

**FISHERMEN!** Clarkspoon, world famous over quarter century for record catches. Equipped with special built-in alluring red bead swivel, re-inforced 3/0 hook. Nickel silver, bright chromium plated. Minnow-like action. Length 3 inches. For fresh and salt water trolling or casting. \$1.00 postpaid. Tomlin Sales, 1731 Roanoke, Lakeland, Florida.

**MOLDS**—For casting your own fishing sinkers. Free illustrated booklet. Reading Instrument Co., Box PM78, Reading, Penna.

**FREE**—Wholesale catalog. Beads. Spinners. Lure parts. Sinker molds. Jigs. Reels. Finnyports (ME), Toledo 14, Ohio.

**BIG** Money raising crickets and 12 inch African fishworms. Free literature. Carter Ranch, Plains, Georgia.

**MOLDS** For fisherman's sinkers, jigs, squids, casting and spinning lures. Free catalog. Sweet's Molds, Tonawanda 1, New York.

**CANNON** Fuse 3/32" diameter, waterproof. Burns under water. 10 ft., \$1.00; 25 ft., \$2.00; ppd. Will Zeller, Hudson, Mich.

### **ATHLETIC EQUIPMENT, BODY BUILDING COURSES**

**PHYSICAL** Perfection. Reducing, gaining, muscles, longevity. Mail 25¢ for all 4 courses, guaranteed, to Sids System, (PM-M-63), 8421-C Evergreen, Southgate, California.

**OUTSTANDING** Physical development! Any age. New guaranteed discovery uses only a rope! Strength, health, muscles. Gain—reduce. Free information. Ropercise, 4834 Art. San Diego 15, California.

**BOXING** Lessons. Expert's secrets. Practise home. No equipment needed. The sport to make you famous. Instructions \$1.00. Physical Arts Gym, 363 Clinton Street, Hempstead, N.Y.

**"GIANT Arms."** Dr. Young's, D.C. revolutionary discovery. \$2. Satisfaction or refund. Gaucho, Box 9309-S7, Chicago 90.

**BIG** Muscles fast—gain up to 4" on arms. 10" on chest in just 7 weeks. Free details. Sinkram Body Builders, Dept. ME-13, Box 11, Brooklyn 36, N.Y.

**ISOPOWER** Fitness through science. Course \$1.00. Box 103, Topeka, Kansas.

**MICKEY** Mantle's Isometric minute-a-day gym builds athletic ability and strong, muscular bodies. Write: 37 Centuck Station, Yonkers 4, New York.

**BAR-BELLS.** Courses, equipment. Catalogue 10¢. Good Barbell, B-1495, Hendersonsville, N. Car.

**"KUNGJU Karate"**. Break bricks within 100 days \$5.00. Prof. Wong's "Kungfu" \$5.00. "Chinese Gungfu" by Bruce Lee \$5.00. Any 2 books \$9.00. All 3 for \$12.00. Free literature. P.O. Box 1183, Oriental Book Sales, Oakland 4, Calif.

### **CAMPING EQUIPMENT AND TENTS**

**FREE** Folder on newest Hellite camping trailers, \$575-\$745. Make camping fun for entire family! Compact, foldout models engineered for rugged back country travel. Hellite, 1379 So. Sacramento, Lodi, California.

**FAMILY** Campers Convert Chevrolet, Ford, VW. Plans \$1.00. R.D.1, Box 372, Sussex, N.J.

**CAMPER'S** Daily log. Record every campout. Loose-leaf \$2.95 postpaid. Box 844M, Oak Park, Illinois.

**GIGANTIC** 1963 catalog. The "bible" for every camper. 116 pages fantastic savings on tents, sleeping bags, camping gear, clothing and government surplus! Choose from our \$1,000,000.00 inventory and save! Send 25¢ today for catalog. I. Goldberg, Dept. PM, 429 Market Street, Philadelphia 6, Pennsylvania.

**CAMPING** Equipment, tents (300 styles—most erected on display). Send 25¢ for new giant catalogue-handbook-camp site directory. Morsan Tents, 810-R, Route 17, Paramus, New Jersey.

### **BINOCULARS, TELESCOPES, MICROSCOPES, MAGNIFIERS**

**BUILD** Your own reflector telescopes. Complete kits; mirrors, eyepieces, tripods, all other accessories. Request free illustrated literature. Criterion Manufacturing, Dept. KPM-2, Hartford, Connecticut.

**SATELLITESCOPES!** Telescopes! Binoculars! etc.! Big discounts! Free catalog! Quality Optics, 9243 Iowa, Livonia, Michigan.

**DYNASCOPE.** Amazing world-famous reflector telescope. Request free brochure. Criterion, Dept. DP-5, Hartford, Connecticut.

**SCIENCE** Bargains! Lenses, telescopes, binoculars, microscopes, kits, parts, war surplus. Send \$1.00 for beginner's 10-lens kit with instruction booklet. Order Stock 2-CH. Request free 144-page Catalog CH. Edmund Scientific Co., Barrington, New Jersey.

### **EARTHWORMS, CRICKETS, FROGS**

**DO** Not attempt to raise redwrigglers until you have read the tale about the worm. Write for free information. Hybrid redwrigglers bedrun 10,000. \$12.00. Bait and breeder size 1,000. \$4.00. Rebel Bait Ranch #4, 1827 Columbia Dr., Decatur, Ga.

**RAISE** Fishworms and rabbits on \$500 month plan. Free details. White's Rabbitry, Mt. Vernon 90, Ohio.

**AFRICAN** Worms. Large, 500—\$7.00, 1,000—\$12.50. Junior bait size, 500—\$5.50, 1,000—\$10.50, postpaid. Dealers wanted. Ozark Worm Farm-J, Willow Springs, Missouri.

**AZTEC** Red wigglers. Texas' largest worm grower. Satisfaction guaranteed. Circle J Farms, Box 4056P, Waco, Texas.

**SUCCESS** For you! Raise fishworms and crickets. Write for free literature and our success story in Life Magazine. Let us teach you our secrets of success. Hybrid redworms 3000, \$5.95. Carter Redworms, Plains, Georgia.

**HYBRED** Redworms. 1000—\$3.00, 2000—\$5.00, 5000—\$8.00, 10,000—\$14.00. Bedruns—\$1.00. In 20,000 orders only. Postpaid. With raising instructions. Brazos Bait Farm, Route 9, Waco, Texas.

**MEN!**—Women! Make money raising bait for us at home. Free details. Red Wigglers, Warsaw 45, Indiana.

**EARN** Money raising fishworms for us! Exciting details free! Oakhaven—56, Cedar Hill, Texas.

**REDWORMS.** Guarantee live delivery. count. 2500—\$4.95, 5000—\$8.95; 10,000—\$16.85. Postpaid. Free literature. Hall Farm, Hilton, Georgia.

### **PLANTS, SEEDS, BULBS, NURSERY SUPPLIES**

**FIBERGLAS** Translucent plastic panels. Flat or corrugated factory closeout! 40¢ square foot. Ideal for barns, greenhouses, nurseries, skylights, patios. No maintenance. Free samples. Dipcraft Fiberglass Manufacturing Co., 4830 Hatfield St., Pittsburgh 1, Pennsylvania.

**GINSENG** Seed. Wisconsin, Canadian type. Leroy Kage, R2, Edgar, Wisconsin.

**10 DIFFERENT** Cactus plants, \$2.00. Phillips, 1290-P Cottonwood, Banning, Calif.

**INSECT** Eating, cactus, terrarium plants. Unusual, atomic mutated seeds. Peter Pauls Nurseries, Bldg. 2, Canandaigua, New York.

### **FARMS, FARM LANDS, REAL ESTATE**

**UNBELIEVABLE** Bargain! Under \$22 an acre gets improved 160 Minnesota acres with 25-acre lake which offers excellent duck hunting! Wonderful deer, small game and partridge hunting, too! See picture in catalog—good 5-room 3-bedroom white frame home, electricity, cellar, enclosed porch, lake view. Summer kitchen and garage, 3-room Finnish bath house, poultry building, 20 acres cropland, 50 pasture, 30 pine timber, barb wire, well. On country road, mile highway, 8 town. Aged owner sacrifices all at only \$3,500! Terms, too. Big Free illustrated Summer catalog, bargains coast to coast! United Farm Agency, 2102-PM Riverside Ave., Minneapolis 4, Minn. Phone: 338-8353

**CAROLINA** Coast homesites in beautiful Boiling Spring Lakes! High, dry, pine-wooded 70x150 lots—\$10 down, \$10 month. Good roads, 50 freshwater lakes. Excellent fishing, hunting. Championship golf course ready for play. Resort motel open year round. Satisfaction guaranteed. Free literature. Boiling Spring Lakes, Southport 1-G, North Carolina.

**NEW Homes** from \$35 per month. Nothing down, custom constructed on your lot. Over 88,000 built. Free information and illustrated brochure. Jim Walter Corporation, Box 9128, Dept. PM-6, Tampa, Florida. 212 branch offices to serve you.

**HOMESTEAD** 640 acres, new Alaska law, no residence requirements! Really worthwhile? Actual homesteader gives all facts—50¢. Pioneers North, Mile 78, Richardson Hwy., Fairbanks, Alaska.

**\$1 ACRE.** Canadian border. Hundreds campsites, islands, farmlands, directly from tax authorities. (Non-profit). Lists, photographs mailed. Bureau, 56 Churches, Toronto 1, Canada.

**FLORIDA** Holiday homesites. Big, beautifully wooded lakeside lots only \$245 at \$10 monthly. Ideal for family vacations, retirement home. Amid five sparkling lakes in Florida's finest fishing, hunting, pleasure area. Electricity, phones, daily mail delivery. Colored maps, full information, FREE! Owen A. Wood, Fountain 15, Florida. (AD62039-F-2)

**FLORIDA** Lake living. Homesites near everything. Established area. \$390 full price. \$5.00 month. Information write: Lake Weir Shores 7, Silver Springs, Fla. (AD 6-1070-F-0)

**FLORIDA** Campsites—deep in the heart of the great Ocala National Forest. Abundance of game, best fishing. Warranty deed. Unrestricted—pitch tent, park trailer, build lodge. Free maps and photos. Howard Vernor, DeLand, Florida, AD60088(Q-O).

**\$5 MONTHLY** Buys 5 acres. Near town, good building site, excellent fishing. Price \$125.00. Free list. Box 425-P Carthage, Missouri.

**CANADIAN** Vacation lands: Full price \$385.00. 40 acres, \$10 month. Suitable cottage sites, hunting, fishing, investment. Free information. Land Corporation, 3768-C Bathurst, Downsview, Ontario, Canada.

**CANADIAN** Lands, seized and sold for taxes. Our 46th annual series of lists, describe many choice properties, situated from coast to coast, acquired by us through Tax Sale. Priced as low as five dollars per acre, guaranteed perfect title, small monthly payments, no mortgage. Beautifully situated hunting and fishing camps, where there is real sport; summer cottage sites, heavily wooded acreages. Now is the time to invest in Canada's minerals, forests and farms. Write to-day for free twenty page booklet with full explanation. Tax Sale Service, Room 301-D, 85 Bloor St., East, Toronto 5, Canada.

**FREE** Strout catalog. The original property catalog of values in farms, homes, businesses, ranches. Nationwide. Over 450 offices. 32 states. 63 years service. World's largest. Write Strout Realty, 7-CJ S. Dearborn, Chicago 3, Ill.

### FARM MACHINERY AND SUPPLIES

3 hp **HOEING** Machine. Hoes between plants, rows. Depth adjustable 0-6". Women operate easily. Self propelled. Month trial. Year warranty. Discount. Autohoe, West De Pere 22, Wisconsin.

### PETS—DOGS, BIRDS, HAMSTERS, ETC.

**FANCY** Rare fowl. Send 25¢ for 48 page catalog. Over 125 varieties pictured, 53 in color. Chicks, bantams, capons, waterfowl, guineas, turkeys, quail, pheasants, partridge, swans, pigeons, hamsters. Stromberg Hatchery, Fort Dodge 25, Iowa.

**LIVE** Seahorses, marine specimens, aquarium supplies. Illustrated catalog 10¢. Marine Life, Dept. 110, Box 626, Dania, Florida.

**PIGEONS,** Supplies, illustrated catalog 25¢. LeBlanc Pigeon Farm, Canton, Maine.

**DESCENTED** Skunks \$9.99. Price list 10¢. Animal World, Elwood, Kansas.

**HAWKS,** Reptiles, raccoons, skunks, squirrels. Catalogue 25¢. Trails End Zoo, St. Stephen, S. C.

**PETS,** Hamsters, mice, rabbits, squirrels, chipmunks, guinea pigs, skunks, raccoons. Picture catalog twenty-five cents. Moore's Hamster Ranch, Shepherdstown 25, West Virginia.

**MAKE** Money raising chinchillas, mink, rabbits, cavies for us. Free catalog. Keeney Brothers, New Freedom 2, Penna.

### RABBITS—FUR BEARING ANIMALS

**EARN** \$10,000 Yearly raising Angora rabbit wool for us. Information 25¢ coin. American Angora Company, Malta 12, Montana.

**RAISE** Rabbits on \$500 month plan. Free details. White's Rabbitry, Mt. Vernon, Ohio.

**RAISE** Rabbits successfully by knowing facts. 48 page book. 38 illustrations describing 25 breeds. Housing. Breeding. Feeding. Markets and Marketing. Bulletin etc. 25 cents. American Rabbit Association, 36 ARBA Building, Pittsburgh, Penna.

### PROFITABLE OCCUPATIONS

**INVESTIGATE** Auto accidents. Pays up to \$750-1,000 a month. Investigators needed everywhere, part or full time. Car furnished; expenses paid. No selling. Meet interesting people. We train you spare time at home in weeks. Hold present job until ready to switch, or start own investigating business. Free information. No obligation. Liberty School, Dept. C-95, 1139 West Park, Libertyville, Illinois.

**AUCTIONEERING**—Home study course. Diploma granted. Auction School, Ft. Smith, Ark.

**BAKE** New greaseless doughnuts in kitchen. Sell stores. Free recipes. Michael, 3605 South 15th, Minneapolis 7, Minn.

**BECOME** Independent with your own franchise business. Thousands earning handsome incomes. Request interesting facts today. National Franchise Reports, PM-528, 333 North Michigan, Chicago 1.

**BIG** Money raising fishworms and crickets. Free literature. Carter Wormery, Plains, Georgia.

**EARN** \$240.00 A month at home, spare time, doing only two \$5.00 invisible mending jobs a day. Big money paid for service that makes cuts, tears disappear from fabrics. Steady demand. Details free. Fabricon, 1586 Howard, Chicago 26, Ill.

**EARN** Money raising fishworms for us! Write: Oakhaven—58, Cedar Hill, Texas.

**SHARPEN** Scissors, pinkers, clippers. Inexpensive machines, supplies. Black-hawks, Sheldahl, Iowa.

**CHROME** Plating. Instructions, equipment and supplies. Platers' Supply, P.O. Box 565, Lugo Station, Los Angeles, Calif.

**BARGAINS!** Buy wholesale! Save money! Free catalog! Norris 273-X Merrick Road, Lynbrook, N. Y.

**VENDING** Machines. No selling. Operate a route of coin machines and earn amazing profits. 32-page catalogue free. Parkway Machine Corporation, 715 PMP Ensor Street, Baltimore 2, Maryland.

**MAKE** More money raising hardy Rocky Mountain hybrid worms. Information free. Dewey's, Henderson, Colorado.

**INVESTIGATE** Accidents. Earn \$750 to \$1,000 monthly. Men urgently needed. Car furnished. Business expenses paid. No selling. No college education necessary. Pick own job location. Investigate full time. Or earn \$8.44 hour spare time. Write for free literature. No obligation. Universal, CPM-6, 6801 Hillcrest, Dallas 5, Texas.

**WHOLESALE** Magazine subscriptions. Highest commissions. Bonus! Qualified Agencies, 451GA, Kingston, Brooklyn 25, N.Y.

**MAKE** Money writing short paragraphs. Information free. Barrett, Dept. C27B-F, 7464 No. Clark, Chicago 26.

**SWIM** At once invisible swim aid for men, women, children; 1/25" thick, 4 oz.; worn under bathing suit. Demonstrator \$6.95 ppd. check or money order; state waist size. Also many other new international patented articles. Reps wanted, 25¢ for details, refundable first order. G & R Industries, 59-15-B 71 Ave., Brooklyn 27, N. Y.

**INVESTIGATE** Automobile accidents. Earn up to \$1,000 monthly. Investigators urgently needed by insurance companies. Car furnished, expenses paid. Free employment help. Or, open your own profitable business full or spare time earning \$6 hour. College unnecessary. Free booklet, no obligation. United Schools, C628, 1626 Glendale, Orlando, Florida.

**STARTING** And Managing a small book-keeping service. \$3.00. Trigo, Box 1551, Houma, Louisiana.

**FREE** Report: "609 Unusual, Successful Businesses." Box 1001-PT, Evanston, Ill.

**TRADE** Association management. Booklet, five dollars Langdon, 426 Alandale, Los Angeles 36, California.

### BOOKS, PERIODICALS, PICTURES, POSTCARDS

**PUBLISH** Your book! Join our successful authors: All subjects invited. Send for free appraisal and detailed booklet. Carlton Press, (Dept. PMR), 84 Fifth Avenue, N.Y.C. 11.

**FREE** Catalog. Specialized magazines self-help books. Commercial Publications Company, Box 55429, Indianapolis 5, Indiana.

**THREE** Books postpaid worth 30¢ to \$1.50 for 30¢. Handwriting analysis 35¢. Lund's Books, 2773 E. 79th, Cleveland 4, Ohio.

**BOOK** Hunters! Send wants! Atlantic Book Service, Cedar Street, Charlestown 29, Mass.

**FREE** Catalog. Self-help books. Write Wilshire, 8721 Sunset, Los Angeles 69P.

**NATIONAL** Geographic magazines, 1888-1960, any issue. Periodical Service, Box 465-PM, Wilmington, Delaware.

**BRITISH** Book bargains—Any subject. Catalogues free. Transatbooks, Wantagh, N. Y.

**BOOKS** Located! Aardvarks Worldwide Booksearch, Box 668-PM, San Diego 12, California.

**BOOKS.** Elusive. Located. Free lists. Del, 12725 Flatbush, Norwalk, California.

**PROPHET** Elijah coming before Christ. Wonderful book free. E. Megiddo Mission, Rochester 19, New York.

**OUT-Of-print** books at lowest prices! You name it, we find it! Fast service. No obligation. International Bookfinders, Box 3003-PM, Beverly Hills, Calif.

**SAVE** to 83% on books, records. Free catalogue. Discounts Reader's Service, MEC-5435 Upland Way, Philadelphia 31.

**COLLECTORS!** The Booklover's Answer, Woodstock 57, New York. Bimonthly magazine for book collectors. Introductory one year subscription \$2.00.

## MAGIC TRICKS, PUZZLES, JOKER NOVELTIES

**CALENDAR** Girl playing cards \$2.00. Samples 25¢. Bernard's, Box 854, Chicago 42.

**PROFESSIONAL** Catalog, 175 pages, 25¢. Williams, 900 Plymouth, Ellwood City, Penna.

**BRAND** New million dollar professional magic catalog just out! 1000 amazing tricks, magic, jokers, stunts! 160 pages thick! Special 25¢. House of 1000 Mysteries, Dept. PM5C-63, Monroe, Connecticut.

**CATALOG** = 19. Free trick, 25¢. (1,500-399 tricks, jokes, novelties). Magico, 7408-P, San Antonio 7, Texas.

**FASTEST** Same-day service to magicians everywhere for 40 years. Send 10¢ for Douglas famous Catalog 500 Tricks, containing magic for pocket, parlor, club, stage. Douglas Magicland, Dept. 21, Dallas, Texas.

**WORLD'S** Finest professional magic. Joker novelties. Giant illustrated catalog 10¢. Top Hat, Evanston 12, Illinois.

**WORLD'S** Finest magic catalog, \$2.50 (\$2.00 magic included free). 3000 tricks, pocket, stage (408 pages). Kanter's, M-200 South 13th, Philadelphia 7.

**BE A Magician!** Introductory catalog with free trick, only 35¢. Ireland, 109-F North Dearborn, Chicago 2.

**VENTRILOQUISM** For fun or money. New method. Easy. R. Marlette, 2N-075 Mildred, Glen Ellyn, Illinois.

## ANTIQUES, RELICS, INDIAN GOODS, CURIOS

**SELLING** 20,000 Ancient arrowheads, spearheads, etc. List free. Lear's, Glenwood, Arkansas.

**500 ANTIQUE** Picture frames. First time offered. Send \$1.00 for photos and prices. World Wide Originals Art Galleries, 5202 W. Bluemound Rd., Milwaukee, Wis.

## COINS, TOKENS, CURRENCY

**SAVE** Your slick nickels where date is worn off. Order a bottle of Coin Date. It will bring the date out in Buffalo, V. Shield nickels. It's easy to use. Satisfaction guaranteed. \$1.00 postpaid. Box 276-F, Mooresville, No. Carolina.

**INDIAN** Pennies — 10 different — \$3.00. "Cy's," Box 1531, Fargo, North Dakota.

**HUNDRED** Assorted "S" Lincoln's \$2.50. Taylor, 9917 Mollyknoll, Whittier, California.

**25¢ BRINGS** Buying and selling lists plus scarce penny. PDS, 114 Nassau Road, Massapequa, N.Y.

**SELLING** Coins reasonable. Free list for stamped envelope. Gene Carlton, Chandler, Okla.

**1957 PROOF** sets \$5.95. Catalogue 50¢. Lacheen, Box 1355, Phila. 5, Pa.

**GOLD** Coins! Austria 4 Florins uncirculated \$8.25. Catalogs at \$15.00! Satisfaction guaranteed. Univex Corporation, Box 965, New Haven, Connecticut.

**BARGAINS.** Fifteen different Indian cents \$5.00. Brilliant proof sets—1957, 1959, 1960 each \$3.95; 1961, 1962, 1963 each \$2.85. In boxes: Pakistan proof set \$5.00; South Africa proof set \$6.25. Bargain lists 25¢. Bebee's, 4514 North 30th, Omaha 11, Nebraska.

**UP TO \$120.00** each for certain Indian-head pennies. 25¢ for list. Eisenberg Coins, 7636-PM Rogers Ave., Chicago 26, Illinois.

**CURRENCY:** 20 different, colorful \$1.00. Gill, 8120 Harwood, Springfield, Va.

**GOLD** Coins at reasonable prices. Everlasting collection values. Free list. Agimpex, Box 65, Snowdon-Montreal, Canada.

**CURIOS** Coins and odd paper money from seven countries! Yours for only 10¢. \$100,000 Confederate "money" facsimile bonus for promptness. Other interesting offers on approval. Littleton Coin Co., Littleton MI, N. H.

**SELLING!** Uncirculated 1903-O silver dollars. Catalogues \$1500, only \$35 each. Indian cents, 30 cents each. Rausch, 605 W. Wayne, So. Bend, Indiana.

**TRUNKFUL** 25,000 Indian-Lincoln cents mixed (from the 1920's & older.) Will pack "grab-bag" style. 400 mixed \$25.00, sample bag of 20—\$2.00. Mrs. Fischer, Box 5490, Sherman Oaks, 32, Calif.

**COIN** Collectors greatest magazine and wooden nickel 10¢. Lawrences, Anamosa, Iowa.

**WOW!** Rare silver dollars! Brilliant! Uncirculated! Low prices! 1903-O only \$35.00! 1892-O, \$5.00! 1898-O, 1899-O, 1900-O, 1901-O, 1902-O, 1904-O, only \$2.00 each! Thousands of other coins! Rush your order, and get our free price list! Silver Center, Box 3293-M, San Francisco 19, California.

**PROOF** Sets 1961 \$3.25, 1962 \$3.00, 5 @ \$2.90, 1963 \$2.80, 5 @ \$2.60. Tom Norman, Corinth, Miss.

**LINCOLN** Cents: 23S, 24S, 21S-P, 16S-D, 17S-D, 18S-D, 19S-D, 20S-D, 25S-D, 25S-D, 29S-D, 30S-D, 28S-D, 27S-D, 5S-S, 54S-P, 32D, 33P, 39S-D, 49S. Good to fine, complete lot \$8.50. Rolls 55S \$12.50 fine to x fine.—49S \$3.50 roll. Berry, Box 1241, Orange, Calif.

**RARE** 1899 Philadelphia silver dollar, uncirculated, \$8.00. Butts, Torrington, Wyoming.

**COIN** Bargains galore. Illustrated lists 10¢ (refundable). Hutchinson's, Box 6256, Philadelphia 36, Penna.

**INDIANHEAD** Cent with terrific bargain list 30¢. Nelson, 346-P, Rye, N.Y.

**VALUABLE** European. 15 coin limited introductory offer. Guaranteed collector's value at least \$8. Send \$2. Also receive free collecting investment information. Collector's Coin Company, Box 6532, Bloomington, Minn.

**ANY** Five Jeffersons except 38SD, 39SD, 50D, 51S, 55P, \$1.10. Traycek, 25 Quinian, Staten Island 14, New York.

**SILVER** Dollars uncirculated. 1898-99-1900-01-02-04 O mint \$2.00 ea. Price list = 31 50¢. Shultz, Salt Lake, 10, Utah.

**2 MEXICAN** Silver dollars \$1.00. 100 foreign coins \$2.95. Browns, Box 188M, Tolleson, Arizona.

**40 PAGE** Illustrated United States and Canadian coin list 10¢. Stoney, 260 Washington, Boston 8, Mass.

**INDIANS,** Lincoln, Liberty nickels. List 10¢. Evans, Box 9912d, Atlanta 19, Ga.

**LARGE** English pennies. Five different dates for 25¢ with coin approvals. Molzan, Box 275, Alameda, California.

**LARGEST** Coin magazine. 288 pages, 50¢. Scrapbook, 7320-J Milwaukee, Chicago 31.

**10 INDIAN** Cents \$3.50, 10 liberty nickels \$3.50, 15 Barber dimes \$7.50. Good, all different in holders. Postpaid. Prager, 470 27th Avenue, San Francisco 21, California.

**35 DIFFERENT** Lincoln cents S/D only before 1942. album, 2 bargain catalogs, \$3.95. Hobby Sales, St. Paul 16, Minn.

**GIANT** Illustrated catalog listing hundreds of bargains in coins and supplies, only 50¢. Rarcoa, 31 North Clark, Chicago 2.

**TWENTY-Four** page 1963 retail price list of USA and Canadian coins 10¢. Our selling prices on thousands of coins and coin collectors' supplies. Bryson Incorporated, 612A White, Toledo 5, Ohio.

**FREE** Coin supplies! Giant coin list 10¢ (refundable). Economy Sales, Mansfield, Massachusetts.

**BARGAIN** List! U. S. coins, accessories. Stamp please. Hugh's, Hickory, N. C.

**25 BEAUTIFUL** Coins from 25 countries. Mostly uncirculated. Terrific assortment. \$1.00. Hindley, Box 708, Aurora, Illinois.

## HOBBIES AND COLLECTIONS

**50 DJUNGLE** Butterflies. 30 Oriental sea-shells, 20 gemstones, each \$2.00. Giant collectors wonderland pricelists 25¢. Haas, Box 1170, New York 8, N.Y.

**COLLECTORS** Matchbook covers. 100 different unused. \$1.00. Catalog 25¢. Helene Edelman, 1311-C East 84, Cleveland 3, Ohio.

**INTRODUCTORY:** 30 Army, Navy, Marine emblems; 150 assorted service stripes (\$5.00 value) only 50¢, catalog included. Sample foreign medal, 50¢. Insignias, Box 71-M, Rockaway 94, N.Y.

**AMERICAN** Newspaper, complete, original, dated before 1860, \$1.50. 25¢ stamps brings catalogue. D. R. Spaight, Book-seller, Tall Timbers 1, Maryland.

## STAMP COLLECTING

**FREE!** Congo triangle set! Boy Scout beauty! 25 others. Different. Approvals. Cambridge, Box 411, Cambridge, Ohio.

**15 PLEASANT** Offers plus valuable tips. Write: Bileski, Station B, Winnipeg, Canada.

**150 DIFFERENT** U.S. stamps 25¢. Approvals. Winchester Stamps, 45 Winchester Rd. Mansfield, Ohio.

**50 YEARS** old. 15 different United States stamps at least 50 years old 10¢ with low priced United States approvals. Jaxon, Box 145-P, Bklyn, 30, N.Y.

**STAMP** Bargains: 100 different worldwide 20¢; Packet British Colonies 20¢; Thirty-three presidents illustrated 25¢; Set Confederate facsimiles 35¢; Set Israel coin stamps 30¢; Four fipex triangles 10¢. Spruceland P2, 115 State, Springfield 3, Mass.

**OVER \$20.00** value for \$1.00. 1,000 different worldwide. Approvals included. Adults only. Universal, Box 6, Kenosha 5, Wisconsin.

**215 DIFFERENT** Worldwide 25¢. Iceland, French Colonies, etc.! Approvals. Bobb's, Box 3045, St. Louis 30, Missouri.

**FREE** Mint set! Approvals accompany. Stampco, Box 737, Memphis 1, Tenn.

**PENNY!** Approvals! Regardless catalog! Kloster, 4164—32nd Street, San Diego 5, California.

**U. S.** approvals. Low prices. Eagle Stamps, Romine Ave., Pittsburgh 26, Penna.

**TOPICALS,** Beautiful stamps, 25 different, only 10¢, approvals. Stamac, 108 Park Place East, North Charleston, S. C.

**200 STAMPS.** 25¢ With approvals. Smith, 508A Brooks, College Station, Texas.

**FREE!** 222 worldwide. 10¢ handling. Penny approvals. Jung, 1601 North Stanley, Los Angeles 46.

**U.S. Mint** specials! Flag set, complete \$1.00; 1¢, 2¢, 3¢ famous Americans (21 different), \$1.00. Free list. Brooks, 2323 Avenue X, Brooklyn 35, New York.

**80 DIFF.** U. S. stamps includes 19th Century commemorative. High values. Plus 1943 flag stamp of occupied nations. All for only 25¢. Approvals included. Willett Co., Box 338-C, Yorktown Heights, N. Y.

UNITED Nations 15th anniversary sheet with first day cancel, as commemorated by Russia. Free! While they last, with approvals, Philatelics, R-J, New Paltz, N. Y.

STAMP Collecting outfit, includes, packet worldwide stamps, package hinges, watermark detector, millimeter gauge. Everything 10¢ with approvals. Loraine Brown, Marlon, Michigan.

INTRODUCING Our better United States approvals we offer 15 United States stamps including Columbian, Bi-Centennials, famous American, airs, others; only 10¢. Ocean Stamps, Box 64-PM, Brooklyn 29, New York.

UNITED States commemorative collection containing 33 different—10¢. Approvals. White, 516-A Avenue L, Brooklyn 30, New York.

PENNY Approvals. Thousands. Bargains for pennies. Gifts with purchases. Penny Stamps, Orange, California.

100 OLD United States between 1861 and 1935. \$1.00. Roush Stamps, 51 Chestnut, Mansfield, Ohio.

FREE Monaco nudes. Approvals. Stamp Ranch, 902 Addison, Chicago 13, Ill.

60 DIFFERENT U. S. (30 commemoratives) 25¢. No approvals. Seidenberg, Appleton, Wisconsin.

225 STAMPS For only 10¢! This mammoth value includes airmails, pictorials; stamps from strange countries cataloging up to 25¢ each! Also approvals. Mystic Stamp Company, Camden 80, New York.

SELL Your surplus good grade stamps. Write, describing fully what you have. Vanroy Shirk, Lebanon, Pennsylvania.

AMAZING OFFER! 200 United States stamps — including commemoratives, airmails, high denominations to \$1.00. Only 10¢ to approval applicants! Illustrated bargain lists free. Mystic Stamp Co., Dept. 80, Camden, New York.

701 U.S.A. 25¢ (plenty commemoratives). Request approvals. Horace Gatewood, Winston-Salem, N. C.

50 DIFFERENT Central and South America, 10¢ with worldwide approvals. Cole, Box 223-A, Buffalo 21, N. Y.

21,000 ALL Different, only pennies a day using our systematic payment plan. Details free. Sjoquist, 1435 Cherrydale, San Jose 25, California.

FREE! 50 Turkey, 10¢ handling. Approvals. Berchtold Stamps, Troy, Ohio.

FREE! World's largest! Strange, valuable 7"x14" beauty. Send 10¢ handling now! Norrisco, Milwaukee 7, Wis.

FREE Macao mint set, approvals. Coretta, GPO, Box 1546, New York 1.

MILLION Foreign stamps! 2¢ each! Send for thrilling, giant approvals! ABC Stamps, Box 6000-MB, San Francisco 1, Calif.

FREE! When you buy our foreign approvals you receive absolutely free stamps equaling your purchase. Coast, 1609 S. Park, Santa Ana, California.

GIANT Approvals. Thousands different 1¢ and 2¢ each. Wahl's Stamp Exchange, 7008P Farragut, Chicago 31, Ill.

HAMMARSKJOLD Error of inverted background (originally quoted \$5000), plus normal stamp for comparison. Both mint stamp plus another error used in mailing — Everything 10¢. Stamp dictionary and approvals included. Stampex, Box 47-MM, White Plains, N.Y.

THE Hard-to-get U.S. used #J101 only 10¢, our U.S. catalogue 20¢. New-Way Stamp, Lawrence, Mass.

500 DIFFERENT includes pictorial. 35¢. Approvals. Knopp, Box 1381, Bristol, Conn.

105 DIFFERENT U.S. stamps only 25¢. Approvals included. Shelron, Box 187K, Hempstead, N.Y.

FREE Stamp wallet with approvals. Wide selection collections by countries. Clark, Box 28-C, Wilmette, Illinois.

25 JAPAN, 10¢. 25 Denmark, 10¢. 25 Sweden, 10¢. Approvals. Cuillo, 521 Hemlock Street, Brooklyn 8, New York.

U. S. Stamps. Giant discount catalog 25¢. Raymax, 37-VZ Maiden Lane, NYC 38.

TRADE Your duplicates. (Toward foreign approvals.) Write: VPT, Box 98, Newton Highlands 61, Mass.

INTERNATIONAL Government philatelic agencies! (Where stamps sold face). Directory \$2.00. Bedard, Box 5215-A, Detroit 36, Michigan.

50 DIFFERENT Stamps from 50 countries! Plus 25 U.S. commemoratives! All 25¢! Illustrated monthly lists! Ewing, 2133 Lunt, Chicago 45.

HELIGOLAND Stamp free. Approvals. W-B Stamps, Wilkes-Barre, Penna.

BARGAIN 50 different US 10¢, with beautiful worldwide approvals. Stamps, Kennebunk, Maine.

FREE—Mammoth collection, including \$10.00 airmail. World's smallest stamp, gorgeous multicolor pictorials plus Scott's Internationals, Master Global albums, Scott's 1963 catalogues, all free when you buy foreign approvals. Bargain Stamps, Box 1112A, Miami Beach 39, Florida.

FREE 400 Genuine postage stamps! Worth \$10.00 at catalogue prices. Africa, Europe, Asia, British Emp.—a fascinating valuable mixture from foreign convents, banks, etc. Who knows what you will find. Also free valuable booklet. Adults only. Approvals enclosed. Frasek Co., PM-6, White Plains, N. Y.

25 DIFFERENT Commemoratives 1893 up 10¢. US approvals. K&B, Box 70, Brooklyn 23, N.Y.

80,000 DIFFERENT. Amazing new plan builds your collection systematically, country by country. Only 50¢ weekly. Free details. Ware, Monroe 75, Conn.

ABSOLUTELY Free. 50 worldwide stamps introducing inexpensive approvals. University, P.O. Box 44-592, Miami 44, Florida.

FREE Sample. Interesting, informative, illustrated. National Stamp News, Anderson, South Carolina.

FREE Mint Africa set with approvals. Lithor, Box 51, Canoga Park, Calif.

1000 DIFFERENT. \$1.00 With approvals. Louis Golden, 6721 Eastwood, Philadelphia 49, Penna.

HAWAII. Three old classics 20¢ with worldwide approvals. Hawaii Stamp, 280 Lewers, Honolulu 15, Hawaii.

FREE! 25 Egypt, 10¢ handling. Approvals. Bellet, Mapledale, Hazel Park, Michigan.

FREE! Giant Bargain Catalog—New Edition listing thousands of bargains including U.S. and B.N.A. stamps, packets, mixtures, albums, accessories and supplies; sent with beautiful approvals. Jamestown Stamp, Dept. E63PM, Jamestown, N.Y.

209 DIFFERENT Stamps 25¢. Exciting collection includes beautiful Monaco set plus Antarctic Explorers, South Africa Gold Mine, many more. Grand total 209 stamps, all genuine, all different. You also get 88 flags of the world and midget encyclopedia of stamp collecting. All this for only 25¢ to introduce our bargain approvals. Satisfaction guaranteed. Send 25¢ today. Ask for Lot FO-47. Zenith Co., 81 Willoughby St., Brooklyn 1, N.Y.

200 DIFFERENT Foreign 15¢. Approvals. Allman, Box 229, Little Rock, Arkansas.

ISRAEL 100 different \$1.00. 150—\$3.50. Weider, 1270 98th, Miami Beach 54, Florida.

THOUSANDS of fascinating stamps: 1¢—3¢; Bonuses! Nations, Box 117-X, Bronx 51, N.Y.

APPROVALS Postpaid both ways. Robert Fine. 256 Chaplin, Toronto, Canada.

FREE 50 different with approvals. Brooks, P.O. Box 17062, Dallas 17, Texas.

SOUTH Seas stamps free. 25 different, exotic pictorials, commemoratives, hula girl, giant New Zealand Christmas bicolors, complete set charity healths. Free. Approvals. Seven Seas Stamps Pty. Ltd., Dubbo, NSW, Australia.

FREE Surprise mint sets! Approvals. Servo, Box 355, Topeka, Kansas.

START Approval business! Details 25¢. Steele, 12-BP Orchard Lane, Salinas, Calif.

25 COLUMBIA 20¢. Approvals included. Reed, Box 980, Chicago 90, Illinois.

TWO Dollar conglomeration includes perforation gauge, watermark detector, discontinued approval sheets, mint blocks, mixtures, packets. Money back guarantee. Norge Company, Ho-Ho-Kus, N.J.

WOW! 110 All Different Germany 10¢! Zeppelins, Semi-Postals, Airmails, High values, etc. Giant Catalog, bargain lists included with beautiful approvals. Jamestown Stamp, Dept. A63PM, Jamestown, N.Y.

U.S. Mint imperforate parks \$2.40. Approvals. Bill Egleston, Clearfield, Utah.

"OLD Glory" in flaming colors! U.S.A. flag giant beauty from Honduras. Enormous United Nations Mexican stamps. Plus strange gorilla issue. Duke of Windsor, Morocco lovely Macao flowers, wild buffalo stamp and others. 10¢ with approvals. Sunny Stamp, Apopka 2, Fla.

HOLY Stamp depicting Christ and cross! Plus triangle discus thrower, enormous multi-colored Balkans diamond issue, wonderful map collection from Timor, Macao and Angola. Extra! Brilliant flag set, etc. only 10¢ with approvals. Capital Stamp Co., Ferrysburg 2C, Michigan.

FREE! Surprise "Mystery" packet. Approvals. Premiums, Dancer, 75-P44, Mansfield, Ohio.

101 DIVERSIFIED British Commonwealth 10¢. Approvals included. Niagara Stamps, St. Catharines 501, Ontario.

100 DIFFERENT Australia free to approval buyers. Gordon Davison, Henniker 8, N. Hamp.

PHILATELIC Jungle 10¢. Fifteen zoological specimens. Approvals included. Free watermark detector. Crown Stamps, Virgil 301, Ontario.

100 DIFFERENT Norway, 25¢! Bargain approvals. Carling, 663-A, Howard City, Michigan.

FREE Sets, inexpensive approvals 10¢ handling. Paradise, Utterson, Ontario, Canada.

SMASHING Collection free. Includes triangles, early United States, rockets, sports, British Colonies, high value pictorials, etc. Complete collection plus big illustrated magazine, all free. Send 10¢ for postage. Gray Stamp Co., Dept. PM, Toronto, Canada.

UNUSUAL Old U.S. defectives. Bargain prices. K. Swartz, Malden Bridge, New York.

25 LARGE American commemoratives 10¢. Accompanying approvals. Free perforation gauge. Linstamps, St. Catharines 101, Ontario.

200 DIFFERENT World's most beautiful stamps \$1.00. 150 different choice U.S. commemoratives \$1.00. 50 different large beauties 25¢. Gray, 506-15th St., Moline, Illinois.

GERMANY: 500 different \$1.00. Special offers. Discounts. Wolverine Stamps, Box 1825, Ann Arbor, Michigan.

FREE! 33 Greenland! Ghana! Ruanda! others. Approvals. Keating, 2520-P Boulevard, Jersey City 4, New Jersey.



UNITED STATES. Rarely offered 1883-1939. 40 different, \$1.00. No approvals. Wetherbee's, 34 Pine, North Billerica, Mass.

FREE! Three mint nudes. Approvals. Economatic, Department H, Box 3984, Grand Central, New York 17, N.Y.

95,000 DIFFERENT! Pennies a day builds collection methodically. Free particulars. Holtzman, 95P Terrace, Levittown, Pennsylvania.

268 DIFFERENT Foreign beauties including cruel Hitler, sports, elephants, flowers, child praying, astronaut. 25¢ with approvals. Jaro, Dept. PM, Box 246, New York 3.

BRITISH Empire mints, 100 all different, \$2.50. Stamperama, 2928 Bouck, Bronx 69, N.Y.

COLORFUL Stamp collection. 200 different 10¢. Approvals. Streff, Dept. 60, 4015 Roosevelt, Philadelphia 24, Pa.

STAMPS. 55 different, Free with approvals. Wagner, 547 Franklin, Buffalo 2, New York.

FREE 40-Page U.S., U.N. price list. Parasco, Box 229T, Brooklyn 1, N.Y.

FLAG Stamp free with U.S. approvals. Wenigman, Box 265, Park Ridge, Illinois.

RUSSIAN! Bear in Berlin. Mint set of 7. 15¢. Approvals. Mack, Box 8021, Houston 4, Texas.

500 FINE Mixed U.S. 15¢. Wright, Box 753M, Hagerstown, Md.

HUNGARY. Latest gigantic "ice skating". Triangles free! Approvals. William Deems, 226a Race, Ravenswood, West Virginia.

COLORFUL Packet free with carefully selected worldwide approvals. Gorliz, 6629 Oshkosh, Chicago 31.

FREE. Three mint sets, with approvals! Ross, 1127 Nichols, Stratford, Conn.

STAMP A day plan. Subscription \$1.00. Box 844, Missoula, Montana.

PRICE List, foreign, U.S. No approvals. Stamps, 5000 Miami, St. Louis 9, Mo.

### PRECIOUS STONES, MINERALS

SEMI-Precious uncut gems. Ten different for \$1.00. Request list 28. Prospectors Shop, 201 San Francisco, Santa Fe, New Mexico.

20 DIFFERENT Mineral stones with descriptive history, \$2.00. Phillips, 1290-P Cottonwood, Banning, Calif.

GET Free catalog no serious rockhound, gem cutter, jewelry maker, hobbyist or craftsman can be without. Full of bargains, exclusive items, low prices from largest suppliers and authorities in the field. Free new catalog just off the press. Yours for the asking! Write Grieger's, Dept. C-12, 1633 E. Walnut, Pasadena, California.

EARTH Science. Rockhound's National Magazine. Subscription \$2.50. Sample 35¢. Box 1357-PM, Chicago 90, Ill.

### COLOR SLIDES

TRANSPARENCIES Wanted. Up to \$500.00 each. For information write American Color, P.O. Box 46372, Hollywood 46, Calif.

"LIFE OF LINCOLN" in color slides. Historical, cultural, educational. Sample slide with catalogue, 35¢. (Credit on \$5.00 purchase.) Willems, Box 1515-A, Chicago 90.

8MM., 16MM. Movie subjects. Silent, sound. New, used. 2"x2" color slides. Biggest selection anywhere! Free each month, big 24-page newspaper-size catalog. Blackhawk Films, Davenport 14, Iowa.

### PHOTO FINISHING, CAMERAS, PHOTO SUPPLIES

PHOTOSTAMPS! Gummed backs. From any snap. Only \$2.00 for 100! Samples. Rodie & Son, P.O. Box 234, Brighton 35, Mass.

FREE! Send now for photographic bargain book. Dept. 1-K-6, Central Camera Company, 230 So. Wabash Ave., Chicago 4, Illinois.

FREE Color roll. Write for details. Don's, Box 84, Brooklyn 19, N.Y.

"STYLOPHOT" 16mm miniature pocket camera. 18 jumbo pictures or slides per roll. Special: camera, case, film \$10.00. Year guarantee! Kimac, Old Greenwich, Conn.

EKTACHROME — Anscochrome 35mm, 620, 127. developed, mounted, \$1.00. Low Kodacolor prices. Complete price list, free mailers. Write Trycolor, P.O. Box 123-M, So. Windsor, Conn.

SLIDES From your negatives, photos. Color or b&w. Ten, \$3.00. 35-Slides, Green Mtn. Falls, Colorado.

A FREE Kodak roll returned with each black and white or Kodacolor developed and printed, fast service, lowest prices, guaranteed quality send for free mailers. Economy Photo Service, Dept. P. M., Box 1111, Albany 1, N. Y.

COLOR Movie fans! Low cost—high quality processing our specialty, 8mm. just \$1 (or \$3 with fresh film). Mailed back next day. Craftsmanship guaranteed. Send exposed reel or request free mailers and price list of complete photo-finishing services. Direct Mail Photo, Box 8352-PM, Pittsburgh 18, Penna.

FAST. Hi-quality finishing. Kodacolor rolls: eight jumbo prints \$1.98. Twelve \$2.49. Twenty \$3.49. Reprints 15¢. Also low B&W prices. Custom Quality Studio, Box 4838, Chicago 80.

12 EXPOSURE Roll 70¢. Wallet 25 for \$1.00. Mail in Photo, Box 707, Lowell, Mass.

CANON, Minolta, Bronica, Asahi-Pentax, Mamiyaflex, Yashica. Order direct thru mail order for tremendous savings. Free catalog. Hero Camera Co., 3-5 chome, Nishi-Ginza, Tokyo, Japan.

FREE Roll of film with each roll developed. Kodacolor \$3.90. B&W \$1.25. Picture Barn, PO Box 791, State College, Pa.

### MOTION PICTURES AND SOUND EQUIPMENT

CHAPLIN, Hart, Mix 8mm 16mm movies. Film Classic, 1926 S. Vermont Avenue, Los Angeles 7, Cal.

16MM sound-projectors, films, new, used for sale. Free catalog. National Cinema, 71 Dey Street, New York City, N.Y.

8mm SILENT Films. 16mm sound films. Bedner, 5300 So. Talman, Chicago.

5,000 8-16 MM. Movie films. Free catalogues. International, Greenvale, N. Y.

MOVIE Film! Free catalog! ESO-R, 47th Holly, Kansas City 12, Missouri.

FREE Catalog! Save on 8/8mm.-16mm. film and supplies. Superior, 448 N. Wells, Chicago 10.

### MUSIC AND MUSICAL INSTRUMENTS

ITALIAN Accordions Manufacturing, 7600-M Cottage Grove, Chicago 19, Illinois. Pianc. Chromatics, Hohners, Concertinas. Wholesale catalogs free.

GUITAR Self-instruction books, chords, melodies. Special \$1.00. Hrudka, P.O. Box 950, Chicago 90, Ill.

SONGPOEMS Wanted immediately. Send poems for offer. Any subject. Nashville Music Institute, Box 532-M, Nashville, Tennessee.

PLAYER Rolls. All kinds. Big List free. Master Piano Works, 6549 Northwest Highway, Chicago.

HI-FI LP records of famous Longines Symphonette, produced by Columbia. Less than 13 cents a selection. Finest quality—not sold in stores. More than 8 hours of music available. Rush card for free details. Longines Symphonette Music, Dept. PM-6, 580 Fifth Avenue, New York 36, N.Y.

VIOLINMAKERS. Repairers. Fine tone woods and supplies. Also headquarters for violins, guitars (regular and electric), cellos. Send for wholesale price lists. International Violin Co., 414-MPM E. Baltimore Street, Baltimore 2, Maryland.

SONGWRITERS Guide to Success, only \$1.00 James Johnson, 4054 Lausdale Station, Knoxville 21, Tenn.

SONGWRITERS! Sell direct! 175 well-known recording vocalists "confidential" addresses plus successful methods. \$3.00. Imperial Creations, Box 80-P, New York City 25.

USED Professional guitars, amplifiers, drums. Write: Music, 1215 War Memorial, Peoria, Ill.

ACCORDIONS, Guitars, chord organs! Famous makes. Free home trial. Easy terms. Trades. Free catalogs. Mention Instrument. International Music Mart, Dept. R, 2003 Chicago Avenue, Chicago 22.

PLAY Guitar. "Teach Yourself" 78 lesson book including 50 photos. Chord method. \$3.00 ppd. Hendrickson Publications, Studio A, Box 5024, Borger, Texas.

BANJOS. Parts, necks, rings, hardware. 6710 Long Beach Blvd., Long Beach 5, Cal.

RECORDS! Discounts on all LP's. Free details. Citadel Record Club, 545 Fifth Ave., Dept. 2, New York 17, N. Y.

GUITAR Making books, plans: imported woods, tools. List 10¢. Satinwood, 510 East 11th Street, New York 9, N. Y.

SONGWRITERS. With publisher contacts, want song ideas. Share royalties. Send poems, free examination: Songwriters' Associates, 1650 Broadway, N.Y. 19-P.

ELECTRIC Guitars, amplifiers, wholesale. Free catalog. Carvin, PMM, Covina, Calif.

POEMS Wanted for musical setting and recording by America's largest song studio. Send poems. Free examination. Five Star Music Masters, 630 Beacon Building, Boston.

POEMS Wanted for musical setting and recording. Send poems. Free examination. Crown Music Company, 49-C West 32 Street, New York 1.

ACCORDION-O-RAMA, 874 Broadway, New York 3, N. Y. Tremendous discounts. Top brands. Free brochure.

SONGPOEMS And songs wanted! Mail to: Tin Pan Alley, Inc., Box 405, Radio City Station, New York 19, N. Y.

SONGPOEMS Wanted! Collaborate with professional songwriters equally. Share royalties. Songwriters Contact, 1619-D Broadway, New York 19.

## RADIO, TELEVISION AND ELECTRONICS

**FIX** Your own TV. Save 80%! Send for free illustrated chart showing how! We'll include giant electronics catalog. Zalytron, 461 Jericho Turnpike, Mineola, N.Y.

**SAVE** Dollars on radio, TV-tubes, parts at less than manufacturer's cost. 100% guaranteed! No rebrands, pulls. Request bargain bulletin. United Radio, 1000-M, Newark, N. J.

**TAPE** Recorders hi-fi components. Sleep learning equipment, tapes. Unusual values. Free catalog. Dressner, 1523 Jericho Tpke, New Hyde Park 3, N. Y.

**SAVE 30% Up!** Blank-stereo recorded tape-recorders, Norelco speakers. Saxitone, 1776 Columbia Road, Washington 9, D. C.

**TRANSISTOR** Radios repaired: \$5.00 covers repair, return postage. Mail radio, \$5.00 to: Davis Transistor, 124 Hilltop, Baxter, W. Va. Guaranteed.

**RADIO** Electronics course only \$14.95. Includes all tubes, parts, tools, instructions. Write for full information. Edu-Kits, Dept. 584B, Hewlett, N. Y.

**CHANGE** Television to color, reduce eye strain. Send size television screen and \$2.98. Delecto Electronics, 4725 45th N. E., Seattle 5, Wash.

## BUSINESS OPPORTUNITIES

**LIQUID** Rubber for plastercraft, figurines, cement ornaments. Catalogue and sample 10¢. W. Wooley, Peoria, Illinois.

**PROFITABLE** Mail order business. Be independent. Details free. Ideal, Box 357-BC, Valley Stream, N.Y.

**READ** Our announcement under Welding, Soldering, Plating. Texas Plater's Supply Co.

**BUSINESS** Guidance service. 20 different setup services for selection. Hermes Company, 152 West 42, New York City 36.

**OPERATE** Mailorder art school. Everything supplied including instructors. Art Studio, 60 Douglas, Lowell, Mass.

**SELL** Advertising book matches. Write us today: we put you in business by return mail, handling complete line ad book matches in demand by every business right in your town! No investment; everything furnished free! Top commissions daily! Superior Match, Dept. MX-663, 7530 S. Greenwood, Chicago 19, Ill.

**ASSEMBLE.** Sell by mail, adhering signs. Free sample. B-1834 Edgeland, Louisville 4, Ky.

**BIG** Money. Operate your own fix-it shop. Service all household appliances: irons, fans, refrigerators, automatic washer-dryers, etc. Know how they work, what goes wrong, and how to fix them. Learn how to do house wiring, commercial wiring, rewind motors of all sizes, sharpen mowers, skates, saws. How to get business, buy spare parts wholesale. What to charge for your work. Free book. Christy Trades School, A-4103, 3214 W. Lawrence, Chicago 25.

**SENSATIONAL** Home business! Buying merchandise U.S.—abroad, selling friends, stores, mailorder. Plan reveals suppliers thousands bargains like 17J. Watches \$2.87, binoculars 25¢, nylons 14¢, rifles \$3.17. Free details. Harvey, Box 29068-CF, Thornton 29, Colorado.

**CO-PUBLISH** Home business digest. Build mail profits easily. Sample instructions 50¢. Box 236, Sumner, Washington.

**MAIL ORDER** Secrets. \$2 for book or free information. Freed, 4020 38th St., Moline, Illinois.

**MAIL-ORDER** home business. Get free Copy. "Make Money in Mail-Order." Mailco, 1554 S. Sepulveda, Dept. J706, Los Angeles 25.

**BECOME** Tax Consultant. Graduates earn \$1,000-\$3,000 every tax season preparing returns evenings. State approved. Union Institute, Lakewood 2-M, N.J.

**FRESH** Names of mail order buyers and opportunity seekers on gummed labels 1,000 \$3.00 postpaid. Torsen Corp., 138 Haven Ave., New York 32, N.Y.

**DOLLS!** Dolls! Dolls! We teach you to make, repair, dress and sell. Study at home. Earn while learning. Free booklet. Doll Hospital School, Studio MC-63, 11826 San Vicente Blvd., Los Angeles 49, Calif.

**TESTED.** Proven, moneymaking, home-operated mailorder opportunity. Write: Mann, 266-PM, Hillsdale, New Jersey.

**"39 TIPS** for Greater Mailorder Profits". Hints on postal regulations, selecting firm name, pricing, low cost testing, copy, envelopes, idea bank, sales letters, etc. Send 25¢. Graham, 2952 Marlboro Road, Ocean-side 10, New York.

**LEARN** Landscaping and plant growing. Start a profitable business part or full time. Free information without obligation. Lifetime Career Schools, Dept. MC-63, 11826 San Vicente Blvd., Los Angeles 49, Calif.

**OPERATE** Home mailorder business. Shaff, 1161 Pacific, Long Beach, California.

**MANAGE** Motel or resort. Men, women, couples can make high salary plus apartment. Pick your own location with our employment assistance. Learn at home. Free booklet. Motel Managers Training School, Dept. PMC-63, 612 So. Serrano, Los Angeles 5, Calif.

**FREE** Booklet. Full details. \$8.40 hour profit. All year. Part time. Full time. Work from home. Own business. Protected area. Non-competitive. No experience needed. New, vital service. Easy to learn. Guaranteed. 21 days from today you can begin earning big money. Act now. Be first in your area. Flex-Cote Chemical, 30 West Sunrise Highway, Valley Stream, New York.

**MAILORDER**—Profitable executive products; dropshipped. Details, sample catalog, 25¢. National, 11544W Pico, Los Angeles 64.

**TWO-In-one** fireplace, heating unit. Amazing. Distributorship open. Tremendous seller. Wonderful profits. Write B.C. Co., 847 5 Road, Richmond, B.C., Canada.

**EXPORT-Import** opportunity, profitable, world-wide mail-order business from home, without capital; or travel abroad. Established world trader ships instructions for no-risk examination. Experience unnecessary. Free details. Mellinger, J-706, Los Angeles 25.

**\$12,000.00 PROFIT** Plan. Install burglar alarms. Even beginners can start home business spare time without previous experience or costly equipment. Profit details free. Nasco, 11071 Massachusetts, Dept. K706, Los Angeles 25.

**LIQUID** Rubber, plaques, figurines, plastercraft supplies. Sample. Details free. Lavin Novelties, Box 296-H, Leavittsburg, Ohio.

**EARN \$10,000** Selling books by mail. Box 51-BY, Des Plaines, Ill.

**WANT** To be successful? Send \$2.00 for "How to Be a Big Fish in a Small Pond", by H. D. Hoffman, President, "Silver Grays", 6166 Seminole Blvd., Largo, Florida.

**CANDIED:** Popcorn and potato chip equipment. Eakins, 316 S. Light St., Springfield, Ohio.

**BE** Your own boss in your own business. Only time limits your income from sales of imported goods to stores in your area. Spend as much or as little time as you wish. Every item sold brings you a handsome profit! Choose from our stock of thousands of imported goods from all over the Free World. You operate as a wholesaler full time or spare time. Membership in SAICO Corporation assures you that you will receive samples and materials in less time—with less waiting for customs processing. Send now for complete information at no obligation to: SAICO Corporation, Exchange Bank Bldg., Dept. P2, Room B-4, Dallas 35, Texas.

**RUBBER** Molds made to order. John Raper, Lucama, N. C.

**\$100.00 WEEKLY** Possible mailing letters, spare time. Free details. Debb Company, 436P2 Bloomfield Ave., Verona, N. J.

**LOVE!** Pays. Bronze baby shoes. Credit available. Free booklet. Box 5036A, Inglewood, California.

**IMPRINT** Wholesale catalogs! Sample, details \$1.00. Ballard's, 134 Crestview, Charlestown, Indiana.

**IDEAS** From self-help money-making publications. Free details, Box 265, Bell, Calif.

**HANDY** With tools? Your own house repair business. High income. Banish unemployment fears forever. Amazingly easy. Full or part time. Free information. House Doctor, 2809-W Balasco, Fort Worth 7, Texas.

**\$10.00 IN** An hour spare time at home possible with amazing "Magic Wonder Method" invisible reweaving. Details free. IRI, Dept. P-1, 8411 La Mesa Blvd., La Mesa, Calif.

**NEW** Mailorder business. No merchandise investment. Brochure free. Gem, Box 4714, Baltimore 11, Maryland.

**SELL** Greeting cards. Make extra money. Christmas, all occasion assortments, stationery, gifts, jewelry, name imprinted Christmas cards. Experience unnecessary. Salable samples on approval. Free catalog. Write Hedenkamp, 361 Broadway, Dept. PM-86, New York.

**MURAL** Artists needed! No experience required. Earn \$10-\$15 per hour! Amazing "Project-A-Mural" method. Project pattern slides, trace-off, paint per color guide. Professional results guaranteed! Huge demand from homes, bars, restaurants, offices, etc. Sell \$100 murals for "pennies" in paint. Free Success Plan. Associated Muralists, Dept. E6C, 135 Vesta, Reno, Nevada.

**OPERATE** Home mailorder business. Simple, inexpensive. Proven successful. Everything supplied. Free details. Paramount, Box 66-PM, Teaneck, New Jersey.

**CONVERT** Ordinary beds into massaging beds with the fabulous "Magic Fingers" massaging unit. Tie up a home sales franchise. Company representatives needed also. Write to: Magic Fingers, Inc., George De Young, Home Sales Division, Route 17, Rochelle Park, N. J.

**PROFITABLE** Catalog mailorder business. Vikari, 468-P Third Avenue, Salt Lake City 3, Utah.

**NEW** Company. Big potential. Terrific ground floor opportunity. Like money in bank. Terry-O, Box 588-F, Hicksville, N.Y.

**AMAZING** New home plastics business! Up to \$10.00 hour if you qualify. Pleasant, easy. No selling. Secrets revealed in free plan. NPC, Box 23321-PE, Los Angeles 23.

**TRIPLE** Garden golf. Larger crowds. Greater income. Brockway, Box 6624, Portland 66, Oregon.

**76 MILLION** Prospects! Immediate profits! Sell Champion, AC, Autolite spark plugs. Precision reconditioned, silver-plated, guaranteed 10,000 miles. Up to 308% profit. Free samples, details. Indy 500 Spark Plug Co., 4620 Braeswood, Houston 35, Texas.

**EXPORT-Import** business made easy. Complete setup service, not just instructions. Hermes, 152 West 42, New York City 36.

**"HOW** To Raise Capital to Make Money". Free details. Advance Publishing, 4455-P N.W. 7th St., Miami 44, Florida.

**SIMPLE.** Pleasant mail-order can net \$12,000 year. Write Rutward, 2010 Bryant, Columbia Station, Ohio.

**\$200.00 MONTHLY.** Spare time. With table saw, bandsaw or jigsaw. Write. Holiday House, A3800 Harnay, Vancouver, Washington.

"HOW To Sell Book by Mail!" Money-making system. Details free. American Distributors, Box 409-P, Niles, Michigan.

FREE "Franchise Profit-Letter" tells how unique NFR service is helping thousands seeking profitable businesses. Write today. National Franchise Reports, W-528, 333 North Michigan, Chicago 1.

HOW And where to obtain capital. Reliable Service, Rome City, Ind.

BIG Money raising fishworms and crickets. Free literature. Carter Farms, Plains, Georgia.

TO \$100.00 Weekly. Sparetime, home operated mailorder business. Successful beginner's plan. Everything supplied. Lynn, 10420-M National, Los Angeles 34.

PIANO Tuning learned quickly at home. Tremendous field! Musical knowledge unnecessary. Information free. Empire School of Piano Tuning, Champaign, Ill. (Founded 1935).

OPERATE Profitable mail order business. Write Walter Service, 4159A East 112th, Cleveland 5, Ohio.

BAKE New greaseless doughnuts in kitchen. Sell stores. Free recipes. Montgomery, 3605 South 15th, Minneapolis 7, Minnesota.

MAKE \$46 From square foot plywood; jigsaw necessary. Free details. Woodart, Bridgewater, Mass.

\$400.00 MONTHLY Raising giant fishworms. Soilless method. Charlie Morgan, Bushnell, Florida.

PLASTERCRAFT Molds, liquid rubber, plasters, flocks, candle supplies. Catalog and manual free. Blue Rapids Supply, Blue Rapids, Kansas.

WORLD'S Largest wholesale supply. Buy from 679 American, European, Japanese wholesalers. Tailormade suits from Hongkong. 123 dropship catalogs. Rock-bottom prices. Free details. International Buyers, 216-MM Jackson, Chicago 6, Ill.

11,000 NEW Prospects daily. Baby record books, shoes, albums. Sell mailorder. Use our literature. Write: No-Co-Ro, Capitola, Calif.

COLORGLAZED Concrete pottery made without molds. Patented method. Cemetery products, novelties, tiles. Basement leak-sealing. Money-making projects. Booklet, details free. Men only. National Potteries Company, Grand Rapids, Minnesota.

WANT To make big money at home? \$10.00 profit in an hour possible with invisible mending. Make tears, holes disappear from clothing, fabrics. Steady year-round demand from cleaners, laundries, homes. Details free. Fabricon, 1585 Howard, Chicago 26, Ill.

EARN Money raising fishworms for us! Write: Oakhaven-38, Cedar Hill, Texas.

RAISE Rabbits on \$500 month plan. Free details. White's Rabbitry, Mt. Vernon, Ohio.

SELL Books by mail. 400% profit. Royal, Box 450-X, Cleveland 27, Ohio.

STOP Throwing away boxtops! They're worth money! Some, 25¢! Inquire: Boxtops-MB, Cedar Hill, Texas.

BUY Direct from factories. Appliances, cameras, watches! Free details! Cam Co., 436 P.M. Bloomfield Ave., Verona, N. J.

COPUBLISH Mail Sale Advertiser, leading mail order paper. Details, latest copy, dime. Vanroy Shirk, Lebanon, Penna.

MAKE Money from old tires. Operators clearing \$400 weekly. Equipment costs \$800. Get facts. S & S Patents, Inc., 3511 N. Lincoln, Chicago 13.

MAILORDER. Lowest-priced catalog house in U.S.A. 25¢. Holliday 914 Burnside Rd., Sharon Hill, Penna.

MAKE Durable building plastic easily. Waterproof. Fireproof, economical. Bays Laboratory, Cedaredge, Colorado.

VENDING Machines. No selling. Operate a route of coin machines and earn amazing profits. 32-page catalogue free. Parkway Machine Corporation, 715 PMB Ensor Street, Baltimore 2, Maryland.

LIQUID Molding rubber, free information. Chaney's, 5415-A San Jose Blvd., Jacksonville 7, Fla.

FREE. 100 money making opportunities. Send stamp. Sheill, Southfield 5, Michigan.

\$70.00 WEEKLY—home, spare time. Simplified mail bookkeeping. Immediate income—easy. Auditax, 34741A, Los Angeles 34.

SELL Champion, AC, Autolite spark plugs. Reconditioned, electroplated, guaranteed 10,000 miles. 100% profit. Free sample. Lee Plugs, 1608-A Roberts, Houston 3, Texas.

MEN—Women! Sparetime earnings. Refundable mail-work literature 50¢. Interstate, 37 Besch, Albany 9, N.Y.

EARN To \$2000.00 month! Sing Sing Bug Chair, Oak Park 37, Michigan.

VITAMIN Business. Complete. \$100.00. Terms. Inventory worth \$330.00. Owner, 2908-P, Beverly, Los Angeles 57.

OPERATE Home mailorder business. Vosack Printing, 4444A1 Ute, San Diego, 17, Calif.

OPERATE Home mail order business. Easy! Fascinating! Write: DeHoven's, P.O. Box 414-P, Chicago 17, Illinois.

LEARN The art of professional poodle grooming. Easy, profitable, home business. Write Poodle Shop, 3777 Sierra, Clovis, California.

AMAZING Manufacturing opportunity. Free list of manufacturing formulas. Presler Oil Company, Postoria 16, Ohio.

WHOLESALE Distributors needed for world's most popular line of bronze baby shoe mountings. Exclusive franchise available for many areas. Must be financially able to maintain adequate inventory and warehouse facility. Not a home workshop proposition. Write, wire, or phone: C. R. Auerbach, Hollywood Bronze Supply, Los Angeles 23, California, ANgelus 2-1151.

PROFIT With Popular Mechanics' subscription plan. No investment, no experience needed. Earnings begin immediately when you obtain subscriptions for Popular Mechanics, Good Housekeeping and others. High commissions, bonus. No experience needed. Deal directly with the publisher. Write Popular Mechanics, Room 6B, 250 West 55th St., New York 19, N. Y.

## MONEYMAKING OPPORTUNITIES

BE Sharp. Do sharpening. Make money sharpening knives, scissors, saws, tools. Big profits. Treyco hollow grinding outfit \$34.95. Write for free book. Treyco Products, N. Tonawanda 15, N.Y.

BECOME A Notary Public! Win extra income, prestige, business contacts. Details free. Stationers Exchange, P.O. Box 617, Kilgore, Texas.

AGENTS Wanted. Advertising specialties, promotional gifts, sales incentives, full or part-time. \$30.00 investment covers samples and carrying case. High income dependent on initiative. Write for details to: Space Age Specialties, Inc., 100 E. Old Country Rd., Mineola, Long Island, New York.

MAKE An extra \$100-\$150 a week with the new mobile car wash and wax trailer unit. Immediate income for you on delivery of compact, quality-built unit to wash and wax cars and trucks. All power, tanks, pumps and hoses mounted on 1/4 ton trailer to hitch to any vehicle. Exclusive spray feature eliminates excess water—no mess in garage or driveway. Get everything you need to start business for just \$875. Money-back guarantee. Write now National Car Wash & Wax Products Co., Inc., Dept. PM, P.O. Box 231, Mattapan 26, Mass.

OWN Boss repair appliances "how to" book \$2.50. Dare Enterprises, P.O. Box 2235, Newport Beach, Calif.

CASH. Making crystallized marble jewelry. Catalog 10¢. Flocraft, Farrell, Penna.

SHELLCRAFT; Fascinating hobby or profitable home business. Make wall plaques, lamps, trays, costume jewelry, decorate handbags. Send \$1.00 for Shellcraft Instruction Manual refundable with first supply order. Plasticraft, Dept. SP, 624 N.W. 8th Avenue, Fort Lauderdale, Florida.

FANTASTIC PROFITS! Foreign-domestic bargains. Details, catalog 25¢. Roland, 3738-PM Wilton, Chicago 13.

MAKE \$5,000 yearly, sparetime, raising mink, chinchillas, nutria, etc. Free booklet reveals proved plans. Write: Furs, 588 Mt. Pleasant Road, Toronto L, Canada.

LEARN Where the attractive money is and how you too can start above beginner's level. Read my ads, located throughout May classifieds. Then write to: Pat Kelley, 373 Dept. X, Carmichael, Pa. There is \$1.00 (refundable) service fee.

MAKE MONEY writing short paragraphs! No tedious study! I tell you what to write, where and how to sell; and supply list of editors buying from beginners. Many small checks add up quickly. Write to sell, right away. Send for free facts. Benson Barrett, Dept. C27A-F, 7464 Clark, Chicago 26.

AMAZING Spare time money catalog. 25¢. Vista, 1230 Purcell Av., Cincinnati 5, Ohio.

\$13.30 HOURLY? Earned better, evenings, home, without merchandising, investment, experience. \$3 complete. (Copyrighted.) Moneyback guarantee. Aichner, Box 1204-MFC, Erie, Pennsylvania.

EARNED \$3,065 in six weeks on my first campaign. Home study course teaches managing money-raising campaigns for churches, institutions. Thirty years experience. Free details. William Arbogast, 229 East Mason Avenue, Alexandria, Virginia.

NEWEST Methods making money in mailorder. Free details, Merrick Enterprises, 3832 W. Jackson, Chicago 24, Illinois.

DOLLAR-Maker "Tips" book. Contains over 1000 tips. Free details. Pawtucket Mail Order, Dept. B, P.O. Box 1222, Pawtucket, R. I.

IMMEDIATE Income. For quick start, you get 10 fast selling assorted samples. Unlimited opportunities. Send \$2.00 to: Billow Co., Box 104, Florissant, Mo.

PAINT Signs! Easy with our letter patterns. Also popular raised letters. Paulow, Crystal Falls, Michigan.

HUSBANDS & Housewives wanted! Big money. Spare or full time cake decorating and candy making. Turn your kitchen into a gold mine. No age, education limits. Complete instruction. Learn and earn at home. Write for free facts. Candy and Cake, Dept. D-743, Fallbrook, Calif.

MAKE Money at home by mail, full time, spare time, without investment. Write: Mid America Sales, Box 597-B, Topeka, Kansas.

WATER And kerosene can make you rich. Details and sample \$1.00. Clancy's, Box 5072, Detroit 36, Michigan.

AMAZING Plan brings quick cash by mail. Details 10¢. Fisher, Lime Springs, Iowa.

LIKE To draw? Regular income. Walp, 1454 Polaris, Mobile, Alabama.

**LEARN** Window displaying. Free information. Trimming, Box 557, Whittier, California.

**AMAZING Results!** For you! New book, "How to Skyrocket Your Income." \$2.00. Airmailed. T.W. Publications, Box 4-1213, Anchorage, Alaska.

**5 FREE Subscriptions.** Magazines containing home business and wholesale opportunities with "Ideas Unlimited" manual. Part-time plans, hundreds, \$2.00. Imperial Creations, Box 80-P, New York City 25.

**START** used appliance business. Obtain at practically no cost. Huge profits reselling. Full instructions \$2.00. MDA Sales, 152 W. 42nd St., Suite 536-PM, New York 36, N. Y.

**FREE Advertising** for mailorder items. Branvold, 5718 Troost, North Hollywood, California.

**MEN! Women!** Make big easy money at home. New positive approach. Follow my copyrighted, proven, easy-to-understand five step outline. Financial security, independence assured. Send \$1.00 (refundable) to: Opportunity Unlimited, Clackamas, Oregon.

**MONEY** In your mail every day. Start well paying mail order business. Six plans only 25¢. H. M. Rose, Box 236, N. Miami Beach, Fla.

**MEN - Women!** Start money-making plastic laminating business at home in spare time. Material that costs 11¢ brings back \$2.58. No canvassing or selling but mail orders bring in \$20 a day. Write for full particulars free. Rush name on postcard to Warner, Room CL-2-D, 1512 Jarvis, Chicago 26, Ill.

**CIGARETTES.** Make 20 plain or filter-  
tip for 9¢. Factory-fresh pipe tobaccos. Mild tropical flavored Philippine cigars. Facts free. Moberly, Box 4027, Owensboro, Kentucky.

**YOUR Own, easy-to-start, home mail-order business, sparetime.** Fascinating; profitable! Information free. Alfano, 19-PM, Pine, Closter, New Jersey.

**RAISE Redworms.** Big demand. Free literature, Hall Redworms, Hilton, Ga.

**LEARN** The secrets of repairing junk batteries, generators, starters, profitable, easy, at home. Free particulars. Batteryman, Prunedale Station, Salinas, Calif.

**VENDING Machines.** No selling. Operate a route of coin machines and earn amazing profits. 32-page catalogue free. Parkway Machine Corporation, 715 P.M. Ensor Street, Baltimore 2, Maryland.

**EARN \$240.00** a month at home, spare time, doing only two \$5.00 invisible mending jobs a day. Big money paid for service that makes cuts, tears disappear from fabrics. Steady demand. Details free. Fabricon, 1532 Howard, Chicago 26, Ill.

**SEASHELLS.** Shellcraft and jewelry supplies. Wholesale catalog 25¢. refunded on first order. Our 29th year. Florida Supply House, Box 847M, Bradenton, Fla.

**WE Purchase** items you make at home for us. Enclose stamp for details. Wolfe Specialties, Box 171, Center Line, Mich.

**EARN Money** evenings, copying and duplicating comic cartoons for advertisers. Adservice, Argyle 1, Wisconsin.

**MAKE Plastic novelties** for extra income. Low cost home training now available. Write for free booklet. Interstate Training Service, Dept. D-3, Portland 12, Oregon.

**BAKE** New greaseless doughnuts in kitchen. Sell stores. Free recipes. Melvin, 3605 South 15th, Minneapolis 7, Minn.

**MINK Raising** information free. Complete. Lake Superior Mink Farm, Superior, EE1, Wisconsin.

**EARN Money** raising fishworms for us! Write: Oakhaven-59, Cedar Hill, Texas.

**BIG Money** raising fishworms and crickets. Free literature. Carter Hatchery, Plains, Georgia.

**AMAZING Successes** through franchises! Become exclusive franchise holder your territory. Information rushed. National Franchise Reports, MP-528, 333 North Michigan, Chicago 1.

**EASY To start** rubber stamp business at home in spare time. Make up to \$9.80 an hour without experience. Facts free. Write Roberts, 1512 Jarvis, Room CR-2-D, Chicago 26.

**MAKE Money** by obtaining permission to ship guaranteed hosiery on free trial. Earn up to \$1.25 per sale. Send for free outfit. No obligation. M. C. Lege & Co., P.O. Box 241, Atlanta 1, Georgia.

**MAILORDER Business.** Work home. Sample, details. Nationwide, 96 Reservoir Butler 1, New Jersey.

**MAKE Up to \$50 per day.** Full or part time. Men or women. Ideal money making product for clubs and church organizations. Send \$1.00 for details and brochure. refundable on first order. Raymar Enterprises, Box 602P, Lynwood, Calif.

## EXPORT - IMPORT

**POSTPAID** from Holland. Clocks, dolls, lamps, Delftware plates, etc. Illustrated list, 20¢. Melco, Box 69, Edwardsville, Illinois.

**CALENDAR Watch** direct from France. \$6.95 plus duty. Valley Distributor, Little Valley, N.Y.

**FREE Material** on novelties from here and overseas. Mrs. Jean Ditterline, Dept. L-6, R.D. =1, Center Valley, Penna.

**JAPAN:** Mail-order 26 page catalogue: dolls, novelties, business information, manufacturers' addresses, \$1.00; Japan Trade Directory, 1000s product illustrations, \$3.00; Tourist Guide, \$1.00. Send cash. Clarence Yamagata, 814 Toginbiru, Marunouchi, Tokyo.

## SCIENCE & CHEMISTRY

**AMAZING** New book of science experiments, formulas, and catalogue of laboratory supplies. Only 35¢. National Scientific Co., 13 S. Park Avenue, Dept. PM-6, Lombard, Illinois.

**232-PAGE Catalog** \$2.00. Laboratory Materials, 7319 Vincennes, Chicago, Ill.

**LARGE Catalog.** 35¢. \$3.00 kit free with \$15.00 order. Laboratory Sales, Box 161-A, Brighton, Mass.

**ROCKETS:** Single, multistage. New science materials catalog 25¢. Central Rocket Company, Waupaca, Wisconsin.

**NEW, Patented, novelty magnetic engine kit.** 4000 RPM, 10 parts. Send 50¢ today! Pontin Products Co., 3234 So. Hudson Street, Seattle 8, Washington.

**EXPERIMENTER'S Handbook** free with bigger discounts catalogue, 25¢. Hagenow Laboratories, Manitowoc, Wisconsin.

**BUDGET Priced chemicals, apparatus, Biology.** Catalogue 25¢. Mid-States Scientific, 7053 N. Clark, Chicago, Ill.

**ROCKETS:** New illustrated catalog 25¢. Single and multistage kits, cones, engines, launchers, trackers, technical information, etc. Fast service. Estes Industries, Penrose 7, Colorado.

**CHEMICALS** And apparatus for industrial, analytical, and private laboratories. Catalog 35¢. Dept. M-50, Biological Supply Co., 1176 Mt. Hope Ave., Rochester 20, N. Y.

**ILLUSTRATED Catalog:** Chemistry, mineralogy, biology 25¢. Tracey Laboratories, Evanston, Illinois.

**UNUSUAL Chemistry** books, courses, kits! Rare chemicals, cheap! Catalog 25¢. NSC, Box 11133, Palo Alto, Calif.

## PLASTICS

**NEW Liquid casting plastic,** clear, colors. Embed real flowers, butterflies, photos, coins. Send 25¢ for two handbooks, "How to Cast Liquid Plastics" and "How to Make Extra Money at Home." Castolite, Dept. G-101, Woodstock, Illinois.

**PLASTIC** And supplies for laminating. Colamco, 12 Center, New Haven, Conn.

**PLASTIC Secrets** revealed! Embedding. Medallions. Windows. Bullees. Dividers. Lamps. Bases. Laminating. Waterfalls. Marble. Mosaics. Jewelry. Casting. Inlaying. Above secrets, 25¢ each; all for \$3.00 (refundable). Newman, 3008-A Montrose, Chicago 18.

**ENGRAVERS.** We specialize in making desk name plate bases. Handsomely beveled, polished, slotted plastic. All sizes. Request prices or send \$1.00 for samples. Jackson Plastics, 21 McKinley Terrace, Westfield, Mass.

**COLORFUL Liquid plastic.** Sample products, details. Bryan, Box 49991, Barrington Station, Los Angeles 49, Calif.

**EMBEDDING,** Casting secrets free. Sample 25¢. Crystal, 4350-B, N. Whipple, Chicago 18.

**PLASTIC Embedders.** We have everything you need. Moulds, miniature findings, etc. Catalog 25¢. David Co., 20 Garden St., Providence 3, R.I.

**BOXES,** Plastic, 200 sizes. Free list. Althor, 2301 Benson Ave., Brooklyn, N. Y.

**NATCOL Resins** are best for casting and laminating. Catalog 25¢. Natcol Plastics, Box 227, Redlands 3, California.

## FORMULAS, PLANS, ETC.

**FILLING Station owners.** Send \$7 for two formulas that will save you hundreds. Service Chemicals, R4 Box 268A, Weatherford, Texas.

**FORMULAS—All kinds.** Amazing big catalog, 10¢. Kemixal, Park Ridge, Ill.

**LATE,** Modern manufacturing formulas. List free. Moon Chemical, Martville, New York.

## AGENTS WANTED

**BUY** From factories! Appliances, cameras, watches, etc! Free details! Cam Company, 436-PJ Bloomfield Ave, Verona, N.J.

**5 USED Watches** \$6.00. Joseph Bros., 5-P So. Wabash, Chicago 3, Ill.

**PRINTING.** Advertising salesmen—Excellent moneymaking sideline selling decalcomania name plates, small quantities. Automobile initials, sign letters. Free samples. Ralco, XL, Boston 19, Mass.

**FREE Sample.** Beautiful curios! Sell on sight! Apartado 9036, Mexico City.

**YOUR Own business—Used suits** \$1.50; overcoats 65¢; mackinaws 35¢; shoes 12½¢; ladies' coats 30¢; dresses 15¢. Enormous profits. Catalog free. Nathan Portnoy Associates, 2109-AA Roosevelt Road, Chicago 8, Ill.

**SALESMEN** Make big profits selling "do-it-yourself" sign kits to merchants. Information free. Signmakers, Inc., Dept. PM4, Box 6626, Denver 16, Colorado.

**MAKE** Most extra cash with world's biggest line everyday greeting card assortments, gifts. Introduce friends, neighbors, to over 150 assortments. 500 big money-makers. Pocket up to 100% profit plus big cash bonus. Free giant color catalog; samples on approval. Write Arrow Greetings, 513 Fourth Ave., S., Dept. 83-E, Minneapolis, Minn.

**FROM \$2.50** to a millionaire possible selling "Liquid Glass Auto Polish"! Details: Voltz, Ypsilanti, Michigan.

AGENTS—300% Profit selling genuine gold window letters; store and offices. Free samples. Metallic Sign Letter Co., 1217-D West Newport, Chicago.

HERE'S A fortune! Sell guaranteed Bacteria Activator, sales literally pile up. Send \$2.25 for sample box and outstanding information, to: Atway Products Co., P.O. Box 802, Joliet, Ill.

EXOTIC Earrings! Details free. Pair, \$1.00. OHGA, PM452, Sigakenkusatu, Japan.

SELL Greeting cards. Make extra money. Christmas, all occasion assortments, stationery, gifts, jewelry, name-imprinted Christmas cards. Experience unnecessary. Salable samples on approval. Free catalog. Write Hedenkamp, 361 Broadway, Dept. PM-86, New York.

### BUY IT WHOLESALE

BARGAINS! Buy wholesale! Save money! Free catalog! Norris, 273-AX Merrick Road, Lynbrook, N. Y.

FREE! Name brands catalog! Your own high profit business. Sell name brands, full or part time. No inventory, no investment. More than 2,000 name brand items; lowest wholesale prices. Watches, jewelry, cameras, hi-fi, stereo radios-phonos, appliances, housewares, hardware, power tools, luggage, musical instruments, garden equipment, sporting goods, toys, many others. 8 floors of name brands. Million dollar inventory. Orders shipped complete in 24 hours! Send for free, beautifully illustrated catalog now! Separate wholesale price list. H. B. Davis Corp., Dept. PM, 145 W. 15 St., New York 11, N. Y.

NEW Deluxe below wholesale catalog Automobile catalog and others. Furniture, clothing, housewares, appliances, refrigerators, freezers, washers, dryers, television, radios, luggage, binoculars, hi-fi, stereo, phonographs, recorders, cameras, projectors, musical instruments, sporting goods, toys, tools, typewriters, watches, jewelry. Huge discounts on thousands of name brand items. For free specimen list of actual factory prices—postcard: Selbyco, Decatur 15, Illinois.

ELECTRIC Guitars, amplifiers, wholesale. Free catalog. Carvin PMW, Covina, Calif.

USED And new watches \$2 up. Free list. Southern Watches, 5-PM So. Wabash, Chicago 3.

BUY Direct from factories! Appliances, cameras, watches! Free details! Cam Company, 436PA Bloomfield Ave., Verona, N.J.

WORLD'S Largest wholesale supply. Buy from 679 American, European, Japanese wholesalers. Tailormade suits from Hongkong. 123 dropship catalogs. Rockbottom prices. Free details. International Buyers, 216-M Jackson, Chicago 6, Illinois.

SWIM At once invisible swim aid for men, women, children; 1/25" thick, 4 oz.; worn under bathing suit. Demonstrator \$6.95 ppd. check or money order; state waist size. Also many other new international patented articles. Reps wanted, 25¢ for details, refundable first order. G & R Industries, 59-15A 71 Ave., Brooklyn 27, N.Y.

WHOLESALE Discount catalog free. Household, automobile products. Corina Discount, Richmond, Cal.

SAVE Up to 70% buy wholesale. Hughes Co., 921 Hull, Clovis, N.M.

LARGEST Wholesale supply source in U.S. Furniture, clothing, electric appliances, housewares, auto accessories, tools, sporting goods, farm equipment, hobby supplies, bargain merchandise, world imports. Free details. Associated Wholesalers, Box 52-DX, Burlington, Iowa.

TOOL Catalog. Send 25¢. Silvo Hardware, 107-PM Walnut, Phila. 6, Penna.

### SALESMEN—DISTRIBUTORS

MAKE Up to \$200.00 weekly. Every business has slow accounts. Send us names. We collect. National Credit, Dept. BP-6, 903 McGee, Kansas City 6, Mo.

WONDER Electro-disk flashlight. No battery or bulb replacement. Attractively designed. Big seller. Free folder. Send \$1.50 for sample. Harrison House, Box 121A, Meriden, Conn.

SELL Quality credit collection system to businessmen. Generous commissions. Expense allowance. No investment. Master System, Box 52, Appleton, Wisconsin.

OIL Portrait business. Make five times more profit per sale. Big demand. Information. Portraits, Box 2834, Washington 13, D.C.

SELL Advertising book matches. Write us today; we put you in business by return mail; handling complete line ad book matches in demand by every business right in your town! No investment; everything furnished free! Top commissions daily! Superior Match, Dept. M-663, 7530 S. Greenwood, Chicago 19, Ill.

AUTOMOBILE Seat belts! \$3.25 (quantities). Samples, \$4.15. Belts, Box 550Q, Freeport, New York.

SIGNS, Stakes, flags, pennants, etc. L. A. Sign, 4503 Eagle Rock Blvd., Los Angeles 41, Calif. Free catalog.

SENSATIONAL New longer-burning light bulb. Amazing free replacement guarantee—never again buy light bulbs. No competition. Multi-million dollar market yours alone. Make small fortune even spare time. Incredibly quick sales. Free sales kit. Merlite (Bulb Div.), 114 East 32nd, Dept. C-74H, New York 16.

MAKE Extra money selling advertising matchbooks. Free catalog and sales outfit. Matchcorp, Dept. PM-63, Chicago 32.

FREE! Novelty feather pictures. Fast selling. Exceptional profits. Apartado 9318, Mexico City.

\$1,000,000 A Month for making dramatic 3-second demonstration of amazing lightweight Presto Fire extinguisher. New chemical used by Airforce snuffs out fires instantly. Only \$4.95. Terrific commissions. Millions want it. Free kit. Merlite, 114 E. 32nd, Dept. P-66H, New York 16.

SALESMEN! Earn triple profits with Tri-truck, the revolutionary new hand-truck that sells on sight! Big commissions, S & H green stamps, retirement bonds. Rush your name for free information to Jet Tool, Inc., Lemon Grove, California.

SALESMEN To sell transparent mirrors and novelties made on Catalina Island. Ye Olde L.A. Press Club, 9026 So. Orchard Avenue, Los Angeles 44, Calif.

SELL Finest shoe polish obtainable. Mail \$1.00 for samples. Money back guarantee. Delft Specialties, 224-PM South Michigan, Chicago 4, Ill.

IF You're interested in making money in selling, see the hundreds of exceptional opportunities in Salesmen's Opportunity Magazine. Send name for your copy, absolutely free. Tell us what you're selling now. Opportunity, 848 N. Dearborn, Dept. 17, Chicago 10, Illinois.

EARN Big commissions full or part time. Show America's largest line low priced business printing and advertising specialties. Big free sales kit samples hundreds items used daily by business people. Build profitable repeat business. Start right now. National Press, Dept. 8, North Chicago, Illinois.

ADVERTISING Specialties, calendars, Xmas cards. Large commissions. Free kit. Full or part time. Novelty Ad-Products, 105 Lafayette St., Dept. P, New York 13.

POWER Stik. Controls cruising speed. New driving thrill. Goodbye leg fatigue. Earn \$10 on each demonstration sale. 67 million prospects. Write: MOR Products, Elkhart, Indiana.

### EMPLOYMENT INFORMATION

TREMENDOUS Opportunities U.S.A., overseas. Choose jobs, locations, transportation. Free details. Occupations, International Airport, Box 100C-17, Jamaica 30, N.Y.

FLORIDA: Work now, retire later. New plants need men. Listings, new businesses, any county, plus valuable information, \$1.00. Associated Enterprises, Box 15282, Tampa, Florida.

JAPAN! Korea! Okinawa! Many hi-paying jobs available. Complete, detailed reports \$2.00. Japan Reports, Box 2202-C, Newport Beach, California.

OVERSEAS—U. S. A. employment. All occupations. Up to \$1,600.00 monthly. Also special Hawaiian, Alaska sections. Free transportation. Latest directory, application form, sent immediately. Satisfaction guaranteed. Send \$2.00 (C.O.D.'s accepted). World-Wide Employment Bureau, Box 185-PM2, Eatontown, New Jersey.

HIGH Pay. Overseas. U.S. firms. Airline, construction. Booklet tells how, who, where, \$2.00. Essco, 1540 Canadian Ave., Akron 6, Ohio.

LOCATE Before moving. Classified sections four different California Newspapers rushed \$1.00. "Papers", 618 Remington, Sunnyvale, Calif.

CHOICE Government jobs. Short cut information 25¢. Careers, 722-P6 East Silver Spring, Milwaukee 17, Wisconsin.

JOIN The Merchant Marine? Men, women, excellent wages. Proper procedure guidebook \$3.00. Frador, Lakeville 3, Ind.

FOREIGN-U.S.A. jobs. All occupations. Up to \$1600.00 monthly. Free transportation, benefits. Complete "directory." Application form. Send \$1.50 (\$2.00 airmail). Why pay more? C.O.D.'s accepted. Satisfaction guaranteed. International Employment, Box 191, P5, Bedford, Indiana.

JOBS, Ships, \$100.00 weekly. Beginners, men, women. Seamans Service, Box 17-M, Brooklyn 8, N. Y.

WORK For the U.S. Government. Send \$1.00 for next five monthly issues containing announcements of Federal job examinations. Good pay plus fringe benefits. Civil Service Reporter, 330 Newbury Street, Boston 15, Massachusetts.

MERCHANT Marine. Men and women. Top wages. Travel. Information. Captain, Box 501-P, Reading, Massachusetts.

DIRECTORY Reports. Construction, aviation, shipping, oilfields, government, manufacturing, trucking, etc. Foreign-stateside. Helpful information plus job-getting tips on preparing application letters. Unconditional money-back-guarantee of satisfaction. Act today. Only \$1.00. (\$1.25 airmail). (C.O.D.'s accepted). Research Services, Meramec Building, St. Louis 5-PM, Missouri.

FOREIGN Employment job possibilities up to \$1600 monthly in Europe, Africa, Asia, South America. Free transportation. Construction workers, clerks, hundreds of occupations men, women. Complete information, proper application form sent promptly. Satisfaction guaranteed. Send \$2.00 (\$2.25 airmail) (C.O.D.'s accepted) to: Jobs, P.O. Box 50512, Dept. E, New Orleans 50, Louisiana.

RESUMES By Richton open doors quickly to best jobs. Expertly prepared, written and printed. Satisfaction guaranteed. We serve clients the world-over, in every field, entirely by mail. Bonus features. Free descriptive literature. Write The Richton Company, Dept. SM, 11 Hill Street, Newark 2, New Jersey.

FOREIGN Employment. Construction, other work projects. Good paying overseas jobs with extras, travel expenses. Write only: Foreign Service Bureau, Dept. PM, Bradenton Beach, Florida.

FEDERAL Job overseas. 300 posts in 100 countries thruout the world. Where to apply. Details \$2.00. Write Chase Industries, Box 8440, Baltimore 34, Md.

### SPECIAL SERVICES

SAVE Big fees! Prepare your patent application yourself. Free details. Inventors Guide, Fort Worth 14, Texas.

**INVENTORS!** We will develop, sell your idea or invention (patented or unpatented)! Our national manufacturer-clients urgently seeking new items for highest outright cash sale or royalties. Financial assistance if needed. 10 years proven performance. For free information write Wall Street Invention Brokerage, 79 Wall Street, Financial District, New York 5, N. Y.

**RESEARCH Service.** Any subject! Product information. Jake Barraco, 478 Gardner, South Beloit, Illinois.

**PATENTS** Skillfully prepared for maximum commercial value, with useful product development. High record of success in proving and claiming patentability. Valuable market service. Patent prepared for a fee as low as \$200.00. Send for self-protecting record of invention forms free. Patent search with valuable engineering report \$10.00. Foreign patents filed at low cost. Thirty years established. Joseph O'Brien, Patent and Development Engineer, 132 Nassau St., New York 38, N. Y.

**INVENTORS—**Write for free literature, "Inventions—Our Business." Inventors & Manufacturers Service, 2094 West Rosecrans, Gardena, Calif. (In the heart of Los Angeles) diversified industry plus speculative capital.)

**BLOWUPS** any size colors from your photos. Stites Portrait Co., Shelbyville, Indiana.

**WE Develop, promote and protect your product or ideas.** Write for information. Product Promotion Development-2, Little Building, Boston 16, Mass.

**PATENT** Drawings your inventions made by our experts. For you or your attorneys. Very reasonable rates. Patent Service Associates, 6910 Madisonville Rd., Cincinnati 27, Ohio.

**PATENT** Searches, prompt, complete \$6.00. Patent Office copies of related patents airmailed. For free "Protection Forms" and "Patent Information" write to Jane Allen, Suite 1024-A Dupont Circle Bldg., Washington 6, D.C.

**PATENT** Searches, complete and thorough. Related copies airmailed with maximum speed. \$6.00. Free "Protection Forms", and "Patent Information". Write Mercury Patent Office Searchers, 1507 M Street, N.W., Suite 103-M, Washington, D.C.

## EDUCATIONAL AND INSTRUCTION

**HOW** to raise rabbits and fishworms on \$500 month plan. Free details. White's Rabbitry, Mt. Vernon 83, Ohio.

**ENGINEERING** Mathematics, Electronics. Pay as you learn. Free brochure. Indiana Home Study, 64 Hemenway Road, Framingham, Mass.

**INVESTIGATOR** Training. Home study. Certificate. Box 374, Garden Grove, California.

**FREE** Sleep-learning catalog. Fletcher, 2407 PM Catherine, Dallas 11, Texas.

**PROFITABLE** National Camera Repair School training at home! 174PM, Englewood, Colorado.

**HIGH** School diploma at home. Licensed teachers. Send age, highest grade completed for free details. No salesman will call. Southern States Academy, Station E-16, Atlanta, Ga.

**OPERATE** Collection agency, home or downtown. Franklin Credit, Roanoke, Virginia.

**REAL** Estate course. Economical home-study. Literature free. Howard Schools, Box 8394-A, Kansas City 5, Missouri.

**DENTAL** Technician's home study student's kits. Instruments, plastic, etc. Illustrated instructions. Write for free lesson. Grant Laboratory, Haas Bldg., Los Angeles, 14, Calif.

**ENGINEERING** And Art degrees earned through home study. Electronics, Mechanical, Liberal Arts, Major Accounting. When writing specify course desired. Pacific International College of Arts & Sciences, primarily a correspondence school. Resident classes also available. 5719-B Santa Monica Blvd., Hollywood 38, California.

**PIANO** Tuning quickly learned with home study course. Diploma granted. American Tuning School, Gilroy, Calif.

**PIANO** Tuning pays. Big money in spare time. Learn at home. No musical knowledge necessary. Phonograph, records, tools and instructions furnished. Electronic tuning also taught. Free catalog. Capital Tuning School, 3160 S.W. 16th Court, Ft. Lauderdale, Fla.

**USED** Courses! Books! List 10¢. Smith's, 124 Marlborough, Salem, Mass.

**FINGERPRINTING** And identification easily learned at home. Diploma awarded. Alabama School of Fingerprinting, Fairfield, Alabama.

**MISSOURI** Auction school. Free catalog. 1330 Linwood, Kansas City 9-x3, Missouri.

**LEARN** Fascinating, profitable invisible reweaving at home. \$10.00 earnings in an hour possible making tears, holes disappear from clothing, fabrics. Steady demand from cleaners, laundries, homes. Details free. Fabricon, 1534 Howard, Chicago 26, Illinois.

**INVESTIGATOR'S** Course. Credentials, diploma. Free information. Southwestern Institute Criminology, Box 201, Geronimo, Oklahoma.

**PENMANSHIP** Corrector. Improve poor penmanship quickly. Details free. Ozment, Box 665-34, St. Louis 88, Mo.

**BE A** Real Estate Broker. Insure security for yourself and your family. Study at home. Prepare for state examination. GI approved. Write for free book today. Weaver School of Real Estate, 3519P Broadway, Kansas City, Missouri.

**SWEDISH** Massage. Foot technique. Post graduate. Home study. Residential. Diploma. Dr. Swanson's Illinois Licensed School, 3809-PL Alta Vista, Chicago 13.

**USED** Correspondence courses and books sold and rented. Money back guarantee. Catalog free. (Courses bought.) Lee Mountain, Pisgah, Alabama.

**WOODWORKING** And cabinetmaking course for beginning and advanced home craftsmen. Only complete low-cost home training program available. Write for free booklet. Interstate Training Service, Dept. G-3, Portland 12, Ore.

**BOOKKEEPERS.** Operate your own "Dollar-A-Week" system. Ellis, Box 200, Cedar Grove, North Carolina.

**LEARN** Asleep or awake! Records, tapes, equipment! Free catalog! Drawer PM-697, Ruidoso, New Mexico.

**MEN** Wanted. Earn \$125 a week and up. Master a trade with a future. Learn auto diesel mechanics in our shops. You learn with tools on real equipment. Earn while you learn. Many of our graduates earn \$125 a week and up. Write for free bulletin: Dept. 256, Auto Diesel College, Nashville 3, Tenn.

**LEARN** While asleep with your recorder, phono. Details, catalog free. Sleep-Learning, Box 24-PX, Olympia, Wash.

**PROFESSIONAL** Investigator. Home study. Lapel pin, certificate, future. Box 41197-F, Los Angeles 41, California.

**SECRET** Investigations. Experience unnecessary. Investigators particulars free. George Wagner, M125 West 86th, New York City 24.

**WANT** A diesel job? Higher pay? Advancement? We can help you qualify! Complete diesel, tractor and heavy equipment and Cummins Diesel Engine Shop-method home-training courses available. Write today. Interstate Training Service, Dept. B-3, Portland 12, Ore.

**FCC** License in 6 weeks. First class radio telephone results guaranteed. Elkins Radio School, 2603D Inwood, Dallas, Tex.

**LEARN** Automatic heating repair and installation at home. Free sample lesson, bonus offer. ETI, 608-A South Dearborn, Chicago 5.

**MAILORDER** Courses. Fantastic discounts. Selmar, Dept.-M, 14808N 30th Drive, Phoenix 23, Arizona.

**COLLEGE** Degree. If over 26, married, with two years job experience you may qualify for Bachelor's or Master's degree in six months or less. Write Registrar, Institute of Applied Science, Box 1581, Melbourne, Florida.

**LEARN** Civil and criminal investigation at home. Earn steady, good pay. State age. Institute Applied Science, 1920 Sunnyside, Dept. 16A, Chicago 40, Illinois.

**BE A** big game guide. Trained men needed, 18 to 45. Lifetime of adventure and thrills. Learn by experts. Big pay. Free information. Malmarch Outfitters & Guide School, Darby, Montana.

**CIVIL** Service guides and do-it-yourself books. Free lists. Raymond's, Dept. 16, 917 N. W. 65th Street, Seattle 7, Washington.

**MINISTERIAL** Home study course. Free qualifying examination. Soms, 5955 Powdermill Road, Kent, Ohio.

**MASTER** Watch making at home. Free sample lesson. Chicago School, 2328-YS, Milwaukee, Chicago 47.

**RADIO—**Electronics course only \$14.95. Includes all tubes, parts, tools, instructions. Write for full information. Edu-Kits, Dept. 585B, Hewlett, N.Y.

**GOOD** Paying jobs open! Operate, repair heavy earth moving equipment! Learn "on the job" operating latest cranes, bulldozers, earth carriers! V. A. approved. Free catalog. Write FP Hutch, Greer Technical Institute, Braidwood, Illinois.

**COMPLETE** Your High School at home in spare time with 66-year-old school. Texts furnished. No classes. Diploma. Information booklet free. American School, Dept. XA45, Drexel at 58th, Chicago 37, Illinois.

**FREE** Information, correspondence school directory, courses, unusual organizations, books. Auree, Central Valley, New York.

**MILLIONS** Of sewing machines need repair. Train now. Sincere Schools, 2042 West Spring, Tucson, Arizona.

**SWEDISH** Massage and physical culture pays big profits. Learn at home. Diploma. Free catalog. National Institute, Dept. E-63, 450 East Ohio, Chicago 11.

**PHOTOGRAPHY:** Earn big money. Travel. Own your own studio. Learn at home in your spare time. Write for big free book. School of Modern Photography, Dept. C-683, Little Falls, New Jersey.

**USED** Correspondence courses, books. Catalog 10¢. Bayles, 78B Courtright, Wilkes-Barre, Penna.

**LEARN** Gunsmithing. America's oldest, most complete, 2-yr course. Earn AAS degree. Recommended by leading firearms companies. Modern equipment. Competent instructors. VA approval. Trinidad State Jr. College, Dept. GS, Trinidad, Colorado.

**WRITE** Well: New penmanship book, "Ornamental and Business Writing." Oblique penholders. Shading pens. Details free. T. Tevis, Chillicothe, Mo.

## PLAYS, STORIES, MANUSCRIPTS

**POEMS** Needed for poetry books. Inquire: Young Publications, Appalachia 1, Virginia.

**WANT** Your book published? Learn how we publish, advertise, promote, distribute. Many successes. Free booklet PM. Vantage, 120 West 31, New York City. Or 6253 Hollywood Blvd., Hollywood 28, Calif.

## ADVERTISING AGENCIES, ADV. SERVICE, MAILING LISTS

**MONEY**-Producing letters written. Sales plans developed. Free counseling. National Mailcraft, Rm. 822, 24 N. Wabash, Chicago 2.

**SALES** Letter improvement guaranteed. Free details. Yost Enterprises, 1025 North Milpas, Santa Barbara, California.

**STOP** Paying fancy fees for sales letters. Write your own. "Doc" Peters Letter Book shows how. 100 sample letters. Free details. Graham, 2952 Marlboro Road, Oceanside 9, New York.

**FREE** Mailing lists! 200,000 names! Details. Box 550R, Freeport, New York.

**PRODUCT** To sell? Adv. on radio & TV stations that take orders on commission. List \$5.00. P.I. Stations, Box 395, Pacific Palisades, Calif.

**FREE!** Redhot book. "More Profit from Your Advertising." Lists—best mailorder magazines, newspapers. Adservice, 516-G, Cornelia, Chicago 13.

**MAILORDER** Record Book. 30 pages. Records inquiries, orders, advertising expense, etc. Most complete. Just send dime for postage and handling. F. W. Johnson, 740RB Rush St., Chicago 11.

**ADVERTISING** Ratebook leading newspapers, magazines, free. Chicago Advertising Agency, 28-E Jackson, Chicago 4.

**MAILING** Lists most all kinds 1000 \$5.00. Free folder. Your circulars mailed \$4.00 1000. Dixie Mailers, King, N. C.

**AMAZING** New Book—"Profits From Classified Advertising." Tells how and what to advertise. Be sure to read this book before you invest one cent in advertising. Write for your copy now. F. W. Johnson, Classified Advertising Manager, Popular Mechanics, 740-PR Rush St., Chicago 11, Illinois.

## TYPEWRITERS, DUPLICATORS, OFFICE DEVICES

**STARTING** And Operating Home Typing Business. Exclusive manual tells secrets, tips. Guaranteed. Send \$2.00: Arrow, Box 3015, Milwaukee 18, Wisconsin.

**SAVE** On typewriter cleaning bills. Use new typewriter correction tape to correct errors. 120 inch roll good for 2,000 corrections. \$1.00 R. & B. Supply, 221 West Wayne, Dunkirk, Ohio.

**RECONDITIONED** Typewriters, mimeograph, printing presses \$25.00 up. Write Dixiegraph, King, N. C.

## RUBBER STAMPS AND OFFICE SUPPLIES

**3 LINES** Self inking \$1.00. Guaranteed. Free booklet. P. Penniston, 2270W Samantha, Ottumwa, Iowa.

**FREE** 32 Page rubber stamp catalog. Signature stamps \$3.50. Youngers Stamp Shop, Princeton, Iowa.

**POCKET** 3 Lines \$1.00. Office stamps \$1.50. Free catalog. Specialty, 8464 Manhattan, Detroit 11, Michigan.

**STAMP** Makers' supplies. Lowest prices. O'Brien's, 421 Jackson, Toledo 4, Ohio.

**FREE** Folder indexed rubber stamps. Dowling Products, Dept. PM63, Pittstown, N.J.

**POCKET** Stamp, 3 lines, 75¢. Signature stamp \$3.00. Ruby's Bargain Center, D-26, Paradise, Penna.

## CARTOONING, COMMERCIAL ART, SHOWCARD & SIGN PAINTING, TATTOOING

"How To Make Money with Simple Cartoons." A book everyone who likes to draw should have. It is free; no obligation. Simply address Cartoonists' Exchange, Dept. 96, Pleasant Hill, Ohio.

**LEARN** Profitable, fascinating tattooing. Illustrated information \$1. Zeis, 728-C Leslie, Rockford, Illinois.

**WANTED**—Cartoonists, Amateurs, professionals. Over 200 markets. Information free. Cartoon Markets-4-63, 11620 Lansdowne, Detroit 24, Michigan.

"HOW I made a living for years with my sketches without selling them." \$1.00. J. Carl Hancock, Box 3091, No. Little Rock, Ark.

**ART** Lessons \$6 a month. Includes drawing, painting, commercial art. Art kits (worth \$25) and materials. Assignments corrected, with overlays, by mail and returned to you. Write for free book. No obligation. Washington School of Art, Studio 146X, Port Washington, L. I., N. Y.

**YOU** Can entertain with chalk talks. Catalog 10¢. Balda the Cartoonist, Oshkosh, Wis.

**LEARN** Sign painting at home. Free talent test. Ben Kerns, Box 812-PM, Greenville, S.C.

**LEARN** Sign painting with fascinating system. Straley, 410 S. Western, Springfield, Ohio.

**CARTOONIST'S** Magazine. Markets, lessons, etc. Trial copy 25¢ coin. Hartman, Box 3097, Lincoln 10, Nebraska.

## PRINTING, MULTIGRAPHING, MIMEOGRAPHING, GUMMED LABELS

**1000** CARDS, raised \$3.75. Two-color \$4.90. Delivered. Guaranteed. Bixler, Benson Ave., Frankfort, Kentucky.

**150** TWO Color letterheads. Envelopes. Low. Samples rushed. J. Butler, Box 4, Maumee, Ohio.

**1000** BUSINESS Cards. Embossed \$3.69 postpaid. Samples. Saleogenics, Box 45702, Los Angeles 45, California.

**1000** BUSINESS Cards. Beautiful raised printing. \$3.75 postpaid. Samples. Frazer, 1093 "D", Springfield, Oregon.

**100** EACH, 6<sup>3</sup>/<sub>4</sub> envelopes, 5<sup>1</sup>/<sub>2</sub> x 8<sup>1</sup>/<sub>2</sub> letterheads—\$2.45. Reavis, Box 1134, Lufkin, Texas.

**1000** NAME, Address labels, \$1.00. Rubber pocket stamp, \$1.00. Conner, 11428<sup>1</sup>/<sub>2</sub> S. Berendo Ave., Los Angeles 44.

**OFFSET**-Letterpress printing. Free samples rushed. Chicke Press, Harvey, Illinois.

**250**—8<sup>1</sup>/<sub>2</sub> x 11 Hammermill letterheads \$2.75. 250 envelopes \$2.75. Samples. Patton, Box 248A South Haven, Mich.

**SALESMAN'S** Wholesale catalogue. Lowest prices anywhere. Anderson Printing, Romeo, Michigan.

**100** PERSONALIZED 5<sup>1</sup>/<sub>2</sub>x8<sup>1</sup>/<sub>2</sub> letterheads with matching envelopes. Red, green, blue or black. Send \$2.75. Moneyback guarantee. B&B Letterpress, P.O. Box 225, Rockaway, N.J.

"HOW To Sell Printing by Mail". More than 100 detailed plans for selling printing by mail. Forty chapters, library binding. Special pre-publication offer: \$4.95 postpaid. P.M. Drullard Press, 210 Fifth Ave., New York 10, N.Y.

**500** PRINTED Shipping labels \$3.50. 1000 gummed name and address labels \$1.00. H. Mull, 405 E. Chestnut, Wauseon, O.

**PRINTLIKE**. Overnight mimeographing. Reasonable. Samples. Dorfmann, 168 West Harrison, Chicago 5.

**FREE** Catalog, samples, fine quality printing, all needs. Low prices! Griffin, 322-PM, West State, Ithaca, New York.

**POSTPAID** Printing, rubber stamps. 10% deductible first order. Free catalog, samples. Burgan Press, 1160 Namdac Ave., Bay Shore, N. Y.

**LABELS**, Blank. Self-adhesive. Stock sizes. Free list. Althor, 2301 Benson Ave., Brooklyn, N. Y.

**OVERNITE** Offset printing 1000 8<sup>1</sup>/<sub>2</sub>" x 11"—\$6.50. Postage extra. Evergreen, 9420 Trumbull, Chicago 42.

**FREE** Catalogs postpaid printing. Rubber stamps. DM Press, Sebastopol, Calif.

**MIMEOGRAPHING**. Offset printing. Free samples. Pennway, Drawer 1340, Scranton, Penna.

**AMAZING** Business printing values. Samples. Print Shop, Box 576, Greenville, R. I.

**SPEEDY** Duplicating service. Electronic stencils perfect mimeograph reproductions; writing; drawings. One to thousands. Maximum 8<sup>1</sup>/<sub>2</sub> x 14. Also Verifax copies. Free price list. Camera Corner, Box 217, Pittsford, New York.

**BUSINESS** Cards. Rubber stamps. Free details. Valley House, Harrisonburg, Virginia.

**OFFSET** Printing, economical, top quality, letterhead, envelopes, forms. All types rubber stamps. Request catalog. Overnight Service, 912 Bob Wallace, Huntsville, Alabama.

## PRINTING OUTFITS AND SUPPLIES

**HARD** Type for rubber stamp making, printing. Introductory offer 10 or 12 pt. 20th Century Medium caps or L.C. \$2.50. Free catalog. Barco Type, 232 Evergreen, Bensenville, Ill.

**ILLUSTRATED** Silk Screen Printing. Instructions with Supply Sources, \$2.00. George Shine, 162-A, Springfield 1, Massachusetts.

**NEW** 1962-63 Illustrated printing equipment and supply catalog. This 9"x12", 336-page book is the most complete catalog of the century. Contains everything used in the graphic arts industry including thousands of offset, letterpress, binders, rubber plate and stamp, composing room, silk screen, art and engraving supplies and equipment. Includes paper cutters, folding machines, printing and proof presses, padding presses and many more. Send \$2.00 to cover mailing. Refund with first order. Also available is our latest 184 page type catalog—add \$1.00. American Printing Equipment & Supply Co., Dept. PM-42-25 Ninth Street, Long Island City 1, N. Y.

**TYPE** And supplies for rubber stamp makers. Send for free brochures. Star Stamp Supply, 712 Federal, Chicago 5, Ill.

**TYPE** CASES. Manufacturer. Catalog. King McKay Company, 23179 Telegraph, Southfield, Michigan.

**PRINTING** Presses, type, supplies. Lists 5¢. Turnbaugh Service, Mechanicsburg, Penna.

**MAKE** Your own self-molding rubber stamps and printing cuts. Plexirubber, Argyle 1, Wisconsin.

**RUBBER** Stamp presses, hydraulic operated, electrically heated. Sizes 5"x8", 8"x12", 10"x15". Starting outfits, supplies. Printing presses. Custom Manufacturing, 1464-P East Commercial, Springfield, Missouri.

**DO** Your own printing. Save money. Simple rules. We supply everything. Print for others; good profit. Raised printing like engraving too. Have home shop. Details free. Kelsey Presses, V-11, Meriden, Connecticut.

**RUBBER** Stamp outfits, supplies. Kiewiet, 2025 Barney Road, Kalamazoo, Mich.

**BUY** Postpaid rubber stamp materials. Free Press. Duckman, Avoca, Arkansas.

## BUSINESS SERVICES

**SMALL** Business or idea needing professional help administration to product representation, expand markets reasonably. Service Associates, 13500 Bartlett, Cleveland 20, Ohio.

## PATENT FOR SALE

**MECHANICAL** Horse. Pictures, details free. You manufacture—I like to sell. Trousdale, 1288 Harbert, Memphis, Tennessee.

## MANUFACTURING

**MODELS** — Small lot manufacturing. Metals, plastics, etc. Milburn, Burlington, Kentucky.

### MODELS—SHIPS, TRAINS, PLANES, ETC.

**ROCKET** Supplies. 1963 list 25¢. Mervin Hill Company, Seward, Pennsylvania.

**CASTINGS** And finished steam-gas engines from simple oscillating to triple expansion. Finest materials and fittings. Catalogue \$1.00. Denison Live Steam Models, PM 1606 Denison, Cleveland 9, Ohio.

**SHIP** Models. Kits, fittings, plans, books, tools, engines, motors. Big illustrated catalog 50¢. James Bliss & Co., Dept. SM, 342 Atlantic Avenue, Boston 10, Massachusetts.

**SHIP** Model kits. Clippers, galleons, liners; Operating power boats for radio control; Send 25¢ for catalog. Ideal, 19 West 18 Street, New York 11, N. Y.

**SHIP** And yacht model fittings; blueprints. Send 50¢ for illustrated catalog listing hundreds of items. A. J. Fisher, Inc., 1002-1 Etowah Ave., Royal Oak, Mich.

**ROCKETS:** New illustrated catalog 25¢. Single and multistage kits, cones, engines, launchers, trackers, technical information, etc. Fast service. Estes Industries, Penrose 2, Colorado.

**SHIP** Model kits and fittings; clippers, frigates, etc. Catalog paint-tool list, book list, 35¢. Model Shipways, Box 85, Bogota, N. J.

**"WHITE HEAT V"** radio-controlled model hydroplane featured June 1962 Popular Mechanics. Full size plans, patterns, accessories and engine available. Literature for stamped addressed envelope. Occura Models, 8144-P No. Milwaukee, Niles 48, Illinois.

**ROCKETS.** Handbook for making rockets. New hard cover book. \$2.00. Spreen, Tuxedo Park, New York.

**HOT** Air engine. Send stamp for free information. W. Huff, 3302 Sharon, Cincinnati 41, Ohio.

**BUILD** Miniature buildings with professional materials. 50¢ for instructions and samples. Architectural Model Materials, PM-63, 2006 No. Keystone, Chicago 39.

**LIVE** Steam engine castings kits, boilers, accessories. Catalog 35¢. HPK Models, Box 34, Centuck Station C, Yonkers, New York.

**LIQUID** Rocket, 75 lbs. thrust. 5' long. Complete plans \$1.98. Missile Research, 517 Elder, Anaheim, California.

## HOME CRAFTSMEN

**WOODWORKERS.** Home Craftsmen! Catalog containing lamp parts, veneers, lazy susan bearings, Swiss movements, chair cane, folding metal legs, wooden legs, finishing materials, etc., only 10¢. Barap Specialties, Box 2044, Chicago 9.

**FREE!** Latest builders calculator. 10¢ handling. Ed Loper, Box 76, Alloway, N.J.

**WOOD** Screws. Non-corrosive flat head aluminum assortment \$1.25. Postpaid in plastic box. Joart Specialty Co., Box 3007, Elmira, N. Y.

101 **PATTERNS** of smart gifts, novelties, shelves, action windmills plus "Make Money Jig Sailing" \$1.00. Mastercraft, 65M, 7641 Olcott, Chicago 31.

2477 **PLANS.** Patterns, things to make, do. Fun. Profit. World's greatest selection. New catalog 10¢. Craftplans, 18250-A Harwood, Homewood, Ill.

**SAVE:** Raw picture frame molding, all species, all styles. We will miter corners. Bauerle Cabinet Works, Inc., Hammond, Louisiana.

**SAVE** Money. Remodel your own kitchen with easy to follow plans. Included: how to measure, graph, details for 80 units. Adapts to bookcases, room dividers, workbenches and storage units. \$2.00. Bardwell Plans, P.O. 417, San Anselmo, Calif.

**FREE** "Do-it-yourself" leathercraft catalog. Tandy Leather Company, Box 791-D47, Fort Worth, Texas.

**PLANS** For pool table with extra two-face top for table tennis and model railroad. Blueprints B1209 and building instructions \$3.50. Popular Mechanics Service Bureau, 740-M Rush St., Chicago 11, Illinois.

**PICTURE** Frame moulding, squares and lumber. Kiln dried walnut, cherry, silver maple. Midland Lumber Company, Box 262, Savannah, Mo.

**SKIL-CRAFTS** New 62-63 catalog. Largest and finest selection of leathercraft, artist, hobbycraft supplies in the world. Free gift with first order. Send 50¢. Refundable with first order. Skil-Crafts, Box 167-P, Joplin, Missouri.

## DO IT YOURSELF

**VALUABLE** Information. 1963 revised edition. Care and repair of the plumbing and heating system for your home. Over 200 pages thoroughly illustrated and easy to understand. Nothing like it ever published. Nation wide sales. \$2.95 plus 24 cents mailing charges. Satisfaction guaranteed or full refund. Chas. J. Geiser & Sons, Inc., P.O. Box 92, Niles Station, Chicago 48, Illinois. P.O. Box 418, Gracie Station, New York 28, N.Y.

**FREE** Check-list covering more than 500 classifications of projects, plans, instructions, service and repair information detailed in Popular Mechanics famous series of instructional booklets, books, patterns, and blueprints. List covers an extremely wide variety of do-it-yourself data on home remodeling, repair and improvement, hobbies, crafts, boating, games, lawn and garden, and hundreds of others. For your free copy of this helpful list, write: Service Bureau, Popular Mechanics, 575 Lexington Ave., New York 22, New York.

**EXERCISE** At home on build-it-yourself physical fitness equipment, including bicycle exerciser, rowing machine, belt massager, and abdominal board. Send \$2.50 for blueprints B1208 and instructions. Popular Mechanics Service Bureau, 740-K Rush St., Chicago 11, Illinois.

**MAKE** Loose screws stay put. Newly developed packing holds screws in metal, wood, plastic and other materials. Easy to apply. \$1.00 postpaid. Striker Enterprises, 1107 Southport, Lisle, Ill.

**HOME.** Build your own. I did! Booklet tells how. Financing to finishing. \$2.00. L. Sheldon, 1624 Melody Lane, Appleton, Wisconsin.

**UNIQUE** One day bookcase plan \$1.00. H. Steele, 100 Adams Place, Delmar, N.Y.

**MAKE** 25 lbs soap 35¢. Free instructions. Send 10¢ handling. Harbor, Box 5394E, Atlanta, Georgia.

## OF INTEREST TO WOMEN

**SAVE** Money, time, effort. Attractive gifts for baby, mother. Free catalog. Alison House, Box 156A, Syosset, New York.

**CANDLEMAKING** & decorating. Terrific hobby. Great business! Learn fascinating molding, dipping, creating & decorating candles for year-round demand—holidays, birthdays, weddings, anniversaries. All events. Spare time fun & extra income now; expand to colorful candle shop later. No age limit. Write for free facts on home instruction method. Candle Institute, Dept. X-32, Fallbrook, Calif.

**LEARN** Expert cake decorating, candy making. Free details on home instruction method. Candy & Cake, Dept. D-742, Fallbrook, Calif.

**DON'T** Be left in embarrassing circumstances! There are today over 8 million American widows. 75% were left without adequate records! Protect yourself against financial loss! Rush 25¢ for full details on "Does Your Wife Know?". Scoop Wainwright, Box 275-PM, Branchville, Maryland.

**OVERWEIGHT?** Lose pounds in one month! No starving, exercises, drugs! Success guaranteed plan. \$2.00 postpaid. Brugenheimer Company, Box 158-H92, Lexington, Massachusetts.

**FINE** Gifts for Mother and baby—10¢ specialty items. Free catalog. Write Chas. Dowell, Box 1064, San Jose, California.

**SELL** Fine fabrics. Get yours wholesale. Box 863, Norwalk, Conn.

**WOMEN!** Make big money at home. \$10.00 profit in an hour possible with invisible mending. Make holes, tears disappear from clothing, fabrics. Steady year-round demand from cleaners, laundries, homes. Details free. Fabricon, 1533 Howard, Chicago 26, Illinois.

**HOUSEWIVES,** Teachers, students, office workers. If you need extra cash each week but household or other duties prevent you from taking a part-time job, learn how you can earn by accepting orders to Popular Mechanics, Good Housekeeping and all other magazines. No experience needed. Write Popular Mechanics, Room 6W, 250 West 55th St., New York 19, New York.

## FOR THE HOME

**HEAT** Homes, cottages. Save dollars. New idea. Free information. Bonanzavilla, Rt. 1, Box 290, Manassas, Va.

### WATCHES, OLD GOLD, JEWELRY

**HIGHEST** Cash. Gold, jewelry, diamonds, silver, platinum. Mail articles. Free information. Chicago Gold & Precious Metals, 6 E. Monroe, Dept. 5158, Chicago 3.

**WATCH** And clock repairing books. Free catalog. North American, 2320-AF, Milwaukee, Chicago 47, Illinois.

**WATCHES** Lowest wholesale, free brochure. Davidson's, Box 3247, Phoebus, Va.

**I'LL** Repair any watch for \$5.00. Cleaning, \$6.00. Both for \$7.50. Ronald Giffin, 1236 Avenue "D", Billings, Montana.

**CASH** Immediately for old gold, jewelry, gold teeth, watches, diamonds, silverware, spectacles, platinum, mercury. Free information. Rose Industries, 29-A East Madison, Chicago 2.

## TREASURE FINDERS

**FUN** & profit finding buried treasure, relics with Transistor M-Scope. Booklet, interesting customer comments Free. Terms. Fisher Research, Dept. AX, Palo Alto, California.

**SUPERSENSITIVE** Transistor treasure finders. \$19.95 up. Kits available. Free catalog. Relko, Box 10563, Houston 18, Texas.

**POCKET** Mechanical radiation detector, geiger counter. Information. Box 219A, Waco, Texas.

**TREASURE.** Find gold, silver, relics with super, powerful, Detectron locators. Free information. Detectron, Dept. PM-6, San Gabriel, California.

**GOLD** In '63! Silver, coins, treasure, relics. Important finds possible using specialized Goldak electronic locators! Established 1933. Free literature. Write: Dept. B-5 The Goldak Co., 1544 W. Glenoaks Blvd., Glendale 1, California.

**FIND** Gold, precious gemstones, minerals in streams and rivers with the Explorer portable sluice box \$14.95. For brochure and valuable information send 25¢ to: Johnson, Box 657-B, Lynwood, California.



NEW Coin locator! Free literature. Howe, 811-C Kansas, Atchison, Kansas.

METAL Locator kits and assembled models from \$39.90. Terms. Transistorized and underwater models available. Free catalog. Electronic Applications, Dept. M, Box 6095, Alexandria, Virginia.

TREASURE. Gold, silver, relics. Find them with new 1963 models. Free information. Raytron Box 715, North Hollywood, California.

EXPLORE Underground, years ahead transistor Metrotech locators detect gold, silver, coins, relics. Information free. Curt Fisher, Dept. A, Box 793, Menlo Park, California.

## PERSONAL

BORROW \$100 to \$1000 by mail. Quick, easy, private. No co-signers. Repay in 24 small monthly payments. For the amount you want write today to Dial Finance Co., 410 Kilpatrick Bldg., Dept. 6-214, Omaha 2, Nebraska.

SENSATIONAL. Truth revealing, 10 lesson Bible course free. Bible Class, 2318 Champa St., Denver 5, Colo.

REPORTS—Credit, missing persons, employment. \$2.50. Jacksonville area. Credit Exchange, Box 541, Jacksonville, Florida.

"LISTEN-In-Coil" picks up any telephone conversation in vicinity. No connection to telephone necessary. Easily concealed. \$2.98 complete. Consolidated Acoustics, 1302-D Washington St., Hoboken, New Jersey.

LIKE To gamble? Send \$1.00 and receive surprise. Limco, 423 Roberts Street, Reno, Nevada.

NEW Scientific face-improver method develops masculine good looks quickly. No drugs, cosmetics or surgery! Amazingly effective. Results guaranteed all ages. Free literature. Face Improvement Foundation, Box 532, Camp Hill 2, Pennsylvania.

INVENTIONS Wanted. Patented: unpatented. Tremendous manufacturers lists. Global Marketing Service, 2420 77th, Oakland 5, California.

FOUR "Will" forms and "Instruction Booklet by Lawyer." \$1.00. National, Box 48313PM, Los Angeles 48, California.

INVESTIGATORS. Free brochure latest miniature electronic listening devices. Ace Electronics, 11500-P NW 7th Ave., Miami 50, Fla.

BIBLE Questions answered. Stamped envelope. Bylon, 17167 Bentler, Detroit 19, Michigan.

DEVELOP Mind power, personality while asleep. Details free. Research Association, Box 24-N, Olympia, Washington.

BORROW \$1,000 Airmail! Repay \$44.82 for twenty-nine months. State licensed. Postal Finance, Dept. 17-E, Kansas City 1, Kansas.

NEED Money? Do as thousands of people are doing—borrow money you need from National Loans by mail, quickly, confidentially. Easily arranged, repay in small monthly amounts. Borrow \$100.00 to \$600.00 without co-signers or collateral. Write—tell us how much you need now. National Loans Dept 5, 101 S. Tejon, Colorado Springs, Colorado.

## REMAILING SERVICE

HAWAII Secret address. Receiving, forwarding, 25¢, \$3.00 monthly. Postcards. Instructions for starting your remailing service \$5.00. Coe, Box 984, Kailua, Hawaii.

GERMANY. Immediate remailing. 50¢ or 75¢ airmail. A. Thornhill, Jaeger Special Services, APO 162, New York, N.Y.

SWITZERLAND. Remail 50¢. Questions answered \$1.00. Postcards. Burrige, Visp, Switzerland.

HOUSTON-NASA area. Prompt remails. 25¢ single. \$3.00 monthly. Confidential receiving-forwarding. Tremaco, Box 5277-F, Houston 12, Texas.

BEN-SUN Remail and forwarding \$3.00 monthly. Meeting Street, Wayzata, Minnesota.

BRAZIL, Argentina, Mexico: \$1.00. Three letters. \$2.00. Francis, Apartado 7216, Mexico City.

CAPE CANAVERAL remails 25¢. Special services. P.O. Box 2415, Cocoa Beach, Florida.

CAPITAL Remail 25¢. Free information. P.O. Box 5851PM, Washington 14, D.C.

DEEP South remails 25¢ each. Harbour, Box 5394E, Atlanta, Georgia.

MIAMI BEACH Remails 25¢: 5 for \$1.00. Monthly \$3.00. National, P.O. Box 678-A, Miami Beach 39, Florida.

CONFIDENTIAL New York City mail address \$3.00 month. Remails 25¢. Details free. Birnhan, 152 W. 42, New York City 36.

LOS ANGELES. Hollywood, San Fernando Valley—25¢ single; \$3.00 monthly. Confidential, 10437P Lanark, Sun Valley 3, California.

TEMPORARY Permanent address. Remails. \$1 monthly. Wayne Forwarding, Clovis, California.

MONTEREY, CARMEL. Forwarding-receiving. Free information. Armstrong, Box 1005, Seaside, California.

REMAILS .30¢. Monthly \$3.00. Remail system kit \$3.00. Write: Henri Labrie, Box 3364, Station C., Ottawa 3, Canada.

## WANTED—MISCELLANEOUS

QUICKSILVER. Platinum, silver, gold. Ores analyzed. Wholesale Terminal, Norwood, Mass.

STAMP Collections, accumulations. Eagle Stamp Co., 2221 Romine, Pittsburgh 26, Penna.

## FOR SALE—MISCELLANEOUS

HEARING Aid batteries wholesale. Free list. Habs, Box 51, York, Penna.

FREE Booklet "The Inside Story of Deafness." Hearing aids, and hearing aid and radio batteries wholesale. Free list. We also repair hearing aids. World-Wide Company, Box 32-P, Willard, Utah.

## MISCELLANEOUS

CESSPOOLS. Septic tanks restored to newness by miracle crystal pellets. Free literature. Electric Sewer Cleaning Co., Allston 34, Mass.

BIBLE Questions answered free. Bible Research, 1819 LaPosada, National City, California.

FREE Wholesale catalog! 100,000 products. Tremendous discounts! Taylor Distributors, Newton 2, New Jersey.

EARN Money raising fishworms for us! Write: Oakhaven—60, Cedar Hill, Texas.

CIGARETTES—Make 20 plain or filter-tip for 9¢. Facts free. Moberly, Box 785, Owensboro, Kentucky.

WANT Your name with 1000 mailers? 25¢ lists your name year with our mailings every month. Dixie Mailers, King, N. C.

SEND Us wool for blankets. Write Eldorado Woolens, Eldorado, Texas.

BOOKS On antiques and their prices. Free circular! P. Warman Publishers, Uniontown, Penna.

"STAMMER, Stutter, No More." (Dr. Young.) Write: Gaucho, Box 9309-S7, Chicago 90.

OUTDOOR Toilets, cesspools, septic tanks. Cleaned, sanitized, deodorized like magic. Amazing new product! Safe. Easy to use. 150,000 customers guarantee your satisfaction. Money back guarantee. Postcard brings free details. Burson Laboratories, Dept. D-67, Chicago 22, Illinois.

ROPES. Nylon, dacron, polypropylene. 1/16 to 3/4. Lowest prices. Mid-West, Box 1, Angola, Indiana.

GLOVE Leather pieces—five pounds \$1.98. Leather, 319 Elgin, Winnipeg, Canada.

IDENTIFICATION Strips. Vinyl all-weather, self-sticking, embossed strips. Label tools, camera, clothing, etc. Other related products available. Information and samples free. Identification, Box 153, Havelock, N. C.

HEARING Aids only \$28.95. Free trial, terms. Write: Cary-B-Sales, Inverness, Fla. Also small rooted shrubbery.

FREE! Illustrated catalog "D." Home and family items: Stanley Wallace, P.O. Box 1039, Bangor, Maine.

INSTANT Spanish. New method. Trial lesson 25¢. Trader, Box 3488-U, Ridgecrest, Calif.

FROM Africa. Bushmen paintings on stone. Airmail delivery includes historic description. Unusual wall decoration. \$10 bill. Brevis, Box 4527, Johannesburg, South Africa.

ELEPHANT Ash trays from Africa. Gift idea in a million. Airmail delivery. \$10 bill each. Brevis, Box 4527, Johannesburg, South Africa.

SENSATIONAL English "no-razor-pull" safety razor with 5 blades (up to 10 shaves each) \$1.95 postpaid. Try it on money-back guarantee. Erickson, Box 157-PM, Muskegon Heights, Mich.

PAINT Roller fountain, flow control, no dipping. Guaranteed time cut 1/2. Reach high spots, Paint large area before refilling. \$4.99 sample details. Box 623, Harbor City, Calif.

BARGAIN! Lighter flints 100 for \$1.00. Box 701, Harlingen, Texas.

FIZZING Pops. Make your own. No equipment needed, instant. Send \$1 for instruction: Economy, P.O. Box 305, Kirkland-Lake, Ontario, Canada.

START Exciting gift shop. Step-by-step guide, \$2.00. Trader, Box D-3488, Ridgecrest, Calif.

BIG Mail. Get listed 25¢. Offers all year long. Daugherty's, 3110 Connecticut Ave., Medford, N.Y.

COBRA Spirals keep mosquitoes and other small flying insects away. Millions used yearly in Puerto Rico. Non-toxic ingredients. Box 12 spirals, 96 hours of protection, \$1.25 postpaid. Cobra Products, Inc., Margaritas 102, Rio Piedras, Puerto Rico.

FREE Catalog! Sensational values in personal and household merchandise. Discount prices—and we pay postage. Satisfaction guaranteed. Paul Ryan Products, Box 371A, RR2, Flemington, New Jersey.

NEW Car? Save \$100.00 to \$1000.00. Details. Vanguard, Box 2246, Idaho Falls, Idaho.

FREE! Exciting new catalog—Western wear, saddles, riding accessories. Western Saddlery, Box 1864 V12, Fort Worth, Texas.

GET On mailing lists. Receive bargain offers. 25¢. Ouroboros, Box 4953-F, Chicago 80.

ACQUIRE Wealth and success. Read "The BMS Formula for Success." \$2.00. Miller Associates, P.O. Box 141, Beaver Falls, Pa.

## BSA ROYAL STAR



### Built to keep young and lively!

Own tomorrow's motorcycle today! A new concept in big twins. Features full-unit construction, entirely enclosed drive, and many other mechanical advances. Beautifully styled. See your BSA dealer.



Write to the nearest address for illustrated free color catalog of the new 1963 models.

Catalog offer limited to U. S. residents only.

West:  
**HAP ALZINA**  
Dept. M63  
3074 Broadway  
Oakland, California

East:  
**BSA INCORPORATED**  
Dept. M63  
639 Passaic Ave.  
Nutley, New Jersey

## NEW! TEN POWER TELESCOPE

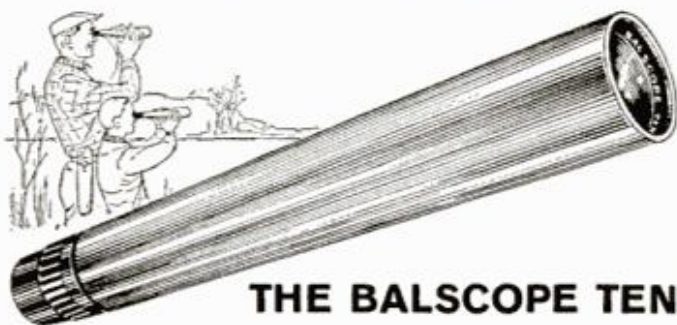

### THE BALSCOPE TEN

at only **\$9<sup>95</sup>**

■ For the first time, due to a manufacturing breakthrough... a *quality* telescope for only \$9.95! Ideal instrument for all kinds of nature study, for vacations, for all outdoors. No clumsy draw tube—focus with a single turn of the eyepiece. Only 10¼" long, and weighs just 9 ounces. Belt holster accessory at 98¢. See it at optical, photographic and sporting goods dealers. Made to American standards of quality by America's most respected optical craftsmen, Bausch & Lomb Incorporated, Rochester 2, N. Y.

**BAUSCH & LOMB**



## Test-Tube Viruses

Viruses—cause of many of man's ills—have been created in a test tube. Reported by Dr. George W. Cochran of Utah State University, the synthesizing of infectious viruses from inert chemicals could lead to an attack on many of man's most persistent ills, such as measles, influenza, the common cold, smallpox and polio.

Using the same chemicals and the same methods, two researchers at the University of California duplicated Dr. Cochran's achievement.

Believed to be a cause of human cancer, viruses can now be studied only inside complex living cells. Production of viruses from chemicals would not only simplify the study of minute life forms, but would accelerate the production of disease vaccines; polio vaccine, for instance, is now laboriously produced in a culture medium of monkey kidney tissue.

The experimenters used tobacco leaves infected with tobacco mosaic virus. They squeezed sap from the leaves and filtered it to eliminate leaf cells and the virus nucleic acid. Four chemicals—adenosine, guanosine, cytidine and uridine triphosphate—were added to the residue. This was applied to fresh tobacco leaves where new virus growths promptly formed.

Scientists say that viruses are on the borderline between living and nonliving matter. His discovery, Dr. Cochran believes, may lead to the extinction of viruses and the diseases they cause.

## Yellow Fever Threat

A potentially deadly mosquito, *Aedes aegypti*, which can act as a carrier of yellow fever virus, infests a 300,000 square-mile area from North Carolina to Texas. Called "a health menace of immense proportions" by the American Medical Association, the mosquito could, if it picked up yellow fever germs from South America, cause epidemics of a killer that people have assumed was eradicated.

The mosquito has been wiped out in South America, but the jungles down there are full of the yellow fever virus. Pan American Health Organization officials say that in this age of jet travel it would be relatively easy for the yellow fever germ and the carrier mosquito to join forces—with probably lethal results.

Wood that sinks in water and rocks that float are common around southern Alaska's Naknek Lake. The rocks which litter the shore are pumice, which is lighter than water; the wood is petrified and without buoyancy.



## My mother's a wizard with Duro-Plastic Aluminum

So it seems to nine-year-old Nancy Joseph of Cleveland, Ohio, as she watches the wonder of Duro-Plastic Aluminum at work. And Mrs. Joan Joseph asserts new independence: "I didn't have to wait for my husband or the plumber to fix that pesky leak under the sink."

There are thousands of satisfied users like Mrs. Joseph. Here's why: First, A good aluminum putty like Duro-Plastic Aluminum is made with Alcoa® Powders. It's workable aluminum in paste form. You apply it cold right out of the tube (like toothpaste). Within two hours, it dries to a metal-like hardness.

Users report that aluminum putties are not affected by water or normal water pressure, and will never rust, rot or deteriorate. They adhere to metal, wood, concrete, glass, even hard plastics. (Talk about versatility!) This means hundreds of uses for home, autos and boats.

Duro-Plastic Aluminum was developed by the Woodhill Chemical Corporation of Cleveland. Your dealer stocks it or can get it for you. Bet-

ter see him today. You may need it tomorrow.

*Alcoa does not make aluminum putties, but Alcoa Aluminum Powders are used in all the best brands. For information, please send coupon.*

-----  
Aluminum Company of America  
1705-F Alcoa Building, Pittsburgh 19, Pa.

Please send more information on cold solders made with Alcoa Aluminum Powders.

Name \_\_\_\_\_

Address \_\_\_\_\_

City \_\_\_\_\_ Zone \_\_\_\_\_ State \_\_\_\_\_



# ALCOA

Entertainment at Its Best... ALCOA PREMIERE Presented by Fred Astaire... Thursday Evenings, ABC-TV

# Tune in on the Inventors

**Drowning victims** can be revived with a mouth-to-mouth resuscitator which insures that the exhaled breath of the operator reaches the person being revived. It provides plastic mouth cups for both operator and victim. The device won patent 3,080,864 for Robert A. Berman, Far Rockaway, N.Y.

**Undersea "islands"** may become sites for oil-drilling derricks through patent 3,080,583 granted to Buckminster Fuller of Forest Hills, N.Y., already noted as the developer of the geodesic dome. The derricks would be contained in a caisson, or buoyant tank, held underwater by anchor ropes.

**Stretchable windshields** that bend with the impact of a body thrown forward in car crashes could provide an extra margin of safety for auto passengers. Egon Orowan, Belmont, Mass., won patent 3,081,127 for the device.

**Typing students** can now learn the keyboard quickly by watching an illuminated typewriter chart instead of looking at their own keyboards. The electric chart is linked to a dummy keyboard on the instructor's desk. Patent 3,080,661 went to Ray N. Conrath, Indiana, Pa.

**Taking photos underwater** should be simplified with a "sea sled" invented by Jacques Cousteau, the French diving expert. Made of sheet metal, the vehicle contains a water-tight box for photographic equipment and a viewing window for shooting film. The sled, patent 3,082,731, is towed along the sea bottom.

**How to bring new products** to the attention of potential manufacturers is the inventor's own special headache. Several firms specialize in finding users for idle patents. Two such are the National Patent Development Corp., with offices in New York and Washington; and the Institute for New Products, Ardsley-on-Hudson, N.Y. First though, says the U.S. Patent Office, inventors should consult a patent attorney or their Better Business Bureau before signing a commercial agreement.

Copies of the original patents may be ordered for 25 cents each from the Commissioner of Patents, Dept. of Commerce, Washington 25, D. C.



New from  
**RIDGID**  
Adjustable  
Wrenches



7 Sizes, 4" through 18" Lengths

## ...with Thin Heads for Fast Work in Close Quarters!

Made of special alloy steel, these new **RIDGID** Adjustable Wrenches are selective induction hardened for extra toughness . . . long service life. Sparkling *chrome plated* finish stays new looking for years. You'll like the fast, easy, one-hand adjustment. When properly tightened, jaw stays tight . . . will not slip. Comfort-grip, forged, I-beam handle has handy hang-up hole.

See and buy them at your Dealer's. For your convenience, he maintains a complete selection of **RIDGID** Work-Saver Tools and parts.

# RIDGID

The Ridge Tool Company, Elyria, Ohio, U.S.A.

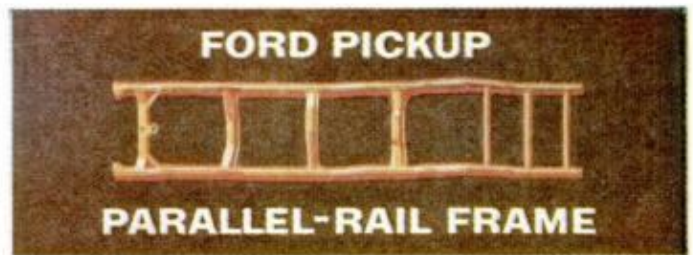
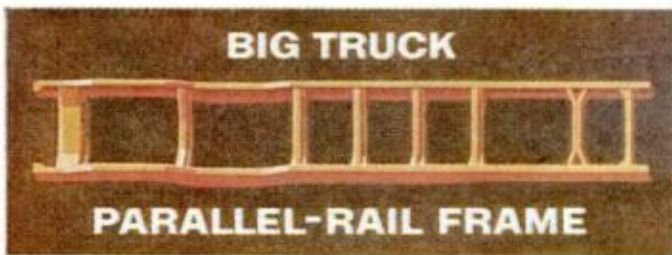

**Built like the big ones from the frame up...and from the frame down!**

## '63 FORD PICKUPS



**Comfort-Conditioned Custom Cab** puts 5 inches of foam cushion beneath you . . . 27 pounds of insulation around you for a softer, quieter ride!

**BUILT LIKE THE BIG ONES FOR BIG-TRUCK DURABILITY!**

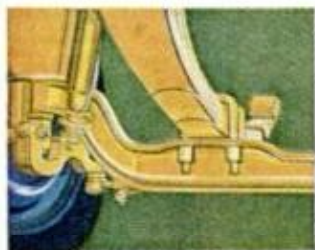

**I-Beam Front Axle** maintains front-end stability on roughest roads. Front wheels track truer . . . tires last much longer. Tests prove it!



**Straddle-Mounted Pinion** has bearings on both sides to hold rear-axle drive gear in positive alignment, increase gear life. Big-truck design!

Don't be misled by the smart looks—or by the smooth ride. Under the solid comfort of new Ford pickups lies solid truck!

Wherever toughness counts, Ford pickups give you the durable design of big trucks. This means extra freedom from breakdowns and repairs. It means a truck that holds up on your job—and holds costs down! Look into and *under* a '63 at your Ford Dealer's!

FOR 60 YEARS THE SYMBOL OF DEPENDABLE PRODUCTS  MOTOR COMPANY

**FORD TRUCKS** For Outstanding Reliability & Durability

New 75 hp Sea-Horse  
Electramatic motor



**NEW**  
2-year warranty  
on every '63 Johnson

## On your mark. Get set. Go Electramatic!

**Most responsive outboard ever built! Now with a 2-year warranty!**

At dockside: crisp, clean, sleek . . . the look of power. At throttle: taut, eager, whip-quick . . . 75 horses you can stampede or stop with one hand. A seagoing V-4. Rugged. Responsive! Electramatically responsive . . . with a revolutionary new electric clutch. One lever for forward or reverse. Works automatically, instantly. More? An alternator-generator, 20 amps. A super silencing system. Plus stay-new styling. And deep-root dependability. All wrapped in the industry's first and finest two-year warranty policy. Complete. Parts *and* labor. Your Johnson dealer is in the Yellow Pages. '63 Sea-Horse motors: 75, 40, 28, 18, 10, 5½ and 3 hp models. Free catalog. Johnson Motors, 1361 Pershing Road, Waukegan, Illinois. Division of Outboard Marine Corporation.

**JOHNSON** First in Dependability



**Exclusive Electramatic Drive**  
Outboarding's first truly automatic transmission. Unique directional throttle (no extra charge) controls both gas and gears. Makes driving sure, docking easy. Available at 75 and 40 hp.

## THE CONTROVERSIAL

## B-70

Military Monster  
or  
Supersonic Transport?

By Thomas E. Stimson

**T**HE BIG JUMP in aviation—from the present to the future—takes place this summer with the testing of America's newest, fastest, costliest bomber.

The B-70 (actually the XB-70 for "experimental bomber") is a weird-looking airplane unlike any that ever flew before. More sophisticated than a space capsule, it is designed for effective operation in the searing temperatures of 2000 miles per hour.

And it was, long before its first flight, a controversy.

Its critics say we don't need bombers any more, that the ICBMs have taken over and, besides, the B-70 is old-fashioned even as an airplane.

Counter-punching, its advocates inquire *when* are intercontinental missiles going to have a bomber's reliability?

Besides, they say, there's no guarantee that a next war would be one of nuclear suicide. They say there are non-nuclear weapons that can be "delivered" cheaper by bomber than by rocket. As for the B-70 being out of date, this can be said of any aircraft by the time it is built; research certainly hasn't stood still since the B-70 design was finalized.

One side says that a single ground-to-air missile can kill a B-70, the other side talks of new electronic counter-measures that would divert or kill the anti-aircraft missile.

Depending on who wins, only three prototype B-70s may be built.

One thing is sure. The B-70 is the big jump, the big breakthrough, that allows aviation engineers to talk positively of supersonic passenger transports. All the major problems of 90-minute coast-to-coast air travel have been or are being solved in the B-70 program—how to insulate passengers and crew so

*Secretary McNamara says that this weapon will be obsolete in 10 years. Others don't agree. Either way, the B-70 does point the way to the first Mach-3 supersonic transport*

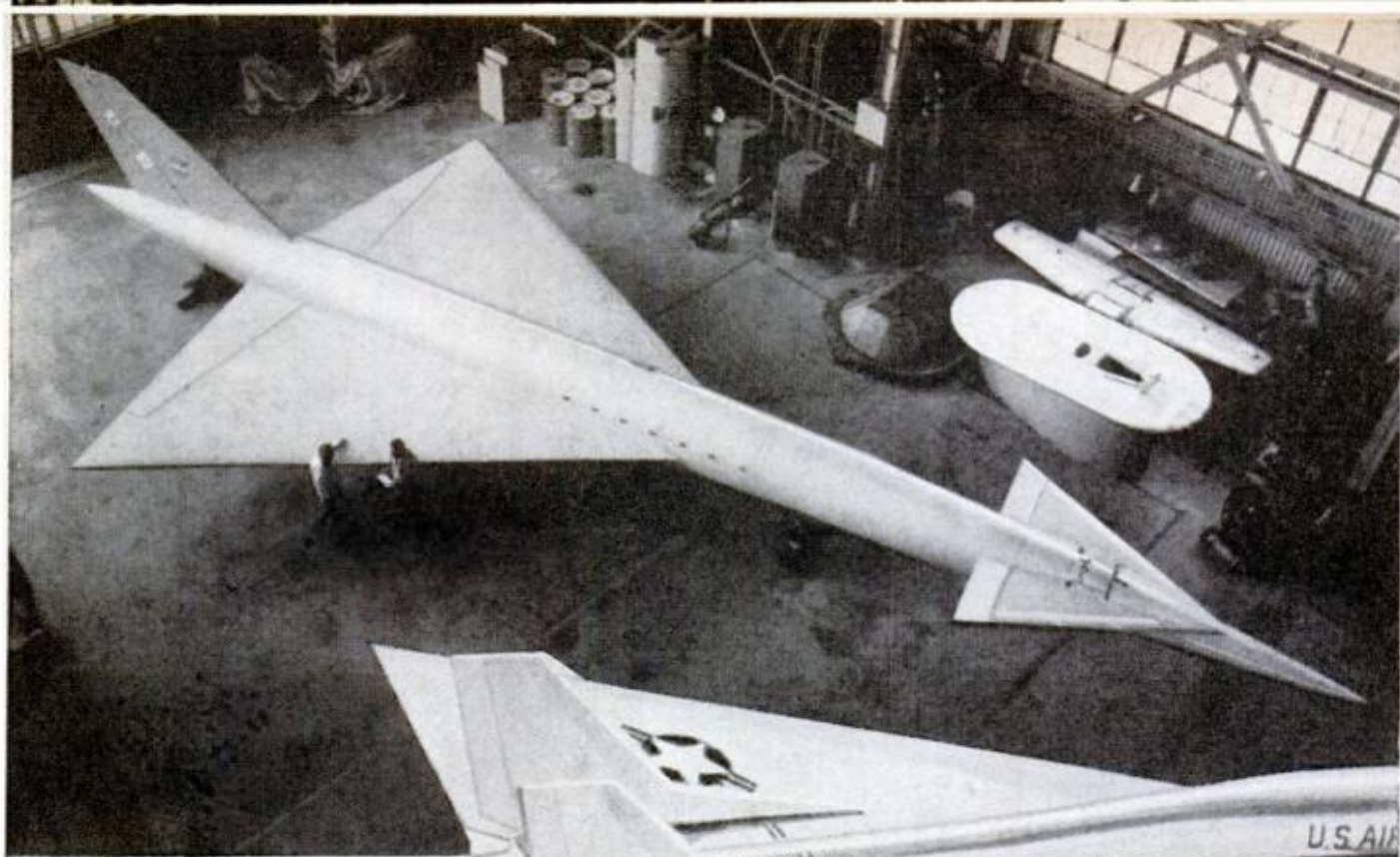

**NASA MODEL** (above) of potential supersonic airliner resembles basic configuration of B-70 (right) with forward canard and delta wing

**B-70 BOMBER**, built for Air Force, may blaze the trail for commercial transports. Basic research for Mach-3 flight that went into its creation may be applied to SST designs

they won't incinerate from aerodynamic heating, how to keep the landing tires from cooking, the windshield from melting, the fuel tanks from exploding. The research that went into the B-70 provides the answers to all these questions.

Even such a "minor" question as whether a pilot can land his craft safely is being solved. (Due to the 180 feet or so of fuselage and the nose-high landing attitude required by the delta wing, the pilot in the cockpit is still 40 or 50 feet in the air at the time his main gear contacts the runway.)

The B-70 has a delta wing and a long fuselage projecting forward from the wing, with two small "canard" control surfaces just aft of the cockpit. The plane is about 180 feet long and its wing is about 125 feet wide. (Pinpointed dimensions were secret when this was written.) Its wing tips can fold down for greater efficiency when flying supersonic in the thin air of 70,000 feet. It lands at about the same speed as today's jet fighters. Its crew works in a shirt-sleeve environment

of 85 or 90 degrees, some 15 degrees warmer than would be agreeable in a passenger transport. It was built by North American Aviation for the U.S. Air Force.

The prototype is powered with six General Electric J-93 afterburning turbojets that were designed as part of the B-70 project. Each engine develops in excess of 30,000 pounds of thrust. The engines have air-inlet ducts of variable geometry, and the shape of the ducts can be changed at high altitude to compress the thin air better. This reduces the amount of power needed to drive each engine's compressor. The turbine blades are of a new steel alloy and can operate at higher, more-efficient temperatures than previously were practical.

#### Steel Aircraft

The B-70 has been called a "steel airplane," and so it is to a considerable degree. A new technology was developed especially for this program, for manufacturing stainless-steel honeycomb from thin-gauge material. The honeycomb is



**SST DESIGNS** now under study by NASA include (from top) variable-wing model in which wing is extended for takeoff and retracted for supersonic flight, delta-wing, and delta-like wing with tail section

**CANARD-DELTA** models (below) feature configuration created for B-70. Unusual canard, which puts tail in nose, created problems—often blocking out vertical stabilizers. Stabilizers were later raised

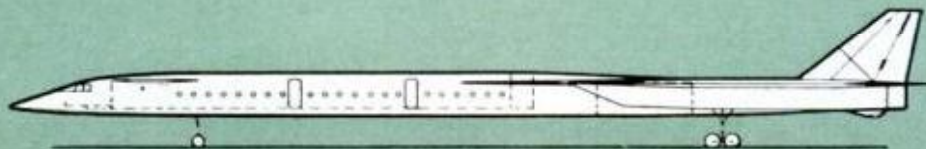
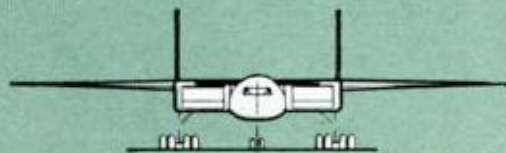
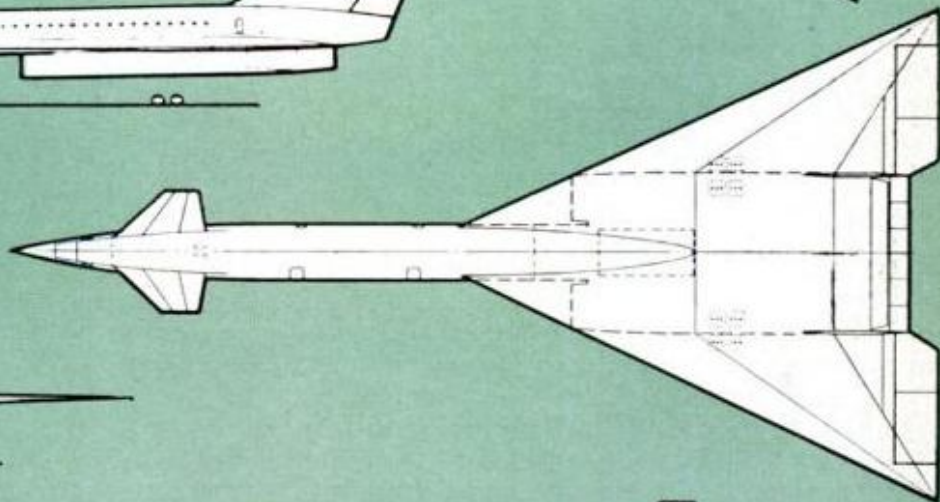
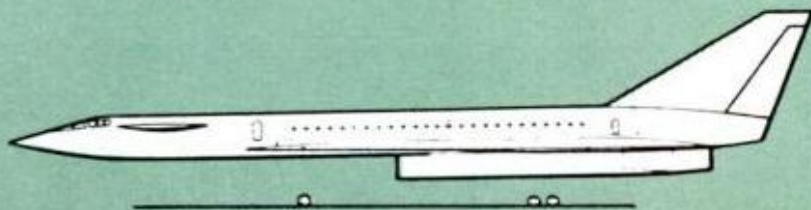
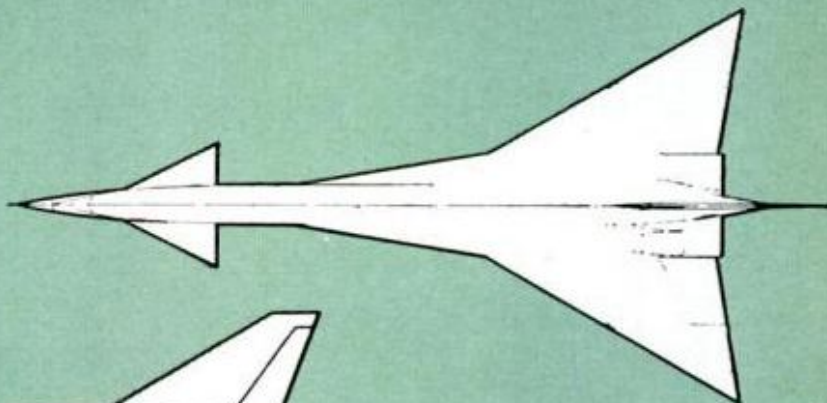
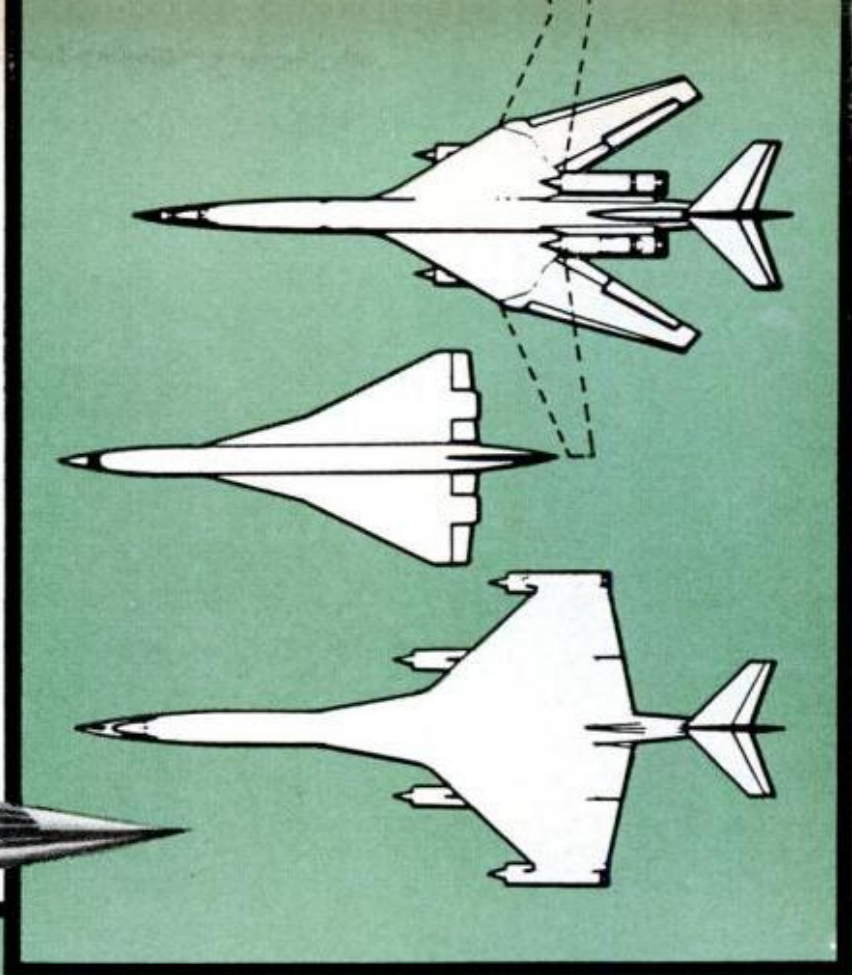
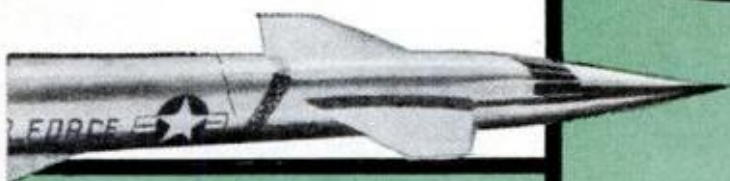

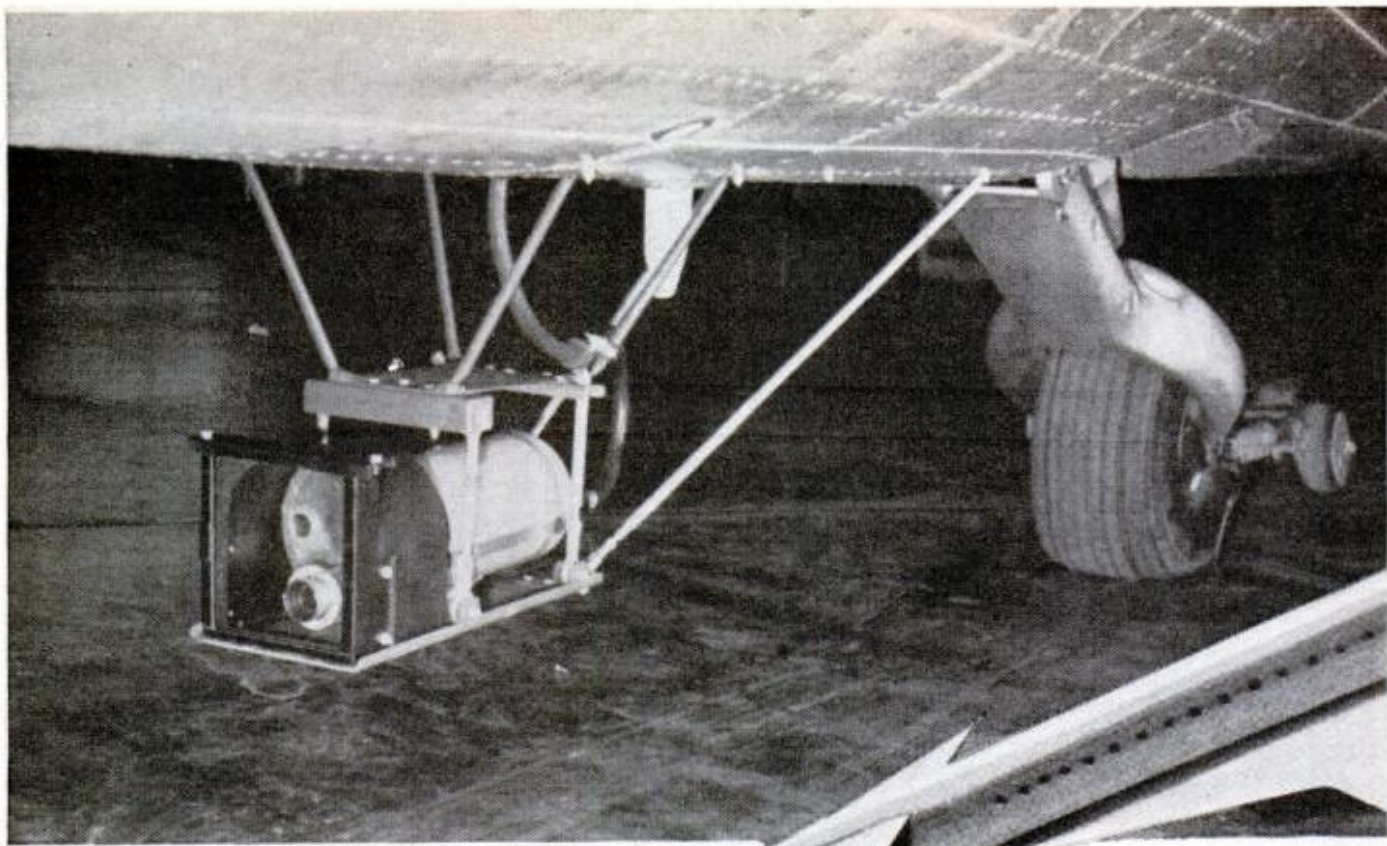

**SST LANDINGS** are major problem. Pilots are 50 feet above ground when wheels touch. Tests with closed-circuit television are being made to give pilot picture of wheels as they approach runway

used in wing surfaces and other areas where aerodynamic heating is greatest. Even thick aluminum sheets would lose strength at the speeds the B-70 is designed to fly. Some structural members that require high strength and light weight are of titanium. Aluminum is used in areas not subject to high temperatures.

Across-the-board developments required for the B-70 include high-temperature tires that withstand 360-degree temperatures for four hours, an electrical system (including motors and generators) that operates in temperatures approaching 600 degrees, and a 4000-p.s.i. hydraulic system using a high-temperature fluid and permanent, brazed fittings.

### Triangles in the Tunnels

More than 14,000 hours of study in more than a dozen high-speed and low-speed wind tunnels have been devoted to the B-70 project. It was from these studies that the canard-delta planform was selected as being the best for the B-70's purposes, yet this unconventional canard-delta shape was found to have inherent problems that called for still more wind-tunnel time.

One such problem was the loss of stability that occurs at low speed and at the high angles of attack required at landing or take-off. In these nose-high atti-

tudes, the nose and the canard surfaces create air vortexes that flow back and envelop the vertical stabilizers, reducing or eliminating their steadying effect and thus reducing pilot control. The best solution has been to increase the size of these vertical tails and to locate them where they are least affected by the unstable air.

No one could afford to test fly an aircraft like this one without knowing ahead of time how it is going to handle, how best to control it. Flight simulators have been built by National Aeronautics and Space Administration for this purpose, for working out the best pilot procedures under both normal and emergency conditions. NASA did the basic research for the B-70 and is now doing the same for the SST (supersonic transport) which NASA is now beginning to call the SCAT (supersonic commercial air transport.)

One of NASA's simulators is a typical cockpit for the pilot, in front of which is a motion picture screen showing the image of the threshold and runway lights of an airport. The lighted picture changes in angle and attitude according to the way the pilot handles his controls, just as it would during an actual landing.

Another simulator, a cage that rides up and down the side of a building like an elevator, is used for testing a pilot's

[\(Please turn to page 200\)](#)

**SST MODEL** (below) shows folded wing tips, unique feature to give aircraft more stability at supersonic speeds in thin air of 70,000 feet where most Mach-3 flying will be done



### CLIMB PERFORMANCE

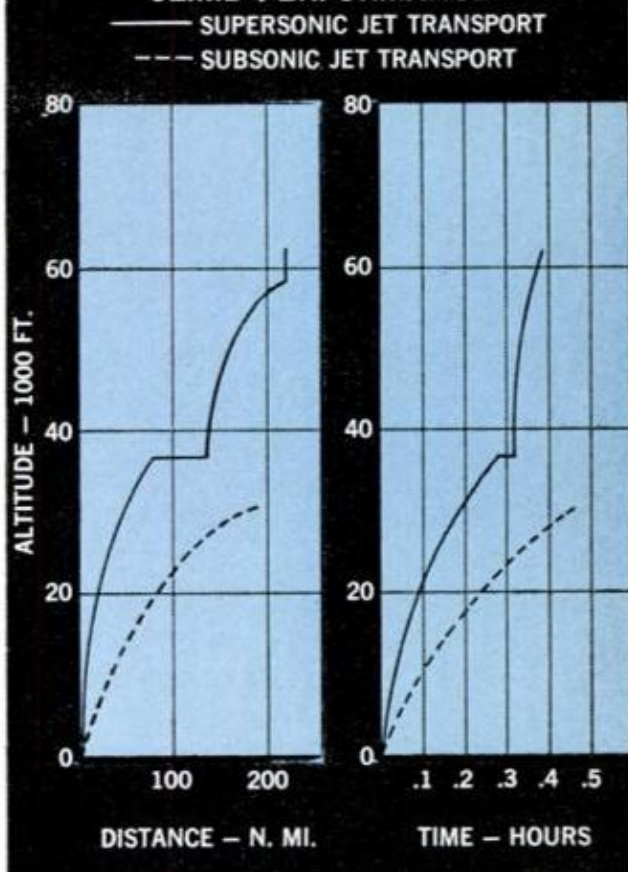

**RATE OF CLIMB** of SSTs is dramatic. Angle of climb is so steep no one can walk in aisles. Jog at 35,000 feet is point at which SST levels off to go supersonic

**RUNWAY SIMULATOR** for SST training includes projector which flashes runway onto rolling belt. Pilot tries to land on it while computer records and overrides his moves

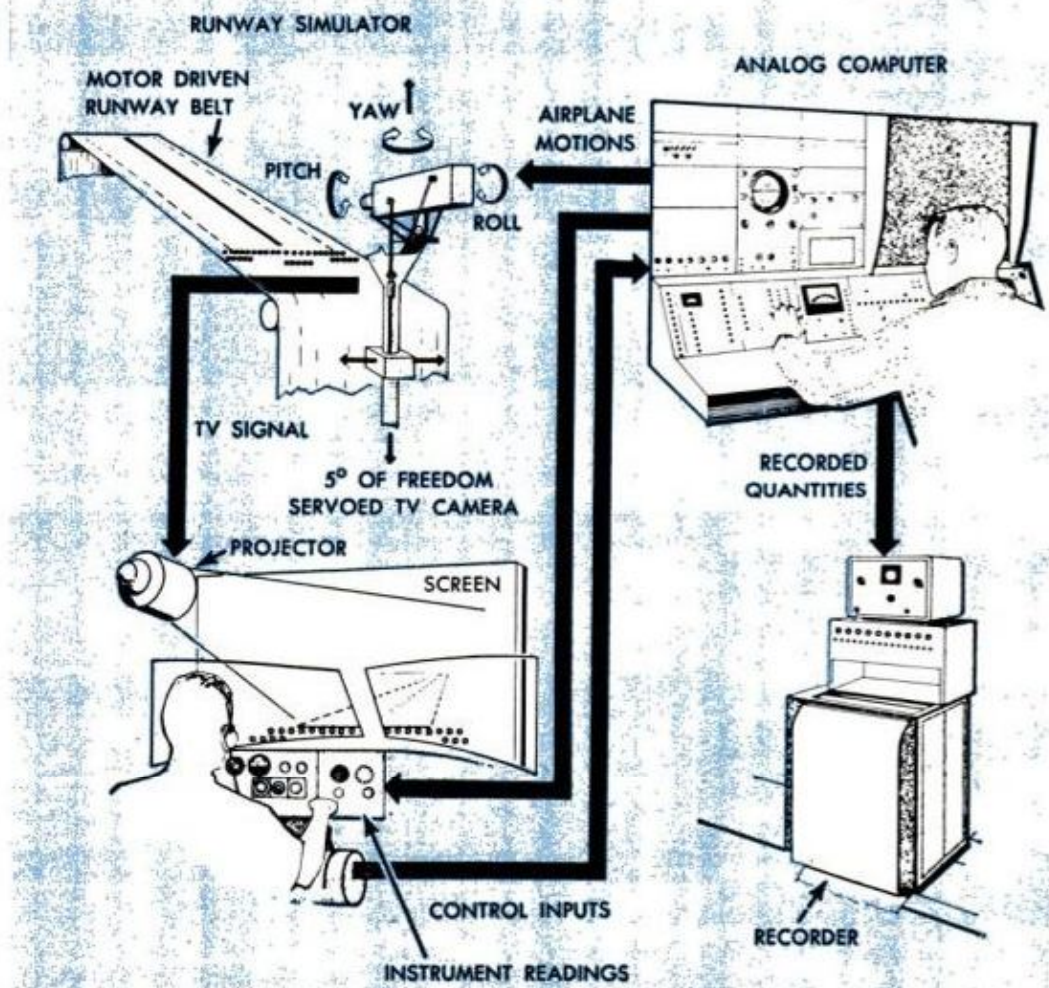

# Out of This World Life Detectors

Dropping out of the blue, the first "earthling" to land on Mars will be unlike anything you've ever seen

By S. David Pursglove

**I**F THERE ARE people on Mars, their first visit from an "earthling" is going to be as startling as any science-fiction artist's conception of Martians on earth.

His name is "Gulliver," and he is scheduled for a parachute drop onto Mars in 1966. He is round and squat, about the size of a quart jar, and his four tiny legs attach his brain to a shiny metal platform. To give him an American touch, he carries two side arms and shoots from the hip.

Gulliver is the robot brainchild of engineer Gilbert Levin, who created him for the National Aeronautics and Space Administration.

A Mariner-B spacecraft will take two Gullivers—in a padded capsule—to Mars. In the vicinity of the Red Planet, the capsule will be ejected and the Gullivers will parachute to the planet's surface, where they will actually

**SCIENTISTS OF THE NASA** shoot a film of Gulliver in action. The tiny robot life detector shot grease-covered strings over the ground, then reeled them back covered with proof of life on earth



**ENVIRONMENTAL CONDITIONS** in space are simulated (right) to test the effects on known organisms

**AUTOMATED MICROSCOPE** (second from top) will collect samples, view them, and televise to earth

**WOLF TRAP** (bottom right) measures the bacteria growth by the effect of CO<sub>2</sub> production on Photometer

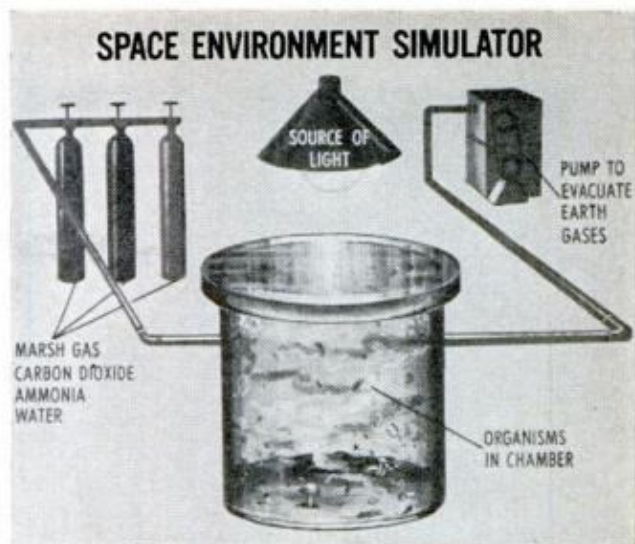

**GULLIVER'S** mechanism (below) is simple. Two projectiles (A) are fired by electric charge (B). Sticky string (C) is spread across the ground, then recoiled by motor (inside D) and wrapped around ampule of culture nutrient (inside D). Pointed plunger (E) is fired by current (E1) to break the ampule, releasing culture onto the string. Geiger tubes in container (H) register production of CO<sub>2</sub>, and radio information to earth. The second Gulliver acts as a control over the first. A plunger (F) is fired by current (F1) to release a vial of poison to kill bacteria and stop signals being transmitted by geiger tubes in chamber

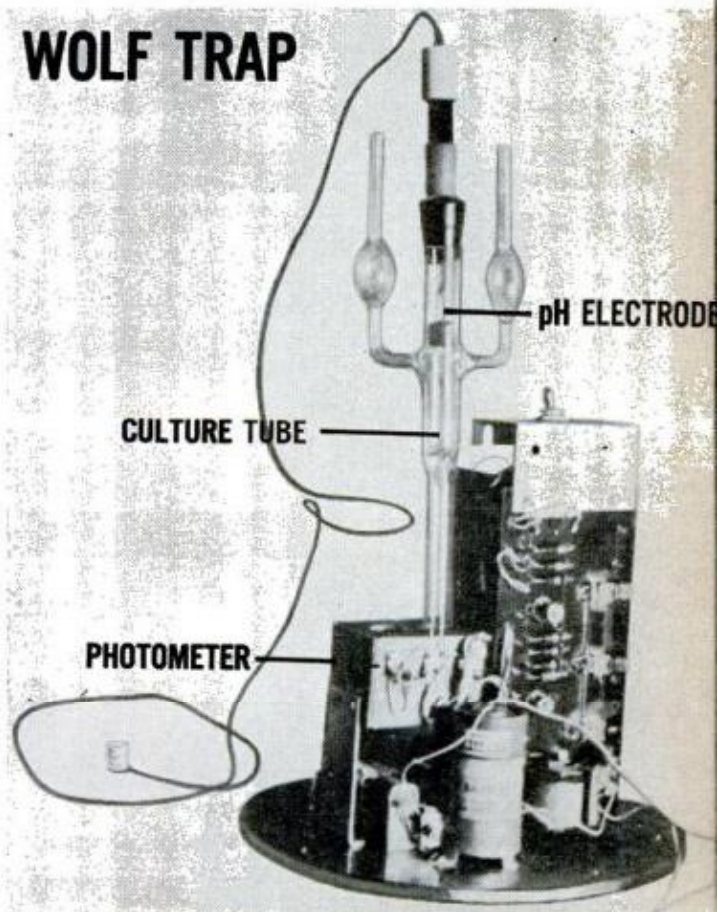
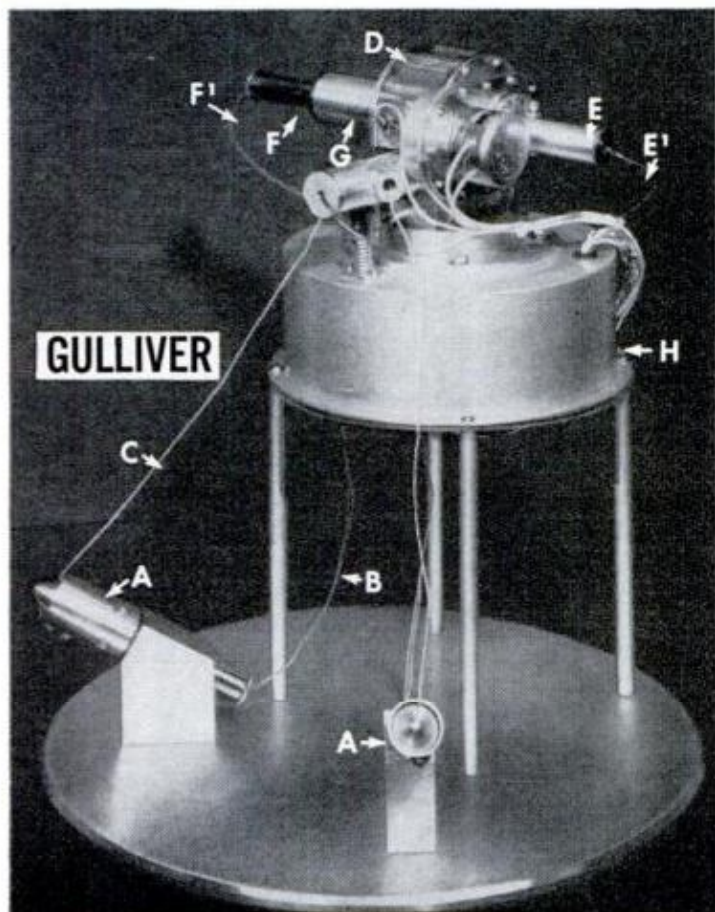
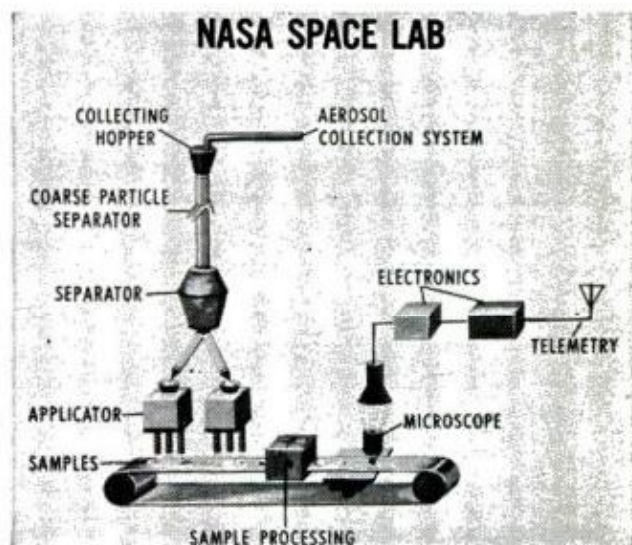

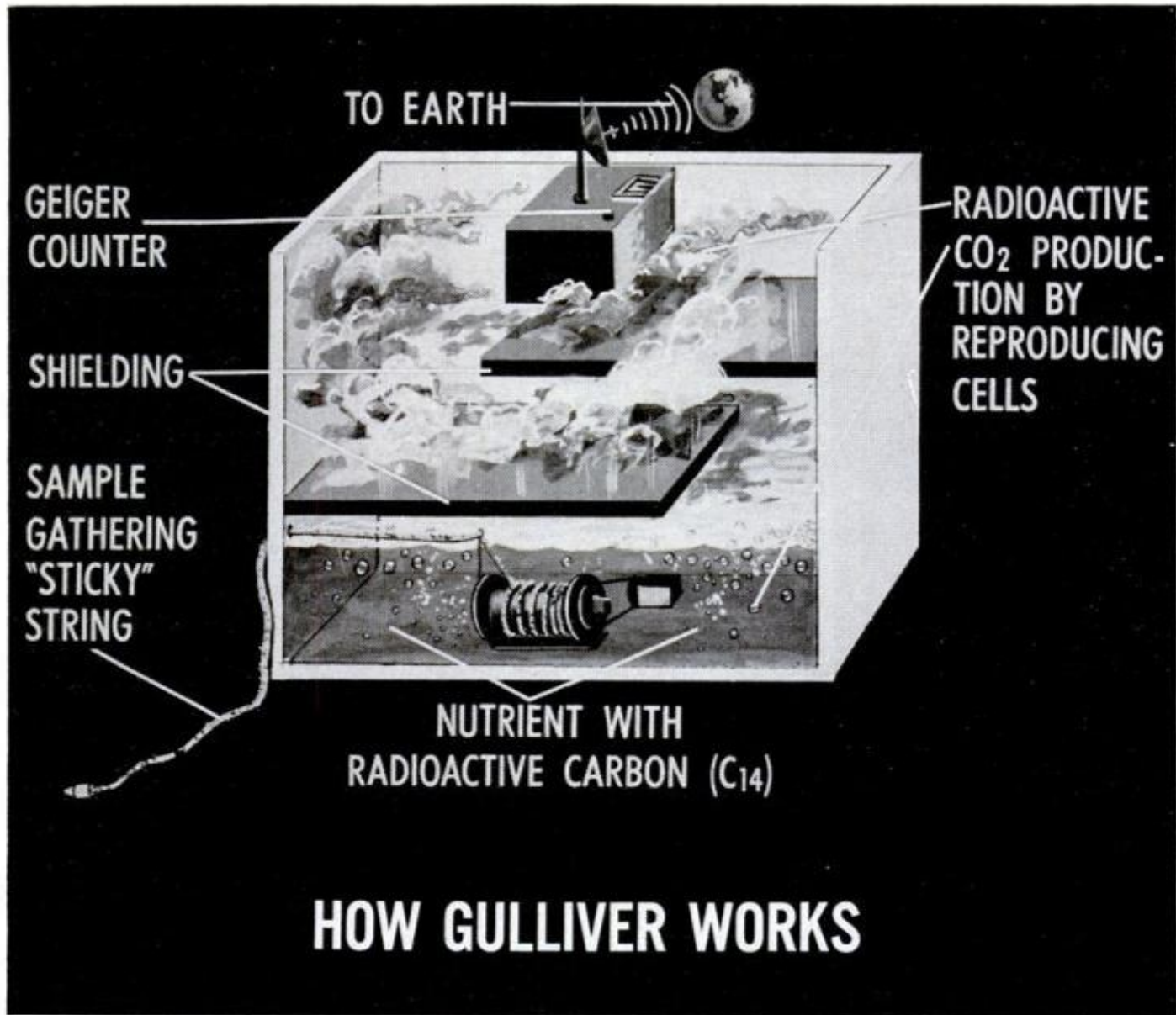

## HOW GULLIVER WORKS

**RADIOACTIVE CO<sub>2</sub>** is produced in model to react on geiger counter that will radio signal back to earth

attempt to capture extraterrestrial life.

Without so much as a "take me to your leader," the Gulliver's immediate function upon landing is to start shooting. Tiny twin cannons mounted at 90-degree angles on the robot's base will fire small projectiles—like plumb lines—each carrying 25 feet of cotton kite string and two feet of fluffy chenille. The strings will be coated with a tacky silicone grease. The instant the strings are laid out, a two-watt motor in each device will begin reeling the lines back into a tank. The grease-coated strings will pick up bits and pieces of Martian soil—and any forms of bacteria that live there.

If Mars harbors life as we know it, there will be bacteria, and Gulliver will detect it by measuring its growth. When the string is reeled into the tank, a plunger releases an ampule of culture nutrient containing food sugar. Bacteria, using carbon from the sugar, will generate carbon dioxide, and Gulliver will apply

an ultra-sensitive radioisotope technique to detect it immediately.

A key step in the process is replacement of part of the normal carbon 12 in a culture nutrient's sugar with radioactive carbon 14, making it possible to measure bacteria growth with geiger counters.

Any Martian bacteria that contact Gulliver's radioactive nutrient will generate radioactive CO<sub>2</sub>. The gas will flow into a chamber containing a geiger-counter tube surrounded by a circle of 11 other geiger tubes. The circle of counters will cancel out signals caused by cosmic rays. The center tube's instantaneous actual reading of radioactive CO<sub>2</sub> will be radioed to earth.

The second Gulliver has the task of making certain that the signal being sent to earth is not being caused by some unknown element reacting on the culture nutrient to create CO<sub>2</sub>. Shortly after the second Gulliver begins signalling CO<sub>2</sub> generation, a microbe-killing antimeta-

bolite will be released into the culture nutrient. If the signal to earth is caused by bacteria growth, it will cease as the poison kills the bacteria. If the signal continues, it means that the gas is being generated by something other than a living organism.

This would mean that Gulliver had failed, but it will by no means signal the end of the program. The next tools of exobiology—as the study of distant planetary life is called—are already under development.

Dr. Wolf Vishniac of the University of Rochester is working on a life collector-detector named the "Wolf Trap." This device will utilize a vacuum to suck soil and atmosphere samples into a tube containing a culture medium. As with Gulliver, if there are microbes present, they will multiply on the nutrient. Besides generating CO<sub>2</sub>, they will turn the clear nutrient cloudy and make it slightly acid. A photo cell will measure the cloudiness and a potentiometer will measure the acidity.

On the assumption that a single nutrient will not have a universal attraction for possible life forms on Mars, Nobel Prize geneticist, Dr. Joshua Lederberg, has developed a "Multivator" that features 12 culture tanks filled with different nutrients. Collecting extraterrestrial life through a funnel, the Multivator has a rotating device that passes over each tank, depositing a sample of atmosphere and dust. The transparent tank lids close and a photo cell passes slowly and continu-

ously over them, monitoring turbidity and signalling changes to earth.

Aside from the devices for detecting actual life activity on Mars, NASA will be sending up instruments to detect organic compounds, such as deoxyribonucleic acid, that are associated with living organisms. These compounds change the character of light striking them, and can be spotted by an ultraviolet spectrometer adapted for optical rotation study. The instrument can be landed for close examination of surface samples, or it can merely fly past a planet and search for evidence of organic compounds in the ultraviolet portion of the spectrum.

A mass spectrograph is being developed at Massachusetts Institute of Technology that will be adapted to identify certain organic compounds by charging gas samples electrically and sending them through deflecting magnetic and electrical fields. A cell at the end of the tube will pick out the presence of ions associated with living organisms.

To see life on Mars, a special microscope is being designed. It will contain a sticky transparent tape for collecting specimens from the atmosphere. The tape will be automatically run under the lens of a microscope and the image will be transmitted to earth by television.

But first of all will be Gulliver. It will take about 250 days for this "astrorobot" to reach Mars. Within 10 hours—with the world anxiously waiting—his message will be received on earth. ★ ★ ★

**MARINER-B ROCKET** will take Gulliver to Mars where capsule will be ejected and dropped by parachute

**PRIOR TO TAKEOFF**, a shroud over the capsule will be filled with gas to kill all surface bacteria

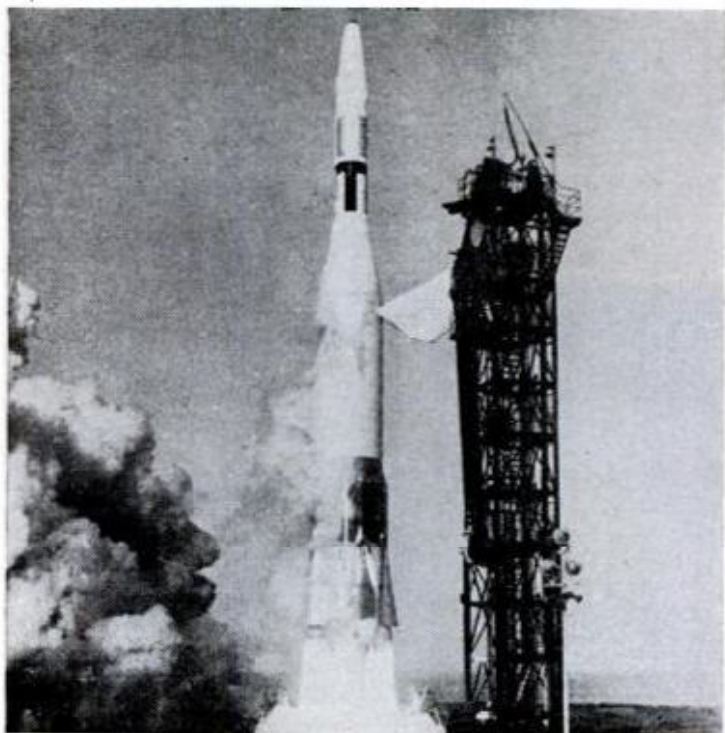

JUNE 1963

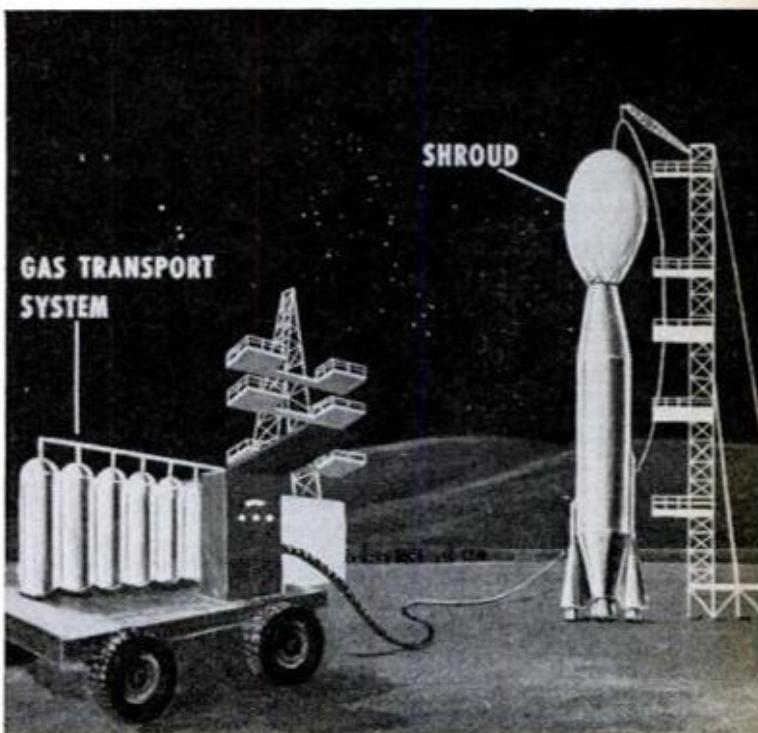



## Trike to Truck

In a matter of minutes, Junior's tricycle can become a tow truck or a dump truck with the addition of Tach-A-Toy, invented by Frank Ewers of Oakland, Calif.

The simple design of Tach-A-Toy makes it easy for any youngster capable of using pliers to attach and remove it by himself. The main brace is attached by removing the seat post through a hole in the brace. Strap brackets encircle the step pan and bolt in place.

Both accessories are available from Tach-A-Toy, 914 Insurance Bldg., Seattle, Wash.

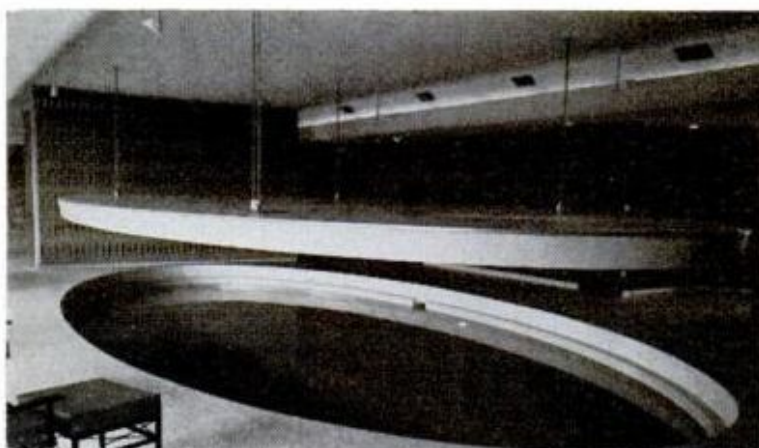
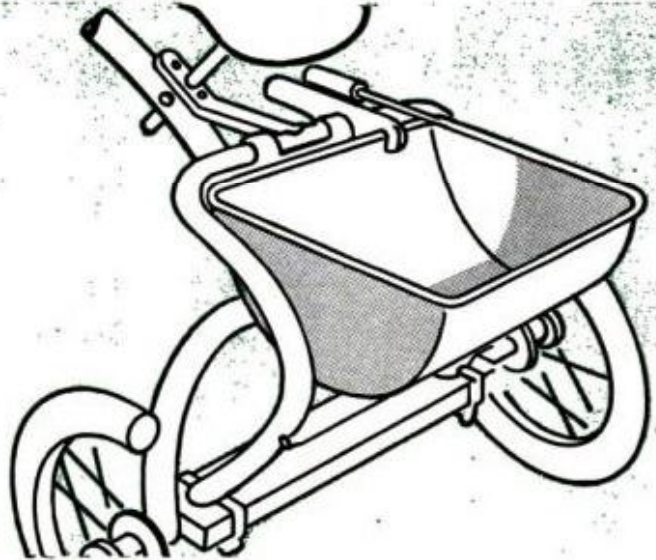

## Hard-Top Pool

From recreation-room floor to a swimming pool with the push of a button is a feature of an indoor pool designed for a Los Angeles residence by architects Williamson and Morris of Long Beach, Calif.

A two-ton plywood and fiberglass lid is raised and lowered by four industrial chain hoists, to transform a 500-square-foot floor into a 37 by 17-foot pool. To avoid moisture damage, the walls of the room are specially treated walnut and glass, and the furniture is water-repellent.

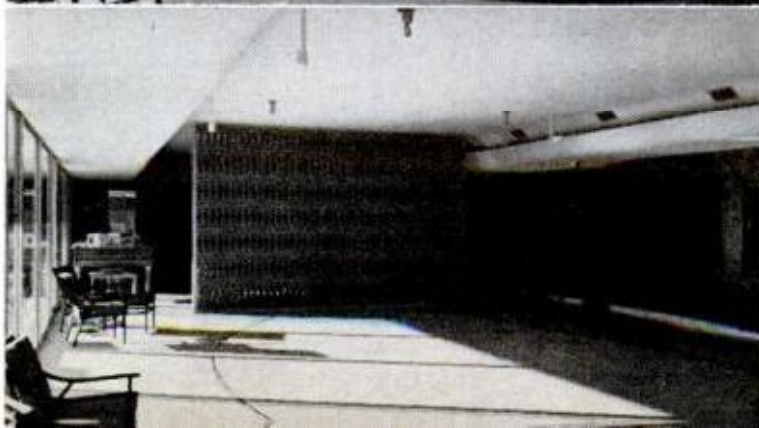

**The Portuguese Man - of - War** (*Physalia physalis*) kills its food—small fish and planktonic animals—with a poison similar to the king cobra's venom.

POPULAR MECHANICS



# BOATING BULLETINS

## Remote-Control Plane

Got a planing problem? You might be able to cure it with a pair of midget afterplanes developed by Tempo Products Co., 2062 E. 70th St., Cleveland, Ohio. These adjustable Trim Tabs mounted on the transom will enlarge your boat's planing platform by a few square inches, which is often enough to compensate for heavy loads or a slight hook in the hull.

One style is controlled from the cockpit, allowing the driver to adjust for load shifts and utilize the tabs for faster planing. Designed for boats from 14 to 21 feet, this kit sells for \$42.50. A manual-set style comes in two sizes: one for boats under 16 feet, which is priced at \$8.95, and another for boats from 16 to 21 feet, retailing at \$14.95.

## No Skidding

Designed for decks and docks, a new surfaced plywood features a waffle pattern formed into the tough plastic-impregnated overlay. Called Skid Guard, it's available on either exterior fir plywood or on hardboard laminated to plywood. Standard 4 by 8-foot panels come in thicknesses from  $\frac{7}{16}$  inch to 1 inch.

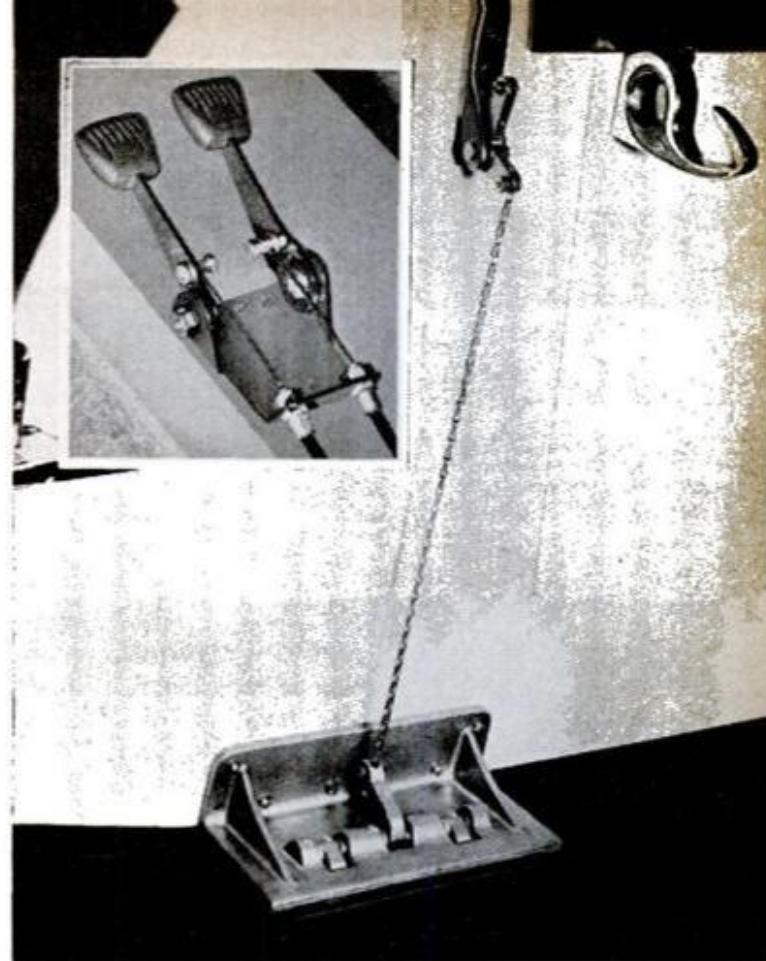

## Troller's Controller

A straight-ahead bow rudder which is easily attached to any 12 to 16-foot boat virtually eliminates wind drift when you're trolling. It offers no resistance to forward motion, but resists any side movement caused by wind. Retailing for \$12.95, it's made by Arco Mfg. Co., Box 817, Grand Forks, N.D.





*A Nationwide Survey  
Based on 905,927  
Owner-Driven Miles*

## ***Cadillac Owners Praise Handling Comfort, Find Ash Trays Distressing***

**Marginal and boldface comments by Jim Whipple, *PM's* Automotive Editor**

***Can you think of another car with a play on Broadway like the → "Solid Gold Cadillac?"***

***Cadillac management has shrewdly resisted temptation to over- → produce for quick profits, thus they always have an order backlog and used models remain high in value***

**C**URIOSITY prompted *PM's* choice of Cadillac as a subject for an owners report. The car has been the unchallenged leader of its class for years and currently outsells its two domestic competitors combined by a three-to-one margin.

Although it is priced at less than half the cost of a Rolls Royce, Cadillac has become a world-wide symbol of a top-quality motor car. It is equally esteemed by Arabian sheiks, Argentine cattle barons and American bankers.

But why do these—and others—choose Cadillac? Although it sounds almost absurd, the reason that most people buy Cadillacs is simply because the car is a Cadillac. For example, 77.1 percent traded another Cadillac for this year's model, and 78 percent cited previous ownership as a primary reason for buying.

Of the entire group responding, a whopping 75.8 percent stated that they did not consider buying another luxury car. Of the 24.2 percent who did consider another car before buying their Cadillacs, 55.6 percent considered the Lincoln Continental, 16.7 percent looked at the big Buick, 11.1 percent considered the Imperial, while 5.6 percent each had looked into Oldsmobile and Thunderbird.

And an overwhelming 98.7 percent stated that they



**ELEGANCE OF CADILLAC STYLING** was mentioned by over half the owners surveyed as a major factor in their decision to buy the General Motors luxury car

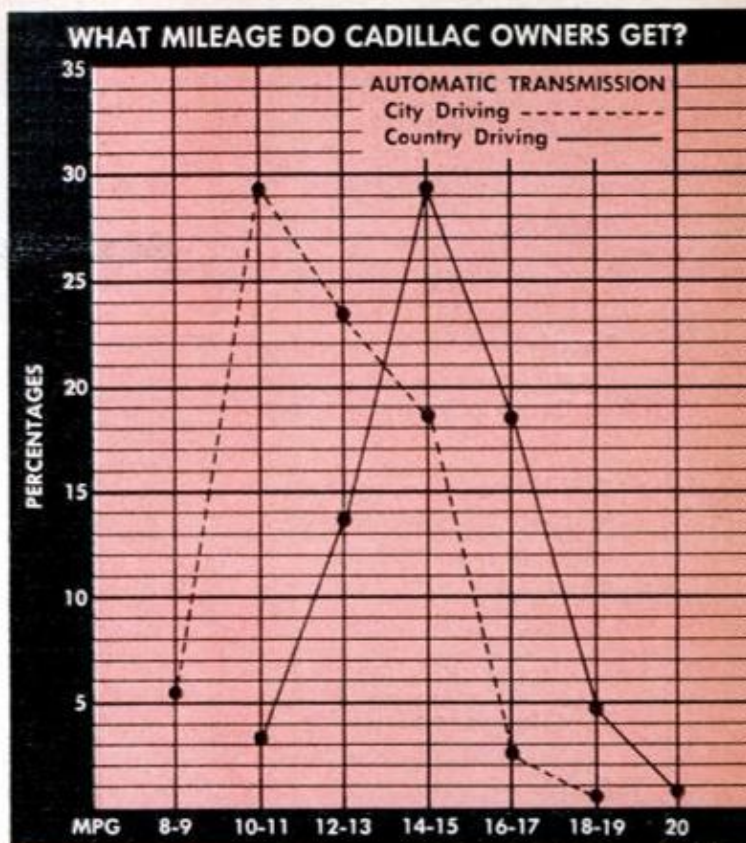

**MORE CITY DRIVERS** got a fuel consumption rate of 10 miles per gallon than any other. On the open road, 15 miles per gallon was the most common figure

**BEGINNING WITH THE P-38 LOOK** right after World War II, Cadillac originated tail fins in the domestic market. They're lower now, but they won't die



Owners Like . . .	But Dislike
Comfort, Luxury Ride (52.0%)	Ash Trays (9.9%)
Easy Handling (38.1%)	Inadequate Heater (7.2%)
Power, Performance (33.6%)	Whistling Wind (4.9%)

**In no other owners report has reputation played so important a role in determining a purchase →**

**People seem to look for these qualities no matter what car they buy →**

**Cadillac owners are not fusspots. Those '63 ash trays are a comedy of errors →**

**That four-speed Hydra-Matic transmission and the 2.94 rear-axle ratio are what make the heavy Cad so surprisingly thrifty →**

**Note similar mileage at 30 and 50 m.p.h.; it's due to transmission characteristics making 50 a very economical cruising speed →**

did not consider an imported luxury car which we assume would include such makes as Rolls Royce, Mercedes Benz and Jaguar.

In addition to previous ownership other important reasons given by owners for their purchases were comfort (62.3 percent), reputation (58.3 percent) and styling (54.3 percent). (Note that these are overlapping percentages.)

After driving their Cadillacs for an average of 4175 miles, the owners checked off as their Best Liked features, a list surprisingly similar to that of a group of low-priced car owners. The top four were Riding Comfort, Handling Ease, Performance and Styling in that order.

Some 46.2 percent of all owners reporting had no complaints whatsoever. Topping the list of what complaints there were was the location of ash trays. This is something of a left-handed compliment; a car must be pretty good if its major fault is misplaced ash trays.

Fuel economy would not seem to be important to owners of a luxury car costing over \$6000, but Cadillac owners are aware of the degree of thirst of their cars.

A solid 69.1 percent felt that their Cadillacs were delivering about the mileage expected, which for most drivers ran between 10 and 14 miles per gallon in city traffic and from 12 to 17 miles per gallon on the open roads.

As a check, and for comparison with other cars, *PM* ran constant speed fuel mileages with a fuel meter on its test Cadillac. The car, a Coupe de Ville hardtop, had a full complement of power accessories including air conditioning. It delivered these fuel mileages:

19.83 miles per gallon at 30 m.p.h.  
22.85 miles per gallon at 40 m.p.h.  
19.18 miles per gallon at 50 m.p.h.  
17.53 miles per gallon at 60 m.p.h.  
15.65 miles per gallon at 70 m.p.h.



**THE CAVERNOUS CADILLAC TRUNK** is even equipped with a neatly painted wooden wedge to block a wheel in the unhappy event that you get a flat tire



**PM'S FUEL METER REPORTED** steady-speed economy up to 22.85 miles per gallon, but weight—nearly three tons—keeps owners' highway results under 20 m.p.g.

Over-all fuel consumption for approximately 850 miles of driving, about 40 percent of which was in city traffic, worked out to 14.9 miles per gallon.

The owners rated their Cadillacs high with 76.2 percent stating that the cars were excellent, while 20.6 percent felt that they were good. Only 1.4 percent of those reporting categorized their Cadillacs as fair, while 1.8 rated them as poor.

One sure proof of a car's worth is the inclination of its owners to buy another one of the same make. Cadillac owners made it almost unanimous with 91.4 percent of all the owners reporting that they would buy again.

Of the remaining 8.6 percent, 6.8 percent was undecided while 1.8 percent said that they would not buy another Cadillac.

*What do the owners themselves say about their Cadillacs? Here, from the affirmative comments made, are the five that were mentioned most often:*

"Rides well on both bumpy roads and smooth pavements."—New York restaurant owner.

"I like the driving comfort and lack of fatigue after a long drive."—Iowa surgeon.

"It's easy handling for its size."—New Jersey housewife.

"It's just like driving a cloud—practically effortless!"—New Jersey salesman.

"A nice running and easily handled automobile."—Illinois steamship agent.

"My Cadillac handles very well at all speeds."—Indiana doctor.

"Like its precision in handling."—New York clergyman.

"I like its smooth, quick acceleration."—Pennsylvania merchant.

"Has speed when needed."—New York sales engineer.

"I like the simplicity of styling; they've eliminated the

(Please turn to page 194)

PM testers found Cadillac's ride generally superior, although on bad washboard surfaces there was some muffled vibration from the massive unsprung rear wheel and axle assembly

Let's put it this way: If clouds were equipped with power steering, they'd handle like Cadillacs!

Steering is precise and the car goes exactly where you point it. But some drivers may feel that the steering is a bit too light and easy

### SUMMARY OF OWNERS REPORT

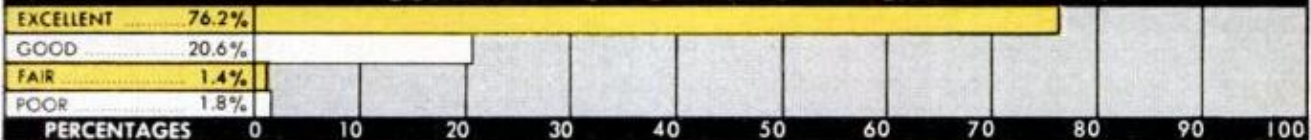

<b>Mileage experience</b>	
About as expected	69.1%
Better	14.5
Not as good	16.4
<b>Best-liked features</b>	
Riding comfort	52.0
Handling ease	38.1
Power, performance	33.6
Styling	31.4
Smooth, quiet	10.3
Roominess	6.7
Adequate headroom	6.3
<b>Specific complaints</b>	
Location of ash trays	9.9
Inadequate heater	7.2
Wind noise	4.9
Doors, windows fit poorly	4.0
<b>Mechanical trouble if any</b>	
No mechanical trouble	76.7
Excessive oil consumption	3.1
Defective oil seal	1.8
Windshield wipers	1.8
Fast engine idle	1.8
<b>Best-liked exterior style features</b>	
Clean, smooth look	10.8
Simple, plain, classic lines	9.0
Lower fins	6.3
Hood	4.5
Grille	4.0
Small rear window	4.0
Long, low lines	3.6
Front end	3.6

<b>Least-liked exterior style features</b>	
Rear window	4.5%
Fins	4.0
Fenders	2.7
Length	1.8
Grille	1.8
Vulnerable front end	1.3
No protective molding	1.3
Plain, undistinguished	1.3
<b>Best-liked interior style features</b>	
Dashboard	13.0
Upholstery	12.6
Comfortable seats	10.3
Adjustable seats	3.6
Arm rests	2.7
Legroom	2.2
Color harmony	2.2
Luxurious, quality look	2.2
Interior lighting	1.8
<b>Least-liked interior style features</b>	
Ash trays	9.0
Transmission hump	5.4
Glove compartment	4.0
Upholstery	3.6
Uncomfortable seats	3.1
Dashboard	2.2
Interior lighting	2.2
<b>Decision to buy Cadillac most influenced by:</b>	
Previous ownership	78.0
Comfort	62.3
Reputation	58.3

<b>Consider buying another luxury car?</b>	
Did not consider	75.8%
Did consider	24.2
<b>What make?</b>	
Lincoln Continental	55.6
Imperial	11.1
Buick	16.7
<b>Consider An Imported Luxury Car?</b>	
Did not consider	98.7
Did consider	1.3
<b>Make of family's other car, if any</b>	
No other car	41.7
Another Cadillac	6.3
Chevrolet	19.7
General Motors compacts	5.4
Other General Motors make	9.0
Ford	10.8
Ford Motor compacts	1.8
Other Ford Motor make	3.1
Chrysler Corp. compacts	0.9
Other Chrysler Corp. make	4.5
Other U.S. make	5.4
<b>How is dealer service?</b>	
Excellent	60.5
Average	36.6
Poor	3.2
<b>Would you buy from him again?</b>	
Yes, would buy again	68.1
No, would not	4.5
<b>Would you buy another Cadillac?</b>	
Yes, would buy	91.4
No, would not buy	1.8



By Jim Whipple



## Piston Engines Move Ahead While Turbines Spin. Compacts Will Sport Many Changes on '64 Models

Although Chrysler Corporation plans to offer half a hundred hand-built turbine-powered cars to a favored few in 1964, the wise money in and around the industry is betting that the piston engine will be around for some years to come. Reason for this feeling: engineers have been, are now and will be designing new life into the century-old, four-cycle piston engine.

If you don't believe it, look back a bit. Ten years ago there were only two overhead valve V8s on the market, Cadillac's and Oldsmobile's. Top horsepower was about 225.

In 1963, though, everybody has an overhead valve V8, and 400 or more horsepower can be ordered in a "low-priced" Ford, Plymouth or Dodge.

In 1953 Ford's flathead V8 was rated at 110 hp., while Plymouth and Chevy had only Sixes.

Less spectacular but more important is the fact that today's 400-horsepower V8s require no more space than their ancestors of a decade ago and they weigh less on the average, thanks to improvements in foundry techniques and thinner castings as well as the continuing trend in aluminum manifolds, timing covers and the like.

A look down the road shows even more in store for the piston engine. Ford is now able to build a dependable racing engine around its compact block Fairlane V8 that will produce 360 horsepower from 256 cubic inches on 103-octane gasoline. This engine operates with carburetors and pushrod valves and takes up less space than the current Chevrolet V8. And Ford's engine produces its output comfortably at 6000 r.p.m.

Reliable sources indicate that Ford is experimenting with an overhead camshaft version of the Fairlane "260" engine cast in aluminum like the Indy powerplant, but with dual valves (i.e. two intakes and two exhaust valves per cylinder). This one should crank out well over 400 horsepower from its 256 cubic inches.

Historically today's racing engines have been tomorrow's production power plants. If this pattern holds true for the future, say the next ten years, turbine engineers

will be hard put to justify the advantages of their pet in automotive use. Although the turbine in its present state of development will produce smooth vibrationless power from a relatively small space, it won't do it with silence or in competitive economy with current piston engines which are cheaper to produce. It's going to be an exciting battle to watch.

Reports on the 1964s are buzzing thick and fast these days. Falcon will be getting its first major restyling with a new body shell which is rumored to resemble the current Rambler American.

Our guess is that it may be more like Ford of England's Cortina (PM April '63, p. 50). Ford stylists in England, Germany and Dearborn seem to be forever looking over each other's shoulders.

Rambler's American will play its game of styling musical chairs with a major body shell change.

Although there's a brand-new body for the Galaxie, Ford is expected to go along with facelifting and trimshifting on Fairlane, Galaxie and T-Bird. We'd expect to see more change on Lincoln Continental than in the past several years although their "luxury compact" approach to the car will no doubt remain.

Most talked-about move at GM will be the "all-new" (and that's for real this time!) compacts Chevy II, Tempest, Olds F-85 and Buick Special.

Out go the unit body and frame constructions in favor of a common body and separate frames for all four cars. External sheet metal will be different. So will wheelbases, suspensions and engines.

Chevy II will keep its light Six, but Tempest is rumored to have dropped the heavy, slanted Four in favor of a light cast-iron Six-cylinder block, topped with an overhead camshaft driven by a toothed belt. This one should be fun to hop up!

Special and F-85 will have a new light, cast-iron V-8 not much heavier than today's aluminum job. The V6 is expected to be continued by Buick Special.

These new BOP compacts will be bigger on the inside, but not much bigger on the outside in contrast to their '63 versions which were larger on the outside only.

## Plays Any Way

If you want to listen to your favorite 45-r.p.m. records while riding a roller coaster, this is one way to do it. No matter how the phonograph is bounced around, it will still play.

The secret? Three spring clips that hold the record securely in place and a special pickup arm. The arm comes up from under the record and is spring loaded to keep the sapphire needle in the record groove. There's also a six-transistor radio built into the unit.

The all-transistor set is powered by four standard flashlight batteries. It weighs six pounds and measures 9 by 9½ by 4 inches. There is storage space for up to 12 45-r.p.m. disks in a compartment at the rear of the set. Priced at \$79.95, it's made by Channel Master Corp., El-len-ville, N.Y.



## Truck Cargo Slides on Air

Heavy loads float into trailer vans on an air-cushion floor developed by Clark Equipment Co., Battle Creek, Mich. A compressor in the van floor forces air through valves in the van floor and dock (via a hose, arrow), creating an air film. Five pounds of "push" moves 1000 pounds.



## No Loose Ends

Mounted on a car seat, a magnetic holder keeps a seat belt from dangling on the car floor or out the door. The magnet is bonded to an aluminum strip and the unit is covered with vinyl plastic. Neet Seat sells for \$1.98; Fore-Sight Enterprises, 2600 Scott Blvd., Santa Clara, Calif.





### Watches TV Watchers

Radio and television-detector cars patrol the streets of London looking for illegal (unlicensed) television receivers. British viewers must have a license from the Post Office before they can tune in TV programs. The cost is four pounds (about \$11.20) per year for a picture-and-sound license.

The detector cars have a revolving cage-like antenna mounted on their roofs and contain almost \$3000 worth of electronic-detection gear. They can spot an operating TV up to two miles away.

### Pictures Help Pick New Hair-Dos Before She Buys Them

It's like trying on a selection of hats before picking the one she wants, only this system is for picking new hair styles.

A Polaroid picture of the lady's face is made on the spot, then placed in a tabletop viewer. A special set of transparencies, each with a different hair style, is then superimposed over the print and the

customer can see how she looks in each one. She then makes her choice, knowing exactly how she'll look in the new hair-do.

Manufacturers of the Dial-A-Style selector are Beauty Industries, Inc., 300 Chancellor Ave., Newark, N.J. The system can be rented by local hairdressers on a franchise basis from the makers.

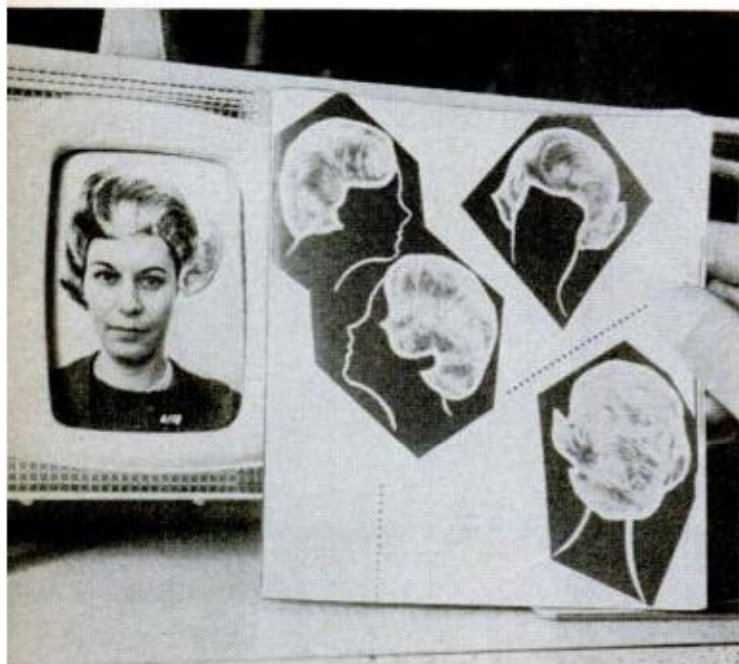





## *And Was It a Silent Spring?*

*What has happened to wildlife, pets, bugs and people in the pesticide-drenched Sheldon, Illinois, area since Rachel Carson said of it: "Perhaps no community has suffered more for the sake of a beetleless world . . .?"*

**By Clifford B. Hicks**

**THE EMOTIONAL HASSLE** over insecticides grows more bitter all the time. Consider these examples:

- A senator from Oregon and a representative from Michigan—two farm and forest states—plan to introduce bills to control the use of pesticides, which are specifically designed to protect farm and forest.
- Hunters and fishermen all over the country are rising in arms to protect wildlife—at least until the opening day of the hunting season.
- Agencies of state and federal governments squabble between themselves. At least one agency is split down the middle in a bitter battle over the effects of insecticides on fish, birds and other wildlife.
- One spokesman, trying to defend the insecticide industry, brings the argument full circle by pointing out "the



rapidity and ease with which many plants and animals . . . develop resistance to new insecticides [and] fungicides." Obviously insects develop such resistance, too.

- A harried businessman, who scarcely takes time to look out the windows of his home, writes scathing letters to the government demanding that "his birds" be protected.

- The states of Washington and California publicly wrangle over, of all things, ladybugs. Washingtonians are accusing Californians of stealing their ladybugs, and the Washington Senate has passed a bill making it a criminal offense to ship a Washington ladybug out of the state. Ladybugs, you see, minimize the need for insecticides because they prey on many insects that damage crops.

- Suburban neighbors feud over the drift of an insect spray.

This strange behavior has been touched off in part by Rachel Carson's book, *Silent Spring*, and in part by the obvious side effects of insecticides. Emotions are running so high that it is difficult to uncover the facts.

In order to find out what happened in one district as a result of a spray program, I visited the Sheldon-Donovan area in Northeastern Illinois. Sheldon and Donovan are two farm communities in the middle of some of America's richest farmland. The soil in Iroquois County is rich and black, the ground is level and the people, ordinarily, are pleasant farm folk.

I chose these communities because, according to Miss Carson, many species of birds, squirrels, farm cats and other animal life in this area were virtually wiped out in a spraying program sponsored by the

state and federal governments. Farm animals suffered, too, she says.

In 1954 the Illinois Department of Agriculture and the USDA initiated a spray program to eradicate Japanese beetles in the area. The program is still continuing. The area thus is a microcosm that may well show what can happen in any area covered with a rain of insecticides.

No one knows the exact moment the trouble started, but the place and circumstances have been pretty well pinned down. Sometime prior to 1954 a freight train pulled into a railroad siding a mile east of Sheldon, and cattle from Pennsylvania were unloaded. In cleaning out the car, a shovelful of straw and manure fell to the ground. With it came a few passengers—Japanese beetles.

The Japanese beetle is a small insect, metallic green in color, which can do damage to farm crops estimated by the USDA at \$10,000,000 per year. It first appeared in this country on nursery stock imported into New Jersey, and in the next 40 years spread over 15 percent of the land area of the U.S.

When beetles were discovered in the Sheldon area, the USDA and the Illinois Department of Agriculture decided to spray the area by plane with a highly toxic insecticide called dieldrin. And it is highly toxic, as are many of the other modern insecticides. The Food and Drug Administration permits a dieldrin residue of only 0.1 to 0.25 parts per million on most food crops, an amount so infinitesimal it is difficult to conceive. A tiny bite of food is about 0.1 part per million of all the food you'll eat in your lifetime.

Dieldrin was not the only insecticide



**RABBITS** were almost annihilated in Sheldon but have since made a comeback, a *PM* editor found **PILOTS** sometimes carelessly overlap treatment zones, spraying some areas two or three times **OVER 1000** dead fish were taken from one fish pond three days after the first spraying

used in the Sheldon-Donovan area. Later, the sprayers turned to aldrin and heptachlor. As far as residue is concerned, the FDA rates aldrin with dieldrin. Heptachlor, though, is even more toxic and has been given a "zero tolerance" by the FDA; that is, not even the slightest trace of heptachlor is permitted on food.

But dieldrin was the original material, and back in 1954 the farmers in the Sheldon area, for the most part, welcomed it.

In that first year, 1400 acres were sprayed at a rate of three pounds of dieldrin per acre, a very high dosage.

Three weeks later the area was virtually desolate of wildlife, 90 percent of the farm cats had been killed and a few sheep were dead. More about wildlife later.

There's no question that beetles were killed. However, the area of infestation continued to expand, so the spray program was expanded, too. By 1960, the spray planes were zooming over the village of Donovan, eight miles north of Sheldon, and the surrounding countryside. That same year they began using aldrin at two pounds per acre, and heptachlor.

Harold (Shorty) Shirtsleeves farms an area just west of Donovan, and in the winter supplements his income by trapping, mainly muskrat. Shorty's farm straddles the boundary line that had been staked out as the limit of the 1960 spraying; in April he was given 24-hour notice that part of his land was to be sprayed. He was instructed to cover any watering troughs, and to move his cattle into a pasture that marked the boundary.

Shorty recalled earlier complaints from farmers around Sheldon. He called some of the other farmers, and soon Shorty and

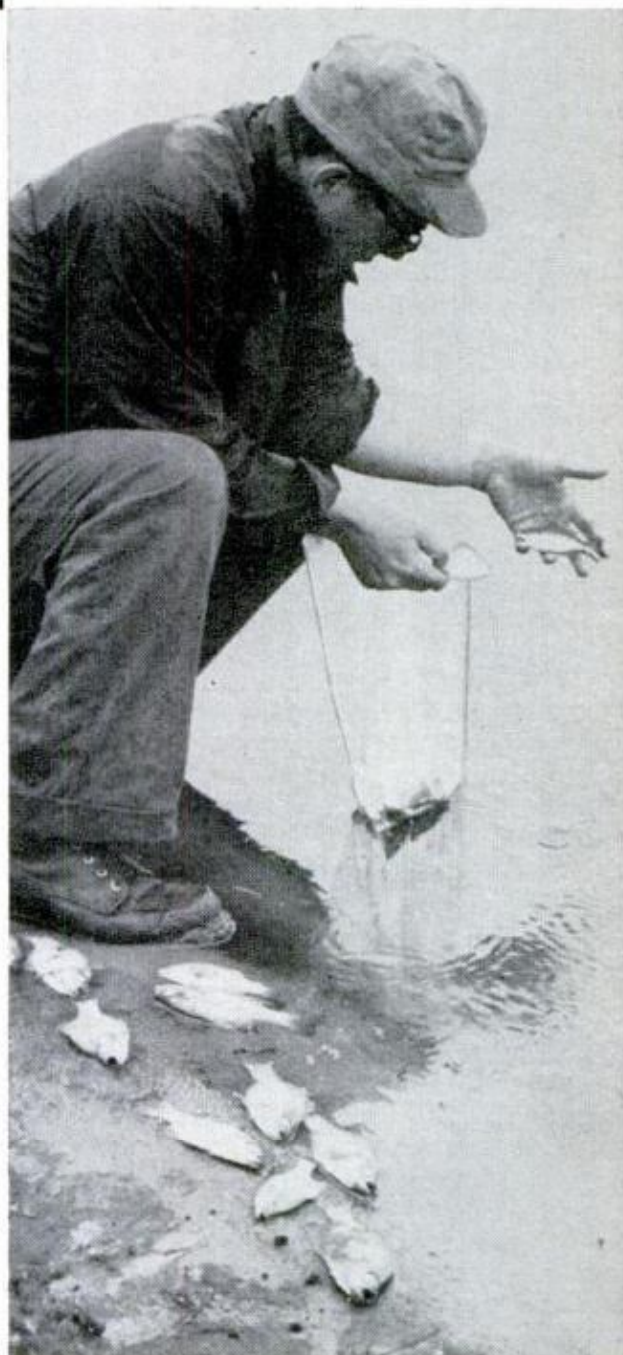

CATEGORY	YELLOW-SHAFTED FLICKERS	BLUE JAYS	BROWN THRASHERS	ROBINS	BLUEBIRDS	STARLINGS	HOUSE SPARROWS	COMMON GRACKLES	CARDINALS	FOX SQUIRRELS	RABBITS	TOTALS
RESIDENCES REPORTING: NUMBER	1	7	4	42	2	21	18	8	8	10	22	52
----- PER CENT	1.9	13.5	7.7	80.8	3.8	40.4	34.6	15.4	15.4	19.2	42.3	100
TOTAL NUMBER REPORTED	1	8	4	128	3	41	49	13	8	13	48	316
ESTIMATED TOTAL MORTALITY (375 RESIDENCES)	7	58	29	923	22	296	353	94	58	94	346	2280

**BIRD AND WILDLIFE** loss for one 1955 spraying in Sheldon was tabulated from questionnaires sent to town residents by the Illinois Natural History Survey

one other man were unofficial delegates on their way to Watseka, the county seat, to find out more about the spraying.

At Watseka they saw the county agent. According to Shorty, he refused to help them. When they threatened a court injunction to postpone the spray program, the agent told them that if they caused trouble their land could be quarantined; nothing could move in or out of their farms, and they could not dispose of crops.

The next day the planes came over.

Shorty watched them crisscross his farm. On the road that marked the edge of the spray area, one pilot failed to shut off in time and the dieldrin rained down on Shorty's cattle in the "safe" pasture. He moved the cattle the same day.

"Thank God I did," he says. "Within three days, all four of my cats were dead. My dog had been tethered outside; as soon as the planes left I went out and swept the ground clean all around the dog. It didn't help any. He died, too."

Were the pilots careful, that spring of 1960? "You'd have to say they were, at least at first," says Shorty. "They didn't spray on windy days and they seemed to be doing a good job, except for failing to shut off now and then. Later, though, when weather interfered and they were behind schedule, they sprayed on some pretty windy days. Also, two of the planes were leaking. They left a trail of insecticide even when the sprayers were turned off."

But it was the damage to wildlife that hurt Shorty in the pocketbook.

"In one ditch there were at least 150 muskrats before the spraying. Three days later I couldn't find a single track, and to this day there aren't 25 muskrats along there, so I don't bother to set out my traps. Usually, I make \$1200 a year from trapping, but in '60-'61 I didn't clear \$400.

"Not far from here there's a little stream, and a few days after the planes came, the water was white with dead minnows and crawdads. I didn't see a single quail

that year. The only thing that seemed to thrive was barn rats. In an average year I catch about 12, maybe 15, barn rats in my traps. In the winter of '60-'61 I caught almost 900. I suppose the barn rats were under cover and mostly ate grain that had been under cover, too. With all the cats gone the rats really multiplied."

Drive about five miles east from Shorty's farm, through Donovan, and you'll find the farm of young Jim Martin.

"When I heard they were going to spray," says Jim, "I went out to talk with the supervisor who was directing the planes. I asked him if the stuff was dangerous. He said no, that he could scoop up all of it that fell on my feed lot and feed it to my cows and it wouldn't hurt them. I asked him about my pond, and he said they'd make sure they didn't spray it. He did tell me that I should keep my cattle out of the pasture for 30 days."

When the planes came over, Jim was working in the garage, and stepped out to watch. "They just about scared the cattle out of the feed lot, but I suppose they couldn't help that. They goofed, though, and sprayed the feed lot four different times. They didn't even pay any

*(Please turn to page 184)*

**SOME BIRD SPECIES** have made a partial comeback in Sheldon; others seem to have disappeared for good



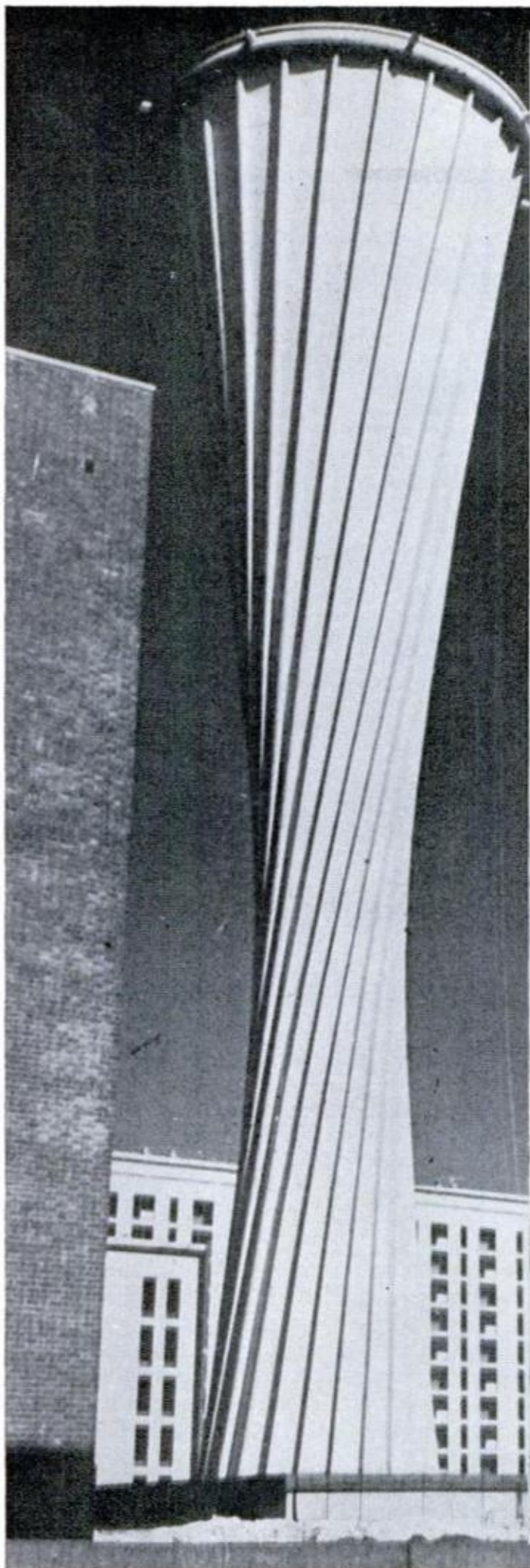

## High Water

Depend on the French for unusual designs in such prosaic things as water towers. The twisted-sculpture tower (left) is at Amiens; the "giant's golf tee" (below, top) is in Brittany; the horn-shaped tower is near Marseilles, and the "fruit basket on stilts" at Le Havre.



**WATER BATH** drenched the Valiant's brakes, but they dried quickly. Some owners mentioned water leaks, mostly in the car trunk where some water entered the test car, too



## ***Nimble Handling Delights, Scant Headroom Depresses Valiant Owners***

Marginal and boldface comments by Jim Whipple, *PM's* Auto Editor

**Valiant sales are up a healthy 50 percent this year and if even half of those who say they'd buy again do so, Valiant will prosper** →

**Valiant's response to steering control, when equipped with "quicker" ratio power, comes close to sports car standards** →

**V**ALIAN'T is a car that's busy winning new friends. Of all owners reporting, only 17.3 percent had previously owned Valiants.

But it's a sure bet that there will be more Valiants around in the years to come as 86.6 percent of all owners say they'll buy another.

Valiant still seems predominantly a family car. It is the only car for 60.3 percent of all owners, most of whom chose the sedan model.

Valiant's economy still is important to owners, but most owners like best its handling ease and riding comfort. Proof that they were not looking for economy to the detriment of all else is the fact that nearly half bought the extra cost 145-horsepower engine.

Of all owners reporting, most felt that fuel mileage was about what they had expected or better. Average consumption for stick shifters falls between 17 and 20 miles per gallon in city driving and from 19 to 26 m.p.g. on the open highways.

**THE SPARE** is covered by a hardboard sheet and trunk carpet. The nearly-flat gas filler pipe was source of complaints from several Valiant owners

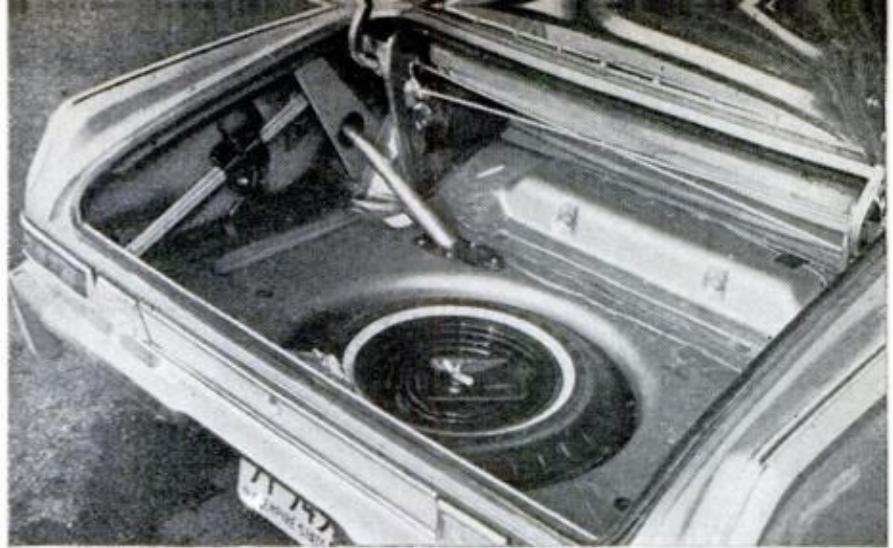

**IN CITY DRIVING**, the bulk of automatic-transmission owners got 17-18 m.p.g. Manual transmission owners did only a little better — about 17-20 m.p.g.

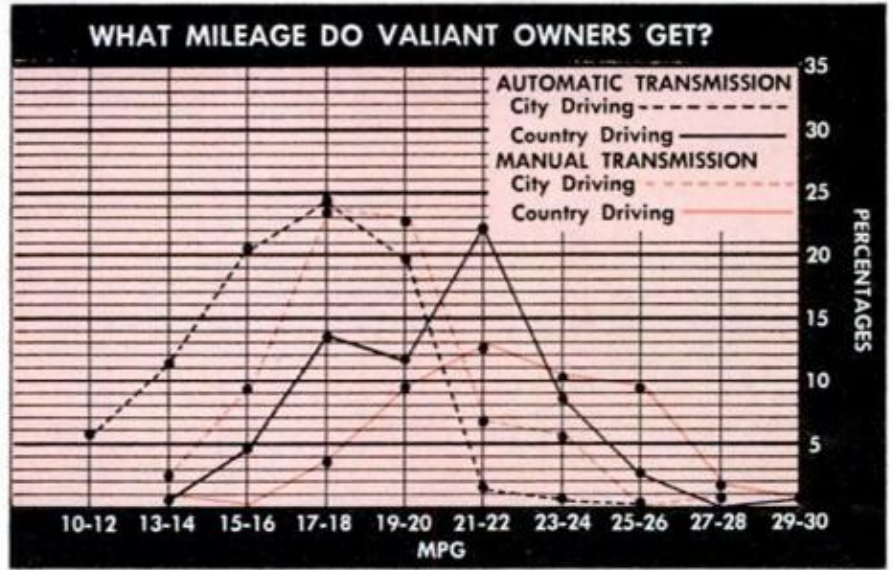

**AMONG THE MOST READABLE** of instrument clusters on domestic cars are Valiant's. Owners appreciate it. Some say the parking brake hits the left knee

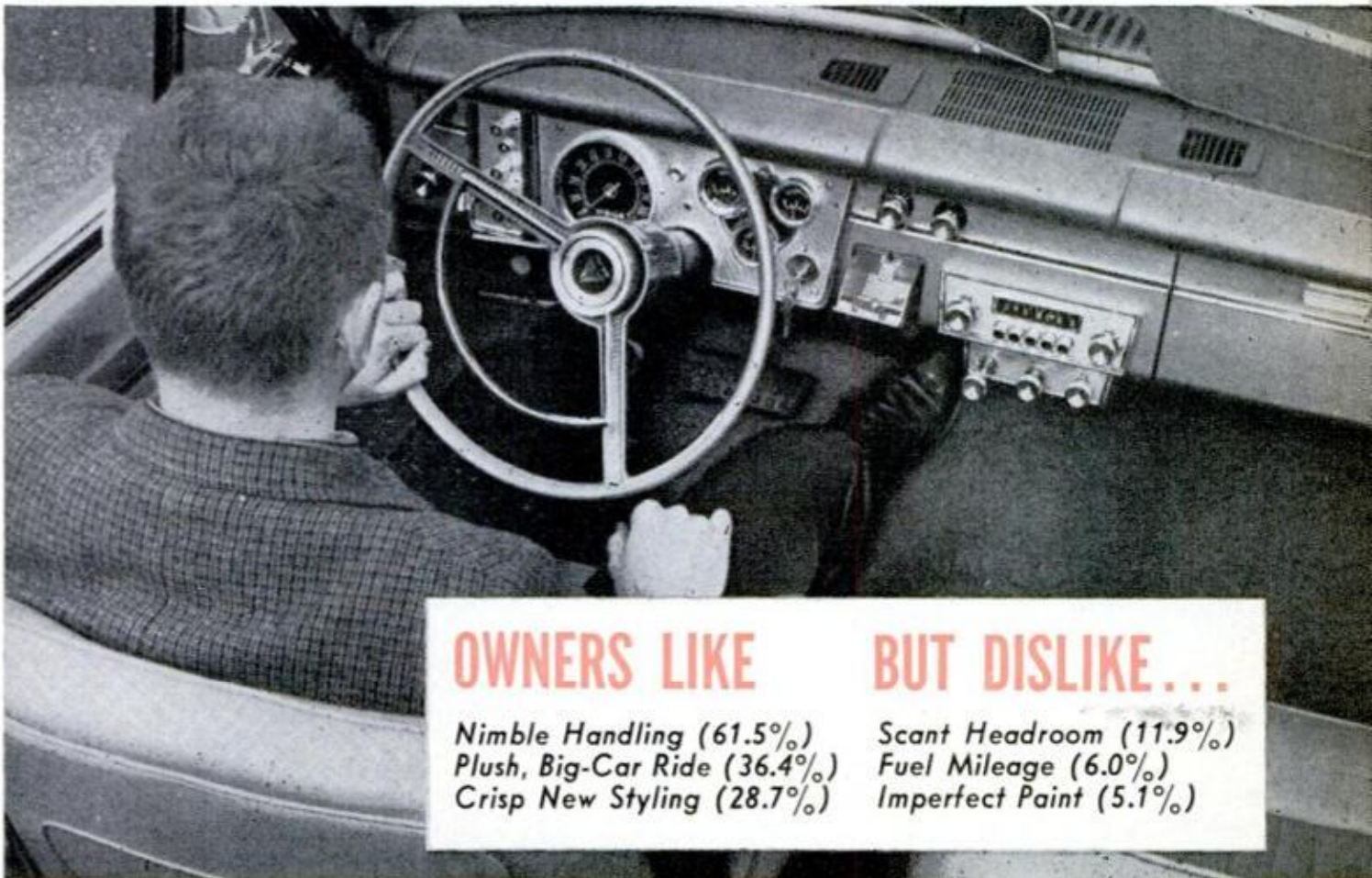

## OWNERS LIKE

*Nimble Handling (61.5%)  
Plush, Big-Car Ride (36.4%)  
Crisp New Styling (28.7%)*

## BUT DISLIKE...

*Scant Headroom (11.9%)  
Fuel Mileage (6.0%)  
Imperfect Paint (5.1%)*

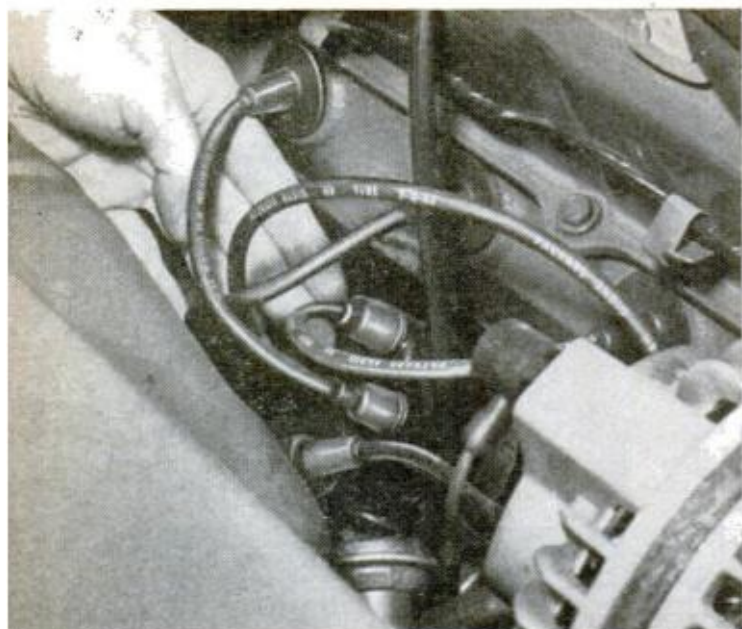

**REMOVING DISTRIBUTOR CAP** on the '63 Valiant can result in toasted fingers. Access to most engine components is good for a V8 under a compact hood

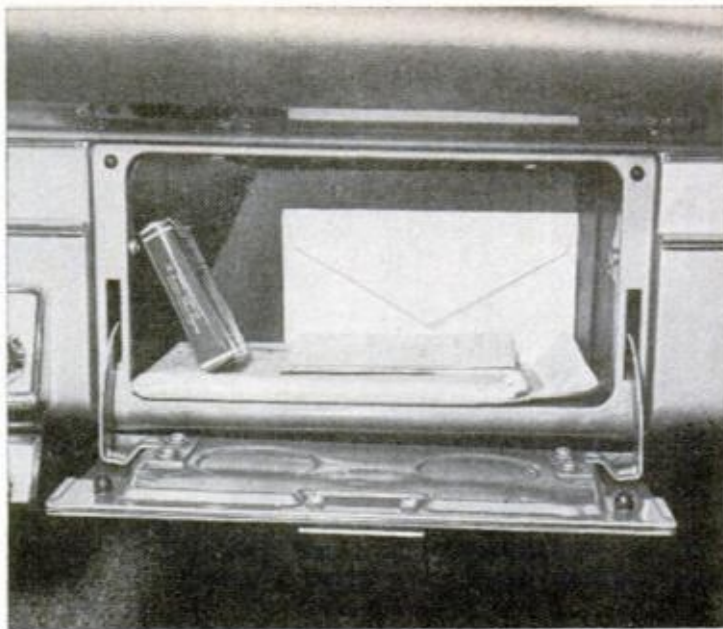

**COMPLAINTS ABOUT MINIATURE** glove compartment led the list of interior styling disappointments. Some owners complained about lack of latch or lock

**Both 170 cubic inch and 225 cubic inch Sixes are lumped together, → but more manual transmissions were paired with small engines with automatics, thus the more noticeable spread between manual and automatic mileages**

**This percentage shift toward the "Excellent" end of the scale indicates a significant increase in quality which was also borne → out by the condition of PM's test car**

**Family sedans currently made in the U.S. that handle as well as → Valiant can be counted on fingers of one hand**

**We'll go a long way → toward agreeing with the Buckeye butcher**

Most pushbutton drivers (comprising about two-thirds of all owners reporting), paid for their automatics with city mileages concentrated between 17 to 18 m.p.g. and long trip mileages between 17 to 20 m.p.g.

To backstop these figures PM put its test car—a Signet convertible with automatic, 145-horsepower optional 225 cubic inch engine and power steering—through a series of constant speed runs, compensated for speedometer error. The results follow:

- 23.58 miles per gallon at 30 m.p.h.
- 23.51 miles per gallon at 40 m.p.h.
- 21.23 miles per gallon at 50 m.p.h.
- 19.67 miles per gallon at 60 m.p.h.
- 16.98 miles per gallon at 70 m.p.h.

Over-all mileage, including about 60 percent of driving done at 65-70 on turnpikes, turned out to be 18.7 m.p.g.

All things considered, Valiant owners gave their cars a healthy vote of confidence with 69.5 percent rating them as Excellent, 25.7 Good, 3.9 Fair and only 0.9 Poor. This is an upbeat series of ratings compared to PM's Valiant Owners Report of last year (*PM*, June 1962, p. 74).

In that report Valiant scored 60.2 percent Excellent, 32.7 percent Good, 5.4 percent Fair and 1.7 percent Poor.

Now, let's turn to the owners themselves and see what they think of the '63 Valiant.

*Here are the five areas in which Valiant owners were most pleased, listed in the order of their frequency:*

"The best controlled car I ever had!"—California retiree.

"It is easy to handle and responds remarkably well for the start-and-stop driving that I do day in and day out."—New York insurance agent.

"It is easy to operate even without power steering or automatic transmission."—Washington, D.C. insurance man.

"Excellent handling over mountains, highways, etc. with sort of a sports car feel."—Virginia government worker.

"I like its comfortable ride and bucket seats."—Kentucky electronics technician.

"It rides better than other compacts I've ridden in."—Ohio meat cutter.

"Sitting position is more comfortable than a full-sized Plymouth."—Florida retiree.





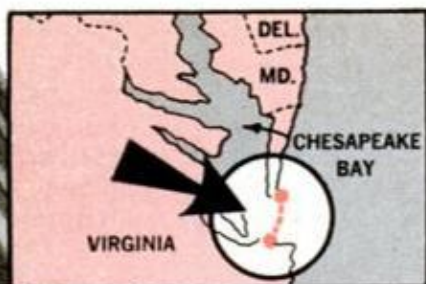

# The Porpoising Highway

*Over the water and under the bay—the newest tunnel-bridge is a 17½-mile wonder*

**H**OW MUCH is a motorist's time worth? To the Chesapeake Bay Bridge and Tunnel Commission, it is worth \$1,546,666.33 per minute.

At a cost of \$139,200,000, an engineering wonder is being completed that will cut the driving time on Virginia's north-south highway by an hour and a half. Across 17½ miles of open water, a combination bridge and tunnel will connect Wise Point and Chesapeake Beach, eliminating the seven-ship Chesapeake Bay ferry fleet that has been carrying cars and passengers across the water since 1880.

The two-lane crossing will consist of low-level trestles and two mile-long tunnels, over which ships can pass freely into Hampton Roads.

The tunnels, double-wall steel cores within an octagonal steel shell, are being built on land at Orange, Tex. Each 300-foot section is sealed, launched and towed by sea 1700 miles for completion at Norfolk, Va. The sections are then sunk in a deep trench, connected by divers and sealed with a concrete sleeve.

Between the tunnels, the road crosses four islands, rising 30 feet above the water, which were built of concrete-reinforced sand and rock in 30 to 40 feet of water.

The trestle consists of 75-foot long spans of prestressed concrete girders and deck, supported at each end by three hollow prestressed concrete piles.

Slated to open in the fall, the crossing has taken three years to build.

**DISAPPEARING** into the horizon, a completed portion of the trestle stands as a symbol of one of the engineering wonders of the world

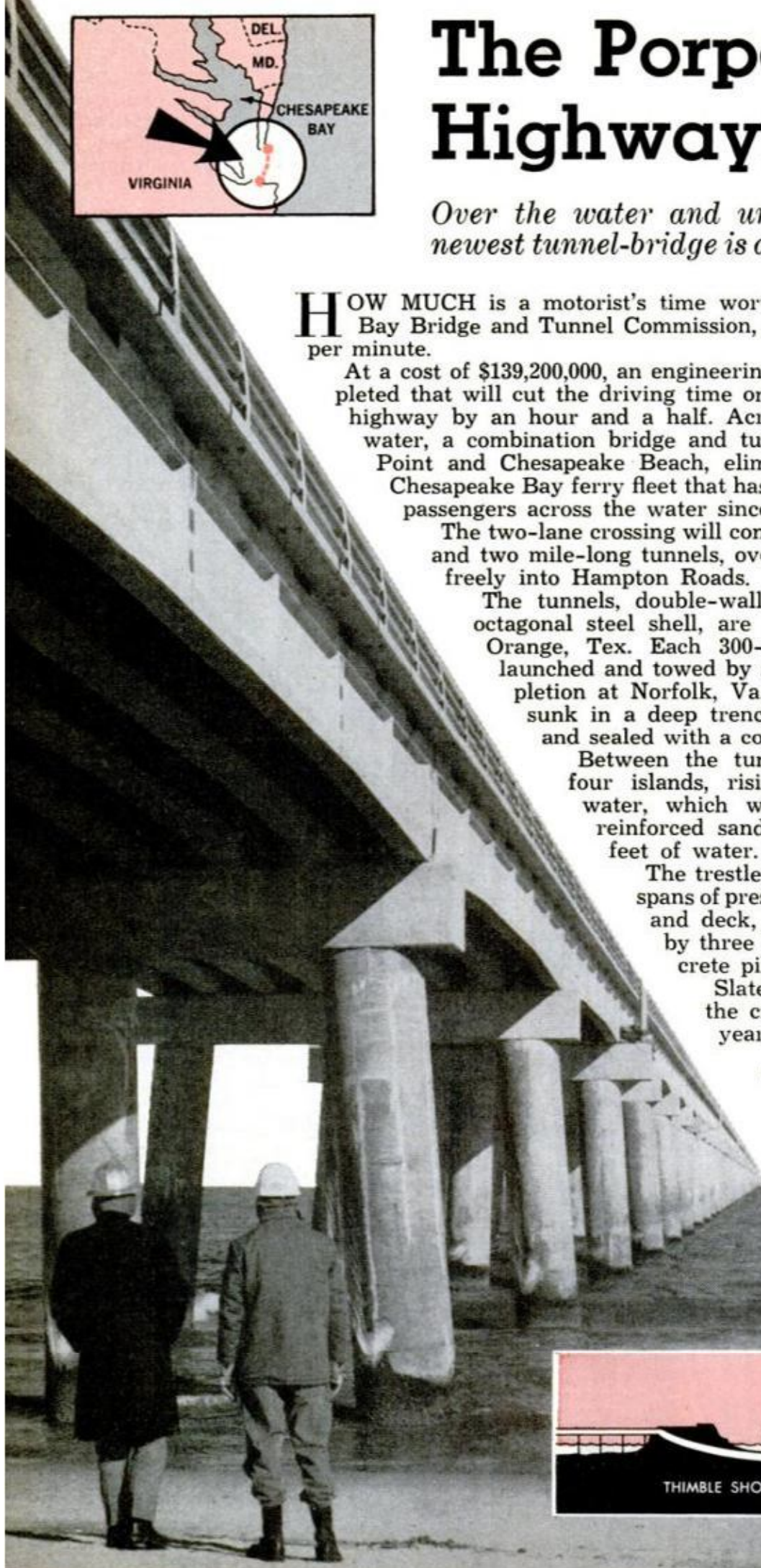

THIMBLE SHOAL TUNNEL — 5,738 FEET

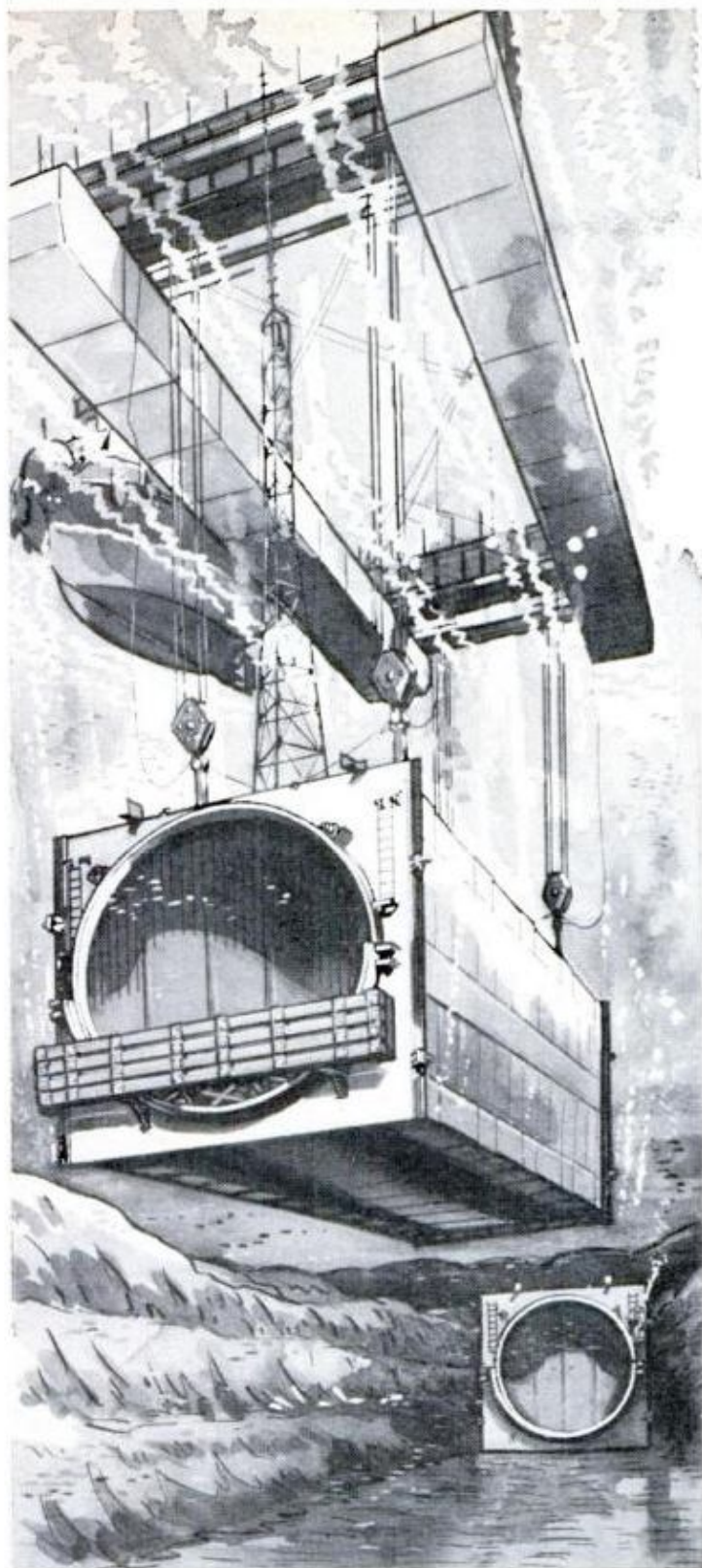

**TUNNEL SECTIONS, 300-foot long, are weighted by pouring tons of concrete between core and outer steel shell. Attached to a special derrick, they are lowered into position and connected by divers**



**ISLANDS TO CONNECT TUNNELS** were built in 30 to 40 feet of water by creating a 22-acre pile of sand and rock reinforced with concrete dikes. Center of each island is the entrance to the mile-long tunnel

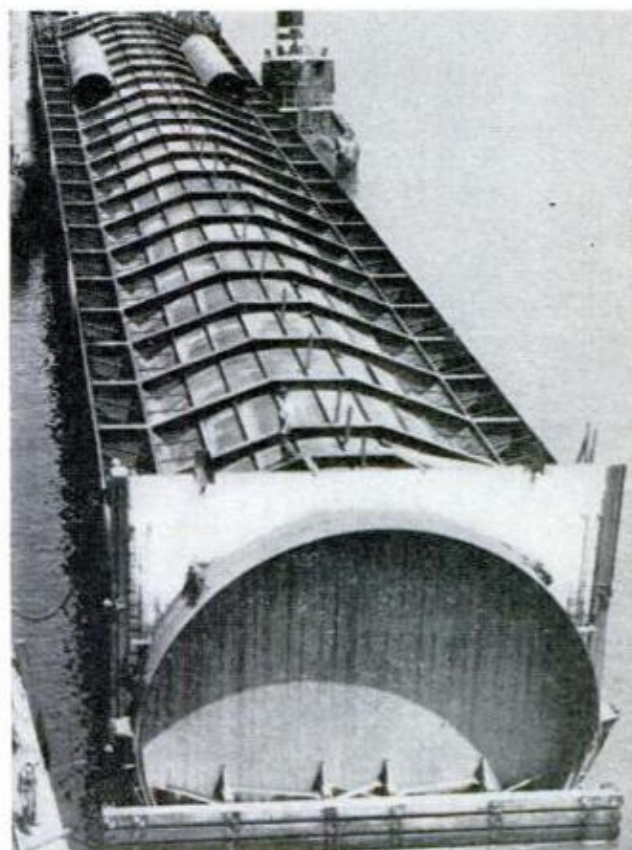

**FLOATING TUNNEL SECTION** is moved into position by tugs. When lowered into the trench on the bay bottom, the sealed ends are cut open and workmen install the ventilation, communication and power systems

**OVER-AND-UNDER HIGHWAY** of trestles and tunnels will cross open water of the Chesapeake Bay, allowing two mile-wide access openings for shipping traffic



BALTIMORE CHANNEL TUNNEL — 5,450 FEET

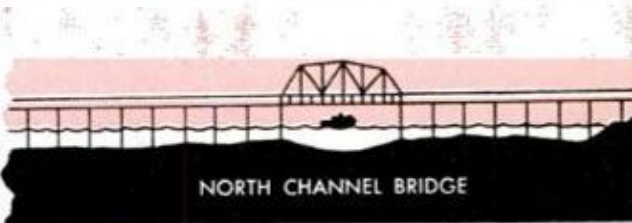

NORTH CHANNEL BRIDGE



## Commuter Scooter

Small enough to be wheeled through doorways, a three-wheel scooter can carry a commuter from his home to office or school and be parked alongside his desk.

Designed and built by two Stanford University graduate students for about \$500, it is powered by an air-cooled, two-cycle engine with a chain-and-belt transmission and centrifugal clutch.

The car is 29 inches wide, narrow enough for most doorways. It has two forward speeds, with top speed about 25 m.p.h. The two antennalike rods carry headlights, and the rods can also support a plastic rain cover, with zipper doors.

Parking is accomplished by tipping the scooter on its rear bumper.



## Word-Shooting Guns

Bristling like cannons, the "guns" mounted on the door of an Air Force transport are actually loudspeakers used to broadcast messages to enemy troops.

Part of psychological warfare, the messages are sent over the plane's air-to-ground public address system in low-level missions by the Tactical Air Command.

## Truck Loads Itself

A special rear frame on a  $\frac{3}{4}$ -ton, front-wheel-drive truck lets the driver take aboard pallet-mounted loads without leaving the cab. The hydraulically operated frame drops and lifts in response to dashboard controls. The pallet under the load serves as the truck's bed.

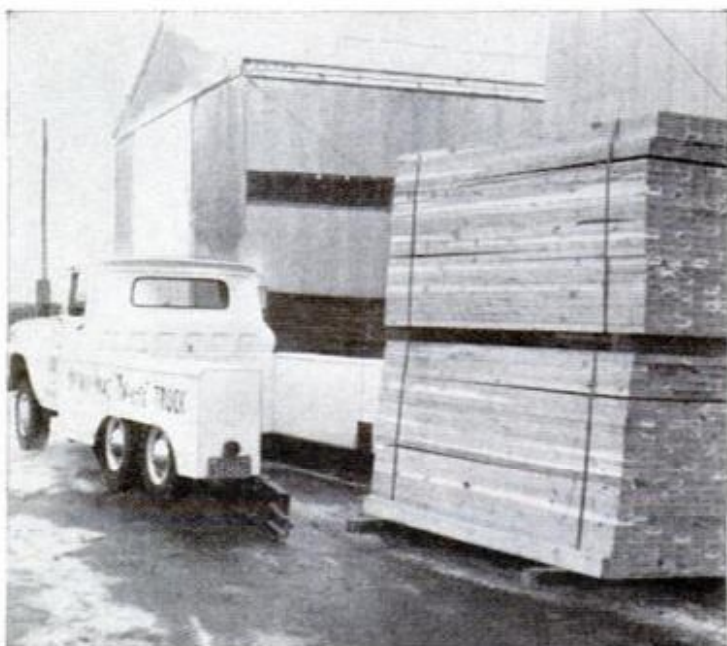



### Amphibian for Duck Hunters

Mechanized warfare has come to the duck blind. "Husky Duck," a two-man amphibian, can do anything a duck can do, except fly. Paddlelike treads on the six wide, squat tires propel the odd craft through water at four knots. On land the car-boat, developed by Warren Neumann of Berkeley, Calif., makes 18 m.p.h.



### Quick-Fix Tire Gun

High-speed repairs on tubeless tires are possible with a gun that fires a rubber plug into the hole. The cutaway demonstration tire allows a view of the plug's flared head on the inside. In most cases, removing the tire from the rim isn't necessary, according to Goodyear officials who have introduced the gun.

### Ground-Effect Machines Appear in Amusement Park

Riding on a cushion of low-pressure air, Disneyland's new Flying Saucers are giving visitors the feel of riding ground-effect machines. Made of fibreglas, the 100 to 150 pound saucers are guided simply by shifting body weight in the desired direction; they seem to slide downhill on air.

Air is provided by huge fans beneath the floor, which is covered by more than 17,000 air valves. These open only when the saucer is directly above; as it passes beyond range, the valves snap shut. Eight blowers, each driven by its own motor, keep 32 saucers aloft at once.



# TAKING THE **PANIC**

## OUT OF BRAKING

*You can't freeze on the brakes with this new system—it pumps the brakes for you*

**C**ONTROLLED PANIC stops on snow and ice? Sound impossible? As veteran drivers know, panic braking on slick surfaces guarantees an out-of-control skid—too often, a fatal skid. But PM has tested a unit for power-assisted braking systems that can change all the old concepts. And it can be attached to your car today.

Experienced drivers know enough brake pressure will lock the wheels. Since two or three tons of rolling steel can't be stopped that easily, the tires' grip on the road is broken and the skid starts. Nearly everyone knows the importance of pumping the brakes—applying and releasing them rapidly. But caught in a panic situa-

tion, few of us can keep from freezing on the pedal. Others, even if they don't freeze, can't pump them fast enough. But now, faster than you could do it yourself, Skidtrol pumps the brakes for you even if you're standing on the pedal. It's from Perma Research and Development, North Attleboro, Mass.

Skidtrol includes a couple of pounds of governor, switches, and valves. And it costs \$129.50 installed. Here's how it works:

When you brake and the wheels slow, a fly-ball governor reacts to their speed. Just before they lock, governor weights collapse and turn a rotating valve to equalize pressure on both sides of the

**EVEN THE WORST OF A SERIES** of snow tests with Skidtrol gave PM testers a smooth stop, well controlled and with a minimum of fishtailing by the car



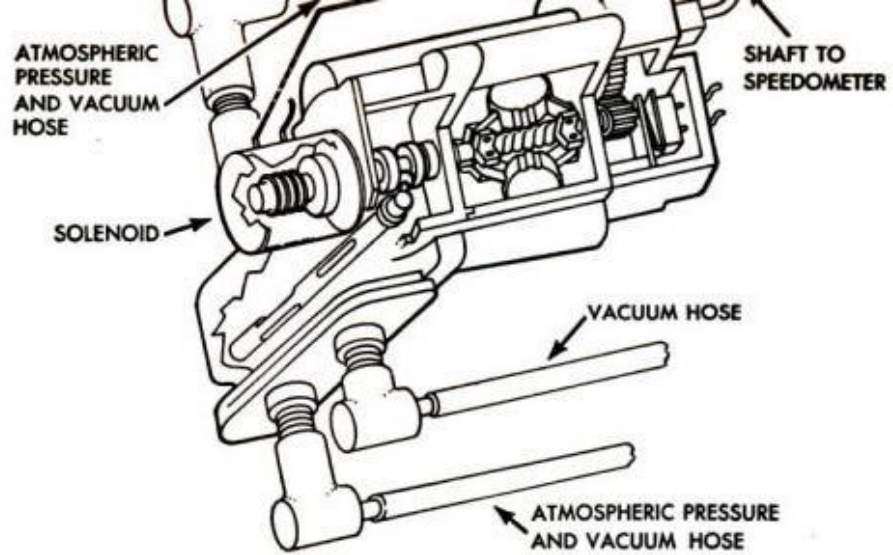

**GOVERNOR WEIGHTS** control position of a rotating valve that says whether or not pressure will be supplied to the power brake piston to apply the car's brakes

power unit piston so its spring releases the brakes. When speed throws the weights out again, the valve turns to supply vacuum to one side, over-riding the spring and reapplying the brakes. The cycle takes only milliseconds, Perma explains, and it continues even though a terrified driver may maintain every ounce of pedal pressure he can apply.

The governor responds to rear wheel speed through the driveshaft, but controls brakes on all four wheels. PM's test showed it operates so fast that the grab-and-release cycles amount almost to a chatter as you're braking. Brakes on our test car could never lock fully before re-

leasing again, so we kept good control of the car. Brake line pressure stayed just below the lock-up point. Straight-line stops were easy and the car headed about where we pointed it during repeated tests on slippery New England roads. It didn't matter whether all wheels lost traction or one pair was on dry pavement.

Perma's anti-skid system includes a Bendix power brake unit adapted for Skidtrol pressure and vacuum lines. Springs are selected to co-operate with the governor. If you're considering the system, don't get power brakes on your car because a power system is supplied with the anti-skid unit.

**WITH SKIDTROL UNIT LOCKED OUT** of operation, there was no chance for the driver to control the test car's skids on snow-slick New England side roads

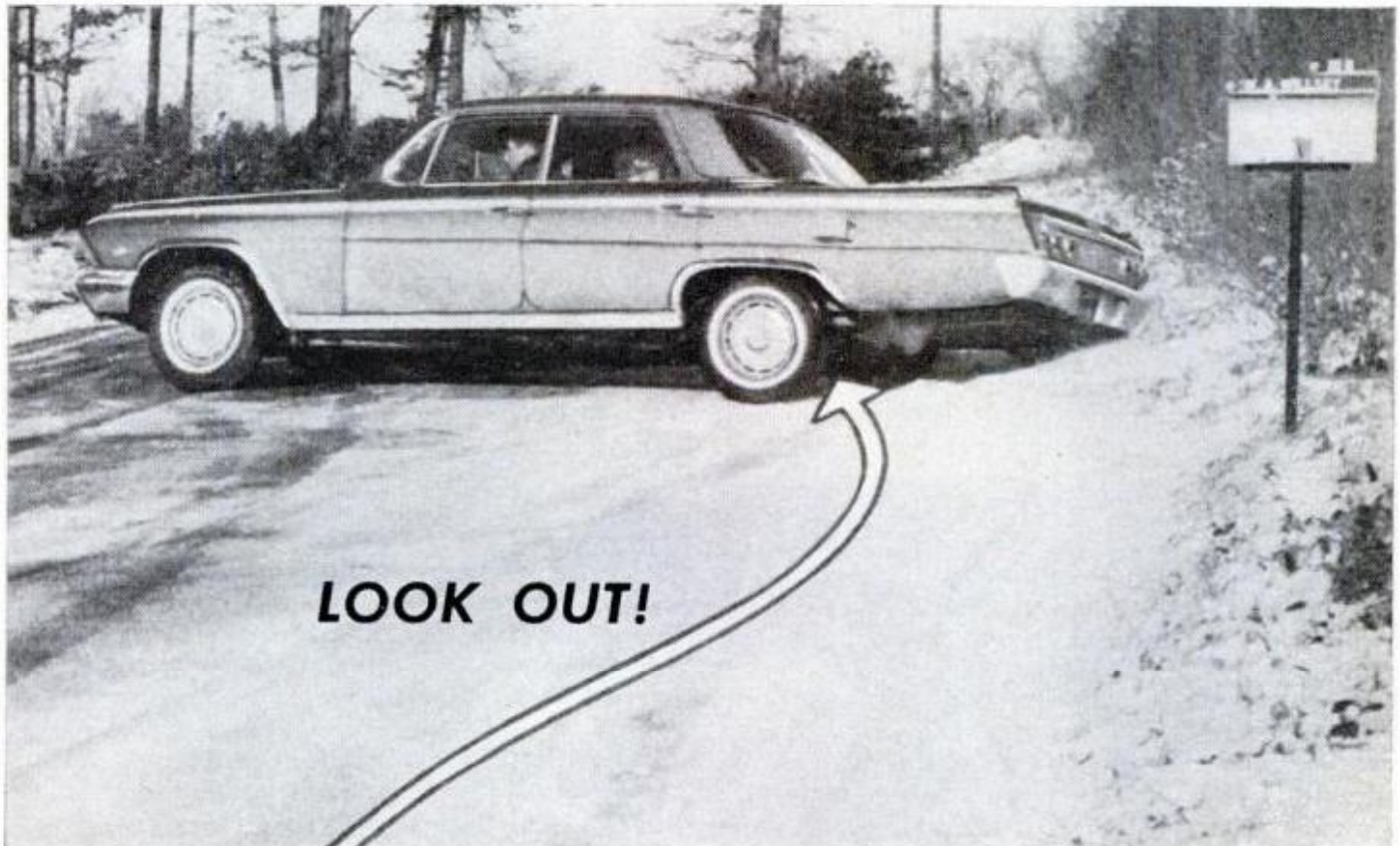

**LOOK OUT!**

# A Power: *Creeping Giant*

By S. David Pursglove

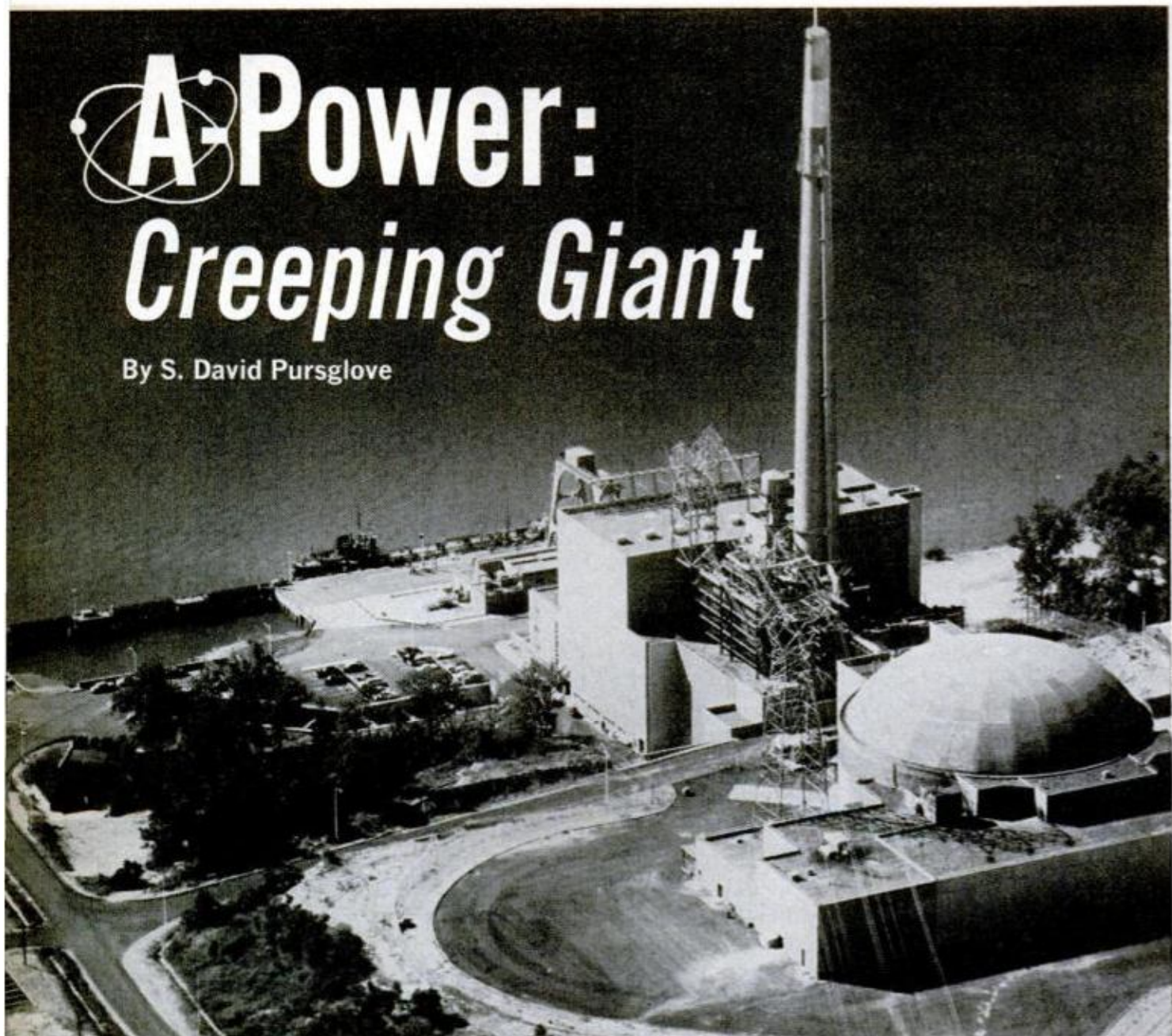

*We're still tiptoeing into the Nuclear Era, but powerful new reactors are "breeding" fresh life into our limping atom program*

**W**HATEVER HAPPENED to the Golden Age of atoms? Where is the cheap nuclear power to make Greenland green and run everything?

At the end of World War II, enthusiastic forecasts for the future of atomic power made it seem like the millenium was at hand. Predictions flowed like clam juice at a clambake. Homes would be lit, heated and air-conditioned, industries operated, transportation run—all by atoms.

None of these bright dreams have come true. Yet most are attainable. Not next year, however, or even in this century.

The trouble with the way out prophets was that they somehow made it sound as though all these things were going to happen overnight. Instead, progress was slow;

mistakes have been made, and wrong directions taken. We're not yet even on the threshold of the nuclear Promised Land.

One problem, says the AEC, is that we were building one kind of reactor when we should have started with a different type. So far, all the power reactors are "burner-converters." They consume fuel.

The reactor we should have started with is the "breeder," which produces—from non-fissionable material, including ordinary granitic rock—more fuel than it consumes. Fuel supplies for burner-converters would last only about as long as our dwindling supply of fossil fuels.

Who goofed? The politicians, partly, because they wanted atomic power soon and voted money to support reactors that





**ATOMIC POWER PLANT** built by Consolidated Edison at Indian Point, N.Y. has a rated capacity of 255,000 kilowatts. It feeds output into New York's power grid. The company now plans a million-kilowatt plant in the heart of New York City

**REACTOR CORE** for gas-cooled nuclear power station will be assembled piece by piece at Peach Bottom, Pennsylvania. Technicians rehearse assembly on half-size dummy of the new reactor at General Dynamics lab to insure proper sequence

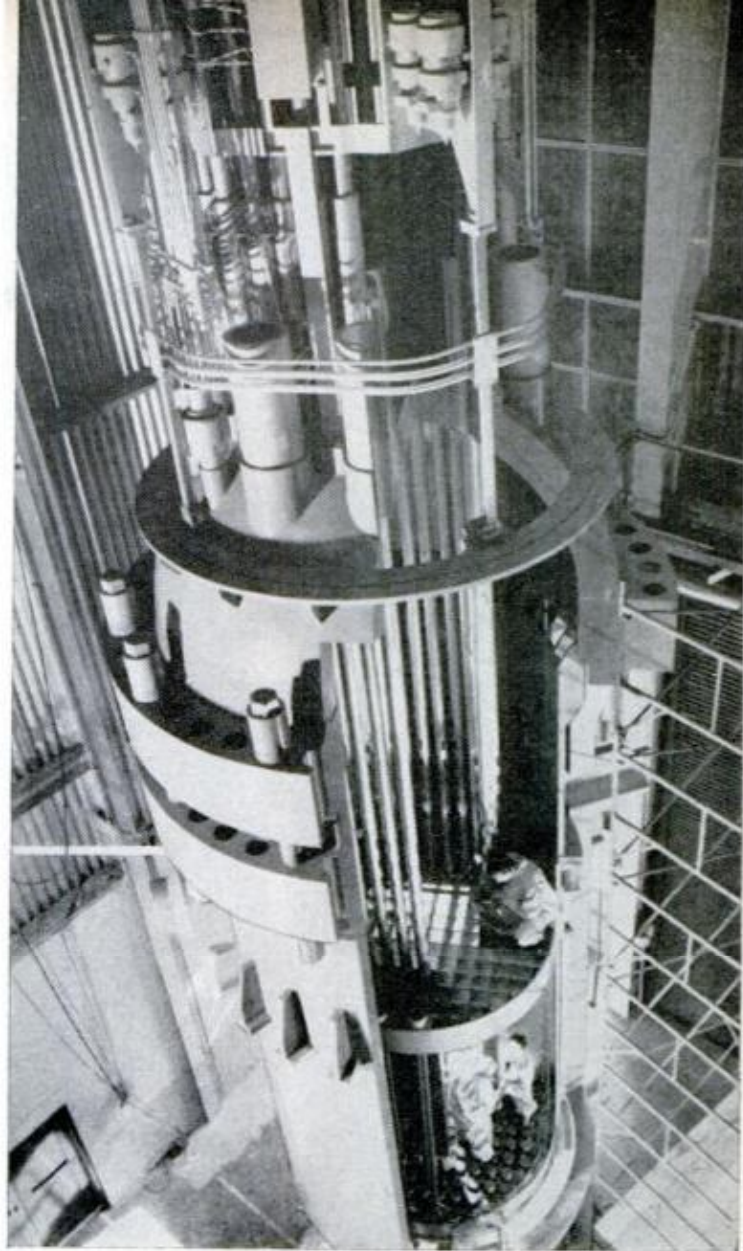

**PRESSURIZED WATER REACTOR** at Shippingport, Pa., (in full-scale mock-up) was first atom plant to produce civilian power

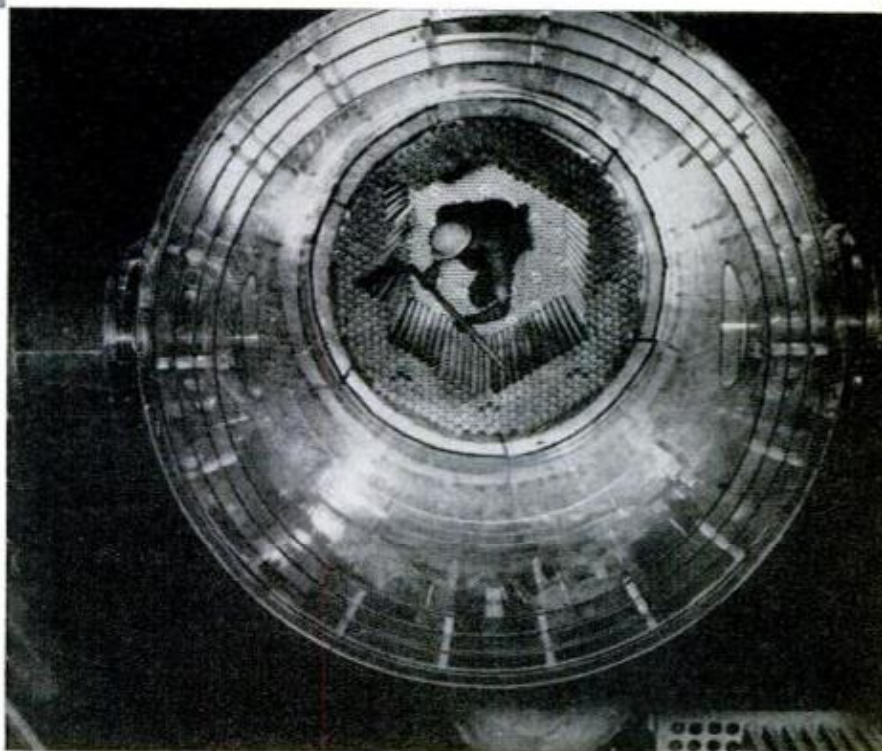

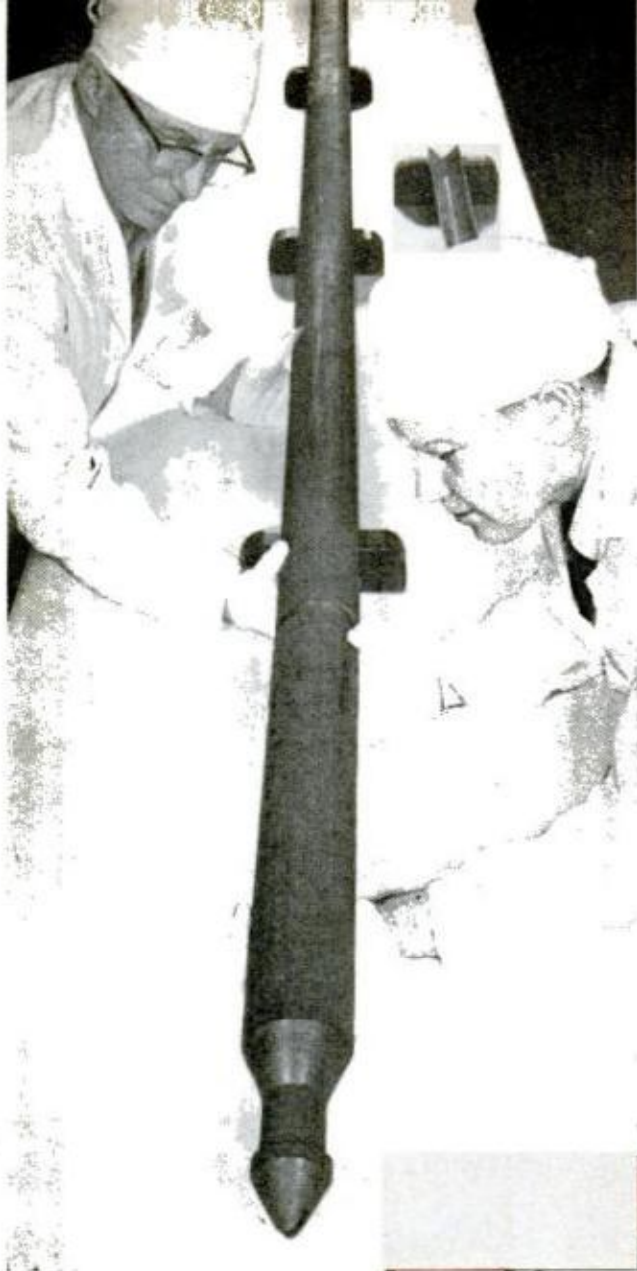

**FUEL ELEMENT** of graphite-clad uranium and thorium, for gas-cooled reactor developed by General Dynamics, is one of 800 of the 12-foot units the plant will need

**BREEDER REACTORS** are basically similar to burner reactors in operation. But breeders convert low-grade uranium into fissionable plutonium, thus perpetuate fuel supply

were closest to being operational. The scientists perhaps went along too easily. However, the error is less costly than might be imagined. The two types of reactors are basically similar. Valuable experience was gained in developing the burner-converter, and we're not starting from scratch on breeders. Some experimental prototypes have been in operation for years. The first to produce commercial electric power is now being completed near Detroit. This giant—the Enrico Fermi breeder power plant—will open some time this year.

The curious “magic” of the breeder process is due to the fact that only one rare form of natural uranium can be used as nuclear fuel. It is plentiful, but contains only 0.7 percent of fissionable U-235. The remainder is non-fissionable U-238.

Breeder reactors burn U-235 to produce heat just as “burner-converters” do. But they have the ability to transform the heretofore worthless U-238 into plutonium 239—a man made isotope which is fissionable and can be used as atomic fuel. In general, the process is simple. Inside a breeder core, two and a half neutrons are liberated when a U-235 nucleus is split. One slams into another U-235 nucleus to continue the chain reaction process. The others are absorbed by the nuclei of

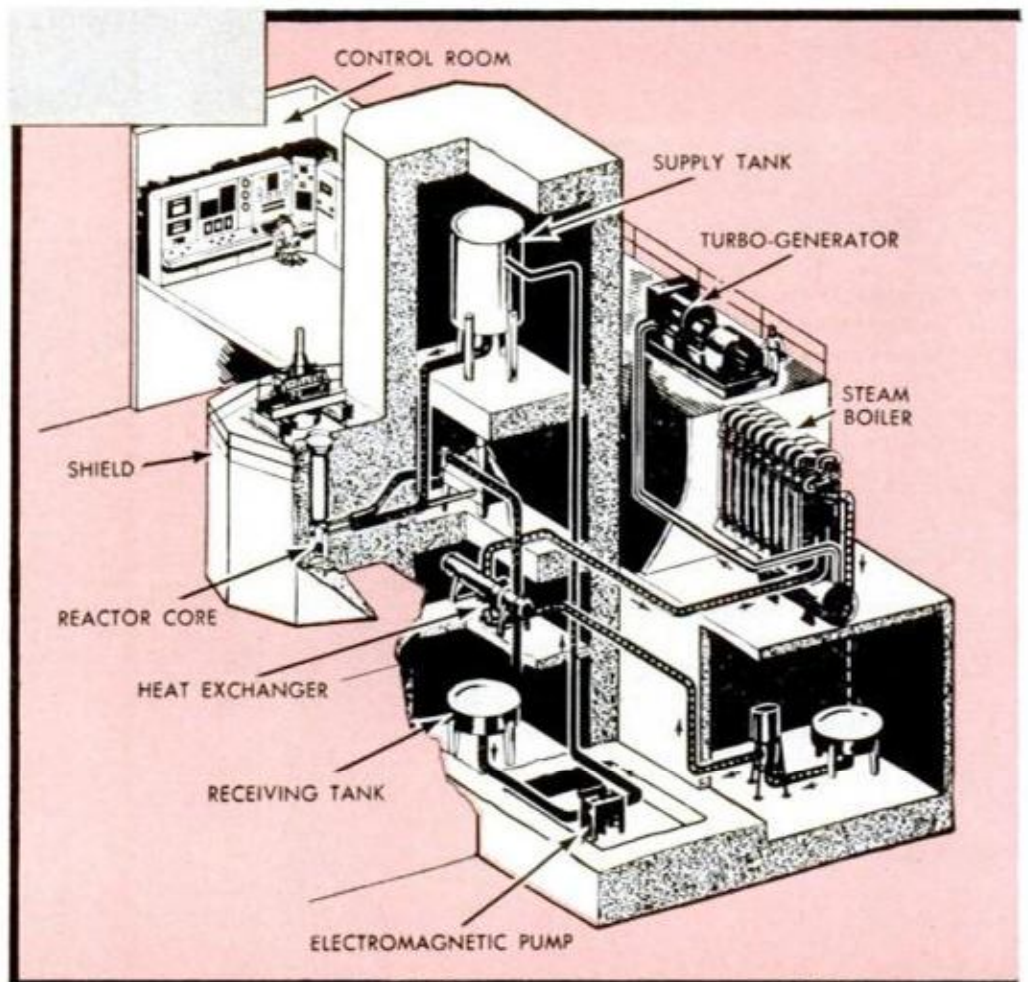

U-238 atoms which, under constant bombardment, slowly change into plutonium. When the transformation has been completed, the plutonium is removed and processed into usable fuel. Although all reactors are capable of this conversion process, the breeders, in a year of operation, will produce three or four percent more fissionable fuel than they use. It's like eating your cake and having more left than you started with.

In any atomic power plant, the reactor core replaces the furnace used in conventional plants. Splitting atoms in the core provide the heat. Water or molten metal circulates around the hot fuel and carries the heat out to a heat exchanger or boiler. Steam from the boiler turns turbines, which spin generators, which generate electricity.

Most burner-converters use ordinary water to moderate and cool them and transfer their heat to the steam generator.

In such water-cooled reactors, hydrogen nuclei slow down speeding neutrons from a velocity of about 30 million to 5000 miles per hour. This permits the neutrons to enter U-235 nuclei and split them. In breeder reactors the neutrons hit the U-235 nuclei at full speed. Fewer nuclei are fissioned, but those that are split release the very high energy neutrons needed to

reach the U-238 nucleus and convert it to plutonium. This type of breeder is called the fast breeder reactor.

Fast breeders use molten sodium for cooling and to transfer heat to the generators. Sodium does not affect the speed of the neutrons but it requires special pumps, piping and heat exchangers made of corrosion-resistant materials. This is one major stumbling block in the development of fast breeders.

One of the most curious breeders is the thermal reactor, or HRE (Homogeneous Reactor Experiment). Its fuel is a U-235 compound dissolved in water. Recently a visiting Russian scientist learned to his astonishment that this reactor needs no control rods. When the reaction becomes too fast, the core overheats and some of the liquid boils to steam. With moderating water gone the reaction slows down, the reactor cools and the steam condenses back into the core. Again the reaction speeds up and the cycle repeats, automatically controlling the atomic fires.

Another kind of thermal breeder uses solid fuel. Both types breed new fuel from the otherwise useless thorium, found in ordinary granite.

Beginning next year, probably half the reactors started with Federal help will be the breeder type. But the fact that breeder

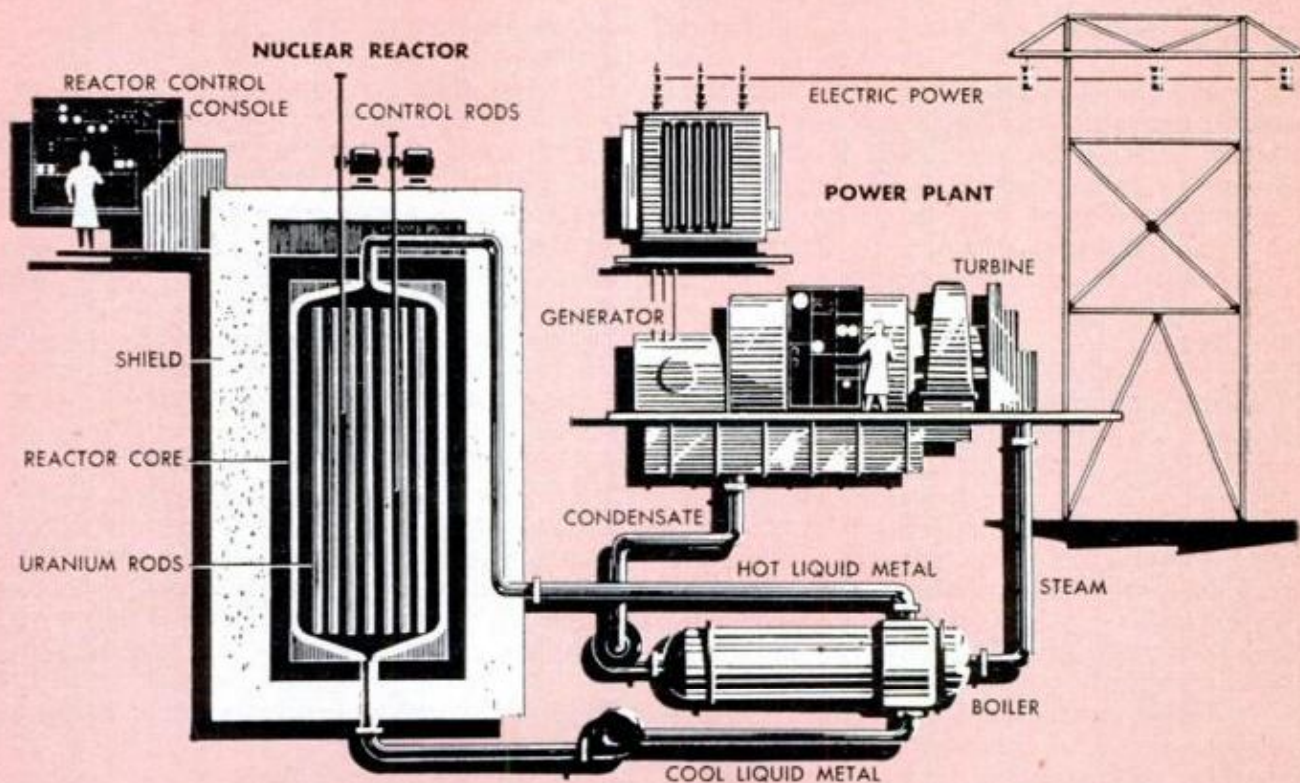

INSIDE ANY ATOM POWER PLANT reactor core replaces furnace of conventional plants. Heat makes steam for generators, which feed power into grid

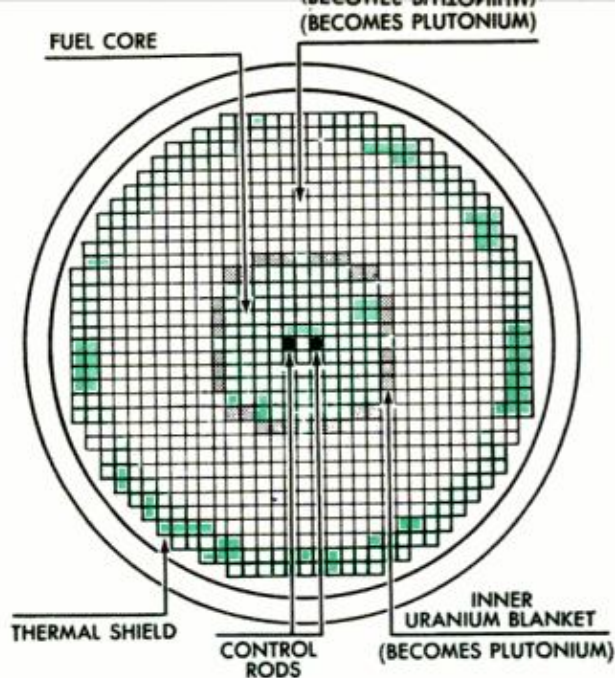

**NEW FUEL** is created in the breeder reactor core, by bombarding blanket of low-grade uranium. Resulting fissionable plutonium is processed as new fuel

reactors are the power plant of the future doesn't mean that the burner-converter types will be tossed into discard. The Government will help build a series of advanced burner-converters to broaden the base of the atomic power industry and give it operating experience.

A highly successful pressurized water reactor, Yankee Atomic, is currently setting the pattern for most commercial burner-converters. In pressurized reactors, the core and water moderator-cooler is enclosed in a thick-walled pressure vessel which prevents the water from turning to steam. The extremely hot liquid feeds through heavy pipes to a heat exchanger. Once there it is permitted to flash to steam in a violent burst of heat energy.

Pressurized reactors produce a higher grade of steam than an unpressurized "boiling water" core which is the easiest and cheapest type of reactor to build. But neither type produces temperatures high enough for truly efficient turbine operation. Result: supplementary superheaters (often oil-fired) are used to do the job.

New types of more efficient and economical burner-converter reactors are on the way, however. One, moderated by "heavy" water, will use less costly "natural" instead of "enriched" uranium fuel. New "spectral shift" reactors begin operating with heavy water but later shift to ordinary water. The reactor produces greater heat, burns fissionable fuels more efficiently and requires fewer control rods than most models. It is considered one of the most promising of the burner-converters

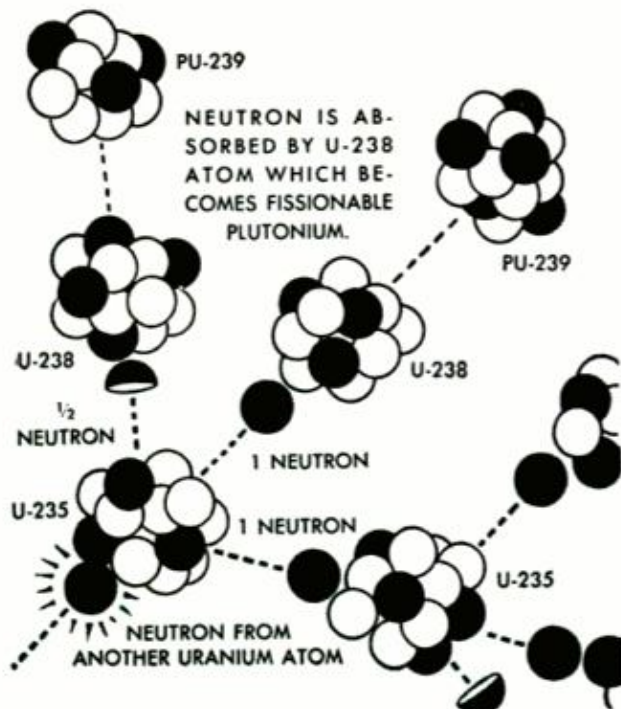

**IN BREEDERS**, splitting U-235 nuclei shoot neutrons into non-fissionable U-238, change it into fissionable Pu-239. Other neutrons continue chain reaction

by the AEC. Unusual new sodium-graphite reactors, using molten sodium for heat transfer and nuclear superheaters, can develop very high temperatures and high-grade steam. Another unique development is the gas-cooled reactor, which uses helium, hydrogen or carbon dioxide to cool it and transfer heat to the power generator. Its non-corrosive gases can produce 1000 degree steam for power generation more economically than a fossil fuel plant.

Where do we stand now on atomic power? We're on our way, at least. There are now 518 nuclear reactors in the world and the number is growing. Though most of them aren't aware of it, the citizens of New York, Pittsburgh, Chicago, New England, Michigan and Nebraska now light their homes partly with atomic power. By the end of 1962, the first of the nuclear reactors built to provide civilian power, Shippingport (Pa.), had generated almost a billion and a half kilowatt hours of electricity. Yankee Atomic Electric Co. in Rowe, Mass., and Dresden Nuclear Power Station in Morris, Ill., have between them churned out more than four billion kilowatt hours. Consolidated Edison's Indian Point plant now pours electricity into the New York power grid at the rate of 280,000 kilowatts per hour, though it must undergo costly shutdowns for test purposes under its AEC license.

Advancing know-how is bringing costs-per-kilowatt-hour down at such a fast clip that more and more private power pro-

(Please turn to page 178)

## Television by Laser

Television pictures were transmitted and received on a laser light beam in a laboratory demonstration by General Telephone & Electronics Corp. It was believed the first laser transmission of microwave signals carrying TV information. A laser system, in theory, can handle over 160 TV programs simultaneously.

## Opel's Two-Door Rekord

Opel, General Motors' German subsidiary, has announced a two-door version of the medium-size Rekord. Buyers choose from two conventional four-cylinder engines, a 90.8-cubic-incher rated at 62 horsepower and a slightly bored-out version rated at 67.

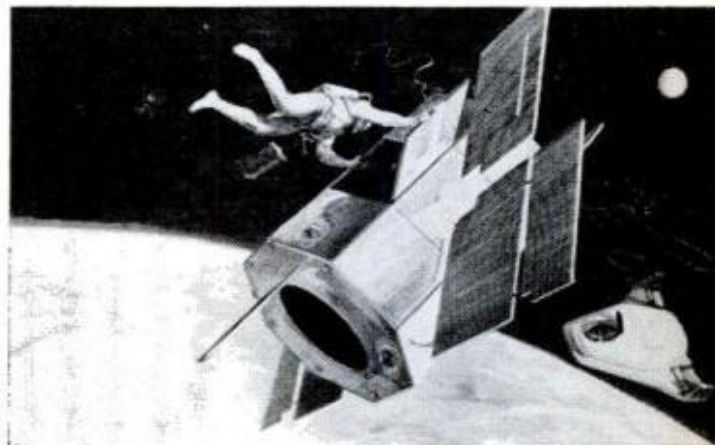
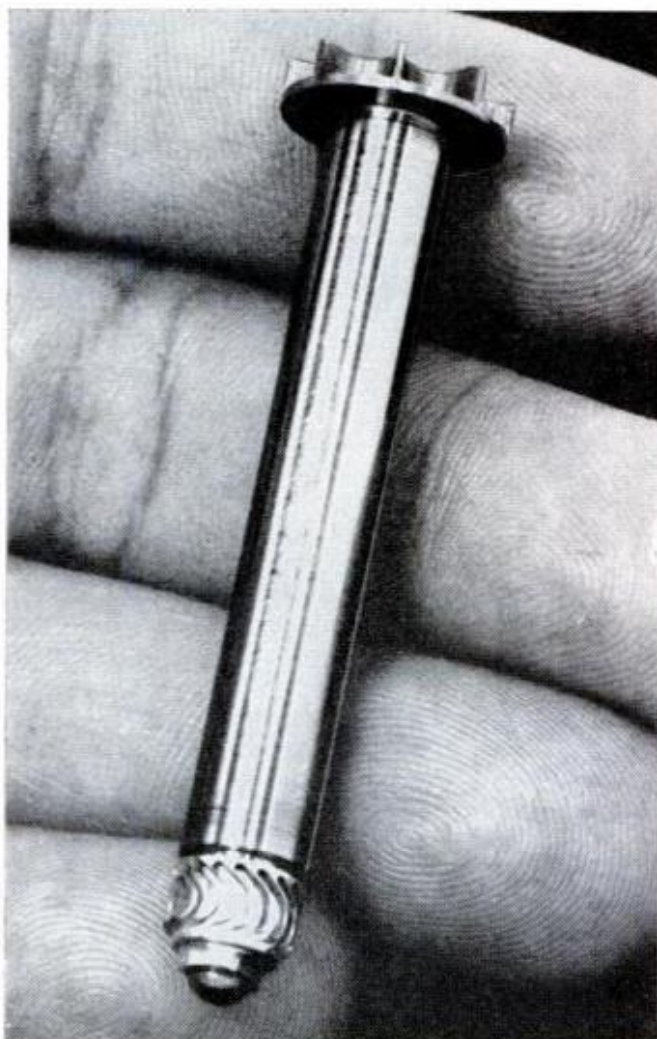

## Sky-High Repairs

Ability to repair satellites in orbit is the goal of a study being made by Grumman for NASA. Grumman is reviewing the design of its Orbiting Astronomical Observatory (shown as it will appear in orbit) to adapt it for orbit repair.

## Turbine Spins on Gas Cushion

Helium gas lubrication has replaced the roller bearings in a tiny helium expansion turbine, allowing it to turn at 6000 r.p.m. without appreciable wear. Used in a laboratory's helium liquifier, the gas-cushioned turbine eliminates the dangers of liquid hydrogen coolant.

# Backpacks and Frames

*For portaging, hiking or mountain climbing? Know which of packs is best—and know how to select the best quality*

By Patrick K. Snook



**OVERSIZED KNAPSACK** (above) is ideal for portages and short hauls. The Himalayan K-2 (left) is a large "L" frame, good all-around pack for long treks

**O**N A WINTER CLIMB up Noonmark Mountain in New York State's Adirondacks, one member of a party of five was foundering under the weight and bulk of a 50-pound pack. Where the going was steep, requiring a concentration of weight forward on the toes of his snowshoes, the pack would pull him off balance and send him tumbling down the slope, hopelessly entangled in snowshoes and pack.

He was simply using the wrong pack. The others carried food for the day and all necessary emergency equipment in small, compact rucksacks adaptable to strenuous vertical climbing.

No single pack can be considered ideal for all purposes. When buying a backpack or frame, one question should be in your mind: What are you going to use it for?

Although there is some confusion and overlap in the nomenclature of packs, even among the experts, there are only three basic types of pack on the market today: the knapsack, the framed rucksack and the rigid frame.

The knapsack is little more than a rect-

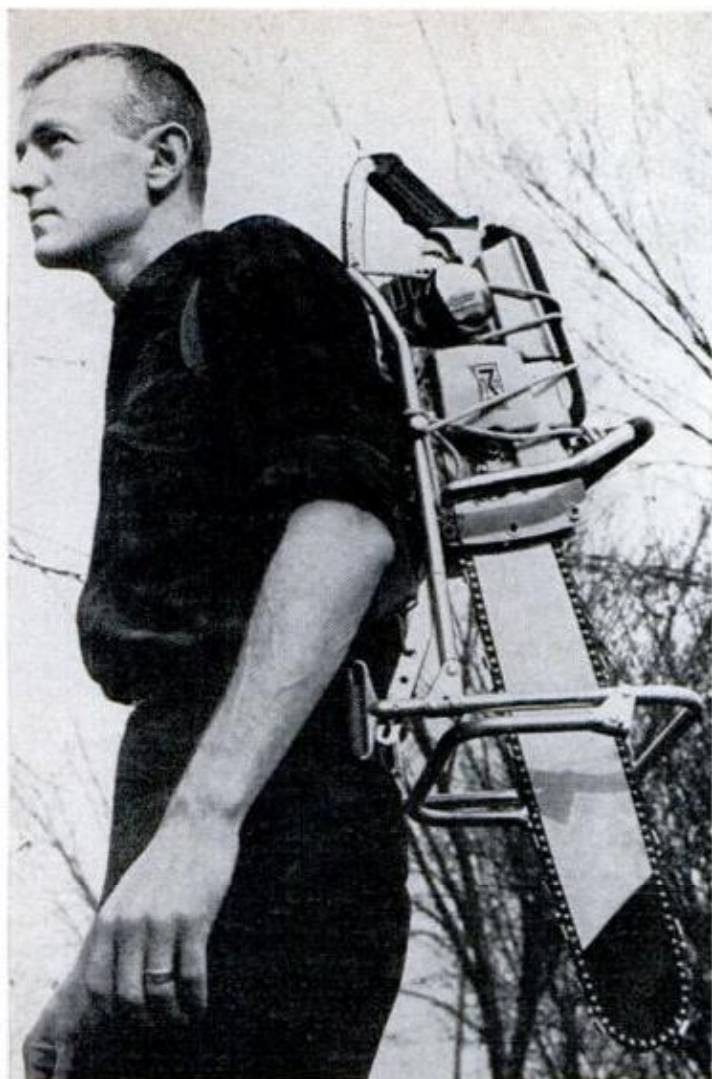

**RIGID ALUMINUM L-FRAME** can carry camping gear, also can be transformed to a carry-all for chain saw, gasoline cans, anything that can be lashed to frame

angular canvas bag fitted with shoulder straps. The traditional Boy Scout pack is a typical example of the knapsack, as is the Duluth or Porier, although these larger versions are usually referred to as pack-sacks. Knapsacks have the advantage of being lightweight and inexpensive. While this type of pack places the load's center of gravity above the bearer's hips without making him lean forward, it has a tendency to sag down and pull away from the shoulders. It is uncomfortable with heavy loads, or where distance is involved, and the lack of air circulation between pack and back makes it chaff in hot weather.

The large knapsacks, with their broad rectangular shape and capacity for bulky gear, are excellent if you're traveling by canoe, toboggan or dog sled. You can carry a tremendous amount on portages or short distances, but for a long hike even a powerful man would be weary from the pull on the shoulder straps.

The rucksack, or Norwegian "Meis," differs from the knapsack in that it employs an A-shape metal frame to stabilize



**MAJOR DIFFICULTY** of the Norwegian "Meis" is the downward pull on the shoulders. Bearer must lean forward to carry this combination A-frame-sack

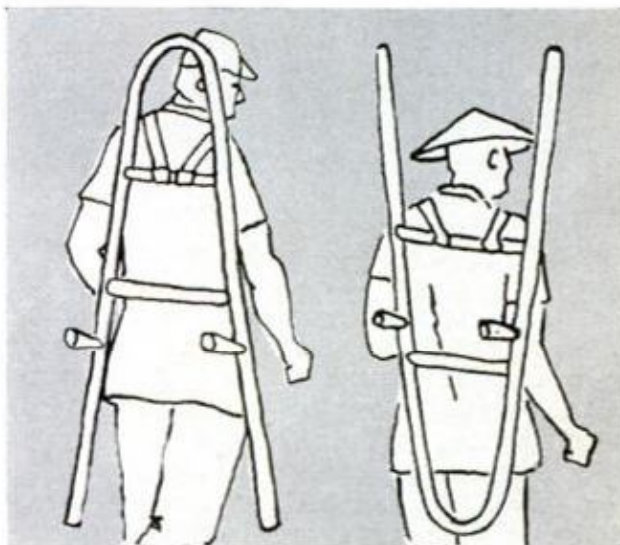

**THE RIGID FRAME**, shown here as an A frame and inverted A frame, has been traced back to the earliest days of Rome and China. It has changed little

it. It also has a wide strap riding on the small of the back to support part of the load and allow air circulation. A pear-shaped bag that rides low on the back, the Meis gives the bearer maximum control of the load, a critical factor for the skier or climber.

Designed for rugged terrain and available in a variety of sizes, the rounded shape and low profile make this pack ideal in thick underbrush. A number of outside pockets eliminates the irritation and difficulty of digging for items in the main bag. Generally there is a small pocket on each side, a large one in the middle of the back and a zippered pouch just inside the flap.

This pack is ideal for mountaineering, and if the bearer does not mind leaning forward to offset a backward pull, it is good for general long-distance hiking.

The rigid-frame design comes the closest to being an all-purpose pack. The pack frame (or board) provides a platform to which the load can be secured, and keeps the load away from the bearer's back.



**INSIDE SEAMS** should be overlapped and double-stitched (arrows). Strap connections should be leather reinforced, and wear areas all multiple-stitched

The rectangular frame, made of wood or lightweight metal tubing, allows the load to be set up in thin profile, keeping the weight close to the back and minimizing the pull on the shoulder straps. A bottom strap across the hips helps carry part of the load. A large model has the frame projecting well over the bearer's head, making it easier to carry a large load by concentrating the bulk of the weight above the shoulders, the ideal position. Since it is a flat platform, the rigid frame will accommodate any size load.

A refinement on this rigid frame is the "L" frame, which adds a platform at the bottom to act as a base for the load and to keep it from slipping down.

Adding to their versatility, many of the frames have detachable pack bags, so you can vary your loads, carrying bulky items like sleeping bags and tents below the bag. This also serves to place the heavier items high on the shoulders.

As in any item of clothing that is going to receive rugged outdoor wear, a pack bag must be judged on the material and craftsmanship that has gone into it. It should be made of heavy-duty canvas. Fold the flap double and roll it between thumb and forefinger to feel the weight of the material while making comparisons between various packs.

A good pack has shoulder straps at least one and one half inches wide. Look for double "box" stitching with heavy thread where straps attach to the top of the pack. A large pack should be reinforced here with leather backing. Leather straps should be stiff and sewn as well as riveted.

Fabric straps should be metal tipped to prevent fraying.

The flap should be long enough to cover completely a rolled sleeping bag placed on top of the filled sack. Exposed edges that are merely turned under and hemmed are signs of poor quality. They should be beaded with fabric tape, leather or vinyl. Main seams on the outside should be beaded. Inside seams should be double-stitched. Small bags should have rings sewn along the side for tying down a sleeping bag or bed roll. Exterior pockets on framed rucksacks should be of box construction. Zippers should be heavy duty with large pulls.

The hip strap should be heavy, two inches wide, and adjustable for stretch.

Evaluate a pack frame on both design and construction. It should be lightweight, but not flimsy. Tubular metal is superior to wood, because it takes a greater beating, and can be contoured to fit your back more comfortably.

To avoid tangling with brush and low branches, the top of the frame should be one continuous bow.

Any jointing of the soft aluminum or alloy tubing should be done with large reinforced flathead rivets or bolts. Nuts should have integral fiber lockwashers to prevent their working loose. Cast fitting should be rugged and well finished.

A final consideration is the matter of weight. Contrary to what you've heard, 60 pounds is not a normal light load. A good average load is 35 pounds, and the best pack in the world will be useless to the bearer who overloads. ★ ★ ★



**JOINTS** of soft aluminum frames (right) should be fastened with large reinforced flathead rivets to prevent tearing of the metal under heavy strain

**OUTSIDE POCKETS** (below, left) should be of the box type for greater carrying capacity. Seams should be beaded, and zippers protected by a weather cover

**PLATFORMS** on the "L" frame (bottom, left) should fold for easier storage. Cross strap for the small of the back should be wide and adjustable for stretch

**STRAPS** should be attached to the pack bag with heavy "box" stitching (below, right) and reinforced with leather to prevent any tearing of the material

**LARGE PACKS** designed for extremely heavy loads should be equipped with a snap fastener (bottom, right) on one of the straps to facilitate easy removal

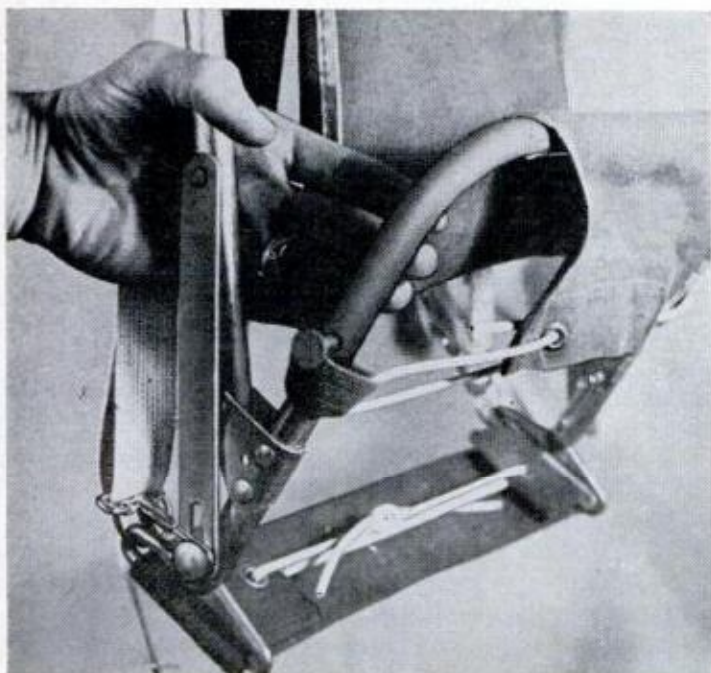
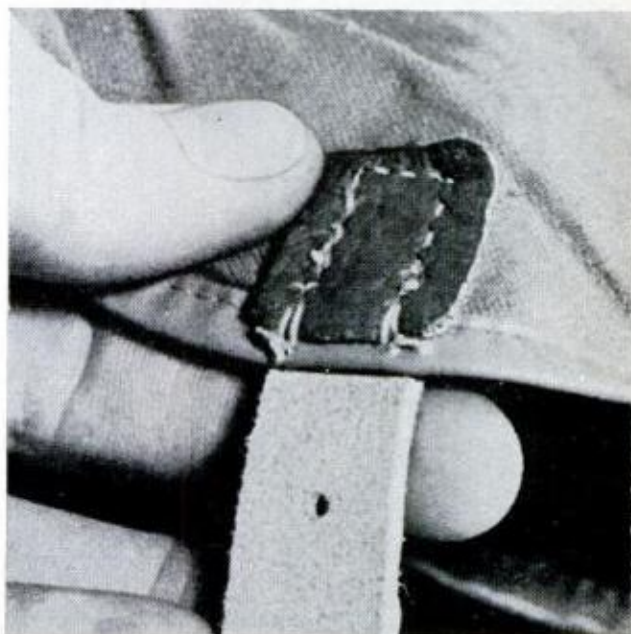
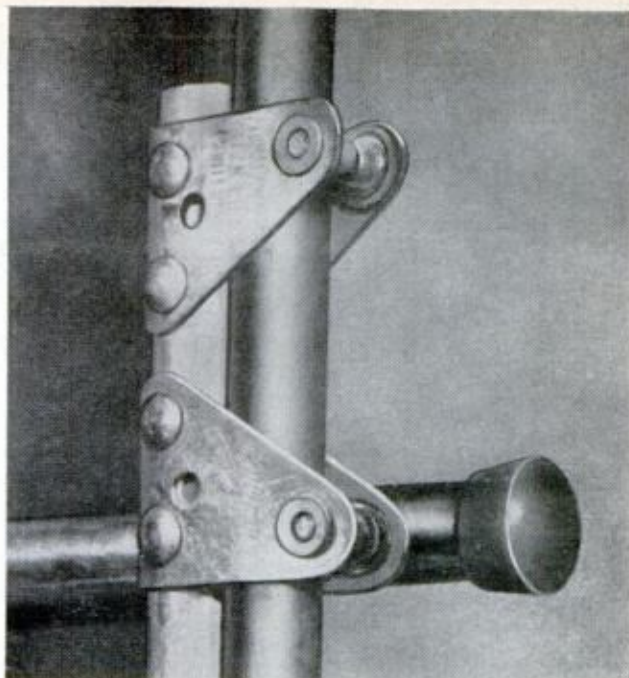



# Swirl-Chamber Engine Runs on What's Handy

By Ken Warner

*No test-stand pipe dream, this engine is hard at work today. It may point the way to family cars that burn anything from kerosene to high-octane*

**O**NE OF THE most important engines going is a hulking 1500 pounds of cast iron. It delivers 140 brake horses at only 2600 r.p.m. and powers an Army truck. The importance becomes obvious when you find it burns nearly any petrochemical fuel all the way from military gasoline to jet fuel or kerosene.

The bugs are all out. Performance is proven. The engine is in full production at Continental Motors—and Studebaker, every working day, drops 20 to 25 into 2½-ton GI trucks. And it's a working fool, a big Six with seven mains and 427 cubic inches of displacement. Main bearings, for example, are 3⅝ inches in diameter and have the beef to go with their size.

Ever since World War II, the Army has been looking for a reliable multi-fuel engine, with good military reason. Whether on a beach head or racing across a desert,

multi-fuel vehicles will run on whatever the driver can pour into the tank. During national shortages, they'll burn whatever refineries produce. Yet in normal times they'll return to the most efficient fuel and do the most work for the least dollars.

Continental's slide-rule team got this magic result by disregarding tradition. They chose the route other compression-ignition engineers have avoided. Since the first Diesel, the principle has been to spray low-octane fuel into an air charge so hot (from compression) that the fuel bursts into flame, driving the piston down. Regardless of changing chamber shape or spray patterns, the motto was always "Burn it fast."

Not so with the multi-fueler. Continental's engineers ignored old ideas. Their Hypercycle combustion system's success comes with **smooth, relatively prolonged**



**CYLINDER HEAD** cutaway and mold for intake manifold show how charge of air is swirled into cylinder and the combustion chamber

**MOLDS FOR** intake and exhaust manifolds and fuel injector are next to piston to demonstrate relative positions in the multi-fuel engine

**COMBUSTION CHAMBER** of the LDS-427 is within piston head. Y-shaped oil gallery allows cooling of chamber walls to avoid cracking fuels

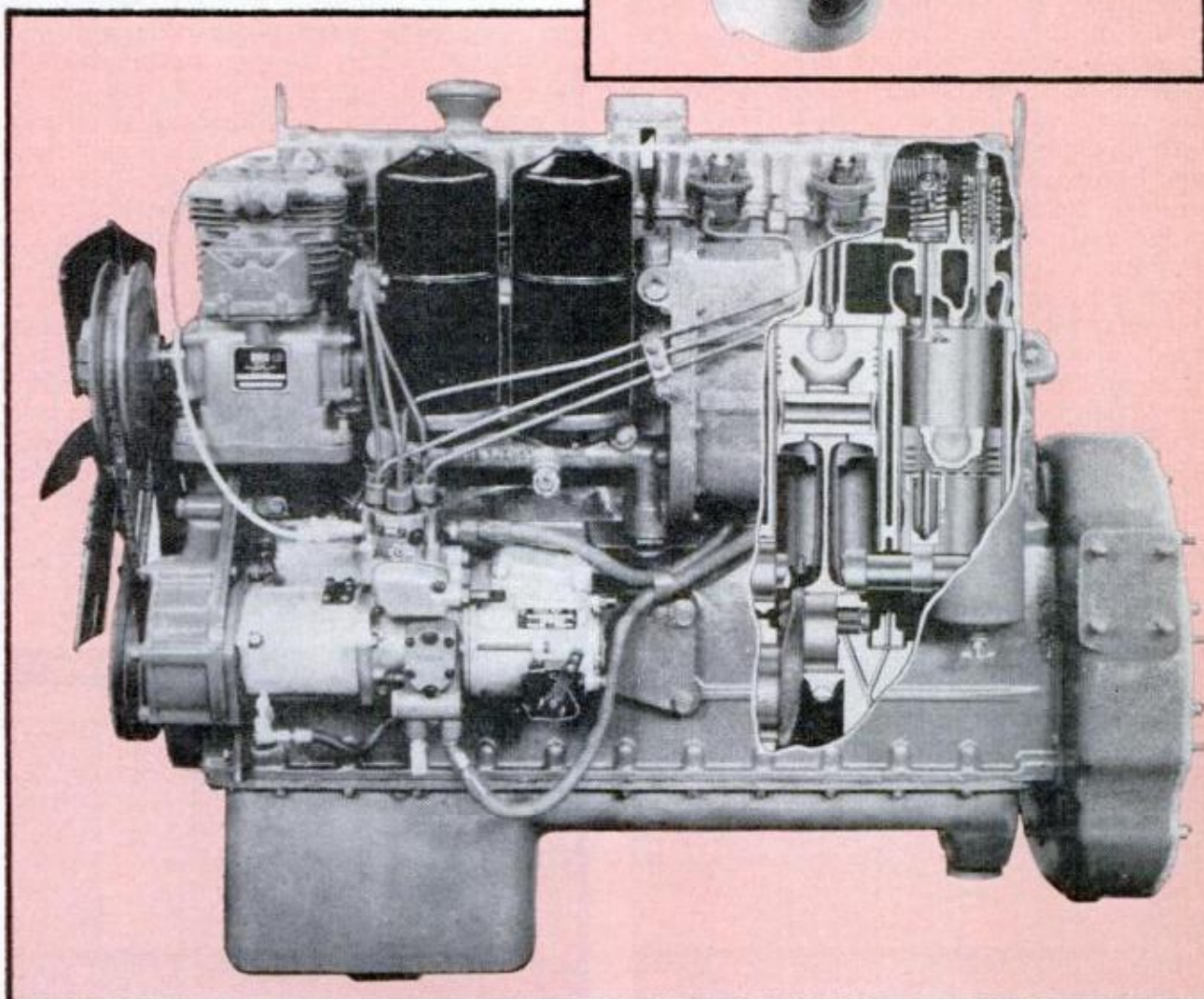
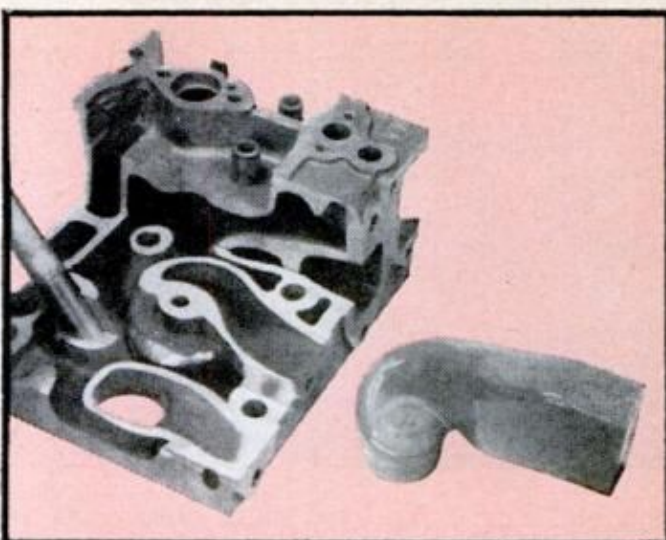

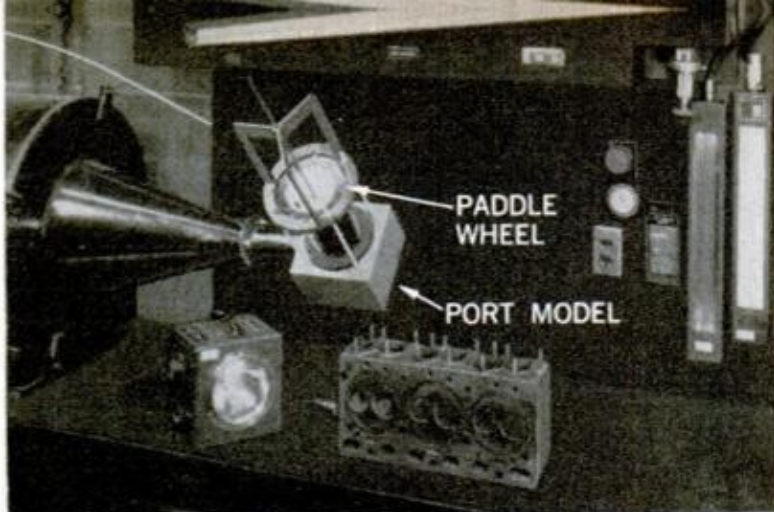

**SPEED OF SWIRLING AIR** charge was measured during development of the multi-fueler by mounting a paddle wheel in the cylinder with the piston removed. Speed was then checked with various swirl port configurations

burning. Fuel is sprayed right onto combustion chamber walls (within the piston crown, not above it). Swirling air scrubs a little off at a time, vaporizes it gradually. As the best fuel-air mix is reached, the vapor ignites. Continuing air swirl picks up more vapor. The self-regulating process continues, making the multi-fueler's burning smoother and slower than the flash in a single-fuel Diesel or spark-ignition type of engine.

A series of special problems had to be licked even after a German combustion genius, Dr. J. S. Meurer, began multi-fuel work.

Perhaps the toughest nut was finding an intake port configuration to give incoming air the right motion.

Heat control proved critical. Overheated chamber walls can crack fuels, liberating hydrogen first for fast burning while carbon burns more slowly and leaves troublesome residue. The solution was an oil gallery within the piston and under the combustion chamber. Now even kerosene burns well and burns clean.

Next, fuel control. An American Bosch injection system was found to meter the right amount of fuel—of any viscosity—into each cylinder.

The Army wanted cold-weather starting reliability, so Continental installed a flame burner on the intake manifold. It's

kicked off by a sparkplug and satisfied with whatever fuel the LDS-427 has aboard. Little oxygen is used up and an exhaust-driven turbocharger helps assure the supply. Continental says starts are successful to 40° below.

Testing was the climax—ordnance tests, desert mileage tests, Arctic functioning tests, troop use tests. Sites were scattered from Fort Yuma, Arizona to Fort Greely, Alaska. All were made in convoy, pitting the LDS-427 against standard spark-ignition engines. The swirl-chamber power plant got 79 percent better gasoline economy.

A long step ahead of other miracle units you may have read about that are still on laboratory test stands, this engine-of-the-future is doing its job today. From pistons on down, it's essentially Diesel and may haul your groceries tomorrow.

In its present form, the LDS-427 is a bit burly for passenger-car use, but compression-ignition is hardly a new idea for family vehicles. Look at the Mercedes 190-D, a Diesel. Continental already is in the passenger-car engine business, providing power plants for Checker, but refuses to discuss a multi-fuel future for your car. Nevertheless, if you're ever to get a car that'll burn any variety of dinosaur squeezings, it'll probably be a descendant of Continental's LDS-427. ★ ★ ★

**RUNNING BETWEEN ARIZONA** and Alaska, the LDS 427 used Diesel and compression-ignition fuels with 51 to 74 percent better economy than others

**TRAVELING ON ARCTIC** highways, the LDS-427 beat a standard engine's fuel economy by 79 percent on gas and more than doubled it on jet and diesel fuel

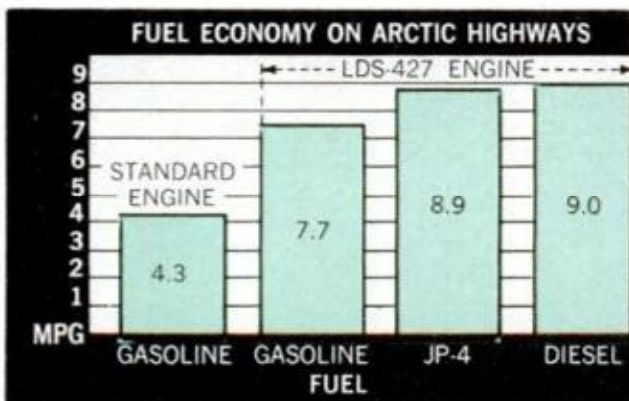
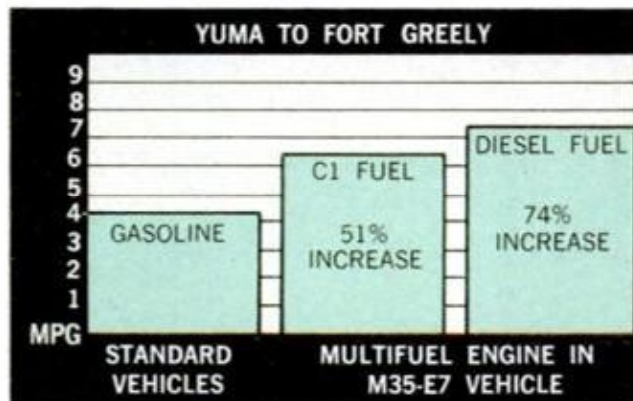

## Britain's Nuclear Missile

England recently unveiled its nuclear-armed air-borne missile, which may be its solution to the controversial *Skybolt* missile that was abandoned last year.

Called *Blue Steel*, the bomber-carried missile is shown being transported from a trolley to an Avro *Vulcan* bomber (background) at Scampton Royal Air Force base. The huge weapon can also be carried in Britain's *Victor* bomber.

The *Skybolt*, the American-made 1000-mile-range air-to-ground missile, was scrapped suddenly amid a storm of protest. It was to have been used by British bombers as well as American.

Royal Air Force spokesmen say that, in its test, *Blue Steel* had exceeded specifications in range and accuracy.

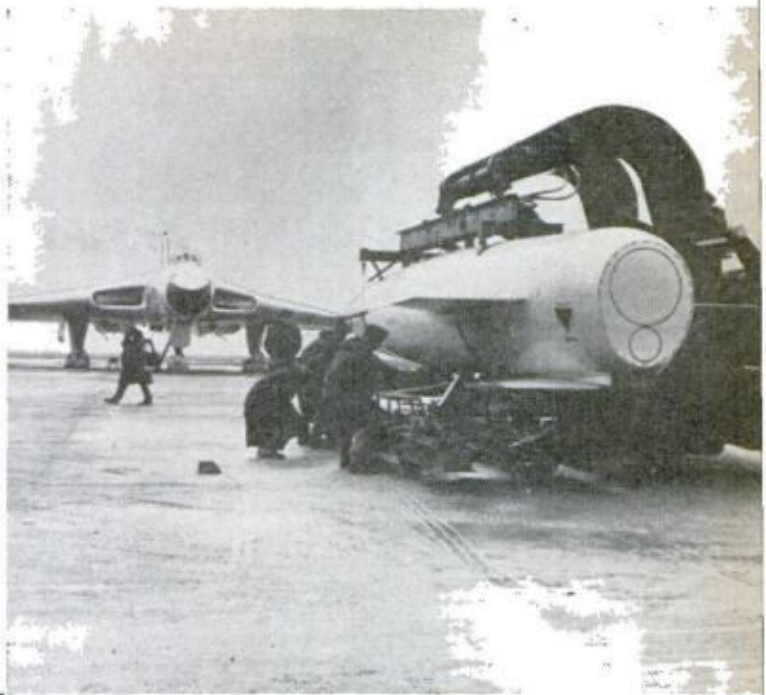

## Portable Lawn Spreader

Carried by the user on a neck strap, a rotary spreader weighs less than 12 pounds loaded and sprays a six-foot-wide path.

Made of plastic, it has a crank mechanism at its base that spreads fertilizer, fertilizer-weed killer and crabgrass preventer. It also sprays pressurized weed killer and flower spray. The materials come in special pellet form or are pressure-packed to be used with the spreader.

Made by S. C. Johnson & Son, Racine, Wis., the J-Way spreader is made to sell at \$8 with fertilizer, \$9 with fertilizer-weed killer and \$10 with crabgrass preventer. The pressurized weed killer and rose-and-flower spray are under \$2.

## Glamour for Fiat 600

This futuristic, bubble-top body is presented as a new set of wrappings for the Fiat 600, a 32-horsepower Italian economy car. The super-streamlined version of the automobile was designed by Carrozzeria Vignale, an Italian body firm, and exhibited recently at the Turin auto show.

Fiat's current model, the 600-D, is a four-cylinder, four-passenger car on a 78¾-inch wheelbase. It measures 131½ inches overall and has a top speed, according to the manufacturer, of about 70 m.p.h. The overhead-valve engine is mounted in the rear. The car has independent suspension all around and turns in only 28½ feet. *Popular Mechanics*, in a 1959 test, got 31 miles per gallon with a 600.





## NEW FOR YOUR HOME

**ELECTRIC FURNITURE POLISHER** operates at two speeds, featuring washable brush and buffer action, shines uniformly with paste, liquid or spray waxes. Compact AC-DC unit comes with 8-foot cord. By Schick Inc., Lancaster, Pa.



**SNAP-ON SHELF** of Formica-covered plywood slides into stainless-steel channel moulding which screws into wall and holds over 100 pounds of weight. Cost: \$3.25 each; \$5.95 a pair from AMPCO Products, Inc., P.O. Box 314, Uleta Branch, Miami 64, Florida

**SCREEN FORMS A WALL** 8 feet high in varying widths which attaches to brackets atop patio or garage, fastens on sides with plated snaps, is raised with pull ropes. Ten-foot width costs under \$30; Barberton Aluminum Specialties, Box 592, Barberton, Ohio





**RECHARGEABLE LIGHTER** needs no flint, no fuel, has no flame. It works like a car lighter, powered by a nickel-cadmium battery with retractable prongs for any wall outlet, lighting three packs of cigarettes on one charge. Of brushed chrome, it's for pocket or table use at \$14.95; Gulton Industries, Metuchen, N.J.



**WATER BROOM** washes as it sweeps. Three spray jets in a 17-inch base produce a wide spray that quickly clears debris. Water valve on 48-inch long handle of steel tubing can shut water off on back pull, leaving area damp-dry. Cost is \$4.95 from Cal-Dak Co., 1933 South Broadway, Los Angeles 7, Calif.

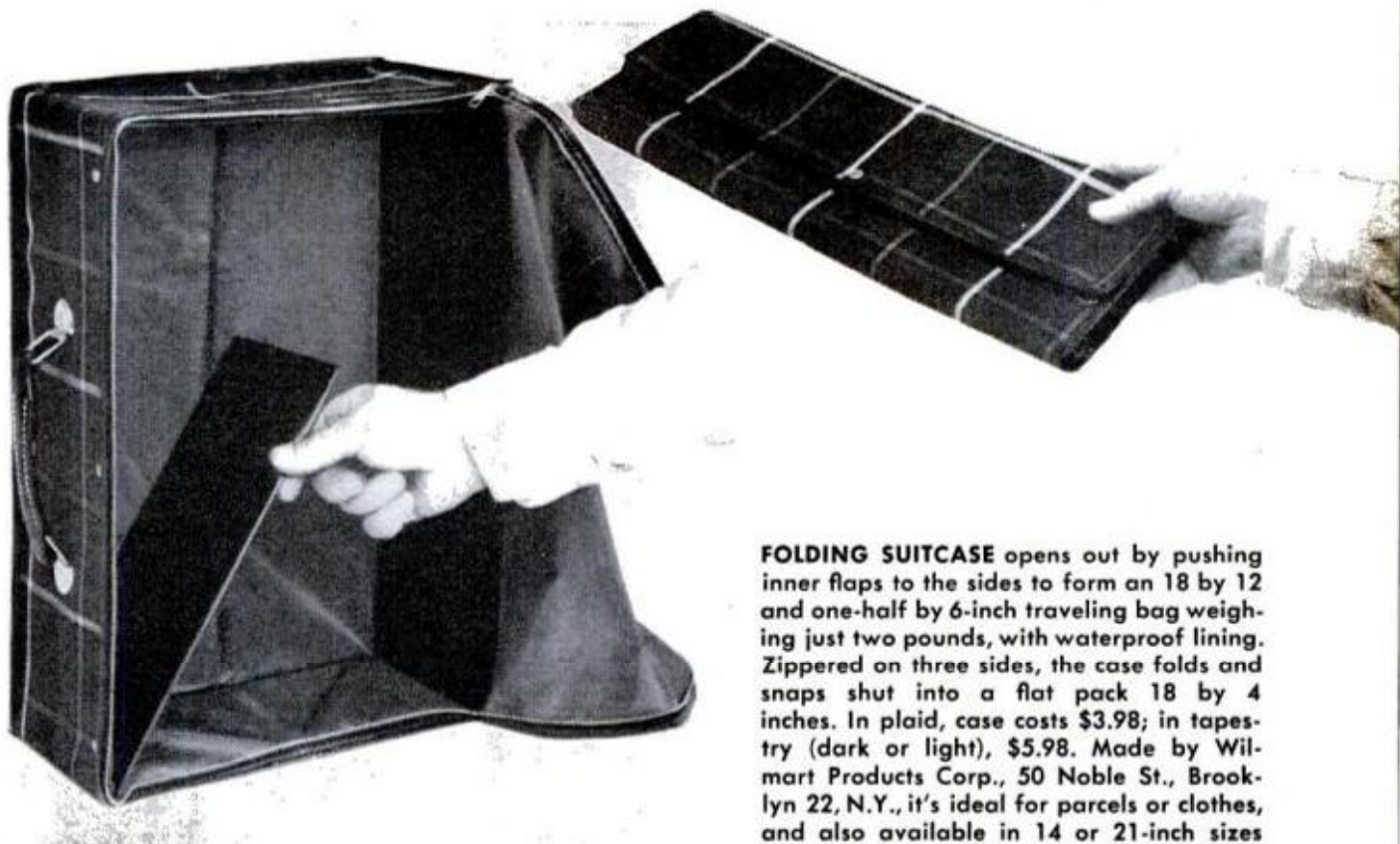

**FOLDING SUITCASE** opens out by pushing inner flaps to the sides to form an 18 by 12 and one-half by 6-inch traveling bag weighing just two pounds, with waterproof lining. Zippered on three sides, the case folds and snaps shut into a flat pack 18 by 4 inches. In plaid, case costs \$3.98; in tapestry (dark or light), \$5.98. Made by Wil-mart Products Corp., 50 Noble St., Brooklyn 22, N.Y., it's ideal for parcels or clothes, and also available in 14 or 21-inch sizes



## *Stereo In a Suitcase*

*15-pound package plays stereo records with a fidelity of 150 to 10,000 cycles*

By Elmer C. Carlson

**I**N ONE SPARE SUITCASE you can take along a summer-full of extra entertainment. For the suitcase can carry this complete stereo phonograph system and AM music center, all powered by standard flashlight batteries which give you from 70 to 135 hours of playing time before needing replacement. And the weight of the complete package is about 15 pounds.

Output power is 350-mw per channel, more than ample for most outdoor locations. Frequency response is surprisingly good (150 to 10,000 cycles) and is limited more by the speakers than any other factor. And by plugging in a microphone you can sing along with your favorite records.

The suitcase shown here—a 6 x 16 x 21 inch—

**1. PLUG IN AN INEXPENSIVE DYNAMIC** or crystal mike, adjust the level control and sing along with your favorite stereo records





is about minimum size for this project (Figs. 1 and 2). If you have a larger suitcase you can easily use it. You can use either the preassembled speakers specified or make your own enclosures to cut costs, which will range between \$48 and \$60 plus the suitcase. Soldering the flashlight cells together with short lengths of wire instead of using battery clips may be a bit less convenient, but it will save close to \$4.

The basic modular form of the complete radio-stereo phono combination is shown in Fig. 6. Although exact dimensions will depend on the size of your suitcase, the relationship between the phono motor and the phono pickup arm must remain the same. The radio dial is positioned so it is covered when a 12-inch record is on the turntable, but this isn't critical as the radio and phono are not used at the same time. Lift out the record and tune the radio.

The only one accurate measurement required is for mounting the phono pickup arm the right distance from the record for proper tracking of the phono needle in the record groove (Fig. 4). A distance of  $6\frac{3}{8}$  inches from the center of the phono turntable seems best for the particular arm I used. But any arm must be mounted so the needle and the center-line of the phono pickup stay as parallel as possible to the grooves in the record. Be careful not to make this distance so short that a 12-inch record will not fit easily into place or you will have to cut a new hole.

**2. PULL OUT SPEAKERS,** hook up the connecting cords, put on a record and you're ready for stereo

The amplifiers are mounted on a small piece of aluminum bent as shown in Fig. 5. Mounting the radio-phono switch, volume control and stereo balance control in the center of this bracket holds it firmly in place. This also puts the controls in a convenient spot for wiring.

Cut the mounting panel (Fig. 3) to fit the particular suitcase you use. It should cover the entire case except for the portion left clear for the speakers. Use short lengths of 1 x 3 or 1 x 4 to support this panel. Next lay out the components and drill all the necessary mounting holes.

Three jack-nuts hold the phono motor in place. Mount these nuts before you cut the hole for the motor. If you cut the motor hole first, the board may split between the jack-nut holes and the motor hole, because the jack-nuts spread to lock themselves into place.

For best reception on the AM radio, keep its ferrite antenna parallel with the ground. To do this and let the radio dial face up out of the suitcase, modify the tuner circuit board by removing the tuning capacitor and its dial from the board. Then remove the four screws holding the capacitor's mounting bracket to the printed board. Next unsolder the three connections under the capacitor and remove the mounting bracket and rebend it so it is flat. Finally, remount the capacitor and bracket and resolder the capacitor leads to the board.

**3. ELECTRONIC SYSTEMS** in the suitcase all fit onto a single removable panel that's cut to fit the case

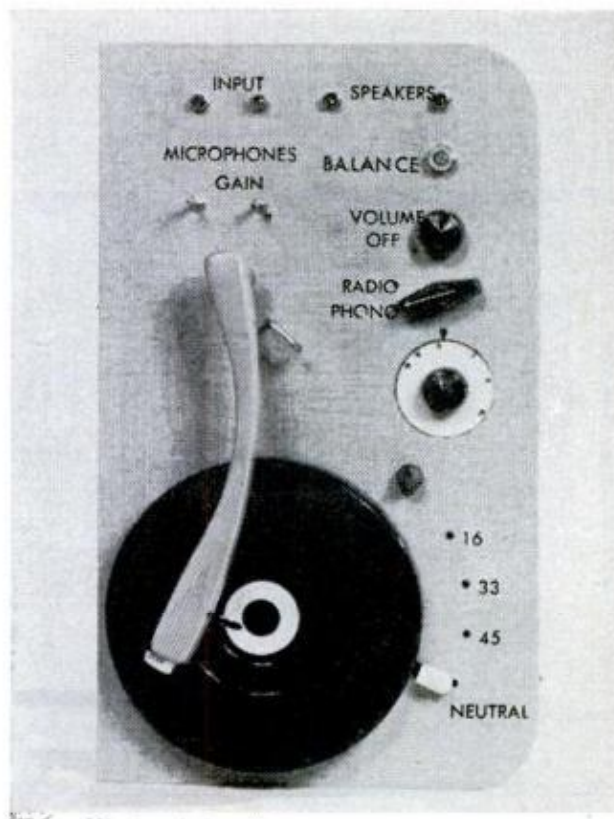

The 9:1 ratio of the vernier drive used permits very fine tuning. To mount this drive, remove the mounting bracket between the tuning capacitor and ferrite antenna on the radio circuit board and turn it around so its base points inward. Move the bracket back and remount with only one of the small machine screws.

When marking the mounting holes for the drive, juggle the tuning capacitor, vernier drive, mounting bracket and printed board to align the drive with the tuning capacitor and drill new mounting holes in the vernier drive as needed.

To attach the radio dial to the vernier drive, drill its center hole to a diameter of  $\frac{21}{64}$  inch to allow clearance for the  $\frac{3}{16}$ -inch diameter base on the  $\frac{1}{4}$ -inch tuning knob shaft.

The output of either the AM tuner or the high-output crystal phono cartridge does not need the input stage of the amplifier to give full volume. So wire them directly to the volume control instead. This makes it easier to add the microphones because they can be connected to the unused amplifier inputs.

The volume control, an assembled-to-order unit, is a TV-type control that normally uses two knobs, one inside the other. To make it into a one-knob control, cut the shafts to the desired  $\frac{3}{4}$ -inch length and solder them so the two shafts turn as one. This allows single knob control.

As a precaution against the shafts getting out of alignment while they are being cut, make a cut halfway through the shafts  $\frac{3}{4}$  inch from the control body. Then turn both shafts fully counterclockwise and run some solder into the cut. This will hold the two shafts firmly together

**4. THIS IS THE ONLY CRITICAL DIMENSION** in the entire unit. Get it right and your record tracking will also be right, keeping distortion down to a minimum

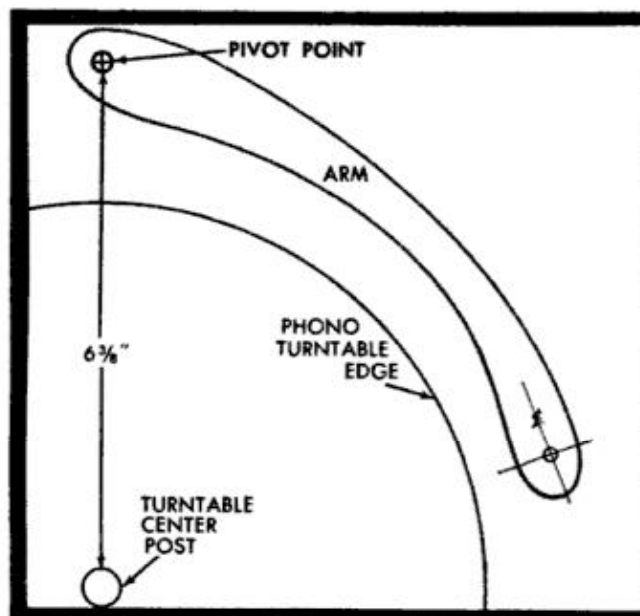

while you finish cutting them to length.

Do not follow the manufacturer's diagrams for the circuit modules; they are not correct for this *Stereo in a Suitcase* project. For example, the blue output lead from the AM tuner actually goes to switch S1 (as shown in Figs. 6 and 8) and not to the volume control. And since the black lead input and the red battery wire duplicate each other, one can be eliminated. If you use the black wire, connect it along with all the other black wires at R4, the stereo balance control.

If you expect to use the unit quite a bit try alkaline D-cells to extend battery life. They'll double playing time. You can

#### Parts List—Suitcase Stereo

- R1, R2—10,000 ohms, miniature gain control (Lafayette VC-28)
  - R3—dual 10,000-ohm pot with dpdt switch (Mallory RU-14L, FA-14L, OF-2875, LS-3375 and dpdt switch)
  - R4—500-ohm balance control (Ohmite CLU-5011)
  - R5, R6, R7, R8—27,000 ohms,  $\frac{1}{2}$  watt, carbon resistors
  - J1, J2, J3, J4—phono jacks
  - S1—4-pole 2-position rotary switch
  - T1, T2—microphone input transformers (Lafayette TR-120)
- The following parts are listed with their Lafayette Radio part numbers. 111 Jericho Turnpike, Syosset, L.I., N.Y.
- 2—PK-544 transistor amplifiers
  - 1—PK-633 transistor AM tuner
  - 1—F-753 vernier drive
  - 1—ML-9 battery phono motor
  - 1—PK-537 pickup arm
  - 2—SK-109 speaker in cabinet
  - 5—MS-176 flashlight cell holders

#### Miscellaneous parts

- Knobs for all controls
- 2—3-terminal tie strips
- 4—5-32 jack-nuts
- Dynamic or crystal mikes
- Pressure-sensitive adhesive plastic
- Pressure-sensitive lettering or decals

**5. SUBCHASSIS HOLDS VOLUME**, balance and selector switch controls. The transistor amplifier boards attach to the side wings of the aluminum chassis

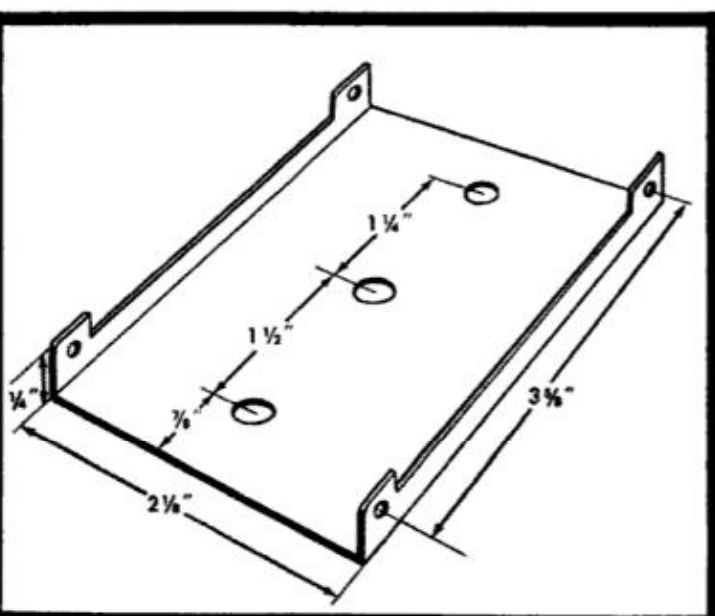

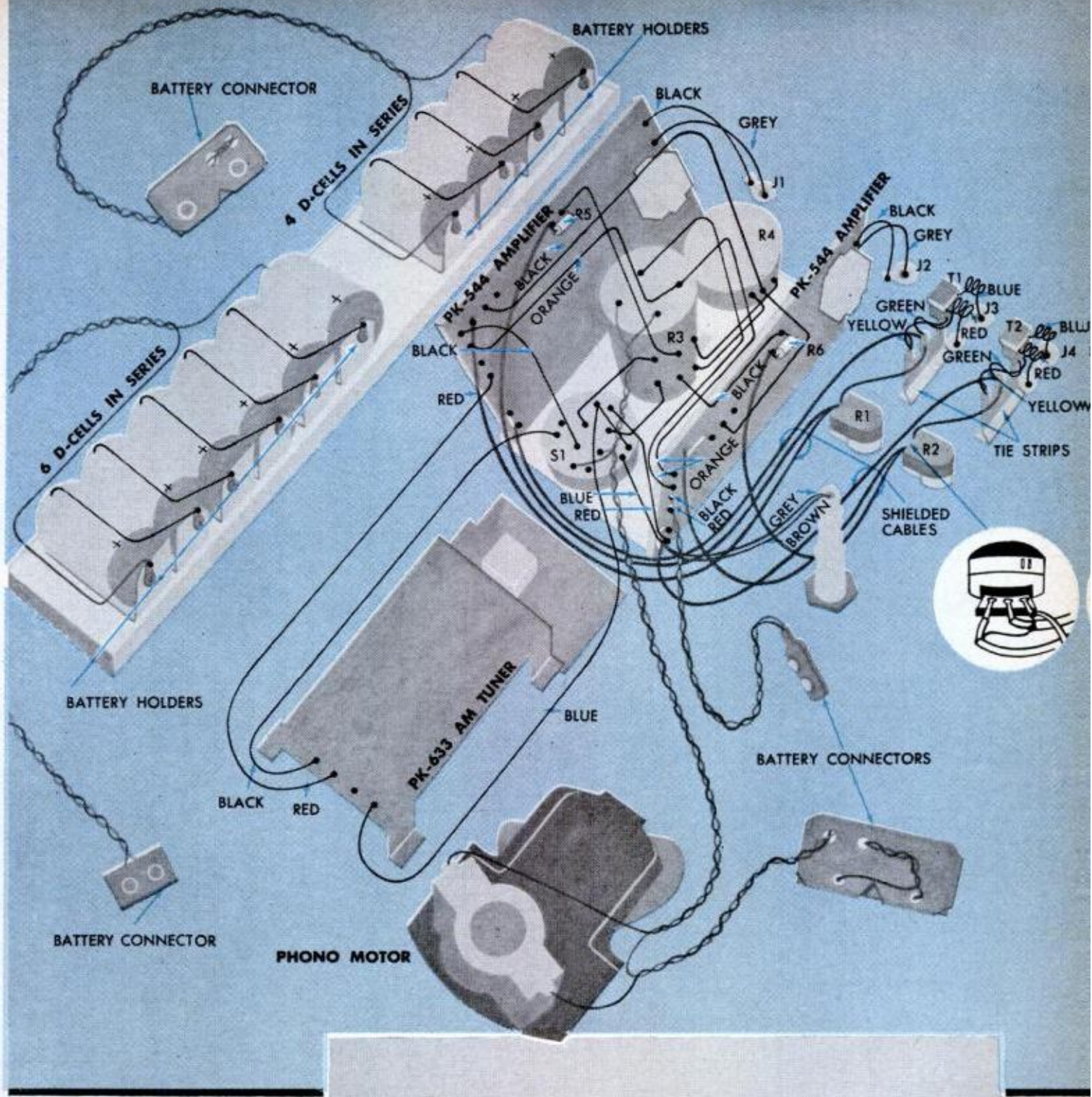

**6. PICTORIAL** is a guide to wiring the stereo suitcase. For greater detail, see the schematic on the next page

**7. FINISHED UNIT.** There's plenty of room but wiring does get crowded around the volume control

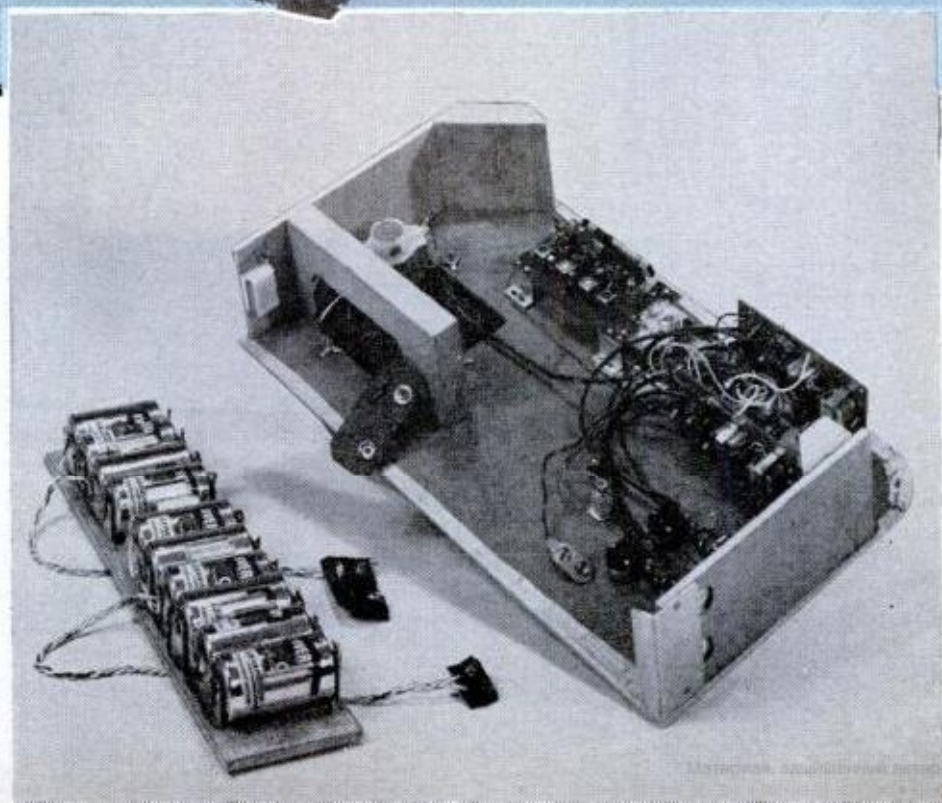

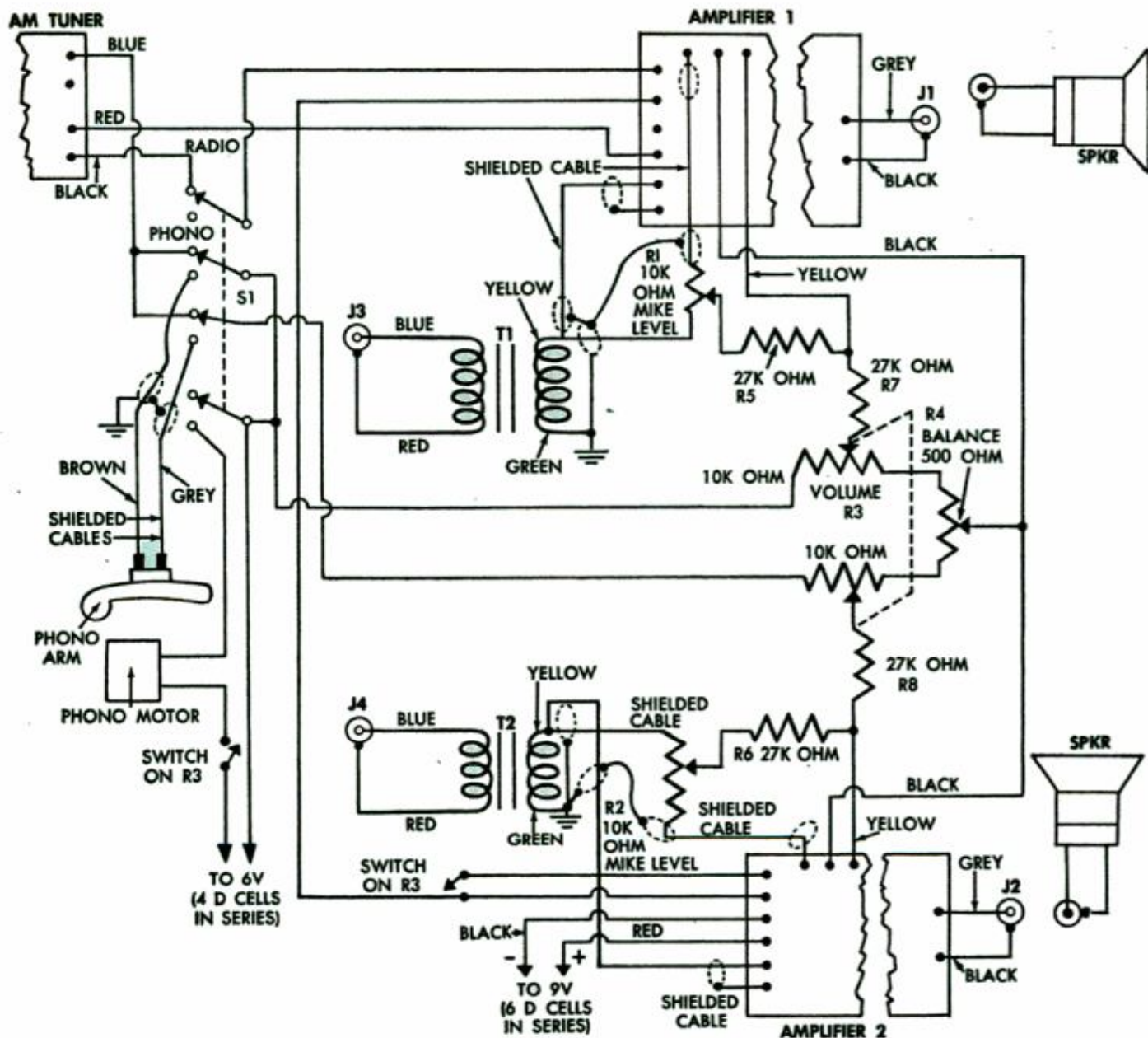

**8. ELECTRONIC CIRCUITRY** of the stereo suitcase. Follow this guide and set will work the first time out

order them from just about all of the mail order electronics houses.

Use dissimilar battery connectors for the amplifiers and motor so that the 6- and 9-volt batteries cannot be connected into the wrong circuits; 9 volts on a 6-volt phono motor can burn it out.

After cleaning all external surfaces carefully to remove all dust and grease, cover them with self-adhesive plastic, available from the hardware store. Work in a warm room and use an electric iron, slightly warmed, to encourage the more unruly edges to lie smooth and flat. Once the covering is in place, cut the control shaft openings through the plastic film, using a sharp knife or razor blade.

If you mount the controls temporarily, you can mark knob and pointer positions and remove the controls so identifying names and labels can be applied. I used

pressure sensitive individual letters—decals are also good. Both are available from the larger mail order electronics firms. No drying time or protective lacquer is needed.

To get a balanced output from the two speakers simply set the balance control to the center of its rotation. For portable use this is good. Indoors, adjust the control to give about equal volume from both speakers while you are seated in your favorite chair, even when the speakers are not actually equidistant from the desired listening point.

Use this portable package on your next trip into the country, and it will add new life to the outing. Trailer owners can build the unit right into some convenient corner and if you have a summer or winter cabin in an out-of-the-way, nonelectrified spot, you can do the same thing. ★ ★ ★

NEW IN

# Electronics

**RADIO-LIGHTER** from Japan sports a full size cigarette lighter atop a 2-transistor reflex receiver. The battery gives 250 hours of service and the set pulls in six stations loud and clear on the streets of New York. They're imported by Leonard Branvold, 5718 Troost Ave., North Hollywood, California. \$9.95

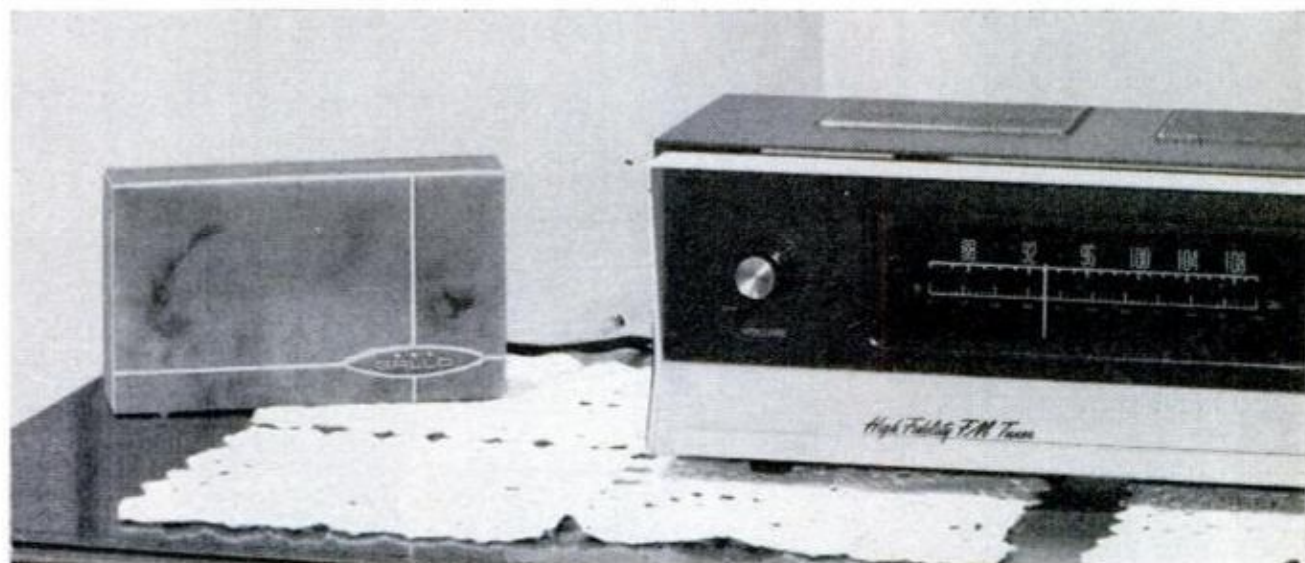

**INDOOR FM ANTENNA SYSTEM** combines a half-wave unipole with a high-gain low-noise transistor amplifier in a hand-sized package. The amplifier boosts signal strength 18 db. and brings in stations you couldn't hear with the ordinary indoor dipole antenna. \$29.95 from Gallo Electronics, 12 Potter Avenue, New Rochelle, N.Y.



**TAPE ACCESSORY KIT** packed in a plastic carrying case. Contains two 7-inch reels of tape, splicer, splicing tape, strobe tape, leader tape, tape clips, marking pencil and assorted empty tape reels. \$13.95 from Ferro-dynamics Corp., Gregg St. & Route 17, Lodi, N.J.

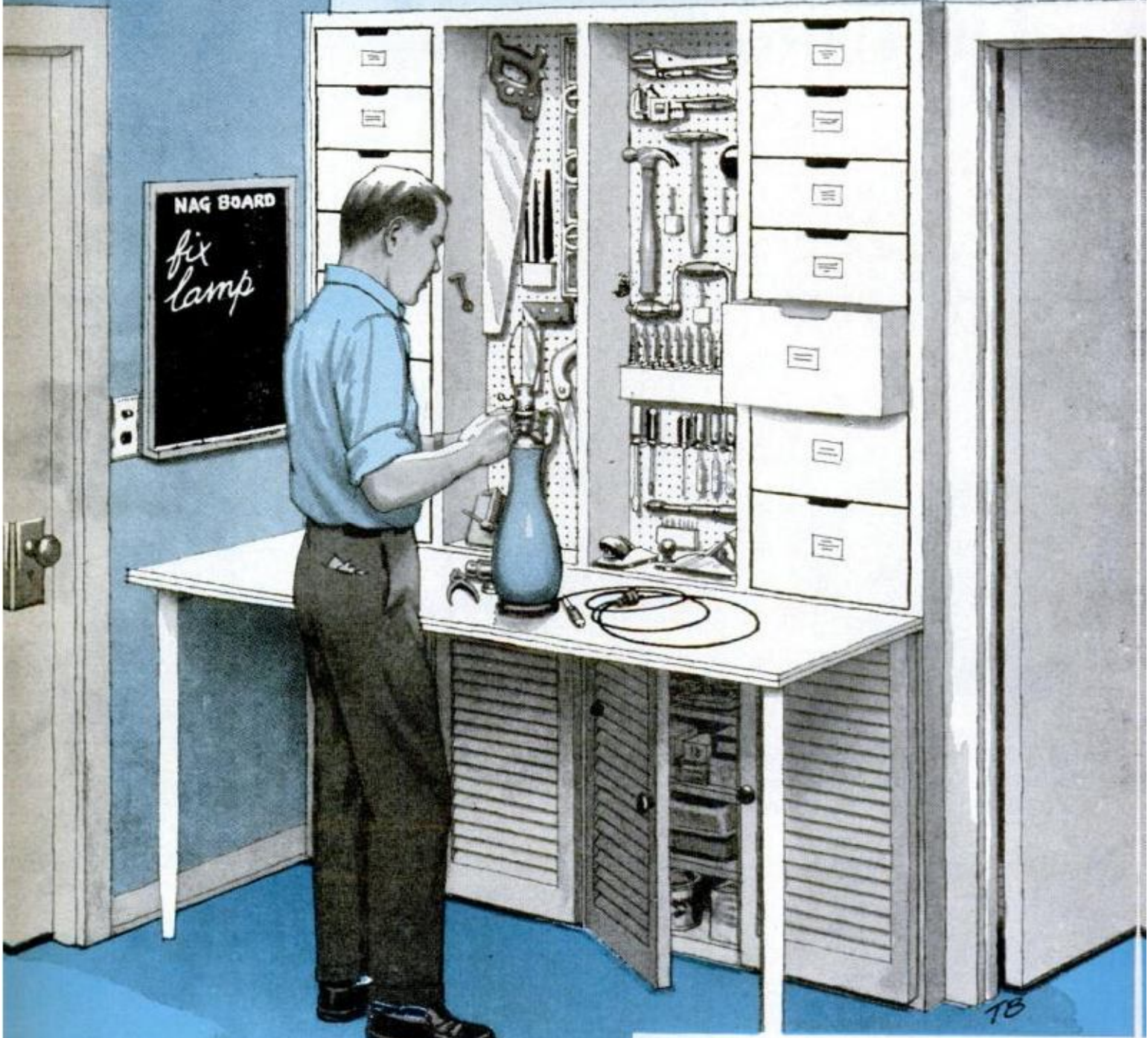

For homeowners without a workshop, this repair center is a must. It stores tools and supplies in one handy place to simplify the job of keeping a house shipshape

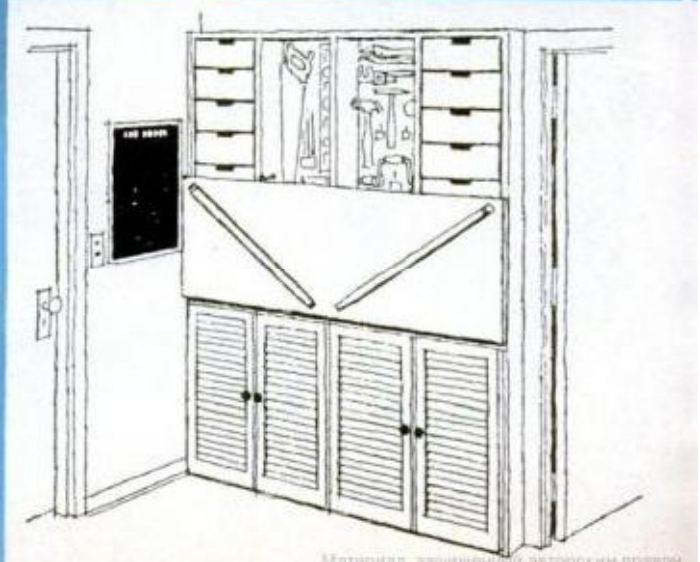



- Claw hammer, 13-oz. head
- Nail set
- Hand crosscut saw, 24-in., 12 point\*
- Hand ripping saw, 26-in., 5 point\*
- Jack Plane, 14-in.
- Block plane, 6-in.
- Ratchet brace, 8 or 10-in. sweep\*\*
- Auger bit set: ¼ to 1-in. by ¼ths\*\*
- Rosehead countersink\*\*\*
- Twist drill set: up to ¼-in.\*\*\*
- Hand drill, ¼-in. chuck\*\*
- Push drill\*\*\*\*
- Screwdriver bit\*\*
- Screwdrivers, 4-in. and 8-in. blades
- Screwdriver, Phillips, medium size
- Folding rule or metal tape, 6 ft.
- Combination square, 12-in. blade
- Wood chisels: ¼, ½, ¾ and 1-in.
- Adjustable wrenches: 6 and 10-in.
- Pipe wrenches: 10 and 14-in.
- Combination pliers, 6"
- Adjustable locking plier-wrench
- Long-nose pliers
- Allen wrench set for socket setscrews
- Soldering gun, 100-watt minimum, or propane torch
- Tin snips, plain or duckbill, 10-in.
- Miter box
- Keyhole (or compass) saw
- Hacksaw and blades
- Carpenter's level, 24-in.
- Mill file, single cut, 8-in.
- 3-Corner taper file, 6 or 8-in.
- Half-round bastard file, medium cut
- Interchangeable file handle
- Clamp-on woodworking vise
- Scratch awl
- Utility knife with retractable blade
- Combination oilstone
- Spout can of light oil
- Cold chisel
- Pencil compass
- Clamps of your choice: C or spring
- Marking gauge
- Crow bar
- Stapling gun

\*If you own or plan to buy a portable electric saw, these items may not be essential.

\*\*If you own a portable electric drill, these may not be essential.

\*\*\*Can be used with either brace or electric drill.

\*\*\*\*Push drill is good substitute for hand drill and will be useful even if you have an electric drill.

**THE SECRET OF AN EFFICIENT SYSTEM** of home maintenance is organization. The important task begins after your in-the-wall storage center is built and you start to assemble the tools you'll need for all the jobs you're likely to encounter. Take a pencil to the basic checklist at left. Once you've acquired this minimum equipment, a few additional items from the specialized lists should complete your shopping. Arrange the tools on the hook board for the best use of space, with most-used tools in easiest reach. If, after several week's trial, you're satisfied with this arrangement, paint silhouettes on the board to indicate tool positions. This facilitates speedy replacement when you use a variety of tools on a job, and clues you as to which tools have strayed and should be tracked down to keep the board complete

## HOME PAINTING KIT

- Brushes: 1, 3 and 4 in. sizes
- Paint roller and tray
- Putty knife, scraper—and beer-can opener for cleaning out cracks
- Spackling compound
- Sandpaper in fine to coarse grits
- Steel wool: 2/0 and 4/0
- Drop cloths
- Turpentine, denatured alcohol, lacquer thinner or equivalent solvents
- Paint remover
- Masking tape

## PAPERHANGING KIT

In addition to spackling compound (for plaster patching), sandpaper, paint scraper and putty knife listed elsewhere:

- Pail for washing walls, mixing paste
- Wall size
- Smoothing brush, 12 in.
- Pastebrush, 6 in.
- Wheel knife, 1½-in. dia.
- Oval seam roller, 1½-in.
- Plumb bob and chalk line
- Homemade 8-ft. straightedge
- Large sponge
- Step ladder, 6 ft.

## CONCRETE PATCHING KIT

- Mason's trowel
- Tuck-pointing trowel
- Mason's jointer
- Groover, edger (for sidewalk patch)
- Concrete/mortar mixing tray (6" x 24" x 48"—can be homemade)



## HOME ELECTRICAL KIT

In addition to the pliers, screwdrivers and soldering gun listed at far left

- Pocket knife or wire stripper
- Lamp cord, 25 ft.
- Cord plugs
- Friction tape and rubber tape
- Solderless connectors (10 or so)
- Replacement fuses (15-amp for 14-ga. wire, 20-amp for 12-ga. wire)
- Replacement toggle wall switch
- Non-acid wire solder (resin core)
- Neon tester (to check outlets)
- Spare incandescent and fluorescent bulbs for all household fixtures

## HOME PLUMBING KIT

In addition to the 10-in. adjustable wrench, two pipe wrenches and 8-in. screwdriver listed at far left:

- Plumber's force cup (plunger)
- 5½-ft. closet-bowl auger
- 25-ft. drain and trap auger
- Graphited packing
- Pipe-joint compound
- Washers, assorted types and sizes
- Seat reamer

## CALKING AND GLAZING KIT

In addition to the chisels, 1-in brush and putty knife listed elsewhere:

- Calking gun, with spare cartridge
- Wire brush with attached scraper
- Glass cutter
- Glazier's points (box)
- Linseed oil (pt. can)
- Glazier's putty (1 to 5 lb. can)
- Yardstick for measuring, laying out and cutting glass

## GENERAL SUPPLIES

- White polyvinyl glue
- Epoxy glue
- Household cement
- Assorted stove bolts or machine screws
- Assorted wood screws (½"-#4 through 2"-#10)
- Mending plates, corner braces
- Screweyes, screw hooks, picture hooks
- Tacks, brads; common and finishing nails from 2d to 8d
- Assorted hollow wall fasteners and fiber, plastic or lead anchors
- Extra casters, furniture glides
- Sack of clean rags
- Pressure-sensitive mending tape
- Work apron and gloves

## WHAT YOU NEED TO STORE AND TOTE TOOLS AND SUPPLIES

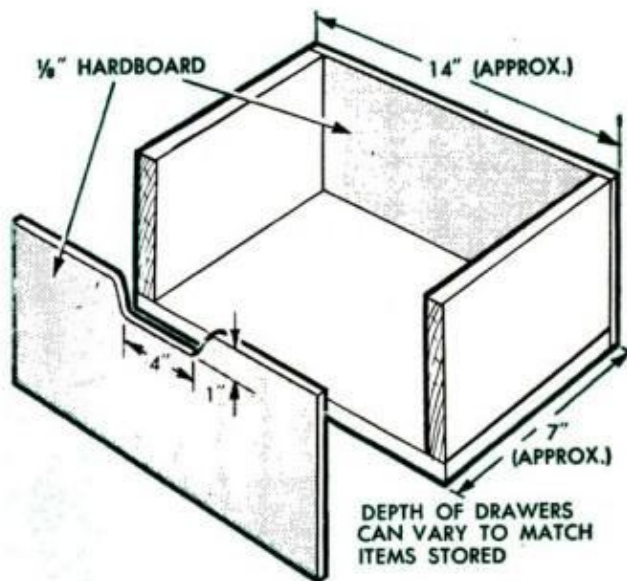

**BOX CONSTRUCTION** lets you make drawers of various sizes quickly. When work must be done away from the fix-it center, load up two-part tool box (below). Tray sections are for variety of nails, screws

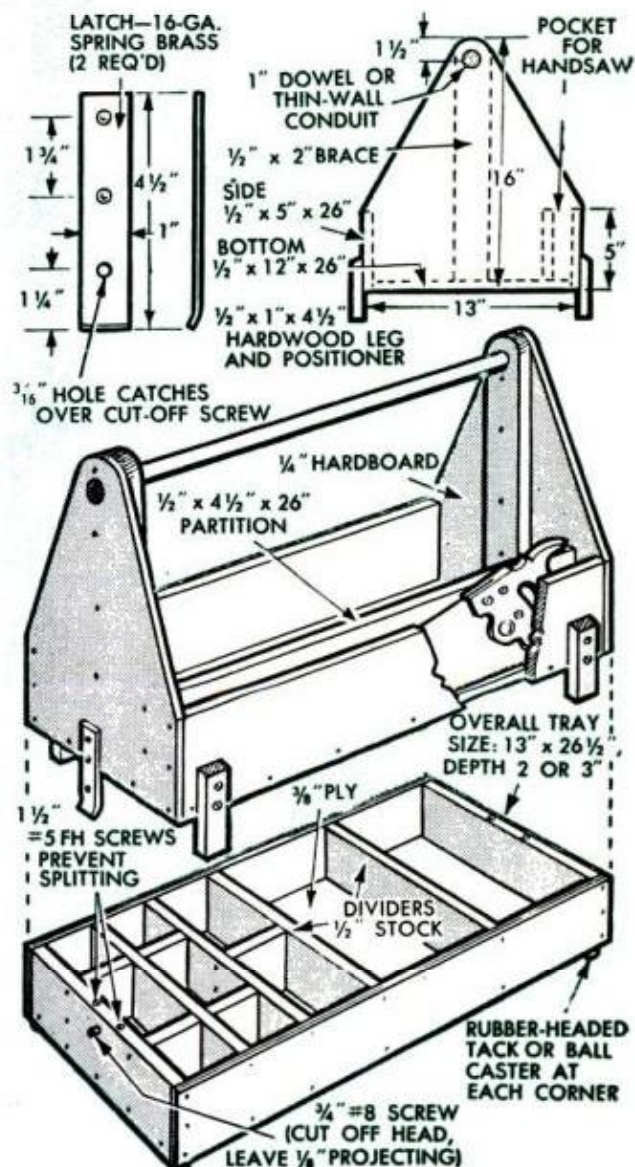

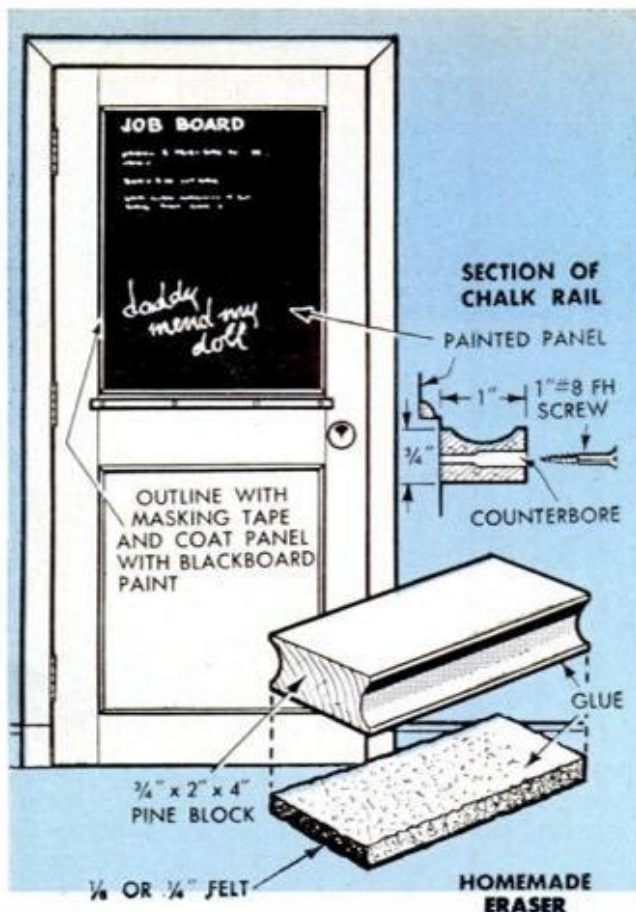

The width of the worktable depends, of course, on the space available. About two feet is an ideal width, but it can be as little as a foot wide and still be of practical use. The length can be the full width of the built-in unless you locate your fix-it center in a corner, as we did. In this case, the table must be shorter, to provide clearance at the corner end.

For rigidity, we bonded two 1/2-in. plywood panels face-to-face, using contact cement. If you want a more durable work surface, you could face this panel with 1/8-in. tempered hardboard, using the same cement and leaving it unfinished.

Are snoopy small fry a problem in your home? The drawers and toolboard are automatically shielded when the top folds up. Only the upper sections remain exposed, and they're well out of a youngster's reach. The cabinet doors will open whether the worktable is up or down, but two hasps would let you padlock them.

Where you locate your maintenance center depends, of course, on available wall space. In our example, we chose a utility-room partition, making use of waste space between two doorways. For appearance and practicality, we let the door frames determine the height of the unit. To run it much higher would only give you inaccessible drawers and out-of-reach space on the perforated-hardboard tool rack between the studs.

Note that these perforated panels are spaced 3/8-in. from the rear wall to provide clearance for the many different types of insert hooks and racks available for tool storage. The check lists on the previous pages will help you make a well-rounded selection of tools and supplies. Or simply take a stroll through your home with a memo pad, jotting down the jobs that need doing—and what you'll need to do them.

The method for opening the stud spaces is sketched at left. You need to locate only one stud, either by means of a stud finder, or by drilling test holes through the wall. In normal construction, other studs will be 16 in. on center to either side. Remove the baseboard. Then, with a 1-in. bit in a handbrace, bore a hole along the outside face of one of the border studs. Insert a keyhole saw and carefully cut all the way to the sole plate, with the blade bearing against the face of the stud. (You'll need a guide line for the horizontal top cut only.) In our sketch, we're working on the *inside* face of the lefthand border stud because our corner location made it impractical to cut along the opposite face. After this cut is made, it will be necessary to chop out the wallboard or plaster to expose the full edge of the stud so the 2 x 4 facing can be toenailed to it.

secured in that position by means of eye-bolts screwed to the faces of two of the studs so as to pivot down into mating slots in the table edge. Wing nuts snug up against the panel to hold it tight.

The legs are mounted at an angle to avoid any overlap when locked in their folded position. The worktable can be put to extra use by pulling the hinge pins and carrying the panel to another work site. With the hinged edge supported on a blocked-up sawhorse, it makes an ideal pasting table for wallpapering jobs.

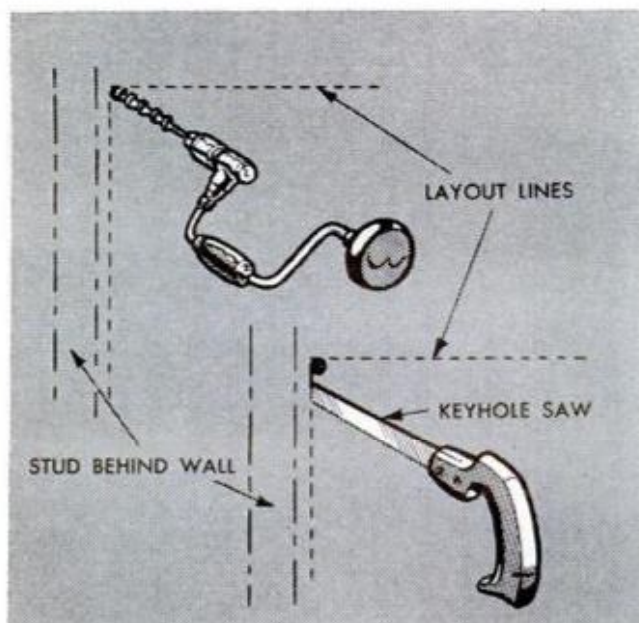

The new sole plate should be anchored to the floor, in addition.

After the facing frame is applied, finish the unit to suit your own needs. You might wish to utilize *all* the above-table space for tool panels, or you might prefer open shelves to our angle-runner drawers. The space below the worktable is plenty deep enough to take quart-size cans of paint. Adjustable shelf brackets offer complete flexibility as to the height of items you can store. You might want to leave at least one cabinet free of shelves, for storing tall items, such as a propane torch or a fire extinguisher.

Another thing you should store in one of the cabinets is an accordion folder with alphabet tabs, for filing all literature that comes with new appliances—installation instructions, warranties or servicing data.

It's a good idea, also, to mount a blackboard near the fix-it center so that you and other members of the family can jot down job reminders. This can be a child's framed slate, or you can simply use a door panel, as shown above. For more permanent records—such as when you last cleaned or changed your furnace filters, the number of gallons of paint or paper it takes to decorate certain rooms, etc.—you might also want to hang a roller windowshade above the reminder board, coating the inside surface of the fabric with blackboard paint. You'd then just pull the shade down, scribble your note in chalk and roll it back up. The note will be there, months or years later—whenever you need to refer to it. ★★



**ACCURATE CUT-OFFS** are much easier with a portable electric saw—one of tool's advantages over hand saws marked (\*) in Basic Tool List. Above, two pieces of scrap are lapped at right angles to provide a T-square fence to run saw's base plate along

**IN BUYING CLAMPS**, start with a set of C-clamps, add several spring clamps for smaller jobs. Wooden-jaw hand screws are for cabinetwork. Three types at bottom are for wide, flat work, like glued-up panels

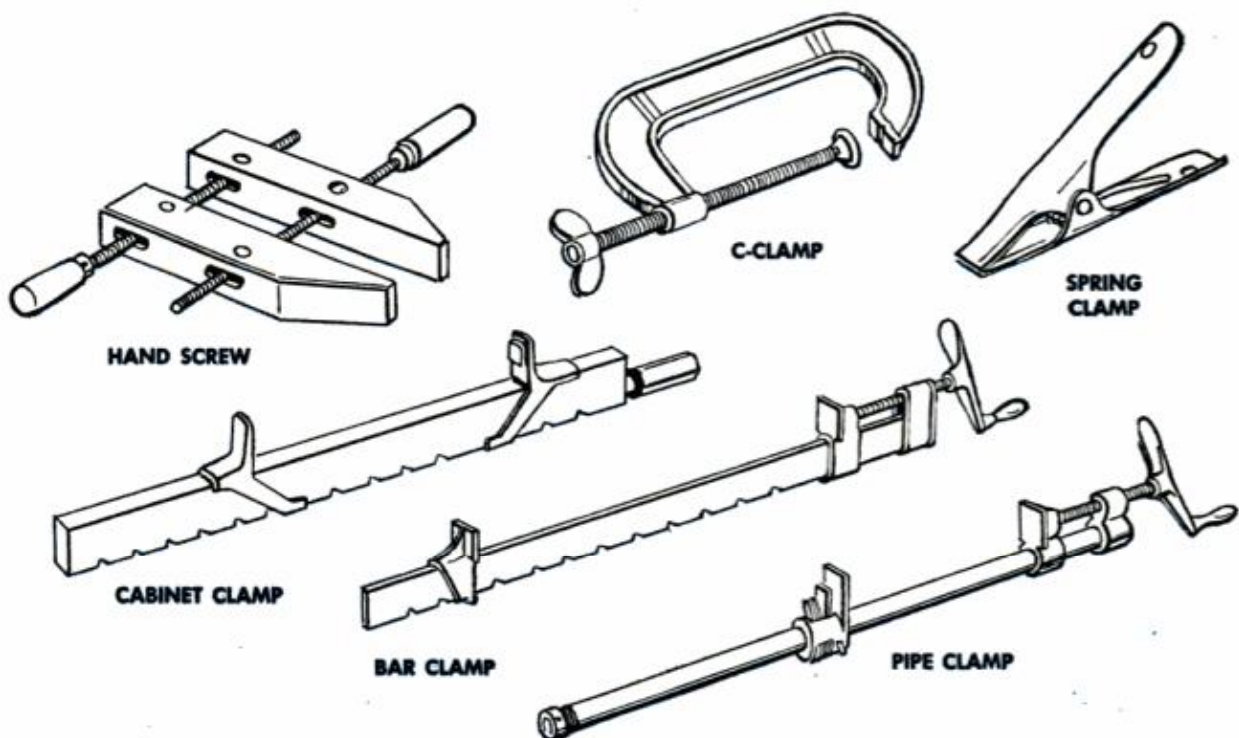

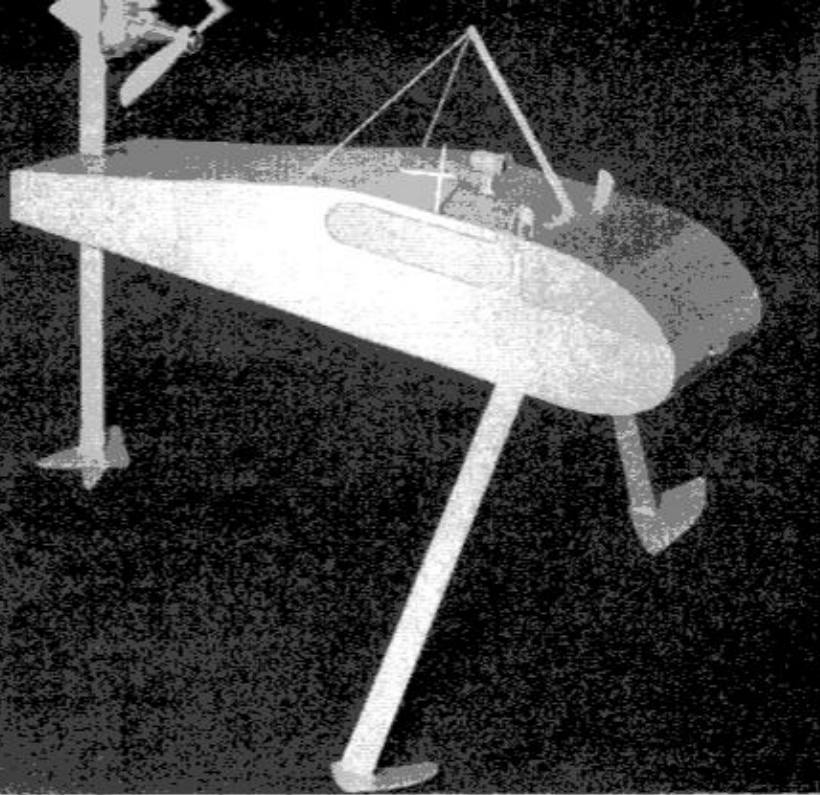

# WATER BUG

by Roy L. Clough, Jr.

**Skims over the surface like a hydrofoil, but it's actually just a wooden waterskier**

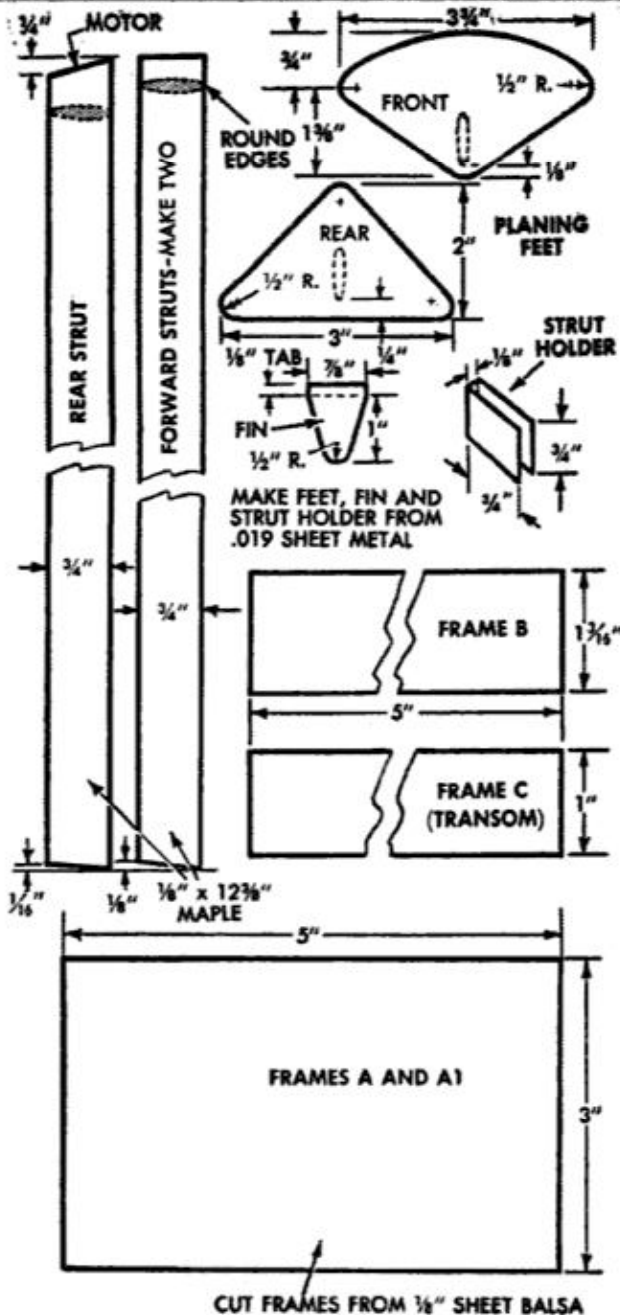

**I**NSPIRED BY those little aquatic insects called "water striders," this unusual model boat flits along the surface of the water on three flipper-shaped planing feet mounted at the ends of long legs.

Although it travels fastest on calm water, *Water Bug* can run through 4 to 5 in. ripples—the scale equivalent of 5-ft. waves—with no trouble. The struts simply slice through the wavelets and keep going. The boat is very stable and can be run with a guide line or turned loose in small ponds where recovery is easy. The original model showed no tendency to trip or tip over, even with the rudder bent sharply for free-running turns.

The hull is a simple box structure of  $\frac{1}{8}$ -in. sheet balsa. It should offer no problems, but remember to soak the sheeting which covers the front section, in hot water before bending. Finish the boat with a couple of coats of sanding sealer and one of dope, or cover the bare wood with a layer of lightweight model tissue laid on with heavy dope.

The motor mount is a disk of plywood pinned and cemented to the rear leg. Drill for the engine mounting bolts, set the engine in place and build up the fairing on the rear of the bulkhead with scrap balsa left over from the hull planking. Don't worry about access to the rear of the bulkhead to tighten up the nuts. If built-in blind this way, they'll stay put. The thrust line of the motor should be almost parallel to the bottom of the boat, but pointed slightly downward.

Cut the planing feet out of .019 sheet metal, then make up the holders and rudder and solder them to the feet at the angles shown. Attach the feet to the

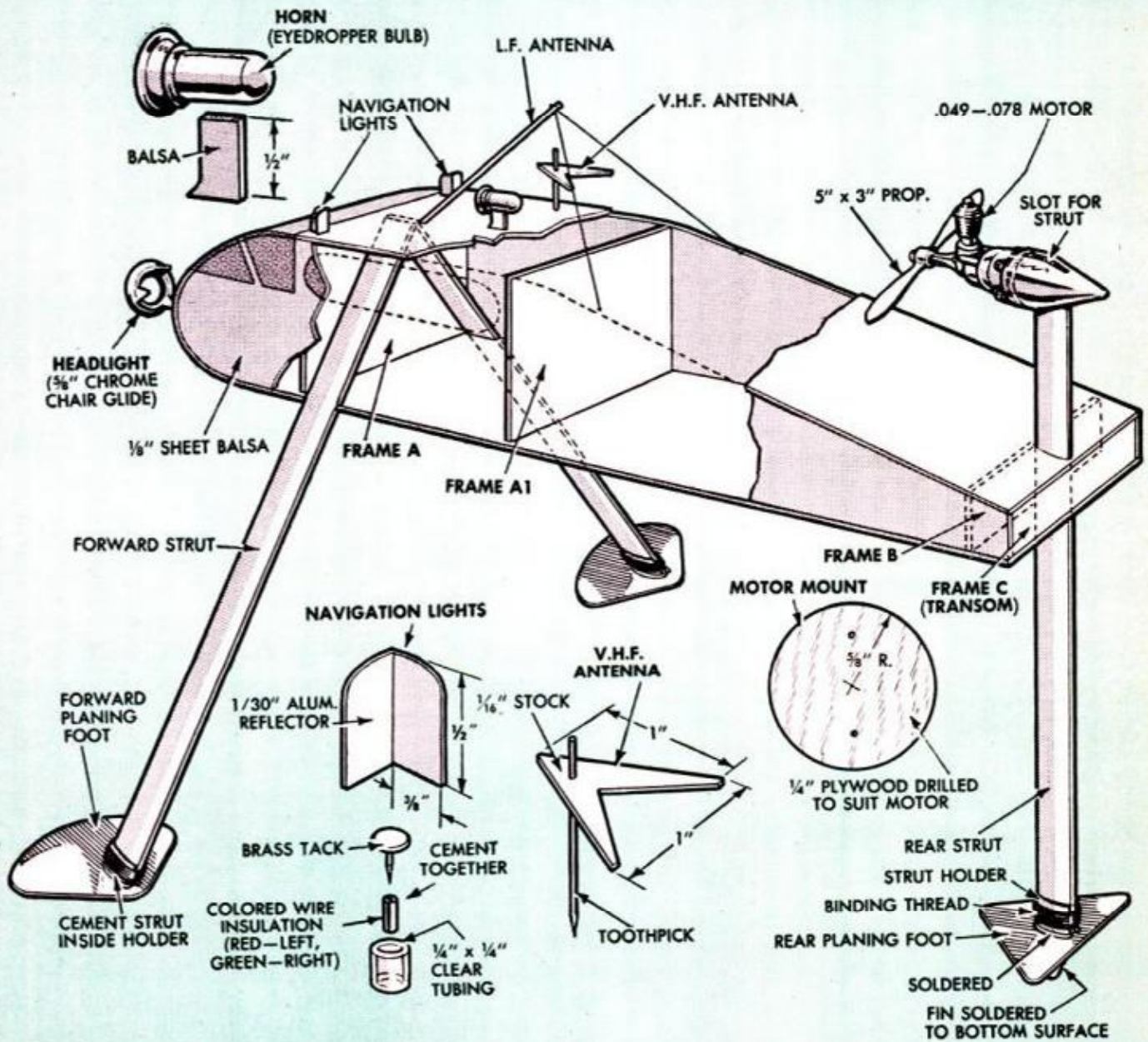
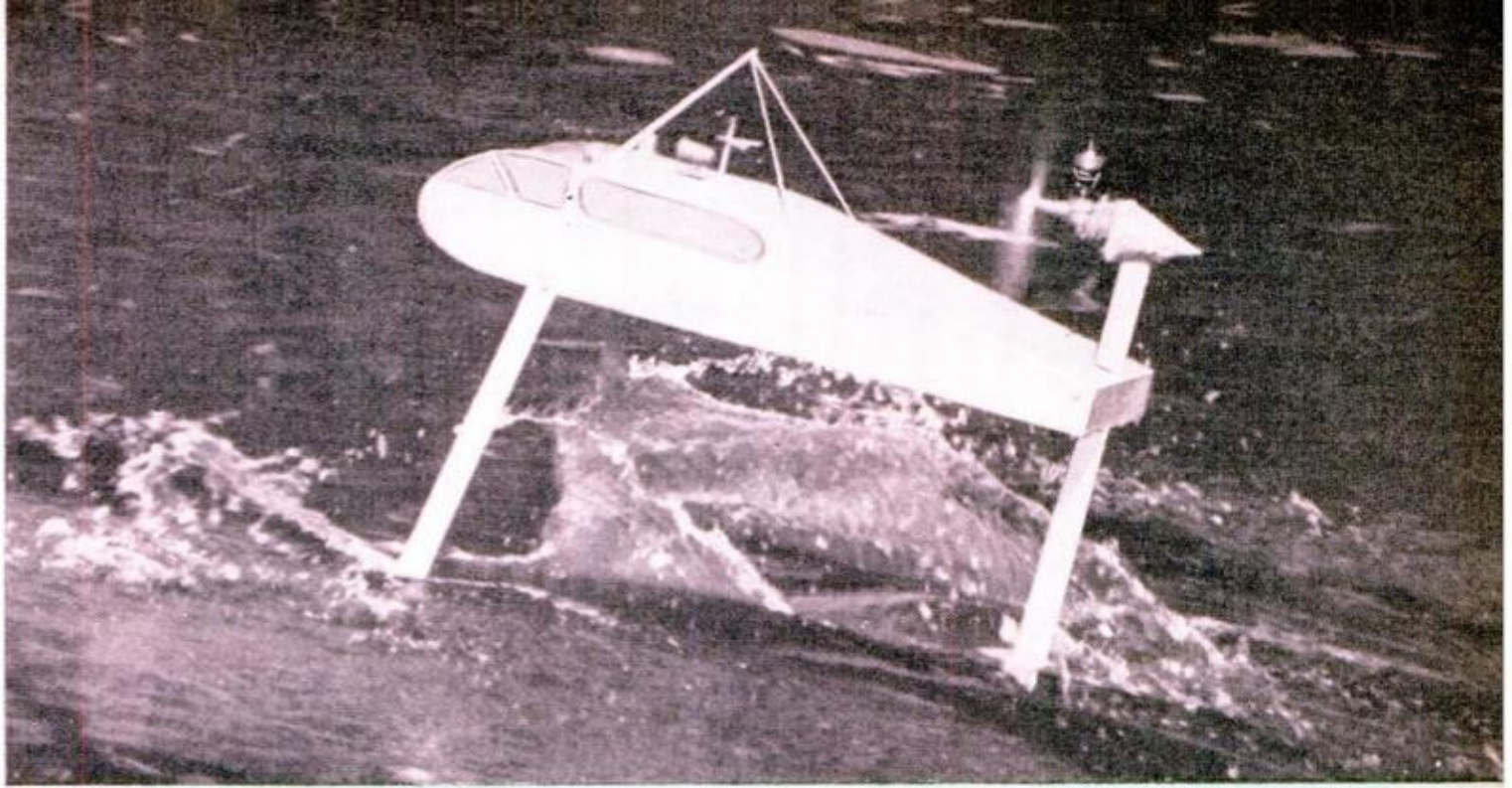

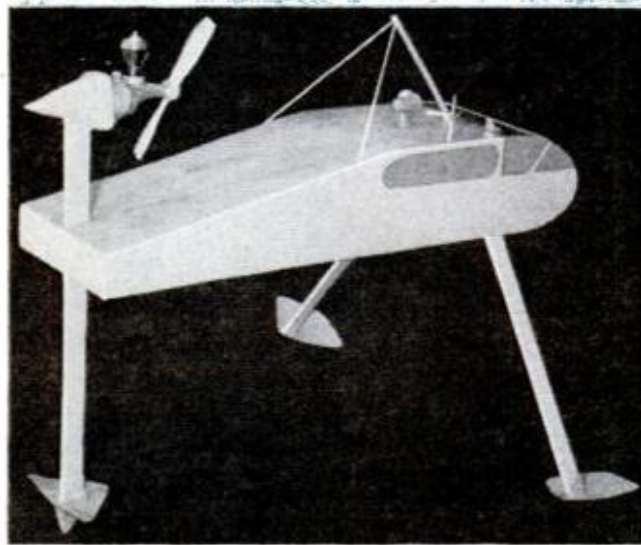
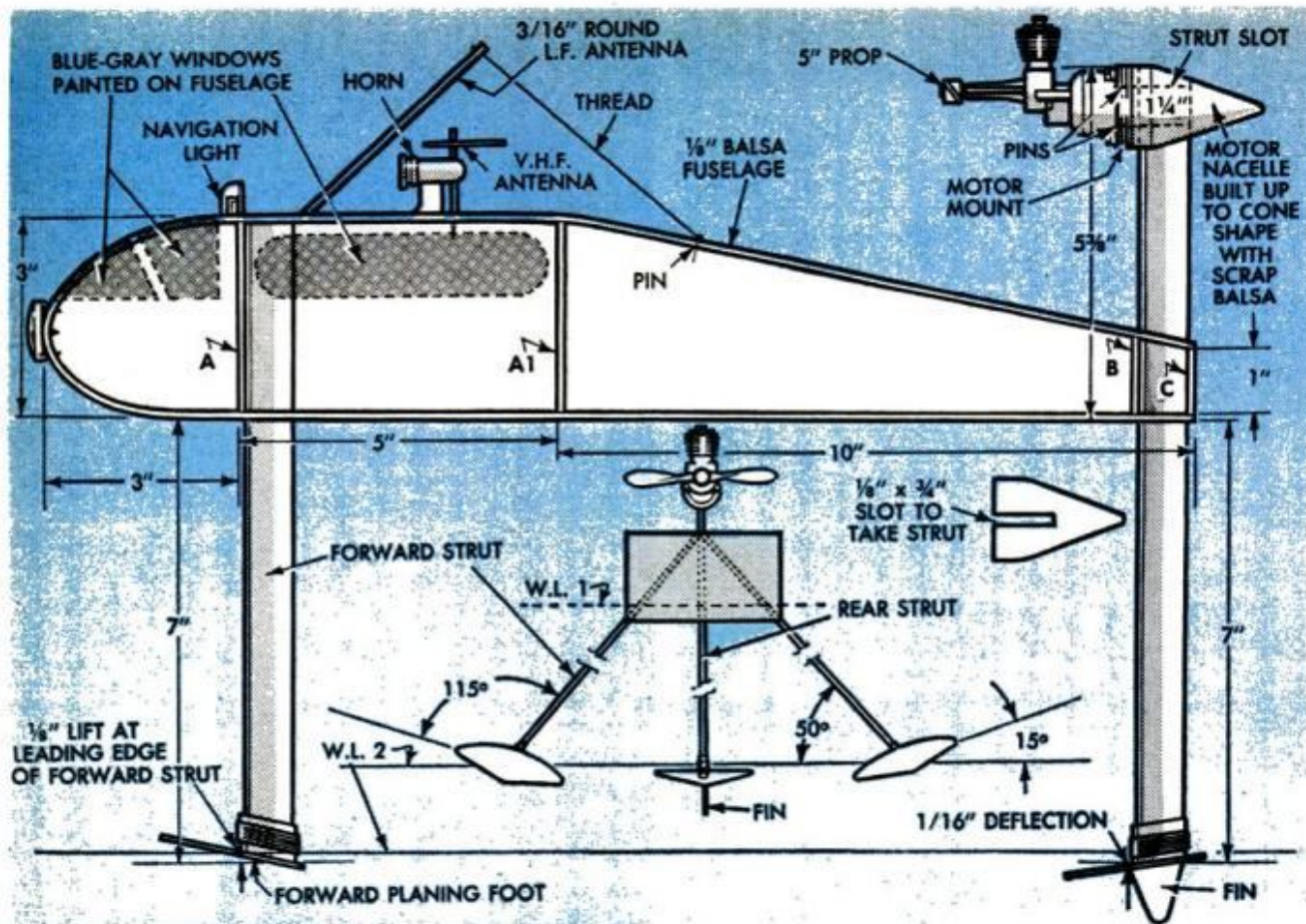

struts by lashing and cementing securely.

Finish off the model with scale radio masts, running lights and foghorn. A couple of screw eyes are used for the restraining bridle. If you use a tether, attach it in such a fashion that the boat dangles level when suspended by it.

If you don't have a model boat basin with tether post, you can run *Water Bug* off a spinning rod from a rowboat.

To launch the boat hold it by the motor mount and give a gentle push. It should climb out of the water in about 6 ft. with an immediate increase in speed. If it doesn't, turn up the front edges of the forward planing feet slightly. ★★★

## Simple Knot Comes in Handy for Shortening Your Anchor Line

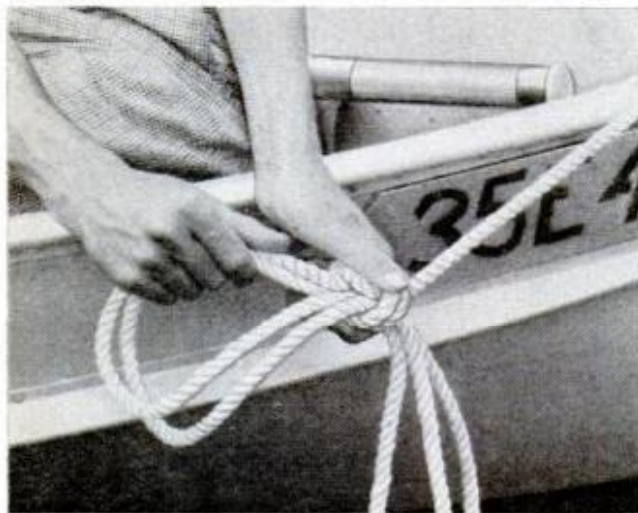

The next time you have to shorten your anchor line temporarily, just reach over the side, double the line and tie it in an openhand eye knot (one half of a bow). You can tie this knot in an instant, yet pull it out easily when you need more line. It comes in especially handy when fishing, allowing you to hold the boat right over that hole where the fish are.

—Jackson Hand

**Stripping insulation** from television lead-in wire without cutting any of the strands is done by holding it over a small flame. Catch the drippings in a tin can as they are very hot and stick like glue.



**MEAL TIME COMFORT** is assured when you take this portable kitchen shelter on your camping trips. It's held together with  $\frac{5}{16}$ -in. carriage bolts and dismantles quickly for easy hauling

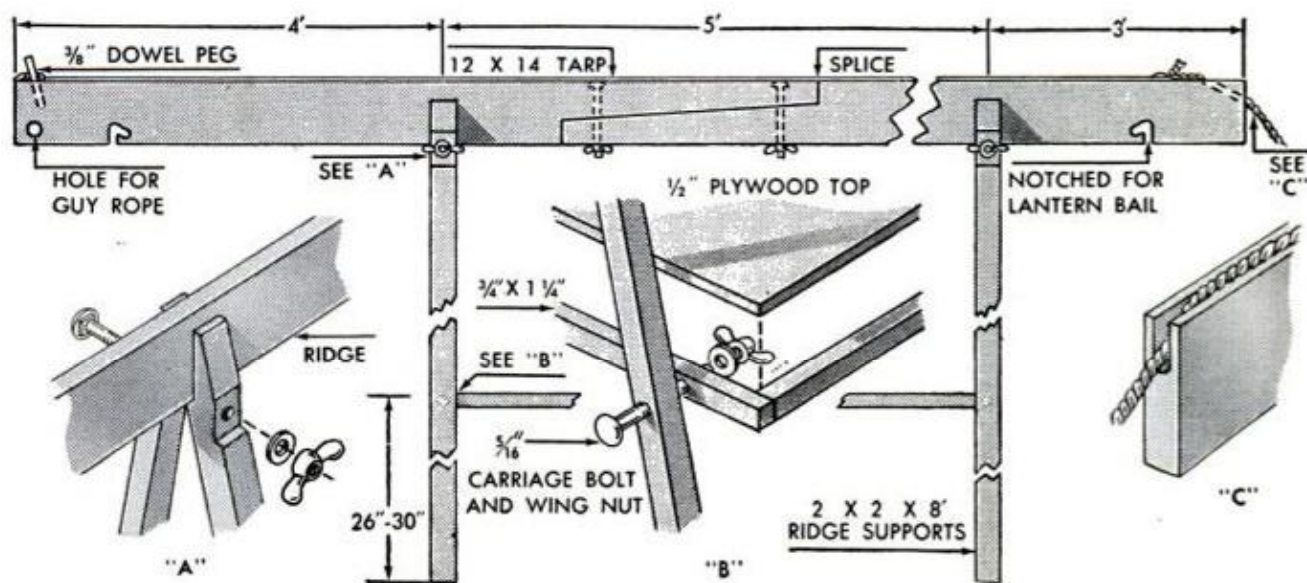

# SECTIONAL PATIO SCREENS





**O**UTDOOR LIVING with indoor privacy—that's the goal of most patio dwellers, but it's a difficult thing to achieve on the average residential lot. Most privacy walls and screens give the patio a closed-in look, destroying that feeling of spaciousness which is one of its most appealing features. A far better solution is this series of narrow sectional screens which can be "aimed" to block a particular view, while retaining as much of that wide-open-spaces feeling as possible.

Economical and attractive, these free-standing redwood-framed hardboard screens are mounted on conduit legs. You can erect them in a variety of different patterns, tailoring the arrangement to suit your particular privacy problem. Mounted alternately in two parallel rows as shown on the opposite page, they can either be lapped to provide a wall effect or aligned for a more open appearance.

Another variable is the distance between the rows. Space them close together for maximum privacy, farther apart for larger see-through openings.

### Other Modular Plans

The double-row arrangement works fine in cases where the view you want to block is at a right angle to one side of your patio. However, if the objectionable view is at another angle, you'd be better off mounting the screens in a single row, louver fashion, so that the screens are all facing the view which you want to block.

A third possibility is a single zigzag row, alternating the direction of the screens. This has the additional advantage of shutting out two different views, and can be a dramatic and decorative addition to your patio if you alternate colors, i.e., finish one screen red, the next one white, the one beyond red, etc.

### Construction Tips

You'll need two 4 x 6-ft. panels of 1/8-in. tempered hardboard for each set of three screens. The use of ready-primed hardboard will eliminate one step in the finishing operation. After cutting the panels into 32-in. widths (one screen being made up from two 18-in. widths), paint each one with at least one coat of exterior enamel, being careful to cover all edges.

Assemble by slipping the conduit uprights into the redwood end boards and fitting the hardboard into the slots. Hardboard edges on the split-panel screen will meet over the center brace and should be screw-fastened in place. Drill lead holes through the hardboard on 8-in. centers and use 3/4-in. galvanized self-tapping screws into the conduit. ★★★

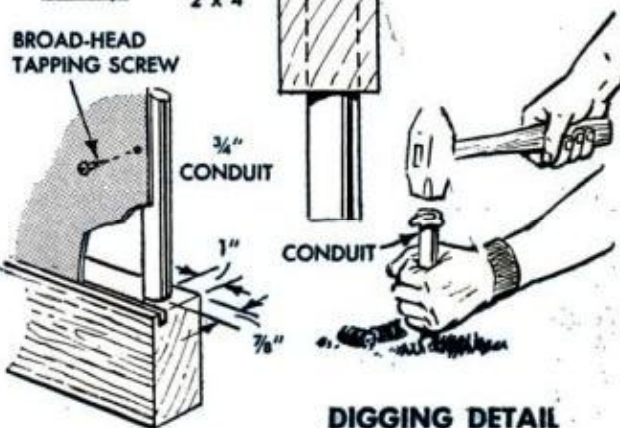
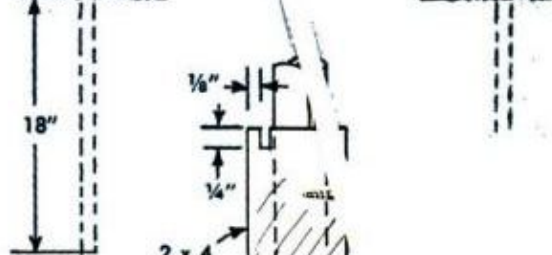
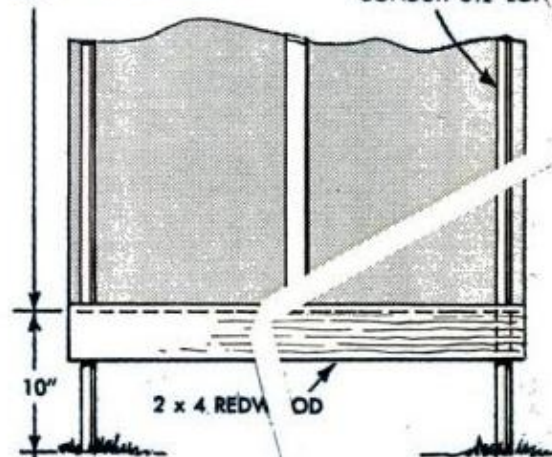
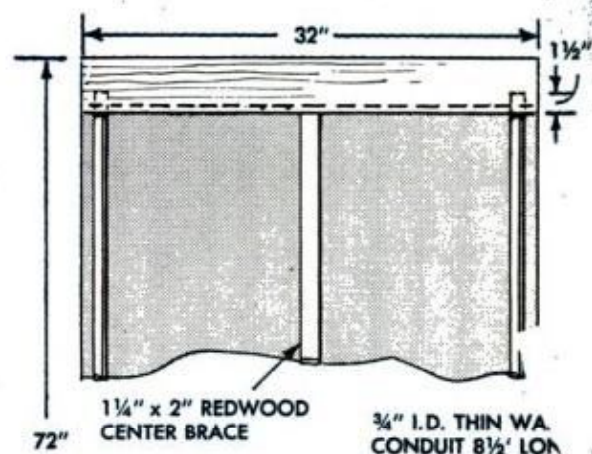
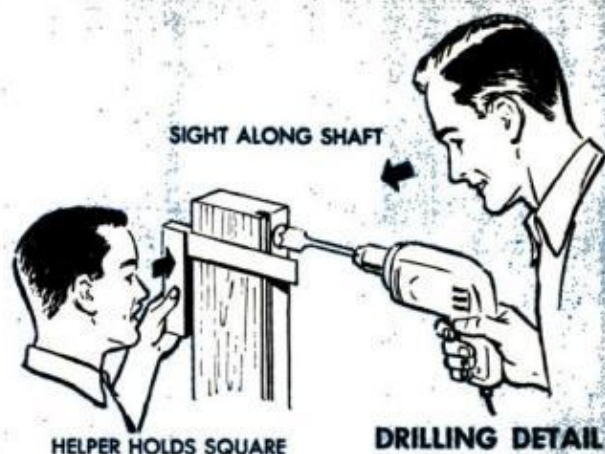

**DIGGING DETAIL**

# PM Tests The New Propane Spray Paint

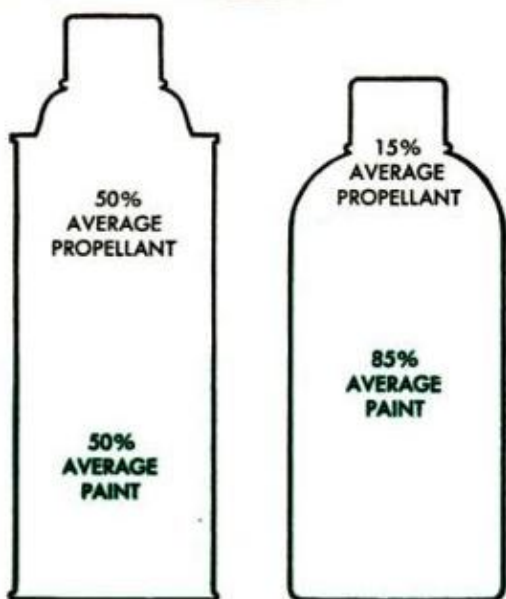
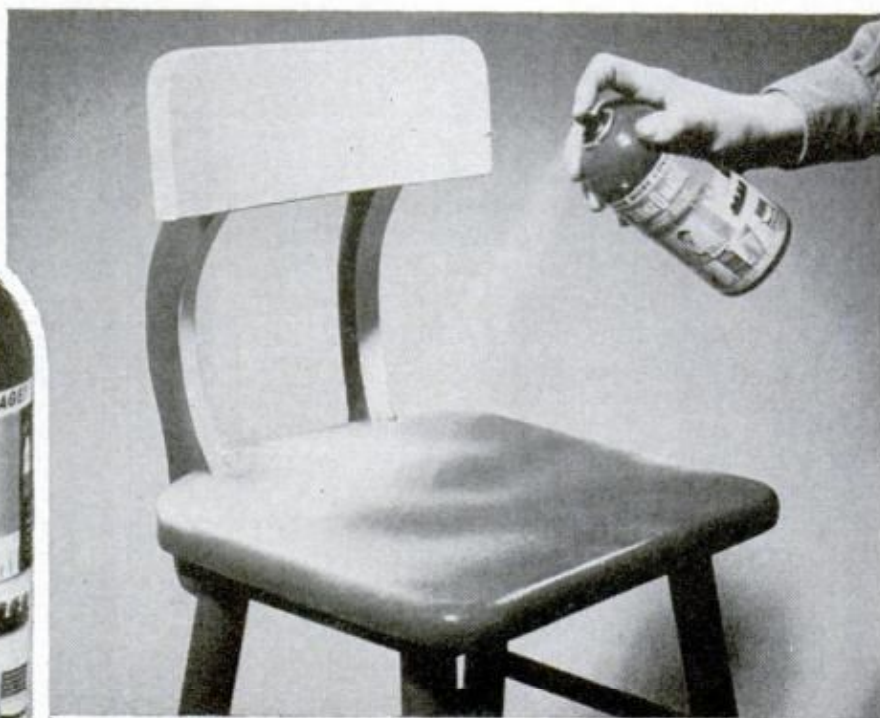

WHAT CAN the home craftsman expect from the new propane spray enamel introduced recently by BernzOmatic? To find out, *PM* editors ran a comparison test and here's how this new paint, which is propelled by propane gas, compared to conventional spray paint propelled by Freon gas:

1. The propane enamel gives more coverage per can primarily because there is more paint in the can. According to the manufacturer, this is made possible due to its seamless aluminum container which

withstands higher pressure and thus permits the use of less propellant. The amount of propane needed to expell the paint is only 15 percent of the can's total contents, whereas the amount of propellant in aerosol cans runs as high as 50 percent.

2. In ease of application, the propane enamel was similar to the Freon can. It was noted, however, that the new can tended to spatter occasionally, and had to be held somewhat closer to the work surface than normal. However, the propane can seemed to cover the surface just as quickly as the conventional spray can.

3. In terms of drying time and appearance of finish, the propane enamel was on a par with the Freon paints.

4. According to the manufacturer, the spray which comes out of the propane can is 100 percent paint, with no propellant mixed in. This does not mean, however, that the propane enamel can be used without the same safety precautions as the Freon paints. Both types require adequate ventilation.

What about cost? The BernzOmatic propane enamel, which is made in 15 colors, comes in two sizes—quarts and pints. The quarts sell for \$2.98 and the pints for \$1.79.

Freon enamels generally come in pint sizes, which retail from \$1.40 to \$1.79. Because of the greater *amount* of paint in a propane can, economy would seem to be the new product's chief advantage.

**NEW WIRE STRIPPER** anneals the inner copper wire while melting off the plastic covering. Eliminates nicking of the wire and is said to make it more flexible. Works with many types of plastic coverings. Two models—\$11.95 and \$19.95, postpaid. Sentry Electronics, Inc., 707 South Okfuskee, Wewoka, Okla.

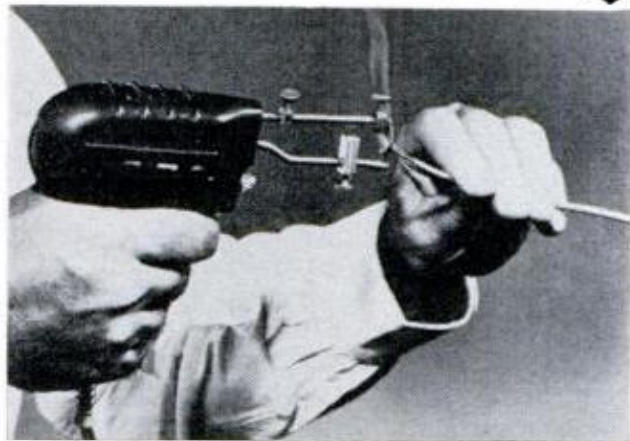

**MARTOR VISE GRIP WRENCH** is said to be safer for industrial use as it clamps tightly to the work and can't fall on workmen below. Also serves as portable vise. Made in 10-, 14- and 18-in. sizes at \$6.50, \$7.50 and \$10.50 respectively, F.O.B. Beaumont. From J. L. Bagarry, Jr., 2646 Liberty Ave., Beaumont, Tex.

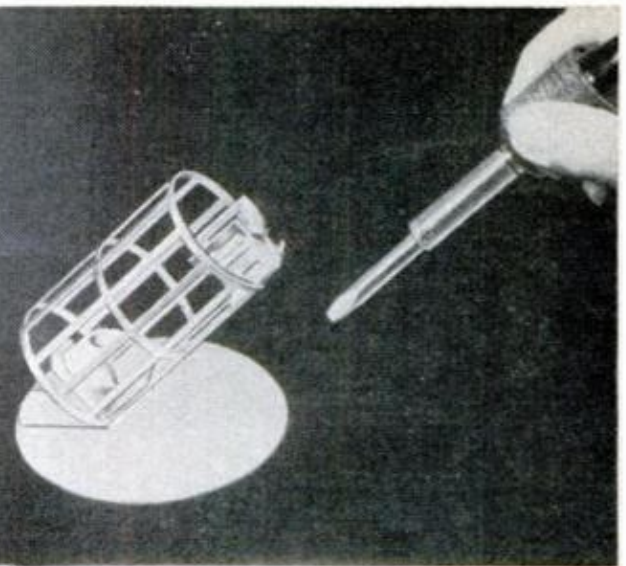

**SOLDERING IRON HOLDER**, called the H-22 "Little Joe," features the "Sta-Tinned" soldering cup and heat retaining liner. Holds tip of iron in molten solder, ready for use. Adjustable slide permits use of pencil-type irons. Price \$2.95. MacDonald & Company, 714 East California Street, Glendale 6, Calif.



**UP TO 300 STAPLES A MINUTE** can be driven with the Duo-Fast Electric Tacker. Said to drive staples up to  $\frac{3}{8}$  in. into hardwoods,  $\frac{1}{16}$  in. into soft woods. Uses no pneumatic equipment; works on 110V a.c. Lists at \$85. Fastener Corp., 3702 River Rd., Franklin Pk, Ill.

**BANTAM-SIZED CHUG A SAW** weighs only 10 lbs. measures 8 x 10 x 24-in. Its 9-in. cutting bar fells trees up to 18 in. in diameter and its  $\frac{3}{4}$ -hp. engine is said to burn only a pint of fuel per hour. Costs \$109.50. Chug A Saw, Box 3521, El Monte, Calif.

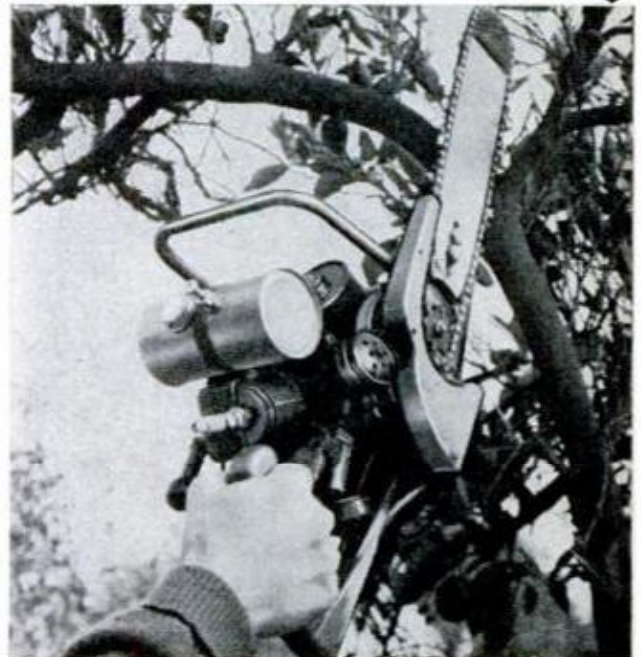
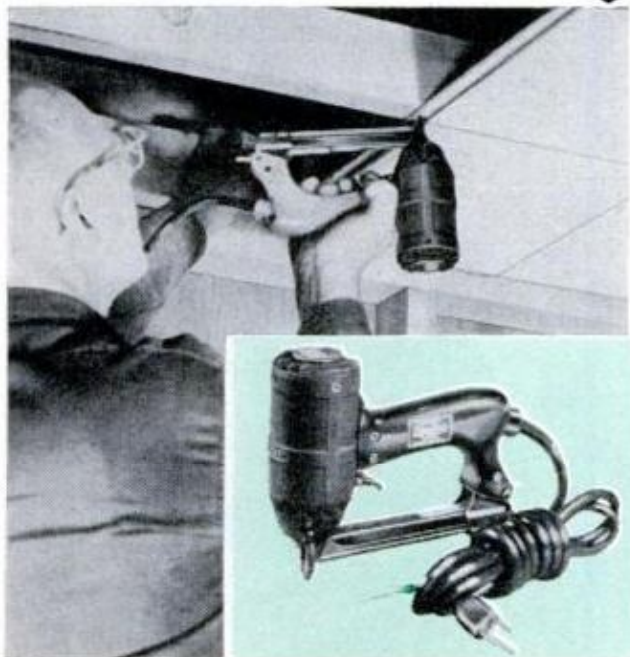

# LAWN PARTY LAMPS

Easily made from aluminum, these two portable yard lights can be used in various combinations to set the perfect mood for after-dark parties

By David M. Swartwout

**A**FTER A RECORD cold winter, lawn and patio entertaining should be especially festive this summer, and these two portable lamp designs will light up your outdoor parties in grand style. They're made from do-it-yourself aluminum which is available in most hardware stores, and you'll want to make a whole set—to plant along dark walls and paths, to hang from low branches and projecting beams or to stand along the border of a paved area.

Together, the lamps present a completely flexible outdoor lighting system. Their light weight makes them easily portable, so you can try many different groupings to shed soft light on a variety of activities or to add dramatic accents to shrubs and rock gardens. They'll even do wonders toward keeping exuberant guests from stumbling into the fish pond.

The parasol type has a pointed stake to push into the turf—or you can equip it with a base disk for standing on the patio. The square coach light simply dangles at the end of its power cord.

If you tucked a naked lightbulb inside a cage of perforated metal, the harsh glare would destroy the grillework effect. So what you shop for first—before starting construction—is a large plastic shaker

or pitcher with relatively straight sides, to act as a diffuser. You should be able to buy these at housewares, hardware or variety stores. The dimensions on the parasol pattern, page 140, accommodate a shaker 7½ in. tall, and about 4¼ in. in diameter. The hanging lantern calls for a 5-in.-tall square quart container. If the polyethylene units you buy are of a different size, simply adjust the cutting measurements to suit. Planning to make several lamps? Use diffusers of various colors—the plastic is usually available in blue, green, pink and yellow.

Any of the perforated patterns in do-it-yourself aluminum sheet can be used for the grille. The Lincane pattern was chosen for the parasol lamp shown, and the cloverleaf design gave a Spanish flavor to the coach light, page 142. Leather-grain was used for both tops—a 16-in.-square sheet for the fluted parasol and a 12 x 13-in. sheet for the coach lamp's pyramid. A 6-ft. length of 1-in. tubing with an embossed pattern serves as the parasol post.

The post is joined to the lamp by means of a standard floor flange for 1-in. tubing. In order to pass the light cord through the flange, you must discard the installation bolt and spring clip and drill or

## SOLDER ALUMINUM ?

It isn't as tricky as you may think—once you master the tips on the following pages

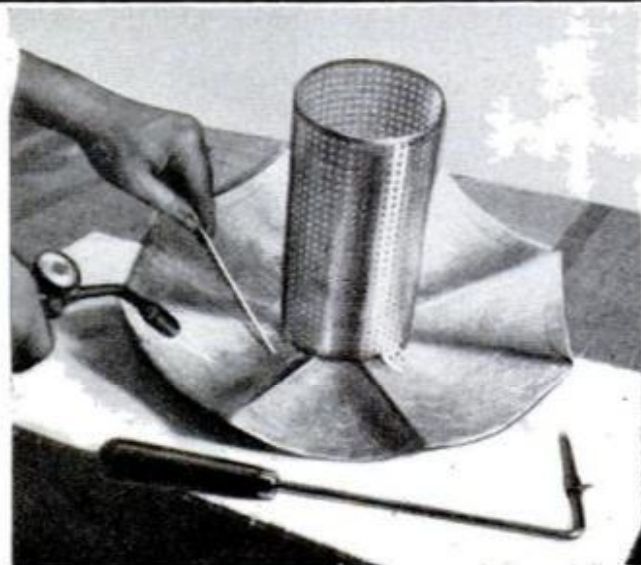
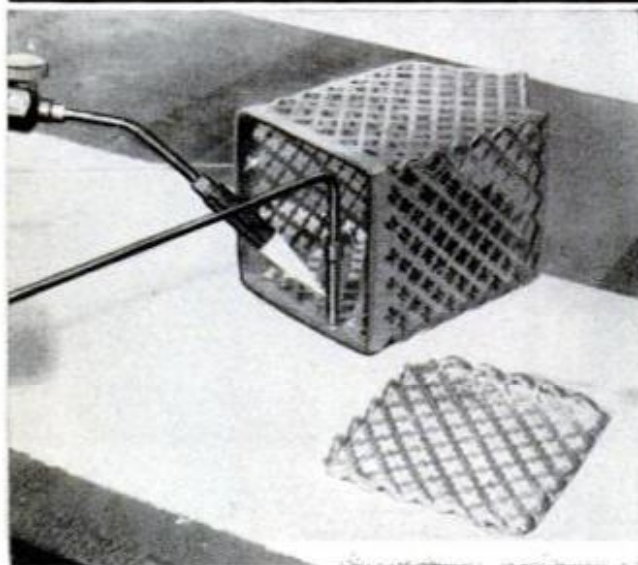



ream out the tapped hole. Then, using the flange as a guide, drill holes in the bottom of the plastic container for the cord and two bolts. These bolts also pass up through the base of the socket (you may have to alter the existing mounting holes) so that when the nuts are turned down, the base of the container is snugly sandwiched between the socket and the flange. To aid in ventilation, drill a ring of holes beyond the edge of the flange, as shown in the sketch, page 141.

To join this assembly to the post, your best bet is to coat the flange's core stub with epoxy cement, since the hole for the wire has destroyed the original means of anchoring the flange in the post.

To push the post in the ground the 6 to 10 inches required to hold the lamp upright, you must insert a pointed wood plug in the bottom, holding it in place with a single screw. Or, for patio use, fasten a second floor flange to a 12-in. disk of exterior plywood with  $\frac{3}{4}$ -in. #10 FH screws. In either case, drill the cord hole close to the ground line.

Regular household scissors can be used to cut the grille pattern. Find a large tin can to serve as a bending form and you're ready to solder the lap joint. The thing

to remember when soldering untreated aluminum is that it's coated with an aluminum oxide film which must be broken through by the friction of a glass fiber brush. The brush is rubbed back and forth (or in tight circles) in molten solder, pressing hard enough to abrade the surface. By sealing the surface from the air, the solder prevents reforming of the oxide film. This is called "tinning".

First, clean all areas to be joined, using a solvent that removes oil and grease. When dry, heat these areas with a mild flame directed on the opposite side or around the area to be soldered. The flame can be natural gas, butane or propane, but beware of that hot-spot at the tip of the blue tongue. Test the flame on a scrap of sheet aluminum to see how much heat the metal can take. Too hot a flame

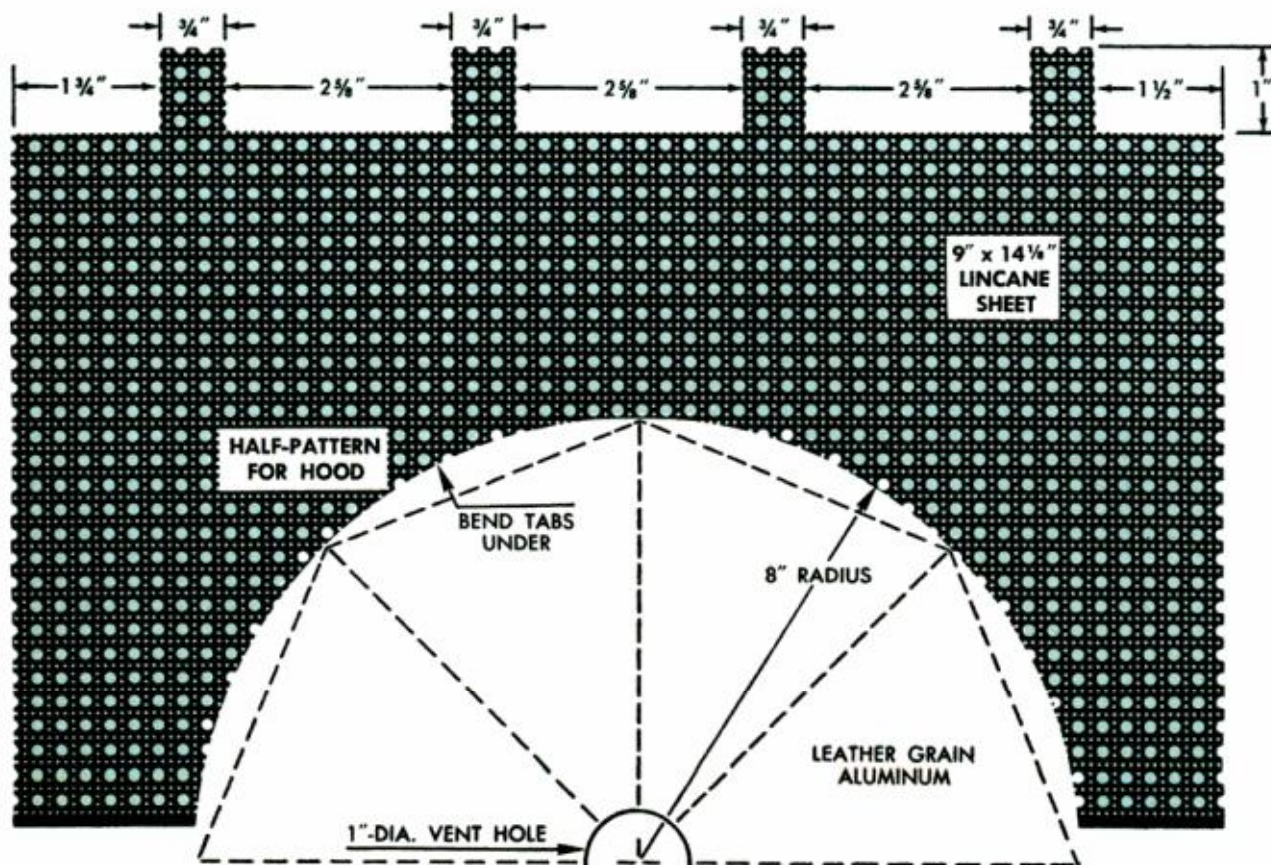
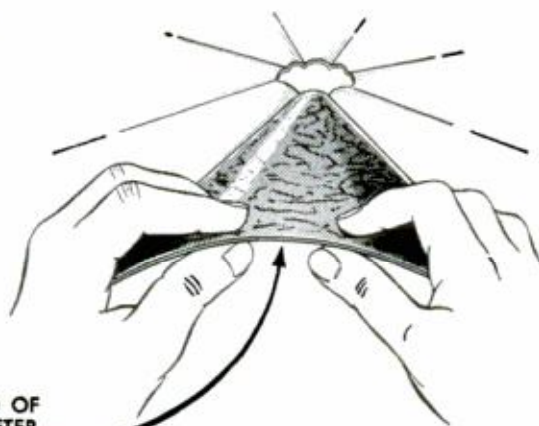
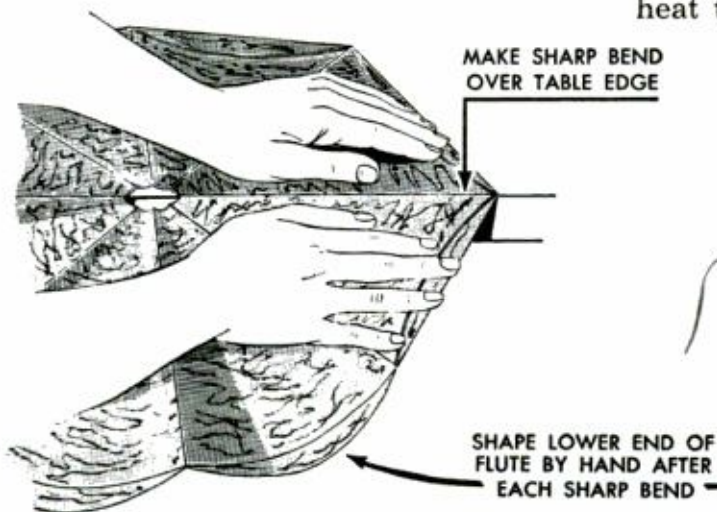
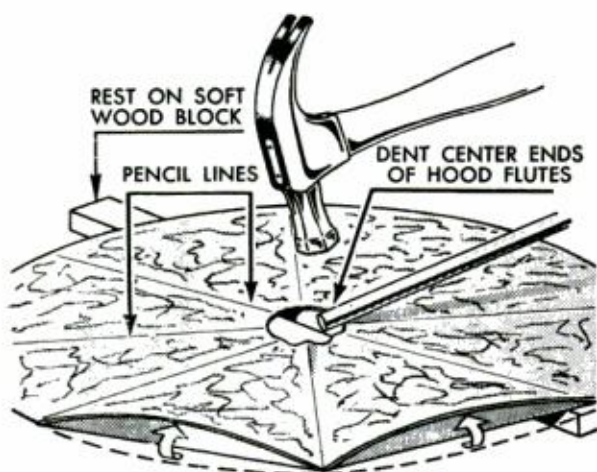

can burn holes in aluminum. The proper temperature is one that causes a drop of aluminum solder to melt when placed on the pre-heated aluminum. Maintain enough heat to keep the solder molten, but never apply heat directly to the solder. An ordinary hot plate supplies enough heat for a soldering job on thin sheeting.

Join the tinned areas while they're at soldering temperature, adding more solder as needed. Hold the joint tight until the assembly cools and the solder solidifies.

For the coach lamp, next page, you'll need a hanging socket and a threaded plastic sleeve to fasten the socket to the roof. Again, it's a good idea to drill several 1/4-in. vent holes in the bottom of the diffuser. The tops of both lamps are removable for access to the socket when a bulb needs replacing. The aluminum can be left natural or sprayed any color. ★★



## SOLDERING TIPS

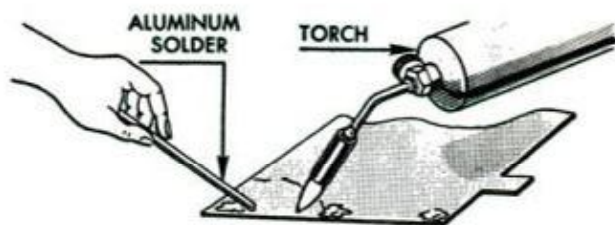

1. MELT SOLDER ON HEATED ALUMINUM.

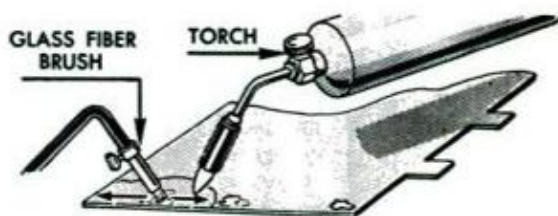

2. ABRASE SURFACE WITH BRUSH IN MOLTEN SOLDER (TINNING).

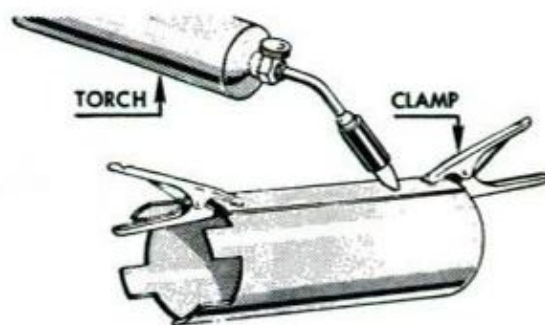

3. HEAT AREA NEAR SOLDER TILL SOLDER MELTS. LET COOL TO FORM BOND.

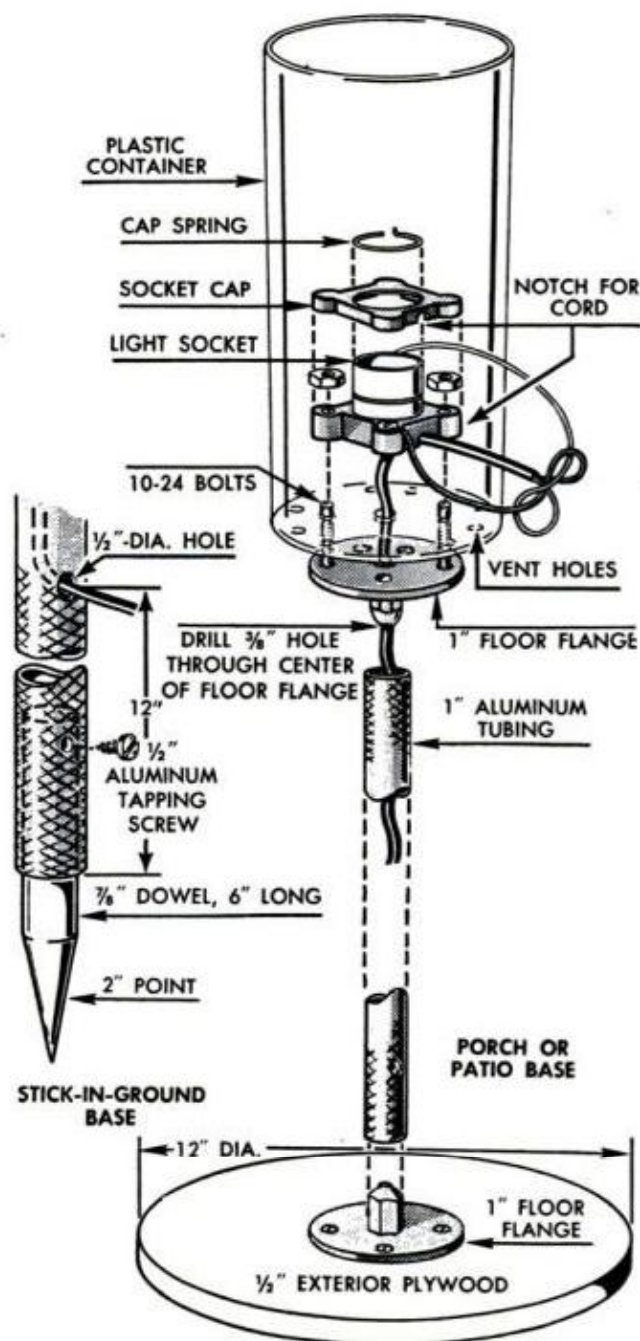

PLANS FOR SECOND  
LAMP ON NEXT PAGE



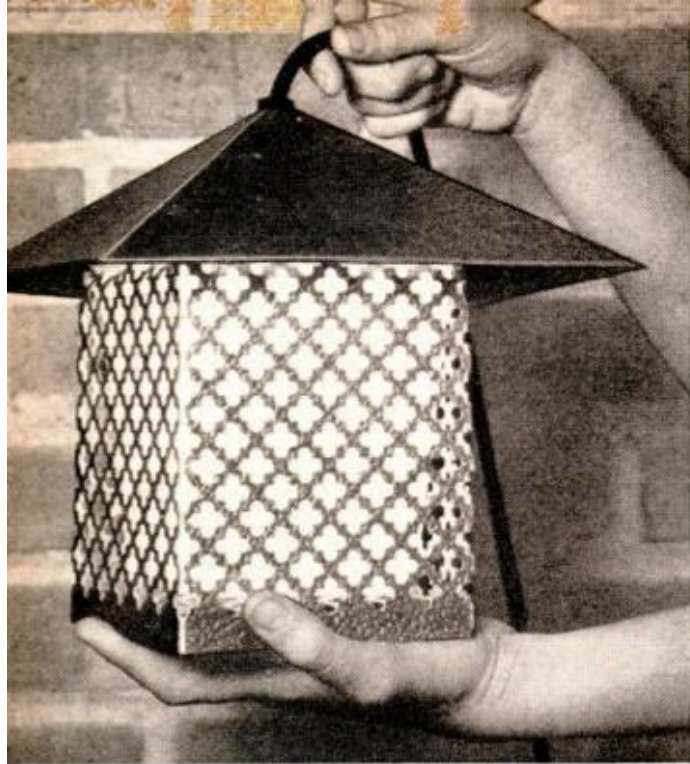

YOU RAISE THE ROOF of this lightweight lamp to replace the bulb. The pyramid is folded from the flat pattern below, and held in place by two brackets pinned through perforated tabs (detail above right)

### HANGING COACH LIGHT

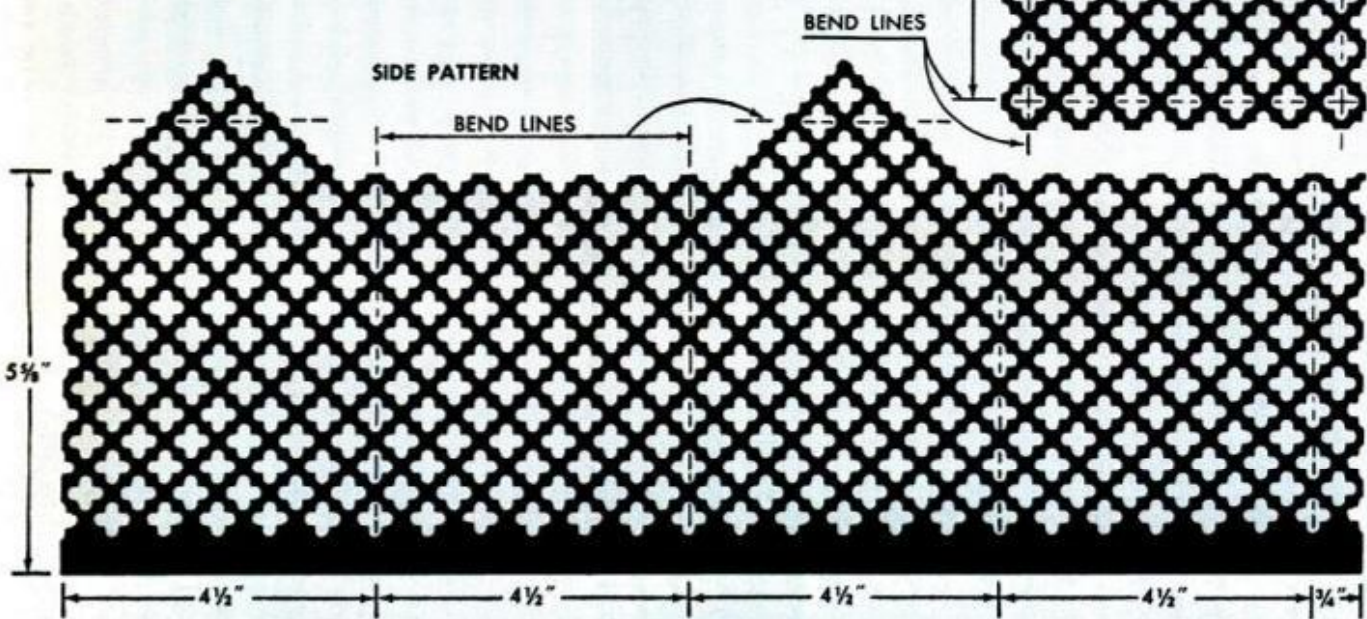
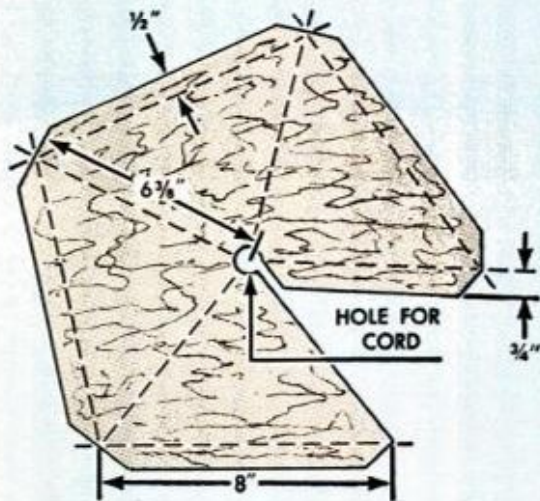
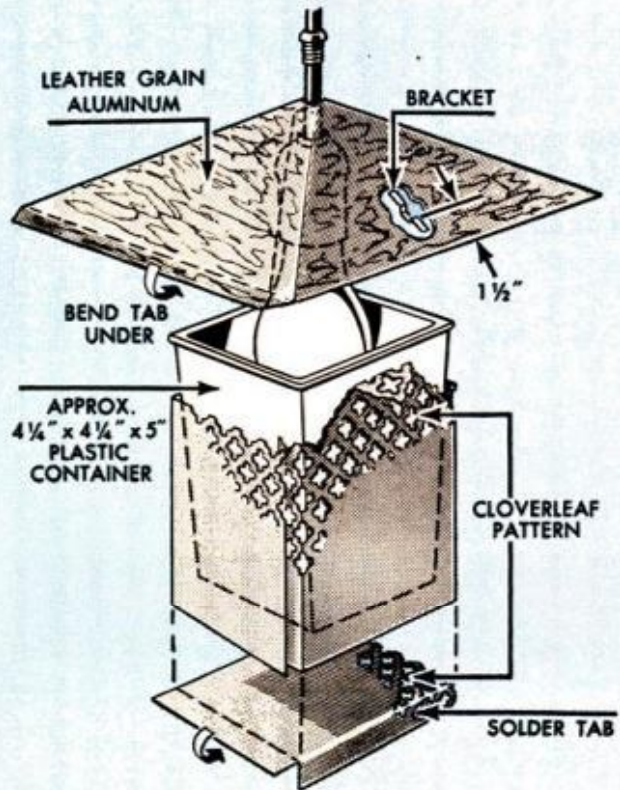
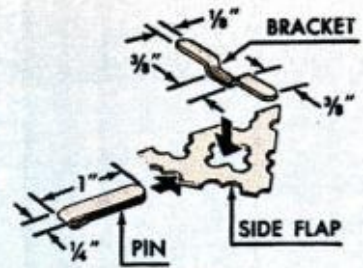



## Backstop for Marble Games

Playing with marbles is a favorite rainy day activity with most children. It's a sure cure for boredom, because a child can make up an unlimited number of games requiring only a sack of marbles. The one drawback from a mother's view is that she finds herself picking up lost marbles for a week afterward. To avoid this, give the children an extension curtain rod to use as a backstop.

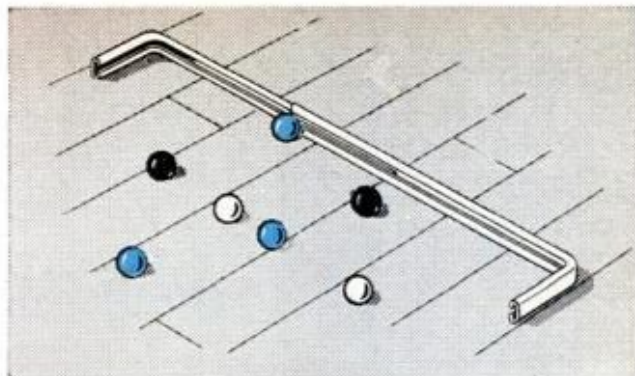

## When Hens Fly the Coop

After a couple of exhausting chases along a straight fence next to the chicken yard, trying to capture a hen which had slipped out of the coop, one Iowa chicken farmer made up a portable screen such as that shown at right. The next time the hen made an escape attempt, the farmer mounted this screen at a right angle to the fence and chased the pullet into this "portable corner."

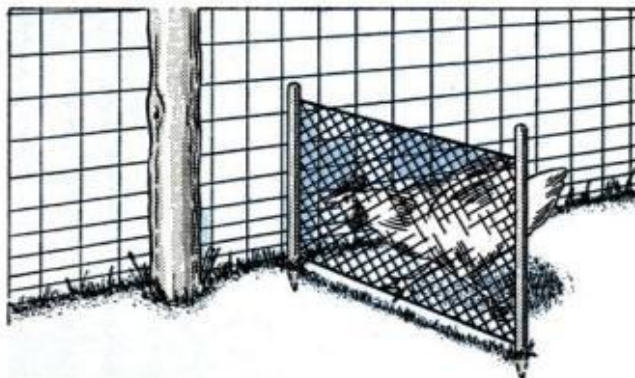

## Handle for Mousetrap

Placing a set mousetrap far back under furniture or in other out-of-the-way places is a delicate job. Often, the trap is accidentally sprung in the process. However, you can avoid such difficulties by bending a coat hanger to form a holder and taping the trap over it. If your wife is a little squeamish about such things, she'll also appreciate being able to remove the trap without touching a dead mouse.

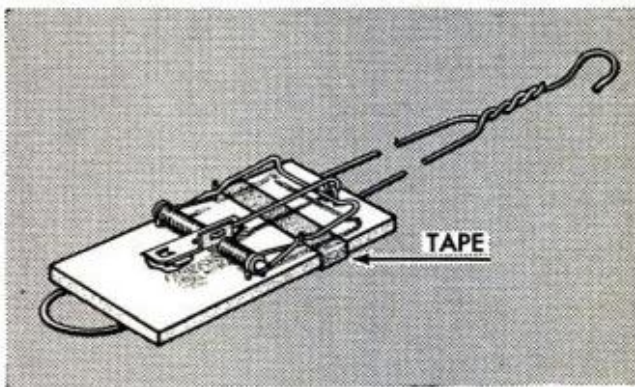

## Tiddlywink Prizes in Teacups

Planning a child's birthday party? Try this new twist on the old game of tiddlywinks. Use inverted tea cups as targets for the flipped disks and conceal small prizes under the cups. The indented bottoms of the teacups will hold the disks and give a three-dimensional thrill to this familiar game. For another unusual wrinkle, place notes under the cups describing penalties for the high and low scorers.

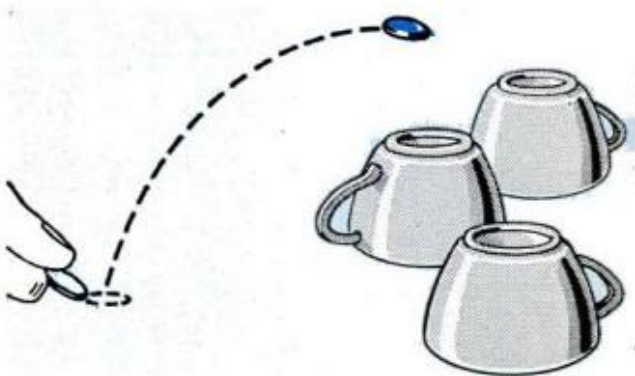

## Tape-On Stop Rides Table

When making a right-angle cut in a piece of stock that is too wide for use of the miter gauge and too long for the saw fence, cut a straight scrap of stock to the length of the board and attach this to the underside with strips of masking tape. This will guide the board for an accurate right-angle cut and also eliminate the need for C-clamps which might mar material.—G. E. Hendrickson

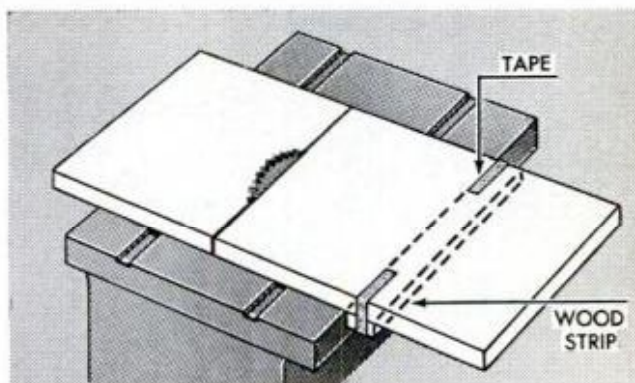



## MERRY-GO-SPIN

HALF THE FUN of this spinning disk is trying to stay on it since there's nothing to hold on to. The faster it spins, the more centrifugal force tries to throw you off. However, youngsters won't hurt themselves in tumbling off as the disk is only 14-in. off the ground.

The disk itself is made by joining two semi-circles cut from 4 x 8 sheets of  $\frac{3}{4}$ -in. exterior plywood with a 1 x 4 cleat. Fasten the cleat to the underside with waterproof glue and  $1\frac{1}{2}$ -in. No. 9 F.H. screws, then round the top and bottom edges of the disk.

The bearing plate should be 6-in. in diameter and of high-carbon steel. Drill its four bolt holes and lubrication hole before welding it to its 2-in. pipe. Next, weld the four flat steel braces to the pipe, then bolt the entire assembly to the plywood disk as shown, using  $\frac{1}{2}$ -in. bolts.

It's best to assemble the fixed axis of the disk completely before embedding it in concrete. Use a 27-in. length of  $1\frac{1}{2}$ -in. pipe and make the anchoring braces of  $\frac{3}{4}$ -in. steel angle, 6 in. long. The  $\frac{5}{8}$ -in. pointed pivot pin should be of tool steel, and should be screwed and welded into its plug before the plug is welded into the pipe. Of course, the pipe must be braced perfectly plumb when the concrete is poured, and the braces left in place until the concrete hardens. Then, wait three or four days before putting the disk onto the axis, as concrete breaks easily until thoroughly cured.

Final step is painting the entire apparatus with a bright-colored enamel, after which, you're ready to spin.—Hi Sibley

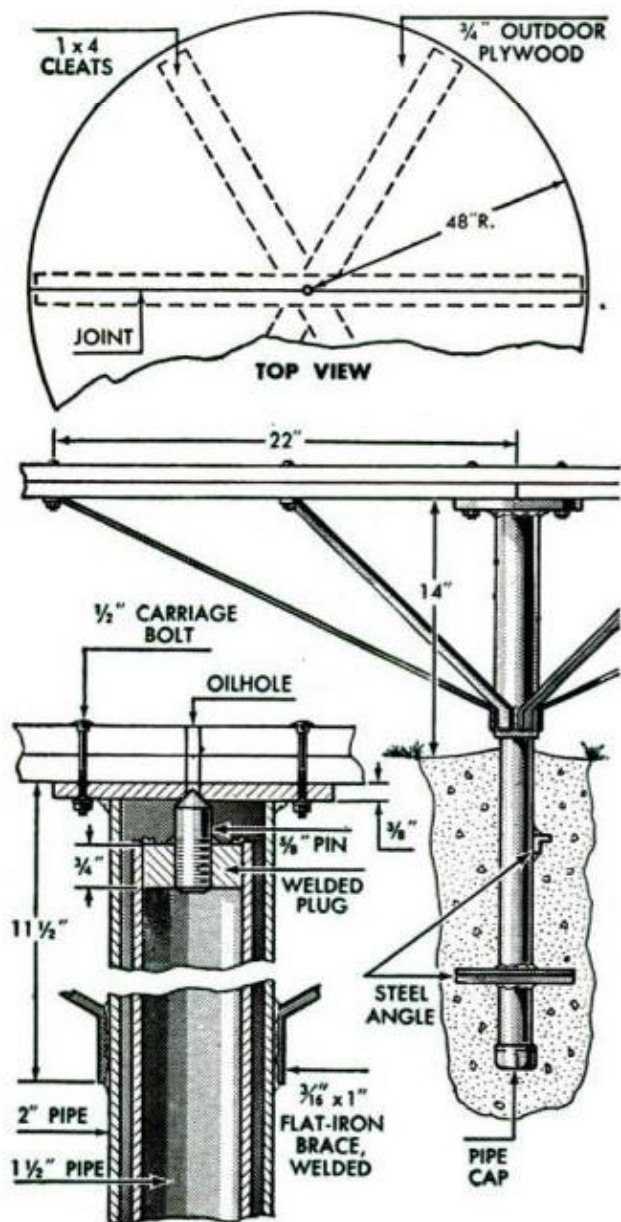

**PLUG-IN CONTROL** is said to vary the speed (without loss of torque) of any power tool equipped with a universal electric motor of up to 1/2 hp. Connects as easily as an extension cord. Also works as dimmer for drop lights. Retail for \$15.95. Seco Electronics, Inc., 1201 South Clover Drive, Minneapolis 10, Minn.



**ADJUSTABLE CLOSET BAR** comes in stock sizes to fit closets up to 120 in. wide. Angled lower screw holes permit fast, easy driving of screws. Said to be 25% stronger than round bars. Prices start at about \$1.47. The nylon hanger glides are ten for 98¢. Made by The Stanley Works, 195 Lake St., New Britain, Conn.

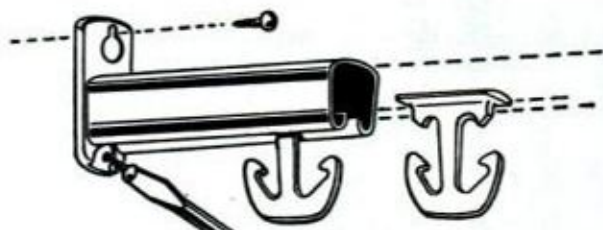

**EPOXY ADHESIVE**, called Minit-Grip, sets in only 60 seconds. Resin and hardener are dispensed from hypodermic-like tubes that allow user to mix exact amount required. Manufacturer says bonding power is the same as other epoxy glues. Price is 98¢. Harvey Home Products, 549-A Tremont St., Boston 16, Mass.

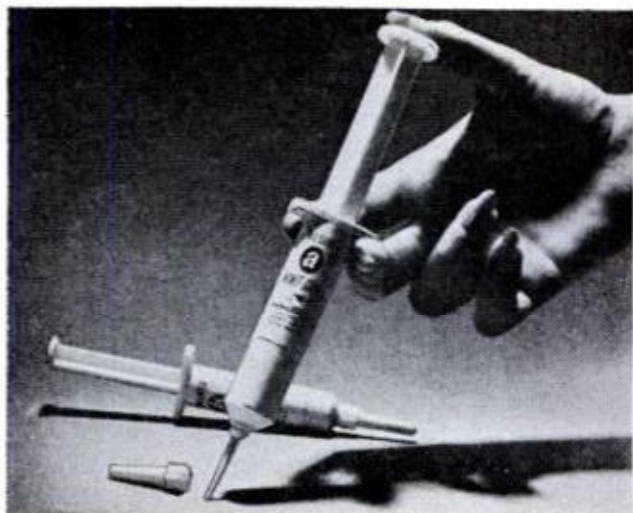

JUNE 1963



**EMULSION-TYPE ADHESIVE** for asphalt and vinyl tile is applied with paint roller, can be cleaned up with soap and water. For use on, above or below grade. Called Grip-Tite Roll-On Adhesive Type 10. Comes in quart, gallon, 3 1/2-gal. and 5-gal. sizes. Write Curtis Products, Inc., 3233 W. 36 St., Chicago, Ill.

**SAFETY ROTARY-MOWER** blade is said to prevent accidental lacerations and injuries from thrown rocks, glass, etc. Its four swiveled cutters are held straight out by centrifugal force, but swing back harmlessly upon striking hard objects. For most 19- to 22-in. mowers, \$8.95. Wellington Corp., Wellington, Ohio

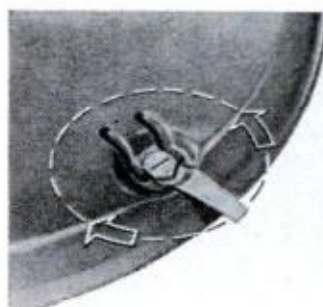
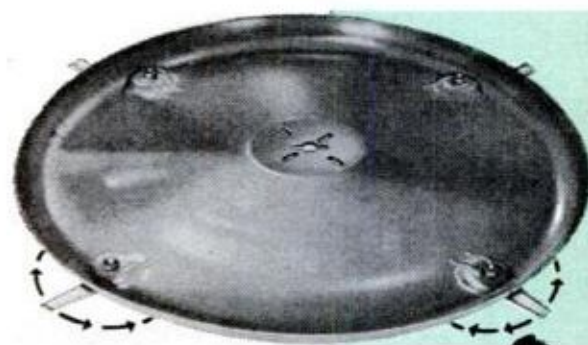

145

# DRIFT SOCK

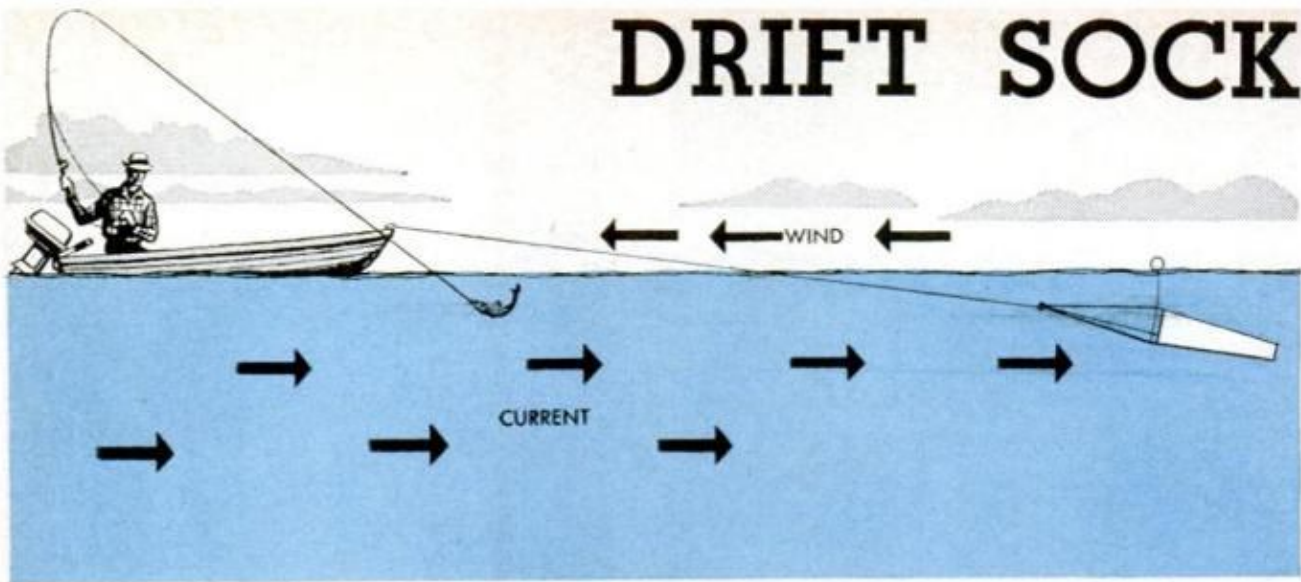

THIS FISHERMAN'S VERSION of the old-fashioned sea anchor will be a welcome accessory on those frustrating days when a strong wind and fast drift make it almost impossible to cast and cover promising weed beds and sand bars. Even when you aren't faced with the ideal current-wind situation illustrated above, the sock will cut your drift speed greatly and keep the bow heading into the wind with no side twisting. Thus, you can spend your time fishing instead of battling the wind.

The sock illustrated here is large enough for boats 14 to 16 ft. long. To make it you'll need: a  $\frac{1}{8}$  x  $\frac{3}{4}$  x 56-in. aluminum bar; three  $\frac{3}{8}$ -in. aluminum rivets or bolts; three  $\frac{1}{2}$ -in. grommets; a 2-in. metal ring; plus canvas, heavy nylon thread and  $\frac{1}{4}$ -in. nylon rope.

Begin by bending the aluminum bar to

form a hoop, overlapping the ends 3-in. Drill three holes in this overlapped portion and rivet or bolt the ends together. After cutting the canvas, double-stitch a 1-in. seam to form a cut-off cone shape and turn the sock inside out so the seam doesn't show. Then slip the hoop over the front of the sock about  $1\frac{3}{4}$ -in. from the edge and fold the canvas back over it. Stitch it at least three times, since this seam will have to take the greatest strain.

Next, install the three grommets in the double thickness of canvas behind the hoop and attach the three tie-ropes with bowline knots. Finally, using the same knot, tie these ropes to the 2-in. ring which is attached to the pull rope. The pull rope should be at least twice as long as the boat. For shallow water operation, add a cork float to the sock.—Don Mathesius

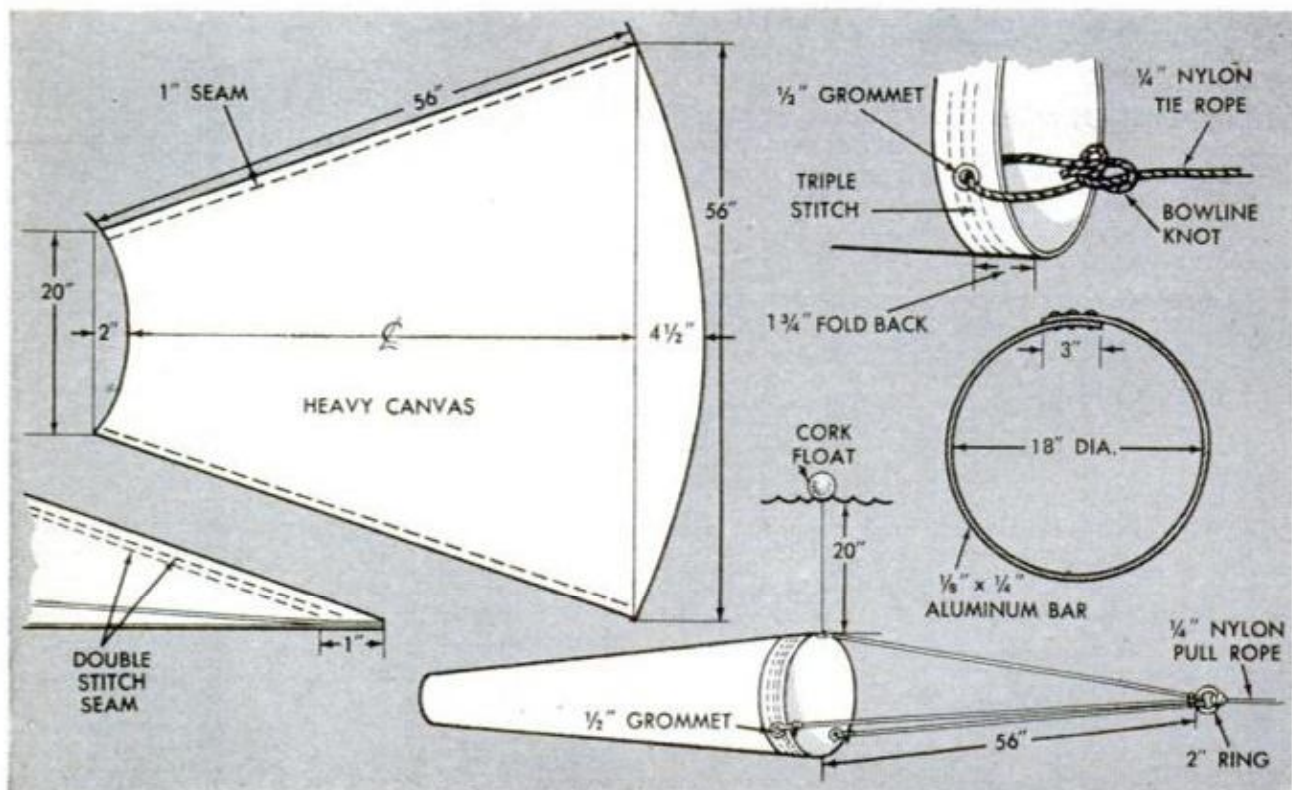

# New Special

**GROUPSHOW REAR PROJECTION SCREEN** folds into its own 3 x 24 x 31-in. carrying case. Its 18 x 24-in. screen works in normal light, with any projector, and is suitable for use with up to 50 people. Ideal for salesmen, teachers, etc. Price is \$95. Made by Hudson Photographic Industries, Irvington-On-Hudson, N.Y.

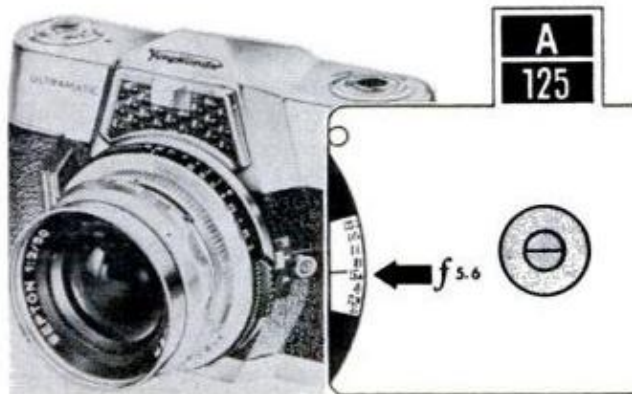
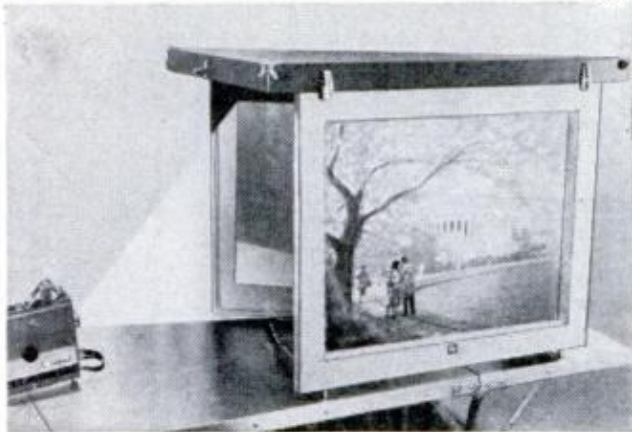

**JET-ACTION PRINT WASHER**, trade named Mid-Jet, washes prints in 30 minutes—half the usual time for amateur equipment. Takes 10 double or 15 single-weight 11x14's, or equivalent number of 8x10's or 4x5's. Measures only 3¼ x 17¾ x 17½ in. Costs \$29.95. Simmon Bros., 30-28 Starr Ave., L.I. City, N.Y.

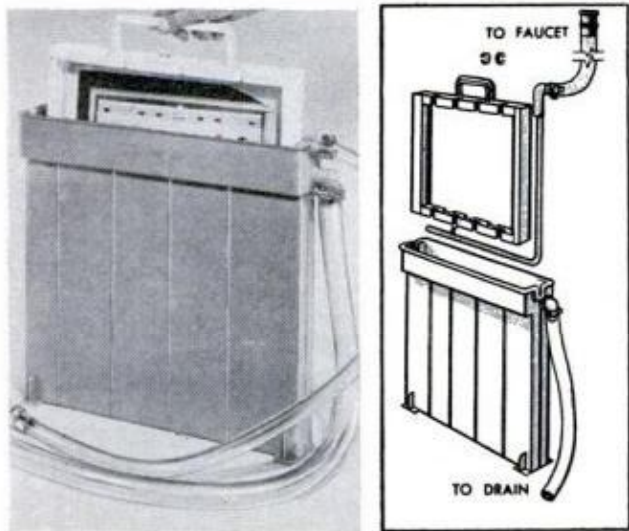

JUNE 1963

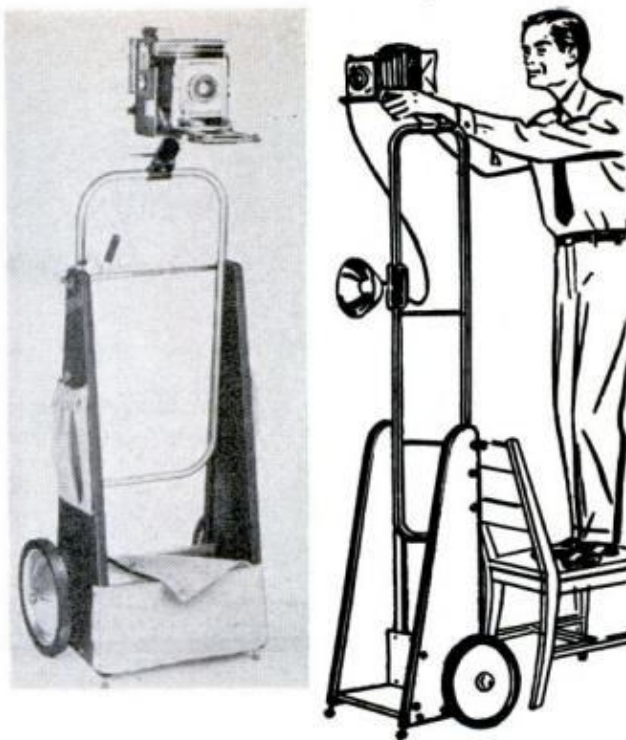

**ROLL-POD** is a highly versatile "gadget bag" and "tripod". Carries heavy, bulky equipment with ease and rigidly supports camera and lights while shooting. Holds the camera at heights of 1 to 5 ft., for standard shots or copying. Price: \$49.95. Kinnard Company, 5703 W. North Avenue, Milwaukee 8, Wis.

**VOIGTLANDER ULTRAMATIC** 35-mm single-lens reflex offers full and semi-automatic, plus manual control. F-stop and shutter speed show in viewfinder, which also warns of high and low light. A dial compensates for back light or filters. Lists at \$295 and up. H. A. Bohm & Co., 2814 W. Peterson, Chicago 45, Ill.

**COMPACT SLIDE PROJECTOR** fits in a briefcase, yet is said to perform as well as larger units. Measures approximately 5½ x 3 x 4-in. when folded. Wide-angle lens fills entire screen from up close. Called Maruya Pet Model V, it sells for \$29.50 plus \$1.25 postage. Seymour's, Inc., 350 W. 31 St., New York 1, N.Y.



147



PRINTING

# Rollaway Darkroom

By F. C. Clark, Jr.



DEVELOPING

**M**ANY SHUTTERBUGS would like to have a darkroom, but lack the necessary space. If that's your problem, you can solve it with this rollaway darkroom which nests when not in use.

Although it stores in a space measuring only 3x5 ft., this unit is large enough for just about every photographic operation. It's ideal for use in a corner of a utility room or basement, and it permits you to use a full-sized enlarger, instead of the less convenient "portable" type.

The rollaway darkroom consists of two separate counters—a sink for developing prints and negatives, and a dry table that nests under the sink for storage (see photo, bottom left). In use, these counters can be arranged at right angles to each other, or parallel as shown above.

To build this darkroom, you'll need three 4x8 sheets of exterior grade plywood—one  $\frac{3}{8}$ -in., one  $\frac{1}{2}$ -in. and one  $\frac{3}{4}$  in. thick. You can cut up the sheets into the required parts yourself, following the cutting diagrams on the opposite page, or have the lumberyard do it for a small additional charge.

It's a good idea to number the pieces as they're cut, to simplify assembly later on. Besides the plywood, you'll need three pieces of 1-in. pine 59 in. long—a 1x4 for the sink front, a 1x4 for the sink back and a 1x8 for the shelf over the sink. For supports and cleats, you'll need two 26 $\frac{1}{2}$ -in. lengths of 2x4, two 24-in. 1x4s and about 30 lineal feet of 1x2.

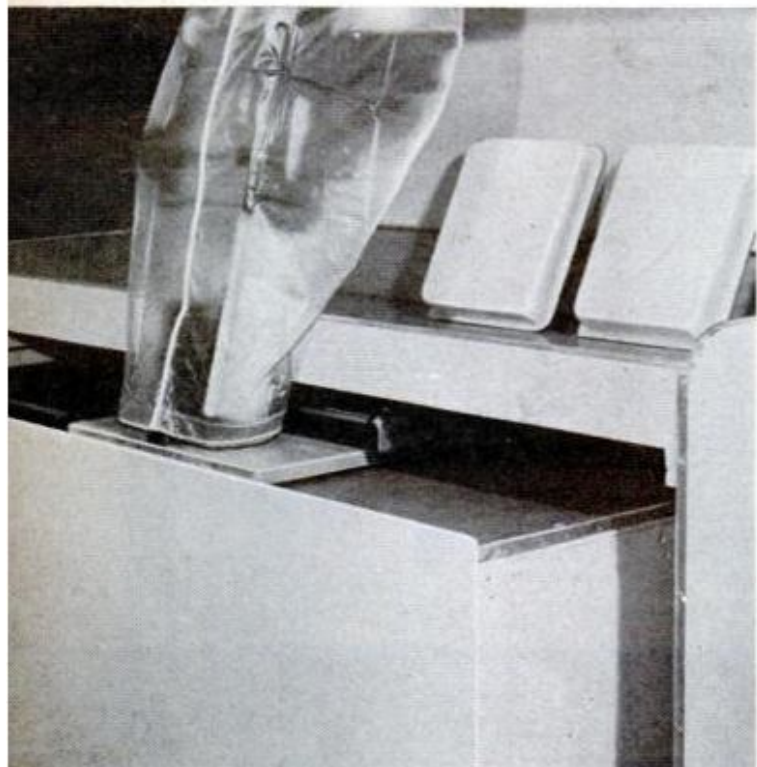



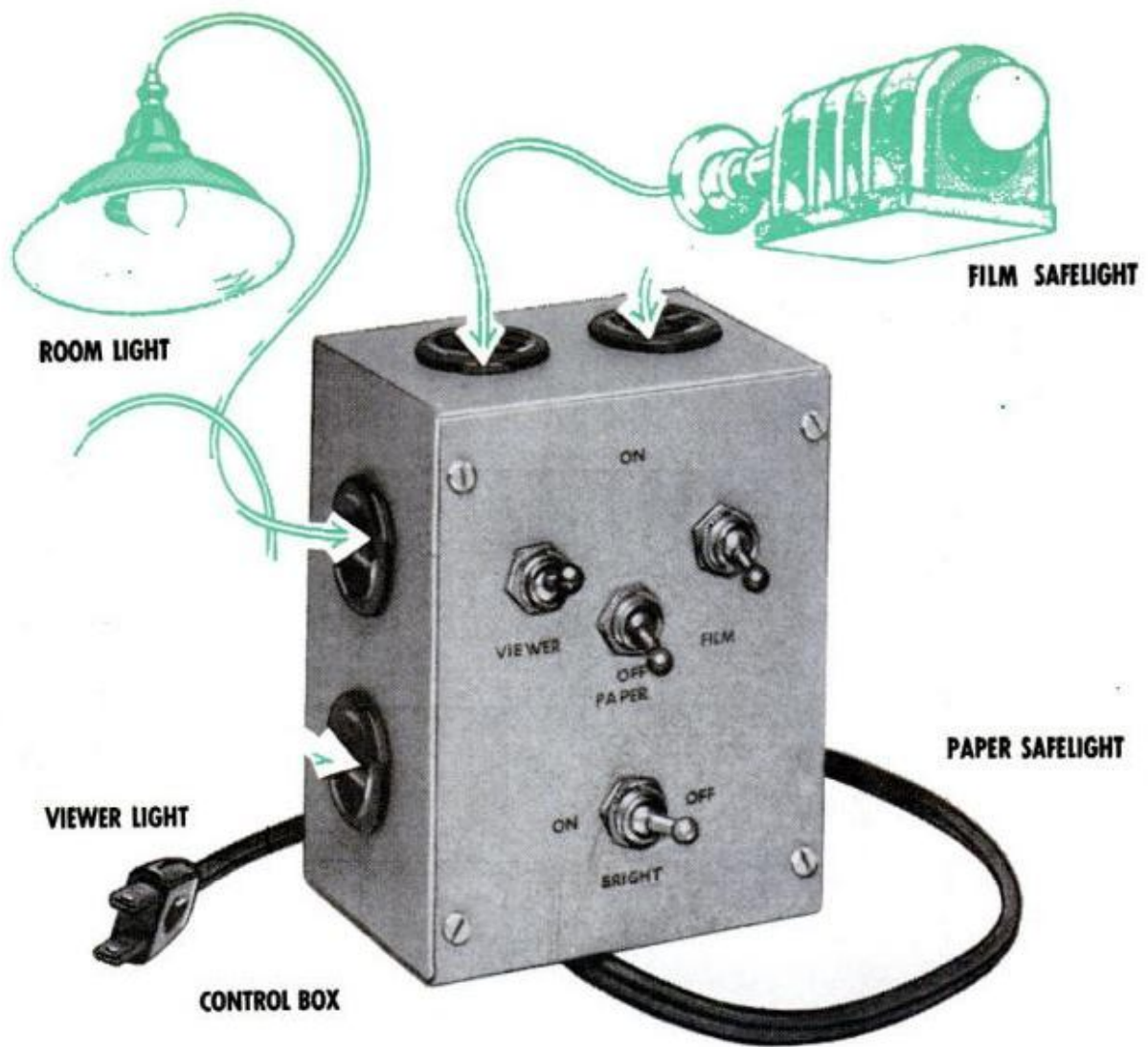

# Darkroom Light-Control Box

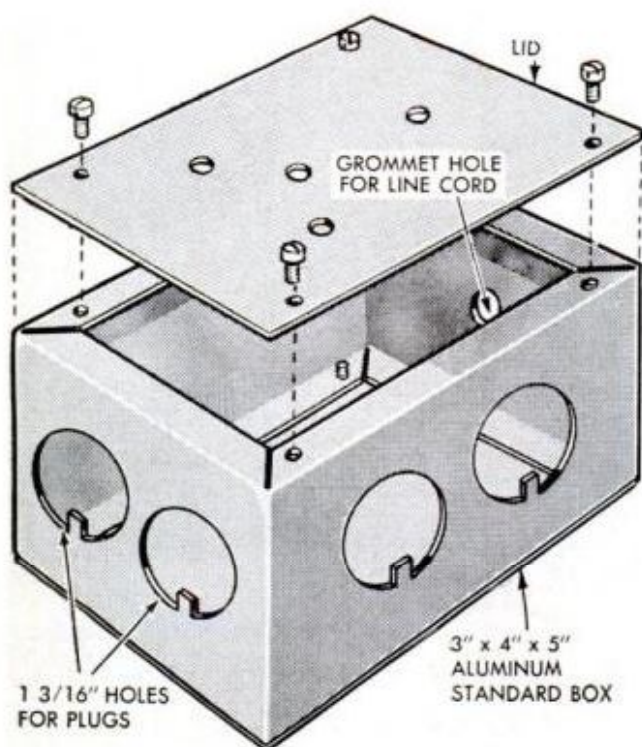

THIS CENTRAL LIGHT control can give a considerable boost to your darkroom efficiency. With it, you won't have to grope in the dark for three or four widely separated switches or worry about electrical shock due to wet hands. Parts cost about \$5. You buy the chassis box, have the holes punched and wire it according to the diagram below.—Frank P. Fritz

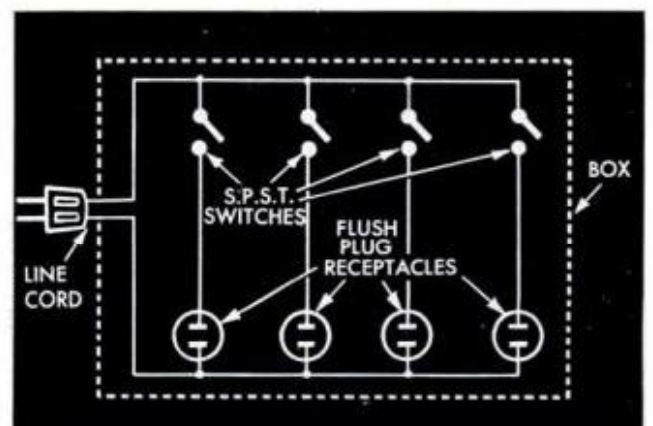



## FOR CAMERA BUGS

### Removing Partly Exposed Roll

When you find it necessary to remove a partly exposed roll of film from the camera, follow this procedure. Open camera in the dark, punch a hole in the center of the film as close to the last exposed frame as possible, then rewind the film. When you load this film into the camera again, wind it in the dark with the back open until you feel the hole. This way you'll only lose one frame, at the most.

### Window-Shade Backdrop

A standard roller shade makes an excellent background for portraits and table-top shots. Screw the mounting brackets on a 1 x 2 and bore a  $\frac{3}{8}$ -in. hole in the edge of the strip at the center. To use it, place the hole over the upper section of a lamp stand, pull down the shade and you're in business. Illustration at right shows the backdrop from the rear, with the shade pulled down only part way.

Sliding bolt mounted on the inside of your darkroom door is good insurance against untimely entrance of outsiders during loading and developing periods.

### Storing Ferrotypes Plates

If you use ferrotypes plates to dry glossy prints, here's a simple, safe and low-cost way of storing them between jobs. Just slip them between the pages of a large-sized magazine, leaving 30 or 40 pages to protect each plate. This will keep the highly polished surfaces separated and free from marring, whether chrome or enameled. While *PM* is a big magazine in almost every other way, it's too small for this job, so use magazines the size of *Motor Boating*, *House Beautiful*, *Esquire*, etc.—Vic Russell

### Warning Bar for Lens Cap

How many times have you missed a good shot simply because you forgot to remove the lens cap from your camera? To prevent making this same mistake in the future, cement a piece of light plastic to the lens cap so that it protrudes in front of the view finder and obstructs your vision. This will warn you at a glance that the cap is in place, and you'll probably have time to remove it and still get the picture. On top of that, it will save you all the effort of kicking yourself for making such a simple mistake.

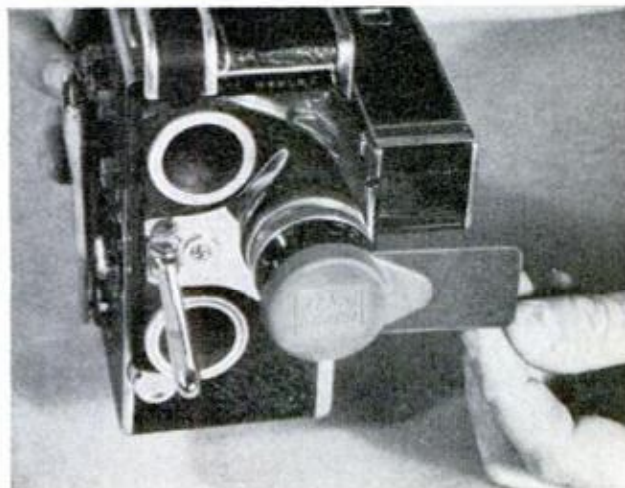
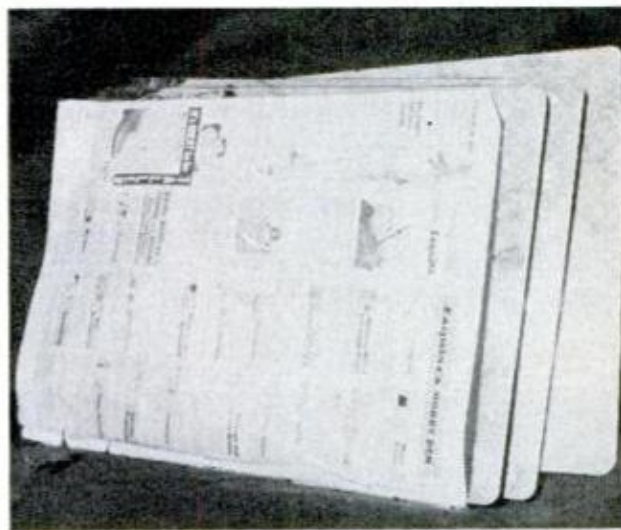
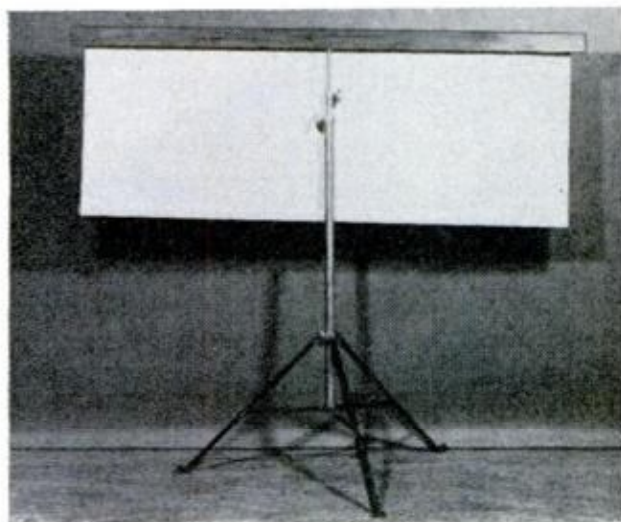
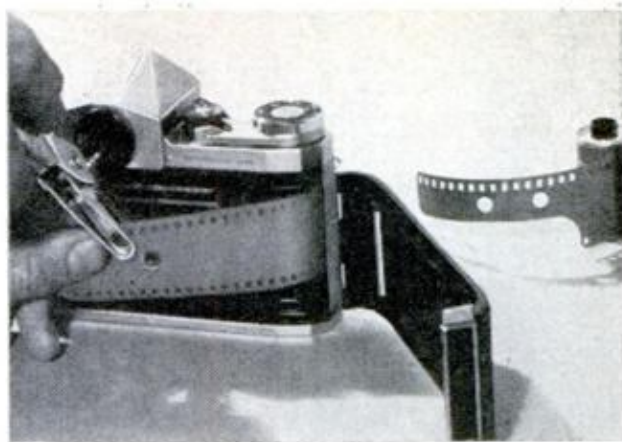



# FOLDING KAYAK

By Jess E. Rathbun

**I**T'S NOT FAST, it's not roomy and you won't find many practical uses for such an outlandish craft. In fact, this center-folding kayak has only one feature to recommend it. *It's fun.* At \$15 apiece, you can afford to make one for every member of the family. And you can tote a whole folded fleet on top of your car.

Construction is also unorthodox. Instead of using screws, nails or other common fasteners, you "tape" the boat together with canvas and contact cement. No metal parts are required.

Built according to the specifications included here, the kayak will weigh only about 40 lbs. and will accommodate an

**40 LBS. OF FUN,** kayak folds down the middle for easy carrying. Note bottom rub rail which protects canvas



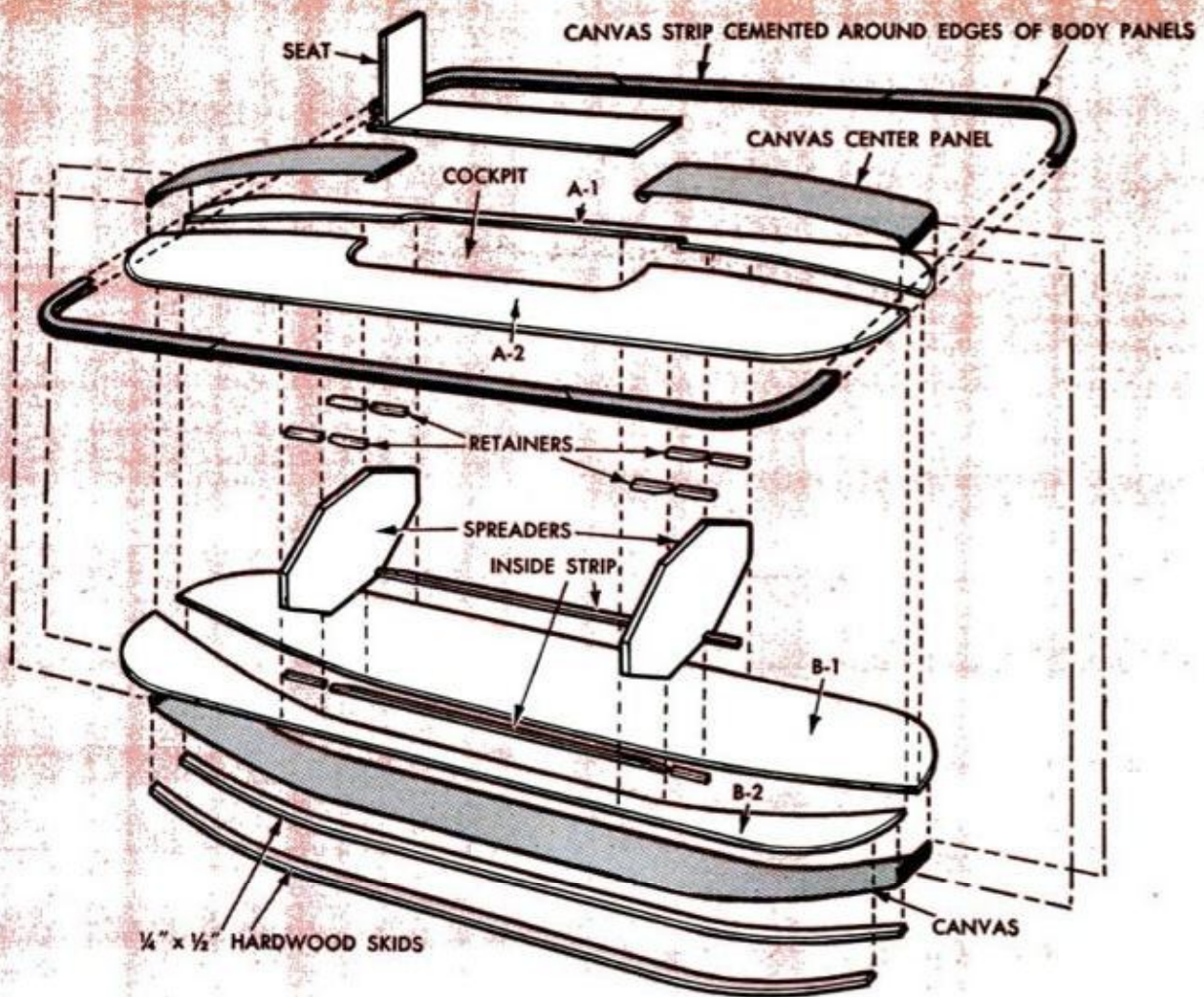

average-sized man. However, so long as the correct proportions are maintained, you can shrink the dimensions to turn out a midget version or increase them slightly to gain a little more leg room.

While marine plywood may be used for the side panels, exterior grade AA (or even AB) will do just as well here. Canvas can be anywhere between 14 and 18-oz. weight, but should have a tight, close weave for easy waterproofing.

Begin construction by cutting the four side panels from a 4 x 10-ft. sheet of  $\frac{1}{4}$ -in. plywood. All these panels have the same outline, the only difference between the top and bottom pair being the cockpit cutouts. If you're planning to make two or three kayaks, cut the required number of panels at one time so that you can use the first two as patterns. The rounded ends of each panel are squared off slightly to present a  $1\frac{1}{2}$ -in. straight edge so that the canvas will go around from top to bottom without wrinkling.

Next, cement the  $\frac{1}{4} \times \frac{1}{2}$ -in. inside strips and retainers to the panels, positioning them flush to the edge with the  $\frac{1}{2}$ -in. face down. The strips are designed to provide reinforcement for the seat bottom-floor board, but also to form notches to hold the spreader boards. Taper the

**INSTALL SPREADERS** after "taping" edges of panels. These should be trimmed for a proper fit before the center gap is covered with canvas. Allow enough slack so that spreader may be removed for folding

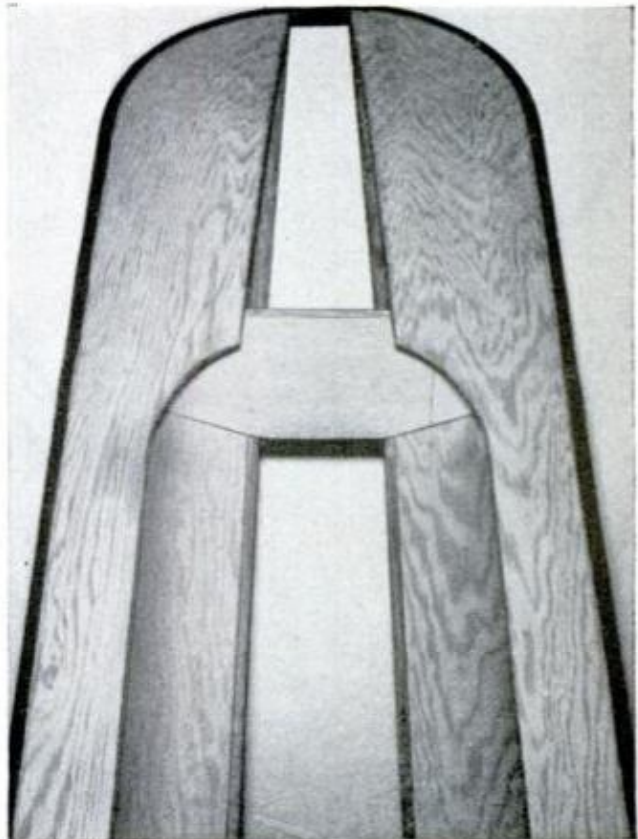

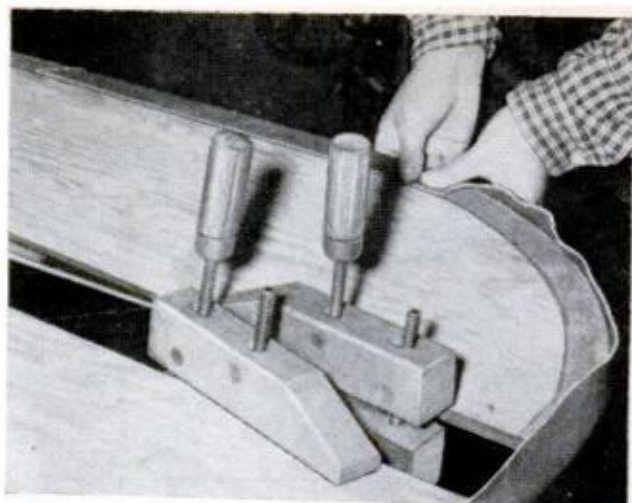
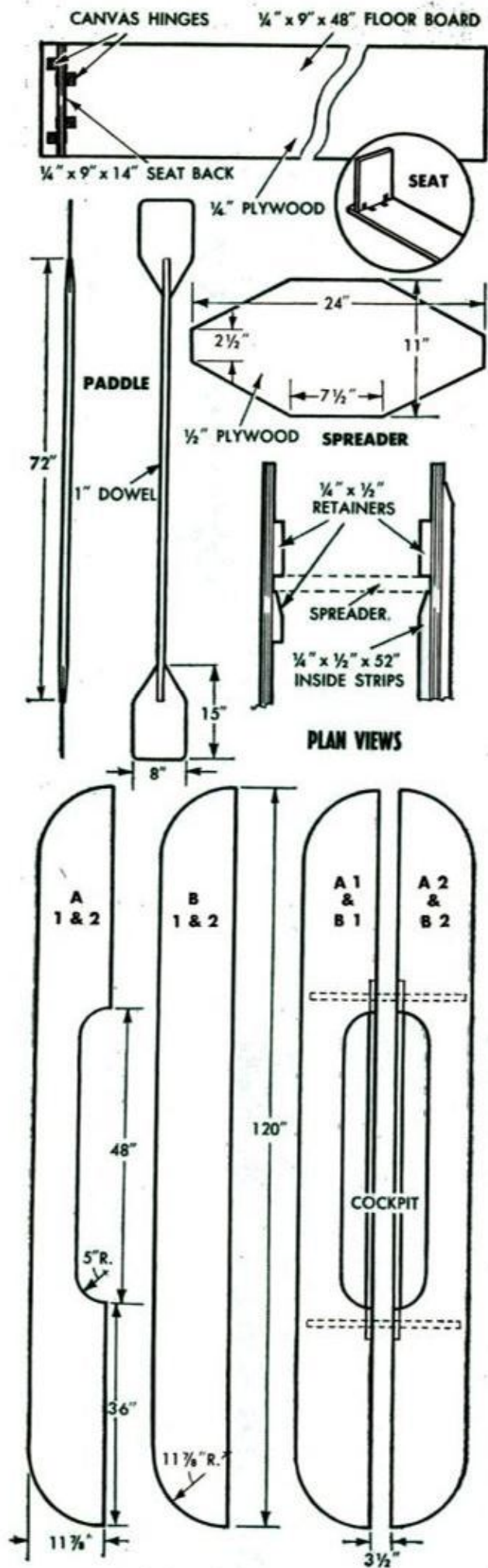

CLAMPS AND SPACER block are used to position the two pairs of panels the correct distance apart so that the 2½-in. strip of canvas edging can be applied

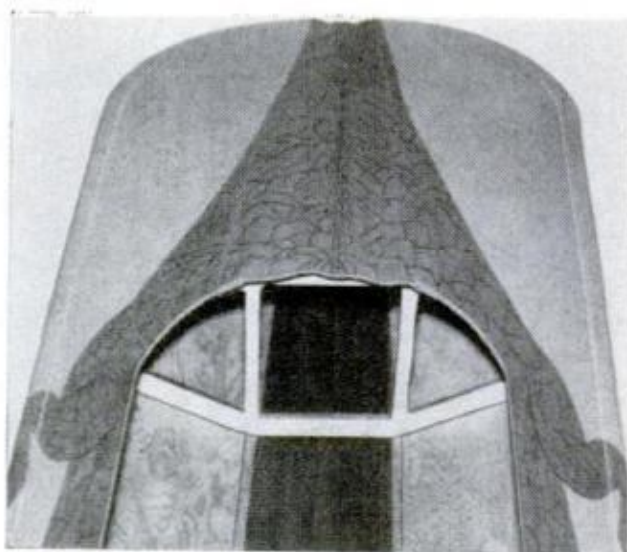

CUTTING OUT portions of the spreader will lighten it without reducing strength to the critical point. Note alligator treatment used to decorate the hull

COVERING GAP between the right and left pairs of panels is the last step before finishing the hull. Allow 2 in. extra at cockpit and fold it underneath



# HOME PROBLEMS

**WHEN YOU NEED** extra grill space for a big cookout, press your steel wheelbarrow into service. First, line the bottom with aluminum foil to reflect the heat, then start the charcoal and place an old oven or refrigerator shelf over it to act as a grill. Prop rear legs up so that your grill is level



**FLATTEN AND SUGAR** drop cookies in one operation. Drop an ice cube in a glass tumbler, dip bottom of tumbler in a dash of sugar and press it down on each cookie. Ice keeps glass moist so sugar will cling

**TRUNDLE DRAWER** added below the bottom drawer of a regular chest offers bonus storage space. Screw a slide-and-guide unit to the legs on each side, as shown, and make a simple drawer to fit the space

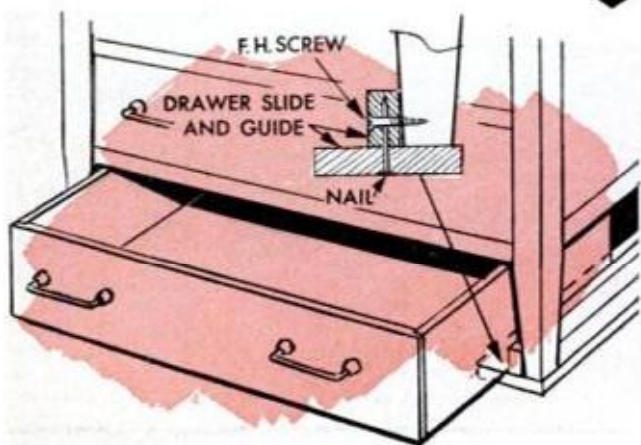

**FLAVORING KIT** makes it possible to measure flavors and extracts accurately without even using a spoon. Just transfer them from original containers to a set of dropper bottles purchased at the drug store



## Engine sound like it's at last gasp? You're lucky if the fuel pump's at fault because it's easy to take apart, cheap to repair

By Morton J. Schultz

**A** CAR'S ENGINE coughs and sputters, and immediately the driver cusses out the carburetor. He might well direct his exasperation toward the fuel pump, instead, because it's a 50-50 chance the cause of the trouble lies there.

With those odds, it makes sense to check the fuel pump first, since ripping apart the carburetor is a tough, comparatively expensive job.

The fuel pump is your car's heart. It automatically pumps an adequate amount of fuel from the gas tank, through the fuel lines and to the carburetor, to meet the engine's requirements at all speeds, loads and altitudes. Like the human heart, it's small for the giant-size job it must do; still, a car's fuel pump is capable of lifting fuel as much as 20 feet—if it's working right.

Your car probably has one of the two types of pumps shown in cutaway at the bottom of the facing page. If your car's

fairly new, you probably don't have the combination type since most windshield wipers are now electrically operated and don't need an air boost.

There's also a third type of fuel pump that's electrically operated, but this type is used primarily on foreign cars. Some American manufacturers have made such pumps optional equipment. You can tell them from the mechanical type illustrated here by the small motor, usually lying beneath the pump body. The checking and trouble-shooting procedures outlined in this article can be applied to electric pumps, too, but disassembly should be left to a mechanic experienced in electric pump repair.

How fuel passes through a mechanical pump is explained on the next page. (It should be pointed out that in some V8 engines the rocker arm rides an eccentric bolted to the front of the camshaft timing gear. This doesn't alter the diaphragm

**FUEL-PUMP PRESSURE TESTER** (left) can detect trouble before it happens. Gauge should read at least 3½ lbs. per sq. in. while engine idles. Low reading can be caused by faulty bowl gasket (right). Pump shown has bowl attached with metal bracket; gasket passes over filter, fits between bowl's rim and flange seat



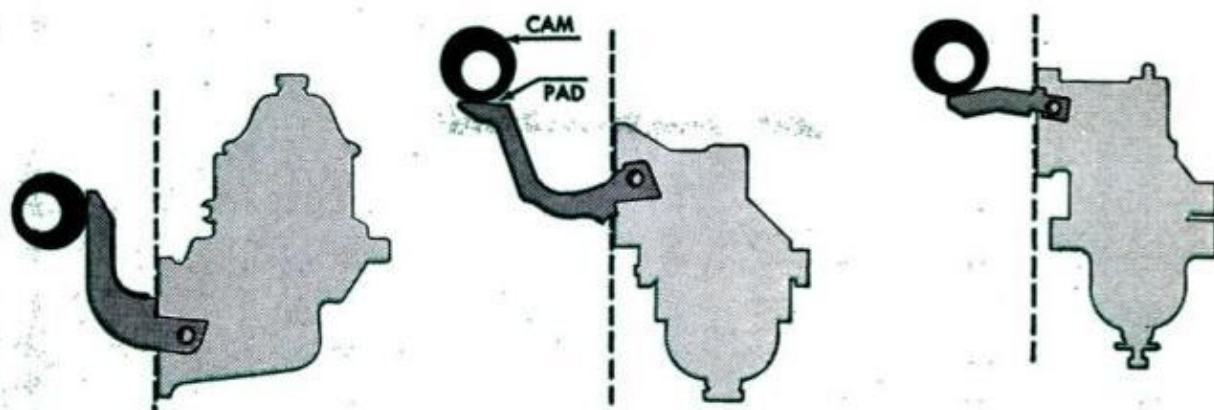

## HOW FUEL PUMPS OPERATE

**THOUGH PUMPS DIFFER** in shape and mounting position (above), there are only two main types. The large cutaway (below) explains the operating principle of a single-action pump. Less common on recent cars is the combination type which not only pumps fuel but has an additional vacuum-booster section to help the intake manifold keep windshield wipers operating uniformly. Both types of pump operate the same way: Rocker arm extends inside engine block for continuous contact with eccentric on camshaft. When cam presents its lowest point, arm activates link in pump to pull diaphragm down, creating vacuum that sucks fuel through intake valve and into bowl. When cam turns to its highest point, compressed spring is released and diaphragm pushes fuel through outlet valve. Sketch of combination pump shows how dual rocker-arm activates both fuel and air diaphragms. This pump can be identified by two extra lines entering at top—one connected to wiper motor, other to intake manifold. Faulty diaphragm in vacuum section can be an oil waster

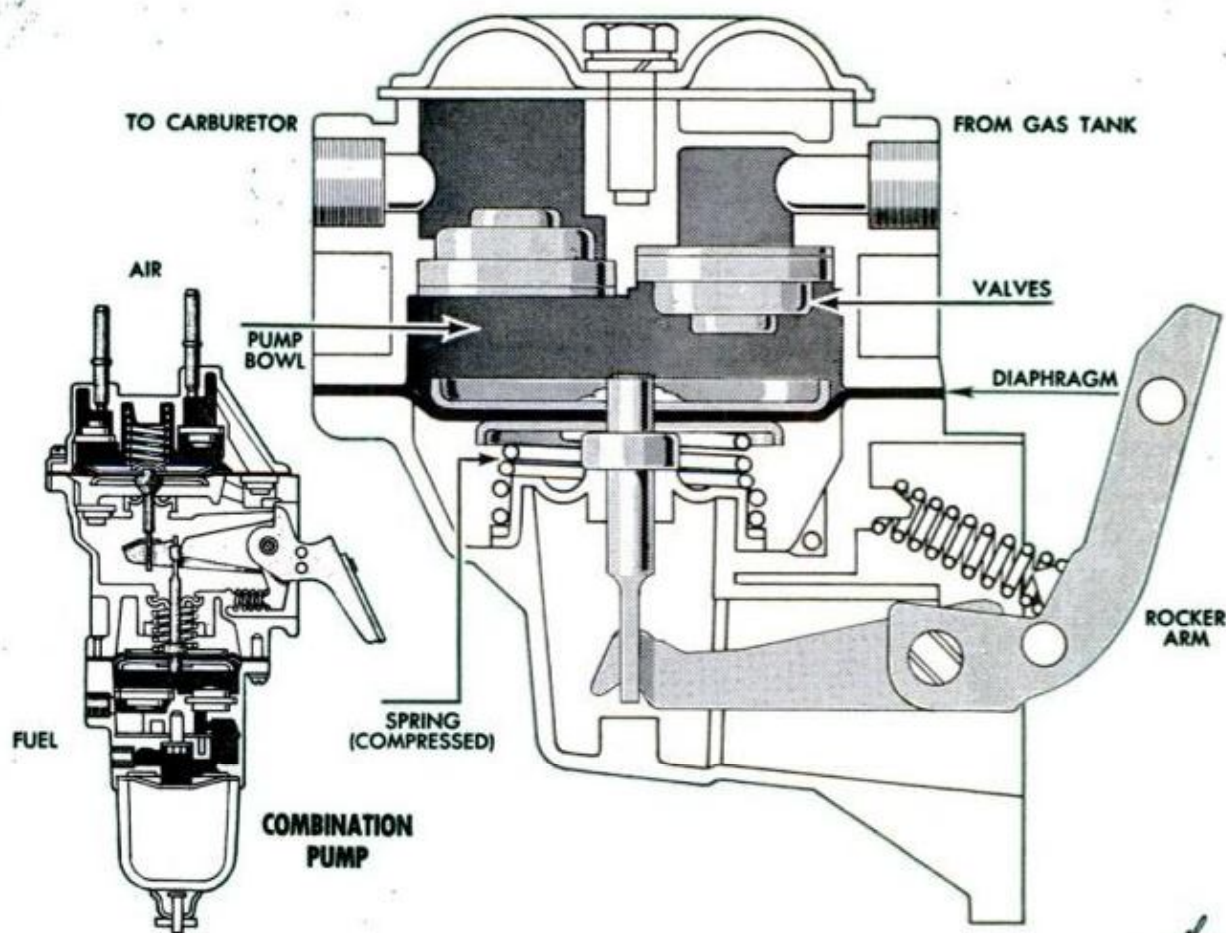

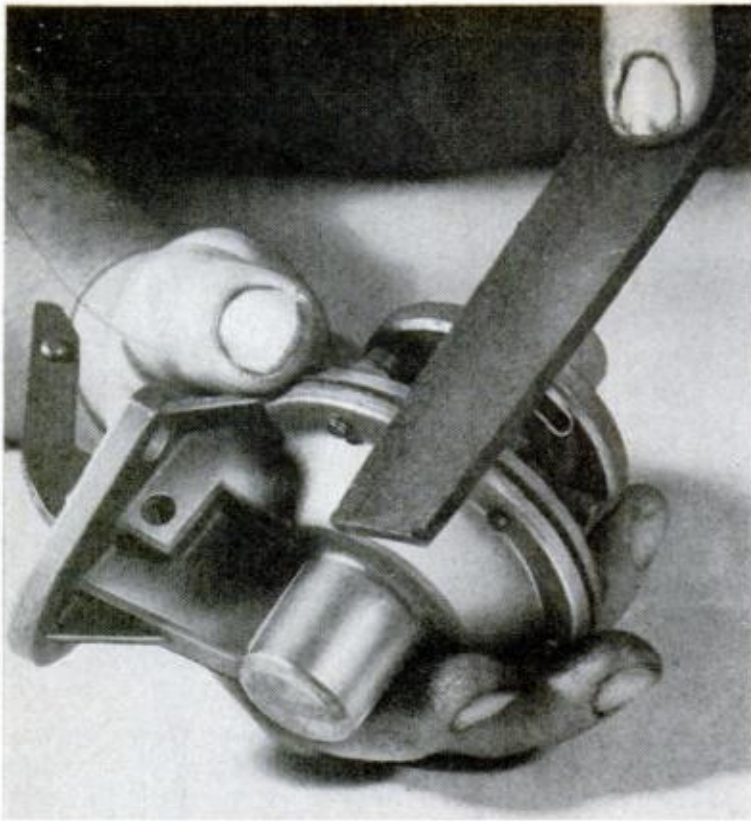

## TAKING THE PUMP APART

### BEFORE YOU START . . .

**FILE MARKS ACROSS FLANGES** to indicate proper alignment. When you're ready to put the pump back together, you'll be able to match the halves perfectly. It is important to have inlet and outlet holes line up

**1. UNSCREW BOLTS JOINING FLANGES** and pump breaks neatly in two, revealing diaphragm against flange at far right. This section also contains the rocker-arm assembly. Left half contains check valves; note they face in opposite directions. In pump shown, this half also has attached fuel bowl. On cars with in-line fuel bowl, valve section contains a pulsator instead

action, of course.) Although each individual pulse meets the engine's immediate fuel needs, the pump keeps operating until the carburetor bowl is filled. When this happens, the carburetor float closes the fuel entrance and fuel backs up through the line to the pump. As pressure builds up, it forces the diaphragm to take shorter and shorter strokes. At maximum pressure, the diaphragm is prevented from moving again until the fuel up ahead is used and more is needed.

The most common pump problem is delivery of *too little* gasoline to the carburetor. A faulty pump can also supply

*too much* fuel, causing flooding, but this is much less common. When it occurs, it's usually with new or rebuilt pumps and is caused by an improperly-mounted pump, a diaphragm spring that's too strong, or a stiff diaphragm. The latter two causes are reasons for returning the pump to your dealer for exchange.

The best way to check a pump is with one of the many fuel-pump pressure testers available. These range in price from \$5 to \$10 and enable you to determine whether the pump is operating within specified pressure limits. Although fuel-pump failure usually happens sud-

**2. TO REMOVE DIAPHRAGM** you must first release the rocker arm. Pry spring from its seat with screwdriver, noting its position for proper reassembly

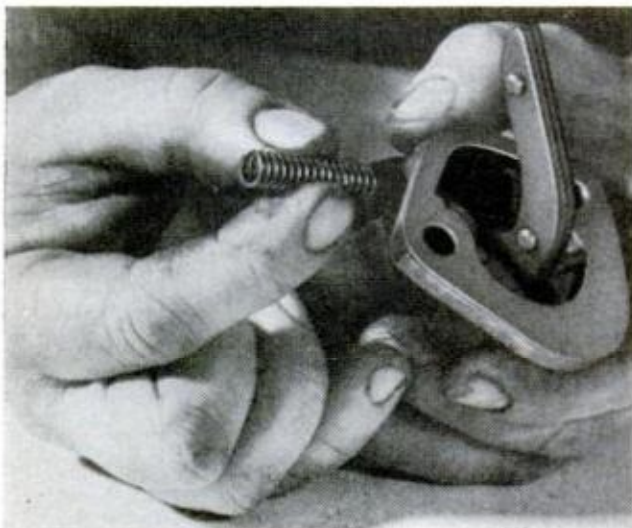

**3. REMOVE ROCKER-ARM PIN** with a punch, tapping lightly with hammer to push it through pump body. Rocker arm and link can now be removed

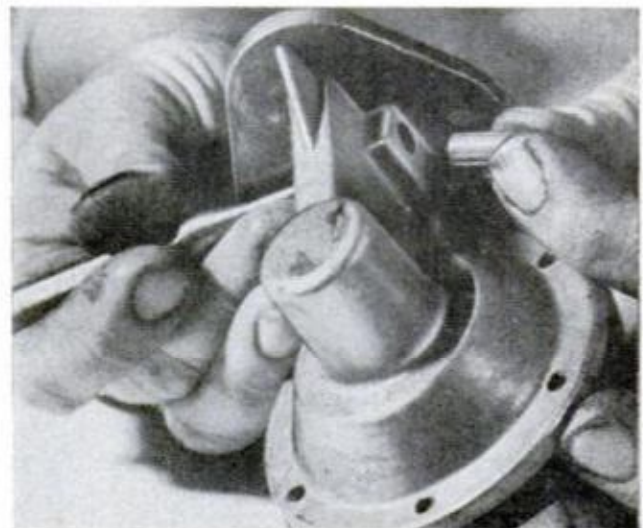



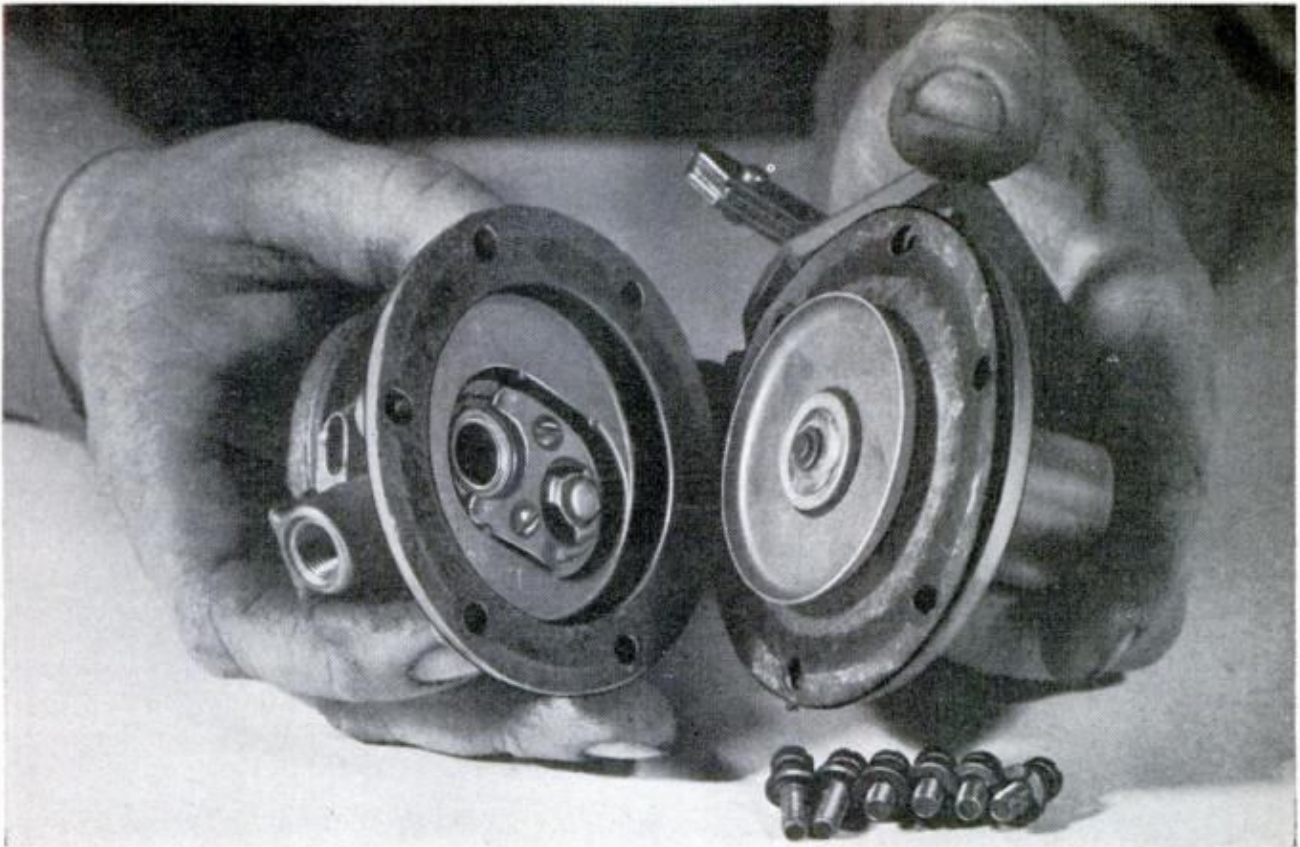

denly, gauge-testing should be part of every tune up. You may be able to catch trouble before it starts.

Here's how to check with a tester:

1. Disconnect the pump-to-carburetor line at the pump and insert a T-fitting in the pump outlet. Connect the fuel line to the other side of this fitting.

2. Connect a 6-in. piece of hose between the top of the T and the pressure gauge. (Hose and fittings are generally included in a tester kit.) If you must use a makeshift hose, it shouldn't be over 6 in. long. A greater length will collect fuel, adding additional weight to pump pressure. This

results in inaccurate gauge readings.

3. Race the engine for a minute or two to vent the pump, driving any trapped air from the fuel bowl. Air could prevent the pump's operating at full capacity, resulting in a lower pressure reading.

4. Shut the engine off, wait a minute or so and start it again. Let it idle while you read the gauge. Although an engine will operate perfectly at a pressure as low as 2 lbs. per sq. in., any reading below 3½ lbs. means the pump isn't operating at full capacity and a breakdown is imminent.

*Maximum* pressure the gauge should read varies with the make engine and

**4. LIFT DIAPHRAGM**, and its spring from flange seat—rocker-arm link had held it in position. Remove oil seal and retainer, out-of-sight in seat above spring

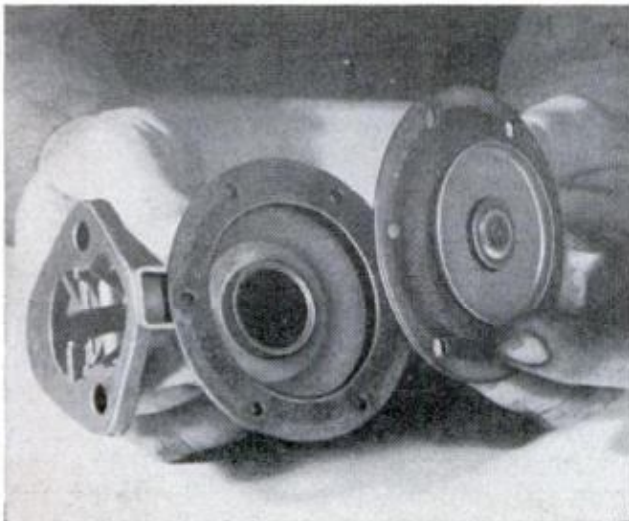

**5. NEW CHECK VALVES** must be positioned like ones you replace. Outlet valve is at left, flat side facing out. Inlet valve has flat side toward seat, as shown

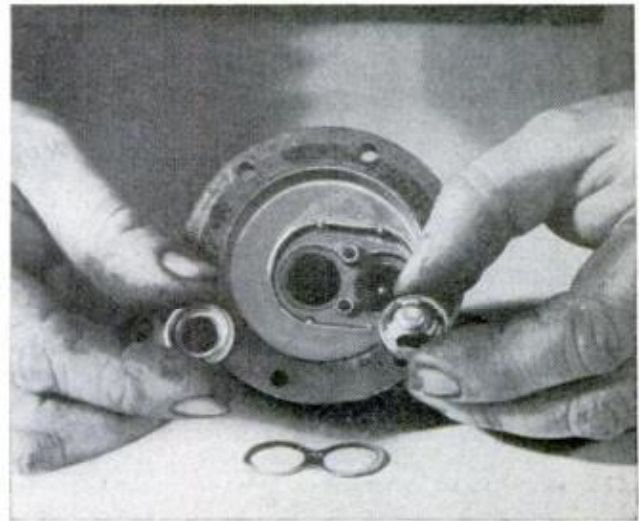

pump, but it's usually no more than 6 lbs. A higher reading should make you wary, since the pump could be supplying too much fuel to the carburetor.

5. Keep an eye on the gauge while you stop the engine. The needle shouldn't drop abruptly back to zero—it should ease back gradually. If the needle drops suddenly, the pump check valves are damaged.

Before condemning a pump that gives less than minimum reading, there are several areas to check. First examine the outside of the fuel bowl carefully. A gas leak here means the gasket needs replacing—this can cause a low reading.

Next, check the fuel line connections for looseness all the way back to the gas tank. At the same time, check the lines



**NEXT TIME YOUR CAR'S STUCK IN MUD** or sand and there's a tree or post nearby to loop a chain around, you needn't wait for a tow—if you've equipped your jack with a clevis as shown. Hook the anchor chain to the jack head and crank the car onto solid ground

themselves for leaks. Deteriorated, chafed, burned, kinked or cracked lines should be replaced even if they don't leak—yet.

Fuel lines, primarily the pump-to-gas tank line, might be clogged with dirt. Blow the line out with compressed air. You don't have to disconnect the line at the tank—just at the pump—since dirt blown into the tank causes no problem.

While you're at it, it might be a good idea to blow out the pump-to-carburetor line as well, although dirt seldom enters this line. To do this, you must disconnect the line at both ends, so dirt isn't blown into the carburetor.

Finally, take off the fuel-bowl cover. If the bowl is equipped with a metal strainer (such as the one shown in the photo at the bottom of page 158) remove it and clean it in a solvent. Use compressed air to blow out dirt. If the bowl has a disposable accreted element, replace it with a new one. Filter service like this should be done every 5000 miles or so anyway to keep fuel flowing freely.

(The pump shown in this article has a self-contained fuel bowl, which houses the gasket and strainer. In some make cars, the fuel bowl is in-line—that is, it is placed in the pump-to-carburetor line. If your car contains an in-line fuel bowl, it should be taken apart for a cleaning during fuel pump service.)

Run the pressure test again. If the reading is still too low, it indicates a leak in the pump check valve, a weak or broken diaphragm spring, a restriction or air leak at the inlet side of the pump or a ruptured diaphragm. In any event, the pump should be removed for overhaul or replacement.

### Testing Without a Tester

If you don't have a pressure tester, you can still check the pump, although the results won't be as accurate.

Disconnect the pump-to-carburetor line at the pump or at the carburetor, whichever is easier to reach. Have someone crank the engine for a few seconds with the ignition off. Does gas *spurt* from the pump or the open end of the line? If so, the pump is probably OK, and the cause of engine coughing and sputtering is in the carburetor.

If there is no gas flow or only a little drip (the gas should spurt), perform the fuel-line and fuel-bowl checks described above and rerun the test. If gas still doesn't spurt, the pump is most likely at fault.

### Capacity Check

Short of a pressure-gauge test, the only way to determine whether a faulty fuel pump is delivering *too much* gasoline to the carburetor is to measure the flow of gas being supplied through the pump over a specified time. This capacity check, as it is called, also tells you whether fuel flow is adequate for the engine. Although the pressure gauge may indicate that the pump is operating within specified limits, it doesn't tell you whether the pump is delivering its rated amount of gas.

Most engines need from  $\frac{3}{4}$  to a full pint of fuel in one minute to operate efficiently. The car's manual should be checked to determine the exact amount.

To make the test, first let the engine run awhile, to fill the carburetor bowl. The engine will run for at least a minute on the

gasoline the bowl accumulates, since you must shut off the flow of fuel from the carburetor by disconnecting the pump-to-carburetor line at the carburetor. Hold a graduated measuring cup with a maximum capacity of at least a pint so it will catch gasoline spurting from the line.

Let the engine run for a minute. If the pump does not deliver the rated capacity, remove it for overhaul or replacement since it indicates a weak diaphragm spring, worn rocker arm, worn rocker-arm link, worn pull rod, leaks at the diaphragm, leaks at the strainer bowl, or worn valves or valve seats.

If more fuel flows from the line than that specified, the pump should be removed for replacement, since carburetor flooding can result. However, if the fuel flow is correct, but the engine is flooding or you are getting poor gas mileage, look for the cause of the trouble as a defective automatic choke, a punctured carburetor float, or a defective needle valve.

### Testing the Vacuum Section

If you are dealing with a combination pump and wish to check the vacuum section, disconnect the lines at the top of the pump, connect a vacuum gauge tightly to the wiper-line fitting, and start the engine. The gauge should read at least 10-in. of vacuum. At any rate, you should check to see whether oil is getting past the vacuum section's diaphragm. There have been cases of engines being completely overhauled to cut down on oil consumption, when all that was wrong was a faulty vacuum diaphragm drawing oil from the crankcase and pumping it into the intake manifold, where it was mixed with fuel, burned, and blown out the exhaust.

To check for this type of leak, simply disconnect the line from the pump to the intake manifold. Look into the line or run a screwdriver around the inside to see if there is any trace of oil. The slightest trace indicates the diaphragm is leaking and drawing oil from the crankcase.

### The Mechanic Says: "Scrap It"

If you find your fuel pump is bad, you can probably handle the solution yourself. You can either replace the pump at a cost of about \$18 or repair the old pump at a cost of a few dollars for a repair kit. Both jobs are easy to do and require only ordinary tools.

You will find that if you take the car to a mechanic, he will usually recommend fuel pump replacement instead of overhaul. Because few mechanics nowadays overhaul pumps, you may have trouble securing a repair kit from your local auto-

[\(Please turn to page 182\)](#)

**I've got a problem with my 1955 six-cylinder Chevrolet. After driving about 20 miles, the hydraulic lifters start rattling. I've cleaned the rocker arms, changed oil regularly, cleaned the oil pan, checked the oil pump—even installed new lifters, but all to no avail. What can you suggest?—R.F.D., Canada.**

The cause of the problem is probably in the oil pump. You may have checked it, but you had better replace it. Oil pumps used as original equipment on this model car were delivered from the factory with weak oil relief valve springs. This keeps oil pressure below allowable limits and literally oil-starves the valve lifters. The problem was recognized early by Chevrolet, and the company issued a new pump with a stronger relief valve spring. Apparently, though, you still have one of the old pumps. If you wish to try to repair the pump, have the valve spring stretched. If this doesn't work, you'll have to replace the pump.

**My 1961 Dodge, equipped with a 318-cubic-inch engine and a two-barrel carburetor, is giving me hard-starting problems. I've checked every cause I know. Is there something inherent that makes it this way?—T.F., New Jersey.**

Yes there is—not only in the 1961 Dodge, but in any year Dodge and Plymouth from 1960 on with that engine and a two-barrel carb. An improperly-positioned air cleaner assembly could cause interference with the choke lever and prevent the choke from closing. Result? Hard starting! The proper way to install the air cleaner is with the looped end of the clamp on the right side about two inches to the rear of the center line of the air cleaner.

As a service to the readers of Popular Mechanics in solving problems relating to their cars or to driving in general, you are invited to submit your questions for answering either through this column or by mail. Address Auto Clinic, Popular Mechanics Magazine, 575 Lexington Avenue, New York 22, New York.

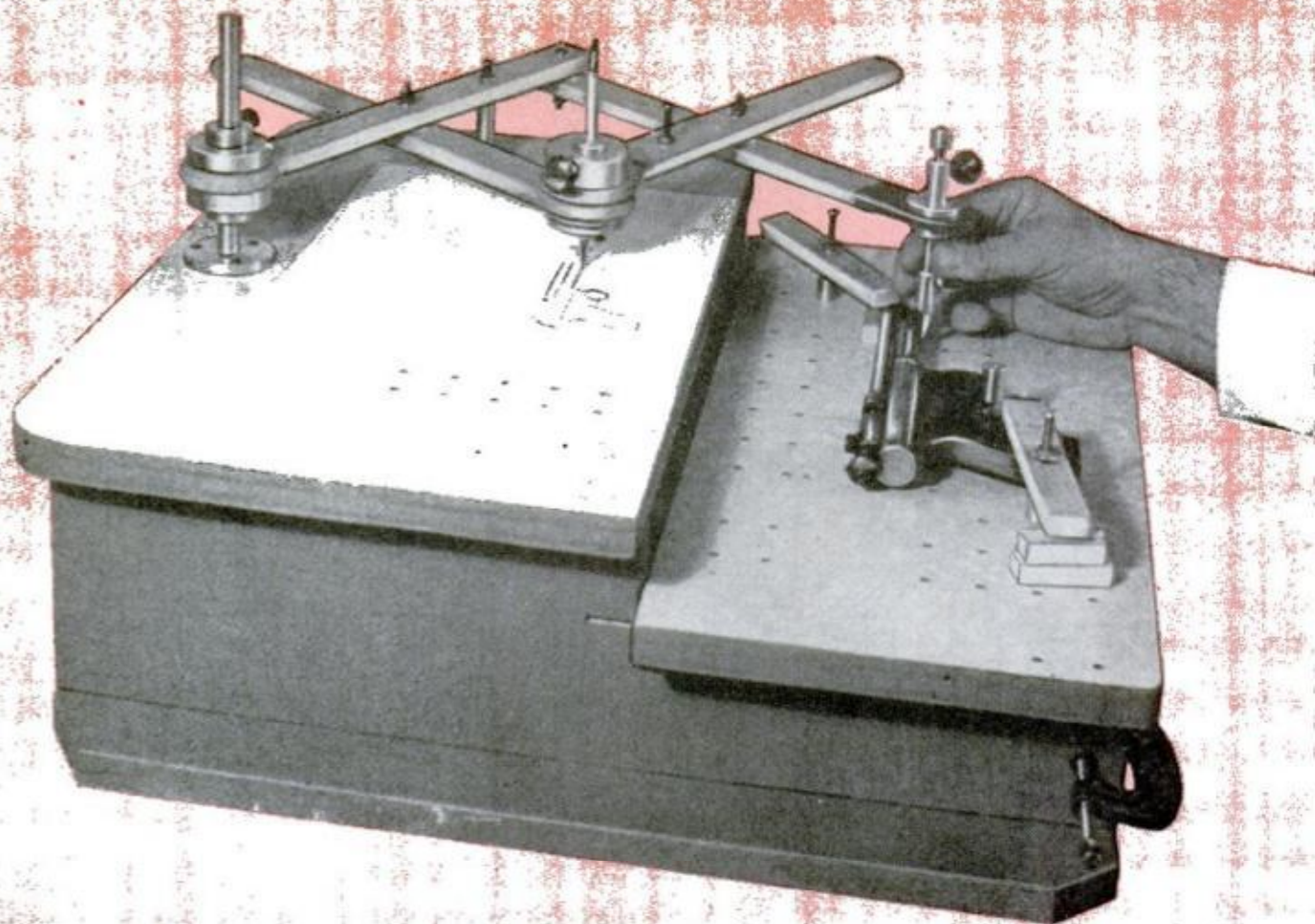

# SHOP PANTOGRAPH COPIES ANYTHING

By John W. Nash

**It makes reduced-scale copies from any master  
—even three-dimensional objects—on paper,  
plastic, wood, or metal, with any marking tool**

**E**VER SEE a copy machine that can make quarter, half or three-quarter scale sketches with a pencil, a pen, a scribe, a power engraver or hand grinder? You just did, in the photo above. This hybrid pantograph even features an adjustable-height stepped table that lets you trace around actual objects, such as the pistol shown. This is of particular value to modelmakers in scaling down individual parts or establishing over-all proportions.

The special swivel stylus (keyed with the letter O on the plans on the following pages) has a point that's cut away to its center line. By keeping the flat of this stylus tangent to the edge of any three-dimensional master, you get a reduction

copy with virtually no distortion—impossible with a conventional cone-point stylus. Also, this special stylus can be raised or lowered as it follows edges which may lie in different planes. The resulting copy will be an accurate plan view.

Where there's no object to trace around, any type of master can be used. The design can be jigsawed from metal or plywood (or even cut from stiff cardboard) and glued to a backing panel. An example of this is the sailboat master shown in the photos on the next page. Or, if the design is simple, you can use the pierced panel from which it has been cut, tracing the swivel stylus around the inside edges. In the same way, you can make use of vari-

ous drafting devices such as triangles and French curves, or lettering stencils.

Or you can create an easily-traced master by scribing with a plain stylus on a heavy sheet of lead or aluminum foil laid on blotting paper or felt. This forms grooves deep enough for the same stylus to track along when used in place of the swivel stylus in the pantograph. A plain stylus is also used, of course, for conventional tracing of flat masters such as paper patterns, when the copy tool is a pencil or pen. (The pen can be a pencil-type ball-point or a Speedball replacement cartridge.)

But when guiding an electric tool, the swivel stylus and a master that provides an edge to follow are recommended. So is two-hand operation, with one hand guiding the stylus and the other holding the mounting chuck. The arm linkage is flexible enough to let you lift the cutting bit above the blank where no cut is desired, such as when shifting the stylus from one edge to another.

With one of the electric tools clamped in the chuck, you can rout or engrave a finished copy in a single operation, without making any layout or pattern marks on the surface of the wood, metal or plastic copy panel. Such blanks—as well as bulky masters—are clamped in place with scrap-block fingers bolted through the holes in the tables. The fingers shown are  $\frac{3}{8}$  in. thick,  $\frac{3}{4}$  in. wide and  $5\frac{1}{2}$  in. long.

To clamp thick blanks or masters, you'll want to run the bolts through spacers cut to a length that roughly matches the thickness of the piece to be clamped. The free end of the finger can then be shimmed up with small blocks to provide a firm bearing pressure. This setup is shown in the lead photo and in the center photo at right. Here the spacers are lengths of metal rod, tapped at both ends to take machine screws, but a simpler method is to pass bolts through center-drilled dowels and snug thumbscrews against the bottom face of the tables. Since both table units are open at the front, the thumbscrews are readily accessible.

The entire working mechanism adjusts up and down on the pivot post to accommodate copy panels and masters of a wide range of thickness. For this reason, you need a set of different-length jacks (Key H) to provide a second bearing point for the pantograph arms, as shown in the bottom photo at right.

Care in setting up your work will assure that this jack won't bump against one of the finger clamps. Extra holes in arm B and the work table give you a choice of location for the jack and clamps. When the copy requires a large sheet of

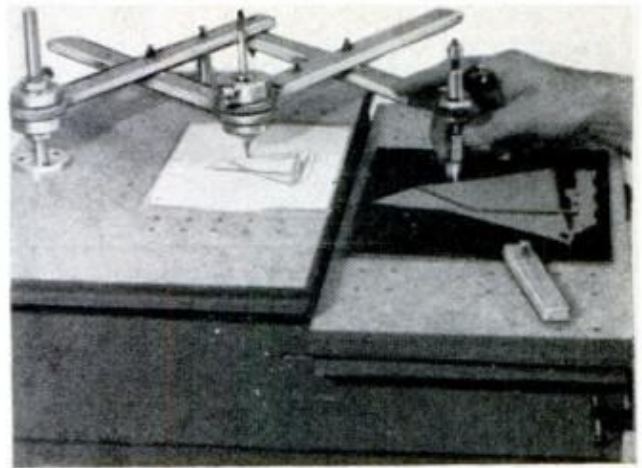

**HALF-SCALE SKETCH** from two-layer master results when swivel stylus is moved around pattern to activate pencil clamped in chuck adapter. Same adapter takes scribe—or ball-pen cartridge for ink copy

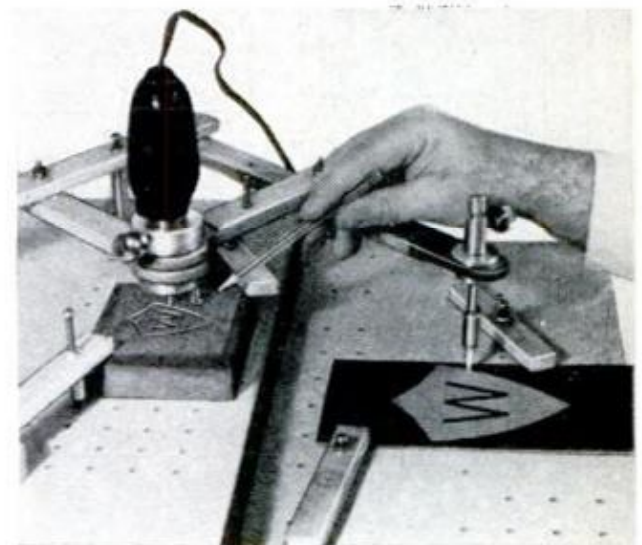

**WITH HAND GRINDER**, adjustable depth stop (pointed out above) controls depth of cut and forms third suspension point. Here, half-scale routed copy is made from two-layer master. Block is finger-clamped

**ENGRAVING COPPER** requires no layout on metal when stylus movement controls chucked engraver. Depth stop, again, is used. Other suspension point—an adjustable jack—is visible to left, behind tool

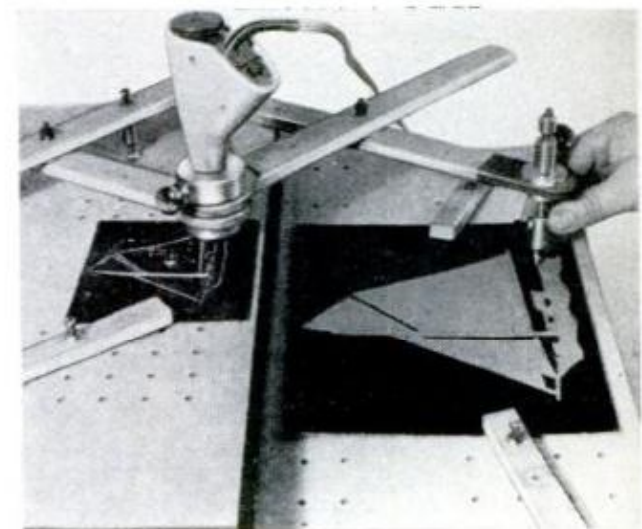

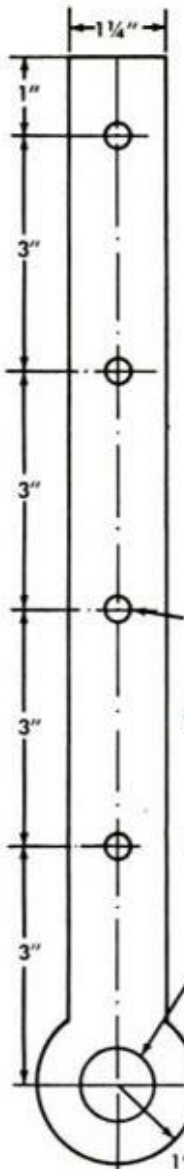

### FLANGED COLLARS

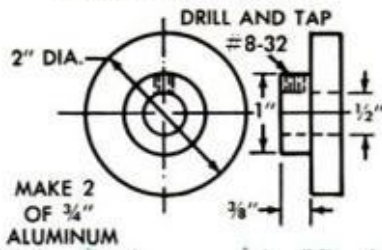

### POST FLANGE

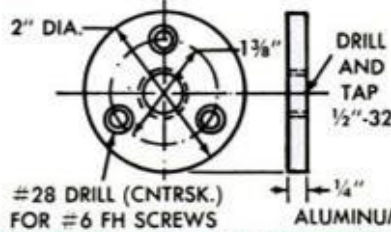

### PIVOT-POST

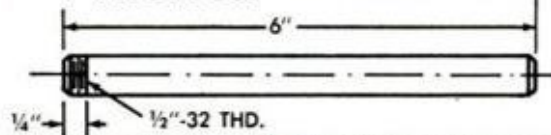

### PANTOGRAPH ARMS

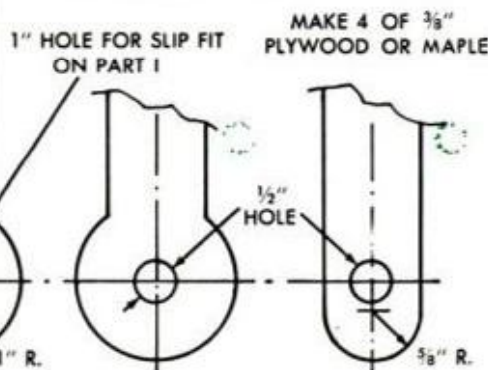

### ADJUSTABLE JACKS

MAKE 4 OF 1/2" ALUM. ROD

'A' DIMENSION DETERMINES SIZE. MAKE ONE EACH 3/4", 1 1/4", 1 3/4" AND 2" LONG

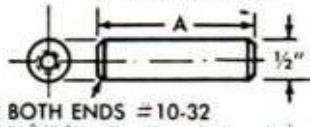

### CHUCK

1 3/4" ALUMINUM



### SOCKET ADAPTERS

ANGLES TO FIT ENGRAVER NECK

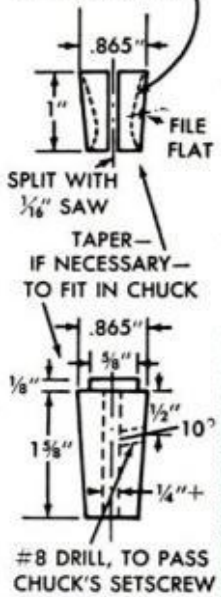

### STYLUS SHAFT GUIDE

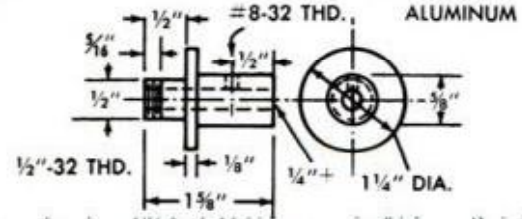

### STYLUS SHAFT

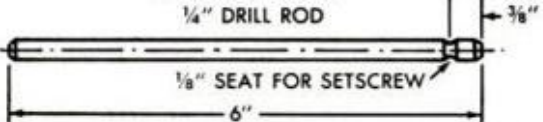

### STYLUS GUIDE LOCK RING

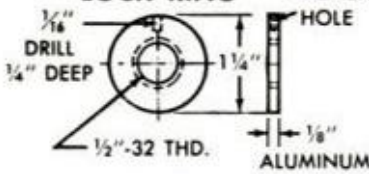

### CHUCK RETAINING RINGS

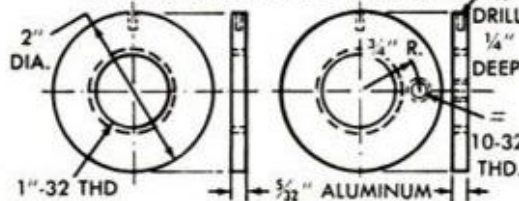

### SWIVEL STYLUS

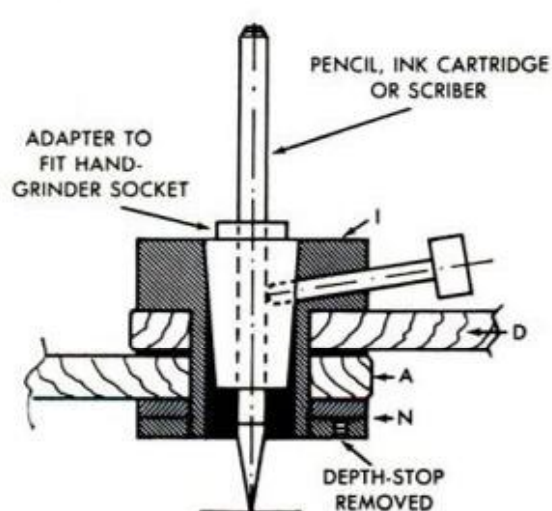
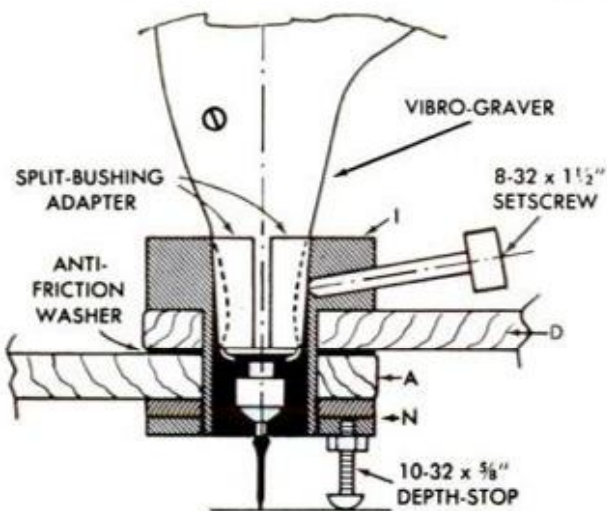
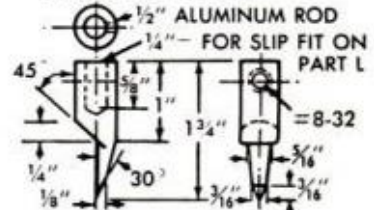

paper, you may have to place a stiff backing sheet under it to keep the pencil from sinking through into the clamp holes. Paper masters and copy blanks can, of course, be held in place with masking or other pressure-sensitive tape.

Both work- and sub-table have 4-in. circles scribed on their plastic tops, directly beneath the work head and stylus, as shown in the plan view on page 168. Brush on black paint and wipe the surface clean, leaving paint only in the scribe lines. These circles serve as targets to help you position the work or master.

The third support of the three-point suspension system is provided by the marking tool in the chuck. In the case of the power tools, this support is a depth stop made by tapping for a short round-head machine screw. Both it and the roundhead screw that turns into the various jacks (to adjust for changing distances between table and arms) should have their slots filled with silver solder and their heads polished to present a smooth bearing point on the work table.

The mounting chuck (Key I) has multiple functions—it's a thrust bearing, a pivot point and a universal tool holder. Its socket is bored to fit the hand grinder, since the neck of that tool is the largest diameter to be accommodated. In the model detailed on these pages, the socket is tapered to match the neck of a Casco electric hand tool (shown in the center photo on page 165). Other grinders, such as Dremel's Moto-Tool and Chicago Wheel's Handee, won't require a tapered socket. In that case, the socket adapters for smaller-diameter tools (J) will be easier to make. Note that the lower of these two sketches (the one-piece adapter for pencil, pen or scribe) calls for a hole that will pass the chuck's setscrew so it can bear directly against the marker, as shown in the lower-right sectional view. To drill this hole, insert the adapter in the chuck socket and use the angled setscrew hole as a drilling guide—preferably before it is tapped. The hole in the adapter can then be redrilled to a larger diameter.

The split bushing adapter at detail J was tailored to the Burgess Vibro-Graver seen in the bottom photo, page 165. This tool's "hourglass" neck is difficult to fit and requires a two-piece collar, formed by sawing the machined bushing down the center. Although this pantograph set-up lacks the precision of a true engraving machine, with a little care you can accomplish many useful operations.

In its lowest position, the sub-table rests directly on the step cut in the side of the work-table base. To elevate it, shim blocks are slipped under the lip of

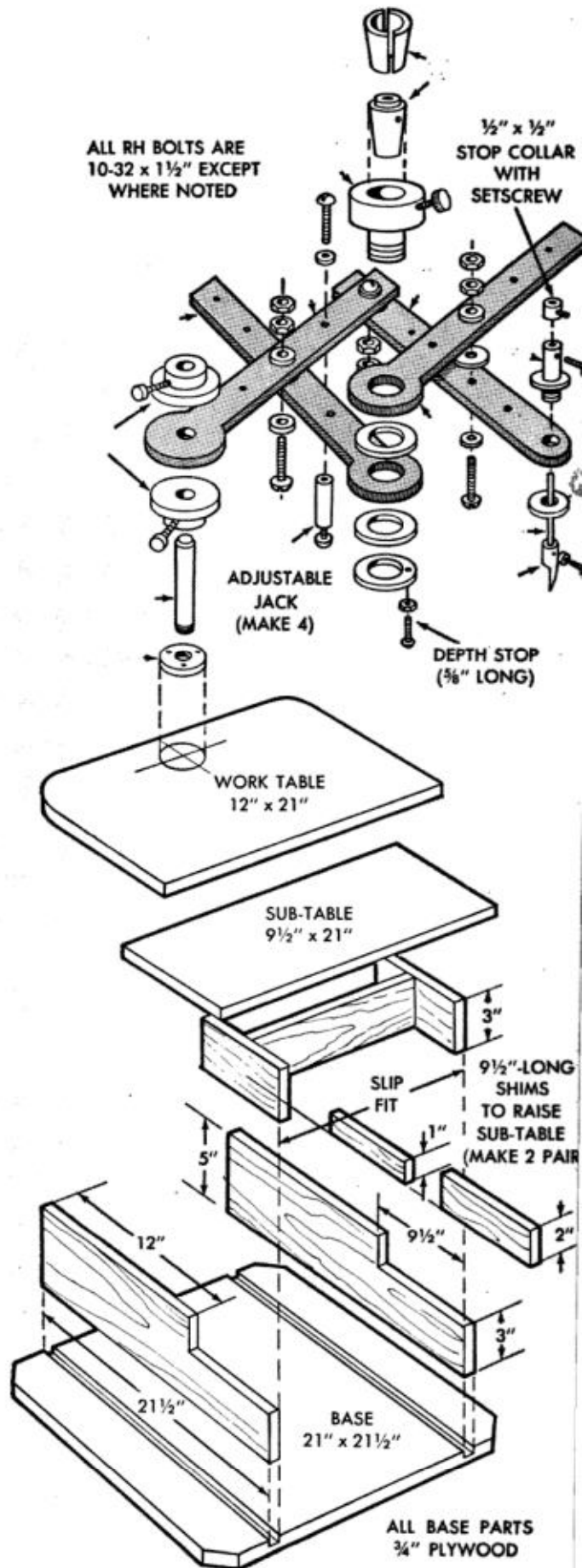







**CIGAR HUMIDORS?** No. They're antique napkin rings that have been polished and fitted with lids and bases. On a desk, they make an ideal stamp box or paperclip cup. On a bureau, they'll hold earrings or cufflinks

## Trinket Boxes from Napkin Rings

AT FIRST GLANCE you'd never guess that these beautifully engraved trinket boxes were once napkin rings. Though they graced all well-set tables a generation or so ago, these fancy metal bands are seldom seen today—but they can be transformed into useful little boxes and decorative conversation pieces by fitting them with lids and bases of wood, metal or plastic.

To convert the silver ring shown at the left, above, a lid and base were turned from maple disks. A neck  $\frac{1}{4}$  in. thick was turned on the lid,  $\frac{3}{64}$  in. smaller than

the inside diameter of the ring. A velvet ribbon glued to this neck gives a smooth-working seal. On the base, a neck  $\frac{1}{8}$  in. thick was turned to give a tight press fit.

The second napkin ring, which is made of brass, was fitted with brass cap and base. A blank for the top was made by sweat-soldering disks  $\frac{1}{8}$ -in. thick to a mandrel rod (see drawing). Disks were cut with a drill-press circle cutter. After turning, the mandrel was rounded into a knob. The base blank was prepared the same way. However, its mandrel was cut off flush and three ball feet soldered on.

**BRASS LID**, already soldered to mandrel, is being fitted with a ring that extends into the napkin ring, machined 0.040 in. smaller than inside diameter of the napkin ring, then soldered into a groove turned in the lid

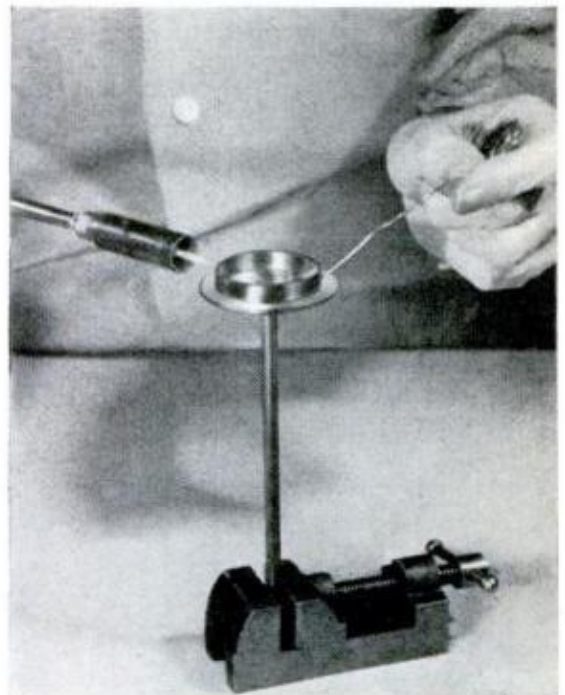
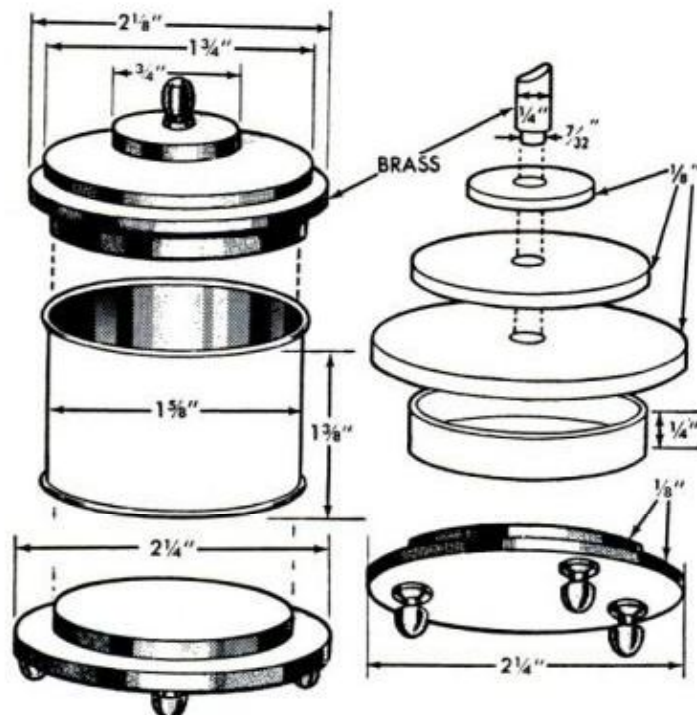



**TO MAKE** the grinder pedestal shown on the opposite page, first braze the two side frames, then clamp the units together with connecting braces in place and braze these joints. Rest work on  $\frac{1}{4}$ -in. asbestos board

**BRAZING-ROD HOLDER** can be made from any steel tube having reasonably small diameter. Use it to hold lengths of rod which are too short to be held safely with hand. This eliminates waste, cuts brazing cost

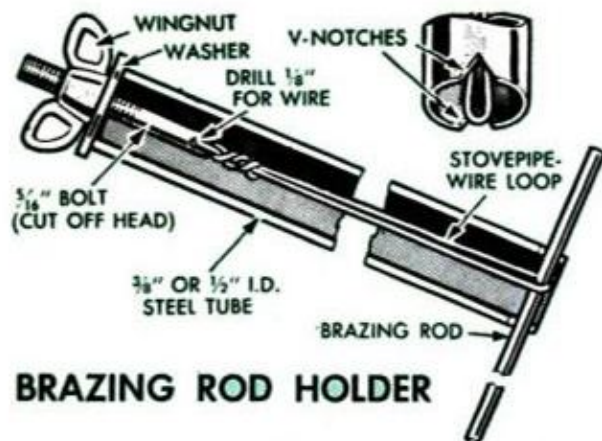

**BRAZING ROD HOLDER**

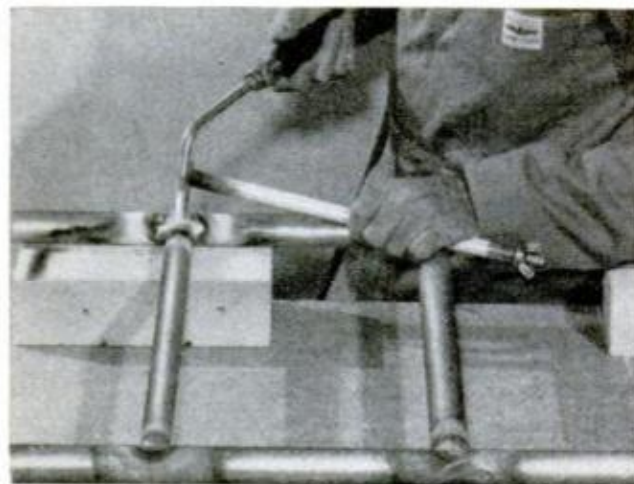

**M**OST CRAFTSMEN use the term "brazing" to cover all types of hard soldering—any soldering with an alloy having a higher fusing point than common lead-tin. A compromise between ordinary soldering and welding, this process creates a mechanically strong, fused-metal joint without melting the metal of the parts to be joined.

Since it requires less heat than welding, you don't have to invest in an oxy-acetylene outfit to do brazing in your own shop. The 4000-deg. flame from a less-expensive air-acetylene torch will be sufficient to take care of just about any brazing job you're likely to attempt. For very light operations, you can even use a small propane torch.

The three common hard-solder alloys—bronze, silver and aluminum—are each used with a different flux which may be a powder, paste or liquid. Each flux has a melting point lower than the alloy with which it is used, and when applied to the joint to be brazed, it cleans the metal so that the brazing alloy will adhere well. Powder and paste fluxes have a special advantage for the home craftsman since they serve as "temperature indicators"—each will melt and flow at a temperature just below the melting point of the brazing alloy with which it is used.

### Brazing with Bronze

Used to join similar or dissimilar ferrous metals, bronze alloys are probably the best known brazing materials. The procedure used when working with bronze brazing rods is basically the same as that used with other brazing alloys—heating the joint to a temperature which will melt the flux and alloy, then applying these two materials to the joint.

Successful brazing requires a bright metal surface. The torch flame will burn off zinc or cadmium plating—be careful not to breathe the fumes—but if the metal

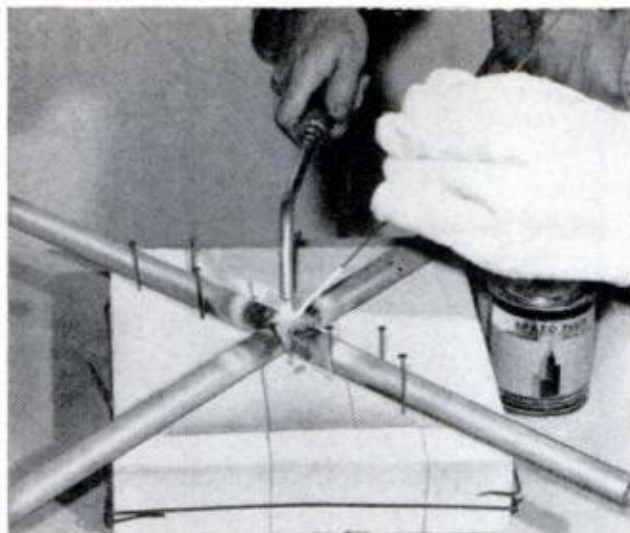

**INSULATION BRICK** is soft enough so that you can drive nails into it to hold work in alignment while brazing. It also resists heat transmission and thus will protect the top of your workbench from damage

is encrusted with dirt, grease or rust, give it a thorough cleaning beforehand with emery or steel wool.

Squaring the units to be brazed and holding the parts firmly in their proper position is of the utmost importance. Secure the joint temporarily with bolts, clamps or wire, or anchor it with wire attached to nails or staples driven into the surface on which the work rests.

Insulating brick, a lightweight, porous material used in the manufacture of ceramic kilns, makes a fine work surface for brazing because it resists the transmission of heat, protects the workbench and radiates absorbed heat back to the joint. Also, it's soft enough so that you can drive nails into it to hold the work.

After selecting the proper size brazing rod for the job at hand ( $\frac{3}{32}$  or  $\frac{1}{8}$ -in.-dia. for heavy joints,  $\frac{1}{16}$ -in.-dia. for light work), pass the end of the rod through the torch flame while heating the joint and dip it into the powdered flux. The flux will adhere to the hot tip, enabling you to use the rod as an applicator. When the joint has been heated enough to glow bright red, touch the tip of the rod to it and the flux will melt off, preparing the metal for the brazing alloy.

As in normal soldering, the joint must be heated to the temperature required to melt and flow the brazing alloy. Since heat applied to the joint area will be quickly dissipated throughout the metal and into the air, an extremely hot flame (such as that from the air-acetylene torch) is required to heat the joint to brazing temperature (1750-1800 deg. F.). When two parts are of unequal weight or thickness, compensate for this by applying more heat to the heavier part.



**GRINDER PEDESTAL**



**JOINT DETAIL**

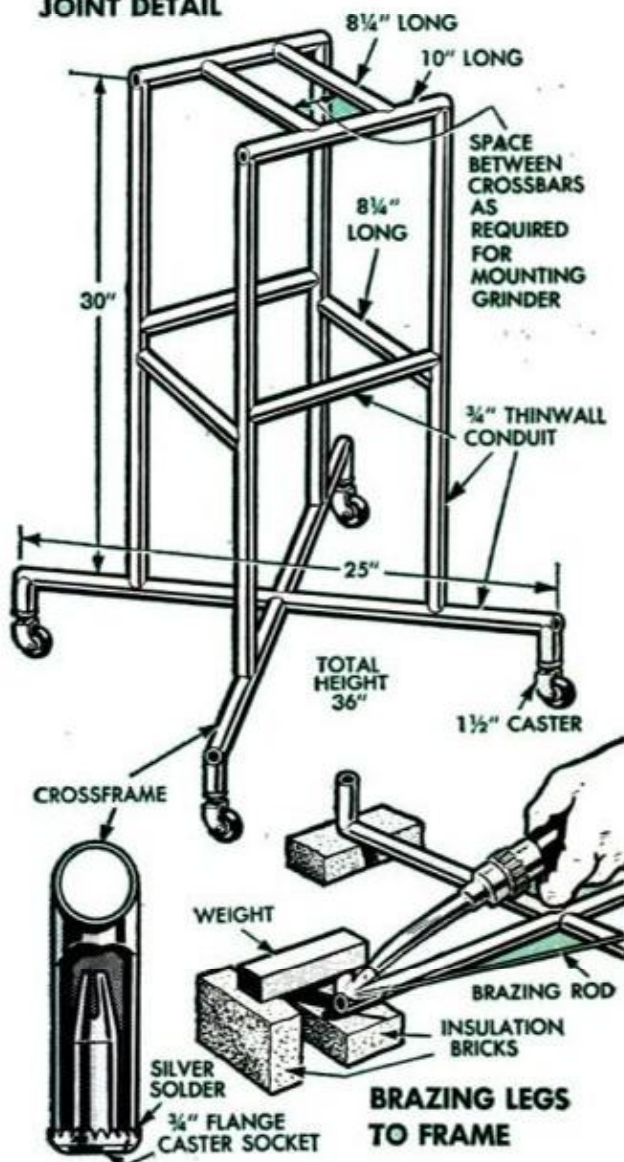

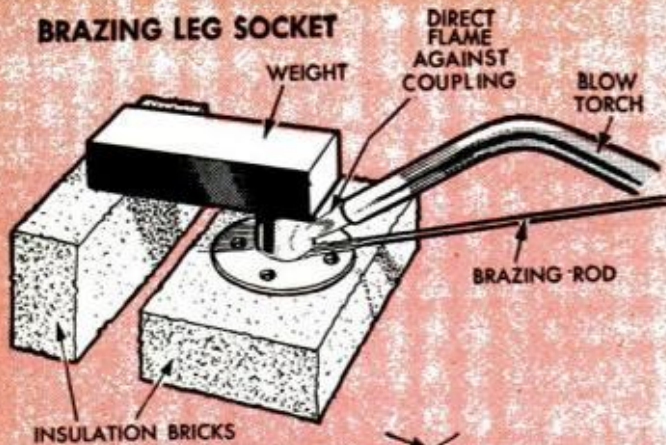

## TABLE FRAME

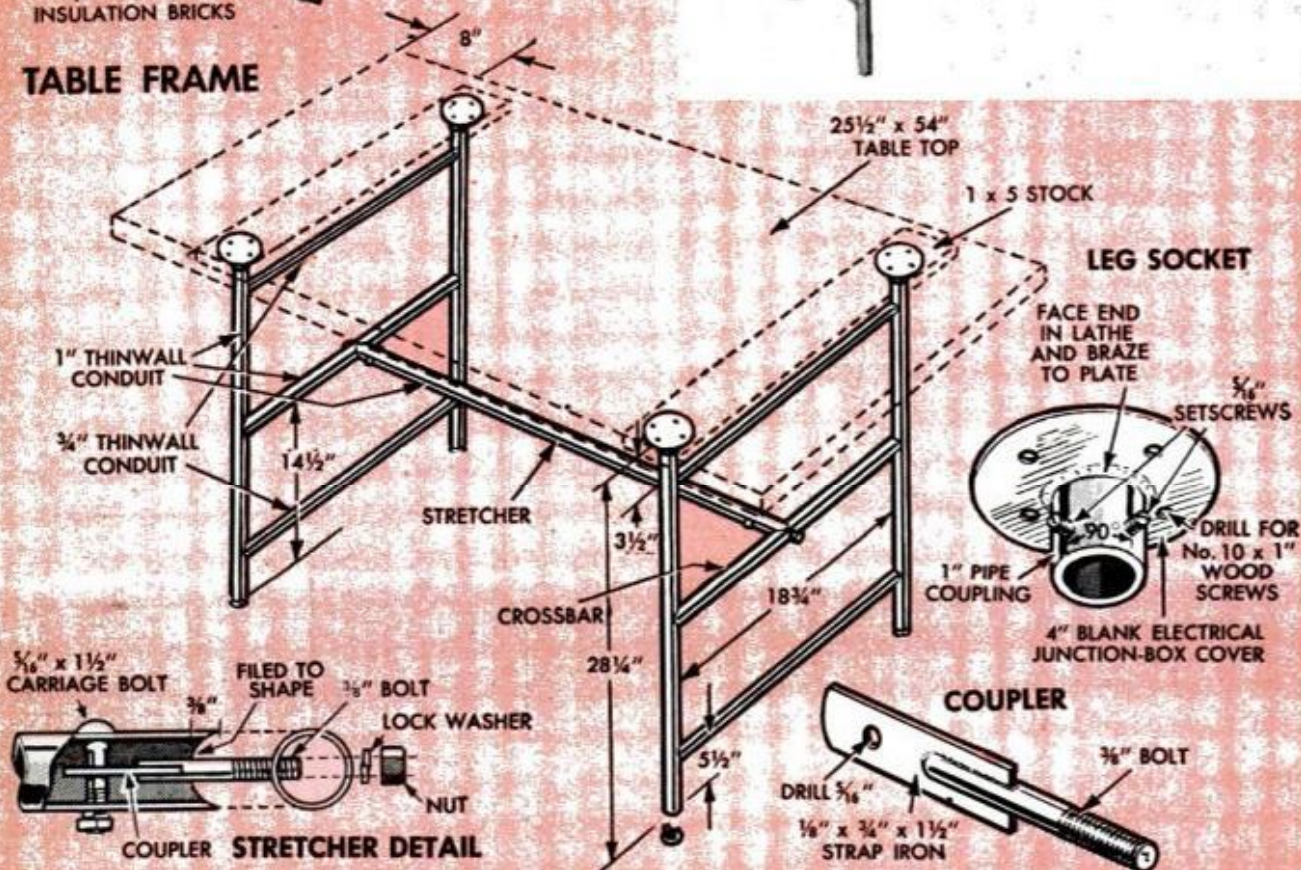

Continue to play the flame over the joint as the alloy begins to melt. This is critical, since the melting point of the alloy isn't a sufficiently high temperature to create a sound bond. Instead, the joint must be heated to the *flow point* of the brazing alloy, which is considerably higher than its melting point. When the alloy suddenly flows over the joint like water, remove the flame. It isn't necessary to pile up a heavy coating of alloy over the joint. Clean the brazed joint with a wire brush or file. Flux cools to a hard, brittle, glassy form and can be removed by chipping. Some paints won't stick to a fluxed joint, so if you're working on wrought iron or tubular steel furniture which is to be painted, use a phosphor bronze rod. This type requires no flux, and thus cuts down the work of cleaning the joint.

Brazing is a very useful technique for repairing broken or over-machined cast-

ings. To braze a break in a small iron casting, clean the break well and file down the sides to form a V where the parts join. If the brazing is to be done on one side only, carry the V on that side all the way through to the other side of the work and grind the casting back for 1/2 in. on both sides of the V. Then flow the brazing alloy into this V-channel and form it into a bead extending about 3/8 in. on either side of the break.

## Silver Soldering

Particularly suited for joining brass and copper or ferrous metals to non-ferrous metals, silver solder may also be used for soldering ferrous metals. Depending on the composition of the alloy, silver is worked through a heat range of 1130-1750 deg. F. For home-shop use, however, only alloys with the lowest melting temperatures need be considered

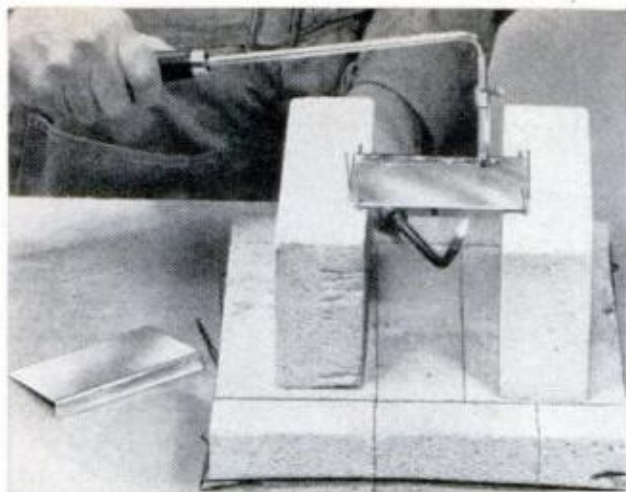

**TO SOLDER ALUMINUM** sheet, tin both faces of joint with aluminum solder, then scrub surface with glass brush through molten solder to achieve good bond. Apply heat from underneath to keep solder molten

since bronze rods will provide equal strength at lower cost than high-temperature silver alloys.

One low-heat alloy (All-State No. 111 Silver Alloy Wire) melts at 1100 deg. F., flows at 1130 deg. F. and turns out a joint having a tensile strength of 50,000 psi, which compares well with the best bronze brazing rods.

Silver solder is also available in sheet form. To use it, cut the sheet into  $\frac{1}{8}$ -in. squares and place two or three of these with some flux between the parts to be soldered, then bind the joint with wire and apply heat until the solder flows.

### Brazing Aluminum

The technique of joining aluminum to aluminum or aluminum to other metals is one of the least understood metal-working operations among home craftsmen. Since aluminum brazing can only be done at a temperature slightly below the melting point of the aluminum itself, there is an ever-present danger of overheating. A further complication is the fact that aluminum doesn't change color during the early stages of heating and glows dull red only *after* it has melted. To avoid this, be sure to keep the flame moving at all times and remove it the minute the alloy begins to flow.

Prepare the joint by cleaning with steel wool and sprinkling with aluminum brazing flux. Use a soft, low-pressure flame to heat the metal, flicking it over the work but avoiding the joint itself. Because of aluminum's high thermal conductivity (three to five times more than steel), heat will be conducted to the joint, but this indirect method of heating will enable you to avoid the oxidation problems caused by direct heat on the joint. Keep the flame moving while applying flux and aluminum

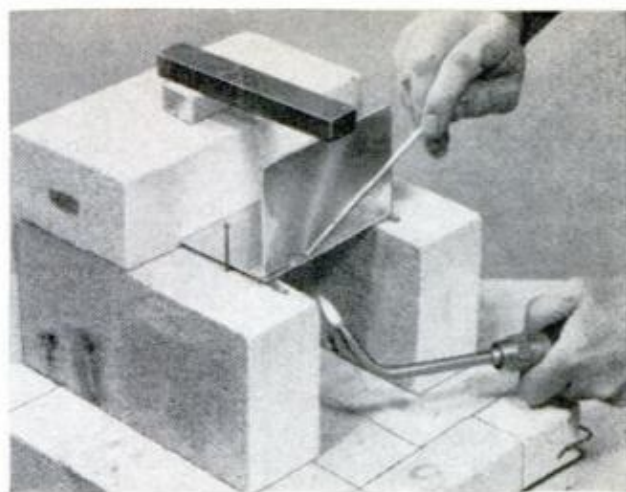

**AFTER TINNING**, place parts together and hold them in position with clamps or a weight. Apply heat to melt tinning, then add a fillet to each side of the joint and finish by sweeping glass brush through it

**BRAZING ALUMINUM** is actually much simpler than soldering, and it produces a stronger joint. The one big danger is overheating, since brazing temperatures are very near the melting point of the metal

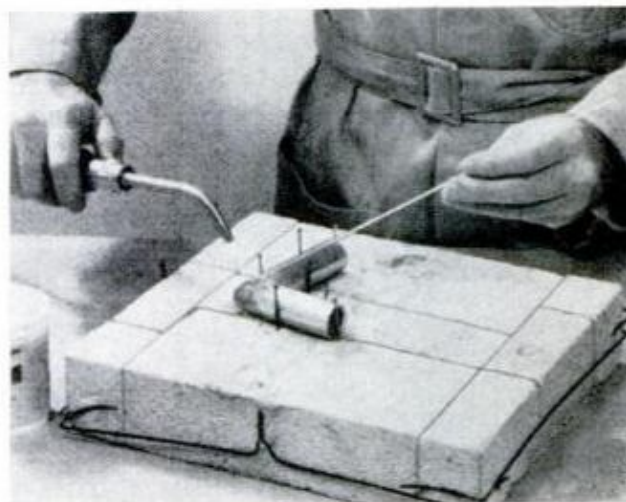

**EQUIPMENT** required for home workshop brazing needn't involve a large investment. Torch outfit shown here is priced at about \$65. Tank contains 40 cu. ft. of acetylene and refills for this will cost you \$3.75



brazing alloy, but remove it as soon as the alloy flows freely.

Aluminum brazing fluxes have a corrosive effect, so scrub the point immediately in hot water and then rinse it with cold water to remove the flux.

### Soldering Aluminum

Aluminum can be soldered at a lower temperature than that required for brazing, but there is still some danger of overheating, so follow the safety rules mentioned in connection with brazing.

After cleaning both faces of the joint to bright metal, apply heat as you would when brazing and "tin" the surfaces with aluminum solder. However, in order to make this "tinning" adhere, you'll have to remove the film of oxide which always covers an aluminum surface exposed to the air. To do this, melt "rub-on" solder on the heated joint area, then rub the end of the solder stick vigorously over the surface under this coating of solder to scrape away the oxide. The molten solder will prevent air from reaching the surface and forming a layer of oxide.

Another method of "friction soldering" requires the use of a glass-fiber brush made by Reynolds Aluminum. This brush takes the place of the solder stick for scrubbing the surface under the molten solder. It's used with a flux-free solder.

After tinning, hold the joint together with clamps, wire, etc., and heat the work until the tinning melts and fuses. To finish the joint, add a fillet of solder to each side. For a smooth, bright surface, sweep the glass brush through the solder while it is still molten. ★★

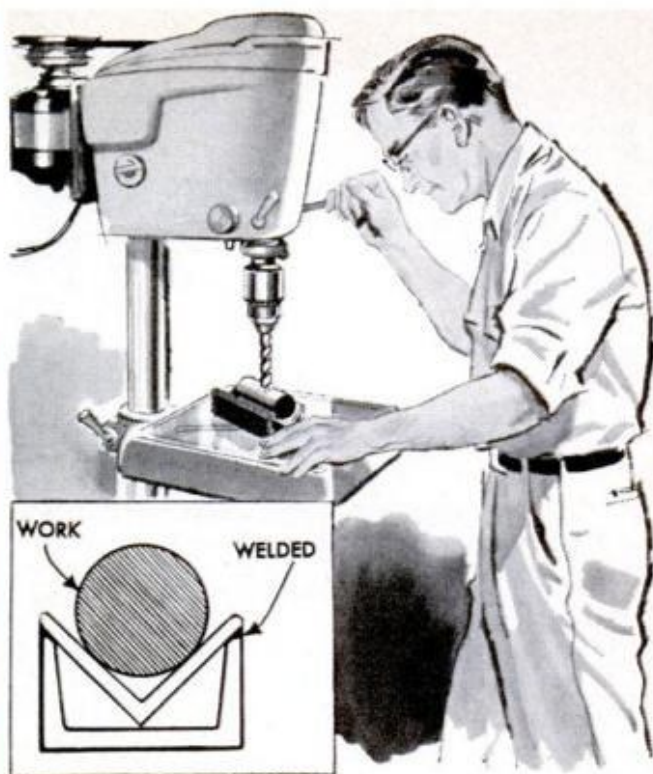

### V-Block from Structural Shapes

Any craftsman who does metalworking eventually runs into a job requiring a V-block to hold round stock for drilling. If you have such a problem, there is no need to go to the bother of cutting a block. Instead, try using the ready-made 90-deg. angle in angle stock. Simply weld a length of angle in a channel and you have a lightweight, easy-to-handle V-block, which can be used in both metal or woodworking.—M. W. Loftus

## COMING UP NEXT . . .

**BENCHTOP FOUNDRY.** For as little as \$35, you can buy the equipment necessary to turn out small sand castings right in your own workshop. Miniature blast furnace lets you work with aluminum, copper, brass or even gold. For the full story, complete with photos and diagrams don't miss "Sandcasting at Home" in next month's issue of *PM*.

**NO SWEAT.** Does your toilet tank have a perspiration problem. You can solve it without using messy roll-ons, sticky creams or watery sprays. The July issue includes five sure cures for that steady drip-drip-drip which develops every summer when vapor condenses on the cold porcelain surface of your toilet tank. Watch for this article next month.

**PATIO GRILL-PLANTER.** If your present patio is little more than a concrete slab, this triple-duty brick pier may be just what it needs to transform it into an inviting outdoor living room. It combines a planter, pole-type yard light and a built-in barbecue in an attractive corner unit, fenced in by the beauty of ornamental iron. A craft feature in the July issue.

**EASEL-PROJECTOR.** You can copy, enlarge and reduce both photos and drawings with this direct copy artist's easel which has its own built-in projector. Image is projected from behind through a glass panel onto the tracing paper, so you don't have to worry about being in the way or reversing the drawing. Enlarges copy up to 5½ times original size or reduces it to ¼. Watch for it in July.



New Merc 110/9.8 hp/2 cylinders

## *Mercs never get steamed up over a few weeds*

When you head into the rough stuff after the big ones, you don't have to worry about your Merc coming to a steaming stop. A Merc doesn't have a protruding nose on the lower unit to hang up weeds, clog the water pump, and cause overheating.

Glide-Angle design lets a Merc slide through weeds, over logs and shallows so easily and quietly that the big sleepers won't hardly know you're there.

Besides that, Merc's one-piece lower unit will take hard knocks that would bust the seams on other outboards.

And you don't shear pins, because it has none. Instead, Merc has a live-rubber clutch that momentarily gives with the impact.

Over open water or through weeds and reeds, Mercury gives you more RUN for your money.

# **MERCURY**

100, 85, 65, 50, 35, 20, 9.8 and 6 hp outboards

**MerCruiser Stern Drive  
Power Packages • 310, 225,  
190, 140, and 110 hp gasoline  
100 and 39 hp diesel**



© 1963, KIEKHAEFER CORPORATION, Fond du Lac, Wisconsin,  
and Toronto. Subsidiary of Brunswick Corporation



**Now! Instant-loading cameras**

# New KODAK INSTAMATIC

You just snap the KODAPAK Film Cartridge into the camera. No threading! The camera's loaded instantly! You're ready to shoot—faster than you can read about it.

New KODAK INSTAMATIC Cameras take care of practically everything automatically. All you do is shoot. Get sharp, bright prints in color or black-and-white, or color slides.

There are four KODAK INSTAMATIC Cameras. Their features range up to automatic electric-eye exposure control, automatic film

advance, and fast lens-shutter combinations.

Model 400, shown at right, gives you automatic electric-eye exposure control *and* power-drive film advance. It lets you fire off 10 shots without lowering the camera from your eye. The electric eye not only sets the lens, but also signals in the viewfinder when to use the built-in flash. The INSTAMATIC 400 Camera is all brain, yet weighs only 15 ounces, is just 4 inches wide! INSTAMATIC 400 Outfit with bulbs, batteries, film—less than \$53. At your Kodak dealer's now!



**KODAK INSTAMATIC 100 Outfit.** Instant-loading camera with built-in flash. No focusing, no settings. Outfit: film, bulbs, batteries — less than \$16.



**KODAK INSTAMATIC 300 Outfit.** Instant-loading camera with automatic electric eye, built-in flash. Outfit with bulbs, batteries, film—less than \$45.



**KODAK INSTAMATIC 700 Camera.** f/2.8 lens, automatic daylight and flash exposure controls, built-in flash, speeds to 1/250. Available soon.

**Kodak**  
TRADE MARK

Enjoy Walt Disney's "Wonderful World of Color" Sunday evenings, NBC-TV





that load like a gun!

# Cameras

...with new  
KODAPAK Film  
Cartridges

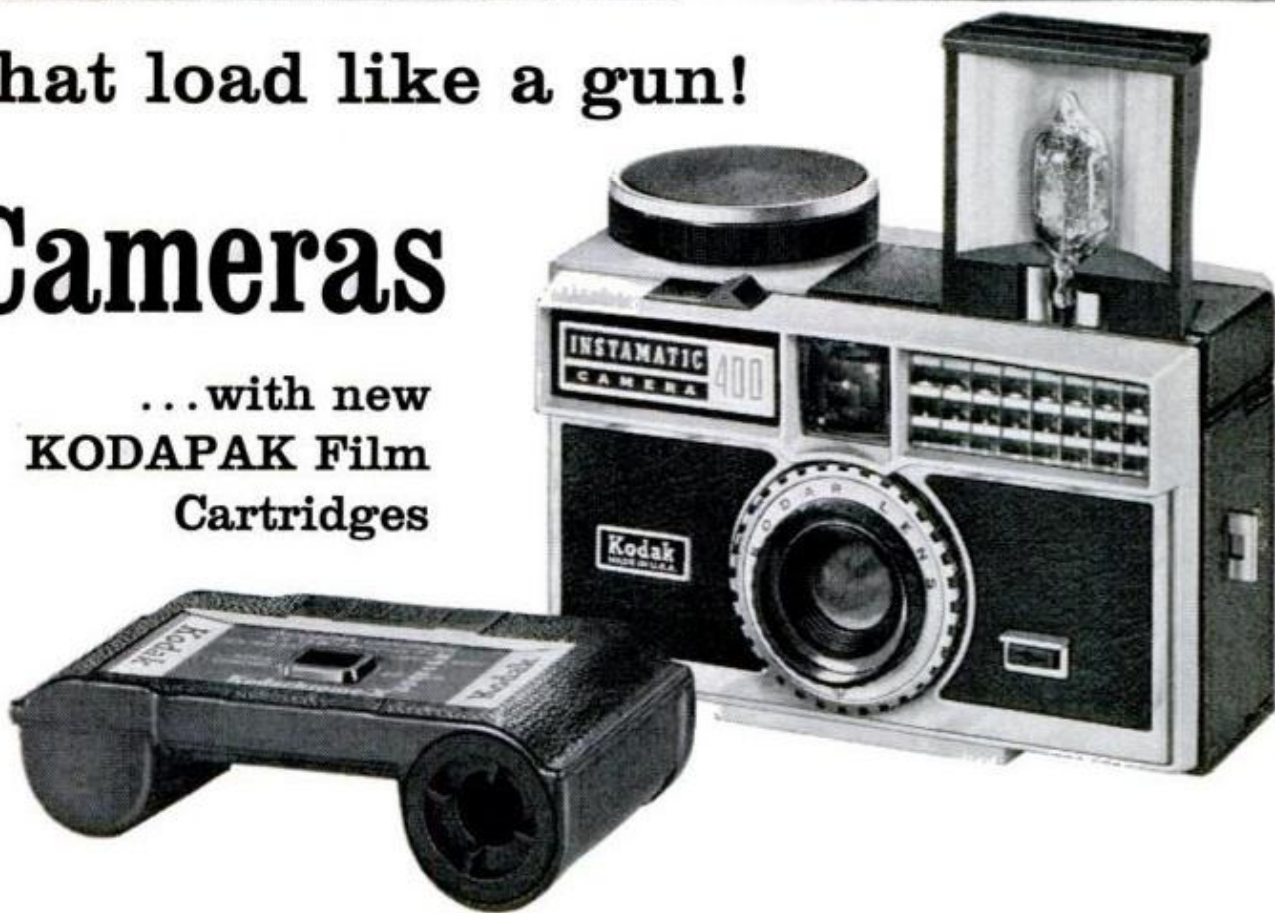

**Shoot color slides or snapshots in color or black-and-white**

New ready-loaded KODAPAK Film Cartridges are designed specifically for use with the KODAK INSTAMATIC Cameras. They drop in instantly—no threading, no mistakes. You can even put them into the camera in bright sun. Choose cartridges of KODAK VERICHROME Pan Film for black-and-white shots. Choose cartridges of KODACHROME-X or KODAK EKTA-

CHROME-X Film for color slides; KODACOLOR-X Film for color prints. (All are fast films, to let you shoot in less light. See your Kodak dealer for details.)

**EASTMAN KODAK COMPANY**  
Rochester 4, N. Y.

*Prices subject to change without notice.*



## Not for Volkswagens

Or any other car that drinks air. But for a car that drinks water, one can of Mac's No. 13 rust inhibitor will keep its cooling system running clear for a whole year. Don't be inhibited. Ask your service station man for Mac's No. 13 today.

**MAC'S SUPER GLOSS CO., INC.**  
Los Angeles 42, Calif., Cincinnati 26, Ohio

## A-Power: Creeping Giant

(Continued from page 104)

ducers are planning to enter the atomic field. The most ambitious project is, perhaps, Con Edison's plan to build a nuclear power plant right in the heart of New York City, with a capacity of one million kilowatts. Completion date: 1970.

One obstacle to atomic power is economics. The cost of producing electricity is figured in mills-per-kilowatt. (A mill is a tenth of a cent.) Conventional power plants in New York State, for instance, can produce electric power at an average cost of about seven mills-per-kilowatt. The Shippingport reactor, first to produce commercial electric power, did so at a cost of about 50 mills. That was in 1958.

Since then, the cost of producing atomic power has dropped sharply. The new million-watt plant just proposed for New York City, says Con Edison, will produce electric power for the same cost as fossil fuel plants.

Two new plants with a combined output of 780,000 kilowatts are projected for California's power grids. A group of New York utilities have joined together to erect an atomic power plant with a capacity between 300,000 and 500,000 kilowatts. A similar group in New England, joined as Connecticut Yankee Co., have set their sights on a half-million kilowatt reactor.

In the Southwest, the South, in Hawaii, New Jersey and many other areas, plans for power reactors are in the works. Thus, the tentacles of atomic power are slowly spreading over the land. But the growth is a slow and costly process.

Of all reactors now in existence or under construction, 286 are in the United States. So far, only six of these produce civilian electric power, with three more scheduled for completion this year. The others are for experimental research, training or for ships and submarines.

Even with the great strides being made, it will be many years before fossil fuel producers will suffer from atomic competition. By 1970, according to the AEC's present figures, atoms will be producing some three million kilowatts—a small nibble of the total 186,000,000 kilowatts produced for America in 1960.

Latest figures from the Atomic Energy Commission indicate that by the year 2000 more than half the power consumed in this country will come from the atom. Within a century, practically all of it will be atom fired electricity.

It may still be quite a few generations before Greenland is an atom-dyed green, but the outlines of the new Atom Era are beginning to take definite shape. ★★★

# 6 REASONS WHY SKILSAW POWER SAWS OUTSELL EVERY OTHER MAKE!

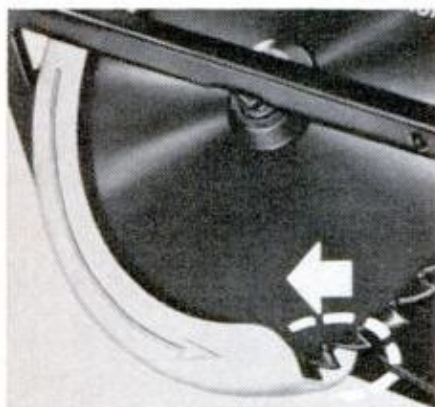

**Bind-free lower guard**—Retracts automatically when saw base is tilted, thus allowing bind-free starts—even on compound miter cuts.

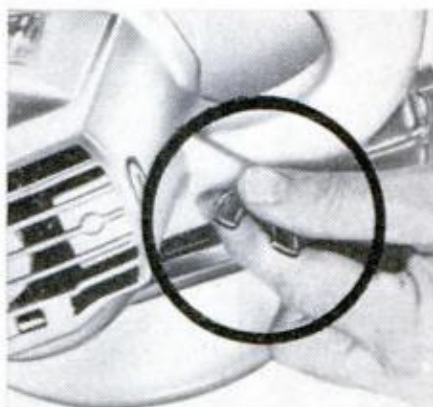

**Easy-to-set depth control**—Conveniently located for easy one hand adjustment. Control locks the saw firmly and quickly at any desired cutting depth.

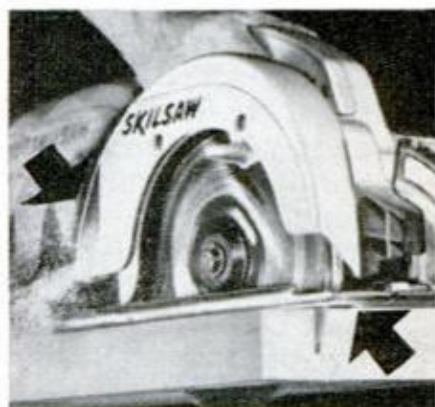

**Exclusive sawdust ejection**—Special air stream ejection system directs sawdust down to floor, away from the operator; blows it off the line of cut.

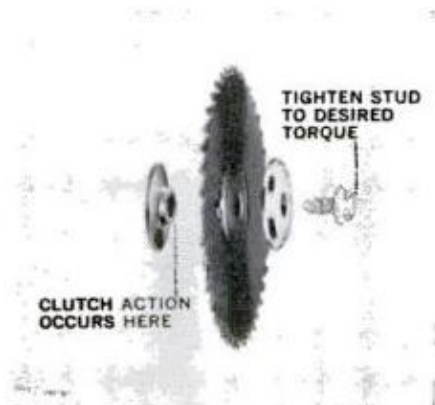

**Vari-Torque safety clutch**—Disengages blade if it binds or jams. Protects gears and other parts from damage, prevents saw kick-back.

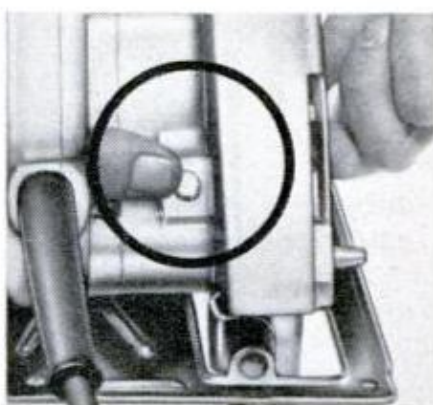

**Exclusive Blade Lock\*** (Patented Feature) For fast, easy blade changes. Push-button engages and locks blade shaft for greater user safety.

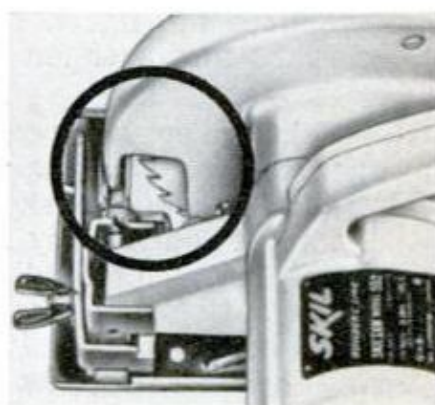

**Full-View Blade**—Upper blade guard designed to allow clear view of blade all through the cut for absolute precision and accuracy.



**Skilsaw Model 536**—World's largest-selling 6½" saw. Makes 45° bevels in 2" lumber, has super burnout protected motor. Other models up to 8¼".

There are many more features, too! Like super burnout protected motors on *all* models, and full ball-bearing construction on heavy-duty models.

Because Skil never compromises on quality, no other saw offers all these features to make every cutting job easier and faster.

Skilsaw Power Saws are made in both deluxe and heavy-duty models with full range of blade sizes from 5½" to 8¼". See them at your nearby lumber and hardware store.

Prices start under \$30—slightly higher in Canada.

**SKIL**  
POWER TOOLS

\* available on heavy-duty models only

# CLINIC FOR HOMEOWNERS

## Does sanding rub you the wrong way?

It needn't! Now you can sand faster, easier and get better results with "Production" Brand Sandpaper. Amazing "Production" Sandpaper is the world's toughest sandpaper. Sands 10 times faster, lasts 10 times longer than old-fashioned sandpaper.

Coated with aluminum oxide, the toughest abrasive known, "Production" Sandpaper cuts down wood, metal, plastic, almost any material. Yet for all its ruggedness, "Production" Sandpaper produces the finest, smoothest finishes that ever felt a coat of paint.

Take the easy way out on your next sanding job... use "Production" Sandpaper. Ask for it by name at your nearby hardware, paint, lumber or building supply dealer. Ask for 3M's free How-To-Do-It booklet on furniture finishing and refinishing, too.



For professional results use  
**PRODUCTION® SANDPAPER**

**3M** MINNESOTA MINING & MANUFACTURING CO.  
\*\*PRODUCTION® IS A REG. TRADEMARK OF 3M CO., ST. PAUL 19, MINN.

**Q** The paint on the siding of my older home, applied less than a year ago, has peeled badly. There's a blow-in insulation in the walls, poured insulation in the attic. I'm thinking of having the siding covered with asbestos shingles. But if dampness caused the paint to peel, what will happen to the siding?—L. W., Minn.

**A** You will have to choose between what is happening now and what will occur, to a lesser degree, if you cover the siding with shingles. Moisture will penetrate the wall from the room side, but it will not be trapped back of an unbroken paint film and for this reason deterioration of the wood siding will occur at a somewhat slower rate. In some cases, in severe winter weather, moisture does collect under the shingles and freezes but usually this will be dissipated during temperature changes with comparatively little damage to the siding or framing. Have you considered the application of wood shingles, colored with a suitable shingle stain? On many older homes these make a very attractive wall and the installation also permits the wall to "breathe", that is, permits the moisture to dissipate and lessen the damage to the wall by entrapped dampness.

**Q** I have wooden Venetian blinds over two double windows. These are on the south side of my home and exposure on the outer face of the slats has checked and darkened the finish making them most unattractive. On the inner faces of the slats the finish is still good. How can I refinish the outer surfaces to match?—I.C., Calif.

**A** It can be done, but it's going to be quite a chore. You would have to remove the old finish from the outer face and one edge. This we would consider impractical to attempt. Better, we think, to remove all the finish from each slat with a varnish remover and then refinish with a varnish stain applied with a sprayer. You can usually rent a suitable sprayer from your paint dealer. After removing the old finish down to the bare wood, sand the faces and edges of the slats smooth, then lay side by side and edge to edge on a flat surface and apply varnish stain in a fine mist spray. Wooden

blind slats usually are finished in a "honey" maple color and this is the varnish stain to use. Allow the first coat to dry and then apply a second if necessary to get the tone depth you want. Turn the slats when dry and proceed with the same sequence of application. Finally, stack the slats, clamp them tightly together and spray the edges very lightly. Then, before the varnish sets, remove from the stack and lay the individual blinds on a flat surface to dry. A light rub with fine steel wool should give you a good surface.

**Q** The plastered walls in my home are textured and have always been painted. Now, I'd like to have a change in decoration and have wondered if it is possible to paper over this textured surface. Can it be done?—T.P., Tex.

**A** Yes, but with only certain wallpapers, and you won't get as smooth a job. You also will find it more difficult to get an invisible butt seam, or joint, a hallmark of good paper hanging. Plaster texture jobs vary in manner of application and irregularity of surface, so it is difficult at long range to say just what to do. Perhaps the best first step is to obtain small sample pieces of several heavy wallpapers (your dealer will supply at reasonable cost) and apply these several pieces to the wall as a preliminary test. Then, when the paste has dried, you can easily judge which paper gives the best result, shows the least irregularity under oblique and direct light.

**Q** I'm new at home shop work. I've just purchased a used table saw and a motor. There's a 2-in.-dia. pulley on the saw, none on the motor. What size pulley do I use on the motor?—J. R., Ala.

**A** If you look on the motor nameplate you will find the speed of the armature given. Usually this is 1750 r.p.m., although motors are wound to turn at 3450 r.p.m. and higher. If you find the former speed given, a 4-in. pulley on the motor will give a saw-spindle speed of about 3450 or 3500 r.p.m., which is a good average speed for saw blades up to 10 in. in diameter. If you have a 3450 r.p.m. motor, use a 2-in. pulley on the motor.

As a service to Popular Mechanics readers in solving the hundreds of problems pertaining to a home—inside or out—you are invited to present your problems to The Home Clinic Editor for his helpful advice. Address your questions to The Home Clinic Editor, Popular Mechanics Magazine, 575 Lexington Ave., New York 22, N.Y.

# Add-a-room IDEAS



## NEW 36-page booklet shows how you can find "room for improvement" with plywood

Cramped for space? Need a family room? Bedroom or bath? This valuable new booklet tells you how to add space—whether it's a single room or a whole new wing—to almost any kind of house. Developed by modernizing experts, these practical, good-looking designs can add livability and resale value to your home. Each one calls for simple, straightforward plywood construction for a quality job at lowest possible cost. Booklet includes before-and-after color pictures, floor plans and decorating ideas. Gives you tips on materials, wiring, plumbing—plus useful information on financing.



Mail Coupon Today for Valuable  
Full-Color Remodeling Booklet

Douglas Fir Plywood Association  
Tacoma 2, Wash. Dept. PM

I enclose 10¢. Please send me  
the Add-a-room Idea Book.

Name \_\_\_\_\_

Address \_\_\_\_\_

City \_\_\_\_\_ Zone \_\_\_\_\_ State \_\_\_\_\_

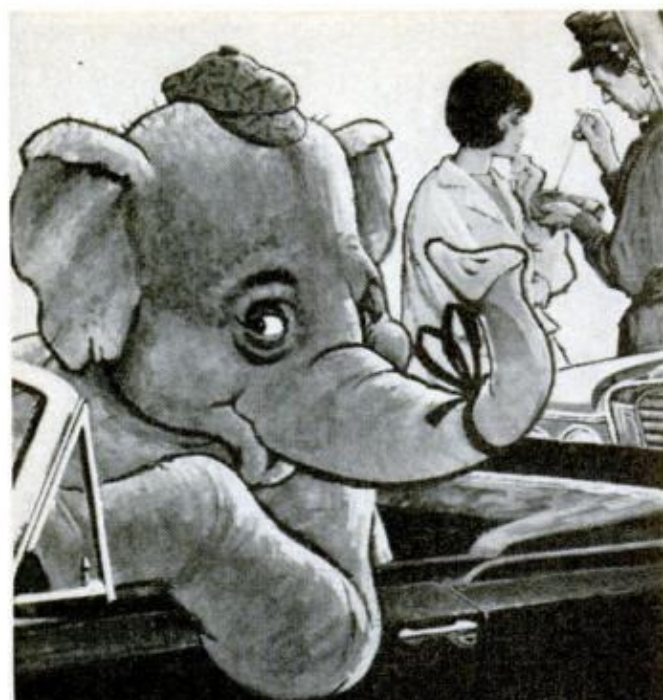

*You don't need a memory  
like an elephant . . .*

**If you forget to  
change oil  
PENNZOIL  
STILL PROTECTS**

©Pennzoil 1963

**Not being elephants,** people are apt to forget. That's why we build *protection reserve* into Pennzoil Z-7, so it will go on protecting even if you forget to change oil when you should. Use Pennzoil Z-7 always, and ask for it even if you don't see it displayed. Pennzoil, Oil City 61, Pa.

**Best time to change oil:** Every 60 days, normally. Every 30 days under severe stop-and-go or cold-weather driving conditions.

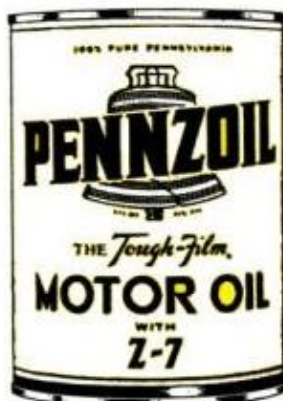

Hear "Chet Huntley's Perspective on the News" Monday through Friday, NBC Radio Network

## Keep the Fuel Flowing

(Continued from page 163)

motive supply dealer. In this case, you can order one from the manufacturer of the fuel pump. Designate the make, year and model of your car, or the fuel-pump part number, which is stamped somewhere on the pump body.

There are two types of kits. One is designed specifically for diaphragm repair, since this is the main cause of fuel-pump failure. The other kit contains all parts needed to do a complete overhaul.

To remove the pump from the engine, disconnect the pump-to-carburetor line at the pump, and the gas-tank-to-pump line at the pump. Put a stopper in the tank-to-pump line to keep gas from flowing. If you're working on a combination pump, disconnect the air lines as well.

Remove the bolts and lockwashers holding the pump to the engine. You'll find a gasket between the pump body and the engine block. Discard and replace it with the new gasket contained in the kit.

### Once It's Off the Car . . .

After removing the pump from the engine, wash it in gasoline or a solvent, using a brush to remove dirt. Disassembly of a standard mechanical pump is demonstrated in the photo series. Combination pumps, of course, contain more parts than single action pumps because of the addition of the vacuum section. However, the vacuum and fuel pump sections are similar.

One type of fuel pump manufactured by AC has a riveted diaphragm and pull rod (you can see the rivet head on the pump body—it's the only one there). Around the pull rod are tight-fitting oil seals that can be damaged if you don't remove the rocker arm assembly first. So, to start your disassembly with this type of pump, remove the rocker arm pin, rocker arm, and link. The diaphragm assembly can then be lifted straight out, with no damage to the seal.

The most critical operation in putting the pump back on the engine after overhaul is to make certain the rocker arm engages the cam eccentric properly. At all times, you must make sure the "pad" (flat surface) of the rocker arm rests against the cam as required by the pump's design. If rocker arm and cam engagement is not correct, broken arms and links or even engine damage may result.

After the pump is placed properly into the engine, hold it in position against the engine and insert the bolts, with lockwashers, in the holes provided. Start the bolts by turning them with your fingers to prevent damage to the threads. ★★★

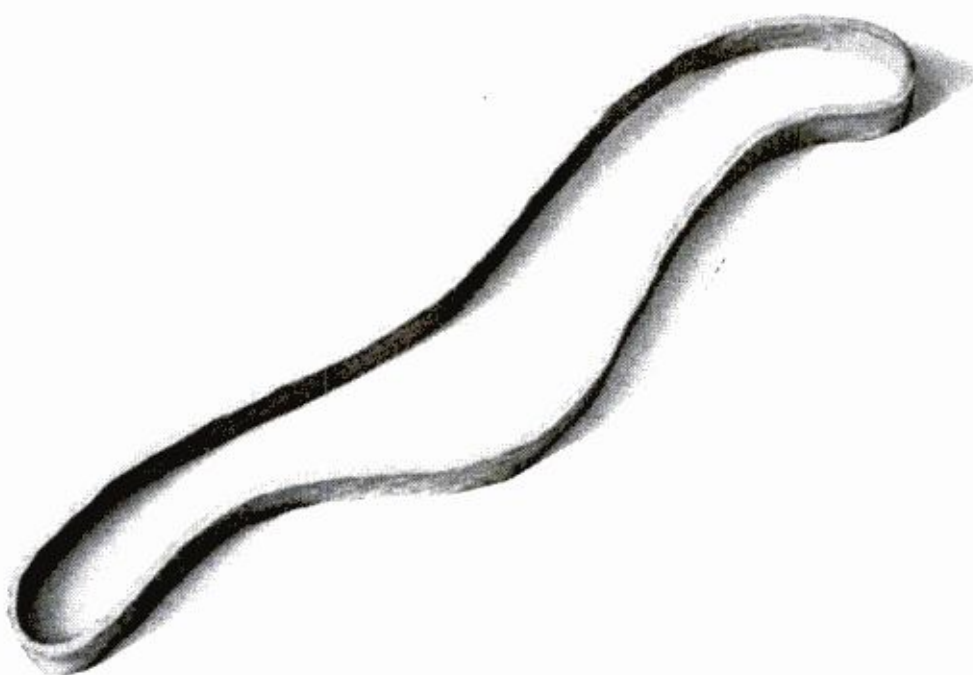

## In one respect, it's an ideal piston ring

A rubber band and a piston ring have one characteristic in common that is very important.

That characteristic is conformability — the key to proper compression and oil control in the engine of your automobile.

Simple enough to achieve — in rubber. But, to create metal rings with this perfection of fit . . . rings that will withstand the explosive impact, abrasion, heat and acids in an engine — requires very precise and specialized engineering.

Every year for several decades we have invested heavily in engineering and research. And the result is improved rings

and new designs with that special Perfect Circle quality which produces top performance and extra long life.

That's why virtually every major American manufacturer of passenger cars, trucks, tractors, and construction equipment specifies Perfect Circle rings as original factory equipment.

It's an important reason why the car you drive gives you more *go* to the gallon, more power to pass.

And a *very* important reason, when you *do* re-ring, for insisting on rings made by Perfect Circle — the power-packing piston rings that engine "pros" prefer.



## PERFECT CIRCLE

**PISTON RINGS • CYLINDER LINERS • PRECISION CASTINGS  
TURBINE BLADES AND WHEELS • ELECTRONIC PROGRAMING EQUIPMENT  
SPEED CONTROLS • HAGERSTOWN, INDIANA**

Plants and Subsidiaries: HAGERSTOWN, RICHMOND, NEW CASTLE, TIPTON AND RUSHVILLE, INDIANA  
THE PERFECT CIRCLE COMPANY, LTD., DON MILLS, ONTARIO, CANADA • SCHELLENS TRUE CORPORATION,  
IVORYTON, CONNECTICUT • PERFECT CIRCLE INTERNATIONAL, FT. WAYNE, INDIANA • PERFECT  
CIRCLE HOLLAND N.V., THE HAGUE, NETHERLANDS • *Factories, Affiliates and Licensees in MEXICO,  
ARGENTINA, AUSTRALIA, BRAZIL AND FRANCE*

## And Was It a Silent Spring?

(Continued from page 88)

attention to the pond, just sprayed it along with everything else.

A few days later Jim found a milk cow "shivering to death." Her milk production fell off, but fortunately she recovered. About then a fine bull that had cost Jim and his wife \$500 began to show signs of bleeding internally and in an hour it was dead. He also found a dead sheep.

"Later, when I described how the bull had acted, the vet said it sounded like he'd been poisoned.

"One day my pigs started acting crazy, staggering all over. I finally had to knock one of them on the head. I began noticing dead birds around the farm and even saw a goofy rabbit. He was running right along beside the tractor and I could have conked him on the head with a hammer."

Mention the farm pond and Jim's wife explodes. The pond had been stocked with crappies and a few hours after the spraying they had begun floating on the surface. Three days later Jim and his wife counted 1003 dead fish. They kept dying for weeks.

Finally, Mrs. Martin went to the farm agent about the pond. He told her he couldn't do anything, but advised her to send a bottle of pond water to the state university for analysis.

"I tied the bottle to a string," she says, "and threw it out into the pond among the dead fish, turtles and muskrats."

Eventually the report came back. It stated, she says, that the water was excellent drinking water, particularly good for children under one year of age because it was so low in nitrates!

These are personal observations by farmers in the area. More complete and authoritative figures are available from the Illinois Natural History Survey. Dr. Thomas G. Scott, head of the Section of Wildlife Research, supervised the program to find out what happened to wildlife under the Sheldon-Donovan sprayings.

"First of all," says Dr. Scott, "we conducted bird counts in Donovan and Beaverville seven miles away, similar to Donovan, except that Beaverville wasn't sprayed. We made the counts during the summer of 1960 [right after the spraying] and again in 1961. An observer walked a predetermined route in each town, and counted the bird species he saw.

"In Donovan in 1960 we observed only 6.4 robins, grackles and starlings per hour; in comparison, 112.8 of these birds were observed per hour in untreated Beaverville. However, by the summer of 1961 the count in Donovan had gone back up to 128.4 birds per hour."

Previously, Dr. Scott had supervised research in the Sheldon area. "We found dead animals of virtually every species. Ground squirrels, muskrats and rabbits were virtually annihilated. Shrews, fox squirrels, woodchucks and meadow mice also seemed to take heavy losses.

"We searched the fields daily throughout the spring and summer of 1954 and never saw a live pheasant. The breeding population seemed to be wiped out.

"In 1955 half the town of Sheldon was sprayed and we immediately distributed a questionnaire to residents. From the returns, we estimate that 58 bluejays were killed, 29 brown thrashers, 923 robins, 22 bluebirds, 58 cardinals, 296 starlings, 94 squirrels, 346 rabbits and other birds and animals, bringing the total to 2280. Robins were almost annihilated.

"It was estimated that 90 percent of the cats on farms died following the application of dieldrin in 1954. In mid-May of that year we counted 106 ground-squirrel dens showing evidence of use. By the last week of June only three still showed activity, and by July there was no sign of activity of any kind."

In the Sheldon area, according to Dr. Scott, dieldrin was found in cow milk being fed to a baby. The University of Illinois immediately notified the parents.

There is one optimistic note to add to this grim recitation and indeed it is optimistic. By the end of the reproduction season the following year, many of the species had repopulated the area in almost normal numbers. Rabbits came back fast, probably because of their rapid reproductive cycle. Birds returned in almost normal numbers. Pheasants didn't come back as fast and the size of the broods has been significantly smaller, but the state conservation officer has been releasing 3000 pheasants per year. Hunting is expected to return to normal in the near future.

I asked Dr. Dean Hungness of Sheldon, a veteran member of the county medical society, if any medical problems in humans had been traced to the spray program. He said that to the best of his knowledge there had never been any diagnosis of pesticide harm to humans, but "there was damage to animals around here."

Certain conclusions can be drawn:

1. This was no amateur job; well-trained professionals did the spraying. A few spots were missed, and a few areas received layer after layer of toxic material.

2. The public was poorly educated and little effort was made to enlist its support. Along this line, the National Research Council of the National Academy of Sciences, which has been studying the

(Please turn to page 186)



# Organize your garage... **PRESTO!**

Use handsome new Presto Peg-Board by Masonite for quick, convenient storage space. These rugged  $\frac{1}{4}$ "-thick hardboard panels come prefinished in handsome tracery design. Nail 'em up, insert hook-on fixtures, then hang everything from tools to heavy garden equipment. Cover an 8 x 12 foot wall for less than \$20.

Find out about Presto Peg-Board and other Masonite hardboard panels for home improvement. Write for your free copy of our "Idea Plans" booklet.



## MASONITE

*shows the way*

Masonite and Peg-Board are registered trademarks of Masonite Corporation.

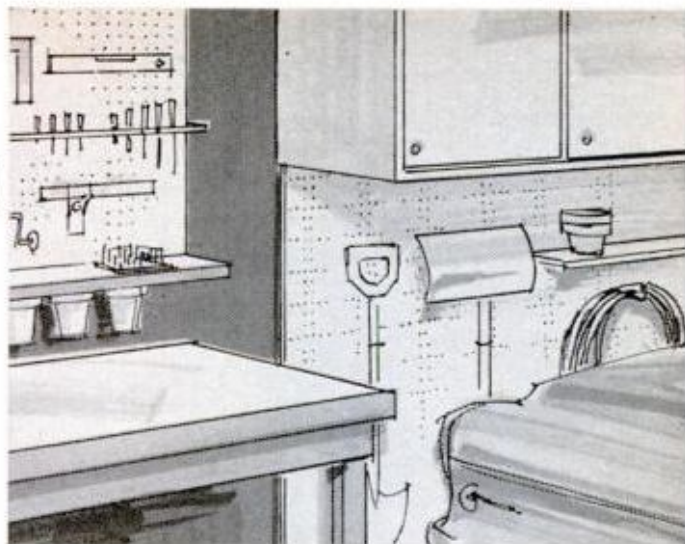

Masonite Corporation, Dept. PM-6, Box 777  
Chicago 90, Illinois

Please send me free plan on garage interior remodeling.

Name \_\_\_\_\_

Address \_\_\_\_\_

City \_\_\_\_\_

County \_\_\_\_\_ State \_\_\_\_\_



### Tool of a dozen uses!

Motorized! Ready to plug in and spray! Use it to paint anything, from a toy to a house. Does an hour's painting in just minutes. Pays for itself on the first big job. Also use it to spray insecticides, weed killers, liquid fertilizer; vacuum, tire inflator, etc. A real professional tool needed in every work-shop. Ask for Speedy Sprayer "Compact" No. 404. **\$39<sup>95</sup>**

Slightly Higher Denver West.

Write for "How to Spray" booklet and catalog.

**W. R. BROWN CORP.**

*Specialists in Portable Sprayers Since 1921*

2635 N. NORMANDY AVE., CHICAGO 35, ILL.

JUNE 1963

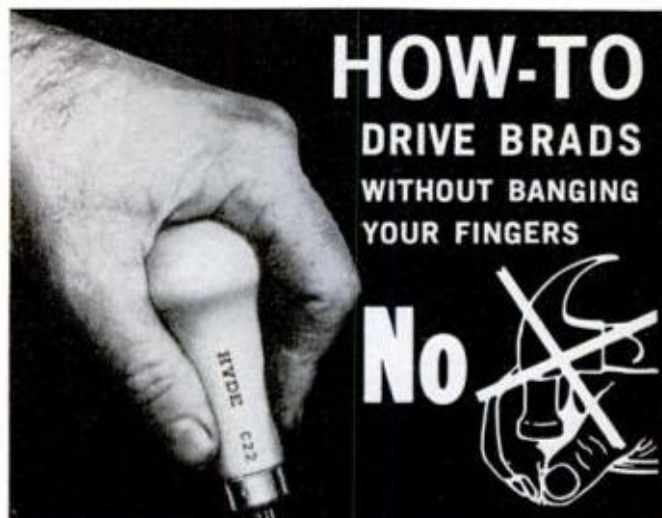

**HOW-TO  
DRIVE BRADS  
WITHOUT BANGING  
YOUR FINGERS**

**No**



**YES**

Pick up this handy tool from your local hardware, paint or building supply store. If not in stock, mail \$2.69 and we will send tool postage paid.

Hyde No. C22 Brad Driver drives and sets small finishing nails 1" long and smaller, 16 to 19 gauge. Special magnet in barrel lifts brad for driving and setting in wood. Dozens of uses for woodwork, miniatures, antiques, models, etc.

**WRITE FOR FREE CATALOG**

**HYDE TOOLS**

SINCE 1875

SOUTHBRIDGE, MASS. U S A

## And Was It a Silent Spring?

(Continued from page 184)

problem of insecticide programs, recommends, in part: "Initial support is best gained by public participation in the early deliberations, before control decisions have been made. . . . It is especially important to keep the public informed of . . . possible hazards . . ." Obviously this wasn't done in Sheldon and Donovan.

3. There unquestionably were heavy losses to every species of wildlife and several species were annihilated.

4. Losses were temporary; in most cases, wildlife showed a substantial recovery the following year.

5. The Japanese beetle has not been eradicated in the district. Each year since 1954 (with the exception of 1959) more land in the Sheldon-Donovan area has been sprayed, and in most years the area covered has been larger than the previous one. In 1961 planes sprayed 54,088 acres.

6. Although the beetle has not been eradicated, it may have suffered a substantial setback. There is no way of knowing how fast the beetles would have spread *without* a spray program, nor how much damage they would have done to crops.

7. Many farmers in the area have no objection, even today, to spraying for Japa-

nese beetles. What they object to is the method. Frequently, it was suggested that the government provide the farmer with the insecticide, along with an attachment for his tractor, and let him apply the poison himself, immediately plowing it under. Evidence indicates, however, that some wildlife—particularly insect-eating birds, and the mammals that prey on those birds—would still suffer losses. Poisoned beetle grubs crawl to the surface where they become a banquet for birds.

8. There could well be a permanent effect on repopulation if dieldrin, aldrin or heptachlor were applied to the same area two or more years in a row.

9. These insecticides should never be used on an area which contains rare or threatened species of wildlife.

10. No reasonable person would argue that agricultural pesticides should be outlawed. About 600 major insect pests cause a crop and livestock loss of at least \$4,000,000,000 a year. However, the production of pesticides has reached the astounding total of one billion pounds annually, a tremendous quantity of poison.

11. We'd better support research on the long-term effects of insecticides. The National Research Council states in part:

(Please turn to page 188)



"This should give him a thrill."



Saber Saw



Radial Power Saw

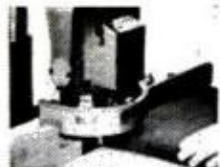

Jointer



Drum Sander



Shaper



Surfacer



Tilt Arbor Saw



Buffer-Polisher



Metal Cutter



Grinder



Dado Saw



12" Lathe



Horizontal Drill



Router



Disc Sander

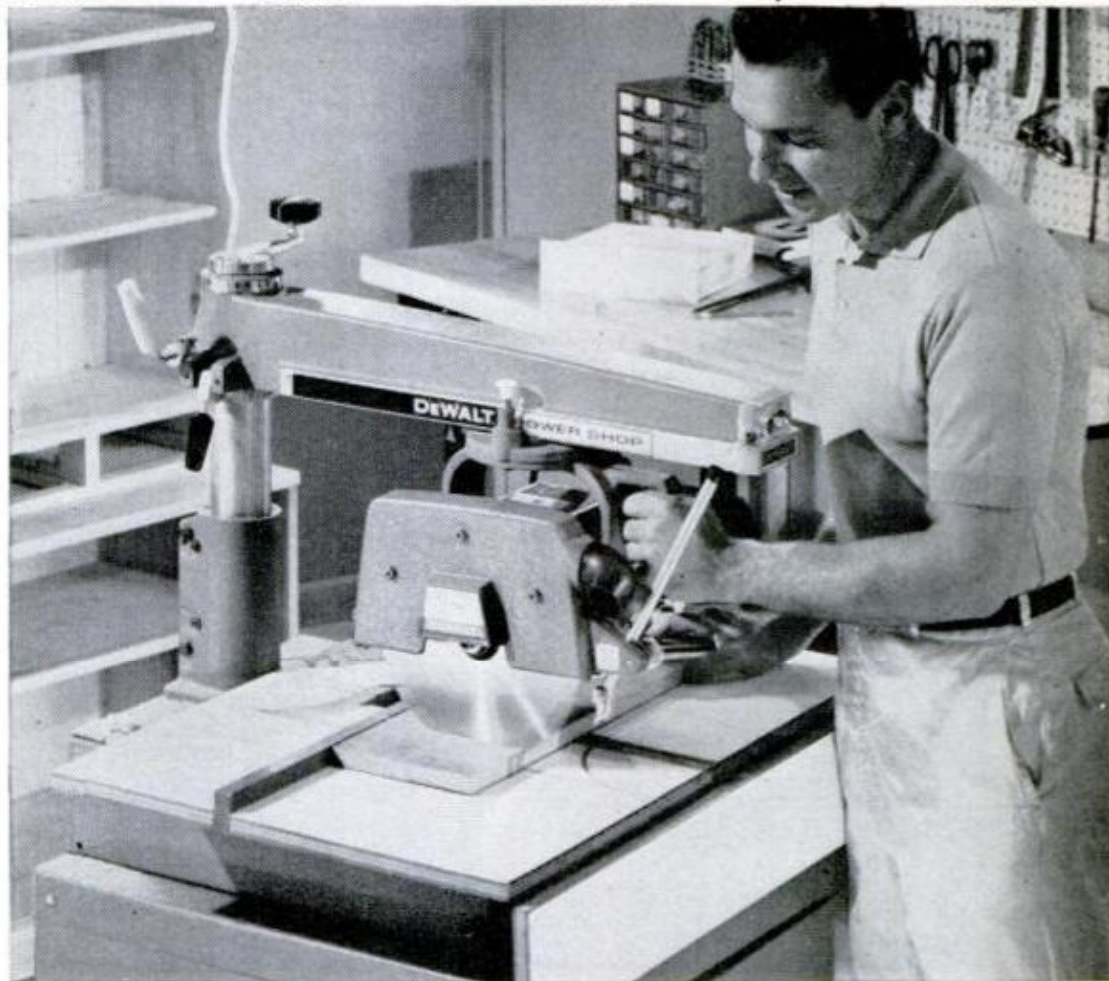

## NEW DEWALT POWER SHOP\* SAVES YOU HUNDREDS OF DOLLARS IN POWER TOOLS

With Minute-Magic Changeovers, this handsome DeWalt Power Shop becomes 15 power tools in one—gives you professional results *faster* and *easier*. DeWalt's power, capacity and flexibility make it a never-ending pleasure for you to build things for the family from a hutch cabinet to a complete house. Compact, it fits into a workbench. Your dealer has the free plans. Ask him for a demonstration and find out why experts and beginners have been saying "There's nothing like DeWalt!" since 1922. And don't forget to ask for low budget terms.

\*T.M. DeWalt



**DEWALT, INC.**

**POWER TOOLS**

A **Black & Decker** Subsidiary

34106 Fountain Ave.  
Lancaster, Pa.

Send free 16 page catalog

I enclose \$3.95 for illustrated book "Newest Ways to Expert Woodworking." (Check or M.O.)

Name.....

Address.....

City..... Zone..... State.....

Newest Ways TO EXPERT WOODWORKING





**Preferred by mechanics  
the world over**

Send today for free pocket catalog of S-K/Lectrolite quality hand tools, including ratchets, sockets and handles . . . adjustable, combination and open end wrenches . . . pliers and special automotive tools. Use the coupon.

**S-K/LECTROLITE TOOLS**

Chicago 32, Illinois

Name \_\_\_\_\_

Address \_\_\_\_\_

City \_\_\_\_\_ State \_\_\_\_\_

**FREE Key Machine**

Kind master locksmiths use. Sells for \$125, but yours FREE with Locksmithing Course



**You Can Learn To Be A  
LOCKSMITH  
in your spare time**

There's a big demand for skilled locksmiths. You can earn big money either full or part-time in your own home. Be your own boss; earn steady, year 'round income with no layoffs. The BELSAW INSTITUTE training, recommended by professional locksmiths, teaches you to make keys, open and repair locks on homes, cars and buildings. Easy, step-by-step illustrated lessons complete with all tools and supplies. We tell you how to get servicing jobs, how much to charge, how to earn while you learn and how to build a secure cash profit business.

**Mail Coupon for FREE Book Today!**

BELSAW INSTITUTE, 103 Field Bldg., Kansas City 11, Mo.

Send FREE book, "Keys To Your Future!"

No obligation. No salesman.

Name \_\_\_\_\_

Address \_\_\_\_\_

City \_\_\_\_\_ State \_\_\_\_\_

**And Was It a Silent Spring?**

(Continued from page 186)

"Research has not yet fully traced the effects of chemical pesticides on wildlife or on plant life or on the soil."

12. Chemicals, in one way or another, spread far beyond a treated area. Less than 25 percent of the land area of the United States has been treated with DDT. Yet studies show that most individuals across the land are storing from 5.3 to 7.4 parts per million of DDT in their bodies.

13. The question of insecticides has become highly emotional on both sides. The farmers and townfolk of the Sheldon-Donovan area reflect the extent of this emotion. The ones I have talked with are bitter, bitter people.

Not everyone would agree, though, that the spray program was a disaster. If you drive straight east from Sheldon on Highway 24 three miles to the Indiana state line, you come to the 728-acre farm of Kenneth Wolfe. In 1961 Wolfe had an estimated 35,000 Japanese beetles per acre on his farm. When he appealed to his state government for help he was told, in effect, that Indiana believes the problem will eventually take care of itself.

Would Wolfe like to see the planes come buzzing across his fields?

"You bet," he says. "Those farmers in Illinois don't know how lucky they are!"

\*\*\*

**Cart for the Course**



Available in gasoline or electric models, a new golf cart has a welded tubular steel frame and molded fiberglass body.

Two bucket seats are upholstered in white to fend off the sun's heat. Low-profile tubeless tires make it easy on the turf and give passengers a smooth ride. A tiller is used for steering, with reduction gears to make turning easy.

Made by the Harley-Davidson Motor Co., the cart sells for \$1055.

*You're always in good company when you*

# Choose the Leader!

When you select *any* Harley-Davidson, you get the world's widest *choice* of models, colors, styles, accessories, clothing, and servicing products . . . all tailor-made to suit your particular riding pleasure. This exclusive combination is why Harley-Davidson continues its long-standing leadership. See your Harley-Davidson dealer. You'll be in the best of company.

▲ Seven basic motorcycle models and the world's snappiest scooter ▲ Largest combination of models for your choice of performance, style, color ▲ Hundreds of special accessories from saddle-bags to side-mirrors ▲ Rider-tailored clothing, smartly-styled, sharpest quality, makes cycling more fun ▲ Many mechanical options . . . Customize for your own riding pleasure ▲ Friendly service . . . Wherever you ride, Harley-Davidson dealers help you feel at home ▲



**HARLEY-DAVIDSON**  
MOTOR CO., MILWAUKEE 1, WISCONSIN

# SMALL PLIER...

## BIG GRIP



### CHAN NEL LOCK

## No. 424 MITY MIDGET

This midget plier will be a problem solver for you on hundreds of small gripping jobs in tight places. Gives you firm parallel-jaw grip... four smooth working, can't slip adjustments. Jaw capacity  $\frac{1}{2}$  inch. Length  $4\frac{1}{2}$  inches. *Be sure it's a genuine Channel-lock. Look for the trademark on the handle. Write for catalog showing complete line of pliers. Made Only By Champion DeArment Tool Company, Meadville, Penna.*

## Owners Report—Valiant

(Continued from page 93)

"The hand brake is in the wrong place."  
—Minnesota office manager.

*Earlier Valiants had a handy pedal-type parking brake with trigger release. Current model's cane-type handle is harder to operate and an obstruction. What goes on here—obsolescence revisited?*

*Returning to the bright side, here are numbers six through ten of the items that most pleased the owners:*

"I like compact size outside and roomy inside."—New York service manager.

*Although neither longer nor wider this year, Valiant has a new body that makes better use of the space available.*

"I like its small size and ease of manipulation when parking; also, there's no loss of leg and body room for driver and passengers."—New Jersey bookkeeper.

"A good solid compact with enough room for my family of five."—Michigan post office clerk.

"It's solidly built with a big car feel."—Ohio credit bureau owner.

*PM's test car was a convertible, the model that leads all others as a potential rattle and shake car, yet it surprised us as being remarkably rattle-free.*

"I think it holds a better curve than most big cars."—Georgia carpenter.

*We agree wholeheartedly.*

*There's a corresponding con for every pro. Here are owners' complaints numbers six through ten:*

"The windshield leaks and water gets in the trunk of car, from where I don't know."—Florida salesman.

*We know! It's through improperly calked seams or loosely-fitted rubber lid gaskets.*

"Dash is supposedly painted dull to cut down reflections on windshield, but the outer edge has a terrific reflection on the window."—Ohio student.

"It's too light a car to drive when there is snow or ice on the road."—Wisconsin mechanic.

*It's not how much weight but where it's located that counts in snow. Most successful snow cars have engine's weight concentrated on the wheels that need the traction.*

"The small engine (101 hp.) is a little slow on take-off and uses too much gasoline (11.7 m.p.g. overall)."—Oklahoma music teacher.

*It may also be just a little out of tune.*

(Please turn to page 192)

# END HIDDEN DANGERS OF FRONT-END SAG



"Bottoming" on bumps and potholes is eliminated by front Load-Leveler stabilizing units.



Rolling on sharp turns and "wind sway" end with stability of front Load-Levelers.

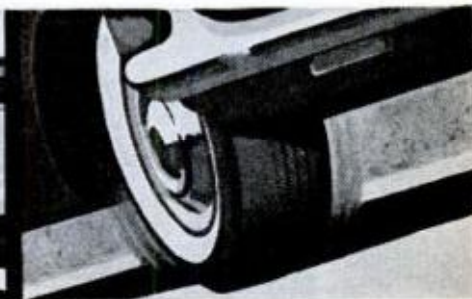

Wheel shimmy at high speeds is ended with front Load-Levelers holding wheels in alignment.

## WITH NEW MONROE *front* Load-Leveler<sup>®</sup> stabilizing units

Front-end sag takes its toll on *every* car. It begins when springs take a "set," and changes the entire geometry of your steering system. Wheels continually get out of line, and shimmy at high speeds. Tires are virtually destroyed. Steering becomes difficult. Control of your car is dangerously reduced. Now you can end front-end sag, without costly spring repair, make your car ride *better* than brand new, and prolong tire life with new front Load-Leveler

stabilizing units by Monroe. Installed in place of your present front shock absorbers, front Load-Levelers give firm support to sagging springs and compensate for "set." They give your car extra stability, for sure-footed cornering and a safer, more comfortable, more economical ride. You'll marvel at the improved roadability you'll get with new Monroe front Load-Levelers. Have a set installed in less than thirty minutes where you have your car serviced.



**MONROE** LOOK FOR THE MONROE DEMONSTRATOR BARREL!

World's largest maker of ride control products including Monro-Matic<sup>®</sup> shock absorbers.

**MONROE AUTO EQUIPMENT COMPANY, Monroe, Michigan**  
In Canada, MONROE-ACME LTD., Toronto, Ont. • In Mexico, MEX-PAR, Box 28154, Mexico City



# THEY'RE OPENING UP A NEW KIND OF Money-Saving Motor Protection



## Yours through THE KENDALL FAMILY of Fine Motor Oils

Your Kendall dealer now offers four quality Kendall Motor Oils. He'll help you select the one best formulated for your type of engine, your driving habits and your pocketbook.

Regardless of the choice, it will be refined from the choicest Pennsylvania Crude Oil. You'll get extra protection for the money you spend. Your engine will stay younger longer.

You'll save through the Economy of Kendall Quality.

KENDALL REFINING CO.  
Bradford, Penna.

Lubrication Specialists since 1881

ASK YOUR DEALER FOR



## Owners Report—Valiant

(Continued from page 190)

The final group of compliments from Valiant owners—numbers 11 through 16—are listed in order of their frequency:

"It's got nimble and precise steering."—California civil engineer.

"There's good driving view."—Utah housewife.

"The new warranty is just what I'm looking for as I average 30,000 miles a year in my job. Therefore, a 12,000-mile guarantee would be meaningless to me."—Pennsylvania insurance man.

**This guarantee may prove to be the greatest thing since four-wheel brakes for owners like this man.**

"It's reliable—starts well in temperatures as low as thirty below zero."—Wisconsin editor.

"It's much more luxurious than other compacts in same price range."—Michigan teacher.

"It has a large and roomy trunk compartment; I also like the spare tire under the cover of trunk."—Ohio retiree.

**The gain in useful space is well worth the effort of uncovering the tire from the bottom of the luggage compartment in case of a flat.**

The last six complaints—numbers 11 through 16—from Valiant owners are listed according to their frequency:

"I don't like to have to stoop and step down into car; it's too hard to get in and out."—California retiree.

**His is an almost universal complaint—a significant percentage of owners mention entry-exit and headroom problems.**

"The only thing I wish it didn't have is the 2-inch step-down when one gets into the car."—Maryland bank clerk.

"Windshield doesn't wrap around enough, door frame blocks vision."—Ohio clerk.

**The windshield corner post is wider than some drivers like, but sharply curved glass makes for distortion and unwipeable areas.**

"I've had trouble with the carburetor (it stalls when temperature is about 32 degrees Fahrenheit)."—Massachusetts college professor.

**It sounds like carburetor icing. Possibly manifold heat riser valve is stuck in the "off" position.**

"I've had trouble with the automatic choke sticking."—Florida electronics worker.

"All doors and rear deck lock poorly (even after so-called 1000-mile service)." —New Jersey technician. ★★★



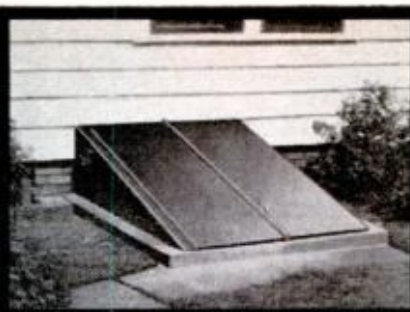
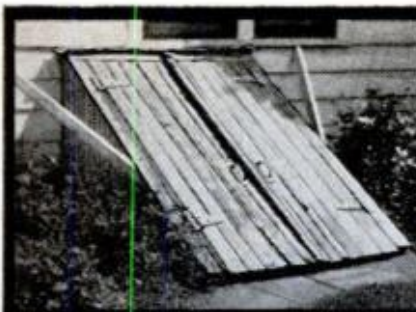

**EASY TO REPLACE**

**THIS MODERN WAY**

**Bilco**

AMERICA'S FINEST  
BASEMENT DOOR

Here's the way to add amazing new beauty and convenience to your home. Replace that troublesome wood door with a modern Bilco. All steel, permanent, watertight, opens and closes at a touch. A new Bilco Door will do wonders for your home . . . and for you!

The Bilco Co., Dept. R-66 New Haven 5, Conn.  
Please send me your free illustrated folder and name of local dealer.

Name \_\_\_\_\_

Address \_\_\_\_\_

City \_\_\_\_\_ Zone \_\_\_\_\_ State \_\_\_\_\_

## Every Home Needs This 'All-Purpose' Oil

Lubricate • Clean • Prevent Rust

### 3-IN-ONE® OIL

REGULAR—OIL SPRAY—ELECTRIC MOTOR

**SHOOT A STAPLE WHEREVER YOU'D DRIVE A NAIL!**

**ARROW**

**T-50 All-Purpose STAPLE GUN**

Same Machine uses 6 Staple Sizes . . .

**"ONE SQUEEZE AND YOU'VE NAILED IT!"**

Available at Hardware, Building, Lumber and Stationery Dealers Everywhere.  
**ARROW FASTENER CO., INC.** 1 Junius St., Brooklyn, N. Y.

## WINDOW REPAIRS



... last longer with DAP

## '33'® GLAZING

Outlasts ordinary putty by years. Elastic—for airtight, watertight seal in wood or metal sash.

DAP INC., DEPT. 35, GENERAL OFFICES: DAYTON 31, OHIO

## WAR SURPLUS AND OTHER BARGAINS SAVE UP TO 90%



### DUAL-PURPOSE NAVY GENERATOR

Rated 200 AMP DC at 24 to 30 V. Also produces at 1200 watts of AC current. Excellent unit for making your own arc welder. We have sold 1000's. Now, due to special purchase, we are able to offer this gen. at lowest price ever—while present supply lasts. Tested prior to shipment—shpg. wt. 55 lbs. Approx. GOVT. COST \$350. SPECIAL \$16.95.



### DELUXE ELECTRIC STORAGE BATTERY WINCH

A ruggedly built, heavy-duty winch with ball bearing construction throughout motor and gear train. 225-lb. gear reduction. Rated cap. 3000 lbs. Contains heavy duty enclosed forward, neutral & reverse switch. Rugged 1 1/4" plate steel mounting base with outrigger support. Dim. 22" L. x 9" W. x 8" H. Handles 250' of 3/4" cable. Built for 12 V. battery operation; will also operate on 6 V. at reduced cap. & speed. A must for scouts, jeeps, trucks, boat loading trailers. Shpg. wt. 80 lbs. Approx. GOVT. COST \$490. New. Model E-D. \$75.00

\*Lighter duty & remote control models also available from \$55.00. Write for spec sheet.

**AIR COOLED WELDING KIT**—Contains Famous P-2 generator (200 amps/30 V.D.C.) with built in fan. Also in kit—D.C. Voltmeter, Control Rheostat, Switch, 300 amp. Electrode holder, welder's gloves, adjustable welder's helmet, 30 ft. rubber covered welding cable and wiring diagram. All units pre-tested prior to shipment. A terrific value. All units guaranteed pre-tested. Shpg. wt. 75 lbs. Approx. GOVT. COST \$475. Most items new—all perfect. \$47.50.



### DOUBLE-ACTION HYDRAULIC CYLINDERS

Can be air or oil operated. Ideal for shop, production machinery, hydraulic steering and 100's of other uses. Steel barrel aircraft quality, precision built. 7 3/4" stroke, 5/8" shaft, 1 1/4" bore, 15" overall length. Shpg. Wt. 7 lbs. per pair. Special AIRBORNE price—2 for \$7.



### FLEXIBLE SPLINE COUPLING

—Lovejoy type. Fits all aircraft gen. with 16 tooth, 7/8" spline shafts. Excellent for direct drive on aircraft gen. New. Highest quality in 1" or 3/4" standard shaft drive. Specify when ordering. \$6.45 ea.



### "BIG 12" ARC WELDING AND BATTERY CHARGING KIT

With Deluxe accessories consisting of one R1 300 amp generator, 30 feet welding cable, welder's adjustable helmet, electrode holder, 300 amp ammeter, 300 amp shunt, rheostat, toggle switch, 300 amp reactor coil arc stabilizer, voltage regulator, battery charging relay, one pair heavy duty welder's gloves. All units guaranteed pre-tested. Approx. Govt. cost \$750. Most items new—all perfect. Wt. 82 lbs. \$49.50



### BIG NEW 1963 CATALOG!

Send 25c in coin for amazing new catalog with 1000's of surplus bargains in hydraulics, electrical, precision tools, marine items, automotive, etc. for hobbyists or industrial. Or order from this ad and receive a free copy. All prices F.O.B. Culver City, Calif. 50¢ dep. for C.O.D. Send check, cash or money order. Order today!

**AIRBORNE SALES CO. INC. DEPT. PM-663**

8501 Stellar Drive • Culver City, California

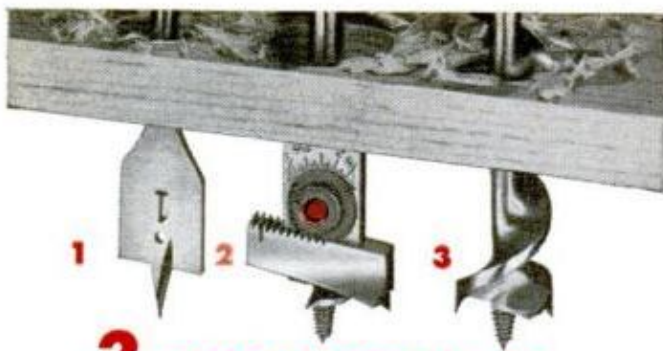

## 3 easy ways to bore holes faster

**1. Irwin Speedbor "88"** for all electric drills. Bores up to 5 times faster in any wood, at any angle. Sizes  $\frac{1}{4}$ " to 1", \$.75 each. Sizes  $1\frac{1}{8}$ " to  $1\frac{1}{2}$ ", \$1.25 each.

**2. Irwin No. 22 Micro-Dial** expansive bit. Fits all hand braces. Just dial your size. Bores 35 standard holes,  $\frac{7}{8}$ " to 3". Only \$4.00. No. 21 small size bores 19 standard holes,  $\frac{5}{8}$ " to  $1\frac{3}{4}$ ". Only \$3.60.

**3. Irwin 62T Solid Center** hand brace type. Only 16 turns to bore 1" holes through 1" wood. Double-cutter boring action. Sizes  $\frac{1}{4}$ " to  $1\frac{1}{2}$ ". As low as \$1.05 each.

**EVERY IRWIN BIT** made of high analysis tool steel, heat tempered, machine sharpened and highly polished, too. Buy from your independent hardware, building supply or lumber dealer.

**Strait-Line Chalk Line Reel Box**  
only \$1.25 for 50 ft. size

**New and improved** Irwin self-chalking design. Durable aluminum alloy box. Practically damage-proof. Fits pocket or hand. 50 ft. and 100 ft. sizes.

**IRWIN** every bit as good as the name  
at Wilmington, Ohio, since 1885



Works in Seconds!



**Loosens Rusted Bolts**  
nuts, screws, "frozen" parts!

**LIQUID WRENCH**  
SUPER-PENETRANT

BONUS USE: Add to crankcase to quiet noisy valve lifters... remove gum, sludge deposits!

THEN ADD . . .

**MOTOR-MEDIC**  
EXTRA LUBRICATION . . .  
SMOOTHER PERFORMANCE



Both at leading dealers everywhere!

FAMOUS



**TEENUT**  
FASTENERS

Can't slip, flush-mounted, strong. ONLY nut that gives steel threads in wood!

- Now available in bright NEW finish!
- NEW red and yellow, skin-pack cards!
- Look for colorful NEW display carton, too!
- Handymen need TEENUTS!
- Sold at hardware stores.

**COLUMBIA FASTENER CO.**

Subsidiary UNITED-CARR FASTENER Corp.  
3229 South Ashland Ave., Chicago 8, Ill.

TEENUTS is a registered trademark of United-Carr Fastener Corp.

## Owners Report—Cadillac

(Continued from page 81)

heavy, bulky appearance."—Connecticut labor union official.

*Each year Cadillac's design grows a bit more tasteful and refined—more like a "gentleman's carriage", less like a space ship.*

"Good general appearance—it's not ornate." Michigan sales manager.

"I like most its over-all length and streamlined appearance."—Ohio clerical worker.

*A couple of years ago Cadillac offered a "compact" model with seven inches lopped off the trunk. It sold like a Valentine card on the 15th of February.*

"Like the clean lines from front to rear."—New York investigator.

"The car has an all-around quality that makes for pleasant operation."—Washington retiree.

"It's the smoothest of the four different cars I've owned."—Ohio physician.

*In normal driving Cadillac goes like a velvet canoe in a lake of pure cream.*

*Corresponding negative comments also were made, of course. Here, in the order of their frequency, are the five most often recorded:*

"Do not like the dash ash tray; driver's side not illuminated."—Ohio executive.

"I wish the ash trays were better located and larger."—Arkansas investment counselor.

*Most '63 Cadillac drivers would agree. The left front tray (and lighter) is so low that driver must take eyes from the road completely; at night it is unlighted so ashes land in trouser cuff, butts go out the window and tray can only be found when you move right foot—then your knee hits it. Only possible conclusion is that Cadillac ash trays must have been designed by a non-smoker.*

"Put the ash tray where it was in the '62 model."—Michigan executive.

"Ash trays difficult to open and midget-sized glove compartment, likewise."—California grain dealer.

*On PM's test car the Auto Editor's wife broke a fingernail trying to get into flush-door right-hand tray.*

"Heating system is too slow."—Illinois executive.

"On cars having air conditioning, there is no arrangement for getting fresh air into the car without having the air conditioner or heater on, or having a window open, and there are many times when

neither of these is desirable."—Florida retiree.

Efforts to "simplify" Cadillac heater controls have gone awry, but completely! You cannot get either hot or cold air without using blower, and car is so tightly sealed that you need top blower speed to demist windshield.

"Heater fan and heater controls should be on right side of steering wheel."—Ohio retiree.

"Defrosters do not heat the bottom of the windshield, so snow sticks at the bottom."—New York restaurant owner.

"There's too much wind noise from wind wings—one cannot even hear the radio or talk."—California contractor.

One of the problems of making a truly quiet running car—little noises become big nuisances. Incidentally the radio (AM-FM) has great tonal quality. What this car needs most is a means of getting a large volume of fresh air into and out of the body quietly.

"Poorly fitting doors and windows which cause whistling noise."—Ohio executive.

"It uses too much oil."—Tennessee pharmacist.

Returning to the bright side, here are numbers 6 through 10 of the praiseworthy points Cadillac owners mentioned. They're listed in the order of their frequency:

"Plenty of space for family travel."—Illinois factory representative.

"It's easy to get into, has good headroom."—New Jersey sales engineer.

Front and rear headroom dimensions are above average on '63 Cadillac.

"I like the higher top; it's easy for a tall person to ride without striking head."—Connecticut retiree.

"I like the convenience and dependability of the Cadillac."—Alabama accountant.

"Like the tip-up steering wheel."—New York physician.

It offers a worthwhile change of position, but the six-way power seat is much more important to driver comfort.

"I like the '63 model better than the '60. It has more headroom and better visibility when in traffic."—New York executive.

Large glass areas and sharply defined "corners" of the car make close-quarter driving less of a problem than you'd expect with a car this size.

"I like the performance, comfort and visibility."—New Jersey contractor.

For each bit of praise, some owner has a corresponding comment about something (Please turn to page 196)

## DYNAMIC INDUSTRIAL TYPE TRANSFORMER WELDER

WELD-CUT-BRAZE-SOLDER-HEAT  
IRON-STEEL-BRONZE-BRASS  
ALUMINUM AND OTHER METALS



Professional Electric Arc Welder. Ideal for Home, Shop, Farm or Industrial use. The handiest tool in your workshop. Weld, Braze, Solder, Cut, Bend all metals. Do expert work on your first job. Build or repair Boats, Trailers, Auto Bodies, parts, fenders, metal and ornamental iron furniture, fixtures, farm equipment, garden tools, bicycles, toys, etc. Operates on any properly wired 110 V. A.C. line. Complete with helmet, arc torch, electrode holders, flux, rods, cables, instruction book. FULL YEAR GUARANTEE. 10 day money back trial. ONLY \$38.50 f.o.b.

Only \$38.50 f.o.b. Send only \$6.00 check or m.o. Pay postman balance plus charges. EASY PAY PLAN. Low down payment. Pay as you weld.

DYNAMIC WELDER CO. 1808 SOUTH FEDERAL STREET  
Dept. D2-F, CHICAGO 16, ILL.

### Permanent Sealer

Ready to use—no mixing required  
Sticks tight on any surface

- metal
- wood
- aluminum
- tile & concrete

49¢, 98¢ tubes & cartridges

W. J. RUSCOE CO.  
Akron 1, Ohio

## Briggs & Stratton — Clinton New Gas Engine Sale

Never before and perhaps never again—this offer of brand new genuine Clinton and Briggs & Stratton engines including 1 yr. factory warranty at less than cost. Perfect power for go-carts, scooters, tractors, mowers, generators, pumps, sprayers, etc. We bailed out 3 big factories who needed cash and the savings are yours while quantities last. Act fast.



Clinton 2 1/2 hp, Md. 500—Re-coil starter Std. 3/8 shaft w. keyway—ready to go. Reg. price \$49.50 Special (item 1002)

**\$29.95**

2 for . . . . \$59.50  
6 for . . . . \$176.50



Briggs & Stratton 2 hp, Md. 60101 Rope start, std. 3/8 shaft w. keyway. Sturdy 4 cycle power. Regular price \$49.80 Special (item 106a)

**\$29.75**

2 for . . . . \$58.90  
6 for . . . . \$175.50

**\$67.50**  
5 3/4 hp.  
Briggs  
&  
Stratton



Briggs & Stratton 5 3/4 hp, Md. 143302. Recoil start. 1" shaft w. keyway, aut. choke & throttle control—a rugged big engine ready to tackle any job. Regular price . . . \$92.60

Special (item 1059) . . . **\$67.50**  
2 for \$130.00 6 for \$350.00

2 3/4 h.p. Clinton—\$34.95  
Model 400. Rugged 4 cycle, Alum. block, castiron cylinder. Rope start—3/8" std. shaft. Item 1107 . . . . .**\$34.95**  
2 for . . . . .**\$67.50**

3 1/2 h.p. Clinton—\$39.95  
A big engine with big power. Model 406. 4 cycle, rope start—3/4" std. shaft. Item 406 . . . . .**\$39.95**  
2 for . . . . .**\$77.50**

Remember these engines are absolutely perfect and standard and under factory warranty. Money back guarantee. Order now while stocks are complete. Factories—write us on any new items that are surplus to your needs. Send 10c for 100 page catalog.



MASTER MECHANIC MFG. CO., Dept. A-663, Burlington, Wis.  
Southern Customers write Dept. A-663, Box 65, Sarasota, Florida

**palley's SPECIAL SURPLUS**

**BOLO-MACHETE**

Has 11 1/4" tempered steel blade, hardwood handle and genuine leather belt sheath. Excellent for hunter, camper, etc. May also be used for clearing brush, meat cleaver or chopping. 20" O/A lgh. **299**



**KNIFE-BAYONET U.S. ARMY**

Ideal skin divers knife, hunting knife or for the collector. Made by Camillus of the finest steel. Has 6-1/2" blade, double-edged for three inches from the point. Handle is laminated leather. Overall lgh. 11-5/8" . . . . **2.98**

**PARATROOP FOLDING MACHETE**

Has an 11" blade of finest blued nickel alloy steel with precision ground edge. Unusual bargain for camper, back packer, hunter, etc. Blade folds into handle and steel guard like a huge pocket knife. Hand fitting handle has knurled grip. Open lgh. overall 17" . . . **399**

Leather MACHETE HOLSTER - Extra hvy. duty. Specially designed for above machete. Fits on belt . . . **150**

**3 SIZES SHOP-KING ROTARY RASP SET**

SHAPE • CUT • FORM • MILL  
Fits any Electric Drill! Drill Press! Motor! Cuts woods, plaster, brass, plastics, copper, aluminum, plywood, wall board, rubber, etc. Ideal for leveling, shaping, sanding, removing paint, etc. Never clogs or needs sharpening. Made of hardened, temper steel - outlasts hundreds of sandpaper drums. Sizes: 1 1/4", 1-7/8" & 3/4" dia. 1/4" SHANK Price includes all 3 sizes in box . . . . **488 SET**

**"TINY TIGER"-300 WATT POWER PLANT**

INSTANT ELECTRICITY ANYWHERE - CHARGE BATTERIES / LIGHT YOUR LIGHTS / PUMP YOUR BILGE / COOK YOUR GOOSE! Here's 12lbs. of gas motor driven power, small enough to fit on the hand. Delivers 115 volts AC or 12 volts DC, 300 Watts. Enough power to light a 3 room house or cabin, any tent, operate power tools or ham radio, etc. Has 3/4 HP, 6300 RPM gas motor with direct drive generator. Length 11", width 7-1/2", height 8-1/2". Uses standard outboard fuel. . . **99.50 COMPLETE**

**PORTABLE 1/2 H.P. AIR COMPRESSOR**

for SKIN DIVER - GARAGE - ARTIST - etc.  
A remarkable surplus conversion - has a surplus Cornelius compressor combined with a NEW 1/2HP, 115/230 V., 60 cycle AC motor plus a mounting frame with built-in carrying handle. Pressure tested to 3000 PSI. Ideal for filling diving tanks, inflating struts, accumulators or to use any high pressure air use. Fills tanks to 2250 PSI. **99.50**

**Unconverted Cornelius COMPRESSORS - Air Force surplus with 1/3 HP, 27 V., DC motor. Delivers 1500PSI. Used but excellent. 34.95**

**3000 PSI PROFESSIONAL AIR COMPRESSOR**

A Big Brother to the above compressors . . . 3 stage Cornelius Compressor that develops 2.0 cubic ft. displacement per min. at 3000 PSI pressure. Fills the average diving tank in approx. 20 minutes. Available in Electric or Hydraulic models. . . . Overall height 14" - Width 11". UNUSED!  
Electric Compressor -24 V. DC. 3000PSI.  
Hydraulic Compressor - Working pressure 2100 PSI - 3000 PSI output. . . . . **Only 199.50**

**HYDRAULIC MOTOR DRIVEN GEAR PUMP - 4.5 GPM**

**1795** Delivers 4.5 GPM at 2300 RPM at 1000 PSI. Motor 24V. DC, 250A. at 2300 RPM No. HPL-15

**260 PAGES of SPECTACULAR BARGAINS!** Government Surplus, Factory Closeouts and hard-to-find items of all kinds. You'll find special bargains in U.S. Army, Navy, Airforce and Industrial surplus - PLUS the World's largest on-the-shelf stocks of New and Used Hydraulic Cylinders, Pumps, Motors, Valves, etc. ORDER NOW!  
**Only 50c** TO COVER HANDLING & MAILING Your 50c will be refunded with your first order of \$1.00 or more

TO ORDER: Send check or M.O. 1/2 dep. with C.O.D.s. P.O.s accepted from D&B firms rated F2½ or better. All items sent freight or postage collect.

**palley's** 2263 E. VERNON AVE., Dept. PM-63 LOS ANGELES 58, CALIFORNIA

**AIR FORCE AN 5851-1 SEXTANT 17.95**

Air Force Navigators bubble type sextant - Has a horizontal indicator, a precision averager, astigmatizer lens, a bubble level prism and a spring wound motor. Complete with carrying case. Can be used for navigating boat, plane, etc.



**400 GPH PUMPS**

Use for draining flooded areas, pumping-out oil or gasoline barrels, etc. Delivers 400 GPH at 20 PSI. Has 3/4" standard pipe ports. Relief valve in head can be adjusted to provide up to 40 PSI. Complete with pump mount to adapt pump to Culley drive. Catalog No. H-P95U . . . **1195**

**2 GPM HYD. PUMP NOW 1995**

Positive displacement, piston pump. Has 2 gal. per minute capacity at 1400 PSI. Displaces .450 cu. in. per revolution. Operates at 3750 RPM with rotation in either direction. Has built-in variable flow control valve. 1" internal pipe ports. Optional pump mount available.

**Owners Report—Cadillac**

(Continued from page 194)

that disappointed him. Following are numbers six through 10 of the shortcomings noted:

"Very, very poor paint job over-all."—Michigan retiree.

"Poor paint job; they didn't tape up the white top when painting body."—Arizona doctor.

**At \$6000-plus, the paint job should be perfect on every single car.**

"Selection of seat upholstery the worst in years. Cadillac buyers are entitled to much better."—Michigan retiree.

"It seems to me that the interiors are less attractive on each model I buy, and I have owned seven to date."—Nebraska retiree.

"Upholstery is not top quality."—South Carolina physician.

**If you consider top quality equal to the grade of materials used in the \$16,000 import whose initials are RR, you'd have to agree with the doctor.**

"Body interior quality not as good as it should have been."—Michigan retiree.

"'Ford' hardtop styling cuts down essential visibility toward rear of vehicle."—Indiana advertising executive.

**He's right, of course, but this "blind rear quarter" styling originated on T-Bird, is the hottest thing in styling since fins went back to the fish.**

"It should get better gas mileage compared to other Cadillacs I've had; I only get 12 to 14 m.p.g."—California businessman.

"It uses too much gas, but this was expected."—California housewife.

"It's too noisy for a luxury car."—Connecticut pharmacist.

"Elimination of dual exhaust makes motor exhaust much noisier. I miss the quietness of the 1960 Cadillac."—California court reporter.

**To wind up the enthusiastic statements by Cadillac owners, here are comments number 11 through 16 on the good side:**

"The workmanship is excellent."—Michigan self-employed man.

"I've had fewer rattles and squeaks than on any other car I have owned."—New York physician.

**There are three reasons for this: 1) conservative engineering, 2) time, 3) money.**

"No annoying mechanical adjustments required."—California food wholesaler.

(Please turn to page 198)

REPAIR ANYTHING  
BUILD ANYTHING

STICKS LIKE A  
**Leech**<sup>®</sup>  
CEMENTS • GLUES • ADHESIVES

FOR EVERY PURPOSE

Wood • Metal • Porcelain • Plastics • Cloth • Leather  
China • Rubber • Crockery • Weatherstripping • Plumbing

**LEECH PRODUCTS, INC.**

HUTCHINSON, KANSAS

ASK YOUR DEALER

MEASURE ANY DISTANCE  
AT WALKING SPEED!

IT'S EASY to measure with a Rolatape. Totalizer visually records measurements in feet and inches... gives precision accuracy every time. Does an hour's work in 5 minutes. No tapes to wind, no helper required.

Used extensively by farmers, contractors, surveyors, utilities, police, and municipalities. Excellent for measuring athletic fields, parking areas. Write for name of dealer or order direct. Handle folds compactly. Complete with leather case... only \$29.75

ROLATAPE, INC., 1301 OLYMPIC BLVD.  
SANTA MONICA 17, CALIFORNIA

**Rolatape**

MEASURING WHEELS

Measure—Vertical,  
Overhead, Curves  
and Contours

NOW

MILLERS FALLS TOOLS

LIFETIME  
GUARANTEE

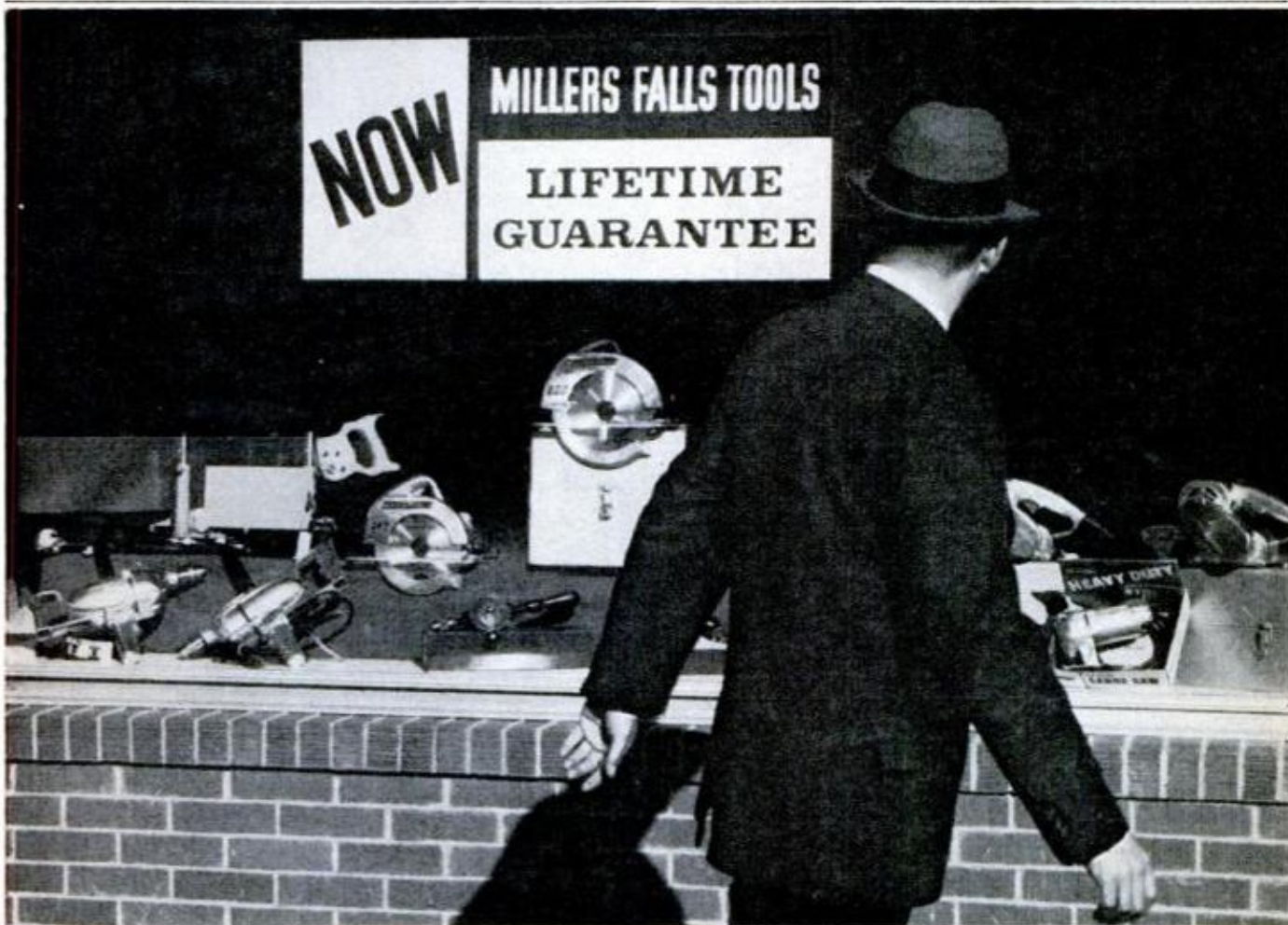

## LIFETIME GUARANTEE

Sure, we mean it!

The Millers Falls name has been trusted by generations of craftsmen. And now we've added new meaning to this 95-year-old tradition of fine quality tools. It's the extra value of a *Lifetime Guarantee*! Here is our promise to you: "If any tool carrying the Millers Falls Lifetime Guarantee fails for any reason except abuse or normal wear, we will repair or replace it free." That's how strongly we believe in our workmanship... and how far we'll go to back it up.

MILLERS FALLS  
TOOLS

SINCE  
1868

MORE THAN 2000  
HAND AND POWER  
TOOLS FOR HOME  
AND INDUSTRY

# NEW Wonder-Paste

**speeds paint removing**  
**NO WASH-UP NEEDED**

Apply with a paint brush. It's heavy-bodied—won't run on uprights. Retains its consistency regardless of temperature. When paint is softened, slide it off with a putty knife. No wash-up with solvent needed. Effective on paint, enamel, varnish and other finishes.

At paint and hardware stores.

● Send 25¢ for illustrated Refinishing Manual  
Free literature on request.

Wilson-Imperial Co., 118 Chestnut St., Newark 5, N. J.

## EVERLITE\* World's THRIFTIEST Light Plants

(Item 869-10T)

**NEW TRANSISTOR ALTERNATOR  
REPLACES GENERATOR**



Now a Service Free Light Plant built with a transistorized alternator. Offers 30% greater efficiency—more power for less fuel. Terrific service life—no brushes to arc and burn. No more commutator to wear, no collector ring trouble. And best of all it costs no more to "go modern with Everlite." Thrifty 1000 watt, 115v. AC plant powered by a rugged easy starting 4 cycle engine—leader priced. Model 869-10T. Wt. 65 lbs. as illustrated

**\$179.50**

fob factory

\*Trade-Mark Registered

All sizes available—can finance. Write for catalog. Special models for public utilities—Approved for Civil Defense. Write.

**MASTER MECHANIC MFG. CO., Dept. A 663, Burlington, Wis.**  
Southern Customers Write to Dept. A 663, Box 65, Sarasota, Florida

## CUPRINOL®

**WOOD PRESERVATIVE**  
**PRESERVES WOOD FOR GOOD!**

**Stops Rot! Kills Termites!**



## Home Appliances Now Run Smoothly

Lubricate • Clean • Prevent Rust

## 3-IN-ONE® OIL

REGULAR—OIL SPRAY—ELECTRIC MOTOR

## Made \$900 in Spare Time



"I made about \$900 last year with my Foley equipment by sharpening saws in my spare time." Leo H. Mix.

### No Experience Needed

With a Foley Automatic Saw Filer anyone can sharpen hand, band and circular saws with professional accuracy. No canvassing—business comes to you.

### We Help You Start.

We give you inside tips on how to build a sound repeat business; how others have succeeded in this profitable saw filing business.

**FOLEY MFG. COMPANY**  
629-3 Foley Bldg.  
Mpls. 18, Minn.

**FREE BOOKLET**  
"Money Making Facts" shows how to start. Write today. No salesman will call.

## Owners Report—Cadillac

(Continued from page 196)

"Cadillac has the reputation and "Fort Knox" association I enjoy and appreciate."  
—Ohio business speech teacher.

"What I consider very important is the trade-in value." New York banker.

*Thousands of people have listed their names with Cadillac dealers waiting for carefully tended two or three-year old Cads to be traded.*

"Holds the road better than previous year models."—Florida housewife.

"It drives well in snow because it's well-weighted."—New Jersey attorney.

"I like the adjustable brakes."—Colorado fire fighter.

"I also like the emergency brake release."—Texas executive.

*This feature is great. When you move gear selector from Neutral to Drive, parking brake is automatically released.*

"It's economical for a large car."—New Jersey physician.

*It never ceases to surprise people, PM staff included, when they get 16 to 17 miles per gallon on the road in a Cadillac that weighs two and one-half tons.*

*Numbers 11 through 16 of the adverse owner comments wrap up negative reactions to the '63 Cadillac owners report:*

"Inside rear view mirror is not in correct position for a tall person. I consider it dangerous."—Wisconsin dentist.

"The inside rear-view mirror is placed too low giving you a blind spot through the windshield."—Michigan plumber.

*On a car in Cadillac's bracket, vertical adjustment of the mirror should be a matter of course.*

"There are rattles indicating poor production supervision."—Illinois city mayor.

"I don't believe the factory inspection at delivery time is thorough enough, for they have passed motor noises and final adjustments in general on to owner who has to appeal to dealer for correction—easier said than done."—Ohio housewife.

"Had electrical failure of windshield wipers."—Colorado dentist.

"The roof is too low—hits my hat when I get in and out."—Minnesota traveling salesman.

"People continually scraping knees as ashtrays open by themselves and have sharp edges."—New York bakery owner.

*This completes the roll call of owners' pros and cons on their 1963 Cadillacs based on a combined experience of 905,927 miles driven.*

★★★

## GIGANTIC SURPLUS SALE!

### STANDARD DIAL PHONE

• Item 716. Gen. dial phone. W. E. modern hi-efficiency dial phone. Use for extension to main line or private system. Use several for complete private system. Work on any system. Wt. 8 lbs. Cost Govt. \$29.50. SALE... **\$7.95**

Prices FOB Lincoln.

WRITE TODAY FOR LARGE 1963 CATALOG

### BATTERY REMOTE CONTROL WINCH

• Item 322. Govt. DC hoist with push-button switch, 20' control cable.  
• 35' 4000-lb. cable. High strength rating 1000-lbs. on 12-v. Fine for boats, docks, trucks, jeeps, farms, etc. Electric brake. Wt. 90 lbs. Size 12"x14"x8". Govt. cost \$395. SALE... **\$68.25**



### GOV'T. AIR COMPRESSOR

• Item 453. Expensive Gov't. Compressor. G.E. motor 115-v. 60-c. Built-in air filter, relief valve, etc. Very compact and efficient.  
• For paint spraying, insecticides, air brush, etc. A "Super Buy." Wt. 55 lbs. Govt. cost over \$250. SALE... **\$24.97**



• Many other bargains in Air Compressors, Tanks.

**SURPLUS CENTER**  
LINCOLN, NEBR. DEPT. 820

## POLYSEAMSEAL®

### TUB CAULK • TILE ADHESIVE

Pure White • Elastic Permanent

Sticks like glue! 101 Household Uses!

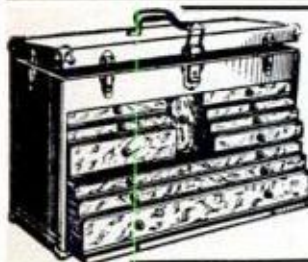

### PRECISION BUILT

For precision tools, cabinet-making at its finest gives you a chest to be proud of. FREE CATALOG.

### GERSTNER TOOL CHESTS

463 Columbia St., Dayton 7, Ohio



## KING MIDGET "WORLD'S MOST EXCITING LOWEST PRICED CAR"

Drive it for 75c a week. Rider Agents Wanted. Send 25c for 32 page book, full details, dealer price. Or send \$1 (refunded first order) for this plus Service and Repair Manual and 16 5x7 photos of car and factory.

**MIDGET MOTORS CORP., Athens 1, Ohio**

Heat, cut, weld, braze, solder, hardface



...with this complete, ready-to-work package. There's nothing else to buy. Contains everything you need to build, rebuild or repair auto and truck bodies, fenders, frames, farm machinery, fixtures, metal furniture, tools, toys, etc. Includes the following Victor top-quality apparatus:

Acetylene and oxygen safety regulators, welding torch, cutting attachment, 3 welding torch nozzles (welds to 3/4"), cutting tip (cuts to 1"), 12 1/2' dual welding hose, spark lighter, goggles, wrench, illustrated instruction book. All for only \$99 in U.S.

More than 25,000 now in use. Write today to Dept. PM for free descriptive literature and dealer's name.

**VICTOR EQUIPMENT COMPANY**  
844 Folsom St., San Francisco 7, Calif.

PROTECTS DIESEL POWER

## BAR'S LEAKS

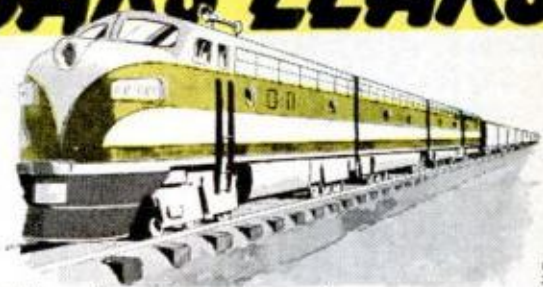

Specified by cooling system engineers at auto and diesel factories for new units coming off production lines... then every 5000 miles. Seals leaks in engine block, stops seepage through gaskets. Ends formation of rust and scale. Lubricates pump seal. Protects all metal, rubber, plastic. Effective right along with anti-freeze, new or old. Neutralizes acid. Does not clog.

U.S. Pat. 2585719  
U.S. Pat. 2625188  
Can. Pat. 581547



LIST PRICE \$7.00

More and More USES

POUR INTO YOUR RADIATOR

At Your Service Station Auto Dealer or Auto Goods Store

USED IN 4 OUT OF 5 CARS ON THE ROAD TODAY

**FRE-BAR, INC., P.O. Box 65, Nelly, Michigan**

Factories: San Jose, Calif., Springfield, Mo., Ft. Worth, Texas, Minneapolis, Minn., Taylor, Mich., Shortsville, N.Y., Harrisburg, Pa., Loganville, Ga. (Blytheswood, Ontario)



## Print Your Own

Cards, Stationery, Advertising, Circulars, labels, photo and movie titles, church work, tags, etc. Save money. Sold direct from factory only. Raised printing like engraving, too.

### Own a Printing Business

Print for Others, Good Profit. Have home shop. Junior press \$15; Senior \$35 up. We supply everything. Easy rules. Pays for itself in short time. Write now for free details. **KELSEY PRESSES, Z-37 Meriden, Conn.**

## Outlasts Varnish 2 to 1

New miracle clear plastic finish dries dust-free in minutes, needs no sealer, goes on any kind of wood—inside or outside. Gives tougher, longer-lasting protection for patio furniture, siding, doors, cabinets, floors, paneling, tables, boats.



Glass-like finish resists alcohol, boiling water, food acids. Won't darken, crack or peel. Odorless. Non-toxic. Gloss or Satin finish. For free brochure and nearest FLECTO VARATHANE dealer, contact:

**Flecto Company Inc., Box 84-PM, Sta. A, Berkeley 2, Calif.**  
**Flecto Coatings Ltd., 7304 Buller Ave., Burnaby, B.C.**

JUNE 1963

199

## The Controversial B-70

(Continued from page 70)

ability to make smooth landings while his cockpit is still many feet above the surface of the runway.

Another research device, called a five-degrees-of-freedom simulator, resembles a big centrifuge. The pilot's cage, or cockpit, can move up or down, yaw, rotate and perform all the motions of flight. The flight characteristics of the design that is being studied are cranked into the centrifuge by a computer and the pilot then simulates an actual flight.

### Engine-Out Insurance

With this device the best flight profiles are worked out ahead of time, including the angle of climb-out and its length of time, the most efficient altitude at which to boost to supersonic speed and how to handle emergency situations. A typical emergency concerns the violent yaw that would occur when supersonic if an outboard engine should fail. The reason the B-70's engines are clustered close to the airplane's centerline is to minimize the effects of an engine-out.

As with the B-70, there is real controversy on whether the U.S. wants a Mach-3 airliner or can afford it. Why not settle for a Mach-2 machine, as the French and British are reported to be doing, with some U.S. assistance?

True, it's easier to build a 1400-m.p.h. craft than one that travels 2000 m.p.h. The slower craft can be built of aluminum and with standard techniques. But the word "aluminum" tells the story. The speed limit of this very popular metal is just about Mach 2.4. Above that velocity it loses much of its strength from the heat of speed. Thus it has no "growth potential." It's a dead end.

U.S. aerodynamicists argue, "Now that the B-70 is showing the way, it's silly not to make use of it. We can leapfrog direct to a Mach-3 airliner and still have a potential for even faster transports if we ever need them."

Setting our sights on Mach-3 will be tremendously expensive. Development of the triple-sonic airliner may run to a billion dollars for the first one and perhaps \$20,000,000 a copy, after the billion is spent in research.

To operate economically, an airline might have to charge \$1000 or \$2500 for a round-trip across-the-country flight. The planes would fly empty.

The Federal Aviation Agency is studying this. In a report due late this month it probably will say: 1) Yes, national prestige demands that we build Mach-3

airliners even though their cost can't be justified on economic grounds, and 2) Uncle Sam will have to pick up most of the check for a commercial transport.

Parallel to the FAA study, NASA is conducting a feasibility study of four proposed planforms for SCAT. One is a canard-delta comparable to the B-70, one a tailless delta with no canard, another a delta with a separate tail aft of the wing, while the fourth has a variable-angle wing that sweeps forward to about the same configuration as present jet transports for subsonic operation, then folds back into delta shape for faster-than-sound flight.

NASA has asked two aircraft companies to evaluate the designs from the standpoint of relative costs, relative weights. This information, due back in November, will guide NASA in deciding into which of the four designs its research efforts should best be put. There is still a long way to go: NASA also is studying rudders of various size, variously twisted and warped wings for highest aerodynamic efficiency, engines in separate pods and, in one version, folding wingtips similar to those of the B-70. One spokesman says the final design for SCAT could be started two years from now. On that basis, it could be flying in 1970.

Apparently noise is going to be an unavoidable accompaniment to the supersonic era. With all its afterburners turned on, the B-70 will make an ear-shattering roar on take-off and climb-out. Even at altitude its supersonic boom will startle people on the ground. But the engineers are saying that the supersonic airliners won't be as bad, that they won't use afterburners or even duct burning, that their noise at take-off will be no greater than our present jet transports.

Today NASA is studying the effect of supersonic overpressures on nearby aircraft in flight. What this means is: "Will a sonic boom created by one aircraft hurt another airplane that is nearby?" It is said that an adjacent airplane will receive only a slight bump, nothing serious.

Military or civilian, any aircraft traveling faster than Mach-1 creates a shock wave, a sonic boom. Can anything be done to minimize this nerve-shattering noise? So far the answer is nothing.

Once upon a time, piston-engine aircraft used to cart us across the country in eight hours, plus. Then, a short five years ago, the jets chopped this time to five hours, or less. That was really traveling, it seemed at first, but now experienced air travelers are becoming bored with the tedium of the five-hour ride. They can hardly wait to go supersonic! ★★



## ELECTRIC WELD - BRAZE & CUT

REPAIR MOST EVERYTHING MADE OF METAL  
BEST WELDER MADE FOR THE MONEY!



Includes full face shield, extra arc goggles, ground clamp, twin carbon arc torch, welding rod holder, supply of welding and brazing rods, solder, flux and full supplies. PLUS ARC WELDING INSTRUCTION BOOK! ONE YEAR GUARANTEE—10 DAY FREE TRIAL. Now you can make or repair metal parts for cars, home, farm, garden, shop or factory. Works on any 110 v. house plug-in. CUT, MELT, BRAZE, SOLDER OR WELD MOST ANY METAL!

SEND ONLY \$2.00 (cash, ck, mo) and pay postman only \$12.95 plus COD postage or send \$14.95 for postpaid delivery. Every EXPERIMENTER, MECHANIC, INVENTOR, CAR OR HOME OWNER NEEDS THIS SMALL WELDER. ORDER YOURS NOW! Ideal gift. MADE ONLY BY: MIDWAY WELDERS CO., Dept. DPM-6, KEARNEY, NEBR.

### BUY GREAT NECK HAND TOOLS

... for long-lasting performance

Precision Balanced  
NAIL HAMMER

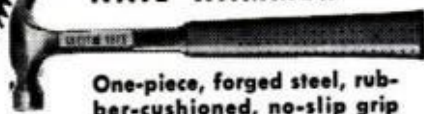

One-piece, forged steel, rubber-cushioned, no-slip grip

## GREAT NECK SAW MFRS., Inc.

MINEOLA, N. Y. — SEE YOUR LOCAL STORE



ASK FOR **HASTINGS**  
PISTON RINGS  
OIL FILTERS  
CASITE ADDITIVES  
Best \$ you can spend on your car

ALL FAMOUS BRANDS!  
**TIRES!** FARM TRUCK AUTO  
AT LESS THAN WHOLESALE  
SAVINGS NEVER LESS THAN 50% up to 70% OFF REG. PRICE!  
HEADQUARTERS for ALL SPORT CAR TIRE SIZES  
FREE - SEND FOR YOUR FREE CATALOG - FREE!

RELIABLE TIRE DIST., 730 Morgan Blvd., Camden 4, N. J.

## GENUINE ALNICO MAGNETS

AMAZING, PERMANENT, NON-ELECTRIC, HIGHLY PRACTICAL.  
Conduct interesting experiments. Hundreds of uses. Retrieve valuable steel items such as guns, tackle from fresh or salt water; tools from tanks & drains. **GUARANTEED.** Try any magnet one week.

M-90 (Wt. 5 oz.)	Has pull of 15 lbs. on steel block	\$ 3.50
M-500 (Wt. 13 oz.)	Has pull of 50 lbs. on steel block	\$ 5.00
M-575 (Wt. 18 oz.)	Has pull of 75 lbs. on steel block	\$ 7.00
M-625 (Wt. 20 oz.)	Has pull of 125 lbs. on steel block	\$10.00
M-710 (Wt. 33 oz.)	Has pull of 225 lbs. on steel block	\$18.00
M-44 Rod Magnets for Electric Guitars 1/4" Dia. x 1 1/4", 12 for \$		4.00
M-47 Hot Pad Magnets. 10 for \$1.00		50 for \$ 4.87
M-35 Science Experimenter Kit of 8 magnets		\$ 2.00

Send M.O. or check. We pay postage. Sorry no C.O.D.'s.

MIAMI MAGNET COMPANY, 3240 N.W. 27th Ave., Miami 42, Fla.

## FOR ACCURACY IT'S HULL COMPASS

When buying a compass, you want accuracy above all else. You get it with HULL—the compass that works—for cars or boats. Easier, more positive compensation.



\$5.95 TO \$7.50 AT YOUR DEALER'S OR WRITE FOR LIT  
HULL MFG. CO., Box 246-D-6, Warren, Ohio

## Free Booklet Tells About Profitable Side Line Business Sharpening Saws



"Since 1932 we've helped hundreds of men start their own business at home in their spare time," says Mr. Ringer. "Many have found it so profitable, they have made it a full time business. Starting at once you can earn \$4 to \$6 an hour and you are your own boss. I will set you up in a service every community needs—and you can start with only one machine—an automatic Foley Saw Filer that can sharpen almost any kind of saw: combination, circular, hand and band saws. Best of all **NO EXPERIENCE IS NECESSARY.** Anyone can operate. All my years of secrets on how to build a profitable repeat CASH business are in my free booklet, "Money Making Facts." Write today to Walter M. Ringer, Jr., President, care of

**FOLEY MANUFACTURING CO.**  
643-3 Foley Bldg., Mpls. 18, Minn.

## DRAINS cellars, cisterns, wash tubs; \$7.95 IRRIGATES - CIRCULATES - SPRAYS



1,001 uses. Stainless shaft. Won't rust or clog! Use 1/6 HP motor or larger . . . 3/4 HP for up to 2,400 GPH; 450 GPH 80" high; or 1800 GPH from 25' well. 1" inlet; 3/4" outlet. Coupling included free. \$7.95. **HEAVY DUTY BALL-BEARING PUMP.** Up to 5,200 GPH; or 3,000 GPH from 25' well. 1 1/4" inlet; 1" outlet. \$12.95. Postpaid if cash with order. **MONEY BACK GUARANTEE**

Centrifugal and Gear Pumps in All Sizes

LABAWCO PUMPS, Belle Mead 7, New Jersey

## GUNK® removes grease -- scourfully! cleans -- degreases -- freshens



- power mowers • engines
- cement floors • kitchen walls • ovens • exhaust ducts
- paint brushes • furnace filters • barbecue grills
- implements • machinery

AT AUTO SUPPLY, FARM & HARDWARE STORES!

GUNK CHICAGO CO., River Forest, Illinois  
covering the Midwest and Southwest  
RADIATOR SPECIALTY CO., Charlotte, N.C.  
covering the East, Southeast and far West

## At Last an Amazingly simple GAS JET TURBINE or TACHOMETER

Build either project from easy to follow plans. Ideal for serious minded hobbyist, scientific and industrial arts classes.

### GAS TURBINE JET ENGINE

Develops 20 H.P., Length 15" Dia. 8 1/2", Wt. 15 lbs. Gasoline or Kerosene.

Make on 9" metal cutting lathe with milling attachment. Use on boats, small cars, industrial, etc. Full size assembly drawings with critical dimensions, bill of material and photos. Price \$5.00. No C.O.D.



### EYE LEVEL TACHOMETER Electronic Transistorized



Reliable Tachometer for sports and domestic cars, boats, planes, etc. Range 0 to 5000 RPM: 3% full scale accuracy. Operates on 6 or 12 Volts. Build from easy to follow plans. Full size assembly drawings with critical dimensions and electronic schematic

for wiring and operating instructions. Bill of material and photos with aluminum body casting. Price \$5.00. No C.O.D.

SAVOY SCIENTIFIC, Box 1398, SANTA MONICA, CALIF.

Cast your ballot for a successful future!

# 249 I.C.S. COURSES



I.C.S. is the oldest, largest school of its kind. Over 249 courses for men and women. High school, business, secretarial, interior decorating, engineering. One for you. Direct, job-related. Bedrock facts and theory plus practical applica-

tion. You learn from experts. Diploma to graduates.

Clip and mail the coupon now. You'll receive, absolutely FREE, 3 valuable booklets that have helped thousands. But don't delay. Cast your "ballot" for future success!



## ACCOUNTING

Accounting  
Auditing  
Cost Accounting  
General Accounting  
Junior Accounting  
Practical Accounting  
Public Accounting

## ADVERTISING

Advertising  
Magazine & Newspaper  
Advertising

## ARCHITECTURE AND BUILDING CONSTRUCTION

Architectural Drawing & Designing  
Architectural Interiors  
Architecture  
Building Contractor  
Building Contractor with Drawing  
Building Estimator  
Building Maintenance  
Carpenter-Building  
Carpentry & Millwork  
House Planning  
Lumber Dealer  
Mason  
Painting Contractor  
Reading Arch. Blueprints  
Reading Struct. Blueprints

## ART

Advertising Layout & Illustration  
Amateur Artist  
Commercial Art  
Commercial Cartooning  
Fashion Illustrating  
Figure Drawing & Painting  
Magazine Illustrating  
Show Card & Sign Prod'n  
Show Card Writing  
Sign Painting & Designing  
Sketching & Painting

## AUTOMOTIVE

Auto Engine Tune-up  
Automobile  
Automobile Body Rebuilding and Refinishing  
Automobile Electrical Technician  
Automobile Technician  
Diesel Engines

Diesel-Gas Motor Vehicle Engines  
Gas Engines  
Internal Combustion Engines

## AVIATION

Aero-Engineering Technology  
Aircraft & Engine Mechanic  
Aircraft Mechanic  
Aviation Engine Mechanic

## BUSINESS

Business Administration  
Business Correspondence  
Business Law  
Business Management & Marketing  
Business Management & Production  
Business Psychology  
Canadian Business Management  
Clerk-Typist  
Commercial  
Condensed Business Practice  
Federal Tax Course  
Managing a Small Business  
Marketing  
Office Administrative Engineering  
Office Management  
Professional Secretary  
Programming for Digital Computers  
Purchasing Agent  
Retail Business Management  
Shorthand  
Stenographic  
Typewriting

## CHEMICAL

Analytical Chemistry  
Chemical Engineering  
Chemical Engineering Unit Operation  
Chemical Laboratory Technician  
Elements of Nuclear Energy  
General Chemistry  
Industrial Analytical Chemistry  
Industrial Chemistry  
Professional Engineer—Chemical

## PULP AND PAPER

Paper Making  
Pulp & Paper Engineering

Pulp & Paper Making  
Pulp Making

## CIVIL ENGINEERING

Bridge & Building Foreman  
Civil Engineering  
Construction Engineering  
Highway Engineering  
Mine Surveying & Mapping  
Principles of Mapping  
Principles of Surveying  
Professional Engineer—Civil  
Railroad Engineering  
Roadmaster  
Sanitary Engineering  
Section Foreman  
Sewage Plant Operator  
Structural Engineering  
Surveying and Mapping  
Water Works Operator

## DRAFTING

Aircraft Drafting  
Architectural Drafting  
Drafting & Machine Design  
Electrical Drafting  
Electrical Engineer Drafting  
Electronic Drafting  
Industrial Piping Drafting  
Junior Mechanical Drafting  
Mechanical Drafting  
Sheet Metal Drafting  
Structural Drafting

## ELECTRICAL

Elec. Appliance Servicing  
Electrical Contractor  
Electrical Eng'r'g (Power Plant option—Electronic option)  
Electrical Engineering Tech.  
Electrical Instrument Tech.  
Electric Motor Repairman  
Illumination Eng'r'g Tech.  
Industrial Electrical Techn.  
Power-House Engineering  
Power Line Design and Construction  
Practical Electrician  
Practical Lineman  
Professional Engineer—Electrical  
Reading Electrical Blueprints

## HIGH SCHOOL

Good English  
High School Business  
High School College Prep (Arts)

High School College Prep (Engineering & Science)  
High School General  
High School Mathematics  
High School Secretarial  
Modern Letter Writing  
Short Story Writing

## LEADERSHIP

Industrial Foremanship  
Industrial Supervision  
Personnel-Labor Relations  
Supervision

## MATHEMATICS

Mathematics and Mechanics for Engineers  
Mathematics and Physics for Engineers  
Mathematics and Physics for Technicians

## MECHANICAL

Industrial Engineering  
Industrial Instrumentation  
Junior Mechanical Engineering  
Mechanical Engineering  
Professional Engineer—Mechanical  
Quality Control  
Introductory Technical Writing

## PETROLEUM

Natural Gas Production & Transmission  
Oil Field Technology  
Petroleum Production  
Petroleum Prod'n Eng'r'g  
Petroleum Refinery Operator  
Petroleum Refining  
Petroleum Technology

## PLASTICS

Plastics Technician

## PLUMBING, HEATING, AIR CONDITIONING

Air Conditioning  
Air Conditioning with Draw'g  
Air Conditioning Maintenance  
Domestic Heating with Oil & Gas  
Domestic Refrigeration  
Heating  
Heating & Air Conditioning with Drawing

Heating, Drawing & Estimat'g  
Plumbing  
Plumbing, Drawing & Estimating  
Plumbing & Heating  
Plumbing & Steamfitting  
Practical Plumbing  
Refrigeration  
Refrigeration & Air Conditioning  
Steamfitting

## RAILROAD

Air Brake Equipment  
Car Inspector & Air Brake  
Diesel Electrician  
Diesel Engineer & Fireman  
Diesel Locomotive  
Diesel Machinist  
Railroad Administration  
Railroad Car Repairer

## SALESMANSHIP

Creative Salesmanship  
Real Estate Salesmanship  
Retail Merchandising  
Retail Selling  
Sales Management  
Salesmanship  
Salesmanship & Sales Management

## SHOP PRACTICE

Boiler-making  
Electric Welding  
Foundry Practice  
Gas and Electric Welding  
Gas Welding  
Heat Treatment of Metals  
Industrial Metallurgy  
Machine Shop Inspection  
Machine Shop Practice  
Machine Shop Practice & Toolmaking  
Metallurgical Engineering Technology  
Physical Quality Control of Metals  
Practical Millwrighting  
Reading Shop Blueprints  
Resistance Welding Technology  
Rigging  
Safety Engin'r'g Technology  
Sheet Metal Worker  
Tool Design  
Tool Engineering Technology

Toolmaking  
Welding Engineering  
Technology

## STEAM AND DIESEL POWER

Combustion Engineering  
Power Plant Engineering  
Stationary Building Eng'r'g  
Stationary Diesel Eng'r'g  
Stationary Diesel-Electric Engineering  
Stationary Fireman  
Stationary Steam Eng'r'g  
Steam Engine Operation

## TEXTILES

Carding and Spinning  
Carding  
Cotton Manufacturing  
Cotton Warping & Weaving  
Dyeing & Finishing  
Hosiery and Circular Knitting  
Loom Fixing  
Spinning  
Synthetic Fabric Manufacturing  
Synthetic Throwing, Warping & Weaving  
Textile Designing  
Textile Engineering  
Textile Mill Supervisor  
Woolen Manufacturing  
Worsted Manufacturing

## TRAFFIC

Motor Traffic Management  
Railroad Rate Clerk  
Traffic Management

## TV-RADIO-ELECTRONICS

Gen'l Electronics Technician  
Industrial Electronics  
Practical Radio-TV Eng'r'g  
Radio Operating  
Radio Servicing  
Radio Servicing with Practical Training  
Radio & TV Servicing  
Radio & TV Servicing with Practical Training  
Servicing Electr'n'c Devices  
Servicing Sound Equip't  
Practical Telephony  
Telephony and Radio Communications  
TV Receiver Servicing  
TV Technician

For Real Job Security—Get an I. C. S. Diploma! I. C. S., Scranton 15, Penna.

Accredited Member,  
National Home Study Council

## INTERNATIONAL CORRESPONDENCE SCHOOLS



BOX F0752F, SCRANTON 15, PENNA.

In Hawaii reply P.O. Box 418, Honolulu

Without cost or obligation, send me "HOW to SUCCEED," the opportunity booklet about the field I have indicated below, and a sample lesson

Name of the course in which you are interested \_\_\_\_\_

Your Name \_\_\_\_\_ Age \_\_\_\_\_ Home Address \_\_\_\_\_

City \_\_\_\_\_ Zone \_\_\_\_\_ State \_\_\_\_\_ Working Hours \_\_\_\_\_ A.M. to \_\_\_\_\_ P.M.

Occupation \_\_\_\_\_ Canadian residents send coupon to International Correspondence Schools, Canadian, Ltd., Montreal, Canada. . . . Special low monthly tuition rates to members of the U. S. Armed Forces.



When  
a  
cigarette  
means  
a lot...

# get Lots More from L&M

**more body in the blend**...there's a special rich-flavor leaf—and more of it—among L&M's choice tobaccos.

**more flavor in the smoke**...every puff is heartier, for L&M has more longer-aged, extra-cured leaf than even some unfiltered cigarettes.

**more taste through the filter**...and L&M's filter is the modern filter — *all white*, inside and outside — so only pure white touches your lips.



**It's the rich-flavor leaf that does it!**



© 1972 United Feature Syndicate, Inc.

There's more to it than that, Charlie Brown. You also get those service-saving features with any new car or wagon you purchase from Ford \*

They go 36,000 miles or two years between major chassis lubrications...6,000 miles between oil changes and minor lubes. Even the brakes adjust themselves! And now V-8 power is available in Falcon sedans, hardtops, convertibles

and wagons—the same V-8 power that did so well in the Monte Carlo Rallye! And with this new V-8 power you get America's *only* fully synchronized 3-speed manual transmission as standard equipment. Visit your Ford Dealer's soon for a Falcon test-drive. Tell him Charlie Brown sent you.

America's longest, liveliest line of wagons

**FORD**

FALCON • FAIRLANE • FORD

\*Except Station Bus and Club Wagons  
FOR 40 YEARS THE SYMBOL OF DEPENDABLE PRODUCTS  MOTOR COMPANY

